

Application to: American Bureau of Shipping

Submitted to US EPA by: Lake Michigan Carferry Service

Dated: March 13, 2014

**ALL CONFIDENTIAL BUSINESS INFORMATION**  
**REDACTED BY LAKE MICHIGAN CARFERRY SERVICE**

**THIS PAGE**  
**INTENTIONALLY LEFT BLANK**

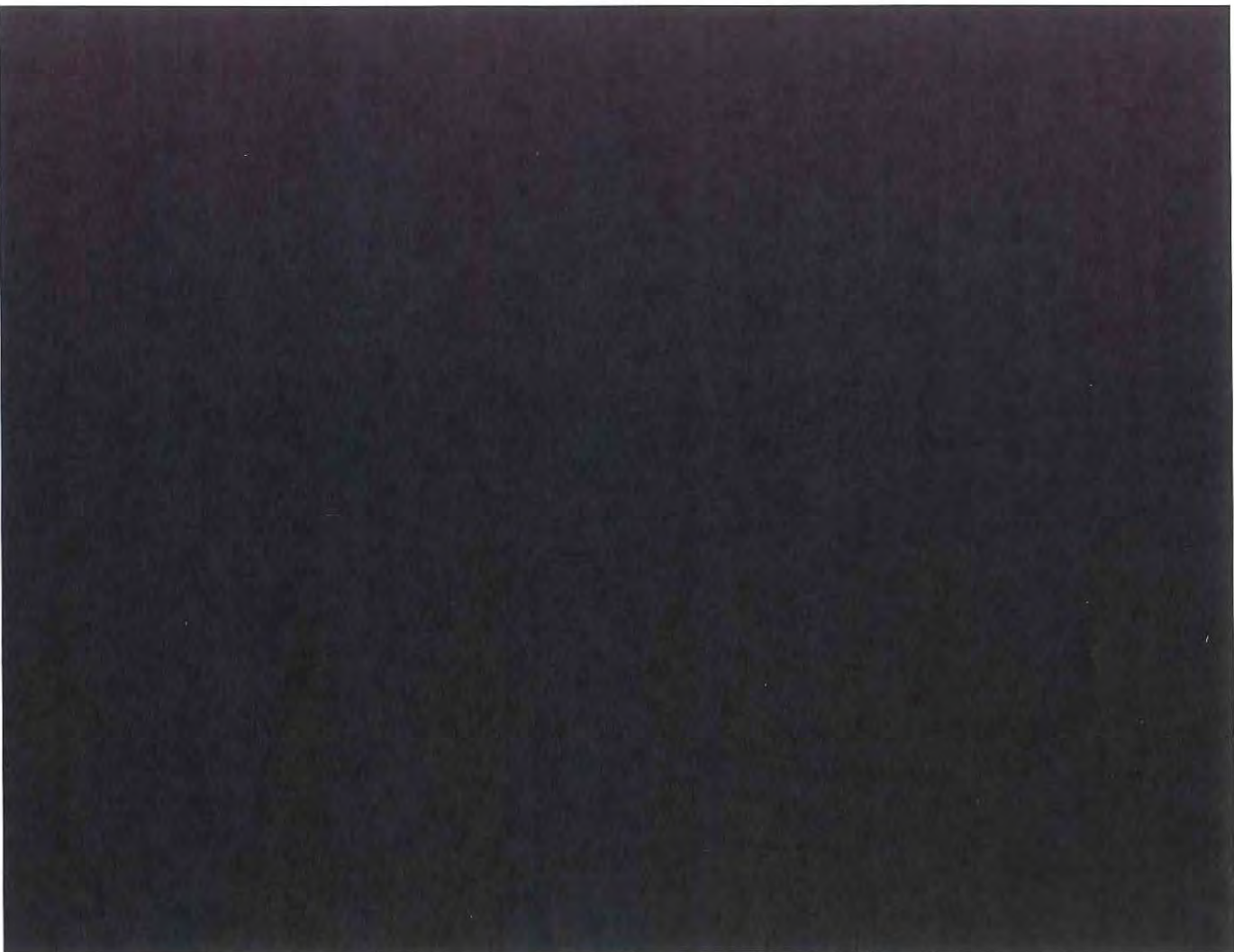

---

**From:** [REDACTED]  
**Sent:** Friday, March 07, 2014 1:10 PM  
**To:** Marine Shop  
**Subject:** FW: SS Badger Boiler Combustion Control Submittals 1 of 2

Chuck

This is our ABS submittal information 1 of 2 emails sent . I will also send you the second half next. Use this for your installation drawings . We have made some changes in Power Distribution drawings.



---

**From:** [REDACTED]  
**Sent:** Friday, March 07, 2014 12:10 PM  
**To:** [HRobles@eagle.org](mailto:HRobles@eagle.org); [MAhmed@eagle.org](mailto:MAhmed@eagle.org)  
**Subject:** FW: SS Badger Boiler Combustion Control Submittals

Dear Henry & Mohammad,

I am sending this Submittal in two or more emails because of the size.

Please find the above SS Badger Boiler Combustion Control project submittals attachments for your review.

Our cover letter is attached giving an overview of the project and a list of Enclosures for your review.

The installation of the new systems is now being performed aboard the SS Badger in Ludington, Michigan during the vessels winter lay-up. The project is to be completed in April to begin testing, dock trials and sea trials to be ready for the first voyage on May 16<sup>th</sup>. In other words we need to have this review treated as urgent. We had the Hindle Power Inc. 24 VDC power supply system that we are using for redundant power to our systems reviewed and factory tested and approved by ABS in January. ABS Project No. 3176956 , Task No. 1134456.

Chuck Cart the SS Badger's Senior Chief Engineer has had the local USCG and ABS office involved in the project.

We will send you a formal purchase order today. The PO number will be BAD030714.

Please feel free to give me a call or email me with any questions.

Respectfully

A large black rectangular redaction covers the signature and name of the sender. The redaction consists of several overlapping black boxes of varying sizes, completely obscuring the text underneath.



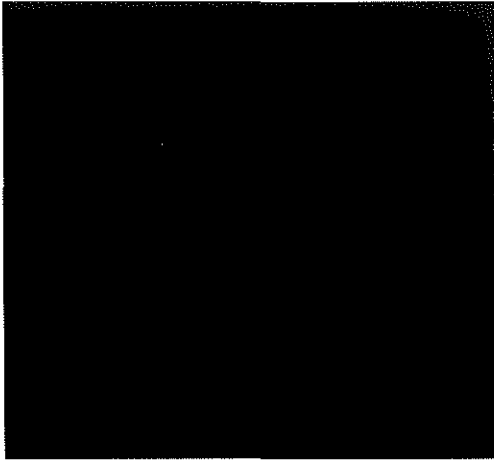

March 6, 2014

Mr. Henry Robles, Principal Engineer  
American Bureau of Shipping  
Ship Systems Group  
Engineering Services Department  
16855 Northchase Drive  
Houston, Texas 77060-6008

Subject: Submittal of Plans in Agreement with Navigation and Vessel Inspection Circular (NVIC) 10-92, for SS Badger, ABSID 5300348, IMO 5033583, Hull 370.

Dear Mr. Robles:

This plan submittal is for the upgrading of the SS Badger's manually-operated coal-burning boiler systems to Automatic Combustion Control, supervised operation. Boiler light-off, shutdown and day-to-day operation will continue as a fully-supervised, operator attended, manual system only. The Automatic Combustion Control systems are intended to provide improved efficiency, economy and emissions. Safety supervision of all lighting, shutdown and ash dumping will continue to be strictly a manual operation.

This plan submittal is NOT for reclassification of vessel's manning. The engine room/boiler room will be manned by a full complement of crew member and engineering officers.

Since it is the intent that this plan submittal be performed in agreement with Navigation and Vessel Inspection Circular (NVIC) 10-92, please review the attached plans and forward approved submittals to the USCG per (NVIC) 10-92, as well as, the USCG Sector Lake Michigan, Milwaukee, WI and ABS surveyor's office in Sturgeon Bay, WI. Please return at least one stamped copy to .

This plan submittal is for the installation of the following systems:

1. Automatic Combustion Control – Each Boiler
2. Drum Level – Each Boiler (To be addressed separately in 2015)
3. Feed pump control (To be addressed separately in 2015)
4. Redundant 24VDC Power Supply systems
5. Consoles and cabinets for Port and Starboard boiler
6. Feedwater Control Panel for Engine Room

### **System Descriptions**

All of the following systems' control and computing functions are performed by Siemens, ABS Type-Approved, Model 353 Loop Controllers. The Operator monitoring and interface stations (HMI) employ ABS Type-Approved PCs. Refer to the systems' I/O Data Sheets for all systems' I/O types and channel addresses. The I/O Data Sheets list the channels for each controller.

The 353 systems hardware and software used in this project have been used and previously approved by ABS & USCG for ACC systems aboard the AAA class ship Steamers Philip R. Clarke, Arthur M. Anderson, LNG/C Matthew, SS Wright & SS Curtiss.

#### **1. Boiler Automatic Combustion Control**

Automatic Combustion Control system consists of Siemens 353 controllers and will be of the GRB, fully-metered and cross-limited design. This design has proven to be stable, repeatable and flexible, and is highly efficient in fuel savings.

#### **2. Boiler Drum-Level, 2-Element (to be integrated in 2015)**

Drum level systems are of the GRB design, utilizing steam flow to characterize the feed water valve position and drum level to trim the results. This system has been proven to be the most accurate and stable of all loop configurations for drum-level control. Two drum level transmitters per boiler, using separate taps, are provided. One transmitter provides level control and High/Low alarm functions. The other drum level transmitter provides separate level indication, Low-Low Drum Level, Coal Feeder trips and alarms. All drum level control computations and I/O are incorporated in Siemens 353 controllers.

#### **4. Systems Power Supply**

All DC systems' power requirements will be supplied by redundant, 24 VDC, Marine Duty, Charging Units, as previously utilized and approved aboard the Steamer Philip R. Clarke, Arthur M. Anderson, Cason J. Callaway, and LNG/C Matthew. These units will also provide power for the 24VDC requirements of the, two HMI, ABS Type-Approved Flat-Panel PCs. AC power feeding the 24 VDC systems will come from two feeders; one from the main and one from the emergency switchboard. This configuration is per ABS 4-9-3/3.5.1 "System power supply".

## **5. Cabinets & Enclosures**

Dedicated and vortex-cooled enclosures will house the two ABS type-approved, Flat Panel, Touchscreen PCs. The engine-room, Feed Panel enclosure, will house the Feedpump 353 controllers (future) and four Dixson Drum Level meters. In addition, there will be one Dixson, D.A. Level meter to be added in the future. The Dixson level indicators have been successfully used aboard the Cason J. Callaway, Arthur M. Anderson, Philip R. Clarke, John G. Munson and many other ABS vessels.

## **6. Supervisory Only**

The ABS Coal Burning Document: Publication 21 and portions of NFPA 86 were used as guides wherever described elements were considered appropriate to this application. Such elements as practicable have been incorporated in the design to provide such supervisory protections as water-level alarms, low-low water trips of coal feeders, high steam and furnace pressure alarms and coal feeder/rotor interlocks. Please refer to the accompanying, ABS Guide for Ships Burning Coal – Annotations document for additional clarification.

Please note: all submittals are in electronic format, comprised of zipped folders, containing MS Word and Excel formatted files or pdf documents.

Respectfully Submitted,



### **Enclosures:**

Boiler Panels' Wiring and Cable Identification Schedule

Analog Transmitter list with cable assignments

Annotated Excerpt from ABS Coal Burning Ships Document – Publication 21

Self-Certification Letter,  – 3 Pages

ABS/Marine Agencies' Type-Approvals with Listings

Siemens Model 353 Controller Logic Drawings – 27 Controllers

System Wiring Drawings:

Port and Starboard Boiler Control Cabinets

Feedwater Control/Monitoring Panel

Siemens Motor Supervisory PLC system I/O

Siemens Model 353 Controllers' Wiring

Copy of letter from USCG Sector Lake Michigan

# LIST OF CERTIFICATIONS

---

1. Siemens 353 Loop Controllers - ABS 02-2HS68273-3-PDA.pdf
2. Danfoss Variable Frequency Drives - ABS TAC 06-LD192435-2-PDA (DK).pdf
3. Vortex Airflow Metering - ABS Type Cert 8800 Vortex.pdf
4. HindlePower Test Instructions - CD5008-00\_80349323.pdf
5. HindlePower Specification- JF5036-00\_80350026.pdf
6. HindlePower ABS Letter- T1134456, letter\_80349328.pdf
7. SITRANS P DSIII Transmitters- 03-HS360494-2-PDA.pdf
8. S7300 PLC - 01-HG189457-5-PDA.pdf
9. Hatteland PC Approvals- 12-LD908273-1-PDA.pdf
10. Hirschmann Ethernet Switches- 3288006.pdf (Germanischer Lloyd)
11. Belden Cat 5e Cables - 1300SB





### ***Confirmation of Product Type Approval***

Please refer to the "Service Restrictions" shown below to determine if Unit Certification is required for this product. This certificate reflects the information on the product in the ABS Records as of the date and time the certificate is printed.

Pursuant to the Rules of the American Bureau of Shipping (ABS), the manufacturer of the below listed product held a valid Manufacturing Assessment (MA) with expiration date of 26/FEB/2018. The continued validity of the Manufacturing Assessment is dependent on completion of satisfactory audits as required by the ABS Rules.

And; a Product Design Assessment (PDA) valid until 04/FEB/2018 subject to continued compliance with the Rules or standards used in the evaluation of the product.

The above entitle the product to be called Product Type Approved.

The Product Design Assessment is valid for products intended for use on ABS classed vessels, MODUs or facilities which are in existence or under contract for construction on the date of the ABS Rules used to evaluate the Product.

ABS makes no representations regarding Type Approval of the Product for use on vessels, MODUs or facilities built after the date of the ABS Rules used for this evaluation.

Due to wide variety of specifications used in the products ABS has evaluated for Type Approval, it is part of our contract that; whether the standard is an ABS Rule or a non-ABS Rule, the Client has full responsibility for continued compliance with the standard.

**Product Name: Process Automation Controller**  
**Model Name(s): TGX:353**

**Presented to:**  
SIEMENS INDUSTRY, INC.  
1201 SUMNEYTOWN PIKE  
P.O. BOX 900  
SPRING HOUSE  
United States

**Intended Service:** Marine & Offshore Application - Capable of Measuring, Controlling, and/or Communicating Thermocouples, RTD's Voltage, Current, Relay I/O's etc. - Flow, Level, Pressure, etc. - On Board ACC, ACCU, and ABCU Classed Vessels

**Description:** Universal Microprocessor Based Multi Purpose Panel Mounted Loop Process Automation Controller.(See User's Manual UM353-I for options).

**Ratings:** Input Power: 120 / 240 V AC, 47 - 63 Hz, 40 VA or 24 V DC, 25 W; Outputs: Analog - 4/20/mA, Digital 0 - 30 V DC, 100 mA, Transmitter Power 28 V DC, 120 mA, Relay Contacts 5 A @ 120 V AC or 2.5 A @ 240 V AC; Inputs: Analog 0 - 5 V DC, Digital 30 V DC Maximum; Maximum Ambient Temperature: 60 °C; Temperature Code: T3C (160 °C) DC Models; T4A (120 °C) AC Models; Non-Incendive for use in Class 1, Division 2, Groups A, B, C and D Hazardous Indoor locations. Only approved options as per Clause 1.2 of FM Approval Report FMRC J.I.3B4A4.AX (3611), dated January 8, 1997 are being utilized;

**Service Restrictions:** Unit Certification is not required for this product. If the manufacturer or purchaser's request an ABS Certificate for compliance with a specification or standard, the specification or standard, including inspection standards and tolerances, must be clearly defined. 1) The integrity of the Automatic or Remote Control and Monitoring Systems utilizing the Model TGX:353, Universal Loop Controller is to be verified by means of a Failure Mode and Effect Analysis on the basis of a Single Failure Mode.

Criteria; 2) Model TGX:353 Universal Loop Controller is to be installed in accordance with FM Controlled Document Drawings, certifying Laboratory (FM and CSA - see Standards) Reports and Certificates and Manufacturer's Specifications; 3) This approval covers Hardware only. Each Ship-specific application must be approved on a case-by-case basis. 4) Emissions within limits for Bridge and Deck Zone except at 159.99 MHZ. To comply the Unit must be used in an Enclosure that provides at least 24dB  $\delta$ V of Attenuation at this Frequency.

**Comments:** The Manufacturer has provided a declaration about the control of, or the lack of Asbestos in this product.

**Notes / Documentation:** Supporting Data: CSA (Certificate of Compliance No. LR 38024-121, Dated Dec. 19, 1996), FM (FM Approval Report No. FMRC J.I 3B4A4.AX (3611), Dated Jan. 8, 1997 & FMRC J.I. 3B4A4.AX dated 14 December 2001 & Revision Report dated 30 Oct 2003 & 12 July 2005 \* Dwg No. 16376-19A,Rev.4, Overview Schematic 353E MPU,10 Shts; \* Dwg No. 16353-34,Rev.8, Bezel & Keyboard Assy 353, 4 Shts; \* Dwg No. 16376-20,Rev.3, Assy Dwg 353E MPU; \* Dwg No. 16353-36,Rev.4, Term Cover 353 Rear Plate; \* Dwg No. 16353-6,Rev.2, Flange-Die Casting; \* Dwg No. 15232-114,Rev.3, PCB SMOBC, GL 353E MPU \* Dwg No. 16281-99A,Rev.3, Schematic 353 LED Display; \* Dwg No. 16297-20,Rev.5, Assy Dwg 353E LIL; \* Dwg No. 16353-21,Rev.3, Machining/Assy Dwg 353E Case; \* Dwg No. 16344-20,Rev.2, Assy Dwg 353E Ethernet; \* Dwg No. 16298-90,Rev.2, Assy Dwg 353E Lonworks;

**Term of Validity:** This Product Design Assessment (PDA) Certificate 02-HS268273-3-PDA, dated 05/Feb/2013 remains valid until 04/Feb/2018 or until the Rules or specifications used in the assessment are revised (whichever occurs first). This PDA is intended for a product to be installed on an ABS classed vessel, MODU or facility which is in existence or under contract for construction on the date of the ABS Rules or specifications used to evaluate the Product. Use of the Product on an ABS classed vessel, MODU or facility which is contracted after the validity date of the ABS Rules and specifications used to evaluate the Product, will require re-evaluation of the PDA. Use of the Product for non ABS classed vessels, MODUs or facilities is to be to an agreement between the manufacturer and intended client.

**ABS Rules:** 2013 Steel Vessels Rules 1-1-4/7.7, 1-1-A3, 4-9-7/13;

**National Standards:**

**International Standards:** EN61010-1, 2nd Ed

**Government Authority:**

**EUMED:**

**Others:**

Model Certificate	Model Certificate No	Issue Date	Expiry Date
PDA	02-HS268273-3-PDA	05/FEB/2013	04/FEB/2018



**ABS Programs**

ABS has used due diligence in the preparation of this certificate and it represents the information on the product in the ABS Records as of the date and time the certificate was printed. Type Approval requires Drawing Assessment, Prototype Testing and assessment of the manufacturer's quality assurance and quality control arrangements. Limited circumstances may allow only Prototype Testing to satisfy Type Approval. The approvals of Drawings and Products remain valid as long as the ABS Rule, to which they were assessed, remains valid. ABS cautions manufacturers to review and maintain compliance with all other specifications to which the product may have been assessed. Further, unless it is specifically indicated in the description of the product, Type Approval does not necessarily waive witnessed inspection or survey procedures (where otherwise required) for products to be used in a vessel, MODU or facility intended to be ABS classed or that is presently in class with ABS. Questions regarding the validity of ABS Rules or the need for supplemental testing or inspection of such products should, in all cases, be addressed to ABS.





### *Confirmation of Product Type Approval*

Please refer to the "Service Restrictions" shown below to determine if Unit Certification is required for this product.

This certificate reflects the information on the product in the ABS Records as of the date and time the certificate is printed.

Pursuant to the Rules of the American Bureau of Shipping (ABS), the manufacturer of the below listed product held a valid Manufacturing Assessment (MA) with expiration date of 05/OCT/2016. The continued validity of the Manufacturing Assessment is dependent on completion of satisfactory audits as required by the ABS Rules.

And; a Product Design Assessment (PDA) valid until 05/MAY/2014 subject to continued compliance with the Rules or standards used in the evaluation of the product.

The above entitle the product to be called Product Type Approved.

The Product Design Assessment is valid for products intended for use on ABS classed vessels, MODUs or facilities which are in existence or under contract for construction on the date of the ABS Rules used to evaluate the Product.

ABS makes no representations regarding Type Approval of the Product for use on vessels, MODUs or facilities built after the date of the ABS Rules used for this evaluation.

Due to wide variety of specifications used in the products ABS has evaluated for Type Approval, it is part of our contract that; whether the standard is an ABS Rule or a non-ABS Rule, the Client has full responsibility for continued compliance with the standard.

**Product Name:** Frequency Converter

**Model Name(s):** VLT® Automation Drive FC300 series type FC301/302, VLT® AQUA Drive series FC202 and VLT® HVAC Drive series FC102

**Presented to:**

DANFOSS POWER ELECTRONICS A/S  
ULSNAES 1  
DK-6300 GRAASTEN  
Denmark

**Intended Service:** Marine and Offshore Installations.

**Description:** FC 102, FC202 and FC30x series configurations are as per attached product description.

**Ratings:** Whole range of ratings is per the configurations in attached product description sheet.

**Service Restrictions:** Unit Certification is required for drive units where required for essential services as per 4-8-3/5.11 and 4-8-5/5.17.9 of the Rules.

**Comments:** 1) Tests and approval are for the basic components. Each configuration and external connection is to be specifically approved. 2) Main propulsion control systems are assigned with System Category II in accordance with 4-9-6/Table 2 of the SVR. If the subject drives are used in main propulsion system, evidence of documentation as required by 4-9-6/Table 3 of the SVR is to be submitted for review when requested.

**Notes / Documentation:** Approval documentation : Danak/Delta Test report Project Nos.: E400877; A401850, A401850-01 and A402498; Test Reports A402342, P407-151/152/154 and P420-316/341/366/367/395/423/539/540/541/543-547/549/550/552/553/554/561/563/575/576

<b>Term of Validity:</b>	This Design Assessment Certificate number 06-LD192435/2-PDA, dated 06/May/2009 will expire on 05/May/2014 or at an earlier date should there be alterations to the product's design or changes to the referenced ABS Rules and other specifications, which affect the product. Product use on or after 1 January 2010, will be subject to compliance with the ABS Rules or specifications in effect when the vessel, MODU or facility is contracted. The product's acceptability on board ABS-classed vessels or facilities is defined in the service restrictions of this certificate.		
<b>ABS Rules:</b>	2009 Steel Vessel Rules 1-1-4/7.7, 4-8-3/1.7, 4-8-3/1.9, 4-8-3/1.11, 4-8-3/1.17, 4-8-3/7.5, and 4-9-7/Table 9 and Table 10		
<b>National Standards:</b>			
<b>International Standards:</b>			
<b>Government Authority:</b>			
<b>EUMED:</b>			
<b>Others:</b>			
<b>Model Certificate</b>	<b>Model Certificate No</b>	<b>Issue Date</b>	<b>Expiry Date</b>
PDA	06-LD192435/2-PDA	06/MAY/2009	05/MAY/2014
			
<b>ABS Programs</b>			
<p>ABS has used due diligence in the preparation of this certificate and it represents the information on the product in the ABS Records as of the date and time the certificate was printed. Type Approval requires Drawing Assessment, Prototype Testing and assessment of the manufacturer's quality assurance and quality control arrangements. Limited circumstances may allow only Prototype Testing to satisfy Type Approval. The approvals of Drawings and Products remain valid as long as the ABS Rule, to which they were assessed, remains valid. ABS cautions manufacturers to review and maintain compliance with all other specifications to which the product may have been assessed. Further, unless it is specifically indicated in the description of the product; Type Approval does not necessarily waive witnessed inspection or survey procedures (where otherwise required) for products to be used in a vessel, MODU or facility intended to be ABS classed or that is presently in class with ABS. Questions regarding the validity of ABS Rules or the need for supplemental testing or inspection of such products should, in all cases, be addressed to ABS.</p>			





### **Confirmation of Product Type Approval**

Please refer to the "Service Restrictions" shown below to determine if Unit Certification is required for this product.

This certificate reflects the information on the product in the ABS Records as of the date and time the certificate is printed.

Pursuant to the Rules of the American Bureau of Shipping (ABS), the manufacturer of the below listed product held a valid Manufacturing Assessment (MA) with expiration date of 18/NOV/2014. The continued validity of the Manufacturing Assessment is dependent on completion of satisfactory audits as required by the ABS Rules.

And; a Product Design Assessment (PDA) valid until 16/SEP/2018 subject to continued compliance with the Rules or standards used in the evaluation of the product.

The above entitle the product to be called Product Type Approved.

The Product Design Assessment is valid for products intended for use on ABS classed vessels, MODUs or facilities which are in existence or under contract for construction on the date of the ABS Rules used to evaluate the Product.

ABS makes no representations regarding Type Approval of the Product for use on vessels, MODUs or facilities built after the date of the ABS Rules used for this evaluation.

Due to wide variety of specifications used in the products ABS has evaluated for Type Approval, it is part of our contract that; whether the standard is an ABS Rule or a non-ABS Rule, the Client has full responsibility for continued compliance with the standard.

**Product Name: Vortex Flow Measuring System**  
**Model Name(s): 8800D**

**Presented to:**  
ROSEMOUNT INC.  
8200 MARKET BOULEVARD  
CHANHASSEN  
United States

**Intended Service:** Measure Fluid Flow in Pipelines.

**Description:** Flanged, Wafer, Reducer and Dual-Sensor, 0.5"-12" Line Sizes;

**Ratings:** Temperature rating: -40 to 450° F (-40 to 232° C), Pressure Rating: 1600 psi. Output Signal: Digital HART signal - 4-20 mA ; Optional Scalable Pulse Output - 0-10 kHz, transistor switch closure w/ adjustable scaling up to 30 vdc, 120mA (maximum) ; Digital Foundation Fieldbus Signal - Manchester-encoded digital signal. Operating Temperature: -50°C to 85 °C and -20°C to 85°C for flowmeters with local indicators. Power Supply: HART Analog - 10.8 to 30 vdc; Foundation fieldbus: 9 to 32 vdc, 17.8 mA (nominal) 20mA (maximum). Intrinsically Safe for use in Class I, II and III, Division 1, Groups A, B, C, D, E, F and G: Temperature Class T4 Ta=70°C; Class 1, Zone 0 AEx ia IIC T4 Ta=70°C; Nonincendive for use in Class 1, Division 2, Groups A, B, C and D: Temperature Class T4 Ta=60°C. Indoor and Outdoor (Type 4X) Hazardous Locations. Ex d [ia] IIC T6 Ga/Gb (integral transmitter) Ex d [ia Ga] IIC T6 Gb (remote transmitter) Ex ia IIC T6 Gb (remote sensor) Ex ia IIC T4 Ga (-60°C =< Ta =< +70°C) - HART Versions Ex ia IIC T4 Ga (-60°C =< Ta =< +60°C) - Fieldbus & FISCO Versions Ex nA ic IIC T5 Gc (-50°C =< Ta =< +70°C) - HART Versions (-50°C =< Ta =< +60°C) - Fieldbus ATEX II 1/2 G Ex d [ia] IIC T6 Ga/Gb (integral transmitter) ATEX II 2(1) G Ex d [ia Ga] IIC T6 Gb (remote transmitter) ATEX II 1G Ex ia IIC T6 Gb (remote sensor) ATEX II 1 G Ex ia IIC T4 Ga (-60°C =< Ta =< +70°C) - HART Versions ATEX II 1 G Ex ia IIC T4 Ga (-60°C =< Ta =< +60°C) - Fieldbus & FISCO Versions ATEX II 3 G



Ex nA ic IIC T5 Gc (-50°C =< Ta =< +70°C) - HART Versions, Maximum Working Voltage = 42Vdc ATEX II 3 G Ex nA ic IIC T5 Gc (-50°C =< Ta =< +60°C) - Fieldbus Versions, Maximum Working Voltage = 32Vdc Please see manufacturer's data sheet 00813-0100-4004, Rev. JB, May 2013 for additional ratings and International Standards information.

**Service Restrictions:** Unit Certification is not required for this product. If the manufacturer or purchaser request an ABS Certificate for compliance with a specification or standard, the specification or standard, including inspection standards and tolerances, must be clearly defined.

**Comments:** The Manufacturer has provided a declaration about the control of, or lack of Asbestos in this product. To be installed in accordance with Control drawing 08800-0116 (IS) and 08800-0017 (XP/IS).

**Notes / Documentation:** Supporting Documentation: FM Approvals, Approval Report, Project ID: 3042011, 27 June 2011 and Certificate of Compliance 3022604. IECEx Certificate No. IECEx KEM 05.0017X, Issue 1, dated 2011-05-13; IECEx BAS 05.0028X, Issue 7, dated 2013-06-06; IECEx BAS 05.0029X, Issue 7, dated 2013-06-06; EC-Type Certificate KEMA99ATEX3852X Issue 2, dated May 9, 2011; Baseefa05ATEX0084 Issue 6, dated 12 October 2011; Baseefa05ATEX0085 Issue 6, dated 12 October 2011.

**Term of Validity:** This Product Design Assessment (PDA) Certificate 08-HS376567-1-PDA, dated 17/Sep/2013 remains valid until 16/Sep/2018 or until the Rules or specifications used in the assessment are revised (whichever occurs first). This PDA is intended for a product to be installed on an ABS classed vessel, MODU or facility which is in existence or under contract for construction on the date of the ABS Rules or specifications used to evaluate the Product. Use of the Product on an ABS classed vessel, MODU or facility which is contracted after the validity date of the ABS Rules and specifications used to evaluate the Product, will require re-evaluation of the PDA. Use of the Product for non ABS classed vessels, MODUs or facilities is to be to an agreement between the manufacturer and intended client.

**ABS Rules:** 2013 Steel Vessels Rules 1-1-4/7.7, 1-1-Appendix 3, 4-6-2/5.13, 4-6-2/5.15, 4-8-3/13.1, 4-8-4/27.5, 5-1-7/17.1.4, 5-1-7/31.9 & Table 1;

**National Standards:** FM 3042011 dated 27 June 2011.

**International Standards:** IEC Standards: IEC 60079-0: 2007-10 (Edition 5); IEC 60079 -1: 2007-04 (Edition 6); IEC 60079 -11: 2006-07 (Edition 5); IEC 60079 -26: 2006-08 (Edition 2). EN Standards: EN 60079-0; EN 60079 -1; EN 60079 -11; EN 60079 -26.

**Government Authority:**  
**EUMED:**  
**Others:**

Model Certificate	Model Certificate No	Issue Date	Expiry Date
PDA	08-HS376567-1-PDA	17/SEP/2013	16/SEP/2018

*Robt. J. Vienneau*

**ABS Programs**

ABS has used due diligence in the preparation of this certificate and it represents the information on the product in the ABS Records as of the date and time the certificate was printed. Type Approval requires Drawing Assessment, Prototype Testing and assessment of the manufacturer's quality assurance and quality control arrangements. Limited circumstances may allow only Prototype Testing to satisfy Type Approval. The approvals of Drawings and Products remain valid as long as the ABS Rule, to which they were assessed, remains valid. ABS cautions manufacturers to review and maintain compliance with all other specifications to which the product may have been assessed. Further, unless it is specifically indicated in the description of the product, Type Approval does not necessarily waive witnessed inspection or survey procedures (where otherwise required) for products to be used in a vessel, MODU or facility intended to be ABS classed or that is presently in class with ABS. Questions regarding the validity of ABS Rules or the need for supplemental testing or inspection of such products should, in all cases, be addressed to ABS.



CD5008-00

# PRODUCTION TEST INSTRUCTIONS

## AT SERIES

### Microprocessor-Controlled FLOAT BATTERY CHARGER

AT10.1 Single Phase Input - Group I (6-25 Adc)

AT10.1 Single Phase Input - Group II (30-100 Adc)

AT30 Three Phase Input (25-1000 Adc)

REV	DATE	DCN No	DESCRIPTION	REVISED BY	APPROVED BY
0	09/24/2003	E1397	Rev. 0 release	MCR	Ted H.
1	08/23/2007	20810	see ECN# 20810 for Rev. 1 changes	MCR	ND
2	12/03/2009	21923	see ECN# 21923 for Rev. 2 changes	MCR	ND
3					
4					

See ABS Washington Letter Ref T1734456 Dated 30 JAN 2014

REVIEWED

Details of this review  
are as indicated in the  
ABS letter



CD5008-00



1075 Saint John Street • Easton, PA 18042-6661  
Phone 610.330.9000 • Fax 610.330.8510  
[www.hindlepowerinc.com](http://www.hindlepowerinc.com)

## TABLE OF CONTENTS

1.0	PURPOSE.....	1
2.0	REFERENCE DOCUMENTS.....	1
3.0	TESTING A STANDARD CHARGER.....	1
3.1.	Dielectric withstand test.....	1
3.2.	Connecting circuit board assemblies.....	1
3.3.	Setting up the test bench.....	2
3.4.	Testing the front panel controls.....	2
3.4.1.	AC ON indicator.....	2
3.4.2.	Lamp Test key.....	3
3.4.3.	Charge Mode key.....	3
3.4.4.	Equalize Method key.....	3
3.4.5.	Meter Mode key.....	3
3.4.6.	Ammeter accuracy.....	3
3.4.7.	Edit key operation.....	4
3.4.8.	Current Limit setting (old key combination).....	4
3.4.9.	High Voltage DC Shutdown operation.....	4
3.5.	Testing the internal functions.....	4
3.5.1.	Testing the front panel disable jumper.....	4
3.6.	Testing current limit.....	5
3.7.	Measuring ripple voltage.....	6
3.8.	Measuring the voltage regulation.....	7
4.0	TESTING ALARMS AND INSTALLED OPTIONS.....	8
4.1.	Testing Built-in (Primary) Alarms.....	8
4.1.1.	High DC Voltage Alarm.....	8
4.1.2.	Low DC Voltage Alarm.....	9
4.1.3.	AC Input Failure Alarm.....	9
4.1.4.	Positive Ground Fault.....	9
4.1.5.	Negative Ground Fault.....	9
4.1.6.	Disabling Ground Fault Detection.....	10
5.0	STORING FINAL SETTINGS.....	10
5.1.	Voltage and current settings.....	10
5.2.	Voltmeter calibration.....	11
5.3.	Order Completion.....	11



## CD5008-00



### 1.0 PURPOSE

This procedure defines the production test methods and parameters for the AT Series Battery Charger product line.

### 2.0 REFERENCE DOCUMENTS

NEMA PE5-1996 - Stationary Battery Chargers

DI5008-00 - AT Series Battery Charger - Production Test Data Sheet

### 3.0 TESTING A STANDARD CHARGER

#### 3.1. Dielectric withstand test

- Disconnect all printed circuit boards from the charger wiring harness(es).
- Place a jumper across the dc filter capacitors (C1, C2).
- Disconnect the ground lead of the noise suppression capacitors (C4, C5), on the dc terminals of the I/O panel.
- Disconnect the lightning arrestor ground wire (if installed).
- Apply a test voltage of 2500 Vrms for at least one second between the following points:
  - AC input voltage terminals to chassis
  - AC input terminals to dc output terminals
- Apply a test voltage of 2500 Vrms for at least one second from the dc output terminals to chassis.
- Enter the test results on the test data sheet.
- Remove jumpers attached to filter capacitors (C1, C2) and reconnect the components that were disconnected in step 3.1.

#### 3.2. Connecting circuit board assemblies

- Locate U6 at the bottom of the main control PC Board.
- Record the program version number on its label in the space provided on the test data sheet.
- Install and/or connect the control circuit board, the gate drive board(s), and any other boards required on the order. Verify that all circuit boards are connected to the correct wire harness(es).

**Note:** If the charger has been ordered with the auxiliary relay board option, verify that the jumper on **J4** is in the position corresponding to the charger dc voltage rating. If the charger is turned on with the jumper in the incorrect position, damage may occur.



## CD5008-00

### 3.3. Setting up the test bench

- Compare the main transformer (T1) jumpers with the connection table:

	RATED INPUT VOLTAGE (VAC)	JUMPER LOCATIONS
AT10.1 Battery Chargers	120	H1 - H3 H2 H5
	208	H2 - H4 (both jumpers)
Single Phase Input	240	H2 - H3 (both jumpers)
	480	none
	other (custom Vac)	consult Engineering

	RATED INPUT VOLTAGE (VAC)	JUMPER LOCATIONS
AT30 Battery Chargers	120	not available
	208	H1, H2 & H3 to 1
Three Phase Input	240	H1, H2 & H3 to 2
	480	none
	other (custom Vac)	consult Engineering

- Verify that the ac supply voltage from the test bench matches the ac input voltage tapped on the transformer.
- Verify that the dc battery voltage of the bench matches the dc output voltage printed on the order.
- If the charger is unfiltered, connect the test load capacitor bank for all measurements, except where noted in the procedure.

### 3.4. Testing the front panel controls

- Close **CB2**, then close **CB1**.
- Adjust the ac input voltage to nominal.
- Connect resistive load to obtain approximately 50% of rated dc load current.

Watch the charger front panel display and verify that it progresses through the initialization and soft start procedures. Verify that the following indicators and controls operate as specified. For each step, enter the results on the test data form.

#### 3.4.1. AC ON indicator

- Verify that the “**AC ON**” indicator (green) is lit.



## CD5008-00



### 3.4.2. *Lamp Test key*

- Press the **LAMP TEST** (down arrow) key; verify that all front panel indicators light, and the display shows **8888**. Hold the key for at least 4 seconds, and verify that the common alarm relay transfers (measure at **TB3** at the bottom left of the control PC board). If the optional auxiliary relay board is installed, also verify that all alarm relays on that board transfer. When you release the key, verify that the indicators and display return to their previous state, and the common alarm relay and optional auxiliary relays return to the non-alarm state. After you release the key, the program version appears on the display for 2 seconds. Check this number against the version number you recorded on the test data sheet in step 3.2.

### 3.4.3. *Charge Mode key*

- Press the **CHRG MODE** key; verify that the charger changes from float to equalize.

### 3.4.4. *Equalize Method key*

- Press the **EQLZ MTHD** key. Verify that the charger changes from manual timer to manual equalize method. If the charger is not initially in the manual timer method, press the **EQLZ MTHD** key repeatedly until it is.
- Press the **EQLZ MTHD** key again; verify that the charger changes from manual equalize to auto equalize timer method.
- Press again; verify that the charger changes back to the manual timer method.

### 3.4.5. *Meter Mode key*

- Press the **METER MODE** key. Verify that the charger displays only the output voltage, and the Volts indicator is steady.
- Press again. Verify that the meter now displays only the output current, and the **Amps** indicator is steady.
- Press again. Verify that the meter displays only the equalize time remaining, and the Time indicator is steady.
- Press the **METER MODE** key one last time. Verify that the display alternates from dc volts to dc amps to time remaining.
- Press the **CHARGE MODE** key to return the charger to float mode.

### 3.4.6. *Ammeter accuracy*

- Press the **METER MODE** key until the display locks on dc amps.
- Compare the measured dc output current of the charger with the current displayed on the front panel. Verify that the difference between measured and displayed current is within the tolerance noted on the test data sheet.

## CD5008-00



### 3.4.7. *Edit key operation*

- Press the **EDIT** key.
- Verify that the charger enters the edit mode. The **Volts** and **Float** indicators should be flashing, and the float voltage should be flashing on the display.
- Press the **UP** and **DOWN** arrow keys repeatedly. Verify that the displayed parameter changes accordingly.
- Press and hold the **UP** arrow key; verify that the displayed value stops flashing and increases continuously. Repeat with the **DOWN** arrow key.
- Press the **EDIT** key repeatedly until charger exits the edit mode.

### 3.4.8. *Current Limit setting (old key combination)*

- Press and hold the **UP** arrow key, then press the **EDIT** key. Verify that the charger enters the current limit edit mode.
- Press the **UP** and **DOWN** arrow keys repeatedly. Verify the current limit setting changes accordingly.
- Set the current limit to 100% of rated output current, then press the **EDIT** key and verify that the charger exits the current limit edit mode.
- Enter the current limit mode again. Verify that it is set to 100%. Change the setting to 110%, then press the **EDIT** key to exit the current limit edit mode.

### 3.4.9. *High Voltage DC Shutdown operation*

- Press and hold the up arrow key, then press the **CHRG MODE** key. Release both keys; note that the display shows "**OFF**" or "**On**." The display toggles between "**OFF**" and "**On**" each time you press the **UP** or **DOWN** key. Press the key until "**OFF**" appears on the display. Wait for the charger to return to normal operation; this should take approximately 6 seconds.

## 3.5. Testing the internal functions

### 3.5.1. *Testing the front panel disable jumper*

- Locate the front panel disable jumper, **J9**, in the middle right side of the control PC board (as viewed from the rear).
- Move **P9** to the "**DISABLE**" position (linking the two top pins).
- Press the **EDIT** key on the front instrument panel and verify that the charger does not enter the edit mode.
- Press the **EQLZ MTHD** key on the front instrument panel and verify that the charger does not change equalize mode.
- Press the **LAMP TEST** key and verify that all indicators, and all segments of the numeric display, light.



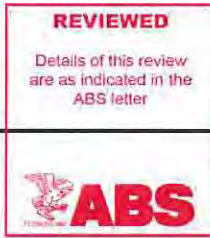

## CD5008-00

- Replace **P9** in the "**ENABLE**" position (linking the two lower pins).
- Enter the results on the test data sheet.

### 3.6. Testing current limit

**Note:** The parameters for this test are independent of the battery type noted on the order acknowledgment. For this test, you will measure ac input current (using an rms-responding meter), dc output voltage, and dc output current.

- Connect the capacitor bank to the output, then disconnect the battery bank.
- Press and hold the up arrow key, then press the **EDIT** key, or enter the edit mode normally, and press **EDIT** until you reach the current limit adjustment, which is the sixth parameter. Use the **UP** and **DOWN** keys to adjust the current limit to the value shown in the table below.
- Press the **EDIT** key to save the current limit value and return the charger to normal operation.

AT10.1 - Group I OUTPUT RATING (A <sub>dc</sub> )	AT10.1 - Group II OUTPUT RATING (A <sub>dc</sub> )	AT30 OUTPUT RATING (A <sub>dc</sub> )	CURRENT LIMIT (A)	TOLERANCE (A)
6	n/a	n/a	6.6	±0.33
12	n/a	n/a	13.2	±0.66
16	n/a	n/a	17.6	±0.88
20	n/a	n/a	22.0	±1.1
25	n/a	25	27.5	±1.4
n/a	30	30	33.0	±1.7
n/a	40	40	44.0	±2.2
n/a	50	50	55.0	±2.8
n/a	75	75	82.5	±4.1
n/a	100	100	110	±5.5
n/a	n/a	125	138	±6.9
n/a	n/a	150	165	±8.3
n/a	n/a	200	220	±11.0
n/a	n/a	250	275	±13.8
n/a	n/a	300	330	±16.5
n/a	n/a	400	440	±22.0
n/a	n/a	500	550	±27.5
n/a	n/a	600	660	±33.0
n/a	n/a	800	880	±44.0
n/a	n/a	1,000	1,100	±55.0

- Set the charger to **FLOAT** mode. Record the float voltage on the test data sheet.



**CD5008-00**

- Add resistive load to the charger until the output voltage starts to decrease. Continue to add resistive load until the output voltage reaches the end voltage shown in the table below. Verify that the output current is within the tolerance shown in the table above. It may take a few seconds for the charger to stabilize at the current limit value after each load change.

DC VOLTAGE RATING	END VOLTAGE (Vdc)
12	10.5
24	21.0
48	42.0
130	105

- Record the dc output voltage, the dc output current, and the ac input current on the test data sheet.
- Reduce the resistive load to obtain rated (100%) output current.

**3.7. Measuring ripple voltage**

Conditions: Nominal ac input voltage, float mode, rated output current.

Connect battery, disconnect capacitor bank.

- Using an rms-responding ac millivoltmeter, measure the ripple voltage at the battery terminals. If the charger current rating is greater than ¼ of the battery AH rating, then adjust the measured value using the formula:

$$\text{Adjusted Ripple} = \frac{\text{Batt AH}}{4 \times \text{ADC Rating}} \times \text{Measured Ripple}$$

- For filtered chargers only: disconnect the battery, and measure the ripple voltage at the charger output terminals. Do not adjust this reading.
- Verify that the ripple voltage is within the limits shown in the table below.

CHARGER TYPE	CONDITION	RIPPLE VOLTAGE LIMITS, mV rms <sup>1</sup>			
		12VDC	24VDC	48VDC	130VDC
UNFILTERED	WITH BATTERY (at battery terminals)	250 (typ.)	500 (typ.)	1000 (typ.)	2600 (typ.)
	WITHOUT BATTERY	DO NOT MEASURE			
FILTERED	WITH BATTERY (at battery terminals)	30	30	30	100
	WITHOUT BATTERY (at charger output terminals)	130 (typ.)	250 (typ.)	500 (typ.)	1320 (typ.)
ELIMINATOR	WITH BATTERY (at battery terminals)	30	30	30	100
	WITHOUT BATTERY (at charger output terminals)	30	30	30	100

<sup>1</sup> Ripple value is adjusted for a battery AH four times the charger rating.





**CD5008-00**

**3.8. Measuring the voltage regulation**

Conditions: Nominal equalize voltage, no battery.

For this test you will measure dc output voltage and current.

Refer to the table in section 3.8 of the test data form. For each listed combination of ac input voltage and output load current, record the input and output values as defined in the table. The numerical test parameters are shown below. Because of the incremental nature of the load bank, it may be difficult to obtain exact current values. A tolerance of 5% is acceptable.

NOMINAL Vac	88% VALUE	110% VALUE
120	105	132
208	183	229
220	193	242
240	211	264
380	334	418
416	366	458
480	422	528

DC CURRENT (AT10.1 RATINGS)			DC CURRENT (AT30 RATINGS)		
RATED (100%)	5%	50%	RATED (100%)	5%	50%
<b>Group I</b>			25	1.3	12.5
6	0.3	3.0	30	1.5	15.0
12	0.6	6.0	40	2.0	20.0
16	0.8	8.0	50	2.5	25.0
20	1.0	10.0	75	3.8	37.5
25	1.3	12.5	100	5.0	50.0
<b>Group II</b>			125	6.3	62.5
30	1.5	15.0	150	7.5	75.0
40	2.0	20.0	200	10.0	100.0
50	2.5	25.0	250	12.5	125.0
75	3.8	37.5	300	15.0	150.0
100	5.0	50.0	400	20.0	200.0
			500	25.0	250.0
			600	30.0	300.0
			800	40.0	400.0
			1,000	50.0	500.0



## CD5008-00



- Calculate the voltage regulation using the equation below. Verify that the regulation is within  $\pm 0.25\%$ . Enter the result into the appropriate section of the test data form.

$$\% \text{ Deviation} = 50 \times (V_{\max} - V_{\min}) \div (V_{\text{nom}})$$

where  $V_{\text{nom}}$  is the nominal equalize voltage,  $V_{\max}$  is the highest voltage measured during the test, and  $V_{\min}$  is the lowest voltage.

## 4.0 TESTING ALARMS AND INSTALLED OPTIONS

### 4.1 Testing Built-in (Primary) Alarms

#### 4.1.1. High DC Voltage Alarm

Conditions: Float mode, nominal Vac, about 10% load.

- Enable HVDC Shutdown. See section 3.4.9
- Press the **EDIT** key until the equalize voltage appears on the display. Record the equalize setting.
- Press the **EDIT** key twice more until the **HIGH DC VOLTAGE** lamp is lit. Adjust the high DC Voltage Alarm level to a value 1.0V less than the equalize setting.
- Press the **EDIT** key three more times to return the charger to normal operation.
- Set the charger to the equalize mode.
- Verify that the **HIGH DC VOLTAGE** alarm indicator lights. This may take a few seconds.
- Wait 30 seconds, and verify that the common alarm relay on the control PC board transfers (measure at **TB3** at the bottom left of the board). If the optional auxiliary alarm board is installed, verify that the HVDC alarm relay contacts transfer. Also verify that the charger shuts down, and the front panel display shows **E 03**.
- Turn CB1 (or external ac power) off for 5 seconds, then on to restart the charger.
- Reset the High DC Voltage alarm so that it is higher than the equalize voltage.
- Disable HVDC Shutdown.
- Enter the results on the test data sheet.

## CD5008-00



### 4.1.2. Low DC Voltage Alarm

Conditions: Equalize mode, nominal Vac, about 10% load.

- Press the **EDIT** key until the float voltage appears on the display. Record the float setting.
- Press the **EDIT** key three more times until the **LOW DC VOLTAGE** lamp is lit. Adjust the low DC Voltage Alarm level to a value 1.0V higher than the float setting.
- Press the **EDIT** key twice more to return the charger to normal operation.
- Set the charger to the float mode.
- Verify that the **LOW DC VOLTAGE** alarm indicator lights. This may take a few seconds.
- Wait 30 seconds, and verify that the common alarm relay on the control PC board transfers (measure at **TB3** at the bottom left of the board). If the optional auxiliary alarm board is installed, also verify that the LVDC alarm relay contacts transfer.
- Readjust the Low DC Voltage Alarm so that it is lower than the float voltage.
- Enter the results on the test data sheet.

### 4.1.3. AC Input Failure Alarm

Conditions: Float mode, nominal Vac, 10% load, battery connected.

- Open **CB1** and verify that the **AC INPUT FAILURE** indicator lights. This may take a few seconds.
- Wait 30 seconds, and verify that the common alarm relay on the control PC board transfers (measure at **TB3** at the bottom left of the board).
- Close **CB1**. Verify that the ac input failure alarm resets.
- Enter the results on the test data sheet.
- Disconnect the battery from the output.

### 4.1.4. Positive Ground Fault

Conditions: Float mode, nominal Vac, 10% load, no battery.

- Turn off all power to the charger. Open **CB1**. On the I/O panel, **TB1**, connect an external 10K Ohm resistor between the **GND** and **(+) DC Output** terminals.
- Reapply power and close **CB1**.
- Verify that the **POS GND** indicator lights.
- Wait 30 seconds, and verify that the common alarm relay on the control PC board transfers (measure at **TB3** at the bottom left of the board).
- Enter the results on the test data sheet.

### 4.1.5. Negative Ground Fault

- Repeat step 4.1.4, except connect the 10K Ohm resistor between **GND** and **(-) DC Output**. Leave the resistor connected for the next step.



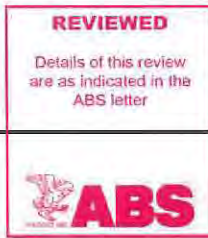

## CD5008-00

### 4.1.6. Disabling Ground Fault Detection

Conditions: Float mode, nominal Vac, 10% load, no battery.

- Open **CB1**.
- Locate jumper **J5** on the left edge of the control PC board, near the top, as viewed from the rear.
- Move **P5** to the **DISABLE** position.
- Close **CB1**.
- Verify that the **NEG GND** indicator is not lit.
- Open **CB1**, and return **P5** to the **ENABLE** position.
- Enter the results on the test data sheet.

## 5.0 STORING FINAL SETTINGS

*This portion of the test must be completed in one session. Any interruptions may result in lost parameter data.*

Conditions: Float mode, nominal Vac, 50% load. Connect battery.

### 5.1. Voltage and current settings

- Enter the edit mode. Adjust the charger operating parameters as indicated in the tables below.

VOLTAGE RATING	FACTORY SETTINGS				
	FLOAT	EQUALIZE	EQLZ TIME	HVDC ALARM	LVDC ALARM
12	13.0	14.0	24 hours	14.4	12
24	26.0	28.0		28.8	24
48	52.0	56.0		57.6	48
130	131.0	139.0		144.0	120

OUTPUT RATING (A <sub>dc</sub> )	CURRENT LIMIT (A)
6	6.6
12	13.2
16	17.6
20	22.0
25	27.5
30	33.0
40	44.0
50	55.0
75	82.5
100	110

OUTPUT RATING (A <sub>dc</sub> )	CURRENT LIMIT (A)
125	138
150	165
200	220
250	275
300	330
400	440
500	550
600	660
800	880
1,000	1,100

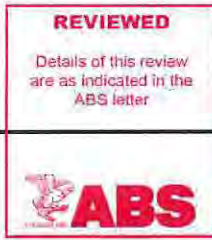

## CD5008-00

- Exit the edit mode. Press and hold the up arrow key, then press the **CHRG MODE** key. If necessary, press the **CHRG MODE** key again until "OFF" appears in the front panel display. Wait a few seconds for the charger to return to normal operation.
- Reduce the connected load to 10%. Keep the battery connected.

### 5.2. Voltmeter calibration

- Press the **METER MODE** key to lock the display on dc volts.
- Compare the measured dc output voltage of the charger (at TB1) with the voltage displayed on the front panel. Verify that the difference between measured and displayed voltage is within limits ( $\pm 0.25\%$ ):

CHARGER DC VOLTAGE RATING	LIMITS (Vdc)
12	$\pm 0.030$
24	$\pm 0.060$
48	$\pm 0.120$
130	$\pm 0.325$

- If the voltmeter is not within the above limits, press and hold the **UP** key, then press the **EQLZ MTHD** key. The display flashes the output voltage value. Press the **UP** or **DOWN** key to increase or decrease the charger output voltage until it agrees with the voltmeter. Wait a few seconds for the charger to return to normal operation.
- Enter the results on the test data sheet.
- Turn off the charger; disconnect the battery and remove all power sources.

### 5.3. Order Completion

- Record results of all tests and calibration steps, mechanical inspection, and the 'ORDER COMPLETION' section of the test data sheet.
- Check that all order options and accessories have been tested and approved for shipping. For accessories not listed, write the part number and description in the table.

The **AT Series Battery Charger** test is now complete.



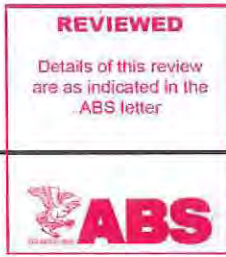

**JF5036-00**

## STANDARD SAMPLE SPECIFICATION

### AT30 Series Microprocessor-Controlled Float Battery Charger (three phase input)

A battery charger shall be furnished in accordance with the following specification:

#### 1.0 – General

1.1 - The battery charger shall be sized to continuously carry the load demand as required in the plans, and have sufficient reserve capacity as deemed appropriate for the application.

1.2 - The battery charger shall provide a continuous regulated DC output derived from an AC source. The output shall be suitable to maintain the battery in a fully charged state, while supporting any additional DC loads as defined in the plans. The battery charger shall also have the ability to automatically or manually provide an equalizing charge as required for recharging the battery after discharge.

1.3 - The battery charger shall be of a design that employs microprocessor technology to control and define all critical operational, calibration, regulation and alarm functions.

#### 2.0 – Applicable Codes

The AT30 Charger product line meets the requirements of the designated versions of the following industry and agency standards:

- NEMA PE5-1996      Stationary type battery chargers
- UL 1564             Standard for industrial battery chargers
- UL 1012             Standard for stationary power supplies
- CSA 22.2             Standard for battery chargers
- ANSI C37.90-1989   Surge withstand capability definitions and tests
- IEC 146              Semiconductor converters
- FCC Part 15 Subpart J Class A

#### 3.0 – Standard Features

3.1 Standard Three Phase Input Voltages include 208, 240 and 480Vac 60Hz. Other input voltages such as 220, 380 and 416Vac 50/60Hz and 575Vac 60Hz are available options.

3.2 Standard Output Voltages include 12, 24, 48 and 130Vdc with output currents ratings ranging from 25 to 1,000 Adc, depending on charger output voltage rating.

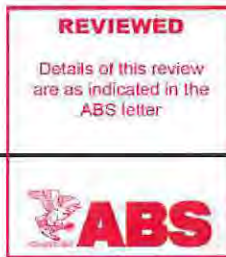

## JF5036-00

3.3 - Output control is constant-voltage, current-limited. Flat temperature coefficient of output voltage is standard. An optional battery temperature probe is available for temperature compensation of the output voltage. The probe is compatible with Lead-Acid and Ni-Cad battery types.

3.4 - The AT30 charger is capable of delivering 100% rated output current at the maximum stated equalize voltage and at the minimum rated ac input voltage, at 50 °C.

3.5 - Current limit adjustable from 50 to 110%; factory set to 110%. The current limit specification does not mean that the charger will be able to deliver greater than 100% rated output current under all operating conditions.

3.6 - Meets the SWC (oscillatory surge) requirements of ANSI C37.90, and the transient suppression levels for category B in IEEE Std. 28/ANSI C62.1.

3.7 - Full wave six-pulse rectifier bridge with free-wheeling diode, single-winding transformer secondary, and dc inductor.

3.8 - AC input circuit breaker, CB1, is standard. Fuses may be specified in place of an input circuit breaker at no charge, or fuses can be added in conjunction with the input circuit breaker to achieve higher AIC ratings.

3.9 - DC output circuit breaker, CB2, is standard. Fuses may be specified in place of an output circuit breaker at no charge, or fuses can be added in conjunction with the output circuit breaker to achieve higher AIC ratings.

3.10 - Starts and operates with a crowbar short circuit on the output without tripping the standard dc circuit breaker. A filtered charger equipped with dc fuses may clear the fuses in the event of a crowbar short circuit during operation, caused by the filter capacitors discharging through the fuses.

3.11 - No blocking diode is provided. A blocking diode is not required, since a dc circuit breaker is standard. The dc load on the battery (without optional equipment) during an ac power failure is less than 0.5 A.

3.12 - Survives a reverse polarity battery connection. The standard circuit breaker trips through the free-wheeling diode on unfiltered chargers; a polarity diode is included with filtered chargers to protect the output capacitors.

3.13 - Cooling: Natural convection for all ratings through 300 Adc in NEMA 1 enclosures. NEMA 4 enclosures may have forced air-cooling for those ratings. Power for the cooling fans is provided internally.



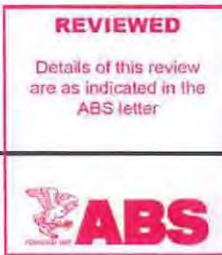

## JF5036-00

3.14 - Solderless CU-AL compression input and output terminals, including chassis ground

3.15 - A clear safety cover over all internal components. The safety cover is marked with an internal wiring diagram.

3.16 - Remote sense terminals.

3.17 - Switchboard wiring is standard, using Hypalon or XLPE (cross-linked polyethylene) insulation system, 600V, 105 °C, except for PC board interconnections, which may use ribbon cable assemblies, or other standard industrial grade PC board interconnections. XLPE insulation is rated for the UL VW-1 vertical wire flame test.

3.18 - Test points are provided for semi-automatic final test.

### 4.0 - Operation

4.1 - Battery charger shall automatically determine the appropriate DC output, in terms of either voltage or current required for maintaining the battery and load either by pre-programming or in-field re-programming, via the touch panel controls.

4.2 - The battery charger shall automatically know and respond to any alarm options or remote sensing options installed according to the manufacturer's instructions without further operator action.

4.3 - The battery charger shall display, via a 1% digital display and associated LED indicators, all functions important to operation.

4.3.1 - During float operation, the digital display shall alternate between DC voltage and DC current indications as designated by the appropriate LED being lit for the respective indication.

4.3.2 - During equalize operation, the digital display shall alternate between DC voltage and DC current indications as designated by the appropriate LED being lit for the respective indication. If the unit is employing a timer, either automatic or manual the LED indicators shall indicate timer function while the Digital display indicates the hours remaining for equalize charge.

4.4 - Error and message codes, indicating certain self-diagnostic anomalies and operating conditions shall be indicated by the digital display, as required.

### 5.0 Protective Devices

5.1 - The charger shall employ a circuit breaker as standard for each AC input and DC output protection.

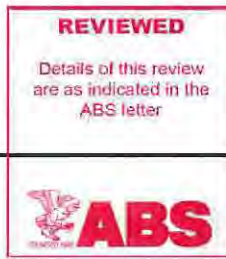

## JF5036-00

5.2 - AC input transient over voltage protection shall be accomplished via a MOV (metal-oxide varistor) on the AC input terminals.

5.3 - DC external transient over voltage protection shall be via a MOV (metal-oxide varistor) on the DC bus. This shall be located on the output terminals of the battery charger.

5.4 - The charger shall be protected against damage in the event that the battery is connected in reverse.

5.5 - Protection from oscillatory surges (SWC) as defined by ANSI C37.90-1978. Battery charger shall operate correctly during and after application of oscillatory surges.

5.6 - Output current limit shall be adjustable from 50% to 110% of rated output.

5.6.1 - The battery charger shall protect itself from a short circuit in the output side electronically so as to limit the current output. When the short is corrected the battery charger will automatically return to normal charger operation. During a short circuit of the output an error code shall be provided as indication. The error code shall be removed when the output voltage rises above 2.0VDC.

### 6.0 - Controls

6.1 - The following controls shall be located on the front panel, using touch sensitive switches to initiate all adjustments.

6.1.1 - Charge mode key (selects float or equalize mode)

6.1.2 - Equalization method key (selects timer method, manual, automatic, or manual timer)

6.1.3 - Edit/Enter key (initiates changes in AT10.1 parameters)

6.1.4 - Meter mode key (selects Volts, Amperes, hours, or alternating display)

6.1.5 - Up key (increases parameter value in Edit mode)

6.1.6 - Down key (decreases parameter value in Edit mode)

6.1.7 - AC circuit breaker

6.1.8 - DC circuit breaker

6.1.9 - Lamp test key



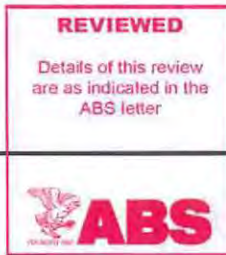

## JF5036-00

### 7.0 - Indicators

7.1 - Standard front panel indicators shall include the following:

7.1.2 - Digital meter, 1% accuracy, 4-digit, 7-segment, that shall indicate the following:

- DC Volts
- DC Amperes
- Equalize hours remaining
- Error and message codes

7.1.3 - DC Volts meter indicator (red LED)

7.1.4 - DC Amperes meter indicator (red LED)

7.1.5 - Equalize Hours Remaining indicator (red LED)

7.1.6 - AC on indicator (green LED)

7.1.7 - Float mode indicator (green LED)

7.1.8 - Equalize mode indicator (yellow LED)

7.1.9 - Manual equalize timer indicator (yellow LED)

7.1.10 - Manual equalize indicator (yellow LED)

7.1.11 - Automatic equalize indicator (yellow LED)

7.2 - Standard Front Panel Primary Alarm indicators shall include the following:

7.2.1 - High voltage DC alarm indicator (red LED)

7.2.2 - Low voltage DC alarm indicator (red LED)

7.2.3 - DC output failure alarm indicator (red LED)

7.2.4 - Positive ground fault indicator (red LED)

7.2.5 - Negative ground fault indicator (red LED)

7.2.6 - AC failure alarm indicator (red LED)

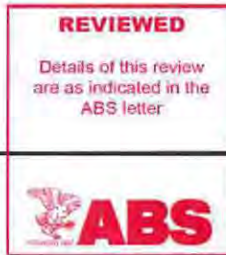

## JF5036-00

**8.0 - Current limit** shall be factory set at 110% of rating. This shall also be the limit available from the battery charger. Field adjustments may be made over a range from 50% to 110% of rating. The current limit shall be displayed directly in amperes.

**9.0 - Parallel operation** of 2 or more chargers with the same DC voltage rating shall be a standard feature of the filtered charger with random load sharing.

**10.0 - Operating environment** shall be 0-50 deg C, storage at -40 to 70 deg C, RH 5 - 95% non-condensing, elevation to 1,000 meters.

### 11.0 - Construction

11.1 - I/O power terminals with CU-AL compression lugs, appropriately sized for field wiring.

11.2 - Alarm function terminals - compression terminal block for #22-14 AWG.

11.3 - Enclosure shall be steel 14 GA for the outer skin, door and chassis. Shall employ adequate knock-outs for top, bottom, and right side conduit entry.

11.4 - Finish will be ANSI-61 gray, baked powder epoxy.

**12.0 - Serviceability:** The battery charger shall be serviceable by a technician using standard hand tools. Addition of any and all options including but not limited to filtering, alarm capabilities, battery eliminator, remote temperature compensation, and medium and high interrupting breakers, shall be able to be added in the field by the customer without any special training, using standard hand tools.

### 13.0 - Alarms, Self-Diagnostics and Error Codes

13.1 - The charger shall be capable of automatic self diagnostics, and indicate any anomaly by means of an error code on the digital display. Error and message code definitions shall be posted within the battery charger.

13.2 - Primary Alarms (*standard with all AT Series Models*) shall provide an alarm sensing capability for all the following:

- 13.2.1 - High voltage DC alarm indicator (red LED)
- 13.2.2 - Low voltage DC alarm indicator (red LED)
- 13.2.3 - DC output failure alarm indicator (red LED)
- 13.2.4 - Positive ground fault indicator (red LED)
- 13.2.5 - Negative ground fault indicator (red LED)
- 13.2.6 - AC failure alarm indicator (red LED)
- 13.2.7 - Summary alarm contact (one Form-C)



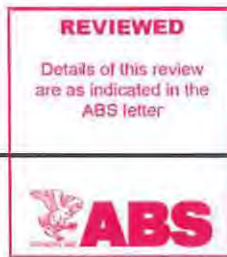

## JF5036-00

**14.0 - Control Panel** shall be a touch sensitive type, permanently laminated for protection, thereby eliminating the need for engraved functional nameplates.

### 15.0 - Documentation

15.1 A manual completely describing the installation, operation, and maintenance of the charger including all accessories and options shall be included. The charger shall have provision for storing the manual in a convenient permanent pocket.

15.2 A customized parts data package, including manufacturer's replacement part number and recommended spares shall be included with charger.

15.3 - Standard drawings consisting of an outline, internal layout, schematic and wiring diagram may be provided as needed.

### 16.0 - Optional Accessories

16.1 - DC output filter, consisting of one inductor and a one or more capacitors capable of limiting the output ripple with battery connected, when measured at the battery terminals, to the limits specified in NEMA PE5 (output ripple may be 20% higher on units operating at 50 Hz).

16.2 - Battery Eliminator filter, consisting of one or more capacitors installed within the battery charger enclosure. The filter reduces the output ripple voltage to 30 mV rms and 100 mV rms for 130 Vdc chargers. Output ripple may be 20% higher on units operating at 50 Hz. The ripple voltage is measured at the charger terminals.

16.3 - Auxiliary Relay PC Board provides 2 sets of Form C contacts for each alarm function listed in Section 13.2, plus an additional summary alarm contact, Form C.

16.3.1 - Auxiliary alarm terminal block with barrier type terminals.

16.4 - Medium/High interrupting capacity circuit breakers are available per customer specification.

16.5 - Copper ground pad with one (1) CU-AL compression lug, appropriately sized for field wiring.

16.6 - Three phase AC input lightning arrester

16.7 - Remote temperature compensation probe, with automatic probe failure detection and fail-safe control override

16.8 - Rack/floor installation kit

...a World Class Organization

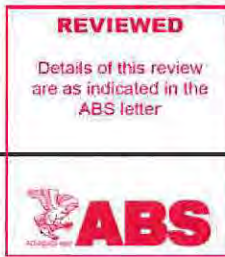

1075 Saint John Street • Easton, PA 18042-6661  
Phone 610.330.9000 • Fax 610.330.9000  
[www.hindlepowerinc.com](http://www.hindlepowerinc.com)

## JF5036-00

16.9 - Drip shield assembly

16.10 - NEMA-4/12/13 enclosure

16.11 - Fungus proofing

16.12 - Anti-static coating

16.13 - Export packaging

16.14 - Certified test data

16.15 End of discharge alarm

16.16 Fan control contactor

**17.0 - Error codes** as indicated on the front panel shall determine certain malfunctions as part of an integral microprocessor controlled self-diagnostic system. The error codes shall appear in the digital display as an alphanumeric indication beginning with the letter "E" followed by a number code, which reveals the problem being identified. Error code definitions shall be posted inside the access door to the charger and shall be listed in the manual. Certain codes, preceded by the letter "A" are provided to indicate special operating conditions.

**18.0 - Fail Safe Operation** featuring a separate circuit from the micro controller to detect a low dc voltage condition and enable the common alarm on the main board to change state. This uniquely protects the battery due a failure of the microprocessor.





RFP/MJR  
Project No. 3176956  
Task No: 1134456

30 January 2014

Hindle Power, Inc.  
1075 Saint John Street  
Easton, PA 18042

Attention: Rich Fauerback

Subject: Battery Charger  
SS BADGER, Christy Corp Hull 370, ABSID 5300348

Gentlemen:

We have your submittal of 13 January 2014 submitting the following documents for the subject vessel:

<b>Engineering Office:</b>	Houston SED Machinery	
<b>Submitter:</b>	HINDLEPOWER INC.	
<b>Drawing No</b>	<b>Rev</b>	<b>Drawing Title</b>
CD5008-00	2	PRODUCTION TEST INSTRUCTIONS AT SERIES FLOAT BATTERY CHARGER
JF5018-00	-	AT30 SERIES MICROPROCESSOR CONTROLLED FLOAT BATTERY CHARGER
JF5036-00	0	STANDARD SAMPLE SPECIFICATION AT30 SERIES MICROPROCESSOR-CONTROLLED FLOAT BATTERY CHARGER

The documents have been reviewed for compliance with the ABS Steel Vessel Rules 2014. We have to advise that the details and arrangements of the AT30 Series Battery Charger are satisfactory to the level of detail shown.

Copies of the reviewed documents appropriately stamped to indicate our review, are being returned. Should you have any questions, please contact Robert Porter ([rporter@eagle.org](mailto:rporter@eagle.org)) or the undersigned at (703) 519-9230. Please refer to the above reference numbers when responding to this correspondence.

Very truly yours,  
Matthew D. Tremblay  
Vice President of Engineering  
ABS Americas

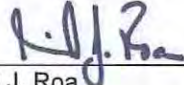
By:   
Michael J. Roa  
Senior Managing Principal Engineer  
Ship Engineering Department  
ABS Americas-Washington



### ***Confirmation of Product Type Approval***

Please refer to the "Service Restrictions" shown below to determine if Unit Certification is required for this product. This certificate reflects the information on the product in the ABS Records as of the date and time the certificate is printed.

Pursuant to the Rules of the American Bureau of Shipping (ABS), the manufacturer of the below listed product held a valid Manufacturing Assessment (MA) with expiration date of 26/FEB/2018. The continued validity of the Manufacturing Assessment is dependent on completion of satisfactory audits as required by the ABS Rules.

And; a Product Design Assessment (PDA) valid until 22/MAY/2018 subject to continued compliance with the Rules or standards used in the evaluation of the product.

The above entitle the product to be called Product Type Approved.

The Product Design Assessment is valid for products intended for use on ABS classed vessels, MODUs or facilities which are in existence or under contract for construction on the date of the ABS Rules used to evaluate the Product.

ABS makes no representations regarding Type Approval of the Product for use on vessels, MODUs or facilities built after the date of the ABS Rules used for this evaluation.

Due to wide variety of specifications used in the products ABS has evaluated for Type Approval, it is part of our contract that; whether the standard is an ABS Rule or a non-ABS Rule, the Client has full responsibility for continued compliance with the standard.

**Product Name: Pressure Transmitter**  
**Model Name(s): 7MF4\*33 & 7MF4\*34, SITRANS P**

**Presented to:**  
SIEMENS INDUSTRY, INC.  
1201 SUMNEYTOWN PIKE  
P.O. BOX 900  
SPRING HOUSE  
United States

<b>Intended Service:</b>	Process Pressure Transmitter (Absolute, Differential, Pressure, & Level);
<b>Description:</b>	A two chamber explosion-proof "Pressure Transmitter" with termination board, and optional LCD indicator. Enclosure is type 4X protection.
<b>Ratings:</b>	Intrinsic Safety "I" Class I, Div I, Groups A, B, C, & D, E, F, & G Flameproof "d", Class I, Div I, Groups B, C, & D, Dustproof CL II, III, Div 1 Group E, F, & G T5, CL I Zone 0, Group IIC, T5, ExII G Exia II CT5. Input 9-32V, 4-20mA, 40°C - +85°C ambient, 5 to 100% RH, Ref: FM report J.I. 3008490 & J.I. 3013026 for rating information
<b>Service Restrictions:</b>	Unit Certification is not required for this product. If the manufacturer or purchaser request an ABS Certificate for compliance with a specification or standard, the specification or standard, including inspection standards and tolerances, must be clearly defined.
<b>Comments:</b>	The Manufacturer has provided a declaration about the control of, or the lack of Asbestos in this product.
<b>Notes / Documentation:</b>	Supporting Documentation: Document No. A5E00118127A Rev. 9, Control Drawing (FISCO) Sitrans P DS III PA and DS III FF, 6 shts;
<b>Term of Validity:</b>	This Product Design Assessment (PDA) Certificate 03-HS360494-2-PDA, dated 23/May/2013 remains valid until 22/May/2018 or until the Rules or specifications



used in the assessment are revised (whichever occurs first). This PDA is intended for a product to be installed on an ABS classed vessel, MODU or facility which is in existence or under contract for construction on the date of the ABS Rules or specifications used to evaluate the Product. Use of the Product on an ABS classed vessel, MODU or facility which is contracted after the validity date of the ABS Rules and specifications used to evaluate the Product, will require re-evaluation of the PDA. Use of the Product for non ABS classed vessels, MODUs or facilities is to be to an agreement between the manufacturer and intended client.

**ABS Rules:**

2013 Steel Vessels Rules 1-1-4/7.7, 1-1-A3, 4-8-3/1.11.1, 4-8-3/13 & 4-8-4/27.5.1; 2013 Facilities on Offshore Installation Rules (FOI Rules) 3-6/15.5, 3-7/5.3 & 5.5;

**National Standards:**

FM Report: Project ID: 302094; Supplements 3008490, 3013026; Class:3610, 3611 dated 10 November 2004 FM Report: J.I. 3008490 rev.10 dated 23 June 2005 FM Report (Corrections to the listing and Certificate of Compliance) dated 26 October 2007

**International Standards:**

**Government Authority:**

**EUMED:**

**Others:**

Model Certificate	Model Certificate No	Issue Date	Expiry Date
PDA	03-HS360494-2-PDA	23/MAY/2013	22/MAY/2018



ABS Programs

ABS has used due diligence in the preparation of this certificate and it represents the information on the product in the ABS Records as of the date and time the certificate was printed. Type Approval requires Drawing Assessment, Prototype Testing and assessment of the manufacturer's quality assurance and quality control arrangements. Limited circumstances may allow only Prototype Testing to satisfy Type Approval. The approvals of Drawings and Products remain valid as long as the ABS Rule, to which they were assessed, remains valid. ABS cautions manufacturers to review and maintain compliance with all other specifications to which the product may have been assessed. Further, unless it is specifically indicated in the description of the product; Type Approval does not necessarily waive witnessed inspection or survey procedures (where otherwise required) for products to be used in a vessel, MODU or facility intended to be ABS classed or that is presently in class with ABS. Questions regarding the validity of ABS Rules or the need for supplemental testing or inspection of such products should, in all cases, be addressed to ABS.



### **Confirmation of Product Type Approval**

Please refer to the "Service Restrictions" shown below to determine if Unit Certification is required for this product.

This certificate reflects the information on the product in the ABS Records as of the date and time the certificate is printed.

Pursuant to the Rules of the American Bureau of Shipping (ABS), the manufacturer of the below listed product held a valid Manufacturing Assessment (MA) with expiration date of 18/SEP/2016. The continued validity of the Manufacturing Assessment is dependent on completion of satisfactory audits as required by the ABS Rules.

And; a Product Design Assessment (PDA) valid until 20/SEP/2014 subject to continued compliance with the Rules or standards used in the evaluation of the product.

The above entitle the product to be called Product Type Approved.

The Product Design Assessment is valid for products intended for use on ABS classed vessels, MODUs or facilities which are in existence or under contract for construction on the date of the ABS Rules used to evaluate the Product.

ABS makes no representations regarding Type Approval of the Product for use on vessels, MODUs or facilities built after the date of the ABS Rules used for this evaluation.

Due to wide variety of specifications used in the products ABS has evaluated for Type Approval, it is part of our contract that; whether the standard is an ABS Rule or a non-ABS Rule, the Client has full responsibility for continued compliance with the standard.

**Product Name: Programmable Control/Monitoring Unit**  
**Model Name(s): SIMATIC S7/M7-300**

**Presented to:**

SIEMENS AG, INDUSTRY SECTOR  
I IA AS TYPE TEST  
D-92224 AMBERG  
Germany

**Intended Service:**

Automation Systems (Monitoring and Control Functions) on AMS, ACC, ACCU, ABCU classed vessels.

**Description:**

Components for S7-300: PS 307, IM 174, IM 178, IM 360, IM 361, IM 365, CPU 312, CPU 313, CPU 314, CPU 315, CPU 316, CPU 317, CPU 318, CPU 319, CPU 614, mEC 677, MC 951, SM 374, DM 370, SM 321, SM 322, SM 323, SM 326, SM 327, SM 331, SM 332, SM 334, SM 335, SM 336, SM 338, FM 350, FM 351, FM 352, FM 353, FM 354, FM 355, FM 357, CP 340, CP 341, CP 342, CP 343, DP/PA 157. Components for M7-300: CPU 388, FM 356, EXM 378, MSM 378, IF 961, IF 962, IF 964, MC 951, MC 952, MC 953, Y-Coupler 197.

**Ratings:**

S7-300 / M7-300 Supply Voltage: 24V DC, Power Supply 307: 120/230V AC, 0.5..3.5A; 24V DC, 2..10A. M7-300 Degree of Protection: IP 20. Following components are of a certified safe type: Ex II3 (2) G EEx nA [ib] IIC T4: SM 321 (6ES7 321-7RD00-0AB0), SM 322 (6ES7 322-5SD00-0AB0; 6ES7 322-5RD00-0AB0), SM 326 (6ES7 326-1RF00-A0B0), SM 331 (6ES7 331-7SF00-0AB0; 6ES7 331-7RD00-0AB0; 6ES7 331-7TB00-0AB0), SM 332 (6ES7 332-5RD00-0AB0; 6ES7 332-5TB00-0AB0); Ex II3 (1) G EEx nA [ja] IIC T4: DP/PA (6ES7 157-0AD81-0XA0); Ex II3 G (1) GD EEx nA [ja] IIC T4: DP/PA (6ES7 157-0AD82-0XA0).

**Service Restrictions:**

Unit Certification is required for this product. 1.) Components with 24 V DC supply only to be used in conjunction with lightning protection units. 2.) Installation of the



<b>Comments:</b>	units, as per manufacturer's instructions.		
<b>Notes / Documentation:</b>	Each particular application/ installation and the user operating software is to be specifically approved in conjunction with the relevant system in which the units are being used. System Category III. Manufacturer is to keep evidence of quality plan for software, inspection of hardware components from sub-suppliers and quality control in production. Performance integration, fault simulation, final system factory acceptance tests, on-board system and integration tests to be witnessed by the Surveyor.		
<b>Term of Validity:</b>	This Product Design Assessment (PDA) is valid only for products intended for use on ABS classed vessels, MODUs or facilities which are in existence or under contract for construction on the date of the ABS Rules used to evaluate the Product.		
<b>ABS Rules:</b>	This product/model is covered under Product Design Assessment (PDA) Certificate # 01-HG189457/5-PDA, dated 21/Sep/2009. This PDA Certificate expires 20/Sep/2014. It will remain valid for 5 years from date of issue or until the Rules or specifications used in the assessment are revised (whichever occurs first). It is valid for all vessels contracted on or before the date of the Rules used in this evaluation.		
<b>National Standards:</b>	2009 Steel Vessel Rules 1-1-4/7.7, 4-8-3/13.1, 4-9-1/9.1, 4-9-6/3.1/3.3/3.5/3.7/3.9/3.17/7.1/7.7.1/9.1, 4-9-6/Table 3, as applicable for the inherent basic operating software, 4-9-7/7/13		
<b>International Standards:</b>	N.A.		
<b>Government Authority:</b>			
<b>EUMED:</b>			
<b>Others:</b>			

Model Certificate	Model Certificate No	Issue Date	Expiry Date
PDA	01-HG189457/5-PDA	21/SEP/2009	20/SEP/2014

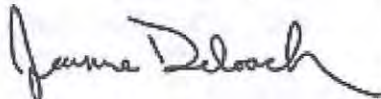

ABS Programs

ABS has used due diligence in the preparation of this certificate and it represents the information on the product in the ABS Records as of the date and time the certificate was printed. Type Approval requires Drawing Assessment, Prototype Testing and assessment of the manufacturer's quality assurance and quality control arrangements. Limited circumstances may allow only Prototype Testing to satisfy Type Approval. The approvals of Drawings and Products remain valid as long as the ABS Rule, to which they were assessed, remains valid. ABS cautions manufacturers to review and maintain compliance with all other specifications to which the product may have been assessed. Further, unless it is specifically indicated in the description of the product; Type Approval does not necessarily waive witnessed inspection or survey procedures (where otherwise required) for products to be used in a vessel, MODU or facility intended to be ABS classed or that is presently in class with ABS. Questions regarding the validity of ABS Rules or the need for supplemental testing or inspection of such products should, in all cases, be addressed to ABS.



### ***Confirmation of Product Type Approval 30/AUG/2012***

Please refer to the "Service Restrictions" shown below to determine if Unit Certification is required for this product.

This is to certify that, pursuant to the Rules of the American Bureau of Shipping (ABS), the manufacturer of the below listed product held a valid Manufacturing Assessment (MA) with expiration date of 26/AUG/2013. The continued validity of the Manufacturing Assessment is dependent on completion of satisfactory audits as required by the ABS Rules.

And; a Product Design Assessment (PDA) valid until 11/JUL/2017 subject to continued compliance with the Rules or standards used in the evaluation of the product.

The above entitle the product to be called Product Type Approved.

The Product Design Assessment is valid for products intended for use on ABS classed vessels, MODUs or facilities which are in existence or under contract for construction on the date of the ABS Rules used to evaluate the Product.

ABS makes no representations regarding Type Approval of the Product for use on vessels, MODUs or facilities built after the date of the ABS Rules used for this evaluation.

Due to wide variety of specifications used in the products ABS has evaluated for Type Approval, it is part of our contract that; whether the standard is an ABS Rule or a non-ABS Rule, the Client has full responsibility for continued compliance with the standard.

#### **HATTELAND DISPLAY AS**

**Model Name(s): Series X Maritime Multi Computers, Model Numbers: HD 08T21 MMC, HD 12T21 MMC, HD 13T21 MMC, HD 15T21 MMC, HD 17T21 MMC, HD 19T21 MMC, HD 24T21 MMC, HD 26T21 MMC**

**Presented to:**  
HATTELAND DISPLAY AS  
AMSOSEN  
NEDRE VATS  
Norway

<b>Intended Service:</b>	Panel Computer for Marine applications.
<b>Description:</b>	Panel Computer with AC&DC power input and with a choice of Intel Celeron P4505, Atom N450, Intel i7-620LE or C2D 2.26 GHz processor. Accessories: HT 00254 OPT-A1 (USB to CAN), PCA100293 (RS422-485 Module) , PCA100294 (USB to RS232 Module)
<b>Ratings:</b>	Operating Temp: -15C to +55C IP Rating: IP66 (front) - IP22 (rear) Models HD 08T21 MMC and HD 13T21 MMC: +24VDC All other models: +24V DC / 115V/230V AC
<b>Service Restrictions:</b>	The computer units will require Unit Certification if intended for use in any machinery monitoring and directional functions onboard an ABS classed vessel, MODU or facility. Unit certification could be performed individually or as an integrated system.
<b>Comments:</b>	Not Applicable
<b>Notes / Documentation:</b>	This Product Design Assessment (PDA) is valid only for products intended for use on ABS classed vessels, MODUs or facilities which are in existence or under contract for construction on the date of the ABS Rules used to evaluate the Product.
<b>Term of Validity:</b>	This Product Design Assessment (PDA) Certificate 12-LD908273-1-PDA, dated



17/Aug/2012 remains valid until 11/Jul/2017 or until the Rules or specifications used in the assessment are revised (whichever occurs first). This PDA is intended for a product to be installed on an ABS classed vessel, MODU or facility which is in existence or under contract for construction on the date of the ABS Rules or specifications used to evaluate the Product. Use of the Product on an ABS classed vessel, MODU or facility which is contracted after the validity date of the ABS Rules and specifications used to evaluate the Product, will require re-evaluation of the PDA. Use of the Product for non ABS classed vessels, MODUs or facilities is to be to an agreement between the manufacturer and intended client.

**ABS Rules:**

The Manufacturer has provided a declaration about the control of, or the lack of Asbestos in this product. The Rules applicable to this assessment are: ABS Rules for Building and Classing Steel Vessels (2012) 1-1-4/7.7, 4-9-7/13.1, 4-9-7/Tables 9 & 10

**National Standards:  
International Standards:**

IACS UR E10 2006 Rev.5, IEC/EN 60945, EN 55022 2006+A1 2007, EN 55024, EN 61000-3-2 2006+A1:2009+A2:2009, EN 61000-3-3 2008

**Government Authority:  
EUMED:  
Others:**

Model Certificate	Model Certificate No	Issue Date	Expiry Date
PDA	12-LD908273-1-PDA	17/AUG/2012	11/JUL/2017



**ABS Programs**

ABS has used due diligence in the preparation of this certificate and it represents the information on the product in the ABS Records as of the date and time the certificate was printed. Type Approval requires Drawing Assessment, Prototype Testing and assessment of the manufacturer's quality assurance and quality control arrangements. Limited circumstances may allow only Prototype Testing to satisfy Type Approval. The approvals of Drawings and Products remain valid as long as the ABS Rule, to which they were assessed, remains valid. ABS cautions manufacturers to review and maintain compliance with all other specifications to which the product may have been assessed. Further, unless it is specifically indicated in the description of the product; Type Approval does not necessarily waive witnessed inspection or survey procedures (where otherwise required) for products to be used in a vessel, MODU or facility intended to be ABS classed or that is presently in class with ABS. Questions regarding the validity of ABS Rules or the need for supplemental testing or inspection of such products should, in all cases, be addressed to ABS.





CERTIFICATE NUMBER

12-LD908273-1-PDA

DATE

17 August 2012

ABS TECHNICAL OFFICE

London Engineering Department

# CERTIFICATE OF DESIGN ASSESSMENT

This is to Certify that a representative of this Bureau did, at the request of  
**HATTELAND DISPLAY AS - NEDRE VATS**

assess design plans and data for the below listed product. This assessment is a representation by the Bureau as to the degree of compliance the design exhibits with applicable sections of the Rules. This assessment does not waive unit certification or classification procedures required by ABS Rules for products to be installed in ABS classed vessels or facilities. This certificate, by itself, does not reflect that the product is Type Approved. The scope and limitations of this assessment are detailed on the pages attached to this certificate.

PRODUCT: **Computer**

MODEL: **Series X Maritime Multi Computers, Model Numbers: HD 08T21 MMC, HD 12T21 MMC, HD 13T21 MMC, HD 15T21 MMC, HD 17T21 MMC, HD 19T21 MMC, HD 24T21 MMC, HD 26T21 MMC**

This Product Design Assessment (PDA) Certificate 12-LD908273-1-PDA, dated 17/Aug/2012 remains valid until 11/Jul/2017 or until the Rules or specifications used in the assessment are revised (whichever occurs first).

This PDA is intended for a product to be installed on an ABS classed vessel, MODU or facility which is in existence or under contract for construction on the date of the ABS Rules or specifications used to evaluate the Product.

Use of the Product on an ABS classed vessel, MODU or facility which is contracted after the validity date of the ABS Rules and specifications used to evaluate the Product, will require re-evaluation of the PDA.

Use of the Product for non ABS classed vessels, MODUs or facilities is to be to an agreement between the manufacturer and intended client.

AMERICAN BUREAU OF SHIPPING

Jean-Claude G. Dennemont  
Engineer

NOTE: This certificate evidences compliance with one or more of the Rules, Codes, standards or other criteria of ABS or a statutory, industrial or manufacturer's standard. It is issued solely for the use of ABS, its committees, its clients or other authorized entities. Any significant changes to the aforementioned product without approval from ABS will result in this certificate becoming null and void. This certificate is governed by the terms and conditions contained in ABS Rules 1-1-2.3/5.9 Terms and Conditions of the Request for Product Type Approval and Agreement (2010)

## HATTELAND DISPLAY AS

AMSOSEN  
NEDRE VATS  
5578  
Norway  
Telephone: +47 48 14 22 00  
Fax: +47 52 76 54 44  
Email: arne.kristiansen@hatteland-display.com  
Web: www.hatteland-display.com

MA Certificate No. 08-BE 1042573-X1

---

**Product:** Computer  
**Model:** Series X Maritime Multi Computers, Model Numbers: HD 08T21 MMC, HD 12T21 MMC, HD 13T21 MMC, HD 15T21 MMC, HD 17T21 MMC, HD 19T21 MMC, HD 24T21 MMC, HD 26T21 MMC

**Intended Service:**  
Panel Computer for Marine applications.

**Description:**  
Panel Computer with AC&DC power input and with a choice of Intel Celeron P4505, Atom N450, Intel i7-620LE or C2D 2.26 GHz processor.  
Accessories: HT 00254 OPT-A1 (USB to CAN), PCA100293 (RS422-485 Module), PCA100294 (USB to RS232 Module)

**Ratings:**  
Operating Temp: -15C to +55C  
IP Rating: IP66 (front) - IP22 (rear)  
Models HD 08T21 MMC and HD 13T21 MMC: +24VDC  
All other models: +24V DC / 115V/230V AC



**Service Restrictions:**  
The computer units will require Unit Certification if intended for use in any machinery monitoring and directional functions onboard an ABS classed vessel, MODU or facility. Unit certification could be performed individually or as an integrated system.

**Comments:**  
Not Applicable

**Notes / Drawings / Documentation:**  
This Product Design Assessment (PDA) is valid only for products intended for use on ABS classed vessels, MODUs or facilities which are in existence or under contract for construction on the date of the ABS Rules used to evaluate the Product.

**Term of Validity:**  
This Product Design Assessment (PDA) Certificate 12-LD908273-1-PDA, dated 17/Aug/2012 remains valid until 11/Jul/2017 or until the Rules or specifications used in the assessment are revised (whichever occurs first).

This PDA is intended for a product to be installed on an ABS classed vessel, MODU or facility which is in existence or under contract for construction on the date of the ABS Rules or specifications used to evaluate the Product.

Use of the Product on an ABS classed vessel, MODU or facility which is contracted after the validity date of the ABS Rules and specifications used to evaluate the Product, will require re-evaluation of the PDA.

Use of the Product for non ABS classed vessels, MODUs or facilities is to be to an agreement between the manufacturer and intended client.

### STANDARDS

**ABS Rules:**  
The Manufacturer has provided a declaration about the control of, or the lack of Asbestos in this product. The Rules applicable to this assessment are: ABS Rules for Building and Classing Steel Vessels (2012) 1-1-4/7.7, 4-9-7/13.1, 4-9-7/Tables 9 & 10

### National:

---

As of 17/Aug/2012

Design Assessment

Page 1 of 2



**HATTELAND DISPLAY AS**

AMSOSEN  
NEDRE VATS  
5578

Norway

Telephone: +47 48 14 22 00

Fax: +47 52 76 54 44

Email: arne.kristiansen@hatteland-display.com

Web: www.hatteland-display.com

MA Certificate No. 08-BE 1042573-X1

---

NA

**International:**

IACS UR E10 2006 Rev.5, IEC/EN 60945, EN 55022 2006+A1 2007, EN 55024, EN 61000-3-2  
2006+A1:2009+A2:2009, EN 61000-3-3 2008

**Government Authority:**

NA

**EUMED:**

NA

**Others:**

NA







# Type Approval Certificate

Germanischer Lloyd

This is to certify that the undernoted product(s) has/have been tested in accordance with the relevant requirements of the GL Type Approval System.

Certificate No. **3288006 HH**

Company **Hirschmann Automation and Control GmbH  
Stuttgarter Straße 45 - 51  
72654 Neckartenzlingen, GERMANY**

Product Description **Ethernet LAN components  
Rail Switch**

Type **RS20, RS30**

Environmental Category **C, EMC 1**

Technical Data /  
Range of Application **The Rail Switch modules support switched ETHERNET networks in accordance with IEEE standard 802.3 or 802.3u using copper and fiber optic technology. The switch modules are plugged onto the standard DIN rail.**

**The RS20 support ETHERNET with 10 MBit/s and 100 MBit/s.  
The RS30 support ETHERNET with 10 MBit/s, 100 MBit/s and 1000 MBit/s.**

**The components covered by this certificate are listed on page 2 and 3.**

Test Standard **Guidelines for the Performance of Type Approvals, Chapter 2, Edition 2003**

Documents **Test reports: see page 3.  
Drawings and User Manuals RS20/RS30 acc. to submitted files.  
Overlook Certification "Design and Performance Standards, Codes of Rules".  
Software Questionnaire according to requirement class 3, dated 2000-03-28.**

Remarks **Application specific system requirements are to be observed for the network layout.**

Valid until **2016-05-08**

Page **1 of 3**

Type Approval Symbol



File No. **1.B.08**

Hamburg, **2012-07-04**

**Germanischer Lloyd**

Dr. Joannis Papanuskas

Klaus-Peter Schröder

This certificate is issued on the basis of "Regulations for the Performance of Type Tests Part 0 Procedure"



# Type Approval Certificate

Germanischer Lloyd

This is to certify that the undernoted product(s) has/have been tested in accordance with the relevant requirements of the GL Type Approval System.

Certificate No. **3288006 HH**

The product designation of the device is made from combining the desired product characteristics in accordance with the following structure (see page 2 and 3).

RSaa-bbccddeefDgh...

Position 3 and 4 (aa): Product Type

20: Rail switch without gigabit ports

30: Rail switch with gigabit ports

Position 5 (-): hyphen

Position 6 and 7 (bb): Number of 10/100 Mbit ports

04: 4 \* 10/100 Mbit Ethernet

08: 8 \* 10/100 Mbit Ethernet

16: 16 \* 10/100 Mbit Ethernet

24: 24 \* 10/100 Mbit Ethernet

Position 8 and 9 (cc): Number of 1000 Mbit ports

00: 0 \* 1000 Mbit Ethernet

02: 2 \* 1000 Mbit Ethernet (without 4 port devices)

Position 10 and 11 (dd): Port 1 (ring port)

T1: Twisted pair TX, RJ45

T5: Twisted pair / M12 (10/100Mbit)

M2: Multimode FX, DSC, 100 Mbit

M4: Multimode FX, ST, 100 Mbit

S2: Singlemode FX, DSC, 100 Mbit

S4: Singlemode FX, ST, 100 Mbit

L2: Singlemode longhaul, FX, DSC, 100 Mbit

G2: Singlemode longhaul, FX, DSC, 200km, 100 Mbit

O6: SFP Slot, 1000 Mbit

OO: 2 \* SFP Slot Gigabit Ethernet, 1000 Mbit

Valid until **2016-05-08**

Page **2 of 3**

File No. **I.B.08**

**Hamburg, 2012-07-04**

Type Approval Symbol



**Germanischer Lloyd**

Dr. Joannis Papanuskas

Klaus-Peter Schröder

This certificate is issued on the basis of "Regulations for the Performance of Type Tests Part 0 Procedure"



# Type Approval Certificate

Germanischer Lloyd

This is to certify that the undernoted product(s) has/have been tested in accordance with the relevant requirements of the GL Type Approval System.

Certificate No. 3288006 HH

RSaa-bbccddeefDgh...

Position 12 and 13 (ee): Uplink port(s)

- T1: Twisted pair TX, RJ45
- T5: Twisted pair / M12 (10/100Mbit)
- M2: Multimode FX, DSC, 100 Mbit
- M4: Multimode FX, ST, 100 Mbit
- S2: Singlemode FX, DSC, 100 Mbit
- S4: Singlemode FX, ST, 100 Mbit
- L2: Singlemode longhaul, FX, DSC, 100 Mbit
- G2: Singlemode longhaul, FX, DSC, 200km, 100 Mbit
- O6: SFP Slot, 1000 Mbit
- ZZ: 2 \* SFP Slot Fast Ethernet, 100 Mbit

Position 14 (f): Temperature range

- S: Standard, 0°C ... +60°C
- T or E: Extended, -40°C<sup>1)</sup> ... +70°C, "E" is inclusive conformal coating of PCB's

Position 15 (D): Voltage range

- D: 9,6V DC to 60V DC or 18V AC to 30V AC<sup>2)</sup>

Position 16 (g): Specifications

- B: With ATEX 100a Zone 2 (on this certificate as information=)
- H: Without ATEX

Position 17 (h): Software variant, optionally be followed by additional digits

- E: Enhanced
- P: Professional
- U: Unmanaged
- B: Basic

Relevant notes for this certificate:

- <sup>1)</sup> type approval test performed down to -25°C only.
  - <sup>2)</sup> type approval test performed to 24V DC (-25% ... +30%) only.
- Software release: 07.x

Test reports TESTLAB no.: U080653E1 (20.11.08), E080653E1 (13.11.08), U080653E2 (11.11.08), E080653E2 (13.11.08), U080653E3 (11.11.08), E080653E3 (13.11.08), U080653E4 (10.11.08), E080653E4 (13.11.08)

Valid until 2016-05-08

Page 3 of 3

Type Approval Symbol



File No. I.B.08

Hamburg, 2012-07-04

Germanischer Lloyd

Dr. Joannis Papanuskas

Klaus-Peter Schröder

This certificate is issued on the basis of "Regulations for the Performance of Type Tests Part 0 Procedure"



# Detailed Specifications & Technical Data

METRIC MEASUREMENT VERSION



## 1300SB Multi-Conductor - Category 5e ScTP Shipboard ABS Type Approved



For more Information  
please call

1-800-Belden1



### General Description:

24 AWG solid bare copper conductors, polypropylene insulation, overall Beldfoil® shield, 24 AWG stranded tinned copper drain wire, low smoke zero halogen jacket.

### Usage (Overall)

**Suitable Applications:** Shipboard LAN/Data, WI-FI, Wireless LAN, Outdoor Antenna, Radio, Broadband, RF, Where ABS Type Approval is Required

### Physical Characteristics (Overall)

#### Conductor

AWG:

# Pairs	AWG	Stranding	Conductor Material
4	24	Solid	BC - Bare Copper

**Total Number of Conductors:** 8

#### Insulation

Insulation Material:

Insulation Material	Wall Thickness (mm)	Dia. (mm)
PP - Polypropylene	0.254	1.0668

#### Outer Shield

Outer Shield Material:

Outer Shield Trade Name	Type	Outer Shield Material	Coverage (%)
Beldfoil®	Tape	Aluminum Foil-Polyester Tape	100

Outer Shield Drain Wire AWG:

AWG	Stranding	Drain Wire Conductor Material
24	7x32	TC - Tinned Copper

#### Outer Jacket

Outer Jacket Material:

Outer Jacket Material
LSZH - Low Smoke Zero Halogen

#### Overall Cable

**Overall Nominal Diameter:** 6.604 mm

#### Pair

Pair Color Code Chart:

Number	Color
1	White/Blue Stripe & Blue
2	White/Orange Stripe & Orange
3	White/Green Stripe & Green
4	White/Brown Stripe & Brown

### Mechanical Characteristics (Overall)

**Operating Temperature Range:** -30°C To +105°C

**Bulk Cable Weight:** 48.218 Kg/Km

**Max. Recommended Pulling Tension:** 111.205 N

# Detailed Specifications & Technical Data



METRIC MEASUREMENT VERSION

## 1300SB Multi-Conductor - Category 5e ScTP Shipboard ABS Type Approved

Min. Bend Radius/Minor Axis: 63.500 mm

### Applicable Specifications and Agency Compliance (Overall)

#### Applicable Standards & Environmental Programs

NEC/(UL) Specification:	CMG-LS
CEC/C(UL) Specification:	CMG-LS
EU Directive 2011/65/EU (ROHS II):	Yes
IEEE Specification:	Std. 45 clause 23
EU CE Mark:	Yes
EU Directive 2000/53/EC (ELV):	Yes
EU Directive 2002/95/EC (RoHS):	Yes
EU RoHS Compliance Date (mm/dd/yyyy):	08/01/2005
EU Directive 2002/96/EC (WEEE):	Yes
EU Directive 2003/11/EC (BFR):	Yes
CA Prop 65 (CJ for Wire & Cable):	Yes
MII Order #39 (China RoHS):	Yes
Other Specification:	NEMA WC-63.1 Category 5e, UL 444, ABS Type Approval Certificate 05-HS500072A

#### Flame Test

UL Flame Test:	UL1685 FT4 Loading, Limited Smoke
C(UL) Flame Test:	FT4, Limited Smoke
IEC Flame Test:	60332-1, 60332-3-22 (Category A)
IEEE Flame Test:	1202

#### Suitability

Suitability - Indoor:	Yes
Suitability - Outdoor:	Yes
Sunlight Resistance:	Yes

#### Plenum/Non-Plenum

Plenum (Y/N):	No
---------------	----

### Electrical Characteristics (Overall)

#### Nom. Mutual Capacitance:

Capacitance (pF/m)  
49.215

Maximum Capacitance Unbalance (pF/100 m): 330

#### Nominal Velocity of Propagation:

VP (%)  
70

#### Maximum Delay:

Delay (ns/100 m)  
538 @ 100MHz

#### Max. Delay Skew:

Delay Skew (ns/100 m)  
45

#### Maximum Conductor DC Resistance:

DCR @ 20°C (Ohm/100 m)  
9.38

#### Max. Operating Voltage - UL:



# Detailed Specifications & Technical Data



METRIC MEASUREMENT VERSION

## 1300SB Multi-Conductor - Category 5e ScTP Shipboard ABS Type Approved

Voltage
300 V RMS

Maximum DCR Unbalanced:

DCR Unbalance @ 20°C (%)
3

### Electrical Characteristics-Premise (Overall)

Premise Cable Electrical Table 1:

Freq. (MHz)	Max. Attenuation (dB/100 m)	Min. NEXT (dB)	Min. PSNEXT (dB)	Min. ACR (dB)	Min. PSACR (dB)	Min RL (dB)	Min. SRL (dB)
1	2.0	65.3	62.3	60.3	60.3	20.0	20.0
4	4.1	56.3	53.3	49.2	49.2	23.0	23.0
8	5.8	51.8	48.8	43.0	43.0	24.5	24.5
10	6.5	50.3	47.3	40.8	40.8	25.0	25.0
16	8.2	47.3	44.3	36.1	36.1	25.0	25.0
20	9.3	45.8	42.8	33.5	33.5	25.0	25.0
25	10.4	44.3	41.3	30.9	30.9	24.3	24.3
31.25	11.7	42.9	39.9	28.2	28.2	23.6	23.6
62.5	17.0	38.4	35.4	18.4	18.4	21.5	21.5
100	22.0	35.3	32.3	10.3	10.3	20.1	20.1

Premise Cable Electrical Table 2:

Freq. (MHz)	Input (Unfitted) Imp. (Ohms)	Fitted Impedance	Min. ELFEXT (dB)	Min. PSELFEXT (dB)
1	100 ± 15	100 ± 15	63.8	60.8
4	100 ± 15	100 ± 15	51.7	48.7
8	100 ± 15	100 ± 15	45.7	42.7
10	100 ± 15	100 ± 15	43.8	40.8
16	100 ± 15	100 ± 15	39.7	36.7
20	100 ± 15	100 ± 15	37.7	34.7
25	100 ± 15	100 ± 15	35.8	32.8
31.25	100 ± 15	100 ± 15	33.9	30.9
62.5	100 ± 15	100 ± 15	27.8	24.8
100	100 ± 15	100 ± 15	23.8	20.8

### Notes (Overall)

Notes: RJ-45 Compat ble. Jacket sequentially marked at 2 ft. intervals.

### Put Ups and Colors:

Item #	Putup	Ship Weight	Color	Notes	Item Desc
1300SB 0101000	305 MT	15.876 KG	BLACK	C	4 PR #24 PP FS FRNHPO

Notes:  
C = CRATE REEL PUT-UP.

Revision Number: 4    Revision Date: 08-14-2012

© 2013 Belden, Inc  
All Rights Reserved.

Although Belden makes every reasonable effort to ensure their accuracy at the time of this publication, information and specifications described herein are subject to error or omission and to change without notice, and the listing of such information and specifications does not ensure product availability.

Belden provides the information and specifications herein on an "AS IS" basis, with no representations or warranties, whether express, statutory or implied. In no event will Belden be liable for any damages (including consequential, indirect, incidental, special, punitive, or exemplary damages) whatsoever, even if Belden has been advised of the possibility of such damages, whether in an action under contract, negligence or any other theory, arising out of or in connection with the use, or inability to use, the information or specifications described herein.

All sales of Belden products are subject to Belden's standard terms and conditions of sale.

Belden believes this product to be in compliance with EU RoHS (Directive 2002/95/EC, 27-Jan-2003). Material manufactured prior to the compliance date may be in stock at Belden facilities and in our Distributor's inventory. The information provided in this Product Disclosure, and the identification of materials listed as reportable or restricted within the Product Disclosure, is correct to the best of Belden's knowledge, information, and belief at the date of its publication. The information provided in this Product Disclosure is designed only as a general guide for the safe handling, storage, and any other operation of the product itself or the one that it becomes a part of. This Product Disclosure is not to be considered a warranty or quality specification. Regulatory information is for guidance purposes only. Product users are responsible for determining the applicability of legislation and regulations based on their individual usage of the product.

Belden declares this product to be in compliance with EU LVD (Low Voltage Directive 73/23/EEC), as amended by directive 93/68/EEC.



# Detailed Specifications & Technical Data

METRIC MEASUREMENT VERSION



**1300SB Multi-Conductor - Category 5e ScTP Shipboard ABS Type Approved**

REV.

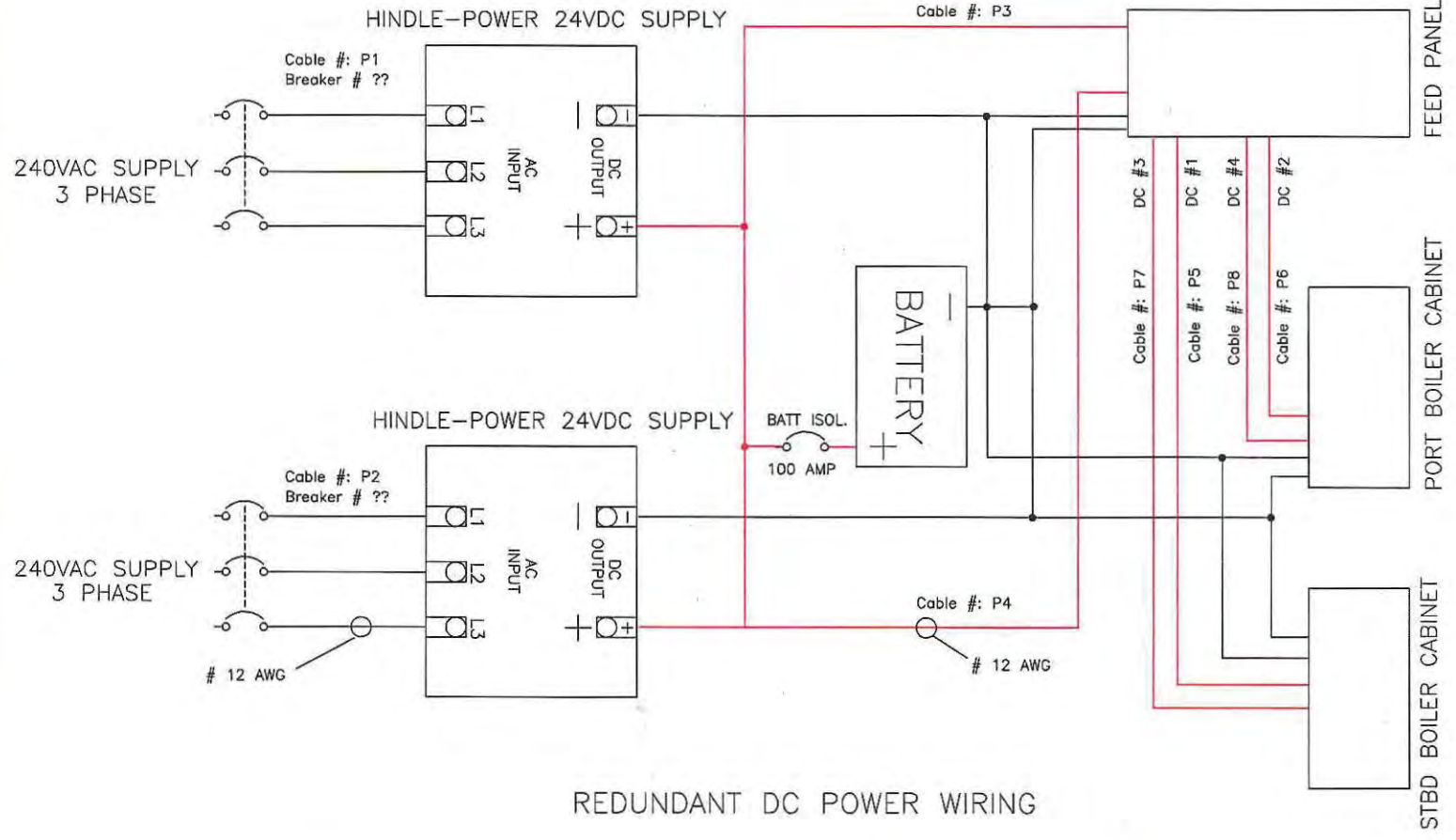

REDUNDANT DC POWER WIRING

SS BADGER  
24VDC BATTERY-BACKED POWER

DRAWING NAME:	DRAWING NO:
BY: JCHLLC	DATE: 2/19/14
	SHEET ___ OF ___

CONTAINS CONFIDENTIAL BUSINESS INFORMATION



REV.	

DC SUPPLY LINE #1 FROM HINDLE-POWER CHARGER #1

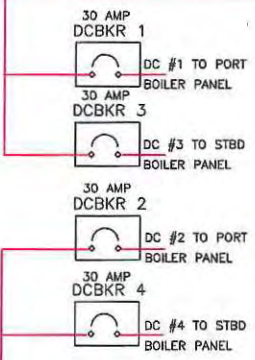

DC SUPPLY LINE #2 FROM HINDLE-POWER CHARGER #2

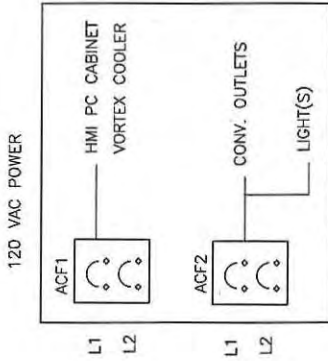

DC-
DC-
DC-
DC-

G
G
G
G

REV. PROTECTION DIODE WIRING DETAILS  
DIODES: GBPC2504

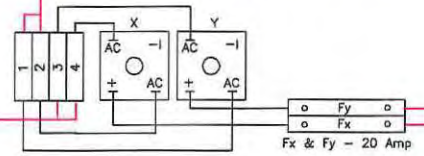

NOTE: TEST DIODES X AND Y BY ALTERNATELY OPENING FUSE HOLDERS Fx AND Fy.

DC POWER - FEEDWATER CABINET

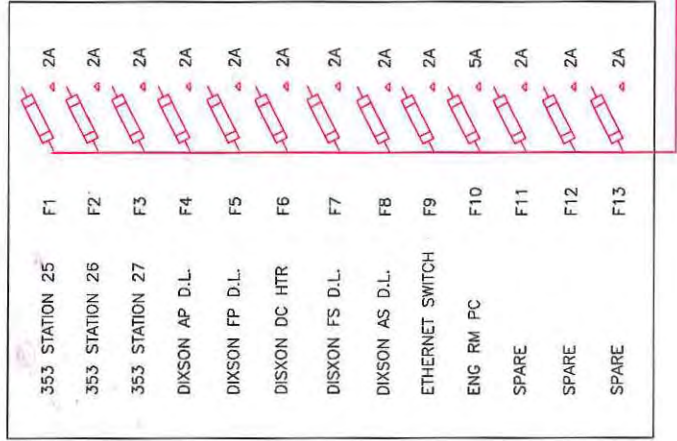

BADGER FEEDWATER PANEL WIRING

DRAWING NAME: FEEDPWR.DWG	DRAWING NUMBER:
BY: JCHLLC	DATE: 2/3/14
SHEET ___ OF ___	

CONTAINS CONFIDENTIAL BUSINESS INFORMATION

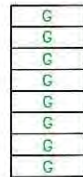
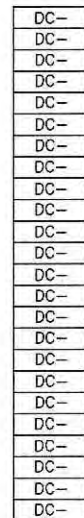
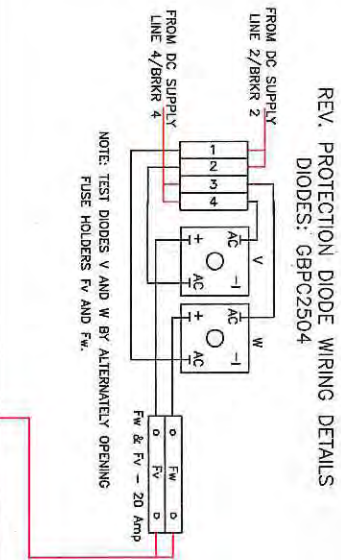
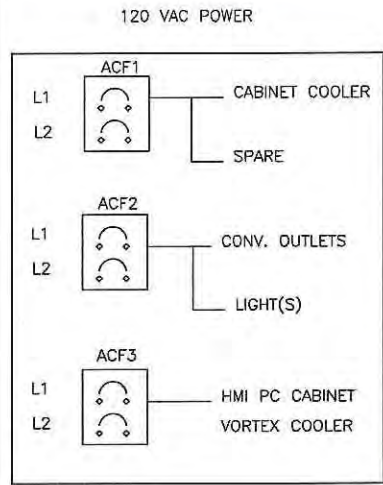

REV.  
1. 2/20/14 - ADDSD AND DIODE SET.

353 STATION 13	F1	2A
353 STATION 14	F2	2A
353 STATION 15	F3	2A
353 STATION 16	F4	2A
353 STATION 17	F5	2A
353 STATION 18	F6	2A
353 STATION 19	F7	2A
353 STATION 20	F8	2A
353 STATION 21	F9	2A
353 STATION 22	F10	2A
353 STATION 23	F11	2A
353 STATION 24	F12	2A
SPARE	F13	2A
PLC CPU A	F14	5A
PLC CPU B	F15	5A
IM153-2A	F16	2A
IM153-2B	F17	2A
PLC ANALOGS	F18	2A
PORT DI #1A	F19	2A
PORT DI #1B	F20	2A
STBD DI #2A	F21	2A
STBD DI #2B	F22	2A
PORT RLY DO 1	F23	5A
PORT RLY DO 2	F24	5A
STBD RLY DO 1	F25	5A
STBD RLY DO 2	F26	5A
PORT DI #3A	F27	2A
PORT DI #3B	F28	2A
STBD DI #4A	F29	2A
STBD DI #4B	F30	2A
PORT RLY DO 3	F31	5A
STBD RLY DO 4	F32	5A
ETHERNET SWITCH	F33	2A
AP DIXSON IND	F34	2A
FP DIXSON IND	F35	2A
FP AIRFLOW XMTR	F36	5A
AP AIRFLOW XMTR	F37	5A
BLR RM HMI PC	F38	10A
SPARE	F39	2A

DC POWER - PORT BOILER CABINET

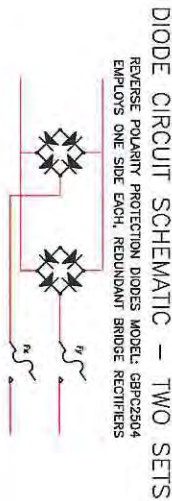
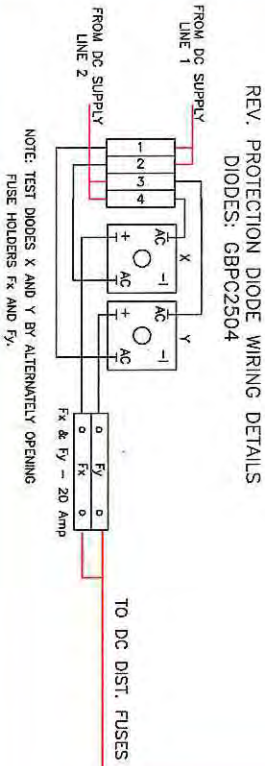

BADGER BOILER PANEL WIRING  
PORT PANEL POWER DISTRIBUTION

DRAWING NAME: PORTPWR.DWG  
DATE: 1/31/14  
DRAWING NUMBER:  
SHEET: 04



120 VAC POWER

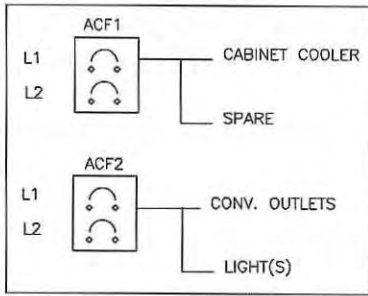

DC POWER - STBD BOILER CABINET

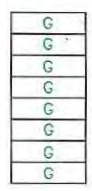
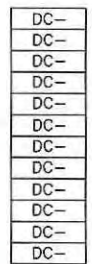
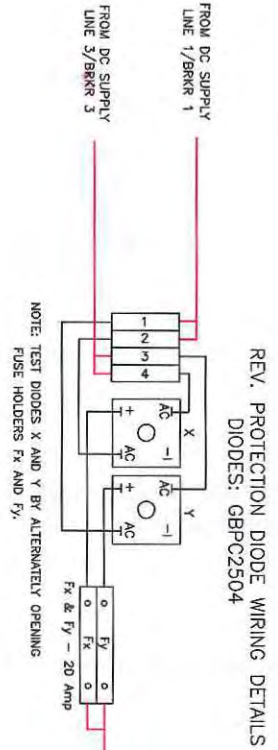
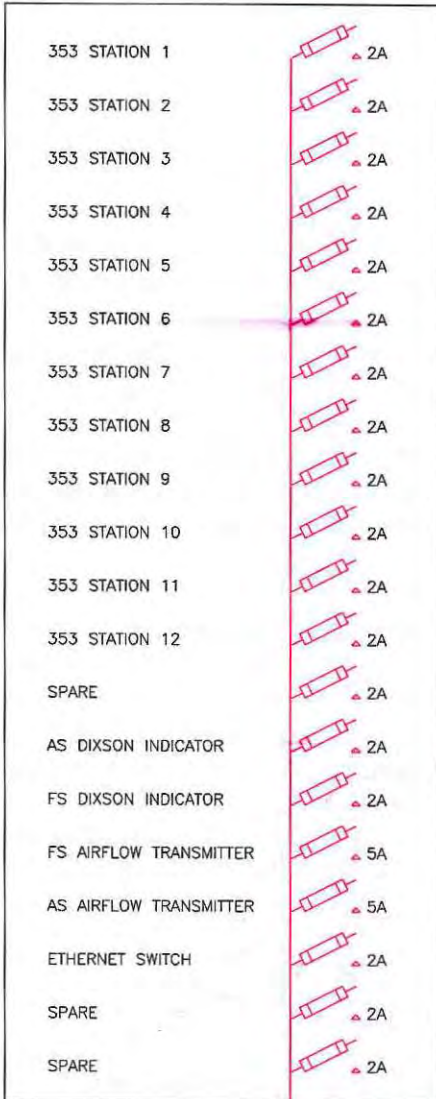

BADGER BOILER PANEL WIRING  
STBD PANEL POWER DISTRIBUTION

BY: JCH/LC DATE: 1/31/14

DRAWING NUMBER: STBDPWR.DWG

ISSUANCE NUMBER: SHEET \_\_\_ OF \_\_\_

# ABS Guide for Ships Burning Coal – 1980 Annotations

---

The applicable ABS document for the SS Badger Combustion Control Optimization Project is the “Guide for Ships Burning Coal” circa 1980.

The ‘Guide’ was intended for new construction of coal-fired ships, where it would be possible to address the elements of parts 1-17.

The SS Badger Combustion Control Optimization Project is being performed aboard a vessel, designed in 1950. The intent is to optimize the combustion process, as well as, to enhance safety wherever practicable.

Most of the ‘Guide’ does not apply to this project because there will be no changes in type of any of the final control elements and neither the operational design of the steam plant nor the manning will be changed from the original 1950s design.

The SS Badger has a three watch system with 1 A/E, 2A/E and 3A/E in charge respectively. Each watch also has one Oiler, one Water-tender, one Fireman and one Coal-passer on duty.

The following discusses each of the seventeen parts of the “Guide for Ships Burning Coal” to explain how G.R.Bowler, Inc. (GRB) is addressing the topics.

## Part 1.0 Application

NFPA 85E , 85F and 85G have been reviewed and used as applicable. (GRB is an NFPA member)

## Part 2.0 Plans and Data

Detail of control, safety, instrumentation and alarm system, including arrangements, schematics, panel layout and description of operation is included in this submittal. No other subjects apply.

## Part 3.0 Operating and Maintenance Manual

An Automatic Combustion Control Manual will be provided to the customer.

## Part 4.0 General

All existing machinery will stay the same. The SS Badger has 4 boilers.

## Part 5.0 Coal Conditions

All existing machinery will stay the same.

## Part 6.0 Environmental Conditions

All existing machinery will stay the same. •



#### Part 7.0 Bunkers

All existing machinery will stay the same.

#### Part 8.0 Independent Manual Control

Manual control will be addressed by providing a selectable, manual mode at each controller.

There is a specific faceplate for boiler coal feeders, FD Fan & ID Fan. The operator can manually operate the coal feeders, F.D Fan & I.D. Fan from the controller face plate.

#### Part 9.0 Coal Transfer Preparation

All existing machinery will stay the same.

#### 10.0 Boiler Control

The Boiler Control system is designed to augment the manual boiler operation, which is supervised 100 % of the time by Fireman, Water Tenders and Engineer of the watch.

#### 11.0 Boiler Protection System

Due to the steam-driven, I.D. Fans and the plant's manual, coal light-off procedures, especially during the time that steam is not available for operation of the I.D. Fan, the described F.D./I.D. Interlocking is not practical.

The original boiler design did not include low water-level alarms or trips, however, low water alarms will be added as a function of the new system.

All functions listed in the 'Condition – Safety' table for High/Low furnace pressure, F.D. Fan & I.D. Fan malfunction are addressed in the new system by alarms that will prompt action by the operator. All safety considerations have been reviewed by the highly experienced, SS Badger's Chief Engineer and all malfunction conditions other than Low-Low water trip will be addressed by an alarm and operator action. This ship has operated over 60 years with no boiler safety related automatic alarms or trips, relying on the monitoring and action of the experienced operators. The new alarm functions that will annunciate in the boiler room and engine room will greatly enhance safety.

#### Part 12.0 Dual Fuel

N/A

#### Part 13.0 Ash Handling and Storage

All existing machinery will stay the same.

#### Part 14.0 Ventilation

All existing machinery will stay the same.

#### Part 15.0 Fire Protection

All existing machinery will stay the same.

Part 16.0 Electrical Installation

No new electrical in hazardous locations.

Part 17.0 Test and Trial

Dock trial and sea trials will be conducted to tune and test the new combustion control systems.



## ***AUTOMATIC COMBUSTION CONTROL SYSTEMS - DESCRIPTION OF OPERATION - SECTION 1***

The following is a description of operation covering the Plant and Boiler Sub-Master systems for the S/S Badger.

- I. PLANT MASTER – The combustion control system monitors and maintains the highest of four boilers' steam drum pressures at a setpoint of 440 Psig, through all variations of plant load, by regulating the firing rate of the boilers. The system is a two-element system consisting of several Siemens Model 353, ABS Type-Approved, Loop Controllers. The system monitors four boilers' drum pressures and steam flows and automatically determines the loading necessary (firing rate) of the online boilers.

### A. Sensing

1. Drum Steam Pressure Transmitters PT103, PT203, PT303 and PT403 sense the drum steam pressure at each boiler. These electronic transmitters, ranged from 300 to 600 Psig, provide a 4-20 Ma signal, representative of the input range, for the Plant Master Controller.
2. Steam Flow Transmitters FT113, FT213, FT313 and FT413 are calibrated to measure the desuperheated, steam flow from each boiler drum, and to transmit a 4-20 Ma signal proportional to the steam flow. Maximum steam flow, per boiler, is 37,000 PPH.

### B. Computing

1. The Plant Master Controller, receives the analog pressure signals from all four boilers' drum steam pressure transmitters. These signals are constantly compared and the highest of the four is selected for control. This pressure is compared to the desired operating setpoint and a control signal is calculated by a reverse-acting, PID block. The output of this block is added to a computed, feed-forward signal, representing a change in plant steam flow (anticipation signal). This computation is effected by selecting the highest of the four boilers' steam flows, comparing their measured changes over a short time span and adding this result to the output of the PID block. Since the steam flow calculation result is the product of a change in steam flow over time, it has no effect on the controller output during steady-state conditions. Any increase or decrease in steam flow to the main engines will result in the generation of the anticipation signal. This signal causes the firing rate demand to increase or decrease

as required in advance of any change in steam pressure, thereby helping to maintain a very stable plant steam pressure.

- II. Individual Boiler Sub-Masters allow the operator to select the automatic transfer of firing rate demand from the Plant Master to each boiler's air and coal controls or to manually adjust the firing rate, as desired. During automatic operation, the operator can adjust a Bias value at each Boiler Sub-Master to help balance the boilers' firing rates.

## ***AUTOMATIC COMBUSTION CONTROL SYSTEMS - DESCRIPTION OF OPERATION - SECTION 2***

The following is a description of operation, regarding the combustion and future drum-level controls installed on the SS Badger.

- III. COMBUSTION CONTROL – In order to maintain the steam pressure at setpoint, the system follows the Plant Master's Demand signal, passed on by each boiler's Sub-Master. This demand signal commands the Forced-Draft, Variable Frequency Drive's output to control and accurately maintain the correct airflow for all firing rates. Subsequently, the measured airflow provides inferential demand signals to the boiler's two coal feeders, rotors and air distributors. Overfire Air is provided by a Variable Frequency Drive-controlled blower. This Overfire Air is adjusted according to the best demonstrated combustion parameters.

### **A. Sensing**

1. Airflow Transmitters FT111, FT211, FT311 and FT411 sense the differential pressure at the inlet of the F.D. Fan and produce a 4-20 Ma output proportional to this differential. Since flow is determined by the square root of these differential signals, these signals are sent to a square root computation section so that a signal, which is proportional to air flow can be calculated. These transmitters are calibrated for 0-100% relative airflow.
2. The discharge pressure from the Overfire Air blowers are monitored by transmitters PT107, PT207, PT307 and PT407 respectively. Comparison of combustion characteristics will provide a pre-determined pressure setpoint for the Overfire Air at each boiler. A secondary control loop in the F.D. Controller will maintain the proper pressure relationship of the Overfire Air.
3. Coal Feed-rate demand is determined as the result of the lesser of either the Boiler Sub-Master Output or the Measured Airflow.



This demand is further characterized to provide exacting coal feeds accordingly.

4. The Coal Feeders are augmented by coal slinging Rotors and an Air Distributing Blower. These components functions are characterized and keyed to the inferred demand for their individual rotors.
5. Steam Flow Transmitters FT113, FT213, FT3132 and FT413 are calibrated to measure desuperheated steamflow between the boiler drum and superheater for each boiler, and transmit a 4-20 Ma signal proportional to this flow. Maximum steam flow is 37,000 PPH.

IV. FURNACE PRESSURE CONTROL – the steam-driven, I.D. Fan will provide the necessary Induced Draft to help maintain the boiler's Furnace Pressure.

1. Furnace pressures are sensed by transmitters: PT106, PT206, PT306 and PT 406 for boilers 1,2,3 and 4, respectively.
2. Furnace pressure is monitored and controlled by a standard PID control loop employing feed-forward action provided by monitoring changes in the F.D. demand output signal. This will allow the Furnace Pressure controller to anticipate pressure changes caused by changes in firing rate.
3. Excessively positive Furnace Pressure will cause an alarm to annunciate, allowing the operator to take appropriate action.

V. DRUM LEVEL CONTROL – (Future) will be accomplished in the Drum Level Controller Station.

A. Sensing

1. Drum Level Transmitters LT121, LT221, LT321 and LT421 sense the difference between the actual drum water level and the water level in a constant-level reservoir. Special closed-vessel calibration is applied, which allows the transmitter to send an output signal, which is representative of the actual drum level. These transmitters are calibrated to represent level measurement from negative 6" to plus 6" of water column by converting the measured values to a 4-20 Ma output.
2. Steam Flow Transmitters FT113, FT213, FT313 and FT413 are described under the combustion control section. These signals are shared by both the Plant Master and Drum Level Controllers for each boiler.

## B. Computing

1. The drum level controllers are configured for two-element control, incorporating the measured steam flow and drum level signals. The measured steam flow is analyzed and characterized to command accurate feed-valve position for all steam flow-rates. The measured water level in the drum is compared with the desired level setpoint by the PID control block, which computes a correction signal. This signal is used to modify the steam flow/valve position equation, in order to maintain the level at the desired value, should an error exist.
2. High or Low Drum Levels will be annunciated by an audible alarm, allowing the operator to take appropriate action.
3. Low-Low Drum Levels will be sensed by additional Level transmitters, LT122, LT222, LT322, and LT422, which are connected to individual boiler, vertical level displays. Each boiler's display unit will also provide a relay contact for the purpose of boiler drum Low-Low Trip.



FWD STBD

NUMBER	SERVICE	ZERO	SPAN	UNITS	353 + TERM	- TERM	CABLE	TYPE	PAIR	LENGTH
PT101	SUPERHEATED STEAM PRESS - CONTROL	300	500	PSIG	FSBM	5	20 K0620	TPS-18TIU-1		
PT102	SUPERHEATED STEAM PRESS - INDICATION	0	600	PSIG	FSBM	5	22 K0641	TPS-18TIU-1		
PT103	DRUM PRESSURE - CONTROL	300	500	PSIG	FSBM	7	23 K0622	TPS-18TIU-1		
PT104	DRUM PRESSURE - INDICATION	0	800	PSIG	FSBM	7	41 K0623	TPS-18TIU-1		
PT105	F.D. DISCHARGE PRESSURE	0	10	IN WC	FSFD	5	22 K0523	TPS-18TIU-1		
PT106	FURNACE PRESSURE	-2	2	IN WC	FSID	5	20 K0420	TPS-18TIU-1		
PT107	OVER-FIRE AIR PRESSURE	0	35	IN WC	FSFD	7	23 K0522	TPS-18TIU-1		
PT108	FLUE GAS PRESS INTO ECONOMIZER	-4	4	IN WC	FSID	5	22 K0422	TPS-18TIU-1		
PT109	FLUE GAS UPTAKE PRESSURE	-4	4	IN WC	FSID	7	23 K0423	TPS-18TIU-1		
FT111	COMBUSTION AIRFLOW	0	100	PCT	FSFD	20	21 K0520	TPS-18TIU-2	PAIR #2	
FT113	STEAMFLOW	0	44,000	lb/hr	FSDL	22	21 K0122			
LT121	DRUM LEVEL - CONTROL To YARWAY Chamber	-6	6	IN WC	FSDL	5	20 K0120	TPS-18TIU-1		
LT122	DRUM LEVEL - INDICATION	-10	10	IN WC	DIXSON		K122	TPS-18TIU-1		
NOTE: 250 OHM RESISTORS TO BE CONNECTED BETWEEN TERMINALS 20 & 21, 22 & 21, 23 & 24 AND 41 & 42, EACH STATION										

FWD PORT

NUMBER	SERVICE	ZERO	SPAN	UNITS	353 + TERM	- TERM	CABLE	TYPE	PAIR	LENGTH
PT201	SUPERHEATED STEAM PRESS CONTROL	300	500	PSIG	FPBM	5	20 K1920	TPS-18TIU-1		
PT202	SUPERHEATED STEAM PRESS INDICATION	0	600	PSIG	FPBM	5	22 K1941	TPS-18TIU-1		
PT203	DRUM PRESSURE - CONTROL	300	500	PSIG	FPBM	7	23 K1922	TPS-18TIU-1		
PT204	DRUM PRESSURE - INDICATION	0	800	PSIG	FPBM	7	41 K1923	TPS-18TIU-1		
PT205	F.D. DISCHARGE PRESSURE	0	10	IN WC	FPFD	5	22 K2023	TPS-18TIU-1		
PT206	FURNACE PRESSURE	-2	2	IN WC	FPID	5	20 K2120	TPS-18TIU-1		
PT207	OVER-FIRE AIR PRESSURE	0	35	IN WC	FPFD	7	23 K2022	TPS-18TIU-1		
PT208	FLUE GAS PRESS INTO ECONOMIZER	-4	4	IN WC	FPID	5	22 K2122	TPS-18TIU-1		
PT209	FLUE GAS UPTAKE PRESSURE	-4	4	IN WC	FPID	7	23 K2123	TPS-18TIU-1		
FT211	COMBUSTION AIRFLOW	0	100	PCT	FPFD	20	21 K2020	TPS-18TIU-2	PAIR #2	
FT213	STEAMFLOW	0	44,000	lb/hr	FPDL	22	21 K2422			
LT221	DRUM LEVEL - CONTROL Yarway Head Chamber	-6	6	IN WC	FPDL	5	20 K2420	TPS-18TIU-1		
LT222	DRUM LEVEL - INDICATION	-10	10	IN WC	DIXSON		K222	TPS-18TIU-1		
NOTE: 250 OHM RESISTORS TO BE CONNECTED BETWEEN TERMINALS 20 & 21, 22 & 21, 23 & 24 AND 41 & 42, EACH STATION										

AFT STBD

NUMBER	SERVICE	ZERO	SPAN	UNITS	353 + TERM	- TERM	CABLE	TYPE	PAIR
PT301	SUPERHEATED STEAM PRESS - CONTROL	300	500	PSIG	FSBM	5	20 K0720	TPS-18TIU-1	
PT302	SUPERHEATED STEAM PRESS - INDICATION	0	600	PSIG	FSBM	5	22 K0742	TPS-18TIU-1	
PT303	DRUM PRESSURE - CONTROL	300	500	PSIG	FSBM	7	23 K0722	TPS-18TIU-1	
PT304	DRUM PRESSURE - INDICATION	0	800	PSIG	FSBM	7	41 K0723	TPS-18TIU-1	
PT305	F.D. DISCHARGE PRESSURE	0	10	IN WC	FSFD	5	22 K0823	TPS-18TIU-1	
PT306	FURNACE PRESSURE	-2	2	IN WC	FSID	5	20 K0920	TPS-18TIU-1	
PT307	OVER-FIRE AIR PRESSURE	0	35	IN WC	FSFD	7	23 K0822	TPS-18TIU-1	
PT308	FLUE GAS PRESS INTO ECONOMIZER	-4	4	IN WC	FSID	5	22 K0922	TPS-18TIU-1	
PT309	FLUE GAS UPTAKE PRESSURE	-4	4	IN WC	FSID	7	23 K0923	TPS-18TIU-1	
FT311	COMBUSTION AIRFLOW	0	100	PCT	FSFD	20	21 K0820	TPS-18TIU-2	PAIR #2
FT313	STEAMFLOW	0	44,000	lb/hr	FSDL	22	21 K1222		
LT321	DRUM LEVEL - CONTROL Yarway Head Chamber	-6	6	IN WC	FSDL	5	20 K1220	TPS-18TIU-1	
LT322	DRUM LEVEL - INDICATION	-10	10	IN WC	DIXSON		K322	TPS-18TIU-1	
NOTE: 250 OHM RESISTORS TO BE CONNECTED BETWEEN TERMINALS 20 & 21, 22 & 21, 23 & 24 AND 41 & 42, EACH STATION									



ART PORT

NUMBER	SERVICE	ZERO	SPAN	UNITS	353 + TERM	- TERM	CABLE	TYPE	PAIR	LENGTH
PT401	SUPERHEATED STEAM PRESS - CONTROL	300	500	PSIG	APBM	5	20 K1820	TPS-18TIU-1		
PT402	SUPERHEATED STEAM PRESS - INDICATION	0	600	PSIG	APBM	5	22 K1841	TPS-18TIU-1		
PT403	DRUM PRESSURE - CONTROL	300	500	PSIG	APBM	7	23 K1822	TPS-18TIU-1		
PT404	DRUM PRESSURE - INDICATION	0	800	PSIG	APBM	7	41 K1823	TPS-18TIU-1		
PT405	F.D. DISCHARGE PRESSURE	0	10	IN WC	APFD	5	22 K1723	TPS-18TIU-1		
PT406	FURNACE PRESSURE	-2	2	IN WC	APID	5	20 K1620	TPS-18TIU-1		
PT407	OVER-FIRE AIR PRESSURE	0	35	IN WC	APFD	7	23 K1722	TPS-18TIU-1		
PT408	FLUE GAS PRESS INTO ECONOMIZER	-4	4	IN WC	APID	5	22 K1622	TPS-18TIU-1		
PT409	FLUE GAS UPTAKE PRESSURE	-4	4	IN WC	APID	7	23 K1623	TPS-18TIU-1		
FT411	COMBUSTION AIRFLOW	0	100	PCT	APFD	20	21 K1720	TPS-18TIU-2	PAIR #2	
FT413	STEAMFLOW	0	44,000	lb/hr	APDL	22	21 K1322			
LT421	DRUM LEVEL - CONTROL To Yarway Head Chamber	-6	6	IN WC	APDL	5	20 K1320	TPS-18TIU-1		
LT422	DRUM LEVEL - INDICATION	-10	10	IN WC	DIXSON	E1-1	E1 PIN 1 K422	TPS-18TIU-1		
NOTE: 250 OHM RESISTORS TO BE CONNECTED BETWEEN TERMINALS 20 & 21, 22 & 21, 23 & 24 AND 41 & 42, EACH STATION										

**SS BADGER  
BOILER  
CONTROL  
CABINETS**

**WIRING SCHEDULES**

TYPICAL 353 TERMINALS

NUMBER	SERVICE
H	24VDC+
N	DC-
G	GROUND
5	XMTR POWER
6	STATION COMMON
7	XMTR POWER
20	A.I. #1
21	XMTR COMMON
22	A.I. #2
23	A.I. #3
24	XMTR COMMON
41	A.I. #4
42	XMTR COMMON
17	A.O. #1+
18	A.O. COMMON
19	A.O. #2+
33	A.O. #3+
34	A.O. COMMON
27	RELAY #1 N.C.
28	RELAY #1 COM
29	RELAY #1 N.O.
30	RELAY #2 N.C.
31	RELAY #2 COM
32	RELAY #2 N.O.
39	XMTR POWER
41	A.I. #4
42	XMTR COMMON
RJ45	ETHERNET CONN



STBD A.I. TERMS AITS

TERMINAL	SERVICE	DESCRIPTION	RESISTORS	TAGNAME	CABLE NUMBER	TYPE
<b>FS DRUM LEVEL CONTROLLER</b>						
STA 1 - 5	STA 1 XMTR POWER	POWER FOR LT121				
STA 1 - 20	A.I. #1	FWD STBD DRUM LEVEL	250 OHM RESISTOR	LT121	K0120	TPS-18TIU-1
STA 1 - 22	A.I. #2	FWD STBD STEAMFLOW(4-WIRE)	250 OHM RESISTOR	FT113	K0122	TPS-18TIU-1
STA 1 - 21	XMTR COMMON		RESISTOR COMMONS			
<b>FS OUTBOARD FEEDER CONTROLLER</b>						
STA 2 - 5	STA 2 XMTR POWER					
STA 2 - 20	A.I. #1					
STA 2 - 22	A.I. #2					
STA 2 - 21	XMTR COMMON					
STA 2 - 46	AIU1 - T/C+	STBD BOILER CABINET TEMP.		TT131	N/A	
STA 2 - 47	AIU1 - T/C-					
STA 2 - 45	Cold Jct Reference					
STA 2 - 48	Cold Jct Reference					
<b>FS INBOARD FEEDER CONTROLLER</b>						
STA 3 - 5	STA 3 XMTR POWER					
STA 3 - 20	A.I. #1					
STA 3 - 22	A.I. #2					
STA 3 - 21	XMTR COMMON					
<b>FS FURNACE PRESSURE CONTROLLER</b>						
STA 4 - 5	STA 4 XMTR POWER	POWER FOR PT106 AND PT108				
STA 4 - 7	STA 4 XMTR POWER	POWER FOR PT109				
STA 4 - 20	A.I. #1	FWD STBD FURN PRESS	250 OHM RESISTOR	PT106	K0420	TPS-18TIU-1
STA 4 - 22	A.I. #2	FWD STBD FLUE GAS INTO ECON	250 OHM RESISTOR	PT108	K0422	TPS-18TIU-1
STA 4 - 21	XMTR COMMON		RESISTOR COMMON			
STA 4 - 23	A.I. #3	FWD STBD UPTAKE PRESS	250 OHM RESISTOR	PT109	K0423	TPS-18TIU-1
STA 4 - 24	XMTR COMMON		RESISTOR COMMON			
<b>FS AIRFLOW CONTROLLER</b>						
STA 5 - 5	STA 5 XMTR POWER	POWER FOR PT107 & PT105				
STA 5 - 20	A.I. #1	FWD STBD AIRFLOW(4-WIRE)	250 OHM RESISTOR	FT111	K0520	TPS-18TIU-2
STA 5 - 22	A.I. #2	FWD STBD OVERFIRE AIR PRESS	250 OHM RESISTOR	PT107	K0522	TPS-18TIU-1
STA 5 - 21	XMTR COMMON		RESISTOR COMMONS			
STA 5 - 23	A.I. #3	FWD STBD F.D. DISCHARGE PRESS	250 OHM RESISTOR	PT105	K0523	TPS-18TIU-1
STA 5 - 24	XMTR COMMON		RESISTOR COMMONS			
<b>FS BOILER SUB-MASTER</b>						
STA 6 - 5	STA 6 AI1 & AI2 POWER	POWER FOR PT 101 AND PT103				
STA 6 - 7	STA 6 AI3 POWER	POWER FOR PT104				
STA 6 - 20	A.I. #1	FWD STBD SUPERHEAT PRESS	250 OHM RESISTOR	PT101	K0620	TPS-18TIU-1
STA 6 - 22	A.I. #2	FWD STBD DRUM PRESS CONTROL	250 OHM RESISTOR	PT103	K0621	TPS-18TIU-1
STA 6 - 21	XMTR COMMON		RESISTOR COMMONS			
STA 6 - 23	A.I. #3	FWD STBD DRUM PRESS IND	250 OHM RESISTOR	PT104	K0623	TPS-18TIU-1
STA 6 - 24	XMTR COMMON		RESISTOR COMMON			
STA 6 - 39	STA 6 AI4 POWER	POWER FOR PT 102				
STA 6 - 41	A.I. #4	FWD STBD SUPERHEAT PRESS IND	250 OHM RESISTOR	PT102	K0641	TPS-18TIU-1
STA 6 - 42	XMTR COMMON		RESISTOR COMMON			
<b>AS BOILER SUB-MASTER</b>						
STA 7 - 5	STA 7 AI1 & AI2 POWER	POWER FOR PT 301 AND PT303				
STA 7 - 7	STA 7 AI3 POWER	POWER FOR PT304				
STA 7 - 20	A.I. #1	AFT STBD SUPERHEAT PRESS	250 OHM RESISTOR	PT301	K0720	TPS-18TIU-1
STA 7 - 22	A.I. #2	AFT STBD DRUM PRESS CONTROL	250 OHM RESISTOR	PT303	K0722	TPS-18TIU-1
STA 7 - 21	XMTR COMMON		RESISTOR COMMONS			
STA 7 - 23	A.I. #3	AFT STBD DRUM PRESS IND	250 OHM RESISTOR	PT304	K0723	TPS-18TIU-1
STA 7 - 24	XMTR COMMON		RESISTOR COMMON			



STBD A.I. TERMS AITS

STA 7 - 39	STA 7 A14 POWER	POWER FOR PT 302				
STA 7 - 41	A.I. #4	AFT STBD SUPERHEAT PRESS IND	250 OHM RESISTOR	PT302	K0741	TPS-18TIU-1
STA 7 - 42	XMTR COMMON		RESISTOR COMMON			
<b>AS AIRFLOW CONTROLLER</b>						
STA 8 - 5	STA 8 XMTR POWER	POWER FOR PT307 & PT305				
STA 8 - 20	A.I. #1	AFT STBD AIRFLOW(4-WIRE)	250 OHM RESISTOR	FT311	K0820	TPS-18TIU-2
STA 8 - 22	A.I. #2	AFT STBD OVERFIRE AIR PRESS	250 OHM RESISTOR	PT307	K0822	TPS-18TIU-1
STA 8 - 21	XMTR COMMON		RESISTOR COMMONS			
STA 8 - 23	A.I. #3	AFT STBD F.D. DISCHARGE PRESS	250 OHM RESISTOR	PT305	K0823	TPS-18TIU-1
STA 8 - 24	XMTR COMMON		RESISTOR COMMONS			
<b>AS FURNACE PRESSURE CONTROLLER</b>						
STA 9 - 5	STA 9 XMTR POWER	POWER FOR PT306 AND PT308				
STA 9 - 7	STA 9 XMTR POWER	POWER FOR PT309				
STA 9 - 20	A.I. #1	AFT STBD FURN PRESS	250 OHM RESISTOR	PT306	K0920	TPS-18TIU-1
STA 9 - 22	A.I. #2	AFT STBD FLUE GAS INTO ECON	250 OHM RESISTOR	PT308	K0922	TPS-18TIU-1
STA 9 - 21	XMTR COMMON		RESISTOR COMMONS			
STA 9 - 23	A.I. #3	AFT STBD UPTAKE PRESS	250 OHM RESISTOR	PT309	K0923	TPS-18TIU-1
STA 9 - 24	XMTR COMMON		RESISTOR COMMON			
<b>AS INBOARD FEEDER CONTROLLER</b>						
STA 10 - 5	STA 10 XMTR POWER					
STA 10 - 20	A.I. #1					
STA 10 - 22	A.I. #2					
STA 10 - 21	XMTR COMMON					
<b>AS OUTBOARD FEEDER CONTROLLER</b>						
STA 11 - 5	STA 11 XMTR POWER					
STA 11 - 20	A.I. #1					
STA 11 - 22	A.I. #2					
STA 11 - 21	XMTR COMMON					
<b>AS DRUM LEVEL CONTROLLER</b>						
STA 12 - 5	STA 12 XMTR POWER	POWER FOR LT321 & FT313				
STA 12 - 20	A.I. #1	AFT STBD DRUM LEVEL	250 OHM RESISTOR	LT321	K1220	TPS-18TIU-1
STA 12 - 22	A.I. #2	AFT STBD STEAMFLOW	250 OHM RESISTOR	FT313	K1222	TPS-18TIU-1
STA 12 - 23	XMTR COMMON		RESISTOR COMMONS			
<b>NOTE: 250 OHM RESISTORS CONNECTED BETWEEN TERMINALS 20 &amp; 21, 22 &amp; 21, 23 &amp; 24 AND 41 &amp; 42 OF EACH 353</b>						



PORT A.I. TERMS AITP

TERMINAL	SERVICE	DESCRIPTION	RESISTORS	TAGNAME	CABLE NUMBER	TYPE
<b>AP DRUM LEVEL CONTROLLER</b>						
STA 13 - 5	STA 13 XMTR POWER	POWER FOR LT421 & FT413				
STA 13 - 20	A.I. #1	AFT PORT DRUM LEVEL	250 OHM RESISTOR	LT421	K1320	TPS-18TIU-1
STA 13 - 22	A.I. #2	AFT PORT STEAMFLOW	250 OHM RESISTOR	FT413	K1322	TPS-18TIU-1
STA 13 - 23	XMTR COMMON		RESISTOR COMMONS			
<b>AP OUTBOARD FEEDER CONTROLLER</b>						
STA 14 - 5	STA 14 XMTR POWER					
STA 14 - 20	A.I. #1					
STA 14 - 22	A.I. #2					
STA 14 - 21	XMTR COMMON					
STA 2 - 46	AIU1 - T/C+	PORT BOILER CABINET TEMP.		TT431	N/A	
STA 2 - 47	AIU1 - T/C-					
STA 2 - 45	Cold Jct Reference					
STA 2 - 48	Cold Jct Reference					
<b>AP INBOARD FEEDER CONTROLLER</b>						
STA 15 - 5	STA 15 XMTR POWER					
STA 15 - 20	A.I. #1					
STA 15 - 22	A.I. #2					
STA 15 - 21	XMTR COMMON					
<b>AP FURNACE PRESSURE CONTROLLER</b>						
STA 16 - 5	STA 16 XMTR POWER	POWER FOR PT406 AND PT408				
STA 16 - 7	STA 16 XMTR POWER	POWER FOR PT409				
STA 16 - 20	A.I. #1	AFT PORT FURN PRESS	250 OHM RESISTOR	PT406	K1620	TPS-18TIU-1
STA 16 - 22	A.I. #2	AFT PORT FLUE GAS INTO ECON	250 OHM RESISTOR	PT408	K1622	TPS-18TIU-1
STA 16 - 21	XMTR COMMON		RESISTOR COMMON			
STA 16 - 23	A.I. #3	AFT PORT UPTAKE PRESS	250 OHM RESISTOR	PT409	K1623	TPS-18TIU-1
STA 16 - 24	XMTR COMMON		RESISTOR COMMON			
<b>AP AIRFLOW CONTROLLER</b>						
STA 17 - 5	STA 17 XMTR POWER	POWER FOR PT407				
STA 17 - 7	STA 17 XMTR POWER	POWER FOR PT405				
STA 17 - 20	A.I. #1	AFT PORT AIRFLOW(4-WIRE)	250 OHM RESISTOR	FT411	K1720	TPS-18TIU-2
STA 17 - 22	A.I. #2	AFT PORT OVERFIRE AIR PRESS	250 OHM RESISTOR	PT407	K1722	TPS-18TIU-1
STA 17 - 21	XMTR COMMON		RESISTOR COMMONS			
STA 17 - 23	A.I. #3	AFT PORT F.D. DISCHARGE PRESS	250 OHM RESISTOR	PT405	K1723	TPS-18TIU-1
STA 17 - 24	XMTR COMMON		RESISTOR COMMONS			
<b>AP BOILER SUB-MASTER</b>						
STA 18 - 5	STA 18 XMTR POWER	POWER FOR PT 401 AND PT403				
STA 18 - 7	STA 18 XMTR POWER	POWER FOR PT404				
STA 18 - 20	A.I. #1	AFT PORT SUPERHEAT PRESS	250 OHM RESISTOR	PT401	K1810	TPS-18TIU-1
STA 18 - 22	A.I. #2	AFT PORT DRUM PRESS CONTROL	250 OHM RESISTOR	PT403	K1822	TPS-18TIU-1
STA 18 - 21	XMTR COMMON		RESISTOR COMMONS			
STA 18 - 23	A.I. #3	AFT PORT DRUM PRESS IND	250 OHM RESISTOR	PT404	K1823	TPS-18TIU-1



PORT A.I. TERMS AITP

STA 18 - 24	XMTR COMMON		RESISTOR COMMON			
STA 18 - 39	STA 18 AI4 POWER	POWER FOR PT 402				
STA 18 - 41	A.I. #4	AFT PORT SUPERHEAT PRESS IND	250 OHM RESISTOR	PT402	K1841	TPS-18TIU-1
STA 18 - 42	XMTR COMMON		RESISTOR COMMON			
<b>FP BOILER SUB-MASTER</b>						
STA 19 - 5	STA 19 XMTR POWER	POWER FOR PT 201 AND PT203				
STA 19 - 7	STA 19 XMTR POWER	POWER FOR PT204				
STA 19 - 20	A.I. #1	FWD PORT SUPERHEAT PRESS	250 OHM RESISTOR	PT201	K1920	TPS-18TIU-1
STA 19 - 22	A.I. #2	FWD PORT DRUM PRESS CONTROL	250 OHM RESISTOR	PT203	K1922	TPS-18TIU-1
STA 19 - 21	XMTR COMMON		RESISTOR COMMONS			
STA 19 - 23	A.I. #3	FWD PORT DRUM PRESS IND	250 OHM RESISTOR	PT204	K1923	TPS-18TIU-1
STA 19 - 24	XMTR COMMON		RESISTOR COMMON			
STA 19 - 39	STA 19 AI4 POWER	POWER FOR PT 202				
STA 19 - 41	A.I. #4	FWD PORT SUPERHEAT PRESS IND	250 OHM RESISTOR	PT202	K1941	TPS-18TIU-1
STA 19 - 42	XMTR COMMON		RESISTOR COMMON			
<b>FP AIRFLOW CONTROLLER</b>						
STA 20 - 5	STA 20 XMTR POWER	POWER FOR PT207 & 205				
STA 20 - 20	A.I. #1	FWD PORT AIRFLOW(4-WIRE)	250 OHM RESISTOR	FT211	K2020	TPS-18TIU-2
STA 20 - 22	A.I. #2	FWD PORT OVERFIRE AIR PRESS	250 OHM RESISTOR	PT207	K2022	TPS-18TIU-1
STA 20 - 21	XMTR COMMON		RESISTOR COMMONS			
STA 20 - 23	A.I. #3	FWD PORT F.D. DISCHARGE PRESS	250 OHM RESISTOR	PT205	K2023	TPS-18TIU-1
STA 20 - 24	XMTR COMMON		RESISTOR COMMONS			
<b>FP FURNACE PRESSURE CONTROLLER</b>						
STA 21 - 5	STA 21 XMTR POWER	POWER FOR PTS06 AND PT208				
STA 21 - 7	STA 21 XMTR POWER	POWER FOR PT209				
STA 21 - 20	A.I. #1	FWD PORT FURN PRESS	250 OHM RESISTOR	PT206	K2120	TPS-18TIU-1
STA 21 - 22	A.I. #2	FWD PORT FLUE GAS INTO ECON	250 OHM RESISTOR	PT208	K2122	TPS-18TIU-1
STA 21 - 21	XMTR COMMON		RESISTOR COMMON			
STA 21 - 23	A.I. #3	FWD PORT UPTAKE PRESS	250 OHM RESISTOR	PT209	K2123	TPS-18TIU-1
STA 21 - 24	XMTR COMMON		RESISTOR COMMON			
<b>FP INBOARD FEEDER CONTROLLER</b>						
STA 22 - 5	STA 22 XMTR POWER					
STA 22 - 20	A.I. #1					
STA 22 - 22	A.I. #2					
STA 22 - 21	XMTR COMMON					
<b>FP OUTBOARD FEEDER CONTROLLER</b>						
STA 23 - 5	STA 23 XMTR POWER					
STA 23 - 20	A.I. #1					
STA 23 - 22	A.I. #2					
STA 23 - 21	XMTR COMMON					
<b>FP DRUM LEVELCONTROLLER</b>						
STA 24 - 5	STA 24 XMTR POWER	POWER FOR LT221 & FT213				
STA 24 - 20	A.I. #1	FWD PORT DRUM LEVEL	250 OHM RESISTOR	LT221	K2420	TPS-18TIU-1

PORT A.I. TERMS AITP

STA 24 - 22	A.I. #2	FWD PORT STEAMFLOW	250 OHM RESISTOR	FT213	K2422	TPS-18TIU-1
STA 24 - 21	XMTR COMMON		RESISTOR COMMONS			
NOTE: 250 OHM RESISTORS CONNECTED BETWEEN TERMINALS 20 & 21, 22 & 21, 23 & 24 AND 41 & 42						
OF EACH 353						



STBD A.O. TERMS AOTS

CONNECTION	SERVICE	SERVICE	TAGNAME	CABLE NUMBER	TYPE	VFD TERMS
<b>FS DRUM LEVEL CONTROLLER</b>						
STA 1 - 17	A.O. #1	FWD STBD FEEDWATER VALVE	FSFWCV	K0117A	TPS-18TIU-1	+/-
STA 1 - 18	COM					
<b>FS OUTBOARD FEEDER CONTROLLER</b>						
STA 2 - 17	A.O. #1 - PAIR #1	FWD STBD OTBD FEEDER DRIVE	FSOBFEDR	K0217A	TPS-18TIU-1	53+/55-
STA 2 - 18	COM					
STA 2 - 19	A.O. #2 - PAIR #1	FWD STBD ROTOR DRIVE	FSOBROTR	K0219A	TPS-18TIU-1	53+/55-
<b>FS INBOARD FEEDER CONTROLLER</b>						
STA 3 - 17	A.O. #1 - PAIR #1	FWD STBD INBD FEEDER DRIVE	FSIBFEDR	K0317A	TPS-18TIU-1	53+/55-
STA 3 - 18	COM					
STA 3 - 19	A.O. #2 - PAIR #1	FWD STBD ROTOR DRIVE	FSIBROTR	K0319A	TPS-18TIU-1	53+/55-
STA 3 - 33	A.O. #3 - PAIR #1	FWD STBD AIR DISTRIBUTOR	FSADIST	K0333A	TPS-18TIU-1	53+/55-
STA 3 - 34	COM					
<b>FS FURNACE PRESSURE CONTROLLER</b>						
STA 4 - 17	A.O. #1	FWD STBD I.D. CTRL VALVE	FSIDCV	K0417A	TPS-18TIU-1	+/-
STA 4 - 18	COM					
<b>FS AIRFLOW CONTROLLER</b>						
STA 5 - 17	A.O. #1 - PAIR #1	FWD STBD F.D. DRIVE	FSFDFAN	K0517A	TPS-18TIU-1	53+/55-
STA 5 - 18	COM					
STA 5 - 19	A.O. #2 - PAIR #1	FWD STBD OFA DRIVE	FSOFA	K0519A	TPS-18TIU-1	53+/55-
<b>AS AIRFLOW CONTROLLER</b>						
STA 8 - 17	A.O. #1 - PAIR #1	AFT STBD F.D. DRIVE	ASFDFAN	K0817A	TPS-18TIU-1	53+/55-
STA 8 - 18	COM					
STA 8 - 19	A.O. #2 - PAIR #1	AFT STBD OFA DRIVE	ASOFA	K0819A	TPS-18TIU-1	53+/55-
<b>AS FURNACE PRESSURE CONTROLLER</b>						
STA 9 - 17	A.O. #1	AFT STBD I.D. CTRL VALVE	ASIDCV	K0917A	TPS-18TIU-1	+/-
STA 9 - 18	COM					
<b>AS INBOARD FEEDER CONTROLLER</b>						
STA 10 - 17	A.O. #1 - PAIR #1	AFT STBD INBD FEEDER DRIVE	ASIBFEDR	K1017A	TPS-18TIU-1	53+/55-
STA 10 - 18	COM					
STA 10 - 19	A.O. #2 - PAIR #1	AFT STBD ROTOR DRIVE	ASIBROTR	K1019A	TPS-18TIU-1	53+/55-
STA 10 - 33	A.O. #3 - PAIR #1	AFT STBD AIR DISTRIBUTOR	ASADIST	K1033A	TPS-18TIU-1	53+/55-
STA 10 - 34	COM					
<b>AS OUTBOARD FEEDER CONTROLLER</b>						
STA 11 - 17	A.O. #1 - PAIR #1	AFT STBD FEEDER 2 DRIVE	ASOBFEDR	K1117A	TPS-18TIU-1	53+/55-
STA 11 - 18	COM					
STA 11 - 19	A.O. #2 - PAIR #1	AFT STBD ROTOR DRIVE	ASOBROTR	K1119A	TPS-18TIU-1	53+/55-
<b>AS DRUM LEVEL CONTROLLER</b>						
STA 12 - 17	A.O. #1	AFT STBD FEEDWATER VALVE	ASFWCV	K1217A	TPS-18TIU-1	+/-
STA 12 - 18	COM					
<b>NOTES:</b>						
1. ALL A.O. CABLES FROM 353 CONTROLLERS ON STBD SIDE ARE SINGLE-PAIR SHIELDED.						
2. STATION 1, 4, 11 AND 12 A.O. CABLES GO TO CONTROL VALVES. ALL OTHERS GO TO VFDs						



PORT A.O. TERMS AOTP

CONNECTION	SERVICE	SERVICE	TAGNAME	CABLE NUMBER	TYPE	VFD TERMS
<b>AP DRUM LEVEL CONTROLLER</b>						
STA 13 - 17	A.O. #1	AFT PORT FEEDWATER VALVE	APFWCV	K1317	TPS-18TIU-1	+/-
STA 13 - 18	COM					
<b>AP OUTBOARD FEEDER CONTROLLER</b>						
STA 14 - 17	A.O. #1 - PAIR #1	AFT PORT FEEDER 2 DRIVE	APOBFEDR	K1417	TPS-18TIU-4	53+/55-
STA 14 - 18	COM					
STA 14 - 19	A.O. #2 - PAIR #1	AFT PORT ROTOR 2 DRIVE	APOBROTR	K1419	TPS-18TIU-4	53+/55-
STA 14 - 33	A.O. #3 - PAIR #1					
STA 14 - 34	COM					
<b>AP INBOARD FEEDER CONTROLLER</b>						
STA 15 - 17	A.O. #1 - PAIR #1	AFT PORT FEEDER 1 DRIVE	APIBFEDR	K1517	TPS-18TIU-4	53+/55-
STA 15 - 18	COM					53+/55-
STA 15 - 19	A.O. #2 - PAIR #1	AFT PORT ROTOR 1 DRIVE	APIBROTR	K1519	TPS-18TIU-4	
STA 15 - 33	A.O. #3 - PAIR #1	AFT PORT DISTRIBUTOR 1 DRIVE	APADIST	K1533	TPS-18TIU-4	
STA 15 - 34	COM					
<b>AP FURNACE PRESSURE CONTROLLER</b>						
STA 16 - 17	A.O. #1	AFT PORT I.D. CTRL VALVE	FPIDCV	K1617	TPS-18TIU-1	+/-
STA 16 - 18	COM					
<b>AP AIRFLOW CONTROLLER</b>						
STA 17 - 17	A.O. #1 - PAIR #1	AFT PORT F.D. DRIVE	APDFAN	K1717	TPS-18TIU-4	53+/55-
STA 17 - 18	COM					
STA 17 - 19	A.O. #2 - PAIR #1	AFT PORT OFA DRIVE	APOFA	K1719	TPS-18TIU-4	53+/55-
<b>FP AIRFLOW CONTROLLER</b>						
STA 20 - 17	A.O. #1 - PAIR #1	FWD PORT F.D. DRIVE	FPDFAN	K2017	TPS-18TIU-4	53+/55-
STA 20 - 18	COM					
STA 20 - 19	A.O. #2 - PAIR #1	FWD PORT OFA DRIVE	FPOFA	K2019	TPS-18TIU-4	53+/55-
<b>FP FURNACE PRESSURE CONTROLLER</b>						
STA 21 - 17	A.O. #1	FWD PORT I.D. CTRL VALVE	FPIDCV	K2117	TPS-18TIU-1	+/-
STA 21 - 18	COM					
<b>FP INBOARD FEEDER CONTROLLER</b>						
STA 22 - 17	A.O. #1 - PAIR #1	FWD PORT FEEDER 1 DRIVE	FPIBFEDR	K2217	TPS-18TIU-4	53+/55-
STA 22 - 18	COM					
STA 22 - 19	A.O. #2 - PAIR #1	FWD PORT ROTOR 1 DRIVE	FPIBROTR	K2219	TPS-18TIU-4	53+/55-
STA 22 - 33	A.O. #3 - PAIR #1	FWD PORT DISTRIBUTOR 1 DRIVE	FPADIST	K2233	TPS-18TIU-4	53+/55-
STA 22 - 34	COM					
<b>FP OUTBOARD FEEDER CONTROLLER</b>						
STA 23 - 17	A.O. #1 - PAIR #1	FWD PORT FEEDER 2 DRIVE	FPOBFEDR	K2317	TPS-18TIU-4	53+/55-
STA 23 - 18	COM					
STA 23 - 19	A.O. #2 - PAIR #1	FWD PORT ROTOR 2 DRIVE	FPOBROTR	K2319	TPS-18TIU-4	53+/55-
STA 23 - 33	A.O. #3 - PAIR #1					
STA 23 - 34	COM					
<b>FP DRUM LEVEL CONTROLLER</b>						
STA 24 - 17	A.O. #1	FWD PORT FEEDWATER VALVE	FPFWCV	K2417	TPS-18TIU-1	+/-
STA 24 - 18	COM					

STBD 353 RELAY OUTPUTS ROTS

CONNECTION	WIRING	CONTACT
STA 1 - 28		RELAY 1 COM
STA 1 - 29		RELAY 1 N.O.
STA 2 - 28		RELAY 1 COM
STA 2 - 29		RELAY 1 N.O.
STA 3 - 28		RELAY 1 COM
STA 3 - 29		RELAY 1 N.O.
STA 4 - 28		RELAY 1 COM
STA 4 - 29		RELAY 1 N.O.
STA 5 - 28		RELAY 1 COM
STA 5 - 29		RELAY 1 N.O.
STA 6 - 28		RELAY 1 COM
STA 6 - 29		RELAY 1 N.O.
STA 7 - 28		RELAY 1 COM
STA 7 - 29		RELAY 1 N.O.
STA 8 - 28		RELAY 1 COM
STA 8 - 29		RELAY 1 N.O.
STA 9 - 28		RELAY 1 COM
STA 0 - 29		RELAY 1 N.O.
STA 10 - 28		RELAY 1 COM
STA 10 - 29		RELAY 1 N.O.
STA 11 - 28		RELAY 1 COM
STA 11 - 29		RELAY 1 N.O.
STA 12 - 28		RELAY 1 COM
STA 12 - 29		RELAY 1 N.O.
JUMP ALL STATIONS' TERMINALS AS SHOWN		
CONNECTIONS TO PLC INPUTS TO BE DONE		
ABOARD SHIP		



PORT 353 RELAY OUTPUTS ROTP

CONNECTION	WIRING	CONTACT
STA 13 - 28		RELAY 1 COM
STA 13 - 29		RELAY 1 N.O.
STA 14 - 28		RELAY 1 COM
STA 14 - 29		RELAY 1 N.O.
STA 15 - 28		RELAY 1 COM
STA 15 - 29		RELAY 1 N.O.
STA 16 - 28		RELAY 1 COM
STA 16 - 29		RELAY 1 N.O.
STA 17 - 28		RELAY 1 COM
STA 17 - 29		RELAY 1 N.O.
STA 18 - 28		RELAY 1 COM
STA 18 - 29		RELAY 1 N.O.
STA 19 - 28		RELAY 1 COM
STA 19 - 29		RELAY 1 N.O.
STA 20 - 28		RELAY 1 COM
STA 20 - 29		RELAY 1 N.O.
STA 21 - 28		RELAY 1 COM
STA 21 - 29		RELAY 1 N.O.
STA 22 - 28		RELAY 1 COM
STA 22 - 29		RELAY 1 N.O.
STA 23 - 28		RELAY 1 COM
STA 23 - 29		RELAY 1 N.O.
STA 24 - 28		RELAY 1 COM
STA 24 - 29		RELAY 1 N.O.
JUMP ALL STATIONS' TERMINALS AS SHOWN		
CONNECTIONS TO PLC INPUTS TO BE DONE		
ABOARD SHIP		

PORT PLC A.I.

MODULE	ADDRESS	TERMINAL	SERVICE	SYMBOLS (Placeholders)	ADDR	DESCRIPTION
DC+			FROM FUSE			
A.I.	SLOT 4	2	A.I. # 1+	AIONE	PIW256	RESERVED ANALOG INPUT CHANNEL
A.I.	SLOT 4	3	A.I. # 1-			
A.I.	SLOT 4	4	A.I. # 2+	AITWO	PIW258	RESERVED ANALOG INPUT CHANNEL
A.I.	SLOT 4	5	A.I. # 2-			
A.I.	SLOT 4	6	A.I. # 3+	AITHREE	PIW260	RESERVED ANALOG INPUT CHANNEL
A.I.	SLOT 4	7	A.I. # 3-			
A.I.	SLOT 4	8	A.I. # 4+	AIFOUR	PIW262	RESERVED ANALOG INPUT CHANNEL
A.I.	SLOT 4	9	A.I. # 4-			
A.I.	SLOT 4	10	COMP+			
A.I.	SLOT 4	11	M <sub>ANA</sub>			
A.I.	SLOT 4	12	A.I. # 5+	AIFIVE	PIW264	RESERVED ANALOG INPUT CHANNEL
A.I.	SLOT 4	13	A.I. # 5-			
A.I.	SLOT 4	14	A.I. # 6+	AISIX	PIW266	RESERVED ANALOG INPUT CHANNEL
A.I.	SLOT 4	15	A.I. # 6-			
A.I.	SLOT 4	16	A.I. # 7+	AISEVEN	PIW268	RESERVED ANALOG INPUT CHANNEL
A.I.	SLOT 4	17	A.I. # 7-			
A.I.	SLOT 4	18	A.I. # 8+	AIEIGHT	PIW270	RESERVED ANALOG INPUT CHANNEL
A.I.	SLOT 4	19	A.I. # 8-			
DC- COM	SLOT 4	20				



PORT DI 1 PWR TS-PORT1

FUSE	T/S TERM	INPUT
F19		1 CHL1 & 2
F19		2 CHL 3 & 4
F19		3 CHL 5 & 6
F19		4 CHL 7 & 8
F19		5 CHL 9 & 10
F19		6 CHL 11 & 12
F19		7 CHL 13 & 14
F19		8 CHL 15 & 16
F20		1 CHL 17 & 18
F20		2 CHL 19 & 20
F20		3 CHL 21 & 22
F20		4 CHL 23 & 24
F20		5 CHL 25 & 26
F20		6 CHL 27 & 28
F20		7 CHL 29 & 30
F20		8 CHL 31 & 32
INTERMEDIATE T/S TO BE INSTALLED		
ALLOWING DC+ WIRING POINTS FOR		
DISCRETE INPUT DEVICES TO PLC		

PORT DI WIRING

MODULE	ADDRESS	TERMINAL	SERVICE	SYMBOL	ADDR	DESCRIPTION	CABLE	PAIR
FROM DC FUSE		FIELD	24VDC-			FROM PORT DI 1 PWR TS-PORT1		
P-DI	SLOT 5	2	DISCRETE INPUT #1	FDFFVFDON	I 0.0	FP FD MOTOR RUNNING	K2017	PAIR #2
P-DI	SLOT 5	3	DISCRETE INPUT #2	FDAPVFDON	I 0.1	AP FD MOTOR RUNNING	K1717	PAIR #2
P-DI	SLOT 5	4	DISCRETE INPUT #3	OFAPVFDON	I 0.2	FP OFA MOTOR RUNNING	K2019	PAIR #2
P-DI	SLOT 5	5	DISCRETE INPUT #4	OFAAPVFDON	I 0.3	AP OFA MOTOR RUNNING	K1719	PAIR #2
P-DI	SLOT 5	6	DISCRETE INPUT #5	IFFPVFDON	I 0.4	FP INBD FEDR MOTOR RUNNING	K2217	PAIR #2
P-DI	SLOT 5	7	DISCRETE INPUT #6	OFFPVFDON	I 0.5	FP OTBD FEDR MOTOR RUNNING	K2317	PAIR #2
P-DI	SLOT 5	8	DISCRETE INPUT #7	IFAPVFDON	I 0.6	AP INBD FEDR MOTOR RUNNING	K1517	PAIR #2
P-DI	SLOT 5	9	DISCRETE INPUT #8	OFAPVFDON	I 0.7	AP OTBD FEDR MOTOR RUNNING	K1417	PAIR #2
P-DI	SLOT 5	12	DISCRETE INPUT #9	IRFPVFDON	I 1.0	FP INBD ROTOR MOTOR RUNNING	K2219	PAIR #2
P-DI	SLOT 5	13	DISCRETE INPUT #10	ORFPVFDON	I 1.1	FP OTBD ROTOR MOTOR RUNNING	K2319	PAIR #2
P-DI	SLOT 5	14	DISCRETE INPUT #11	IRAPVFDON	I 1.2	AP INBD ROTOR MOTOR RUNNING	K1519	PAIR #2
P-DI	SLOT 5	15	DISCRETE INPUT #12	ORAPVFDON	I 1.3	AP ORBD ROTOR MOTOR RUNNING	K1419	PAIR #2
P-DI	SLOT 5	16	DISCRETE INPUT #13	ADAPVFDON	I 1.4	AP AIR DISTRIB MOTOR RUNNING	K1533	PAIR #2
P-DI	SLOT 5	17	DISCRETE INPUT #14	ADFPVFDON	I 1.5	FP AIR DISTRIB MOTOR RUNNING	K2233	PAIR #2
P-DI	SLOT 5	18	DISCRETE INPUT #15	FDFFVFDFLT	I 1.6	FP FD VFD FAULT	K2017	PAIR #3
P-DI	SLOT 5	19	DISCRETE INPUT #16	FDAPVFDFLT	I 1.7	AP FD VFD FAULT	K1717	PAIR #3
FROM DC DIST DC-		20						
P-DI	SLOT 5	22	DISCRETE INPUT #17	OFAPVFDFLT	I 2.0	FP OFA VFD FAULT	K2019	PAIR #3
P-DI	SLOT 5	23	DISCRETE INPUT #18	OFAAPVFDFLT	I 2.1	AP OFA VFD FAULT	K1719	PAIR #3
P-DI	SLOT 5	24	DISCRETE INPUT #19	IFFPVFDFLT	I 2.2	FP INBD FEDR VFD FAULT	K2217	PAIR #3
P-DI	SLOT 5	25	DISCRETE INPUT #20	OFFPVFDFLT	I 2.3	FP OTBD FEDR VFD FAULT	K2317	PAIR #3
P-DI	SLOT 5	26	DISCRETE INPUT #21	IFAPVFDFLT	I 2.4	AP INBD FEDR VFD FAULT	K1517	PAIR #3
P-DI	SLOT 5	27	DISCRETE INPUT #22	OFAPVFDFLT	I 2.5	AP OTBD FEDR VFD FAULT	K1417	PAIR #3
P-DI	SLOT 5	28	DISCRETE INPUT #23	IRFPVFDFLT	I 2.6	FP INBD ROTOR VFD FAULT	K2219	PAIR #3
P-DI	SLOT 5	29	DISCRETE INPUT #24	ORFPVFDFLT	I 2.7	FP OTBD ROTOR VFD FAULT	K2319	PAIR #3
P-DI	SLOT 5	32	DISCRETE INPUT #25	IRAPVFDFLT	I 3.0	AP INBD ROTOR VFD FAULT	K1519	PAIR #3
P-DI	SLOT 5	33	DISCRETE INPUT #26	ORAPVFDFLT	I 3.1	AP ORBD ROTOR VFD FAULT	K1419	PAIR #3
P-DI	SLOT 5	34	DISCRETE INPUT #27	ADAPVFDFLT	I 3.2	AP AIR DISTRIB VFD FAULT	K1533	PAIR #3
P-DI	SLOT 5	35	DISCRETE INPUT #28	ADFPVFDFLT	I 3.3	FP AIR DISTRIB VFD FAULT	K2233	PAIR #3
P-DI	SLOT 5	36	DISCRETE INPUT #29	PORTALMS	I 3.4	PORT 353 ALARMS		
P-DI	SLOT 5	37	DISCRETE INPUT #30	PPLACE2	I 3.5	PEQUENCE PLACEHOLDER 2		
P-DI	SLOT 5	38	DISCRETE INPUT #31	PPLACE3	I 3.6	PEQUENCE PLACEHOLDER 3		
P-DI	SLOT 5	39	DISCRETE INPUT #32	PPLACE4	I 3.7	PEQUENCE PLACEHOLDER 4		
FROM DC DIST DC-		40						

NOTE: ALL D.I. CABLES ARE 4-PAIR SHIELDED. PAIRS 2, 3 & 4 CONNECT TO VFDs. PAIR #1 CONNECTS 353 A.O. FROM PORT CABINET TO VFD DEMAND INPUT TERMINALS.



SRBD DI 1 PWR TS-STBD1

FUSE	TERMINAL	INPUT
F21		1 CHL1 & 2
F21		2 CHL 3 & 4
F21		3 CHL 5 & 6
F21		4 CHL 7 & 8
F21		5 CHL 9 & 10
F21		6 CHL 11 & 12
F21		7 CHL 13 & 14
F21		8 CHL 15 & 16
F22		1 CHL 17 & 18
F22		2 CHL 19 & 20
F22		3 CHL 21 & 22
F22		4 CHL 23 & 24
F22		5 CHL 25 & 26
F22		6 CHL 27 & 28
F22		7 CHL 29 & 30
F22		8 CHL 31 & 32
INTERMEDIATE T/S TO BE INSTALLED		
ALLOWING DC+ WIRING POINTS FOR		
DISCRETE INPUT DEVICES TO PLC		

STBD DI WIRING

MODULE	ADDRESS	TERMINAL	SERVICE	SYMBOL	ADDR	DESCRIPTION	CABLE	PAIR
FROM DC FUSE		FIELD	24VDC+			FROM STBD TS-STBD1		
S-DI	SLOT 4	2	DISCRETE INPUT #1	FDFSVFDON	I 4.0	FWD STBD FD MOTOR RUNNING	K0517	PAIR 2
S-DI	SLOT 6	3	DISCRETE INPUT #2	FDASVFDON	I 4.1	AFT STBD FD MOTOR RUNNING	K0817	PAIR 2
S-DI	SLOT 6	4	DISCRETE INPUT #3	OFAFSVFDON	I 4.2	FWD STBD OVER FIRE AIR MOTOR RUNNING	K0519	PAIR 2
S-DI	SLOT 6	5	DISCRETE INPUT #4	OFAASVFDON	I 4.3	AFT STBD OVER FIRE AIR MOTOR RUNNING	K0819	PAIR 2
S-DI	SLOT 6	6	DISCRETE INPUT #5	IFFSVFDON	I 4.4	FWD STBD INBOARD FEEDER RUNNING	K0317	PAIR 2
S-DI	SLOT 6	7	DISCRETE INPUT #6	OFFSVFD	I 4.5	FWD STBD OUTBOARD FEEDER RUNNING	K0217	PAIR 2
S-DI	SLOT 6	8	DISCRETE INPUT #7	IFASVFDON	I 4.6	AFT STBD INBOARD FEEDER RUNNING	K1017	PAIR 2
S-DI	SLOT 6	9	DISCRETE INPUT #8	OFASVFDON	I 4.	AFT STBD OUTBOARD FEEDER RUNNING	K1117	PAIR 2
S-DI	SLOT 6	12	DISCRETE INPUT #9	IRFSVFDON	I 5.0	FWD STBD INBOARD ROTOR RUNNING	K0319	PAIR 2
S-DI	SLOT 6	13	DISCRETE INPUT #10	ORFSVFDON	I 5.1	FWD STBD OUTBOARD ROTOR RUNNING	K0219	PAIR 2
S-DI	SLOT 6	14	DISCRETE INPUT #11	IRASVFDON	I 5.2	AFT STBD INBOARD ROTOR RUNNING	K1019	PAIR 2
S-DI	SLOT 6	15	DISCRETE INPUT #12	ORASVFDON	I 5.3	AFT STBD OUTBOARD ROTOR RUNNING	K1119	PAIR 2
S-DI	SLOT 6	16	DISCRETE INPUT #13	ADASVFDON	I 5.4	AFT STBD AIR DISTRIB MOTOR RUNNING	K1033	PAIR 2
S-DI	SLOT 6	17	DISCRETE INPUT #14	ADFSVFDON	I 5.5	FWD STBD AIR DISTRIB MOTOR RUNNING	K0333	PAIR 2
S-DI	SLOT 6	18	DISCRETE INPUT #15	FDFSVDFLT	I 5.6	FWD STBD FD VFD FAULT	K0517	PAIR 3
S-DI	SLOT 6	19	DISCRETE INPUT #16	FDASVDFLT	I 5.7	AFT STBD FD VFD FAULT	K0817	PAIR 3
FROM DC DIST DC-		20						
S-DI	SLOT 6	22	DISCRETE INPUT #17	OFAFSVDFLT	I 6.0	FWD STBD OVER FIRE AIR VFD FAULT	K0519	PAIR 3
S-DI	SLOT 6	23	DISCRETE INPUT #18	OFAASVDFLT	I 6.1	AFT STBD OVER FIRE AIR VFD FAULT	K0819	PAIR 3
S-DI	SLOT 6	24	DISCRETE INPUT #19	IFFSVDFLT	I 6.2	FWD STBD INBOARD FEEDER VFD FAULT	K0317	PAIR 3
S-DI	SLOT 6	25	DISCRETE INPUT #20	OFFSVDFLT	I 6.3	FWD STBD OUTBOARD FEEDER VFD FAULT	K0217	PAIR 3
S-DI	SLOT 6	26	DISCRETE INPUT #21	IFASVDFLT	I 6.4	AFT STBD INBOARD FEEDER VFD FAULT	K1017	PAIR 3
S-DI	SLOT 6	27	DISCRETE INPUT #22	OFASVDFLT	I 6.5	AFT STBD OUTBOARD FEEDER VFD FAULT	K1117	PAIR 3
S-DI	SLOT 6	28	DISCRETE INPUT #23	IRFSVDFLT	I 6.6	FWD STBD INBOARD ROTOR VFD FAULT	K0319	PAIR 3
S-DI	SLOT 6	29	DISCRETE INPUT #24	ORFSVDFLT	I 6.7	FWD STBD OUTBOARD ROTOR VFD FAULT	K0219	PAIR 3
S-DI	SLOT 6	32	DISCRETE INPUT #25	IRASVDFLT	I 7.0	AFT STBD INBOARD ROTOR VFD FAULT	K1019	PAIR 3
S-DI	SLOT 6	33	DISCRETE INPUT #26	ORASVDFLT	I 7.1	AFT STBD OUTBOARD ROTOR VFD FAULT	K1119	PAIR 3
S-DI	SLOT 6	34	DISCRETE INPUT #27	ADASVDFLT	I 7.2	FWD STBD AIR DISTRIBUTOR VFD FAULT	K1033	PAIR 3
S-DI	SLOT 6	35	DISCRETE INPUT #28	ADFSVDFLT	I 7.3	AFT STBD AIR DISTRIBUTOR VFD FAULT	K0333	PAIR 3
S-DI	SLOT 6	36	DISCRETE INPUT #29	STBDALMS	I 7.4	STBD 353 ALARMS		
S-DI	SLOT 6	37	DISCRETE INPUT #30	SPLACE2	I 7.5	SEQUENCE PLACEHOLDER 2		
S-DI	SLOT 6	38	DISCRETE INPUT #31	SPLACE3	I 7.6	SEQUENCE PLACEHOLDER 3		
S-DI	SLOT 6	39	DISCRETE INPUT #32	SPLACE4	I 7.7	SEQUENCE PLACEHOLDER 4		
FROM DC DIST DC-		40						

NOTE: ALL D.I. CABLES ARE 4-PAIR SHIELDED. PAIRS 2, 3 & 4 CONNECT TO VFDs. PAIR #1 UNUSED.



PORT-DO1 WIRING

MODULE	ADDRESS	TERMINAL	SERVICE	SYMBOL	ADDR	DESCRIPTION	CABLE	PAIR
S-DO1	SLOT 7	1	DC+ COILS		F23			
S-DO1	SLOT 7	3	N.O.	FDFPVFDST	Q 0.0	RUN FP FD DRIVE	K2017	PAIR #4
S-DO1	SLOT 7	4	COM					
S-DO1	SLOT 7	8	N.O.	FDAPVFDST	Q 0.1	AP FD DRIVE	K1717	PAIR #4
S-DO1	SLOT 7	9	COM					
S-DO1	SLOT 7	12	N.O.	OFAPVFDST	Q 0.2	RUN FP OFA DRIVE	K2019	PAIR #4
S-DO1	SLOT 7	13	COM					
S-DO1	SLOT 7	17	N.O.	OFAAPVFDST	Q 0.3	RUN AP OFA DRIVE	K1719	PAIR #4
S-DO1	SLOT 7	18	COM					
S-DO1	SLOT 7	20	DC- COM			TO DC-		
S-DO1	SLOT 7	23	N.O.	IFFPVFDST	Q 0.4	RUN FP INBD FEDR DRIVE	K2217	PAIR #4
S-DO1	SLOT 7	24	COM					
S-DO1	SLOT 7	27	N.O.	OFFPVFDST	Q 0.5	RUN FP OTBD FEDR DRIVE	K2317	PAIR #4
S-DO1	SLOT 7	28	COM					
S-DO1	SLOT 7	32	N.O.	IFAPVFDST	Q 0.6	RUN AP INBD FEDR DRIVE	K1517	PAIR #4
S-DO1	SLOT 7	33	COM					
S-DO1	SLOT 7	36	N.O.	OFAPVFDST	Q 0.7	RUN AP OTBD FEDR DRIVE	K1417	PAIR #4
S-DO1	SLOT 7	37	COM					

PORT-DO2 WIRING

MODULE	ADDRESS	TERMINAL	SERVICE	SYMBOL	ADDR	DESCRIPTION	CABLE	PAIR
S-DO2	SLOT 8	1	DC+ COILS		F24			
S-DO2	SLOT 8	3	N.O.	IRFPVFDST	Q 1.0	RUN FP INBD ROTOR DRIVE	K2219	PAIR #4
S-DO2	SLOT 8	4	COM					
S-DO2	SLOT 8	8	N.O.	ORFPVFDST	Q 1.1	RUN FP OTBD ROTOR DRIVE	K2319	PAIR #4
S-DO2	SLOT 8	9	COM					
S-DO2	SLOT 8	12	N.O.	IRAPVFDST	Q 1.2	RUN RUN AP INBD ROTOR DRIVE	K1519	PAIR #4
S-DO2	SLOT 8	13	COM					
S-DO2	SLOT 8	17	N.O.	ORAPVFDST	Q 1.3	RUN AP ORBD ROTOR DRIVE	K1419	PAIR #4
S-DO2	SLOT 8	18	COM					
S-DO2	SLOT 8	20	DC-COM			TO DC-		
S-DO2	SLOT 8	23	N.O.	ADAPVFDST	Q 1.4	RUN AP AIR DISTRIB DRIVE	K1533	PAIR #4
S-DO2	SLOT 8	24	COM					
S-DO2	SLOT 8	27	N.O.	ADFPVFDST	Q 1.5	RUN FP AIR DISTRIB DRIVE	K2233	PAIR #4
S-DO2	SLOT 8	28	COM					
S-DO2	SLOT 8	32	N.O.	PORTALARM	Q 1.6	ALARM OUTPUT PORT		
S-DO2	SLOT 8	33	COM					
S-DO2	SLOT 8	36	N.O.	POUTPLACE1	Q 1.7	POUT PLACEHOLDER 1		
S-DO2	SLOT 8	37	COM					



STBD-DO1 WIRING

MODULE	ADDRESS	TERMINAL	SERVICE	SYMBOL	ADDR	DESCRIPTION	CABLE	PAIR
P-DO1	SLOT 9		1 DC+ COILS		F25			
P-DO1	SLOT 9		3 N.O.	FDFSVFDST	Q 2.0	RUN FS FD DRIVE	K0517	PAIR #4
P-DO1	SLOT 9		4 COM					
P-DO1	SLOT 9		8 N.O.	FDASVFDST	Q 2.1	RUN AS FD DRIVE	K0817	PAIR #4
P-DO1	SLOT 9		9 COM					
P-DO1	SLOT 9		12 N.O.	OFASVFDST	Q 2.2	RUN FS OFA DRIVE	K0519	PAIR #4
P-DO1	SLOT 9		13 COM					
P-DO1	SLOT 9		17 N.O.	OFAASVFDST	Q 2.3	RUN AS OFA DRIVE	K0819	PAIR #4
P-DO1	SLOT 9		18 COM					
P-DO1	SLOT 9		20 DC- COM			TO DC-		
P-DO1	SLOT 9		23 N.O.	IFFSVFDST	Q 2.4	RUN FS INBD FEDR DRIVE	K0317	PAIR #4
P-DO1	SLOT 9		24 COM					
P-DO1	SLOT 9		27 N.O.	OFFSVFDST	Q 2.5	RUN FS OTBD FEDR DRIVE	K0217	PAIR #4
P-DO1	SLOT 9		28 COM					
P-DO1	SLOT 9		32 N.O.	IFASVFDST	Q 2.6	RUN AS INBD FEDR DRIVE	K1017	PAIR #4
P-DO1	SLOT 9		33 COM					
P-DO1	SLOT 9		36 N.O.	OFASVFDST	Q 2.7	RUN AS OTBD FEDR DRIVE	K1117	PAIR #4
P-DO1	SLOT 9		37 COM					

STBD-DO2 WIRING

MODULE	ADDRESS	TERMINAL	SERVICE	SYMBOL	ADDR	DESCRIPTION	CABLE	PAIR
P-DO2	SLOT 10		1 DC+ COILS		F26			
P-DO2	SLOT 10		3 N.O.	IRFSVFDST	Q 3.0	RUN FS INBD ROTOR DRIVE	K0319	PAIR #4
P-DO2	SLOT 10		4 COM					
P-DO2	SLOT 10		8 N.O.	ORFSVFDST	Q 3.1	RUN FS OTBD ROTOR DRIVE	K0219	PAIR #4
P-DO2	SLOT 10		9 COM					
P-DO2	SLOT 10		12 N.O.	IRASVFDST	Q 3.2	RUN AS INBD ROTOR DRIVE	K1019	PAIR #4
P-DO2	SLOT 10		13 COM					
P-DO2	SLOT 10		17 N.O.	ORASVFDST	Q 3.3	RUN AS ORBD ROTOR DRIVE	K1119	PAIR #4
P-DO2	SLOT 10		18 COM					
P-DO2	SLOT 10		20 DC- COM			TO DC-		
P-DO2	SLOT 10		23 N.O.	ADASVFDST	Q 3.4	RUN AS AIR DISTRIB DRIVE	K1033	PAIR #4
P-DO2	SLOT 10		24 COM					
P-DO2	SLOT 10		27 N.O.	ADFSVFDST	Q 3.5	RUN FS AIR DISTRIB DRIVE	K0333	PAIR #4
P-DO2	SLOT 10		28 COM					
P-DO2	SLOT 10		32 N.O.	STBDALARM	Q 3.6	ALARM OUTPUT STBD		
P-DO2	SLOT 10		33 COM					
P-DO2	SLOT 10		36 N.O.	SOUTPLACE1	Q 3.7	SOUTPUT HOLDER 1		
P-DO2	SLOT 10		37 COM					

PORT DI PWR TS-PORT2

FUSE	T/S TERM	INPUT
F27		1 CHL1 & 2
F27		2 CHL 3 & 4
F27		3 CHL 5 & 6
F27		4 CHL 7 & 8
F27		5 CHL 9 & 10
F27		6 CHL 11 & 12
F27		7 CHL 13 & 14
F27		8 CHL 15 & 16
F28		1 CHL 17 & 18
F28		2 CHL 19 & 20
F28		3 CHL 21 & 22
F28		4 CHL 23 & 24
F28		5 CHL 25 & 26
F28		6 CHL 27 & 28
F28		7 CHL 29 & 30
F28		8 CHL 31 & 32
INTERMEDIATE T/S TO BE INSTALLED		
ALLOWING DC+ WIRING POINTS FOR		
DISCRETE INPUT DEVICES TO PLC		



PORT-DI 2 WIRING

MODULE	ADDRESS	TERMINAL	SERVICE	SYMBOL	ADDR	DESCRIPTION	CABLE	TYPE
FROM DC FUSE		FIELD	24VDC+			FROM TS-PORT2 TO FIELD DEVICES		
S-DI	SLOT 5	2	DISCRETE INPUT #1	APIBTRSW	I 12.0	AFT PORT INBD ROTOR TACH SWITCH	2600 PAIR 1	TPS-18TIU-4
S-DI	SLOT 5	3	DISCRETE INPUT #2	APOBTRSW	I 12.1	AFT PORT OTBD ROTOR TACH SWITCH	2600 PAIR 2	TPS-18TIU-4
S-DI	SLOT 5	4	DISCRETE INPUT #3	FPIBTRSW	I 12.2	FWD PORT INBD ROTOR TACH SWITCH	2601 PAIR 1	TPS-18TIU-4
S-DI	SLOT 5	5	DISCRETE INPUT #4	FPOBTRSW	I 12.3	FWD PORT OTBD ROTOR TACH SWITCH	2601 PAIR 2	TPS-18TIU-4
S-DI	SLOT 5	6	DISCRETE INPUT #5					
S-DI	SLOT 5	7	DISCRETE INPUT #6					
S-DI	SLOT 5	8	DISCRETE INPUT #7					
S-DI	SLOT 5	9	DISCRETE INPUT #8					
S-DI	SLOT 5	12	DISCRETE INPUT #9					
S-DI	SLOT 5	13	DISCRETE INPUT #10					
S-DI	SLOT 5	14	DISCRETE INPUT #11					
S-DI	SLOT 5	15	DISCRETE INPUT #12					
S-DI	SLOT 5	16	DISCRETE INPUT #13					
S-DI	SLOT 5	17	DISCRETE INPUT #14					
S-DI	SLOT 5	18	DISCRETE INPUT #15					
S-DI	SLOT 5	19	DISCRETE INPUT #16					
FROM DC DIST DC-		20						
S-DI	SLOT 5	22	DISCRETE INPUT #17					
S-DI	SLOT 5	23	DISCRETE INPUT #18					
S-DI	SLOT 5	24	DISCRETE INPUT #19					
S-DI	SLOT 5	25	DISCRETE INPUT #20					
S-DI	SLOT 5	26	DISCRETE INPUT #21					
S-DI	SLOT 5	27	DISCRETE INPUT #22					
S-DI	SLOT 5	28	DISCRETE INPUT #23					
S-DI	SLOT 5	29	DISCRETE INPUT #24					
S-DI	SLOT 5	32	DISCRETE INPUT #25					
S-DI	SLOT 5	33	DISCRETE INPUT #26					
S-DI	SLOT 5	34	DISCRETE INPUT #27					
S-DI	SLOT 5	35	DISCRETE INPUT #28					
S-DI	SLOT 5	36	DISCRETE INPUT #29					
S-DI	SLOT 5	37	DISCRETE INPUT #30					
S-DI	SLOT 5	38	DISCRETE INPUT #31					
S-DI	SLOT 5	39	DISCRETE INPUT #32					
FROM DC DIST DC-		40						

STBD DI PWR TS-STBD2

FUSE	T/S TERM	INPUT
F29		1 CHL1 & 2
F29		2 CHL 3 & 4
F29		3 CHL 5 & 6
F29		4 CHL 7 & 8
F29		5 CHL 9 & 10
F29		6 CHL 11 & 12
F29		7 CHL 13 & 14
F29		8 CHL 15 & 16
F30		1 CHL 17 & 18
F30		2 CHL 19 & 20
F30		3 CHL 21 & 22
F30		4 CHL 23 & 24
F30		5 CHL 25 & 26
F30		6 CHL 27 & 28
F30		7 CHL 29 & 30
F30		8 CHL 31 & 32
INTERMEDIATE T/S TO BE INSTALLED		
ALLOWING DC+ WIRING POINTS FOR		
DISCRETE INPUT DEVICES TO PLC		

STBD-DI 2 WIRING

MODULE	ADDRESS	TERMINAL	SERVICE	SYMBOL	ADDR	DESCRIPTION	CABLE	TYPE
FROM DC FUSE		FIELD	24VDC+			FROM TS-STBD2 TO FIELD DEVICES		
P-DI	SLOT 6	2	DISCRETE INPUT #1	ASIBRTRSW	I 8.0	AFT STBD INBD ROTOR TACH SWITCH	2500 PAIR 1	TPS-18TIU-4
P-DI	SLOT 6	3	DISCRETE INPUT #2	ASOBRTRSW	I 8.1	AFT STBD OTBD ROTOR TACH SWITCH	2500 PAIR 2	TPS-18TIU-4
P-DI	SLOT 6	4	DISCRETE INPUT #3	FSIBRTRSW	I 8.2	FWD STBD INBD ROTOR TACH SWITCH	2501 PAIR 1	TPS-18TIU-4
P-DI	SLOT 6	5	DISCRETE INPUT #4	FSOBRTRSW	I 8.3	FWD STBD OTBD ROTOR TACH SWITCH	2501 PAIR 2	TPS-18TIU-4
P-DI	SLOT 6	6	DISCRETE INPUT #5					
P-DI	SLOT 6	7	DISCRETE INPUT #6					
P-DI	SLOT 6	8	DISCRETE INPUT #7					
P-DI	SLOT 6	9	DISCRETE INPUT #8					
P-DI	SLOT 6	12	DISCRETE INPUT #9					
P-DI	SLOT 6	13	DISCRETE INPUT #10					
P-DI	SLOT 6	14	DISCRETE INPUT #11					
P-DI	SLOT 6	15	DISCRETE INPUT #12					
P-DI	SLOT 6	16	DISCRETE INPUT #13					
P-DI	SLOT 6	17	DISCRETE INPUT #14					
P-DI	SLOT 6	18	DISCRETE INPUT #15					
P-DI	SLOT 6	19	DISCRETE INPUT #16					
FROM DC DIST DC-		20						
P-DI	SLOT 6	22	DISCRETE INPUT #17					
P-DI	SLOT 6	23	DISCRETE INPUT #18					
P-DI	SLOT 6	24	DISCRETE INPUT #19					
P-DI	SLOT 6	25	DISCRETE INPUT #20					
P-DI	SLOT 6	26	DISCRETE INPUT #21					
P-DI	SLOT 6	27	DISCRETE INPUT #22					
P-DI	SLOT 6	28	DISCRETE INPUT #23					
P-DI	SLOT 6	29	DISCRETE INPUT #24					
P-DI	SLOT 6	32	DISCRETE INPUT #25					
P-DI	SLOT 6	33	DISCRETE INPUT #26					
P-DI	SLOT 6	34	DISCRETE INPUT #27					
P-DI	SLOT 6	35	DISCRETE INPUT #28					
P-DI	SLOT 6	36	DISCRETE INPUT #29					
P-DI	SLOT 6	37	DISCRETE INPUT #30					
P-DI	SLOT 6	38	DISCRETE INPUT #31					
P-DI	SLOT 6	39	DISCRETE INPUT #32					
FROM DC DIST DC-		40						



P-DO3 WIRING

MODULE	ADDRESS	TERMINAL	SERVICE	SYMBOL	ADDR	DESCRIPTION
P-DO3	SLOT 13	1	DC+ COILS		F31	
P-DO3	SLOT 13	3	N.O.			
P-DO3	SLOT 13	4	COM			
P-DO3	SLOT 13	8	N.O.			
P-DO3	SLOT 13	9	COM			
P-DO3	SLOT 13	12	N.O.			
P-DO3	SLOT 13	13	COM			
P-DO3	SLOT 13	17	N.O.			
P-DO3	SLOT 13	18	COM			
<b>P-DO3</b>	<b>SLOT 13</b>	<b>20</b>	<b>DC- COM</b>			<b>TO DC-</b>
P-DO3	SLOT 13	23	N.O.			
P-DO3	SLOT 13	24	COM			
P-DO3	SLOT 13	27	N.O.			
P-DO3	SLOT 13	28	COM			
P-DO3	SLOT 13	32	N.O.			
P-DO3	SLOT 13	33	COM			
P-DO3	SLOT 13	36	N.O.			
P-DO3	SLOT 13	37	COM			

S-DO4 WIRING

MODULE	ADDRESS	TERMINAL	SERVICE	SYMBOL	ADDR	DESCRIPTION
S-DO3	SLOT 14		1 DC+ COILS		F32	
S-DO3	SLOT 14		3 N.O.			
S-DO3	SLOT 14		4 COM			
S-DO3	SLOT 14		8 N.O.			
S-DO3	SLOT 14		9 COM			
S-DO3	SLOT 14		12 N.O.			
S-DO3	SLOT 14		13 COM			
S-DO3	SLOT 14		17 N.O.			
S-DO3	SLOT 14		18 COM			
S-DO3	SLOT 14		20 DC- COM		TO DC-	
S-DO3	SLOT 14		23 N.O.			
S-DO3	SLOT 14		24 COM			
S-DO3	SLOT 14		27 N.O.			
S-DO3	SLOT 14		28 COM			
S-DO3	SLOT 14		32 N.O.			
S-DO3	SLOT 14		33 COM			
S-DO3	SLOT 14		36 N.O.			
S-DO3	SLOT 14		37 COM			

AC POWER DIST

RATING	FUSE	DEVICE	TERMINAL	DEVICE NAME/TAG
		<b>PORT BOILER CABINET</b>		
15	ACF2	CABINET COOLING SYSTEM	L1	PORT BOILER CONTROL CABINET
15	ACF2	CABINET COOLING SYSTEM	L2	PORT BOILER CONTROL CABINET
15	ACF3	CONVENIENCE OUTLET	L1	PORT BLR CABINET OUTLETS AND LIGHTS
15	ACF3	CONVENIENCE OUTLET	L2	PORT BLR CABINET OUTLETS AND LIGHTS
15	ACF1	VORTEX COOLER SYS	L1	HMI PC CABINET - BOILER ROOM
15	ACF1	VORTEX COOLER SYS	L2	HMI PC CABINET - BOILER ROOM
		<b>STBD BOILER CABINET</b>		
15	ACF1	CABINET COOLING SYSTEM	L1	PORT BOILER CONTROL CABINET
15	ACF1	CABINET COOLING SYSTEM	L2	PORT BOILER CONTROL CABINET
15	ACF2	CONVENIENCE OUTLET	L1	PORT BLR CABINET OUTLETS AND LIGHTS
15	ACF2	CONVENIENCE OUTLET	L2	PORT BLR CABINET OUTLETS AND LIGHTS
		<b>FEEDWATER PANEL</b>		
15	ACF1	CONVENIENCE OUTLET	L1	FEEDWATER CABINET OUTLETS AND LIGHTS
15	ACF1	CONVENIENCE OUTLET	L2	FEEDWATER CABINET OUTLETS AND LIGHTS
15	ACF2	VORTEX COOLER SYS	L1	HMI PC CABINET - ENGINE ROOM
15	ACF2	VORTEX COOLER SYS	L2	HMI PC CABINET - ENGINE ROOM



STBD PANEL DC POWER DIST.

RATING	FUSE	DEVICE	TERMINAL	DEVICE NAME/TAG
15 AMP	Fx	FUSE	N/A	DIODE ISOLATION
15 AMP	Fy	FUSE	N/A	DIODE ISOLATION
2 AMP	F1	M353 #1	H (DC+)	FWD STBD DRUM LEVEL
2 AMP	F2	M353 #2	H (DC+)	FWD STBD FEEDER #2
2 AMP	F3	M353 #3	H (DC+)	FWD STBD FEEDER #1
2 AMP	F4	M353 #4	H (DC+)	FWD STBD I.D.
2 AMP	F5	M353 #5	H (DC+)	FWD STBD AIRFLOW
2 AMP	F6	M353 #6	H (DC+)	FWD STBD SUB MASTER
2 AMP	F7	M353 #7	H (DC+)	AFT STBD SUB MASTER
2 AMP	F8	M353 #8	H (DC+)	AFT STBD AIRFLOW
2 AMP	F9	M353 #9	H (DC+)	AFT STBD I.D.
2 AMP	F10	M353 #10	H (DC+)	AFT STBD FEEDER #1
2 AMP	F11	M353 #11	H (DC+)	AFT STBD FEEDER #2
2 AMP	F12	M353 #12	H (DC+)	AFT STBD DRUM LEVEL
	F13	SPARE		
2 AMP	F14	DIXSON IND		AS DIXSON DRUM PRESS
2 AMP	F15	DIXSON IND		FS DIXSON DRUM PRESS
5 AMP	F16	AIRFLOW	TERM 15	FS AIRFLOW XMTR
5 AMP	F17	AIRFLOW	TERM 15	AS AIRFLOW XMTR
2 AMP	F18	SPARE		
2 AMP	F19	SPARE		
2 AMP	F20	SPARE		
DC-		M353 #1	N (DC-)	STBD FWD DRUM LEVEL
DC-		M353 #3	N (DC-)	STBD FWD FEEDER #2
DC-		M353 #5	N (DC-)	STBD FWD FEEDER #1
DC-		M353 #7	N (DC-)	STBD FWD I.D.
DC-		M353 #9	N (DC-)	STBD FWD AIRFLOW
DC-		M353 #11	N (DC-)	STBD FWD SUB MASTER
DC-		M353 #13	N (DC-)	STBD AFT SUB MASTER
DC-		M353 #15	N (DC-)	STBD AFT AIRFLOW
DC-		M353 #17	N (DC-)	STBD AFT I.D.
DC-		M353 #19	N (DC-)	STBD AFT FEEDER #1
DC-		M353 #21	N (DC-)	STBD AFT FEEDER #2
DC-		M353 #23	N (DC-)	STBD AFT DRUM LEVEL
DC-		DIXSON IND	TERM	DISXON DRUM PRESS
DC-		AIRFLOW	TERM 16	AIRFLOW XMTRS
G				STATION GROUNDS
G				STATION GROUNDS
G				STATION GROUNDS
G				STATION GROUNDS



PORT PANEL DC POWER DIST

RATING	FUSE	DEVICE	TERMINAL	DEVICE NAME/TAG
15 AMP	Fx	FUSE	N/A	DIODE ISOLATION
15 AMP	Fy	FUSE	N/A	DIODE ISOLATION
2 AMP	F1	M353 # 13	H (DC+)	AFT PORT DRUM LEVEL
2 AMP	F2	M353 # 14	H (DC+)	AFT PORT FEEDER #2
2 AMP	F3	M353 # 15	H (DC+)	AFT PORT FEEDER #1
2 AMP	F4	M353 # 16	H (DC+)	AFT PORT FURNACE
2 AMP	F5	M353 # 17	H (DC+)	AFT PORT AIRFLOW
2 AMP	F6	M353 # 18	H (DC+)	AFT PORT SUB MASTER
2 AMP	F7	M353 # 19	H (DC+)	FWD PORT SUB MASTER
2 AMP	F8	M353 # 20	H (DC+)	FWD PORT AIRFLOW
2 AMP	F9	M353 # 21	H (DC+)	FWD PORT I.D.
2 AMP	F10	M353 # 22	H (DC+)	FWD PORT FEEDER #1
2 AMP	F11	M353 # 23	H (DC+)	FWD PORT FEEDER #2
2 AMP	F12	M353 # 24	H (DC+)	FWD PORT DRUM LEVEL
	F13	SPARE		
5 AMP	F14	PLC CPU-A	H (DC+)	MOTOR CONTROLS
5 AMP	F15	PLC CPU-B	H (DC+)	MOTOR CONTROLS
2 AMP	F16	M153-2	H (DC+)	PROFIBUS INTERFACE 1
2 AMP	F17	M153-2	H (DC+)	PROFIBUS INTERFACE 2
5 AMP	F18	PLC I/O	NO CONN	ANALOG XMTRS
2 AMP	F19	P-PLC D.I.1A		DC FOR DISCRETE INPUTS 1-16
2 AMP	F20	P-PLC D.I.1B		DC FOR DISCRETE INPUTS 17-32
15 AMP	Fw	FUSE	N/A	DIODE ISOLATION
15 AMP	Fv	FUSE	N/A	DIODE ISOLATION
2 AMP	F21	S-PLC D.I.2A		DC FOR DISCRETE INPUTS 1-16
2 AMP	F22	S-PLC D.I.2B		DC FOR DISCRETE INPUTS 17-32
5 AMP	F23	P-PLC RLY-1	T1	OUTPUT RELAY COILS
5 AMP	F24	P-PLC RLY-2	T1	OUTPUT RELAY COILS
5 AMP	F25	S-PLC RLY-1	T1	OUTPUT RELAY COILS
5 AMP	F26	S-PLC RLY-2	T1	OUTPUT RELAY COILS
2 AMP	F27	P-PLC D.I.3A		DC FOR DISCRETE INPUTS 1-16
2 AMP	F28	P-PLC D.I.3B		DC FOR DISCRETE INPUTS 17-32
2 AMP	F29	S-PLC D.I.4A		DC FOR DISCRETE INPUTS 1-16
2 AMP	F30	S-PLC D.I.4B		DC FOR DISCRETE INPUTS 17-32
5 AMP	F31	P-PLC RLY-3	T1	OUTPUT RELAY COILS
5 AMP	F32	S-PLC RLY-4	T1	OUTPUT RELAY COILS
2 AMP	F33	SWITCH		ETHERNET SWITCH
2 AMP	F34	DIXSON		DIXSON DRUM PRESS AP
2 AMP	F35	DIXSON		DIXSON DRUM PRESS FP
5 AMP	F36	AIRFLOW		FP AIRFLOW XMTR
5 AMP	F37	AIRFLOW		AP AIRFLOW XMTR
5 AMP	F38	PC		ENG ROOM HMI PC
2 AMP	F39	SPARE		SPARE
DC-		M353 #2	N (DC-)	STBD FWD DRUM LEVEL
DC-		M353 #4	N (DC-)	STBD FWD FEEDER #2

PORT PANEL DC POWER DIST

DC-		M353 #6	N (DC-)	STBD FWD FEEDER #1
DC-		M353 #8	N (DC-)	STBD FWD I.D.
DC-		M353 #10	N (DC-)	STBD FWD AIRFLOW
DC-		M353 #12	N (DC-)	STBD FWD SUB MASTER
DC-		M353 #14	N (DC-)	STBD AFT SUB MASTER
DC-		M353 #16	N (DC-)	STBD AFT AIRFLOW
DC-		M353 #18	N (DC-)	STBD AFT I.D.
DC-		M353 #20	N (DC-)	STBD AFT FEEDER #1
DC-		M353 #22	N (DC-)	STBD AFT FEEDER #2
DC-		M353 #24	N (DC-)	STBD AFT DRUM LEVEL
DC-		PLC MAIN	N (DC-)	MOTOR CONTROLS
DC-		PLC I/O	S4T20	ANALOG XMTRS
DC-		PLC PROFIBUS	N (DC-)	PROFIBUS TEMINATORS
DC-		PLC D.I.	S4T20 & 40	DISCRETE INPUTS
DC-		PLC D.I.	S5T20 & 40	DISCRETE INPUTS
DC-		PLC D.I.	S4T20 & 40	DISCRETE INPUTS
DC-		PLC D.I.	S5T20 & 40	DISCRETE INPUTS
DC-		PLC RELAYS	T20	RELAY COILS
DC-		PLC RELAYS	T20	RELAY COILS
DC-		PLC RELAYS	T20	RELAY COILS
DC-		PLC RELAYS	T20	RELAY COILS
DC-		DIXSON		DISXON LEVEL
DC-		AIRFLOW	TERM 16	AIRFLOW XMTR
DC-		HMI PC		BLR ROOM HMI PC
DC-		ETHERNET SW		ETHERNET SWITCH
G				STATION GROUNDS
G				STATION GROUNDS
G				STATION GROUNDS
G				STATION GROUNDS



**RATING      FUSE      DEVICE      TERMINAL      DEVICE NAME/TAG**

15 AMP	Fx	FUSE	N/A	DIODE ISOLATION
15 AMP	Fy	FUSE	N/A	DIODE ISOLATION
2 AMP	F1	M353 # 25	H (DC+)	AFT PORT DRUM LEVEL
2 AMP	F2	M353 # 26	H (DC+)	AFT PORT FEEDER #2
2 AMP	F3	M353 # 27	H (DC+)	AFT PORT FEEDER #1
2 AMP	F4	DIXSON		DIXSON DRUM LEVEL AP
2 AMP	F5	DIXSON		DIXSON DRUM LEVEL FP
2 AMP	F6	DIXSON		DIXSON D.A. LEVEL
2 AMP	F7	DIXSON		DIXSON DRUM LEVEL AP
2 AMP	F8	DIXSON		DIXSON DRUM LEVEL FP
2 AMP	F9	SWITCH	H (DC+)	ETHERNET SWITCH
5 AMP	F10	HMI PC	H (DC+)	ENGINEER ROOM PC
2 AMP	F11	SPARE		
2 AMP	F12	SPARE		
	F13	SPARE		

U.S. Department of  
Homeland Security

United States  
Coast Guard



Officer in Charge, Marine Inspection  
United States Coast Guard  
Sector Lake Michigan

2420 S. Lincoln Memorial Drive  
Milwaukee, WI 53207  
Phone: (414) 747-7128  
Fax: (414) 747-7883

16711

**FEB 27 2014**

Lake Michigan Carferry  
Attn: Mr. Charles Cart, Senior Chief Engineer  
701 Maritime Dr.  
Ludington, MI 49431

Subj: S/S BADGER, O.N. 265156, ABSID 5300348  
DRAWING REVIEW, COMBUSTION CONTROL  
COAL FIRED PROPULSION BOILERS

Ref: (a) Your email request dated February 19, 2014  
(b) USCG NVIC 10-82, Change 2

Dear Mr. Cart:

Your request for ABS to review modifications to S/S BADGER, "Propulsion Boiler Combustion Control", on behalf of the U.S. Coast Guard in accordance with reference (b) is hereby granted. Copies of all ABS reviewed plans and their associated ABS letters shall be provided to Sector Lake Michigan, Milwaukee, WI as required by reference (b).

Sector Lake Michigan will maintain oversight of the project to the degree necessary to fulfill statutory mandates and establish appropriate ABS and USCG liaisons. If the need arises, we will make every effort to be responsive to you, the owners, or ABS in matters of interpretation, policy, or appeal decisions.

Please feel free to contact Richard Baker, Sector Lake Michigan at (414) 747-7127 if you have any questions.

Sincerely,

A handwritten signature in blue ink, appearing to read "M. C. Farrell".

M. C. FARRELL  
Commander, U. S. Coast Guard  
Officer in Charge, Marine Inspection  
By direction

Encl: Email message from Chuck Cart dated February 19, 2014

Copy: ABS Sturgeon Bay w/o encl.  
Lake Michigan Carferry

REV.

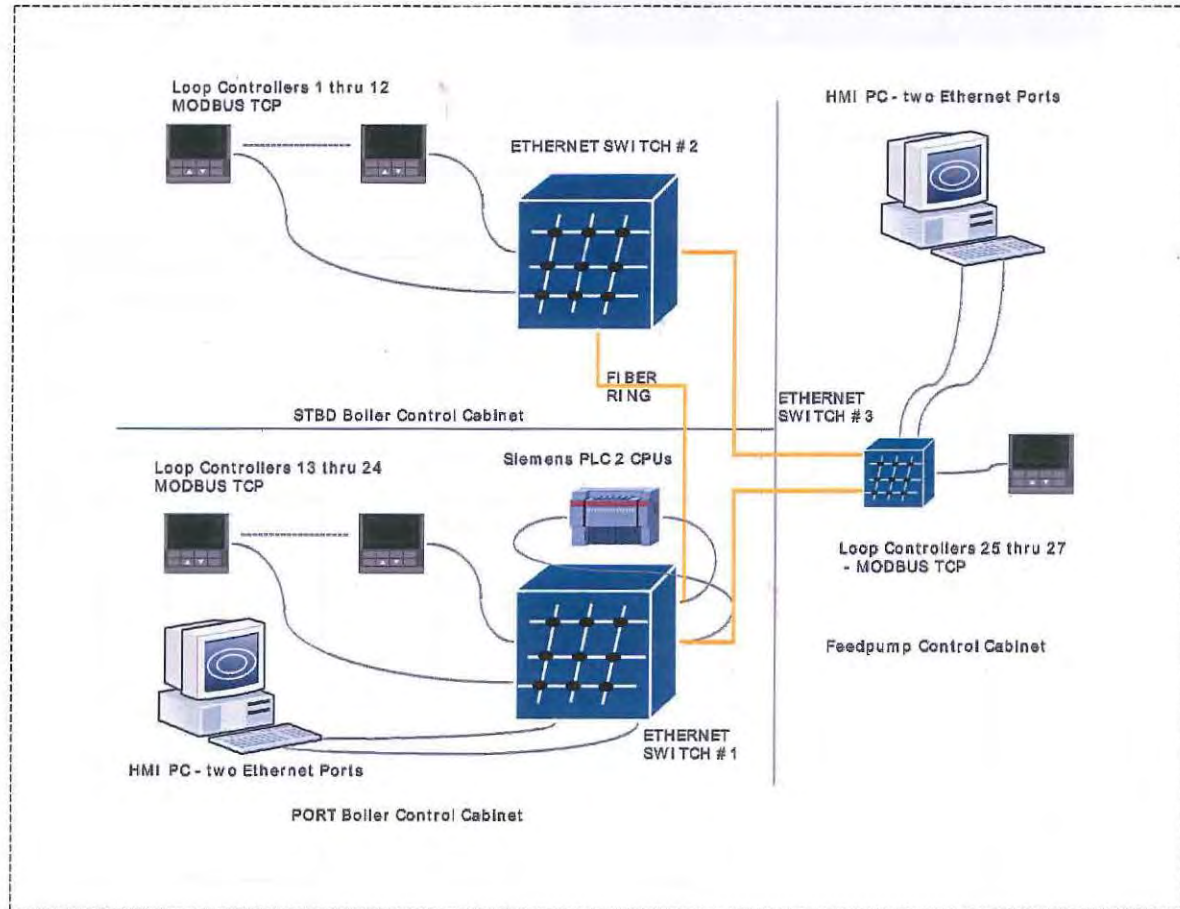

PRELIMINARY

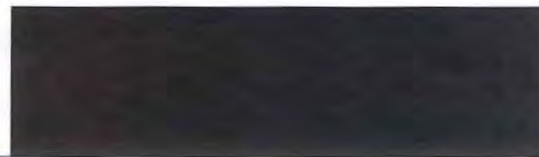

SS BADGER BOILER MODBUS CONTROL NETWORK	
DRAWING NAME: BLRMODBUS.DWG	DRAWING NO:
DRAWN BY:	DATE: 1/14/14
SHEET ___ OF ___	



CONTAINS CONFIDENTIAL BUSINESS INFORMATION

REV.

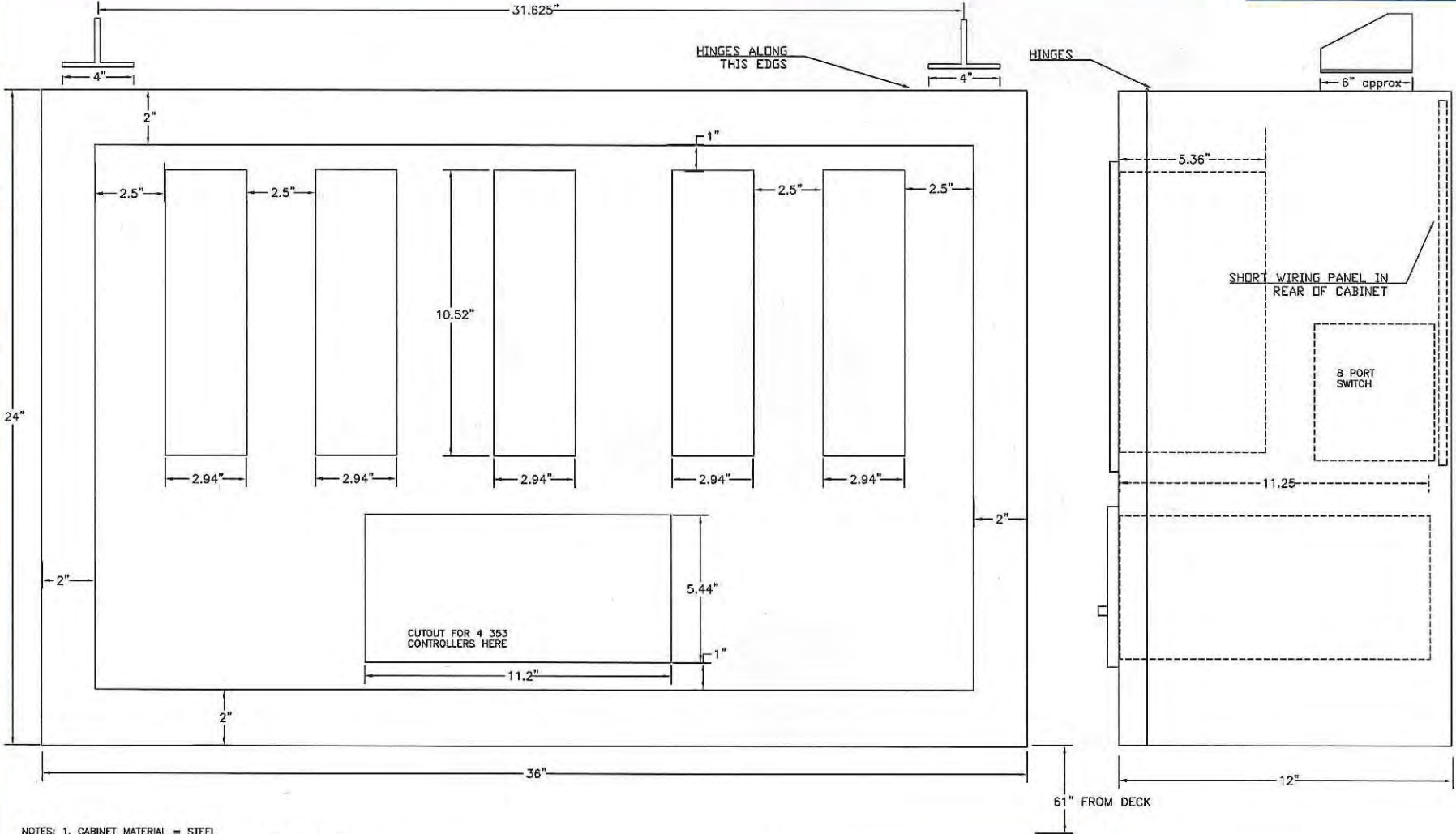

- NOTES: 1. CABINET MATERIAL = STEEL  
 2. PAINTED DARK BLUE - PPC 0CB3B CADET  
 3. FRONT PANEL HINGES MAY BE ON TOP OR BOTTOM OF CABINET

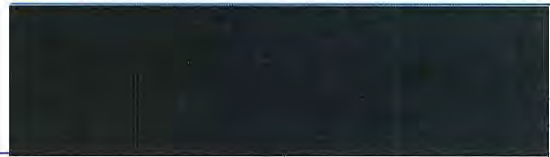

SS BADGER FEEDWATER PANEL	
DRAWING NAME: FEEDFRONT.DWG	DRAWING NO.
DRAWN BY:  DATE: 12/2/2013	SHEET ___ OF ___

REV.

# BOILER DRUM LEVELS

AFT PORT      FWD PORT      D.C. HEATER LEVEL      FWD STBD      AFT STBD

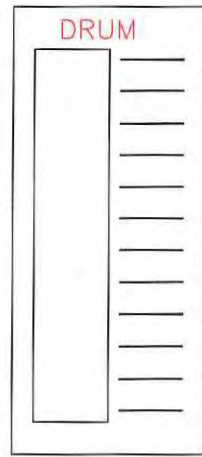
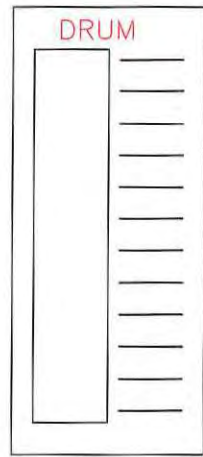
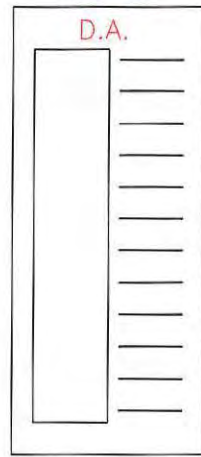
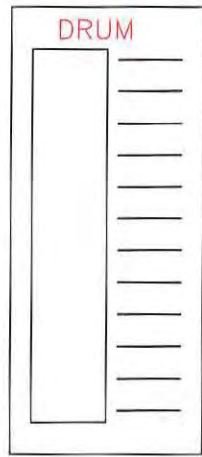
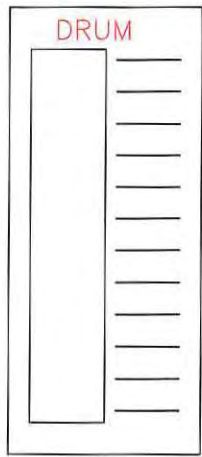

# FEEDPUMPS & CONDENSATE

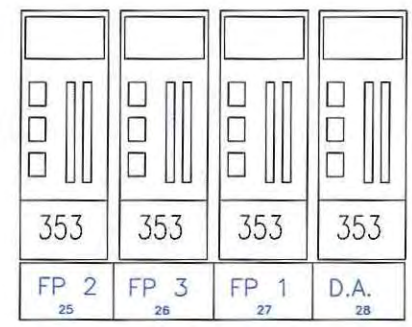

LEGEND  
 25. FEEDPUMP # 2  
 26. FEEDPUMP # 3  
 27. FEEDPUMP # 1  
 28. D.A. & CONDENSER

FEEDWATER PANEL INDICATORS AND CONTROLLERS

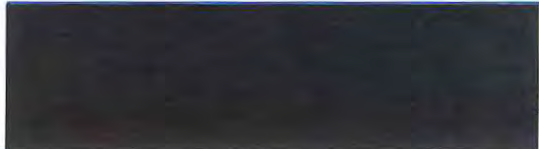

SS BADGER  
 FEEDWATER PANEL  
 INDICATORS & CTRLRS

DRAWING NAME: FEED 353S.DWG      DRAWING NUMBER:  
 BY: JCH/LLC      DATE: 2/3/14      SHEET \_\_\_ OF \_\_\_

CONTAINS CONFIDENTIAL BUSINESS INFORMATION

CONTAINS CONFIDENTIAL BUSINESS INFORMATION

REV.
1, 12/2/13 - ADDED 3 PLC I/O MODULES.

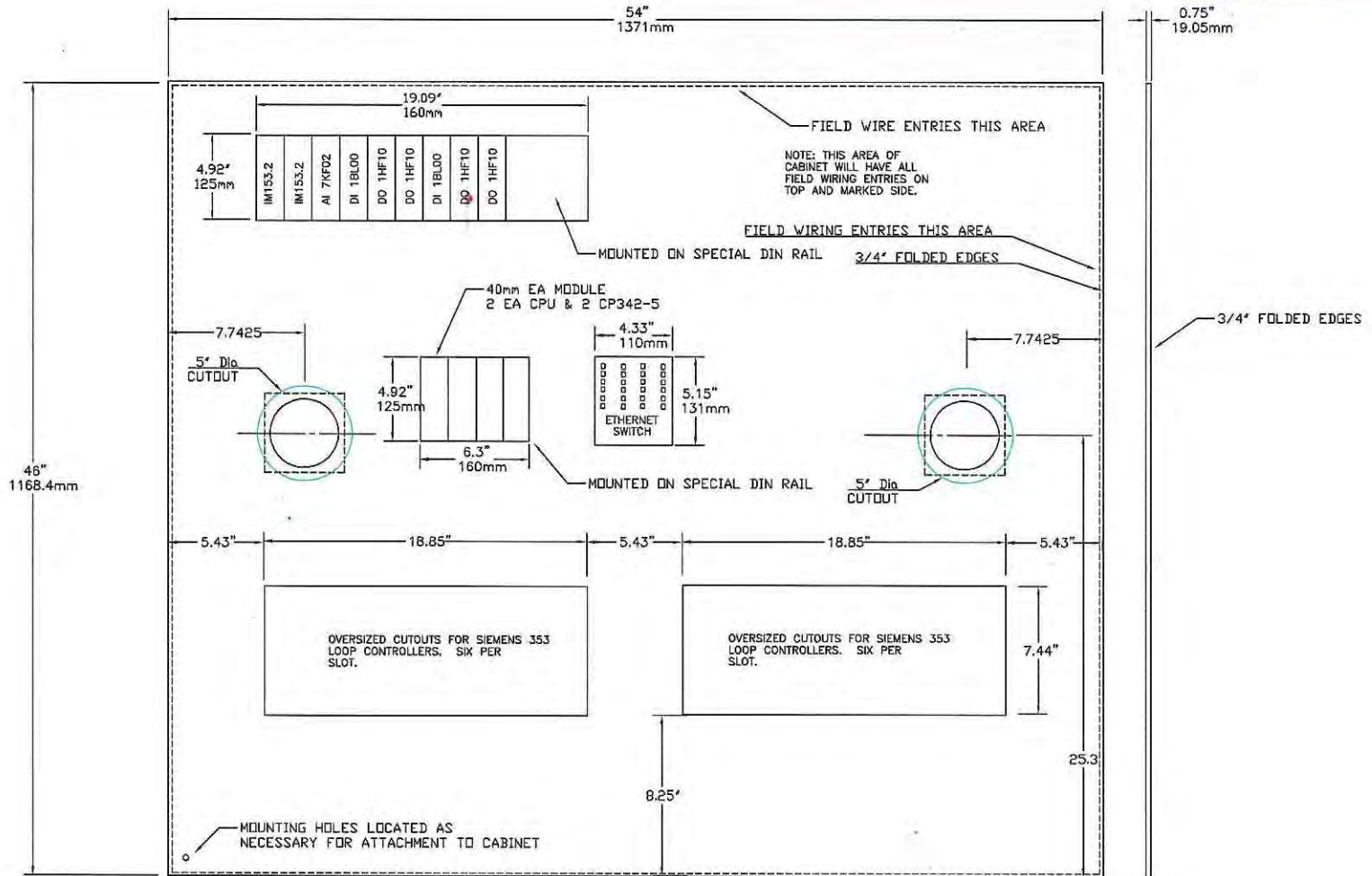

NOTE: PORT BOILER CABINET INTERNAL WIRING PANEL

SS BADGER  
PORT BOILER CONTROL CABINET

DRAWING NAME: P-BLRB IN.DWG	DRAWING NO:
DRAWN BY: [Signature]	DATE: 11/26/2013 SHEET ___ OF ___



CONTAINS CONFIDENTIAL BUSINESS INFORMATION

REV.

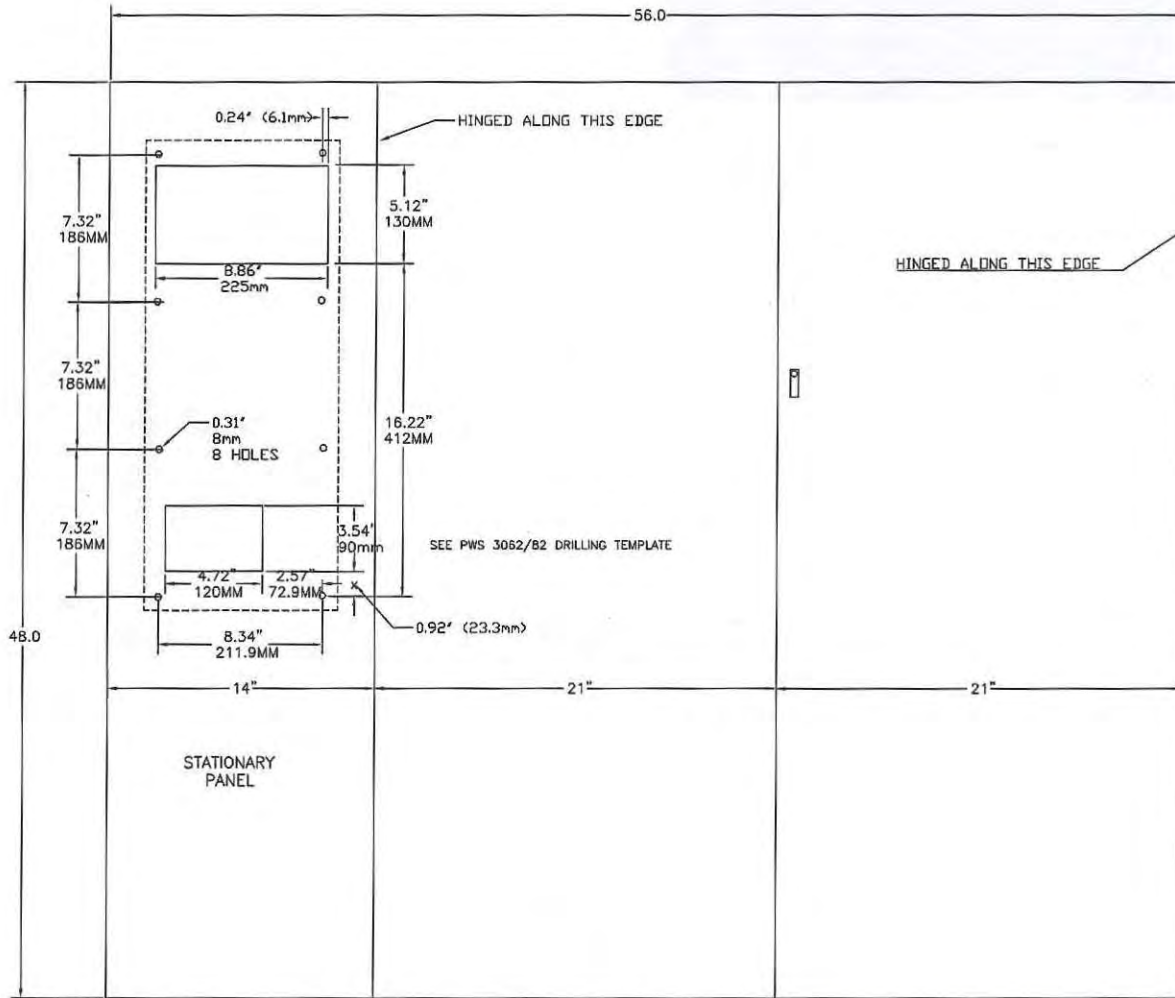

SS BADGER  
PORT BOILER CONTROL CABINET

DRAWING NAME: P-BLRCAB R.DWG	DRAWING NO:
DRAWN BY: [Signature]	DATE: 11/25/2013 SHEET ___ OF ___

CONTAINS CONFIDENTIAL BUSINESS INFORMATION

REV.

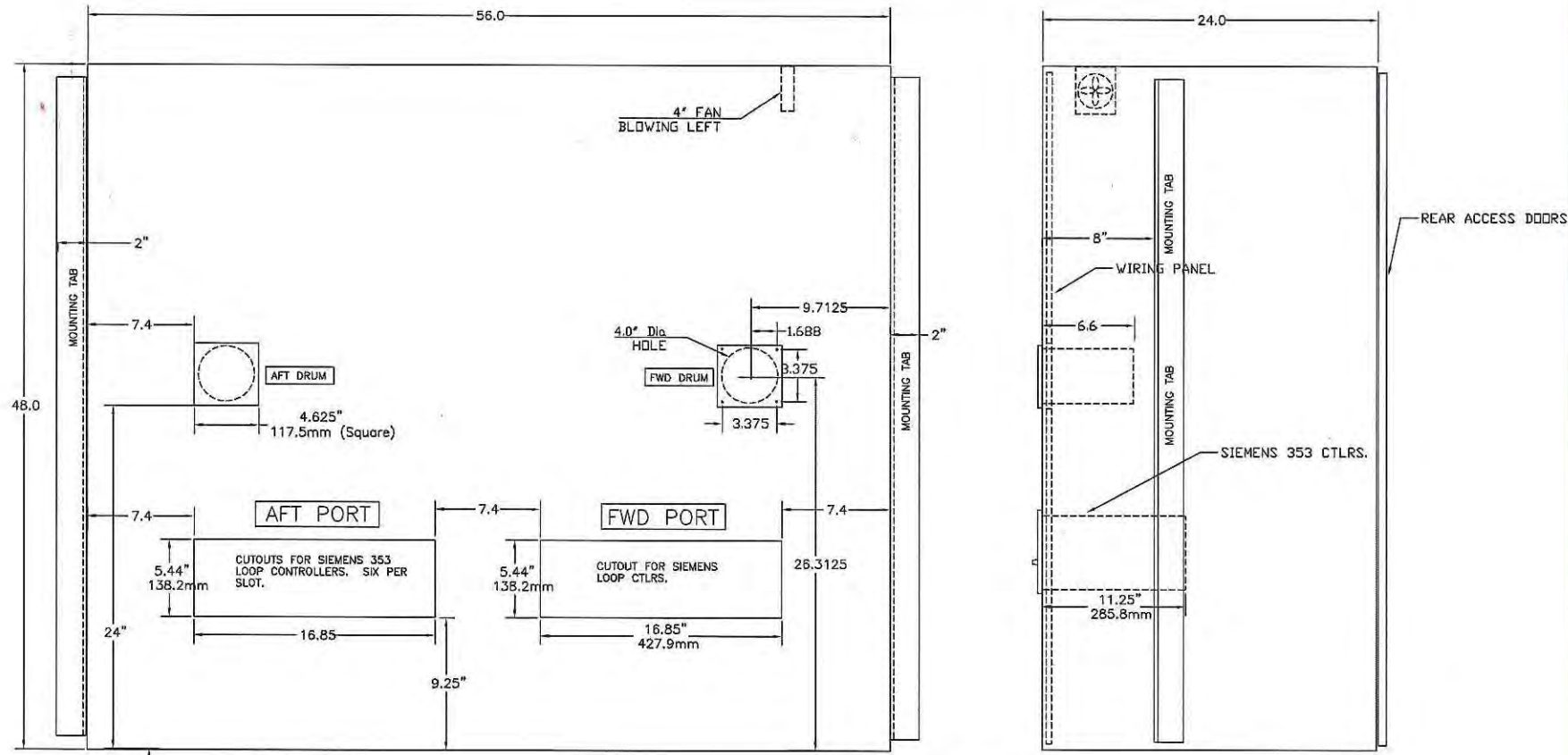

NOTE: MOUNTING TABS - BOTH SIDES MAY BE WELDED OR BOLTED TO EXISTING COLUMNS ON VESSEL

48.0 ABOVE DECK (NOT TO SCALE)

SS BADGER PORT BOILER CONTROL CABINET

DRAWING NAME: P-BLRCAB.DWG	DRAWING NO:
DRAWN BY: [Signature]	DATE: 11/25/2013 SHEET ___ OF ___

REV.

# AFT PORT

# FWD PORT

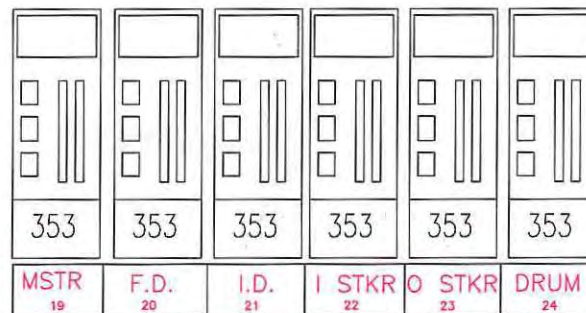
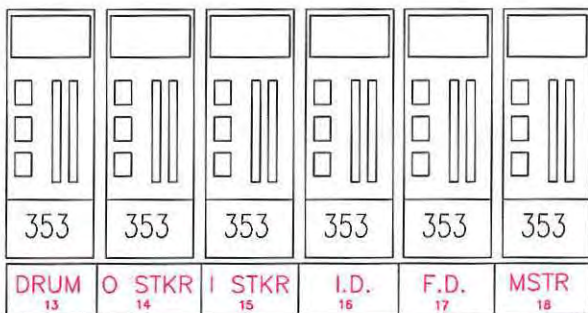

- LEGEND
- 13. AFT PORT DRUM LEVEL
  - 14. AFT PORT OTBD FEEDER
  - 15. AFT PORT INBD FEEDER
  - 16. AFT PORT I.D. FAN
  - 17. AFT PORT F.D. FAN & OFA
  - 18. AFT PORT SUB MASTER
  - 19. FWD PORT SUB-MASTER
  - 20. FWD PORT F.D. FAN & OFA
  - 21. FWD PORT I.D. FAN
  - 22. FWD PORT INBD FEEDER
  - 23. FWD PORT OTBD FEEDER
  - 24. FWD PORT DRUM LEVEL

PORT CABINET COMBUSTION CONTROLS LAYOUT



SS BADGER  
PORT BOILER PANEL  
353 CONTROLLERS

DRAWING NAME: PORT 353S.DWG	DRAWING NUMBER:
BY: JCHLLC	DATE: 2/3/14
	SHEET ___ OF ___

CONTAINS CONFIDENTIAL BUSINESS INFORMATION



CONTAINS CONFIDENTIAL BUSINESS INFORMATION

REV.

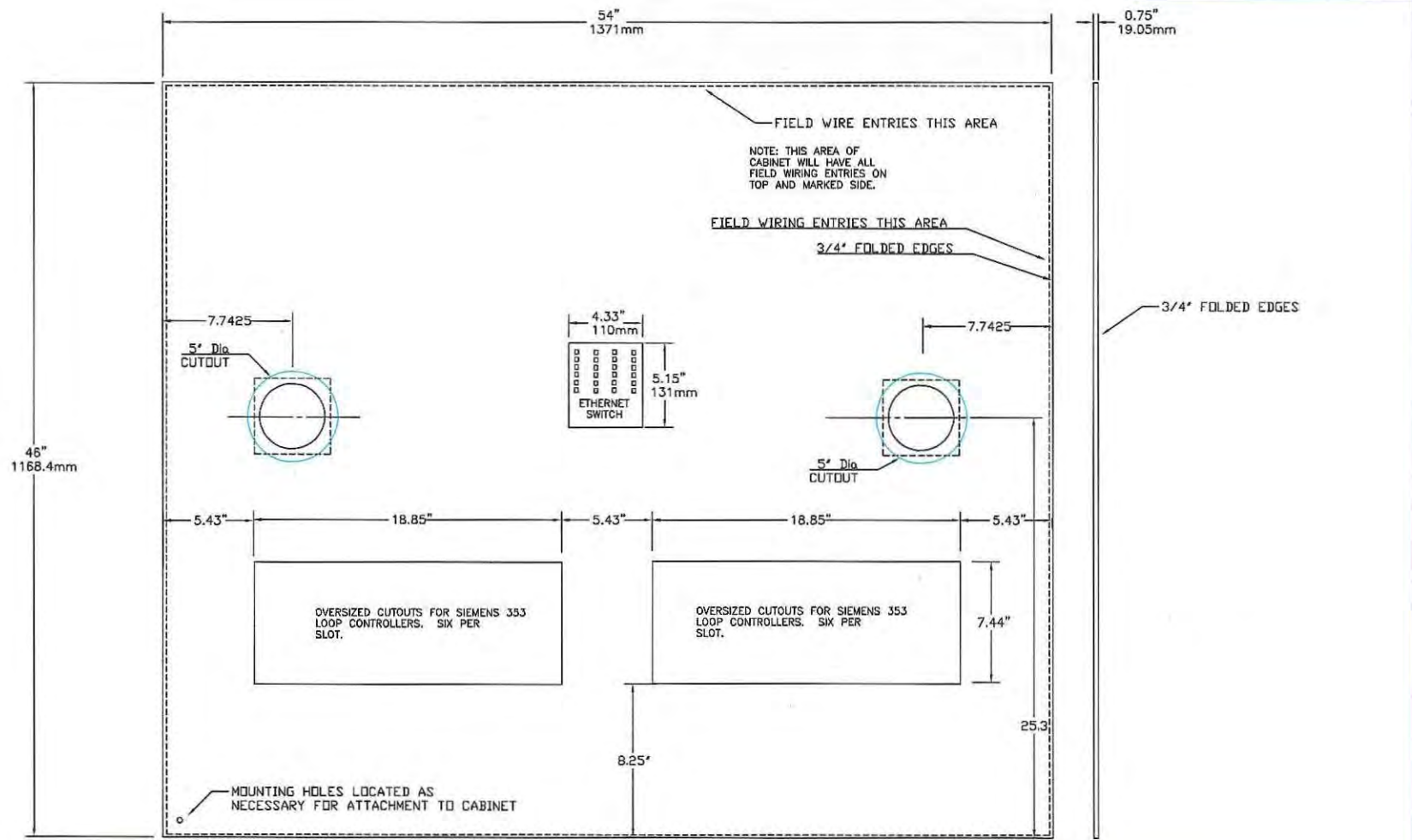

NOTE: PORT BOILER CABINET INTERNAL WIRING PANEL

SS BADGER  
STBD BOILER CONTROL CABINET

DRAWING NAME: S-BLR CAB IN.DWG	DRAWING NO:
DRAWN BY: [Signature]	DATE: 11/26/2013 SHEET ___ OF ___

CONTAINS CONFIDENTIAL BUSINESS INFORMATION

REV.

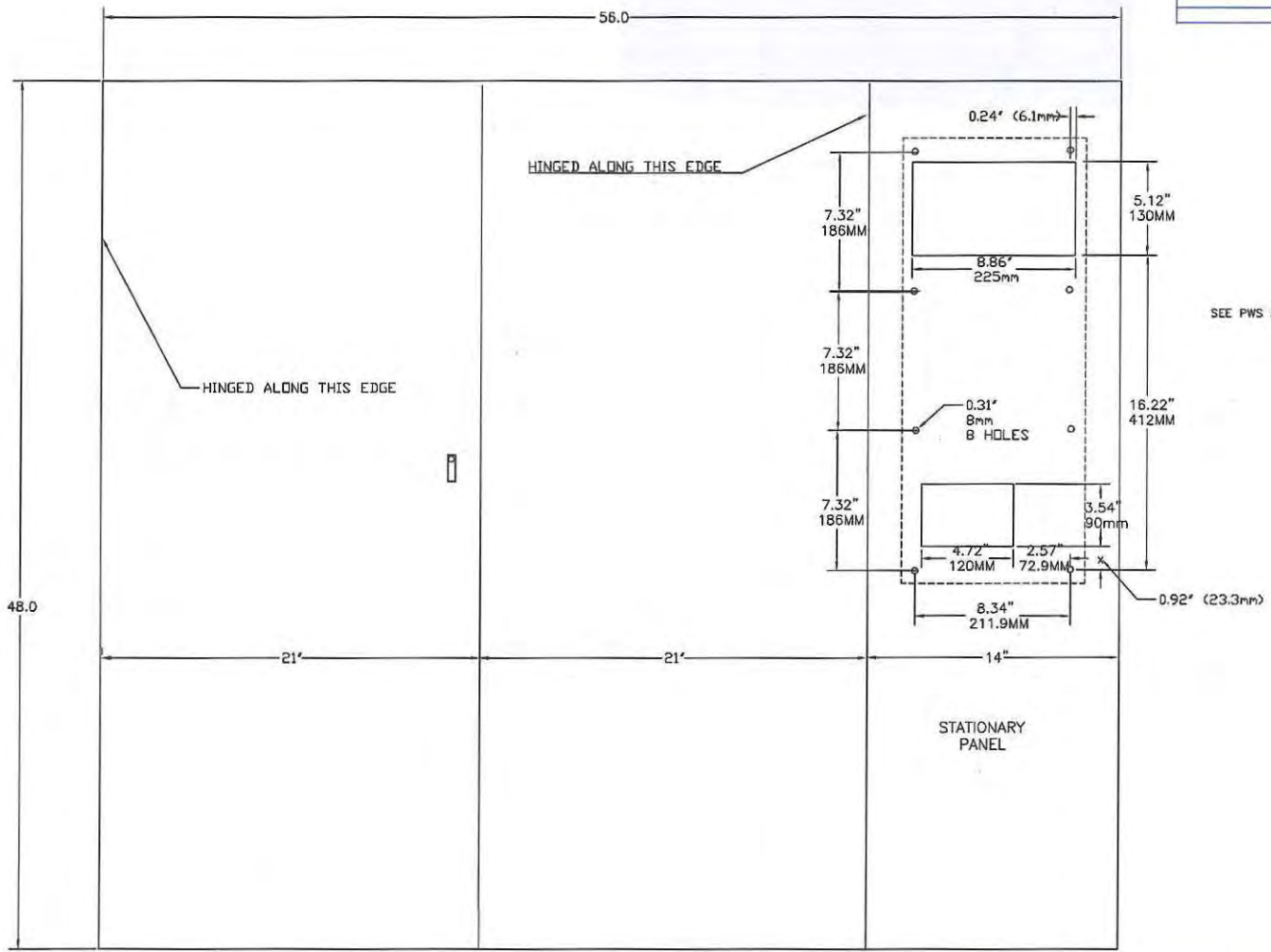

SEE PWS 3062/B2 DRILLING TEMPLATE



SS BADGER  
STBD BOILER CONTROL CABINET

DRAWING NAME: S-BLR CAB R.DWG	DRAWING NO:
DRAWN BY:	DATE: 12/2/2013
SHEET ___ OF ___	

CONTAINS CONFIDENTIAL BUSINESS INFORMATION

REV.

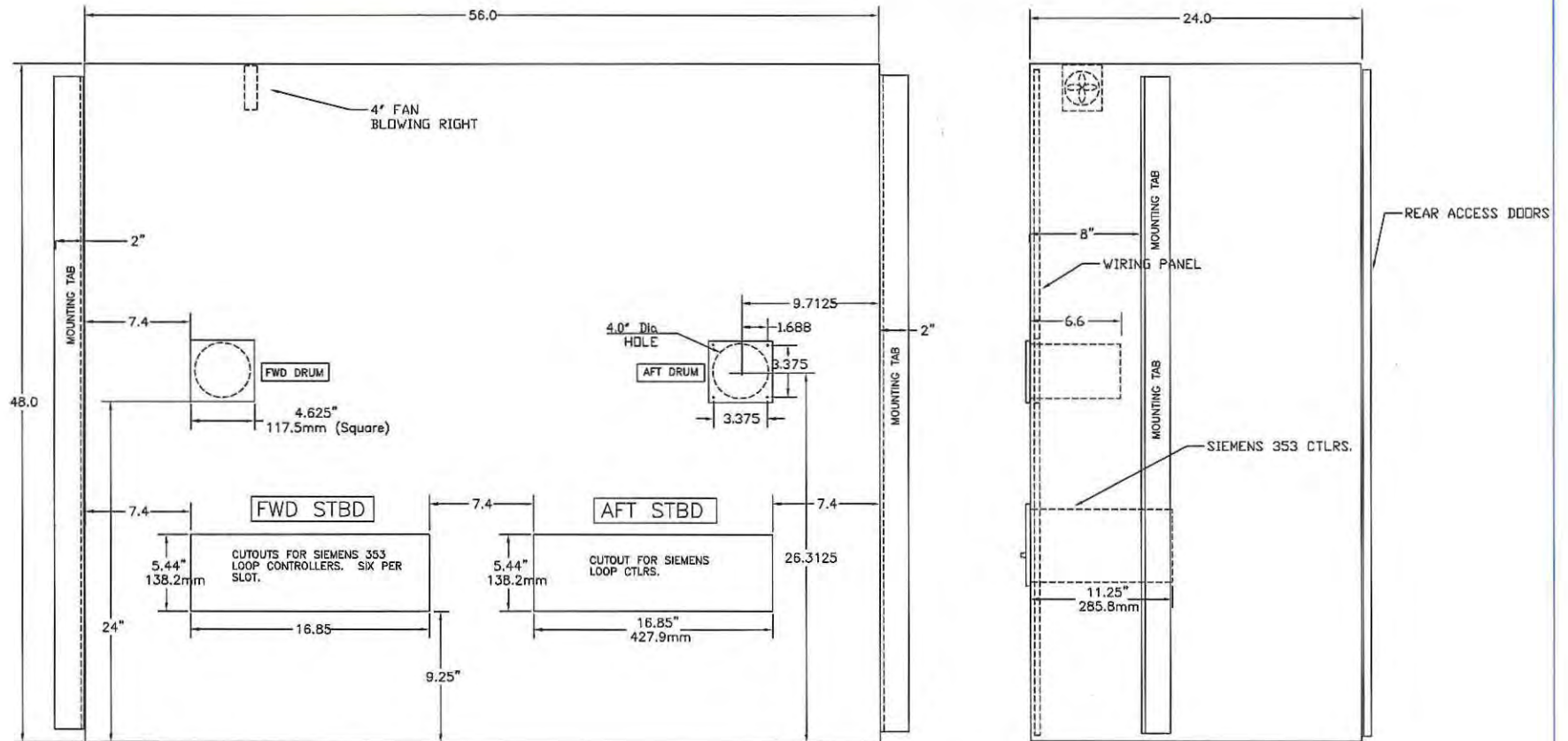

NOTE: MOUNTING TABS - BOTH SIDES MAY BE WELDED OR BOLTED TO EXISTING COLUMNS ON VESSEL

48.0  
ABOVE DECK (NOT TO SCALE)



SS BADGER  
STBD BOILER CONTROL CABINET

DRAWING NAME: S-BLR CAB.DWG	DRAWING NO:
DRAWN BY: [Signature]	DATE: 12/2/2013
SHEET ___ OF ___	



# FWD STBD

# AFT STBD

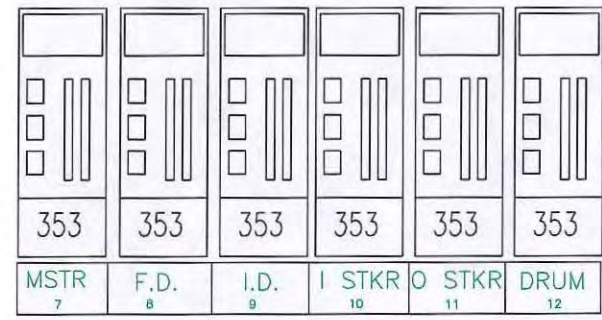
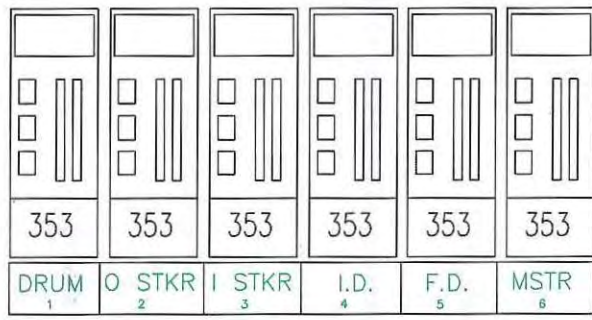

STBD CABINET COMBUSTION CONTROLS LAYOUT

- LEGEND**
1. FWD STBD DRUM LEVEL
  2. FWD STBD OTBD FEEDER
  3. FWD STBD INBD FEEDER
  4. FWD STBD I.D. FAN
  5. FWD STBD F.D. FAN & OFA
  6. FWD STBD SUB MASTER
  7. AFT STBD SUB-MASTER AND PLANT MASTER
  8. AFT STBD F.D. FAN & OFA
  9. AFT STBD I.D. FAN
  10. AFT STBD INBD FEEDER
  11. AFT STBD OTBD FEEDER
  12. AFT STBD DRUM LEVEL

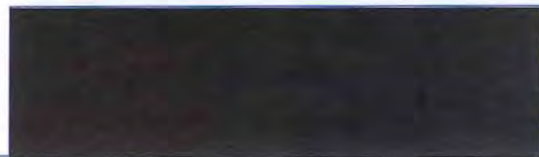

SS BADGER  
STBD BOILER PANEL  
353 CONTROLLERS

DRAWING NAME: STBD 353S.DWG	DRAWING NUMBER:
BY: JCHLLC	DATE: 1/13/14 SHEET ___ OF ___

CONTAINS CONFIDENTIAL BUSINESS INFORMATION

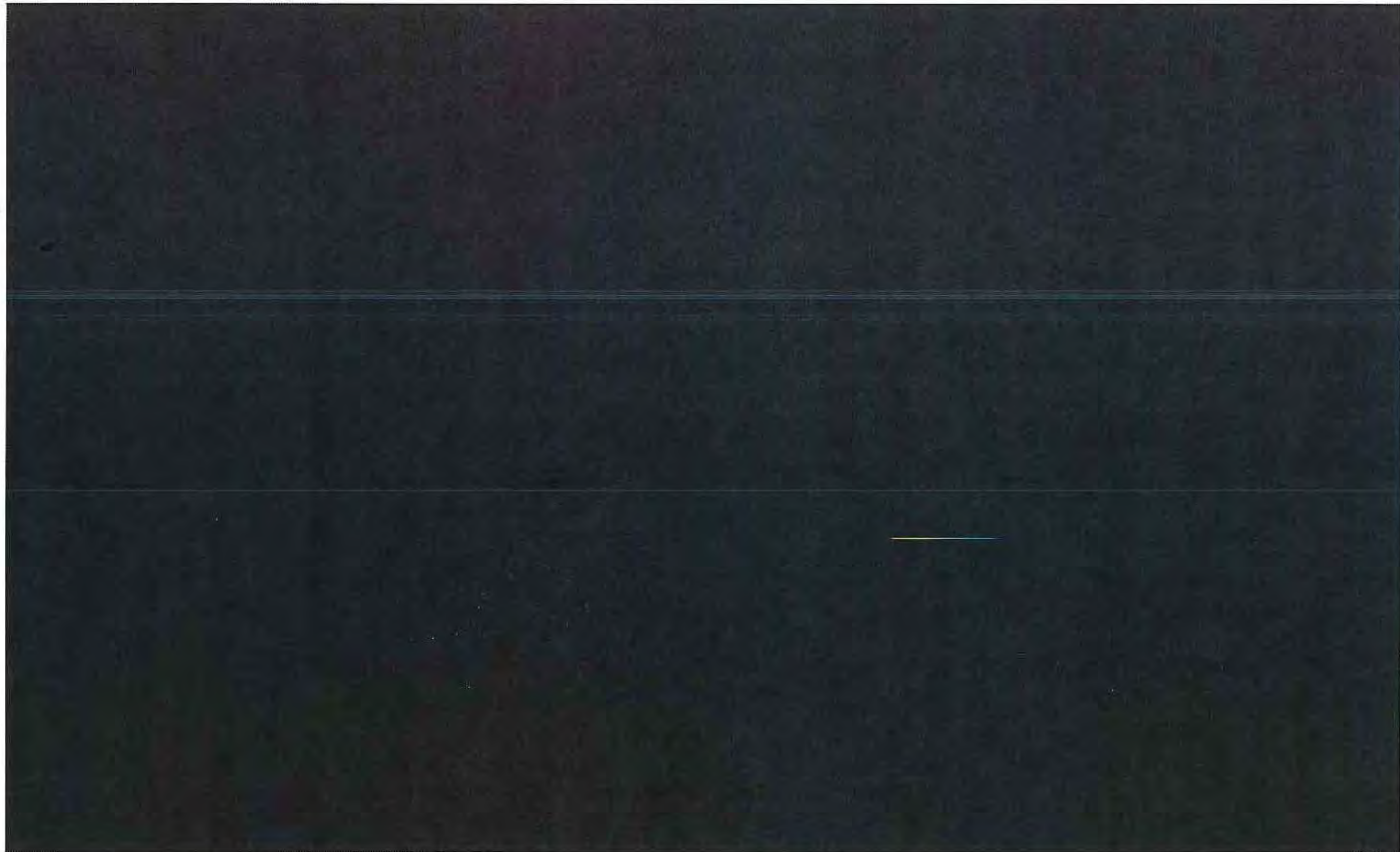

---

**From:** [REDACTED]  
**Sent:** Friday, March 07, 2014 1:15 PM  
**To:** 'Marine Shop'  
**Cc:** Chuck Leonard  
**Subject:** FW: SS Badger Boiler Combustion Control Submittals 2 of 2

Chuck  
You may want to ask Mr. Leonard to copy all of the attachments on a CD or Memory Stick for a print shop to make prints.

[REDACTED]

---

**From:** [REDACTED]  
**Sent:** Friday, March 07, 2014 12:12 PM  
**To:** [HRobles@eagle.org](mailto:HRobles@eagle.org); [MAhmed@eagle.org](mailto:MAhmed@eagle.org)  
**Subject:** FW: SS Badger Boiler Combustion Control Submittals 2 of 2

Dear Henry and Mohammad,

This is my second email with submittals attached.

Please find the above SS Badger Boiler Combustion Control project submittals attachments for your review. Our cover letter is attached giving an overview of the project and a list of Enclosures for your review. The installation of the new systems is now being performed aboard the SS Badger in Ludington, Michigan during the vessels winter lay-up. The project is to be completed in April to begin testing, dock trials and sea trials to be ready for the first voyage on May 16<sup>th</sup>. In other words we need to have this review treated as urgent. We had the Hindle Power Inc. 24 VDC power supply system that we are using for redundant power to our systems reviewed and factory tested and approved by ABS in January. ABS Project No. 3176956 , Task No. 1134456. Chuck Cart the SS Badger's Senior Chief Engineer has had the local USCG and ABS office involved in the project. We will send you a formal purchase order today. The PO number will be BAD030714. Please feel free to give me a call or email me with any questions.

Respectfully

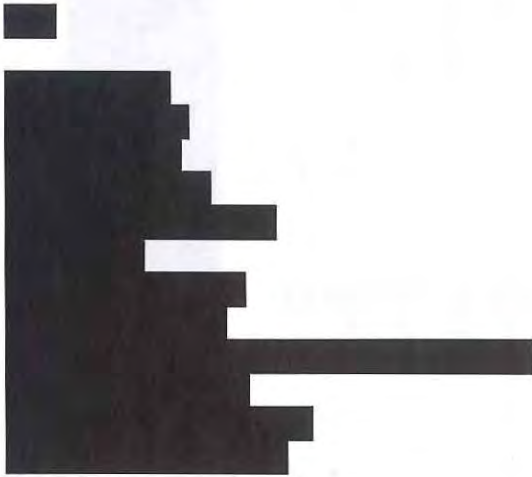
A large black rectangular redaction covers the signature and name of the sender. The redaction is composed of several overlapping black boxes of varying sizes, completely obscuring any text that might have been present.



REV.

	[+]	—	FROM PORT1 TS - (FUSE F19)
CH0	[2]	—	FDFPVFDON FWD PORT F.D. MOTOR RUNNING
CH1	[3]	—	FDAPVFDON AFT PORT F.D. MOTOR RUNNING
CH2	[4]	—	OFAPVFDON FWD PORT OFA MOTOR RUNNING
CH3	[5]	—	OFAPVFDON AFT PORT OFA MOTOR RUNNING
CH4	[6]	—	IFFPVFDON FWD PORT INBD FEEDER RUNNING
CH5	[7]	—	OFFPVFDON FWD PORT OTBD FEEDER RUNNING
CH6	[8]	—	IFAPVFDON AFT PORT INBD FEEDER RUNNING
CH7	[9]	—	OFAPVFDON AFT PORT OTBD FEEDER RUNNING
CH8	[12]	—	IRFPVFDON FWD PORT INBD ROTOR RUNNING
CH9	[13]	—	ORFPVFDON FWD PORT OTBD ROTOR RUNNING
CH10	[14]	—	IRAPVFDON AFT PORT INBD ROTOR RUNNING
CH11	[15]	—	ORAPVFDON AFT PORT OTBD ROTOR RUNNING
CH12	[16]	—	ADAPVFDON AFT PORT AIR DISTRIB RUNNING
CH13	[17]	—	ADFPVFDON FWD PORT AIR DISTRIB RUNNING
CH14	[18]	—	FDFPVDFLT FWD PORT F.D. FAULT
CH15	[19]	—	FDAPVDFLT AFT PORT F.D. FAULT
	[20]	—	24VDC-

	[+]	—	FROM PORT1 TS - (FUSE F20)
CH16	[22]	—	OFAPVDFLT FWD PORT OFA FAULT
CH17	[23]	—	OFAAPVDFLT AFT PORT OFA FAULT
CH18	[24]	—	IFFPVDFLT FWD PORT INBD FEEDER FAULT
CH19	[25]	—	OFFPVDFLT FWD PORT OTBD FEEDER FAULT
CH20	[26]	—	IFAPVDFLT AFT PORT INBD FEEDER FAULT
CH21	[27]	—	OFAPVDFLT AFT PORT OTBD FEEDER FAULT
CH22	[28]	—	IRFPVDFLT FWD PORT INBD ROTOR FAULT
CH23	[29]	—	ORFPVDFLT FWD PORT OTBD ROTOR FAULT
CH24	[32]	—	IRAPVDFLT AFT PORT INBD ROTOR FAULT
CH25	[33]	—	ORAPVDFLT AFT PORT OTBD ROTOR FAULT
CH26	[34]	—	ADAPVDFLT AFT PORT AIR DISTRIB FAULT
CH27	[35]	—	ADFPVDFLT FWD PORT AIR DISTRIB FAULT
CH28	[36]	—	PORTALMS PORT ALARMS
CH29	[37]	—	PPLACE2 PORT PLACEHOLDER 2
CH30	[38]	—	PPLACE3 PORT PLACEHOLDER 3
CH31	[39]	—	PPLACE4 PORT PLACEHOLDER 4
	[40]	—	24VDC-

BADGER PLC MODULE  
 PORT DISCRETE INPUT SLOT 5  
 PROJECT NO. 8819-580

DRAWING NAME: PLCSLOTS.DWG	DRAWING NO:
BY: JCHLLC	DATE: 1/31/14
SHEET ___ OF ___	

REV.

### PLC DISCRETE INPUT FIELD DEVICE DC+ TERMINALS

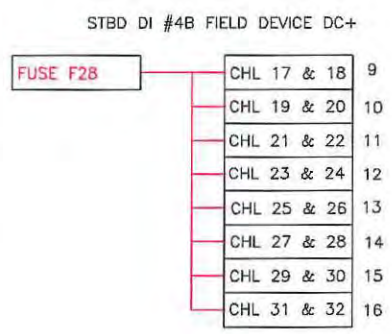
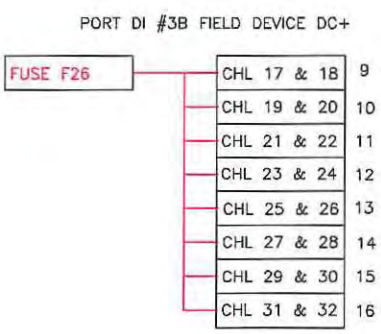
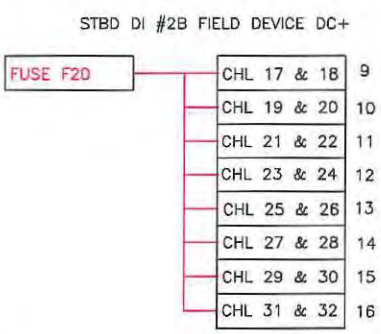
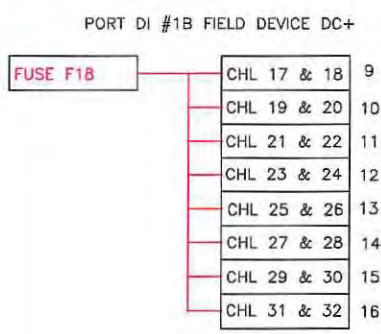
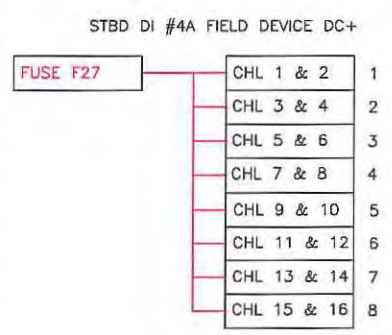
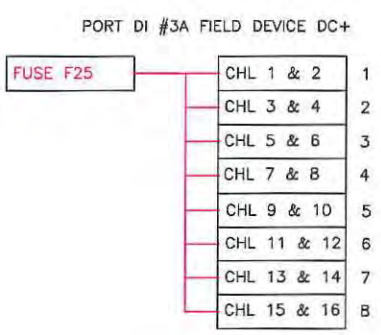
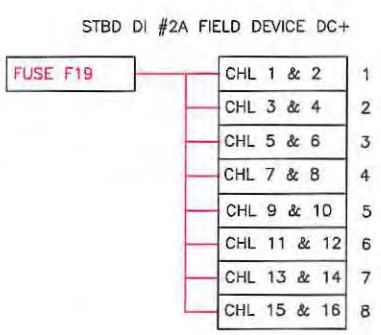
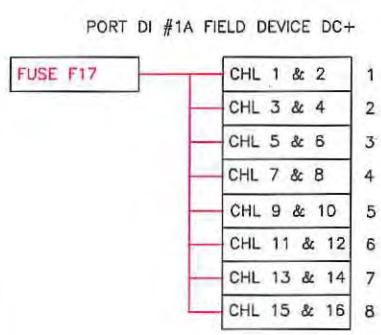

TERMINAL STRIPS TO BE LOCATED ADJACENT TO PLC I/O



BADGER BOILER PANEL WIRING  
PORT PANEL D.I. POWER TERMINALS

DRAWING NAME: PORTDIPWR.DWG	DRAWING NUMBER:
BY: JCHLLC	DATE: 1/31/14
SHEET ___ OF ___	

CONTAINS CONFIDENTIAL BUSINESS INFORMATION

REV.

PORT BOILER CABINET – MAIN PLC LAYOUT

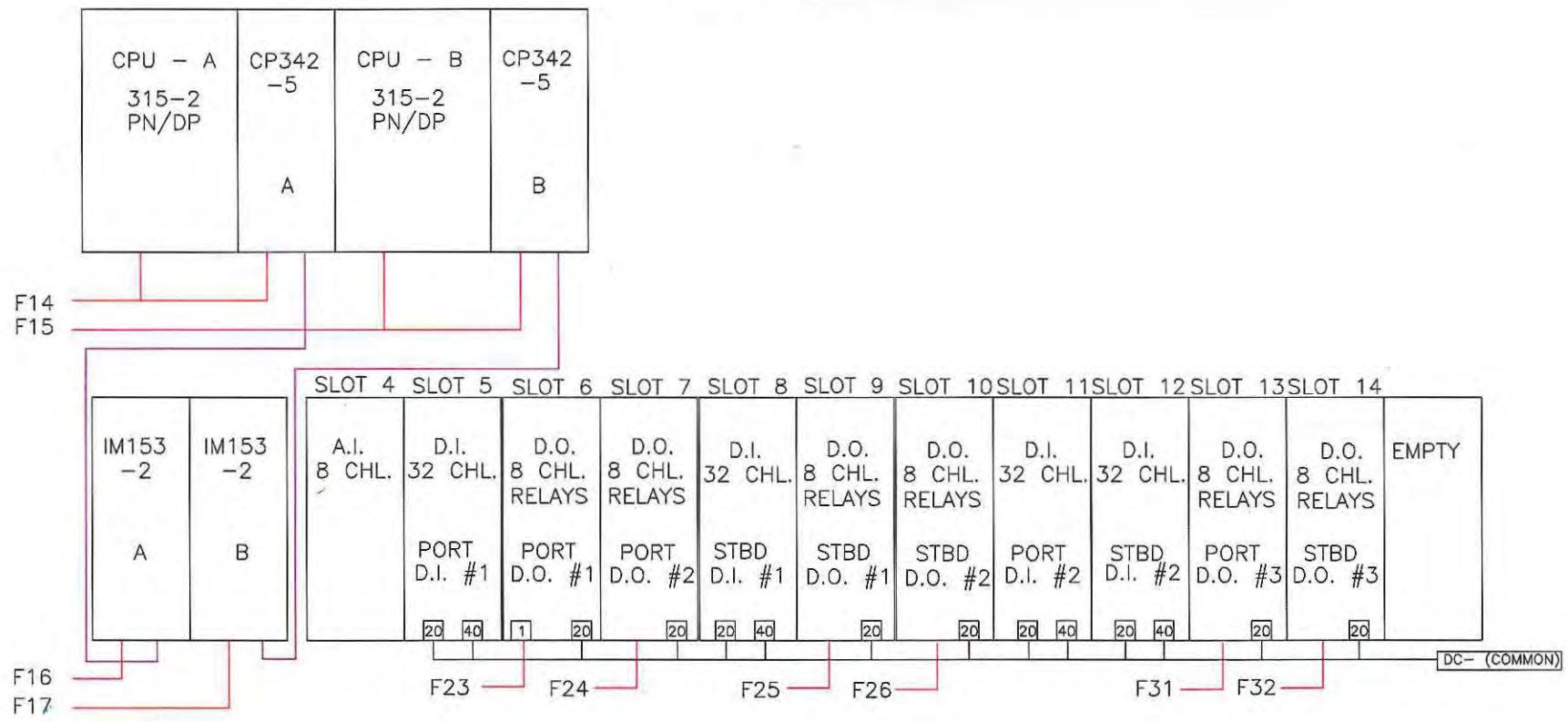

NOTE: DC+ SUPPLY FOR DISCRETE FIELD INPUTS SHOWN ON PLC D.I. POWER TERMINALS DRAWING.

BADGER PLC OVERVIEW	
DRAWING NAME: PLC LAYOUT.DWG	DRAWING NUMBER:
BY: JCHLLC	DATE: 2/5/14
SHEET ___ OF ___	

CONTAINS CONFIDENTIAL BUSINESS INFORMATION



REV.

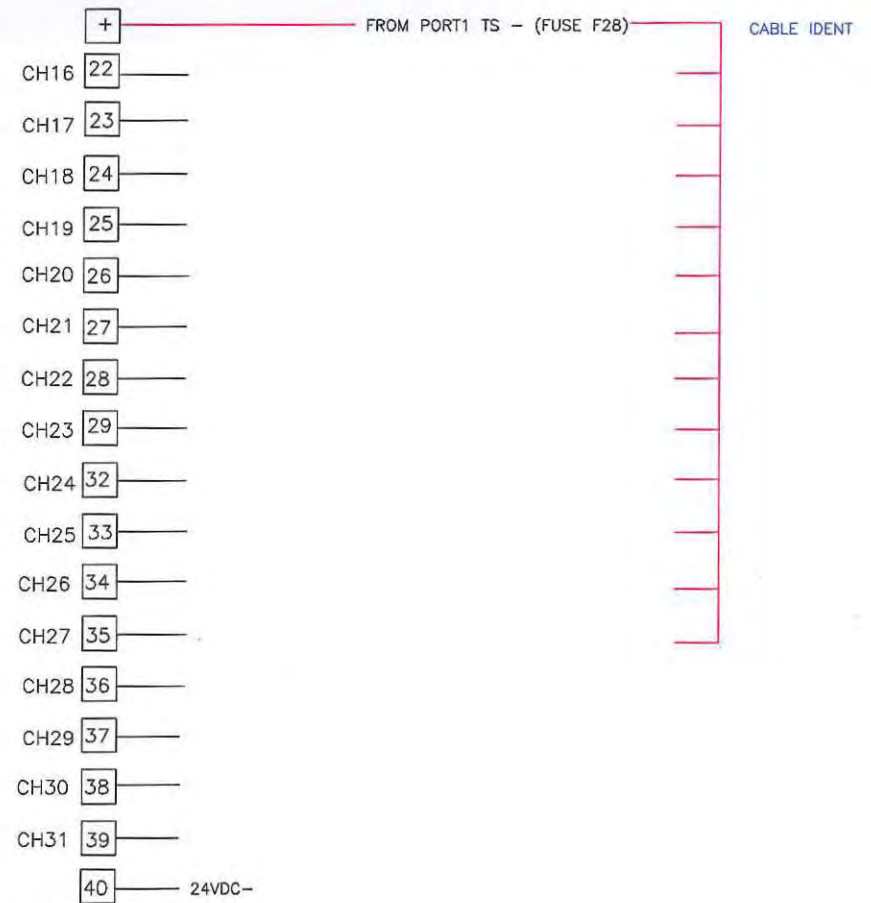
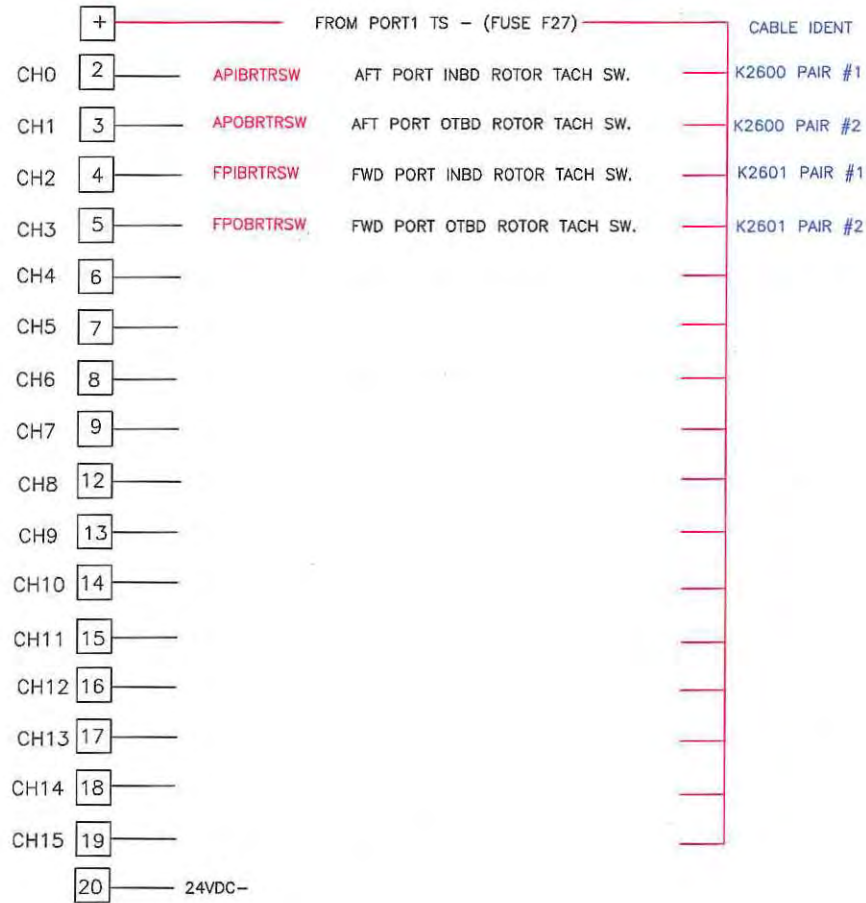

BADGER PLC MODULE  
PORT DISCRETE INPUT SLOT 11

DRAWING NAME: PLCSLOT11.DWG	DRAWING NO.:
BY: JCHLLC	DATE: 2/9/14
	SHEET ___ OF ___

REV.

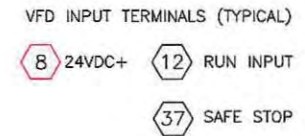

BADGER PLC MODULE  
PORT RELAY OUTPUT MODULE #1

DRAWING NAME: PLCSLOT7.DWG	DRAWING NO.:
BY: JCHLLC	DATE: 2/7/14
SHEET ___ OF ___	

REV.

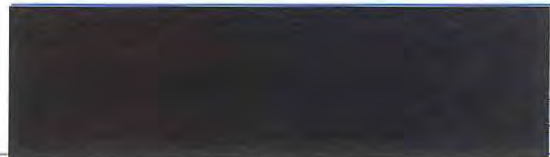
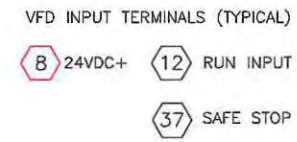
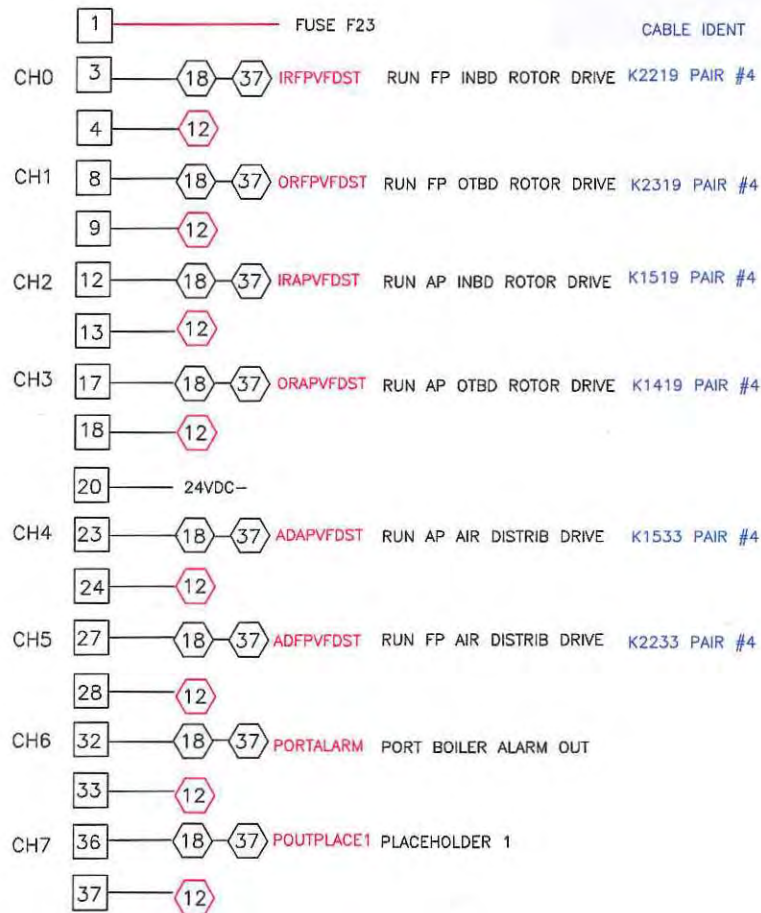

BADGER PLC MODULE  
 PORT RELAY OUTPUT MODULE #2

DRAWING NAME: PLCSLOTS.DWG	DRAWING NO:
BY: JCHLLC	DATE: 2/7/14
SHEET ___ OF ___	



REV.

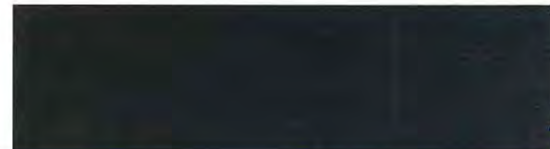
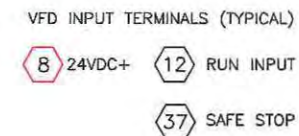

BADGER PLC MODULE  
 STBD RELAY OUTPUT MODULE #2

DRAWING NAME: PLCSLOT10.DWG	DRAWING NO.
BY: JCHILLIC (signature)	DATE: 2/11/14
SHEET ___ OF ___	

CONTAINS CONFIDENTIAL BUSINESS INFORMATION

REV.

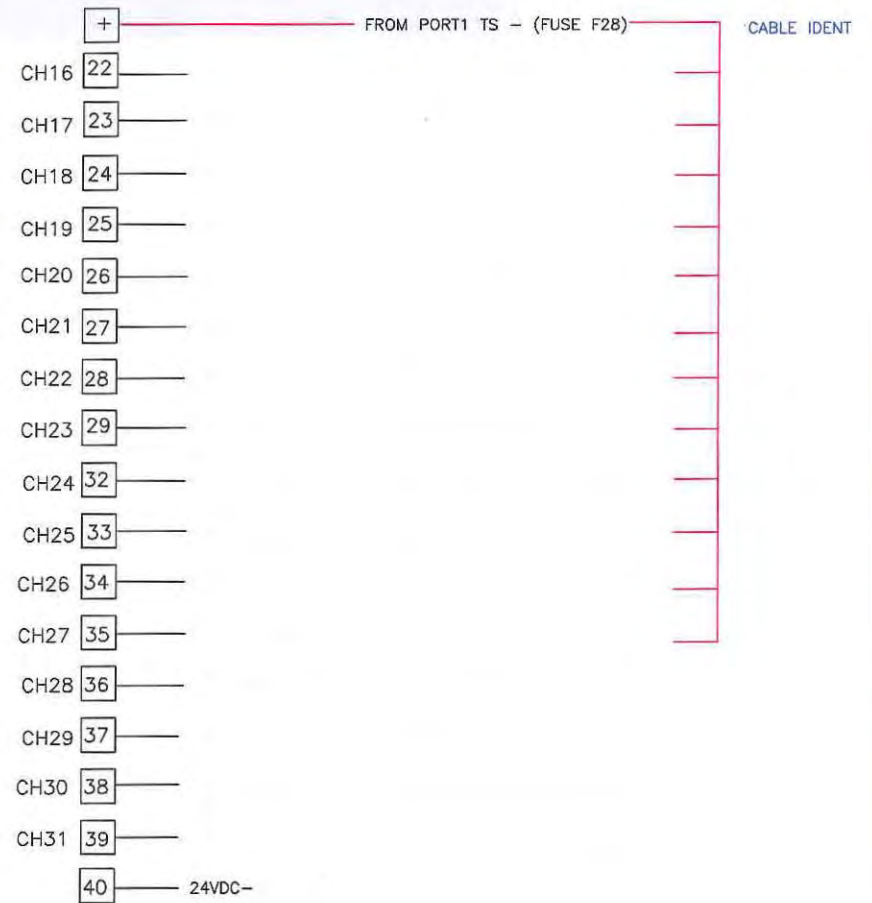

BADGER PLC MODULE STBD DISCRETE INPUT SLOT 12		
DRAWING NAME: PLCSLOT12.DWG	DRAWING NO.	
BY: JCHLLC	DATE: 2/9/14	SHEET ___ OF ___

REV.

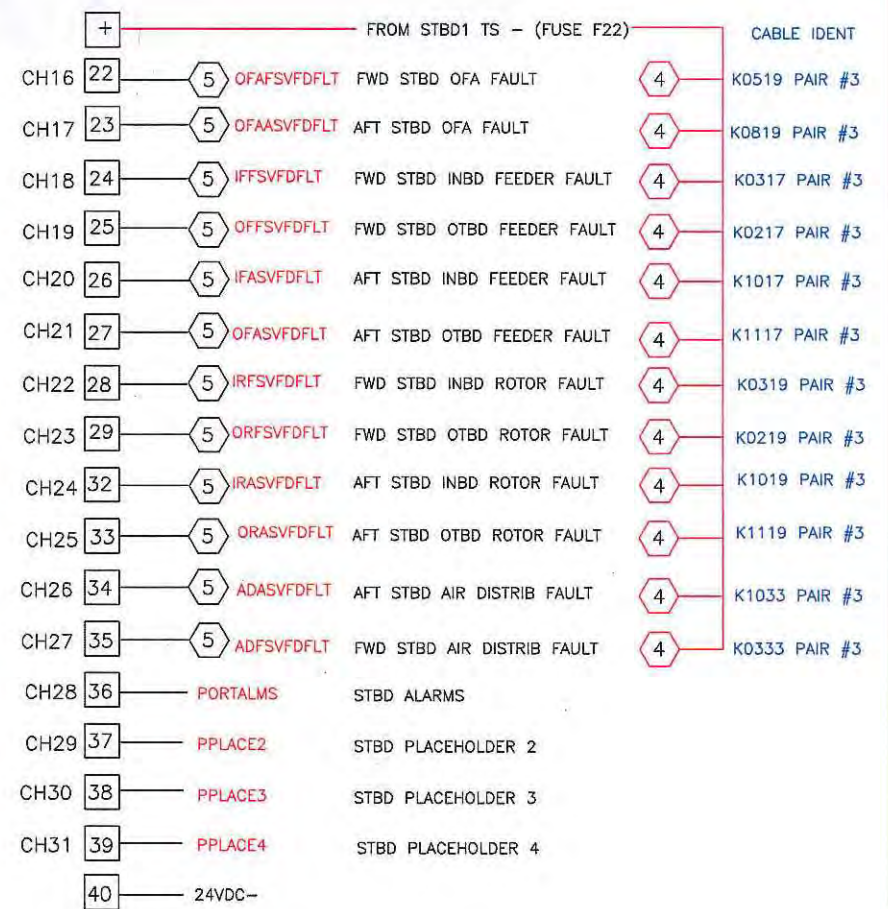
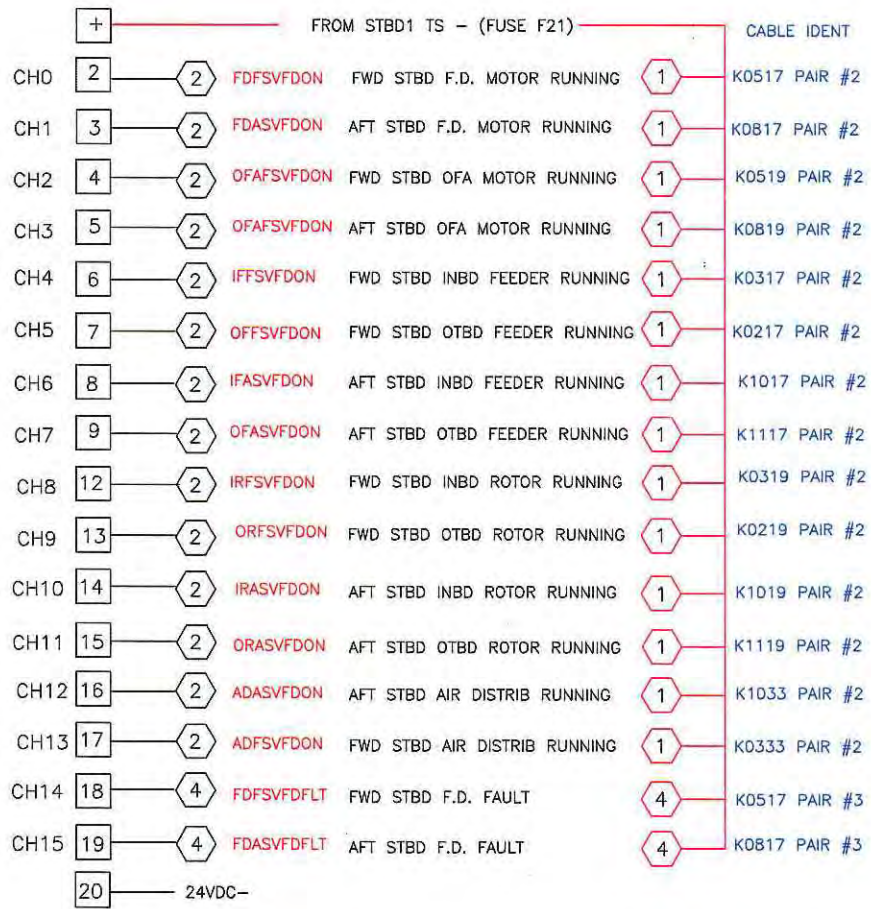

VFDS' RELAY OUTPUTS (TYPICAL)

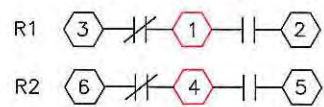

<b>BADGER PLC MODULE</b>	
STBD DISCRETE INPUT SLOT 6	
DRAWING NAME: <b>PLCSLOTS.DWG</b>	DRAWING NO:
BY: JCHLLC	DATE: 2/4/14
SHEET 1 OF 1	



REV.

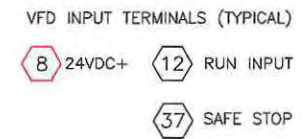

BADGER PLC MODULE STBD RELAY OUTPUT MODULE #1	
DRAWING NAME: <b>PLCSLOT9.DWG</b>	DRAWING NO.
BY: JCHLLC	DATE: 2/11/14
SHEET ___ OF ___	

VFD TAGNAMES

TAGNAME	DESCRIPTOR
PPDFAN	FWD PORT F.D. FAN
APDFAN	AFT PORT F.D. FAN
FPOFA	FWD PORT OVERFIRE AIR
APOFA	AFT PORT OVERFIRE AIR
FPIBFEDR	FWD PORT INBD FEEDER
FPOBFEDR	FWD PORT OTBD FEEDER
APIBFEDR	AFT PORT INBD FEEDER
APOBFEDR	AFT PORT OTBD FEEDER
FPIBROTR	FWD PORT INBD ROTOR
FPOBROTR	FWD PORT OTBD ROTOR
APIBROTR	AFT PORT INBD ROTOR
APOBROTR	AFT PORT OTBD ROTOR
APAIRDIST	AFT PORT AIR DISTRIB
FPAIRDIST	FWD PORT AIR DISTRIB
FSDFAN	FWD STBD F.D. FAN
ASDFAN	AFT STBD F.D. FAN
FSOFA	FWD STBD OVERFIRE AIR
ASOFA	AFT STBD OVERFIRE AIR
FSIBFEDR	FWD STBD INBD FEEDER
FSOBFEDR	FWD STBD OTBD FEEDER
ASIBFEDR	AFT STBD INBD FEEDER
ASOBFEDR	AFT STBD OTBD FEEDER
FSIBROTR	FWD STBD INBD ROTOR
FSOBROTR	FWD STBD OTBD ROTOR
ASIBROTR	AFT STBD INBD ROTOR
ASOBROTR	AFT STBD OTBD ROTOR
ASAIRDIST	AFT STBD AIR DISTRIB
FSAIRDIST	FWD STBD AIR DISTRIB

CONTAINS CONFIDENTIAL BUSINESS INFORMATION

REV.
1. 1/21/14 - CHG'D TO US DIMENSIONS

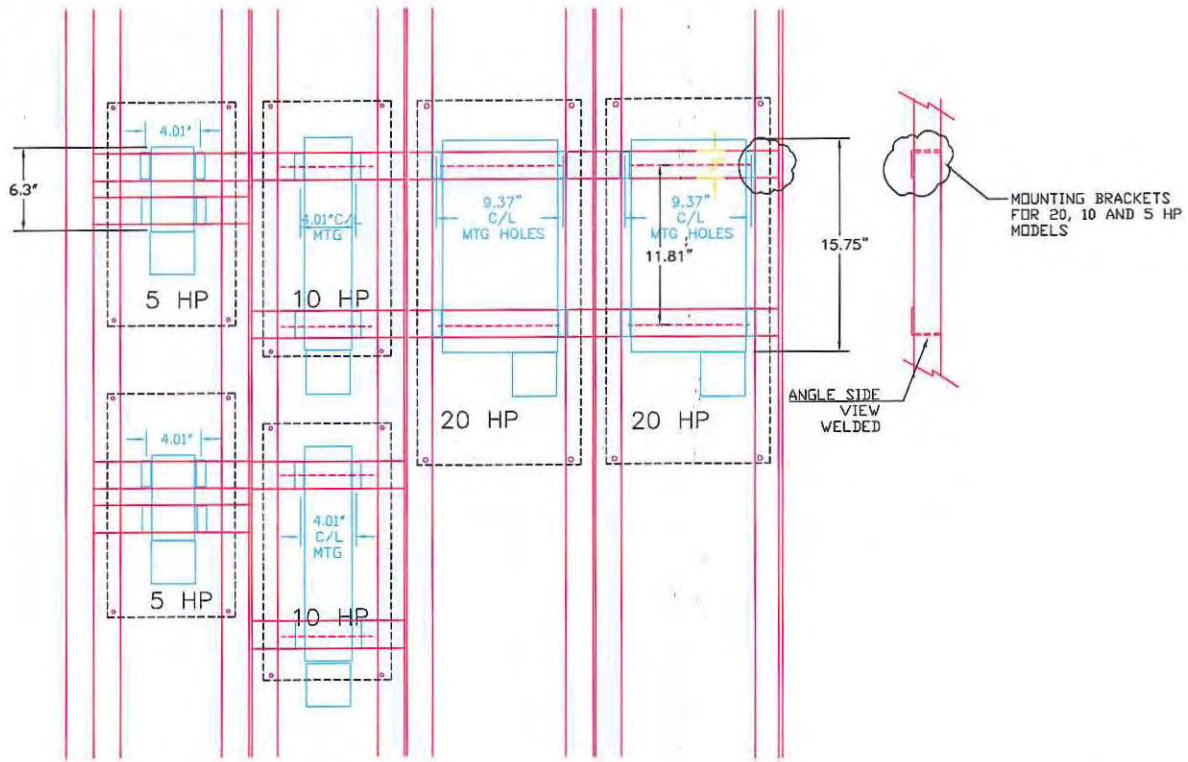

VIEW FROM REAR OF VFD MOUNTING RACK

SS BADGER  
PORT VFD BRAKE RESISTOR MOUNTING

DRAWING NAME: PORTVFD BRAKE.DWG	DRAWING NO:
DRAWN BY: [Signature]	DATE: 1/7/2014
SHEET ___ OF ___	



REV.
1. 1/21/14 - CHG'D TO US DIMENSIONS

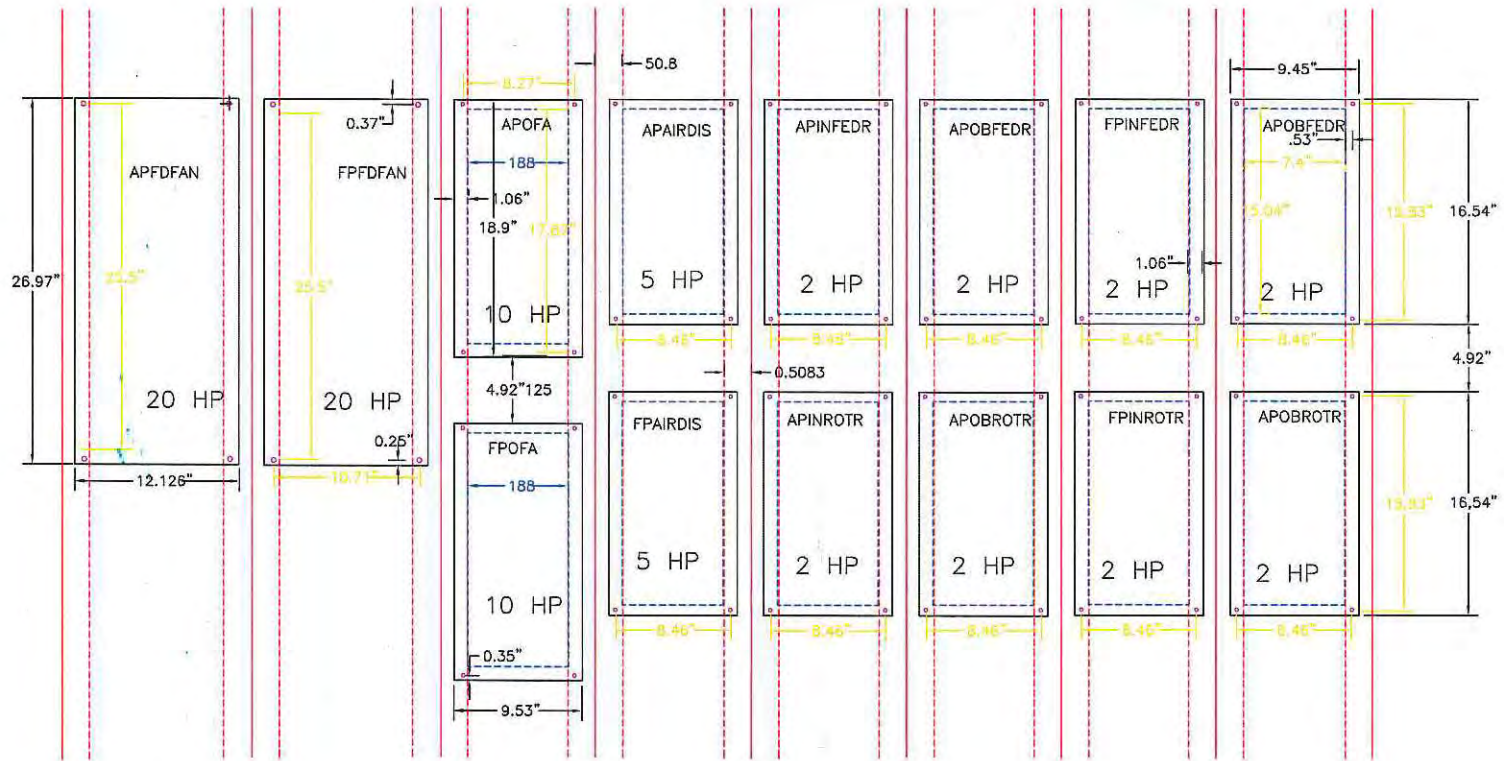

- NOTES:
1. ALL DIMENSIONS IN INCHES
  2. 2 HP AND 5 HP UNITS ARE THE SAME SIZE
  3. PLEASE IDENTIFY BACKING PLATES IN SHIPMENT OF DRIVES – USE PLATES AS TEMPLATES TO CONFIRM/ ASSIST WITH FRAME ASSY AND MOUNTING HOLE LOCATIONS.

SS BADGER  
PORT VFD RACK LAYOUT

DRAWING NAME: PORTVFDPNL.DWG	DRAWING NO:
DRAWN BY: [Signature]	DATE: 1/7/2014
SHEET ___ OF ___	

CONTAINS CONFIDENTIAL BUSINESS INFORMATION

REV.
1. 1/21/14 - CHG'D TO US DIMENSIONS

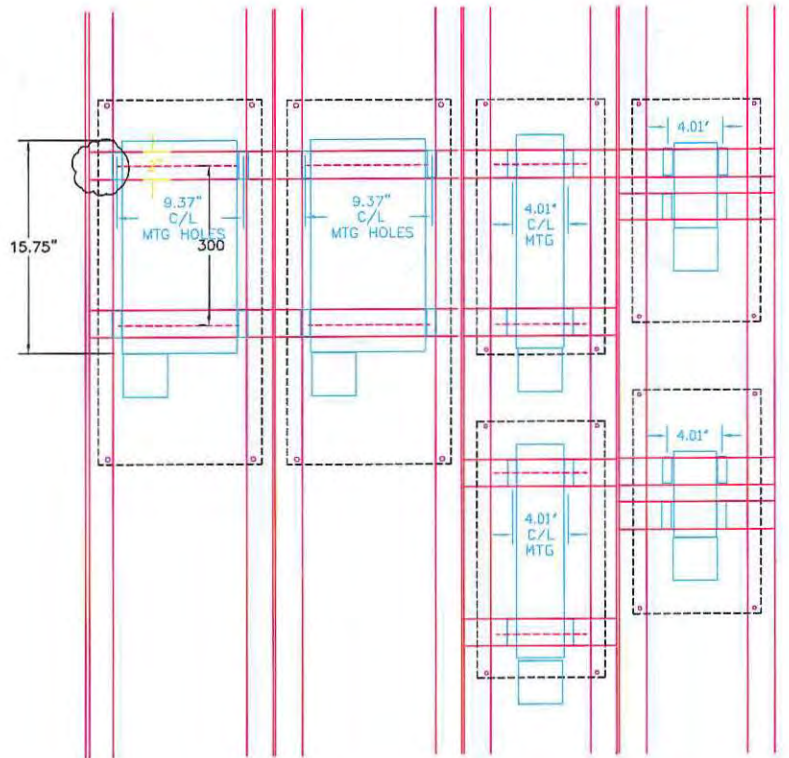
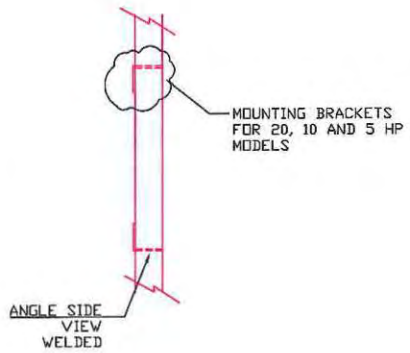

VIEW FROM REAR OF VFD MOUNTING RACK

SS BADGER  
STBD VFD BRAKE RESISTOR MOUNTING

DRAWING NAME: STBDVFD BRAKE.DWG	DRAWING NO:
DRAWN BY: 	DATE: 1/7/2014
SHEET ___ OF ___	





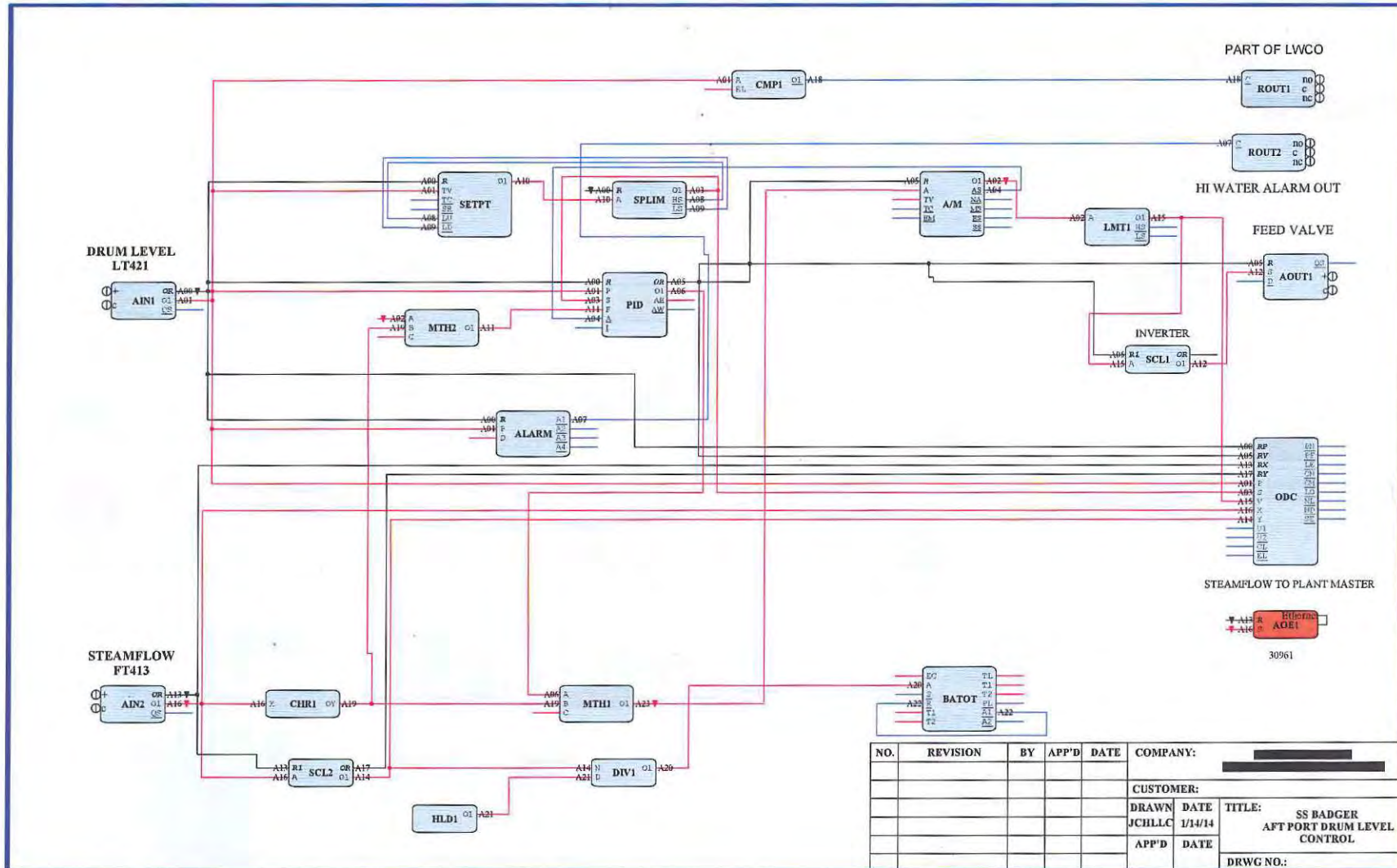

NO.	REVISION	BY	APP'D	DATE	COMPANY:	CUSTOMER:	
						DRAWN	DATE
						JCHLLC	1/14/14
						APP'D	DATE
						TITLE: SS BADGER AFT PORT DRUM LEVEL CONTROL	
						DRWG NO.:	

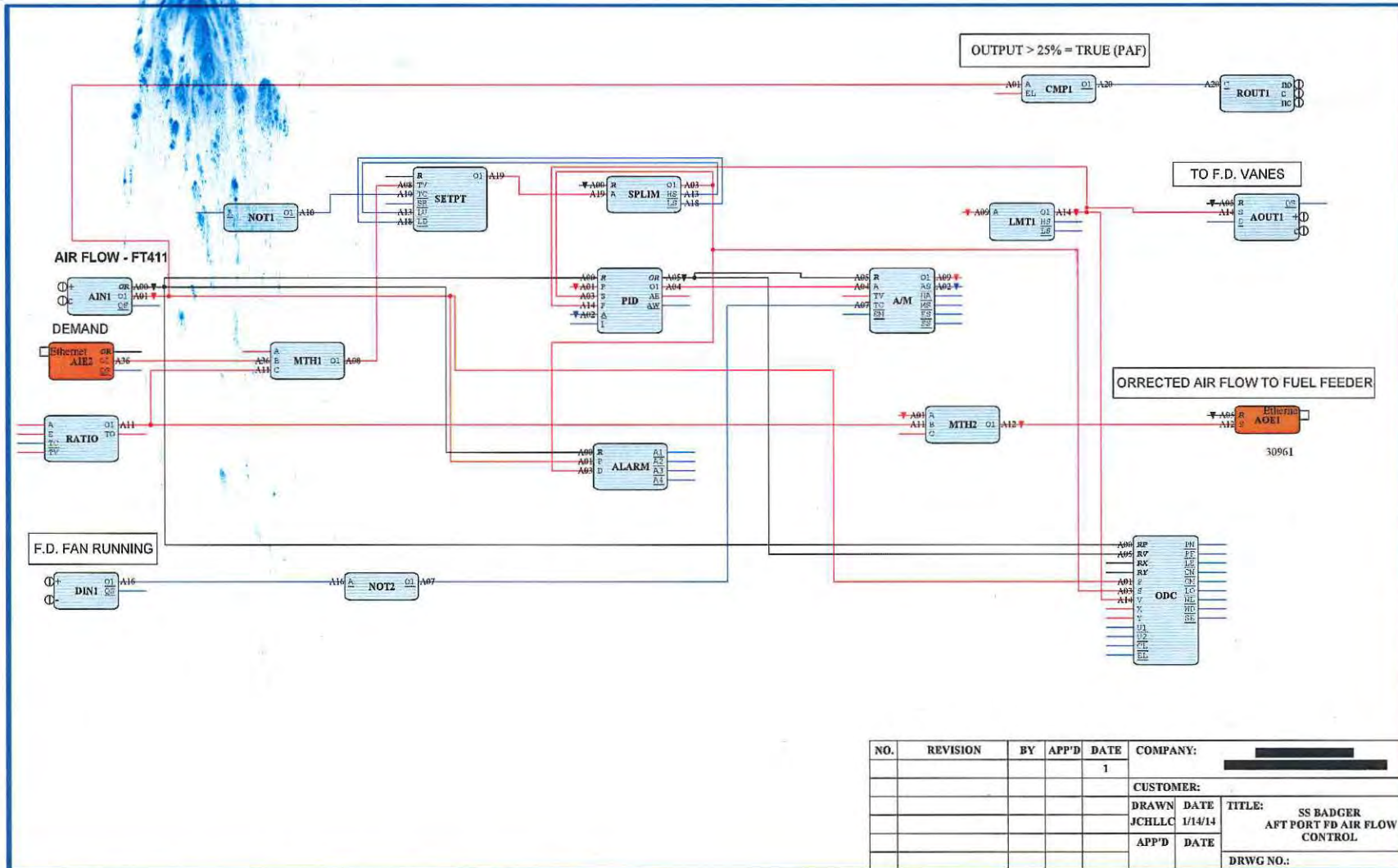

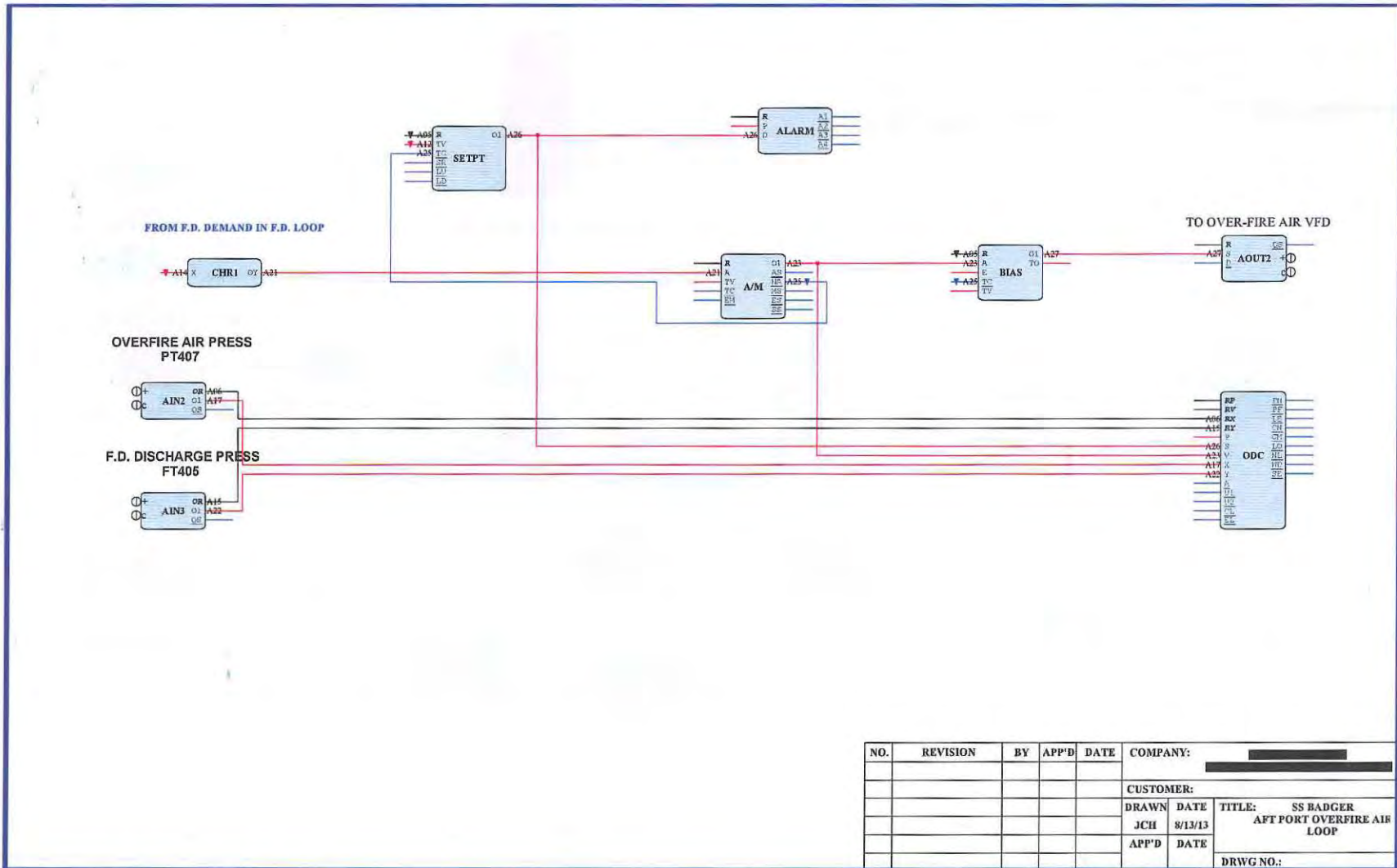

NO.	REVISION	BY	APP'D	DATE	COMPANY:			
						CUSTOMER:		
					DRAWN	DATE	TITLE: SS BADGER	
					JCH	8/13/13	AFT PORT OVERFIRE AIR LOOP	
					APP'D	DATE	DRWG NO.:	



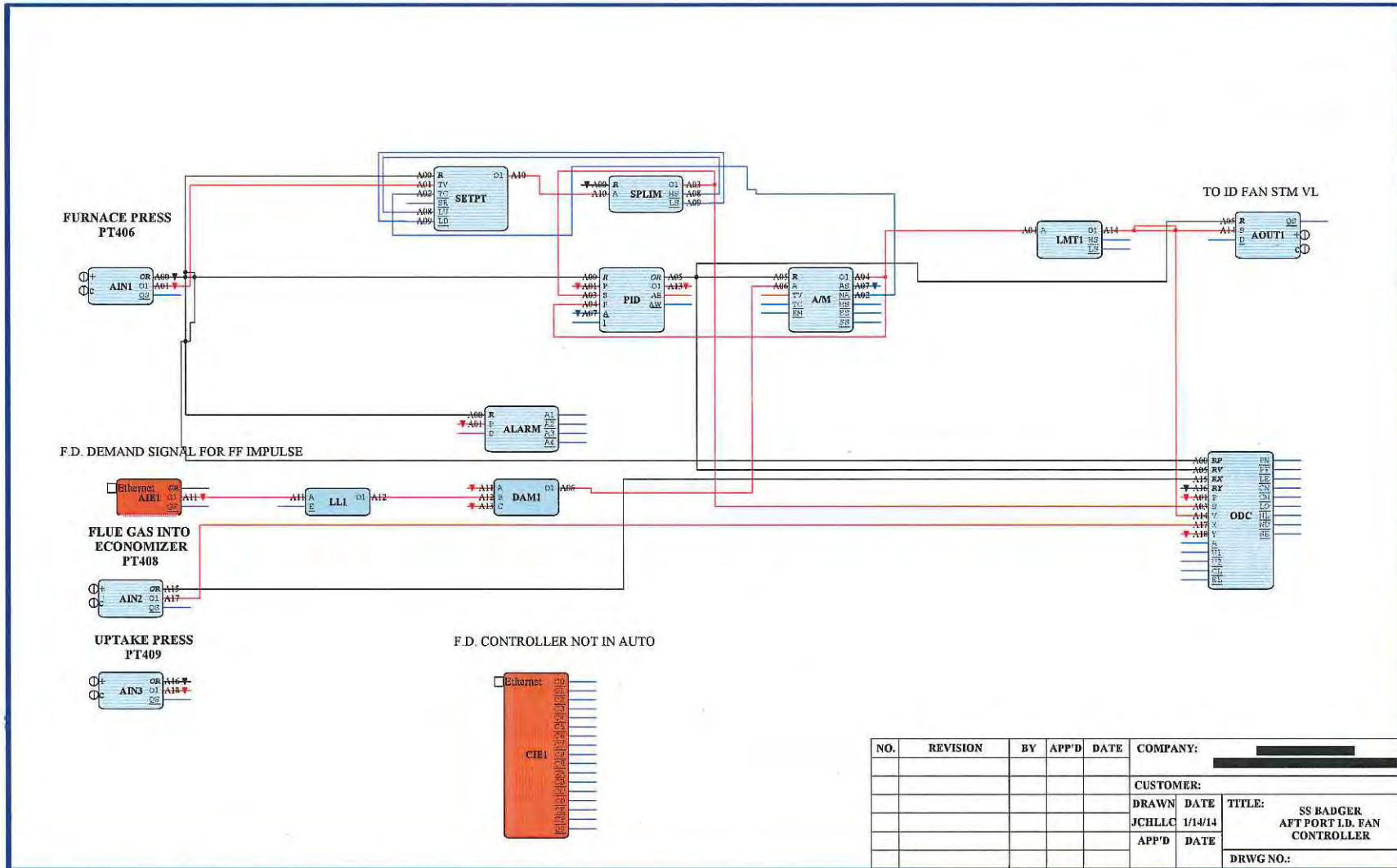

NO.	REVISION	BY	APP'D	DATE	COMPANY:		
					CUSTOMER:		
					DRAWN	DATE	TITLE:
					JCHLLC	1/14/14	SS BADGER AFT PORT I.D. FAN CONTROLLER
					APP'D	DATE	DRWG NO.:

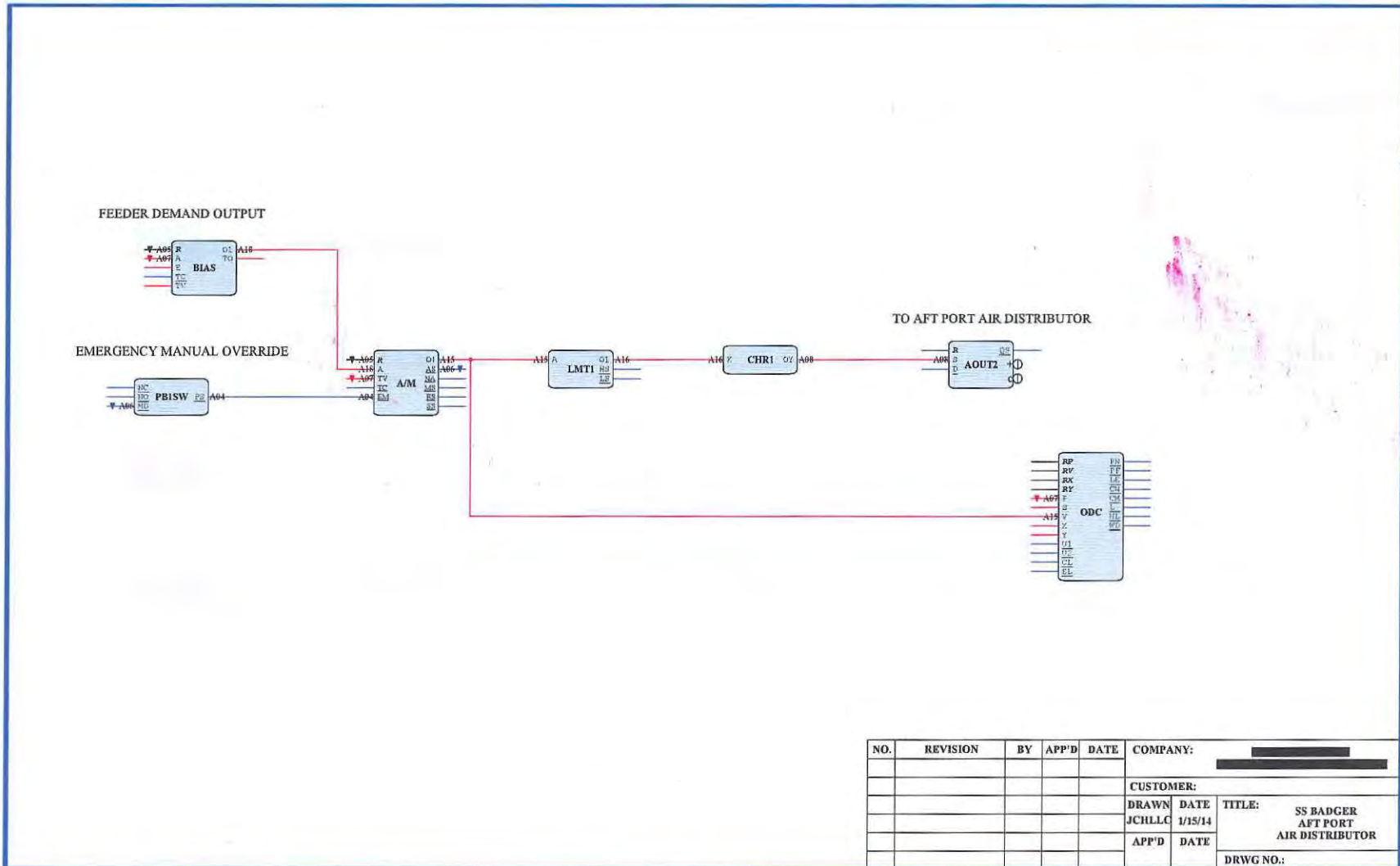

NO.	REVISION	BY	APP'D	DATE	COMPANY:	CUSTOMER:	
					DRAWN	DATE	TITLE:
					JCHLLC	1/15/14	SS BADGER AFT PORT AIR DISTRIBUTOR
					APP'D	DATE	DRWG NO.:

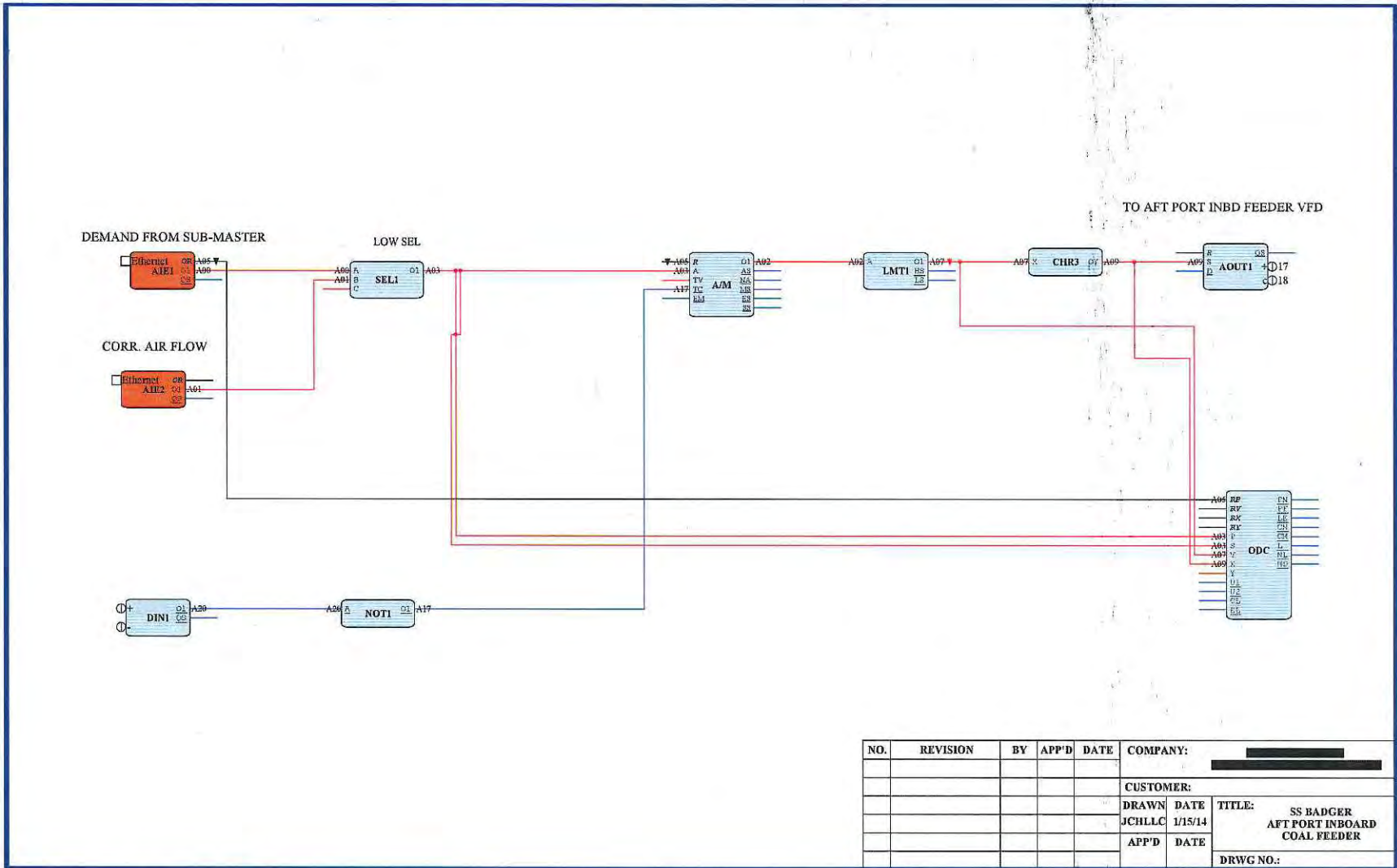

NO.	REVISION	BY	APP'D	DATE	COMPANY:		
					CUSTOMER:		
					DRAWN	DATE	TITLE:
					JCHLLC	1/15/14	SS BADGER AFT PORT INBOARD COAL FEEDER
					APP'D	DATE	
							DRWG NO.:

Friday, January 24, 2014 11:35:22 AM

CONTAINS CONFIDENTIAL BUSINESS INFORMATION



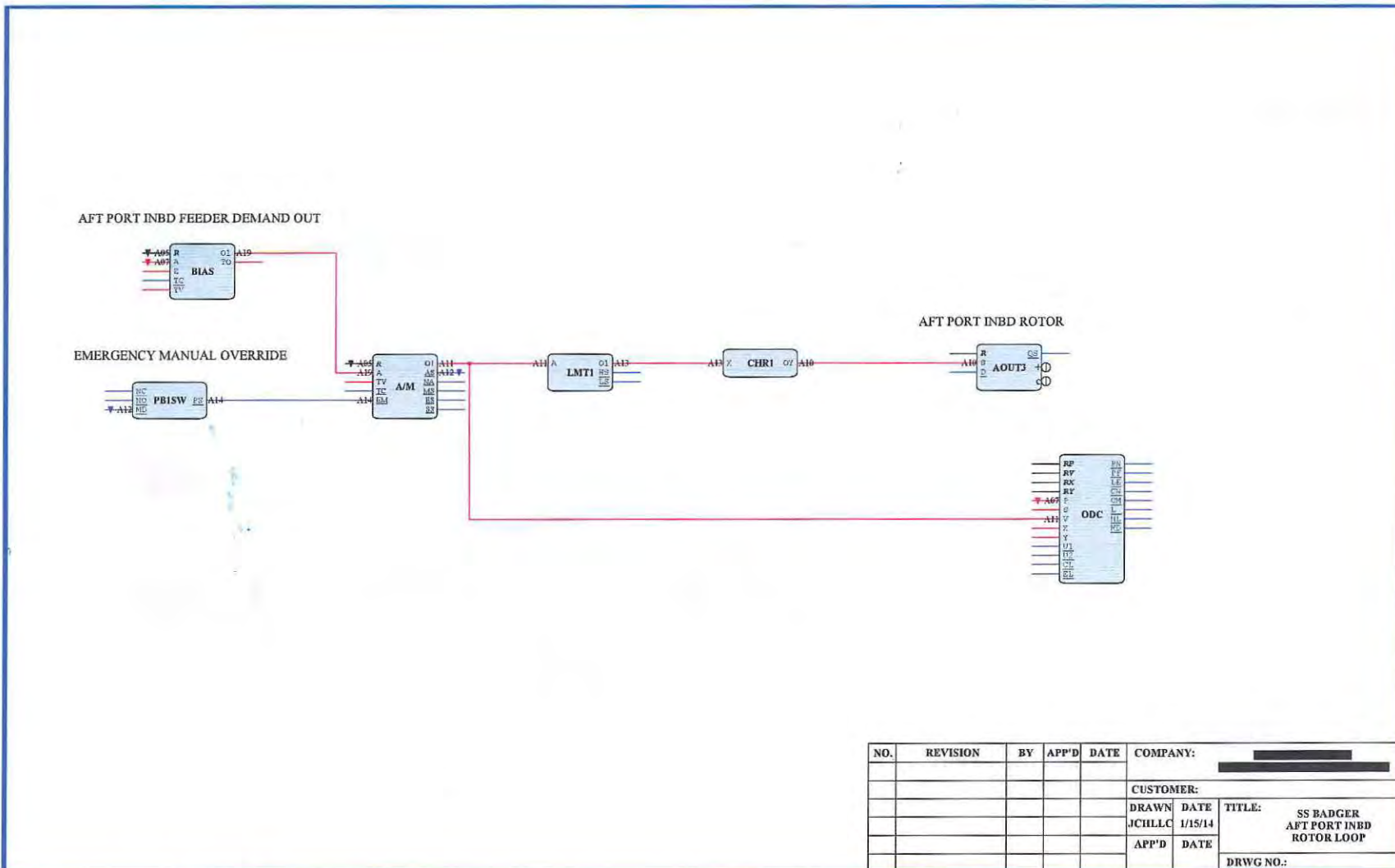

NO.	REVISION	BY	APP'D	DATE	COMPANY:		
					CUSTOMER:		
					DRAWN	DATE	TITLE: SS BADGER
					JCHLLC	1/15/14	AFT PORT INBD
					APP'D	DATE	ROTOR LOOP
							DRWG NO.:

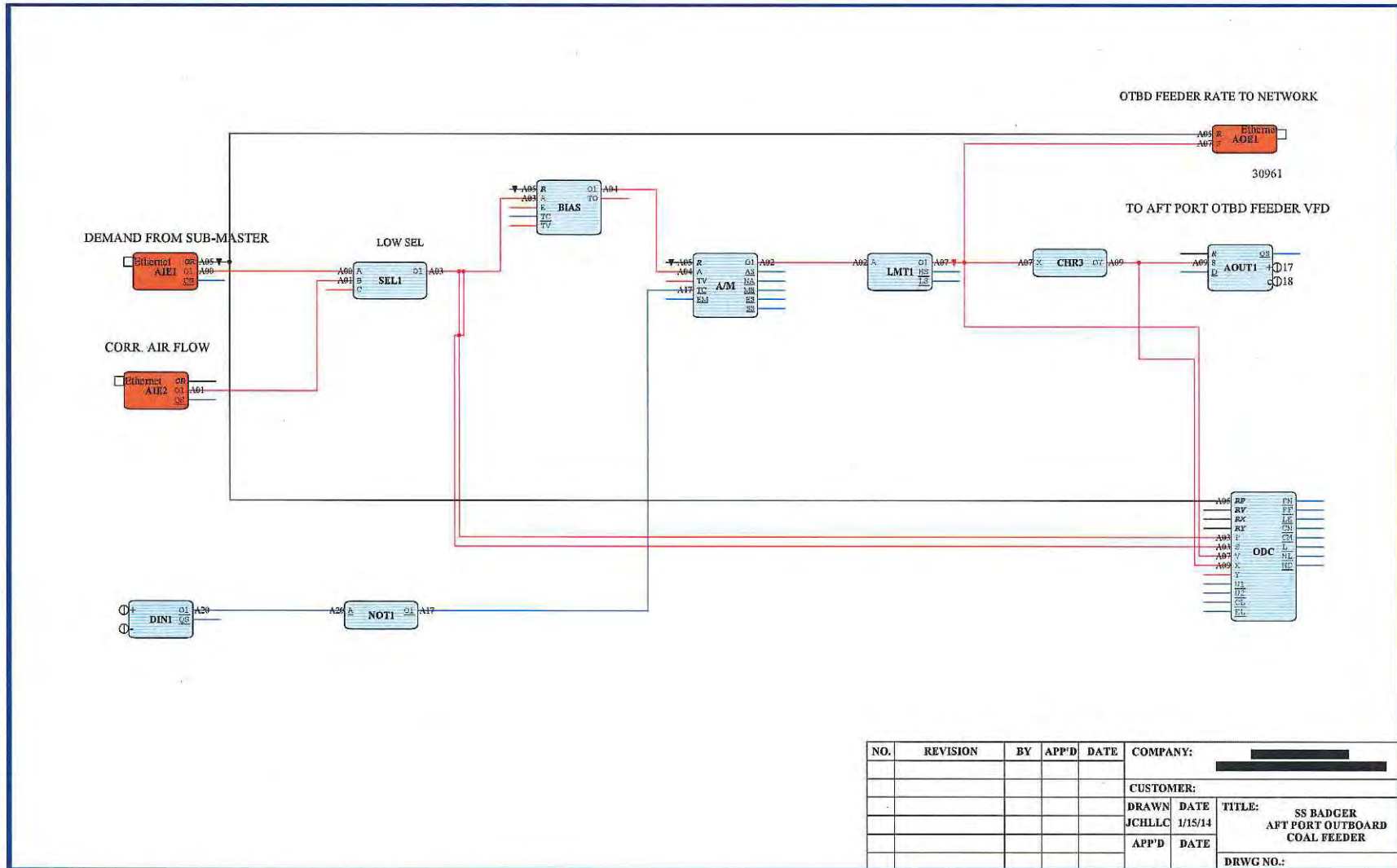

NO.	REVISION	BY	APP'D	DATE	COMPANY:	
					CUSTOMER:	
					DRAWN	DATE
					JCHLLC	1/15/14
					APP'D	DATE
						TITLE: SS BADGER AFT PORT OUTBOARD COAL FEEDER
						DRWG NO.:

Friday, January 24, 2014 11:37:03 AM

CONTAINS CONFIDENTIAL BUSINESS INFORMATION

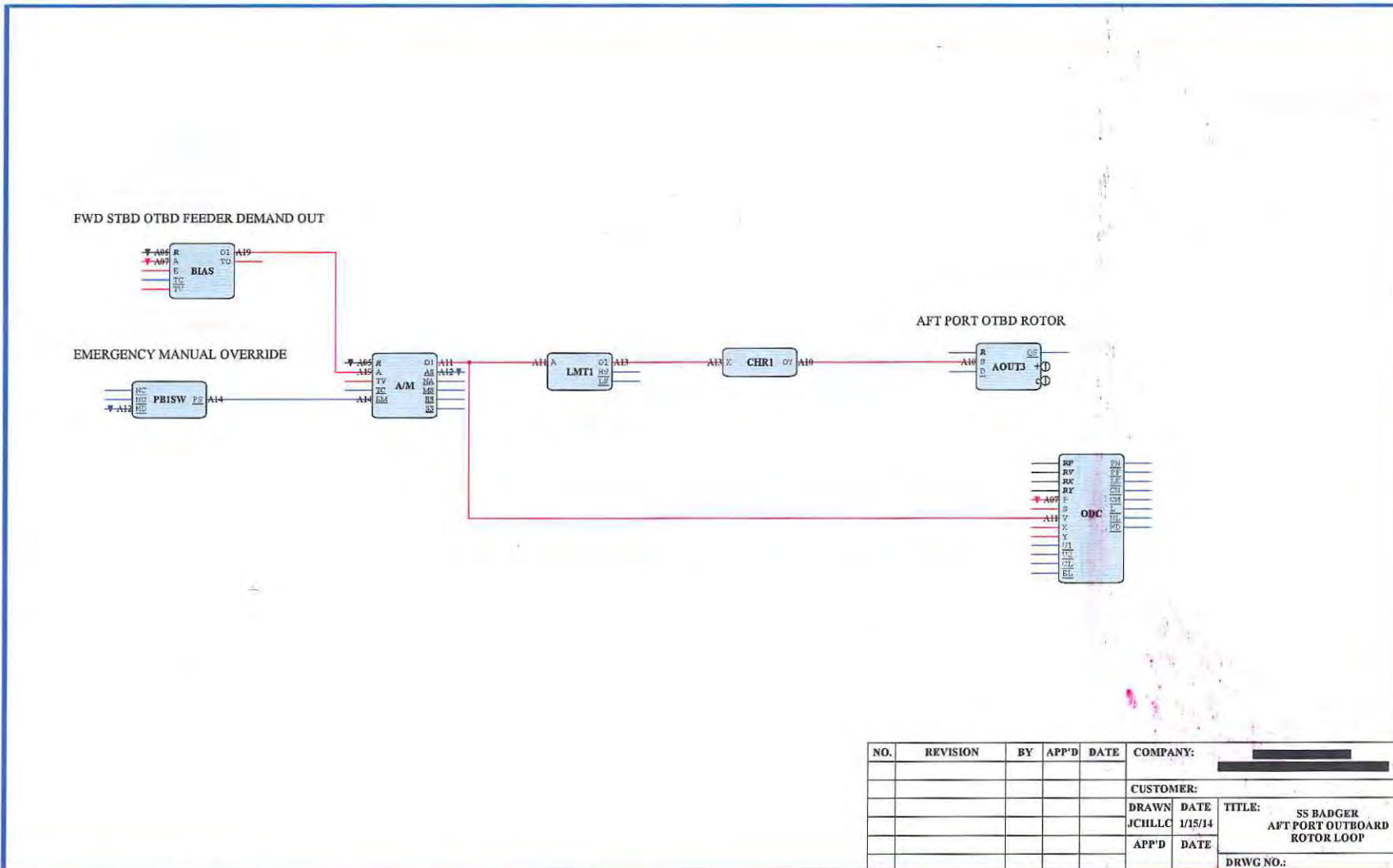

NO.	REVISION	BY	APP'D	DATE	COMPANY:		
					CUSTOMER:		
					DRAWN	DATE	TITLE:
					JCHLLC	1/15/14	SS BADGER AFT PORT OUTBOARD ROTOR LOOP
					APP'D	DATE	DRWG NO.:



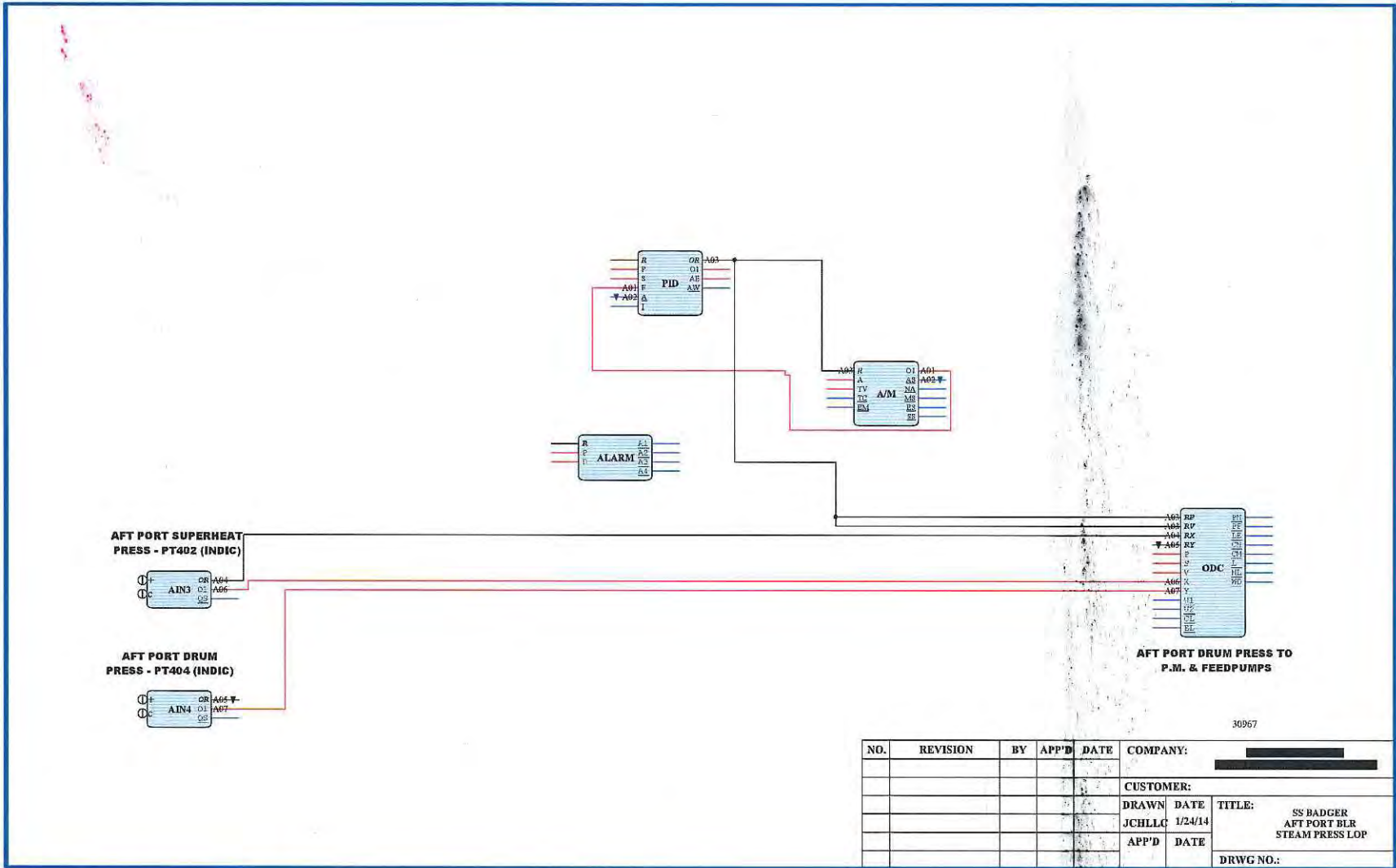

30967

NO.	REVISION	BY	APP'D	DATE	COMPANY:		
					CUSTOMER:		
					DRAWN	DATE	TITLE:
					JCHLLC	1/24/14	SS BADGER AFT PORT BLR STEAM PRESS LOP
					APP'D	DATE	DRWG NO.:

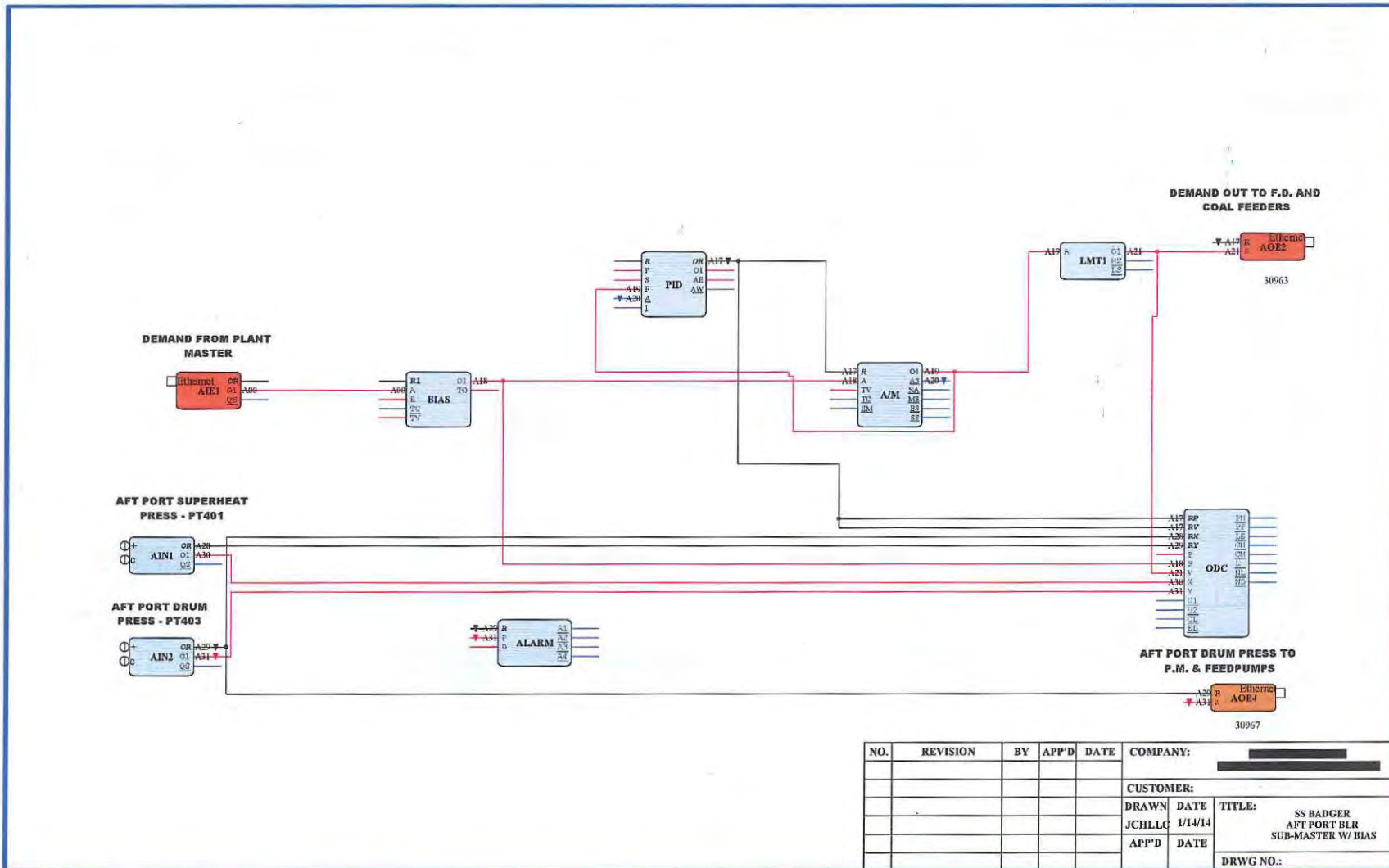

NO.	REVISION	BY	APP'D	DATE	COMPANY:		
						CUSTOMER:	
						DRAWN	DATE
					JCHLLC	1/14/14	TITLE:
					APP'D	DATE	SS BADGER AFT PORT BLR SUB-MASTER W/ BIAS
							DRWG NO.:

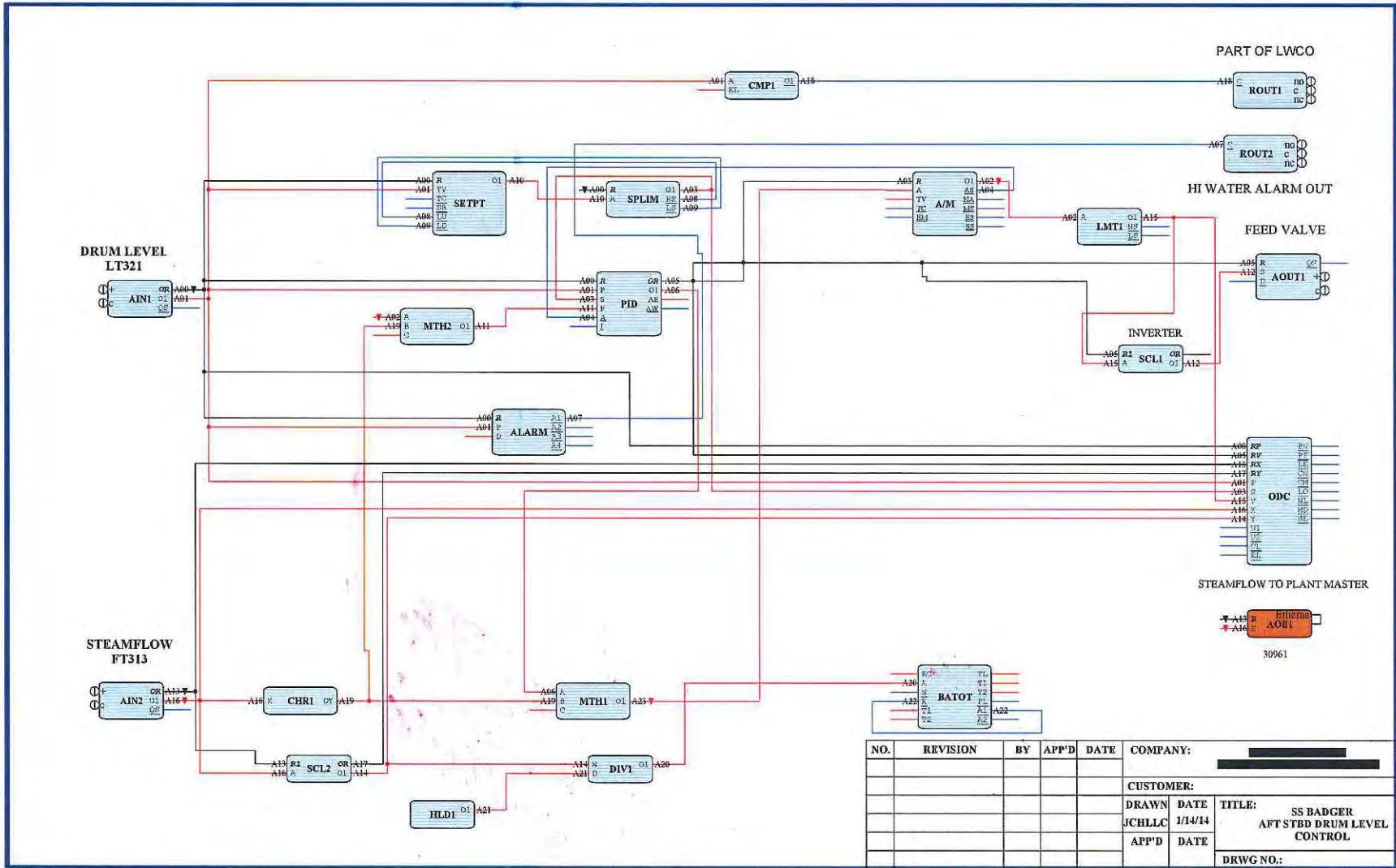

NO.	REVISION	BY	APP'D	DATE	COMPANY:	CUSTOMER:	TITLE:
							SS BADGER
							AFT STBD DRUM LEVEL CONTROL
							DRWG NO.:



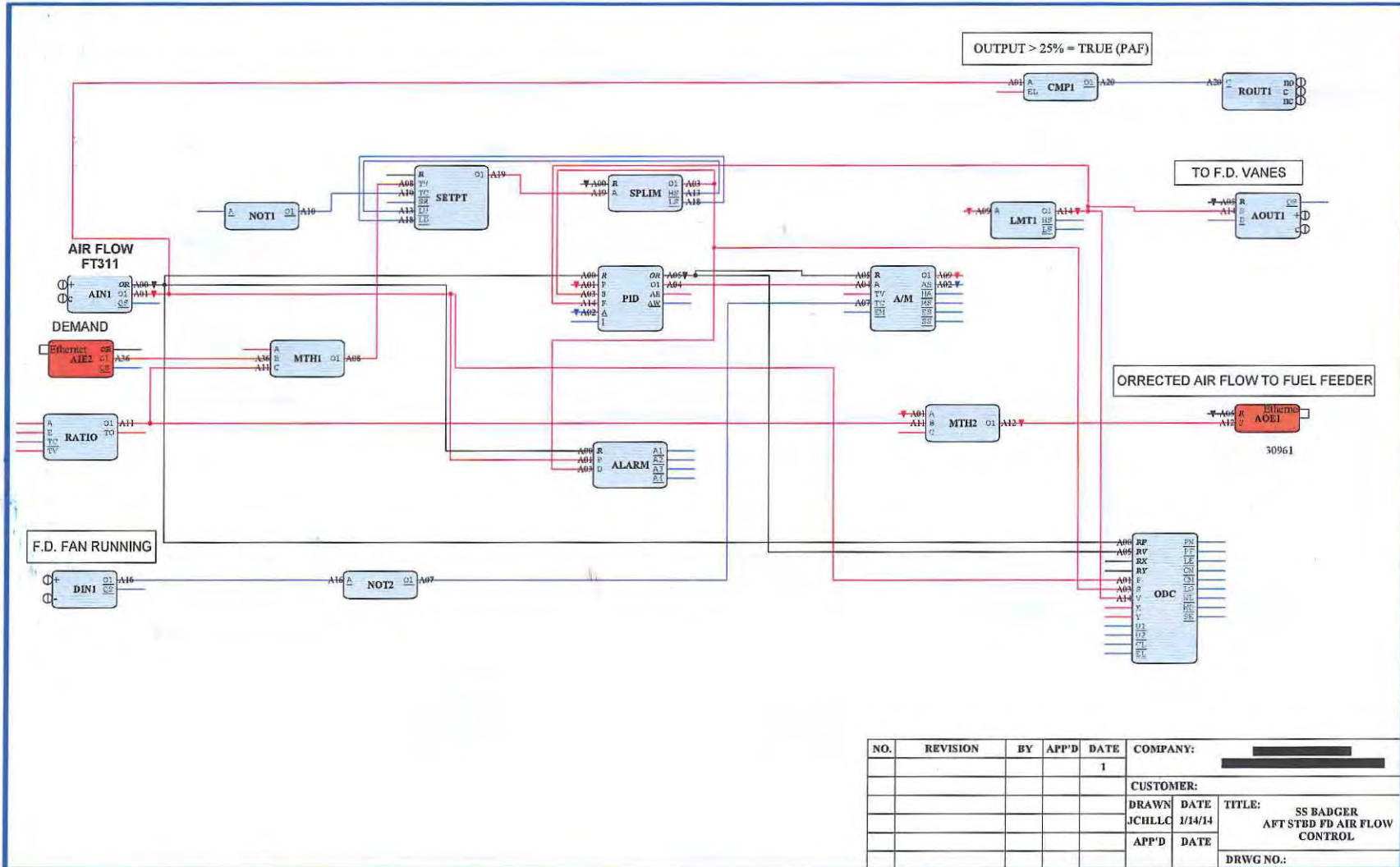

NO.	REVISION	BY	APP'D	DATE	COMPANY:	
				1		
CUSTOMER:						
DRAWN	DATE	TITLE:				
JCHLLC	1/14/14	SS BADGER AFT STBD FD AIR FLOW CONTROL				
APP'D	DATE	DRWG NO.:				



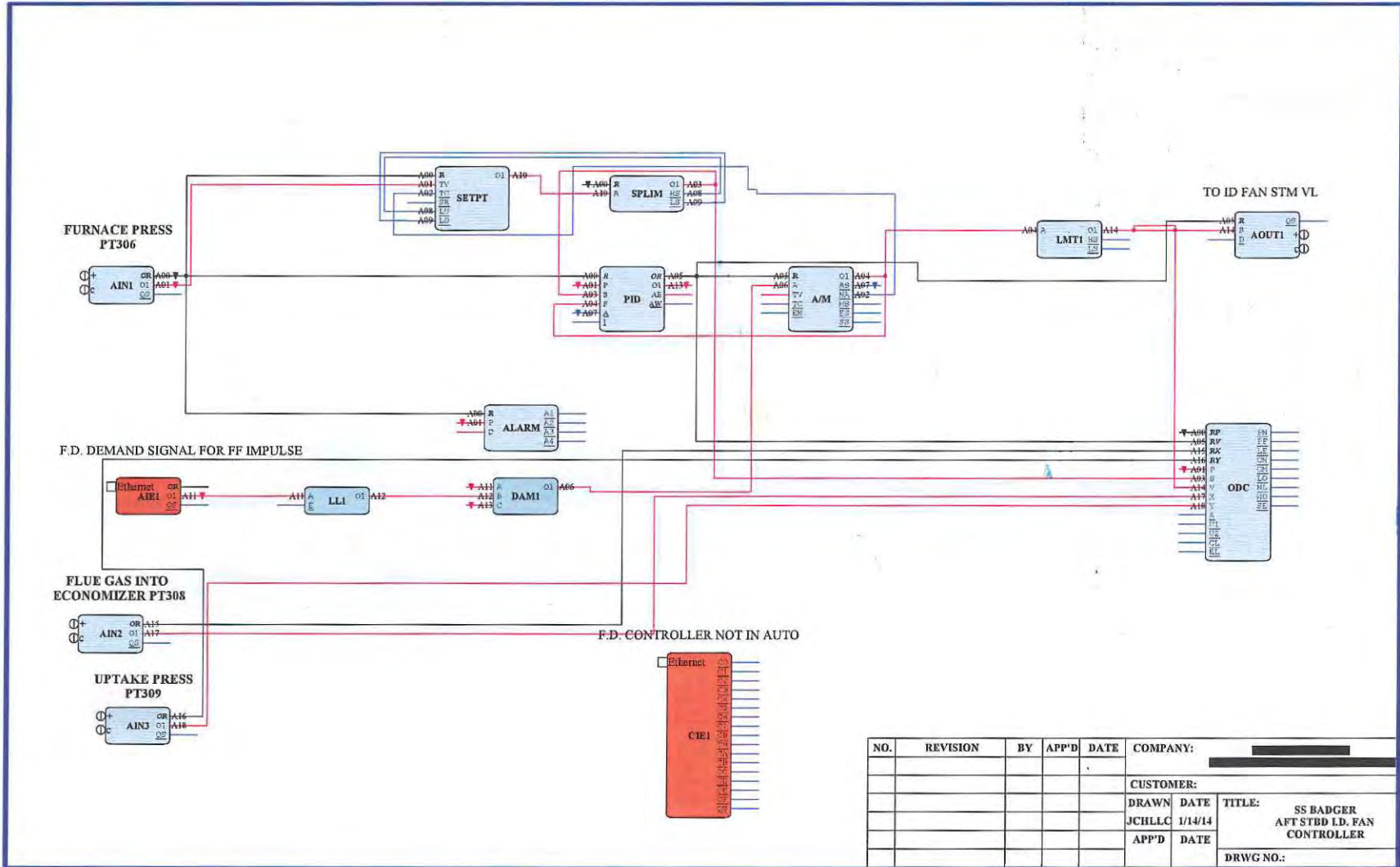

Friday, January 24, 2014 2:15:04 PM

CONTAINS CONFIDENTIAL BUSINESS INFORMATION



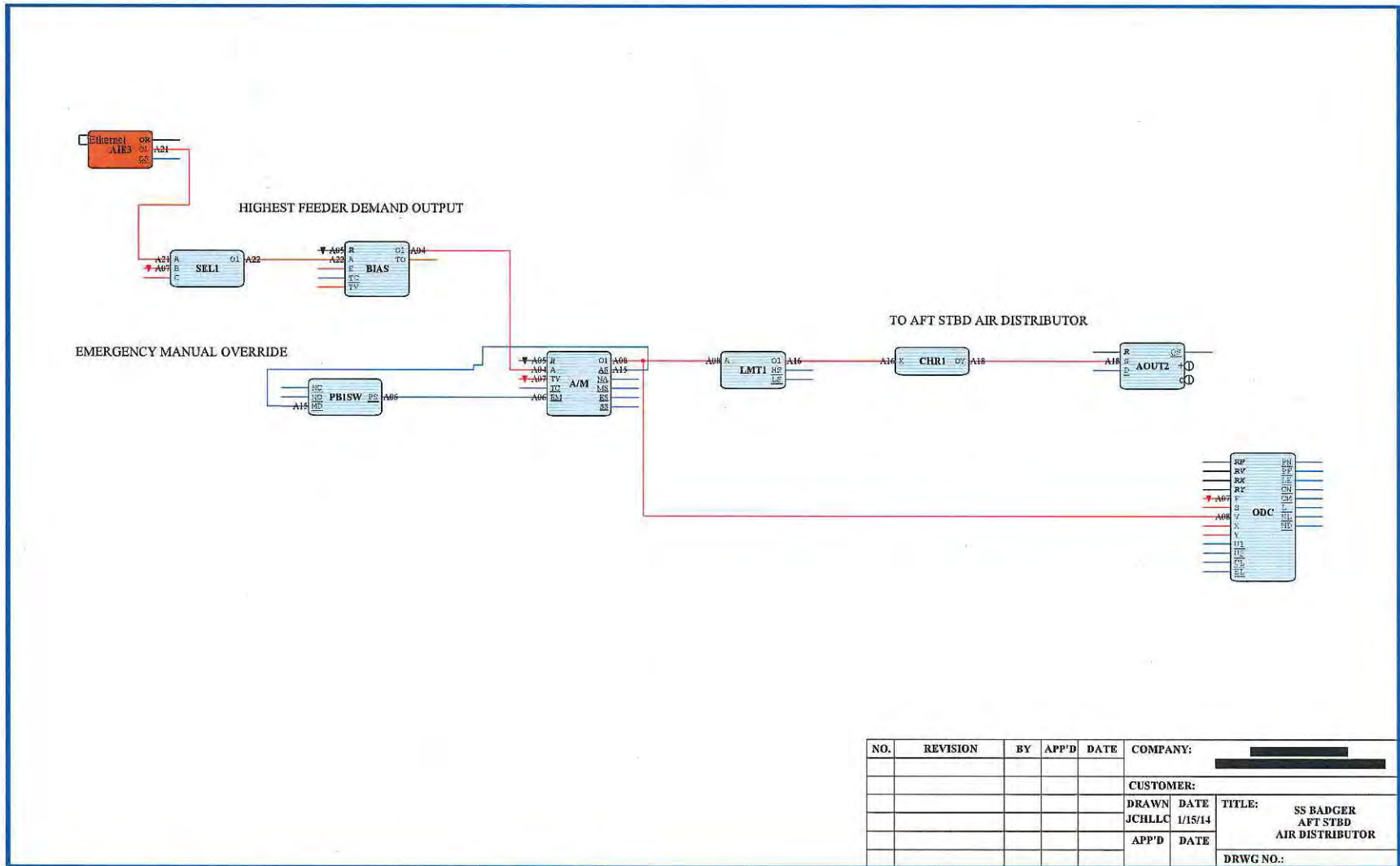

NO.	REVISION	BY	APP'D	DATE	COMPANY:
					CUSTOMER:
					DRAWN DATE
					JCHLLC 1/15/14
					APP'D DATE
					TITLE: SS BADGER AFT STBD AIR DISTRIBUTOR
					DRWG NO.:

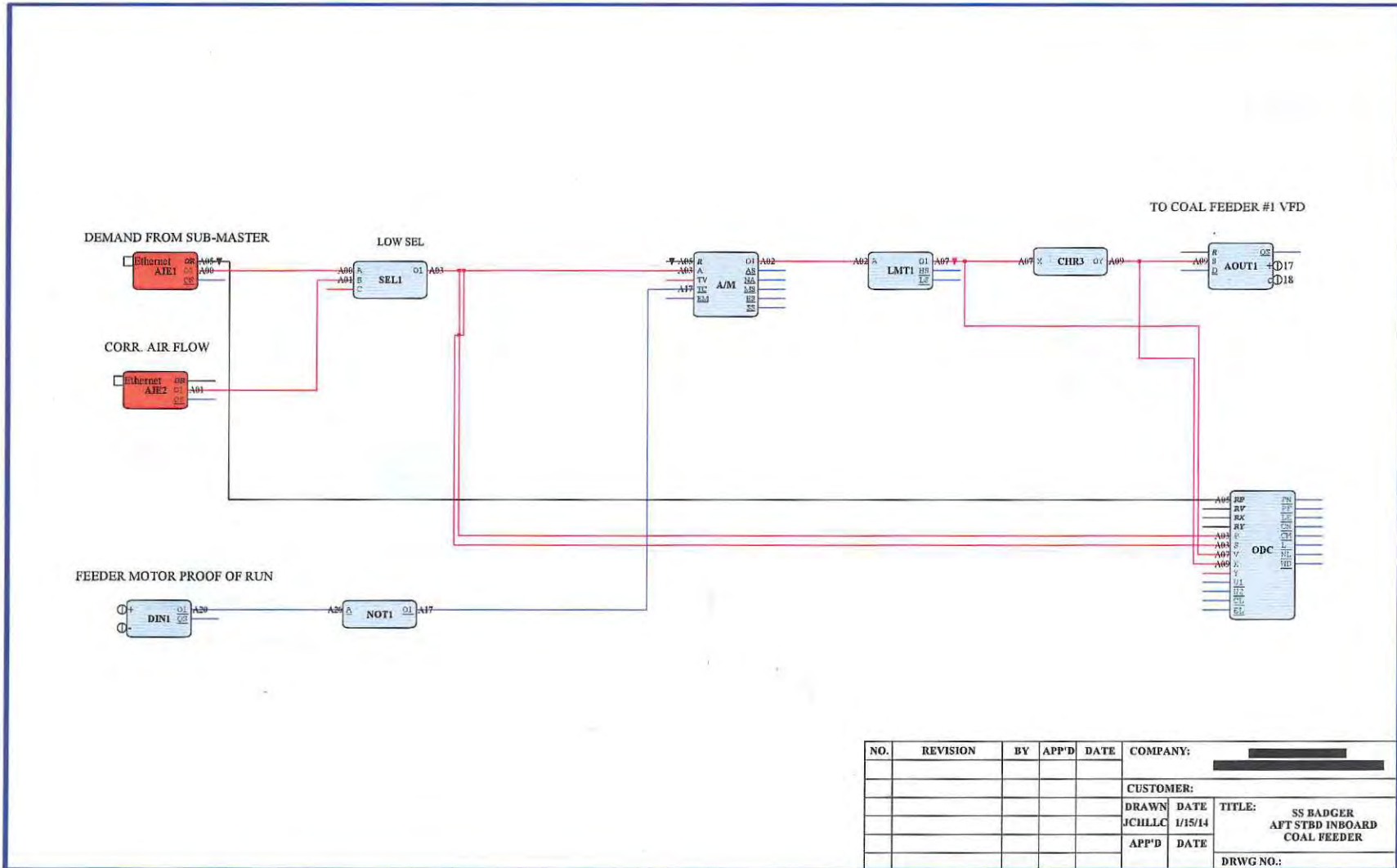

NO.	REVISION	BY	APP'D	DATE	COMPANY:
					CUSTOMER:
					DRAWN DATE
					JCHLLC 1/15/14
					APP'D DATE
					TITLE: SS BADGER AFT STBD INBOARD COAL FEEDER
					DRWG NO.:

Friday, January 24, 2014 2:15:48 PM

CONTAINS CONFIDENTIAL BUSINESS INFORMATION

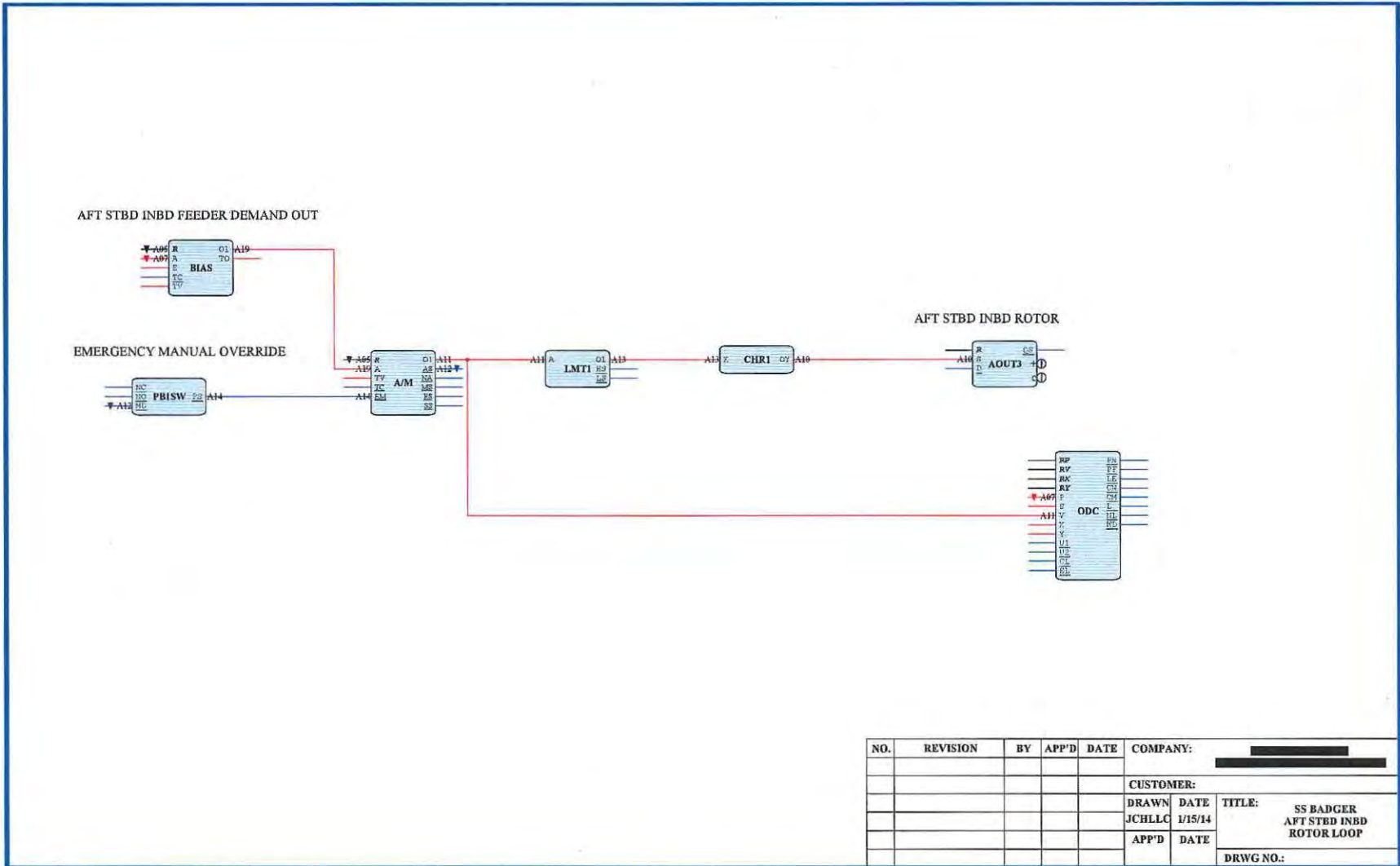

NO.	REVISION	BY	APP'D	DATE	COMPANY:		
					CUSTOMER:		
					DRAWN	DATE	TITLE:
					JCHLLC	1/15/14	SS BADGER AFT STBD INBD ROTOR LOOP
					APP'D	DATE	DRWG NO.:





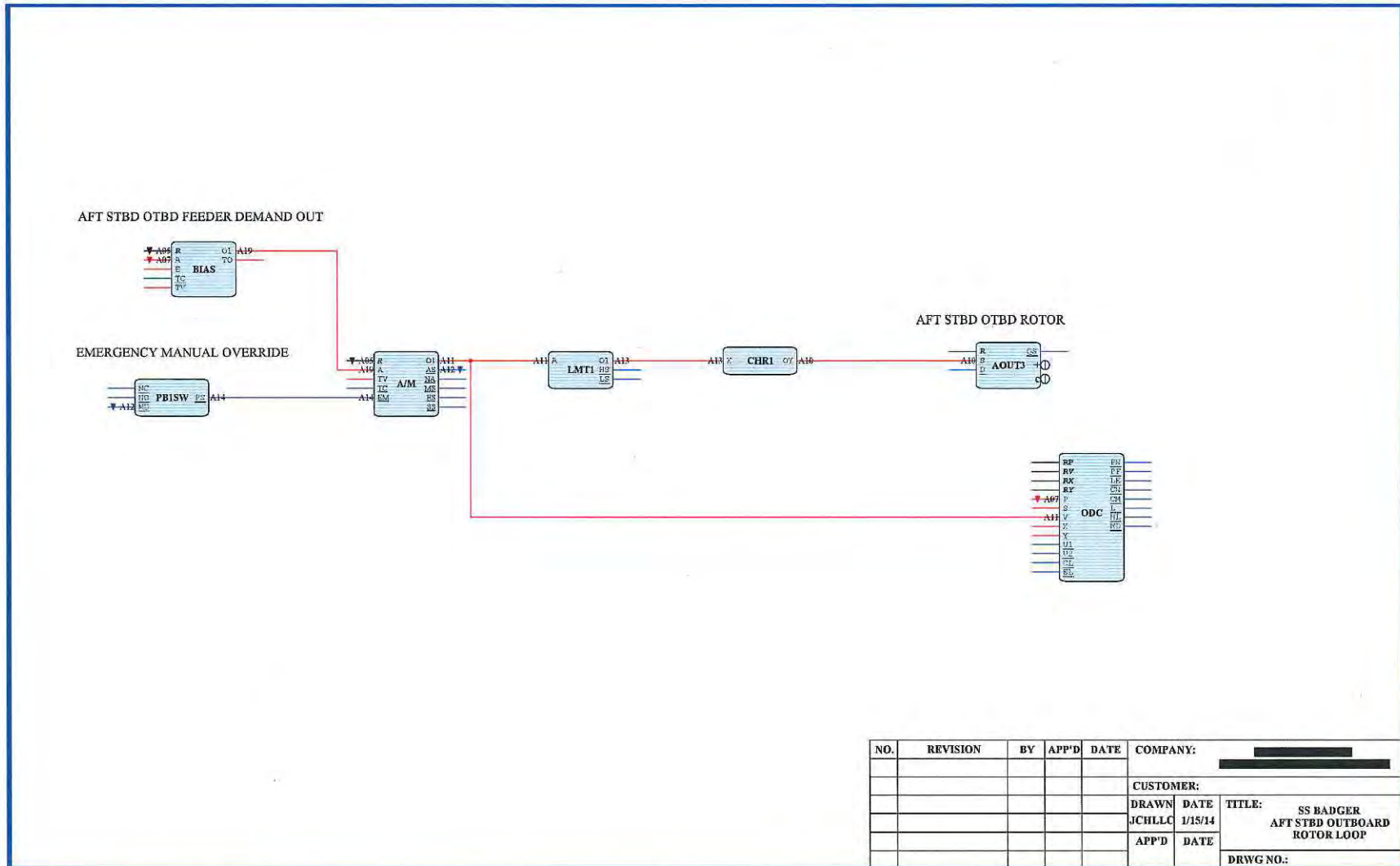

NO.	REVISION	BY	APP'D	DATE	COMPANY:		
					CUSTOMER:		
					DRAWN	DATE	TITLE: SS BADGER AFT STBD OUTBOARD ROTOR LOOP
					JCHLLC	1/15/14	
					APP'D	DATE	
							DRWG NO.:

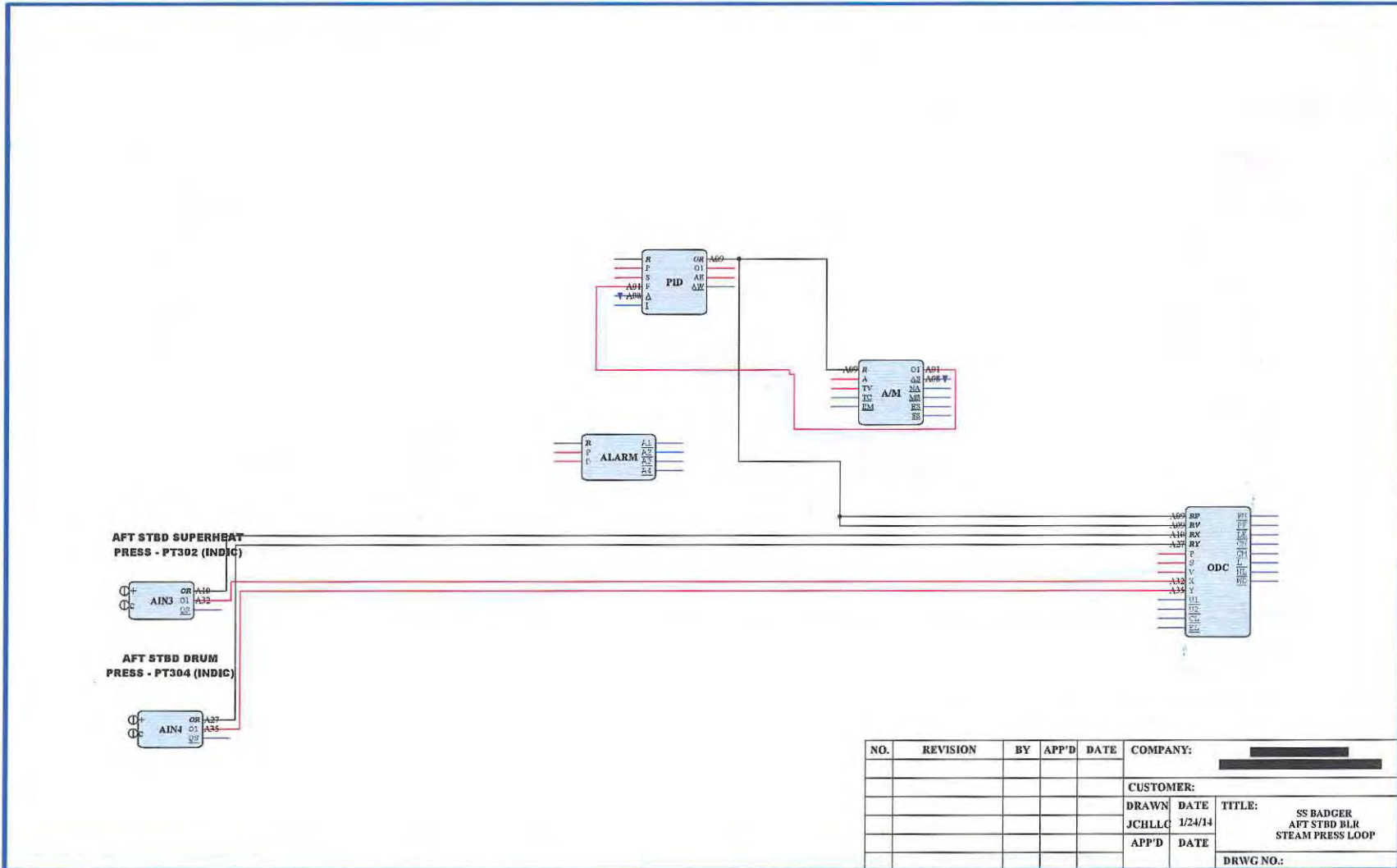

NO.	REVISION	BY	APP'D	DATE	COMPANY:		
					CUSTOMER:		
					DRAWN	DATE	TITLE:
					JCHLLC	1/24/14	SS BADGER AFT STBD BLR STEAM PRESS LOOP
					APP'D	DATE	DRWG NO.:



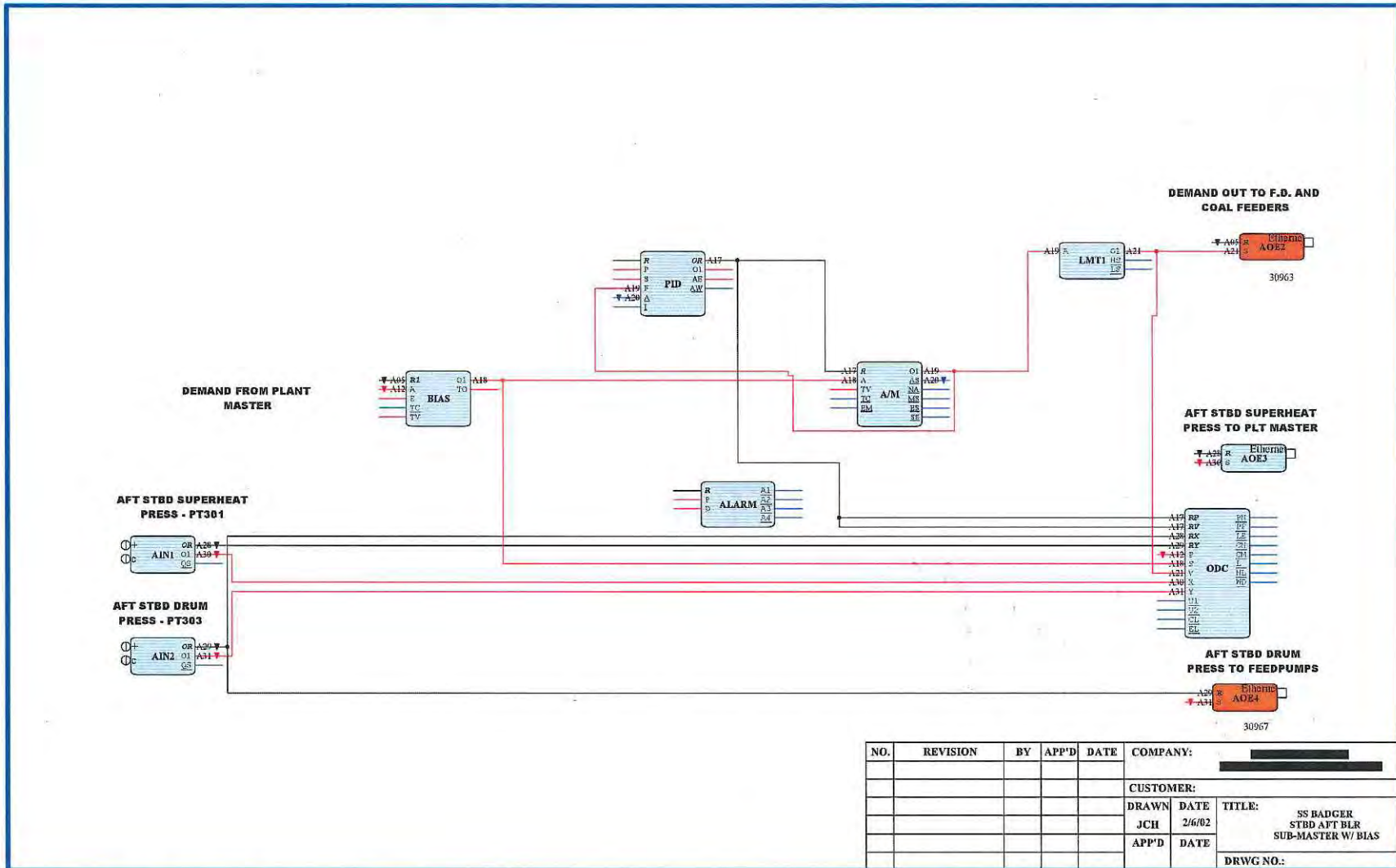

NO.	REVISION	BY	APP'D	DATE	COMPANY:		
					CUSTOMER:		
					DRAWN	DATE	TITLE:
					JCH	2/6/02	SS BADGER STBD AFT BLR SUB-MASTER W/ BIAS
					APP'D	DATE	DRWG NO.:

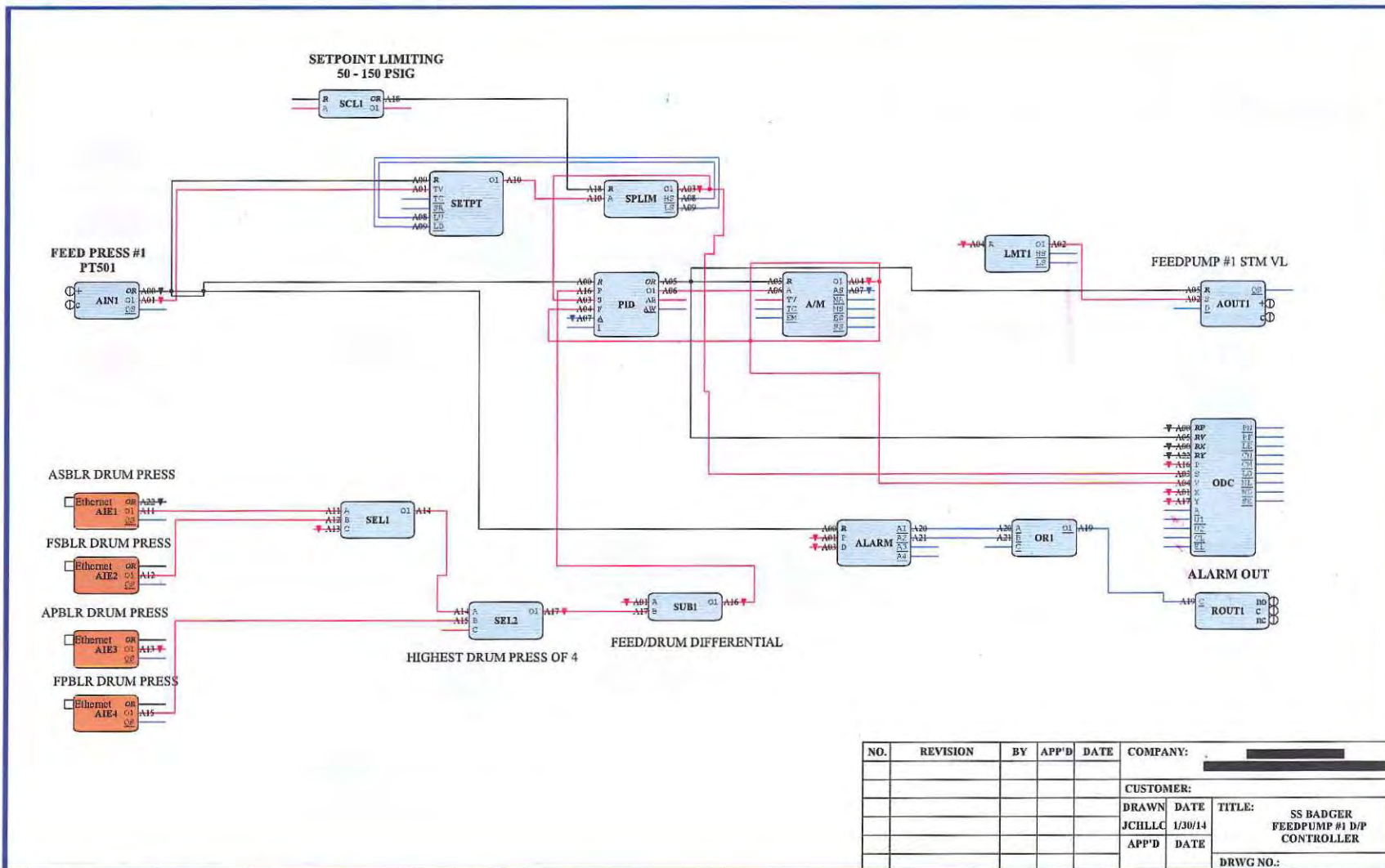

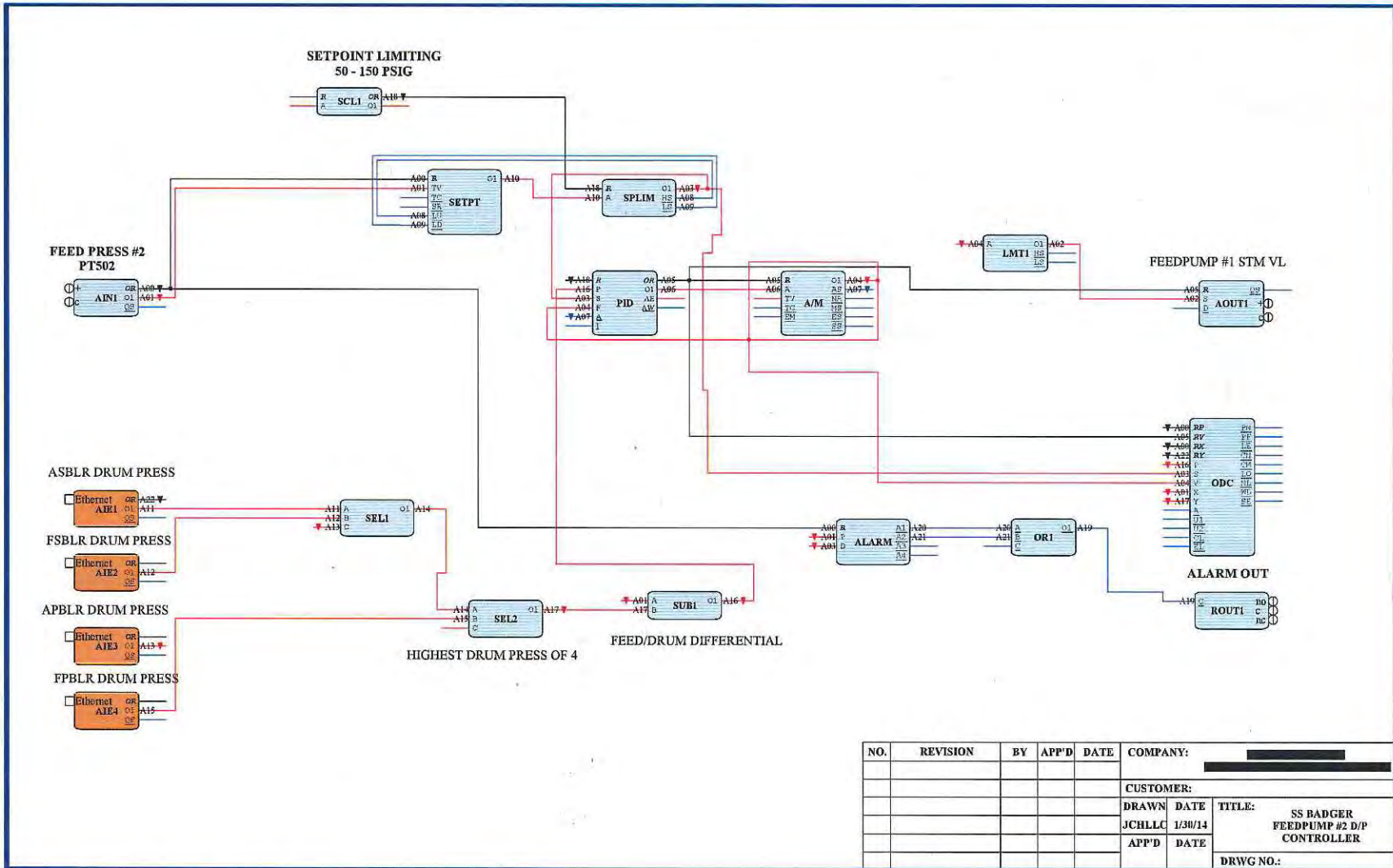

NO.	REVISION	BY	APP'D	DATE	COMPANY:		
					CUSTOMER:		
					DRAWN	DATE	TITLE:
					JCHLLC	1/30/14	SS BADGER FEEDPUMP #2 D/P CONTROLLER
					APP'D	DATE	DRWG NO.:





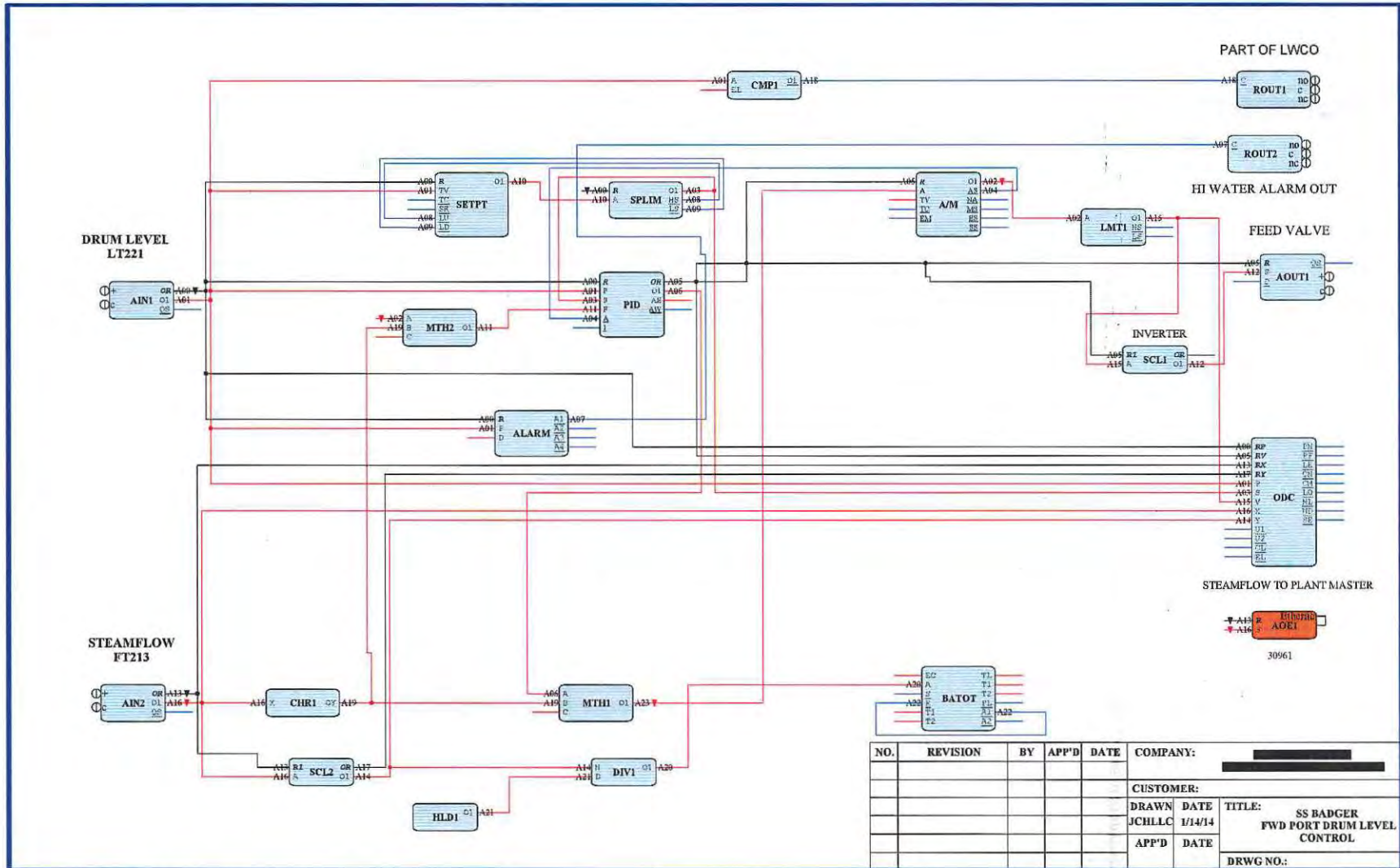

NO.	REVISION	BY	APP'D	DATE	COMPANY:	
					CUSTOMER: <td></td>	
					DRAWN DATE	TITLE:
					JCHLLC 1/14/14	SS RADGER
					APP'D DATE	FWD PORT DRUM LEVEL CONTROL
						DRWG NO.:





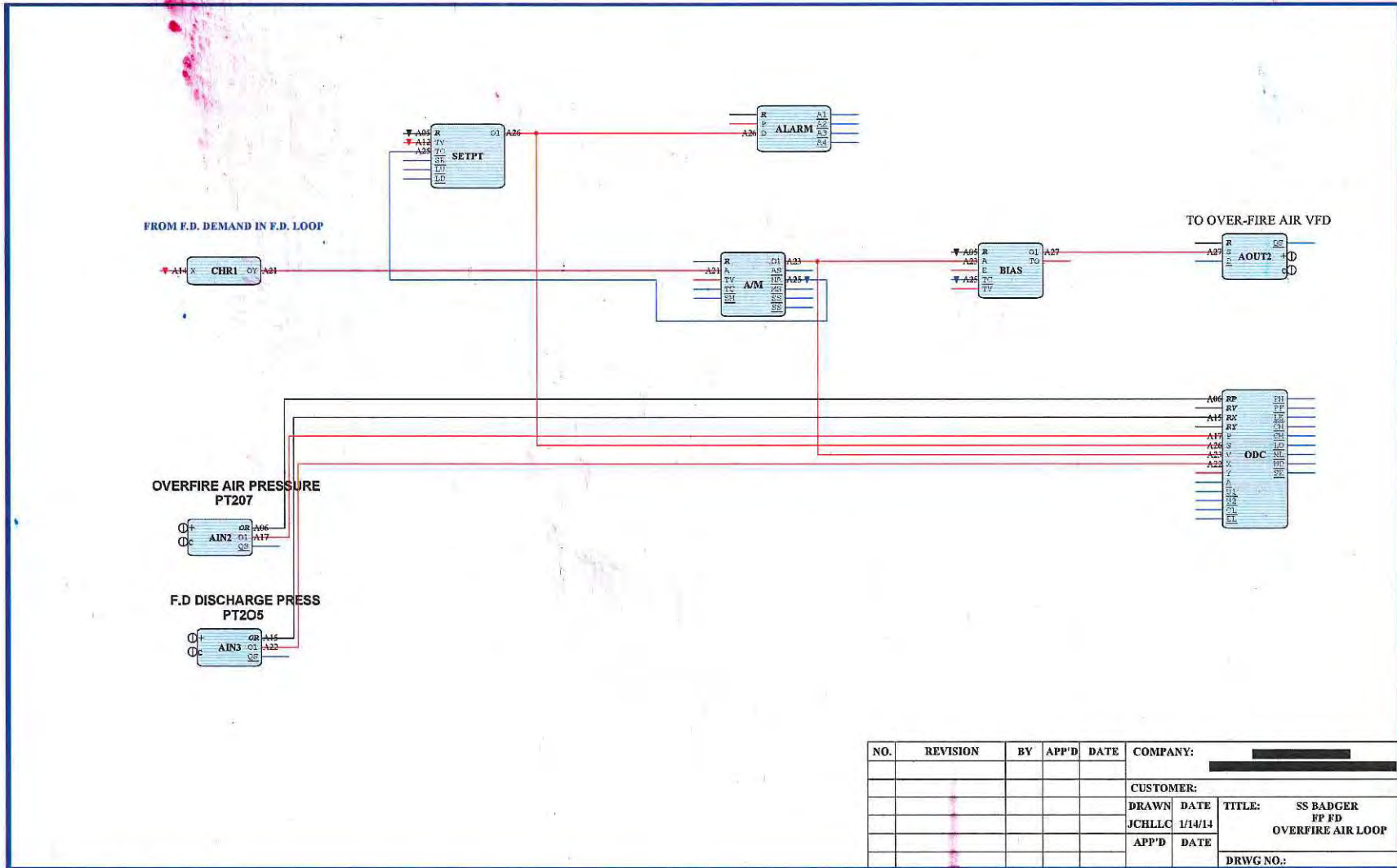

NO.	REVISION	BY	APP'D	DATE	COMPANY:		
					CUSTOMER:		
					DRAWN	DATE	TITLE: SS BADGER FP FD OVERFIRE AIR LOOP
					JCHLLC	1/14/14	
					APP'D	DATE	
							DRWG NO.:

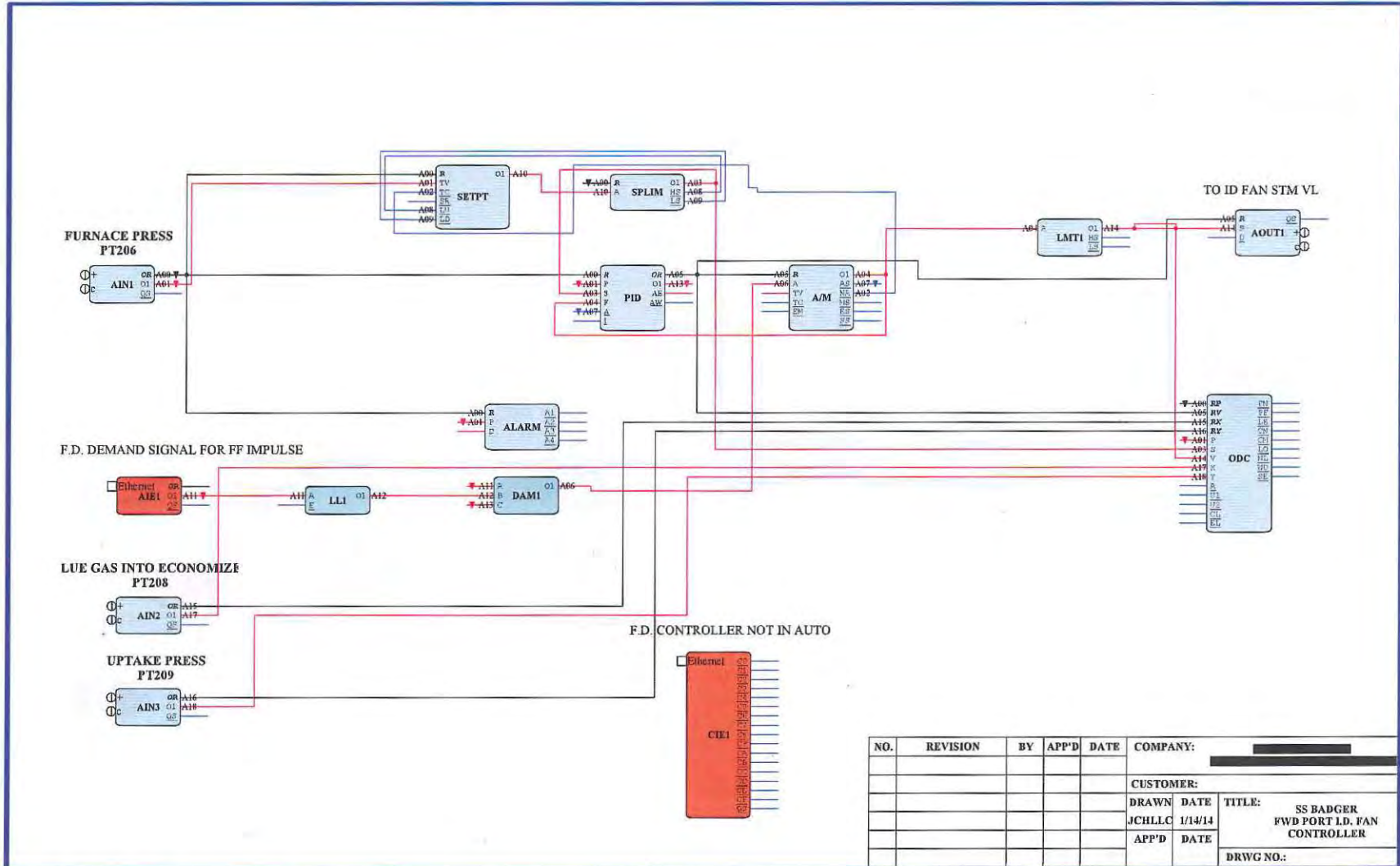

NO.	REVISION	BY	APP'D	DATE	COMPANY:	
					CUSTOMER:	
					DRAWN DATE	TITLE:
					JCHLLC 1/14/14	SS BADGER FWD PORT I.D. FAN CONTROLLER
					APP'D DATE	DRWG NO.:

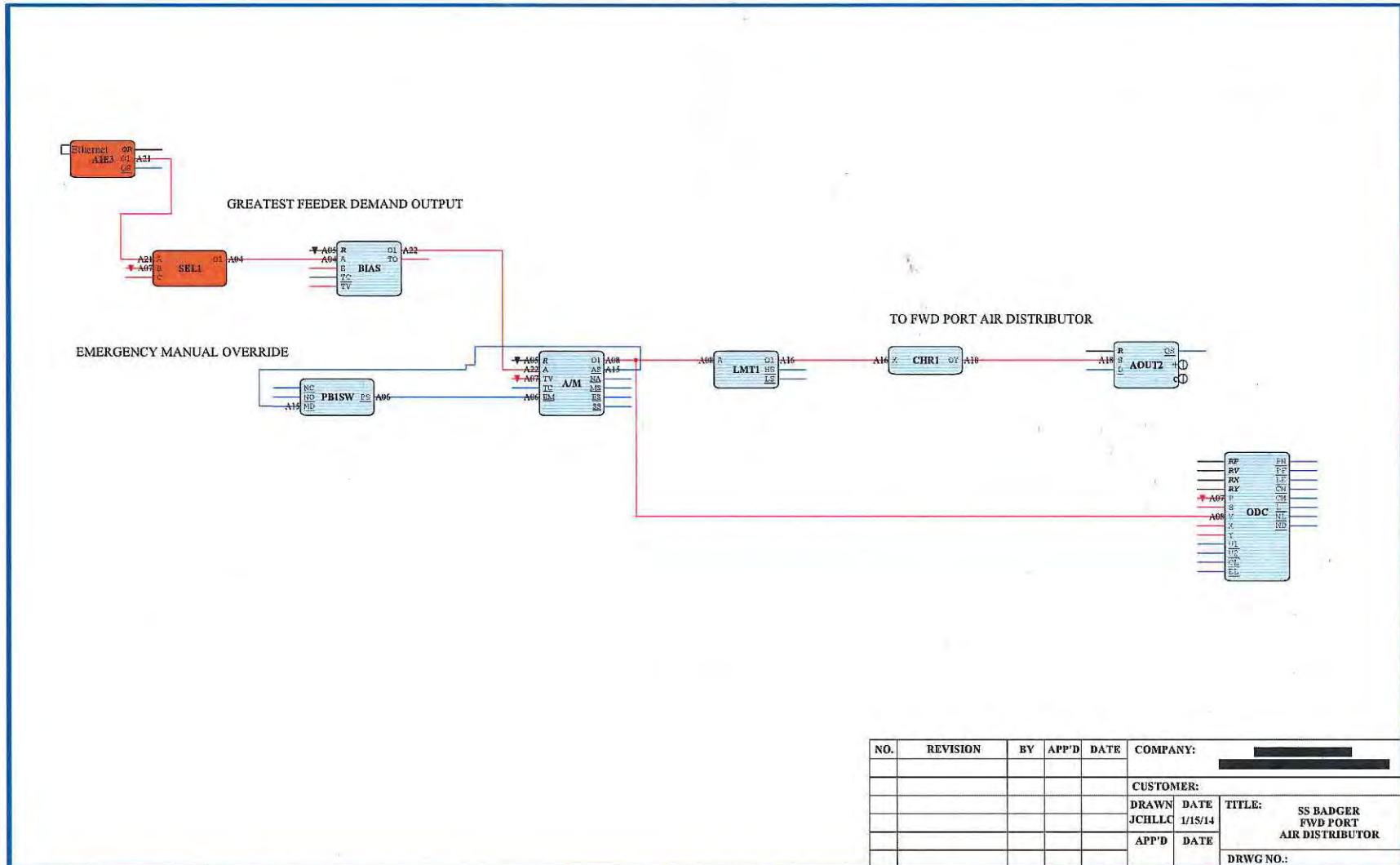

NO.	REVISION	BY	APP'D	DATE	COMPANY:		
					CUSTOMER:		
					DRAWN	DATE	TITLE:
					JCHLLC	1/15/14	SS BADGER FWD PORT AIR DISTRIBUTOR
					APP'D	DATE	DRWG NO.:

Friday, January 24, 2014 2:35:07 PM

CONTAINS CONFIDENTIAL BUSINESS INFORMATION



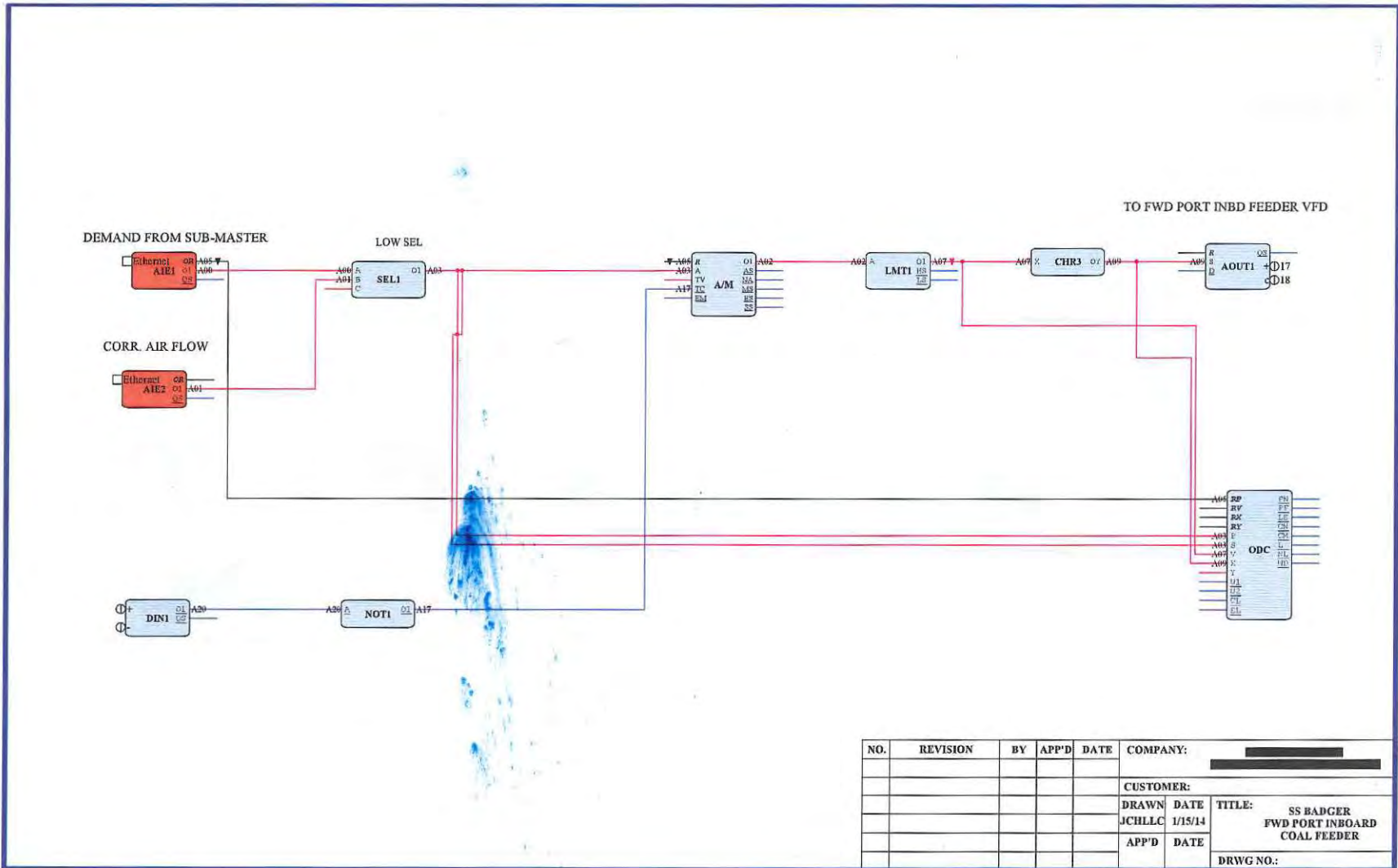

NO.	REVISION	BY	APP'D	DATE	COMPANY:
					CUSTOMER:
					DRAWN DATE
					JCHLLC 1/15/14
					APP'D DATE
					TITLE: SS BADGER FWD PORT INBOARD COAL FEEDER
					DRWG NO.:

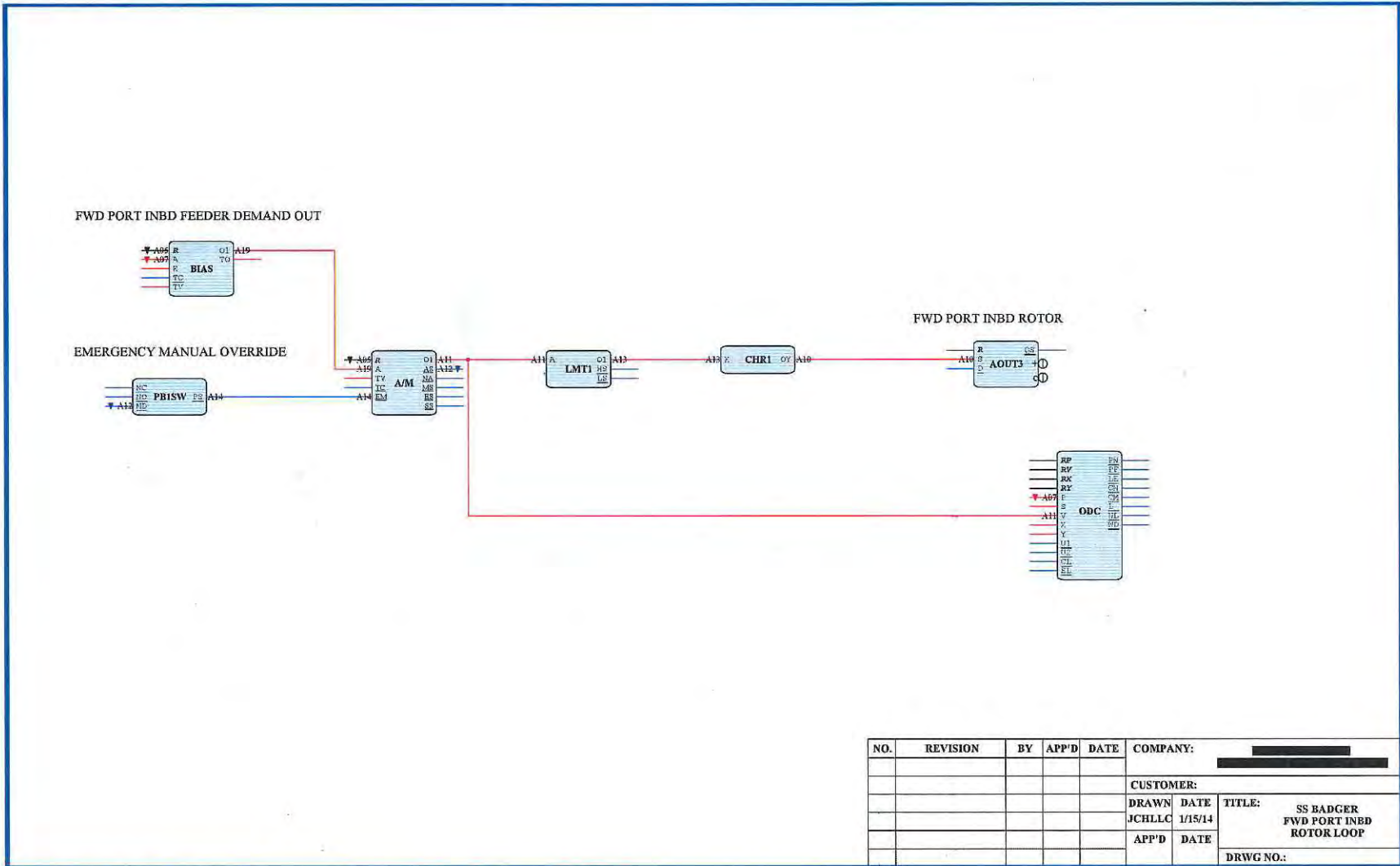

NO.	REVISION	BY	APP'D	DATE	COMPANY:		
					CUSTOMER:		
					DRAWN	DATE	TITLE:
					JCHLLC	1/15/14	SS BADGER FWD PORT INBD ROTOR LOOP
					APP'D	DATE	DRWG NO.:

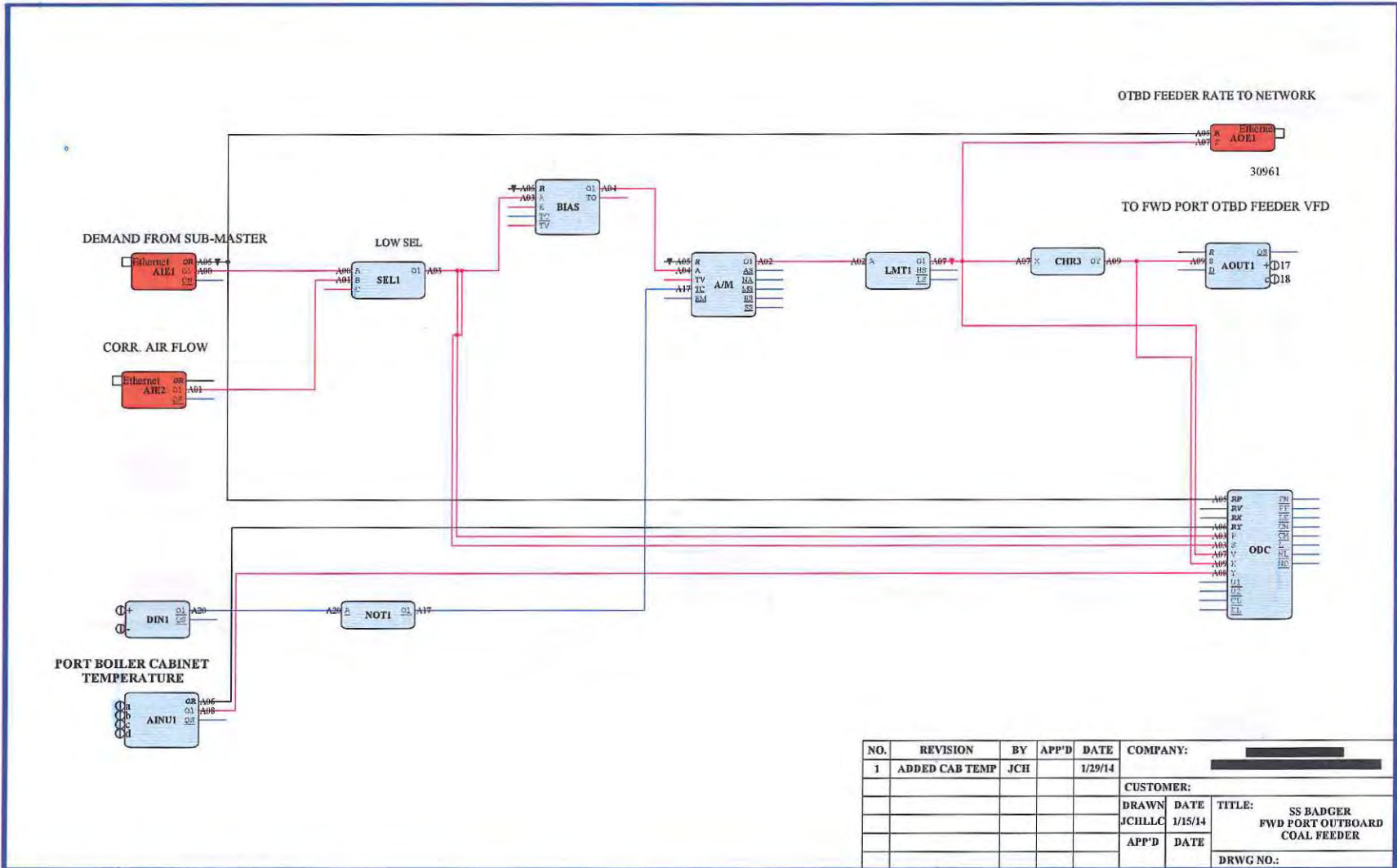

NO.	REVISION	BY	APP'D	DATE	COMPANY:
1	ADDED CAB TEMP	JCH		1/29/14	
					CUSTOMER:
					DRAWN DATE
					JCHLLC 1/15/14
					APP'D DATE
					TITLE: SS BADGER FWD PORT OUTBOARD COAL FEEDER
					DRWG NO.:

Wednesday, January 29, 2014 8:38:42 AM

CONTAINS CONFIDENTIAL BUSINESS INFORMATION



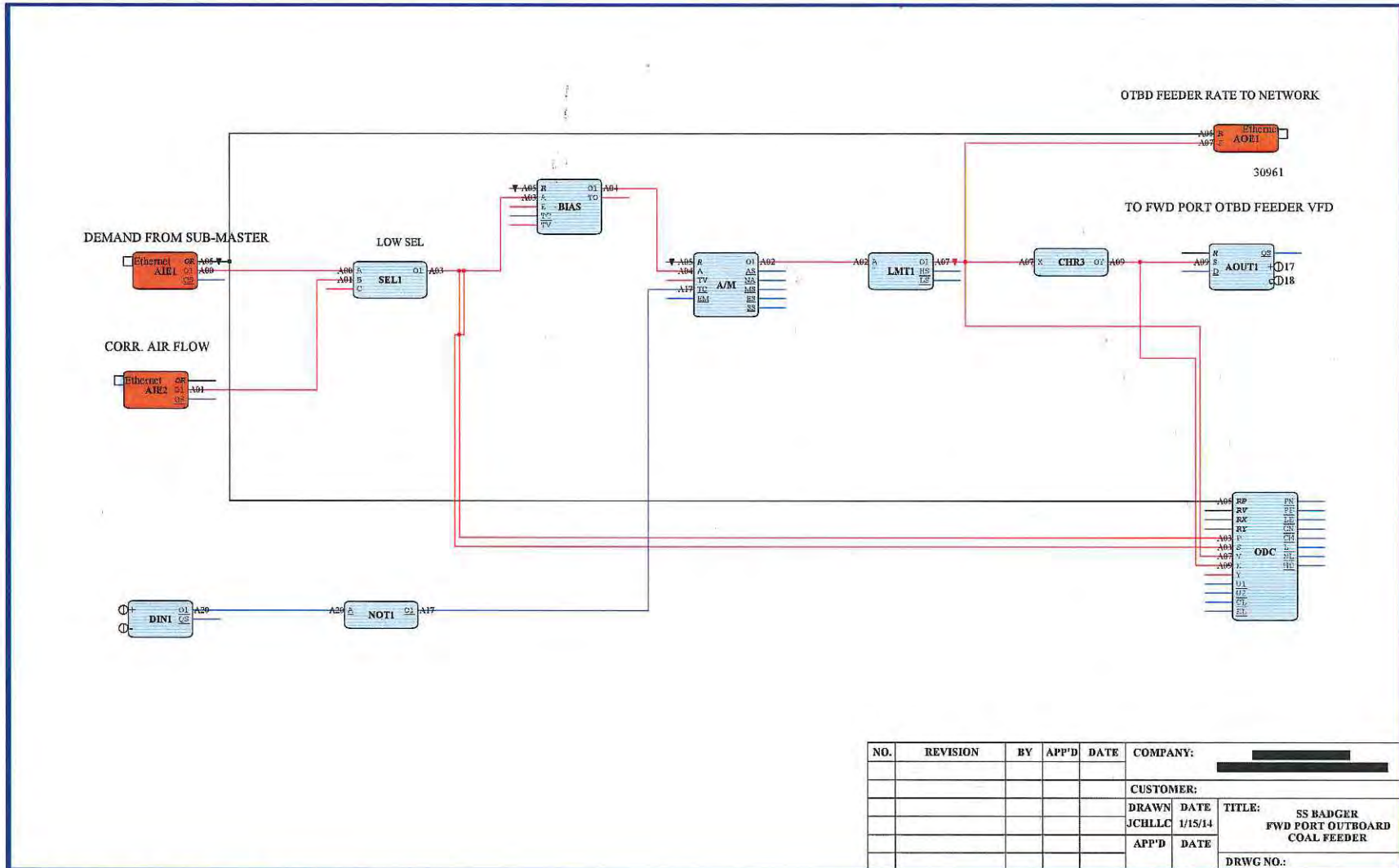

NO.	REVISION	BY	APP'D	DATE	COMPANY:	
					CUSTOMER:	
					DRAWN	DATE
					JCHLLC	1/15/14
					APP'D	DATE
					TITLE:	SS BADGER FWD PORT OUTBOARD COAL FEEDER
					DRWG NO.:	

Friday, January 24, 2014 2:35:46 PM

CONTAINS CONFIDENTIAL BUSINESS INFORMATION

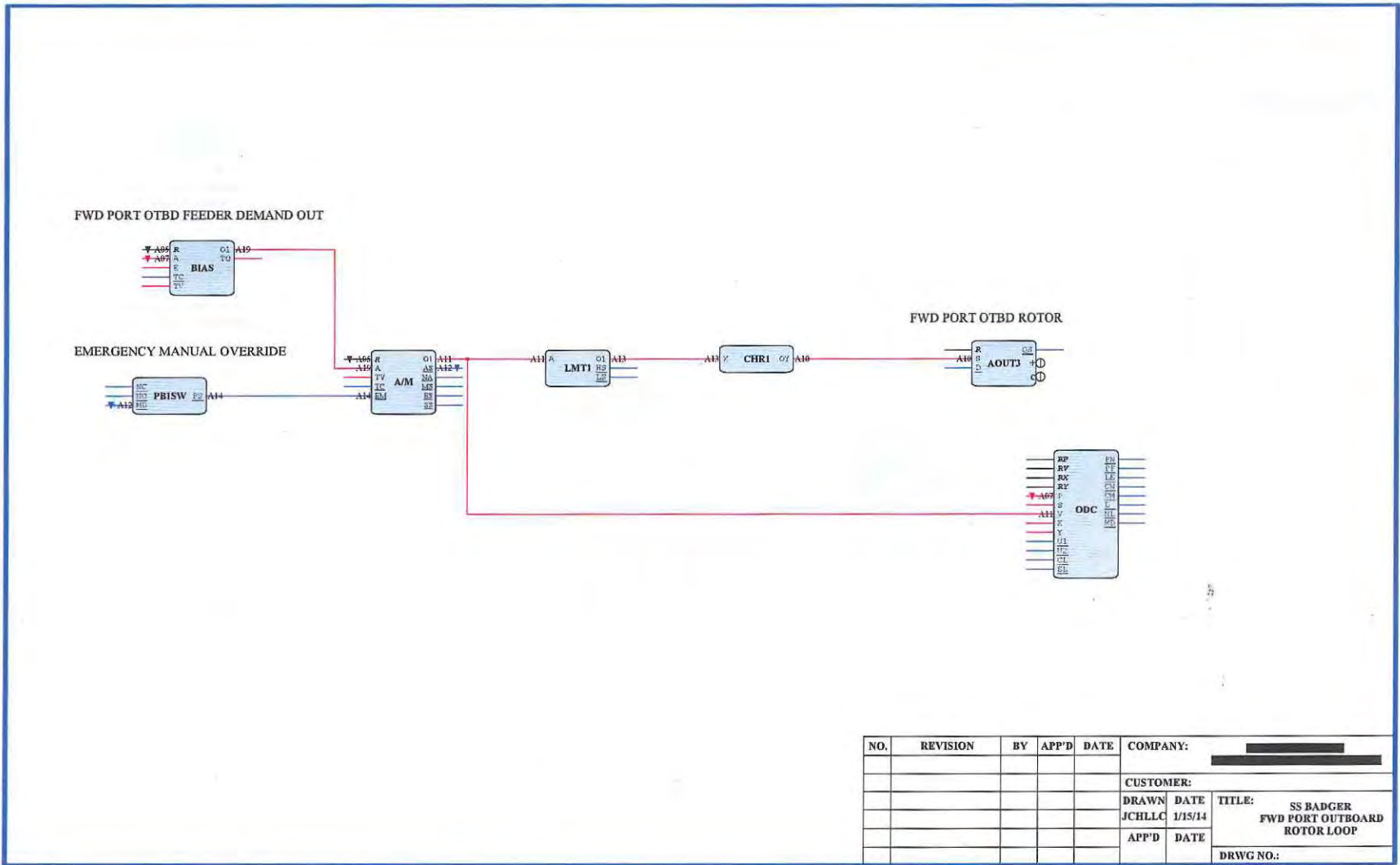

NO.	REVISION	BY	APP'D	DATE	COMPANY:		
					CUSTOMER:		
					DRAWN	DATE	TITLE:
					JCHLLC	1/15/14	SS BADGER FWD PORT OUTBOARD ROTOR LOOP
					APP'D	DATE	DRWG NO.:





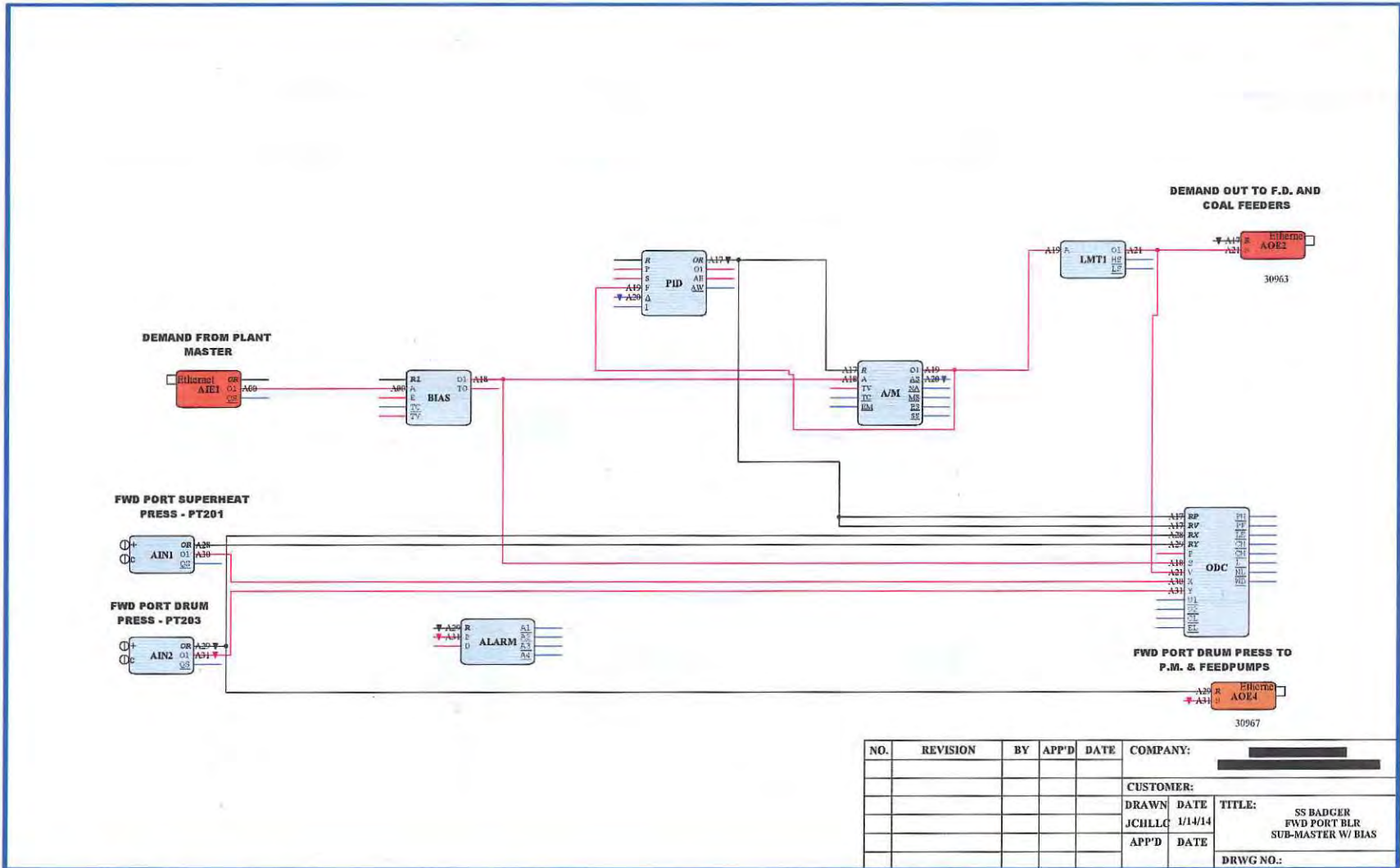

NO.	REVISION	BY	APP'D	DATE	COMPANY:	
					CUSTOMER:	
					DRAWN	DATE
					JCHLLC	1/14/14
					APP'D	DATE
						TITLE:
						SS BADGER
						FWD PORT BLR
						SUB-MASTER W/ BIAS
						DRWG NO.:

Friday, January 24, 2014 2:41:25 PM

CONTAINS CONFIDENTIAL BUSINESS INFORMATION

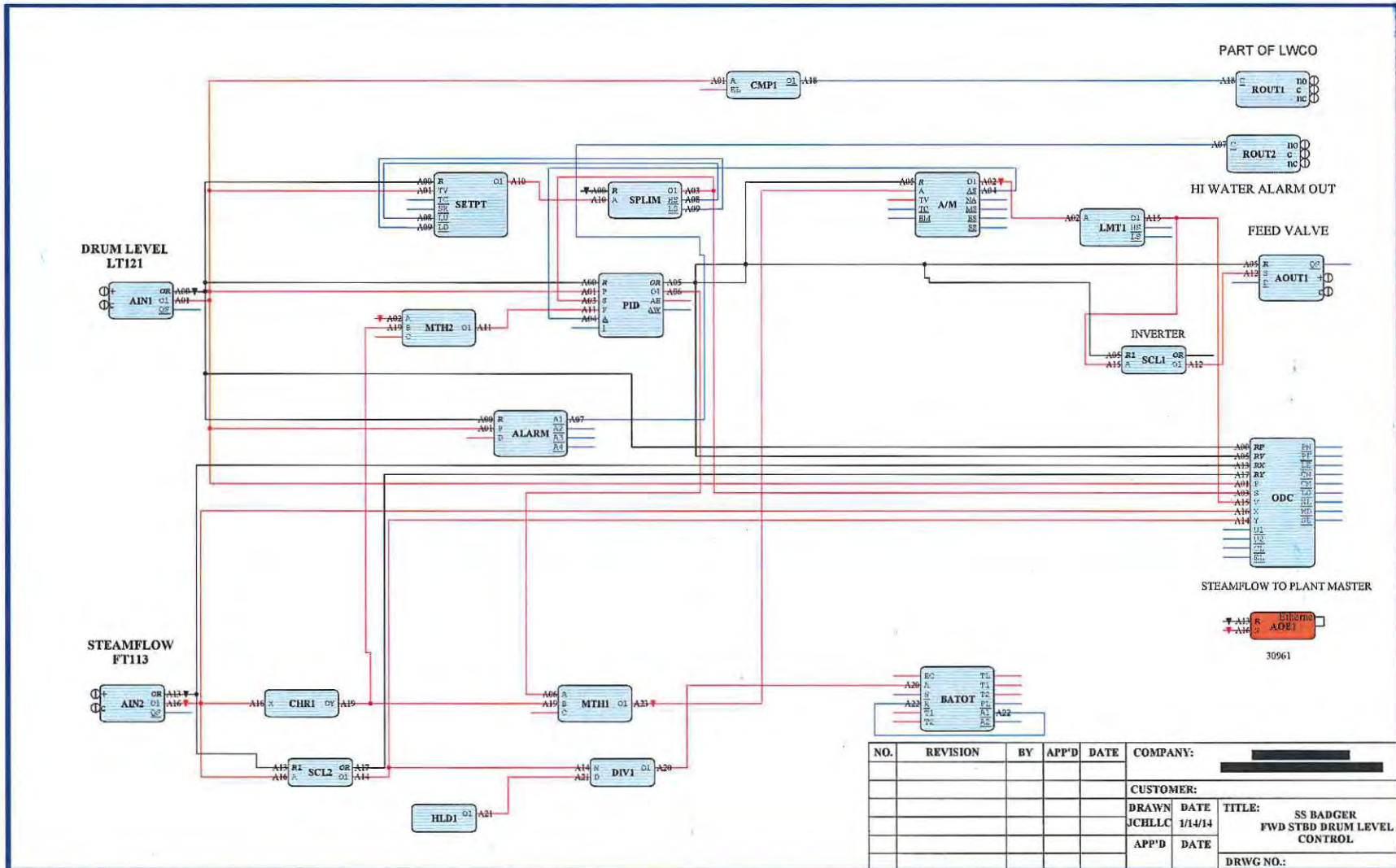

NO.	REVISION	BY	APP'D	DATE	COMPANY:		
					CUSTOMER:		
					DRAWN	DATE	TITLE:
					JCHLLC	1/14/14	SS BADGER FWD STBD DRUM LEVEL CONTROL
					APP'D	DATE	DRWG NO.:

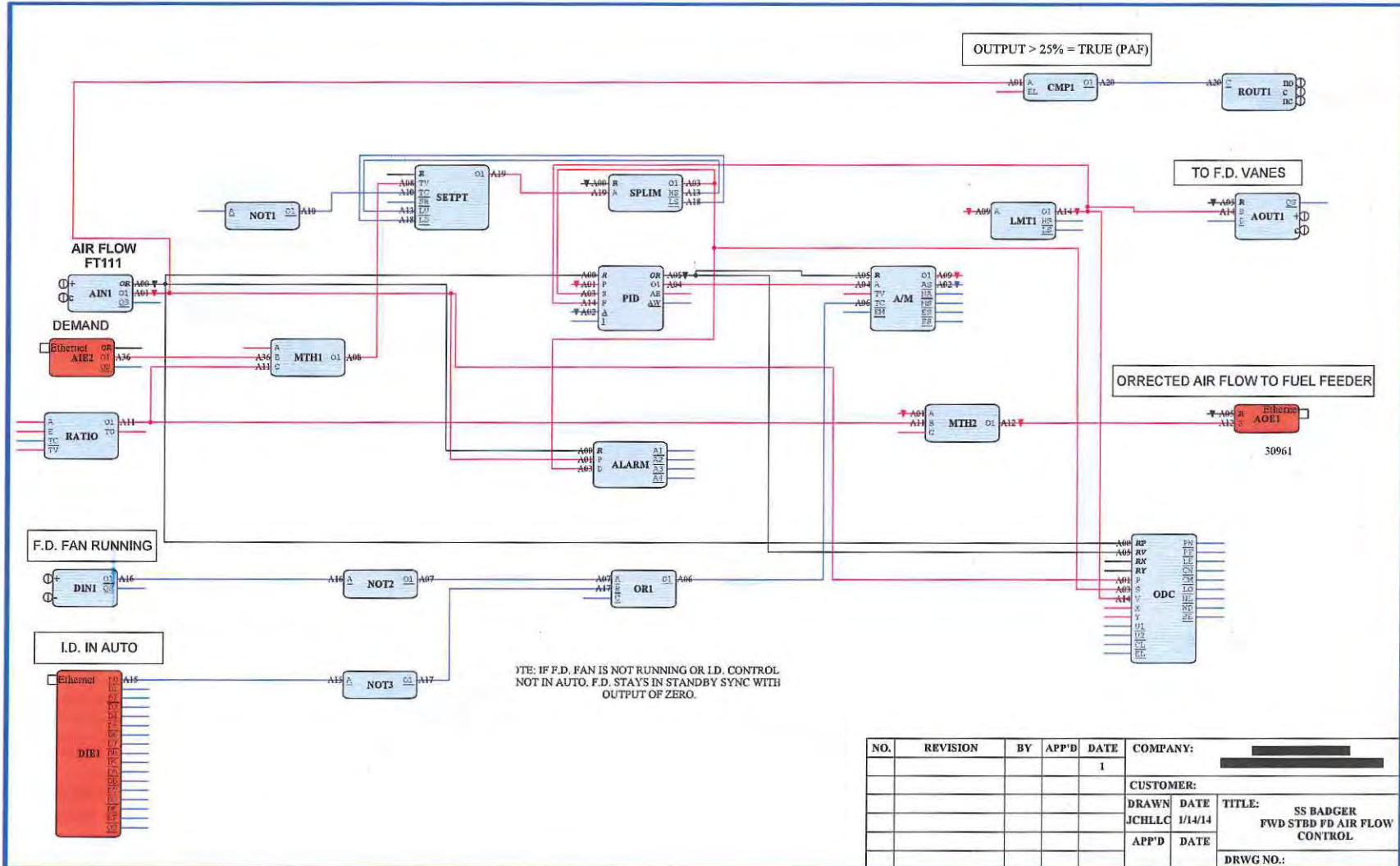

Friday, January 24, 2014 12:40:33 PM

CONTAINS CONFIDENTIAL BUSINESS INFORMATION



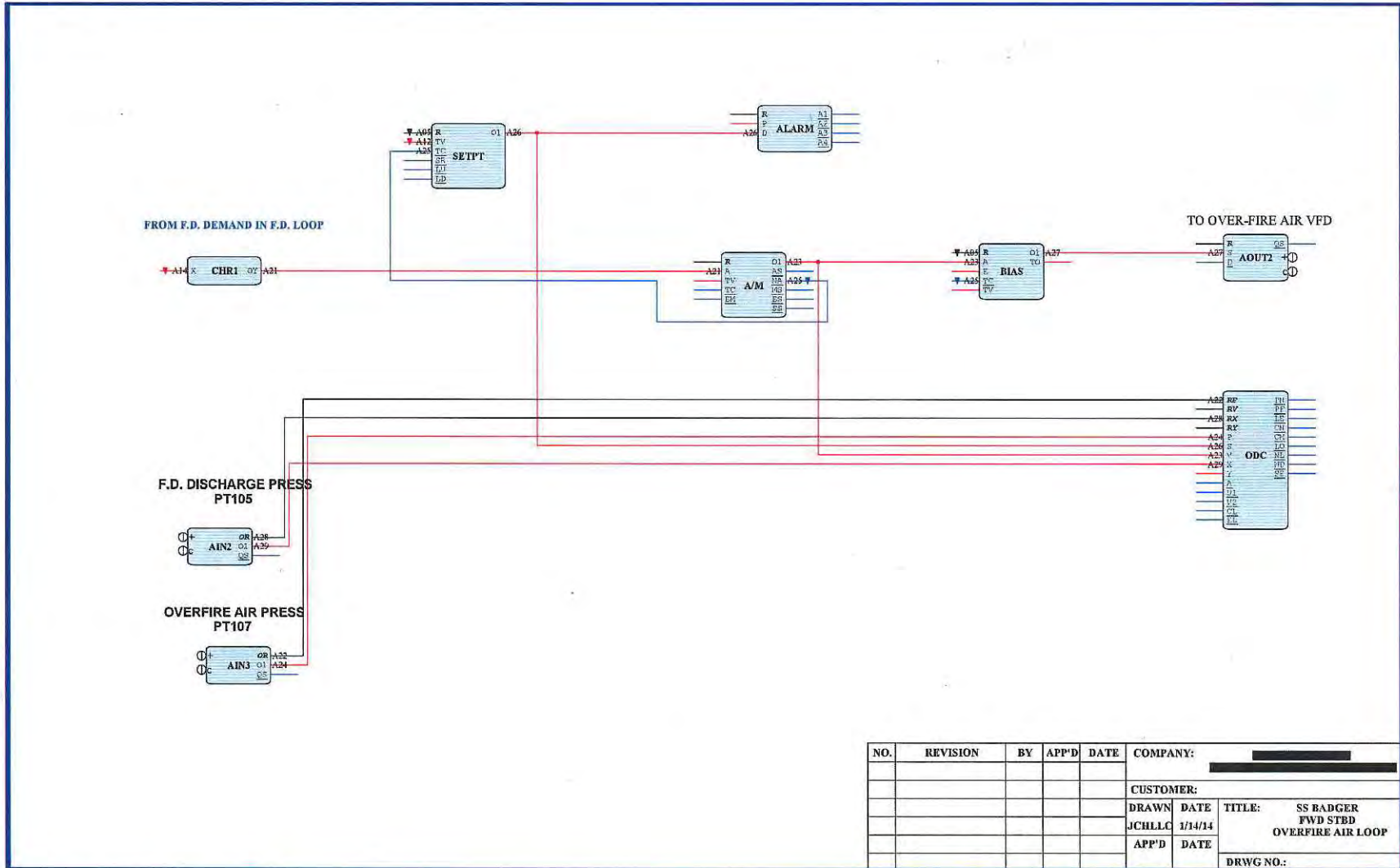

NO.	REVISION	BY	APP'D	DATE	COMPANY:	CUSTOMER:	
						DRAWN	DATE
					JCHLLC	1/14/14	TITLE: SS BADGER FWD STBD OVERFIRE AIR LOOP
					APP'D	DATE	DRWG NO.:

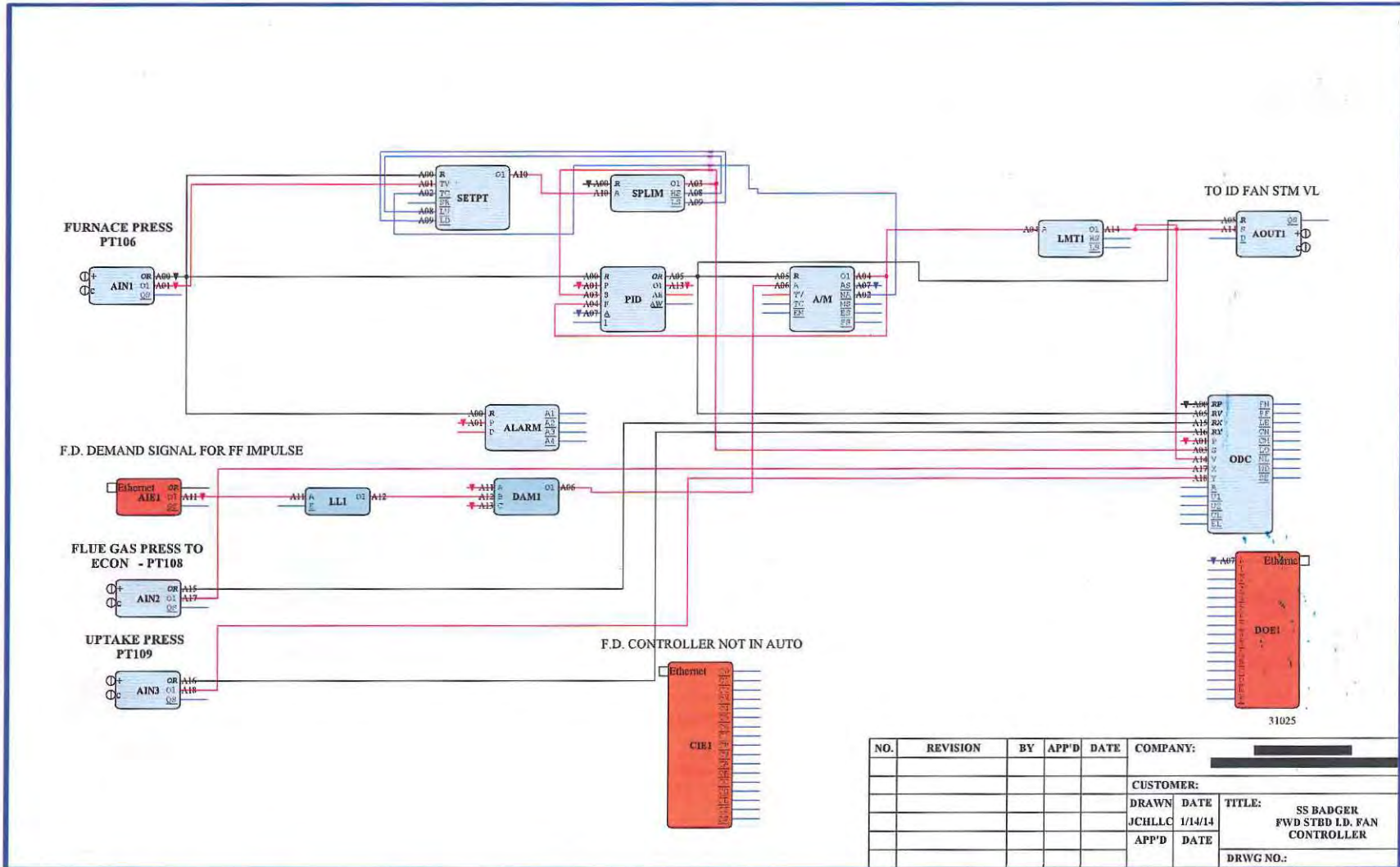

NO.	REVISION	BY	APP'D	DATE	COMPANY:		
					CUSTOMER:		
					DRAWN	DATE	TITLE:
					JCHLLC	1/14/14	SS BADGER FWD STBD I.D. FAN CONTROLLER
					APP'D	DATE	DRWG NO.:

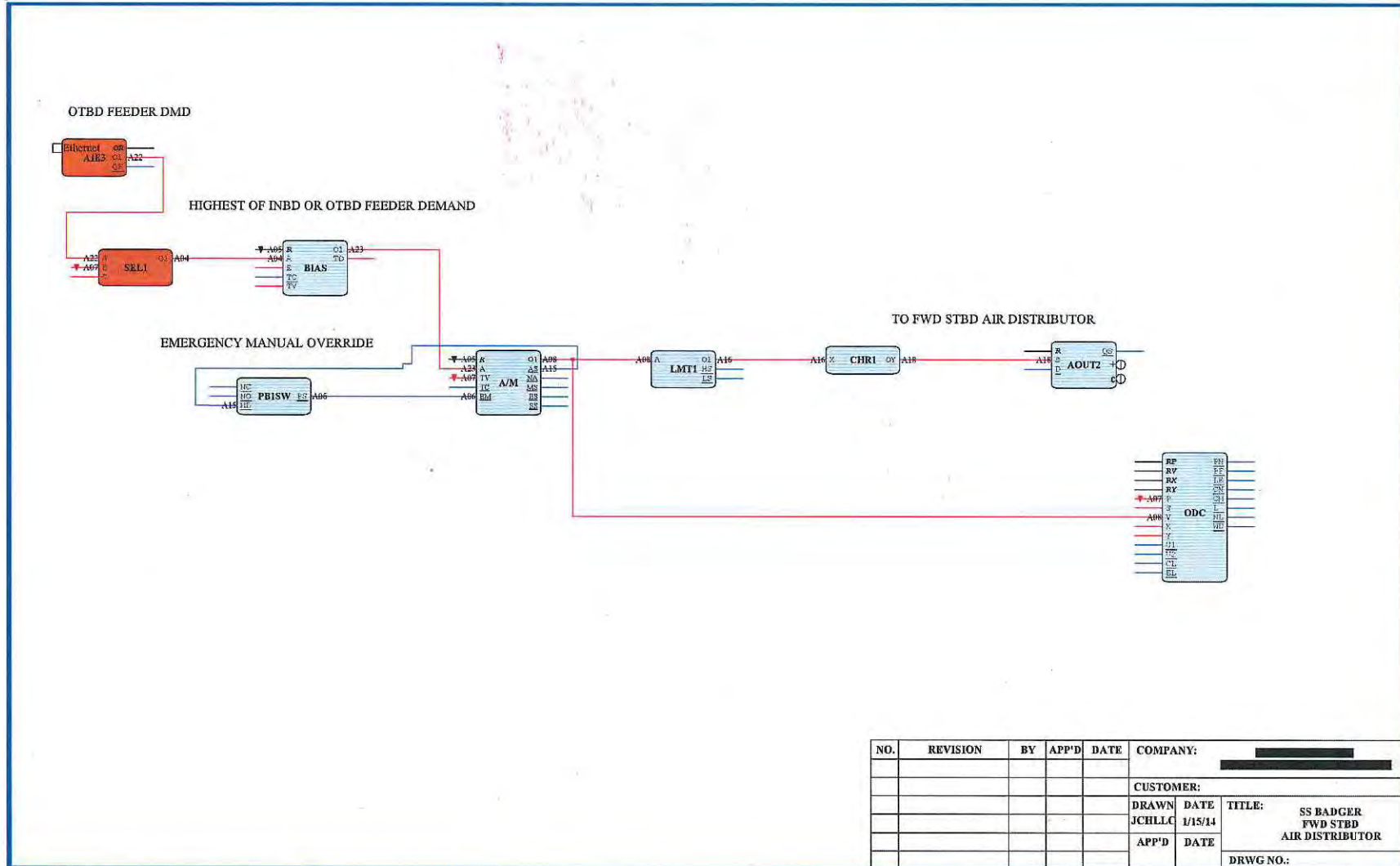

NO.	REVISION	BY	APP'D	DATE	COMPANY:	
					CUSTOMER:	
					DRAWN	DATE
					JCHLLC	1/15/14
					APP'D	DATE
					DRWG NO.:	





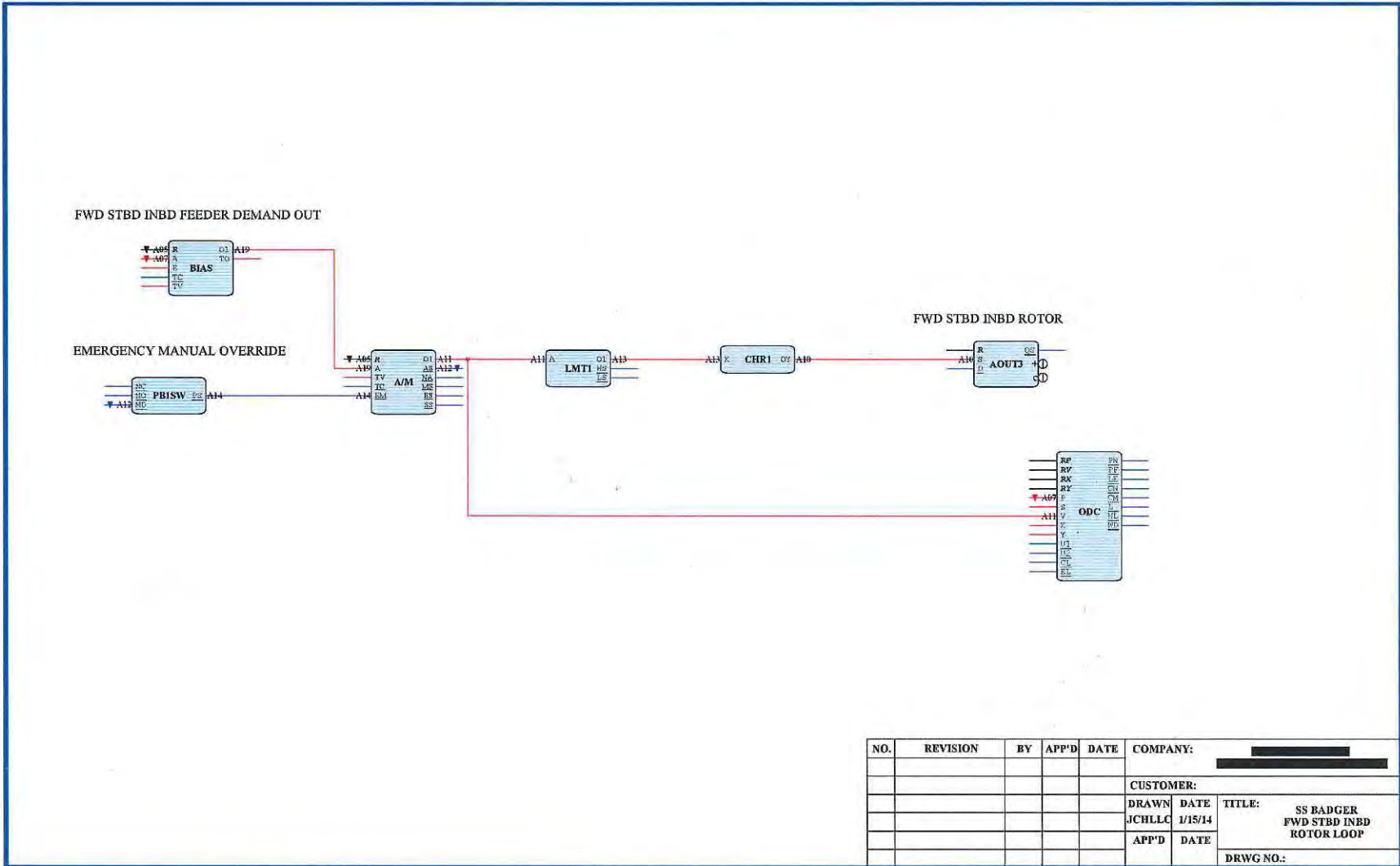

NO.	REVISION	BY	APP'D	DATE	COMPANY:	CUSTOMER:	
					DRAWN	DATE	TITLE:
					JCHLLC	1/15/14	SS BADGER FWD STBD INBD ROTOR LOOP
					APP'D	DATE	DRWG NO.:

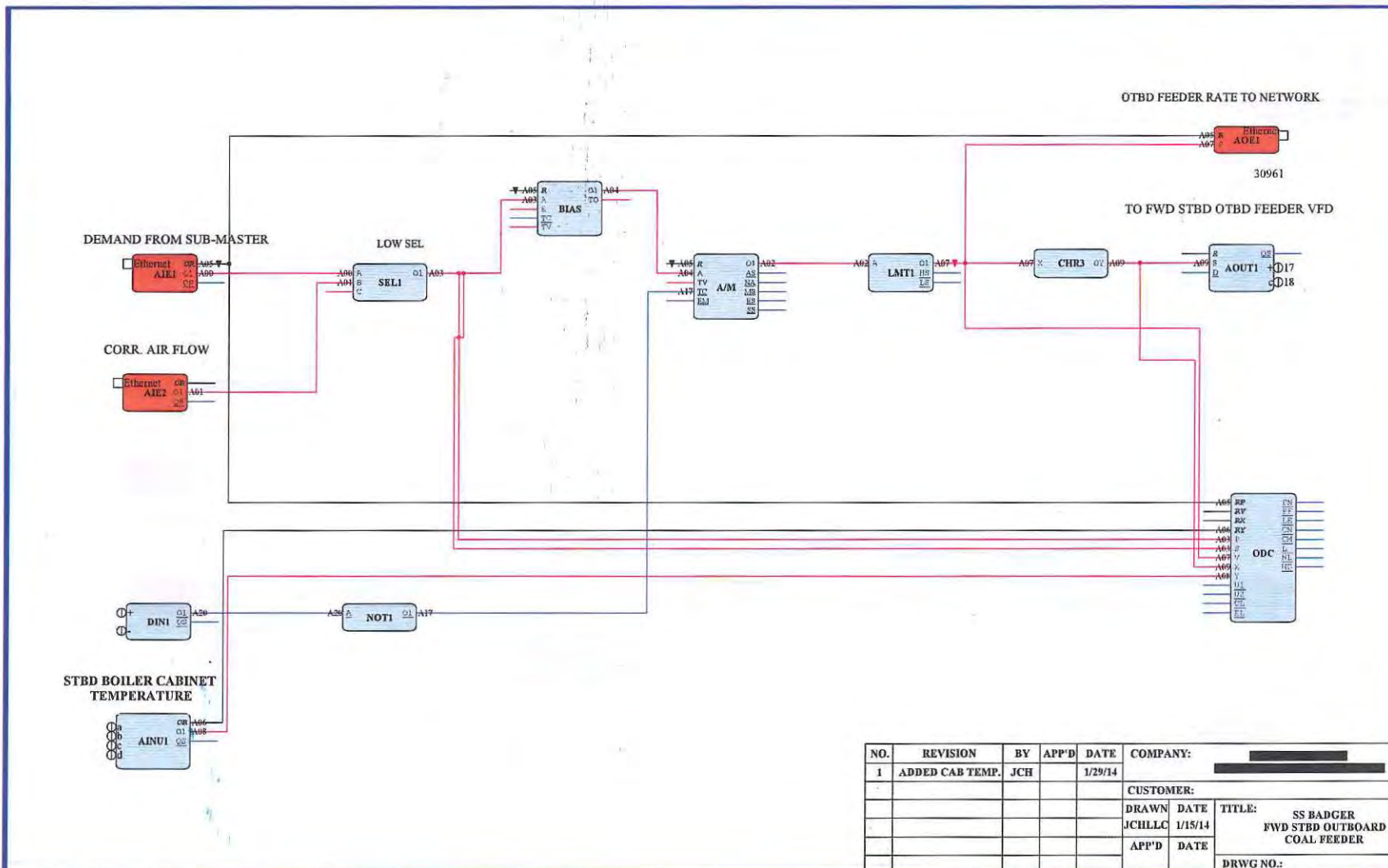

NO.	REVISION	BY	APP'D	DATE	COMPANY:
1	ADDED CAB TEMP.	JCH		1/29/14	
					CUSTOMER:
					DRAWN DATE
					JCHLLC 1/15/14
					APP'D DATE
					TITLE: SS BADGER FWD STBD OUTBOARD COAL FEEDER
					DRWG NO.:

Wednesday, January 29, 2014 8:43:41 AM

CONTAINS CONFIDENTIAL BUSINESS INFORMATION



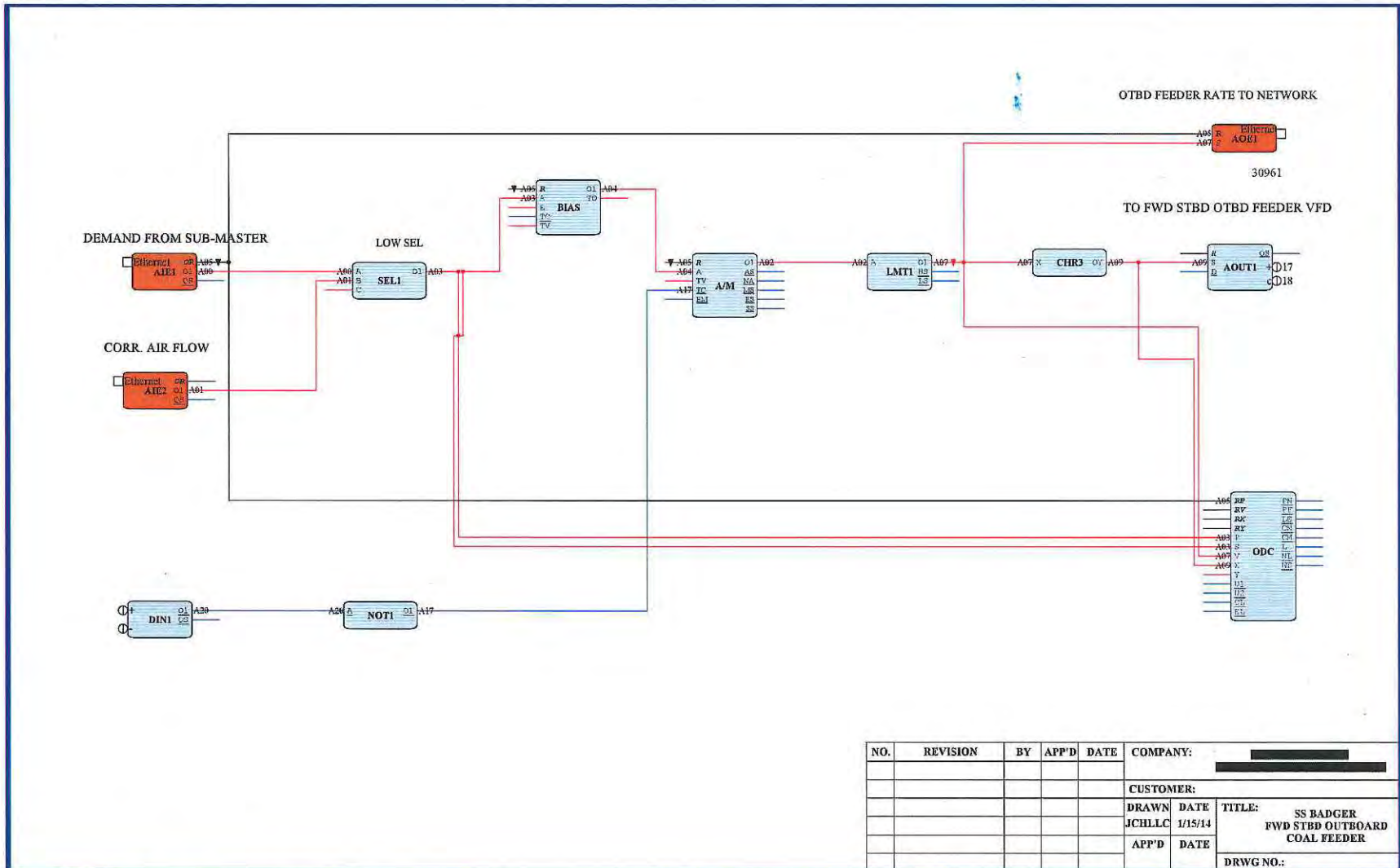



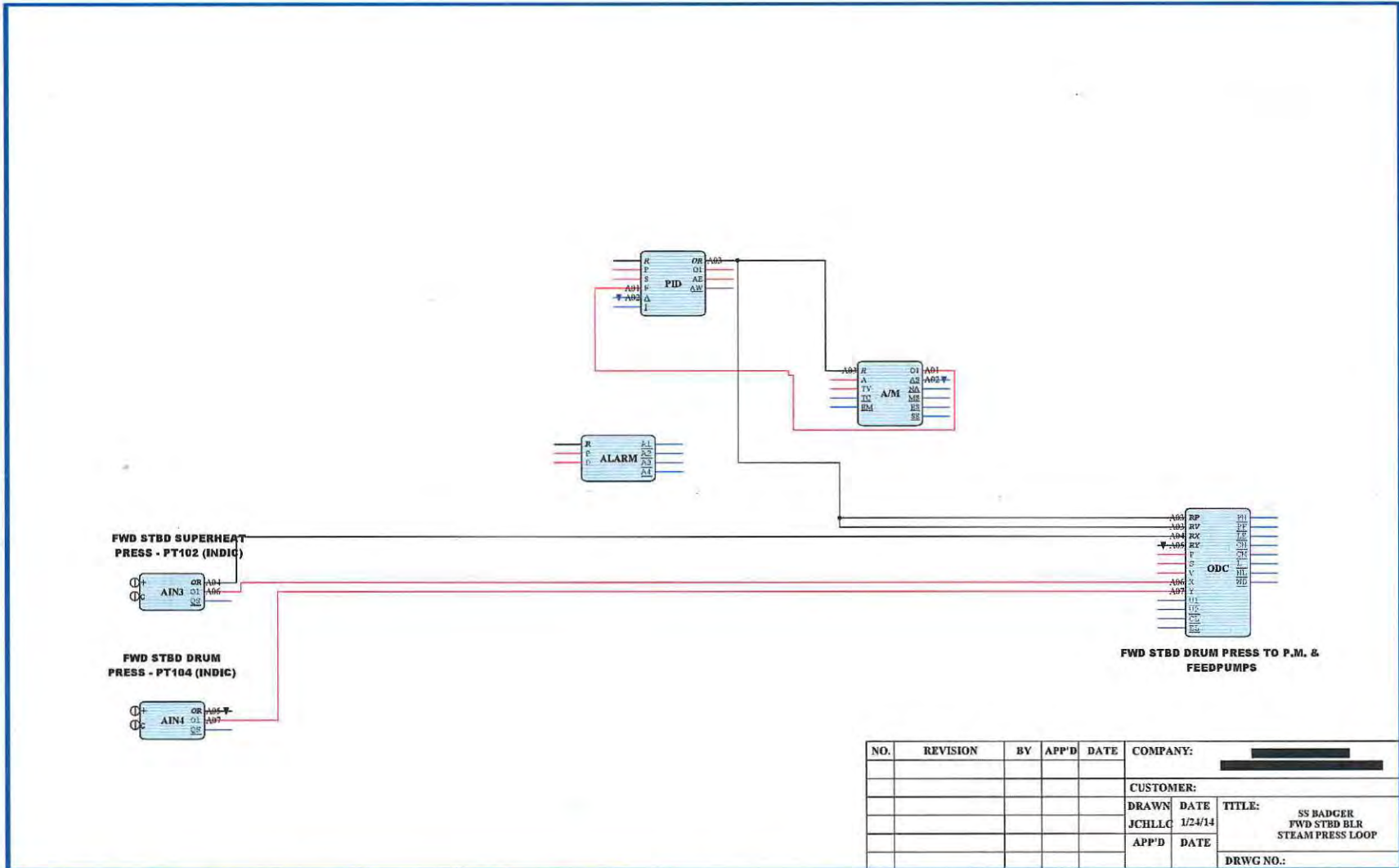

NO.	REVISION	BY	APP'D	DATE	COMPANY:	[REDACTED]	
					CUSTOMER:	[REDACTED]	
					DRAWN	DATE	TITLE:
					JCHLLC	1/24/14	SS BADGER FWD STBD BLR STEAM PRESS LOOP
					APP'D	DATE	DRWG NO.:



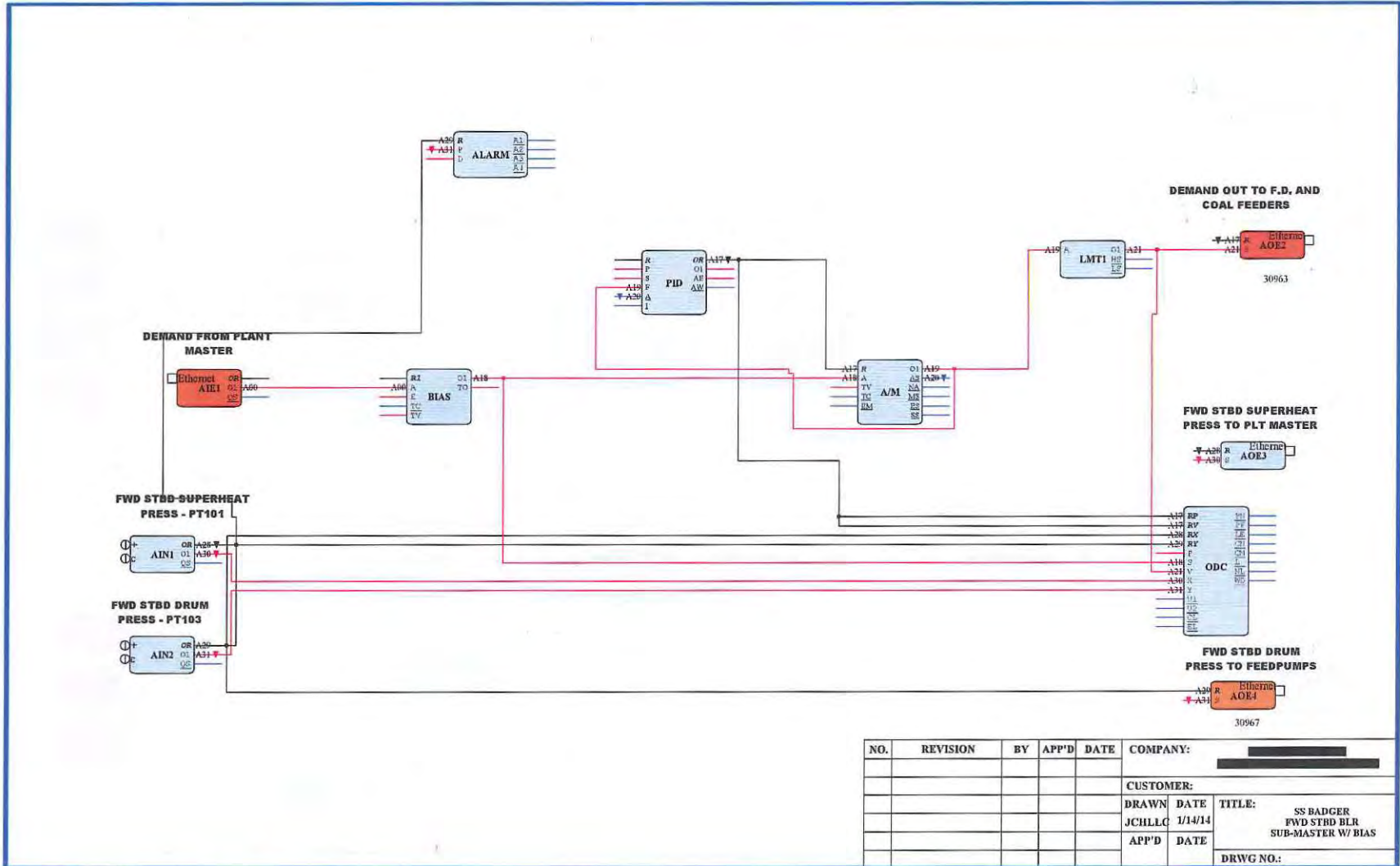

NO.	REVISION	BY	APP'D	DATE	COMPANY:		
					CUSTOMER:		
					DRAWN	DATE	TITLE:
					JCHLLC	1/14/14	SS BADGER
					APP'D	DATE	FWD STBD BLR
							SUB-MASTER W/ BIAS
							DRWG NO.:

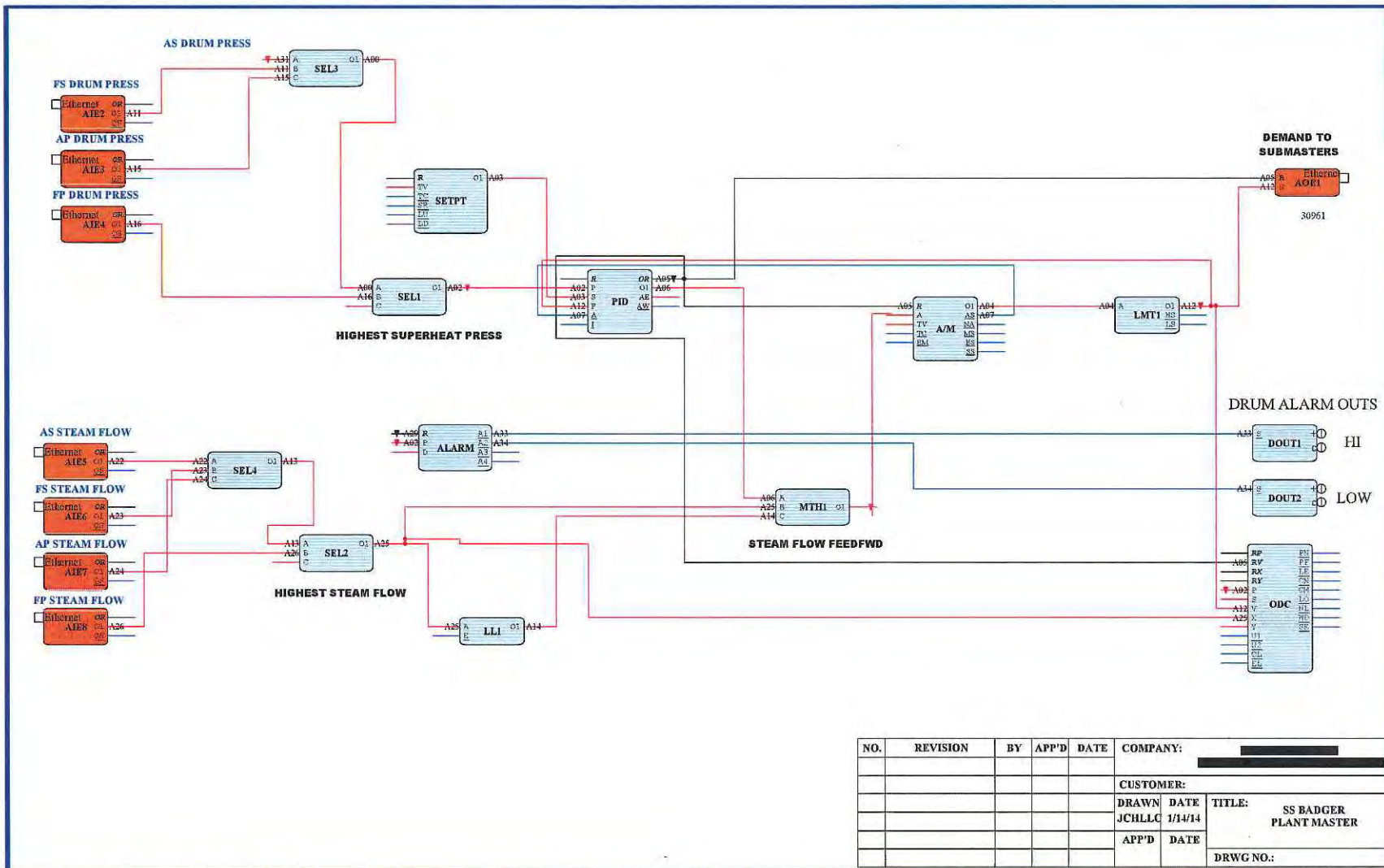

NO.	REVISION	BY	APP'D	DATE	COMPANY:		
					CUSTOMER:		
					DRAWN	DATE	TITLE: SS BADGER PLANT MASTER
					JCHLLC	1/14/14	
					APP'D	DATE	
							DRWG NO.:

REV.

STA. POWER TERMINALS

CABINET DC POWER DISTRIBUTION



ANALOG INPUTS

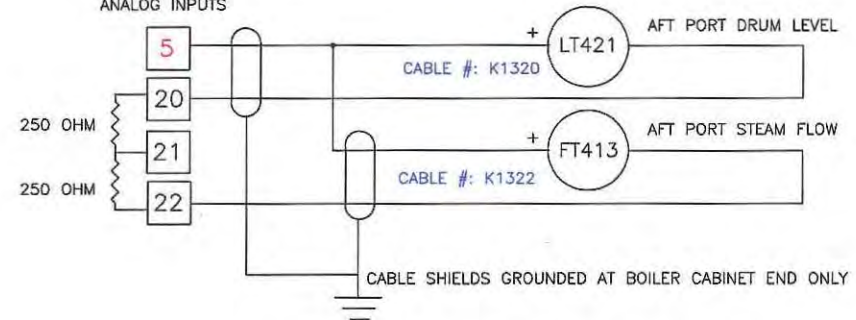

ALARM RELAY OUT

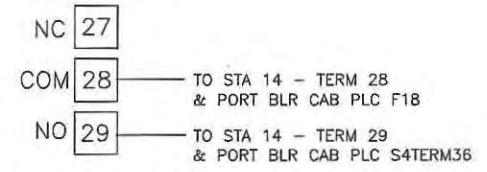

RELAY #2

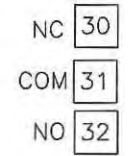

ANALOG OUTPUTS

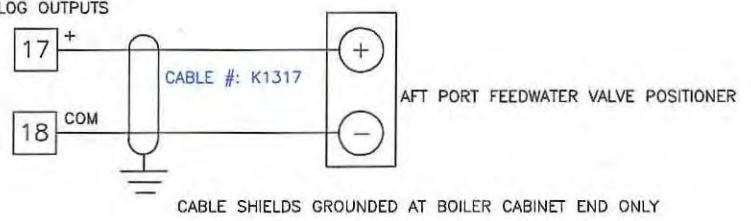

CONTAINS CONFIDENTIAL BUSINESS INFORMATION

SS BADGER STATION 13 - AFT PORT DRUM LEVEL WIRING DETAILS	
DRAWING NAME: STA13.DWG	DRAWING NUMBER:
BY: JCHLLE	DATE: 1/29/14
SHEET ___ OF ___	



REV.

STA. POWER TERMINALS

CABINET DC POWER DISTRIBUTION

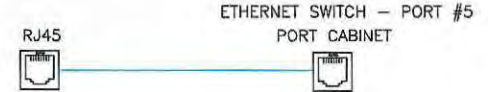

ANALOG INPUTS

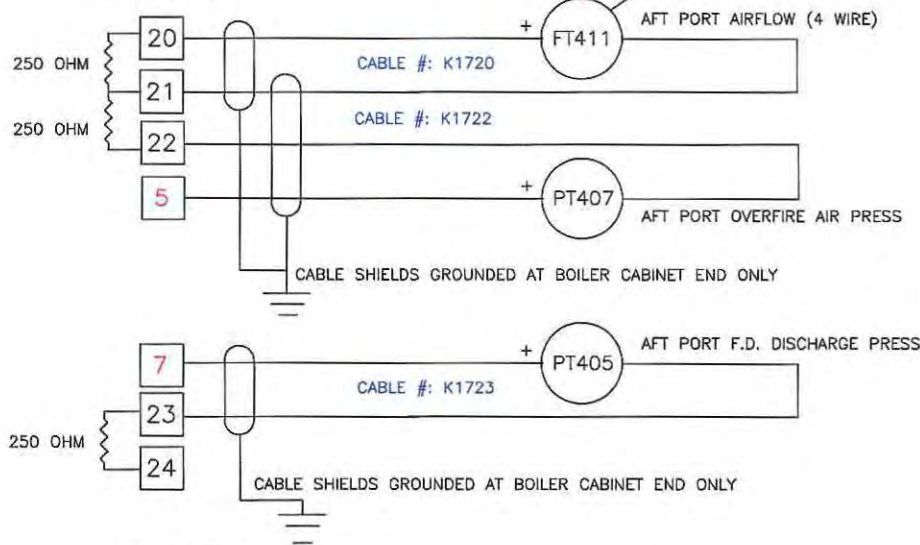

ALARM RELAY OUT

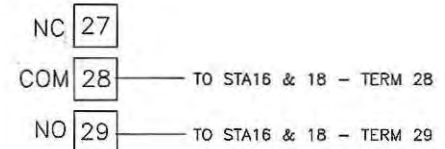

RELAY #2

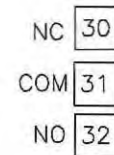

ANALOG OUTPUTS

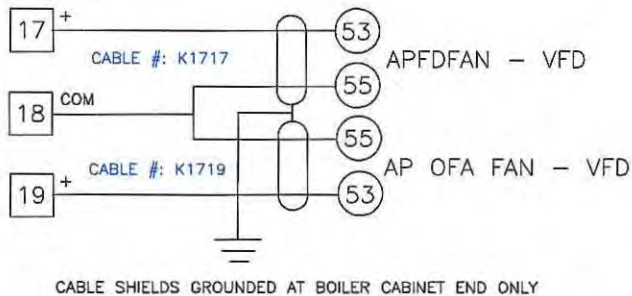

SS BADGER  
 STATION 17 - AFT PORT FORCED DRAFT  
 WIRING DETAILS

DRAWING NAME: STA17.DWG	DRAWING NUMBER:
BY: JCHLLC	DATE: 1/28/14
SHEET	OF

CONTAINS CONFIDENTIAL BUSINESS INFORMATION

REV.

STA. POWER TERMINALS

CABINET DC POWER DISTRIBUTION

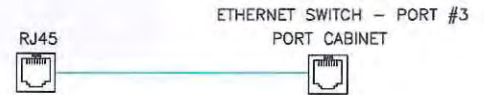

ANALOG OUTPUTS

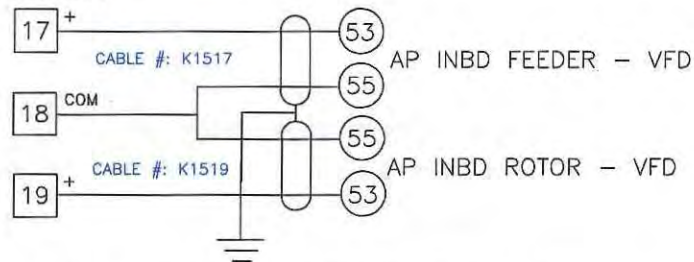

CABLE SHIELDS GROUNDED AT BOILER CABINET END ONLY

ANALOG OUTPUTS

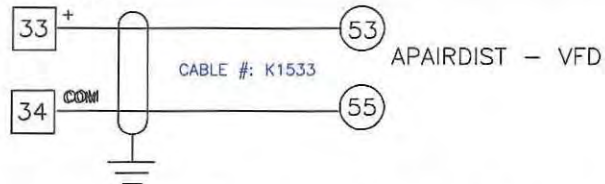

CABLE SHIELDS GROUNDED AT BOILER CABINET END ONLY

ALARM RELAY OUT

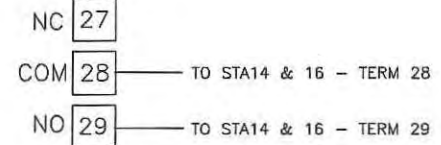

RELAY #2

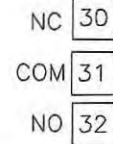

SS BADGER  
STATION 15 - AFT PORT INBD FEEDER  
WIRING DETAILS

DRAWING NAME: STA15.DWG	DRAWING NUMBER:
BY: JCHILLI	DATE: 1/30/14
SHEET ___ OF ___	

CONTAINS CONFIDENTIAL BUSINESS INFORMATION

REV.

STA. POWER TERMINALS

CABINET DC POWER DISTRIBUTION

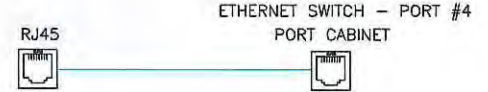

ANALOG INPUTS

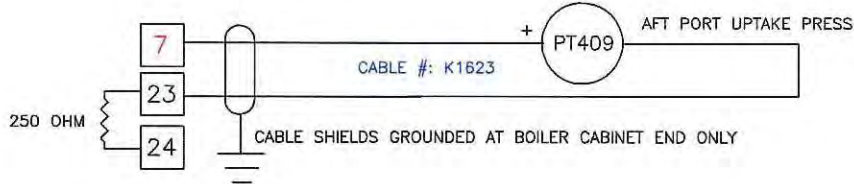
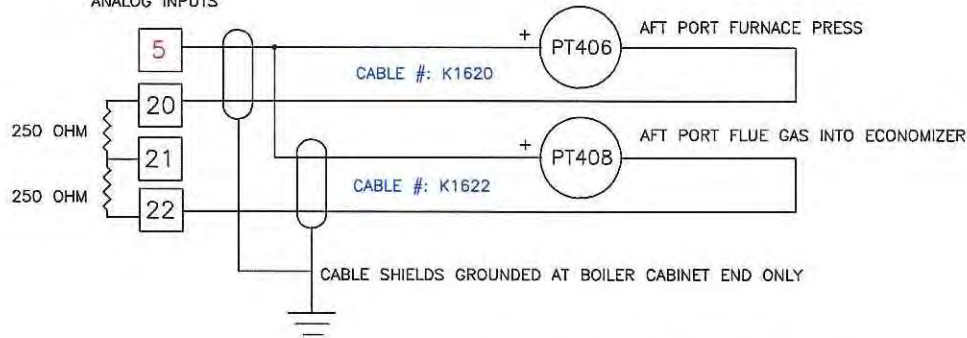

ANALOG OUTPUTS

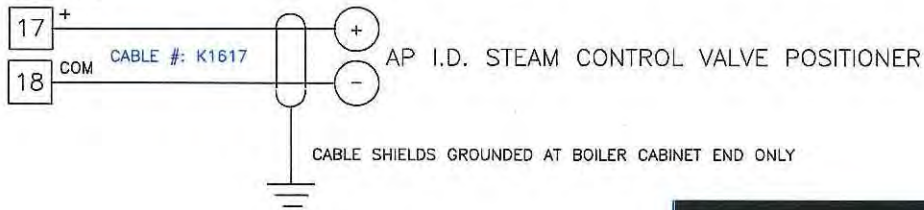

ALARM RELAY OUT

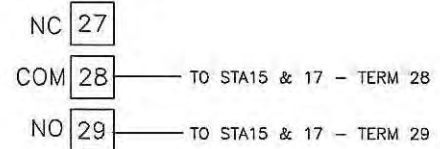

RELAY #2

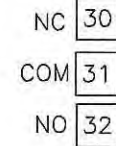

SS BADGER  
STATION 16 - AFT PORT INDUCED DRAFT  
WIRING DETAILS

DRAWING NAME: STA16.DWG DRAWING NUMBER:  
BY: JCHILLE DATE 1/30/14 SHEET \_\_\_ OF \_\_\_

CONTAINS CONFIDENTIAL BUSINESS INFORMATION



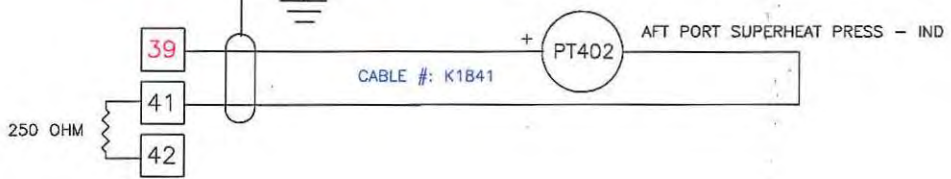
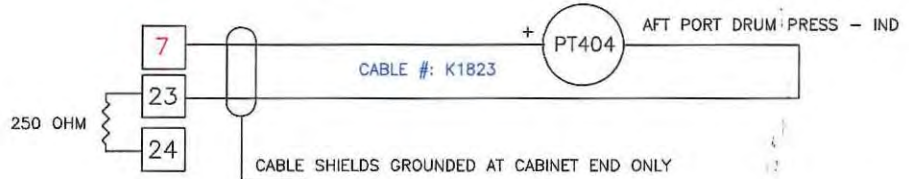
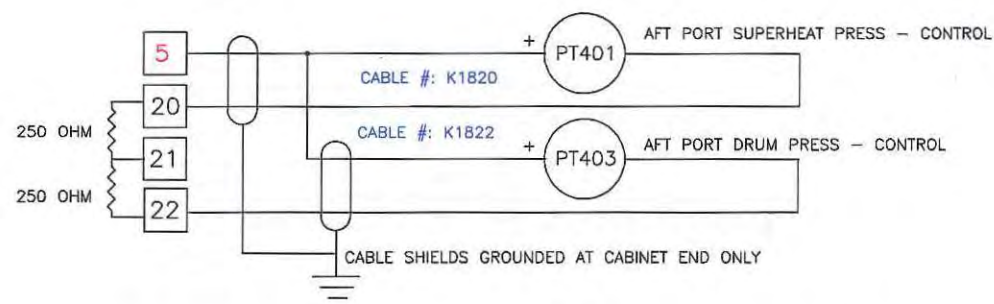
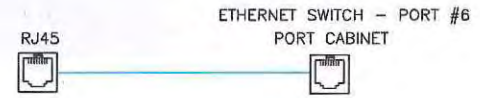

ALARM RELAY OUT

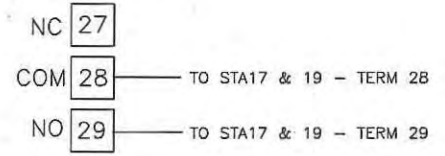

RELAY #2



SS BADGER  
 STATION 18 - AFT PORT MASTER  
 WIRING DETAILS

DRAWING NAME: STA1B.DWG	DRAWING NUMBER:
BY: JCHLLC	DATE: 1/28/14
SHEET ___ OF ___	

REV.

STA. POWER TERMINALS

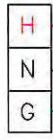

CABINET DC POWER DISTRIBUTION



DC+ FROM PORT PANEL FUSE F2



ETHERNET SWITCH - PORT #2  
STBD CABINET



ANALOG INPUT UNIVERSAL #1

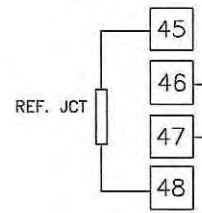

PORT CAB TEMP - TT431

ANALOG OUTPUTS

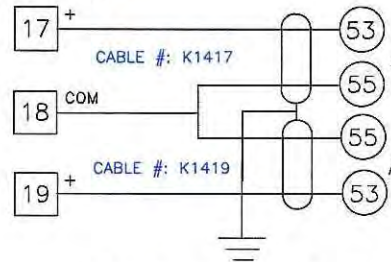

AP OTBD FEEDER - VFD

AP OTBD ROTOR - VFD

CABLE SHIELDS GROUNDED AT BOILER CABINET END ONLY

ALARM RELAY OUT

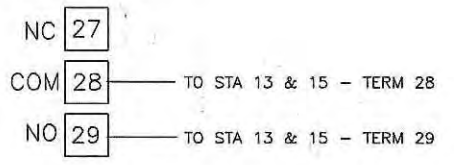

RELAY #2

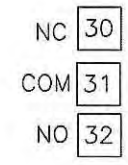

SS BADGER  
STATION 14 - AFT PORT OTBD FEEDER  
WIRING DETAILS

DRAWING NAME: STA14.DWG	DRAWING NUMBER:
BY: JCHILLIC	DATE: 1/30/14
SHEET ___ OF ___	

CONTAINS CONFIDENTIAL BUSINESS INFORMATION

REV.

STA. POWER TERMINALS

CABINET DC POWER DISTRIBUTION

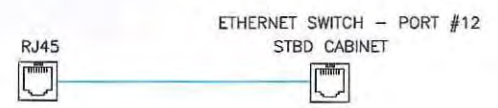

ANALOG INPUTS

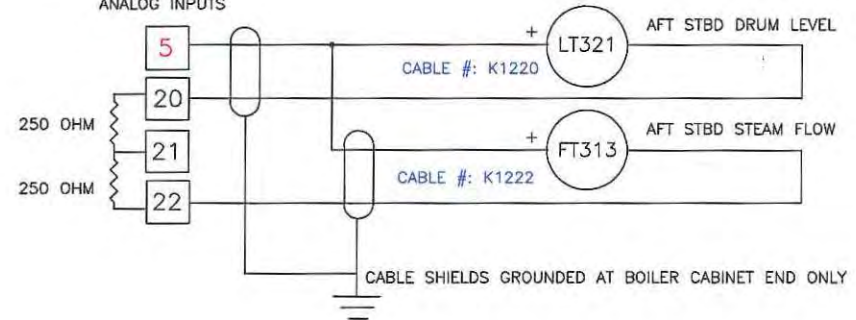

ALARM RELAY OUT

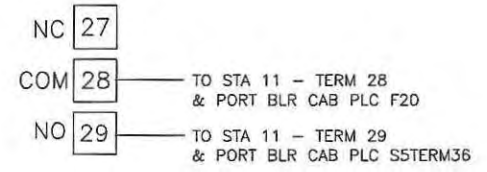

RELAY #2

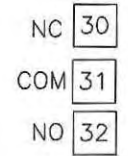

ANALOG OUTPUTS

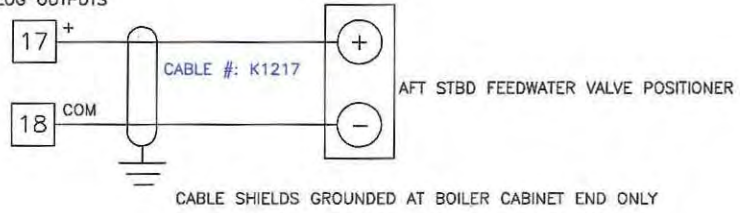

SS BADGER STATION 12 - AFT STBD DRUM LEVEL WIRING DETAILS	
DRAWING NAME: STA12.DWG	DRAWING NUMBER:
BY: JCHILLC	DATE: 1/29/14
SHEET ___ OF ___	

CONTAINS CONFIDENTIAL BUSINESS INFORMATION



REV.

STA. POWER TERMINALS

CABINET DC POWER DISTRIBUTION

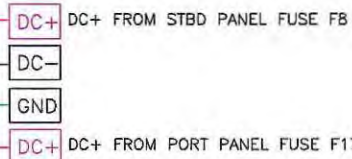
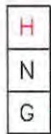

ANALOG INPUTS

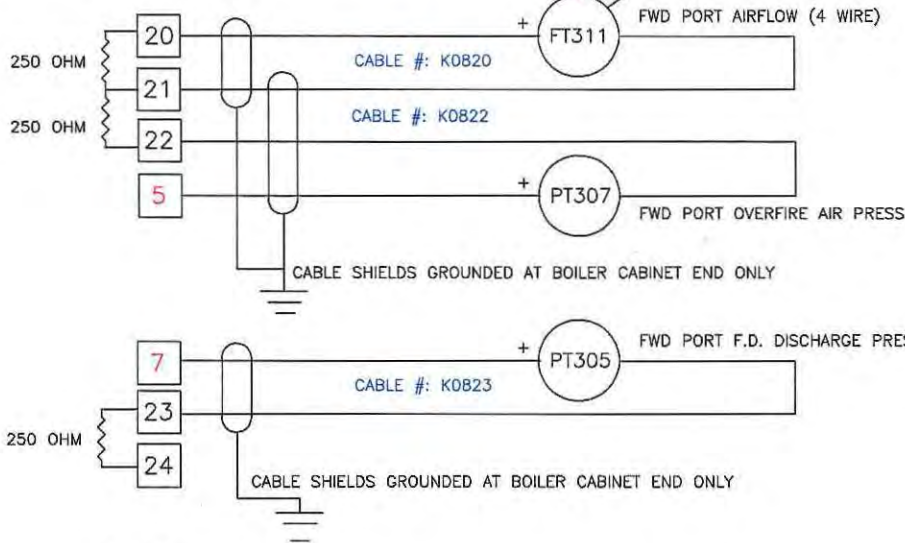

ALARM RELAY OUT

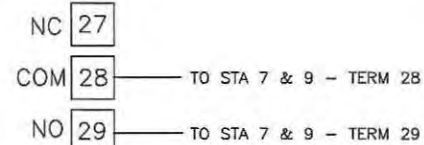

RELAY #2

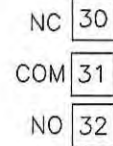

ANALOG OUTPUTS

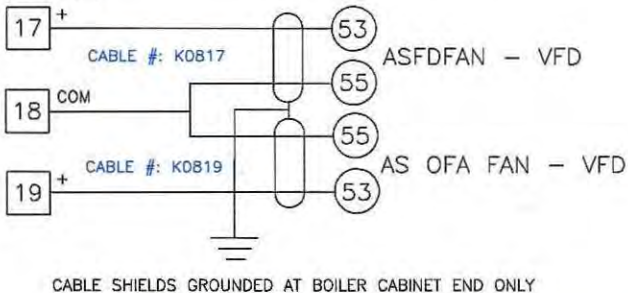

SS BADGER  
STATION 8 - FWD STBD FORCED DRAFT  
WIRING DETAILS

DRAWING NAME: STAB.DWG DRAWING NUMBER:  
BY: JCHILLIC DATE: 1/29/14 SHEET \_\_\_ OF \_\_\_

CONTAINS CONFIDENTIAL BUSINESS INFORMATION

STA. POWER TERMINALS

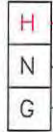

CABINET DC POWER DISTRIBUTION

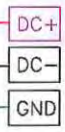

DC+ FROM STBD PANEL FUSE F10



ETHERNET SWITCH - PORT #10  
STBD CABINET



ANALOG OUTPUTS

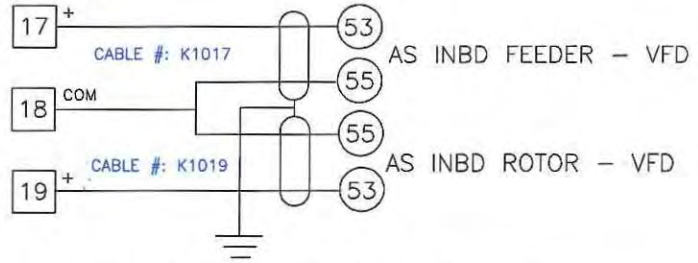

CABLE SHIELDS GROUNDED AT BOILER CABINET END ONLY

ANALOG OUTPUTS

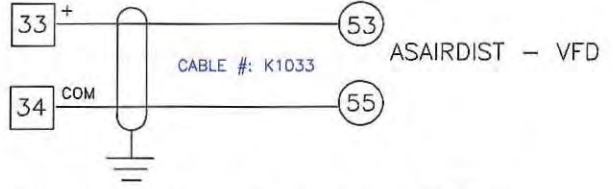

CABLE SHIELDS GROUNDED AT BOILER CABINET END ONLY

ALARM RELAY OUT

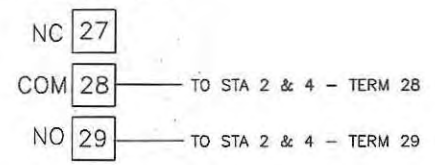

RELAY #2

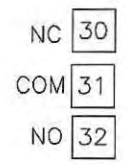

SS BADGER  
STATION 10 - AFT STBD INBD FEEDER  
WIRING DETAILS

DRAWING NAME: STA10.DWG	DRAWING NUMBER:
BY: JCHLLC (S) DATE: 1/30/14	SHEET ___ OF ___

REV

STA. POWER TERMINALS

CABINET DC POWER DISTRIBUTION



ANALOG INPUTS

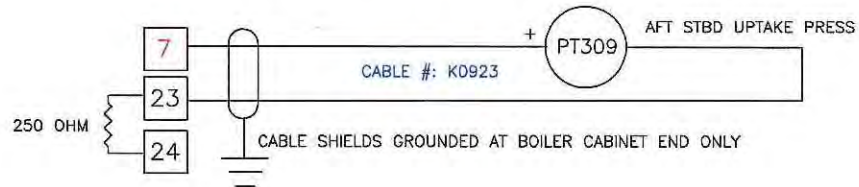
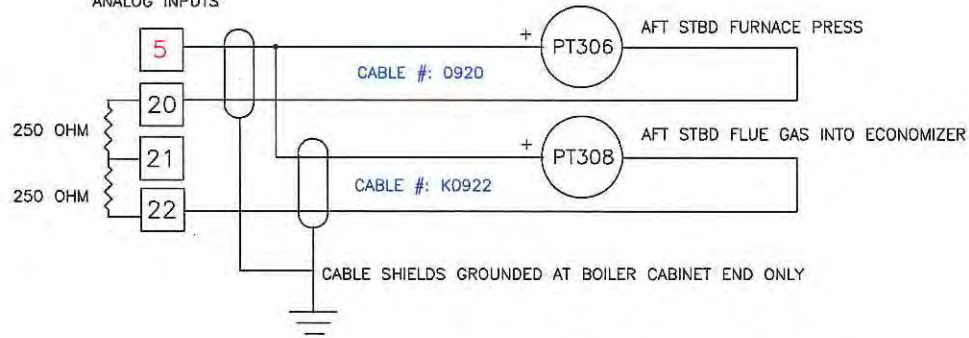

ALARM RELAY OUT

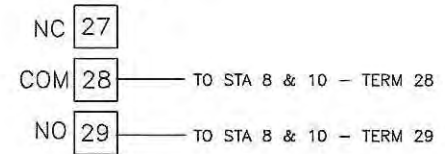

RELAY #2

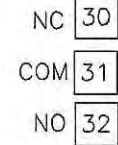

ANALOG OUTPUTS

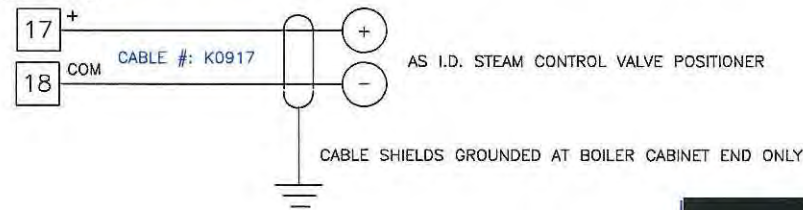

SS BADGER  
STATION 9 - AFT STBD INDUCED DRAFT  
WIRING DETAILS

DRAWING NAME: STA9.DWG	DRAWING NUMBER:
BY: JCHLLC	DATE: 1/30/14
	SHEET ___ OF ___

CONTAINS CONFIDENTIAL BUSINESS INFORMATION



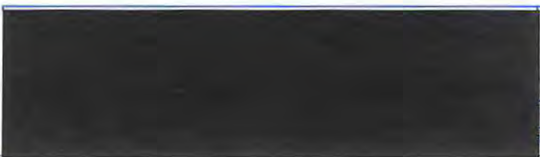
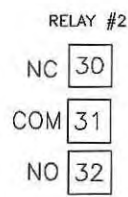
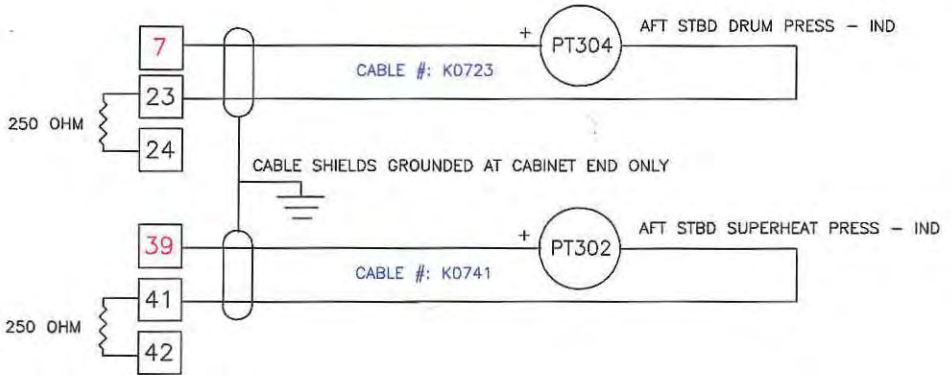
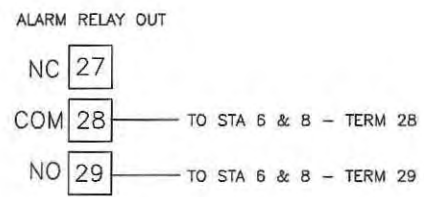
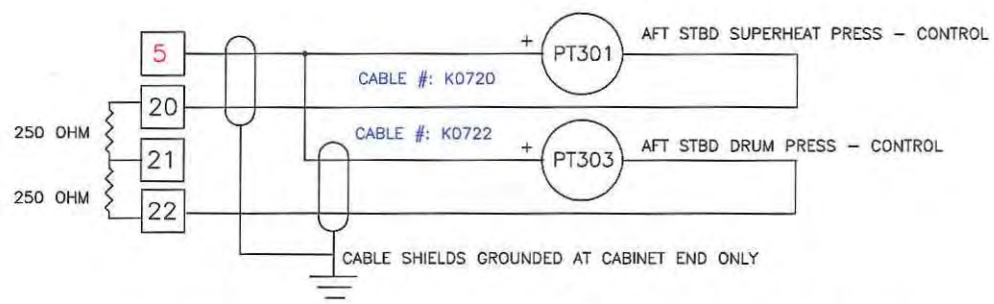
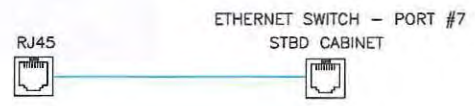

SS BADGER STATION 7 - AFT STBD MASTER WIRING DETAILS	
DRAWING NAME: STA7.DWG	DRAWING NUMBER:
BY: JCHILLIC	DATE: 1/29/14
SHEET ___ OF ___	

CONTAINS CONFIDENTIAL BUSINESS INFORMATION

REV.

STA. POWER TERMINALS

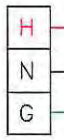

CABINET DC POWER DISTRIBUTION

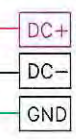

DC+ FROM STBD PANEL FUSE F11



ETHERNET SWITCH - PORT #11  
STBD CABINET

ANALOG INPUT UNIVERSAL #1

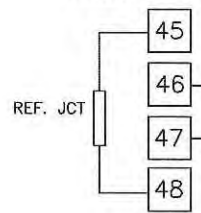

STBD CAB TEMP - TT131

ANALOG OUTPUTS

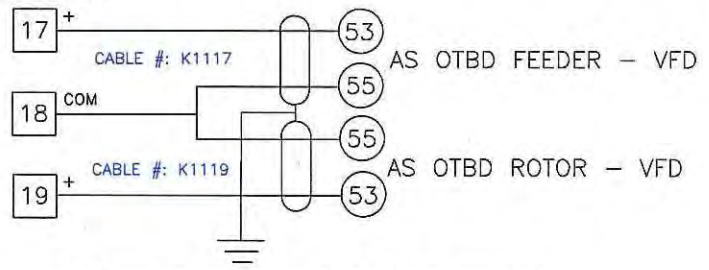

CABLE SHIELDS GROUNDED AT BOILER CABINET END ONLY

ALARM RELAY OUT

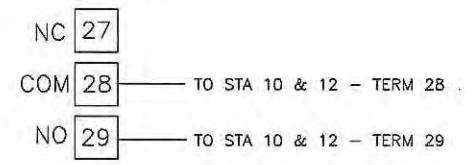

RELAY #2

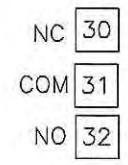

CONTAINS CONFIDENTIAL BUSINESS INFORMATION

SS BADGER  
STATION 11 - AFT STBD OTBD FEEDER  
WIRING DETAILS

DRAWING NAME: STA11.DWG	DRAWING NUMBER:
BY: JCHLLC	DATE: 1/30/14
SHEET	OF

REV.

STA. POWER TERMINALS

CABINET DC POWER DISTRIBUTION



ANALOG INPUTS

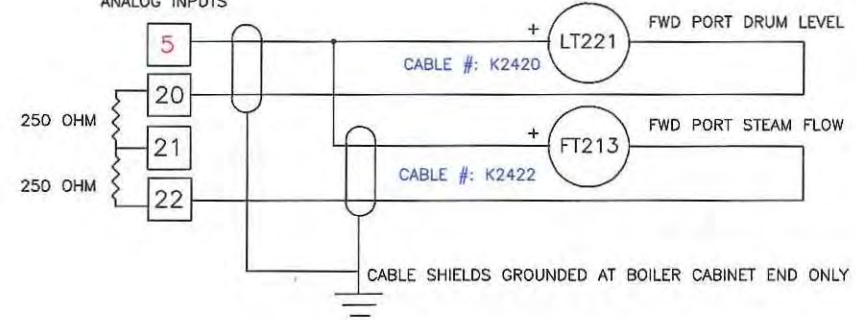

ALARM RELAY OUT

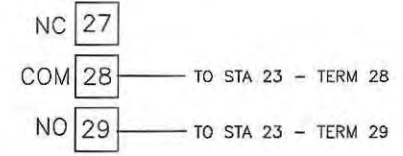

RELAY #2

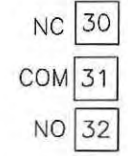

ANALOG OUTPUTS

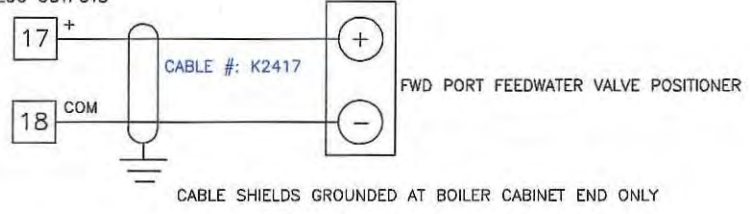

SS BADGER  
 STATION 24 - FWD PORT DRUM LEVEL  
 WIRING DETAILS

DRAWING NAME: STA24.DWG	DRAWING NUMBER:
BY: JCHLLC	DATE: 1/29/14
SHEET ___ OF ___	

CONTAINS CONFIDENTIAL BUSINESS INFORMATION



REV.

STA. POWER TERMINALS

CABINET DC POWER DISTRIBUTION

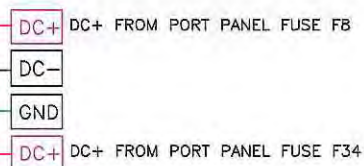
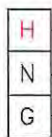

ANALOG INPUTS

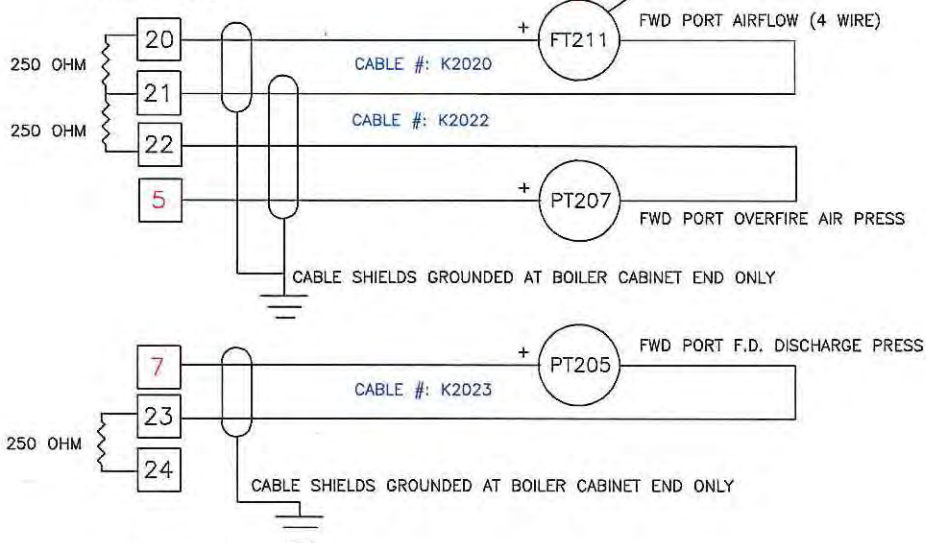

ALARM RELAY OUT

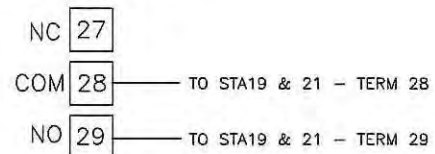

RELAY #2

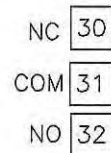

ANALOG OUTPUTS

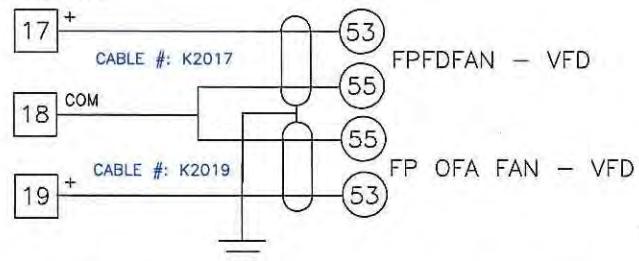

CABLE SHIELDS GROUNDED AT BOILER CABINET END ONLY

SS BADGER  
STATION 20 - FWD PORT FORCED DRAFT  
WIRING DETAILS

DRAWING NAME: STA20.DWG DRAWING NUMBER:  
BY: JCHLLC DATE: 1/29/14 SHEET \_\_\_ OF \_\_\_

CONTAINS CONFIDENTIAL BUSINESS INFORMATION

REV.

STA. POWER TERMINALS

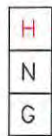

CABINET DC POWER DISTRIBUTION

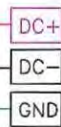

DC+ FROM PORT PANEL FUSE F10



ETHERNET SWITCH - PORT #10  
PORT CABINET



ANALOG OUTPUTS

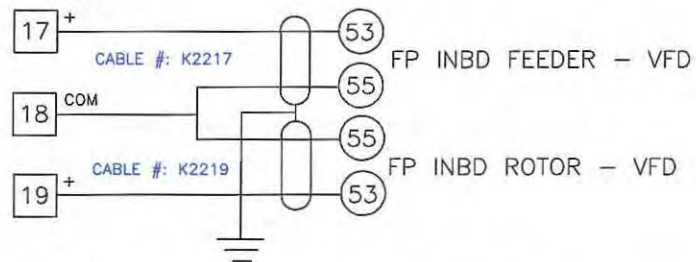

CABLE SHIELDS GROUNDED AT BOILER CABINET END ONLY

ANALOG OUTPUTS

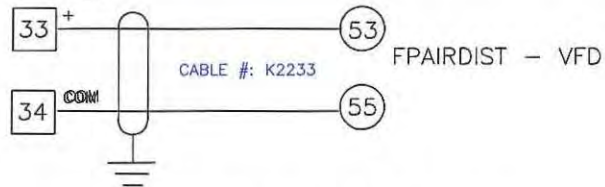

CABLE SHIELDS GROUNDED AT BOILER CABINET END ONLY

ALARM RELAY OUT

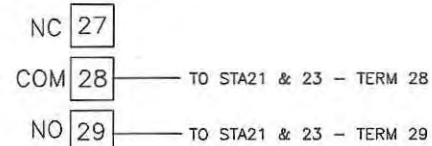

RELAY #2

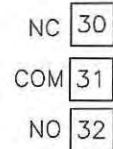

SS BADGER  
STATION 22 - FWD PORT INBD FEEDER  
WIRING DETAILS

DRAWING NAME: STA22.DWG	DRAWING NUMBER:
BY: JCHILLIC	DATE: 1/30/14
SHEET ___ OF ___	

CONTAINS CONFIDENTIAL BUSINESS INFORMATION

REV.

STA. POWER TERMINALS

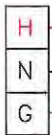

CABINET DC POWER DISTRIBUTION

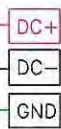

DC+ FROM PORT PANEL FUSE F9



ETHERNET SWITCH - PORT #9  
PORT CABINET



ANALOG INPUTS

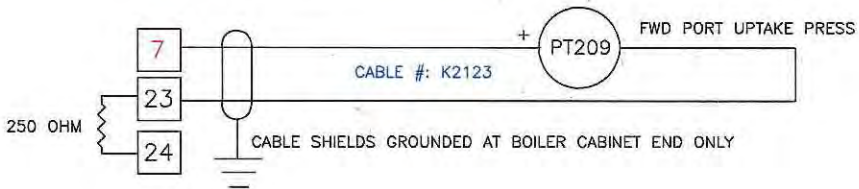
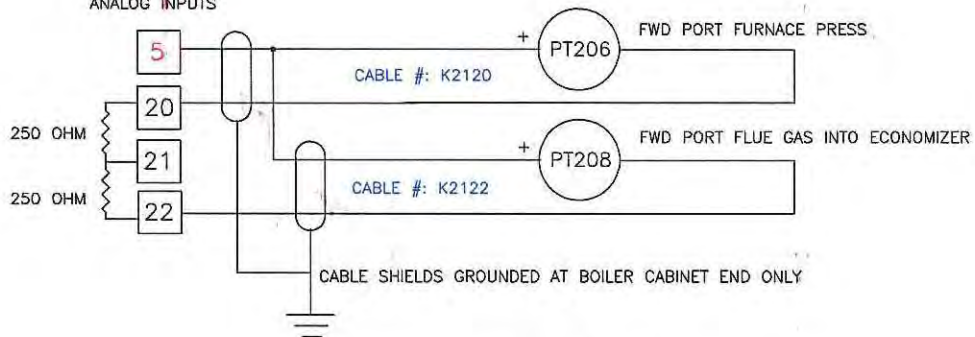

ANALOG OUTPUTS

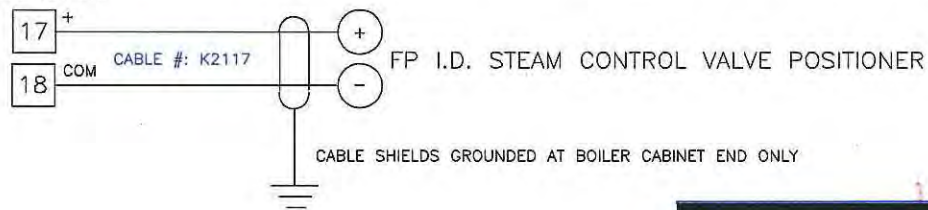

ALARM RELAY OUT

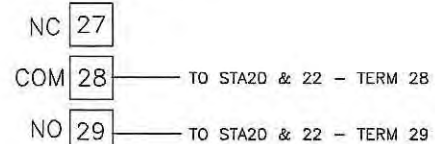

RELAY #2

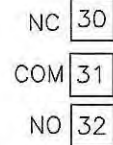

SS BADGER  
STATION 21 - FWD PORT INDUCED DRAFT  
WIRING DETAILS

DRAWING NAME: STA21.DWG	DRAWING NUMBER:
BY: JCHLLC	DATE: 1/30/14
SHEET	OF

CONTAINS CONFIDENTIAL BUSINESS INFORMATION



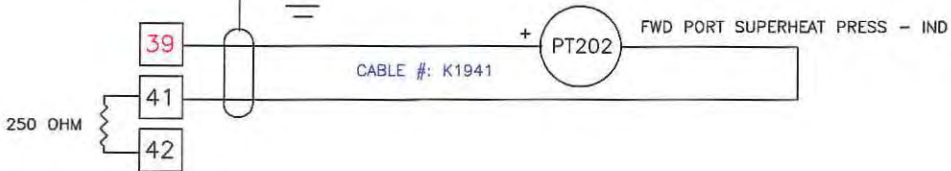
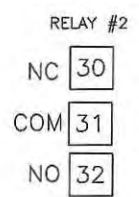
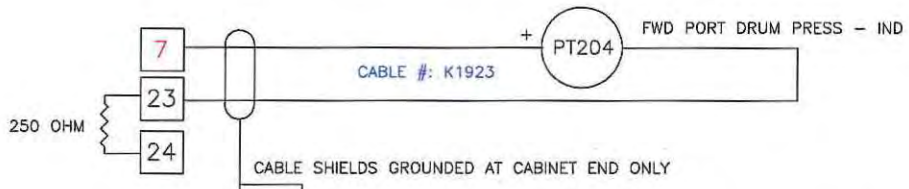
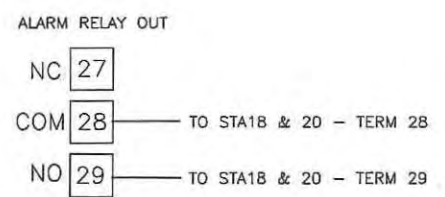
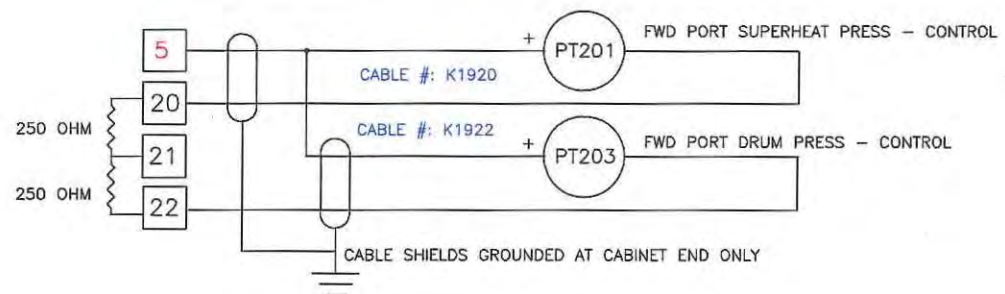

SS BADGER  
STATION 19 - FWD PORT MASTER  
WIRING DETAILS

DRAWING NAME: STA19.DWG	DRAWING NUMBER:
BY: JCHLIC	DATE: 1/28/14
SHEET ___ OF ___	

CONTAINS CONFIDENTIAL BUSINESS INFORMATION

STA. POWER TERMINALS

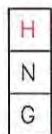

CABINET DC POWER DISTRIBUTION

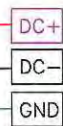

DC+ FROM PORT PANEL FUSE F11



ETHERNET SWITCH - PORT #11  
STBD CABINET



ANALOG OUTPUTS

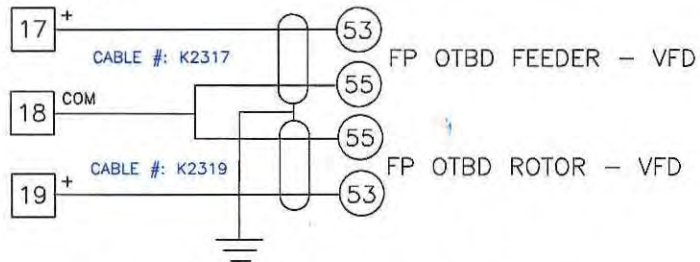

CABLE SHIELDS GROUNDED AT BOILER CABINET END ONLY

ALARM RELAY OUT

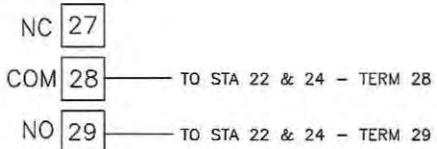

RELAY #2

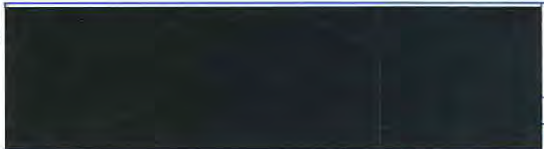
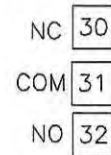

SS BADGER  
STATION 23 - FWD PORT OTBD FEEDER  
WIRING DETAILS

DRAWING NAME: STA23.DWG DRAWING NUMBER:  
BY: JCHLLC DATE: 1/30/14 SHEET \_\_\_ OF \_\_\_

REV.

STA. POWER TERMINALS

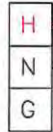

CABINET DC POWER DISTRIBUTION



DC+ FROM STBD PANEL FUSE F1



ETHERNET SWITCH - PORT #1  
STBD CABINET



ANALOG INPUTS

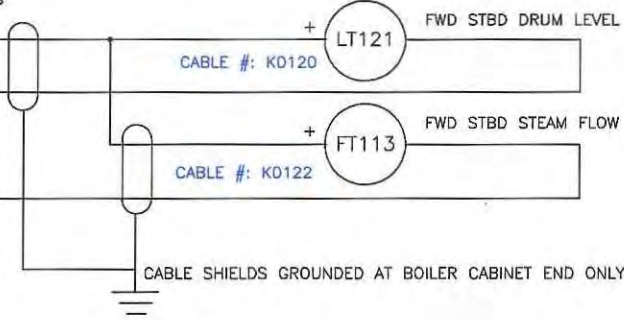
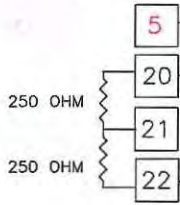

CABLE SHIELDS GROUNDED AT BOILER CABINET END ONLY

ALARM RELAY OUT

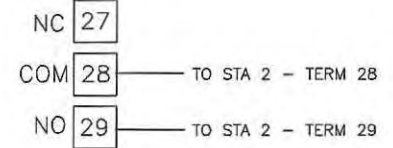

RELAY #2

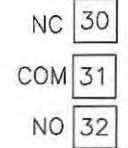

ANALOG OUTPUTS

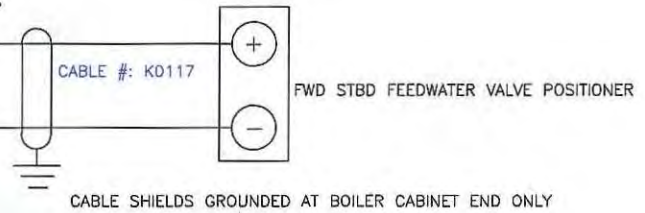

CABLE SHIELDS GROUNDED AT BOILER CABINET END ONLY

SS BADGER  
STATION 1 - FWD STBD DRUM LEVEL  
WIRING DETAILS

DRAWING NAME: STA1.DWG	DRAWING NUMBER:
BY: JCHLLC	DATE: 1/29/14
	SHEET ___ OF ___

CONTAINS CONFIDENTIAL BUSINESS INFORMATION



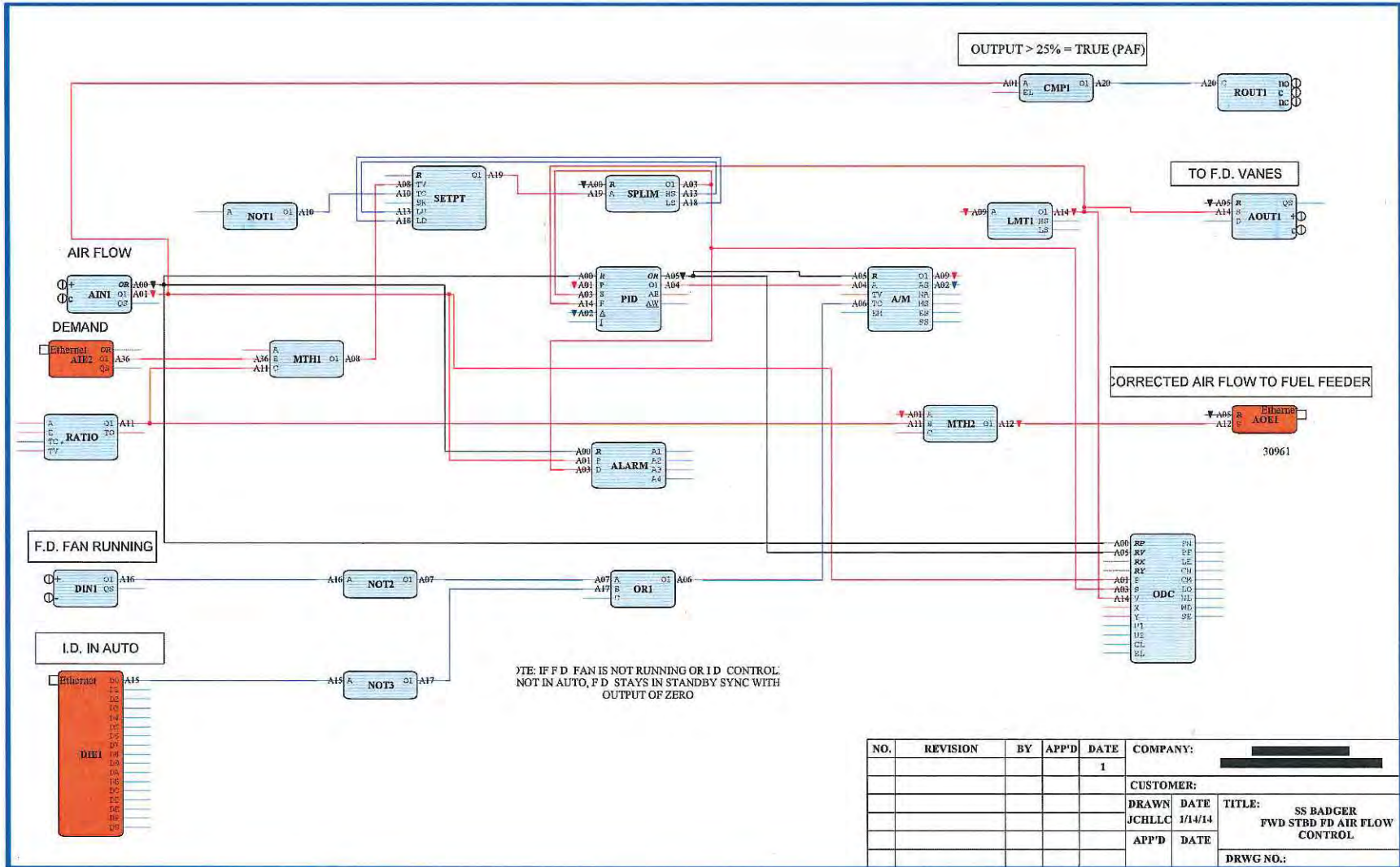

STA. POWER TERMINALS

CABINET DC POWER DISTRIBUTION



ANALOG INPUTS

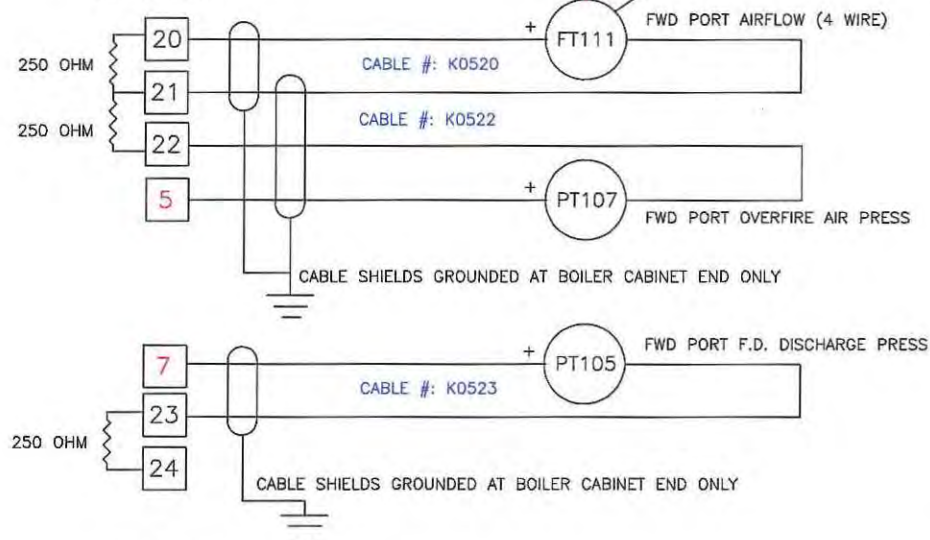

ALARM RELAY OUT

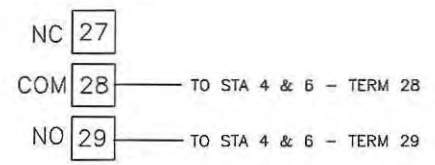

RELAY #2

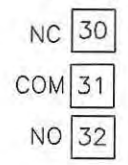

ANALOG OUTPUTS

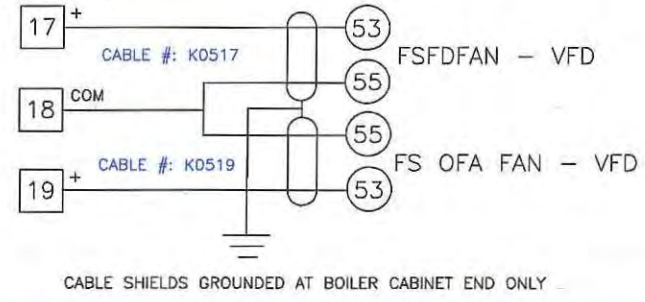

SS BADGER STATION 5 - FWD STBD FORCED DRAFT WIRING DETAILS	
DRAWING NAME: STAS.DWG	DRAWING NUMBER:
BY: JCHLLC	DATE: 1/29/14
SHEET ___ OF ___	

CONTAINS CONFIDENTIAL BUSINESS INFORMATION

REV.

STA. POWER TERMINALS

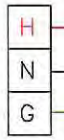

CABINET DC POWER DISTRIBUTION

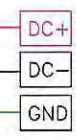

DC+ FROM STBD PANEL FUSE F3



ETHERNET SWITCH - PORT #3  
STBD CABINET



ANALOG OUTPUTS

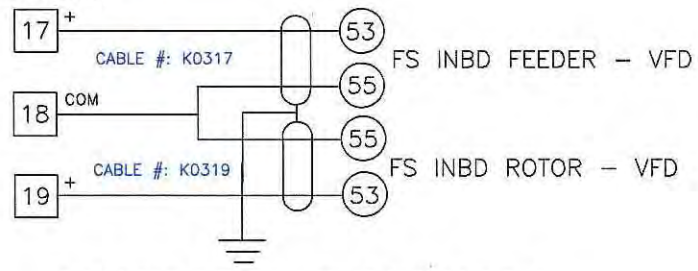

CABLE SHIELDS GROUNDED AT BOILER CABINET END ONLY

ANALOG OUTPUTS

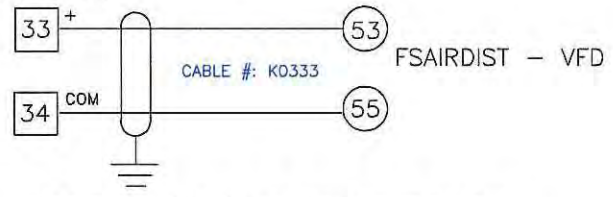

CABLE SHIELDS GROUNDED AT BOILER CABINET END ONLY

ALARM RELAY OUT

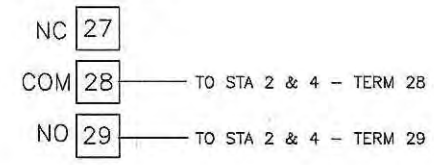

RELAY #2

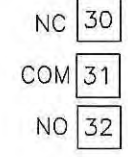

SS BADGER  
STATION 3 - FWD STBD INBD FEEDER  
WIRING DETAILS

DRAWING NAME: STA3.DWG	DRAWING NUMBER:
BY: SCHLIC	DATE: 1/30/14
SHEET	OF

CONTAINS CONFIDENTIAL BUSINESS INFORMATION



REV.

STA. POWER TERMINALS



CABINET DC POWER DISTRIBUTION

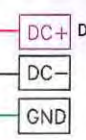

DC+ FROM STBD PANEL FUSE F4



ETHERNET SWITCH - PORT #4  
PORT CABINET



ANALOG INPUTS

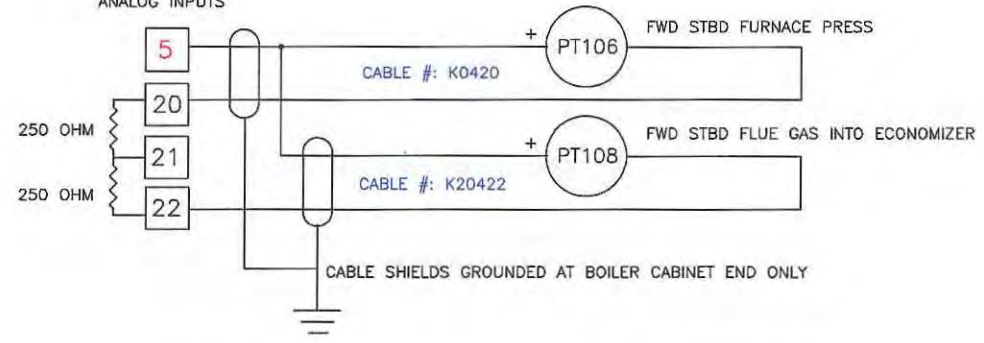

CABLE SHIELDS GROUNDED AT BOILER CABINET END ONLY

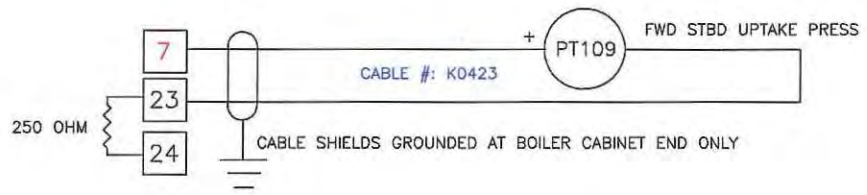

CABLE SHIELDS GROUNDED AT BOILER CABINET END ONLY

ANALOG OUTPUTS

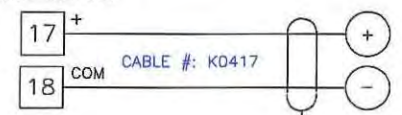

CABLE SHIELDS GROUNDED AT BOILER CABINET END ONLY

ALARM RELAY OUT

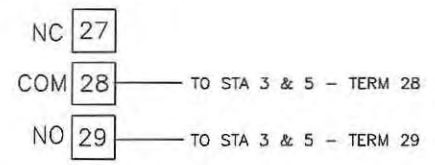

RELAY #2



SS BADGER STATION 4 - FWD STBD INDUCED DRAFT WIRING DETAILS	
DRAWING NAME: STA4.DWG	DRAWING NUMBER:
BY: JCHLLC	DATE: 1/30/14
SHEET ___ OF ___	

CONTAINS CONFIDENTIAL BUSINESS INFORMATION

REV.

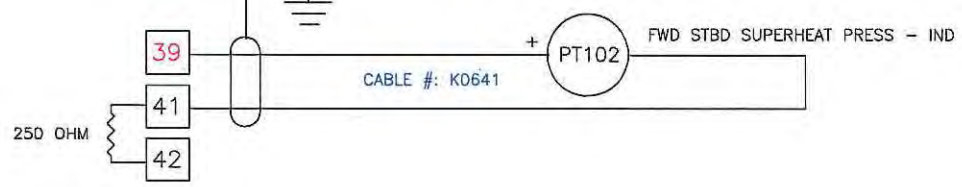
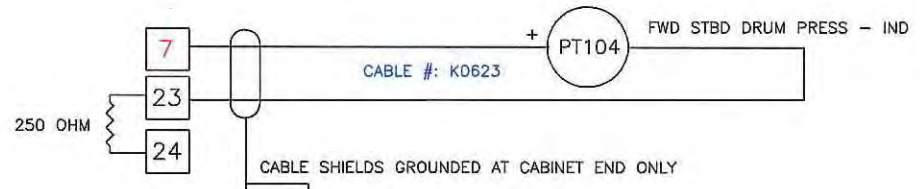
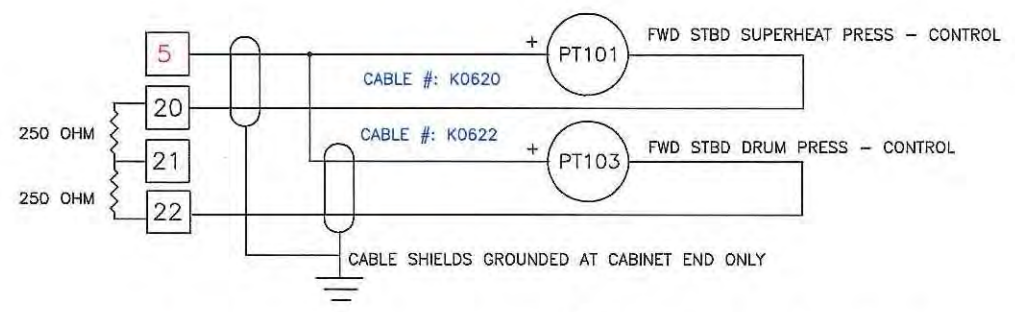
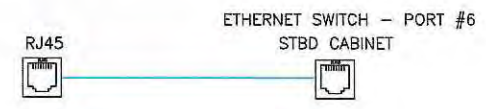

ALARM RELAY OUT

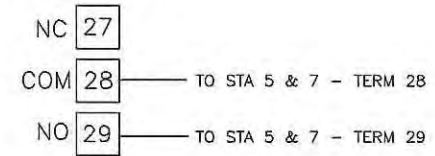

RELAY #2

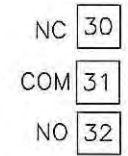

SS BADGER  
STATION 6 - FWD STBD MASTER  
WIRING DETAILS

DRAWING NAME: STA6.DWG	DRAWING NUMBER:
BY: JCHILLI	DATE: 1/29/14
SHEET ___ OF ___	

CONTAINS CONFIDENTIAL BUSINESS INFORMATION

STA. POWER TERMINALS

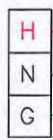

CABINET DC POWER DISTRIBUTION

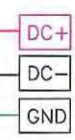

DC+ FROM STBD PANEL FUSE F2



ETHERNET SWITCH - PORT #2  
STBD CABINET



ANALOG OUTPUTS

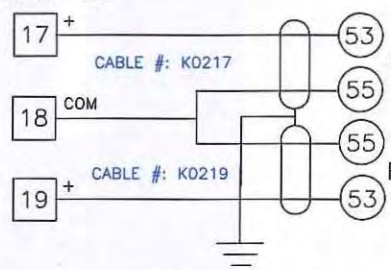

FS OTBD FEEDER - VFD

FS OTBD ROTOR - VFD

CABLE SHIELDS GROUNDED AT BOILER CABINET END ONLY

ALARM RELAY OUT

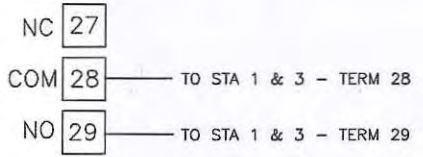

RELAY #2

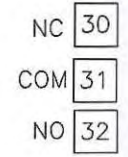

SS BADGER  
STATION 2 - FWD STBD OTBD FEEDER  
WIRING DETAILS

DRAWING NAME: STA2.DWG	DRAWING NUMBER:
BY: JCHLLC	DATE: 1/30/14
	SHEET ___ OF ___

CONTAINS CONFIDENTIAL BUSINESS INFORMATION





Thursday, October 27, 2011

**SELF - CERTIFICATION**

**████████████████████ Marine & Industrial Control Systems  
Expertise:**

This letter is a ██████████ self-certificate of qualifications as a provider of control systems, which meet or exceed the rules and requirements of NFPA, FM, OCSA, USCG, ABS, Lloyd's, TUV & DNV.

██████████ is a certified systems integrator and or factory trained for Siemens Energy and Automation, Wonderware, Rockwell Allen Bradley and Modicon hardware and software.

██████████ is a member of SNAME, NFPA, ISA and CSIA (Control Systems Integrators Association) and is a Preferred Integrator of Systems for Siemens Energy & Automation (originally Moore Products Company).

PRISM systems integrators are formally reviewed, trained, and approved in order to be qualified to Siemens-Moore's, exacting standards for Advanced Process Automation and Control System (APACS) and QUADLOG critical safety systems. The PRISM program was developed in response to increased customers' needs for qualified support services in the disciplines of the industries served. PRISM members must have the training and track record to provide detailed engineering studies, local system integration, software application and configuration, local support and knowledge of the rules and regulations of their serviced industry. Members of the Siemens-Moore, Process Automation Solutions, PRISM program are selected, according on their ability to provide complete customer satisfaction in these areas.

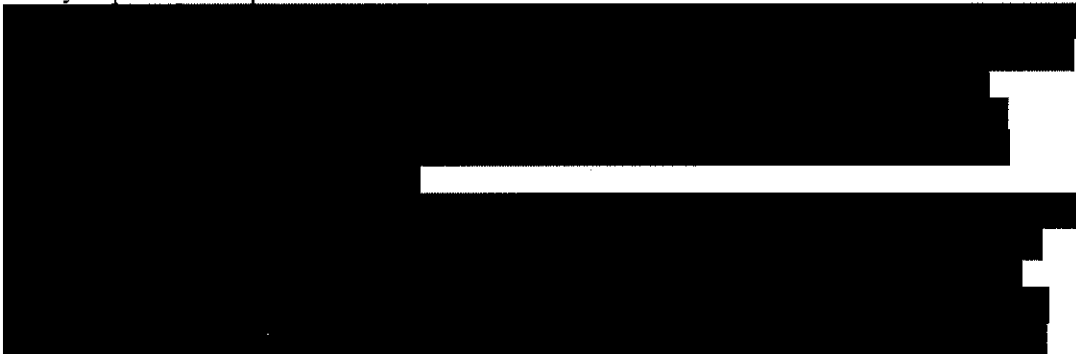

[REDACTED]

Projects by

[REDACTED]

[REDACTED], president of [REDACTED] has been involved with design, installation and commissioning of control systems of numerous commercial and combat vessels worldwide [REDACTED] as well as systems for the power & process industries.

The following is an overview of some of the project involvement:

- [REDACTED]

- [REDACTED]

i  
[Redacted text block]

Respectfully Submitted,

[Redacted signature]

President

[Redacted text]

[Redacted text]