

TR-909 SERVICE NOTES *First Edition*

SPECIFICATIONS

Memory Capacity

48 Rhythm Patterns (16 x 3 Pattern Groups)
x 2 (Bank I, II)

Tracks

4 Tracks (1 to 4: Continuous Maximum measures 896)
x 2 (Banks I, II)

Steps (per measure)

1 to 16 steps

Tempo

♩ = 37 to 290

Rear Panel

Master Out (L, R/MONO) [6 V_{p-p}, 1kΩ]

Multi OutSee P.9

Bass Drum, Snare, Low Tom, Mid Tom, Hi Tom,
Rim Shot, Claps, Hi-Hat, Crash, Ride

Trigger Out

(Rim Shot: + 14V, 20 ms pulse)

Sync In (5P-DIN)

(1: Run/Stop, 2: GND, 3: Clock, 5: Continue)

Power Consumption: 14W

Dimensions:

486(W) x 105(H) x 300(D) mm/
19-1/8(W) x 4-1/8(H) x 11-13/16(D) in

Weight: 4.5 kg/9 lb 15 oz

Option: Memory cartridge M-64C

Pedal Switch DP-2

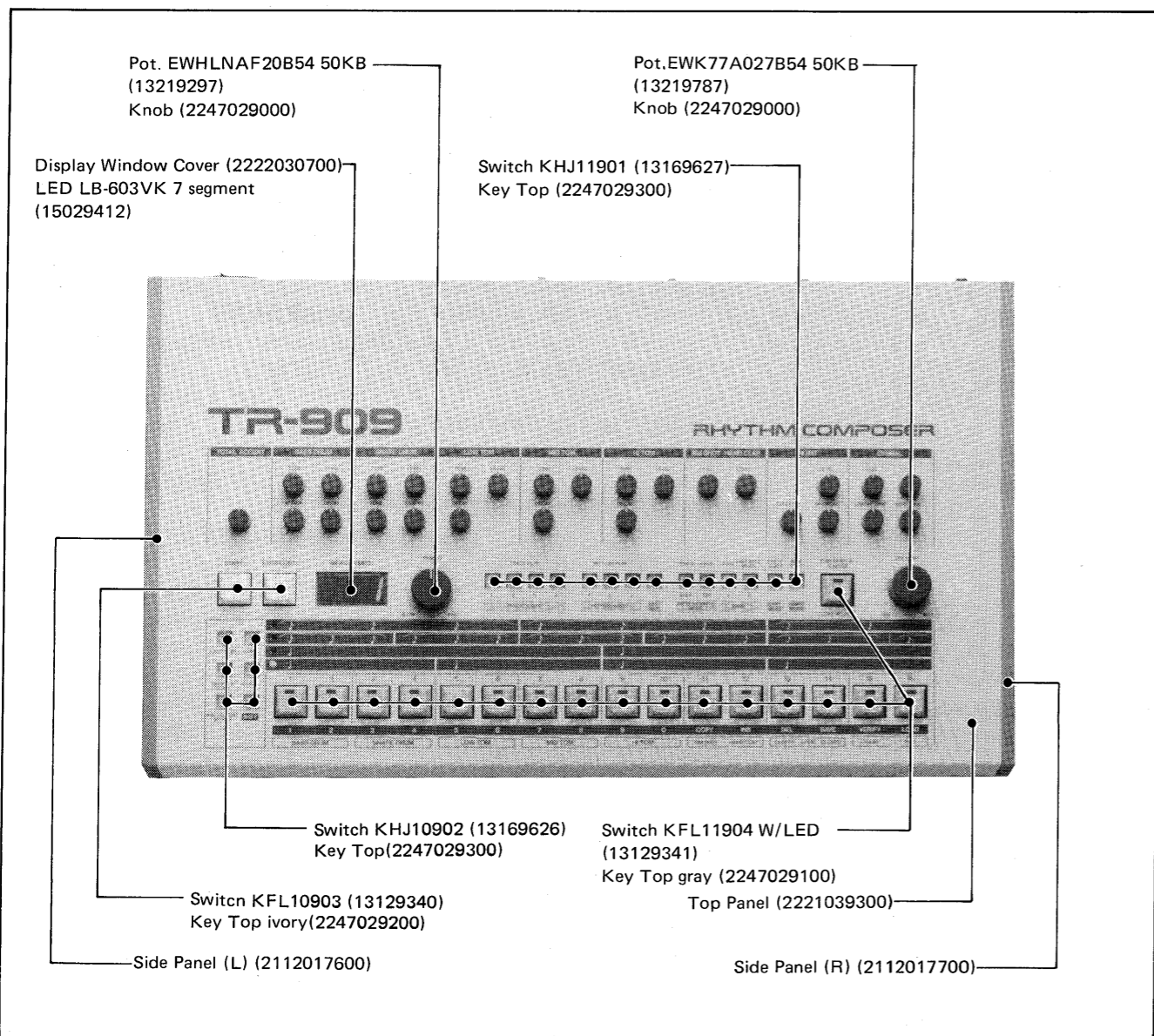
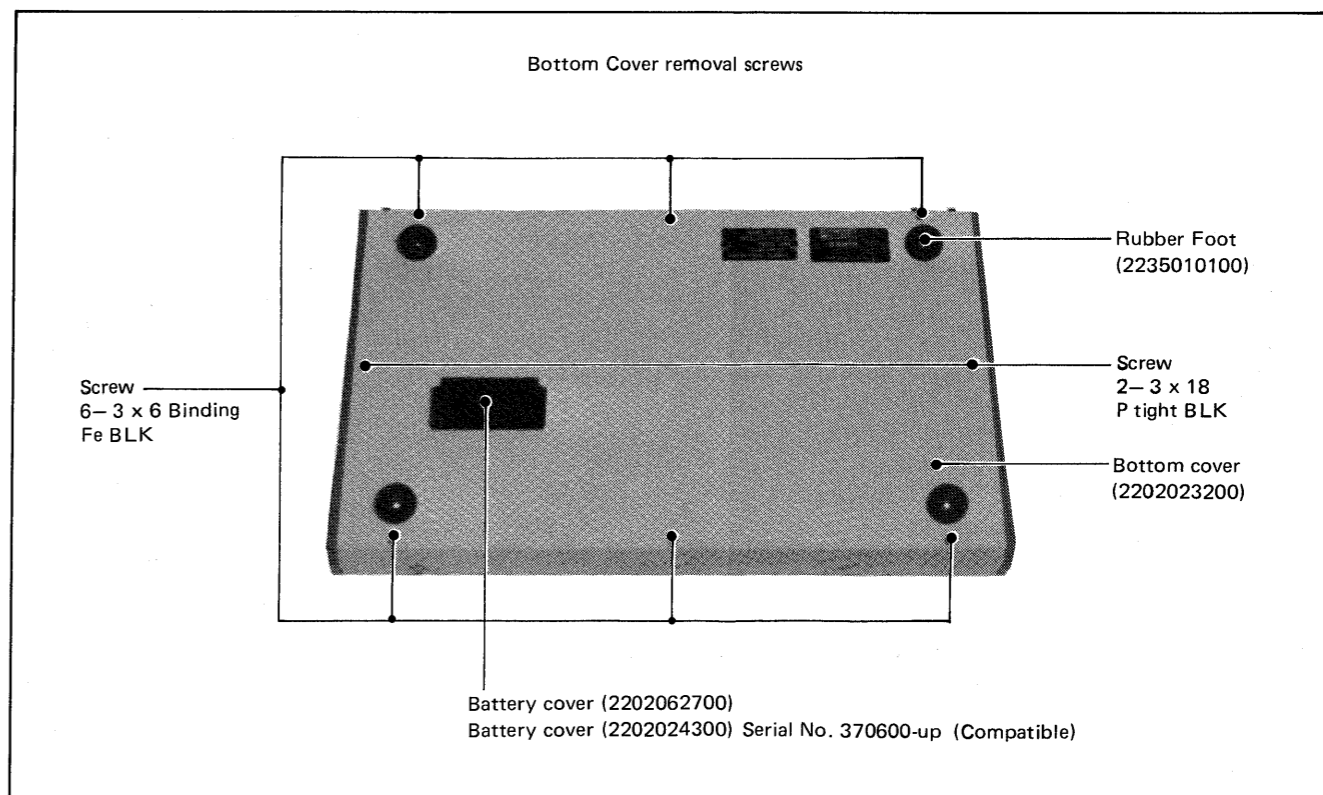
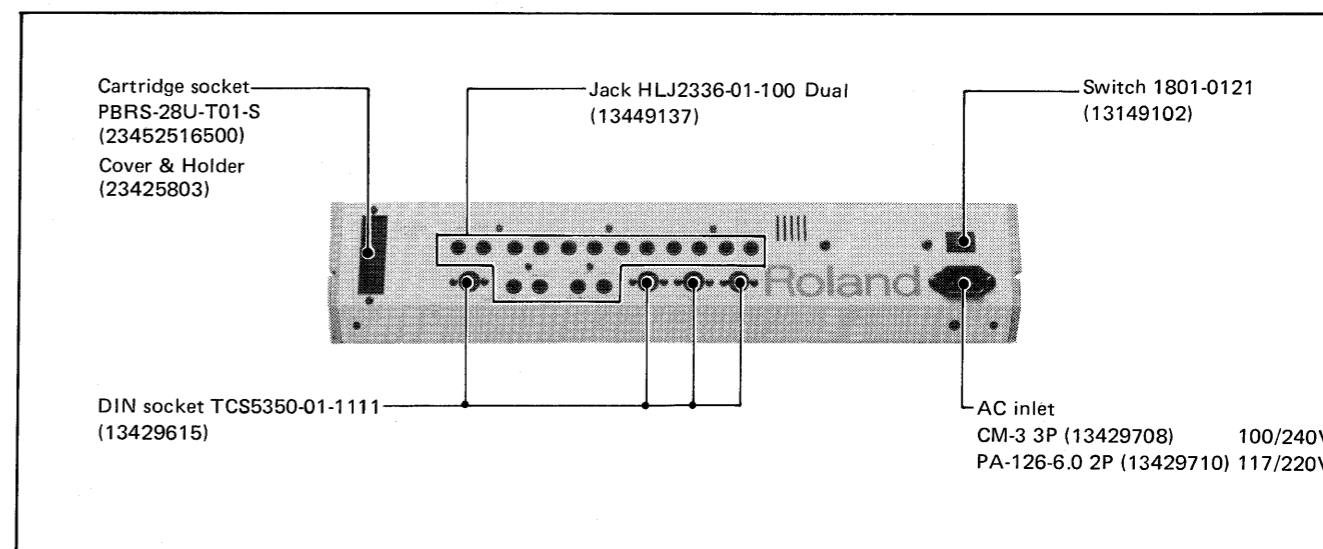
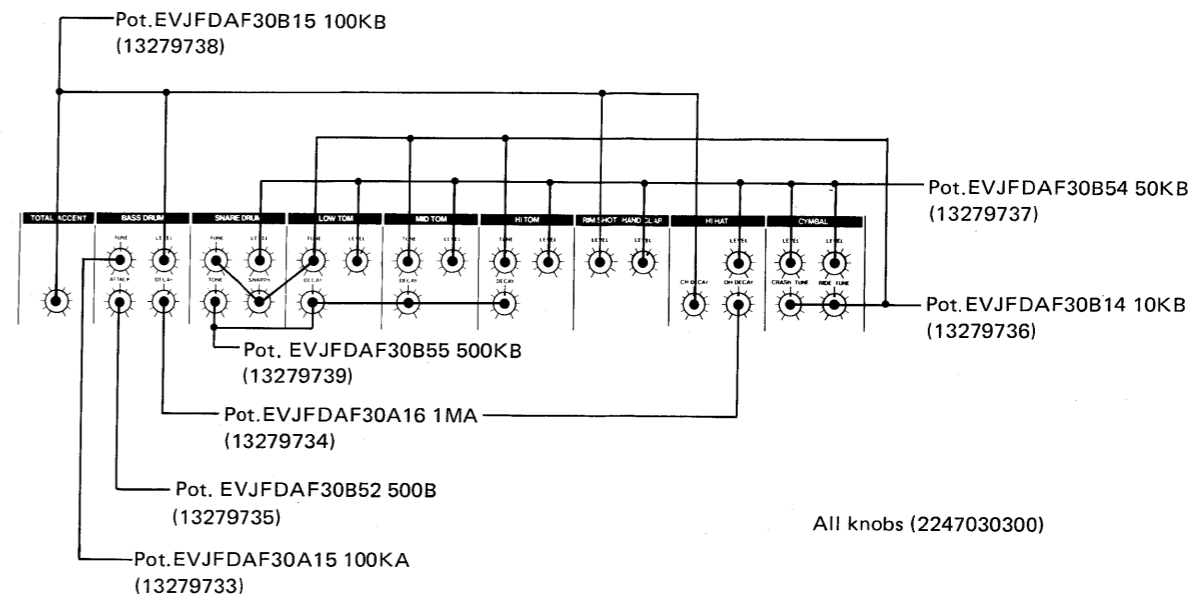

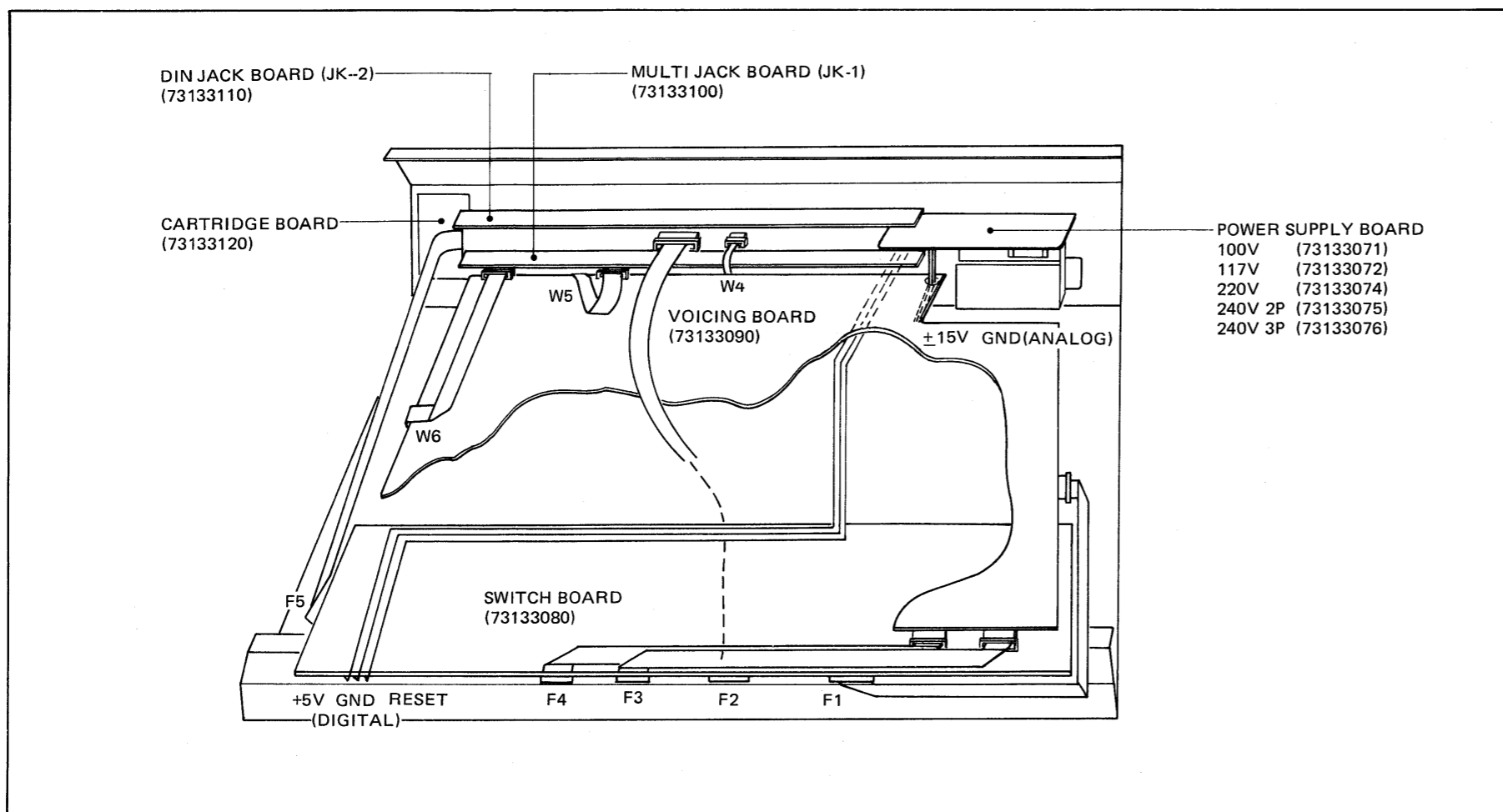

PARTS LIST

CASING

| | |
|------------|----------------------|
| 2221039300 | Panel top |
| 2202023200 | Cover bottom |
| 2112017700 | Panel side (R) |
| 2112017600 | Panel side (L) |
| 2202024300 | Cover battery box |
| 2222030700 | Cover display window |
| 2235010100 | Rubber Foot |

KNOB, BUTTON, KEY TOP

| | | |
|------------|-----------------|------------------------|
| 2247029000 | Knob | tempo, volume |
| 2247030300 | Knob | all small rotary knobs |
| 2247029300 | Button | light touch switch |
| 2247029100 | Key Top (gray) | |
| 2247029200 | Key Top (Ivory) | |

PCB ASSEMBLY

| | | |
|----------|--|---------|
| 73133071 | Power Supply Board (pcb 2291084703 1/2) | 100V |
| 73133072 | Power Supply Board (pcb 2291084703 1/2) | 117V |
| 73133074 | Power Supply Board (pcb 2291084703 1/2) | 220V |
| 73133075 | Power Supply Board (pcb 2291084703 1/2) | 240V 2P |
| 73133076 | Power Supply Board (pcb 2291084703 1/2) | 240V 3P |
| 73133080 | Switch Board (pcb 2291084703 2/2) | |
| 73133100 | Multi Jack Board JK-1 (pcb 2291084903 1/3) | |

| | |
|----------|--|
| 73133110 | DIN Jack Board JK-2 (pcb 2291084903 2/3) |
| 73133090 | Voicing Board (pcb 2291084903 3/3) |
| 73133120 | Cartridge Board (pcb 2291085000) |

TRANSFORMER

| | |
|------------|-------|
| 22450364U0 | Power |
|------------|-------|

FUSE, FUSE HOLDER

| | | |
|----------|--------------------|-----------|
| 12559356 | SGC-1A | 100, 117V |
| 12559509 | CEE-T315mA | 220, 240V |
| 12199519 | TF-758 Fuse Holder | |

SOCKET, JACK

| | | |
|------------|--|-----------|
| 13429708 | CM-3 AC Inlet 3P | 100, 240V |
| 13429710 | PA-126-6.0 AC Inlet 2P | 117, 220V |
| 13429615 | TCS5350-01-1111 DIN Socket | |
| 13429166 | HIF3FA-30P-2.54 CARTRIDGE BRD-SW BRD | |
| 2342516500 | PBR5-28U-T01-S MEMORY CARTRIDGE Socket 30P | |
| 13449137 | HLJ2336-01-100 | dual |

CARTRIDGE SOCKET ACCESSORY

| | |
|----------|------------------|
| 23425803 | Cover and Holder |
|----------|------------------|

SWITCH

| | | |
|----------|------------------------------|------------------|
| 13149102 | 1801-0121 (rocker) | power |
| 13129341 | KFL11904 (push) w/LED | |
| 13129340 | KFL10903 (push) | start, stop/cont |
| 13169627 | KHL11901 (light touch) w/LED | |
| 13169626 | KHL10902 (light touch) | |

POTENTIOMETER

| | | | |
|----------|--------------|---------|---------|
| 13219297 | EWHLNAF20B54 | 50K(B) | tempo |
| 13279735 | EVJFDAF30B52 | 500(B) | attack |
| 13279736 | EVJFDAF30B14 | 10K(B) | |
| 13279737 | EVJFDAF30B54 | 50K(B) | |
| 13279733 | EVJFDAF30A15 | 100K(A) | |
| 13279738 | EVJFDAF30B15 | 100K(B) | |
| 13279739 | EVJFDAF30B55 | 500K(B) | |
| 13279734 | EVJFDAF30A16 | 1M(A) | |
| 13219787 | EWK77A027B54 | 50K(B) | volume |
| 13299114 | H1051A013 | 10K(B) | trimmer |

IC

| | | |
|-------------|-----------------------------|-----------------------|
| 15179149 | MPD7811G-033-036 | NMOS CPU |
| 15179645 | M5M2764P-250NS-645 | P-ROM |
| or 15179646 | M5M2364P-250NS-646 | MASK ROM |
| 15179633 | HN61256P-PC42 | CMOS MASK ROM Crash |
| 15179634 | HN61256P-PC43 | CMOS MASK ROM Hi-hat |
| 15179635 | HN61256P-PC44 | COMS MASK ROM Ride |
| 15179336 | TC5565 PL-15 | CMOS S-RAM |
| 15159307 | HD14511BP | CMOS |
| | BCD to 7-segment | Latch/Decoder/Driver |
| 15159140HO | HD14006BP | CMOS |
| | 18-bit | Static Shift Register |
| 15159103TO | TC4011UBP | CMOS |
| | Quadruple 2-input | NAND Gate |
| 15159105T1 | TC4013BP | CMOS |
| | Dual D-Flip-Flop | |
| 15159141HO | HD14040BP | CMOS |
| | 12-bit | Binary Counter |
| 15159301TO | TC4520BP | CMOS |
| | Dual Binary Up Counter | |
| 15159116TO | TC4069UBP | CMOS Hex inverter |
| 15159117HO | HD14070BP | CMOS |
| | Quadruple Exclusive-OR Gate | |
| 15159133HO | HD14174BP | CMOS Hex D-Flip-Flop |
| 15169301HO | HD74LS00P | TTL |
| | Quadruple 2-input | NAND Gate |
| 15169318HO | HD74LS138P | TTL |
| | 3 to 8 | Demultiplexer |
| 15169331XO | SN74LS244N | TTL Octal Buffers |
| 15169358HO | HD74LS373 | TTL Octal D Latch |
| 15169327HO | HD74LS367AP | TTL Hex Bus Drivers |
| 15169324XO | SN74LS245N | TTL |
| | Octal Bus | Tranceivers |
| 15189136 | M5218L | OP Amp |
| 15189113 | AN6912 | Quad Comparator |
| 15229802 | BA662A | Vari-conductance Amp |
| 15229712 | PC-900 | Photo Coupler |
| 15199106 | UA7805UC | V RGL +5V |
| 15199105 | UA7815 | V RGL +15V |
| 15199102 | UA7915 | V RGL -15V |
| 15149110 | M54562 | Transistor array |
| 15149113 | M54516 | Transistor array |

TRANSISTOR

| | | |
|----------|----------------|-----|
| 15119108 | 2SA798-G | PNP |
| 15119125 | 2SA1115-28-F | PNP |
| 15129137 | 2SC2603-28-F | NPN |
| 15129136 | 2SC2878-A or B | NPN |
| 15129612 | 2SD1469-R | NPN |

DIODE

| | | |
|----------|-------------|------------------|
| 15019245 | 1B4B41 | rectifier bridge |
| 15019305 | RD6.8JB2 | zener |
| | RD5.6JB2 | zener SW board |
| 15019125 | 1SS-133 | |
| 15019126 | 1SS-133T-77 | |
| 15019661 | RD18JB2-T | zener |

LED

| | | |
|----------|----------|-----------|
| 15029412 | LB-603VK | 7-segment |
| 15029140 | SEL102R | |

CRYSTAL

| | |
|----------|----------|
| 12389717 | 12.00MHz |
|----------|----------|

RESISTOR ARRAY

| | | |
|----------|---------------|--------|
| 13919143 | RGSD8x102-720 | 1K x 8 |
| 13919133 | RM-0621 | |

CONNECTOR

| | | |
|----------|------------------|----------------|
| 13439133 | 5046-06A (MOLEX) | VOICING board |
| 13439135 | 5046-09A (MOLEX) | VOICING board |
| 13439136 | 5046-10A (MOLEX) | VOICING board |
| 13439130 | 5046-3A (MOLEX) | DIN JACK board |

AC CORD SET

| | | |
|------------|------------|---------|
| 13439816FO | DC-357-J01 | 100V |
| 13439812FO | UC-704-J01 | 117V |
| 13439813FO | EC-210-J06 | 220V 2P |
| 13439817FO | EC-702-J05 | 240V 2P |
| 13439814FO | SC-415-J06 | 240V 3P |

WIRING ASS'Y

| | | |
|------------|-----|---------------|
| 2341044001 | 10P | SWITCH board |
| 2341044201 | 9P | SWITCH board |
| 2341044300 | 30P | SWITCH board |
| 2341044100 | 6P | VOICING board |
| 2341043500 | 3P | VOICING board |
| 2341043700 | 10P | VOICING board |

OTHERS

| | | |
|------------|---------------------------|--------------------|
| 12469117 | Heat Sink MT-25-BS | IC703 PS board |
| 12469116 | Heat Sink MT-50-BS | IC701,702 PS board |
| 12199414 | Battery Holder | |
| 2219044200 | Battery Box | |
| 2219044600 | LED Holder | |
| 2219041000 | Holder | MULTI JK Board |
| 2219041100 | Holder | DIN JK Board |
| 13419206 | Battery Snap T-250L | |
| 2226034900 | Cushion LED segment cover | |
| 2224052400 | Switch Mask A (375x27 mm) | |
| 2224052500 | Switch Mask B (27x27 mm) | |

COMMERCIALLY AVAILABLE ACCESSORIES

| | | |
|------------|------------------------|------|
| 12569105 | Battery UM3G | 1.5V |
| 2343067500 | Connection Cable LP-25 | |

IC DATA

**HD14511BP
BCD-TO-7SEGMENT
LATCH/DECODER/DRIVER**

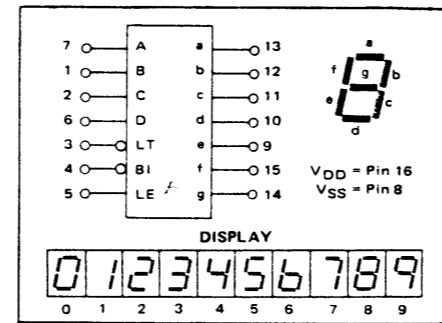

TRUTH TABLE

| INPUTS | | | | OUTPUTS | | | | | | | |
|--------|----|----|---------|---------|---|---|---|---|---|---|---------|
| LE | BI | LT | DCBA | a | b | c | d | e | f | g | DISPLAY |
| X | X | 0 | X X X X | 1 | 1 | 1 | 1 | 1 | 1 | 1 | Blank |
| X | 0 | 1 | X X X X | 0 | 0 | 0 | 0 | 0 | 0 | 0 | Blank |
| 0 | 1 | 1 | 0 0 0 0 | 1 | 1 | 1 | 1 | 1 | 1 | 1 | 0 |
| 0 | 1 | 1 | 0 0 0 1 | 0 | 1 | 1 | 1 | 1 | 1 | 1 | 1 |
| 0 | 1 | 1 | 0 0 1 0 | 1 | 1 | 0 | 1 | 1 | 1 | 1 | 2 |
| 0 | 1 | 1 | 0 0 1 1 | 1 | 1 | 1 | 0 | 1 | 1 | 1 | 3 |
| 0 | 1 | 1 | 0 1 0 0 | 0 | 1 | 1 | 0 | 0 | 1 | 1 | 4 |
| 0 | 1 | 1 | 0 1 0 1 | 1 | 1 | 0 | 0 | 0 | 1 | 1 | 5 |
| 0 | 1 | 1 | 0 1 1 0 | 1 | 1 | 1 | 0 | 0 | 0 | 1 | 6 |
| 0 | 1 | 1 | 0 1 1 1 | 1 | 1 | 1 | 1 | 0 | 0 | 0 | 7 |
| 0 | 1 | 1 | 1 0 0 0 | 1 | 1 | 1 | 1 | 1 | 1 | 1 | 8 |
| 0 | 1 | 1 | 1 0 0 1 | 1 | 1 | 1 | 0 | 1 | 1 | 1 | 9 |
| 0 | 1 | 1 | 1 0 1 0 | 0 | 0 | 0 | 0 | 0 | 0 | 0 | Blank |
| 0 | 1 | 1 | 1 0 1 1 | 0 | 0 | 0 | 0 | 0 | 0 | 0 | Blank |
| 0 | 1 | 1 | 1 1 0 0 | 0 | 0 | 0 | 0 | 0 | 0 | 0 | Blank |
| 0 | 1 | 1 | 1 1 0 1 | 0 | 0 | 0 | 0 | 0 | 0 | 0 | Blank |
| 0 | 1 | 1 | 1 1 1 0 | 0 | 0 | 0 | 0 | 0 | 0 | 0 | Blank |
| 0 | 1 | 1 | 1 1 1 1 | 0 | 0 | 0 | 0 | 0 | 0 | 0 | Blank |
| 1 | 1 | 1 | X X X X | - | - | - | - | - | - | - | - |

X = Don't Care
*Depends upon the BCD code previously applied when LE = 0

**HD14040BP
12-BIT BINARY COUNTER**

TRUTH TABLE

| CLOCK | RESET | OUTPUT STATE |
|-------|-------|-----------------------|
| ↑ | 0 | No Change |
| ↓ | 0 | Advance to next state |
| X | 1 | All Outputs are low |

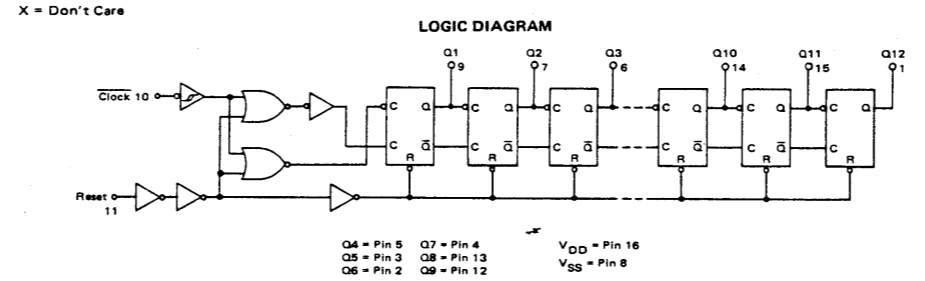

Q4 = Pin 5 Q7 = Pin 4
Q5 = Pin 3 Q8 = Pin 13
Q6 = Pin 2 Q9 = Pin 12
VDD = Pin 16
VSS = Pin 8

**TC4520BP
DUAL BINARY UP COUNTER**

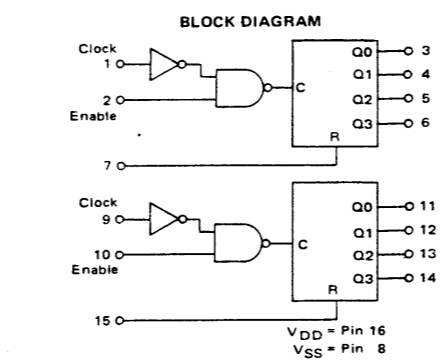

TRUTH TABLE

| CLOCK | ENABLE | RESET | ACTION |
|-------|--------|-------|-------------------|
| ↑ | 1 | 0 | Increment Counter |
| 0 | ↓ | 0 | Increment Counter |
| ↓ | X | 0 | No Change |
| X | ↑ | 0 | No Change |
| ↑ | 0 | 0 | No Change |
| 1 | ↓ | 0 | No Change |
| X | X | 1 | Q0 thru Q3 = 0 |

X = Don't Care

**HD14006BP
18-BIT STATIC SHIFT REGISTER**

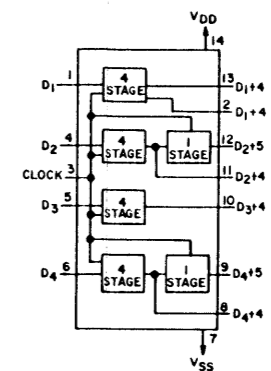

TRUTH TABLE FOR SHIFT REGISTER STAGE

| D | CL ^Δ | D + 1 |
|---|-----------------|-------|
| 0 | ↓ | 0 |
| 1 | ↑ | 1 |
| X | ↑ | NC |

1 = HIGH X = DON'T CARE
0 = LOW Δ = LEVEL CHANGE
NC = NO CHANGE

**HD74LS138P
3 TO 8 DEMULTIPLEXER**

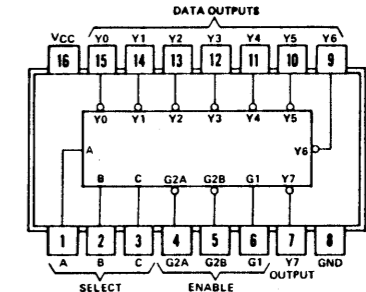

TRUTH TABLE

| INPUTS | | | OUTPUTS | | | | | | | |
|--------|--------|---|---------|----|----|----|----|----|----|----|
| ENABLE | SELECT | | Y0 | Y1 | Y2 | Y3 | Y4 | Y5 | Y6 | Y7 |
| X | H | X | X | X | X | H | H | H | H | H |
| L | X | X | X | X | X | H | H | H | H | H |
| H | L | L | L | L | L | H | H | H | H | H |
| H | L | L | L | H | H | L | H | H | H | H |
| H | L | L | H | L | H | L | H | H | H | H |
| H | L | L | H | H | H | L | H | H | H | H |
| H | L | H | L | L | H | H | H | L | H | H |
| H | L | H | L | H | L | H | H | H | L | H |
| H | L | H | H | L | H | H | H | H | L | H |
| H | L | H | H | H | H | H | H | H | L | L |

*G2 = G2A + G2B

BLOCK DIAGRAM

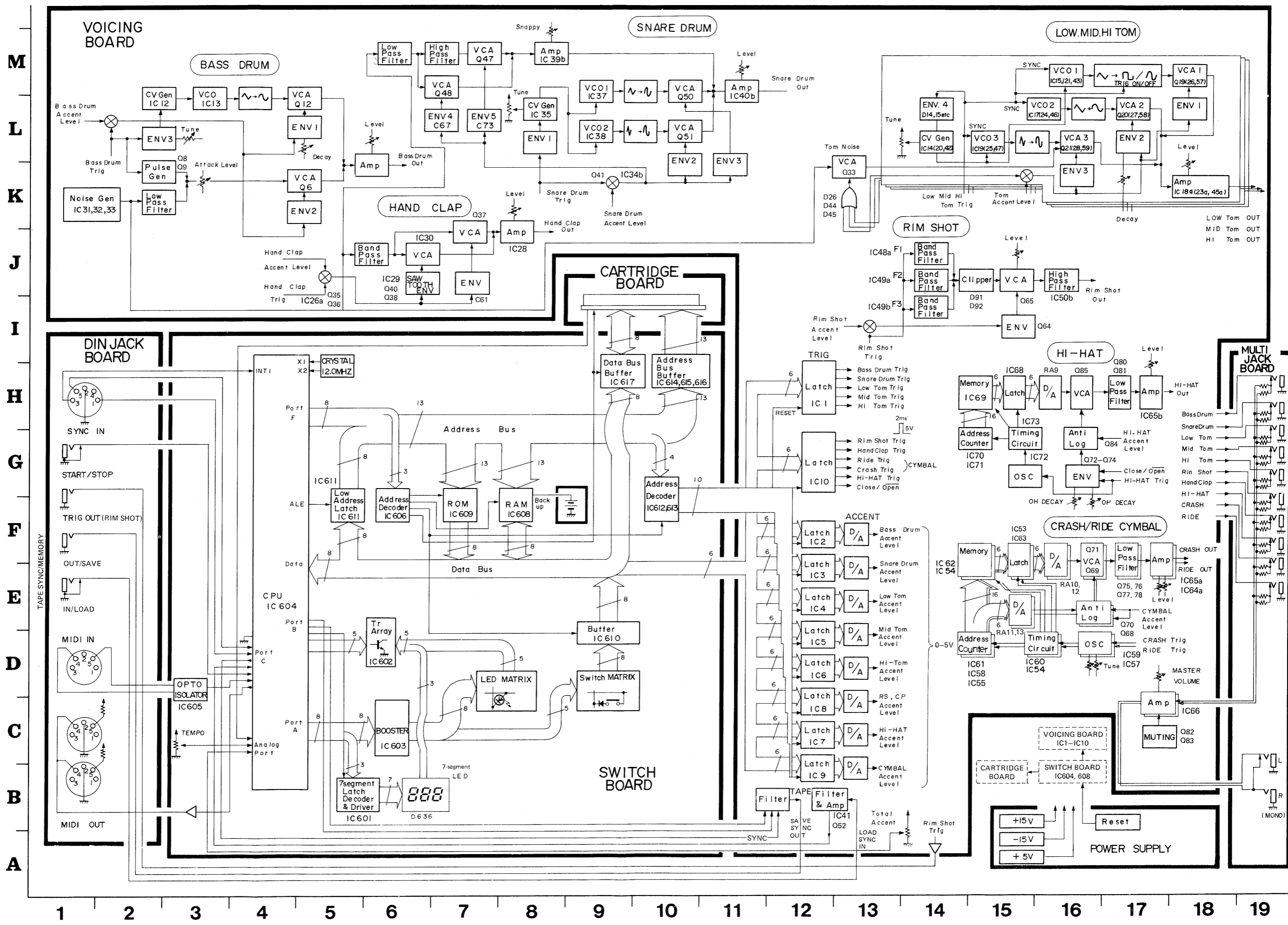

CIRCUIT DESCRIPTIONS

IC604 CPU μ PD7811G-033-036 (SWITCH BOARD) PORT ASSIGNMENT

| | |
|---|---|
| PA 0 } 1 } 2 } 3 } 4 } 5 } 6 } 7 } | Scanning Signal Outputs to Switches LED Driving Signal Outputs |
| PB 0 } 1 } 2 } 3 } 4 } 5 } 6 } 7 } | Scanning Signal Outputs to LED Latch Signal Output to 7-seg LED Driver Data Outputs to Tape Interface |
| PC 0 1 2 3 4 5 6 7 | Serial Transmitter to MIDI Serial Receiver from MIDI Input from Foot Switch Data Input from Tape Interface (Rhythm or SYNC data) Tape SYNC Output Start/Stop Signal Input from DIN Socket Continue Signal Input from DIN Socket Unused (Input) |
| PD 0 } 1 } 2 } 3 } 4 } 5 } 6 } 7 } | Data Bus Multiplexed Address Bus (Lower) |
| PF 0 } 1 } 2 } 3 } 4 } 5 } 6 } 7 } | Address Bus (Higher) |
| NMI | Unused |
| INT 1 | Clock Signal Input from DIN |
| AN 0 1 2 3 4 5 6 7 | Analog Voltage Input from TEMPO Control Unused Analog Voltage Input from TOTAL Control Unused |

The TR-909 combines Voice Generators and CPU based controller. In basic operation, the CPU scans panel switches, stores switch outputs, and generates trigger (TRIG) and volume (ACCENT) data for the voice generators which are categorized into two: Digital and Analog. The CPU provides them with TRIG and ACCENT data in an identical way.

ACCENT & TRIG

ACCENT

Accent data on the CPU bus is latched into one of ACCENT latches (IC2-IC9) selected by Address Decoder (IC612, 613). Latched ACCENT code is converted to analog equivalent at the output of associated resistor array RM0621. The voltage is clamped to the level until it is replaced by the next incoming data.

TRIG

Almost concurrent with ACCENT, TRIG is latched into IC1 or IC10, and appears as 5V positive going pulse on the correct output pin for 2ms. TRIG is used either solely or in combination with ACCENT to reset generator(s) and to create various envelopes for controlling pitch, tone color, contour, loudness, etc. of the particular rhythm sound being sounded.

DIGITAL VOICE GENERATORS

Hi-Hat, Ride and Crash cymbals are reproduced out of digital sound memories which have been sampled from an actual instrument, modified to be useful as data and stored into the ROM by way of PCM. Circuit configurations and operations of these voices are basically the same. The following description takes Hi-Hat as a representative.

HI-HAT

Pressing Hi-Hat button(s) develops a positive pulse (TRIG) on pin 7 of IC10, resetting Address Counters IC70 and IC71 to have "0's" on their all outputs. These 0's cause IC72a output to swing to H(run) irrespective of a CLOSED/OPEN being applied to diode OR's (D196-199).

Upon receiving this "run" from IC72a, a combination of two gates (IC72 c and d) starts oscillation and outputs about 60kHz, which is divided by two and shaped up by IC73 flip-flop (TIMING GEN), clocking the address counters. With the same bits applied from the address counters, a logic (D196 - 199 OR gates) places ROM beginning and end at different locations according to H or L of the CLOSED/OPEN as shown in the table. IC72a turns its output to L (stop) when the counter increments to:

110 0000 0000 0000 in OPEN mode
010 0000 0000 0000 in CLOSED mode

ADDRESS TABLE

| | |
|----------------|--------------------|
| OPEN HI-HAT | 000 0000 0000 0000 |
| | ↓ |
| COMMON ADDRESS | 110 0000 0000 0000 |
| | ↓ |
| CLOSED HI-HAT | 111 1111 1111 1111 |

Voice data clocked out of ROM IC69 are latched into IC68 and then converted to analog voltages while passing through RA9. The sound results at RA9 output has an envelope somewhat different from that of actual Hi-Hat sound. This is because the Hi-Hat sounds have been compressed before being digitalized and Pulse Code Modulated (PCM) in order to have greater S/N ratio and higher digital resolution. The envelope of this Hi-Hat sound can be controlled manually with DECAY control (VR21 or VR23).

CLOSED A high CLOSED/OPEN on Q72 base removes a positive voltage from its collector which in turn allows Q73 to charge DECAY capacitor C135 through R451 and VR21. Since this charging path is 1/10th the total resistance of R452 and VR23, the charging rate of C135 depends on VR21 setting.

OPEN With low CLOSED/OPEN, CH charging path is disconnected from the DC supply source at Q73 OH path becomes conductive.

CRASH & RIDE

These voices also have unique envelopes that are quite different from actual sounds when the data are directly reproduced. The reason is the same as described in Hi-Hat section. Restoration of the envelopes are made by the use of ROM addresses as the envelope data. Before being stored into the ROM, the envelope of CRASH is changed with the following compensation measure taken into consideration. When CRASH sound data are read successively from ROM (IC62) with correct addresses, the same addresses are also converted to analog voltages through RA11, anti-log tapered by IC52b and Q70, and are applied to the base of Q71 (VCA) which is configured as a voltage controlled potentiometer to give the incoming voltage the CRASH decay curve.

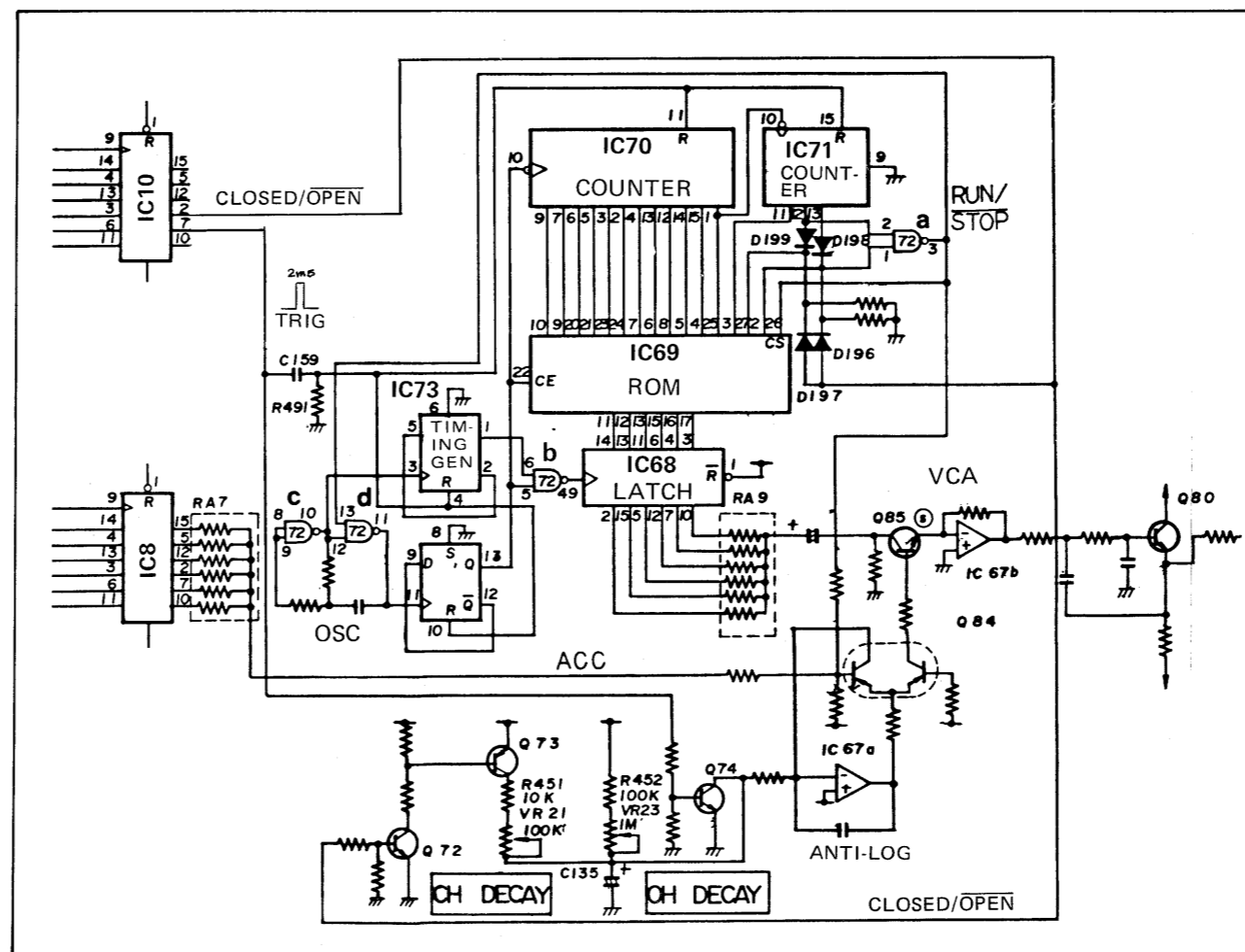

ANALOG VOICE GENERATORS

SNARE, BASS, TOM TOM operate basically in the same manner and share the same Noise Generator. For discussion purposes the schematic references for SNARE DRUM are used in the description below.

SNARE DRUM

SNARE DRUM consists of Drum and Snappy, each further separated into two parts.

DRUM

Drum voice is composed of VCO-1 and VCO-2 with associated Control Voltage Generator (IC35). VCO-1 and VCO-2 have similar circuitry except that charging capacitors C69 and C71 have different capacitance so that they can oscillate at different frequency: VCO-1 runs at lower frequency.

VCO-1 comprises a hysteresis comparator IC37a, inverting buffers configured as voltage-dependent resistor (in IC36) and an integrator consisting of IC37b and C69 with Q44 switcher. In this arrangement VCO-1 generates triangle waveform. When TRIG is applied to the base of Q39 VCO-1 receives a positive pulse from Q40 collector at the following places.

- a) One input of IC37a via D62. When the pulse is applied, IC37a turns its output to low.
- b) The base of Q44 which discharges C69, canceling VCO-1 output. The combination of a) and b) resets VCO-1 to the starting point at which VCO-2 also starts oscillation, phasing the initial waveforms of both VCOs.
- c) The base of Q46 which cuts off VCA Q50, muting unwanted noises in the VCO-1 path.
- d) VCO-1 also sees the effects of trigger pulse from Q40 at V_{DD} and V_{SS} terminals of buffer IC36 through the control voltage generator.

The outputs of IC35 gives the buffers output amplitude proportional to ENV-1 as shown in figure; the charging rate of C69 also continuously changes for about 20ms. The resultant effect is a pitch bend of Snare drum sound for that period.

The amount of drum voice from VCO-1 is determined by VCA Q50 whose gain follows ENV 3 which is in turn controlled by an ACCENT coming through Q4 currently gated by the TRIG.

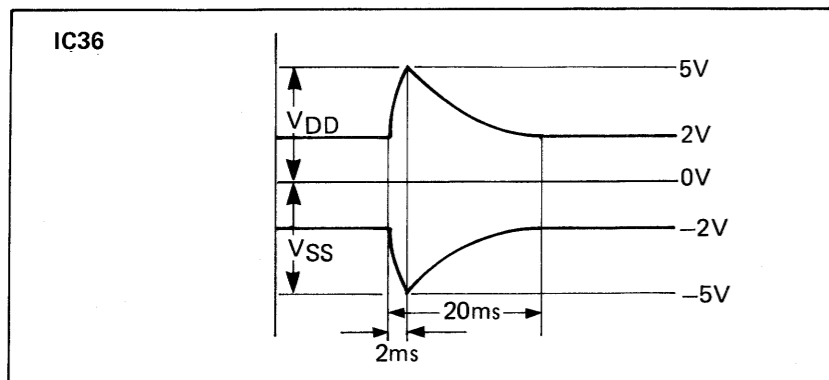

SNAPPY

ACCENT signal is gated through Q41 by the trigger from Q39 collector and is coupled to the base of Q47 VCA as ENV 5. ENV 5 determines the amount of high frequency noise components in the SNAPPY which becomes articulate when noises passing through a high pass filter (IC39a and associated RC's) are combined with the noises from the low pass filter at IC39b.

NOISE

This is a quasi-random noise generator having two shift registers (IC32, IC33) connected in cascade making up 32 stages. Chaining of 32 stages provides a longer interval between the beginning and the end of shift cycles. This means that the frequency changes occurring at end/start points of shifting cycle are made less noticeable to the human ear. Two Ex-OR gates of IC31 clock the shift registers at a higher frequency, allowing them to create noises that contain favorable higher frequency contents.

On power-up, a trigger is applied into pin 1 of IC32 via D48 for starting running.

RESET

Q701, Q702, D701 and associated circuits on the Power Supply Board cause RESET inputs to IC604 CPU and IC608 RAM on Switch Board to be held low on power-up to allow DC supplies and signals to stabilize before starting processing. When the voltage on input terminal of IC703 (Power Supply Board) reaches 7.0V, Q701 conducts and cuts off Q702. The circuit also provides power down reset when the IC703 input voltage goes sufficiently below 7.0V on power down or power fail. The RESET is also routed to:

Cartridge Board and TRIG and ACCENT latches (IC1-IC10) on VOICING Board via Switch Board. When the unit is operated from a poor AC line and is forced to stop or reset, first check the unit's serial number. If prior to 393000, replace D701 (zener diode) of Power Supply Board with RD5.6JB2. Refer to "CHANGE INFORMATION" in this manual.

TAPE INTERFACE

TAPE INTERFACE on VG BRD consists of two sections: Output-to-TAPE and Input-from-TAPE. The Interface will take dual duties; either a) or b) described below depending on TR-909 operation mode.

a) MEMORY SAVE & LOAD

To allow rhythm data stored in TR-909's memory to be preserved on cassette tape recorder and vice versa.

b) TAPE SYNC

To allow a signal (TEMPO CLOCK) on a tape to control the speed of operation of TR-909. Also to provide such sync signal for recording on tape.

In normal PLAY mode TAPE INTERFACE sends out TAPE & SYNC signal from OUT/SAVE jack.

In basic WRITE mode TR-909's CPU does not accept data coming through the Interface.

SAVE & LOAD/VERIFY

SAVE

During SAVE routine, the CPU (on SW BRD) represents rhythm data, which is to be recorded on tape, as 2-bit code on Port B- 6 and 7. CPU can select one of two codes for one "0", and another one of two for each "1" to make successive 1's and 0's distinguishable from the adjacents when they are chained at the output of D-to-A arrangement composed of R318-R322.

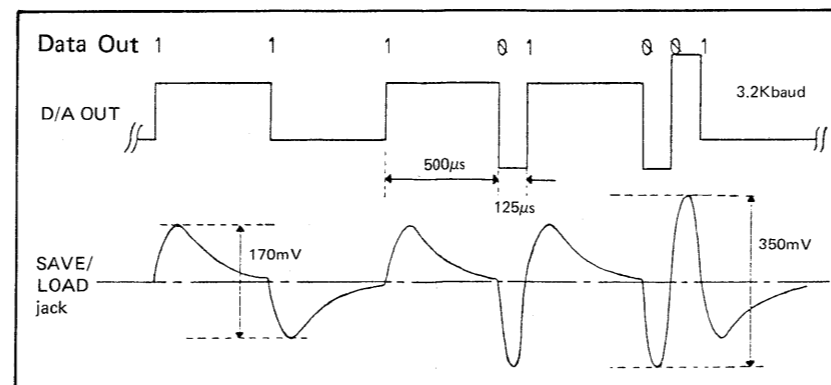

LOAD & VERIFY

Rhythm data from tape passing through IN/LOAD jack is first differentiated, smoothed at IC41b, shaped up to a rectangular at IC41a comparator, then entered into the CPU via Port C-3. The CPU measures the length of each incoming half-period by detecting every edge. Depending on the length the CPU recognizes a "0" or a "1" as follows:

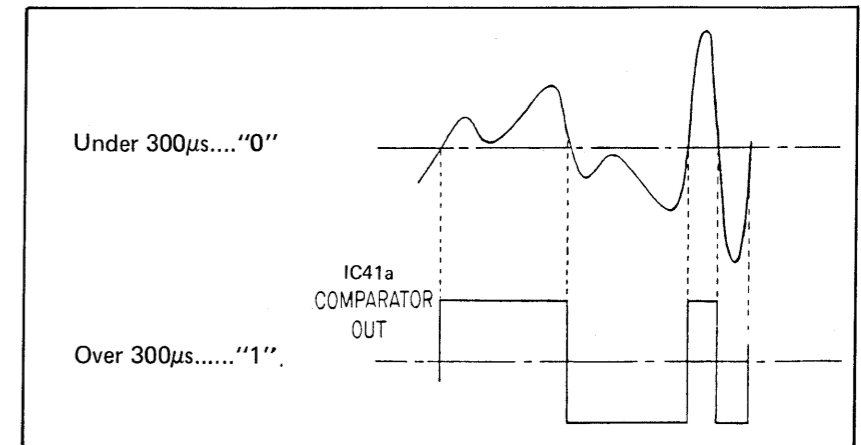

TAPE SYNC

IN STOP MODE . . . The CPU develops continual 1200Hz pulse at Port C-4;

IN normal PLAY MODE . . . The CPU generates 1200Hz and 2400Hz alternately.

The CPU changes frequency between 1200 and 2400Hz at every half-period of T which is 1/24 of the time required for most of Roland products to process a quarter note.

These 1200 or/and 2400Hz coming to TAPE INTERFACE have their high components filtered out by C93, R328, C94 and R329 before being routed to OUT/SAVE jack for use by the tape recorder as shown below.

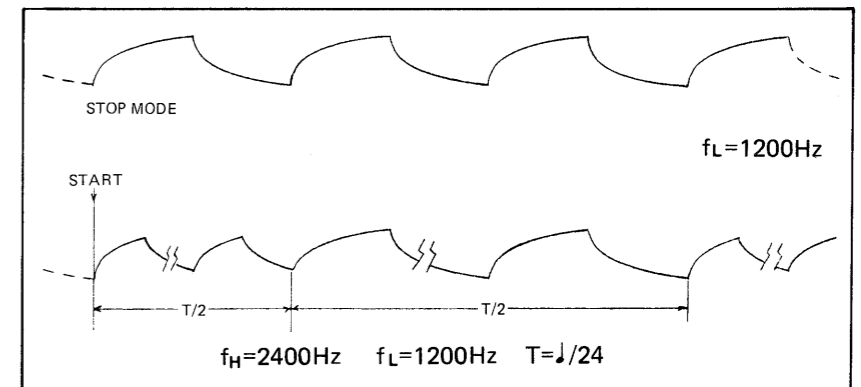

IN SYNC-TO-TAPE MODE . . . IC41, Q52 and surrounding circuits work on incoming signal in just the same way they do in LOAD or VERIFY mode.

The CPU converts this signal to the actual useful information. That is, the number of times per second that the signal changes frequency between 1200 and 2400Hz.

RELOADING FACTORY-PATTERNS

1. The TR-909 contains factory-rhythm patterns in BANK I, TRACK 1 under as-delivered condition. When the need arises to reload the patterns, follow the procedure below.

Note: Confirm that the resident voice data (especially, user's program) allows replacing.

While holding down TRACK 1 and PATTERN 1, turn the unit ON.

2. RE-LOADING BANKs I, II, TRACK 4

(See "Change Information" No. 1 in the subsequent paragraph to decide whether the following steps are necessary.)

- 1) While depressing SHIFT, tap TRACK 4.
- 2) Tap ENTER.
- 3) Depress TRACK 4.
- 4) While depressing SHIFT, tap BANK II.
- 5) While depressing SHIFT, tap TRACK 4.
- 6) Tap ENTER.

CHANGE INFORMATION

ROM IC609 SWITCH BOARD

| GROUP | SERIAL NUMBER | ROM USED | REMARKS |
|-------|------------------|---|--|
| A | 360100 393899 | 2764-250NS (Revision 0) | without version number on the label EPROM Part Number 15179645 |
| B | 403900 | 2764-250NS (Revision 1) or 2364-250NS | |
| | | both contain the same program MASK ROM Part Number 15179646 | |

Description

ROM in Group A

If measures in TRACK 1, 2 or 3 are incremented or decremented while there is no measure in TRACK 4, and one of subsequent TRACKs is selected for writing, all rhythm patterns may be lost or re-written. This can be avoided by implementing "RELOADING FACTORY-PATTERNS" paragraph 2 in the preceding section, or by replacing the existing ROM with the one in Group B.

ROMs in Group A and B

When synchronizing to MIDI clocks, there are glitches. TR-909 sometimes falls behind if STOP is pressed, then CONTINUE is pressed (this won't happen when MIDI clocks are transferred between TR-909's). Software revision 2 cures this problem and is incorporated in 2764-250NS labeled Ver. 2. To check if existing ROM is Ver. 2, turn the power ON while holding down TRACK 1 key, and MAIN key 2 (BASS DRUM) will blink, if version 2. ROMs of Ver. 2 are available from the factory to upgrade units on the market.

| SERIAL NUMBER | PART AFFECTED | DESCRIPTION |
|---------------|--|--|
| 370600 | Battery Compartment Lid | From rubber-made to metal-made. For positive engagement. As a replacement Metal one should be used (compatible). |
| 381500 | TAPE SYNC Filter & Amp VOICING BOARD | C87. From 10pF to delete. R306. From 4.7k to 47k. R312. From 470k to 4.7M. For optimizing waveforms coming from tape in LOAD mode. |
| | BASS DRUM VOICING BOARD | Capacitor C9. From 0.22μF to 0.33μF. For expanding the TUNE range. |
| 393000 | RESET POWER SUPPLY BOARD | D701. From RD6.8JB2 to RD5.6JB2. TR-909 would be forced to stop or its LED would start blinking when high power electrical instrument(s) is powered ON or OFF under poor AC supply condition (about less 10% nominal voltage). This simple diodes change will ensure reliable operation even at 20% below the nominal voltage. |
| 415300 | RIM SHOT VOICING BOARD | Resistor R417. From 12k to 3.3k. For giving the voice more realistic sound. |
| | HI-HAT VOICING BOARD | Capacitor C134. From 10μF to 0.01μF. For rolling off unnecessary lower frequencies. |
| | RIM SHOT/TRIG OUT (TAPE SYNC) VOICING BOARD DIN JACK BOARD (JK-2) | From jumper wire to R495 1k. R393. From 10k to 1M. R392. From 22k to 1M. Add capacitor C600 0.1μF between terminal No. 30 and the ground (TRIG OUT jack -- Hot-Ground). For preventing RIM SHOT signal from being induced onto TAPE SYNC signal which otherwise may cause glitches. |
| 426700 | TOM Noises VOICING BOARD | Capacitor C54. From 0.0022μF to 0.0047μF. R194 47k to 100k. This change will emphasize attack of TOM TOMs. |

FAULT ISOLATION GUIDE

| Symptom | CAUSE & ACTION TO BE TAKEN |
|---|---|
| The Unit fails to reproduce programmed rhythm sequence. Some memories have been replaced by other data. | PROM IC609 Ver. 1.0 has new program which should solve the problem of unreliability. Refer to "CHANGE INFORMATION" Check DC rails. Check IC702 on the Power Supply Board. Check RA600 and RA602 on Switch Board. |
| The unit stops running upon power ON/OFF transient of other electrical devices. | RESET circuitry is too sensitive to AC power drop. Check zener diode D701 on Power Supply Board. If it is RD6.8JB2, replace with RD5.6JB2. Refer to "CHANGE INFORMATION" |
| Data transfer between Internal Memory and Memory Cartridge (SAVE/LOAD) fails. | There should be an additional instruction to "3. Memory Cartridge" of the Owner's Manual (p.33). ENTER KEY must be UNLIT (Internal Memory Mode) during SAVE or LOAD from Memory Cartridge. That is . . . "Press ENTER when it is lit, then hold SHIFT." |
| Noise is high in OUTPUT | For the units prior to Serial Number 415300. Add capacitor 0.01μF across jack circuits on Multi Jack Board (MULTI JACK BOARD Diagram denotes these capacitor as C500-C512). |

M
L
K
J
I
H
G
F
E
D
C
B
A

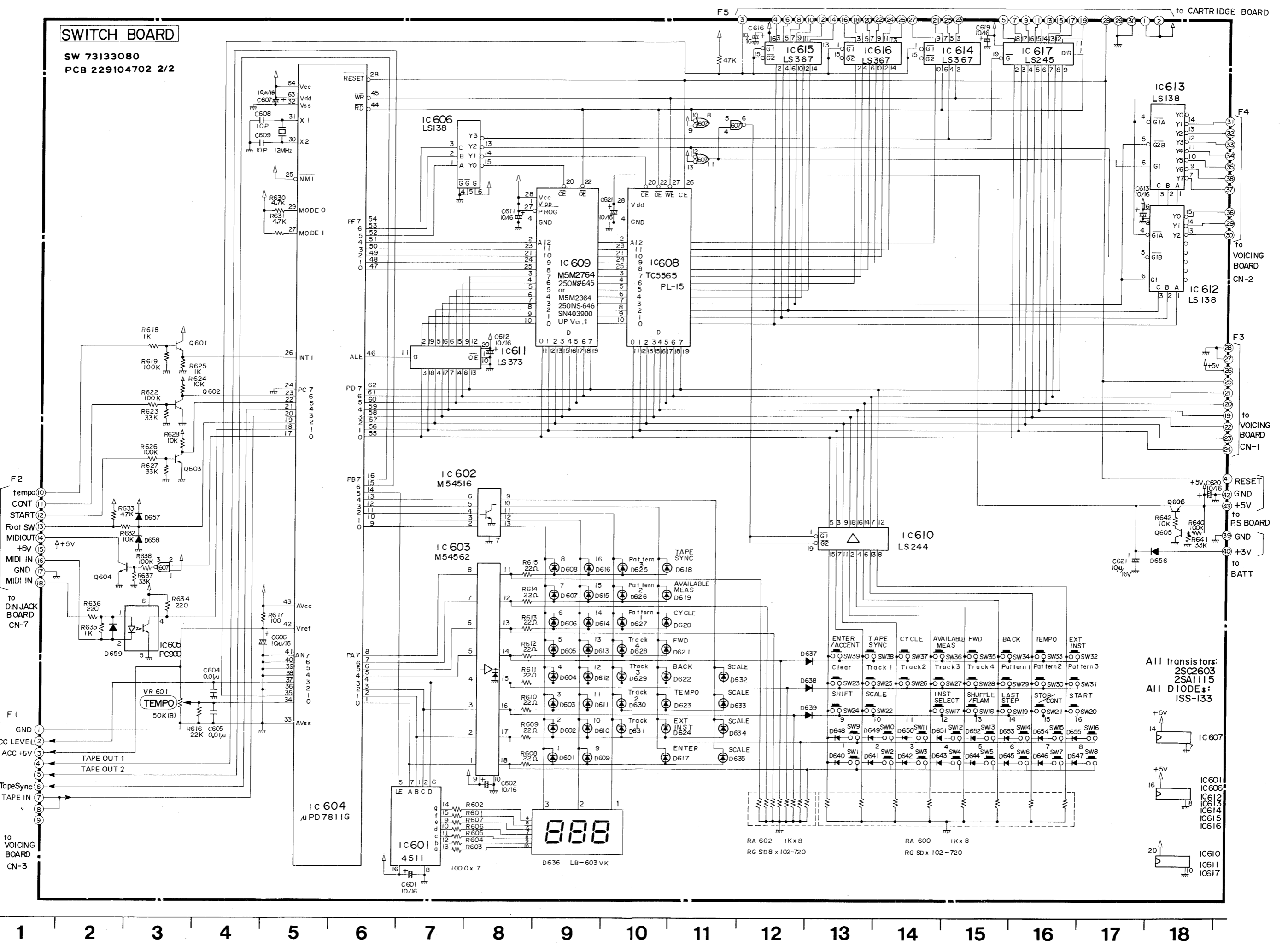

All transistors:
2SC2603
2SA1115
All DIODES:
ISS-133

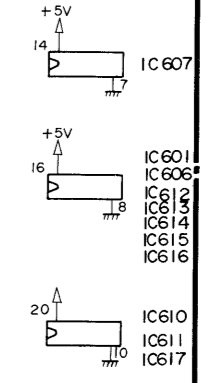

1 2 3 4 5 6 7 8 9 10 11 12 13 14 15 16 17 18 19 20 21 22 23 24 25 26 27 28 29 30 31 32 33 34 35 36 37 38 39 40 41 42 43 44 45 46

A
B
C
D
E
F
G
H
I
J
K
L
M
N
O
P
Q
R
S
T
U
V
W
X
Y
Z

Observed at MULTI OUT jack with all knobs set to center.

BD

200mV/div
5ms/div
with accent

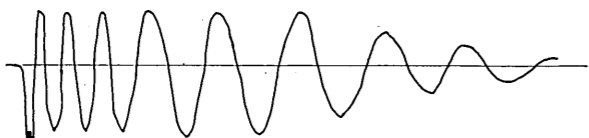

w/o accent

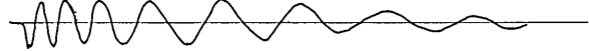

SD

0.5V/div
2ms/div
with accent

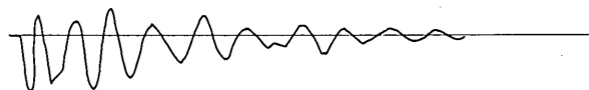

w/o accent

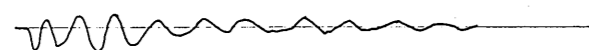

LT

0.5V/div
with accent

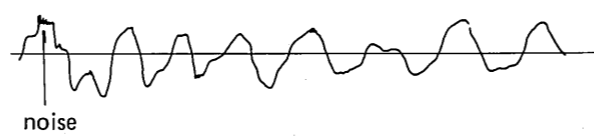

noise

w/o accent



50ms/div

LT with accent

MT, HT with accent



RS

2ms/div

R417=3.3K

R417=12K

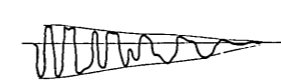
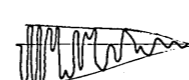

HAND CLAP

500mV/div
10ms/div



**HI-HAT
CLOSED**

500mV/div
20ms/div

with accent



w/o accent



OPEN

500mV/div
0.1s/div



CRASH

500mV/div
0.1s/div



RIDE

500mV/div
0.1s/div

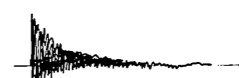

SWITCH BOARD

73133080

(pcb 2291084701 2/2)

View from foil side

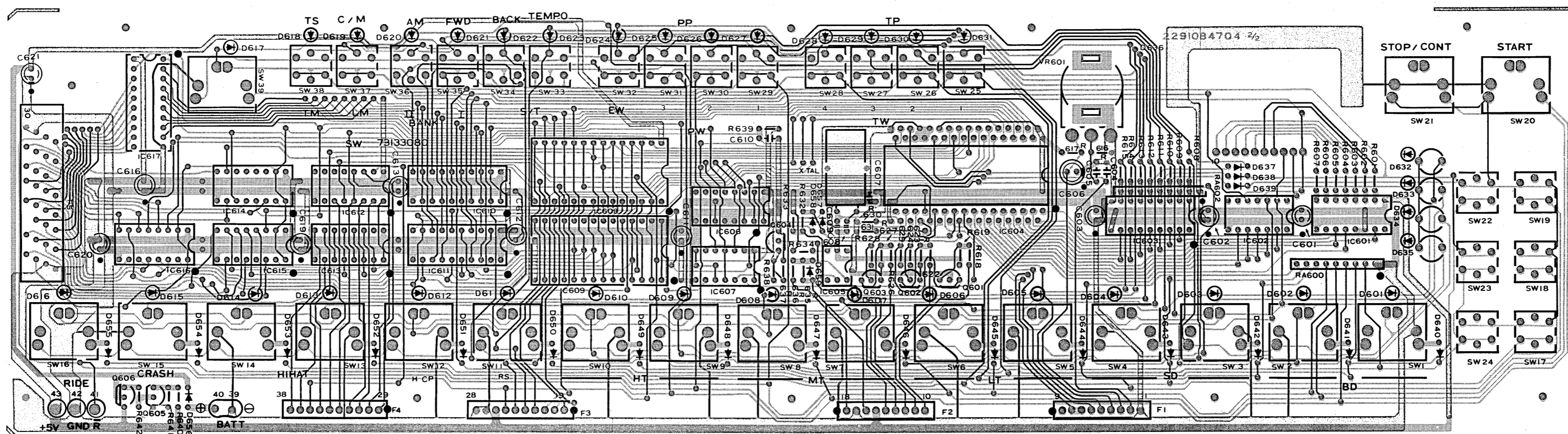

1 2 3 4 5 6 7 8 9 10 11 12 13 14 15 16 17 18 19 20 21 22 23 24 25 26 27 28 29 30 31 32 33 34 35 36 37 38 39 40 41 42 TR 43 44 45 VR 46 47 48

CIRCUIT DIAGRAM ADDRESS MAP

NOTE: On early PCBs two Q-40's exist one of which is denoted as Q-86 on later PCBs.

| | | | | | | | | |
|--------------------|----------------------|--------------------|---------------------|--------------------|----------------------|------------------|---------------------|-----------|
| IC1 M-3 | IC16 R-20,R-23, R-25 | IC26 a J-11 b G-13 | IC36 P-5,P-9 | IC48 a J-7 b J-6 | IC59 a F-13 b E-11 | IC72 a E-8 b D-6 | Q1 N-6 | VR1 S-17 |
| IC2 K-3 | IC17 a R-24 | IC27 a N-16 b M-15 | IC37 a P-4 b P-6 | IC49 a I-7 b H-7 | IC60 a E-12 b F-12 | c D-5 | Q2 N-7 | VR2 M-8 |
| IC3 I-3 | IC18 a Q-25 b Q-20 | IC28 a H-16 b | IC38 a P-8 b P-10 | IC50 a J-9 b J-10 | IC61 F-14 | d D-5 | Q3 L-7 | VR3 L-10 |
| IC4 H-3 | IC19 a R-22 b R-23 | IC29 a I-12 b J-12 | IC39 a Q-6 b R-7 | IC51 a C-24 b C-17 | IC62 D-14 | d D-5 | Q4 L-7 | VR4 M-12 |
| IC5 G-3 | IC20 a N-19 b M-19 | IC29 a I-12 b J-12 | IC40 a Q-5 b R-12 | IC52 a E-24 b E-17 | IC63 D-14 | b C-5 | Q5 M-7 | VR5 M-11 |
| IC6 F-3 | IC21 a N-20 b N-21 | IC30 H-15 | IC41 a Q-14 b Q-15 | IC53 D-21 | IC64 a D-26 b unused | | Q6 L-10 | VR6 P-1 |
| IC7 E-3 | IC22 N-20,N-23, N-25 | IC31 a K-15 b K-15 | IC42 I-19 | IC54 E-21 | IC65 a C-20 b C-12 | | Q7 N-7 | VR7 R-3 |
| IC8 D-3 | IC23 a M-25 b M-20 | IC32 L-15 | IC43 a J-20 b J-21 | IC55 F-22 | IC66 a A-25 b B-25 | | Q8 M-8 | VR8 R-12 |
| IC9 B-3 | IC24 a N-24 b N-26 | IC33 L-16 | IC44 J-20,J-23,J-25 | IC56 a E-19 b F-19 | IC67 a B-8 b C-9 | | Q9 M-9 | VR9 S-7 |
| IC10 L-3 | IC25 a N-22 b N-23 | IC34 a Q-2 b R-2 | IC45 a H-26 b I-20 | IC57 a F-18 b F-18 | IC68 D-7 | | Q10 M-9 | VR10 R-18 |
| IC11 a M-12 b M-6 | | IC35 a P-3 b P-3 | IC46 a J-24 b J-26 | IC58 a F-15 b F-21 | IC69 E-6 | | Q11 N-10 | VR11 P-25 |
| IC12 a N-8 b N-9 | | | IC47 a J-22 b J-23 | | IC70 F-8 | | Q12 M-12 | VR12 Q-26 |
| IC13 a M-10 b M-11 | | | | | IC71 F-6 | | Q13 R-21 | VR13 N-18 |
| IC14 a R-19 b Q-19 | | | | | | | Q14 R-25 | VR14 L-26 |
| IC15 a R-20 b R-21 | | | | | | | Q15 P-21 | VR15 M-26 |
| | | | | | | | Q16 O-20 | VR16 J-18 |
| | | | | | | | Q17 P-20 | VR17 H-26 |
| | | | | | | | Q18 Q-21 | VR18 I-26 |
| | | | | | | | Q19 Q-22 | VR19 J-9 |
| | | | | | | | Q20 P-25 | VR20 H-16 |
| | | | | | | | Q21 P-23 | VR21 B-6 |
| | | | | | | | Q22 R-23 | VR22 D-12 |
| | | | | | | | Q23 M-21 | VR23 B-7 |
| | | | | | | | Q24 L-21 | VR24 C-20 |
| | | | | | | | Q25 L-20 | VR25 E-11 |
| | | | | | | | Q26 L-22 | VR26 E-26 |
| | | | | | | | Q27 L-25 | VR27 E-27 |
| | | | | | | | Q28 L-23 | VR28 B-26 |
| | | | | | | | Q29 L-20 | |
| | | | | | | | Q30 N-21 | |
| | | | | | | | Q31 N-25 | |
| | | | | | | | Q32 N-23 | |
| | | | | | | | Q33 N-16 | |
| | | | | | | | Q34 N-15 | |
| | | | | | | | Q35 I-11 | |
| | | | | | | | Q36 J-11 | |
| | | | | | | | Q37 H-15 | |
| | | | | | | | Q38 J-15 | |
| | | | | | | | Q39 P-2 | |
| | | | | | | | Q40 Q-2, I-14 (Q86) | |
| | | | | | | | Q41 R-2 | |
| | | | | | | | Q42 R-3 | |
| | | | | | | | Q43 Q-7 | |
| | | | | | | | Q44 P-5 | |
| | | | | | | | Q45 P-10 | |
| | | | | | | | Q46 Q-9 | |
| | | | | | | | Q47 R-7 | |
| | | | | | | | Q48 R-5 | |
| | | | | | | | Q49 Q-12 | |
| | | | | | | | Q50 R-9 | |
| | | | | | | | Q51 R-12 | |
| | | | | | | | Q52 R-14 | |
| | | | | | | | Q53 J-21 | |
| | | | | | | | Q54 J-25 | |
| | | | | | | | Q55 J-23 | |
| | | | | | | | Q56 I-21 | |
| | | | | | | | Q57 H-22 | |
| | | | | | | | Q58 H-25 | |
| | | | | | | | Q59 H-23 | |
| | | | | | | | Q60 H-21 | |
| | | | | | | | Q61 G-20 | |
| | | | | | | | Q62 H-20 | |
| | | | | | | | Q63 I-6 | |
| | | | | | | | Q64 J-7 | |
| | | | | | | | Q65 J-8 | |
| | | | | | | | Q66 H-9 | |
| | | | | | | | Q67 H-9 | |
| | | | | | | | Q68 E-24 | |
| | | | | | | | Q69 D-24 | |
| | | | | | | | Q70 E-17 | |
| | | | | | | | Q71 C-17 | |
| | | | | | | | Q72 Q-5 | |
| | | | | | | | Q73 B-6 | |
| | | | | | | | Q74 B-7 | |
| | | | | | | | Q75 C-19 | |
| | | | | | | | Q76 C-20 | |
| | | | | | | | Q77 D-26 | |
| | | | | | | | Q78 D-26 | |
| | | | | | | | Q79 B-25 | |
| | | | | | | | Q80 D-10 | |
| | | | | | | | Q81 D-11 | |
| | | | | | | | Q82 A-27 | |
| | | | | | | | Q83 A-26 | |
| | | | | | | | Q84 C-8 | |
| | | | | | | | Q85 D-8 | |
| | | | | | | | Q86 I-14 (Q40) | |

VOICING BOARD 73133090 (pcb 2291084900 3/3)

View from foil side

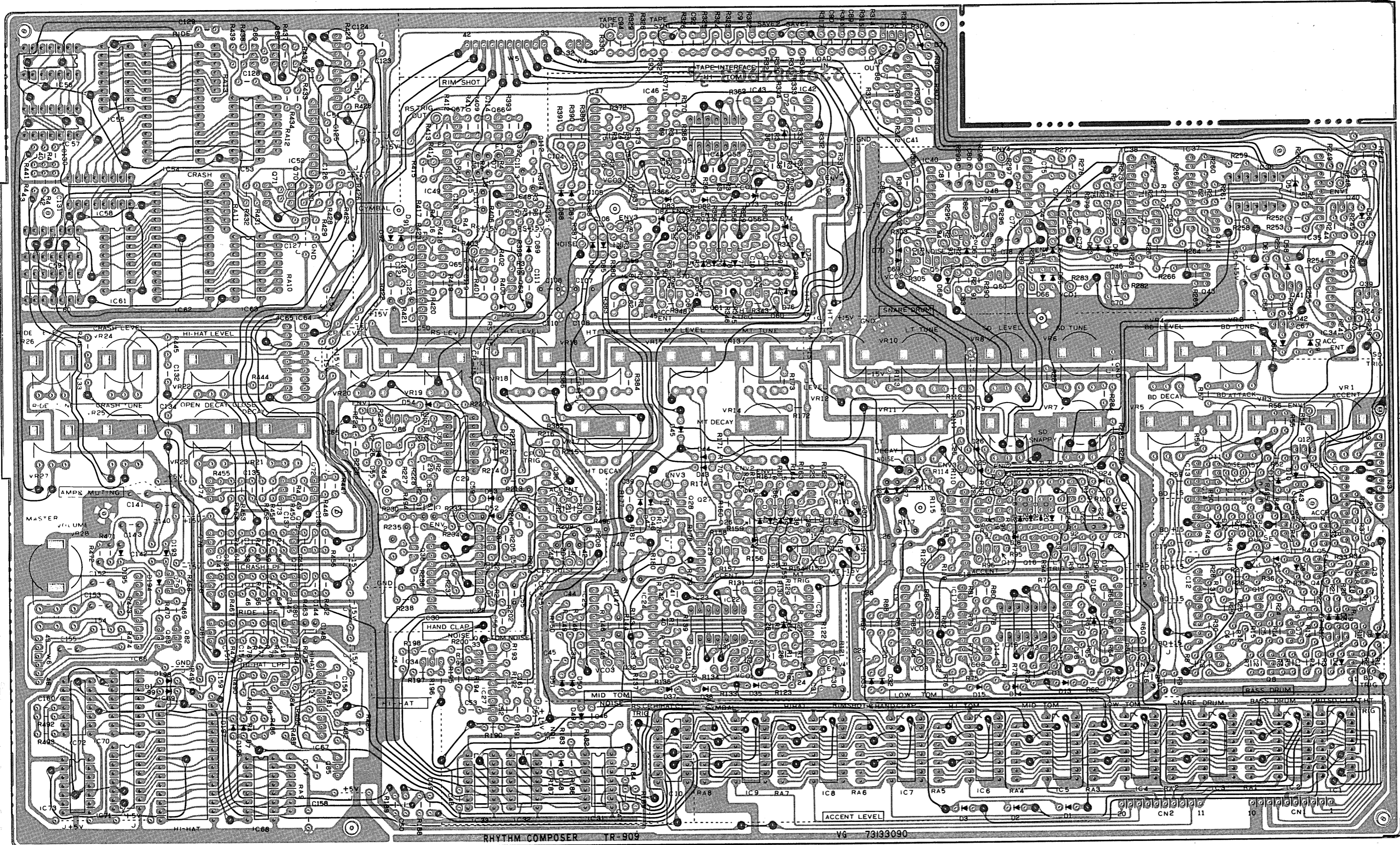

CIRCUIT DIAGRAM

VOICING BOARD V6 73133090 PCB 2291084903 3/3

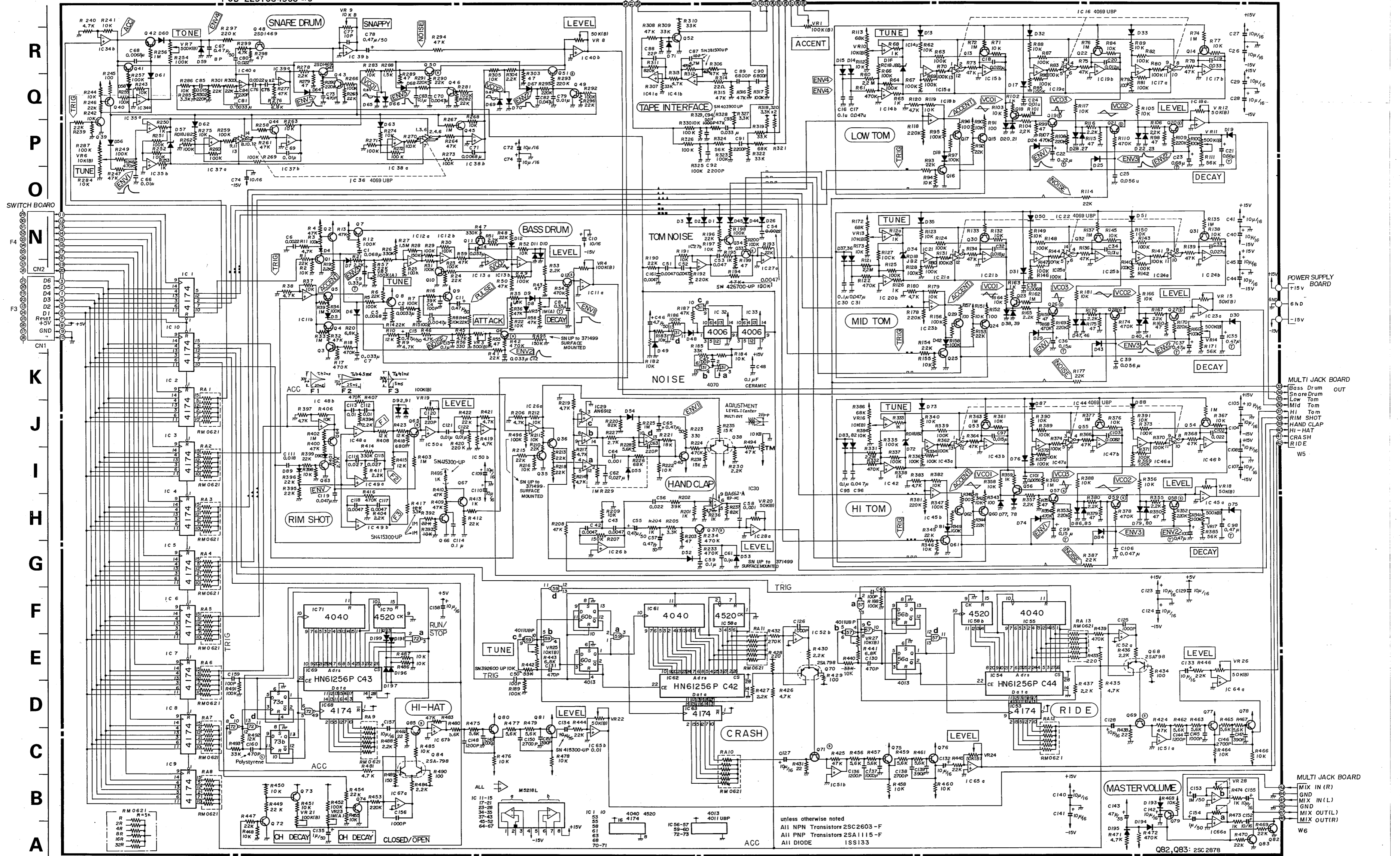

unless otherwise noted
 All NPN Transistors 2SC2603-F
 All PNP Transistors 2SA1115-F
 All DIODE 1SS133

Q82, Q83: 2SC2878

R
Q
P
O
N
K
J
I
H
G
F
E
D
C
B
A

1 2 3 4 5 6 7 8 9 10 11 12 13 14 15 16 17 18 19 20 21 22 23 24 25 26

MULTI JACK BOARD

(JK-1) 73133100
(pcb 2291084900 1/3)

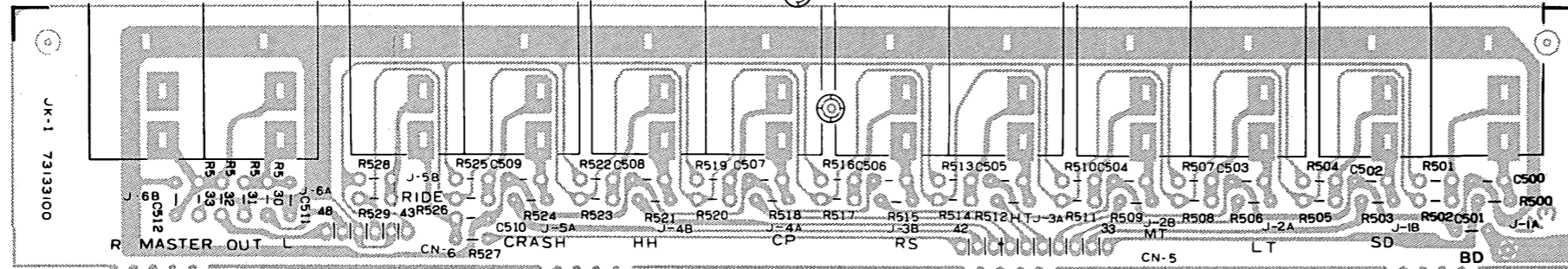

View from foil side

DIN JACK BOARD

(JK-2) 73133110
(pcb 2291084900 2/3)

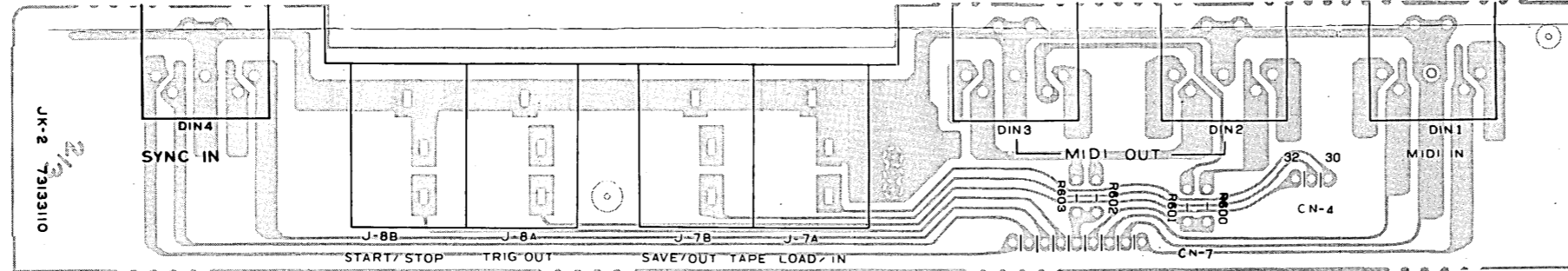

View from foil side

POWER SUPPLY BOARD

- 73133071 100V
- 73133072 117V
- 73133074 220V
- 73133075 240V 2P
- 73133076 240V 3P

(pcb 2291084700 1/2)

View from foil side

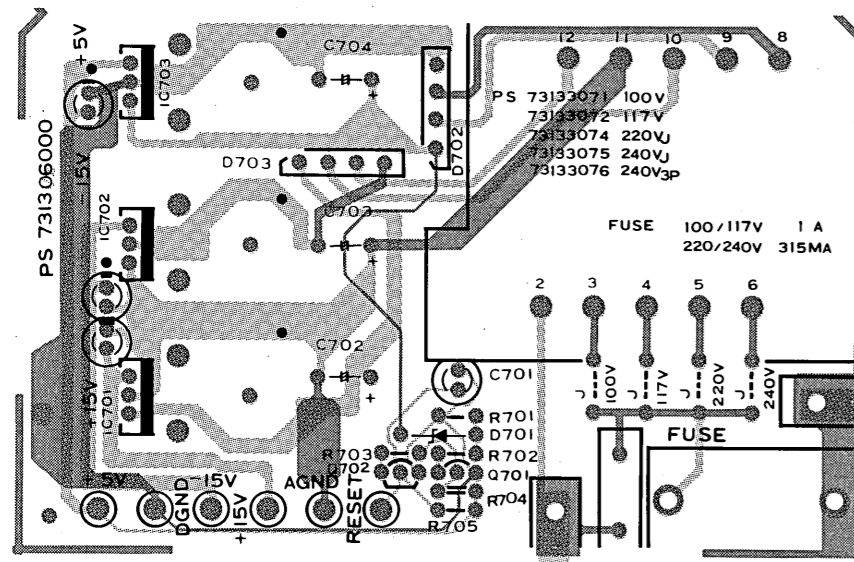

CARTRIDGE BOARD

73133120
(pcb 2291085000)

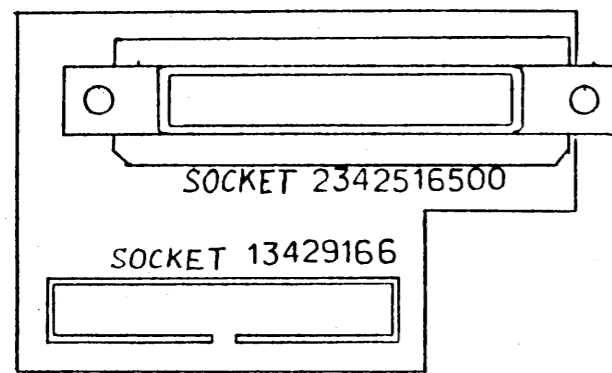

PCB 2291085000

CARTRIDGE BOARD 73133120 (PCB 2291085000)

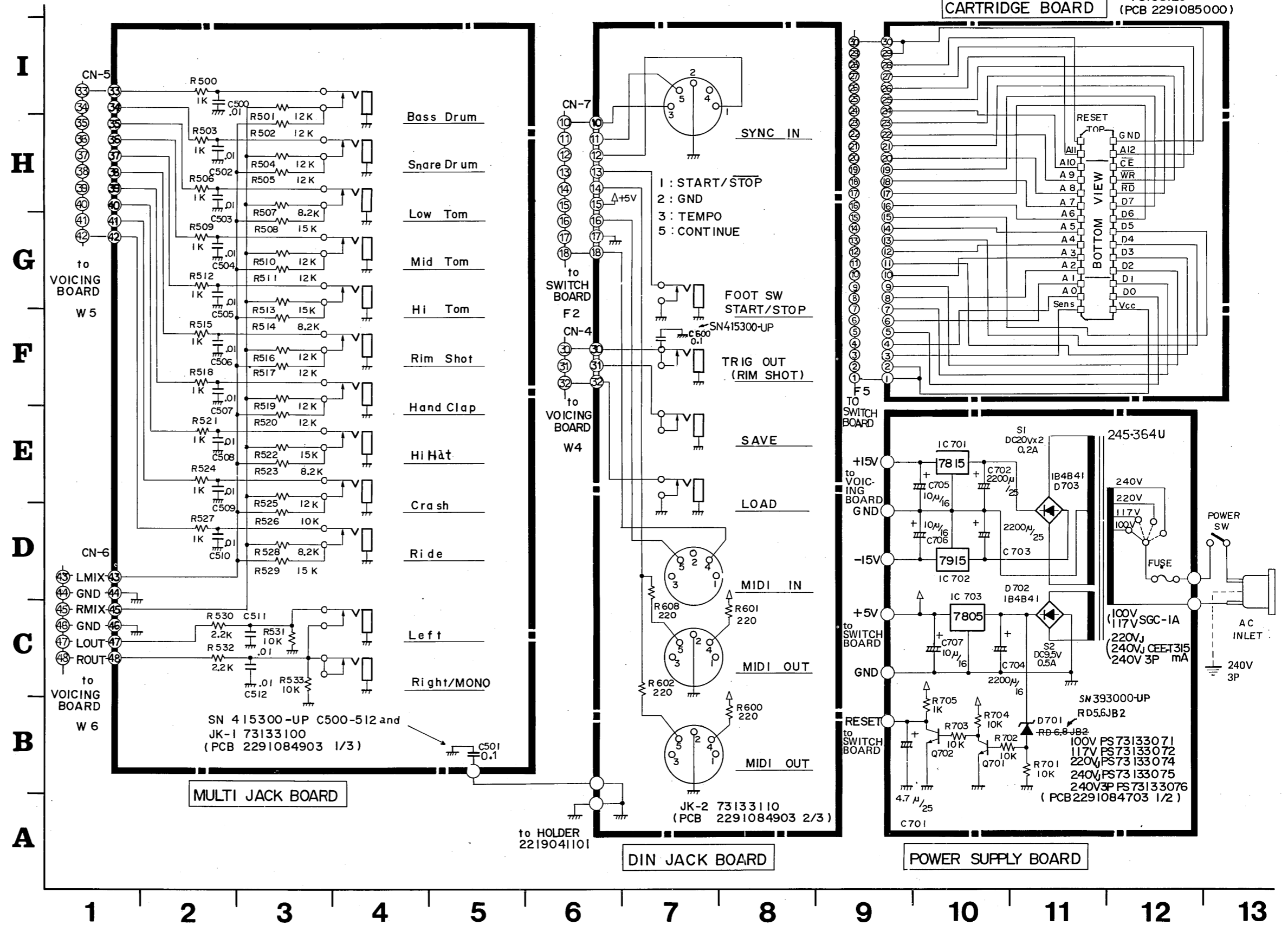
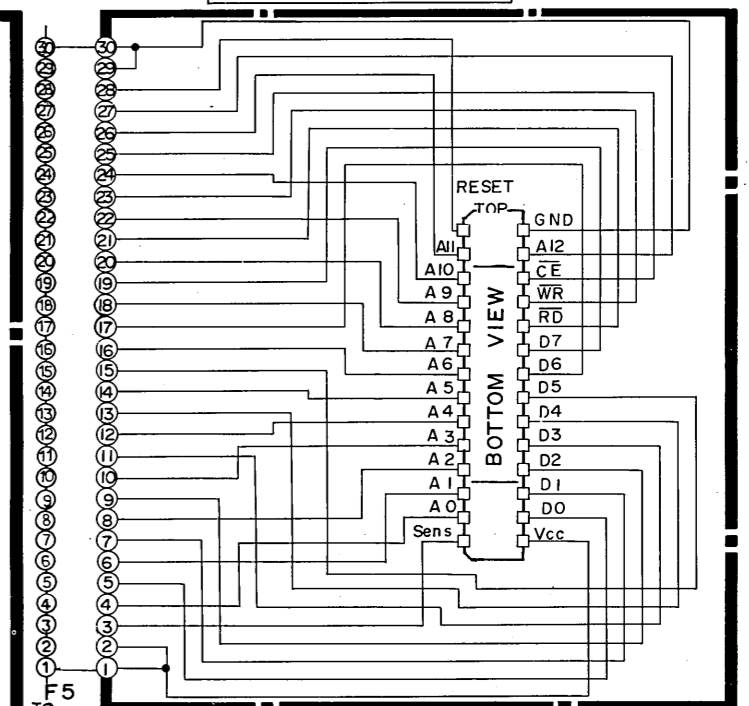

A
B
C
D
E
F
G
H
I
J
K
L
M
N
O
P
Q
R
S
T
U
V
W
X
Y
Z

1 2 3 4 5 6 7 8 9 10 11 12 13 14 15 16 17 18 19 20 21 22 23 24 25 26 27 28 29 30 31 32 33 34 35 36 37 38

A B C D E F G H I J K L M N O P Q R S T U V W X Y Z

M-64C

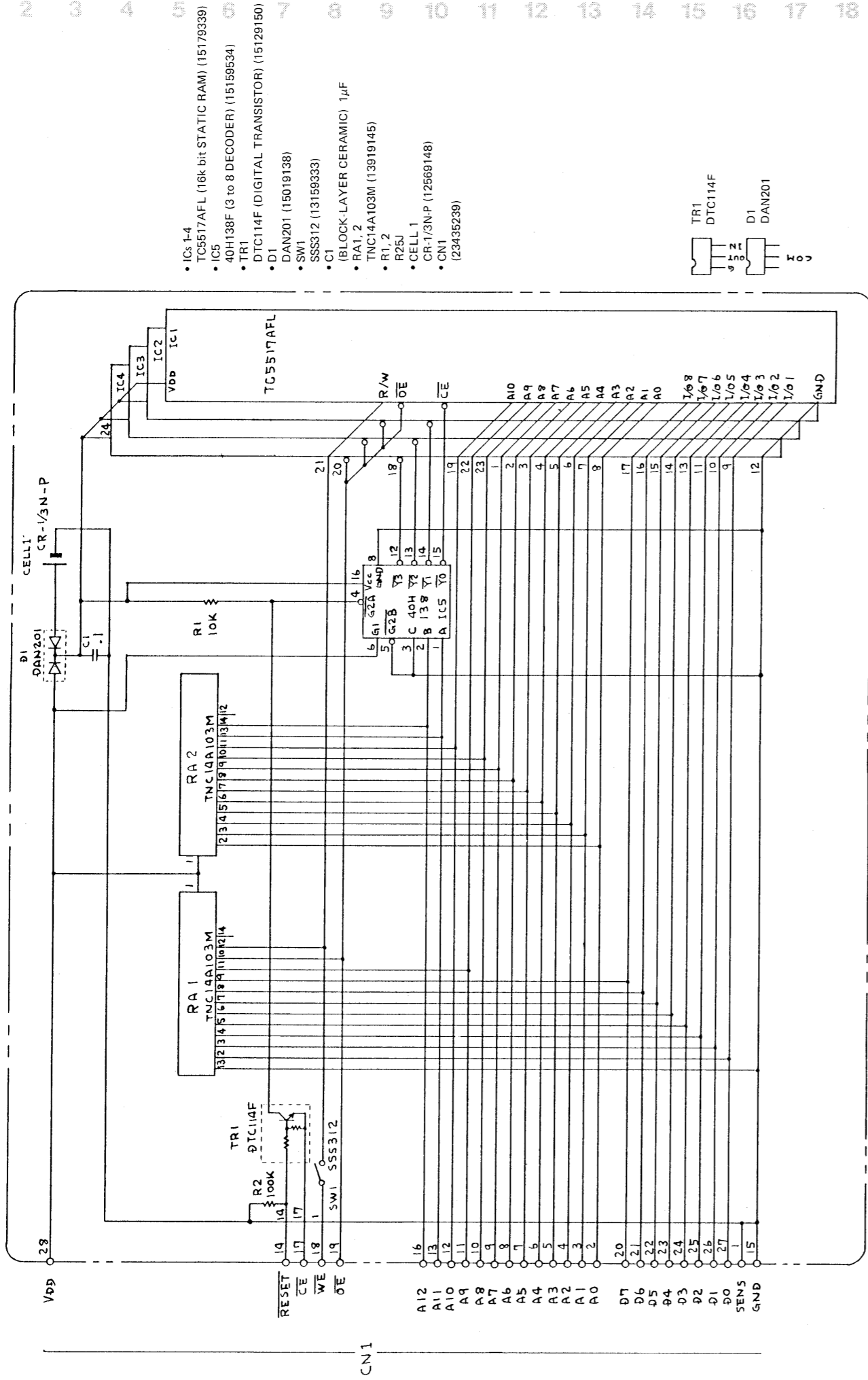

- ICs 1-4 TC5517AFL (16k bit STATIC RAM) (15179339)
- IC5 40H138F (3 to 8 DECODER) (15159534)
- TR1 DTC114F (DIGITAL TRANSISTOR) (15129150)
- D1 DAN201 (15019138)
- SW1 SSS312 (13159333)
- C1 (BLOCK-LAYER CERAMIC) 1μF
- RA1, 2 TNC14A103M (13919145)
- R1, 2 R25J
- CELL 1 CR-1/3N/P (12569148)
- CN1 (23435239)

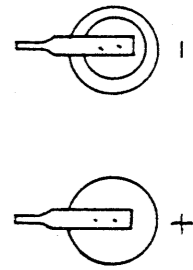
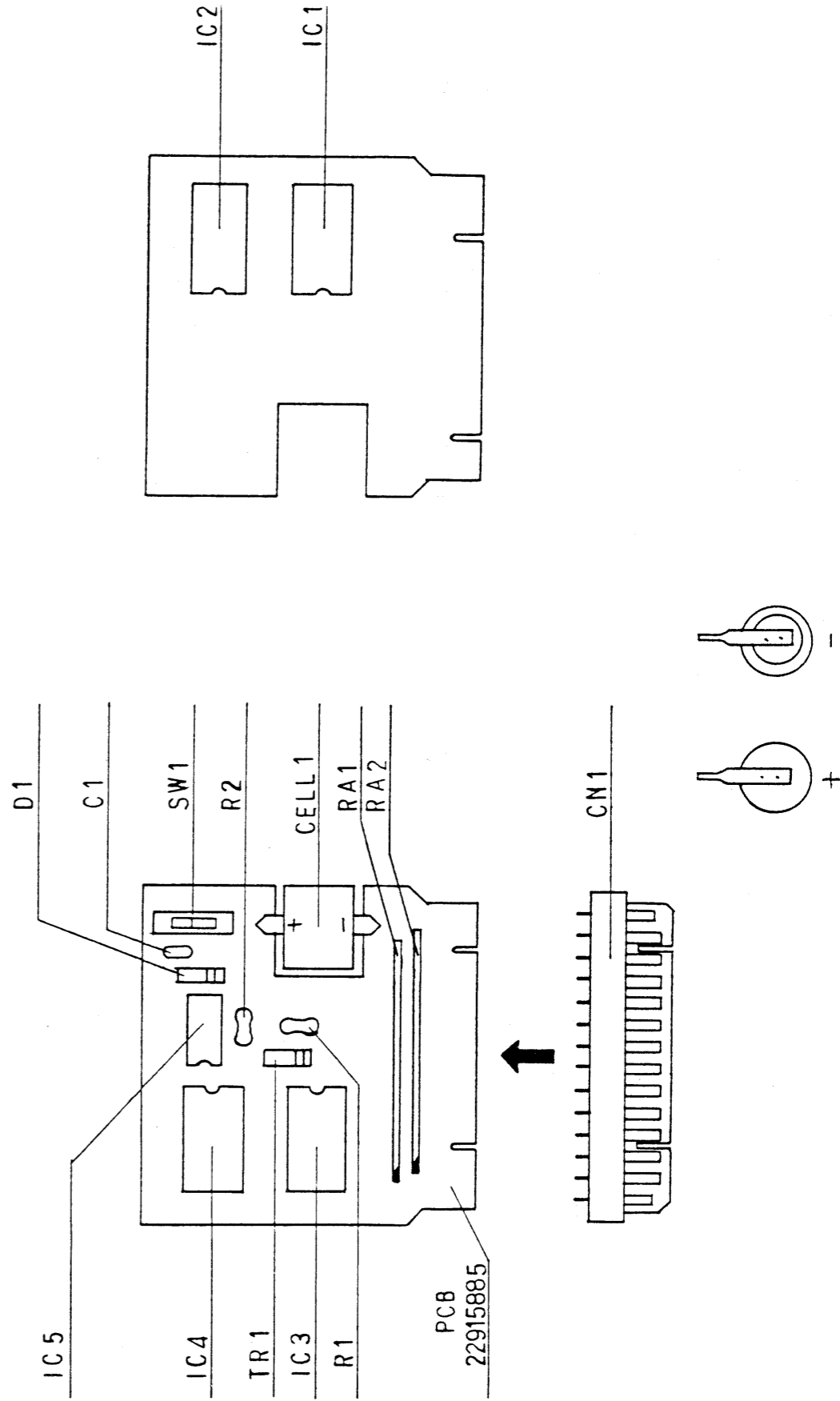
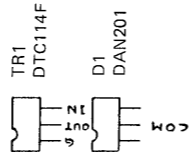

MIDI NOTES

The TR-909 is designed to accept voice messages sent over MIDI channel(s) in any of four channel modes defined in the MIDI Specification as shown in the table below.

| MODE | RECEIVER |
|-----------------|---|
| 1 OMNI ON POLY | Voice messages are received from all Voice Channels and assigned to voices polyphonically. |
| 2 OMNI ON MONO | Voice messages are received from all Voice Channels, and control only one voice, monophonically. |
| 3 OMNI OFF POLY | Voice messages are received in Voice Channel N only, and are assigned to voices polyphonically. |
| 4 OMNI OFF MONO | Voice messages are received in Voice Channels N thru N+M-1, and assigned monophonically to voices 1 thru M, respectively. The number of voices M is specified by the third byte of the Mono Mode Message. |

N: Basic Channel

This is an inherent channel of an instrument, which cannot be changed by MIDI messages but may be changed by the panel function on the instrument.

The TR-909 has channel selections on the front panel.

To fully take advantage of this feature, however, proper Channel Mode must be selected to receive necessary voice messages only, and to reject unnecessary ones.

Before proceeding to this text, please note the following:

- * TR-909 is a one voice rhythm machine.
- * The rhythm sounds (rhythm voice generators) are assigned to KEY (NOTE) numebrs, respectively, as shown below.
- * A given MIDI message will take effect only when recognized by TR-909.
- * Do not put TR-909 into MIDI-loop circuit. Feedback may lead to malfunction.

MIDI KEY ASSIGNMENT

| | |
|----------------|---------------|
| kkkkkkk=35, 36 | Bass Drum |
| 37 | Rim Shot |
| 38, 40 | Snare Drum |
| 39 | Hand Clap |
| 41, 43 | Low Tom |
| 42, 44 | Closed Hi-Hat |
| 45, 47 | Mid Tom |
| 46 | Open Hi-Hat |
| 48, 50 | High Tom |
| 49 | Crash Cymbal |
| 51 | Ride Cymbal |

Keys not listed are ignored. Two keys are for duplicating a sound with convenient key play.

MODES AND CHANNELS IN TR-909 MIDI CONNECTIONS

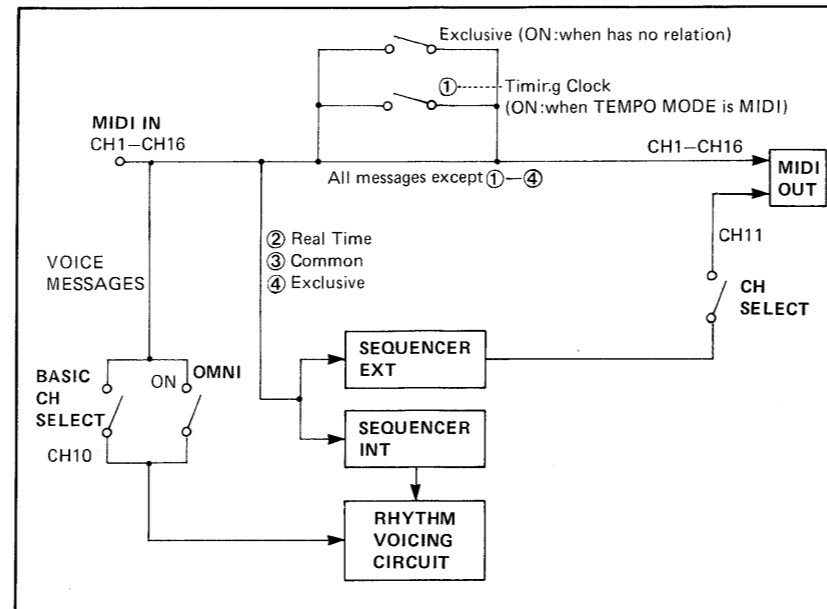

As can be seen from the diagram, TR-909 MIDI OUT does dual duties; it also serves as a kind of MIDI THRU. Using this route, additional data can be sent in different channels, and yet can be mixed with TR-909 output data in one channel at the TR-909 MIDI OUT. Thus, an external voice will be controlled both through TR-909 and by the data that TR-909 cannot provide. MIDI messages common to internal and external voices are coordinated by TR-909.

To prevent the data already applied to TR-909 from being re-fed to the subsequent unit, receiving and transmitting channels are set to different channels at the factory.

MODE 1.....OMNI ON, POLY

MODE 2.....OMNI ON, MONO

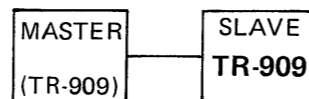

With this connection, slave unit can recognize voice messages on whichever channels the master unit transmits. There is no difference between MODEs 1 and 2 in TR-909 function since it contains only one voice.

MODE 3.....OMNI OFF, POLY

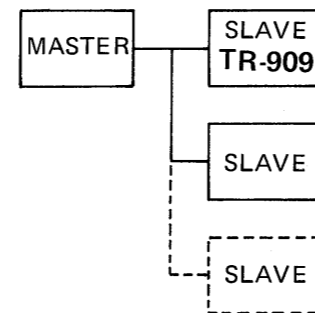

All slaves in different channels

In a system as shown, each slave should be in OMNI OFF mode with its basic channel match the channel number assigned by the master respectively. Once set, it will response to voice messages sent over its current basic channel only (see "GENERAL PRECAUTIONS" on page 16).

As for TR-909, it must be set to MODE 3. The table below will help set TR-909 to correct mode and channel.

NOTE:

Roland products with preliminary MIDI turn to OMNI OFF upon receiving POLY ON.

CHANNELS & CHANNEL MODES

| | RECEIVER | TRANSMITTER |
|----------------------------------|--|--|
| ON POWER-UP MODE CHANNEL | Defaults to MODE 1 (OMNI ON, POLY) 10 (1001) | Defaults to POLY 11 (1010) |
| HOW TO CHANGE CHANNELS AND MODES | Both receiving and transmitting channels can be changed to any of 16 channels from front panel. 1. Press SHUFFLE/FLAM. This will display the current channel number. On power up, without any input message, "10" will be replaced by "0" to indicate OMNI ON. 2. Holding SHUFFLE, select new channel, as necessary, by pushing MAIN KEY (1 thru 16). This also sets the new channel to MODE 3 (OMNI OFF, POLY). | 1. Press LAST STEP. This will display the current channel number. 2. Holding LAST STEP, select new channel, as needed, by pushing MAIN Key (1 thru 16). This will cause transmission of OMNI OFF and POLY mode messages in the new channel. This function should be adopted when need arises to set its slave (which is incapable of changing receiving channels by itself) to OMNI OFF mode. |

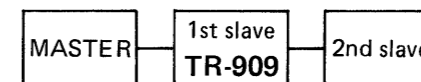

When the slave(s) has no capability of channel selection or mode change to OMNI OFF (like some Roland preliminary instruments), this can be cured by using the TR-909 transmitter's feature listed above. (See "GENERAL PRECAUTIONS" on page 16.)

MODE 4.....OMNI OFF, MONO

When TR-909 receives MONO mode message with OMNI OFF mode, it recognizes the number (M) represented by the 3rd byte of the message. TR-909, then accepts voicing messages on the basic channels and upward according to M.

Example: Basic channel--4, M--3, then 4 + 3 - 1. i.e. channels 4, 5 and 6. Result numbers exceeding 16 are ignored.

MIDI IMPLEMENTATION

(Complies with MIDI 1.0)

TRANSMITTED DATA

| Status | Second | Third | Description |
|--------------|-------------------|--------------|--|
| 1001 [*1] | nnnn 0kkk kkkk | Ovvv vvvv | Note On kkkkkkk = 36 - 51 vvvvvvv = 64 - 96 (accent min-max) Note off vvvvvvv = 0 |
| 1011 | nnnn Occc cccc | Ovvv vvvv | Mode Message [*2] ccccccc = 124: Omni mode off 127: Poly mode on vvvvvvv = 0 |
| 1111 0010 | Oxxx xxxx | Oyyy yyyy | Song Position Pointer [*3] xxxxxxx: Least significant yyyyyyy: Most significant |
| 1111 0011 | Osss ssss | --- | Song Select [*4] sssssss: Track # |
| 1111 1000 | | | Timing Clock [*5] |
| 1111 1010 | | | Start |
| 1111 1011 | | | Continue |
| 1111 1100 | | | Stop |

RECOGNIZED RECEIVE DATA

| Status | Second | Third | Description |
|--------------|-------------------|--------------|--|
| 1001 [*6] | mmmm 0kkk kkkk | Ovvv vvvv | Note On (Trigger) kkkkkkk = 35 - 51 [*7] vvvvvvv = 1 - 127 |
| 1011 | mmmm Occc cccc | Ovvv vvvv | Mode Message ccccccc = 124: Omni mode off vvvvvvv = 0 ccccccc = 125: Omni mode on vvvvvvv = 0 ccccccc = 126: Mono mode on vvvvvvv = M [*8] ccccccc = 127: Poly mode on vvvvvvv = 0 |
| 1111 0010 | Oxxx xxxx | Oyyy yyyy | Song Position Pointer [*9] xxxxxxx: Least significant yyyyyyy: Most significant |
| 1111 0011 | Osss ssss | --- | Song Select [*10] sssssss: Track # |
| 1111 1000 | | | Timing Clock [*11] |
| 1111 1010 | | | Start |
| 1111 1011 | | | Continue |
| 1111 1100 | | | Stop |
| 1111 1111 | | | System Reset |

- *1 On power-up "nnnn" is set to 1010 (channel 11). Can be changed to 0000(1) through 1111(16) from the front panel.
- *2 When a channel number is set, "OMNI OFF" and "POLY ON" are sent in that channel.
- *3 Sent only when in TRACK PLAY and STOP modes, and after a measure number has been set.
- *4 Sent when TRACK number or BANK is selected. (The same number is applied to the Memory Cartridge, if selected.)

| | | |
|------------|--------|---------|
| ssssss = 0 | Bank-1 | Track-1 |
| 1 | | Track-2 |
| 2 | | Track-3 |
| 3 | | Track-4 |
| 4 | Bank-2 | Track-1 |
| 5 | | Track-2 |
| 6 | | Track-3 |
| 7 | | Track-4 |

- *5 One of the following, according to TEMPO MODE setting.
 - INTERNAL mode
This is synced to the internal TEMPO clock (MIDI clock and DIN SYNC Inputs are ignored).
 - MIDI mode
MIDI clock input is selected (Internal TEMPO clock and DIN SYNC input are ignored).
 - DIN SYNC mode
This is synced to the positive going edge of clock pulses from DIN jack (MIDI and Internal TEMPO clocks are ignored).

- *6 The TR-909 always powers-up with channel set to "10"(1001) and with OMNI mode ON. The channel can be changed to "1"(0000) through "16"(1111) from the front panel with its mode switched to OMNI OFF.
- *7 Note On message works as a trigger pulse.
Note Off message and Note On with vvvv=0 are ignored.

| MIDI KEY ASSIGNMENT | kkkkkkk = | |
|---------------------|-----------|---------------|
| | 35, 36 | Bass Drum |
| | 37 | Rim Shot |
| | 38, 40 | Snare Drum |
| | 39 | Hand Clap |
| | 41, 43 | Low Tom |
| | 42, 44 | Closed Hi-Hat |
| | 45, 47 | Mid Tom |
| | 46 | Open Hi-Hat |
| | 48, 50 | High Tom |
| | 49 | Crash Cymbal |
| | 51 | Ride Cymbal |

NOTE:
When sounding TR-909's voices only with MIDI rhythm patterns, select a blank TRACK. Patterns programmed in a selected track will be forced to run whenever START comes from MIDI IN.

- *8 Voice messages are received in Voice Channels "mmmm" through "mmmm+M-1".
- *9 Recognized only when in TRACK PLAY and STOP modes.
- *10 Effective only when the TR-909 is in STOP during PLAY, TRACK WRITE PATTERN PLAY, or PATTERN WRITE. Upon receiving, the TR-909 enters TRACK PLAY mode.
- *11 Recognized only when TEMPO MODE is set to MIDI.

All valid MIDI IN messages are transferred to MIDI OUT except Timing Clock and System Exclusive.

While the Tape Interface is functioning (SAVE/LOAD/VERIFY), all MIDI routine is frozen.

TR-909 SYSTEM EXCLUSIVE

1. INTRODUCTION

Using system exclusive messages, a bank of rhythm data can be transmitted to or received from the TR-909 (TR-909 has two banks).

To interact with TR-909 by using system exclusive a host computer must be linked together.

The host computer must first send REQUEST to the TR-909 which does not take the initiative in transferring system exclusive.

The TR-909 can process the system exclusive only when in TRACK PLAY and STOP modes.

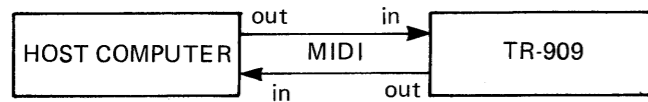

2. DATA SAVE TO THE HOST COMPUTER

(1) REQUEST HOST → TR-909

| Byte | Description |
|-----------|------------------------|
| 1111 0000 | Exclusive status |
| 0100 0001 | Roland ID # |
| 0101 0001 | Operation Code |
| 1111 0111 | EOX (End of Exclusive) |

(2) DATA HOST ← TR-909

| Byte | Description |
|-----------|--|
| 1111 0000 | Exclusive status |
| 0100 0001 | Roland ID # |
| 0101 0010 | Operation Code (or 0111 0000 = abort) |
| 0000 0001 | Format type |
| 0100 nnnn | Block # (nnnn: 0000 – 1111) |
| 0000 xxxx | Rhythm data (yyyyxxxx) |
| 0000 yyyy | |
| 0000 | |
| 0000 | |
| 0sss ssss | Check sum (for the preceding 512 data bytes) |
| 1111 0111 | EOX |
| 1111 0000 | Exclusive status |
| 0100 0001 | Roland ID # |
| 0101 0100 | Operation Code (or 0101 0101 = no data follow) |
| 1111 0111 | EOX |

(3) ACKNOWLEDGE HOST → TR-909

| Byte | Description |
|-----------|---------------------------------------|
| 1111 0000 | Exclusive status |
| 0100 0001 | Roland ID # |
| 0101 0011 | Operation Code (or 0111 0001 = Error) |
| 1111 0111 | EOX |

(4) Repeat (2) and (3) increasing Block # until nnnn = 1111. (A bank of rhythm data is divided into 16 blocks.)

3. DATA LOAD FROM THE HOST COMPUTER

(1) REQUEST HOST → TR-909

| Byte | Description |
|-----------|------------------------|
| 1111 0000 | Exclusive status |
| 0100 0001 | Roland ID # |
| 0101 0000 | Operation Code |
| 1111 0111 | EOX (End of Exclusive) |

(2) ANSWER HOST ← TR-909

| Byte | Description |
|-----------|---------------------------------------|
| 1111 0000 | Exclusive status |
| 0100 0001 | Roland ID # |
| 0101 0001 | Operation Code (or 0111 0000 = abort) |
| 1111 0111 | EOX (End of Exclusive) |

(3) DATA HOST → TR-909

| Byte | Description |
|-----------|--|
| 1111 0000 | Exclusive status |
| 0100 0001 | Roland ID # |
| 0101 0010 | Operation Code |
| 0000 0001 | Format type |
| 0100 nnnn | Block # (nnnn: 0000 – 1111) |
| 0000 xxxx | Rhythm data (yyyyxxxx) |
| 0000 yyyy | |
| 0000 | |
| 0000 | |
| 0sss ssss | Check sum (for the preceding 512 data bytes) |
| 1111 0111 | EOX |
| 1111 0000 | Exclusive status |
| 0100 0001 | Roland ID # |
| 0101 0100 | Operation Code (or 0101 0101 = no data follow) |
| 1111 0111 | EOX |

(4) ACKNOWLEDGE HOST ← TR-909

| Byte | Description |
|-----------|---------------------------------------|
| 1111 0000 | Exclusive status |
| 0100 0001 | Roland ID # |
| 0101 0011 | Operation Code (or 0111 0001 = Error) |
| 1111 0111 | EOX |

(5) Repeat (3) and (4) increasing Block # until nnnn = 1111. (A bank of rhythm data is divided into 16 blocks.)

GENERAL PRECAUTIONS ON MIDI CONNECTION

Although all MIDI instruments function to MIDI specification, some precautions must be taken for satisfactory operation.

This is mainly due to MIDI revision. One of primary procedures to be correctly followed is setting of "Channel Mode" otherwise MIDI function fails from the beginning. Also remember that MIDI information is effective only when receiving device can recognize a given message and has software and hardware that duplicate function defined by the message.

On power up most Roland products complying with MIDI specification 1.0 default to OMNI ON, POLY. On the contrary, they transmit OMNI OFF and POLY mode messages from MIDI OUT jack. The reason is as follows.

Receiving instrument must be reset to OMNI OFF mode when it is to accommodate voice messages sent over the channel to which it is currently assigned while other voice messages are present in other channels. (Example. a system consists of one master and more than one slave, each assigned to different channel.) However, some instruments are incapable of changing modes on the front panel and need external OMNI OFF message.

To cure this problem a system including such instruments as slaves should be configured as below.

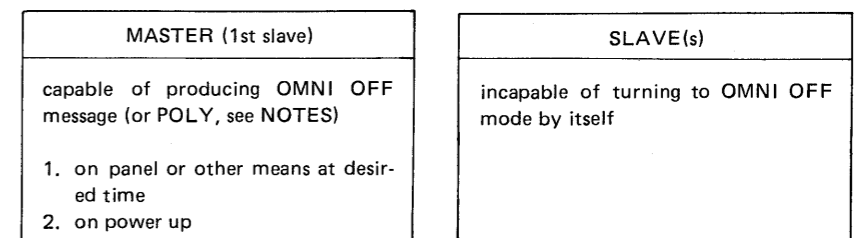

In the above combination:

- Slave must be powered ON before the master is turned ON. (When the second slave connects to MIDI OUT of the first slave, it is the first to be turned ON.)
- Master and Slave(s) must be set in the same channel since mode messages will be recognized by the slave only when set in the channel to which the slave's receiver has been assigned.

NOTES:

- Roland products with preliminary MIDI turn to OMNI OFF upon receiving POLY mode ON.
- TR-909 does not send OMNI OFF and POLY messages on power-up but on transmitting channel setting.

 **Roland** SERVICE INFORMATION
SERVICE DEPARTMENT

NO.

100236

DATE

Feb. 6, 1985

PRODUCT AFFECTED: TR-909

TO SERVICE ENGINEERS:
SUBJECT
TR-909 PROM VERSION UP

PROBLEM

TR-909 will rarely miss-read a \$F8 (MIDI Clock) just after Start data.

REASON

The interval between Start data and the first Clock of MPU-401 is so short (about 1msec).

CHANGES

PROM on TR-909
Ver 1.0 —————> Ver 4.0

NOTE

When you meet above problem, please order us this PROM Ver 4.0 for we have this as Service Parts in our stock.