

**St. Lucie West Services District**  
**Board of Supervisors Meeting Agenda**  
**Tuesday, August 19, 2008 at 9:00 a.m.**  
**Sunlight Community Church**  
**477 S.W. Cashmere Boulevard, Port St. Lucie, Florida 34986**

**I - Call to Order**

**II - Pledge of Allegiance**

**III - Invocation**

**IV - Roll Call**

**V - Public Comment**

**VI - District Attorney**

**DA 1** Interlocal Agreement for Water and Wastewater Service – West Gate K-8 School and Manatee Academy

**VII - District Engineer**

**DE 1** Approval of Work Authorization No 3B-27-0804-SU between SLWSD and Temple Beth El Israel regarding the construction of an additional phase to the project known as Temple Beth EL Israel

**DE 2** Approval of Work Authorization No 7A-29-0311-Mod 2 between SLWSD and Interpark Plaza, LLC regarding the modification of a previous work authorization to allow for the construction of an additional building

**DE 3** Approval of Work Authorization No 4C-17-0806-SU between SLWSD and the Diocese of Palm Beach regarding the construction of an additional phase to the project known as St. Bernadette's Catholic Church

**DE 4** Approval of SFWMD Permit Conversion Forms. Converting various SFWMD permits from Construction Phase to Operation Phase and requesting transfer of the permits into the name of St Lucie West Services District as the operating entity

**DE 5** Administrative Approvals

**VIII - Finance**

**FA 1** Financial Statements for July 2008

**FA 2** Approval to transfer funds for R&R Fund, WCF and WWCF Requisitions

**FA 3** Approval of Resolution 2008-05 to adopt Budget Amendment 2008-03

**IX - District Manager**

**Action Items**

**DM 1** Approval of Work Authorization No SLWSD-ICI-08-02 Upgrade of existing 900 Mhz spread spectrum radios to 220 Mhz fixed frequency radios; Project No. SW006

**DM 2** Approval of the Odor Control System Modifications Equipment at the Wastewater Treatment Facility; Project No. SW021

**DM 2a** Approval of Budget Amendment 2008-04

- DM 3** Approval of the Odor Control System Modifications Equipment at the Wastewater Treatment Facility; Project No. SW021
- DM 4** Approval of the 16" Fiberglass Raw Water Line Replacement at the Water Treatment Facility; Project No. SW037

**Information Items**

- DM 5** Monthly Report on Public Works Operations
- DM 6** Monthly Report on Utilities Operations
- DM 7** Monthly Report on Capital Improvement Projects
- DM 8** Monthly Reports on Billing and Customer Service
- DM 9** Other Items/Updates

**X - Supervisors' Requests**

**XI - Minutes**

- Approval of the Minutes of the July 15, 2008 Regular Meeting
- Approval of the Minutes of the July 15, 2008 Budget Workshop

**XII - Adjournment**



*ST LUCIE WEST*  
SERVICES DISTRICT

**VI**

**DISTRICT ATTORNEY**

---

# *St. Lucie West Services District*

## **Board Agenda Item**

**Tuesday, August 19, 2008**

**Item**

---

**DA 1      Interlocal Agreement for Water and Wastewater Service – West Gate K-8 School  
and Manatee Academy**

---

Law Offices  
of  
**GONANO & HARRELL**  
A PARTNERSHIP OF PROFESSIONAL ASSOCIATIONS  
ATTORNEYS AND COUNSELORS AT LAW

DOUGLAS E. GONANO  
Board Certified Real Estate Lawyer  
email: dgonano@gh-law.com

RIVERSIDE NATIONAL BANK BUILDING  
1600 South Federal Highway, Suite 200  
Fort Pierce, Florida 34950-5194  
Telephone (772) 464 - 1032  
Facsimile (772) 464 - 0282

DANIEL B. HARRELL  
email: dharrell@gh-law.com

MOLLY L. ROTTINGHAUS  
email: mrottinghaus@gh-law.com

MEMORANDUM NO. 08-06

August 1, 2008

MEMORANDUM TO MEMBERS OF BOARD OF SUPERVISORS OF ST. LUCIE WEST SERVICES DISTRICT

Re: Interlocal Agreement for Water and Wastewater Service - West Gate K-8 School and Manatee Academy

G&H File No. 698-001

Attached is the draft of an interlocal agreement between the St. Lucie West Services District and the School Board of St. Lucie County, whereby the District would continue providing water and wastewater service to West Gate K-8 School and Manatee Academy, and the School Board would pay its proportionate cost of utility system improvements (capacity) required to service those facilities. The draft is in form and substance similar to agreements that the School Board has entered recently with other public utility systems, except that the School Board contributions have been calculated based upon the District's service availability fee schedule.

Also attached is a copy of correspondence from me to the Chair. As explained in the correspondence, my firm's simultaneous representation of both the District and the School Board in this matter presents a conflict requiring the acknowledgment and consent of each client. After careful review of Rule 4-1.7 of the Rules of Professional Conduct governing members of the Florida Bar, and the facts and circumstances of this particular transaction, I have concluded that my firm's simultaneous representation of both the District and the School Board will not adversely affect our responsibilities to or relationship with either client.

By copy of this memorandum, I respectfully request that the District Manager place this matter on the agenda of the Board's meeting scheduled for August 19, 2008. At that time, the Board should consider whether (1) to consent to my simultaneous representation of the District and the School Board in this matter, or to have the agreement reviewed by other counsel, and (2) to approve an interlocal agreement in substantially the form attached.

Please advise if you have any question.

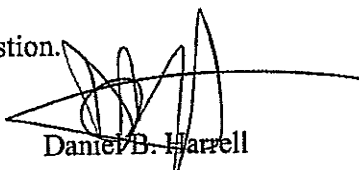
  
Daniel B. Harrell

DBH/mm  
Attachments

cc: Mr. John Imperato  
Mr. William K. Hayden

Mr. Dennis Pickle  
Ms. Heidi Snyder

Mr. Robert W. Lawson, P.E.

This instrument prepared by (and return to)  
Daniel B. Harrell  
Gonano & Harrell  
(Courthouse Box #34)  
1600 S. Federal Highway, Suite 200  
Fort Pierce, FL 34950-5194  
(772) 464-1032 Ext. 1010

## INTERLOCAL AGREEMENT FOR WATER AND WASTEWATER SERVICE

(West Gate K-8 School and Manatee Academy)

THIS AGREEMENT is made and entered into as of the \_\_\_\_ day of \_\_\_\_\_, 2008, by and between the SCHOOL BOARD OF ST. LUCIE COUNTY, governing body of the School District of St. Lucie County, Florida ("School Board"), and the ST. LUCIE WEST SERVICES DISTRICT, a community development district created pursuant to Chapter 190, Florida Statutes ("District").

### WITNESSETH

WHEREAS, the Florida Interlocal Cooperation Act of 1969, Section 163.01, Florida Statutes, permits local governmental units to make the most efficient use of their respective powers by enabling them to cooperate with one another on a basis of mutual advantage and thereby to provide services and facilities in a manner and pursuant to forms of governmental organization that will accord best with geographic, economic, population, and other factors influencing the needs and development of local communities; and

WHEREAS, the School Board owns and operates a public school facility, currently known as West Gate K-8 School ("WGKS"), recently constructed on certain lands located in St. Lucie County, Florida, as more fully described in the attached Exhibit A ("WGKS Property"); and

WHEREAS, the School Board also owns and operates another public school facility, currently known as Manatee Academy ("MA"), recently redeveloped from an elementary school to a K-8 school on certain lands located in St. Lucie County, Florida, as more fully described in the attached Exhibit B ("MA Property," and, together with the WGKS Property, the "Properties"); and

WHEREAS, the District operates a water, wastewater, and reuse utility system ("System") that provides potable water supply and wastewater treatment services to the Properties; and

WHEREAS, the District recognizes that in accordance with Sections 1013.371(1)(a) and 1013.51, Florida Statutes, the School Board is exempt from impact fees or service availability fees, and agreed development exactions assessed against school boards may not exceed the proportionate cost of system improvements necessitated by the educational facility development.

NOW, THEREFORE, for and in consideration of these premises, the School Board and the District hereby covenant and agree as follows:

1. Required Facilities. The District has determined that the facilities, on the System side of the point of delivery of service to the WGKS Property, required to serve the WGKS Property ("WGKS Required Facilities"), and the facilities, on the System side of the point of delivery of service to the MA Property, required to serve the MA Property ("MA Required Facilities"), have been properly constructed and turned over to the District.

2. Payment. Upon execution of this Agreement by both parties, the School Board shall be responsible for the payment of agreed fees as set forth in the attached Exhibits C and D. Payment shall be due within thirty (30) days of the effective date of this Agreement. The District hereby acknowledges and agrees that it does not, and will not, charge any impact fee, service availability fee, or development exaction that is violative of Section 1013.371(1)(a) or 1013.51, Florida Statutes. The School Board has reviewed the provisions of this Agreement and acknowledges that this Agreement complies with the requirements of Sections 1013.371(1) (a) and 1013.51, Florida Statutes.

3. Water and Wastewater Service.

a. The District shall provide water and wastewater service to the Properties, and the School Board shall pay for such service, in accordance with the terms of this Agreement and the rules, regulations, and tariffs adopted by the District in its operation of the System.

b. The point of delivery for service to the WGKS Property shall be, (i) for water service, the discharge side of the water meter and (ii) for wastewater service, the upstream connection of the clean-out, or in the absence of a clean-out, unless otherwise indicated, the sewer lateral connection to the sewer main of the District. The point of delivery for service to the MA Property shall be, (i) for water service, the discharge side of the water meter and (ii) for wastewater service, the upstream connection of the clean-out, or in the absence of a clean-out, unless otherwise indicated, the sewer lateral connection to the sewer main of the District.

c. The School Board shall own, operate, and maintain all facilities on the customer side of the point of delivery for service to the Properties.

4. Equivalent Residential Connections Reserved.

a. The proportionate share of System improvements needed to provide service on the WGKS Property is estimated to be twenty-six and one half (26.5) equivalent residential connections ("ERCs") for water service and twenty-six and one half (26.5) ERCs for wastewater service. The proportionate share of System improvements needed to accommodate the expansion from an elementary school to a K-8 school on the MA Property

is estimated to be eight and one tenth (8.1) ERCs for water service and eight and one tenth (8.1) ERCs for wastewater service.

b. The parties reserve the right to review and monitor actual flows to each of the Properties as compared to flows expected to be generated by the estimated ERC value. For purposes of this Agreement, "actual flows" shall be the flows generated during three (3) consecutive peak months occurring during any twelve (12) month period following the effective date of this Agreement. If actual flows, for either of the Properties, vary from the expected flows by more than the equivalent of ten percent (10%) of the then reserved number of ERCs, the parties shall promptly adjust the capital charges for such variance by either (i) the School Board paying additional capital charges for any excess flow, or (ii) the District refunding overpaid capital charges for any excess capacity.

5. Easements. The School Board hereby grants and gives to the District, its successors and assigns, the exclusive right or privilege to own, maintain, alter, replace, and operate water and wastewater facilities in, under, upon, over, and across the present and future streets, roads, alleys, easements, reserved utility strips and utility sites, and any public place as provided and dedicated to public use in the record plats, or as provided for in agreements, dedications, or grants made otherwise, and is independent of such record plats.

6. Notice. Until further written notice by either party to the other, all notices provided for in this Agreement shall be in writing and transmitted by messenger, mail, telegram, or facsimile transmission, and if to the School Board, shall be mailed or delivered to the School Board at:

Superintendent  
School Board of St. Lucie County  
4204 Okeechobee Road  
Fort Pierce, FL 34947

with copies to:

School Board Attorney  
School Board of St. Lucie County  
4204 Okeechobee Road  
Fort Pierce, FL 34947

Director of Facilities  
School Board of St. Lucie County  
327 N.W. Commerce Park Drive  
Port St. Lucie, FL 34986

and if to the District, at:



District Manager  
St. Lucie West Service District  
450 S.W. Utility Drive  
Port St. Lucie, FL 34986

with a copy to:

District Attorney  
St. Lucie West Service District  
450 S.W. Utility Drive  
Port St. Lucie, FL 34986

7. Recording of Agreement. Upon execution of this Agreement, the District shall, at the District's expense, cause this Agreement to be recorded with the Clerk of the Circuit Court of St. Lucie County, Florida.

8. Effective Date. This Agreement shall be effective upon filing with the Clerk of the Circuit Court of St. Lucie County, Florida, in accordance with Section 163.01(11), Florida Statutes.

9. Venue. Venue of any action to enforce the terms of this Agreement shall be in St. Lucie County if filed in state court, and in the Southern District of Florida if filed in federal court.

10. Agreement Not Waiver. No acknowledgment, recognition, operative term, or other provision of this Agreement shall operate as a waiver by either party respecting the subject matter of such provision generally and apart from water and wastewater services to the Properties, nor shall any such provision be binding upon the parties or construed as precedential in any subsequent transaction between the parties respecting water and wastewater services to other real property.

11. Entire Agreement: Amendment. This Agreement constitutes the entire agreement between the parties with respect to the subject matter hereof and supersedes all prior oral or written agreements between the parties with respect thereto. This Agreement may be amended only by written document, properly authorized, executed, and delivered by both parties.

20. Counterparts. This Agreement may be executed in several counterparts, each of which shall be considered an original.

IN WITNESS WHEREOF, the School Board and the District have executed or have caused this Agreement, with the named exhibits attached, to be duly executed as of the date set forth above.

\* \* \*

ATTEST:

SCHOOL BOARD OF ST. LUCIE COUNTY,  
FLORIDA

\_\_\_\_\_  
Michael J. Lannon, Superintendent  
and Ex Officio Secretary

By: \_\_\_\_\_  
Carol A. Hilson, Chair

Approved as to form and correctness:

\_\_\_\_\_  
Daniel B. Harrell  
Attorney for the School Board of St. Lucie  
County, Florida

STATE OF FLORIDA  
COUNTY OF ST. LUCIE

The foregoing instrument was acknowledged before me this \_\_\_\_\_ day of \_\_\_\_\_, 2008, by Carol A. Hilson, as Chair of the School Board of St. Lucie County, Florida. She  is personally known to me, or  has produced \_\_\_\_\_ as identification and  did  did not take an oath.

[Notary Seal]

\_\_\_\_\_  
Notary Public-State of Florida  
Print Name: \_\_\_\_\_  
My commission expires: \_\_\_\_\_

\* \* \*

ATTEST:

ST. LUCIE WEST SERVICES DISTRICT

\_\_\_\_\_  
Harvey Cutler, Secretary

By: \_\_\_\_\_  
Charles Altwein, Chair

Approved as to form and correctness:

\_\_\_\_\_  
Daniel B. Harrell  
Attorney for the St. Lucie West Services  
District

STATE OF FLORIDA  
COUNTY OF ST. LUCIE

The foregoing instrument was acknowledged before me this \_\_\_\_\_ day of \_\_\_\_\_, 2008, by Charles Altwein, as Chairman of the Board of Supervisors of the St. Lucie West Services District, a community development district created pursuant to Chapter 190, Florida Statutes. He  is personally known to me, or  has produced \_\_\_\_\_ as identification and  did  did not take an oath.

[Notary Seal]

\_\_\_\_\_  
Notary Public-State of Florida  
Print Name: \_\_\_\_\_  
My commission expires \_\_\_\_\_

\* \* \*

## EXHIBIT A

### LEGAL DESCRIPTION OF THE WGKS PROPERTY

(Parcel ID No. 3323-915-0006-000-2)

A parcel of land lying in Section 19, Township 36 South, Range 40 East, St. Lucie County, Florida, being a portion of Parcel 7, U.L.T. No. 2, U.L.T. No. 3 and a portion of N.W. Cashmere Boulevard and all of Parcel 18, all as shown on the Plat of St. Lucie West Plat No. 81, recorded in Plat Book 36, Pages 25, 25A through 25F, Public Records of St. Lucie County, Florida, being more particularly described as follows:

Begin at the Northeast corner of said St. Lucie West Plat No. 81; thence South 00 degrees 01 minutes 34 seconds West along the East line of said St. Lucie West Plat No. 81, a distance of 656.63 feet to the North line of W.M.T. 5-4 as shown on said St. Lucie West Plat No. 81, thence departing said East line of St. Lucie West Plat No. 81, along the North line of said W.M.T. 5-4, North 89 degrees 58 minutes 26 seconds West, a distance of 476.10 feet to the beginning of a curve concave to the Southeast having a radius of 45.00 feet and a central angle of 90 degrees 00 minutes 00 seconds; thence continue along the North and West line of said W.M.T. 5-4, Southwesterly along the arc of said curve, an arc distance of 70.69 feet to a point of tangency; thence South 00 degrees 01 minutes 34 seconds West, a distance of 200.00 feet; thence departing the West line of said W.M.T. 5-4, North 89 degrees 58 minutes 26 seconds West, a distance of 198.83 feet; thence North 23 degrees 23 minutes 28 seconds West, along the West line of said W.M.T. 5-4, a distance of 131.06 feet to the beginning of a curve concave to the Southwest having a radius of 1210.00 feet and a central angle of 39 degrees 22 minutes 09 seconds; thence Northwesterly along the arc of said curve, an arc distance of 831.42 feet to a point of non-radial intersection; the radius point of said curve bears South 27 degrees 14 minutes 24 seconds West from this point; thence North 00 degrees 17 minutes 10 seconds West, a distance of 178.94 feet to a point on the North line of said St. Lucie West Plat No. 81; thence North 89 degrees 42 minutes 50 seconds East along said North line, a distance of 1330.00 feet to the Point of Beginning.

## EXHIBIT B

### LEGAL DESCRIPTION OF THE MA PROPERTY

(Parcel ID No. 3323-721-0009-000-8)

Parcel 32A, as shown on the Plat of St. Lucie West Plat No. 29 - The Villages at St. Lucie West – Parcel 2, Phase 2, a Plat to be approved for recording by the City of Port St. Lucie, Florida, said Parcel 32A being further described as a parcel of land lying in Section 36, Township 36 South, Range 39 East, St. Lucie County, Florida, being a portion of Tract “B,” as shown on the Plat of St. Lucie West Plat No. 6 – The Villages at St. Lucie West – Parcel 2, as recorded in Plat Book 27, Pages 7 and 7A-B, Public Records of St. Lucie County, Florida, together with a portion of the unplatted area of said Section 36, more particularly described as follows:

Commence at the Southeast corner of Block 12, as shown on the Plat of St. Lucie West Plat No. 5 – Country Club Estates – Parcel 8, Block 12, as recorded in Plat Book 27, Pages 13 and 13A-C, Public Records of St. Lucie County, Florida; thence run North  $82^{\circ}54'46''$  West along the Southerly line of said Block 12 a distance of 1041.75 feet; thence run South  $7^{\circ}05'14''$  West a distance of 80.00 feet to the Point of Beginning; thence run South  $82^{\circ}54'46''$  East, parallel with the Southerly line of said Block 12, a distance of 1041.75 feet to a point of curvature; thence run Easterly along the arc of a curve, concave to the North, with a radius of 1494.64 feet and central angle of  $12^{\circ}02'54''$  a distance of 314.29 feet to a point of reverse curvature; thence run Southeasterly along the arc of a curve, concave to the Southwest, with radius of 25.00 feet and central angle of  $87^{\circ}32'55''$  a distance of 38.20 feet to a point of tangency; thence run South  $7^{\circ}24'45''$  East a distance of 141.12 feet; thence run North  $89^{\circ}18'19''$  West a distance of 327.84 feet; thence run South  $25^{\circ}49'28''$  West a distance of 469.59 feet; thence run North  $90^{\circ}00'00''$  West a distance of 333.01 feet; thence run North  $28^{\circ}49'04''$  West a distance of 271.74 feet; thence run North  $74^{\circ}23'08''$  West a distance of 106.59 feet; thence run North  $82^{\circ}54'46''$  West a distance of 346.61 feet; thence run North  $7^{\circ}05'14''$  East a distance of 408.26 feet to the Point of Beginning; containing 13.362 acres;

Reserving a Private Utility Easement over the Northerly 20.00 feet and the Easterly 20.00 feet thereof, and the Northerly 70.00 feet of the Easterly 70.00 feet thereof;

Further reserving a Landscaping and Signage Easement over the Easterly 20.00 feet thereof, and the Northerly 70.00 feet of the Easterly 70.00 feet thereof.

EXHIBIT C

AGREED PAYMENT SCHEDULE FOR WEST GATE K-8 SCHOOL

Fees. The District and the School Board agree that the School Board's water and wastewater fees and costs for the WGKS Property are as follows:

Agreed development exaction:	Amount
1. Water Capacity:	
[26.5 ERCs x \$1,915.50 (connection fees)]	\$50,760.75
[26.5 ERCs x \$679.50 (AFPI fees)]	18,006.75
Total Water Charges	\$68,767.50
2. Wastewater Capacity:	
[26.5 ERCs x \$1,437.50 (connection fees)]	\$38,093.75
[26.5 ERCs x \$562.50 (AFPI fees)]	14,906.25
Total Wastewater Charges	\$53,000.00
<b>TOTAL</b>	<b>\$121,767.50</b>

EXHIBIT D

AGREED PAYMENT SCHEDULE FOR MANATEE ACADEMY

Fees. The District and the School Board agree that the School Board's water and wastewater fees and costs for the expansion of the MA Property are as follows:

Agreed development exaction:	Amount
1. Water Capacity:	
[8.1 ERCs x \$1,915.50 (connection fees)]	\$15,515.55
[8.1 ERCs x \$679.50 (AFPI fees)]	5,503.95
Total Water Charges	\$21,019.50
2. Wastewater Capacity:	
[8.1 ERCs x \$1,437.50 (connection fees)]	\$11,643.75
[8.1 ERCs x \$562.50 (AFPI fees)]	4,556.25
Total Wastewater Charges	\$16,200.00
<b>TOTAL</b>	<b>\$37,219.50</b>

Law Offices  
of  
**GONANO & HARRELL**  
A PARTNERSHIP OF PROFESSIONAL ASSOCIATIONS  
ATTORNEYS AND COUNSELORS AT LAW

---

DOUGLAS E. GONANO  
Board Certified Real Estate Lawyer  
email: dgonano@gh-law.com

RIVERSIDE NATIONAL BANK BUILDING  
1600 South Federal Highway, Suite 200  
Fort Pierce, Florida 34950-5194  
Telephone (772) 464 - 1032  
Facsimile (772) 464 - 0282

DANIEL B. HARRELL  
email: dharrell@gh-law.com

MOLLY L. ROTTINGHAUS  
email: mrottinghaus@gh-law.com

August 1, 2008

The Honorable Charles Altwein  
Chairman, Board of Supervisors  
St. Lucie West Services District  
450 S.W. Utility Drive  
Port St. Lucie, FL 34986

Re: Proposed Interlocal Agreement for Water and Wastewater Service - West Gate K-8  
School and Manatee Academy

Our File No.: 689-001

Dear Chairman Altwein:

This confirms previous discussions with the St. Lucie West Services District relating to my firm's representation of the District in the preparation and approval of an interlocal agreement between the District and the School Board of St. Lucie County, whereby the District will continue providing water and wastewater service to the School Board's facilities known as West Gate K-8 School and Manatee Academy, and the School Board will pay its proportionate cost of utility system improvements (capacity) required to service those facilities. As you know, my current clients include the School Board, for whom I serve as Board counsel.

Provisions of the proposed interlocal agreement, including the payment schedules, track the water and wastewater tariff provisions of the District. The proposed agreement is also in form virtually identical to similar agreements that the School Board has entered in the last few years with the City of Port St. Lucie and the Fort Pierce Utilities Authority. Nonetheless, the simultaneous representation of both the District and the School Board respecting the agreement presents a conflict that my firm must disclose to each client.

After careful review of Rule 4-1.7 of the Rules of Professional Conduct governing members of the Florida Bar, and the facts and circumstances of this particular transaction, I have concluded that my firm's continued representation of both the District and the School Board will not adversely affect our responsibilities to or relationship with either client, and that my firm's exercise of independent professional judgment in the representation of one client will not materially limit our



The Honorable Charles A. Altwein

August 1, 2008

Page 2

responsibilities to or representation of the other. I am obliged to review these matters continually so long as the conflict exists, and if my professional judgment changes, I will advise both clients immediately and withdraw from representing either in the preparation and approval of the interlocal agreement.

Moreover, I can continue to represent both clients in this matter only if each consents after consultation. If either client declines to acknowledge and consent to the simultaneous representation, again I must withdraw from representing either in the preparation and approval of the interlocal agreement.

By this letter, I confirm previous discussions with the District, I offer the opportunity for further consultation if desired, and I respectfully request the acknowledgment and consent of the District Board of Supervisors to the simultaneous representation of both clients in this matter. The consent of the District may be indicated by execution below, and return of the original to me in the envelope enclosed for your convenience; a copy of this letter is also enclosed for the records of the District. Simultaneously with transmission of this letter, I am providing to the School Board the same confirmation, opportunity for consultation, and request for consent to continued representation.

Thank you for your consideration, and please let me know if you need additional information.

Sincerely,



Daniel B. Harrell

DBH/mm

Enclosures: Copy of letter  
Envelope

cc: Members, Board of Supervisors  
Mr. John A. Imperato

Mr. Dennis Pickle  
Mr. William K. Hayden

\* \* \*

The Honorable Charles A. Altwein  
August 1, 2008  
Page 3

ACCEPTED

The Board of Supervisors of the St. Lucie West Services District acknowledges review of the foregoing disclosure and consents to the representation of the District and the School Board of St. Lucie County by Gonano & Harrell in the preparation and approval of an interlocal agreement for water and wastewater service to West Gate K-8 School and Manatee Academy.

Dated: \_\_\_\_\_, 2008

\_\_\_\_\_  
Charles Altwein, Chairman



*ST LUCIE WEST*  
SERVICES DISTRICT

**VII**

**DISTRICT ENGINEER**

# St. Lucie West Services District

## Board Agenda Item Tuesday, August 19, 2008

### Item

---

**DE 1      Approval of Work Authorization No 3B-27-0804-SU between SLWSD and Temple Beth El Israel regarding the construction of an additional phase to the project known as Temple Beth EL Israel**

---

### Summary

---

This application is for the construction of an additional class room building on an existing 3.50 acre site, shown as Lot 1, St. Lucie West Plat No. 80, First Replat of Parcel 11A, located on the southeast corner of Bethany Drive and Utility Drive.

Water quality treatment of 1/2" over the entire site is provided within a dry storage area overflowing to the Basin 3B lake.

A additional water source will be supplied by a tap on the existing line located along Bethany Drive. Sanitary sewer service to this site is existing.

All onsite water services and fire supply lines will be privately owned and maintained by the Applicant.

All policies and procedures of the District applicable to this type of development have been adhered to.

### Recommendation

---

Staff recommends approval of Work Authorization No. 3B-27-0804-SU for the additional phase of construction for the project known as Temple Beth El Israel with one condition, which are stated in the Work Authorization.

---

### Budget Impact

---

Project Number:		Available Project Budget: \$0.00
ORG Number:	N/A	This Project: \$0.00
OBJ Number:		Available Balance Amount: \$0.00

---

### Board Action

---

Moved by:	Seconded by:	Action Taken:
-----------	--------------	---------------

---

# WORK AUTHORIZATION NO. 3B-27-0804-SU

Between the

**St. Lucie West Services District,**

a community development district organized and existing in accordance with chapter 190, Florida Statutes ("SLWSD")

and

**Temple Beth El Israel**

A. SUMMARY OF SERVICES TO BE RENDERED

This application is for the construction of an additional class room building on an existing 3.50 acre site, shown as Lot 1, St. Lucie West Plat No. 80, First Replat of Parcel 11A, located on the southeast corner of Bethany Drive and Utility Drive.

Water quality treatment of 1/2" over the entire site is provided within a dry storage area overflowing to the Basin 3B lake.

A additional water source will be supplied by a tap on the existing line located along Bethany Drive. Sanitary sewer service to this site is existing.

All onsite water services and fire supply lines will be privately owned and maintained by the Applicant.

All policies and procedures of the District applicable to this type of development have been adhered to.

B. SCHEDULE OF FEES:

N/A

C. PROJECT SCHEDULE:

N/A

D. SPECIAL CONDITIONS:

1. Appropriate fees to the Utility Department must be paid prior to issuance of meters.

E. ST LUCIE WEST SERVICES DISTRICT

ST LUCIE WEST SERVICES DISTRICT

\_\_\_\_\_  
Public Works Director

\_\_\_\_\_  
Utilities Director

\_\_\_\_\_  
Robert Lawson, P.E., District Engineer  
2081 Vista Parkway  
West Palm Beach, Florida 33411

\_\_\_\_\_  
Charles Altwein, Chairman  
St. Lucie West Services District  
450 SW Utility Drive  
Port St. Lucie, FL 34986

Certification that Sufficient Funds are Available, if applicable:

\_\_\_\_\_  
District Treasurer

\_\_\_\_\_  
John Imperato  
District Manager

Dated this \_\_\_\_ day of \_\_\_\_\_ 2008.

# St. Lucie West Services District

## Board Agenda Item Tuesday, August 19, 2008

### Item

---

**DE 2      Approval of Work Authorization No 7A-29-0311-Mod 2 between SLWSD and Interpark Plaza, LLC regarding the modification of a previous work authorization to allow for the construction of an additional building**

---

### Summary

---

This application is for the second modification of a previously approved project to allow for the construction of an additional 8400 SF building at the rear of the site. The new building is necessitating the construction of a second potable water meter and the construction of additional privately maintained sewer lines on the subject site.

Water quality treatment was provided with the original project however minor modifications to the exfiltration system are being proposed to accommodate the revised site plan.

All onsite water services and fire supply lines will be privately owned and maintained by the Applicant.

All policies and procedures of the District applicable to this type of development have been adhered to.

### Recommendation

---

Staff recommends approval of Work Authorization No. 7A-29-0311-Mod 2 with two conditions:

1. Appropriate fees to the Utility Department must be paid prior to issuance of the project meter.
2. The applicant shall grant a utility easement in favor of the St Lucie West Services District for access to the water meter onsite. Final copies of the recorded easements must be provided prior to final Work Authorization issuance.

### Budget Impact

---

Project Number:		Available Project Budget: \$0.00
ORG Number:	N/A	This Project: \$0.00
OBJ Number:		Available Balance Amount: \$0.00

---

### Board Action

---

Moved by:

Seconded by:

Action Taken:

---

# WORK AUTHORIZATION NO. 7A-29-0311-Mod 2

Between the

**St. Lucie West Services District,**

a community development district organized and existing in accordance with chapter 190, Florida Statutes ("SLWSD")  
and

**Interpark Plaza, LLC**

A. SUMMARY OF SERVICES TO BE RENDERED

This application is for the second modification of a previously approved project to allow for the construction of an additional 8400 SF building at the rear of the site. The new building is necessitating the construction of a second potable water meter and the construction of additional privately maintained sewer lines on the subject site.

Water quality treatment was provided with the original project however minor modifications to the exfiltration system are being proposed to accommodate the revised site plan.

All onsite water services and fire supply lines will be privately owned and maintained by the Applicant.

All policies and procedures of the District applicable to this type of development have been adhered to.

B. SCHEDULE OF FEES:

To be determined by Utility Director prior to setting meter.

C. PROJECT SCHEDULE:

N/A

D. SPECIAL CONDITIONS:

1. Appropriate fees and connection charges must be paid to prior to issuance of the project meter.
2. The applicant shall grant a utility easement in favor of the St Lucie West Services District for access to the water meter onsite. Final copies of the recorded easements must be provided prior to final Work Authorization issuance.



E. ST LUCIE WEST SERVICES DISTRICT

ST LUCIE WEST SERVICES DISTRICT

\_\_\_\_\_  
Public Works Director

\_\_\_\_\_  
Utilities Director

\_\_\_\_\_  
Robert Lawson, P.E., District Engineer  
2081 Vista Parkway  
West Palm Beach, Florida 33411

\_\_\_\_\_  
Charles Altwein, Chairman  
St. Lucie West Services District  
450 SW Utility Drive  
Port St. Lucie, FL 34986

Certification that Sufficient Funds are Available, if applicable:

\_\_\_\_\_  
District Treasurer

\_\_\_\_\_  
John Imperato  
District Manager

Dated this \_\_\_\_ day of \_\_\_\_\_ 2008.

# St. Lucie West Services District

## Board Agenda Item Tuesday, August 19, 2008

### Item

---

**DE 3      Approval of Work Authorization No 4C-17-0806-SU between SLWSD and the Diocese of Palm Beach regarding the construction of an additional phase to the project known as St. Bernadette's Catholic Church**

---

### Summary

---

This application is for the construction of an additional building and associated parking lot and utilities on an existing 18.63 acre site, St. Lucie West Plat No. 36, Parcel 26, located on the west side of NW California Boulevard south of the intersection of University Boulevard and NW California Boulevard.

Water quality treatment of 1/2" over the entire site is provided within a wet detention area overflowing to the Basin 4C lake.

An additional water source will be supplied by connecting to an existing line located onsite. Sanitary sewer service to this site is existing.

All onsite water services and fire supply lines will be privately owned and maintained by the Applicant.

All policies and procedures of the District applicable to this type of development have been adhered to.

### Recommendation

---

Staff recommends approval of Work Authorization No. 4C-17-0806-SU for the additional phase of construction for the project known as St. Bernadette's Catholic Church with two conditions, which are stated in the Work Authorization.

---

### Budget Impact

---

Project Number:		Available Project Budget: \$0.00
ORG Number:	N/A	This Project: \$0.00
OBJ Number:		Available Balance Amount: \$0.00

---

### Board Action

---

Moved by:	Seconded by:	Action Taken:
-----------	--------------	---------------

---

# WORK AUTHORIZATION NO. 4C-17-0806-SU

Between the

**St. Lucie West Services District,**

a community development district organized and existing in accordance with chapter 190, Florida Statutes ("SLWSD")

and

**Diocese of Palm Beach**

A. SUMMARY OF SERVICES TO BE RENDERED

This application is for the construction of an additional building and associated parking lot and utilities on an existing 18.63 acre site, St. Lucie West Plat No. 36, Parcel 26, located on the west side of NW California Boulevard south of the intersection of University Boulevard and NW California Boulevard.

Water quality treatment of 1/2" over the entire site is provided within a wet detention area overflowing to the Basin 4C lake.

An additional water source will be supplied by connecting to an existing line located onsite. Sanitary sewer service to this site is existing.

All onsite water services and fire supply lines will be privately owned and maintained by the Applicant.

All policies and procedures of the District applicable to this type of development have been adhered to.

B. SCHEDULE OF FEES:

N/A

C. PROJECT SCHEDULE:

N/A

D. SPECIAL CONDITIONS:

1. Appropriate fees to the Utility Department must be paid prior to issuance of meters.
2. Recorded ingress/egress easement must be provided.

E. ST LUCIE WEST SERVICES DISTRICT

ST LUCIE WEST SERVICES DISTRICT

\_\_\_\_\_  
Public Works Director

\_\_\_\_\_  
Utilities Director

\_\_\_\_\_  
Robert Lawson, P.E., District Engineer  
2081 Vista Parkway  
West Palm Beach, Florida 33411

\_\_\_\_\_  
Charles Altwein, Chairman  
St. Lucie West Services District  
450 SW Utility Drive  
Port St. Lucie, FL 34986

Certification that Sufficient Funds are Available, if applicable:

\_\_\_\_\_  
District Treasurer

\_\_\_\_\_  
John Imperato  
District Manager

Dated this \_\_\_\_ day of \_\_\_\_\_ 2008.

# St. Lucie West Services District

## Board Agenda Item Tuesday, August 19, 2008

### Item

---

- DE 4 Approval of SFWMD Permit Conversion Forms. Converting various SFWMD permits from Construction Phase to Operation Phase and requesting transfer of the permits into the name of St Lucie West Services District as the operating entity**
- 

### Summary

---

Provided for your review and consideration is the SFWMD permit conversion form for Lowes of St Lucie West. The construction of the water management system is complete and Lowe's Home Centers, Inc. is requesting that the St Lucie West Services District execute the SFWMD permit conversion form and accept responsibility as the operating entity for the master surface water management system.

During final inspection of the project, a question arose whether repairs to Manhole S-33, on a drainage line from NW Cashmere Boulevard to the new lake location, that is a part of our master water management system would perform adequately over time. As a result of this concern, the contractor was asked to pay a \$2500.00 re-inspection fee and supply a maintenance bond in favor of St Lucie West Services District in the amount of \$75,000.00 to assure that the District would have adequate funding should a scheduled re-inspection after 24 months indicate that additional repairs or replacement of the structure was necessary.

The contractor has agreed to the conditions stated above and District staff is in possession of the re-inspection fee and original bond.

At this time, the Board is being asked to execute the SFWMD conversion form necessary to change the permit, for those aspects of the permit specifically related to the master water management system, from construction to operation. This action, when complete and acknowledged by SFWMD, will officially make St Lucie West Services District the party responsible for the ongoing maintenance of the master surface water management system consistent with the policies of the District.

### Recommendation

---

Staff recommends that the SFWMD conversion form be executed by the Board of Supervisors.

---

### Budget Impact

---

Project Number:		Available Project Budget: \$0.00
ORG Number:	N/A	This Project: \$0.00
OBJ Number:		Available Balance Amount: \$0.00

---

### Board Action

---

Moved by:	Seconded by:	Action Taken:
-----------	--------------	---------------

---

**ADMINISTRATIVE APPROVALS GRANTED AT STAFF LEVEL**

1. City Gas gas service to Holiday Inn Express – Right of Way Permit - 4A-77-0806-R

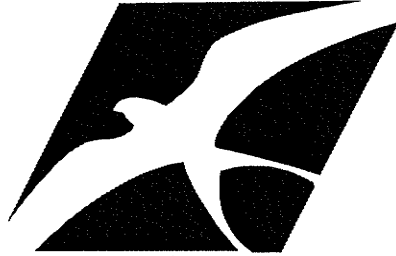

*ST LUCIE WEST*  
SERVICES DISTRICT

**VIII**

**FINANCE**

# *St. Lucie West Services District*

## **Board Agenda Item Tuesday, August 19, 2008**

### **Item**

---

**FA 1            Financial Statements for July 2008**

---

### **Summary**

---

Attached for your review are the Financial Reports for the period ending July 31, 2008.

- Financial Statements for all District Funds
- Check Register for General Fund and Water & Sewer Fund
  - Summary of checks over \$35,000
- Balance Sheet Report for all Funds
- Bank Reconciliation Summary for all depository accounts

### **Recommendation**

---

No Action Required.

---

### **Budget Impact**

---

None

---

### **Board Action**

---

Moved by: \_\_\_\_\_ Seconded by: \_\_\_\_\_ Action Taken: \_\_\_\_\_

---





ST LUCIE WEST SERVICES DISTRICT  
FINANCIAL STATEMENTS  
AS OF JULY 31, 2008

Period 10  
83%

GENERAL FUND	ORIGINAL	REVISED	ACTUAL			NT*	PRIOR YEAR	BUDGET VARIANCES	
	BUDGET	BUDGET	MTD ACTUAL	YTD ACTUAL	ENCUMB		FY 2007	AVAIL. BUDG. / UNCLCTD REVS	% RCVDD/ USED
534008-1 LEGAL SERVICES	55,000	55,000	2,032	26,411	-		79,435	28,589	48%
<b>SUB-TOTAL GENERAL COUNSEL</b>	<b>55,000</b>	<b>55,000</b>	<b>2,032</b>	<b>26,411</b>	<b>-</b>		<b>79,435</b>	<b>28,589</b>	<b>48%</b>
01114054 SPECIAL COUNSEL									
534008-1 LEGAL SERVICES	40,000	65,000	10,258	44,466	-		110,212	20,534	88%
<b>SUB-TOTAL SPECIAL COUNSEL</b>	<b>40,000</b>	<b>65,000</b>	<b>10,258</b>	<b>44,466</b>	<b>-</b>		<b>110,212</b>	<b>20,534</b>	<b>88%</b>
01115071 ENGINEERING									
534007-1 ENGINEERING SERVICES	72,840	72,840	-	59,299	-		70,573	13,341	82%
<b>SUB-TOTAL ENGINEERING</b>	<b>72,840</b>	<b>72,840</b>	<b>-</b>	<b>59,299</b>	<b>-</b>		<b>70,573</b>	<b>13,341</b>	<b>82%</b>
01137120 AIR & WATER MANAGEMENT									
536001-1 WATER QUALITY MONITOR	25,000	13,000	-	5,425	-		10,176	7,575	42%
<b>SUB-TOTAL AIR &amp; WATER MANAGEMENT</b>	<b>25,000</b>	<b>13,000</b>	<b>-</b>	<b>5,425</b>	<b>-</b>		<b>10,176</b>	<b>7,575</b>	<b>42%</b>
01137121 POLLUTION CONTROL									
549005-1 REGULATORY PERMIT	500	500	-	-	-		496	500	0%
<b>SUB-TOTAL POLLUTION CONTROL</b>	<b>500</b>	<b>500</b>	<b>-</b>	<b>-</b>	<b>-</b>		<b>496</b>	<b>500</b>	<b>0%</b>
01137122 AQUATIC WEED CONTROL									
534117-1 DISPOSAL SERVICES	-	25,000	-	-	-		-	25,000	0%
552002-1 CHEMICALS	100,000	110,000	17,629	112,151	-		-	(2,151)	102%
564000-1 MACHINERY & EQUIPMENT	7,500	7,500	-	-	-		-	7,500	0%
<b>SUB-TOTAL POLLUTION CONTROL</b>	<b>107,500</b>	<b>142,500</b>	<b>17,629</b>	<b>112,151</b>	<b>-</b>		<b>-</b>	<b>30,349</b>	<b>79%</b>
01139160 OTHER PHYSICAL ENVIRONMENT									
534000-1 OTHER CONTRACTUAL SERVICES	-	8,604	-	8,604	-		(8,590)	-	100%
549008-1 CONTINGENCIES-HURRICANE	25,000	25,000	-	-	-		-	25,000	0%
565000-1 CONSTRUCTION SERVICES	25,000	25,000	-	-	-		-	25,000	0%
<b>SUB-TOTAL OTHER PHYSICAL ENVIRONMENT</b>	<b>50,000</b>	<b>58,604</b>	<b>-</b>	<b>8,604</b>	<b>-</b>		<b>(8,590)</b>	<b>50,000</b>	<b>15%</b>
01141181 LANDSCAPING									
534035-1 MAINTENANCE CONTRACTS	35,000	23,300	-	18,940	-		-	4,360	81%
538003-1 STORM DITCH MAINTENANCE	30,000	30,000	-	15,279	-		-	14,721	51%
541005-1 LANDSCAPING	30,000	50,000	1,240	43,871	-		61,441	6,129	88%
552002-1 CHEMICALS	2,500	2,500	-	492	-		-	2,008	20%
<b>SUB-TOTAL LANDSCAPING</b>	<b>97,500</b>	<b>105,800</b>	<b>1,240</b>	<b>78,582</b>	<b>-</b>		<b>61,441</b>	<b>27,218</b>	<b>74%</b>
01141182 ELECTRICITY									
543005-1 ELECTRICITY	22,730	22,730	938	13,399	-		20,939	9,332	59%
<b>SUB-TOTAL ELECTRICITY</b>	<b>22,730</b>	<b>22,730</b>	<b>938</b>	<b>13,399</b>	<b>-</b>		<b>20,939</b>	<b>9,332</b>	<b>59%</b>
<b>TOTAL GENERAL FUND EXPENSES</b>	<b>\$ 2,202,989</b>	<b>\$ 2,381,813</b>	<b>\$ 229,425</b>	<b>\$ 1,596,649</b>	<b>\$ 12,646</b>		<b>\$ 1,968,334</b>	<b>\$ 772,318</b>	<b>68%</b>
<b>TOTAL GENERAL FUND REVENUE</b>	<b>2,459,400</b>	<b>2,544,253</b>	<b>79,434</b>	<b>2,513,660</b>	<b>-</b>		<b>2,415,848</b>	<b>30,593</b>	<b>89%</b>
<b>TOTAL GENERAL FUND EXPENSES (OPERATING EXP'S)</b>	<b>2,202,989</b>	<b>2,381,813</b>	<b>229,425</b>	<b>1,596,649</b>	<b>12,646</b>		<b>1,968,334</b>	<b>772,318</b>	<b>88%</b>
<b>GENERAL FUND NET REVENUE (OPERATING EXP'S)</b>	<b>\$ 256,411</b>	<b>\$ 162,640</b>	<b>\$ (149,991)</b>	<b>\$ 917,011</b>			<b>\$ 447,513</b>		
<b>CAPITAL PROJECTS</b>									
SG001 EQUIPMENT REPLACEMENT	\$ 17,000	\$ 17,000	\$ -	\$ 16,582	\$ -		\$ -	\$ 418	98%
SG004 ADMIN & SHOP BUILDING EXPANSION	57,500	57,500	-	1,365	-		-	56,135	2%
<b>SUB-TOTAL CAPITAL PROJECTS</b>	<b>\$ 74,500</b>	<b>\$ 74,500</b>	<b>\$ -</b>	<b>\$ 17,947</b>	<b>\$ -</b>		<b>\$ 128,045</b>	<b>\$ 56,135</b>	<b>24%</b>
<b>NET GENERAL FUND REVENUE - (WITH CIP'S)</b>	<b>\$ 181,911</b>	<b>\$ 88,140</b>	<b>\$ (149,991)</b>	<b>\$ 899,063</b>			<b>\$ 319,468</b>		
<b>UNRESTRICTED FUND BALANCE CARRY FORWARD PY</b>	<b>298,219</b>	<b>298,219</b>	<b>298,219</b>	<b>298,219</b>			<b>(21,249)</b>		
<b>ENDING FUND BALANCE FY 2008</b>	<b>\$ 480,130</b>	<b>\$ 386,359</b>	<b>\$ 148,228</b>	<b>\$ 1,197,282</b>			<b>\$ 298,219</b>		

ST LUCIE WEST SERVICES DISTRICT  
 FINANCIAL STATEMENTS  
 AS OF JULY 31, 2008

Period 10  
 83%

WATER MANAGEMENT BENEFIT SERIES FUND	ORIGINAL	REVISED	ACTUAL			NT*	PRIOR YEAR	BUDGET VARIANCES	
	BUDGET	BUDGET	MTD ACTUAL	YTD ACTUAL	ENCUMB		FY 2007	AVAIL. BUDG./ UNCLCTD REVS	% RCVD/ USED
<b>2010 WTR MGMT BEN SRS 1999A REVENUE</b>									
361100-1 INTEREST	\$ 180,714	\$ 180,714	\$ 4,992	\$ 93,003	\$ -	\$ 172,624	\$ 87,711	51%	
363100-1 SPECIAL ASSESSMENT	2,692,750	2,692,750	218	2,527,553	-	2,546,184	165,197	94%	
384002-1 MISCELLANEOUS	1,000	1,000	-	-	-	-	1,000	0%	
<b>TOTAL WTR MGMT BEN REVENUE</b>	<b>\$ 2,874,464</b>	<b>\$ 2,874,464</b>	<b>\$ 5,210</b>	<b>\$ 2,620,557</b>	<b>\$ -</b>	<b>\$ 2,718,808</b>	<b>\$ 253,907</b>	<b>91%</b>	
<b>20117902 WTR MGMT SRS 1999A DEBT SVC</b>									
519001-1 ASSESSMENT FEES	35,902	35,902	26,874	26,874	-	53,406	9,028	75%	
534009-1 BANKING SERVICES	-	-	-	-	-	9,374	-	100%	
571000-1 PRINCIPAL	950,000	950,000	-	950,000	-	915,000	-	100%	
572000-1 INTEREST	1,493,003	1,493,003	(1)	1,493,003	-	1,537,778	1	100%	
573000-1 OTHER DEBT SERVICES	9,500	9,500	1	1	-	-	9,499	0%	
591004-1 OTHER TRANSFERS	140,000	224,853	-	224,853	-	180,117	-	100%	
<b>TOTAL WTR MGMT BEN EXPENSES</b>	<b>\$ 2,628,405</b>	<b>\$ 2,713,258</b>	<b>\$ 26,874</b>	<b>\$ 2,694,730</b>	<b>\$ -</b>	<b>\$ 2,695,675</b>	<b>\$ 18,528</b>	<b>99%</b>	
<b>NET REVENUE WTR MGMT BEN.</b>	<b>\$246,059</b>	<b>\$161,206</b>	<b>(\$21,664)</b>	<b>(74,174)</b>	<b>\$0</b>	<b>\$23,134</b>			

ST LUCIE WEST SERVICES DISTRICT  
 FINANCIAL STATEMENTS  
 AS OF JULY 31, 2008

Period 10  
 83%

	ORIGINAL	REVISED	ACTUAL			NT*	PRIOR YEAR	BUDGET VARIANCES	
	BUDGET	BUDGET	MTD ACTUAL	YTD ACTUAL	ENCUMB		FY 2007	AVAIL. BUDG. / UNCLCTD REVS	% RCVD / USED
<b>WMB CAPITAL PROJECT FUND</b>									
3010 WMB CAPITAL PROJECTS REVENUE									
361100-1 INTEREST REV	141,930	141,930	4,861	74,062	-	152,043	67,868	52%	
<b>TOTAL WMB CAPITAL PROJ REVENUE</b>	<b>\$ 141,930</b>	<b>\$ 141,930</b>	<b>\$ 4,861</b>	<b>\$ 74,062</b>	<b>\$ -</b>	<b>\$ 152,043</b>	<b>\$ 67,868</b>	<b>52%</b>	
30113037 PROJECT/GRANT MANAGEMENT									
534009-1 BANKING	-	-	-	-	-	-	-	100%	
<b>TOTAL PROJECT/GRANT MGNT EXPENSES</b>	<b>\$ -</b>	<b>\$ -</b>	<b>\$ -</b>	<b>\$ -</b>	<b>\$ -</b>	<b>\$ -</b>	<b>\$ -</b>	<b>100%</b>	
30138100 WASTE WATER SERVICES									
565000-1 CONSTRUCTION SERVICES	-	-	-	-	-	185,549	-	100%	
<b>TOTAL PROJECT/GRANT MGNT EXPENSES</b>	<b>\$ -</b>	<b>\$ -</b>	<b>\$ -</b>	<b>\$ -</b>	<b>\$ -</b>	<b>\$ 185,549</b>	<b>\$ -</b>	<b>100%</b>	
<b>NET REVENUE WMB CAPITAL PROJ</b>	<b>\$ 141,930</b>	<b>\$ 141,930</b>	<b>\$ 4,861</b>	<b>\$ 74,062</b>		<b>\$ (33,506)</b>			

ST LUCIE WEST SERVICES DISTRICT  
 FINANCIAL STATEMENTS  
 AS OF JULY 31, 2008

Period 10  
 83%

CASCADES SERIES 1998 BOND FUND	ORIGINAL	REVISED	ACTUAL			PRIOR YEAR	BUDGET VARIANCES		
	BUDGET	BUDGET	MTD ACTUAL	YTD ACTUAL	ENCUMB	NT*	FY 2007	AVAIL. BUDG./ UNCLCTD REVS	% RCVD/ USED
<b>2020 CASCADES SERIES 1998 REVENUE</b>									
361100-1 INTEREST	\$ 18,690	\$ 18,690	\$ 533	\$ 9,845	\$ -	\$ 17,729	\$ 8,845	53%	
363100-1 SPECIAL ASSESSMENTS	237,000	237,000	-	235,367	-	238,479	1,633	99%	
<b>TOTAL CASCADES SERIES 1998 REVENUE</b>	<b>\$ 255,690</b>	<b>\$ 255,690</b>	<b>\$ 533</b>	<b>\$ 245,212</b>	<b>\$ -</b>	<b>\$ 256,208</b>	<b>\$ 10,478</b>	<b>96%</b>	
<b>20217903 CASCADES SERIES 1998 DEBT SVC</b>									
519001-1 ASSESSMENT FEES	\$ 2,502	\$ 2,502	\$ 2,502	\$ 2,502	\$ -	\$ -	\$ (0)	100%	
534009-1 BANKING SERVICES	3,600	3,600	-	3,233	-	-	368	90%	
571000-1 PRINCIPAL	125,000	125,000	-	125,000	-	115,000	-	100%	
572000-1 INTEREST	114,070	114,070	-	114,070	-	121,085	-	100%	
573000-1 OTHER D	-	-	-	-	-	5,004	-	100%	
<b>TOTAL CASCADES EXPENSES</b>	<b>\$ 245,172</b>	<b>\$ 245,172</b>	<b>\$ -</b>	<b>\$ 244,805</b>	<b>\$ -</b>	<b>\$ 241,089</b>	<b>\$ 388</b>	<b>100%</b>	
<b>NET REVENUE CASCADES</b>	<b>\$ 10,518</b>	<b>\$ 10,518</b>	<b>\$ 533</b>	<b>\$ 408</b>	<b>\$ -</b>	<b>\$ 15,119</b>			





***St. Lucie West Services District***

***Financial Statements***

***July 31, 2008***

**NOTES TO THE FINANCIAL STATEMENTS**

**No abnormal discrepancies were noted during review.**



**St. Lucie West Service District  
Check Register  
July 31, 2008**

<u>CHECK #</u>	<u>CHECK DATE</u>	<u>NAME</u>	<u>GF</u>	<u>W&amp;S</u>	<u>Total</u>
13207	7/10/2008	ACTON MOBILE INDUSTRIES	-	143.10	143.10
13203	7/3/2008	ADP RETIREMENT SERVICES	495.40	-	495.40
13303	7/25/2008	ADVANCED DATA NETWORK, IN	-	1,243.84	1,243.84
13304	7/25/2008	ALPHA BOATS UNLIMITED	867.05	-	867.05
13305	7/25/2008	AMERIGAS	-	8.05	8.05
13156	7/3/2008	ARCADIS G&M INC.	6,964.23	6,101.06	\$ 13,065.29
13208	7/10/2008	ASSURANT - EMPLOYEE BENEF	1,117.31	836.79	1,954.10
13157	7/3/2008	AT&T	133.78	133.79	267.57
13306	7/25/2008	AT&T	206.99	207.00	413.99
13307	7/25/2008	AT&T	522.88	522.88	1,045.76
13308	7/25/2008	AT&T	50.33	50.34	100.67
13158	7/3/2008	BARNEY'S PUMP	-	2,196.61	2,196.61
13209	7/10/2008	BENDERSON DEVELOPMENT CO.	-	343.20	343.20
13159	7/3/2008	BENOIT GAGNON	-	42.48	42.48
13210	7/10/2008	BLOSSER ELECTRIC	-	1,490.00	1,490.00
13262	7/17/2008	BLOSSER ELECTRIC	-	3,359.50	3,359.50
13211	7/10/2008	BLUE CROSS BLUE SHIELD OF	18,735.78	11,844.28	30,580.06
13212	7/10/2008	BRAD LLOYD	-	7.95	7.95
13213	7/10/2008	CARLOS LOPEZ	-	26.80	26.80
13160	7/3/2008	CHARIOT AUTO GLASS INC.	-	590.00	590.00
13309	7/25/2008	CHEMICAL INJECTION TECHNO	-	151.31	151.31
13310	7/25/2008	CHEVRON	4,508.31	7,663.02	12,171.33
13214	7/10/2008	CHRIS STINSON	-	6.17	6.17
13161	7/3/2008	CITY ELECTRIC SUPPLY CO.	-	256.52	256.52
13215	7/10/2008	CNH CAPITAL AMERICA LLC	-	860.04	860.04
13263	7/17/2008	CNH CAPITAL AMERICA LLC	763.68	-	763.68
13216	7/10/2008	COMO OIL COMPANY OF FLORI	4,027.98	1,342.67	5,370.65
13311	7/25/2008	COMO OIL COMPANY OF FLORI	1,399.64	466.55	1,866.19
13162	7/3/2008	COOKES ENVIRONMENTAL SERV	-	-	-
13217	7/10/2008	COOKES ENVIRONMENTAL SERV	-	1,100.00	1,100.00
13163	7/3/2008	CUMMINS POWER SOUTH	-	435.60	435.60
13218	7/10/2008	CUSTOM PUMP & CONTROLS, I	-	372.50	372.50
13164	7/3/2008	CUSTOM WELDING DIVERSIFIE	782.00	20.88	802.88
13219	7/10/2008	CUSTOM WELDING DIVERSIFIE	-	300.00	300.00
13264	7/17/2008	CUSTOM WELDING DIVERSIFIE	42.00	101.40	143.40
13312	7/25/2008	CUSTOM WELDING DIVERSIFIE	-	449.45	449.45
13265	7/17/2008	DAN RYAN	-	125.19	125.19
13224	7/10/2008	DARREN FOGEL	-	24.05	24.05
13220	7/10/2008	DAVID BROWN	-	30.19	30.19
13313	7/25/2008	DAY DREAMS UNIFORMS INC.	-	50.88	50.88
13165	7/3/2008	DEBONAIR SERVICES	-	4,250.00	4,250.00
13166	7/3/2008	DECLAN FREISBERG	-	53.34	53.34
13167	7/3/2008	DIRECTV	38.49	38.49	76.98
13168	7/3/2008	ENCLAVE PROPERTIES LLC	-	69.53	69.53
13266	7/17/2008	ENCLAVE PROPERTIES LLC	-	39.20	39.20
13169	7/3/2008	FEDEX	55.05	181.62	236.67
13221	7/10/2008	FEDEX	28.38	28.38	56.76
13314	7/25/2008	FEDEX	17.62	17.63	35.25
13267	7/17/2008	FIRST CHOICE CLEANING	-	460.06	460.06
13301	7/23/2008	FL DEPT OF ENVIRONMENTAL	-	-	-
13302	7/23/2008	FL DEPT OF ENVIRONMENTAL	-	500.00	500.00
13204	7/3/2008	FLORIDA DEPARTMENT OF EDU	47.49	-	47.49
13315	7/25/2008	FLORIDA DEPARTMENT OF EDU	68.07	-	68.07
13268	7/17/2008	FLORIDA POWER & LIGHT COM	938.09	-	938.09
13316	7/25/2008	FLORIDA POWER & LIGHT COM	-	48,886.41	48,886.41
13222	7/10/2008	FLORIDA PROPERTIES	-	6.81	6.81
13170	7/3/2008	FLOWERS CHEMICAL LABORATO	-	1,781.00	1,781.00
13223	7/10/2008	FLOWERS CHEMICAL LABORATO	-	1,972.00	1,972.00
13269	7/17/2008	FLOWERS CHEMICAL LABORATO	-	268.00	268.00
13317	7/25/2008	FLOWERS CHEMICAL LABORATO	-	278.00	278.00
13225	7/10/2008	GIANCARLO MAIUCCI	-	48.72	48.72
13318	7/25/2008	GIANCARLO MAIUCCI	-	274.33	274.33
13226	7/10/2008	GONANO & HARRELL	2,484.79	(2,484.79)	-
13270	7/17/2008	GONANO & HARRELL	2,032.00	2,032.00	4,064.00
13227	7/10/2008	GOVERNMENT SERVICES GROUP	1,422.11	2,076.16	3,498.27

**St. Lucie West Service District  
Check Register  
July 31, 2008**

<u>CHECK #</u>	<u>CHECK DATE</u>	<u>NAME</u>	<u>GF</u>	<u>W&amp;S</u>	<u>Total</u>
13319	7/25/2008	GOVERNMENT SERVICES GROUP	2,994.80	4,492.20	7,487.00
13171	7/3/2008	GRAINGER	-	361.75	361.75
13271	7/17/2008	GRAINGER	-	427.52	427.52
13320	7/25/2008	HD SUPPLY WATERWORKS, LTD	-	1,251.60	1,251.60
13172	7/3/2008	HELENA CHEMICAL CO.	8,790.60	-	8,790.60
13228	7/10/2008	HELENA CHEMICAL CO.	1,696.50	-	1,696.50
13272	7/17/2008	HELENA CHEMICAL CO.	382.50	-	382.50
13321	7/25/2008	HELENA CHEMICAL CO.	2,369.70	-	2,369.70
13229	7/10/2008	HELENA KENNEDY	-	47.94	47.94
13173	7/3/2008	HOME DEPOT CREDIT SERVICE	212.81	721.02	933.83
13174	7/3/2008	HOME DEPOT CREDIT SERVICE	-	2,053.85	2,053.85
13273	7/17/2008	HOYT C. MURPHY, REALTORS	-	42.37	42.37
13230	7/10/2008	HYDROPRO INC	-	924.00	924.00
13274	7/17/2008	HYDROPRO INC	-	9,594.00	9,594.00
13322	7/25/2008	HYDROPRO INC	-	1,233.75	1,233.75
13275	7/17/2008	INDIAN RIVER OXYGEN INC.	19.50	-	19.50
13323	7/25/2008	INFRA MAP CORP	-	2,400.00	2,400.00
13175	7/3/2008	INTEGRATION CONCEPTS, INC	-	6,708.50	6,708.50
13231	7/10/2008	INTEGRATION CONCEPTS, INC	-	6,180.71	6,180.71
13276	7/17/2008	IRON MOUNTAIN INTELLECTUA	87.50	87.50	175.00
13232	7/10/2008	JACQUESON BIEN-AIME	-	44.42	44.42
13176	7/3/2008	JANE CHAPDELAINE	-	51.80	51.80
13177	7/3/2008	JEFF FURST PROPERTY APPRA	39,914.29	-	39,914.29
13178	7/3/2008	JOHN IMPERATO	2,275.00	3,412.50	5,687.50
13233	7/10/2008	JOHN LEATHERS	-	805.63	805.63
13277	7/17/2008	JOSEPH MITOLO	-	53.02	53.02
13179	7/3/2008	KEN REED PRINTING	-	456.75	456.75
13234	7/10/2008	KING EQUIPMENT COMPANY	212.85	-	212.85
13235	7/10/2008	KURT LITTS	-	107.82	107.82
13324	7/25/2008	LAB SAFETY SUPPLY	-	807.92	807.92
13180	7/3/2008	LEGEND COMMUNICATIONS INC	28.00	-	28.00
13278	7/17/2008	LEGEND COMMUNICATIONS INC	-	80.00	80.00
13181	7/3/2008	LI YING LI	-	48.28	48.28
13279	7/17/2008	LOWE'S	-	352.97	352.97
13325	7/25/2008	LUBRICATION ENGINEERING I	258.80	-	258.80
13280	7/17/2008	M SPARROW	-	52.44	52.44
13182	7/3/2008	M&S ELECTRIC MOTOR & PUMP	1,702.34	-	1,702.34
13183	7/3/2008	MAINLINE SUPPLY COMPANY	-	24.54	24.54
13236	7/10/2008	MAINLINE SUPPLY COMPANY	-	170.00	170.00
13281	7/17/2008	MAINLINE SUPPLY COMPANY	-	61.08	61.08
13237	7/10/2008	MANUEL GONZALEZ	-	65.17	65.17
13184	7/3/2008	MARGARET FRONTERA	-	33.60	33.60
13185	7/3/2008	MELTRA	9.00	-	9.00
13238	7/10/2008	MICHAEL LUDOVICO	-	22.89	22.89
13186	7/3/2008	MICHAEL MCMULLEN	-	42.19	42.19
13239	7/10/2008	MICHAEL VERNSEY	-	31.73	31.73
13240	7/10/2008	MORGAN RUSSUM	-	47.97	47.97
13187	7/3/2008	NAPA AUTO & TRUCK PARTS	70.74	137.23	207.97
13241	7/10/2008	NAPA AUTO & TRUCK PARTS	501.59	374.12	875.71
13282	7/17/2008	NAPA AUTO & TRUCK PARTS	336.10	24.44	360.54
13326	7/25/2008	NAPA AUTO & TRUCK PARTS	76.86	413.15	490.01
13188	7/3/2008	NATURE'S KEEPER INC.	-	606.38	606.38
13283	7/17/2008	NATURE'S KEEPER INC.	1,200.00	-	1,200.00
13242	7/10/2008	PATRICIA BOYD	-	6.87	6.87
13189	7/3/2008	PITNEY BOWES	-	5,080.38	5,080.38
13284	7/17/2008	PITNEY BOWES	-	127.96	127.96
13285	7/17/2008	PRAXAIR DISTRIBUTION SE L	27.62	-	27.62
13243	7/10/2008	PRINCIPAL LIFE	1,205.76	1,710.91	2,916.67
13286	7/17/2008	PSION TEKLOGIX	-	892.00	892.00
13190	7/3/2008	RICHESON & COKE, P.A.	1,946.77	5,840.29	7,787.06
13287	7/17/2008	RICHESON & COKE, P.A.	2,471.00	3,706.50	6,177.50
13288	7/17/2008	RITEWAY RECYCLING	945.00	945.00	1,890.00
13191	7/3/2008	RIVERSIDE LEASING CO.	-	122.68	122.68
13244	7/10/2008	ROBERT E. LIGHT	-	880.00	880.00
13192	7/3/2008	RUSSELL FRONTERA	-	18.02	18.02

**St. Lucie West Service District  
Check Register  
July 31, 2008**

<u>CHECK #</u>	<u>CHECK DATE</u>	<u>NAME</u>	<u>GF</u>	<u>W&amp;S</u>	<u>Total</u>
13289	7/17/2008	SCRIPPS TREASURE COAST NE	-	303.45	303.45
13327	7/25/2008	SHERWIN WILLIAMS	-	180.23	180.23
13290	7/17/2008	SOPHIE DEMIS	-	6.42	6.42
13193	7/3/2008	SPIRIT SERVICES CO.	158.45	-	158.45
13245	7/10/2008	SPIRIT SERVICES CO.	-	158.45	158.45
13291	7/17/2008	SPIRIT SERVICES CO.	158.45	-	158.45
13328	7/25/2008	SPIRIT SERVICES CO.	158.45	-	158.45
13292	7/17/2008	SPRINT	717.59	743.73	1,461.32
13246	7/10/2008	ST LUCIE CO BALING & RECY	415.95	-	415.95
13330	7/25/2008	ST LUCIE WEST COUNTRY CLU	32,500.00	-	32,500.00
13329	7/25/2008	ST LUCIE WEST SERVICES DI	1,251.20	5,174.15	6,425.35
13194	7/3/2008	STAPLES CREDIT PLAN	-	405.26	405.26
13205	7/3/2008	STATE OF FLORIDA DISBURSE	674.62	-	674.62
13331	7/25/2008	STATE OF FLORIDA DISBURSE	663.54	-	663.54
13293	7/17/2008	STORAGE WEST	24.00	96.00	120.00
13247	7/10/2008	SUN PIPE AND VALVES, LLC	-	180.81	180.81
13332	7/25/2008	SUN PIPE AND VALVES, LLC	-	47.26	47.26
13248	7/10/2008	SUNCOAST SPRAYER EQUIPMEN	135.67	-	135.67
13294	7/17/2008	SUNCOAST SPRAYER EQUIPMEN	19.95	-	19.95
13281	7/10/2008	SUNLIGHT COMMUNITY CHURCH	-	500.00	500.00
13333	7/25/2008	SUNRISE TRACTOR & EQUIPME	1,950.00	-	1,950.00
13334	7/25/2008	SYNAGRO SOUTHWEST	-	22,894.75	22,894.75
13195	7/3/2008	SYSTEMATIC SERVICES INC.	-	8,228.11	8,228.11
13249	7/10/2008	SYSTEMATIC SERVICES INC.	-	190.00	190.00
13335	7/25/2008	T.J. BAYER	-	47.82	47.82
13206	7/3/2008	TEAMSTERS LOCAL UNION NO.	532.00	-	532.00
13196	7/3/2008	TEKLEEN AUTOMATIC FILTERS	-	400.00	400.00
13197	7/3/2008	THOMAS SETTEDUCATI	-	38.51	38.51
13250	7/10/2008	THOMPSON PUMP	-	188.10	188.10
13251	7/10/2008	TOW MASTERS OF PORT ST. L	288.00	-	288.00
13252	7/10/2008	TRACEY STARLING	-	55.84	55.84
13253	7/10/2008	TREASURE COAST HONDA KAWA	823.61	-	823.61
13295	7/17/2008	TREASURE COAST HONDA KAWA	83.50	-	83.50
13198	7/3/2008	TREASURE COAST LAWN EQUIP	141.44	-	141.44
13254	7/10/2008	TREASURE COAST LAWN EQUIP	71.92	-	71.92
13336	7/25/2008	TREASURE COAST LAWN EQUIP	194.42	-	194.42
13255	7/10/2008	TREASURE COAST PUMP SUPPL	-	1,726.30	1,726.30
13296	7/17/2008	TREASURE COAST PUMP SUPPL	-	589.20	589.20
13199	7/3/2008	TURNER INDUSTRIAL SUPPLY	-	20.14	20.14
13297	7/17/2008	TURNER INDUSTRIAL SUPPLY	-	29.82	29.82
13337	7/25/2008	TURNER INDUSTRIAL SUPPLY	175.71	153.89	329.60
13298	7/17/2008	TYLER TECHNOLOGIES, INC.	1,010.13	1,010.12	2,020.25
13338	7/25/2008	UNITED RENTALS	235.94	-	235.94
13200	7/3/2008	USABLUEBOOK	-	1,751.38	1,751.38
13256	7/10/2008	USABLUEBOOK	-	515.03	515.03
13299	7/17/2008	USABLUEBOOK	-	211.93	211.93
13339	7/25/2008	USABLUEBOOK	378.24	811.22	1,189.46
13257	7/10/2008	VELDE FORD, INC.	258.33	-	258.33
13340	7/25/2008	VELDE FORD, INC.	100.00	-	100.00
13201	7/3/2008	VERO CHEMICAL DISTRIBUTOR	99.15	22,069.30	22,168.45
13258	7/10/2008	VERO CHEMICAL DISTRIBUTOR	-	1,940.45	1,940.45
13300	7/17/2008	VERO CHEMICAL DISTRIBUTOR	63.50	705.90	769.40
13341	7/25/2008	VERO CHEMICAL DISTRIBUTOR	151.00	2,452.50	2,603.50
13259	7/10/2008	WACHOVIA BANK N.A.	694.96	792.00	1,486.96
13260	7/10/2008	WASTE PRO - FT. PIERCE	122.82	122.83	245.65
13202	7/3/2008	YOHELY DELABRA	-	48.72	48.72
			<b>\$ 161,737.62</b>	<b>\$ 242,655.96</b>	<b>\$ 404,393.58</b>

# St. Lucie West Services District

Checks > \$35k with Explanations

July 31, 2008

---

<b>1 Florida Power &amp; Light</b>	<b>\$ 48,886.41</b>
<i>Utility bill for July services</i>	
<b>2 Jeff Furst Property Appraiser</b>	<b>\$ 39,914.29</b>
<i>Charges for placing special assessments on the 2007 tax roll</i>	

**ST LUCIE WEST SERVICES DISTRICT  
GENERAL FUND  
BALANCE SHEET  
AS OF JULY 31, 2008**

			<b>ACCOUNT BALANCE</b>
<b>ASSETS</b>			
S011A	101302	CSH DISBS WACH #2696604777264	\$ 1,357,868.99
S011A	102000	PETTY CASH	200.00
S011A	151000	INVESTMENTS-CURRENT	6,366.79
S011A	155000	PREPAID ITEMS	9,832.00
<b>TOTAL ASSETS</b>			<b>\$ 1,374,267.78</b>
<b>LIABILITIES</b>			
S011L	202000	ACCOUNTS PAYABLE	85,439.23
S011L	216001	PAYROLL LEVIES PAYABLE	(347.92)
S011L	216002	HEALTH INSURANCE PAYABLE	(1,133.34)
S011L	216004	DENTAL INSURANCE PAYABLE	(64.42)
S011L	216005	LIFE INSURANCE PAYABLE	(355.00)
S011L	216006	PENSION PAYABLE	521.37
S011L	220001	DEPOSITS PAYABLE	92,926.30
<b>TOTAL LIABILITIES</b>			<b>\$ 176,986.22</b>
<b>FUND BALANCE</b>			
S011U	271000	FUND BALANCE-UNRESERVED	\$ 298,218.36
S011U	272001	FUND BALANCE CURRENT YEAR	899,063.20
S011U	272207	FUND BALANCE RESVD FOR ENCUMBR	-
<b>TOTAL FUND BALANCE</b>			<b>\$ 1,197,281.56</b>
<b>TOTAL LIABILITIES + FUND BALANCE</b>			<b>\$ 1,374,267.78</b>

**ST LUCIE WEST SERVICES DISTRICT  
WATER MANAGEMENT BENEFIT SERIES BOND  
BALANCE SHEET  
AS OF JULY 31, 2008**

<b>ASSETS</b>		<b>ACCOUNT BALANCE</b>
S201A	101322 CSH REV BENFT TX #4076006812	\$ 898,398.86
S201A	101325 CSH RES A BNFT TX #4076006849	1,939,077.50
S201A	101326 CSH RES B BNFT TX #4076006876	519,125.94
<b>TOTAL ASSETS</b>		<b><u>\$ 3,356,602.30</u></b>
<b>FUND BALANCE</b>		
S201U	271000 FUND BALANCE-UNRESERVED	\$ 3,430,775.83
S201U	272000 FUND BALANCE CURRENT YEAR	(74,173.53)
<b>TOTAL FUND BALANCE</b>		<b><u>\$ 3,356,602.30</u></b>
<b>TOTAL LIABILITIES + FUND BALANCE</b>		<b><u>\$ 3,356,602.30</u></b>

**ST LUCIE WEST SERVICES DISTRICT  
 CASCADES SERIES 1998 BOND FUND  
 BALANCE SHEET  
 AS OF JULY 31, 2008**

		<b>ACCOUNT BALANCE</b>
<b>ASSETS</b>		
S202A	101310 CSH RES CASCADES #4076003049	\$ 238,714.55
S202A	101313 CSH REV CASCADES #4076003012	108,650.87
	<b>TOTAL ASSETS</b>	<b><u>\$ 347,365.42</u></b>
<b>Liabilities</b>		
S202L	207000 DUE TO OTHER FUNDS	\$ -
	<b>TOTAL LIABILITIES</b>	<b><u>\$ -</u></b>
<b>FUND BALANCE</b>		
S202U	271000 FUND BALANCE-UNRESERVED	\$ 346,957.69
S202U	272000 FUND BALANCE CURRENT YEAR	407.73
	<b>TOTAL FUND BALANCE</b>	<b><u>\$ 347,365.42</u></b>
	<b>TOTAL LIABILITIES + FUND BALANCE</b>	<b><u>\$ 347,365.42</u></b>

**ST LUCIE WEST SERVICES DISTRICT  
WMB CAPITAL PROJECT FUND  
BALANCE SHEET  
AS OF JULY 31, 2008**

			<b>ACCOUNT BALANCE</b>
<b>ASSETS</b>			
S301A	101357	CSH CNST 99 A&B BT #4076006885	\$ 3,171,804.62
S301A	101358	CSH CNST 95 WTR BN #4076877514	2,275.07
<b>TOTAL ASSETS</b>			<b><u>\$ 3,174,079.69</u></b>
<b>LIABILITIES</b>			
S301L	205000	RETAINAGE PAYABLE	\$ -
<b>TOTAL LIABILITIES</b>			<b><u>\$ -</u></b>
<b>FUND BALANCE</b>			
S301U	271000	FUND BALANCE-UNRESERVED	\$ 3,100,017.39
S301U	272000	FUND BALANCE CURRENT YEAR	74,062.30
<b>TOTAL FUND BALANCE</b>			<b><u>\$ 3,174,079.69</u></b>
<b>TOTAL LIABILITIES + FUND BALANCE</b>			<b><u>\$ 3,174,079.69</u></b>



**ST LUCIE WEST SERVICES DISTRICT  
WATER SEWER FUND  
BALANCE SHEET  
AS OF JULY 31, 2008**

<b>ASSETS</b>			<b>ACCOUNT BALANCE</b>
S450A	101301	CSH OPERATING WS #3110097861	\$ 150,332.22
S450A	101304	CSH DEP WACH WS #2000007343111	267,420.72
S450A	101327	INVESTMENT IN US TREASURER	2,108,462.50
S450A	101340	CSH CONST REV BND #4076011281	79,884.43
S450A	101343	CSH RES SR REV BND #4076011192	580,850.00
S450A	101345	CSH RESV SR REV #4076011183	867,267.50
S450A	101347	CSH R&R REV BNDS #4076011209	563,844.78
S450A	101349	CSH WTR CONN RV BD #4076011227	3,935,561.27
S450A	101350	CSH WW CONN RV BD #4076011236	4,282,333.10
S450A	101351	CSH REV REV BND #4076011165	1,415,783.75
S450A	101354	CSH UTL REV BND PRN#4076036781	417,880.00
S450A	102000	PETTY CASH	300.00
S450A	115000	ACCOUNTS RECEIVABLE	244,228.85
S450A	117000	ALLOWANCE UNCOLLECTIBLE A/R	(13,136.04)
S450A	151001	INVESTMENTS - SBA	550.81
S450A	154004	ISSUANCE COST 04	507,012.00
S450A	154007	ISSUANCE COST 00	830,746.51
S450A	154015	LOSS/ GAIN ON REFUNDING	779,869.18
S450A	155000	PREPAID ITEMS	27,522.76
S450A	156000	OTHER ASSETS-CURRENT	4,735.00
S450A	161900	FIXED ASSETS LAND	1,200,000.00
S450A	162900	FIXED ASSETS-BUILDINGS	4,435.91
S450A	163900	ACCUMULATED DEPRECIATION-BLG	(3,171.39)
S450A	164900	FIXED ASSETS-IMPROVEMENTS	39,192,596.03
S450A	165900	ACCUMULATED DEPRECIATION-INFRASTR	(9,799,798.01)
S450A	166900	FIXED ASSETS-FURNITURE & EQUIP	1,219,620.23
S450A	167900	ACCUM. DEPRECIATION - EQUIP	(430,461.39)
S450A	169900	CONSTRUCTION WORK IN PROGRESS	189,203.29
		<b>TOTAL ASSETS</b>	<b>\$ 48,623,874.01</b>
<b>LIABILITIES</b>			
S450L	202000	ACCOUNTS PAYABLE	\$ 64,369.05
S450L	213000	OUTDOORS RESORTS LIABILITY	147,485.16
S450L	213001	DEFERRED REVENUE CURRENT	73,742.72
S450L	216003	ACCRUED VACATION	7,556.76
S450L	220001	UTILITY DEPOSITS PAYABLE	245,855.57
S450L	224901	UNAMORT DISC 2000 BONDS	(173,101.87)
S450L	224902	UNAMORT DISC 2004 BONDS	(34,202.00)
S450L	232000	REVENUE BONDS-CURRENT PORTION	470,000.00
S450L	232900	REVENUE BONDS-LONG-TERM PORT	38,165,000.00
		<b>TOTAL LIABILITIES</b>	<b>\$ 38,966,705.39</b>
<b>FUND BALANCE</b>			
S450U	272000	FUND BALANCE-UNRESERVED ENT	\$ 9,133,887.13
S450U	272001	FUND BALANCE CURRENT YEAR	523,281.49
S450U	272007	FUND BALANCE RESVD FOR ENCUMBR	-
		<b>TOTAL FUND BALANCE</b>	<b>\$ 9,657,168.62</b>
		<b>TOTAL LIABILITIES + FUND BALANCE</b>	<b>\$ 48,623,874.01</b>

**ST LUCIE WEST DISTRICT SERVICE  
CASH ACCOUNT RECONCILIATION  
FOR THE MONTH ENDED JULY 31, 2008**

Account No.	Account Name	Agency	Account Type	Balance	Change	Balance	Change	Balance	Change
<b>WACHOVIA OPERATING</b>									
S011A	101302	Public Fund Checking	WA	289860477284	1,437,546.74	(79,877.75)	1,357,888.99	1,357,888.99	
S450A	101301	Public Fund Checking	WA	269860477264	150,332.22	-	150,332.22	150,332.22	
		<b>TOTAL</b>	<b>WA</b>	<b>289860477284</b>	<b>1,587,878.96</b>	<b>(79,877.75)</b>	<b>1,508,201.21</b>	<b>1,508,201.21</b>	<b>YES</b>
<b>GENERAL FUND</b>									
S011A	151000	Surplus Funds Account	SBA	271912	6,366.79	-	6,366.79	6,366.79	YES
<b>TOTAL OPERATING GENERAL FUND</b>							<b>1,514,568.00</b>	<b>1,514,568.00</b>	
<b>DEBT SERVICE FUNDS - WATER MANAGEMENT BONDS</b>									
S201A	101320	Interest Account-TRF	US	4076008821	0.00	-	0.00	0.00	YES
S201A	101321	Interest B Account-TRF	US	4076008858	0.00	-	0.00	0.00	YES
S201A	101322	Revenue Fund-TRF	US	4076008812	898,398.86	-	898,398.86	898,398.86	YES
S201A	101323	Sinking A Account	US	4076008830	0.00	-	0.00	0.00	YES
S201A	101324	Sinking B Account	US	4076008867	0.00	-	0.00	0.00	YES
S201A	101325	Reserve A Fund	US	4076006849	1,939,077.50	-	1,939,077.50	1,939,077.50	YES
S201A	101326	Reserve B Fund	US	4076006876	519,125.94	-	519,125.94	519,125.94	YES
S202A	101310	Reserve Fund	US	4076003049	238,714.55	-	238,714.55	238,714.55	YES
S202A	101311	Interest Account	US	4076003021	0.00	-	0.00	0.00	YES
S202A	101312	Pre-Payment Account	US	4076003030	0.00	-	0.00	0.00	YES
S202A	101313	Revenue Fund-Cascades	US	4076003012	108,650.87	-	108,650.87	108,650.87	YES
S202A	101315	Sinking Fund -Cascades	US	4076019149	0.00	-	0.00	0.00	YES
S301A	101357	Construction Fund 1999B	US	4076006865	3,171,804.62	-	3,171,804.62	3,171,804.62	YES
S301A	101358	Construction 95 Benefits	US	4076877514	2,275.07	-	2,275.07	2,275.07	YES
<b>TOTAL GOVT ACCOUNTS</b>							<b>6,876,047.41</b>	<b>6,876,047.41</b>	
<b>WATER &amp; SEWER ACCOUNTS</b>									
S450A	101304	Cash Depository	WA	200007343111	267,420.72	-	267,420.72	267,420.72	YES
S450A	101340	Construction Fund-URB	US	4076011281	79,884.43	-	79,884.43	79,884.43	YES
S450A	101342	Operating/Maintenance	US	4076011174	0.00	-	0.00	0.00	YES
S450A	101343	Senior Reserve	US	4076011192	580,850.00	-	580,850.00	580,850.00	YES
		Investment in US Treasurer (Note Bayarrische Landesbank Inv. Agmt:							
S450A	101327	\$2,108,462.50	US	4076011192	2,108,462.50	-	2,108,462.50	2,108,462.50	YES
		<b>TOTAL</b>		<b>4076011192</b>	<b>2,689,312.50</b>	<b>-</b>	<b>2,689,312.50</b>	<b>2,689,312.50</b>	<b>YES</b>
S450A	101345	Senior Interest	US	4076011183	867,267.50	-	867,267.50	867,267.50	YES
S450A	101347	Renewal/Replacement	US	4076011209	563,844.78	-	563,844.78	563,844.78	YES
S450A	101348	Rate Stabilization	US	4076011218	0.00	-	0.00	0.00	YES
S450A	101349	Water Connection	US	4076011227	3,935,561.27	-	3,935,561.27	3,935,561.27	YES
S450A	101350	Wastewater Connection	US	4076011236	4,282,333.10	-	4,282,333.10	4,282,333.10	YES
S450A	101351	Revenue Fund-URB	US	4076011185	1,415,783.75	-	1,415,783.75	1,415,783.75	YES
S450A	101352	Surplus Fund	US	4076011272	0.00	-	0.00	0.00	YES
S450A	101354	Principal Account	US	4076036761	417,880.00	-	417,880.00	417,880.00	YES
S450A	151001	Surplus Funds Account	SBA	271911	550.81	-	550.81	550.81	YES
<b>TOTAL WATER/SEWER FUND</b>							<b>17,519,838.88</b>	<b>17,519,838.88</b>	
<b>GRAND TOTAL</b>							<b>2,032,405.27</b>	<b>2,032,405.27</b>	

COMPLETED BY: *James M. Kelly* DATE: August 6, 2008

APPROVED BY: *[Signature]* DATE: 8/8/08

# *St. Lucie West Services District*

## **Board Agenda Item Tuesday, August 19, 2008**

### **Item**

---

**FA 2      Approval to transfer funds for R&R Fund, WCF and WWCF Requisitions**

### **Summary**

---

Attached for your review and approval is a request to transfer funds from the Renewal & Replacement (R&R) Fund, the Water Connection Fee Fund (WCF) and the Wastewater Connection Fee Funds (WWCF) for expenses that are previously budgeted project-related expenses and have been previously approved by the Board to be funded from one of the above mentioned accounts.

All of the expenditures are appropriate for payment from the R&R Fund, the WCF and/or the WWCF Accounts. All expenditures are in compliance with the District's policy where the cost exceeds the capitalization threshold for Fixed Assets.

- \$51,217.69 – Renewal & Replacement Account
- \$500.00 – Water Capacity Fee Account
- \$8,600.00 – Wastewater Connection Fee Account

All Invoices for these requisitions are attached for your review.

### **Recommendation**

---

Staff recommends Board approval to transfer funds from the Wastewater Connection Fee Fund for \$8,600.00, the WCF Account for \$500.00 and the R&R account for \$51,217.69 to the Public Fund Checking account for reimbursement for payments made that have been budgeted to be funded by these accounts.

### **Budget Impact**

---

N/A

### **Board Action**

---

Moved by: \_\_\_\_\_      Seconded by: \_\_\_\_\_      Action Taken: \_\_\_\_\_

---

**ST LUCIE WEST SERVICES DISTRICT**

**Reimbursement Analysis - 2008-08**

As of 07/31/08

<b>Renewal &amp; Replacement Fund</b>		<b>Requisition: 2008-16</b>				
<b>Vendor</b>	<b>Invoice Date</b>	<b>Invoice #</b>	<b>Invoice Amount</b>	<b>Check #</b>	<b>PROJ</b>	
FDEP	7/22/2008	072208A	500.00	13302	SW008	
ARCADIS	12/31/2007	0210249	240.00	13156	SW037	
CUSTOM WELDING DIVERSIFIED	7/21/2008	24965	46,750.00	13395	SW037	
HOME DEPOT CREDIT SVC	5/12/2008	8055833	48.00	13173	SW038	
HOME DEPOT CREDIT SVC	6/2/2008	7013084	285.12	13174	SW038	
HOME DEPOT CREDIT SVC	6/2/2008	7167059	(9.25)	13173	SW038	
INTEGRATION CONCEPTS	7/12/2008	2008-17-01	3,403.82	13361	SW038	
<b>Total to be reimbursed</b>			<b>\$ 51,217.69</b>			

<b>Wastewater Capacity Fees</b>		<b>Requisition: 2008-17</b>				
<b>Vendor</b>	<b>Invoice Date</b>	<b>Invoice #</b>	<b>Invoice Amount</b>	<b>Check #</b>	<b>PROJ</b>	
INTEGRATION CONCEPTS	7/12/2008	2008-03-01	8,600.00	13361	SW022	
<b>Total to be reimbursed</b>			<b>\$ 8,600.00</b>			

<b>Water Connection Fees</b>		<b>Requisition: 2008-18</b>				
<b>Vendor</b>	<b>Invoice Date</b>	<b>Invoice #</b>	<b>Invoice Amount</b>	<b>Check #</b>	<b>PROJ</b>	
FDEP	7/22/2008	072208B	500.00	13401	SW043	
<b>Total to be reimbursed</b>			<b>\$ 500.00</b>			

**TOTAL REQUISITIONS      \$ 60,317.69**

**ST. LUCIE WEST SERVICES DISTRICT  
REQUISITION FOR PAYMENT  
RENEWAL & REPLACEMENT TRUST ACCOUNT**

The undersigned, an Authorized Officer of St. Lucie West Services District (the "District") hereby submits the following requisition for disbursement under and pursuant to the terms of the Indenture of Trust from the District to US Bank, as trustee (the "Trustee"), dated as of February 1, 2000 (the "Indenture") (all capitalized terms used herein shall have the meaning as such term in the Indenture):

(A) Requisition Number:

**2008-16**

(B) Name of Payee:

***St. Lucie West Services District, Public Fund Checking Account  
269660477264***

(C) Amount Payable:

***\$ 51,217.69***

(D) Purpose for which paid or incurred (refer also to specific contract if amount is due and payable pursuant to a contract involving progress payments, or, state Costs of issuance, if applicable):

***Per attached letter and invoices; all of these expenditures are for renewal and replacement projects where the costs exceeds the capitalization threshold for fixed assets held by the St. Lucie West Services District.***

(E) Fund or Account and subaccount, if any, from which disbursement to be made:

***Renewal/Replacement, Account Number 4076011209***

The undersigned hereby certifies that obligations in the stated amount set forth above have been incurred by the District, that each disbursement set forth above is a proper charge against the [√] Renewal/Replacement Fund that each disbursement set forth above was incurred in connection with the cost of extensions, improvements or

additions to, or the replacement or renewal of capital assets of the Utility System, or extraordinary repairs of the Utility System.

The undersigned hereby further certifies that there has not been filed with or served upon the District notice of lien, right to lien, or attachment upon, or claim affecting the right to receive payment of, any of the moneys payable to the Payee set forth above, which has not been released or will not be released simultaneously with the payment hereof.

The undersigned hereby further certifies that such requisition contains no item representing payment on account of any retained percentage which the District is at the date of such certificate entitled to retain.

If this requisition is for a disbursement from other than the Transaction Cost Account or for payment of capitalized interest, there shall be attached a resolution of the Governing Body of the District approving the specific contract with respect to which disbursements pursuant to this requisition are due and payable.

Attached hereto are originals of the invoice(s) from the vendor of the property acquired or services rendered with respect to which disbursement is hereby requested.

**ST. LUCIE WEST SERVICES DISTRICT**

By:

\_\_\_\_\_  
Chairman  
Charles B. Altwein

**CONSULTING ENGINEER'S APPROVAL FOR NON-COST OF ISSUANCE  
AND CAPITALIZED INTEREST REQUESTS ONLY**

If this requisition is for a disbursement from other than Capitalized Interest or Costs of Issuance, the undersigned Consulting Engineer hereby certifies that this disbursement is for a Cost of the Renewal & Replacement Project and is consistent with: (i) the applicable acquisition or construction contract; (ii) the plans and specifications for the portion of the Renewal & Replacement Project with respect to which such disbursement is being made; and (iii) the report of the Consulting Engineer shall have been amended or modified on the date hereof.

\_\_\_\_\_  
Consulting Engineer  
Robert W. Lawson, P.E.

13447

# St. Lucie West Services District

Check Request

Date 7/22/08	Amount \$500.00	Authorized By Dennis Pichl
-----------------	--------------------	-------------------------------

Payable To:  
TIM POWELL, PE FLORIDA DEPT. OF ENVIRONMENTAL PROTECTION

Date Check Needed: ASAP	Budget Category SW008
----------------------------	--------------------------

Interfused Use of Funds Requested

\* PER DENNIS CUT ASAP

SEND TO: TIM POWELL, P.E.

FL DEP SOUTHEAST DISTRICT OFFICE

400 NORTH CONGRESS AVE. SUITE #21

WEST PALM BEACH, FL 33401

REF CPH JOB # S4618

(Attach supporting documentation for request.)

District Fax Transmittal Memo		# of pg. 2
To: HEIDI	From: LISA	
District GSG	District SLWSD	
Dept. FINANCE	Phone # (772) 340-0220	
Fax # <del>SEN</del>	Fax #	
EMAILED 7/22/08		



July 18, 2008

Tim Powell, P.E.  
Florida Department of Environmental Protection  
Southeast District Office  
400 North Congress Avenue, Suite 200  
West Palm Beach, Florida 33401

500 West Fullon Street  
Sanford, Florida 32771  
P.O. Box 2808  
Sanford, Florida 32772-2808  
Phone: 407.322.6841  
Fax: 407.330.0639  
[www.cphengineers.com](http://www.cphengineers.com)

Re: St. Lucie County – St. Lucie West Services District Wastewater Treatment Plant  
Surge Tank Rehabilitation  
CPH Job # S4618

Dear Mr. Powell,

We are submitting the application for a minor permit revision for St. Lucie West Services District Wastewater Treatment Plant. Generally, the permit is for the following activities:

- Rehabilitation of the surge tank (all the temporary pipes will be removed after the rehabilitation)
- Replacement of the existing air headers with new stainless steel headers for the surge tank
- Replacement of the existing diffuser drop pipes and diffusers for the surge tank aeration system
- Installation of additional drop pipes and diffusers along the north side of the north digester
- Replacement of the splitter box

Enclosed please find the following listed documents in support of this permit application:

- One copy of DEP Form 62-620.910(1)
- One copy of DEP Form 62-620.910(9)
- A permit application check in the amount of \$500.00 per FAC 62-4.050
- One copy of the Preliminary Design Report

Thank you for your attention on this application. Please contact me by email [ylee@cphengineers.com](mailto:ylee@cphengineers.com) or phone call at 407-322-6841 if you have any questions or need more information.

Sincerely,  
CPH Engineers, Inc.

Ying Chun Lee, P.E.  
Florida P.E. Registration No. 31371

Cc: Dennis Pickle, St. Lucie West Services District

J:\S4618\Documents\Permits\application\Cover letter.doc





RECEIVED

JUN 16 2008

St. Lucie West Services District  
Finance

RECEIVED

JUN 23 2008

6/23/08

December 31, 2007

Project No: WF003609.0000

Invoice No: 0210249

ST LUCIE WEST SERVICES DISTRICT  
GOVERNMENT SERVICES GROUP  
ATTN: LARRY KOCH  
280 WEKIVA SPRINGS ROAD, STE 2000  
LONGWOOD, FL 32779

RECEIVED

JUL 31 2008

ST LUCIE WEST SERVICES DISTRICT  
FINANCE

ENGINEERING AND GEOTECHNICAL SERVICES TO STUDY SEEPAGE AT UTILITY SITE  
IRRIGATION POND - WORK AUTHORIZATION AGM - SW 06-13

Professional Services from October 28, 2007 to November 28, 2007

Professional Personnel

	Hours	Rate	Amount	
EXPERT	1.50	160.00	240.00	
Totals	1.50		240.00	
<b>Total Labor</b>				<b>240.00</b>
		<b>Total this Invoice</b>		<b>\$240.00</b>

Billings to date

Contract Total	22,600.00
Less This Invoice	240.00
Less Prior Invoices	20,928.00
<b>Amount Remaining</b>	<b>1,432.00</b>

Payment Approval:

PO: 8914  
Vendor #: \_\_\_\_\_  
Invoice: 0210249  
Amount: 240.00  
Inv Date: 12/31/07  
ORG: 45015071  
OBJECT: 534007  
Project: \_\_\_\_\_  
Prepared By: \_\_\_\_\_  
Approved by: DW  
St. Lucie WSD

SW  
037

CK# 15595



**Custom Welding Diversified, Inc.**  
 1983 SW Biltmore St.  
 Port St. Lucie, FL 34984  
 772-879-6928 Fax 772-879-6390

APR 23 2008

**Invoice**

PO/Project #: 8650

Date	Invoice #
7/21/2008	24965

Vendor #: \_\_\_\_\_

<b>Bill To</b>
St. Lucie West Service District 450 SW Utility Dr. Port St. Lucie, FL 34986

Invoice #: 24965

Inv. Date: 7/21/08

Code 1: SW037

Code 2: \_\_\_\_\_

Amt. 1: 46,750.00 Amt. 2: \_\_\_\_\_

P.O. No.	Terms	Due Date	Account No.	Project/Job	Orig. Inv. Date
20081013-...		8/1/2008		Air Header	

SLWSD APPROVAL: *[Signature]*

Item	Description	Qty	Rate	Amount
Fabricate	Custom Welding to furnish and fabricate as per plans the material below. Deliver to job site to be installed by others.	1	46,750.00	46,750.00
Misc. Materi...	Weld 16" cap domestic source	1	0.00	0.00
Misc. Materi...	16" 316 SS sch10 pipe 100 liner feet	1	0.00	0.00
Misc. Materi...	16" x 316 SS sch 10 LR 90 bend	2	0.00	0.00
Misc. Materi...	16" x 316 SS sch10 45 bend	3	0.00	0.00
Misc. Materi...	16" x 8" 316 SS sch 10 red tee	1	0.00	0.00
Misc. Materi...	8" 316 SS Sch 10 LR 90 bend	3	0.00	0.00
Misc. Materi...	16" x 8" conc. 316 SS reducer sch10	1	0.00	0.00
Misc. Materi...	8" 316 SS sch 10 pipe x10'	1	0.00	0.00
Misc. Materi...	16" 316 SS plate flange 3/4" thick	9	0.00	0.00
Misc. Materi...	8" 316 SS plate flange 1/2" thick (No bid on valves)	6	0.00	0.00

Thank you for your business.

**Please make check payable to Custom Welding. Invoices are due at time of receipt. Interest will be charged on invoices 30 days past due at 1.5% per month (18% per annum) Accounts 90 days past due will become C.OD. You will incur a daily 45.00 lot charge if your item is not picked up promptly after you are notified or scheduled date. No warranty or guarantees on large machinery such as front end loaders, dump trucks etc. You will incur, but not limited to, reasonable fees if an attorney or collection agency is used. Consumer agrees & accepts the Terms & Conditions at account opening.**

Subtotal	\$46,750.00
Sales Tax (0.0%)	\$0.00
<b>Total</b>	<b>\$46,750.00</b>
Payments	\$0.00
Balance Due	\$46,750.00

THE HOME DEPOT 6376  
700 SW ST LUCIE W BLVD  
PORT ST LUCIE, FL 34986 (772)8784206

*Migration U*

SALE 6376 00023 14532 05/14/08  
72 JXJ395 07:54 AM

RECEIVED

MAY 14 2008



084298012372	KNEEPAD <A>	9.97
079765132820	BOTTLE WATER <A>	3.97N
088712941118	CABLE-75 <A>	64.98
088712942030	CUTTER SET <A>	21.49
037103214553	FILE BRUSH <A>	
	204.97	9.94
088712003311	DECLOG KIT <A>	8.95
079340306226	LOC4G REDW <A>	2.88
731919051332	GLOVES <A>	
	3019.96	59.88
731919051233	GLOVES <A>	
	208.93	17.86
077089150070	4"FMBRSHWDHN <A>	
	1203.97	47.64
077089150056	3"WHTBRBRSH <A>	
	701.37	9.59
077089150032	2"WHTBRBRSH <A>	
	1000.97	9.70
012758035104	PSERIESLINER <A>	
	1204.99	59.88
	SUBTOTAL	326.73
	SALES TAX	0.00
TAX EXEMPT		
	TOTAL	\$326.7
XXXXXXXXXXXX9922	HOME DEPOT	326.7
AUTH CODE 014331/6233362		T:

WEST SERVICE

THE HOME DEPOT 6376  
700 SW ST LUCIE W BLVD  
PORT ST LUCIE, FL 34986 (772)8784206

SALE 6376 00005 22755 05/12/08  
11 630509 10:59 AM

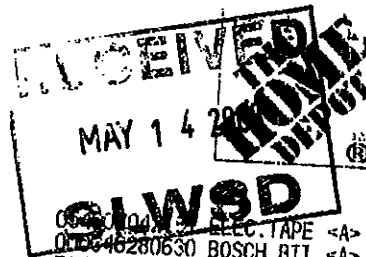

084298012372	KNEEPAD <A>	9.97
079765132820	BOTTLE WATER <A>	3.97N
088712941118	CABLE-75 <A>	64.98
088712942030	CUTTER SET <A>	21.49
037103214553	FILE BRUSH <A>	
	204.97	9.94
088712003311	DECLOG KIT <A>	8.95
079340306226	LOC4G REDW <A>	2.88
731919051332	GLOVES <A>	
	3019.96	59.88
731919051233	GLOVES <A>	
	208.93	17.86
077089150070	4"FMBRSHWDHN <A>	
	1203.97	47.64
077089150056	3"WHTBRBRSH <A>	
	701.37	9.59
077089150032	2"WHTBRBRSH <A>	
	1000.97	9.70
012758035104	PSERIESLINER <A>	
	1204.99	59.88
	SUBTOTAL	326.73
	SALES TAX	0.00
TAX EXEMPT		
	TOTAL	\$51.32
XXXXXXXXXXXX6690	HOME DEPOT	51.32
AUTH CODE 012671/8055833		TA

T LUCIE W SVCS DIST  
ILLER JOSH

*with open supplies*  
*RAS REQUIRED*  
*(Water Plumb)*

RECEIVED

MAY 22 2008

St. Lucie West Service  
Finance

PO/Project #: 8581

Vendor #: \_\_\_\_\_

Invoice #: 6233362

Inv. Date: 5/14/08

Code 1: 45036100 534001

Code 2: \_\_\_\_\_

Amt. 1: 326.73 Amt. 2: \_\_\_\_\_

SLWSD APPROVAL: [Signature]

PO/Project #: 8582

Vendor #: \_\_\_\_\_

Invoice #: 8055833

Inv. Date: 5/12/08

Code 1: 45036100 536002

Code 2: SW038

Amt. 1: 3.32 Amt. 2: 48.00

SLWSD APPROVAL: [Signature]

DEPOT 6376  
700 SW S LUCIE W BLVD  
PORT ST LUCIE, FL 34986 (772)8784206

2

6376 0001 25955 06/02/08  
51 TAC242 11:06 AM

THE HOME DEPOT 6376  
700 SW S LUCIE W BLVD  
PORT ST LUCIE, FL 34986 (772)8784206

6376 00016 23776 06/02/08  
RETURN 22 AK08CR 01:29 PM



*FLEX  
HOOPPERS  
+  
RAS PUMPS  
INSTALLATION*

C32886042126 FLEX COND <A>	26.63
C32886230430 10 STR GN FL <A>	99.00
C32886230232 10 STR RO FL <A>	99.00
C51411643621 3/4XSRCONDIMP <A>	
201.73	3.46
C20066133831 PAINT <A>	4.97
C42266653658 RECT CVR SIL <A>	
201.07	2.14
C42266650329 1G 5-IL 3/4EX <A>	6.62
C42266650312 1G 4-IL 3/4EX <A>	6.10
C32076056135 5PK TAPE <A>	3.93
C50169342331 COND.JIT <A>	
207.79	15.53
C50169340337 COND.JIT <A>	
404.17	16.63
C51411261979 COND.JIT LCKN <A>	0.91
SUBTOTAL	285.12
SALES TAX	0.00
TAX EXEMPT	
TOTAL	\$285.12
XXXXXXXXXXXX6690 HOME DEPOT	285.12
AUTH CODE J02551/7013084	TA

**\*\* REFUND \*\***

\* ORIG REC: 6376 001 2595 06/02/08 TA \*

050169340387 CONDUIT	
2.00000-8.34/2.0000	-8.34
051411261979 CONDUIT LCKN	-0.91
SUBTOTAL	-9.25
SALES TAX	0.00
TAX EXEMPT	
TOTAL	-\$9.25
XXXXXXXXXXXX6690 HOME DEPOT	-9.25
INVOICE 7167059	TA

**\*\* REFUND \*\***  
CUSTOMER COPY

ST LUCIE W SVCS DIST

RECEIVED  
JUN 13 2008  
ST. LUCIE, FL 34986

PO/Project #: 8772

PO/Project #: 8773

Vendor #: \_\_\_\_\_

Vendor #: \_\_\_\_\_

Invoice #: 7013084

Invoice #: 7167059

Inv. Date: \_\_\_\_\_

Inv. Date: 6/2/08

Code 1: SW038

Code 1: REFUND

Code 2: \_\_\_\_\_

Code 2: \_\_\_\_\_

Amt. 1: 275.87 Amt. 2: \_\_\_\_\_

Amt. 1: (9.25) CR. Amt. 2: \_\_\_\_\_

SLWSD APPROVAL: DMP

SLWSD APPROVAL: DMP

Integration Concepts, Inc.  
 3022 Russet Pass  
 Lakeland, FL 33813

# Invoice

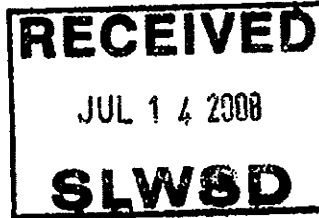

Invoice #: 2008-17-01  
 Invoice Date: 7/12/2008  
 Due Date: 8/11/2008  
 Project: 2008-17, RA...  
 P.O. Number: 8920

Bill To:  
 St. Lucie West Services District  
 450 SW Utility Drive  
 Port St. Lucie, FL 34986  
 Dennis Pickle

Date	Description	Amount
7/12/2008	24Vdc (DH+) Surge Protector	237.60
	Phoenix Contact, DIN Rail, Perforated, NS 35/7.5, 0801733	26.07
	Phoenix Contact, 50 PCs, #6-#24 MAG Compression Terminals, 3001381	73.92
	Phoenix Contact, FTB, W/Knif Switch, 500V, 26-10 AWG, Black, UK 5-HESI, 3004100	10.45
	Phoenix Contact, Terminal Block End Anchor, E/UK, 1201442	4.09
	Phoenix Contact, UGTB, 28-12 AWG, Green & Yellow, USLKG 3, 0441083	21.47
	Phoenix Contact, Universal Terminal Blocks, 600V, 24-6 AWG, Gray, UK3 N, 3001501	32.74
	Phoenix Contact, Terminal Strip Marking Carrier, UBE/D, 0800307	12.76
	Phoenix Contact, Universal Terminal Blocks, End Cover Plate, Gray, D-UK 4/10, 3003020	5.15
	Potentiometer, W/Resistive Element, 10K, 800H-UR29	356.00
	Speed Pot Lredgend Plate, Speed, 800T-X608	8.95
	A/B, 30.5mm Type 4/4X/13 3 Pos. Sel. Switch-Non-Illum., 800T-J2KC1B	175.14
	30.5mm Selector Switch Legend Plate, Hand Off Auto, A/B 800T-X511	8.45
	Allen Bradley, Pilot Light, 4/4x/13, Incandescent, Red, 800H-QRH10R	201.92
	A/B 800T-X559E, Custom Legend	23.94
	PowerFlex 70 Drive I/O Interface, 20COMR	775.17
	Subtotal	1,973.82
	Construction Labor	
	Engineering, Travel Expense, Get and Deliver Panels	520.00
	Panel Construction Labor	390.00
	Control Panel Wiring Labor	520.00
	Subtotal	1,430.00

PO/Project #: 8920

Vendor #: \_\_\_\_\_

Invoice #: 20081701

Inv. Date: 7/12/08

Code 1: SW038

Code 2: \_\_\_\_\_

Amt. 1: 3403.82 Amt. 2: \_\_\_\_\_

SLWSD APPROVAL: [Signature]

Total	\$3,403.82
Payments/Credits	\$0.00
Balance Due	\$3,403.82

**ST. LUCIE WEST SERVICES DISTRICT  
REQUISITION FOR PAYMENT  
WASTEWATER CAPACITY TRUST ACCOUNT**

The undersigned, an Authorized Officer of St. Lucie West Services District (the "District") hereby submits the following requisition for disbursement under and pursuant to the terms of the Indenture of Trust from the District to US Bank, as trustee (the "Trustee"), dated as of February 1, 2000 (the "Indenture") (all capitalized terms used herein shall have the meaning as such term in the Indenture):

(A) Requisition Number:

*2008-17*

(B) Name of Payee:

*St. Lucie West Services District, Public Fund Checking Account  
2696604777264*

(C) Amount Payable:

*\$ 8,600.00*

(D) Purpose for which paid or incurred (refer also to specific contract if amount is due and payable pursuant to a contract involving progress payments, or, state Costs of issuance, if applicable):

*Per the attached invoices relate to projects in which were budgeted to be funded by the Wastewater Connection fee account and therefore are appropriate for payment out of the Wastewater Connection Fee Fund.*

(E) Fund or Account and subaccount, if any, from which disbursement to be made:

*Wastewater Connection Fund, Account Number 4076011236*

The undersigned hereby certifies that [obligations in the stated amount set forth above have been incurred by the District, that each disbursement set forth above is a proper charge against the [√] Wastewater Connection Fees Fund and that each disbursement set for the above was incurred in connection with the cost of acquiring and/or constructing improvements or additions to the water facilities of the Utility System

for which the Wastewater Connection Fees were imposed in accordance with the requisitions for disbursement for moneys provided to the Trustee by the District.

The undersigned hereby further certifies that there has not been filed with or served upon the District notice of lien, right to lien, or attachment upon, or claim affecting the right to receive payment of, any of the moneys payable to the Payee set forth above, which has not been released or will not be released simultaneously with the payment hereof.

The undersigned hereby further certifies that such requisition contains no item representing payment on account of any retained percentage which the District is at the date of such certificate entitled to retain.

If this requisition is for a disbursement from other than the Transaction Cost Account or for payment of capitalized interest, there shall be attached a resolution of the Governing Body of the District approving the specific contract with respect to which disbursements pursuant to this requisition are due and payable.

Attached hereto are originals of the invoice(s) from the vendor of the property acquired or services rendered with respect to which disbursement is hereby requested.

**ST. LUCIE WEST SERVICES DISTRICT**

By:

---

Chairman  
Charles B. Altwein

**CONSULTING ENGINEER'S APPROVAL FOR NON-COST OF ISSUANCE  
AND CAPITALIZED INTEREST REQUESTS ONLY**

If this requisition is for a disbursement from other than Capitalized Interest or Costs of Issuance, the undersigned Consulting Engineer hereby certifies that this disbursement is for a Cost of the Waste Water Capacity Project and is consistent with: (i) the applicable acquisition or construction contract; (ii) the plans and specifications for the portion of the Waste Water Capacity Project with respect to which such disbursement is being made; and (iii) the report of the Consulting Engineer shall have been amended or modified on the date hereof.

---

Consulting Engineer  
Robert W. Lawson, P.E.

Automation Concepts, Inc.  
 Russet Pass  
 Island, FL 33813

# Invoice

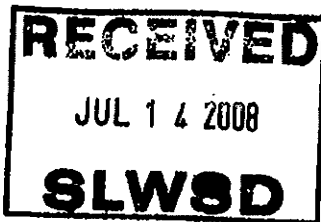

Invoice #: 2008-03-01  
 Invoice Date: 7/12/2008  
 Due Date: 8/11/2008  
 Project: 2008-03, WW Plant Automati...  
 P.O. Number: 20081008-00

**Bill To:**  
 St. Lucie West Services District  
 450 SW Utility Drive  
 Port St. Lucie, FL 34986  
 Bill Hayden

*[Faint stamp: RECEIVED JUL 14 2008]*

Description	Hours/Qty	Rate	Amount
Equipment Ordering & Receiving	12	65.00	780.00
Auto CAD Drafting Labor	60	65.00	3,900.00
Control Panel Design Labor	40	75.00	3,000.00
Control Panel Equipment Research	12	75.00	900.00
Binders, Dividers & Printing Cost	1	20.00	20.00

PO/Project #: 9029

Vendor #: \_\_\_\_\_

Invoice #: 20080301

Inv. Date: 7/12/08

Code 1: 50022

Code 2: \_\_\_\_\_

Amt. 1: 8600.00 Amt. 2: \_\_\_\_\_

SLWSD APPROVAL: *John Imperato*

It's been a pleasure working with you!

<b>Total</b>	<b>\$8,600.00</b>
<b>Payments/Credits</b>	<b>\$0.00</b>
<b>Balance Due</b>	<b>\$8,600.00</b>



**ST. LUCIE WEST SERVICES DISTRICT  
REQUISITION FOR PAYMENT  
WATER CAPACITY TRUST ACCOUNT**

The undersigned, an Authorized Officer of St. Lucie West Services District (the "District") hereby submits the following requisition for disbursement under and pursuant to the terms of the Indenture of Trust from the District to US Bank, as trustee (the "Trustee"), dated as of February 1, 2000 (the "Indenture") (all capitalized terms used herein shall have the meaning as such term in the Indenture):

(A) Requisition Number:

**2008-18**

(B) Name of Payee:

***St. Lucie West Services District, Public Fund Checking Account  
2696604777264***

(C) Amount Payable:

***\$ 500.00***

(D) Purpose for which paid or incurred (refer also to specific contract if amount is due and payable pursuant to a contract involving progress payments, or, state Costs of issuance, if applicable):

***Per the attached invoices relate to projects in which were budgeted to be funded by the Water Connection fee account and therefore are appropriate for payment out of the Water Connection Fee Fund.***

(E) Fund or Account and subaccount, if any, from which disbursement to be made:

***Water Connection Fund, Account Number 4076011227***

The undersigned hereby certifies that [obligations in the stated amount set forth above have been incurred by the District, that each disbursement set forth above is a proper charge against the [] Water Connection Fees Fund and that each disbursement set for the above was incurred in connection with the cost of acquiring and/or constructing improvements or additions to the water facilities of the Utility System for which the

Water Connection Fees were imposed in accordance with the requisitions for disbursement for moneys provided to the Trustee by the District.

The undersigned hereby further certifies that there has not been filed with or served upon the District notice of lien, right to lien, or attachment upon, or claim affecting the right to receive payment of, any of the moneys payable to the Payee set forth above, which has not been released or will not be released simultaneously with the payment hereof.

The undersigned hereby further certifies that such requisition contains no item representing payment on account of any retained percentage which the District is at the date of such certificate entitled to retain.

If this requisition is for a disbursement from other than the Transaction Cost Account or for payment of capitalized interest, there shall be attached a resolution of the Governing Body of the District approving the specific contract with respect to which disbursements pursuant to this requisition are due and payable.

Attached hereto are originals of the invoice(s) from the vendor of the property acquired or services rendered with respect to which disbursement is hereby requested.

**ST. LUCIE WEST SERVICES DISTRICT**

By:

---

Chairman  
Charles B. Altwein

**CONSULTING ENGINEER'S APPROVAL FOR NON-COST OF ISSUANCE  
AND CAPITALIZED INTEREST REQUESTS ONLY**

If this requisition is for a disbursement from other than Capitalized Interest or Costs of Issuance, the undersigned Consulting Engineer hereby certifies that this disbursement is for a Cost of the Water Capacity Project and is consistent with: (i) the applicable acquisition or construction contract; (ii) the plans and specifications for the portion of the Water Capacity Project with respect to which such disbursement is being made; and (iii) the report of the Consulting Engineer shall have been amended or modified on the date hereof.

---

Consulting Engineer  
Robert W. Lawson, P.E.

St. Lucie West  
Services District

13448

CK # 13401

Check Request

Date	Amount	Authorized By
7/22/08	\$500.00	Dennis Pichl

Payable To:

JOSE CALAS - FLORIDA DEPT OF ENVIRONMENTAL PROTECTION

Date Check Needed:	Budget Category
ASAP	SW043

Intended Use of Funds Requested

* PER DENNIS CUT ASAP
SEND TO: JOSE CALAS
FL DEP SOUTHEAST DISTRICT OFFICE
400 NORTH CONGRESS AVE. SUITE #200
WEST PALM BEACH, FL 33401
REF. CPH JOB # S4617
(Attach supporting documentation for request.)

District Fax Transmittal Memo		# of pg. 2
To:	HEIDI	From:
District	GSG	LISA
Dept.	FINANCE	District
Fax #	EMAILED	SLWSD
	7/22/08	Phone #
		(772) 340-0220
		Fax #



July 18, 2008

Mr. Jose Calas  
Florida Department of Environmental Protection  
Southeast District Office  
400 North Congress Avenue, Suite 200  
West Palm Beach, Florida 33401

500 West Fullon Street  
Sanford, Florida 32771

P.O. Box 2808  
Sanford, Florida 32772-2808

Phone: 407.322.6841  
Fax: 407.330.0639

[www.cphengineers.com](http://www.cphengineers.com)

Re: St. Lucie County  
St. Lucie West Services District Water Treatment Plant 2.0 MG Ground Storage  
Tank Recommission  
CPH Job # S4617

Dear Mr. Calas,

We are submitting the application for a specific permit to construct PWS component for St. Lucie West Services District Water Treatment Plant. The permit is for the project to recommission a 2.0 million gallon reclaimed water ground storage tank to a potable water storage tank. A 200,000 gallon reject water ground storage tank will be built in order to meet the storage requirement.

Enclosed please find the following listed documents in support of this permit application:

- One copy of Form 62-555.900(1)
- A permit application check in the amount of \$500.00 for a permit minor revision per Drinking Water Permit Fees as of July 1, 2008
- One copy of the Preliminary Design Report

Thank you for your attention on this application. Please contact me by email [ylee@cphengineers.com](mailto:ylee@cphengineers.com) or phone call at 407-322-6841 if you have any questions or need more information.

Sincerely,  
CPH Engineers, Inc.

Ying Chun Lee, P.E.  
Florida P.E. Registration No. 31371

Cc: Dennis Pickle, St. Lucie West Services District

J:\S4617\Documents\Permits\Application\Cover letter.doc

# *St. Lucie West Services District*

## **Board Agenda Item Tuesday, August 19, 2008**

### **Item**

---

**FA 3                      Approval of Resolution 2008-05 to adopt Budget Amendment 2008-03**

### **Summary**

---

At the Board Meeting held on July 15, 2008 the Board of Supervisors approved Budget Amendment 2008-03 to add CIP SW060 for a total of \$47,338. Provided for your review and approval is a Resolution to formally adopt the Budget Amendment for that project.

Attached is a copy of the Budget Amendment and the back up for your review.

### **Recommendation**

---

Staff recommends approval of Resolution 2008-05 to adopt Budget Amendment 2008-03 to increase the CIP Budget by \$47,338.

### **Budget Impact**

---

Please see attached.

### **Board Action**

---

Moved by: \_\_\_\_\_                      Seconded by: \_\_\_\_\_                      Action Taken: \_\_\_\_\_

---

**RESOLUTION NO. 2008-05**

**A RESOLUTION OF THE BOARD OF SUPERVISORS OF THE ST. LUCIE WEST SERVICES DISTRICT AMENDING THE CAPITAL IMPROVEMENT PROJECT BUDGET FOR THE FISCAL YEAR ENDING SEPTEMBER 30, 2008 IN ACCORDANCE WITH THE TERMS AND CONDITIONS OF BUDGET RESOLUTION NO. 2007-04 AND PROVIDING FOR APPLICABILITY AND EFFECTIVE DATE.**

WHEREAS, the Board of Supervisors of the St. Lucie West Services District in the City of Port St. Lucie, Florida, has determined the Budget for the Fiscal Year 2007-2008 should be amended; and

WHEREAS, Section II (C) of Resolution No. 2007-04 provides for amendments of the FY 2007-2008 Budget.

**NOW THEREFORE, BE IT RESOLVED BY THE BOARD OF SUPERVISORS OF THE ST LUCIE WEST SERVICES, THAT:**

Section 1: The St Lucie West Services District, hereby amends its 2007-2008 Budget as provided in the schedules attached hereto and made part hereof, in accordance with the terms and provisions of the Budget Resolution No. 2007-04.

Section 3: This Resolution shall take effect immediately upon adoption by the Board of Supervisors.

**PASSED AND DULY ADOPTED** at the meeting of the Board of Supervisors of the St. Lucie West Services District, on the 19<sup>th</sup> day of August, 2008.

**ST. LUCIE WEST SERVICES DISTRICT**

By: \_\_\_\_\_

Chairman

ATTEST:

\_\_\_\_\_  
Secretary-Treasurer

# *St. Lucie West Services District*

## **Board Agenda Item**

**Tuesday, July 15, 2008**

### **Item**

---

**DM            Approval of Budget Amendment 2008-03**

---

### **Summary**

---

Staff is requesting that the Board approve Budget Amendment 2008-03 to add Project SW060 to the FY 2008 CIP projects. The project total results in a \$47,338 increase to the CIP Budget.

### **Recommendation**

---

Staff recommends approval of Budget Amendment 2008-03 to add CIP Project SW060 for a total cost of \$47,338.

---

### **Budget Impact**

---

A Budget Worksheet is attached.

---

### **Board Action**

---

Moved by: \_\_\_\_\_            Seconded by: \_\_\_\_\_            Action Taken: \_\_\_\_\_

---



ARCADIS U.S., Inc.  
 2081 Vista Parkway  
 West Palm Beach  
 Florida 33411  
 Tel 561.697.7000  
 Fax 561.697.7751

**MEMO**

To:  
 John Imperato - District Manager  
 St Lucie West Services District  
 450 SW Utility Drive  
 Port St Lucie, FL 34986

Copies:  
 Billl Hayden – Public Works Director  
 Dennis Pickle – Utilities Director

Heidi Snyder  
 District Financial Services

**Florida License Numbers**

**Engineering**  
 EB00007917

**Geology**  
 GB310

**Landscape Architecture**  
 LC26000269

**Surveying**  
 LB7062

From:  
 Robert W. Lawson, P.E.

Date:  
 May 30, 2008

ARCADIS Project No.:  
 WF003606.0000

Subject:  
 Wetland Monitoring Plan Program

Attached please find one copy of the proposal for set up and annual monitoring in connection with the District's approval from SFWMD to use the shallow aquifer wells as a source of irrigation water. The proposal was presented by the sub-consultant that ARCADIS contracted to assist in acquiring the water use permit. In addition to the costs identified in the R.L. Weigt proposal, I have added the surveying costs associated with the establishment of the transect information required for the initial report.

The cost to implement the monitoring plan includes both capital and annual operating costs and can be summarized as follows:

**Capital Costs for Installation**

- Materials and installation of wetland monitoring wells \$ 11,424.00
- Purchase and set up of data loggers and rain gauges \$ 20,914.00
- Surveying for original transect cross-sections ( ARCADIS) \$ 15,000.00
- \$ 47,338.00

**Operating Costs**

- Annual Transect Monitoring \$ 9,033.00
- Hydrograph Preparation \$ 1,500.00
- Annual Monitoring Report \$ 2,200.00
- Expenses \$ 2,253.55
- \$ 14,986.55



# ARCADIS

The capital budget, as currently stated, includes line item SW060 in the amount of \$40,000 and we may want to consider increasing that line item to \$48,000 to cover the projected set up costs.

The District may want to consider purchase and installation of the wells directly or solicitations of quotes from other environmental consultants to assure that the fees quoted in the attached proposal are fair.

Thanks

Robert W. Lawson, P.E.  
District Engineer

**St. Lucie West Services District  
Budget Amendment No. 2008-03**

**1) Decrease Unappropriated Fund Balance, Wastewater Impact Fee Fund**

**FUNDING SOURCE**

Organization	Description	Estimated Balance @ 09/30/08	Increase (Decrease)	Revised Balance
S450U	Cash Carry Forward from:	\$ 3,896,601	\$ (47,338)	\$ 3,849,263
<b>Totals</b>		\$ 3,896,601	\$ (47,338)	\$ 3,849,263

**2) Add Budget Expenditure for CIP SW060**

**EXPENDITURE**

Organization	Object/Project	Description	Current Budget	Increase (Decrease)	Revised Budget
45036100	565000-SW060	Construction Services	-	47,338	47,338
<b>Totals</b>			\$ -	\$ 47,338	\$ 47,338

**ST. LUCIE WEST SERVICES DISTRICT  
CAPITAL IMPROVEMENTS PROGRAM (2008-2012)  
PROJECT REQUEST FORM**

Project Name: Irrigation PH 1 - Wetland Monitoring Project No.: SW060  
 Priority Rating: 4 General Fund, Water or Wastewater: Water Proposer: Bob Lawson  
 Category: IRR Required By Date: 9/30/2008 Phone No.: 561-697-7000

**1. PROJECT LOCATION/DESCRIPTION:**

This project dedicates the funds necessary to establish 10 water level data logger stations and photographic transect monumentation in accordance with the Wetland Monitoring Plan required as part of the SFWMD water use permit issued in February of 2008.

**2. JUSTIFICATION OF PROJECT:**

Condition 26 of the SFWMD water use permit 56-00637-W issued to the District in February, 2008 requires that the Wetland Monitoring Plan, as presented in Exhibit 9 of the permit, be implemented. It is required that the District monitor the water levels and hydrologic condition of the wetlands in the near proximity of the wells that are being pumped on a semi-annual basis. The first annual reporting of conditions was due in April of 2008.

**3. ESTIMATED PROJECT COST**

	PRIOR	FY 2007	FY 2008	FY 2009	FY 2010	FY 2011	FY 2012
Engineering & Design							
Permits/Regulatory Fees							
Construction			47,338.0				
Contingency							
Mgmt. & Other							
<b>TOTALS</b>	-	-	47,338.0	-	-	-	-

**4. FUNDING SOURCE**

	PRIOR	FY 2007	FY 2008	FY 2009	FY 2010	FY 2011	FY 2012
Repair & Replacement							
General Fund							
Water & Sewer Fund							
2004 Bonds							
Water Connection							
Wastewater Connection			47,338.0				
<b>TOTALS</b>	-	-	47,338.0	-	-	-	-

**5. ANNUAL OPERATING IMPACT CREATED BY PROJECT**

	PRIOR	FY 2007	FY 2008	FY 2009	FY 2010	FY 2011	FY 2012
New Positions (FT/PT)							
Personnel costs:							
Electric Power:							
Chemicals:							
Other:			14,986.6				
<b>Total Operating Costs:</b>	-	-	14,986.6	-	-	-	-



*ST LUCIE WEST*  
SERVICES DISTRICT

**IX**

**DISTRICT MANAGER**

# St. Lucie West Services District

## Board Agenda Item Tuesday, August 19, 2008

### Item

**DM 1 Approval of Work Authorization No SLWSD-ICI-08-02 Upgrade of existing 900 Mhz spread spectrum radios to 220 Mhz fixed frequency radios; Project No. SW006**

### Summary

Provided for your review and consideration is the Work Authorization from Integration Concepts, Inc. for the Upgrade of the existing 900 Mhz spread spectrum radios to 220 Mhz fixed frequency radios as part of the Radio Telemetry System Upgrade planned in the Capital Improvement Plan. As part of the conversion from 900 Mhz to 220 Mhz the District needs to convert the radios and antennas at the master site and eight (8) remote sites prior to the Lift Station telemetry project. Integration Concepts, Inc. is the Districts radio and computer services provider and assisted the District in researching and acquiring the 220 Mhz fixed frequency for the upgrade.

Integration Concepts, Inc. will replace the nine radios with new MDS 2710NR radios and nine new 200 Mhz antennas. The new antennas will be aligned to maximize gain and the appropriate acceptance testing will be performed on each of the links. Integration Concepts, Inc. will perform a detailed analysis on the system and provide the District with baseline reliability expectations for each link.

Integration Concepts, Inc. proposal is for a fixed fee amount of \$61,990.00.

This project was funded out of the Water and Sewer Capital Improvement Program.

### Recommendation

*Staff recommends approval of Work Authorization No. SLWSD-ICI-08-02 for the Upgrade of the existing 900 Mhz spread spectrum radios to 220 Mhz fixed frequency radios, to Integration Concepts, Inc., of Lakeland, Florida for the lump sum amount of \$61,990.00*

Utilities Director Dennis Pickle District Manager John Imperato

### Budget Impact

Project Number: SW006	Available Project Budget: \$452,137.00
ORG Number: 45036100	This Project: \$ 61,990.00
OBJ Number: 565000	Available Balance for future Repair and Replacement Projects: \$390,147.00

### Board Action

Moved by: \_\_\_\_\_ Seconded by: \_\_\_\_\_ Action Taken: \_\_\_\_\_

# WORK AUTHORIZATION NO. SLWSD/ICI SLWSD-ICI-08-02

Between the

## **St. Lucie West Services District,**

A community development district organized and existing in accordance with chapter 190, Florida Statutes ("SLWSD")

and

## Integration Concepts, Inc.

### A. SUMMARY OF SERVICES TO BE RENDERED

Upgrade, installation and commissioning of nine (9) new MDS 2710NR radios and nine (9) new 200 MHz antennas. This equipment will replace the existing radios at the master radio telemetry site and the eight (8) existing remote radio telemetry sites. In addition, new RF Coaxial Cable will be reinstalled as necessary at each site. The new antennas will be aligned to maximize gain and the appropriate acceptance testing will be performed on each of the radio telemetry links. Integration Concepts will perform a detailed analysis of the new system and will provide St. Lucie West Services District with baseline reliability expectations for each radio telemetry link. A detailed installation report will be provided to St. Lucie West Services District and will include the RF engineering models used, expected radio telemetry link reliabilities and other pertinent information.

### B. SCHEDULE OF FEES:

Turn key fixed fee price... \$61,990.00

### C. PROJECT SCHEDULE:

Project to commence upon issuance of approved work authorization. Approximate execution time not to exceed eight weeks.

### D. SPECIAL CONDITIONS:

The deployment process required for converting the master radio telemetry site and each remote site will require a disruption in communication and the automatic operation of the Districts Irrigation Distribution system. The disruption in communication will last for three days for the Irrigation Distribution system and an additional ten (10) days for the existing surface raw water well sites.

### E. NOTICE/PROJECT MANAGER OF CONSULTANT

---

Brian K. Callahan, President  
Integration Concepts, Inc.  
3022 Russet Pass  
Lakeland, FL 33813

---

Charles Altwein, Chairman  
St. Lucie West Services District  
450 SW Utility Drive  
Port St. Lucie, FL 34986

Certification that Sufficient Funds are Available, if applicable:

\_\_\_\_\_  
Carol Rogers  
District Treasurer

\_\_\_\_\_  
John Imperato  
District Manager

**Dated this \_\_\_\_ day of \_\_\_\_\_ 2007.**

**Integration Concepts, Inc.**  
*Advanced Process Automation*

3022 Russet Pass  
Lakeland FL 33813  
Phone: (863) 647-3133  
Cell: (863) 409-7339

2044 Palm Vista Drive  
Apopka, FL 32712  
Phone: (407) 367-9277  
Fax: (407) 886-6501

July 27, 2008

To: St. Lucie West Services District  
450 SW Utility Drive  
Port St. Lucie, FL 34986

Attn: Mr. Dennis Pickle, Utility Manager

Subject: Upgrade of existing 900 Mhz spread spectrum radios to 220 Mhz fixed frequency radios.

Dear Mr. Pickle

As per St. Lucie West Services District's request for quotation, Integration Concepts, Inc. is pleased to provide the following quote for engineering, system integration & installation services relating to the St. Lucie West Services District Radio Telemetry System upgrade project in Port St. Lucie Florida.

This proposal is based on Integration Concepts review of the current radio system and site survey of the existing radio telemetry sites. The upgrade includes installation and commissioning of nine (9) new MDS 2710NR radios and nine (9) new 200 MHz antennas. This equipment will replace the existing radios at the Master Site and the eight (8) remote sites. In addition, RF Coaxial Cable will be reinstalled as necessary at each site. The new antennas will be aligned to maximize gain and the appropriate acceptance testing will be performed on each of the links. Integration Concepts will perform a detailed analysis on the system and will provide St. Lucie West Services District with baseline reliability expectations for each link. A detailed installation report will be provided to St. Lucie West Services District and will include the RF engineering models used, expected link reliabilities and other pertinent information.

The turn key fixed fee price for this service is... \$61,990.00

Integration concepts request the following payment schedule for services provided in this proposal.

- a. 50% of the Total Project Cost (\$30,995.00), representing pre-project engineering and design, and equipment, will be invoiced when ICI receives the equipment for the project.
- b. 40% of the Total Project Cost (\$24,796.00) will be invoiced upon completion of the installation and commissioning.
- c. 10% of the Total Project Cost (\$6,199.00) will be invoiced upon delivery of the final report.

Integration Concepts, Inc. recognizes the importance of this project to St. Lucie West Services District, and fully understands that results must be delivered as agreed. We look forward to having the chance to be part of the project team.

Thank you for the opportunity to submit this proposal. Please call if there are questions or if we can be of service in any way.

Sincerely,



Brian K. Callahan  
Sr. Systems Engineer

---

Integration Concepts, Inc.



# St. Lucie West Services District

## Board Agenda Item Tuesday, August 19, 2008

### Item

**DM 2 Approval of the Odor Control System Modifications at the Wastewater Treatment Facility; Project No. SW021**

### Summary

Provided for your review and consideration are the Bids for the Odor Control System Modifications at the Wastewater Treatment Facility. Arcadis accepted bids for the Odor control project on May 9, 2008 for the demolition of the old system and labor to install the new system. The District will purchase the Odor Control System directly from the manufacturer.

The Bids are as follows:

- 1<sup>st</sup> Bid from Florida Design Contractors of Lake Park, FL. for the amount of \$259,940.00
- 2<sup>nd</sup> Bid from TLC Diversified, of Palmetto, FL. for the amount of \$156,621.00

This project was funded out of the Water and Sewer Capital Improvement Program. Arcadis reviewed the bids and recommends the low bid provided by TLC Diversified.

### Recommendation

*Staff recommends approval to award the Bid for Odor Control System Modifications to TLC Diversified, of Palmetto, Florida for the lump sum amount of \$156,621.00*

Utilities Director Dennis Pickle District Manager John Imperato

### Budget Impact

Project Number: SW021	Available Project Budget: \$180,000.00
ORG Number: 45036100	This Project: \$156,621.00
OBJ Number: 565000	Available Balance for future Repair and Replacement Projects: \$ 23,379.00

### Board Action

Moved by: \_\_\_\_\_ Seconded by: \_\_\_\_\_ Action Taken: \_\_\_\_\_



ARCADIS RMA., Inc.  
2081 Vista Parkway  
West Palm Beach  
Florida 33411  
Tel 561.697.7000  
Fax 561.697.7751  
www.arcadis-us.com

Mr. Dennis Pickle  
Utility Director  
Port St. Lucie Services District  
450 S.W. Utility Drive  
Port St. Lucie, FL 34986

WATER RESOURCES

Subject:  
Odor Control System Modifications  
WWTP Plant Lift Station

Dear Mr. Pickle:

Date:  
July 5, 2008

I have reviewed the bids for this project and recommend that you award the work to the low bidder, TLC Diversified..

Contact:  
Ben Kough, P.E.

Please contact me if you have any questions.

Phone:  
561.697.7071

Sincerely,

Email:  
bkough@arcadis-us.com

ARCADIS RMA., Inc.

Our ref:  
WF0056101.0000

Ben Kough, P.E.  
Senior Engineer

Florida License Numbers  
Engineering  
EB00004757

Copies:  
File

Enclosure

Imagine the result

g:\projects\wrf\ projects\correspondence (e)\wp80\corresp\bk letters\pickle 081808.doc

**ODOR CONTROL SYSTEM MODIFICATIONS  
St. Lucie West Services District**

Bid Date: 5/19/08

	RJ Sullivan	Florida Design \$259,940	TLC Diversified \$156,621	Palm Beach Grading	Interstate	Hinterland	Ocean Gate
Demolition							
BioFilter Installation							
Aluminum Covers							
Air Piping							
Dumpster Piping							
Bar Screen							
Bid Allowance							
<b>TOTAL BID</b>	<b>\$ -</b>	<b>\$ 259,940.00</b>	<b>\$ 156,621.00</b>	<b>\$ -</b>	<b>\$ -</b>	<b>\$ -</b>	<b>\$ -</b>



**LUMP SUM BID AMOUNT**

The lump sum bid amount for the St. Lucie West Services District WWTP Odor Control System Modifications including all work specified in these documents is:

Two hundred fifty nine thousand nine hundred forty

\_\_\_\_\_ Dollars and Zero Cents.

(\$ 259,940 ).

**Note: The Bidder shall include a \$10,000 bidding allowance in the Lump Sum Bid Amount. This amount shall be to cover additional work on this project not otherwise identified by these documents and is subject to separate written approval by the District Engineer.**

Accompanying this bid is a certified or cashier's check or a bid bond in the amount of \$ Bid Bond (not less than 10% of the bid) made payable to the St. Lucie West Services District which is to be forfeited as liquidated damages if, in the event this bid is accepted, the undersigned fails to execute the agreement and furnish and pay for satisfactory performance and payment bonds under the conditions and within the time specified in the bid; otherwise said certified or cashier's check or bid bond is to be returned to the undersigned. Additional requirements for the bid bond are set forth in the Invitation for Bids and Instructions to Bidders.

The undersigned agrees within fifteen (15) days from the date of Owner acceptance of this bid, to execute the agreement and furnish and pay for satisfactory performance and payment bonds, in the amount of 100% of the Contract price, guaranteeing the faithful performance of the work and payment of bills. Said bonds shall be in accordance with the requirements of Section 255.05, Florida Statutes and satisfy all criteria set forth in this document.

The undersigned also agrees to substantially complete the work within one hundred and fifty (150) days after the date when the Contract Time commences to run and to be completed and ready for final payment within one hundred and eighty (180) days after the Contract Time commences to run.

The undersigned further agrees to reimburse the Owner, for each calendar day elapsing between the date herein specified as the date of substantial completion and the actual date of such substantial completion of the contract Work in the amount of \$500 per calendar day as liquidated damages.

The undersigned further agrees to reimburse the Owner, for each calendar day elapsing between the date herein specified as the date of final completion and the actual date of such final completion of the Contract Work in the amount of \$350 per calendar day as liquidated damages.

The Contractor acknowledges existence of, and guarantees full compliance with the Florida Trench Safety Act.

The Bidder acknowledges the receipt of Addenda No's. 1, 2, 3



Florida Design Contractors, Inc.

Schedule of Values  
 St. Lucie West Services District  
 WWTP Odor Control System Modifications

Item No.	Description	Estimated Quantity	Unit	Estimated Amount
<b>I.</b>	<b>Demolition and Removal:</b>			
	1. Existing Wet Scrubber Unit and associated piping	1	LS	\$ <u>15,000</u>
	2. Chlorine Suppression System (including associated piping and concrete secondary storage)	1	LS	\$ <u>20,000</u>
	3. Fiberglass panels and grating	1	LS	\$ <u>10,000</u>
	<b>Subtotal, Item I (Demolition and Removal)</b>			\$ <u>45,000</u>
<b>II.</b>	<b>Biofilter Unit (including electrical, water, drain, air piping and concrete pad)</b>	1	LS	\$ <u>140,390</u>
<b>III.</b>	<b>Aluminum Covers and Supports</b>	1	LS	\$ <u>35,550</u>
<b>IV.</b>	<b>Piping at Dumpster</b>	1	LS	\$ <u>15,500</u>
<b>V.</b>	<b>Replacement Panel for Bar Screen</b>		LS	\$ <u>3,500</u>
	<b>Bid Allowance</b>			\$ <u>20,000</u>
	<b>TOTAL BASE BID</b>			\$ <u>259,940</u>

SV-1

WF056101

LUMP SUM BID AMOUNT

The lump sum bid amount for the St. Lucie West Services District WWTP Odor Control System Modifications including all work specified in these documents is:

ONE HUNDRED FIFTY SIX THOUSAND SIX HUNDRED TWENTY ONE Dollars and NO Cents.

(\$ 156,621.00).

\$20,000 - Addendum #2

Note: The Bidder shall include a ~~\$10,000~~ bidding allowance in the Lump Sum Bid Amount. This amount shall be to cover additional work on this project not otherwise identified by these documents and is subject to separate written approval by the District Engineer.

Accompanying this bid is a certified or cashier's check or a bid bond in the amount of \$10% of Amt bid (not less than 10% of the bid) made payable to the St. Lucie West Services District which is to be forfeited as liquidated damages if, in the event this bid is accepted, the undersigned fails to execute the agreement and furnish and pay for satisfactory performance and payment bonds under the conditions and within the time specified in the bid; otherwise said certified or cashier's check or bid bond is to be returned to the undersigned. Additional requirements for the bid bond are set forth in the Invitation for Bids and Instructions to Bidders.

The undersigned agrees within fifteen (15) days from the date of Owner acceptance of this bid, to execute the agreement and furnish and pay for satisfactory performance and payment bonds, in the amount of 100% of the Contract price, guaranteeing the faithful performance of the work and payment of bills. Said bonds shall be in accordance with the requirements of Section 255.05, Florida Statutes and satisfy all criteria set forth in this document.

The undersigned also agrees to substantially complete the work within one hundred and fifty (150) days after the date when the Contract Time commences to run and to be completed and ready for final payment within one hundred and eighty (180) days after the Contract Time commences to run.

The undersigned further agrees to reimburse the Owner, for each calendar day elapsing between the date herein specified as the date of substantial completion and the actual date of such substantial completion of the contract Work in the amount of \$500 per calendar day as liquidated damages.

The undersigned further agrees to reimburse the Owner, for each calendar day elapsing between the date herein specified as the date of final completion and the actual date of such final completion of the Contract Work in the amount of \$350 per calendar day as liquidated damages.

The Contractor acknowledges existence of, and guarantees full compliance with the Florida Trench Safety Act.

The Bidder acknowledges the receipt of Addenda No's. 1, 2, 3.

1193 ARCADIS

Schedule of Values  
 St. Lucie West Services District  
 WWTP Odor Control System Modifications

Item No.	Description	Estimated Quantity	Unit	Estimated Amount
<b>I. Demolition and Removal:</b>				
1.	Existing Wet Scrubber Unit and associated piping	1	LS	\$ <u>16,759.00</u>
2.	Chlorine Suppression System (Including associated piping and concrete secondary storage)	1	LS	\$ <u>5,237.00</u>
3.	Fiberglass panels and grating	1	LS	\$ <u>5,047.00</u>
Subtotal, Item I (Demolition and Removal)				\$ <u>27,043.00</u>
II.	Biofilter Unit (including electrical, water, drain, air piping and concrete pad)	1	LS	\$ <u>55,450.00</u>
III.	Aluminum Covers and Supports	1	LS	\$ <u>49,290.00</u>
IV.	Piping at Dumpster	1	LS	\$ <u>3,191.00</u>
V.	Replacement Panel for Bar Screen		LS	\$ <u>2,647.00</u>
Bid Allowance				\$ <u>20,000</u>
<b>TOTAL BASE BID</b>				\$ <u>156,621.00</u>

SV-1

WF056101

# St. Lucie West Services District

## Board Agenda Item Tuesday, August 19, 2008

### Item

---

**DM 2a      Approval of Budget Amendment 2008-04**

---

### Summary

---

Agenda Item DM 2 requests approval of additional costs associated with CIP SW021 for the Odor Control System Modifications.

The original Budget amount approved for this project was \$180,000. A Budget Amendment must be approved to increase total expenditures for this project of \$116,621. This project is funded from the Wastewater Capacity Fee Fund.

### Recommendation

---

Staff recommends approval of Resolution 2008-07 approving Budget Amendment 2008- 04 to increase CIP project SW021 by \$116,621 to fund the full Odor Control System Modifications required.

---

### Budget Impact

---

A Budget Worksheet is attached.

---

### Board Action

---

Moved by: \_\_\_\_\_      Seconded by: \_\_\_\_\_      Action Taken: \_\_\_\_\_

---



**St. Lucie West Services District  
Budget Amendment No. 2008-04**

**1) Decrease Unappropriated Fund Balance, Wastewater Impact Fee Fund**

**FUNDING SOURCE**

Organization	Description	Estimated Balance @ 09/30/08	Increase (Decrease)	Revised Balance
		\$	\$	\$
S450U	Cash Carry Forward from:	3,849,263	(116,621)	3,732,642
		\$	\$	\$
Totals		3,849,263	(116,621)	3,732,642

**2) Add Budget Expenditure for CIP SW021**

**EXPENDITURE**

Organization	Object/Project	Description	Current Budget	Increase (Decrease)	Revised Budget
45036100	565000-SW021	Construction Services	-	116,621	116,621
			\$	\$	\$
Totals			\$ -	116,621	116,621

# St. Lucie West Services District

## Board Agenda Item

Tuesday, August 19, 2008

### Item

**DM 3 Approval of the Odor Control System Modifications Equipment at the Wastewater Treatment Facility; Project No. SW021**

### Summary

Provided for your review and consideration are the Bids for the Odor Control System Modifications Equipment at the Wastewater Treatment Facility. Staff decided to bid the Odor Control Unit out separately to keep the cost of the over all project down and Arcadis accepted bids for the Odor control unit on August 8, 2008.

The Bids are as follows:

- 1<sup>st</sup> Bid from Bio Rem Technologies, of Ontario, Canada for the amount of \$140,000.00
- 2<sup>nd</sup> Bid from Siemens, of San Diego, CA. for the amount of \$158,500.00
- 3<sup>rd</sup> Bid from Shaw Environmental, of Lawrenceville, NJ. for the amount of \$156,200.00

This project was funded out of the Water and Sewer Capital Improvement Program. Arcadis reviewed the bids and recommends the low bid provided by Bio Rem Technologies.

### Recommendation

Staff recommends approval to award the Bid for Odor Control System Modifications Equipment to Bio Rem Technologies, of Ontario, Canada for the lump sum amount of \$140,000.00

Utilities Director Dennis Pickle District Manager John Imperato

### Budget Impact

Project Number: SW021  
ORG Number: 45036100  
OBJ Number: 565000

Available Project Budget: \$ 23,379.00  
Budget Increase: \$ 116,621.00  
This Project: \$140,000.00  
Remaining Available Budget Balance: \$ 0

### Board Action

Moved by: \_\_\_\_\_ Seconded by: \_\_\_\_\_ Action Taken: \_\_\_\_\_

**ODOR CONTROL SYSTEM EQUIPMENT  
St. Lucie West Services District**

	Bio Rem	Siemens	Shaw Environmental	
Model	Mytilus 8	BTF-0726	BTF-500	
Delivery	10 weeks	24 weeks		
Bio Trickling Filter	\$ 138,000.00	\$ 158,500.00	\$ 150,750.00	
De-mister	\$ 2,000.00	Included	\$ 5,450.00	
TOTAL BID \$	138,000.00 \$	158,500.00 \$	156,200.00 \$	\$ -

**Dennis Pickle**

---

**From:** Kough, Ben [Ben.Kough@arcadis-us.com]  
**Sent:** Monday, August 11, 2008 1:50 PM  
**To:** Dennis Pickle  
**Cc:** Lawson, Bob  
**Subject:** WWTP Odor Control Equipment Award Recommendation

Dear Mr. Pickle:

We have reviewed the bids for the new Bio Trickling filter for the Wastewater Treatment Plant.

We recommend award to the bid to the low bidder, Bio Rem.

Please contact me if you have any questions.

Sincerely,

ARCADIS RMA., Inc.

Ben Kough, P.E.  
Senior Engineer

ARCADIS Inc.  
2081 Vista Parkway  
West Palm Beach FL 33411  
Tel: 561.697.7000  
Direct Dial: 561.697.7071  
Cell: 561.420.5756  
Fax: 561.697.7751  
E-mail: ben.kough@arcadis-us.com

---

**NOTICE:** This e-mail and any files transmitted with it are the property of ARCADIS U.S., Inc. and its affiliates. All rights, including without limitation copyright, are reserved. The proprietary information contained in this e-mail message, and any files transmitted with it, is intended for the use of the recipient(s) named above. If the reader of this e-mail is not the intended recipient, you are hereby notified that you have received this e-mail in error and that any review, distribution or copying of this e-mail or any files transmitted with it is strictly prohibited. If you have received this e-mail in error, please notify the sender immediately and delete the original message and any files transmitted. The unauthorized use of this e-mail or any files transmitted with it is prohibited and disclaimed by ARCADIS U.S., Inc. and its affiliates.

8/11/2008

**ST.LUCIE WEST SERVICES DISTRICT BID FORM**

**ONE (1) ORIGINAL AND TWO (2) COPIES OF FORM MUST BE SUBMITTED**

PROJECT: Bio Tricking Filter System Date: 8/6/08  
BIDDER: Biorem Technologies, Inc.

THIS BID IS SUBMITTED TO:  
St. Lucie West Services District  
450 SW Utility Drive  
Port St. Lucie, FL 34986

In accordance with all terms and conditions, specifications and requirements, the bidder offers the following:

<u>ITEM NO.</u>	<u>QTY</u>	<u>DESCRIPTION</u>	<u>TOTAL PRICE</u>
1	1	Bio trickling filter odor control system	\$ <u>138,000</u>
2	1	De-mister for filter Exhaust air stream	\$ <u>2,000</u>

Exceptions \_\_\_\_\_  
\_\_\_\_\_  
\_\_\_\_\_

Manufacturer Offered: Biorem Technologies, Inc.

Model Offered: Mytilus 8

Delivery shall be within 70 calendar days of the receipt of Purchase Order  
Delivery must be FOB destination, freight included and shall be inclusive of all costs.

Name of Company: Biorem Technologies, Inc.

Authorized Signature: 

Revision 1

**COPY**

**ST.LUCIE WEST SERVICES DISTRICT BID FORM**

**ONE (1) ORIGINAL AND TWO (2) COPIES OF FORM MUST BE SUBMITTED**

PROJECT: Bio Trickling Filter System Date: August 8, 2008\_  
BIDDER: Shaw Environmental, Inc.

THIS BID IS SUBMITTED TO:  
St. Lucie West Services District  
450 SW Utility Drive  
Port St. Lucie, FL 34986

In accordance with all terms and conditions, specifications and requirements, the bidder offers the following:

ITEM NO.	QTY	DESCRIPTION	TOTAL PRICE
1	1	Bio trickling filter odor control system	\$ <u>150,750.00</u>
2	1	Exhaust De-mister (required)	\$ <u>5,450.00</u>
Total base system price			\$ <u>156,200.00</u>

- o **Exception:** Shaw will utilize timers to control the Frequency and Duration of water fill to regulate the pH via blow down function. Therefore, we do not require a pH meter/transmitter, and have not included in our bid.
- o **Exception:** Shaw utilizes a magnetic drive corrosion resistant pump with 3 HP motor, in lieu of 1 HP motor
- o **Exception:** Nutrient Tank Mixer not required for our system, and has not been included in our bid.
- o **Exception:** Our standard Systems provides a 316 SS NEMA 4X Enclosure Upgraded Panel.

Manufacturer Offered: Shaw Environmental, Inc.

Model Offered: BTF-500

Delivery shall be within 112 calendar days of the receipt of submittal approval.  
Submittals will be within 14 days of Shaw's acceptance of a Purchase Order..  
Delivery must be FOB destination, freight included and shall be inclusive of all costs.

Name of Company: Shaw Environmental, Inc.

**ST.LUCIE WEST SERVICES DISTRICT BID FORM**

**ONE (1) ORIGINAL AND TWO (2) COPIES OF FORM MUST BE SUBMITTED**

PROJECT: Bio Trickling Filter System Date: 8/8/08  
BIDDER: Siemens Water Technologies

THIS BID IS SUBMITTED TO:  
St. Lucie West Services District  
450 SW Utility Drive  
Port St. Lucie, FL 34986

In accordance with all terms and conditions, specifications and requirements, the bidder offers the following:

<u>ITEM NO.</u>	<u>QTY</u>	<u>DESCRIPTION</u>	<u>TOTAL PRICE</u>
1	1	Bio trickling filter odor control system	\$ 158,500
2	1	De-mister for filter Exhaust air stream	\$ Included *

Exceptions A mixer is not required for the nutrient tank and not included  
\* Note that a demister is included integral to the biotrickling filter

Manufacturer Offered: Siemens Water Technologies

Model Offered: BTF-0726

Delivery shall be within \*\* calendar days of the receipt of Purchase Order. Delivery must be FOB destination, freight included and shall be inclusive of all costs.

\*\* Design submittals for approval: 6-8 weeks after receipt of executed purchase order  
Delivery: 12-14 weeks after approval of design submittal and release for fabrication

Name of Company: Siemens Water Technologies Corp.

Authorized Signature: \_\_\_\_\_

Revision 1

This bid is subject to Bidder's list of Equipment and Services Provided by Others (Items 1-16) and Bidder's Standard Terms of Sale (Articles 1-12) as presented in Bidder's Bid Proposal No. M08-222 dated August 5, 2008 which must form a binding part of any resulting contract and shall govern in the event of conflicting language on any resulting contract or any other documents or attachments relating to the order. In the event Owner should have any questions regarding our terms, we will be happy to discuss any portion of them with you in efforts to reach a mutually agreeable set of terms and conditions.

# St. Lucie West Services District

## Board Agenda Item Tuesday, August 19, 2008

### Item

**DM 4 Approval of the 16" Fiberglass Raw Water Line Replacement at the Water Treatment Facility; Project No. SW037**

### Summary

Provided for your review and consideration is the 16" fiberglass raw water supply line replacement. On July 4, 2008 the 16" fiberglass raw water supply line developed a leak at a tee. There is no way to isolate this section of pipe to perform a permanent repair. I requested a quote from Custom Welding who was the low bidder on the 16" stainless steel air header project at the WWTP. He said the stainless steel price has not gone up and he can get the materials delivered and fabricated in 3 ½ weeks. The quote for the fiberglass pipe to be replaced with stainless steel is \$24,990.00 and we received a quote from Armadillo Dirt Works to take out the fiberglass line and replace it with the stainless steel for \$5,800.00. The pipe would be replaced overnight and back in service for the normal startup time. We received a quote to change the line out in PVC which is about \$8,000 less but the glue fittings require 24 hour cure time and with PVC there would be more joints that could allow future leaks. We meet with CPH Engineers and they agree with us that for a long term fix the stainless steel would be the better way to go. Attached is a drawing supplied by Custom Welding of the pipe replacement.

This project will be funded out of the Water and Sewer Capital Improvement Program.

### Recommendation

Staff recommends approval to award the 16" fiberglass pipe replacement with stainless steel to Custom Welding for the pipe fabrication for the lump sum price of \$24,990.00 and to Armadillo Dirt Works to perform the installation of the stainless steel pipe for the lump sum price of \$5,800.00 for a total of \$30,790.00

Utilities Director Dennis Pickle District Manager John Imperato

### Budget Impact

Project Number: SW037	Available Project Budget: \$82,634.00
ORG Number: 45036100	This Project: \$30,790.00
OBJ Number: 565000	Available Balance for future Repair and Replacement Projects: \$51,844.00

### Board Action

Moved by: \_\_\_\_\_ Seconded by: \_\_\_\_\_ Action Taken: \_\_\_\_\_





**ST. LUCIE WEST  
SERVICES DISTRICT**

August 7, 2008

Gentlemen,

On July 4<sup>th</sup> the primary feed pipe from the three Floridan Aquifer wells developed a leak. This pipe is only about four years old, but, it has been problematic and has already been repaired twice. A number of engineers recommended that for the best long term results, we should replace the fiberglass pipe with stainless steel and redesign the pipe run to include an additional isolation valve. The project is split amongst two contractors, one fabricator and one installer. The cost of stainless steel pipe, welded connections and fittings is \$24,990.00. The cost of installation is \$5,800.00. With the total cost(s) hovering around \$30,000.00 I wanted to poll the Board to insure that I have your full support to sign contracts and proceed. The time between July 4<sup>th</sup> and today has been spent with fabricators looking into both stainless steel and PVC. While we could save about \$8,000.00 by using PVC, the installation time would be extended because of the 24 hour curing requirements of the glued joints, and the reliability and life cycle would be less than that of stainless steel. I would appreciate either a phone call, e-mail or fax indicating your approval.

If you have any questions please call Dennis Pickle.

Thank You!

John



**ST. LUCIE WEST  
SERVICES DISTRICT**

**Memorandum**

**TO: John Imperato**  
**FROM: Dennis Pickle**  
**DATE: Thursday, August 7, 2008**  
**SUBJECT: Emergency 16" Fiberglass Raw Water Line Replacement**

---

John,

On July 4, 2008 the 16" fiberglass raw water supply line developed a leak at a tee. There is no way to isolate this section of pipe to perform a permanent repair. I requested a quote from Custom Welding who was the low bidder on the 16" stainless steel air header project at the WWTP. He said the stainless steel price has not gone up and he can get the materials delivered and fabricated in 3 ½ weeks. The quote for the fiberglass pipe to be replaced with stainless steel is \$24,990.00 and we received a quote from Armadillo Dirt Works to take out the fiberglass line and replace it with the stainless steel for \$5,800.00. The pipe would be replaced overnight and back in service for the normal startup time. We received a quote to change the line out in PVC which is about \$8,000 less but the glue fittings require 24 hour cure time and with PVC there would be more joints that could allow future leaks. We meet with CPH Engineers and they agree with us that for a long term fix the stainless steel would be the better way to go. Attached is a drawing supplied by Custom Welding of the pipe replacement.

If this meets with your approval I would like to order the materials as soon as possible.

*From the desk of Dennis Pickle, Utilities Director*  
450 S.W. Utility Drive • Port St Lucie, FL 34986 • Office (772) 340-0220 • Fax (772) 340-3773

2-weeks material  
1/2 weeks FAB.

ALL 316 Stainless steel SCH 10

Measurements are approximate  
Custom Welding will Shute Erections

Arthur-Dennis

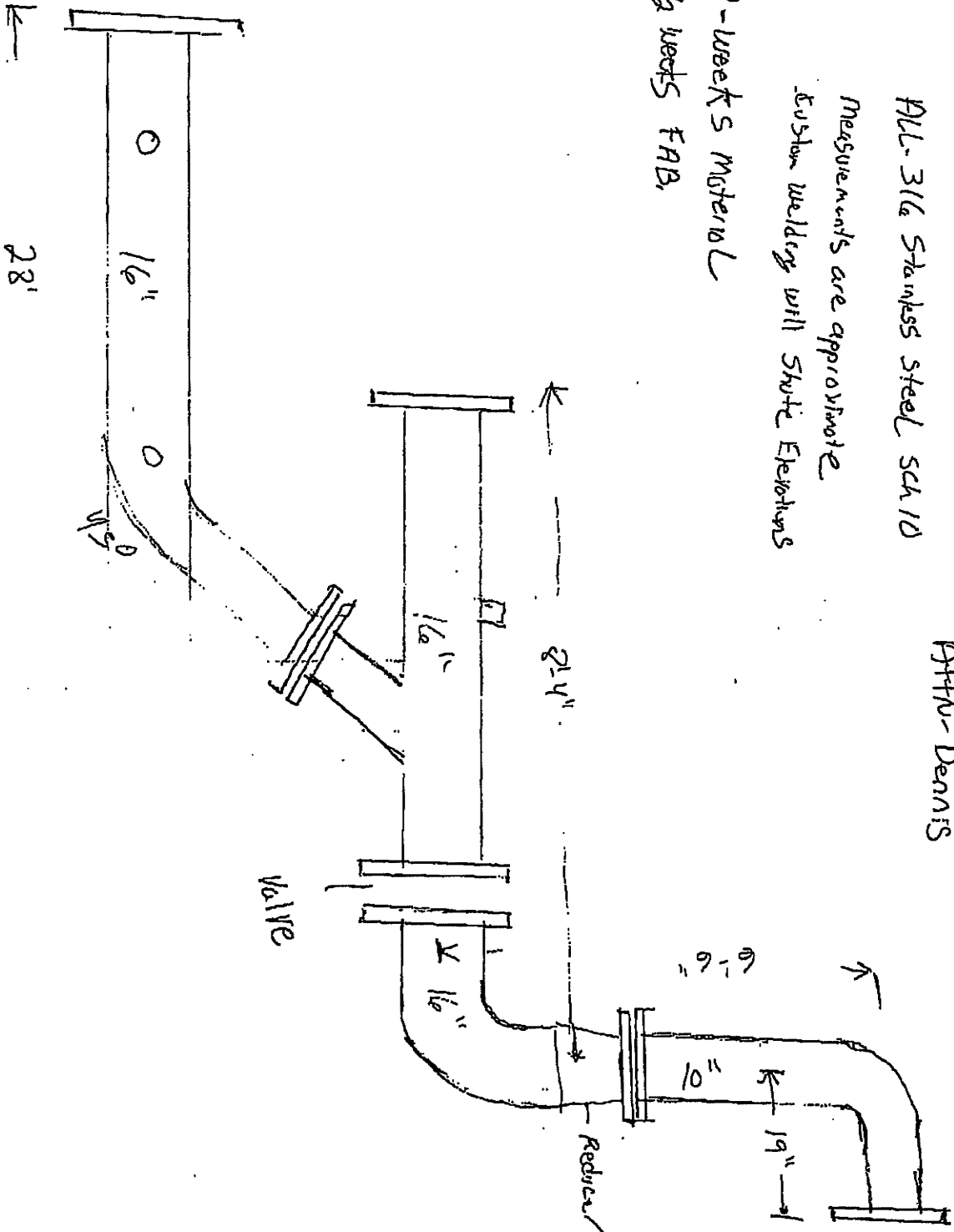

2008-2778 Fax



*Custom Welding Diversified, Inc.*  
 1983 SW Biltmore St.  
 Port St. Lucie, FL 34984  
 772-879-6928 Fax 772-879-6390

**Estimate**

Date	Estimate #
8/7/2008	2140

<i>Name / Address</i>
St. Lucie West Service District 450 SW Utility Dr. Port St. Lucie, FL 34986

P.O. No.	Project/Job	Contract #

Item	Description	Qty	Cost	Total
Misc. Materi...	16" x 3/4" slip on flange	6	0.00	0.00
Misc. Materi...	16" x 90 degree	2	0.00	0.00
Misc. Materi...	weld on couplings	3	0.00	0.00
Misc. Materi...	10" x 1/2" slip on flange	3	0.00	0.00
Misc. Materi...	10" x 90 degree	1	0.00	0.00
Misc. Materi...	10" sch 10 pipe	1	0.00	0.00
Misc. Materi...	16" sch 10 pipe	2	0.00	0.00
Misc. Materi...	16" sch 10 tee	1	0.00	0.00
Misc. Materi...	16" to 10" reducer	1	0.00	0.00
Fabricate	Fabricate and weld all the above using 316 stainless steel. This price is for the inside #2 section 2-weeks for material and 1-1/2 weeks fabrication	1	24,990.00	24,990.00

This quote is good for 15 days

Please sign and fax back if you are in agreement with this estimate.

Signature \_\_\_\_\_

Subtotal	\$24,990.00
Sales Tax (0.0%)	\$0.00
<b>Total</b>	<b>\$24,990.00</b>

## PROPOSAL & CONTRACT

### R/O WATER PLANT 16 INCH WATER LINE REPLACEMENT

Contact: Patrick Paparella

Submitted to:

ST LUCIE WEST SERVICES DIST.

DATE:

8/7/2008

Address:

450 SW UTILITY DR  
PORT ST LUCIE FL 34986

PHONE :

772-340-0220

FAX:

772-340-3773

JOB NAME:

WATER LINE  
REPLACEMENT

Contact: DENNIS PICKLE

JOB LOCATION:

ST LUCIE WEST

DESCRIPTION	QTY	UNIT	AMOUNT
PROVIDE LABOR & EQUIPMENT TO REPLACE EXISTING 16 INCH FIBERGLASS WATER LINE. AND ADD 16 INCH VALVE TO EXISTING SYSTEM TO ALLOW FOR ISOLATION OF EACH PUMP			
NOTE: QUOTE IS BASED ON REMOVAL OF EXISTING LINE AND INSTALL OF NEW MATERIALS IN QUOTE # 2132	1	LS	\$ 5,800.00
<b>GRAND TOTAL</b>			<b>\$ 5,800.00</b>

**NOTES:**

- 1) Items not specifically included are excluded , subject to negotiation and clarification.
- 2) Excludes asbuilts.
- 3 ) Excludes relocation of any existing utilities that may conflict with proposed work.
- 4 ) Excludes cost for any materials.
- 5 ) Excludes retrofitting aluminum walkway to accommodate new piping.
- 6 ) Excludes all permit fees.
- 7) This proposal is valid for 30 days and void thereafter at the option of ArmadilloDirt Works LLC.

SUBMITTED BY:

ACCEPTED BY:

\_\_\_\_\_  
PATRICK J. PAPARELLA

DATE: \_\_\_\_\_

\_\_\_\_\_  
DATE: \_\_\_\_\_

# St. Lucie West Services District

## Board Agenda Item Tuesday, August 19, 2008

### Item

### DM 5 Monthly Report on Public Works Operations

#### Summary

This report is provided for your review and information as an update on the monthly Public Works operations.

#### Irrigation

- The irrigation system is running better, but at night we continue to experience low pressure due to commercial properties running their irrigation after 2:00am.
- We are still at times having problems with the filters at Lake Ernie and Lake Charles.
- Irrigation complaints are down.
- Completed locates for I.Q.

#### Lakes

- In the first couple of weeks the lakes have come up and slowly are going down. We are still transferring water for irrigation.

#### Preserves

- The preserves crew is working in Lake Forest and will continue in that area for a few weeks. Next location will be Lake Forest Pointe.

#### Aquatic

- Continuing to spray when weather permits
- Lakes came up the first few weeks of July due to the rainfall.
- The harvester is busy with tape grass and once again the warm weather is causing the tape grass to shed in the lakes that are known to be issues.
- The warm weather is creating lots of algae blooms. We are spraying for algae when weather is optimal for the application.
- The summer hours are working out very well for the Aquatic team.
- Ditches and canals have all been sprayed and maintained for the hurricane season. Continue to spray if need arises.

#### Maintenance

- The maintenance team continues mowing, edging, trimming, and weed eating, and picking up the garbage along the following areas: lift stations, pump stations, lake banks, and control gates, around SLW signs and I-95, wells, SLWSD compound, ditches, and canals.

#### Additional Comments:

- We have received many phone calls in regards to:
  - Preserves Team is doing a very good job cleaning out the pepper trees.
  - Aquatic Team is doing a very good job and the lakes are looking much better.
  - Irrigation Team has received comments that the IQ is running much better and the water is cleaner.

These words of acknowledgement have been passed along to each of the teams and expressed my gratitude for a job well done.

# *St. Lucie West Services District*

**Board Agenda Item**  
**Tuesday, August 19, 2008**

## **Item**

---

**DM 6      Monthly Report on Utilities Operations**

---

## **Summary**

---

This report is provided for your review and information as an update on the day-to-day Utilities operations of the St. Lucie West Services District, and will be provided once a month.



# St. Lucie West Services District Monthly Utilities Operations Report

July 2008

## St. Lucie West Services District Board Agenda Item Tuesday, August 19, 2008

Summary

ERC Water/Wastewater Update

### WATER

Total Plant Capacity Based on 3.4 MGD	13,600.00	ERC's (Factor 250 gpd)
Sold prior to February 2008 including the Reserve	10,032.00	ERC's
The Reserve Commitment for 2007	1,000.00	ERC's
Available ERC's as of June 2008	3,568.00	ERC's
Sold in FY 2007-2008 (see water table below)	7.95	ERC's
<b>Total Remaining Capacity for Water</b>	<b>3,560.05</b>	

WATER	RESIDENTIAL	COMMERCIAL	THE RESERVE & PREVIOUS COMMITMENTS	WATER FEES COLLECTED
ERC's sold in Oct-07	1	0		\$ 2,100.00
ERC's sold in Nov-07	0	0	163.16	\$ 185,122.07
ERC's sold in Dec-07	0	1		\$ 2,595.00
ERC's sold in Jan-08	0	0	6.03	\$ 16,147.69
ERC's sold in Feb-08	1	0		\$ 2,600.50
ERC's sold in Mar-08	0	0		\$ 500.00
ERC's sold in Apr-08	0	3.75		\$ 10,228.70
ERC's sold in May-08	1	3.2		\$ 11,056.00
ERC's sold in Jun-08	0	0		\$ -
ERC's sold in Jul-08	0	0		\$ -
ERC's sold in Aug-08				
ERC's sold in Sep-08				
<b>Total ERC's sold since Oct 2007 - May 2008</b>	<b>3</b>	<b>7.95</b>	<b>169.19</b>	<b>\$ 230,349.96</b>

### WASTEWATER

Total Plant Capacity Based on 2.0 MGD	10,000.00	ERC's (Factor 200 gpd)
Sold prior to February 2008 including the Reserve	10,014.00	ERC's
The Reserve Commitment for 2007	900.00	ERC's
Available ERC's as of June 2008	-14.00	ERC's
Sold in FY 2007-2008 (see wastewater table below)	9.35	ERC's
<b>Total Remaining Capacity for Wastewater</b>	<b>-23.35</b>	

WASTEWATER	RESIDENTIAL	COMMERCIAL	THE RESERVE & PREVIOUS COMMITMENTS	WASTEWATER FEES COLLECTED
ERC's sold in Oct-07	1	0		\$ 2,000.00
ERC's sold in Nov-07	0	0	163.16	\$ 164,220.05
ERC's sold in Dec-07	0	1		\$ 2,000.00
ERC's sold in Jan-08	0	0	7.54	\$ 15,570.00
ERC's sold in Feb-08	1	0		\$ 2,500.50
ERC's sold in Mar-08	0	0		\$ 500.00
ERC's sold in Apr-08	0	4.85		\$ 9,215.70
ERC's sold in May-08	1	3.5		\$ 9,652.00
ERC's sold in Jun-08	0	0		\$ -
ERC's sold in Jul-08	0	0		\$ -
ERC's sold in Aug-08				
ERC's sold in Sep-08				
<b>Total ERC's sold since Oct 2007 - May 2008</b>	<b>3</b>	<b>9.35</b>	<b>170.7</b>	<b>\$ 205,658.25</b>

# St. Lucie West Services District Monthly Utilities Operations Report

July 2008

## Water Treatment Facility

- Total finished water produced for July was 40.584 mg
- The finished water produced for the previous twelve months was 535.219 mg
- The average daily flow of finished water for July was 1.309 mg
- The annual average daily flow of finished water for July was 1.46 mg
- The three month average daily flow of finished water for July was 1.44 mg
- The Water Plant is operating at 38.6% of treatment capacity and 79.6% of Annual withdrawal capacity per SFWMD WUP

## Water Treatment Plant Projects for July:

- Odessey Manufacturing worked on the liquid chlorine conversion at the WTP
- The 16" fiberglass raw water pipe developed a leak, performed a temporary patch.

## Wastewater Treatment Facility

- Total Influent Wastewater flow for July was 40.44 mg
- Total Effluent Wastewater flow for July was 33.81 mg
- The average daily flow of Influent Wastewater for July was 1.30 mg
- The average daily flow of Effluent Wastewater for July was 1.09 mg
- The annual average daily flow of Influent treated for July was 1.281 mg
- The three month average daily flow of Influent treated for July was 1.165 mg
- The Wastewater Plant is operating at 58.3% of rated capacity

## Wastewater Treatment Plant Projects for July:

- ICI started preliminary design for SCADA at WWTP
- Odessey Manufacturing worked on the liquid chlorine conversion at the WWTP
- Started erecting the 16" S.S. Air Header
- Clarifier #2 repainted by contractor under warranty
- Completed 90% of the RAS pump project

## Underground Utilities Field Work

### Locates

Sunlight Church, Lake Charles Blvd., Harbor Isles Cir., Grand Reserve Blvd. & Piedmont, All of University Dr., Bentley Circle, California & University Dr., Mockingbird Dr. & Mockingbird Cir., Sanctuary Dr., Flamingo & Country Club, 950 Palmetto Court, Osprey Court, Bethany & Utility Dr., Horseshoe Bay Lake Charles.

Reading meters, work orders, turn ons, check for leaks, replace broken meter boxes and lids, inspect lift station, change out meters & lock offs

- Repaired 8" potable water leak at the Bedford's.
- Repaired potable water leak at 477 Casanova Cir. in Kings Isle.
- Repaired potable water leak at 460 Casanova Cir. in Kings Isle.
- Repaired potable water leak at 869 Piedmont in Vinyard's.
- Repaired potable water leak at 307 Sycamore in Heatherwood.
- Repaired potable water leak at 562 Lambrusco in Kings Isle.
- Repaired potable water leak at 307 Sycamore in Heatherwood.
- Repaired potable water leak at 211 & 212 Minstril Ct. in Cascades.
- Repaired potable water leak at 1080 Country Club Dr.
- Repaired potable water leak at 1101 Lombardy in Kings Isle.
- Repaired potable water leak at 571 New Castle in Lake Charles.
- Repaired potable water leak at Baycrest in Magnolia Lakes.
- Repaired potable water leak at 1051 Bentley in Bedford's.
- Repaired potable water leak at 421 Fairway Landings in Fairway Isle.
- Cleanout sewer line at 1333 Cedar Cir.
- Repair fire hydrant in Fairway Isle.
- Rotated fire hydrant 180 degree for Sunlight Church
- Perform training for emergency generators to lift stations.
- Assisted in a 2" tap for WTP for pressure system.
- Lombardy LS #41 20 year old ABS pump stopped working.
- Continued flushing program.

### Lift Stations Cleaned

LS# 35 Walmart, LS# 36 Rave, LS# 28 Belmont, LS# 47 Grandville, LS# 23 The Club, LS# 1 Bank of America, LS# 16 New Castle, LS# 17 Romona Bay, LS# 7 Heatherwood Blvd., LS# 11 Lake Forest Club House.

St. Lucie West Services District  
Water & Wastewater Average Daily Flows

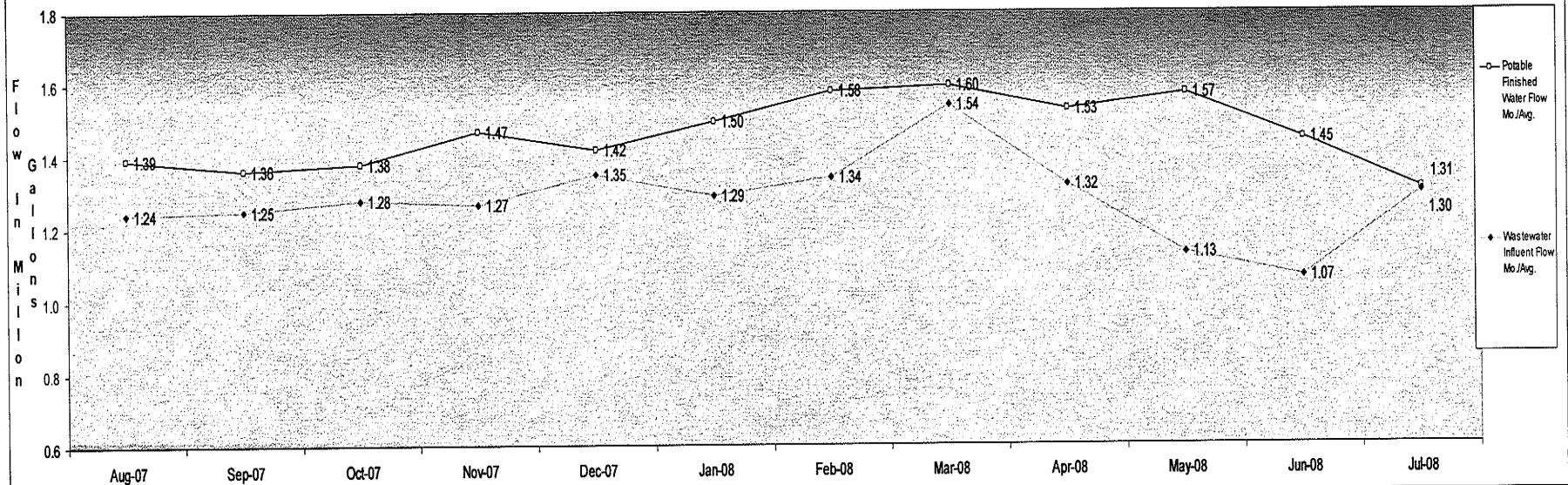

St. Lucie West Services District  
Water & Wastewater Monthly Total Flows

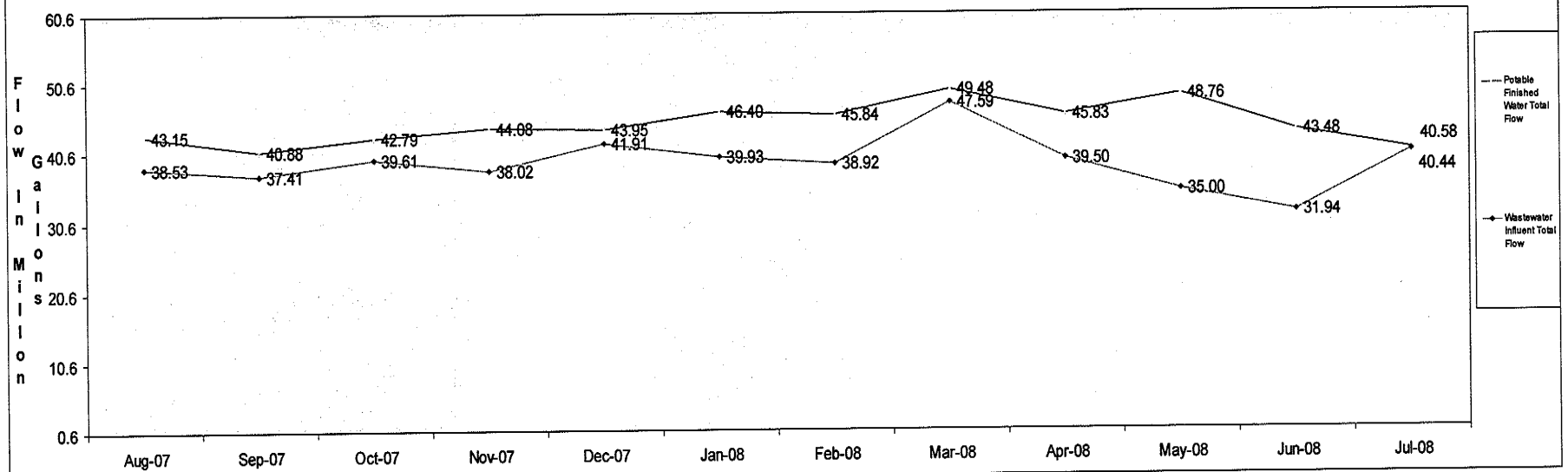

**St. Lucie West Services District  
Water & Wastewater Percent Capacity**

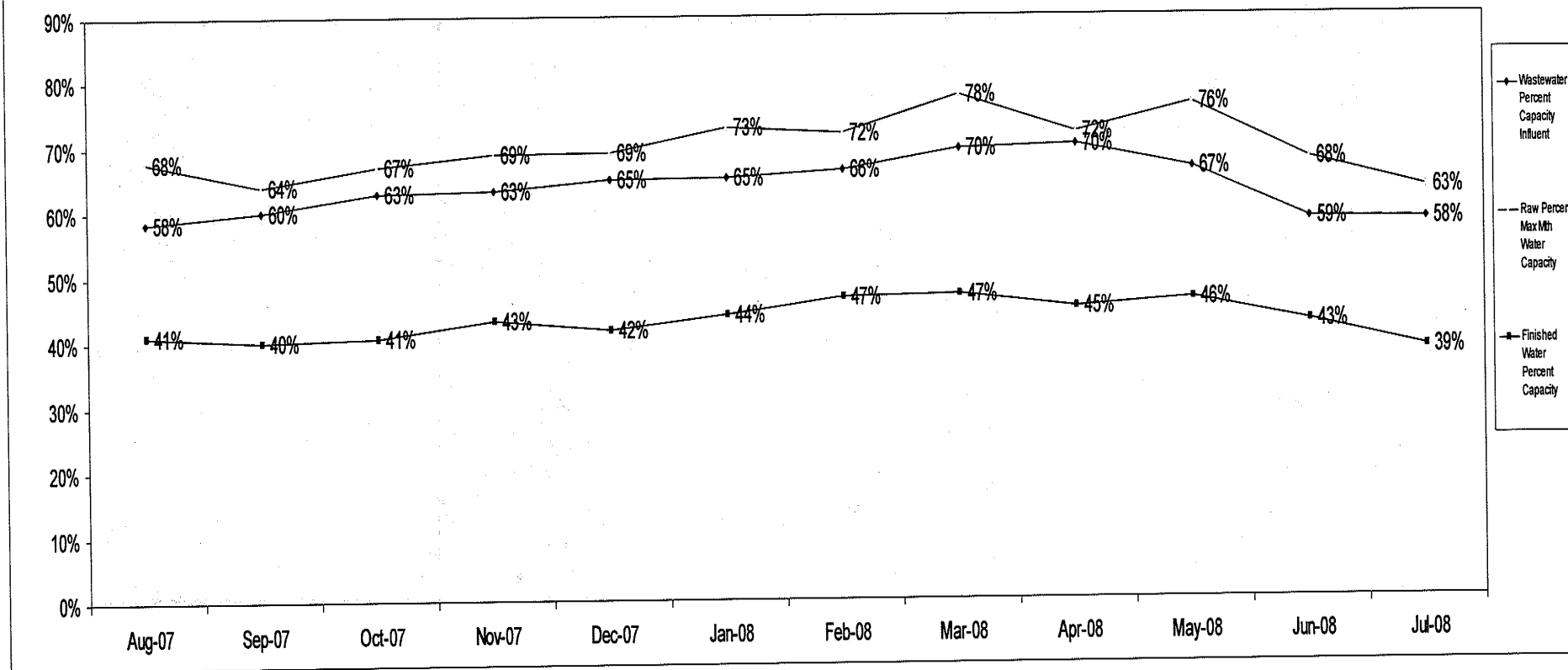

# *St. Lucie West Services District*

## **Board Agenda Item**

**Tuesday, August 19, 2008**

### **Item**

---

**DM 7      Monthly Report on Capital Improvement Projects**

---

### **Summary**

---

This report is provided for your review and information as an update on the Capital Improvement Projects for the St. Lucie West Services District, and will be provided once a month.

CPH 100 % Preliminary Design Report for the re-commission of the 2 mg water tank project # SW043

CPH 100% Design Report for the Surge Tank Rehab at the Wastewater Treatment Plant, project # SW008

Odyssey Manufacturing performed the start up of the liquid chlorine conversion for the WWTP

Started erecting the 16" S.S. air header at the WWTP

No other new projects started this month.



# St. Lucie West Services District

## Board Agenda Item Tuesday, August 19, 2008

### Item

---

### DM 8      Monthly Reports on Billing and Customer Service

---

### Summary

---

This report is provided for your review and information as an update on the monthly Billing and Customer Service Operations.

The following are the totals from the accounts receivable reports for the July billing cycle.

1. Actual Consumption

Sewer	33,745,480mg
Water	34,804,627.78mg
2. Billing

Total water	6,544
Total sewer	6,475
Total irrigation	6,259
3. Revenue

Total water	\$ 215,445.72
Total sewer	\$ 240,537.57
Total irrigation	\$ 126,769.67

Reports are attached.



**Actual Consumption  
July 2008**

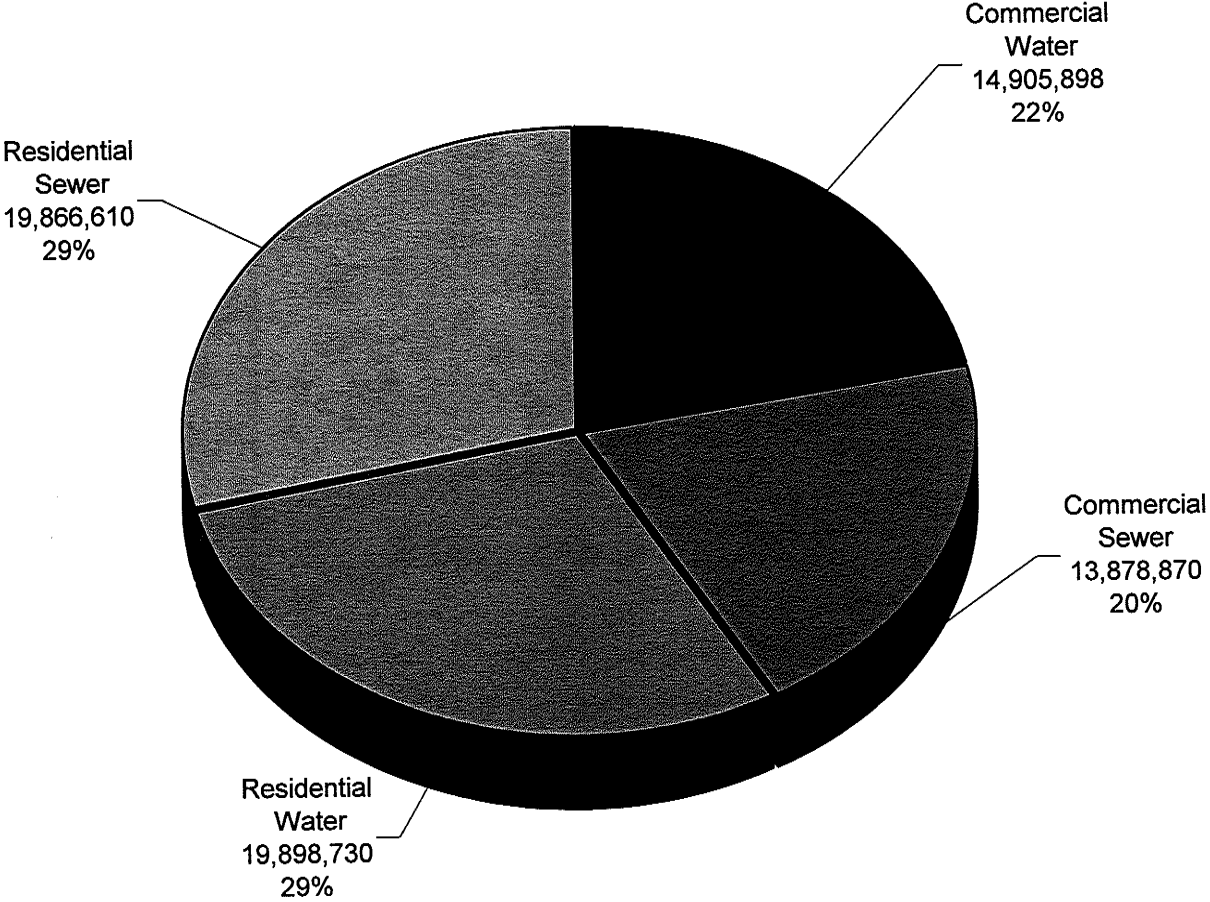

**Billing Revenue  
July 2008  
Commercial Revenue \$168,698.96**

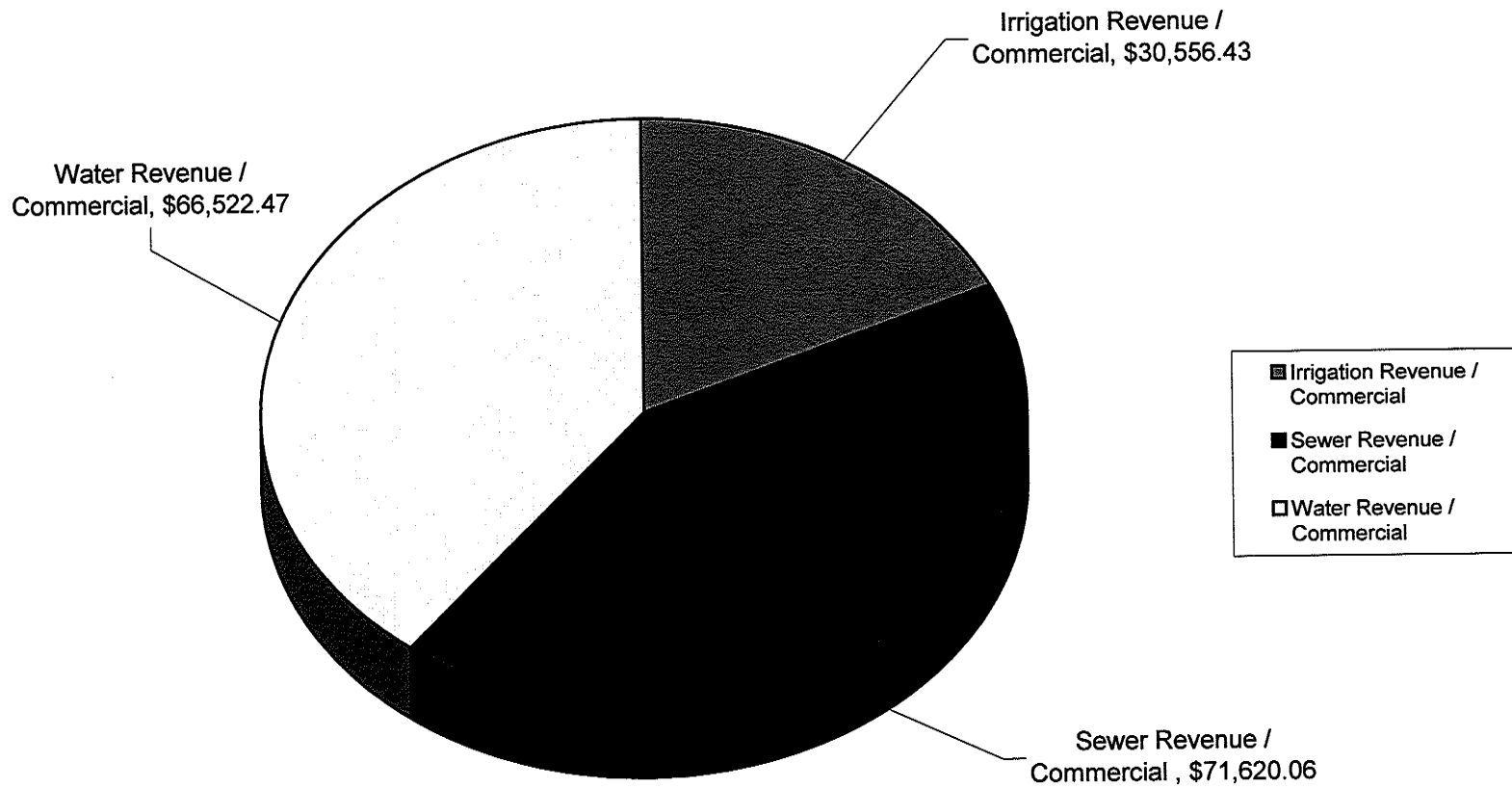

**Billing Revenue  
July 2008  
Residential Revenue \$407,795.00**

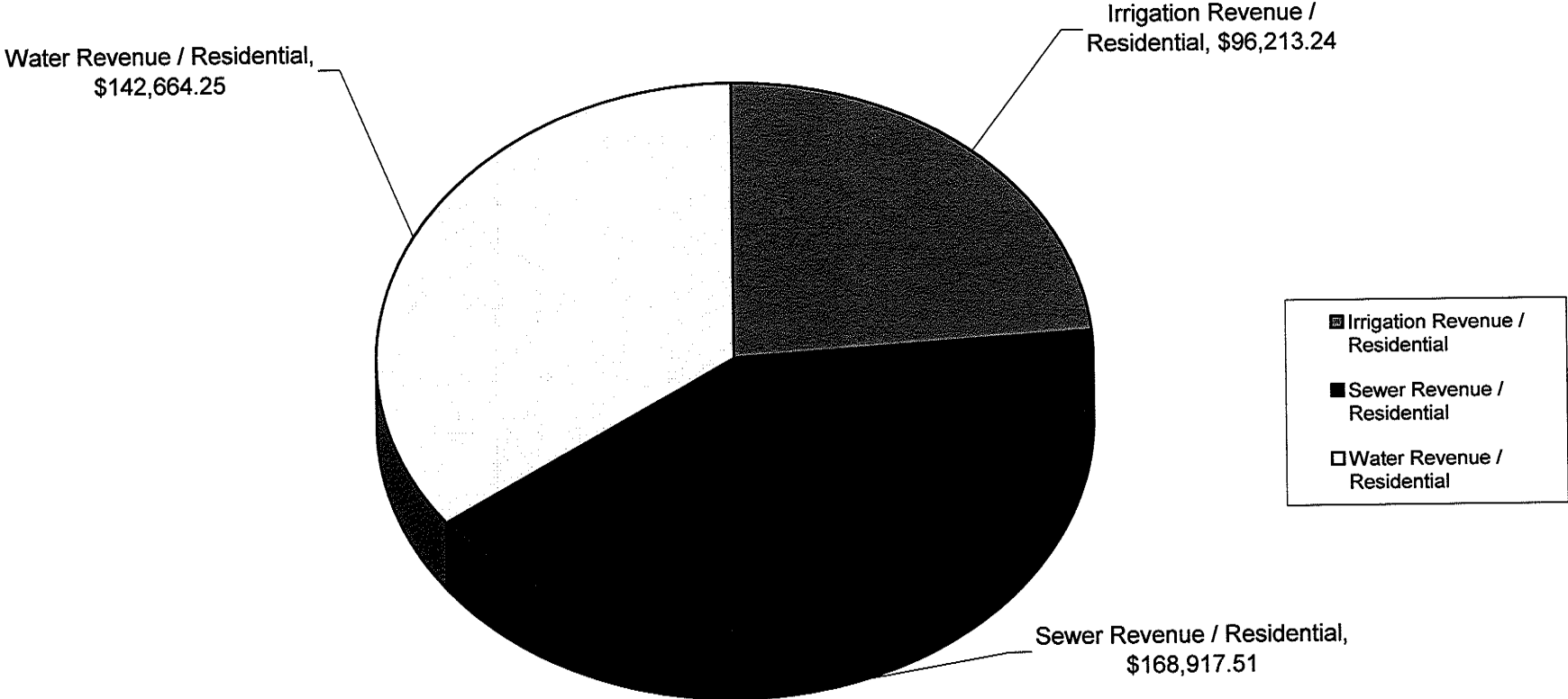

Revenue Class Billing Count  
July 2008

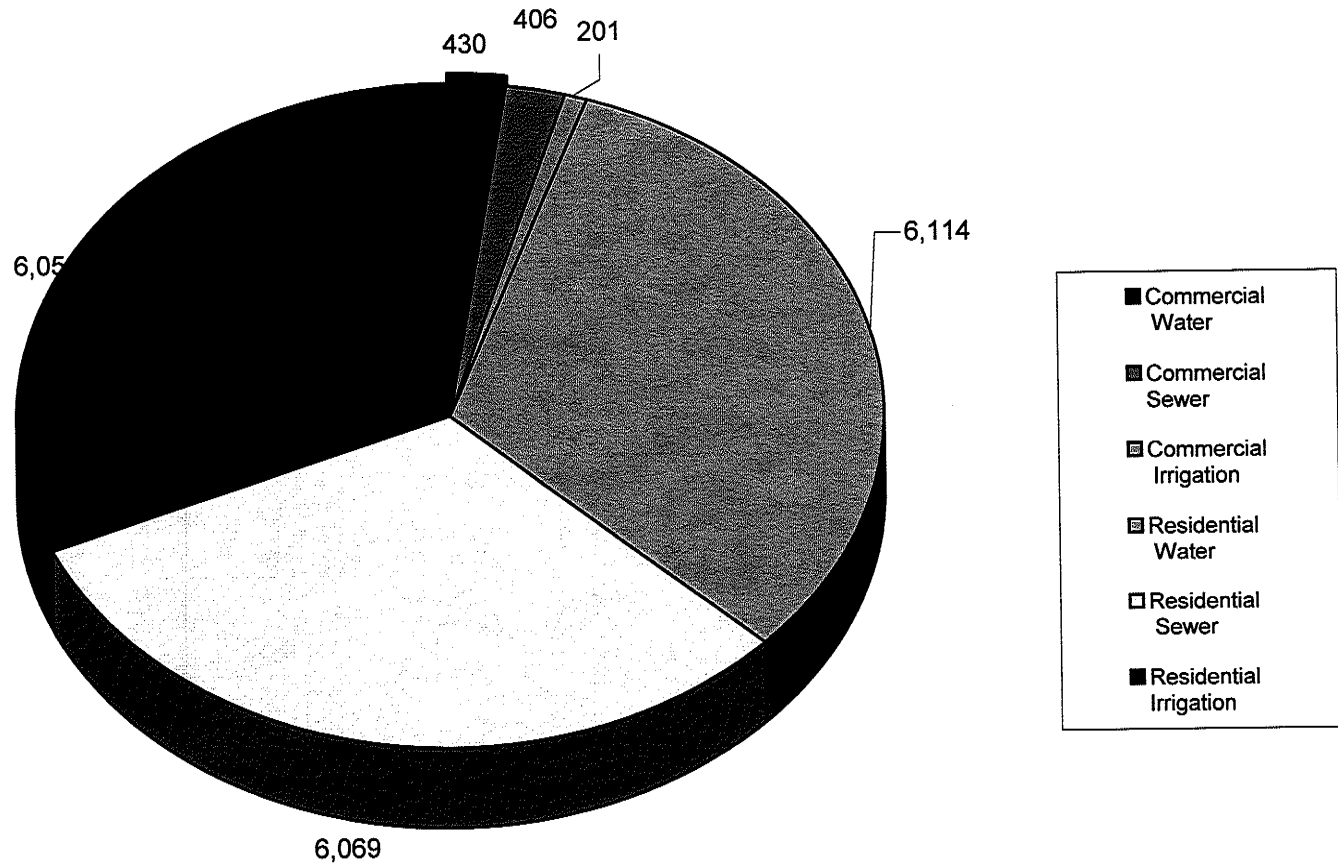

# St. Lucie West Services District

## Board Agenda Item Tuesday, August 19, 2008

### Item

---

### DM 9 Other Items/Updates

---

### Summary

---

- Board Member Conduct, Responsibility, and Authority Section 13 (d) (iii)  
Amendment I to Chapter A - II of the Rules of the St. Lucie West Services District, relative to its rules of the Board of Supervisors (approved 2-26-06)  
"Individual members of the Board shall direct to the District Manager or designee, the District Engineer, or the District Counsel all questions and concerns relating District Operations. Any member of the Board desiring to discuss matters of District operations with any District employee, contractor, or subcontractor shall coordinate such discussion with the District Manager or designee."
- Invoice from District Manager
- Administrative Services Activity
- CUSI Server Status
- Election Results
- Main Well Feed Pipe at Water Treatment Plant
- Emergency Readiness Committee meeting at Lake Forest
- Greg Vaday meeting (C. Altwein)
- City of Port St. Lucie meeting (H. Cutler)
- Status of Assessment Rolls
- Change to Monday Teleconference schedule from 52 times a year to 24 times a year.

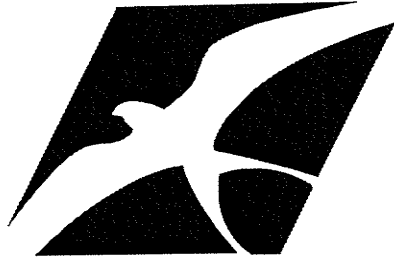

*ST LUCIE WEST*  
SERVICES DISTRICT

**X**

**SUPERVISORS' REQUESTS**



*ST LUCIE WEST*  
SERVICES DISTRICT

**XI**

**MINUTES**

# **St. Lucie West Services District**

## **Board of Supervisors Meeting Minutes**

**July 15, 2008 at 9:00 a.m.**

**Sunlight Community Church**

**477 S.W. Cashmere Boulevard, Port St. Lucie, Florida 34986**

**(Please note: This is not verbatim, a CD recording of the board meeting is available on file)**

### **Board Members Present**

Charles B. Altwein, Chairman  
Everett Child, Vice-Chairman  
Sal Mancuso, Supervisor  
Harvey Cutler, Supervisor

### **Board Members Present**

George Hyde, Supervisor

### **Staff Present**

John Imperato, District Manager, St. Lucie West Services District ("SLWSD")  
Bill Hayden, Public Works Director/ Assistant District Manager, SLWSD  
Dennis Pickle, Utility Director/Assistant District Manager, SLWSD  
Maddie Maldonado, Administrative Assistant, SLWSD  
Carol Rogers, District Treasurer, Government Services Group, Inc. ("GSG")  
Heidi Snyder, Assistant District Treasurer, GSG  
Tabitha Wilmot, Accounting Clerk, GSG

### **Guests Present**

(See Sign-In Sheet Attached)

### **I - Call to Order**

Chairman Altwein called the meeting to order at 9:00 a.m.

### **II - Pledge of Allegiance**

### **III - Invocation**

### **IV - Roll Call**

Chairman Altwein noted that George Hyde was not present due to an excused absence.

### **V - Public Comment**

The Chairman requested that public comments be heard prior to the budget workshop in order to move quickly through the regular meeting agenda.



## VI – Finance

### Financial Statements for June 2008

Mrs. Snyder presented the financial reports for June 2008.

Supervisor Cutler asked if the District received any impact based on the current economic situation. Mr. Imperato stated yes; there has been a revenue shortfall in water and waste water based on the bankruptcies and foreclosures where the District can not collect.

Supervisor Mancuso referred to page 1 of 17 and page 6 of 17, and asked if the numbers in the FY 2007 Prior Year Column represent actual or estimate dollars. He stated that whichever is correct it should be noted as such and represent actual for the General and Water & Sewer Funds. Mr. Imperato requested Finance staff to make the change requested. Supervisor Mancuso questioned on page 9 of 17 why the District reimbursed Enclave \$7,437.72 on June 27<sup>th</sup>. Ms. Snyder clarified that the transaction was for a retainage release that was approved by the Board at the June 17<sup>th</sup> meeting.

Chairman Altwein questioned the payment to John Whitmer on page 8 of 17. Mr. Imperato stated it was put on as a reminder; the payment to Mr. Whitmer was approved by the Board.

### Approval to Transfer Funds for June Requisitions

Ms. Snyder presented item FA-2 and noted that all invoices related to the requisitions are included in the agenda packet. Ms. Snyder recommended the Board's approval to transfer funds from the Wastewater Connection Fee Fund for \$8,658.50 and the R&R account for \$70,067.46 to the Public Fund Checking account for reimbursement for payments made that have been budgeted to be funded by these accounts.

**Vice-Chairman Child so moved to approve the transfer of funds from the Wastewater Connection Fee Fund for \$8,658.50 and the R&R account for \$70,067.46 to the Public Fund Checking account. Supervisor Mancuso seconded the motion.** Supervisor Mancuso requested the clarification of the Public Fund Checking account is the same as the Water & Sewer Fund. Ms. Snyder agreed. **Approved 4-0.**

### FY 2008 Audit Engagement Letter

Ms. Snyder presented item FA-3, for the approval of James Moore & Co. to perform the FY 2008 Audit as required per Florida Statutes. Ms. Snyder noted that the total fee to perform the Audit is an all inclusive amount of \$34,949; however, there is a deduction of \$3,412 if no Federal or State single audit is required for a total audit price of \$31,537. Ms. Snyder also noted that the letter explains an increase of approximately 15% due to additional work that is now required due to new auditing standards. Ms. Snyder stated that this would be James Moore & Co.'s fourth year of doing the District's audit. Ms. Snyder recommended the Board's approval for the Chairman to sign the engagement letter.

**Supervisor Mancuso so moved to approve the engagement letter with James, Moore & Co. to perform the FY 2008 Audit. Vice-Chairman Child seconded the motion. Approved 4-0.**

## VII – District Manager

### Monthly Report on Public Works Operations

Chairman Altwein stated that the system seems to be running better; however he was concerned with commercial irrigation. Mr. Hayden stated that previously the time clocks were staged; however, some customers are resetting their timers. Mr. Hayden stated when they are running illegally; the District issues a penalty. Chairman Altwein requested a letter be sent to them to advise that it is St. Lucie West Services District Meeting Minutes July 15, 2008

their responsibility to ensure the timers are correct and if not they will be subjected to a penalty. Mr. Hayden agreed. Mr. Imperato suggested a reminder be placed on the back of the bills to all customers.

Supervisor Mancuso questioned if it is part the procedures to inform customers that if any movement of the timers are due to be penalized and if all homeowners associations are made aware. Mr. Hayden stated that it is in the tariff. Mr. Imperato noted that the first occurrence receives a warning and the second time is a \$50 penalty and the District has been advised by Mr. Harrell for some legal purpose not to call it a fine but to call it a penalty.

### **Monthly Report on Utilities Operations**

Chairman Altwein asked if the District is going to move forward with another 200,000 gallon tank. Mr. Imperato stated that it is work underway. Mr. Pickle stated that it is close to 90% complete and staff is currently in the stage of getting permits with the Department of Environmental Protection (DEP), which should be to the District to sign and submit to DEP with a \$300 to \$500 fee. Mr. Pickle stated that the bid will be out this fiscal year so that the money will be spent from this fiscal year's budget. Mr. Pickle noted that the completion of the tank installation should be in approximately six months.

Supervisor Mancuso commented that he received a letter from a resident yesterday regarding the use of the District's hydrants for pressure cleaning without permission from the District. Supervisor Mancuso stated that it would make everyone happy if a letter was sent out from the District to all the homeowner associations that under no circumstances will any person be allowed to remove water from the fire hydrants to refill their tanks or for pressure cleaning without authorization from the District. Discussion ensued. Chairman Altwein stated that this has been done and noted that there is an issue between the president of the association and one of their members; which the District should not be involved. Mr. Imperato requested Ms. Maldonado send an email to all HOA Presidents advising them of the District's process and procedure on usage of fire hydrants. Supervisor Mancuso requested a copy of the letter to be sent to him. Mr. Imperato stated that all Supervisors will be copied on the email and Supervisor Mancuso will be sent a fax.

### **Monthly Report on Capital Improvement Projects**

Supervisor Mancuso asked when the District plans to start the telemetry system and what stations will be selected to install the telemetry positions. Mr. Imperato stated that there will be phases to the project. Mr. Imperato noted that Phase 1 is to get the 220 mega hertz radio system up and running. Mr. Pickle stated that the bid should be out in less than two weeks, as the attorneys were reviewing the bid documents and their comments were received late yesterday afternoon. Mr. Pickle stated that he will be going over the comments with Brian Callahan. Mr. Pickle stated that there will be many projects coming before the Board in September.

Supervisor Mancuso requested that the District consider lift stations in commercial areas for the installation of telemetry positions because they are out of the way, not normally within public audible range or in the range of homeowners. Mr. Imperato stated that he agrees with Supervisor Mancuso and noted that the utility staff will get back with the high priority stations first.

### **Monthly Report on Billing and Customer Service**

Supervisor Cutler commented on a concern with the percentages of consumption versus with the assigned ERCs on residential and commercial accounts. Mr. Pickle stated that the actual consumption is lower than what the allocated ERCs are. Mr. Pickle noted that it is hard to break down residential and commercial as far as ERCs each month. Discussion ensued. Mr. Imperato provided a document to the Board showing the commercial ERCs which was created by Mr. Pickle.

Mr. Imperato stated that the biggest problem with ERCs is the commercial accounts. Mr. Imperato stated that every commercial property is defined with what they paid initially and Mr. Pickle has a chart of their usage. If there is a discrepancy between the payment that was made and the actual usage as being done with the Outdoor Resorts, each account will go down systematically. The account will be analyzed, if it is exceeding by more than 2 ERCs or 5%, which per the tariff the District is entitled to proceed to get the funds for the additional ERCs.

Supervisor Mancuso commented that in the ERCs Policy, he does not want to confuse ERCs with impact fees.

### **Other Items/Updates**

Mr. Imperato stated that he received an email regarding the Calvary Church, which states that the District has satisfied the church, the engineering company that shares the building with them and the only person that has not been satisfied at this point is the building owner (who rents the space to the church). Mr. Imperato stated that he believes the amount was approximately \$130,000 and the cap is \$100,000. Mr. Imperato stated that the District has received a letter from the property owner's attorney, which he and Mr. Harrell reviewed and replied to. Mr. Imperato noted that he does not believe that they have filed a claim against FP&L, because it was caused by a power outage.

Mr. Hayden stated that he received a letter from the Florida League of Cities, Inc. stating that the Florida Municipal Insurance Trust is pleased to announce that the District's safety grant applications have been reviewed and approved for \$1,586. Mr. Imperato commented that this is the District's first grant. Chairman Altwein stated that he and Mr. Imperato will be meeting with a member of the South Florida Regional Resource Center to tour the plant and discuss ways the District can obtain grant funds for the District. Discussion ensued. Mr. Imperato noted that Steve Spratt of GSG came to the District and met with him. Mr. Imperato stated that Mr. Spratt has agreed to contact his grant writing staff in Tallahassee to see if there is something that they can do for the District. Mr. Imperato noted that there is also a security proposal to see if Homeland Security has any funds available for the District.

### **Approval Request for Administrative Services (Walk-on Item)**

Mr. Imperato stated that per the Board's request, he provided the Board with the Request for Qualifications for Administrative Services to go out to bid. Mr. Imperato noted that it has been reviewed by Mr. Harrell and the reason it is not in the book as it was received yesterday afternoon with Mr. Harrell's comments and revisions.

**Supervisor Cutler so moved to approve that the District Manager is authorized to solicit qualifications and proposals from qualified Administrative Services Contractors and authorization of the advertisement for the publication of notice of request. Vice-Chairman Child seconded the motion.** Supervisor Mancuso requested if the District Manager would mind if he submits a firm that has proposed two times to provide these services for the District. Mr. Imperato stated that he reviewed the bids submitted years ago and as a courtesy will include them all on the mailing. **Approved 4-0.**

### **Pre-Approval of the Assessment Roll (Walk-on Item)**

Chairman Altwein read item DM-7 into the record, for the review and approval of the Non Ad Valorem Assessment Roll prepared by Mr. Robert Fromm. Chairman Altwein noted that the Cascades Benefit Assessment Bond of \$237,000 has not changed from last year. The Benefit D/S Assessment total of \$2,550,000 has been reduced this year actual/estimated collections; part of that assessment roll is the Special Assessment for Maintenance which totals \$1,060,000.

Chairman Altwein called for a motion on staff's recommendation to approve the Non Ad Valorem Pre Assessment Roll.

**Vice-Chairman Child so moved to approve the Non Ad Valorem Pre Assessment Roll. Supervisor Mancuso seconded the motion.** Mr. Imperato commented that in the course of this activity he believes Mr. Fromm has done some things over and beyond. Mr. Imperato stated that he believes it would be a fair and right gesture to make a payment of \$4,000 to Mr. Fromm as opposed to the \$3,500 that was agreed upon in the original contract. Mr. Imperato noted that one of the things Mr. Fromm did was reviewed the District's bonds and made recommendations to refinance the bonds in a 2010 timeframe, which could make a tremendous benefit in the budget. Mr. Imperato stated that Mr. Fromm pointed out that the District is probably under-collecting from "industrial condos". Mrs. Rogers stated that this is the first she has seen this item and noted that when Special Assessments are implemented in conjunction with Debt Service, the two are tied together so she is not clear about how they could reduce the amount being collected, because enough money must be collected to pay the Debt Service. Mrs. Rogers requested that the Finance staff be giving an opportunity to review this for the implications with the budget. Mrs. Rogers noted the Special Assessments are structured in order to pay the Debt Service, which is in the provisions of the Bond Issue. Mr. Imperato stated that rather than hold the process up; he would like the Board to make the approval of the motion with the provision that GSG has the opportunity to review. **Chairman restated that motion and noted that the provision that GSG has the opportunity to review to ensure it meets the bond requirements. Vice-Chairman Child and Supervisor Mancuso agreed to the provision on the motion.** Discussion ensued in regards to the District Manager's authority make payments of up to \$5,000 without Board approval. Supervisor Cutler, Vice-Chairman Child and Supervisor Mancuso stated their approval of the motion however, for the record believes the additional payment to Mr. Fromm should be brought to the Board for approval. **Approved 4-0.**

**Approval of SFWMD Permit Conversion Forms converting various SFWMD permits from Construction Phase to Operation Phase and requesting transfer of the permits into the name of St. Lucie West Services District as the operating entity (Walk-on Item)**

Mr. Imperato provided the Board with item DM-8, and noted that it is a package sponsored by the District Engineer.

**Supervisor Mancuso motioned to table item DM-8. There was no second to the motion.**

Chairman Altwein stated that the Board can not table something that they are not aware of. Supervisor Mancuso commented that is exactly his point. Chairman Altwein requested to discuss the item prior to making the decision to table.

Mr. Imperato reiterated that this item was provided by Mr. Lawson and apologized that it is an extensive item and was walked on. Mr. Imperato stated that he understands Supervisor Mancuso's concern and noted that if this item is tabled to a later meeting he will call Mr. Gallagher and attorney to apologize and place the item on a later agenda.

Supervisor Cutler stated that he does not see a reason to handle the item today. It is a simple everyday mechanical occurrence. Chairman Altwein stated that he agrees with Supervisor Cutler as this item has been discussed at previous meetings. Supervisor Cutler noted that there are no budget implications.

**Supervisor Cutler motioned to approve Item DM-8 as presented; for the Chairman of the Board to execute the SFWMD conversion forms to convert various SFWMD permits from Construction Phase to Operation Phase and transfer permits into the name of the St. Lucie West Services District. Chairman Altwein passed the gavel to the Vice-Chairman and seconded the motion.**

**Supervisor Mancuso motioned to table this item.** Chairman Altwein called Supervisor Mancuso out of order. Mr. Imperato stated that he is not a parliamentarian but believes the original motion should be voted on. Chairman Altwein stated that there is already a motion and noting his recollection of parliamentary procedure does not allow this for another motion to table after a second has been made. **Vice-Chairman Child seconded the motion to table.** The Chairman called for a vote on the motion to table the item. Discussion ensued as members of the audience commented that the original motion should be voted on. Chairman Altwein stated the motion that has precedence is the original motion and the motion to table is invalid. **Chairman Altwein declared the second motion illegal and invalid.**

Chairman Altwein called for a vote on the original motion. Vice-Chairman Child commented that he has no objection to the motion, but believes it should be handled in a much more professional and timely way. **Vice-Chairman Child stated that he hopes in the future other items that may be controversial be presented to the Board with enough time for the Board to review the item, with this said Vice-Chairman voted yes. Supervisor Mancuso stated that he abstains from voting on the motion because parliamentary procedure is not being followed.** Mr. Imperato stated that this is for a conflict of interest. Chairman Altwein requested Supervisor Mancuso to vote no; as it is required by law or refuse to vote. Supervisor Mancuso stated that he does not refuse to vote and will not vote no; he reiterated that he abstains from voting on the motion. **Supervisor Cutler voted yes. Chairman Altwein voted yes. Approved 3-0.**

Chairman Altwein requested Mr. Imperato to discuss this issue with Mr. Harrell for the documents that Supervisor Mancuso has to complete in regards to his action on the motion. Mr. Imperato agreed.

### **Approval of Budget Amendment 2008-03**

Mr. Imperato stated that he apologizes for the walk-on items and will come up with a better method of distribution. Mr. Imperato stated that SFWMD will only give approval to use the shallow wells if the District puts in monitoring. Mr. Imperato stated that there is an increase of \$47,338 in the Capital Budget for this project, which is mandate by SFWMD.

**Supervisor Cutler so moved to approve Budget Amendment 2008-03. Vice-Chairman Child seconded the motion. Approved 4-0.**

### **VIII – Supervisors’ Requests**

Vice-Chairman Child stated that he can sympathize with Mr. Imperato as far as last minute items coming up and is encouraged by his previous statement to find a more suitable way to bringing the information to the Board in a more timely fashion.

Supervisor Mancuso requested that a copy of Robert’s Rules of Order should be present at all District meetings for consultation. Supervisor Mancuso stated that he noticed in the minutes in the last meeting that Mr. Pickle has taken an interest to consolidate the District’s procedures to be compatible, in regards to ERCs, etc., with the City of Port St. Lucie. Supervisor Mancuso asked if Mr. Pickle has made a formal recommendation to the Board to consider. Mr. Pickle stated that he will have this as an item at the next meeting.

Mr. Imperato commented for the record that he has requested Ms. Maldonado to order a Robert's Rules of Order book to have at the meetings. Chairman Altwein stated that he has two and will bring one in for the meetings. Supervisor Mancuso commented that Mr. Harrell has previously presented each of the Board Supervisors with a suggestion regarding parliamentary procedure. Discussion ensued in regards to the parliamentary procedure on tabling items. Supervisor Mancuso stated that he will read the procedure at the next meeting.

Chairman Altwein asked if in the boil water processing, if it's vented in the atmosphere or can it be burned off. Mr. Pickle stated that it is vented to the atmosphere; it is treated to eliminate odors at the water and wastewater plants. Mr. Pickle stated that he has never heard of burning sulfur prior to elimination; it is typically done with chemical addition. Mr. Pickle noted that it could be something he could look at.

Chairman Altwein commented on administrative changes needed to the District's website, such as GSG is still listed as District Manager. Mr. Imperato stated that he will look into the changes on the website.

Chairman Altwein commented on his concern with the status of the Fixed Assets Inventory as it seems to have been delayed. Ms. Snyder stated that the Fixed Assets report received from Maximus was approximately twenty million dollars off of what the District's book value. There are significant items missing from their report. Ms. Snyder stated that the Maximus staff member who did the inventory is no longer working with the company and she has been having a very hard time contacting someone to assist in this matter. Ms. Snyder stated that she is trying to reconcile the records. Chairman Altwein stated that this is a project started by Charles Sweat. Ms. Snyder stated that there was an inventory performed by GSG in 2005, but the auditors required an outside agency to come in and do an annual audit of the Fixed Assets. Ms. Snyder stated that the inventory performed by GSG was completed in 2005 for the fiscal record on the books; however, the records prior to GSG were incomplete. Ms. Snyder stated that the Board hired Maximus to complete the audit of all the fixed assets the District owns; they prepared a report which was received in August 2007 and that is the report that does not reconcile with GSG's previously audited report and is twenty million dollars less than what the previous audit report has. Chairman Altwein questioned which report is going to be depended on. Mrs. Rogers stated that the report was not properly completed by Maximus and staff has been unable to get them to complete the report to reconcile. Mrs. Rogers noted that Maximus has been paid a substantial sum to prepare this work and staff is asking that they perform. Mrs. Rogers stated that it would not serve useful purpose to go out and start over because a significant amount of the work was done; Maximus just did not value the assets correctly. Ms. Snyder stated that Maximus has been paid just under \$4,000 and the total contract price is approximately \$7,650. Chairman Altwein stated that there may be some legal approach. Discussion ensued. Mrs. Rogers stated that this will be completed by the end of the Fiscal Year. Mr. Imperato stated that this has been discussed during the staff weekly conference calls and he will bring up the matter with Mr. Harrell.

## **IX - Minutes**

### **Approval of the Minutes of the July 1, 2008 Regular Meeting**

**Supervisor Cutler motioned to approve the July 1, 2008 meeting minutes. Supervisor Mancuso seconded the motion. Approved 4-0.**

## **X - Adjournment**

Hearing no objections, Chairman Altwein adjourned the meeting at 11:01 a.m.

\*\*\*\*\*

**Meeting Minutes Signature Page**

\_\_\_\_\_  
**Chairman / Vice-Chairman**

\_\_\_\_\_  
**Secretary / Assistant Secretary**

**Date Approved** \_\_\_\_\_

# St. Lucie West Services District

## Guest Sign - In Sheet

Tuesday, July 15, 2008

\*\*\*\*PLEASE PRINT\*\*\*\*

Name & Company

E-Mail Address

Phone

✓1. Dick MUSIAL (Cascades) rsmsem2@yahoo.com

✓2. MARYellen McGARRY, MARYMACIE@aol.com

3. Sue Snyder on file

4. VINCENT D'Amico on file

5.

6.

7.

8.

9.

10.

11.

12.

13.

14.

15.

16.

17.

18.

19.

20.



**St. Lucie West Services District**  
**Board of Supervisors Budget Workshop Minutes**  
**July 15, 2008**  
**Sunlight Community Church**  
**477 S.W. Cashmere Boulevard, Port St. Lucie, Florida 34986**

**(Please note: This is not verbatim, a CD recording of the board meeting is available on file)**

**Board Members Present**

Charles B. Altwein, Chairman  
Everett Child, Vice-Chairman  
Sal Mancuso, Supervisor  
Harvey Cutler, Supervisor

**Board Members Present**

George Hyde, Supervisor

**Staff Present**

John Imperato, District Manager, St. Lucie West Services District ("SLWSD")  
Bill Hayden, Public Works Director/ Assistant District Manager, SLWSD  
Dennis Pickle, Utility Director/Assistant District Manager, SLWSD  
Maddie Maldonado, Administrative Assistant, SLWSD  
Carol Rogers, District Treasurer, Government Services Group, Inc. ("GSG")  
Heidi Snyder, Assistant District Treasurer, GSG  
Tabitha Wilmot, Accounting Clerk, GSG

**Guests Present**

(See Sign-In Sheet Attached)

**I – Call to Order**

Chairman Altwein called the meeting to order at 11:15 a.m.

**II – Public Comments**

Dick Musial addressed the Board and commented in regards to an article in the Cascadian Magazine concerning a 15% increase in water charges. Mr. Musial now realizes that it is just a proposed 15% increase, which he is not against, and realizes the endeavors needed to develop a budget but was curious about it. Mr. Musial stated that he does not know how the reserve has been set up for replacements or if an outside study was done for the District in the upcoming years, but if not he strongly suggest that the District does. Mr. Musial also suggested that in the future the Board create a 1% increase rather than a walloping 15%, as it is easier on people's budget. Mr. Imperato stated that the District is currently engaged in a rate study. Mr. Imperato noted that he was disappointed with the article in the Cascadian because it was never stated that there was going to be a 15% increase.

Sue Snyder addressed the Board and asked if the District has spoke to Robert Ori in regards to his suggestion in the past of a 4% increase. Mr. Imperato stated that staff is engaged with Robert Ori on a regular basis and he will be present at the next meeting. Mr. Imperato noted that Mr. Ori offered to come to the meeting but since this is a preliminary budget and Mr. Ori's is paid time and travel, he suggested that he not attend the workshop. Mr. Imperato noted that 3 to 4 years ago there was a recommendation by Mr. Ori for the District to do 4% rate increases which was not executed by the Board.

### **III – Fiscal Year 2008-2009 Budget Workshop**

Ms. Snyder addressed the Board and stated the purpose of the workshop is to update the proposed budget presentation that was presented to the Board in June, with changes recommended by staff within the last month. Ms. Snyder noted that the handouts she provided to the Board this morning, regarding the General Fund and Water & Sewer Fund include the changes. Ms. Snyder stated that there were no significant changes, except for the electricity costs and minor changes to insurance cost. Ms. Snyder continued by stating that the workshop is to discuss assumptions used to develop the budgets, provide a forum with all parties to discuss any items the Board wishes to address and accumulate suggested changes to implement into the final budget. Ms. Snyder noted that no formal action is to be taken on the budget at the workshop. Ms. Snyder that if the Board should have any questions after the workshop they should provide them to her, Mrs. Rogers or Mr. Imperato to respond or make changes.

Mr. Imperato commented that the Board will receive the final budget prior to the meeting to have time to review.

Ms. Snyder presented a PowerPoint presentation noting the Budget Calendar for the remaining budget process, assumptions and methodology, highlights of the District's funds (see District's website: <http://www.slwsd.org/>)

Mr. Imperato noted that the District will receive an earlier distribution of the Storm Drainage Fee from the City of Port St. Lucie.

Ms. Snyder pointed out that a line item in the budget called "Interfund Transfers", is a transfer that comes from the Water Management Bond and is the interest that incurs on the money that's held in the Revenue Fund which then goes back to pay the bond. Ms. Snyder stated that when residents decide to pay off that bond then the revenue decreases which means the interest that the District is earning on that revenue decreases, so that line item will and can decrease throughout the year as the assessments are paid off in advance.

Supervisor Mancuso commented that he is aware of how the funds are broken down into divisions and assumes that the District has the means of internally controlling the funds that are being spent for each action within the divisions. Supervisor Mancuso asked if there is a procedure in place for controlling the funds in-house. Mr. Hayden replied yes. Supervisor Mancuso requested to receive a copy of the procedure regarding this.

Mr. Imperato commented that each unit and manager is responsible for their operating and capital budget; it is approved at an overall level. Mr. Imperato noted that it allows for a more efficient and effective job of managing the funds that the rate payers provide to the District. Mr. Imperato stated expenses are being controlled much better this year than in the past, which is a result of doing it this way.

Supervisor Mancuso also commented on his concern regarding the excessive amount the District expends for Special Counsel legal fees. Supervisor Mancuso stated that last year the District spent \$272,000 and this year approaching approximately \$108,600; which is a big problem. Supervisor

Mancuso noted that he is not counting the amount of money that the General Counsel expends along with the Special Counsel.

Supervisor Mancuso asked why there are no actual budget dollars for FY 2008 as of May 2008 noted. Supervisor Mancuso stated that he would think at this time, there would be some idea of what the actual funds were spent. Mr. Imperato stated that this is the budget to date with amendments that have been passed by the Board. Ms. Snyder noted that the green column is the estimated expenditures for FY 2008 according to current June 2008 numbers.

Mr. Imperato pointed out that the District may have a Wastewater expansion plan required in a 5-year period. Mr. Pickle stated that the CPH evaluation added the expansion in 2012, but he believes it will be more in the 2010 range.

Supervisor Mancuso questioned why there is an increase in budgeting for the District Manager's services. Mr. Imperato stated within those items it says the management contract is \$26,000 and on the Utility Fund it says the management contract is \$39,000; which is a total of \$65,000 and is not an increase from this year. Mr. Imperato noted that other amounts listed are expenses associated with but are not in the District Manager contract. Supervisor Mancuso asked what Mr. Imperato anticipates for District Manager services by contract for FY 2009. Mr. Imperato stated that in the budget it states \$65,000 and the contract is written to not exceed \$65,000 without approval of the Board.

Supervisor Mancuso asked what is anticipated for Financial Services for FY 2009. Ms. Snyder stated that Accounting Services, Clerk to the Board and Other Contractual Services line items are GSG's services. Mr. Imperato noted that all lines items are described in the budget book.

Supervisor Mancuso asked how much of an increase for FY 2009 will GSG bill the District for services. Ms. Snyder stated that the amount that GSG will have billed from October 1, 2007 to September 30, 2008 for services will equal \$93,568. Discussion ensued in regards to GSG's contract and service fees. Supervisor Mancuso stated for the record that for one meeting a month the District paid the previous District Manager, Charles Sweat, \$8.17 per hour for the fiscal year.

Ms. Snyder completed the PowerPoint presentation.

Mr. Imperato stated that last evening he received a phone call that union representatives have been visiting the homes of staff members. Mr. Imperato stated that he is in discussions with Labor Counsel in regards to what can be done. Mr. Imperato thanked GSG staff and District staff for the work done on the budget.

#### **IV - Adjournment**

**Vice-Chairman Child motioned to adjourn the meeting. Supervisor Cutler seconded the motion. Approved 4-0.**

Chairman Altwein adjourned the meeting at 12:19 p.m.

\*\*\*\*\*

**Meeting Minutes Signature Page**

\_\_\_\_\_  
**Chairman / Vice-Chairman**

\_\_\_\_\_  
**Secretary / Assistant Secretary**

**Date Approved** \_\_\_\_\_

# St. Lucie West Services District

## Guest Sign - In Sheet

Tuesday, July 15, 2008

\*\*\*\*PLEASE PRINT\*\*\*\*

Name & Company

E-Mail Address

Phone

✓1. Dick MUSIAL (Cascades) rsmsem2@yahoo.com

✓2. MARYellen McGARRY, MARYMACIE@aol.com

3. Sue Snyder on file

4. VINCENT D'Amico on file

6.

7.

8.

9.

10.

11.

12.

13.

14.

15.

16.

17.

18.

19.

20.