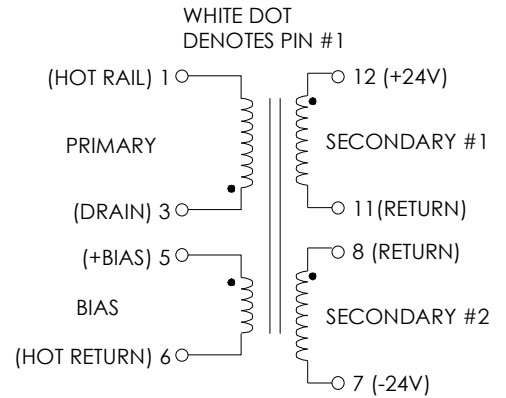

TABLE 1: ELECTRICAL SPECIFICATIONS AT 25 °C
 SWITCHING TRANSFORMER DESIGNED FOR USE WITH POWER INTEGRATIONS
 PWR-TOP227Y. REFER TO APPLICATION CIRCUITS OF FIGURE 3 & 4.

PARAMETER	SPEC LIMITS			UNITS
	MIN.	TYP.	MAX.	
PRIMARY INDUCTANCE (3-1) VOLTAGE = 0.250Vrms FREQUENCY = 100 KHZ	675	750	825	μHY
TURN RATIO'S: SEC (12-11) : PRIMARY (3-1) SEC (8-7) : PRIMARY (3-1) BIAS (5-6) : PRIMARY (3-1)	-----	1:5.091 ----- 1:5.091 ----- 1:9.333	-----	± 4% ----- ± 4% ----- ± 4%
PRI LEAKAGE IND. (SEC SHORTED) VOLTAGE = 0.250Vrms FREQUENCY = 100 KHZ	-----	-----	20	μHY
HIPOT: PRIMARY TO SECONDARIES BIAS TO SECONDARIES	3000 3000	----- -----	----- -----	Vrms Vrms
FIGURE 3 CIRCUIT PARAMETERS: AC LINE VOLTAGE 47/400 Hz OUTPUT VOLTAGE OUTPUT CURRENT CONTINUOUS OUTPUT CURRENT PEAK LINE REGULATION (85 TO 265Vac) LOAD REGULATION 10-100% RIPPLE	85 ----- 0.10 ----- ----- ----- ----- -----	----- ----- +/-24.0 ----- ----- 0.20 ----- 0.20 ----- 50.0	265 ----- +/-1.9 4.4 ----- ----- ----- ----- -----	Vac +/-Vdc +/-Amps Amps ±% ±% ±mV

FIGURE 1: SCHEMATIC DIAGRAM



NOTE1:
REINFORCED INSULATION SYSTEM, UL1950, IEC950, CSA-950:
 A) ALL MATERIALS MEET "UL", "CSA" & "IEC" REQUIREMENTS
 B) TRIPLE BASIC INSULATED SECONDARY.
 C) DESIGNED TO MEET ≥6.2mm CREEPAGE REQUIREMENTS.
 D) VARNISH FINISHED ASSEMBLY.
 E) UL1950 & CSA-950 CERTIFIED: FILE #E162344.
 F) UL CLASS (B) 130 INSULATION SYSTEM PM130-## UL FILE #E177139).

FIGURE 2: PHYSICAL DIMENSIONS mm (INCHES)

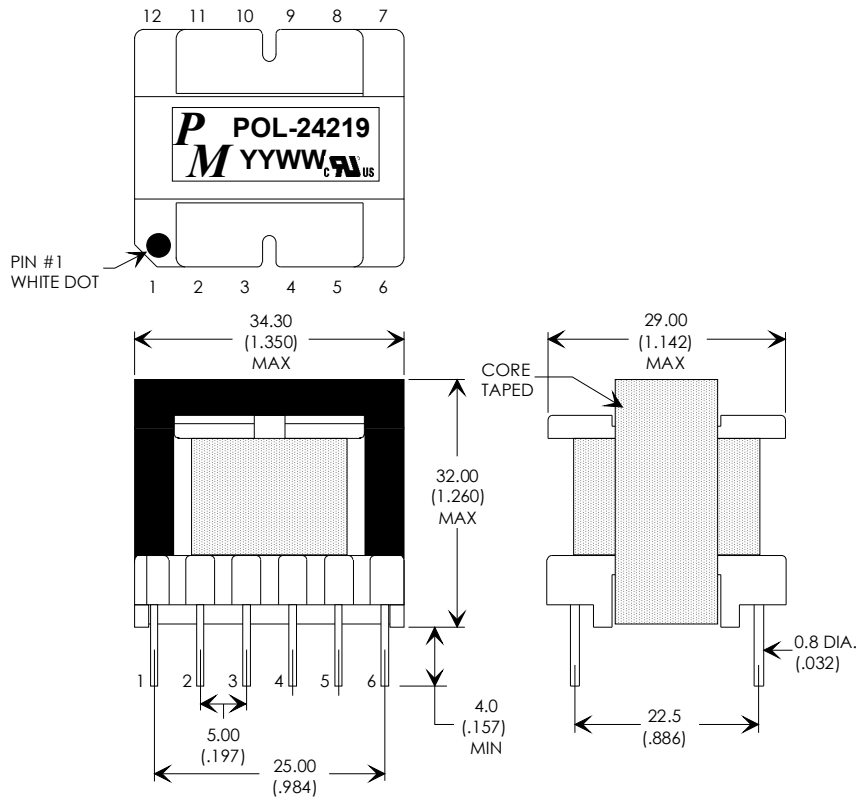

RoHS



UNLESS OTHERWISE SPECIFIED
 DIMENSIONS ARE IN MM
 DIMENSIONAL TOLERANCES ARE:
 DECIMALS ANGLES
 .X ± .25 ±0° 30'
 .XX ± .15
 DO NOT SCALE DRAWING

FLYBACK TRANSFORMER CONTROL DRAWING

PREMIER P/N: POL-24219	REVISION: 05/07/20
DRAWN BY: PETER PHAM	REF: PWR-TOP227
SCALE: NONE	SHEET: 1 OF 3

APPLICATION NOTES +/- 24V @ +/-1.875A

Premier Magnetics POL-24219 Switch Mode Transformer was designed for use with Power Integrations, Inc. PWR-TOP227. All three terminal off-line PWM switching regulator in the Flyback Buck-Boost circuit configuration. This conversion topology can provide isolated multiple outputs with efficiencies up to 90%. Premier's POL-24219 transformer has been optimized to provide maximum power throughput.

The PWR-TOPXXX series from Power Integrations, Inc. are self contained 100KHz three terminal voltage controlled PWM switching regulators. This series contains all necessary functions for an off-line switched mode control DC power source. These switching regulators provide a very simple solution to off-line designs. The inductors and transformer used with the PWR-TOPXXX are critical to the performance of the circuit. They define the overall efficiency, output power and overall physical size.

Below is a universal input high precision 90 watt application circuit utilizing Power Integrations PWR-TOP227 switching regulator in the flyback buck-boost configuration. The component values listed are intended for reference purposes only. Properly sized heat sinks for the TOP227Y & D3 as well as proper thermal management & board layout are critical requirements for efficient and reliable operation.

FIGURE 3: TYPICAL APPLICATION CIRCUIT

PREMIER MAGNETICS PART NUMBERS:
 (REQUEST DATA SHEETS BY PART#)
 L1 = PMCE-0160, 16mHy EMI/RFI CMC
 T1 = POL-24219, MAIN TRANSFORMER
 L2 = VPT-01001, 10uHy INDUCTOR

ALUMINUM ELECTROLYTIC FILTER CAPACITOR RATINGS:
 C1: $\geq 400V$, Ripple Rated $\geq 740mA$ @ 120Hz @ Max. Operating Temp.
 (Nichicon P/N LLQ2G471MHSC, 85C)
 C8, C9: $\geq 50V$, Ripple Rated $\geq 2075mA$ @ 100KHz @ Max. Op. Temp.
 (Panasonic P/N EEUFA1H681L, 105C)

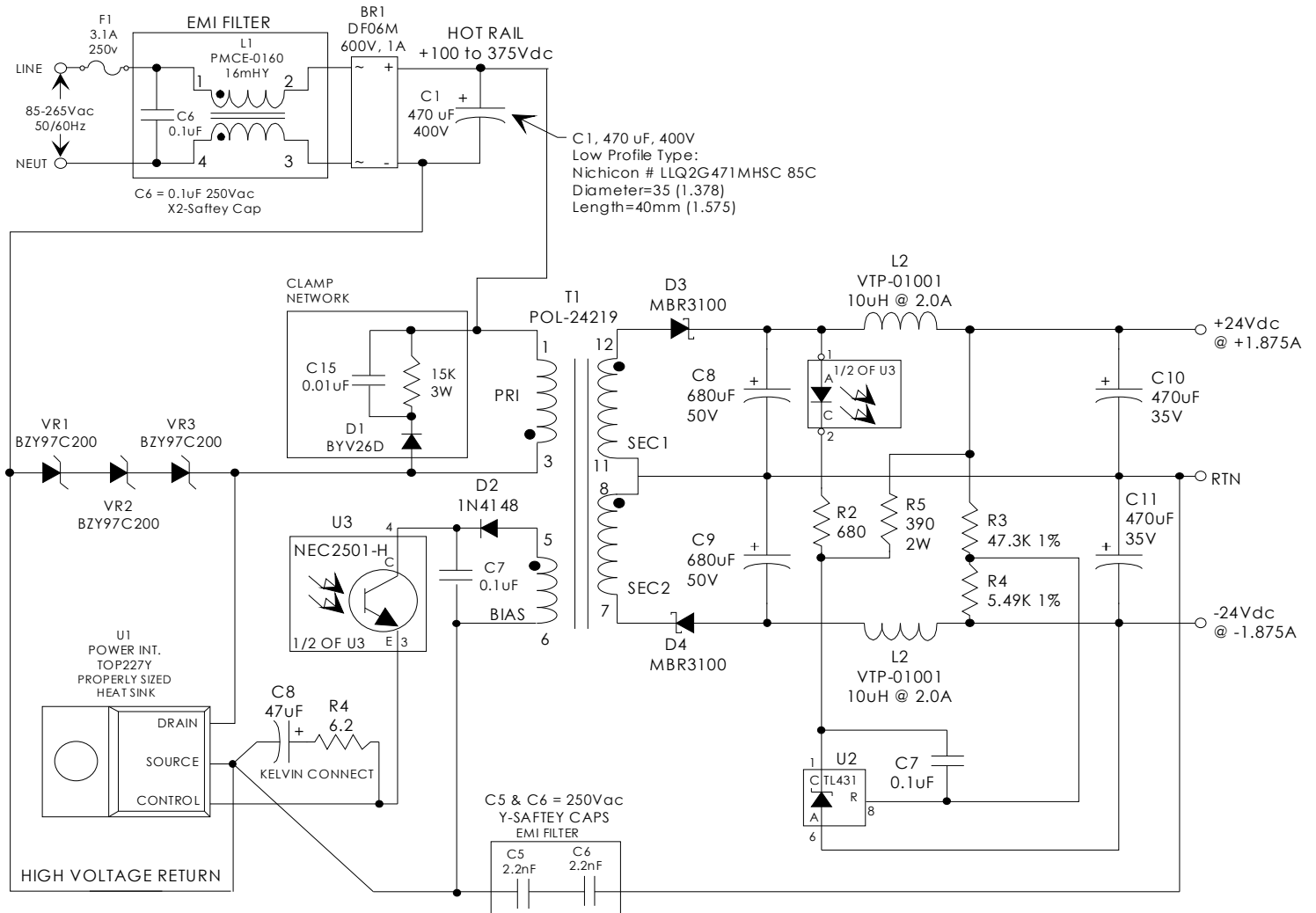

UNLESS OTHERWISE SPECIFIED
 DIMENSIONS ARE IN MM
 DIMENSIONAL TOLERANCES ARE:
 DECIMALS ANGLES
 .X $\pm .25$ $\pm 0^\circ 30'$
 .XX $\pm .15$
 DO NOT SCALE DRAWING

FLYBACK TRANSFORMER CONTROL DRAWING	
PREMIER P/N: POL-24219	REVISION: 05/07/20
DRAWN BY: PETER PHAM	REF: PWR-TOP227
SCALE: NONE	SHEET: 2 OF 3

APPLICATION NOTES +24V @ 3.8A

Premier Magnetics POL-24219 Switch Mode Transformer was designed for use with Power Integrations, Inc. PWR-TOP227. All three terminal off-line PWM switching regulator in the Flyback Buck-Boost circuit configuration. This conversion topology can provide isolated multiple outputs with efficiencies up to 90%. Premier's POL-24219 transformer has been optimized to provide maximum power throughput.

The PWR-TOPXXX series from Power Integrations, Inc. are self contained 100KHz three terminal voltage controlled PWM switching regulators. This series contains all necessary functions for an off-line switched mode control DC power source. These switching regulators provide a very simple solution to off-line designs. The inductors and transformer used with the PWR-TOPXXX are critical to the performance of the circuit. They define the overall efficiency, output power and overall physical size.

Below is a universal input high precision 90 watt application circuit utilizing Power Integrations PWR-TOP227 switching regulator in the flyback buck-boost configuration. The component values listed are intended for reference purposes only. Properly sized heat sinks for the TOP227Y & D3 as well as proper thermal management & board layout are critical requirements for efficient and reliable operation.

FIGURE 4: TYPICAL APPLICATION CIRCUIT

PREMIER MAGNETICS PART NUMBERS:
 (REQUEST DATA SHEETS BY PART#)
 L1 = PMCE-0160, 16mHy EMI/RFI CMC
 T1 = POL-24219, MAIN TRANSFORMER
 L2 = VPT-01005, 10uHy INDUCTOR

ALUMINUM ELECTROLYTIC FILTER CAPACITOR RATINGS:
 C1: $\geq 400V$, Ripple Rated $\geq 740mA$ @ 120Hz @ Max. Operating Temp.
 (Nichicon P/N LLQ2G471MHSC, 85C)
 C8, C9: $\geq 50V$, Ripple Rated $\geq 4000mA$ @ 100KHz @ Max. Op. Temp.
 (2 x Panasonic P/N EEUFA1H681L, 105C)

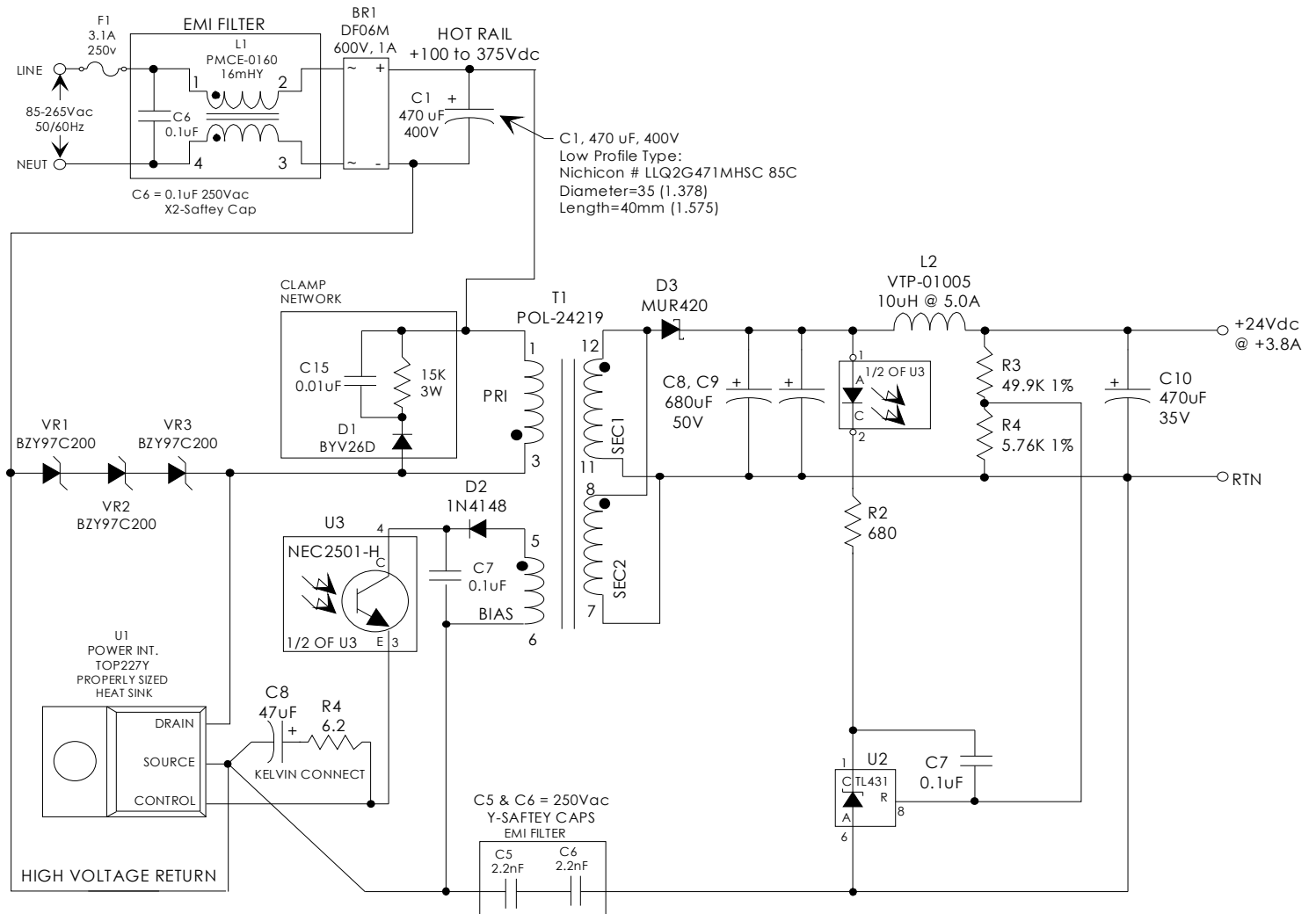

UNLESS OTHERWISE SPECIFIED
 DIMENSIONS ARE IN MM
 DIMENSIONAL TOLERANCES ARE:
 DECIMALS ANGLES
 .X ± .25 ±0° 30'
 .XX ± .15
 DO NOT SCALE DRAWING

FLYBACK TRANSFORMER CONTROL DRAWING	
PREMIER P/N: POL-24219	REVISION: 05/07/20
DRAWN BY: PETER PHAM	REF: PWR-TOP227
SCALE: NONE	SHEET: 3 OF 3