

SERVICE MANUAL—SYSTEM

Mobile Surgical X-ray System

BV29 - RELEASE 3.0.

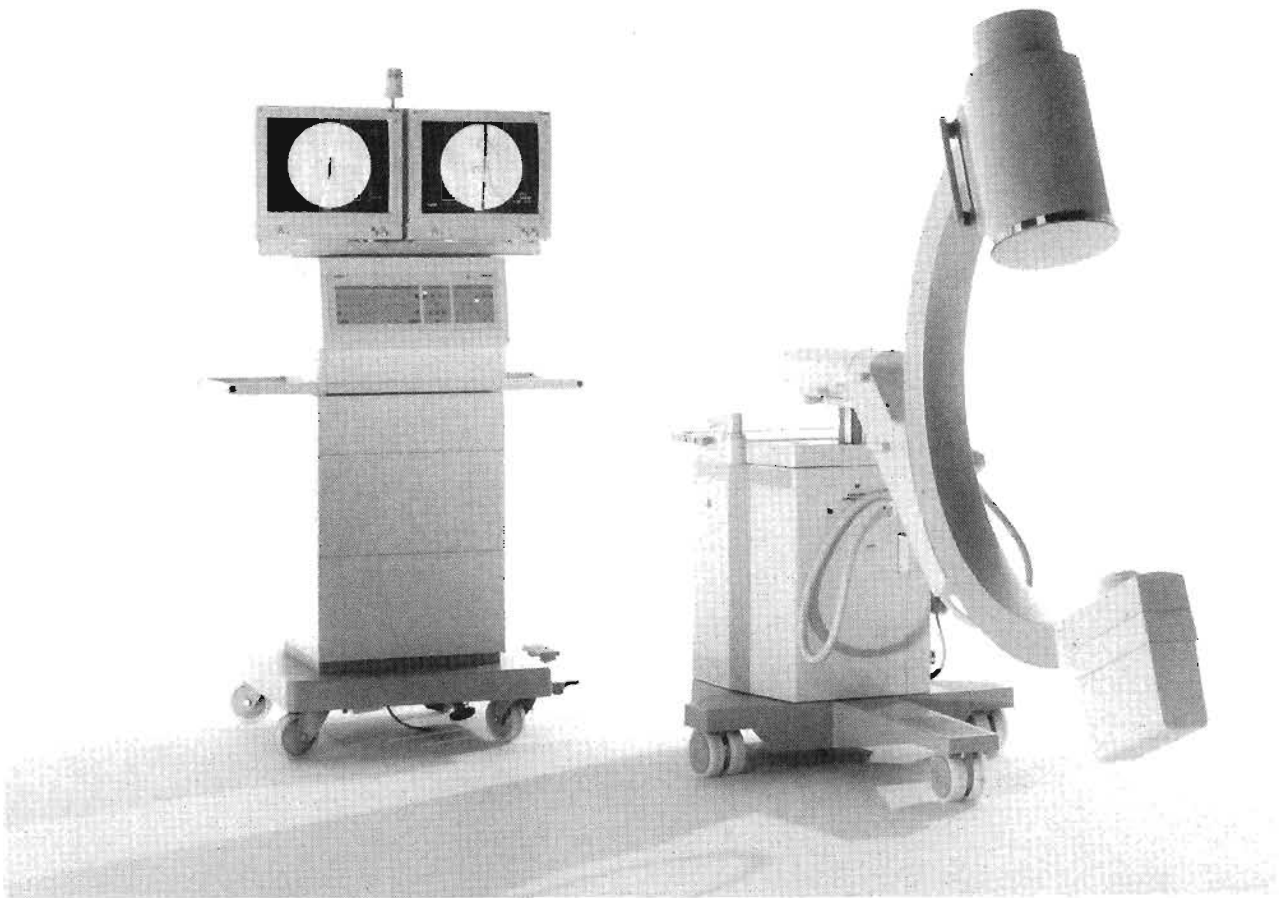

This manual contains information on the Mobile Surgical X-ray System BV29. It is used for TV fluoroscopy with image intensifier and for radiography in operating and emergency rooms.

SERVICE SYSTEM MANUALS
BV29 SYSTEM

MODULE CODE NUMBER : 4522 983 52203

LIST OF PAGES AND DRAWINGS

0.1	(b/93.0)
0.6	(92.0)
0.7	(92.0)
1.	(b/93.0)
2.1	(b/93.0)

SERVICE MANUAL UNIT
BV29 PHYSICAL PLANNING

MODULE CODE NUMBER : 4522 983 50053

LIST OF PAGES AND DRAWINGS

0.5	(b/93.0)
2.1	(b/93.0)
1-1	(92.0)E
1-2	(92.0)E
1-3	(92.0)E
1-4	(92.0)E
1-5	(92.0)E
1-6	(92.0)E
1-7	(b/93.0)E
1-8	(b/93.0)E
1-9	(b/93.0)E
1-10	(92.0)E
1-11	(92.0)E

Section :**PHYSICAL PLANNING****Contents**

1.	INTRODUCTION	1-2
2.	PRODUCT DATA	1-2
2.1.	TECHNICAL DATA	1-2
2.1.1.	Dimensions and Weights Packed	1-2
2.1.2.	Dimensions and Weights Unpacked	1-2
2.2.	ENVIRONMENTAL DATA	1-3
2.3.	POWER DATA	1-3
2.3.1.	Product Mains Data	1-3
2.3.2.	Mains Performance Data	1-3
3.	PRODUCT RELATION	1-4
4.	CABLE/CONNECTIONS	1-4
5.	UNPACKING/TRANSPORT /MOUNTING	1-5
5.1.	UNPACKING	1-5
5.2.	TRANSPORT	1-5
5.3.	MOUNTING	1-5
6.	TOOLS & MATERIALS REQUIRED	1-5
6.1.	TO BE ARRANGED LOCALLY	1-5
6.2.	TO BE ORDERED	1-5
7.	ROOM MAINS STATUS REPORT	1-6
7.1.	GENERAL	1-6
7.2.	MAINS STATUS REPORT	1-7
7.3.	MAINS STATUS REPORT	1-8
7.4.	MAINS STATUS REPORT	1-9
8.	DIMENSIONAL DRAWINGS	1-10

1. INTRODUCTION

The BV29 is a Mobile X-Ray System for surgical applications.

This document contains all information to prepare the X-ray room for installation.

Although the BV29 is a mobile X-ray system, the information given in this section can be helpful for checking and measuring the room conditions.

2. PRODUCT DATA

2.1. TECHNICAL DATA**2.1.1. Dimensions and Weights Packed**

The BV29 mobile X-ray system is delivered in one crate.

Dimensions : 2640 x 1150 x 1880 mm (l x w x h).
Weight : 6600 N gross, 5000 N nett.

2.1.2. Dimensions and Weights Unpacked

BV29 Stand
Dimensions : 1790 x 900 x 1800 mm (l x w x h).
Weight : 3000 N.

BV29 Trolley
Dimensions : 800 x 1000 x 1860 mm (l x w x h).
Weight : 2000 N.

For dimensional drawings see chapter 8.

NOTE

*This weight does not include options such as:
Video Hard Copy Unit
Video Tape Recorder.*

2.2. ENVIRONMENTAL DATA

Storage conditions,

- Temperature : -40 °C to +70 °C
- Relative humidity : 5% to 95%

Operating conditions,

- Temperature : +10 °C to +40 °C
- Relative humidity : 20% to 80%

2.3. POWER DATA**2.3.1. Product Mains Data**

Power required : 4.8 KVA max.

Supply config. : Single phase, 3 wire (power, neutral, separate earth).

Nominal voltage : 100/110/120/127/190/208/
220/240 Volts ac.

Nominal freq. : 50 Hz or 60 Hz (two versions)

Mains resistance : 100 V 100 mOhm (max.)
110 V 100 mOhm (max.)
120 V 120 mOhm (max.)
127 V 150 mOhm (max.)
190 V 500 mOhm (max.)
208 V 550 mOhm (max.)
220 V 600 mOhm (max.)
240 V 750 mOhm (max.)

Room mains fuse : 100/110/120/127 Vac,
30 A slow blow

190/208/220/240 Vac,
16 A slow blow

Current : In-rush, 60 A, duration 10 msec
Standby, 7.9 A
Maximum, 40 A, (radiography).

2.3.2. Mains Performance Data

Voltage variation : +10% , -5%

Frequency variation : +/- 2 Hz (static)

3. PRODUCT RELATION

The BV29 mobile X-Ray system consists of a mobile Stand and a mobile Trolley.

Therefore there is no fixed relation between the patient support table and the BV29 items.

Due to this flexible configuration and wide range of applications, only the following general remarks can be taken into account.

1. The trolley is not sterile, this means that the distance trolley - patient support must be at least 1.5 meter.
2. The Stand is anaesthetic proof this means that the stand can be used in the presence of gasses. AP according to IEC 601-1 section 6.

4. CABLE/CONNECTIONS

The following remarks must be taken into consideration.

1. Cable between Stand and Trolley has a fixed length of 7 meter.
2. The mains supply cable has a length of 7 meter, and is fixed at the Stand.
3. The mains connection plug of the mains supply cable is EURO-type or an US type.

NOTE

Check if the plug fits the local hospital mains socket. In case the plug does not fit, a correct plug has to be obtained locally.

-
4. Never extend the mains cord of the BV29.

NOTE

The Trolley can also be used as a stand alone viewing station, in that case the trolley has its own mains cable, length 5 meter.

No specific room conditions required.

**5. UNPACKING/TRANSPORT
/MOUNTING**

5.1. UNPACKING

The UNPACKING/TRANSPORT AND MOUNTING instructions are delivered with the shipping package.

5.2. TRANSPORT

For routing through hospital, see dimensions given in chapter 2: PRODUCT DATA.

5.3. MOUNTING

No mounting has to be carried out.

**6. TOOLS & MATERIALS
REQUIRED**

6.1. TO BE ARRANGED LOCALLY

No special tools have to be arranged locally.

6.2. TO BE ORDERED

Mains resistance meter,
Panensa MIC20: 4522 980 35231

Power scope,
BMI 4800: 4522 980 37421

7. ROOM MAINS STATUS REPORT

7.1. GENERAL

The BV29 is a Mobile X-Ray System, this means that for all the rooms where the BV29 is used the room mains conditions have to be checked.

- The mains resistance can be measured with the mains resistance meter: Panensa MIC20 with codenumber 4522 980 35231.
- The mains voltage specifications can be measured with a Power scope BMi 4800 with codenumber 4522 980 37421.

NOTE

This report has to be made for each room in which the BV29 is used. There are three copies of the status report for three different rooms

7.2. MAINS STATUS REPORT

CUSTOMER :
 EQUIPMENT : BV29 SYSTEM
 SERIAL NUMBER : CL
 ROOM NUMBER :

MAINS VOLTAGE

Static line voltage : Phase - Neutral Vrms. Within specification: yes []
 no []

Line voltage variation : Phase - Neutral Vrms min. , Vrms max. Within specification: yes []
 no []

Frequency variation : Phase - Neutral Hz min. , Hz max. Within specification: yes []
 no []

MAINS RESISTANCE

Standard : Phase - Neutral mOhms Within specification: yes []
 no []

Emergency : Phase - Neutral mOhms Within specification: yes []
 no []

ROOM MAINS FUSE : A, slow blow / fast

EARTH LEAKAGE : Earth leakage protector present / not present (switch-off leveluA).

7.3. MAINS STATUS REPORT

CUSTOMER :
 EQUIPMENT : BV29 SYSTEM
 SERIAL NUMBER : CL
 ROOM NUMBER :

MAINS VOLTAGE

Static line voltage : Phase - Neutral Vrms.
 Within specification: yes []
 no []

Line voltage variation : Phase - Neutral Vrms min. , Vrms max.
 Within specification: yes []
 no []

Frequency variation : Phase - Neutral Hz min. , Hz max.
 Within specification: yes []
 no []

MAINS RESISTANCE

Standard : Phase - Neutral mOhms
 Within specification: yes []
 no []

Emergency : Phase - Neutral mOhms
 Within specification: yes []
 no []

ROOM MAINS FUSE : A, slow blow / fast

EARTH LEAKAGE : Earth leakage protector present / not present (switch-off leveluA).

7.4. MAINS STATUS REPORT

CUSTOMER :
 EQUIPMENT : BV29 SYSTEM
 SERIAL NUMBER : CL
 ROOM NUMBER :

MAINS VOLTAGE

Static line voltage : Phase - Neutral Vrms. Within specification: yes []
 no []

Line voltage variation : Phase - Neutral Vrms min. , Vrms max. Within specification: yes []
 no []

Frequency variation : Phase - Neutral Hz min. , Hz max. Within specification: yes []
 no []

MAINS RESISTANCE

Standard : Phase - Neutral mOhms Within specification: yes []
 no []

Emergency : Phase - Neutral mOhms Within specification: yes []
 no []

ROOM MAINS FUSE : A, slow blow / fast

EARTH LEAKAGE : Earth leakage protector present / not present (switch-off leveluA).

8. DIMENSIONAL DRAWINGS

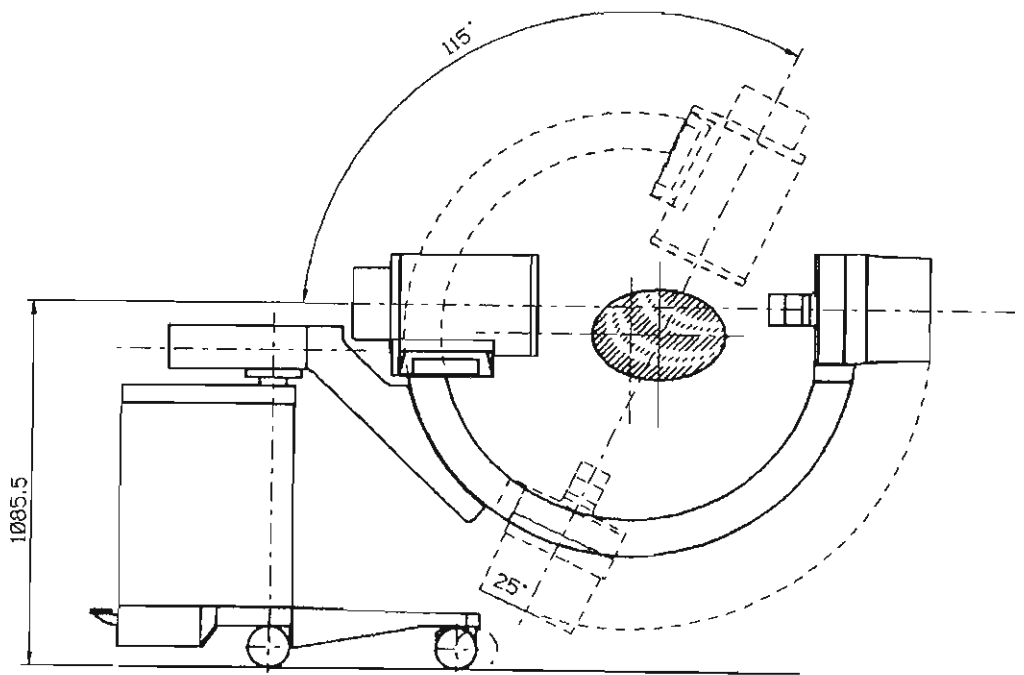
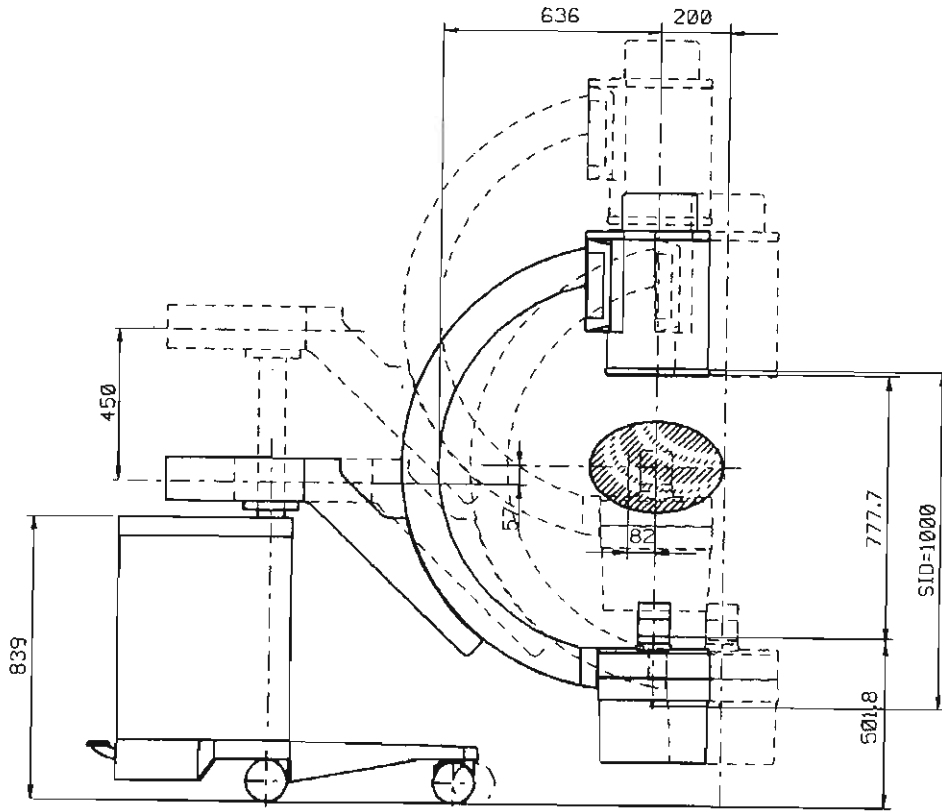

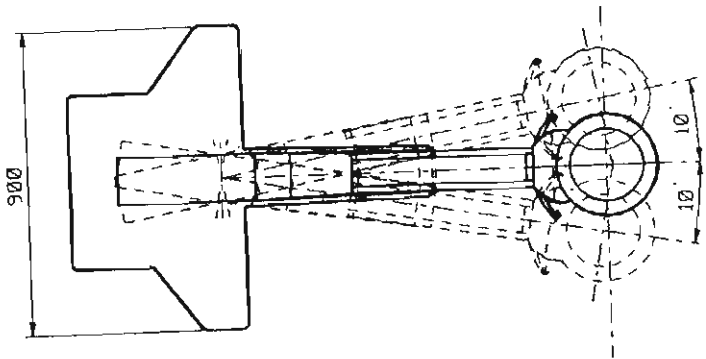
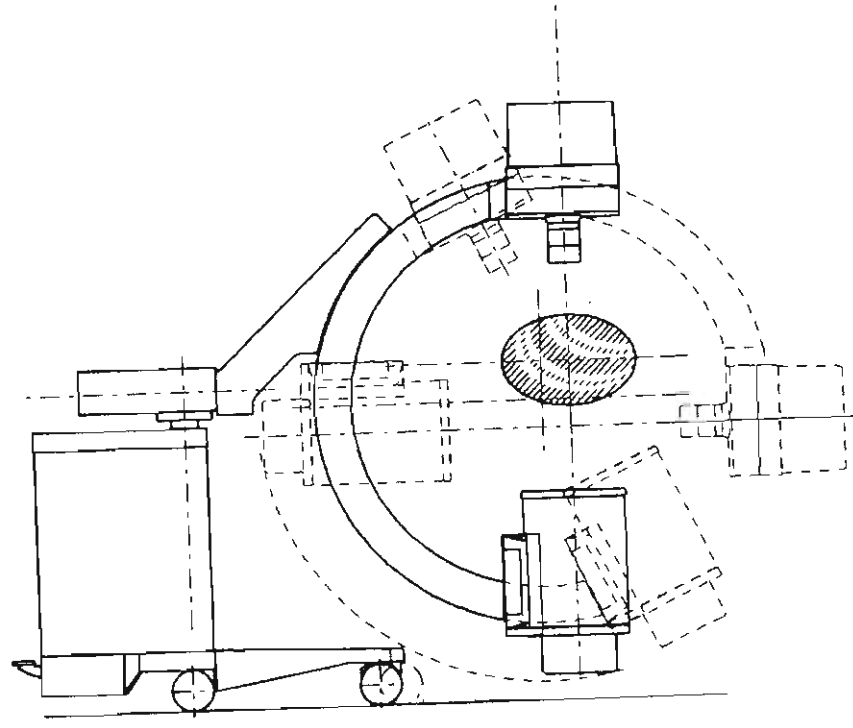

TECHNICAL DATA	1	▶
<hr/>		
SPECIFICATION, PACKING & DOCUMENTATION LIST	2	▶
<hr/>		
UNPACKING INSTRUCTIONS	3	▶
<hr/>		
INSTALLATION INSTRUCTIONS	4	▶
<hr/>		
CABLING & EARTHING DIAGRAMS	5	▶
<hr/>		
RECORD OF PROGRAMMINGS	6	▶
<hr/>		
SETTING TO WORK INSTRUCTIONS	7	▶
<hr/>		
RECORD OF MEASURED DATA	8	▶
<hr/>		
MODIFICATIONS	9	▶
<hr/>		
FILMS	10	▶

SERVICE MANUAL UNIT
BV29 INSTALLATION

MODULE CODE NUMBER : 4522 983 50063

LIST OF PAGES AND DRAWINGS

0.5	(b/93.0)		
2.	(b/93.0)	4-1	(92.0)E
2.1	(b/93.0)	4-2	(92.0)E
		4-3	(92.0)E
		4-4	(92.1)E
1-1	(92.0)E		
1-2	(92.0)E		
1-3	(92.0)E	5-1	(92.0)E
1-4	(b/93.0)E	5-2	(92.0)E
1-5	(a/92.1)E	5-3	(92.0)E
1-6	(a/92.0)E		
1-7	(b/93.0)E	6-1	(92.0)E
1-8	(a/93.0)E	6-2	(92.0)E
1-9	(92.0)E		
1-10	(92.0)E	7-1	(92.0)E
1-11	(92.0)E	7-2	(92.0)E
		7-3	(92.0)E
		7-4	(92.0)E
3-1	(92.0)E		
3-2	(92.0)E		
3-3	(92.0)E		
3-4	(92.0)E		
3-5	(92.0)E		
3-6	(92.0)E		
3-7	(92.0)E		
3-8	(92.0)E		
3-9	(92.0)E		
3-10	(92.0)E		

Section :**TECHNICAL DATA****Contents**

1.	INTRODUCTION	1-2
2.	TOOLS	1-2
3.	ITEMS SUPPLIED	1-2
3.1.	MOBILE STAND	1-3
3.2.	MOBILE TROLLEY	1-3
3.3.	SMALL ITEMS AND DOCUMENTS	1-4
4.	IDENTIFICATION	1-4
5.	CERTIFIABLE ITEMS	1-5
6.	TECHNICAL DATA	1-6
6.1.	PERFORMANCE DATA	1-6
6.1.1.	X-RAY	1-6
6.1.2.	FLUOROSCOPY	1-6
6.1.3.	RADIOGRAPHY	1-7
6.1.4.	DIGITAL PROCESSOR	1-7
6.1.5.	DIGITAL PROCESSOR OPTIONS	1-8
6.1.6.	FILTERING	1-8
6.1.7.	CLEANABILITY	1-8
6.1.8.	MANOEUVRABILITY	1-9
7.	STANDARDS	1-11

1. INTRODUCTION

This section gives general information about the BV29 Mobile X-Ray system.

2. TOOLS

A standard toolset is required to unpack and install the BV29 system.
No special tools required or to be ordered.

3. ITEMS SUPPLIED

NOTE

For specific contents of delivery, PEI numbers and shoporder numbers, see section 2: "SPECIFICATION, PACKING AND DOCUMENTATION LIST."

The BV29 System delivery contains the following items:

- MOBILE STAND
- MOBILE TROLLEY
- SMALL ITEMS
- DOCUMENTATION

3.1. MOBILE STAND

Mobile stand with C-arm, X-ray generator, and II/TV imaging system.

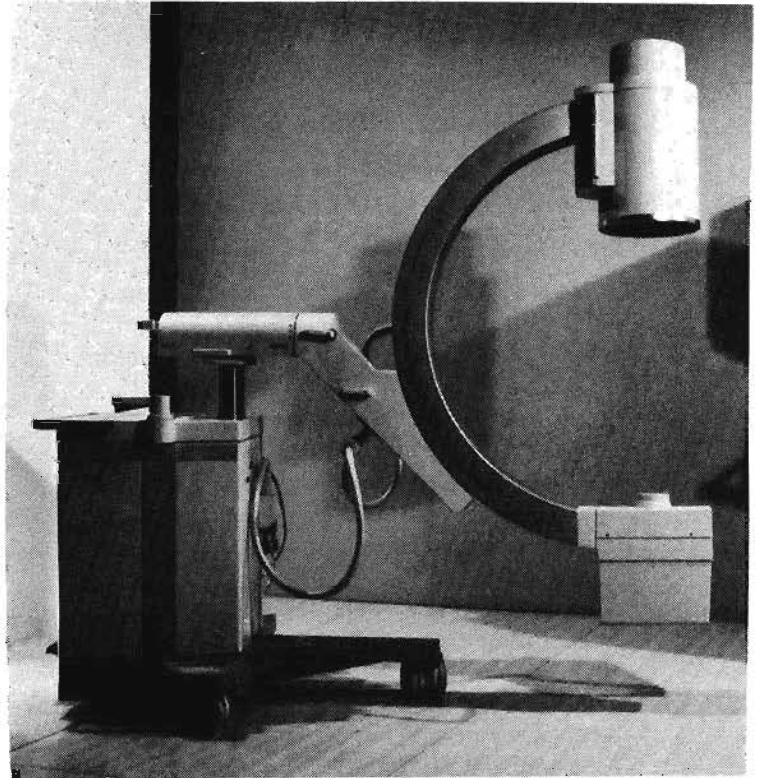

3.2. MOBILE TROLLEY

Mobile trolley with two monitors, digital image processor/memory, image store disk and control panel.

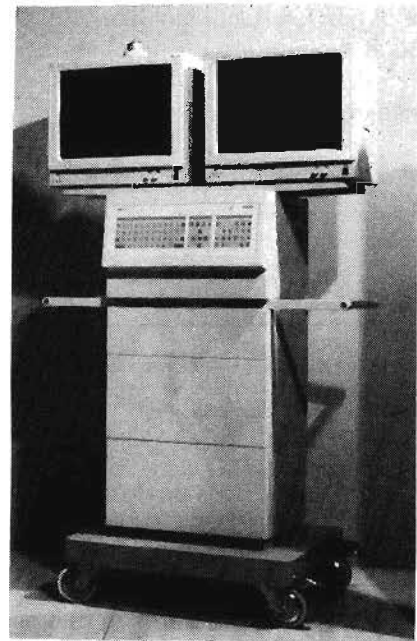

3.3. SMALL ITEMS AND DOCUMENTS

The following parts are packed in a plastic box:

- Plastic bag with Allen-keys 2.0 and 2.5 mm.
- Equipotential conductor and mounting material.
- Spare fuses 30 A, 15 A, 10 A.
- Tube P4 silicon paste and lenspaper.
- Paint set: mushroom, grey and pink.
- Set of two socket head screwdrivers: 2 and 2.5 mm
- Tube heat conducting paste for XTV8S
- Extension boards F3

- Manufacturing documents:
 - . Status report fluoroscopy.
 - . Configuration list
 - . Licence for practix tank (HH 42/82 Ro).
 - . A.P. certificate (IEC).
 - . List of service documentation.
- Set of service documentation.
- Operators manual.

- Footswitch.

Manufacturing documents and plastic box are stored in wooden cabinet.

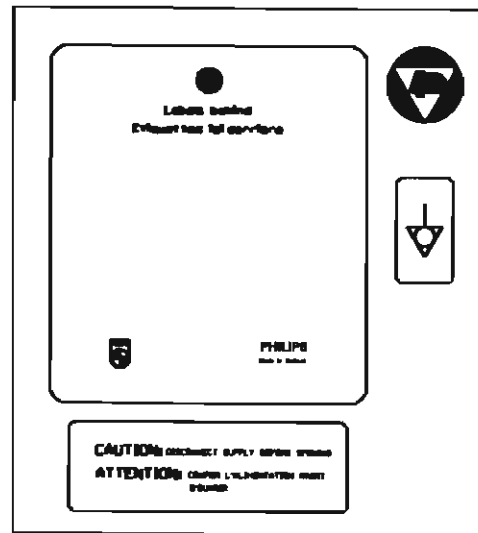

4. IDENTIFICATION

The type number plates are located on the PEI units. The location of PEI number plates and labels is given in the appropriate PEI documentation. A central information plate, marked "I", for labels is given on the Mobile Stand, see photograph. Identification of BV29 by serial number: CL This number is unique for each BV29 system.

Warning: the appropriate labels on this panel must be replaced when replacing certified components!

RAY CONTROL (STAGE)	TUBE HOUSING ASSEMBLY	RAY CONTROL (STAGE)
Type 1 s/n. 1	Type 1 s/n. 1	Type 1 s/n. 1
Philips Medical Systems Model-land SA, 1975/76 and 1976/77. For Replacement.	Philips Medical Systems Model-land SA, 1975/76 and 1976/77. For Replacement.	Philips Medical Systems Model-land SA, 1975/76 and 1976/77. For Replacement.
MANUFACTURED: February 1978	MANUFACTURED: February 1978	MANUFACTURED: February 1978
Philips Medical Systems Model-land SA, 1975/76 and 1976/77. For Replacement.	3-Ray Tube Type 1	
	Philips Medical Systems Model-land SA, 1975/76 and 1976/77. For Replacement.	
BEAM LIA. DEV.	IMAGE INTENSIFIER	SYSTEM
Type 1 s/n. 1	Type 1 s/n. 1	MAC CEL. No.
Philips Medical Systems Model-land SA, 1975/76 and 1976/77. For Replacement.	Philips Medical Systems Model-land SA, 1975/76 and 1976/77. For Replacement.	MAC
MANUFACTURED: February 1978	MANUFACTURED: February 1978	MAC
Philips Medical Systems Model-land SA, 1975/76 and 1976/77. For Replacement.	Philips Medical Systems Model-land SA, 1975/76 and 1976/77. For Replacement.	MAC
		MAC

5. CERTIFIABLE ITEMS

The BV29 system consists of the following certifiable components:

COMPONENT TYPE
Tube Housing Assembly
Beam limiting Device
Image Intensifier
X-Ray Control (XTV)
X-Ray Control (STAND)

Spotfilm device (labels only on spotfilm device)

Television Receiver (labels only on television receiver device)

Warning

*IN CASE OF REPLACEMENT OF CERTIFIABLE ITEMS ALWAYS REPLACE DUPLICATE LABEL ON
CENTRAL LABELLING STATION.*

6. TECHNICAL DATA

6.1. PERFORMANCE DATA

6.1.1. X-RAY

X-Ray generator : High voltage DC converter
 X-Ray Tube F014 : Dual focus fixed anode,
 focal spot sizes 0.6/1.5 mm.

6.1.2. FLUOROSCOPY

Image Intensifier : Triple mode 23/17/13 cm
 With fibre output.
 TV Camera : CCD Sensor.
 kV/mA range : 40 -105 kV , 0.1 - 3.1 mA.
 Focal spot : 0.6 mm.
 Max. load
 X-Ray Tube : 30 sec ON - 90 sec OFF
 during 90 minutes at 105 kV
 and 3.1 mA.
 Average load continuous:
 60 Watt.
 Grid : Circular, 44 lines/cm, ratio
 1:10 , SID 100 cm.
 Iris Collimator : Min. beam diameter at
 entrance to II: 5 cm.
 Semi transparent
 Shutters : Width adjustment down to 4
 cm slit at II.
 Rotation +/- 90 degrees.
 Remotely controlled.
 Fluoroscopy mode : Continuous fluoroscopy,
 Pulsed fluoroscopy,
 High Definition Fluoroscopy,
 (7.4 mA during 20 sec
 max.).

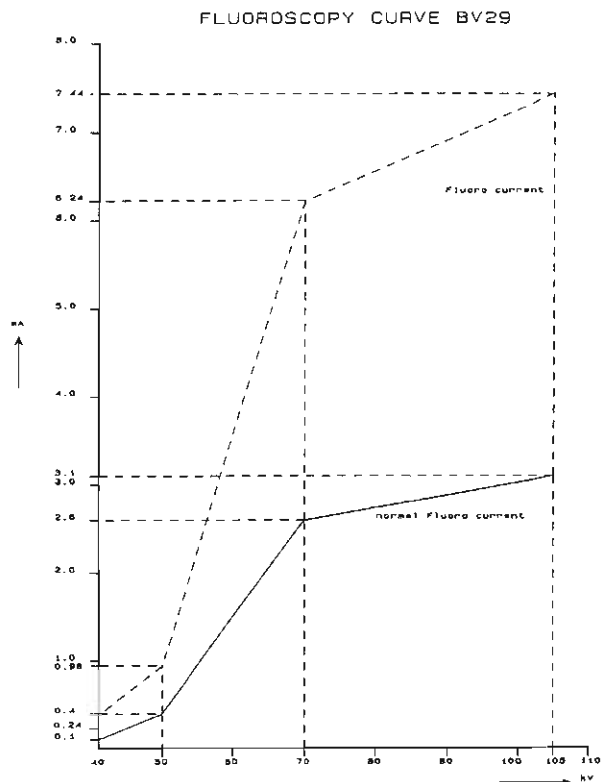

TV System : XTV-8S with standard line rate:
625 lines (50 Hz),
525 lines (60 Hz).
Iris diaphragm control and remote image rotation

TV Monitor : Diameter 43 cm, remote control of brightness and contrast.
Automatic control of brightness and contrast in relation to room lighting conditions.

6.1.3. RADIOGRAPHY

X-Ray Tube voltage : 40 kV - 20 mA up to current
105 kV - 20 mA.

Exposure time : 0.01 - 4.0 sec at 20 mA.

Preparation time : 0.8 sec.

Focal spot : 1.5 mm.

Maximum load

X-Ray tube : 105 kV - 20 mA,
4 sec ON, 120 sec OFF,
(apprx. 30 exp/hour).

Cassette holder : 24 x 30 cm, adj. to 20 x 40 cm.

6.1.4. DIGITAL PROCESSOR

Image store : 2 images

Matrix : 575 x 1237 x 12 (50 Hz)
512 x 1400 x 12 (60 Hz)

Video out : 625-100Hz, 525-120Hz.

Functions : Dynamic noise reduction
Windowing (contrast and brightness adjusted).
Image swap, Text display.

6.1.5. DIGITAL PROCESSOR OPTIONS

- Image storage and handling extension : Image storage disk, 190 images,
Mosaic of 16 images from disk, displayed on the monitor for quick image search,
Image zoom of region of interest,
Measurement of relative distances on the image (relative stenosis).
- Angiography ext. : Subtraction
Dye trace subtraction (Maximum opacification)
Dye trace subtraction road-mapping.
- Video memory ext. : 32/128 image video memory for cine display,
Replay last fluoro scene,
Cine loop editing,
Selectable acquisition frame speed.

6.1.6. FILTERING

Total inherent filtration of 4 mm Al equivalent, at 75 kV.

6.1.7. CLEANABILITY

The BV29 System is resistant against:

- Water drip
- Soap
- Hot water
- Desinfectants, except on PHENOL base.

6.1.8. MANOEUVRABILITY

C-arm:

- Displacement : 20 cm longitudinal.
- Panning movement : +/- 10 degrees.
- Height movement : 45 cm (motorized).
- Rotation : +/- 205 degrees.
- Angulation : + 90 degrees to
- 25 degrees.
- SID : 100 cm.

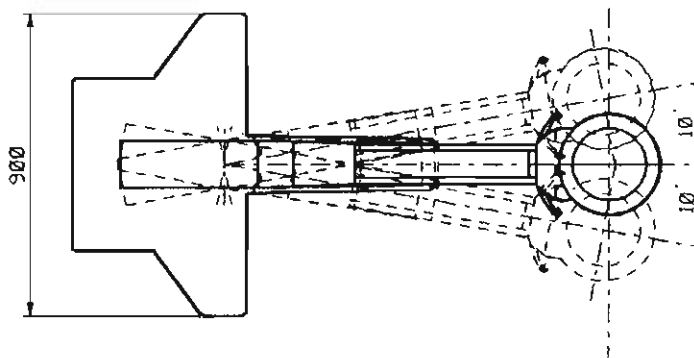
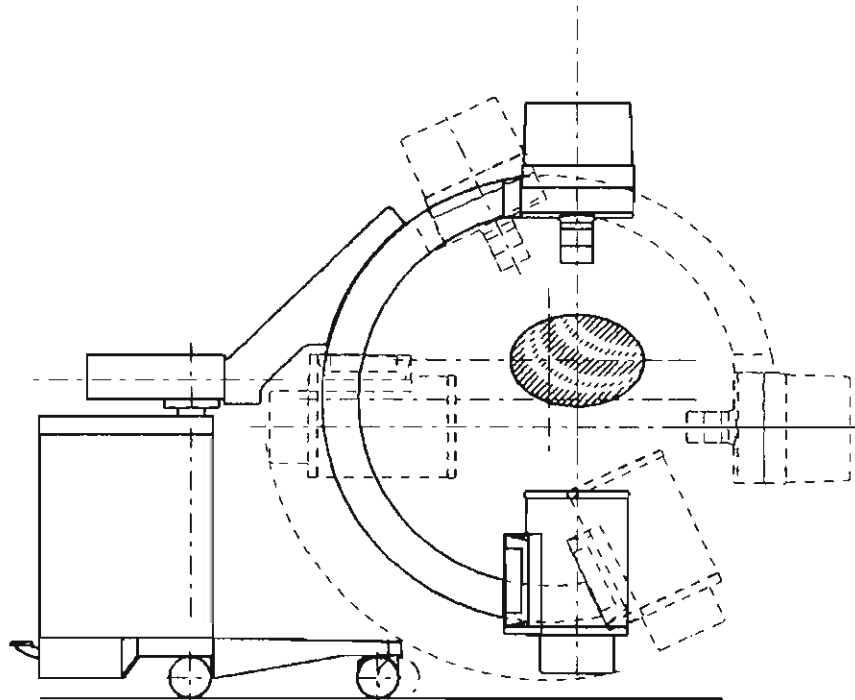

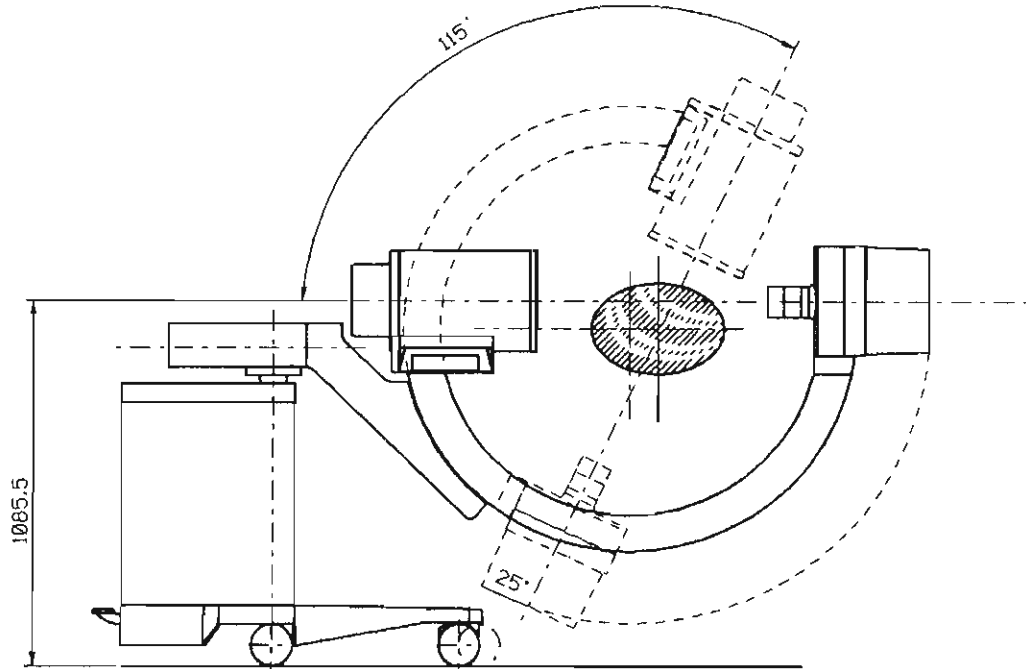
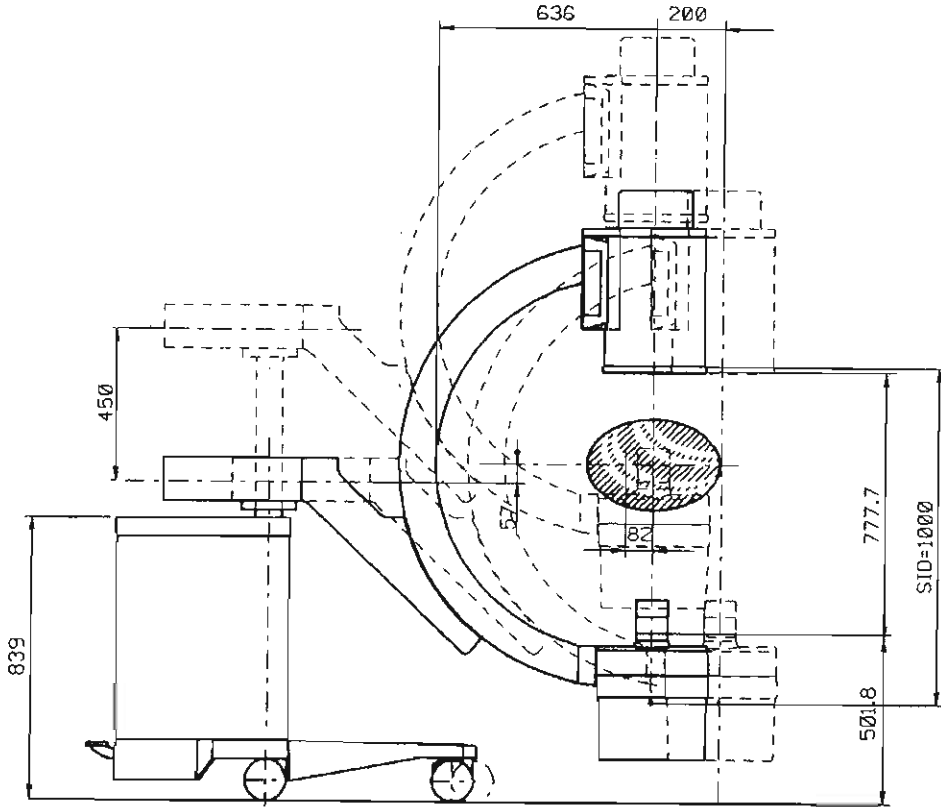

7. STANDARDS

Compliance Status with STANDARDS is obtainable at:

Philips Medical Systems International
Corporate Quality Department
REGULATING and STANDARDS group
Building QM118
PO Box 10.000
5680 DA BEST
The Netherlands

Fax No. : 31-40-762205/762420
Tel No. : 31-40-762408
Telex No. : 35000 PHCT NL
routing indicator XLQBUXA

Section : **UNPACKING INSTRUCTIONS**

Contents

1.	UNPACKING INSTRUCTIONS	3-2
1.1.	UNPACKING TIME	3-2
1.2.	TRANSPORTATION	3-2
1.3.	MOUNTING	3-2
1.4.	DOCUMENTS	3-2
2.	UNPACKING INSTRUCTIONS	3-3

1. UNPACKING INSTRUCTIONS

This section contains instructions for unpacking transportation and mounting.

The unpacking instructions are also delivered with the shipping package.

1.1. UNPACKING TIME

The time needed to unpack the system:
1.5 hours for one engineer.

1.2. TRANSPORTATION

For transportation through hospital:

1. Dimensions of stand and trolley must be taken in consideration when using elevators or passing doors.
2. The stand has three double-wheels for easy manoeuvrability, the two rear wheels are steerable. The steering mechanism must not be used during transportation, steering only by using the handgrip with rear wheels in forward position.
3. The trolley has four freely swivable wheels, of which the rear wheels can be locked, so steering is done via the handgrips.

1.3. MOUNTING

No mounting has to be done

1.4. DOCUMENTS

The documentation is delivered with the BV29 system.
Filed in wooden "book cabinet"
A proper place must be found to store this documentation.

2. UNPACKING INSTRUCTIONS

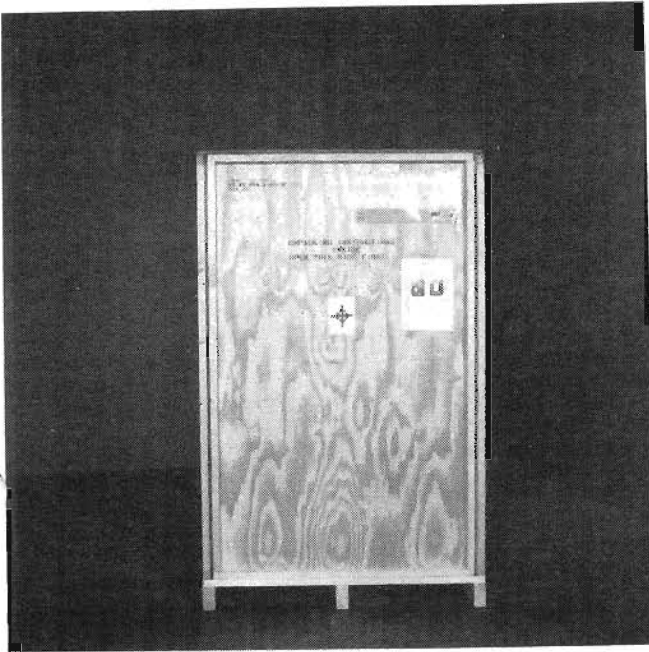

1

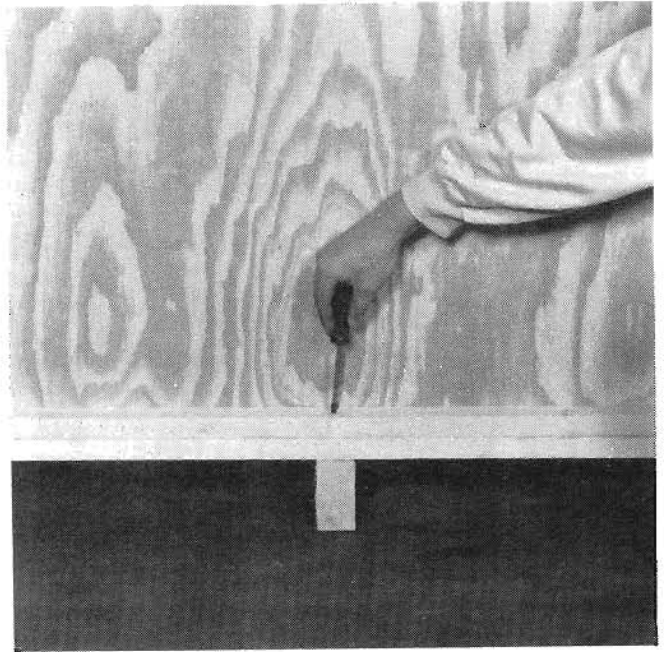

2

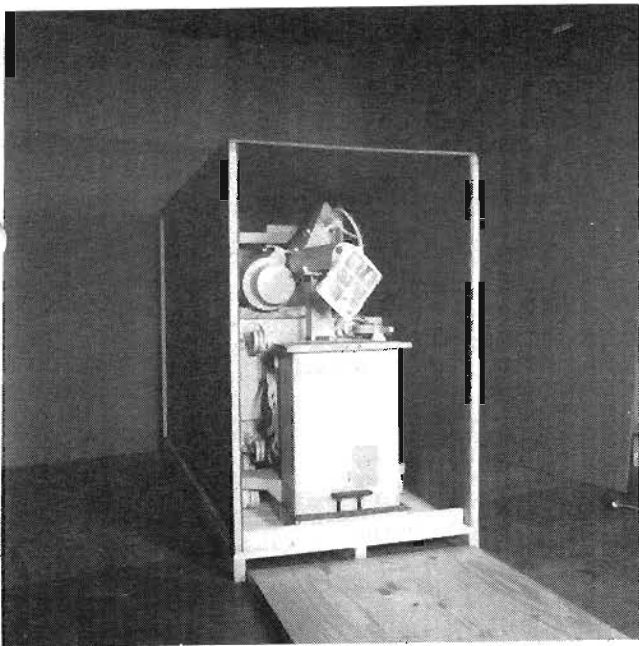

3

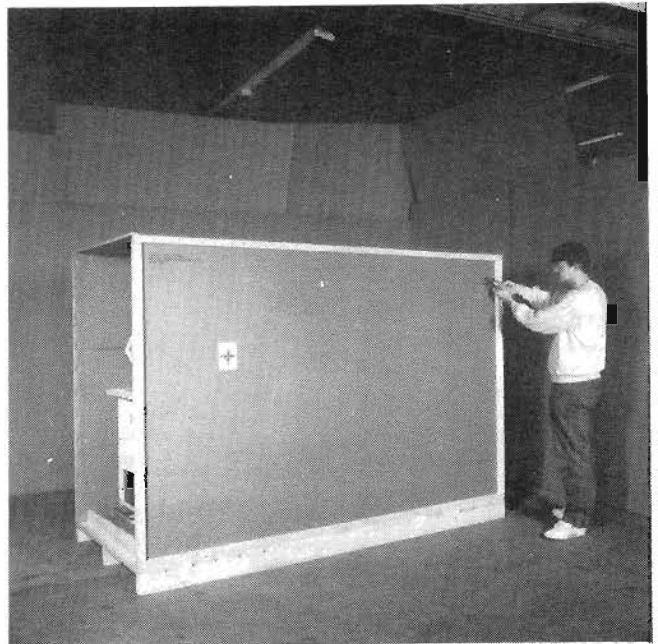

4

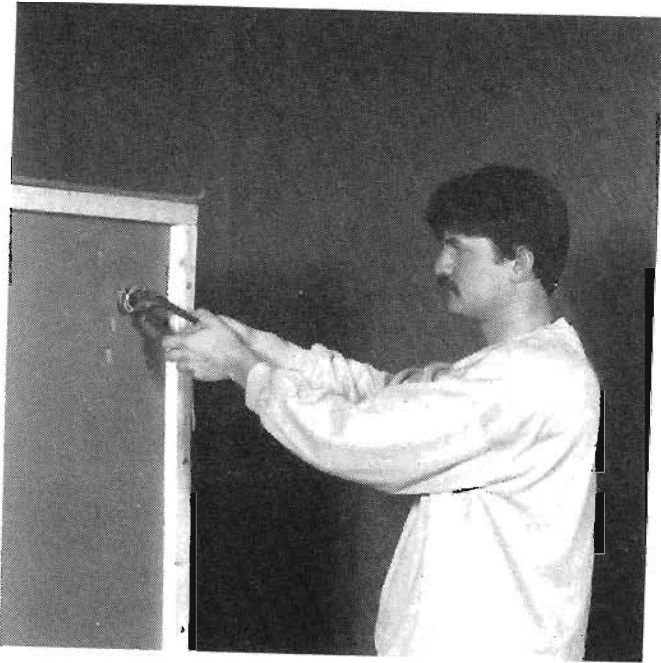

5

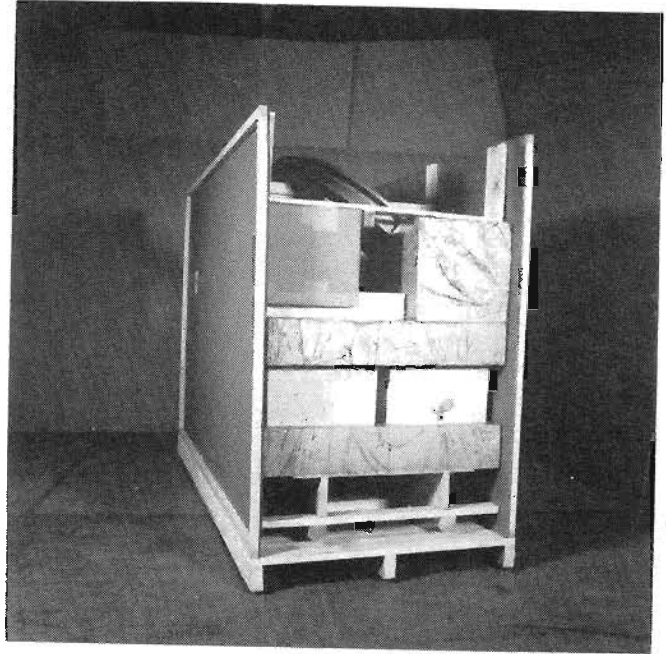

6



7

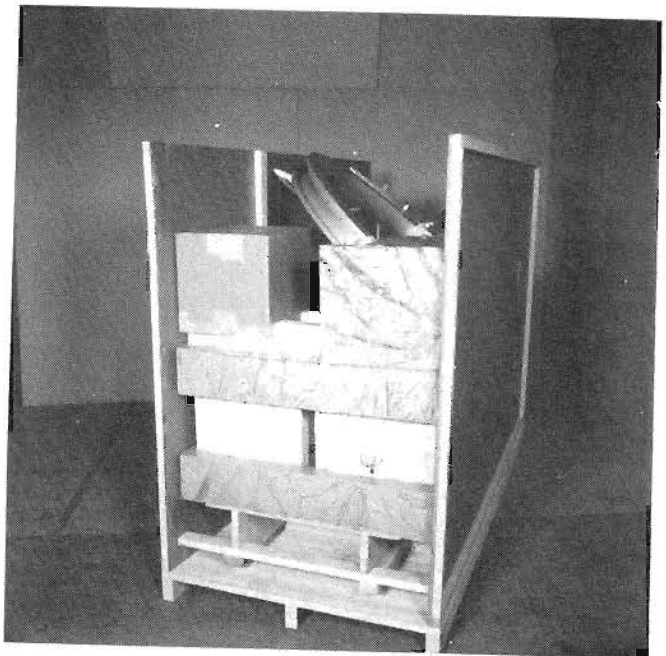

8

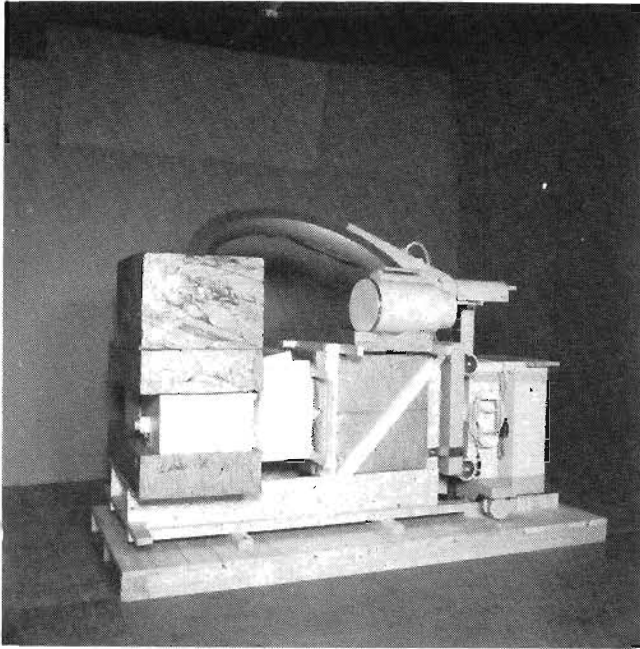

9

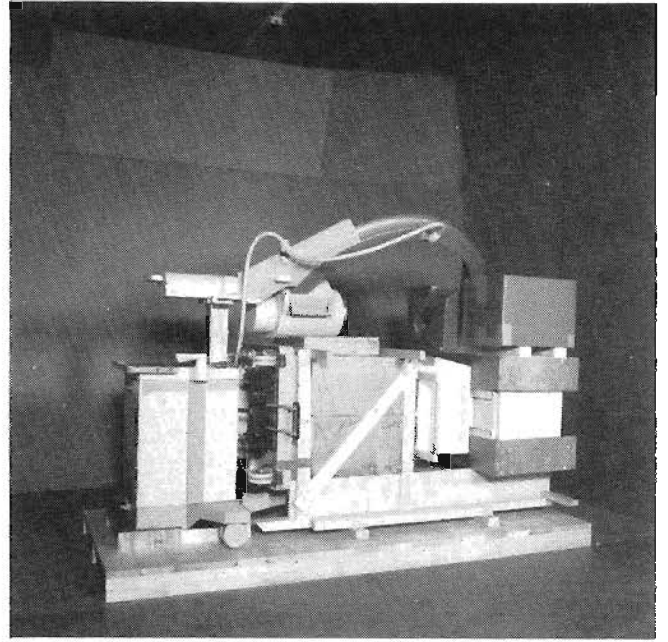

10

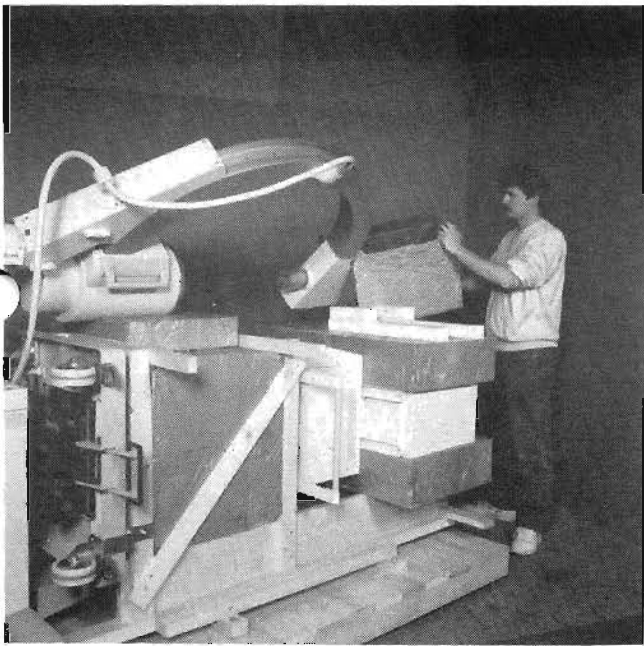

11

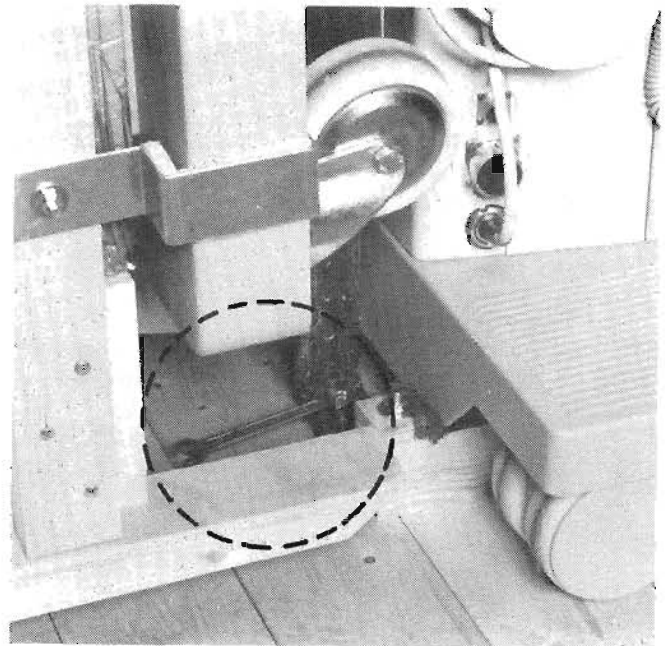

12

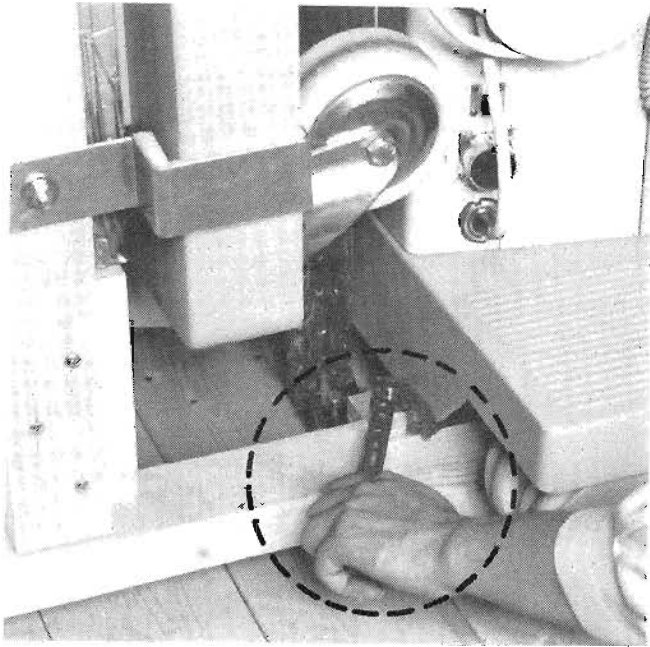

13

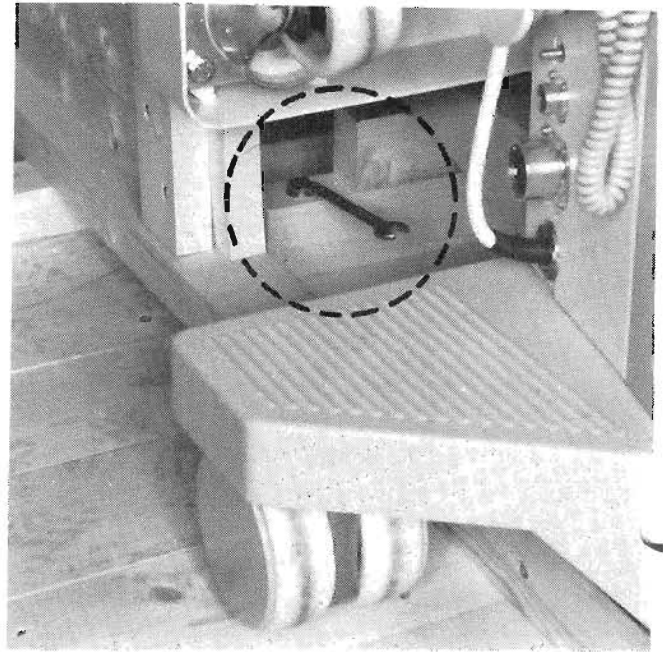

14

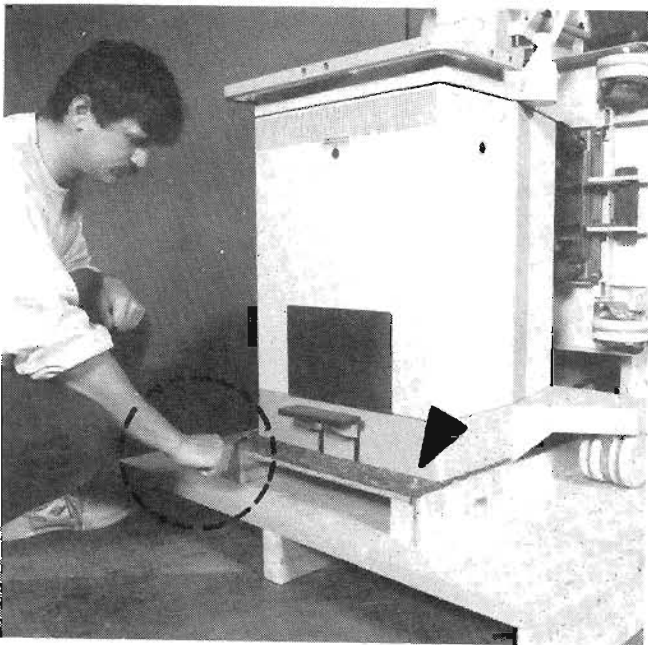

15

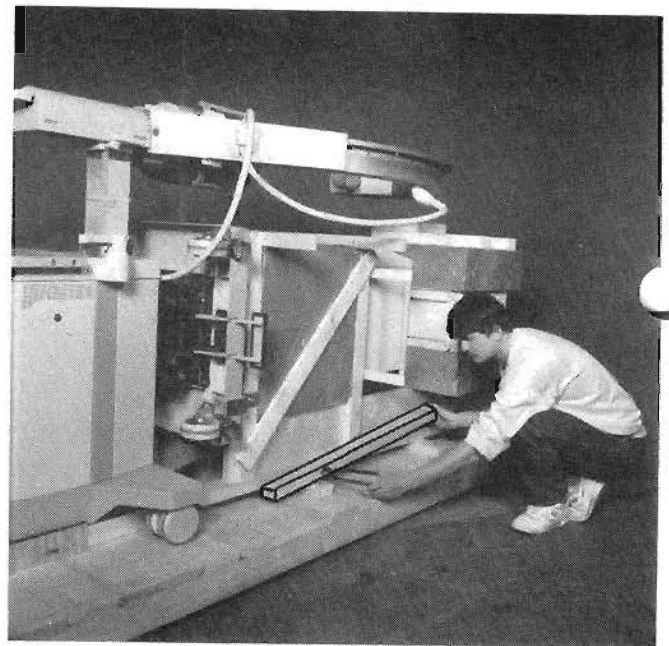

16

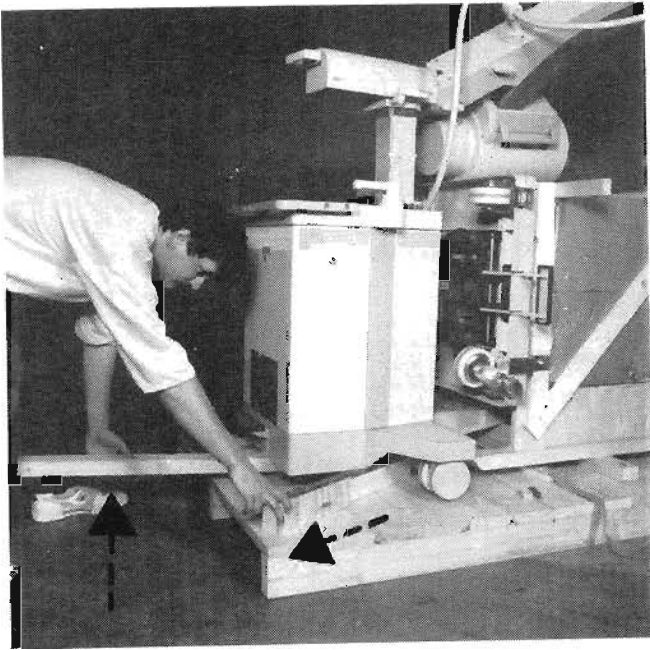

17

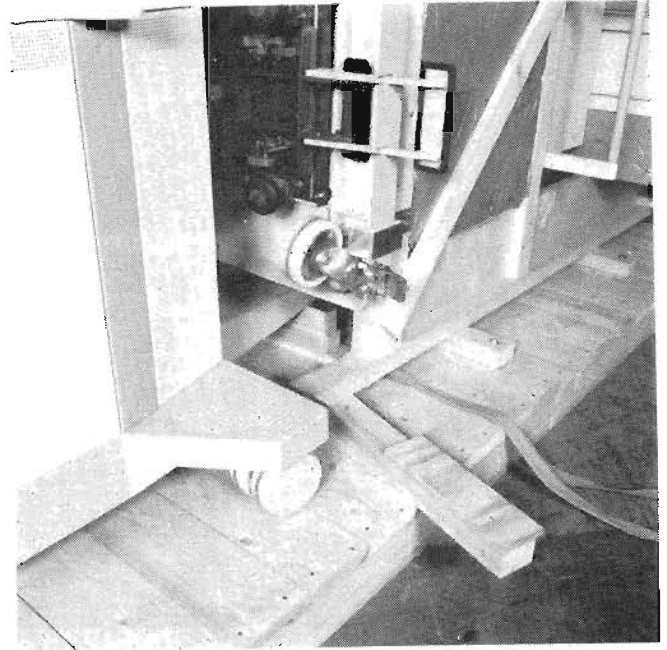

18

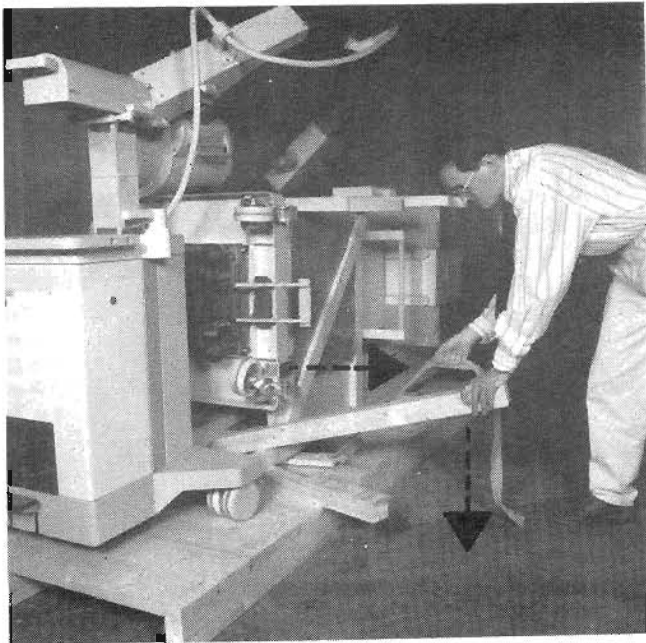

19

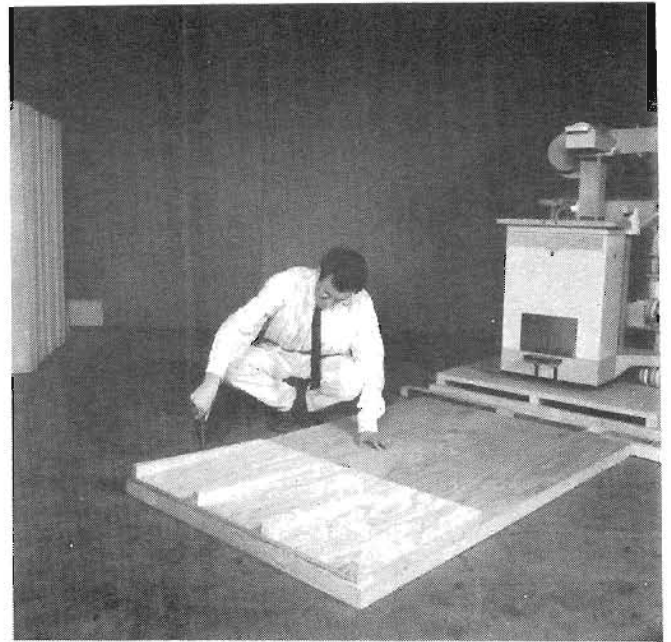

20

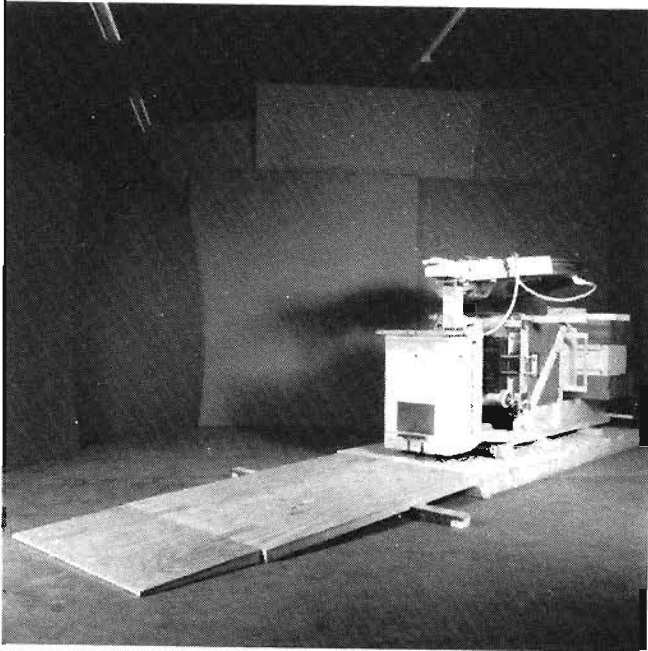

21

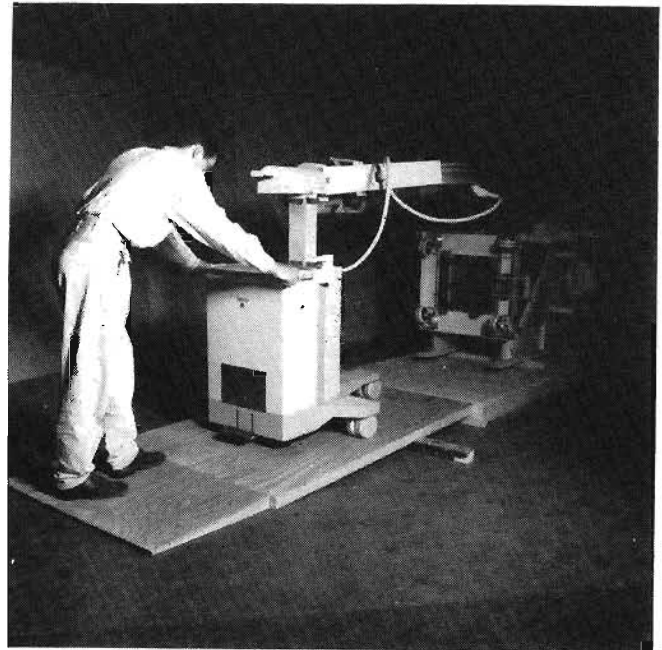

22

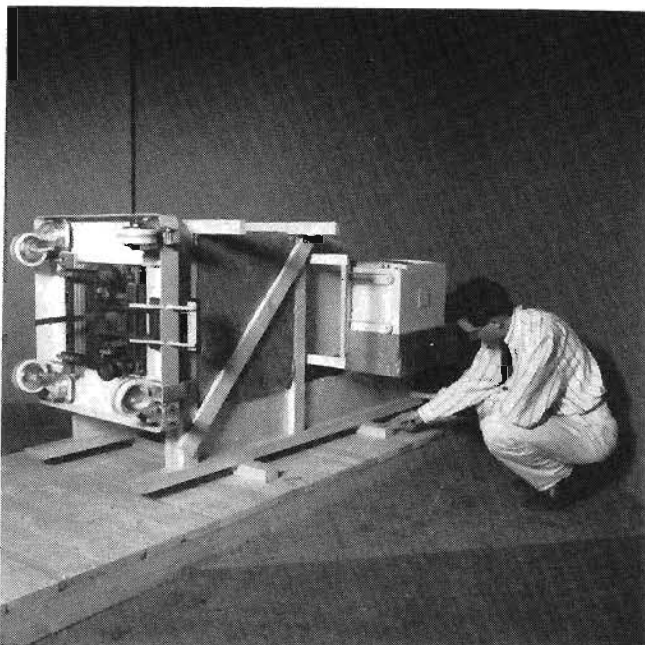

23

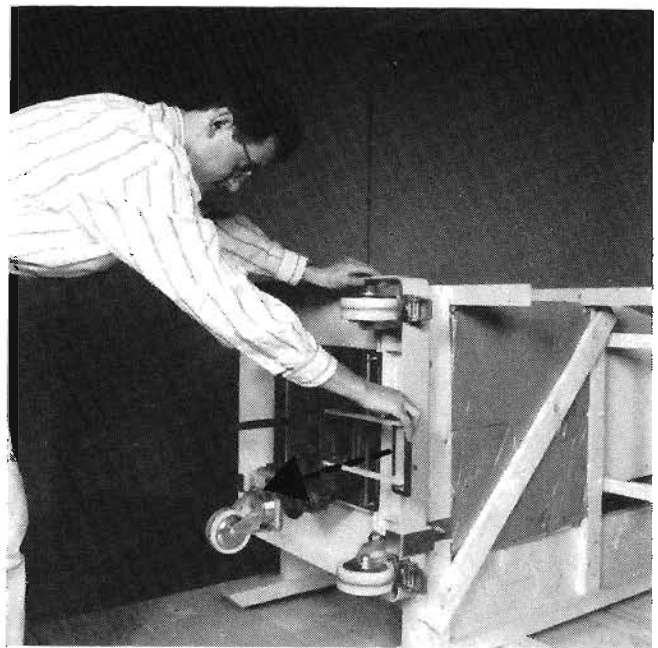

24

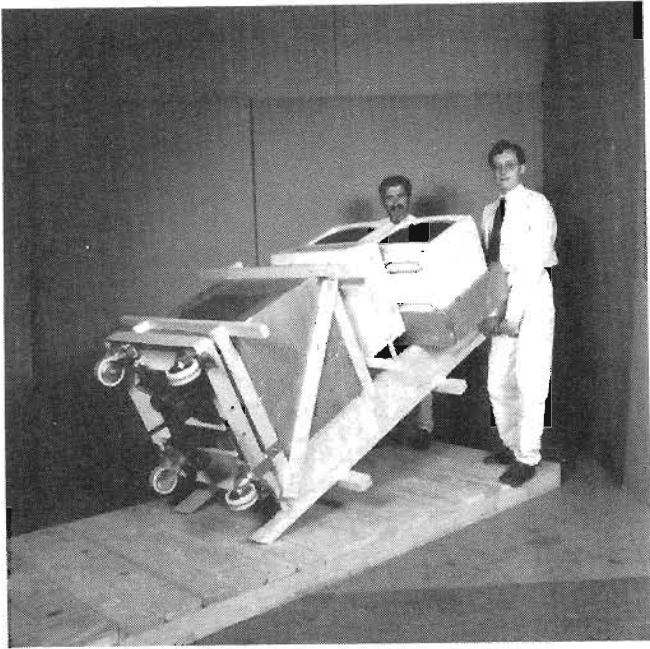

25

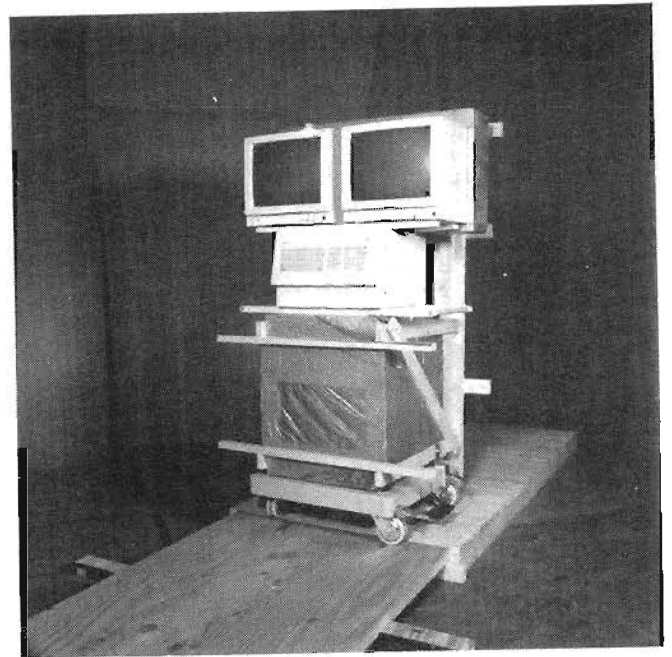

26

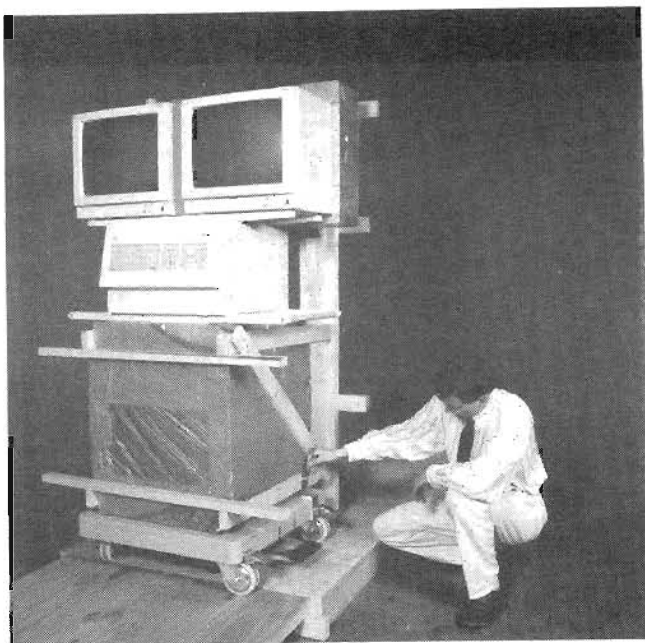

27

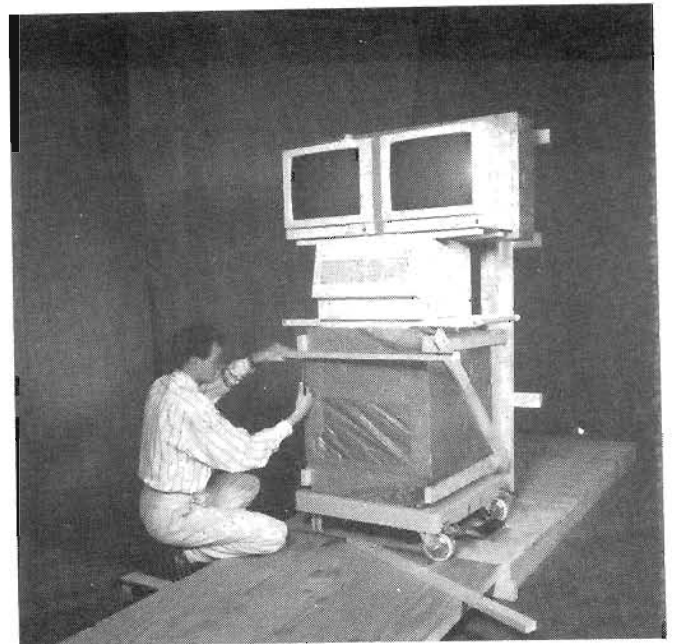

28

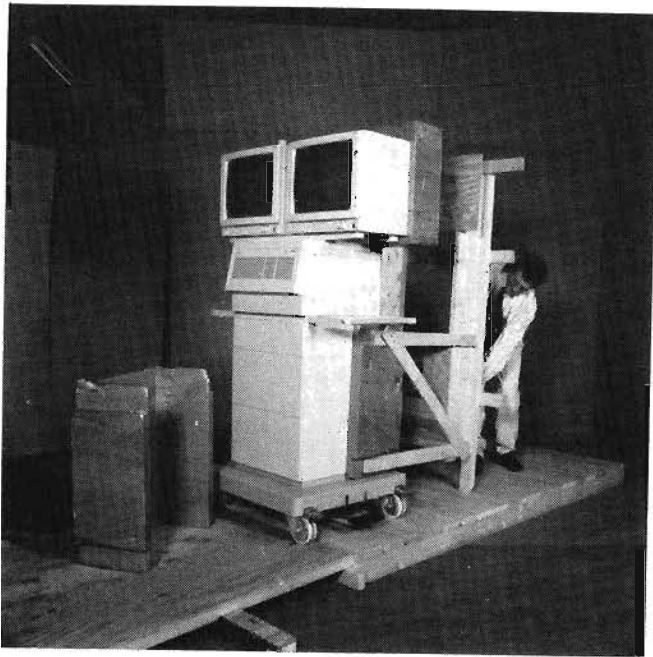

29

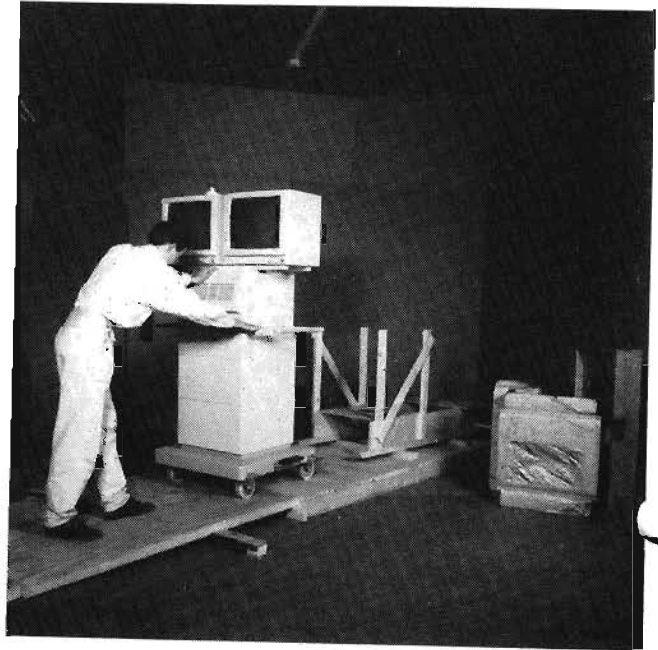

30

Section : **INSTALLATION INSTRUCTIONS**

Contents

1.	INTRODUCTION	4-2
2.	MAINS VOLTAGE ADAPTATION	4-2
2.1.	STANDARD DELIVERY	4-2
2.2.	MAINS VOLTAGE ADAPTATION STAND	4-3
2.3.	MAINS VOLTAGE ADAPTATION TROLLEY	4-4

1. INTRODUCTION

The BV29 is a pre-installed, pre-adjusted 50 Hz or 60 Hz dedicated system. This means that only the installation instructions mentioned in this section have to be carried out.

NOTE

It is recommended to connect the BV29 system to a separate phase group, in case more equipment uses the same group.

2. MAINS VOLTAGE ADAPTATION

The BV29 uses an internal voltage of 220 Vac.
The hospital mains supply can be:
100/110/120/127/200/210/220/240 Vac.
To adapt the BV29 to the different hospital voltages perform the procedure mentioned below.

NOTE

Perform the mains voltage procedure only in case the standard delivery is not correct.

2.1. STANDARD DELIVERY

For typenumbers for the BV29 versions can be found in the commercial catalogue. The following versions are available:

- IEC, 220 Vac, 50 Hz version.
- HHS, 120 Vac, 60 Hz version.
- IEC, 220 Vac, 60 Hz version.

2.2. MAINS VOLTAGE ADAPTATION STAND

To adapt the BV29 to the mains voltage proceed as follows:

- Remove the front cover of the Stand.
See photograph 1.
- Program the mains input voltage at terminal block WA100, by connecting the 6 programming wires according TABLE 1.
See photograph 2, item 1.
- Insert the proper fuses for F1 and F2.
See photograph 2, item 2.

NOTE

The fuses are delivered with the BV29 system delivery, and can be found in the box containing small items delivered.

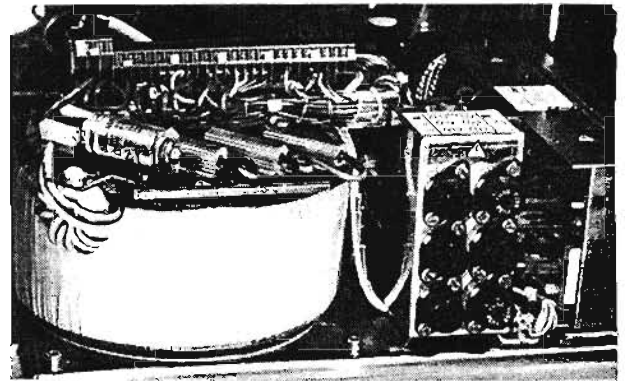
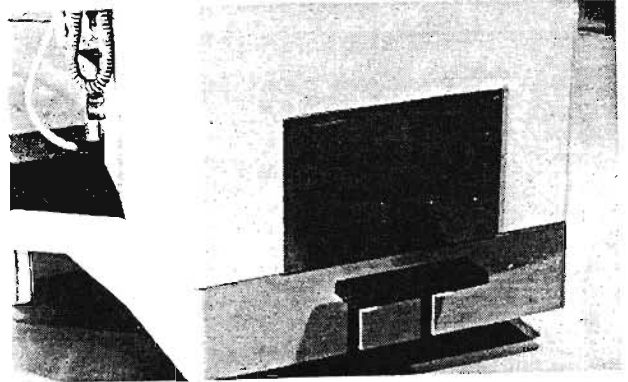

TABLE 1: Mains voltage programming

MAINS VOLTAGE	FUSES F1,F2	LEAD CONNECTED TO:					
		1	2	3	4	5	6
100 V	30 A	104	107	110	109	122	125
110 V	30 A	104	107	108	105	122	125
120 V	30 A	104	107	108	109	122	125
130 V	30 A	104	107	108	110	122	125
200 V	15 A	105	106	110	108	123	124
220 V	15 A	105	106	108	107	123	124
240 V	15 A	105	106	108	110	123	124

2.3. MAINS VOLTAGE ADAPTATION TROLLEY

In case of stand alone Trolley use.

To adapt the BV29 Trolley to the mains voltage proceed as follows:

- Remove cover
- Program on WT1:
 - . W1 and W2 in position 1-2 for 220 Vac
 - . W1 and W2 in position 2-3 for 120 Vac
- The fuses F1 and F2 are for all mains voltages 10 A.

For location of fuses, see rear side Trolley.

WT1
MAINS SWITCHING CIRCUIT

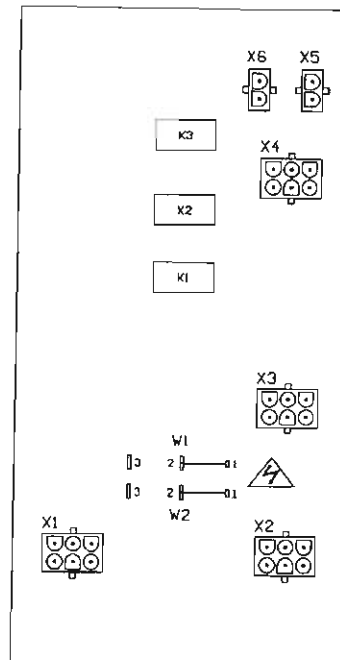

Section : **CABLING AND EARTHING**

Contents

1.	INTRODUCTION	5-2
2.	CABLING INSTRUCTIONS	5-2
3.	EARTHING	5-2
4.	CABLING DIAGRAM	5-3

1. INTRODUCTION

This section gives information about cabling instructions.

2. CABLING INSTRUCTIONS

Caution

*ADAPT THE BV29 TO THE MAINS VOLTAGE BEFORE CONNECTING THE CABLING
SEE SECTION 7 "SETTING TO WORK INSTRUCTIONS"*

The cables for connecting the:

1. BV29 Stand to the BV29 Trolley, length: 7 meters, (not labelled)
2. BV29 Stand to hospital mains, length: 7 meters, fixed at Stand-side.
3. BV29 Trolley to hospital mains, (only in case of stand alone use), length: 5 meters, not labelled.
There are two cables available with US and Europe mains plugs.
4. Footswitch cable.

are delivered with the BV29 system.

3. EARTHING

The BV29 system is connected to earth via the mains cable.

If required, connect the yellow/green equipotential conductor from the grounding pin at the mobile stand to the operating table.

The equipotential cable is delivered with the BV 29 system and can be found in the box containing the small items.

4. CABLING DIAGRAM

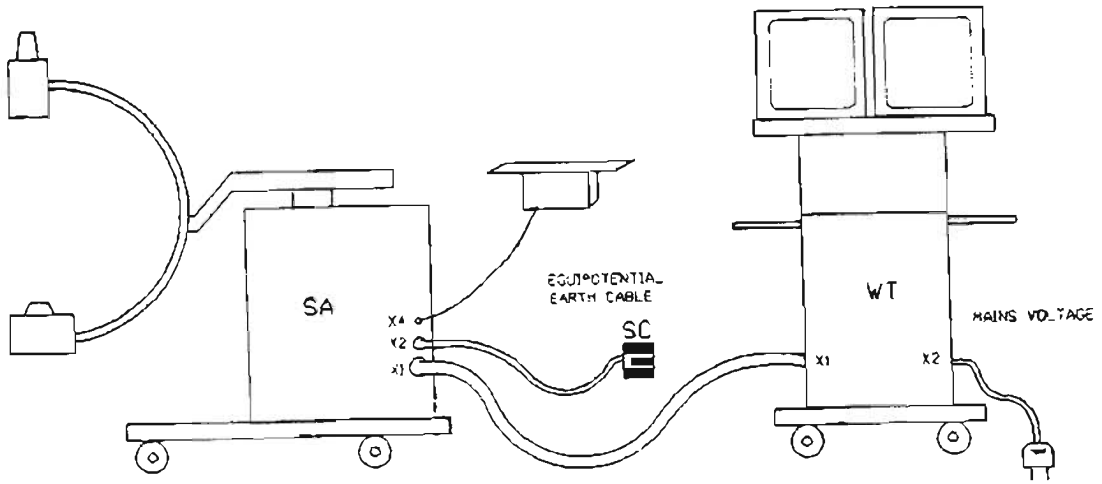

Section :

PROGRAMMINGS

Contents

1. **INTRODUCTION** 6-2

1. INTRODUCTION

A record of the programmings is given in the SYSTEM MANUAL CORRECTIVE MAINTENANCE, section 7: PROGRAMMING FACILITIES .

The factory delivered system settings are indicated by a *.

Section : **SETTING TO WORK INSTRUCTIONS**

Contents

1. INTRODUCTION 7-2

2. TEST EQUIPMENT 7-2

3. SETTING UP AND TESTING 7-2

3.1. SWITCHING ON THE BV29 7-2

3.2. WARMING UP PROCEDURE FOR THE X-RAY TUBE 7-3

3.3. FUNCTIONAL TESTS 7-4

3.3.1. CHECKING MOVEMENTS 7-4

3.3.2. CHECKING FLUOROSCOPY 7-4

3.3.3. CHECKING RADIOGRAPHY 7-4

3.3.4. CHECKING THE MMP SCOPOFIX 7-4

1. INTRODUCTION

The BV29 is a pre-assembled, pre-adjusted system, this means that no adjustments have to be carried out.

2. TEST EQUIPMENT

There is no special test equipment required for setting to work and checking the BV29 system.

3. SETTING UP AND TESTING

3.1. SWITCHING ON THE BV29

1. Connect the mains plug to the mains supply wall socket.
2. Switch on the BV29 system with the power on button on the stand control panel.
3. Switch on the TV monitors, if necessary.

3.2. WARMING UP PROCEDURE FOR THE X-RAY TUBE.

NOTE

PERFORM THE X-RAY WARMING-UP PROCEDURE ONLY IN CASE THE BV29 HAS NOT BEEN USED BEFORE, OR IN CASE THE BV29 HAS BEEN OUT OF USE FOR MORE THAN 3 MONTHS

1. Put a lead plate on the diaphragm cover to prevent damage of the TV-camera.
2. Switch on the BV29 system and select manual fluoroscopy at 40 kV.
3. Perform fluoroscopy as shown in the table.
4. Set jumper SE21:W4 in position 1-3; LED H2 will light up (large focus selected).
5. Select 80 kV.
6. Perform fluoroscopy for 90 sec.
7. Put jumper SE21:W4 back to position 1-2.

kV VALUE	TIME
40 kV	30 sec
50 kV	30 sec
60 kV	30 sec
70 kV	30 sec
PAUSE	60 sec
80 kV	30 sec
PAUSE	120 sec
90 kV	30 sec
PAUSE	120 sec
100 kV	30 sec
PAUSE	120 sec
100 kV	90 sec
PAUSE	120 sec

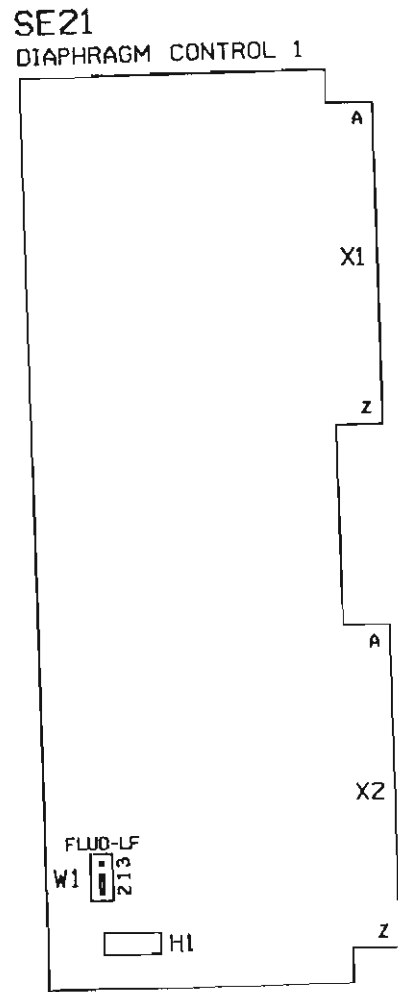

3.3. FUNCTIONAL TESTS

After the system is switched on, the following checks have to be performed to check the proper functioning of the BV 29 system.

The function of all operator controls and indicators are listed in the users manual.

In case the system does NOT function properly:
SEE SYSTEM MANUAL CORRECTIVE
MAINTENANCE BV29.

3.3.1. CHECKING MOVEMENTS

Check all movements of BV29 system as described in the users manual.

3.3.2. CHECKING FLUOROSCOPY

Check all functions of BV29 system as described in the users manual.

3.3.3. CHECKING RADIOGRAPHY

Check all functions of BV29 system as described in the users manual.

3.3.4. CHECKING THE MMP SCOPOFIX

Check all functions of BV29 system as described in the users manual.

INTRODUCTION & TOOLS 1 ►
QUICK CHECKS & ERROR LISTS

POWER-ON SEQUENCE & STAND-BY 2 ►

FLUOROSCOPY 3 ►

RADIOGRAPHY 4 ►

WHAT-TO-DO TABLES 5 ►

REPLACEMENT PROCEDURES 6 ►

PROGRAMMING FACILITIES 7 ►

ADJUSTMENT PROCEDURES 8 ►

PARTS LIST 9 ►

IMAGE PERFORMANCE CHECKS 10 ►

DRAWINGS 11 ►

SERVICE MANUAL UNIT
 BV29 CORRECTIVE MAINTENANCE

MODULE CODE NUMBER : 4522 983 50073

LIST OF PAGES AND DRAWINGS

0.5	(b/93.0)	3-6	(a/92.0)E
		3-7	(92.0)E
2.	(b/93.0)	4-1	(92.0)E
2.1	(b/93.0)	4-2	(92.0)E
2.2	(b/93.0)	4-3	(92.0)E
2.3	(b/93.0)	4-4	(92.0)E
1-1	(92.0)E	5-1	(92.0)E
1-2	(93.0)E	5-2	(a/93.0)E
1-3	(93.0)E		
1-4	(93.0)E	6-1	(92.0)E
1-5	(92.0)E	6-2	(92.0)E
1-6	(93.0)E	6-3	(92.0)E
1-7	(92.0)E	6-4	(92.0)E
1-8	(a/93.0)E	6-5	(92.0)E
1-9	(b/93.0)E	6-6	(92.0)E
1-10	(a/92.0)E	6-7	(92.0)E
1-11	(92.0)E	6-8	(92.0)E
1-12	(92.0)E	6-9	(92.0)E
1-13	(a/92.0)E	6-10	(92.0)E
1-14	(93.0)E	6-11	(92.0)E
		6-12	(92.0)E
2-1	(92.0)E	6-13	(92.0)E
2-2	(92.0)E	6-14	(92.0)E
2-3	(92.0)E	6-15	(92.0)E
2-4	(92.0)E	6-16	(92.0)E
2-5	(92.0)E	6-17	(92.0)E
2-6	(92.0)E	6-18	(92.0)E
2-7	(92.0)E	6-19	(92.0)E
2-8	(92.0)E	6-20	(92.0)E
2-9	(92.0)E	6-21	(92.0)E
2-10	(92.0)E	6-22	(92.0)E
2-11	(92.0)E	6-23	(92.0)E
2-12	(92.0)E	6-24	(92.0)E
2-13	(92.0)E	6-25	(92.0)E
		6-26	(92.0)E
		6-27	(92.0)E
		6-28	(92.0)E
3-1	(92.0)E		
3-2	(92.0)E		
3-3	(92.0)E		
3-4	(92.0)E		
3-5	(a/92.0)E		

7-1	(a/92.0)E	8-1	(b/93.0)E
7-2	(b/93.0)E	8-2	(a/93.0)E
7-3	(a/92.0)E	8-3	(a/93.0)E
7-4	(a/93.0)E	8-4	(a/93.0)E
7-5	(a/93.0)E	8-5	(a/93.0)E
7-6	(a/93.0)E	8-6	(b/93.0)E
7-7	(a/93.0)E	8-7	(a/93.0)E
7-8	(a/93.0)E	8-8	(b/93.0)E
7-9	(a/93.0)E	8-9	(a/93.0)E
7-10	(a/92.0)E	8-10	(a/93.0)E
7-11	(92.0)E	8-11	(a/93.0)E
7-12	(92.0)E	8-12	(b/93.0)E
7-13	(92.0)E	8-13	(b/93.0)E
7-14	(92.0)E	8-14	(b/93.0)E
7-15	(92.0)E	8-15	(a/93.0)E
7-16	(93.0)E	8-16	(b/93.0)E
7-17	(92.0)E	8-17	(a/93.0)E
7-18	(92.0)E	8-18	(b/93.0)E
7-19	(92.0)E	8-19	(b/93.0)E
7-20	(92.0)E	8-20	(a/93.0)E
7-21	(a/93.0)E	8-21	(a/93.0)E
7-22	(a/93.0)E	8-22	(a/93.0)E
7-23	(a/93.0)E	8-23	(a/93.0)E
7-24	(a/92.0)E	8-24	(a/93.0)E
7-25	(92.0)E	8-25	(a/93.0)E
7-26	(92.0)E	8-26	(a/93.0)E
7-27	(92.0)E	8-27	(b/93.0)E
7-28	(92.0)E	8-28	(b/93.0)E
7-29	(92.0)E	8-29	(b/93.0)E
7-30	(92.0)E	8-30	(b/93.0)E
7-31	(92.0)E	8-31	(b/93.0)E
7-32	(92.0)E	8-32	(b/93.0)E
7-33	(a/93.0)E	8-33	(b/93.0)E
7-34	(a/93.0)E	8-34	(b/93.0)E
7-35	(a/93.0)E	8-35	(92.0)E
7-36	(92.0)E	8-36	(92.0)E
7-37	(a/92.0)E	8-37	(92.0)E
7-38	(b/93.0)E	8-38	(92.0)E
7-39	(b/93.0)E	8-39	(92.0)E
7-40	(a/92.0)E	8-40	(92.0)E
7-41	(b/93.0)E	8-41	(92.0)E
7-42	(b/93.0)E	8-42	(92.0)E
7-43	(92.0)E	8-43	(92.0)E
7-44	(92.0)E	8-44	(92.0)E
		8-45	(92.0)E
		8-46	(92.0)E
		8-47	(92.0)E
		8-48	(92.0)E
		8-49	(92.0)E
		8-50	(92.0)E

8-51	(92.0)E
8-52	(92.0)E
8-53	(93.0)E
8-54	(93.0)E
8-55	(93.0)E
8-56	(93.0)E
8-57	(93.0)E
8-58	(93.0)E
8-59	(93.0)E
8-60	(93.0)E
8-61	(93.0)E
8-62	(93.0)E
8-63	(93.0)E
8-64	(93.0)E
8-65	(93.0)E
8-66	(93.0)E Transparent sheet

Z0-1	(92.0)
Z0-2	(93.0)
Z0-3	(93.0)
Z0-4	(93.0)
Z0-5	(93.0)
Z0-6	(93.0)

Z1-1	(a/93.0)
Z1-2	(a/93.0)
Z1-3	(a/93.0)
Z1-4	(93.0)
Z1-5	(a/93.0)
Z1-6	(a/93.0)
Z1-7	(b/93.0)
Z1-8	(93.0)
Z1-9	(a/93.0)
Z1-10	(b/93.0)
Z1-11	(a/93.0)
Z1-12	(93.0)
Z1-13	(a/93.0)

Z2-1	(93.0)
Z2-2	(a/93.0)
Z2-3	(b/93.0)
Z2-4	(b/93.0)
Z2-5	(b/93.0)
Z2-6	(92.0)
Z2-7	(a/93.0)

Z3-1	(92.0)
Z3-2	(a/93.0)
Z3-3	(92.0)
Z3-4	(a/93.0)
Z3-5	(a/93.0)

Section : INTRODUCTION & QUICK CHECKS

Contents

1.	INTRODUCTION	1-2
2.	TOOLS	1-2
3.	QUICK CHECKS - COVERS CLOSED	1-2
3.1.	SERVICE INDICATION CHECK	1-3
3.1.1.	CHECK AT FLAT PANEL (ON BV29-STAND)	1-3
3.1.2.	CHECK AT MEMORY BOX PANEL (ON BV29-TROLLEY)	1-3
4.	QUICK CHECKS - BV29 COVERS OPENED	1-4
4.1.	XRC-UNIT TEST	1-4
4.1.1.	INTRODUCTION	1-4
4.1.2.	PROCEDURE	1-4
4.2.	FPC UNIT TEST	1-5
4.2.1.	INTRODUCTION	1-5
4.2.2.	PROCEDURE	1-5
4.3.	MBC-UNIT TEST	1-9
4.3.1.	INTRODUCTION	1-9
4.3.2.	PROCEDURE	1-9
4.4.	CAN COMMUNICATION	1-12
5.	ERROR LISTS	1-13
5.1.	ALARM INDICATORS (ON BV29-STAND)	1-13
5.2.	NOT READY INDICATORS (ON BV29-STAND)	1-13
6.	ALARM HISTORY INDEX	1-14
6.1.	INTRODUCTION	1-14
6.2.	PROCEDURE	1-14

1. INTRODUCTION

This section contains information about:

- quick checks
- errors (not ready/alarm indications)
- alarm history index
- tools required

2. TOOLS

- Standard toolset
- Oscilloscope
- Rofo meter / PTW Dali
- Multimeter
- Funkline phantom

3. QUICK CHECKS - COVERS CLOSED

The following QUICK CHECKS can be performed without opening the covers of the BV29 system:
SEE NEXT PAGE.

3.1. SERVICE INDICATION CHECK

3.1.1. CHECK AT FLAT PANEL (ON BV29-STAND)

Pressing the buttons "SWITCH-ON SYSTEM" and "HIDDEN SWITCH" simultaneously activates the service indication check.

All LCD displays and lamps are ON, on both FLATPANEL and on MEMORY BOX CONTROL PANEL, radiation lamp on TV monitor "ON" and bell sounds.

This test checks:

- All LCD indicators on FP.
- All lamps on both FP as MB-panel; incl. rad lamp and bell.
- Communication between FPC and MBC.

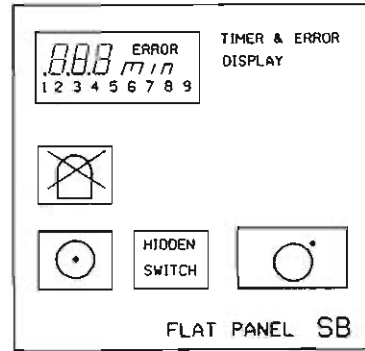

NOTES:

- Additionally all LEDs on FPC and MBC board are activated, and all LEDs on XRC-unit.
- If test fails run the FPC-test, see CHAPTER 4.2.

3.1.2. CHECK AT MEMORY BOX PANEL (ON BV29-TROLLEY)

Pressing the buttons "ACC" and "HIDDEN SWITCH" simultaneously activates the service indication check. All LCD displays and lamps are ON, on both FLATPANEL and on MEMORY BOX CONTROL PANEL, radiation lamp on TV monitor "ON" and bell sounds.

This test checks:

- All LCD indicators on FP.
- All lamps on both FP as MB-panel; incl. rad lamp and bell.
- Communication between FPC and MBC.

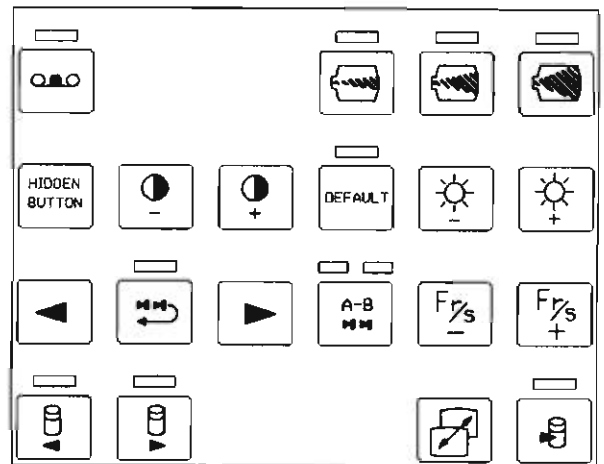

NOTES:

- Additionally all LEDs on FPC and MBC board are activated, and all LEDs on XRC-unit.
- If test fails run the MBC-TEST, see CHAPTER 4.3.

4. QUICK CHECKS - BV29 COVERS OPENED

4.1. XRC-UNIT TEST

4.1.1. INTRODUCTION

This test checks:

- SE13 board (EPROM/RAM/IO).
- Communication possible between SE13 and SE15/SE17/SE19 and SE21 by sending data to the IO ports.

4.1.2. PROCEDURE

- Remove the front and side covers of the BV29 STAND.
- Set switch SE13:S2-1 in position "ON" (= SERVICE MODE).
- The XRC test starts immediately.
- The SE13:H1-RUN led stops flashing.
- Board SE13 up to and including board SE21 are tested.

Board under test indicated as follows:

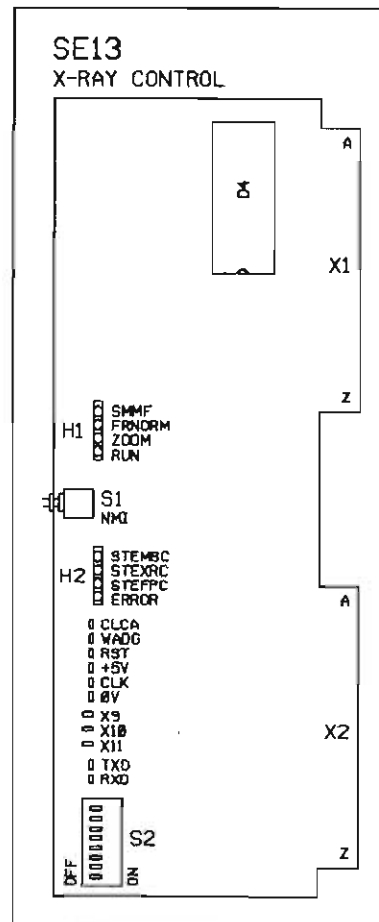

SE13	SE15	SE17	SE19	SE21	NOT USED	WATCH DOG	INDICATOR
X	0	X	0	X	0	X	SE13:H1-STEMBC
0	X	X	0	0	X	X	SE13:H1-STEXRC
0	0	0	X	X	X	X	SE13:H1-STEFPC
0	0	0	0	0	0	0	SE13:H1-ERROR

X = INDICATOR (LED) "ON"
 0 = INDICATOR (LED) "OFF"

In case a test fails the error led flashes with the corresponding board number.
 In case of NO ERRORS the test repeats itself automatically.

- Exit XRC-unit test:
 - . Put switch SE13:S2-1 in position "OFF"
 - . Press switch SE13:S1 (XRC reset).

4.2. FPC UNIT TEST

4.2.1. INTRODUCTION

This test checks:

- Flat panel (SB1).
- Flat panel controller (SB2).

4.2.2. PROCEDURE

- Remove the front and side covers of the BV29 STAND.
- Set switch SB2:S1-1 in position "ON" (= SERVICE MODE).
- The SB2:H1-RUN led stops flashing.
- The SB2:H1-TEST led will light-up.
- There are 15 tests which can be performed by pressing the HANDSWITCH FLUO COMMAND.
- The following tests can be performed, see TABLE 1.
- The TEST-number is displayed in the Fluo kV display.
- The test results are displayed as follows, see TABLE 1.

- Press handswitch (fluo command) until test-number is visible in the kV FLUO DISPLAY.
- Release handswitch, a beep is audible which means that the selected test has been executed.

NOTE:

- Results of TEST 04 up to and including TEST 14 can only be checked visually.

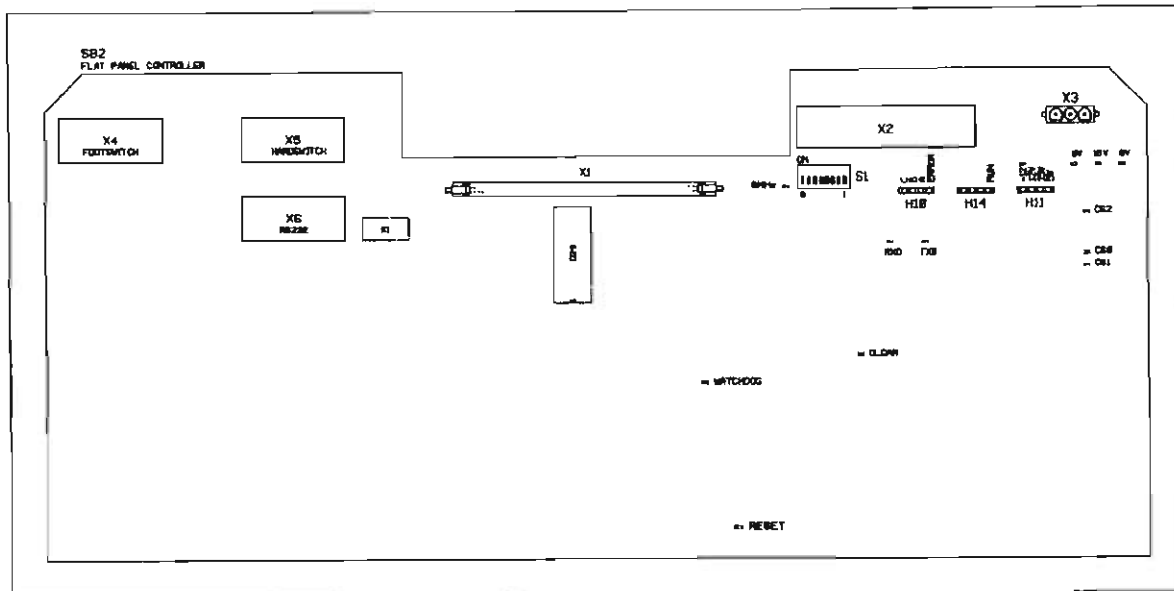

TABLE 1:

TEST-NR DISPLAYED IN KV-FLUO DISPLAY	TEST	RESULT OF TEST DISPLAYED IN	TEST RESULT WHEN OK
01	EPROM CHECKSUM	FLUO TIMER DISPLAY	00
02	RAM CHECK	FLUO TIMER DISPLAY	00 (errors)
03	IO CHECK	FLUO TIMER DISPLAY	00 (errors)
04	FLUO TIMER LCD CHECK	FLUO TIMER DISPLAY	969 - 696 - . . - MIN - displayed 3 times.
05	FLUO TIMER ERROR INDICATION CHECK	FLUO TIMER DISPLAY	All error-nr indicators displayed, 3 times.
06	FLUO KV DISPLAY CHECK	FLUO KV DISPLAY	169 - 96 - kV - mA displayed 3 times, g.
07	FLUO mA DISPLAY CHECK	FLUO mA DISPLAY	69 - 96 - . . - kV - mA displayed 3 times.
08	RAD KV DISPLAY CHECK;	RAD KV DISPLAY	169 - 96 - kV - mAs displayed 3 times.
09	RAD mAs DISPLAY CHECK	RAD mAs DISPLAY	69 - 96 - . . - kV - mAs displayed 3 times.
10	DISPLAY AND BELL CHECK	FPC DISPLAY	All LCD-Displays and bell activated simultaneously, 3 times.
11	LED CHECK	FPC DISPLAY	All LEDs activated simultaneously, 3 times.
12	SINGLE LED CHECK	FPC DISPLAY	All LEDs activated sequentially, 3 times.
13	BELL CHECK		Bell sounds, 3 times.

14	SWITCH CHECK	FLUO kV DISPLAY, FLUO mA DISPLAY	<p>Each switch has its own code; activated when pressed, displayed in FLUO kV display.</p> <p>Second switch pressed when holding first pressed switch, is displayed in FLUO mA DISPLAY.</p> <p>For switch-codes, see TABLE 2.</p> <p>No switch activated; 77 77 displayed in kV and mA displays.</p>
15	WATCHDOG CHECK	FLUO TIMER DISPLAY	<p>increasing value displayed, starting at 20 and ending at 130, with steps of 10.</p> <p>When 130 (msec) is reached a RESET is generated and test jumps to TEST-NR 00, displaying 130 in FLUO TIMER DISPLAY.</p>

NOTE:

If test 01-10-13-15 fails: replace Flat panel controller.

The other tests CANNOT INDICATE WHETHER THE FLAT PANEL or FLAT PANEL CONTROLLER IS DEFECTIVE.

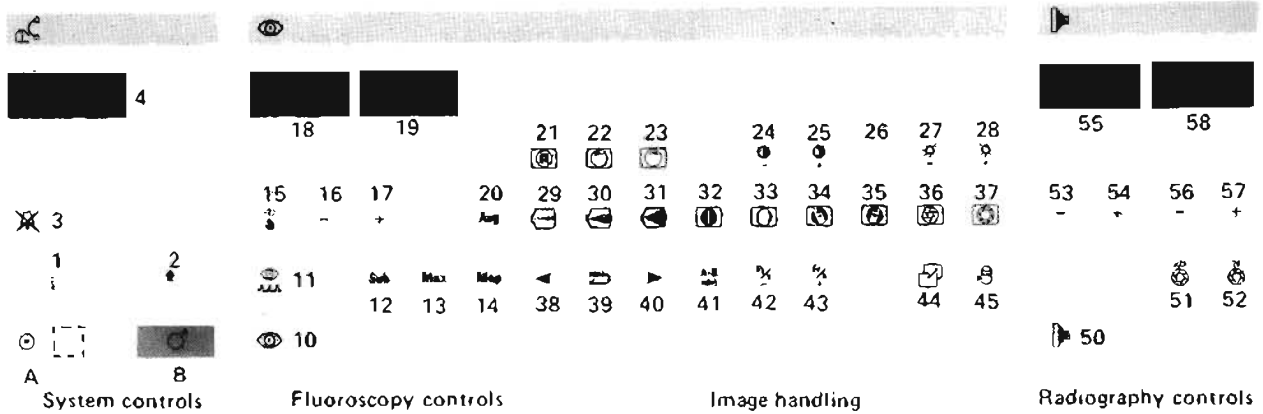

TABLE 2:

A->00	B->	3->03	10->10	11->01	12->21	13->31	14->41	15->13	16->23
17->33	20->53	21->55	22->65	23->06	24->26	25->36	26->46	27->56	28->66
29->63	30->04	31->14	32->24	33->34	34->44	35->54	36->64	37->05	38->51
39->61	40->02	41->12	42->22	43->32	44->52	45->62	50->20	51->	52->72
53->15	54->25	56->35	57->45	HID. SW.-> 70					

- SELECTING AND EXECUTING A SPECIFIC TEST:

- . SET switch SB2:S1-4 in position "ON".
- . Press handswitch and select the test MINUS 1.
- . Put switch SB2:S1-4 back in position "OFF".
- . The selected test is automatically executed.

- REPEATING A SELECTED TEST:

- . SET switch SB2:S1-4 in position "ON".
- . Press handswitch and select the test to be repeated MINUS 1.
- . Set switch SB2:S1-3 in position "ON".
- . Put switch SB2:S1-4 back in position "OFF".
- . The selected test is automatically executed, and repeated.

- PERFORMING FAST TEST

- . SET switch SB2:S1-2 in position "ON".
- . All tests performed 10 times faster.

NOTE:

This fast test can be performed in combination with NORMAL/FAST/REPEATED tests.

- EXIT FPC TEST MODE

- . Put switch SB2:S1-1 in position "OFF".
- . Press SE13:S1 (XRC reset).

4.3. MBC-UNIT TEST

4.3.1. INTRODUCTION

This test checks MEMORY BOX CONTROL (WT2).

4.3.2. PROCEDURE

- Remove 4 screws on both side of the MMP.
- Pull out the MMP-unit.
- Press the <ACC> button on MEMORY BOX PANEL (to leave patient ID area).
- Set switch WT2:S1-1 in position "ON" (= SERVICE MODE).
- The WT2:H1-RUN led stops flashing.
- The WT2:H2-MMPNR led lights-up.
- The WT2:H1-TEST led lights-up.
- The following information is given on the TV-monitor:

"START TEST PROG press hidden".

- Start test by pressing the "HIDDEN" switch on MEMORY BOX PANEL.
- Results of test displayed on TV-monitor.
- Next test use "HIDDEN" switch.
- The test and results are displayed on TV-monitor as follows, see TABLE 3.

TABLE 3:

TEST NR	TEST	RESULTS	REMARK
01	EPROM 1 TEST	checksum = ...	press hidden
02	EPROM 2 TEST	checksum = ...	press hidden
03	RAM TEST	NO ERRORS	press hidden
04	EEPROM TEST	NO ERRORS	press hidden
05	IO TEST	00 ERRORS	press hidden
06	LED TEST	All lamps on MBC light-up simultaneously, bell sounds, Rad lamp on TV-monitor "on". Executed 3 times.	press hidden
07	SINGLE LED TEST	All lamps on MBC light-up one after one, bell sounds, Rad lamp on TV-monitor "on". Executed 3 times.	press hidden
08	BELL TEST	Bell sounds 3 times	press hidden
09	SWITCH TEST	see TABLE 4.	
10	WATCHDOG TEST	counting from 020 up to 130 msec with steps of 10 msec. when 130 msec is reached a reset is given.	

NOTES:

- Results of TEST 04 up to and including TEST 09 can only be checked visually.
- In case a test fails replace the WT2 board.

- SELECTING AND EXECUTING A SPECIFIC TEST

- . SET switch WT2:S1-4 in position "ON"
- . Press hidden switch and select the test MINUS 1. (i.e. to run test 11, select test 10).
- . Put switch WT2:S1-4 in position "OFF".
- . Press hidden switch.

- REPEATING A SPECIFIC TEST:

- . SET switch WT2:S1-4 in position "ON"
- . Press hidden switch and select the test to be repeated.
- . Set switch WT2:S1-3 in position "ON".
- . Put switch WT2:S1-4 in position "OFF".
- . Press hidden switch.
- . Put switch WT2:S1-3 in position "OFF" to stop the test.

- PERFORMING FAST TEST
 - . SET switch WT2:S1-2 in position "ON"
 - . All tests will be performed 10 times faster.

NOTE:
This fast test can be performed in combination with NORMAL/FAST/REPEATED tests.

- EXIT MBC-TEST
 - . Put switch WT2:S1-1 in position "OFF".
 - . Give reset on MBC with WT2:S2.

TABLE 4:

A->96	B->A3	C->67	D->76	E->85	F->66	G->56	H->A2	I->91	J->92
K->82	L->72	M->83	N->93	O->81	P->71	Q->A5	R->75	S->86	T->65
U->A1	V->56	W->95	X->77	Y->55	Z->87				
1->A4	2->94	3->84	4->74	5->64	6->54	7->A0	8->90	9->80	0->70
;->61	;->51	,->62	RET ->52	SPACE RIGHT ->63	SPACE LEFT ->A7	SHIFT ->A6	BACK SPACE ->50	=->60	.->73
61->25	62->27	63->36	64->16	65->26	66->44	67->34	68->24	69->14	
81->04	82->20	83->10	84->00	85->41	86->31	87->21	88->11	89->01	90->06
91->42	92->32	93->22	94->12	95->02	96->07	97->43	98->13	99->03	

- NOTE:
- Switches with lamps; also lamps activated
 - For UPPER CASE symbols: Press shift and symbol.
Displayed as follows (example):
SHIFT + A -> A6 (code for shift) + 96 (code for A).

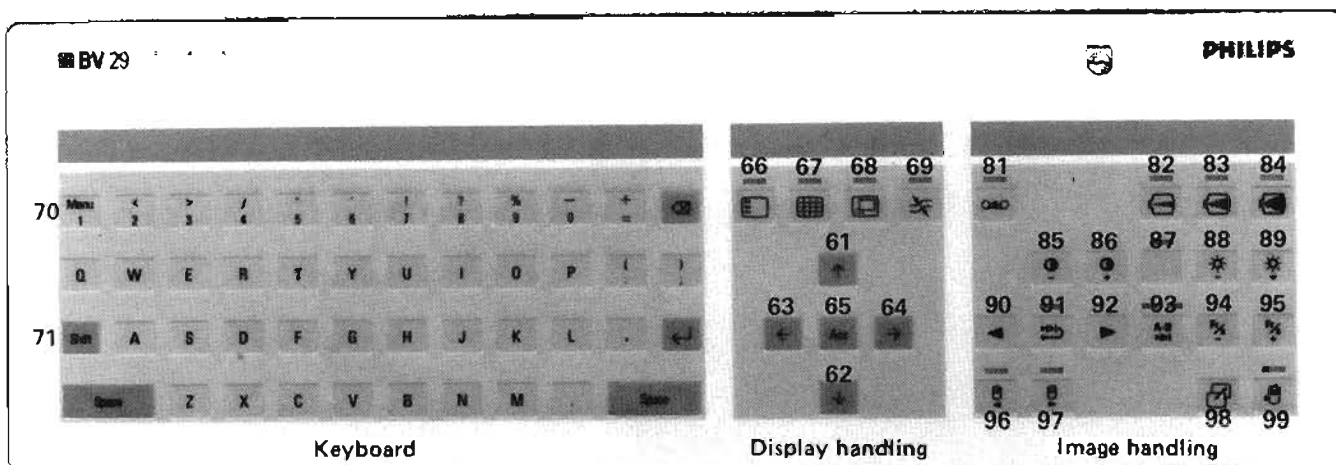

4.4. CAN COMMUNICATION

The communication between FPC-MBC-XRC is done via CAN interfaces.

CAN = Control Area Network.

The CAN communication is continuously monitored. In case a communication error occurs an alarm is generated and displayed by a FLASHING LED on the SE13 board, where:

- STEMBC = Serial transmission error MBC
- STEXRC = Serial transmission error XRC
- STEFPC = Serial transmission error FPC

That means that in case of an STEMBC error, NO COMMUNICATION possible with MBC.

Check CAN-interface MBC.

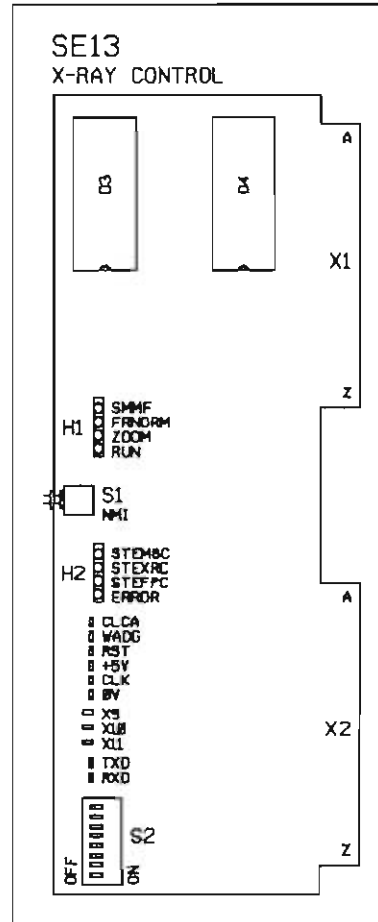

5. ERROR LISTS

SEE FLOWCHARTS AND DRAWINGS FOR INFORMATION HOW TO SOLVE THE ERRORS.

5.1. ALARM INDICATORS (ON BV29-STAND)

In case of an ALARM, the indicator ERROR and the ERROR-NUMBER are flashing, displayed in the FLUO TIMER DISPLAY.

ERROR-NUMBER	DESCRIPTION
ERROR 1	TV ALARM
ERROR 2	FILAMENT ALARM
ERROR 3	INVERTOR ALARM
ERROR 4	MAINS CONTROL UNIT ALARM
ERROR 5	TANK TEMPERATURE ALARM
ERROR 6	TIMER ALARM
ERROR 7	SYSTEM CLOCK ALARM

5.2. NOT READY INDICATORS (ON BV29-STAND)

In case of a NOT READY SITUATION, the indicators ERROR and the ERROR-NUMBER are displayed when the "HIDDEN KEY" button is pressed on the flatpanel control, for location of HIDDEN SWITCH see para 3.1.

In case more NOT READY SITUATIONS are present, ALL NOT READY SITUATIONS are displayed in the FLUO TIMER DISPLAY.

ERROR-NUMBER	DESCRIPTION
ERROR 1	HIGH VOLTAGE NOT READY
ERROR 2	KEYSWITCH NOT READY
ERROR 3	DIAPHRAGM NOT READY
ERROR 4	MMP/MBC NOT READY
ERROR 5	STAND POWER SUPPLY NOT READY
ERROR 6	FLAT PANEL CONTROL NOT READY
ERROR 7	FLUO BOOST NOT READY
ERROR 8	FLUOROSCOPY TIMER NOT READY
ERROR 9	X-RAY CONTROL NOT READY

6. ALARM HISTORY INDEX

The ALARM HISTORY INDEX operable ONLY in case VIDEO MEMORY EXTENSION OPTION is present.

6.1. INTRODUCTION

The ALARM HISTORY INDEX stores the STATUS OF THE FLAT PANEL at moment error occurs.

The date and time of occurrence are also stored.

A total of 100 errors can be stored in the ALARM HISTORY INDEX.

(Alarm 101 will overwrite alarm 001).

The contents of the ALARM HISTORY INDEX are shown on:

- TV-monitor
- Flat panel.

6.2. PROCEDURE

- Press <ACC> on MEMORY BOX PANEL (to leave patient ID area).
- Press HIDDEN SWITCH and BELL button SIMULTANUOUSLY on FLAT PANEL,
- Indication ALARM HISTORY INDEX activated:
Lamps TEXT ON DISPLAY/MOSAIC/ZOOM/MEASUREMENT -on MEMORY BOX PANEL- flashing.

- The following ALARM HISTORY INDEX will be displayed on the TV-monitor,
(example):

Always last alarm situation displayed.

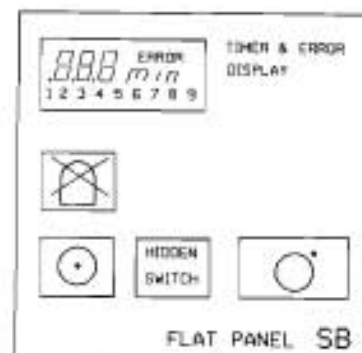
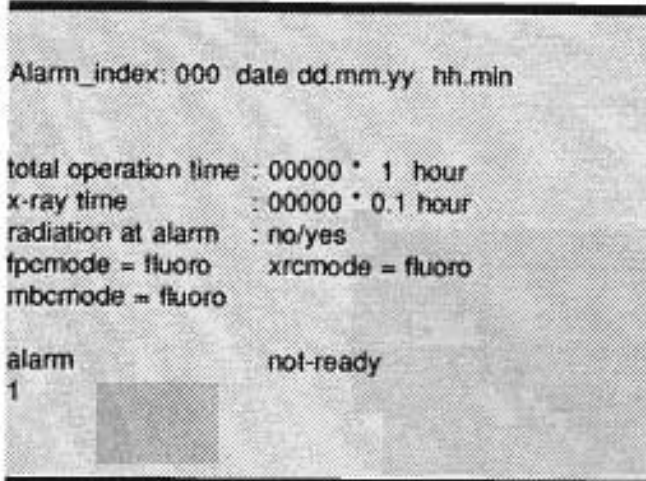

- The STATUS OF THE FLAT PANEL at moment of error is shown on the FLAT PANEL.
- In case radiation present at moment error occurrence also RAD LAMP on TV-monitor "ON".
- The last error is always displayed first.

With FR+/FR- button on FLAT PANEL stepping through ALARM HISTORY INDEX POSSIBLE.

Section : **POWER-UP & SYSTEM CHECK**

Contents

POWER-UP & SYSTEM CHECK FLOWCHARTS

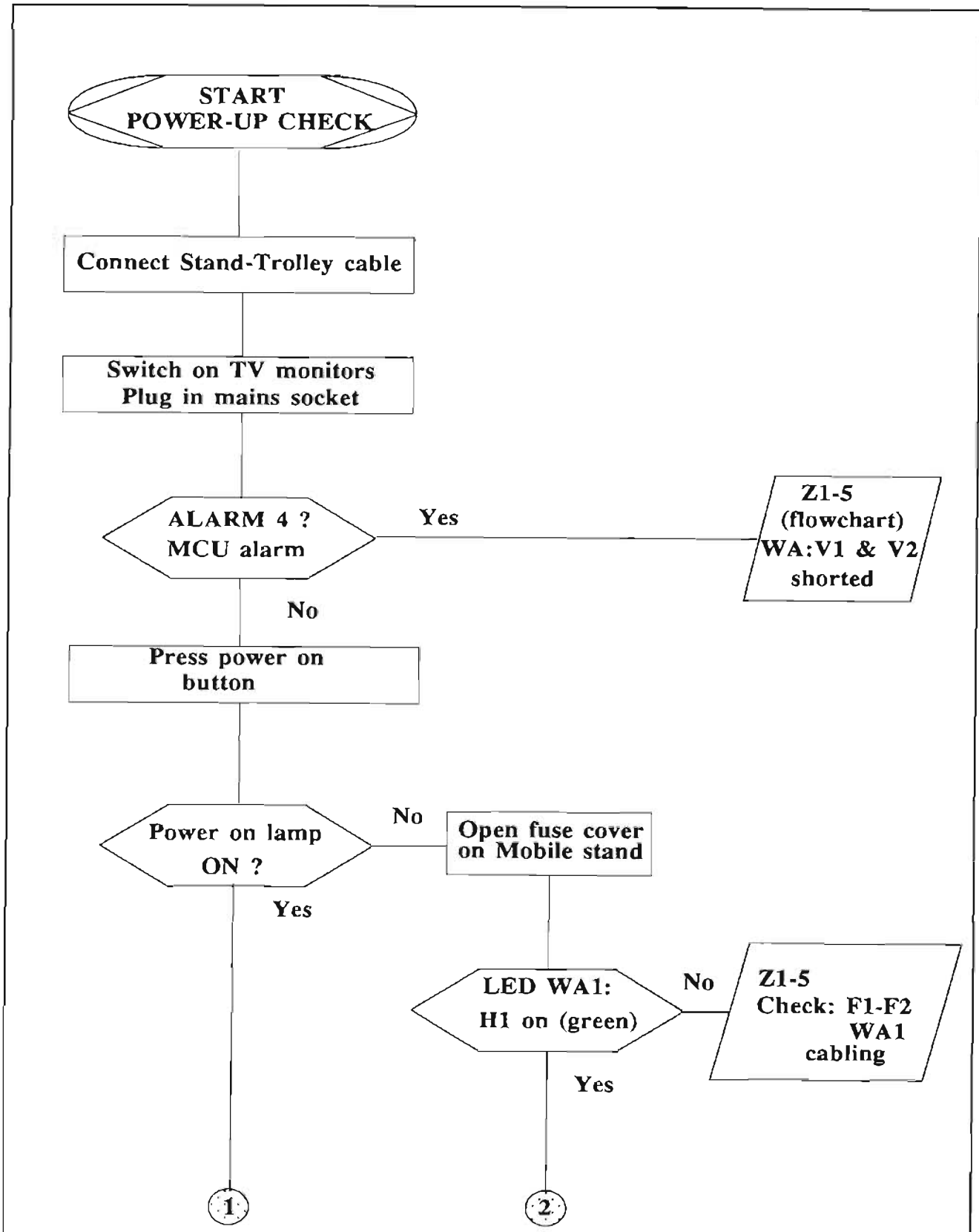

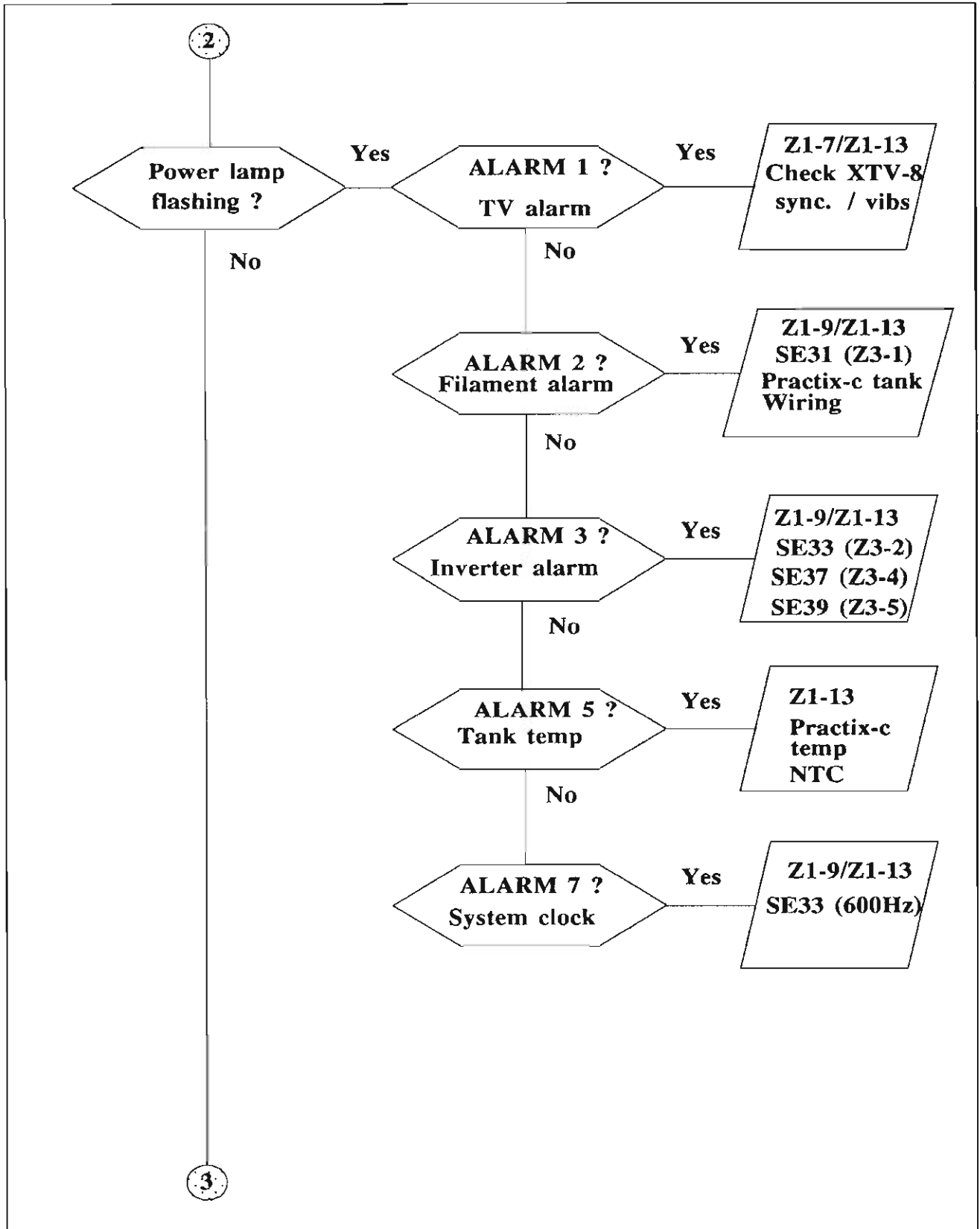

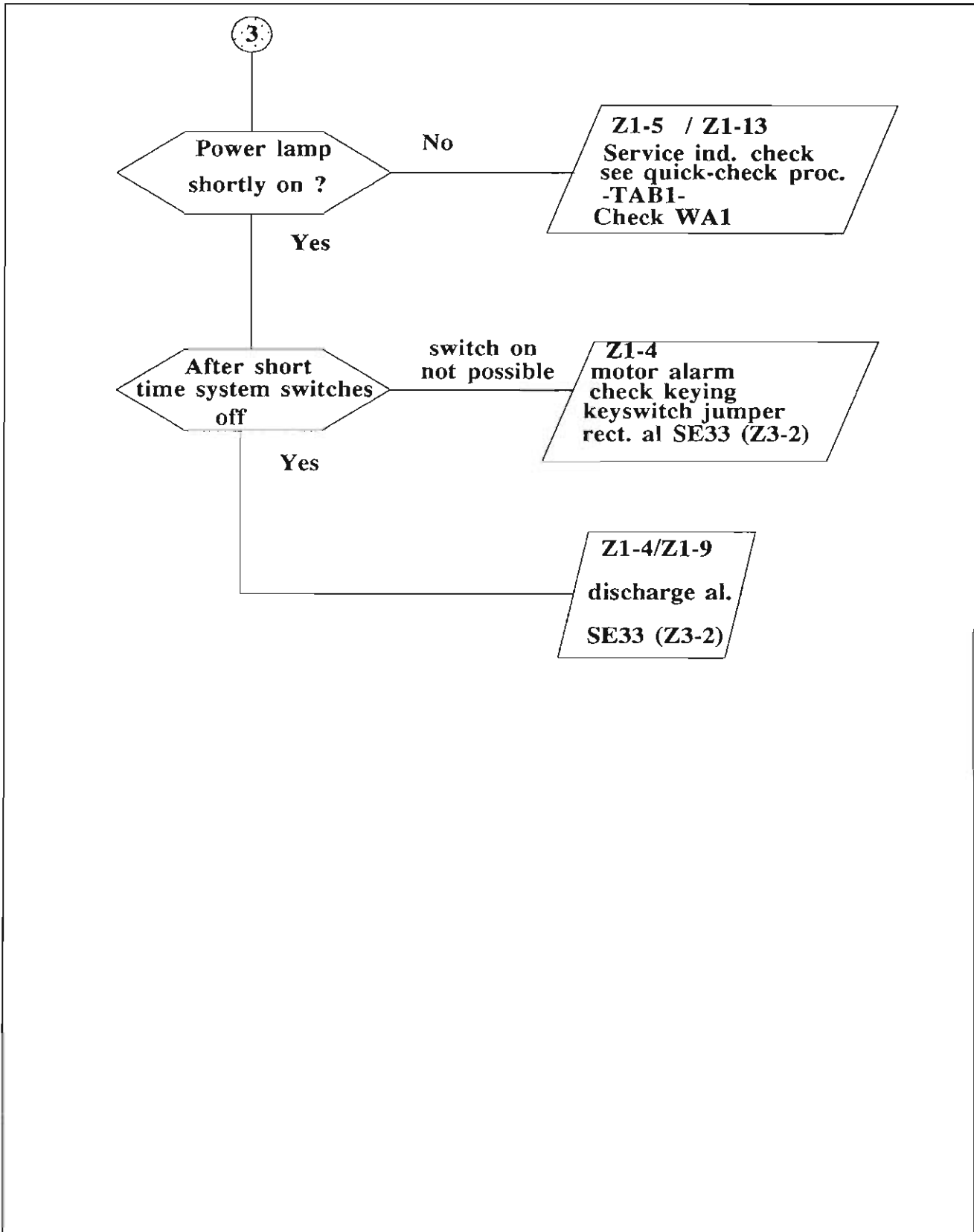

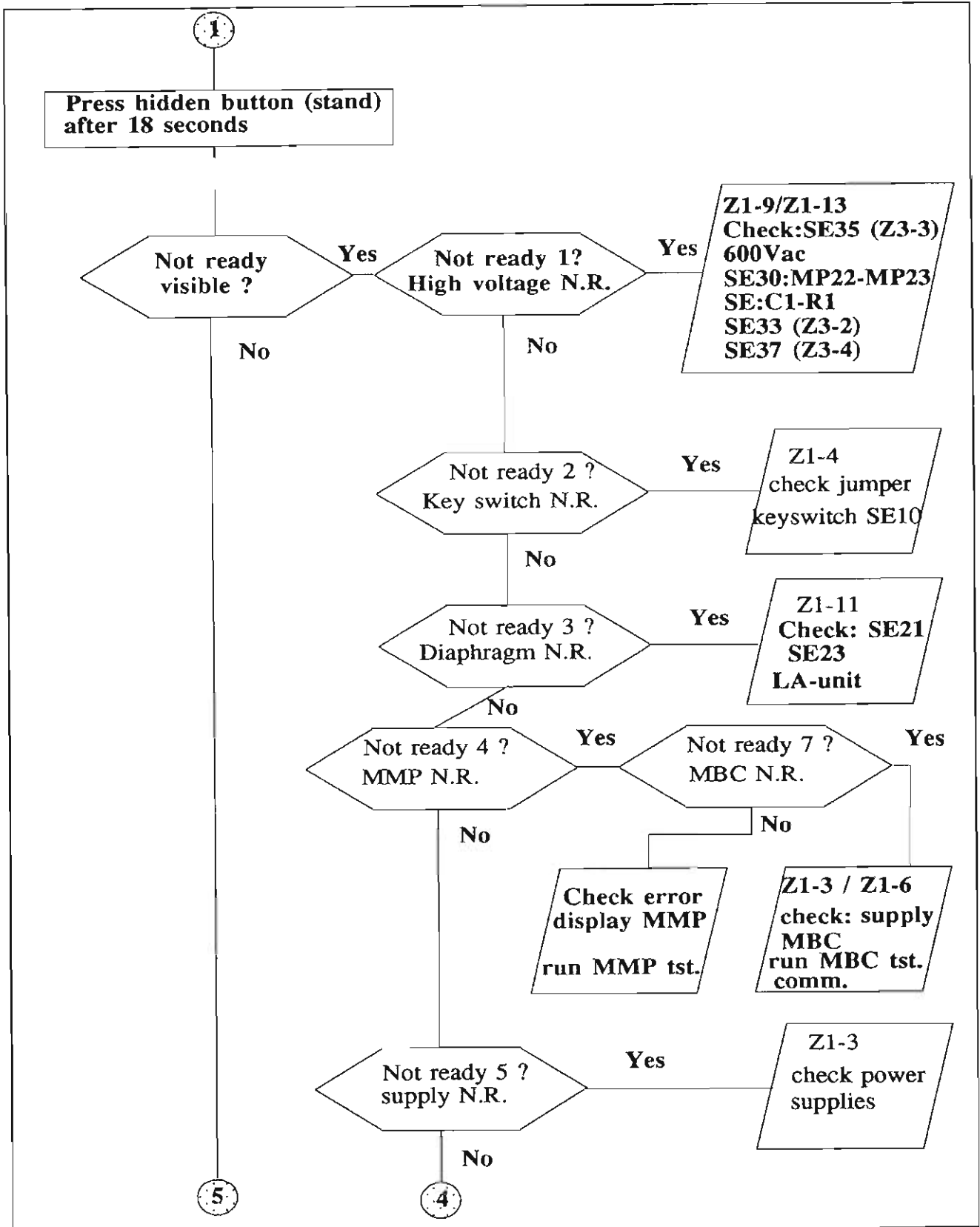

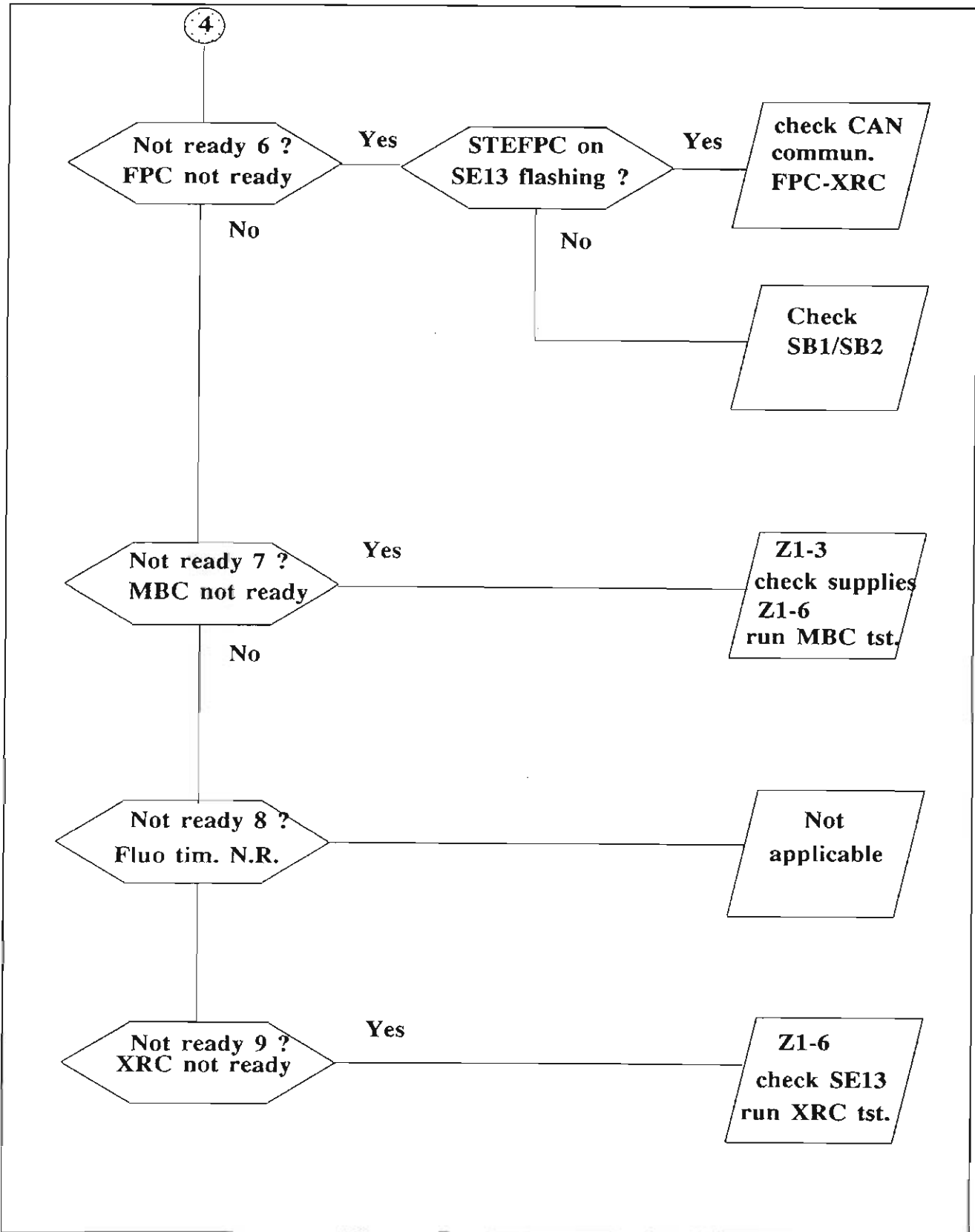

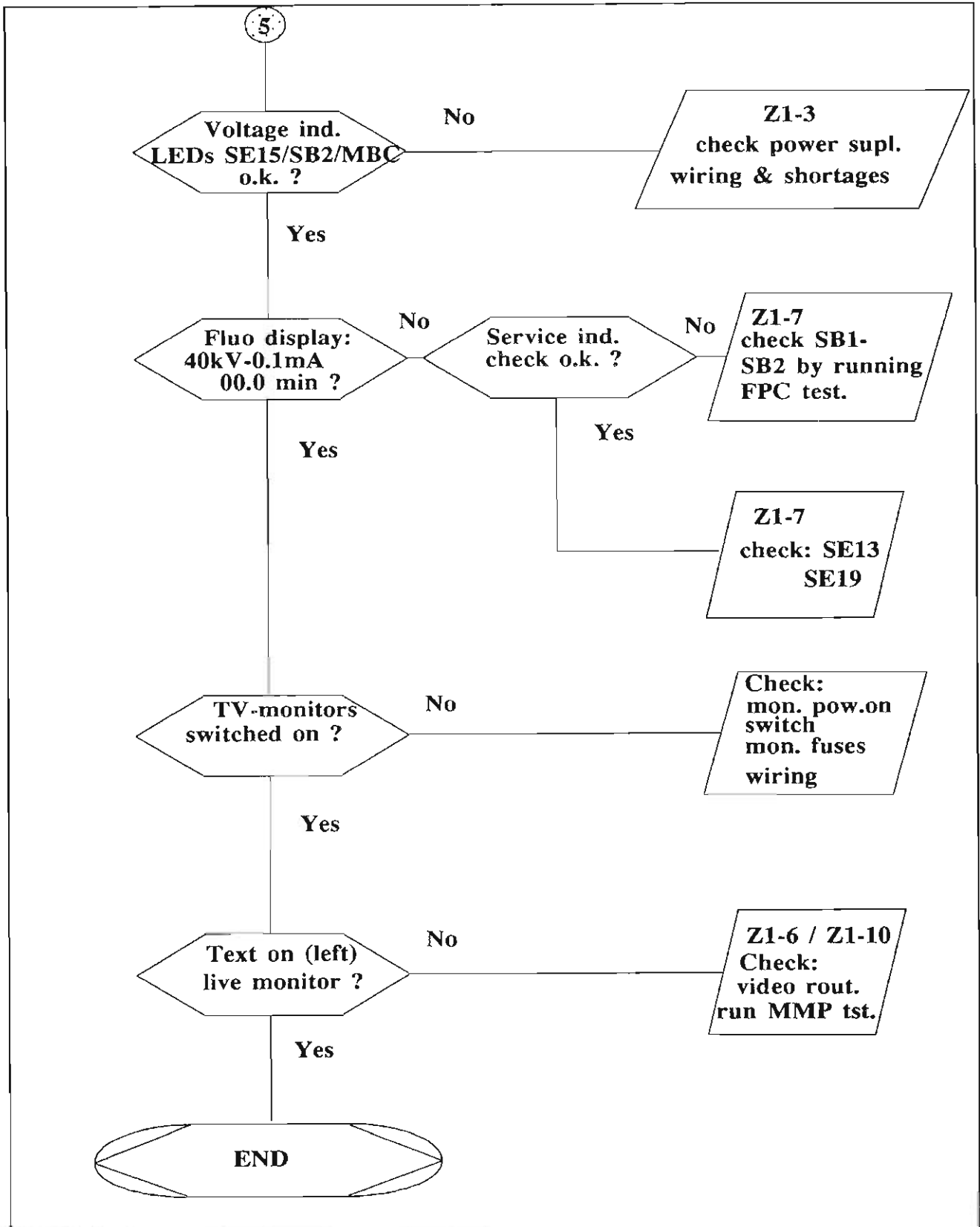

BEFORE STARTING SYSTEM CHECK, ENSURE THAT POWER-UP CHECK IS OK.

START SYSTEM CHECK

Operate buttons C-arm up/down.

NOTE:

RUN FPC-TEST TO CHECK IF ALL BUTTON-COMMANDS ARE ACCEPTED. IF NOT CHECK SB1/SB2.

C-arm up/down ?

No

Motor running ?

Yes

Check V-belts

No

**Z1-12 Check:
SB3/4
SM1
Power sup.
Endswitch.
Thermal-switch**

Operate image rotation at stand.

1

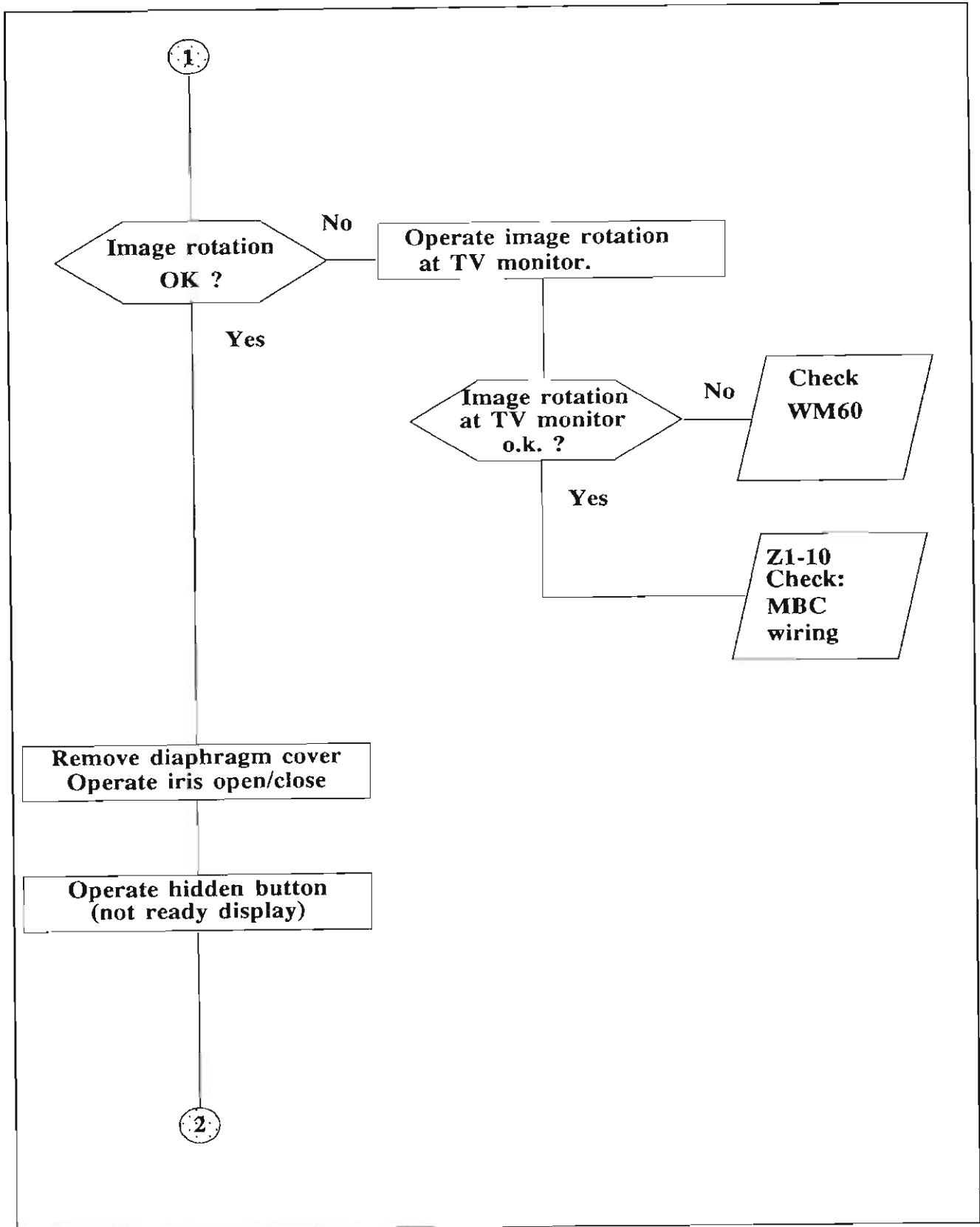

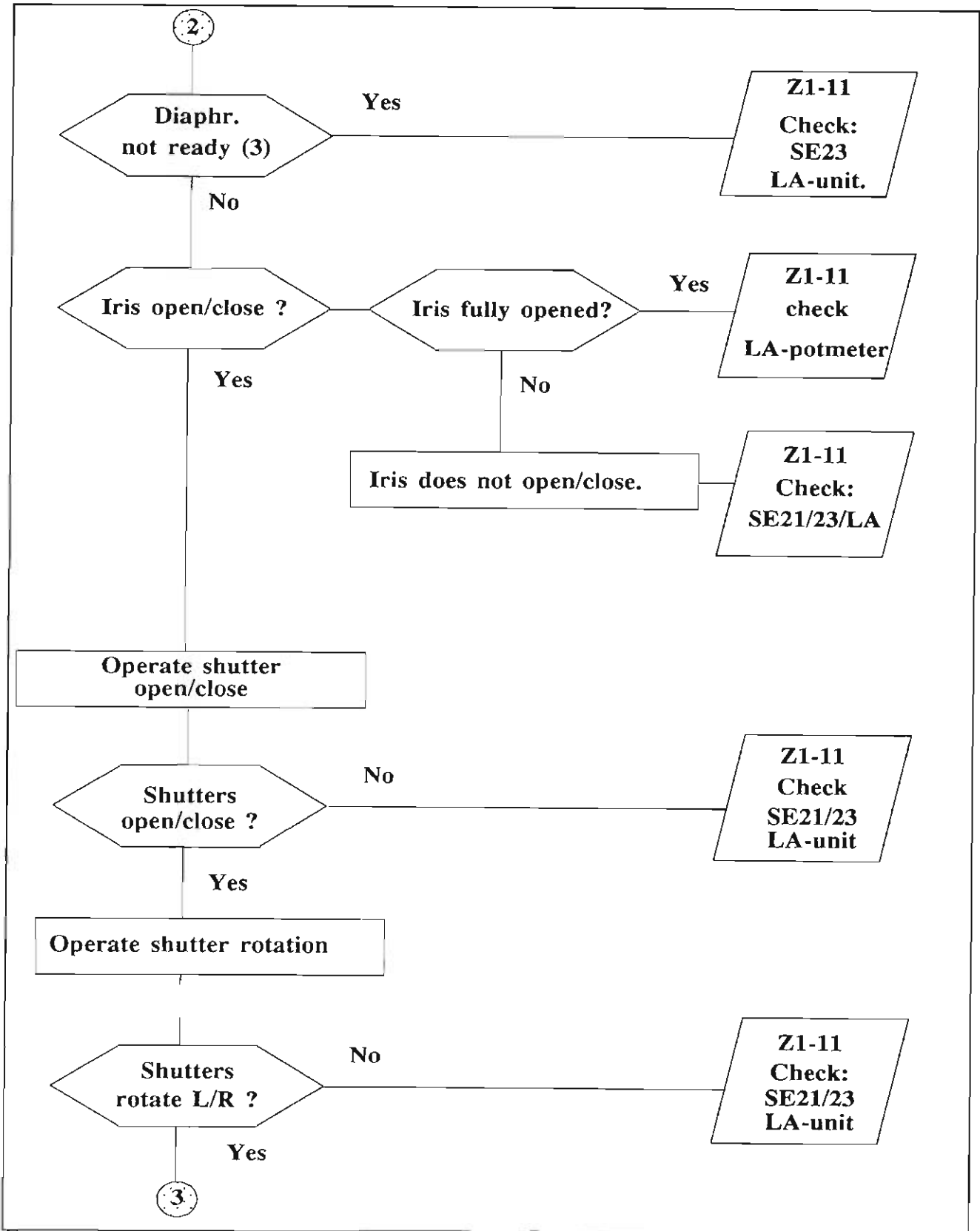

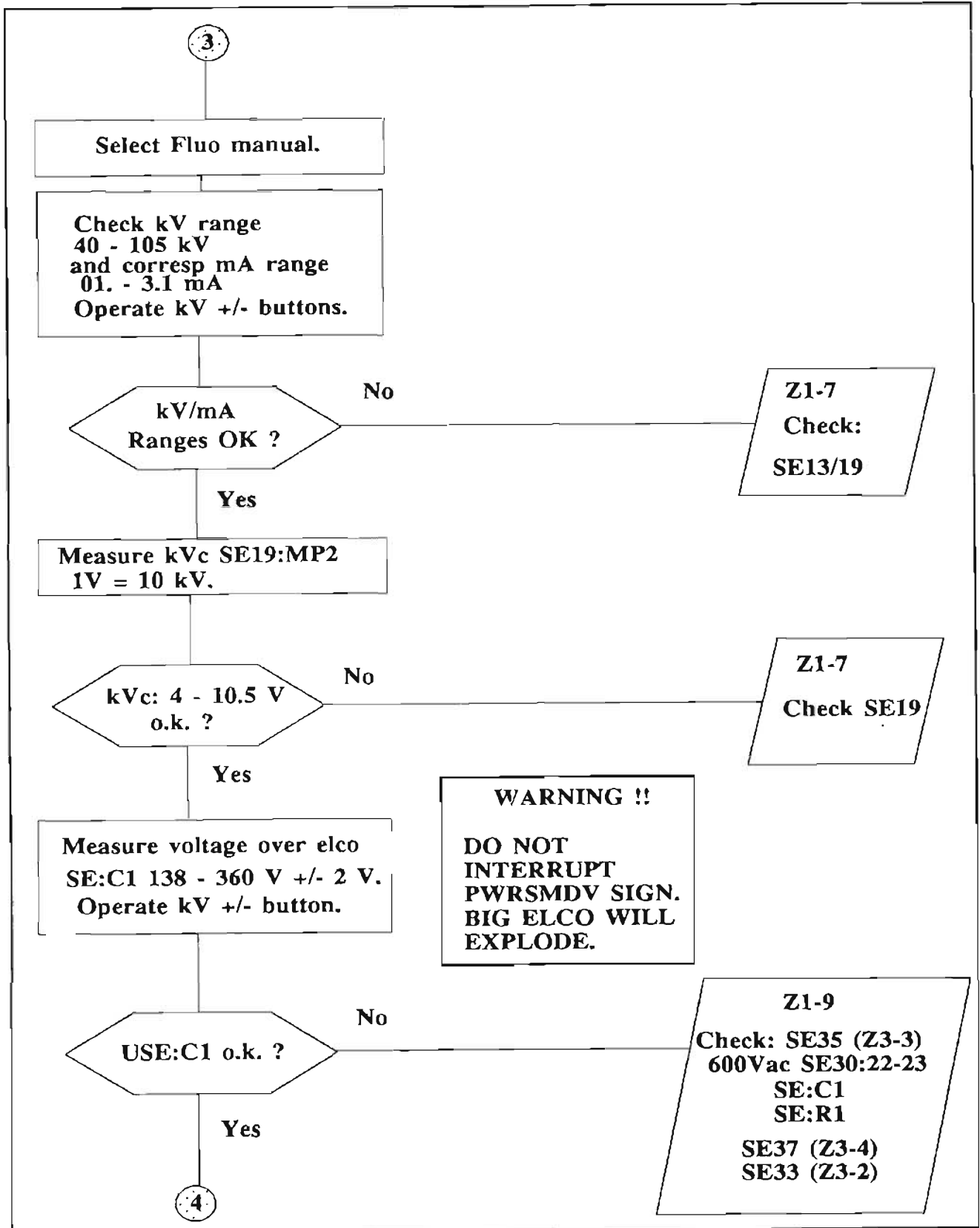

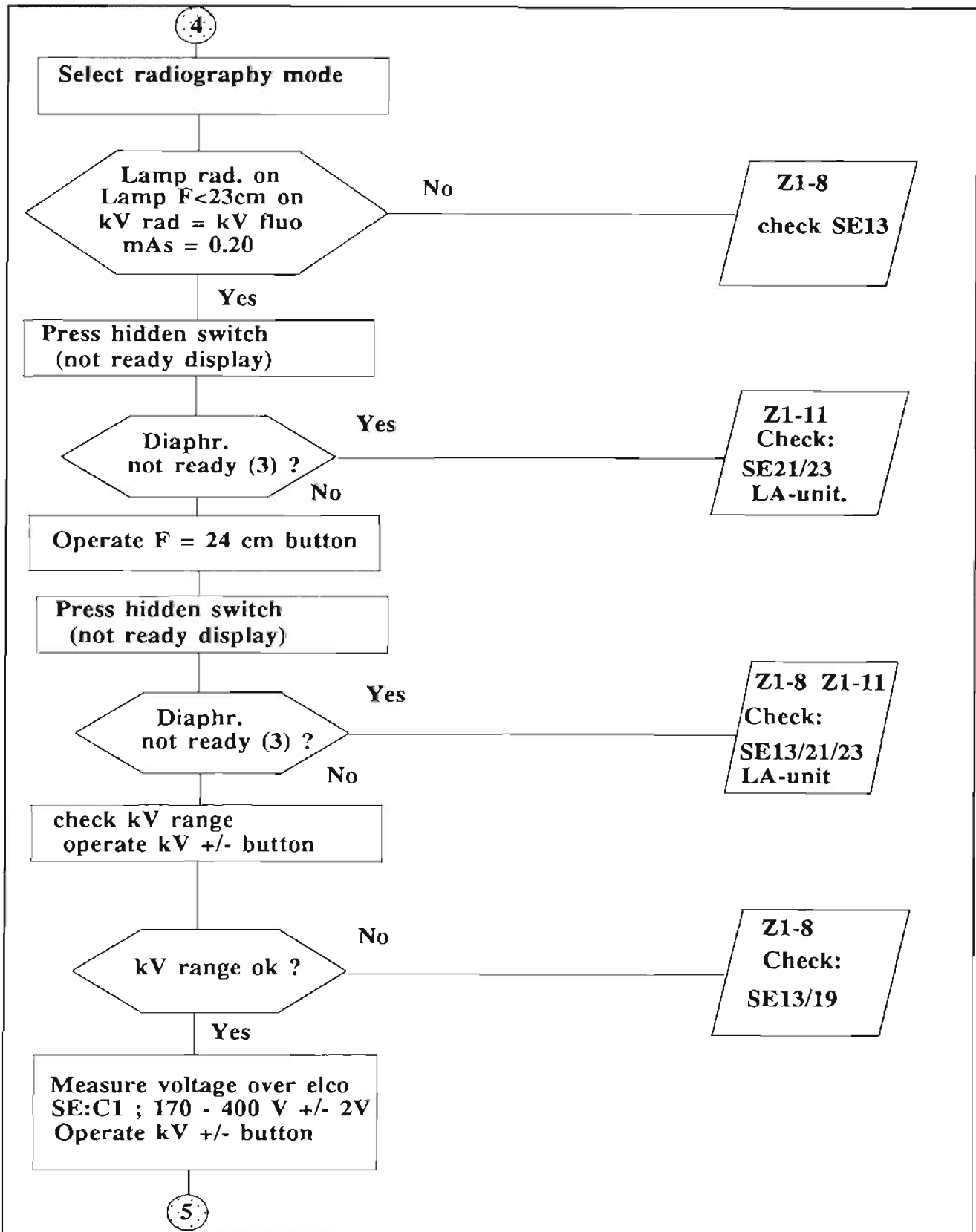

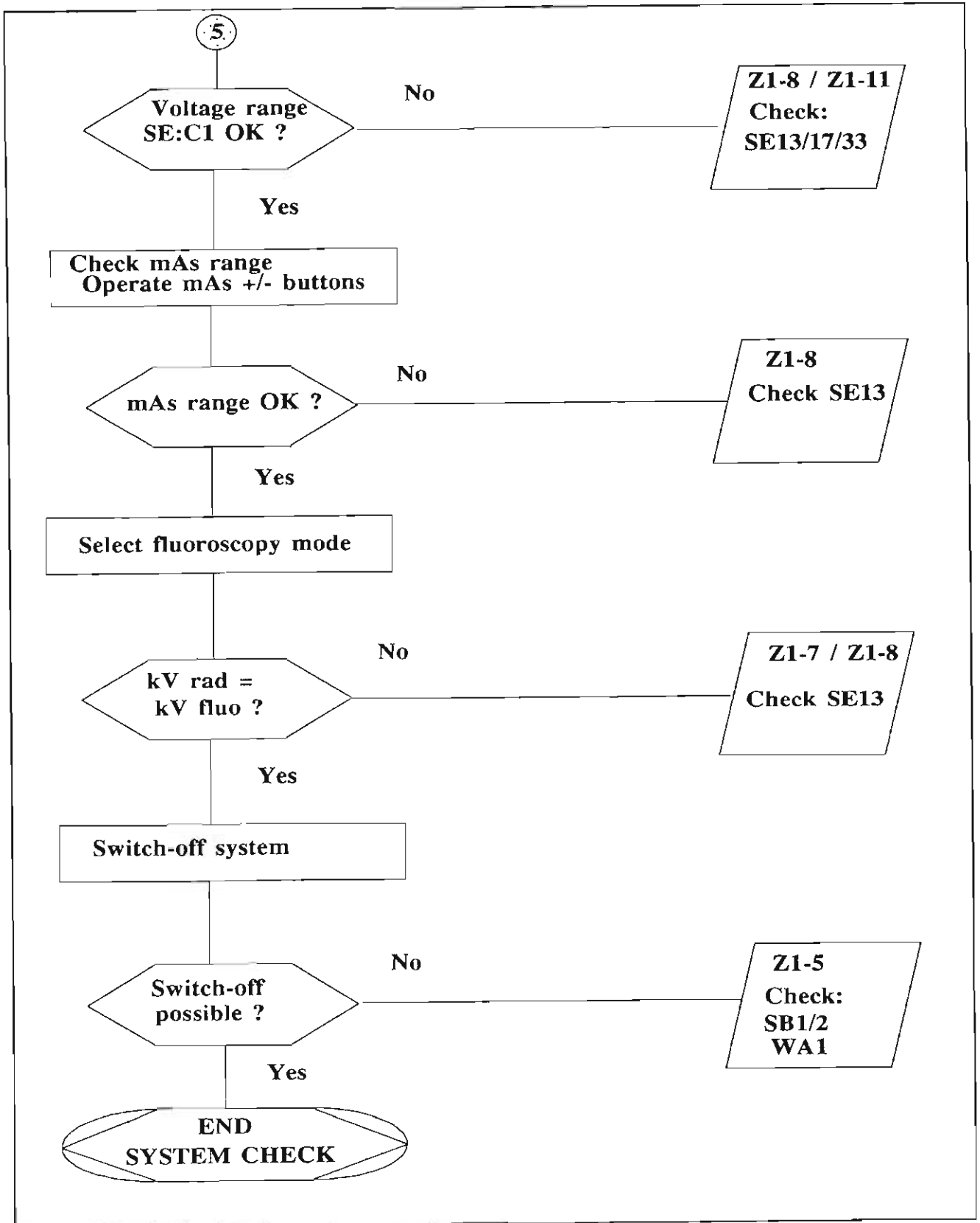

Section : **FLUOROSCOPY CHECK**

Contents

FLUOROSCOPY FLOWCHARTS

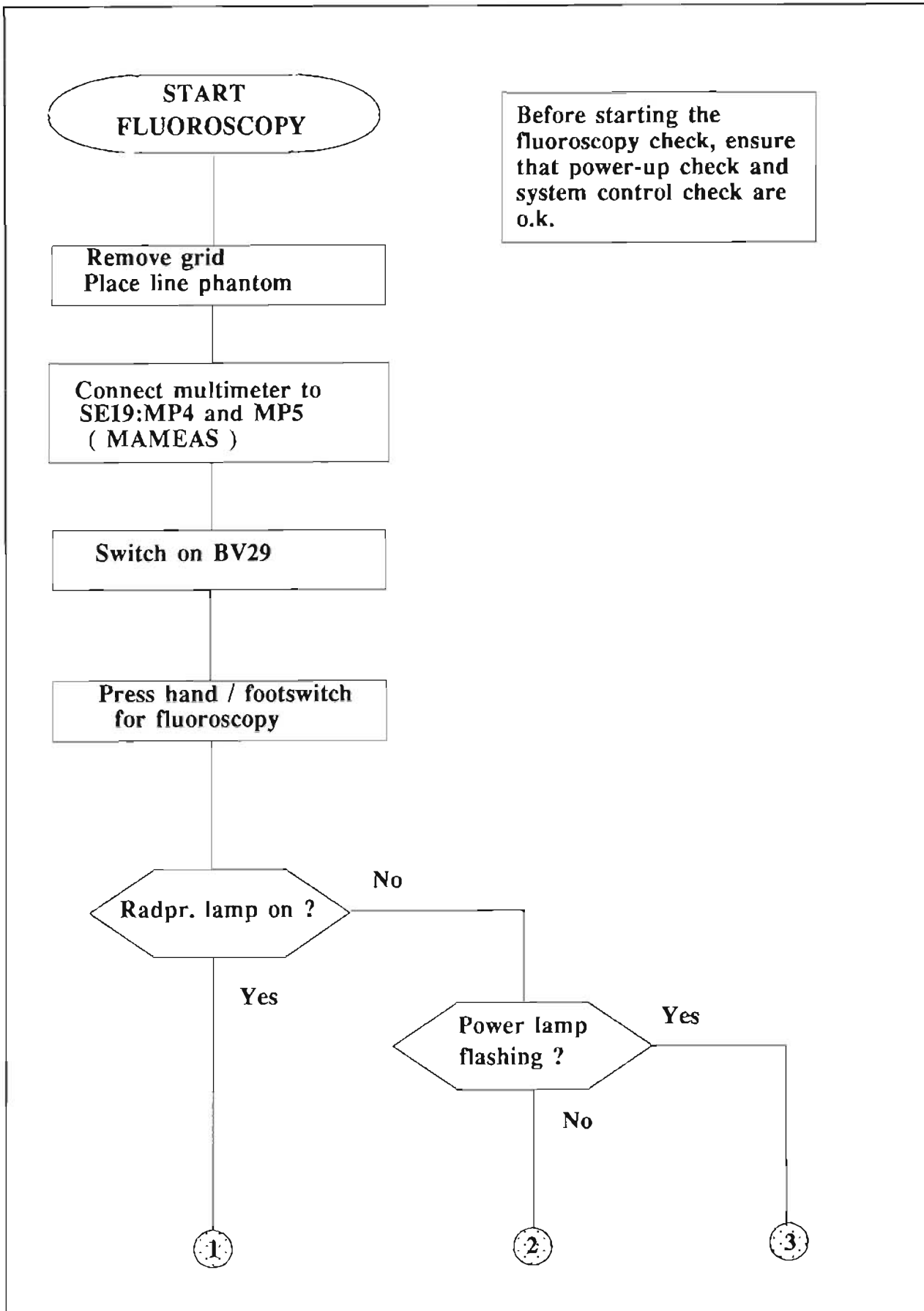

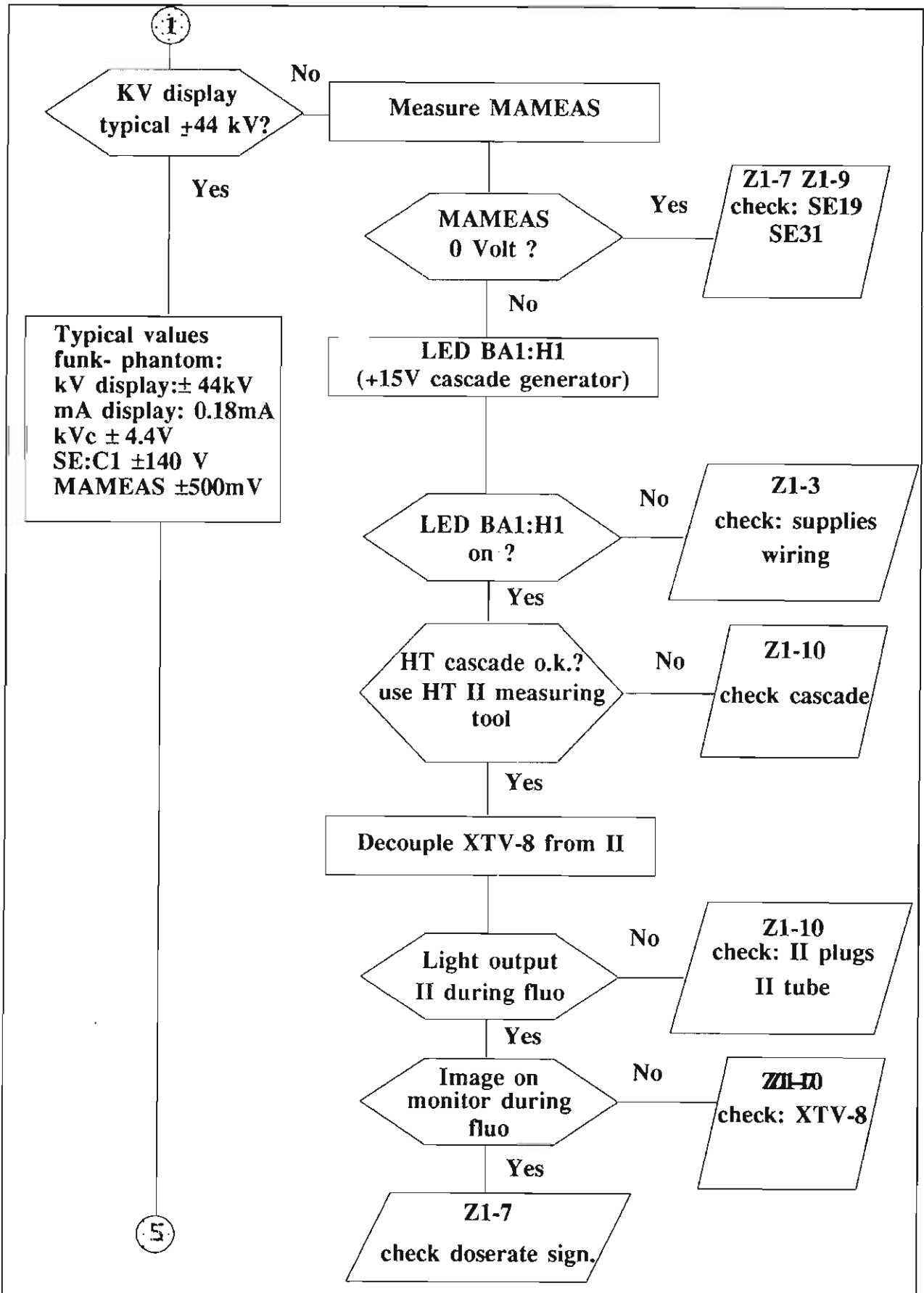

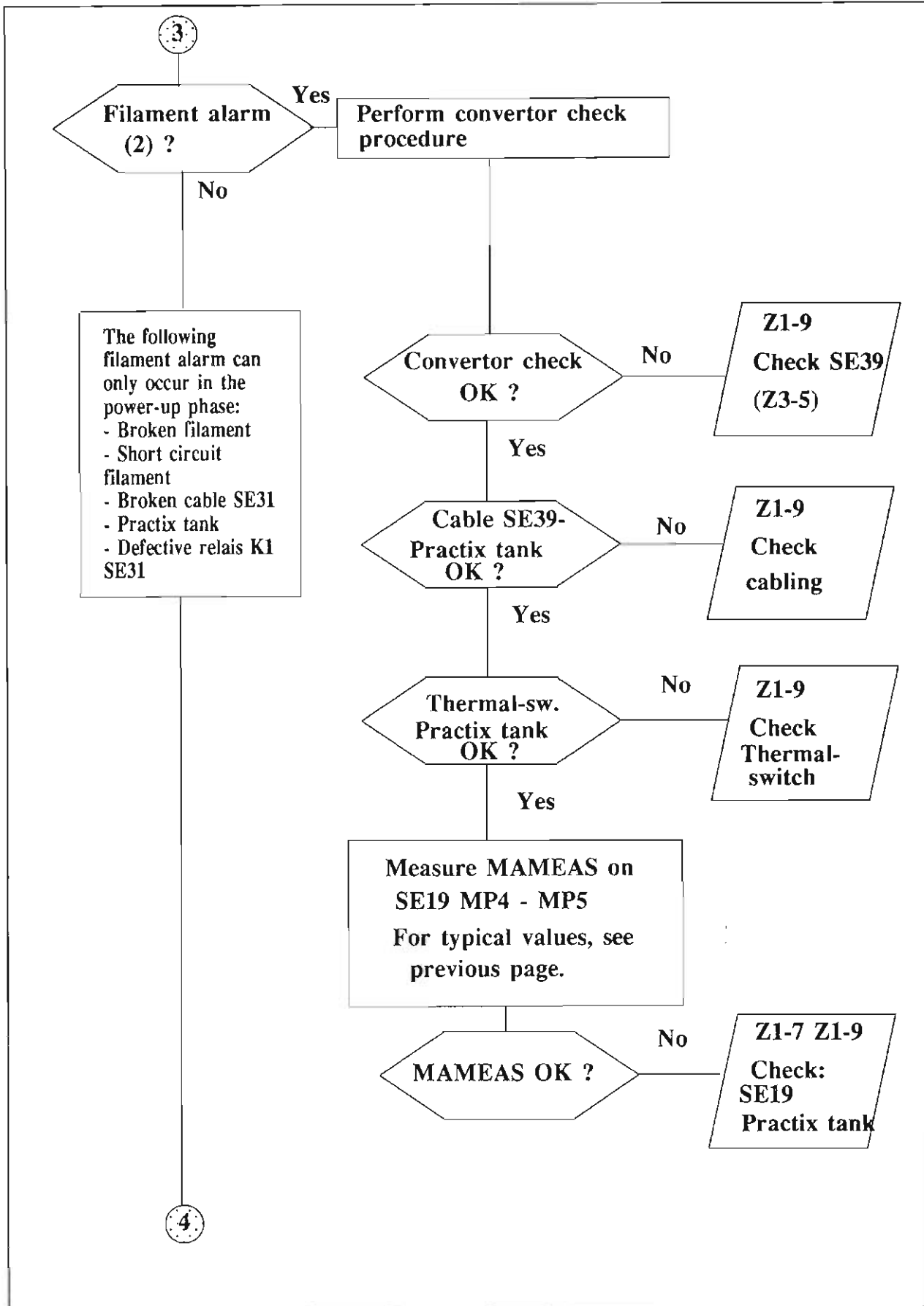

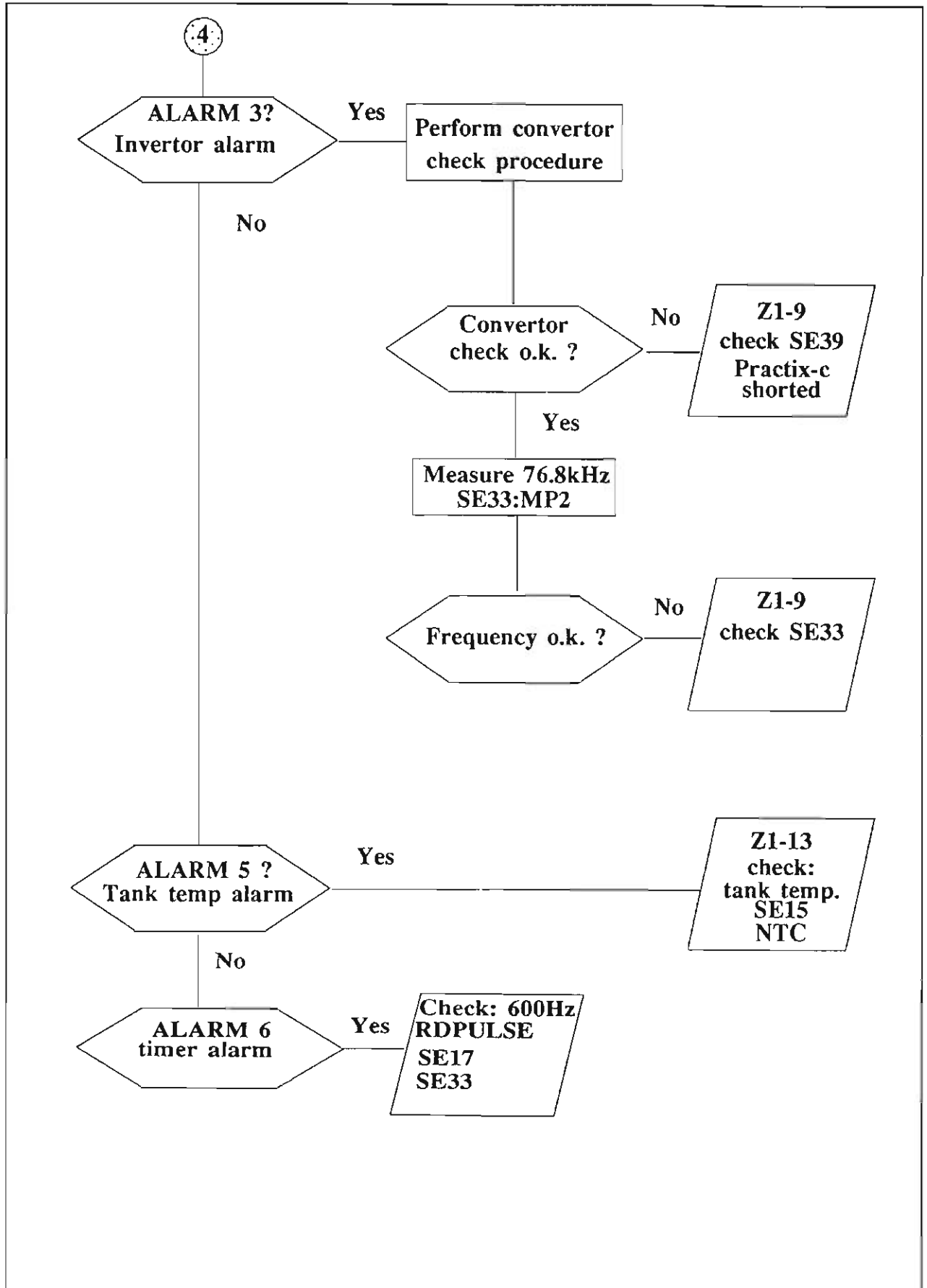

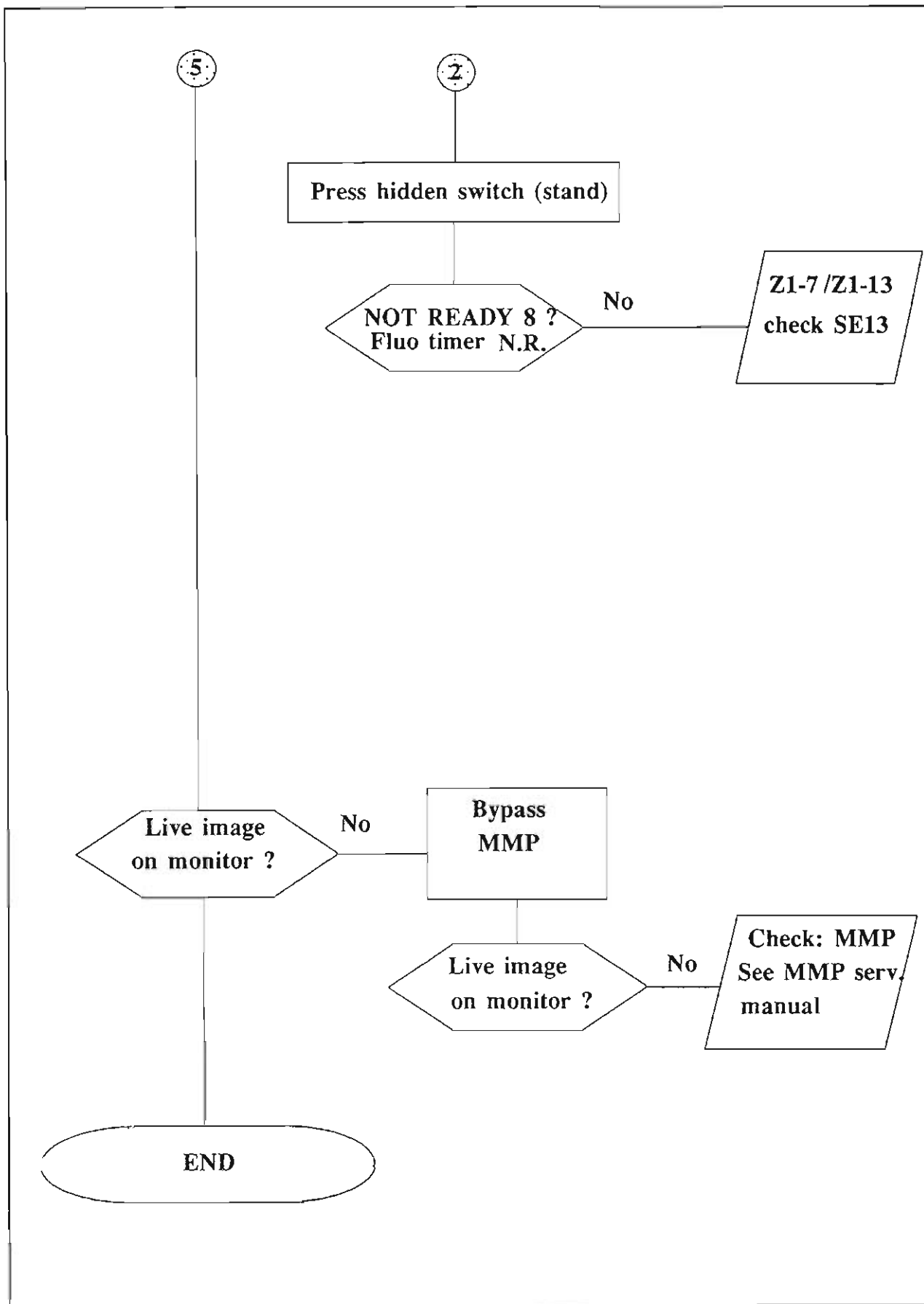

Output of DC convertor can be checked by means of 220V/100W lamp, connected to SE30:16 and 17. Select manual fluoroscopy at 55 kV and press hand/footswitch. Keep for about 10 seconds pressed. The lamp is ON. Release handswitch, lamp remains ON for about 5 - 10 seconds. If lamp test o.k. then DC convertor is functionally o.k.

The oscillograms show the filament current and the convertor current to the HV transformer of the Practix-tank

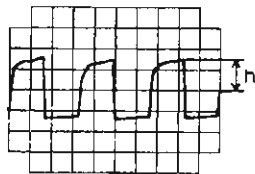

FILAMENT CURRENT

Fluo. measured at SE30: X1-A

	h
40 - 50 kV	0.6 A
60 - 80 kV	0.7 A
90 - 100 kV	0.75 A

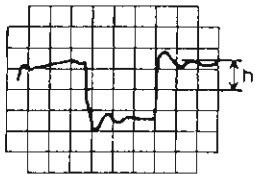

CONVERTOR CURRENT

Fluo. measured at SE30: 17

	h
40 kV	0.25 A
50 kV	0.5 A
60 kV	1.25 A
70 kV	2.0 A
80 kV	2.2 A
90 kV	2.4 A
100 kV	2.5 A

Section : **RADIOGRAPHY CHECK**

Contents

RADIOGRAPHY CHECK

Before starting radiography check, ensure that power-up check, system control check and fluoroscopy check are o.k.

**START
RADIOGRAPHY**

**Set jumper SE19 in pos RAD
& connect multim./osc. MP4-MP5**

**Power-up and select
radiography mode**

Select 40kV-80mAs

**Press and hold
hand switch**

**Lamp RADPR
on ?**

Yes

No

1

2

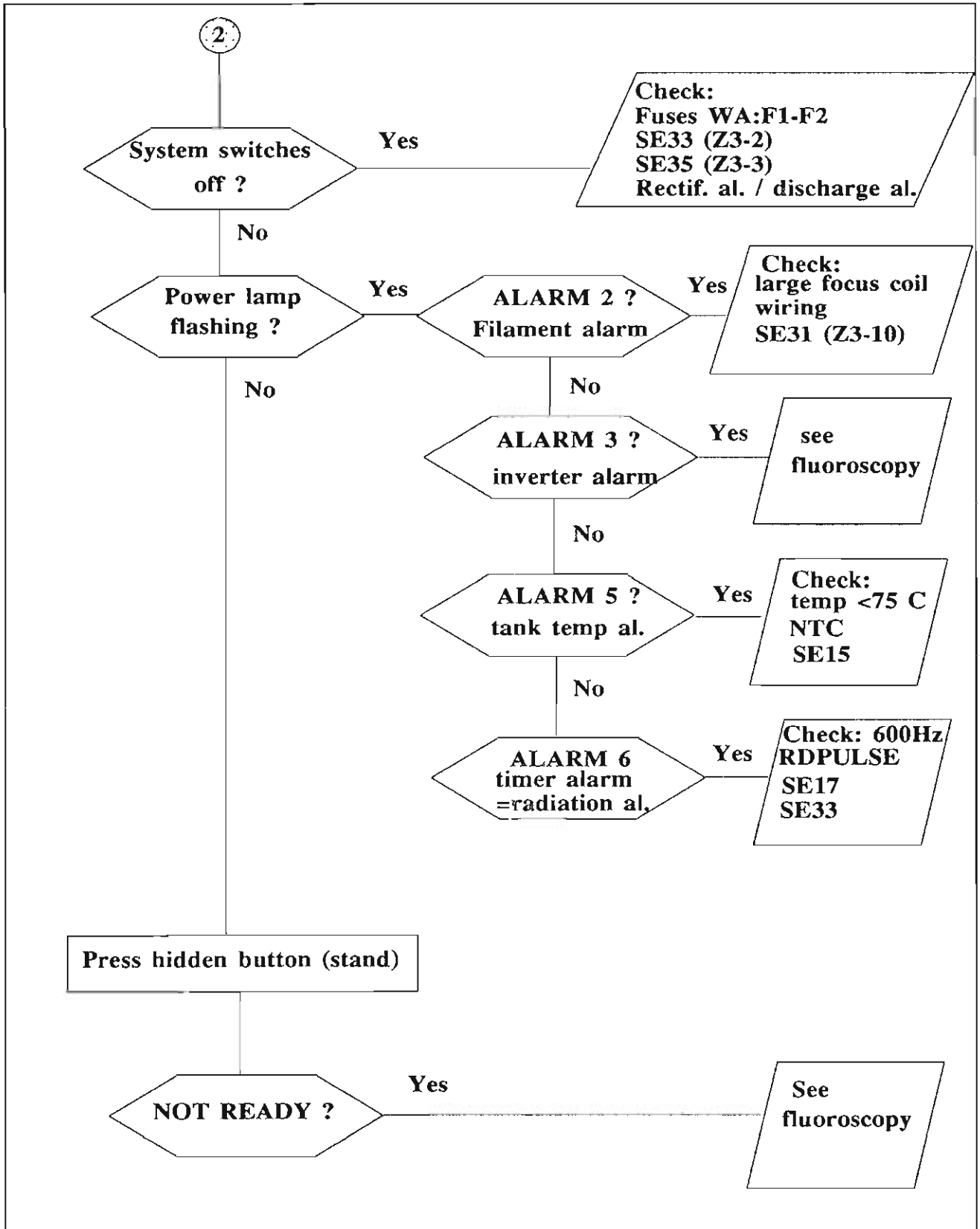

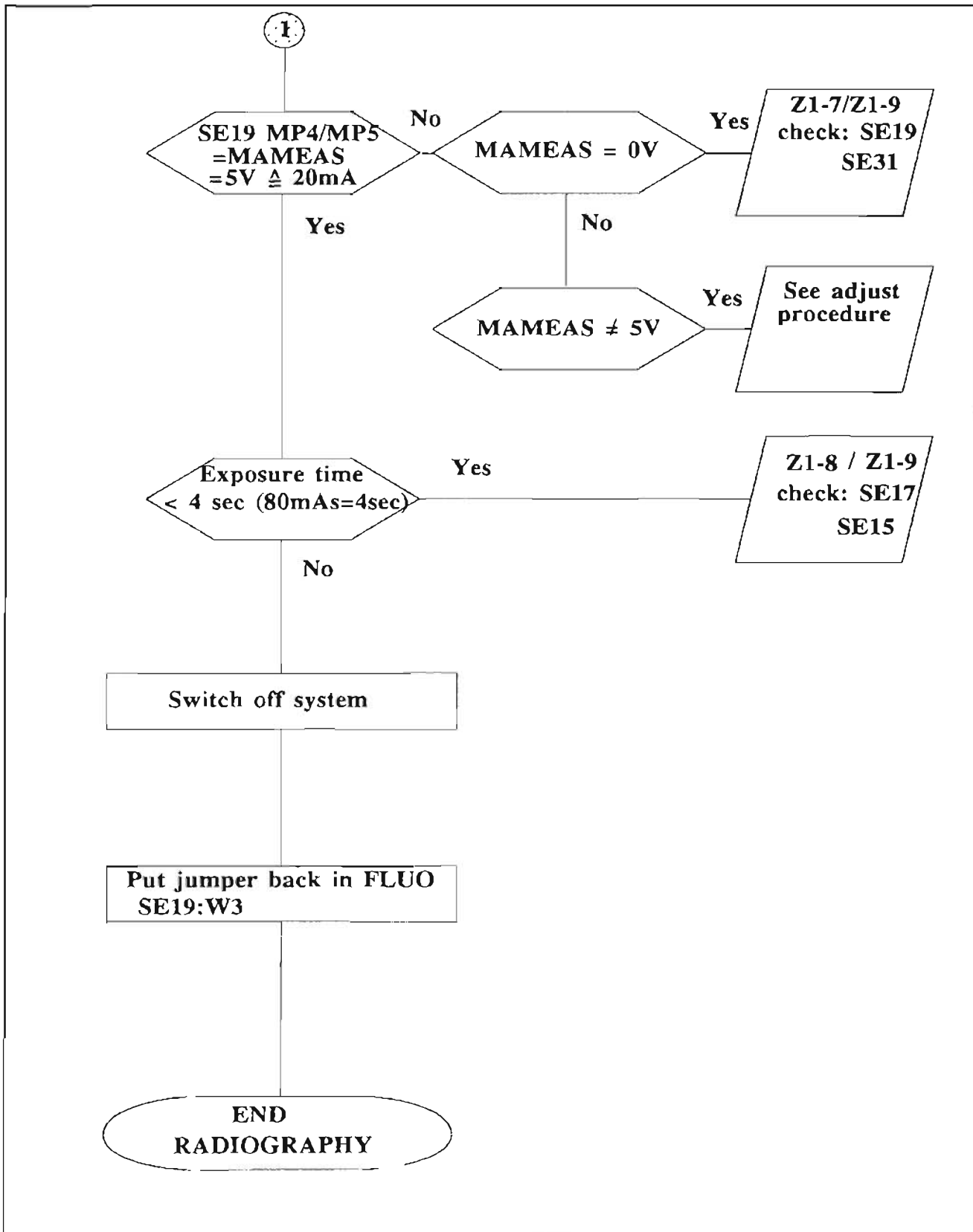

Section :

WHAT TO DO

Contents

1.	INTRODUCTION	5-2
2.	WHAT TO DO TABLE	5-2

1. INTRODUCTION

This section describes the repair and adjustment procedures which must be performed after replacement actions.

2. WHAT TO DO TABLE

IF YOU REPAIR	REPLACEMENT PROCEDURE	ADJUSTMENT PROCEDURE
Image Intensifier	Image Intensifier	Electrical focusing Optical focusing Dose rate
XTV8S Camera	XTV8S Camera	Optical focusing Dose rate Centring of image Centring of rotation movement
II-Cascade Generator	II-Cascade Generator	Electrical focusing
Practix-C Tank	Practix-C Tank	X-Ray Tube warm up X-Ray Tube Current Alignment Diaphragm- Image Intensifier Focus near
Diaphragm Unit	Diaphragm Unit	Alignment: Iris potmeters Diaphragm - II Diaphragm size
TV Monitor	TV Monitor	-----
Video Hard Copy Unit	-----	-----
SE19 pcb	-----	X-Ray Tube current Dose rate
SE23 pcb	-----	Alignment Diaphragm size
SE31 pcb	-----	X-Ray Tube Current Dose rate
SE33 pcb	-----	X-Ray Tube Current
WT1	-----	Video routing

Section : **REPLACEMENT PROCEDURES**

Contents

1.	REPLACEMENT PROCEDURE C-ARM SLIDING BALL BEARINGS	6-2
2.	REPLACEMENT BALL BEARINGS HORIZONTAL MOVEMENT	6-7
3.	REPLACEMENT PROCEDURE BRAKE DISC C-ARM ROTATION	6-11
4.	REPLACEMENT BRAKE C-ARM SLIDING	6-16
5.	REPLACING THE STAND WHEELS	6-18
6.	REPLACEMENT PROCEDURE C-ARM CABLE	6-19
7.	REPLACEMENT PROCEDURE CONNECTOR SAX1	6-25
8.	REPLACEMENT VERTICAL MOVEMENT MOTOR	6-27

Warning

** IN CASE OF REPLACEMENT OF CERTIFIABLE ITEMS ALWAYS REPLACE DUPLICATE LABEL ON CENTRAL LABELLING STATION*

1. REPLACEMENT PROCEDURE C-ARM SLIDING BALL BEARINGS

The slide block has two kinds of ball bearings: 4 x 4 running and 2 x 2 side ball bearings.

At the inner side of C-arm there are 4 x 2 running bearings (upper part) and 2 x 2 side bearings; at the outside there are 4 x 2 running bearings (lower part).

The ball bearings at the outside are adjustable, by eccentric.

NOTE

After a long standstill position of c-arm, the sliding movement can be irregular by flattened nylon ball bearings, caused by the weight of the c-arm.

After some sliding movements the flattened nylon ball bearings are round again and the sliding movement runs smooth.

To replace the nylon ball bearings, the c-arm must run off the slide block; proceed as follows:

- 1) Put C-arm manually in horizontal position and lock.

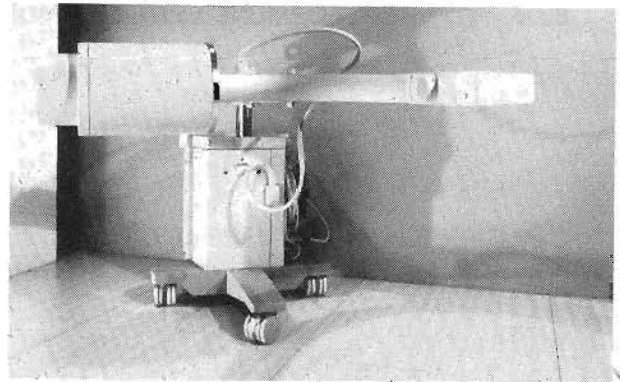

- 2) Move c-arm up/down to let it bear on a table.
- 3) Switch off mobile stand.
- 4) Remove cable holder and coverplate of sliding block (2xM5 + 4xM4).

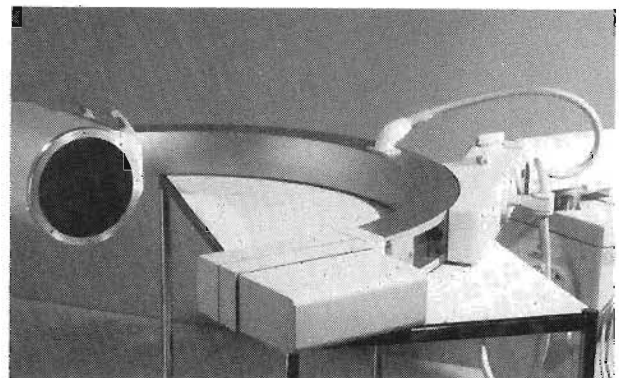

5) Remove the cover of the diaphragm.

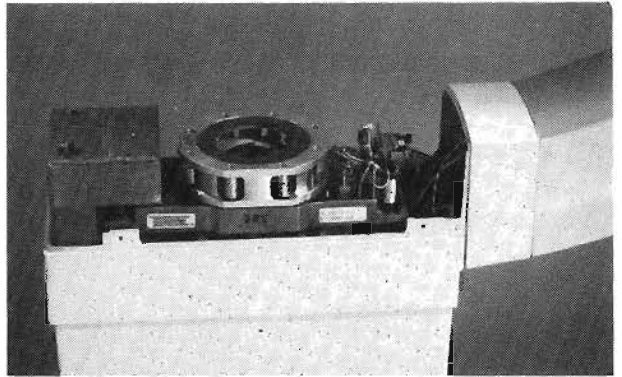

6) Remove lead block.

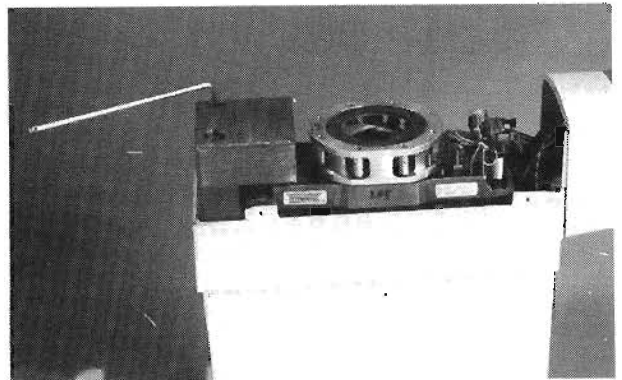

7) Detach the cable plugs from the connectors.

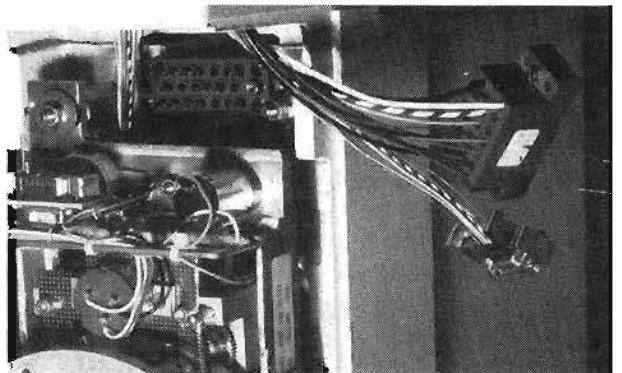

8) Remove the diaphragm.

9) Remove earthing connection.

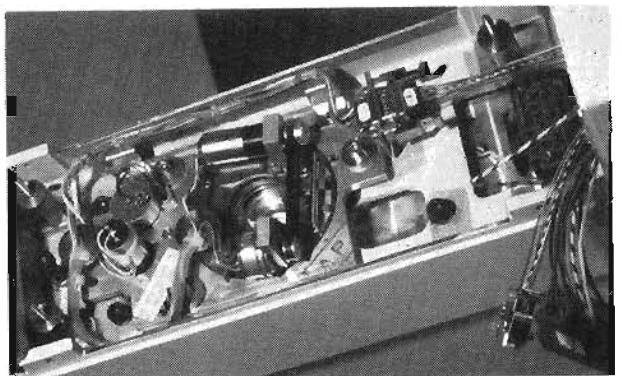

- 10) Remove diaphragm console with the Practix C-tank (4x socket screw M6.).

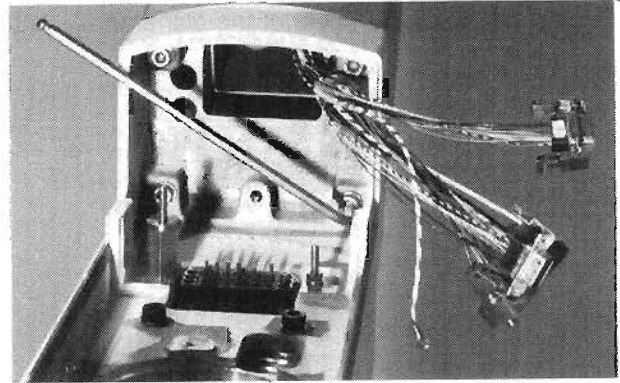

- 11) Remove coupling plate (4x socket screw + 2x countersunk screws).

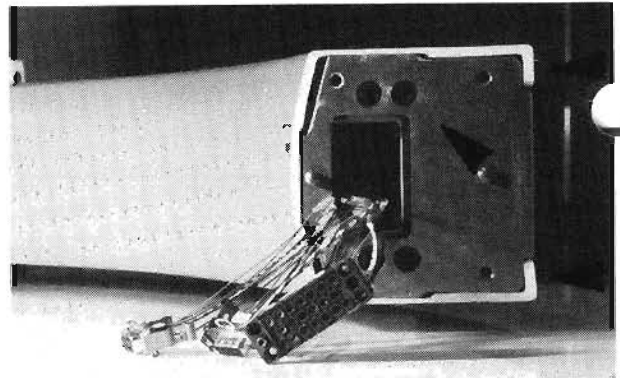

- 12) Remove inside end block of the C-arm (4x M. socket screw).

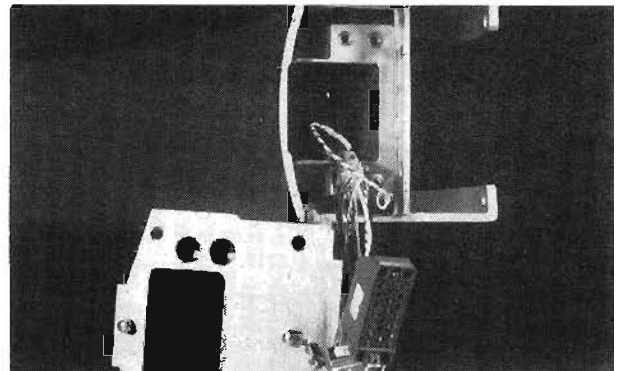
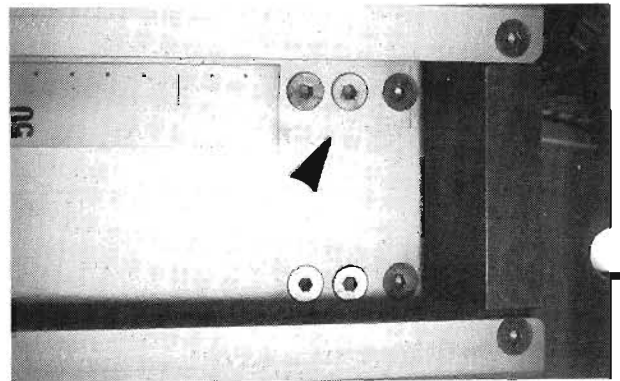

NOTE

*The countersunk screws are locked with Loctite.
When screws are damaged use new ones.*

- 13) Remove 4 big bolts which hold the bearing block against the C-arm.

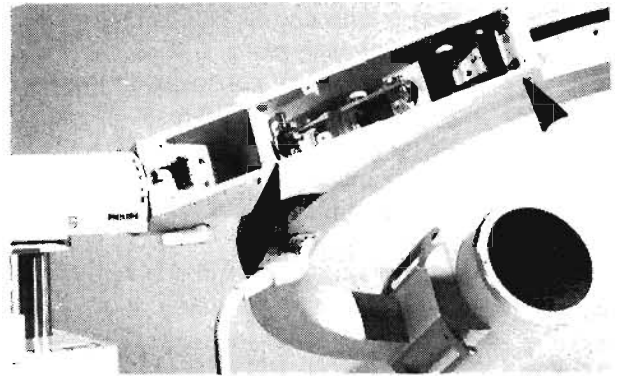

- 14) Detach the C-arm with bearing block from the stand.



- 15) Slide bearing block out of the C-arm.

- 16) Check surface and running of ball bearings to find out which bearing should be replaced.

- 17) In case of running ball bearings detach retaining ring(s) and pull of the ball bearing(s).
In case of side ball bearings push pin out of the ball bearing or screw eccentric pin out of ball bearing.

- 18) Fit new running and/or side ball bearings with retaining ring and pin.

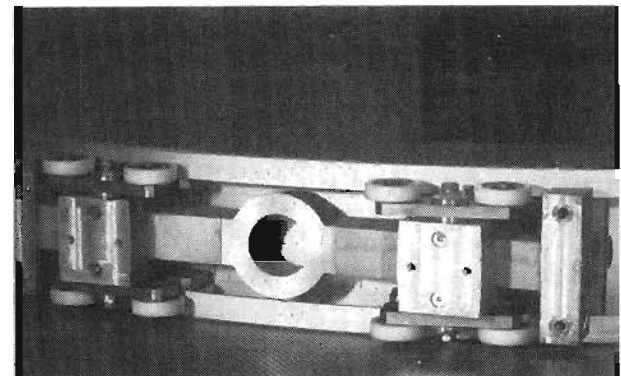

NOTE

Do not touch screw settings at bearing block to avoid more mechanical adjustment.

- 19) Ride ball bearing block in the C-arm and check for smooth sliding; especially the side ball bearings. The side ball bearing touching can be adjusted by screw pins; the running ball bearing touching can be adjusted by screws (see adjustment procedure).
- 20) When ball bearing block run smoothly in the C-arm, all parts can be reassembled.
- 21) - Attach bearing block with C-arm to the stand
- Attach inside end block into C-arm.
- Attach coupling plate.
- Mount diaphragm console with the Practix C-tank to the C-arm.
- Attach earthing
- Connect plugs and connectors.
- Mount lead block
- 22) Check smooth C-arm running with full weight. When not satisfied carry out adjustment procedure.

2. REPLACEMENT BALL BEARINGS HORIZONTAL MOVEMENT

The horizontal slide block has two kinds of ball bearings: 2 x 4 running and 2 x 2 side ball bearings. Two ball bearings at the outside are adjustable, by eccentric.

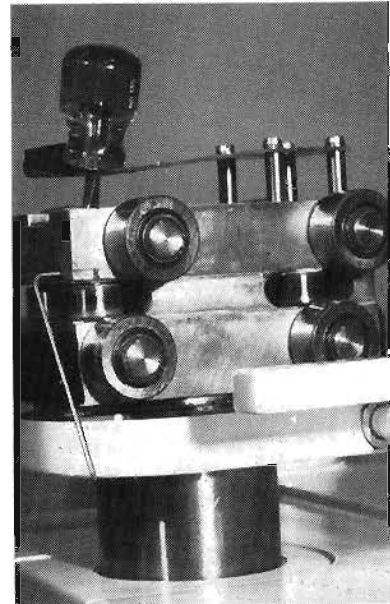

- 1) Rotate C-arm horizontally and position a table such that the C-arm at moving downwards can rest on the table.

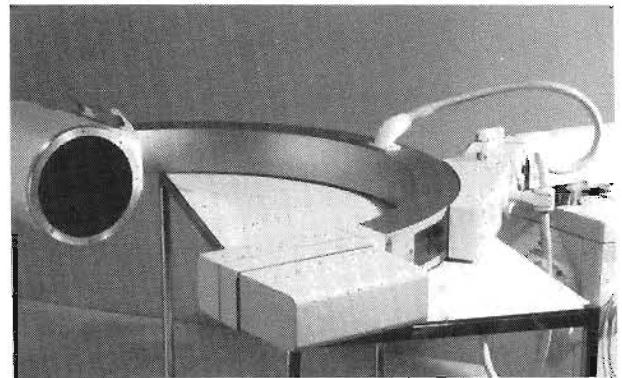

- 2). Loosen the C-arm cable holder.

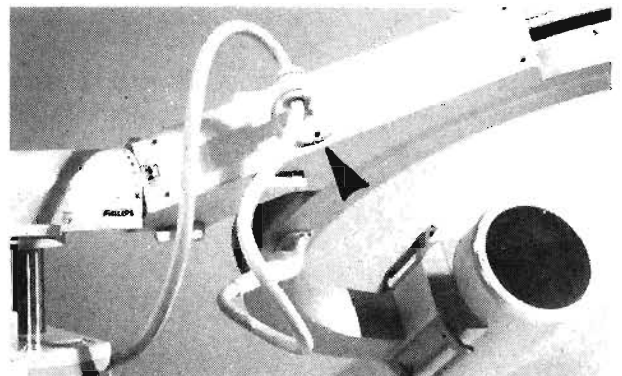

- 3) Remove the brake handle and cover plate of the horizontal bearing block.

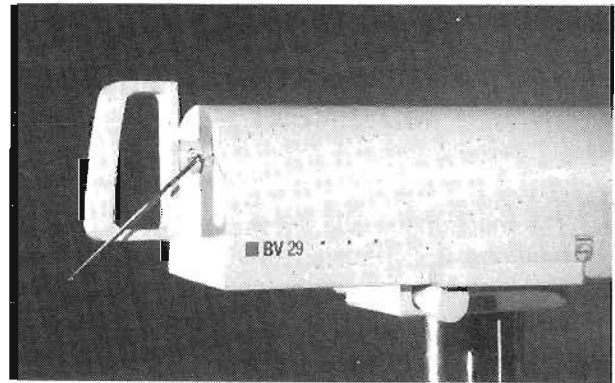

- 4). Remove the zig-zag sheets.

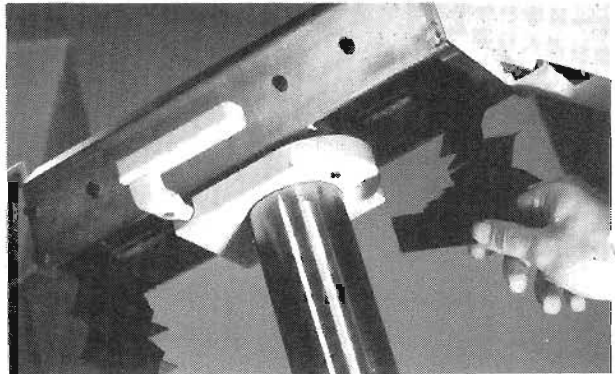

- 5). Unscrew the backplate of the bearing block (2x socket M6. in plate, 5x socket M6. in the side).

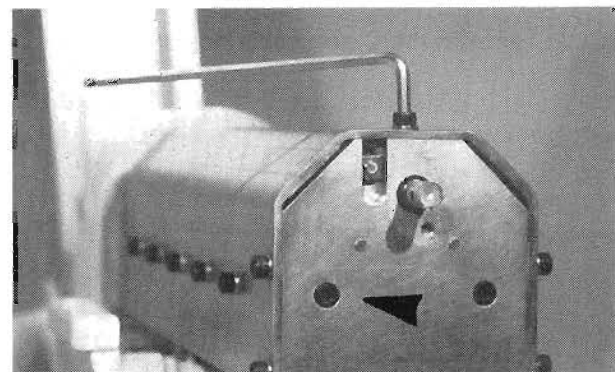

- 6). Mount the brake handle for pulling out the back plate with the shaft.

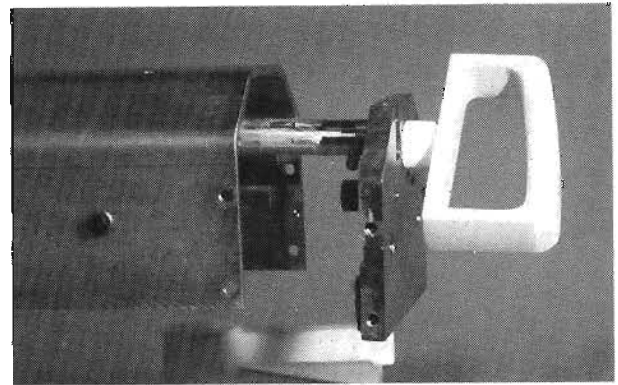

NOTE

Do not drop the ring at the end of the shaft, when pulling out.

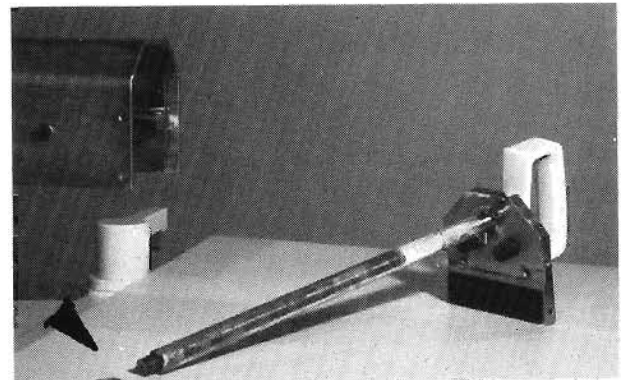

Caution

Due to unbalance when C-arm is removed from the electronic box, the box will tilt and rest on the back side board.

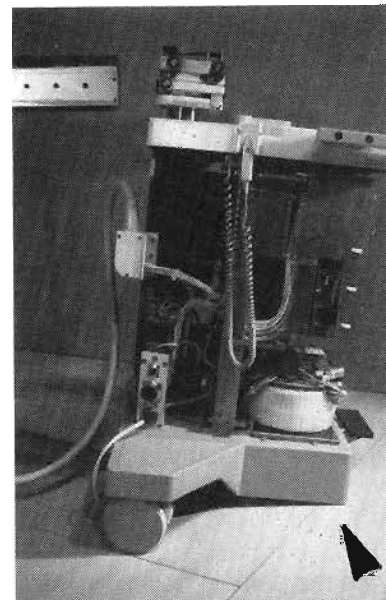

- 7) Decouple the C-arm from the electronic container.

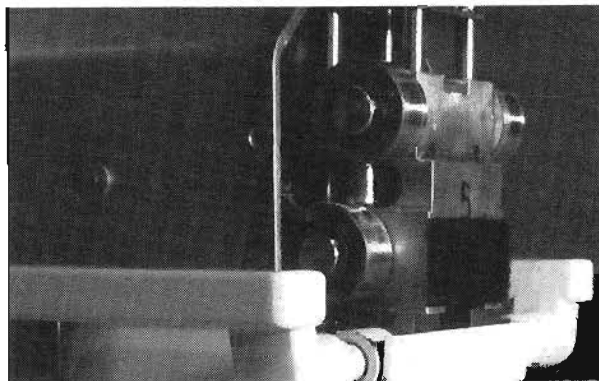

- 8) Remove the defective running bearing by loosening the retaining ring.

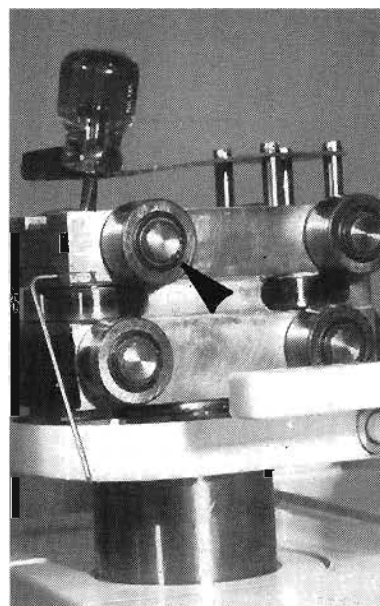

- 9) Remove the defective side bearing by loosening the locking screw, and the eccentric screw (two bearings have eccentrics, two have normal screws).

- 10) Replace the parts in reversed order, accept the cover for the horizontal slide block and the zig zag sheets.

- 11) Adjust side ball bearings (see adjustment ball bearings horizontal movement item 4 - 10).

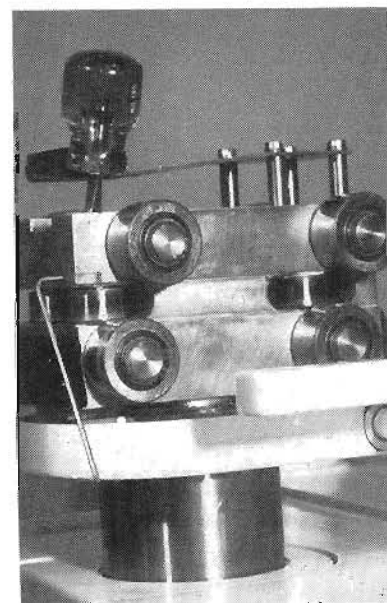

3. REPLACEMENT PROCEDURE BRAKE DISC C-ARM ROTATION

To replace brake disc for the rotational movement of the C-arm, proceed as follows:

- 1) Remove cover plate of the rotation brake housing (3 x M3).

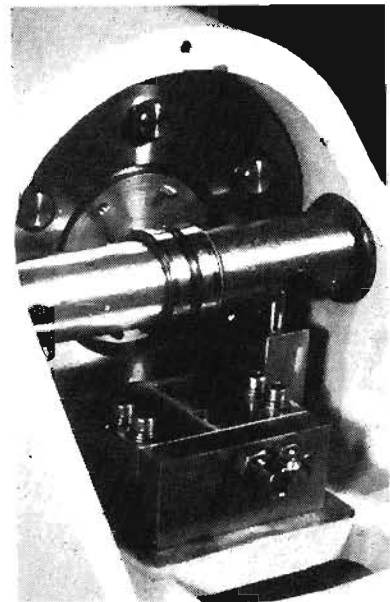
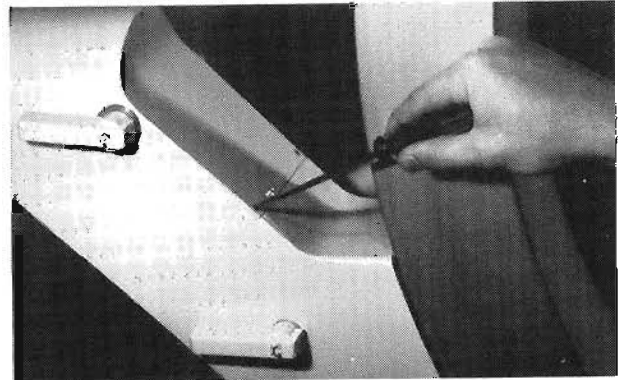

- 2) Remove C-arm cable holder (2 x M4) and plate underneath (4 x M3).

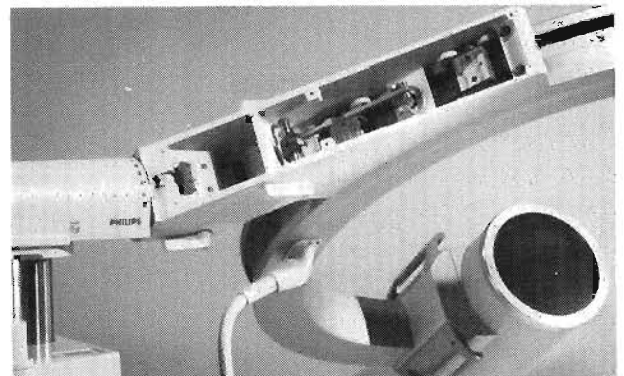

- 3) Unscrew 4 screws to loosen brake block, and remove brake block by turning the brake handle such that the block will come free.

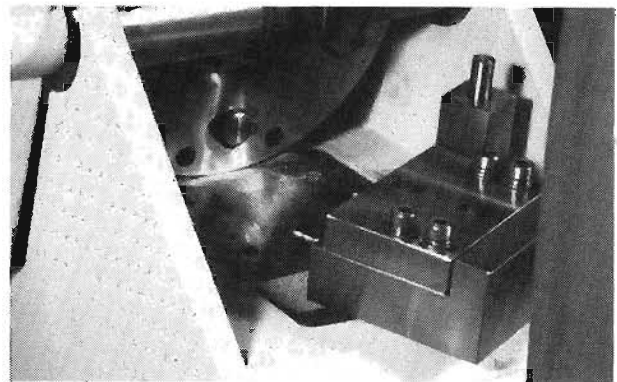
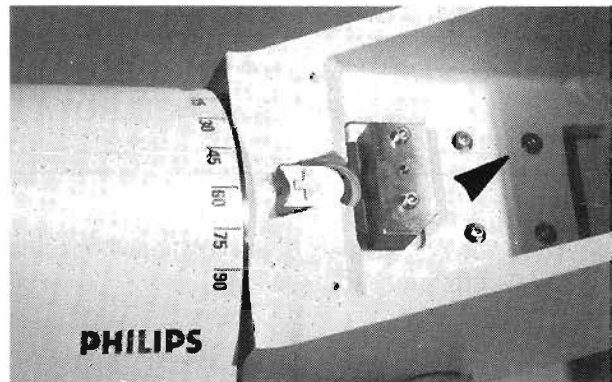

- 4) Remove brake handle and cover of the horizontal sliding block (6x M3).

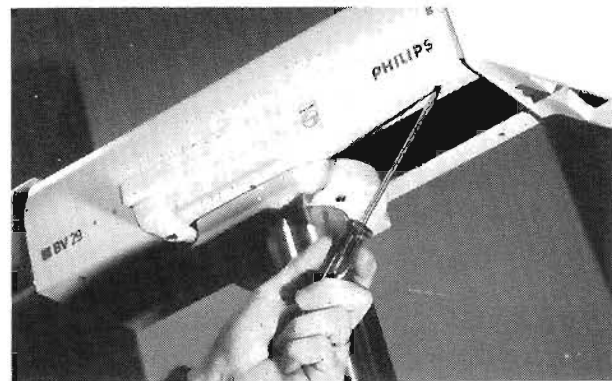

- 5) Remove zig-zag sheets.

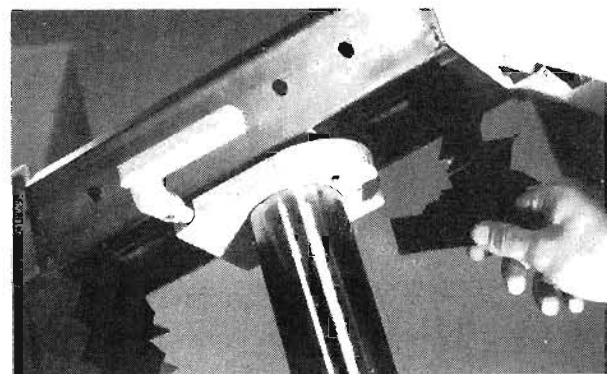

- 6) Remove one rotation brake handle and pull the other handle which is attached to the shaft completely with bearing and washers, out of the frame.
- 7) Remove pressure plate.
- 8) Unscrew lock nut M8 behind the zig-zag sheet, and loosen the bolt by hammering on the nut side.

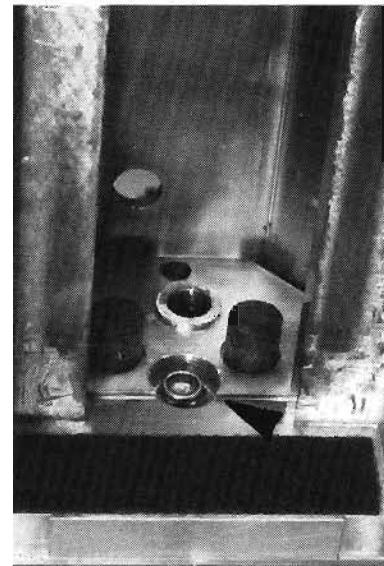
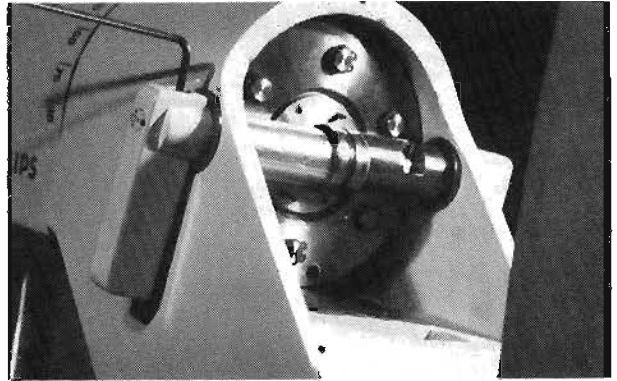

NOTE

It is not possible to turn the bolt. The head is locked with a lock pin.

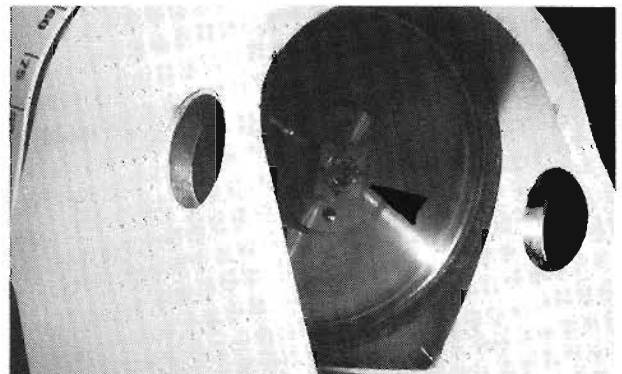

- 9) Turn two screws M4 in holes from the brake disc as a help to remove the disc, and pull off the disc.

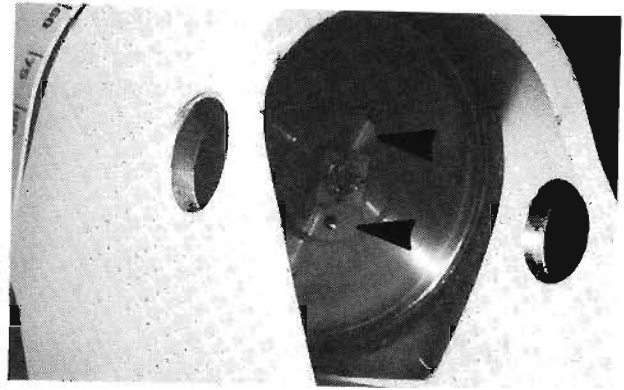

- 10) After replacement of new brake disc, mount a new lock nut M8 on bolt M8.



- 11) Replace pressure piece, the holes must point downwards.

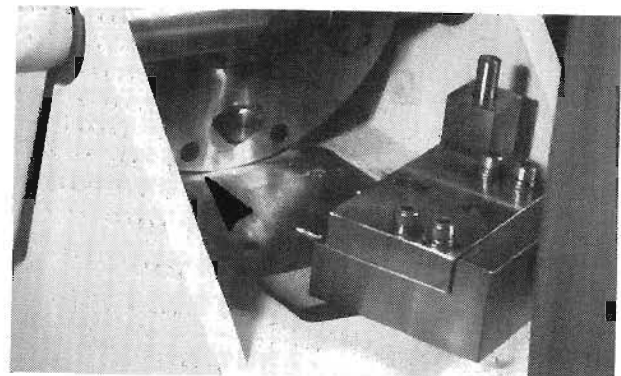

- 12) Replace bearing, washers, shaft and brake handles.

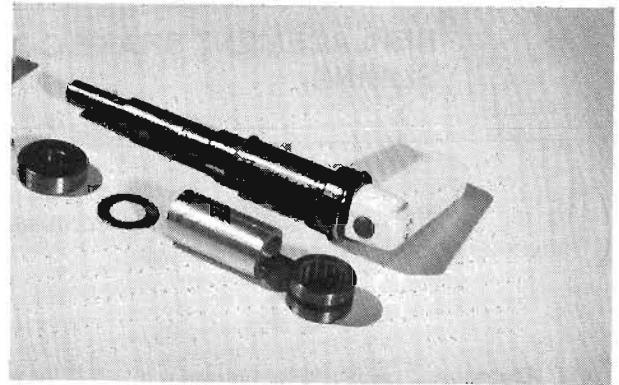

- 13) Replace brake block, and fit it into the brake handle shaft.

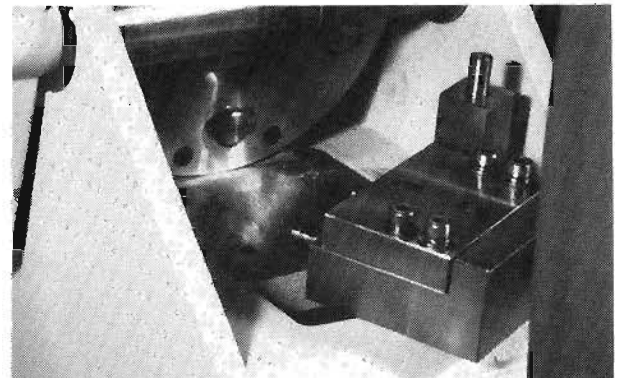

- 14) Adjust breaking force, (see paragraph Adjustment brake C-arm rotation).
- 15) Adjust horizontal position of brake handle.
- 16) Replace C-arm cable cable holder and plate underneath, zig zag sheets and covers.

4. **REPLACEMENT BRAKE C-ARM SLIDING**

To replace the rubber buffer of the C-arm sliding movement brake, proceed as follows:

1) Remove C-arm cable holder (2 x screw M5) and cover plate underneath.

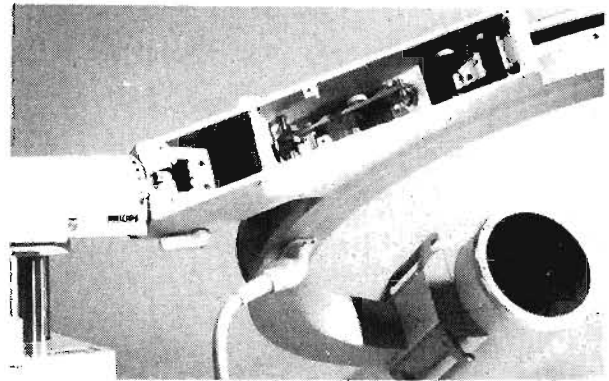

2) Remove fixing screws of the brake assembly (2 x socket screw M4).

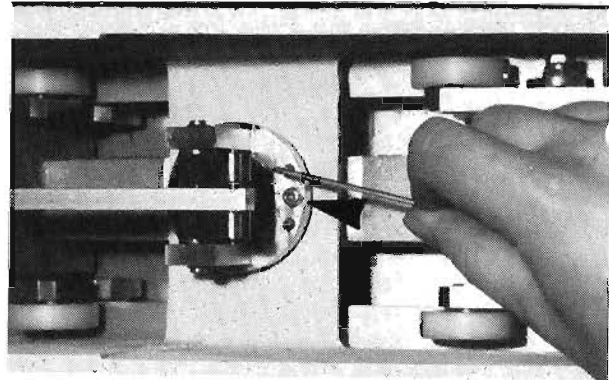

3) Take assembly with rubber buffer and eccentric out of the slide block.

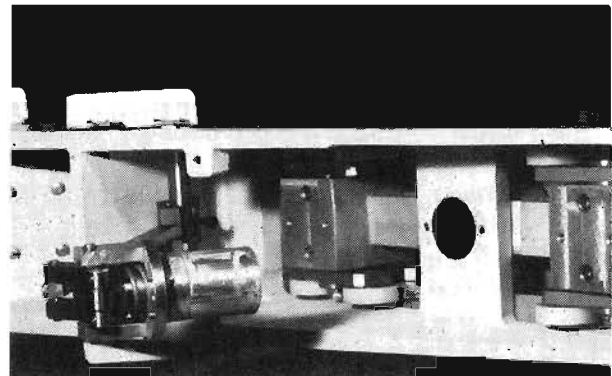

4) Detach eccentric by removing retaining ring. Attention for spring pressure pushing up rubber buffer.

5) Remove buffer assembly and put new one in.

6) Attach washer and retaining ring at buffer bush.

7) Push buffer in housing against spring pressure.

8) Fit eccentric in position and place retaining ring.

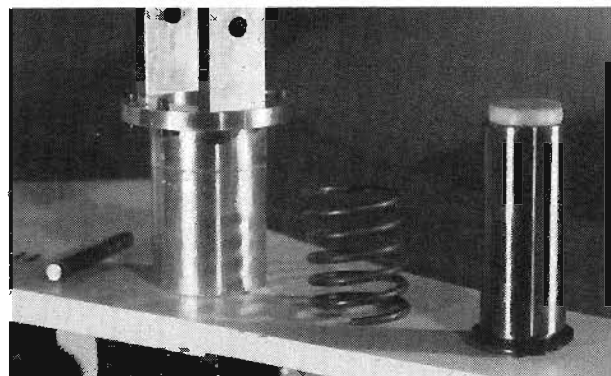

NOTE

The buffer housing has a front and rear side.

- 9) Fit assembly with rubber buffer and eccentric in the slide block.
- 10) Tighten assembly with 2 socket screws.
- 11) Adjust braking force of sliding movement (see adjustment brake C-arm sliding).
- 12) Replace C-arm cable holder and plate underneath.

5. REPLACING THE STAND WHEELS

- 1) Carry out chapter TILTING THE STAND.
- 2) Unscrew the socket screw in the middle of the wheel and remove the disc.
- 3) Pull off the wheel and replace a new one.

6. REPLACEMENT PROCEDURE C-ARM CABLE

Due to unbalance - the I.I. container has to be removed - it is necessary to support the Practics - C tank.

Removal C-arm cable

- 1). Check if all brakes are activated.
- 2). Remove the diaphragm cover.

- 3). Remove lead block.

- 4). Disconnect plugs LAI:X1, LAH:X1, GAX1.

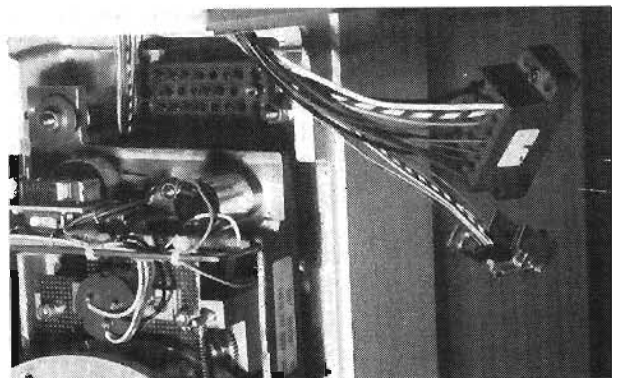
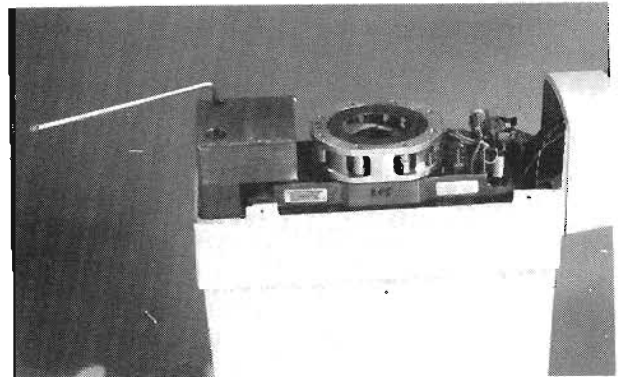
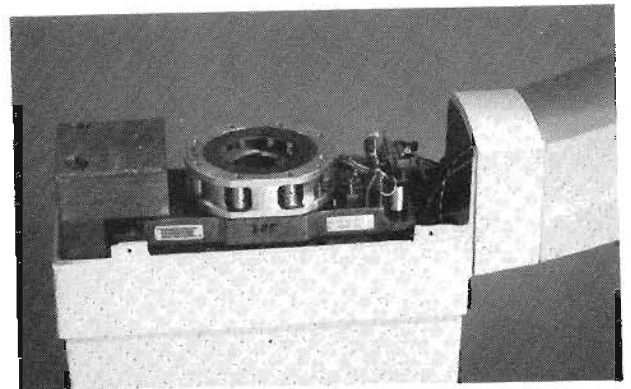
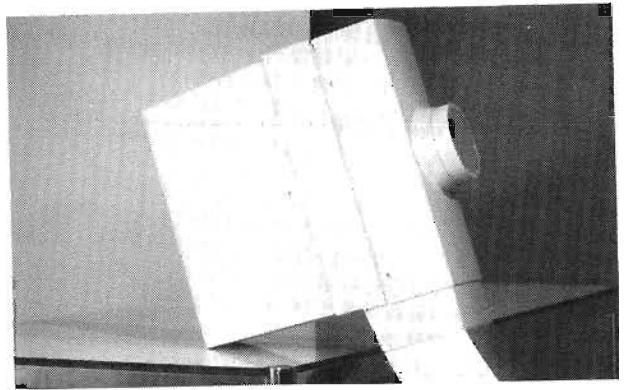

5). Remove the diaphragm.

6). Loosen earth wire.

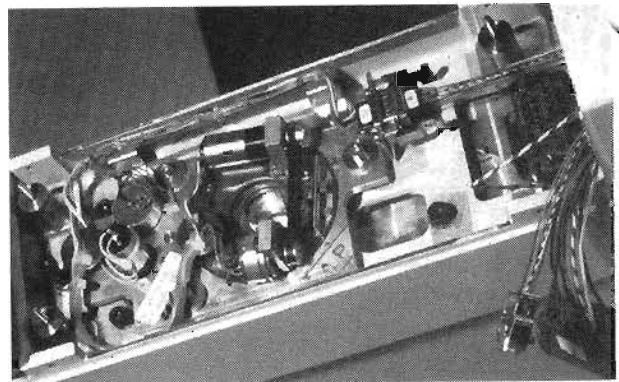

7). Remove top cover and handgrips of the I.I. container.

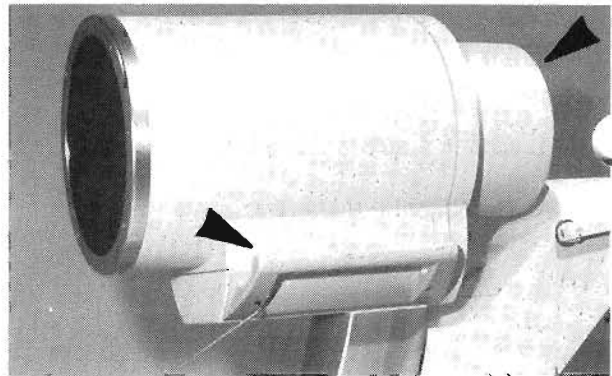

8). Remove connectors, red plug and earth wires from the I.I.

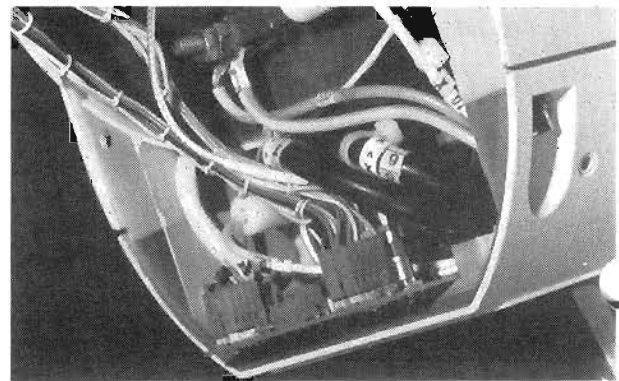

9). Unscrew 6 x M6 socket screw and remove I.I. container.

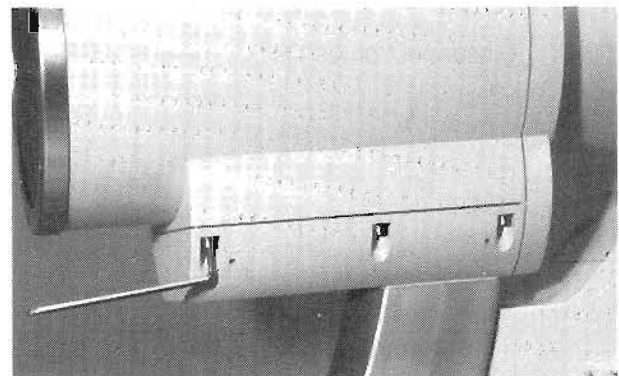

10). Remove copper earth block.

11). Unscrew 8 x M3. and lift interface board.

NOTE

Be carefull that no material can fall into the C-arm.

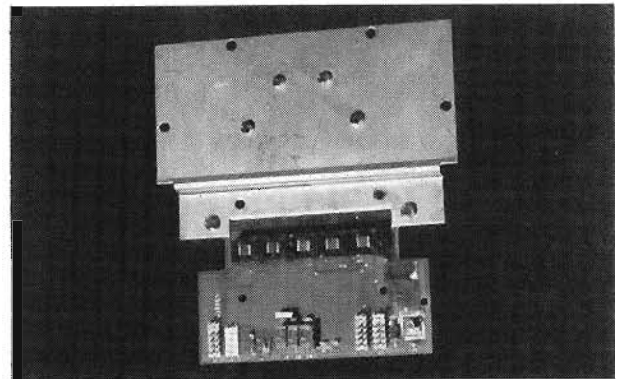

12). Disconnect connector BA1:X1 and earth wires.

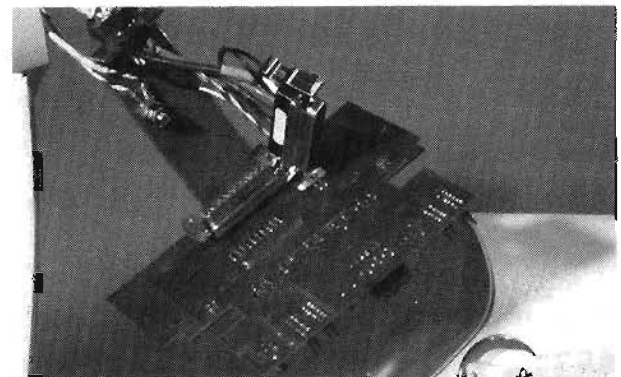

13). Disconnect cable from metal plate.

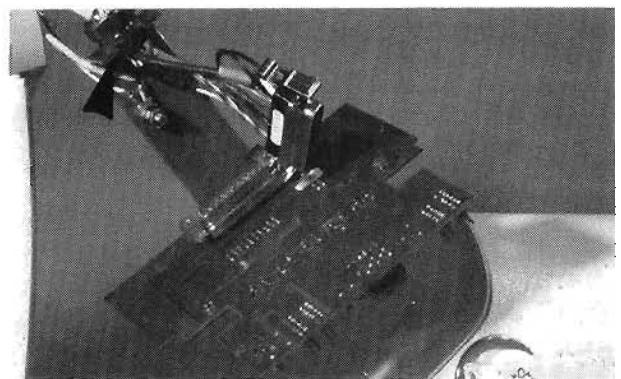

- 14). Remove suspension bracket (4 x M4. socket screws) from the C-arm.

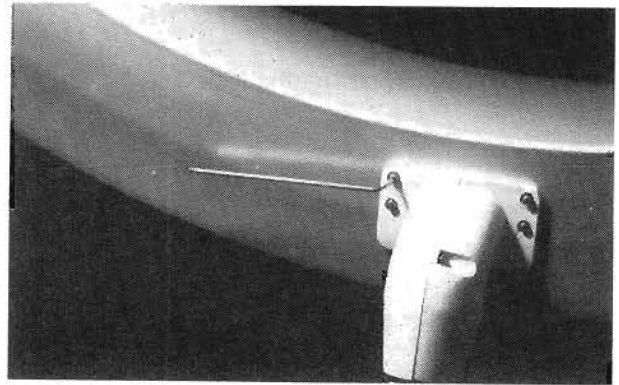

- 15). Remove suspension bracket from the cable (2 x M4. screws).

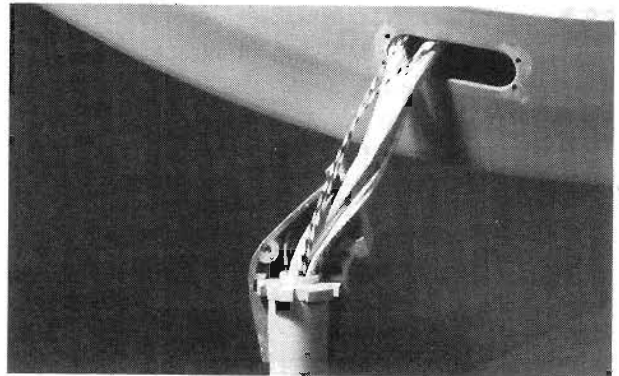

- 16). Remove covers of the electronic container.

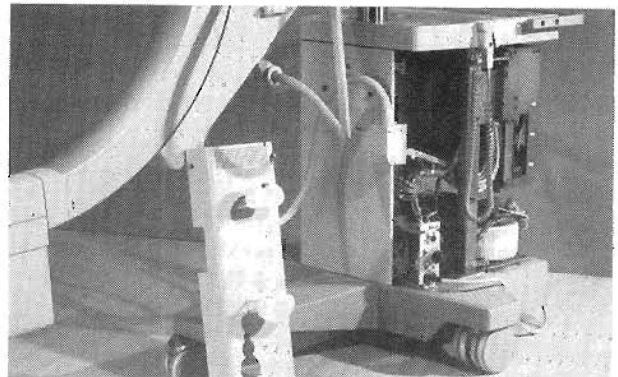

- 17). Disconnect the connectors on Backpanel SE30:
SE 30X1 + wires
SE 10X11
SE 10X7

- 18). Remove tie wraps and disconnect 4 earth wires
SA:3 (2x) + SA:4 (2x).

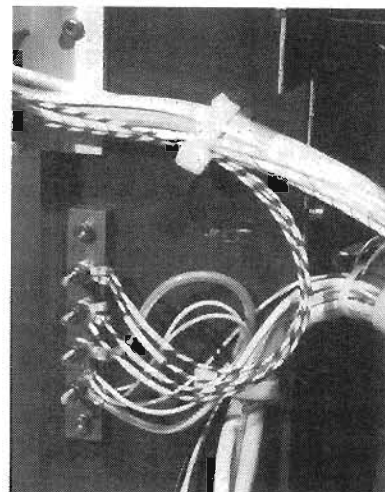

- 19). Remove bracket cable holder.
- 20). Remove cover of the cable bracket (3x M. screws) and remove the cable.

Installation of the C-arm cable.

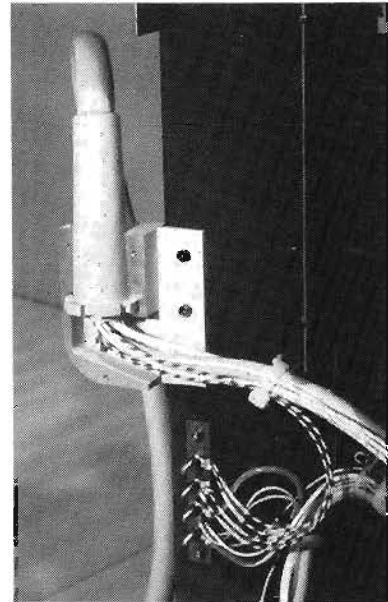

- 21). Pull the part of the cable with the connectors GA:X1 ; LAH:X1 ; LAI:X1 and earth wire through the C-arm to the Practics C-tank side.
- 22). Pull the part of the cable with the connector BA1:X1 and earth wires BA:1 through the C-arm to the I.I. side.
- 23). Mount all items of paragraph " Removal C-arm cable " in reversed sequence.
 - Mount suspension bracket to the C-arm cable.
 - Mount suspension bracket with cable to the C-arm.
 - Mount C-arm cable with cable holder to the C-arm.
 - Mount BA1 X1 and earth wires to metal plate, and connect connector to interface board.
 - Mount interface board and copper earth block to the C-arm.
 - Mount I.I. container with connectors plugs and wires to the C-arm.
 - Mount top cover and hand grips to the I.I. container.
 - Mount diaphragm, plugs and lead block to the Practics - C tank.
 - Mount diaphragm cover.

- 24) Check the system for proper functioning after replacement of the C-arm cable.

7. **REPLACEMENT PROCEDURE
CONNECTOR SAX1**

1) Remove the covers from the Stand.

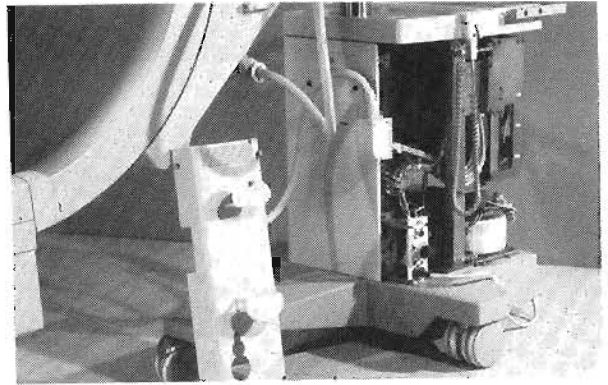

2) Remove 4 socket screws from the plate.

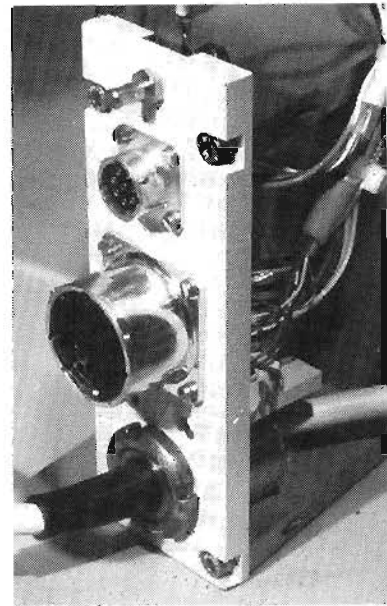

3) Loosen the earth wire from the plate and black wires from the copper block.

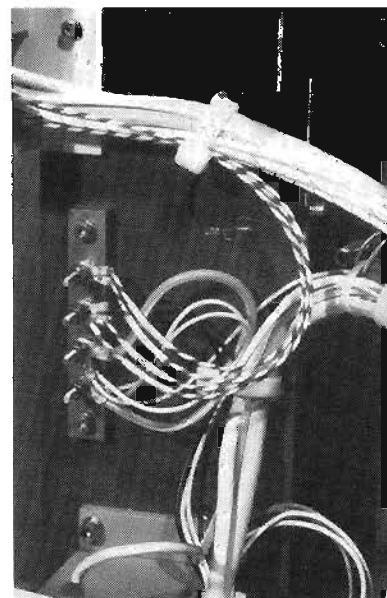

- 4) Loosen the mains and earth wire on WA100 (X1, X2, X3).
- 5) Cut the relevant tyewraps.

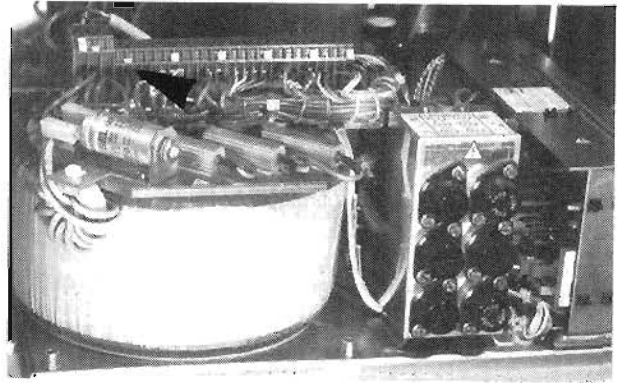

- 6) Disconnect WAX1 SE10X3 and SB2X4.
- 7) Mount new set and perform procedure in reversed order.
- 8) Check the system for proper function.

8. REPLACEMENT VERTICAL MOVEMENT MOTOR

To replace the motor for vertical movement, the C-arm must first be decoupled and the electronic container tilted (see paragraph tilting the stand). Before tilting remove the covers from the stand.

- 1) Carefully open the SE door, and let it rest on the ground.
- 2) Remove nut M6 for spring adjustment.
- 3) Remove the three screws of the mounting base (socket screws M6 with elongated holes).

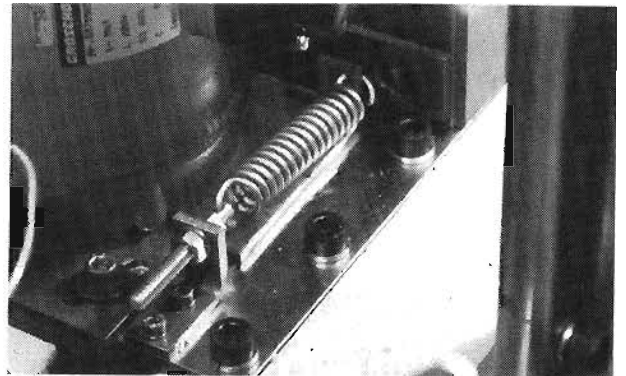

- 4) Disconnect SM1X4.

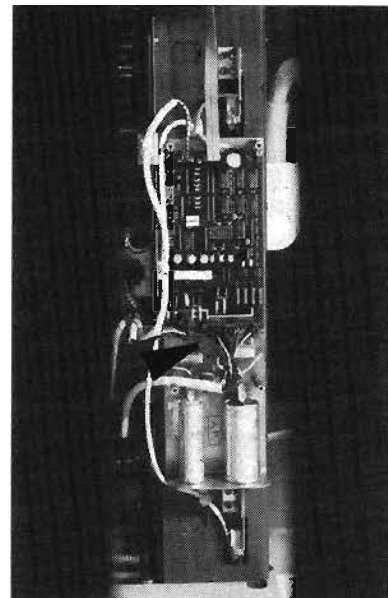

- 5) Put off the V-belts and remove the motor from the Stand.
- 6) Remove motor from mounting base (4 x screw M6), remove pulley and replace motor by a new one. Mount pulley again.
- 7) Mount motor on base.
- 8) Check the V-belts for excessive wear.
- 9) Put the four V-belts on the spindle.
- 10) Mount pulley with V-belts to the spindle and tighten the fixing screws.
Take care that the V-belts do not come loose.
- 11) Mount the motor/base in the stand and put the V-belts on the motor pulley.
Turn the fixing screws in the elongated holes finger tight and adjust the spring for some V-belt tension.
- 12) Adjust the V-belt tension by tightening the nut M6 until mechanical stop.
- 13) Tighten the fixing screws.
- 14) Connect SM1X4.
- 15) Close SE-door.
- 16) Lift electronic container on its wheels.
- 17) Switch on the stand and check C-arm up/down movements, and listen to V-belts for smooth operation.

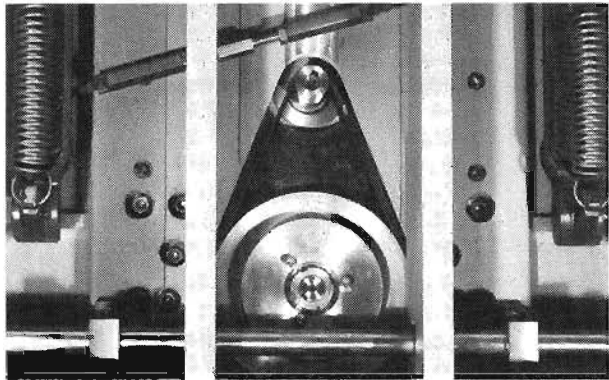

- 18) Replace covers and C-arm.

Warning

Motor pulley and spindle pulley must be aligned to 0 ± 0.05 mm to prevent excessive wear of V-belts.

The position of the motor pulley can be adjusted on the motor shaft. Use a ruler as alignment tool.

-
- 12) Adjust the V-belt tension by tightening the nut M6 until mechanical stop.

Section : PROGRAMMING FACILITIES

Contents

1.	INTRODUCTION	7-4
2.	BV29 STAND SETTINGS	7-4
3.	X-RAY CONTROL UNIT	7-4
3.1.	SE10 -CONTROL BACKPANEL-	7-4
3.1.1.	JUMPERS	7-4
3.1.2.	PCB LAY OUT	7-5
3.2.	SE13 -XRC CONTROL-	7-6
3.2.1.	SWITCH SETTINGS	7-6
3.2.2.	INDICATORS	7-7
3.2.3.	MEASURING POINTS	7-8
3.2.4.	PCB LAY OUT	7-9
3.3.	SE15 -GENERAL & ERROR PROCESSING-	7-10
3.3.1.	INDICATORS	7-10
3.3.2.	MEASURING POINTS	7-11
3.3.3.	PCB LAY OUT	7-11
3.4.	SE17 -RAD & FLUO PROCESSING-	7-12
3.4.1.	JUMPERS	7-12
3.4.2.	INDICATORS	7-12
3.4.3.	MEASURING POINTS	7-12
3.4.4.	PCB LAY OUT	7-13
3.5.	SE19 -KV & MA CONTROL	7-14
3.5.1.	JUMPERS	7-14
3.5.2.	MEASURING POINTS	7-14
3.5.3.	POTENTIOMETERS	7-14
3.5.4.	PCB LAY OUT	7-15
3.6.	SE21 -DIAPHRAGM 1-	7-16
3.6.1.	JUMPERS	7-16
3.6.2.	INDICATORS	7-16
3.6.3.	PCB LAY OUT	7-17
3.7.	SE23 -DIAPHRAGM 2-	7-18
3.7.1.	JUMPER	7-18
3.7.2.	PCB LAY OUT	7-18

3.8.	SE31 -FILAMENT SUPPLY-	7-19
3.8.1.	MEASURING POINTS	7-19
3.8.2.	POTENTIOMETERS	7-19
3.8.3.	PCB LAY OUT	7-20
3.9.	SE33 -FET POWER CONTROL-	7-21
3.9.1.	JUMPERS	7-21
3.9.2.	MEASURING POINTS	7-21
3.9.3.	POTENTIOMETERS	7-21
3.9.4.	PCB LAY OUT	7-22
3.10.	SE37 -FET INVERTER POWER 1-	7-23
3.10.1.	JUMPERS	7-23
3.10.2.	MEASURING POINTS	7-23
3.10.3.	PCB LAY OUT	7-23
4.	OPERATOR CONTROL PANEL	7-24
4.1.	SB2 -FLAT PANEL CONTROL-	7-24
4.1.1.	SWITCHES	7-24
4.1.2.	INDICATORS	7-25
4.1.3.	MEASURING POINTS	7-26
4.1.4.	PCB LAY OUT	7-26
5.	MAINS CONTROL UNIT	7-28
5.1.	WA1 -MAINS CONTROL 1-	7-28
5.1.1.	INDICATORS	7-28
5.1.2.	MEASURING POINTS	7-28
5.1.3.	PCB LAY OUT	7-29
6.	MOTOR UNIT	7-30
6.1.	SM1 -Vertical Movement Control	7-30
6.1.1.	JUMPERS	7-30
6.1.2.	PCB LAY OUT	7-30
7.	IITV INTERFACE	7-31
7.1	BA1	7-31
7.1.1.	INDICATORS	7-31
7.1.2.	MEASURING POINTS	7-31
7.1.3.	POTENTIOMETERS	7-31
7.1.4.	PCB LAY OUT	7-32
8.	XTV-8SRI CAMERA	7-33
8.1.	XTV8-SRI	7-33
8.1.1.	SETTINGS	7-33
8.1.2.	JUMPER SETTINGS WK UNIT	7-33
8.1.3.	SWITCH SETTINGS WK UNIT	7-33
8.1.4.	POTENTIOMETERS	7-34
8.1.5.	MEASURING POINTS	7-35
9.	DIAPHRAGM UNIT	7-36

9.0.1.	POTENTIOMETERS	7-36
10.	BV29 TROLLEY SETTINGS	7-37
11.	DIGITAL SCOPOFIX MMP	7-37
11.1.	SWITCH SETTINGS SCOPOFIX MMP	7-37
12.	MONITOR	7-38
12.1.	17"/20" MONITOR	7-38
13.	MEMORY BOX CONTROL	7-39
13.1.	MBC29	7-39
13.1.1.	JUMPERS	7-39
13.1.2.	SWITCHES	7-39
13.1.3.	INDICATORS	7-40
13.1.4.	MEASURING POINTS	7-41
13.1.5.	POTENTIOMETERS	7-41
13.1.6.	PCB LAY OUT	7-42
13.2.	MAINS SUPPLY UNIT	7-43
13.2.1.	WT1:MAINS SWITCHING CIRCUIT	7-43
13.2.2.	PCB LAY OUT	7-43

1. INTRODUCTION

This section describes for each pc board:

- Settings of jumpers and switches
- Indicators
- Potentiometers
- Measuring points

2. BV29 STAND SETTINGS

The BV29 STAND settings can be found on:

- SB: Operators control panel
- SE: X-Ray Control Unit
- SM: Motor Unit
- SU: Power Unit
- WA: Mains supply unit
- WK: XTV8-SRI

3. X-RAY CONTROL UNIT

3.1. SE10 -CONTROL BACKPANEL-

3.1.1. JUMPERS

X13 A1-B1	INSTALLED* REMOVED	Enable x-ray generation Enable x-ray generation by means of service-key.
X13 A3-B3	INSTALLED* REMOVED	Enable switching-on BV29 Enable switching-on BV29 by means of service-key.

* Factory delivered system settings.

3.1.2. PCB LAY OUT

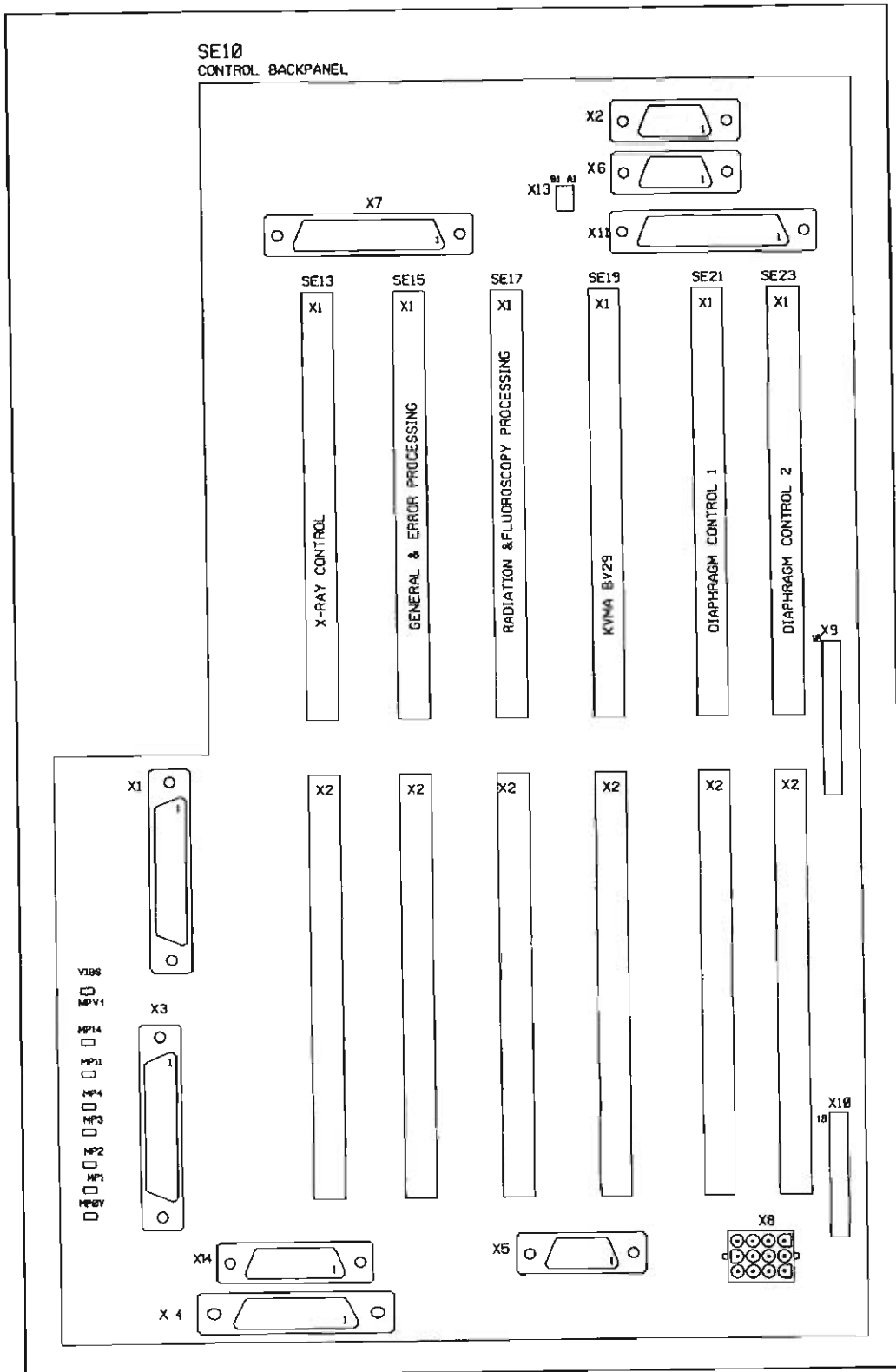

3.2. SE13 -XRC CONTROL-

3.2.1. SWITCH SETTINGS

S2-1	OFF*	When S2-1 is in position "OFF" the function of the switches S2-2 up to S2-8 are as follows;
S2-2	ON OFF*	With switches S2:2, S2:3 and S2:4 you can select 8 different kV-mA curves. (Future extension)
S2-3	ON OFF*	With switches S2:2, S2:3 and S2:4 you can select 8 different kV-mA curves. (Future extension)
S2-4	ON OFF*	With switches S2:2, S2:3 and S2:4 you can select 8 different kV-mA curves. (Future extension)
S2-5	ON OFF*	Measuring field kV dependent Always small measuring field selected
S2-6	ON OFF*	Homologation on Homologation off
S2-7	ON OFF*	Diaphragm programming on Diaphragm programming off
S2-8	ON OFF*	Debug on Debug off

* Factory delivered system settings.

S2-1	ON	When S2-1 is in position "ON" (= SERVICE TEST) the function of the switches S2-2 up to S2-8 are as follows;
S2-2	ON OFF	Run selftest at high speed Run selftest at normal speed
S2-3	ON OFF	Repeat selftest No repeat selftest
S2-4	ON OFF	Not used Not used
S2-5	ON OFF	Not used Not used
S2-6	ON OFF	Not used Not used
S2-7	ON OFF	Not used Not used
S2-8	ON OFF	Dump on Dump off

3.2.2. INDICATORS

H1-SMMF	Small measuring field selected
H1-FRNORM	French norm (101-105 kV, 30 mA radiography) selected
H1-ZOOM	Diaphragm adjustment selected
H1-RUN	Microprocessor is running
H2-STEMBC	Self test MBC / serial transmission error
H2-STEXRC	Self test XRC / serial transmission error
H2-STEFPFC	Self test FPC / serial transmission error
H2-ERROR	Selftest busy or μ P not running

3.2.3. MEASURING POINTS

CLCA	1 MHz clock frequency from can
WADG	Watchdog
RST	Reset
+ 5 V	
CLK	24 MHz clock frequency
0 V	
X9	Not used
X10	Not used
X11	Not used
TXD	Send data
RXD	Receive data

3.2.4. PCB LAY OUT

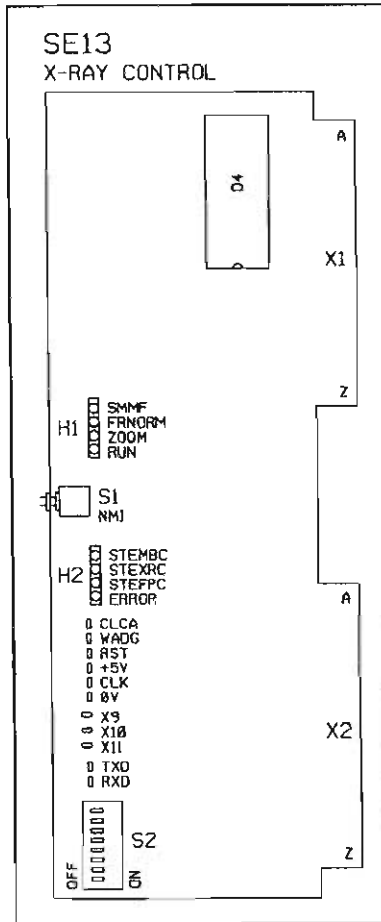

3.3. SE15 -GENERAL & ERROR PROCESSING-

3.3.1. INDICATORS

H1-HVNR	High voltage not ready
H1-KSWNR	Key switch not ready
H1-DIANR	Diaphragm not ready
H1-MMPNR	Scopofix MMP not ready
H2-SUPNR	Power supply not ready
H2-FPCNR	FPC not ready
H2-MBCNR	MBC not ready
H2-TIMNR	10-min. fluoroscopy timer not ready
H3-TVAL	TV alarm
H3-FILAL	Filament alarm
H3-INVAL	Invertor alarm
H3-MCUAL	Mains control unit alarm
H4-TKTAL	Tank temperature alarm
H4-TIMAL	Timer alarm
H4-CLAL	Clock frequency alarm
H4-	Not used
H5-24 V	
H5-15 V	
H5-12 V	
H5- 6.4 V	
H6-5 V	
H6- -12 V	
H6- -15 V	
H6- SYON	Same function as power-on lamp

Note: All alarm and not-ready indicators are related to the Flatpanel error LCD.

3.3.2. MEASURING POINTS

X7-NTC	Measuring tank temperature
X8-HVT	High voltage divided
X6- 2.6 V	
X4- -12 V	
X3- 12 V	
X5- 0 V	

3.3.3. PCB LAY OUT

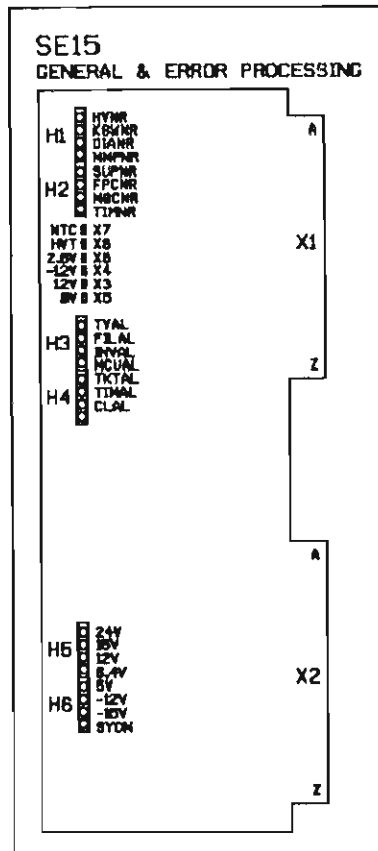

3.4. SE17 -RAD & FLUO PROCESSING-

3.4.1. JUMPERS

W1	AUTO* FIX	Automatic gain control in manual fluoroscopy Manual gain control in manual fluoroscopy
W2	NORM* ADJUST	Normal dose rate adjustment Check high dose rate during fluoroscopy

* Factory delivered system settings.

3.4.2. INDICATORS

H1	Indication high dose check
----	----------------------------

3.4.3. MEASURING POINTS

VIDCOR	Video correct
ODD FIELD	Odd field
FLUO	Fluoroscopy command
RAD	Radiography command
STOP FL	Stop fluoroscopy (pulsed fluo and snapshot)
0 V	

3.4.4. PCB LAY OUT

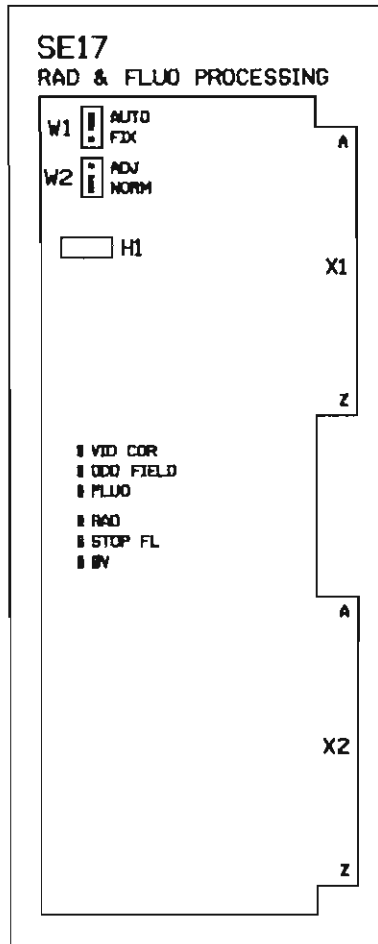

3.5. SE19 -KV & MA CONTROL

3.5.1. JUMPERS

W1	SERV CONTR*	Manual mA control Automatic kV/mA control
W2	FLUO*	Installed for measuring mA fluoroscopy
W3	RAD	Installed for measuring mA radiography

* Factory delivered system settings.

3.5.2. MEASURING POINTS

MP1	Dose rate control measurement (DRFLC)
MP2	kV control (KVC)
MP3	Reference mA (IREF)
MP4	Actual mA (IACT)
MP5	DC 0 V

3.5.3. POTENTIOMETERS

R57	Adjustment KVC 105 kV
R58	Adjustment mA reference
R59	Adjustment KVC 40 kV
R62	Adjustment manual mA control

3.5.4. PCB LAY OUT

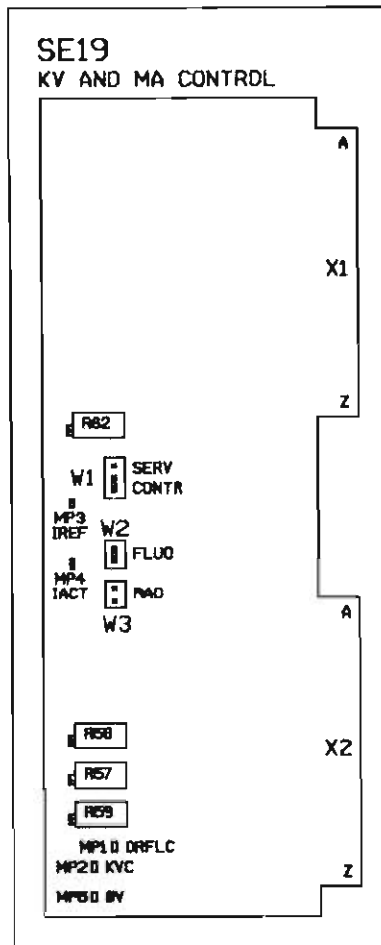

3.6. SE21 -DIAPHRAGM 1-

3.6.1. JUMPERS

W1	FLUO SF 1-2* FLUO LF 1-3	1-2 small focus during fluoroscopy 1-3 Large focus during fluoroscopy
----	------------------------------------	--

** Factory delivered system settings.*

3.6.2. INDICATORS

H1	Large focus fluoroscopy
----	-------------------------

3.6.3. PCB LAY OUT

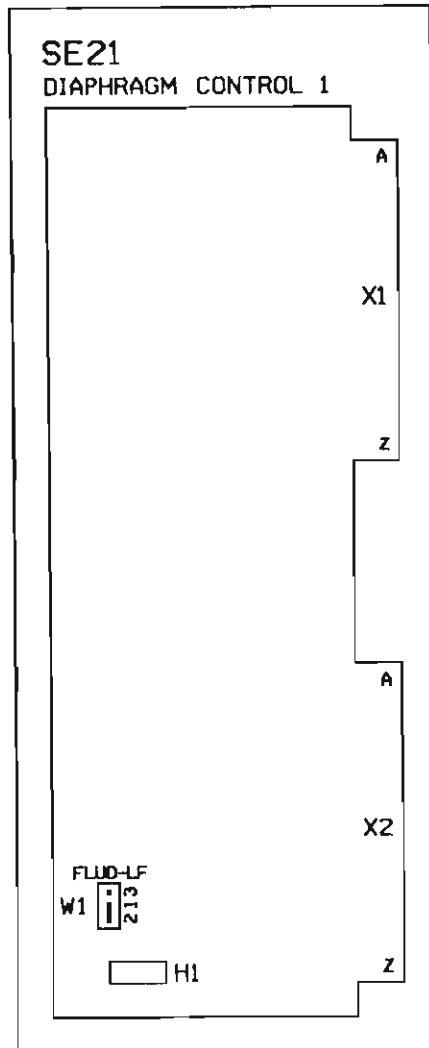

3.7. SE23 -DIAPHRAGM 2-

3.7.1. JUMPER

W1	BV25 BV29*	Installed for BV25 Installed for BV29
----	---------------	--

* Factory delivered system settings.

3.7.2. PCB LAY OUT

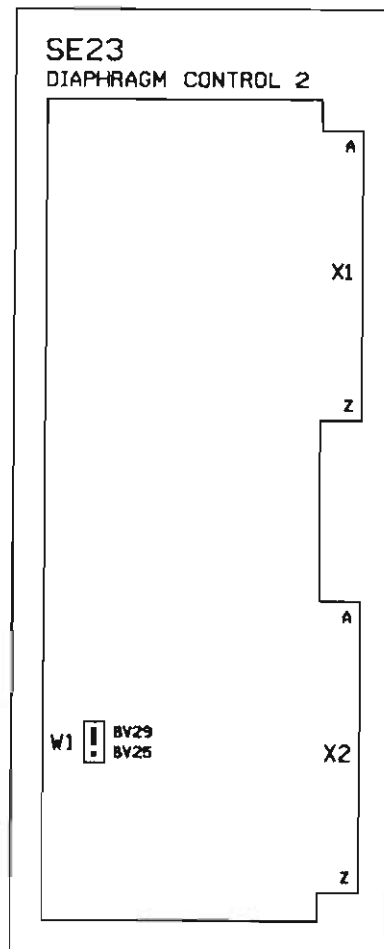

3.8. SE31 -FILAMENT SUPPLY-

3.8.1. MEASURING POINTS

MP6	Primary filament current
MP7	Primary filament current

3.8.2. POTENTIOMETERS

R1	Preheating radiography
R2	100 kV - 20 mA adjustment
R3	40 kV - 20 mA adjustment
R60	105 kV - 30 mA adjustment homologation

3.8.3. PCB LAY OUT

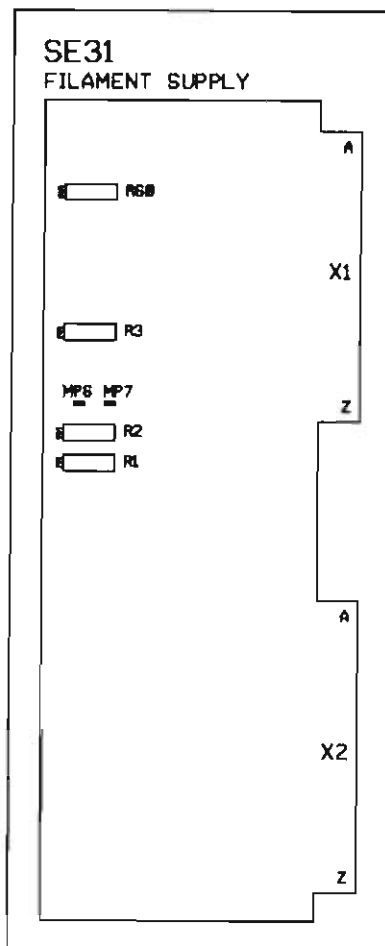

3.9. SE33 -FET POWER CONTROL-**3.9.1. JUMPERS**

X3	50 Hz 60 Hz	Version dependent
----	----------------	-------------------

3.9.2. MEASURING POINTS

X4	Triggerpulse
X5	PWRSM
X6	0 Volt
X7	HVCOM-HC

3.9.3. POTENTIOMETERS

R1	Adjustment 76.8 kHz oscillator
R116	Adjustment primary high tension

3.9.4. PCB LAY OUT

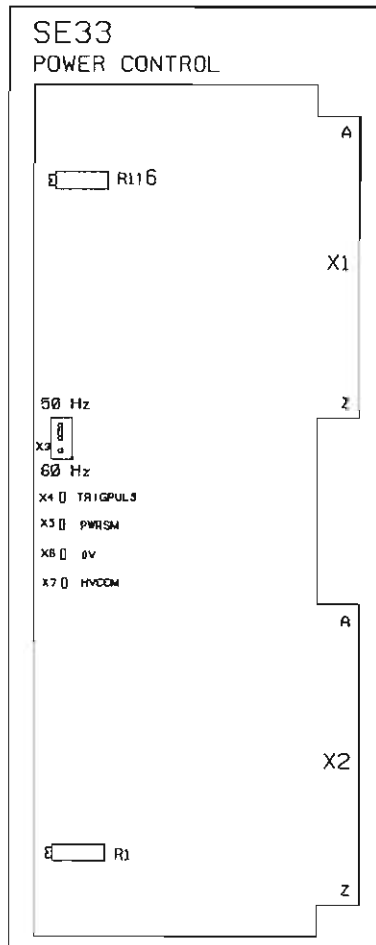

3.10. SE37 -FET INVERTER POWER 1-

3.10.1. JUMPERS

TEST	Invertor alarm service jumper
------	-------------------------------

3.10.2. MEASURING POINTS

+PRHV	Ref. voltage for primary high tension
-PRHV	Ref. voltage for primary high tension
TEST	Test invertor alarm

3.10.3. PCB LAY OUT

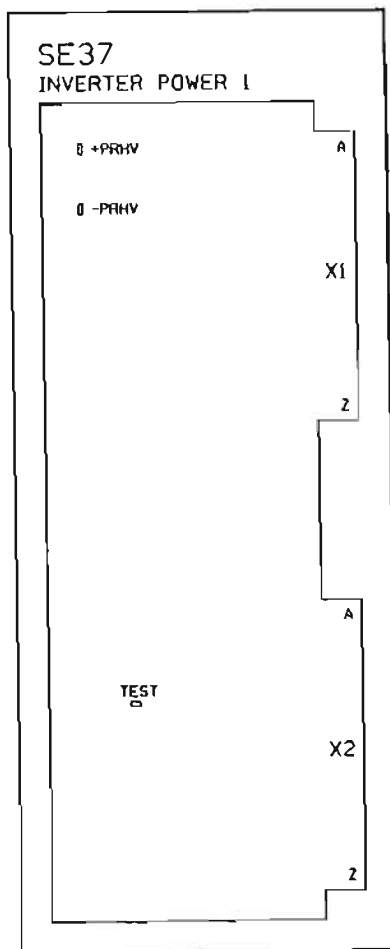

4. OPERATOR CONTROL PANEL

4.1. SB2 -FLAT PANEL CONTROL-

4.1.1. SWITCHES

S1-1	OFF*	When S2-1 is in position "OFF" the function of the switches S2-2 up to S2-8 are as follows:
S1-2	ON OFF*	Not used Not used
S1-3	ON OFF*	Not used Not used
S1-4	ON OFF*	Not used Not used
S1-5	ON OFF*	Not used Not used
S1-6	ON OFF*	Not used not used
S1-7	ON OFF*	Not used not used
S1-8	ON OFF*	Not used Not used

* *Factory delivered system settings.*

S1-1	ON	When S2-1 is in position "ON" the function of the switches S2-2 up to S2-8 are as follows;
S1-2	ON OFF	Run selftest at high speed Run selftest at normal speed
S1-3	ON OFF	Repeat selftest No repeat selftest
S1-4	ON OFF	Skip test No skip test
S1-5	ON OFF	Not used Not used
S1-6	ON OFF	Not used Not used
S1-7	ON OFF	Not used Not used
S1-8	ON OFF	Debug on Debug off

4.1.2. INDICATORS

-12 V	
12 V	
15 V	
5 V	
RUN	Microprocessor is running
	Selftest is running
ERROR	Selftest busy or μ P not running
A	Not used
B	Not used
C	Not used

4.1.3. MEASURING POINTS

5 V	
15 V	
0 V	
8 MHz	8 MHz clock frequency
WATCHD	Watchdog
RXD	Receive data
TXD	Send data
CLCAN	1 MHz clock frequency from can
RESET	Reset

4.1.4. PCB LAY OUT

Switches and LED array are easy accessible and located on the lay out side of the SB2 board. Measuring points are situated on the component side of the SB2 board.

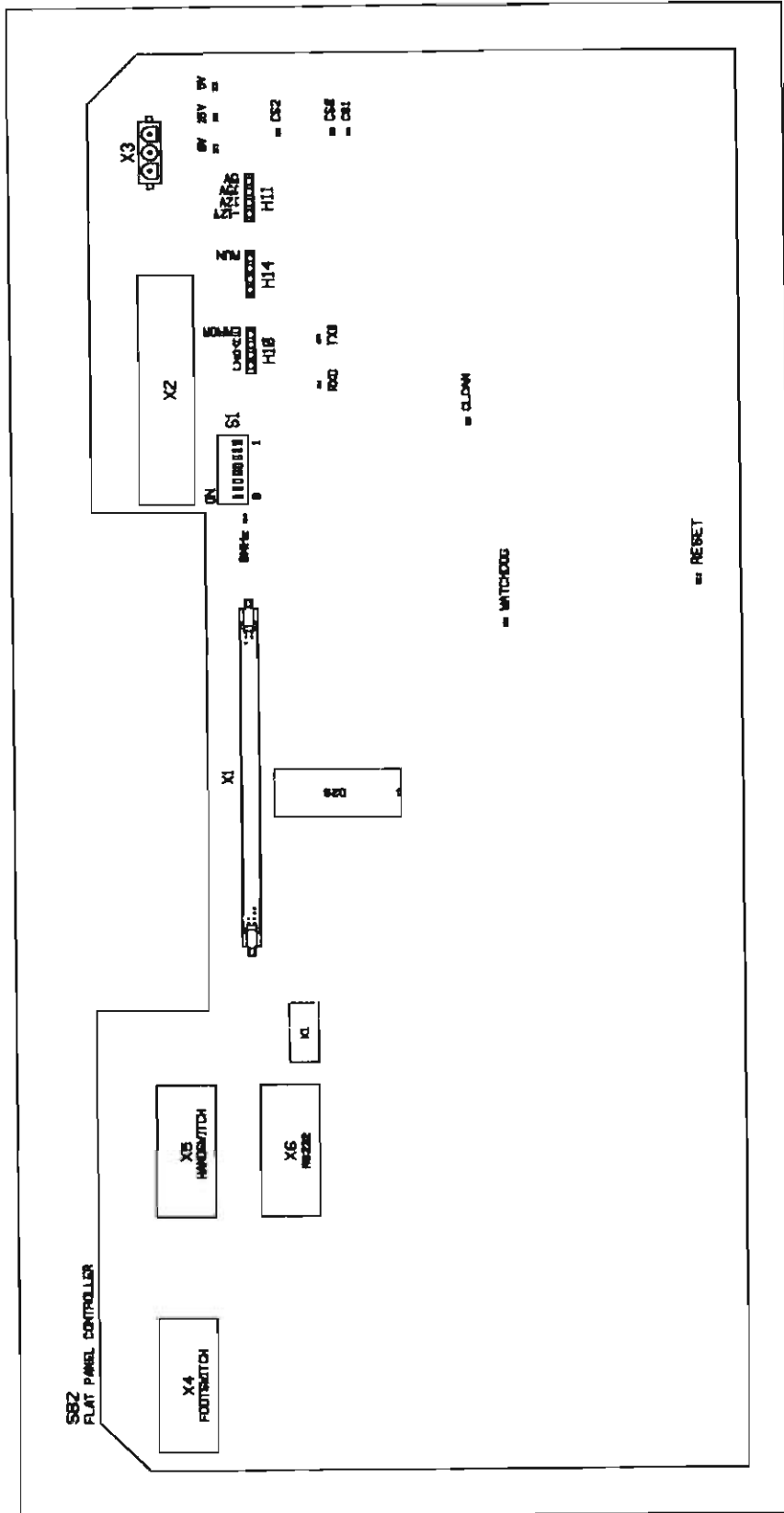

5. MAINS CONTROL UNIT

5.1. WA1 -MAINS CONTROL 1-**5.1.1. INDICATORS**

H1	Input voltage to mains control present
H2	Alarm situation in mains control unit

5.1.2. MEASURING POINTS

MP1	MP1 and MP2 can be interconnected to bridge the keying circuit
MP2	MP1 and MP2 can be interconnected to bridge the keying circuit

5.1.3. PCB LAY OUT

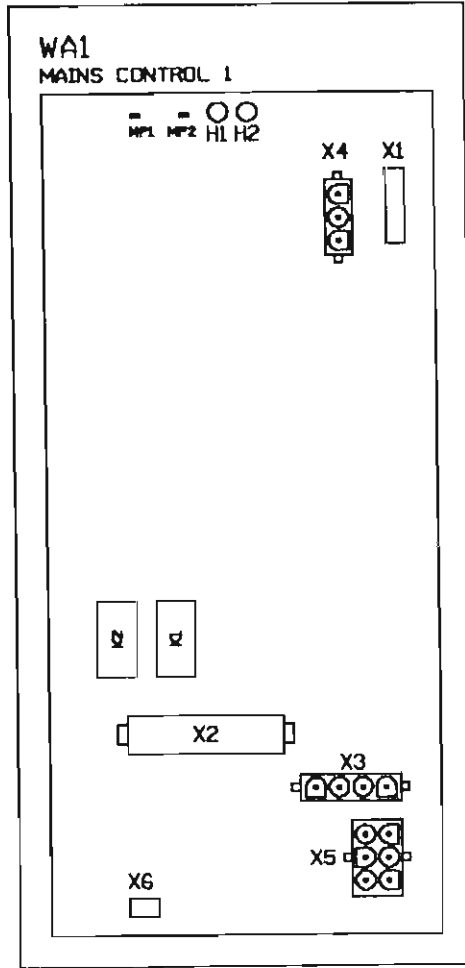

6. MOTOR UNIT

6.1. SM1 -VERTICAL MOVEMENT CONTROL

6.1.1. JUMPERS

W1	1-2	Not used
----	-----	----------

** Factory delivered system settings*

6.1.2. PCB LAY OUT

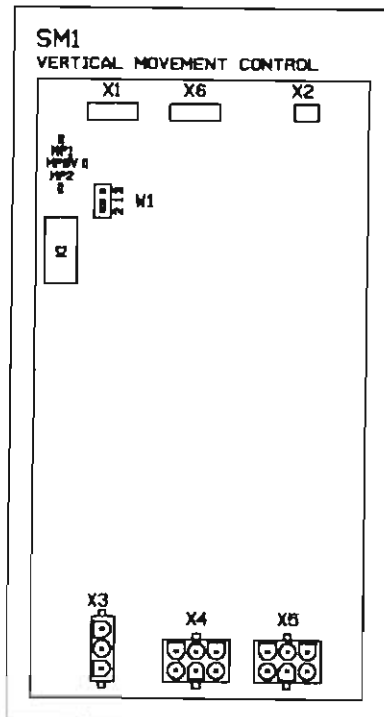

7. II/TV INTERFACE

7.1. BA1

7.1.1. INDICATORS

H1	15 V present to I.I. and XTV8
----	-------------------------------

7.1.2. MEASURING POINTS

MP1	Focusing voltage
MP2	Focusing voltage
MP3	VIBS

7.1.3. POTENTIOMETERS

R1	Adjustment focusing voltage 23 cm
R2	Adjustment focusing voltage 17 cm
R3	Adjustment focusing voltage 13 cm

7.1.4. PCB LAY OUT

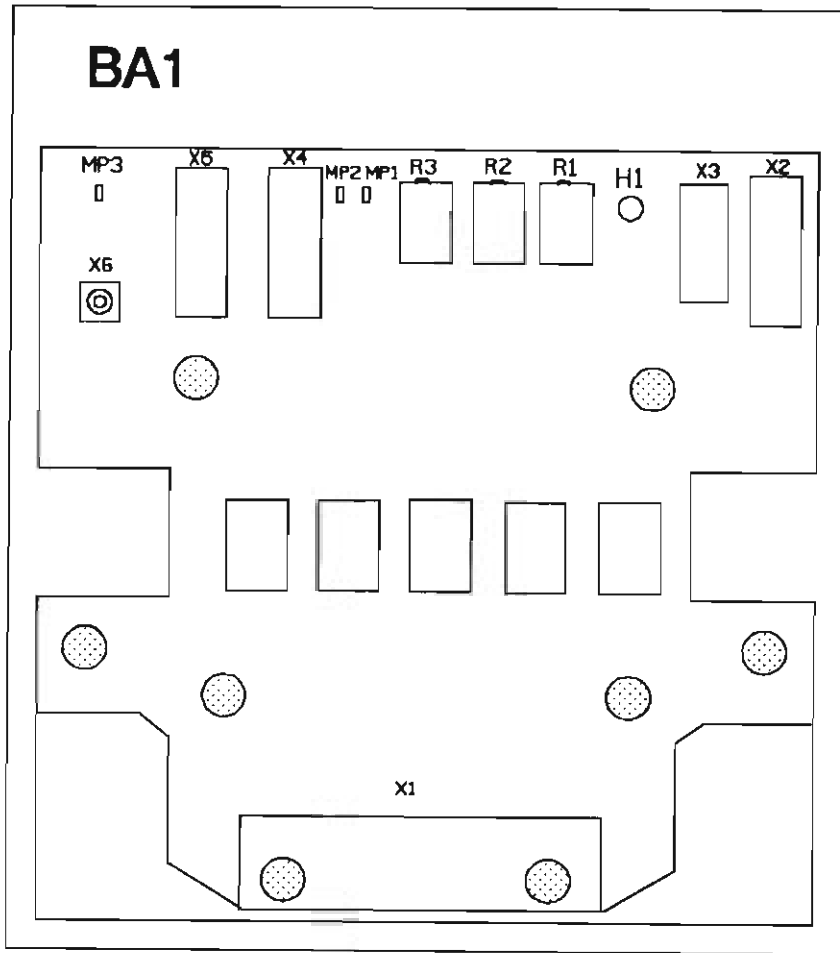

8. XTV-8SRI CAMERA

8.1. XTV8-SRI

For detailed information see SERVICE MANUAL XTV8-SRI.
The XTV8-SRI camera contains following printed circuit boards:

8.1.1. SETTINGS

WK1: Preprocessing 1 board
WK2: Preprocessing 2 board
WK3: AGC/ADC 1 board
WK4: AGC/ADC 2 board
WK5: Videoprocessing board
WK6: Rotairis board

8.1.2. JUMPER SETTINGS WK UNIT

PCB	JUMPER	POSITION	REMARK
WK3	W1	2-3*	blockgenerator OFF
WK3	W2	2-3*	rampgenerator OFF
WK3	W3	2-3*	videoproc. bypass OFF
WK3	X19	other*	cable comp. 0 - 3.3 m
WK4	W1	1-2*	clean circle "ON"

* Factory delivered system settings

8.1.3. SWITCH SETTINGS WK UNIT

PCB	SWITCH	POSITION	REMARKS
WK4	S1	ON*	SURGERY
	S2:1	ON*	X-tal lock
	S2:2	ON*	Contour correction on
	S2:3	ON*	Frame accumulation
	S2:4	ON*	White compression curve 1

	S2:5	OFF*	Not used
	S2:6	ON*	1100mV max VIBS level
	S3:1	ON*	Normal image
	S3:2	ON*	Not used
	S3:3	OFF*	Absolute MF value
	S3:4	ON*	Not used
	S3:5	ON*	Not used
	S3:6	ON*	MF remote selectable
	S3:7	ON*	Large MF
	S3:8	OFF*	AGC soft rise on
WK5	S1	7*	Circle blanking size
WK5	S2	LEFT*	Normal use

* Factory delivered system settings

8.1.4. POTENTIOMETERS

PCB	POTENTIOMETER	REMARKS
WK1	R24	+15 V
	R28	V sub.
	R57	Cross talk comp.
	R58	Gain
WK3	P1	Amplitude blockgenerator
	P2	Dose-rate medium format
	P3	Dose-rate small format
	P4	Black level
	P5	Fixed gain
	P6	AGC threshold small MF
	P7	AGC threshold large MF
	P8	Offset
WK5	P1	Video gain
WK6	P1	Iris diaphragm opening
	P4	Offset

8.1.5. MEASURING POINTS

WK3	MP1	VIN (video in)
	MP2	VINADJ (video in after first gain)
	MP3	VIAGC (video after AGC)
	MP4	VICOMP (video after white compression)
	MP5	VIDAC (video from the videoproc.)
	MP6	VICORR (video after contour correction)
	MP7	VIBS (video out)
	MP8	IRPOT 1 (irispotentiometer pin 1)
	MP9	IRPOT 2 (irispotentiometer pin 2 slider)
	MP10	IRPOT 3 (irispotentiometer pin 3)
	MP11	Video without sync and cable compensation
	MP12	Video after fixed gain
WK4	MP1	Ground
	MP2	Ground
WK5	MP1	Midline (sync. pulse)
WK6	MP1	Ground
	MP2	Iris position difference
	MP3	Iris target
	MP4	Watchdog
	MP5	Rotation position difference
	MP6	Rotation speed
	MP7	Rotation movement enable

9. DIAPHRAGM UNIT

The diaphragm unit has feedback potentiometers, the adjustments for these potentiometers are described in the adjustment procedure.

9.0.1. POTENTIOMETERS

POTENTIOMETER	REMARKS
LAR1	Iris field size potentiometer
LAR2	Shutter field size potentiometer
LAR3	Shutter rotate potentiometer
LAR4	Focus position potentiometer

10. BV29 TROLLEY SETTINGS

The BV29 TROLLEY setting can be found on:

- WHD : Digital Scopofix MMP
- WM : 17"/20" TV Monitor
- WSU : Weir Supply Unit
- WT : Mains Supply Unit / Memory Control Box

For each part the settings are given in the following tables

11. DIGITAL SCOPOFIX MMP

DIGITAL MMP SCOPOFIX

- P0: Video board
- P1: Scan convertor
- P2: Processing 1
- P3: Processing 2
- P4: Image board
- P5: Cine memory (option)
- P6: Control Processing
- P7: Disk interface (option)
- P8: Post processing (option)
- P9: MMPMB Backpanel & Rack

11.1. SWITCH SETTINGS SCOPOFIX MMP

For detailed information of measuring points, indicators, switches, and jumpers:
see TOKO SERVICE MANUAL, delivered with this system.

12. MONITOR

For detailed information of measuring points, indicators, switches, and jumpers:
see SERVICE MANUAL 17"/20" MONITOR, delivered with this system.

12.1. 17"/20" MONITOR

PCB	JUMPER	POSITION	REMARKS
WM10	W1	B*	Double frame frequency
	W2	B*	Double frame frequency
	W3	A*	3:4 scan ratio
	W4	1-2*	sync. from VIBS
	W5	1-2*	LDR switched off
	W6	1-2*	3:4 scan ratio High line rate
	W7	1-2*	Amb. light dependent contrast control
	W8	1-2*	Amb. light dependent brightness control
	W9	1-2*	Fixed low line
	W10	B*	Low line selection or fixed low line
	S1	1-2*	75 Ohm termination of WM10X1

* Factory delivered system settings.

13. MEMORY BOX CONTROL

13.1. MBC29

13.1.1. JUMPERS

X21	1-2 1-3	Can bus terminated Can bus not terminated
X28	RS232 RS422	Not used Interface with MMP via RS422 bus
X29	1-2 1-3	Not used Not used
X33	50Hz 100Hz	Mem_L Mem_L
X46		Not used

* Factory delivered system settings.

13.1.2. SWITCHES

S1-1	OFF*	S1-1 in position "OFF": switches S1-2 up to S1-8 functions as follows:
S1-2	ON OFF*	VTR direct to Monitor VTR through MMP memory
S1-3	ON OFF*	Not used Not used
S1-4	ON OFF*	Not used Not used
S1-5	ON OFF*	Service menu write enable EEPROM Service menu write protect
S1-6	ON OFF*	Not used Not used
S1-7	ON OFF*	Simulation of stand-alone operation memory box No stand-alone operation from memory box
S1-8	ON OFF*	Dump on Dump off

* Factory delivered system settings

S1-1	ON	When S2-1 is in position "ON" the function of the switches S2-2 up to S2-8 are as follows;
S1-2	ON OFF	Run selftest at high speed Run selftest at normal speed
S1-3	ON OFF	Repeat selftest No repeat selftest
S1-4	ON OFF	Skip test No skip test
S1-5	ON OFF	Not used Not used
S1-6	ON OFF	Not used Not used
S1-7	ON OFF	Not used Not used
S1-8	ON OFF	Debug on Debug off

13.1.3. INDICATORS

H1-ERROR	Selftest busy or μ P not running
H1-MMPNR	MMP memory not ready
H1-	Not used
H1-	Not used
H2-RUN	Microprocessor is running
H2-MBCSA	Stand-alone memory box indication
H2-	Not used
H2-TEST	Selftest busy indicator
H3- 5 V	
H3- 12 V	
H3- -12 V	
H3-	Not used

13.1.4. MEASURING POINTS

X15- -12 V	
X16- 12 V	
X17- 5 V	
X18- 0 V	
X19- VIBS	Video from XTV-8 Camera
X20- 0V	
X22- VCRI	Video-in from VTR
X23-VHCU	Video to VHCU
X24-MONL	Video to monitor-L
X25-VCRO	Video-out from VTR
X26-MEML	Video from memory-L 50Hz
X30-WADG	Watchdog
X31-RST	μ Processor reset
X32-8MHz	24 MHz clock
X34-CS2	Not used
X35-RXD	Receive data
X36-TXD	Send data
X37-CLCAN	1 MHz clock from can
X38-CS0	Not used
X39-CS1	Not used
X40-MEM	Video to memory
X41-MEML	Video from memory-L 100Hz

13.1.5. POTENTIOMETERS

R124	Adjust video level to VTR
R125	Adjust video level from VTR

13.1.6. PCB LAY OUT

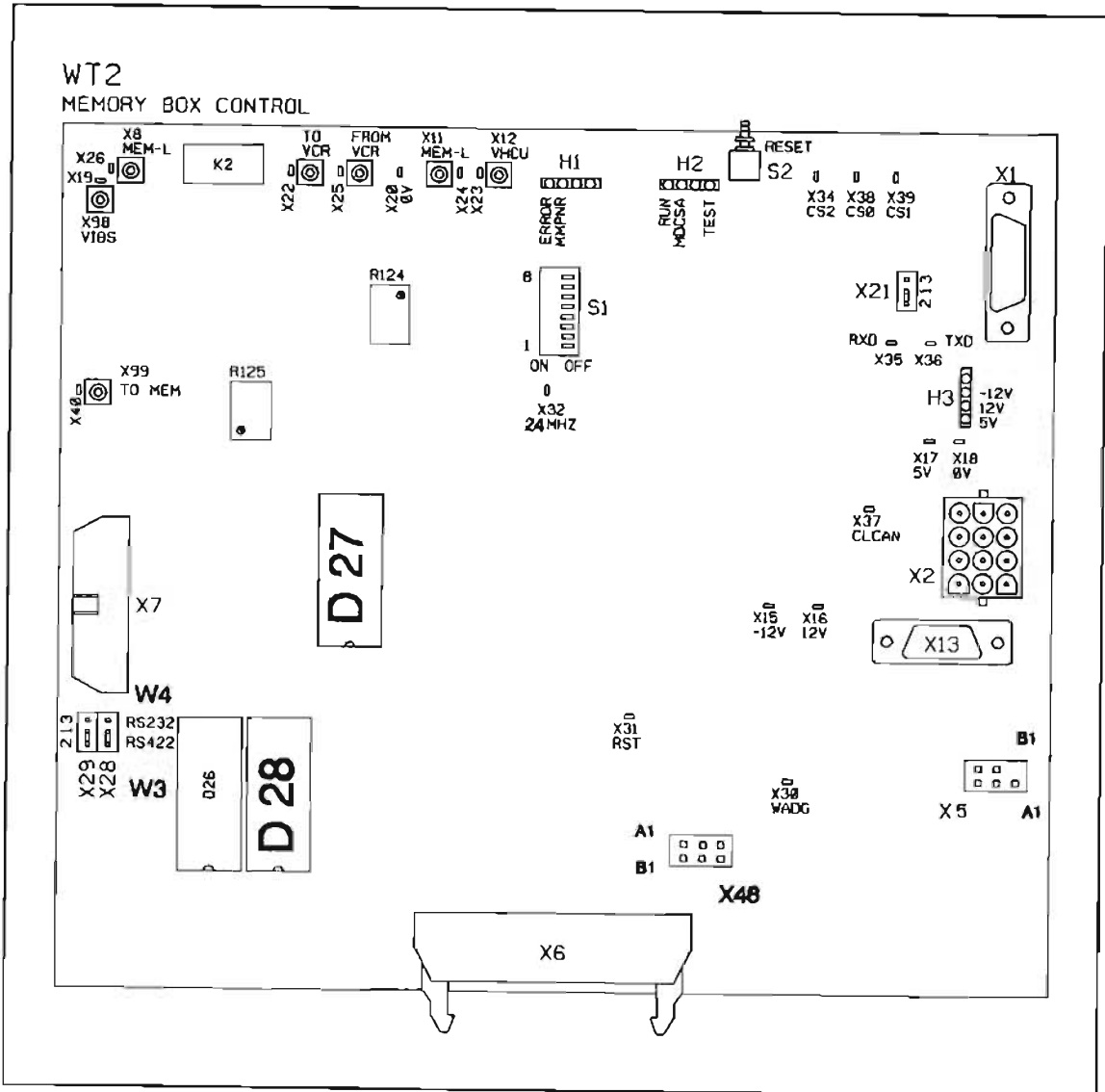

13.2. MAINS SUPPLY UNIT

13.2.1. WT1:MAINS SWITCHING CIRCUIT

TABLE 1: JUMPERS MAINS SUPPLY UNIT

PCB	JUMPER	POSITION	REMARK
WT1	W1 W2	1-2 1-2	VERSION DEPENDENT VERSION DEPENDENT

13.2.2. PCB LAY OUT

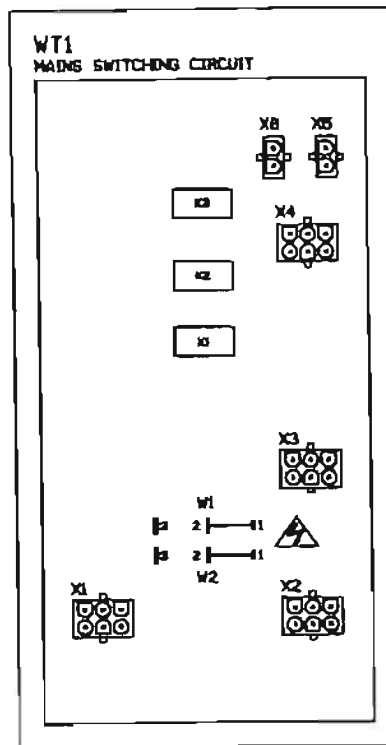

Section: ADJUSTMENT PROCEDURES

Contents

1. **DOSE-RATE ADJUSTMENT** 8-5

1.1. Presettings 8-5

1.2. Video gain 8-5

1.3. AGC threshold small MF 8-5

1.4. AGC threshold large MF 8-5

1.5. Vica preset for 17cm and 13cm II-format 8-6

1.6. Black level adjustment 8-6

1.7. Doserate adjustment 8-6

2. **HIGH DOSE-RATE IN HIGH-DEFINITION FLUOROSCOPY MODE** 8-8

3. **FIXED GAIN ADJUSTMENT** 8-8

3.1. INTRODUCTION 8-8

3.2. PROCEDURE 8-8

4. **ELECTRICAL FOCUSING II-GENERATOR.** 8-9

5. **XTV8-SRI CAMERA** 8-10

5.1. OPTICAL FOCUSING XTV8-SRI CAMERA 8-10

5.2. CENTRING OF THE ROTATION MOVEMENT 8-11

5.3. Centring of the image 8-12

5.4. Horizon adjustment 8-12

6. **ADJUSTMENT OF X-RAY TUBE CURRENT.** 8-13

6.1. FLUOROSCOPY 8-13

6.2. RADIOGRAPHY 8-14

7. **POSITIONING OF MMP CIRCLE** 8-15

7.1.	INTRODUCTION	8-15
7.2.	PROCEDURE	8-15
7.2.1.	Selection of service menu	8-15
7.2.2.	Adjustment blanking size of the MMP circle, coarse setting.	8-16
7.2.3.	Adjustment blanking size of the MMP circle, fine setting.	8-19
8.	IRIS DIAPHRAGM ADJUSTMENT	8-20
8.1.	INTRODUCTION	8-20
8.2.	PROCEDURE	8-20
9.	VTR VIDEO LEVEL ADJUSTMENT	8-22
9.1.	INTRODUCTION	8-22
9.2.	PROCEDURE	8-22
10.	SERVICE MENU SYSTEM SETTINGS	8-23
10.1.	INTRODUCTION	8-23
10.2.	ENTERING THE SERVICE MENU	8-23
10.3.	FPC SETTINGS	8-24
10.3.1.	FPC Menu	8-24
10.3.2.	Explanations	8-24
10.4.	XRC TIME SETTINGS	8-24
10.4.1.	XRC menu	8-24
10.4.2.	Explanations	8-24
10.5.	XRC kV & DIA SETTINGS	8-25
10.5.1.	XRC kV & DIA menu	8-25
10.5.2.	Explanations	8-25
11.	SERVICE MENU APPLICATION SETTINGS	8-26
11.1.	INTRODUCTION	8-26
11.2.	PROCEDURE	8-26
11.3.	EXPLANATIONS	8-27
11.4.	MBC UTIL SETTINGS	8-29
11.4.1.	MBC Util SETTINGS menu	8-29
11.4.2.	Explanations	8-29
11.5.	OPTIONS menu	8-30
11.5.1.	Introduction	8-30
11.5.2.	Explanations	8-30
12.	FORMATTING THE HARDDISK	8-31
12.1.	INTRODUCTION	8-31

12.2.	PROCEDURE	8-31
13.	RESETTING THE WORKING HOURS	8-32
13.1.	INTRODUCTION	8-32
13.2.	PROCEDURE	8-32
14.	RESETTING THE X-RAY HOURS	8-33
14.1.	INTRODUCTION	8-33
14.2.	PROCEDURE	8-33
15.	IMAGE WRITE PROTECTION FOR DEMO PURPOSE	8-34
15.1.	INTRODUCTION	8-34
15.2.	Procedure	8-34
16.	TILTING THE STAND	8-35
17.	ADJUSTMENT C-ARM BALL BEARINGS IN SLIDE BLOCK	8-37
18.	ADJUSTMENT BRAKE C-ARM ROTATION	8-39
19.	ADJUSTMENT BRAKE C-ARM SLIDING	8-41
20.	ADJUSTMENT SCAN BRAKE	8-43
21.	ADJUSTMENT BALL BEARINGS HORIZONTAL MOVEMENT	8-44
22.	ADJUSTMENT V-BELT MOTOR FOR VERTICAL MOVEMENT	8-46
23.	ADJUSTMENT PROCEDURE OF UPPER AND LOWER END SWITCHES	8-47
24.	ALIGNMENT PROCEDURE DIAPHRAGM UNIT	8-48
24.1.	ALIGNMENT OF FOCUS-NEAR RING	8-49
24.2.	ALIGNMENT OF SHUTTER UNIT	8-51
24.3.	ALIGNMENT OF IRIS DIAPHRAGM	8-52
25.	VIDEO HARD COPY UNIT ADJUSTMENT	8-53
25.1.	ADJUSTMENT PROCEDURE VHCU PMI100	8-53
25.2.	INSTALLATION	8-53
25.2.1.	Installation in a BV25 mobile system	8-54
25.2.2.	Installation in a BV26 mobile system	8-54
25.2.3.	Installation in a BV29 mobile system	8-54
25.3.	50 Hz / 60 Hz video input changing	8-54
25.4.	VHCU monitor alignment	8-55

25.5. Film calibration of positive and negative mode for normal FLUO images 8-60

25.5.1. Calibrating positive mode 8-61

25.5.2. Calibrating negative mode 8-62

25.6. Film calibration of positive and negative mode for subtracted images 8-63

25.7. Fine contrast and brightness adjustments 8-63

25.8. APPENDIX 8-64

1. DOSE-RATE ADJUSTMENT

NOTE

For dose-rate adjustment perform following procedures in sequence as mentioned below!!

1.1. PRESETTINGS

See drawing Z3-1 XTV8-SRI doc. for the location of the jumpers, switches and potentiometers.

Carry out the following settings:

- jumper WK4 W1:2-3 (clean circle off)
- switch WK4 S2-6: on (max. VIBS = 1100 mV)
- jumper WK3 W1:1-2 (block gen. on) and turn WK3:P1 clock wise (amplitude = 0V)
- measure with a oscilloscope on WK3:MP7 VIBS (0V = WK4:MP1 or MP2), trigger external on the midline WK5:MP1
- adjust the black level with WK3:P4 to 45mV

1.2. VIDEO GAIN

- set: WK3 W2:1-2 (rampgenerator on)
- WK4 S2-4: off (white compression curve 2)
- measure VIBS WK3:MP7 and adjust the top of the video to 1100 mV with WK5:P1 see fig. 1
- set: WK3 W2:2-3 (rampgenerator off)
- WK4 S2-4: on (white compression curve 1)
- adjust the black level once more with WK3:P4 to 45mV
- measure on WK3:MP1 / MP14 VIN and adjust the block gen. with WK3:P1 to 360 mV.

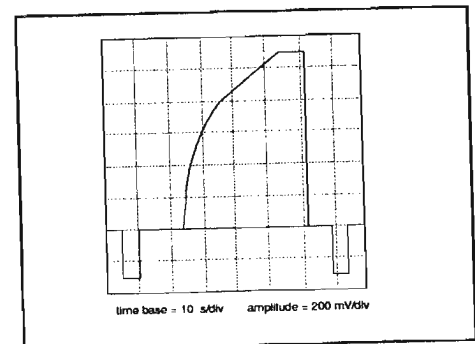

Figure 1, max. video level

1.3. AGC THRESHOLD SMALL MF

- set: WK4 S3-6: off (MF local selectable)
- WK4 S3-7: off (small MF selected)
- measure VIBS WK3:MP7 and adjust the threshold to 400 mV with WK3:P6

1.4. AGC THRESHOLD LARGE MF

- set: WK4 S3-7: on (large MF selected)
- measure VIBS WK3:MP7 and adjust the threshold to 400 mV with WK3:P7

1.5. VICA PRESET FOR 17CM AND 13CM II-FORMAT

- select the middle (17cm) format
- measure the video on VIN WK3:MP1 and adjust with WK3:P1 the block generator to 360 mV
- measure with a voltmeter the DRFLDFPA signal WK3:MP13 (0V = WK4:MP1 or MP2) and adjust it to 2.04 V with WK3:P2
- select the small (13cm) format
- measure with a voltmeter the DRFLDFPA signal WK3:MP13 and adjust it to 2.33 V with WK3:P3

1.6. BLACK LEVEL ADJUSTMENT

- set WK3 W1:2-3 (block gen. off)
- measure the signal on VIBS WK3:MP7 and adjust the black level to 45 mV with WK3:P4

Put the jumper/switch setting back to its original position (check section 5 XTV8-SRI doc, Programmings)

- jumper WK4 W1:1-2 (cleancircle on)
- switch WK4 S2-6 (max. VIBS, monitor depended see section 5 XTV8-SRI doc, Programmings)
- switch WK4 S3-6: on (MF remote selectable)

1.7. DOSERATE ADJUSTMENT

NOTE

ALLOW THE X-RAY PHOTOMETER TO WARM UP FOR AT LEAST ONE HOUR BEFORE PERFORMING THIS PROCEDURE.

- Remove grid from II-shield.
- Put the 1.5 mm Cu plate on top of the X-Ray diaphragm.
- Put the probe of the X-Ray photometer as close as possible to the entrance plane of the II-tube.
Position of probe: in the centre of the II-tube.
- Select "uR/sec" readout of X-Ray photometer.

- Calibrate X-Ray photometer so that readout indicates zero.
- Put jumper SE19:W1 in position: SERV. (= manual mA control).
- Select the largest II-format.
- Initiate fluoroscopy manual mode.
- Set manually 75 kV.
- Adjust the entrance dose to:

17 uR/sec for the 23 cm II-format,
(0.15 uG/sec).

by varying the mA value with potentiometer: SE19:R62.

- Stop fluoro, remove the X-Ray photometer probe.

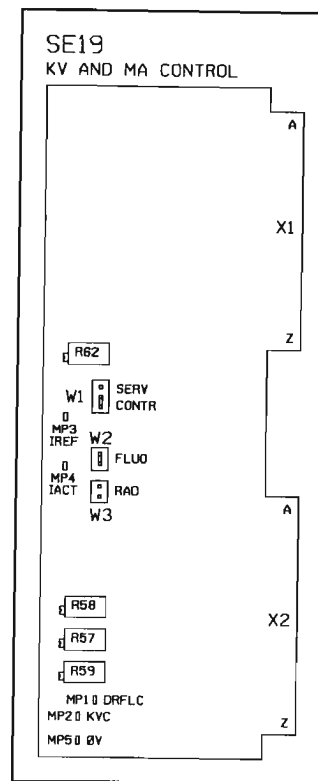

DOSE ADJUSTMENT 23 CM FORMAT

- Connect the oscilloscope to testpoint: SE19:MP1 DRFLC.
Use probe 1:10.
- Interconnect WK6 MP1 to WK6 MP4
Only in case of 23cm format adjustment
- Carry out fluoroscopy
- Adjust this DRFLC signal with potentiometer WK6:P1, located on the XTV-8SRI camera to:
0 V +/- 100 mV.
- Stop fluoroscopy.
- Disconnect interconnection between WK6 P1 to WK6 P4

DOSE ADJUSTMENT 17CM AND 13CM FORMAT

NOTE

PERFORM THIS PROCEDURE ALSO FOR THE 17 cm AND 13 cm II-FORMATS.

FOR 17 cm: DRFLC ADJUSTMENT WITH WK3:P2. - DO NOT INTERCONNECT WK6 MP1-MP4-

*DOSE-RATE : 25 uR/sec
(0.53 uG/sec)*

FOR 13 cm: DRFLC ADJUSTMENT WITH WK3:P3.- DO NOT INTERCONNECT WK6 MP1-MP4-

*DOSE-RATE : 33 uR/sec
(0.70 uG/sec)*

- Put back jumper SE19:W1 to CONTR.

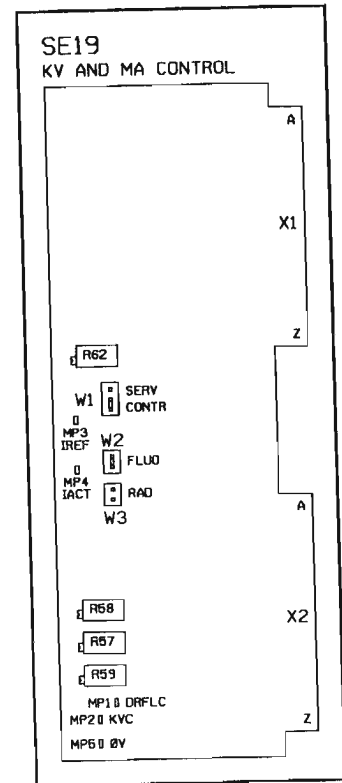

2. HIGH DOSE-RATE IN HIGH-DEFINITION FLUOROSCOPY MODE

The dose-rate in HIGH-DEFINITION FLUO mode is a factor 2.4 higher than during normal fluoroscopy.

The factor 2.4 is a FIXED factor and CANNOT be adjusted.

3. FIXED GAIN ADJUSTMENT

3.1. INTRODUCTION

Check first:
Procedure "AGC-THRESHOLD".

3.2. PROCEDURE

- Remove grid from II-shield.
- Put the 1.5 mm Cu plate on top of the X-Ray diaphragm.
- Check if jumper SE17: W1 is in position FIX.
- Connect an oscilloscope to testpoint: WK3:MP7 (VIBS).
- Initiate fluoroscopy in automatic mode.
- Measure the VIBS signal.
- Switch over to manual fluoroscopy.
- Initiate fluoroscopy.
- Adjust the VIBS signal with potentiometer WK3:P5 (FIXED GAIN), so that the measured signal during manual mode is equal to automatic mode.
- Put back grid.

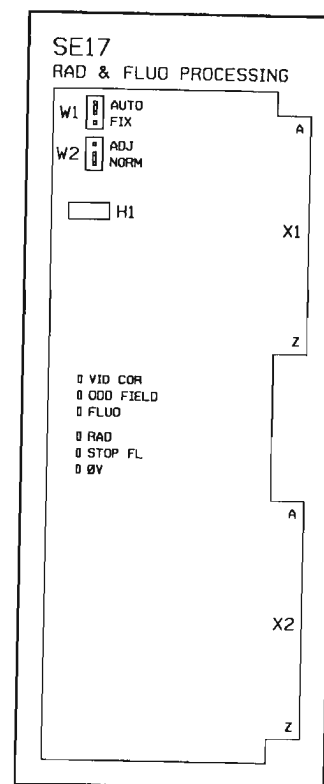

4. ELECTRICAL FOCUSING II-GENERATOR.

- Remove all filters between the X-Ray Tube and the II-Tube.
- Install a 23 cm Funk test phantom on the shield of the II.
- Select the 23 cm II-format.
- Connect a multimeter between BA1:MP1 and BA1:MP2 of the "focus-service board" in the side-box of the II-container.
- Switch on fluoroscopy in automatic mode.
- Adjust the focusing voltage (VC) of the II-tube to an optimum with potentiometer BA1:R3.
- Switch off fluoroscopy
- Select 17 cm II-format.
- Switch on fluoroscopy in automatic mode.
- Adjust the focusing voltage (VC) of the II-tube to an optimum with potentiometer BA1:R2.
- Switch off fluoroscopy
- Select the 13 cm II-format
- Switch on fluoroscopy in automatic mode.
- Adjust the focusing voltage (VC) of the II-tube to an optimum with potentiometer BA1:R1.
- Switch off fluoroscopy

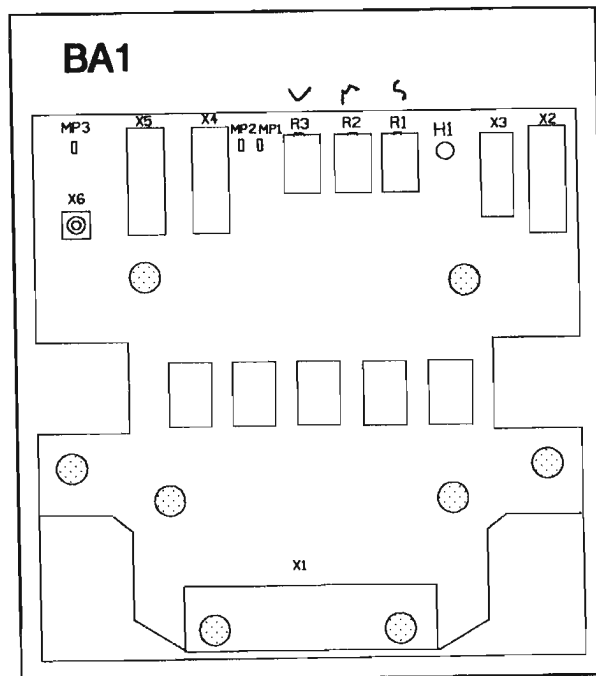

5. XTV8-SRI CAMERA

For procedures see also XTV8-SRI service documentation.

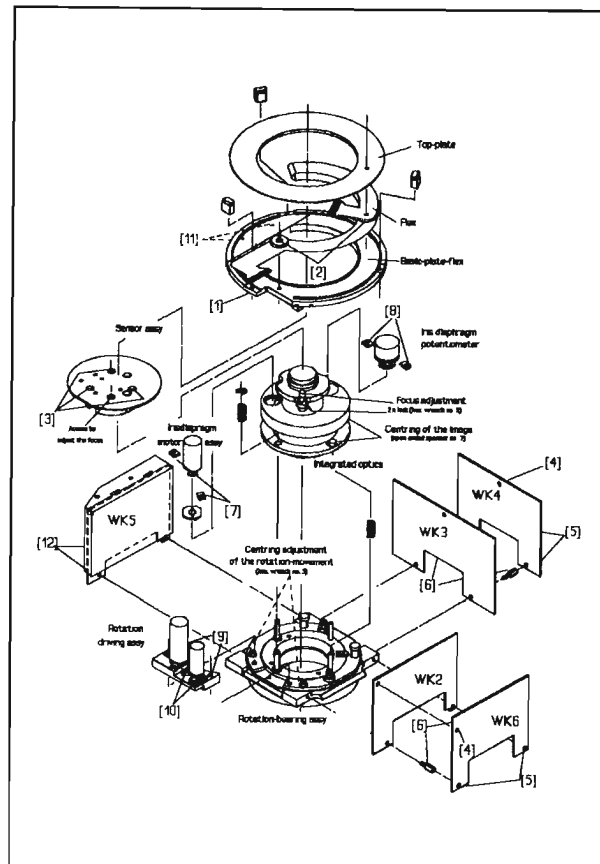

5.1. OPTICAL FOCUSING XTV8-SRI CAMERA

NOTE

The XTV8-SRI system should be switched on for at least 20 minutes before performing the optical focusing procedure.

- Remove all filters between X-Ray tube and II-tube.
- Install a 23 cm Funk test phantom on the shield of the II-container.

NOTE

Read out of the test phantom should be perpendicular to the tv lines.

-
- Select the 23 cm II-format.
 - Operate the iris diaphragm buttons so that only the central funk phantom is exposed.
 - Unlock the focusing screw.
See page Z6-1 of the XTV8-SRI service manual.
 - The focusing screw is accessible through the preproc. 1 board (see figure 2 pag.6-4 of XTV8-SRI doc.)
 - Switch on fluoroscopy with low kV's and high mA's (boost).
 - Check focusing.
 - Stop fluoroscopy
 - Focus the image
 - Repeat procedure until maximum resolution is obtained.
 - Lock the focusing screw.

5.2. CENTRING OF THE ROTATION MOVEMENT

- remove all objects between the collimator and the II-tube
- select the largest blanking circle on the videoproc. board WK5:S1-7
- select large format
- put a phantom, with a marked centre, in front of the II-tube
- switch on the system
- rotate the **MARKER 90° left**, use buttons for image rotation (on the stand).
- Make "LIH" image (by initiating fluoroscopy).
- Mark the centre of the phantom on the monitor (1)
- rotate the camera to +90° - **MARKER starts on top again and runs 180° !!! right -**, mark the centre (2)
- rotate the camera to 0° (push both rotation buttons on the stand)
- draw a line between the two points on the monitor and mark the middle of the two points (3)
- the image will move diagonally on the monitor when turning one of the two nuts see Fig 2
- adjust the camera (4) to the marked middle (3) with an hexagonal wrench (use fluoroscopy)

Between WK1 and the flex, at the top of the camera, is enough space to reach the screws with a hexagonal wrench (no. 3) see Fig.2.

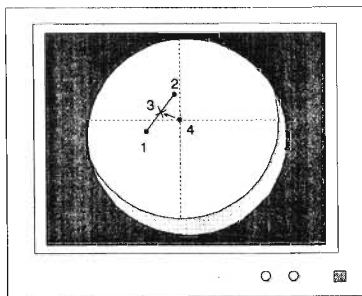

Fig 1, Centring of the rotation

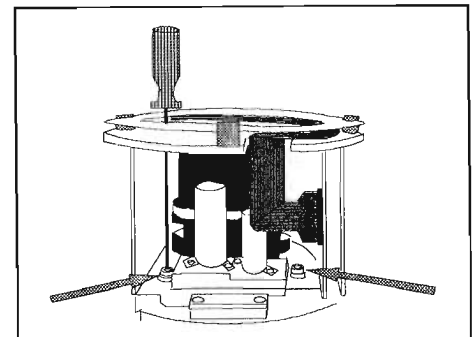

Fig 2, The nuts can be reached via the top of the camera

5.3. CENTRING OF THE IMAGE

- remove all objects between the collimator and the II-tube and put a cross section phantom in front of the II-tube
- select large format
- set; WK5 S2 to the right, WK4 S3:4 off, WK4 S3:5 off (service cross chosen)
- select KV manual, start fluoroscopy and examine the last image-hold on the monitor
- see Fig. 4 for centring of the image use the two nuts (both nuts are reachable via WK3, rotate the camera + and - 90°)
- adjust (with an open-ended spanner) the image exactly in the middle of the blanking circle, check the position during fluoroscopy

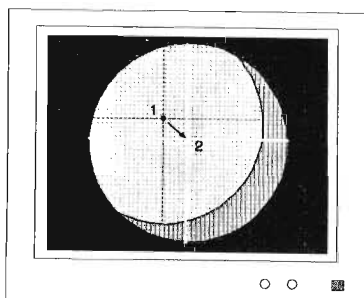

Fig 3, Centring of the image

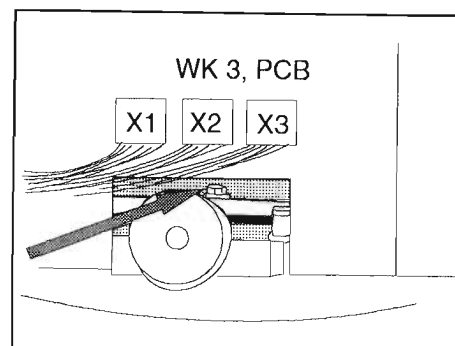

Fig 4, Use open ended spanner no. 7

5.4. HORIZON ADJUSTMENT

- put the C-arm of the stand in the 0° position
- remove all objects between the collimator and the II-tube and put a cross section phantom in front of the II-tube
- select large format
- set; WK5 S2 to the right, WK4 S3:4 off, WK4 S3:5 off (service cross chosen)
- select KV manual, start fluoroscopy and examine the last image-hold on the monitor
- loosen the rotation potentiometer a bit and turn the pot.meter housing until the horizontal line of the phantom is in the 0° position (= the cross section phantom lies exactly on the service cross)
- check the 0° position, during fluoroscopy, using image reverse horizontal (WK4:S3-1) or use the scan reverse button on the stand

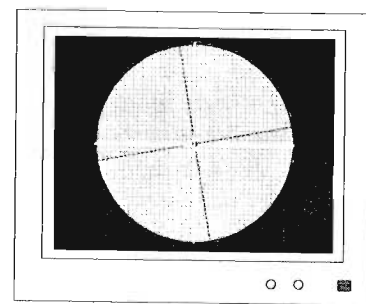

Fig 5, Horizon adjustment

- rotate the camera + and - 180° during fluoroscopy and check if the centre of the phantom is the same as the centre of the image. If not execute adjustment 5.2. and 5.3. again.
- set WK5 S2 to the left position and WK4 S3:4 and S3:5 back to the original position see also section 5 XTV8-SRI manual.

6. ADJUSTMENT OF X-RAY TUBE CURRENT.

6.1. FLUOROSCOPY

- Select manual fluoroscopy
- Set 100 kV at operators panel

Check/adjust the kVC voltage, (no FLUO)

- Connect multimeter between SE19:MP2 (kVC) and SE19:MP5 (0 V). (1 V = 10 kV).
- Adjust the voltage with SE19:R57 to 10.00 V +/- 0.01 V.

Check/adjust the IREF, (no FLUO)

- Connect multimeter between SE19:MP3 (IREF) and SE19:MP5 (0 V). (3 V = 1 mA).
- Adjust the voltage with SE19:R58 to 9.00 V +/- 0.01 V.

Check/adjust PWRSM, (no FLUO)

- Connect multimeter between terminals of the large blue capacitor SEC1.
- Adjust the voltage with SE33:R116 to 348 V +/- 2 V.

Check IACT at 100 kV, (under FLUO)

- Connect multimeter between SE19:MP4 (IACT) and SE19:MP5 (0 V) (3 V = 1 mA).
- Activate hand/foot switch
- The measured voltage must be 9 V +/- 10%

Check IACT at 40 kV, (under FLUO)

- Set 40 kV at operators panel
- Connect multimeter between SE19:MP4 (IACT) and SE19:MP5 (0 V) (3 V = 1 mA).
- Operate the hand/foot switch
- The measured voltage must be 0.3 V +/- 10%

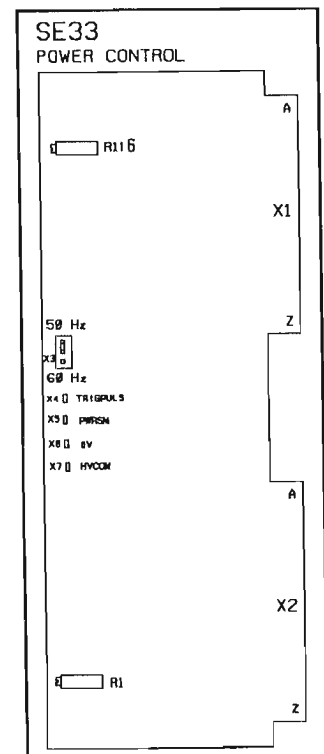
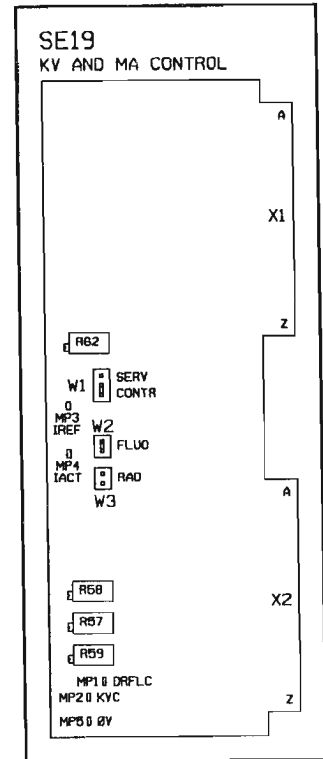

6.2. RADIOGRAPHY

Caution

*PERFORM WARMING-UP PROCEDURE FIRST,
(see SYSTEM MANUAL INSTALLATION TAB 7
SETTING TO WORK)*

*WHEN USING A MULTIMETER MAKE SURE TO
WAIT 2 MINUTES AFTER EACH EXPOSURE
DUE TO THE HIGH LOAD OF THE X-RAY TUBE*

*AN OSCILLOSCOPE IS NOT RECOMMENDED
BECAUSE OF ITS INACCURACY*

- Put jumper SE19:RAD/FLUO in position RAD
- Put potentiometer SE31:R1 (20 turn) in midposition
- Put SE31:R1, R2, R3 and R60 (20 turn) fully counterclockwise.
- Switch on the system
- Select radiography mode

- Set 80 kV, 10 mAs at operators panel.
- Operate the handswitch
- Connect multimeter between SE19:MP3 (IACT) and SE19:MP5 (0 V)
- Adjust with SE31:R1 the voltage to 0.5 V +/- 5% (0.5 V = 2 mA), by making exposures.

- Adjust with SE31:R2 the voltage to 4.7 V, coarse setting.

- Set 100 kV, 10 mAs at operators panel
- Operate the handswitch
- Adjust with SE31:R2 the voltage to 5.0 V +/- 5% (5 V = 20 mA), by making exposures.

- Set 40 kV, 10 mAs at operators panel
- Operate the handswitch
- Adjust with SE31:R3 the voltage to 5.0 V +/- 5% (5 V = 20 mA), by making exposures.

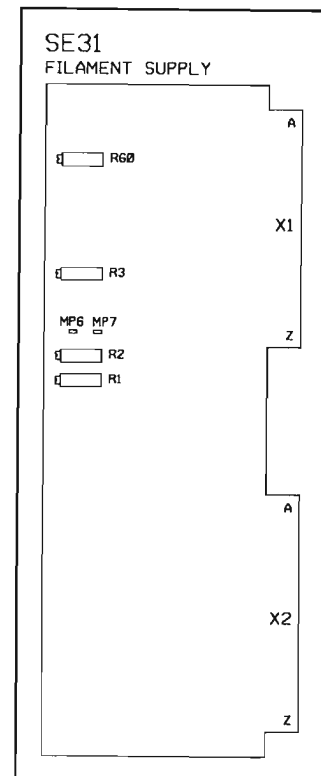
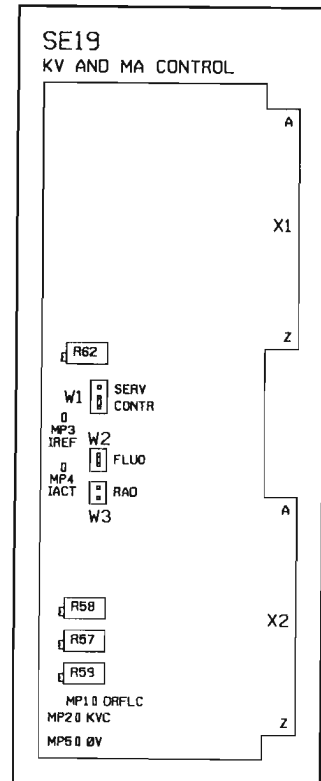

7. POSITIONING OF MMP CIRCLE

7.1. INTRODUCTION

The circle of the MMP must be positioned so that the II-output screen is just covered by the MMP circle.

7.2. PROCEDURE

7.2.1. Selection of service menu

- Enter the service menu, as described in "SERVICE MENU SYSTEM SETTINGS"
- The service main menu will be displayed:

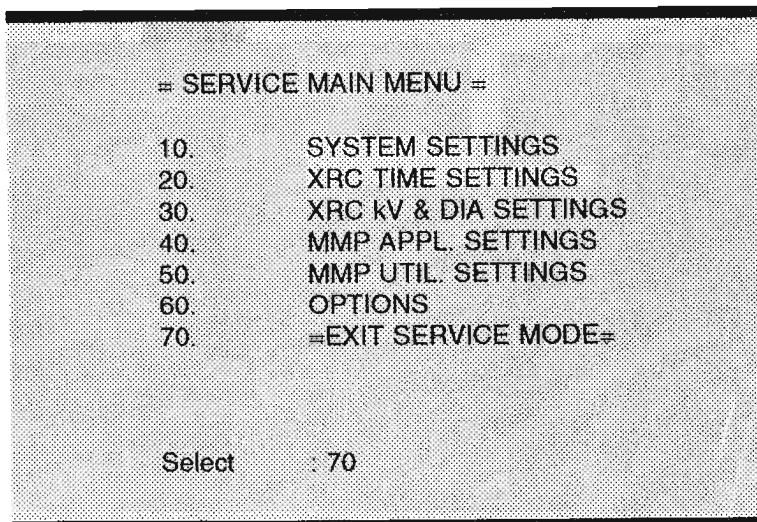

- Select menu line 50: MMP UTIL SETTINGS.
- Press <ACC>
- The following menu will be displayed:

```

MMP UTIL. SETTINGS

51.      50/60Hz frequency : 50 Hz
52.      MMP Clean Circle X   319
53.      MMP Clean Circle Y   289
54.      MMP Clean Circle R   189
55.      MMP text leftm (0-20) 08
56.      Send util cmd (y/n)
57.      Format Disk ? (y/n)
58.      Return to Main Menu

Select      : 58

```

- Set CHANGE MODE (EEPROM write enable) in order to change MMP menu settings. Proceed as follows:
 - . Loosen the four screws which holds the MMP-unit.
 - . Pull out MMP-unit.
 - . Put jumper WT2:S1-5 in position "ON".

7.2.2. Adjustment blanking size of the MMP circle, coarse setting.

- Set the following initial settings:
 - . X = 320 (320) for 50Hz (60Hz)
 - . Y = 290 (243) for 50Hz (60Hz)
 - . R = 190 (192) for 50Hz (60Hz)
- Select line 52
- Press <ACC>
- The cursor jumps to end of line 52.
- Enter X-value; use numeric keys or arrow up/down buttons.
- Press <ACC>
- The entered X-value replaces the former X-value.
- Select line 53
- Press <ACC>
- The cursor jumps to end of line 53.
- Enter Y-value; use numeric keys or arrow up/down buttons.

- Press <ACC>
The entered Y-value replaces the former Y-value.
- Select line 54
- Press <ACC>
- The cursor jumps to end of line 54.
- Enter R-value; use numeric keys or arrow up/down buttons.
- Press <ACC>
The entered R-value replaces the former Y-value.
- Select line 56; the cursor jumps to end of line.
- Enter "Y" and wait until service menu is displayed again with modified values.
This takes about 10 seconds.
Neglect ** X-ray ** if you have a video image on the screen, if not carry out fluoro
During this waiting time the MMP circle is set according the new parameters.
- RETURN TO MAIN MENU
- EXIT the SERVICE MENU (= reset)
- Wait until MMP is ready (text on monitor)
- Make fluoroscopy, NO OBJECTS IN X-RAY BEAM and check if black circle is just covering the video circle.

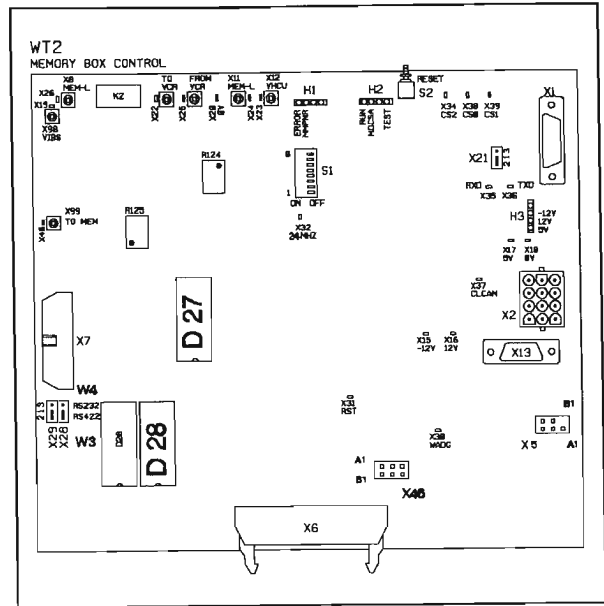

PROCEDURE IN CASE THE SUB/MAX/MAP OPTION IS NOT PRESENT:

- The TV circle is now visible WITHIN the MMP circle, as indicated in figure 1.
Turn up brightness -with Brightness button on MBC- if necessary.

- Measure the following distances on the TV monitor, visible as dark parts:
 - . $R - R' = R1$
 - . $A - A' = A1$
 - . $B - B' = B1$
 - . $C - C' = C1$
 - . $D - D' = D1$

Write results down.

Where:

$R1 \rightarrow$ DIAMETER CHANGE

$(A1 + B1) / 2 \rightarrow$ VERTICAL SHIFT

$(C1 + D1) / 2 \rightarrow$ HORIZONTAL SHIFT

See figure 1.

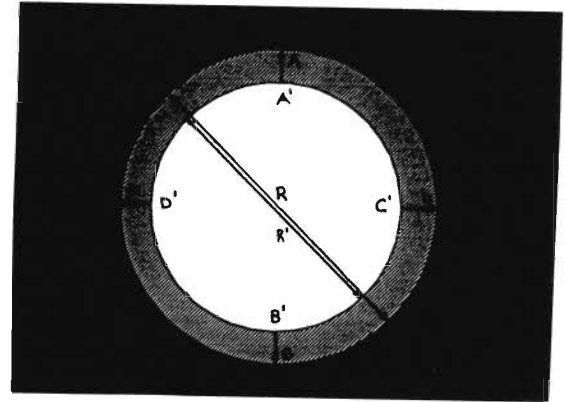

PROCEDURE IN CASE THE SUB/MAX/MAP OPTION IS PRESENT:

- Make fluoroscopy in SUB-mode, wait until "INJECT" is displayed on TV-monitor, and close the iris-diaphragm.

- Measure the following distances on the TV monitor, visible as white parts:
 - . $R - R' = R1$
 - . $A - A' = A1$
 - . $B - B' = B1$
 - . $C - C' = C1$
 - . $D - D' = D1$

Write down the results.

Where:

$R1 \rightarrow$ DIAMETER CHANGE

$(A1 + B1) / 2 \rightarrow$ VERTICAL SHIFT

$(C1 + D1) / 2 \rightarrow$ HORIZONTAL SHIFT

See figure 2.

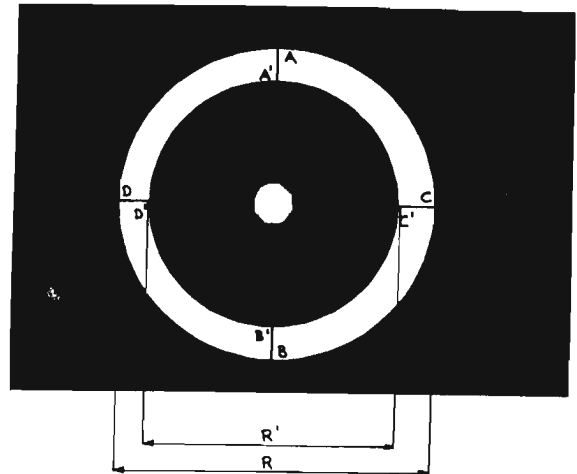

7.2.3. Adjustment blanking size of the MMP circle, fine setting.

Use the values, derived from procedure 7.2.2.
 $[R1, (A1+B1)/2, (C1+D1)/2]$

- The MMP-circle must be adjusted so that the TV circle is just covered by the MMP-circle.
- . X = shift circle horizontally
 values < 320 = shift circle to the left
 values > 320 = shift circle to the right
 (range 000-640)

10 steps correspond with approx. 8 mm shift on TV monitor.

- . Y = shift circle vertically
 values < 290 = shift circle upwards
 values > 290 = shift circle downwards
 (range 000-575).

10 steps correspond with approx. 5 mm shift on TV monitor.

- . R = circle radius
 values < 180 = circle size smaller
 values > 180 = circle size larger
 (range 000-320).

10 steps correspond with approx. 15 mm DIAMETER change on TV monitor.

- Select line 56; the cursor jumps to end of line.
- Enter "Y" and wait until service menu is displayed again with modified values.
 This takes about 10 seconds.
 Neglect ** X-ray ** message
 During this waiting time the MMP circle is set according the new parameters.
- RETURN TO MAIN MENU
- EXIT the SERVICE MENU (=reset)
- Wait until MMP is ready (text on monitor)
- Make fluoroscopy
- Check that TV circle is just covered by MMP circle, if not repeat this procedure.

- After correct positioning leave CHANGE MODE (EEPROM write enable)
- Put jumper WT2:S1-5 in position "OFF".
- Push back MMP-unit.
- Tighten the four screws which holds the MMP-unit.

REMARKS:

- . In case of typing errors cancel via backspace.

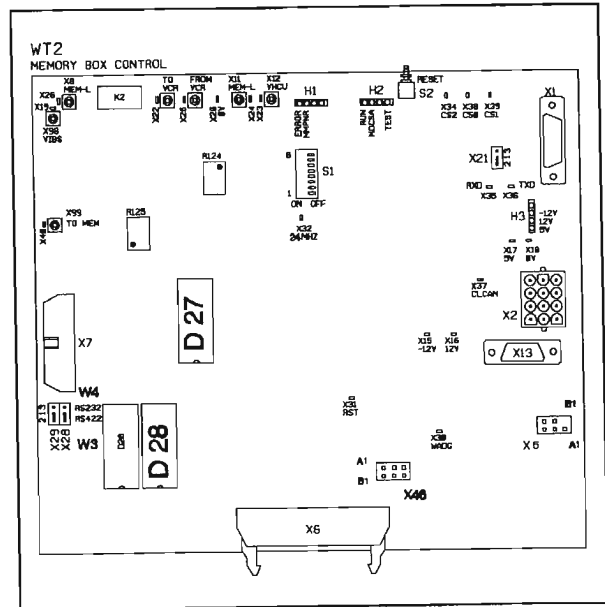

8. IRIS DIAPHRAGM ADJUSTMENT

8.1. INTRODUCTION

Check first alignment X-Ray Tube and II-Tube; the procedure uses the TV-monitor image for adjusting.

8.2. PROCEDURE

- Put C-arm in 0-degree position.
- Select 23cm II-format
- Set switch SE13:S2-7 in position "ON" (diaphragm programming on).
- Fluoroscopy timer display shows iris opening e.g. 21.0 (= approx. iris opening in mm).
- Initiate fluoroscopy
- Operate the iris open/close buttons DURING FLUOROSCOPY (toggle), so that the iris is just not visible (on the TV-monitor).

NOTE:

Each time the iris button is pushed a new iris opening is set (visible on the TV-monitor) and the new iris opening value displayed in the Fluo timer display.

- Press "hidden button" and 23cm II-format selection button SIMULTANEOUSLY until a "BEEP" signal is audible, (= new iris size stored in EEPROM).
- Select the 18cm II-format
- Initiate fluoroscopy
- Operate the iris open/close buttons DURING FLUOROSCOPY, so that the iris is just not visible (on the TV-monitor).
- Press "hidden button" and 18cm II-format selection button SIMULTANEOUSLY until a "BEEP" signal is audible, (= new iris size stored in EEPROM).

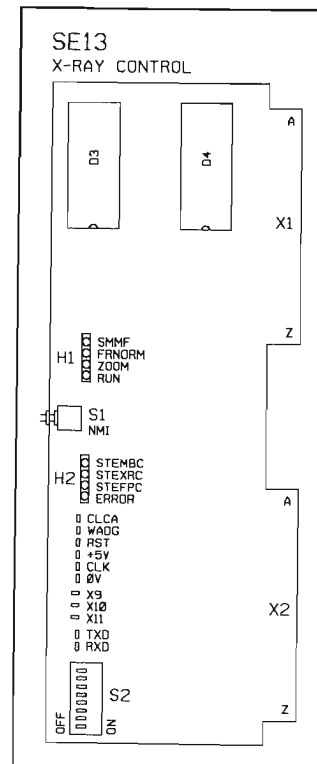

- Select the 13cm II-format
- Initiate fluoroscopy
- Operate the iris open/close buttons DURING FLUOROSCOPY, so that the iris is just not visible (on the TV-monitor).
- Press "hidden button" and 13cm II-format selection button SIMULTANEOUSLY until a "BEEP" signal is audible, (= new iris size stored in EEPROM).
- Set switch SE13:S2-7 in position "OFF" (diaphragm programming off).
- Press during 4 sec the fluoroscopy timer reset switch (=BV29 system reset).

Note:

The iris diaphragm opening values can be checked and changed in the SERVICE MENU. Changing the iris opening with the help of the SERVICE MENU is NOT recommended (takes more time than procedure described above). In order to check the iris values proceed as follows:

PROCEDURE:

- Enter the SERVICE MENU
- Select menu line 30" XRC kV & DIA SETTINGS"
- The following menu is showed.
See menu lines 35 - 38 for iris opening (in mm).

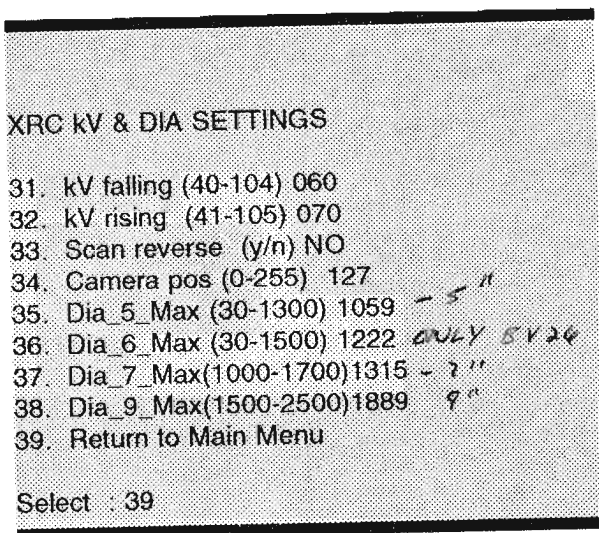
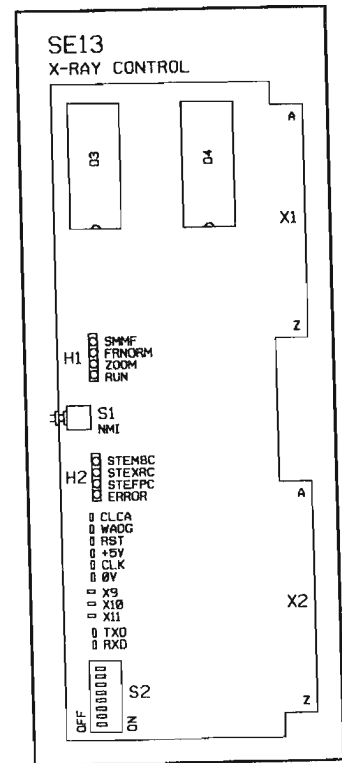

9. VTR VIDEO LEVEL ADJUSTMENT

9.1. INTRODUCTION

The video level must be adjusted in such a way that the correct video level is applied to and from the Video Tape recorder.

NOTE:

The VTR is an option which has to be obtained locally.

9.2. PROCEDURE

- Loosen the four screws which holds the MMP-unit.
- Pull out MMP-unit.
- With potentiometer WT2:R125 (on MBC-board) the correct video level TO the VTR can be adjusted.
- With potentiometer WT2:R124 (on MBC-board) the correct video level FROM the VTR can be adjusted.

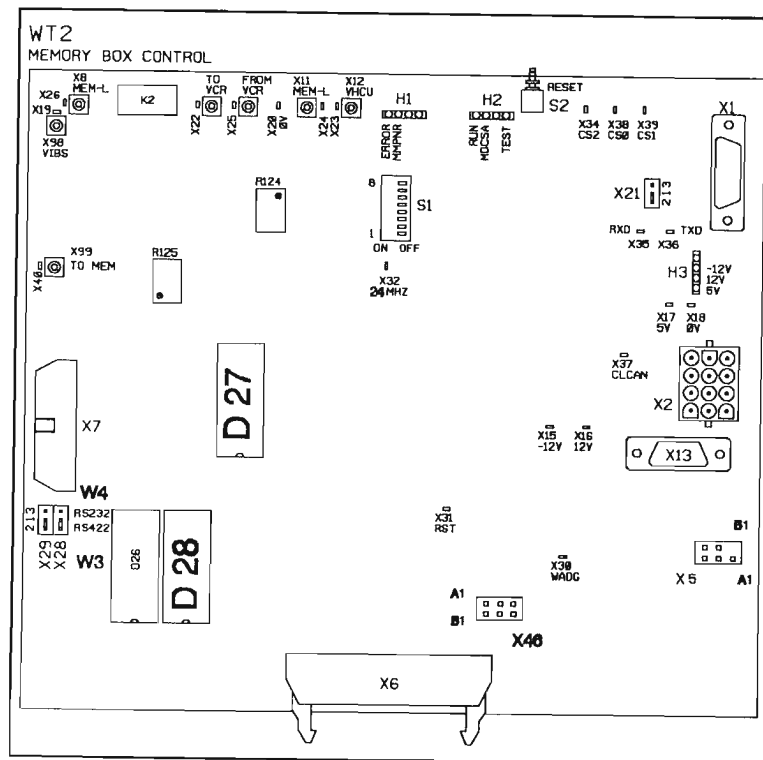

10. SERVICE MENU SYSTEM SETTINGS

10.1. INTRODUCTION

NOTE

The SERVICE MENU settings described are systems setting and must not be changed

10.2. ENTERING THE SERVICE MENU

Procedure:

- Press "hidden button" on MBC and <MENU> button SIMULTANEOUSLY.
- The following menu will be displayed:
- Select line 01 (use ARROW-UP / ARROW DOWN knobs or use numeric keys).
- Press <ACC> button
The cursor will automatically jump at end of line 01.
- Enter password "JIM29BV".
The characters of the password are NOT displayed. For each character the * symbol is displayed. In case of a typing error "*****" is displayed and the correct password must be entered again, no <CR> needed.

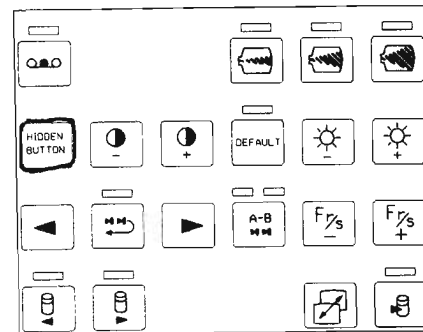

SWITCH PANEL TROLLEY

NOTE:

If an image is present when entering the SERVICE MODE, the image will be suppressed during service menu modes.

When entering the SERVICE MODE after switching on the BV29 system, enter patient name and <ACC> or just <ACC>

10.3. FPC SETTINGS**10.3.1. FPC Menu**

```

SYSTEM SETTINGS

11. System rel number : 301
12. System choice      :BV29
13. IEC or HHS norm   :IEC
14. Language (E/G/F/S) English
15. Default examination
16. Auto store         never
17. Bell at X-ray (y/n) NO
18. Default eeprom (y/n)
19. Return to Main Menu

Select: 19

```

10.3.2. Explanations

- 11 - System rel number: 301
Function: release number indication.
Range: 111 fixed (read only).
- 12 - System choice:
Function: SW initialisation for BV26 or BV29
Range: BV26 / BV29
- 13 - IEC or HHS norm
Function: initialisation of IEC norm (Europe) or
HHS norm (USA). Controls iris max. size
Range: IEC / HHS
- 14 - Language (E/G/F/S)
Function: Language of **user menu**
Range: only (E)nglish available
- 15 - Default examination
Function: - not applicable -
Range: - not applicable -
- 16 - Auto store:
Function: Store image on disk after release of
fluoro button.
Range: never / all LIH / after boost
- 17 - Bell at X-ray
Function: Beep during X-ray
Range: yes /no
- 18 - Default eeprom
Function: storing default values in EEPROM

10.4. XRC TIME SETTINGS**10.4.1. XRC menu**

```

XRC TIME SETTINGS

21. Short Beep (* 20ms) 010
22. En.KVAC Delay (* 1ms) 160
23. IntWaitTime (* 10ms) 200
24. Min.RadLamp (* 10ms) 050
25. Exp.PrepTime (* 10ms) 080
26. Bell freq. (* 10us) 100
27. Working Hours (* 1h) 00000
28. X-Ray Hours (* 0.1h) 00000
29. Return to Main Menu

Select: 29

```

10.4.2. Explanations

- Short Beep:
Function: Exposures < 80 msec, cause always
80 msec BEEP-signal
Range: 0 - 255 (* 20ms)
- En.KVAC Delay:
Function: Enable kV actual delay
Range: 0 - 255 (* 1ms)
- IntWaitTime:
Function: Intermittent wait-time (fluoroscopy)
(wait time between two pulses).
Range: 010 - 255 (* 10ms)
- Min.RadLamp:
Function: Minimum Time Radiation Lamp On
Range: 0 - 255 (* 10ms)
- Exp.PrepTime:
Function: Exposure after Preparation time.
Range: 0 - 255 (* 10ms)
- Bell freq
Function: adjust bell frequency at X-ray
Range 0-255 (* 10 usec)
- Working Hours
Function: Displaying of working hours
See procedure "RESETTING THE WORKING
HOURS"
Range: 0 - 99999 (* 1h)
- X-Ray Hours
Function: Displaying of X-Ray hours
See procedure "RESETTING THE X-RAY
HOURS"
Range: 0 - 99999 (* 0.1h)

10.5. XRC kV & DIA SETTINGS

10.5.1. XRC kV & DIA menu

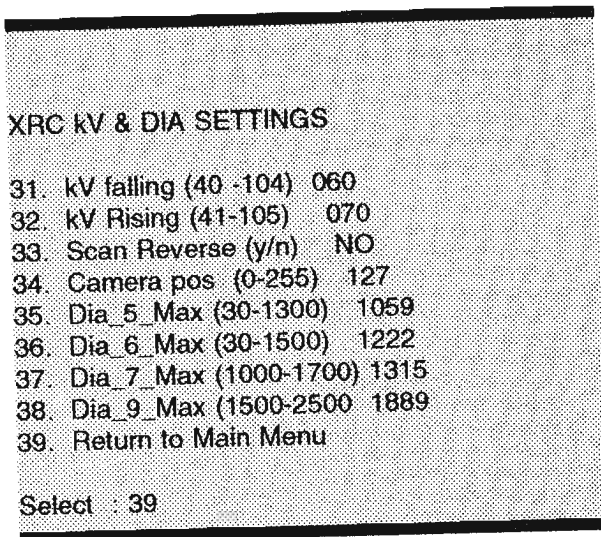

10.5.2. Explanations

- kV Falling:
Function: Lower limit, switch-over point
Large -> Small measuring field.
- Range: 40 - 104 kV
- kV Rising:
Function: Upper limit, switch-over point
Small -> Large measuring field.
- Range: 41 - 105 kV
- Scan reverse
Function: default at power up horizontal scan
reverse
Range: yes / no
- Dia_5_Max:
Function: Iris diaphragm opening at 13 cm.
Range: 30 - 1300
- Dia_6_Max:
Function: Iris diaphragm opening at 15 cm.(only
working on BV26)
Range: 30 - 1500
- Dia_7_Max:
Function: Iris diaphragm opening at 18 cm.
Range: 1000 - 1700
- Dia_9_Max:
Function: Iris diaphragm opening at 23 cm.
Range: 1500 - 2500

11. SERVICE MENU APPLICATION SETTINGS

11.1. INTRODUCTION

The settings as given in the APPLICATION SETTINGS MENU are determined by the APPLICATION DEPARTMENT.

NOTE

ONLY CHANGE THESE VALUES ON SPECIAL REQUEST OF THE USER.

11.2. PROCEDURE

- Enter the SERVICE MENU
- Select the MMP APPL(ICATION) SETTINGS menu (line 40).
- The following menu is displayed:

MMP APPL. SETTINGS

- 41. Mask Time (* 10 ms) = 210
- 42. Frs/sec (0-6) = 4
- 43. Mode-Phase = Fluo-live
- 44. Contrast (28-255) = 085
- 45. Brightness (0-255) = 127
- 46. Average = Avg2
- 47. Movement Detection = Mov6
- 48. Return to Main Menu

Select: 48

- Set CHANGE MODE in order to change current settings.
Proceed as follows:
 - . Loosen the four screws which holds the MMP-unit.
 - . Pull out MMP-unit.
 - . Put jumper WT2:S1-5 in position "ON".
- Select line 43.
- Press <ACC>
- Select the "MODE-PHASE" combination which has to be changed, see TABLE below.
- The menu lines 44, 45, 46, 47 will for show the MODE-PHASE combination and the related application settings.
- Select line to be changed (i.e. line 44, 45, 46, 47).
- Press <ACC>
- Enter new application setting, with "ARROWS" or numeric keys.
- Press <ACC>
- RETURN TO MAIN MENU
- EXIT SERVICE MENU
- Leave CHANGE MODE
 - . Put jumper WT2:S1-5 in position "OFF".
 - . Push back MMP-unit.
 - . Tighten the four screws which holds the MMP-unit.

11.3. EXPLANATIONS

- Mask Time:
Function: Backup timer if no hardware mask pulse available.
Range: 0 - 255
- Frs/sec:
Function: Selection of frames second
Range: 0 - 6
Where: 0 -> 0 fr/sec; 1 -> 0.5 fr sec; 2 -> 1 fr/sec; 3 -> 2 fr/sec
4 -> 3 fr/sec; 5 -> 5 fr/sec; 6 -> 10 fr/sec.
- Mode-Phase:
Function: Fluoroscopy mode with related phase selection.
Range: see TABLE below.
- Contrast:
Function: DEFAULT contrast value.
Range: C 000 - C 255
- Brightness:
Function: DEFAULT brightness value.
Range: B 000 - B 255
- Average:
Function: DEFAULT Average value
Range: Avg 0, Avg 2, Avg 4, Avg 5, Avg 8.
- Movement
Function: DEFAULT Movement Detection value
Range: Mov 0, Mov 2, Mov 4, Mov 6.

For each fluoroscopic mode: FLUO - FLUO boost - SUB - MAX - MAP and Phase: live - inject - catheterisation, settings can be made, DEFAULT VALUES GIVEN:

MODE-PHASE	CONTRAST	BRIGHTNESS	AVERAGE	MOVEMENT
Fluo-live	85	127	1	2
Fluo-boost	= fluo	=fluo	2	6
Sub-live	85	127	8	0
Sub-inject	85	127	8	0
Max-live	85	127	8	0
Max-inject	85	127	4	0
Map-live	85	127	8	0
Map-inject	85	127	4	0
Map-catheter	85	127	2	6

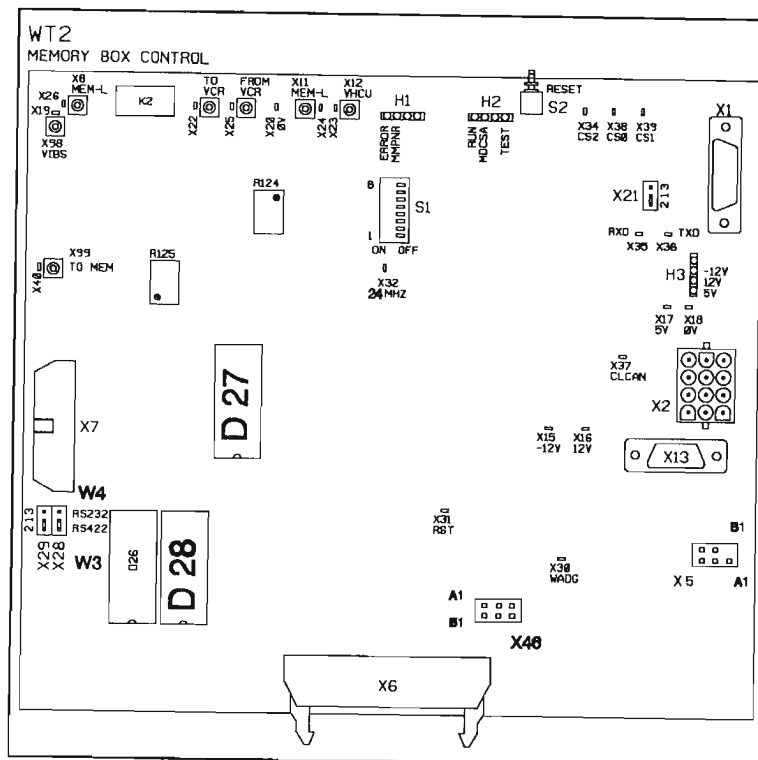

11.4. MBC UTIL SETTINGS

11.4.1. MBC Util SETTINGS menu

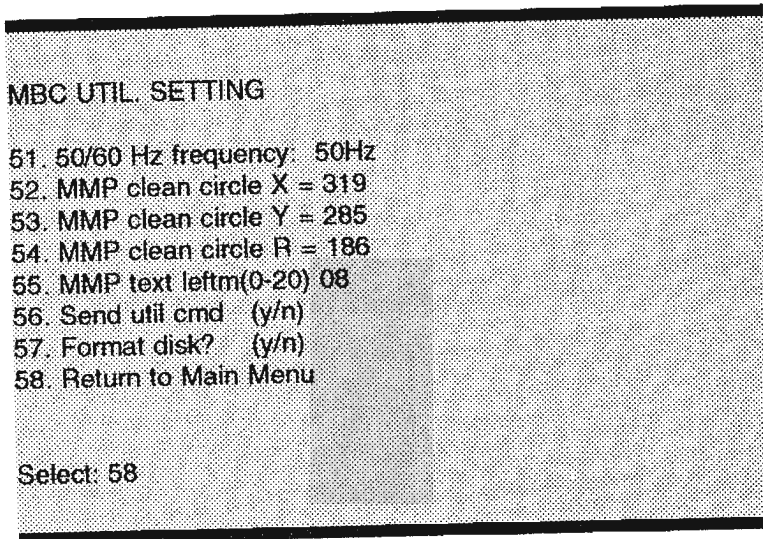

11.4.2. Explanations

- 50/60Hz frequency :
Function: setting of video frequency
Range: 50Hz /60Hz
- MMP clean circle X:
Function: move MMP circle over X axis
Range: .
- MMP clean circle Y:
Function: move MMP circle over Y axis
Range: .
- MMP clean circle R:
Function: move MMP circle over R axis
Range: .
- MMP text leftm (0-20)
Function: shift text to left or right
Range: 0-20
- Send util cmd:
Function: Send utility command.
Range: Y/N
- Format disk?:
Function: Format disk (see chapter 13).
Range: Y/N

11.5. OPTIONS MENU

11.5.1. Introduction

This menu should only be used with demo systems.

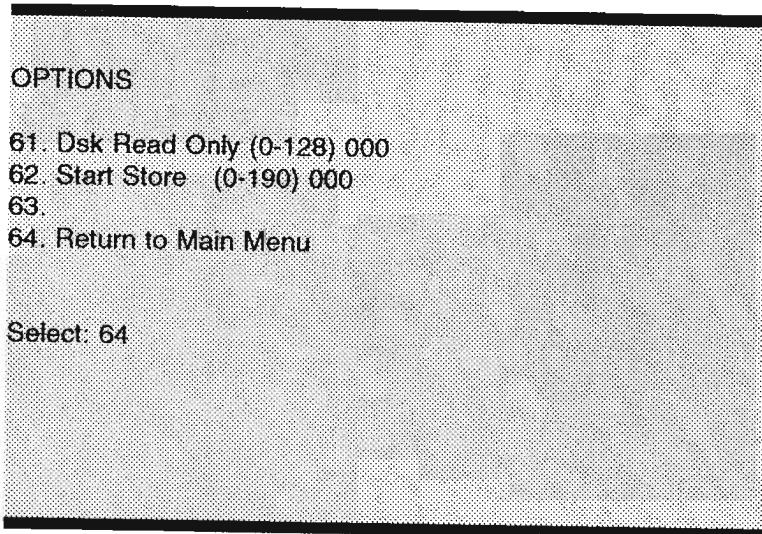

11.5.2. Explanations

- Dsk Read Only :
Function: Image 1 up to XXX (filled in value) write protect.
Range: 0-128
- Start Store :
Function: start value of first image store loop. Factory use only.
Range: .0-190

12. FORMATTING THE HARDDISK

12.1. INTRODUCTION

This procedure must be performed after replacement of the MMP TOKO hard-disk.

12.2. PROCEDURE

- Enter the SERVICE MENU
- Select the MMP UTIL SETTINGS menu (line 50).
- The following menu is displayed:

```

MBC UTIL. SETTING

51. 50/60 Hz frequency: 50Hz
52. MMP clean circle X = 319
53. MMP clean circle Y = 285
54. MMP clean circle R = 186
55. MMP text leftm(0-20) 08
56. Send util cmd (y/n)
57. Format disk? (y/n)
58. Return to Main Menu

Select: 58
  
```

- Set CHANGE MODE in order to change current settings (WRITE ENABLE).
Proceed as follows:
 - . Loosen the four screws which holds the MMP-unit.
 - . Pull out MMP-unit.
 - . Put jumper WT2:S1-5 in position "ON".
- Select line 57.
- Press <ACC>
- Give "Y"
- The service menu disappears and text: "DO YOU WANT TO FORMAT DISK Y/N" appears.
- Give "Y"
- Wait until refreshed menu appears (after 5 sec)
Text in left lower corner: "FORMATTING DISK".
- Service menu appears after the DISK is formatted (10 min.).
- RETURN TO MAIN MENU
- EXIT SERVICE MENU
- Leave CHANGE MODE
 - . Put jumper WT2:S1-5 in position "OFF".
 - . Push back MMP-unit.
 - . Tighten the four screws which holds the MMP-unit.

13. RESETTING THE WORKING HOURS

13.1. INTRODUCTION

This procedure must be performed after replacement of the II-Tube.

13.2. PROCEDURE

- Enter the SERVICE MENU
- Select the XRC TIME SETTINGS menu (line 20).
- The following menu is displayed:

XRC TIME SETTINGS

```

21. Short Beep (* 20ms) 010
22. En.KVAC Delay (* 1ms) 160
23. IntWaitTime (* 40ms) 200
24. Min.RadLamp (* 10ms) 050
25. Exp.PrepTime (* 10ms) 080
26. Bell freq. (* 10us) 100
27. Working Hours (* 1h) 00000
28. X-Ray Hours (* 0.1h) 00000
29. Return to Main Menu

```

Select: 28

- Set CHANGE MODE in order to change current settings.
Proceed as follows:
 - . Loosen the four screws which holds the MMP-unit.
 - . Pull out MMP-unit.
 - . Put jumper WT1:S1-5 in position "ON".
- Select line 27.
- Press <ACC>
- Enter a value: any value entered will cause a reset of the working hours counter.
- Press <ACC>
- Leave SERVICE MENU
- Leave CHANGE MODE
 - . Put jumper WT2:S1-5 in position "OFF".
 - . Push back MMP-unit.
 - . Tighten the four screws which holds the MMP-unit.

14. RESETTING THE X-RAY HOURS

14.1. INTRODUCTION

This procedure must be performed after replacement of the X-Ray Tube.

14.2. PROCEDURE

- Enter the SERVICE MENU
- Select the XRC TIME SETTINGS menu (line 20).
- The following menu is displayed:

```

XRC TIME SETTINGS

21. Short Beep (* 20ms) 010
22. En.KVAC Delay (* 1ms) 160
23. IntWaitTime (* 40ms) 200
24. Min.RadLamp (* 10ms) 050
25. Exp.PrepTime (* 10ms) 080
26. Bell freq. (* 10us) 100
27. Working Hours (* 1h) 00000
28. X-Ray Hours (* 0.1h) 00000
29. Return to Main Menu

Select: 28
  
```

- Set CHANGE MODE in order to change current settings.
Proceed as follows:
 - . Loosen the four screws which holds the MMP-unit.
 - . Pull out MMP-unit.
 - . Put jumper WT2:S1-5 in position "ON".
- Select line 28.
- Press <ACC>
- Enter a value: any value entered will cause a reset of the X-Ray hours counter.
- Press <ACC>
- Leave SERVICE MENU
- Leave CHANGE MODE
 - . Put jumper WT2:S1-5 in position "ON".
 - . Push back MMP-unit
 - . Tighten the four screws which holds the MMP-unit.

15. IMAGE WRITE PROTECTION FOR DEMO PURPOSE

15.1. INTRODUCTION

This procedure must be performed if a number of images on harddisk must be protect against overwriting. A maximum of 128 images can be protected.

15.2. PROCEDURE

- Enter the SERVICE MENU
- Select the OPTIONS menu (line 60).
- The following menu is displayed:

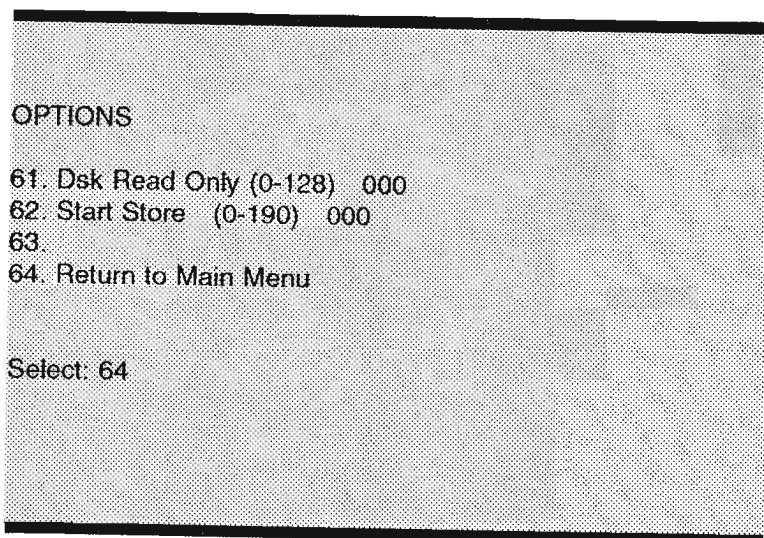

- Set CHANGE MODE in order to change current settings.
Proceed as follows:
 - . Loosen the four screws which holds the MMP-unit.
 - . Pull out MMP-unit.
 - . Put jumper WT2:S1-5 in position "ON".
- Select line 61.
- Press <ACC>
- Enter a value, image 1 to XXX is now protected
- Press <ACC>
- Leave SERVICE MENU
- Leave CHANGE MODE
 - . Put jumper WT2:S1-5 in position "ON".
 - . Push back MMP-unit.
 - . Tighten the four screws which holds the MMP-unit.

16. TILTING THE STAND

NOTE

It is possible to tilt the BV29 stand by one person. However it is safer with two persons.

- 1). Rotate C-arm horizontally and position a table such that the C-arm at moving downwards can rest on the table.
- 2). Loosen the C-arm cable holder.
- 3). Remove the brake handle and cover plate of the horizontal bearing block.

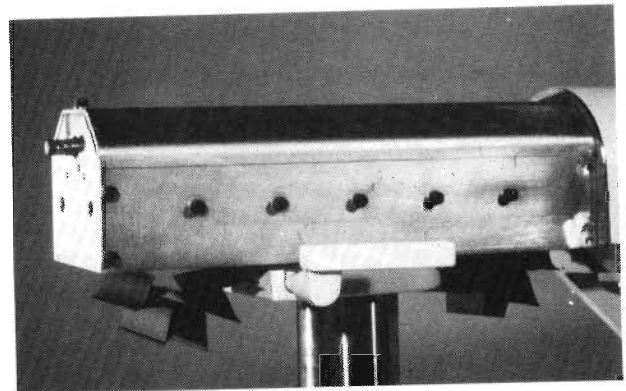
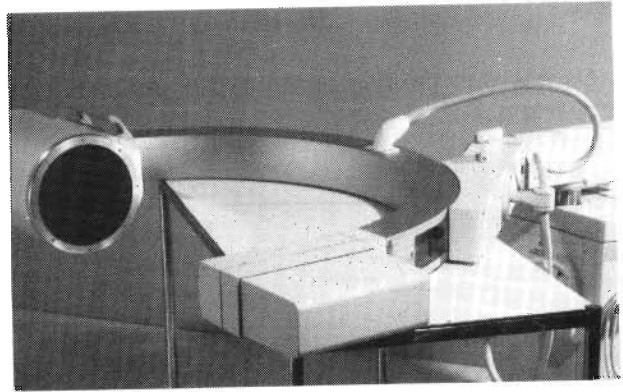

- 4). Remove the zig-zag sheets.

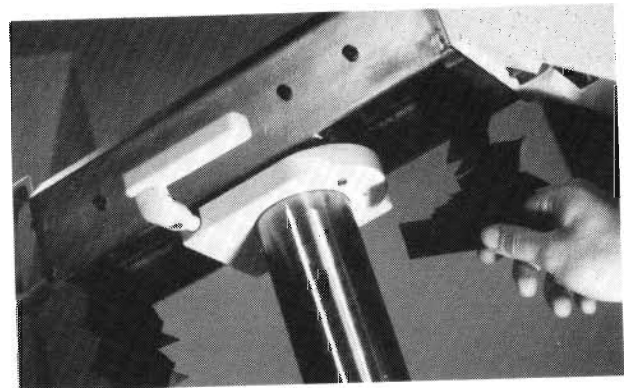

- 5). Unscrew the backplate of the bearing block (2x socket M. in plate, 5x socket M. in the side).

- 6). Mount the brake handle for pulling out the back plate with the shaft.

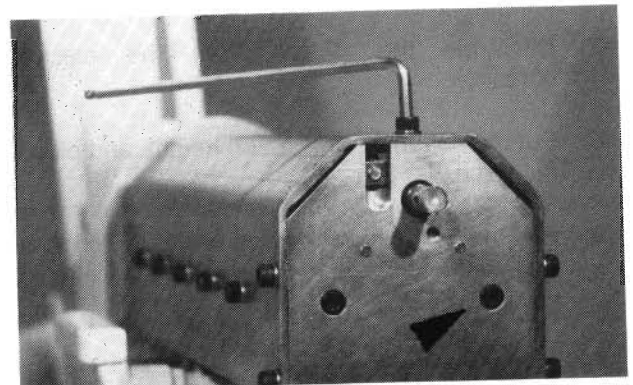

NOTE

Do not drop the ring at the end of the shaft, when pulling out.

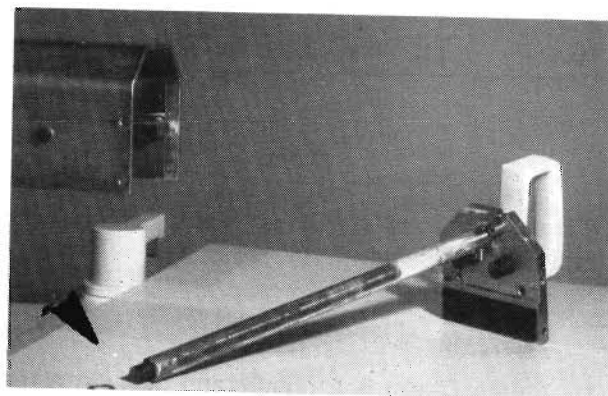

Caution

Due to unbalance when C-arm is removed from the electronic box, the box will tilt and rest on the back side board.

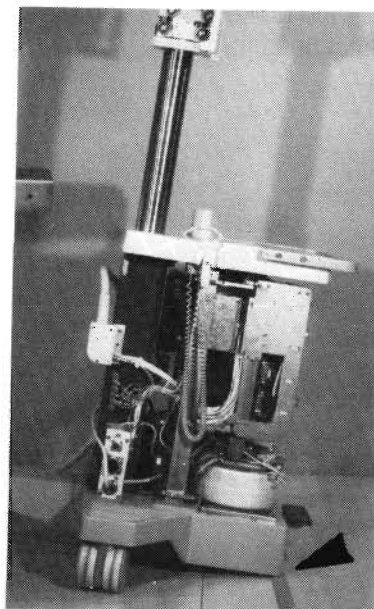

- 7) Decouple the C-arm from the electronic container.
- 8) Put the column in maximum height, and plug out the mains.
- 9) Put the wheels in forward drive direction and protect the spots of the stand which will touch the ground.
- 10) Tilt stand over one side.

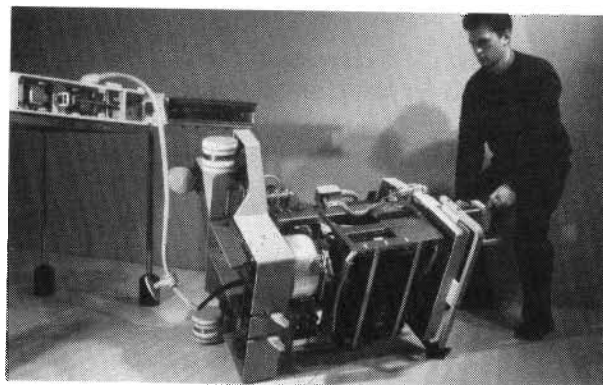

17. ADJUSTMENT C-ARM BALL BEARINGS IN SLIDE BLOCK

To adjust the C-arm ball bearings to the C-arm surface for a smooth sliding movement, proceed as follows:

- 1) Position C-arm with I.I. up and rotate C-arm over 90° to put C-arm horizontally.
- 2) Remove lower cover plate of slide block (4x screw M3 and 2xM5).
- 3) At each side of the C-arm, two sets of ball bearings have been mounted on a mounting plate, each as a set of two.
- 4) Loosen locking screw of eccentric

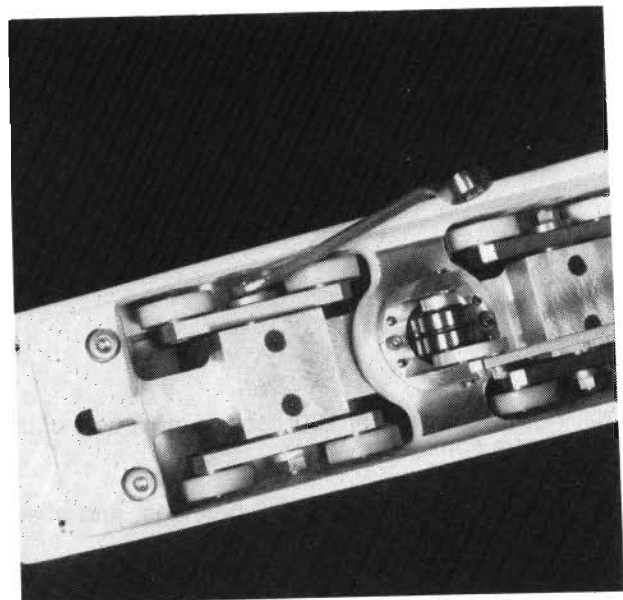
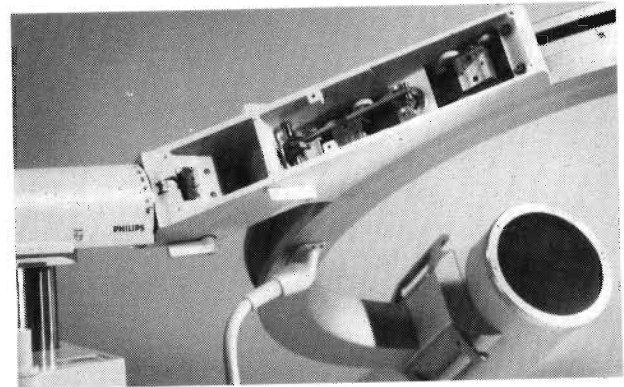
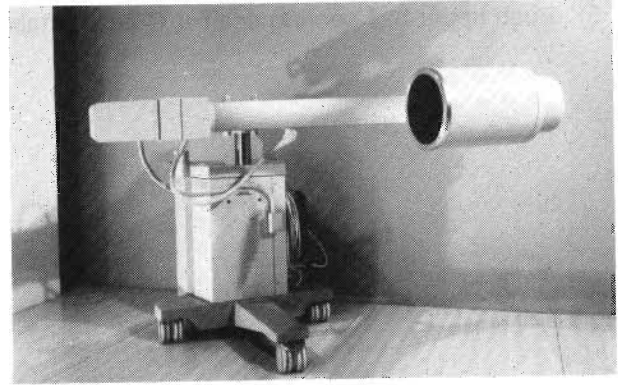

- 5) Push upper ball bearing against C-arm surface

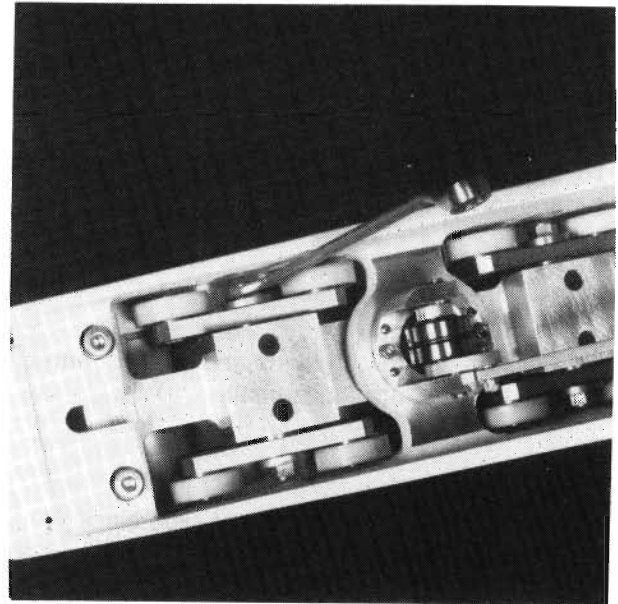

- 6) By adjusting the eccentric, adjust clearance between the other ball bearing and C-arm surface to 0.5 mm.
- 7) Tighten locking screw, and repeat adjustment for the other set of ball bearings.

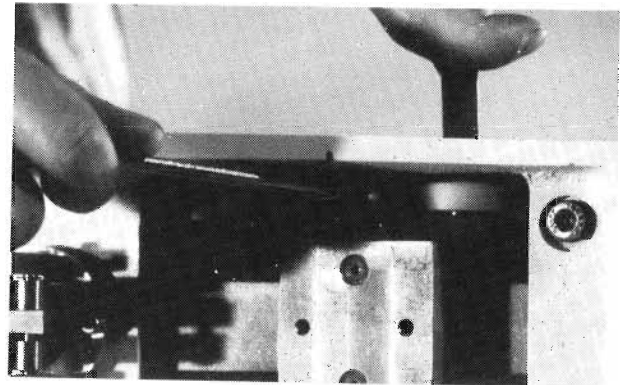

- 8) Rotate C-arm over 180°, so the other side of the C-arm comes up.
- 9) Repeat adjustment of ball bearings, and check for a smooth running of C-arm.
- 10) Replace cable holder and coverplate of slide block.

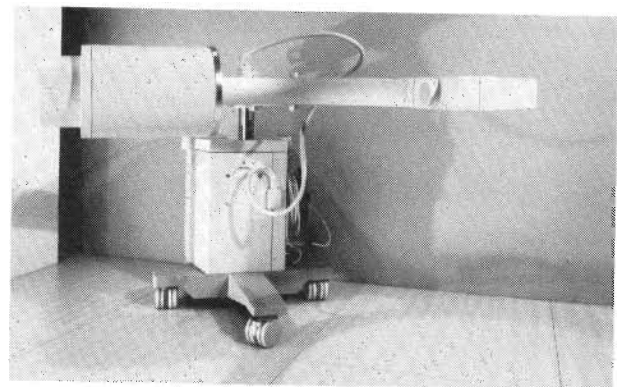

18. ADJUSTMENT BRAKE C-ARM ROTATION

If the moment of braking force is smaller than 50Nm, the brake can be adjusted as follows:

- 1) Remove cover plate of sliding block (3x screws M3) and release brake handle C-arm rotation.
- 2) Remove the two locking screws in inner brake ring (socket screws M1).
- 3) Unscrew the brake ring manually until it hits the eccentric.
- 4) Replace the two locking screws and tighten them (there are six holes for easily positioning of the screws).

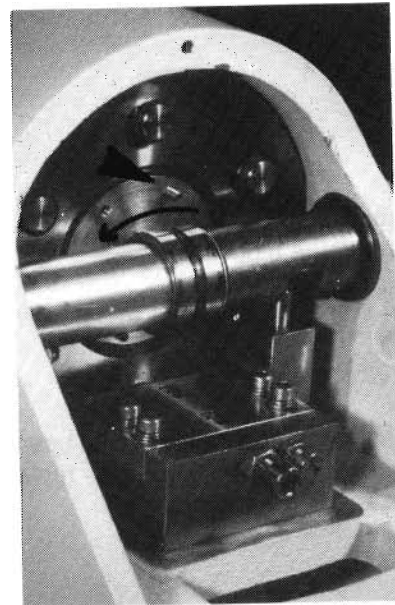
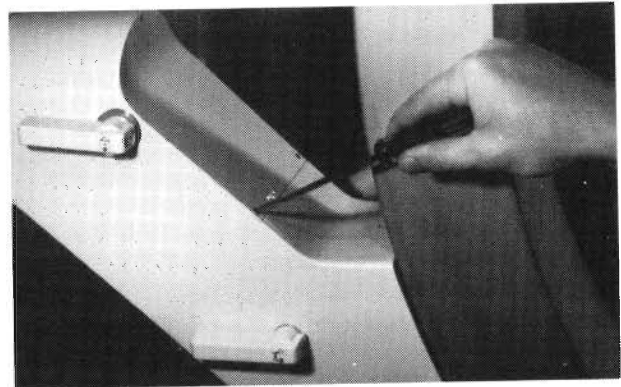

- 5) Lock the brake handle.
- 6) Loosen 4 socket screws M3 of metal block, for adjusting brake handle horizontally.

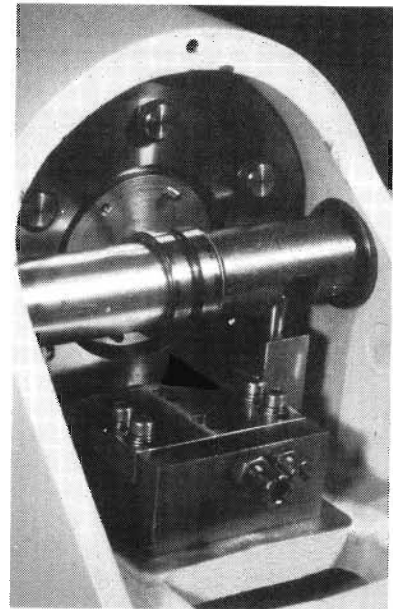

- 7) Use sockethead screw M5 and screw M4 for positioning the block.
- 8) Fasten 4 socket screws of metal block.
- 9) Fasten 2 locking screws in disc.
- 10) If adjustment procedure has not been sufficient, the brake disc should be replaced, See replacement procedure.
- 11) Replace cover plate of slide block (3 screws M3).

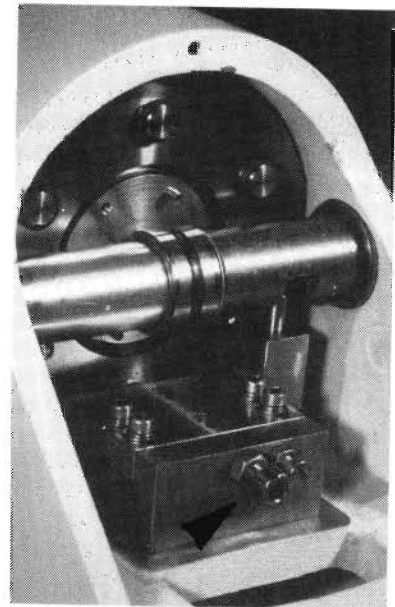

19. ADJUSTMENT BRAKE C-ARM SLIDING

If the moment of braking force is smaller than 50 Nm the brake can be adjusted as follows:

- 1) Put C-arm upside down for easily working position, and release brake handle C-arm sliding.
- 2) Remove cable holder and cover plate of sliding block (2x M5 + 4x M4).

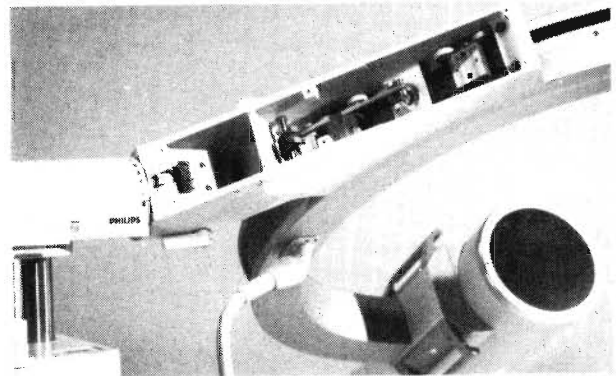
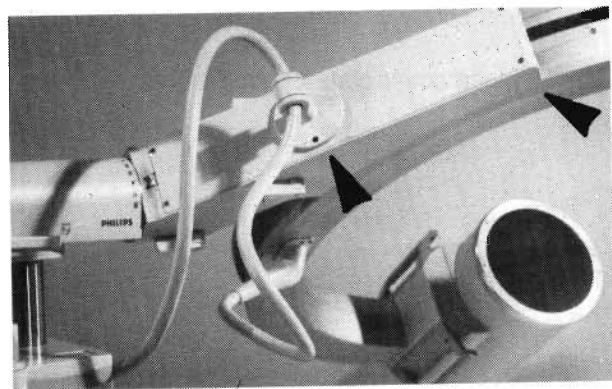
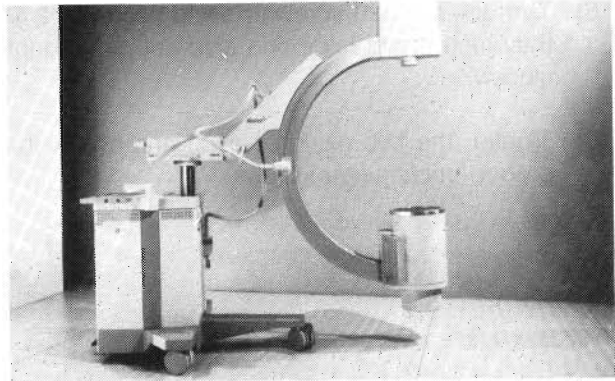

- 3) Loosen the two fixing screws of the brake unit.
- 4) Loosen the four set screws (socket screw M2) and push the brake with rubber buffer against C-arm surface with the brake handle in braking position.
When sliding the C-arm, some friction of brake can be felt.

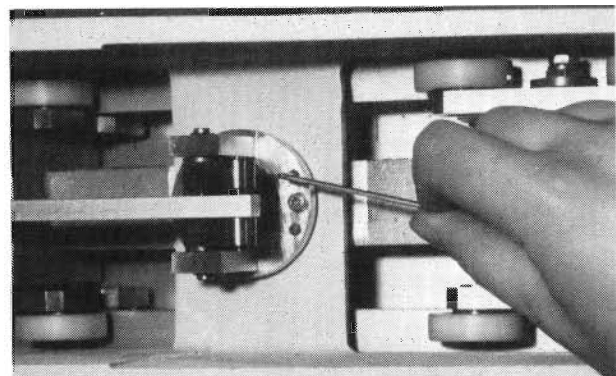

Section ADJUSTMENT PROCEDURES

BV29

- 5) Turn the four set screws (socket screw M2) till they touch the bracket and give one turn counter clockwise.
- 6) Tighten the two fixing screws, and check for a proper functioning of brake.

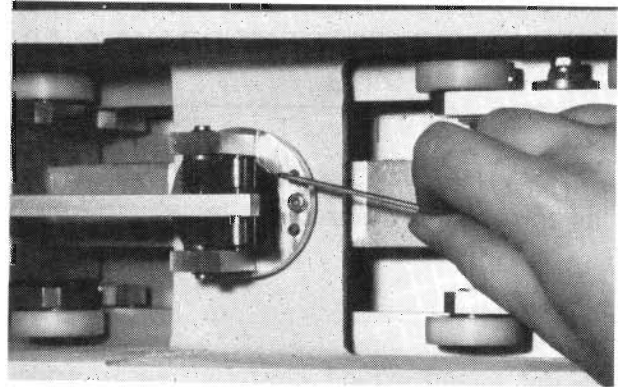

- 7) Adjust screw to set brake handle horizontal.
- 8) Replace cover plate of slide block.

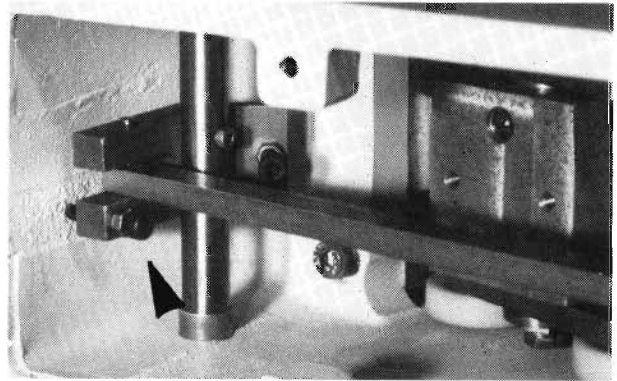

20. ADJUSTMENT SCAN BRAKE

If the moment of braking force is smaller than 90 Nm, the brake can be adjusted as follows:

- 1) Move column up to have free working space under the horizontal sliding block.
- 2) Remove plastic dust cover (2x M3).
- 3) Release scan brake.
- 4) Loosen 4 socket screws M2 in adjusting ring at the left side of the Stand.
- 5) Adjust brake tension by turning the ring manually until correct braking force is reached.
- 6) Fasten the 4 socket screws.
- 7) Replace plastic cover.

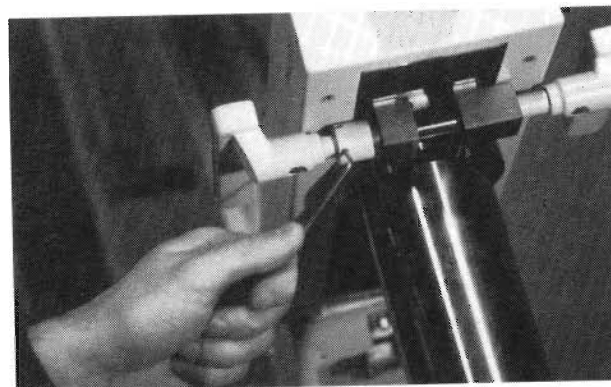
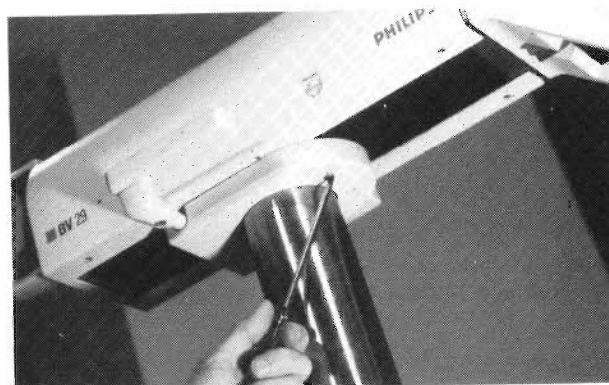
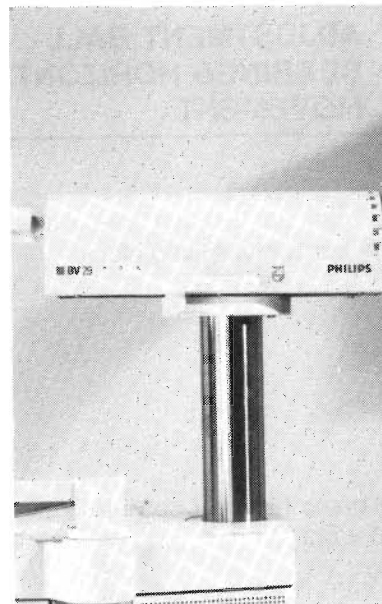

21. ADJUSTMENT BALL BEARINGS HORIZONTAL MOVEMENT

1) Move column up to have free working space under the horizontal sliding block.

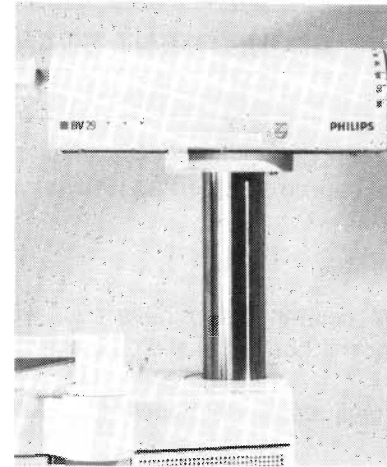

2) Remove brake handle (socket screw M5) and cover (6 x M3).

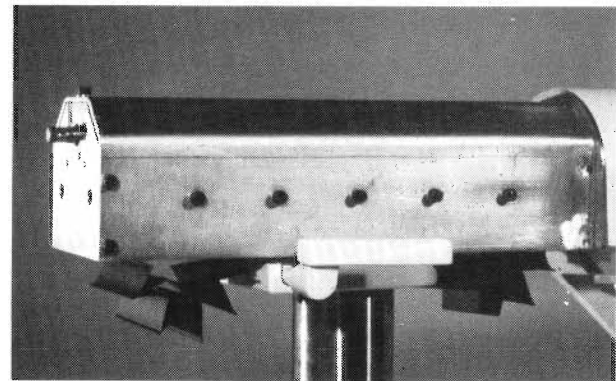

3) Replace handle for operating brake.

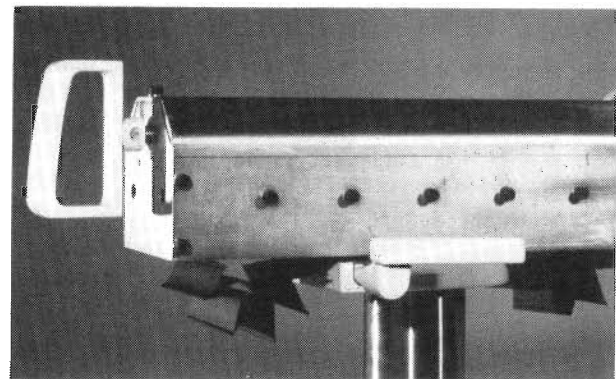

4) Remove front and back zig-zag sheet.

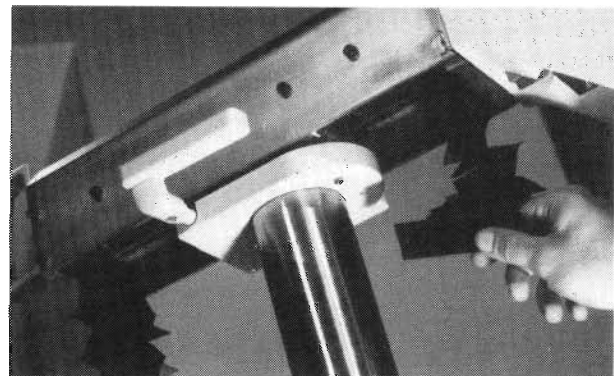

BV29

Section ADJUSTMENT PROCEDURES

- 5) Move C-arm in horizontal forward position.

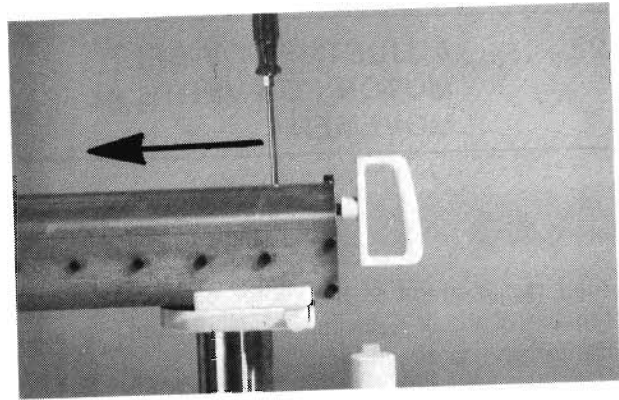

- 6) Loosen small socket screw.

NOTE

Only the left side has adjustable bearings, (do not touch the screws on the right side).

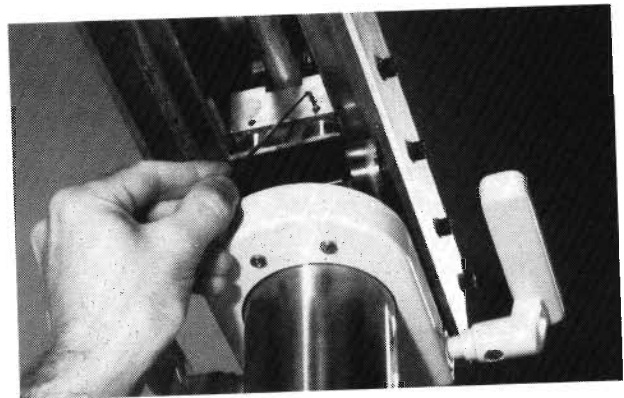

- 7) Turn the eccentric screw, using the hole on top, to reduce the space for motion.
8) Fasten the socket screw

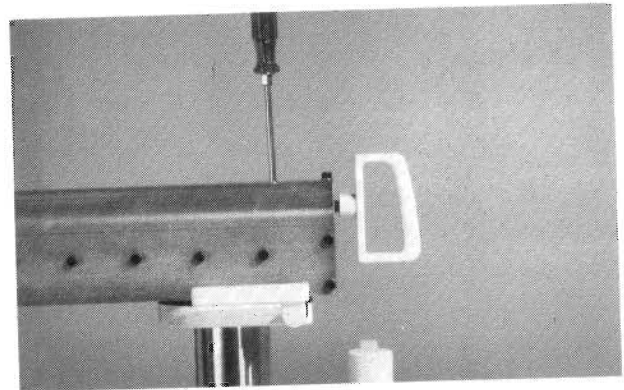

- 9) Move C-arm in horizontal backward position
10) Carry out item 5, 6 and 7
11) Replace handle, cover and zig zag sheet

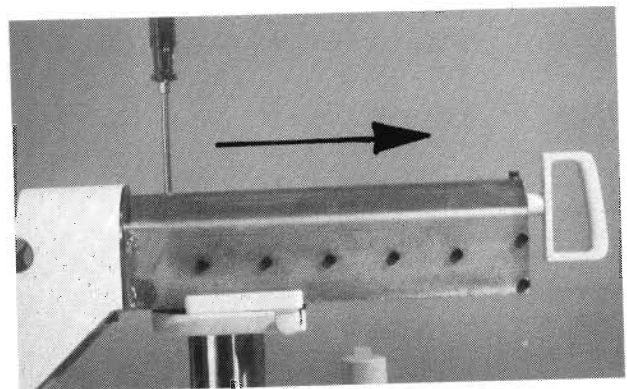

**22. ADJUSTMENT V-BELT
MOTOR FOR VERTICAL
MOVEMENT**

After replacement of the motor or the V-belts, the tension of the V-belts must be adjusted. To adjust the tension, proceed as follows:

- 1) Remove front cover and open SE door.
- 2) Loosen a bit the 3 screws of the mounting base of motor (socket screws M6 + washers in elongated holes).
Now the tension of the V-belts can be adjusted by tightening the nut M6.
- 3) Tighten nut until mechanical stop.
- 4) Tighten the 3 fixing screws.
- 5) Close SE-door and replace front cover.

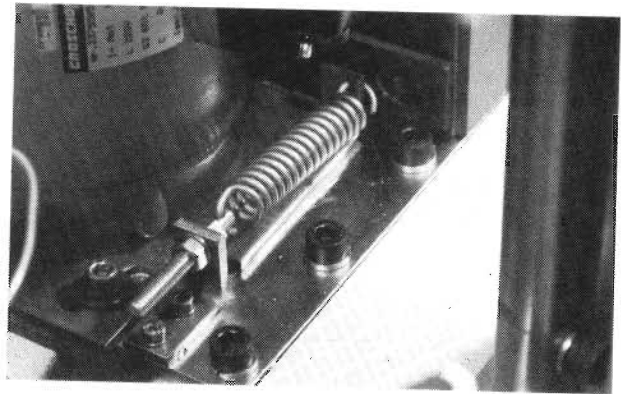

**23. ADJUSTMENT PROCEDURE
OF UPPER AND LOWER END
SWITCHES**

Caution

Do not run the motor when the mechanical end stop has been reached; it can damage the v-belts or motor

- 1) Move the tube to its highest position, until the mechanical end stop is reached.
- 2) Loosen a bit the 2 screws in the mounting plate of the upper end switch.
- 3) Shift the plate with switch until a "click" has been heard; the switch is now activated.
- 4) Fasten the two screws.
- 5) Move the tube to its lowest position, until the mechanical stop is reached.
- 6) Carry out item 2, 3 and 4.
- 7) Replace covers.

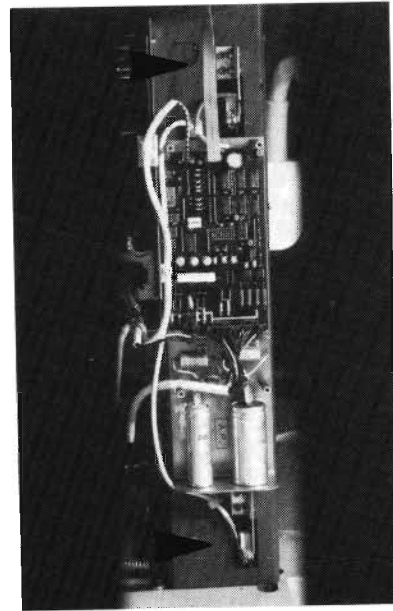

**24. ALIGNMENT PROCEDURE
DIAPHRAGM UNIT**

This procedure must be done at replacement of Practix-C tank, diaphragm unit or motor/potentiometers of diaphragm unit. After the alignments, the centres of Practix-C tank, diaphragm and image intensifier are matched.

The procedure deals with the following adjustments:

- (1) Alignment of "focus-near" ring with respect to Practix-C tank.
- (2) Alignment of shutters with respect to Practix-C tank.
- (3) Alignment of iris diaphragm with respect to Practix-C tank.

Before starting the procedure:

- Mark centre of I.I. plane, e.g. by a washer on the centre of grid.
- Operate C-arm up button for easily working position of diaphragm unit.

24.1. ALIGNMENT OF FOCUS-NEAR RING

- 1) Switch off the system and remove diaphragm cover.
- 2) Remove lead block.
- 3) Remove iris diaphragm and shutter units from mounting bracket.
- 4) Connect pin MPD1 to MPD2 on SE10 (control backpanel) to activate the signal Diaphragm Ready (DIRD).
- 5) Place the small brass pot inside the focus-near ring.
Turn the four fixing screws in the ring finger tight, so it can be moved easily.
- 6) Position jumper SE21: W1 in 1-3 to select large focus.

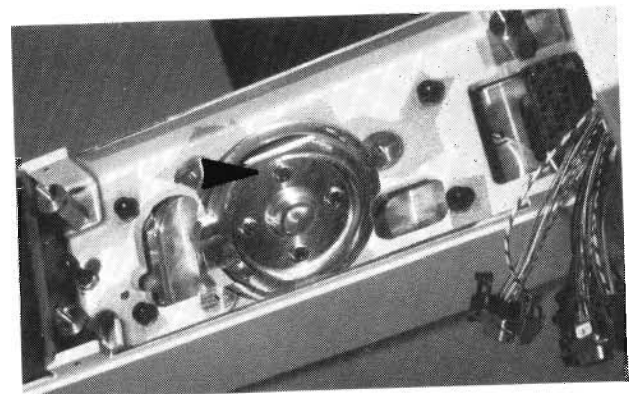
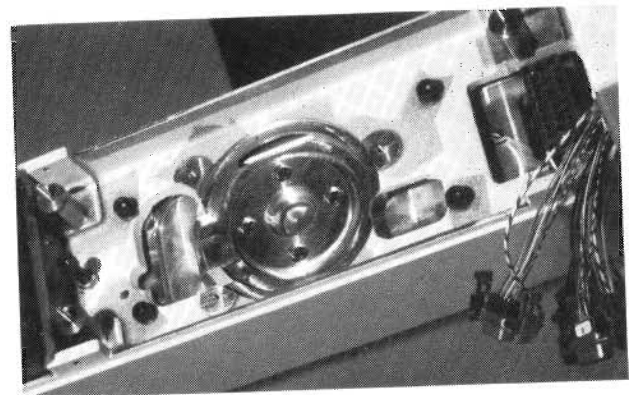
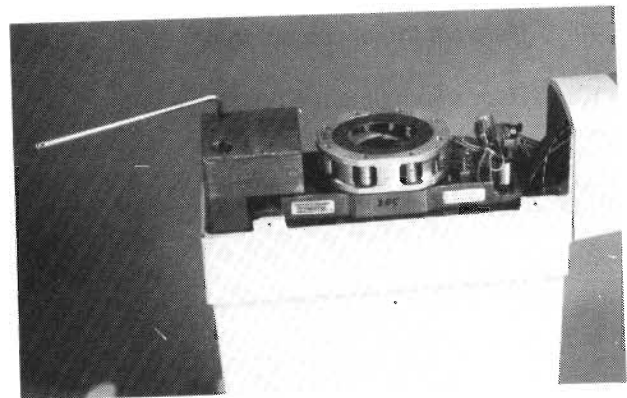
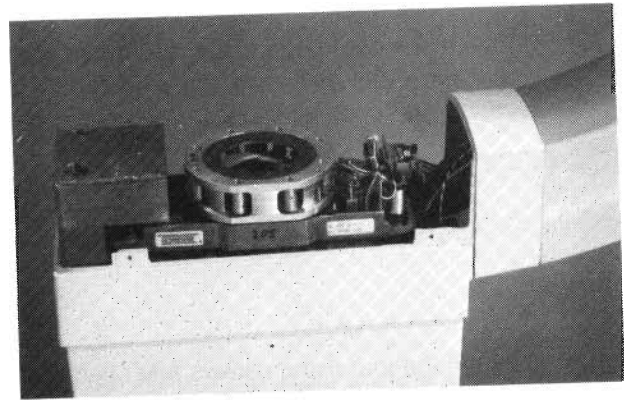

- 7) Move the spot of large focus on TV monitor to the centre of II entrance plane (washer), by shifting the focus-near ring.
- 8) Tighten the four fixing screws and check if the spot is still in the centre of I.I. entrance plane. Readjust if necessary.
- 9) Remove the alignment tool.
- 10) Reposition jumper SE21:W1 in 1-2.

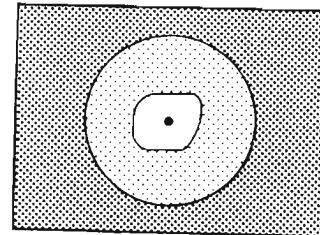
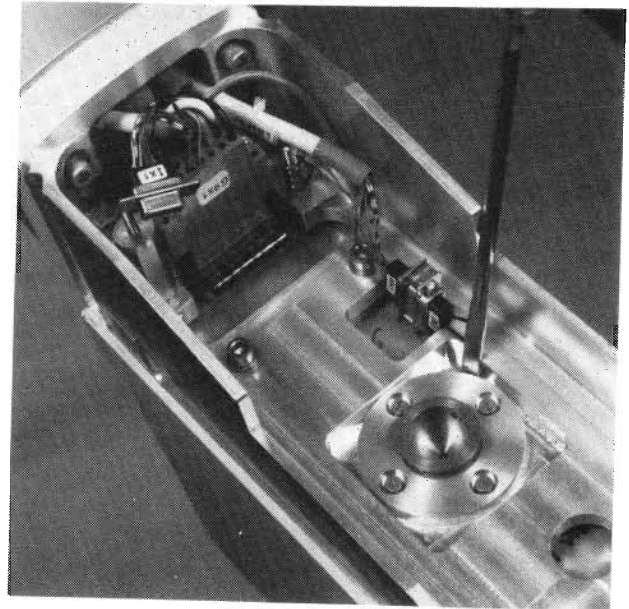

24.2. ALIGNMENT OF SHUTTER UNIT

Caution

Be sure that small focus has been selected before starting this alignment. (SE21:W1 in 1-2).

- 1) Fit the shutter unit on mounting bracket and turn the free fixing-screws finger tight.



- 2) Operate button to close shutters for smallest slitwidth, and operate button to rotate slit in B-direction.
During fluoroscopy, a horizontal slit is visible on TV monitor.
Position the slit in the horizontal centre line of TV monitor circle by shifting the unit.

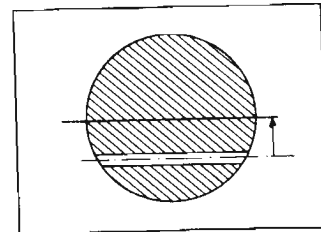

- 3) Operate button to rotate slit in A-direction.
During fluoroscopy, a vertical slit is visible on TV monitor.
Position the slit in the vertical centre line of TV monitor circle by shifting the unit.

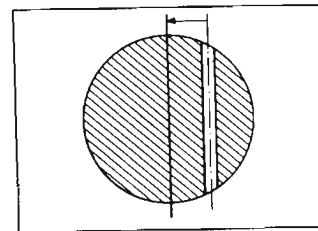

- 4) Tighten the three fixing screws.
Check if the slit remains in the centre lines of TV monitor when rotating the slit unit.
Readjust if necessary.

24.3. ALIGNMENT OF IRIS DIAPHRAGM

To centre the iris diaphragm in the monitor circle, proceed as follows:

- 1) Fit iris diaphragm unit on mounting bracket and turn nuts finger tight. Connect cable LAX1 and remove connection between SE10:MPD1 and MPD2.
- 2) During fluoroscopy, operate iris - button until iris is visible on TV monitor. Centre the iris in TV monitor circle, the corners of iris are just inscribed in the circle. The diaphragm unit can be shifted by putting a screwdriver through the alignment hole, using it as joystick.
- 3) Tighten the three nuts of diaphragm unit. Check for a centred picture of iris on TV monitor and readjust if necessary.

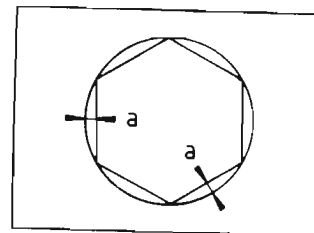
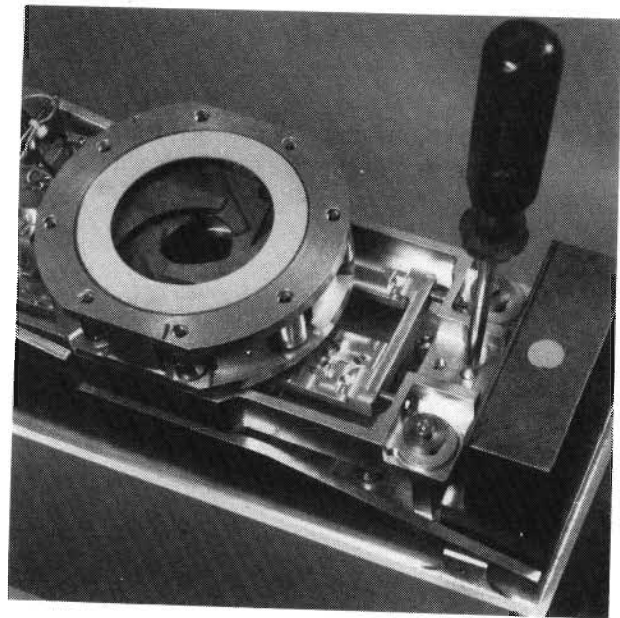
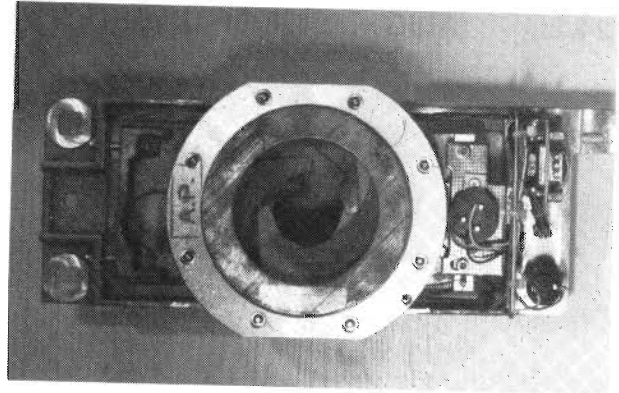

25. VIDEO HARD COPY UNIT ADJUSTMENT

NOTE

*FOR CALIBRATION AND PEDESTAL ADJUSTMENTS IN VHCU:
SEE MATRIX VHCU SERVICE MANUAL.*

25.1. ADJUSTMENT PROCEDURE VHCU PMI100

BV25/BV26/BV29 can be delivered as a preferred system, with a Video Hard Copy Unit (VHCU) installed by the factory.

In this case, the VHCU has been tested and set to the following darkroom techniques:

Film: KODAK NMB, average gradient: 2.2 - 2.7
Dev. system: Agfa Curix 402
Developer: Agfa gevaert G 138 A/B/C

T=31 degr.C
t=2 min
Fixer: Agfa Gevaert G 334 A/B

In case of other film or chemicals fine adjustment is always necessary.

Following procedures are described:

- * Installation in BV25/26/29
- * 50 Hz / 60 Hz video input changing
- * VHCU monitor alignment
- * Film calibration of positive and negative mode
- * Fine contrast and brightness adjustment (customer taste)

25.2. INSTALLATION

NOTE

*Before you install the VHCU in the system check the mains voltage and the video frequency.
If VHCU mains and video frequency is not corresponding with system data first carry out hardware adjustments before you build in the unit.*

25.2.1. Installation in a BV25 mobile system

Remove front and rear cover of the BV25 trolley.
Mount VHCU on trolley base plate.

Connect premounted wiring in the BV25 trolley

Mains : premounted

Video : X5

Computer interface cable is not used for the PMI100

25.2.2. Installation in a BV26 mobile system

Remove front and rear cover of the BV26 trolley.
Mount VHCU on trolley base plate

Connect wiring:

Mains: WT100 (remove mains connector of delivered cable)

Video: WZ outside bnc

25.2.3. Installation in a BV29 mobile system

Remove front and rear cover of the BV29 trolley.
Mount VHCU on trolley base plate

Connect wiring:

Mains : WT100 (remove mains connector of delivered cable)

Video : WT X6

Mount new small front and rear cover plates.(In preparation, delivery approx sept 93)

25.3. 50 Hz / 60 Hz VIDEO INPUT CHANGING

To change between 50 Hz and 60 Hz operation, remove cover and set jumper X1 as indicated in the figure.

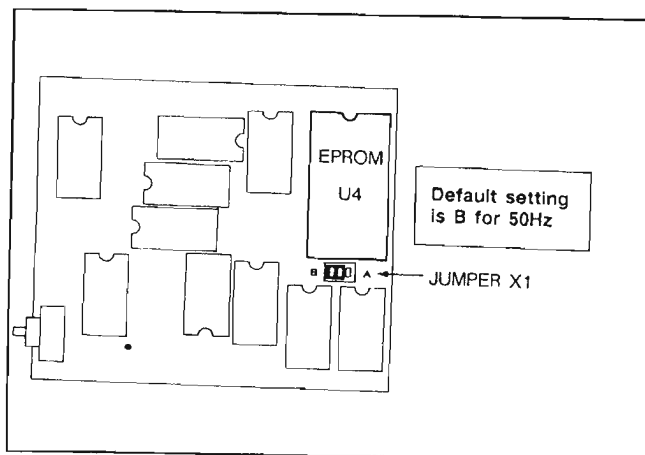

NOTE

When changing the video frequency always carry out chapter VHCU MONITOR ALIGNMENTS !!, and chapter film calibration.

25.4. VHCU MONITOR ALIGNMENT

For matching the system video signal with the VHCU image geometry proceed as follows:

Be sure that jumper X1 is set in the correct position (50Hz/60Hz video input).

NOTE: VHCU is not build in, but placed near the BV system.

- * Remove top cover of the VHCU
- * Lift the monitor electronics plate

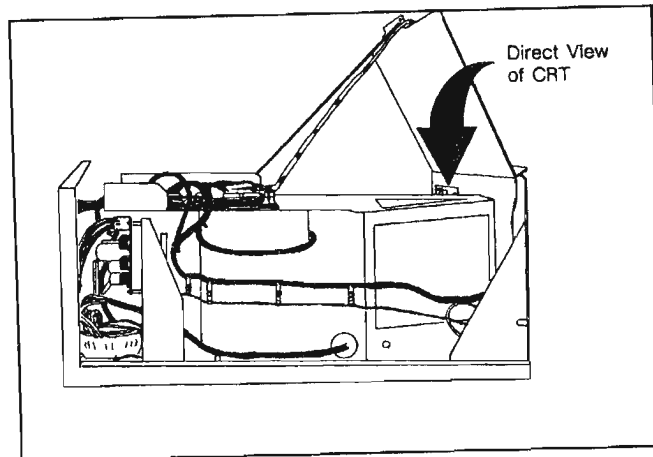

- * connect mains and video coax (see installation)
- * Switch on BV system and VHCU
- * Retrieve an image or carry out fluoroscopy.

- * Wait for warming up (1min)
- * When IMG 1/* USR * *** appears push simultaneously RESET and PROG to enter service mode.
- * Use >> button to go to VW mode (=view mode, image permanent displayed on VHCU)
- * Turn up B =brightness and C =contrast to obtain a bright image on the VHCU monitor, use +/- buttons.
- * Place MASK phantom, delivered with this doc., on the screen of the VHCU monitor.

Use following potentiometers to adjust the image geometry.
See also VHCU documentation paragraph 3.3.7

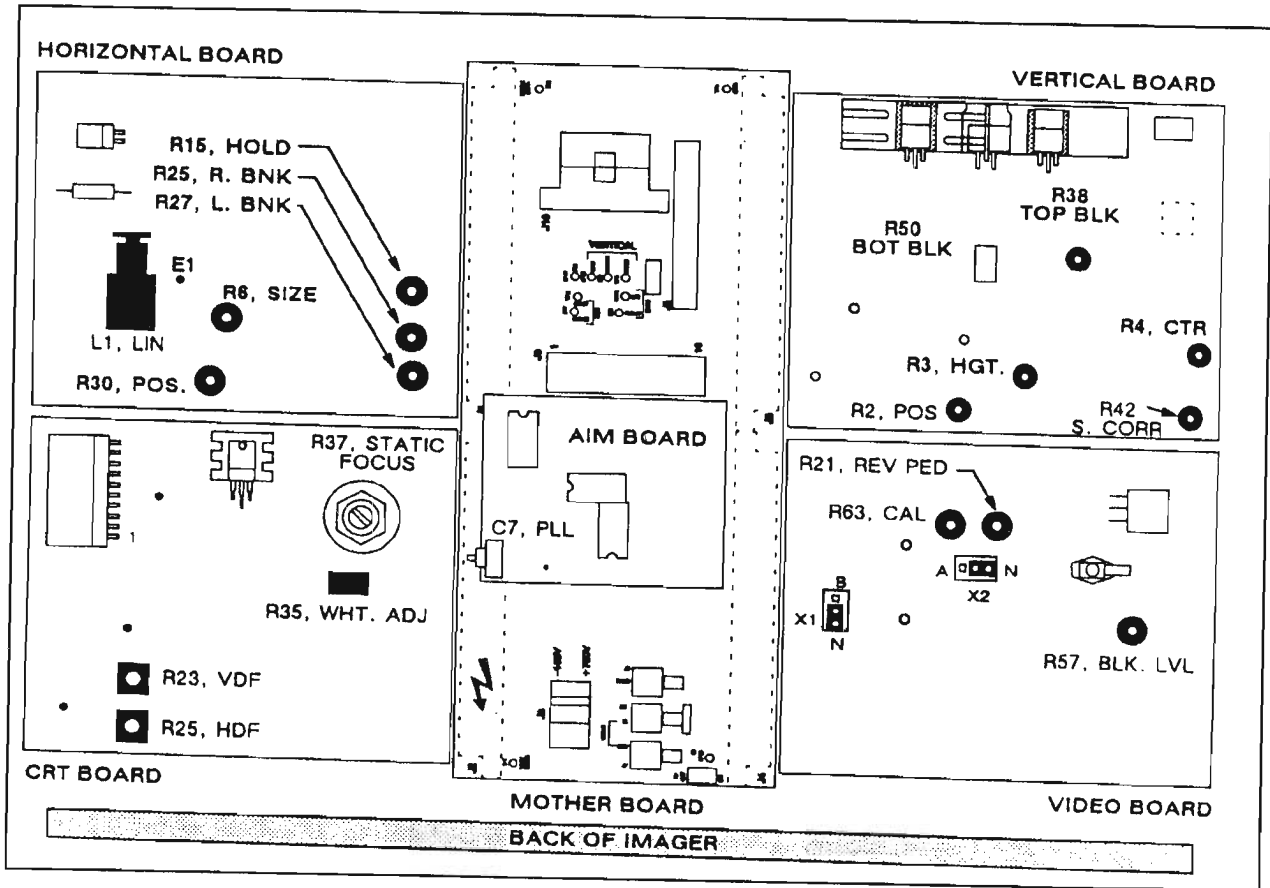

Horizontal adjustments

* Adjust **R15** to midpoint between lock-in limits.

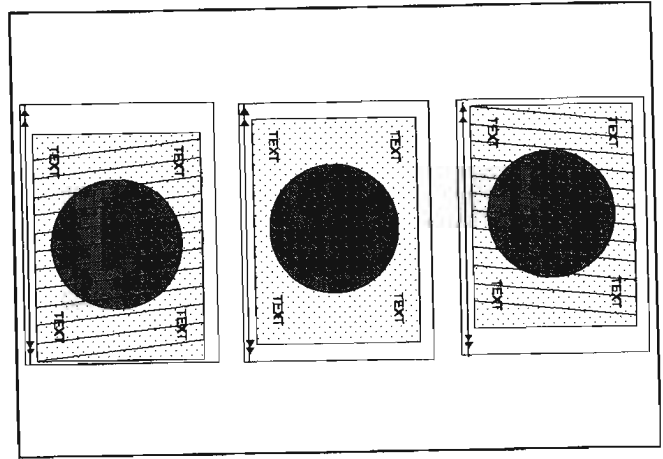

* Adjust **R30** for picture centring.

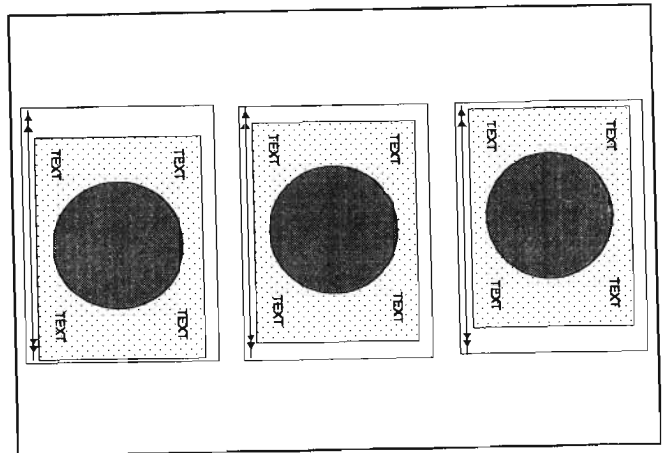

* Adjust **R6** for horizontal picture size.

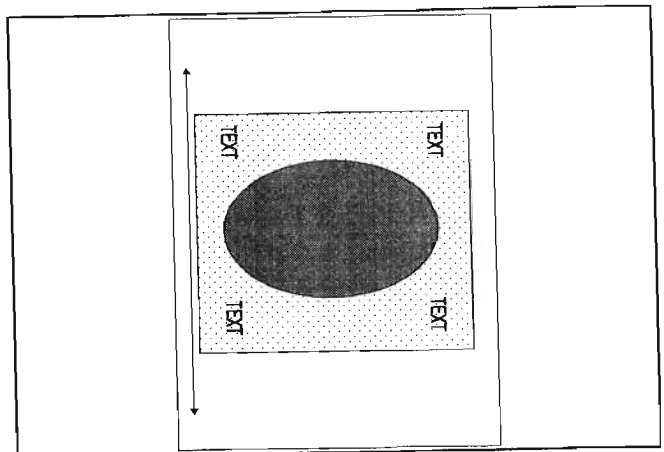

* Adjust **R25** for right blanking

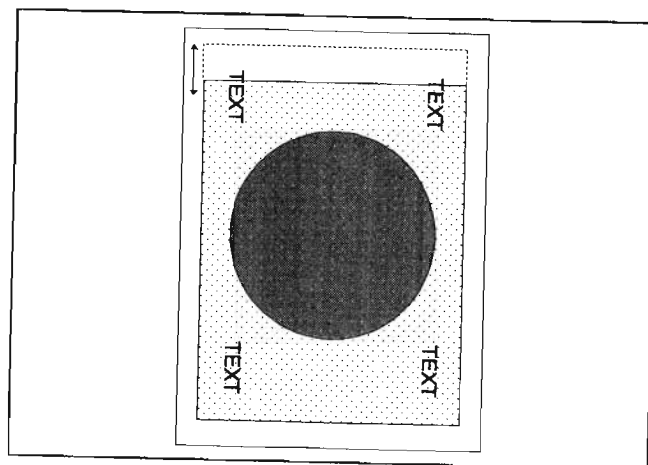

* Adjust **R27** for left blanking

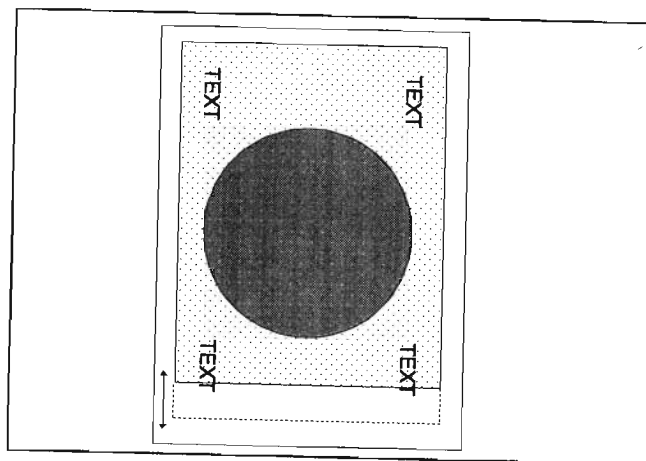

Vertical adjustments

* Adjust **R50** for bottom blanking

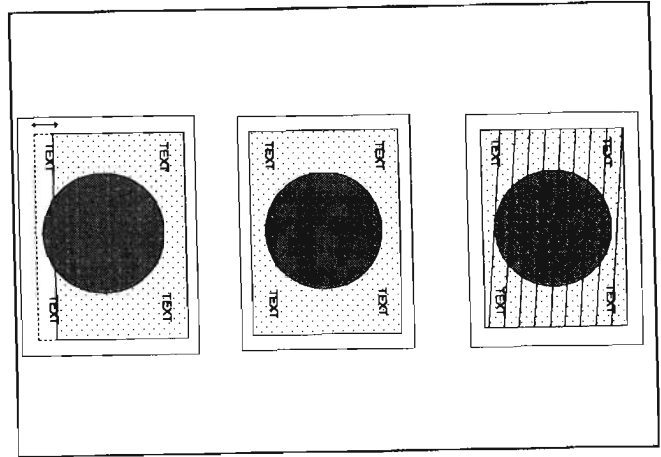

* Adjust **R38** for top blanking

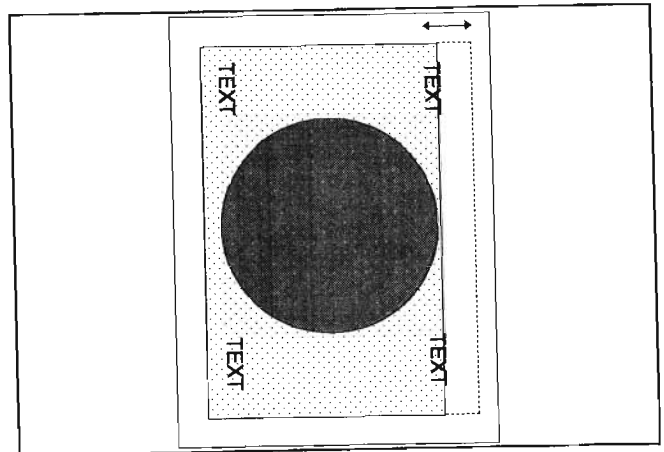

* Adjust **R4** for picture centring

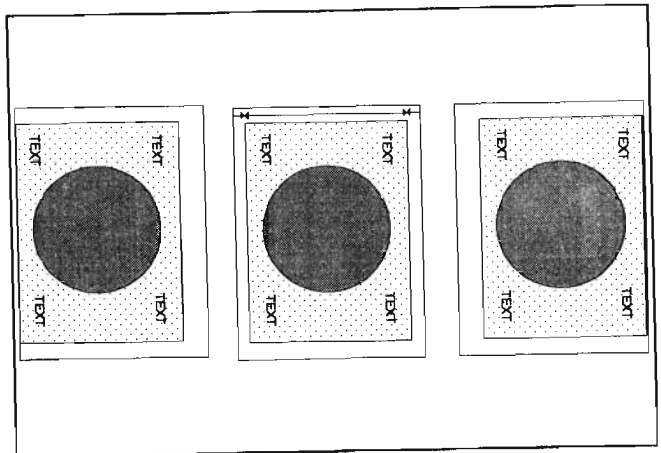

* Adjust **R3** for vertical picture size

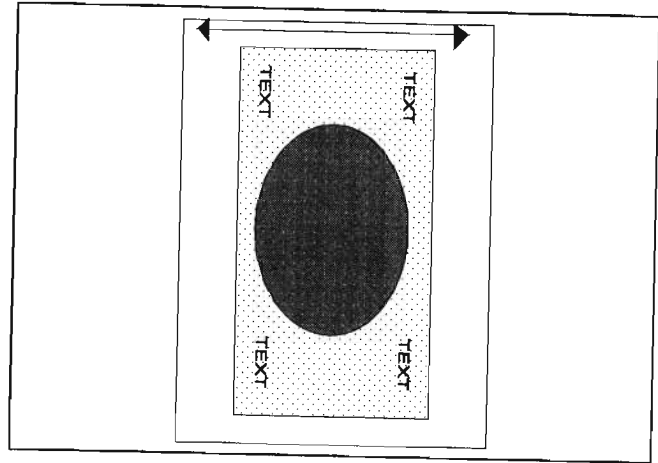

25.5. FILM CALIBRATION OF POSITIVE AND NEGATIVE MODE FOR NORMAL FLUO IMAGES

Connect VHCU camera (VIDEO IN) to the mobile system (see paragraph installation).

Connect an oscilloscope to VHCU (VIDEO OUT). Use 75 Ohm terminator.

Fluo values has to be programmed under following menus:

Programm VHCU user mode IMG 1/x > USR 1 POS (= normal fluoro images)

IMG 1/x > USR 1 NEG (= normal fluoro images)

IMG 1/x > USR 3 POS (= normal fluoro images)

IMG 1/x > USR 3 NEG (= normal fluoro images)

FLUOROSCOPY					
50Hz Video, interlace = X2					
USER 1 POS. and USER 3 POS.			USER 1 NEG. and USER 3 NEG		
B: ***	C: ***	D: 056	B: ***	C: ***	D: 056
Video in: 400mV = 0.75 +/- 0.2 optical density 0mV = 1.8 +/- 0.2 optical density			Video in: 400mV = 1.05 +/- 0.2 optical density 0mV = 0.3 +/- 0.2 optical density		

FLUOROSCOPY					
60Hz Video, interlace = X2					
USER 1 POS. and USER 3 POS.			USER 1 NEG and USER 3 NEG		
B: ***	C: ***	D: 064	B: ***	C: ***	D: 064
Video in: 400mV = 0.75 +/- 0.2 optical density 0mV = 1.8 +/- 0.2 optical density			Video in: 400mV = 1.05 +/- 0.2 optical density 0mV = 0.3 +/- 0.2 optical density		

25.5.1. Calibrating positive mode

Carry out following step by step

- * Switch on the mobile system and VHCU

Obtain a 400mV video signal from the system to find correct brightness, proceed as follows:

- 1 Set system in smallest II format as possible.
- 2 Use highest averaging factor as possible.
- 3 Make a smooth fluoroscopy image.
- 4 Measure with the oscilloscope the amplitude of the image (400 mV) neglect the text peaks.
- 5 If signal is too small/high use the brightness button on the system to correct to 400mV. (On BV25 use man Kv)

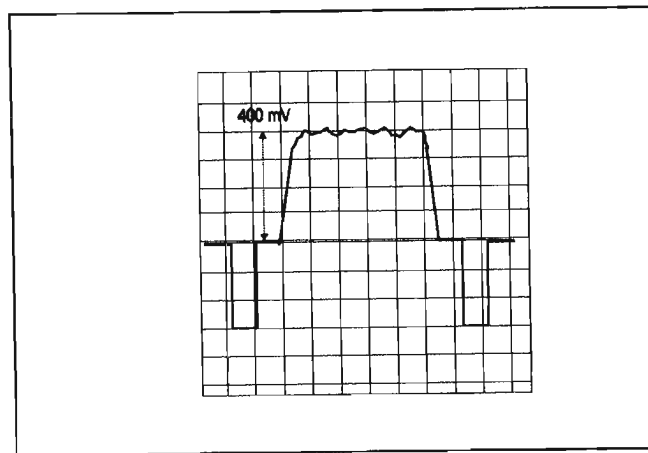

- * On VHCU enter desired user and pos mode e.g. IMG 1/x > USR1 POS by using POS/NEG and 1/3 button.
- * Enter program mode by pressing PROG
- * Step with >> button to B*** >C*** D056 and fill in value 000 for (C)ontrast
- * Step with the >> button to B*** C000 >D056 and check if D=56 (50Hz) or D=64 (60Hz)
- * Step with the >> button to >B*** C000 D056 and fill in value of (B)rightness, use for estimating the values the reference film delivered with the VHCU.
- * Make exposures, develop film and measure if density is 0.75 +/- 0.2
- * If density is too high/low increase or decrease the (B)rightness value and make new exposures.
- * Correct brightness value for density 0.75 is now programmed for User 1 (=normal fluoro images) positive mode.

To find correct (C)ontrast value, measure density outside the video circle (0mV).

- 1 If image is not 0mV, reset the system by pressing the fluoroscopy timer and buzzer reset button and leave the patient menu by pressing ACC (BV26/BV29), a complete black image is the result.

- * Step with > button to > B and make sure the correct brightness with density 0.75 (found earlier) is programmed
- * Step with > button to B*** >C*** D056
- * Fill in value of (C)ontrast, use for estimating the values the reference film delivered with the VHCU.
- * Make exposures develop film and measure if density is 1.8 +/- 0.2 outside the circle (=0mV)!!
- * If density is too high/low increase or decrease the (C)ontrast value and make new exposures.
- * Correct contrast value for density is 1.8 is now programmed for User 1 (= **normal fluoro** images) positive mode.

The camera is now calibrated for user 1 positive mode (= **normal fluoroscopy** images).
Program same values of contrast and brightness under user 3 positive mode.

25.5.2. Calibrating negative mode

Carry out following step by step

- * Switch on the BV system and VHCU

Obtain a 400mV video signal from the system to find correct brightness, proceed as follows:

- 1 Set system in smallest II format as possible.
- 2 Use highest averaging factor as possible.
- 3 Make a smooth fluoroscopy image.
- 4 Measure with the oscilloscope the amplitude of the image (400 mV) neglect the text peaks.
- 5 If signal is too small/high use the brightness button on the system to correct to 400mV. (BV25 use man Kv)

- * On VHCU enter desired user and neg mode e.g. IMG 1/x > USR1 NEG by using POS/NEG and 1/3 button.
- * Enter program mode by pressing PROG
- * Step with >> button to B*** >C*** D056 and fill in value 000 for (C)ontrast
- * Step with the >> button to B*** C000 >D056 and check if D=56 (50Hz) or D=64 (60Hz)
- * Step with the >> button to >B*** C000 D056 and fill in value of (B)rightness, use for estimating the values the reference film delivered with the VHCU.
- * Make exposures, develop film and measure if density is 1.05 +/- 0.2
- * If density is too high/low increase or decrease the (B)rightness value and make new exposures.
- * Correct brightness value for density is 1.05 is now programmed for User 1 (=normal fluoro images) negative mode.

To find correct (C)ontrast value, measure density outside the video circle (0mV).

- 1 If image is not 0mV, reset the system by pressing the fluoroscopy timer and buzzer reset button and leave the patient menu by pressing ACC (BV26/BV29), a complete black image is the result.
- * Step with > button to B > and make sure the correct brightness with density 1.05 (found earlier) is programmed
 - * Step with > button to B*** >C*** D056
 - * Fill in value of (C)ontrast, use for estimating the values the reference film delivered with the VHCU.
 - * Make exposures develop film and measure if density is 0.3 +/- 0.2 measure outside the video circle (0mV)!!
 - * If density is too high/low increase or decrease the (C)ontrast value and make new exposures.
 - * Correct contrast value for density is 0.3 is now programmed for User 1 (=normal fluor images) negative mode.

The camera is now calibrated for user 1 negative mode (= **Subtracted fluoroscopy** images).
Program same values of contrast and brightness under user 3 negative mode.

25.6. FILM CALIBRATION OF POSITIVE AND NEGATIVE MODE FOR SUBTRACTED IMAGES

Carry out film calibration of positive and negative mode for normal images. use following parameters:

- SUB values has to be programmed under following menus:
 Programm VHCU user mode IMG 1/X > USR 2 POS (= subtracted images)
 IMG 1/X > USR 2 NEG (= subtracted images)
 IMG 1/X > USR 4 POS (= subtracted images)
 IMG 1/x > USR 4 NEG (= subtracted images)

SUBTRACTION 50Hz Video, interlace = X2					
USER 2 POS. and USER 4 POS			USER 2 NEG and USER 4 NEG		
B: ***	C: ***	D: 056	B: ***	C: ***	D: 056
Video in: 400mV = 0.6 +/- 0.2 optical density 0mV = 2.0 +/- 0.2 optical density			Video in: 400mV = 0.95 +/- 0.2 optical density 0mV = 0.2 +/- 0.2 optical density		

SUBTRACTION 60Hz Video, interlace = X2					
USER 2 POS. and USER 4 POS			USER 2 NEG and USER 4 NEG		
B: ***	C: ***	D: 064	B: ***	C: ***	D: 064
Video in: 400mV = 0.6 +/- 0.2 optical density 0mV = 2.0 +/- 0.2 optical density			Video in: 400mV = 0.95 +/- 0.2 optical density 0mV = 0.2 +/- 0.2 optical density		

25.7. FINE CONTRAST AND BRIGHTNESS ADJUSTMENTS

Only if necessary:

- * Retrieve a clinical image on the system
- * Chose user and mode on the VHCU
- * Press programm mode and toggle with the > button to change the (C)ontrast and (B)rightness values.
- * Press PROG to leave the programm mode.
- * Repeat session till desired image is achieved.

25.8. APPENDIX

PMI 100-2 Fluoroscopy

B=13 C=150 D=056/064 i=2x

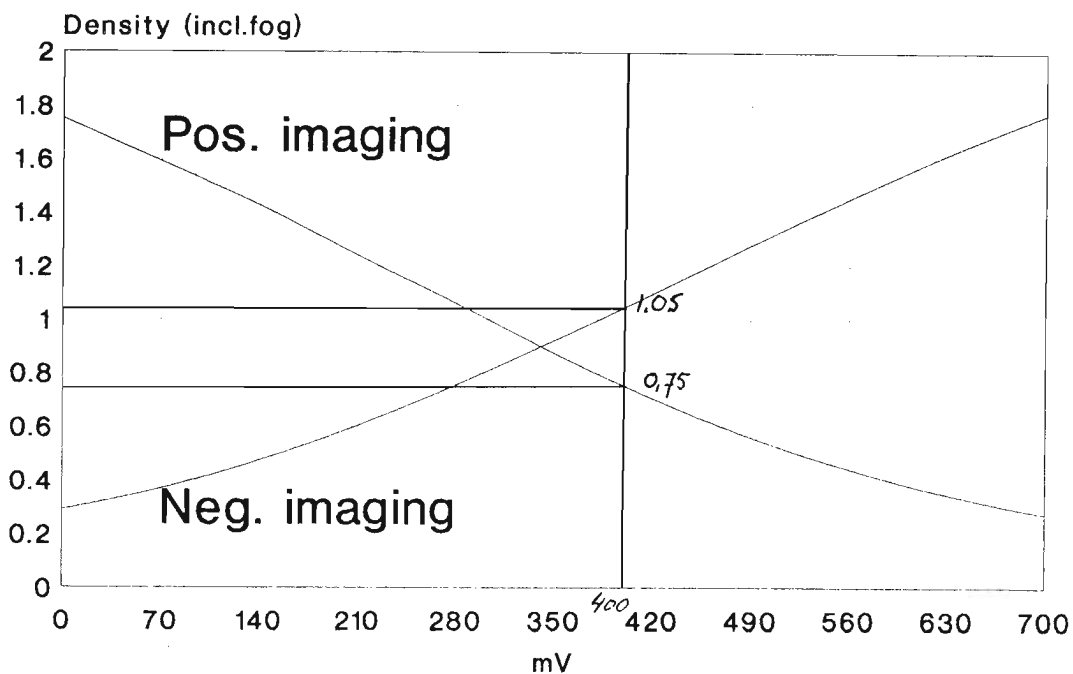

PMI 100-2 Subtraction

B=11 C=200 D=056/064 i=2x

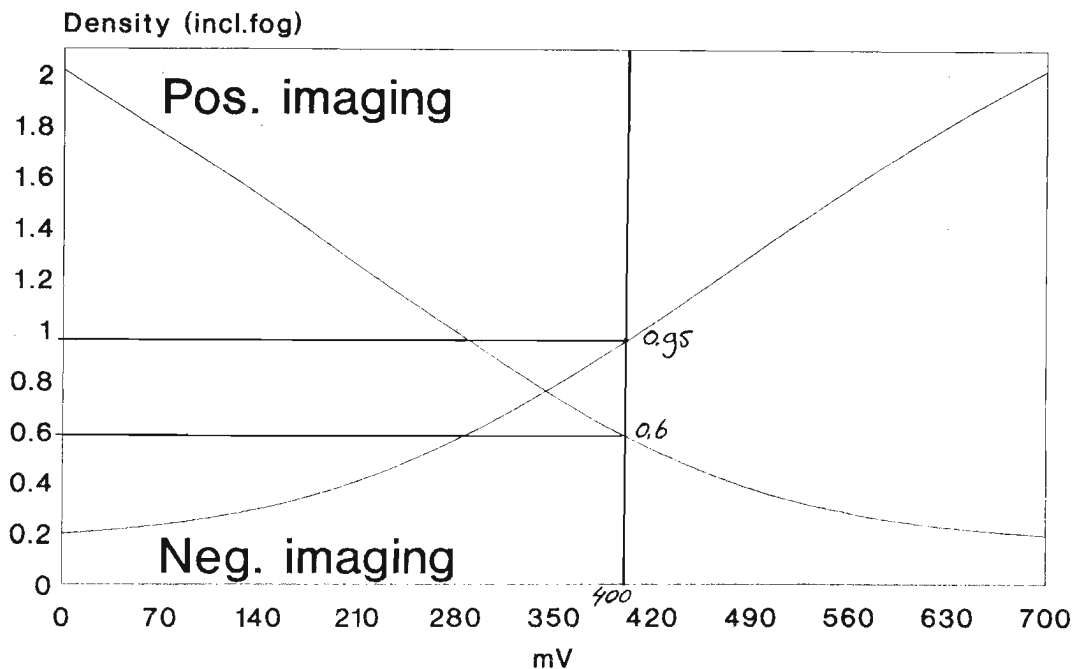

Calibration of Video Hard Copy Unit

The Unit is adjusted for Kodak NMB film. Readjusting may be necessary, depending on the developing system or by using other film. In case of readjusting, see service manual System, section F4 (Corrective maintenance / adjustments)

Factory adjustment:

Positive				Negative			
Program	BRT	CNT	D	Program	BRT	CNT	D
USR1				USR1			
USR3				USR3			
USR2				USR2			
USR4				USR4			

Film: Kodak NMB
 Developing System: AGFA Curix 402
 Temperature: 31 degr. C

Processing time: 2 minutes
 Average Gradient: 2.2 - 2.7
 Chemicals
 Developer: Agfa Gevaert G138
 Fixer: Agfa Gevaert G334

A/B/C

A/B/

Service adjustment: Date: _____ Name: _____

Positive				Negative			
Program	BRT	CNT	EXP	Program	BRT	CNT	EXP
USR1				USR1			
USR3				USR3			
USR2				USR2			
USR4				USR4			

Film: _____
 Developing System: _____
 Temperature: _____

Processing time: _____
 Average Gradient: _____
 Chemicals
 Developer: _____
 Fixer: _____

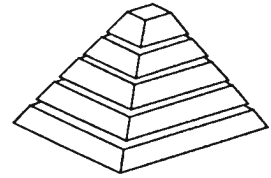

PARTS LIST

Service

Description	: UNIVERSAL PART BV29 RELEASE 3.0	Ref. No.	: 9896 000 06281
Publication No.	: 4522 983 34511	Product Group	: 718

LIST OF PAGES AND DRAWINGS

P-00	93.1	
P- 1	93.1	
P- 2	93.1	
P- 3	93.1	
P- 4	93.1	
P- 5	93.1	
P- 6	93.1	
P- 7	93.1	
P- 8	93.1	
P- 9	93.1	
P-10	93.1	
P-11	93.1	
P-12	93.1	
P-13	93.1	
P-14	93.1	
PZ- 1	93.0	
PZ- 2	91.0	9849 100 00..1
PZ- 3	92.0	9896 000 06051
PZ- 4	91.0	9849 100 00..1
PZ- 5	92.0	9896 000 06051
PZ- 6	93.0	
PZ- 7	91.0	9849 100 00..1
PZ- 8	91.0	9849 100 00..1
PZ- 9	92.0	9896 000 06051
PZ-10	92.0	9896 000 06051
PZ-11	92.0	9896 000 06051
PZ-12	93.0	
PZ-13	93.0	

Diaphragm and parts	scheme LA	P- 2
Stand	scheme SA	P- 2
Touch control unit	scheme SB	P- 2
Footswitch and parts	scheme SC	P- 2,3
Footswitch and parts (option)	scheme SC (opt.)	P- 3
Handswitch	scheme SD	P- 3
X-ray control unit	scheme SE	P- 3,4
Motor unit	scheme SM	P- 4
Power unit	scheme SU	P- 4
Mains control unit	scheme WA	P- 4,5
Touch control unit trolley	scheme WB	P- 5
Winchester disk	scheme WF	P- 5
Scopofix	scheme WHD	P- 5
Indicating lamp X-ray	scheme WL	P- 5
Ornamental cable monitor	scheme WM	P- 5
Power unit trolley	scheme WSU	P- 5
Memorybox	scheme WT	P- 5,6

Mechanical parts and drawings :

Baseframe	PZ- 1	P- 7
Vertical drive assy	PZ- 2	P- 7,8
C-arc and guiding	PZ- 3	P- 8,9
pre-assembled Stand	PZ- 4	P-10
Stand	PZ- 5,6	P-10
Trolley	PZ- 7	P-10,11
Handswitch and parts	PZ- 8	P-11
Cable assy C-arc	PZ- 9	P-11
Covers stand	PZ-10	P-11,12
Covers Trolley	PZ-11	P-12
Cable shovel	PZ-12,13	P-12,13

Other parts, fuses, tools, repair paints	P-14
Supplement HHS - IEC	P-14

SCHEME/ PAGE 1	INDEX 2	CODENUMBER 3	DESCRIPTION 4	DATA 5
LAH		4522 128 10191	shutter unit	
LAH		2622 855 18953	toothed belt	
LAH	M 2	4522 126 50902	motor assy shutter	
LAH	M 3	4522 126 51631	motor rotation assembly	
LAH	R 2	4522 126 50841	potmeter assy shutter	
LAH	R 3	2122 374 00007	resistor adjustment	
LAI		4522 126 51001	iris diaphragm unit	
LAI	M 1	4522 126 51391	motor iris drive	
LAI	M 4	2432 102 11174	motor reduction	
LAI	R 1	2122 374 00011	resistor wirewound	
LAI	R 4	2122 374 00007	resistor adjustment	
SA	M 1	4522 125 98902	motor	
SA	M 1S1	2412 129 00159	thermo switch	
SA	S 1	2422 120 00549	microswitch	
SA	S 1	4022 189 70111	holder microswitch	
SA	S 2-3	2422 120 00549	microswitch	2x
SA	S 2-3	4522 160 34601	insulation plate long	2x
SA	S 2-3	4522 160 34402	insulation plate short	2x
SA	S 2-3	2422 135 00013	roller for microswitch	2x
SA	X 1	4522 126 08961	socket connector	
SA	X 1	4522 126 50052	pin for SAX1	
SA	X 1-WTX 1	4522 103 64931	stand-trolley cable	
SA	X 1:B/C/D/H/J/K X 1:L/M/N/P/R/S	4522 103 16011	socket contact 0.14-0.22	12x
SA	X 1:G/T/U	4522 103 16011	socket contact 0.14-0.22	3x
SA	X 1:X/Z	4522 103 16051	socket contact 0.5	2x
SA	X 1:Y	2422 034 17671	socket coax	
SA	X 1:a/b/3/4	2422 034 19328	socket contact 2.1	4x
SA	X 2	4522 126 72141	connector housing	8 skt
SA	X 2:A/B/C/E/F/G	4522 103 16011	socket contact 0.14-0.22	6x
SA	X 2:D/H	4522 103 16051	socket contact 0.5	2x
SA	X 4	2432 011 01009	potential compensating pin	
SB 1		4522 126 76043	switch panel Stand BV29	
SB 1	X 1-SB 2X 1	4522 103 64991	flat cable	
SB 2		4522 127 00651	flat panel control basic	
SB 2	D20	4522 105 23511	set firmware FPC R3.01	
SB 2	X 4	2422 034 18334	D-connector	9skt
SB 2	X 4:2/3/4	2422 034 11628	socket contact 0.1-0.26	6x
SB 3-4		4522 126 76032	pcb switch vertical mov.	2x
SC		4522 126 68353	footswitch	
SC		4522 126 57033	cover (fluorosc. pulse)	
SC		4522 126 57042	cover (fluorosc.)	
SC		4522 126 63911	cable feedtrough	2x

SCHEME/ PAGE	INDEX	CODENUMBER	DESCRIPTION	DATA
1	2	3	4	5
SC		4522 126 57121	spring (fluo pulse-fluo)	2x
SC	S 1-2	4522 104 26671	microswitch	2x
SC	X 1	4522 103 16041	contact pin 0.5	7x
SC	X 1	2422 026 03296	connector 8p	
SC	X 1	4522 128 09413	housing 8p	
SC	X 1	4522 128 09421	end cover	
SC	X 1	4522 126 56222	relief block	
SC	X 1-SC	4522 103 59892	cable footswitch	
SC (opt)		4522 126 57121	spring (fluo pulse-fluo)	2x
SC (opt)		4522 126 76993	footswitch	optional
SC (opt)		4522 126 57033	cover (fluorosc. pulse)	
SC (opt)		4522 126 57042	cover (fluorosc.)	
SC (opt)		4522 126 77022	pedal (fluoro sub etc.)	
SC (opt)		2622 115 03272	spring (fluoro-sub etc.)	
SC (opt)	S 1-2-3	4522 104 26671	microswitch	3x
SC (opt)	X 1	4522 103 16041	contact pin 0.5	7x
SC (opt)	X 1	2422 026 03296	connector 8p	
SC (opt)	X 1	4522 128 09413	housing 8p	
SC (opt)	X 1	4522 126 56222	relief block	
SC (opt)	X 1	4522 128 09421	end cover	
SC (opt)	X 1	4522 126 63911	cable feedtrough	
SC (opt)	X 1-SC	4522 103 65073	cable footswitch	
SD		4522 128 09352	handswitch	
SD 1		4522 127 01821	handswitch panel	
SE	C 1	2022 005 00032	electr. cap. 2000uF/450V	
SE	L 1	4522 103 99511	controlled rectific. choke	
SE	R 1	2113 265 00356	resistor pwr 10K/5%/HSA50	
SE10		4522 127 00771	control backpanel	
SE10	X 3	2422 034 18309	D-connector	25skt
SE10	X 3:1	2422 034 11629	socket contact 0.26-0.56	
SE10	X 3:2/14	2422 034 11629	socket contact 0.26-0.56	2x
SE10	X 3:3/4/6/7/8	2422 034 11628	socket contact 0.1-0.26	13x
SE10	X 4-WA 1X 2	4522 103 65201	connecting cord	
SE10	X 5-SM 1X 1	4522 103 65211	connecting cord	
SE10	X 7-SB 2X 3	4522 103 61753	connecting cord	
SE10	X 8-SB 2X 6	4522 103 61721	connecting cord	
SE13		4522 127 00801	XRC-control 29 basic	
SE13	D 3	4522 105 23501	set firmware XRC R3.01	
SE15		4522 127 00521	pcb gen.&error processing	
SE17		4522 127 00534	pcb radio&fluo processing	

SCHEME/ PAGE	INDEX	CODENUMBER	DESCRIPTION	DATA
1	2	3	4	5
SE19		4522 127 00544	kV & mA control board	
SE21		4522 127 00762	pcb diaphragm control 1	
SE23		4522 127 00572	pcb diaphragm control 2	
SE30		4522 127 01631	power backpanel	
SE31		4522 107 78513	pcb filament supply	
SE33		4522 127 01601	pcb power control	
SE35		4522 107 78605	pcb rectifier power	
SE37		4522 127 01611	pcb inverter power 1	
SE39		4522 127 01621	pcb inverter power 2	
SM	C 1	2019 317 00034	capacitor 4uF/400V/MP38	
SM	C 2	2019 317 00032	capacitor 8uF/400V/MP38	
SM	R 1-2	2113 265 00169	resistor pwr 3E3/5%/HSA25	2x
SM	R 3	2113 265 00405	resistor pwr 4K7/5%/HSA25	
SM 1		4522 107 96453	pcb vertical move control	
SM 1	X 2-SAS 2/3	4522 103 55993	connecting cord	
SM 1	X 3-SUG1	4522 103 65221	connecting cord	
SM 1	X 6-SB 3/4X 1	4522 103 62222	flat cable	
SU	G 1	4522 103 99523	system power supply	
SU	R 1-2	2113 265 00355	resistor pwr 3E3/5%/HSA50	
WA	100	4522 103 65151	mains cable	
WA	100:1/3	2422 013 00719	clamp 10mm2	3x
WA	100:4/29	2422 013 00676	clamp 4mm2 9700B/6	26x
WA	C 1-2-3	2008 201 13683	capacitor 68nF/630Vdc	3x
WA	C 4	2019 317 00034	capacitor 4uF	
WA	C 5	2722 171 00008	filter B84150-A-A110	
WA	F 1-2	2422 086 00546	UL-fuse 15A/600V	2x
WA	F 1-2-3-4-5-6	2422 092 00025	fuseholder 30A/600V	6x
WA	F 3-4-5-6	2422 086 00545	UL-fuse 10A/600V	4x
WA	R 1-2-3	2113 265 00366	resistor pwr 1E8/5%/HSA50	3x
WA	S 1	4322 020 97022	toroid	
WA	T 1	4522 103 99483	mains transformer	
WA	T 2	4522 103 99491	switch-on transformer	
WA	V 1-2-3	9338 142 50682	thyristor module	3x
WA	X 1	2422 025 02701	plug UMNL	15p
WA	X 1:1/2/3/6	2422 034 17447	socket UMNL 0.5-1.3	4x
WA	X 2-SE30	4522 103 64941	connecting cord	
WA 1		4522 107 96505	pcb mains control 1	
WA 1	X 1-WA 2X 1	4522 103 54492	flat cable	

SCHEME/ PAGE	INDEX	CODENUMBER	DESCRIPTION	DATA
1	2	3	4	5
WA 2		4522 107 96553	pcb mains control 2	
WB 1		4522 126 76611	packing for flat panel	
WB 1		4522 126 76052	flat panel trolley	
WB 1		4522 126 76202	nut for flat panel	8x
WF		2822 062 40716	131MB disk drive	optional
WHD	P 0	4522 128 27774	video board	
WHD	P 1	4522 128 27782	scan board	
WHD	P 2	4522 128 27793	pros 1 board	
WHD	P 3	4522 128 27801	dummy pros 2 board	
WHD	P 3	4522 128 27852	pros 2 board	optional
WHD	P 4	4522 128 27811	image board	
WHD	P 5	4522 128 27872	cine 32 board	optional
WHD	P 5	4522 128 27822	cine 128 board	optional
WHD	P 6	4522 128 27834	contp board	
WHD	P 7	4522 128 27842	disk interface board	optional
WHD	P 7J 1-WFX 2	4522 104 39042	flat cable	optional
WHD	P 7J 2-WFX 1	4522 104 39021	connecting cord	optional
WHD	P 8	4522 128 27862	post proc board	optional
WHD	X 2-WHDP6J2	4522 104 39051	flat cable	
WHD	X 3-WHDP0 IN	4522 104 39002	coax cables memory box	
	X 4-WHDP0 OUT 3			
	X 5-WHDP0 OUT 1			
	X 6-WHDP0 OUT 2			
WL	L 1	2430 500 00066	housing lamp yellow	
WL	L 1	2430 500 00065	lamp 60-E14-K-024-005W	
WM 1/2	-WT100/2X3/X10	4522 104 39081	ornamental cable monitor	2x
WSU		4522 105 07711	power supply	
WT	C 1	2019 317 00034	capacitor 4µF/400V	
WT	F 1-2	2422 086 00545	UL-fuse 10A/600V	2x
WT	M 1-2	2822 031 01235	fan 220V 125XR01-81-001	2x
WT	R 1	2122 256 00277	resistor pwr 470E/5%/HSA50	
WT	T 1	4522 105 07321	transformer memory box	
WT	V 1-2	9334 504 00682	diode TVS510	2x

SCHEME/ PAGE 1	INDEX 2	CODENUMBER 3	DESCRIPTION 4	DATA 5
WT	X 1-SAX 1	4522 103 64931	stand-trolley cable	
WT	X 1:Y-WT 2X98	4522 104 36522	coax cable	
WT	X 4-5-6	2432 020 00496	adaptor BNC-BNC	3x
WT	X 4-WT 2X 9	4522 103 64801	coax cable	3x
WT	X 4-WTX 3	4522 104 39121	coax cable assy	
WT	X10-WT 2X11	4522 104 39091	coax cable assy	
WT 1		4522 127 00591	mains switching circuit	
WT 2		4522 127 00791	MBC 100Hz 24 MHz	
WT 2	D27-28	4522 105 23521	set firmware MBC R3.01	
WT 2	X 5-WTX 8	4522 104 39102	connecting cord	partial
WT 2	X 6-WB 1X 1	4522 103 64871	flat cable	
WT 2	X 7-WHDX 2	4522 104 39351	flat cable	
WT 2	X 8-WHDX 4	4522 104 39131	coax cable assy	3x

Rel 3.3
130792B

SCHEME/ PAGE	INDEX	CODENUMBER	DESCRIPTION	DATA
1	2	3	4	5
PZ- 1	a	4522 128 10872	baseframe (single)	
PZ- 1	j	4522 128 10782	conducting strip	
PZ- 1	k	2622 115 00159	tension spring 13x1.2x48.2	2x
PZ- 1	l	2622 115 15106	springholder M6x10	6x
PZ- 1	m	2622 115 00224	tension spring 11x1x25.4	2x
PZ- 1	n	4522 126 62596	blocking pawl	2x
PZ- 1	o	2622 115 15106	springholder 6x10	2x
PZ- 1	p	4522 126 60282	hinge pin	2x
PZ- 1	q	2622 008 37146	bearing GE12PW	2x
PZ- 1	r	2622 008 01059	sleeve bearing bush 15x15	2x
PZ- 1	s	4522 126 77203	chain rod	
PZ- 1	t	4522 128 09342	chain block	2x
PZ- 1	u	4522 126 77222	chain bolt	2x
PZ- 1	v	4522 126 62521	tension spring	2x
PZ- 1	w	4522 128 10791	steel cable	2x
PZ- 1	x	4522 126 61262	roller	2x
PZ- 1	y	2522 670 03098	dowel pin 8x32	2x
PZ- 1	z	4522 128 10771	buffer	2x
PZ- 1	aa	4522 126 76191	chain	
PZ- 1	ab	2622 855 21062	connecting link	4x
PZ- 1	ac	4522 128 09282	chain bolt. left	
PZ- 1	ad	4522 128 09292	chain bolt. right	
PZ- 1	ae	4522 126 77052	chain	
PZ- 1	af	4522 128 09302	coupling	
PZ- 1	ag	4522 126 76141	driving wheel	
PZ- 1	ah	2522 703 01057	key 5x5x12	
PZ- 1	aj	4522 126 76161	gearwheel	36 teeth
PZ- 1	ak	2622 001 30033	ball bearing 2SP 8x22x7	
PZ- 1	al	4522 126 76183	shaft	
PZ- 1	am	2622 001 30088	ball bearing 2SP 20x42x12	
PZ- 1	an	4522 126 76174	driving shaft	
PZ- 1	as	2611 000 03038	bearing bush BP25-20/28x32	2x
PZ- 1	at	4522 126 60291	compression spring	2x
PZ- 1	au	4522 126 61252	brake foot	2x
PZ- 1	av	2522 670 07084	cylindrical pin 6x20	2x
PZ- 1	aw	4522 126 62461	ring	2x
PZ- 1	ax	2612 890 11113	rubber stop D20 H15 M6	2x
PZ- 1	ay	4522 128 10811	rubber pad for brake pedal	
PZ- 1	az	4522 128 09316	brake pedal	
PZ- 1	ba	4522 128 10752	bearing block	2x
PZ- 1	bb	2611 000 05034	bearing BP25-C12/15x20	2x
PZ- 1	bc	4522 128 09721	tumbler	2x
PZ- 1	bd	2622 008 01048	sleeve bearing bush 6x10	2x
PZ- 2	a	4522 126 24664	horizontal brake assy	
PZ- 2	b	2622 855 39103	guiding roller	4x
PZ- 2	c	2622 855 39711	supporting roller 35x15	8x
PZ- 2	d	4522 125 16801	supporting ring	
PZ- 2	e	4522 126 33551	set V-belts	
PZ- 2	f	4522 126 33532	pulley small	
PZ- 2	g	4522 126 43241	tension spring	
PZ- 2	h	4522 126 33851	spring tensioner	
PZ- 2	j	2522 043 39037	set screw M3x4	2x
PZ- 2	k	4522 126 56243	cover	

SCHEME/ PAGE	INDEX	CODENUMBER	DESCRIPTION	DATA
1	2	3	4	5
PZ- 2	l	2522 043 39048	set screw M4x6	4x
PZ- 2	m	4522 126 76471	spacer horizontal brake	4x
PZ- 2	n	4522 126 76402	eccentric shaft	2x
PZ- 2	o	4522 126 76412	pin	2x
PZ- 2	p	4522 126 43102	plain bearing	
PZ- 2	q	4522 126 24702	ring	
PZ- 2	r	4522 125 16882	pressure washer	
PZ- 2	s	4522 126 43861	bearing housing	
PZ- 2	t	4522 126 43901	bush	
PZ- 2	u	4522 102 37541	key 5x5x20	
PZ- 2	v	2622 890 02003	shaft nut M15x1 KM2	
PZ- 2	v	2622 890 01003	locking ring for shaft nut	
PZ- 2	w	2622 001 30103	ball bearing 2SP 25x52x15	2x
PZ- 2	x	4522 126 33543	pulley big	
PZ- 2	y	4522 126 43912	leadscrew assy	
PZ- 2	z	4522 126 27681	disc	
PZ- 2	aa	2622 009 01006	bearing 35x55x27	
PZ- 2	ab	4522 126 27671	bush	
PZ- 2	ac	2622 006 13078	needle bearing 40x62x23	
PZ- 2	ad	4522 126 76443	shaft scanbrake	
PZ- 2	ae	4522 126 27664	lid	
PZ- 2	af	4522 126 43062	roller-bearing	
PZ- 2	ag	4522 126 33563	punch holder plate	
PZ- 2	ah	4522 126 43072	roller bearing (eccentric)	
PZ- 2	aj	4522 126 43052	roller bearing	2x
PZ- 2	ak	4522 126 43042	key	
PZ- 2	al	2522 043 39066	set screw M6x12	4x
PZ- 2	am	4522 126 34607	grip (right)	
PZ- 2	an	4522 126 34053	bush	
PZ- 2	ao	4522 126 34043	retaining ring	
PZ- 2	ap	4522 128 09712	friction ring	2x
PZ- 2	aq	4522 126 34617	grip (left)	
PZ- 2	ar	4522 126 56101	countersunk screw M5x18	2x
PZ- 2	as	4522 126 76347	lid for column	
PZ- 2	at	2512 785 02058	spiral clamping pin 4x16	2x
PZ- 3	a	4522 126 76223	horizontal guide assy	
PZ- 3	a	4522 126 76261	guide strip hor. carriage	2x
PZ- 3	a	4522 126 76253	backplate hor. carriage	
PZ- 3	b	2512 785 02002	spiral clamping pin 1.5x12	
PZ- 3	c	4522 128 09083	plate	
PZ- 3	d	4522 128 09091	plate	
PZ- 3	e	4522 128 09121	brake plate	
PZ- 3	f	4522 128 09131	plate	
PZ- 3	g	2622 115 10033	Belleville washer	36x
PZ- 3	h	4522 128 09142	disc	
PZ- 3	j	4522 128 09161	pin	6x
PZ- 3	k	4522 126 34914	pressure disc	
PZ- 3	l	4522 126 72321	bearing pin	2x
PZ- 3	m	4522 126 72331	ring	6x
PZ- 3	o	2522 043 39037	set screw M3x4	5x
PZ- 3	p	4522 126 72311	bearing pin	2x
PZ- 3	q	4522 126 76025	bearing block C-arc	
PZ- 3	r	4522 128 09853	brake housing	

SCHEME/ PAGE	INDEX	CODENUMBER	DESCRIPTION	DATA
1	2	3	4	5
PZ- 3	s	2611 000 03112	bearing bush BP25-25/32x25	
PZ- 3	t	2522 043 39052	set screw M4x12	4x
PZ- 3	u	4522 128 09931	brake pin	
PZ- 3	v	4522 126 76814	diaphragm console	
PZ- 3	w	4522 128 09913	coupling block	
PZ- 3	w	4522 128 09913	coupling block	
PZ- 3	y	4522 128 09904	C-arc	
PZ- 3	z	4512 909 81801	vibration damper	2x
PZ- 3	aa	4522 128 09243	cover bearing block	1x
PZ- 3	ab	4522 126 76116	C-arc support	
PZ- 3	ac	2611 000 03067	bearing bush BP25-5/8x8	2x
PZ- 3	ad	4522 126 67522	pin	
PZ- 3	ae	2611 000 05056	bearing BP25-C6/10X6	2x
PZ- 3	af	4522 125 18582	shaft	
PZ- 3	ag	2522 043 39225	set screw M2.5x4	2x
PZ- 3	ah	2522 670 03076	dowel pin 5x32	
PZ- 3	aj	2622 855 39351	travelling roller	16x5
PZ- 3	ak	2622 890 14208	supporting ring 22x30x2	
PZ- 3	al	4522 126 44201	compression spring	
PZ- 3	am	4522 128 09871	fork	
PZ- 3	an	4522 128 09751	brake rod	
PZ- 3	ao	4522 126 56101	countersunk screw M5x18	8x
PZ- 3	ap	2622 008 01059	sleeve bearing bush 15x15	2x
PZ- 3	aq	4522 128 09233	shaft C-arc brake	
PZ- 3	ar	4522 126 50333	grip	
PZ- 3	as	4522 126 50363	grip	
PZ- 3	at	4522 126 64532	pin	
PZ- 3	au	4522 128 09862	stop bracket	
PZ- 3	az	4522 126 50992	compression spring	
PZ- 3	ba	4522 126 43942	knob	
PZ- 3	bc	4522 126 43935	shaft	
PZ- 3	bd	2622 008 01053	sleeve bearing bush 8x12	2x
PZ- 3	be	2622 007 00021	taper roller bearing	2x
PZ- 3	bf	4522 126 76421	interface plate	
PZ- 3	bg	4522 126 24723	bolt	
PZ- 3	bh	4522 126 33462	bearing bush brake shaft	
PZ- 3	bj	4522 126 50353	grip	
PZ- 3	bk	4522 128 09202	retaining ring	2x
PZ- 3	bl	2622 001 30376	ball bearing 2SP 6201 LLU	2x
PZ- 3	bm	4522 128 09191	spacer	
PZ- 3	bn	4522 128 09173	eccentric shaft	
PZ- 3	bo	4522 128 09181	dustring	2x
PZ- 3	bp	2622 006 13028	needle bearing	
PZ- 3	bq	4522 128 09213	block	
PZ- 3	br	4522 128 09223	stop block	
PZ- 3	bs	4522 126 50343	grip	
PZ- 3	bt	4522 125 16242	guide roller	16x
PZ- 3	bu	4522 126 44002	ring	8x
PZ- 3	bv	4522 125 18842	bearing bush	4x
PZ- 3	bw	4522 128 09052	shaft	2x
PZ- 3	bx	4522 126 44161	bearing block	4x
PZ- 3	by	4522 126 44222	adjusting bearing	4x
PZ- 3	bz	4522 128 09062	shaft	2x
PZ- 3	ca	4522 128 09811	bearing block	4x
PZ- 3	cb	4522 128 09835	scale	

SCHEME/ PAGE	INDEX	CODENUMBER	DESCRIPTION	DATA
1	2	3	4	5
PZ- 4	a	4522 126 33426	grip horizontal carriage	
PZ- 4	b	4522 126 56101	countersunk screw M5x18	1x
PZ- 4	c	2622 890 98223	buffer D16x15-M5	2x
PZ- 4	c	4522 128 09731	buffer D16x10-M5	2x
PZ- 4	d	4522 126 76362	brake shaft	
PZ- 4	e	4522 126 33462	bearing bush brake shaft	
PZ- 4	f	2522 670 01086	cylindrical pin 6x28	
PZ- 5	b	4522 126 42411	ring	9x
PZ- 5	c	4522 126 51461	spacer	3x
PZ- 5	d	4522 126 42263	ring	
PZ- 5	e	4522 128 27921	focus near diaphragm IEC	
PZ- 5	f-g	4522 128 10841	cable support (left+right)	
PZ- 5	h	4522 128 09004	lid c-arc support (short)	
PZ- 5	j	4522 126 76274	cover horizontal carriage	
PZ- 5	k	4522 126 76302	bellows	2x
PZ- 5	l	4522 128 09761	lid c-arc support (long)	
PZ- 5	m	4522 126 56684	clamping block cable	
PZ- 5	m	4522 126 56673	clamping block cable	
PZ- 6	a	4522 126 77492	grip for Stand	
PZ- 6	b	4522 126 77071	Packing (big) for SB1	
PZ- 6	c	4522 126 58351	pin	
PZ- 6	d	2622 890 12041	pressure piece	
PZ- 6	e	4522 126 77254	steering grip	
PZ- 6	f	4522 126 77263	key for steering grip	
PZ- 6	g	2622 115 02348	compression spring	
PZ- 6	h	2522 670 03058	dowel pin	
PZ- 6	j	4522 126 77276	steering shaft	
PZ- 6	k	4522 126 77321	stop ring	
PZ- 6	l	2512 785 02071	spiral clamping pin 5x20	
PZ- 6	m	4522 126 77341	lid steering column	
PZ- 6	n	4522 126 36521	cover control desk	
PZ- 6	o	4522 126 77434	shaft gear wheel	
PZ- 6	p	4522 126 77462	locking disc	
PZ- 6	q	2522 670 03063	dowel pin 4x24	
PZ- 6	r	2622 001 30099	ball bearing 2SP 25x47x12	2x
PZ- 6	s	4522 126 58311	bush	
PZ- 6	t	4522 126 77303	toothed wheel z=40	
PZ- 6	u	2622 001 30033	ball bearing 2SP 8x22x7	4x
PZ- 6	v	4522 126 77452	steering rod	
PZ- 6	w	4522 126 77421	pear wheel steering rod	
PZ- 6	x	4522 126 43231	Packing (small)for SB3-4	2x
PZ- 6	y	4522 126 77401	gear wheel	
PZ- 6	z	4522 126 77413	plate gear wheel	
PZ- 6	aa	4522 126 77441	key steering rod	
PZ- 7	a	4522 128 10611	carrier	
PZ- 7	b	4522 126 76922	intermediate plate	2x
PZ- 7	c	4522 128 10381	intermediate plate VHCU	

SCHEME/ PAGE	INDEX	CODENUMBER	DESCRIPTION	DATA
1	2	3	4	5
PZ- 7	d	4522 128 10811	rubber pad for brake pedal	
PZ- 7	e	4522 128 10273	brake pedal	
PZ- 7	f	4522 128 10322	swivelling wheel with lock	2x
PZ- 7	g	4522 128 10821	brake assy	
PZ- 7	h	4522 126 09242	collector strip	
PZ- 7	j	4522 128 10791	steel cable	2x
PZ- 7	k	4522 126 62521	tension spring	2x
PZ- 7	l	4522 128 10311	swivelling wheel	2x
PZ- 7	m	4522 128 09612	grip	2x
PZ- 7	n	2522 670 07084	cylindrical pin 6x20	2x
PZ- 7	o	2622 115 00224	tension spring 11x1x25.4	2x
PZ- 7	p	4522 128 10752	bearing block	2x
PZ- 7	q	2622 115 15106	spring holder M6x10	6x
PZ- 7	r	4522 126 62596	blocking pawl	2x
PZ- 7	s	2622 115 00159	tension spring 13x1.2x48.2	2x
PZ- 7	t	2622 115 15106	spring holder 6x10	2x
PZ- 7	u	4522 128 10581	buffer	2x
PZ- 7	v	2611 000 05034	bearing BP25-C12/15x20	2x
PZ- 7	w	4522 128 09721	tumbler	2x
PZ- 7	x	4522 128 10262	mounting plate	
PZ- 7	y	2612 890 11006	vibration damper D25H20M6	4x
PZ- 7	z	4522 128 10252	drip plate	
PZ- 7	aa	4522 128 10281	filling strip	2x
PZ- 7	ab	4522 126 60282	hinge pin	2x
PZ- 8	a	4522 128 09352	handswitch	
PZ- 8	b	4522 126 50755	housing	
PZ- 8	c	4522 127 01821	handswitch panel	
PZ- 8	d	2522 206 00005	screw KB40x12	
PZ- 8	e	4522 104 10972	retractile cord	
PZ- 8	f	2422 034 11628	socket contact 0.1-0.26	4x
PZ- 8	g	4522 128 09582	bracket	
PZ- 8	h	2422 034 18334	D-connector	9skt
PZ- 9	a	4522 103 64894	C-arc cable assy	
PZ- 9	b	2422 034 11628	socket contact 0.1-0.26	56x
PZ- 9	c	2422 034 18334	D-connector	9skt 2x
PZ- 9	d	2422 032 00081	socket contact 0.14	8x
PZ- 9	e	2422 032 00082	socket contact 0.5	12x
PZ- 9	f	2422 032 00083	socket contact 0.8-1.5	3x
PZ- 9	g	2422 032 00038	housing M-connector	20skt
PZ- 9	h	4512 100 10641	housing M-connector	20skt
PZ- 9	j	2422 034 18309	D-connector	25skt 3x
PZ- 9	k	4522 102 64601	insulation plate	
PZ- 9	l	2422 034 11629	socket contact 0.26-0.56	12x
PZ- 9	m	2422 032 00082	socket contact 0.5	
PZ- 9	n	4522 128 09041	distance bush	
PZ- 9	o	4522 128 09012	T-shape mounting part	
PZ- 9	p	4522 128 09031	distance ring	
PZ-10	a	4522 128 09505	back cover Stand BV29	
PZ-10	b	4522 128 09591	plate Stand BV29	symbol p

SCHEME/ PAGE	INDEX	CODENUMBER	DESCRIPTION	DATA
1	2	3	4	5
PZ-10	c	4522 128 09533	side cover Stand BV29	green 2x
PZ-10	d	4522 128 09522	cover right Stand BV29	
PZ-10	e	4522 128 09601	information cover Stand	symbol I
PZ-10	f	2522 700 98103	knurled knob M4	black 2x
PZ-10	g	4522 128 09515	cover left Stand BV29	
PZ-10	h	4522 126 60452	cable "roll-up" bracket	upper
PZ-10	j	4522 126 50292	suspension knob footswitch	
PZ-10	k	4522 126 60442	cable "roll-up" bracket	2x
PZ-10	l	4522 128 10831	diaphragm cover assy	
PZ-10	m	4522 126 76843	sealing ring	
PZ-11	a	4522 126 76901	side cover Trolley. upper	2x
PZ-11	b	4522 126 76893	side cover Trolley	2x
PZ-11	c	4522 126 76981	knob	d=30 4x
PZ-11	d	4522 126 76914	back cover Trolley. upper	
PZ-11	e	4522 126 76972	front/back cover Trolley	H=154 2x
PZ-11	f	4522 126 76962	front/back cover Trolley	H=270 2x
PZ-11	g	4522 126 76882	front/back cover Trolley	lower 2x
PZ-12		4522 126 36581	swivelling castor assy	
PZ-12	a	4522 126 77212	chainwheel	
PZ-12	b	4522 128 27692	fork sidewheel BV29	
PZ-12	c	4522 126 36621	rubber flap	2x
PZ-12	d	4522 126 36561	guiding	2x
PZ-12	e	4522 126 36551	pin	2x
PZ-12	f	4522 126 36571	coverplate	2x
PZ-12	g	2522 629 01001	fixing washer gefosf 10	2x
PZ-12	h	2622 115 02081	pressure spring	2x
PZ-12	j	4522 128 27722	frame cable shovel	
PZ-12	k	4522 128 27712	strip	
PZ-12	l	4522 128 09454	bearing bolt	2x
PZ-12	m	2522 022 13039	screw M5x12	3x
PZ-12	n	2522 629 02027	fixing washer gefost 40	
PZ-12	o	4522 128 09261	countersunk screw	
PZ-12	p	2622 001 36046	bearing	
PZ-12	q	4522 126 77247	wheelcover	2x
PZ-12	r	4522 126 77233	wheelshaft	
PZ-12	s	2822 075 03153	wheel 123x45	2x
PZ-12	t	2622 890 14159	curved washer	2x
PZ-12	u	4522 128 09253	wheelplate	
PZ-12	v	2522 043 39051	set screw M4x10	
PZ-12	w	2522 006 04022	screw M4x12	
PZ-12	x	2522 001 17172	Screw M4x12	4x
PZ-12	z	2512 700 08203	spring washer 4.1	
PZ-13		4522 126 36591	swivelling roller assy	2x
PZ-13	a	4522 128 09253	wheelplate	
PZ-13	b	4522 128 27702	fork swivelling wheel BV29	..
PZ-13	c	4522 126 36621	rubber flap	2x
PZ-13	d	4522 126 36561	guiding	2x

SCHEME/ PAGE 1	INDEX 2	CODENUMBER 3	DESCRIPTION 4	DATA 5
PZ-13	e	4522 126 36551	pin	2x
PZ-13	f	4522 126 36571	coverplate	2x
PZ-13	g	2522 629 01001	fixing washer gefosf 10	2x
PZ-13	h	2622 115 02081	pressure spring	2x
PZ-13	j	4522 128 27722	frame cable shovel	
PZ-13	k	4522 128 27712	strip	
PZ-13	l	4522 128 09454	bearing bolt	2x
PZ-13	m	2522 022 13039	screw. M5x12	
PZ-13	n	2522 629 02027	fixing washer gefosf 40	
PZ-13	o	4522 128 09261	countersunk screw	
PZ-13	p	2622 001 36046	bearing	
PZ-13	q	4522 126 77247	wheelcover	2x
PZ-13	r	4522 126 77233	wheelshaft	
PZ-13	s	2822 075 03153	wheel 123x45	2x
PZ-13	t	2622 890 14159	curved washer	2x
PZ-13	v	2522 043 39051	set screw M4x10	
PZ-13	w	2522 006 04022	screw. M4x12	
PZ-13	x	2522 001 17172	Screw M4x12	4x
PZ-13	z	2512 700 08203	spring washer 4.1	

SCHEME/ PAGE 1	INDEX 2	CODENUMBER 3	DESCRIPTION 4	DATA 5
~	31	4522 107 25604 2432 011 01009 4522 103 55241	OTHER PARTS measuring panel potential compensating pin potential cable	2x 3x
		2422 086 00545 2422 086 00546 2422 086 00549	FUSES UL-fuse 10A/600V UL-fuse 15A/600V UL-fuse 30A/600v	
		1322 051 11168 1322 052 11174 1322 054 11156	REPAIR PAINTS repair paint light-grey repair paint pink repair paint mushroom	
		2622 150 09002 2622 150 09003 4522 128 27651	TOOLS hex wrench S=0.9 hex wrench S=1.27 adjusting jig	
~	HHS 60Hz HHS 60Hz HHS 60Hz HHS 60Hz IEC 50Hz IEC 60Hz	4522 103 64972 4522 126 76862 2422 028 00229 2422 086 00549 4522 103 64961 4522 103 64961	SUPPLEMENT HHS - IEC mains cable for HHS syst. spacer HHS mains conn. for HHS syst. UL-fuse 30A/600V mains cable mains cable	125V/15A 2x

REPLACEMENT KIT

IQ upgrade kit for BV25/26/29/212

4522 300 05621

For serial numbers, see list of pages and drawings

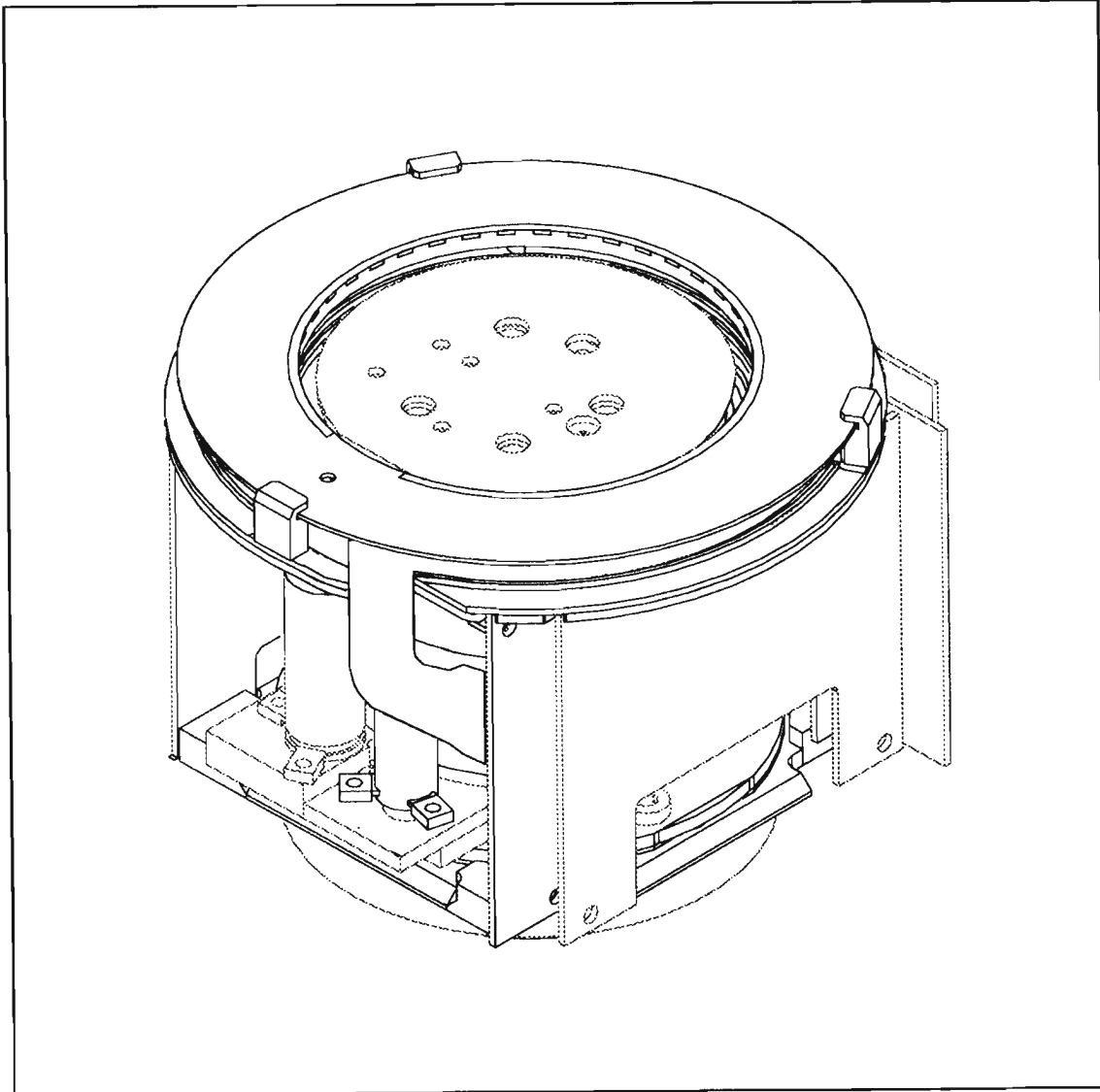

This manual contains descriptive information on the equipment identified by the number stated above. For information on specific application, see the system manual.

PMSN Best

Copyright © 1995 Philips Medical Systems Nederland B.V.

All rights are reserved. Reproduction in whole or in part is prohibited without the written consent of the copyright owner. Use of the information contained herein in any form and/or by any means whatsoever is strictly reserved for Philips and its licensees. Use of this manual by unauthorised persons is strictly prohibited.

Replacement kit
IQ upgrade kit for BV25/26/29/212

REPLACEMENT KIT
IQ UPGRADE KIT FOR BV25/26/29/212
TYPE NO. : 4522 300 05621

SERIAL NO. :

Manual codenumber : 4522 983 62531

List of Pages and Drawings

1	(95.0)
2	(95.0)
3	(95.0)
4	(95.0)
5	(95.0)
6	(95.0)
7	(95.0)
8	(95.0)
9	(95.0)
10	(95.0)
11	(95.0)
12	(95.0)
13	(95.0)
14	(95.0)
15	(95.0)
16	(95.0)
17	(95.0)
18	(95.0)
19	(95.0)
20	(95.0)
Z-1	(95.0)
Z-2	(95.0)

IQ upgrade kit for BV25/26/29/212

Contents

1.	Introduction	4
2.	Exchanging the boards WK3 and WK5	4
3.	Electrical adjustments	7
3.1.	Presets	7
3.2.	Video gain	8
3.3.	AGC threshold small MF	9
3.4.	AGC threshold large MF	9
3.5.	Vica preset for middle and small II format	10
3.6.	Dose rate adjustment	11
3.7.	Fixed gain adjustment	13
4.	MMP/MDPM memory adjustments	15
4.1.	MMP offset adjustment	15
4.2.	Entering the service menu	15
4.3.	MBC util setting menu, to open clean circle	16
4.4.	MMP input offset adjustment	17
4.5.	Final settings to restore the clean circle	18
4.6.	MDPM memory adjustment	19
4.7.	Equipment required	19
4.8.	Input adjustment	19
4.9.	Finishing touch	20

1. INTRODUCTION

This document describes the replacement and adjustment procedure for the IQ upgrade kit for BV25/26/29/212. The replacement procedures of the boards WK3 and WK5 are illustrated with the aid of photographs.

2. EXCHANGING THE BOARDS WK3 AND WK5

NOTE

- Use a 1:1 probe.
- Drawing Z-1 shows the positions of the potentiometers, jumpers and measuring points.
- Use static electricity protection tools.
- Do not touch the optics.
- Allow the X-ray photometer to warm up for at least one hour before adjusting the dose rate.
- Handle the flex with care. Do not remove the flex from the connector. Loose connections may cause oxidation of the contacts.

-
- a) Before starting, check all the functions of the system.
 - b) Remove the camera cover.
 - c) Remove cables WK4:X1, WK4:X2 and WK4:X3, and the coax cable, from the camera.
 - d) Remove the camera from the II by loosening big screw.
 - e) Set the jumpers and switches on the new boards as indicated in Table 1.
 - f) Follow the replacement procedure in the correct sequence as indicated by the following photographs.

PCB	Jumper/switch	Position
WK3 AGC/ADC 1	X19	A2-3
	W1	2-3
	W2	2-3
	W3	2-3
WK5 Video proc.	S2	Left

Table 1

Replacement kit
IQ upgrade kit for BV25/26/29/212

The required tools are: - No. 3 screwdriver
- No. 5 and 5.5 open-ended spanners
- Static electricity protection tools

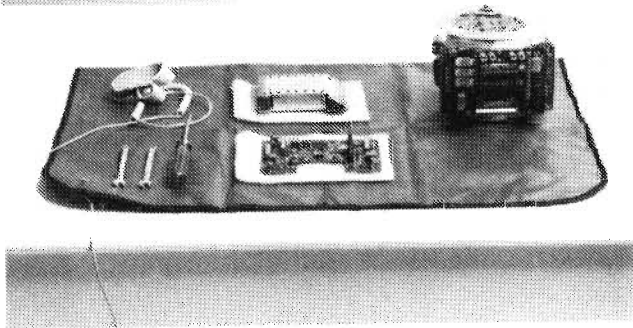

1

Place the indicated stickers from page Z-2
on the appropriate PCBs

2

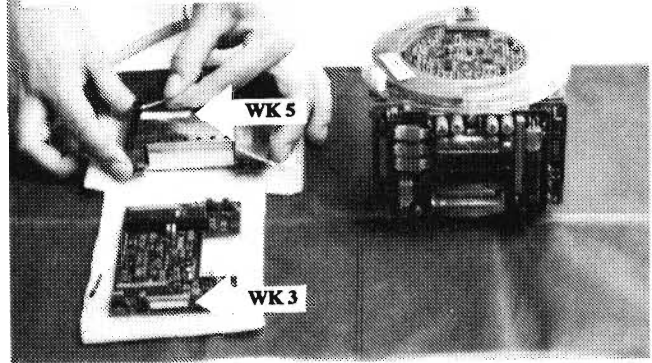

1. Loosen the screw from the white plastic spacer

3

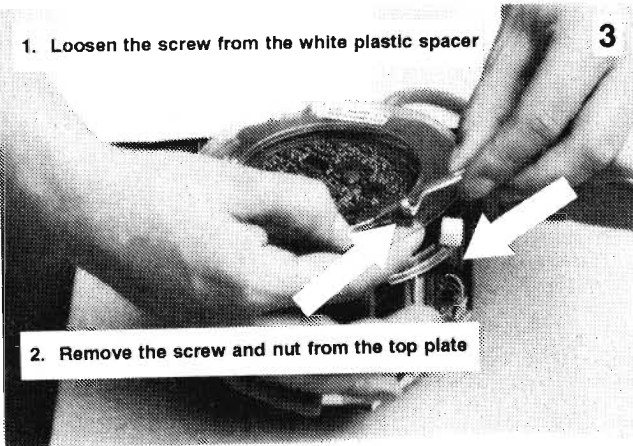

2. Remove the screw and nut from the top plate

Remove the top plate from the camera

4

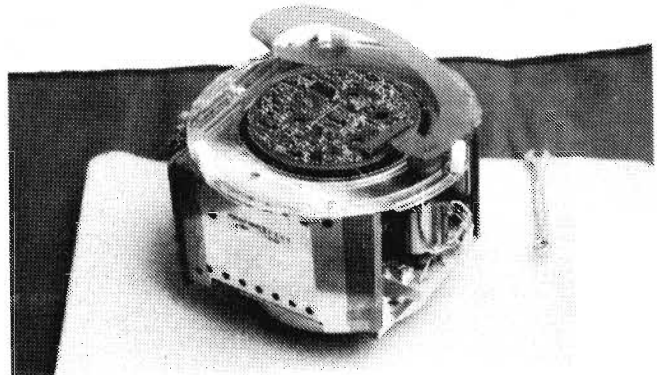

5

Remove the two indicated screws

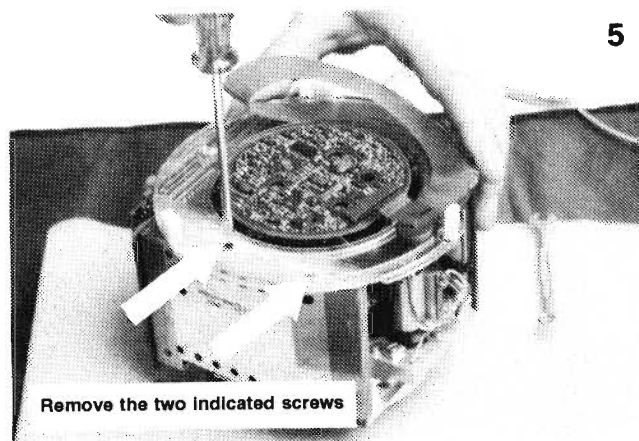

Remove the three indicated
screws from the camera

6

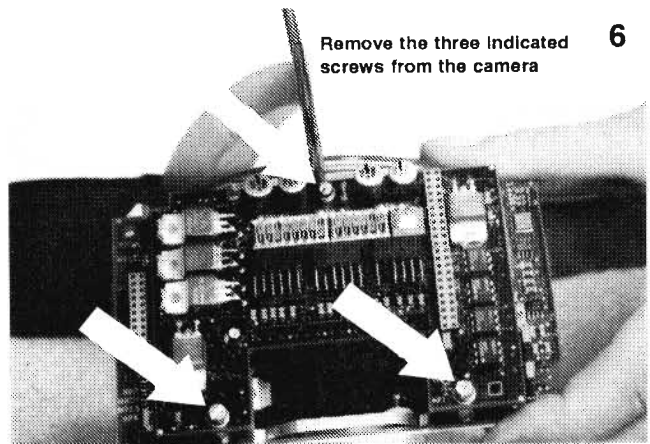

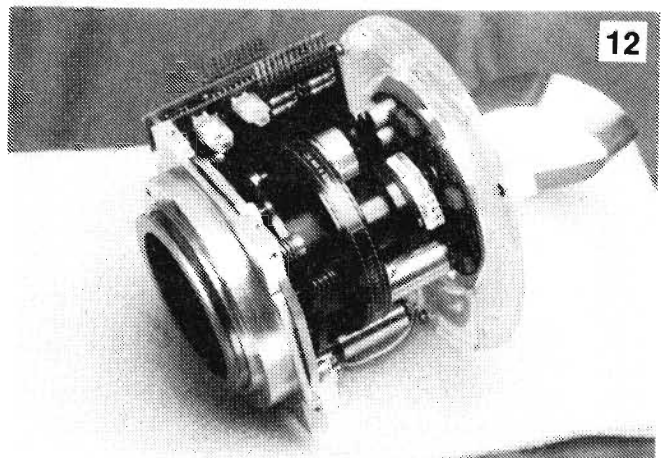
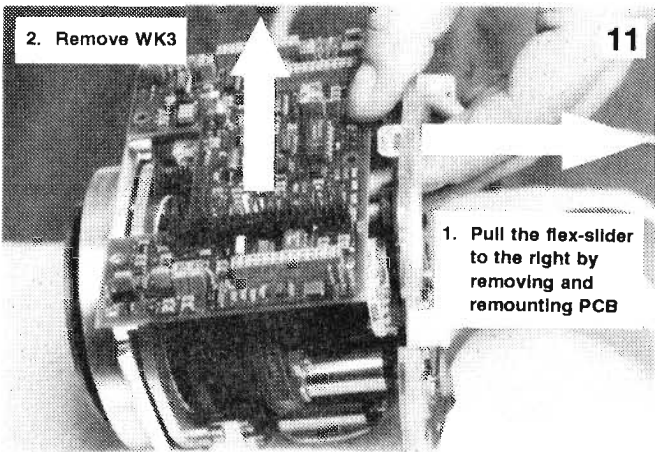
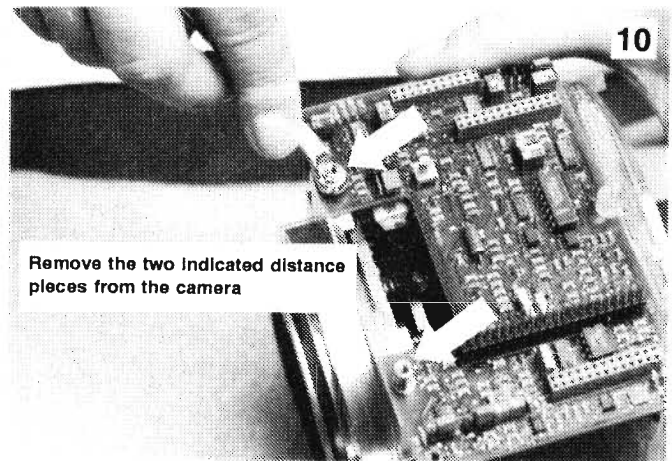
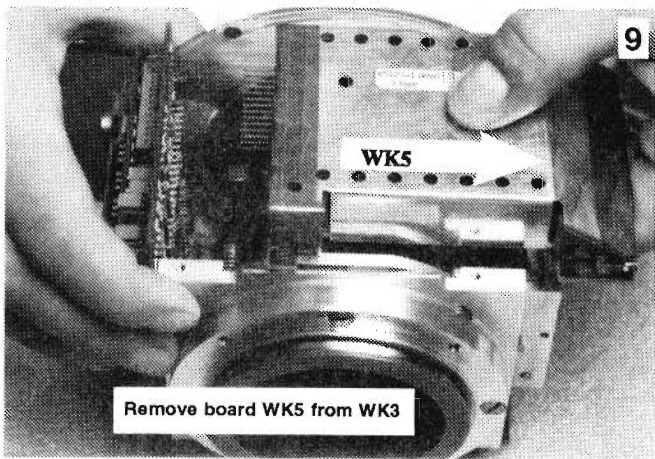
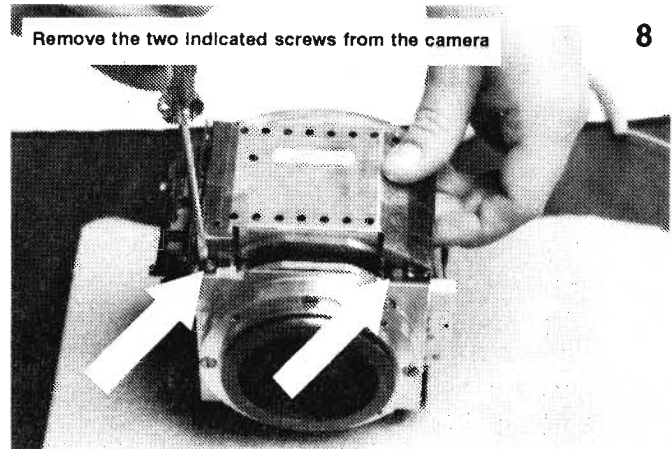
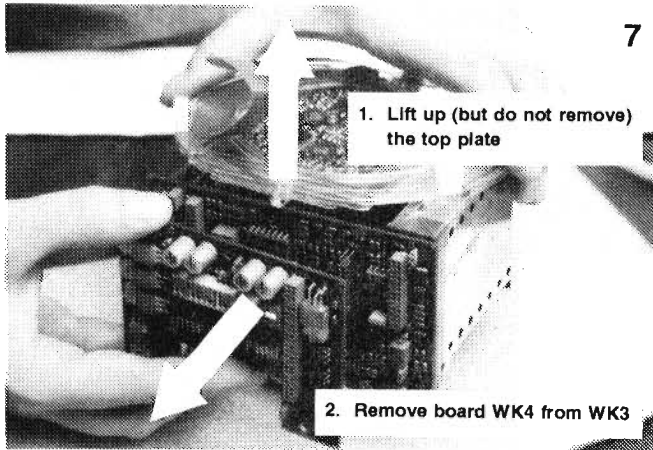

- g) Mount the new boards on the camera in the reverse order, as illustrated by the photographs.
- h) Mount the camera on the II, and connect the appropriate cables to the camera.

3. ELECTRICAL ADJUSTMENTS

NOTE

To obtain a better measurement, connect a 2 kΩ resistor in series with WK3mp:7(VIBS) or WK3:MP1 (VICA). This reduces the noise band (see Figure 1).

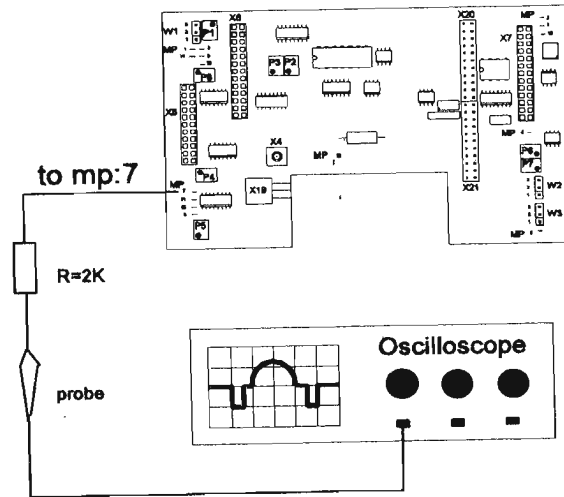

Figure 1

3.1. PRESETS

Carry out the following settings:

- Set jumper **WK3:W1** to position 1-2 (block generator on).
- Set jumper **WK4:W1** to position 2-3 (clean circle off).
- Set switch **WK4:S2-5** to position "ON" (fixed gain on).
- Set switch **WK4:S2-6** to position "ON" (max. VIBS = 1100 mV).
- Adjust **WK3:MP1** (vica) with respect to **WK4:MP1** (0 V) to the value stated in Table 2 with **WK3:P1** (vica).

S3:1 OFF in the case of a BV212
S3:3 OFF in the case of a BV29 or BV212
In other cases, as shown below

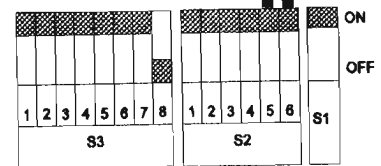

Figure 2

System name	Block generator
BV 25	250 mV
BV 26	250 mV
BV 29	375 mV
BV 212	360 mV

Table 2

f) Measure VIBS (WK3:MP7) with respect to 0 V (WK4:MP1), trigger external on the mid-line WK5:MP1 and adjust the fixed gain to 400 mV_{top} with WK3:P5 (see Figure 3).

g) Turn WK3:P1 completely clockwise (amplitude = 0 V).

h) Measure VIBS, trigger external on the mid-line of WK5:MP1 and adjust the black level with WK3:P4 to 45 mV (see Figure 4).

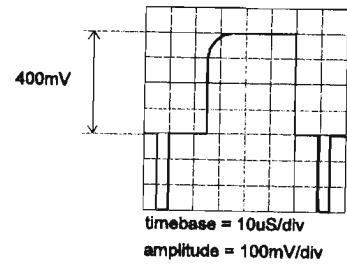

Figure 3

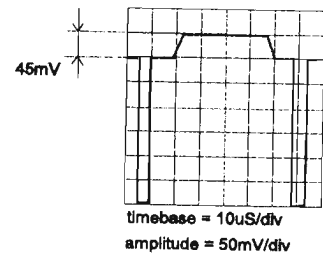

Figure 4

3.2. VIDEO GAIN

a) Set jumper WK3:W2 to position 1-2 (ramp generator on).
Set switch WK4 S2-4 to "OFF" position (white compression curve 2) (see Figure 5).

b) Measure VIBS and adjust the top of the video to 1100 mV_{top} with WK5:P1 (see Figure 6).

c) Set jumper WK3:W2 to position 2-3 (ramp generator off).

d) Set switch WK4 S2-4 to "ON" position (white compression curve 1) (see Figure 7).

e) Measure VIBS (WK3:MP7) with respect to 0 V (WK4:MP1), trigger external on the mid-line WK5:MP1 and adjust the black level with WK3:P4 to 45 mV (see Figure 4).

f) Set switch WK4:S2-5 in "OFF" position (fixed gain off).

S3:1 OFF in the case of a BV212
S3:3 OFF in the case of a BV29 or BV212
In other cases, as shown below.

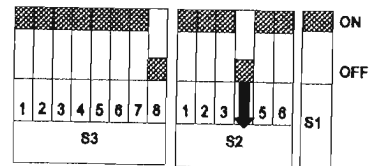

Figure 5

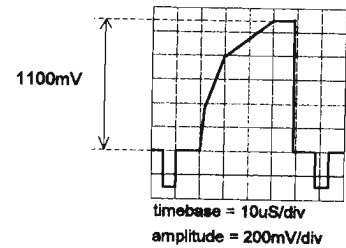

Figure 6

S3:1 OFF in case of a BV212
S3:3 OFF in case of a BV29 or BV212
In other cases, as shown below

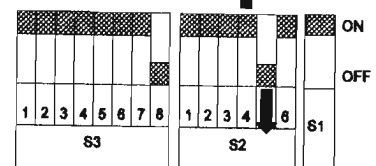

Figure 7

3.3. AGC THRESHOLD SMALL MF

- a) Set switch **WK4 S3-6** to "OFF" position (select MF locally).
 Set switch **WK4 S3-7** to "OFF" position (small MF selected) (see Figure 8).
- b) With WK3:P1, measure WK3:MP1 with respect to WK4:MP1 and adjust the block generator as shown in Table 2.
- c) Measure VIBS (WK3:MP7) with respect to 0 V (WK4:MP1), trigger external on the mid-line WK5, and adjust the threshold to $400\text{ mV}_{\text{top}}$ with **WK3:P6** (see Figure 9).

S3:1 OFF in case of a BV212
 S3:3 OFF in case of a BV29 or BV212
 In other cases, as shown below

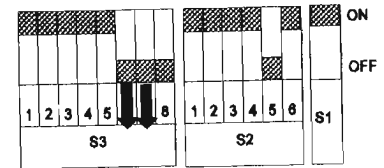

Figure 8

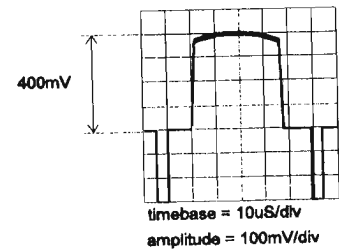

Figure 9

3.4. AGC THRESHOLD LARGE MF

- a) Set switch **WK4:S3-7** to "ON" position (large MF selected) (see Figure 10).
- b) Measure VIBS and adjust the threshold to $400\text{ mV}_{\text{top}}$ with **WK3:P7** (see Figure 9).
- c) Set switch **WK4 S3-6** to "ON" position (select MF locally).

S3:1 OFF in case of a BV212
 S3:3 OFF in case of a BV29 or BV212
 In other cases, as shown below

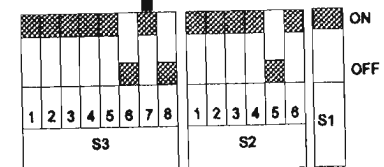

Figure 10

S3:1 OFF in case of a BV212
 S3:3 OFF in case of a BV29 or BV212
 In other cases, as shown below

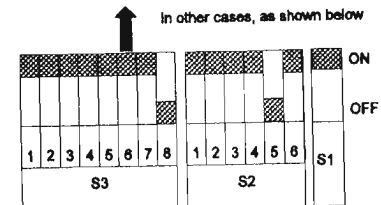

Figure 11

NOTE

In the case of a BV25 or BV26, go to paragraph 3.5 (f).

3.5. VICA PRESET FOR MIDDLE AND SMALL II FORMAT

- a) Select the middle II format on the system.
- b) Measure the video on VIN WK3:MP1 and adjust it with **WK3:P1** (the block generator) as shown in Table 2.
- c) Measure DRFLDFPA with a voltmeter on measuring point **WK3:MP13** (0 V = WK4:MP1) and adjust it to 2.0 V with **WK3:P2**.
- d) Select the small II format.
- e) Measure with a voltmeter **DRFLDFPA** on measuring point **WK3:MP13** (0 V = WK4:MP1) and adjust it to 2.3 V with **WK3:P3**.
- f) Set **WK3:W1** to position 2-3 (Block generator off).
- g) Set **WK4:W1** to position 1-2 (clean circle off).

NOTE

Before starting the dose rate adjustment, check the switch/jumper settings of the camera as stated below (for jumper settings, see table 4 on page 13).

Switch settings in the case of a BV 25/BV 26

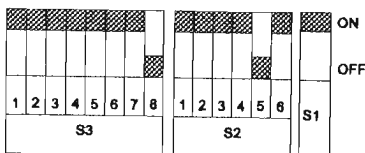

Figure 12

Switch settings in the case of a BV 29

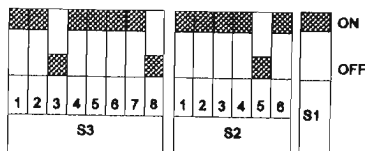

Figure 13

Switch settings in the case of a BV 212

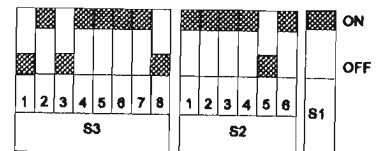

Figure 14

3.6. DOSE RATE ADJUSTMENT

System name	Large II Format	Middle II format	Small II format
BV 25	25 μ R/s	*****	*****
	0.22 μ G/s	*****	*****
BV 26	25 μ R/s	*****	*****
	0.22 μ G/s	*****	*****
BV 29	17 μ R/s	25 μ R/s	33 μ R/s
	0.15 μ G/s	0.22 μ G/s	0.29 μ G/s
BV 212	20 μ R/s	27 μ R/s	35 μ R/s
	0.18 μ G/s	0.24 μ G/s	0.31 μ G/s

Table 3

- Remove the grid from the II shield.
- Put the 1.5 mm copper plate on the top of the X-ray diaphragm.
- Put the probe of the X-ray photometer as close as possible to the entrance plane of the II tube, and position the probe in the middle of the II tube.
- Select a " μ R/s" or " μ G/s" readout on the X-ray photometer.
- Calibrate the X-ray meter so that the readout indicates zero.
- Set jumper **SE19:W1** to "**SERV**" position (manual mA control) (see Figure 15).
- Select the largest II format.
- Set the kV-value manually to 75 kV.
- Adjust the entrance dose given in Table 3 by varying the mA value with potentiometer **SE19:R62** (see Figure 15).
- Stop fluoroscopy and remove the X-ray photometer probe.
- Connect the oscilloscope to test point **SE19:MP1** (DRFLC).

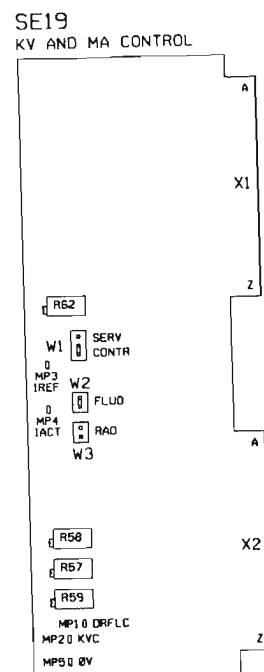

Figure 15

In the case of a large format adjustment:

- l) Connect **WK6:MP1** to **WK6MP4** (watch dog., see Figure 16).
- m) Start fluoroscopy.
- n) Adjust this DRFLC signal with potentiometer **WK6:P1** to $0\text{ V} \pm 100\text{ mV}$.
- o) Stop fluoroscopy.
- p) Remove the interconnection between **WK6:MP1** and **WK6:MP4**.

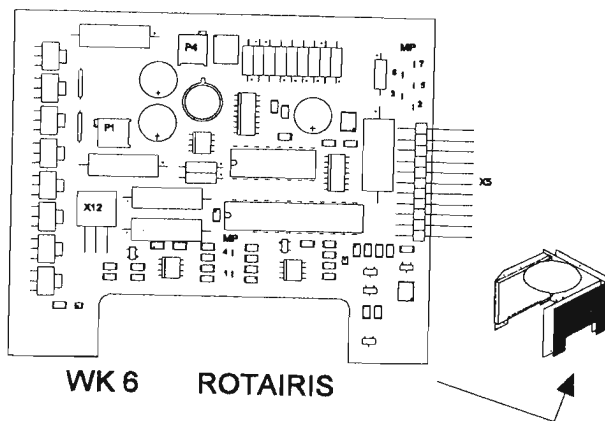

Figure 16

Dose adjustment for the middle II format

NOTE

Ensure that the interconnection between WK6:MP1 and MP4 is removed.

- q) Select the middle II format.
- r) Carry out steps **c**, and **h** up to and including **k**.
- s) Start fluoroscopy.
- t) Adjust the DRFLC signal with potentiometer **WK3:P2** to $0\text{ V} \pm 100\text{ mV}$.
- u) Stop fluoroscopy.

*cannot do
iris drop broken*

Dose adjustment for the SMALL II format

NOTE

Ensure that the interconnection between WK6:MP1 and MP4 is removed.

- v) Select the smallest II format.
- w) Carry out steps **c**, and **h** up to and including **k**.
- x) Start fluoroscopy.
- y) Adjust the DRFLC signal with potentiometer **WK3:P3** to $0\text{ V} \pm 100\text{ mV}$.
- z) Stop fluoroscopy and set jumper **SE19:W1** to "**CONTR**" position (see Figure 15).

3.7. FIXED GAIN ADJUSTMENT

- Place the grid in front of the II tube.
- Put the 1.5 mm copper plate on the top of the X-ray diaphragm.
- Select the largest II format.
- Check whether jumper SE17:W1 is in "FIX" position (see Figure 17).
- Start fluoroscopy in automatic mode, measure VIBS (WK3:MP7) with respect to 0 V (WK4:MP1), and trigger external on the mid-line WK5:MP1. This must be approximately 400 mV_{top}.
- Switch over to manual fluoroscopy and adjust VIBS (WK3:MP7) with respect to 0 V (WK4:MP1) with potentiometer WK3:P5 (fixed gain) so that the measuring signal during manual mode is equal to that of the automatic mode.
- Check steps e and f. If there are deviations, carry out steps e up to and including g again.
- Check the positions of all jumpers/switches of the camera given in Table 4 and in Figures 18, 19 and 20.

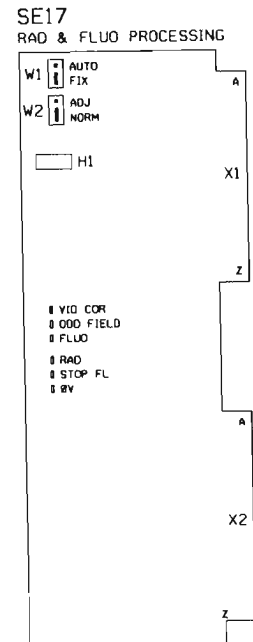

Figure 17

PCB	Jumper/switch	Position
WK3 AGC/ADC 1	X19	A2-3
	W1	2-3
	W2	2-3
	W3	2-3
WK4 AGC/ADC 2	W1	1-2
WK5 Video proc.	S2	Left

Table 4

Switch settings in the case of a BV 25/BV 26

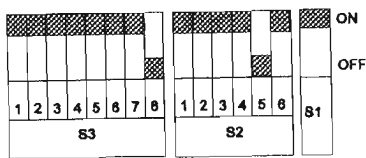

Figure 18

Switch settings in the case of a BV 29

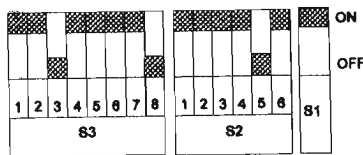

Figure 19

Switch settings in the case of a BV 212

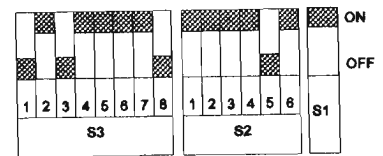
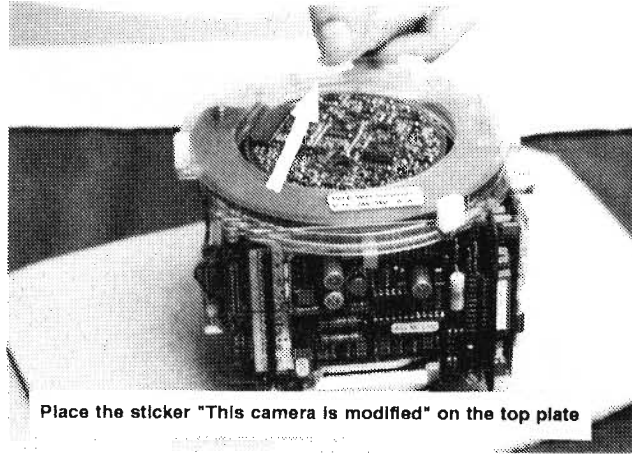

Figure 20

- i) After all the adjustments have been completed, place the sticker (from page Z-2) "This camera is modified" as illustrated in the photograph.



- j) Mount the camera cover to the II.

4522 127 00762 SE 21
DIA (+) 1
4522 127 00572 SE 23
DIA (+) 2

4. MMP/MDPM MEMORY ADJUSTMENTS

NOTE

For BV25 go to chapter 4.6 page 19 MDPM ADJUSTMENT.

4.1. MMP OFFSET ADJUSTMENT

NOTE

All adjustments are also described in the SERVICE MANUAL DIGITAL SCOPOFIX-MMP 100 Hz, located in Volume 2 of the system documentation.

Proceed as follows:

4.2. ENTERING THE SERVICE MENU

Procedure:

- Loosen the front 2 screws of the right and left cover, located at the trolley keyboard (see drawing).
- Pull out the Memory Box Unit (MBU) as far as possible (Unit is secured by blocking screws).
- Switch on the system.
- Set dipswitch **S1:5** on **WT2** board to position "ON" to activate write enable, this PCB is located on top of the memory box.

- Press "hidden switch" on Memory Box Unit flatpanel and **<MENU>** button (left top corner of flatpanel) SIMULTANEOUSLY.

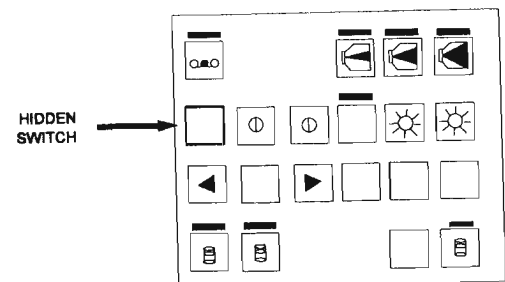
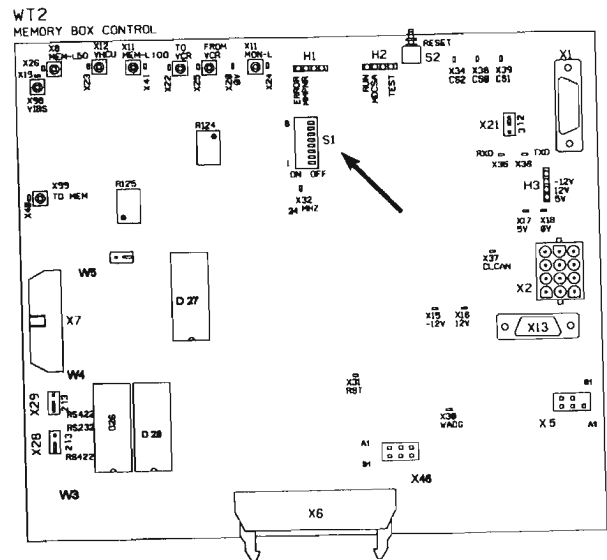
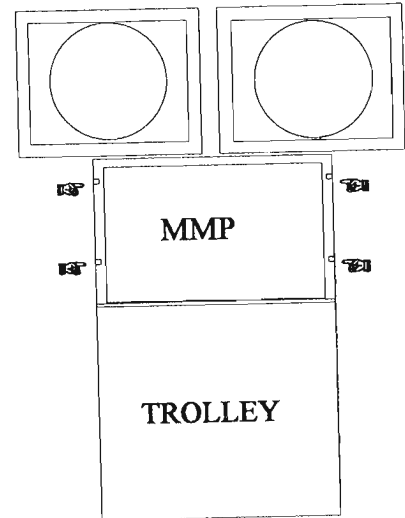

- f) Select line **01** (use ARROW-UP / ARROW DOWN knobs or use numeric keys).
- g) Press **<ACC>** button.
The cursor will automatically jump at end of line 01.
- h) Enter password "**JIM29BV**" and press **<ACC>**.
The characters of the password are NOT displayed.
For each character the * symbol is displayed.
In case of a typing error "*****" is displayed and the correct password must be entered again, no **<ACC>** needed.

NOTE

If an image is present when entering the SERVICE MODE, it will be suppressed during service menu modes. When entering the SERVICE MODE after switching on the system, enter patient name and <ACC> or just <ACC>.

4.3. MBC UTIL SETTING MENU, TO OPEN CLEAN CIRCLE

- a) Select **50** "MBC UTIL SETTING" and press **<ACC>**.

NOTE

The below mentioned values are for example purposes only.

The following screen will appear on the monitor:

MBC UTIL. SETTING

- 51. 50/60 Hz frequency: 50Hz
- 52. MMP clean circle X = 319
- 53. MMP clean circle Y = 285
- 54. MMP clean circle R = 186
- 55. MMP text leftm(0-20) 08
- 56. Send util cmd (y/n)
- 57. Format disk? (y/n)
- 58. Return to Main Menu

Select: 58

- b) Write down value of MMP clean circle R = ... **183**
- c) Select line "**54** MMP clean circle R = ... ", set value to **320** (clean circle max.) and press **<ACC>**.
- d) Select line "**56** Send util cmd (y/n)" and select "**Y**", wait for about 15 sec. for rebooting.
- e) After rewriting the menu chose "**58** Return to main menu", press **<ACC>** and exit the Service menu.

Replacement kit
IQ upgrade kit for BV25/26/29/212

4.4. MMP INPUT OFFSET ADJUSTMENT

- a) Press <ACC>.
- b) Set contrast **C085** and brightness **B255**.
- c) Press the **VCR knob** on trolley flatpanel.

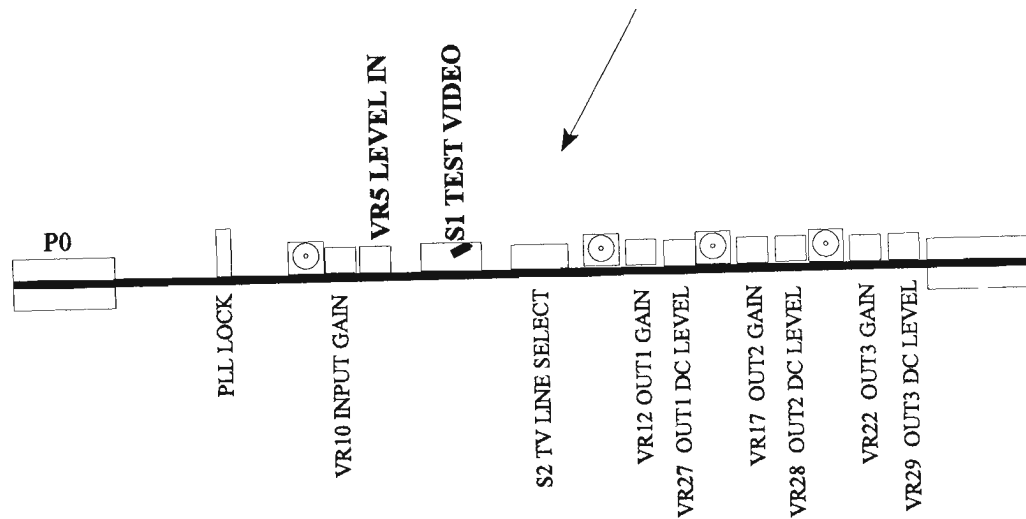
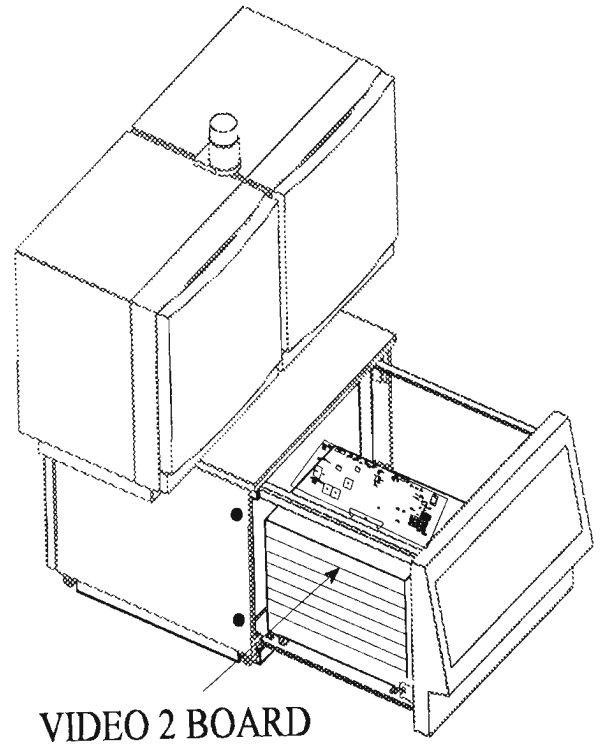
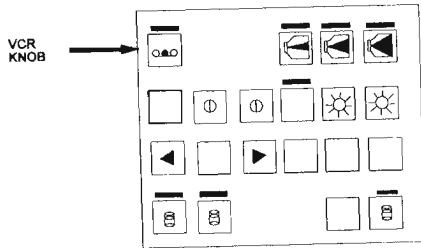

- d) Hold switch **S1** "test video" on the **video 2 board** of the MMP memory to "ON" while turning potmeter **VR5** "level in".

- e) Start turning potmeter **VR5** clockwise until you see the left bar getting wider (see Figure 21).

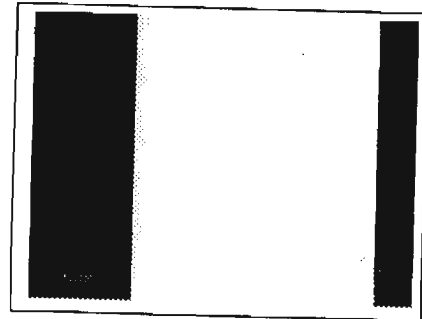

Figure 21

- f) When you see on your monitor the image like Figure 21, start turning potmeter **VR5** counter-clockwise until you see on the monitor that pixels are visible like Figure 22.

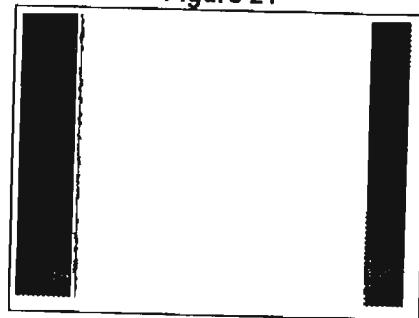

Figure 22

- g) Turn potmeter **VR5** slowly counter-clockwise **just until** you see no more pixels like in Figure 22 (Figure 22 changing into Figure 23).
- h) Press **VCR knob** on the trolley flatpanel (Led above knob goes off).

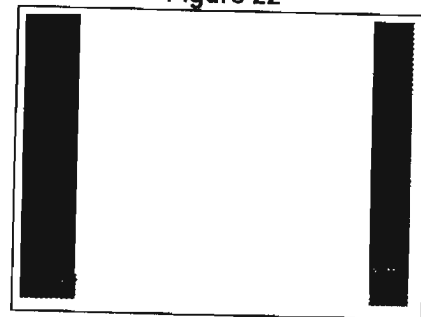

Figure 23

4.5. FINAL SETTINGS TO RESTORE THE CLEAN CIRCLE

- a) Enter service menu (point 4.2).
- b) Select "**50**" (MMP Util Settings) press **<ACC>**.
- c) Select "**54**" press **<ACC>** and restore MMP clean circle **R= . . .** (point 4.3).
- d) Select "**56**" (send util cmd y/n) press "**Y**", wait for about 15 sec. for rebooting.
- e) Exit service menu.
- f) Set dipswitch **S1:S5** on **WT2** board back in the position "**OFF**" (write protect).
- g) Push back the Memory Box Unit, watch out for cabling at rear side and tighten the four screws to secure the Memory Box.
- h) Check system.
- i) Put this FCO after completion under tab modifications.

Replacement kit
 IQ upgrade kit for BV25/26/29/212

4.6. MDPM MEMORY ADJUSTMENT

This section gives the procedure for Input offset adjustment of the MDPM Memory for a BV25 system.

4.7. EQUIPMENT REQUIRED

- Standard toolset.
- Oscilloscope (dual channel).

4.8. INPUT ADJUSTMENT

- a) To open MDPM Memory, loosen the front 2 screws of the right and 2 of the left cover, located at the trolley keyboard (see drawing).
- b) Remove cover MDPM Memory (watch out for flatcable to display).
- c) Remove the two screws with bolts which hold the MDPM unit (see drawing) and pull out unit for 10 cm.
- d) Remove cover plate MDPM unit by removing the fixing screws.
- e) Disconnect the remote control connector WHD-X2 (located at rear side of MDPM unit).
- f) Connect oscilloscope to video-signal on WHD15:MP1 (Memory board) or the output connector WHD:X4 (rear side MDPM unit).
- g) Disconnect input-signal on connector WHD:X3 of the unit.
- h) Switch on the power.
- i) Turn the potentiometer WHD11:R2 on the AD Converter/ADNR board fully counter clock wise (CCW).
 On the oscilloscope a DC-level with sync-pulses appears.
- j) Turn the potentiometer WHD11:R2 slowly clock wise (CW). The DC-level will decrease with steps of 4 mV (can only be seen with a 1:1-probe).
- k) Turn the potentiometer WHD11:R2 CW until the DC-level just equals zero.

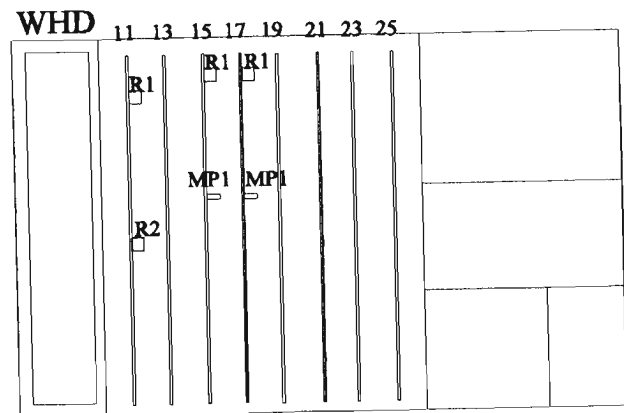
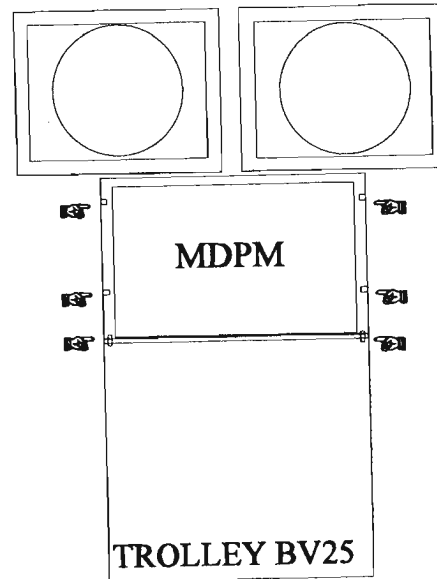

MDPM UNIT FRONT VIEW

4.9. FINISHING TOUCH

- a) Close covers.
- b) Check system.
- c) Put this FCO after completion under tab modifications.

Replacement kit
IQ upgrade kit for BV25/26/29/212

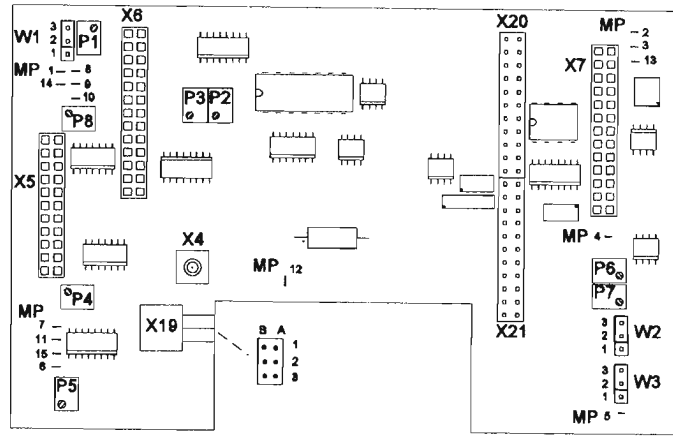

WK 3 AGC/ADC 1

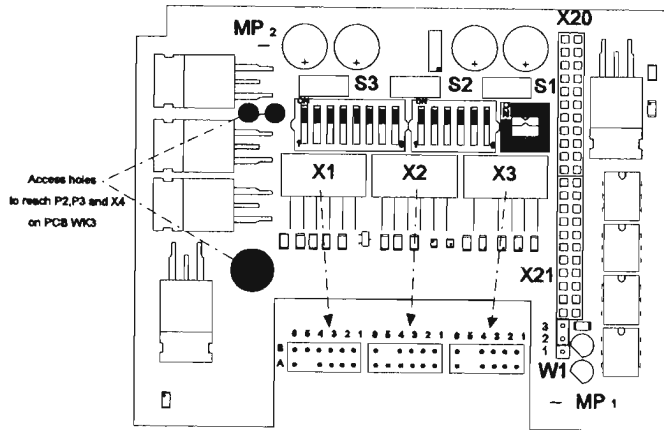

WK 4 AGC/ADC 2

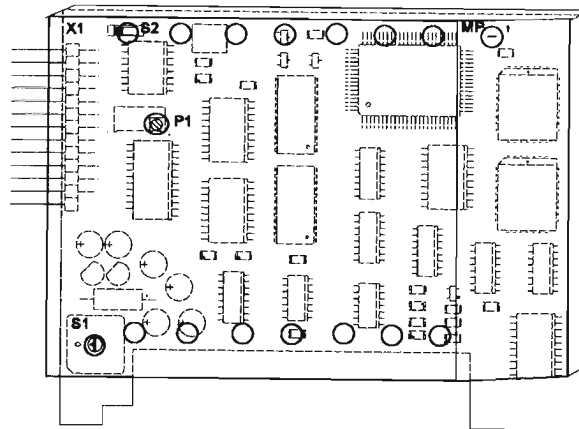

WK 5 VIDEOPROC

Dr.Nr.	Description
Fuctional Diagrams	
Z1-1	System block diagram.
Z1-2	System functions.
Z1-3	Power supplies & safety earth.
Z1-4	Keying.
Z1-5	Mains Control Unit.
Z1-6	Microcomputer Architecture & test.
Z1-7	Fluoroscopy processing.
Z1-8	Radiography processing.
Z1-9	High Voltage Converter.
Z1-10	Image processing.
Z1-11	Collimator Control.
Z1-12	Vertical Movement Control.
Z1-13	Alarm & Not Ready processing.
Wiring Diagrams	
Z2-1	Connector & Unit Locations Stand.
Z2-2	Connector & Unit Locations Trolley.
Z2-3	Cabling & Wiring Diagram System.
Z2-4	Cabling & Wiring Diagram Stand.
Z2-5	Cabling & Wiring Diagram Trolley.
Z2-6	Connector & Wiring Control backpanel SE10.
Z2-7	Connector & Wiring Power backpanel SE30.
P.C. Board Drawings.	
Z3-1	Filament Supply (SE31).
Z3-2	Power Control (SE33).
Z3-3	Rectifier Power (SE35).
Z3-4	Inverter Power 1 (SE37).
Z3-5	Inverter Power 2 (SE39).
Dimensioned Drawings.	
Z9-1	Mobile Stand.
Z9-2	Mobile Trolley.

MNEMONICS LIST

+12VG	+12V	Z1-3 4C 5C
+5VSENSE	+5V FOR SENSING	Z1-3 9B
+HVT1	POSITIVE INPUT TO INVERTOR	Z1-9 7A
0VG	0V FOR 12V	Z1-3 4C 5C
0VSENSE	0V FOR SENSING	Z1-3 9B
1200Hz	CLOCK FREQUENCY OF 1200 Hz	Z1-9 3A 8B
-12VG	-12V	Z1-3 4C 5C
600Hz	CLOCK FREQUENCY OF 600 Hz	Z1-9 3A Z1-13 1B
A220VF5	220V~(FROM FUSE 5)	Z1-5 4C
A220VF6	220V~(FROM FUSE 6)	Z1-5 4C
AC15V1	15V~(1)	Z1-5 3C 7B
AC15V2	15V~(2)	Z1-5 3C 7B
AC220VF1	220V~ MAINS 1	Z1-3 2C 5B Z1-12 1A 4A
AC220VF2	220V~ MAINS 2	Z1-3 2C 5B Z1-12 1A 4A
AC220VFR1	220V~ MAINS 1 FROM SWITCH	Z1-5 6B 6C
AC220VFR2	220V~ MAINS 2 FROM SWITCH	Z1-5 6B 6C
AC600VF1	600V~(FROM FUSE 1)	Z1-5 4B
AC600VF2	600V~(FROM FUSE 2)	Z1-5 4B
ACHVTI-1	AC VOLTAGE FROM INVERTOR TO HT TRANSFORMER 1	Z1-9 10A
ACHVTI-2	AC VOLTAGE FROM INVERTOR TO HT TRANSFORMER 2	Z1-9 10A
ALARM RESET	SIGNAL FOR RESETING ALARM	Z1-2 3A 4A 3C
ALARM	SYSTEM ALLARM	Z1-7 5C Z1-13 3A 7B 8C
ALRSCM	ALARM RESET COMMAND	Z1-9 1B 8C Z1-13 2C 3C
BELL	SIGNAL TO ACTIVATE BUZZER	Z1-8 4B 5C 7C
CADOCM-L	C-ARM DOWN COMMAND (LOW ACTIVE)	Z1-12 1B 1C 2C
CAN 0	CAN-BUS LINE 0	
CAN 1	CAN-BUS LINE 1	
CAUPCM-L	C-ARM UP COMMAND (LOW ACTIVE)	Z1-12 1A 1C 2A
CL13	TRIGGER PULSE 76.8 KHz	Z1-9 4B
CL13N	TRIGGER PULSE 76.8 KHz INVERTED	Z1-9 4B
CLCAN	SYNCHRONISATION CLOCK FROM CAN CONTROLLER	Z1-6 2B 3B 6B
CLCL	CLEAN CIRCLE SIGNAL FOR CAMERA	Z1-2 3C 5C 6A 7B Z1-10 3B 4B
CMXRST	COMMAND X-RAY BY STAND	Z1-7 5B
CMXRSTV	COMMAND X-RAY BY STAND	Z1-2 4A 7B 7C Z1-6 5B Z1-7 4A
CMXRSTV-L	COMMAND X-RAY BY STAND (LOW ACTIVE)	Z1-10 4B 4C
DC 0V	0V _±	Z1-5 3C
DC+12V	+12V DC SUPPLY	Z1-3 4C Z1-13 1C
DC+15V	+15V SUPPLY ±5%	Z1-3 2A 2C Z1-13 1C
DC+24V	+24V SUPPLY ±5%	Z1-3 2B Z1-12 3C
DC+5V	+5V SUPPLY ±5%	Z1-3 2C 4C 9A Z1-13 1C
DC+6.4V	+6.4V SUPPLY	Z1-3 2C Z1-13 1C
DC-12V	-12V DC SUPPLY	Z1-3 4C Z1-13 1C
DC-15V	-15V SUPPLY ±5%	Z1-3 2A 2C Z1-13 1C
DECR MA	DECREASE mA	Z1-8 1B
DECR.DR	DECREASE DOSERATE	Z1-7 1B
DECRKV	DECREASE KV	Z1-7 1B Z1-8 1B
DIANR	DIAPHRAGM NOT READY	Z1-13 2B
DIAPHRAGM	FORMAT INFORMATION FOR X-RAY COLLIMATOR	Z1-2 3C 5C 7C Z1-7 4B Z1-8 4B
DIRD	DIAPHRAGM READY	Z1-11 8A Z1-13 1B
DISAL-H	DISCHARGE ALARM	Z1-9 3B 2C
DISCOMH	DISCHARGE COMMAND FOR ELCO	Z1-9 3B
DITVC0-LC	II-CAMERA DIAPHRAGM PULSE MODE CODE 0	Z1-10 3A Z1-11 5B
DITVC1-LC	II-CAMERA DIAPHRAGM PULSE MODE CODE 1	Z1-10 3A Z1-11 5B
DITVC2-LC	II-CAMERA DIAPHRAGM PULSE MODE CODE 2	Z1-10 3A Z1-11 5B
DITVRD-L	II-CAMERA DIAPHRAGM READY	Z1-10 3A
DRFLDFNA	DOSERATE FLUOROSCOPY DIFFERENTIAL NEGATIVE	Z1-2 2B 7A
DRFLDFPA	DOSERATE FLUOROSCOPY DIFFERENTIAL POSITIVE	Z1-2 2B 7A Z1-7 4C
DTR1A	DETECTION THYRISTOR V1 WIRE 1	Z1-5 8A
DTR1B	DETECTION THYRISTOR V1 WIRE 2	Z1-5 8A
DTR2A	DETECTION THYRISTOR V2 WIRE 1	Z1-5 8B
DTR2B	DETECTION THYRISTOR V2 WIRE 2	Z1-5 8B
DTR3A	DETECTION THYRISTOR V3 WIRE 1	Z1-5 8B
DTR3B	DETECTION THYRISTOR V3 WIRE 2	Z1-5 8B
DUMP	DISPLAY CONTEENCE OF REGISTER	Z1-6 1C 6C
ELDIS-L	ELCO DISCHARGE	Z1-9 1C 5A

ENDSWDOL	ENDSWITCH DOWN	
ENDSWUPL	ENDSWITCH UP	
ENKAV	ENABLE AUTOMATIC KV/mA CONTROL	Z1-7 5C 6C
ENKVAC	ENABLE KILOVOLT AUTOMATIC	Z1-7 4B
ENKVMN	ENABLE KILOVOLT MANUAL	Z1-7 4A 6C Z1-8 4B 7B
ENMAC	ENABLE mA CONTROL	Z1-7 7B
ERROR	ERROR DETECTED DURING SELFTEST	Z1-6 3C
ERROR DATA	DATACODE FOR ERROR REPORT	Z1-2 4A 4C
EXP PREP COM	EXPOSURE COMMAND	Z1-8 7B 9B Z1-9 1B 8B
FAST	FAST SERVICE TESTS	Z1-6 1C 6C
FF0	TRIGGER FREQUENCY 300 Hz	Z1-9 4B
FF0N	TRIGGER FREQUENCY 300 Hz INVERTED	Z1-9 4B
FILAL-H	FILAMENT ALARM	Z1-9 9B Z1-13 1A
FIXED GAIN	SIGNAL FOR FIXED GAIN IN CAMERA	Z1-2 3C 5C
FL BOOST	BOOSTED FLUOROSCOPY	Z1-2 3C 4B 5C 6A Z1-7 3B
FLUO TIM NR	FLUO TIMER NOT READY	Z1-7 9A Z1-13 6B
FLUO MAN	FLUOROSCOPY MANUAL	Z1-7 3B 4B
FLUO BOOST	BOOSTED FLUOROSCOPY	Z1-7 3B 4A
FLUO	X-RAY COMMAND IN FLUO MODE	Z1-7 6B
FLUO AUT	FLUOROSCOPY AUTOMATIC	Z1-7 3A 3B
FLUO TIM RES	FLUO TIMER RESET	Z1-7 8A 9A
FLUO MAN/AUT	FLUOROSCOPY MANUAL/AUTOMATIC	Z1-7 3A
FLUOROSCOPY	COMMAND FOR FLUOROSCOPY	Z1-7 1A
FOCREF	FOCUS REFERENCE VOLTAGE	-11 6C
FOOTSW	SIGNALS DETECTED FROM FOOTSWITCH	Z1-2 3B
FPCNR	FLAT PANEL CONTROL NOT READY	Z1-13 2B
FPMT1	FOCUS POSITION MOTOR WIRE 1	Z1-11 8C
FPMT2	FOCUS POSITION MOTOR WIRE 2	Z1-11 8C
FPPO	ACTUAL FOCUS POSITION	Z1-11 8C
FRNORM	FRANCH NORM	Z1-6 3C 4C
FSDTFL	ACTUAL IRIS SIZE	Z1-11 7A 7B
FSDTRG	SIGNAL FOR DIAPHRAGM MOTOR	Z1-11 7B
FSMT1	FIELD SIZE MOTOR WIRE 1	Z1-11 8B
FSMT2	FIELD SIZE MOTOR WIRE 2	Z1-11 8B
FSPO	ACTUAL IRIS SIZE VOLTAGE	Z1-11 8B
FTMSW	MODE SELECTION BY FOOTSWITCH	Z1-7 1C
FTSWCML	FOOTSWITCH COMMAND	Z1-9 1C
GENRES	GENERAL RESET	Z1-9 8C Z1-13 3C
GRESET	GENERAL RESET	Z1-7 5C Z1-8 6C
HANDSW	SIGNALS DETECTED FROM HANDSWITCH	Z1-2 3A 3B
HDF	HIGH DEFINITION FLUOROSCOPY	Z1-7 1C
HDSW	HANDSWITCH	Z1-8 4B
HDSWSFL	HANDSWITCH FLUORO	Z1-9 2B
HFSACM	HAND-FOOT SAFETY COMMAND (LOW ACTIVE)	Z1-2 2C 4A Z1-6 2B 2C
HFSWCM	HAND/FOOTSWITCH COMMAND	Z1-7 3C Z1-9 1C
HIDDEN SW	HIDDEN SWITCH	Z1-2 1A Z1-13 4C 6A 6C
HSWCM<0--7>	HORIZONTAL SWITCH COMMAND (8 BITS BUS)	
HVCOM	HIGH VOLTAGE COMMAND	Z1-7 7B Z1-8 9A Z1-9 1B 2A 3C
HVCOMFL	HIGH VOLTAGE COMMAND FLUORO	Z1-7 5A 6B
HVCOMFLL	HIGH VOLTAGE COMMAND FLUOROSCOPY	Z1-7 5A 6B Z1-8 9B
HVNR	HIGH VOLTAGE DIVIDED SIGNAL NOT READY	Z1-13 2B
HVON	HIGH VOLTAGE ON	Z1-9 3B
-HVT1	NEGATIVE INPUT TO INVERTOR	Z1-9 7A
HVTDV-H	HIGH VOLTAGE DIVIDED SIGNAL	Z1-9 1C 7A 7B Z1-13 1B
ID30MA	INDICATION 30 mA MODE	Z1-8 4B 7A 9B Z1-9 8C
ID5FL	INDICATION FLUO TIMER RESET	Z1-7 10B
ID5INC	INDICATE 5" II-FORMAT	Z1-7 1A Z1-11 2A
ID5MFL	INDICATE 5 MINUTES OF FLUOROSCOPY	Z1-7 1A Z1-11 2A
ID7INC	INDICATE 7" II-FORMAT	Z1-7 1A Z1-11 2A
ID9INC	INDICATE 9" II-FORMAT	Z1-7 1A Z1-11 2A
IDCIM1	INDICATION CINE MODE 1 SELECTED	Z1-10 2A 2C
IDCIM2	INDICATION CINE MODE 2 SELECTED	Z1-10 2A 2C
IDCINE	INDICATION CINE SELECTED	Z1-10 2A 2C
IDCOP	INDICATION COPY	Z1-10 2A 2C
IDFLAT	INDICATION FLUOROSCOPY SELECTED	Z1-7 1A
IDFLIT	INDICATION INTERMITTEND FLUOROSCOPY SELECTED	Z1-7 1A
IDFLMN	INDICATION MANUAL FLUOROSCOPY SELECTED	Z1-7 1A 4B
IDHOME	INDICATION DEFAULT SETTINGS SELECTED	Z1-10 2A 2C

IDIRLA	INDICATION LARGE IMAGE SELECTED	Z1-8 1A 4B	Z1-11 2A
IDIRSM	INDICATION SMALL IMAGE SELECTED	Z1-8 4B	Z1-11 2A
IDMAP	INDICATION ROADMAP FLUOROSCOPY SELECTED	Z1-10 2A	
IDMAX	INDICATION MAXIMUM OPACIFICATION FLUORO. SELECT.	Z1-10 2A	
IDMEAS	INDICATION MEASUREMENT SELECTED	Z1-10 2C	
IDMOSA	INDICATION IMAGE OVERVIEW SELECTED	Z1-10 2C	
IDRADPR	INDICATION RADIATION IS PRESENT	Z1-9 7C	
IDRETN	INDICATION RET. 1 IMAGE BACKWARDS IS SELECTED	Z1-10 2C	
IDRETP	INDICATION RET. 1 IMAGE FORWARDS IS SELECTED	Z1-10 2B	
IDRG	INDICATION RADIOGRAPHY MODE	Z1-8 7B 9B	Z1-9 1B 8C
IDRGMN	INDICATION RADIOGRAPHY MODE SELECTED	Z1-8 4B	
IDRGMV	INDICATION RADIOGRAPHY MANUAL MODE	Z1-8 1A	
IDSRHO	INDICATION SCAN REVERSE HORIZONTAL	Z1-10 2A	
IDSUB	INDICATION SUBTRACTION IS SELECTED	Z1-10 2A	
IDSYON-H	INDICATE SYSTEM IS ON (HIGH ACTIVE)	Z1-5 10C	Z1-13 2C
IDSYON-L	INDICATE SYSTEM IS ON (LOW ACTIVE)	Z1-5 10C	Z1-13 2C
IDTEXT	INDICATION TEXT ON SCREEN	Z1-10 2B	
IDTKTP	INDICATE TANK TEMPERATURE TOO HIGH	Z1-13 9C	
IDVTR	INDICATION VIDEO TAPE RECORDER	Z1-10 2C	
IDZOOM	INDICATION ZOOM-IN IS SELECTED	Z1-10 2C	
IFC0	II-FORMAT CODE 0	Z1-10 3A 4A	Z1-11 5A 6A
IFC1	II-FORMAT CODE 1	Z1-10 3A 4A	Z1-11 5A 6A
II FIELD 13CM	IMAGE INTENSIFIER FORMAT 13cm	Z1-7 1B	
II FORMAT	IMAGE INTENSIFIER FORMAT	Z1-2 3C 5C 6A 7B	Z1-7 3B 4B
II GEN	IMAGE INTENSIFIER GENERATOR	Z1-7 4B	
II FIELD 17CM	IMAGE INTENSIFIER FORMAT 17cm	Z1-7 1B	
II FIELD 23CM	IMAGE INTENSIFIER FORMAT 23cm	Z1-7 1B	
IIGEN	FORMAT INFORMATION FOR II-GENERATOR	Z1-7 4B	
INCR.DR	INCREASE DOSERATE	Z1-7 1B	
INCRKV	INCREASE KV	Z1-7 1B	Z1-8 1B
INCRMA	INCREASE mA	Z1-8 1B	
INRAD	INITIATE RADIATION	Z1-7 1C	
INVAL-H	INVERTER ALARM	Z1-9 2B 4C	Z1-13 1A
IRIS DATA	DATA FOR DIAPHRAGM IRIS FORMAT	Z1-11 4B	
IRREF	REFERENCE VOLTAGE FOR IRIS SIZE	Z1-11 6B	
KEYBOX1	TROLLEY STAND ALONE MAINS PREVENTION CIRCUIT1	Z1-5 5C	
KEYBOX2	TROLLEY STAND ALONE MAINS PREVENTION CIRCUIT2	Z1-5 5C	
KEYSWNR	KEYSWITCH NOT READY	Z1-13 2B	
KEYSWRD	KEYSWITCH READY	Z1-4	Z1-13 1B
KV DATA	SELECTED KILOVOLT VALUE DATA	Z1-7 3B	
KV BIT AUTO	KV VALUE AUTOMATIC	Z1-7 7B	
KVC	KV CONTROL CORRECT	Z1-7 5C 8C	Z1-9 1B 8C
KVVALUE	KILOVOLT VALUE	Z1-8 4B	
LCDDA	LIQUID CRYSTAL DISPLAY DATA	Z1-7 10A	Z1-8 7C
mA DATA	CONTROLBUS FOR mA DATA	Z1-2 4A 4B	
mA BIT MAN/AUT	mA VALUE MANUAL / AUTOMATIC	Z1-7 7B	
MAMEAS1	GROUND FOR mA MEASURING POINT	Z1-7 7B	Z1-9 10A
MAMEAS2	mA MEASURING POINT	Z1-7 7B	Z1-9 10A
MAN.DOSER.C	MANUAL DOSERATE CONTROL	Z1-7 1B	
MASK 10 4C	MASK THE VIDEO SIGNAL (LOW ACTIVE)	Z1-2 3B 5C 7B	Z1-6 5B Z1-7 3B 4A 6B Z1-
MAVALUE	VALUE OF MILIAMPERES	Z1-8 4B	
MBCNR	MEMORY BOX CONTROL NOT READY	Z1-13 2B	
MCU ALARM	ALARM FROM MAINS CONTROL	Z1-5 9B	
MCU+15V	DC+15V FROM MAINS CONTROL UNIT	Z1-3 1B	Z1-5 5A 9A 9B
MCUAL-H	MAIN CONTROL UNIT ALARM	Z1-5 9A 9B	Z1-13 2A
MEML	MEMORY SIGNAL FOR LEFT MONITOR	Z1-6 8B	
MEMR	MEMORY SIGNAL FOR RIGHT MONITOR	Z1-6 8C	
MFSM	MEASURING FIELD SMALL (FOR CAMERA)	Z1-10 3B 4B	
MNPH-A	MAIN PHASE (ANALOG)	Z1-5 6B	
MNSYNC	MAIN-SUPPLY SYNCHRONISATION PULSE	Z1-8 6A	Z1-9 3A
MON-LROL	IMAGE OF LEFT MONITOR ROTATE LEFT	Z1-10 10B	
MON-LRON	IMAGE OF LEFT MONITOR ROTATE NORTH	Z1-10 10B	
MON-LROR	IMAGE OF LEFT MONITOR ROTATE RIGHT	Z1-10 10B	
MON-LROZ	IMAGE OF LEFT MONITOR ROTATE SOUTH	Z1-10 10B	
MON-RROL	IMAGE OF RIGHT MONITOR ROTATE LEFT	Z1-10 10A	
MON-RRON	IMAGE OF RIGHT MONITOR ROTATE NORTH	Z1-10 10A	
MON-RROR	IMAGE OF RIGHT MONITOR ROTATE RIGHT	Z1-10 10A	
MON-RROZ	IMAGE OF RIGHT MONITOR ROTATE SOUTH	Z1-10 10A	
NLEA	SAFETY EARTH	Z1-12 2A 4A	
NMI	NON MASKEBLE INTERRUPT	Z1-6 3B	

NMISC	NON MASKEBLE INTERRUPT COMMAND	Z1-6 3B
NOT READY	PROCESSING NOT READY	Z1-2 4A 4C
NTC1	TANK NTC WIRE 1	Z1-13 1A
NTC2	TANK NTC WIRE 2	Z1-13 1A
NTRD	NOT READY	Z1-7 5B Z1-8 6B Z1-13 3C
ODDFIELD	ODD FIELD OF VIDEO-SYNC IS ACTIVE	Z1-7 5B
OVCURRL	OVERCURRENT SIGNAL	Z-9 1B 7A
P60	TRIGGER PULSES AFTER 60 μ s	Z1-9 4B
P60N	TRIGGER PULSES AFTER 60 μ s INVERTED	Z1-9 4B
P8N	TRIGGER PULSES AFTER 8 μ s INVERTED	Z1-9 4B
PROF	REFERENCE VOLTAGE FOR DIAPHRAGM UNIT	Z1-11 6C 8A
PULSED FLUO	COMMAND FOR PULSED FLUOROSCOPY	Z1-7 1A
PULSED FL.MAN	PULSED FLUORO MANUAL	Z1-7 3A
PULSED FL.AUT	PULSED FLUORO AUTOMATIC	Z1-7 3A
PWRGND	POWER GROUND SIGNAL	Z1-3 1A,4A,6B Z1-5
PWRSM	POWER SMOOTHED SIGNAL	Z-9 4A 6A
PWRSMOV	POWER SMOOTHED DIVIDED SIGNAL FROM RECTIFIER	Z1-9 1B 6A 7A
PWRSYNC1	SYNCHRONISATION FROM MAINS CONTROL 1	Z1-5 5A Z1-9 1A
PWRSYNC2	SYNCHRONISATION FROM MAINS CONTROL 2	Z1-5 5A Z1-9 1A
RAD 24CM	COLLIMATOR SELECTION 24CM	Z1-11 2A
RADIOGR	RADIOGRAPHY	Z1-8 1B 1C
RADL	RADIATION LAMP	Z1-9 7C
RADON	RADIATION ON	Z1-7 6B Z1-8 7A 8A
RADPR-H	RADIATION PRESENT	Z1-9 3C 5C
RAPR	RADIATION PRESENT	Z1-7 3B 4B 6B Z1-8 8A
RD-PULSE	RADIATION PULSE	Z1-9 4B
RDPUIS	RADIATION PULSE	Z1-8 6A Z1-9 4C
RDX	RECEIVE DATA BY COMMUNICATION CONTROLLER	Z1-6 3B
RECTAL-H	RECTIFIER ALARM	Z1-9 2B 3B 4B
RECTTR	RECTIFIER TRIGGER SIGNAL	Z1-9 3B 4A
REPEAT	REPEAT THE SERVICE TEST	Z1-6 1C 6C
RESAL	RESET ALARM	Z1-13 3B
RQHIDO	REQUEST HIGH DOSE	Z1-7 4A 5A 6B 9B Z1-10 3B 4B
RUN	PROCES RUNNING	Z1-6 3C
SEL MA	SELECT mA VALUE ON DISPLAY	Z1-7 10A Z1-8 7C
SEL TIM	SELECT TIMER ON DISPLAY	Z1-7 10B
SEL ER	SELECT ERROR NUMBER ON DISPLAY	Z1-7 10B
SEL KV	SELECT KV VALUE ON DISPLAY	Z1-7 10A Z1-8 7C
SEL RADIOGR	SELECT RADIOGRAPHY	Z1-2 3A 3C
SELECT RAD	SELECT RADIATION	Z1-9 8B 8C
SELECT FLUO	SELECT FLUOROSCOPY	Z1-9 8B 8C
SERV S.LARGE F	SERVICE SELECT LARGE FOCUS	Z1-9 8C Z1-11 4C 5C 6C
SHORT	SHORT CIRCUIT AT MAINS TRANSFORMER DETECTED	Z1-5 8B
SKIP	SKIP THE SERVICE TEST	Z1-6 1C 6C
SLFG	SELECT FIXED GAIN FOR CAMERA (LOW ACTIVE)	Z1-10 3B 4B
SLHDSW	SELECT HANDSWITCH	Z1-8 2C
SLINT	SELECT INTERNAL SWITCH PANEL	Z1-8 2B
SLIT ROT DATA	DATA FOR SLIT ROTATION	Z1-11 4B 5C
SLLCD	SELECT LIQUID CRYSTAL DISPLAY	Z1-8 7C
SLREF	SLIT WITH REFERENCE VOLTAGE	Z1-11 6B
SLRREF	SLIT ROTATION REFERENCE VOLTAGE	Z1-11 6C
SLSYOF	SELECT SYSTEM OFF	Z1-5 7C
SLSYON1	SELECT SYSTEM SWITCH ON WIRE 1	Z1-5 7C Z1-13 4C
SLSYON2	SELECT SYSTEM SWITCH ON WIRE 2	Z1-5 7C Z1-13 4C
SMMF	SMALL MEASURING FIELD	Z1-6 3C
SNAPSHOT	COMMAND FOR PICTURE STORAGE	Z1-2 3C 4B 5C 6A Z1-7 3B
SRHO	SCAN REVERSE HORIZONTAL	Z1-10 4A
SRPO	SLIT ROTATION ACTUAL POSITION VOLTAGE	Z1-11 8B
SSWCM		
STEFPC	SELF TEST FLAT PANEL CONTROL	Z1-6 3C
STEMBC	SELF TEST MEMORY BOX CONTROL	Z1-6 3C
STEXRC	SELF TEST XRC CONTROL	Z1-6 3C
STOP FL.PR	STOP FLUORO PRESENT	Z1-7 3A
SUPNR	POWER SUPPLY NOT READY	Z1-13 2C
SVSLLFLC	SERVICE SELECTION OF LARGE FOCUS	Z1-9 8C Z1-11 5C 6C
SWMT1	SLIT ROTATION MOTOR WIRE 1	Z1-11 8C
SWMT2	SLIT ROTATION MOTOR WIRE 2	Z1-11 8C
SWONCM-L	SWITCH-ON COMMAND (LOW ACTIVE)	Z1-5 9C

SWPO	SLIT WITH ACTUAL POSITION VOLTAGE	Z1-11 8B
SWTRG	SLIT WITH ACTUAL POSITION VOLTAGE	Z1-11 6B
TAKE MASK	MASK THE VIDEO SIGNAL	Z1-10 5C
TDX	TRANSMIT DATA BY COMMUNICATION CONTROLLER	Z1-6 3B
TEXT CLK	CLOCK FOR TEXT GENERATION	Z1-10 6B 6C
TEXT-H	TEXT FOR VIDEO DISPLAY	Z1-10 5B 6C
TIM ERR DISP	TIMER & ERROR DISPLAY	Z1-13 9B
TIMAL	TIMER ALARM	Z1-8 9A Z1-13 1B
TIMNR	FLUO TIMER CONTROL NOT READY	Z1-13 2B
TIMRES	TIMER RESET	Z1-13 6A 6C
TKTP50	TANK TEMPERATURE 50°C	Z1-13 2A 3B
TKTP70	TANK TEMPERATURE 70°C	Z1-13 2A 3B
TKTPAL	TANK TEMPERATURE ALARM	Z1-13 2A
TVAL	TV SYNC ALARM	Z1-13 2A
TVSYNC1	SYNCHRONISATION SIGNAL FOR TV CAMERA	Z1-5 5B
UP/DOWN	INCREASE / DECREASE KV SIGNAL	Z1-7 6C
UPAUT	INCREASE KV COMMAND FROM CAMERA	Z1-7 5C
VACTROT-A	II-CAMERA ACTUAL-ROTATION-ANGLE VOLTAGE	Z1-10 3A
VDSGCO	VIDEO SIGNAL CORRECT	Z1-7 5A 6B 8C
VIBS	VIDEO OUTPUT FROM CAMERA	Z1-2 3C 4C 5B 5C Z1-6 5B 5C Z1-7 4C Z1-
10 5B		
VID.COR	VIDEO SIGNAL CORRECT	Z1-7 5A 6B 8C
VIDBP	VIDEO BYPASS	Z1-10 2C
VSETROT-A	II-CAMERA REQUESTED-ROTATION-ANGLE VOLTAGE	Z1-10 3A
VSWCM<0--7>	VERTICAL SWITCH COMMAND (8 BITS BUS)	
VSYNC-L	VERTICAL SYNCHRONISATION PULSE	Z1-7 6B 7B Z1-13 1A
VTROUT	VIDEO TAPERECORDER OUTPUT	Z1-10 5B 10B
WADG	WATCHDOG	Z1-6 3B
WATCHDOG	DETECTED MAINS FAILURE	Z1-6 2A 3B
WITH DATA	DATA FOR DIAPHRAGM SHUTTER WITH	Z1-11 4B 5A
XTV8	FORMAT INFORMATION FOR CAMERA	Z1-7 4B
ZOOM	ZOOM FUNCTION	Z1-6 3C

SERVICE MANUAL - TECHNICAL UNIT

High Tension Converter Tank

9896 010 00221

For serial numbers, see list of pages and drawings

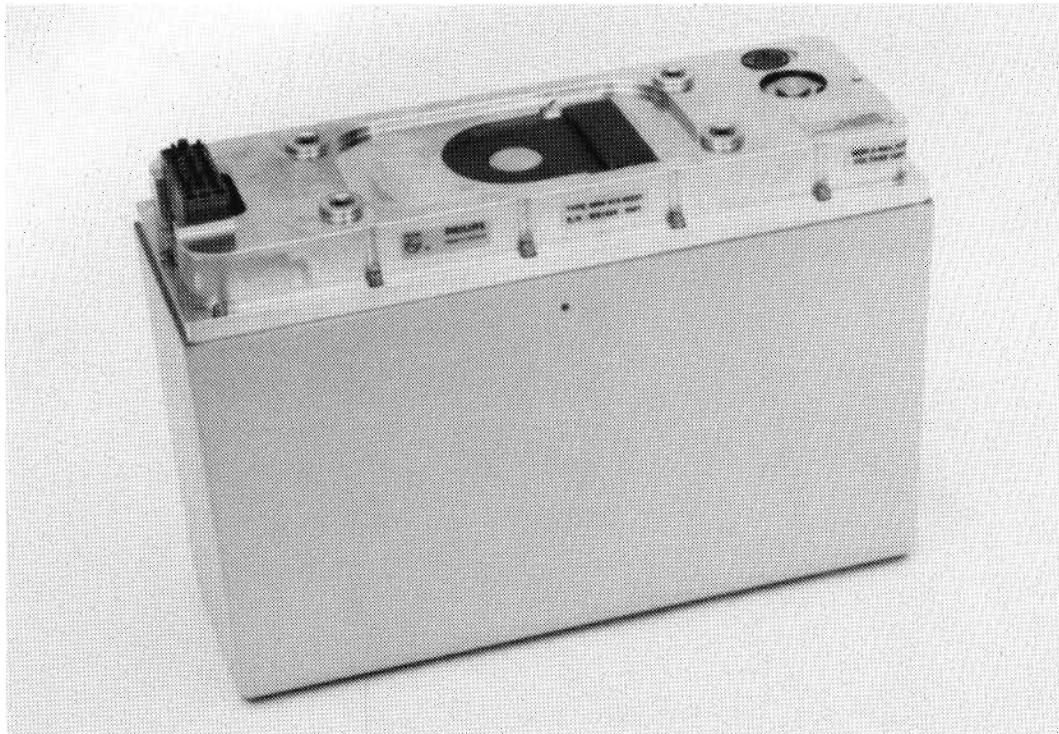

This manual contains descriptive information of the equipment identified by the typenumber and production series stated above.

For information on specific applications refer to the System Manual of the surgical Stand

PMSN Best

Copyright © 1993 Philips Medical Systems International B.V.

All rights are reserved. Reproduction in whole or in part is prohibited without the written consent of the copyright owner. Use of the information contained herein in any form and/or by any means whatsoever is strictly reserved for Philips and its licenses. Use of this manual by unauthorised persons is strictly prohibited.

HT Converter Tank

SERVICE MANUAL - TECHNICAL UNIT
HIGH TENSION CONVERTER TANK

TYPE NO. : 9896 010 00221

SERIAL NO. :

Manual codenumber : 4522 983 54321

List of Pages and Drawings

0.5	(93.0)	
1	(93.0)	
2	(93.0)	
3	(93.0)E	
4	(93.0)E	
5	(93.0)E	
6	(93.0)E	
7	(93.0)E	
3	(93.0)G	
4	(93.0)G	
5	(93.0)G	
6	(93.0)G	
7	(93.0)G	
Z1-1	(b/89.1)	9807 700 3..01
Z3-1	(93.0)	

High Tension Converter Tank

Contents

1.	Introduction and technical data	4
1.1.	Purpose	4
1.2.	Technical data	4
1.2.1.	Performance Data	4
1.2.2.	Dimensions and Weights	6
1.2.3.	Relevant standards	6
2.	Installation	7
3.	Setting to work	7
4.	Corrective maintenance	7

1. INTRODUCTION AND TECHNICAL DATA

1.1. PURPOSE

The High Tension Converter Tank is a HT-tank with X-ray Tube and is intended for use in the BV25, BV26 and BV29 mobile surgical stand.

1.2. TECHNICAL DATA

NOTE

This specification gives maximum rating for the tank. Depending on the type and version of the system it may not be possible to operate at the maximum ratings.

1.2.1. Performance Data

Temperature:

- Operational temperature: $0^{\circ}\text{C} < T < 40^{\circ}\text{C}$.
- At 25°C ambient temperature, the tank housing (except the mounting plane) without sterile cover will not exceed a temperature of 50°C within a time of 1.5 hours of operation at average power of 65 W.
- Oil temperature is sensed with an NTC resistor.
- For emergency a thermal switch in the tank will interrupt power at $85^{\circ}\text{C} \pm 5^{\circ}\text{C}$ oil temperature.

Inherent Filtration:

- 3.0 mm Al equivalent.

Leakage technique factors:

- The leakage technique factors are 105 kV, 200 W.

X-Ray tube:

- FO 14, with double focus and stationary anode.

Fluoroscopy:

- 0.6 mm Focus is used.
- Duty cycle at maximum ratings (105 kV - 3.1 mA):
30 sec on, 120 sec off during 90 minutes, ==> duty cycle 20%.
Maximum continuous "on" time: 105 sec. at 105 kV.

HT Converter Tank

- Nominal voltage : 40 - 105 kV.
- Tube current : 0.1 - 3.1 mA.
- Average continuous load : 65 W.
- Radiation output : > 3.5 R/min. (measured at 60 cm from focus at 100 kV - 3mA).

Snapshot

- Focus : 0.6 mm.
- Tube voltage : 40....105 kV.
- Tube current : 0.2 - 7.2 mA.
- Max. "on" time : 300 msec at 105 kV.

Radiography A:

- 1.5 mm Focus is used.
- Duty cycle at maximum ratings (105 kV - 20 mA) : maximum 30 exposures/hour with 3% duty cycle.
- Nominal voltage : 40 - 105 kV.
- Tube current : 20 mA for max. 4.0 sec.
- Max. load : 2.1 kW during 1 sec.
- Repetition Rate : a: First two exposures : 1 exp./min. (100 kV - 20 mA).
b: Wait for next two exposures : > 213 sec. [= 3.5 min.] (100 kV - 20 mA).
- Radiation output: > 350 mR/sec (measured at 60 cm from focus at 100 kV - 20 mA).

Radiography B:

- Focus : 1.5 mm.
- Tube voltage : 100....105 kV.
- Tube current : 30 mA.
- Max. Exposure time : 320 msec.
- Cooling time : 20 sec.

Input voltage:

140 - 400 V, 300 Hz square wave.

Input voltage filament:

Maximum 17 V, 600 Hz square wave.

Electrical adaptation:

For the electrical interface of the tank, see the table below:

INTERFACE ON CONNECTOR	MNEMONIC	DESCRIPTION
GAX1: 1	FILSM1	Filament transformer small focus 1
2	FILSM2	Filament transformer small focus 2
3	NTC1	NTC temperature measuring circuit
4	MAMEAS1	mA measuring circuit 1
7	ACHVT1	AC voltage for high voltage transformer 1
8	FILCOM	Filament transformer common
11	PWRGND	Power ground
12	NLEA	Protective earth
14	FILLA1	Filament transformer large focus 1
15	FILLA2	Filament transformer large focus 2
16	NTC2	NTC temperature measuring circuit 2
17	MAMEAS2	mA measuring circuit 2
20	ACHVT2	AC voltage for high voltage transformer 2

1.2.2. Dimensions and Weights

For the dimensions of the tank, see drawing sheet Z3-1.

Weight: 14.5 kg. \pm 0.15 kg.

1.2.3. Relevant standards

Compliance Status with STANDARDS is obtainable from:

Philips Medical Systems International
Corporate Quality Department
REGULATING and STANDARD group
Building QM118
PO Box 10.000
5680 DA BEST
The Netherlands

Fax. No. : 31-40-762205/762420
Tel. No. : 31-40-762408
Telex No. : 35000 PHTC NL
routing indicator XLQBUXA

2. INSTALLATION

For installation of the tank, see the instructions in the System Manual of the surgical Stand.

3. SETTING TO WORK

For warm-up procedure of the tube, see the System Manual of the surgical Stand.

4. CORRECTIVE MAINTENANCE

Due to legal prescriptions it is not allowed to exchange the tube in the tank.

If the tank is defective, replace it by a new one.

Fit the additionally supplied identification label(s) and date of manufacture label on the central labelling station, marked "I", of the surgical Stand.

NOTE

When the tank is defective within 1 year after installation you can return the defective tank with a questionnaire form. For return shipment use the package of the new tank.

Hochspannungs-Konvertertank

Inhalt

1.	Einleitung und technische Daten	4
1.1.	Verwendungszweck	4
1.2.	Technische Daten	4
1.2.1.	Leistungsdaten	4
1.2.2.	Abmessungen und Gewicht	6
1.2.3.	Gültige Normen	6
2.	Montage	7
3.	Inbetriebnahme	7
4.	Korrigierende wartung	7

1. EINLEITUNG UND TECHNISCHE DATEN

1.1. VERWENDUNGSZWECK

Der Hochspannungs-Konvertertank ist ein Hochspannungs-tank mit Röntgenröhre und ist für die Verwendung in dem BV25, BV26 und BV29 mobilen chirurgischen Stativ bestimmt.

1.2. TECHNISCHE DATEN

ANMERKUNG

Diese Spezifikation gibt maximale Werte für den Tank. Abhängig von der Typ und der Ausführung des Systemes ist es möglich die maximale Werte nicht angewendet werden können.

1.2.1. Leistungsdaten

Temperatur:

- Betriebstemperatur: $0^{\circ}\text{C} < T < 40^{\circ}\text{C}$.
- Die Gehäusetemperatur des Tanks wird nicht höher werden als 50°C innerhalb eine Betriebszeit von 1,5 Stunde, ausgenommen in der Montagefläche, unter folgende Bedingungen:
Bei einer Umgebungstemperatur von 25°C , bei spezifizierter Einschaltzeit und maximaler Leistung, ohne sterilen Abdeckungen.
- Die Oeltemperatur wird mit Hilfe eines NTC-Widerstandes gemessen.
- Im Notfall unterbricht ein Thermoschalter im Tank bei einer Oeltemperatur von $85^{\circ}\text{C} \pm 5^{\circ}\text{C}$ die Spannung.

Eigenfilterung:

- 3,0 mm Al äquivalent.

Röntgenröhre:

- FO 14, mit doppeltem Brennfleck und fester Anode.

Durchleuchtung:

- Brennfleck 0,6 mm.
- Einschaltdauer bei maximaler Leistung (105 kV - 3,1 mA):
30 s ein, 120 s aus während 90 min, ==> Einschaltdauer 20%.
Maximal ununterbrochen eingeschaltet: 105 s bei 105 kV.

Hochspannungs-Konvertertank

- Nennspannung : 40 bis 105 kV.
- Röhrenstrom : 0,1 bis 3,1 mA.
- Mittlere Kontinuleistung : 65 W.
- Dosisleistung : > 3,5 R/min. (gemessen in 60 cm vom Focus bei 100 kV-3mA).

Schnappschuss:

- Brennfleck : 0,6 mm.
- Röhrenspannung : 40....105 kV.
- Röhrenstrom : 0,2 bis 7,2 mA.
- Max. Einschaltdauer : 300 ms bei 105 kV.

Aufnahmen A:

- 1,5 mm-Brennfleck.
- Einschaltdauer bei maximaler Leistung (105 kV - 20 mA) : Maximal 30 Aufnahmen pro Stunde bei einer Einschaltdauer von 3%.
- Nennspannung : 40 - 105 kV.
- Röhrenstrom : 20 mA während max. 4,0 s.
- Maximale Leistung : 2,1 kW während 1 sec.
- Wiederholungsfrequenz :
 - a: Die erste zwei Aufnahmen : 1 Aufnahme pro Minute (bei 100kV - 20 mA).
 - b: Warten Sie für die folgenden 2 Aufnahmen : >213 s [= 3,5 min.] (bei 100kV - 20 mA).
- Dosisleistung : >350 mR/sec (gemessen an 60 cm vom Focus bei 100kV - 20mA).

Aufnahmen B:

- Brennfleck : 1,6 mm.
- Röhrenspannung : 100....105 kV.
- Röhrenstrom : 30 mA.
- Max. Aufnahmezeit : 320 ms.
- Kühlzeit : 20 s.

Eingangsspannung:

140 - 400 V, 300 Hz-Rechteckspannung.

Eingangsspannung, Heizung:

Maximum 17 V, 600 Hz-Rechteckspannung.

Elektrische Anpassung:

Für die elektrischen Anschlüsse des Tanks siehe untenstehende Tabelle.

INTERFACE ON CONNECTOR	MNEMONIC	BESCHREIBUNG
GAX1: 1	FILSM1	Heizspannungstransformator, kleiner Brennfleck 1
2	FILSM2	Heizspannungstransformator, kleiner Brennfleck 2
3	NTC1	NTC Temperatormessschaltung 1
4	MAMEAS1	mA-Messschaltung 1
7	ACHVT1	Wechselspannung für transformator 1
8	FILCOM	Heizspannungstransformator
11	PWRGND	Netz Erdleitung
12	NLEA	Schutzerdleitung
14	FILLA1	Heizspannungstransformator, grosser Brennfleck 1
15	FILLA2	Heizspannungstransformator, grosser Brennfleck 2
16	NTC2	NTC-Temperatormessschaltung 2
17	MAMEAS2	mA-Messschaltung 2
20	ACHVT2	Wechselspannung für transformator 2

1.2.2. Abmessungen und Gewicht

Für die Abmessungen des Tanks siehe Zeichnung Blatt Z3-1.

Gewicht: 14,5 kg \pm 0,15.

1.2.3. Gültige Normen

Uebereinstimmung mit Normen sind zu bekommen von:

Philips Medical Systems International
Corporate Quality Department
REGULATING and STANDARD group
Building QM118
PO Box 10.000
5680 DA BEST
The Netherlands

Fax. No. : 31-40-762205/762420
Tel. No. : 31-40-762408
Telex No. : 35000 PHTC NL
routing indicator XLQBUXA

2. MONTAGE

Für die Montage des Tanks, siehe die Anweisungen in der BV2.-Systemanleitung.

3. INBETRIEBNAHME

Für das Hochheizen der Röhre, siehe die BV2.-Systemanleitung.

4. KORRIGIERENDE WARTUNG

Aufgrund behördlicher Vorschriften ist es nicht erlaubt, die Röhre auszuwechseln.

Wenn der Tank defekt ist, soll er von einem Neuem ersetzt werden.

Die Identifikationsschilder und das Schild mit dem Fabrikationsdatum, welche zusätzlich mitgeliefert sind, befestigen an der zentrale Stelle markiert "I" von dem mobilen chirurgischen Stativ.

ANMERKUNG

Wann der Tank defekt ist innerhalb 1 Jahr nach Installation können Sie diesen Tank zurücksenden mit einem "Questionnaire"-Formular. Für Rücksendung des defekten Tanks, benutzen Sie die Verpackung des neuen Tanks.

These ERRATA are only applicable to monitors with the basic board WN10 with code number > 4522 167 00274. After all modifications are implemented, the board will be modified upto level 4522 167 00276. Please mark the board accordingly.

Location of relevant parts on board WN10 are indicated through the diagram on page 4 of this errata. Exact positions can be found, using the lay-out diagram in the manual, page Z3-1.1.

PHENOMENON 1

Only applicable for monitors with a Ring-shaped Mains Transformer mounted. Due to the much lower internal resistance of this type of transformer, the switch mode HV supply is not stable enough and creates a visible disturbance in images. The disturbance shows as a small ripple mark in vertical lines.

Solution

- Replace C83 (value 100 nF) with 22 nF, 12NC 2222 344 51223.
C83 can be found in location B4 on diagram Z3-1.3. For the approx. position of C83 on the board see the diagram on page 4 of this errata.
- Replace R98 (value 100 k Ω) with 392 k Ω , 12NC 2322 156 13924.
R98 can be found in location B2 on diagram Z3-1.3. For the approx. position of R98 on the board see the diagram on page 4 of this errata.

This modification to be checked for and executed if necessary.

PHENOMENON 2

Sometimes a horizontal disturbance, with SLR video only, can be seen.

Solution

- Replace R115 (value 2,2 M Ω) with 3,3 M Ω , 12NC 2322 242 83325.
R115 can be found in location A2 on diagram Z3-1.3. For the approx. position of R115 on the board see the diagram on page 4 of this errata.

This modification is only to be implemented when the phenomenon occurs.

PHENOMENON 3

At the outer left side in a screen with text, a part of the characters may be partly highlighted (vertically only).

Solution

- Replace R49 (value 27,4 k Ω) with 22,1 k Ω , 12NC 2322 156 12213.
R49 can be found in location C4 on diagram Z3-1.2. For the approx. position of R49 on the board see the diagram on page 4 of this errata.

This modification is only to be implemented when the phenomenon occurs.

PHENOMENON 4

After large video-signal changes (black to white or v.v.) a black band effect might be visible (also after blanking to high white signal).

Solution

- Remove from the tube-socket board capacitor C6 (value 22nF).
Use page Z3-3 of the manual to locate C6. Its is closely located to coaxial connector X2 on the tube socket board.
- Replace R14 (value 1 k Ω) on the tube socket board with 5,11 Ω , 12NC: 2322 156 15118. Use page Z3-3 of the manual to locate R14.
R14 is located next to coaxial connector X2 on the tube socket board.
- Remove from the basic board R133 (value 3,92 k Ω) and C47 (value 100pF)
R133 can be found in location A4 on diagram Z3-1.2. For the approx. position of R133 on the board see the diagram on page 4 of this errata.
C47 can be found in location B4 on diagram Z3-1.2. For the approx. position of C47 on the board see the diagram on page 4 of this errata.
- Replace R168 (value 3,92 k Ω) with 6,81 k Ω , 12NC 2322 156 16812.
R168 can be found in location A4 on diagram Z3-1.2. For the approx. position of R168 on the board see the diagram on page 4 of this errata.
- Add C101 and C102 (22nF), 12NC 2222 344 51223:
C101 between D2:4 and D2:2
C102 between D3:4 and D3:2
D2 and D3 can be found in location A3/B3 on diagram Z3-1.6. For the approx. position of D2 and D3 on the board see the diagram on page 4 of this errata.

Implement these modifications only when the described phenomenon is observed.

PHENOMENON 5

It is not always possible to achieve optimal focussing of the image.
(The focussing potmeter will be completely CCW.)

Solution

- The focussing adjustment voltage range can be set to o.a. -75 Volt by removing diode V52 from the basic board. Re-adjustment of focussing will be required with R13.
V52 can be found in location B4 on diagram Z3-1.4. For the approx. position of V52 on the board, see the diagram on page 4 of this errata.

Perform this action only if focussing is not optimal and remarks are made by the user(s).

COMPONENT-SIDE VIEW

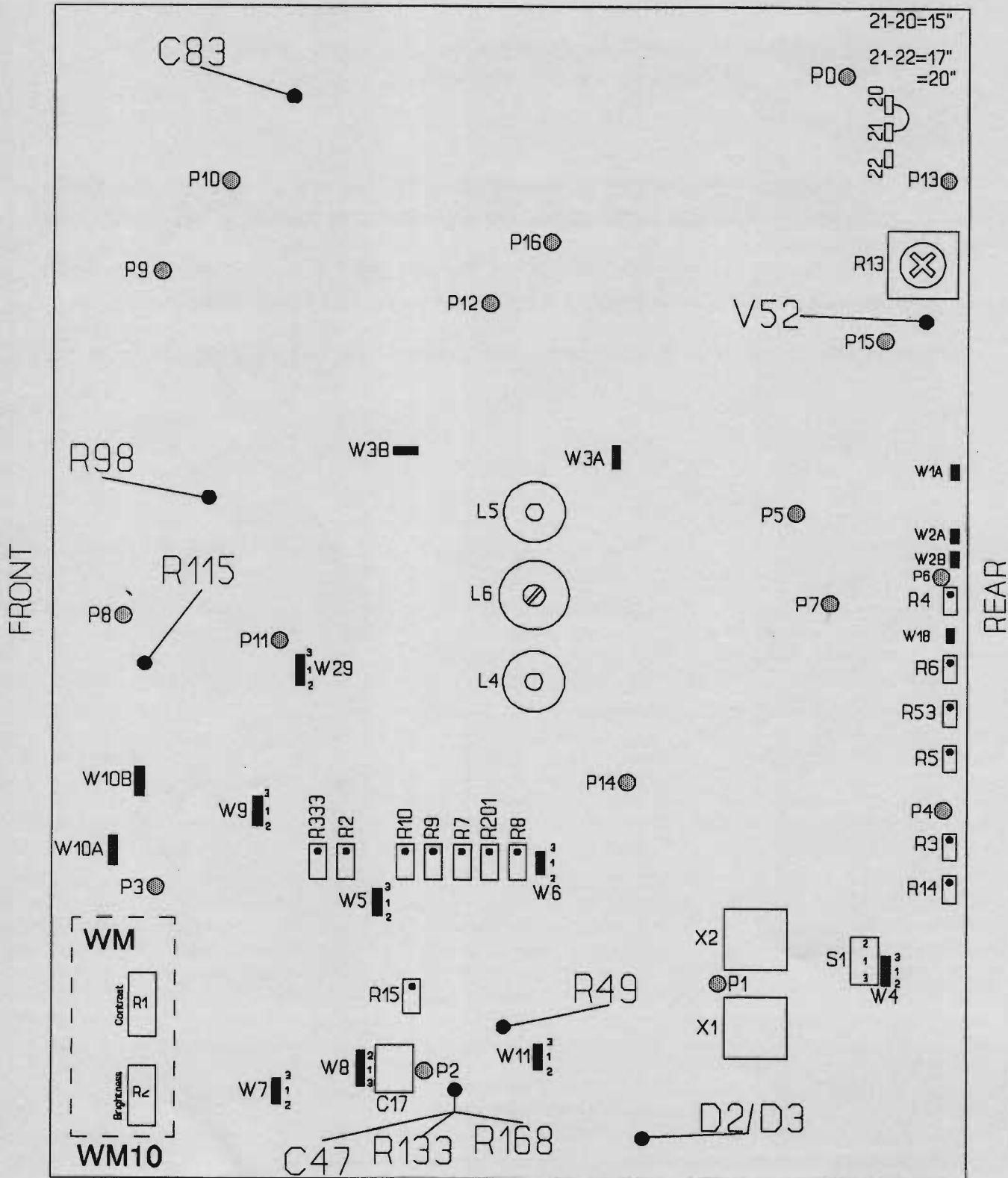

Approx. Component Positions for the Errata

SERVICE MANUAL-UNIT
HM(R)17S 17" TV Monitor

9807 753 (0/1)..01

9896 010 022(0/1)1

For serial numbers, see list of pages and drawings

WARNING

TO REDUCE THE RISK OF FIRE OR ELECTRIC SHOCK,
DO NOT EXPOSE THIS APPLIANCE TO WET LOCATIONS.
SEE ALSO SAFETY INFORMATION FOLLOWING THIS PAGE.

**This manual contains descriptive information
on the equipment identified by
the typenumber as stated above.**

IPSC: Best

**Copyright © 1991,1992,1993 PHILIPS MEDICAL SYSTEMS NEDERLAND B.V.
BEST THE NETHERLANDS**

1. SERVICE SAFETY INFORMATION

1. All work on the exposed monitor chassis shall be performed by qualified service personnel only. No work should be attempted without carefully consulting this manual.
2. The rotatable version of this monitor has a rotation motor and a motor drive p.c.b. which are connected to the mains supply. In case of servicing those units an isolation transformer should always be used.
3. It is advised to ground the chassis during any service handling. Check the interconnection of the two earth screws (safety earth and functional earth) located at the back side of the monitor behind the back cover. When working on the exposed chassis use only one hand during testing to avoid severe electrical shock.
4. As rough handling of the picture tube may cause implosion it should be handled with great care. The use of safety goggles and protective gloves is strongly advised. Replace the picture tube only with the type Philips M41EAA27WW dark tinted picture tube; see also clause 9.
5. As possibly danger of personal injury might result from unnecessary exposure to X-ray radiation generated by the picture tube, prolonged exposure at close range to unshielded areas of the picture tube should be avoided.
6. In case of repair, always switch off the monitor first. After switching off, wait at least 30 seconds, because the monitor has a self-discharging Cathode Ray Tube which takes 30 seconds to discharge. The only electrical parts of the monitor that may be exchanged are printed circuit boards. After exchanging printed circuit boards which might influence the high voltage of the monitor, the value of this voltage shall be checked to be 19 ± 1 kV. If a deviating value is found, it shall be corrected by adjusting R8, R7 and R201 on WM10 along the lines of the test instructions.
7. After exchanging PCB's in the supply unit, check the voltage on X1:1 to be $+120 \pm 1$ Volt. If a deviating value is found, readjust R1 on WM20. Use only an isolated screw driver.
8. The monitor is supplied connected for 220 V mains supply only. The mains cord, being a part of the cable harness (see Z2-2: cable harness) must be connected according to the relevant System Documentation. The mains cord contains 3 wires. Their colours indicate the following:
GREEN (GN) : SAFETY EARTH
BLACK (BK) }
WHITE (WH) } : 220 Vac
9. The monitor shall be installed at least 6 feet (1,83 m.) beyond the perimeter of the patient's bed, or table etc., and at least 7,5 feet (2,29 m.) above the floor.
- 10a. All components, indicated on the schematics with Δ have safety functions. They may only be replaced by components having exactly the same properties. This can only be guaranteed if components of the same manufacturer or supplier are used.
- 10b. Normal repair of the monitor shall be carried out by exchanging complete Printed Circuit Boards. If repair on a Board is unavoidable, refer to manufacturer's parts list for safety critical components as mentioned under 10a.
11. When mounting the cable harness (code nمبر.: 9807 750 31101), make sure the protective sleeve of the harness does not stick into the monitor for more than 1 cm. Lengths of cables from the cable harness inside the monitor must be kept as short as possible. Cables should be drawn back if, e.g. during transport, the sleeve has been shifted too much.

12. Before returning the serviced monitor to a client or before putting it into operation at least the following safety tests should be performed:
 - a. Earth continuity test:

An ohm meter is used to measure the resistance between each separate accessible metal part and the earth connection of the mains inlet.

All measured values should be $\leq 0,1$ Ohm.
 - b. Earth leakage test:

An AC meter with an impedance of 1500 ohm, shunted by 0,15 μ F is connected between the safety earth screw and the earth connection of the wall outlet.

During this measurement the monitor may not be connected to the mains earth connection.

The measured value should be $\leq 0,7$ Volt.

WARNING

In case of a defect in the monitor, the enclosure may be under voltage stress, if the measured voltage is over the indicated value.

13. This monitor is supplied with 2 fuses, 2 spare fuses and a copper bar.

When using the monitor with a mains plug which can be reversed, both phase and neutral must be fused.

In all other cases only the phase (L) must be fused and the copper bar must be inserted into the neutral (N) fuseholder. If not indicated, to be determined by measuring with a low impedance ohm measuring device, or voltage measuring device. (IEC 601).

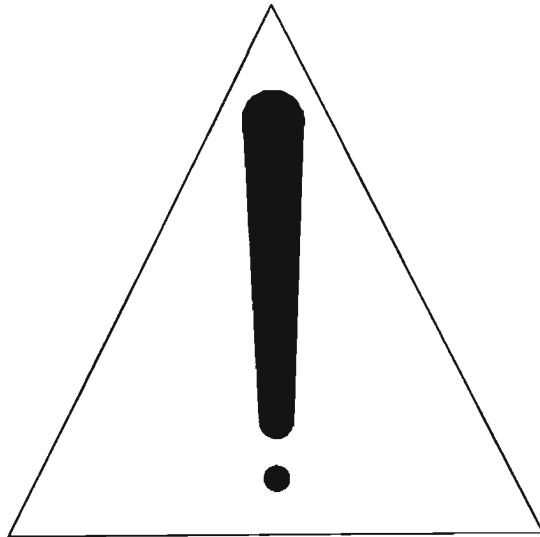

The exclamation point within an equilateral triangle is intended to alert the user to the presence of important operating and maintenance (servicing) instructions in the literature accompanying the appliance.



An appliance and cart combination should be moved with care. Quick stops, excessive force, and uneven surfaces may cause the appliance and cart combination to overturn.

TECHNICAL DATA, PLANNING A ▶

INSTALLATION B ▶

SETTING TO WORK C ▶

CORRECTIVE MAINTENANCE F ▶

PARTS LIST P ▶

DRAWINGS Z ▶

ADDITIONAL INFORMATION AI ▶

▶

▶

▶

▶

HM(R)17S 17" TV Monitor

SERVICE MANUAL UNIT
 HM(R)17S 17" TV MONITOR
 TYPE NR: 9807 753 (0/1)..01 and 9896 010 022(0/1)1

SERIAL NR:

Manual codenumber: 4522 983 49091

LIST OF PAGES AND DRAWINGS

0.5	(93.2)	F-9	(93.2)
1	(93.2)	F-10	(93.2)
1.1	(93.2)	F-11	(93.2) Transparency
1.2	(93.2)	F-12	(93.2) Transparency
1.3	(93.2)		
2	(93.2)	FZ-1	(93.2)
2.1	(93.2)	FZ-2	(93.2)
A-1	(93.0)	Z-0	(93.0)
A-2	(93.0)	Z1-1	(93.0) 15"/17"/20" Basic Monitor Block Diagram
A-3	(93.0)	Z1-2	(93.0) 15"/17"/20" Basic Monitor Rot.
A-4	(93.0)	Z2-1	(93.0) 15"/17"/20" Basic Monitor Wiring Diagram
A-5	(93.0)	Z2-2	(93.0) 15"/17"/20" Basic Monitor Cable Harness
		Z3-1.0	(93.0) 17" Basic Monitor Reference list
B-1	(93.0)	Z3-1.1	(93.0) 17" Basic Monitor Comp. Layout
B-2	(93.0)	Z3-1.2	(93.0) 17" Basic Monitor 4522 167 00273
		Z3-1.3	(93.0) " "
		Z3-1.4	(93.0) " "
		Z3-1.5	(93.0) " "
		Z3-1.6	(93.0) " "
C-1	(93.1)	Z3-1.0	(93.0) 15"/17"/20" Basic Monitor Reference list
C-2	(93.1)	Z3-1.1	(93.0) 15"/17"/20" Basic Monitor Comp. Layout
C-3	(93.1)	Z3-1.2	(93.0) 15"/17"/20" Basic Monitor 4522 167 00274
C-4	(93.1)	Z3-1.3	(93.0) " "
		Z3-1.4	(93.0) " "
CZ-1	(93.1)	Z3-1.5	(93.0) " "
CZ-2	(93.1)	Z3-1.6	(93.0) " "
		Z3-1.7	(93.0) " "
F-1	(93.2)	Z3-2	(91.0) Power Supply board WM20 4522 107 87853
F-2	(93.2)	Z3-3	(91.0) Tube Socket board WM30 4522 107 87805
F-3	(93.2)	Z3-4	(91.0) Rot. control board WM60 4522 108 10002
F-4	(93.2)		
F-5	(93.2)		
F-6	(93.2)		
F-7	(93.2)		
F-8	(93.2)		

Section A: INTRODUCTION AND TECHNICAL DATA

Contents

1.	GENERAL	A-2
1.1.	SCOPE OF PRODUCT	A-2
1.2.	BASIC PROPERTIES	A-2
2.	DEFINITION OF TERMS	A-2
3.	TECHNICAL REQUIREMENTS	A-2
3.1.	OPERATIONAL PERFORMANCE	A-2
3.1.1.	Electrical	A-2
3.1.2.	CRT	A-3
3.1.3.	Mechanical	A-4
3.1.4.	Compatibility	A-4
3.2.	MAINTENANCE AND LOGISTICS	A-4
3.3.	OPERABILITY	A-4
3.3.1.	Reliability	A-4
3.3.2.	Operational Environment	A-4
3.4.	DESIGN CONSTRAINTS	A-4
4.	INTERFACES	A-5
5.	OPERATION	A-5
5.1.	FUNCTIONAL DESCRIPTION	A-5
5.2.	PERFORMANCE	A-5
5.3.	DESIGN CONSTRAINTS	A-5
6.	MONITOR SCREEN CLEANING	A-5

1. GENERAL

1.1. SCOPE OF PRODUCT

This section describes the performance of a high resolution dual standard TV monitor for display of monochrome video signals.

The monitor is considered to be a segment of an X-ray TV system.

Styling is in correspondence with this environment.

The 50Hz version has code nrs. 9807 753 0..01 and 9807 753 8..01, while the 60Hz version has code nrs. 9807 753 1..01 and 9807 753 9..01 for rotatable versions. The non-rotatable versions have code nrs. 9896 010 02201 and 9896 010 02221 for 50Hz and 9896 010 02211 and 9896 010 02231 for 60Hz.

The rotatable monitor types have image rotation (by rotation of the deflection coil), while all monitors have ambient light controlled brightness and contrast, clickpositions for brightness and contrast and automatic switching of line rate (Standard or High-line).

The product is a non-dividable functional unit. All properties can be easily verified.

1.2. BASIC PROPERTIES

The monitor is equipped with a 17 inch high resolution dark tinted, antiglare (direct grind) picture tube M41EAA27WW, deflection angle 110 degrees. The monitor will accept both standard TV signals and high resolution signals. Switching over is done automatically.

Without an input signal the monitor will switch to low lines.

In the high resolution mode, an aspect ratio of 3:4 or 1:1 can be selected by internal jumpers. After changing the aspect ratio readjustment of the picture width and geometry will not be necessary.

The monitor can display 100/120 Hz pictures by internal jumpering. Readjustment of picture height will be necessary after changing jumper setting.

The application area of the 17" monitor will be in medical diagnostic imaging systems.

2. DEFINITION OF TERMS

- STANDARD SIGNALS are video signals that comply with CCIR or EIA broadcast standards.
- NON-STANDARD SIGNALS are video signals that do not exactly meet the CCIR or EIA standard. Possible deviations are:
 - o absence of equalizing pulses
 - o line and frame frequency, up to max. +/- 4%
 - o set up levels
 - o fall and rise times of synchronization pulses
 - o non-standard ratio of video/sync.

3. TECHNICAL REQUIREMENTS

3.1. OPERATIONAL PERFORMANCE

3.1.1. Electrical

- Power

Supply voltage : 220 V \pm 10%

Frequency range : 48-62 Hz

Input power : ca. 70W

CRT high voltage: 18.5 \pm 1 kV at zero beam current.

Breathing < 2% from zero to max. beam current.

- Video Amplifier

The monitor will accept the following input signals:

- Standard signals CCIR or EIA.
- Non-standard signals with the line and field frequency within the range of CCIR or EIA.
- High resolution signals 1249 lines 50 Hz or 1049 lines 60 Hz.
- Signals with 100 or 120 Hz field frequency (line frequency 32 KHz).
- Separated video and composite synchronization pulse.
- Signals from VCR and VTR.

- Input level

- Composite video: 0.5 Vpp to 2 Vpp.
Nominal 1 Vpp.
- Video 0.35 Vpp to 1.4 Vpp;
- Sync. 0.15 Vpp to 0.6 Vpp.

- Ratio peak video/sync.: max. 4.5

- Frequency response maximal deviation from a flat characteristic:

- Up to 20 MHz -1 dB to +1 dB.
- At 25 MHz \leq -3 dB.

- Tilt
 - Tilt on 50 Hz square wave $\leq 5\%$
 - Tilt on line frequency square wave $\leq 5\%$
 - Overshoot on 250 kHz square wave $\leq 5\%$

Figures defined at 100 cd/m² peak white level.

- Hum
50% added hum at nominal video level will give no significant picture disturbance.

- Horizontal Deflection

Nominal line frequency 15680 Hz or 31350 Hz.

Synchronization lock and hold: 4%

Flyback time : max. 6.5 μ S

Stability of amplitude : better than 2% of picture height.

- Vertical Deflection

Synchronization: 48 Hz to 62 Hz or
96 Hz to 124 Hz.

Stability of amplitude: better than 2% of picture height.

- Dynamic Focus

Horizontal and vertical dynamic focus is applied.

3.1.2. CRT

- Display Size

243 x 243 mm or 243 x 324 mm

- Aspect Ratio

In Low Line Rate mode an aspect ratio of 3:4. Internal jumper selectable aspect ratio in High Line Rate mode; 1:1 {for XTV5 and XTV6 (9807 733 5/6..01)} or 3:4 {for XTV6 (9807 736 7..01) and higher}, without the need for readjustments.

- Interlace Factor

Better than 45:55.

- Geometry

Inside monitor circle better than 1% of picture height; 2% for rotatable version.
Outside monitor circle 2%.

- Resolution

Modulation of 20 MHz bars in the centre $\geq 20\%$ (high line rate).

Modulation at 500 kHz is 100%.

- Positional Hum

Peak to peak displacement is less than 0.2% of picture height.

- Picture Position

The theoretical centre of the monitor circle is centered to the displayed area with a maximal deviation of 1% of the picture height.

During a full rotation the maximal allowed swing of the monitor circle is 3.5 mm.

After switching from low to high line rate or back, an additional shift of 1% is allowed. This is only valid if for the input sync. the ratio (front porch + sync. pulse width) / blanking width is the same for both high and low line rate.

- Black level

With the black level adjusted to 4 cd/m² this level will be reached within 10 minutes.

From picture appearance until stabilization the level will be ≤ 10 cd/m².

Drift versus temperature: ≤ 2 cd/m² over operating temp. range.

Change due to 50% white at 250 cd/m²:

≤ 5 cd/m².

Black level luminance : max. ≥ 15 cd/m²
equivalent min. $\leq - 50$ cd/m².

- White level

front control:

dark tinted picture tube: max. 600 cd/m²

min. equal to black level.

- Picture height stability

In all normal operating conditions, including empty tape play back, the picture dimensions shall not drop below 70% of the useful screen dimensions.

- Deviations after switching line rates

Switched from low line rate to high line rate:

change in white level: < 10 cd/m²

change in black level: < 2 cd/m²

change of picture position: $< 1\%$.

- Breathing

Breathing < 2% from zero to maximal beamcurrent.

- Ambient light controlled brightness and contrast levels

Click stops on brightness and contrast control are factory set to allow the optimal control settings to be easily reinstated, if they should be disturbed.

- Control at ambient light levels between 1 and 1000 lux.
- Control characteristics jumper selectable, depending on application.
- Wide field of view optical sensor.

3.1.3. Mechanical

The monitor consists of a plastic cabinet.
Mounting facilities for a cushion / handgrip are provided.
All connectors are located inside the monitor.
Overall dimensions height x width x depth :
365 x 405 x 350 mm.
Weight: approx. 24.5 kg.

3.1.4. Compatibility

- The monitor is compatible with the following systems:
 - o TV CHAIN XTV4
 - o TV CHAIN XTV5
 - o TV CHAIN XTV6
 - o TV CAMERA XTV8
 - o TV CHAIN XTV11
 - o DCI systems
 - o DVI systems
 - o DSI systems
 - o VCR and VTR

3.2. MAINTENANCE AND LOGISTICS

- Several measures have been taken to assure good serviceability:
 - o Printed circuit boards can easily be exchanged.
 - o Good accessibility for measuring purposes.
 - o Easy exchange of picture tube.

3.3. OPERABILITY**3.3.1. Reliability**

MTBF: 15000 hours excluding picture tube, picture tube 24000 hours.
MTTR: 0.5 hours
Economic life: 7 years

3.3.2. Operational Environment

Temperature range (in C.) :
+10 to +40 degrees during operation
-25 to +70 degrees during transport

Humidity:
max. 90% during operation

Mains supply:

The monitor will show no significant picture deterioration under the following conditions:
Mains voltage drops of 25% during 10 ms.
Mains voltage drops of 100% during 1 ms.
Spikes of 500 V on mains voltage according to UXW 13850.

No defects may occur due to voltage spikes of 1000 Vpp according to UXW 13850.

3.4. DESIGN CONSTRAINTSApplicable Standards and Regulations- Safety

IEC 601-1
AP requirements only applicable for remote control functions
UL 1410
CSA C22.2

- Electro Magnetic Compatibility

EMC behaviour in accordance with UXW 13850
UXW 13850 covers VDE 0871 (level B)
VDE 0875 (level N)
FCC rules

- X-ray Radiation

The monitor complies with: DHHS
NH+W
Röntgenverordnung

- Mechanical Environment :

M1 - Acc. to UXW 13600 -

- Climatic Environment :

C1 - Acc. to UXW 13600 -

4. INTERFACES

2 BNC connectors for video with loop-through facility. When no loop through is required (75 Ohm termination), the second BNC connector can be used for external composite synchronization or parking a second video cable.

1 DIN plug and 1 MOD connector for remote control of rotatable scan system.

1 9-pin D connector for remote control of brightness and contrast (when applicable).

Mains: 3 flat pins IEC connector for mains cord.

Video earth / mains earth connection with strip.

5. OPERATION

Click position for default setting of brightness and contrast adjustment by knobs at the front of the monitor.

For flawless functioning of automatic brightness / contrast control both potentiometers must be in their click position.

All other adjustments are located inside the monitor and are not user operated.

For rotatable scan control: 3 switches for left-, right rotation and zero position are provided.

5.1. FUNCTIONAL DESCRIPTION

For the rotatable monitors there is the possibility of rotating the image in any desired position. Rotating can be done either by three pushbuttons on the front of the monitor, or by remote control.

5.2. PERFORMANCE

- Mains voltage: 220 Vac 50 Hz or 60 Hz only.

- Rotation control:

- o 3 pushbuttons on the front for left, right and zero.
- o Remote control via a 10 pole MOD connector (WM60:X1) or 6 pole DIN plug (WM60:X7).

- Zero position: Maximal deviation from the nominal zero position ± 5 degrees. When switching on, the image automatically moves to this position.

- Rotation time: circa 10 seconds.

- Picture position: An extra deviation of the picture position in a rotated position is allowed.

- Operation of the image rotation mechanism shall not generate any visible disturbance in the image.

5.3. DESIGN CONSTRAINTS

Apart from standards and regulations mentioned in 3.4 the remote control connections also meet the AP requirements.

6. MONITOR SCREEN CLEANING

Use for cleaning the monitor screen a soft cotton cloth moistured with water and soft soap.

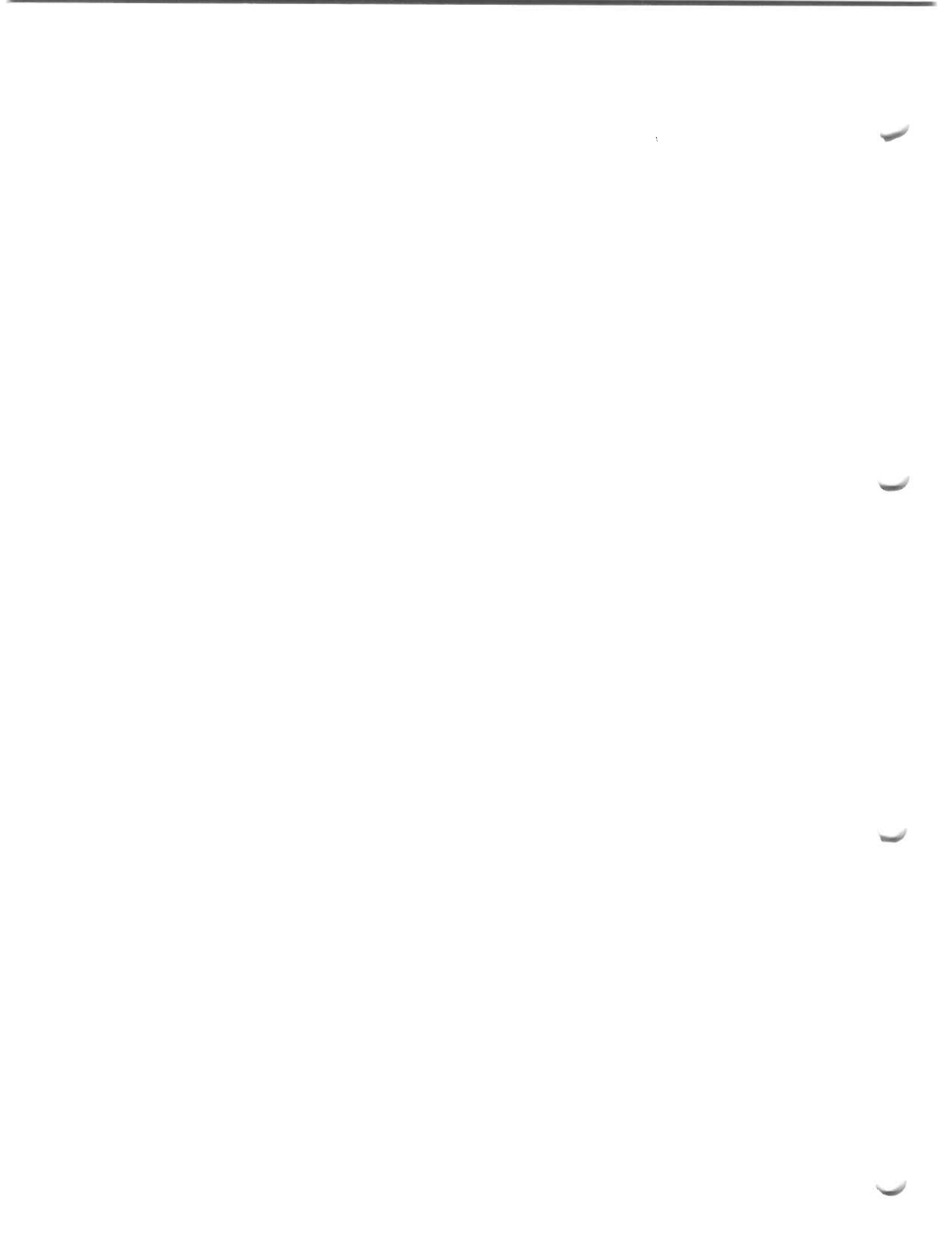

Section :B

INSTALLATION

Contents

1.	CABLE ASSIGNMENTS	B-2
2.	DISMOUNTING AND MOUNTING OF THE CABLE HARNESS	B-2

1. CABLE ASSIGNMENTS

- WM10:X1 Video IN termination at 75 ohm via switch WM10:S1 if not looped through
- :X2 Video OUT (Loop Through) or External Synchronization or for parking a second video cable.

NOTE

*With cable harness 9807 750 31101 two video cables are provided.
If a second monitor or loop through situation is not needed the second video cable can be parked at WM10:X2, provided that WM10:X2 is disconnected from the circuitry by switching S1 to the right, as seen from the rear, and putting W4 on 1-2.*

- Now, the cable harness plus strain relief clamp can be loosened by lifting up the clamp a little.
- This clamp exists of two clamp halves, one clamp cover and a plug. Those parts are attached to each other by four screws M3x20.
- By removing those four screws the parts can be taken apart and in this way the clamp can be removed from the cable harness.

NOTE

The second hole is for looping-through possibilities, if not used the second hole must be covered with the delivered plug.

- WMX1 220 Vac Mains
- WM1 yel/grn Ground
- WM60:X1 MOD connection for remote control of rotation system.
- :X7 DIN connection for remote control of rotation system.
- :X8 D connection for remote control of brightness and contrast levels.

NOTE

Above cables are integral part of cable harness 9807 750 31101.

Mounting of the cable harness takes place by carrying out the actions mentioned above in the reversed order.

IMPORTANT

- Make sure the protective sleeve of the harness does not stick into the monitor for more than 1 cm. Lengths of cables from the cable harness inside the monitor must be kept as short as possible. Cables must be drawn back if, e.g. during transport the sleeve has been shifted too much.
- If applicable :
the guiding of the cable harness must be such that, independent of the position of the monitor, the protective sleeve always stays at least 92 cm above the floor.

2. DISMOUNTING AND MOUNTING OF THE CABLE HARNESS

- Remove the cable harness from the clamp by pulling the harness backwards (away from the monitor housing).
- Loosen the four screws at the rear and remove back cover.

Section C:

SETTING TO WORK

Contents

1. **GENERAL** C-2

OVERVIEW 4522 167 00273 C-3

OVERVIEW 4522 167 00274 C-4

Component view of basic board WM10 CZ-1

Component view of basic board WM10 CZ-2

1. GENERAL

- Check and ensure all plugs are in (the right) place, and programming is accomplished according to the installation.
- Connect mains supply, apply VIBS signal, terminate with 75 ohm, and check the image for cosmetics.
- Brightness and contrast control are factory adjusted for correct settings, with front control potentiometers in click position. However, in some applications the user might prefer a different setting.
When using the Automatic Brightness and Contrast control (ABC) (WM10:W5 in on position), it is important to bear in mind, that a deviation from the click position influences the correct behaviour of the ABC. There are limited possibilities to correct this:
 - a) Contrast up or down without changing brightness.
 - b) Slightly bringing Brightness down and putting jumper W8 in position 1-3.
 - c) Brightness down, Contrast up and putting jumpers W7 + W8 in position 1-3.
- If ABC control is not desired (WM10:W5 in off position), adjust brightness and contrast levels as follows: under normal light conditions: first apply image then turn brightness and contrast (front controls) counter-clockwise. Turn brightness up until image just becomes visible. Then turn contrast up to a desired value.
- In most cases this will be the extent of the adjustments. A list of switches, jumper settings and potentiometers with the effects of their adjustment has been included if the need for further adjustments are required.

OVERVIEW of switches, jumpers, potentiometers, capacitors and coils with the effect of their adjustment.

For board 4522 167 00273

Name	Position	Function
WM10: S1	1-2	Terminates WM10:X1 with 75 ohm. With WM10:W4 on 1-2, WM10:X2 is suitable for parking a second video cable. With WM10:W4 on 1-3, WM10:X2 is suitable for a separate sync. input (if applicable). Loop through (WM10:X1 = WM10:X2), WM10:X1 not terminated.
	1-3	
WM10: W1A		Double frame frequency
W1B		Normal frame frequency
W2A		Double frame frequency
W2B		Normal frame frequency
W3A		3:4 scan ratio High Line rate
W3B		1:1 scan ratio High Line rate
		Sync. from VIBS at WM10:X1
W4	1-2	Separate sync. input at WM10:X2 (terminate externally !)
	1-3	LDR switched off
W5	1-2	LDR switched on
	1-3	1:1 scan ratio High Line rate
W6	1-2	3:4 scan ratio High Line rate
	1-3	Ambient Light Dependent Contrast Control : Standard
W7	1-2	Ambient Light Dependent Contrast Control : Low
	1-3	Ambient Light Dependent Brightness Control : On
W8	1-2	Ambient Light Dependent Brightness Control : Off
	1-3	Automatic High / Low Line selection or fixed High Line
W9	1-2	Fixed Low Line (in combination with WM10:W10)
W10A	1-3	Fixed High Line
W10B		Automatic High / Low Line selection or fixed Low Line (in combination with WM10:W9)
WM: R1		Contrast adj. (front panel)
R2		Brightness adj. (front panel)
WM10: R3		Maximum H.T. adj. (21 kV)
R4		Vertical linearity
R5		Vertical shift
R6		Low Line height adj.
R7		High Line H.T. & image width adj. for 1:1 scan ratio
R8		Low Line H.T. & image width adj.
R9		Horizontal shift
R10		Line (Hor.) time adj. (64.0 or 63.5 µsec)
R13		Centre focus
R14		G1 adjust
R15		Cathode adjust (white limiting)
R53		High Line height adj.
R201		High Line H.T. & image width adj. for 3:4 scan ratio
WM10: C17		Frequency correction (minimal overshoot video)
L4		Low Line horizontal linearity
L5		High Line horizontal linearity
L6		Low Line image width
WM20: R1		+120 volt adj.
WM30:		No adjustments
WM60:		No adjustments

OVERVIEW of switches, jumpers, potentiometers, capacitors and coils with the effect of their adjustment.For boards \geq 4522 167 00274

Name	Position	Function
WM10: S1	1-2	Terminates WM10:X1 with 75 ohm. With WM10:W4 on 1-2, WM10:X2 is suitable for parking a second video cable.
	1-3	With WM10:W4 on 1-3, WM10:X2 is suitable for a separate sync. input (if applicable). Loop through (WM10:X1 = WM10:X2), WM10:X1 not terminated.
WM10: W1A		Double frame frequency
W1B		Normal frame frequency
W2A		Double frame frequency
W2B		Normal frame frequency
W3A		3:4 scan ratio High Line rate
W3B		1:1 scan ratio High Line rate
W4	1-2	Sync. from VIBS at WM10:X1
	1-3	Separate sync. input at WM10:X2 (terminate externally !)
W5	1-2	LDR switched on
	1-3	LDR switched off
W6	1-2	1:1 scan ratio High Line rate
	1-3	3:4 scan ratio High Line rate
W7	1-2	Ambient Light Dependent Contrast Control : Standard
	1-3	Ambient Light Dependent Contrast Control : Low
W8	1-2	Ambient Light Dependent Brightness Control : On
	1-3	Ambient Light Dependent Brightness Control : Off
W9	1-2	Automatic High / Low Line selection or fixed High Line
W10A	1-3	Fixed Low Line
W10B		Fixed High Line
		Automatic High / Low Line selection or fixed Low Line
W11	1-2	Normal mode (1100mV)
	1-3	DCAS mode (700mV)
W29	1-2	VCR mode
	1-3	Normal mode
WM: R1		Contrast adj. (front panel)
R2		Brightness adj. (front panel)
WM10: R2		Horizontal shift HLR
R3		Maximum H.T. adj. (21 kV)
R4		Vertical linearity
R5		Vertical shift
R6		Low Line height adj.
R7		High line H.T. & image width adj. for 1:1 scan ratio
R8		Low Line H.T. & image width adj.
R9		Horizontal shift
R10		Line (Hor.) time adj. (64.0 or 63.5 μ sec)
R13		Centre focus
R14		G1 adjust
R15		Cathode adjust (white limiting)
R53		High Line height adj.
R201		High Line H.T. & image width adj. for 3:4 scan ratio
R333		ABC adjustment
WM10: C17		Frequency correction (minimal overshoot video)
L4		Low Line horizontal linearity
L5		High Line horizontal linearity
L6		Low Line image width
WM20: R1		+120 volt adj.
WM30:		No adjustments
WM60:		No adjustments

Component view of basic board WM10

COMPONENT-SIDE VIEW

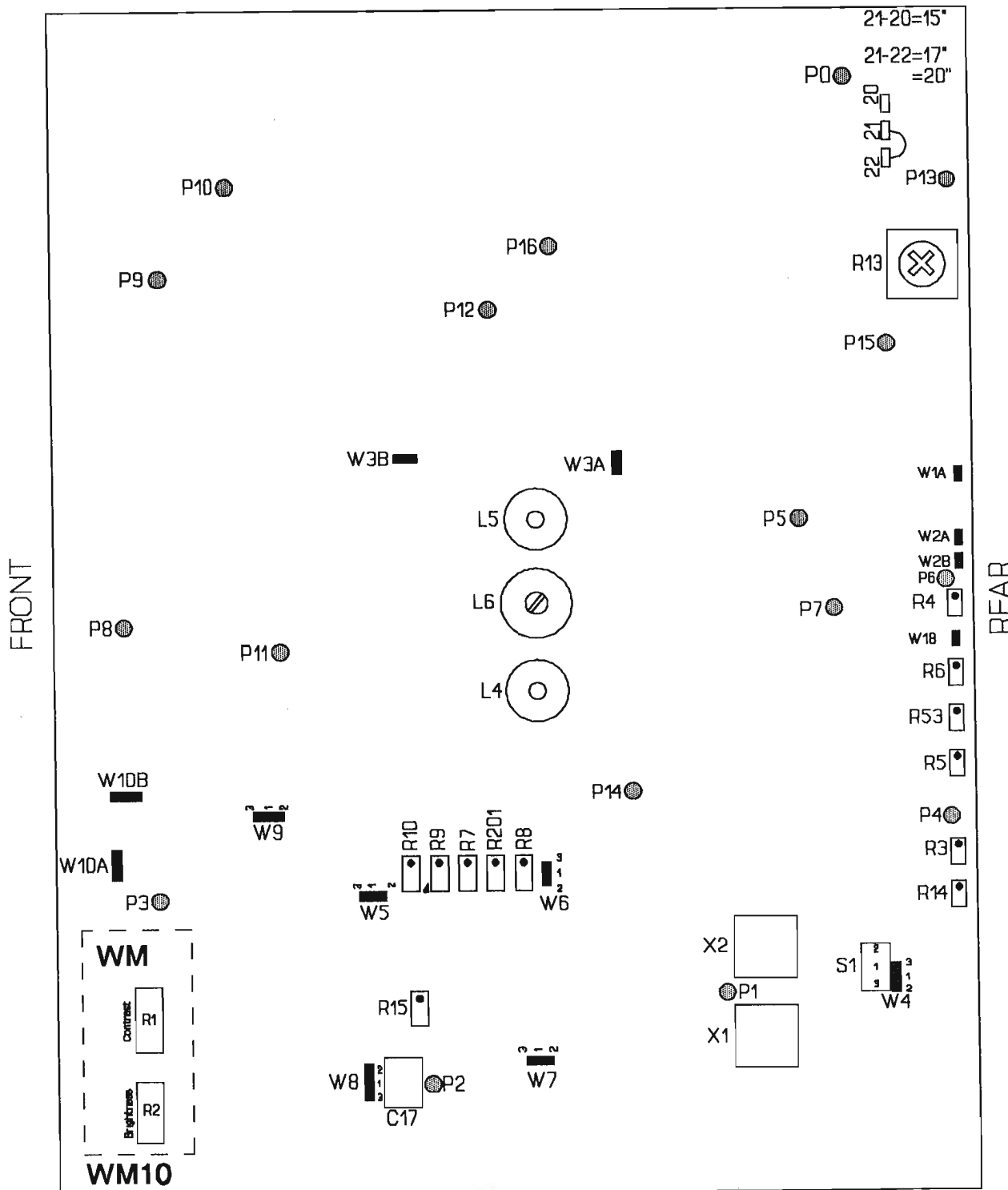

4522 167 00273

Component view of basic board WM10

COMPONENT-SIDE VIEW

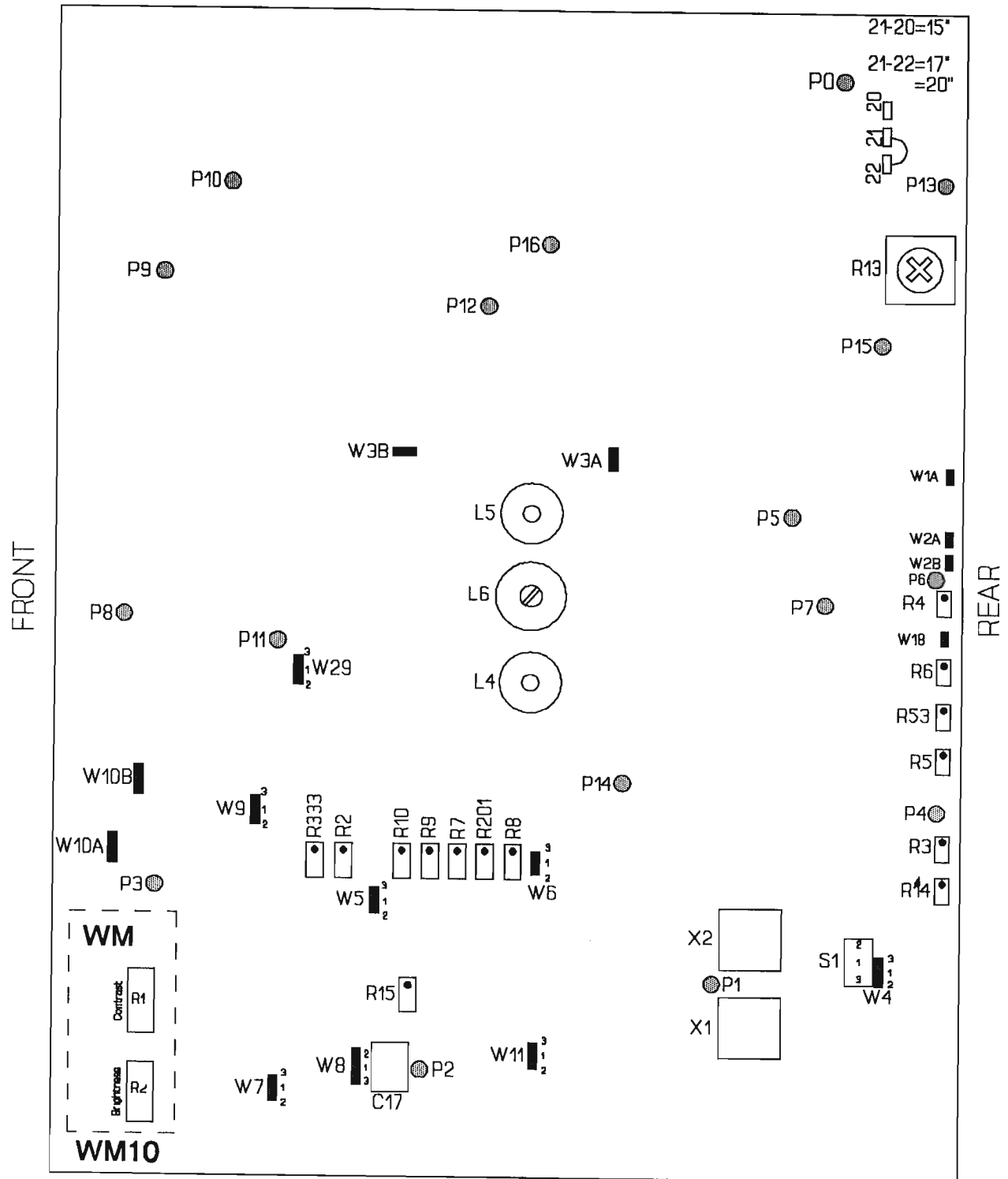

4522 167 00274

Section : F**Corrective Maintenance****Contents**

1.	INTRODUCTION	F-2
1.1.	TOOLS	F-2
1.2.	GENERAL	F-2
2.	ADJUSTMENT PROCEDURES	F-2
2.1.	BASIC BOARD	F-2
2.1.1.	Free running frequency	F-3
2.1.2.	High Tension	F-3
2.1.3.	Image geometry	F-3
2.1.4.	Focus	F-4
2.1.5.	Video amplifier and brightness & contrast adjustment	F-4
2.1.6.	Rotation control	F-7
2.1.7.	Delivery	F-7
2.1.8.	Final evaluation	F-7
2.2.	DEFLECTION CENTERING	F-7
2.3.	OVERVIEW OF ADJUSTMENT FACILITIES ON BASIC BOARD WM10	F-9
2.4.	OVERVIEW OF ADJUSTMENT FACILITIES ON BASIC BOARD WM10	F-10

Illustrations and Drawings

Circle Transparency Right	F-11
Circle Transparency Left	F-12
Component-side view of basic board WM10	FZ-1
Component-side view of basic board WM10	FZ-2

1. INTRODUCTION

1.1. TOOLS

- Oscilloscope (>15 MHz) with TV triggering and delayed time base.
- Lightmeter (recommended measuring devices: MAVO MONITOR(Gossen), or MINOLTA LS(110).
- Digital Multimeter plus High tension probe (recommended device: PM 9246/03)

1.2. GENERAL

The basic board WM10 is not preadjusted in the factory, so when replacing this board it has to be fully adjusted, see paragraph 2.1 for the procedures.

After each repair in the monitor, the maximum high tension adjustment mentioned in 2.1.2 must be carried out (legal requirement).

Fuse WM20:F1 may only be replaced by one of exactly the same type, which can be ordered under code nr. 2422 086 01042 (1A-SB-250V).

In case of mounting a new deflection coil or a new monitor tube (CRT), also the adjustment mentioned in 2.2 (Deflection) must be carried out, together with the adjustments in 2.1!

All adjustments are to be done on WM10 unless otherwise specified.

Indications on direction of turning WM:R1 and WM:R2 are as seen from the front of the unit.

2. ADJUSTMENT PROCEDURES

2.1. BASIC BOARD

The adjustments have to be done with video signals applied from the system in which the monitor is used. Otherwise it may be necessary to readjust V-shift and H-shift after installation of the monitor in the system.

Use the video signal coming from the TV-chain (VIBS).

NOTE

If not present, mount a WM10:R1/R2 support on the basic panel and connect plug WM10:X11.

NOTE

A spare fuse WM20:F1 (2422 086 01042) is needed for the HT adjustment.

Mechanical adjustment of potmeters contrast R1 and brightness R2.

Before placing a new basic board WM10, adjust the two potmeters brightness WM:R2 and contrast WM:R1 mechanically. Fix the ring around the axis with the hexagonal screw. If it is difficult to turn the potmeter, loosen the nut which presses the drum against the ring. Adjust the drum with a screwdriver, to make turning easier. Fix the drum with the nut. Return the ring to the "click" position. Loosen the hexagonal screw to allow the potmeter to turn whilst the ring is held in the "click" position by the drum.

Plugs, jumpers and potmeters

- Check whether all plugs are in (the right) place.
- Turn all potmeters on basic panel WM10 in their mid-position, including R1 and R2 at the front of the monitor, except for R3, R7, R8 and R201: Turn R3, R7, R8 and R201 completely counter-clockwise.
- Check whether all jumpers are in the right place. (see page F-9 or page F-10)
- Jumper positions (WM10) :
 - W1, W2 in position B;
 - W3 in position A;
 - W4 in position 1-2;
 - W5, W6, W7, W8 in position 1-3.

- Put switch WM10:S1 (1-2) to the right, as seen from the rear (75 ohm termination).
- Check : WM60:X5, WM60:X6 and WM60:X9 are disconnected.
- Check that a wire is connected between solder tag WM10:MP21 and WM10:MP22 (HT-kV adaptation for 17" Monitor).

Connect the monitor to the mains voltage and apply power to the monitor.

2.1.1. Free running frequency

Adjust the period time (R10), measured at measuring point 11 to 64.0 μsec for 50 Hz or 63.5 μsec for 60Hz while no video signal is being applied to the monitor.

2.1.2. High Tension

NOTE

- An H.T.-probe is needed for this measurement.
- Spare fuse WM20:F1 needed.
- Put jumper W4 in position (1-2).
Leave S1 to the right. Apply the composite video signal from the TV-chain to input WM10:X1.

Hiccup circuit test

For this test an overall white image signal has to be supplied to the monitor.(700mV excl. sync.) Measure the HT-actual voltage with the HT-probe and multimeter on the HT-coonection on the CRT. !! Before connecting the HT-probe, disconnect the monitor from the mains life voltage. Afterwards switch it back on !!

- 1- Put WM:R1 (contrast) and WM:R2 (brightness) potmeters fully clockwise.
- 2- Turn R8 clockwise until the circuit starts to hiccup (requirement < 21 kV).
- 3- Turn R8 back to V-anode ≈ 19.5 kV.

Switch over to HLR using the same image signal of all white.

- 1- Increase (turn clockwise) R201 until the scanwidth becomes unstable.
- 2- Turn R201 back to V-anode ≈ 19.5 kV.

Maximum high tension

- Turn WM:R1 (contrast) and WM:R2 (brightness) fully counter-clockwise
- Turn R3 completely counter clockwise.
- Mount an 820 ohm resistor between measuring point 16 and 0 V.
- Adjust the High Voltage for SLR (Standard Line Rate) to 21 kV with R8.
Measure the voltage at the high tension point on the picture tube.
- Turn R3 clockwise **very slowly**, until the fuse blows.

- Disconnect the monitor from mains.
- Seal R3, such that turning becomes impossible.
- Remove the 820 ohm resistor.
- Turn R8 a few turns (2-3) back and place a new fuse WM20:F1.
- Put jumper W4 back to (1-2)!
- Connect the monitor back to mains voltage.

2.1.3. Image geometry

Apply the video output signal (VIBS) of the TV-chain to the monitor input WM10:X1.
Put W4 in position 1-2.

Programming for the line rate

When the system applies only SLR (Standard Line Rate) or only HLR (High Line Rate) images, select SLR or HLR. When the system applies both SLR and HLR images, select automatic switching from SLR to HLR. First the monitor is adjusted for SLR and then for HLR.

The line rate can be selected by jumper setting according the table below.

line rate	jumper position	
	W9	W10
SLR	1-3	B
HLR	1-2	A
Automatic	1-2	B

- HLR : High Line Rate
- SLR : Standard Line Rate

MONITOR Geometry Adjustment

TIP

- * Use of the transparent circle sheets on the pages F-11 + F-12):
- create a complete circle with both sheets and fix the sheets with transparent tape.
- measure the mechanical centre of the CRT screen and mark it.
- position the transparent sheets such that the centre of the circle coincides with the measured mechanical centre of the screen.
- adjustment will be easier now, but take care not to make parallax errors.

- (1) Apply a monitor circle with standard line rate video to the monitor.
- (2) Adjust the brightness potmeter (WM:R2) such that the video lines become visible.
- (3) Adjust the image width (R8) such that the displayed rectangular image formed by the video lines just fits in the monitor bezel. (See figure 1) This means that all of the video information is displayed.
- (4) Adjust the image height (R6) such that the raster just fits in the monitor bezel.
- (5) Adjust the linearity with R4 (vertical) and L4 (horizontal) to correct distortions of the circle.
- (6) Adjust the image to the centre of the bezel with horizontal-shift (R9) and with vertical shift (R5)

*** Repeat 3 through 6 until all conditions are met.

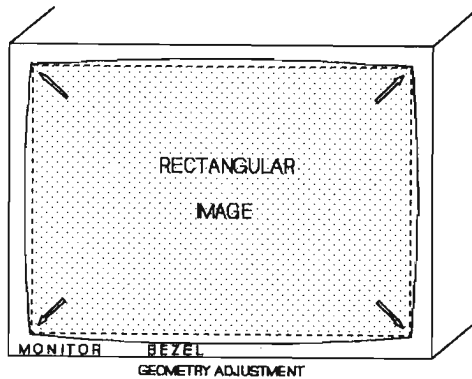

Figure 1

- (7) If available in the system, apply a HLR monitor circle to the monitor.
- (8) Adjust the image width (R201) so that the rectangular image formed by the video lines just fits in the monitor bezel.
- (9) Adjust the image height (R53) so that the raster just fits in the monitor bezel.
- (10) Adjust linearity with L5 to correct distortions of the circle.

*** Repeat 7 through 10 until all conditions are met.

The equality of the High Tension for SLR & HLR is more important than the exact equality of deflection, so repeat the adjustment of SLR High Tension with R8 and HLR High Tension with R201 as necessary.

For SLR, the image width and High Tension can also be influenced by L6.

If necessary also repeat the geometry setup steps 4, 5 and 6 for SLR and 9 and 10 for HLR.

NOTE

The adjustments for SLR and HLR are interactive (influence each other), so first adjust the monitor globally and then concentrate on meeting all conditions.

NOTE

For systems that produce HLR images of 1:1 scan ratio, program W6 to (1-2) and W3 to position B and adjust the image width for HLR with R7 instead of R201, here the HT for HLR should be 250 V lower than for SLR.

NOTE

The image geometry can also be influenced by the round magnets, around the deflection coil.

2.1.4. Focus

Adjust focussing of the image in the middle of the screen with R13, by displaying, for instance a line pair phantom, for optimal definition.

2.1.5. Video amplifier and brightness & contrast adjustment

Monitor light output must have stabilized (at least 1/2 hour after switch-on).

Loosen the rings for click positions around both the front potmeters for contrast and brightness, if this has not already been done.

Switch the LDR off by putting jumper W5 in position off. (see pages F-9 and F-10 for correct setting)

The selection of SLR or HLR is system dependent. The adjustments in the factory are done with SLR images.

(1) BRIGHTNESS CONTROL AND BACKGROUND LIGHT

- Apply composite video signal from the TV-chain to input WM10:X1.

BRIGHTNESS CONTROL ('click-position')

- Turn the contrast potmeter (WM:R1) completely counter-clockwise.
- Adjust with the brightness potmeter (WM:R2) the cathode voltage to 90 volt (see also figure 2). Connect the oscilloscope probe to the lower end of one of the large sized resistors at the left top corner of the tube-socket board (WM30).
- **Only for non-rotatable versions :** Fix the ring of the potmeter in this position for "click". Check the click position by turning the brightness potmeter (WM:R2) a few times (the cathode voltage should return to 90V ; see also figure 2).
- **For rotatable versions:** Leave the potmeter in the adjusted position. Do not fix the "click" position yet.

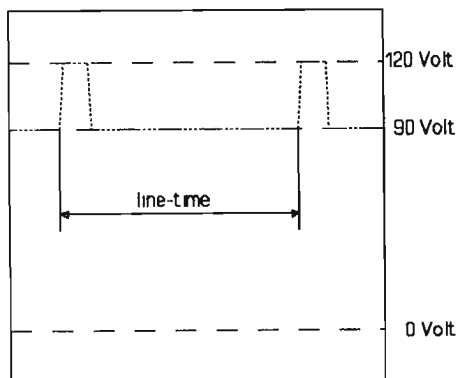

FIGURE 2 : Cathode Voltage
Figure 2

BACKGROUND LIGHT

- Leave the contrast potmeter (WM:R1) in the counter-clockwise position and the brightness potmeter (WM:R2) in the "click" or adjusted position.
- Adjust with R14 (VG1) the light output (image middle) to 1.5 cd/m^2 ($\pm 0.05 \text{ cd/m}^2$). For Intgeris V/H/B System Families adjust to $0.3 \text{ cd/m}^2 \pm 0.05 \text{ cd/m}^2$.

(2) WHITE LIMITING AND CONTRAST & BRIGHTNESS

For the adjustments, white limiting and contrast & brightness, apply the video signal (VIBS) of the TV-chain to the video input (WM10:X1) of the monitor. The video level measured at WM10:MP1 (video in) can be varied by varying the dose rate in the system. The level is also adjustable with the set-up potmeter in the TV-chain for lower signal levels. The system must generate an overall white monitor circle, so do not place an object in the X-ray beam. Only a 1.5 mm copper plate may be placed in the beam as long as the overall white image is not disturbed.

WHITE LIMITING

- Switch on fluoroscopy.
- Set the amplitude of the video signal at WM10:MP1 to 700mV excl. sync, by varying the dose rate. Use the X-ray collimator to create a square of approx. 4x4 cm. in the middle of the screen.
- Turn the contrast potmeter (WM:R1) completely clockwise and adjust the light output in the middle of the square to $600 \pm 5 \text{ cd/m}^2$, with the light limiting potmeter R15.

CONTRAST (for non-rotatable monitors)

- Switch on fluoroscopy.
- Set the amplitude of the video signal at WM10:MP1 to 700mV excl. sync., by varying the dose rate. Use the X-ray collimator to create a square of approx. 4x4 cm. in the middle of the screen.
- Put the brightness potmeter (WM:R2) in the "click" position
- Adjust the light output on the monitor measured in the middle of the square to $300 \pm 5 \text{ cd/m}^2$, with the contrast potmeter (WM:R1). For Intgeris V/H/B System Families $250 \text{ cd/m}^2 \pm 5 \text{ cd/m}^2$.
- Fix the ring of the contrast potmeter (WM:R1) for "click" position. Check the click position by turning the potmeter a few times. The lightoutput should retuen to 300 resp. 250 cd/m^2 .

CLICK-POSITION ADJUSTMENTS for rotatable-version monitors only.

The start-off position is the previously adjusted brightness potmeter (cathode voltage = 90 Volt). The 'click' adjustments are to be done on an adjusted square of 4x4 cm on the screen, created with the shutters of the X-ray collimator

- (A) Apply a video signal of 700mV excl.sync., by varying the dose. Measure at WM10:P1.
- (B) Wait for about 2 minutes for light output stabilisation.
- (C) Adjust the light output in the square to 450 cd/m^2 ($\pm 15 \text{ cd/m}^2$) with the contrast potmeter WM:R1.
- (D) Adjust the light output in the square to 300 cd/m^2 ($\pm 25 \text{ cd/m}^2$) with the brightness potmeter (WM:R2).
- (E) Apply a video signal of 180mV excl.sync..
- (F) Wait for about 2 minutes for light output stabilisation.
- (G) Check the light output in the square is 4 cd/m^2 ($\pm 0.05 \text{ cd/m}^2$). If the value is not correct, adjust with WM:R2 (brightness potmeter).
- (H) Apply a video signal of 700mV excl.sync..
- (I) Wait for about 2 minutes for light output stabilisation.
- (J) Check the light output in the square is 300 cd/m^2 ($\pm 25 \text{ cd/m}^2$). If the value is not correct, adjust with WM:R1 (contrast potmeter).
- (K) Repeat, if necessary the adjustments (E) through (J) until the light output is within the given specifications.
- (L) Fix both potmeters in the adjusted positions for "click" setting.
- (M) Check the proper click-settings by turning both potmeters a few times CW and CCW. Set them back in click and check light output values are according and (G) and (J) with corresponding signal settings.

(3) OVERSHOOT

Overshoot can be adjusted by displaying an image and eliminate the echo or shade.

- Put a strongly X-ray absorbing object e.g. a coin, on the image intensifier input surface plane with adhesive tape.
- Switch on fluoroscopy.
- Eliminate the echo or shade in the displayed image by turning the minimal overshoot capacitor C17 in the monitor.

(4) ABC CONTROL & ADJUSTMENT

Put the ABC to on with jumper W5. (see page F-9 or page F-10)

Apply a video signal of 700mV excl.sync..

Check the working of the LDR circuitry by observing the brightness of the screen :

- when covering the LDR with a finger the screen light output should decrease.
- when illuminating the LDR with e.g. a torch the screen light output should increase.

ABC sensitivity adjustment (only applicable to boards $\geq 4522 \ 167 \ 00274$)

- Connect a Multimeter between W8-2 and ground.
- Apply a lightsource of 30 Lux* to the LDR.
- Adjust with R333 the voltage on the multimeter to 4.50 Volt.
- Check with covered LDR (not illuminated) the brightness on the CRT is $70 \pm 10 \text{ cd/m}^2$.
For Integris V/H/B System Families :
 $30 \pm 10 \text{ cd/m}^2$.
Check with maximal illumination ($\geq 1000 \text{ Lux}$) the brightness on the CRT is $300 \pm 20 \text{ cd/m}^2$.
For Integris V/H/B System Families :
 $250 \pm 20 \text{ cd/m}^2$.

* 30 Lux can be achieved through a circuitry as in figure 5 on page F-8.

(5) FINAL EVALUATION

- Put jumper W5 (temporarily) to off.
- Go back to the adjustment of image geometry to check the image width, height, linearity and the monitor circle position, for the contrast and brightness potmeters in the "click" positions.

2.1.6. Rotation control

This adjustment is only applicable for rotatable versions of the monitor.

Connect WM60:X5, WM60:X6 and WM60:X9.
 (X5 : mains supply)
 (X6 : \pm 15 Volt supply for operating buttons)
 (X9 : low voltage supply for rotation logic)

If present: connect the remote control for rotation (WM60:X1 or WM60:X7).

When switching-on the monitor the deflection coil must automatically turn to its zero position. Check left- and right turning of the deflection coil, both in local- and remote control. Check (with a circle signal) whether the swinging of the circle during rotation remains within 1% of the image height.

Warning

Take care that the flat-cable from Basic board WM10 to the rotation control board WM60 is not running too close to the HT-transformer. This will cause line artifacts in the image. Keep this cable as far as possible away from the transformer and fix it in such a position.

2.1.7. Delivery

- Metal strip for grounding must be parked between 1 and 2.
- Shove basic panel back.
- Put covers in potmeter holes.
- Fix all items and close the rear cover.

2.1.8. Final evaluation

Check the image critically for imperfections like:

- (a) Extreme noise
- (b) A tendency to oscillation
- (c) Stripes

Also check for scratches or dirt on the monitor.

NOTE

The adjustment procedure as described in this section is valid for both 50 Hz and 60 Hz mains frequency applications, only:

- *for low line rate one should read 625 lines for 50 Hz or 525 lines for 60 Hz.*
- *for high line rate one should read 1249 lines for 50 Hz or 1049 lines for 60 Hz.*

2.2. DEFLECTION CENTERING

This adjustment is only needed in case of replacement of the deflection coil or the CRT.

NOTE

A second deflection coil is needed for this adjustment.

- Install the CRT and the deflection coil.
- Do not yet connect the deflection coil to WM10:X6.
- Attach a separate deflection coil on the connector WM10:X6 instead.
 (All other connectors and wires are left in place.)
- Turn brightness (WM:R2) and contrast (WM:R1) potmeters completely counter-clockwise.
- Switch on the monitor and **very carefully** turn up the brightness (WM:R2) until a little point of light becomes just visible. If necessary also turn the contrast (WM:R1) up a little.

Warning

If the brightness is turned up too high the CRT will become irreversibly damaged because of burning-in of the light point !!

Circuit diagram

- Adjust, with the magnet rings around the deflection coil on the CRT, the little point of light to the mechanical centre of the CRT.
- Turn brightness (WM:R2) and contrast potmeters completely counter clockwise again.
- Switch the monitor off.
- Disconnect the separate deflection coil from WM10:X6.
- Connect the deflection coil on the CRT to connector WM10:X6.
- Check the image geometry (see paragraph 2.1.3), the video amplification and brightness & contrast adjustment (see paragraph 2.1.5). If not correct, readjust the basic board.

To create a lightsource of 30 Lux, use the circuitry as shown below.

Take care that the current through the LED's is adjusted such that the emitted light is 30 Lux \pm 10%.

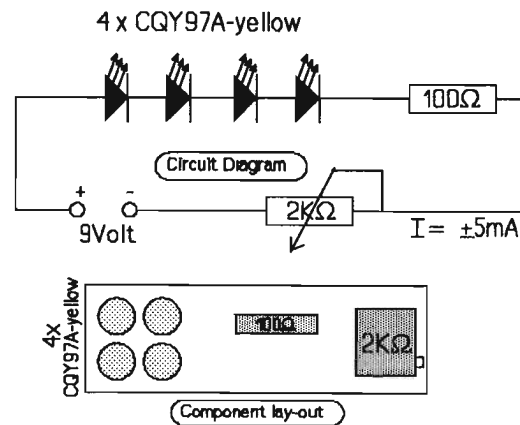

Figure 5

Measure with the lightmeter the light-output of the circuitry and adjust with the potmeter to 30 \pm 10%. When measuring, take care that no other light-sources influence the measurement.

Mount the four LED's as close as possible together to get a lightsource with as much as possible homogeneous light-output. Also the LED's will fit better into the window of the monitor bezel where the LDR is located. Fix the Lux-unit temporarily onto the bezel with a piece of adhesive tape.

Afterwards the adjustment on page F-6 for ABC can be easily made.

NOTE:

If more monitors are used in the same room, it is more important to have all monitors adjusted equally than having them exactly adjusted to 30 Lux.

2.3. OVERVIEW OF ADJUSTMENT FACILITIES ON BASIC BOARD WM10

For board 4522 167 00273

Name	Position	Function
WM10: S1	1-2	Terminates WM10:X1 with 75 ohm. With WM10:W4 on 1-2, WM10:X2 is suitable for parking a second video cable.
	1-3	With WM10:W4 on 1-3, WM10:X2 is suitable for a separate sync. input (if applicable). Loop through (WM10:X1 = WM10:X2), WM10:X1 not terminated.
WM10: W1A		Double frame frequency
W1B		Normal frame frequency
W2A		Double frame frequency
W2B		Normal frame frequency
W3A		3:4 scan ratio High Line rate
W3B		1:1 scan ratio High Line rate
W4	1-2	Sync. from VIBS at WM10:X1
	1-3	Separate sync. input at WM10:X2 (terminate externally !)
W5	1-2	LDR switched off
	1-3	LDR switched on
W6	1-2	1:1 scan ratio High Line rate
	1-3	3:4 scan ratio High Line rate
W7	1-2	Ambient Light Dependent Contrast Control : Standard
	1-3	Ambient Light Dependent Contrast Control : Low
W8	1-2	Ambient Light Dependent Brightness Control : On
	1-3	Ambient Light Dependent Brightness Control : Off
W9	1-2	Automatic High / Low Line selection or fixed High Line
	1-3	Fixed Low Line (in combination with WM10:W10)
W10A		Fixed High Line
W10B		Automatic High / Low Line selection or fixed Low Line (in combination with WM10:W9)
WM: R1		Contrast adj. (front panel)
R2		Brightness adj. (front panel)
WM10: R3		Maximum H.T. adj. (21 kV)
R4		Vertical linearity
R5		Vertical shift
R6		Low Line height adj.
R7		High Line H.T. & image width adj. for 1:1 scan ratio
R8		Low Line H.T. & image width adj.
R9		Horizontal shift
R10		Line (Hor.) time adj. (64.0 or 63.5 µsec)
R13		Centre focus
R14		G1 adjust
R15		Cathode adjust (white limiting)
R53		High Line height adj.
R201		High Line H.T. & image width adj. for 3:4 scan ratio
WM10: C17		Frequency correction (minimal overshoot video)
L4		Low Line horizontal linearity
L5		High Line horizontal linearity
L6		Low Line image width
WM20: R1		+120 volt adj.
WM30:		No adjustments
WM60:		No adjustments

2.4. OVERVIEW OF ADJUSTMENT FACILITIES ON BASIC BOARD WM10

For boards \geq 4522 167 00274

Name	Position	Function
WM10: S1	1-2	Terminates WM10:X1 with 75 ohm. With WM10:W4 on 1-2, WM10:X2 is suitable for parking a second video cable.
	1-3	With WM10:W4 on 1-3, WM10:X2 is suitable for a separate sync. input (if applicable). Loop through (WM10:X1 = WM10:X2), WM10:X1 not terminated.
WM10: W1A		Double frame frequency
W1B		Normal frame frequency
W2A		Double frame frequency
W2B		Normal frame frequency
W3A		3:4 scan ratio High Line rate
W3B		1:1 scan ratio High Line rate
W4	1-2	Sync. from VIBS at WM10:X1
	1-3	Separate sync. input at WM10:X2 (terminate externally !)
W5	1-2	LDR switched on
	1-3	LDR switched off
W6	1-2	1:1 scan ratio High Line rate
	1-3	3:4 scan ratio High Line rate
W7	1-2	Ambient Light Dependent Contrast Control : Standard
	1-3	Ambient Light Dependent Contrast Control : Low
W8	1-2	Ambient Light Dependent Brightness Control : On
	1-3	Ambient Light Dependent Brightness Control : Off
W9	1-2	Automatic High / Low Line selection or fixed High Line
	1-3	Fixed Low Line (in combination with WM10:W10)
W10A		Fixed High Line
W10B		Automatic High / Low Line selection or fixed Low Line (in combination with WM10:W9)
W11	1-2	Normal mode (1100mV)
	1-3	DCAS mode (700mV)
W29	1-2	Normal mode
	1-3	VCR mode
WM: R1		Contrast adj. (front panel)
		Brightness adj. (front panel)
WM10: R2		Horizontal shift HLR
		Maximum H.T. adj. (21 kV)
		Vertical linearity
		Vertical shift
		Low Line height adj.
		High Line H.T. & image width adj. for 1:1 scan ratio
		Low Line H.T. & image width adj.
		Horizontal shift
		Line (Hor.) time adj. (64.0 or 63.5 μ sec)
		Centre focus
		G1 adjust
		Cathode adjust (white limiting)
		High Line height adj.
		High Line H.T. & image width adj. for 3:4 scan ratio
		ABC adjustment
WM10: C17		Frequency correction (minimal overshoot video)
L4		Low Line horizontal linearity
L5		High Line horizontal linearity
L6		Low Line image width
WM20: R1		+120 volt adj.
WM30:		No adjustments
WM60:		No adjustments

Component-side view of basic board WM10

COMPONENT-SIDE VIEW

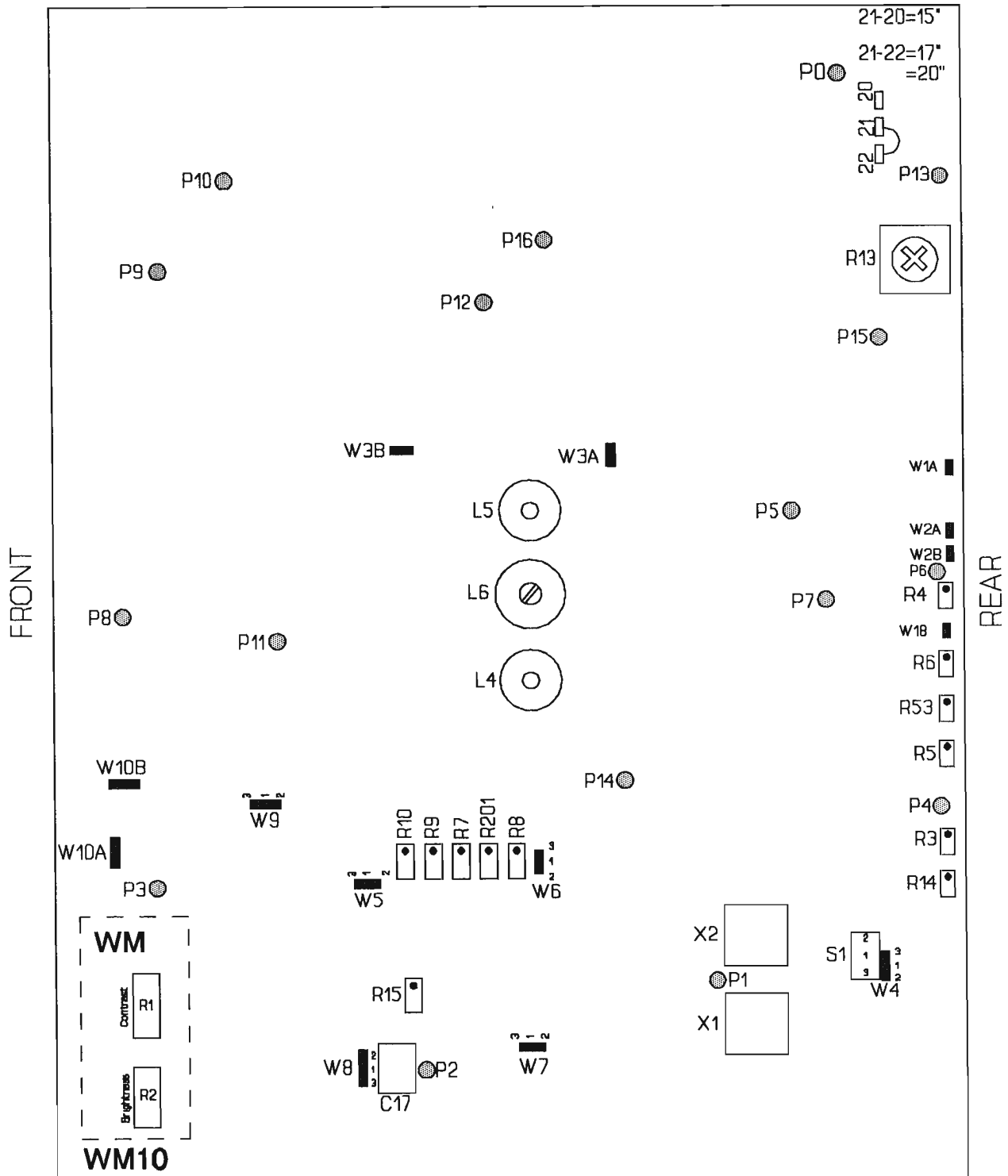

4522 167 00273

Component-side view of basic board WM10

COMPONENT-SIDE VIEW

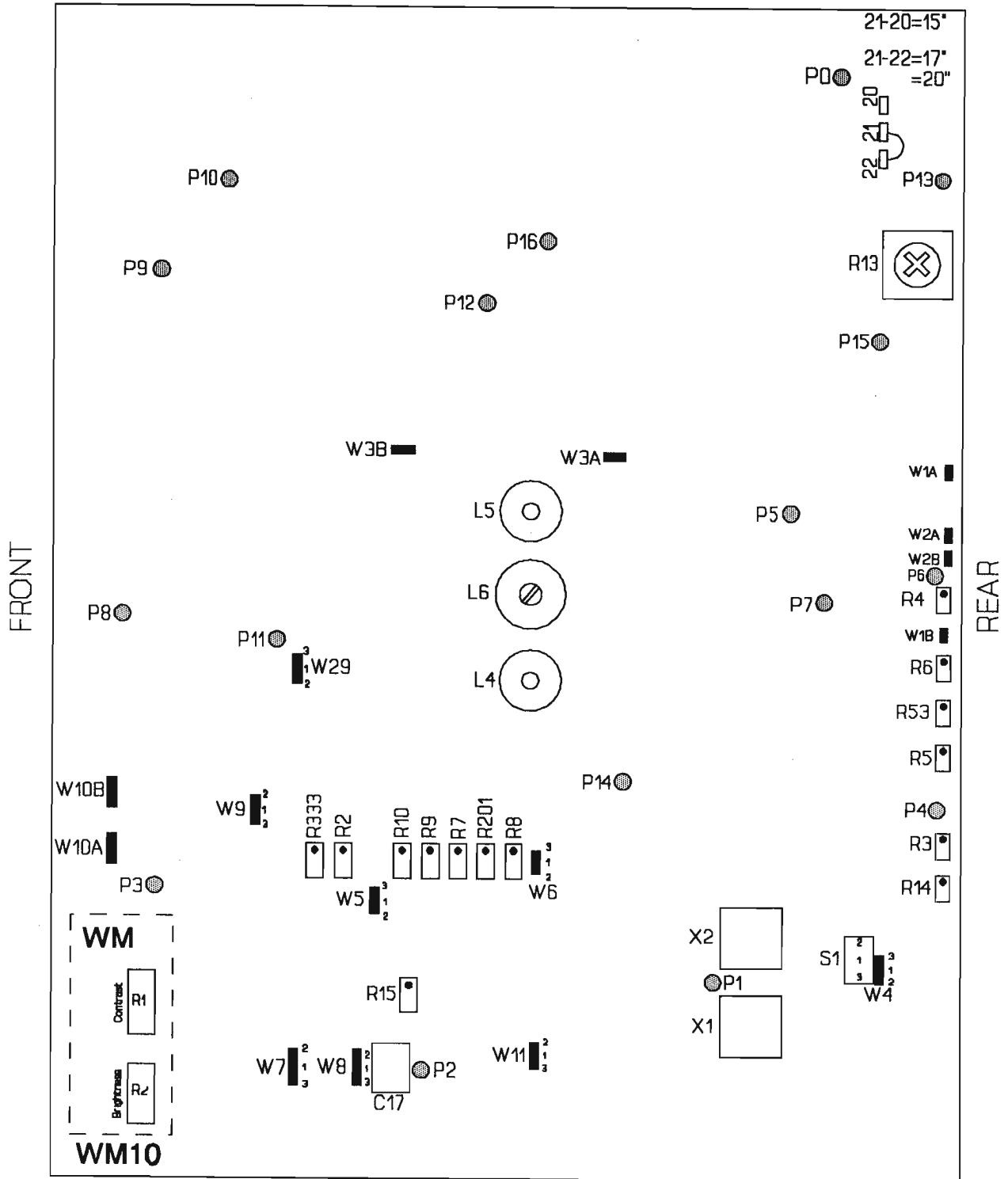

4522 167 00274

Section Z:

DRAWINGS

Contents

Table of contents		Z-0
Block diagram of 15"/17"/20" Basic Monitor		Z1-1
Block diagram of 15"/17"/20" Basic Monitor Rotatable		Z1-2
Wiring diagram 15"/17"/20" Basic Monitor		Z2-1
Cable harness 15"/17"/20" Basic Monitor		Z2-2
Reference list WM10 4522 167 00273		Z3-1.0
Basic board WM10 4522 167 00273		Z3-1.1
Basic board WM10 4522 167 00273		Z3-1.2
Basic board WM10 4522 167 00273		Z3-1.3
Basic board WM10 4522 167 00273		Z3-1.4
Basic board WM10 4522 167 00273		Z3-1.5
Reference list WM10 4522 167 00274		Z3-1.6
Basic board WM10 4522 167 00274		Z3-1.0
Basic board WM10 4522 167 00274		Z3-1.1
Basic board WM10 4522 167 00274		Z3-1.2
Basic board WM10 4522 167 00274		Z3-1.3
Basic board WM10 4522 167 00274		Z3-1.4
Basic board WM10 4522 167 00274		Z3-1.5
Basic board WM10 4522 167 00274		Z3-1.6
Power supply WM20 4522 107 87853		Z3-1.7
Tube socket WM30 4522 107 87805		Z3-2
Rotation control WM60 4522 107 10002		Z3-3
		Z3-4