



OFFICE OF THE PROBATE COURT  
 ADMINISTRATOR  
 186 NEWINGTON ROAD  
 WEST HARTFORD, CT 06110  
 (860) 231-2442 FAX: (860) 231-1055

**REQUEST FOR PROPOSAL**

The State of Connecticut Office of the Probate Court Administrator (hereinafter “PCA”), is seeking written proposals for the renovation of a portion of its building located at 186 Newington Road, West Hartford, Connecticut.

Please provide us your proposal as outlined in this Request for Proposal (hereinafter “RFP”) in writing, delivered to the address indicated no later than the date specified below.

Issued by (Agency): <b>Office of the Probate Court Administrator</b>	Return Bid Attention of: <b>Vincent Russo</b>	Bid Number: PA17-01
Agency Address & Telephone: <b>186 Newington Road, West Hartford CT 06110 – (860) 231-2442</b>		Date Issued: <b>March 16, 2017</b>
<b>PROJECT TIMELINE</b>		
Request for Proposal Distributed <b>Not later than Friday, March 17, 2017</b>		
Mandatory Pre-Bid Conference <b>Monday, March 27, 2017 at 1:00 p.m.</b>		
Deadline for submission of written Requests For Information: <b>Wednesday, March 29, 2017 at 4:00 p.m.</b>		
Responses to RFI’s will be provided not later than: <b>Friday, March 31, 2017 by 4:00 p.m.</b>		
Deadline for submission of bids: <b>Friday, April 7, 2017 at 4:00 p.m.</b>		
Bid Opening – Date and Time: <b>Monday, April 10, 2017 at 10:00 a.m.</b>		
Signed for Agency: <i>Vincent J. Russo</i>	Title: Manager of Communications & Intergovernmental Relations	

**The following attachments are incorporated into and deemed part of this RFP:**

- I. General Information – Scope of Work**
- II. Submission Requirements**
- III. Standard Instructions to Bidders**
- IV. Terms and Conditions**
- V. Form of Bid**
- VI. Exhibits**
- VII. Form of Contract**
- VIII. Plans and Specifications**

**Company Name** \_\_\_\_\_  
*An Equal Opportunity/Affirmative Action Employer*

## **I. GENERAL INFORMATION – SCOPE OF WORK**

### **1. Project**

The State of Connecticut, Office of the Probate Court Administrator (PCA), is soliciting written proposals for the renovation of a portion of its building located at 186 Newington Road, West Hartford, Connecticut. The scope of work is as set forth in the plans and specifications entitled “Probate Court Administration Interior Renovations, 186 Newington Road, West Hartford, Connecticut”, which are attached hereto and made a part of this RFP, and in accordance with the terms and conditions contained herein.

The scope of work bid under the specifications contained herein shall, in general, consist of the major items required to complete the work. Minor work and work incidental to or arising from any part of this specification may not be listed herein, but shall be performed under this contract and may be necessary for the full completion of this project.

### **2. Form of Contract**

The successful bidder shall enter into a contract with PCA in substantially the form attached hereto, which contract contains the following components:

- a. American Institute of Architects (“AIA”) Document A105, Standard Form of Agreement Between Owner and Contractor for Residential or Small Commercial Project, as modified herein; and
- b. Addendum to AIA Document A105.

### **3. Mandatory Pre-Bid Conference**

Attendance at the job-site bidders’ conference is required. Please assemble in the main lobby of 186 Newington Road, West Hartford, Connecticut on Monday, March 27, 2017 at 1:00 p.m. Bidders will be required to sign an attendance sheet verifying their attendance at this mandatory conference, and will provide their contact information.

In order for all potential bidders to be on an equal footing, prospective bidders will not be provided access to the project area or be briefed at other than the time designated. After award of the contract, adjustments in pricing will not be permitted based on job conditions, hours of work, materials used or other factors. Pricing must be firm and fixed for the entire, completed project.

### **4. Bid Bond Requirement**

In accordance with C.G.S. §4b-92, every general bid shall be accompanied by a bid bond or certified check in an amount equal to 10% of the bid price where the bid price exceeds \$49,999.99. Bids submitted without the required bid bond or certified check shall be rejected.

**5. Performance Bond Requirement**

For any contract that exceeds \$49,999.99, a Performance Bond is required. The Contractor shall submit a Performance Bond in an amount equal to the total contract price. Failure to deliver said Performance Bond within 10 business days of the date of the notice of award shall nullify and void any contract award.

**6. Labor and Materials Bond Requirement**

Pursuant to C.G.S. §49-41, for any contract that exceeds \$100,000, the Contractor must furnish a bond in the contract amount for the protection of persons supplying labor or materials under the contract. Any such bond shall have as principal the name of the person awarded the contract and shall be binding upon the award of the contract to that person. For any contract that is estimated to exceed \$500,000, any such bond shall contain the following provision: “In the event that the surety assumes the contract or obtains a bid or bids for completion of the contract, the surety shall ensure that the Contractor chosen to complete the contract is prequalified pursuant to section 4a-100 of the Connecticut general statutes in the requisite classification and has the aggregate work capacity rating and single project limit necessary to complete the contract.” Failure to deliver said Labor and Materials Bond within 10 business days of the date of the Notice of Award shall nullify and void such award.

**7. Bid Prices**

Bidders shall furnish a detailed breakdown of proposed labor and materials using the Form of Bid provided, including overtime if applicable.

If applicable, bidders are to use Prevailing Wage Rates when quoting this project.

**8. Prevailing Wages**

When the total cost of all work to be performed by all contractors and subcontractors in connection with any remodeling, rehabilitation, alternation or repair of any public works project is \$100,000 or more, the wages paid on an hourly basis to any person performing the work of any mechanic, laborer or worker on the work herein contracted to be done and the amount of payment or contribution paid or payable on behalf of each such person to any employee welfare fund, as defined in C.G.S. §31-53(i), shall be at a rate equal of the rate customary or prevailing for the same work in the same trade or occupation in the town in which such public works project is being constructed. Any contractor who is not obligated by agreement to make payment or contribution on behalf of such persons to any such employee welfare fund shall pay to each mechanic, laborer or worker as part of such person’s wages the amount of payment or contribution for such person’s classification on each pay day.

Contractor must submit certified payroll to the PCA Financial Department for the duration of the project. Current Prevailing Wage Rates may be found at [www2.ctdol.state.ct.us/WageRatesWeb](http://www2.ctdol.state.ct.us/WageRatesWeb).

**9. Hours of Operation/Overtime**

The Contractor's normal schedule work hours shall be 6:00 a.m. to 5:00 p.m., Monday through Friday. All other time including Saturdays, Sundays and holidays are considered outside of normal work hours or overtime hours.

Contractor should anticipate the weekend and/or after work hours may be necessary to complete the project as required. After hours will be Monday through Friday, 5:00 p.m. to 11:00 pm. Weekend hours will be Saturday and Sunday, 7:00 a.m. to 4:30 p.m.

The Contractor shall request approval from the Project Manager and/or Construction Administrator to work overtime. Requests made at least 72 hours in advance. All costs for overtime work must be included in the cost of the project.

**10. Project Payments**

The Contractor shall submit the Schedule of Values to the Project Manager at the earliest possible date but no later than 21 calendars days from the issuance of a purchase order. The Schedule of Values shall total the contract sum and be broken down by division with unit Quantities and material unit costs. The Schedule of Values must include all costs associated with the completion of the project and must be in sufficient detail to be an effective tool for monitoring the progress of the work.

The Contractor shall submit periodic applications for payment to the Project Manager who shall examine the Contractor's applications for payments to determine whether the payment amount properly represents the value of the work completed and the materials suitably stored on site.

The Project Manager will deduct 10% of the amount of each payment and such funds will be retained by PCA until final completion and acceptance of the project by PCA.

**11. Payment to Subcontractors**

- A. Within 30 days after receiving payment under the contract, the prime Contractor shall pay any amounts due any subcontractor, whether for labor performed or materials furnished, when the labor or materials have been included in a requisition submitted by the prime Contractor and paid by PCA.
- B. The prime Contractor shall include in each of its subcontractors a provision requiring each subcontractor to pay any amounts due any of its subcontractors, whether for labor performed or materials furnished, within 30 days after such subcontractor receives a payment from the prime contractor which encompasses labor or materials furnished by such subcontractor.

**12. Project Timeframe and Liquidated Damages**

- A. All work is to be substantially completed within 42 calendar days from issuance of a purchase order.

- B. Project submittals to start no later than 14 calendar days from issuance of a purchase order.
- C. The project shall mobilize construction no later than 14 calendar days after receiving submittal approvals from the Project Manager and/or Construction Administrator.
- D. Any delay in the completion of the work beyond the above mentioned time period will interfere with the daily operation and business at this site. As such, time is of the essence in completing the work. Moreover, it is impracticable to fix the actual damage sustained as a result of such a delay. In the event that the work is not completed on or before this time period, PCA shall be entitled to receive as damages \$500 per calendar day until the work is completed. The Contractor agrees that it will pay such amount as liquidated damages, not as a penalty, and that such sum is reasonable.
- E. The Contractor shall be responsible for scheduling and sequencing all work activities to facilitate any simultaneous work activities and operations of the facility. Scheduling of work shall be fully coordinated to ensure a quick and efficient construction period and that the overall contract is completed within the contract completion period established for this project.
- F. The amount due to PCA as liquidated damages may be deducted by PCA from any money payable to the Contractor pursuant to the contract. PCA shall notify the Contractor of any claim for liquidated damages at least 15 days before PCA deducts such sum from money payable to the Contractor. Payment of liquidated damages does not constitute a release from adherence to the provisions of this Agreement. Notwithstanding the payment of any liquidated damages hereunder, PCA may avail itself of any and all of the remedies afforded under Paragraph F of the Terms and Conditions in the event that the Contractor is in breach of, or otherwise fails to comply with, the terms and conditions of the agreement.

**13. Parts and Workmanship: Warranties and Guarantees**

- A. All parts and materials furnished shall be new, of first-class quality and shall be delivered, erected, connected and installed as to fit and function properly. Where no specific kind or quality of material is given, a first-class standard article as accepted by industry standards shall be furnished.
- B. All work shall be performed by experienced, skilled and licensed personnel. All work shall be of a quality consistent with good trade practice and shall be installed or performed in a neat, professional manner. PCA reserves the right to reject any work which, in its opinion, has been performed in a substandard, dangerous or unserviceable manner. The Contractor shall correct said deficiencies expeditiously, in a satisfactory manner and at no extra cost to PCA.
- C. All parts, materials and workmanship shall be guaranteed for at least a period of 18 months after final acceptance of all work by PCA, in addition to all

warranties that are specified in the specifications and provided by the manufacturer, and/or are implied by law. The Contractor shall be responsible for repairing any defects in parts, materials and/or workmanship during the guarantee period, including any parts, material and labor necessary to honor any manufacturer's warranty, at no expense to PCA. Warranty periods in excess of the contract term shall survive the contract termination or expiration for the full duration of the warranty period.

**14. Site Conditions**

- A. All work must be performed in a manner that is safe for the public and staff of the subject building. The Contractor shall, at its sole expense, immediately correct any dangerous conditions caused by or resulting from Contractor's work which PCA believes to be hazardous to persons or property.
- B. The facility will be occupied and open to the public throughout the duration of the project. All work must be accomplished in such manner as to not disrupt operations or court proceedings if applicable. The Contractor will be responsible to maintain and protect the egress ways during the construction period and all costs of any temporary protection shall be included in the contract price.
- C. Parking of the Contractor's vehicles shall be the responsibility of the vehicle owner and done at the risk of the vehicle owner.
- D. Upon completion of work, the Contractor shall clean up and sweep the site. All rubbish, materials, parts and debris must be removed from the site by the Contractor upon completion of the work. The work site must be kept neat and orderly at all times.
- E. No advertising or signage (except for safety purposes) will be allowed on or around PCA premises prior to, during or upon completion of the project.

**15. Rejection of Bids**

In addition to other grounds for rejection specified in this RFP, PCA, pursuant to C.G.S. §4b-94, reserves the right to reject any or all bids received under this RFP if: (1) PCA determines that the general bidder or bidders involved are not competent to perform the work as specified, based upon past performance, financial responsibility or other objective criteria, (2) the low bid price exceeds the amount of money available for the project, (3) PCA determines that the project shall not go forward or (4) PCA finds cause to reject such bids, including the Contractor's failure to meet the requirements of Paragraph 15, Subcontracting, above.

**16. References**

Bidders shall complete the enclosed reference sheet which must be included with the bid submission. Provide examples of jobs successfully completed that are similar to the work to be performed under the contract.

**17. Proper Conduct**

The Contractor's employees shall adhere to proper conduct at all times. It shall be the Contractor's sole responsibility to make known to its employees the rules of proper conduct, and the Contractor shall be held solely responsible for the behavior of its employees. Contractor's employees shall be removed from PCA premises for violation of the contract. Proper conduct shall include, but is not limited to, the following rules:

- A. Weapons of any sort shall not be carried by employees of the Contractor or employees of any subcontractor on PCA premises.
- B. There shall be no alcohol or illegal drugs carried or consumed on PCA premises.
- C. There shall be no smoking in PCA buildings or within 30 feet of any entrance to a PCA building.
- D. There shall be no unauthorized use of PCA facilities or property, including, but not limited to, shower rooms, phones, computers, desks, and other equipment.
- E. There shall be no exterior doors left open, propped open or unlocked.
- F. The Contractor's employees shall be courteous and polite.
- G. The Contractor shall report any property loss or damage to the PCA Project Manager immediately and follow up within 24 hours with a written report specifying the location and extent of the damage.



## II. SUBMISSION REQUIREMENTS

An original and 6 copies of submissions must be delivered to the Office of the Probate Court Administrator, Communications Department, 186 Newington Road, West Hartford, Connecticut, 06110. The original must be identified as such.

For consistency and efficiency in the evaluation of responses, proposals submitted should be in the following order:

- A. **RFP** - completed and signed.
- B. **Agents and Address** - List the address, telephone and facsimile numbers of the office from which the services are to be provided, and designate the person to serve as project manager during the development, testing and implementation phases. Resumes summarizing the qualifications and experience of the individuals who will assist with system design and implementation must be provided.
- C. **Form of Bid** - Failure to submit Form of Bid in accordance with Paragraph 7 of the General Information – Scope of Work will be cause for disqualification from the bid process.
- D. **Bid Bond** - Failure to provide a bid bond or certified check in the amount of 10% of the bid will be cause for disqualification from the bid process.
- E. **Consulting Affidavit** - Exhibit A must be submitted with the bid. Refusal to return the Affidavit will be cause for disqualification from the bid process.
- F. **Bidder Contract Compliance Monitoring Report (JD-ES-113)** - Exhibit B must be submitted with the bid. Refusal to return the JD-ES-113 will be cause for disqualification from the bid process.
- G. **Gift Certification** - Exhibit C must be submitted with bid. Failure to return the Certification with the bid submission will be cause for disqualification from the bid process.
- H. **References** - All proposals must include names, addresses, telephone numbers, and contact persons at 3 references.

### III. STANDARD INSTRUCTIONS TO BIDDERS

All Requests for Proposal issued by the Office of the Probate Court Administrator, (hereinafter “PCA”), will bind bidders to the Standard Instructions listed below, unless specified otherwise in any individual RFP.

- A. **Sealed Proposals** - Written proposals must be received in sealed envelopes. Telephone or facsimile proposals will not be considered. Reply envelope shall show the bidder name and RFP number.
- B. **Authorized Signature** - Written proposals must be signed by a company officer or representative authorized to make contractual commitments.
- C. **Late Bids** - Written proposals received after the date and time specified for submission on Page 1 of this document will not be accepted. Late bids will be returned unopened.
- D. **Taxes** - The State of Connecticut is exempt from the payment of Federal Excise Taxes and the Connecticut Sales Tax, therefore bids should not include such taxes.
- E. **Changes to Bid** - No additions or changes to the original proposal will be allowed after the specified date and time for submission. While changes are not permitted, clarification at the request of PCA may be required at bidder’s expense.
- F. **Rejection of Qualified Bids** - PCA reserves the right to reject in whole or in part, any or all bids submitted, including but not limited to bids that limit or modify any of the terms and or specifications set forth herein.
- G. **Rejection for Default or Misrepresentation** - PCA reserves the right to reject the bid of any bidder that is in default of any prior contract or for misrepresentation.
- H. **Award Criteria** - Bids will be evaluated and awarded to the lowest competitive bidder based on quality of the goods and services to be supplied, their compliance with specifications, price, administrative costs, ability to perform within the required time or without delay, skill, judgment and experience, past performance and financial responsibility. PCA reserves the right to award the RFP in whole or in part as may be in the best interest of the State of Connecticut. Upon notification of the award, the successful bidder and PCA will execute a contract in conformance with this RFP.
- I. **Clerical Errors** - PCA reserves the right to correct inaccurate awards resulting from its clerical and administrative errors.
- J. **CHRO Compliance** - Bidders shall complete the enclosed Bidder Contract Compliance Monitoring Report (JD-ES-113) and return with the bid response.
- K. **Collusion** - The individual submitting the bid or proposal affirms that he or she is duly authorized to execute this contract, that this company, corporation, firm, partnership or individual has not prepared this bid/proposal in collusion with any other bidder/proposer, and that the contents of this bid/proposal as to prices, terms or conditions of said

did/proposal have not been communicated by said individual nor by any employee or agent to any other person engaged in this type of business prior to the official opening of this bid.

- L. **Presentation of Supporting Evidence** - If requested, bidder(s) must be prepared to present evidence of experience, ability, service facilities, and financial standing necessary to satisfactorily meet the requirements set forth in the bid or those implied in the bid.
- M. **Ownership of Bids** - Responses to this RFP are the sole property of PCA, and subject to the provisions of Chapter 14 of the Connecticut General Statutes (Re: Freedom of Information).
- N. **Amendment or Cancellation of the RFP** - PCA reserves the right to amend, modify, cancel or otherwise change this RFP at any time if it deems it is in the best interest of the State of Connecticut to do so.
- O. **Insurance** - An insurance certificate showing the following minimum requirements must be received by PCA prior to commencement of services.
  - i. Worker's Compensation -Connecticut Statutory Coverage required
  - ii. Automobile liability -\$1,000,000 (where applicable)
  - iii. General Liability -\$1,000,000
  - iv. Professional Liability -\$1,000,000 (where applicable)

The required certificate of insurance shall also include a statement that PCA shall be notified ten (10) days in advance of any policy amendment, revocation, cancellation, non-renewal or material change in coverage. Neither the Contractor nor, to the extent of the policy limits, the Contractor's insurer shall use the defense of sovereign immunity without prior approval of PCA in any Claim involving PCA and the Contractor. For purposes of this provision, "Claim" shall include all actions, suits, demands, investigations and proceedings of any kind, open, pending or threatened, whether matured, unmatured, contingent, known or unknown, at law or in equity, in any forum.

- P. **Deadline to Submit Written Questions:** Bidders may submit written questions seeking clarification of this RFP until 4:00 p.m. on Wednesday, March 29, 2017. Written questions may be submitted to Vincent Russo fax at (860) 231-1055 or e-mail at [vrusso@ctprobate.gov](mailto:vrusso@ctprobate.gov), by the above time and date. Questions received after the deadline may, or may not, be answered in the discretion of PCA.
- Q. **Bid Submission Deadline** - Sealed bids must be received no later than 4:00 p.m. on Friday, April 7, 2017. No extensions will be granted. Bids received after that deadline will be rejected. Bids must be addressed and delivered to:

Office of the Probate Court Administrator  
Financial Services Department  
186 Newington Road  
West Hartford, CT 06110

PCA assumes no responsibility for untimely or improperly delivered parcels or U.S. Mail. Bids received after the deadline stated above will not be accepted.

**R. Ex Parte Contact Prohibited** - Except as provided under paragraph Q, above, any form of ex parte contact regarding this RFP or any bid being prepared or considered under this RFP, whether directly or indirectly, is hereby strictly prohibited. This includes, but is not limited to, any contact with elected or appointed state officials, state employees or probate court employees, seeking advice, assistance, information or support, at any time commencing with the issue date of this RFP and up to and including the date when actual notification of the results is given.

**S. Bidder Representations** - Bidders must initial the following remarks, attach forms where required, and sign the bottom of this offer in the space provided.

- (a) \_\_\_\_\_ I have read and understand the specifications and accept all RFP requirements, including, but not limited to, the General Information – Scope of Work, Submission Requirements, Standard Instructions to Bidders, Terms and Conditions, Form of Contract and Plans and Specifications.
- (b) \_\_\_\_\_ I have enclosed all materials required under the RFP.
- (c) \_\_\_\_\_ I have enclosed the completed and signed Bidder Contract Compliance Monitoring Report (JD-ES-113).
- (d) \_\_\_\_\_ The bidder name and bid number appears on the sealed envelope.

Company Name:		Telephone No:	F.E.I.N. No.	
		Fax No.		
Business Address:	Street/P.O. Box	City	State	Zip
Authorized Signature:		Title:	Date Signed:	
Print Name:				

Failure to return this page signed will result in disqualification from the bid process.

#### IV. TERMS AND CONDITIONS

- A. **Acceptance** - The Bidder agrees to and accepts the terms and conditions stated herein.
- B. **Payment Terms** - Payment for services provided to the Office of the Probate Court Administrator (PCA) are net 45 days upon receipt of invoice unless otherwise agreed to in writing by both parties.
- C. **Tax Exempt** - PCA is exempt from Connecticut Sales Tax under C.G.S. §12-412, Federal Excise Taxes, and the provisions of the federal Robinson-Patman Act.
- D. **Applicable Law** - The Bidder shall comply with all Federal, State and local laws, standards and regulations applicable to the services being provided under this RFP.
- E. **Hold Harmless** - The Bidder shall defend and save PCA harmless against any actions or claims brought against it for losses, costs, or damages by reason of actual or alleged infringements of letter of patent and/or copyright.
- F. **Default by the Bidder** - If the Bidder defaults or otherwise fails to comply with any of the terms, conditions and provisions set forth in this RFP and any contract arising from it, PCA may elect to pursue any one or more of the following remedies in any combination or sequence:
- seek damages.
  - withhold or reduce payments.
  - suspend services.
  - require that unexpended funds be returned to PCA.
  - require the Bidder to correct or cure such default to the satisfaction of PCA.
  - terminate the contract.
  - take such other action as deemed appropriate and in the best interests of PCA, along with other remedies provided by law, including but not limited to procuring the services from another source(s) and charging the Bidder for any excess costs incurred or damages occasioned thereby.
- G. **Controversies or Claims** - Any controversy or claim arising out of this RFP and any contract arising from it, shall be construed and interpreted in accordance with applicable State of Connecticut and federal law. This provision shall not be deemed to constitute a waiver of sovereign immunity. The Bidder shall notify PCA of any claim or controversy brought against it by any person or entity in connection with this RFP and any contract arising from it.
- H. **Warranty** - The Bidder agrees that all services provided hereafter will conform to specifications, drawings, samples or other descriptions furnished or adopted by PCA, and that such services will be fit and sufficient for the purposes intended, of merchantable and good quality and workmanship, and free from defect, liens, and encumbrances. Warranty periods in excess of the contract term shall survive contract termination and/or expiration for the full warranty period.

- I. **Final Inspection** - All services provided hereunder shall be subject to final inspection by PCA before acceptance thereof. PCA reserves the right to reject services that are not provided in compliance with these terms, conditions and specifications.
- J. **Ownership Rights** - All material received in response to this RFP shall become the property of PCA and will not be returned to the vendor. Upon Contract award, PCA reserves the right to use any information presented in any Proposal.
- K. **Delay** - If services are not provided within the time specified or within a reasonable time if no time is specified, PCA may exercise its options as outlined in Paragraph F herein in addition to seeking liquidated damages.
- L. **Contingencies** - Neither party hereto shall be liable to the other for default or delay in delivering or accepting services hereunder if such default or delay is caused by fire, strike, riot, war, Acts of God, delay of carriers, governmental order or regulation or other contingency beyond the reasonable control of the respective parties. The Bidder shall give notice to PCA of any such unavoidable delays or defaults.
- M. **Non-Waiver** - Failure of PCA to insist upon strict performance of any terms and conditions herein shall not be deemed a waiver of any rights or remedies that PCA may have, nor deemed a waiver of any rights or remedies PCA may have for any subsequent default.
- N. **Equal Opportunity** - PCA is an Equal Opportunity employer and purchaser. No employee or applicant for employment or vendor will be discriminated against because of race, color, religious creed, marital status, national origin, ancestry, sex, sexual orientation, age, present or past history of mental disorder, developmental or physical disability, including but not limited to blindness, or veteran's status.
- O. **Civil Rights Agreement** - The provisions of C.G.S. §4a-60 relating to nondiscrimination and affirmative action are incorporated herein, and will be incorporated in any contract arising out of this RFP, and PCA and the Bidder mutually agree to be bound by all of the provisions contained therein.
- P. **Non-discrimination Regarding Sexual Orientation** - The provisions of C.G.S. §4a-60a relating to nondiscrimination regarding sexual orientation are incorporated herein, and will be incorporated in any contract arising out of this RFP, and PCA and the Bidder mutually agree to be bound by all of the provisions contained therein.
- Q. **Americans With Disabilities Act of 1990** - This clause applies to those Bidders that are or will come to be responsible for compliance with the terms of the Americans with Disabilities Act of 1990 (43 USCS Sections 12101-12189 and Sections 12201-12213) (Supp. 1993); 47 USCS Sections 225.611 (Supp. 1993). In connection with this RFP and during the term of any contract arising from it, the Bidder represents that it is familiar with the terms of this Act and that it is in compliance with the law. The Bidder warrants that it will hold the State harmless from any liability that may be imposed upon the State as a result of any failure of the Bidder to be in compliance with this Act.

Where applicable, the Bidder agrees to abide by the provisions of section 504 of the federal Rehabilitation Act of 1973, as amended, 29 USC Section 794 (Supp. 1993), regarding access to programs and facilities by people with disabilities.

- R. **Governing Law** - This RFP and any resulting contract shall be governed by and construed in accordance with the laws of the State of Connecticut.
- S. **Termination** - PCA may terminate any contract arising under this RFP without cause upon 30 days written notice to the Contractor, or for cause without prior notice to Contractor if PCA deems that such termination is in the best interest of the State of Connecticut. In the event of cancellation, all monies due shall be prorated against the value of services accepted by PCA. Notwithstanding the foregoing, termination due to Contractor's breach is governed by Paragraph F herein.
- T. **Contract Price** - Price quoted in response to this RFP must remain firm during the contract period. Price reductions may be taken at any time. Price increases shall not be granted unless specifically allowed for in the contract and described in a document signed by both parties.
- U. **Amendments** - Any changes to the bid specifications will be made in the form of written amendments issued by PCA. Verbal instructions are to be disregarded unless these same instructions are documented in the form of a written amendment issued in accordance with this section.
- V. **No Joint Venture** - Nothing contained herein shall be construed as creating a joint venture, partnership, or employment relationship among the parties hereto, nor shall any party have the right, power, or authority to create any obligation or duty, express or implied, on behalf of any other party.
- W. **Employment of Workers** - In accordance with C.G.S. §31-52, in the employment of labor to perform the work specified herein, preference shall be given to citizens of the United States, who are, and continuously for at least 3 months prior to the date hereof have been, residents of the labor market area, as established by the Labor Commissioner, in which such work is to be done, and if no such qualified person is available, then to citizens who have continuously resided in the county in which the work is to be performed for at least 3 months prior to the date hereof, and then to citizens of the state who have continuously resided in the state at least 3 months prior to the date hereof.
- X. **Indemnification** - The Bidder hereby agrees to indemnify and hold PCA, its agents, employees, public officials and representatives harmless from any and all claims, causes of action, demands for damages, or liabilities of any kind, including the reasonable costs to defend such action regardless of whether such action is successful or not, brought by any person or entity whatsoever, arising from any act, error, or omission of the Bidder and or its employees during or resulting from Bidder's activities (including those of its subcontractors) hereunder.

- Y. **Notice of Litigation** - The Bidder shall notify PCA if the Bidder is, or has a reasonable cause to expect to be, subject to litigation which might adversely affect the Bidder's ability to perform the agreed services or affect the Bidder's financial capacity.

The Bidder shall provide written notice to PCA of any final decision by any tribunal, arbitrator or arbitration panel, or state or federal agency or court which is adverse to the Bidder or which results in a settlement, compromise of claim or agreement of any kind for any action or proceeding brought against the Bidder or its employees or agents.

- Z. **Subcontractors** - The Bidder shall not subcontract for any of the services required hereunder without prior written approval from PCA. Subcontractors shall be bound by all the terms and conditions hereunder, and shall not relieve the prime Bidder(s) of its responsibilities hereunder. PCA reserves the right to approve or reject any and all subcontractor and/or subcontractor agreements.

- AA. **Confidentiality of Records and Computer Files** - The Bidder agrees on behalf of the Bidder and the Bidder's principals, employees, agents, heirs, successors, and assigns that (1) they may only access such PCA and probate court data, documents, books, volumes, files, records, computers, or other systems, as specifically set forth herein, and as are necessary for the performance of the Bidder's duties hereunder, and, (2) they may not disclose, advertise, advertise for sale, sell, or rent, in any form or use any information obtained or created from, or by the work performed, pursuant to this RFP and any contract arising it. The Bidder shall take such reasonable actions as are necessary to protect the confidentiality of PCA and probate court records and computer files including, at a minimum, obtaining a written confidentiality agreement from each person assigned to work on the Bidder's behalf hereunder, of the prohibition against access, use, or disclose of information not specifically authorized by such contract. Any claim, harm or alleged harm, injury or alleged injury, resulting from the unauthorized use or unauthorized disclosure of such information obtained by the Bidder and/or the Bidder's principals, employees, agents, heirs, successors, and assigns from work performed hereunder, shall subject the Bidder to the indemnification provisions stated herein, in addition to all other rights and remedies available to PCA pursuant to law.

- AB. **Financial Instability** - PCA may terminate any contract arising from this RFP, without termination costs if the Bidder becomes financially unstable, thereby threatening the ability of PCA to obtain the services provided for under such contract. PCA shall give 30 days prior written notice to the Bidder of the intent to terminate such contract.

- AC. **Record Keeping and Access** - The Bidder shall maintain books, records, documents, programs and individual service records and other evidence of its accounting and billing procedures and practices, which sufficiently and properly reflect all direct and indirect costs of any nature incurred in the performance of any contract arising from this RFP. These records shall be subject at all reasonable times to monitoring, inspection, review or audit by authorized employees or agents of the State or applicable Federal agencies. The Bidder shall retain all such books, records, other financial and program and individual service documents concerning such contract for a period of 3 years after each completed audit.



AD. **Prohibited Interest** - The Bidder warrants that no state appropriated funds have been paid or will be paid by or on behalf of the Bidder to contract with or retain any company or person, other than bona fide employees working solely for the Contractor, to influence or attempt to influence an officer or employee of any state agency in connection with the awarding, extension, continuation, renewal, amendment or modification of any contract arising out of this RFP, or to pay any company or person, other than bona fide employees working solely for the Bidder, any fee, commission, percentage, brokerage fee, gift or any other consideration contingent upon or resulting from the award or making of such contract.

AE. **Employee Status** - Pursuant to the requirements of C.G.S. §1-84(i), the Bidder represents that its owners, members, directors, officers, shareholders or employees, or any member of its owners', members', directors', officers', shareholders' or employees' immediate family, are not public officials or state employees as defined in C.G.S. §1-79.

AF. **Compliance with Training Requirements (Construction and Telecommunications)** - In accordance with C.G.S. §31-53b, for any contract for the remodeling, refinishing, refurbishing, rehabilitation, alteration or repair of any public works project by PCA where the total cost of all work to be performed by all contractors and subcontractors is \$100,000 or more, the contractor shall furnish proof with the weekly certified payroll form for the first week each employee begins work on such project that any person performing the work of a mechanic, laborer or worker pursuant to the classifications of labor under C.G.S. §31-53 on such public works project, pursuant to such contract, has completed a course of at least 10 hours in duration in construction safety and health approved by the federal Occupational Safety and Health Administration, and that any plumber or electrician subject to the continuing education requirements of C.G.S. §20-334d, who has completed a course of at least 10 hours in duration in construction safety and health approved by the federal Occupational Safety and Health Administration 5 or more years prior to the date such electrician or plumber begins work on such public works project, has completed a supplemental refresher training course of at least 4 hours in duration in contraction safety and health taught by a federal Occupational Safety and Health Administration authorized trainer.

A student course completion card issued by the federal Occupational Safety and Health Administration Training Institute or such other proof deemed appropriate by the Labor Commissioner shall be sufficient proof of compliance, provide that it is dated no earlier than 5 years before the commencement date of such public works project.

Any person required to complete a course or program hereunder who has not completed the course or program shall be subject to removal from the worksite by the Labor Commissioner or his/her designee if the person does not provide documentation of having completed such course or program by the 15<sup>th</sup> day after the date the person is found to be in noncompliance.

AG. **Notice of Consulting Affidavit Requirements** - Section 4a-81 of the Connecticut General Statutes (the "Act") requires that this solicitation include a notice of the

consulting affidavit requirements described in the Act. Accordingly, pursuant to the Act, bidders are notified as follows:

(a) No state agency shall execute a contract for the purchase of goods or services, which contract has a total value to the state of fifty thousand dollars or more in any calendar or fiscal year, unless the state agency obtains the affidavit described in paragraph (b).

(b)(1) Any principal or key personnel of a person, firm or corporation who submit bids or proposals for a contract described in paragraph (a) above shall attest in an affidavit as to whether any consulting agreement has been entered into in connection with any such contract. Such affidavit shall be required if any duties of the consultant included communications concerning business of a state or quasi-public agency, whether or not direct contact with a state agency, state or public official or state employee was expected or made. "Consulting agreement" means any written or oral agreement to retain the services, for a fee, of a consultant for the purposes of (A) providing counsel to a contractor, vendor, consultant or other entity seeking to conduct, or conducting, business with the State, (B) contacting, whether in writing or orally, any executive, judicial, or administrative office of the state, including any department, institution, bureau, board, commission, authority, official or employee for the purpose of solicitation, dispute resolution, instruction or requests for information or (C) any other similar activity related to such contracts. "Consulting agreement" does not include any agreements entered into with a consultant who is registered under the provisions of Chapter 10 of the Connecticut General Statutes concerning the State's Codes of Ethics, as of the date such affidavit is submitted. (2) Such affidavit shall be sworn as to true to the best knowledge and belief of the person signing the certification on the affidavit and shall be subject to the penalties of false statement. (3) Such affidavit shall include the following information for each consulting agreement listed: The name of the consultant, the consultant's firm, the basic terms of the consulting agreement, a brief description of the services provided, and an indication as to whether the consultant is a former state employee or public official. If the consultant is a former state employee or public official, such affidavit shall indicate his or her former agency and the date such employment terminated. (4) After the initial submission of such affidavit, the principal or key personnel of the person, firm or corporation shall not be required to resubmit such affidavit unless there is a change in the information contained in such affidavit. If there is any change in the information contained in the most recently filed affidavit required under the paragraph, the principal or key personnel of a person, firm or corporation who submit bids or proposals for a contract described in paragraph (a) above shall submit an updated affidavit either (A) not later than 30 days after the effective date of any such change, or (B) upon the submittal of any new bid or proposal, whichever is earlier.

(c) In the event that a bidder or vendor refuses to submit the affidavit required under paragraph (b) above, such bidder or vendor shall be disqualified and the state agency or quasi-public agency shall award the contract to the next highest

ranked vendor or the next lowest responsible qualified bidder or seek new bids or proposals.

- AH. **Prohibition Against Assignment** - The Bidder shall not transfer, pledge or otherwise assign any contract arising out of this RFP or any rights or responsibilities thereunder, to any third party without prior written consent of PCA.

**REFERENCES**

List 3 references which reflect projects for which similar work to that specified herein was successfully completed.

1. Project name \_\_\_\_\_ Date of completion of work: \_\_\_\_\_  
Owner of project \_\_\_\_\_ Owner's Representative \_\_\_\_\_  
Telephone \_\_\_\_\_ Email \_\_\_\_\_  
Brief description of work \_\_\_\_\_  
\_\_\_\_\_

2. Project name \_\_\_\_\_ Date of completion of work: \_\_\_\_\_  
Owner of project \_\_\_\_\_ Owner's Representative \_\_\_\_\_  
Telephone \_\_\_\_\_ Email \_\_\_\_\_  
Brief description of work \_\_\_\_\_  
\_\_\_\_\_

3. Project name \_\_\_\_\_ Date of completion of work: \_\_\_\_\_  
Owner of project \_\_\_\_\_ Owner's Representative \_\_\_\_\_  
Telephone \_\_\_\_\_ Email \_\_\_\_\_  
Brief description of work \_\_\_\_\_  
\_\_\_\_\_

Signature \_\_\_\_\_  
Name \_\_\_\_\_  
Company Name \_\_\_\_\_  
Date \_\_\_\_\_

**V. FORM OF BID**

**PART ONE - GENERAL**

**1.01 GENERAL REQUIREMENTS:**

- A. The State reserves the right to reject any or all bids. Each bid form shall be accompanied by bid security in the amount stated in the Request For Proposal.
- B. The Undersigned agrees that the bid security shall become the property of the State if this bid is accepted by the State and he/she does not submit executed copies of the Agreement within 10 days of receipt of a written request.
- C. Overtime work at night or on weekends may be required. The Undersigned acknowledges the limitations on hours of work set forth in Section 010000 Summary of Work and General Requirements. The limitations were also reviewed during the mandatory pre-bid conference.
- D. The Undersigned acknowledges receipt and review of all Addenda, if any, to the Contract Documents on the above website, listed by number in the space below:

---

---

---

---

**1.02 LABOR AND MATERIALS BREAKDOWN:**

- A. The Undersigned shall provide a breakdown of labor and materials required for this project. Fill in each blank. Use N/A where appropriate to indicate Not Applicable.
- B. The Undersigned proposes to perform the Work required for this project in accordance with the Contract Documents for the following amount:

Division	Labor	Materials	Total
1. General Requirements			
2. Site Construction			
3. Concrete			
4. Concrete			
5. Masonry			
6. Metals			
7. Wood and Plastics			
8. Doors and Windows			
9. Finishes			
10. Specialties			
11. Equipment			
12. Furnishings			
13. Special Construction			
14. Conveying Systems			
15. Mechanical			
16. Electrical			
<b>Total</b>			

**1.03 ALTERNATES (As Described in Section 01 23 00):**

ALTERNATE NO. 1	ADD	\$ _____	.00
ALTERNATE NO. 2	ADD	\$ _____	.00
ALTERNATE NO. 3	ADD	\$ _____	.00
ALTERNATE NO. 4	ADD	\$ _____	.00
ALTERNATE NO. 5	ADD	\$ _____	.00
ALTERNATE NO. 6	ADD	\$ _____	.00

SIGN BID HERE \_\_\_\_\_  
Authorized Signature

PRINT NAME OF SIGNER \_\_\_\_\_

TITLE OF SIGNER \_\_\_\_\_

OFFICIAL COMPANY NAME \_\_\_\_\_

MAILING ADDRESS \_\_\_\_\_  
Street

\_\_\_\_\_ City State Zip

TELEPHONE NO. \_\_\_\_\_ FAX NO. \_\_\_\_\_  
Area Code Area Code

E-MAIL ADDRESS \_\_\_\_\_

**END OF SECTION**



STATE OF CONNECTICUT
CONSULTING AGREEMENT AFFIDAVIT

Affidavit to accompany a bid or proposal for the purchase of goods and services with a value of \$50,000 or more in a calendar or fiscal year, pursuant to Connecticut General Statutes §§ 4a-81(a) and 4a-81(b). For sole source or no bid contracts the form is submitted at time of contract execution.

INSTRUCTIONS:

If the bidder or vendor has entered into a consulting agreement, as defined by Connecticut General Statutes § 4a-81(b)(1): Complete all sections of the form. If the bidder or contractor has entered into more than one such consulting agreement, use a separate form for each agreement. Sign and date the form in the presence of a Commissioner of the Superior Court or Notary Public. If the bidder or contractor has not entered into a consulting agreement, as defined by Connecticut General Statutes § 4a-81(b)(1): Complete only the shaded section of the form. Sign and date the form in the presence of a Commissioner of the Superior Court or Notary Public.

Submit completed form to the awarding State agency with bid or proposal. For a sole source award, submit completed form to the awarding State agency at the time of contract execution.

This affidavit must be amended if there is any change in the information contained in the most recently filed affidavit not later than (i) thirty days after the effective date of any such change or (ii) upon the submittal of any new bid or proposal, whichever is earlier.

AFFIDAVIT: [Number of Affidavits Sworn and Subscribed On This Day: \_\_\_\_\_]

I, the undersigned, hereby swear that I am a principal or key personnel of the bidder or contractor awarded a contract, as described in Connecticut General Statutes § 4a-81(b), or that I am the individual awarded such a contract who is authorized to execute such contract. I further swear that I have not entered into any consulting agreement in connection with such contract, except for the agreement listed below:

Consultant's Name and Title \_\_\_\_\_ Name of Firm (if applicable) \_\_\_\_\_

Start Date \_\_\_\_\_ End Date \_\_\_\_\_ Cost \_\_\_\_\_

Description of Services Provided:

Is the consultant a former State employee or former public official? [ ] YES [ ] NO

If YES: Name of Former State Agency \_\_\_\_\_ Termination Date of Employment \_\_\_\_\_

Sworn as true to the best of my knowledge and belief, subject to the penalties of false statement.

Printed Name of Bidder or Contractor \_\_\_\_\_ Signature of Principal or Key Personnel \_\_\_\_\_ Date \_\_\_\_\_

Printed Name (of above) \_\_\_\_\_ Awarding State Agency \_\_\_\_\_

Sworn and subscribed before me on this \_\_\_\_\_ day of \_\_\_\_\_, 20\_\_\_\_.

Commissioner of the Superior Court or Notary Public \_\_\_\_\_

My Commission Expires \_\_\_\_\_





## STATE OF CONNECTICUT GIFT AND CAMPAIGN CONTRIBUTION CERTIFICATION

*Written or electronic certification to accompany a State contract with a value of \$50,000 or more, pursuant to C.G.S. §§ 4-250, 4-252(c) and 9-612(f)(2) and Governor Dannel P. Malloy's Executive Order 49.*

### INSTRUCTIONS:

Complete all sections of the form. Attach additional pages, if necessary, to provide full disclosure about any lawful campaign contributions made to campaigns of candidates for statewide public office or the General Assembly, as described herein. Sign and date the form, under oath, in the presence of a Commissioner of the Superior Court or Notary Public. Submit the completed form to the awarding State agency at the time of initial contract execution and if there is a change in the information contained in the most recently filed certification, such person shall submit an updated certification either (i) not later than thirty (30) days after the effective date of such change or (ii) upon the submittal of any new bid or proposal for a contract, whichever is earlier. Such person shall also submit an accurate, updated certification not later than fourteen days after the twelve-month anniversary of the most recently filed certification or updated certification.

**CHECK ONE:**     Initial Certification     12 Month Anniversary Update (Multi-year contracts only.)  
 Updated Certification because of change of information contained in the most recently filed certification or twelve-month anniversary update.

### GIFT CERTIFICATION:

As used in this certification, the following terms have the meaning set forth below:

- 1) "Contract" means that contract between the State of Connecticut (and/or one or more of its agencies or instrumentalities) and the Contractor, attached hereto, or as otherwise described by the awarding State agency below;
- 2) If this is an Initial Certification, "Execution Date" means the date the Contract is fully executed by, and becomes effective between, the parties; if this is a twelve-month anniversary update, "Execution Date" means the date this certification is signed by the Contractor;
- 3) "Contractor" means the person, firm or corporation named as the contractor below;
- 4) "Applicable Public Official or State Employee" means any public official or state employee described in C.G.S. §4-252(c)(1)(i) or (ii);
- 5) "Gift" has the same meaning given that term in C.G.S. § 4-250(1);
- 6) "Principals or Key Personnel" means and refers to those principals and key personnel of the Contractor, and its or their agents, as described in C.G.S. §§ 4-250(5) and 4-252(c)(1)(B) and (C).

I, the undersigned, am a Principal or Key Personnel of the person, firm or corporation authorized to execute this certification on behalf of the Contractor. I hereby certify that, no gifts were made by (A) such person, firm, corporation, (B) any principals and key personnel of the person firm or corporation who participate substantially in preparing bids, proposals or negotiating state contracts or (C) any agent of such, firm, corporation, or principals or key personnel who participates substantially in preparing bids, proposals or negotiating state contracts, to (i) any public official or state employee of the state agency or quasi-public agency soliciting bids or proposals for state contracts who participates substantially in the preparation of bid solicitations or request for proposals for state contracts or the negotiation or award of state contracts or (ii) any public official or state employee of any other state agency, who has supervisory or appointing authority over such state agency or quasi-public agency.

I further certify that no Principals or Key Personnel know of any action by the Contractor to circumvent (or which would result in the circumvention of) the above certification regarding **Gifts** by providing for any other Principals, Key Personnel, officials, or employees of the Contractor, or its or their agents, to make a **Gift** to any Applicable Public Official or State Employee. I further certify that the Contractor made the bid or proposal for the Contract without fraud or collusion with any person.

**CAMPAIGN CONTRIBUTION CERTIFICATION:**

I further certify that, on or after January 1, 2011, neither the Contractor nor any of its principals, as defined in C.G.S. § 9-612(f)(1), has made any **campaign contributions** to, or solicited any contributions on behalf of, any exploratory committee, candidate committee, political committee, or party committee established by, or supporting or authorized to support, any candidate for statewide public office, in violation of C.G.S. § 9-612(f)(2)(A). I further certify that **all lawful campaign contributions** that have been made on or after January 1, 2011 by the Contractor or any of its principals, as defined in C.G.S. § 9-612(f)(1), to, or solicited on behalf of, any exploratory committee, candidate committee, political committee, or party committee established by, or supporting or authorized to support any candidates for statewide public office or the General Assembly, are listed below:

**Lawful Campaign Contributions to Candidates for Statewide Public Office:**

<u>Contribution Date</u>	<u>Name of Contributor</u>	<u>Recipient</u>	<u>Value</u>	<u>Description</u>

**Lawful Campaign Contributions to Candidates for the General Assembly:**

<u>Contribution Date</u>	<u>Name of Contributor</u>	<u>Recipient</u>	<u>Value</u>	<u>Description</u>

Sworn as true to the best of my knowledge and belief, subject to the penalties of false statement

Printed Contractor Name \_\_\_\_\_ Printed Name of Authorized Official \_\_\_\_\_

**Signature of Authorized Official**

Subscribed and acknowledged before me this \_\_\_\_\_ day of \_\_\_\_\_ 20\_\_\_\_.

**Commissioner of the Superior Court (or Notary Public)**

**My Commission Expires** \_\_\_\_\_

\_\_\_\_\_



**EXHIBIT B**  
**COMMISSION ON HUMAN RIGHTS AND OPPORTUNITIES**  
**CONTRACT COMPLIANCE REGULATIONS**  
**NOTIFICATION TO BIDDERS**

(Revised 09/17/07)

The contract to be awarded is subject to contract compliance requirements mandated by Sections 4a-60 and 4a-60a of the Connecticut General Statutes; and, when the awarding agency is the State, Sections 46a-71(d) and 46a-81i(d) of the Connecticut General Statutes. There are Contract Compliance Regulations codified at Section 46a-68j-21 through 43 of the Regulations of Connecticut State Agencies, which establish a procedure for awarding all contracts covered by Sections 4a-60 and 46a-71(d) of the Connecticut General Statutes.

According to Section 46a-68j-30(9) of the Contract Compliance Regulations, every agency awarding a contract subject to the contract compliance requirements has an obligation to "aggressively solicit the participation of legitimate minority business enterprises as bidders, contractors, subcontractors and suppliers of materials." "Minority business enterprise" is defined in Section 4a-60 of the Connecticut General Statutes as a business wherein fifty-one percent or more of the capital stock, or assets belong to a person or persons: "(1) Who are active in daily affairs of the enterprise; (2) who have the power to direct the management and policies of the enterprise; and (3) who are members of a minority, as such term is defined in subsection (a) of Section 32-9n." "Minority" groups are defined in Section 32-9n of the Connecticut General Statutes as "(1) Black Americans . . . (2) Hispanic Americans . . . (3) persons who have origins in the Iberian Peninsula . . . (4) Women . . . (5) Asian Pacific Americans and Pacific Islanders; (6) American Indians . . ." An individual with a disability is also a minority business enterprise as provided by Section 4a-60g of the Connecticut General Statutes. The above definitions apply to the contract compliance requirements by virtue of Section 46a-68j-21(11) of the Contract Compliance Regulations.

The awarding agency will consider the following factors when reviewing the bidder's qualifications under the contract compliance requirements:

- (a) the bidder's success in implementing an affirmative action plan;
- (b) the bidder's success in developing an apprenticeship program complying with Sections 46a-68-1 to 46a-68-17 of the Administrative Regulations of Connecticut State Agencies, inclusive;
- (c) the bidder's promise to develop and implement a successful affirmative action plan;
- (d) the bidder's submission of employment statistics contained in the "Employment Information Form", indicating that the composition of its workforce is at or near parity when compared to the racial and sexual composition of the workforce in the relevant labor market area; and
- (e) the bidder's promise to set aside a portion of the contract for legitimate minority business enterprises. See Section 46a-68j-30(10)(E) of the Contract Compliance Regulations.

---

**INSTRUCTIONS AND OTHER INFORMATION**

The following BIDDER CONTRACT COMPLIANCE MONITORING REPORT must be completed in full, signed, and submitted with the bid for this contract. The contract awarding agency and the Commission on Human Rights and Opportunities will use the information contained thereon to determine the bidders compliance to Sections 4a-60 and 4a-60a CONN. GEN. STAT., and Sections 46a-68j-23 of the Regulations of Connecticut State Agencies regarding equal employment opportunity, and the bidder's  good faith efforts to include minority business enterprises as subcontractors and suppliers for the work of the contract.

**1) Definition of Small Contractor**

Section 4a-60g CONN. GEN. STAT. defines a small contractor as a company that has been doing business under the same management and control and has maintained its principal place of business in Connecticut for a one year period immediately prior to its application for certification under this section, had gross revenues not exceeding ten million dollars in the most recently completed fiscal year, and at least fifty-one percent of the ownership of which is held by a person or persons who are active in the daily affairs of the company, and have the power to direct the management and policies of the company, except that a nonprofit corporation shall be construed to be a small contractor if such nonprofit corporation meets the requirements of subparagraphs (A) and (B) of subdivision 4a-60g CONN. GEN. STAT.

**MANAGEMENT:** Managers plan, organize, direct, and control the major functions of an organization through subordinates who are at the managerial or supervisory level. They make policy decisions and set objectives for the company or departments. They are not usually directly involved in production or providing services. Examples include top executives, public relations managers, managers of operations specialties (such as financial, human resources, or purchasing managers), and construction and engineering managers.

**BUSINESS AND FINANCIAL OPERATIONS:** These occupations include managers and professionals who work with the financial aspects of the business. These occupations include accountants and auditors, purchasing agents, management analysts, labor relations specialists, and budget, credit, and financial analysts.

**MARKETING AND SALES:** Occupations related to the act or process of buying and selling products and/or services such as sales engineer, retail sales workers and sales representatives including wholesale.

**LEGAL OCCUPATIONS:** In-House Counsel who is charged with providing legal advice and services in regards to legal issues that may arise during the course of standard business practices. This category also includes assistive legal occupations such as paralegals, legal assistants.

**COMPUTER SPECIALISTS:** Professionals responsible for the computer operations within a company are grouped in this category. Examples of job titles in this category include computer programmers, software engineers, database administrators, computer scientists, systems analysts, and computer support specialists

**ARCHITECTURE AND ENGINEERING:** Occupations related to architecture, surveying, engineering, and drafting are included in this category. Some of the job titles in this category include electrical and electronic engineers, surveyors, architects, drafters, mechanical engineers, materials engineers, mapping technicians, and civil engineers.

**OFFICE AND ADMINISTRATIVE SUPPORT:** All clerical-type work is included in this category. These jobs involve the preparing, transcribing, and preserving of written communications and records; collecting accounts; gathering and distributing information; operating office machines and electronic data processing equipment; and distributing mail. Job titles listed in this category include telephone operators, bill and account collectors, customer service representatives, dispatchers, secretaries and administrative assistants, computer operators and clerks (such as payroll, shipping, stock, mail and file).

**BUILDING AND GROUNDS CLEANING AND MAINTENANCE:** This category includes occupations involving landscaping, housekeeping, and janitorial services. Job titles found in this category include supervisors of landscaping or housekeeping, janitors, maids, grounds maintenance workers, and pest control workers.

**CONSTRUCTION AND EXTRACTION:** This category includes construction trades and related occupations. Job titles found in this category include boilermakers, masons (all types), carpenters, construction laborers, electricians, plumbers (and related trades), roofers, sheet metal workers, elevator installers, hazardous materials removal workers, paperhangers, and painters. Paving, surfacing, and tamping equipment operators; drywall and ceiling tile installers; and carpet, floor and tile installers and finishers are also included in this category. First line supervisors, foremen, and helpers in these trades are also grouped in this category..

**INSTALLATION, MAINTENANCE AND REPAIR:** Occupations involving the installation, maintenance, and repair of equipment are included in this group. Examples of job titles found here are heating, ac, and refrigeration mechanics and installers; telecommunication line installers and repairers; heavy vehicle and mobile equipment service technicians and mechanics; small engine mechanics; security and fire alarm systems installers; electric/electronic repair, industrial, utility and transportation equipment; millwrights; riggers; and manufactured building and mobile home installers. First line supervisors, foremen, and helpers for these jobs are also included in the category.

**MATERIAL MOVING WORKERS:** The job titles included in this group are Crane and tower operators; dredge, excavating, and lading machine operators; hoist and winch operators; industrial truck and tractor operators; cleaners of vehicles and equipment; laborers and freight, stock, and material movers, hand; machine feeders and offbearers; packers and packagers, hand; pumping station operators; refuse and recyclable material collectors; and miscellaneous material moving workers.

**PRODUCTION WORKERS:** The job titles included in this category are chemical production machine setters, operators and tenders; crushing/grinding workers; cutting workers; inspectors, testers sorters, samplers, weighers; precious stone/metal workers; painting workers; cementing/gluing machine operators and tenders; etchers/engravers; molders, shapers and casters except for metal and plastic; and production workers.

3) Definition of Racial and Ethnic Terms (as used in Part IV Bidder Employment Information) (Page 3)

<p><u>White</u> (not of Hispanic Origin)- All persons having origins in any of the original peoples of Europe, North Africa, or the Middle East.</p> <p><u>Black</u>(not of Hispanic Origin)- All persons having origins in any of the Black racial groups of Africa.</p> <p><u>Hispanic</u>- All persons of Mexican, Puerto Rican, Cuban, Central or South American, or other Spanish culture or origin, regardless of race.</p>	<p><u>Asian or Pacific Islander</u>- All persons having origins in any of the original peoples of the Far East, Southeast Asia, the Indian subcontinent, or the Pacific Islands. This area includes China, India, Japan, Korea, the Philippine Islands, and Samoa.</p> <p><u>American Indian or Alaskan Native</u>- All persons having origins in any of the original peoples of North America, and who maintain cultural identification through tribal affiliation or community recognition.</p>
---	---

**BIDDER CONTRACT COMPLIANCE MONITORING REPORT**

**PART I - Bidder Information**

Judicial RFP/RFQ # \_\_\_\_\_

<p>Company Name Street Address City &amp; State Chief Executive</p>	<p>Bidder Federal Employer Identification Number _____ Or Social Security Number _____</p>
<p>Major Business Activity (brief description)</p>	<p>Bidder Identification (response optional/definitions on page 1)</p> <p>-Bidder is a small contractor. Yes ___ No ___ -Bidder is a minority business enterprise Yes ___ No ___ (If yes, check ownership category) Black ___ Hispanic ___ Asian American ___ American Indian/Alaskan Native ___ Iberian Peninsula ___ Individual(s) with a Physical Disability ___ Female ___</p>
<p>Bidder Parent Company (If any)</p>	<p>- Bidder is certified as above by State of CT Yes ___ No ___</p>
<p>Other Locations in Ct. (If any)</p>	<p>- DAS Certification Number _____</p>

**PART II - Bidder Nondiscrimination Policies and Procedures**

<p>1. Does your company have a written Affirmative Action/Equal Employment Opportunity statement posted on company bulletin boards? Yes ___ No ___</p>	<p>7. Do all of your company contracts and purchase orders contain non-discrimination statements as required by Sections 4a-60 &amp; 4a-60a Conn. Gen. Stat.? Yes ___ No ___</p>
<p>2. Does your company have the state-mandated sexual harassment prevention in the workplace policy posted on company bulletin boards? Yes ___ No ___</p>	<p>8. Do you, upon request, provide reasonable accommodation to employees, or applicants for employment, who have physical or mental disability? Yes ___ No ___</p>
<p>3. Do you notify all recruitment sources in writing of your company's Affirmative Action/Equal Employment Opportunity employment policy? Yes ___ No ___</p>	<p>9. Does your company have a mandatory retirement age for all employees? Yes ___ No ___</p>
<p>4. Do your company advertisements contain a written statement that you are an Affirmative Action/Equal Opportunity Employer? Yes ___ No ___</p>	<p>10. If your company has 50 or more employees, have you provided at least two (2) hours of sexual harassment training to all of your supervisors? Yes ___ No ___ NA ___</p>
<p>5. Do you notify the Ct. State Employment Service of all employment openings with your company? Yes ___ No ___</p>	<p>11. If your company has apprenticeship programs, do they meet the Affirmative Action/Equal Employment Opportunity requirements of the apprenticeship standards of the Ct. Dept. of Labor? Yes ___ No ___ NA ___</p>
<p>6. Does your company have a collective bargaining agreement with workers? Yes ___ No ___ 6a. If yes, do the collective bargaining agreements contain non-discrimination clauses covering all workers? Yes ___ No ___ 6b. Have you notified each union in writing of your commitments under the nondiscrimination requirements of contracts with the state of Ct? Yes ___ No ___</p>	<p>12. Does your company have a written affirmative action Plan? Yes ___ No ___ If no, please explain.</p>
<p>13. Is there a person in your company who is responsible for equal employment opportunity? Yes ___ No ___ If yes, give name and phone number.</p>	<p>_____</p>

1. Will the work of this contract include subcontractors or suppliers? Yes\_\_ No\_\_

1a. If yes, please list all subcontractors and suppliers and report if they are a small contractor and/or a minority business enterprise. (defined on page 1 / use additional sheet if necessary)

1b. Will the work of this contract require additional subcontractors or suppliers other than those identified in 1a. above?

Yes\_\_ No\_\_

**PART IV - Bidder Employment Information**

Date:

JOB CATEGORY *	OVERALL TOTALS	WHITE (not of Hispanic origin)		BLACK (not of Hispanic origin)		HISPANIC		ASIAN or PACIFIC ISLANDER		AMERICAN INDIAN or ALASKAN NATIVE	
		Male	Female	Male	Female	Male	Female	Male	Female	male	female
Management											
Business & Financial Ops											
Marketing & Sales											
Legal Occupations											
Computer Specialists											
Architecture/Engineering											
Office & Admin Support											
Bldg/ Grounds Cleaning/Maintenance											
Construction & Extraction											
Installation , Maintenance & Repair											
Material Moving Workers											
Production Occupations											
TOTALS ABOVE											
Total One Year Ago											
FORMAL ON THE JOB TRAINEES (ENTER FIGURES FOR THE SAME CATEGORIES AS ARE SHOWN ABOVE)											
Apprentices											
Trainees											

\*NOTE: JOB CATEGORIES CAN BE CHANGED OR ADDED TO (EX. SALES CAN BE ADDED OR REPLACE A CATEGORY NOT USED IN YOUR COMPANY)

1. Which of the following recruitment sources are used by you? (Check yes or no, and report percent used)				2. Check (X) any of the below listed requirements that you use as a hiring qualification  (X)		3. Describe below any other practices or actions that you take which show that you hire, train, and promote employees without discrimination
SOURCE	YES	NO	% of applicants provided by source			
State Employment Service					Work Experience	
Private Employment Agencies					Ability to Speak or Write English	
Schools and Colleges					Written Tests	
Newspaper Advertisement					High School Diploma	
Walk Ins					College Degree	
Present Employees					Union Membership	
Labor Organizations					Personal Recommendation	
Minority/Community Organizations					Height or Weight	
Others (please identify)					Car Ownership	
					Arrest Record	
					Wage Garnishments	

Certification (Read this form and check your statements on it CAREFULLY before signing). I certify that the statements made by me on this BIDDER CONTRACT COMPLIANCE MONITORING REPORT are complete and true to the best of my knowledge and belief, and are made in good faith. I understand that if I knowingly make any misstatements of facts, I am subject to be declared in non-compliance with Section 4a-60, 4a-60a, and related sections of the CONN. GEN. STAT.

(Signature)	(Title)	(Date Signed)	(Telephone)
-------------	---------	---------------	-------------

# DRAFT AIA® Document A105™ - 2007

## Standard Form of Agreement Between Owner and Contractor for a Residential or Small Commercial Project

AGREEMENT made as of the «[Fifteenth](#)» day of «[April](#)» in the year «[Two Thousand Seventeen](#)»

(In words, indicate day, month and year.)

BETWEEN the Owner:

(Name, legal status, address and other information)

«[Office of the Probate Court Administration](#)»«[, State of Connecticut](#)»  
«[186 Newington Road](#)  
[West Hartford, CT 06110](#)»  
«[Telephone Number: \(860\) 231-2442 ext. 332](#)»  
«[Fax Number: \(860\) 231-1055](#)»

and the Contractor:

(Name, legal status, address and other information)

«[TBD](#)»« »  
« »  
« »  
« »

for the following Project:

(Name, location and detailed description)

«[Probate Court Administration](#)»  
«[Interior Renovations](#)»  
«[186 Newington Road, West Hartford, Connecticut](#)»

The Architect:

(Name, legal status, address and other information)

«[Clohessy Harris & Kaiser, LLC](#)»«[, Clohessy Harris & Kaiser, LLC](#)»  
«[PO Box 95](#)  
[573 Hopmeadow Street](#)  
[Simsbury, CT 06070](#)»  
«[Telephone Number: \(860\) 651-3777](#)»  
«[Fax Number: \(860\) 651-7316](#)»

The Owner and Contractor agree as follows.

**ADDITIONS AND DELETIONS:** The author of this document has added information needed for its completion. The author may also have revised the text of the original AIA standard form. An *Additions and Deletions Report* that notes added information as well as revisions to the standard form text is available from the author and should be reviewed.

This document has important legal consequences. Consultation with an attorney is encouraged with respect to its completion or modification.

State or local law may impose requirements on contracts for home improvements. If this document will be used for Work on the Owner's residence, the Owner should consult local authorities or an attorney to verify requirements applicable to this Agreement.

**ELECTRONIC COPYING** of any portion of this AIA® Document to another electronic file is prohibited and constitutes a violation of copyright laws as set forth in the footer of this document.



TABLE OF ARTICLES

- 1 THE CONTRACT DOCUMENTS
- 2 DATE OF COMMENCEMENT AND SUBSTANTIAL COMPLETION DATE
- 3 CONTRACT SUM
- 4 PAYMENT
- 5 INSURANCE
- 6 GENERAL PROVISIONS
- 7 OWNER
- 8 CONTRACTOR
- 9 ARCHITECT
- 10 CHANGES IN THE WORK
- 11 TIME
- 12 PAYMENTS AND COMPLETION
- 13 PROTECTION OF PERSONS AND PROPERTY
- 14 CORRECTION OF WORK
- 15 MISCELLANEOUS PROVISIONS
- 16 TERMINATION OF THE CONTRACT
- 17 OTHER TERMS AND CONDITIONS

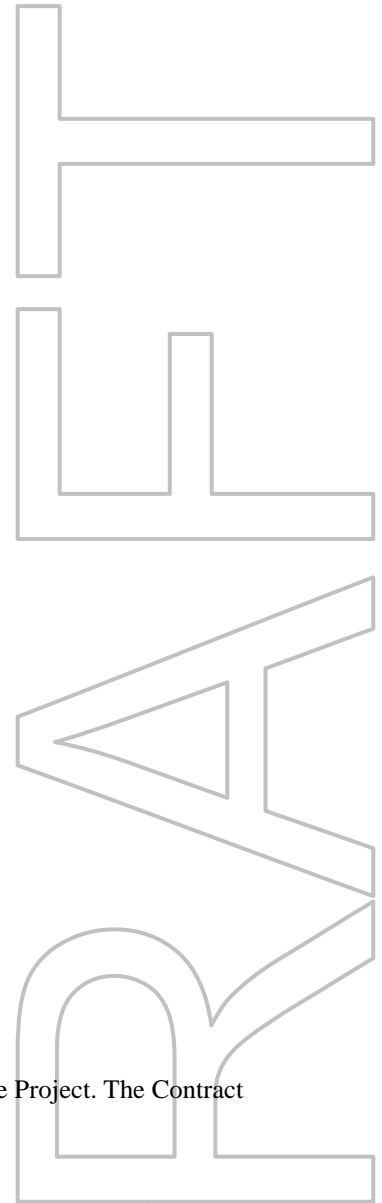

ARTICLE 1 THE CONTRACT DOCUMENTS

§ 1.1 The Contractor shall complete the Work described in the Contract Documents for the Project. The Contract Documents consist of

- .1 this Agreement signed by the Owner and Contractor;
- .2 the drawings and specifications prepared by the Architect, dated « » , and enumerated as follows:

Drawings:		
Number	Title	Date
« »	[Redacted]	[Redacted]

Specifications:		
Section	Title	Pages
« »	[Redacted]	[Redacted]

- .3 addenda prepared by the Architect as follows:
- |        |            |            |
|--------|------------|------------|
| Number | Date       | Pages      |
| « »    | [Redacted] | [Redacted] |

- .4 written orders for changes in the Work issued after execution of this Agreement; and
- .5 other documents, if any, identified as follows:

«(1) [Addendum to Contract](#)  
 (2) [Request for Proposal](#)  
 If any term or condition in this Contract or the Addendum conflicts with the Request for Proposal, the Contract or Addendum provision will control. The Contract Documents cannot include any AIA document not specifically referenced.»

**ARTICLE 2 DATE OF COMMENCEMENT AND SUBSTANTIAL COMPLETION**

The number of calendar days available to the Contractor to substantially complete the Work is the Contract Time. The date of commencement of the Work shall be the date of this Agreement unless otherwise indicated below. The Contractor shall substantially complete the Work, no later than «forty-two» ( «42» ) calendar days from the date of commencement, subject to adjustment as provided in Article 10 and Article 11.  
*(Insert the date of commencement, if it differs from the date of this Agreement.)*

« Date of commencement is date of issuance of “Purchase Order” »

**ARTICLE 3 CONTRACT SUM**

§ 3.1 Subject to additions and deductions in accordance with Article 10, the Contract Sum is:

«~~One Hundred Thousand Dollars and Zero Cents~~TBD» (\$ «~~100,000.00~~TBD»)»

§ 3.2 For purposes of payment, the Contract Sum includes the following values related to portions of the Work:  
*(Itemize the Contract Sum among the major portions of the Work.)*

Portion of Work	Value
« »	

§ 3.3 Unit prices, if any, are as follows:  
*(Identify and state the unit price; state the quantity limitations, if any, to which the unit price will be applicable.)*

Item	Units and Limitations	Price per Unit (\$0.00)
« »		

§ 3.4 Allowances included in the Contract Sum, if any, are as follows:  
*(Identify allowance and state exclusions, if any, from the allowance price.)*

Item	Price
« »	

§ 3.5 The Contract Sum is based upon the following alternates, if any, which are described in the Contract Documents and hereby accepted by the Owner:  
*(State the numbers or other identification of accepted alternates. If the bidding or proposal documents permit the Owner to accept other alternates subsequent to the execution of this Agreement, attach a schedule of such other alternates showing the amount for each and the date when that amount expires.)*

« »

§ 3.6 The Contract Sum shall include all items and services necessary for the proper execution and completion of the Work.

**ARTICLE 4 PAYMENT**

§ 4.1 Based on Contractor’s Applications for Payment certified by the Architect, the Owner shall pay the Contractor, in accordance with Article 12, as follows:

*(Insert below timing for payments and provisions for withholding retainage, if any.)*

~~§ 4.2 Payments due and unpaid under the Contract Documents shall bear interest from the date payment is due at the rate below, or in the absence thereof, at the legal rate prevailing at the place of the Project.~~

<< >> % << >>

**ARTICLE 5 — INSURANCE**

~~§ 5.1 The Contractor shall provide Contractor’s general liability and other insurance as follows:  
(Insert specific insurance requirements and limits.)~~

Type of insurance	Limit of liability (\$0.00)
-------------------	-----------------------------

~~§ 5.2 The Owner shall provide property insurance to cover the value of the Owner’s property, including any Work provided under this Agreement. The Contractor is entitled to receive an increase in the Contract Sum equal to the insurance proceeds related to a loss for damage to the Work covered by the Owner’s property insurance.~~

~~§ 5.3 The Contractor shall obtain an endorsement to its general liability insurance policy to cover the Contractor’s obligations under Section 8.12.~~

~~§ 5.4 Each party shall provide certificates of insurance showing their respective coverages prior to commencement of the Work.~~

~~§ 5.5 Unless specifically precluded by the Owner’s property insurance policy, the Owner and Contractor waive all rights against (1) each other and any of their subcontractors, suppliers, agents and employees, each of the other; and (2) the Architect, Architect’s consultants and any of their agents and employees, for damages caused by fire or other causes of loss to the extent covered by property insurance or other insurance applicable to the Work.~~

**ARTICLE 6 GENERAL PROVISIONS**

**§ 6.1 THE CONTRACT**

The Contract represents the entire and integrated agreement between the parties and supersedes prior negotiations, representations or agreements, either written or oral. The Contract may be amended or modified only by a written modification in accordance with Article 10.

**§ 6.2 THE WORK**

The term “Work” means the construction and services required by the Contract Documents, and includes all other labor, materials, equipment and services provided, or to be provided, by the Contractor to fulfill the Contractor’s obligations.

**§ 6.3 INTENT**

The intent of the Contract Documents is to include all items necessary for the proper execution and completion of the Work by the Contractor. The Contract Documents are complementary, and what is required by one shall be as binding as if required by all.

**§ 6.4 OWNERSHIP AND USE OF ARCHITECT’S DRAWINGS, SPECIFICATIONS AND OTHER DOCUMENTS**

Documents prepared by the Architect are instruments of the Architect’s service for use solely with respect to this Project. The Architect shall retain all common law, statutory and other reserved rights, including the copyright. The Contractor, subcontractors, sub-subcontractors, and material or equipment suppliers are authorized to use and reproduce the instruments of service solely and exclusively for execution of the Work. The instruments of service may not be used for other Projects or for additions to this Project outside the scope of the Work without the specific written consent of the Architect.

## ARTICLE 7 OWNER

### § 7.1 INFORMATION AND SERVICES REQUIRED OF THE OWNER

§ 7.1.1 If requested by the Contractor, the Owner shall furnish all necessary surveys and a legal description of the site.

§ 7.1.2 Except for permits and fees that are the responsibility of the Contractor under the Contract Documents, the Owner shall obtain and pay for other necessary approvals, easements, assessments and charges.

### § 7.2 OWNER'S RIGHT TO STOP THE WORK

If the Contractor fails to correct Work which is not in accordance with the Contract Documents, the Owner may direct the Contractor in writing to stop the Work until the correction is made.

### § 7.3 OWNER'S RIGHT TO CARRY OUT THE WORK

If the Contractor defaults or neglects to carry out the Work in accordance with the Contract Documents and fails within a seven day period after receipt of written notice from the Owner to commence and continue correction of such default or neglect with diligence and promptness, the Owner may, without prejudice to other remedies, correct such deficiencies. In such case, the Contract Sum shall be adjusted to deduct the cost of correction from payments due the Contractor.

### § 7.4 OWNER'S RIGHT TO PERFORM CONSTRUCTION AND TO AWARD SEPARATE CONTRACTS

§ 7.4.1 The Owner reserves the right to perform construction or operations related to the Project with the Owner's own forces, and to award separate contracts in connection with other portions of the Project.

§ 7.4.2 The Contractor shall coordinate and cooperate with the Owner's own forces and separate contractors employed by the Owner.

§ 7.4.3 Costs caused by delays or by improperly timed activities or defective construction shall be borne by the party responsible therefor.

## ARTICLE 8 CONTRACTOR

### § 8.1 REVIEW OF CONTRACT DOCUMENTS AND FIELD CONDITIONS BY CONTRACTOR

§ 8.1.1 Execution of the Contract by the Contractor is a representation that the Contractor has visited the site, become familiar with local conditions under which the Work is to be performed and correlated personal observations with requirements of the Contract Documents.

§ 8.1.2 The Contractor shall carefully study and compare the Contract Documents with each other and with information furnished by the Owner. Before commencing activities, the Contractor shall (1) take field measurements and verify field conditions; (2) carefully compare this and other information known to the Contractor with the Contract Documents; and (3) promptly report errors, inconsistencies or omissions discovered to the Architect.

### § 8.2 CONTRACTOR'S CONSTRUCTION SCHEDULE

The Contractor, promptly after being awarded the Contract, shall prepare and submit for the Owner's and Architect's information a Contractor's construction schedule for the Work.

### § 8.3 SUPERVISION AND CONSTRUCTION PROCEDURES

§ 8.3.1 The Contractor shall supervise and direct the Work, using the Contractor's best skill and attention. The Contractor shall be solely responsible for and have control over construction means, methods, techniques, sequences and procedures, and for coordinating all portions of the Work.

§ 8.3.2 The Contractor, as soon as practicable after award of the Contract, shall furnish in writing to the Owner through the Architect the names of subcontractors or suppliers for each portion of the Work. The Contractor shall not contract with any subcontractor or supplier to whom the Owner or Architect have made a timely and reasonable objection.

### § 8.4 LABOR AND MATERIALS

§ 8.4.1 Unless otherwise provided in the Contract Documents, the Contractor shall provide and pay for labor, materials, equipment, tools, utilities, transportation, and other facilities and services necessary for proper execution and completion of the Work.

§ 8.4.2 The Contractor shall enforce strict discipline and good order among the Contractor's employees and other persons carrying out the Contract Work. The Contractor shall not permit employment of unfit persons or persons not skilled in tasks assigned to them.

#### § 8.5 WARRANTY

The Contractor warrants to the Owner and Architect that: (1) materials and equipment furnished under the Contract will be new and of good quality unless otherwise required or permitted by the Contract Documents; (2) the Work will be free from defects not inherent in the quality required or permitted; and (3) the Work will conform to the requirements of the Contract Documents.

#### § 8.6 TAXES

The Contractor shall pay sales, consumer, use and similar taxes that are legally required when the Contract is executed.

#### § 8.7 PERMITS, FEES AND NOTICES

§ 8.7.1 The Contractor shall obtain and pay for the building permit and other permits and governmental fees, licenses and inspections necessary for proper execution and completion of the Work.

§ 8.7.2 The Contractor shall comply with and give notices required by agencies having jurisdiction over the Work. If the Contractor performs Work knowing it to be contrary to applicable laws, statutes, ordinances, codes, rules and regulations, or lawful orders of public authorities, the Contractor shall assume full responsibility for such Work and shall bear the attributable costs. The Contractor shall promptly notify the Architect in writing of any known inconsistencies in the Contract Documents with such governmental laws, rules and regulations.

#### § 8.8 SUBMITTALS

The Contractor shall promptly review, approve in writing and submit to the Architect Shop Drawings, Product Data, Samples and similar submittals required by the Contract Documents. Shop Drawings, Product Data, Samples and similar submittals are not Contract Documents.

#### § 8.9 USE OF SITE

The Contractor shall confine operations at the site to areas permitted by law, ordinances, permits, the Contract Documents and the Owner.

#### § 8.10 CUTTING AND PATCHING

The Contractor shall be responsible for cutting, fitting or patching required to complete the Work or to make its parts fit together properly.

#### § 8.11 CLEANING UP

The Contractor shall keep the premises and surrounding area free from accumulation of debris and trash related to the Work. At the completion of the Work, the Contractor shall remove its tools, construction equipment, machinery and surplus material; and shall properly dispose of waste materials.

#### § 8.12 INDEMNIFICATION

~~To the fullest extent permitted by law, the Contractor shall indemnify and hold harmless the Owner, Architect, Architect's consultants and agents and employees of any of them from and against claims, damages, losses and expenses, including but not limited to attorneys' fees, arising out of or resulting from performance of the Work, provided that such claim, damage, loss or expense is attributable to bodily injury, sickness, disease or death, or to injury to or destruction of tangible property (other than the Work itself), but only to the extent caused by the negligent acts or omissions of the Contractor, a subcontractor, anyone directly or indirectly employed by them or anyone for whose acts they may be liable, regardless of whether or not such claim, damage, loss or expense is caused in part by a party indemnified hereunder.~~

### ARTICLE 9 ARCHITECT

§ 9.1 The Architect will provide administration of the Contract as described in the Contract Documents. The Architect will have authority to act on behalf of the Owner only to the extent provided in the Contract Documents.

§ 9.2 The Architect will visit the site at intervals appropriate to the stage of construction to become generally familiar with the progress and quality of the Work.

§ 9.3 The Architect will not have control over or charge of, and will not be responsible for, construction means, methods, techniques, sequences or procedures, or for safety precautions and programs in connection with the Work, since these are solely the Contractor's responsibility. The Architect will not be responsible for the Contractor's failure to carry out the Work in accordance with the Contract Documents.

§ 9.4 Based on the Architect's observations and evaluations of the Contractor's Applications for Payment, the Architect will review and certify the amounts due the Contractor.

§ 9.5 The Architect has authority to reject Work that does not conform to the Contract Documents.

§ 9.6 The Architect will promptly review and approve or take appropriate action upon Contractor's submittals, but only for the limited purpose of checking for conformance with information given and the design concept expressed in the Contract Documents.

§ 9.7 The Architect will promptly interpret and decide matters concerning performance under, and requirements of, the Contract Documents on written request from either the Owner or Contractor.

§ 9.8 Interpretations and decisions of the Architect will be consistent with the intent of and reasonably inferable from the Contract Documents and will be in writing or in the form of drawings. When making such interpretations and decisions, the Architect will endeavor to secure faithful performance by both Owner and Contractor, will not show partiality to either and will not be liable for results of interpretations or decisions rendered in good faith.

§ 9.9 The Architect's duties, responsibilities and limits of authority as described in the Contract Documents shall not be changed without written consent of the Owner, Contractor and Architect. Consent shall not be unreasonably withheld.

## ARTICLE 10 CHANGES IN THE WORK

§ 10.1 The Owner, without invalidating the Contract, may order changes in the Work within the general scope of the Contract consisting of additions, deletions or other revisions, the Contract Sum and Contract Time being adjusted accordingly in writing. If the Owner and Contractor can not agree to a change in the Contract Sum, the Owner shall pay the Contractor its actual cost plus reasonable overhead and profit.

§ 10.2 The Architect will have authority to order minor changes in the Work not involving changes in the Contract Sum or the Contract Time and not inconsistent with the intent of the Contract Documents. Such orders shall be in writing and shall be binding on the Owner and Contractor. The Contractor shall carry out such orders promptly.

§ 10.3 If concealed or unknown physical conditions are encountered at the site that differ materially from those indicated in the Contract Documents or from those conditions ordinarily found to exist, the Contract Sum and Contract Time shall be subject to equitable adjustment.

## ARTICLE 11 TIME

§ 11.1 Time limits stated in the Contract Documents are of the essence of the Contract.

§ 11.2 If the Contractor is delayed at any time in progress of the Work by changes ordered in the Work, or by labor disputes, fire, unusual delay in deliveries, unavoidable casualties or other causes beyond the Contractor's control, the Contract Time shall be subject to equitable adjustment.

## ARTICLE 12 PAYMENTS AND COMPLETION

### § 12.1 CONTRACT SUM

The Contract Sum stated in the Agreement, including authorized adjustments, is the total amount payable by the Owner to the Contractor for performance of the Work under the Contract Documents.

## § 12.2 APPLICATIONS FOR PAYMENT

§ 12.2.1 At least ten days before the date established for each progress payment, the Contractor shall submit to the Architect an itemized Application for Payment for Work completed in accordance with the values stated in the Agreement. Such Application shall be supported by data substantiating the Contractor's right to payment as the Owner or Architect may reasonably require. Payments shall be made on account of materials and equipment delivered and suitably stored at the site for subsequent incorporation in the Work. If approved in advance by the Owner, payment may similarly be made for materials and equipment stored, and protected from damage, off the site at a location agreed upon in writing.

§ 12.2.2 The Contractor warrants that title to all Work covered by an Application for Payment will pass to the Owner no later than the time of payment. The Contractor further warrants that upon submittal of an Application for Payment, all Work for which Certificates for Payment have been previously issued and payments received from the Owner shall, to the best of the Contractor's knowledge, information and belief, be free and clear of liens, claims, security interests or other encumbrances adverse to the Owner's interests.

## § 12.3 CERTIFICATES FOR PAYMENT

The Architect will, within seven days after receipt of the Contractor's Application for Payment, either issue to the Owner a Certificate for Payment, with a copy to the Contractor, for such amount as the Architect determines is properly due, or notify the Contractor and Owner in writing of the Architect's reasons for withholding certification in whole or in part.

## § 12.4 PROGRESS PAYMENTS

§ 12.4.1 After the Architect has issued a Certificate for Payment, the Owner shall make payment in the manner provided in the Contract Documents.

§ 12.4.2 The Contractor shall promptly pay each subcontractor and supplier, upon receipt of payment from the Owner, an amount determined in accordance with the terms of the applicable subcontracts and purchase orders.

§ 12.4.3 Neither the Owner nor the Architect shall have responsibility for payments to a subcontractor or supplier.

§ 12.4.4 A Certificate for Payment, a progress payment, or partial or entire use or occupancy of the Project by the Owner shall not constitute acceptance of Work not in accordance with the requirements of the Contract Documents.

## § 12.5 SUBSTANTIAL COMPLETION

§ 12.5.1 Substantial Completion is the stage in the progress of the Work when the Work or designated portion thereof is sufficiently complete in accordance with the Contract Documents so the Owner can occupy or utilize the Work for its intended use.

§ 12.5.2 When the Work or designated portion thereof is substantially complete, the Architect will make an inspection to determine whether the Work is substantially complete. When the Architect determines that the Work is substantially complete the Architect shall prepare a Certificate of Substantial Completion that shall establish the date of Substantial Completion, shall establish the responsibilities of the Owner and Contractor, and shall fix the time within which the Contractor shall finish all items on the list accompanying the Certificate. Warranties required by the Contract Documents shall commence on the date of Substantial Completion of the Work or designated portion thereof unless otherwise provided in the Certificate of Substantial Completion.

## § 12.6 FINAL COMPLETION AND FINAL PAYMENT

§ 12.6.1 Upon receipt of a final Application for Payment, the Architect will inspect the Work. When the Architect finds the Work acceptable and the Contract fully performed, the Architect will promptly issue a final Certificate for Payment.

§ 12.6.2 Final payment shall not become due until the Contractor submits to the Architect releases and waivers of liens, and data establishing payment or satisfaction of obligations, such as receipts, claims, security interests or encumbrances arising out of the Contract.

§ 12.6.3 Acceptance of final payment by the Contractor, a subcontractor or material supplier shall constitute a waiver of claims by that payee except those previously made in writing and identified by that payee as unsettled at the time of final Application for Payment.

#### ARTICLE 13 PROTECTION OF PERSONS AND PROPERTY

The Contractor shall be responsible for initiating, maintaining and supervising all safety precautions and programs, including all those required by law in connection with performance of the Contract. The Contractor shall take reasonable precautions to prevent damage, injury or loss to employees on the Work, the Work and materials and equipment to be incorporated therein, and other property at the site or adjacent thereto. The Contractor shall promptly remedy damage and loss to property caused in whole or in part by the Contractor, or by anyone for whose acts the Contractor may be liable.

#### ARTICLE 14 CORRECTION OF WORK

§ 14.1 The Contractor shall promptly correct Work rejected by the Architect as failing to conform to the requirements of the Contract Documents. The Contractor shall bear the cost of correcting such rejected Work, including the costs of uncovering, replacement and additional testing.

§ 14.2 In addition to the Contractor's other obligations including warranties under the Contract, the Contractor shall, for a period of one year after Substantial Completion, correct work not conforming to the requirements of the Contract Documents.

§ 14.3 If the Contractor fails to correct nonconforming Work within a reasonable time, the Owner may correct it in accordance with Section 7.3.

#### ARTICLE 15 MISCELLANEOUS PROVISIONS

##### § 15.1 ASSIGNMENT OF CONTRACT

Neither party to the Contract shall assign the Contract as a whole without written consent of the other.

##### § 15.2 TESTS AND INSPECTIONS

§ 15.2.1 At the appropriate times, the Contractor shall arrange and bear cost of tests, inspections and approvals of portions of the Work required by the Contract Documents or by laws, statutes, ordinances, codes, rules and regulations, or lawful orders of public authorities.

§ 15.2.2 If the Architect requires additional testing, the Contractor shall perform those tests.

§ 15.2.3 The Owner shall bear cost of tests, inspections or approvals that do not become requirements until after the Contract is executed.

##### ~~§ 15.3 GOVERNING LAW~~

~~The Contract shall be governed by the law of the place where the Project is located.~~

#### ARTICLE 16 TERMINATION OF THE CONTRACT

##### § 16.1 TERMINATION BY THE CONTRACTOR

If the Architect fails to certify payment as provided in Section 12.3 for a period of 30 days through no fault of the Contractor, or if the Owner fails to make payment as provided in Section 12.4.1 for a period of 30 days, the Contractor may, upon seven additional days' written notice to the Owner and Architect, terminate the Contract and recover from the Owner payment for Work executed including reasonable overhead and profit, and costs incurred by reason of such termination.

##### § 16.2 TERMINATION BY THE OWNER FOR CAUSE

§ 16.2.1 The Owner may terminate the Contract if the Contractor

- .1 repeatedly refuses or fails to supply enough properly skilled workers or proper materials;
- .2 fails to make payment to subcontractors for materials or labor in accordance with the respective agreements between the Contractor and the subcontractors;



- .3 persistently disregards laws, ordinances, or rules, regulations or orders of a public authority having jurisdiction; or
- .4 is otherwise guilty of substantial breach of a provision of the Contract Documents.

§ 16.2.2 When any of the above reasons exist, the Owner, after consultation with the Architect, may without prejudice to any other rights or remedies of the Owner and after giving the Contractor and the Contractor's surety, if any, seven days' written notice, terminate employment of the Contractor and may

- .1 take possession of the site and of all materials thereon owned by the Contractor, and
- .2 finish the Work by whatever reasonable method the Owner may deem expedient.

§ 16.2.3 When the Owner terminates the Contract for one of the reasons stated in Section 16.2.1, the Contractor shall not be entitled to receive further payment until the Work is finished.

§ 16.2.4 If the unpaid balance of the Contract Sum exceeds costs of finishing the Work, such excess shall be paid to the Contractor. If such costs exceed the unpaid balance, the Contractor shall pay the difference to the Owner. This obligation for payment shall survive termination of the Contract.

§ 16.3 TERMINATION BY THE OWNER FOR CONVENIENCE

The Owner may, at any time, terminate the Contract for the Owner's convenience and without cause. The Contractor shall be entitled to receive payment for Work executed, and costs incurred by reason of such termination, along with reasonable overhead and profit on the Work not executed.

ARTICLE 17 OTHER TERMS AND CONDITIONS

(Insert any other terms or conditions below.)

« »

This Agreement entered into as of the day and year first written above.

(If required by law, insert cancellation period, disclosures or other warning statements above the signatures.)

« »

« »

OWNER (Signature)

«Vincent Russo», Program Manager I, Communications & Intergovernmental Relations  
 «186 Newington Road  
 West Hartford, CT 06110»

(Printed name, title and address)

« »

CONTRACTOR (Signature)

« »  
 « »

(Printed name, title and address)

LICENSE NO.:  
 JURISDICTION:

**Addendum to  
Contract Documents by and between  
State of Connecticut, PCA and Contractor**

Owner: State of Connecticut, Office of the Probate Court Administrator  
186 Newington Road  
West Hartford, CT 06110

Contractor:

The Parties hereby agree to amend and change the Contract Documents as defined in AIA Document A105-2007, Standard Form Agreement Between Owner and Contractor for a Residential or Small Commercial Project dated as of April \_\_, 2017 (the "Agreement") by adding the following provisions:

1. DIVISION 01, SECTION 01 10 00, SUMMARY OF WORK:

A. Regulations. All work shall be in strict accordance with the State of Connecticut Basic Building Code, State Fire Safety Code, National Fire Protection Association, NEC, UL, NEMA and OSHA with all requirements of all Governmental Departments having jurisdiction. These requirements shall take precedence over plans and specifications.

B. Use of Premises. Limit use of the premises to work in areas indicated. Confine operations to areas within contract limits indicated. Do not disturb portions of the Site beyond the areas in which the Work is indicated.

i. Allow for Owner occupancy and use by the public of the existing facility during the entire construction period.

ii. The Contractor shall confine his operations, including storage of materials, supplies, equipment and apparatus to the areas bounded by the contract limits indicated and as directed in the Contract Documents. At the completion of the project, the Contractor shall restore to an equivalent or improved condition as approved by owner pavement, sidewalks, lawn and landscaped areas.

iii. Contractor to provide lockable barriers to secure work areas and to prevent unauthorized entry into the work site.

iv. Existing roads, drives, walks and parking areas which are not within the contract limit line are to be kept free and clear at all times. Contractor is not to use these areas for parking or storage of materials. Schedule deliveries to minimize space and time requirements for storage of materials and equipment on site. Position delivery trucks in such a manner to limit exposure to people and property.

v. If the work of the contract affects public use of any street, road, highway or thoroughfare, the Contractor shall confer with the police authority having jurisdiction to determine if and how many police are needed for public safety in addition to any barriers and signals that may be needed. The Contractor will be responsible for coordination, scheduling and payment of any needed police services.

vi. Contractor to provide all necessary rigging, scaffolding and/or high lift and safety equipment for removal and installation of all work associated with project. Temporary fencing/barricades and signage to be provided by contractor in compliance with OSHA requirements.

vii. The Contractor shall comply with building Owner's working hour restrictions and any applicable local city ordinances, unless specifically approved otherwise in writing.

viii. The Contractor shall take all precautions necessary to protect the building and its occupants during the construction period. Any damage caused by construction operations shall be repaired by Contractor at his own expense. Check with Project Manager for areas within the building that may require special security considerations.

ix. The Contractor shall maintain the building in a weather-tight condition throughout the construction period.

x. Contractor is to secure project area/site from intrusions during unoccupied (after hours) period of time.

xi. Temporary sanitary facilities include temporary toilets, wash facilities, and drinking-water fixtures to be furnished by Contractor. Comply with regulations and health codes for the type, number, location, operation, and maintenance of fixtures and facilities. Install where facilities will best serve the Project's needs. This requirement maybe waived only by the Owner allowing the Contractor to use the existing facilities within the premises.

xii. No space within the building will be available for use by the Contractor as a temporary field office.

xiii. All contractor workers on site must wear identification badges and/or must have visible on outer garments the contractor's company name and carry personal identification.

xiv. Contractor personnel are not allowed to use Probate Court Administration telephones, computers, office equipment or furnishings and vending machines within the existing buildings unless authorized in writing by the Owner/Project Manager.

xv. Contractor's superintendent to be on site during inspections/testing of all new work/systems. All inspections/testing to be coordinated with the Owner at least **48 hours in advance**.

xvi. The Contractor shall be responsible for keeping the premises clean and shall pick up rubbish and debris and promptly remove from site.

C. Occupancy Requirements.

i. Every reasonable means shall be employed by the Contractor to minimize excessive vibration, noise, dust and odors which may result from its work. The Contractor shall notify the Owner at least **48 hours in advance** of any work to be completed that potentially can produce strong odors.

a. Owner reserves the right to stop work if it becomes disruptive to the daily business/operation of the Office of the Probate Court Administrator.

b. Any disruptive work shall be completed after 5:00 p.m. Monday through Friday or over weekends.

c. Subsequent claims by the Contractor for additional time or costs due to such shut-downs will not be entertained by PCA or the State of Connecticut.

ii. Unless otherwise shown or specified, the building's utilities, heating, air conditioning, lighting, power, plumbing, gas, etc. are to be kept in operation at all times. Contractor shall notify the Owner at least **48 hours in advance** of any proposed time for shutting down or interrupting any utilities, services or facilities which may affect the daily operations within the building.

2. REPRESENTATIONS AND WARRANTIES: Contractor represents and warrants to the Owner that:

A. It is a duly and validly existing [INSERT TYPE OF ORGANIZATION] under the laws of the State of Connecticut and authorized to conduct its business in the State of Connecticut in the manner contemplated by this Contract. Further, the Contractor has taken all necessary action to authorize the execution, delivery and performance of this Contract and has the power and authority to execute, deliver and perform its obligations under this Contract;

B. It will comply with all applicable State and Federal laws and municipal ordinances in satisfying its obligations to the Owner under and pursuant to this Contract;

C. The execution, delivery and performance of this Contract by the Contractor will not violate, be in conflict with, result in a breach of or constitute (with or without due notice and/or lapse of time) a default under any of the following, as applicable: (i) any provision of law; (ii) any order of any court or any governmental department, commission, board, bureau, agency, office, council, institution or instrumentality (collectively, "Agencies"); or (iii) any indenture, agreement, document or other instrument to which it is a party or by which it may be bound;

D. The Contractor agrees to notify the Owner if the Contractor is, or has a reasonable cause to expect to be, subject to litigation which might adversely affect the Contractor's ability to perform the agreement services or affect the Contractor's financial capacity. The Contractor shall provide written notice to the Owner of any final decision by any tribunal, arbitrator or arbitration panel, or state or federal agency or court which is adverse to the Contractor or which results in a settlement, compromise of claim or agreement of any kind for any action or proceeding brought against the Contractor or its employees or agents;

E. It is not presently debarred, suspended, proposed for debarment, declared ineligible, or voluntarily excluded from covered transactions by any Federal or State department or agency;

F. It has not, in the three years preceding this Contract, had one or more public transactions (federal, state or local) terminated for cause or default; and

G. The Contractor represents that it has not, in connection with this Agreement, entered into any consulting agreement as defined in Conn. Gen. Stat. §4a-81.

3. INDEMNIFICATION: The Contractor shall indemnify, defend and hold harmless the Owner, the Architect and their successors and assigns from and against any and all (A) actions, suits, claims, demands, investigations and legal, administrative or arbitration proceedings pending or threatened, whether mature, unmatured, contingent, known or unknown, at law or in equity, in any forum

(collectively, the “Claims”) arising, directly or indirectly, in connection with this Agreement including, but not limited to, acts of commission or omission (collectively, the “Acts”) by the Contractor or any of its owners, members, directors, officers, shareholders, or employees or any other person or entity with whom the Contractor is in privity of oral or written contract (collectively, the “Contractor Parties”); (B) liabilities arising, directly or indirectly, in connection with this Agreement, out of the Acts of the Contractor or Contractor Parties concerning its or their duties and obligations as set forth in this Agreement; and (C) all damages, losses, costs and expenses, including but not limited to, attorneys’ and other professionals’ fees, that may arise out of such Claims and/or liabilities. The Contractor shall reimburse the Administrator for any and all damages to the real or personal property of the Administrator caused by the Acts of the Contractor or any Contractor Parties. The Administrator shall give to the Contractor reasonable notice of any such Claim. The Contractor shall use counsel reasonably acceptable to the Administrator in carrying out its obligations hereunder. The provisions of this section shall survive the expiration or early termination of this Agreement, and shall not be limited by reason of any insurance coverage.

#### 4. INSURANCE REQUIREMENTS:

A. The Contractor shall, at a minimum, carry the following types and amounts of insurance:

- i. Worker’s Compensation insurance in an amount not less than the minimum Connecticut statutory coverage;
- ii. General liability insurance with a limit of not less than \$1,000,000 for personal injury and property damage;
- iii. Automobile Liability insurance with a limit of not less than \$1,000,000; and
- iv. Professional liability insurance with minimum coverage limits of \$1,000,000.

B. The Owner shall be named as an additional insured on all general liability and property insurance policies and as certificate holder on all other insurance policies set forth in paragraph A above. Each policy shall include an endorsement which states that the Owner will be given 30 days prior notice of cancellation. The Contractor shall furnish the Owner with a certificate evidencing the Contractor’s compliance with the obligations set forth in this section and, upon request, shall promptly furnish the Owner with a copy of the policy. The Contractor shall be solely responsible for the payment of all premiums required for the insurance coverage(s) required under this section.

#### 5. BOND REQUIREMENTS:

A. Performance Bond. The Contractor shall submit a performance bond in an amount equal to 100% of the Contract Price. Additional performance bond protection shall be required in connection with any modification effecting an increase in price under the Contract if the modification is:

- i. for new or additional work which is beyond the scope of the existing contract; or
- ii. is pursuant to an existing provision of the contract and is expected to increase the contract price by \$50,000 or 25% of the original total contract price, whichever is less.

The amount of the performance bond shall be increased so that the protection is 100% of the contract price as revised by both the modification requiring such additional protection and the aggregate of any previous modification requiring such additional protection and the aggregate of

any previous modification. The increased amount may be secured either by increasing the bond protection provided by existing surety or sureties or by obtaining an additional performance bond from a new surety.

B. Payment Bond. The Contractor shall submit a payment bond in and amount not less than 50% of the total amount payable by the terms of the contract. Additional payment bond protection shall be required in connection with any modification effecting an increase in price under the Contract if the modification is:

- i. for new or additional work which is beyond the scope of the existing contract; or
- ii. is pursuant to an existing provision of the contract and is expected to increase the contract price by \$50,000 or 25% of the original total contract price, whichever is less.

The amount of the additional payment bond protection shall generally be such that the total payment bond protection is 50% of the contract price as revised by both the modification requiring such additional protection, and the aggregate of any previous modifications. The additional protection may be secured either by increasing the bond protection provided by the existing surety or sureties or by obtaining an additional payment bond from a new surety.

C. Bond Source. The bonds may be obtained from any surety company authorized by the U.S. Treasury Department as acceptable sureties on Federal Bonds and authorized to transact business in the State of Connecticut.

6. **OFFER OF GRATUITIES:** Contractor warrants, represents, and certifies that no elected or appointed official or employee of the State of Connecticut has, or agrees to, benefit financially or materially from this procurement. This Contract may be terminated by the Owner or without liability attaching to the Owner if it is determined that gratuities of any kind were either offered to, or received by, any of the aforementioned officials or employees from the Contractor, the Contractor's agent(s), representatives(s), employees(s) or subcontractors.

7. **NONDISCLOSURE, CONFIDENTIALITY AND CARE OF INFORMATION:**

A. The Contractor agrees on behalf of itself and its principals, officers, directors, employees, subcontractors, successors, and assigns that: (i) it shall not access any information, files, data, materials, computers or other systems of the Probate Court Administrator's Office, unless required for the performance its duties under this Agreement; and (ii) it shall not disclose or use any information, files, data or other materials obtained in the performance of this Agreement, except as provided in this Agreement.

B. The Contractor agrees to indemnify the Probate Court Administrator and the State of Connecticut and their officers, employees and agents for any and all claims and expenses, including but not limited to, the cost of legal counsel, whether or not a claim is successful: (i) resulting from any improper access, disclosure or use of any information, files, data or materials obtained in the performance of this Agreement; or (ii) occasioned by the loss, destruction or erasure of any information, files, data, materials, computers or other systems under this section.

8. **NON-DISCRIMINATION:** The provisions of C.G.S. §§4a-60 and 4a-60a are hereby incorporated into this Agreement and the Owner and Contractor mutually agree to be bound by all of the provisions contained therein.

9. **EMPLOYMENT OF WORKERS:** In the employment of labor to perform the work specified herein, preference shall be given to citizens of the United States, who are, and continuously for at least three months prior to the date hereof have been, residents of the labor market area, as established by the Labor Commissioner, in which such work is to be done, and if no such qualified person is available, then to citizens who have resided in the county in which the work is to be performed for at least three months prior to the date hereof, and then to citizens of the state who have continuously resided in the state at least three months prior to the date hereof.

Any Contractor who knowingly and willfully employs any person in violation of C.G.S. §31-52(a) is subject to a fine of \$200 for each week or fraction thereof that such person is so employed.

9. **AMERICANS WITH DISABILITIES ACT:** Contractor shall comply with the Americans with Disabilities Act in accordance with Public Law 101-336 and any other applicable federal Laws and regulations.

10. **EXECUTIVE ORDERS:** Contractor shall comply with the provisions of Executive Order No. Three of Governor Thomas J. Meskill promulgated June 16, 1971, concerning labor employment practices; the provisions of Executive Order No. Seventeen of Governor Thomas J. Meskill promulgated February 15, 1973, concerning the listing of employment openings; and the provisions of Executive Order No. Sixteen of Governor John G. Rowland promulgated August 4, 1999, concerning violence in the workplace. In addition, this Agreement is subject to Executive Order No. 7C of Governor M. Jodi Rell promulgated July 13, 2006, concerning review by the State Contracting Standards Board.

11. **APPLICABLE LAW, VENUE AND AGENT FOR SERVICE:** Both parties agree that it is fair and reasonable for the validity and construction of this Agreement to be, and that the Agreement shall be, governed by the laws and court decisions of the State of Connecticut, without giving effect to its principles of conflicts of laws. Contractor agrees that the sole and exclusive means for the presentation of any claim against the Owner shall be in accordance with Chapter 53 of the Connecticut General Statutes (Claims Against the State). Contractor further agrees not to initiate legal proceedings in any State or Federal Court in addition to, or in lieu of, said Chapter 53 proceedings. Any matter arising out of this Agreement that is not subject to the provisions of Chapter 53 shall be subject to the jurisdiction of the courts of the State of Connecticut and the U.S. District Court for the District of Connecticut, as appropriate, and with respect to venue in the Judicial District of Hartford at Hartford or the U.S. District Court for the District of Connecticut in Hartford, as appropriate. Contractor waives any objection it may now have or will have to the laying of venue of any claims in accordance with this section and further irrevocably submits to such jurisdiction in any suit, action or proceeding. Contractor shall appoint agents in Connecticut to receive service of process. If Contractor fails to appoint said agent, the Secretary of the State of Connecticut is hereby appointed by Contractor as its agent for service of process. Such appointment shall be in effect throughout the term of this Agreement, including its supplements, amendments or renewals, if any, and six (6) years thereafter, except as provided by law.

12. **SOVEREIGN IMMUNITY:** The parties acknowledge and agree that nothing in this Contract shall be construed as a waiver by the Owner of any rights or defenses of sovereign immunity, which it may have had, now has or will have with respect to all matters arising out of this Contract. To the extent this provision conflicts with any other provision, this provision shall govern.

State of Connecticut,  
Office of the Probate Court Administrator

---

Paul, J. Knierim  
Probate Court Administrator

---

Its



**PROJECT MANUAL**  
**PROBATE COURT ADMINISTRATION**  
**INTERIOR RENOVATIONS**  
**186 NEWINGTON ROAD**  
**WEST HARTFORD, CONNECTICUT**



**STATE OF CONNECTICUT**  
**OFFICE OF THE PROBATE COURT ADMINISTRATOR**  
**186 NEWINGTON ROAD**  
**WEST HARTFORD, CONNECTICUT, 06107**

*ARCHITECT:*  
**CLOHESSY HARRIS & KAISER, LLC**  
**573 HOPMEADOW STREET**  
**SIMSBURY, CONNECTICUT**

*MEP ENGINEER:*  
**BVH INTEGRATED SERVICES**  
**50 GRIFFIN ROAD SOUTH**  
**BLOOMFIELD, CONNECTICUT**

*STRUCTURAL ENGINEER:*  
**DESIGNS AND ENGINEERED SOLUTIONS, LLC**  
**114 SCOVILLE HILL ROAD**  
**HARWINTON, CONNECTICUT**

**MARCH 10, 2017**



**PROJECT MANUAL**

for

**PROBATE COURT ADMINISTRATION  
INTERIOR RENOVATIONS  
186 Newington Road  
West Hartford, Connecticut**

**March 10, 2017**

OWNER:

**THE STATE OF CONNECTICUT  
OFFICE OF THE PROBATE ADMINISTRATOR**  
186 Newington Road  
West Hartford, CT 06110  
(860) 231-2442  
Project Manager: Vincent Russo

ARCHITECT/CONSTRUCTION  
ADMINISTRATOR:

**CLOHESSY HARRIS & KAISER, LLC**  
573 Hopmeadow Street. P. O. Box 95  
Simsbury, CT 06070  
(860) 651-3777  
Project Manager: Jack Zuccon

MEP ENGINEER:

**BVH INTEGRATED SERVICES, INC.**  
50 Griffin Road South  
Bloomfield, CT 06002  
(860) 286-9171  
Project Manager: Larry Jones

STRUCTURAL ENGINEER:

**DESIGNS AND ENGINEERED SOLUTIONS, LLC**  
114 Scoville Hill Road  
Harwinton, CT 06791  
(860) 605-9120  
Project Manager: Matthew Szydlo



**TABLE OF CONTENTS**

Cover  
Title Page  
Table of Contents  
Drawing List – See Cover Sheet of Drawings

**CONTRACT FORMS AND CONDITIONS OF THE CONTRACT**

General Conditions of the Contract for Construction AIA-201 CMA - 1997 – To be provided by Owner  
Bid Document Package – To be provided by Owner

**DIVISION 1- GENERAL REQUIREMENTS**

01 10 00	Summary of Work & General Requirements
01 23 00	Alternates
01 31 00	Project Management & Coordination
01 32 00	Schedules, Reports & Payments
01 33 00	Submittals
01 40 00	Quality Requirements
01 42 00	References
01 50 00	Construction Facilities and Temporary Controls
01 63 10	Equals and Substitutions
01 73 29	Cutting and Patching
01 77 00	Closeout Procedures

**DIVISION 6 - CARPENTRY**

06 10 00	Rough Carpentry
06 20 00	Finish Carpentry
06 40 00	Architectural Woodwork

**DIVISION 7- MOISTURE CONTROL**

07 92 00	Joint Sealants
----------	----------------

**DIVISION 8 - DOORS, WINDOWS**

08 11 16	Aluminum Doors
08 14 00	Wood Doors
08 71 00	Finish Hardware
08 81 00	Glass and Glazing

**DIVISION 9 - FINISHES**

09 21 16	Gypsum Board Systems
09 53 00	Suspended Acoustical Ceilings
09 65 19	Resilient Base
09 68 13	Tile Carpeting
09 91 01	Painting

**DIVISION 23- HEATING VENTILATING AND AIR CONDITIONING**

23 00 10	General Conditions for Heating, Ventilating, and Air Conditioning
23 05 53	Identification for HVAC Piping and Equipment
23 05 93	Testing, Adjusting, and Balancing for HVAC
23 07 13	Duct Insulation
23 31 13	Metal Ducts
23 33 00	Air Duct Accessories
23 37 13	Diffusers, Registers, and Grilles
23 82 36	Finned-Tube Radiator Heaters

**DIVISION 26- ELECTRICAL**

26 00 10	General Conditions for Electrical
26 05 19	Low-Voltage Electrical Power Conductors and Cables
26 05 23	Control-Voltage Electrical Power Cables
26 05 26	Grounding and Bonding for Electrical Systems
26 05 29	Hangers and Supports for Electrical Systems
26 05 33	Raceway and Boxes for Electrical Systems
26 05 44	Sleeves and Sleeve Seals for Electrical Raceways and Cabling
26 05 53	Identification for Electrical Systems
26 09 23	Lighting Control Devices
26 24 16	Panelboards
26 27 26	Wiring Devices
26 29 13	Enclosed Controllers
26 51 19	LED Interior Lighting

END OF TABLE OF CONTENTS



**SECTION 01 10 00 – SUMMARY OF WORK AND GENERAL REQUIREMENTS**

**PART ONE - GENERAL**

**1.01 GENERAL REQUIREMENTS:**

- A. This specification defines basic standards of procedure, material and workmanship required for all projects for which contract documents are prepared by the Facilities Office of the Probate Court Administration and/or their authorized representative.
- B. Requirements of this project may be amplified or modified for individual projects by drawing notes or "Specification Modifications" issued as part of individual contract documents.
- C. The general requirements of this contract apply to all work included herein. All Contractors are responsible for familiarizing themselves with all plans, specifications and other documents made a part of this agreement. Contractors must coordinate work with all trades effecting or effected by work under this agreement.

**1.02 REGULATIONS:**

- A. All work shall be done in strict accordance with the State of Connecticut Basic Building Code, State Fire Safety Code, National Fire Protection Association, NEC, UL, NEMA, and OSHA with all requirements of all Governmental Departments having jurisdiction.
- B. Requirements of the above shall take precedence over plans and specifications.

**1.03 RELATED DOCUMENTS:**

- A. Construction Documents, Specifications and general provisions of the Contract apply to this Section.

**1.04 WORK COVERED BY CONTRACT DOCUMENTS:**

- A. Project scope includes but is not limited to the following:
  - 1. Selective demolition of building structure and systems in support of new work.
  - 2. Enlarge IT Office 104, and provide new finishes at Lobby 201, Lower Lobby 105, Conference 106, and stairs.
  - 3. Provide Structural and MEP modifications as needed to support the new design.
- B. Project Location: **PROBATE COURT ADMINISTRATION, 186 NEWINGTON ROAD, WEST HARTFORD, CONNECTICUT.**
- C. Owner:
  - 1. Owner: The Owner is the State of Connecticut, Probate Court Administration, 186 Newington Road, West Hartford, CT 06110.
  - 2. The authorized representative for the Owner is **Vincent Russo**, located at 186 Newington Road, West Hartford, CT 06110. Phone: 231-2442 ext. 332; Fax: (860) 231-1055; e-mail: [VRusso@ctprobate.gov](mailto:VRusso@ctprobate.gov)



- a. The Project Manager is the authorized representative for the State of Connecticut Probate Court Administration. The Project Manager will act in matters involving revoking, altering, enlarging or relaxing any requirement of the contract documents.

D. Architect and Engineer:

1. The Architectural Firm is: Clohessy Harris & Kaiser, LLC located at 573 Hopmeadow Street, Simsbury CT 06070. The Architect representing the firm for this project is Jack Zucco, 860-651-3777 [jackz@chkarch.com](mailto:jackz@chkarch.com).
2. The Engineering Firm is: BVH Integrated Services, Inc. located at 50 Griffin Road South, Bloomfield CT 06002. The Engineer representing the firm for this project is Larry Jones, 860-286-9171 [larryj@bvhis.com](mailto:larryj@bvhis.com).

The Architect and Engineer or their accredited representative is referred to in the Contract Documents as "Architect" or "Architects" or "Engineer" or "Engineers" or by pronouns which imply them. As information to the Contractor, the Architect's or Engineer's status is defined as follows:

- a. The Architect and engineer will make interpretations or decisions directly to the Contractor. As needed and prior to rendering interpretations or decisions Architect and engineer may also consult with the Owner's Project Manager.
- b. As the authorized representative of the Probate Court Administration, the Architect and Engineer is responsible for review of shop drawings, materials, and equipment intended for the work, in accordance with the "General Conditions".
- c. Wherever the Architect or Engineer is mentioned in the documents in connection with an administrative function, it shall include the Construction Administrator in that function.

E. Construction Administrator:

1. Construction Administration services are provided by the design team. The point of contact is: Clohessy Harris & Kaiser Architects, located at 573 Hopmeadow Street Simsbury, Connecticut, 06070. The Construction Administration Architect representing the firm for this project is Jack Zucco, phone 860-651-3777. Email [jackz@chkarch.com](mailto:jackz@chkarch.com).
  - a. The Construction Administrator is referred to in the Contract Documents as "Construction Administrator" or by pronouns which imply it.
  - b. As information to the Contractor, the Construction Administrator's status is defined as follows:

The Construction Administrator is the Owner's Agent. Their duties include, but are not limited to the monitoring of the following:

- 1) the General Contractor's overall performance
- 2) the General Contractor's scheduling and construction progress

PROBATE COURT  
ADMINISTRATION  
INTERIOR RENOVATIONS  
186 NEWINGTON ROAD  
WEST HARTFORD, CONNECTICUT

- 3) will process shop drawings, materials, and equipment submittals
  - 4) will review the Contractor's periodic billings
  - 5) will review any change order costs that may be proposed by the Contractor
- c. The Construction Administrator will process all requests for information, interpretations and decisions regarding the meaning and intent of the Contract Documents, consulting with appropriate parties prior to rendering the interpretations or decisions for the Owner/Project Coordinator to the Contractor. All such requests and replies shall be in writing.
- F. The Contractor will include in his bid all items required in order to carry out the intent of the work as described, shown and implied in the construction documents.
- G. It shall be the Contractor's responsibility upon discovery to immediately notify the Architect, in writing, of errors, omissions, discrepancies and instances of noncompliance with applicable codes and regulations within the documents, and of any work which will not fit or properly function if installed as indicated on the Contract Documents. Any additional costs arising from the Contractor's failure to provide such notification shall be borne by the Contractor.

#### 1.05 **WORK SEQUENCE:**

- A. ALL work is to be substantially completed and ready within **Forty-Two (42) calendar days** from issuance of a "Purchase Order".
- B. Project submittals to start no later than **Fourteen (14) calendar days** from issuance of a "Purchase Order".
- C. The Project shall mobilize and construction starts no later than **Fourteen (14) calendar days** after receiving submittal approvals from the Project Manager and/or Construction Administrator.
- D. The Contractor shall be responsible for scheduling and sequencing all work activities to facilitate any simultaneous work activities and operations of the facility. Scheduling of work shall be fully coordinated to ensure a quick and efficient construction period and that the overall contract is completed within the contract completion period established for this Project.
1. The Contractor's use of work hours outside of the "normal business" hours (second shift, overtime, and weekends) **will be** necessary. All costs associated with work scheduled outside of "normal business" hours are to be included in the contractor's competitive bid price.
  2. Contractor must have all materials for the project on site before work can commence.

**1.06 CONTRACTOR USE OF PREMISES:**

- A. General: During the construction period the Contractor shall have full use of the Project area for construction operations. However the owner reserves the right to perform additional work on the premises that is not part of this contract. The contractor shall cooperate with the owner and other contractors and shall coordinate his/her work so that work by others may be incorporated in a timely manner.
- B. Use of the Site: Limit use of the premises to work in areas indicated. Confine operations to areas within contract limits indicated. Do not disturb portions of the Site beyond the areas in which the Work is indicated.
1. Owner Occupancy: Allow for Owner occupancy and use by the public of the existing facility during the entire construction period.
  2. The Contractor shall confine his operations including storage of materials, supplies, equipment and apparatus to the areas bounded by the contract limits indicated and as directed in the Contract Documents. At the completion of the project, the Contractor shall restore to an equivalent or improved condition as approved by owner pavement, sidewalks, lawn and landscaped areas.
  3. Contractor to provide barriers to secure work areas and to prevent unauthorized entry into the work site.
  4. Existing roads, drives, walks and parking areas which are not within the contract limit line are to be kept free and clear at all times. Contractor is not to use these areas for parking or storage of materials. Schedule deliveries to minimize space and time requirements for storage of materials and equipment on site. Position delivery trucks in such a manner to limit exposure to people and property.
  5. Traffic Ways: If the work of the contract affects public use of any street, road, highway or thoroughfare, the Contractor shall confer with the police authority having jurisdiction to determine if and how many police are needed for public safety in addition to any barriers and signals that may be needed. The Contractor will be responsible for coordination, scheduling and payment of any needed police services.
  6. Parking for the Contractor's employees will be limited to an area designated by the Owner and/or Project Manager and the Contractor may be required to provide identification stickers for all employees' cars.
  7. No signs, other than those approved by the Owner /Construction Administrator, will be visible on the premises. The Contractor will not install and/or permit installation of unauthorized signs
  8. Contractor to provide all necessary rigging, scaffolding and/or high lift and safety equipment for removal and installation of all work associated with project. Temporary fencing/barricades and signage to be provided by contractor in compliance with OSHA and Town requirements.
  9. The Contractor shall comply with building Owner's working hour restrictions and any applicable local city ordinances, unless specifically approved otherwise in writing.

10. The Contractor shall take all precautions necessary to protect the building and its occupants during the construction period. Any damage caused by construction operations shall be repaired by Contractor at his own expense. Check with Project Manager for areas within the building that may require special security considerations.
11. The Contractor shall maintain the building in a weather-tight condition throughout the construction period.
12. Contractor is to secure project area/site from intrusions during unoccupied (after hours) period of time.
13. Temporary sanitary facilities include temporary toilets and wash facilities to be furnished by Contractor. Comply with regulations and health codes for the type, number, location, operation, and maintenance of fixtures and facilities. Install where facilities will best serve the Project's needs. This requirement maybe waived only by the Owner allowing the Contractor to use the existing facilities within the premises.
14. All contractor workers on site must wear identification badges and/or must have visible on outer garments the contractor's company name and carry personal identification.
15. The Contractor's employees shall adhere to proper conduct at all times. No smoking, no weapons of any type, alcohol or illegal drugs shall be carried or consumed by employees of the Contractor on Probate Court premises.
16. Contractor personnel are not allowed to use Probate Court telephones, computers, office equipment or furnishings and vending machines within the existing buildings unless authorized in writing by the owner/project manager.
17. Inspections/testing: Contractors superintendent to be on site during inspections/testing of all new work/systems. All inspections/testing to be coordinated with Construction Administrator, Owner and/or Project Manager and shall be made at least **48 hours in advance**.
18. Contractor must provide product MSDS sheets to the on- site building supervisor with copies to Construction Administrator and Project Manager.
19. The Contractor shall be responsible for keeping the premises clean and shall pick up rubbish and debris and promptly remove from site.

#### **1.07 OCCUPANCY REQUIREMENTS:**

- A. The Owner will occupy the site and existing building during the entire construction period.
  1. Prior to the commencement of work, Contractor shall confer and coordinate with the Construction Administrator and Project Manager regarding any special protection measures, of a temporary nature, that may be required by the Owner, Drawings and Specifications, and applicable sections of the Connecticut State Building Code or Fire Safety Code. The Contractor will be responsible to maintain and protect egress ways during the construction sequence as required.
    - a. Costs of such temporary protection shall be included in the contract price.

PROBATE COURT  
ADMINISTRATION  
INTERIOR RENOVATIONS  
186 NEWINGTON ROAD  
WEST HARTFORD, CONNECTICUT

- B. Cooperate with the Owner during construction operations to minimize conflicts and facilitate Owner usage. Perform the Work so as not to interfere with the Owner's operations.
- C. Every reasonable means shall be employed by the Contractor to minimize excessive vibration, noise, dust and odors which may result from their work. Contractor shall notify Construction Administrator and Project Manager at a minimum of **48 hours in advance** of any work to be completed that potentially can produce strong odors.
1. Owner reserves the right to stop work if it becomes disruptive to daily business operations.
  2. Any disruptive work shall be completed after **5:00pm** Monday-Friday and over weekends.
  3. Subsequent claims by the Contractor for additional time or costs due to such shut-downs will not be entertained by the State.
- D. Unless otherwise shown or specified, the building's utilities; heating, air conditioning, lighting, power, plumbing, gas, etc. are to be kept in operation at all times.
1. Contractor shall notify Construction Administrator and Project Manager at a minimum of **48 hours in advance** of any proposed time for shutting down or interrupting any utilities, services, or facilities which may affect the daily operations within the building.

#### **1.08 MISCELLANEOUS PROVISIONS:**

- A. Examination of Site:
1. It is not the intent of the Documents to show all existing conditions. All contractors are required to visit and examine the site prior to submitting bids.
  2. Contractors should investigate and satisfy themselves as to the conditions affecting the work, including but not restricted to those bearing upon transportation, disposal, handling and storage of materials and equipment, availability of labor, water, electric power, uncertainties of weather, roads or similar physical conditions of the ground, the character of equipment and facilities needed preliminary to and during the prosecution of the Work. The Contractor should further satisfy himself as to the character, quality and quantity of the surface and subsurface materials or obstacles to be encountered insofar as this information is reasonably ascertainable from inspection of the site, as well as from information presented by the Contract Documents. Any failure by the Contractor to acquaint himself with the available information shall not relieve him from the responsibility for estimating properly the difficulty and cost of successfully performing the Work.
- B. Pre-Bid Conference:
1. A Pre-Bid Conference and tour of the site will be conducted as scheduled in the bid documents. This scheduled conference is the only official opportunity for the bidders to tour the site with the Owner, Project Manager, Architect, Engineer and/or Construction Administrator.

- C. Project Documents:
1. The Specifications and Drawings are intended to describe and illustrate the materials and labor necessary for the work of this Project.
- D. Construction Responsibility:
1. The Contractor shall be responsible for his construction means, methods, techniques, sequences and procedures employed in the performance of his work and shall have full responsibility for his failure to carry out any part of his work in accordance with the Contract Documents.
  2. Contractor shall utilize only workers who are trained, skilled and authorized to perform the specialized work required by the project scope of work.
  3. Before ordering any material or doing any work, the Contractor shall verify all measurements and/or quantities and be responsible for the correctness of same. No extra charge or compensation will be allowed on account of differences between actual dimensions and the measurements and/or quantities indicated on the drawings or in specifications.
  4. Photographic Documentation: On the date the work is begun and at a daily interval, the Contractor shall have photographs of the construction taken by a professional photographer OR an individual approved by the Owner and/or Owner's representative.
- E. Hours of Operations/Overtime:
1. Contractor "Normal" scheduled work hours are **6:00 AM to 5:00 PM**, Monday through Friday. ALL OTHER TIMES, including Saturday, Sunday and Holidays are considered outside of "Normal" work hours or overtime hours.
  2. Contractor shall anticipate that weekend and/or after work hours will be necessary to complete the project as required. After hours work will be Monday – Friday 5:00pm – 11:00pm. Holiday and Weekend hours will be 7:00am – 4:30pm.
  3. The Contractor shall request approval from the Judicial Project Manager to work overtime. Said request shall be made at least **72 hours in advance**. All costs for overtime are to be included in the Contract Sum.
- F. Compliance with Local Requirements:
1. The Contractor is responsible for compliance with applicable regulatory requirements of the Town of West Hartford in completing the work indicated in these documents.
  2. The Contractor is required to submit and receive written approval from the Town prior to performing any staging or rigging work on, in or near the public way in the completion of the Work indicated in these documents.
  3. All costs associated with the compliance with the above items shall be included in the Contractor's bid sum.

### 1.09 DEFINITIONS:

- A. The Contract Time is the period of time allotted in the Contract Documents for completion of the work.

PROBATE COURT  
ADMINISTRATION  
INTERIOR RENOVATIONS  
186 NEWINGTON ROAD  
WEST HARTFORD, CONNECTICUT

- B. The date of commencement of the work is the date established in a notice to proceed. If there is no notice to proceed, it shall be the date of the Agreement or such other date as may be established therein.
- C. The date of substantial completion of the work is the date mutually agreed upon by the Project Manager, Construction Administrator and the General Contractor.
- D. Unless otherwise noted, "Provide" is intended to mean "Furnish and Install".

**1.10 PROJECT MEETINGS:**

- A. Pre-Construction Conference; the Contractor will attend a pre-construction conference before starting construction, as scheduled by the Construction Administrator and Judicial Administration Project Manager.
- B. Progress meetings; the Construction Administrator and Judicial Administration Project Manager will conduct progress meetings at the project site at regular intervals as agreed upon at the pre-construction conference.

**1.11 CONSTRUCTION SCHEDULE:**

- A. Work shall be completed within the contract completion period established for this project.
- B. A construction schedule is to be prepared by the General Contractor and submitted to the Construction Administrator and Project Manager within (7) days of notice to proceed.
- C. This schedule is to cover all items of Work from start for the project up to the completion of the project. Content at a minimum should include:
  - 1. Show complete sequence of construction by activity, with dates beginning and completion of each element of construction.
  - 2. Identify each item by specification section numbers
  - 3. Indicate critical path with original baseline indicated.
- D. This schedule must be revised to indicate progress of each activity to date of submittal, and projected completion date of each activity.

**1.12 LIQUIDATED DAMAGES:**

- A. The Probate Court Administration will assess against the contract as liquidated damages and not by way of penalty, the sum specified in the project information section for each day beyond the date given for completion of the project.
- B. Liquidated Damages: Five hundred dollars (\$500.00) per calendar day.
- C. The Owner (Probate Court Administration), at their discretion, may waive liquidated damages, or any portion thereof.

**1.13 SUBMITTALS:**

- A. All submittals; shop drawings, manufacturer's product information and samples shall be accompanied by transmittal letter with exact project title and address noted.

- B. Do not proceed with fabrication or installation until shop drawings and/or samples are approved by the Project Manager and the Judicial Administration Construction Administrator. All materials furnished shall be new materials and of first class quality. Corrective work is at the expense of the contractor without added time or expense to the Owner.
- C. Coordinate each submittal with fabrication, purchasing, testing, delivery, other submittals, and all related activities that require sequential activity.
- D. Coordinate transmittal of different types of submittals for related elements of the Work so that processing will not be delayed by the need to review submittals concurrently for coordination.
1. The Architect, Engineer and/or Construction Administrator/Project Manager reserve the right to withhold action on a submittal requiring coordination with other submittals until all related submittals are received.
  2. The Architect, Engineer and/or Construction Administrator/Project Manager reserve the right to reject incomplete submitted packages.
  3. Digital submissions are preferred.
  4. When physical submittals are requested, the minimum number of copies required for each submittal shall be three (3) or as determined at the pre-construction meeting of by the Construction Administrator and/or Judicial Administration Project Manager.
- E. Processing: To avoid the need to delay installation as a result of the time required to process submittals, allow sufficient time for submittal review, including time for re-submittals.
1. Allow seven (7) days from the day of receipt of the submittal for initial review. Allow additional time if the Architect and/or Judicial Administration Construction Administrator must delay processing to permit coordination with subsequent submittal(s).
  2. If an intermediate submittal is necessary, process the same as the initial submittal.
  3. Allow seven (7) days for reprocessing each submittal.
  4. No extension of Contract Time will be authorized because of failure to transmit submittals to the Architect and/or Judicial Administration Construction Administrator sufficiently in advance of the Work to permit processing.

#### **1.14 EQUALS AND SUBSTITUTIONS**

- A. Related Sections: The following Sections contain requirements that relate to Equals or Substitutions: Section 01 63 10 Equals and Substitutions.
- B. Definition: Changes in products, materials, equipment, and methods of construction as required by the Contract Documents and proposed by the Contractor **prior to** the submission of the Competitive Bid.



- C. General: No alternates or substitutes or methods or materials are acceptable unless by written request along with the information on all materials consistent with the requirements as noted in Section 01 63 10 Equals and Substitutions. If such permission is granted, it becomes the Contractor's responsibility that the approved change fits in the project as far as space requirements are concerned and performs equally or better than the specified method or part.

**1.15 MATERIALS, WORKMANSHIP, GUARANTEES AND WARRANTIES**

- A. The Contractor shall guarantee all materials and workmanship for a period of eighteen (18) months from the date of acceptance of the Work. Warranty periods in excess of the contract term shall survive the contract termination or expiration for the full duration of the warranty period.
- B. Submit written warranties prior to the date certified for Substantial Completion.
- C. Refer to each Division in Project Specifications for specific content requirements and particular requirements for submitting special warranties.
- D. Submit at final completion two (2) copies of each required warranty properly executed by the contractor, or by the Contractor subcontractor, supplier or manufacturer. Organize the warranty documents into a durable 3-ring binder in an orderly sequence based on the table of contents of the Project Specifications.

**1.16 ABBREVIATED WRITTEN SUMMARY OF WORK:**

- A. The following describes the Project briefly and without force and effect upon the Contract Documents: The Owner of the building wishes to renovate portions of existing interior space. Supporting changes to building structure and systems will be necessary.

**PART TWO - PRODUCTS – (NOT APPLICABLE).**

**PART THREE - EXECUTION – (NOT APPLICABLE)**

END OF SECTION

**SECTION 01 23 00 – ALTERNATES**

**PART ONE - GENERAL**

**1.01 RELATED DOCUMENTS:**

- A. Drawings and Supplemental Provisions of Contract, including other Division-1 Specification Sections, apply to Work of this Section.
- B. Definitions: Alternates are defined as alternate products, materials, equipment or systems for Work, which may, at the Owner's option and under terms established, be selected and recorded in the Contract to either supplement or displace corresponding basic requirements of the Contract Documents.
- C. Section: Selection by the Owner may occur prior to the Contract Date, or may, by the Agreement, be deferred for possible selection at a subsequent date.
- D. Alternate Provisions:
  - 1. Numbering: Each Alternate is identified by number, and describes the basic changes to be incorporated into the Work, only when that Alternate is made a part of the Work by specified provisions in the Contract.
  - 2. Language: Each Alternate is defined by abbreviated language, recognizing that drawings and specification sections document the requirements. Information contained herein is intended to summarize alternates, but does not necessarily include references to every trade or every operation involved.
  - 3. Coordination: Coordination of related work is required to ensure that work affected by each selected Alternate is complete and properly interfaced with the Work.
    - a. Referenced sections of specifications stipulate pertinent requirements to achieve the work stipulated under each Alternate.
    - b. Coordinate pertinent related Work and modify surrounding work to integrate Work under each Alternate. Provide complete construction required by the Contract Documents as affected by alternates which are accepted and made part of the Contract.
  - 4. Notification: Immediately following award of the Contract, prepare and distribute to each entity to be involved in the performance of Work a notification of status of Alternate. Indicate which alternates have been:
    - a. Accepted
    - b. Rejected
    - c. Deferred for consideration at a later date as indicated. Include full description of negotiated modifications to alternates, if any.

**1.02 SCHEDULE OF ALTERNATES:**

A. Alternate No. 1 – Storefront Modifications:

Modify existing hollow metal entry. Remove double doors and associated hardware; provide new single leaf glass and aluminum door with sidelight infill construction. Patch, prime and paint existing metal storefront system. Remove paint down to bare metal and inspect for decay and/or rusting. Inspect metal condition and advise architect on condition prior to ordering new aluminum door and sidelight. All work to be performed during non-business hours with all work being completed during the course of one weekend. See drawings and specifications for additional details.

B. Alternate No. 2 – Door with Vision Panel:

Within existing frame, provide new door 102, with vision panel. See drawings and specifications for additional details.

C. Alternate No. 3 – Omitted

D. Alternate No. 4 – New Carpet, Wall Base and Paint:

Provide new carpet, wall base and paint in IT Manager's Office 103 and Office 108.

E. Alternate No. 5 – Shelving Replacement:

At existing bookshelves to remain in Conference/Law Library 106, replace existing deflected shelves with new shelves. See drawings for more information. Paint shelves to match carcass.

F. Alternate No. 6 – Storefront Replacement:

Remove existing double doors, hollow metal entry frame and sidelight system within masonry opening. Prep opening and replace with new 14000 series aluminum storefront framing system (2" x 4-1/2" profile), with 1" insulated glass and outboard glazed by Tubelite ([www.tubeliteinc.com](http://www.tubeliteinc.com)) or architect approved equal. Provide single leaf glass and aluminum door (3'-0"w x 7'-0"h x 1-3/4"t) similar to door 'Type A' on drawings and door hardware similar to 'Set A' on drawings. Provide formed edge infill panels, Mapeshape by Mapes ([www.mapespanels.com](http://www.mapespanels.com)) or architect approved equal, at bottom section of storefront and installed flush with exterior framing. Panel core with polystyrene insulation and substrate with solid plastic (SPS). Factory finish of storefront and infill panel to be Kynar (white). See design concept drawing on sheet A701 for more information.

CLOHESSY HARRIS & KAISER, LLC

ALTERNATES  
SECTION 01 23 00  
PAGE 3 OF 3

**PART TWO - PRODUCTS** (Not Applicable).

**PART THREE - EXECUTION** (Not Applicable).

**END OF SECTION**

PN 17001  
03/10/17

PROBATE COURT  
ADMINISTRATION  
INTERIOR RENOVATIONS  
186 NEWINGTON ROAD  
WEST HARTFORD, CONNECTICUT



**SECTION 01 31 00 - PROJECT MANAGEMENT AND COORDINATION**

**PART ONE - GENERAL**

**1.01 RELATED DOCUMENTS:**

- A. Drawings and General Provisions of Contract, including General and Supplementary Conditions and other Division-1 Specification Sections, apply to Work of this Section.

**1.02 DESCRIPTION OF WORK:**

- A. Minimum administrative and supervisory requirements necessary for coordination of Work on the project to be fulfilled collectively by the Contractors include but are not necessarily limited to the following:
1. Coordination and Meetings
  2. Administrative and Supervisory Personnel
  3. Surveys and Records or Reports
  4. Limitations for Use of Site
  5. Special Reports
  6. General Installation Provisions
  7. Cleaning and Protection
  8. Conservation and Salvage
- B. Each Contractor must participate in these coordination requirements, where applicable, even though certain items of Work may be assigned to a specific Contractor, and even though the General Contractor shall be responsible for overall general coordination.

**1.03 COORDINATION AND MEETINGS:**

- A. General: The General Contractor shall prepare a written memorandum on required coordination activities. He shall include such items as required notices, reports, and attendance at meetings and shall distribute this memorandum to each entity performing Work at the project site. Similar memorandums for separate contractors shall be prepared by the General Contractor where interfacing of their Work is required.
- B. Weekly Project Meetings: The Architect, Owner and General Contractor shall coordinate the scheduling and administration of regular project meetings. Unless scheduled otherwise by the Owner, project meetings shall be held every week at regularly scheduled times. The General Contractor shall record and distribute meeting minutes to all participants, including the Owner and others which may be affected by decisions made at the meetings.

**1.04 CONSTRUCTION DOCUMENTATION:**

- A. It is the duty of the General Contractor to ensure that each sub-contractor has a complete set of all construction documentation to maintain and use for reference throughout the duration of their involvement in this project.

**1.05 ADMINISTRATIVE/SUPERVISORY PERSONNEL:**

- A. General: In addition to a General Superintendent and other administrative and supervisory personnel required for performance of the Work, each contractor shall provide specific coordinating personnel as reasonable required for interfacing Work with other Work of the total project.
- B. Project Coordinator: The General Contractor shall provide a full-time Project Coordinator, who is experienced in administration and supervision of building construction, including mechanical and electrical work. The Project Coordinator is hereby authorized to act as the General Coordinator of interface between the Work of the separate contracts. For purpose of this provision, "interface" is defined to include scheduling and sequencing of Work, sharing of access to Work spaces, installations, protection of each other's work, cutting and patching, tolerances, cleaning, selections for compatibility, review of coordination drawings, inspections, tests, and temporary facilities and services.

**PART TWO - PRODUCTS** (Not Applicable)

**PART THREE – EXECUTION**

**3.01 PRE-INSTALLATION COORDINATION:**

- A. Generally and without exclusion or force or effect on the Contract Documents, the following work items require pre-installation coordination:
1. Use of Project Site.
  2. Scheduling of Work to avoid disruption of building employees activities or work spaces.
  3. Work which may result in odors that could migrate into the building(s) through windows or the mechanical system.
  4. Maintaining existing or providing temporary alternate means of emergency egress from the building, as required by the local Building Official and Fire Marshal.
  5. Entrance Door Assemblies

**3.02 GENERAL INSTALLATION PROVISIONS:**

- A. Pre-Installation Conferences: The Contractor with the most involvement (as designated by the General Contractor) shall schedule and hold a pre-installation meeting at the project site well before installation of each unit of work which requires coordination with other units of work. Other contractors involved in the unit of work as well as the installer and representatives of manufacturers and fabricators who are involved in or affected by that unit of work and in its coordination or integration with other work which has preceded or will follow shall attend this meeting. The Contractor with the most involvement shall advise the General Contractor of scheduled meeting dates.
- B. At each meeting the Contractor shall review progress of other work and preparations for particular work under consideration, including specific requirements for the following:
1. Contract Documents
  2. Options
  3. Related Change Orders
  4. Purchases
  5. Deliveries
  6. Shop Drawings, Product Data and Quality Control Samples
  7. Possible Conflicts and Compatibility Problems
  8. Time Schedules
  9. Weather Limitations
  10. Manufacturer's Recommendations
  11. Compatibility of Materials
  12. Acceptability of Substrates
  13. Temporary Facilities
  14. Space and Access Limitations
  15. Governing Regulations
  16. Safety
  17. Inspection and Testing Requirements
  18. Required Performance Results
  19. Recording Requirements
  20. Protection
- C. The Contractor with the most involvement shall record significant discussions of each conference and shall record agreements and disagreements along with the final plan of action. The Contractor with the most involvement shall distribute the record of the meeting promptly to everyone concerned, including the Architect/Engineer.



- D. The unit of work shall not proceed if the pre-installation conference has not been concluded successfully. The Contractor with the most involvement shall initiate whatever actions are necessary to resolve impediments to performance of the work and shall reconvene pre-installation conference at the earliest feasible date.
- E. Installer's Inspection of Conditions: The Contractor involved shall require the Installer of each major unit of work to inspect the substrate to receive work and the conditions under which the work is to be performed. The Installer shall report all unsatisfactory conditions in writing to the Contractor. Do not proceed with the work until unsatisfactory conditions have been corrected in a manner acceptable to the Installer.
- F. Manufacturer's Instructions: Where installations include manufactured products, comply with the manufacturer's applicable instructions and recommendations for installation, to the extent that these instructions and recommendations are more explicit or more stringent than requirements indicated in the Contract Documents.
- G. Inspect each item of materials or equipment immediately prior to installation, and reject damaged and defective items.
- H. Provide attachment and connection devices and methods for securing work properly. Secure work true to line and level, and within recognized tolerances. Allow expansion and building movement. Provide uniform joint width in exposed work. Arrange joints in exposed work to obtain the best visual effect. Refer questionable visual-effect choices to the General Contractor for final decision.
- I. Recheck measurements and dimensions of the work, as an integral step of starting each installation.
- J. Install each unit of work during weather conditions and project status which will ensure the best possible results in coordination with the entire work. Isolate each unit of work from incompatible work as necessary to prevent deterioration.
- K. Enclosure of the Work: Each contractor shall coordinate the closing-in of the work with required inspections and tests, so as to minimize the necessity of uncovering work for that purpose.
- L. Mounting Heights: Where mounting heights are not indicated, mount individual units of work at industry-recognized, ADA compliant, standard mounting heights for the particular applications indicated. Refer questionable mounting height choices to the General Contractor and Architect for final decision.

**3.03 CLEANING AND PROTECTION:**

- A. General: During handling and installation of work at the project site, each contractor shall clean and protect work in progress and adjoining work on a basis of continuous maintenance. Apply protective covering on installed work where it is required to ensure freedom from damage or deterioration at the time of substantial completion.
- B. Clean and perform maintenance on installed work as frequently as necessary through the remainder of the construction period. Adjust and lubricate operable components to ensure operability without damaging effects.
- C. Limiting Exposure of Work: To the extent possible through reasonable control and protection methods, each contractor shall supervise performance of the work in such a manner and by means which will ensure that none of the work, whether completed or in progress, will be subjected to harmful, dangerous, damaging, or otherwise deleterious exposure during the construction period.
- D. Such exposure includes, where applicable, but not by way of limitation the following:
1. Excessive Static or Dynamic Loading
  2. Excessive Internal or External Pressures
  3. Excessively High or Low Temperatures
  4. Thermal Shock
  5. Excessively High or Low Humidity
  6. Air Contamination or Pollution
  7. Water or Ice
  8. Solvents
  9. Chemicals
  10. Light
  11. Radiation
  12. Puncture
  13. Abrasion
  14. Heavy traffic
  15. Soiling
  16. Bacteria
  17. Insect Infestation
  18. Combustion
  19. Electrical Current
  20. High speed operation, improper lubrication, unusual wear or other misuse
  21. Incompatible Interface
  22. Destructive Testing
  23. Misalignment
  24. Excessive Weathering
  25. Unprotected Storage

- 26. Improper Shipping or Handling
- 27. Theft
- 28. Vandalism

**3.03 CONSERVATION AND SALVAGE:**

- A. General: It is a requirement for each Contractor's supervision and administration of the work that construction operations be carried out with the maximum possible consideration given to conservation of energy, water and materials. In addition maximum consideration shall be given to salvaging materials and equipment involved in performance of the work but not incorporated therein. Refer to other sections for required disposition of salvage materials which are the Owner's property.

**END OF SECTION**

**SECTION 01 32 00 - SCHEDULES, REPORTS, & PAYMENTS**

**PART ONE - GENERAL**

**1.01 RELATED DOCUMENTS:**

- A. Drawings and General Provisions of Contract, including General and Supplementary Conditions and other Division-1 Specification Sections, apply to Work of this Section.

**1.02 COORDINATION:**

- A. Coordinate both the timing and the listing of reports and other activities required by provisions of this section and other sections, so as to provide consistency and logical coordination between the reports. Maintain coordination and correlation between separate reports by updating at monthly or shorter time intervals. Make appropriate distribution of each report and updated report to all parties involved in the work including the General Contractor, Architect/Engineer and Owner. In particular, provide close coordination of the progress schedule, schedule of values, listing of subcontracts, schedule of submittals, progress reports, and payment requests.

**1.03 MASTER PROJECT SCHEDULE:**

- A. The General Contractor shall generate and maintain a Master Project Schedule and monitor the progress of the Project.
- B. Each Contractor shall provide scheduling data required for the generation and maintenance of the master Project Schedule. Within 20 days of the Contractor's issuance of Notice to Proceed, the Contractor shall submit to the Owner and Architect a detailed listing of scheduling data which shall include but not be limited to the following:
  - 1. Itemization (as appropriate) of major stages of work
  - 2. Itemization (as appropriate) of major areas of work
  - 3. Itemization of work activities within each stage and/or area
  - 4. Durations of each activity
  - 5. Sequencing of activities and milestones within states and/or areas
    - a. Such sequencing shall be itemized to include subcontract letting, submittals, purchases, mock-ups, fabrication, testing, deliveries, installation, adjusting, curing, start-up procedures, placement into final use and operation, etc.
  - 6. Projected contract commencement
  - 7. Projected substantial completion

- C. Indicate how sequence of work is affected by requirements for factors influencing the project such as the following:
1. Phased completion of work by area
  2. Separate Contractors
  3. Owner
  4. Pre-purchases Materials
  5. Coordination with Existing Work
  6. Non-interruptible Services
  7. Site Restrictions
  8. Provisions for future work
  9. Seasonal Variations
  10. Environmental Control
- D. Refer to other Sections of Division-1 and other Contract Documents for additional requirements.
- E. Cost Correlation: The Contractor shall be responsible for providing cash flow requirement projections in conjunction with the scheduling data.
- F. To facilitate comprehensive coordination of scheduling and cash flow projections, the contractor shall utilize the same categories for the Payment Application Schedule of Values, required by the General Conditions, and Project areas, stages, and/or work items utilized in itemizing scheduling data.
- G. Prior to submitting itemized scheduling data, the sub-contractor shall meet with the General Contractor, review the scope of work, and develop an outline of the schedule defining major areas, stages, work items, and milestones.
- H. Distribution: The General Contractor will generate the Master Project Schedule and maintain it. The General Contractor will distribute 2 copies of the schedule and each updated version to each sub-contractor and others on a need-to-know schedule compliance basis. Copies will also be posted in the project meeting room and General Contractor's field office.

**1.04 PROGRESS MEETINGS, REPORTING:**

- A. General: In addition to specific coordination and pre-installation meetings for each element of work, and other regular project meetings held for other purposes, the General Contractor shall hold a general progress meeting each month with time coordinated with preparation of payment request. Each entity then involved in planning, coordination, or performance of work shall be required to be properly represented at each meeting. The General Contractor shall review each entity's present and future needs including interface requirements, time,

sequences, deliveries, access, site utilization, temporary facilities and services, hours of work, hazards and risks, housekeeping, change orders, and documentation of information for payment requests. The General Contractor shall discuss whether each element of current work is ahead of schedule, on time, or behind schedule in relation with updated progress schedule and, determine how behind-schedule work will be expedited, and secure commitments from entities involved in doing so. The General Contractor shall discuss whether schedule revisions are required to ensure that current work and subsequent work will be completed within Contract time and, review everything of significance which could affect progress of the work.

- B. Initial Progress Meeting: The General Contractor shall schedule an initial progress meeting, recognized as "Pre-Construction Meeting", for a date not more than 15 days after date of commencement of the work. It shall be used as an organizational meeting, where responsibilities and personnel assignments will be reviewed.
1. Reporting: Within 3 days after each progress meeting date, the General Contractor shall distribute copies of minutes-of-the-meeting to each entity present and to others who should have been present. Minutes shall include a brief summary (in narrative form) of progress of the work since previous meeting and report.
  2. Schedule Updating: Immediately following each progress meeting, where revisions to progress schedule have been made or recognized, Project Schedule shall be revised. The General Contractor shall reissue the revised schedule concurrently with a report of each meeting.
- C. Daily Reports: Each Contractor shall prepare a daily report, recording the following information concerning events at the site; and submit duplicate copies to the General Contractor weekly:
1. List of Subcontractors at the site
  2. List of separate Contractors at the site
  3. Approximate count of personnel at the site
  4. High/low temperatures, general weather conditions
  5. Accidents (refer to accident reports)
  6. Meetings and significant decisions
  7. Unusual events (refer to special reports)
  8. Stoppages, delays, shortages, losses
  9. Meter readings and similar recordings
  10. Emergency procedures, field orders
  11. Orders/requests by governing authorities
  12. Change orders received, implemented
  13. Services connected, disconnected
  14. Equipment or system tests and start-ups
  15. Partial completions, occupancies

PROBATE COURT  
ADMINISTRATION  
INTERIOR RENOVATIONS  
186 NEWINGTON ROAD  
WEST HARTFORD, CONNECTICUT

16. Substantial completions authorized

**1.05 SCHEDULE OF VALUES:**

A. Schedule of Values shall be as outlined and defined in the Master Agreement and Schedule.

**1.06 PAYMENT REQUESTS:**

A. Payment Requests shall be as outlined and defined in the Agreement between the Owner and Contractor.

**PART TWO - PRODUCTS** (Not Applicable)

**PART THREE - EXECUTION** (Not Applicable)

END OF SECTION

**SECTION 01 33 00 - SUBMITTALS**

**PART ONE - GENERAL**

**1.01 RELATED REQUIREMENTS SPECIFIED ELSEWHERE:**

- A. Other requirements pertaining to submittals are included in the General Conditions and in the various sections of the Specifications.
- B. Summary of the Work: Section 01 10 00.
- C. Closeout Procedures: Section 01 77 00.

**1.02 DEFINITIONS:**

- A. Deviation: Changes in products, materials, equipment and methods of construction from those required by the Contract Documents and proposed by the Contractor.
- B. Acceptable Manufacturer, Company or Product: A manufacturer, company or product capable of achieving the requirements established in the Contract Documents and demonstrating compliance.
- C. Portable Document Format (PDF): An open standard file format used for representing documents in a device-independent and display resolution-independent fixed layout document format.

**1.03 “OR EQUAL” TO BRAND NAME PRODUCTS:**

- A. Whenever a product is specified by brand name, a comparable brand, equal to that named, may be submitted for approval subject to the requirements of the Agreement between Owner and Contractor.
  - 1. The Contractor shall bear the burden of proving that the proposed product is equal to the specified product. The submission of an “or equal” shall be done in a timely manner to allow the Owner sufficient time to review the proposed product.
  - 2. Whenever a color or pattern is indicated by a specific manufacturer’s name or number, the intent is to communicate the required color or pattern of the material. Other manufacturers’ comparable colors or patterns may be submitted for approval as equal.



**1.04 WAIVER OF CERTAIN SUBMITTAL REQUIREMENTS:**

- A. Unless otherwise specified, the requirement to submit product data and samples for approval will be waived for products specified by brand name if the specifically named products are furnished for the Work.

**1.05 ADMINISTRATIVE REQUIREMENTS:**

- A. Identify submittals by project title and number. Include Contractor's name, date, and revision date. On shop drawings, product data and samples, also include the name of the supplier and subcontractor (if any), and applicable specification section number. Stamp each submittal and initial or sign the stamp to certify review and approval of submittal.
- B. Assemble submittals in accordance with the requirements in the individual sections of the Specifications and as required by this section. It is the Contractor's responsibility to review and verify that all information required for each submittal is included in the submittal package. Errors or omissions found by the Contractor are to be corrected prior to the submission of the submittal package for approval. Incomplete submittal packages that have been submitted for review and approval will be returned.
1. It is the Contractor's responsibility to verify that portions of the submittal package to be provided by a subcontractor (or supplier) are complete, as well as portions of the submittal package being provided directly by the Contractor.
  2. Do not combine the submittals of more than one specification section with submittals required by other specification sections unless specifically stated in the contract Specifications.
- C. If a submittal is based on, or the result of, a change order or field order to the Contract Documents, include copies of the applicable change order or field order with the submittal.
- D. Coordination: Coordinate preparation and processing of submittals with performance of construction activities.
1. Coordinate each submittal with fabrication, purchasing, testing, delivery, other submittals, and related activities that require sequential activity.
  2. Submit all submittal items required for each specification section concurrently unless instructions for partial submittals are required in a specific specification section requiring sequential submissions.
  3. Submit action submittals and informational submittals required by the same specification section as separate packages under separate transmittals.
  4. Coordinate transmittals of different types of submittals for related parts of the Work so processing will not be delayed because of need to review submittals concurrently for coordination.

- a. The Owner reserves the right to withhold action on a submittal requiring coordination with other submittals until related submittals are received.
  
- E. Processing Time: Allow time for submittal review, including time for resubmittals, as follows. Time for review shall commence on uploading the submittal to the Architect. No extension of the project schedule will be authorized because of failure to transmit submittals enough in advance of the Work to permit processing, including resubmittals.
  - 1. Initial Review: Allow time for the initial review of each submittal. Allow additional time if coordination with subsequent submittals is required. The Designer of Record will advise the Owner when a submittal being processed must be delayed for coordination.
  - 2. Resubmittal Review: Allow time for review of each resubmittal.
  - 3. Sequential Review: Where sequential review of submittals by the project team is necessary for coordination, allow time for review.

**1.06 RE-EVALUATION FEE:**

- A. A re-evaluation processing fee will be levied against the Contractor for each re-evaluation of a Submittal or Submittal Package submission that was returned for failure to comply with the submittal requirements relative to completeness, content or format.

**1.07 ELECTRONIC SUBMITTALS:**

- A. Electronic Submittals are used to provide an on-line database and repository which shall be used to transmit and track project related documents. The intent is to expedite the construction process by reducing paperwork, improving information flow, and decreasing submittal review turnaround time.
  - 1. Project submittals (shop drawing, product data and quality assurance submittals) shall be transmitted by the Contractor in PDF, where it will be tracked and stored for retrieval for review. After the submittal is reviewed it is transmitted for action or use by the Contractor and Owner.
  
- B. For each submittal, the Contractor shall review and apply electronic stamp certifying that the submittal complies with the requirements of the Contract Documents, including verification of manufacturer/product, dimensions and coordination of information with other parts of the work.
  
- C. It is the Contractor's responsibility to provide submittals in PDF.
  
- D. Image Quality:
  - 1. Image resolution: The PDF files shall be created at a minimum resolution of 200 dots per inch utilizing the original document size. The Contractor will be responsible to increase the resolution of the scanned file or images being submitted as required to adequately present the information.

2. Image Color Rendition: When information represented requires color to convey the intent and compliance, provide full color PDF reproduction.
- E. Internet Service and Equipment Requirements:
1. The Contractor will be required to have an Email address and Internet access at Contractor's main office.
  2. Unless the Contractor will exclusively be using a Scanning Service to create PDF documents, the Contractor will be required to own a PDF reviewing, creating and editing software, such as Adobe Acrobat (www.adobe.com), Bluebeam PDF Revu® (www.bluebeam.com), or other similar PDF reviewing, creating and editing software for applying electronic stamps and comments.
- F. Paper prints (hardcopies) of reviewed submittals:
1. Record Copy: Each Contractor shall provide one paper copy of each submittal they are responsible for to the Owner within 14 days of receipt of a released submittal (i.e. marked "Approved", "Approved As Noted", or other implied acceptance of a submittal), or meeting the requirements of Waiver Of Certain Submittal Requirements Article of this specification section.
    - a. Exception: Paper copies are not required for a submittal that is disapproved or requiring resubmission.
    - b. Paper copies shall be printed in a size format equal to the original document.
    - c. Scaled Shop Drawings shall be printed to the scale noted on the drawings.
    - d. The resolution of the printed copy shall be equal to that of the PDF file that it is being printed from.
    - e. The Record Copy shall be used by the Owner during the construction of the project and shall be retained as a turn-over item to the facility at the end of the project as required under Section 01 77 00 Closeout Procedures.
  2. Use for Construction: Retain complete copies of submittals on project site. The Contractor shall not commence work for related activities until the appropriate submittals are approved and the corresponding record copies are delivered to the Owner.
  3. Distribution: The Contractor will furnish copies of final submittals to manufacturers, subcontractors, suppliers, fabricators, installers, authorities having jurisdiction, and others as necessary for performance of construction activities. Maintain transmittal forms indicating distribution of submittals.

**1.08 SHOP DRAWINGS:**

- A. Provide shop drawings in the format required by the Specifications. Show the information, dimensions, connections and other details necessary to insure that the shop drawings accurately interpret the Contract Documents. Show adjoining construction in such detail as required indicating proper connections. Where adjoining connected construction requires shop drawings or product data, submit such information for approval at the same time so that connections can be accurately checked.
- B. Electronic copies of CAD Drawings of the Contract Drawings will be provided by the Owner for Contractor's use in preparing submittals.
1. The Owner will furnish one set of digital data drawing files of the Contract Drawings for use in preparing Shop Drawings.
    - a. The Owner makes no representations as to the accuracy or completeness of digital data drawing files as they relate to the Contract Drawings.
  2. The Contractor will be required to sign a Use Agreement for Project Documents prior to release of digital data drawing files of the Contract Drawings.
- C. Have shop drawings prepared by a qualified detailer. Shop drawings shall be neatly drawn and clearly legible. Machine duplicated copies of Contract Drawings will not be accepted as shop drawings.
1. Where shop drawings are indicated to be drawn to scale:
    - a. Use scale normally found on an "Architect" or "Engineer" scale.
    - b. Written Scale: Clearly label scales being used on each drawing and/or on each detail on the drawing.
      - 1) Examples: 1/8" = 1'-0" 1" = 40'-0".
    - c. Graphic Scale: Adjacent to each Written Scale, provide a graphic scale delineating the scale being used. Graphic scale shall be divided into measuring units relating to the accuracy required for the drawing or details.
    - d. Clearly dimension key elements of the drawing or detail.
  2. When the drawing sheet is printed full size, the minimum text size shall be 1/8" (3.2 mm) for hand drafting and 3/32" (2.5 mm) for CADD drawings.
- D. Submit the shop drawings electronically. The shop drawings will be reviewed and the Contractor will receive email notice of completed review. If the review results in disposition of "DISAPPROVED" or "RETURNED FOR CORRECTION", promptly correct the deficiencies and resubmit the shop drawings meeting Contract requirements.

**1.09 PRODUCT DATA:**

- A. Provide product data in the format required by the Specifications. Modify product data by deleting information that is not applicable to the project or by marking the product data to identify pertinent products. Supplement standard information, if necessary, to provide additional information applicable to project.
- B. Submit the product data electronically. The product data will be reviewed and the review results will be transmitted to the Contractor, who will receive email notice of completed review. If the review results in disposition of “DISAPPROVED” or “RETURNED FOR CORRECTION”, promptly correct the deficiencies and resubmit the product data meeting Contract requirements.
- C. Comply with applicable federal, state and local law provisions. Provide Safety Data Sheets (SDS) documents for products that have SDS data prior to use on the project site.

**1.10 QUALITY ASSURANCE:**

- A. Provide quality assurance information in the format required by the Specifications, including supporting documentation as required.
- B. Submit the quality assurance information electronically. The quality assurance information will be reviewed and the Contractor will receive email notice of completed review. If the review results in disposition of “DISAPPROVED” or “RETURNED FOR CORRECTION”, promptly correct the deficiencies and resubmit the quality assurance information meeting Contract requirements.

**1.11 SAMPLES:**

- A. Submit 2 (unless a different number is specified) of each sample required by the Specifications.
- B. Samples will become the property of the Owner when submitted and will not be incorporated in the Work unless specifically stated otherwise.
- C. The electronic submittal process is not intended for color samples, color charts, or physical material samples.

**1.12 REVIEW OF SUBMITTALS:**

- A. Items submitted for review will be reviewed for compliance with the Contract Documents, based upon the information submitted. The items will be acted upon with the following dispositions:

1. No Exception Taken:  
No Exception Taken means that fabrication, manufacture or construction may proceed, providing the submittal complies with Contract Documents. Contractor assumes sole responsibility for the required compliance. No response is required of the Contractor.
2. Make Corrections Noted:  
Make Corrections Noted means that fabrication, manufacture or construction may proceed, provided submittal is amended and resubmitted to comply with Architect's notations and the Contract Documents, or the Contractor confirms in writing that he will do so. If for any reason, Contractor cannot confirm compliance with notations, Contractor shall resubmit as described for submittals stamped Rejected.
3. Rejected:  
Rejected means that submittals does not comply with Contract Documents, and that fabrication, manufacture or construction as submitted must not proceed under any circumstances. Submittals stamped Rejected are not permitted on job site.
4. Revise and Resubmit:  
Revise and Resubmit means that fabrication, manufacture or construction may not proceed until submittal is amended and resubmitted to comply with Architects notations and the Contract Documents.
6. No Action:  
No Action means that no review was made of this item, see comments noted on submittal and take appropriate action.

**PART TWO - PRODUCTS** (Not Used)

**PART THREE - EXECUTION** (Not Used)

**END OF SECTION**



**SECTION 01 40 00 - QUALITY REQUIREMENTS**

**PART ONE - GENERAL**

**1.01 RELATED DOCUMENTS:**

- A. Drawings and General Provisions of Contract, including General and Supplementary Conditions and other Division-1 Specification Sections, apply to Work of this Section.
- B. Section 01 33 30 - Shop Drawings, Product Data, and Samples: Submittal of Manufacturer's Instructions.

**1.02 QUALITY CONTROL, GENERAL:**

- A. Maintain quality control over suppliers, manufacturers, products, services, site conditions, and workmanship, to produce work of specified quality.
- B. Perform Work by persons qualified to produce workmanship of specified quality
- C. Secure products in place with positive anchorage devised designed and sized to withstand stresses, vibration, and racking.

**1.03 MANUFACTURERS' INSTRUCTIONS:**

- A. Comply with instructions in full detail, including each step in sequence. Should instructions conflict with Contract Documents, request clarification from Architect/Engineer before proceeding.

**1.04 MANUFACTURERS' CERTIFICATES:**

- A. When required by individual Specifications Sections, submit manufacturer's certificate, in duplicate, that products meet or exceed specified requirements.

**1.05 MOCKUPS:**

- A. When required by individual Specifications Sections, erect complete, full-scale mockup of assembly at Project site. Tests will be performed in accordance with Architect/Engineer's instructions. Remove mockup at completion of project, when approved by Architect/Engineer.



**1.06 MANUFACTURERS' FIELD SERVICES:**

- A. When required by individual Specifications Section, require supplier/manufacturer to provide qualified personnel to observe field conditions, conditions of surfaces and installation, quality of workmanship, start-up of equipment, test, adjust and balance of equipment as applicable, and to make appropriate recommendations.
- B. Representative shall submit written report to Architect/Engineer listing observations and recommendations.

**1.07 TESTING LABORATORY SERVICES:**

- A. Owner will employ and pay for services of an Independent Testing laboratory to perform inspections, tests, and other services required by individual Specification Sections, except that inspections and tests required by public authorities are to be paid for by Contractor whose Work is being tested.
- B. Services will be performed in accordance with requirements of governing authorities and with specified standards.
- C. Reports will be submitted to Architect/Engineer, with required number of copies, giving observations and results of test, indicating compliance or noncompliance with specified standards and with Contract Documents.
- D. Contractor shall cooperate with Testing Laboratory personnel; furnish tools, samples of materials, design mix, equipment, storage and assistance as requested.
  - 1. Notify Architect/Engineer and Testing Laboratory 24 hours prior to expected time for operations requiring testing services.
  - 2. Make arrangements with Testing Laboratory and pay for any additional samples and tests conducted for Contractor's convenience.
- E. Contractor shall employ and pay for the services of testing laboratory to perform additional inspections, sampling and testing required when initial tests indicate work does not comply with Contract Documents.

**PART TWO – PRODUCTS** (Not Used)

**PART THREE – EXECUTION** (Not Used)

**END OF SECTION**

**SECTION 01 42 00 - REFERENCES**

**PART ONE - GENERAL**

**1.01 RELATED DOCUMENTS:**

- A. Drawings and General Provisions of Contract, including General and Supplementary Conditions and other Division-1 Specification Sections, apply to Work of this Section.

**1.02 DESCRIPTION OF REQUIREMENTS:**

- A. General: This section specifies procedural and administrative requirements for compliance with governing regulations and codes and standards imposed upon the Work. These requirements include obtaining permits, licenses, inspections, releases and similar documentation, as well as payments, statements and similar requirements associated with regulations, codes and standards.
  - 1. The term, "Regulations", is defined to include laws, statutes, ordinances and lawful orders issued by governing authorities, as well as those rules, conventions and agreements within the construction industry which effectively control the performance of the work regardless of whether they are lawfully imposed by governing authority or not.
- B. Governing Regulations: Refer to General and Supplementary Conditions for requirements related to compliance with governing regulations.

**1.03 DEFINITIONS:**

- A. General Explanation: A substantial amount of specification language consists of definitions of terms found in other Contract Documents, including drawings. Drawings are recognized as being diagrammatic in nature and not completely descriptive of the requirements indicated thereon. Certain terms used in Contract Documents are defined in this article. Definitions and explanations contained in this Section are not necessarily either complete or exclusive, but are general for the Work to the extent that they are not stated more explicitly in another element of the Contract Documents.
- B. General Requirements: The provisions or requirements of other Division-1 sections apply to entire work of the Contract and, where so indicated, to other elements which are included in the project.

- C. Indicated: The term "indicated" is a cross-reference to graphic representations, notes or schedules on the drawings, other paragraphs or schedules in the specifications and similar means of recording requirements in the Contract Documents. Where terms such as "shown", "noted", "scheduled", and "specified" are used in lieu of "indicated", it is for the purpose of helping the reader locate the cross-reference, and no limitation of location is intended except as specifically noted.
- D. Directed, Requested, Etc.: Where not otherwise explained, terms such as "directed", "requested", "authorized", "selected", "approved", "required", "accepted", and "permitted" mean "directed by the General Contractor", "requested by the General Contractor", and similar phrases. However, no such implied meaning will be interpreted to extend the General Contractor's responsibility into the Contractor's area of construction supervision.
- E. Approve: Where used in conjunction with the Architect's/Engineer's response to submittals, requests, applications, inquiries, reports and claims by the Contractor, the meaning of the term "approved" will be held to limitations of the Architect's/Engineer's responsibilities and duties as specified in General and Supplementary Conditions. In no case will the Architect's/Engineer's approval be interpreted as a release of the Contractor from responsibilities to fulfill requirements of Contract Documents.
- F. Project Site: The term, "project site", is defined as the space available to the Contractor for performance of the Work, either exclusively or in conjunction with others performing other work as part of the project. The extent of the project site is shown on the drawings, and may or may not be identical with the description of the land upon which the project is to be built.
- G. Furnish: Except as otherwise defined in greater detail, the term "furnish" is used to mean "supply and deliver to the project site, ready for unloading, unpacking, assembly, installation, and similar operations", as applicable in each instance.
- H. Install: Except as otherwise defined in greater detail, the term "install" is used to describe operations at project site including the actual "unloading, unpacking, assembly, erection, placing, anchoring, applying, working to dimension, finishing, curing, protecting, cleaning and similar operations", as applicable in each instance.
- I. Provide: Except as otherwise defined in greater detail, the term "provide" means "to furnish and install, complete and ready for intended use", as applicable in each instance.
- J. Installer: The term "installer" is defined as "the entity" (person or firm) engaged by the Contractor, its subcontractor or sub-subcontractor for performance of a particular unit of work at the project site, including installation, erection, application and similar required operations. It is a requirement that installers are experienced in the operations they are engaged to perform.

- K. Testing Laboratories: The term "testing laboratory" is defined as an independent entity engaged to perform specific inspections or tests of the work, either at the project site or elsewhere, and to report, and (if required) interpret results of those inspections or tests.

**1.04 SPECIFICATION FORMAT AND CONTENT EXPLANATION:**

- A. General: This article is provided to help the user of these specifications more readily understand the format, language, implied requirements and similar conventions of content. None of the following explanations shall be interpreted to modify the substance of the contract requirements.
1. Production Methods: Portions of these Specifications have been produced by the Architect's/Engineer's standard method of editing master specifications; they may contain minor deviations from traditional writing formats. Such deviations are a natural result of this production technique, and no other meaning shall be implied.
- B. Specification Format: These Specifications are organized based upon the Construction Specifications Institute's 33-Division format. The organization of these Specifications into Divisions, Sections or Trade Headings conforms generally to recognized industry practice.
1. Divisions are groupings of related or similar sections. The divisions are recognized as the construction industry consensus method of uniform specification organization.
  2. Sections: For convenience "Sections" are considered as the basic units of work. The section title is descriptive only and not intended to limit the meaning or content of a section or to be completely descriptive of requirements specified therein.
- C. Section Numbering is used to facilitate cross-references in the Contract Documents. Sections are placed in the Project Manual in numeric sequence; however, the numeric sequence is not complete and the listing of the sections in the "Table of Contents" at the beginning of the Project Manual must be consulted to determine the numbers and names of specification sections in the Contract Documents.
- D. Project identification: The project name and number are recorded at the top and bottom, respectively, of each page of the Specifications.
- E. Page Numbering: Pages are numbered independently for each Section. The Project name and address and number is shown together to facilitate the location of text in the Project Manual.
- F. Text Subordination: Portions of the specification text may be subordinated to other portions of the text in the following manner.

1. Certain sections may be subordinate to other sections or parts of other sections. When that occurs, the degree of subordination is described in those sections.
2. Sub-articles, which are printed in upper/lower case lettering, are subordinate to Article titles, which are printed entirely in upper case lettering.
3. Paragraphs and lines of text are subordinate to sub-article titles.
4. Paragraphs and lines of text that are indented from the left margin are subordinate to the preceding text that is either not indented, or is indented by a lesser amount.
5. Underscoring is used strictly to assist the reader of specification text in scanning the text of key words. No emphasis on or relative importance is intended for text where underscoring is used.

G. Specification Content: This project specification has been produced employing certain conventions in the use of language as well as conventions regarding the intended meaning of certain terms, words, and phrases when used in particular situations or circumstances. These conventions are explained as follows:

1. In certain circumstances, the language of the Specifications and other Contract Documents is of the abbreviated type. It implies words and meanings that will be appropriately interpreted. Singular words will be interpreted as plural and plural words will be interpreted as singular where applicable and where the full context of the Contract Documents so indicates.
2. Imperative Language is used generally in the specifications. Requirements expressed imperatively are to be performed by the Contractor. At certain locations in the text, for clarity, contrasting subjective language is used to describe responsibilities which must be fulfilled indirectly by the Contractor, or by others when so noted.
3. Methods of Specifying: The techniques or methods of specifying requirements varies throughout the text. The method used for specifying one element of the Work has no bearing on requirements for another element of the Work. The methods of specifying may include the following, or any combination of the following:
  - a. Prescriptive
  - b. Open Generic-Descriptive
  - c. Performance
  - d. Proprietary
  - e. Compliance with Reference Standards
4. Assignment of Specialists: In certain circumstances, the specification text requires or implies that specific elements of the Work are to be assigned to specialist who must be engaged to perform that element of the Work. Such assignments are special requirements over which the Contractor has no choice or option. Such assignments are intended to establish which party or entity involved in a specific element of the Work is considered as being sufficiently experienced in the indicated construction processes or operations to be recognized as "expert" in those processes or operations.

PROBATE COURT  
ADMINISTRATION  
INTERIOR RENOVATIONS  
186 NEWINGTON ROAD  
WEST HARTFORD, CONNECTICUT

- a. Nevertheless, the ultimate responsibility for fulfilling all contract requirements remains with the Contractor.
  - b. These requirements should not be interpreted to conflict with the enforcement of building codes and similar regulations governing the work. They are also not intended to interfere with local trade union jurisdictional settlements and similar conventions.
5. Trades: The use of certain titles such as "carpentry" in the Specification text, is not intended to imply that the Work must be performed by accredited or unionized individuals of a corresponding generic name, such as "carpenter". It also is not intended to imply that the requirements specified apply exclusively to work by trades persons of that corresponding generic name.

#### **1.05 DRAWING SYMBOLS:**

- A. General: Except as otherwise indicated, graphic symbols used on the drawings are those symbols recognized in the construction industry for purposes indicated. Where not otherwise noted, symbols are defined by "Architectural Graphic Standards", published by John Wiley & Sons, Inc., latest edition.
- B. Mechanical/Electrical Drawings: Graphic symbols used on mechanical and electrical drawings are generally aligned with symbols recommended by ASHRAE. Where appropriate, these symbols are supplemented by more specific symbols as recommended by other technical associations including ASME, ASPE, IEEE and similar organizations. Refer instances of uncertainty to the Architect/Engineer for clarification before proceeding.
- C. Should any symbols appear as the documents which are not conventionally understood, clarify definition by reference to the document legends and the Architect/Engineer.

#### **1.06 INDUSTRY STANDARDS:**

- A. Applicability of Standards: Except where more explicit or stringent requirements are written into the Contract Documents, applicable construction industry standards have the same force and effect as if bound into or copied directly into the Contract Documents. Such industry standards are made a part of the Contract Documents by reference. Individual specification sections indicate which codes and standards the Contractor must keep available at the project site for reference.
  1. Referenced standards (standards referenced directly in the Contract Documents) take precedence over non-referenced standards that are recognized in the industry for applicability to the Work.
  2. Non-referenced standards are defined as not being applicable to the Work, except as a general requirement of whether the Work complies with recognized construction industry standards.

PROBATE COURT  
ADMINISTRATION  
INTERIOR RENOVATIONS  
186 NEWINGTON ROAD  
WEST HARTFORD, CONNECTICUT

- B. Publication Dates: Except as otherwise indicated, where compliance with an industry standard is required, comply with standard in effect as of date of Contract Documents.
1. Updated Standards: At the request of the General Contractor, Contractor or governing authority, submit a change order proposal where an applicable industry code or standard has been revised and reissued after the date of the Contract Documents and before the performance of the work affected. The General Contractor will decide whether to issue the change order to proceed with the updated standard.
- C. Conflicting Requirements: Where compliance with two or more standards is specified, and where these standards establish different or conflicting requirements for minimum quantities or quality levels, the most stringent requirement will be enforced, unless the Contract Documents specifically indicate a less stringent requirement. Refer requirements that are different, but apparently equal, and uncertainties as to which quality level is more stringent to the Architect/Engineer for a decision before proceeding.
1. Minimum Quantities or Quality Levels: In every instance the quantity or quality level shown or specified is intended to be the minimum for the work to be provided or performed. Unless otherwise indicated, the actual work may either comply exactly, within specified tolerances, with the minimum quantity or quality specified, or may exceed that minimum within reasonable limits. In complying with these requirements, the indicated numeric values are either minimum or maximum values, as noted, or as appropriate for the context of the requirements. Refer instances of uncertainty to the General Contractor for decision before proceeding.
- D. Copies of Standards: The Contract Documents require that each entity performing work be experienced in that part of the work being performed. Each entity is also required to be familiar with industry standards applicable to that part of the work. Copies of applicable standards are not bound with the Contract Documents.
1. Where copies of standards are needed for proper performance of the Work, the Contractor is required to obtain such copies directly from the publication source.
  2. Although certain copies of standards needed for enforcement of the requirements may be required submittals, the General Contractor reserves the right to require the Contractor to submit additional copies of these standards as necessary for enforcement of requirements.
  3. Abbreviations and Names: Where acronyms or abbreviations are used in Specifications or other Contract Documents, they are defined to mean the industry recognized name of trade associations, standards generating organization, governing authority or other entity applicable to context of text provision. Refer to "Encyclopedia of Associations", published by Gale Research Company, available in large libraries.

**1.07 SUBMITTALS:**

- A. Permits, Licenses, and Certificates: for the Owner's records, submit copies of permits, licenses, certifications, inspection reports, releases, jurisdictional settlements, notices, receipts for fee payments, judgments and similar documents, correspondence and records established in conjunction with compliance with standards and regulations bearing upon performance of the work.

**PART TWO - PRODUCTS** (Not Applicable)

**PART THREE - EXECUTION** (Not Applicable)

END OF SECTION





**SECTION 01 50 00 - CONSTRUCTION FACILITIES & TEMPORARY CONTROLS**

**PART ONE - GENERAL**

**1.01 PROJECT CONDITIONS:**

- A. Provide construction facilities and temporary controls necessary for the Work.

**1.02 TEMPORARY LIGHT AND POWER:**

- A. Electric energy will be made available without charge, at source or sources directed, for lighting and for power tools. Power supply for motors rated in excess of 1/2 hp will be made available within the limits of the existing circuitry and usage.
- B. Provide temporary lighting as required to maintain a minimum of 10 foot candles in the work areas.
- C. Provide ground-fault protection for personnel (such as portable plug-in type ground-fault circuit-interrupters) on single phase 15 and 20 ampere receptacle outlets which are in use.
- D. Receptacle outlets and portable cord connectors shall have standard NEMA configuration.
- E. Provide temporary wiring and equipment in conformance with the National Electrical Code.

**1.03 TEMPORARY WATER:**

- A. Water will be made available for the Work without charge at source or sources directed within the limits of the existing supply and usage.

**1.04 TEMPORARY TOILETS:**

- A. Construction Work Contract: The General Contractor shall provide toilet facilities for Contractors' and subcontractors' employees engaged on the Project, including employees of other contractors. Locate toilets where directed, and maintain them in a sanitary condition.

**1.05 BARRIERS AND ENCLOSURES:**

- A. Provide barriers during performance of the Work to:
1. Prevent unauthorized entry to work areas.
  2. Allow for the Owner's occupancy of Site.
  3. Protect existing facilities and adjacent properties from damage.

4. Protect pedestrian traffic.
- B. Temporary Dust Barriers: Provide temporary dust barriers to prevent the spread of dust from the work areas. Construct the dust barriers of wood framing sheathed with 6 mil polyethylene film. Secure the dust barriers in place without damaging existing construction.
- C. Scaffolding, Hoist, and Equipment Barriers: Provide temporary fence enclosures as required to prevent unauthorized persons from coming in contact with ground supported scaffolding, hoists, and equipment.

**1.06 PROTECTION OF WORK AND EXISTING PROPERTY:**

- A. Protect installed Work and existing construction and finishes during performance of the Work.
- B. Maintain the building in a watertight condition during performance of the Work.
- C. Provide temporary and removable protection for installed products. Control activity in immediate work area to prevent damage.
- D. Provide protective coverings at wall projections, jambs, sills, and soffits of openings.
- E. Protect finished floors, stairs, and other surfaces from traffic, dirt, wear, damage, and movement of heavy objects by covering them with durable sheet materials.
- F. Protect smoke detectors from airborne dust and debris.
  1. At the beginning of each work day, provide protective coverings over smoke detectors in areas where airborne dust and debris will be generated by the Work.
  2. At the end of the work day, clean the areas in which the smoke detectors are located by whatever means necessary to assure that airborne dust and debris will not contaminate the smoke detectors, then remove protective coverings.
  3. Provide signs, instructions and alternate methods for reporting a fire during the periods that the smoke detectors are covered.
  4. Notify the Owner's On-Site Facility Manager and have procedures approved.
- G. Prohibit traffic or storage upon waterproofed and roofed surfaces. If traffic or activity is necessary, obtain recommendations for protection from waterproofing or roofing material manufacturer.
- H. Protect existing trees and plants during performance of the Work unless otherwise indicated. Box trees and plants within the grading limit lines. Do not deposit excavated materials or store building materials around trees or plants. Do not attach guy wires to trees.

- I. Prohibit traffic from landscaped areas.
- J. Cleaning tools of cementitious and other insoluble materials:
  - 1. Do not wash tools in sinks or other sanitary drainage systems. Protect all drainage systems from debris that can clog or damage piping and fixtures.
  - 2. Take all precautions necessary to prevent cementitious and other insoluble materials from flowing into floor drains.
  - 3. Dispose of excess cementitious and other insoluble debris with the other rubbish.

**1.07 SECURITY:**

- A. Restore, by the end of each work day, existing in place safety/security items such as doors, screens, alarm systems components, that required removal, replacement, or adjustment to perform the Work, unless otherwise authorized in writing by the Owner's On-Site Facility Manager.

**1.08 FIRE PREVENTION:**

- A. Take precautions necessary to prevent fires.
- B. Fuel for cutting and heating torches shall be gas only, and shall be contained in Underwriters Laboratory approved containers.
- C. Furnish and maintain a currently inspected 20 pound capacity multi-class A B C fire extinguisher in the immediate vicinity where welding tools or torches are in use.
- D. Furnish and maintain a currently inspected fire extinguisher of the appropriate class and size whenever the temporary storage of materials changes that areas classification of fire load or life safety.
- E. Do not use flammable liquids, other than those specified, within a building without written approval from the Owner's On-Site Facility Manager.
- F. Tarpaulins shall be flameproof and shall be securely anchored when attached to scaffolding or when used to enclose any portion of a building.
- G. If required by the nature of the work and facility regulations, the Contractor shall obtain from the facility and pay all costs associated with "Hot Work Permits" including fire watches to execute the work of its contract. Prior to, during and after performing hot work, inspect the hot work area for compliance with the requirements of the permitted Hot Work Program.

1. Post signage "Caution: Hot Work In Progress - Stay Clear" in conspicuous locations warning others before they enter a hot work area where the area is accessible to persons other than the operator of the hot work equipment.

**1.09 TEMPORARY FIRE PROTECTION:**

- A. If the existing building is to be partially occupied during the course of the project, all existing exits, fire walls, fire barriers and fire protection systems shall be continuously maintained in the occupied phases in compliance with Fire Codes.
- B. The cost of all labor, fire watches, variances, materials, installations, maintenance and removal of such temporary fire protection systems or modifications to the existing systems are the responsibility of the Contractor. Install permanent fire walls, fire barriers and fire protection systems, if provided as part of the work, as soon as practical.

**1.10 PARKING:**

- A. Parking areas shall be where designated by the Owner's On-Site Facility Manager.
  1. Keep designated parking areas clear of dirt and debris resulting from the Work.
  2. If requested, register vehicles which are to be parked at the Facility with the Facility Safety/Security Department.
  3. Remove ignition key from unattended vehicles and lock doors.

**1.11 RUBBISH REMOVAL:**

- A. Clean up and containerize the rubbish (refuse, debris, waste materials, and removed materials and equipment) resulting from the Work at the end of each work day and leave work areas broom clean, except where more stringent cleaning is specified. Locate containerized rubbish where directed.
- B. Remove rubbish from work site at least once a week and more often if the rubbish presents a hazard. Properly dispose of rubbish.
- C. Burning of rubbish will not be permitted.
- D. Also comply with the requirements of Section 01 74 19.

**1.12 RELOCATION AND REMOVALS:**

- A. Remove the construction facilities and temporary controls when they are no longer required. Restore permanent facilities used for or connected to temporary facilities to their original condition or better.

**1.13 ELEVATOR:**

- A. Contractor use of the existing passenger elevator is permitted by the Owner provided that:
1. Contractors operate, maintain and repair the elevator for the duration of construction.
  2. Contractors provide padding or other protection for the car.

**PART TWO - PRODUCTS (Not Used)**

**PART THREE - EXECUTION (Not Used)**

**END OF SECTION**



**SECTION 01 63 10 – EQUALS AND SUBSTITUTIONS**

**PART ONE - GENERAL**

**1.01 RELATED DOCUMENTS:**

- A. Drawings and general provisions of the Contract, including General and Supplementary Conditions and other Division 1 Specification Sections, apply to this Section.

**1.02 SUMMARY:**

- A. This Section includes administrative and procedural requirements for handling requests for equals and substitutions made prior to the submission of the Competitive Bid.
- B. Related Sections: The following Sections contain requirements that relate to this Section:
  - 1. Division 1 Section "Summary of Work & General Requirements"

**1.03 DEFINITIONS:**

- A. Definitions in this Article do not change or modify the meaning of other terms used in the Contract Documents.
- B. Equals or Substitutions General: Changes in products, materials, equipment, and methods of construction required by the Contract Documents proposed by the Contractor **prior to** the submission of the Competitive Bid.
  - 1. Equal: Any deviation from the specification which is defined as follows: A replacement for the specified material, device, procedure, equipment, etc., which is recognized and accepted as substantially equal to the first listed manufacturer or first listed procedure specified, after review, by the Architect and may be rejected or approved at the sole discretion of the owner. All equals must be substantially equivalent to the first manufacturer or first procedure listed in the Specifications with reference to all of the following areas: the substance and function considering quality, workmanship, economy of operation, durability and suitability for purposes intended; size, rating and cost. The equal does not constitute a modification in the scope of Work, the Schedule or Architect/Engineer's design intent of the specified material, device, procedure, equipment, etc.
  - 2. Substitution: Any deviation from the specified requirements, which is defined as follows: A replacement for the specified material, device, procedure, equipment, etc., which is not recognized or accepted as equal to the first manufacturer or procedure listed in the Specification after review by the Architect and may be rejected or approved by the Owner. The Substitution is not equal to the specified requirement in comparison to the first manufacture or first procedure listed in the Specifications in one or more of the following areas: the substance and function considering quality, workmanship, economy of operation, durability and suitability for purposes intended; size; cost and rating. The Substitution constitutes a modification in the scope of Work, the Schedule or the Architect/Engineer's design intent of the specified material, device, procedure, equipment, etc.



3. The following are not considered to be requests for Equals or Substitutions:
  - a. Revisions to the Contract Documents requested by the Owner or Architect.
  - b. Specified options of products and construction methods included in the Contract Documents.
  - c. The Contractor's determination of and compliance with governing regulations and orders issued by governing authorities having jurisdiction.

#### **1.04 SUBMITTALS:**

- A. Equals and Substitution Request Submittals: The Owner will consider requests for equals or substitutions if made **prior to** the submission of the Competitive Bid. The information on all materials shall be consistent with the information herein. After the contract award, substitutions will be considered for materials or systems specified that are no longer available. It will not be considered if the product was not purchased in a reasonable time after award. The contractor shall submit all equal and substitutions request in writing as follows below.
  1. The Contractor is required to prepare and submit three (3) copies of the required data for the first manufacturer listed or procedure listed in the specifications section with reference to all of the following areas: the substance and function considering quality, workmanship, economy of operation, durability and suitability for purposes intended including the size, rating and cost. All submissions must include all the required data for the first listed manufacturer or procedure as specified, as well as the required data for the proposed Equal or Substitution. This will enable the Owner and Architect to determine that the proposed Equal or Substitution is or is not substantially equal to the first listed manufacturer or procedure.
  2. Identify the product or the fabrication or installation method to be replaced in each request. Include related Specification Section and Drawing numbers.
  3. Provide complete documentation showing compliance with the requirements for equals or substitutions, and the following information, as appropriate:
    - a. Coordination information, including a list of changes or modifications needed to other parts of the Work and to construction performed by the Owner and separate contractors that will be necessary to accommodate the proposed Equal or Substitution.
    - b. A detailed comparison chart of significant qualities of the proposed substitution with those of the Work specified. Significant qualities may include elements, such as performance, weight, size, durability, and visual effect.
    - c. Product Data, including Shop Drawings and descriptions of products and fabrication and installation procedures.
    - d. Samples, where applicable or requested.

- e. A statement indicating the effect on the Contractor's Construction Schedule or CPM Schedule compared to the schedule without approval of the Equal or Substitution. Indicate the effect on overall Contract Time.
  - f. Cost information, broken down for comparison to the purposes intended.
  - g. The Contractor's certification that the proposed Equal or Substitution conforms to requirements in the Contract Documents in every respect and is appropriate for the applications indicated.
  - h. The Contractor's waiver of rights to additional payment or time that may subsequently become necessary because of the failure of the Equal or Substitution to perform adequately.
4. Project Coordinator/Architect's Action: If necessary, the Architect will request additional information or documentation for evaluation within seven (7) days of receipt of the original request for equal or substitution request. The Architect will notify the Construction Administrator who will notify the Owner of recommended acceptance or rejection of the proposed equal or substitution, within seven (7) days of receipt of the request, or five (5) days of receipt of additional information or documentation, whichever is later. The Construction Administrator will give final acceptance or rejection by the Owner not less than seven (7) days after notification.
- a. Any request deemed an "Equal" and accepted by the Construction Administrator, Architect, Owner, and Agency will result in written notification to the Contractors and will not be in the form of a change order for an "Equal".
  - b. Any request deemed a "Substitution" and rejected or approved by Construction Administrator, Architect, and Owner may result in written notification to the Contractors and may be in the form of a change order if the "Substitution" is approved.

## **PART TWO - PRODUCTS**

### **2.01 EQUAL OR SUBSTITUTIONS:**

- A. Conditions: The Architect will consider the Contractor's request for Equal or Substitution of a product or method of construction when one or more of the following conditions are satisfied, as determined by the Architect. If the following conditions are not satisfied, the Architect will return the requests to the Construction Administrator without action except to record noncompliance with these requirements.
- 1. The proposed request does not require extensive revisions to the Contract Documents.
  - 2. The proposed request is in accordance with the general intent of the Contract Documents.
  - 3. The proposed request is timely, fully documented, and/or properly submitted.
  - 4. The proposed request can be provided within the Contract Time. However, the Architect will not consider the proposed request if it is a result of the Contractor's failure to pursue the Work promptly or coordinate activities properly.

5. The proposed request will offer the Owner a substantial advantage, in cost, time, energy conservation, or other considerations, after deducting additional responsibilities the Owner must assume. However, if the proposed request requires the Owner to incur additional responsibilities, including but not limited to, additional compensation to the Architect for redesign and evaluation services, increased cost of other construction by the Owner or similar considerations, then the Owner will have just cause to reject the request for Equal or Substitution.
  6. The proposed request can receive the necessary approvals, in a timely manner, required by governing authorities having jurisdiction.
  7. The proposed request can be provided in a manner that is compatible with the Work as certified by the Contractor.
  8. The proposed request can be coordinated with the Work as certified by the Contractor.
  9. The proposed request can uphold the warranties required by the Contract Documents as certified by the Contractor.
- B. The Contractor's submission and the Architect's review of Submittals, including but not limited to, Samples, Manufacturer's Data, Shop Drawings, or other such items, which are not clearly identified as a request for an Equal or Substitution, will not be considered or accepted as a valid request for an Equal or Substitution, nor does it constitute an approval.

**PART THREE - EXECUTION** (Not Applicable)

**END OF SECTION**

**SECTION 01 73 29 - CUTTING AND PATCHING**

**PART ONE - GENERAL**

**1.01 RELATED DOCUMENTS:**

- A. Drawings and General Provisions of Contract, including General and Supplementary Conditions and other Division-1 Specification Sections, apply to Work of this Section.

**1.02 DESCRIPTION OF REQUIREMENTS:**

- A. Definition: "Cutting and Patching" includes cutting into existing construction to provide for the installation or performance of other work and subsequent fitting and patching required to restore surfaces to their original condition.
  - 1. "Cutting and Patching" is performed for coordination of the work, to uncover work for access or inspection, to obtain samples for testing, to permit alterations to be performed or for other similar purposes.
  - 2. Cutting and patching performed during the manufacture of products, or during the initial fabrication, erection or installation processes is not considered to be "Cutting and Patching" under this definition. Drilling of holes to install fasteners and similar operations are also not considered to be "Cutting and Patching".
- B. Refer to other Sections of these Specifications for specific cutting and patching requirements and limitations applicable to individual units of work.
  - 1. Unless otherwise specified, requirements of this section apply to mechanical and electrical work. Refer to Division-23 and Division-26 Sections or Drawing for additional requirements and limitations on cutting and patching of mechanical and electrical work.

**1.03 QUALITY ASSURANCE:**

- A. Requirements for Structural Work: Do not cut and patch structural work in a manner that would result in a reduction of load-carrying capacity or of load-deflection ratio.
- B. Before cutting and patching the following categories, or similar categories, of work, obtain the General Contractor approval to proceed with cutting and patching as described in the procedural proposal for cutting and patching.
  - 1. Structural Steel
  - 2. Miscellaneous structural metals, including lintels, equipment supports, stair systems and similar categories of work
  - 3. Structural Concrete
  - 4. Foundation Construction
  - 5. Bearing and Retaining Walls
  - 6. Structural Decking

7. Pre-cast Concrete Panels
  8. Piping, Ductwork, Vessels and Equipment
- C. Operational and Safety Limitations: Do not cut and patch operational elements or safety related components in a manner that would result in a reduction of their capacity to perform in the manner intended, including energy performance, or that would result in increased maintenance, or decreased operational life or decreased safety.
- D. Before cutting and patching the following elements, or similar elements, of work, and similar work elements where directed, obtain the General Contractor and Owner's approval to proceed with cutting and patching as proposed in the proposal for cutting and patching.
1. Shoring, Bracing and Sheeting
  2. Primary Operational Systems and Equipment
  3. Water/moisture/vapor/air/smoke barriers, membranes and flashings
  4. Noise and Vibration Control Elements and Systems
  5. Control, Communication, Conveying, and Electrical Wiring Systems
  6. Special Construction, as Specified by Division-13 Sections
- E. Visual Requirements: Do not cut and patch work exposed on the building's exterior or in its occupied spaces, in a manner that would, in the Architect and Owner's opinion, result in lessening the building's aesthetic qualities. Do not cut and patch work in a manner that would result in substantial visual evidence of cut and patch work. Remove and replace work judged by the Architect and Owner to be cut and patched in a visually unsatisfactory manner.
- F. If possible, retain the original installer or fabricator, or another recognized experienced and specialized firm to cut and patch the following categories, and similar categories, of exposed work.
1. Process Concrete Finishes
  2. Stonework and Stone Masonry
  3. Ornamental Metal
  4. Matched-Veneer Woodwork
  5. Roofing
  6. Preformed Metal Panels
  7. Insulated Metal Panels
  8. Window wall System
  9. Gypsum Drywall System
  10. Acoustical Ceilings
  11. Brick Masonry
  12. HVAC Enclosures, Cabinets or Covers

**1.04 SUBMITTALS:**

- A. Procedural Proposal for Cutting and Patching: Where prior approval of cutting and patching is required, submit proposed procedures for this work well in advance of the time work will be performed and request approval to proceed. Include the following information, as applicable, in the submittal:
1. Describe nature of the work and how it is to be performed, indicating why cutting and patching cannot be avoided. Describe anticipated results of the work in terms of changes to existing work, including structural, operational, and visual changes as well as other significant elements.
  2. List products to be used and firms that will perform work.
  3. Give dates when work is expected to be performed.
  4. List utilities that will be disturbed or otherwise be affected by work, including those that will be relocated and those that will be out-of-service temporarily. Indicate how long utility service will be disrupted.
  5. Where cutting and patching of structural work involves the addition of reinforcement, submit details and engineering calculations to show how that reinforcement is integrated with original structure to satisfy requirements.
  6. Where cutting and patching of exposed finishes is to be involved, submit a drawing clearly describing in detail the location and extent of the work for the General Contractor's and the Architect's/Engineer's approval.
  7. Approval by the General Contractor and the Architect/Engineer to proceed with cutting and patching work does not waive the Architect's/Engineer's right to later require complete removal and replacement of work found to be cut and patched in an unsatisfactory manner.

**PART TWO - PRODUCTS****2.01 MATERIALS:**

- A. General: Except as otherwise indicated, or as directed by the General Contractor and the Architect/Engineer, use materials for cutting and patching that are identical to existing materials. If identical materials are not available, or cannot be used, use materials that match existing adjacent surfaces to the fullest extent possible with regard to visual effect. Use materials for cutting and patching that will result in equal-or-better performance characteristics than existing construction.

**PART THREE - EXECUTION**

**3.01 INSPECTION:**

- A. Before cutting, examine the surfaces to be cut and patched and the conditions under which the work is to be performed. If unsafe or otherwise unsatisfactory conditions are encountered, take corrective action before proceeding with the work.
  - 1. Before the start of cutting work, meet at the work site with all parties involved in cutting and patching, including mechanical and electrical trades. Review areas of potential interference and conflict between the various trades. Coordinate layout of the work and resolve potential conflicts before proceeding with the work.

**3.02 PREPARATION:**

- A. Temporary Support: To prevent failure, provide temporary support of work to be cut.
- B. Protection: Protect other work during cutting and patching to prevent damage. Provide protection from adverse weather conditions for that part of the project that may be exposed during cutting and patching operations.
  - 1. Avoid interference with use of adjoining areas or interruptions of free passage to adjoining areas.
- C. Take precautions not to cut existing pipe, conduit, or duct serving the building, but scheduled to be relocated until provisions have been made to bypass them.

**3.03 PERFORMANCE:**

- A. General: Employ skilled workmen to perform cutting and patching work. Except as otherwise indicated or as approved by the General Contractor, proceed with cutting and patching at the earliest feasible time and complete work without delay.
- B. Cutting: Cut the work using methods that are least likely to damage work to be retained or adjoining work. Where possible review proposed procedures with the original installer; comply with original installer's recommendations.
  - 1. In general, where cutting is required, use hand or small power tools designed for sawing or grinding, not hammering and chopping. cut through concrete and masonry using a cutting machine such as a carborundum saw or core drill to insure a neat hole. Cut holes and slots neatly to size required with minimum disturbance of adjacent work. To avoid marring existing finished surfaces, cut or drill from the exposed or finished side into concealed surfaces. Temporarily cover openings when not in use.
  - 2. Comply with requirements of applicable sections of Division-2 where cutting and patching requires excavating and back-filling.

3. By-pass utility services such as pipe and conduit, before cutting, where such utility services are shown or required to be removed, relocated or abandoned. Cut-off conduit and pipe in walls or partitions to be removed. After by-pass and cutting, cap valve or plug and seal tight remaining portion of pipe and conduit to prevent entrance of moisture or other foreign matter.
- C. Patching: Patch with seams which are durable and as invisible as possible. Comply with specified tolerances for the work.
1. Where feasible, inspect and test patched areas to demonstrate integrity of work.
  2. Restore exposed finishes of patched areas and where necessary extend finished restoration into retained adjoining work in a manner which will eliminate evidence of patching and refinishing.
  3. Where removal of walls or partitions extends one finished area into another finished area, patch and repair floor and wall surfaces in the new space to provide an even surface of uniform color and appearance. If necessary to achieve uniform color and appearance, remove existing floor and wall coverings and replace with new materials.
  4. Where patch occurs in a smooth painted surface, extend final paint coat over entire unbroken surface containing patch, after patched area has received prime and base coat.
  5. Patch, repair or rehang existing ceilings as necessary to provide an even plane surface of uniform appearance.

**3.04 CLEANING:**

- A. Thoroughly clean areas and spaces where work is performed or used as access to work. Remove completely paint, mortar, oils, putty and items of similar nature. Thoroughly clean piping, conduit and similar features before painting or other finishing is applied. Restore damaged pipe covering to its original condition.

**END OF SECTION**





**SECTION 01 77 00 – CLOSEOUT PROCEDURES**

**PART ONE - GENERAL**

**1.01 RELATED DOCUMENTS:**

- A. Drawings and General Provisions of Contract, including General and Supplementary Conditions and other Division-1 Specification Sections, apply to Work of this Section.

**1.02 DESCRIPTION OF REQUIREMENTS:**

- A. Definitions: Project closeout is the term used to describe certain collective project requirements, indicating completion of the Work that are to be fulfilled near the end of the Contract time in preparation for final acceptance and occupancy of the Work by the Owner, as well as final payment to the Contractor and the normal termination of the Contract.
  - 1. Specific requirements for individual units of work are included in the appropriate sections in Divisions 2 through 31.
  - 2. Time of closeout is directly related to "Substantial Completion"; therefore, the time of closeout may be either a single time period for the entire Work or a series of time periods for separate contractors or individual elements of the Work that have been certified as substantially complete at different dates. This time variation, if any, shall be applicable to the other provisions of this Section.

**1.03 PREREQUISITES TO SUBSTANTIAL COMPLETION:**

- A. General: Complete the following before requesting the Architect/Engineer's inspection for certification of substantial completion, either for the entire Work or for portions of the Work. List known exceptions in the request. Refer to Specification Section 01 32 00 - "Schedules, Reports, and Payments" for additional requirements.
- B. In the progress payment request that coincides with, or is the first request following, the date substantial completion is claimed, show either 100% completion for the portion of the Work claimed as "substantially complete", or list incomplete items, the value of incomplete work, and reasons for the Work being incomplete.
  - 1. Include supporting documentation for completion as indicated in these Contract Documents.
- C. Submit a statement showing an accounting of changes to the Contract Sum.
- D. Advise Owner and General Contractor of pending insurance change-over requirements.

- E. Submit specific warranties, workmanship/maintenance bonds, maintenance agreements, final certifications and similar documents.
- F. Obtain and submit to the General Contractor releases enabling the Owner's full, unrestricted use of the Work and access to services and utilities. Where required, include occupancy permits, operating certificates and similar releases.
- G. Deliver tools, spare parts, extra stock of material and similar physical items to the Owner or General Contractor.
- H. Where applicable, make the final change-over of locks and transmit the keys to the Owner. Advise the Owner's personnel of the change-over in security provisions.
- I. Where applicable, complete start-up testing of systems, and instruction of the Owner's operating and maintenance personnel. Discontinue or change over and remove temporary facilities and services from the project site, along with construction tools and facilities, mark-ups, and similar elements.
- J. Touch-up and otherwise repair and restore marred exposed finishes.
- K. Inspection Procedures: Upon receipt of the Contractor's request for inspection, the Architect/ Engineer will either proceed with inspection or advise the General Contractor and Contractor of unfilled prerequisites.
  - 1. Following the initial inspection, the Architect/Engineer will either prepare the certificate of substantial completion, or will advise the General Contractor and Contractor of work which must be performed before the certificate will be issued. The Architect/Engineer will repeat the inspection one time when requested and when assured that the Work has been substantially completed. Additional inspections are not part of the Architect's basic services.
  - 2. Results of the completed inspection will form the initial "punch-list" for final acceptance.

#### **1.04 PREREQUISITES TO FINAL ACCEPTANCE:**

- A. General: Complete the following before requesting the Architect's/Engineer's final inspection for certification of final acceptance, to enable the General Contractor's release of final payment as required by the General Conditions and Supplemental General Conditions. List known exceptions, if any, in the request. Make all submittals to the Architect.
  - 1. Submit the final payment request as outlined and defined in the Master Agreement and Schedule.
  - 2. Submit an updated final statement as outlined and defined in the Master Agreement and Schedule.

3. Submit a certified copy of the Architect's/Engineer's final punch-list of itemized work to be completed or corrected, stating that each item has been completed or otherwise resolved for acceptance and has been endorsed and dated by the Architect/Engineer.
  4. Submit consent of surety.
  5. Submit evidence of final, continuing insurance coverage complying with insurance requirements as outlined and defined in the Master Agreement and Schedule.
  6. Complete final cleaning up requirements including touching-up, repair or replacement of marred surfaces.
- B. Re-inspection Procedures: As part of their base scope of work, the Architect/Engineer will re-inspect the Work once upon receipt of the Contractor's notice that the work, including punch-list items resulting from earlier inspections, has been completed, except for these items whose completion has been delayed because of circumstances that are acceptable to the General Contractor.
1. Upon completion of re-inspection, the Architect/Engineer will either prepare a certificate of final acceptance, or will advise the General Contractor and Contractor of work that is incomplete or of obligations that have not been fulfilled, but are required for final acceptance.
  2. If necessary, the re-inspection procedure will be repeated at the Contractor's expense.

#### 1.05 RECORD DOCUMENT SUBMITTALS:

- A. General: Specific requirements for record documents are indicated in the individual sections of these specifications. Other requirements are indicated in the General Conditions. General submittal requirements are indicated in the various "submittals" Sections.
- B. No final payment will be released without completion of the requirements of this Section and as outlined and defined in the Master Agreement and Schedule.
1. Do not use record documents for construction purposes; protect from deterioration and loss in a secure, fire-resistive location; provide access to record documents for the General Contractor and Architect's/Engineer's reference during normal working hours.
- C. Record Drawings: Maintain a record set of blue or black line white-prints of contract drawings and shop drawings in a clean, undamaged condition. Mark-up the set of record documents to show the actual installation where the installed work areas from the work as originally shown. Mark which ever drawing is most capable of showing the actual "field" condition fully and accurately; however, where shop drawings are used for mark-up, record a cross-reference at the corresponding location on the working drawings. Give

particular attention to concealed work that would be difficult to measure and record at a later date.

1. Mark record sets with red erasable pencil and, where feasible, use other colors to distinguish between variations in separate categories of work.
  2. Mark-up new information which is known to be important to the Owner, but for some reason was not shown on either contract drawings or Shop Drawings.
  3. Note related change-order numbers where applicable.
  4. Organize record drawing sheets into manageable sets, bind with durable paper cover sheets, and print suitable titles, dates and other identification on the cover of each set.
  5. At the commencement of work on record drawing sets, the contractor shall notify the General Contractor and Architect/Engineer so that they may inspect the drawing quality and technique. Drawings must be done in a professional, clear, draftsman-like manner.
- D. Record Specifications: Maintain one complete copy of the Project Manual, including specifications and addenda, and one copy of other written construction documents such as change orders and similar modifications issued in printed form during construction. Mark these documents to show substantial variations in the actual work performed in comparison with the text of the specifications and modifications as issued. Give particular attention to substitutions, selection of options and similar information on work where it is concealed or cannot otherwise be readily discerned at a later date by direct observation. Note related record drawing information and product data, where applicable.
1. Upon completion of the Work, submit record specifications to the General Contractor for the Owner's records.
- E. Record Product Data: Maintain one copy of each product data submittal. Mark these documents to show significant variations information. Include both variations in the products as delivered to the site, and variations from the manufacturer's instructions and recommendations for installation. Give particular attention to concealed products and portions of the Work which cannot otherwise be readily discerned at a later date by direct observation. Note related change orders and mark-up of record drawings and specifications.
1. Upon completion of mark-up, submit complete set of record product data organized in a single 3-ring loose-leaf binder, to the General Contractor for the Owner's records.
- F. Record Sample Submitted: Immediately prior to the date or dates of substantial completion, the Contractor will meet at the site with the General Contractor desired, to determine which, if any, of the submitted samples that have been maintained by the Contractor during progress of the Work, are to be transmitted to the Owner for record purposes. Comply with delivery to the Owner's sample storage area.

- G. Miscellaneous Record Submittals: Refer to other sections of these specifications for requirements of miscellaneous record keeping and submittals in connection with the actual performance of the Work. Immediately prior to the date or dates of substantial completion, complete miscellaneous records and place in good order, properly identified and bound or filed, ready for continued use and reference. Submit to the General Contractor for the Owner's records.
- H. Maintenance Manuals: Organize operating and maintenance data into suitable sets of manageable size. Bind data into individual binders properly identified and indexed. Bind each set of data in a heavy-duty 2-inch, 3-ring vinyl-covered binder, with pocket folders for folded sheet information. Mark the appropriate identification on both front and spine of each binder.
- I. Include the following types of information in operation and maintenance manuals:
1. Emergency Instructions
  2. Spare Parts Listing
  3. Copies of Warranties
  4. Wiring Diagrams
  5. Recommended "Turn-Around" Cycles
  6. Inspection Procedures
  7. Shop Drawings and Product Data

**PART TWO - PRODUCTS** (Not Applicable)

**PART THREE - EXECUTION**

**3.01 CLOSEOUT PROCEDURES:**

- A. General Operating and Maintenance Instructions: Arrange for each installer of operating equipment and other work that requires regular or continuing maintenance, to meet at the site with the Owner's personnel to provide necessary basic instruction in the proper operation and maintenance of the entire Work. Where installers are not experienced in the required procedures, include instruction by the manufacturer's representatives.
1. As part of this instruction, provide a detailed review of the following items:
    - a. Maintenance Manuals
    - b. Record Documents
    - c. Spare Parts and Materials
    - d. Tools
    - e. Lubricants
    - f. Identification Systems
    - g. Control Sequences
    - h. Hazards
    - i. Cleaning

- j. Warranties, bonds, maintenance agreements and similar, continuing, commitments
- 2. As part of this instruction for operating equipment, demonstrate the following procedures:
  - a. Emergency Operations
  - b. Safety Procedures

### 3.02 FINAL CLEANING:

- A. General: Special cleaning requirements for specific units of Work are included in the appropriate sections of Divisions 2 through 26. General Cleaning during the regular progress of the Work is required by the General Conditions and is included under Section "Temporary Facilities".
- B. Cleaning: Provide final cleaning of the Work at the time indicated. Employ experienced workers or professional cleaners for final cleaning. Clean each surface or unit of work to the condition expected from a normal, commercial building cleaning and maintenance program. Comply with the manufacturer's instructions for operations.
- C. Complete the following cleaning operations before requesting the Architect's/Engineer's inspection for certification of substantial completion.
  - 1. Remove labels which are not required as permanent labels.
  - 2. Clean transparent materials, including mirrors and glass in doors and windows, to a polished condition. Remove putty and other substances which are noticeable as vision-obscuring materials. Replace chipped or broken glass and other damaged transparent materials.
- D. Clean exposed exterior and interior hard-surfaced finishes to a dust-free condition; free of dust, stains, films and similar noticeable distracting substances. Restore reflective surfaces to their original reflective condition. Vacuum and damp mop concrete floors. Vacuum carpeted surfaces.
- E. Wipe surface of mechanical and electrical equipment clean. Remove excess lubrication and other substances. Clean plumbing fixtures to a sanitary condition. Clean light fixtures and lamps.
- F. Removal of Protection: Except as otherwise indicated or requested by the General Contractor, remove temporary protection devices and facilities which were installed during the course of the work to protect previously completed work during the remainder of the construction period.

- G. Compliance: Comply with safety standards and governing regulations for cleaning operations. Do not burn waste materials at the site. Do not bury debris or excess materials on the Owner's property. Do not discharge volatile or other harmful or dangerous materials into drainage systems. Remove waste materials from the site and dispose of in a lawful manner.
1. Where extra materials of value remaining after completion of associated work have become the Owner's property, dispose of these materials to the Owner's best advantage as directed.

**END OF SECTION**





**SECTION 06 10 00 – ROUGH CARPENTRY**

**PART ONE - GENERAL**

**1.01 REFERENCES:**

- A. Standards: Comply with the following unless otherwise specified or indicated on the Drawings:
1. Lumber: American Softwood Lumber Standard PS 20 by the U.S. Department of Commerce. Comply with applicable provisions for each indicated use.
  2. Plywood: Product Standard PS 1 for Softwood Plywood, Construction and Industrial by the U.S. Department of Commerce.
  3. Plywood Installation: APA Design/Construction Guide, Residential & Commercial by the American Plywood Association (APA).
  4. Grading Rules:
    - a. Douglas Fir, Hem-Fir, Idaho White Pine, and other Western Woods: Western Wood Products Association (WWPA) or West Coast Lumber Inspection Bureau (WCLIB).
    - b. Southern Pine: Southern Pine Inspection Bureau (SPIB).
    - c. Redwood: Redwood Inspection Service (RIS).
    - d. Spruce-Pine-Fir: National Lumber Grades Authority (NLGA).
  5. Preservative Treatment: American Wood Preservers' Association (AWPA) and American Wood Preservers Bureau (AWPB) Standards, quality control methods, and inspection requirements.
  6. Fire-Retardant Treatment: American Wood Preservers' Association (AWPA) Standards.
  7. Framing Installation: American Forest and Paper Association (AFPA).

**1.02 QUALITY ASSURANCE:**

- A. Mill and Producers Mark: Each piece of lumber and plywood shall be grade stamped indicating type, grade, mill, and grading agency certified by the Board of Review of the American Lumber Standards Committee. Mark shall appear on unfinished surface, or ends of pieces with finished surfaces.
1. Pressure Preservative Treated Material: Accredited agency quality mark, on each piece of wood, indicating treatment.
  2. Fire-Retardant Treated Material: Accredited testing agency mark, on each piece of wood, indicating compliance with the fire hazard classification.

**1.03 DELIVERY, STORAGE, AND HANDLING:**

- A. Keep materials dry. Make provision for air circulation around and between stacks of wood products.

**PART TWO - PRODUCTS**

**2.01 LUMBER:**

- A. General: Furnish seasoned dimension lumber dressed to nominal sizes indicated with 19 percent maximum moisture content at time of dressing, marked "S-DRY". Comply with dry size requirements of PS 20.
  - 1. Dress: Surfaced 4 sides (S4S) unless otherwise indicated.
- B. Framing Lumber: Species: Douglas Fir or Hem-Fir (WWPA or WCLIB), or Southern Pine (SPIB), or Spruce-Pine-Fir (NGLA) unless otherwise indicated.
  - 1. Light Framing; 2 inches through 4 inches thick, less than 6 inches wide: Standard and Better grade, except Stud grade for stud framing.
- C. Board Lumber: less than 2 inches thick:
  - 1. Concealed Board Lumber: Southern Pine No. 3 (SPIB), any species No. 4 (WWPA), any species Standard (WCLIB), or Spruce-Pine-Fir No. 1 / No. 2 (NGLA).
- D. Miscellaneous Lumber: Standard grade, No. 3 grade, or better grade of the following species unless otherwise indicated:
  - 1. Nailers and Blocking: Douglas Fir, Hem-Fir, Idaho White Pine, Southern Pine, or Spruce-Pine-Fir.
  - 2. Furring: Spruce, Hem-Fir, or Spruce-Pine-Fir except Douglas Fir or Southern Pine for furring required to receive preservative treatment.

**2.02 PLYWOOD:**

- A. Sheathing: APA RATED SHEATHING, EXPOSURE 1. Furnish APA PS 1 veneered panels, with span ratings for the required thicknesses as listed below unless otherwise indicated.

THICKNESS	SPAN RATING
3/8 inch	24/0
1/2 inch	32/16
5/8	40/20
3/4	48/24

**2.03 PRESERVATIVE TREATMENT:**

- A. Treat lumber and plywood where indicated and as specified. Comply with applicable AWPB Standards and quality control and inspection requirements.
- B. Complete fabrication of items to be treated to the greatest extent possible prior to treatment. Where items must be cut after treatment, coat cut surfaces with heavy brush coat of the same chemical used for treatment or other solution recommended by AWPB Standards for the treatment.
- C. Pressure Treatment (Above Ground Use): Treat the following wood items with waterborne preservatives for above ground use, complying with AWPB LP-2. Redry wood to a maximum moisture content of 19 percent after treatment.
  - 1. Nailers, blocking, cants, shim stock, and similar members used in conjunction with roofing (including related flashings, trim and vapor barrier) and coping.
  - 2. Nailers, blocking, furring, stripping, and similar concealed members in contact with exterior masonry and concrete (including interior wythe of exterior walls).
  - 3. Wood items indicated or scheduled on the Drawings to be preservative treated.
- D. Pressure Treatment (Ground Contact Use): Treat the following wood items with waterborne preservatives for below ground use, complying with AWPB LP-22:
  - 1. Wood members encased in concrete.

**2.04 FIRE-RETARDANT TREATMENT:**

- A. Furnish "FR-S" lumber complying with AWPB Standards for pressure impregnation with fire-retardant chemicals to achieve a flamespread rating of 25 or less, when tested in accordance with UL Test 723, ASTM E 84 or NFPA Test 255.
  - 1. Where treated items are indicated to receive a transparent or paint finish, use a fire-retardant treatment which will not bleed through or adversely affect bond of finish.
  - 2. Provide UL label or identifying mark on each piece of fire-retardant lumber.
  - 3. Redry treated items to a maximum moisture content of 19 percent after treatment.

**2.05 FASTENERS AND ANCHORING DEVICES:**

- A. Select and furnish items of type, size, style, grade, and class as required for secure installation of the Work. Items shall be galvanized for exterior locations, high humidity locations, and for use with treated wood. Unless shown or specified otherwise, comply with the following:
  - 1. Nails and Staples: FS FF-N-105.

2. Wood Screws: FS FF-S-111.
3. Bolts and Studs: FS FF-B-575.
4. Nuts: FS FF-N-836.
5. Washers: FS FF-W-92.
6. Lag Bolts or Lag Screws: FS FF-B-561.
7. Masonry Anchoring Devices: Expansion shields, masonry nails and drive screws: FS FF-S-325.
8. Toggle Bolts: FS FF-B-588.
9. Bar or Strap Anchors: ASTM A575 carbon steel bars.
10. Wall Plugs: Corrugated type, galvanized steel, 24 USS gage min, not less than 2 inches wide x 2-1/2 inches deep.
11. Metal Hangers and Framing Anchors: Size and type for intended use, galvanized finish, manufacturer's recommended fasteners.

### **PART THREE - EXECUTION**

#### **3.01 INSTALLATION:**

- A. Wood Framing: Install in accordance with applicable provisions of the AFPA "Manual for Wood Frame Construction", unless otherwise indicated.
- B. Plywood:
  1. Install in accordance with APA Design/Construction Guide, Residential & Commercial, unless otherwise indicated.
  2. Fasten in accordance with APA recommendations.
- C. Nailers and Blocking: Attach to substrate as required to support applied loading.
- D. Wood Framing: Install true to lines within a tolerance of 1/8 inch in 10 feet.
- E. Treated Wood: Brush-coat field cut surfaces with same treatment material.

**END OF SECTION**

**SECTION 06 20 00 – FINISH CARPENTRY**

**PART ONE - GENERAL**

**1.01 RELATED WORK SPECIFIED ELSEWHERE:**

- A. Nailers and Blocking: Section 061000.
- B. Casework: Section 064000.
- C. Wood Doors: Section 081400.
- D. Finish Hardware: Section 087100.

**1.02 REFERENCES:**

- A. Comply with the applicable provisions of the "Architectural Woodwork Standards" (First Edition-2009) (AWS) except as otherwise specified herein. References to "Premium", "Custom" and "Economy" Grades herein, shall be as defined in that Standard.
- B. Lumber Standard: AWS Section 3.
- C. Panel Products: AWS Section 4.
- D. Preservative Treatment Standard: American Wood Protection Association Standard (AWPA) U1-02

**1.03 SUBMITTALS:**

- A. Shop Drawings: Show fabrication details and connections to adjacent Work.

**1.04 QUALITY ASSURANCE:**

- A. Mill and Producer's Label: Each lumber and panel item shall bear label indicating type, grade, mill, and grading agency on unfinished surface, or on end of material with finished surfaces.
  - 1. Panels shall bear APA or equivalent grade-mark; each panel.

**1.05 DELIVERY, STORAGE, AND HANDLING:**

- A. Store materials and completed fabricated wood items in a dry, well ventilated area completely protected from the weather. Comply with temperature and humidity requirements for storage and installation as specified in the applicable quality standards.

- B. Protect sanded and prefinished surfaces during handling and installation. Keep such surfaces covered with polyethylene film or other suitable protective covering.

**1.06 PROJECT CONDITIONS:**

- A. Environmental Requirements: Maintain constant minimum temperature of 60 degrees F and maximum relative humidity of 55 percent in spaces to receive the Work of this Section.

**PART TWO - PRODUCTS**

**2.01 MATERIALS:**

- A. Lumber: Kiln-dried to 12 percent average moisture content for exterior Work; 8 percent for interior Work.
- B. Fasteners:
  - 1. Nails, Spikes, and Staples: Size and type to suit application; non-ferrous metal or galvanized steel for exterior locations, high humidity locations, treated wood, and wood to receive transparent finishes; plain finish for other interior locations.
  - 2. Bolts, Nuts, Washers, Lags, and Screws: Medium carbon steel; size and type to suit application; galvanized for exterior locations, high humidity locations, and treated wood; plain finish for other interior locations.
  - 3. Anchors: Toggle bolt type for anchorage to hollow masonry; expansion shield and lag bolt type for anchorage to solid masonry or concrete; galvanized steel or stainless steel.

**2.02 STANDING AND RUNNING TRIM:**

- A. Comply with AWS Sections 6 and/or 12 as applicable, and as otherwise specified herein.
- B. Interior Woodwork (to receive transparent stain to match existing): AWS Custom Grade.
  - 1. Species; Solid Wood: Maple.
  - 2. Cut; Solid Wood: Plain sawn to match existing.
  - 3. Panel Products: Veneer core plywood (no particleboard core plywood permitted).
    - a. Face and Back Veneer Species: Any Group 1 species, A-D-INT APA, Exterior glue.
    - b. Cut; Face and Back Veneer: Plain sliced to match existing.
- B. Interior Woodwork (to receive paint finish): AWS Custom Grade.

1. Species; Solid Wood: Any closed-grain hardwood complying with AWS Section 3 for the quality grade specified.
2. Panel Products: Veneer core plywood (no particleboard core plywood permitted).
  - a. Face and Back Veneer Species: Any Group 1 species, A-D-INT APA, Exterior glue.

**2.03 FABRICATION:**

- A. Machine and sand wood surfaces to comply with the requirements of the AWS Quality Grade specified.
- B. Mill assemble items to largest sizes practicable, to minimize field cutting and jointing. Allow for cutting and fitting where necessary to fit at the Site.

**PART THREE - EXECUTION**

**3.01 EXAMINATION:**

- A. Verification of Conditions: Examine substrate conditions and surfaces upon which finish Work is to be installed. Do not proceed with finish Work until unsatisfactory substrate conditions are corrected.

**3.02 PREPARATION:**

- A. Condition the Work of this Section to average prevailing humidity conditions in installation areas prior to installing.

**3.03 INSTALLATION:**

- A. Comply with workmanship and finishing standard requirements of the AWS Quality Grade specified herein.
- B. Install the Work plumb, level, and free of distortion. Shim where required, with concealed shims.
- C. Cut wood items to fit unless specified to be shop-fabricated, or shop-cut to exact size. Scribe and cut for accurate fit where Work abuts other finish Work. Drill pilot holes at corners before making cutouts.
- D. Distribute defects to the greatest appearance advantage possible.



- E. Trim and Moulding: Install in single, unjointed lengths at openings and for runs less than the maximum lumber length available. For long runs, use only 1 piece less than the maximum length available in any straight run. Stagger joints in adjacent members. Cope moulding at returns. Miter at corners.
- F. Attach the Work securely in place.
  - 1. Nailing: Blind nail where possible. Use finishing nails where exposed. Set nail heads for filling, except for exterior wood scheduled to receive natural finish (if any).
  - 2. Anchoring: Secure the Work to anchors or to blocking which is built-into or directly attached to substrates.
- G. Casework: Install Work in a manner consistent with the AWS Quality Grade specified.
  - 1. Secure casework to grounds, stripping, or blocking with countersunk concealed fasteners and blind nailing, as required to provide a rigid installation. Scribe and cut for accurate fit to other finish Work.
  - 2. Adjust and lubricate casework hardware for proper operation.
- H. Plastic Laminated Finish Work: Comply with finish requirements of AWS Quality Grade specified herein.
  - 1. Coordinate and verify sizes and locations of openings for fixtures with actual fixture sizes. Form inside corners to a radius of not less than 1/8 inch. Rout cutouts, and file cut edges to smooth surfaces free of cracks.
  - 2. Wire grommet: Size as shown on drawings by Doug Mockett.  
Color: Close match laminate countertops

**3.04 CLEANING:**

- A. Clean exposed surfaces of prefinished Work.

**3.05 PROTECTION:**

- A. Protect installed Work from damage by Work of other trades. Maintain temperature and humidity requirements during the construction period in interior installation areas.

**END OF SECTION**

**SECTION 06 40 00 – ARCHITECTURAL WOODWORK**

**PART ONE - GENERAL**

**1.01 RELATED WORK SPECIFIED ELSEWHERE:**

- A. Rough Carpentry: Section 061000.
- B. Finish Carpentry: Section 062000.

**1.02 REFERENCES:**

- A. Comply with the applicable provisions of the "Architectural Woodwork Standards" (First Edition-2009) (AWS) except as otherwise specified herein. References to "Premium", "Custom", and "Economy" Grades herein, shall be as defined in that Standard.

**1.03 SUBMITTALS:**

- A. Shop Drawings: Show fabrication details and connections to adjacent Work.
- B. Product Data: Manufacturers' catalog sheets, specifications, and installation instructions for plastic laminates and hardware items.
- C. Samples:
  - 1. Plastic Laminate: 12 inch square section, each type.
    - a. Color Samples: Manufacturer's standard colors, textures, and finish.

**PART TWO - PRODUCTS**

**2.01 CABINETS AND COUNTERTOPS:**

- A. Comply with AWS Sections 10 and 11 except as otherwise specified herein.
- B. Cabinets:
  - 1. For Laminate Finish: Custom Grade, with plastic laminate cover on exposed cabinetwork and on inside face of hinged doors. Box construction with furniture grade veneer core plywood (no particle or pressed board permitted).
- C. Countertops: As indicated in the drawings.
  - 1. Provide Custom Grade with plastic laminate cover as shown in the drawings. Include backsplash and endsplash if shown.
  - 2. Finish exposed edges and ends of counter tops with matching plastic laminate.
  - 3. Substrate with veneer core plywood plywood or solid wood.

- D. Plastic Laminate: NEMA Standards Publication LD3 for the following types; color, texture, and finish as indicated, or if not indicated, as selected by the Owner.
1. Horizontal Surfaces: General Purpose Type; GP 50 Grade; 0.050 inch nominal thickness.
  2. Vertical Surfaces: General Purpose Type; GP 28 Grade; 0.028 inch nominal thickness.
  3. Concealed Back Faces: Backer Type; BK 20 Grade; 0.020 inch nominal thickness.
  4. Wilsonart International, Inc., 2400 Wilson Pl. P.O. Box 6110, Temple, TX 76503-6110, (800) 433-3222, [www.wilsonart.com](http://www.wilsonart.com).
  5. Lamin-Art, Inc., 1670 Basswood Road, Schaumburg, IL 60173, (800) 323-7624, [www.laminart.com](http://www.laminart.com)

**2.02 HARDWARE:**

- A. Provide hardware as required for architectural woodwork, including cabinet hardware and miscellaneous items. Provide dull chrome finish (US26D), or nearest match available, except as otherwise indicated.
1. Adjustable Shelf Pilaster Standards and Supports: Steel with bright nickel or zinc finish; Knape & Vogt 255 x 256.
  2. Hinges: Concealed European; Blum CLIP top BLUMOTION 110° to accommodate ¾" and 1" thick cabinet doors or approved equal.
  3. Drawer Slides: Full extension, concealed undermount with Soft-Close, 75 lb capacity; Knape & Vogt MuV+ (medium-duty) or approved equal.
  4. Cabinet Door/Drawer Pulls: For cabinets A901/5 & A901/3: Mockett #DP105B/2 Finish: Satin Nickel 17S. For cabinet A901/2: Mockett DP105C/2 Finish: Satin Nickel 17S.
  5. Cabinet Door Lock: CCL Security Cabinet Lock 0666 with strike, or National Cabinet Lock M2-3700, or approved equal.
  6. Magnetic Touch Latches: Sugatsune ML-80/BLK, or approved equal.

**PART THREE - EXECUTION**

**3.01 INSTALLATION:**

- A. Install the Work of this Section in strict accordance with the manufacturer's printed instructions and approved shop drawings (if any).
- B. Fit joints neatly and accurately with adjoining surfaces in same plane. Maintain field joint tolerances equal to those specified in AWS Standards.

- C. Fastening:
1. Use concealed fasteners for work to receive transparent finish.
  2. Fasten assembled items together securely.
  3. Fasten items securely to supporting surfaces.
  4. Set exposed nails for putty stopping.
  5. Plug stop screws in exposed-to-view surfaces.
  6. Perform gluing operations in such a manner that the glued surfaces will be in close contact throughout, firmly cemented together and with joints as nearly invisible as possible.

**3.02 CLEANING:**

- A. After installation, clean exposed surfaces to remove dirt, adhesive, sealant, and other blemishes. Comply with panel manufacturer's printed cleaning instructions.

**3.03 PROTECTION:**

- A. Apply heavy kraft paper or other heavy protective coating approved by the Owner's Project Manager, masked in place to prevent surface damage.

**END OF SECTION**



**SECTION 07 92 00 – JOINT SEALANTS**

**PART ONE - GENERAL**

**1.01 SUBMITTALS:**

- A. Product Data: Catalog sheets, specifications, and installation instructions for each product specified except miscellaneous materials.
- B. Quality Control Submittals:
  - 1. Installer's Qualifications Data: Affidavit required under Quality Assurance Article.

**1.02 QUALITY ASSURANCE:**

- A. Installer's Qualifications: The persons installing the sealants and their supervisor shall be personally experienced in the installation of sealants and shall have been regularly employed by a company engaged in the installation of sealants for a minimum of two years.
- B. Container Labels: Include manufacturer's name, trade name of product, kind of material, federal specification number (if applicable), expiration date (if applicable), and packaging date or batch number.
- C. Warranties:
  - 1. Silicone sealants: 20 years Weatherseal Warranty.
  - 2. Polyurethane or Silicone: 5 year Weatherseal Warranty.
  - 3. Sealants for Granite, Marble and Limestone: 20 year Non-Stain Warranty.

**1.03 PROJECT CONDITIONS:**

- A. Environmental Requirements:
  - 1. Temperature: Unless otherwise approved or recommended in writing by the sealant manufacturer, do not install sealants at temperatures below 40 degrees F or above 85 degrees F for non-silicone sealants and below minus 20 degrees F or above 125 degrees F for silicone sealants.
  - 2. Humidity and Moisture: Do not install the Work of this section under conditions that are detrimental to the application, curing, and performance of the materials.
  - 3. Ventilation: Provide sufficient ventilation wherever sealants, primers, and other similar materials are installed in enclosed spaces. Follow manufacturer's recommendations.

- B. Protection:
1. Protect all surfaces adjacent to sealants with non-staining removable tape or other approved covering to prevent soiling or staining.
  2. Protect all other surfaces in the Work area with tarps, plastic sheets, or other approved coverings to prevent defacement from droppings.

## **PART TWO - PRODUCTS**

### **2.01 GENERAL REQUIREMENTS:**

- A. Before installation check each sealer for compatibility with adjacent materials and surfaces and with indicated exposures. Select sealers which are recommended by the manufacturer for each application indicated. Where exposed to pedestrian or vehicular traffic, provide sealers which are non-tracking and are strong enough to withstand the traffic without damage.
- B. Colors: Provide colors as selected by Architect from manufacturer's standard colors.

### **2.02 SILICONE SEALANT (EXTERIOR):**

- A. Provide 795 by Dow Coming, 864 by Pecora, or Spectrem 2 by Tremco or architect approved equal.
- B. Extent: Provide non-sag silicone sealer for all other joints not indicated to be sealed with another type of sealer.
- C. Colors: Provide colors as selected by the Architect from manufacturer standard colors.

### **2.03 SILICONE SEALANT (INTERIOR):**

- A. Provide one part, mold and mildew resistant, sanitary interior type silicone rubber based elastomeric sealant, complying with ASTM C 920 Type S, Class 25, Grade NS. Provide one of the following products if they meet or exceed the requirements of these specifications.
1. Dow 786
  2. General Electric SCS1700 or 1702
  3. Pecora 863 or 898
  4. Tremco Tremsil 200
- B. Extent: Provide silicone rubber sealant for all interior joints at back and sidesplashes.

**2.04 ACRYLIC LATEX SEALANT:**

- A. Provide permanently flexible, paintable latex rubber modified acrylic emulsion sealant, complying with ASTM C834. Provide one of the following products if they meet or exceed the requirements of these specifications:
  - 1. Pecora AC-20
  - 2. Sonneborne Sonolac
  - 3. Tremco TremFlex 834
- B. Extent: Provide acrylic latex sealer for use for exposed acoustical sealant, access doors before painting, and for all interior joints except where silicone rubber sealer is indicated.
- C. At interior joints greater than 1/2 In. in width or subjected to periodic building movement, substitute exterior type sealant specified above.
- D. Where surrounding wail surfaces are to be left unpainted, substitute exterior type sealant as specified above.

**2.05 CONCEALED BEDDING SEALANT:**

- A. Provide: One-part butyl rubber sealant; Pecora's BC-158, PTI's 707, or Bostik's Chem-Calk 300.

**2.06 JOINT FILLERS:**

- A. Expanded Polyethylene Joint Filler: Flexible, compressible, closed-cell polyethylene of not less than 10 psi compression deflection (25 percent).

**2.07 MISCELLANEOUS MATERIALS:**

- A. Backer Rod: Compressible rod stock of expanded, extruded polyethylene.
- B. Cleaning Solvents: Oil free solvents as recommended by the sealant manufacturer. Do not use re-claimed solvents.
- C. Masking Tape: Removable paper or fiber tape, self-adhesive, non-staining.



**PART THREE - EXECUTION**

**3.01 EXAMINATION:**

- A. Examine all joint surfaces for conditions that may be detrimental to the performance of the completed Work. Do not proceed until satisfactory corrections have been made.

**3.02 PREPARATION:**

- A. Clean joint surfaces immediately before installation of sealant and other materials specified in this Section.
  - 1. Remove all loose materials, dirt, dust, rust, oils and other foreign matter that will impair the performance of materials installed under this Section.
  - 2. Remove lacquers, protective coatings and similar materials from joint faces with manufacturer's recommended solvents.
  - 3. Do not limit cleaning of joint surfaces to solvent wiping. Use methods such as grinding, acid etching or other approved and manufacturer's recommended means, if required, to clean the joint surfaces, assuring that the sealant materials will obtain positive and permanent adhesion.
- B. Set joint fillers at proper depth and position as required for installation of bond breakers, backer rods, and sealants. Do not leave voids or gaps between the ends of joint filler units.

**3.03 JOINT BACKING INSTALLATION:**

- A. Install bond breaker tape in relaxed condition as it comes off the roll. Do not stretch the tape. Lap individual lengths.
- B. Install backer rod of sufficient size to fill the joint width at all points in a compressed state. Compress backer rod at the widest part of the joint by a minimum of 25 percent. Do not cut or puncture the surface skin of the rod.

**3.04 SEALANT INSTALLATION:**

- A. Except as shown or specified otherwise, install sealants in accordance with the manufacturer's printed instructions.
- B. Install sealants with ratchet hand gun or other approved mechanical gun. Where gun application is impractical, install sealant by knife or by pouring as applicable.
- C. Types 2 and 2A Sealants: If low temperature makes application difficult, preheat sealants using manufacturer's recommended heating equipment.

- D. Finishing: Tool all vertical, non-sag sealants so as to compress the sealant, eliminating all air voids and providing a neat smoothly finished joint. Provide slightly concave joint surface, unless otherwise indicated or recommended by the manufacturer.

**3.05 CLEANING:**

- A. Immediately remove misapplied sealant and droppings from metal surfaces with solvents and wiping cloths. On other materials, remove misapplied sealant and droppings by methods and materials recommended in writing by the manufacturer of the sealant material.
- B. After sealants are applied and before skin begins to form on sealant, remove all masking and other protection and clean up remaining defacement caused by the Work.

**END OF SECTION**



**SECTION 08 11 16 - ALUMINUM DOORS**

**PART ONE - GENERAL**

**1.01 RELATED WORK SPECIFIED ELSEWHERE:**

- A. Finish Hardware and Thresholds: Section 087100.
- B. Glass and Glazing: Section 088100.

**1.02 SUBMITTALS:**

- A. Shop Drawings: Show details of each door type, conditions at openings, location and installation requirements for finish hardware (including cutouts and reinforcements), details of connections, and anchorage and accessory items.
- B. Product Data: Catalog sheets, specifications, and installation instructions for each type door specified.
- C. Samples:
  - 1. Color Samples: Manufacturer's standard colors showing maximum variation of each color. Submit actual production sections large enough to establish the allowable color shade range.

**PART TWO - PRODUCTS**

**2.01 MATERIALS:**

- A. Aluminum:
  - 1. Extruded Shapes: 6063 alloy, T5 temper.
  - 2. Rolled Shapes: 6061 alloy, T6 temper.
  - 3. Sheet, and Shapes Formed of Sheet: 1100 alloy, H14 temper.
  - 4. Color Anodized Aluminum: 5005 alloy of temper for required shapes.
- B. Steel Subframes: ASTM A 36 plates, shapes and bars.
- C. Reinforcement: Manufacturer's standard formed or fabricated steel units, of shapes, plates or bars; galvanized after reinforcement fabrication, ASTM A 123.
- D. Fasteners: Aluminum, non-magnetic stainless steel, or other non-corrosive metal fasteners compatible with aluminum door components and other items to be fastened; Phillips flat-head screws for exposed fasteners (if any), finished to match fastened item.
  - 1. Do not use exposed fasteners except for necessary application of surface mounted hardware. Use concealed screws when required for application of glazing stops.

- E. Inserts: Cast iron, malleable iron, 12 gage galvanized steel, ASTM A 153, for required anchorage to concrete or masonry Work.
- F. Expansion Anchors: Anchor bolt and sleeve assembly of material indicated below with capability to sustain, without failure, a load equal to six times the load imposed when installed in unit masonry and equal to four times the load imposed when installed in concrete, as determined by testing per ASTM E 488, conducted by a qualified independent test agency.
1. Carbon Steel: Zinc-Plated; ASTM B 633, Class Fe/Zn 5.
  2. Stainless Steel: Bolts, Alloy Group 1 or 2; ASTM F593, Nuts; ASTM F 594.
- G. Machine Screws for Steel Subframes: ASME B18.6.3.
- H. Bituminous Paint: Cold-applied asphalt emulsion complying with ASTM D 1187.
- I. Compression Weatherstripping: Replaceable stripping of either molded neoprene gaskets complying with ASTM D 2000, Designation 2BC415 to 3BC620, or molded PVC gaskets complying with ASTM D 2287.
- J. Sliding Weatherstripping: Replaceable stripping of wool, polypropylene or nylon woven pile, with nylon fabric and aluminum strip backing, complying with AAMA 701.1.
- K. Sealants and Gaskets: Manufacturer's standard for the fabrication, assembly and installation of the Work; guaranteed by the manufacturer to remain permanently elastic, non-shrinking, non-migrating and weatherproof.

## **2.02 FABRICATION:**

- A. Glazed Doors:
1. Fabricate stiles and rails of extruded aluminum tubular shapes, 1/8 inch min wall thickness, not less than 3 inches wide. Attach extrusions together by means of concealed mechanical fasteners and concealed welding.
  2. Glazing Beads: Formed or extruded, not less than 0.05 inch wall thickness. Fasten glazing beads to frames with self-tapping screws spaced not more than 12 inches apart.
  3. Door Edges: Lock stile edge of single acting doors shall be beveled 1/8 inch in 2 inches. Double acting doors shall have 4 inch radius rounded edges. Meeting stile edges of pairs of single acting doors shall be "V" beveled or rounded, as indicated.

- B. Finish Hardware Preparation: Attach concealed reinforcements and cut mortises of sizes required and where located by the approved hardware schedule, for the proper installation of finish hardware.
1. Reinforcements: 1/4 inch thick aluminum.
  2. Install reinforcements within mortises at the depths required to bring the hardware surfaces flush with the door and jamb surfaces.
  3. Extend reinforcements for hinges, pivots, floor hinges, 4 inches above and below mortises on side jambs and door edges.
  4. Reinforce all doors not mortised for concealed door closers on both sides for surface door closer application; and all frames on both sides for closer arm application.

### 2.03 FINISHES:

- A. Preparation: After fabrication of doors, prepare the aluminum surfaces for finishing in accordance with the Aluminum Association recommendations and standards. Process all components of each assembly simultaneously to attain complete uniformity of color.
- B. Finish exposed aluminum door components as follows:
1. Colored Anodized Finish: NAAMM AA-M21C22A42 heavy colored, (minimum thickness of 0.7 mils), integral color anodized finish.
  2. Color: To be selected by the Architect from the manufacturer's standard offerings.

## PART THREE - EXECUTION

### 3.01 INSTALLATION:

- A. Securely anchor sub-framing to supporting structures, plumb and level and properly prepared to receive aluminum doors.
- B. Protect areas of panels to be in contact with sealants and surfaces of glazing rebates and glazing beads with protective, strippable tape. Do not apply lacquer to such areas. Remove tape immediately before application of caulking or glazing compound.
- C. Paint aluminum surfaces in contact with masonry and incompatible metals with bituminous paint.
- D. Door Installation: Fit doors accurately in their frames, with the following clearances:
1. Jambs and Head: 3/32 inch.
  2. Bottom, at Threshold or Carpet: 1/8 inch.

**3.02 PROTECTION:**

- A. Provide protective covering to protect aluminum doors from damage or defacement after erection.

**3.03 ADJUSTING AND CLEANING:**

- A. Final Adjustments: Check and readjust operating finish hardware items just prior to final inspection. Leave Work in complete and proper operating condition.
- B. When directed, or just prior to final inspection remove protective coverings and clean aluminum surfaces with products specifically formulated for aluminum and known to be compatible with finishes specified herein.

**END OF SECTION**

**SECTION 081400 - WOOD DOORS**

**PART ONE - GENERAL**

**1.01 RELATED WORK SPECIFIED ELSEWHERE:**

- A. Steel Frames: Section 081102.
- B. Finish Hardware: Section 087100.
- C. Glass and Glazing: Section 088100.
- D. Painting (Site Finishing Doors): Section 099101.

**1.02 REFERENCES:**

- A. Standards: Unless otherwise specified, comply with the applicable requirements of the "Architectural Woodwork Standards" (First Edition-2009) (AWS).

**1.03 SUBMITTALS:**

- A. Shop Drawings: Show details, elevation, and construction for each door type, location and installation requirements for Finish Hardware (including cutouts and reinforcements), and accessory items.
  - 1. Include a schedule of doors using the same reference numbers for details and openings as those on the Contract Drawings.
- B. Product Data: Catalog sheets, specifications, and installation instructions for each type door specified.
- C. Samples:
  - 1. 12 x 12 inch corner sample of each door type, with panel (if any).
    - a. Factory Finished Doors: Include shop finish on samples.
- D. Quality Control Submittals:
  - 1. Affidavit required under Quality Assurance Article.

**1.04 QUALITY ASSURANCE:**

- A. Certifications: Affidavit by door manufacturer certifying that each door meets the specified requirements and standards.



- B. Fire Rated Doors: Carry metal label, fastened on hinge edge with drive screws, indicating fire class/rating certified by an independent testing agency.

**1.05 DELIVERY, STORAGE, AND HANDLING:**

- A. Factory Finished Doors: Deliver doors in factory applied plastic bags or heavy paper protective cartons. Mark packaging with sufficient identification to insure proper door location.
- B. Comply with manufacturer's storage instructions.

**1.06 PROJECT CONDITIONS:**

- A. Environmental Requirements: Do not store doors within the building or install doors until after completion of cast-in-place concrete, masonry, plastering, gypsum board and tile Work, and until after the building has dried out.

**PART TWO - PRODUCTS**

**2.01 MATERIALS:**

- A. Lumber: Comply with applicable AWS species requirements for door type and grade.
  - 1. Exposed Surfaces: As indicated on the Drawings or specified. Furnish matching exposed surface material on both faces and both edges of each door unless otherwise indicated.
  - 2. Fire Rated Doors: Exposed faces to match non-fire rated doors in same building area.
- B. Wood Veneers: Comply with applicable AWS species requirements for door type and grade.
- C. Glue: Type I waterproof adhesives for bonding faces and crossbands to core, for both exterior and interior door fabrication.

**2.02 FABRICATION:**

- A. Interior Flush Wood Doors (Non-Fire Rated): 2 or 3 ply face panel construction each side over a solid glued wood block (stave) core edge bonded to stiles and rails, complying with AWS SLC-5 or SLC-7; or 2 or 3 ply face panel construction each side over a solid wood particleboard core edge bonded to stiles and rails, complying with AWS PC-5 or PC-7.

1. Exposed Surfaces for Transparent Stain Finish: AWS Premium Grade, rotary cut, matched, natural white birch veneer face panels, match existing wood veneer species.
- B. Interior Flush Wood Doors (3/4, 1, and 1-1/2 Hour Fire Rated): 2 or 3 ply face panel construction each side over fire rated solid mineral core, with hinge stile construction having equivalent stile edge split resistance and screw withdrawal resistance of one inch thick wood, and complying with applicable AWS FD for the indicated fire rating.
  1. Exposed Surfaces for Transparent Stain Finish: AWS Premium Grade, rotary cut, matched, natural white birch veneer face panels.
- C. Light and Louver Openings: Fully trimmed openings. Comply with the applicable provisions of the referenced standards for core treatment and stop application.
  1. Light Openings For Fire Rated Doors: Factory cut and trim openings to comply with applicable codes.

**2.03 FACTORY FINISHING, PREFITTING, AND PREPARATION FOR HARDWARE:**

- A. Factory Finishing: Prefinish wood doors at the factory or finishing shop as follows:
  1. Comply with AWS factory finishing recommendations including final sanding requirements.
  2. Finishing System: Comply with the requirements of the following AWS Finish System:
    - a. Transparent Finish: System No. 5 - Conversion Varnish, Premium Grade.
      - 1) Sheen: Dull satin; 15 to 20 degrees.
      - 2) Stain Color: Match existing adjacent doors to remain.
      - 3) Sheen: Match existing adjacent doors to remain.
- B. Factory Prefitting and Premachining for Hardware: Prefit doors scheduled or indicated to receive factory finishing. Premachine these doors for hardware.
  1. Comply with AWS clearance requirements for prefitting. Machine doors for hardware requiring cutting of doors. Comply with finish hardware schedule, door frame shop drawings, and hardware templates to insure proper fit and alignment of doors and hardware.
  2. Verify hardware mortises in steel frames in the field to verify dimensions and proper alignment prior to proceeding with factory machining of doors.

**PART THREE - EXECUTION**

**3.01 PREPARATION:**

- A. Condition doors to average prevailing humidity in installation area prior to hanging.
- B. Prepare doors to receive scheduled mortise hardware. Coordinate doors with the finish hardware schedule and with the door frame shop drawings for proper location of mortise hardware. Machine doors for hardware.
- C. Touch-up cut surfaces of factory primed doors with primer compatible with primer specified for factory priming.

**3.02 INSTALLATION:**

- A. Install the Work of this Section in accordance with manufacturer's printed installation instructions, except as shown or specified otherwise.
- B. Fit doors to prepared frames for proper fit. Allow 3/32 to 1/8 inch clearance at head and both jambs. Trim doors when necessary by planing. Slightly chamfer edge of lock stiles. Bevel lock stile as follows:
  - 1. Non-fire Rated Doors: 1/8 inch in 2 inches.
  - 2. Fire Rated Doors: 1/16 inch in 2 inches.
- C. Prefit Doors: Do not alter prefit factory finished doors.
- D. Fire Rated Doors: Install doors in corresponding fire rated frames in accordance with the requirements of NFPA No. 80.
- E. Factory Finished Doors: Field touch-up and restore finishes damaged during installation.

**END OF SECTION**

**SECTION 08 71 00 - FINISH HARDWARE AND THRESHOLDS**

**PART ONE – GENERAL**

**1.01 RELATED WORK IN OTHER SECTIONS:**

- A. Detention Locksets: Section 11 19 00 Detention Equipment.
- B. Mortise Locksets: Section 01 21 00 Allowances.

**1.02 REFERENCES:**

- A. NFPA 80 Fire Doors and Windows (2007).
- B. NFPA 101 Life Safety Code (2006).
- C. 2003 International Building Code with 2005 Connecticut Supplement and 2009, 2011 and 2013 Amendments.
- D. ICC/ANSI A117.1-2003 Accessible and Usable Buildings and Facilities.
- E. ANSI/BHMA Standard A156.1 Butts and Hinges (2006).
- F. ANSI/BHMA Standard A156.4 Door Controls – Closers (2008).
- G. ANSI/BHMA Standard A156.6 Architectural Door Trim (2005).
- H. ANSI/BHMA Standard A156.7 Template Hinge Dimensions (2009).
- I. ANSI/BHMA Standard A156.8 Door Controls – Overhead Stops and Holders (2005).
- J. ANSI/BHMA Standard A156.13 Mortise Locks and Latches Series 1000 (2005).
- K. ANSI/BHMA Standard A156.16 Auxiliary Hardware (2008).
- L. ANSI/BHMA Standard A156.18 Materials and Finishes (2006).
- M. ANSI/BHMA Standard A156.22 Door Gasketing Systems (2005).
- N. ANSI/BHMA Standard A156.26 Continuous Hinges (2006).
- O. DHI - Door and Hardware Institute.
- P. NAAM Standard HMMA 800-96- Hollow Metal Manufacturers Association.

- Q. NAAM Standard HMMA 831-97 Recommended Hardware Locations for Custom Hollow Metal Doors and Frames.

**1.03 DEFINITIONS:**

- A. Architectural Hardware Distributor: A company that regularly purchases architectural hardware from manufacturers and specializes in the sale, service and support of that hardware to contractors and/or end users.
- B. Company Field Advisor(s): Hardware manufacturers' representatives who are certified in writing by manufacturer to be technically qualified in design, installation, and servicing of products.
- C. Installation Supervisor: Designated supervisor/installer, who has a minimum three years experience in finish hardware installation, and is qualified and responsible to ensure approved finish hardware is installed, adjusted, and operates properly.
- D. Benchmark: Finish hardware installed on full size door and frame assembly that is constructed on-site. Benchmarks are constructed to verify qualities of materials and execution; to review coordination between frames, doors, and architectural hardware; to show interface between partitions and frames; and to demonstrate compliance with specified installation tolerances. Benchmarks are not samples. Unless otherwise indicated, approved benchmarks establish the standard by which the Work will be judged. The approved benchmark may be incorporated into the work of this section.

**1.04 SUBMITTALS:**

- A. Submittal Package Cover Sheets: The Hardware Distributor shall provide a cover sheet, which identifies each package by:
1. CHK project number.
  2. Project name.
  3. Submittal Package name.
  4. Specification section name and number.
  5. Construction Contractor's company name, address, e-mail address, and telephone number.
  6. Finish Hardware Distributor's company name, address, e-mail address, and telephone number.
  7. Submittal Date.

**B. Submittal Packages:****1. Finish Hardware Package:**

- a. Finish Hardware Schedule: Use vertical format and indicate finish hardware items, both mechanical and electrical in one document, required to complete Work of this section. Submit Hardware Schedule that includes complete hardware sets for each door and frame shown on Door Schedule.
  - 1) Preface schedule with following:
    - a) Certified Architectural Hardware Consultant's statement of preparation of/or certification of, Finish Hardware Schedule.
    - b) Index.
    - c) List of manufacturers.
    - d) List of finishes.
    - e) Explanation of abbreviations.
    - f) Keying instructions and key schedule.
  - 2) Create hardware groups, each group consisting of similar doors and hardware. Do not combine labeled and non-labeled openings. Do not combine doors and frames with dissimilar door sizes and/or materials.
  - 3) For each opening include the following:
    - a) Door and frame materials and dimensions.
    - b) Fire rating.
    - c) Door number, location and handing.
    - d) Degree of opening required for closer and/or overhead stop.
    - e) Installation and detailing notes.
  - 4) Under each group heading, list hardware items in detail, required for ordering. For each hardware item include:
    - a) Type (Hinges).
    - b) Quantity (Hinges 3ea).
    - c) Manufacturers' name (Hinges 3ea Stanley).
    - d) Catalog number (Hinges 3ea Stanley FBB199).
    - e) Size (Hinges 3ea Stanley FBB199 4 ½ x 4 ½ ).
    - f) Options or accessories (Hinges HTFBB199 4 ½ x 4 ½ ).
    - g) Finish (Hinges HTFBB199 4 ½ x 4 ½ x 630).
    - h) Fasteners (Hinges HTFBB199 4 ½ x 4 ½ x 630 x torx with center security pin).
    - i) Indicate location of protection plates: Push side or pull side.
    - j) Installation Notes, as written in this section, for each hardware group.

PROBATE COURT  
ADMINISTRATION  
INTERIOR RENOVATIONS  
186 NEWINGTON ROAD  
WEST HARTFORD, CONNECTICUT

- 5) Use a separate hardware group in Hardware Schedule that lists attic stock hardware items, key cabinets, key control system, special tools required to install hardware, lubricants, and Operations and Maintenance Manuals.
  - b. Product Data: Furnish six copies of manufacturers' catalog sheets, specifications, sizing charts, and installation instructions, for each item specified. Highlight information pertaining specifically to product (s) submitted.
  - c. Submit samples as requested.
2. Closeout Submittals: Submit as a complete package.
- a. Operation and Maintenance Manuals: Furnish 2 hardcover three ring binders with the project name and number displayed on the front cover and spine. Include:
    - 1) List of Manufacturers.
    - 2) Approved Finish Hardware Schedule.
    - 3) Approved Manufacturers' Product Data Sheets.
    - 4) Manufacturer's operation, installation, maintenance, and repair instructions for each type of hardware furnished.
    - 5) Templates for kind of hardware furnished.
    - 6) Parts List for each type of finish hardware furnished.
    - 7) Manufacturers' dated written warranty for each type of finish hardware furnished.
    - 8) Certifications: Written certification from Company Field Advisors that their products are installed according to manufacturers' printed installation instructions, are operating properly, and manufacturers' written warranty will be in effect upon physical completion of the Work.
    - 9) Special Tools: List of special tools required to install hardware, and their purpose.
  - b. Special Tools:
    - 1) At conclusion of finish hardware installation, turn over to Owner's Representative 2 of each special tool required to install hardware together with a list of these tools and their purpose.

**1.05 TEMPLATES:**

- A. After receipt of approved submittals, furnish templates to affected trades, to enable fabricators to make provision for finish hardware without delaying the Work of the Project.

**1.06 DELIVERY AND STORAGE:**

- A. Coordinate delivery to avoid delay.

- B. Clearly label each item for identification and installation location as it corresponds to the approved Finish Hardware Schedule and subsequent information bulletins.
- C. Deliver hardware to the jobsite in the manufacturers' original packages complete with fasteners, parts, installation instructions, and templates required for proper installation.
- D. Inventory hardware at jobsite to identify shortages or backorders. Resolve delivery shortages and damaged items prior to installing hardware.
- E. Store finish hardware where directed by Owner's Representative. Provide locked, dry storage for finish hardware.

**1.07 QUALITY ASSURANCE:**

- A. Hardware Distributor's Qualification:
  - 1. Hardware Distributor who has been in the business of furnishing, and/ or installing finish hardware for a minimum of three years.
  - 2. Hardware Distributor shall have the DHI certified Architectural Hardware Consultant prepare or certify the Finish Hardware Submittal meets specification requirements, and the schedule is written accurately and in accordance with DHI recommendations, and requirements of this specification.
- B. Installation Supervisor: Employ a qualified Installation Supervisor who will be responsible to ensure approved finished hardware is installed, adjusted and operates properly.
- C. Installers: Employ experienced finish hardware installers who have been regularly employed by a Company installing finish hardware for a minimum of 5 years.
- D. Uniformity of Hardware and Single Source Responsibility: For each kind of hardware provide product(s) of a single manufacturer.
- E. Size Variations: Manufacturers' products may vary slightly from sizes specified except where minimum size or thickness is specified.

**1.08 WARRANTY:**

- A. Manufacturer's Warranty: Ten year minimum warranty for door closers.
- B. Manufacturer's Warranty: Three year minimum for locksets.



**1.09 MAINTENANCE:**

- A. Special Tools: At the conclusion of finish hardware installation, turn over to Owner's Representative 2 sets of each special tools required for proper installation and adjustment of hardware, together with a list of these tools and their purpose.
- B. Lubricants: Provide manufacturer's recommended lubricants for locksets and closers sufficient for 1 year of maintenance. Turn over to Owner's Representative.

**PART TWO - PRODUCTS**

**2.01 ACCESSORIES:**

- A. Provide brackets, plates, arms, spacers, and special templates to mount door closers in combination with overhead stops and coordinators, on narrow top rails and for special ceiling and jamb conditions.
- B. Provide curved lip strikes, with wrought boxes, specific to individual lock functions. Universal strikes that fit a variety of lock functions are not acceptable.

**2.02 FASTENINGS:**

- A. Provide fasteners that harmonize with finish hardware material and finish.
- B. Provide torx center pin security fasteners for exposed hardware, including full mortise hinges.
- C. Provide machine screws for hardware secured to metal; and machine screws and metal expansion shields for attachment to masonry substrates. Self-tapping or self-drilling screws are not acceptable.
- D. Provide undercut shallow head torx center pin security fasteners where necessary for proper seating.
- E. Attach door closers and overhead stops with sex bolts.

**2.03 MATERIALS AND FINISHES:**

- A. General: Requirements for design, grade, function, finish, size, and other distinctive qualities of each type of finish hardware are indicated in this section and in the Hardware Groups.

- B. Locks, Latches and Bolts:
1. Comply with UL requirements for throw of bolts and latch bolts on rated fire openings.
  2. Provide 3/4" minimum throw on other latch bolts.
  3. Provide 1" minimum throw deadbolts.
- C. Closers and Door Control Devices:
1. Closer bodies: Provide closer bodies with the same hole template pattern regardless of type or application.
  2. Closer arms: Non-handed forged steel.
  3. Closer size: Provide sized closers.
  4. Provide all-weather fluid to eliminate seasonal adjustment of closer speed.
  5. Powder coat closer body, arm, and adapter plate or pre-treat closer body, arm, and adapter plate with rust-inhibiting coating before painted finish is applied.

#### **2.04 LOCKSETS AND LATCHSETS:**

- A. Locksets and Latchsets: Except where scheduled otherwise, provide latchsets and locks with cylindrical knob and rose by one of the manufacturers listed below. Provide cylinders and keyway to Owner's requirements.
1. Corbin Russwin or approved equal.
- B. Locksets shall be Corbin Russwin cylindrical knob type. Function of lockset shall be as noted in the Schedule.
1. CK4300 Series  
Global knob, wrought brass – finish to match existing.
- C. Throws: Provide 1/2" minimum. Comply with UL requirements for fire rated hardware.
- D. Strikes: Provide manufacturer's standard box strike with extended curved lip. Finish strikes and lips to match lock or latch. Provide custom strikes where required.
1. Provide electric strikes as indicated on door schedule.
- E. Metals: Provide cylinders and keys from brass matching type and finish of metal for hardware.

#### **2.05 HINGES AND BUTTS:**

- A. Provide products of one of the following manufacturers that meet or exceed the requirements of these specifications:
1. Stanley - #FBB 179 4-1/2" High
  2. Hager
  3. McKinney

- B. Butt Hinges shall be Stanley full mortise, five knuckle type, ball bearing FBB179 4 ½” high.
- C. Hinge Width: Consultant shall determine proper hinge width based upon door thickness and trim conditions. Provide minimum 4-1/2 in. wide hinges.
- D. Hinge Quantity: Provide three (1 ½ pair) hinges for doors up to 7 ft.-6 in. high, and four (2 pair) hinges for doors over 7’-6” high. Provide one additional hinge for doors over 3 ft.-6 in. wide.
- E. Pins: Provide flat button pins matching hinges in finish and material. Provide non-removable pins on outswinging exterior and corridor doors. Provide non-rising pins for all other hinges.
- F. Provide the following manufacturer for electric hinge: Stanley CE Series.

**2.06 CLOSERS:**

- A. Provide products of one of the following manufacturers that meet or exceed the requirements specified.
  - 1. LCN
  - 2. Corbin Russwin
  - 3. Dorma
- B. Closers shall be heavy duty LCN 4010 series.
- C. Provide closers with hold-open features where required. Provide closers with built-in door stop function at an adjustable angle where indicated. Provide closers which will open 180 degrees where required. Provide concealed closers where required per Hardware Schedule.
- D. Mount closers on the least public side of doors to the greatest extent possible. Provide closers with parallel arms wherever closers are on the stop side of doors which swing out into corridors and public spaces. Where parallel arms are used, provide closers which are one size larger than manufacturer's recommendation.
- E. Follow manufacturer's recommendations for size of closer based upon size and weight of door, exposure, and frequency of use.
- F. Finish of closer cover shall match existing closers.

**2.07 STOPS AND BUMPERS:**

- A. Provide products of one of the following manufacturers that meet or exceed the requirements specified:
  - 1. Ives

2. Rockwood
  3. Glynn-Johnson
- B. Wall bumpers shall be Ives 407 ½ or 408 ½ or Rockwood #409 to suit wall condition. Where indicated or where wall bumper is not practical, floor stops shall be Ives 436 or 438 to suit floor conditions and clearances. Provide carpet risers where required.

**2.08 WEATHERSTRIPPING AND THRESHOLDS:**

- A. Provide products of one of the following manufacturers that meet or exceed the requirements specified:
1. Reese
  2. Pemko
  3. Zero
- B. Thresholds for General Applications: Refer to schedule for material.
- C. Weather-stripping: Provide neoprene concealed gasket-type weather-stripping at exterior doors. Weather-stripped doors are required to provide a continuous seal at the entire perimeter of door with no cracks.

**2.09 EXIT DEVICES:**

- A. Provide hardware to match storefront manufacturer. See Door schedule.
- B. Where scheduled as vertical rod exit device, all vertical rods shall be concealed.

**2.10 KEYING:**

- A. Continue the existing key system established for Facility.

**PART THREE - EXECUTION**

**3.01 EXAMINATION:**

- A. Examine doors and frames and related items for conditions such as, but not limited to, incorrect handing, hardware preparation, misaligned lock and strike preparations, that would prevent proper application of finish hardware. Do not proceed until defects are corrected.
- B. Report conditions or hardware applications that are incorrect to the Owner's Representative.

**3.02 INSTALLATION:**

- A. Do not proceed with installation of finish hardware prior to attending referenced pre-installation conference.
- B. Installation Sequence: Use proper installation sequence, i.e., install coordinators, and overhead stops and holders before surface mounted door closers.
- C. Install hardware in accordance with manufacturer's printed installation instructions, and adjust for smooth operation, free of sticking, binding or rattling.
1. Template surface overhead stops and holders for proper operation
  2. Template and adjust closers for proper operation.
- D. Use proper tools and methods to prevent scratches, burrs or other defacement.
- E. Threshold Installation:
1. Drill holes 3 inches from each end of threshold and intermediate holes 12 inches maximum o.c. for required fasteners. Prepare holes for countersunk fasteners.
  2. Level and align thresholds with frames and doors. Where required, use non-corrosive shims.
  3. Exterior Doors: Set thresholds in a solid bed of Type 3 sealant.
  4. Secure thresholds to substrate with countersunk fasteners.
- F. Door Bottom Installation:
1. Mount sweep type door bottom protection/drip caps on exterior side of doors.
  2. Before mounting apply Type 2 sealant on the back side of bearing surface. Secure to door with required fasteners.
- G. Gasket Installation:
1. Install continuous stripping at each opening without unnecessary interruptions.
  2. Where fasteners are required, secure fasteners for stripping and seals so they will not work loose during door operation. Exposed heads of fasteners shall be free of sharp edges.
  3. Coordinate meeting stile gasket with hardware before installation.
  4. Install units plumb and level at the optimum location to maintain a permanent effective seal.
- H. After installation, cover and protect hardware to prevent damage during remaining construction. Remove protection upon completion of construction.

**3.03 LOCATIONS:**

- A. Locate hardware as follows:

1. Door Closers: Template for maximum door swing allowed by wall placement and jamb conditions. Where overhead stop prevents door from swinging to wall, template the closer to exceed degree of opening allowed by overhead stop.
2. Protection Plates: 1/8 inch from door bottom.
3. Wall Stops: Centerline of bumper to match centerline of locking trim.

**3.04 FIELD QUALITY CONTROL:**

- A. Post Installation Review: After hardware is adjusted for proper operation, Owner's Representative will hold a Post-Installation Review with the Contractor, Hardware Designer, Company Field Advisors, Hardware Distributor and Hardware Installers.
  1. Physically inspect to verify proper application, installation, adjustment and operation of finish hardware, and in particular that:
    - a) Latches engage freely without binding. Filing of strike plates to relieve latch bind is not acceptable.
    - b) Closers are adjusted for proper spring power; sweep speed, latching speed; and hydraulic back check.
    - c) Locations and proper attachment of installed protective hardware are as specified.
    - d) There is no field modification of fasteners.
    - e) Damaged fasteners are replaced.
  2. Defective hardware is repaired or replaced.
  3. Hardware is to be left clean and free from disfigurement.
- B. Turn referenced Operations and Maintenance Manuals over to Facility through Owner's Representative.

**END OF SECTION**



**SECTION 08 81 00 - GLASS AND GLAZING**

**PART ONE - GENERAL**

**1.01 RELATED WORK SPECIFIED ELSEWHERE:**

- A. Security Glass and Glazing: Section 088853.
- B. Plastic Sheet Glazing: Section 088400.

**1.02 REFERENCES:**

- A. Comply with recommendations in the "Glazing Manual" of the Glass Association of North America and the "Sealant Manual" of the Flat Glass Marketing Association except as shown or specified otherwise, and except as specifically recommended otherwise by the manufacturers of the glass and glazing materials.

**1.03 SUBMITTALS:**

- A. Product Data: Manufacturer's specifications and installation instructions for each type of glass and glazing material specified, and spacers and compressible filler rod.
- B. Samples:
  - 1. Glass: 12 x 12 inch pieces for each type of glass specified.
    - a. Insulating glass samples need not be hermetically sealed, but include edge construction materials.
  - 2. Setting blocks, full size.
  - 3. Color Samples for Glazing Materials: Manufacturer's standard colors.
    - a. Marking Decals: Manufacturer's standard colors.
    - b. Tinted Glass: Manufacturer's standard colors.
    - c. Spandrel Glass Ceramic Coat: Manufacturer's standard colors.
  - 4. Pattern Samples:
    - a. Type C-1 Glass: Manufacturer's standard patterns.
    - b. Type F Glass: Manufacturer's standard patterns.
- C. Quality Control Submittals:
  - 1. Test Reports: Certified test data to sufficiently substantiate glass or glass assembly compliance with requirements specified.
  - 2. Certificates:
    - a. Affidavit required under Quality Assurance Article.



**1.04 QUALITY ASSURANCE:**

- A. Compatibility of Materials: All components of the glazing system shall be manufactured or recommended by one manufacturer to assure the compatibility of materials.
- B. Safety Glazing Material: Type indicated, meeting requirements of ANSI Z97.1 with label on each piece.
- C. Certification:
  - 1. Affidavit by the material supplier, certifying type and quality of glass furnished.

**1.05 DELIVERY, STORAGE, AND HANDLING:**

- A. Protect glass from edge damage during handling, storage, and installation.

**1.06 PROJECT CONDITIONS:**

- A. Environmental Requirements: Comply with glazing materials manufacturer's written recommendations regarding environmental conditions under which glazing materials can be installed.
- B. Glazing channel dimensions shown are intended to provide for necessary minimum bite on the glass, minimum edge clearance and adequate glazing material thicknesses, with reasonable tolerances. Provide correct glass size for each opening, within the tolerances and necessary dimensions required.

**PART TWO - PRODUCTS**

**2.01 GLASS:**

- A. Tempered Float Glass; ASTM C 1048, Kind FT, Condition A, Type I, Class 1, tempered by the manufacturer's standard process (after cutting to final size).
  - 1. Thickness: 1/4 inch.
- B. Clear Fire-Rated Glass (No Wire): Fire Lite distributed by Technical Glass Products, 5525 Lake View Dr., Kirkland, WA 98033, or approved equal.
  - 1. Surface Condition: Standard (unpolished surfaces).
  - 2. Classification Mark Location: Lower right corner.

- C. Organically Sealed Insulating Glass Units; ASTM C 1036, applicable Type and Class for glass indicated below, quality q3 for Type I glass; manufacturer's standard edge construction of spacers and sealants permanently bonded to glass surfaces and hermetically sealed to provide a dehydrated air space 1/2 inch thick with -60 degrees F. dew point; fabricated of the following glass.
1. Exterior Glass: Clear float glass to match appearance of existing adjacent glass to remain.
  2. Interior Glass: Clear float glass to match appearance of existing adjacent glass to remain.
  3. Temper both panes of glass in each unit.
  4. Glass Thickness(es): 1/4".

**2.02 GLAZING MATERIALS:**

- A. Glazing Material at Entrance:
1. Silicone Rubber Glazing Sealant; silicone rubber one-part elastomeric sealant; FS TT-S-001543, Class A; acid-type for non-porous channel surfaces, and non-acid type where any of the channel surfaces are porous; or
  2. Polysulfide Glazing Sealant; polysulfide two-part elastomeric sealant; FS TT-S-00227, Type II, Class A, compounded by manufacturer specifically for glazing.
- B. Glazing Material at Door Lites: Polyvinyl Chloride Glazing Gaskets; ASTM D 2287; extruded, flexible PVC gaskets of the profile and hardness shown, or as required for watertight construction.
- C. Glazing Material at Fire-Rated Lites: Pure silicone caulk, closed cell PVC tape, or DAP 33 putty as recommended by Technical Glass Products to comply with U.L. Listing.
- D. Colors: For exposed materials provide color as indicated or, if not indicated, as selected by the Architect from the manufacturer's standard colors. For concealed materials, provide any of the manufacturer's standard colors.
- E. Setting Blocks: Neoprene, 70-90 durometer hardness, with proven compatibility with sealants used.
- F. Spacers: Neoprene, 40-50 durometer hardness, with proven compatibility with glazing materials used.
- G. Compressible Filler Rod: Closed-cell or waterproof-jacketed rod stock of synthetic rubber or plastic foam, proven to be compatible with glazing materials used, flexible and resilient, with 5-10 psi compression strength for 25 percent deflection.

PROBATE COURT  
ADMINISTRATION  
INTERIOR RENOVATIONS  
186 NEWINGTON ROAD  
WEST HARTFORD, CONNECTICUT

H. Cleaners, Primers and Sealers: Type recommended by glazing material manufacturer.

**2.03 MISCELLANEOUS:**

A. Safety Marking Decals: Opaque decals, 4 inch diameter, color as selected by the Architect from manufacturer's standard colors.

**PART THREE - EXECUTION**

**3.01 PREPARATION:**

A. Clean the glazing channel, or other framing members to receive glass, immediately before glazing. Remove coatings which are not firmly bonded to the substrate. Remove lacquer from metal surfaces wherever elastomeric sealants are used.

B. Inspect each piece of glass immediately before installation, and eliminate pieces which have observable damage or face imperfections.

C. Apply primer or sealer to joint surfaces wherever recommended by sealant manufacturer.

**3.02 INSTALLATION:**

A. Each installation shall withstand normal temperature changes, wind loading, and impact loading (for operating sash and doors) without failure of any kind including loss or breakage of glass, failure of sealants or gaskets to remain watertight and airtight, deterioration of glazing materials and other defects in the Work.

B. Install glass in accordance with the standards detailed in the "Glazing Manual" of the Glass Association of North America and the "Sealant Manual" of the Flat Glass Marketing Association except as shown and specified otherwise, and except as specifically recommended otherwise by the manufacturers of the glass and glazing materials.

C. Unify appearance of each series of lights by setting each piece to match others as nearly as possible. Inspect each piece and set with pattern, draw and bow oriented in the same direction as other pieces.

D. Install glazing materials in accordance with the manufacturer's printed instructions.

**3.03 GLAZING:**

- A. Install setting blocks of proper size at quarter points of sill rabbet. If required to keep in place set blocks in thin course of the heel-bead compound.
- B. Provide spacers inside and out, and of proper size and spacing, for all glass sizes larger than 50 united inches, except where gaskets are used for glazing. Provide 1/8 inch minimum bite of spacers on glass and use thickness equal to sealant width, except with sealant tape use thickness slightly less than final compressed thickness of tape.
- C. VOIDS and Filler Rods: Prevent exudation of sealant or compound by forming voids or installing filler rods in the channel at the heel of jambs and head (do not leave voids in the sill channels) except as otherwise indicated, depending on light sizes, thickness and type of glass, and complying with manufacturer's recommendations.
- D. Do not cut, seam, nip, or abrade glass which is tempered, heat strengthened, or coated.
- E. Force glazing materials into channel to eliminate voids and to ensure complete "wetting" or bond of glazing material to glass and channel surfaces.
- F. Tool exposed surfaces of glazing sealants and compounds to provide a substantial "wash" away from the glass. Install pressurized tapes and gaskets to protrude slightly out of the channel, so as to eliminate dirt and moisture pockets.
- G. Where wedge-shaped gaskets are driven into one side of the channel to pressurize the sealant or gasket on the opposite side, provide adequate anchorage to ensure that gasket will not "walk" out when subjected to dynamic movement. Anchor gasket to stop with matching ribs, or by proven adhesives, including embedment of gasket tail in cured heel bead.
- H. Gasket Glazing: Miter cut and bond ends together at corners where gaskets are used for channel glazing, so that gaskets will not pull away from corners and result in voids or leaks in the glazing system.

**3.04 CURE, PROTECTION AND CLEANING:**

- A. Cure glazing materials in accordance with manufacturer's printed instructions and recommendations, to obtain high early bond strength, internal cohesive strength, and surface durability.
- B. Mark glazed openings immediately upon installation of glass by attaching crossed streamers to framing. Do not apply markers of any type to surfaces of glass.

- C. Replace glass included in the work which is broken, or otherwise damaged, from the time Work is started at the site until the date of physical completion.
- D. Maintain glass in a reasonably clean condition until date of physical completion.
  - 1. Clean and trim excess glazing material from the glass and stops or frames promptly after installation.
- E. When directed, or just before the project is turned over to the State, remove dirt and other foreign material and wash and polish glass included in the work on both sides.

**3.05 MARKING DECALS:**

- A. Install two marking decals on each transparent glass door, and on each transparent glass sidelight which is wider than 20 inch between stiles. Locate decals midway between stiles 34 inch and 64 inch above the floor line.

**END OF SECTION**

**SECTION 09 21 16 - GYPSUM BOARD SYSTEMS**

**PART ONE - GENERAL**

**1.01 DEFINITIONS:**

- A. Gypsum Board Terminology: ASTM C 11 - Standard Terminology Relating to Gypsum and Related Building Materials and Systems.

**1.02 SUBMITTALS:**

- A. Product Data: Catalog sheets, specifications, and installation instructions for each item specified.

**1.03 DELIVERY, STORAGE AND HANDLING:**

- A. Deliver materials in original packages, containers, or bundles bearing brand name and identification of manufacturer.
- B. Store materials inside under cover and keep them dry and protected against damage from weather, direct sunlight, surface contamination, corrosion, construction traffic, and other causes. Stack gypsum panels flat to prevent sagging.

**1.04 PROJECT CONDITIONS:**

- A. Environmental Requirements: Comply with gypsum board manufacturer's printed temperature and ventilation requirements during application and finishing. Ventilate installation areas to relieve excess moisture.

**PART TWO - PRODUCTS**

**2.01 FRAMING:**

- A. Studs, Tracks, and Furring: ASTM C 645; 25 gage (minimum base metal thickness 0.0179 inch) galvanized steel, with additional framing members, reinforcing, accessories, and anchors necessary for the complete framing system.

**2.02 GYPSUM BOARD:**

- A. Standard Gypsum Board: ASTM C 1396; long edges as follows:
  - 1. Long Edges: Tapered.

**2.03 FASTENERS:**

- A. Steel Drill Screws: ASTM C 1002; gypsum board manufacturer's recommended types and sizes for substrates involved.
- B. Laminating Adhesive: Gypsum board manufacturer's recommended type for substrates involved.
- C. Expansion Anchors: Anchor bodies AISI 1018 or 12L14, of dimensions indicated; with nuts, ASTM A 563; and flat washers. Expansion sleeves AISI 1010, of dimensions indicated; with bolts, SAE Grade 5; and flat washers.
- D. Toggle Bolts: Tumble wing type.
  - 1. Wing Body: AISI 1008-1010 or equivalent cold rolled steel.
  - 2. Trunnion Nut: 1/4 inch thru 3/8 inch AISI 1010 steel; 1/2 inch Zamac alloy.
  - 3. Screw: Carbon steel.
- E. Self Threading Masonry Screws: Zinc plated; Tapcon Fasteners by ITW Buildex 1349 West Bryn Mawr Ave. Itasca, IL 60143, (800) 284-5339.

**2.04 TRIM:**

- A. Interior Trim: ASTM C 1047.
  - 1. Material: Galvanized steel or extruded vinyl.
  - 2. Shapes:
    - a. Cornerbead: Use at outside corners.
    - b. Bullnose Bead: Use where indicated.
    - c. LC-Bead: J-Shaped, exposed long flange receives joint compound. Use at exposed panel edges.
    - d. L-Bead: L-shaped, exposed long leg receives joint compound with tear away bead. Use where gypsum board abuts or intersects dissimilar material.
    - e. U-Bead: J-shaped, exposed short flange does not receive joint compound. Use where indicated.
    - f. Expansion (Control) Joint: Use where indicated.

**2.05 ACCESSORIES:**

- A. Sound Attenuation Blankets: ASTM C 665, Type 1; semi-rigid, mineral fiber blankets without membrane covering. Furnish blankets of thickness, density, and type tested by the gypsum board manufacturer for the required rating.

- B. Acoustical Sealant for Exposed and Concealed Joints: Nonsag, paintable, nonstaining, latex sealant complying with ASTM C 834 that effectively reduces airborne sound transmission through perimeter joints and openings in building construction as demonstrated by testing representative assemblies according to ASTM E 90.
- C. Acoustical Sealant for Concealed Joints: Non drying, nonhardening, nonskinning, nonstaining, gunnable, synthetic-rubber sealant recommended for sealing interior concealed joints to reduce airborne sound transmission.

**2.06 JOINT TREATMENT MATERIALS:**

- A. Joint Tapes: ASTM C 475; plain or perforated.
- B. Joint Compound: ASTM C 475; gypsum board manufacturer's recommended dry powder or ready-mixed, either of the following:
  - 1. One Compound Treatment: One compound for both bedding and finishing joints.
  - 2. Two Compound Treatment: Compatible joint compounds; one compound for bedding and the other compound for finishing joints.

**PART THREE - EXECUTION**

**3.01 EXAMINATION:**

- A. Examine substrates to which gypsum board system attaches or abuts, preset steel door frames, cast in anchors, and structural framing, with installer present for compliance with requirements for installation tolerances and other conditions affecting performance of gypsum board system construction. Do not proceed with installation until unsatisfactory conditions have been corrected.

**3.02 CONSTRUCTION TOLERANCES:**

- A. Do not exceed 1/8 inch in 8 feet variation from plumb or level in any exposed line or surface, except at joints between boards do not exceed 1/16 inch variation between planes or abutting edges or ends. Shim as required to comply with specified tolerances.

**3.03 STEEL FRAMING INSTALLATION:**

- A. Installation Standards: ASTM C 754, and ASTM C 840 requirements that apply to framing installation.



- B. Install supplementary framing, blocking, and bracing at terminations in gypsum board system to support fixtures, equipment services, heavy trim, grab bars, toilet accessories, furnishings, or similar construction. Comply with details indicated and with gypsum board manufacturer's written recommendations.
- C. Isolate partitions from structural elements with slip or cushion-type joints between steel framing and structure as recommended by steel framing manufacturer to prevent transfer of structural loads or movements to partitions.
- D. Partition Framing Installation:
1. Align tracks accurately at floor and ceiling. Secure tracks as recommended by the framing manufacturer for the floor and ceiling construction involved, except do not exceed 24 inches oc spacing for powder-driven fasteners, or 16 inches oc for other types of attachment. Provide fasteners approximately 2 inches from corners and ends of tracks.
  2. Position studs vertically and engage both floor and ceiling tracks. Install studs so flanges point in the same direction and leading edge or end of each panel can be attached to open (unsupported) edge of stud flanges first. Space studs 16 inches on center, unless otherwise indicated on the Drawings. Fasten studs to track flanges with screws or by crimping.
  3. Use full length studs between tracks wherever possible. If necessary, splice studs with a minimum 8 inch nested lap and fasten with two screws per stud flange.
  4. Install additional studs to support inside corners at partition intersections and corners, and to support outside corners, terminations of partitions, and both sides of control joints (if any).
  5. Extend partition framing full height to structural supports or substrates above suspended ceilings, except where partitions are indicated to terminate at suspended ceilings. Continue framing over frames for doors and openings and frame around ducts penetrating partitions above ceiling to provide support for gypsum board.
  6. Brace chase wall framing horizontally to opposite studs with 12 inch wide gypsum board gussets or metal framing braces, spaced vertically not more than 4 feet on center.
    - a. Attach gypsum board gussets with a minimum 3 screws per stud flange.
    - b. Attach metal framing braces with a minimum 2 screws per stud flange.
  7. Install rough framing at openings consisting of full-length studs adjacent to jambs and horizontal header and sill tracks. Cut horizontal tracks to length and split flanges and bend webs at ends for flange overlap and screw to jamb studs. Install intermediate studs between jamb studs at head and sill sections, at same spacing as full-length studs.

8. At door frames, install rough framing as specified above. Install jamb studs to comply with framing manufacturer's recommendations for the types of frames and weights of doors required. Fasten jamb studs to metal frames with anchor clips using 2 self tapping screws or bolts per clip. Where wood frames are shown, fasten jamb studs to rough framing with screws.
9. Where solid core wood doors, double doors, or doors weighing more than 50 lb are indicated or scheduled, install two studs at each jamb and one additional stud not more than 6 inches from jamb studs.

**3.05 ACOUSTICAL ACCESSORIES INSTALLATION:**

- A. Sound Attenuation Blankets: Install in partitions tight within spaces, around cut openings, behind and around electrical and mechanical items within or behind partitions, and tight to items passing through partitions.
- B. Acoustical Sealant: ASTM C 919; install continuous bead of acoustical sealant at gypsum board perimeter. Seal wherever gypsum board abuts dissimilar materials. Seal spaces between gypsum board and all penetrating items. Seal sides and backs of electrical and mechanical items.

**3.06 GYPSUM BOARD INSTALLATION:**

- A. Install gypsum board in the most economical direction, of maximum lengths to minimize end butt joints. Where unavoidable, locate end butt joints as far from center of walls or ceilings as possible.
- B. Install gypsum board with face side out. Butt boards together at edges and ends over firm bearing with not more than 1/16 inch of open space between boards. Do not force into place.
- C. Fasteners: Fasten gypsum board to supports and furring with steel drill screws of required size and spacing as recommended by the gypsum board manufacturer.
- D. Provide additional framing and blocking required to support gypsum board at openings and cutouts.
- E. Wood Supports: Provide "floating" interior angle construction between gypsum board at interior corners.
- F. Reinforce joints formed by tapered edges, butt edges, and interior corners or angles with joint tape.

**3.07 TRIM INSTALLATION:**

- A. Coordinate installation of trim progressively with gypsum board installation where trim is of type required to be installed prior to, or progressively with installation of gypsum board.
- B. Securely fasten trim pieces in accordance with manufacturer's printed instructions.
- C. Install cornerbeads at external corners. Install LC-Bead (J-Bead) beads at unprotected (exposed) edges and where gypsum board abuts dissimilar materials. Use single unjointed lengths unless otherwise approved by the Architect.
- D. Install control joint trim in accordance with ASTM C 840, where indicated.
- E. Comply with joint compound manufacturer's recommended drying time for the relative humidity and temperature at time of application. Allow minimum of 24 hours drying time between applications of joint compound.
- F. Except Type X Gypsum Board: Joint compound treatment is not required on gypsum board surfaces installed above suspended ceiling lines.

**3.08 LEVELS OF GYPSUM BOARD FINISH:**

- A. General: Finish panels to levels indicated below, in accordance with ASTM C 840, for locations indicated.
  - 1. Level 4 Finish: Joints and angles, provide tape embedded in joint compound and provide three separate coats of joint compound over all joints, angles, and fastener heads. Accessories to be covered with three separate coats of joint compound. Joint compounds to be smooth and free of tool marks and ridges. Cover the prepared surface with a drywall primer prior to the application of the final decoration.

**END OF SECTION**

**SECTION 09 53 00 - SUSPENDED ACOUSTICAL CEILING SYSTEMS**

**PART ONE - GENERAL**

**1.01 REFERENCES:**

- A. ASTM C 635 - Metal Suspension Systems for Acoustical Tile and Lay-in Panel Ceilings.
- B. ASTM C 636 - Installation of Metal Ceiling Suspension Systems for Acoustical Tile and Lay-in Panels.
- C. ASTM E 1414 - Standard Test method for Air-born Sound Attenuation Between Rooms Sharing a Common Ceiling Plenum.
- D. ASTM E 1264 - Standard Classification for Acoustical Ceiling Products.
- E. Ceilings and Interior Systems Contractors Association (CISCA) Acoustical Ceilings: Use and Practice.
- F. UL - Fire Resistance Directory and Building Material Directory.

**1.02 SYSTEM DESCRIPTION:**

- A. Suspended Ceiling System consisting of main runners and cross runner tees snapped together to form modules or grids for the installation of lay-in acoustical tiles or panels, air diffusers, and light fixtures.
- B. Structural Performance and Suspension System Types:
  - 1. Type ID/EG: Intermediate duty, direct hung, exposed grid. (Minimum load carrying capability of main runner: 12 lb/lin ft).

**1.03 SUBMITTALS:**

- A. Product Data: Manufacturer's catalog sheets, specifications, and installation instructions for the following:
  - 1. Each suspension system type specified.
  - 2. Acoustical units specified.
  - 3. Integral access units.

- B. Samples:
1. Suspension System Materials: 12 inches long of exposed suspension system, component members, including moldings, for each color and system type required.
  2. Acoustical Units: 12 inches square, each type, pattern, and color specified.
- C. Quality Control Submittals:
1. Certification: Manufacturer's written statement, certifying that the suspension system meets or exceeds the specified structural requirements.
- D. Contract Closeout Submittals:
1. Maintenance Instructions: Two copies of the manufacturer's printed recommendations for cleaning and refinishing the acoustical units. Include precautions regarding materials and methods which may be detrimental to finish and acoustical efficiency.

**1.04 QUALITY ASSURANCE:**

- A. Installers Qualifications: The persons installing the suspended acoustical ceiling system and their supervisor shall be personally experienced in suspended acoustical ceiling installation and shall have been regularly employed by a company installing systems for a minimum of 2 years.

**1.05 DELIVERY, STORAGE, AND HANDLING:**

- A. Deliver acoustical units and suspension system components to the Project Site in original, unopened packages and store them in a fully enclosed space protected against damage from moisture, direct sunlight, surface contamination, and other causes.
- B. Open ends of acoustical unit packages 24 hours before installation to stabilize moisture content and temperature.
- C. Handle acoustical units carefully to avoid chipping edges or damaging units in any way.

**1.06 PROJECT CONDITIONS:**

- A. Environmental Requirements: Comply with acoustical units manufacturer's printed temperature and ventilation requirements before, during, and after installation.
- B. Space Enclosure: Do not install interior acoustical units until space is enclosed and weatherproof, wet work in spaces is completed, and work above ceilings is complete.

**1.07 MAINTENANCE:**

- A. Furnish extra materials described below to match products installed, are packaged with protective covering for storage, and are identified with appropriate labels. Furnish quantities equal to 2 percent of acoustical units and exposed suspension system components installed.

**PART TWO - PRODUCTS**

**2.01 METAL SUSPENSION SYSTEM MATERIALS:**

- A. Provide manufacturer's standard metal suspension systems of types, structural classifications, and finishes indicated that comply with applicable ASTM C 635 requirements.
- B. Recycled Content: Provide products made from steel sheet with average recycled content such that post-consumer recycled content plus one-half of pre-consumer recycled content is not less than 25 percent.
- C. Grid - Type G1: Acceptable manufacturers include Armstrong and USG.
  - 1. Manufacturer: Armstrong  
Product: Silhouette XL 9/16" Bolt-Slot System with 1/4" reveal  
Edge: Provide shadow reveal profile where ceilings meet walls and column covers  
Color: White Factory Finish
  - 2. Manufacturer: USG  
Product: Fineline 9/16" Slotted Grid with 1/4" Reveal.  
Edge: Provide shadow reveal profile where ceilings meet walls and column covers  
Color: White Factory Finish
- D. Accessories:
  - 1. Wall Moldings and Trim: Steel or extruded aluminum of types and profiles indicated, or if not indicated, manufacturer's standard prefinished moldings for edge penetrations that fit type of edge detail and suspension indicated.
- E. Attachment Devices:
  - 1. Wire Hangers, Braces, and Ties: Galvanized carbon steel, soft temper; pre-stretched. Yield stress at least 3 times design load but not less than 12 gage, .106 diameter.

2. Miscellaneous Fasteners: Bolts, screws, and other fasteners recommended by suspension system manufacturer and necessary to install the Work.

**2.02 ACOUSTICAL UNIT MATERIALS:**

- A. Standard for Acoustical Units: Manufacturer's standard units of configuration indicated that comply with ASTM E 1414 and ASTM E 1264.
  1. Noise Reduction Coefficient (NRC): 0.95 or greater.
  2. Light Reflectance Coefficient (LR): 0.90 or greater.
  3. Recycled Content: Provide acoustical panels with recycled content such that postconsumer recycled content plus one-half of pre-consumer content constitutes a minimum of 45-70% by weight.
  
- B. Acoustical Units – Type T1: Acceptable manufacturers include Armstrong and USG.
  1. Manufacturer: Armstrong  
Product: Optima Open Plan 3251  
Size: 24" x 24" x 1"  
Edge: Beveled Tegular  
Pattern: Fine texture  
Color: White
  
  2. Manufacturer: USG  
Product: Halcyon # 98225  
Size: 24" x 24" x 1"  
Edge: FL Edge  
Pattern: Fine texture  
Color: White

**PART THREE - EXECUTION**

**3.01 EXAMINATION:**

- A. Examine substrates and structural framing scheduled to receive the ceiling system for compliance with requirements specified. Do not install the Work until unsatisfactory conditions are corrected.

**3.02 INSTALLATION OF SUSPENSION SYSTEM:**

- A. Install acoustical ceiling suspension system to comply with installation standard ASTM C 636, in accordance with the manufacturer's printed instructions, and CISCA "Ceiling System Handbook".
- B. Lay-out system to a balanced design with edge units no less than 50 percent of acoustical unit size.
- C. Hang suspension system independent of walls, columns, ducts, pipes, and conduit.
- D. Hangers:
  - 1. Attach hangers to supporting construction, spaced 4 feet or maximum and within 6 inches of ends of main beams. Where ducts or other items, including items provided under related contracts (if any), interfere with the spacing of hangers, install trapeze type hangers under the obstructing items to support ceiling hangers.
  - 2. Wrap hanger wire ends a minimum of three times horizontally, forming tight loops and turning ends upward.
  - 3. Do not kink or bend hangers as a means of leveling components.
- E. Attachment of Hangers to Supporting Construction: Unless otherwise shown, secure the hangers to the construction as follows:
  - 1. Attachment to Existing Cast-in-Place Concrete: Attach hangers to clip angles, fastened to the concrete with expansion bolts or drive pins.
  - 2. Attachment to Structural Steel Framing: Clinch hanger around top of flange of steel member approximately 135 degrees. If framing member supports roof planks or precast slabs, bolt hanger to center of web or weld to bottom flange. Where applicable, hanger wires may be directly double wound around steel members with wires twisted together.
  - 3. Attachment to Steel Joists: Secure hanger with special clip or clamp designed for such use. Where applicable, hanger wires may be directly double wound around steel members with wires twisted together.
  - 4. Attachment to Precast Tees, Slabs, and Planks: Insert "T" hangers through joints between the units. Where concrete fill is required, lay out and install hangers prior to placing fill.
  - 5. Attachment to Steel Decks: Secure hangers with welded studs. Locate studs as close to the deck supports as possible. Install studs in accordance with manufacturer's printed instructions. After installation, clean stud welds and repair the affected areas of deck and studs with cold galvanizing compound. Attach hangers to studs with double nuts.



6. Attachment to Wood Framing (Except Trusses): Secure hangers with threaded fasteners.
  7. Attachment to Wood Trusses: Double wind hanger wire around bottom chord member and twist wire together securely.
- F. Suspension System Installation Tolerances:
1. Form right angles at intersections of main and cross runners.
  2. Install main runners level to within 1/8 inch in 12 feet. Install cross runners to within 1/32 inch of the required center distances (non-cumulative beyond 12 feet).
  3. Align vertical distance of exposed surfaces between intersecting runners to within 0.015 inch.
  4. Limit horizontal gaps in exposed surfaces of intersecting or abutting members to within 0.020 inch.
- G. Wall Moldings and Trim: Install moldings and trim of type indicated where ceilings intersect vertical surfaces. Use manufacturer's recommended fasteners suited for secure attachment to the particular substrate.
1. Screw attach moldings to substrate at intervals not over 16 inches oc and not more than 3 inches from ends, leveling with ceiling suspension system to tolerance of 1/8 inch in 12 feet. Miter corners accurately and connect securely.

### **3.03 INSTALLATION OF ACOUSTICAL UNITS:**

- A. Install acoustical units in accordance with the manufacturer's printed instructions, unless otherwise shown or specified.
1. Fit acoustical units in place, free from damaged edges or other defects detrimental to appearance and function.
  2. Install acoustical units level, in uniform plane, and free from twist, warp, and dents.
  3. Scribe and cut acoustical units to fit accurately at borders and at penetrations.
  4. Where tiles are not supported by suspension members, install splines at unsupported joints.
  5. Keep border tiles in compression by inserting spring steel spacers between tiles and moldings. Place one spacer bar at the center of each tile.

**3.04 CLEANING AND ADJUSTING:**

- A. Clean exposed surface of acoustical ceilings, including trim, wall moldings, and suspension members. Comply with manufacturer's printed instructions for cleaning and touch-up of minor finish damage.

**END OF SECTION**



**SECTION 09 65 19 - RESILIENT BASE**

**PART ONE - GENERAL**

**1.01 SUBMITTALS:**

- A. Product Data: Manufacturer's specifications, and surface preparation and installation instructions, for each material specified except primer.
- B. Samples:
  - 1. Base: 12 inch long sections, each type, size, and color required.
- C. Quality Control Submittals:
  - 1. Certificates: Certificates required under Quality Assurance Article.
- D. Contract Closeout Submittals:
  - 1. Maintenance Data: Deliver 2 copies covering the installed products, to the Director's Representative.

**1.02 QUALITY ASSURANCE:**

- A. Compatibility of Materials: For each type of tile specified, furnish associated materials made by or recommended by the tile manufacturer.
- B. Certifications: Furnish certification from flooring installer that the substrate surfaces have been examined and are acceptable for installation of the Work of this Section.
- C. Performance Criteria:
  - 1. The following criteria are required for products included in this section:
    - a. Adhesives must not exceed the volatile organic compound (VOC) content limits established in South Coast Air Quality Management District (SCAQMD) Rule 1168.

**1.03 PROJECT CONDITIONS:**

- A. Environmental Requirements: Make arrangements thru the Director's Representative for having the temperature in the spaces to receive flooring maintained at 68 degrees F for 48 hours prior to flooring installation, during the installation, and for 48 hours after installation.
- B. Condition flooring materials by placing them in the spaces where they will be installed for at least 48 hours prior to installation.

**PART TWO - PRODUCTS**

**2.01 MATERIALS:**

- A. Vinyl Base:
  - 1. Reference drawings for specification.  
Style: Straight wall base without cove with matching preformed external corner units.  
Adhesive and Filler/Wall Patch: As recommended by the base manufacturer for the type of substrate indicated.
- B. Resilient Edge Strips: Homogeneous vinyl; not less than one inch wide, 1/8 inch gage; tapered bullnose edge.
- C. Vinyl Stair Nosings:
  - 1. Reference drawings for specifications.

**PART THREE - EXECUTION**

**3.01 EXAMINATION:**

- A. Verification of Conditions:
  - 1. Examine substrate surfaces to receive the Work of this Section for defects that will adversely affect the execution and quality of the Work. Do not proceed until unsatisfactory conditions are corrected, and installer's substrate surface acceptability certification has been acknowledged by the Director's Representative.
    - a. Concrete Subfloor Bond Tests: Check for surface moisture and coatings on concrete subfloor by bond tests as recommended by the tile manufacturer.
  - 2. Do not install the Work of this Section until after all other finishing operations, including painting, have been completed unless otherwise indicated or directed by the Director's Representative.
    - a. Where movable partitions are indicated, install flooring before partitions are erected without interrupting floor pattern.

**3.02 SURFACE PREPARATION:**

- A. Unless otherwise specified, follow the materials manufacturers' written instructions.

- B. Remove dirt, grease, oil, paint, varnish, wax, sealers, and other contaminants which may impair the full bonding of the materials.

**3.03 INSTALLATION:**

- A. Install resilient base in compliance with manufacturer's printed instructions. Install base on walls, partitions, columns, and permanent fixtures unless otherwise indicated. Install base in as long lengths as practicable, with preformed external corner units. Miter internal corners. Scribe and fit base to door frames and other interruptions.
  - 1. On masonry and other irregular surfaces, fill voids behind base with filler/wall patch.

**3.04 CLEANING:**

- A. Remove any excess adhesive and other surface soiling from face of installed materials with cleaning agents recommended by the manufacturer of the material being cleaned.

**3.05 PROTECTION:**

- A. Protect installed flooring from traffic and damage. Apply non-staining kraft paper covering where necessary. Maintain covering until directed to remove it by the Director's Representative.

**END OF SECTION**



**SECTION 09 68 13 – TILE CARPETING**

**PART ONE - GENERAL**

**1.01 REFERENCES:**

- A. AATCC - The American Association of Textile Chemists and Colorists, Research Triangle Park, NC 27709, www.aatcc.org.
- B. CRI – Carpet and Rug Institute, Dalton, GA 30722-2048, www.carpet-rug.com.

**1.02 SUBMITTALS:**

- A. Shop Drawings: Show dimensions of carpeted areas, locations of edges, columns, doorways, enclosing partitions, built-in furniture, cabinets, cutouts edge strips, and other installation details. Show details of special patterns.
- B. Product Data: Catalog sheets, specifications, and installation instructions for the following:
  - 1. Tile Carpeting:
    - a. Trade name and number.
    - b. Manufacturer.
    - c. Address of mill constructing carpet.
    - d. Construction type.
    - e. Gage.
    - f. Stitches per inch.
    - g. Pile height.
    - h. Face yarn.
    - i. Face yarn weight.
    - j. Weight density factor.
    - k. Primary backing.
    - l. Secondary backing.
    - m. Total weight.
    - n. Dye method.
    - o. Tuft bind.
    - p. Static resistance.
    - q. Flammability.
  - 2. Edge strips.
  - 3. Adhesive.
- C. Samples:
  - 1. Tile Carpeting: Full size piece of each type, color, and pattern specified.
  - 2. Edge Strip: 12 inches long, each type specified.



3. Color Samples: Manufacturer's standard color samples of each type and pattern specified.
- D. Quality Control Submittals:
1. Certificates: Affidavits required under Quality Assurance Article.
- E. Contract Closeout Submittals:
1. Maintenance and Cleaning Instructions: Furnish 2 copies to the Owner's Representative.
  2. Warranty: Copy of specified warranty.

**1.02 QUALITY ASSURANCE:**

- A. Flammability Certification:
1. Radiant Panel Flooring Flammability Test: NFPA 253. Class I, Minimum 0.45 watts per sq centimeter.
  2. Methenamine Tablet Test: DOC-FF-1-70 and ASTM D 2859. Meet the "Standards for the Surface Flammability of Carpets".
  3. Smoke Density Test: NFPA 258 and ASTM E 662. Specific optical density (DM) of 450 or less (flaming).
- B. Colorfastness to Light: AATCC 16, Option E. Minimum rating of 4 on grey scale after 80 hours exposure.
- C. Colorfastness to Crocking: AATCC 165. Minimum rating of 4 wet and dry.
- D. Appearance Retention Rating: ASTM D 5252. CRI TM-101 "Severe" rating.
- E. Stain Resistance: AATCC 175. Rating of 8 or better.
- F. Static Resistance: AATCC 134. 3.5 kv or less, at 70 degrees F and 20 percent RH.
- G. Tuft Bind: ASTM D 1335. Average pounds of force not less than 12 pounds.
- H. Dimensional Stability: Aachen Method DIN 54318, 0.2 percent or less.
- I. Installer Qualifications: The persons installing the tile carpeting and their Supervisor shall be experienced in carpeting installation, including the requirements of the tile carpeting manufacturer, and shall have been regularly employed by a company engaged in installation of carpeting for a minimum of 5 years.

- J. Certifications: Furnish certification from tile carpeting installer that the substrate surfaces have been examined and are acceptable for installation of the Work of this Section.
- K. Performance Criteria:
  - 1. The following criteria are REQUIRED for products included in this section:
    - a. All carpet installed in the building interior must meet the testing and product requirements of the Carpet and Rug Institute Green label Plus program.
    - b. All carpet products shall be certified to meet the NSF/ANSI 140-2007 Standard, Platinum level.
    - c. All carpet cushion installed in the building interior must meet the requirements of the Carpet and Rug Institute Green Label program.

**1.03 DELIVERY, STORAGE AND HANDLING:**

- A. Deliver tile carpeting in original carpet mill packaging with each package having labels legible and intact.
- B. Store tile carpeting and related materials in an enclosed and dry area protected from damage and soiling.

**1.04 PROJECT CONDITIONS:**

- A. Environmental Requirements: Make arrangements thru the Owner's Representative for having the temperature in the spaces to receive tile carpeting maintained at 68 degrees F for 48 hours prior to flooring installation, during the installation, and for 72 hours after installation.
- B. Do not install the Work of this Section over concrete substrate until concrete has cured 30 days minimum.
- C. Do not install the Work of this Section until painting, finishing Work, and Work of other trades has been completed.

**1.05 WARRANTY:**

- A. Manufacturer's Warranty: Minimum 15 year wear warranty.

**1.06 EXTRA MATERIALS:**

- A. Furnish extra materials that match products installed and that are packaged with protective covering for storage and identified with labels describing contents.
  - 1. Tile Carpeting: Full size units equal to 5 percent of amount installed, but not less than 10 square yards for each color, pattern and type of tile carpeting installed.

**PART TWO - PRODUCTS**

**2.01 CARPETING MANUFACTURERS:**

- A. Mannington Mills, Inc, Calhoun, GA 30703, (800) 241-2262 [www.mannington.com](http://www.mannington.com)
- B. Shaw Industries, Inc, Dalton, GA 30722 (877) 502-7429, [www.shawcontractgroup.com](http://www.shawcontractgroup.com)

**2.02 MATERIALS:**

- A. Type A Tile Carpeting: Tufted, Textured Loop Pile (Brick Pattern):
  - 1. Fiber Type: Eco Solution Nylon.
  - 2. Minimum Face Yarn Weight: 20 oz.
  - 3. Maximum Pile Height (inches): .156.
  - 4. Minimum Pile Thickness (inches): .130.
  - 5. Minimum Stitches per Inch: 8.3.
  - 6. Minimum Gage: 1/8.
  - 7. Minimum Density: 5000.
  - 8. Dye Method: Yarn Dyed, Injection Dyed, or Solution Dyed.
  - 9. Backing System: Manufacturer's standard vinyl or thermoplastic hard-backing or integral-cushion thermoplastic backing system, recyclable content, maintaining a 100 percent moisture barrier between secondary backing and the floor substrate. Pre-adhered backing system may be used as an alternate without an applied releasable adhesive to surface substrate.
  - 10. Size: 24 x 24 inches.
  - 11. LEED Building Criteria:
    - a. Sustainability: Recyclable back to tile carpeting manufacturer's designated facility for re-manufacturing processing at end of its useful life, with third party certification.

- B. C1: See drawings for specification.
- C. C2 – Walkoff Tile: See drawings for specification.
- D. Resilient Edge Strips: Not less than one inch wide, tapered bullnose edge, thickness and color as selected.
- E. Metal Edge Strips: Extruded aluminum, mill finish; butt type for concealed anchorage; countersunk stainless steel fasteners, with anchors suitable for substrate surface.
- F. Trowelable Leveling and Patching Compounds: Latex-modified Portland cement based or blended hydraulic-cement-based formulation provided or approved by tile carpeting manufacturer for application on substrate surface and grade level.
- G. Adhesives: Tile carpeting manufacturer's recommended water resistant materials formulated for application on substrate surface and grade level.
- H. Cleaning Solvents: Low toxicity, and a flash point in excess of 100 degrees F.

**PART THREE - EXECUTION**

**3.01 EXAMINATION:**

- A. Examine surfaces scheduled to receive tile carpeting for defects that will adversely affect the proper installation. Do not proceed until unsatisfactory conditions are corrected.

**3.02 PREPARATION:**

- A. Clean floors of dust, dirt, solvents, oil, grease, loose paint, and other substances. Allow floors to dry thoroughly.
- B. Concrete Floors: Level uneven surfaces and patch cracks and small holes with patching compound.
- C. Wood Floors:
  - 1. Renail loose and cracked boards.
  - 2. Patch cracks and depressions with floor filler.
  - 3. Remove wax using liquid stripper or sander.
  - 4. Seal substrate with wood floor primer.

**3.03 INSTALLATION:**

- A. Install tile carpeting in accordance with CRI 104, Section 14 and with tile carpeting manufacturer's written installation instructions.
  - 1. Maintain dye lot integrity. Do not mix dye lots in the same area.
- B. Cut and fit tile carpeting neatly around projections through floor and to walls and other vertical surfaces. Bind or seal cut edges as recommended by the tile carpeting manufacturer.
- C. Install edge strips where tile carpeting terminates at other floor coverings or finishes. Use one full length piece where possible. Where splicing cannot be avoided, butt ends tight and flush.

**3.04 CLEANING AND PROTECTION:**

- A. Upon completion of the tile carpeting installation, immediately remove spots and smears of excessive adhesive from tile carpeting with cleaning solvent. Remove loose pieces of face yard with sharp scissors.
- B. Place usable remnants of tile carpeting in an area designated by the Director's Representative.
- C. Remove waste materials and tools.
- D. Upon completion, thoroughly vacuum clean carpeted areas.
- E. After each area of tile carpeting has been installed, protect from soiling and damage.
- F. Allow glue-down installation a minimum of 48 hours to cure before subjecting it to any traffic, moving of furniture, or other heavy equipment.

**END OF SECTION**

**SECTION 09 91 01 - PAINTING**

**PART ONE - GENERAL**

**1.01 DEFINITIONS:**

- A. The word “paint” in this Section refers to substrate cleaners, fillers, sealers, primers, undercoats, enamels and other first, intermediate, last or finish coatings.
- B. The word “primer” in this Section refers to substrate cleaners, fillers, sealers, undercoats, and other first or intermediate coats beneath the last or finish coating.
- C. The words “finish paint” in this Section refers to the last or final coat and previous coats of the same material or product directly beneath the last or final coat.
- D. Finish Paint Systems: Finish paint and primers applied over the same substrate shall be considered a paint system of products manufactured or recommended by the finish coat manufacturer.
  - 1. Finish paint products shall meet or exceed specified minimum physical properties.

**1.02 SUBMITTALS:**

- A. Product Data Sheets: Manufacturer’s published product data sheets describing the following for each finish paint product to be applied:
  - 1. Percent solids by weight and volume, solvent, vehicle, weight per gallon, ASTM D 523 gloss/reflectance angle, recommended wet and dry film thickness, volatile organic compound (VOC) content in lbs./gallon, product use limitations and environmental restrictions, substrate surface preparation methods, directions and precautions for mixing and thinning, recommended application methods, square foot area coverage per gallon, storage instructions, and shelf-life expiration date.
  - 2. Manufacturer’s recommended primer for each finish paint product and substrate to be painted.
  - 3. Manufacturer’s complete range of available colors for each finish paint product to be applied.
- B. Finish Paint Type Samples: Two finish paint samples applied over recommended primers for each substrate to be painted.
  - 1. Samples shall be in the designated color and specified ASTM D 523 reflectance.
  - 2. Label each sample with the following information:
    - a. Project number and Painting Schedule designation describing substrates and locations represented by the sample.

- b. Finish paint and primer manufacturer, product names and numbers, finish paint color and reflectance.
- 3. Leave a 1 inch wide exposed strip of unpainted substrate and each coat of primer and finish paint.
- 4. Sample Sizes:
  - a. Wall, Ceiling, and Floor Substrates: 12 inch square panels.
  - b. Concrete and Concrete Masonry Unit Substrates: 4 inch square blocks.
  - c. Sheet Metals: 4 inch by 8 inch flat sheets.
  - d. Bar and Tubular Metals: 8 inch long bars or tubular stock.
- C. Quality Control Submittals:
  - 1. Test Reports: Furnish certified test results from an independent testing laboratory, showing that products submitted comply with the specifications, when requested by the Director's Representative
  - 2. Certificates: Furnish certificates of compliance required under QUALITY ASSURANCE Article.

**1.03 QUALITY ASSURANCE:**

- A. Container Labels: Label each product container with paint manufacturer's name, product name and number, color name and number, thinning and application instructions, date of manufacture, shelf-life expiration date, required surface preparations, recommended coverage per gallon, wet and dry film thickness, drying time, and clean up procedures.
- B. Compatibility of Paint Materials: Primers and intermediate paints shall be products manufactured or recommended by the finish paint manufacturer.

**1.04 DELIVERY, STORAGE, AND HANDLING:**

- A. Delivery: Deliver materials to the Site in original, unopened containers and cartons bearing manufacturer's printed labels. Do not deliver products which have exceeded their shelf life, are in open or damaged containers or cartons, or are not properly labeled as specified.
- B. Storage and Handling: Store products in a dry, well ventilated area in accordance with manufacturer's published product data sheets. Storage location shall have an ambient air temperature between 45 degrees F and 90 degrees F.

**1.05 PROJECT CONDITIONS:**

- A. Environmental Requirements:
1. Ambient Air Temperature, Relative Humidity, Ventilation, and Surface Temperature: Comply with paint manufacturer's published product data sheet or other printed product instructions.
  2. If paint manufacturer does not provide environmental requirements, use the following:
    - a. Ambient Air Temperature: Between 45 degrees F and .75 degrees F.
    - b. Relative Humidity: Below 75 percent.
    - c. Ventilation: Maintain the painting environment free from fumes and odors throughout the Work of this Section.
    - d. Surface Temperature: At least 5 degrees F above the surface dew point temperature.
  3. Maintain environmental requirements throughout the drying period.
- B. The following items are not to be painted unless otherwise specified, noted or directed:
1. Exposed stainless steel, chrome, copper, bronze, brass, and aluminum.
  2. Steel to be encased in cast-in-place concrete.
  3. Top flanges of structural beams and girders in composite concrete-steel construction.
  4. Factory prefinished items.
  5. Exposed structural wood floor joists, subflooring, rafters, roof sheathing and other framing lumber.
  6. Galvanized items not exposed in finished spaces.

**1.06 EXTRA MATERIALS:**

- A. Provide extra finish paint materials, from the same production run as paints to be applied, in the following quantities for each color installed:
1. Four gallons each type.

**PART TWO - PRODUCTS**

**2.01 PAINT MANUFACTURERS:**

- A. Where noted, the following finish paint manufacturers produce the paint types specified.
1. Ameron Protective Coatings, 201 Berry St., Brea, CA 92621, (800) 926-3766.
  2. Benjamin Moore and Co., 51 Chestnut Ridge Rd., Montvale, NJ 07645, (201) 573-9600.
  3. ICI Dulux Paints, 4000 Dupont Cr., Louisville, KY 40207, (800) 984-5444.
  4. Inorganic Coatings, Inc., 500 Lapp Rd., Malvern, PA 19355 (800) 345-0531.



5. PPG Architectural Finishes, One PPG Plaza, Pittsburgh, PA 15272, (800) 441-9695.
6. Sherwin-Williams Co., Cleveland, OH 44101, (800) 321-8194.
7. Valspar Corp., 1401 Severn St., Baltimore, MD 21230, (800) 638-7756.
8. Wm. Zinsser & Co., 39 Belmont Dr., Somerset, NJ 08875-1285, (908) 469-8100.

**2.02 MISCELLANEOUS PRODUCTS:**

- A. Bedding Compound: Water based pre-mixed gypsum wallboard joint compound.
- B. Cleaning Solvents: Low toxicity with flash point in excess of 100 degrees F.
- C. Masking Tape: Removable paper or fiber tape, self-adhesive and non-staining.
- D. Metal Filler: Polyester resin base autobody filler.
- E. Mineral Spirits: Low odor type recommended by finish paint manufacturer.
- F. Paint Stripper: As recommended by finish paint manufacturer.
- G. Spackling Compound: Water based pre-mixed plaster and gypsum wallboard finishing compound.
- H. Stain Blocker, Primer-Sealer: As recommended by finish paint manufacturer.
- I. Turpentine: ASTM D 13.

**2.03 FINISH PAINT TYPES:**

- A. Physical Properties:
  1. Specified percent solids by weight and volume, pigment by weight, wet and dry film thickness per coat, and weight per gallon are minimum physical properties of acceptable materials.
    - a. Opaque Pigmented Paints: Physical properties specified are for white titanium dioxide base before color pigments are added.
    - b. Specified minimum wet and dry film thickness per coat are for determining acceptable finish paint products. Minimum wet and dry film thickness per coat to be applied shall comply with approved finish paint manufacturer's product data sheets.
  2. Gloss or Reflectance: The following ASTM D 523 specified light levels and angles of reflectance:
    - a. Flat: Below 15 at 85 degrees.
    - b. Eggshell: Between 5 and 20 at 60 degrees.

PROBATE COURT  
ADMINISTRATION  
INTERIOR RENOVATIONS  
186 NEWINGTON ROAD  
WEST HARTFORD, CONNECTICUT

- c. Satin: Between 15 and 35 at 60 degrees.
- d. Semigloss: Between 30 and 65 at 60 degrees.
- e. Gloss: Over 65 at 60 degrees.

B. Exterior Finish Paint Types:

- 1. Paint Type EAL-2: Exterior Acrylic Latex, Semigloss Enamel.
  - a. Solids by Weight: 47.0 percent.
  - b. Solids by Volume: 33.2 percent.
  - c. Solvent: Water.
  - d. Vehicle: 100 percent acrylic resin.
  - e. Weight Per Gallon: 10.0 lbs.
  - f. Wet Film Thickness: 4.0 mils.
  - g. Dry Film Thickness: 1.3 mils.
  - h. Manufacturers: ICI Dulux, PPG, Sherwin-Williams.
- 2. Paint Type ESP: Exterior Steel Zinc-Rich Primer, Flat.
  - a. Solids by Weight: 79.0 percent.
  - b. Solids by Volume: 68.0 percent.
  - c. Pigment by Weight: 90.0 percent zinc.
  - d. Solvent: Water.
  - e. Weight per Gallon: 24.6 lbs.
  - f. Dry Film Thickness: 3.0 mils if finish coated, 4.0 mils if not finish coated.
  - g. Manufacturers: Ameron Protective Coatings, Inorganic Coatings, Valspar.

C. Interior Finish Paint Types:

- 1. Interior Acrylic Latex, Flat.
  - a. Solids by Weight: 50.0 percent.
  - b. Solids by Volume: 32.0 percent.
  - c. Solvent: Water.
  - d. Vehicle: Vinyl acrylic resin.
  - e. Weight Per Gallon: 10.9 lbs.
  - f. Wet Film Thickness: 3.8 mils.
  - g. Dry Film Thickness: 1.3 mils.
  - h. Apply where directed in on-drawing finish schedule.
- 2. Interior Acrylic Latex, Eggshell.
  - a. Solids by Weight: 51.0 percent.
  - b. Solids by Volume: 35.0 percent.
  - c. Solvent: Water.
  - d. Vehicle: Vinyl acrylic resin.
  - e. Weight Per Gallon: 11.0 lbs.
  - f. Wet Film Thickness: 3.8 mils.
  - g. Dry Film Thickness: 1.3 mils.
  - h. Apply where directed in on-drawing finish schedule.

3. Interior Acrylic Latex, Semigloss Enamel.
  - a. Solids by Weight: 49.0 percent.
  - b. Solids by Volume: 35.0 percent.
  - c. Solvent: Water.
  - d. Vehicle: Vinyl acrylic resin.
  - e. Weight Per Gallon: 10.0 lbs.
  - f. Wet Film Thickness: 3.8 mils.
  - g. Dry Film Thickness: 1.2 mils.
  - h. Apply where directed in on-drawing finish schedule.
  
- D. Colors: Provide paint colors either shown on contract drawings or to be selected by the Owner from finish paint manufacturers' available color selections.
  1. Approved finish paint manufacturers to match designated colors of other manufacturers where colors are shown on contract documents.

**PART THREE - EXECUTION**

**3.01 EXAMINATION:**

- A. Examine surfaces to be prepared, primed, or painted for compliance with contract documents, required environmental conditions, manufacturer's product data sheets, product label instructions and other written requirements.
  1. Do not begin any phase of the work without first checking and verifying that surfaces and environmental conditions are acceptable for such work and that any earlier phase deficiencies and discrepancies have been properly corrected.
    - a. The commencement of new work shall be interpreted to mean acceptance of surfaces to be affected.

**3.02 PREPARATION:**

- A. Protection: Cover and protect surfaces to be painted, adjacent surfaces not to be painted, and removed furnishings and equipment from existing paint removals, airborne sanding particles, cleaning fluids and paint spills using suitable drop cloths, barriers and other protective devices.
  1. Adjacent exterior surface protections include roofs, walls, landscaping, driveways and walkways. Interior protections include floors, walls, furniture, furnishings and electronic equipment.
  2. Remove and replace removable hardware, lighting fixtures, telephone equipment, other devices and cover plates over concealed openings in substrates to be painted.
    - a. Cover and neatly mask permanently installed hardware, lighting fixtures, cover plates and other devices which cannot be removed and are not scheduled for painting.

3. Schedule and coordinate surface preparations so as not to interfere with work of other trades or allow airborne sanding dust particle to fall on freshly painted surfaces.
  4. Provide adequate natural or mechanical ventilation to allow surfaces to be prepared and painted in accordance with product manufacturer's instructions and applicable regulations.
  5. Provide and maintain "Wet Paint" signs, temporary barriers and other protective devices necessary to protect prepared and freshly painted surfaces from damages until Work has been accepted.
- B. Clean and prepare surfaces to be painted in accordance with specifications, paint manufacturer's approved product data sheets and printed label instructions. In the event of conflicting instructions or directions, the more stringent requirements shall apply.
1. Cleaners: Use only approved products manufactured or recommended by finish paint manufacturer. Unless otherwise recommended by cleaner manufacturer, thoroughly rinse with clean water to remove surface contaminants and cleaner residue.
- C. Surfaces:
1. Existing Exterior Painted Surfaces: Thoroughly clean to remove dirt, soot, grease, mildew, chalkiness and stains using finish paint manufacturer's recommended spray-on liquid cleaner.  
to be applied and rinsed or removed in accordance with product manufacturer's
  2. Existing Steel Doors and Frames:
    - a. Prepare existing steel to be painted by cleaning in accordance with Structural Steel Painting Council (SSPC) standards:
      - 1) SSPC-SP2: Remove loose rust, mill scale, and paint to the degree specified by hand chipping, scraping, sanding, and wire-brushing.
      - 2) Fill indentations and cracks with metal filler; sand smooth to match adjacent undamaged surfaces.
  3. Wood:
    - a. Remove surface dirt, stains, markings, discolorations and other contaminants using finish paint manufacturer's recommended cleaning methods and solvents.
    - b. Sand raised grain, rough saw cut edges, planed mill glaze, old paint, and other surface imperfections clean and smooth using medium and fine sandpaper. Sand in the direction of grain.
    - c. Fill open cracks, knot holes, countersunk fastener holes and other surface indentations with wood filler putty. Sand putty smooth and flush to adjacent unfilled surface.

- d. Seal knots, pitch streaks, sap spots, stains and graffiti with finish paint manufacturer's recommended primer/sealer.
- 4. Plaster, Cement Plaster, and Gypsum Wallboard:
  - a. Fill cracks, holes, and other indentations smooth to adjacent surfaces using specified bedding, spackling, and finishing compounds.
  - b. Plaster: Scrape and sand smooth ridges, spills, nibs, and other surface projections.
  - c. Cement Plaster: Coat surfaces to be patched with a bonding agent. Patch cement plaster with an approved mortar patching mix and finish to match adjacent surface and texture.
  - d. Gypsum Wallboard: Fill and sand smooth minor bedding and finishing compound defects.
  - e. Vacuum and wipe surfaces free of all sanding residue and dust
- 5. Glazing Repairs: Cut out and replace dry, loose, and cracked glazing compound or putty.
- 6. Other Substrates: See finish paint manufacturer's recommendations.

D. Painting Material Preparations:

- 1. Prepare painting materials in accordance with manufacturer's approved product data sheets and printed label instructions.
  - a. Stir materials before and during application for a consistent mixture of density. Remove container surface paint films before stirring and mixing.
  - b. Slightly tint first opaque finish coat where primer and finish coats are the same color.
  - c. Do not thin paints unless allowed and directed to do so in writing within limits stated on approved product data sheets.

**3.03 APPLICATION:**

A. Environmental Conditions:

- 1. Water-based Paints: Apply when surface temperatures will be 50 degrees Fahrenheit to 90 degrees Fahrenheit throughout the drying period.
- 2. Other Paints: Apply when surface temperatures will be 45 degrees Fahrenheit to 95 degrees Fahrenheit throughout the drying period.
- 3. Apply exterior paints during daylight hours free from rain, snow, fog and mist when ambient air conditions are more than 5 degrees above the surface dewpoint temperature and relative humidity less than 85 percent.
  - a. When exterior painting is allowed or required during nondaylight hours, provide portable outdoor weather recording station with constant printout showing hourly to diurnal air temperature, humidity, and dewpoint temperature.

4. Exterior Cold Weather Protection: Provide heated enclosures necessary to maintain specified temperature and relative humidity conditions during paint application and drying periods.
- B. Install approved paints where specified, or shown on the drawings, and to match approved field examples.
1. Paint Applicators: Brushes, rollers or spray equipment recommended by the paint manufacturer and appropriate for the location and surface area to be painted.
    - a. Approved minimum wet and dry film thicknesses shall be the same for different application methods and substrates.
- C. Paint Type Coats To Be Applied: Refer to on-drawing finish schedule for additional direction. Unless specified otherwise by finish paint manufacturer's product data sheet, the number of coats to be applied for each paint type are as follows:
1. Interior Paint:
    - a. New Unpainted Surfaces: Apply 1 coat of primer and 2 coats of finish paint.
    - b. Existing Painted Surfaces:
      - 1) Apply 2 coats of finish paint when existing paint has a lower gloss.
      - 2) Apply one coat of primer and 2 finish coats when existing paint has a higher gloss.
    - c. Provide mildewcide additive for bathrooms, kitchens, janitor closets, laundry rooms, restrooms and other wet or damp areas.
- D. Surfaces: Unless otherwise specified or shown on the drawings, paint surfaces as follows:
1. Interior Surfaces:
    - a. Ceilings: Paint soffits with Type IAL-2.
    - b. Walls: Paint Type IAL-2.
    - c. Doors, Windows, Frames and Trim: Paint Type IAL-3.
    - d. Natural Wood Trim:
      - 1) Tinted Oil Stain with Varnish: Paint Type ITS with Paint Type IPV-2 topcoat.
  2. Unless otherwise noted, paint interior exposed wall and ceiling air supply and return grilles; plumbing pipes; electrical panel and fuse boxes, raceways and conduits; heating convector cabinets, radiators, radiator cabinets, unit heaters, and similar existing and installed devices and equipment by other trades.
    - a. Paint substrates to match adjacent wall or ceiling surfaces.
    - b. Paint exposed surfaces when any part of the surface is on or within 8 inches of ceiling or wall surface to be painted.
    - c. Paint visible interior surfaces behind grilles, guards and screens.

3. Doors and Frames: Unless otherwise noted, paint doors and frames the same color in the next highest gloss as adjacent wall surfaces.
  - a. Where walls are not the same color on both sides of a door frame, change frame color at the inside corner of the frame stop.
  - b. Prime and finish paint door faces and edges before installation.
    - 1) Paint door edges the same paint type color as the exterior side of the door.
  - c. Do not paint door components which are clearly not intended to be painted such as non-ferrous hardware, frame mutes, and weather stripping.
  - d. Do not allow doors and frames to touch until paint is thoroughly dry on both surfaces.
4. Ferrous Metal Door and Window Hardware: Unless otherwise noted, prime and paint to match adjacent doors, windows and frames.
5. Case Work: Paint factory unfinished exposed and semi exposed surfaces when doors and drawers are either open or closed including:
  - a. Both faces and edges of cabinet doors, shelving, dividers including interior side, rear, and bottom panel surfaces.
  - b. Both faces and edges of drawer face, side, rear, and bottom panels.
  - c. Exposed bottom or underside of case work more than 4 feet above the floor.
  - d. Do not paint plastic laminate surfaces, special countertop materials, glazing, factory finished surfaces, finish hardware, and similar items clearly not intended to be painted.

**3.04 FIELD QUALITY CONTROL:**

- A. Paint Samples: Assist the Director's Representative in obtaining random one quart paint samples for testing at any time during the Work.
  1. Notify the Director's Representative upon delivery of paints to the Site.
  2. Furnish new one quart metal paint containers with tight fitting lids and suitable labels for marking.
    - a. Furnish labor to thoroughly mix paint before sampling and provide assistance with sampling when required.

**3.05 ADJUSTING AND CLEANING:**

- A. Reinstall removed items after painting has been completed.
  1. Restore damaged items to a condition equal to or better than when removed.  
Replace damaged items that cannot be restored.
- B. Touch up and restore damaged finish paints. Touch up and restoration paint coats are in addition to the number of specified finish paint coats.

- C. Remove spilled, splashed, or spattered paint without marring, staining or damaging the surface. Restore damaged surfaces to the satisfaction of the Director's representative.
- D. Remove temporary barriers, masking tape, and other protective coverings upon completion of painting, cleaning and restoration work.

**END OF SECTION**





**SECTION 230010 - GENERAL CONDITIONS FOR HEATING, VENTILATING, AND AIR  
CONDITIONING**

**PART 1 - GENERAL**

**1.1 RELATED DOCUMENTS**

- A. Drawings and general provisions of the Contract, including General and Supplementary Conditions and other Division 01 Specification Sections, apply to this Section.
- B. This section is intended to supplement the requirements of Division 01 requirements. For any conflicting requirements for minimum quantities or quality levels between this Section and Division 01, comply with the most stringent requirement.

**1.2 SUMMARY**

- A. This Section includes the following when associated with Divisions 21, 22, and 23 work:
  - 1. Permits and fees, code requirements, work under other contracts.
  - 2. Work restrictions.
  - 3. Specification formats and conventions.
  - 4. Request for information.
  - 5. Coordination.
  - 6. Conflicting requirements.
  - 7. Quality assurance and control.
  - 8. Coordination drawings.
  - 9. Construction coordination BIM model.
  - 10. Product delivery, storage, and handling.
  - 11. Product warranties.
  - 12. Submittals.
  - 13. Product selection procedures.
  - 14. Product interoperability requirements.
  - 15. General execution of project scope of work.
  - 16. Record drawings.
  - 17. Demonstration and training.
  - 18. Minimum commissioning responsibilities.
- B. Related Sections include the following:
  - 1. Division 01 Sections.

**1.3 PERMITS AND FEES**

- A. Give all necessary notices, obtain all permits; pay all government and state sales taxes and fees where applicable, and other costs, including utility connections or extensions in connection with the Project scope of work. File all necessary drawings, prepare all documents and obtain all necessary approvals of all governmental and state departments having jurisdiction, obtain all required certificates of inspections for Project scope of work and deliver a copy to the Architect/Engineer before request for acceptance and final payment for the Project scope of work.

**1.4 CODE REQUIREMENTS**

- A. Project Code: Confirm the codes in effect at the time of permitting.
- B. Project Legislative Requirements: Confirm the State and Local Legislations in effect at the time of permitting or those that affect construction.
- C. Compliance: Comply with all codes and legislations applicable to the project, including energy related:
  - 1. Means and Methods
  - 2. Equipment and Devices.
  - 3. Materials and Work Product.

**1.5 WORK UNDER OTHER CONTRACTS**

- A. General: Cooperate fully with separate contractors so work on those contracts may be carried out smoothly, without interfering with or delaying work under this Contract. Coordinate the Work of this Contract with work performed under separate contracts.

**1.6 WORK RESTRICTIONS**

- A. Existing Utility Interruptions: Do not interrupt utilities serving facilities occupied by Owner or others unless permitted under the following conditions and then only after arranging to provide temporary utility services:
  - 1. Notify Construction Manager or Owner not less than 10 days in advance of proposed utility interruptions.
  - 2. Do not proceed with utility interruptions without Construction Manager's or Owner's written permission.

**1.7 REQUESTS FOR INFORMATION (RFIs)**

- A. General: Immediately on discovery of the need for additional information or interpretation of the Contract Documents, Contractor shall prepare and submit an RFI in the form specified.

1. Coordinate and submit RFIs in a prompt manner so as to avoid delays in Contractor's work or work of subcontractors.
- B. Content of the RFI: Include a detailed, legible description of item needing information or interpretation and the following:
1. Project name.
  2. Project number.
  3. Date.
  4. Name of Contractor.
  5. Name of Engineer, Architect and Construction Manager.
  6. RFI number, numbered sequentially.
  7. RFI subject.
  8. Specification Section number and title and related paragraphs, as appropriate.
  9. Drawing number and detail references, as appropriate.
  10. Field dimensions and conditions, as appropriate.
  11. Contractor's suggested resolution.
  12. Contractor's signature.
  13. Attachments: Include sketches, descriptions, measurements, photos, product data, shop drawings, coordination drawings, and other information necessary to fully describe items needing interpretation.
    - a. Include dimensions, thicknesses, structural grid references, and details of affected materials, assemblies, and attachments on attached sketches.
- C. The following RFIs will be returned without action:
1. Requests for approval of submittals.
  2. Requests for approval of substitutions.
  3. Requests for coordination information already indicated in the Contract Documents.
  4. Requests for adjustments in the Contract Time or the Contract Sum.
  5. Requests for interpretation of Architect's actions on submittals.
  6. Incomplete RFIs or inaccurately prepared RFIs.
- D. Action may include a request for additional information, in which case time for response will date from time of receipt of additional information.

## **1.8 COORDINATION**

- A. Coordination: Each Contractor shall coordinate its construction operations with those of other Contractors and entities to ensure efficient and orderly installation of each part of the Work. Each Contractor shall coordinate its operations with operations, included in different Sections that depend on each other for proper installation, connection, and operation.

1. Schedule construction operations in sequence required to obtain the best results where installation of one part of the Work depends on installation of other components, before or after its own installation.
  2. Coordinate installation of different components with other Contractors to ensure maximum performance and accessibility for required maintenance, service, and repair.
  3. Make adequate provisions to accommodate items scheduled for later installation.
- B. Utility Coordination: Contractor shall coordinate all final specific utility requirements.
- C. Utilizing Two and Three Dimensional Information:
1. Design Intent Model: The Design Intent Model has been developed to a Level of Development LOD 200 and LOD 300 Model Content Requirements as defined by AIA G-202-2013. The contract documents are solely a two dimensional set of documents. The Design Intent Model is a three dimensional tool utilized to create a two dimensional contract document. A two dimensional contract document requires, for reason of clarity and otherwise, that components of the design not be modeled in three dimensions and/or that the model be formed in a way that construction means and methods will dictate other ways of performing the installation. It is at the sole discretion of BVH Integrated Services, P.C. as to which portions of the design are modeled, which are not and to what degree each portion of the design requires coordination to convey design intent for contractual purposes. The Design Intent Model is not a substitute for the contractors' coordination process as outlined in the contract documents; full coordination remains the responsibility of this contractor and their sub-contractors. The contents of the model are not to be used for the basis of detailed cost estimating, coordinating equipment locations and systems routing with all other trades. The model does not include three dimensional detailed field survey work of existing conditions or new work in existing conditions. The contractor may use the Design Intent Model to help establish the backgrounds and/or starting point for the coordination drawings based on the stipulations of the release form that can be provided if and when the model is requested.
  2. Construction Coordination Model: The Construction Coordination Model shall be developed to a minimum Level of Development LOD 400 Model Content Requirements as defined by AIA G-202-2013. The contractor shall be fully responsible for creating and maintaining a Construction Coordination Model and coordination drawings as required for detailed construction installation and coordination with all other trades.
  3. Differences between the Design Intent Model and the Construction Coordination Model and/or actual installation location, means and methods are included in this contract and shall not constitute a change order on the basis of drawing, engineering and/or coordination time.

## **1.9 CONFLICTING REQUIREMENTS**

- A. General: If compliance with two or more standards or directives is specified and the standards establish different or conflicting requirements for minimum quantities or quality levels, comply

with the most stringent requirement. Refer uncertainties and requirements that are different, but apparently equal, to Architect/Engineer for a decision before proceeding.

- B. Minimum Quantity or Quality Levels: The quantity or quality level shown or specified shall be the minimum provided or performed. The actual installation may comply exactly with the minimum quantity or quality specified, or it may exceed the minimum within reasonable limits. To comply with these requirements, indicated numeric values are minimum or maximum, as appropriate, for the context of requirements. Refer uncertainties to Engineer for a decision before proceeding.

#### **1.10 MINOR CHANGES IN THE WORK**

- A. Engineer/Architect will issue through the Construction Manager, supplemental instructions authorizing minor changes in the Work, not involving adjustment to the Contract Sum or the Contract Time.
- B. Drawings are diagrammatic, the Contractor shall relocate devices a reasonable distance for coordination.
  - 1. A reasonable distance is considered to be 15 feet at no additional cost.

#### **1.11 QUALITY ASSURANCE AND CONTROL**

- A. General: Qualifications paragraphs in this Article establish some of the minimum qualification levels required; Division 01 and individual Specification Sections specify additional requirements.
- B. Code Compliance: Work and equipment shall comply with all latest applicable codes and legislations.
- C. Factory-Authorized Service Representative Qualifications: An authorized representative of manufacturer who is trained and approved by manufacturer to inspect installation of manufacturer's products that are similar in material, design, and extent to those required for this Project.
- D. Instructor Qualifications: A factory-authorized service representative, complying with requirements in "Quality Requirements," experienced in operation and maintenance procedures and training.
- E. Tests and inspections not explicitly assigned to Owner are Contractor's responsibility. Unless otherwise indicated, provide quality-control services specified and those required by authorities having jurisdiction. Perform quality-control services required of Contractor by authorities having jurisdiction, whether specified or not.

1. Where services are indicated as Contractor's responsibility, engage a qualified testing agency to perform these quality-control services.
    - a. Contractor shall not employ same entity engaged by Owner, unless agreed to in writing by Owner.
  2. Testing and inspecting requested by Contractor and not required by the Contract Documents are Contractor's responsibility.
  3. Submit additional copies of each written report directly to authorities having jurisdiction, when they so direct.
- F. **Manufacturer's Field Services:** Where indicated, engage a factory-authorized service representative to inspect field-assembled components and equipment installation, including service connections.
- G. **Retesting/Reinspecting:** Regardless of whether original tests or inspections were Contractor's responsibility, provide quality-control services, including retesting and reinspecting, for construction that replaced Work that failed to comply with the Contract Documents.
- H. **Associated Services:** Cooperate with agencies performing required commissioning, tests, inspections, and similar quality-control services, and provide reasonable auxiliary services as requested. Notify agency sufficiently in advance of operations to permit assignment of personnel. Provide the following:
1. Access to the Work.
  2. Incidental labor and facilities necessary to facilitate tests and inspections.
  3. Adequate quantities of representative samples of materials that require testing and inspecting. Assist agency in obtaining samples.
  4. Facilities for storage and field curing of test samples.
  5. Delivery of samples to testing agencies.
  6. Preliminary design mix proposed for use for material mixes that require control by testing agency.
  7. Security and protection for samples and for testing and inspecting equipment at Project site.
- I. **Coordination:** Coordinate sequence of activities to accommodate required quality-assurance and control services with a minimum of delay and to avoid necessity of removing and replacing construction to accommodate testing and inspecting.
1. Schedule times for tests, inspections, obtaining samples, and similar activities.
- J. **Compatibility of Options:** If Contractor is given option of selecting between two or more products for use on Project, product selected shall be compatible with products previously selected, even if previously selected products were also options.

1. Each contractor is responsible for providing products and construction methods compatible with products and construction methods of other contractors.
  2. If a dispute arises between contractors over concurrently selectable but incompatible products, Engineer will determine which products shall be used at no additional cost to the project.
- K. Acceptance of Work: Failure on the part of the Engineer to reject shop drawings or to reject Work in progress shall not be interpreted as acceptance of Work not in conformance with Code, Legislation, the Drawings and/or Specifications. Correct Work not in conformance whenever non-conformance is discovered.

### **1.12 COORDINATION DRAWINGS**

- A. Coordination Drawings, General: Prepare coordination drawings in accordance with requirements in this Section and individual equipment and distribution sections, to facilitate integration of products and materials fabricated or installed by more than one entity. Maintain maximum headroom, where space conditions appear inadequate to maintain proposed ceiling heights or code clearances, notify Architect/Engineer with proposed solutions.
1. Content: Project-specific information, drawn accurately to a scale large enough to indicate and resolve conflicts, but no less than 1/4" equals 1'-0". Do not base coordination drawings on standard printed data. Include the following information, as applicable:
    - a. Use applicable Drawings as a basis for preparation of coordination drawings. Prepare sections, elevations, and details as needed to describe relationship of various systems and components.
    - b. Coordinate the addition of trade-specific information to the coordination drawings by multiple contractors in a sequence that best provides for coordination of the information and resolution of conflicts between installed components before submitting for review.
    - c. Indicate functional and spatial relationships of components of architectural, structural, civil, mechanical, and electrical systems.
    - d. Indicate space requirements for routine maintenance and for anticipated replacement of components during the life of the installation.
    - e. Show location and size of access doors required for access to concealed equipment, devices, junction boxes.
    - f. Indicate required installation sequences.
    - g. Indicate dimensions shown on the Drawings. Specifically note dimensions that appear to be in conflict with submitted equipment and minimum clearance requirements. Provide alternate sketches to Architect indicating proposed resolution of such conflicts. Minor dimension changes and difficult installations will not be considered changes to the Contract.



B. Coordination Drawing Process:

1. Particular emphasis is placed on timely installation of major apparatus and furnishing other Contractors, especially the General Contractor or Construction Manager, with information as to openings, chases, sleeves, bases, inserts, equipment locations, panels, access doors, etc., required by other trades.
2. In general, ductwork, heating piping, sprinkler piping and drainage lines take precedence over water, gas and electrical conduits. The Engineer regarding the arrangement of Work, which cannot be agreed upon by the Contractors, will make final decisions.
3. Where the Work of the Contractor will be installed in close proximity to or will interfere with Work of other trades, assist in working out space conditions to make a satisfactory adjustment.
4. If Work is installed before coordinating with other Divisions or so as to cause interference with Work of other Sections, the Contractor causing the interference will make necessary changes to correct the condition without extra charge to the Owner.
5. The Construction Manager/General Contractor shall coordinate the coordination process between the trades. Each trade shall incorporate their systems electronically using a different color code. Establish a meeting schedule where the Architect/Engineer can be present, including initiation of a kickoff meeting to establish the process with all parties, Contractor Coordination Meetings, and Architect/Engineer/Contractor Coordination Review Meetings. Regular Contractor Coordination Meetings of all Contractors involved shall be held to resolve all conflicts, assure accessibility, coordinate sequences and make adjustment to the layout to achieve the Architectural/Engineering intent of spaces, ceiling heights, accessibility, and to maximize headroom clearances in preparation for the Architect/Engineer/Contractor Coordination Review Meetings. Forward one (1) preliminary copy to the Architect and Engineer each, one (1) week prior to the Architect/Engineer Review Meeting identifying all unresolved conflicts. Upon resolving any outstanding conflicts (which may take a couple of rounds), drawings shall be completed and all trades shall sign acceptance of the drawings and submit a minimum of six (6) prints of each drawing to the Architect/Engineer for review.

C. Coordination drawing creation is an iterative process. Submit multiple options and configurations at no additional cost until the Engineer's and Architect's acceptance is given.

D. Coordination Drawing Organization: Organize coordination drawings as follows:

1. Floor Plans and Reflected Ceiling Plans: Show architectural and structural elements, and mechanical, plumbing, fire protection, fire alarm, and electrical work. Show locations of visible ceiling-mounted devices relative to acoustical ceiling grid. Supplement plan drawings with section drawings where required to adequately represent the Project scope of work.
2. Plenum Space: Indicate subframing for support of ceiling and wall systems, mechanical and electrical equipment, and related Work. Locate components within ceiling plenum to accommodate layout of light fixtures indicated on Drawings. Indicate areas of conflict between light fixtures and other components.

PROBATE COURT  
ADMINISTRATION  
INTERIOR RENOVATIONS  
186 NEWINGTON ROAD  
WEST HARTFORD, CONNECTICUT

3. Mechanical Rooms: Provide coordination drawings for mechanical rooms showing plans and elevations of mechanical, plumbing, fire protection, fire alarm, and electrical equipment.
  4. Structural Penetrations: Indicate penetrations and openings required for all disciplines.
  5. Slab Edge and Embedded Items: Indicate slab edge locations and sizes and locations of embedded items for metal fabrications, sleeves, anchor bolts, bearing plates, angles, door floor closers, slab depressions for floor finishes, curbs and housekeeping pads, and similar items.
  6. Mechanical and Plumbing Work: Show the following:
    - a. Sizes and bottom elevations of ductwork, piping, and conduit runs, including insulation, bracing, flanges, and support systems.
    - b. Dimensions of major components, such as dampers, valves, diffusers, access doors, cleanouts and electrical distribution equipment.
    - c. Fire-rated enclosures around ductwork.
  7. Electrical Work: Show the following:
    - a. Runs of vertical and horizontal conduit 1-1/4 inch diameter and larger.
    - b. Light fixture, exit light, emergency battery pack, smoke detector, and other fire alarm locations.
    - c. Panel board, switch board, switchgear, transformer, busway, generator, and motor control center locations.
    - d. Location of pull boxes and junction boxes, dimensioned from column center lines.
  8. Fire Protection System: Show the following:
    - a. Locations of standpipes, mains piping, branch lines, pipe drops, and sprinkler heads.
  9. Review: Architect/Engineer will review coordination drawings to confirm that the Work is being coordinated, but not for the details of the coordination, which are the Contractor's responsibility. If the Architect determines that the coordination drawings are not being prepared in sufficient scope or detail, or are otherwise deficient, the Architect will so inform the Contractor, who shall make changes as directed and resubmit.
  10. Coordination Drawing Prints: Prepare coordination drawing prints in accordance with requirements of this Section "Submittal Procedures."
- E. Coordination Digital Data Files: Prepare coordination digital data files in accordance with the following requirements:
1. File Preparation Format: Autodesk Revit .rvt file format in Microsoft Windows operating system.
  2. File Submittal Format: Submit or post coordination digital data files in the file preparation format and in Adobe .pdf format.

3. Upon receipt of a signed release form, Engineer/Architect will furnish to the Contractor one set of digital data files for use in preparing coordination digital data files.
  - a. Engineer/Architect makes no representations as to the accuracy or completeness of digital data files as they relate to the drawings.
  - b. Contractor shall execute a data licensing agreement in the form of AIA Document C106.

F. Construction Coordination Building Information Model:

1. Prepare Construction Coordination Building Information Model for the project utilizing Autodesk Revit software.
2. Construction coordination model to reflect the as-installed conditions of the project and the characteristics of installed equipment.

**1.13 PRODUCT DELIVERY, STORAGE, AND HANDLING**

- A. Deliver, store, and handle products using means and methods that will prevent damage, deterioration, and loss, including theft. Comply with manufacturer's written instructions and generally accepted construction practice.
- B. Storage:
  1. Store products to allow for inspection and measurement of quantity or counting of units.
  2. Store materials in a manner that will not endanger Project structure.
  3. Store products that are subject to damage by the elements, under cover in a weathertight enclosure above ground, with ventilation adequate to prevent condensation.
  4. Store cementitious products and materials on elevated platforms.
  5. Store foam plastic from exposure to sunlight, except to extent necessary for period of installation and concealment.
  6. Comply with product manufacturer's written instructions for temperature, humidity, ventilation, and weather-protection requirements for storage.
  7. Protect stored products from damage and liquids from freezing.
  8. Provide a secure location and enclosure at Project site for storage of materials and equipment by Owner's construction forces. Coordinate location with Owner.

**1.14 PRODUCT WARRANTIES**

- A. Refer to Division 01 and individual sections for requirements.
- B. The following requirements are supplemental and in addition to those stated in other specific sections and Division 01.
  1. Warranty all materials and workmanship under these Specifications and the Contract for a period of one year from the date of final acceptance by the Owner.

2. During this warranty period, correct or replace all defects developing through materials or workmanship immediately as directed by the Engineer without expense to the Owner; make all such repairs or replacements to the Owner's satisfaction.
- C. Warranties specified in other Sections shall be in addition to, and run concurrent with, other warranties required by the Contract Documents. Manufacturer's disclaimers and limitations on product warranties do not relieve Contractor of obligations under requirements of the Contract Documents.
- D. Warranty Start Date: From the date of final acceptance by the Owner.

**1.15 SUBMITTAL PROCEDURES**

- A. Comparable Product: Product that is demonstrated and approved through submittal process to have the indicated qualities related to type, function, dimension, in-service performance, physical properties, appearance, and other characteristics that equal or exceed those of specified product.
- B. Product List: Submit a list, in tabular form, showing specified products. Include generic names of products required. Include manufacturer's name and proprietary product names for each product.
  1. Initial Submittal: Within 30 days after date of commencement of the Work, submit 3 copies of initial product list. Include a written explanation for omissions of data and for variations from Contract requirements.
- C. Substitution Requests: Submit four copies of each request for consideration. Identify product or fabrication or installation method to be replaced. Include Specification Section number and title and Drawing numbers and titles.
  1. Substitution: A submittal shall be considered a substitution when the Engineer/Architect does not accept the product or material as an "equivalent" or where one of the listed manufacturers is not submitted.
  2. Substitution Requirements: Substitutions shall meet the requirements of "Comparable Products."
  3. Documentation: Show compliance with requirements for substitutions and the following, as applicable:
    - a. Statement indicating why specified material or product cannot be provided.
    - b. Coordination information, including a list of changes or modifications needed to other parts of the Work and to construction performed by Owner and separate contractors, that will be necessary to accommodate proposed substitution.
    - c. Detailed comparison of significant qualities of proposed substitution with those of the Project scope of work specified. Significant qualities may include attributes

such as performance, weight, size, durability, visual effect, and specific features and requirements indicated.

- d. Product Data, including drawings and descriptions of products and fabrication and installation procedures.
- e. Samples, where applicable or requested.
- f. Cost information, including a proposal of change, if any, in the Contract Sum.
- g. Contractor's certification that proposed substitution complies with requirements in the Contract Documents and is appropriate for applications indicated.
- h. Contractor's waiver of rights to additional payment or time that may subsequently become necessary because of failure of proposed substitution to produce indicated results.
- i. Statement indicating why the requested substitution offers Owner a substantial advantage in cost, time, energy conservation, or other considerations.

D. Delegated-Design Services:

1. Performance and Design Criteria: Where professional design services or certifications by a design professional are specifically required of the Contractor by the Contract Documents, the Contractor shall provide products and systems complying with specific performance and design indicated.
  - a. If criteria indicated are not sufficient to perform services or certification required, submit a written request for additional information to the Architect.
2. Delegated-Design Services Certification: In addition to Shop Drawings, Product Data, and other required submittals, submit digitally signed PDF electronic file copies of certificate, signed and sealed by the responsible design professional, for each product and system specifically assigned to the Contractor to be designed or certified by a design professional.
  - a. Indicate that products and systems comply with performance and design criteria in the Contract Documents. Include list of codes, loads, and other factors used in performing these services.

**1.16 RECORD DRAWINGS AND RECORD DIGITAL FILES**

A. Record Drawings and Record Digital Files: Comply with the following:

1. Submit Record Drawings and Record Digital Files as follows:
  - a. Initial Submittal: Submit one set of plots from corrected Record CAD Drawings and one set of marked-up Record Prints. Engineer will initial and date each plot and mark whether general scope of changes, additional information recorded, and quality of drafting are acceptable. Engineer will return plot for organizing into sets, printing, binding, and final submittal.

- b. Final Submittal: Submit three sets of Record CAD Drawing files, three sets of Construction Coordination Building Information Model, and one set of Record CAD Drawing plots. Plot and print each drawing, whether or not changes and additional information were recorded.

- 1) Electronic Media: CD-R.

B. Qualification Data: For training instructor.

**1.17 PRODUCT SELECTION PROCEDURES**

A. General Product Requirements: Provide products that comply with the Contract Documents, that are undamaged and, unless otherwise indicated, that are new at time of installation.

- 1. Provide products complete with accessories, trim, finish, fasteners, and other items needed for a complete installation and indicated use and effect.
- 2. Standard Products: If available, and unless custom products or nonstandard options are specified, provide standard products of types that have been produced and used successfully in similar situations on other projects.
- 3. Owner reserves the right to limit selection to products with warranties not in conflict with requirements of the Contract Documents.
- 4. Where products are accompanied by the term "as selected," Engineer and/or Architect will make selection.
- 5. Descriptive, performance, and reference standard requirements in the Specifications establish "salient characteristics" of products.
- 6. Or Equal: Where products are specified by name and accompanied by the term "or equal" or "or approved equal" or "or approved," comply with provisions in "Comparable Products" Article to obtain approval for use of an unnamed product.

B. Product Selection Procedures:

- 1. Design Basis: The design has been based on the single manufacturer indicated in the contract documents. The Contractor is responsible for verifying prior to submission, that any other manufacturer even though listed complies with dimensional and performance characteristics of the base specified product. Modifications shall be made by the Contractor as part of this contract to accommodate changes to the design basis.
- 2. Product: Where Specifications name a single product and manufacturer, provide the named product that complies with requirements.
- 3. Manufacturers: Where Specifications include a list of manufacturers' names, provide a product by one of the manufacturers listed that complies with requirements.
- 4. Equivalent Product: Equipment, material or devices submitted for review as an "accepted equivalent" shall meet all of the following requirements:
  - a. A product of a listed manufacturer.

- b. The equivalent shall have the same construction features such as, but not limited to:
  - 1) Material thickness, gauge, weight, density, etc.
  - 2) Welded, riveted, bolted, etc., construction
  - 3) Finish, undercoating, corrosion protection
- c. The equivalent shall perform with the same or better operating efficiency.
- d. The equivalent shall have equal or greater reserve capacity.
- e. The equivalent shall be locally represented by the manufacturer for service, parts and technical information.
- f. The equivalent shall bear the same labels of performance certification as is applicable to the specified item, such as UL, AMCA or ARI labels.

### **1.18 PRODUCT INTEROPERABILITY REQUIREMENTS**

- A. Interoperability Coordination Meeting: Attend a minimum of 3 weekly coordination meetings to coordinate interoperability between all systems and equipment. Meetings shall be scheduled by the construction manager.
- B. General Networking and Protocol Interoperability Requirements: Provide products that are fully BACNet interoperable.
  - 1. All systems and equipment shall interface with the primary building management network provided under "Instrumentation and Controls for HVAC" using Ethernet standards and BACNet protocol.
  - 2. Equipment that is native BACNet may connect directly to a BACNet MS/TP subnet that is provided by "Instrumentation and Controls for HVAC" when coordinated with that Section Contractor.
  - 3. Communication involving control components (i.e., all types of controllers and operator interfaces) shall conform to the most current ANSI/ASHRAE Standard 135, BACnet.
  - 4. The MS/TP trunks support all of the ASHRAE 135 approved baud rates.
  - 5. All MS/TP devices support all baud rates of the ASHRAE 135.
  - 6. All MS/TP devices shall be BTL approved ( BACnet Testing Lab).
  - 7. All BACnet routers must support B-BC (BIBB) and support BBMD routing.
  - 8. Lonworks and Modbus subnets may be utilized where no BACNet protocol is available provided full 2-way compatibility is provided through a gateway.
    - a. Exception: Fire alarm systems shall be 1-way, read only communication.
  - 9. Each individual system and/or equipment manufacturer/installer shall provide all necessary gateways/translators Provide Gateway with all products as required facilitating full BACNet interoperability with BACNet Protocol.

10. It must be possible to read and display the value of any property, including all required properties, supported optional properties, and proprietary extensions of every object of every networked device.
  11. Operating setpoints and parameters must be available for modification via BACnet services via a graphical user interface (GUI).
  12. An operator shall be able to display at any time the operational status of any device on the BACnet internetwork. An operator shall be able to display at any time any property of any BACnet object. An operator shall also be able to display property values of objects grouped by object type, object location, building system, and by user defined parameters.
  13. An operator shall have the ability to issue re-initialization commands to any device that supports remote re-initialization.
  14. An operator shall have the ability to backup and restore all BACnet devices on the network.
  15. It shall be each contractor's responsibility to configure each router using the network numbering scheme for the project. Each router shall be configured such that all network layer error messages shall be directed to a specific workstation using the BACnet Confirmed Text Message service. It shall be the contractor's responsibility to initially configure each router with routing tables containing all network numbers that are part of the project's internet. The router shall be able to receive messages at each port of any length that is valid for the LAN technology connected to that port, and to forward the message to any directly-connected network that can convey a message of that size.
  16. Legacy Systems: Bi-directional gateways shall be provided for systems and equipment operating on a legacy/proprietary system. The operator workstation shall display information from both the BACnet and non-BACnet devices. Any information specified or required for system functionality shall be made readable and modifiable. Gateways shall have 10% expansion capacity. Gateways shall support archiving, uploading, trending, scheduling, and alarm/event detection, notification and acknowledgement.
  17. Systems and equipment shall have full 2- way communications and interoperability.
    - a. Exception: Fire safety systems and equipment shall have only read access to outside systems:
      - 1) Fire alarm.
  18. Coordinate with "Instrumentation and Controls for HVAC" and other building operational systems for specific interoperability requirements.
- C. Communications Standard: Coordinate communications standards requirements with other Sections and Divisions.
1. MS/TP LAN: RS 485
  2. Systems with dedicated network(s) shall connect on the BACNet Ethernet LAN: utilizing a switch and shall meet standard Ethernet requirements.
    - a. Utilize RJ-45 terminations.



- b. Utilize CAT 6 cabling.
  - c. Meet IEEE Standard 802.3 standards and requirements.
  - d. Speed: 100 Mbps.
3. Equipment without dedicated networks shall connect to the BACNet MS/TP LAN.
- a. RS 485 communications standard.
  - b. Speed: 1 Mbps.
- D. Information Availability: Make all product information, points, variables, setpoints, etc., available for access of building operational systems upon request.
- 1. Provide bi-directional point mapping/addressing instructions.
  - 2. Provide on-site technicians as required to ensure proper information exchange.
- E. Factory Provided Equipment Controllers: Provide all information, points, variables, setpoints, etc., indicated and referenced in all documentation, including "Instrumentation and Controls for HVAC." Products shall have full interoperability as indicated in this Section, in BACNet standards and elsewhere.

**1.19 MINIMUM CONTRACTOR'S COMMISSIONING RESPONSIBILITIES**

- A. Each Contractor shall assign representatives with expertise and authority to act on its behalf and shall schedule them to participate in and perform commissioning process activities including, but not limited to, the following:
- 1. Evaluate performance deficiencies identified in test reports and, in collaboration with entity responsible for system and equipment installation, recommend corrective action.
  - 2. Cooperate with the CxA for resolution of issues recorded in the Issues Log.
  - 3. Attend commissioning team meetings held on a weekly basis.
  - 4. Integrate and coordinate commissioning process activities with construction schedule.
  - 5. Review and accept construction checklists provided by the CxA.
  - 6. Complete paper or electronic construction checklists as Work is completed and provide to the Commissioning Authority on a weekly basis.
  - 7. Review and accept commissioning process test procedures provided by the Commissioning Authority.
  - 8. Complete commissioning process test procedures.
- B. Refer to related information in other sections for additional requirements.

**PART 2 - PRODUCTS**

**2.1 COORDINATION DRAWINGS**

- A. Coordination Drawings: Prepare Project-specific information, drawn accurately to scale. Do not base Coordination Drawings on reproductions of the Contract Documents or standard printed data.
1. Preparation: Fully illustrate requirements in the Contract Documents and actual special restrictions.
  2. Sheet Size: Submit Coordination Drawings on sheets at least 30 by 42 inches.
  3. Submit Shop Drawings in the following format:
    - a. PDF electronic file.
    - b. Autodesk AutoCAD and Autodesk Revit file in the latest version.
    - c. Six opaque (bond) copies of each submittal. Engineer will return five copies.

**2.2 SHOP DRAWINGS**

- A. Shop Drawings: Prepare Project-specific information, drawn accurately to scale. Do not base Shop Drawings on reproductions of the Contract Documents or standard printed or electronic data.
1. Preparation: Fully illustrate requirements in the Contract Documents. Include the following information, as applicable:
    - a. Identification of products.
    - b. Schedules.
    - c. Compliance with specified standards.
    - d. Notation of coordination requirements.
    - e. Notation of dimensions established by field measurement.
    - f. Relationship and attachment to adjoining construction clearly indicated.
    - g. Seal and signature of professional engineer if specified.
  2. Sheet Size: Except for templates, patterns, and similar full-size drawings, submit Shop Drawings on sheets at least 8-1/2 by 11 inches but no larger than 30 by 42 inches.

**2.3 RECORD DRAWINGS**

- A. Record Prints: Maintain one set of black-line white prints of the Contract Drawings and Shop Drawings.
1. Preparation: Mark Record Prints to show the actual installation where installation varies from that shown originally. Require individual or entity who obtained record data,

whether individual or entity is Installer, subcontractor, or similar entity, to prepare the marked-up Record Prints.

- a. Give particular attention to information on concealed elements that would be difficult to identify or measure and record later.
  - b. Accurately record information in an understandable drawing technique.
  - c. Record data as soon as possible after obtaining it. Record and check the markup before enclosing concealed installations.
2. Content: Types of items requiring marking include, but are not limited to, the following:
- a. Revisions to details shown on Drawings.
  - b. Locations and depths of underground system entities.
  - c. Revisions to routing of piping.
  - d. Actual equipment locations.
  - e. Duct size and routing.
  - f. Locations of concealed internal utilities.
  - g. Changes made by Change Order or Change Directive.
  - h. Changes made following Engineer's written orders.
  - i. Details not on the original Contract Drawings.
  - j. Field records for variable and concealed conditions.
  - k. Record information on the Project scope of work that is shown only schematically.
3. Mark the Contract Drawings or Shop Drawings, whichever is most capable of showing actual physical conditions, completely and accurately. If Shop Drawings are marked, show cross-reference on the Contract Drawings.
4. Mark record sets with erasable, colored pencil. Use multiple colors to distinguish between changes for different categories of the Work at same location.
5. Mark important additional information that was either shown schematically or omitted from original Drawings.
6. Note Construction Change Directive numbers, alternate numbers, Change Order numbers, and similar identification, where applicable.
- B. Record CAD Drawings: Immediately before observation for Certificate of Substantial Completion, review marked-up Record Prints with Engineer and Construction Manager. When authorized, prepare a full set of corrected CAD Drawings of the Contract Drawings, as follows:
1. Format: Autodesk .dwg format of the same version, and operating system as the original Contract Drawings.
  2. Incorporate changes and additional information previously marked on Record Prints. Delete, redraw, and add details and notations where applicable.
  3. Refer instances of uncertainty to Engineer for resolution.
  4. Contractor may request one set of CAD Drawings of the Contract Drawings for use in recording information.

- a. Engineer makes no representations as to the accuracy or completeness of CAD Drawings as they relate to the Contract Drawings.
- C. Construction Coordination Building Information Model:
1. Prepare Construction Coordination Building Information Model for the project utilizing Autodesk Revit software.
  2. Construction coordination model to reflect the as-installed conditions of the project and the characteristics of installed equipment.
- D. Format: Identify and date each Record Drawing; include the designation "PROJECT RECORD DRAWING" in a prominent location.
1. Record Prints: Organize Record Prints and newly prepared Record Drawings into manageable sets. Bind each set with durable paper cover sheets. Include identification on cover sheets.
  2. Record CAD/Revit Drawings: Organize information into separate electronic files that correspond to each sheet of the Contract Drawings. Name each file with the sheet identification. Include identification in each file.
  3. Identification: As follows:
    - a. Project name.
    - b. Date.
    - c. Designation "PROJECT RECORD DRAWINGS."
    - d. Name of Engineer, Architect and Construction Manager.
    - e. Name of Contractor.

## **2.4 RECORDING AND MAINTENANCE**

- A. Recording: Maintain one copy of each submittal during the construction period for Project Record Document purposes. Post changes and modifications to Project Record Documents as they occur; do not wait until the end of Project.
- B. Maintenance of Record Documents and Samples: Store Record Documents and Samples in the field office apart from the Contract Documents used for construction. Do not use Project Record Documents for construction purposes. Maintain Record Documents in good order and in a clean, dry, legible condition, protected from deterioration and loss. Provide access to Project Record Documents for Engineer's reference during normal working hours.

## **2.5 TRAINING AND INSTRUCTION PROGRAM**

- A. Program Structure: In addition to Division 01 and individual section requirements, develop an instruction program that includes individual training modules for each system and equipment not part of a system.

- B. Training Modules: Develop a learning objective and teaching outline for each module. Include a description of specific skills and knowledge that participant is expected to master. Provide instruction for the following modules.
  - 1. Basis of System Design and Operational Requirements
  - 2. Documentation
  - 3. Emergencies
  - 4. Adjustments
  - 5. Troubleshooting
  - 6. Maintenance
  - 7. Repairs
- C. Engage qualified instructors to instruct Owner's personnel to adjust, operate, and maintain systems, subsystems, and equipment not part of a system.
- D. Video Record: Training shall be recorded as video.
  - 1. Format: Standard DVD format.
  - 2. Quantity: Three discs of each individual DVD.
  - 3. Labeling: Label each DVD with its library of training sections based on equipment type and system type.

**2.6 COMPARABLE PRODUCTS**

- A. Conditions for Consideration: Engineer/Architect will consider Contractor's request for comparable product when the following conditions are satisfied. If the following conditions are not satisfied, Engineer/Architect may return requests without action, except to record noncompliance with these requirements:
  - 1. Evidence that the proposed product does not require revisions to the Contract Documents, that it is consistent with the Contract Documents and will produce the indicated results, and that it is compatible with other portions of the Work.
  - 2. Detailed comparison of significant qualities of proposed product with those named in the Specifications. Significant qualities include attributes such as performance, weight, size, durability, visual effect, and specific features and requirements indicated.
  - 3. Evidence that proposed product provides specified warranty.
  - 4. List of similar installations for completed projects with project names and addresses and names and addresses of architects and owners, if requested.
  - 5. Samples, if requested.

**PART 3 - EXECUTION**

**3.1 EXAMINATION**

- A. Existing Conditions: The existence and location of underground and other utilities and construction indicated as existing are not guaranteed. Before beginning work, investigate and verify the existence and location of underground utilities, mechanical and electrical systems, and other construction affecting the Work.
1. Before construction, verify the location and invert elevation at points of connection of sanitary sewer, storm sewer, and water-service piping; underground electrical services, and other utility and system connections.
  2. Furnish location data for work related to Project that must be performed by public utilities serving Project site.
  3. Existing Utility Information: Furnish information to local utility and Owner that is necessary to adjust, move, or relocate existing utility structures, utility poles, lines, services, or other utility appurtenances located in or affected by construction. Coordinate with authorities having jurisdiction.
- B. Acceptance of Conditions: Examine substrates, areas, and conditions, for compliance with requirements for installation tolerances and other conditions affecting performance. Record observations.
1. Written Report: Where a written report listing conditions detrimental to performance of the Project scope of work is required by other Sections, include the following:
    - a. Description of the Work.
    - b. List of detrimental conditions, including substrates.
    - c. List of unacceptable installation tolerances.
    - d. Recommended corrections.
  2. Verify compatibility with and suitability of substrates, including compatibility with existing finishes or primers.
  3. Examine roughing-in for mechanical and electrical systems to verify actual locations of connections before equipment and fixture installation.
  4. Examine walls, floors, and roofs for suitable conditions where products and systems are to be installed.
  5. Proceed with installation only after unsatisfactory conditions have been corrected. Proceeding with the Work indicates acceptance of surfaces and conditions.

**3.2 PREPARATION**

- A. Existing Utility Information: Furnish information to local utility and Owner that is necessary to adjust, move, or relocate existing utility structures, utility poles, lines, services, or other utility

appurtenances located in or affected by construction. Coordinate with authorities having jurisdiction.

- B. **Field Measurements:** Take field measurements as required to fit the Work properly. Recheck measurements before installing each product. Where portions of the Work are indicated to fit to other construction, verify dimensions of other construction by field measurements before fabrication. Coordinate fabrication schedule with construction progress to avoid delaying the Work.
- C. **Space Requirements:** Verify space requirements and dimensions of items shown diagrammatically on Drawings.
- D. **Review of Contract Documents and Field Conditions:** Immediately on discovery of the need for clarification of the Contract Documents, submit a request for information to Engineer. Include a detailed description of problem encountered, together with recommendations for changing the Contract Documents.

### **3.3 DEMOLITION**

- A. Work indicated to be removed includes removal of all auxiliary materials, accessories, anchorage, fasteners, and etc., down to bare substrate. No residual materials shall remain from work to be removed. Contractor will use whatever means necessary; including removal of all materials attached or related to those items designated to be removed, as acceptable to Owner and Engineer, to provided complete and thorough removal of existing work.
- B. Protect existing equipment and installations indicated to remain. If damaged or disturbed in the course of the Work, remove damaged portions and install new products of equal capacity, quality, and functionality.
- C. **Accessible Work:** Remove exposed equipment and installations, indicated to be demolished, in their entirety.
- D. **Abandoned Work:** Cut and remove buried MEP system materials, equipment, raceways, piping and distribution, indicated to be abandoned in place, 2 inches below the surface of adjacent construction. Cap and patch surface to match existing finish.
- E. Remove demolished materials from Project site.
- F. Remove, store, clean, reinstall, reconnect, and make operational components indicated for relocation.
- G. Field verify all existing MEP system materials, equipment, raceways, piping and distribution to be removed for exact quantities.

- H. Remove all existing MEP system materials, equipment, raceways, piping and distribution located above ceilings and in walls that are not being reused.
- I. Remove all MEP systems and appurtenances, which are to be removed, in their entireties back to the source or source panels.
- J. Remove all existing MEP system materials, equipment, raceways, piping and distribution located in walls or ceilings being demolished. Abandon no devices that have been disconnected unless specifically noted.
- K. Maintain continuity of all existing MEP devices, and utilization equipment not removed.
- L. Remove, store, protect, and reinstall existing work as required to accommodate alteration indicated.
- M. The existing work to be removed, in general, is as indicated on the Drawings and in this Section, but also includes any materials or work necessary to permit installation of new materials, as approved by Owner and Engineer.
- N. Disconnect, demolish, and remove systems, equipment, and components indicated to be removed, abandoned or as made obsolete by this project.
  - 1. To Be Removed: Remove portion of systems, equipment, and components indicated to be removed and cap or plug remaining with same or compatible material.
  - 2. To Be Abandoned in Place: Drain piping and cap or plug systems, equipment, and components with same or compatible material.
  - 3. Equipment to Be Removed: Disconnect, make safe and cap services and remove equipment.
  - 4. Equipment to Be Removed and Reinstalled: Disconnect, make safe and cap services and remove, clean, and store equipment; when appropriate, reinstall, reconnect, and make equipment operational.
  - 5. Equipment to Be Removed and Salvaged: Disconnect, make safe and cap services and remove equipment and deliver at direction of Owner.
- O. If systems, equipment, and components to remain is damaged in appearance or is unserviceable, remove damaged or unserviceable portions and replace with new products of equal capacity and quality.
- P. In finished areas, all systems, equipment, and components shall be cut back to a concealed location, i.e., within walls, above ceilings, etc., before capping.

### **3.4 INSTALLATION**

- A. General: Locate the Work and components of the Work accurately, in correct alignment and elevation, as indicated.



1. Make vertical work plumb and make horizontal work level.
  2. Where space is limited, install components to maximize space available for maintenance and ease of removal for replacement.
  3. Conceal pipes, ducts, and wiring in finished areas, unless otherwise indicated.
  4. Maintain minimum headroom clearance as indicated by Architect and/or Construction Manager in spaces without a suspended ceiling.
- B. Comply with manufacturer's written instructions and recommendations for installing products in applications indicated.
- C. Install products at the time and under conditions that will ensure the best possible results. Maintain conditions required for product performance until Substantial Completion.
- D. Conduct construction operations so no part of the Work is subjected to damaging operations or loading in excess of that expected during normal conditions of occupancy.
- E. Tools and Equipment: Do not use tools or equipment that produces harmful noise levels.
- F. Templates: Obtain and distribute to the parties involved templates for work specified to be factory prepared and field installed. Check Shop Drawings of other work to confirm that adequate provisions are made for locating and installing products to comply with indicated requirements.
- G. Anchors and Fasteners: Provide anchors and fasteners as required to anchor each component securely in place, accurately located and aligned with other portions of the Work.
1. All equipment and piping not supported from the building structural steel shall not exceed a combined load of 7 psf when supported from the metal deck/slab. Any condition that may exceed this limit shall be reviewed and approved by the Design-Builder and Structure Engineer before installation.
  2. Mounting Heights: Where mounting heights are not indicated, mount components at heights directed by Engineer and/or to allow for proper access.
  3. Allow for building movement, including thermal expansion and contraction.
  4. Coordinate installation of anchorages. Furnish setting drawings, templates, and directions for installing anchorages, including sleeves, concrete inserts, anchor bolts, and items with integral anchors, that are to be embedded in concrete or masonry. Deliver such items to Project site in time for installation.
- H. Hazardous Materials: Use products, cleaners, and installation materials that are not considered hazardous.

### **3.5 CUTTING AND PATCHING**

- A. See Division 01 for additional requirements. The Contractor shall furnish sketches showing the location and sizes of all openings, chases, etc., required for the installation of Work.

- B. Work under this Division shall include furnishing, locating and setting inserts and/or sleeves required before the floors and walls are built or be responsible for cutting, drilling or chopping where sleeves and inserts were not installed, where wall or floors are existing or not correctly located. The Contractor shall do all drilling required for the installation of hangers.
- C. Exercise extreme caution when core drilling or punching openings in concrete floor slabs in order to avoid cutting or damaging structural members. No structural members or structural slabs/floors shall be cut without the written acceptance of the Structural Engineer and all such cutting shall be done in a manner directed by him.
- D. Cleaning: Clean areas and spaces where cutting and patching are performed. Remove paint, mortar, oils, putty, and similar materials from adjacent finished surfaces.

**3.6 SCAFFOLDING, RIGGING, HOISTING**

- A. Excavation and backfilling shall be done per Division 2 of the Specifications.
- B. The Contractor shall furnish all scaffolding, rigging, hoisting and services necessary for erection and delivery into the premises any equipment and apparatus furnished under this Division. Remove same from premises when no longer required.

**3.7 EXCAVATION AND BACKFILLING**

- A. It is the responsibility of the Contractor to coordinate sizes, depths, fill and bedding requirements and any other excavation work required under this Division.

**3.8 ACCESSIBILITY AND ACCESS PANELS**

- A. The Contractor shall be responsible for the sufficiency of the size of shafts and chases, the adequate thickness of partitions, and the adequate clearance in double partitions and hung ceilings for the proper installation of the Work.
- B. Locate all equipment which must be serviced, operated or maintained in fully accessible positions. Access doors shall be furnished for accessibility. Minor deviations from the Drawings may be made to allow better accessibility, but changes of magnitude or which involve extra cost shall not be made without the acceptance of the Engineer.
- C. Locate all equipment which must be serviced, operated or maintained in fully accessible positions. Equipment shall include, but not be limited to: motors, controllers, coil, valves, switchgear, drain points, etc. Access doors shall be furnished if required for better accessibility. Minor deviations from the Drawings may be made to allow better accessibility, but changes of magnitude or which involve extra cost shall not be made without the acceptance of the Engineer.

- D. Access doors in walls, ceilings, floors, etc., shall be field coordinated. It is the responsibility of the Contractor to coordinate and provide information regarding the sizes and quantities of access doors required for his work. The Contractor shall arrange his work in such a manner as to minimize the quantity of access doors required, such as grouping shutoff valves in the same area. Where possible, locate valves in already accessible areas, such as lay-in ceilings, etc.
- E. On a clean set of prints, the Contractor shall mark in red pencil the location of each required access door, including its size and fire rating (if any), and shall submit the print to the Architect for review before access doors are purchased or installed.
- F. Upon completion of the Project, the Contractor shall physically demonstrate that all equipment and devices installed have been located and/or provided with adequate access panels for repair, maintenance and/or operation. Any equipment not so furnished shall be relocated or provided with additional access panels by the installing Contractor at no additional cost to the Owner.

### **3.9 STARTING AND ADJUSTING**

- A. Start equipment and operating components to confirm proper operation. Remove malfunctioning units, replace with new units, and retest.
- B. Adjust operating components for proper operation without binding. Adjust equipment for proper operation.
- C. Test each piece of equipment to verify proper operation. Test and adjust controls and safeties. Replace damaged and malfunctioning controls and equipment.
- D. Manufacturer's Field Service: Provide a factory-authorized service representative to inspect field-assembled components and equipment installation, comply with qualification requirements in "Quality Requirements."

### **3.10 PROTECTION OF INSTALLED CONSTRUCTION**

- A. Provide final protection and maintain conditions that ensure installed Work is without damage or deterioration at time of Substantial Completion.
- B. Comply with manufacturer's written instructions for temperature and relative humidity.
- C. Remove debris from concealed spaces before enclosing the space.
- D. Remove liquid spills promptly.
- E. Where dust would impair proper execution of the Project scope of work, broom-clean or vacuum the entire work area, as appropriate.
- F. Installed Work: Keep installed work clean.

- G. Exposed Surfaces in Finished Areas: Clean exposed surfaces and protect as necessary to ensure freedom from damage and deterioration at time of Substantial Completion.
- H. During handling and installation, clean and protect construction in progress and adjoining materials already in place. Apply protective covering where required to ensure protection from damage or deterioration at Substantial Completion.
- I. Clean and provide maintenance on completed construction as frequently as necessary through the remainder of the construction period. Adjust and lubricate operable components to ensure operability without damaging effects.
- J. Limiting Exposures: Supervise construction operations to assure that no part of the construction completed or in progress, is subject to harmful, dangerous, damaging, or otherwise deleterious exposure during the construction period.

**3.11 CORRECTION OF THE WORK**

- A. The cost of corrective work shall be included under the contract.
- B. Repair or remove and replace defective construction.
  - 1. Repairing includes replacing defective parts, refinishing damaged surfaces, touching up with matching materials, and properly adjusting operating equipment.
- C. Restore permanent facilities used during construction to their specified or original condition.
- D. Remove and replace damaged surfaces that are exposed to view if surfaces cannot be repaired without visible evidence of repair.
- E. Repair components that do not operate properly. Remove and replace operating components to new condition.
- F. Remove and replace chipped, scratched, and broken glass or reflective surfaces.

**END OF SECTION 230010**

03/07/2017



**SECTION 230553 - IDENTIFICATION FOR HVAC PIPING AND EQUIPMENT**

**PART 1 - GENERAL**

**1.1 RELATED DOCUMENTS**

- A. Drawings and general provisions of the Contract, including General and Supplementary Conditions and Division 01 Specification Sections, apply to this Section.
- B. Products specified are for applications referenced in other HVAC specifications.

**1.2 SUMMARY**

- A. Section Includes:
  - 1. Equipment labels.
  - 2. Access panel and door labels.
  - 3. Pipe labels.
  - 4. Duct labels.
  - 5. Volume damper location flags.
  - 6. Valve tags.
  - 7. Valve schedules.
  - 8. Warning tags.

**1.3 ACTION SUBMITTALS**

- A. Product Data: For each type of product indicated.
- B. Samples: For color, letter style, and graphic representation required for each identification material and device.
- C. Equipment Label Schedule: Include a listing of all equipment to be labeled with the proposed content for each label. Furnish extra copies, in addition to mounted copies, for inclusion in maintenance manuals. Provide one copy on electronic media, type specified by Owner.
- D. Valve numbering scheme.
- E. Valve Schedules: Provide separate schedule for each piping system. Furnish extra copies, in addition to mounted copies, for inclusion in maintenance manuals. Provide one copy on electronic media, type specified by Owner.

**1.4 QUALITY ASSURANCE**

- A. ASME Compliance: Comply with ASME A13.1, "Scheme for the Identification of Piping Systems," for letter size, length of color field, colors, and viewing angles of identification devices for piping. Comply with recommendations in ASME A13.1 for labeling of equipment and ducts.

**1.5 COORDINATION**

- A. Coordinate installation of identifying devices with completion of covering and painting of surfaces where devices are to be applied.
- B. Coordinate installation of identifying devices with locations of access panels and doors.
- C. Install identifying devices before installing acoustical ceilings and similar concealment.
- D. Coordinate names, abbreviations, and other designations used in mechanical identification with Owner's desired identification scheme, regardless of numbering indicated on the drawing and specifications. Coordinate Owner's desired identification scheme with ASME and OSHA standards.
- E. Coordinate with Architect, locations of all identifying devices in public view areas.

**PART 2 - PRODUCTS**

**2.1 EQUIPMENT LABELS**

- A. Plastic Labels for Equipment:
  - 1. Material and Thickness: Multilayer, multicolor, plastic labels for mechanical engraving, 1/16 inch thick, and having predrilled holes for attachment hardware.
  - 2. Letter Color: White.
  - 3. Background Color: Blue.
  - 4. Maximum Temperature: Able to withstand temperatures up to 160 deg F.
  - 5. Minimum Label Size: Length and width vary for required label content, but not less than 2-1/2 by 3/4 inch.
  - 6. Minimum Letter Size: 1/4 inch for name of units if viewing distance is less than 24 inches, 1/2 inch for viewing distances up to 72 inches, and proportionately larger lettering for greater viewing distances. Include secondary lettering two-thirds to three-fourths the size of principal lettering.
  - 7. Fasteners: Stainless-steel rivets or self-tapping screws.
  - 8. Adhesive: Contact-type permanent adhesive, compatible with label and with substrate.

- B. Equipment Label Content: Include equipment's Drawing designation and Owner specified unique equipment number, Drawing numbers where equipment is indicated (plans, details, and schedules), plus the Specification Section number and title where equipment is specified.
- C. Equipment Label Schedule: For each item of equipment to be labeled, on 8-1/2-by-11-inch bond paper. Tabulate equipment identification number and identify Drawing numbers where equipment is indicated (plans, details, and schedules), plus the Specification Section number and title where equipment is specified. Equipment schedule shall be included in operation and maintenance data.

## **2.2 PIPE LABELS**

- A. General Requirements for Manufactured Pipe Labels: Preprinted, color-coded, with lettering indicating service, and showing flow direction. Color shall comply with ASME A13.1 unless otherwise indicated.
- B. Pretensioned Pipe Markers: Precoiled, semirigid plastic formed to cover circumference of pipe and to attach to pipe without fasteners or adhesive.
  - 1. For Pipes Equal To or Greater Than 6 Inches Outside Diameter with Insulation: Partial cover of circumference with a minimum length and width three times greater than the total lettering size or shaped pipe markers.
  - 2. For Pipes Less Than 6 Inches Outside Diameter with Insulation: Full cover of circumference.
- C. Pipe Label Contents: Include identification of piping service using same designations or abbreviations as used on Drawings, pipe size, and an arrow indicating flow direction.
  - 1. Flow-Direction Arrows: Integral with piping system service lettering to accommodate both directions, or as separate unit on each pipe label to indicate flow direction.
  - 2. Lettering Size: Manufacturer's standard preprinted captions appropriate for piping systems indicated or 1-1/2 inches high, if requested by Owner.
- D. Use metal labels for bare pipes conveying fluids at temperatures of 125 deg F or higher.

## **2.3 DUCT LABELS**

- A. General Requirements for Manufactured Duct Labels: Preprinted, color-coded with lettering indicating service and showing flow direction.
- B. Adhesive Duct Markers: Plastic with adhesive backing and peel off covering to attach to pipe without fasteners.
- C. Maximum Temperature: Able to withstand temperatures up to 160 deg F.



- D. Minimum Label Size: Length and width vary for required label content, but not less than 2-1/2 by 3/4 inch.
- E. Minimum Letter Size: 1/4 inch for name of units if viewing distance is less than 24 inches, 1/2 inch for viewing distances up to 72 inches, and proportionately larger lettering for greater viewing distances. Include secondary lettering two-thirds to three-fourths the size of principal lettering.
- F. Adhesive: Contact-type permanent adhesive, compatible with label and with substrate.
- G. Duct Label Contents: Include identification of duct service using same designations or abbreviations as used on Drawings, duct size, and an arrow indicating flow direction.
  - 1. Flow-Direction Arrows: Integral with duct system service lettering to accommodate both directions, or as separate unit on each duct label to indicate flow direction.
  - 2. Quantity of airflow and airflow type (i.e., supply, return, exhaust outdoor air, etc.).
  - 3. Lettering Size: At least 1-1/2 incheshigh.

#### **2.4 VALVE TAGS**

- A. Valve Tags: Stamped or engraved with 1/4-inch letters for piping system abbreviation and 1/2-inch numbers, with numbering scheme approved by Owner.
  - 1. Tag Material: Brass, 0.032-inch minimum thickness, and having predrilled or stamped holes for attachment hardware.
  - 2. Fasteners: Brass beaded chain.
- B. Valve Schedules: For each piping system, on 8-1/2-by-11-inch bond paper. Tabulate valve number, piping system, system abbreviation (as shown on valve tag), location of valve (room or space), normal-operating position (open, closed, or modulating), and variations for identification. Mark valves for emergency shutoff and similar special uses.
  - 1. Valve-tag schedule shall be included in operation and maintenance data.
  - 2. Valve Schedule Frames: Glazed display frame for removable mounting on masonry walls for each page of valve schedule. Include mounting screws.
  - 3. Frame: Extruded aluminum.
  - 4. Glazing: ASTM C 1036, Class 1, glazing quality B, 2.5 mm, single thickness glass.
- C. Schedule on Electronic Media:
  - 1. In addition to the framed paper schedule, provide valve schedule on electronic media, type specified by Owner, and identified points on as-built drawings.

**2.5 WARNING TAGS**

- A. Warning Tags: Preprinted or partially preprinted, accident-prevention tags, of plasticized card stock with matte finish suitable for writing.
1. Size: Approximately 4 by 7 inches.
  2. Fasteners: Brass grommet and wire.
  3. Nomenclature: Large-size primary caption such as "DANGER," "CAUTION," or "DO NOT OPERATE."
  4. Color: Yellow background with black lettering.

**2.6 VOLUME DAMPER LOCATION FLAGS**

- A. Flags: Yellow one-inch wide tape, minimum 18 inches long.

**PART 3 - EXECUTION****3.1 PREPARATION**

- A. Clean piping and equipment surfaces of substances that could impair bond of identification devices, including dirt, oil, grease, release agents, and incompatible primers, paints, and encapsulants.

**3.2 LABELING COLOR CODING**

- A. Color coding table for ducts, piping and equipment:

System	Background Color	Lettering Color
Supply Air	Dark Blue	White
Return Air	Yellow	Black
Exhaust Air (General)	Green	White

**3.3 EQUIPMENT LABEL INSTALLATION**

- A. Install or permanently fasten labels on each major item of mechanical equipment. Major equipment includes, but is not limited to, the following:
1. Fans, blowers, primary balancing dampers, variable air volume boxes, and mixing boxes.
  2. Packaged HVAC central-station and zone type units.
- B. Locate equipment labels where accessible and visible.
- C. Metal Label Content: Provide the following equipment information on metal labels only:
1. Equipment drawing designation and Owner specified unique equipment identification number.

2. Drawing numbers where equipment is located or specified (floor plans and schedules).
3. Specification section equipment is specified.
4. Manufacturer, model name and number, serial number(s).
5. Labels of equipment listings by testing agencies (e.g., UL listings).

D. Plastic Label Content: Provide the following equipment information on plastic labels:

1. Capacity, operating and power characteristics (e.g., entering and leaving conditions, speed, pressure drop).
2. Operating instructions and warnings.
3. Safety warnings.
4. Access panels and doors.

### **3.4 PIPE LABEL INSTALLATION**

A. Manufactured Pipe Labels: Provided on all piping except piping in return air plenums.

B. Locate pipe labels where piping is exposed or above accessible ceilings in finished spaces; machine rooms; accessible maintenance spaces such as shafts, tunnels, and plenums; and exterior exposed locations as follows:

1. Near each valve and control device.
2. Near each branch connection, excluding short takeoffs for fixtures and terminal units. Where flow pattern is not obvious, mark each pipe at branch.
3. Near penetrations through walls, floors, ceilings, and inaccessible enclosures.
4. At access doors, manholes, and similar access points that permit view of concealed piping.
5. Near major equipment items and other points of origination and termination.
6. Spaced at maximum intervals of 50 feet along each run. Reduce intervals to 25 feet in areas of congested piping and equipment.

C. Pipe Label Color Schedule: According to ASME 13.1, unless otherwise specified.

### **3.5 DUCT LABEL INSTALLATION**

A. Install self-adhesive duct labels with permanent adhesive on air ducts.

B. Locate labels near points where ducts enter into concealed spaces and at maximum intervals of 50 feet in each space where ducts are exposed or concealed by removable ceiling system.

### **3.6 VOLUME DAMPER FLAG INSTALLATION**

A. Install volume damper flags at each volume damper prior to insulation installation. Flags shall remain visible throughout construction.

- B. Remove flags from ductwork exposed in finished spaces after balancing reports are accepted.

**3.7 VALVE-TAG INSTALLATION**

- A. Install tags on valves and control devices in piping systems, with the following exceptions: check valves; valves within factory-fabricated equipment units; shutoff valves; faucets; and HVAC terminal devices and similar roughing-in connections of end-use fixtures and units. List tagged valves in a valve schedule.
- B. Valve-Tag Application Schedule: Tag valves according to size, shape, and color scheme and with captions similar to those indicated in the following subparagraphs:
  - 1. Valve-Tag Size and Shape: 1-1/2 inches, round.
  - 2. Valve-Tag Color: Natural.
  - 3. Letter Color: Black.

**3.8 WARNING-TAG INSTALLATION**

- A. Write required message on, and attach warning tags to, equipment and other items where required.

**3.9 VALVE SCHEDULE INSTALLATION**

- A. Mount valve schedule on wall in accessible location in each major equipment room.

**3.10 ADJUSTING**

- A. Relocate mechanical identification materials and devices that have become visually blocked by other work.

**3.11 CLEANING**

- A. Clean faces of mechanical identification devices and glass frames of valve schedules.

**END OF SECTION 230553**

03/07/2017



**SECTION 230593 - TESTING, ADJUSTING, AND BALANCING FOR HVAC**

**PART 1 - GENERAL**

**1.1 RELATED DOCUMENTS**

- A. Drawings and general provisions of the Contract, including General and Supplementary Conditions and Division 01 Specification Sections, apply to this Section.

**1.2 SUMMARY**

- A. Section Includes:
  - 1. Balancing Air Systems:
    - a. Constant-volume air systems.
    - b. Variable-air-volume systems.

**1.3 DEFINITIONS**

- A. AABC: Associated Air Balance Council.
- B. NEBB: National Environmental Balancing Bureau.
- C. TAB: Testing, adjusting, and balancing.
- D. TABB: Testing, Adjusting, and Balancing Bureau.
- E. TAB Specialist: An entity engaged to perform TAB Work.

**1.4 INFORMATIONAL SUBMITTALS**

- A. Qualification Data: Within 30 days of Contractor's Notice to Proceed, submit documentation that the TAB contractor and this Project's TAB team members meet the qualifications specified in "Quality Assurance" Article.
- B. Contract Documents Examination Report: Within 45 days of Contractor's Notice to Proceed, submit the Contract Documents review report as specified in Part 3.
- C. Strategies and Procedures Plan: Within 60 days of Contractor's Notice to Proceed, submit TAB strategies and step-by-step procedures as specified in "Preparation" Article.
- D. Certified TAB reports.
- E. Sample report forms.

- F. Sample pressure profile diagrams.
- G. Proposed pressure profile locations.
- H. Instrument calibration reports, to include the following:
  - 1. Instrument type and make.
  - 2. Serial number.
  - 3. Application.
  - 4. Dates of use.
  - 5. Dates of calibration.

**1.5 QUALITY ASSURANCE**

- A. TAB Contractor Qualifications: Engage a TAB entity certified by AABC or NEBB.
  - 1. TAB Field Supervisor: Employee of the TAB contractor and certified by AABC or NEBB.
  - 2. TAB Technician: Employee of the TAB contractor and who is certified by AABC or NEBB as a TAB technician.
- B. TAB Conference: Meet with Architect on approval of the TAB strategies and procedures plan to develop a mutual understanding of the details. Require the participation of the TAB field supervisor and technicians. Provide seven days' advance notice of scheduled meeting time and location.
  - 1. Agenda Items:
    - a. The Contract Documents examination report.
    - b. The TAB plan.
    - c. Coordination and cooperation of trades and subcontractors.
    - d. Coordination of documentation and communication flow.
- C. Certify TAB field data reports and perform the following:
  - 1. Review field data reports to validate accuracy of data and to prepare certified TAB reports.
  - 2. Certify that the TAB team complied with the approved TAB plan and the procedures specified and referenced in this Specification.
- D. TAB Report Forms: Use standard TAB contractor's forms approved by Architect.
- E. Instrumentation Type, Quantity, Accuracy, and Calibration: As described in ASHRAE 111, Section 5, "Instrumentation."

- F. ASHRAE Compliance: Applicable requirements in ASHRAE 62.1, Section 7.2.2 - "Air Balancing."
- G. ASHRAE/IESNA Compliance: Applicable requirements in ASHRAE/IESNA 90.1, Section 6.7.2.3 - "System Balancing."

**1.6 PROJECT CONDITIONS**

- A. Full Owner Occupancy: Owner will occupy the site and existing building during entire TAB period. Cooperate with Owner during TAB operations to minimize conflicts with Owner's operations.

**1.7 COORDINATION**

- A. Notice: Provide seven days' advance notice for each test. Include scheduled test dates and times.
- B. Perform TAB after leakage and pressure tests on air distribution systems have been satisfactorily completed.

**PART 2 - PRODUCTS (Not Applicable)**

**PART 3 - EXECUTION**

**3.1 EXAMINATION**

- A. Examine the Contract Documents to become familiar with Project requirements and to discover conditions in systems' designs that may preclude proper TAB of systems and equipment.
- B. Examine systems for installed balancing devices, such as test ports, gage cocks, thermometer wells, flow-control devices, balancing valves and fittings, and manual volume dampers. Verify that locations of these balancing devices are accessible.
- C. Examine the approved submittals for HVAC systems and equipment.
- D. Examine design data including HVAC system descriptions, statements of design assumptions for environmental conditions and systems' output, and statements of philosophies and assumptions about HVAC system and equipment controls.
- E. Examine ceiling plenums and underfloor air plenums used for supply, return, or relief air to verify that they meet the leakage class of connected ducts as specified in Section 233113 "Metal Ducts" and are properly separated from adjacent areas. Verify that penetrations in plenum walls are sealed and fire-stopped if required.
- F. Examine equipment performance data including fan and pump curves.



1. Relate performance data to Project conditions and requirements, including system effects that can create undesired or unpredicted conditions that cause reduced capacities in all or part of a system.
  2. Calculate system-effect factors to reduce performance ratings of HVAC equipment when installed under conditions different from the conditions used to rate equipment performance. To calculate system effects for air systems, use tables and charts found in AMCA 201, "Fans and Systems," or in SMACNA's "HVAC Systems - Duct Design." Compare results with the design data and installed conditions.
- G. Examine system and equipment installations and verify that field quality-control testing, cleaning, and adjusting specified in individual Sections have been performed.
- H. Examine test reports specified in individual system and equipment Sections.
- I. Examine HVAC equipment and filters and verify that bearings are greased, belts are aligned and tight, and equipment with functioning controls is ready for operation.
- J. Examine terminal units, such as variable-air-volume boxes, and verify that they are accessible and their controls are connected and functioning.
- K. Examine three-way valves for proper installation for their intended function of diverting or mixing fluid flows.
- L. Examine heat-transfer coils for correct piping connections and for clean and straight fins.
- M. Examine operating safety interlocks and controls on HVAC equipment.
- N. Report deficiencies discovered before and during performance of TAB procedures. Observe and record system reactions to changes in conditions. Record default set points if different from indicated values.

### **3.2 PREPARATION**

- A. Prepare a TAB plan that includes strategies and step-by-step procedures.
- B. Complete system-readiness checks and prepare reports. Verify the following:
1. Permanent electrical-power wiring is complete.
  2. Automatic temperature-control systems are operational.
  3. Equipment and duct access doors are securely closed.
  4. Balance, smoke, and fire dampers are open.
  5. Ceilings are installed in critical areas where air-pattern adjustments are required and access to balancing devices is provided.
  6. Windows and doors can be closed so indicated conditions for system operations can be met.

**3.3 GENERAL PROCEDURES FOR TESTING AND BALANCING**

- A. Perform testing and balancing procedures on each system according to the procedures contained in AABC's "National Standards for Total System Balance" or NEBB's "Procedural Standards for Testing, Adjusting, and Balancing of Environmental Systems" and in this Section.
1. Comply with requirements in ASHRAE 62.1, Section 7.2.2 - "Air Balancing."
- B. Cut insulation, ducts, pipes, and equipment cabinets for installation of test probes to the minimum extent necessary for TAB procedures.
1. After testing and balancing, patch probe holes in ducts with same material and thickness as used to construct ducts.
  2. After testing and balancing, install test ports and duct access doors that comply with requirements in Section 233300 "Air Duct Accessories."
  3. Install and join new insulation that matches removed materials. Restore insulation, coverings, vapor barrier, and finish according to Section 230713 "Duct Insulation," Section 230716 "HVAC Equipment Insulation," and Section 230719 "HVAC Piping Insulation."
- C. Mark equipment and balancing devices, including damper-control positions, valve position indicators, fan-speed-control levers, and similar controls and devices, with paint or other suitable, permanent identification material to show final settings.
- D. Upon successful completion of air and hydronic balancing, measure, record and provide for final reports, pressure profiles of all air and hydronic systems. Pressure profiles shall include, but not be limited to the following:
1. Air Handling Equipment (AHU, RTU, ERU, MUA, EF, Etc.): Pressure measurements across filters, coils, blenders, dampers, fans, etc.
  2. Pumps, Prime Movers: Pressure measurements across suction diffuser heads, pump suction/discharge, triple duty valves, and other pressure loss appurtenances.
  3. Supply Duct Systems: Record operating static pressures at various locations (minimum 2 readings) downstream of the fan discharge focusing on any major duct transitions, elbows, change in directions, split flow fittings more than 25% of total upstream flow.
  4. Return Duct Systems: Record operating static pressures at various locations (minimum 2 readings) downstream of the fan discharge focusing on any major duct transitions, elbows, change in directions, split flow fittings more than 25% of total downstream flow.
  5. Pressure profiles shall be in diagrammatic format representative of the system and its components and locations where measurements are taken.
  6. Coordinate measurement locations in field with Engineer and Commissioning Agent prior to taking readings.
- E. Take and report testing and balancing measurements in inch-pound (IP) units.

**3.4 PRELIMINARY PROCEDURES - RENOVATION / REMODEL WORK**

- A. In remodel area, a complete preliminary test and balance report shall be accomplished prior to any work. Any obvious deficiencies shall be identified at that time. A complete report of all readings, recommendations, etc., shall be submitted to the Engineer.

**3.5 GENERAL PROCEDURES FOR BALANCING AIR SYSTEMS**

- A. Prepare test reports for both fans and outlets. Obtain manufacturer's outlet factors and recommended testing procedures. Crosscheck the summation of required outlet volumes with required fan volumes.
- B. Prepare schematic diagrams of systems' "as-built" duct layouts.
- C. For variable-air-volume systems, develop a plan to simulate diversity.
- D. Determine the best locations in main and branch ducts for accurate duct-airflow measurements.
- E. Check airflow patterns from the outdoor-air louvers and dampers and the return- and exhaust-air dampers through the supply-fan discharge and mixing dampers.
- F. Locate start-stop and disconnect switches, electrical interlocks, and motor starters.
- G. Verify that motor starters are equipped with properly sized thermal protection.
- H. Check dampers for proper position to achieve desired airflow path.
- I. Check for airflow blockages.
- J. Check condensate drains for proper connections and functioning.
- K. Check for proper sealing of air-handling-unit components.
- L. Verify that air duct system is sealed as specified in Section 233113 "Metal Ducts."

**3.6 PROCEDURES FOR CONSTANT-VOLUME AIR SYSTEMS**

- A. Adjust fans to deliver total indicated airflows within the maximum allowable fan speed listed by fan manufacturer.
  - 1. Measure total airflow.
    - a. Where sufficient space in ducts is unavailable for Pitot-tube traverse measurements, measure airflow at terminal outlets and inlets and calculate the total airflow.

2. Measure fan static pressures as follows to determine actual static pressure:
    - a. Measure outlet static pressure as far downstream from the fan as practical and upstream from restrictions in ducts such as elbows and transitions.
    - b. Measure static pressure directly at the fan outlet or through the flexible connection.
    - c. Measure inlet static pressure of single-inlet fans in the inlet duct as near the fan as possible, upstream from the flexible connection, and downstream from duct restrictions.
    - d. Measure inlet static pressure of double-inlet fans through the wall of the plenum that houses the fan.
  3. Measure static pressure across each component that makes up an air-handling unit, rooftop unit, and other air-handling and -treating equipment.
    - a. Report the cleanliness status of filters and the time static pressures are measured.
  4. Measure static pressures entering and leaving other devices, such as sound traps, heat-recovery equipment, and air washers, under final balanced conditions.
  5. Review Record Documents to determine variations in design static pressures versus actual static pressures. Calculate actual system-effect factors. Recommend adjustments to accommodate actual conditions.
  6. Obtain approval from Architect for adjustment of fan speed higher or lower than indicated speed. Comply with requirements in HVAC Sections for air-handling units for adjustment of fans, belts, and pulley sizes to achieve indicated air-handling-unit performance.
  7. Do not make fan-speed adjustments that result in motor overload. Consult equipment manufacturers about fan-speed safety factors. Modulate dampers and measure fan-motor amperage to ensure that no overload will occur. Measure amperage in full-cooling, full-heating, economizer, and any other operating mode to determine the maximum required brake horsepower.
- B. Adjust volume dampers for main duct, submain ducts, and major branch ducts to indicated airflows within specified tolerances.
1. Measure airflow of submain and branch ducts.
    - a. Where sufficient space in submain and branch ducts is unavailable for Pitot-tube traverse measurements, measure airflow at terminal outlets and inlets and calculate the total airflow for that zone.
  2. Measure static pressure at a point downstream from the balancing damper, and adjust volume dampers until the proper static pressure is achieved.
  3. Remeasure each submain and branch duct after all have been adjusted. Continue to adjust submain and branch ducts to indicated airflows within specified tolerances.
- C. Measure air outlets and inlets without making adjustments.

1. Measure terminal outlets using a direct-reading hood or outlet manufacturer's written instructions and calculating factors.
- D. Adjust air outlets and inlets for each space to indicated airflows within specified tolerances of indicated values. Make adjustments using branch volume dampers rather than extractors and the dampers at air terminals.
  1. Adjust each outlet in same room or space to within specified tolerances of indicated quantities without generating noise levels above the limitations prescribed by the Contract Documents.
  2. Adjust patterns of adjustable outlets for proper distribution without drafts.

### **3.7 PROCEDURES FOR VARIABLE-AIR-VOLUME SYSTEMS**

- A. Compensating for Diversity: When the total airflow of all terminal units is more than the indicated airflow of the fan, place a selected number of terminal units at a minimum set-point airflow with the remainder at maximum-airflow condition until the total airflow of the terminal units equals the indicated airflow of the fan. Select the reduced-airflow terminal units so they are distributed evenly among the branch ducts.
- B. Pressure-Independent, Variable-Air-Volume Systems: After the fan systems have been adjusted, adjust the variable-air-volume systems as follows:
  1. Set outdoor-air dampers at minimum, and set return- and exhaust-air dampers at a position that simulates full-cooling load.
  2. Select the terminal unit that is most critical to the supply-fan airflow and static pressure. Measure static pressure. Adjust system static pressure so the entering static pressure for the critical terminal unit is not less than the sum of the terminal-unit manufacturer's recommended minimum inlet static pressure plus the static pressure needed to overcome terminal-unit discharge system losses.
  3. Measure total system airflow. Adjust to within indicated airflow.
  4. Set terminal units at maximum airflow and adjust controller or regulator to deliver the designed maximum airflow. Use terminal-unit manufacturer's written instructions to make this adjustment. When total airflow is correct, balance the air outlets downstream from terminal units the same as described for constant-volume air systems.
  5. Set terminal units at minimum airflow and adjust controller or regulator to deliver the designed minimum airflow. Check air outlets for a proportional reduction in airflow the same as described for constant-volume air systems.
    - a. If air outlets are out of balance at minimum airflow, report the condition but leave outlets balanced for maximum airflow.
  6. Remeasure the return airflow to the fan while operating at maximum return airflow and minimum outdoor airflow.

- a. Adjust the fan and balance the return-air ducts and inlets the same as described for constant-volume air systems.
7. Measure static pressure at the most critical terminal unit and adjust the static-pressure controller at the main supply-air sensing station to ensure that adequate static pressure is maintained at the most critical unit.
8. Record final fan-performance data.

### **3.8 PROCEDURES FOR MOTORS**

- A. Motors, 1/2 HP and Larger: Test at final balanced conditions and record the following data:
  1. Manufacturer's name, model number, and serial number.
  2. Motor horsepower rating.
  3. Motor rpm.
  4. Efficiency rating.
  5. Nameplate and measured voltage, each phase.
  6. Nameplate and measured amperage, each phase.
  7. Starter thermal-protection-element rating.
- B. Motors Driven by Variable-Frequency Controllers: Test for proper operation at speeds varying from minimum to maximum. Test the manual bypass of the controller to prove proper operation. Record observations including name of controller manufacturer, model number, serial number, and nameplate data.

### **3.9 PROCEDURES FOR CONDENSING UNITS**

- A. Verify proper rotation of fans.
- B. Measure entering- and leaving-air temperatures.
- C. Record compressor data.

### **3.10 PROCEDURES FOR HEAT-TRANSFER COILS**

- A. Measure, adjust, and record the following data for each water coil:
  1. Entering- and leaving-water temperature.
  2. Water flow rate.
  3. Water pressure drop.
  4. Dry-bulb temperature of entering and leaving air.
  5. Wet-bulb temperature of entering and leaving air for cooling coils.
  6. Airflow.
  7. Air pressure drop.

- B. Measure, adjust, and record the following data for each electric heating coil:
1. Nameplate data.
  2. Airflow.
  3. Entering- and leaving-air temperature at full load.
  4. Voltage and amperage input of each phase at full load and at each incremental stage.
  5. Calculated kilowatt at full load.
  6. Fuse or circuit-breaker rating for overload protection.
- C. Measure, adjust, and record the following data for each steam coil:
1. Dry-bulb temperature of entering and leaving air.
  2. Airflow.
  3. Air pressure drop.
  4. Inlet steam pressure.
- D. Measure, adjust, and record the following data for each refrigerant coil:
1. Dry-bulb temperature of entering and leaving air.
  2. Wet-bulb temperature of entering and leaving air.
  3. Airflow.
  4. Air pressure drop.
  5. Refrigerant suction pressure and temperature.

**3.11 PROCEDURES FOR TESTING, ADJUSTING, AND BALANCING EXISTING SYSTEMS**

- A. Perform a preconstruction inspection of existing equipment that is to remain and be reused.
1. Measure and record the operating speed, airflow, and static pressure of each fan.
  2. Measure motor voltage and amperage. Compare the values to motor nameplate information.
  3. Check the refrigerant charge.
  4. Check the condition of filters.
  5. Check the condition of coils.
  6. Check the operation of the drain pan and condensate-drain trap.
  7. Check bearings and other lubricated parts for proper lubrication.
  8. Report on the operating condition of the equipment and the results of the measurements taken. Report deficiencies.
- B. Before performing testing and balancing of existing systems, inspect existing equipment that is to remain and be reused to verify that existing equipment has been cleaned and refurbished. Verify the following:
1. New filters are installed.
  2. Coils are clean and fins combed.

3. Drain pans are clean.
  4. Fans are clean.
  5. Bearings and other parts are properly lubricated.
  6. Deficiencies noted in the preconstruction report are corrected.
- C. Perform testing and balancing of existing systems to the extent that existing systems are affected by the renovation work.
1. Compare the indicated airflow of the renovated work to the measured fan airflows, and determine the new fan speed and the face velocity of filters and coils.
  2. Verify that the indicated airflows of the renovated work result in filter and coil face velocities and fan speeds that are within the acceptable limits defined by equipment manufacturer.
  3. If calculations increase or decrease the air flow rates and water flow rates by more than 5 percent, make equipment adjustments to achieve the calculated rates. If increase or decrease is 5 percent or less, equipment adjustments are not required.
  4. Balance each air outlet.

### **3.12 TOLERANCES**

- A. Set HVAC system's air flow rates and water flow rates within the following tolerances:
1. Supply, Return, and Exhaust Fans and Equipment with Fans: Plus or minus 10 percent.
  2. Air Outlets and Inlets: Plus or minus 10 percent; plus or minus 5 percent for laboratory applications.

### **3.13 REPORTING**

- A. Initial Construction-Phase Report: Based on examination of the Contract Documents as specified in "Examination" Article, prepare a report on the adequacy of design for systems' balancing devices. Recommend changes and additions to systems' balancing devices to facilitate proper performance measuring and balancing. Recommend changes and additions to HVAC systems and general construction to allow access for performance measuring and balancing devices.

### **3.14 FINAL REPORT**

- A. General: Prepare a certified written report; tabulate and divide the report into separate sections for tested systems and balanced systems.
1. Include a certification sheet at the front of the report's binder, signed and sealed by the certified testing and balancing engineer.
  2. Include a list of instruments used for procedures, along with proof of calibration.



- B. Final Report Contents: In addition to certified field-report data, include the following:
1. Pump curves.
  2. Fan curves.
  3. Manufacturers' test data.
  4. Field test reports prepared by system and equipment installers.
  5. Other information relative to equipment performance; do not include Shop Drawings and product data.
- C. General Report Data: In addition to form titles and entries, include the following data:
1. Title page.
  2. Name and address of the TAB contractor.
  3. Project name.
  4. Project location.
  5. Architect's name and address.
  6. Engineer's name and address.
  7. Contractor's name and address.
  8. Report date.
  9. Signature of TAB supervisor who certifies the report.
  10. Table of Contents with the total number of pages defined for each section of the report. Number each page in the report.
  11. Summary of contents including the following:
    - a. Indicated versus final performance.
    - b. Notable characteristics of systems.
    - c. Description of system operation sequence if it varies from the Contract Documents.
  12. Nomenclature sheets for each item of equipment.
  13. Data for terminal units, including manufacturer's name, type, size, and fittings.
  14. Notes to explain why certain final data in the body of reports vary from indicated values.
  15. Test conditions for fans and pump performance forms including the following:
    - a. Settings for outdoor-, return-, and exhaust-air dampers.
    - b. Conditions of filters.
    - c. Cooling coil, wet- and dry-bulb conditions.
    - d. Face and bypass damper settings at coils.
    - e. Fan drive settings including settings and percentage of maximum pitch diameter.
    - f. Inlet vane settings for variable-air-volume systems.
    - g. Settings for supply-air, static-pressure controller.
    - h. Other system operating conditions that affect performance.

- D. System Diagrams: Include schematic layouts of air and hydronic distribution systems. Present each system with single-line diagram and include the following:
1. Quantities of outdoor, supply, return, and exhaust airflows.
  2. Water and steam flow rates.
  3. Duct, outlet, and inlet sizes.
  4. Pipe and valve sizes and locations.
  5. Terminal units.
  6. Balancing stations.
  7. Position of balancing devices.
- E. Air-Handling-Unit Test Reports: For air-handling units with coils, include the following:
1. Unit Data:
    - a. Unit identification.
    - b. Location.
    - c. Make and type.
    - d. Model number and unit size.
    - e. Manufacturer's serial number.
    - f. Unit arrangement and class.
    - g. Discharge arrangement.
    - h. Sheave make, size in inches, and bore.
    - i. Center-to-center dimensions of sheave, and amount of adjustments in inches.
    - j. Number, make, and size of belts.
    - k. Number, type, and size of filters.
  2. Motor Data:
    - a. Motor make, and frame type and size.
    - b. Horsepower and rpm.
    - c. Volts, phase, and hertz.
    - d. Full-load amperage and service factor.
    - e. Sheave make, size in inches, and bore.
    - f. Center-to-center dimensions of sheave, and amount of adjustments in inches.
  3. Test Data (Indicated and Actual Values):
    - a. Total air flow rate in cfm.
    - b. Total system static pressure in inches wg.
    - c. Fan rpm.
    - d. Discharge static pressure in inches wg.
    - e. Filter static-pressure differential in inches wg.
    - f. Preheat-coil static-pressure differential in inches wg.
    - g. Cooling-coil static-pressure differential in inches wg.
    - h. Heating-coil static-pressure differential in inches wg.

- i. Outdoor airflow in cfm.
- j. Return airflow in cfm.
- k. Outdoor-air damper position.
- l. Return-air damper position.
- m. Vortex damper position.

F. Apparatus-Coil Test Reports:

1. Coil Data:

- a. System identification.
- b. Location.
- c. Coil type.
- d. Number of rows.
- e. Fin spacing in fins per inch o.c.
- f. Make and model number.
- g. Face area in sq. ft..
- h. Tube size in NPS.
- i. Tube and fin materials.
- j. Circuiting arrangement.

2. Test Data (Indicated and Actual Values):

- a. Air flow rate in cfm.
- b. Average face velocity in fpm.
- c. Air pressure drop in inches wg.
- d. Outdoor-air, wet- and dry-bulb temperatures in deg F.
- e. Return-air, wet- and dry-bulb temperatures in deg F.
- f. Entering-air, wet- and dry-bulb temperatures in deg F.
- g. Leaving-air, wet- and dry-bulb temperatures in deg F.
- h. Water flow rate in gpm.
- i. Water pressure differential in feet of head or psig.
- j. Entering-water temperature in deg F.
- k. Leaving-water temperature in deg F.
- l. Refrigerant expansion valve and refrigerant types.
- m. Refrigerant suction pressure in psig.
- n. Refrigerant suction temperature in deg F.
- o. Inlet steam pressure in psig.

G. Electric-Coil Test Reports: For electric furnaces, duct coils, and electric coils installed in central-station air-handling units, include the following:

1. Unit Data:

- a. System identification.
- b. Location.

- c. Coil identification.
  - d. Capacity in Btu/h.
  - e. Number of stages.
  - f. Connected volts, phase, and hertz.
  - g. Rated amperage.
  - h. Air flow rate in cfm.
  - i. Face area in sq. ft..
  - j. Minimum face velocity in fpm.
2. Test Data (Indicated and Actual Values):
- a. Heat output in Btu/h.
  - b. Air flow rate in cfm.
  - c. Air velocity in fpm.
  - d. Entering-air temperature in deg F.
  - e. Leaving-air temperature in deg F.
  - f. Voltage at each connection.
  - g. Amperage for each phase.

H. Fan Test Reports: For supply, return, and exhaust fans, include the following:

1. Fan Data:
- a. System identification.
  - b. Location.
  - c. Make and type.
  - d. Model number and size.
  - e. Manufacturer's serial number.
  - f. Arrangement and class.
  - g. Sheave make, size in inches, and bore.
  - h. Center-to-center dimensions of sheave, and amount of adjustments in inches.
2. Motor Data:
- a. Motor make, and frame type and size.
  - b. Horsepower and rpm.
  - c. Volts, phase, and hertz.
  - d. Full-load amperage and service factor.
  - e. Sheave make, size in inches, and bore.
  - f. Center-to-center dimensions of sheave, and amount of adjustments in inches.
  - g. Number, make, and size of belts.
3. Test Data (Indicated and Actual Values):
- a. Total airflow rate in cfm.
  - b. Total system static pressure in inches wg.

- c. Fan rpm.
  - d. Discharge static pressure in inches wg.
  - e. Suction static pressure in inches wg.
- I. Round, Flat-Oval, and Rectangular Duct Traverse Reports: Include a diagram with a grid representing the duct cross-section and record the following:
- 1. Report Data:
    - a. System and air-handling-unit number.
    - b. Location and zone.
    - c. Traverse air temperature in deg F.
    - d. Duct static pressure in inches wg.
    - e. Duct size in inches.
    - f. Duct area in sq. ft..
    - g. Indicated air flow rate in cfm.
    - h. Indicated velocity in fpm.
    - i. Actual air flow rate in cfm.
    - j. Actual average velocity in fpm.
    - k. Barometric pressure in psig.
- J. Air-Terminal-Device Reports:
- 1. Unit Data:
    - a. System and air-handling unit identification.
    - b. Location and zone.
    - c. Apparatus used for test.
    - d. Area served.
    - e. Make.
    - f. Number from system diagram.
    - g. Type and model number.
    - h. Size.
    - i. Effective area in sq. ft..
  - 2. Test Data (Indicated and Actual Values):
    - a. Air flow rate in cfm.
    - b. Air velocity in fpm.
    - c. Preliminary air flow rate as needed in cfm.
    - d. Preliminary velocity as needed in fpm.
    - e. Final air flow rate in cfm.
    - f. Final velocity in fpm.
    - g. Space temperature in deg F.

K. System-Coil Reports: For reheat coils and water coils of terminal units, include the following:

1. Unit Data:
  - a. System and air-handling-unit identification.
  - b. Location and zone.
  - c. Room or riser served.
  - d. Coil make and size.
  - e. Flowmeter type.
2. Test Data (Indicated and Actual Values):
  - a. Air flow rate in cfm.
  - b. Entering-water temperature in deg F.
  - c. Leaving-water temperature in deg F.
  - d. Water pressure drop in feet of head or psig.
  - e. Entering-air temperature in deg F.
  - f. Leaving-air temperature in deg F.

L. Instrument Calibration Reports:

1. Report Data:
  - a. Instrument type and make.
  - b. Serial number.
  - c. Application.
  - d. Dates of use.
  - e. Dates of calibration.

### 3.15 **INSPECTIONS**

A. Initial Inspection:

1. After testing and balancing are complete, operate each system and randomly check measurements to verify that the system is operating according to the final test and balance readings documented in the final report.
2. Check the following for each system:
  - a. Measure airflow of at least 10 percent of air outlets.
  - b. Measure water flow of at least 5 percent of terminals.
  - c. Measure room temperature at each thermostat/temperature sensor. Compare the reading to the set point.
  - d. Verify that balancing devices are marked with final balance position.
  - e. Note deviations from the Contract Documents in the final report.

B. Final Inspection:

1. After initial inspection is complete and documentation by random checks verifies that testing and balancing are complete and accurately documented in the final report, request that a final inspection be made by Architect.
2. The TAB contractor's test and balance engineer shall conduct the inspection in the presence of Architect.
3. Architect shall randomly select measurements, documented in the final report, to be rechecked. Rechecking shall be limited to either 10 percent of the total measurements recorded or the extent of measurements that can be accomplished in a normal 8-hour business day.
4. If rechecks yield measurements that differ from the measurements documented in the final report by more than the tolerances allowed, the measurements shall be noted as "FAILED."
5. If the number of "FAILED" measurements is greater than 10 percent of the total measurements checked during the final inspection, the testing and balancing shall be considered incomplete and shall be rejected.

C. TAB Work will be considered defective if it does not pass final inspections. If TAB Work fails, proceed as follows:

1. Recheck all measurements and make adjustments. Revise the final report and balancing device settings to include all changes; resubmit the final report and request a second final inspection.
2. If the second final inspection also fails, Owner may contract the services of another TAB contractor to complete TAB Work according to the Contract Documents and deduct the cost of the services from the original TAB contractor's final payment.

D. Prepare test and inspection reports.

**3.16 ADDITIONAL TESTS**

- A. Within 90 days of completing TAB, perform additional TAB to verify that balanced conditions are being maintained throughout and to correct unusual conditions.
- B. Seasonal Periods: If initial TAB procedures were not performed during near-peak summer and winter conditions, perform additional TAB during near-peak summer and winter conditions.

**END OF SECTION 230593**

03/07/2017

**SECTION 230713 - DUCT INSULATION**

**PART 1 - GENERAL**

**1.1 RELATED DOCUMENTS**

- A. Drawings and general provisions of the Contract, including General and Supplementary Conditions and Division 01 Specification Sections, apply to this Section.

**1.2 DEFINITIONS**

- A. Outside Air: Air originating from outside the building, from the primary environment surrounding the building. Outside air includes make-up air, combustion air, fresh air, and other types of air.
- B. Exterior Space: Spaces outside the exterior building envelope that separate conditioned space from the exterior or outside.
- C. Conditioned Space: An enclosed space within a building that is both mechanically heated and mechanically cooled.
- D. Heated Space: An enclosed space within a building that is mechanically heated but not mechanically cooled.
- E. Indirectly Conditioned Space: An enclosed space within a building that is not mechanically heated or cooled, which is heated or cooled by being connected to adjacent spaces. Select examples include spaces above non-insulated ceilings, return air ceiling plenums, unventilated attics with the building envelope insulation at the roof line.
- F. Semi-Heated Space: An enclosed space within a building that is heated and controlled to a temperature maximum of 55 deg. F. Select examples include mechanical rooms, electrical rooms, tunnels.
- G. Unconditioned Space: An enclosed space within a building that is not mechanically cooled or heated and is not indirectly conditioned. Select examples include crawl spaces, storage rooms connecting to the outside, ventilated attics, unventilated attics where the building envelope insulation is located at the ceiling below the attic.
- H. Concealed Ducts/Pipes: Ducts/Pipes not visible within the room where they are located, after project is completed.
- I. Exposed Ducts/Pipes: Ducts/Pipes visible within the room where they are located, after project is completed.



- J. Ceiling Space/Plenum: An enclosed portion of the building structure, other than an occupiable space being conditioned, that is designed to allow air movement, and thereby serve as part of an air distribution system.
- K. Plenum: Part of the duct system connected to diffusers, registers, grilles, louvers for air movement applications.
- L. Moisture Exhaust: Exhaust air that carries a higher than ambient level of moisture/humidity in the stream. Examples include, but are not limited to dishwashers, shower areas, wash areas (clothing, process, etc.), hospital equipment/device cleaning and sterilizing.

### **1.3 SUMMARY**

- A. Section includes insulating the following duct services:
  - 1. Indoor, concealed supply and outdoor air.
  - 2. Indoor, exposed supply and outdoor air.
  - 3. Indoor, concealed return located in unconditioned space.
  - 4. Indoor, exposed return located in unconditioned space.
  - 5. Supply diffuser plenums 4 sq. ft. and larger.
  - 6. Return/Exhaust register/grille plenums 4 sq. ft. and larger in conditioned spaces.

### **1.4 ACTION SUBMITTALS**

- A. Product Data: For each type of product indicated. Include thermal conductivity, water-vapor permeance thickness, and jackets (both factory- and field-applied if any).
- B. Shop Drawings: Include plans, elevations, sections, details, and attachments to other work.
  - 1. Detail application of protective shields, saddles, and inserts at hangers for each type of insulation and hanger.
  - 2. Detail insulation application at elbows, fittings, dampers, specialties and flanges for each type of insulation.
  - 3. Detail application of field-applied jackets.
  - 4. Detail application at linkages of control devices.
  - 5. Manufacturer's installation requirements, instructions and details of fire-rated insulation, including through-penetration and access door details, in accordance with Nationally Recognized Testing Laboratory (NRTL) listings and testing criteria for listed product and project specific applications and codes. Include maximum duct size, minimum duct gauge, and number of layers and thickness product is tested and listed for.
    - a. Submit ICC Evaluation Service Report (ESR) indicating compliance with installation requirements for grease exhaust applications.
  - 6. Submit application schedule indicating each system and barrier provided.
  - 7. Submit proof of manufacturer's certified installer.

**1.5 INFORMATIONAL SUBMITTALS**

- A. Qualification Data: For qualified Installer.
  - 1. For fire-rated blanket, proof of installer certified by manufacturer.
- B. Material Test Reports: From a qualified testing agency acceptable to authorities having jurisdiction indicating, interpreting, and certifying test results for compliance of insulation materials, sealers, attachments, cements, and jackets, with requirements indicated. Include dates of tests and test methods employed.
- C. Field quality-control reports for fire-rated insulation systems.

**1.6 QUALITY ASSURANCE**

- A. Installer Qualifications: Skilled mechanics who have successfully completed an apprenticeship program or another craft training program certified by the Department of Labor, Bureau of Apprenticeship and Training.
  - 1. For fire-rated blanket, proof of installer certified by manufacturer.
- B. Surface-Burning Characteristics: For insulation and related materials, as determined by testing identical products according to ASTM E 84, by a testing agency acceptable to authorities having jurisdiction. Factory label insulation and jacket materials and adhesive, mastic, tapes, and cement material containers, with appropriate markings of applicable testing agency.
  - 1. Insulation Installed Indoors: Flame-spread index of 25 or less, and smoke-developed index of 50 or less.
  - 2. Insulation Installed Outdoors: Flame-spread index of 25 or less, and smoke-developed index of 50 or less.
- C. Fire-Rated Insulation Characteristic: Insulation product and related materials identified to those specified in this Section and according to standards below and acceptable to authorities having jurisdiction. Factory label insulation and jacket materials and sealer material containers with appropriate markings of applicable test standards and NRTL listings. Products for grease exhaust applications shall be reviewed by ICC Evaluation Service with results report submitted.
  - 1. Grease Duct Fire-Rated Insulation Enclosure System Test Standards:
    - a. ASTM E 2336 (AC101): "Standard Test Methods for Fire Resistive Grease Duct Enclosure Systems Acceptance Criteria for Grease Duct Enclosures."
      - 1) ASTM E 2336 Section 16.1 - ASTM E 136: "Standard Test Method for Materials in a Vertical Tube Furnace at 750C."
      - 2) ASTM E 2336 Section 16.2 - ASTM E 119: "Standard Test Methods for Fire Test of Building Construction and Materials" applied to wall configuration."

- 3) ASTM E 2336 Section 16.3 - ASTM C 518: "Standard Test Method for Steady-State Thermal Transmission Properties by Means of the Heat Flow Meter Apparatus."
  - 4) ASTM E 2336 Section 16.4 - Internal fire test tested to 500 deg. F for 4 hours and 2,000 deg. F for 30 minutes.
  - 5) ASTM E 2336 Section 16.5 - ASTM E 119: "Standard Test Methods for Fire Tests of Building Construction and Materials" applied to an elbow-shaped duct configuration.
- b. ASTM E 814 (UL 1479): "Standard Test Method for Fire Test of Through-Penetration Firestops."
  - c. ASTM E 84: "Standard Test Method for Surface Burning Characteristics of Building Materials."
  - d. NFPA 96: "Standard for Ventilation Control and Fire Protection of Commercial Cooling Operations."
  - e. ASTM D 6329: "Standard Guide for Developing Methodology for Evaluating the Ability of Indoor Materials to Support Microbial Growth Using Static Environmental Chambers."
2. Ventilation Air Fire-Rated Insulation Enclosure System Test Standards:
    - a. ISO 6944-1985: "Fire Resistive Tests - Ventilation Ducts."
    - b. ISO 834: "Fire Resistive Tests - Elements of Building Construction."
    - c. ASTM E 814 (UL 1479): "Standard Test Method for Fire Test of Through-Building Materials."
    - d. ASTM E 84: "Standard Test Method for Surface Burning Characteristics of Building Materials."
    - e. ASTM E 119.

### **1.7 DELIVERY, STORAGE, AND HANDLING**

- A. Packaging: Insulation material containers shall be marked by manufacturer with appropriate ASTM standard designation, type and grade, and maximum use temperature.

### **1.8 COORDINATION**

- A. Coordinate sizes and locations of supports, hangers, and insulation shields specified in Section 230529 "Hangers and Supports for HVAC Piping and Equipment."
- B. Coordinate clearance requirements with duct Installer for duct insulation application. Before preparing ductwork Shop Drawings, establish and maintain clearance requirements for installation of insulation and field-applied jackets and finishes and for space required for maintenance.
- C. Coordinate installation and testing of heat tracing.

**1.9 SCHEDULING**

- A. Schedule insulation application after pressure testing systems and, where required, after installing and testing heat tracing. Insulation application may begin on segments that have satisfactory test results.
- B. Complete installation and concealment of plastic materials as rapidly as possible in each area of construction.

**PART 2 - PRODUCTS**

**2.1 INSULATION MATERIALS**

- A. Comply with requirements in "Duct Insulation Schedule, General," "Indoor Duct and Plenum Insulation Schedule," and "Aboveground, Outdoor Duct and Plenum Insulation Schedule" articles for where insulating materials shall be applied.
- B. Products shall not contain asbestos, lead, mercury, or mercury compounds.
- C. Insulation materials for use on austenitic stainless steel shall be qualified as acceptable according to ASTM C 795.
- D. Foam insulation materials shall not use CFC or HCFC blowing agents in the manufacturing process.
- E. Mineral-Fiber Blanket Insulation: Mineral or glass fibers bonded with a thermosetting resin. Comply with ASTM C 553, Type II. Factory-applied jacket requirements are specified in "Factory-Applied Jackets" Article.
  - 1. Minimum Density: 0.75 pcf.
  - 2. Products: Subject to compliance with requirements, provide one of the following:
    - a. CertainTeed Corporation; SoftTouch Duct Wrap.
    - b. Johns Manville; a Berkshire Hathaway company; Microlite.
    - c. Knauf Insulation; Atmosphere Duct Wrap with ECOSE Technology.
    - d. Manson Insulation Inc.; Alley Wrap.
    - e. Owens Corning; SOFTR All-Service Duct Wrap.
- F. Mineral-Fiber Board Insulation: Mineral or glass fibers bonded with a thermosetting resin. Comply with ASTM C 612, Type IA or Type IB. For duct and plenum applications, provide insulation with factory-applied FSK jacket. Factory-applied jacket requirements are specified in "Factory-Applied Jackets" Article.
  - 1. Minimum Density: 2.25 pcf.
  - 2. Products: Subject to compliance with requirements, provide one of the following:
    - a. CertainTeed Corporation; Commercial Board.

- b. Johns Manville; a Berkshire Hathaway company; 800 Series Spin-Glas.
- c. Knauf Insulation; Earthwool Insulation Board with ECOSE Technology.
- d. Owens Corning; Fiberglas 700 Series.

**2.2 ADHESIVES**

- A. Materials shall be compatible with insulation materials, jackets, and substrates and for bonding insulation to itself and to surfaces to be insulated unless otherwise indicated.
- B. Mineral-Fiber Adhesive: Comply with MIL-A-3316C, Class 2, Grade A.
  - 1. Products: Subject to compliance with requirements, provide one of the following:
    - a. Childers Brand; H. B. Fuller Construction Products; CP-127.
    - b. Eagle Bridges - Marathon Industries; CP-127. Eagle Bridges - Marathon Industries; 225.
    - c. Foster Brand; H. B. Fuller Construction Products; 85-60/85-70.
    - d. Mon-Eco Industries, Inc.; 22-25.
- C. ASJ Adhesive, and FSK Jacket Adhesive: Comply with MIL-A-3316C, Class 2, Grade A for bonding insulation jacket lap seams and joints.
  - 1. Products: Subject to compliance with requirements, provide one of the following:
    - a. Childers Brand; H. B. Fuller Construction Products; CP-82.
    - b. Foster Brand; H. B. Fuller Construction Products; 85-50.
    - c. Mon-Eco Industries, Inc.; 22-25.

**2.3 MASTICS**

- A. Materials shall be compatible with insulation materials, jackets, and substrates; comply with MIL-PRF-19565C, Type II.
- B. Vapor-Barrier Mastic: Water based; suitable for indoor use on below ambient services.
  - 1. Products: Subject to compliance with requirements, provide one of the following:
    - a. Childers Brand, Specialty Construction Brands, Inc.; CP-30.
    - b. Foster Brand; H. B. Fuller Construction Products; 30-80/30-90.
    - c. Knauf Insulation; EXPERT Mastics - KI-900 ASJ.
  - 2. Water-Vapor Permeance: ASTM E 96/E 96M, Procedure B, 0.013 perm at 43-mil dry film thickness.
  - 3. Service Temperature Range: Minus 20 to plus 180 deg F.
  - 4. Solids Content: ASTM D 1644, 58 percent by volume and 70 percent by weight.
  - 5. Color: White.

- C. Breather Mastic: Water based; suitable for indoor and outdoor use on above ambient services.
  - 1. Products: Subject to compliance with requirements, provide one of the following:
    - a. Childers Brand; H. B. Fuller Construction Products; CP-10.
    - b. Foster Brand; H. B. Fuller Construction Products; 46-50.
    - c. Knauf Insulation; EXPERT Mastics - KI-700 ASJ
    - d. Mon-Eco Industries, Inc.; 55-50.
    - e. Vimasco Corporation; WC-1/WC-5.
  - 2. Water-Vapor Permeance: ASTM F 1249, 1.8 perms at 0.0625-inch dry film thickness.
  - 3. Service Temperature Range: Minus 20 to plus 180 deg F.
  - 4. Solids Content: 60 percent by volume and 66 percent by weight.
  - 5. Color: White.

**2.4 SEALANTS**

A. FSK and Metal Jacket Flashing Sealants:

- 1. Products: Subject to compliance with requirements, provide one of the following:
  - a. Childers Brand; H. B. Fuller Construction Products; CP-76.
  - b. Eagle Bridges - Marathon Industries; CP-76. Eagle Bridges - Marathon Industries; 405.
  - c. Foster Brand; H. B. Fuller Construction Products; 95-44.
  - d. Mon-Eco Industries, Inc.; 44-05.
- 2. Materials shall be compatible with insulation materials, jackets, and substrates.
- 3. Fire- and water-resistant, flexible, elastomeric sealant.
- 4. Service Temperature Range: Minus 40 to plus 250 deg F.
- 5. Color: Aluminum.

B. ASJ Flashing Sealants and Jacket Flashing Sealants:

- 1. Products: Subject to compliance with requirements, provide one of the following:
  - a. Childers Brand; H. B. Fuller Construction Products; CP-76.
  - b. Eagle Bridges-Marathon Industries; 405.
  - c. Foster Brand, Specialty Construction Brands, Inc.; 30-45, 95-44.
- 2. Materials shall be compatible with insulation materials, jackets, and substrates.
- 3. Fire- and water-resistant, flexible, elastomeric sealant.
- 4. Service Temperature Range: Minus 40 to plus 250 deg F.
- 5. Color: White.

**2.5 FACTORY-APPLIED JACKETS**

- A. Insulation system schedules indicate factory-applied jackets on various applications. When factory-applied jackets are indicated, comply with the following:
1. ASJ: White, kraft-paper, fiberglass-reinforced scrim with aluminum-foil backing; complying with ASTM C 1136, Type I.
  2. ASJ-SSL: ASJ with self-sealing, pressure-sensitive, acrylic-based adhesive covered by a removable protective strip; complying with ASTM C 1136, Type I.
  3. FSK Jacket: Aluminum-foil, fiberglass-reinforced scrim with kraft-paper backing; complying with ASTM C 1136, Type II.

**2.6 TAPES**

- A. ASJ Tape: White vapor-retarder tape matching factory-applied jacket with acrylic adhesive, complying with ASTM C 1136.
1. Products: Subject to compliance with requirements, provide one of the following:
    - a. Avery Dennison Corporation, Specialty Tapes Division; Fasson 0836.
    - b. Compac Corporation; 104 and 105.
    - c. Ideal Tape Co., Inc., an American Biltrite Company; 428 AWF ASJ.
    - d. Knauf Insulation; EXPERT Tapes - ASJ Tape.
    - e. Venture Tape; 1540 CW Plus, 1542 CW Plus, and 1542 CW Plus/SQ.
  2. Width: 3 inches.
  3. Thickness: 11.5 mils.
  4. Adhesion: 90 ounces force/inch in width.
  5. Elongation: 2 percent.
  6. Tensile Strength: 40 lbf/inch in width.
  7. ASJ Tape Disks and Squares: Precut disks or squares of ASJ tape.
- B. FSK Tape: Foil-face, vapor-retarder tape matching factory-applied jacket with acrylic adhesive; complying with ASTM C 1136.
1. Products: Subject to compliance with requirements, provide one of the following:
    - a. Avery Dennison Corporation, Specialty Tapes Division; Fasson 0827.
    - b. Compac Corporation; 110 and 111.
    - c. Ideal Tape Co., Inc., an American Biltrite Company; 491 AWF FSK.
    - d. Knauf Insulation; EXPERT Tapes - FSK Tape.
    - e. Venture Tape; 1525 CW NT, 1528 CW, and 1528 CW/SQ.
  2. Width: 3 inches.
  3. Thickness: 6.5 mils.
  4. Adhesion: 90 ounces force/inch in width.
  5. Elongation: 2 percent.

6. Tensile Strength: 40 lbf/inch in width.
  7. FSK Tape Disks and Squares: Precut disks or squares of FSK tape.
- C. Aluminum-Foil Tape: Vapor-retarder tape with acrylic adhesive.
1. Products: Subject to compliance with requirements, provide one of the following:
    - a. Avery Dennison Corporation, Specialty Tapes Division; Fasson 0800.
    - b. Compac Corporation.
    - c. Ideal Tape Co., Inc., an American Biltrite Company; 488 AWF.
    - d. Knauf Insulation; EXPERT Tapes - 2 Mil Foil Tape.
    - e. Venture Tape; 3520 CW.
  2. Width: 2 inches.
  3. Thickness: 3.7 mils.
  4. Adhesion: 100 ounces force/inch in width.
  5. Elongation: 5 percent.
  6. Tensile Strength: 34 lbf/inch in width.

## 2.7 SECUREMENTS

- A. Bands:
1. Products: Subject to compliance with requirements, provide one of the following:
    - a. Band-It-Idex, Inc.; a unit of Idex Corp.; Band-Fast.
    - b. ITW Insulation Systems; Illinois Tool Works, Inc.; Gerrard Strapping and Seals.
    - c. RPR Products, Inc.; Insul-Mate Strapping, Seals, and Springs.
  2. Stainless Steel: ASTM A 167 or ASTM A 240/A 240M, Type 304 or Type 316; 0.015 inch thick, 3/4 inch wide with wing seal or closed seal.
  3. Aluminum: ASTM B 209, Alloy 3003, 3005, 3105, or 5005; Temper H-14, 0.020 inch thick, 3/4 inch wide with wing seal or closed seal.
  4. Springs: Twin spring set constructed of stainless steel with ends flat and slotted to accept metal bands. Spring size determined by manufacturer for application.
- B. Insulation Pins and Hangers:
1. Cupped-Head, Capacitor-Discharge-Weld Pins: Copper- or zinc-coated steel pin, fully annealed for capacitor-discharge welding, 0.135-inch- diameter shank, length to suit depth of insulation indicated with integral 1-1/2-inch galvanized carbon-steel washer.
    - a. Products: Subject to compliance with requirements, provide one of the following:
      - 1) AGM Industries, Inc; CHP-1.
      - 2) CL WARD & Family Inc.; CL WARD Weld Pins.
      - 3) Gemco; Cupped Head Weld Pin.



- 4) Hardcast, Inc.
  - 5) Midwest Fasteners, Inc; Cupped Head.
  - 6) Nelson Stud Welding; CHP.
2. Insulation-Retaining Washers: Self-locking washers formed from 0.016-inch- thick, aluminum sheet, with beveled edge sized as required to hold insulation securely in place but not less than 1-1/2 inches in diameter.
- a. Products: Subject to compliance with requirements, provide one of the following:
    - 1) AGM Industries, Inc; RC-150.
    - 2) Gemco; R-150.
    - 3) Hardcast, Inc.
    - 4) Midwest Fasteners, Inc; WA-150.
    - 5) Nelson Stud Welding; Speed Clips.
  - b. Protect ends with capped self-locking washers incorporating a spring steel insert to ensure permanent retention of cap in exposed locations.
- C. Staples: Outward-clinching insulation staples, nominal 3/4-inch- wide, stainless steel or Monel.

### **PART 3 - EXECUTION**

#### **3.1 EXAMINATION**

- A. Examine substrates and conditions for compliance with requirements for installation tolerances and other conditions affecting performance of insulation application.
  1. Verify that systems to be insulated have been tested and are free of defects.
  2. Verify that surfaces to be insulated are clean and dry.
- B. Proceed with installation only after unsatisfactory conditions have been corrected.

#### **3.2 PREPARATION**

- A. Surface Preparation: Clean and dry surfaces to receive insulation. Remove materials that will adversely affect insulation application.

#### **3.3 GENERAL INSTALLATION REQUIREMENTS**

- A. Install insulation materials, accessories, and finishes with smooth, straight, and even surfaces; free of voids throughout the length of ducts and fittings.
- B. Install insulation materials, vapor barriers or retarders, jackets, and thicknesses required for each item of duct system as specified in insulation system schedules.

- C. Install accessories compatible with insulation materials and suitable for the service. Install accessories that do not corrode, soften, or otherwise attack insulation or jacket in either wet or dry state.
- D. Install insulation with longitudinal seams at top and bottom of horizontal runs.
- E. Install multiple layers of insulation with longitudinal and end seams staggered.
- F. Keep insulation materials dry during application and finishing.
- G. Install insulation with tight longitudinal seams and end joints. Bond seams and joints with adhesive recommended by insulation material manufacturer.
- H. Install insulation with least number of joints practical.
- I. Where vapor barrier is indicated, seal joints, seams, and penetrations in insulation at hangers, supports, anchors, and other projections with vapor-barrier mastic.
  - 1. Install insulation continuously through hangers and around anchor attachments.
  - 2. For insulation application where vapor barriers are indicated, extend insulation on anchor legs from point of attachment to supported item to point of attachment to structure. Taper and seal ends at attachment to structure with vapor-barrier mastic.
  - 3. Install insert materials and install insulation to tightly join the insert. Seal insulation to insulation inserts with adhesive or sealing compound recommended by insulation material manufacturer.
- J. Apply adhesives, mastics, and sealants at manufacturer's recommended coverage rate and wet and dry film thicknesses.
- K. Install insulation with factory-applied jackets as follows:
  - 1. Draw jacket tight and smooth.
  - 2. Cover circumferential joints with 3-inch- wide strips, of same material as insulation jacket. Secure strips with adhesive and outward clinching staples along both edges of strip, spaced 4 inches o.c.
  - 3. Overlap jacket longitudinal seams at least 1-1/2 inches. Clean and dry surface to receive self-sealing lap. Staple laps with outward clinching staples along edge at 4 inches o.c.
    - a. For below ambient services, apply vapor-barrier mastic over staples.
  - 4. Cover joints and seams with tape, according to insulation material manufacturer's written instructions, to maintain vapor seal.
  - 5. Where vapor barriers are indicated, apply vapor-barrier mastic on seams and joints and at ends adjacent to duct flanges and fittings.
  - 6. Where two layers of insulation are utilized, the vapor barrier may be omitted from the inner layer.

- L. Cut insulation in a manner to avoid compressing insulation more than 75 percent of its nominal thickness.
- M. Finish installation with systems at operating conditions. Repair joint separations and cracking due to thermal movement.
- N. Repair damaged insulation facings by applying same facing material over damaged areas. Extend patches at least 4 inches beyond damaged areas. Adhere, staple, and seal patches similar to butt joints.

### **3.4 PENETRATIONS**

- A. Insulation Installation at Interior Wall and Partition Penetrations (That Are Not Fire Rated): Install insulation continuously through walls and partitions.
- B. Insulation Installation at Fire-Rated Wall and Partition Penetrations: Terminate insulation at fire damper sleeves for fire-rated wall and partition penetrations. Externally insulate damper sleeves to match adjacent insulation and overlap duct insulation at least 2 inches.
  - 1. Comply with requirements in Section 078413 "Penetration Firestopping."
- C. Insulation Installation at Floor Penetrations:
  - 1. Duct: For penetrations through fire-rated assemblies, terminate insulation at fire damper sleeves and externally insulate damper sleeve beyond floor to match adjacent duct insulation. Overlap damper sleeve and duct insulation at least 2 inches.
  - 2. Seal penetrations through fire-rated assemblies. Comply with requirements in Section 078413 "Penetration Firestopping."

### **3.5 INSTALLATION OF MINERAL-FIBER INSULATION**

- A. Blanket Insulation Installation on Ducts and Plenums:
  - 1. All Duct Faces: On longitudinal and transverse seams, install butt joint with 2-inch overlapping jacket, outward clinching staples.
    - a. Place staples 6 inches o.c. each way; and 3 inches maximum from insulation joints.
    - b. Do not over-compress insulation during installation.
    - c. Cover exposed staples with tape matching insulation facing.
  - 2. Bottom and Vertical Faces of Ducts 24 Inches and Greater: Install cupped-head, capacitor-discharge-weld pins on sides and bottom of horizontal ducts and sides of vertical ducts as follows:
    - a. Place pins 16 inches o.c. each way, and 3 inches maximum from insulation joints. Install additional pins to hold insulation tightly against surface at cross bracing.
    - b. Do not overcompress insulation during installation.

- c. Impale insulation over pins and attach speed washers.
  - d. Cut excess portion of pins extending beyond speed washers or bend parallel with insulation surface. Cover exposed pins and washers with tape matching insulation facing.
3. For ducts and plenums with surface temperatures below ambient, install a continuous unbroken vapor barrier. Create a facing lap for longitudinal seams and end joints with insulation by removing 2 inches from one edge and one end of insulation segment. Secure laps to adjacent insulation section with 1/2-inch outward-clinching staples, 1 inch o.c. Install vapor barrier consisting of factory- or field-applied jacket, adhesive, vapor-barrier mastic, and sealant at joints, seams, and protrusions.
    - a. Repair punctures, tears, and penetrations with tape or mastic to maintain vapor-barrier seal.
    - b. Install vapor stops for ductwork and plenums operating below 50 deg F at 18-foot intervals. Vapor stops shall consist of vapor-barrier mastic applied in a Z-shaped pattern over insulation face, along butt end of insulation, and over the surface. Cover insulation face and surface to be insulated a width equal to two times the insulation thickness, but not less than 3 inches.
  4. Overlap unfaced blankets a minimum of 2 inches on longitudinal seams and end joints. At end joints, secure with steel bands spaced a maximum of 18 inches o.c.
  5. Install insulation on rectangular duct elbows and transitions with a full insulation section for each surface. Install insulation on round and flat-oval duct elbows with individually mitered gores cut to fit the elbow.
  6. Insulate duct stiffeners, hangers, and flanges that protrude beyond insulation surface with 6-inch- wide strips of same material used to insulate duct. Secure on alternating sides of stiffener, hanger, and flange with pins spaced 6 inches o.c.

### **3.6 FIELD QUALITY CONTROL**

- A. Testing Agency: Fire-rated insulation manufacturer to perform tests and inspections.
- B. Perform tests and inspections for fire-rated insulation systems.
- C. Tests and Inspections:
  1. Inspect ductwork insulation installation, including all cleanout and through firestop penetration locations. Extent of inspection shall be for each entire duct system insulated with fire-rated insulation defined in the "Duct Insulation Schedule, General" Article and/or indicated on drawings. Submit written report indicating acceptance or deficiencies requiring correction.
- D. All insulation applications will be considered defective Work if sample inspection reveals noncompliance with requirements.

**3.7 DUCT INSULATION SCHEDULE, GENERAL**

A. Plenums and Ducts Requiring Insulation:

1. Indoor, concealed supply and outdoor air.
2. Indoor, exposed supply and outdoor air.
3. Indoor, concealed return located in unconditioned space.
4. Indoor, exposed return located in unconditioned space.
5. Supply diffuser plenums.
6. Return/Exhaust register/grille plenums and larger in unconditioned spaces.
7. Terminal coils (duct and VAV box mounted) shall be insulated the same as supply air ducts.

B. Items Not Insulated:

1. Fibrous-glass ducts.
2. Metal ducts with duct liner of sufficient thickness to comply with listed thickness.
3. Factory-insulated flexible ducts.
4. Factory-insulated ducts, plenums and casings.
5. Vibration-control devices.
6. Factory-insulated access panels and doors.

C. General Insulation Schedule:

1. Round and Flat Oval Ductwork: Mineral-fiber blanket unless noted otherwise.
2. Exposed Ductwork: Mineral-fiber board unless noted otherwise.
3. Concealed Ductwork: Mineral-fiber blanket unless noted otherwise.
4. Maximum Conductivity (BTU x in./(hr. x ft<sup>2</sup> x deg. F)) at 75 Deg. F: 0.24.
5. Ductwork Below Grade: Interstitial insulation.
6. Vapor Barrier: FSK acceptable for use with a 2-inch stapling tab unless noted otherwise.

**3.8 DUCT AND PLENUM BLANKET INSULATION SCHEDULE**

A. Duct insulation shall be per the following table with minimum thickness number of layers and minimum (R-value) as indicated:

	Conditioned Spaces	Indirectly Conditioned Spaces	Heated, Semi-Heated and Unconditioned	Exterior and Attic Spaces	Buried
Supply	1"	1.5" (R-6)	3" (R-6)	2-2" (R-12)	1.5" (R-3.5)
Return	None	None	3" (R-6)	2-2" (R-12)	1.5" (R-3.5)
Exhaust	None	None	None	None	None
Exhaust on O.A. Side of Damper	1"	1.5"	1.5"	None	None

PROBATE COURT  
 ADMINISTRATION  
 INTERIOR RENOVATIONS  
 186 NEWINGTON ROAD  
 WEST HARTFORD, CONNECTICUT

	Conditioned Spaces	Indirectly Conditioned Spaces	Heated, Semi-Heated and Unconditioned	Exterior and Attic Spaces	Buried
Exhaust Upstream of Energy Recovery	None	None	3"	2-2"	1.5"
Outside Air	2"	1.5"	1"	None	None
Moist Air	1.5"	1.5"	2"	3"	1.5"

### 3.9 **DUCT AND PLENUM BOARD INSULATION SCHEDULE**

- A. Duct insulation shall be per the following table with minimum thickness number of layers and minimum (R-value) as indicated.

	Conditioned Spaces	Indirectly Conditioned Spaces	Heated, Semi-Heated and Unconditioned	Exterior and Attic Spaces	Buried
Supply	1"	1.5" (R-6)	1.5" (R-6)	3" (R-12)	N/A
Return	None	None	1.5" (R-6)	3" (R-12)	N/A
Exhaust	None	None	None	None	N/A
Exhaust on O.A. Side of Damper	1"	1.5"	1.5"	None	N/A
Exhaust Upstream of Energy Recovery	None	None	2"	3"	N/A
Outside Air	2"	1.5"	1"	None	N/A
Moist Air	1"	1.5"	2"	2"	N/A

**END OF SECTION 230713**

03/07/2017



**SECTION 233113 - METAL DUCTS**

**PART 1 - GENERAL**

**1.1 RELATED DOCUMENTS**

- A. Drawings and general provisions of the Contract, including General and Supplementary Conditions and Division 01 Specification Sections, apply to this Section.

**1.2 SUMMARY**

- A. Section Includes:
  - 1. Single-wall rectangular ducts and fittings.
  - 2. Single-wall round ducts and fittings.
  - 3. Sheet metal materials.
  - 4. Duct liner.
  - 5. Sealants and gaskets.
  - 6. Hangers and supports.
- B. Related Sections:
  - 1. Division 07 Section "Joint Sealants" for fire-resistant sealants for use around duct penetrations and fire damper installations in fire-rated floors, partitions and walls.
  - 2. Division 23 Section "Testing, Adjusting, and Balancing for HVAC" for testing, adjusting, and balancing requirements for metal ducts.
  - 3. Division 23 Section "Air Duct Accessories" for dampers, sound-control devices, duct-mounting access doors and panels, turning vanes, and flexible ducts.
  - 4. Division 23 Section "Seismic Restraint for HVAC" for support, seismic restraint and vibration isolation requirements.

**1.3 DEFINITIONS**

- A. Outside Air: Air originating from outside of the building, from the primary environment surrounding the building. Outside air includes make-up air, combustion air, fresh air and other types of air.
- B. Conditioned Space: An area, room, ceiling space/plenum or space within the building structure being heated or cooled (by direct expansion or chilled water) or both, by equipment or appliance and is not subject to outdoor ambient conditions.
- C. Unconditioned Space: An area, room or space within the building structure not being conditioned and subject to outdoor ambient conditions. Above ceiling spaces in ducted return systems are considered unconditioned.



- D. Concealed Ducts/Pipes: Ducts/pipes not visible within the room they are located, after the project is completed.
- E. Exposed Ducts/Pipes: Ducts/pipes visible within the room they are located, after the project is completed.
- F. Ceiling Space/Plenum: An enclosed portion of the building structure, other than an occupiable space being conditioned, that is designed to allow air movement, and thereby serve as part of an air distribution system.
- G. Plenum: Part of duct system connected to diffusers, registers, grilles, louvers for air movement applications.
- H. Moist Exhaust: Exhaust air that carries a higher than ambient level of moisture/humidity in the stream.
  - 1. Examples (including, but not limited to): Dishwasher, shower areas, wash areas (clothing, process, etc.), hospital equipment/devices cleaning and sterilizing.
- I. Primary Ductwork: Ductwork between the air moving device and the terminal unit (in VAV systems) or the air inlet/outlet (in CV system).
- J. Secondary Ductwork: In VAV systems, the ductwork between the terminal unit and the air inlet/outlet.

#### **1.4 PERFORMANCE REQUIREMENTS**

- A. Delegated Duct Design: Duct construction, including sheet metal thicknesses, seam and joint construction, reinforcements, and hangers and supports, shall comply with SMACNA's "HVAC Duct Construction Standards - Metal and Flexible" and performance requirements and design criteria indicated in "Duct Schedule" Article.
- B. Structural Performance: Duct hangers and supports and seismic restraints shall withstand the effects of gravity and seismic loads and stresses within limits and under conditions described in SMACNA's "HVAC Duct Construction Standards - Metal and Flexible," ASCE/SEI 7, and SMACNA's "Seismic Restraint Manual: Guidelines for Mechanical Systems."
- C. Airstream Surfaces: Surfaces in contact with the airstream shall comply with requirements in ASHRAE 62.1-2004.

#### **1.5 SUBMITTALS**

- A. Product Data: For each type of the following products:
  - 1. Liners and adhesives.
  - 2. Sealants and gaskets.
  - 3. Seismic-restraint devices.

## B. Shop Drawings:

1. Fabrication, assembly, and installation, including plans, elevations, sections, components, and attachments to other work.
2. Factory- and shop-fabricated ducts and fittings.
3. Duct layout indicating sizes, configuration, liner material, and static-pressure classes.
4. Elevation of top of ducts.
5. Dimensions of main duct runs from building grid lines.
6. Fittings.
7. Reinforcement and spacing.
8. Seam and joint construction.
9. Penetrations through fire-rated and other partitions.
10. Equipment installation based on equipment being used on Project.
11. Locations for duct accessories, including dampers, turning vanes, and access doors and panels.
12. Hangers and supports, including methods for duct and building attachment and vibration isolation.

## C. Delegated-Design Submittal:

1. Sheet metal thicknesses.
2. Joint and seam construction and sealing.
3. Reinforcement details and spacing.
4. Materials, fabrication, assembly, and spacing of hangers and supports.
5. Design Calculations: Calculations for selecting hangers and supports.

## D. Coordination Drawings: Plans, drawn to scale, on which the following items are shown and coordinated with each other, using input from installers of the items involved:

1. Duct installation in congested spaces, indicating coordination with general construction, building components, and other building services. Indicate proposed changes to duct layout.
2. Suspended ceiling components.
3. Structural members to which duct will be attached.
4. Size and location of initial access modules for acoustical tile.
5. Penetrations of smoke barriers and fire-rated construction.
6. Items penetrating finished ceiling including the following:
  - a. Lighting fixtures.
  - b. Air outlets and inlets.
  - c. Speakers.
  - d. Sprinklers.
  - e. Access panels.
  - f. Perimeter moldings.

## E. Welding certificates.

- F. Field quality-control reports.
- G. Contractor Certification for Compliance that all ductwork has been fabricated and installed in accordance with the SMACNA's "HVAC Duct Construction Standards--Metal and Flexible," including duct thickness, joining methods and reinforcing for the applicable pressure classifications.

## **1.6 QUALITY ASSURANCE**

- A. Welding Qualifications: Qualify procedures and personnel according to AWS D1.1/D1.1M, "Structural Welding Code - Steel," for hangers and supports, AWS D1.2/D1.2M, "Structural Welding Code - Aluminum," for aluminum supports, and AWS D9.1M/D9.1, "Sheet Metal Welding Code," for duct joint and seam welding.
- B. Welding Qualifications: Qualify procedures and personnel according to the following:
  - 1. AWS D1.1/D1.1M, "Structural Welding Code - Steel," for hangers and supports.
  - 2. AWS D1.2/D1.2M, "Structural Welding Code - Aluminum," for aluminum supports.
  - 3. AWS D9.1M/D9.1, "Sheet Metal Welding Code," for duct joint and seam welding.
- C. ASHRAE Compliance: Applicable requirements in ASHRAE 62.1-2004, Section 5 - "Systems and Equipment" and Section 7 - "Construction and System Start-Up."
- D. ASHRAE/IESNA Compliance: Applicable requirements in ASHRAE/IESNA 90.1-2004, Section 6.4.4 - "HVAC System Construction and Insulation."
- E. Duct Cleaning: Qualify procedures and personnel with the National Air Duct Cleaners Association (NADCA) recommendations and industry standards for HVAC system cleaning.

## **PART 2 - PRODUCTS**

### **2.1 SINGLE-WALL RECTANGULAR DUCTS AND FITTINGS**

- A. General Fabrication Requirements: Comply with SMACNA's "HVAC Duct Construction Standards - Metal and Flexible" based on indicated static-pressure class unless otherwise indicated.
- B. Transverse Joints: Select joint types and fabricate according to SMACNA's "HVAC Duct Construction Standards - Metal and Flexible," Figure 1-4, "Transverse (Girth) Joints," for static-pressure class, applicable sealing requirements, materials involved, duct-support intervals, and other provisions in SMACNA's "HVAC Duct Construction Standards - Metal and Flexible."
- C. Longitudinal Seams: Select seam types and fabricate according to SMACNA's "HVAC Duct Construction Standards - Metal and Flexible," Figure 1-5, "Longitudinal Seams - Rectangular Ducts," for static-pressure class, applicable sealing requirements, materials involved, duct-

support intervals, and other provisions in SMACNA's "HVAC Duct Construction Standards - Metal and Flexible."

- D. Elbows, Transitions, Offsets, Branch Connections, and Other Duct Construction: Select types and fabricate according to SMACNA's "HVAC Duct Construction Standards - Metal and Flexible," Chapter 2, "Fittings and Other Construction," for static-pressure class, applicable sealing requirements, materials involved, duct-support intervals, and other provisions in SMACNA's "HVAC Duct Construction Standards - Metal and Flexible."

## **2.2 SINGLE-WALL ROUND AND FLAT-OVAL DUCTS AND FITTINGS**

- A. General Fabrication Requirements: Comply with SMACNA's "HVAC Duct Construction Standards - Metal and Flexible," Chapter 3, "Round, Oval, and Flexible Duct," based on indicated static-pressure class unless otherwise indicated.
1. Manufacturers: Subject to compliance with requirements, provide products by one of the following:
    - a. Lindab Inc.
    - b. EHG Duct.
    - c. McGill AirFlow LLC.
    - d. SEMCO Incorporated.
    - e. Sheet Metal Connectors, Inc.
    - f. Spiral Manufacturing Co., Inc.
  - B. Flat-Oval Ducts: Indicated dimensions are the duct width (major dimension) and diameter of the round sides connecting the flat portions of the duct (minor dimension).
  - C. Transverse Joints: Select joint types and fabricate according to SMACNA's "HVAC Duct Construction Standards - Metal and Flexible," Figure 3-2, "Transverse Joints - Round Duct," for static-pressure class, applicable sealing requirements, materials involved, duct-support intervals, and other provisions in SMACNA's "HVAC Duct Construction Standards - Metal and Flexible," and SMACNA's "Guyed Steel Stacks – Welded Longseam and Spiral Lockseam."
    1. Transverse Joints in Ducts Larger Than 60 Inches in Diameter: Flanged.
  - D. Longitudinal Seams: Select seam types and fabricate according to SMACNA's "HVAC Duct Construction Standards - Metal and Flexible," Figure 3-1, "Seams - Round Duct and Fittings," for static-pressure class, applicable sealing requirements, materials involved, duct-support intervals, and other provisions in SMACNA's "HVAC Duct Construction Standards - Metal and Flexible," and SMACNA's "Guyed Steel Stacks – Welded Longseam and Spiral Lockseam."
    1. Fabricate round ducts larger than 90 inches in diameter with butt-welded longitudinal seams.
    2. Fabricate flat-oval ducts larger than 72 inches in width (major dimension) with butt-welded longitudinal seams.

- E. Tees and Laterals: Select types and fabricate according to SMACNA's "HVAC Duct Construction Standards - Metal and Flexible," Figure 3-4, "90 Degree Tees and Laterals," and Figure 3-5, "Conical Tees," for static-pressure class, applicable sealing requirements, materials involved, duct-support intervals, and other provisions in SMACNA's "HVAC Duct Construction Standards - Metal and Flexible."

### **2.3 SHEET METAL MATERIALS**

- A. General Material Requirements: Comply with SMACNA's "HVAC Duct Construction Standards - Metal and Flexible," and SMACNA's "Guyed Steel Stacks – Welded Longseam and Spiral Lockseam" for acceptable materials, material thicknesses, and duct construction methods unless otherwise indicated. Sheet metal materials shall be free of pitting, seam marks, roller marks, stains, discolorations, and other imperfections.
- B. Galvanized Sheet Steel: Comply with ASTM A 653/A 653M.
  - 1. Galvanized Coating Designation: G60.
  - 2. Finishes for Surfaces Exposed to View: Mill phosphatized.
- C. Carbon-Steel Sheets: Comply with ASTM A 1008/A 1008M, with oiled, matte finish for exposed ducts.
- D. Aluminum Sheets: Comply with ASTM B 209 Alloy 3003, H14 temper; with mill finish for concealed ducts, and standard, one-side bright finish for duct surfaces exposed to view.
- E. Reinforcement Shapes and Plates: ASTM A 36/A 36M, steel plates, shapes, and bars; black and galvanized.
  - 1. Where black- and galvanized-steel shapes and plates are used to reinforce aluminum ducts, isolate the different metals with butyl rubber, neoprene, or EPDM gasket materials.
- F. Tie Rods: Galvanized steel, 1/4-inch minimum diameter for lengths 36 inches or less; 3/8-inch minimum diameter for lengths longer than 36 inches.
- G. Guy Wires: Comply with SMACNA's "Guyed Steel Stacks – Welded Longseam and Spiral Lockseam."
- H. Cable, Stiffener and Anchor Rings: Comply with SMACNA's "Guyed Steel Stacks – Welded Longseam and Spiral Lockseam."

### **2.4 DUCT LINER**

- A. Flexible Elastomeric Duct Liner: Preformed, cellular, closed-cell, sheet materials complying with ASTM C 534, Type II, Grade 1; and with NFPA 90A or NFPA 90B.

1. Manufacturers: Subject to compliance with requirements, provide products by one of the following:
    - a. Aeroflex USA Inc.
    - b. Armacell LLC.
    - c. Rubatex International, LLC
  2. Surface-Burning Characteristics: Maximum flame-spread index of 25 and maximum smoke-developed index of 50 when tested according to UL 723; certified by an NRTL.
  3. Liner Adhesive: As recommended by insulation manufacturer and complying with NFPA 90A or NFPA 90B.
    - a. For indoor applications, use adhesive that has a VOC content of 50 g/L or less when calculated according to 40 CFR 59, Subpart D (EPA Method 24).
- B. Insulation Pins and Washers:
1. Cupped-Head, Capacitor-Discharge-Weld Pins: Copper- or zinc-coated steel pin, fully annealed for capacitor-discharge welding, 0.135-inch- diameter shank, length to suit depth of insulation indicated with integral 1-1/2-inch galvanized carbon-steel washer.
  2. Insulation-Retaining Washers: Self-locking washers formed from 0.016-inch- thick galvanized steel; with beveled edge sized as required to hold insulation securely in place but not less than 1-1/2 inches in diameter.
- C. Shop Application of Duct Liner: Comply with SMACNA's "HVAC Duct Construction Standards - Metal and Flexible," Figure 2-19, "Flexible Duct Liner Installation."
1. Adhere a single layer of indicated thickness of duct liner with at least 90 percent adhesive coverage at liner contact surface area. Attaining indicated thickness with multiple layers of duct liner is prohibited.
  2. Apply adhesive to transverse edges of liner facing upstream that do not receive metal nosing.
  3. Butt transverse joints without gaps, and coat joint with adhesive.
  4. Fold and compress liner in corners of rectangular ducts or cut and fit to ensure butted-edge overlapping.
  5. Do not apply liner in rectangular ducts with longitudinal joints, except at corners of ducts, unless duct size and dimensions of standard liner make longitudinal joints necessary.
  6. Apply adhesive coating on longitudinal seams in ducts with air velocity of 2500 fpm.
  7. Duct Velocities 1,800 FPM and Lower: Secure liner with mechanical fasteners 4 inches from corners and at intervals not exceeding 12 inches transversely; at 3 inches from transverse joints and at intervals not exceeding 18 inches longitudinally.
  8. Secure transversely oriented liner edges facing the airstream with metal nosings that have either channel or "Z" profiles or are integrally formed from duct wall. Fabricate edge facings at the following locations:
    - a. Fan discharges.
    - b. Intervals of lined duct preceding unlined duct.

- c. Upstream edges of transverse joints in ducts where air velocities are higher than 2500 fpm or where indicated.
9. Duct Velocities Greater Than 1,800 FPM: Secure insulation between perforated sheet metal inner duct of same thickness as specified for outer shell. Use mechanical fasteners that maintain inner duct at uniform distance from outer shell without compressing insulation.
    - a. Sheet Metal Inner Duct Perforations: 3/32-inch diameter, with an overall open area of 23 percent.
  10. Terminate inner ducts with buildouts attached to fire-damper sleeves, dampers, turning vane assemblies, or other devices. Fabricated buildouts (metal hat sections) or other buildout means are optional; when used, secure buildouts to duct walls with bolts, screws, rivets, or welds.

## **2.5 SEALANT AND GASKETS**

- A. General Sealant and Gasket Requirements: Surface-burning characteristics for sealants and gaskets shall be a maximum flame-spread index of 25 and a maximum smoke-developed index of 50 when tested according to UL 723; certified by an NRTL.
- B. Water-Based Joint and Seam Sealant:
  1. Application Method: Brush on.
  2. Solids Content: Minimum 65 percent.
  3. Shore A Hardness: Minimum 20.
  4. Water resistant.
  5. Mold and mildew resistant.
  6. VOC: Maximum 75 g/L (less water).
  7. Maximum Static-Pressure Class: 10-inch wg, positive and negative.
  8. Service: Indoor or outdoor.
  9. Substrate: Compatible with galvanized sheet steel (both PVC coated and bare), stainless steel, or aluminum sheets.
- C. Flanged Joint Sealant: Comply with ASTM C 920.
  1. General: Single-component, acid-curing, silicone, elastomeric.
  2. Type: S.
  3. Grade: NS.
  4. Class: 25.
  5. Use: O.
  6. For indoor applications, use sealant that has a VOC content of 250 g/L or less when calculated according to 40 CFR 59, Subpart D (EPA Method 24).
- D. Flange Gaskets: Butyl rubber, neoprene, or EPDM polymer with polyisobutylene plasticizer.

- E. Round Duct Joint O-Ring Seals:
1. Seal shall provide maximum leakage class of 3 cfm/100 sq. ft. at 1-inch wg and shall be rated for 10-inch wg static-pressure class, positive or negative.
  2. EPDM O-ring to seal in concave bead in coupling or fitting spigot.
  3. Double-lipped, EPDM O-ring seal, mechanically fastened to factory-fabricated couplings and fitting spigots.
  4. Sump assemble and control provided by the same manufacturer.

## **2.6 HANGERS AND SUPPORTS**

- A. Hanger Rods for Noncorrosive Environments: Cadmium-plated steel rods and nuts.
- B. Hanger Rods for Corrosive Environments: Electrogalvanized, all-thread rods or galvanized rods with threads painted with zinc-chromate primer after installation.
- C. Strap and Rod Sizes: Comply with SMACNA's "HVAC Duct Construction Standards - Metal and Flexible," Table 4-1, "Rectangular Duct Hangers Minimum Size," and Table 4-2, "Minimum Hanger Sizes for Round Duct."
- D. Steel Cables for Galvanized-Steel Ducts: Galvanized steel complying with ASTM A 603.
- E. Steel Cables for Stainless-Steel Ducts: Stainless steel complying with ASTM A 492.
- F. Steel Cable End Connections: Cadmium-plated steel assemblies with brackets, swivel, and bolts designed for duct hanger service; with an automatic-locking and clamping device.
- G. Duct Attachments: Sheet metal screws, blind rivets, or self-tapping metal screws; compatible with duct materials.
- H. Trapeze and Riser Supports:
1. Supports for Galvanized-Steel Ducts: Galvanized-steel shapes and plates.
  2. Supports for Stainless-Steel Ducts: Stainless-steel shapes and plates.
  3. Supports for Aluminum Ducts: Aluminum or galvanized steel coated with zinc chromate.
- I. Metal Stack Support and Guy System: Comply with SMACNA's "Guyed Steel Stacks – Welded Longseam and Spiral Lockseam."

## **PART 3 - EXECUTION**

### **3.1 DUCT INSTALLATION**

- A. Drawing plans, schematics, and diagrams indicate general location and arrangement of duct system. Indicated duct locations, configurations, and arrangements were used to size ducts and calculate friction loss for air-handling equipment sizing and for other design considerations.



Install duct systems as indicated unless deviations to layout are approved on Shop Drawings and Coordination Drawings.

- B. Install ducts according to SMACNA's "HVAC Duct Construction Standards - Metal and Flexible" unless otherwise indicated.
- C. Install round and flat-oval ducts in maximum practical lengths.
- D. Install ducts with fewest possible joints.
- E. Install factory- or shop-fabricated fittings for changes in direction, size, and shape and for branch connections.
- F. Unless otherwise indicated, install ducts vertically and horizontally, and parallel and perpendicular to building lines.
- G. Install ducts close to walls, overhead construction, columns, and other structural and permanent enclosure elements of building.
- H. Install ducts with a clearance of 1 inch, plus allowance for insulation thickness.
  - 1. Exception: Where code required clearances are greater.
- I. Route ducts to avoid passing through egress areas, egress stairwells, transformer vaults and electrical equipment rooms and enclosures.
- J. Where ducts pass through non-fire-rated interior partitions and exterior walls and are exposed to view, cover the opening between the partition and duct or duct insulation with sheet metal flanges of same metal thickness as the duct. Overlap openings on four sides by at least 1-1/2 inches.
- K. Where ducts pass through fire-rated interior partitions and exterior walls, install fire dampers. Comply with requirements in Division 23 Section "Air Duct Accessories" for fire and smoke dampers.
- L. Protect duct interiors from moisture, construction debris and dust, and other foreign materials. Comply with SMACNA's "Duct Cleanliness for New Construction Guidelines."

### **3.2 INSTALLATION OF EXPOSED DUCTWORK**

- A. Protect ducts exposed in finished spaces from being dented, scratched, or damaged.
- B. Trim duct sealants flush with metal. Create a smooth and uniform exposed bead. Do not use two-part tape sealing system.

- C. Grind welds to provide smooth surface free of burrs, sharp edges, and weld splatter. When welding stainless steel with a No. 3 or 4 finish, grind the welds flush, polish the exposed welds, and treat the welds to remove discoloration caused by welding.
- D. Maintain consistency, symmetry, and uniformity in the arrangement and fabrication of fittings, hangers and supports, duct accessories, and air outlets.
- E. Repair or replace damaged sections and finished work that does not comply with these requirements.

### **3.3 DUCT SEALING**

- A. Seal ducts for duct static-pressure, seal classes, and leakage classes specified in "Duct Schedule" Article according to SMACNA's "HVAC Duct Construction Standards - Metal and Flexible."
- B. Seal ducts to the following seal classes according to SMACNA's "HVAC Duct Construction Standards - Metal and Flexible":
  - 1. Comply with SMACNA's "HVAC Duct Construction Standards - Metal and Flexible."

### **3.4 HANGER AND SUPPORT INSTALLATION**

- A. Comply with SMACNA's "HVAC Duct Construction Standards - Metal and Flexible," Chapter 4, "Hangers and Supports."
- B. Building Attachments: Concrete inserts, powder-actuated fasteners, or structural-steel fasteners appropriate for construction materials to which hangers are being attached.
  - 1. Where practical, install concrete inserts before placing concrete.
  - 2. Install powder-actuated concrete fasteners after concrete is placed and completely cured.
  - 3. Use powder-actuated concrete fasteners for standard-weight aggregate concretes or for slabs more than 4 inches thick.
  - 4. Do not use powder-actuated concrete fasteners for lightweight-aggregate concretes or for slabs less than 4 inches thick.
  - 5. Do not use powder-actuated concrete fasteners for seismic restraints.
- C. Hanger Spacing: Comply with SMACNA's "HVAC Duct Construction Standards - Metal and Flexible," Table 4-1, "Rectangular Duct Hangers Minimum Size," and Table 4-2, "Minimum Hanger Sizes for Round Duct," for maximum hanger spacing; install hangers and supports within 24 inches of each elbow and within 48 inches of each branch intersection.
- D. Hangers Exposed to View: Threaded rod and angle or channel supports.
- E. Support vertical ducts with steel angles or channel secured to the sides of the duct with welds, bolts, sheet metal screws, or blind rivets; support at each floor and at a maximum intervals of 16 feet.

- F. Install upper attachments to structures. Select and size upper attachments with pull-out, tension, and shear capacities appropriate for supported loads and building materials where used.

### **3.5 CONNECTIONS**

- A. Make connections to equipment with flexible connectors complying with Division 23 Section "Air Duct Accessories."
- B. Comply with SMACNA's "HVAC Duct Construction Standards - Metal and Flexible" for branch, outlet and inlet, and terminal unit connections.

### **3.6 FIELD QUALITY CONTROL**

- A. Perform tests and inspections.
- B. Leakage Tests:
  - 1. Comply with SMACNA's "HVAC Air Duct Leakage Test Manual." Submit a test report for each test.
  - 2. Test the following systems:
    - a. Ducts with a Pressure Class Lower Than 3-Inch wg : Test all duct sections.
  - 3. Disassemble, reassemble, and seal segments of systems to accommodate leakage testing and for compliance with test requirements.
  - 4. Test for leaks after all system access doors are installed.
    - a. Include access doors/access door duct segments in leakage testing and calculations.
  - 5. Test for leaks before applying external insulation.
  - 6. Conduct tests at static pressures equal to maximum design pressure of system or section being tested. If static-pressure classes are not indicated, test system at maximum system design pressure. Do not pressurize systems above maximum design operating pressure.
  - 7. Give seven days' advance notice for testing.
- C. Duct System Cleanliness Tests:
  - 1. Visually inspect duct system to ensure that no visible contaminants are present.
  - 2. Where contaminants are discovered, re-clean and reinspect ducts.
  - 3. Test sections of metal duct system, chosen randomly by Owner, for cleanliness according to "Vacuum Test" in NADCA ACR, "Assessment, Cleaning and Restoration of HVAC Systems."
    - a. Acceptable Cleanliness Level: Net weight of debris collected on the filter media shall not exceed 0.75 mg/100 sq. cm.
  - 4. Verification of Existing Coil Cleaning: Cleaning must restore coil pressure drop to within 5 percent of pressure drop measured when coil was first installed. If original

pressure drop is not known, coil will be considered clean only if it is free of foreign matter and chemical residue, based on thorough visual inspection.

5. Verify cleanliness after mechanical cleaning and before application of treatment, including biocidal agents and protective coatings.

D. Duct system will be considered defective if it does not pass tests and inspections.

E. Prepare test and inspection reports.

### **3.7 DUCT CLEANING**

A. Clean new and existing duct system(s) before testing, adjusting, and balancing.

1. Extent of Existing Ductwork to be Cleaned: Clean all existing ductwork of systems serving the project area and as indicated.
2. SMACNA Duct Cleanliness Level for New Ductwork: B. Intermediate Level.

B. Cleaning of new ductwork may be waived by the Engineer if in the sole judgment of the Engineer, appropriate precautions have been taken during construction to cover open ends of ducts and otherwise keep the ductwork clean.

C. Use service openings for entry and inspection.

1. Create new openings and install access panels appropriate for duct static-pressure class if required for cleaning access. Provide insulated panels for insulated or lined duct. Patch insulation and liner as recommended by duct liner manufacturer. Comply with Division 23 Section "Air Duct Accessories" for access panels and doors.
2. Disconnect and reconnect flexible ducts as needed for cleaning and inspection.
3. Remove and reinstall ceiling to gain access during the cleaning process.

D. Particulate Collection and Odor Control:

1. When venting vacuuming system inside the building, use HEPA filtration with 99.97 percent collection efficiency for 0.3-micron-size (or larger) particles.
2. When venting vacuuming system to outdoors, use filter to collect debris removed from HVAC system, and locate exhaust downwind and away from air intakes and other points of entry into building.

E. Clean the following components by removing surface contaminants and deposits:

1. Air outlets and inlets (registers, grilles, and diffusers).
2. Supply, return, and exhaust fans including fan housings, plenums (except ceiling supply and return plenums), scrolls, blades or vanes, shafts, baffles, dampers, and drive assemblies.
3. Air-handling unit internal surfaces and components including mixing box, coil section, air wash systems, spray eliminators, condensate drain pans, humidifiers and dehumidifiers, filters and filter sections, and condensate collectors and drains.

4. Coils and related components.
5. Return-air ducts, dampers, actuators, and turning vanes except in ceiling plenums and mechanical equipment rooms.
6. Supply-air ducts, dampers, actuators, and turning vanes.
7. Dedicated exhaust and ventilation components and makeup air systems.

F. Mechanical Cleaning Methodology:

1. Clean metal duct systems using mechanical cleaning methods that extract contaminants from within duct systems and remove contaminants from building.
2. Use vacuum-collection devices that are operated continuously during cleaning. Connect vacuum device to downstream end of duct sections so areas being cleaned are under negative pressure.
3. Use mechanical agitation to dislodge debris adhered to interior duct surfaces without damaging integrity of metal ducts, duct liner, or duct accessories.
4. Clean fibrous-glass duct liner with HEPA vacuuming equipment; do not permit duct liner to get wet. Replace fibrous-glass duct liner that is damaged, deteriorated, or delaminated or that has friable material, mold, or fungus growth.
5. Clean coils and coil drain pans according to NADCA 1992. Keep drain pan operational. Rinse coils with clean water to remove latent residues and cleaning materials; comb and straighten fins.
6. Provide drainage and cleanup for wash-down procedures.
7. Antimicrobial Agents and Coatings: Apply EPA-registered antimicrobial agents if fungus is present. Apply antimicrobial agents according to manufacturer's written instructions after removal of surface deposits and debris.

G. Additional Requirements for Cleaning Existing Systems:

1. Use service openings, as required, for physical and mechanical entry and for inspection.
  - a. Use existing service openings where possible.
  - b. Create other openings to comply with duct standards.
  - c. Disconnect flexible ducts as needed for cleaning and inspection.
  - d. Reseal rigid fiberglass duct systems according to NAIMA recommended practices.
  - e. Remove and reinstall ceiling sections to gain access during the cleaning process.
2. Mark position of dampers and air-directional mechanical devices before cleaning, and restore to their marked position on completion.
3. Clean the following metal duct systems by removing surface contaminants and deposits:
  - a. Air outlets and inlets (registers, grilles, and diffusers).
  - b. Supply, return, and exhaust fans including fan housings, plenums (except ceiling supply and return plenums), scrolls, blades or vanes, shafts, baffles, dampers, and drive assemblies.
  - c. Air handling unit internal surfaces and components including mixing box, coil section, air wash systems, spray eliminators, condensate drain pans, humidifiers and dehumidifiers, filters and filter sections, and condensate collectors and drains.

PROBATE COURT  
ADMINISTRATION  
INTERIOR RENOVATIONS  
186 NEWINGTON ROAD  
WEST HARTFORD, CONNECTICUT

- d. Coils and related components.
- e. Return air ducts, dampers, and actuators.
- f. Supply air ducts, dampers, actuators, and turning vanes.
- g. Dedicated exhaust and ventilation components and make-up air systems.

### 3.8 START UP

- A. Air Balance: Comply with requirements in Division 23 Section "Testing, Adjusting, and Balancing for HVAC."

### 3.9 DUCT SCHEDULE

- A. Duct static pressure classifications shall be a minimum of the higher of either the fan developed static pressure or the scheduled value below.

Category	Connecting	Pressure Class <sup>ab</sup>	Seal Class <sup>a</sup>	Leakage Class <sup>a</sup>		Material <sup>f</sup>
				Rect.	Round	
Supply Air	Terminal <sup>c</sup>	2"	A	LC-16	LC-8	G
	AHU <sup>d</sup>	4"	A	LC-8	LC-4	G
	Other	4"	A	LC-8	LC-4	G
Return Air	Terminal <sup>c</sup>	2"	A	LC-16	LC-8	G
	AHU <sup>d</sup>	4"	A	LC-8	LC-4	G
	Other	4"	A	LC-8	LC-4	G
Exhaust Air	Class 1 & 2 <sup>e</sup>	2"	A	LC-16	LC-8	G
	AHU <sup>d</sup>	3"	A	LC-8	LC-4	G
	Kitchen	4"	Welded	LC-8	LC-4	B/S1 <sup>g</sup>
	Moisture	3"	A	LC-8	LC-4	S1
	Class 3 & 4 <sup>e</sup>	6"	A	LC-4	LC-2	S2
	Other	3"	A	LC-8	LC-4	G
Outside Air	Terminal <sup>c</sup>	1"	A	LC-16	LC-8	G
	AHU <sup>d</sup>	3"	A	LC-8	LC-4	G
	Other	3"	A	LC-8	LC-4	G

1. Table Notes:

- a. Duct classifications according to the latest versions of SMACNA.
- b. Pressure class in inches water gauge (" w.g.).
- c. Terminal designation includes ducts connected to fan coil units, furnaces, heat pumps, and terminal units.
- d. "AHU" indicates all air handling equipment including rooftop units, air handlers, dedicated outside air units, energy recovery units, etc., moving primary and secondary air through the building.
- e. Air classifications as defined by ASHRAE 62.1.
  - 1) Ducts connected to fans exhausting Class 1 and 2 air.

PROBATE COURT  
ADMINISTRATION  
INTERIOR RENOVATIONS  
186 NEWINGTON ROAD  
WEST HARTFORD, CONNECTICUT

2) Ducts connected to fans exhausting laboratory and process Class 3 and 4 air.

- f. Material Designations: G = galvanized sheetmetal, S1 = 304L stainless steel, S2 = 316L stainless steel, A = aluminum, B = black iron.
- g. Exposed to View/Outdoors: Type 304, stainless steel sheet, No. 4 finish. Concealed: carbon-steel sheet.

B. Intermediate Reinforcement:

- 1. Galvanized-Steel Ducts: Galvanized steel.
- 2. Aluminum Ducts: Aluminum.

C. Liner:

- 1. Liner Schedule (Minimum Thickness):

	Conditioned Spaces	Unconditioned Spaces	Outside of Building or in Uninsulated Side of Attics
Supply	1"	2"	2"
Return	1"	2"	2"
Exhaust	1"	1"	1"
Exhaust on O.A. Side of Dampers	1"	2"	1"
Outside Air	1"	2"	1"
Moist Exhaust	Not Allowed	Not Allowed	Not Allowed

- 2. Plenums: Flexible elastomeric, 2 inches thick.
- 3. Transfer Ducts: Flexible elastomeric, 1-1/2 inches thick.
- 4. Additional thickness of duct liner may be substituted for external insulation to match external insulation R-value specification.
- 5. Increase sheet metal dimensions to maintain specified clear opening duct dimensions.
- 6. Applications:
  - a. In Proximity of Fans: 15 ft. up or downstream in direction of outlets.
  - b. Fan Coil Units, Furnaces, Heat Pumps, and Terminal Units: 10 ft. up or downstream in direction of outlets.
  - c. Other Locations: As indicated.

D. Elbow Configuration:

- 1. Rectangular Duct: Comply with SMACNA's "HVAC Duct Construction Standards - Metal and Flexible," Figure 2-2, "Rectangular Elbows."
  - a. Velocity 1000 fpm or Lower and Secondary Ductwork:
    - 1) Radius Type RE 1 with minimum 0.5 radius-to-diameter ratio.

PROBATE COURT  
 ADMINISTRATION  
 INTERIOR RENOVATIONS  
 186 NEWINGTON ROAD  
 WEST HARTFORD, CONNECTICUT

- 2) Mitered Type RE 4 without vanes.
- b. Velocity 1000 to 1500 fpm:
  - 1) Radius Type RE 1 with minimum 1.0 radius-to-diameter ratio.
  - 2) Radius Type RE 3 with minimum 0.5 radius-to-diameter ratio and two vanes.
  - 3) Mitered Type RE 2 with vanes complying with SMACNA's "HVAC Duct Construction Standards - Metal and Flexible," Figure 2-3, "Vanes and Vane Runners," and Figure 2-4, "Vane Support in Elbows."
- c. Velocity 1500 fpm or Higher:
  - 1) Radius Type RE 1 with minimum 1.5 radius-to-diameter ratio.
  - 2) Radius Type RE 3 with minimum 1.0 radius-to-diameter ratio and two vanes.
  - 3) Mitered Type RE 2 with vanes complying with SMACNA's "HVAC Duct Construction Standards - Metal and Flexible," Figure 2-3, "Vanes and Vane Runners," and Figure 2-4, "Vane Support in Elbows."
2. Rectangular Duct: Comply with SMACNA's "HVAC Duct Construction Standards - Metal and Flexible," Figure 2-2, "Rectangular Elbows."
  - a. Radius Type RE 1 with minimum 1.5 radius-to-diameter ratio.
  - b. Radius Type RE 3 with minimum 1.0 radius-to-diameter ratio and two vanes.
  - c. Mitered Type RE 2 with vanes complying with SMACNA's "HVAC Duct Construction Standards - Metal and Flexible," Figure 2-3, "Vanes and Vane Runners," and Figure 2-4, "Vane Support in Elbows."
  - d. Kitchen Exhaust: Radius Type RE 1 with minimum 1.5 radius-to-diameter ratio.
3. Round Duct: Comply with SMACNA's "HVAC Duct Construction Standards - Metal and Flexible," Figure 3-3, "Round Duct Elbows."
  - a. Minimum Radius-to-Diameter Ratio and Elbow Segments: Comply with SMACNA's "HVAC Duct Construction Standards - Metal and Flexible," Table 3-1, "Mitered Elbows." Elbows with less than 90-degree change of direction have proportionately fewer segments.
    - 1) Velocity 1000 fpm or Lower and Secondary Ductwork: 0.5 radius-to-diameter ratio and three segments for 90-degree elbow.
    - 2) Velocity 1000 to 1500 fpm: 1.0 radius-to-diameter ratio and four segments for 90-degree elbow.
    - 3) Velocity 1500 fpm or Higher: 1.5 radius-to-diameter ratio and five segments for 90-degree elbow.
    - 4) Radius-to Diameter Ratio: 1.5.
    - 5) Kitchen Exhaust Radius-to-Diameter Ratio: 1.5.

PROBATE COURT  
ADMINISTRATION  
INTERIOR RENOVATIONS  
186 NEWINGTON ROAD  
WEST HARTFORD, CONNECTICUT



- b. Round Elbows, 12 Inches and Smaller in Diameter: Stamped or pleated.
- c. Round Elbows, 14 Inches and Larger in Diameter: Standing seam.

E. Branch Configuration:

1. Rectangular Duct: Comply with SMACNA's "HVAC Duct Construction Standards - Metal and Flexible, Chapter: "Fittings and Other Construction."
  - a. Rectangular Main to Rectangular Branch: Bell-mouth or 45-degree entry.
  - b. Rectangular Main to Round Branch: Bell-mouth.
  - c. Divided Supply Flow Branches Above 1,000 FPM and Primary Ductwork: Types 1, 2W, 4A and 4B are acceptable.
  - d. Divided Supply Flow Branches 1,000 FPM and Below and Secondary Ductwork: Types 1, 2W, 3, 4A and 4B are acceptable.
  - e. Divided Return Flow Branches Above 1,000 FPM: Types 1, 2W, 4A and 4B are acceptable.
2. Round and Flat Oval: Comply with SMACNA's "HVAC Duct Construction Standards - Metal and Flexible," Figure 3-4, "90 Degree Tees and Laterals," and Figure 3-5, "Conical Tees." Saddle taps are permitted in existing duct.
  - a. Velocity 1000 fpm or Lower and Secondary Ductwork: Conical tap.
  - b. Velocity 1000 to 1500 fpm: Conical tap.
  - c. Velocity 1500 fpm or Higher: 45-degree lateral.

**END OF SECTION 233113**

03/07/2017

**SECTION 233300 - AIR DUCT ACCESSORIES**

**PART 1 - GENERAL**

**1.1 RELATED DOCUMENTS**

- A. Drawings and general provisions of the Contract, including General and Supplementary Conditions and Division 01 Specification Sections, apply to this Section.

**1.2 SUMMARY**

A. Section Includes:

- 1. Manual volume dampers.
- 2. Fire dampers.
- 3. Smoke dampers.
- 4. Combination fire and smoke dampers.
- 5. Turning vanes.
- 6. Duct-mounted access doors.
- 7. Flexible ducts.
- 8. Duct accessory hardware.

B. Related Sections:

- 1. Division 08 Section "Access Doors and Frames" for wall- and ceiling-mounted access doors and panels.
- 2. Division 08 Section "Louvers and Vents" for intake and relief louvers and vents connected to ducts and installed in exterior walls.
- 3. Division 23 Section "Instrumentation and Controls for HVAC" for electric and pneumatic damper actuators and control dampers.
- 4. Division 23 Section "Air Terminal Units" for constant volume and variable air volume control boxes and reheat boxes.
- 5. Division 23 Section "Diffusers, Registers, and Grilles".
- 6. Division 23 Section "HVAC Gravity Ventilators" for roof-mounted ventilator caps.
- 7. Division 28 Section "Fire Detection and Alarm" for duct-mounted fire and smoke detectors.

**1.3 SUBMITTALS**

A. Product Data: For each type of product indicated.

- 1. For duct sound attenuators, include pressure drop and dynamic insertion loss data. Include breakout noise calculations for high transmission loss casings.

B. Shop Drawings: For duct accessories. Include plans, elevations, sections, details and attachments to other work.

1. Detail duct accessories fabrication and installation in ducts and other construction. Include dimensions, weights, loads, and required clearances; and method of field assembly into duct systems and other construction. Include the following:
  - a. Special fittings.
  - b. Manual volume damper installations.
  - c. Fire-damper, smoke-damper, combination fire- and smoke-damper, ceiling, and corridor damper installations, including sleeves; and duct-mounted access doors and remote damper operators. Include manufacturer's NRTL rating installation instructions in submittal.
  - d. Duct security bars.
  - e. Wiring Diagrams: For power, signal, and control wiring.
- C. Coordination Drawings: Reflected ceiling plans, drawn to scale, on which ceiling-mounted access panels and access doors required for access to duct accessories are shown and coordinated with each other, using input from Installers of the items involved.
- D. Source quality-control reports.
- E. Operation and Maintenance Data: For air duct accessories to include in operation and maintenance manuals.

#### **1.4 QUALITY ASSURANCE**

- A. Comply with NFPA 90A, "Installation of Air Conditioning and Ventilating Systems," and with NFPA 90B, "Installation of Warm Air Heating and Air Conditioning Systems."
- B. Comply with AMCA 500-D testing for damper rating.

### **PART 2 - PRODUCTS**

#### **2.1 MATERIALS**

- A. Comply with SMACNA's "HVAC Duct Construction Standards - Metal and Flexible" for acceptable materials, material thicknesses, and duct construction methods unless otherwise indicated. Sheet metal materials shall be free of pitting, seam marks, roller marks, stains, discolorations, and other imperfections.
- B. Galvanized Sheet Steel: Comply with ASTM A 653/A 653M.
  1. Galvanized Coating Designation: G60.
  2. Exposed-Surface Finish: Mill phosphatized.
- C. Stainless-Steel Sheets: Comply with ASTM A 480/A 480M, Type 304, and having a No. 2D finish for concealed ducts and No. 4 finish for exposed ducts.

- D. Aluminum Sheets: Comply with ASTM B 209, Alloy 3003, Temper H14; with mill finish for concealed ducts and standard, 1-side bright finish for exposed ducts.
- E. Extruded Aluminum: Comply with ASTM B 221, Alloy 6063, Temper T6.
- F. Reinforcement Shapes and Plates: Galvanized-steel reinforcement where installed on galvanized sheet metal ducts; compatible materials for aluminum and stainless-steel ducts.
- G. Tie Rods: Galvanized steel, 1/4-inch minimum diameter for lengths 36 inches or less; 3/8-inch minimum diameter for lengths longer than 36 inches.

## 2.2 MANUAL VOLUME DAMPERS

- A. Standard, Steel, Manual Volume Dampers:
  - 1. Manufacturers: Subject to compliance with requirements, provide products by one of the following:
    - a. Air Balance Inc.; a division of Mestek, Inc.
    - b. American Warming and Ventilating; a division of Mestek, Inc.
    - c. McGill AirFlow LLC.
    - d. METALAIRE, Inc.
    - e. Nailor Industries Inc.
    - f. Ruskin Company.
  - 2. Standard leakage rating, with linkage outside airstream.
  - 3. Suitable for horizontal or vertical applications.
  - 4. Frames:
    - a. Hat-shaped, galvanized or stainless-steel channels, 0.064-inch minimum thickness suitable for application.
    - b. Mitered and welded corners.
    - c. Flanges for attaching to walls and flangeless frames for installing in ducts.
  - 5. Blades:
    - a. Multiple or single blade. Use multiple blade dampers in ducts greater than 2 sq. ft. in cross-section.
    - b. Opposed-blade design.
    - c. Stiffen damper blades for stability.
    - d. Galvanized or stainless-steel, 0.064 inch thick suitable for application.
  - 6. Blade Axles: Galvanized steel or stainless steel suitable for application.
  - 7. Bearings:
    - a. Oil-impregnated bronze or molded synthetic or stainless-steel sleeve suitable for application.

- b. Dampers in ducts with pressure classes of 3-inch wg or less shall have axles full length of damper blades and bearings at both ends of operating shaft.
  - 8. Tie Bars and Brackets: Galvanized steel.
- B. Standard, Aluminum, Manual Volume Dampers:
  - 1. Manufacturers: Subject to compliance with requirements, provide products by one of the following:
    - a. Air Balance Inc.; a division of Mestek, Inc.
    - b. American Warming and Ventilating; a division of Mestek, Inc.
    - c. McGill AirFlow LLC.
    - d. METALAIRE, Inc.
    - e. Nailor Industries Inc.
    - f. Ruskin Company.
  - 2. Standard leakage rating, with linkage outside airstream.
  - 3. Suitable for horizontal or vertical applications.
  - 4. Frames: Hat-shaped, 0.10-inch- thick, aluminum sheet channels; frames with flanges for attaching to walls and flangeless frames for installing in ducts.
  - 5. Blades:
    - a. Multiple or single blade. Use multiple blade dampers in ducts greater than 2 sq. ft. in cross-section.
    - b. Opposed-blade design.
    - c. Stiffen damper blades for stability.
    - d. Roll-Formed Aluminum Blades: 0.10-inch- thick aluminum sheet.
    - e. Extruded-Aluminum Blades: 0.050-inch- thick extruded aluminum.
  - 6. Blade Axles: Stainless steel.
  - 7. Bearings:
    - a. Stainless-steel sleeve.
    - b. Dampers in ducts with pressure classes of 3-inch wg or less shall have axles full length of damper blades and bearings at both ends of operating shaft.
  - 8. Tie Bars and Brackets: Aluminum.

### **2.3 FIRE DAMPERS**

- A. Manufacturers: Subject to compliance with requirements, provide products by one of the following:
  - 1. Air Balance Inc.; a division of Mestek, Inc.
  - 2. Greenheck Fan Corporation.
  - 3. McGill AirFlow LLC.

4. NCA Manufacturing, Inc.
  5. Prefco; Perfect Air Control, Inc.
  6. Ruskin Company.
- B. Type: Dynamic; rated and labeled according to UL 555 by an NRTL. Static rated dampers will be unacceptable.
- C. Closing rating in ducts up to 4-inch wg static pressure class and minimum 2000 fpm velocity.
1. Ducts up to 2000 fpm velocity, 2000 fpm rated.
  2. Ducts above 2000 fpm velocity, 3000 fpm rated.
  3. Ducts above 3000 fpm to 4000 fpm velocity, 4000 fpm rated.
- D. Fire Rating: 1-1/2 or 3 hours as required by code for the rating of the construction penetrated.
- E. Frame: Curtain type with blades outside airstream for 2000 fpm rated dampers, multiple-blade type for dampers rated above 2000 fpm; fabricated with roll-formed, 0.034-inch- thick galvanized steel; with mitered and interlocking corners.
1. Provide stainless steel type for applications per Part 3.
- F. Mounting Sleeve: Factory-supplied, galvanized sheet steel. Field-fabricated sleeves will be unacceptable unless special conditions warrant, upon which request must be submitted to the engineer for review and acceptance prior to installation.
1. Provide stainless steel type for applications per Part 3.
  2. Minimum Thickness: As required by manufacturer's installation instructions for NRTL rating, and of length to suit application.
  3. Exception: Omit sleeve where damper-frame width permits direct attachment of perimeter mounting angles on each side of wall or floor; thickness of damper frame must comply with sleeve requirements.
- G. Mounting Orientation: Vertical or horizontal as indicated.
- H. Blades: Roll-formed, interlocking, 0.034-inch- thick, galvanized sheet steel. In place of interlocking blades, use full-length, 0.034-inch- thick, galvanized-steel blade connectors.
1. Provide stainless steel type construction for applications per Part 3.
- I. Horizontal Dampers: Include blade lock and stainless-steel closure spring.
- J. Heat-Responsive Device: Replaceable, 165 deg Frated, fusible links.

**2.4 SMOKE DAMPERS**

- A. Manufacturers: Subject to compliance with requirements, provide products by one of the following:
1. Air Balance Inc.; a division of Mestek, Inc.
  2. American Warming and Ventilating.
  3. Greenheck Fan Corporation.
  4. National Controlled Air.
  5. Prefco Products, Inc.
  6. Ruskin Company.
- B. General Requirements: Label according to UL 555S by an NRTL. Coordinate all features with fire alarm and HVAC control systems, including interface with fire alarm system, power and control wiring requirements. See Division 23 HVAC control sections for requirements and sequence of operations.
- C. Frame: Multiple-blade type; fabricated with roll-formed, 0.034-inch- thick galvanized steel; with mitered and interlocking corners.
1. Provide stainless steel type construction for applications per Part 3.
- D. Blades: Roll-formed, horizontal, interlocking, 0.034-inch- thick, galvanized sheet steel. In place of interlocking blades, use full-length, 0.034-inch- thick, galvanized-steel blade connectors.
1. Provide stainless steel type construction for applications per Part 3.
- E. Leakage: Class I for engineered smoke control and/or evacuation systems, Class II for smoke isolation of air handling unit and of smoke barrier duct penetrations.
- F. Rated pressure and velocity to exceed design airflow conditions.
- G. Mounting Sleeve: Factory-installed, 0.052-inch- thick, galvanized sheet steel; length to suit wall or floor application.
1. Provide stainless steel type construction for applications per Part 3.
- H. Smoke Damper Actuators:
1. Size for torque required for damper seal at load conditions.
  2. Coupling: V-bolt dual nut clamp with a V-shaped toothed cradle. Aluminum clamps or set screws are not acceptable.
  3. Overload Protection: Microprocessor or an electronic based motor controller providing burnout protection if stalled before full rotation is reached. The actuator shall be electronically cut off at full open to eliminate noise generation with the holding noise level to be inaudible.

4. Power Requirements (Two-Position Spring Return): 24 Vac.
  5. Power Requirements (Proportional): Maximum (running) 12 VA at 24 Vac or 8 W at 24 Vdc. Maximum (holding) 5 VA at 25 Vac or 3 W at 24 Vdc holding.
  6. Proportional Actuators (24 Vac/dc): Control signal shall be 2-10 Vdc or 4-20 mA, with a 2-10 Vdc position feedback signal.
  7. Actuator timing shall meet 15 sec.
  8. Temperature Rating: Actuator shall have a UL 555S listing by the damper manufacturer for 350 deg. F.
  9. Housing: Steel housing, aluminum is unacceptable.
  10. Agency Listing: ISO 9001, UL873, or UL60730.
  11. The manufacturer shall warrant all components for a period of five years from the date of production, with the first two years unconditional.
  12. Auxiliary switches for fan control.
- I. Fail Safe Position: Power open and fail closed for smoke isolation of air handling units, smoke barrier duct penetrations, and smoke partition transfers. Power closed/fail open for elevator shaft vents. For engineered smoke control and/or evacuation systems, power open/fail closed or power closed/fail open suitable for fail safe operation recommended by manufacturer and approved by authority having jurisdiction for system application and operation.
- J. Accessories:
1. Auxiliary End Switches: Two damper end switches, one to monitor open position and one to monitor closed position. Contacts rated for field coordinated voltage with fire alarm and HVAC control systems.

## **2.5 COMBINATION FIRE AND SMOKE DAMPERS**

- A. Manufacturers: Subject to compliance with requirements, provide products by one of the following:
1. Air Balance Inc.; a division of Mestek, Inc.
  2. American Warming and Ventilating.
  3. Greenheck Fan Corporation.
  4. National Controlled Air.
  5. Prefco Products, Inc.
  6. Ruskin Company.
- B. General Requirements: Dynamic; rated and labeled according to UL 555 and UL 555S by an NRTL. Static rated dampers will be unacceptable.
1. Coordinate all features with fire alarm and HVAC control systems, including interface with the fire alarm system, power and control wiring requirements. See Division 23 HVAC control sections for requirements and sequence of operations.
- C. Closing rating in ducts up to 4-inch wg static pressure class and minimum 2000 fpm velocity.



1. Ducts up to 2000 fpm velocity, 2000 fpm rated.
  2. Ducts above 2000 fpm velocity, 3000 fpm rated.
  3. Ducts above 3000 fpm to 4000 fpm velocity, 4000 fpm rated.
- D. Fire Rating: 1-1/2 or 3 hours as required by code for the rating of the construction penetrated.
- E. Frame: Multiple-blade type; fabricated with roll-formed, 0.034-inch- thick galvanized steel; with mitered and interlocking corners.
1. Provide stainless steel type construction for applications per Part 3.
- F. Heat-Responsive Device and Override Control: Electric resettable link and switch package, factory installed, rated, for combination fire and smoke dampers in engineered smoke control, a primary electric temperature sensor (165 deg F) and a secondary fusible link (350 deg F). Electric sensor shall be factory installed and wired to terminal point, ready for field wiring of remote override control switch.
- G. Blades: Roll-formed, horizontal, interlocking, 0.034-inch- thick, galvanized sheet steel. In place of interlocking blades, use full-length, 0.034-inch- thick, galvanized-steel blade connectors.
1. Provide stainless steel type construction for applications per Part 3.
- H. Leakage: Class I for engineered smoke control and/or evacuation systems, Class II for smoke isolation of air handling unit and of smoke barrier duct penetrations.
- I. Rated pressure and velocity to exceed design airflow conditions.
- J. Mounting Sleeve: Factory-installed, 0.052-inch- thick, galvanized sheet steel; length to suit wall or floor application.
1. Provide stainless steel type construction for applications per Part 3.
- K. Combination Fire/Smoke Damper Actuators:
1. Size for torque required for damper seal at load conditions.
  2. Coupling: V-bolt dual nut clamp with a V-shaped toothed cradle. Aluminum clamps or set screws are not acceptable.
  3. Overload Protection: Microprocessor or an electronic based motor controller providing burnout protection if stalled before full rotation is reached. The actuator shall be electronically cut off at full open to eliminate noise generation with the holding noise level to be inaudible.
  4. Power Requirements (Two-Position Spring Return): 24 Vac.
  5. Power Requirements (Proportional): Maximum (running) 12 VA at 24 Vac or 8 W at 24 Vdc. Maximum (holding) 5 VA at 25 Vac or 3 W at 24 Vdc holding.
  6. Proportional Actuators (24 Vac/dc): Control signal shall be 2-10 Vdc or 4-20 mA, with a 2-10 Vdc position feedback signal.

7. Actuator timing shall meet 15 sec.
  8. Temperature Rating: Actuator shall have a UL 555S listing by the damper manufacturer for 350 deg. F.
  9. Housing: Steel housing, aluminum is unacceptable.
  10. Agency Listing: ISO 9001, UL873, or UL60730.
  11. The manufacturer shall warrant all components for a period of five years from the date of production, with the first two years unconditional.
  12. Auxiliary switches for fan control.
- L. Fail Safe Position: Power open and fail closed for smoke isolation of air handling units, smoke barrier duct penetrations, and smoke partition transfers. Power closed/fail open for elevator shaft vents. For engineered smoke control and/or evacuation systems, power open/fail closed or power closed/fail open suitable for fail safe operation recommended by manufacturer and approved by authority having jurisdiction for system application and operation.
- M. Accessories:
1. Auxiliary End Switches: Two damper end switches, open and closed position, for damper position status and control function interfaces for each damper, contacts rated for field coordinated voltage with fire alarm and HVAC control systems.

## **2.6 TURNING VANES**

- A. Manufacturers: Subject to compliance with requirements, provide products by one of the following:
1. Ductmate Industries, Inc.
  2. Duro Dyne Inc.
  3. METALAIRE, Inc.
  4. SEMCO Incorporated.
  5. Ward Industries, Inc.; a division of Hart & Cooley, Inc.
- B. Turning Vanes for Metal Ducts: Curved blades of galvanized sheet steel; support with bars perpendicular to blades set; set into vane runners suitable for duct mounting.
- C. General Requirements: Comply with SMACNA's "HVAC Duct Construction Standards - Metal and Flexible"; Figures 2-3, "Vanes and Vane Runners," and 2-4, "Vane Support in Elbows."
- D. Vane Construction: Double wall.

## **2.7 DUCT-MOUNTED ACCESS DOORS**

- A. Manufacturers: Subject to compliance with requirements, provide products by one of the following:
1. Ductmate Industries, Inc.; Model "Sandwich."
  2. McGill AirFlow LLC; Model "Standard Bolted Access Door."

3. Pottorff; a division of PCI Industries, Inc.; Model "DMHC."
4. Ruskin.
5. Ward Industries, Inc.; a division of Hart & Cooley, Inc.; Model "DSA."

B. Panels:

1. Insulated Ducts: Access door consists of three layers of precision stamped steel. The inside panel consists of two layers of metal which are spot welded together along the rim encapsulating high density fiberglass or closed cell foam insulation UL classified FHC25/50.
2. Uninsulated Ducts: Access door consists of two layers of precision stamped steel.

C. Gasket: Closed cell neoprene gasket is UL94HF1 listed with a service temperature range of (ASTM D746) -20 deg. F to 200 deg. F. The gasket is bonded to the inside panel of the access door to insure consistent installations.

D. Springs: Zinc-plated conical springs are installed, between the inner and outer door, to facilitate opening.

E. Knobs: Polypropylene molded knobs have threaded metal inserts to eliminate thread stripping. Knobs are easily turned by hand. Knobs are UL94HB listed.

F. Bolts: Zinc-plated carriage bolts are secured to inner door.

G. Leakage Rating: Less than 1 cfm at 8" wg.

## 2.8 FLEXIBLE DUCTS

A. Manufacturers: Subject to compliance with requirements, provide products by one of the following:

1. Buckley Associates, Inc.
2. Flexmaster U.S.A., Inc.
3. Novaflex Inc.
4. Ward Industries, Inc.; a division of Hart & Cooley, Inc.

B. Non-Insulated, Flexible Duct: UL 181, Class 1, multiple layers of aluminum laminate, aluminum laminate and polyester film with latex adhesive, vinyl-coated fiberglass cloth, or similar material, supported by helically wound, spring-steel wire.

1. Pressure Rating: 10-inch wg positive and 5.0-inch wg negative.
2. Maximum Air Velocity: 4000 fpm.
3. Temperature Range: Minus 20 to plus 210 deg. F

C. Insulated, Flexible Duct: UL 181, Class 1, multiple layers of aluminum laminate, aluminum laminate and polyester film with latex adhesive, vinyl-coated fiberglass cloth, or similar

material, supported by helically wound, spring-steel wire; fibrous-glass insulation; polyethylene or aluminized vapor-barrier film.

1. Pressure Rating: 10-inch wg positive and 5.0-inch wg negative.
2. Maximum Air Velocity: 4000 fpm.
3. Temperature Range: Minus 20 to plus 210 deg F.
4. Insulating Value: R6.0.

D. Acoustical, Flexible Duct: UL 181, Class 0, triple interlocking spiral of perforated aluminum foil; fibrous-glass insulation; polyethylene or aluminized vapor-barrier film.

1. Pressure Rating: 8-inch wg positive or negative.
2. Maximum Air Velocity: 5000 fpm.
3. Temperature Range: Minus 20 to plus 250 deg F.
4. Acoustical Performance: Attenuation rated at 500 fpm in dB, 125 Hz = 2, 250 Hz = 16, 500 Hz = 17, 1,000 Hz = 18, 2000 Hz = 13, 4000 Hz = 0.

E. Flexible Duct Connectors:

1. Clamps: Stainless-steel band with cadmium-plated hex screw to tighten band with a worm-gear action in sizes 3 through 18 inches, to suit duct size.

F. Flexible Duct Accessories:

1. Elbow Forms: 100 percent recycled copolymer polypropylene "I" shaped form attached with nylon bands.

## **2.9 DUCT ACCESSORY HARDWARE**

A. Instrument Test Holes: Cast iron or cast aluminum to suit duct material, including screw cap and gasket. Size to allow insertion of pitot tube and other testing instruments and of length to suit duct-insulation thickness.

B. Adhesives: High strength, quick setting, neoprene based, waterproof, and resistant to gasoline and grease.

## **PART 3 - EXECUTION**

### **3.1 INSTALLATION**

A. Install duct accessories according to applicable details in SMACNA's "HVAC Duct Construction Standards - Metal and Flexible" for metal ducts.

B. Install duct accessories of materials suited to duct materials; use galvanized-steel accessories in galvanized-steel, stainless-steel accessories in stainless-steel ducts, and aluminum accessories in aluminum ducts.

- C. Install volume dampers at points on supply, return, and exhaust systems where branches extend from larger ducts and as follows. Where dampers are installed in ducts having duct liner, install dampers with hat channels of same depth as liner, and terminate liner with nosing at hat channel.
1. Coordinate subparagraphs below with Division 23 Section "Metal Ducts." Install steel volume dampers in steel ducts.
  2. Install aluminum volume dampers in aluminum ducts.
  3. Install stainless steel volume dampers in stainless steel ducts.
  4. Constant volume supply, return, exhaust, and outdoor air branch duct takeoffs.
  5. Constant volume supply, return, exhaust, and outdoor air mains upstream/downstream of branch duct takeoffs.
  6. Secondary variable volume supply air branch duct takeoffs.
  7. Large primary variable volume supply air branch duct takeoffs from mains and at shafts.
  8. Takeoffs to diffusers, registers, and grilles.
  9. Branch duct takeoffs to specialized program equipment or apparatus.
  10. Additional locations as required for air balancing to achieve specified airflows.
  11. Exceptions: Volume dampers are not required to be installed in individual primary supply ducts to air terminals, grease exhaust ducts, fume exhaust ducts, and where specifically indicated on drawings for special and acoustic applications.
  12. Provide remotely operated manual volume dampers wherever damper location will be difficult to access.
- D. Set dampers to fully open position before testing, adjusting, and balancing.
- E. Install test holes at fan inlets and outlets and elsewhere as required for testing and balancing.
- F. Install fire dampers in all fire-rated walls and partitions as required by code. Install fire dampers according to UL listing.
1. Install galvanized steel dampers in galvanized steel duct systems.
  2. Install stainless steel dampers in aluminum and stainless steel duct systems.
- G. Install smoke dampers in duct penetrations of all smoke barriers, in duct penetrations of smoke partitions where smoke can readily pass from one space to another (i.e., transfers), and in the main supply and return ducts of all air handling equipment 15,000 cfm and over, and in all elevator shaft vents. Install smoke dampers according to manufacturer's UL approved written instructions.
1. Install galvanized steel dampers in galvanized steel duct systems.
  2. Install stainless steel dampers in aluminum and stainless steel duct systems.
  3. Coordinate damper operation, features, accessories, power and control with fire alarm and HVAC control systems.
  4. Smoke barrier, smoke partition, air handling equipment shall:
    - a. Have damper position end switches interfaced with ATC system to indicate damper position status to HVAC control system and to provide necessary control

- functions and interlocks. Alarm when damper fails under normal conditions and when closed under fire alarm condition.
- b. Close through a hardwire interlock upon signal from the fire alarm system and/or when associated air system fan is off by automatic or manual means.
- 5. Install duct access panels to allow access and inspection of smoke/fire damper, including fusible link replacement.
  - 6. Test and verify operation of all dampers, according to the requirements of the authority having jurisdiction.
- H. Label access doors according to Division 23 Section "Identification for HVAC Piping and Equipment" to indicate the purpose of access door.
  - I. Connect dryers to low pressure ducts with minimum 60-inch lengths of non-insulated flexible duct suitable for application, clamped in place without penetration into duct.
  - J. Connect flexible ducts to metal ducts with draw bands.
  - K. Install duct test holes where required for testing and balancing purposes.
  - L. Install elbow forms at every flexible duct bend.
  - M. Flexible Duct Applications:
    - 1. Fan-Powered Terminal Units: Acoustical flexible duct, 5-ft. minimum straight run.
    - 2. Supply Diffusers and Light Troffers: Insulated flexible duct, 5-ft. to 6-ft. length with a minimum of one 90-degree bend in addition to the diffuser connection.

### **3.2 FIELD QUALITY CONTROL**

- A. Tests and Inspections:
  - 1. Operate dampers to verify full range of movement.
  - 2. Inspect locations of access doors and verify that purpose of access door can be performed.
  - 3. Operate fire, smoke, and combination fire and smoke dampers to verify full range of movement and verify that proper heat-response device is installed.
  - 4. Inspect turning vanes for proper and secure installation.
  - 5. Operate remote damper operators to verify full range of movement of operator and damper.

**END OF SECTION 233300**

03/07/2017



**SECTION 233713 - DIFFUSERS, REGISTERS, AND GRILLES**

**PART 1 - GENERAL**

**1.1 RELATED DOCUMENTS**

- A. Drawings and general provisions of the Contract, including General and Supplementary Conditions and Division 01 Specification Sections, apply to this Section.

**1.2 SUMMARY**

- A. Section Includes:
  - 1. Ceiling- and wall-mounted diffusers, registers, and grilles.
- B. Related Sections:
  - 1. Section 233300 "Air Duct Accessories" for fire and smoke dampers and volume-control dampers not integral to diffusers, registers, and grilles.
  - 2. Section 230713 "Duct Insulation" for insulating of components related to diffusers, registers, and grilles.

**1.3 ACTION SUBMITTALS**

- A. Product Data: For each type of product indicated, include the following:
  - 1. Data Sheet: Indicate materials of construction, finish, and mounting details; and performance data including throw and drop, static-pressure drop, and noise ratings.
  - 2. Diffuser, Register, and Grille Schedule: Indicate drawing designation, room location, quantity, model number, size, and accessories furnished.
- B. Samples for Initial Selection: Manufacturer color charts showing full range of colors available for diffusers, registers, and grilles with factory-applied color finishes.

**1.4 INFORMATIONAL SUBMITTALS**

- A. Coordination Drawings: Reflected ceiling plans, drawn to scale, on which the following items are shown and coordinated with each other, using input from Installers of the items involved:
  - 1. Ceiling suspension assembly members.
  - 2. Method of attaching hangers to building structure.
  - 3. Size and location of initial access modules for acoustical tile.
  - 4. Ceiling-mounted items including lighting fixtures, diffusers, grilles, speakers, sprinklers, access panels, and special moldings.
  - 5. Duct access panels.



- B. Source quality-control reports.

**PART 2 - PRODUCTS**

**2.1 MANUFACTURERS**

- A. Manufacturers: Subject to compliance with requirements, provide diffusers, registers, and grilles by one of the following:
  - 1. Diffusers, registers, and grilles, except as indicated otherwise:
    - a. Anemostat.
    - b. Krueger.
    - c. Nailor.
    - d. Price Industries.
    - e. Titus.
    - f. Tuttle & Bailey.
  - 2. Laminar Flow Diffusers:
    - a. Precision Air.
    - b. Price Industries.
    - c. Tuttle & Bailey.
    - d. Anemostat.

**2.2 MANUFACTURED UNITS**

- A. Diffuser, register, and grille accessories and requirements are scheduled on the drawings.

**2.3 COLOR AND MATERIAL**

- A. Color and finish of outlets and inlets shall be as selected by the Architect from the manufacturer's standard finishes, unless otherwise indicated.

**2.4 SOURCE QUALITY CONTROL**

- A. Verification of Performance: Rate diffusers, registers, and grilles according to ASHRAE 70, "Method of Testing for Rating the Performance of Air Outlets and Inlets."

**PART 3 - EXECUTION**

**3.1 APPLICATION**

- A. Provide materials listed in Schedules, except where indicated and as follows:
  - 1. Provide units of all aluminum construction in high humidity environments, including but not limited to bathrooms, showers, locker rooms, kitchens, sterilizer rooms, etc.
  - 2. Provide units of stainless steel construction in corrosive environments.

**3.2 EXAMINATION**

- A. Examine areas where diffusers, registers, and grilles are to be installed for compliance with requirements for installation tolerances and other conditions affecting performance of equipment.
- B. Proceed with installation only after unsatisfactory conditions have been corrected.

**3.3 INSTALLATION**

- A. Install diffusers, registers, and grilles level and plumb.
- B. Ceiling-Mounted Outlets and Inlets: Drawings indicate general arrangement of ducts, fittings, and accessories. Air outlet and inlet locations have been indicated to achieve design requirements for air volume, noise criteria, airflow pattern, throw, and pressure drop. Make final locations where indicated, as much as practical. For units installed in lay-in ceiling panels, locate units in the center of panel. Where architectural features or other items conflict with installation, notify Architect for a determination of final location. Coordinate with the architectural reflected ceiling plans for exact locations. Provide mounting flanges and frames compatible with the ceiling construction types in all areas.
- C. Install diffusers, registers, and grilles with airtight connections to ducts and to allow service and maintenance of dampers, air extractors, and fire dampers.
- D. Support ceiling-mounted outlets and inlets from ductwork and associated hangers to building structure. Ceiling-mounted outlets and inlets may be supported from the suspended ceiling system only where the ceiling system is seismically rated.
- E. Maximum run of flexible duct to diffusers, registers, and grilles per Division 23 Section "Duct Accessories."
- F. Install diffusers, registers, and grilles without screws or fasteners visible from finished side. Provide mounting clips, frames, brackets, or other materials necessary to firmly mount inlets and outlets in walls or ceilings.

- G. Insulate portions of the diffuser system not insulated by the factory or where field-fabricated such as plenums on all portions subject to temperatures below ambient conditions. Match duct system insulation requirements in Section 230713 "Duct Insulation."

**3.4 ADJUSTING**

- A. After installation, adjust diffusers, registers, and grilles to air patterns indicated, or as directed, before starting air balancing.

**3.5 CLEANING**

- A. After installation of diffusers, registers, and grilles, inspect exposed finish. Clean exposed surfaces to remove burrs, dirt, and smudges. Replace diffusers, registers, and grilles that have damaged finishes.

**END OF SECTION 233713**

03/07/2017

**SECTION 238236 - FINNED-TUBE RADIATION HEATERS**

**PART 1 - GENERAL**

**1.1 RELATED DOCUMENTS**

- A. Drawings and general provisions of the Contract, including General and Supplementary Conditions and other Division 01 Specification Sections, apply to this Section.

**1.2 SUMMARY**

- A. Section includes electric, baseboard and finned-tube radiation heaters.

**1.3 ACTION SUBMITTALS**

- A. Product Data: For each type of product.
  - 1. Include rated capacities, operating characteristics, furnished specialties, and accessories.
- B. Shop Drawings:
  - 1. Include plans, elevations, sections, and details.
  - 2. Include details of equipment assemblies. Indicate dimensions, weights, loads, required clearances, method of field assembly, components, and location and size of each field connection.
  - 3. Include details and dimensions of custom-fabricated enclosures.
  - 4. Indicate location and size of each field connection.
  - 5. Indicate location and arrangement of piping valves and specialties.
  - 6. Indicate location and arrangement of integral controls.
  - 7. Include enclosure joints, corner pieces, access doors, and other accessories.
  - 8. Include diagrams for power, signal, and control wiring.
- C. Color Samples for Initial Selection: For finned-tube radiation heaters with factory-applied color finishes.
- D. Color Samples for Verification: For each type of exposed finish.

**1.4 INFORMATIONAL SUBMITTALS**

- A. Coordination Drawings: Floor plans and other details, drawn to scale, on which the following items are shown and coordinated with each other, using input from installers of the items involved:
  - 1. Structural members, including wall construction, to which finned-tube radiation heaters will be attached.

2. Method of attaching finned-tube radiation heaters to building structure.
3. Penetrations of fire-rated wall and floor assemblies.

B. Field quality-control reports.

## **PART 2 - PRODUCTS**

### **2.1 ELECTRIC BASEBOARD RADIATION HEATERS**

- A. Basis-of-Design Product: Subject to compliance with requirements, provide product indicated on Drawings or comparable product by one of the following:
1. Berko; Marley Engineered Products.
  2. Chromalox, Inc.
  3. INDEECO.
  4. Markel Products; TPI Corporation.
  5. Marley Engineered Products.
  6. QMark; Marley Engineered Products.
- B. Description: Factory-packaged units constructed according to UL 499, UL 1030, and UL 2021.
1. Electrical Components, Devices, and Accessories: Listed and labeled as defined in NFPA 70, by a qualified testing agency, and marked for intended location and application.
- C. Heating Elements: Nickel-chromium-wire heating element enclosed in metallic sheath mechanically bonded to fins, with high-temperature cutout and sensor running the full length of the element. Element supports shall eliminate thermal expansion noise.
- D. Enclosures: Minimum 0.0329-inch- thick steel, removable front cover.
1. Full-height back.
  2. Full-length damper.
  3. End panel.
  4. End caps.
  5. Inside and outside corners.
  6. Joiner pieces to snap together.
  7. Finish: Baked-enamel finish in manufacturer's standard color as selected by Architect.
  8. Element Brackets: Primed and painted steel to support front panel and element.
- E. Unit Controls: Remote line-voltage thermostat.
- F. Accessories:
1. Filler sections without a heating element matching the adjacent enclosure.

2. Straight-blade-type receptacles complying with DSCC W-C-596G/GEN, NEMA WD 1, NEMA WD 6, and UL 498; in color selected by Architect.

**PART 3 - EXECUTION**

**3.1 EXAMINATION**

- A. Examine areas to receive finned-tube radiation heaters for compliance with requirements for installation tolerances and other conditions affecting performance of the Work.
- B. Examine roughing-in for electrical connections to verify actual locations before installation of finned-tube radiation heaters.
- C. Proceed with installation only after unsatisfactory conditions have been corrected.

**3.2 BASEBOARD RADIATION HEATER INSTALLATION**

- A. Install units level and plumb.
- B. Install enclosure continuously around corners, using outside and inside corner fittings.
- C. Join sections with splice plates and filler pieces to provide continuous enclosure.
- D. Install enclosure continuously from wall to wall.
- E. Terminate enclosures with manufacturer's end caps except where enclosures are indicated to extend to adjoining walls.

**3.3 FINNED-TUBE RADIATION HEATER INSTALLATION**

- A. Install units level and plumb.
- B. Install enclosure continuously around corners, using outside and inside corner fittings.
- C. Join sections with splice plates and filler pieces to provide continuous enclosure.
- D. Install access doors for access to valves.
- E. Install enclosure continuously from wall to wall.
- F. Terminate enclosures with manufacturer's end caps except where enclosures are indicated to extend to adjoining walls.
- G. Install valves within reach of access door provided in enclosure.
- H. Install air-seal gasket between wall and recessed flanges or front cover of fully recessed unit.

- I. Install piping within pedestals for freestanding units.

**3.4 CONNECTIONS**

- A. Install piping adjacent to finned-tube radiation heaters to allow service and maintenance.
- B. Ground electric finned-tube radiation heaters according to Section 260526 "Grounding and Bonding for Electrical Systems."
- C. Connect wiring according to Section 260519 "Low-Voltage Electrical Power Conductors and Cables."

**3.5 FIELD QUALITY CONTROL**

- A. Perform the following field tests and inspections:
  - 1. Operational Test: After electrical circuitry has been energized, start units to confirm proper operation.
  - 2. Test and adjust controls and safeties. Replace damaged and malfunctioning controls and equipment.
- B. Units will be considered defective if they do not pass tests and inspections.
- C. Prepare test and inspection reports.

**END OF SECTION 238236**

03/07/2017

**SECTION 260010 - GENERAL CONDITIONS FOR ELECTRICAL**

**PART 1 - GENERAL**

**1.1 RELATED DOCUMENTS**

- A. Drawings and general provisions of the Contract, including General and Supplementary Conditions and other Division 01 Specification Sections, apply to this Section.
- B. This section is intended to supplement the requirements of Division 01 requirements. For any conflicting requirements for minimum quantities or quality levels between this Section and Division 01, comply with the most stringent requirement.

**1.2 SUMMARY**

- A. This Section includes the following when associated with Divisions 26, 27, and 28 work:
  - 1. Permits and fees, code requirements, work under other contracts.
  - 2. Work restrictions.
  - 3. Specification formats and conventions.
  - 4. Request for information.
  - 5. Coordination.
  - 6. Conflicting requirements.
  - 7. Quality assurance and control.
  - 8. Coordination drawings.
  - 9. Construction coordination BIM model.
  - 10. Product delivery, storage, and handling.
  - 11. Product warranties.
  - 12. Submittals.
  - 13. Product selection procedures.
  - 14. Product interoperability requirements.
  - 15. General execution of project scope of work.
  - 16. Record drawings.
  - 17. Demonstration and training.
  - 18. Minimum commissioning responsibilities.
- B. Related Sections include the following:
  - 1. Division 01 Sections.

**1.3 PERMITS AND FEES**

- A. Give all necessary notices, obtain all permits; pay all government and state sales taxes and fees where applicable, and other costs, including utility connections or extensions in connection with the Project scope of work. File all necessary drawings, prepare all documents and obtain all



necessary approvals of all governmental and state departments having jurisdiction, obtain all required certificates of inspections for Project scope of work and deliver a copy to the Architect/Engineer before request for acceptance and final payment for the Project scope of work.

#### **1.4 CODE REQUIREMENTS**

- A. Project Code: Confirm the codes in effect at the time of permitting.
- B. Project Legislative Requirements: Confirm the State and Local Legislations in effect at the time of permitting or those that affect construction.
- C. Compliance: Comply with all codes and legislations applicable to the project, including energy related:
  - 1. Means and Methods
  - 2. Equipment and Devices.
  - 3. Materials and Work Product.

#### **1.5 WORK UNDER OTHER CONTRACTS**

- A. General: Cooperate fully with separate contractors so work on those contracts may be carried out smoothly, without interfering with or delaying work under this Contract. Coordinate the Work of this Contract with work performed under separate contracts.

#### **1.6 WORK RESTRICTIONS**

- A. Existing Utility Interruptions: Do not interrupt utilities serving facilities occupied by Owner or others unless permitted under the following conditions and then only after arranging to provide temporary utility services:
  - 1. Notify Construction Manager or Owner not less than 20 business days in advance of proposed utility interruptions limited to this specific project and 2 months if other buildings or services are affected.
  - 2. Do not proceed with utility interruptions without Construction Manager's or Owner's written permission.

#### **1.7 REQUESTS FOR INFORMATION (RFIs)**

- A. General: Immediately on discovery of the need for additional information or interpretation of the Contract Documents, Contractor shall prepare and submit an RFI in the form specified.
  - 1. Coordinate and submit RFIs in a prompt manner so as to avoid delays in Contractor's work or work of subcontractors.

- B. Content of the RFI: Include a detailed, legible description of item needing information or interpretation and the following:
1. Project name.
  2. Project number.
  3. Date.
  4. Name of Contractor.
  5. Name of Engineer, Architect and Construction Manager.
  6. RFI number, numbered sequentially.
  7. RFI subject.
  8. Specification Section number and title and related paragraphs, as appropriate.
  9. Drawing number and detail references, as appropriate.
  10. Field dimensions and conditions, as appropriate.
  11. Contractor's suggested resolution.
  12. Contractor's signature.
  13. Attachments: Include sketches, descriptions, measurements, photos, product data, shop drawings, coordination drawings, and other information necessary to fully describe items needing interpretation.
    - a. Include dimensions, thicknesses, structural grid references, and details of affected materials, assemblies, and attachments on attached sketches.
- C. The following RFIs will be returned without action:
1. Requests for approval of submittals.
  2. Requests for approval of substitutions.
  3. Requests for coordination information already indicated in the Contract Documents.
  4. Requests for adjustments in the Contract Time or the Contract Sum.
  5. Requests for interpretation of Architect's actions on submittals.
  6. Incomplete RFIs or inaccurately prepared RFIs.
- D. Action may include a request for additional information, in which case time for response will date from time of receipt of additional information.

## **1.8 COORDINATION**

- A. Coordination: Each Contractor shall coordinate its construction operations with those of other Contractors and entities to ensure efficient and orderly installation of each part of the Work. Each Contractor shall coordinate its operations with operations, included in different Sections that depend on each other for proper installation, connection, and operation.
1. Schedule construction operations in sequence required to obtain the best results where installation of one part of the Work depends on installation of other components, before or after its own installation.
  2. Coordinate installation of different components with other Contractors to ensure maximum performance and accessibility for required maintenance, service, and repair.

3. Make adequate provisions to accommodate items scheduled for later installation.
- B. Utility Coordination: Contractor shall coordinate all final specific utility requirements.
- C. Utilizing Two and Three Dimensional Information:
1. Design Intent Model: The Design Intent Model has been developed to a Level of Development LOD 200 and LOD 300 Model Content Requirements as defined by AIA G-202-2013. The contract documents are solely a two dimensional set of documents. The Design Intent Model is a three dimensional tool utilized to create a two dimensional contract document. A two dimensional contract document requires, for reason of clarity and otherwise, that components of the design not be modeled in three dimensions and/or that the model be formed in a way that construction means and methods will dictate other ways of performing the installation. It is at the sole discretion of BVH Integrated Services, P.C. as to which portions of the design are modeled, which are not and to what degree each portion of the design requires coordination to convey design intent for contractual purposes. The Design Intent Model is not a substitute for the contractors' coordination process as outlined in the contract documents; full coordination remains the responsibility of this contractor and their sub-contractors. The contents of the model are not to be used for the basis of detailed cost estimating, coordinating equipment locations and systems routing with all other trades. The model does not include three dimensional detailed field survey work of existing conditions or new work in existing conditions. The contractor may use the Design Intent Model to help establish the backgrounds and/or starting point for the coordination drawings based on the stipulations of the release form that can be provided if and when the model is requested.
  2. Construction Coordination Model: The Construction Coordination Model shall be developed to a minimum Level of Development LOD 400 Model Content Requirements as defined by AIA G-202-2013. The contractor shall be fully responsible for creating and maintaining a Construction Coordination Model and coordination drawings as required for detailed construction installation and coordination with all other trades.
  3. Differences between the Design Intent Model and the Construction Coordination Model and/or actual installation location, means and methods are included in this contract and shall not constitute a change order on the basis of drawing, engineering and/or coordination time.

#### **1.9 CONFLICTING REQUIREMENTS**

- A. General: If compliance with two or more standards or directives is specified and the standards establish different or conflicting requirements for minimum quantities or quality levels, comply with the most stringent requirement. Refer uncertainties and requirements that are different, but apparently equal, to Architect/Engineer for a decision before proceeding.
- B. Minimum Quantity or Quality Levels: The quantity or quality level shown or specified shall be the minimum provided or performed. The actual installation may comply exactly with the minimum quantity or quality specified, or it may exceed the minimum within reasonable limits. To comply with these requirements, indicated numeric values are minimum or maximum, as

appropriate, for the context of requirements. Refer uncertainties to Engineer for a decision before proceeding.

**1.10 MINOR CHANGES IN THE WORK**

- A. Engineer/Architect will issue through the Construction Manager, supplemental instructions authorizing minor changes in the Work, not involving adjustment to the Contract Sum or the Contract Time.
- B. Drawings are diagrammatic, the Contractor shall relocate devices a reasonable distance for coordination.
  - 1. A reasonable distance is considered to be 15 feet at no additional cost.

**1.11 QUALITY ASSURANCE AND CONTROL**

- A. General: Qualifications paragraphs in this Article establish some of the minimum qualification levels required; Division 01 and individual Specification Sections specify additional requirements.
- B. Code Compliance: Work and equipment shall comply with all latest applicable codes and legislations.
- C. Factory-Authorized Service Representative Qualifications: An authorized representative of manufacturer who is trained and approved by manufacturer to inspect installation of manufacturer's products that are similar in material, design, and extent to those required for this Project.
- D. Instructor Qualifications: A factory-authorized service representative, complying with requirements in "Quality Requirements," experienced in operation and maintenance procedures and training.
- E. Tests and inspections not explicitly assigned to Owner are Contractor's responsibility. Unless otherwise indicated, provide quality-control services specified and those required by authorities having jurisdiction. Perform quality-control services required of Contractor by authorities having jurisdiction, whether specified or not.
  - 1. Where services are indicated as Contractor's responsibility, engage a qualified testing agency to perform these quality-control services.
    - a. Contractor shall not employ same entity engaged by Owner, unless agreed to in writing by Owner.
  - 2. Testing and inspecting requested by Contractor and not required by the Contract Documents are Contractor's responsibility.

3. Submit additional copies of each written report directly to authorities having jurisdiction, when they so direct.
- F. **Manufacturer's Field Services:** Where indicated, engage a factory-authorized service representative to inspect field-assembled components and equipment installation, including service connections.
- G. **Retesting/Reinspecting:** Regardless of whether original tests or inspections were Contractor's responsibility, provide quality-control services, including retesting and reinspecting, for construction that replaced Work that failed to comply with the Contract Documents.
- H. **Associated Services:** Cooperate with agencies performing required commissioning, tests, inspections, and similar quality-control services, and provide reasonable auxiliary services as requested. Notify agency sufficiently in advance of operations to permit assignment of personnel. Provide the following:
1. Access to the Work.
  2. Incidental labor and facilities necessary to facilitate tests and inspections.
  3. Adequate quantities of representative samples of materials that require testing and inspecting. Assist agency in obtaining samples.
  4. Facilities for storage and field curing of test samples.
  5. Delivery of samples to testing agencies.
  6. Preliminary design mix proposed for use for material mixes that require control by testing agency.
  7. Security and protection for samples and for testing and inspecting equipment at Project site.
- I. **Coordination:** Coordinate sequence of activities to accommodate required quality-assurance and control services with a minimum of delay and to avoid necessity of removing and replacing construction to accommodate testing and inspecting.
1. Schedule times for tests, inspections, obtaining samples, and similar activities.
- J. **Compatibility of Options:** If Contractor is given option of selecting between two or more products for use on Project, product selected shall be compatible with products previously selected, even if previously selected products were also options.
1. Each contractor is responsible for providing products and construction methods compatible with products and construction methods of other contractors.
  2. If a dispute arises between contractors over concurrently selectable but incompatible products, Engineer will determine which products shall be used at no additional cost to the project.
- K. **Acceptance of Work:** Failure on the part of the Engineer to reject shop drawings or to reject Work in progress shall not be interpreted as acceptance of Work not in conformance with Code,

Legislation, the Drawings and/or Specifications. Correct Work not in conformance whenever non-conformance is discovered.

### **1.12 COORDINATION DRAWINGS**

- A. Coordination Drawings, General: Prepare coordination drawings in accordance with requirements in this Section and individual equipment and distribution sections, to facilitate integration of products and materials fabricated or installed by more than one entity. Maintain maximum headroom, where space conditions appear inadequate to maintain proposed ceiling heights or code clearances, notify Architect/Engineer with proposed solutions.
1. Content: Project-specific information, drawn accurately to a scale large enough to indicate and resolve conflicts, but no less than 1/4" equals 1'-0". Do not base coordination drawings on standard printed data. Include the following information, as applicable:
    - a. Use applicable Drawings as a basis for preparation of coordination drawings. Prepare sections, elevations, and details as needed to describe relationship of various systems and components.
    - b. Coordinate the addition of trade-specific information to the coordination drawings by multiple contractors in a sequence that best provides for coordination of the information and resolution of conflicts between installed components before submitting for review.
    - c. Indicate functional and spatial relationships of components of architectural, structural, civil, mechanical, and electrical systems.
    - d. Indicate space requirements for routine maintenance and for anticipated replacement of components during the life of the installation.
    - e. Show location and size of access doors required for access to concealed equipment, devices, junction boxes.
    - f. Indicate required installation sequences.
    - g. Indicate dimensions shown on the Drawings. Specifically note dimensions that appear to be in conflict with submitted equipment and minimum clearance requirements. Provide alternate sketches to Architect indicating proposed resolution of such conflicts. Minor dimension changes and difficult installations will not be considered changes to the Contract.
    - h. Provisions for scheduling, sequencing, moving and positioning large equipment in the building during construction.
    - i. Floor plans, elevations and details, including the following:
      - 1) Clearances to meet safety requirements and for servicing and maintaining equipment, including space for equipment disassembly required for periodic maintenance.
      - 2) Equipment support details.
      - 3) Exterior wall, roof and foundation penetrations of cable and raceway; and their relation to offer penetrations and installations.
      - 4) Fire-rated interior wall and floor penetrations by electrical installations.

PROBATE COURT  
ADMINISTRATION  
INTERIOR RENOVATIONS  
186 NEWINGTON ROAD  
WEST HARTFORD, CONNECTICUT

- 5) Sizes and locations of required concrete pads and bases.
2. Electrical Room Coordination Drawing: Prepare a drawing at 1/2" = 1'-0" scale including the following approved equipment: switchboards, panelboards, transformers, metering equipment, transfer switches, enclosed switches, enclosed controllers, pull boxes, lighting control equipment, dimming equipment, fire alarm equipment, security equipment, luminaires and switches, receptacles, raceways large than 1 inch, busduct, plywood backboards, and all foreign equipment. Indicated required clearances for all equipment. Indicate ceiling height of room.
- B. Coordination Drawing Process:
1. Particular emphasis is placed on timely installation of major apparatus and furnishing other Contractors, especially the General Contractor or Construction Manager, with information as to openings, chases, sleeves, bases, inserts, equipment locations, panels, access doors, etc., required by other trades.
  2. In general, ductwork, heating piping, sprinkler piping and drainage lines take precedence over water, gas and electrical conduits. The Engineer regarding the arrangement of Work, which cannot be agreed upon by the Contractors, will make final decisions.
  3. Where the Work of the Contractor will be installed in close proximity to or will interfere with Work of other trades, assist in working out space conditions to make a satisfactory adjustment.
  4. If Work is installed before coordinating with other Divisions or so as to cause interference with Work of other Sections, the Contractor causing the interference will make necessary changes to correct the condition without extra charge to the Owner.
  5. The Construction Manager/General Contractor shall coordinate the coordination process between the trades. Each trade shall incorporate their systems electronically using a different color code. Establish a meeting schedule where the Architect and Engineer can be present, including initiation of a kickoff meeting to establish the process with all parties, Contractor Coordination Meetings, and Architect/Engineer/Contractor Coordination Review Meetings. Regular Contractor Coordination Meetings of all Contractors involved shall be held to resolve all conflicts, assure accessibility, coordinate sequences and make adjustment to the layout to achieve the Architectural/Engineering intent of spaces, ceiling heights, accessibility, and to maximize headroom clearances in preparation for the Architect/Engineer/Contractor Coordination Review Meetings. Forward one (1) preliminary copy to the Architect and Engineer each, one (1) week prior to the Architect/Engineer Review Meeting identifying all unresolved conflicts. Upon resolving any outstanding conflicts (which may take a couple of rounds), drawings shall be completed and all trades shall sign acceptance of the drawings and submit a minimum of six (6) prints of each drawing to the Architect/Engineer for review.
- C. Coordination drawing creation is an interactive process. Submit multiple options and configurations at no additional cost until the Engineer's and Architect's acceptance is given.

- D. Coordination Drawing Organization: Organize coordination drawings as follows:
1. Floor Plans and Reflected Ceiling Plans: Show architectural and structural elements, and mechanical, plumbing, fire protection, fire alarm, and electrical work. Show locations of visible ceiling-mounted devices relative to acoustical ceiling grid. Supplement plan drawings with section drawings where required to adequately represent the Project scope of work.
  2. Plenum Space: Indicate subframing for support of ceiling and wall systems, mechanical and electrical equipment, and related Work. Locate components within ceiling plenum to accommodate layout of luminaires indicated on Drawings. Indicate areas of conflict between luminaires and other components.
  3. Mechanical Rooms: Provide coordination drawings for mechanical rooms showing plans and elevations of mechanical, plumbing, fire protection, fire alarm, and electrical equipment.
  4. Structural Penetrations: Indicate penetrations and openings required for all disciplines.
  5. Slab Edge and Embedded Items: Indicate slab edge locations and sizes and locations of embedded items for metal fabrications, sleeves, anchor bolts, bearing plates, angles, door floor closers, slab depressions for floor finishes, curbs and housekeeping pads, and similar items.
  6. Mechanical and Plumbing Work: Show the following:
    - a. Sizes and bottom elevations of ductwork, piping, and conduit runs, including insulation, bracing, flanges, and support systems.
    - b. Dimensions of major components, such as dampers, valves, diffusers, access doors, cleanouts and electrical distribution equipment.
    - c. Fire-rated enclosures around ductwork.
  7. Electrical Work: Show the following:
    - a. Runs of vertical and horizontal conduit 1-1/4 inch diameter and larger.
    - b. Light fixture, exit light, emergency battery pack, smoke detector, and other fire alarm locations.
    - c. Panelboard, switchboard, switchgear, transformer, busway, generator, and motor control center locations.
    - d. Location of pull boxes and junction boxes, dimensioned from column center lines.
  8. Fire Protection System: Show the following:
    - a. Locations of standpipes, mains piping, branch lines, pipe drops, and sprinkler heads.
  9. Review: Architect/Engineer will review coordination drawings to confirm that the Work is being coordinated, but not for the details of the coordination, which are the Contractor's responsibility. If the Architect determines that the coordination drawings are not being prepared in sufficient scope or detail, or are otherwise deficient, the Architect will so inform the Contractor, who shall make changes as directed and resubmit.



10. Coordination Drawing Prints: Prepare coordination drawing prints in accordance with requirements of this Section "Submittal Procedures."
- E. Coordination Digital Data Files: Prepare coordination digital data files in accordance with the following requirements:
1. File Preparation Format: Autodesk Revit .rvt file format in Microsoft Windows operating system.
  2. File Submittal Format: Submit or post coordination digital data files in the file preparation format and in Adobe .pdf format.
  3. Upon receipt of a signed release form, Engineer/Architect will furnish to the Contractor one set of digital data files for use in preparing coordination digital data files.
    - a. Engineer/Architect makes no representations as to the accuracy or completeness of digital data files as they relate to the drawings.
    - b. Contractor shall execute a data licensing agreement in the form of AIA Document C106.
- F. Construction Coordination Building Information Model:
1. Prepare Construction Coordination Building Information Model for the project utilizing Autodesk Revit software.
  2. Construction coordination model to reflect the as-installed conditions of the project and the characteristics of installed equipment.

**1.13 PRODUCT DELIVERY, STORAGE, AND HANDLING**

- A. Deliver, store, and handle products using means and methods that will prevent damage, deterioration, and loss, including theft. Comply with manufacturer's written instructions and generally accepted construction practice.
- B. Storage:
1. Store products to allow for inspection and measurement of quantity or counting of units.
  2. Store materials in a manner that will not endanger Project structure.
  3. Store products that are subject to damage by the elements, under cover in a weathertight enclosure above ground, with ventilation adequate to prevent condensation.
  4. Store cementitious products and materials on elevated platforms.
  5. Store foam plastic from exposure to sunlight, except to extent necessary for period of installation and concealment.
  6. Comply with product manufacturer's written instructions for temperature, humidity, ventilation, and weather-protection requirements for storage.
  7. Protect stored products from damage and liquids from freezing.
  8. Provide a secure location and enclosure at Project site for storage of materials and equipment by Owner's construction forces. Coordinate location with Owner.

**1.14 PRODUCT WARRANTIES**

- A. Refer to Division 01 and individual sections for requirements.
- B. The following requirements are supplemental and in addition to those stated in other specific sections and Division 01.
  - 1. Warranty all materials and workmanship under these Specifications and the Contract for a period of one year from the date of final acceptance by the Owner.
  - 2. During this warranty period, correct or replace all defects developing through materials or workmanship immediately as directed by the Engineer without expense to the Owner; make all such repairs or replacements to the Owner's satisfaction.
- C. Warranties specified in other Sections shall be in addition to, and run concurrent with, other warranties required by the Contract Documents. Manufacturer's disclaimers and limitations on product warranties do not relieve Contractor of obligations under requirements of the Contract Documents.
- D. Warranty Start Date: From the date of final acceptance by the Owner.

**1.15 SUBMITTAL PROCEDURES**

- A. Comparable Product: Product that is demonstrated and approved through submittal process to have the indicated qualities related to type, function, dimension, in-service performance, physical properties, appearance, and other characteristics that equal or exceed those of specified product.
- B. Product List: Submit a list, in tabular form, showing specified products. Include generic names of products required. Include manufacturer's name and proprietary product names for each product.
  - 1. Initial Submittal: Within 30 days after date of commencement of the Work, submit 3 copies of initial product list. Include a written explanation for omissions of data and for variations from Contract requirements.
- C. Substitution Requests: Submit four copies of each request for consideration. Identify product or fabrication or installation method to be replaced. Include Specification Section number and title and Drawing numbers and titles.
  - 1. Substitution: A submittal shall be considered a substitution when the Engineer/Architect does not accept the product or material as an "equivalent" or where one of the listed manufacturers is not submitted.
  - 2. Substitution Requirements: Substitutions shall meet the requirements of "Comparable Products."

3. Documentation: Show compliance with requirements for substitutions and the following, as applicable:
  - a. Statement indicating why specified material or product cannot be provided.
  - b. Coordination information, including a list of changes or modifications needed to other parts of the Work and to construction performed by Owner and separate contractors, that will be necessary to accommodate proposed substitution.
  - c. Detailed comparison of significant qualities of proposed substitution with those of the Project scope of work specified. Significant qualities may include attributes such as performance, weight, size, durability, visual effect, and specific features and requirements indicated.
  - d. Product Data, including drawings and descriptions of products and fabrication and installation procedures.
  - e. Samples, where applicable or requested.
  - f. Cost information, including a proposal of change, if any, in the Contract Sum.
  - g. Contractor's certification that proposed substitution complies with requirements in the Contract Documents and is appropriate for applications indicated.
  - h. Contractor's waiver of rights to additional payment or time that may subsequently become necessary because of failure of proposed substitution to produce indicated results.
  - i. Statement indicating why the requested substitution offers Owner a substantial advantage in cost, time, energy conservation, or other considerations.

#### **1.16 RECORD DRAWINGS AND RECORD DIGITAL FILES**

- A. Record Drawings and Record Digital Files: Comply with the following:
  1. Submit Record Drawings and Record Digital Files as follows:
    - a. Initial Submittal: Submit one set of plots from corrected Record CAD Drawings and one set of marked-up Record Prints. Engineer will initial and date each plot and mark whether general scope of changes, additional information recorded, and quality of drafting are acceptable. Engineer will return plot for organizing into sets, printing, binding, and final submittal.
    - b. Final Submittal: Submit three sets of Record CAD Drawing files, three sets of Construction Coordination Building Information Model, and one set of Record CAD Drawing plots. Plot and print each drawing, whether or not changes and additional information were recorded.
      - 1) Electronic Media: CD-R.
- B. Qualification Data: For training instructor.

**1.17 PRODUCT SELECTION PROCEDURES**

- A. General Product Requirements: Provide products that comply with the Contract Documents, that are undamaged and, unless otherwise indicated, that are new at time of installation.
1. Provide products complete with accessories, trim, finish, fasteners, and other items needed for a complete installation and indicated use and effect.
  2. Standard Products: If available, and unless custom products or nonstandard options are specified, provide standard products of types that have been produced and used successfully in similar situations on other projects.
  3. Owner reserves the right to limit selection to products with warranties not in conflict with requirements of the Contract Documents.
  4. Where products are accompanied by the term "as selected," Engineer and/or Architect will make selection.
  5. Descriptive, performance, and reference standard requirements in the Specifications establish "salient characteristics" of products.
  6. Or Equal: Where products are specified by name and accompanied by the term "or equal" or "or approved equal" or "or approved," comply with provisions in "Comparable Products" Article to obtain approval for use of an unnamed product.
- B. Product Selection Procedures:
1. Design Basis: The design has been based on the single manufacturer indicated in the contract documents. The Contractor is responsible for verifying prior to submission, that any other manufacturer even though listed complies with dimensional and performance characteristics of the base specified product. Modifications shall be made by the Contractor as part of this contract to accommodate changes to the design basis.
  2. Product: Where Specifications name a single product and manufacturer, provide the named product that complies with requirements.
  3. Manufacturers: Where Specifications include a list of manufacturers' names, provide a product by one of the manufacturers listed that complies with requirements.
  4. Equivalent Product: Equipment, material or devices submitted for review as an "accepted equivalent" shall meet all of the following requirements:
    - a. A product of a listed manufacturer.
    - b. The equivalent shall have the same construction features such as, but not limited to:
      - 1) Material thickness, gauge, weight, density, etc.
      - 2) Welded, riveted, bolted, etc., construction
      - 3) Finish, undercoating, corrosion protection
    - c. The equivalent shall perform with the same or better operating efficiency.
    - d. The equivalent shall have equal or greater reserve capacity.
    - e. The equivalent shall be locally represented by the manufacturer for service, parts and technical information.

- f. The equivalent shall bear the same labels of performance certification as is applicable to the specified item, such as UL, AMCA or ARI labels.

### **1.18 PRODUCT INTEROPERABILITY REQUIREMENTS**

- A. Interoperability Coordination Meeting: Attend a minimum of 3 weekly coordination meetings to coordinate interoperability between all systems and equipment. Meetings shall be scheduled by the construction manager.
- B. General Networking and Protocol Interoperability Requirements: Provide products that are fully BACNet interoperable.
1. All systems and equipment shall interface with the primary building management network provided under "Instrumentation and Controls for HVAC" using Ethernet standards and BACNet protocol.
  2. Equipment that is native BACNet may connect directly to a BACNet MS/TP subnet that is provided by "Instrumentation and Controls for HVAC" when coordinated with that Section Contractor.
  3. Communication involving control components (i.e., all types of controllers and operator interfaces) shall conform to the most current ANSI/ASHRAE Standard 135, BACnet.
  4. The MS/TP trunks support all of the ASHRAE 135 approved baud rates.
  5. All MS/TP devices support all baud rates of the ASHRAE 135.
  6. All MS/TP devices shall be BTL approved ( BACnet Testing Lab).
  7. All BACnet routers must support B-BC (BIBB) and support BBMD routing.
  8. Lonworks and Modbus subnets may be utilized where no BACNet protocol is available provided full 2-way compatibility is provided through a gateway.
    - a. Exception: Fire alarm systems shall be 1-way, read only communication.
  9. Each individual system and/or equipment manufacturer/installer shall provide all necessary gateways/translators Provide Gateway with all products as required facilitating full BACNet interoperability with BACNet Protocol.
  10. It must be possible to read and display the value of any property, including all required properties, supported optional properties, and proprietary extensions of very object of every networked device.
  11. Operating setpoints and parameters must be available for modification via BACnet services via a graphical user interface (GUI).
  12. An operator shall be able to display at any time the operational status of any device on the BACnet internetwork. An operator shall be able to display at any time any property of any BACnet object. An operator shall also be able to display property values of objects grouped by object type, object location, building system, and by user defined parameters.
  13. An operator shall have the ability to issue re-initialization commands to any device that supports remote re-initialization.
  14. An operator shall have the ability to backup and restore all BACnet devices on the network.

15. It shall be each contractor's responsibility to configure each router using the network numbering scheme for the project. Each router shall be configured such that all network layer error messages shall be directed to a specific workstation using the BACnet Confirmed Text Message service. It shall be the contractor's responsibility to initially configure each router with routing tables containing all network numbers that are part of the project's internet. The router shall be able to receive messages at each port of any length that is valid for the LAN technology connected to that port, and to forward the message to any directly-connected network that can convey a message of that size.
  16. Legacy Systems: Bi-directional gateways shall be provided for systems and equipment operating on a legacy/proprietary system. The operator workstation shall display information from both the BACnet and non-BACnet devices. Any information specified or required for system functionality shall be made readable and modifiable. Gateways shall have 10% expansion capacity. Gateways shall support archiving, uploading, trending, scheduling, and alarm/event detection, notification and acknowledgement.
  17. Systems and equipment shall have full 2- way communications and interoperability.
    - a. Exception: Fire safety systems and equipment shall have only read access to outside systems:
      - 1) Fire alarm.
  18. Coordinate with "Instrumentation and Controls for HVAC" and other building operational systems for specific interoperability requirements.
- C. Communications Standard: Coordinate communications standards requirements with other Sections and Divisions.
1. MS/TP LAN: RS 485
  2. Systems with dedicated network(s) shall connect on the BACNet Ethernet LAN: utilizing a switch and shall meet standard Ethernet requirements.
    - a. Utilize RJ-45 terminations.
    - b. Utilize CAT 6 cabling.
    - c. Meet IEEE Standard 802.3 standards and requirements.
    - d. Speed: 100 Mbps.
  3. Equipment without dedicated networks shall connect to the BACNet MS/TP LAN.
    - a. RS 485 communications standard.
    - b. Speed: 1 Mbps.
- D. Information Availability: Make all product information, points, variables, setpoints, etc., available for access of building operational systems upon request.
1. Provide bi-directional point mapping/addressing instructions.
  2. Provide on-site technicians as required to ensure proper information exchange.

- E. Factory Provided Equipment Controllers: Provide all information, points, variables, setpoints, etc., indicated and referenced in all documentation, including "Instrumentation and Controls for HVAC." Products shall have full interoperability as indicated in this Section, in BACNet standards and elsewhere.

### **1.19 MINIMUM CONTRACTOR'S COMMISSIONING RESPONSIBILITIES**

- A. Each Contractor shall assign representatives with expertise and authority to act on its behalf and shall schedule them to participate in and perform commissioning process activities including, but not limited to, the following:
1. Evaluate performance deficiencies identified in test reports and, in collaboration with entity responsible for system and equipment installation, recommend corrective action.
  2. Cooperate with the CxA for resolution of issues recorded in the Issues Log.
  3. Attend commissioning team meetings held on a weekly basis.
  4. Integrate and coordinate commissioning process activities with construction schedule.
  5. Review and accept construction checklists provided by the CxA.
  6. Complete paper or electronic construction checklists as Work is completed and provide to the Commissioning Authority on a weekly basis.
  7. Review and accept commissioning process test procedures provided by the Commissioning Authority.
  8. Complete commissioning process test procedures.
- B. Refer to related information in other sections for additional requirements.

## **PART 2 - PRODUCTS**

### **2.1 COORDINATION DRAWINGS**

- A. Coordination Drawings: Prepare Project-specific information, drawn accurately to scale. Do not base Coordination Drawings on reproductions of the Contract Documents or standard printed data.
1. Preparation: Fully illustrate requirements in the Contract Documents and actual special restrictions.
  2. Sheet Size: Submit Coordination Drawings on sheets at least 30 by 42 inches.
  3. Submit Shop Drawings in the following format:
    - a. PDF electronic file.
    - b. AutoCAD/Revit file in the latest version.
    - c. Six opaque (bond) copies of each submittal. Engineer will return five copies.

**2.2 SHOP DRAWINGS**

- A. Shop Drawings: Prepare Project-specific information, drawn accurately to scale. Do not base Shop Drawings on reproductions of the Contract Documents or standard printed or electronic data.
1. Preparation: Fully illustrate requirements in the Contract Documents. Include the following information, as applicable:
    - a. Identification of products.
    - b. Schedules.
    - c. Compliance with specified standards.
    - d. Notation of coordination requirements.
    - e. Notation of dimensions established by field measurement.
    - f. Relationship and attachment to adjoining construction clearly indicated.
    - g. Seal and signature of professional engineer if specified.
  2. Sheet Size: Except for templates, patterns, and similar full-size drawings, submit Shop Drawings on sheets at least 8-1/2 by 11 inches but no larger than 30 by 42 inches.

**2.3 RECORD DRAWINGS**

- A. Record Prints: Maintain one set of black-line white prints of the Contract Drawings and Shop Drawings.
1. Preparation: Mark Record Prints to show the actual installation where installation varies from that shown originally. Require individual or entity who obtained record data, whether individual or entity is Installer, subcontractor, or similar entity, to prepare the marked-up Record Prints.
    - a. Give particular attention to information on concealed elements that would be difficult to identify or measure and record later.
    - b. Accurately record information in an understandable drawing technique.
    - c. Record data as soon as possible after obtaining it. Record and check the markup before enclosing concealed installations.
  2. Content: Types of items requiring marking include, but are not limited to, the following:
    - a. Revisions to details shown on Drawings.
    - b. Locations and depths of underground system entities.
    - c. Revisions to routing of piping.
    - d. Actual equipment locations.
    - e. Duct size and routing.
    - f. Locations of concealed internal utilities.
    - g. Changes made by Change Order or Change Directive.
    - h. Changes made following Engineer's written orders.



- i. Details not on the original Contract Drawings.
    - j. Field records for variable and concealed conditions.
    - k. Record information on the Project scope of work that is shown only schematically.
  3. Mark the Contract Drawings or Shop Drawings, whichever is most capable of showing actual physical conditions, completely and accurately. If Shop Drawings are marked, show cross-reference on the Contract Drawings.
  4. Mark record sets with erasable, colored pencil. Use multiple colors to distinguish between changes for different categories of the Work at same location.
  5. Mark important additional information that was either shown schematically or omitted from original Drawings.
  6. Note Construction Change Directive numbers, alternate numbers, Change Order numbers, and similar identification, where applicable.
- B. Record CAD Drawings: Immediately before observation for Certificate of Substantial Completion, review marked-up Record Prints with Engineer and Construction Manager. When authorized, prepare a full set of corrected CAD Drawings of the Contract Drawings, as follows:
  1. Format: DWG or Revit format of the same version, and operating system as the original Contract Drawings.
  2. Incorporate changes and additional information previously marked on Record Prints. Delete, redraw, and add details and notations where applicable.
  3. Refer instances of uncertainty to Engineer for resolution.
  4. Contractor may request one set of CAD Drawings of the Contract Drawings for use in recording information.
    - a. Engineer makes no representations as to the accuracy or completeness of CAD Drawings as they relate to the Contract Drawings.
- C. Construction Coordination Building Information Model:
  1. Prepare Construction Coordination Building Information Model for the project utilizing Autodesk Revit software.
  2. Construction coordination model to reflect the as-installed conditions of the project and the characteristics of installed equipment.
- D. Format: Identify and date each Record Drawing; include the designation "PROJECT RECORD DRAWING" in a prominent location.
  1. Record Prints: Organize Record Prints and newly prepared Record Drawings into manageable sets. Bind each set with durable paper cover sheets. Include identification on cover sheets.
  2. Record CAD/Revit Drawings: Organize information into separate electronic files that correspond to each sheet of the Contract Drawings. Name each file with the sheet identification. Include identification in each file.

3. Identification: As follows:
  - a. Project name.
  - b. Date.
  - c. Designation "PROJECT RECORD DRAWINGS."
  - d. Name of Engineer, Architect and Construction Manager.
  - e. Name of Contractor.

#### **2.4 RECORDING AND MAINTENANCE**

- A. Recording: Maintain one copy of each submittal during the construction period for Project Record Document purposes. Post changes and modifications to Project Record Documents as they occur; do not wait until the end of Project.
- B. Maintenance of Record Documents and Samples: Store Record Documents and Samples in the field office apart from the Contract Documents used for construction. Do not use Project Record Documents for construction purposes. Maintain Record Documents in good order and in a clean, dry, legible condition, protected from deterioration and loss. Provide access to Project Record Documents for Engineer's reference during normal working hours.

#### **2.5 TRAINING AND INSTRUCTION PROGRAM**

- A. Program Structure: In addition to Division 01 and individual section requirements, develop an instruction program that includes individual training modules for each system and equipment not part of a system.
- B. Training Modules: Develop a learning objective and teaching outline for each module. Include a description of specific skills and knowledge that participant is expected to master. Provide instruction for the following modules.
  1. Basis of System Design and Operational Requirements
  2. Documentation
  3. Emergencies
  4. Adjustments
  5. Troubleshooting
  6. Maintenance
  7. Repairs
- C. Engage qualified instructors to instruct Owner's personnel to adjust, operate, and maintain systems, subsystems, and equipment not part of a system.
- D. Video Record: Training shall be recorded as video.
  1. Format: Standard DVD format.
  2. Quantity: Three discs of each individual DVD.

3. Labeling: Label each DVD with it's library of training sections based on equipment type and system type.

## **2.6 COMPARABLE PRODUCTS**

- A. Conditions for Consideration: Engineer/Architect will consider Contractor's request for comparable product when the following conditions are satisfied. If the following conditions are not satisfied, Engineer/Architect may return requests without action, except to record noncompliance with these requirements:
  1. Evidence that the proposed product does not require revisions to the Contract Documents, that it is consistent with the Contract Documents and will produce the indicated results, and that it is compatible with other portions of the Work.
  2. Detailed comparison of significant qualities of proposed product with those named in the Specifications. Significant qualities include attributes such as performance, weight, size, durability, visual effect, and specific features and requirements indicated.
  3. Evidence that proposed product provides specified warranty.
  4. List of similar installations for completed projects with project names and addresses and names and addresses of architects and owners, if requested.
  5. Samples, if requested.

## **PART 3 - EXECUTION**

### **3.1 EXAMINATION**

- A. Existing Conditions: The existence and location of underground and other utilities and construction indicated as existing are not guaranteed. Before beginning work, investigate and verify the existence and location of underground utilities, mechanical and electrical systems, and other construction affecting the Work.
  1. Before construction, verify the location and invert elevation at points of connection of sanitary sewer, storm sewer, and water-service piping; underground electrical services, and other utility and system connections.
  2. Furnish location data for work related to Project that must be performed by public utilities serving Project site.
  3. Existing Utility Information: Furnish information to local utility and Owner that is necessary to adjust, move, or relocate existing utility structures, utility poles, lines, services, or other utility appurtenances located in or affected by construction. Coordinate with authorities having jurisdiction.
- B. Acceptance of Conditions: Examine substrates, areas, and conditions, for compliance with requirements for installation tolerances and other conditions affecting performance. Record observations.

1. Written Report: Where a written report listing conditions detrimental to performance of the Project scope of work is required by other Sections, include the following:
  - a. Description of the Work.
  - b. List of detrimental conditions, including substrates.
  - c. List of unacceptable installation tolerances.
  - d. Recommended corrections.
2. Verify compatibility with and suitability of substrates, including compatibility with existing finishes or primers.
3. Examine roughing-in for mechanical and electrical systems to verify actual locations of connections before equipment and fixture installation.
4. Examine walls, floors, and roofs for suitable conditions where products and systems are to be installed.
5. Proceed with installation only after unsatisfactory conditions have been corrected. Proceeding with the Work indicates acceptance of surfaces and conditions.

### **3.2 PREPARATION**

- A. Existing Utility Information: Furnish information to local utility and Owner that is necessary to adjust, move, or relocate existing utility structures, utility poles, lines, services, or other utility appurtenances located in or affected by construction. Coordinate with authorities having jurisdiction.
- B. Field Measurements: Take field measurements as required to fit the Work properly. Recheck measurements before installing each product. Where portions of the Work are indicated to fit to other construction, verify dimensions of other construction by field measurements before fabrication. Coordinate fabrication schedule with construction progress to avoid delaying the Work.
- C. Space Requirements: Verify space requirements and dimensions of items shown diagrammatically on Drawings.
- D. Review of Contract Documents and Field Conditions: Immediately on discovery of the need for clarification of the Contract Documents, submit a request for information to Engineer. Include a detailed description of problem encountered, together with recommendations for changing the Contract Documents.

### **3.3 DEMOLITION**

- A. Work indicated to be removed includes removal of all auxiliary materials, accessories, anchorage, fasteners, and etc., down to bare substrate. No residual materials shall remain from work to be removed. Contractor will use whatever means necessary; including removal of all materials attached or related to those items designated to be removed, as acceptable to Owner and Engineer, to provided complete and thorough removal of existing work.

- B. Protect existing equipment and installations indicated to remain. If damaged or disturbed in the course of the Work, remove damaged portions and install new products of equal capacity, quality, and functionality.
- C. Accessible Work: Remove exposed equipment and installations, indicated to be demolished, in their entirety.
- D. Abandoned Work: Cut and remove buried MEP system materials, equipment, raceways, piping and distribution, indicated to be abandoned in place, 2 inches below the surface of adjacent construction. Cap and patch surface to match existing finish.
- E. Remove demolished materials from Project site.
- F. Remove, store, clean, reinstall, reconnect, and make operational components indicated for relocation.
- G. Field verify all existing MEP system materials, equipment, raceways, piping and distribution to be removed for exact quantities.
- H. Remove all existing MEP system materials, equipment, raceways, piping and distribution located above ceilings and in walls that are not being reused.
- I. Remove all MEP systems and appurtenances, which are to be removed, in their entireties back to the source or source panels.
- J. Remove all existing MEP system materials, equipment, raceways, piping and distribution located in walls or ceilings being demolished. Abandon no devices that have been disconnected unless specifically noted.
- K. Maintain continuity of all existing MEP devices, and utilization equipment not removed.
- L. Remove, store, protect, and reinstall existing work as required to accommodate alteration indicated.
- M. The existing work to be removed, in general, is as indicated on the Drawings and in this Section, but also includes any materials or work necessary to permit installation of new materials, as approved by Owner and Engineer.
- N. Disconnect, demolish, and remove systems, equipment, and components indicated to be removed, abandoned or as made obsolete by this project.
  - 1. To Be Removed: Remove portion of systems, equipment, and components indicated to be removed and cap or plug remaining with same or compatible material.
  - 2. To Be Abandoned in Place: Drain piping and cap or plug systems, equipment, and components with same or compatible material.

3. Equipment to Be Removed: Disconnect, make safe and cap services and remove equipment.
  4. Equipment to Be Removed and Reinstalled: Disconnect, make safe and cap services and remove, clean, and store equipment; when appropriate, reinstall, reconnect, and make equipment operational.
  5. Equipment to Be Removed and Salvaged: Disconnect, make safe and cap services and remove equipment and deliver at direction of Owner.
- O. If systems, equipment, and components to remain is damaged in appearance or is unserviceable, remove damaged or unserviceable portions and replace with new products of equal capacity and quality.
- P. In finished areas, all systems, equipment, and components shall be cut back to a concealed location, i.e., within walls, above ceilings, etc., before capping.

### **3.4 INSTALLATION**

- A. General: Locate the Work and components of the Work accurately, in correct alignment and elevation, as indicated.
1. Make vertical work plumb and make horizontal work level.
  2. Where space is limited, install components to maximize space available for maintenance and ease of removal for replacement.
  3. Conceal pipes, ducts, and wiring in finished areas, unless otherwise indicated.
  4. Maintain minimum headroom clearance as indicated by Architect and/or Construction Manager in spaces without a suspended ceiling.
- B. Comply with manufacturer's written instructions and recommendations for installing products in applications indicated.
- C. Install products at the time and under conditions that will ensure the best possible results. Maintain conditions required for product performance until Substantial Completion.
- D. Conduct construction operations so no part of the Work is subjected to damaging operations or loading in excess of that expected during normal conditions of occupancy.
- E. Tools and Equipment: Do not use tools or equipment that produces harmful noise levels.
- F. Templates: Obtain and distribute to the parties involved templates for work specified to be factory prepared and field installed. Check Shop Drawings of other work to confirm that adequate provisions are made for locating and installing products to comply with indicated requirements.
- G. Anchors and Fasteners: Provide anchors and fasteners as required to anchor each component securely in place, accurately located and aligned with other portions of the Work.

1. All electrical equipment and piping not supported from the building structural steel shall not exceed a combined load of 7 psf when supported from the metal deck/slab. Any condition that may exceed this limit shall be reviewed and approved by the Design-Builder and Structure Engineer before installation.
2. Mounting Heights: Where mounting heights are not indicated, mount components at heights directed by Engineer and/or to allow for proper access.
3. Allow for building movement, including thermal expansion and contraction.
4. Coordinate installation of anchorages. Furnish setting drawings, templates, and directions for installing anchorages, including sleeves, concrete inserts, anchor bolts, and items with integral anchors, that are to be embedded in concrete or masonry. Deliver such items to Project site in time for installation.

H. Hazardous Materials: Use products, cleaners, and installation materials that are not considered hazardous.

### **3.5 CUTTING AND PATCHING**

- A. See Division 01 for additional requirements. The Contractor shall furnish sketches showing the location and sizes of all openings, chases, etc., required for the installation of Work.
- B. Work under this Division shall include furnishing, locating and setting inserts and/or sleeves required before the floors and walls are built or be responsible for cutting, drilling or chopping where sleeves and inserts were not installed, where wall or floors are existing or not correctly located. The Contractor shall do all drilling required for the installation of hangers.
- C. Exercise extreme caution when core drilling or punching openings in concrete floor slabs in order to avoid cutting or damaging structural members. No structural members or structural slabs/floors shall be cut without the written acceptance of the Structural Engineer and all such cutting shall be done in a manner directed by him.
- D. Cleaning: Clean areas and spaces where cutting and patching are performed. Remove paint, mortar, oils, putty, and similar materials from adjacent finished surfaces.

### **3.6 SCAFFOLDING, RIGGING, HOISTING**

- A. The Contractor shall furnish all scaffolding, rigging, hoisting and services necessary for erection and delivery into the premises any equipment and apparatus furnished under this Division. Remove same from premises when no longer required.

### **3.7 EXCAVATION AND BACKFILLING**

- A. It is the responsibility of the Contractor to coordinate sizes, depths, fill and bedding requirements and any other excavation work required under this Division.

**3.8 ACCESSIBILITY AND ACCESS PANELS**

- A. The Contractor shall be responsible for the sufficiency of the size of shafts and chases, the adequate thickness of partitions, and the adequate clearance in double partitions and hung ceilings for the proper installation of the Work.
- B. Locate all equipment which must be serviced, operated or maintained in fully accessible positions. Equipment shall include, but not be limited to: motors, controllers, coil, valves, switchgear, drain points, etc. Access doors shall be furnished if required for better accessibility. Minor deviations from the Drawings may be made to allow better accessibility, but changes of magnitude or which involve extra cost shall not be made without the acceptance of the Engineer.
- C. Access doors in walls, ceilings, floors, etc., shall be field coordinated. It is the responsibility of the Contractor to coordinate and provide information regarding the sizes and quantities of access doors required for his work. The Contractor shall arrange his work in such a manner as to minimize the quantity of access doors required, such as grouping shutoff valves in the same area. Where possible, locate valves in already accessible areas, such as lay-in ceilings, etc.
- D. On a clean set of prints, the Contractor shall mark in red pencil the location of each required access door, including its size and fire rating (if any), and shall submit the print to the Architect for review before access doors are purchased or installed.
- E. Upon completion of the Project, the Contractor shall physically demonstrate that all equipment and devices installed have been located and/or provided with adequate access panels for repair, maintenance and/or operation. Any equipment not so furnished shall be relocated or provided with additional access panels by the installing Contractor at no additional cost to the Owner.

**3.9 STARTING AND ADJUSTING**

- A. Start equipment and operating components to confirm proper operation. Remove malfunctioning units, replace with new units, and retest.
- B. Adjust operating components for proper operation without binding. Adjust equipment for proper operation.
- C. Test each piece of equipment to verify proper operation. Test and adjust controls and safeties. Replace damaged and malfunctioning controls and equipment.
- D. Manufacturer's Field Service: Provide a factory-authorized service representative to inspect field-assembled components and equipment installation, comply with qualification requirements in "Quality Requirements."



**3.10 PROTECTION OF INSTALLED CONSTRUCTION**

- A. Provide final protection and maintain conditions that ensure installed Work is without damage or deterioration at time of Substantial Completion.
- B. Comply with manufacturer's written instructions for temperature and relative humidity.
- C. Remove debris from concealed spaces before enclosing the space.
- D. Remove liquid spills promptly.
- E. Where dust would impair proper execution of the Project scope of work, broom-clean or vacuum the entire work area, as appropriate.
- F. Installed Work: Keep installed work clean.
- G. Exposed Surfaces in Finished Areas: Clean exposed surfaces and protect as necessary to ensure freedom from damage and deterioration at time of Substantial Completion.
- H. During handling and installation, clean and protect construction in progress and adjoining materials already in place. Apply protective covering where required to ensure protection from damage or deterioration at Substantial Completion.
- I. Clean and provide maintenance on completed construction as frequently as necessary through the remainder of the construction period. Adjust and lubricate operable components to ensure operability without damaging effects.
- J. Limiting Exposures: Supervise construction operations to assure that no part of the construction completed or in progress, is subject to harmful, dangerous, damaging, or otherwise deleterious exposure during the construction period.

**3.11 CORRECTION OF THE WORK**

- A. The cost of corrective work shall be included under the contract.
- B. Repair or remove and replace defective construction.
  - 1. Repairing includes replacing defective parts, refinishing damaged surfaces, touching up with matching materials, and properly adjusting operating equipment.
- C. Restore permanent facilities used during construction to their specified or original condition.
- D. Remove and replace damaged surfaces that are exposed to view if surfaces cannot be repaired without visible evidence of repair.

- E. Repair components that do not operate properly. Remove and replace operating components to new condition.
- F. Remove and replace chipped, scratched, and broken glass or reflective surfaces.

**END OF SECTION 260010**

03/07/2017



SECTION 260519 - LOW-VOLTAGE ELECTRICAL POWER CONDUCTORS AND CABLES

PART 1 - GENERAL

1.1 RELATED DOCUMENTS

- A. Drawings and general provisions of the Contract, including General and Supplementary Conditions and Division 01 Specification Sections, apply to this Section.

1.2 SUMMARY

A. Section Includes:

- 1. Building wires and cables rated 600 V and less.
- 2. Connectors, splices, and terminations rated 600 V and less.

B. Related Requirements:

- 1. Section 260523 "Control-Voltage Electrical Power Cables" for control systems communications cables and Classes 1, 2 and 3 control cables.
- 2. Section 271300 "Communications Backbone Cabling" and Section 271500 "Communications Horizontal Cabling" for cabling used for voice and data circuits.
- 3. Section 280513 "Conductors and Cables for Electronic Safety and Security" for cabling used for fire alarm circuit.

1.3 DEFINITIONS

- A. EPDM: Ethylene-propylene-diene terpolymer rubber.
- B. NBR: Acrylonitrile-butadiene rubber.
- C. VFC: Variable frequency controller.

1.4 ACTION SUBMITTALS

- A. Product Data: For each type of product.

1.5 INFORMATIONAL SUBMITTALS

- A. Qualification Data: For testing agency.
- B. Field quality-control reports.

1.6 QUALITY ASSURANCE

- A. Testing Agency Qualifications: Member company of NETA or an NRTL.
  - 1. Testing Agency's Field Supervisor: Certified by NETA to supervise on-site testing.

PART 2 - PRODUCTS

2.1 GENERAL REQUIREMENTS

- A. Comply with the requirements in Part 3 Articles for where materials shall be applied.

2.2 CONDUCTORS AND CABLES

- A. Basis-of-Design Product: Subject to compliance with requirements, provide product indicated on Drawings or comparable product by one of the following:
  - 1. Alpha Wire Company.
  - 2. American Insulated Wire Corp.
  - 3. Belden Inc.
  - 4. Cerro Wire LLC.
  - 5. Encore Wire Corporation.
  - 6. General Cable Technologies Corporation.
  - 7. General Cable; General Cable Corporation.
  - 8. Senator Wire & Cable Company.
  - 9. Southwire Company.
- B. Copper Conductors: Comply with NEMA WC 70/ICEA S-95-658.
- C. Conductor Insulation: Comply with NEMA WC 70/ICEA S-95-658 for Type THHN/THWN-2.
- D. Low Leakage Conductor: Type.
- E. Multiconductor Cable: Comply with NEMA WC 70/ICEA S-95-658 for metal-clad cable, Type MC with insulated equipment ground conductor, healthcare facilities cable (Type AC cable with 90 deg. C cable and insulated equipment ground conductor).

1. Cable shall be steel or aluminum clad. "MC-Lite" cable will not be permitted.
2. Two-Hour Fire-Rated Cable: Mineral-insulated, metal-sheathed cable, Type MI.

### 2.3 CONNECTORS AND SPLICES

- A. Manufacturers: Subject to compliance with requirements, provide products by one of the following:
1. 3M.
  2. AFC Cable Systems, Inc.
  3. Gardner Bender.
  4. Hubbell Power Systems, Inc.
  5. Ideal Industries, Inc.
  6. ILSCO.
  7. NSi Industries LLC.
  8. O-Z/Gedney; an EGS Electrical Group brand; an Emerson Industrial Automation business.
  9. Tyco Electronics Corp.
- B. Description: Factory-fabricated connectors and splices of size, ampacity rating, material, type, and class for application and service indicated.

### 2.4 SYSTEM DESCRIPTION

- A. Electrical Components, Devices, and Accessories: Listed and labeled as defined in NFPA 70, by a qualified testing agency, and marked for intended location and application.
- B. Comply with NFPA 70.

## PART 3 - EXECUTION

### 3.1 CONDUCTOR MATERIAL APPLICATIONS

- A. Feeders: Copper. Solid for No. 12 AWG and smaller; stranded for No. 10 AWG and larger.
- B. Branch Circuits: Copper. Solid for No. 12 AWG and smaller; stranded for No. 10 AWG and larger.

3.2 CONDUCTOR INSULATION AND MULTICONDUCTOR CABLE APPLICATIONS AND WIRING METHODS

- A. Exposed Feeders: Type THHN/THWN-2, single conductors in raceway.
- B. Feeders Concealed in Ceilings, Walls, Partitions, and Crawlspace: Type THHN/THWN-2, single conductors in raceway.
- C. Feeders Concealed in Concrete, below Slabs-on-Grade, and Underground: Type XHHW-2, single conductors in raceway.
- D. Exposed Branch Circuits, Including in Crawlspace: Type THHN/THWN-2, single conductors in raceway.
- E. Branch Circuits Concealed in Ceilings, Walls and Partitions: Type THHN/THWN, single conductors in raceway to outlet box located within 10 ft. of first wiring device, luminaire of utilization equipment indicated on documents served by branch circuit. Metal-clad cable, Type MC may be used on load side of this outlet box.
- F. Branch Circuits Concealed in Concrete, below Slabs-on-Grade, and Underground: Type XHHW-2, single conductors in raceway.
- G. Branch Circuits Connected to Generator, Emergency or Essential Power Systems of Any Type: Type XHHW-2 in raceway independent from all other wiring and equipment. Emergency (life safety and critical) branch circuits shall be installed in non-flexible metal raceways.
- H. Electrical Feeders Connected to Generator, Emergency or Essential Power Systems of Any Type: Type MI mineral insulated, metal sheathed cable.
- I. Feeders and Branch Circuits Connected to Generator, Emergency or Essential Power Systems of Any Type: Type XHHW-2 in raceway independent from all other wiring and equipment.
- J. Emergency Feeders Run in Unsprinklered Spaces: Type MI mineral insulated, metal sheathed cable.
- K. Cord Drops and Portable Appliance Connections: Type SO, hard service cord with stainless-steel, wire-mesh, strain relief device at terminations to suit application.
- L. Class 1 Control Circuits: Type THHN/THWN, in raceway.
- M. Class 2 Control Circuits: Type THHN/THWN, in raceway.
- N. Minimum Branch Circuit Conductor Size: No. 12 AWG. For all 120-volt circuits in excess of 100 ft. from power source to last device, provide No. 10 AWG entire length of circuit. For all 120-volt circuits in excess of 200 ft. from power source to last device, provide No. 8 AWG

entire length of circuit. For all 208-volt circuits in excess of 200 ft. from power source to last device, provide No. 10 AWG entire length of circuit.

- O. VFC Output Circuits: Type XHHW-2 in metal conduit.
- P. Install dedicated neutral for every circuit.

### 3.3 INSTALLATION OF CONDUCTORS AND CABLES

- A. Conceal cables in finished walls, ceilings, and floors unless otherwise indicated.
- B. Complete raceway installation between conductor and cable termination points according to Section 260533 "Raceways and Boxes for Electrical Systems" prior to pulling conductors and cables.
- C. Use manufacturer-approved pulling compound or lubricant where necessary; compound used must not deteriorate conductor or insulation. Do not exceed manufacturer's recommended maximum pulling tensions and sidewall pressure values.
- D. Use pulling means, including fish tape, cable, rope, and basket-weave wire/cable grips, that will not damage cables or raceway.
- E. Install exposed cables parallel and perpendicular to surfaces of exposed structural members, and follow surface contours where possible.
- F. Support cables according to Section 260529 "Hangers and Supports for Electrical Systems" and Section 260548 "Vibration and Seismic Controls for Electrical Systems."
- G. Complete cable tray systems installation according to Section 260536 "Cable Trays for Electrical Systems" prior to installing conductors and cables.

### 3.4 CONNECTIONS

- A. Tighten electrical connectors and terminals according to manufacturer's published torque-tightening values. If manufacturer's torque values are not indicated, use those specified in UL 486A-486B.
- B. Make splices, terminations, and taps that are compatible with conductor material and that possess equivalent or better mechanical strength and insulation ratings than unspliced conductors.
- C. Wiring at Outlets: Install conductor at each outlet, with at least 6 inches of slack.



3.5 IDENTIFICATION

- A. Identify and color-code conductors and cables according to Section 260553 "Identification for Electrical Systems."
- B. Identify each spare conductor at each end with identity number and location of other end of conductor, and identify as spare conductor.

3.6 SLEEVE AND SLEEVE-SEAL INSTALLATION FOR ELECTRICAL PENETRATIONS

- A. Install sleeves and sleeve seals at penetrations of exterior floor and wall assemblies. Comply with requirements in Section 260544 "Sleeves and Sleeve Seals for Electrical Raceways and Cabling."

3.7 FIRESTOPPING

- A. Apply firestopping to electrical penetrations of fire-rated floor and wall assemblies to restore original fire-resistance rating of assembly according to Section 078413 "Penetration Firestopping."

3.8 FIELD QUALITY CONTROL

- A. Perform tests and inspections and prepare test reports.
- B. Perform the following tests and inspections:
  - 1. After installing conductors and cables and before electrical circuitry has been energized, test panelboards, and equipment feeder conductors for compliance with requirements.
  - 2. Perform each visual and mechanical inspection and electrical test stated in NETA Acceptance Testing Specification. Certify compliance with test parameters.
  - 3. Infrared Scanning: After Substantial Completion, but not more than 60 days after Final Acceptance, perform an infrared scan of each splice in conductors No. 3 AWG and larger. Remove box and equipment covers so splices are accessible to portable scanner. Correct deficiencies determined during the scan.
    - a. Instrument: Use an infrared scanning device designed to measure temperature or to detect significant deviations from normal values. Provide calibration record for device.
    - b. Record of Infrared Scanning: Prepare a certified report that identifies splices checked and that describes scanning results. Include notation of deficiencies detected, remedial action taken, and observations after remedial action.

- C. Test and Inspection Reports: Prepare a written report to record the following:
  - 1. Procedures used.
  - 2. Results that comply with requirements.
  - 3. Results that do not comply with requirements and corrective action taken to achieve compliance with requirements.
  
- D. Cables will be considered defective if they do not pass tests and inspections.

**END OF SECTION 260519**  
03/07/2017



**SECTION 260523 - CONTROL-VOLTAGE ELECTRICAL POWER CABLES**

**PART 1 - GENERAL**

**1.1 RELATED DOCUMENTS**

- A. Drawings and general provisions of the Contract, including General and Supplementary Conditions and Division 01 Specification Sections, apply to this Section.

**1.2 SUMMARY**

- A. Section Includes:
  - 1. Low-voltage control cabling.
  - 2. Control-circuit conductors.
  - 3. Identification products.

**1.3 DEFINITIONS**

- A. EMI: Electromagnetic interference.
- B. Low Voltage: As defined in NFPA 70 for circuits and equipment operating at less than 50 V or for remote-control and signaling power-limited circuits.
- C. Plenum: A space forming part of the air distribution system to which one or more air ducts are connected. An air duct is a passageway, other than a plenum, for transporting air to or from heating, ventilating, or air-conditioning equipment.
- D. RCDD: Registered Communications Distribution Designer.

**1.4 ACTION SUBMITTALS**

- A. Product Data: For each type of product.

**1.5 INFORMATIONAL SUBMITTALS**

- A. Qualification Data: For testing agency, RCDD, layout technician, installation supervisor, and field inspector.
- B. Source quality-control reports.
- C. Field quality-control reports.

**1.6 QUALITY ASSURANCE**

- A. Testing Agency Qualifications: Accredited by NETA.
  - 1. Testing Agency's Field Supervisor: Currently certified by BICSI as an RCDD to supervise on-site testing.

**PART 2 - PRODUCTS**

**2.1 PERFORMANCE REQUIREMENTS**

- A. Electrical Components, Devices, and Accessories: Listed and labeled as defined in NFPA 70, by a qualified testing agency, and marked for intended location and application.
- B. Flame Travel and Smoke Density in Plenums: As determined by testing identical products according to NFPA 262, by a qualified testing agency. Identify products for installation in plenums with appropriate markings of applicable testing agency.
  - 1. Flame Travel Distance: 60 inches or less.
  - 2. Peak Optical Smoke Density: 0.5 or less.
  - 3. Average Optical Smoke Density: 0.15 or less.
- C. Flame Travel and Smoke Density for Riser Cables in Non-Plenum Building Spaces: As determined by testing identical products according to UL 1666.
- D. Flame Travel and Smoke Density for Cables in Non-Riser Applications and Non-Plenum Building Spaces: As determined by testing identical products according to UL 1685.
- E. RoHS compliant.

**2.2 LOW-VOLTAGE CONTROL CABLE**

- A. Plenum-Rated, Paired Cable: NFPA 70, Type CMP.
  - 1. Multi-pair, twisted, No. 16 AWG, stranded (19x29) or No. 18 AWG, stranded (19x30) tinned-copper conductors.
  - 2. PVC insulation.
  - 3. Unshielded.
  - 4. PVC jacket.
  - 5. Flame Resistance: Comply with NFPA 262.
  - 6. <Double click to insert sustainable design text for lead content.>

**2.3 CONTROL-CIRCUIT CONDUCTORS**

- A. Basis-of-Design Product: Subject to compliance with requirements, provide product indicated on Drawings or comparable product by one of the following:
  - 1. Encore Wire Corporation.
  - 2. General Cable; General Cable Corporation.
  - 3. Service Wire Co.
  - 4. Southwire Company.
- B. Class 1 Control Circuits: Stranded copper, Type THHN/THWN-2, complying with UL 83 in raceway or Type MC, complying with UL 1569.
- C. Class 2 Control Circuits: Stranded copper, Type THHN/THWN-2, complying with UL 83 in raceway.
- D. Class 3 Remote-Control and Signal Circuits: Stranded copper, Type THHN/THWN-2, complying with UL 83 in raceway.
- E. Class 2 Control Circuits and Class 3 Remote-Control and Signal Circuits That Supply Critical Circuits: Circuit Integrity (CI) cable.
  - 1. Smoke control signaling and control circuits.

**2.4 SOURCE QUALITY CONTROL**

- A. Testing Agency: Engage a qualified testing agency to evaluate cables.
- B. Factory test twisted pair cables according to TIA-568-C.2.
- C. Cable will be considered defective if it does not pass tests and inspections.
- D. Prepare test and inspection reports.

**PART 3 - EXECUTION**

**3.1 EXAMINATION**

- A. Test cables on receipt at Project site.
  - 1. Test each pair of twisted pair cable for open and short circuits.

**3.2 INSTALLATION OF RACEWAYS AND BOXES**

- A. Comply with requirements in Section 260533 "Raceways and Boxes for Electrical Systems" for raceway selection and installation requirements for boxes, conduits, and wireways as supplemented or modified in this Section.
1. Outlet boxes shall be no smaller than 2 inches wide, 3 inches high, and 2-1/2 inches deep.
  2. Outlet boxes for cables shall be no smaller than 4 inches square by 2-1/8 inches deep with extension ring sized to bring edge of ring to within 1/8 inch of the finished wall surface.
  3. Flexible metal conduit shall not be used.
- B. Comply with TIA-569-D for pull-box sizing and length of conduit and number of bends between pull points.
- C. Install manufactured conduit sweeps and long-radius elbows if possible.
- D. Raceway Installation in Equipment Rooms:
1. Position conduit ends adjacent to a corner on backboard if a single piece of plywood is installed, or in the corner of the room if multiple sheets of plywood are installed around perimeter walls of the room.
  2. Install cable trays to route cables if conduits cannot be located in these positions.
  3. Secure conduits to backboard if entering the room from overhead.
  4. Extend conduits 3 inches above finished floor.
  5. Install metal conduits with grounding bushings and connect with grounding conductor to grounding system.
- E. Backboards: Install backboards with 96-inch dimension vertical. Butt adjacent sheets tightly and form smooth gap-free corners and joints.

**3.3 INSTALLATION OF CONDUCTORS AND CABLES**

- A. Comply with NECA 1.
- B. General Requirements for Cabling:
1. Comply with TIA-568-C Series of standards.
  2. Comply with BICSI ITSIMM, Ch. 5, "Copper Structured Cabling Systems."
  3. Terminate all conductors; no cable shall contain unterminated elements. Make terminations only at indicated outlets, terminals, and cross-connect and patch panels.
  4. Cables may not be spliced and shall be continuous from terminal to terminal. Do not splice cable between termination, tap, or junction points.
  5. Cables serving a common system may be grouped in a common raceway. Install network cabling and control wiring and cable in separate raceway from power wiring. Do not group conductors from different systems or different voltages.

6. Secure and support cables at intervals not exceeding 30 inches and not more than 6 inches from cabinets, boxes, fittings, outlets, racks, frames, and terminals.
7. Bundle, lace, and train conductors to terminal points without exceeding manufacturer's limitations on bending radii, but not less than radii specified in BICSI ITSIMM, Ch. 5, "Copper Structured Cabling Systems." Install lacing bars and distribution spools.
8. Do not install bruised, kinked, scored, deformed, or abraded cable. Remove and discard cable if damaged during installation and replace it with new cable.
9. Cold-Weather Installation: Bring cable to room temperature before dereeling. Do not use heat lamps for heating.
10. Pulling Cable: Comply with BICSI ITSIMM, Ch. 5, "Copper Structured Cabling Systems." Monitor cable pull tensions.
11. Support: Do not allow cables to lie on removable ceiling tiles.
12. Secure: Fasten securely in place with hardware specifically designed and installed so as to not damage cables.
13. Provide strain relief.
14. Keep runs short. Allow extra length for connecting to terminals. Do not bend cables in a radius less than 10 times the cable OD. Use sleeves or grommets to protect cables from vibration at points where they pass around sharp corners and through penetrations.
15. Ground wire shall be copper, and grounding methods shall comply with IEEE C2. Demonstrate ground resistance.

C. Balanced Twisted Pair Cable Installation:

1. Comply with TIA-568-C.2.
2. Install termination hardware as specified in Section 271513 "Communications Copper Horizontal Cabling" unless otherwise indicated.
3. Do not untwist balanced twisted pair cables more than 1/2 inch at the point of termination to maintain cable geometry.

D. Installation of Control-Circuit Conductors:

1. Install wiring in raceways.
2. Use insulated spade lugs for wire and cable connection to screw terminals.
3. Comply with requirements specified in Section 260533 "Raceways and Boxes for Electrical Systems."

E. Open-Cable Installation:

1. Install cabling with horizontal and vertical cable guides in telecommunications spaces with terminating hardware and interconnection equipment.
2. Suspend copper cable not in a wireway or pathway a minimum of 8 inches above ceilings by cable supports not more than 30 inches apart.
3. Cable shall not be run through or on structural members or in contact with pipes, ducts, or other potentially damaging items. Do not run cables between structural members and corrugated panels.



## F. Separation from EMI Sources:

1. Comply with BICSI TDMM and TIA-569-D recommendations for separating unshielded copper voice and data communications cable from potential EMI sources including electrical power lines and equipment.
2. Separation between open communications cables or cables in nonmetallic raceways and unshielded power conductors and electrical equipment shall be as follows:
  - a. Electrical Equipment or Circuit Rating Less Than 2 kVA: A minimum of 5 inches.
  - b. Electrical Equipment or Circuit Rating between 2 and 5 kVA: A minimum of 12 inches.
  - c. Electrical Equipment or Circuit Rating More Than 5 kVA: A minimum of 24 inches.
3. Separation between communications cables in grounded metallic raceways and unshielded power lines or electrical equipment shall be as follows:
  - a. Electrical Equipment or Circuit Rating Less Than 2 kVA: A minimum of 2-1/2 inches.
  - b. Electrical Equipment or Circuit Rating between 2 and 5 kVA: A minimum of 6 inches.
  - c. Electrical Equipment or Circuit Rating More Than 5 kVA: A minimum of 12 inches.
4. Separation between communications cables in grounded metallic raceways and power lines and electrical equipment located in grounded metallic conduits or enclosures shall be as follows:
  - a. Electrical Equipment or Circuit Rating Less Than 2 kVA: No requirement.
  - b. Electrical Equipment or Circuit Rating between 2 and 5 kVA: A minimum of 3 inches.
  - c. Electrical Equipment or Circuit Rating More Than 5 kVA: A minimum of 6 inches.
5. Separation between Communications Cables and Electrical Motors and Transformers, 5 kVA or 5 HP and Larger: A minimum of 48 inches.
6. Separation between Communications Cables and Fluorescent Fixtures: A minimum of 5 inches.

**3.4 REMOVAL OF CONDUCTORS AND CABLES**

- A. Remove abandoned conductors and cables. Abandoned conductors and cables are those installed that are not terminated at equipment and are not identified with a tag for future use.

**3.5 CONTROL-CIRCUIT CONDUCTORS**

- A. Minimum Conductor Sizes:
  - 1. Class 1 remote-control and signal circuits; No 14 AWG.
  - 2. Class 2 low-energy, remote-control, and signal circuits; No. 16 AWG.
  - 3. Class 3 low-energy, remote-control, alarm, and signal circuits; No 12 AWG.

**3.6 FIRESTOPPING**

- A. Comply with requirements in Section 078413 "Penetration Firestopping."
- B. Comply with TIA-569-D, Annex A, "Firestopping."
- C. Comply with BICSI TDMM, "Firestopping" Chapter.

**3.7 GROUNDING**

- A. For data communication wiring, comply with TIA-607-B and with BICSI TDMM, "Bonding and Grounding (Earthing)" Chapter.
- B. For low-voltage control wiring and cabling, comply with requirements in Section 260526 "Grounding and Bonding for Electrical Systems."

**3.8 IDENTIFICATION**

- A. Comply with requirements for identification specified in Section 260553 "Identification for Electrical Systems."
- B. Identify data and communications system components, wiring, and cabling according to TIA-606-B; label printers shall use label stocks, laminating adhesives, and inks complying with UL 969.
- C. Identify each wire on each end and at each terminal with a number-coded identification tag. Each wire shall have a unique tag.

**3.9 FIELD QUALITY CONTROL**

- A. Testing Agency: Owner will engage a qualified testing agency to perform tests and inspections.
- B. Testing Agency: Engage a qualified testing agency to perform tests and inspections.
- C. Manufacturer's Field Service: Engage a factory-authorized service representative to test and inspect components, assemblies, and equipment installations, including connections.
- D. Perform tests and inspections.

- E. Tests and Inspections:
1. Visually inspect cable jacket materials for UL or third-party certification markings. Inspect cabling terminations to confirm color-coding for pin assignments, and inspect cabling connections to confirm compliance with TIA-568-C.1.
  2. Visually inspect cable placement, cable termination, grounding and bonding, equipment and patch cords, and labeling of all components.
  3. Test cabling for direct-current loop resistance, shorts, opens, intermittent faults, and polarity between conductors. Test operation of shorting bars in connection blocks. Test cables after termination, but not after cross-connection.
    - a. Test instruments shall meet or exceed applicable requirements in TIA-568-C.2. Perform tests with a tester that complies with performance requirements in its "Test Instruments (Normative)" Annex, complying with measurement accuracy specified in its "Measurement Accuracy (Informative)" Annex. Use only test cords and adapters that are qualified by test equipment manufacturer for channel or link test configuration.
- F. Document data for each measurement. Print data for submittals in a summary report that is formatted using Table 10.1 in BICSI TDMM as a guide, or transfer the data from the instrument to the computer, save as text files, print, and submit.
- G. End-to-end cabling will be considered defective if it does not pass tests and inspections.
- H. Prepare test and inspection reports.

**END OF SECTION 260523**

03/07/2017

**SECTION 260526 - GROUNDING AND BONDING FOR ELECTRICAL SYSTEMS**

**PART 1 - GENERAL**

**1.1 RELATED DOCUMENTS**

- A. Drawings and general provisions of the Contract, including General and Supplementary Conditions and Division 01 Specification Sections, apply to this Section.

**1.2 SUMMARY**

**1.3 ACTION SUBMITTALS**

- A. Product Data: For each type of product indicated.

**1.4 INFORMATIONAL SUBMITTALS**

- A. As-Built Data: Plans showing dimensioned as-built locations of grounding features specified in "Field Quality Control" Article, including the following:
  - 1. Grounding arrangements and connections for separately derived systems.
  - 2. Grounding for sensitive electronic equipment.
- B. Qualification Data: For testing agency and testing agency's field supervisor.
- C. Field quality-control reports.

**1.5 QUALITY ASSURANCE**

- A. Electrical Components, Devices, and Accessories: Listed and labeled as defined in NFPA 70, by a qualified testing agency, and marked for intended location and application.
- B. Comply with UL 467 for grounding and bonding materials and equipment.

**PART 2 - PRODUCTS**

**2.1 MANUFACTURERS**

- A. Manufacturers: Subject to compliance with requirements, provide products by one of the following:
  - 1. Burndy; Part of Hubbell Electrical Systems.
  - 2. ERICO International Corporation.
  - 3. O-Z/Gedney; a brand of Emerson Industrial Automation.

**2.2 SYSTEM DESCRIPTION**

- A. Electrical Components, Devices, and Accessories: Listed and labeled as defined in NFPA 70, by a qualified testing agency, and marked for intended location and application.
- B. Comply with UL 467 for grounding and bonding materials and equipment.

**2.3 CONDUCTORS**

- A. Insulated Conductors: Copper wire or cable insulated for 600 V unless otherwise required by applicable Code or authorities having jurisdiction.
- B. Bare Copper Conductors:
  - 1. Solid Conductors: ASTM B 3.
  - 2. Stranded Conductors: ASTM B 8.
  - 3. Bonding Cable: 28 kcmil, 14 strands of No. 17 AWG conductor, 1/4 inch in diameter.
  - 4. Bonding Conductor: No. 4 or No. 6 AWG, stranded conductor.
  - 5. Bonding Jumper: Copper tape, braided conductors terminated with copper ferrules; 1-5/8 inches wide and 1/16 inch thick.

**2.4 CONNECTORS**

- A. Listed and labeled by an NRTL acceptable to authorities having jurisdiction for applications in which used and for specific types, sizes, and combinations of conductors and other items connected.
- B. Bolted Connectors for Conductors and Pipes: Copper or copper alloy.
- C. Welded Connectors: Exothermic-welding kits of types recommended by kit manufacturer for materials being joined and installation conditions.
- D. Bus-Bar Connectors: Mechanical type, cast silicon bronze, solderless compression-type wire terminals, and long-barrel, two-bolt connection to ground bus bar.

**PART 3 - EXECUTION**

**3.1 APPLICATIONS**

- A. Conductors: Install solid conductor for No. 8 AWG and smaller, and stranded conductors for No. 6 AWG and larger unless otherwise indicated.
- B. Isolated Grounding Conductors: Green-colored insulation with continuous yellow stripe. On feeders with isolated ground, identify grounding conductor where visible to normal inspection,

with alternating bands of green and yellow tape, with at least three bands of green and two bands of yellow.

C. Conductor Terminations and Connections:

1. Pipe and Equipment Grounding Conductor Terminations: Bolted connectors.
2. Underground Connections: Welded connectors except at test wells and as otherwise indicated.
3. Connections to Ground Rods at Test Wells: Bolted connectors.
4. Connections to Structural Steel: Welded connectors.

**3.2 GROUNDING AT THE SERVICE**

- A. Equipment grounding conductors and grounding electrode conductors shall be connected to the ground bus. Install a main bonding jumper between the neutral and ground buses.

**3.3 GROUNDING SEPARATELY DERIVED SYSTEMS**

- A. Generator: Install grounding electrode(s) at the generator location. The electrode shall be connected to the equipment grounding conductor and to the frame of the generator.

**3.4 EQUIPMENT GROUNDING**

- A. Install insulated equipment grounding conductors with all feeders and branch circuits.
- B. Air-Duct Equipment Circuits: Install insulated equipment grounding conductor to duct-mounted electrical devices operating at 120 V and more, including air cleaners, heaters, dampers, humidifiers, and other duct electrical equipment. Bond conductor to each unit and to air duct and connected metallic piping.
- C. Water Heater, Heat-Tracing, and Antifrost Heating Cables: Install a separate insulated equipment grounding conductor to each electric water heater and heat-tracing cable. Bond conductor to heater units, piping, connected equipment, and components.
- D. Isolated Grounding Receptacle Circuits: Install an insulated equipment grounding conductor connected to the receptacle grounding terminal. Isolate conductor from raceway and from panelboard grounding terminals. Terminate at equipment grounding conductor terminal of the applicable derived system or service unless otherwise indicated.
- E. Isolated Equipment Enclosure Circuits: For designated equipment supplied by a branch circuit or feeder, isolate equipment enclosure from supply circuit raceway with a nonmetallic raceway fitting listed for the purpose. Install fitting where raceway enters enclosure, and install a separate insulated equipment grounding conductor. Isolate conductor from raceway and from panelboard grounding terminals. Terminate at equipment grounding conductor terminal of the applicable derived system or service unless otherwise indicated.

- F. Signal and Communication Equipment: In addition to grounding and bonding required by NFPA 70, provide a separate grounding system complying with requirements in TIA/ATIS J-STD-607-A.
1. For telephone, alarm, voice and data, and other communication equipment, provide No. 3/0 AWG minimum insulated grounding conductor in raceway from grounding electrode system to each service location, terminal cabinet, wiring closet, and central equipment location.
  2. Service and Central Equipment Locations and Wiring Closets: Terminate grounding conductor on a 1/4 by 4 by 12-inch grounding bus.
  3. Terminal Cabinets: Terminate grounding conductor on cabinet grounding terminal.

### **3.5 INSTALLATION**

- A. Grounding Conductors: Route along shortest and straightest paths possible unless otherwise indicated or required by Code. Avoid obstructing access or placing conductors where they may be subjected to strain, impact, or damage.
- B. Bonding Straps and Jumpers: Install in locations accessible for inspection and maintenance except where routed through short lengths of conduit.
1. Bonding to Structure: Bond straps directly to basic structure, taking care not to penetrate any adjacent parts.
  2. Bonding to Equipment Mounted on Vibration Isolation Hangers and Supports: Install bonding so vibration is not transmitted to rigidly mounted equipment.
  3. Use exothermic-welded connectors for outdoor locations; if a disconnect-type connection is required, use a bolted clamp.

### **3.6 LABELING**

- A. Comply with requirements in Section 260553 "Identification for Electrical Systems" for instruction signs. The label or its text shall be green.
1. Label Text: "IF THIS CONNECTOR OR CABLE IS LOOSE OR IF IT MUST BE REMOVED FOR ANY REASON, NOTIFY THE FACILITY MANAGER."

### **3.7 FIELD QUALITY CONTROL**

- A. Perform tests and inspections.
1. Manufacturer's Field Service: Engage a factory-authorized service representative to inspect components, assemblies, and equipment installations, including connections, and to assist in testing.

- B. Tests and Inspections:
  - 1. After installing grounding system but before permanent electrical circuits have been energized, test for compliance with requirements.
  - 2. Inspect physical and mechanical condition. Verify tightness of accessible, bolted, electrical connections with a calibrated torque wrench according to manufacturer's written instructions.
- C. Grounding system will be considered defective if it does not pass tests and inspections.
- D. Prepare test and inspection reports.
- E. Report measured ground resistances that exceed the following values:
  - 1. Power and Lighting Equipment or System with Capacity of 500 kVA and Less: 10 ohms.
  - 2. Power and Lighting Equipment or System with Capacity of 500 to 1000 kVA: 5 ohms.
  - 3. Power and Lighting Equipment or System with Capacity More Than 1000 kVA: 3 ohms.
- F. Excessive Ground Resistance: If resistance to ground exceeds specified values, notify Architect promptly and include recommendations to reduce ground resistance.

**END OF SECTION 260526**

03/07/2017





**SECTION 260529 - HANGERS AND SUPPORTS FOR ELECTRICAL SYSTEMS**

**PART 1 - GENERAL**

**1.1 RELATED DOCUMENTS**

- A. Drawings and general provisions of the Contract, including General and Supplementary Conditions and Division 01 Specification Sections, apply to this Section.

**1.2 SUMMARY**

- A. This Section includes the following:
  - 1. Hangers and supports for electrical equipment and systems.
  - 2. Construction requirements for concrete bases.

**1.3 DEFINITIONS**

- A. EMT: Electrical metallic tubing.
- B. RMC: Rigid metal conduit.

**1.4 PERFORMANCE REQUIREMENTS**

- A. Delegated Design: Design supports for multiple raceways, including comprehensive engineering analysis by a qualified professional engineer, using performance requirements and design criteria indicated.
- B. Design supports for multiple raceways capable of supporting combined weight of supported systems and its contents.
- C. Design equipment supports capable of supporting combined operating weight of supported equipment and connected systems and components.
- D. Rated Strength: Adequate in tension, shear, and pullout force to resist maximum loads calculated or imposed for this Project, with a minimum structural safety factor of five times the applied force.

**1.5 ACTION SUBMITTALS**

- A. Product Data: For the following:
  - 1. Steel slotted support systems.

- B. Shop Drawings: Show fabrication and installation details and include calculations for the following:
  - 1. Trapeze hangers. Include Product Data for components.
  - 2. Steel slotted channel systems. Include Product Data for components.
  - 3. Equipment supports.

**1.6 INFORMATIONAL SUBMITTALS**

- A. Welding certificates.

**1.7 QUALITY ASSURANCE**

- A. Welding: Qualify procedures and personnel according to AWS D1.1/D1.1M, "Structural Welding Code - Steel."
- B. Comply with NFPA 70.

**1.8 COORDINATION**

- A. Coordinate size and location of concrete bases. Cast anchor-bolt inserts into bases. Concrete, reinforcement, and formwork requirements are specified together with concrete Specifications.
- B. Coordinate installation of roof curbs, equipment supports, and roof penetrations. These items are specified in Section 077200 "Roof Accessories."

**PART 2 - PRODUCTS**

**2.1 SUPPORT, ANCHORAGE, AND ATTACHMENT COMPONENTS**

- A. Steel Slotted Support Systems: Comply with MFMA-4, factory-fabricated components for field assembly.
  - 1. Manufacturers: Subject to compliance with requirements, provide products by one of the following:
    - a. Allied Tube & Conduit.
    - b. Cooper B-Line, Inc.; a division of Cooper Industries.
    - c. ERICO International Corporation.
    - d. GS Metals Corp.
    - e. Thomas & Betts Corporation, A Member of the ABB Group.
    - f. Unistrut; an Atkore International company.
    - g. Wesanco, Inc.
  - 2. Metallic Coatings: Hot-dip galvanized after fabrication and applied according to MFMA-4.

3. Painted Coatings: Manufacturer's standard painted coating applied according to MFMA-4.
  4. Channel Dimensions: Selected for applicable load criteria.
- B. Raceway and Cable Supports: As described in NECA 1 and NECA 101.
- C. Conduit and Cable Support Devices: Steel and malleable-iron hangers, clamps, and associated fittings, designed for types and sizes of raceway or cable to be supported.
- D. Structural Steel for Fabricated Supports and Restraints: ASTM A 36/A 36M, steel plates, shapes, and bars; black and galvanized.
- E. Mounting, Anchoring, and Attachment Components: Items for fastening electrical items or their supports to building surfaces include the following:
1. Powder-Actuated Fasteners: Threaded-steel stud, for use in hardened portland cement concrete, steel, or wood, with tension, shear, and pullout capacities appropriate for supported loads and building materials where used.
    - a. Manufacturers: Subject to compliance with requirements, provide products by one of the following:
      - 1) Hilti, Inc.
      - 2) ITW Ramset/Red Head; Illinois Tool Works, Inc.
      - 3) MKT Fastening, LLC.
      - 4) Simpson Strong-Tie Co., Inc.
  2. Mechanical-Expansion Anchors: Insert-wedge-type, zinc-coated or stainless steel, for use in hardened portland cement concrete with tension, shear, and pullout capacities appropriate for supported loads and building materials in which used.
    - a. Manufacturers: Subject to compliance with requirements, provide products by one of the following:
      - 1) Cooper B-Line, Inc.; a division of Cooper Industries.
      - 2) Empire Tool and Manufacturing Co., Inc.
      - 3) Hilti, Inc.
      - 4) ITW Ramset/Red Head; Illinois Tool Works, Inc.
      - 5) MKT Fastening, LLC.
  3. Concrete Inserts: Steel or malleable-iron, slotted support system units similar to MSS Type 18; complying with MFMA-4 or MSS SP-58.
  4. Clamps for Attachment to Steel Structural Elements: MSS SP-58, type suitable for attached structural element.
  5. Through Bolts: Structural type, hex head, and high strength. Comply with ASTM A 325.
  6. Toggle Bolts: All-steel springhead type.

7. Hanger Rods: Threaded steel.

## **2.2 FABRICATED METAL EQUIPMENT SUPPORT ASSEMBLIES**

- A. Description: Welded or bolted, structural-steel shapes, shop or field fabricated to fit dimensions of supported equipment.
- B. Materials: Comply with requirements in Section 055000 "Metal Fabrications" for steel shapes and plates.

## **PART 3 - EXECUTION**

### **3.1 APPLICATION**

- A. Comply with NECA 1 and NECA 101 for application of hangers and supports for electrical equipment and systems except if requirements in this Section are stricter.
- B. Maximum Support Spacing and Minimum Hanger Rod Size for Raceway: Space supports for EMT and RMC as required by NFPA 70. Minimum rod size shall be 1/4 inch in diameter.
- C. Multiple Raceways or Cables: Install trapeze-type supports fabricated with steel slotted or other support system, sized so capacity can be increased by at least 25 percent in future without exceeding specified design load limits.
  1. Secure raceways and cables to these supports with two-bolt conduit clamps, single-bolt conduit clamps, or single-bolt conduit clamps using spring friction action for retention in support channel.

### **3.2 SUPPORT INSTALLATION**

- A. Comply with NECA 1 and NECA 101 for installation requirements except as specified in this Article.
- B. Raceway Support Methods: In addition to methods described in NECA 1, EMT and RMC may be supported by openings through structure members, as permitted in NFPA 70.
- C. Strength of Support Assemblies: Where not indicated, select sizes of components so strength will be adequate to carry present and future static loads within specified loading limits. Minimum static design load used for strength determination shall be weight of supported components plus 200 lb.
- D. Mounting and Anchorage of Surface-Mounted Equipment and Components: Anchor and fasten electrical items and their supports to building structural elements by the following methods unless otherwise indicated by code:
  1. To Wood: Fasten with lag screws or through bolts.

2. To New Concrete: Bolt to concrete inserts.
  3. To Masonry: Approved toggle-type bolts on hollow masonry units and expansion anchor fasteners on solid masonry units.
  4. To Existing Concrete: Expansion anchor fasteners.
  5. Instead of expansion anchors, powder-actuated driven threaded studs provided with lock washers and nuts may be used in existing standard-weight concrete 4 inches thick or greater. Do not use for anchorage to lightweight-aggregate concrete or for slabs less than 4 inches thick.
  6. To Steel: Welded threaded studs complying with AWS D1.1/D1.1M, with lock washers and nuts, beam clamps (MSS Type 19, 21, 23, 25, or 27) complying with MSS SP-69, or spring-tension clamps.
  7. To Light Steel: Sheet metal screws.
  8. Items Mounted on Hollow Walls and Nonstructural Building Surfaces: Mount cabinets, panelboards, disconnect switches, control enclosures, pull and junction boxes, transformers, and other devices on slotted-channel racks attached to substrate by means that meet seismic-restraint strength and anchorage requirements.
- E. Drill holes for expansion anchors in concrete at locations and to depths that avoid reinforcing bars.

### **3.3 INSTALLATION OF FABRICATED METAL SUPPORTS**

- A. Comply with installation requirements in Section 055000 "Metal Fabrications" for site-fabricated metal supports.
- B. Cut, fit, and place miscellaneous metal supports accurately in location, alignment, and elevation to support and anchor electrical materials and equipment.
- C. Field Welding: Comply with AWS D1.1/D1.1M.

**END OF SECTION 260529**

03/07/2017



**SECTION 260533 - RACEWAYS AND BOXES FOR ELECTRICAL SYSTEMS**

**PART 1 - GENERAL**

**1.1 RELATED DOCUMENTS**

- A. Drawings and general provisions of the Contract, including General and Supplementary Conditions and Division 01 Specification Sections, apply to this Section.

**1.2 SUMMARY**

- A. Section Includes:
  - 1. Metal conduits and fittings.
  - 2. Metal wireways and auxiliary gutters.
  - 3. Surface raceways.
  - 4. Boxes, enclosures, and cabinets.
- B. Related Requirements:
  - 1. Section 078413 "Penetration Firestopping" for firestopping at conduit and box entrances.

**1.3 DEFINITIONS**

- A. ARC: Aluminum rigid conduit.
- B. GRC: Galvanized rigid steel conduit.

**1.4 ACTION SUBMITTALS**

- A. Product Data: For surface raceways, wireways and fittings, floor boxes, hinged-cover enclosures, and cabinets.
- B. Sustainable Design Submittals:
  - 1. VOC Content: 510 g/L or less for PVC conduit and fittings.
- C. Shop Drawings: For custom enclosures and cabinets. Include plans, elevations, sections, and attachment details.

**1.5 INFORMATIONAL SUBMITTALS**

- A. Coordination Drawings: Conduit routing plans, drawn to scale, on which the following items are shown and coordinated with each other, using input from installers of items involved:
  - 1. Structural members in paths of conduit groups with common supports.



2. HVAC and plumbing items and architectural features in paths of conduit groups with common supports.
- B. Qualification Data: For professional engineer.
- C. Seismic Qualification Data: Certificates, for enclosures, cabinets, and conduit racks and their mounting provisions, including those for internal components, from manufacturer.
1. Basis for Certification: Indicate whether withstand certification is based on actual test of assembled components or on calculation.
  2. Dimensioned Outline Drawings of Equipment Unit: Identify center of gravity and locate and describe mounting and anchorage provisions.
  3. Detailed description of equipment anchorage devices on which the certification is based and their installation requirements.
  4. Detailed description of conduit support devices and interconnections on which the certification is based and their installation requirements.
- D. Source quality-control reports.

## **1.6 COORDINATION**

- A. Coordinate layout and installation of raceways, boxes, enclosures, cabinets, and suspension system with other construction that penetrates ceilings or is supported by them, including luminaries, HVAC equipment, fire suppression system, and partition assemblies.

## **PART 2 - PRODUCTS**

### **2.1 METAL CONDUITS AND FITTINGS**

- A. Metal Conduit:
1. Basis-of-Design Product: Subject to compliance with requirements, provide product indicated on Drawings or comparable product by one of the following:
    - a. AFC Cable Systems; a part of Atkore International.
    - b. Allied Tube & Conduit; a part of Atkore International.
    - c. Anamet Electrical, Inc.
    - d. Calconduit.
    - e. Electri-Flex Company.
    - f. FSR Inc.
    - g. Korkap.
    - h. NEC, Inc.
    - i. Opti-Com Manufacturing Network, Inc (OMNI).
    - j. O-Z/Gedney; a brand of Emerson Industrial Automation.
    - k. Patriot Aluminum Products, LLC.
    - l. Perma-Cote.

- m. Picoma Industries, Inc.
  - n. Plasti-Bond.
  - o. Republic Conduit.
  - p. Southwire Company.
  - q. Thomas & Betts Corporation; A Member of the ABB Group.
  - r. Topaz Electric; a division of Topaz Lighting Corp.
  - s. Western Tube and Conduit Corporation.
  - t. Wheatland Tube Company.
- 2. Listing and Labeling: Listed and labeled as defined in NFPA 70, by a qualified testing agency, and marked for intended location and application.
  - 3. GRC: Comply with ANSI C80.1 and UL 6.
  - 4. ARC: Comply with ANSI C80.5 and UL 6A.
  - 5. EMT: Comply with ANSI C80.3 and UL 797.
  - 6. FMC: Comply with UL 1; zinc-coated steel.
  - 7. LFMC: Flexible steel conduit with PVC jacket and complying with UL 360.

B. Metal Fittings:

- 1. Basis-of-Design Product: Subject to compliance with requirements, provide product indicated on Drawings or comparable product by one of the following:
  - a. AFC Cable Systems; a part of Atkore International.
  - b. Allied Tube & Conduit; a part of Atkore International.
  - c. Anamet Electrical, Inc.
  - d. Calconduit.
  - e. Electri-Flex Company.
  - f. FSR Inc.
  - g. Korkap.
  - h. NEC, Inc.
  - i. NewBasis.
  - j. Opti-Com Manufacturing Network, Inc (OMNI).
  - k. O-Z/Gedney; a brand of Emerson Industrial Automation.
  - l. Patriot Aluminum Products, LLC.
  - m. Perma-Cote.
  - n. Picoma Industries, Inc.
  - o. Plasti-Bond.
  - p. Republic Conduit.
  - q. Southwire Company.
  - r. Thomas & Betts Corporation; A Member of the ABB Group.
  - s. Topaz Electric; a division of Topaz Lighting Corp.
  - t. Western Tube and Conduit Corporation.
  - u. Wheatland Tube Company.
- 2. Comply with NEMA FB 1 and UL 514B.

3. Listing and Labeling: Listed and labeled as defined in NFPA 70, by a qualified testing agency, and marked for intended location and application.
  4. Fittings, General: Listed and labeled for type of conduit, location, and use.
  5. Conduit Fittings for Hazardous (Classified) Locations: Comply with UL 1203 and NFPA 70.
  6. Fittings for EMT:
    - a. Material: Steel.
    - b. Type: Setscrew or compression.
  7. Expansion Fittings: Steel to match conduit type, complying with UL 651, rated for environmental conditions where installed, and including flexible external bonding jumper.
- C. Joint Compound for GRC or ARC: Approved, as defined in NFPA 70, by authorities having jurisdiction for use in conduit assemblies, and compounded for use to lubricate and protect threaded conduit joints from corrosion and to enhance their conductivity.

## **2.2 SURFACE RACEWAYS**

- A. Listing and Labeling: Surface raceways and tele-power poles shall be listed and labeled as defined in NFPA 70, by a qualified testing agency, and marked for intended location and application.
- B. Surface Metal Raceways: Galvanized steel with snap-on covers complying with UL 5. Manufacturer's standard enamel finish in color selected by Architect.
1. Basis-of-Design Product: Subject to compliance with requirements, provide product indicated on Drawings or comparable product by one of the following:
    - a. Hubbell Incorporated; Wiring Device-Kellems.
    - b. MonoSystems, Inc.
    - c. Panduit Corp.
    - d. Wiremold / Legrand.

## **2.3 BOXES, ENCLOSURES, AND CABINETS**

- A. Basis-of-Design Product: Subject to compliance with requirements, provide product indicated on Drawings or comparable product by one of the following:
1. Adalet.
  2. Crouse-Hinds, an Eaton business.
  3. EGS/Appleton Electric.
  4. Erickson Electrical Equipment Company.
  5. FSR Inc.
  6. Hoffman; a brand of Pentair Equipment Protection.

7. Hubbell Incorporated.
  8. Hubbell Incorporated; Wiring Device-Kellems.
  9. Kraloy.
  10. Milbank Manufacturing Co.
  11. MonoSystems, Inc.
  12. Oldcastle Enclosure Solutions.
  13. O-Z/Gedney; a brand of Emerson Industrial Automation.
  14. Plasti-Bond.
  15. RACO; Hubbell.
  16. Spring City Electrical Manufacturing Company.
  17. Stahlin Non-Metallic Enclosures.
  18. Thomas & Betts Corporation; A Member of the ABB Group.
  19. Topaz Electric; a division of Topaz Lighting Corp.
  20. Wiremold / Legrand.
- B. General Requirements for Boxes, Enclosures, and Cabinets: Boxes, enclosures, and cabinets installed in wet locations shall be listed for use in wet locations.
- C. Sheet Metal Outlet and Device Boxes: Comply with NEMA OS 1 and UL 514A.
- D. Cast-Metal Outlet and Device Boxes: Comply with NEMA FB 1, ferrous alloy or aluminum, Type FD, with gasketed cover.
- E. Luminaire Outlet Boxes: Nonadjustable, designed for attachment of luminaire weighing 50 lb. Outlet boxes designed for attachment of luminaires weighing more than 50 lb shall be listed and marked for the maximum allowable weight.
- F. Paddle Fan Outlet Boxes: Nonadjustable, designed for attachment of paddle fan weighing 70 lb.
1. Listing and Labeling: Paddle fan outlet boxes shall be listed and labeled as defined in NFPA 70, by a qualified testing agency, and marked for intended location and application.
- G. Small Sheet Metal Pull and Junction Boxes: NEMA OS 1.
- H. Cast-Metal Access, Pull, and Junction Boxes: Comply with NEMA FB 1 and UL 1773, cast aluminum or galvanized, cast iron with gasketed cover.
- I. Box extensions used to accommodate new building finishes shall be of same material as recessed box.
- J. Gangable boxes are prohibited.
- K. Hinged-Cover Enclosures: Comply with UL 50 and NEMA 250, Type 1, Type 3R, Type 4, or Type 12 with continuous-hinge cover with flush latch unless otherwise indicated.

1. Metal Enclosures: Steel, finished inside and out with manufacturer's standard enamel.
2. Interior Panels: Steel; all sides finished with manufacturer's standard enamel.

L. Cabinets:

1. NEMA 250, Type 1, Type 3R, or Type 12 galvanized-steel box with removable interior panel and removable front, finished inside and out with manufacturer's standard enamel.
2. Hinged door in front cover with flush latch and concealed hinge.
3. Key latch to match panelboards.
4. Metal barriers to separate wiring of different systems and voltage.
5. Accessory feet where required for freestanding equipment.
6. Nonmetallic cabinets shall be listed and labeled as defined in NFPA 70, by a qualified testing agency, and marked for intended location and application.

**2.4 SOURCE QUALITY CONTROL FOR UNDERGROUND ENCLOSURES**

- A. Handhole and Pull-Box Prototype Test: Test prototypes of handholes and boxes for compliance with SCTE 77. Strength tests shall be for specified tier ratings of products supplied.
1. Tests of materials shall be performed by an independent testing agency.
  2. Strength tests of complete boxes and covers shall be by either an independent testing agency or manufacturer. A qualified registered professional engineer shall certify tests by manufacturer.
  3. Testing machine pressure gages shall have current calibration certification complying with ISO 9000 and ISO 10012 and traceable to NIST standards.

**PART 3 - EXECUTION**

**3.1 RACEWAY APPLICATION**

- A. Outdoors: Apply raceway products as specified below unless otherwise indicated:
1. Exposed Conduit: GRC.
  2. Concealed Conduit, Aboveground: GRC.
  3. Underground Conduit: RNC, Type EPC-80-PVC, direct buried.
  4. Connection to Vibrating Equipment (Including Transformers and Hydraulic, Pneumatic, Electric Solenoid, or Motor-Driven Equipment): LFMC.
  5. Boxes and Enclosures, Aboveground: NEMA 250, Type 3R.
- B. Indoors: Apply raceway products as specified below unless otherwise indicated:
1. Exposed, Not Subject to Physical Damage: EMT.
  2. Exposed, Not Subject to Severe Physical Damage: EMT.

3. Exposed and Subject to Severe Physical Damage: GRC. Raceway locations include the following:
    - a. Loading dock.
    - b. Corridors used for traffic of mechanized carts, forklifts, and pallet-handling units.
    - c. Mechanical rooms.
    - d. Gymnasiums.
    - e. Raceways penetrating roof to within 3 ft. of enclosed switch.
  4. Concealed in Ceilings and Interior Walls and Partitions: EMT. Include raceways in the following locations:
    - a. Open parking garages.
  5. Connection to Vibrating Equipment (Including Transformers and Hydraulic, Pneumatic, Electric Solenoid, or Motor-Driven Equipment): FMC, except use LFMC in damp or wet locations.
  6. Damp or Wet Locations: GRC.
- C. Minimum Raceway Size: 3/4-inch trade size.
- D. Raceway Fittings: Compatible with raceways and suitable for use and location.
1. Rigid Steel Conduit: Use threaded rigid steel conduit fittings unless otherwise indicated. Comply with NEMA FB 2.10.
  2. EMT: Comply with NEMA FB 2.10.
    - a. Utilize steel compression fittings in the following locations:
      - 1) Dump locations.
      - 2) Boiler rooms.
      - 3) Mechanical rooms.
      - 4) Within block walls.
    - b. Utilize steel set-screw fittings in the following locations:
      - 1) Dry locations.
      - 2) Above suspended ceilings.
      - 3) Within stud walls.
  3. Flexible Conduit: Use only fittings listed for use with flexible conduit. Comply with NEMA FB 2.20.
- E. Install nonferrous conduit or tubing for circuits operating above 60 Hz. Where aluminum raceways are installed for such circuits and pass through concrete, install in nonmetallic sleeve.

- F. Install surface raceways only where indicated on Drawings.

**3.2 INSTALLATION**

- A. Comply with requirements in Section 260529 "Hangers and Supports for Electrical Systems" for hangers and supports.
  - 1. Whenever any raceway crosses an expansion or seismic joint, provide a pull box on each side of the joint with sufficient length of flexible raceways to accommodate movement in all directions. See section regarding seismic control for electrical work for additional requirements. Coordinate movement requirements at expansion and seismic joints with Structural Engineer of Record.
- B. Comply with NECA 1 and NECA 101 for installation requirements except where requirements on Drawings or in this article are stricter. Comply with NECA 102 for aluminum conduits. Comply with NFPA 70 limitations for types of raceways allowed in specific occupancies and number of floors.
- C. Do not install raceways or electrical items on any "explosion-relief" walls or rotating equipment.
- D. Do not fasten conduits onto the bottom side of a metal deck roof.
- E. Keep raceways at least 6 inches away from parallel runs of flues and steam or hot-water pipes. Install horizontal raceway runs above water and steam piping.
- F. Complete raceway installation before starting conductor installation.
- G. Arrange stub-ups so curved portions of bends are not visible above finished slab.
- H. Make bends in raceway using large-radius preformed ells. Field bending shall be according to NFPA 70 minimum radii requirements. Use only equipment specifically designed for material and size involved.
- I. Conceal raceway within finished walls, ceilings, and floors unless otherwise indicated. Install conduits parallel or perpendicular to building lines.
- J. Support raceway within 12 inches of enclosures to which attached.
- K. Raceways Embedded in Slabs:
  - 1. Run conduit larger than 1-inch trade size, parallel or at right angles to main reinforcement. Where at right angles to reinforcement, place conduit close to slab support. Secure raceways to reinforcement at maximum 10-foot intervals.
  - 2. Arrange raceways to cross building expansion joints at right angles with expansion fittings.

3. Arrange raceways to keep a minimum of 1 inch of concrete cover in all directions.
  4. Do not embed threadless fittings in concrete.
  5. Raceways may not be installed in structural concrete slabs without express written instruction for the Structural Engineer.
  6. Install rigid steel conduit sweeps with ten times diameter from RNC run below slab or below grade.
- L. Stub-Ups to Above Recessed Ceilings:
1. Use RMC for raceways.
  2. Use a conduit bushing or insulated fitting to terminate stub-ups not terminated in hubs or in an enclosure.
- M. Threaded Conduit Joints, Exposed to Wet, Damp, Corrosive, or Outdoor Conditions: Apply listed compound to threads of raceway and fittings before making up joints. Follow compound manufacturer's written instructions.
- N. Join raceways with fittings designed and approved for the purpose and make joints tight.
1. Use insulating bushings to protect conductors. Within return air plenums, utilize plenum-rated bushings.
- O. Raceway Terminations at Locations Subject to Moisture or Vibration: Use insulating bushings to protect conductors including conductors smaller than No. 4 AWG.
- P. Terminate threaded conduits into threaded hubs or with locknuts on inside and outside of boxes or cabinets. Install bushings on conduits up to 1-1/4-inch trade size and insulated throat metal bushings on 1-1/2-inch trade size and larger conduits terminated with locknuts. Install insulated throat metal grounding bushings on service conduits.
- Q. Install raceways square to the enclosure and terminate at enclosures with locknuts. Install locknuts hand tight plus 1/4 turn more.
- R. Do not rely on locknuts to penetrate nonconductive coatings on enclosures. Remove coatings in the locknut area prior to assembling conduit to enclosure to assure a continuous ground path.
- S. Cut conduit perpendicular to the length. For conduits 2-inch trade size and larger, use roll cutter or a guide to make cut straight and perpendicular to the length.
- T. Install pull wires in empty raceways. Use polypropylene or monofilament plastic line with not less than 200-lb tensile strength. Leave at least 12 inches of slack at each end of pull wire. Within return air plenums, utilize a No. 10 AWG conductor in place of a plastic line. Cap underground raceways designated as spare above grade alongside raceways in use.



- U. Surface Raceways:
1. Install surface raceway with a minimum 2-inch radius control at bend points.
  2. Secure surface raceway with screws or other anchor-type devices at intervals not exceeding 48 inches and with no less than two supports per straight raceway section. Support surface raceway according to manufacturer's written instructions. Tape and glue are not acceptable support methods.
- V. Install raceway sealing fittings at accessible locations according to NFPA 70 and fill them with listed sealing compound. For concealed raceways, install each fitting in a flush steel box with a blank cover plate having a finish similar to that of adjacent plates or surfaces. Install raceway sealing fittings according to NFPA 70.
- W. Install devices to seal raceway interiors at accessible locations. Locate seals so no fittings or boxes are between the seal and the following changes of environments. Seal the interior of all raceways at the following points:
1. Where conduits pass from warm to cold locations, such as boundaries of refrigerated spaces.
  2. Where an underground service raceway enters a building or structure.
  3. Conduit extending from interior to exterior of building.
  4. Conduit extending into pressurized duct and equipment.
  5. Conduit extending into pressurized zones that are automatically controlled to maintain different pressure set points.
  6. Where otherwise required by NFPA 70.
- X. Comply with manufacturer's written instructions for solvent welding RNC and fittings.
- Y. Expansion-Joint Fittings:
1. Install in each run of aboveground RNC that is located where environmental temperature change may exceed 30 deg F and that has straight-run length that exceeds 25 feet. Install in each run of aboveground RMC and EMT conduit that is located where environmental temperature change may exceed 100 deg F and that has straight-run length that exceeds 100 feet.
  2. Install type and quantity of fittings that accommodate temperature change listed for each of the following locations:
    - a. Outdoor Locations Not Exposed to Direct Sunlight: 125 deg F temperature change.
    - b. Outdoor Locations Exposed to Direct Sunlight: 155 deg F temperature change.
    - c. Indoor Spaces Connected with Outdoors without Physical Separation: 125 deg F temperature change.
  3. Install fitting(s) that provide expansion and contraction for at least 0.00041 inch per foot of length of straight run per deg F of temperature change for PVC conduits. Install

- fitting(s) that provide expansion and contraction for at least 0.000078 inch per foot of length of straight run per deg F of temperature change for metal conduits.
4. Install expansion fittings at all locations where conduits cross building or structure expansion joints.
  5. Install each expansion-joint fitting with position, mounting, and piston setting selected according to manufacturer's written instructions for conditions at specific location at time of installation. Install conduit supports to allow for expansion movement.
- Z. Flexible Conduit Connections: Comply with NEMA RV 3. Use a maximum of 72 inches of flexible conduit for recessed and semirecessed luminaires, equipment subject to vibration, noise transmission, or movement; and for transformers and motors.
1. Use LFMC in damp or wet locations subject to severe physical damage.
  2. Use LFMC in damp or wet locations not subject to severe physical damage.
- AA. Mount boxes at heights indicated on Architectural Drawings.
- BB. Recessed Boxes in Masonry Walls: Saw-cut opening for box in center of cell of masonry block, and install box flush with surface of wall. Prepare block surfaces to provide a flat surface for a raintight connection between box and cover plate or supported equipment and box.
- CC. Horizontally separate boxes mounted on opposite sides of walls so they are not in the same vertical channel.
- DD. Locate boxes so that cover or plate will not span different building finishes.
- EE. Support boxes of three gangs or more from more than one side by spanning two framing members or mounting on brackets specifically designed for the purpose.
- FF. Fasten junction and pull boxes to or support from building structure. Do not support boxes by conduits.
- GG. Set metal floor boxes level and flush with finished floor surface.
- HH. Set nonmetallic floor boxes level. Trim after installation to fit flush with finished floor surface.
- 3.3 FIRESTOPPING**
- A. Install firestopping at penetrations of fire-rated floor and wall assemblies. Comply with requirements in Section 078413 "Penetration Firestopping."
- 3.4 PROTECTION**
- A. Protect coatings, finishes, and cabinets from damage and deterioration.

1. Repair damage to galvanized finishes with zinc-rich paint recommended by manufacturer.
2. Repair damage to PVC coatings or paint finishes with matching touchup coating recommended by manufacturer.

**END OF SECTION 260533**

03/07/2017

**SECTION 260544 - SLEEVES AND SLEEVE SEALS FOR ELECTRICAL RACEWAYS AND CABLING**

**PART 1 - GENERAL**

**1.1 RELATED DOCUMENTS**

- A. Drawings and general provisions of the Contract, including General and Supplementary Conditions and Division 01 Specification Sections, apply to this Section.

**1.2 SUMMARY**

- A. Section Includes:
  - 1. Sleeves for raceway and cable penetration of non-fire-rated construction walls and floors.
  - 2. Sleeve-seal fittings.
  - 3. Grout.
  - 4. Silicone sealants.
- B. Related Requirements:
  - 1. Section 078413 "Penetration Firestopping" for penetration firestopping installed in fire-resistance-rated walls, horizontal assemblies, and smoke barriers, with and without penetrating items.

**1.3 ACTION SUBMITTALS**

- A. Product Data: For each type of product.

**PART 2 - PRODUCTS**

**2.1 SLEEVES**

- A. Wall Sleeves:
  - 1. Steel Pipe Sleeves: ASTM A 53/A 53M, Type E, Grade B, Schedule 40, zinc coated, plain ends.
  - 2. Cast-Iron Pipe Sleeves: Cast or fabricated "wall pipe," equivalent to ductile-iron pressure pipe, with plain ends and integral waterstop unless otherwise indicated.
- B. Sleeves for Conduits Penetrating Non-Fire-Rated Gypsum Board Assemblies: Galvanized-steel sheet; 0.0239-inch minimum thickness; round tube closed with welded longitudinal joint, with tabs for screw-fastening the sleeve to the board.
- C. Molded-PVC Sleeves: With nailing flange for attaching to wooden forms.

- D. Molded-PE or -PP Sleeves: Removable, tapered-cup shaped, and smooth outer surface with nailing flange for attaching to wooden forms.
- E. Sleeves for Rectangular Openings:
  - 1. Material: Galvanized sheet steel.
  - 2. Minimum Metal Thickness:
    - a. For sleeve cross-section rectangle perimeter less than 50 inches and with no side larger than 16 inches, thickness shall be 0.052 inch.
    - b. For sleeve cross-section rectangle perimeter equal to, or more than 50 inches or more and one or more sides equal to, or more than 16 inches, thickness shall be 0.138 inch.

## **2.2 SLEEVE-SEAL FITTINGS**

- A. Description: Manufactured plastic, sleeve-type, waterstop assembly made for embedding in concrete slab or wall. Unit shall have plastic or rubber waterstop collar with center opening to match piping OD.
  - 1. Basis-of-Design Product: Subject to compliance with requirements, provide product indicated on Drawings or comparable product by one of the following:
    - a. Flexicraft Industries.
    - b. HOLDRITE.
    - c. Link-Seal.

## **2.3 GROUT**

- A. Description: Nonshrink; recommended for interior and exterior sealing openings in non-fire-rated walls or floors.
- B. Standard: ASTM C 1107/C 1107M, Grade B, post-hardening and volume-adjusting, dry, hydraulic-cement grout.
- C. Design Mix: 5000-psi, 28-day compressive strength.
- D. Packaging: Premixed and factory packaged.

## **2.4 SILICONE SEALANTS**

- A. Silicone Sealants: Single-component, silicone-based, neutral-curing elastomeric sealants of grade indicated below.

1. Grade: Pourable (self-leveling) formulation for openings in floors and other horizontal surfaces that are not fire rated.
  2. Sealant shall comply with the testing and product requirements of the California Department of Health Services' "Standard Practice for the Testing of Volatile Organic Emissions from Various Sources Using Small-Scale Environmental Chambers."
- B. Silicone Foams: Multicomponent, silicone-based liquid elastomers that, when mixed, expand and cure in place to produce a flexible, nonshrinking foam.

**PART 3 - EXECUTION**

**3.1 SLEEVE INSTALLATION FOR NON-FIRE-RATED ELECTRICAL PENETRATIONS**

- A. Comply with NECA 1.
- B. Comply with NEMA VE 2 for cable tray and cable penetrations.
- C. Sleeves for Conduits Penetrating Above-Grade Non-Fire-Rated Concrete and Masonry-Unit Floors and Walls:
1. Interior Penetrations of Non-Fire-Rated Walls and Floors:
    - a. Seal annular space between sleeve and raceway or cable, using joint sealant appropriate for size, depth, and location of joint. Comply with requirements in Section 079200 "Joint Sealants."
    - b. Seal space outside of sleeves with mortar or grout. Pack sealing material solidly between sleeve and wall so no voids remain. Tool exposed surfaces smooth; protect material while curing.
  2. Use pipe sleeves unless penetration arrangement requires rectangular sleeved opening.
  3. Size pipe sleeves to provide 1/4-inch annular clear space between sleeve and raceway or cable unless sleeve seal is to be installed or unless seismic criteria require different clearance.
  4. Install sleeves for wall penetrations unless core-drilled holes or formed openings are used. Install sleeves during erection of walls. Cut sleeves to length for mounting flush with both surfaces of walls. Deburr after cutting.
  5. Install sleeves for floor penetrations. Extend sleeves installed in floors 2 inches above finished floor level. Install sleeves during erection of floors.
- D. Sleeves for Conduits Penetrating Non-Fire-Rated Gypsum Board Assemblies:
1. Use circular metal sleeves unless penetration arrangement requires rectangular sleeved opening.
  2. Seal space outside of sleeves with approved joint compound for gypsum board assemblies.

- E. Aboveground, Exterior-Wall Penetrations: Seal penetrations using steel pipe sleeves and mechanical sleeve seals. Select sleeve size to allow for 1-inch annular clear space between pipe and sleeve for installing mechanical sleeve seals.
- F. Underground, Exterior-Wall and Floor Penetrations: Install cast-iron pipe sleeves. Size sleeves to allow for 1-inch annular clear space between raceway or cable and sleeve for installing sleeve-seal system.

**3.2 SLEEVE-SEAL-FITTING INSTALLATION**

- A. Install sleeve-seal fittings in new walls and slabs as they are constructed.
- B. Assemble fitting components of length to be flush with both surfaces of concrete slabs and walls. Position waterstop flange to be centered in concrete slab or wall.
- C. Secure nailing flanges to concrete forms.
- D. Using grout, seal the space around outside of sleeve-seal fittings.
- E. Install seal fittings on conduits and cables, as required by NEC, which are in or pass through hazardous areas.
- F. Use sealing bushings on conduit and cable ends to effectively prevent the intrusion of water, a damp or corrosive atmosphere, hot or cold air, or dust.

**3.3 SLEEVE INSTALLATION FOR FIRE-RATED ELECTRICAL PENETRATIONS**

- A. Apply firestopping to penetrations of fire-rated floor and wall assemblies for electrical installations to restore original fire-resistance rating of assembly. Firestopping materials and installation requirements are specified in Section 078413 "Penetration Firestopping."
- B. Fire-Rated Assemblies: Install sleeves for penetrations of fire-rated floor and wall assemblies unless openings compatible with firestop system used are fabricated during construction of floor or wall.
- C. Fire-Rated-Assembly Penetrations: Maintain indicated fire rating of walls, partitions, ceilings, and floors at raceway and cable penetrations. Install sleeves and seal raceway and cable penetration sleeves with firestop materials.

**END OF SECTION 260544**

03/07/2017

**SECTION 260553 - IDENTIFICATION FOR ELECTRICAL SYSTEMS**

**PART 1 - GENERAL**

**1.1 RELATED DOCUMENTS**

- A. Drawings and general provisions of the Contract, including General and Supplementary Conditions and Division 01 Specification Sections, apply to this Section.

**1.2 SUMMARY**

- A. Section Includes:
  - 1. Identification for raceways.
  - 2. Identification of power and control cables.
  - 3. Identification for conductors.
  - 4. Warning labels and signs.
  - 5. Instruction signs.
  - 6. Equipment identification labels.
  - 7. Miscellaneous identification products.

**1.3 ACTION SUBMITTALS**

- A. Product Data: For each electrical identification product indicated.
- B. Samples: For each type of label and sign to illustrate size, colors, lettering style, mounting provisions, and graphic features of identification products.
- C. Identification Schedule: An index of nomenclature of electrical equipment and system components used in identification signs and labels. Furnish extra copies, in addition to mounted copies, for inclusion in maintenance manuals. Provide one copy on electronic media, type specified by Owner.

**1.4 QUALITY ASSURANCE**

- A. Comply with ANSI A13.1.
- B. Comply with NFPA 70.
- C. Comply with 29 CFR 1910.144 and 29 CFR 1910.145.
- D. Comply with ANSI Z535.4 for safety signs and labels.
- E. Adhesive-attached labeling materials, including label stocks, laminating adhesives, and inks used by label printers, shall comply with UL 969.



**1.5 COORDINATION**

- A. Coordinate identification names, abbreviations, colors, and other features with requirements in other Sections requiring identification applications and with Owner's desired identification scheme, regardless of numbering indicated on the drawings and specifications, Drawings, Shop Drawings, manufacturer's wiring diagrams, and the Operation and Maintenance Manual; and with those required by codes, standards, and 29 CFR 1910.145. Use consistent designations throughout Project. Coordinate Owner's desired identification scheme with NEMA and OSHA standards.
- B. Coordinate installation of identifying devices with completion of covering and painting of surfaces where devices are to be applied.
- C. Coordinate installation of identifying devices with location of access panels and doors.
- D. Install identifying devices before installing acoustical ceilings and similar concealment.

**PART 2 - PRODUCTS****2.1 POWER AND CONTROL RACEWAY IDENTIFICATION MATERIALS**

- A. Comply with ANSI A13.1 for minimum size of letters for legend and for minimum length of color field for each raceway size.
- B. Colors for Raceways Carrying Circuits at 600 V or Less:
  - 1. Black letters on an orange field.
  - 2. Legend: Indicate voltage and system or service type.
- C. Snap-Around Labels for Raceways Carrying Circuits at 600 V or Less: Slit, pretensioned, flexible, preprinted, color-coded acrylic sleeve, with diameter sized to suit diameter of raceway or cable it identifies and to stay in place by gripping action.

**2.2 ARMORED AND METAL-CLAD CABLE IDENTIFICATION MATERIALS**

- A. Comply with ANSI A13.1 for minimum size of letters for legend and for minimum length of color field for each cable size.
- B. Colors for Cables Carrying Circuits at 600 V and Less:
  - 1. Black letters on an orange field.
  - 2. Legend: Indicate voltage and system or service type.
- C. Self-Adhesive Vinyl Labels: Preprinted, flexible label laminated with a clear, weather- and chemical-resistant coating and matching wraparound clear adhesive tape for securing ends of legend label.

- D. Heat-Shrink Preprinted Tubes: Flame-retardant polyolefin tube with machine-printed identification label. Sized to suit diameter of and shrinks to fit firmly around cable it identifies. Full shrink recovery at a maximum of 200 deg F. Comply with UL 224.

**2.3 POWER AND CONTROL CABLE IDENTIFICATION MATERIALS**

- A. Comply with ANSI A13.1 for minimum size of letters for legend and for minimum length of color field for each cable size.
- B. Snap-Around Labels: Slit, pretensioned, flexible, preprinted, color-coded acrylic sleeve, with diameter sized to suit diameter of cable it identifies and to stay in place by gripping action.

**2.4 CONDUCTOR IDENTIFICATION MATERIALS**

- A. Color-Coding Conductor Tape: Colored, self-adhesive vinyl tape not less than 3 mils thick by 1 to 2 inches wide.
- B. Snap-Around Labels: Slit, pretensioned, flexible, preprinted, color-coded acrylic sleeve, with diameter sized to suit diameter of conductor it identifies and to stay in place by gripping action.
- C. Heat-Shrink Preprinted Tubes: Flame-retardant polyolefin tube with machine-printed identification label. Sized to suit diameter of and shrinks to fit firmly around conductor it identifies. Full shrink recovery at a maximum of 200 deg F. Comply with UL 224.
- D. Write-On Tags: Polyester tag, 0.010 inch thick, with corrosion-resistant grommet and cable tie for attachment to conductor or cable.
  - 1. Marker for Tags: Permanent, waterproof, black ink marker recommended by tag manufacturer.

**2.5 WARNING LABELS AND SIGNS**

- A. Comply with NFPA 70 and 29 CFR 1910.145.
- B. Self-Adhesive Warning Labels: Factory-printed, multicolor, pressure-sensitive adhesive labels, configured for display on front cover, door, or other access to equipment unless otherwise indicated.
- C. Warning label and sign shall include, but are not limited to, the following legends:
  - 1. Multiple Power Source Warning: "DANGER - ELECTRICAL SHOCK HAZARD - EQUIPMENT HAS MULTIPLE POWER SOURCES."
  - 2. Workspace Clearance Warning: "WARNING - OSHA REGULATION - AREA IN FRONT OF ELECTRICAL EQUIPMENT MUST BE KEPT CLEAR FOR 36 INCHES."

**2.6 INSTRUCTION SIGNS**

- A. Engraved, laminated acrylic or melamine plastic, minimum 1/16 inch thick for signs up to 20 sq. inches and 1/8 inch thick for larger sizes.
  - 1. Engraved legend with black letters on white face.
  - 2. Punched or drilled for mechanical fasteners.
  - 3. Framed with mitered acrylic molding and arranged for attachment at applicable equipment.

**2.7 EQUIPMENT IDENTIFICATION LABELS**

- A. Self-Adhesive, Engraved, Laminated Acrylic or Melamine Label: Adhesive backed, with white letters on a dark-gray background. Minimum letter height shall be 3/8 inch.
- B. Equipment Label Content: Include equipment's drawing designation and Owner specified unique equipment number, drawing numbers where equipment is indicated (plans, details, and schedules), plus the specification section number and title where equipment is specified.

**2.8 CABLE TIES**

- A. Plenum-Rated Cable Ties: Self-extinguishing, UV stabilized, one piece, self-locking.
  - 1. Minimum Width: 3/16 inch.
  - 2. Tensile Strength at 73 deg F, According to ASTM D 638: 7000 psi.
  - 3. UL 94 Flame Rating: 94V-0.
  - 4. Temperature Range: Minus 50 to plus 284 deg F.
  - 5. Color: Black.

**2.9 MISCELLANEOUS IDENTIFICATION PRODUCTS**

- A. Paint: Comply with requirements in painting Sections for paint materials and application requirements. Select paint system applicable for surface material and location (exterior or interior).
- B. Fasteners for Labels and Signs: Self-tapping, stainless-steel screws or stainless-steel machine screws with nuts and flat and lock washers.

**PART 3 - EXECUTION**

**3.1 INSTALLATION**

- A. Verify identity of each item before installing identification products.
- B. Location: Install identification materials and devices at locations for most convenient viewing without interference with operation and maintenance of equipment.

- C. Apply identification devices to surfaces that require finish after completing finish work.
- D. Self-Adhesive Identification Products: Clean surfaces before application, using materials and methods recommended by manufacturer of identification device.
- E. Attach signs and plastic labels that are not self-adhesive type with mechanical fasteners appropriate to the location and substrate.
- F. Attach plastic raceway and cable labels that are not self-adhesive type with clear vinyl tape with adhesive appropriate to the location and substrate.
- G. System Identification Color-Coding Bands for Raceways and Cables: Each color-coding band shall completely encircle cable or conduit. Place adjacent bands of two-color markings in contact, side by side. Locate bands at changes in direction, at penetrations of walls and floors, at 50-foot maximum intervals in straight runs, and at 25-foot maximum intervals in congested areas.
- H. Aluminum Wraparound Marker Labels and Metal Tags: Secure tight to surface of conductor or cable at a location with high visibility and accessibility.
- I. Cable Ties: For attaching tags. Use general-purpose type, except as listed below:
  - 1. Outdoors: UV-stabilized nylon.
  - 2. In Spaces Handling Environmental Air: Plenum rated.
- J. Painted Identification: Comply with requirements in painting Sections for surface preparation and paint application.

### **3.2 IDENTIFICATION SCHEDULE**

- A. Accessible Raceways and Metal-Clad Cables, 600 V or Less, for Service, Feeder, and Branch Circuits More Than 30 A, and 120 V to ground: Identify with self-adhesive vinyl label. Install labels at 10-foot maximum intervals.
- B. Power-Circuit Conductor Identification, 600 V or Less: For conductors in vaults, pull and junction boxes, manholes, and handholes, use color-coding conductor tape to identify the phase.
  - 1. Color-Coding for Phase and Voltage Level Identification, 600 V or Less: Use colors listed below for ungrounded service, feeder and branch-circuit conductors.
    - a. Color shall be factory applied or field applied for sizes larger than No. 8 AWG, if authorities having jurisdiction permit.
    - b. Colors for 208/110-V Circuits:
      - 1) Phase A: Black.
      - 2) Phase B: Red.

- 3) Phase C: Blue.
  - c. Field-Applied, Color-Coding Conductor Tape: Apply in half-lapped turns for a minimum distance of 6 inches from terminal points and in boxes where splices or taps are made. Apply last two turns of tape with no tension to prevent possible unwinding. Locate bands to avoid obscuring factory cable markings.
- C. Power-Circuit Conductor Identification, More than 600 V: For conductors in vaults, pull and junction boxes, manholes, and handholes, use write-on tags, nonmetallic plastic tag holder with adhesive-backed phase tags, and a separate tag with the circuit designation.
- D. Install instructional sign including the color-code for grounded and ungrounded conductors using adhesive-film-type labels.
- E. Control-Circuit Conductor Identification: For conductors and cables in pull and junction boxes, manholes, and handholes, use write-on tags, self-adhesive vinyl labels with the conductor or cable designation, origin, and destination.
- F. Control-Circuit Conductor Termination Identification: For identification at terminations provide self-adhesive, self-laminating polyester labels with the conductor designation.
- G. Conductors to Be Extended in the Future: Attach write-on tags to conductors and list source.
- H. Auxiliary Electrical Systems Conductor Identification: Identify field-installed alarm, control, and signal connections.
  1. Identify conductors, cables, and terminals in enclosures and at junctions, terminals, and pull points. Identify by system and circuit designation.
  2. Use system of marker tape designations that is uniform and consistent with system used by manufacturer for factory-installed connections.
  3. Coordinate identification with Project Drawings, manufacturer's wiring diagrams, and the Operation and Maintenance Manual.
- I. Workspace Indication: Install floor marking tape to show working clearances in the direction of access to live parts. Workspace shall be as required by NFPA 70 and 29 CFR 1926.403 unless otherwise indicated. Do not install at flush-mounted panelboards and similar equipment in finished spaces.
- J. Warning Labels for Indoor Cabinets, Boxes, and Enclosures for Power and Lighting: Self-adhesive warning labels.
  1. Comply with 29 CFR 1910.145.
  2. Identify system voltage with black letters on an orange background.
  3. Apply to exterior of door, cover, or other access.

4. For equipment with multiple power or control sources, apply to door or cover of equipment including, but not limited to, the following:
    - a. Power transfer switches.
    - b. Controls with external control power connections.
  5. Color code all junction boxes and associated cover plates serving emergency equipment with red paint.
- K. Operating Instruction Signs: Install instruction signs to facilitate proper operation and maintenance of electrical systems and items to which they connect. Install instruction signs with approved legend where instructions are needed for system or equipment operation.
- L. Emergency Operating Instruction Signs: Install instruction signs with white legend on a red background with minimum 3/8-inch- high letters for emergency instructions at equipment used for power transfer and load shedding.
- M. Equipment Identification Labels: On each unit of equipment, install unique designation label that is consistent with wiring diagrams, schedules, and the Operation and Maintenance Manual. Apply labels to disconnect switches and protection equipment, central or master units, control panels, control stations, terminal cabinets, and racks of each system. Systems include power, lighting, control, communication, signal, monitoring, and alarm systems unless equipment is provided with its own identification.
1. Labeling Instructions:
    - a. Indoor Equipment: Self-adhesive, engraved, laminated acrylic or melamine label. Unless otherwise indicated, provide a single line of text with 1/2-inch- high letters on 1-1/2-inch- high label; where two lines of text are required, use labels 2 inches high.
    - b. Elevated Components: Increase sizes of labels and letters to those appropriate for viewing from the floor.
    - c. Unless provided with self-adhesive means of attachment, fasten labels with appropriate mechanical fasteners that do not change the NEMA or NRTL rating of the enclosure.
  2. Equipment to Be Labeled:
    - a. Panelboards: Typewritten directory of circuits in the location provided by panelboard manufacturer. Panelboard identification shall be self-adhesive, engraved, laminated acrylic or melamine label.
    - b. Enclosures and electrical cabinets.
    - c. Access doors and panels for concealed electrical items.
    - d. Switchgear.
    - e. Emergency system boxes and enclosures.
    - f. Enclosed switches.

- g. Enclosed controllers.
- h. Variable-speed controllers.
- i. Push-button stations.
- j. Power transfer equipment.
- k. Contactors.
- l. Remote-controlled switches, dimmer modules, and control devices.
- m. Monitoring and control equipment.

**END OF SECTION 260553**

03/07/2017

**SECTION 260923 - LIGHTING CONTROL DEVICES**

**PART 1 - GENERAL**

**1.1 RELATED DOCUMENTS**

- A. Drawings and general provisions of the Contract, including General and Supplementary Conditions and Division 01 Specification Sections, apply to this Section.

**1.2 SUMMARY**

- A. Section Includes:
  - 1. Standalone daylight-harvesting switching and dimming controls.
  - 2. Indoor occupancy and vacancy sensors.
  - 3. Switchbox-mounted occupancy sensors.
  - 4. Lighting contactors.
  - 5. Emergency shunt relays.
- B. Related Requirements:
  - 1. Section 262726 "Wiring Devices" for wall-box dimmers, non-networkable wall-switch occupancy sensors, and manual light switches.

**1.3 ACTION SUBMITTALS**

- A. Product Data: For each type of product.
- B. Shop Drawings:
  - 1. Show installation details for the following:
    - a. Vacancy sensors.
    - b. Daylight sensors.
  - 2. Interconnection diagrams showing field-installed wiring.
  - 3. Include diagrams for power, signal, and control wiring.

**1.4 INFORMATIONAL SUBMITTALS**

- A. Coordination Drawings: Reflected ceiling plan(s) and elevations, drawn to scale, on which the following items are shown and coordinated with each other, using input from installers of the items involved:
  - 1. Suspended ceiling components.
  - 2. Structural members to which equipment will be attached.



3. Items penetrating finished ceiling, including the following:
  - a. Luminaires.
  - b. Air outlets and inlets.
  - c. Speakers.
  - d. Sprinklers.
  - e. Access panels.
  - f. Control modules.
  - g. Occupancy/Vacancy sensors.
  - h. Daylight sensors.

- B. Field quality-control reports.
- C. Sample Warranty: For manufacturer's warranties.

**1.5 CLOSEOUT SUBMITTALS**

- A. Operation and Maintenance Data: For each type of lighting control device to include in operation and maintenance manuals.
- B. Software and Firmware Operational Documentation:
  1. Software operating and upgrade manuals.
  2. Program Software Backup: On USB media. Provide names, versions, and website addresses for locations of installed software.
  3. Device address list.
  4. Printout of software application and graphic screens.

**1.6 WARRANTY**

- A. Manufacturer's Warranty: Manufacturer and Installer agree to repair or replace lighting control devices that fail(s) in materials or workmanship within specified warranty period.
  1. Failures include, but are not limited to, the following:
    - a. Faulty operation of lighting control software.
    - b. Faulty operation of lighting control devices.
  2. Warranty Period: Five years from date of Substantial Completion.

**PART 2 - PRODUCTS****2.1 DAYLIGHT-HARVESTING DIMMING CONTROLS**

- A. Basis-of-Design Product: Subject to compliance with requirements, provide product indicated on Drawings or comparable product by one of the following:
1. Cooper Industries, Inc.
  2. Crestron.
  3. Deep Roof Lighting.
  4. Douglas Lighting Controls.
  5. Hubbell Building Automation, Inc.
  6. Leviton Manufacturing Co., Inc.
  7. Lithonia Lighting; Acuity Brands Lighting, Inc.
  8. WattStopper; a Legrand® Group brand.
- B. System Description: Sensing daylight and electrical lighting levels, the system adjusts the indoor electrical lighting levels. As daylight increases, the lights are dimmed.
1. Lighting control set point is based on two lighting conditions:
    - a. When no daylight is present (target level).
    - b. When significant daylight is present.
  2. System programming is done with two hand-held, remote-control tools.
    - a. Initial setup tool.
    - b. Tool for occupants to adjust the target levels by increasing the set point up to 25 percent, or by minimizing the electric lighting level.
- C. Ceiling-Mounted Dimming Controls: Solid-state, light-level sensor unit, with separate power pack, to detect changes in indoor lighting levels that are perceived by the eye.
- D. Electrical Components, Devices, and Accessories:
1. Listed and labeled as defined in NFPA 70, by a qualified testing agency, and marked for intended location and application.
  2. Sensor Output: 0- to 10-V dc to operate luminaires. Sensor is powered by controller unit.
  3. Light-Level Sensor Set-Point Adjustment Range: 5 to 80 fc.
- E. Power Pack: Digital controller capable of accepting 3 RJ45 inputs with one outputs rated for 20-A LED load at 120- and 277-V ac, for 16-A LED at 120- and 277-V ac, and for 1 hp at 120-V ac. Sensor has 24-V dc Class 2 power source, as defined by NFPA 70.

1. With integral current monitoring
  - a. Compatible with digital addressable lighting interface.
    - 1) Plenum rated.

**2.2 INDOOR OCCUPANCY AND VACANCY SENSORS**

A. Basis-of-Design Product: Subject to compliance with requirements, provide product indicated on Drawings or comparable product by one of the following:

1. Cooper Industries, Inc.
2. Crestron.
3. Douglas Lighting Controls.
4. Hubbell Building Automation, Inc.
5. Intermatic, Inc.
6. Leviton Manufacturing Co., Inc.
7. Lithonia Lighting; Acuity Brands Lighting, Inc.
8. Lutron Electronics Co., Inc.
9. Philips Lighting Controls.
10. Sensor Switch, Inc.
11. WattStopper; a Legrand® Group brand.

B. General Requirements for Sensors:

1. Wall or ceiling-mounted, solid-state indoor vacancy]sensors.
2. Dual technology.
3. Separate power pack.
4. Hardwired connection to switch.
5. Hardwired secondary connection to switch BMS.
6. Listed and labeled as defined in NFPA 70, by a qualified testing agency, and marked for intended location and application.
7. Operation:
  - a. Occupancy Sensor: Unless otherwise indicated, turn lights on when coverage area is occupied, and turn them off when unoccupied; with a time delay for turning lights off, adjustable over a minimum range of 1 to 30 minutes.
  - b. Vacancy Sensor: Unless otherwise indicated, lights are manually turned on and sensor turns lights off when the room is unoccupied; with a time delay for turning lights off, adjustable over a minimum range of 1 to 30 minutes.
  - c. Combination Sensor: Unless otherwise indicated, sensor shall be programmed to turn lights on when coverage area is occupied and turn them off when unoccupied, or to turn off lights that have been manually turned on; with a time delay for turning lights off, adjustable over a minimum range of 1 to 30 minutes.
8. Sensor Output: Contacts rated to operate the connected relay, complying with UL 773A.

9. Power: Line voltage or integral photovoltaic collector].
10. Power Pack: Dry contacts rated for 20-A ballast or LED load at 120- and 277-V ac, for 13-A tungsten at 120-V ac, and for 1 hp at 120-V ac. Sensor has 24-V dc, 150-mA, Class 2 power source, as defined by NFPA 70.
11. Mounting:
  - a. Sensor: Suitable for mounting in any position on a standard outlet box.
  - b. Relay: Externally mounted through a 1/2-inch knockout in a standard electrical enclosure.
  - c. Time-Delay and Sensitivity Adjustments: Recessed and concealed behind hinged door.
12. Indicator: Digital display, to show when motion is detected during testing and normal operation of sensor.
13. Bypass Switch: Override the "on" function in case of sensor failure.
14. Automatic Light-Level Sensor: Adjustable from 2 to 200 fc; turn lights off when selected lighting level is present.

- C. Dual-Technology Type: Wall or ceiling mounted; detect occupants in coverage area using PIR and ultrasonic detection methods. The particular technology or combination of technologies that control on-off functions is selectable in the field by operating controls on unit.

1. Sensitivity Adjustment: Separate for each sensing technology.
2. Detector Sensitivity: Detect occurrences of 6-inch- minimum movement of any portion of a human body that presents a target of not less than 36 sq. in., and detect a person of average size and weight moving not less than 12 inches in either a horizontal or a vertical manner at an approximate speed of 12 inches/s.
3. Detection Coverage (Standard Room): Detect occupancy anywhere within a circular area of 1000 sq. ft. when mounted on a 96-inch- high ceiling.
4. Detection Coverage (Room, Wall Mounted): Detect occupancy anywhere within a 180-degree pattern centered on the sensor over an area of 1000 square feet when mounted 48 inches above finished floor.

### **2.3 SWITCHBOX-MOUNTED OCCUPANCY SENSORS**

- A. Basis-of-Design Product: Subject to compliance with requirements, provide product indicated on Drawings or comparable product by one of the following:

1. Cooper Industries, Inc.
2. Crestron.
3. Douglas Lighting Controls.
4. Hubbell Building Automation, Inc.
5. Intermatic, Inc.
6. Leviton Manufacturing Co., Inc.
7. Lithonia Lighting; Acuity Brands Lighting, Inc.
8. Lutron Electronics Co., Inc.

9. Philips Lighting Controls.
10. Sensor Switch, Inc.
11. WattStopper; a Legrand® Group brand.

B. General Requirements for Sensors: Automatic-wall-switch occupancy sensor with manual on-off switch, suitable for mounting in a single gang switchbox, with provisions for connection to BAS.

1. Listed and labeled as defined in NFPA 70, by a qualified testing agency, and marked for intended location and application.
2. Occupancy Sensor Operation: Unless otherwise indicated, turn lights on when coverage area is occupied, and turn lights off when unoccupied; with a time delay for turning lights off, adjustable over a minimum range of 1 to 15 minutes.
3. Operating Ambient Conditions: Dry interior conditions, 32 to 120 deg F.
4. Switch Rating: Not less than 800-VA ballast or LED load at 120 V, 1200-VA ballast or LED load at 277 V, and 800-W incandescent.
5. Include ground wire.

C. Wall-Switch Sensor Tag:

1. Standard Range: 180-degree field of view, field adjustable from 180 to 40 degrees; with a minimum coverage area of 900 sq. ft..
2. Sensing Technology: Dual technology - PIR and ultrasonic.
3. Switch Type: SP, field-selectable automatic "on," or manual "on," automatic "off."
4. Capable of controlling load in three-way application.
5. Voltage: Match the circuit voltage.
6. Ambient-Light Override: Concealed, field-adjustable, light-level sensor from 2 to 200 fc. The switch prevents the lights from turning on when the light level is higher than the set point of the sensor.
7. Concealed, field-adjustable, "off" time-delay selector at up to 30 minutes.
8. Concealed, "off" time-delay selector at 30 seconds and 5, 10, and 20 minutes.
9. Adaptive Technology: Self-adjusting circuitry detects and memorizes usage patterns of the space and helps eliminate false "off" switching.
10. Color: As selected by Architect.
11. Faceplate: Color matched to switch.

## 2.4 **LIGHTING CONTACTORS**

A. Basis-of-Design Product: Subject to compliance with requirements, provide product indicated on Drawings or comparable product by one of the following:

1. Allen-Bradley/Rockwell Automation.
2. ASCO Power Technologies, LP; a business of Emerson Network Power.
3. Eaton.
4. General Electric Company.
5. Square D.

- B. Description: Electrically operated and mechanically held, combination-type lighting contactors with nonfused disconnect, complying with NEMA ICS 2 and UL 508.
1. Current Rating for Switching: Listing or rating consistent with type of load served, including tungsten filament, inductive, and high-inrush ballast (ballast with 15 percent or less THD of normal load current).
  2. Fault Current Withstand Rating: Equal to or exceeding the available fault current at the point of installation.
  3. Enclosure: Comply with NEMA 250.
  4. Provide with control and pilot devices as indicated on Drawings, matching the NEMA type specified for the enclosure.
  5. Control-Coil Voltage: Match control power source.
- C. Interface with DDC System for HVAC: Provide a hardware interface and software to allow the HVAC DDC system to monitor and control all lighting contactors.
1. Monitoring: On-off status.
  2. Control: On-off operation.

## **2.5 EMERGENCY SHUNT RELAY**

- A. Basis-of-Design Product: Subject to compliance with requirements, provide product indicated on Drawings or comparable product by one of the following:
1. Bodine.
  2. Lighting Control and Design.
  3. LVS, Inc.
  4. WattStopper; a Legrand® Group brand.
- B. Description: NC, electrically held relay, arranged for wiring in parallel with manual or automatic switching contacts; complying with UL 924.
1. Coil Rating: 120 or 277 V.
  2. Contact Rating: 20-A.
  3. Mounting: Mount on a 4" x 4" x 2-1/8" two-gang outlet box, located above nearest accessible ceiling.
  4. Barrier: Steel to isolate normal and emergency circuits.
  5. Rated Number of Operations: 40,000 at 20-A.

## **2.6 CONDUCTORS AND CABLES**

- A. Power Wiring to Supply Side of Remote-Control Power Sources: Not smaller than No. 12 AWG. Comply with requirements in Section 260519 "Low-Voltage Electrical Power Conductors and Cables."

- B. Classes 2 and 3 Control Cable: Multiconductor cable with stranded-copper conductors not smaller than No. 18 AWG. Comply with requirements in Section 260519 "Low-Voltage Electrical Power Conductors and Cables."
- C. Class 1 Control Cable: Multiconductor cable with stranded-copper conductors not smaller than No. 14 AWG. Comply with requirements in Section 260519 "Low-Voltage Electrical Power Conductors and Cables."
- D. Install unshielded, twisted-pair cable for control and signal transmission conductors.

**PART 3 - EXECUTION**

**3.1 EXAMINATION**

- A. Examine lighting control devices before installation. Reject lighting control devices that are wet, moisture damaged, or mold damaged.
- B. Examine walls and ceilings for suitable conditions where lighting control devices will be installed.
- C. Proceed with installation only after unsatisfactory conditions have been corrected.

**3.2 SENSOR INSTALLATION**

- A. Comply with NECA 1.
- B. Coordinate layout and installation of ceiling-mounted devices with other construction that penetrates ceilings or is supported by them, including light fixtures, HVAC equipment and devices, smoke detectors, fire-suppression systems, and partition assemblies, and architectural features.
- C. Install and aim sensors in locations to achieve not less than 90-percent coverage of areas indicated. Do not exceed coverage limits specified in manufacturer's written instructions.

**3.3 APPLICATION OF OCCUPANCY / VACANCY SENSORS**

- A. Install dual technology type devices within all areas where occupancy/vacancy sensors are indicated.

**3.4 CONTACTOR INSTALLATION**

- A. Comply with NECA 1.
- B. Mount electrically held lighting contactors with elastomeric isolator pads to eliminate structure-borne vibration unless contactors are installed in an enclosure with factory-installed vibration isolators.

**3.5 WIRING INSTALLATION**

- A. Comply with NECA 1.
- B. Wiring Method: Comply with Section 260519 "Low-Voltage Electrical Power Conductors and Cables." Minimum conduit size is 3/4 inch.
- C. Wiring within Enclosures: Comply with NECA 1. Bundle, lace and train conductors to terminal points. Separate power-limited and nonpower-limited conductors according to conductor manufacturer's written instructions.
- D. Size conductors according to lighting control device manufacturer's written instructions unless otherwise indicated.
- E. Splices, Taps, and Terminations: Make connections only on numbered terminal strips in junction, pull, and outlet boxes; terminal cabinets; and equipment enclosures.

**3.6 IDENTIFICATION**

- A. Identify components and power and control wiring according to Section 260553 "Identification for Electrical Systems."
  - 1. Identify controlled circuits in lighting contactors.
  - 2. Identify circuits or luminaires controlled by photoelectric and occupancy sensors at each sensor.
- B. Label time switches and contactors with a unique designation.

**3.7 FIELD QUALITY CONTROL**

- A. Perform the following tests and inspections with the assistance of a factory-authorized service representative:
  - 1. Operational Test: After installing time switches and sensors, and after electrical circuitry has been energized, start units to confirm proper unit operation.
  - 2. Test and adjust controls and safeties. Replace damaged and malfunctioning controls and equipment.
- B. Lighting control devices will be considered defective if they do not pass tests and inspections.
- C. Prepare test and inspection reports.

**3.8 ADJUSTING**

- A. Occupancy Adjustments: When requested within 12 months from date of Substantial Completion, provide on-site assistance in adjusting lighting control devices to suit actual



occupied conditions. Provide up to two visits to Project during other-than-normal occupancy hours for this purpose.

1. For occupancy and motion sensors, verify operation at outer limits of detector range. Set time delay to suit Owner's operations.
2. For daylighting controls, adjust set points and deadband controls to suit Owner's operations.

### **3.9 SOFTWARE SERVICE AGREEMENT**

- A. Technical Support: Beginning at Substantial Completion, service agreement shall include software support for two years.
- B. Upgrade Service: At Substantial Completion, update software to latest version. Install and program software upgrades that become available within two years from date of Substantial Completion. Upgrading software shall include operating system and new or revised licenses for using software.
  1. Upgrade Notice: At least 30 days to allow Owner to schedule and access the system and to upgrade computer equipment if necessary.

### **3.10 DEMONSTRATION**

- A. Coordinate demonstration of products specified in this Section with demonstration requirements for low-voltage, programmable lighting control systems specified in Section 260943.16 "Addressable-Luminaire Lighting Controls" and Section 260943.23 "Relay-Based Lighting Controls," and Section 260943.33 "Distributive Network Lighting Control."
- B. Engage a factory-authorized service representative to train Owner's maintenance personnel to adjust, operate, and maintain lighting control devices. As a minimum and in addition to the requirements of other sections. Provide two 4-hour days of owner training sessions in addition to multiple start-up visits to properly support the contractor.

**END OF SECTION 260923**

03/07/2017

**SECTION 262416 - PANELBOARDS**

**PART 1 - GENERAL**

**1.1 RELATED DOCUMENTS**

- A. Drawings and general provisions of the Contract, including General and Supplementary Conditions and Division 01 Specification Sections, apply to this Section.
- B. Submittals will not be reviewed or accepted without a protective device coordination study report.

**1.2 SUMMARY**

- A. Section Includes:
  - 1. Distribution panelboards.
  - 2. Lighting and appliance branch-circuit panelboards.

**1.3 DEFINITIONS**

- A. SPD: Surge protective device.
- B. SVR: Suppressed voltage rating.
- C. TVSS: Transient voltage surge suppressor.

**1.4 ACTION SUBMITTALS**

- A. Product Data: For each type of panelboard, switching and overcurrent protective device, transient voltage suppression device, accessory, and component indicated. Include dimensions and manufacturers' technical data on features, performance, electrical characteristics, ratings, and finishes.
- B. Shop Drawings: For each panelboard and related equipment.
  - 1. Include dimensioned plans, elevations, sections, and details. Show tabulations of installed devices, equipment features, and ratings.
  - 2. Detail enclosure types and details for types other than NEMA 250, Type 1.
  - 3. Detail bus configuration, current, and voltage ratings.
  - 4. Short-circuit current rating of panelboards and overcurrent protective devices.
  - 5. Detail features, characteristics, ratings, and factory settings of individual overcurrent protective devices and auxiliary components.
  - 6. Include wiring diagrams for power, signal, and control wiring.

7. Include time-current coordination curves for each type and rating of overcurrent protective device included in panelboards. Submit on translucent log-log graft paper; include selectable ranges for each type of overcurrent protective device.

### **1.5 INFORMATIONAL SUBMITTALS**

- A. Qualification Data: For qualified testing agency.
- B. Seismic Qualification Certificates: Submit certification that panelboards, overcurrent protective devices, accessories, and components will withstand seismic forces defined in Section 260548 "Vibration and Seismic Controls for Electrical Systems." Include the following:
  1. Basis for Certification: Indicate whether withstand certification is based on actual test of assembled components or on calculation.
  2. Dimensioned Outline Drawings of Equipment Unit: Identify center of gravity and locate and describe mounting and anchorage provisions.
  3. Detailed description of equipment anchorage devices on which the certification is based and their installation requirements.
- C. Panelboard Schedules: For installation in panelboards. Submit final versions after load balancing.

### **1.6 CLOSEOUT SUBMITTALS**

- A. Operation and Maintenance Data: For panelboards and components to include in emergency, operation, and maintenance manuals. In addition to items specified in Section 017823 "Operation and Maintenance Data," include the following:
  1. Manufacturer's written instructions for testing and adjusting overcurrent protective devices.
  2. Time-current curves, including selectable ranges for each type of overcurrent protective device that allows adjustments.

### **1.7 QUALITY ASSURANCE**

- A. Source Limitations: Obtain panelboards, overcurrent protective devices, components, and accessories from single source from single manufacturer.
- B. Product Selection for Restricted Space: Drawings indicate maximum dimensions for panelboards including clearances between panelboards and adjacent surfaces and other items. Comply with indicated maximum dimensions.
- C. Electrical Components, Devices, and Accessories: Listed and labeled as defined in NFPA 70, by a qualified testing agency, and marked for intended location and application.
- D. Comply with NEMA PB 1.

- E. Comply with NFPA 70.

**1.8 DELIVERY, STORAGE, AND HANDLING**

- A. Remove loose packing and flammable materials from inside panelboards; install temporary electric heating (250 W per panelboard) to prevent condensation.
- B. Handle and prepare panelboards for installation according to NEMA PB 1.

**1.9 PROJECT CONDITIONS**

- A. Environmental Limitations:
  - 1. Do not deliver or install panelboards until spaces are enclosed and weathertight, wet work in spaces is complete and dry, work above panelboards is complete, and temporary HVAC system is operating and maintaining ambient temperature and humidity conditions at occupancy levels during the remainder of the construction period.
  - 2. Rate equipment for continuous operation under the following conditions unless otherwise indicated:
    - a. Ambient Temperature: Not exceeding 23 deg F to plus 104 deg F.
    - b. Altitude: Not exceeding 6600 feet.
- B. Service Conditions: NEMA PB 1, usual service conditions, as follows:
  - 1. Ambient temperatures within limits specified.
  - 2. Altitude not exceeding 6600 feet.
- C. Interruption of Existing Electric Service: Do not interrupt electric service to facilities occupied by Owner or others unless permitted under the following conditions and then only after arranging to provide temporary electric service according to requirements indicated:
  - 1. Notify Architect and Owner no fewer than five days in advance of proposed interruption of electric service.
  - 2. Do not proceed with interruption of electric service without Architect's and Owner's written permission.
  - 3. Comply with NFPA 70E.

**1.10 COORDINATION**

- A. Coordinate layout and installation of panelboards and components with other construction that penetrates walls or is supported by them, including electrical and other types of equipment, raceways, piping, encumbrances to workspace clearance requirements, and adjacent surfaces. Maintain required workspace clearances and required clearances for equipment access doors and panels.

- B. Coordinate sizes and locations of concrete bases with actual equipment provided. Cast anchor-bolt inserts into bases. Concrete, reinforcement, and formwork requirements are specified with concrete.

## **PART 2 - PRODUCTS**

### **2.1 GENERAL REQUIREMENTS FOR PANELBOARDS**

- A. Fabricate and test panelboards according to IEEE 344 to withstand seismic forces defined in Section 260548 "Vibration and Seismic Controls for Electrical Systems."

### **2.2 LIGHTING AND APPLIANCE BRANCH-CIRCUIT PANELBOARDS**

- A. Basis-of-Design Product: Subject to compliance with requirements match existing
- B. Panelboards: NEMA PB 1, lighting and appliance branch-circuit type.
- C. Mains: Refer to drawings.
- D. Branch Overcurrent Protective Devices: Plug-in or bolt-on circuit breakers, replaceable without disturbing adjacent units.
- E. Doors: Concealed hinges; secured with flush latch with tumbler lock; keyed alike.

### **2.3 DISCONNECTING AND OVERCURRENT PROTECTIVE DEVICES**

- A. Molded-Case Circuit Breaker (MCCB): Comply with UL 489, with interrupting capacity to meet available fault currents.
  - 1. Thermal-Magnetic Circuit Breakers: Inverse time-current element for low-level overloads, and instantaneous magnetic trip element for short circuits.
  - 2. Adjustable Instantaneous-Trip Circuit Breakers: Magnetic trip element with front-mounted, field-adjustable trip setting.
  - 3. Electronic trip circuit breakers with rms sensing; field-replaceable rating plug or field-replicable electronic trip; and the following field-adjustable settings:
    - a. Instantaneous trip.
    - b. Long- and short-time pickup levels.
    - c. Long- and short-time time adjustments.
    - d. Ground-fault pickup level, time delay, and  $I^2 t$  response.
  - 4. GFCI Circuit Breakers: Single- and two-pole configurations with Class A ground-fault protection (6-mA trip).
  - 5. Ground-Fault Equipment Protection (GFEP) Circuit Breakers: Class B ground-fault protection (30-mA trip).
  - 6. Arc-Fault Circuit Interrupter (AFCI) Circuit Breakers: Comply with UL 1699; 120/240-V, single-pole configuration.

7. Molded-Case Circuit-Breaker (MCCB) Features and Accessories:
  - a. Standard frame sizes, trip ratings, and number of poles.
  - b. Lugs: Mechanical style, suitable for number, size, trip ratings, and conductor materials.
  - c. Application Listing: Appropriate for application; Type SWD for switching fluorescent lighting loads; Type HID for feeding fluorescent and high-intensity discharge (HID) lighting circuits.
  - d. Ground-Fault Protection: Integrally mounted relay and trip unit with adjustable pickup and time-delay settings, push-to-test feature, and ground-fault indicator.
  - e. Communication Capability: Circuit-breaker-mounted communication module with functions and features compatible with power monitoring and control system specified in Section 260913 "Electrical Power Monitoring and Control."
  - f. Shunt Trip: 120-V trip coil energized from separate circuit, set to trip at 75 percent of rated voltage.
  - g. Auxiliary Contacts: One SPDT switch with "a" and "b" contacts; "a" contacts mimic circuit-breaker contacts and "b" contacts operate in reverse of circuit-breaker contacts.
  - h. Multipole units enclosed in a single housing or factory assembled to operate as a single unit.
  - i. Handle Padlocking Device: Fixed attachment, for locking circuit-breaker handle in on or off position.
  - j. Handle Clamp: Loose attachment, for holding circuit-breaker handle in on position.

## **2.4 ACCESSORY COMPONENTS AND FEATURES**

- A. Accessory Set: Include tools and miscellaneous items required for overcurrent protective device test, inspection, maintenance, and operation.
- B. Portable Test Set: For testing functions of solid-state trip devices without removing from panelboard. Include relay and meter test plugs suitable for testing panelboard meters and switchboard class relays.

## **PART 3 - EXECUTION**

### **3.1 CIRCUIT BREAKER APPLICATION**

- A. Install the following types of circuit breakers within distribution type panelboards as follows:
  1. Thermal-Magnetic: OCPDs under 200A.
  2. Electronic Trip Unit: OCPDs 200A and larger and for all elevators.
  3. Type HACR (Heating, Air Conditioning and Refrigeration): OCPDs serving motor feeder and branch circuits requiring HACR devices.
  4. Type GFEP 30 mA (Ground-Fault): OCPDs serving electric heating cable systems, sump pumps, and laboratory bench power branch circuits.

5. Shunt-Trip: OCPDs serving electric devices under kitchen hood and elevator shutdown control.
- B. Install the following types of circuit breakers within lighting and appliance and electronic-grade type panelboards as follows:
1. Thermal-Magnetic: OCPDs under 400A.
  2. Electronic Trip Unit: OCPDs 400A and larger and for all elevators.
  3. Type SWD (Switching Duty): OCPDs serving lighting branch circuits without local switches.
  4. Type HACR (Heating, Air Conditioning and Refrigeration): OCPDs serving motor feeder and branch circuits requiring HACR devices.
  5. Type HID (High Intensity Discharge): OCPDs serving HID luminaire branch circuits.
  6. Type HM (High Magnetic): OCPDs serving corridor receptacle branch circuits. Provide a minimum of three in each 208Y/120V panel.
  7. Type AF (Arc-Fault): OCPDs serving dwelling unit bedroom lighting and power branch circuits.
  8. Type GF 5 mA (Ground-Fault): OCPDs serving receptacles, except as listed below, or where GF receptacles are utilized.
  9. Type GFEP 30 mA (Ground-Fault): OCPDs serving electric heating cable systems, sump pumps, and laboratory bench power branch circuits.
  10. Shunt-Trip: OCPDs serving electric devices under kitchen hood and elevator shutdown control.
  11. GF breakers for all circuits serving devices within 6 ft. of sinks, except where GF receptacles are utilized.

### **3.2 EXAMINATION**

- A. Receive, inspect, handle, and store panelboards according to NEMA PB 1.1.
- B. Examine panelboards before installation. Reject panelboards that are damaged or rusted or have been subjected to water saturation.
- C. Examine elements and surfaces to receive panelboards for compliance with installation tolerances and other conditions affecting performance of the Work.
- D. Proceed with installation only after unsatisfactory conditions have been corrected.

### **3.3 INSTALLATION**

- A. Install panelboards and accessories according to NEMA PB 1.1.
- B. Comply with mounting and anchoring requirements specified in Section 260548 "Vibration and Seismic Controls for Electrical Systems."
- C. Mount panelboard so that centerline of top device is no higher than 79 inches above finished floor.

- D. Mount panelboard cabinet plumb and rigid without distortion of box. Mount recessed panelboards with fronts uniformly flush with wall finish and mating with back box.
- E. Install overcurrent protective devices and controllers not already factory installed.
  - 1. Set field-adjustable, circuit-breaker trip ranges.
- F. Install filler plates in unused spaces.
- G. Arrange conductors in gutters into groups and bundle and wrap with wire ties after completing load balancing.
- H. Comply with NECA 1.

### **3.4 IDENTIFICATION**

- A. Identify field-installed conductors, interconnecting wiring, and components; provide warning signs complying with Section 260553 "Identification for Electrical Systems."
- B. Create a directory to indicate installed circuit loads after balancing panelboard loads; incorporate Owner's final room designations. Obtain approval before installing. Use a computer or typewriter to create directory; handwritten directories are not acceptable. Identify circuit breakers for future use as SPARE. Turn all spare circuit breakers to the OFF position.
- C. Panelboard Nameplates: Label each panelboard with a nameplate complying with requirements for identification specified in Section 260553 "Identification for Electrical Systems."
- D. Device Nameplates: Label each branch circuit device in distribution panelboards with a nameplate complying with requirements for identification specified in Section 260553 "Identification for Electrical Systems."

### **3.5 FIELD QUALITY CONTROL**

- A. Perform tests and inspections.
  - 1. Manufacturer's Field Service: Engage a factory-authorized service representative to inspect components, assemblies, and equipment installations, including connections, and to assist in testing.
- B. Acceptance Testing Preparation:
  - 1. Test insulation resistance for each panelboard bus, component, connecting supply, feeder, and control circuit.
  - 2. Test continuity of each circuit.



- C. Tests and Inspections:
1. Perform each visual and mechanical inspection and electrical test stated in NETA Acceptance Testing Specification. Certify compliance with test parameters.
  2. Correct malfunctioning units on-site, where possible, and retest to demonstrate compliance; otherwise, replace with new units and retest.
  3. Perform the following infrared scan tests and inspections and prepare reports:
    - a. Initial Infrared Scanning: After Substantial Completion, but not more than 60 days after Final Acceptance, perform an infrared scan of each panelboard. Remove front panels so joints and connections are accessible to portable scanner.
    - b. Instruments and Equipment:
      - 1) Use an infrared scanning device designed to measure temperature or to detect significant deviations from normal values. Provide calibration record for device.
- D. Panelboards will be considered defective if they do not pass tests and inspections.
- E. Prepare test and inspection reports, including a certified report that identifies panelboards included and that describes scanning results. Include temperature differentials for each panel, notation of deficiencies detected, remedial action taken, and observations after remedial action.

### 3.6 ADJUSTING

- A. Adjust moving parts and operable component to function smoothly, and lubricate as recommended by manufacturer.
- B. Set field-adjustable circuit-breaker trip ranges.
- C. Load Balancing: After Substantial Completion, but not more than 60 days after Final Acceptance, measure load balancing and make circuit changes.
1. Measure as directed during period of normal system loading.
  2. Perform load-balancing circuit changes outside normal occupancy/working schedule of the facility and at time directed. Avoid disrupting critical 24-hour services such as fax machines and on-line data processing, computing, transmitting, and receiving equipment.
  3. After circuit changes, recheck loads during normal load period. Record all load readings before and after changes and submit test records.
  4. Tolerance: Difference exceeding 20 percent between phase loads, within a panelboard, is not acceptable. Rebalance and recheck as necessary to meet this minimum requirement.

**END OF SECTION 262416**

03/07/2017

**SECTION 262726 - WIRING DEVICES**

**PART 1 - GENERAL**

**1.1 RELATED DOCUMENTS**

- A. Drawings and general provisions of the Contract, including General and Supplementary Conditions and Division 01 Specification Sections, apply to this Section.

**1.2 SUMMARY**

- A. Section Includes:
  - 1. Straight-blade convenience, hospital-grade, isolated-ground, and tamper-resistant receptacles.
  - 2. USB charger devices.
  - 3. GFCI receptacles.
  - 4. Toggle switches.
  - 5. Wall-box dimmers.
  - 6. Wall plates.
  - 7. Poke-through assemblies.
  - 8. Prefabricated multioutlet assemblies.

**1.3 DEFINITIONS**

- A. Abbreviations of Manufacturers' Names:
  - 1. Cooper: Cooper Wiring Devices; Division of Cooper Industries, Inc.
  - 2. Hubbell: Hubbell Incorporated: Wiring Devices-Kellems.
  - 3. Leviton: Leviton Mfg. Company, Inc.
  - 4. Pass & Seymour: Pass& Seymour/Legrand.
- B. BAS: Building automation system.
- C. EMI: Electromagnetic interference.
- D. GFCI: Ground-fault circuit interrupter.
- E. Pigtail: Short lead used to connect a device to a branch-circuit conductor.
- F. RFI: Radio-frequency interference.
- G. SPD: Surge protective device.
- H. UTP: Unshielded twisted pair.

**1.4 ADMINISTRATIVE REQUIREMENTS**

- A. Coordination:
  - 1. Receptacles for Owner-Furnished Equipment: Match plug configurations.
  - 2. Cord and Plug Sets: Match equipment requirements.

**1.5 ACTION SUBMITTALS**

- A. Product Data: For each type of product.
- B. Shop Drawings: List of legends and description of materials and process used for premarking wall plates.
- C. Samples: One for each type of device and wall plate specified, in each color specified.

**1.6 INFORMATIONAL SUBMITTALS**

- A. Field quality-control reports.

**1.7 CLOSEOUT SUBMITTALS**

- A. Operation and Maintenance Data: For wiring devices to include in all manufacturers' packing-label warnings and instruction manuals that include labeling conditions.

**PART 2 - PRODUCTS**

**2.1 GENERAL WIRING-DEVICE REQUIREMENTS**

- A. Wiring Devices, Components, and Accessories: Listed and labeled as defined in NFPA 70, by a qualified testing agency, and marked for intended location and application.
- B. Comply with NFPA 70.
- C. Devices that are manufactured for use with modular plug-in connectors may be substituted under the following conditions:
  - 1. Connectors shall comply with UL 2459 and shall be made with stranding building wire.
  - 2. Devices shall comply with the requirements in this Section.
- D. Devices for Owner-Furnished Equipment:
  - 1. Receptacles: Match plug and NEMA configurations.
  - 2. Cord and Plug Sets: Match equipment requirements.
- E. Source Limitations: Obtain each type of wiring device and associated wall plate from single source from single manufacturer.

**2.2 STRAIGHT-BLADE RECEPTACLES**

- A. Duplex Convenience Receptacles: 125 V, 20 A; comply with NEMA WD 1, NEMA WD 6 Configuration 5-20R, UL 498, and FS W-C-596.
1. Basis-of-Design Product: Subject to compliance with requirements, provide product indicated on Drawings or comparable product by one of the following:
    - a. Cooper - 5351 (single); CR5352 (duplex).
    - b. Hubbell - 5361 (single); 5362 (duplex).
    - c. Leviton - 5361 (single); 5362 (duplex).
    - d. Pass & Seymour - 5361 (single); 5362 (duplex).
- B. Isolated-Ground, Duplex Convenience Receptacles: 125 V, 20 A; comply with NEMA WD 1, NEMA WD 6 Configuration 5-20R, UL 498, and FS W-C-596.
1. Basis-of-Design Product: Subject to compliance with requirements, provide product indicated on Drawings or comparable product by one of the following:
    - a. Cooper - IG5362RN.
    - b. Hubbell - IG5362.
    - c. Leviton - 5362-IG.
    - d. Pass & Seymour - IG5362.
  2. Description: Straight blade; equipment grounding contacts shall be connected only to the green grounding screw terminal of the device and with inherent electrical isolation from mounting strap. Isolation shall be integral to receptacle construction and not dependent on removable parts.

**2.3 USB CHARGER DEVICES**

- A. Tamper-Resistant, USB Charger Receptacles: 125 V, 20 A; comply with NEMA WD 1, NEMA WD 6 Configuration 5-20R, UL 498, UL 1310, and FS W-C-596.
1. Basis-of-Design Product: Subject to compliance with requirements, provide product indicated on Drawings or comparable product by one of the following:
    - a. Cooper - TR7756.
    - b. Hubbell - USB20X2.
    - c. Leviton - T5832.
    - d. Pass & Seymour - TR5362USB.
  2. Description: Single-piece, rivetless, nickel-plated, all-brass grounding system. Nickel-plated, brass mounting strap.
  3. USB Receptacles: Dual, Type A.
  4. Line Voltage Receptacles: Dual, two pole, three wire, and self-grounding.

**2.4 GF RECEPTACLES**

## A. General Description:

1. 125 V, 20 A, straight blade, self-testing feed-through type.
2. Comply with NEMA WD 1, NEMA WD 6 Configuration 5-20R, UL 498, UL 943 Class A, and FS W-C-596.
3. Include indicator light that shows when the GFCI has malfunctioned and no longer provides proper GFCI protection.

## B. Duplex GF Convenience Receptacles:

1. Basis-of-Design Product: Subject to compliance with requirements, provide product indicated on Drawings or comparable product by one of the following:
  - a. Cooper - SGF20.
  - b. Hubbell - GFRST20.
  - c. Leviton - GFTR2.
  - d. Pass & Seymour - 2097.

**2.5 CONTROLLED RECEPTACLES**

## A. Single, Recessed Duplex Receptacles with Controlled Receptacle Marking, 125V, 20A: Comply with NEMA WD 1, NEMA WD 6 Configuration 5-20R, UL 498, and FS W-C-596.

1. Basis-of-Design Product: Subject to compliance with requirements, provide comparable product by one of the following:
  - a. Leviton - 16352-1P (split-controlled), 1652-2P (dual-controlled).
  - b. Pass & Seymour - 26352CH (split-controlled), 26352CD (dual-controlled).
2. Description:
  - a. Duplexed receptacle with engraved NEMA approved controlled receptacle marking and engraved label stating "controlled" receptacle.
  - b. Marked outlet to be controlled by automatic means which removes power from the outlet.

**2.6 TOGGLE SWITCHES**

## A. Comply with NEMA WD 1, UL 20, and FS W-S-896.

## B. Switches, 120/277 V, 20 A:

## 1. Single Pole:

a. Basis-of-Design Product: Subject to compliance with requirements, provide product indicated on Drawings or comparable product by one of the following:

- 1) Cooper - AH1221.
- 2) Hubbell - 1221.
- 3) Leviton - 1221-S.
- 4) Pass & Seymour - CS20AC.

## 2. Three Way:

a. Basis-of-Design Product: Subject to compliance with requirements, provide product indicated on Drawings or comparable product by one of the following:

- 1) Cooper - AH1223.
- 2) Hubbell - 1223.
- 3) Leviton - 1223-S.
- 4) Pass & Seymour - CSB20AC.

## C. Pilot-Light Switches: 120/277 V, 20 A.

1. Basis-of-Design Product: Subject to compliance with requirements, provide product indicated on Drawings or comparable product by one of the following:

- a. Cooper - 1221PL for 120-V and 277-V.
- b. Hubbell - HBL1201PL for 120-V and 277-V.
- c. Leviton - 1221-LH1.
- d. Pass & Seymour - PS20AC1RPL for 120-V, PS20AC1RPL7 for 277-V.

2. Description: Single pole, with LED-lighted handle, illuminated when switch is off.

## D. Single-Pole, Double-Throw, Momentary-Contact, Center-off Switches: 120/277 V, 20 A; for use with mechanically held lighting contactors.

1. Basis-of-Design Product: Subject to compliance with requirements, provide product indicated on Drawings or comparable product by one of the following:

- a. Cooper Wiring Devices, Inc.; Division of Cooper Industries, Inc. - 1995.
- b. Hubbell Incorporated; Wiring Device-Kellems - HBL1557.
- c. Leviton Manufacturing Co., Inc. - 1257.
- d. Pass & Seymour/Legrand (Pass & Seymour) - 1251.

**2.7 WALL-BOX DIMMERS**

- A. LED Lamp Dimmer Switches: Modular; compatible with LED lamps; trim potentiometer to adjust low-end dimming; capable of consistent dimming with low end not greater than 20 percent of full brightness.

**2.8 WALL PLATES**

- A. Single and combination types shall match corresponding wiring devices.
1. Plate-Securing Screws: Metal with head color to match plate finish.
  2. Material for Finished Spaces: 0.035-inch- thick, satin-finished, Type 302 stainless steel.
  3. Material for Unfinished Spaces: Smooth, high-impact thermoplastic.
  4. Material for Damp Locations: Thermoplastic with spring-loaded lift cover, and listed and labeled for use in wet and damp locations.
- B. Wet-Location, Weatherproof Cover Plates: NEMA 250, complying with Type 3R, weather-resistant thermoplastic with lockable cover.

**2.9 PREFABRICATED MULTIOUTLET ASSEMBLIES**

- A. Basis-of-Design Product: Subject to compliance with requirements, provide product indicated on Drawings or comparable product by one of the following:
1. Hubbell Incorporated; Wiring Device-Kellems.
  2. Wiremold / Legrand.
  3. Mono-Systems.
- B. Description:
1. Two-piece surface metal raceway, with factory-wired multioutlet harness.
  2. Components shall be products from single manufacturer designed for use as a complete, matching assembly of raceways and receptacles.
- C. Raceway Material: Aluminum finish.
- D. Multioutlet Harness:
1. Receptacles: 15-A, 125-V, NEMA WD 6 Configuration 5-15R receptacles complying with NEMA WD 1, UL 498, and FS W-C-596.
  2. Receptacle Spacing: 12 inches.
  3. Wiring: No. 12 AWG solid, Type THHN copper, two circuit, connecting alternating receptacles.

**2.10 HANDICAPPED CALL-FOR-AID DEVICES**

- A. Basis-of-Design Product: Subject to compliance with requirements, provide Tektone or comparable product by one of the following:
  - 1. Edwards.
  - 2. Tektone.
  
- B. Description:
  - 1. Horn/Strobe: Unit contains an audible horn signal which generates an 82 dBA sound pressure level at 10 ft. and high intensity strobe. Current draws 175 mA at 24-V, 50/60 Hz. Strobe output shall be 50 cd on-axis.
    - a. Edwards No. 6536-G5.
    - b. Tektone No. LI123B.
  
  - 2. Transformer: To power the horn/strobe is equipped with grounding wire. Transformer primary voltage shall be 120-V ac and secondary shall be 24-V ac, 20 VA.
    - a. Edwards No. 592.
    - b. Tektone No. SS106.
  
  - 3. Pull Cord Station: Provide emergency call activation and reset. Device to have stainless steel face plate with Double Pole Single Throw (DPST) switch.
    - a. Edwards No. 6537.
    - b. Tektone No. SF118/4C.

**2.11 FINISHES**

- A. Device Color:
  - 1. Wiring Devices Connected to Normal Power System: As selected by Architect unless otherwise indicated or required by NFPA 70 or device listing.
  
- B. Wall Plate Color: For plastic covers, match device color.

**PART 3 - EXECUTION**

**3.1 INSTALLATION**

- A. Comply with NECA 1, including mounting heights listed in that standard, unless otherwise indicated.



## B. Coordination with Other Trades:

1. Protect installed devices and their boxes. Do not place wall finish materials over device boxes and do not cut holes for boxes with routers that are guided by riding against outside of boxes.
2. Keep outlet boxes free of plaster, drywall joint compound, mortar, cement, concrete, dust, paint, and other material that may contaminate the raceway system, conductors, and cables.
3. Install device boxes in brick or block walls so that the cover plate does not cross a joint unless the joint is troweled flush with the face of the wall.
4. Install wiring devices after all wall preparation, including painting, is complete.

## C. Conductors:

1. Do not strip insulation from conductors until right before they are spliced or terminated on devices.
2. Strip insulation evenly around the conductor using tools designed for the purpose. Avoid scoring or nicking of solid wire or cutting strands from stranded wire.
3. The length of free conductors at outlets for devices shall meet provisions of NFPA 70, Article 300, without pigtails.
4. Existing Conductors:
  - a. Cut back and pigtail, or replace all damaged conductors.
  - b. Straighten conductors that remain and remove corrosion and foreign matter.
  - c. Pigtailing existing conductors is permitted, provided the outlet box is large enough.

## D. Device Installation:

1. Replace devices that have been in temporary use during construction and that were installed before building finishing operations were complete.
2. Keep each wiring device in its package or otherwise protected until it is time to connect conductors.
3. Do not remove surface protection, such as plastic film and smudge covers, until the last possible moment.
4. Connect devices to branch circuits using pigtails that are not less than 6 inches in length.
5. When there is a choice, use side wiring with binding-head screw terminals. Wrap solid conductor tightly clockwise, two-thirds to three-fourths of the way around terminal screw.
6. Use a torque screwdriver when a torque is recommended or required by manufacturer.
7. When conductors larger than No. 12 AWG are installed on 15- or 20-A circuits, splice No. 12 AWG pigtails for device connections.
8. Tighten unused terminal screws on the device.
9. When mounting into metal boxes, remove the fiber or plastic washers used to hold device-mounting screws in yokes, allowing metal-to-metal contact.
10. Horn/Strobe for handicapped call-for-aid shall be located in a single gang 2" x 4" box located above the door.

11. Transformer for handicapped call-for-aid shall be installed in a NEMA 1 rated enclosure and remote mounted above the nearest accessible ceiling. Provide 120-volt power from local receptacle circuit unless otherwise noted.
  12. Pull cord station for handicapped call-for-aid shall be located in a single gang 2" x 4" box. Locate device 48 inches above finished floor at toilet location and 60 inches above finished floor at outside of shower stall. Provide cord to extend to within 6 inches of the finished floor. Pull cord device to be flush-mounted to wall.
- E. Receptacle Orientation:
1. Install ground pin of vertically mounted receptacles up, and on horizontally mounted receptacles to the left.
- F. Device Plates: Do not use oversized or extra-deep plates. Repair wall finishes and remount outlet boxes when standard device plates do not fit flush or do not cover rough wall opening.
- G. Dimmers:
1. Install dimmers within terms of their listing.
  2. Verify that dimmers used for fan-speed control are listed for that application.
  3. Install unshared neutral conductors on line and load side of dimmers according to manufacturers' device listing conditions in the written instructions.
- H. Arrangement of Devices: Unless otherwise indicated, mount flush, with long dimension vertical and with grounding terminal of receptacles on top. Group adjacent switches under single, multigang wall plates.
- I. Adjust locations of floor service outlets and service poles to suit arrangement of partitions and furnishings.

### **3.2 IDENTIFICATION**

- A. Comply with Section 260553 "Identification for Electrical Systems."
- B. Identify each receptacle with panelboard identification and circuit number. Use hot, stamped, or engraved machine printing with black-filled lettering on face of plate, and durable wire markers or tags inside outlet boxes.

### **3.3 FIELD QUALITY CONTROL**

- A. Test Instruments: Use instruments that comply with UL 1436.
- B. Test Instrument for Convenience Receptacles: Digital wiring analyzer with digital readout or illuminated digital-display indicators of measurement.

- C. Perform the following tests and inspections:
1. In healthcare facilities, prepare reports that comply with recommendations in NFPA 99.
  2. Test Instruments: Use instruments that comply with UL 1436.
  3. Test Instrument for Convenience Receptacles: Digital wiring analyzer with digital readout or illuminated digital-display indicators of measurement.
- D. Tests for Convenience Receptacles:
1. Line Voltage: Acceptable range is 105 to 132 V.
  2. Percent Voltage Drop under 15-A Load: A value of 6 percent or higher is unacceptable.
  3. Ground Impedance: Values of up to 2 ohms are acceptable.
  4. GFCI Trip: Test for tripping values specified in UL 1436 and UL 943.
  5. Using the test plug, verify that the device and its outlet box are securely mounted.
  6. Tests shall be diagnostic, indicating damaged conductors, high resistance at the circuit breaker, poor connections, inadequate fault current path, defective devices, or similar problems. Correct circuit conditions, remove malfunctioning units and replace with new ones, and retest as specified above.
- E. Wiring device will be considered defective if it does not pass tests and inspections.
- F. Prepare test and inspection reports.

**END OF SECTION 262726**

03/07/2017

**SECTION 262913 - ENCLOSED CONTROLLERS**

**PART 1 - GENERAL**

**1.1 RELATED DOCUMENTS**

- A. Drawings and general provisions of the Contract, including General and Supplementary Conditions and Division 01 Specification Sections, apply to this Section.

**1.2 SUMMARY**

- A. Section includes the following enclosed controllers rated 600 V and less:
  - 1. Full-voltage manual.
  - 2. Full-voltage magnetic.
- B. Related Section:
  - 1. Section 262923 "Variable-Frequency Motor Controllers" for general-purpose, ac, adjustable-frequency, pulse-width-modulated controllers for use on variable torque loads in ranges up to 200 hp.

**1.3 DEFINITIONS**

- A. CPT: Control power transformer.
- B. MCCB: Molded-case circuit breaker.
- C. MCP: Motor circuit protector.
- D. N.C.: Normally closed.
- E. N.O.: Normally open.
- F. OCPD: Overcurrent protective device.
- G. SCR: Silicon-controlled rectifier.

**1.4 PERFORMANCE REQUIREMENTS**

- A. Seismic Performance: Enclosed controllers shall withstand the effects of earthquake motions determined according to ASCE/SEI 7.
  - 1. The term "withstand" means "the unit will remain in place without separation of any parts from the device when subjected to the seismic forces specified.

**1.5 ACTION SUBMITTALS**

- A. Product Data: For each type of enclosed controller. Include manufacturer's technical data on features, performance, electrical characteristics, ratings, and enclosure types and finishes.
- B. Shop Drawings: For each enclosed controller. Include dimensioned plans, elevations, sections, details, and required clearances and service spaces around controller enclosures.
  - 1. Show tabulations of the following:
    - a. Each installed unit's type and details.
    - b. Factory-installed devices.
    - c. Nameplate legends.
    - d. Short-circuit current rating of integrated unit.
  - 2. Wiring Diagrams: For power, signal, and control wiring.

**1.6 INFORMATIONAL SUBMITTALS**

- A. Seismic Qualification Certificates: For enclosed controllers, accessories, and components, from manufacturer.
  - 1. Basis for Certification: Indicate whether withstand certification is based on actual test of assembled components or on calculation.
  - 2. Dimensioned Outline Drawings of Equipment Unit: Identify center of gravity and locate and describe mounting and anchorage provisions.
  - 3. Detailed description of equipment anchorage devices on which the certification is based and their installation requirements.
- B. Field quality-control reports.
- C. Load-Current and Overload-Relay Heater List: Compile after motors have been installed, and arrange to demonstrate that selection of heaters suits actual motor nameplate full-load currents.
- D. Load-Current and List of Settings of Adjustable Overload Relays: Compile after motors have been installed, and arrange to demonstrate that switch settings for motor running overload protection suit actual motors to be protected.

**1.7 CLOSEOUT SUBMITTALS**

- A. Operation and Maintenance Data: For enclosed controllers to include in emergency, operation, and maintenance manuals. In addition to items specified in Section 017823 "Operation and Maintenance Data," include the following:
  - 1. Routine maintenance requirements for enclosed controllers and installed components.
  - 2. Manufacturer's written instructions for testing and adjusting circuit breaker and MCP trip settings.

3. Manufacturer's written instructions for setting field-adjustable overload relays.
4. Manufacturer's written instructions for testing, adjusting, and reprogramming reduced-voltage solid-state controllers.

### **1.8 MATERIALS MAINTENANCE SUBMITTALS**

- A. Furnish extra materials that match products installed and that are packaged with protective covering for storage and identified with labels describing contents.
  1. Fuses for Fused Switches: Equal to 10 percent of quantity installed for each size and type, but no fewer than three of each size and type.
  2. Control Power Fuses: Equal to 10 percent of quantity installed for each size and type, but no fewer than two of each size and type.
  3. Indicating Lights: Two of each type and color installed.
  4. Auxiliary Contacts: Furnish one spare(s) for each size and type of magnetic controller installed.
  5. Power Contacts: Furnish three spares for each size and type of magnetic contactor installed.

### **1.9 QUALITY ASSURANCE**

- A. Testing Agency Qualifications: Member company of NETA or an NRTL.
  1. Testing Agency's Field Supervisor: Currently certified by NETA to supervise on-site testing.
- B. Electrical Components, Devices, and Accessories: Listed and labeled as defined in NFPA 70, by a qualified testing agency, and marked for intended location and application.
- C. Comply with NFPA 70.
- D. IEEE Compliance: Fabricate and test enclosed controllers according to IEEE 344 to withstand seismic forces defined in Section 260548 "Vibration and Seismic Controls for Electrical Systems."

### **1.10 DELIVERY, STORAGE, AND HANDLING**

- A. Store enclosed controllers indoors in clean, dry space with uniform temperature to prevent condensation. Protect enclosed controllers from exposure to dirt, fumes, water, corrosive substances, and physical damage.

### **1.11 PROJECT CONDITIONS**

- A. Environmental Limitations: Rate equipment for continuous operation under the following conditions unless otherwise indicated:
  1. Ambient Temperature: Not less than minus 22 deg F and not exceeding 104 deg F.

2. Altitude: Not exceeding 6600 feet.
- B. Interruption of Existing Electrical Systems: Do not interrupt electrical systems in facilities occupied by Owner or others unless permitted under the following conditions and then only after arranging to provide temporary electrical service according to requirements indicated:
1. Notify Architect and Owner no fewer than two days in advance of proposed interruption of electrical systems.
  2. Indicate method of providing temporary utilities.
  3. Do not proceed with interruption of electrical systems without Architect's and Owner's written permission.
  4. Comply with NFPA 70E.

### **1.12 COORDINATION**

- A. Coordinate layout and installation of enclosed controllers with other construction including conduit, piping, equipment, and adjacent surfaces. Maintain required workspace clearances and required clearances for equipment access doors and panels.
- B. Coordinate sizes and locations of concrete bases with actual equipment provided. Cast anchor-bolt inserts into bases. Concrete, reinforcement, and formwork requirements are specified with concrete.
- C. Coordinate installation of roof curbs, equipment supports, and roof penetrations.

## **PART 2 - PRODUCTS**

### **2.1 FULL-VOLTAGE CONTROLLERS**

- A. General Requirements for Full-Voltage Controllers: Comply with NEMA ICS 2, general purpose, Class A.
- B. Motor-Starting Switches: "Quick-make, quick-break" toggle or push-button action; marked to show whether unit is off or on.
1. Basis-of-Design Product: Subject to compliance with requirements, provide Eaton or comparable product by one of the following:
    - a. Eaton Electrical Inc.; Cutler-Hammer Business Unit.
    - b. General Electric Company; GE Consumer & Industrial - Electrical Distribution.
    - c. Rockwell Automation, Inc.; Allen-Bradley brand.
    - d. Siemens Energy & Automation, Inc.
    - e. Square D; a brand of Schneider Electric.
  2. Configuration: Nonreversing.
  3. Surface mounting.
  4. Red pilot light.

- C. Fractional Horsepower Manual Controllers: "Quick-make, quick-break" toggle or push-button action; marked to show whether unit is off, on, or tripped.
1. Basis-of-Design Product: Subject to compliance with requirements, provide Eaton or comparable product by one of the following:
    - a. Eaton Electrical Inc.; Cutler-Hammer Business Unit.
    - b. General Electric Company; GE Consumer & Industrial - Electrical Distribution.
    - c. Rockwell Automation, Inc.; Allen-Bradley brand.
    - d. Siemens Energy & Automation, Inc.
    - e. Square D; a brand of Schneider Electric.
  2. Configuration: Nonreversing.
  3. Overload Relays: Inverse-time-current characteristics; NEMA ICS 2, Class 10 tripping characteristics; heaters matched to nameplate full-load current of actual protected motor; external reset push button; bimetallic type.
  4. Surface mounting.
  5. Red pilot light.
- D. Magnetic Controllers: Full voltage, across the line, electrically held.
1. Basis-of-Design Product: Subject to compliance with requirements, provide Eaton or comparable product by one of the following:
    - a. Eaton Electrical Inc.; Cutler-Hammer Business Unit.
    - b. General Electric Company; GE Consumer & Industrial - Electrical Distribution.
    - c. Rockwell Automation, Inc.; Allen-Bradley brand.
    - d. Siemens Energy & Automation, Inc.
    - e. Square D; a brand of Schneider Electric.
  2. Configuration: Nonreversing.
  3. Contactor Coils: Pressure-encapsulated type with coil transient suppressors.
    - a. Operating Voltage: Depending on contactor NEMA size and line-voltage rating, manufacturer's standard matching control power or line voltage.
  4. Power Contacts: Totally enclosed, double-break, silver-cadmium oxide; assembled to allow inspection and replacement without disturbing line or load wiring.
  5. Control Circuits: 24-V ac; obtained from integral CPT, with primary and secondary fuses, with CPT of sufficient capacity to operate integral devices and remotely located pilot, indicating, and control devices.
    - a. CPT Spare Capacity: 100 VA.
  6. Solid-State Overload Relay:
    - a. Switch or dial selectable for motor running overload protection.



- b. Sensors in each phase.
- c. Class 10/20 selectable tripping characteristic selected to protect motor against voltage and current unbalance and single phasing.

## 2.2 ENCLOSURES

- A. Enclosed Controllers: NEMA ICS 6, to comply with environmental conditions at installed location.
  - 1. Dry and Clean Indoor Locations: Type 1.
  - 2. Outdoor Locations: Type 3R.
  - 3. Other Wet or Damp Indoor Locations: Type 4.
  - 4. Indoor Locations Subject to Dust, Falling Dirt, and Dripping Noncorrosive Liquids: Type 12.

## 2.3 ACCESSORIES

- A. General Requirements for Control Circuit and Pilot Devices: NEMA ICS 5; factory installed in controller enclosure cover unless otherwise indicated.
  - 1. Push Buttons, Pilot Lights, and Selector Switches: Heavy-duty, oiltight type.
    - a. Push Buttons: Covered types; momentary as indicated.
    - b. Pilot Lights: LED types; colors as indicated; push to test.
    - c. Selector Switches: Rotary type.
  - 2. Elapsed Time Meters: Heavy duty with digital readout in hours; resettable.
- B. Two sets of reversible N.C./N.O. auxiliary contact(s).
- C. Control Relays: Auxiliary and adjustable solid-state time-delay relays.
- D. Phase-Failure, Phase-Reversal, and Undervoltage and Overvoltage Relays: Solid-state sensing circuit with isolated output contacts for hard-wired connections. Provide adjustable undervoltage, overvoltage, and time-delay settings.
- E. Sun shields installed on fronts, sides, and tops of enclosures installed outdoors and subject to direct and extended sun exposure.
- F. Cover gaskets for Type 1 enclosures.

## PART 3 - EXECUTION

### 3.1 EXAMINATION

- A. Examine areas and surfaces to receive enclosed controllers, with Installer present, for compliance with requirements and other conditions affecting performance of the Work.

- B. Examine enclosed controllers before installation. Reject enclosed controllers that are wet, moisture damaged, or mold damaged.
- C. Proceed with installation only after unsatisfactory conditions have been corrected.

### **3.2 APPLICATIONS**

- A. The contractor who furnishes equipment requiring a motor controller shall provide motor controllers for all motors with all specified options and accessories.
- B. Select features of each enclosed control to coordinate with ratings and characteristics of supply circuit and motor.
- C. Select horsepower rating of controllers to suit motor controlled.
- D. Provide each enclosed controller with an H.O.A. switch, pilot lights, pushbuttons, elapsed time meter, integral transformer and fusing.
- E. Location: Locate enclosed controller within sight of motor controller in readily accessible location, unless otherwise required. When controller is not located within sight of the motor, provide an additional maintenance enclosed switch at the motor.

### **3.3 INSTALLATION**

- A. Wall-Mounted Controllers: Install enclosed controllers on walls with tops at uniform height unless otherwise indicated, and by bolting units to wall or mounting on lightweight structural-steel channels bolted to wall. For controllers not at walls, provide freestanding racks complying with Section 260529 "Hangers and Supports for Electrical Systems."
- B. Seismic Bracing: Comply with requirements specified in Section 260548 "Vibration and Seismic Controls for Electrical Systems."
- C. Temporary Lifting Provisions: Remove temporary lifting eyes, channels, and brackets and temporary blocking of moving parts from enclosures and components.
- D. Install fuses in each fusible-switch enclosed controller.
- E. Install fuses in control circuits if not factory installed. Comply with requirements in Section 262813 "Fuses."
- F. Install, connect, and fuse thermal-protector monitoring relays furnished with motor-driven equipment.
- G. Comply with NECA 1.

**3.4 IDENTIFICATION**

- A. Identify enclosed controllers, components, and control wiring. Comply with requirements for identification specified in Section 260553 "Identification for Electrical Systems."
1. Identify field-installed conductors, interconnecting wiring, and components; provide warning signs.
  2. Label each enclosure with engraved nameplate.
  3. Label each enclosure-mounted control and pilot device.

**3.5 CONTROL WIRING INSTALLATION**

- A. Install wiring between enclosed controllers and remote devices. Comply with requirements in Section 260523 "Control-Voltage Electrical Power Cables."
- B. Bundle, train, and support wiring in enclosures.
- C. Connect selector switches and other automatic-control selection devices where applicable.
1. Connect selector switches to bypass only those manual- and automatic-control devices that have no safety functions when switch is in manual-control position.
  2. Connect selector switches with enclosed-controller circuit in both manual and automatic positions for safety-type control devices such as low- and high-pressure cutouts, high-temperature cutouts, and motor overload protectors.

**3.6 FIELD QUALITY CONTROL**

- A. Perform tests and inspections.
1. Manufacturer's Field Service: Engage a factory-authorized service representative to inspect components, assemblies, and equipment installations, including connections, and to assist in testing.
- B. Acceptance Testing Preparation:
1. Test insulation resistance for each enclosed controller, component, connecting supply, feeder, and control circuit.
  2. Test continuity of each circuit.
- C. Tests and Inspections:
1. Inspect controllers, wiring, components, connections, and equipment installation. Test and adjust controllers, components, and equipment.
  2. Test insulation resistance for each enclosed-controller element, component, connecting motor supply, feeder, and control circuits.
  3. Test continuity of each circuit.

4. Verify that voltages at controller locations are within plus or minus 10 percent of motor nameplate rated voltages. If outside this range for any motor, notify Architect and Owner before starting the motor(s).
  5. Test each motor for proper phase rotation.
  6. Perform each electrical test and visual and mechanical inspection stated in NETA Acceptance Testing Specification. Certify compliance with test parameters.
  7. Correct malfunctioning units on-site, where possible, and retest to demonstrate compliance; otherwise, replace with new units and retest.
  8. Perform the following infrared (thermographic) scan tests and inspections and prepare reports:
    - a. Initial Infrared Scanning: After Substantial Completion, but not more than 60 days after Final Acceptance, perform an infrared scan of each multi-pole enclosed controller. Remove front panels so joints and connections are accessible to portable scanner.
    - b. Follow-up Infrared Scanning: Perform an additional follow-up infrared scan of each multi-pole enclosed controller 11 months after date of Substantial Completion.
    - c. Instruments and Equipment: Use an infrared scanning device designed to measure temperature or to detect significant deviations from normal values. Provide calibration record for device.
  9. Test and adjust controls, remote monitoring, and safeties. Replace damaged and malfunctioning controls and equipment.
- D. Enclosed controllers will be considered defective if they do not pass tests and inspections.
- E. Prepare test and inspection reports including a certified report that identifies enclosed controllers and that describes scanning results. Include notation of deficiencies detected, remedial action taken, and observations after remedial action.

### **3.7 ADJUSTING**

- A. Set field-adjustable switches, auxiliary relays, time-delay relays, timers, and overload-relay pickup and trip ranges.
- B. Adjust overload-relay heaters or settings if power factor correction capacitors are connected to the load side of the overload relays.
- C. Set field-adjustable switches and program microprocessors for required start and stop sequences in reduced-voltage solid-state controllers.
- D. Set field-adjustable circuit-breaker trip ranges.

**3.8**     **PROTECTION**

- A.    Replace controllers whose interiors have been exposed to water or other liquids prior to Substantial Completion.

**3.9**     **DEMONSTRATION**

- A.    Train Owner's maintenance personnel to adjust, operate, and maintain enclosed controllers.

**END OF SECTION 262913**  
03/07/2017

**SECTION 265119 - LED INTERIOR LIGHTING**

**PART 1 - GENERAL**

**1.1 RELATED DOCUMENTS**

- A. Drawings and general provisions of the Contract, including General and Supplementary Conditions and Division 01 Specification Sections, apply to this Section.

**1.2 SUMMARY**

- A. Section includes the following types of LED luminaires:
  - 1. Materials.
  - 2. Finishes.
  - 3. Luminaire support.
- B. Related Requirements:
  - 1. Section 260923 "Lighting Control Devices" for automatic control of lighting, including time switches, photoelectric relays, occupancy sensors, and multipole lighting relays and contactors.

**1.3 DEFINITIONS**

- A. CCT: Correlated color temperature.
- B. CRI: Color Rendering Index.
- C. Fixture: See "Luminaire."
- D. IP: International Protection or Ingress Protection Rating.
- E. LED: Light-emitting diode.
- F. Lumen: Measured output of lamp and luminaire, or both.
- G. Luminaire: Complete lighting unit, including lamp, reflector, and housing.

**1.4 ACTION SUBMITTALS**

- A. Product Data: For each type of product.
  - 1. Arrange in order of luminaire designation.
  - 2. Include data on features, accessories, and finishes.
  - 3. Include physical description and dimensions of luminaires.
  - 4. Include emergency lighting units, including batteries and chargers.

5. Include life, output (lumens, CCT, and CRI), and energy efficiency data.
  6. Photometric data and adjustment factors based on laboratory tests IES LM-79 and IES LM-80.
    - a. Manufacturers' Certified Data: Photometric data certified by manufacturer's laboratory with a current accreditation under the National Voluntary Laboratory Accreditation Program for Energy Efficient Lighting Products.
    - b. Testing Agency Certified Data: For indicated luminaires, photometric data certified by a qualified independent testing agency. Photometric data for remaining luminaires shall be certified by manufacturer.
  7. Plans: Plans containing computer-generated point-by-point layouts in all spaces that interior luminaires submitted or substitutions are located.
- B. Shop Drawings: For nonstandard or custom luminaires.
1. Include plans, elevations, sections, and mounting and attachment details.
  2. Include details of luminaire assemblies. Indicate dimensions, weights, loads, required clearances, method of field assembly, components, and location and size of each field connection.
  3. Include diagrams for power, signal, and control wiring.
- C. Samples: For each luminaire and for each color and texture with standard factory-applied finish.
1. Each sample shall include the following:
    - a. Lamps and ballasts, installed.
    - b. Cords and plugs.
    - c. Pendant support system.
- D. Product Schedule: For luminaires and lamps. Use same designations indicated on Drawings.

## 1.5 **INFORMATIONAL SUBMITTALS**

- A. Coordination Drawings: Reflected ceiling plan(s) and other details, drawn to scale, on which the following items are shown and coordinated with each other, using input from installers of the items involved:
1. Luminaires.
  2. Suspended ceiling components.
  3. Partitions and millwork that penetrate the ceiling or extend to within 12 inches of the plane of the luminaires.
  4. Structural members to which equipment and or luminaires will be attached.
  5. Initial access modules for acoustical tile, including size and locations.
  6. Items penetrating finished ceiling, including the following:
    - a. Other luminaires.

- b. Air outlets and inlets.
  - c. Speakers.
  - d. Sprinklers.
  - e. Access panels.
  - f. Ceiling-mounted projectors.
- 7. Moldings.
  - 8. Architectural features.
- B. Qualification Data: For testing laboratory providing photometric data for luminaires.
  - C. Seismic Qualification Certificates: For luminaires, accessories, and components, from manufacturer.
    - 1. Basis for Certification: Indicate whether withstand certification is based on actual test of assembled components or on calculation.
    - 2. Dimensioned Outline Drawings of Equipment Unit: Identify center of gravity and locate and describe mounting and anchorage provisions.
  - D. Detailed description of equipment anchorage devices on which the certification is based and their installation requirements.
  - E. Product Certificates: For each type of luminaire.
  - F. Product Test Reports: For each luminaire, for tests performed by manufacturer and witnessed by a qualified testing agency.
  - G. Sample warranty.

**1.6 CLOSEOUT SUBMITTALS**

- A. Operation and Maintenance Data: For luminaires and lighting systems to include in operation and maintenance manuals.
  - 1. Provide a list of all lamp types used on Project; use ANSI and manufacturers' codes.

**1.7 MAINTENANCE MATERIAL SUBMITTALS**

- A. Furnish extra materials that match products installed and that are packaged with protective covering for storage and identified with labels describing contents.
  - 1. LED Boards: One for every 20 of each type. Furnish at least one board for each luminaire type.
  - 2. LED Drivers: One for every 20 of each type. Furnish at least one driver for each luminaire type.
  - 3. Diffusers and Lenses: One for every 100 of each type and rating installed. Furnish at least one of each type.



4. Globes and Guards: One for every 20 of each type and rating installed. Furnish at least one of each type.

### **1.8 QUALITY ASSURANCE**

- A. Luminaire Photometric Data Testing Laboratory Qualifications: Luminaire manufacturer's laboratory that is accredited under the NVLAP for Energy Efficient Lighting Products.
- B. Provide luminaires from a single manufacturer for each luminaire type.
- C. Each luminaire type shall be binned within a three-step MacAdam Ellipse to ensure color consistency among luminaires.
- D. Mockups: For interior luminaires in room or module mockups, complete with power and control connections.
  1. Obtain Architect's approval of luminaires in mockups before starting installations.
  2. Maintain mockups during construction in an undisturbed condition as a standard for judging the completed Work.
  3. Approval of mockups does not constitute approval of deviations from the Contract Documents contained in mockups unless Architect specifically approves such deviations in writing.
  4. Subject to compliance with requirements, approved mockups may become part of the completed Work if undisturbed at time of Substantial Completion.

### **1.9 DELIVERY, STORAGE, AND HANDLING**

- A. Protect finishes of exposed surfaces by applying a strippable, temporary protective covering before shipping.

### **1.10 COORDINATION**

- A. Coordinate layout and installation of luminaires and suspension system with other construction that penetrates ceilings or is supported by them, including HVAC equipment, fire-suppression system, and partition assemblies. Coordinate type of luminaire with ceiling type and insulation. Notify Engineer of conflicts prior to ordering fixtures via Coordination Drawings described in this Section.

### **1.11 WARRANTY**

- A. Warranty: Manufacturer and Installer agree to repair or replace components of luminaires that fail in materials or workmanship within specified warranty period.
- B. Warranty Period: Five years from date of Substantial Completion.

**PART 2 - PRODUCTS**

**2.1 MANUFACTURERS**

- A. Products: Subject to compliance with requirements below.
  - 1. Luminaires:
    - a. If only one manufacturer is listed in Luminaire Schedule, contractor must submit on this product.
    - b. If multiple manufacturers are listed in Luminaire Schedule, the first named manufacturer listed in the Luminaire Schedule is the basis of design, if the Electrical Contractor chooses to provide one of the listed acceptable equivalent manufacturers, the light fixture submittal in addition to proposed light fixtures shall include lighting calculations for interior areas to demonstrate equivalent fixture performance. Light fixture samples shall be provided at the request of the Architect and/or Engineer.
    - c. If one manufacturer is listed in Luminaire Schedule followed by the words "or equal," contractor may submit on any manufacturer with similar characteristics to those listed under description.
  - 2. LED Boards:
    - a. Cree.
    - b. Nichia.
    - c. Lumileds.
    - d. Samsung.

**2.2 PERFORMANCE REQUIREMENTS**

- A. Seismic Performance: Luminaires and lamps shall be labeled vibration and shock resistant.
  - 1. The term "withstand" means "the luminaire will remain in place without separation of any parts when subjected to the seismic forces specified and the luminaire will be fully operational during and after the seismic event."

**2.3 LUMINAIRE REQUIREMENTS**

- A. Electrical Components, Devices, and Accessories: Listed and labeled as defined in NFPA 70, by a qualified testing agency, and marked for intended location and application.
- B. Standards:
  - 1. ENERGY STAR certified.
  - 2. California Title 24 compliant.
  - 3. NRTL Compliance: Luminaires for hazardous locations shall be listed and labeled for indicated class and division of hazard by an NRTL.

4. FM Global Compliance: Luminaires for hazardous locations shall be listed and labeled for indicated class and division of hazard by FM Global.
  5. UL Listing: Listed for damp location.
  6. Recessed luminaires shall comply with NEMA LE 4.
  7. User Replaceable Lamps:
    - a. Bulb shape complying with ANSI C78.79.
- C. CRI of minimum 80. CCT of as shown on Luminaire Schedule..
- D. Rated lamp life of 50,000 hours to L70.
- E. Lamps Dimming Range: As indicated in Luminaire Schedule.
- F. Internal driver.
- G. Nominal Operating Voltage: As shown on Luminaire Schedule.
1. Lens Thickness: At least 0.125 inch minimum unless otherwise indicated.
- H. Mounting Provisions for Ceiling Trim: Mounting provisions and ceiling trim are not indicated on the specific luminaire type specification. Coordinate mounting provisions and ceiling trim in the field, prior to ordering of luminaires to match all ceiling types and installation configurations. Provide all necessary mounting hardware, hangers, rails, yokes, steams, chains, cables, etc.

#### **2.4 DRIVERS - GENERAL REQUIREMENTS**

- A. Description: Include the following features, unless otherwise indicated.
1. Rebate Program Compliance: All electronic drivers must be on the local utility company's list of approved ballasts.
  2. Voltage: Field verify all voltage requirements prior to releasing lighting package and provide driver voltages as required by circuiting on plans.
  3. Disconnecting Means: Code-approved disconnecting means within each luminaire.

#### **2.5 DRIVERS FOR LED BOARDS**

- A. Description: Electronic driver designed for applicable fixture(s) and load indicated by LED boards. Driver shall be designed for full light output with full range dimming.
1. Input Voltage Range: 120 to 277, +-10%.
  2. Input Frequency: 50 to 60 Hz.
  3. Power Factor: >90% at full load.
  4. THD: <20% at full load.
  5. Case temperature rated for -40 deg. C through +80 deg. C.
  6. Overheat protection, self-limited short-circuit protection and overload protected.

7. Primary fused.
8. Dimming Range: 100 to 10 percent of normal.
9. Compatibility: Certified manufacturer for use with specific dimming control system and lamp type indicated.
10. Control: Coordinate wiring from driver to control device to ensure that the driver, controller, and connecting wiring are compatible.

## **2.6 MATERIALS**

### **A. Metal Parts:**

1. Free of burrs and sharp corners and edges.
2. Sheet metal components shall be steel unless otherwise indicated.
3. Form and support to prevent warping and sagging.

### **B. Doors, Frames, and Other Internal Access: Smooth operating, free of light leakage under operating conditions, and designed to permit relamping without use of tools. Designed to prevent doors, frames, lenses, diffusers, and other components from falling accidentally during relamping and when secured in operating position.**

### **C. Diffusers and Globes:**

1. Acrylic Diffusers: One hundred percent virgin acrylic plastic, with high resistance to yellowing and other changes due to aging, exposure to heat, and UV radiation.
2. Glass: Annealed crystal glass unless otherwise indicated.
3. Lens Thickness: At least 0.125 inch minimum unless otherwise indicated.

### **D. Factory-Applied Labels: Comply with UL 1598. Include recommended lamps. Locate labels where they will be readily visible to service personnel, but not seen from normal viewing angles when lamps are in place.**

1. Label shall include the following lamp characteristics:
  - a. "USE ONLY" and include specific lamp type.
  - b. Lamp diameter, shape, size, wattage, and coating.
  - c. CCT and CRI for all luminaires.

## **2.7 METAL FINISHES**

### **A. Variations in finishes are unacceptable in the same piece. Variations in finishes of adjoining components are acceptable if they are within the range of approved Samples and if they can be and are assembled or installed to minimize contrast.**

## **2.8 LUMINAIRE SUPPORT**

### **A. Comply with requirements in Section 260529 "Hangers and Supports for Electrical Systems" for channel and angle iron supports and nonmetallic channel and angle supports.**

- B. Single-Stem Hangers: 1/2-inch steel tubing with swivel ball fittings and ceiling canopy. Finish same as luminaire.
- C. Wires: ASTM A 641/A 641 M, Class 3, soft temper, zinc-coated steel, 12 gage.
- D. Rod Hangers: 3/16-inch minimum diameter, cadmium-plated, threaded steel rod.
- E. Hook Hangers: Integrated assembly matched to luminaire, line voltage, and equipment with threaded attachment, cord, and locking-type plug.

### **PART 3 - EXECUTION**

#### **3.1 EXAMINATION**

- A. Examine substrates, areas, and conditions, with Installer present, for compliance with requirements for installation tolerances and other conditions affecting performance of the Work.
- B. Examine roughing-in for luminaire to verify actual locations of luminaire and electrical connections before luminaire installation. Proceed with installation only after unsatisfactory conditions have been corrected.

#### **3.2 TEMPORARY LIGHTING**

- A. If approved by the Architect, use selected permanent luminaires for temporary lighting. When construction is sufficiently complete, clean luminaires used for temporary lighting and install new lamps.

#### **3.3 INSTALLATION**

- A. Comply with NECA 1.
- B. Install luminaires level, plumb, and square with ceilings and walls unless otherwise indicated.
- C. Install lamps in each luminaire.
- D. Supports:
  - 1. Sized and rated for luminaire weight.
  - 2. Able to maintain luminaire position after cleaning and relamping.
  - 3. Provide support for luminaire without causing deflection of ceiling or wall.
  - 4. Luminaire mounting devices shall be capable of supporting a horizontal force of 100 percent of luminaire weight and vertical force of 400 percent of luminaire weight.
- E. Flush-Mounted Luminaire Support:
  - 1. Secured to outlet box.

2. Attached to ceiling structural members at four points equally spaced around circumference of luminaire.
  3. Trim ring flush with finished surface.
- F. Wall-Mounted Luminaire Support:
1. Attached per manufacturer recommendations.
  2. Do not attach luminaires directly to gypsum board.
- G. Suspended Luminaire Support:
1. Pendants and Rods: Where longer than 48 inches, brace to limit swinging.
  2. Stem-Mounted, Single-Unit Luminaires: Suspend with twin-stem hangers. Support with approved outlet box and accessories that hold stem and provide damping of luminaire oscillations. Support outlet box vertically to building structure using approved devices.
  3. Do not use ceiling grid as support for pendant luminaires. Connect support wires or rods to building structure.
  4. Pendant Stem-Mounted Fixtures: Connect luminaire body to building structure with aircraft cable run through the fixture stem.
- H. Ceiling-Grid-Mounted Luminaires:
1. Secure to any required outlet box.
  2. Secure luminaire to the luminaire opening using approved fasteners in a minimum of four locations, spaced near corners of luminaire.
  3. Use approved devices and support components to connect luminaire to ceiling grid and building structure in a minimum of four locations, spaced near corners of luminaire.
  4. Install ceiling support system rods or wires, independent of the ceiling suspension devices, for each fixture. Locate not more than 6 inches from luminaire corners.
  5. Support Clips: Fasten to luminaires and to ceiling grid members at or near each fixture corner with clips that are UL listed for the application.
  6. Fixtures of Sizes Less Than Ceiling Grid: Install as indicated on reflected ceiling plans or center in acoustical panel, and support fixtures independently with at least two 3/4-inch metal channels spanning and secured to ceiling tees.
- I. Comply with requirements in Section 260519 "Low-Voltage Electrical Power Conductors and Cables" for wiring connections.
- J. Remote Mounting of Drivers: Distance between the driver and fixture shall not exceed that recommended by driver manufacturer. Verify, with driver manufacturers, maximum distance between driver and luminaire.
- K. Luminaire Locations: Refer to architectural reflected ceiling plans, sections, elevations, and details for exact luminaire locations, mounting heights, and mounting arrangements.

**3.4 IDENTIFICATION**

- A. Identify system components, wiring, cabling, and terminals. Comply with requirements for identification specified in Section 260553 "Identification for Electrical Systems."

**3.5 FIELD QUALITY CONTROL**

- A. Perform the following tests and inspections:
  - 1. Operational Test: After installing luminaires, switches, and accessories, and after electrical circuitry has been energized, test units to confirm proper operation.
  - 2. Test for Emergency Lighting: Interrupt power supply to demonstrate proper operation. Verify transfer from normal power to battery power and retransfer to normal.
- B. Luminaire will be considered defective if it does not pass operation tests and inspections.
- C. Prepare test and inspection reports.

**3.6 STARTUP SERVICE**

- A. Comply with requirements for startup specified in Section 260943.16 "Addressable-Luminaire Lighting Controls."
- B. Comply with requirements for startup specified in Section 260943.23 "Relay-Based Lighting Controls."

**3.7 ADJUSTING**

- A. Luminaire Aiming: For adjustable luminaires, aim all luminaires per Engineer's direction.
- B. Occupancy Adjustments: When requested within 12 months of date of Substantial Completion, provide on-site assistance in adjusting the direction of aim of luminaires to suit occupied conditions. Make up to two visits to Project during other-than-normal hours for this purpose. Some of this work may be required during hours of darkness.
  - 1. During adjustment visits, inspect all luminaires. Replace lamps or luminaires that are defective.
  - 2. Parts and supplies shall be manufacturer's authorized replacement parts and supplies.
  - 3. Adjust the aim of luminaires in the presence of the Architect.

**END OF SECTION 265119**

03/07/2017

# STATE OF CONNECTICUT

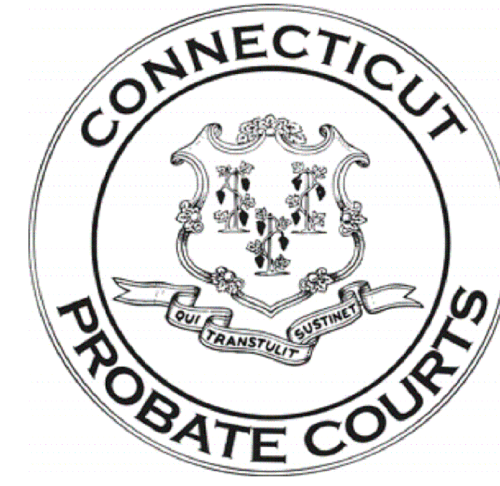

## INTERIOR RENOVATIONS AT THE OFFICE OF THE PROBATE COURT ADMINISTRATOR 186 NEWINGTON ROAD, WEST HARTFORD, CT 06107

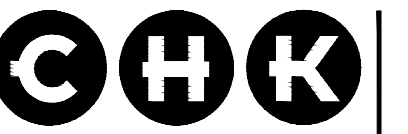

CLAPHESSEY  
HARRIS &  
KAISER, LLC

GREYSTONE COURT WEST  
573 HOPMEADOW STREET  
PO BOX 95  
SIMSBURY, CT 06070-0095  
860-651-3777  
Fax 860-651-7316  
chk@chkarch.com

Consultants

MEP ENGINEER  
BVH INTEGRATED SERVICES, INC.  
50 GRIFFIN ROAD SOUTH  
BLOOMFIELD, CT 06002  
860-286-9171

STRUCTURAL ENGINEER  
DESIGNS AND ENGINEERED SOLUTIONS, LLC  
114 SCOVILLE HILL ROAD  
HARTWINTON, CT 06791  
860-605-9120

ARCHITECTURE • INTERIOR DESIGN • FACILITIES PLANNING

STATE OF CONNECTICUT  
INTERIOR RENOVATIONS AT THE  
OFFICE OF THE PROBATE COURT ADMINISTRATOR  
186 NEWINGTON ROAD  
WEST HARTFORD, CT

COVER SHEET, DRAWING LIST, CODE DATA

Revisions

Date 3/10/2017  
Scale N/A  
Project Number 17001  
Drawn By JWZ

AG01

### SYMBOLS

**3** DETAIL  
SCALE: 1/4"=1'-0"

DETAIL NAME

SECTION CUT

DETAIL

ROOM NUMBER

DOOR NUMBER

WALL TAG

ELEVATION MARK

DIMENSION TO FACE OF AN OBJECT

DIMENSION TO CENTERLINE OF AN OBJECT

CASEWORK

### ABBREVIATIONS

AFF	ABOVE FINISH FLOOR	KIT	KITCHEN
ACT	ACOUSTIC TILE	KP	KICK PLATE
ALUM	ALUMINUM	KDF	KNOCK DOWN FRAME
ANG	ANGLE	LAM	LAMINATE
ANOD	ANODIZED	LAV	LAVATORY
ARCH	ARCHITECTURAL	LT	LIGHT
AUTO	AUTOMATIC	LP	LOW POINT
BATH	BATHROOM	MANUF	MANUFACTURER
BDRM	BEDROOM	MAS	MASONRY
BM	BEAM	MO	MASONRY OPENING
BFF	BELOW FINISH FLOOR	MAT	MATERIAL
BLK	BLOCKING	MAX	MAXIMUM
BD	BOARD	MECH	MECHANICAL
BOT	BOTTOM	MET	METAL
BRK	BRICK	MIN	MINIMUM
BF	BROOM FINISH	NOM	NOMINAL
BLD	BUILDING	NIC	NOT IN CONTRACT
BY	BY OTHERS	NTS	NOT TO SCALE
CAR	CARPET	NO/#	NUMBER
CAS	CASEMENT	O/C	ON CENTER
CLG	CEILING	OPNG	OPENING
CEM	CEMENT	OPP	OPPOSITE
CL	CENTER LINE	OP HD	OPPOSITE HAND
CT	CERAMIC TILE	OD	OUTSIDE DIMENSION
CH	CLEAR HOISTWAY	OH	OVERHEAD
CLOS	CLOSET	PTD	PAINTED
COL	COLUMN	PR	PAIR
CONC	CONCRETE	PAR	PARTITION
CMU	CONCRETE MASONRY UNIT	PER	PERIMETER
CJ	CONTROL JOINT	PLAS	PLASTIC
CONST	CONSTRUCTION	P. LAM	PLASTIC LAMINATE
CG	CORNER GUARD	PL	PLATE
DES	DESIGNATED	PLYW	PLYWOOD
DET	DETAIL	PLUMB	PLUMBING
DIA	DIAMETER	QT	QUARRY TILE
DIM	DIMENSION	RAD	RADIUS
DR	DOOR	RL	RAIN LEADER
DO	DOOR OPENING	REF	REFLECTOR
DH	DOUBLE HUNG	REQ'D	REQUIRED
DN	DOWN	RESIL	RESILIENT
DWG	DRAWING	REV	REVISION
DF	DRINKING FOUNTAIN	RS	RISERS
EA	EACH	RD	ROOF DRAIN
ELEC	ELECTRIC	RM	ROOM
ELEV	ELEVATOR	RUB	ROUGH OPENING
EMR	ELEVATOR MACHINE ROOM	RUB	RUBBER
EPOX	EQUAL	SEC	SECOND
EQ	EQUIPMENT	SECT	SECTION
EQUIP	EQUIVALENT	SHT	SHEET
EXIST	EXISTING	SV	SHEET VINYL
EXP	EXPANSION	SHWR	SHOWER
EJ	EXPANSION JOINT	SIM	SIMILAR
EXT	EXTERIOR	SC	SOLID CORE
EW	ELECTRIC WATER COOLER	SQ	SQUARE
EW	EYE WASH	ST	STAIN
FO	FACE OF	STD	STANDARD
FIN	FINISH	STL	STEEL
FIR	FIRST	STOR	STORAGE
FF	FINISH FLOOR	STRUC	STRUCTURE
FC	FIRE CODE	SUSP	SUSPENDED
FE	FIRE EXTINGUISHER	SYS	SYSTEM
FLR	FLOOR	TEL	TELEPHONE
FD	FLOOR DRAIN	TH	THEREFORE
FT	FOOT/FEET	THK	THICK
FT'G	FOOTING	THRESH	THRESHOLD
FR	FRAME	TOIL	TOILET
FUR	FURRING	TOC	TOP OF CURB
GALV	GALVANIZED	TOP	TOP OF FOUNDATION
GA	GAUGE	TOS	TOP OF STEEL
GC	GENERAL CONTRACTOR	TOW	TOP OF WALL
GL	GLASS	TP	TYPICAL
GYP	GYPSUM	UNF	UNFINISHED
GW	GYPSUM WALL BOARD	VEN	VENEER
HD	HAND	VEST	VESTIBULE
H.C	HANDICAPPED	VERT	VERTICAL
H.CONC	HARDENED CONCRETE	VP	VIEW PANEL
HORM	HEAD ROOM	VCT	VINYL COMPOSITION TILE
HT	HEIGHT	VVC	VINYL WALL COVERING
HP	HIGH POINT	VOL	VOLUME
HLP	HOLLOW CORE	WC	WATER CLOSET
HM	HOLLOW METAL	WEL	WELDED FRAME
HR	HOUR	WGT	WEIGHT
HORIZ	HORIZONTAL	WMM	WELDED WIRE MESH
ID	INTERIOR DIMENSION	WIND	WINDOW
IN	INCH	W/	WITH
INSUL	INSULATION	W/I	WITHIN
INT	INTERIOR	W/O	WITHOUT
JAN	JANITOR		
JC	JANITOR CLOSET		
JT	JOINT		
JTS	JOINTS		

### CODE DATA

I. USE GROUP: (302.1) B - BUSINESS (NO CHANGE)

II. CONSTRUCTION CLASSIFICATION: (602.1) 5B (COMBUSTIBLE, UNPROTECTED)

III. HEIGHT AND AREA LIMITATIONS: (503.0 - 508.0)

A: Existing Building Area

Lower Level Area	1,562 SF (NO CHANGE)
Upper Level Area	3,502 SF (NO CHANGE)
Total:	5,164 SF (NO CHANGE)

B: Allowable Building Area: (TABLE 503) 9,000 SF

C: Existing Building Height: 2 stories (NO CHANGE)

D: Allowable Building Height: (TABLE 503) 2 stories

IV. FIRE RESISTANCE RATINGS OF STRUCTURAL ELEMENTS: (IBC TABLE 601)

A. Primary Structural Frame	0 hour
B. Bearing Walls	0 hour
Exterior	0 hour
Interior	0 hour
C. Nonbearing walls and partitions	0 hour
Exterior	0 hour
Interior	0 hour
D. Floor Construction (including supporting beams and joists)	0 hour
E. Roof Construction (including supporting beams and joists)	0 hour
F. Fire Wall & Party Wall (including structural members)	2 hour (Table 706.4)
G. Fire Barriers	2 hour (Table 707.3.10)
H. Shaft Enclosures	1 hour where connecting less than four stories (713.4)

V. INTERIOR FINISH REQUIREMENTS: (IBC TABLE 803.9)

A. Vertical Exits (stairs, ramps)	- Class A
B. Exit Access Corridors	- Class B
(incl. enclosure for exit access stairways and ramps)	
C. Rooms and Enclosed Spaces	- Class C

VI. OCCUPANCY LOAD: (IBC TABLE 1004.1.2)

Lower Level:	Business: 1,562 sf / 100 = 16 Occupants (NO CHANGE)
Upper Level:	Business: 3,502 sf / 100 = 37 Occupants (NO CHANGE)
Total:	53 Occupants (NO CHANGE)

VII. ALLOWABLE TRAVEL DISTANCES:

Common Path of Egress Travel (Table 1014.3) = Max. 75 ft. (without sprinkler system) Existing to Remain (NO CHANGE)

Exit Access Travel Distance (Table 1016.2) = Max. 200 ft. (without sprinkler system) Existing to Remain (NO CHANGE)

VIII. EGRESS WIDTH PER OCCUPANT (Table 1005.1)

DOORS, RAMPS AND CORRIDORS (.2" PER PERSON)	Existing Width to Remain (NO CHANGE)
DOORS: (32" clear min. per Sect 1008.1.1)	Existing Width to Remain (NO CHANGE)
CORRIDORS: (44" min. per Table 1018.2)	Existing Width to Remain (NO CHANGE)

### GENERAL NOTES

- DO NOT SCALE DRAWINGS. PLEASE USE DIMENSIONS. CONTACT ARCHITECT FOR CLARIFICATIONS NEEDED.
- THE GENERAL CONTRACTOR/CONSTRUCTION MANAGER IS TO FIELD VERIFY ALL DIMENSIONS AND CONDITIONS AND SHALL BE RESPONSIBLE FOR SAME.
- THESE DOCUMENTS ARE THE SOLE PROPERTY OF THE ARCHITECT AND SHALL NOT BE USED FOR CONSTRUCTION ON ANY OTHER SITE WITHOUT THE WRITTEN PERMISSION OF THE ARCHITECT.
- CONSTRUCTION DOCUMENTS ARE TO BE USED AS A COMPLETE SET. THE ARCHITECT SHALL NOT BE RESPONSIBLE FOR ERRORS OR MISINTERPRETATIONS RESULTING FROM THE USE OF AN INCOMPLETE SET OF DOCUMENTS. CONTRACT DOCUMENTS ARE COMPLEMENTARY AND WHAT IS REQUIRED BY ONE SHALL BE AS BINDING AS IF REQUIRED BY ALL.

**APPLICABLE CODES**

- 2016 Connecticut State Building Code
- 2012 International Building Code
- 2012 International Existing Building Code
- 2012 International Plumbing Code
- 2012 International Mechanical Code
- 2012 International Energy Conservation Code
- 2012 International Electrical Code (NFPA 70)
- 2014 National Electrical Code (NFPA 70)
- ICC/ANSI A117.1 - 2009 Accessible and Usable Buildings and Facilities
- 2016 Connecticut Fire Safety Code
- 2012 International Fire Code (New Construction, Renovations or Change of Use)
- 2012 NFPA 101, Life Safety Code (Existing Buildings/Occupancies)

### LIST OF DRAWINGS

**GENERAL:**

AG01 COVER SHEET, DRAWING LIST, CODE DATA

**ARCHITECTURAL:**

AD01 LOWER LEVEL AND UPPER LEVEL DEMOLITION PLANS

AD02 LOWER LEVEL AND UPPER LEVEL REFLECTED CEILING DEMOLITION PLANS

A101 LOWER LEVEL AND UPPER LEVEL FLOOR PLANS, STRUCTURAL DETAILS

A701 DOOR SCHEDULE AND DETAILS

A801 LOWER LEVEL AND UPPER LEVEL REFLECTED CEILING PLANS

A901 MILLWORK PLANS AND ELEVATIONS

A902 MILLWORK SECTIONS

AF101 LOWER LEVEL AND UPPER LEVEL FURNITURE PLANS

AF201 LOWER LEVEL AND UPPER LEVEL FINISH TREATMENT PLANS

**MEP:**

MEP001 MEP GENERAL NOTES AND ABBREVIATIONS

MEP002 MEP SYMBOL LIST

MEP003 MEP SCHEDULES

HD01 LOWER LEVEL AND UPPER LEVEL HVAC DEMOLITION PLANS

H101 LOWER LEVEL AND UPPER LEVEL HVAC PLANS

H201 HVAC DETAILS

ED01 LOWER LEVEL AND UPPER LEVEL ELECTRICAL DEMO PLANS

EL101 LOWER LEVEL AND UPPER LEVEL ELECTRICAL LIGHTING PLANS

EPS101 LOWER LEVEL AND UPPER LEVEL ELECTRICAL POWER AND SPECIAL SYSTEMS PLANS

E201 ELECTRICAL DETAILS

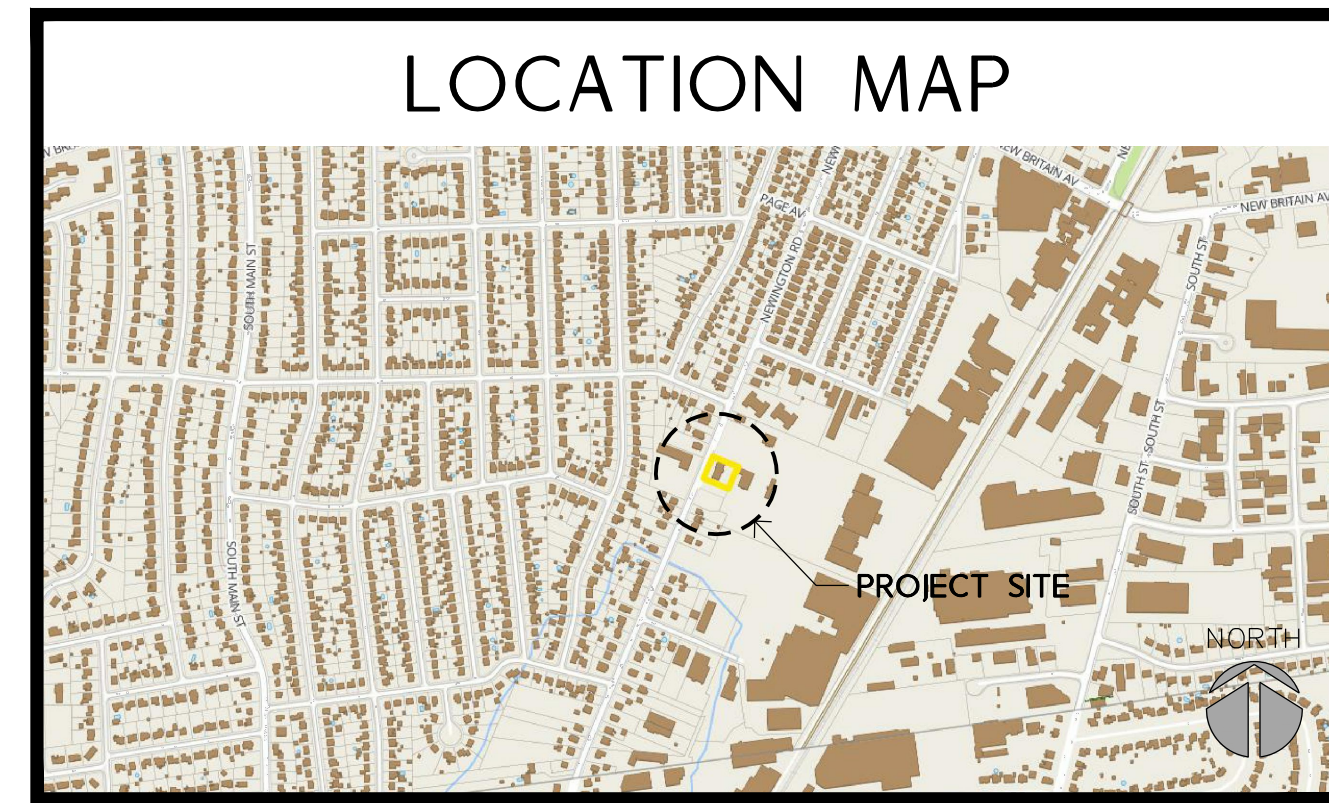





Consultants

MEP ENGINEER  
BVH INTEGRATED SERVICES, INC.  
50 GRIFFIN ROAD SOUTH  
BLOOMFIELD, CT 06002  
860-286-9171

STRUCTURAL ENGINEER  
DESIGNS AND ENGINEERED SOLUTIONS, LLC  
114 SCOVILLE HILL ROAD  
HARWINTON, CT 06791  
860-605-9120

**STATE OF CONNECTICUT  
INTERIOR RENOVATIONS AT THE  
OFFICE OF THE PROBATE COURT ADMINISTRATOR**

186 NEWINGTON ROAD  
WEST HARTFORD, CT

Revisions

Date 3/10/2017  
Scale 1/4" = 1'-0"  
Project Number 17001  
Drawn By JWZ

**LOWER LEVEL AND UPPER LEVEL REFLECTED CEILING DEMOLITION PLANS**

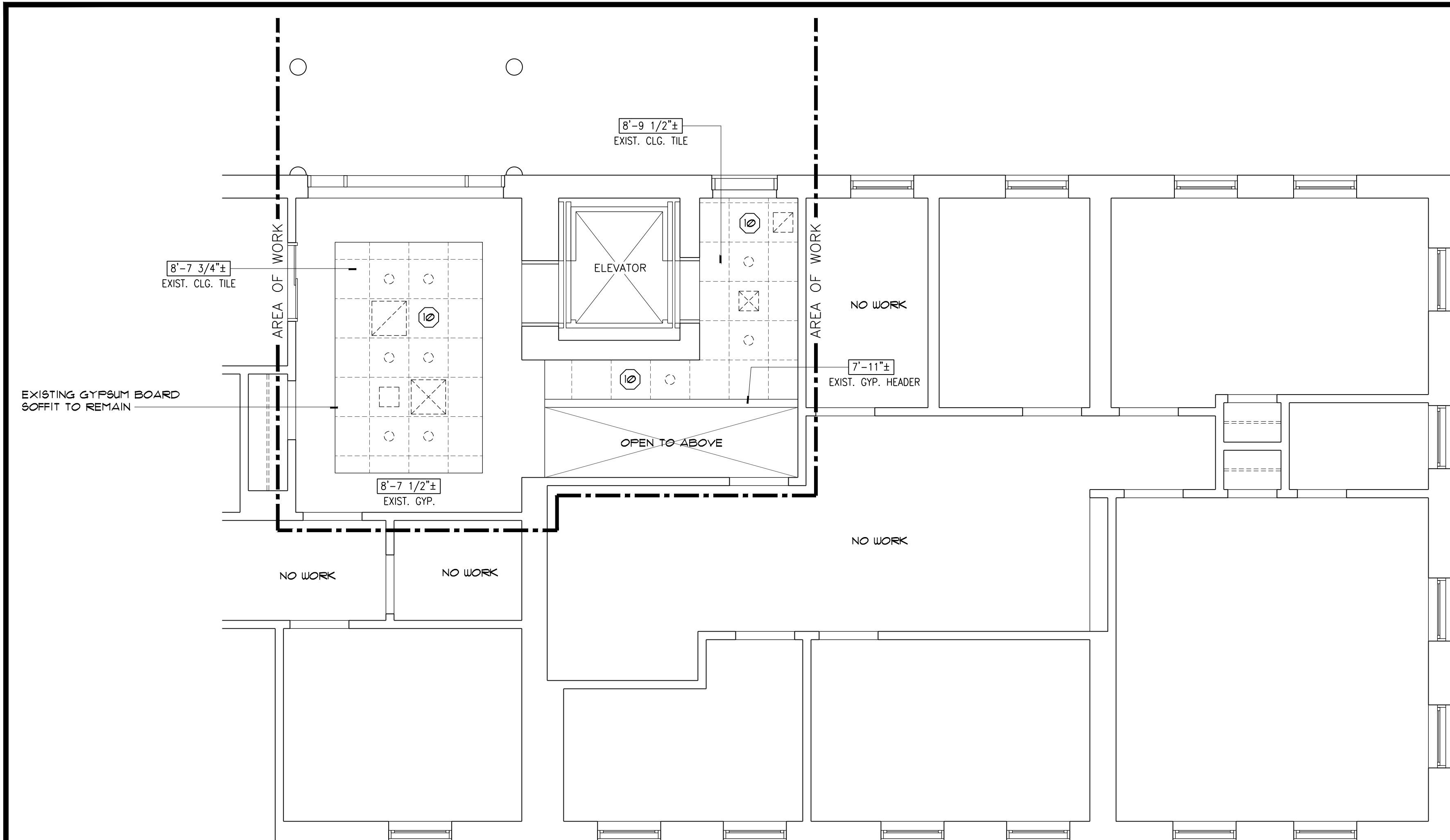

**1** UPPER LEVEL REFLECTED CEILING DEMOLITION PLAN  
SCALE: 1/4"=1'-0"

**REFLECTED CEILING DEMOLITION PLAN KEY NOTES**

- ⓐ REMOVE EXISTING CEILING TILES AND GRID
- ⓑ REMOVE EXISTING GYPSUM BOARD SOFFIT

**REFLECTED CEILING DEMOLITION PLAN LEGEND**

- EXISTING 2' X 2' CEILING GRID AND TILES TO BE REMOVED
- EXISTING 2' X 2' LIGHT FIXTURE TO BE REMOVED
- EXISTING 2' X 4' LIGHT FIXTURE TO BE REMOVED
- EXISTING RECESSED LIGHT FIXTURE TO BE REMOVED
- EXISTING DIFFUSER TO BE REMOVED, SEE MECHANICAL DRAWINGS
- EXISTING GYPSUM BOARD SOFFIT TO BE REMOVED, UNLESS OTHERWISE NOTED
- PROJECT LIMIT LINE

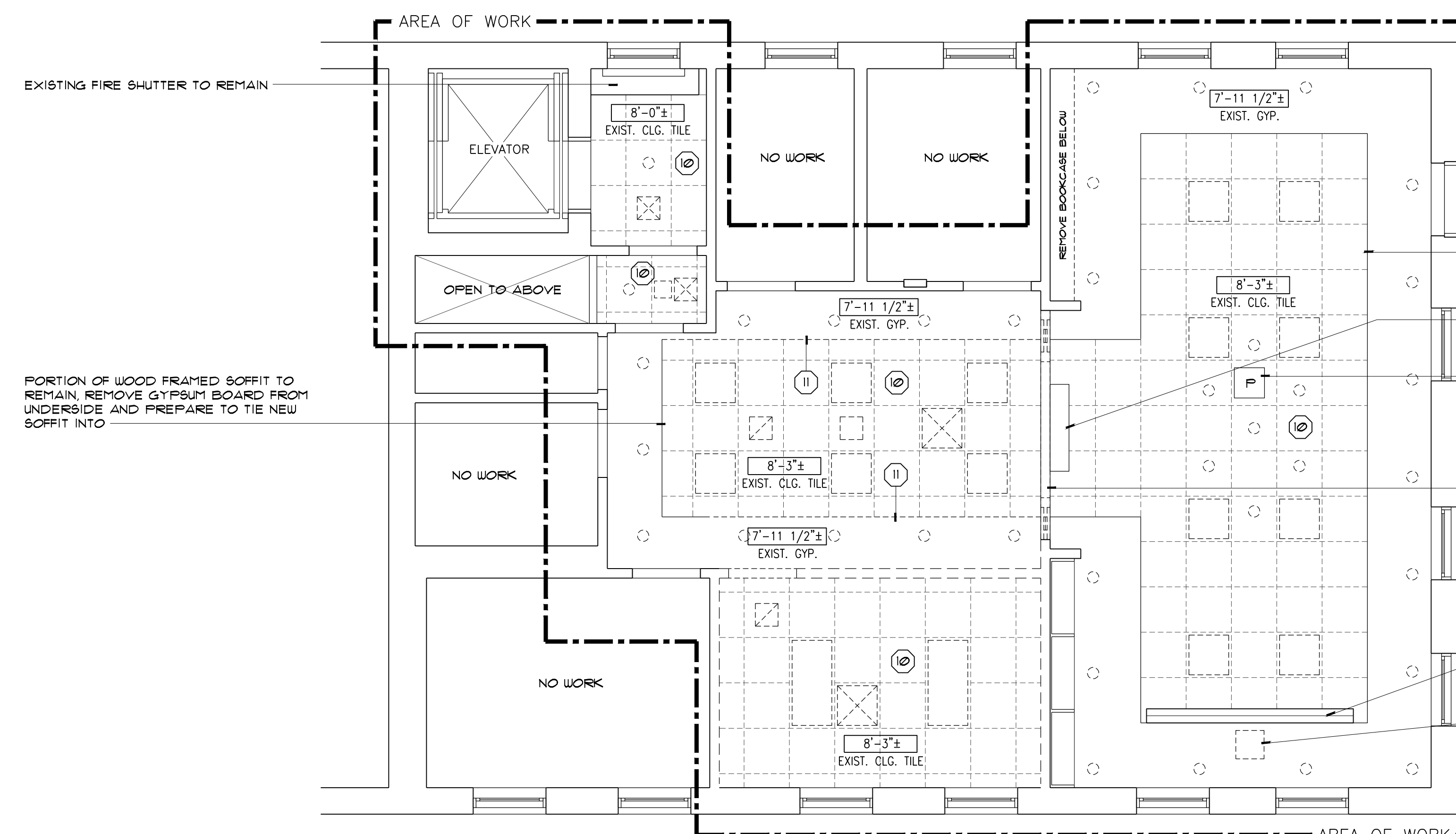

**2** LOWER LEVEL REFLECTED CEILING DEMOLITION PLAN  
SCALE: 1/4"=1'-0"



- EXISTING GYPSUM BOARD SOFFIT TO REMAIN
- EXISTING AIR CONDITIONING UNIT TO REMAIN
- EXISTING CEILING MOUNTED PROJECTOR TO REMAIN. PROTECT IN PLACE DURING DEMOLITION AND CONSTRUCTION. WRAP WITH HEAVY MIL PLASTIC COVER AND TAPE COMPLETELY TO PREVENT DUST INFILTRATION
- EXISTING HEADER TO REMAIN. REMOVE DOORS AND SIDELITES BELOW
- REMOVE EXISTING VENT AND RELATED EQUIPMENT

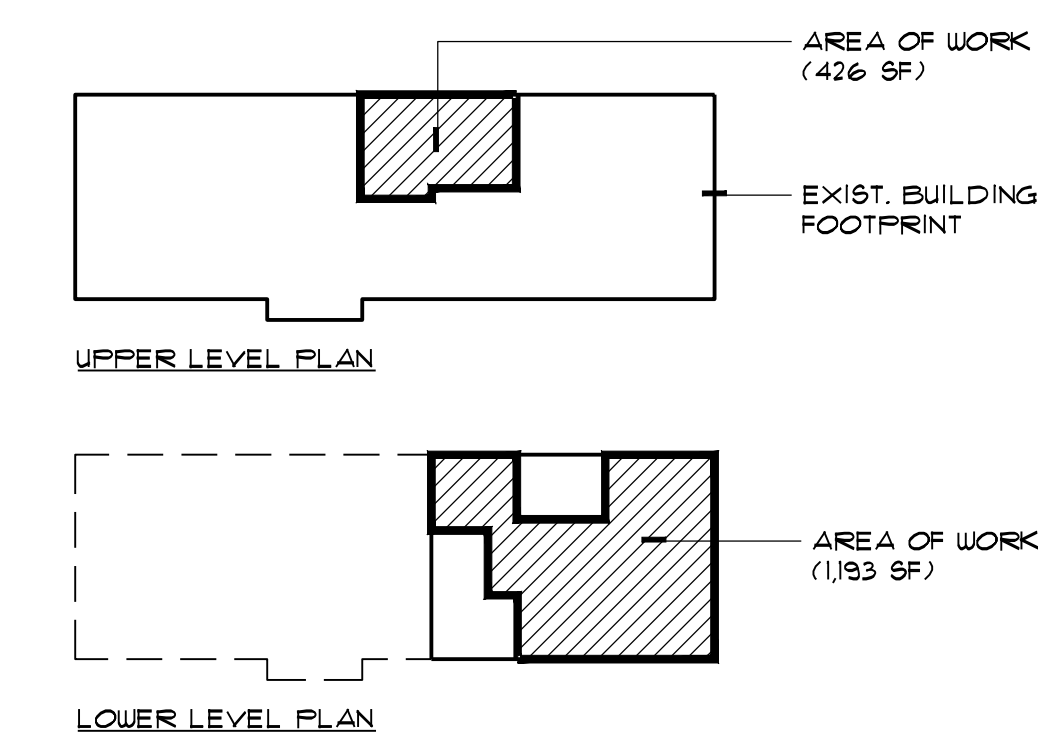

KEY PLANS



**Consultants**

MEP ENGINEER  
BVH INTEGRATED SERVICES, INC.  
50 GRIFFIN ROAD SOUTH  
BLOOMFIELD, CT 06002  
860-286-9171

STRUCTURAL ENGINEER  
DESIGNS AND ENGINEERED SOLUTIONS, LLC  
114 SCOVILLE HILL ROAD  
HARWINTON, CT 06791  
860-605-9120

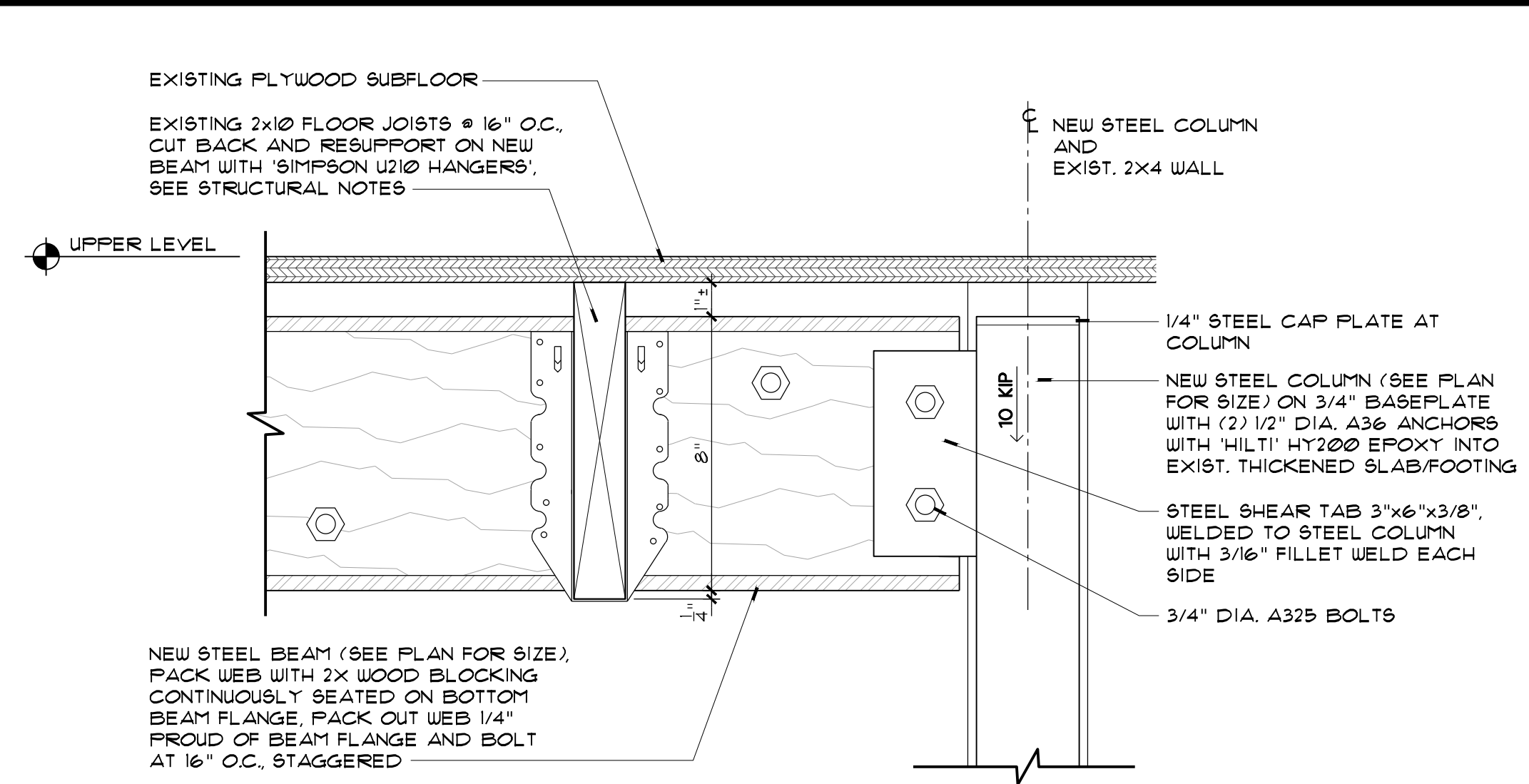
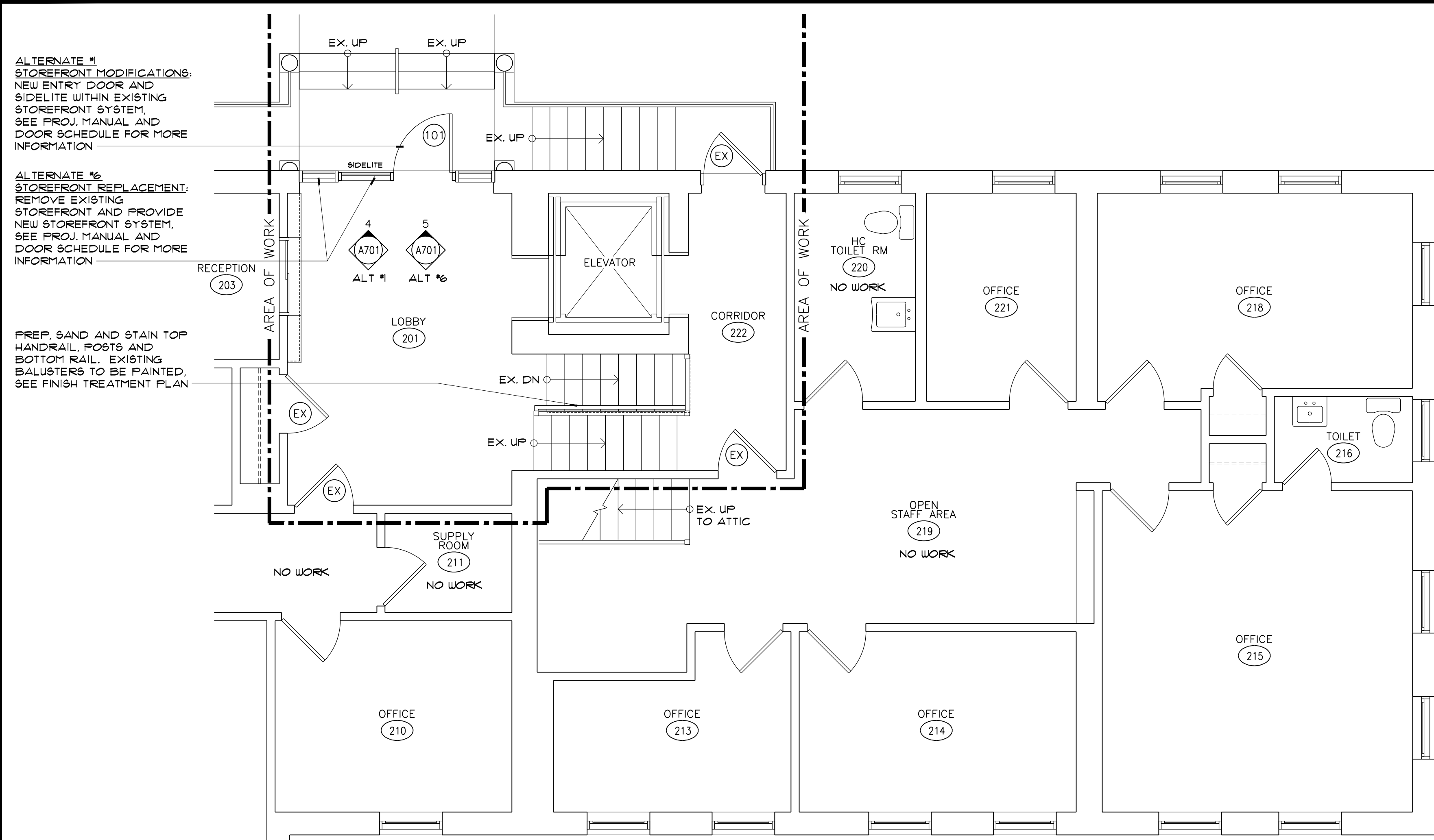

**STRUCTURAL NOTES**

- PRIOR TO EXISTING BEARING WALL REMOVAL (SEE DEMOLITION PLAN), EXISTING 2x10 FLOOR JOISTS TO BE SHORED AND SUPPORTED ON BOTH SIDES OF BEARING WALL. CUT BACK EXISTING JOISTS AS REQUIRED TO FIT NEW BEAM AS DETAILED.
- EXISTING FOOTING VERIFICATION IS REQUIRED PRIOR TO BEARING WALL REMOVAL. CONTRACTOR TO VERIFY PRESENCE OF 2" WIDE (MIN.) x 12" DEEP (MIN.) STRIP FOOTING / THICKENED SLAB BY AVAILABLE DOCUMENTATION OR BY DRILLING HOLES IN THE FLOOR AND PROBING.
- ALL WORK SHALL BE IN CONFORMANCE WITH THE AMERICAN INSTITUTE OF STEEL CONSTRUCTION (AISC) SPECIFICATIONS AND ITS CODE OF STANDARD PRACTICE.
- STEEL FABRICATOR SHALL BE AISC CATEGORY 2 CERTIFIED.
- MATERIAL SPECIFICATIONS:
  - W, WT SHAPES - ASTM A992 (50 KSI)
  - SQUARE AND RECTANGULAR HSS - ASTM A500 GRADE B (46 KSI)
  - L SHAPES, MISC PLATES, AND BARS - ASTM A36
  - BOLTS (STEEL TO STEEL) - ASTM A325
  - BOLTS (STEEL TO WOOD) - ASTM A307
  - ANCHOR RODS - ASTM F1554, GRADE 36
- ALL BOLTS AND NUTS SHALL BE CLEARLY MARKED AS REQUIRED BY AISC SPECIFICATIONS. CONNECTIONS MADE WITH UNMARKED BOLTS AND NUTS WILL BE REJECTED.
- ALL WELDING (SHOP AND FIELD) SHALL BE PERFORMED BY AWS CERTIFIED WELDERS IN CONFORMANCE WITH ALL APPLICABLE REQUIREMENTS. USE E-70XX WELDING ELECTRODES. WELDERS SHALL HAVE CURRENT EVIDENCE OF PASSING THE APPROPRIATE AWS QUALIFICATION TESTS. THE ENGINEER MAY REQUEST SUCH EVIDENCE AT ANY TIME DURING THE PROJECT.
- ALL CONNECTIONS, SPLICES, AND ERECTION PIECES SHALL BE DESIGNED BY THE FABRICATOR'S ENGINEER REGISTERED IN THE STATE OF CONNECTICUT. CALCULATIONS AND SHOP DRAWINGS SHALL BE SUBMITTED BEARING THE ENGINEER'S SEAL AND SIGNATURE.
- STRUCTURAL STEEL CONNECTIONS SHALL BE DESIGNED FOR THE LOADS INDICATED ON THE PLANS. IF NO LOAD IS INDICATED THE CONNECTION SHALL BE DESIGNED FOR 1/2 THE MEMBER'S UNIFORM LOAD CARRYING CAPACITY IN ACCORDANCE WITH THE AISC MANUAL OF STEEL CONSTRUCTION (ALLOWABLE STRESS DESIGN) AND THE RCSC SPECIFICATION FOR STRUCTURAL JOINTS USING ASTM A325 OR A490 BOLTS (ASD). CONNECTIONS SHALL BE SNUG TIGHT UNLESS NOTED OTHERWISE.
- NO CONNECTION SHALL CONSIST OF LESS THAN (2) 3/4" A325N BOLTS OR WELDS DEVELOPING LESS THAN 10 KIPS. MINIMUM WELD SHALL BE 3/16".
- ALL NEW STRUCTURAL STEEL SHALL BE GIVEN ONE COAT OF AN APPROVED SHOP PRIMER APPLIED IN ACCORDANCE WITH MANUFACTURER'S RECOMMENDATIONS UNLESS NOTED OTHERWISE. SURFACE PREPARATION OF STEEL PRIOR TO SHOP PAINTING SHALL CONFORM TO SSPC SP9.
- AFTER ERECTION IS COMPLETE, TOUCH UP ALL SHOP PRIMED COATS DAMAGED DURING TRANSPORTATION AND ERECTION AND PRIME ALL FIELD WELDS USING THE SAME PAINT USED FOR SHOP PRIMING.
- ALL EXPOSED STRUCTURAL STEEL AND CONNECTIONS SHALL BE HOT-DIPPED GALVANIZED, OR MAY BE PRIMED AND PAINTED WITH AN APPROVED EPOXY PAINT SYSTEM. TOUCH UP ALL CONNECTIONS AND DAMAGED SURFACES WITH THE SAME PAINT SYSTEM.
- GAS CUTTING TORCHES SHALL NOT BE USED TO CORRECT FABRICATION ERRORS WITHOUT THE APPROVAL OF THE STRUCTURAL ENGINEER.
- WHEN INSTALLING EXPANSION BOLTS OR ADHESIVE ANCHORS, THE CONTRACTOR SHALL TAKE MEASURES TO AVOID DRILLING OR CUTTING OF ANY EXISTING REINFORCING AND DESTRUCTION OF CONCRETE. HOLES SHALL BE WIRE BRUSHED AND BLOWN CLEAN A MINIMUM OF THREE TIMES PRIOR TO PLACING BOLTS OR ADHESIVE ANCHORS.
- SUBMIT SHOP DRAWINGS FOR REVIEW PRIOR TO FABRICATION.

**FLOOR PLAN LEGEND**

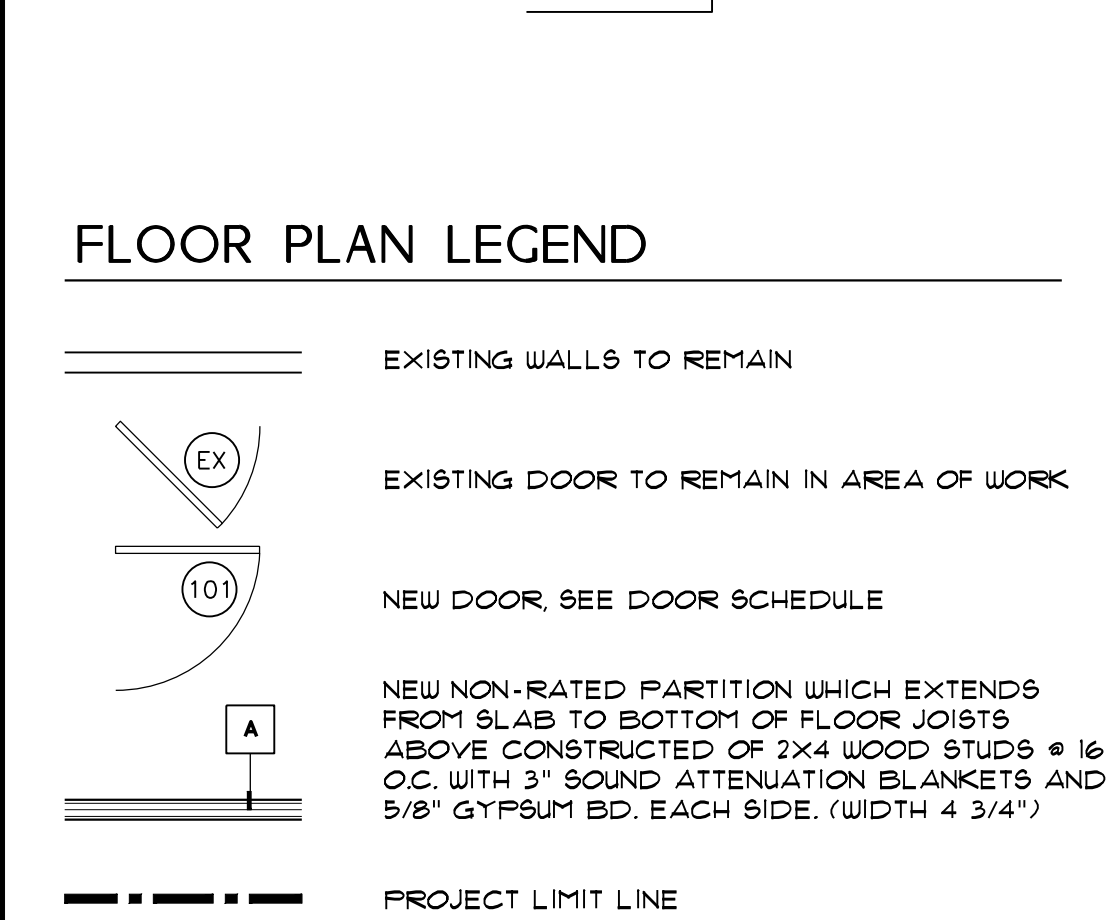

**FLOOR PLAN NOTES**

- ALL DIMENSIONS ARE TO THE FINISH FACE OF THE WALL (—) OR TO THE CENTERLINE OF OBJECT (—+).
- REPAIR ANY DAMAGED WALL AND FLOOR SURFACES, EITHER EXISTING OR AS A RESULT OF DEMOLITION/CONSTRUCTION ACTIVITIES, TO A CONDITION WHICH IS ACCEPTABLE TO THE OWNER AND WHICH PROVIDES A SUITABLE SUBSTRATE FOR NEW FINISHES.
- CONTRACTOR SHALL CLEAN ANY AREA OUTSIDE OF THE CONTRACT LIMIT THAT BECOMES DIRTY AS A RESULT OF CONSTRUCTION CLEANING SHALL BE DONE DAILY.
- PROTECT ALL EXISTING SURFACES SCHEDULED TO REMAIN DURING ALL CONSTRUCTION PHASES.
- THE CONTRACTOR SHALL LIMIT THEIR USE OF THE PREMISES TO THE WORK INDICATED. DO NOT UNREASONABLY ENCUMBER THE SITE WITH MATERIALS AND EQUIPMENT.
- THE WORK SHALL BE CONDUCTED IN A MANNER WHICH WILL PROVIDE THE LEAST POSSIBLE INTERFERENCE TO THE ACTIVITIES OF THE BUILDING TENANTS.
- REMOVE FROM THE SITE DEBRIS, RUBBISH, AND OTHER MATERIALS RESULTING FROM CONSTRUCTION ACTIVITIES. TRANSPORT REMOVED MATERIALS AND DISPOSE OF OFF SITE IN A LAWFUL MANNER.
- FOR IT OFFICE 104, PROVIDE BLOCKING IN WALLS AS REQUIRED FOR WALL MOUNTED CABINETS AND MONITOR. COORDINATE LOCATIONS WITH FURNITURE VENDOR AND ARCHITECT.

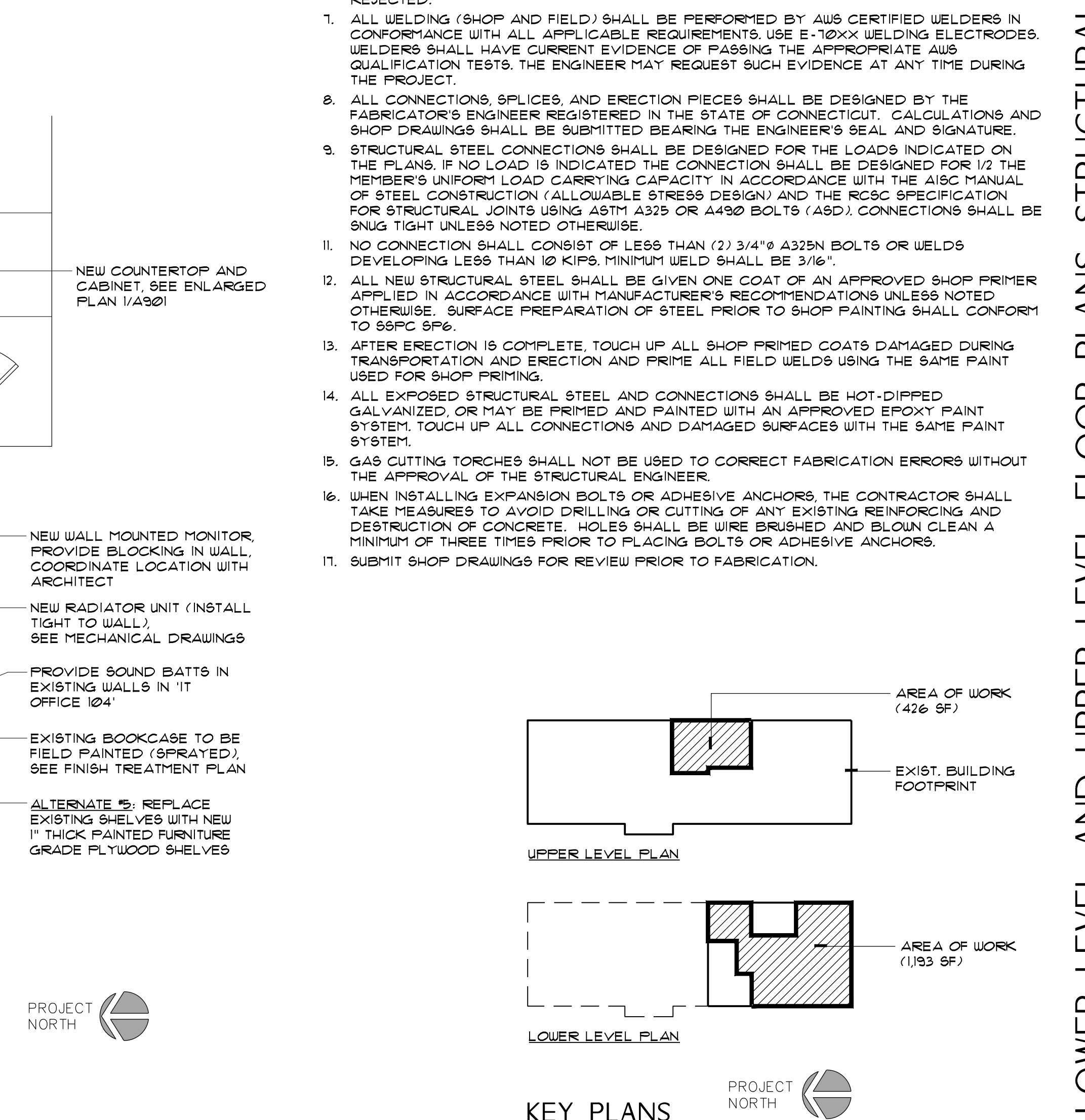
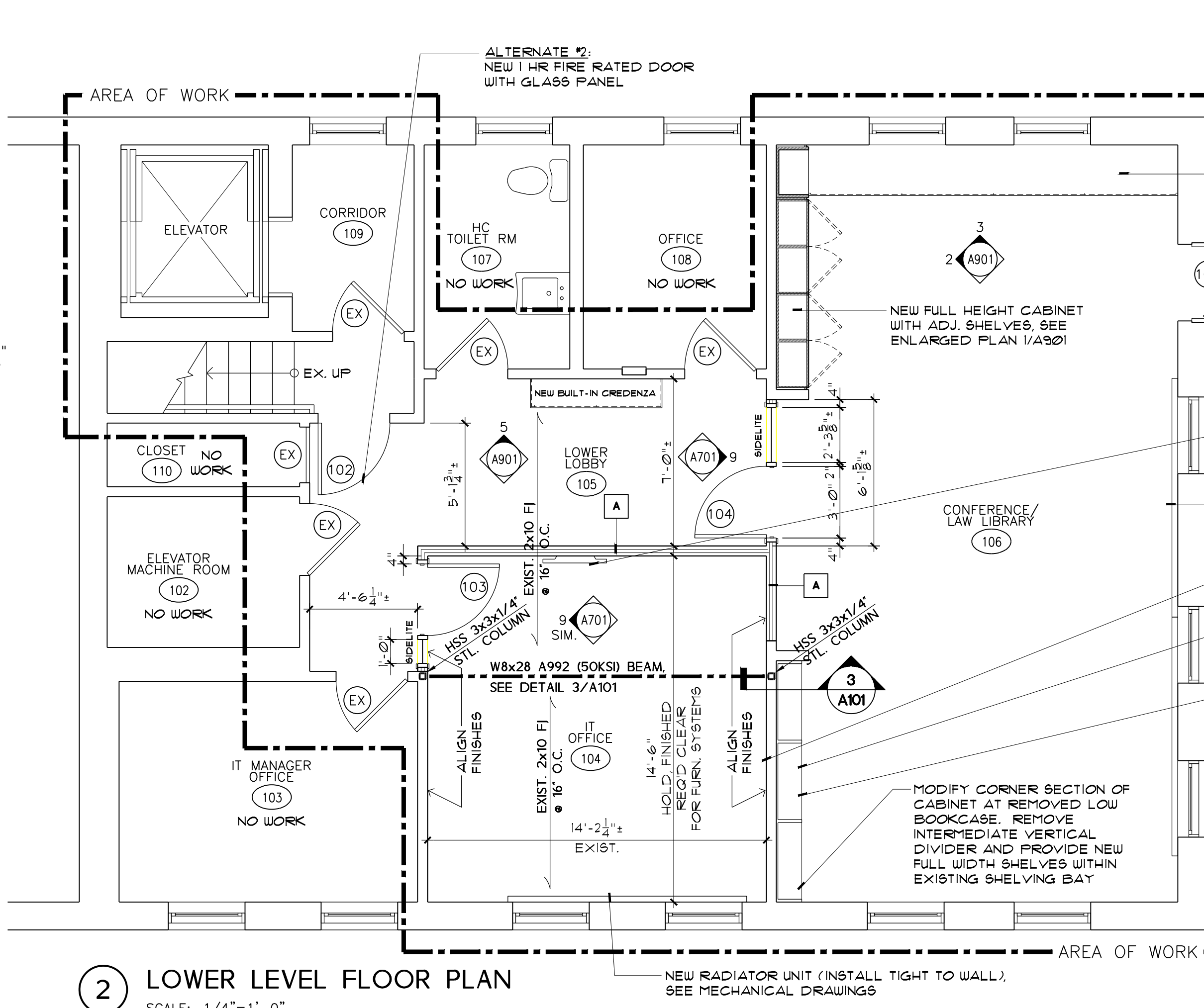

LOWER LEVEL AND UPPER LEVEL FLOOR PLANS, STRUCTURAL DETAILS

STATE OF CONNECTICUT  
INTERIOR RENOVATIONS AT THE  
OFFICE OF THE PROBATE COURT ADMINISTRATOR

186 NEWINGTON ROAD  
WEST HARTFORD, CT

Revisions

Date 3/10/2017  
Scale 1/4" = 1'-0"  
Project Number 17001  
Drawn By JWZ

**A101**

Consultants

MEP ENGINEER  
BVH INTEGRATED SERVICES, INC.  
50 GRIFFIN ROAD SOUTH  
BLOOMFIELD, CT 06002  
860-286-9171

STRUCTURAL ENGINEER  
DESIGNS AND ENGINEERED SOLUTIONS, LLC  
114 SCOVILLE HILL ROAD  
HARWINTON, CT 06791  
860-605-9120

STATE OF CONNECTICUT  
INTERIOR RENOVATIONS AT THE  
OFFICE OF THE PROBATE COURT ADMINISTRATOR  
186 NEWINGTON ROAD  
WEST HARTFORD, CT

DOOR SCHEDULE AND DETAILS

Revisions

Date: 3/10/2017  
Scale: 1/4" = 1'-0"  
Project Number: 17001  
Drawn By: JWZ

DOOR SCHEDULE

DOOR NUMBER	LOCATION		DOOR					FRAME			THRESHOLD	FIRE RATING	HARDWARE	REMARKS			
	FROM	TO	WIDTH	HEIGHT	THICKNESS	MATERIAL	FINISH	TYPE	TYPE	DEPTH					DETAILS	MATERIAL	FINISH
101	201	EXTER	3'-0"	6'-6" VIF	1-3/4"	ALUM. AND GLASS	FACTORY FINISH, KYNAR WHITE	A	I	4-1/2"	1, 2, 3 ELEV 4 ELEV 5	ALUM.	FACTORY FINISH, KYNAR WHITE	ALUM	N/A	SET A	NEW 'TUBELITE' WIDE STILE ALUMINUM AND GLASS DOOR OR APPROVED EQUAL. PROVIDE NEW ALUMINUM STOREFRONT WITH EXISTING TO REMAIN, VERIFY SIZE IN FIELD.
102	STAIR	105	3'-0" VIF	6'-8" VIF	1-3/4"	WOOD AND GLASS	STAIN	B	EXISTING FRAME TO REMAIN			N/A	60 MIN	SET B	NEW 'TRUSTILE' DOOR OR APPROVED EQUAL, FIRE-RATED WOOD AND GLASS DOOR IN EXISTING FRAME, VERIFY SIZE WOOD VENEER AND STAIN TO MATCH EXISTING		
103	105	104	3'-0"	6'-8"	1-3/4"	WOOD	STAIN	C	II	4-3/4"	6, 7, 8 ELEV 8	WOOD	STAIN	N/A	N/A	SET C	NEW 'TRUSTILE' DOOR OR APPROVED EQUAL, WOOD VENEER AND STAIN TO MATCH EXISTING GLASS STOPS ON 'IT OFFICE' SIDE
104	106	105	3'-0"	6'-8"	1-3/4"	WOOD AND GLASS	STAIN	D	II	4-3/4"	6, 7, 8 ELEV 8	WOOD	STAIN	N/A	N/A	SET D	NEW 'TRUSTILE' DOOR OR APPROVED EQUAL, WOOD VENEER AND STAIN TO MATCH EXISTING GLASS STOPS ON 'CONFERENCE/LAW LIBRARY' SIDE
105	106	EXTER	EXISTING DOOR TO REMAIN			EXISTING FRAME TO REMAIN			EXISTING FRAME TO REMAIN			SEE NOTES	N/A	EXISTING	PROVIDE NEW WEATHERSTRIPPING AROUND DOOR PERIMETER AND FILL GAP BELOW THRESHOLD AT EXTERIOR AT CONCRETE WALKWAY		

NOTES:

- SEE FLOOR PLAN ON A-101 FOR DOOR NUMBER DESIGNATIONS.
- ALL DOOR SIZES TO BE FIELD VERIFIED BY GENERAL CONTRACTOR.
- ALL WOOD DOORS TO BE SOLID CORE.
- ALL WOOD DOORS TO MATCH EXISTING DOOR VENEER INCLUDING WOOD SPECIES, GRAINING, COLOR AND STAIN.
- PROVIDE SHOP DRAWINGS OF ALL DOORS FOR APPROVAL BY ARCHITECT.
- N/A DENOTES NOT APPLICABLE.
- CONTRACTOR TO SUBMIT MATERIAL SAMPLES TO ARCHITECT FOR APPROVAL PRIOR TO ORDERING/INSTALLING DOORS AND FRAMES.
- CONTRACTOR TO COORDINATE WITH OWNER'S SECURITY VENDOR FOR DOORS WITH CARD READER ACCESS AND ELECTRIC STRIKES INCLUDING POWER REQUIREMENTS AND DOOR FRAME PREPARATION. CARD READERS AND SENSOR RELEASES PROVIDED AND INSTALLED BY SECURITY VENDOR.

HARDWARE FUNCTIONS

- OFFICE: PUSH-BUTTON LOCKING; PUSHING BUTTON LOCKS OUTSIDE LEVER UNTIL UNLOCKED WITH KEY OR BY ROTATING INSIDE LEVER.
- CLASSROOM: OUTSIDE LEVER LOCKED AND UNLOCKED BY KEY. INSIDE LEVER ALWAYS FREE.
- PASSAGE: BOTH LEVERS ALWAYS FREE.

HARDWARE SETS

SET A

- STOREFRONT MANUFACTURER SUPPLIED HARDWARE INCLUDING:
- CONTINUOUS ALUM. GEAR HINGE
  - OVERHEAD CONCEALED CLOSER
  - MORTISE DEADLATCH LOCK
  - LEVER HANDLE OUTSIDE
  - ELECTRIC STRIKE
  - CARD READER (BY SECURITY VENDOR)
  - EXIT DEVICE INSIDE (CONCEALED ROD PANIC BAR)
  - EXTRUDED ALUM. THRESHOLD
  - WEATHERSWEEP AND WEATHERSTRIPPING

SET B

- BUTT HINGES: 1 1/2 PAIR
- LOCKSET: CLASSROOM FUNCTION
- GLOSER
- WALL STOP
- KICK PLATE
- EXISTING MAG HOLD OPEN
- EXISTING CARD READER (HOOKUP BY OWNER'S SECURITY VENDOR)
- EXISTING ELECTRIC STRIKE

SET C

- BUTT HINGES: 1 1/2 PAIR
- LOCKSET: OFFICE FUNCTION
- WALL STOP

SET D

- BUTT HINGES: 1 1/2 PAIR
- LATCHSET: PASSAGE FUNCTION
- WALL STOP
- CLOSER (WITH HOLD-OPEN FEATURE) CLOSER ON CONFERENCE ROOM SIDE

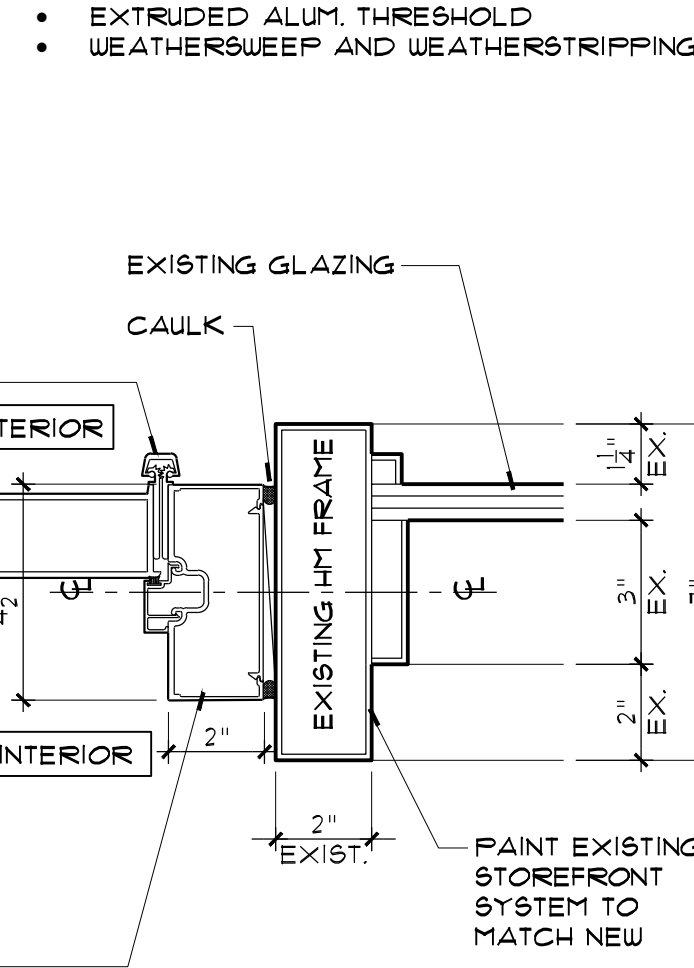

1 SIDELITE DETAIL  
SCALE: 3"=1'-0"

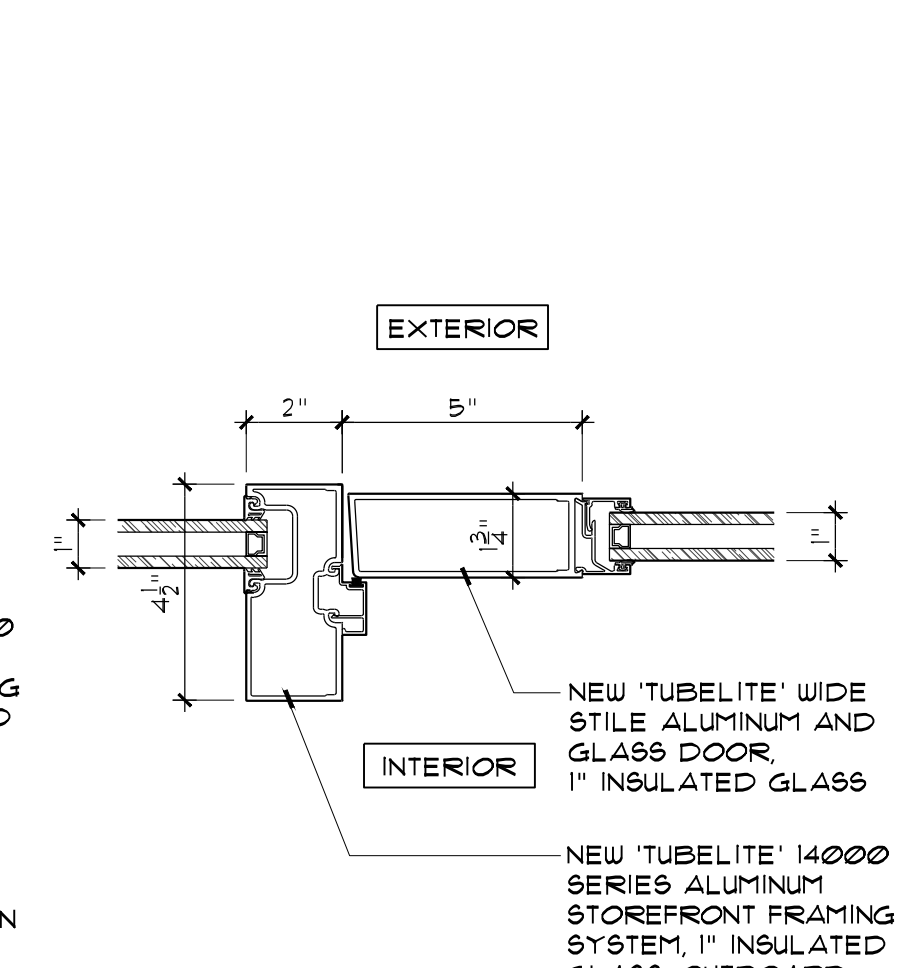

2 INTERMEDIATE JAMB DETAIL  
SCALE: 3"=1'-0"

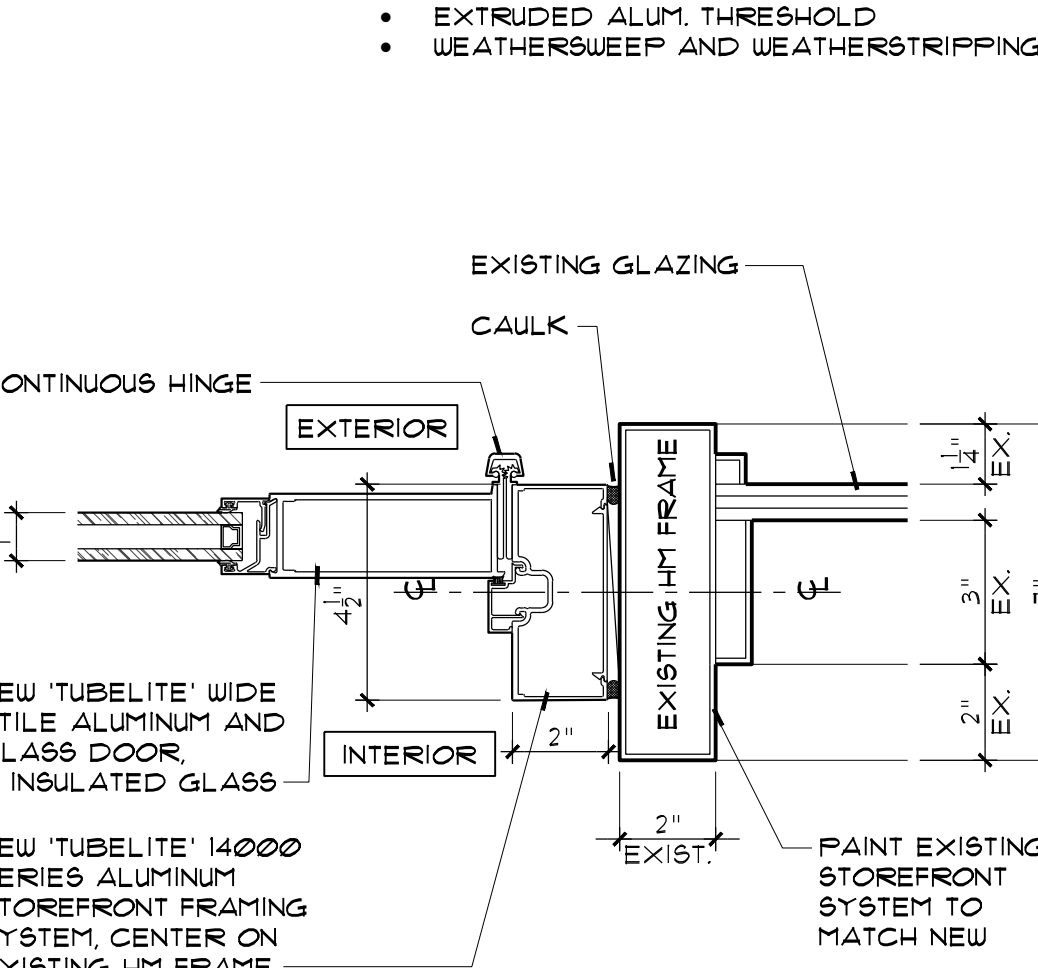

3 JAMB DETAIL (HEAD SIM.)  
SCALE: 3"=1'-0"

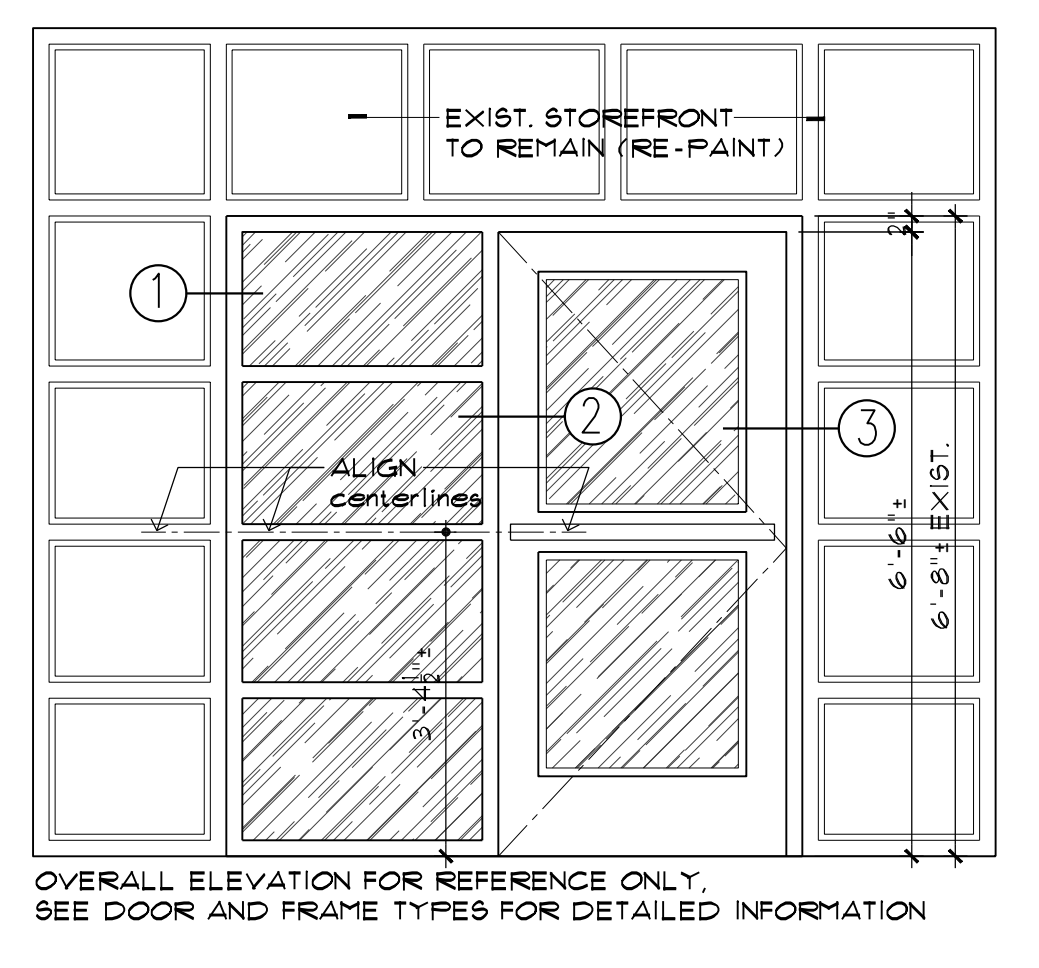

4 ALTERNATE #1 STOREFRONT MODIFICATIONS  
SCALE: 1/2"=1'-0"  
VIEW FROM INTERIOR

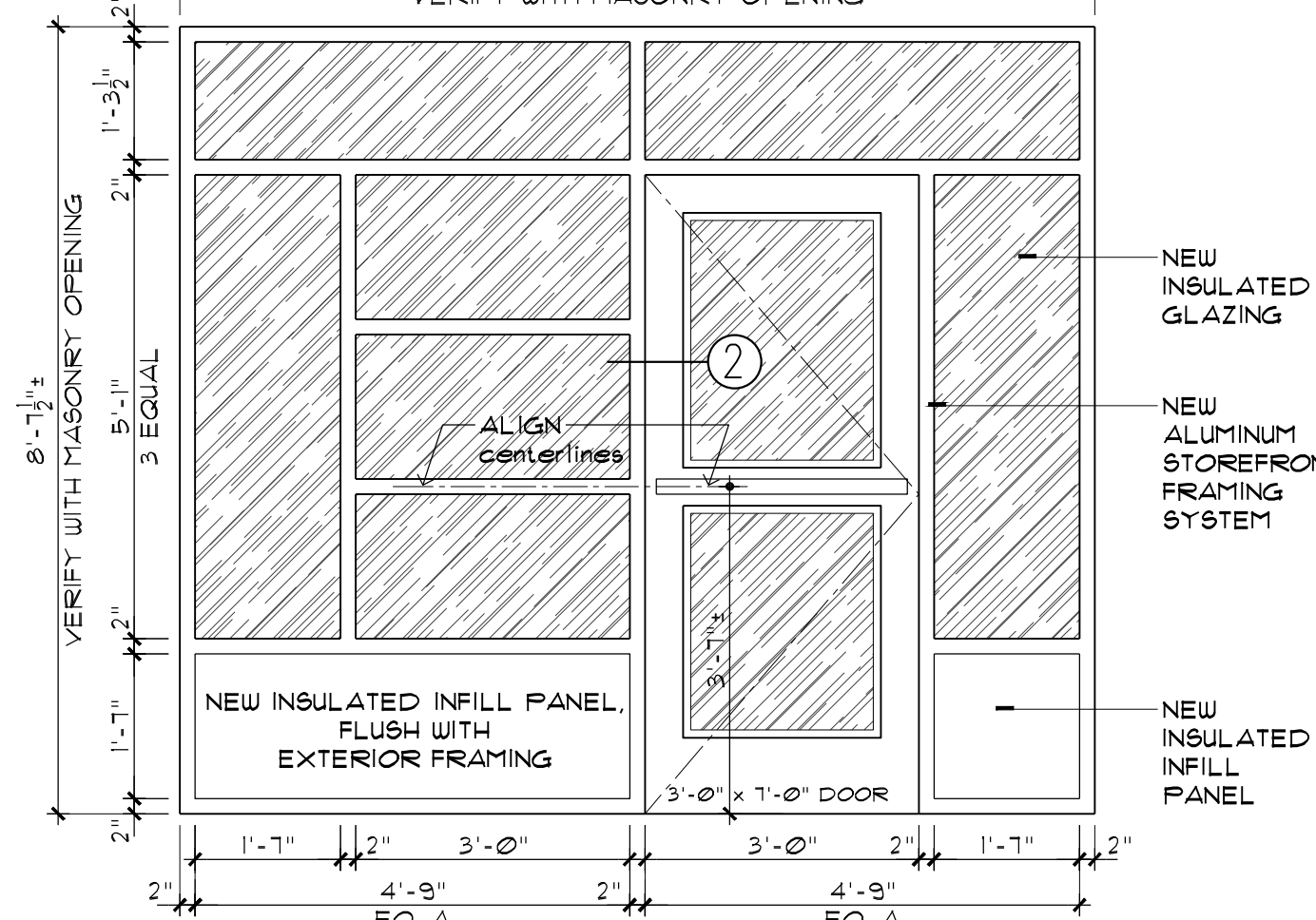

5 ALTERNATE #6 STOREFRONT REPLACEMENT  
SCALE: 1/2"=1'-0"  
VIEW FROM INTERIOR

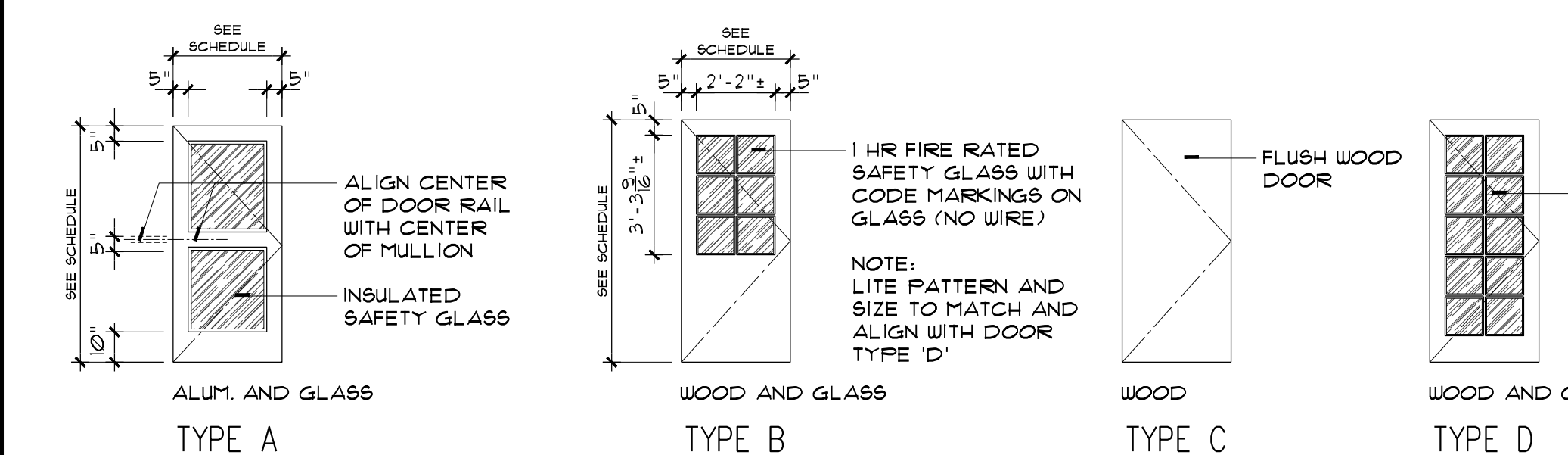

DOOR TYPES  
SCALE: 1/4"=1'-0"

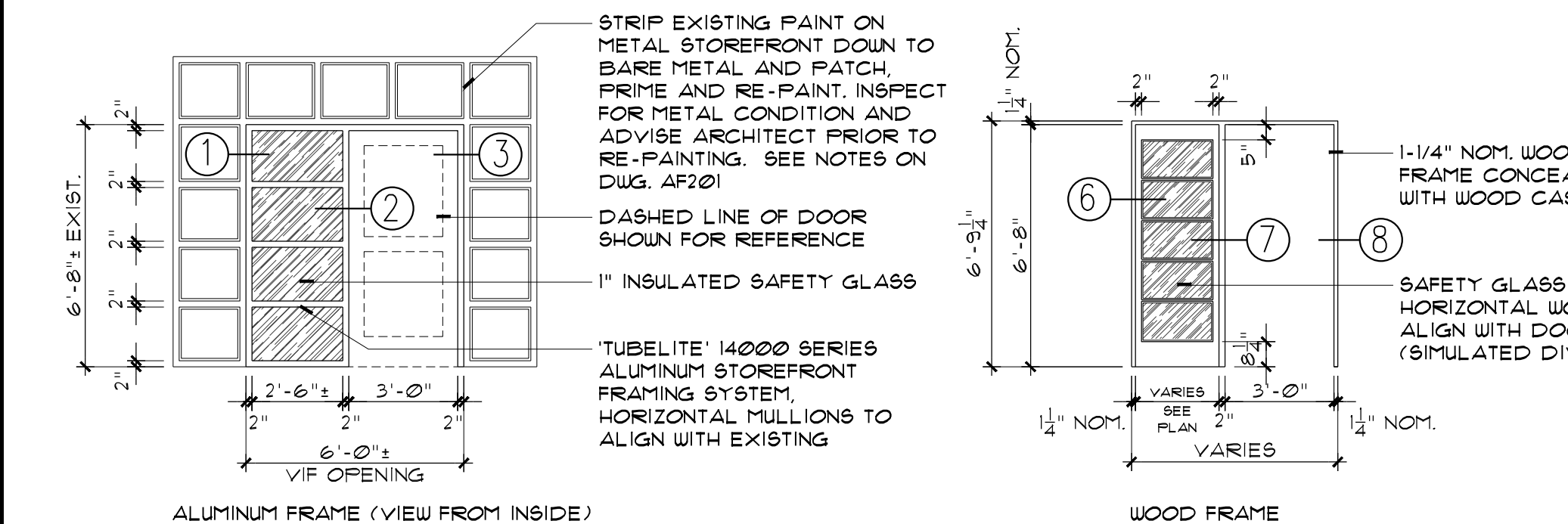

FRAME TYPES AND SIDELIGHTS  
SCALE: 1/4"=1'-0"

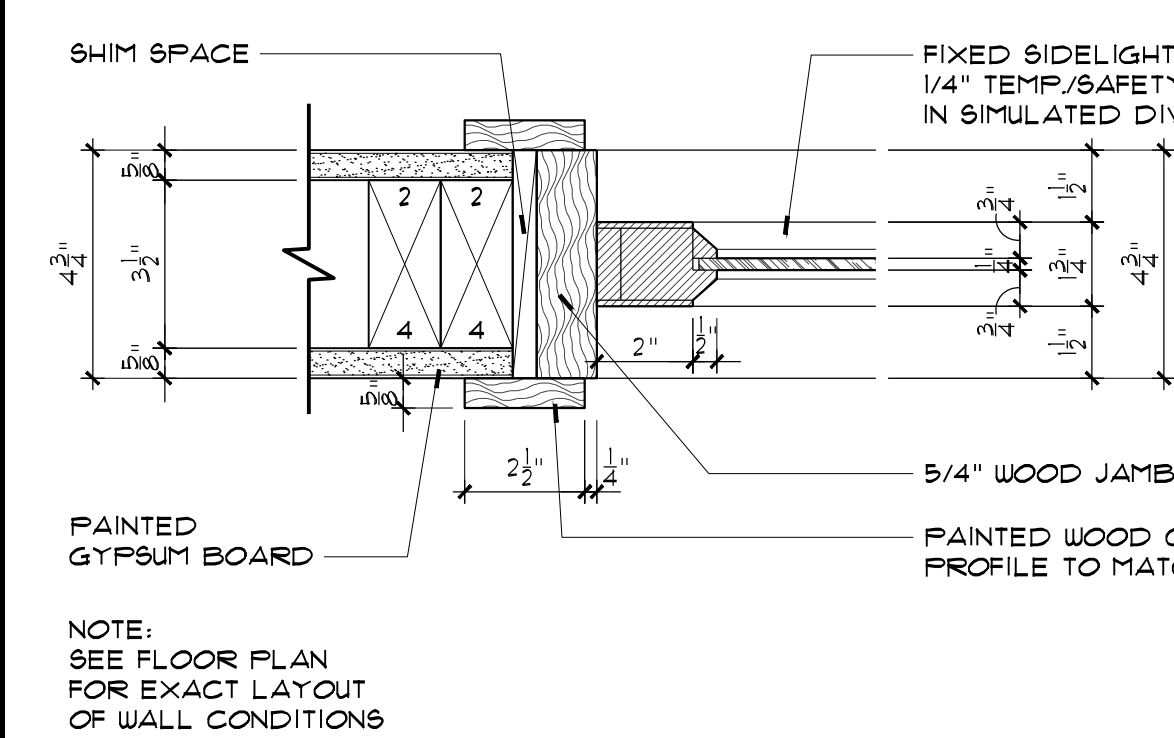

6 SIDELITE DETAIL  
SCALE: 3"=1'-0"

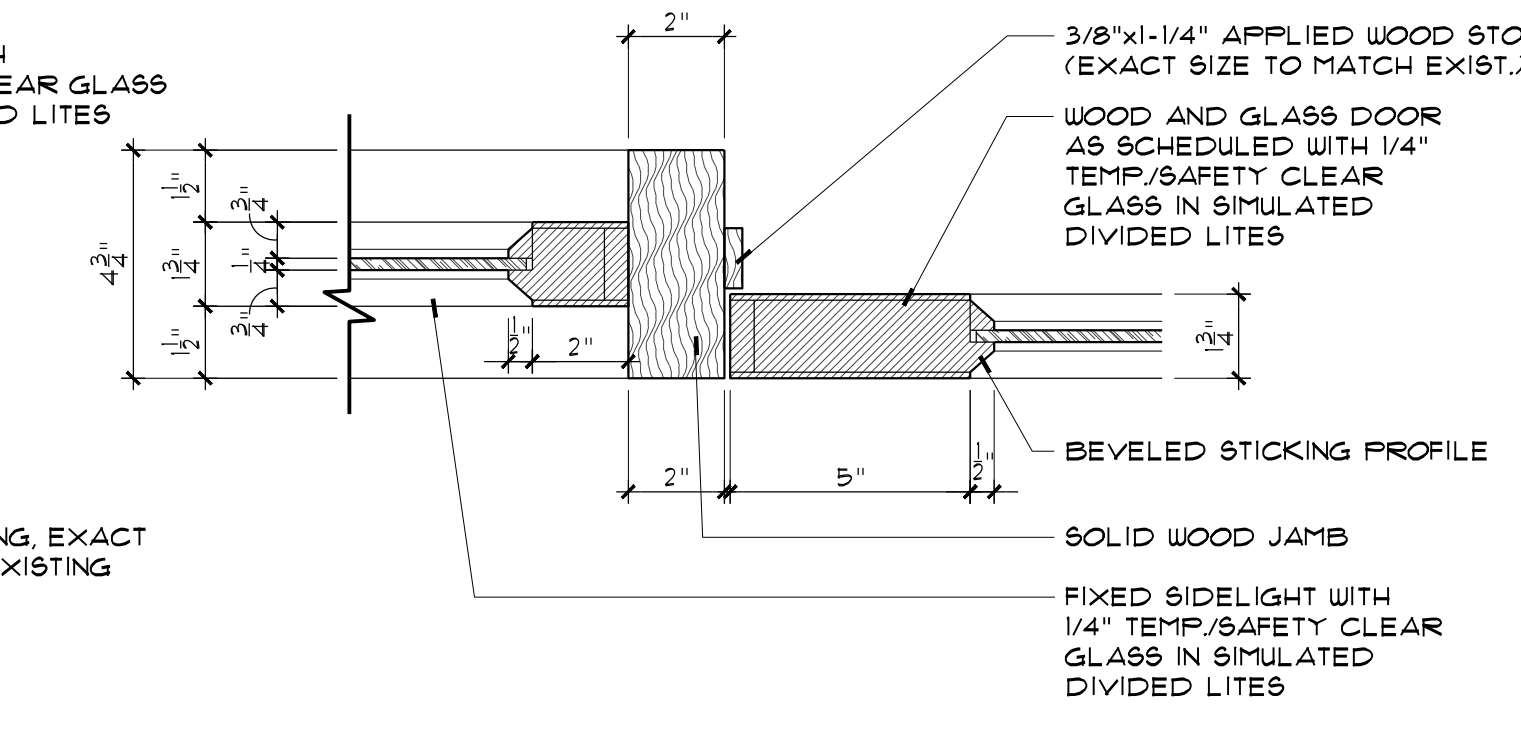

7 INTERMEDIATE JAMB DETAIL  
SCALE: 3"=1'-0"

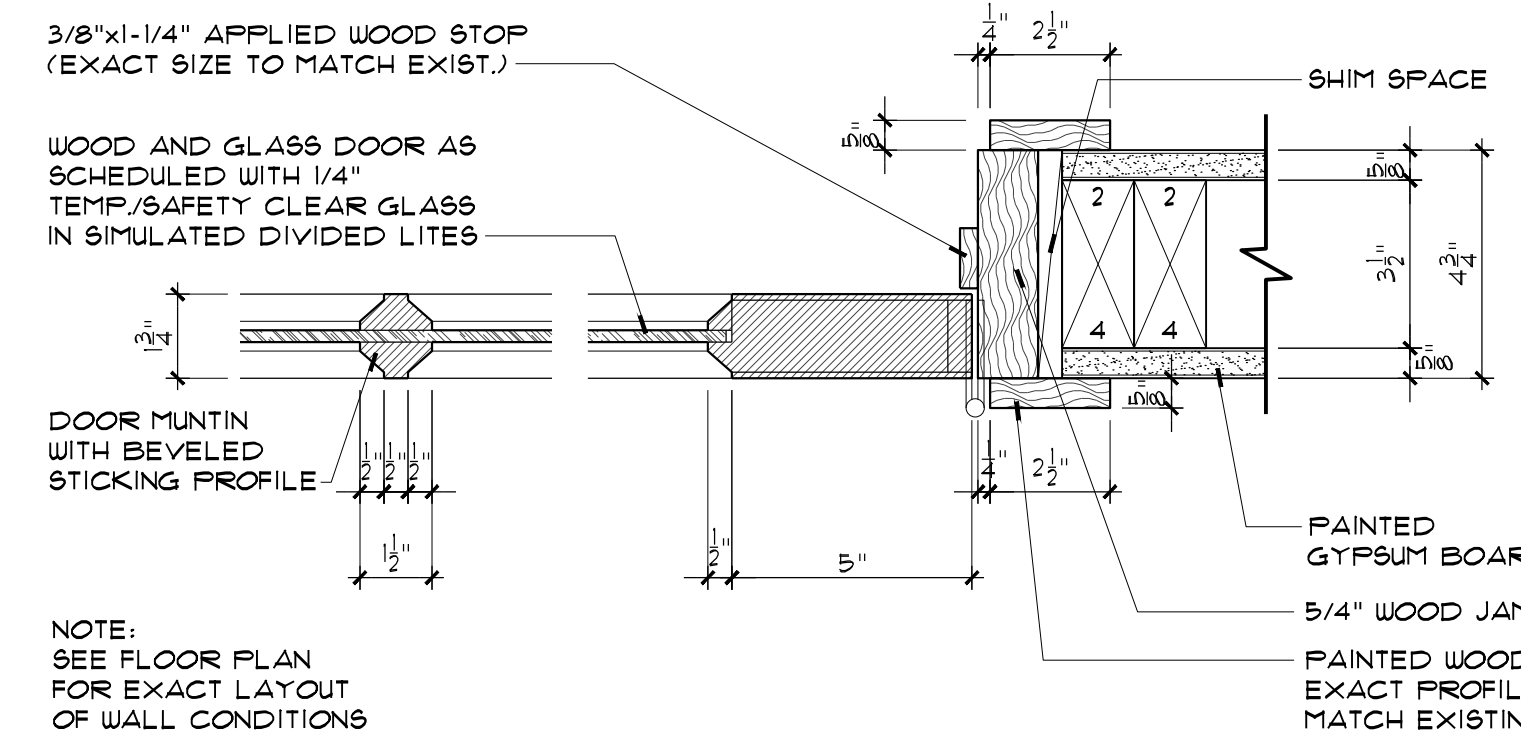

8 JAMB DETAIL (HEAD SIM.)  
SCALE: 3"=1'-0"

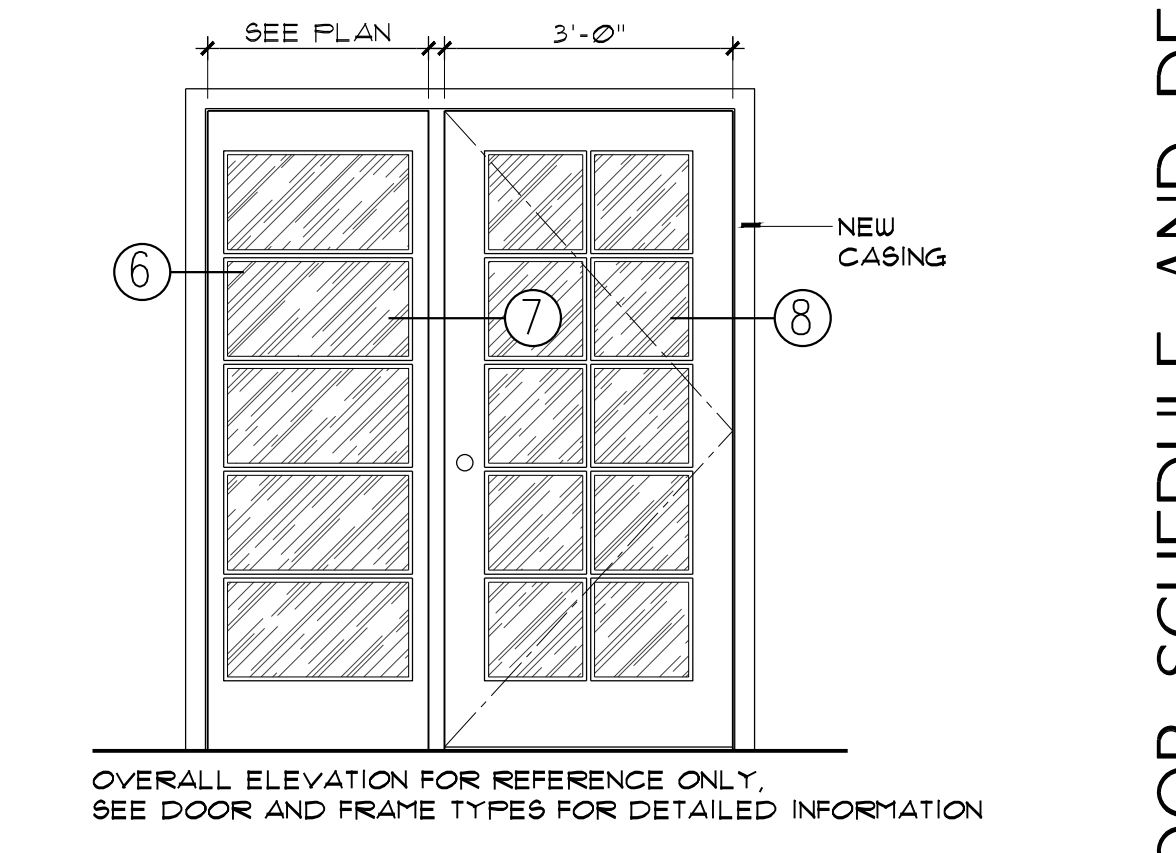

9 CONF. ROOM DOOR ELEVATION  
SCALE: 1/2"=1'-0"





Consultants

MEP ENGINEER  
BVH INTEGRATED SERVICES, INC.  
50 GRIFFIN ROAD SOUTH  
BLOOMFIELD, CT 06002  
860-286-9171

STRUCTURAL ENGINEER  
DESIGNS AND ENGINEERED SOLUTIONS, LLC  
114 SCOVILLE HILL ROAD  
HARWINTON, CT 06791  
860-605-9120

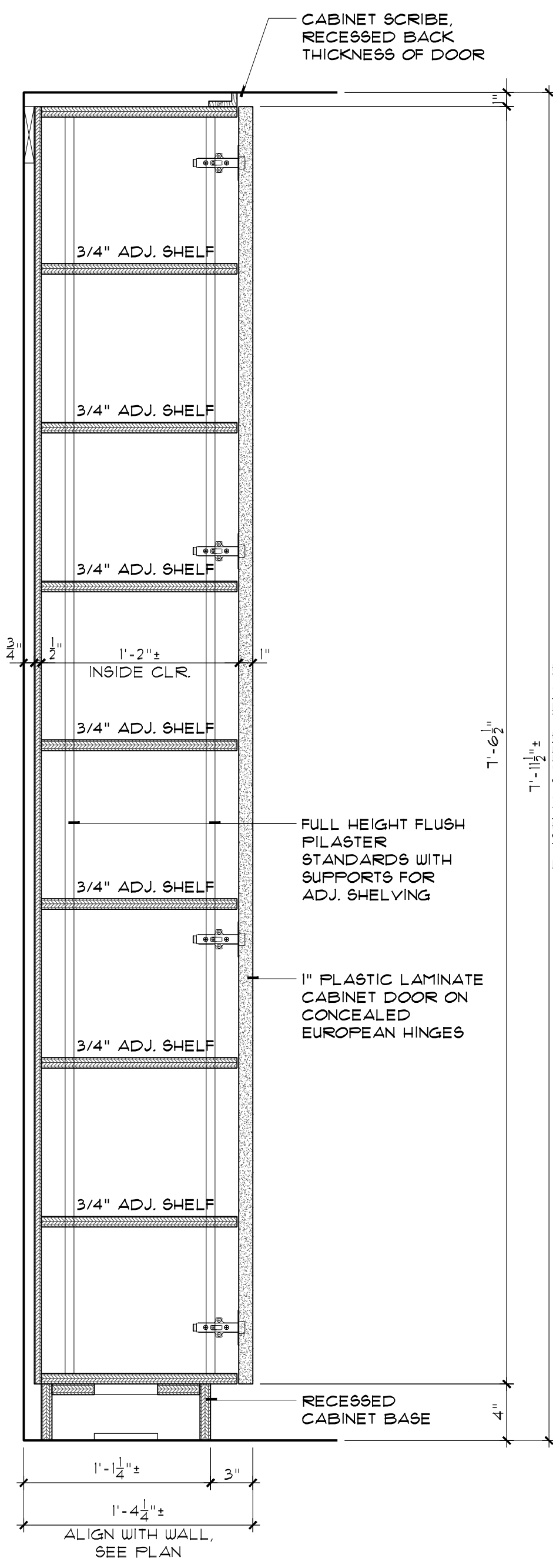

**1 SECTION**  
SCALE: 1-1/2" = 1'-0"

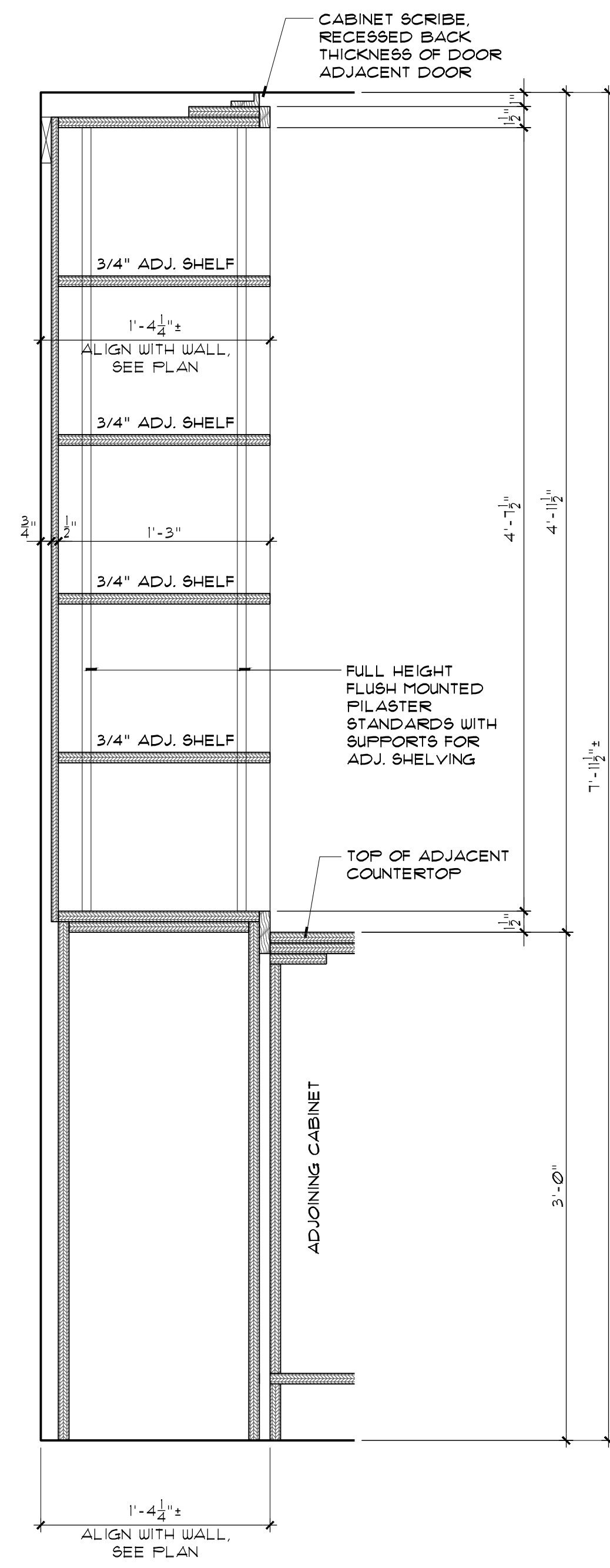

**2 SECTION**  
SCALE: 1-1/2" = 1'-0"

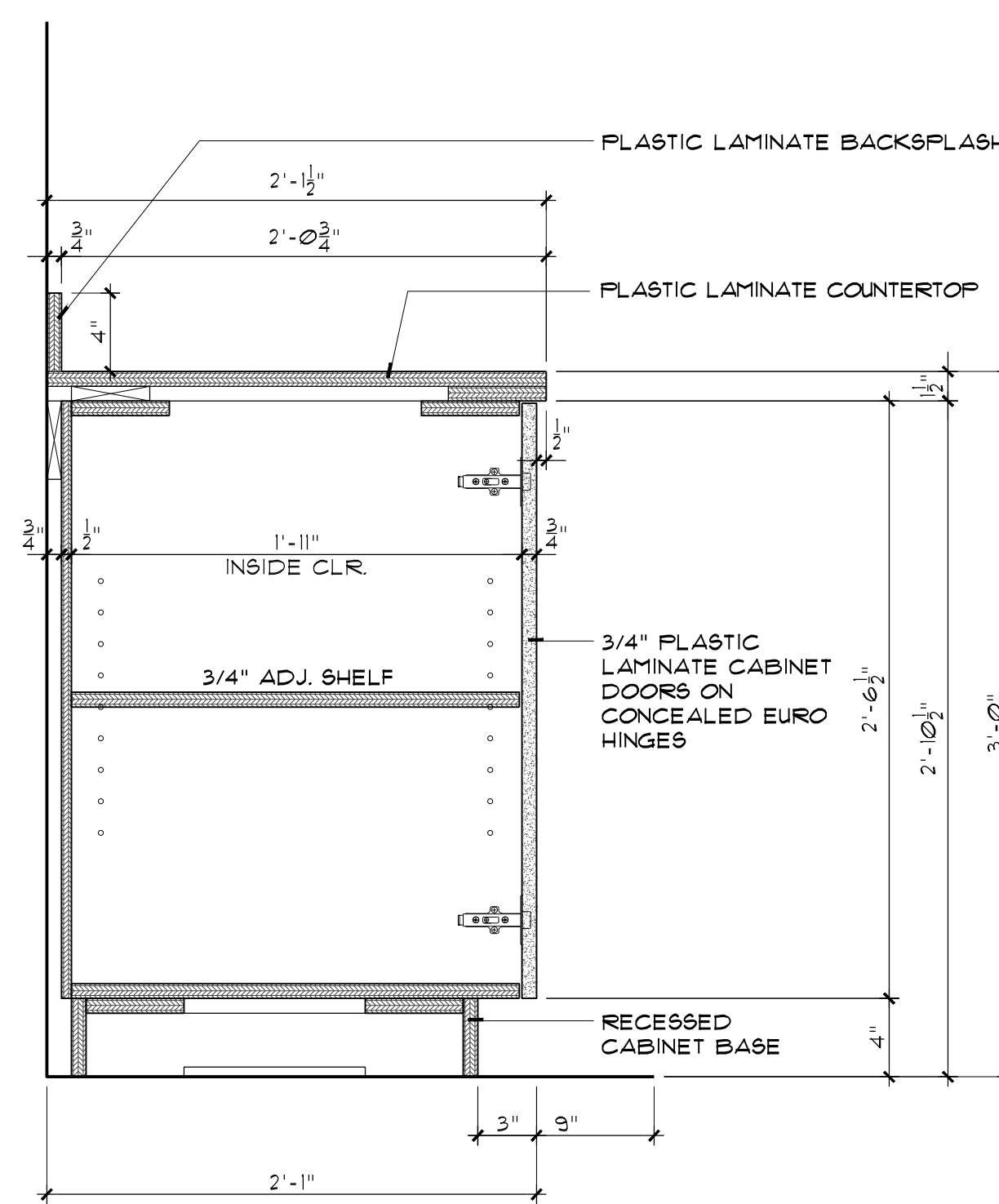

**3 SECTION**  
SCALE: 1-1/2" = 1'-0"

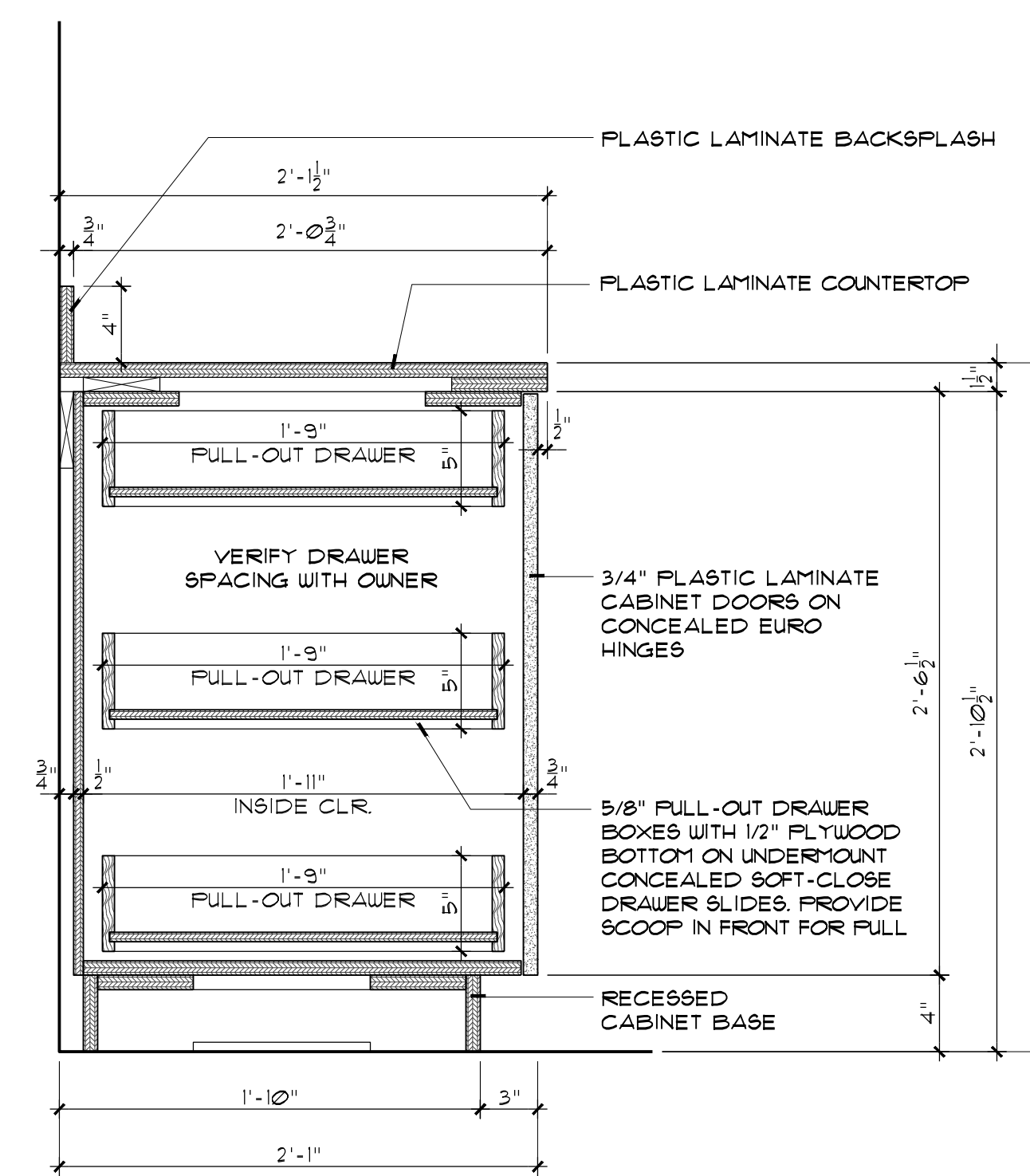

**4 SECTION**  
SCALE: 1-1/2" = 1'-0"

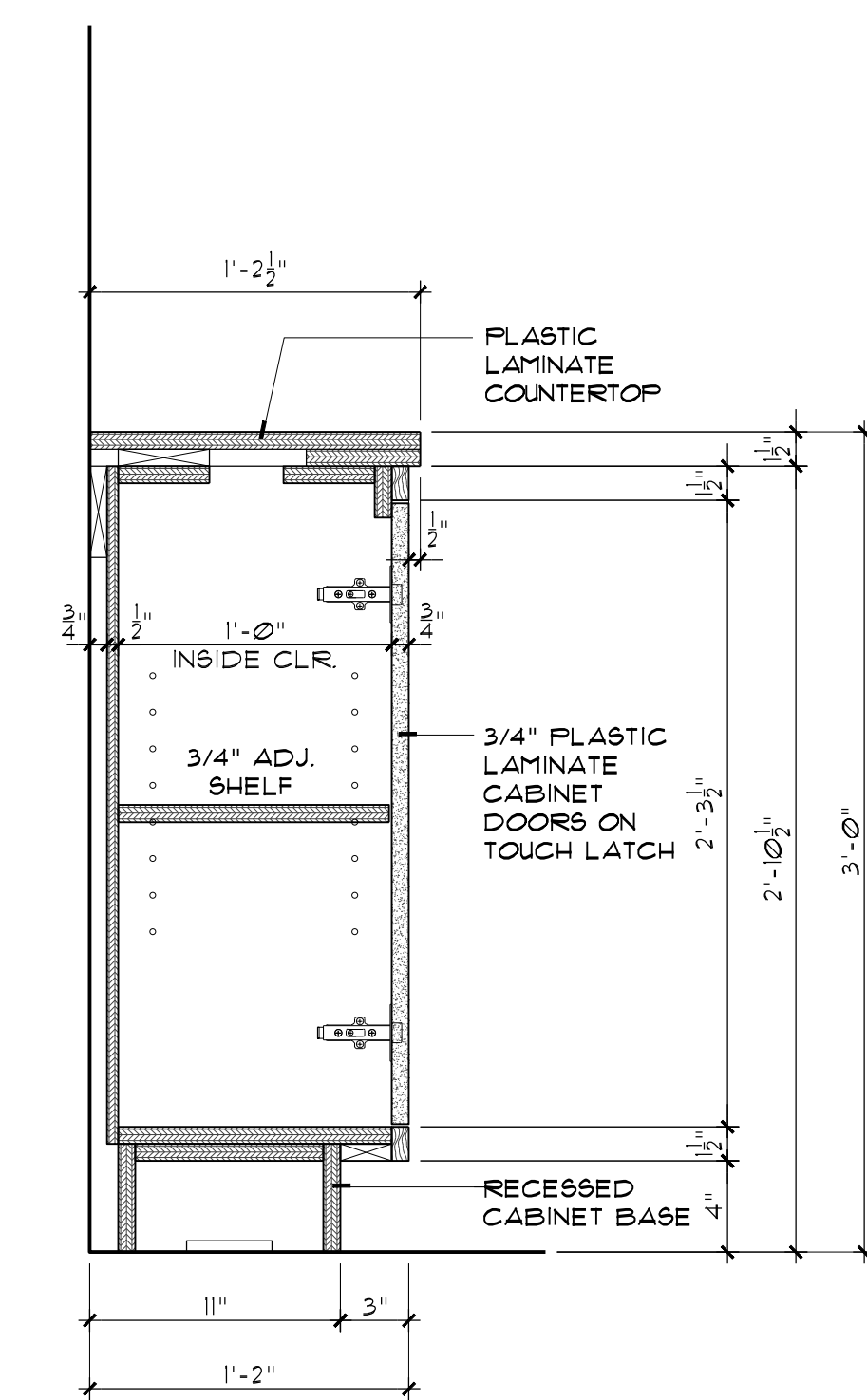

**5 SECTION**  
SCALE: 1-1/2" = 1'-0"

MILLWORK SECTIONS

STATE OF CONNECTICUT  
INTERIOR RENOVATIONS AT THE  
OFFICE OF THE PROBATE COURT ADMINISTRATOR  
186 NEWINGTON ROAD  
WEST HARTFORD, CT

Revisions

Date 3/10/2017  
Scale 1-1/2" = 1'-0"  
Project Number 17001  
Drawn By JWZ

**A902**

C:\17001\Drawings\GS\Current Drawings\17001\_A901\_A902.dwg, A902, 3/15/2017 12:55:05 PM, jkdc, 1:1

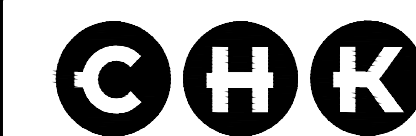

Consultants

MEP ENGINEER  
BVH INTEGRATED SERVICES, INC.  
50 GRIFFIN ROAD SOUTH  
BLOOMFIELD, CT 06002  
860-286-9171

STRUCTURAL ENGINEER  
DESIGNS AND ENGINEERED SOLUTIONS, LLC  
114 SCOVILLE HILL ROAD  
HARTWTON, CT 06791  
860-605-9120

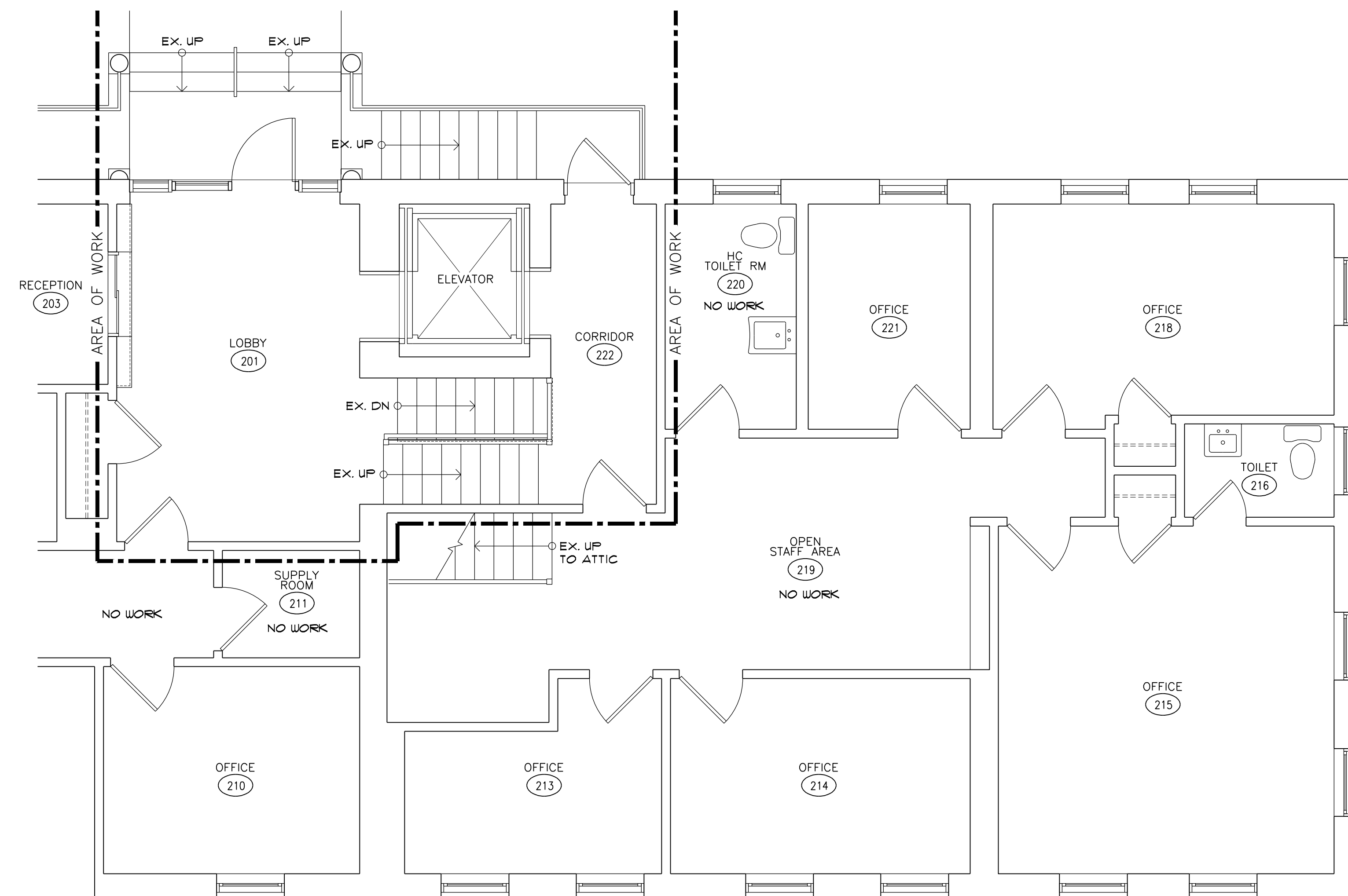

1 UPPER LEVEL FURNITURE PLAN  
SCALE: 1/4"=1'-0"

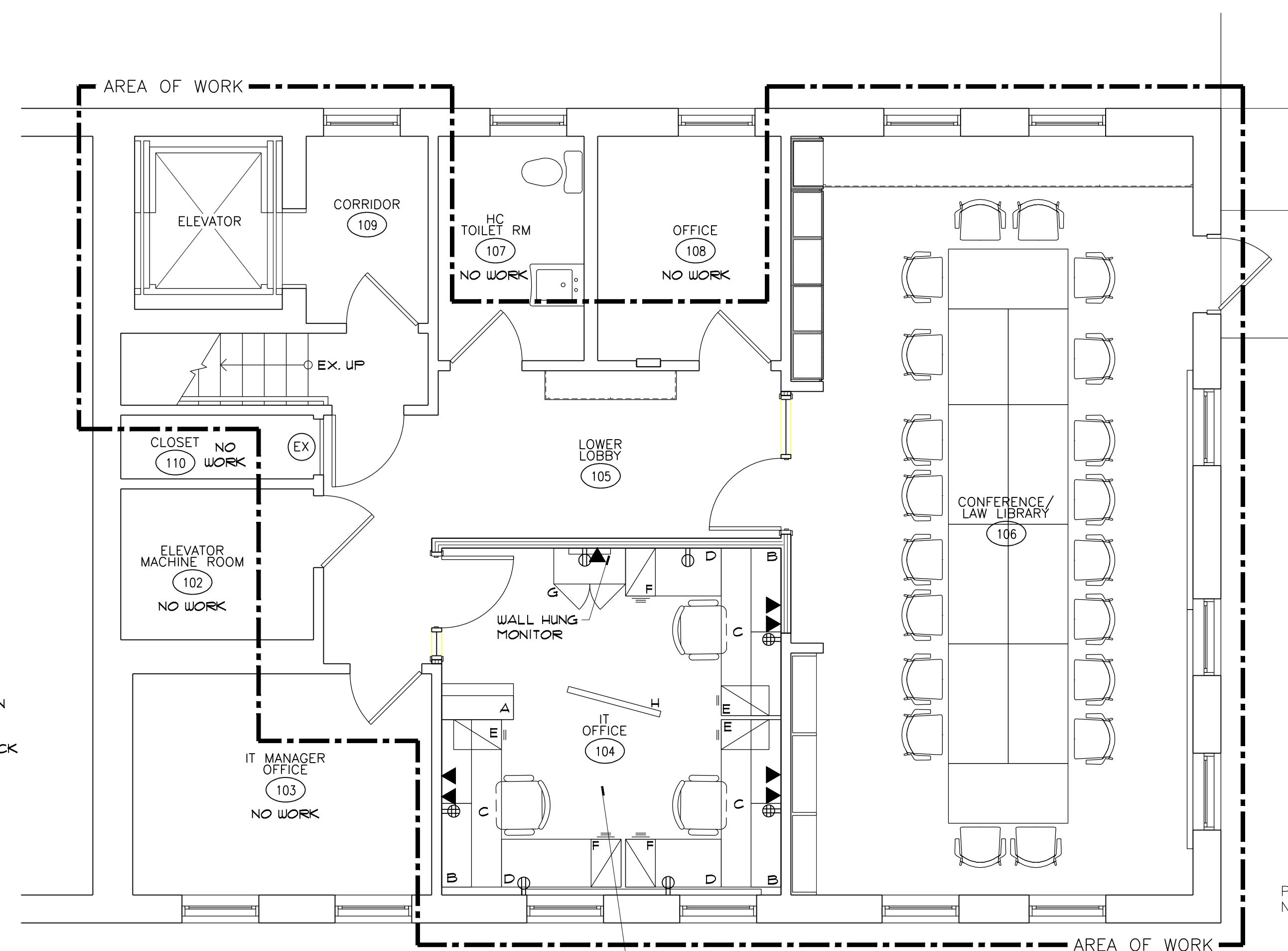

2 LOWER LEVEL FURNITURE PLAN  
SCALE: 1/4"=1'-0"

POWER AND DATA IN IT OFFICE 104  
SHOWN FOR REFERENCE ONLY.  
SEE ELECTRICAL PLANS

- A- CABINET WITH DRAWERS ON BOTTOM & SHELVES ON TOP
- B- OVERHEAD SHELF WITH TACK BOARD BELOW
- C- 30" X 84" WORKSURFACE
- D- 24" X 60" WORKSURFACE
- E- BOX/BOX/FILE DRAWERS
- F- FILE/FILE DRAWERS
- G- LOW STORAGE CABINET
- H- MOBILE WHITE BOARD

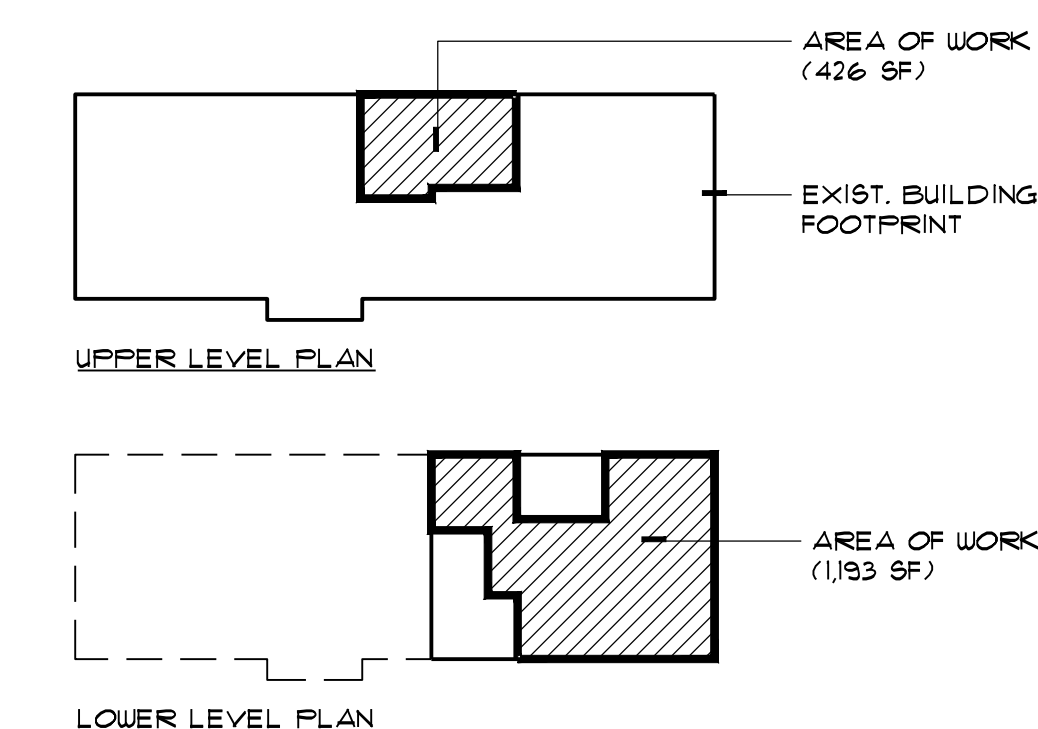

KEY PLANS



LOWER LEVEL AND UPPER LEVEL FURNITURE PLANS

STATE OF CONNECTICUT  
INTERIOR RENOVATIONS AT THE  
OFFICE OF THE PROBATE COURT ADMINISTRATOR

186 NEWINGTON ROAD  
WEST HARTFORD, CT

Revisions

Date 3/10/2017  
Scale 1/4" = 1'-0"  
Project Number 17001  
Drawn By

AF101



Consultants

MEP ENGINEER  
BVH INTEGRATED SERVICES, INC.  
50 GRIFFIN ROAD SOUTH  
BLOOMFIELD, CT 06002  
860-286-9171

STRUCTURAL ENGINEER  
DESIGNS AND ENGINEERED SOLUTIONS, LLC  
114 SCOVILLE HILL ROAD  
HARWINTON, CT 06791  
860-605-9120

LOWER LEVEL AND UPPER LEVEL FINISH TREATMENT PLANS

STATE OF CONNECTICUT  
INTERIOR RENOVATIONS AT THE  
OFFICE OF THE PROBATE COURT ADMINISTRATOR

186 NEWINGTON ROAD  
WEST HARTFORD, CT

Revisions



Date 3/10/2017  
Scale 1/4" = 1'-0"  
Project Number 17001  
Drawn By

AF201

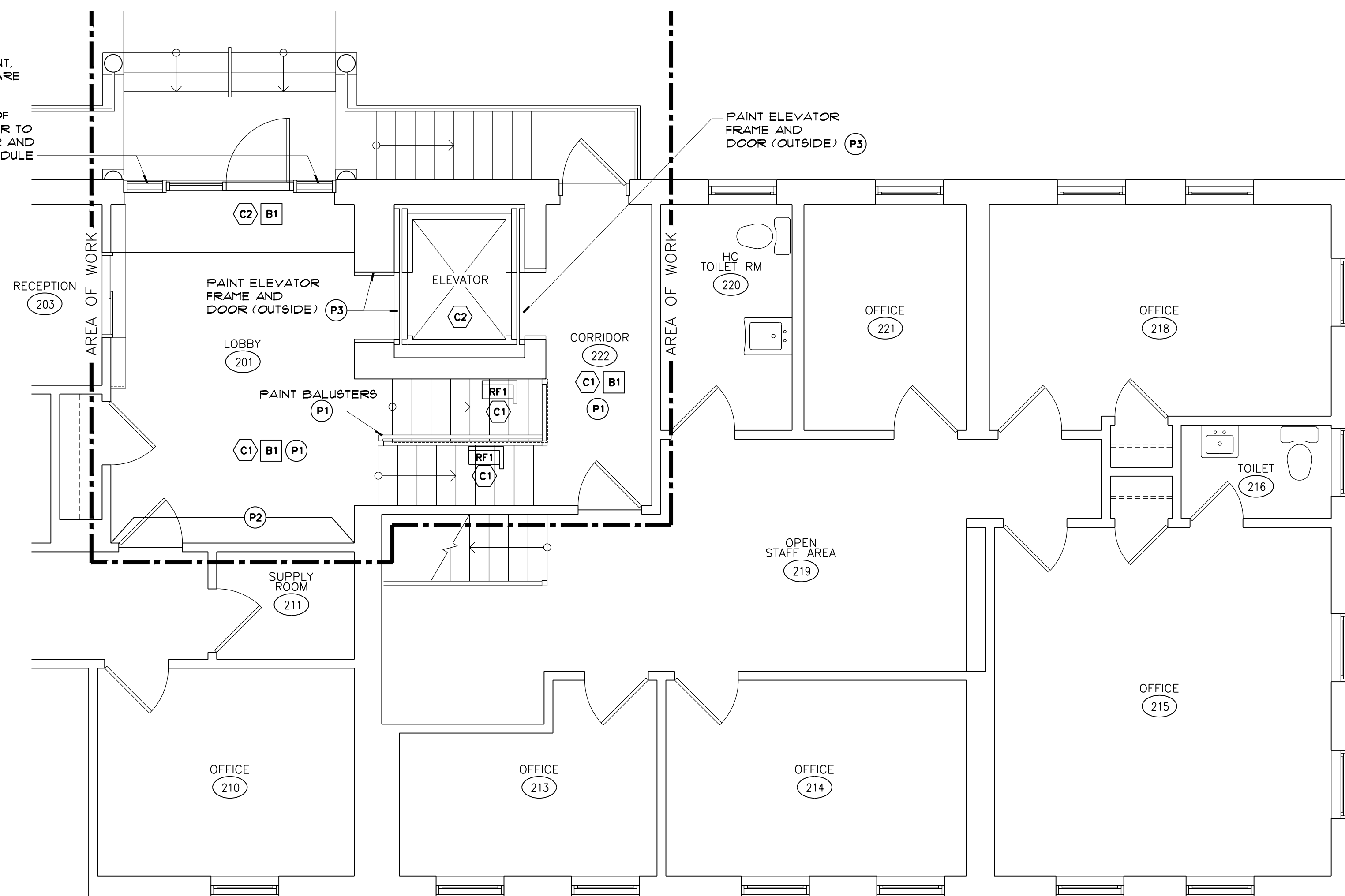
ALTERNATE #1  
PATCH, PRIME AND PAINT  
EXISTING METAL STOREFRONT.  
REMOVE PAINT DOWN TO BARE  
METAL AND INSPECT FOR  
DECAY/ RUSTING. ADVISE  
ARCHITECT ON CONDITION OF  
EXISTING STOREFRONT PRIOR TO  
ORDERING NEW ALUM. DOOR AND  
SIDELIGHT, SEE DOOR SCHEDULE

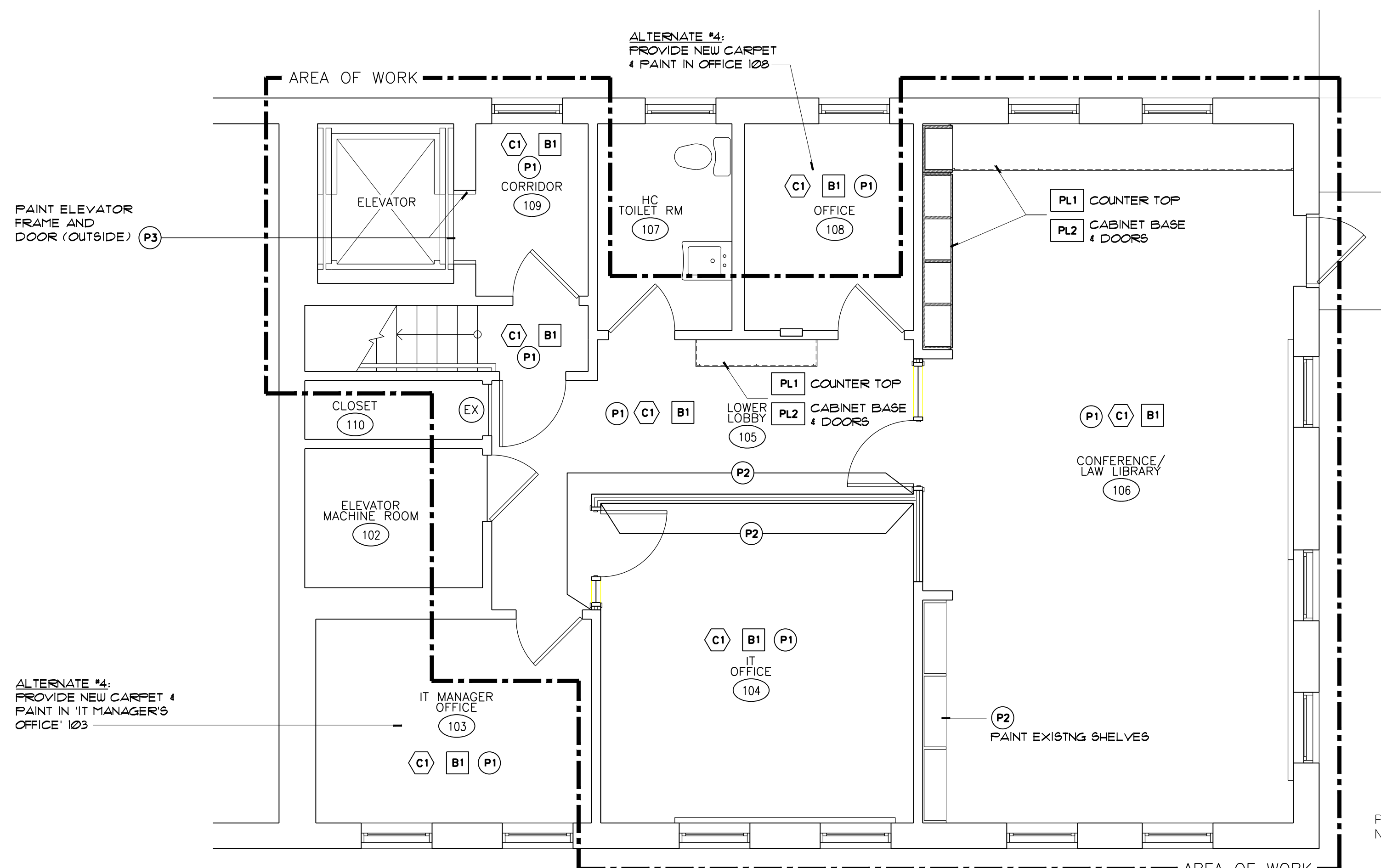

1 UPPER LEVEL FINISH TREATMENT PLAN  
SCALE: 1/4"=1'-0"



2 LOWER LEVEL FINISH TREATMENT PLAN  
SCALE: 1/4"=1'-0"



WALL PAINT

- P1 MANUF.: BENJAMIN MOORE  
COLOR: \*OC-13 SEAPEARL  
FINISH: EGGSHHELL  
LOCATION: ALL AREAS U.O.N.  
DOOR FRAMES & BALUSTERS-  
SEMI-GLOSS FINISH
- P2 MANUF.: BENJAMIN MOORE  
COLOR: \*998 CABOT TRAIL  
FINISH: EGGSHHELL  
LOCATION: ACCENT WALLS
- P3 MANUF.: BENJAMIN MOORE  
COLOR: \*998 CABOT TRAIL  
FINISH: SEMI-GLOSS  
LOCATION: ELEVATOR DOORS & TRIM
- PL1 MANUF.: LAMINART  
COLOR: \*2433-T FORTABELLA  
LOCATION: COUNTER TOPS
- PL2 MANUF.: WILSONART  
COLOR: \*4944-38 CASUAL LINEN  
LOCATION: CABINET BASES AND DOORS

NOTE: PAINT SOFFITS  
BENJAMIN MOORE  
\*OC-111 SIMPLY WHITE

CARPET TILE

- C1 MANUF.: SHAW CONTRACT GROUP  
STYLE: DIFFUSE TILE 59575  
COLOR: FLUTTER 15161  
TYPE: 24"x24" TILE  
LOCATION: TYPICAL U.O.N.  
INSTALLATION: BRICK
- C2 MANUF.: MANNINGTON  
STYLE: RUFFIAN II  
COLOR: BROWN BRANCHES \*9503  
TYPE: 24"x24" TILE  
LOCATION: 2ND FLOOR ENTRY  
INSTALLATION: MONOLITHIC

WALK OFF CARPET TILE

- RTR MANUF.: ROPPE  
STYLE: SINGLE FLANGE NOSING #13  
COLOR: #102 BROWN  
USE WITH #28 COVE CAP AT EDGE

LINEAR STAIR NOSING

- B1 MANUF.: JOHNSONITE  
STYLE: 4" VINYL STRAIGHT BASE  
COLOR: #21 CEMENT CB

BASE

- MANUF.: JOHNSONITE  
STYLE: 4" VINYL STRAIGHT BASE  
COLOR: #21 CEMENT CB

TRANSITION STRIP

- MANUF.: JOHNSONITE  
STYLE: INSTALLER TO RECOMMEND  
COLOR: #21 CEMENT CB

FINISH NOTES

1. EXISTING OR NEW SURFACES TO BE PAINTED SHALL BE SANDED, LEVEL, AND SMOOTH PRIOR TO NEW FINISH APPLICATION. SURFACES SHOULD BE FREE OF DIRT, DUST, AND OIL RESIDUE.
2. NEW WALLS AND SURFACES SHALL RECEIVE THE FOLLOWING TREATMENT: SANDING AND (3) COATS OF COMPOUND AND TAPE PRIOR TO FINISH TREATMENT.
3. CONTRACTOR TO PROTECT FINISHED SURFACES DURING OTHER WORK.
4. CONTRACTOR IS REQUIRED TO SUBMIT ALL SPECIFIED WALL AND FLOOR FINISH PRODUCTS FOR APPROVAL PRIOR TO ORDERING.
5. CONTRACTOR IS TO INSTALL FINISH PRODUCTS PER MANUFACTURER'S INSTRUCTIONS.
6. ALL WALLS AND TRIM TO BE PAINTED ARE TO RECEIVE A PRIMER COAT AND TWO COATS OF FINISH PAINT.
7. DO NOT PAINT OVER CODE-REQUIRED LABELS AFFIXED TO DOORS, EQUIPMENT, VENTS, SIGNS, ETC.
8. UPON COMPLETION, THE PAINTED SURFACES SHOULD BE UNIFORM IN COLOR AND APPEARANCE.
9. ALL WALLS INCLUDING INTERIOR OF CLOSETS TO BE PAINTED P1 UNLESS OTHERWISE NOTED.
10. CONTRACTOR IS TO CLEAN FLOOR PRIOR TO NEW FINISH INSTALLATION. THIS INCLUDES REMOVAL OF ANY EXISTING FLOORING ADHESIVE AND OTHER PRODUCTS UNLESS NOTED OTHERWISE.
11. SUBSTRATE IS TO BE CLEAN, DRY, LEVEL AND SMOOTH PRIOR TO NEW FLOOR INSTALLATION.
12. CONTRACTOR IS TO USE MANUFACTURER'S RECOMMENDED ADHESIVES FOR ALL SPECIFIED FLOORING PRODUCTS.
13. ALL ROOMS INCLUDING INTERIOR OF CLOSETS TO RECEIVE CARPET C1 UNLESS OTHERWISE NOTED.
14. DELIVER OVERRUN ON NEW FLOOR FINISH MATERIALS TO OWNER. CONFIRM ACCEPTABLE USABLE SCRAPS AND PRODUCT PRIOR TO DISCARDING.
15. CARPET SHOULD BE VACUUMED AND CLEANED OF DIRT AND CONSTRUCTION DEBRIS DAILY AFTER INSTALLATION.
16. UPON COMPLETION OF INSTALLATION, NEW CARPET SHOULD BE LEVEL AND TIGHT TO WALL AND UNIFORM IN COLOR. COORDINATE QUANTITY AND DYE LOTS ACCORDINGLY.
17. REMOVE WOOD BASE IN AFFECTED AND PATCH WALL BEFORE INSTALLING VINYL BASE.
18. PROVIDE MANUFACTURER'S RECOMMENDED TRANSITIONS AS REQUIRED BETWEEN FLOORING MATERIALS.
19. REPLACEMENT OF FLOORING MATERIALS TO BE PHASED WITH WORK TO OCCUR OFF HOURS, COORDINATE WITH TENANT'S PROJECT MANAGER.
20. STRIP AND RE-STAIN STAIR HANDRAIL AND BASE TO MATCH EXISTING.

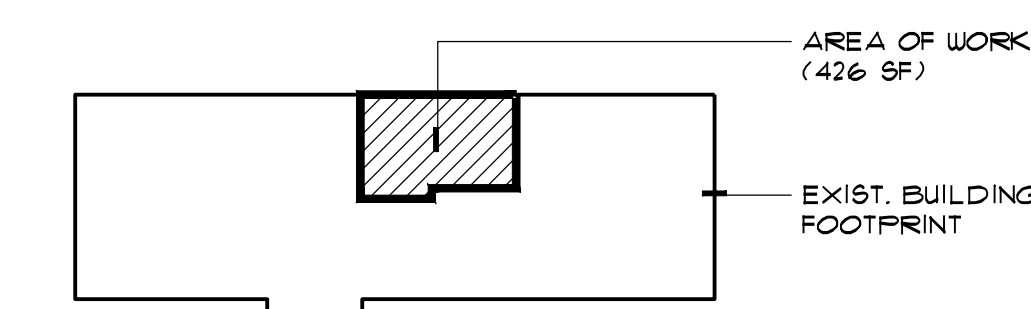

UPPER LEVEL PLAN

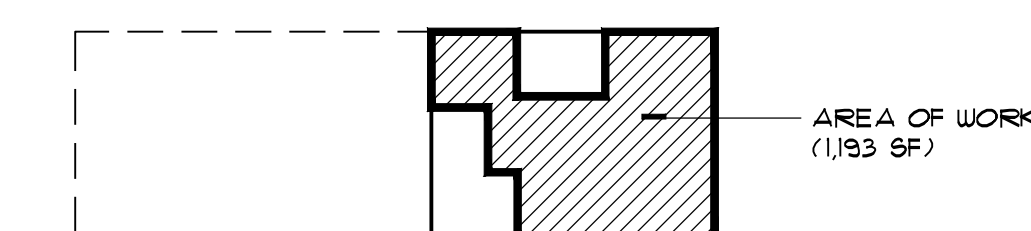

LOWER LEVEL PLAN

KEY PLANS



**MEP ABBREVIATIONS**

A	GENERAL SERVICE COMPRESSED AIR	FDC	FIRE DEPARTMENT CONNECTION
a	48" ABOVE FINISHED FLOOR	FDV	FIRE DEPARTMENT VALVE
A/AMP	AMPERE	FHC	FIRE HOSE CABINET
AC	AIR COMPRESSOR	FM	FLOW METER
AC	ALTERNATING CURRENT	FMC	FLEXIBLE METALLIC TUBING
ACD	AUTOMATIC COOLING CONDENSATE PUMP	FOB	FLAT ON BOTTOM
ACU	AIR CONDITIONING UNIT(S)	FOT	FLAT ON TOP
AD	ACCESS DOOR	FP	FIRE PUMP
AD	AREA DRAIN	FFM	FEET PER MINUTE
AF	ARC FAULT	FE	FEET PER SECOND
AFF	ABOVE FINISHED FLOOR	FS	FLOOR SINK
AFG	ABOVE FINISHED GRADE	FT	FOOT OR FEET
AHU	AIR HANDLING UNIT	FVC	FIRE VALVE CABINET
AMB	AMPS INTERRUPTING CURRENT		
ANN	ANNUNCIATOR	G	GAS
ANSI	AMERICAN NATIONAL STANDARDS INSTITUTE	GA	GAUGE
APD	AIR PRESSURE DROP	GAL	GALLONS
APPROX	APPROXIMATE	GE	GROUNDING ELECTRODE CONDUCTOR
ATC	AUTOMATIC TEMPERATURE CONTROL	GF	GROUND FAULT
ATS	AUTOMATIC TRANSFER SWITCH	GND	GROUND
AV	ACID VENT (CHEMICAL)	GPM	GALLONS PER HOUR
AVG	AVERAGE	GPM	GALLONS PER MINUTE
AVTR	ACID VENT THRU ROOF	GR	GRAINS
AW	ACID WASTE	GRU	GREASE RECOVERY UNIT
AWG	AMERICAN WIRE GAUGE	GW	GREASE WASTE
AWT	AVERAGE WATER TEMPERATURE	GWA	GREASE WASTE ABOVE GRADE
		GWB	GREASE WASTE BURIED
		GWH	GAS WATER HEATER
b	42" ABOVE FINISHED FLOOR		
BCT	BONDING CONDUCTOR FOR TELECOMMUNICATIONS	H	HEIGHT
BDD	BACK DRAFT DAMPER	H/C	HEATING/COOLING
CAT	COMMUNITY ANTENNA TELEVISION	HC	HEATING COIL
BICSI	BUILDING INDUSTRY CONSULTING SERVICE INTERNATIONAL	HC	HORIZONTAL CROSS-CONNECT
BNC	BAYONET NEIL-CONCELMAN	HD	HEAD
BSMT	BASEMENT	HDCP	HANDICAP
BTU	BRITISH THERMAL UNITS	HP	HORSEPOWER
BTUH	BRITISH THERMAL UNITS/HOUR	HR	HOUR(S)
		HT	HEAT
c	CEILING MOUNTED	HTR	HEATING/VENTILATION UNIT
C	CONDUIT(S)	HVAC	HEATING, VENTILATION AND AIR CONDITIONING
C/B	CIRCUIT BREAKER	HW	HOT WATER
CAT	CATEGORY ETHERNET CABLE	HWR	HOT WATER RETURN
CCTV	CLOSED CIRCUIT TELEVISION	HWRP	HOT WATER RETURN PUMP
CC	COOLING COIL	HWRP	HOT WATER REVERSE RETURN
CCTV	CLOSED CIRCUIT TELEVISION	HWS	HOT WATER SUPPLY
CFM	CUBIC FEET PER MINUTE	HX	HEAT EXCHANGER
CI	CAST IRON	HZ	FREQUENCY (CYCLES PER SECOND)
CKT	CIRCUIT		
CLG	CEILING	IC	INTERMEDIATE CROSS-CONNECT
CLGWTR	COOLING WATER	IC	INSIDE DIAMETER
CO	CLEANOUT	IDC	INSIDE DISPLACEMENT CONNECTOR
CO2	CARBON DIOXIDE	IG	ISOLATED GROUND
COAX	COAXIAL CABLE	IN	INCHES
COMP	COMPRESSOR	IN WG	INCHES OF WATER, GAUGE (PRESSURE)
COND	CONDENSER	IW	INDIRECT WASTE
CONV	CONVECTOR		
COP	COPPER CABLING	JB	JUNCTION BOX
CP	CONDENSATE PUMP	JP	JOCKEY PUMP
CPU	CENTRAL PROCESSING UNIT		
CT	CABLE TRAY	KH-WST	KITCHEN HOT WATER STORAGE TANK
CT	CURRENT TRANSFORMER	KVA	KILOVOLT AMPERE
CU	CONDENSING UNIT	KW	KILOWATT
CU FT	CUBIC FEET	KWH	KITCHEN WATER HEATER
CUH	CABINET UNIT HEATER		
CV	COEFFICIENT, VALVE FLOW	L	LENGTH
CV	CONSTANT VOLUME	L/LS	LOCAL SOUND SPEAKER
CVP	CEILING VIDEO PRESENTATION	LAN	LOCAL AREA NETWORK
CW	COLD WATER	LAT	LEAVING AIR TEMPERATURE
		LAV	LAVATORY
D	DATA	LBS/HR	POUNDS PER HOUR
D	DEPTH	LF	LINEAR FEET
DA	DISTRIBUTOR A	LG	LABORATORY GAS
DB	DISTRIBUTOR B	LQ	LIQUID
DB	DRY BULB TEMPERATURE	LV	LABORATORY VACUUM
dB	DECIBEL	LVP	LOW VIDEO PRESENTATION
DC	DIRECT CURRENT	LWT	LEAVING WATER TEMPERATURE
DC	DISTRIBUTOR C		
DCV	DOUBLE CHECK VALVE	MA	MEDICAL COMPRESSED AIR
DE	DEIONIZED PROCESS WATER	MA	MILLIAMPERE
DEG or °	DEGREE	MA	MIXED AIR
DEMARC	DEMARCATION	MAGR	MASTER ALARM GAS PANEL
DET	DOMESTIC EXPANSION TANK (PLUMBING)	MAX	MAXIMUM
DI	DISTILLED WATER	MBH	BTU PER HOUR (THOUSAND)
DI	DIA or DIAMETER	MC	MAIN CROSS-CONNECT
DN	DOWN	MC	METAL CLAD CABLE
DP	DIFFERENTIAL PRESSURE	MCC	MOTOR CONTROL CENTER
DWBP	DOMESTIC WATER BOOSTER PUMP	MD	MOTORIZED DAMPER
DWG	DRAWING	MECH	MECHANICAL
DX	DIRECT EXPANSION	MFR	MANUFACTURER
		MH	METAL HALIDE
EA	EXHAUST AIR	MIN	MINIMUM
EAT	ENTERING AIR TEMPERATURE	MLO	MAIN LUGS ONLY
EBR	ELECTRIC BASEBOARD RADIATION	MM	MULTI-MODE
EDR	EQUIVALENT DIRECT RADIATION	MV	MEDICAL VACUUM
ELEC	ELECTRICAL		
ELEV	ELEVATOR	N2	NITROGEN
EM	EMERGENCY	N2O	NITROUS OXIDE
EMNL	EMERGENCY/NIGHT LIGHT WALK-THRU	N.C.	NORMALLY CLOSED
EMI	ELECTROMAGNETIC INTERFERENCE	N.O.	NORMALLY OPEN
EMT	ELECTRICAL METALLIC TUBING	N/A	NOT APPLICABLE
ER	EQUIPMENT ROOM	NEC	NATIONAL ELECTRICAL CODE
ESP	EXTERNAL STATIC PRESSURE	NIC	NOT IN CONTRACT
ETP	ELECTRIC TRAP PRIMER	NL	NIGHT LIGHT WALK-THRU
EVAP	EVAPORATOR	NTS	NOT TO SCALE
EWB	ENTERING WET BULB TEMPERATURE	O	OXYGEN
EWC	ELECTRIC WATER COOLER	OA	OUTSIDE AIR
EWH	ELECTRIC WATER HEATER	OD	OUTSIDE DIAMETER
EWTR	ENTERING WATER TEMPERATURE	OF	OPTICAL FIBER
EXH	EXHAUST	ORD	OVERFLOW ROOF DRAIN
EXP	EXPANSION	ORWL	OVERFLOW RAIN WATER LEADER
		P	POLE
F	FAHRENHEIT	PA	PUBLIC ADDRESS
FA	FIRE ALARM	PBX	PRIVATE BRANCH EXCHANGE
FC	FOOT CANDLE	PD	PRESSURE DROP
FD	FIRE DAMPER	PE	PRIMARY ELECTRIC SERVICE
FD	FLOOR DRAIN	PF	POWER FACTOR

PH / Ø	PHASE	QTY	QUANTITY
PIV	POST INDICATOR VALVE	R	RELAY
PNL	PANELBOARD	RA	RETURN AIR
POE	POWER OVER ETHERNET	RD	ROOF DRAIN
PP	PATCH PANEL	RE	EXISTING EQUIPMENT TO BE DISCONNECTED AND REMOVED
PR	PRESSURE	REF	REFRIGERANT PIPING (MULTIPLE PIPES)
PR	PRESSURE	REF	ROOF EXHAUST FAN
PRV	PRESSURE REDUCING VALVE	RF	RELIEF FAN
PSI	POUNDS PER SQUARE INCH	RGS	RIGID GALVANIZED STEEL CONDUIT
PT	POTENTIAL TRANSFORMER	RH	RELATIVE HUMIDITY
PVC	POLYVINYL CHLORIDE	RHC	REHEAT COIL
		RHG	REFRIGERANT HOT GAS
		RL	REMOVE AND RELOCATED
		RM	ROOM
		RMS	ROOT MEAN SQUARED
		RO	REVERSE OSMOSIS WATER
		RPD	REVERSE PRESSURE DEVICE
		RPM	REVOLUTIONS PER MINUTE
		RTU	ROOF TOP UNIT
		RJ	RAJACK UNIT
		RV	RAIN WATER LEADER
		RWL	RAIN WATER LEADER
		s	SWITCHED RECEPTACLE
		S	SLEEVE(S)
		SOIL	SOIL
		S&R	SUPPLY AND RETURN
		S&R	SUPPLY AIR
		SAC	SHOP AIR COMPRESSOR
		SCC	SPRINKLER CONTROL CABINET
		SE	SECONDARY ELECTRIC SERVICE
		SEP	SEWAGE EJECTOR PUMP
		SM	SINGLE-MODE
		SP	STANDPIPE
		SP	STATIC PRESSURE
		SP	SUMP PUMP
		SPDT	SINGLE POLE DOUBLE THROW
		SPEC	SPECIFICATION
		SPK	SPRINKLER
		SPK/SP	COMBINED SPRINKLER/ STANDPIPE
		SPST	SINGLE POLE SINGLE THROW
		SQ	STAIRWELL
		SS	STAINLESS STEEL
		ST	STORM
		STD	STANDARD
		STD	SHIELDED TWISTED PAIR
		SUCT	SUCTION
		SW	SWITCH
		SWBD	SWITCHBOARD
		SWH	STEAM WATER HEATER
		T*STAT	THERMOSTAT
		TAG	IDENTIFICATION OF EQUIPMENT
		TBB	TELECOMMUNICATIONS BONDING BACKBONE
		TD	TEMPERATURE DIFFERENCE
		TE	TELECOMMUNICATIONS ENCLOSURE
		TEBC	TELECOMMUNICATIONS EQUIPMENT BONDING CONDUCTOR
		TEL	TELECOMMUNICATIONS SERVICE
		TEMP	TEMPERATURE
		TGB	TELECOMMUNICATIONS GROUNDING BUSBAR
		TIA	TELECOMMUNICATIONS INDUSTRY ASSOCIATION
		TIMGB	TELECOMMUNICATIONS MAIN GROUNDING BUSBAR
		TMV	THERMOSTATIC MIXING VALVE
		TP	TAMPERPROOF
		TP	TRAP PRIMER
		TR	TELECOMMUNICATIONS ROOM
		TS	TELEPHONE SERVICE
		TSP	TOTAL STATIC PRESSURE
		TV	TELEVISION
		TVS	TRANSIENT VOLTAGE SUPPRESSOR
		TW	TEMPERED WATER
		TWR	TEMPERED WATER RETURN
		TX	TRANSFORMER
		TYP	TYPICAL
		U	USB
		UF	UNFUSED
		UH	UNIT HEATER
		UPS	UNINTERRUPTIBLE POWER SUPPLY
		UR	UNSHIELDED TWISTED PAIR
		UTP	UNSHIELDED TWISTED PAIR
		V	VENT
		V	VOICE
		V	VOLTAGE
		V	VOLT AMPERE
		VAC	VACUUM
		VAV	VARIABLE AIR VOLUME
		VD	VOLUME DAMPER
		VEL	VELOCITY
		VFC	VARIABLE FREQUENCY CONTROLLER
		VIF	VERIFY IN FIELD
		VOIP	VOICE OVER INTERNET PROTOCOL
		VOL	VOLUME
		VTR	VENT THRU ROOF
		W	WALL TELEPHONE
		W	WASTE
		W	WATT
		WAO	WORK AREA OUTLET
		WAP	WIRELESS ACCESS POINT
		WB	WET BULB TEMPERATURE
		WC	WATER CLOSET
		WG	WIREGUARD
		WH	WALL HYDRANT (HOSE BIBB)
		WHA	WATER HAMMER ARRESTER
		WI	WIDTH
		WP	WEATHERPROOF
		WPD	WATER PRESSURE DROP
		WTR	WATER
		WV	WASTE AND VENT COMBINATION
		WWM	WELDED WIRE MESH

**GENERAL**

- THE PROJECT DRAWINGS AND SPECIFICATIONS ARE BASED ON THE CONSTRUCTION SPECIFICATIONS INSTITUTE (CSI) DOCUMENTATION FORMAT. SPECIFICATION AND DRAWING CONTENTS ARE ARRANGED BY TOPIC AND CATEGORY AND ARE NOT INTENDED TO AWARD DIVISION OF WORK.
- THE INTENT OF THESE DOCUMENTS IS FOR THE MEP TRADES TO FURNISH AND INSTALL COMPLETE MECHANICAL AND ELECTRICAL SYSTEMS. THE SPECIFIED FIRE PROTECTION, PLUMBING, HVAC, ELECTRICAL, AND SPECIAL SYSTEMS SHALL BE COMPLETE IN ALL RESPECTS, OPERATIONAL, TESTED, ADJUSTED, CALIBRATED, APPROVED BY THE AUTHORITIES HAVING JURISDICTION AND READY FOR BENEFICIAL USE BY THE OWNER.
- THE TRADES SHALL OBTAIN AND REVIEW ALL CONTRACT DOCUMENTS BEFORE SUBMITTING A BID. INFORMATION IS PROVIDED ON THE VARIOUS DRAWINGS, SCHEDULES AND FINISHES AND ALL OF THE VARIOUS DOCUMENTS IN THE BIDDING PACKAGE. THE CONTRACT DOCUMENTS ARE COMPLEMENTARY AND FORM A TOTAL PROJECT DESIGN AND INFORMATION SOURCE FOR CONSTRUCTION PURPOSES.
- THE DRAWINGS ARE DIAGRAMMATIC AND INDICATE THE GENERAL ARRANGEMENT OF SYSTEMS AND WORK INCLUDED IN THE CONTRACT. COORDINATE LOCATIONS OF EQUIPMENT WITH OTHER TRADES BEFORE AND DURING CONSTRUCTION. ANY MODIFICATION TO THE EQUIPMENT LAYOUT, REQUIRED FOR INSTALLATION, IS TO BE PERFORMED UNDER THE CONTRACT AGREEMENT, AT NO ADDITIONAL COST.
- REFER TO THE ARCHITECTURAL DRAWINGS FOR THE EXACT LOCATION AND MOUNTING HEIGHTS OF VARIOUS EQUIPMENT. ALL SUCH EQUIPMENT AND EQUIPMENT COLORS AND FINISHES SHALL BE COORDINATED WITH THE ARCHITECT. MOUNTING HEIGHTS SHALL BE APPROVED BY THE ARCHITECT.
- PERFORM ALL WORK IN COMPLIANCE WITH THE SPECIFICATIONS, APPLICABLE CODES, ORDINANCES AND THE REGULATORY AGENCIES HAVING JURISDICTION. THE SPECIFICATIONS MAY EXCEED THE REQUIREMENTS OF THE CODE, IN WHICH CASE, THE SPECIFICATION MUST BE FOLLOWED.
- INSTALL ALL EQUIPMENT IN ACCESSIBLE LOCATIONS. WHERE EQUIPMENT MUST BE INSTALLED ABOVE AN INACCESSIBLE CEILING OR BEHIND A WALL, AN APPROPRIATE ACCESS DOOR SHALL BE PROVIDED AND THE LOCATION SHALL BE COORDINATED WITH THE ARCHITECT.
- COORDINATE PIPING AND CONDUITS ENTERING OR LEAVING THE BUILDING WITH THE SITE CONTRACTOR(S) BEFORE INSTALLATION. COORDINATE INVERTS WITH THE STRUCTURE AND SYSTEM REQUIREMENTS PRIOR TO INSTALLATION.
- WHERE A CONFLICT OCCURS BETWEEN THE DOCUMENTS, IT SHALL BE BROUGHT TO THE ATTENTION OF THE ARCHITECT. CARRY AS PART OF THE BID THE LARGER QUANTITY AND/OR MORE EXPENSIVE ITEM(S).
- BEFORE INSTALLATION, COORDINATE THE WORK WITH OWNER-FURNISHED EQUIPMENT, INCLUDING REQUIRED SERVICE CONNECTIONS, FACTORY START UPS AND INSTALLATION OF FIELD DEVICES.
- PROVIDE THE REQUIRED/SPECIFIED SLEEVES AND SEALS FOR PIPES OR CONDUIT PENETRATING INTERIOR AND EXTERIOR WALLS OR FLOOR SLABS.
- INSTALL FLOOR-MOUNTED EQUIPMENT ON A CONCRETE HOUSEKEEPING PAD.
- SEISMICALLY SUPPORT THE EQUIPMENT AS REQUIRED BY CODE. THE AUTHORITY HAVING JURISDICTION, AND/OR AS SPECIFIED. SUBMIT ENGINEERED INSTALLATION DETAILS PER THE SPECIFICATIONS. THE CONTRACTOR'S SEISMIC ENGINEER SHALL REVIEW THE INSTALLATION AND PROVIDE A REPORT ON THE FINDINGS.
- PROVIDE MEP COORDINATION DRAWINGS AS REQUIRED BY THE SPECIFICATIONS.
- ENCLOSED CONTROLLERS SHALL BE PROVIDED BY THE CONTRACTOR PROVIDING THE EQUIPMENT INCLUDING AN ENCLOSED CONTROLLER. REQUIREMENTS ARE SPECIFIED UNDER DIVISION 26 "ENCLOSED CONTROLLERS". MOTOR EFFICIENCIES SHALL BE AS INDICATED IN THE SPECIFICATIONS.
- PROVIDE PIPING, DUCTWORK, CONDUIT AND ALL OTHER ACCESSORIES AS REQUIRED FOR PROPER AND PROFESSIONAL SYSTEMS INSTALLATION.
- TEST AND BALANCE ALL MECHANICAL AND ELECTRICAL SYSTEMS. PROVIDE ADDITIONAL TESTS AS REQUIRED BY THE SPECIFICATIONS.
- DO NOT INSTALL PIPING OR DUCTWORK OVER ELECTRICAL PANELS, TRANSFORMERS, SPECIAL EQUIPMENT, ELEVATOR MACHINE ROOMS OR SHAFTS.
- DO NOT INSTALL ANY SYSTEMS OR THROUGH ELEVATOR MACHINE ROOMS THAT DO NOT SERVE THE ROOM. MAINTAIN A MINIMUM OF SEVEN (7) FOOT HEAD CLEARANCE IN THE ELEVATOR MACHINE ROOM.
- DO NOT INSTALL IN STAIRWELL OR STAIRWELL WALLS, PIPING, DUCTWORK, CONDUIT OR OTHER DEVICES OR EQUIPMENT NOT ASSOCIATED WITH OR SERVING THE RESPECTIVE STAIR.
- PROVIDE FIRE EXTINGUISHING EQUIPMENT AS REQUIRED BY CODE. THE CONTRACTOR'S CONSULTING ENGINEER SHALL REVIEW THE INSTALLATION AND PROVIDE A REPORT OF THE FINDINGS.
- PROVIDE ADDITIONAL TRANSITIONS AND OFFSETS IN ALL PIPING, DUCTWORK OR CONDUIT FOR COORDINATION WITH BUILDING STRUCTURE AND CONSTRUCTION.
- NO MECHANICAL OR ELECTRICAL SYSTEM COMPONENTS MAY BE SUPPORTED FROM STRUCTURAL BRACED FRAMES.

**RENOVATION**

- THIS PROJECT INVOLVES THE RENOVATION OF AN EXISTING FACILITY. BEFORE SUBMITTING THE BID, CONTRACTORS SHALL VISIT THE SITE AND BECOME THOROUGHLY FAMILIAR WITH THE EXISTING CONDITIONS UNDER WHICH THE PROJECT IS TO BE COMPLETED.
- CONTRACTORS SHALL BE HELD RESPONSIBLE FOR ASSUMPTIONS, OMISSIONS OR ERRORS MADE AS A RESULT OF FAILURE TO BECOME FULLY FAMILIAR WITH THE EXISTING CONDITIONS.
- IT IS NOT THE INTENT OF THESE DOCUMENTS TO SHOW EVERY DEVICE, APPURTENANCE, PIPE, WIRE OR CONDUIT TO BE REMOVED. MEP EQUIPMENT, UNITS, AND SYSTEMS NOT BEING REUSED, SHALL BE REMOVED IN THEIR ENTIRETY INCLUDING ASSOCIATED HANGERS, SUPPORTS, BASES, PADS, PIPES, DUCTS, CONDUITS, WIRES, INSULATION, AND CONTROLS BACK TO THE POINT OF ORIGIN.
- EQUIPMENT, PIPING, OR CONDUIT SHALL NOT BE ABANDONED IN-PLACE UNLESS SPECIFICALLY SO NOTED. PROPERLY DISPOSE OF DEMOLISHED EQUIPMENT IN COMPLIANCE WITH CODES, REGULATIONS, AND DEEP STANDARDS. TURN OVER TO THE OWNER EQUIPMENT SO INDICATED.
- RELOCATE EXISTING EQUIPMENT, DEVICES, PIPING, AND RELATED SYSTEMS AS REQUIRED FOR CONSTRUCTION PURPOSES. ALL EXISTING SYSTEMS SHALL BE FULLY OPERATIONAL, INCLUDING RECONNECTION TO SERVICES AND UPGRADED SYSTEMS. ALL RELOCATED EQUIPMENT SHALL BE PROTECTED DURING CONSTRUCTION.
- PROVIDE TEMPORARY CONNECTIONS AND SYSTEM MODIFICATIONS AS REQUIRED FOR CONSTRUCTION AND PHASING PURPOSES.
- INCLUDE ALL WORK REQUIRED TO ALLOW PHASED CONSTRUCTION WHEN NECESSARY. COORDINATE WITH GENERAL CONTRACTOR/CONSTRUCTION MANAGER FOR PHASING REQUIREMENTS.
- ALL EXISTING EQUIPMENT, FIXTURES, AND DEVICES TO BE REMOVED AND RELOCATED SHALL BE FIELD VERIFIED FOR EXACT QUANTITY AND CONDITION. KEEP AN ACCURATE RECORD OF STORED EQUIPMENT AND ITS CONDITION.
- REBALANCE NEW AND EXISTING MECHANICAL AND ELECTRICAL SYSTEMS ASSOCIATED WITH THE RENOVATION, INCLUDING RENOVATED AREAS AND AREAS AFFECTED BY SYSTEM MODIFICATIONS.
- SYSTEMS REQUIRING TO REMAIN IN OPERATION DURING DEMOLITION SHALL BE CAREFULLY PROTECTED FROM DAMAGE AND CONTAMINATION BY THE CONSTRUCTION PROCESS.

**HVAC**

- PROVIDE DUCT TAKE-OFF TYPES AND VOLUME DAMPERS PER THE SPECIFICATIONS AND DUCT TAKE-OFF DETAILS ON DRAWINGS. TAKE-OFFS SHOWN ON FLOOR PLANS DO NOT REPRESENT THE SPECIFIC TYPE OF TAKE-OFF REQUIRED. CONSULT THE DETAILS AND SPECIFICATIONS.
- EXT. TO AUTOMATIC TEMPERATURE CONTROL, SYSTEM COMPLETE IN ALL REGARDS. ALL ZONES, AND SYSTEMS SHALL BE THERMOSTATICALLY CONTROLLED. REVIEW THE PLANS AND SPECIFICATIONS OF ALL MEP TRADES FOR A COMPLETE SCOPE OF THE WORK.
- PIPING SHALL BE SUPPORTED FROM STRUCTURE ABOVE. TO MAXIMIZE HEAD ROOM, INSTALL TIGHT TO BOTTOM OF BEAMS WHEN RUNNING PERPENDICULAR TO BEAM. INSTALL PIPING TIGHT TO FLOOR SLAB WHEN RUNNING PARALLEL TO BEAM. PROVIDE ALL NECESSARY FITTINGS AND TRANSITIONS.
- PROVIDE AIR VENTS AT ALL HIGH POINTS AND DRAINS AT ALL LOW POINTS.
- PROVIDE FIRE DAMPERS AT DUCT PENETRATIONS OF FIRE-RATED CONSTRUCTION, INCLUDING WALLS, SHAFTS AND FLOOR PENETRATIONS. COORDINATE WITH ARCHITECTURAL DRAWINGS.

**MEP GENERAL NOTES**

**ELECTRICAL**

- IT IS NOT THE INTENTION TO SHOW EVERY FITTING, WIRE, OR DEVICE. ALL SUCH ITEMS SHALL BE FURNISHED AND INSTALLED AS NECESSARY FOR A COMPLETE SYSTEM.
- CONCEAL RACEWAYS IN FINISHED AREAS. RACEWAYS WITHIN MECHANICAL AND ELECTRICAL ROOMS MAY BE SURFACE-MOUNTED.
- DO NOT INSTALL CONDUIT IN CONCRETE SLABS, UNLESS SPECIFICALLY APPROVED BY THE STRUCTURAL ENGINEER.
- EACH INDIVIDUAL ELECTRICAL HOMERUN SHOWN ON FLOOR PLANS, DETAILS, OR SCHEDULES SHALL BE PROVIDED IN A DEDICATED RACEWAY.
- SERIES RATING OF PROTECTIVE ISOLATION DEVICES AND/OR ELECTRICAL EQUIPMENT IS UNACCEPTABLE. ALL ELECTRICAL EQUIPMENT AND PROTECTIVE DEVICES SHALL BE "FULLY" RATED.
- PROVIDE POWER TO MECHANICAL EQUIPMENT SHOWN ON MECHANICAL PLANS, RISERS, SCHEDULES, OR IN SPECIFICATIONS. MECHANICAL EQUIPMENT IS NOT NECESSARILY SHOWN ON ELECTRICAL PLANS. REFER TO MECHANICAL PLANS AND SCHEDULES ON MEP DRAWINGS FOR LOCATIONS AND SPECIFIC ELECTRICAL REQUIREMENTS. COORDINATE EXACT LOCATION AND ORIENTATION OF EQUIPMENT WITH OTHER TRADES. MAKE CONNECTIONS TO LUMINAIRES IN ACCORDANCE WITH THE DETAILS SHOWN ON THE DRAWINGS.
- PROVIDE SWITCHING, AND OCCUPANCY SENSORS AND NORMAL CIRCUIT MONITORING AS PER THE DETAILS.
- EXIT SIGNS ARE NOT NECESSARILY SHOWN WIRED ON THE DRAWINGS. PROVIDE SINGLE CIRCUIT EXIT SIGNS WITH BATTERY BACKUP; CONNECT POWER TO THE UN-SWITCHED LIGHTING CIRCUIT IN THE AREA SERVED BY THE EXIT SIGN.
- CONNECT EMERGENCY POWER UNITS (BATTERY DRIVERS) OR EMERGENCY LIGHTING UNITS TO LINE SIDE OF SWITCHING. THESE UNITS MUST MONITOR THE NORMAL LIGHTING CIRCUIT WITHIN THE SPACE.
- REFER TO THE ARCHITECTURAL REFLECTED CEILING PLANS FOR THE EXACT LOCATION OF ALL CEILING MOUNTED LUMINAIRES SHOWN ON ELECTRICAL PLANS.
- PROVIDE GROUND FAULT RECEPTACLES WITHIN SIX FEET (6') OF SINK OR OTHER WATER SOURCE; PROVIDE GROUND FAULT WEATHER PROOF RECEPTACLES AT ALL EXTERIOR LOCATIONS.

**TECHNOLOGY**

- COORDINATE WITH CONSTRUCTION MANAGER, OTHER TRADES AND THE OWNER DURING ALL PHASES. ALL COMMUNICATIONS MUST BE MAINTAINED AT ALL TIMES UNLESS PHASING REQUIRES OTHERWISE. INTERRUPTIONS AND SHUTDOWNS SHALL BE SCHEDULED IN ADVANCE AND APPROVED FOR TIME TO COMPLETE WORK. TAG CABLES TO REMAIN DURING ALL PHASES TO PROPERLY KEEP THE TELECOMMUNICATIONS ACTIVE. UPON COMPLETION OF CONSTRUCTION, ANY CABLES THAT ARE NOT ACTIVE OR TAGGED TO REMAIN FOR FUTURE USE SHALL BE REMOVED PER THE NEC.
- BEFORE CONSTRUCTION CAN BEGIN IN ANY TELECOMMUNICATIONS ROOM (TR) OR TELECOMMUNICATIONS EQUIPMENT ROOM (ER) THE CONTRACTOR SHALL COORDINATE LAYOUT LOCATIONS AND CLEARANCES OF ALL EQUIPMENT WITH THE TECHNOLOGY OWNER TO APPROVE THE INSTALLATIONS AND ANY FUTURE SPACE. REFER TO THE ARCHITECTURAL DRAWINGS FOR THE EXACT LOCATION AND MOUNTING HEIGHTS OF EQUIPMENT. ALL SUCH EQUIPMENT AND COLORS SHALL BE COORDINATED WITH THE ARCHITECT. CONTACT ARCHITECT FOR ANY CLARIFICATION.
- REFER TO REFLECTED CEILING PLANS FOR FLUSH MOUNTED CEILING DEVICES.
- PROVIDE SEPARATION BETWEEN RACEWAY, CABLES AND OTHER SOURCES (EMI) PER ANSIT/IA-569-B.
- ELBOW RADIUS FOR RACEWAYS SMALLER THAN 2" TO BE (6) SIX TIMES THE RACEWAY DIAMETER. ELBOW RADIUS FOR CONDUITS 2" OR LARGER TO BE (10) TEN TIMES THE RACEWAY DIAMETER.
- ALL EMPTY RACEWAYS SHALL BE PROVIDED WITH A (PLENUM RATED, IF PLENUM CEILING SPACE) NYLON PULL CORD.
- COORDINATE PROPER METHODS FOR PENETRATIONS WITH FIRESTOPPING AS REQUIRED THROUGH FIRE/SMOKE RATED CONSTRUCTION PER DIVISION 07 SPECIFICATIONS.

GENERAL SYMBOLS	
	THICK, DARK SOLID LINES INDICATE NEW OR RELOCATED ITEMS OR NEW RACEWAY AND WIRING
	THIN, LIGHT LINES INDICATE EXISTING ITEMS OR RACEWAY TO REMAIN IN PLACE AND BE REUSED
	THICK, DASHED LINES INDICATE EXISTING ITEMS TO BE REMOVED
	POINT OF NEW TO EXISTING CONNECTION, INCLUDING TRANSITIONS
EX	SUB LETTERS "EX" INDICATES EXISTING EQUIPMENT TO REMAIN INTACT
RE	SUB LETTER "RE" INDICATES EXISTING EQUIPMENT TO BE DISCONNECTED AND REMOVED
RL	SUB LETTER "RL" INDICATES EXISTING EQUIPMENT TO BE DISCONNECTED, REMOVED AND RELOCATED
NL	SUB LETTER "NL" INDICATES NEW LOCATION OF RELOCATED EQUIPMENT
NR	SUB LETTER "NR" INDICATES NEW EQUIPMENT TO REPLACE EXISTING
RR	SUB LETTER "RR" INDICATES REMOVE EQUIPMENT AND REPLACE ON NEW SURFACE
*	* = a, b, dg, AF, GF, IG OR TP. WHEN TAGGED IN THE ELECTRICAL SYMBOL LIST, REFER TO THE ABBREVIATION LIST

HVAC SYMBOLS	
	RECTANGULAR, FLAT OVAL OR ROUND AIR DUCT
	AIR DUCT WITH ACOUSTICAL LINING
	SUPPLY AIR DUCT UP
	SUPPLY AIR DUCT DOWN
	RETURN AIR DUCT UP
	RETURN AIR DUCT DOWN
	EXHAUST AIR DUCT UP
	EXHAUST AIR DUCT DOWN
	ACCESS DOOR
	FLEXIBLE DUCT CONNECTION
	CEILING SUPPLY DIFFUSERS
	CEILING RETURN / EXHAUST GRILLE
	HARD DUCTED DIFFUSER OR GRILLE WITH FULL SIZE BOTTOM TAKE-OFF
	DIRECTION OF SUPPLY OR OUTDOOR AIRFLOW DIRECTION OF RETURN OR EXHAUST AIRFLOW DOOR UNDERCUT
	BACK DRAFT DAMPER
	VOLUME DAMPER
	FIRE DAMPER
XXX	SUPPLY PIPING. REFER TO ABBREVIATION LIST FOR DESIGNATION (XXX)
XXX	RETURN PIPING. REFER TO ABBREVIATION LIST FOR DESIGNATION (XXX)
EHC	ELECTRICAL HEATING CABLE. REFER TO ABBREVIATION LIST FOR DESIGNATION (XXX)
	MOTORIZED DAMPER
	DUCT SMOKE DETECTOR WITH REMOTE INDICATING LIGHT AND TEST SWITCH
	DUCT STATIC PRESSURE SENSOR
	DIFFERENTIAL PRESSURE SENSOR
	ROOM THERMOSTAT OR TEMPERATURE SENSOR
	ROOM TEMPERATURE WITH CARBON DIOXIDE SENSOR
	CARBON MONOXIDE SENSOR
	CARBON DIOXIDE SENSOR
	FINNED TUBE RADIATION
	VAV PERFORMANCE TAG
	FIN TUBE TAG

DUCT SIZING	
20x12	RECTANGULAR DUCT
200	ROUND DUCT
20/12	FLAT OVAL DUCT

FITTINGS AND VALVES	
	PIPE ANCHOR
	BACKFLOW PREVENTER
	STRAINER OR STRAINER WITH BLOW-DOWN VALVE HOSE END, CAP AND CHAIN
	WALL CLEANOUT OR BLIND FLANGE
	"T" TRAP
	PIPE TEE DOWN
	IN-LINE EXPANSION COMPENSATOR
	FLOOR CLEANOUT
	STEAM TRAP ASSEMBLY
	STEEL PENETRATION / PIPE SLEEVE
	PIPE ELBOW UP OR PIPE TEE UP
	PIPE ELBOW DOWN
	COMPANION FLANGE
	PIPE CAP OR CAPPED END OF PIPE
	UNION
	PIPE GUIDES
	PUMP
	WATER HAMMER ARRESTOR
	TAKEOFF FROM TOP OF MAIN PIPE
	TAKEOFF FROM BOTTOM OF MAIN PIPE
	DIRECTION OF FLUID FLOW
	VALVE ON RISER
	VALVE ON DROP
	METERING ORIFICE
	AIR VENT
	FLOW SENSOR
	PIPE DROP WITH VALVE
	2-WAY CONTROL VALVE
	3-WAY CONTROL VALVE
	BALL VALVE
	CALIBRATED BALANCING VALVE
	SHUT-OFF VALVE (SEE SPECIFICATIONS FOR APPLICATION TYPE)
	BUTTERFLY VALVE
	CHECK VALVE
	THERMOSTATIC MIXING VALVE
	GLOBE VALVE
	GATE VALVE
	PRESSURE REDUCING VALVE
	GAS COCK
	TRIPLE DUTY VALVE
	OS&Y VALVE
	FUSOMATIC VALVE (FIREMATIC)
	DRAIN VALVE WITH HOSE END, CAP & CHAIN OR WALL HYDRANT / HOSE BIBB
	MOTORIZED BUTTERFLY VALVE
	PRESSURE RELIEF SAFETY VALVE
	AQUASTAT
	SOLENOID VALVE
	TEMPERATURE SENSOR WITH SEPARABLE SOCKET IN IMMERSIBLE WELL
	TEMPERATURE GAUGE WITH SEPARABLE SOCKET IN IMMERSIBLE WELL
	THERMOMETER WITH SEPARABLE SOCKET IN IMMERSIBLE WELL
	PRESSURE GAUGE
	PRESSURE SENSOR WITH SYPHON (STEAM)
	FLEXIBLE CONNECTOR

ELECTRICAL SYMBOLS	
	PENDANT LIGHT FIXTURE
	LINEAR LIGHT FIXTURE
	PENDANT MOUNTED LIGHT FIXTURE
	RECESSED DOWNLIGHT FIXTURE
	RECESSED WALL WASH DOWNLIGHT FIXTURE
	SURFACE-MOUNTED LIGHT FIXTURE
	WALL-MOUNTED LIGHT FIXTURE
	RECESSED OR SURFACE-MOUNTED FIXTURE
	OPEN LAMP LIGHT FIXTURE
	LIGHTING TRACK (NUMBER OF FIXTURES INDICATED ON PLANS)
	CEILING OR WALL-MOUNTED EXIT LIGHT FIXTURE
	CEILING OR WALL-MOUNTED EMERGENCY LIGHT UNIT
	LIGHT FIXTURE (PART OF EMERGENCY ILLUMINATION SYSTEM)
S	SINGLE-POLE SWITCH
2 S	DOUBLE-POLE SWITCH
3 S	3-WAY SWITCH
4 S	4-WAY SWITCH
P S	SINGLE-POLE SWITCH (TOGGLE LIGHTED - LOAD ON)
L S	LOW VOLTAGE SWITCH
E S	EMERGENCY OFF SWITCH
R S	EMERGENCY LIGHTING RELAY
D S	SINGLE-POLE DIMMER SWITCH
D3 S	THREE-WAY DIMMER SWITCH
K S	SINGLE-POLE KEYED SWITCH
K3 S	KEYED, 3-WAY SWITCH
K4 S	KEYED, 4-WAY SWITCH
	OCCUPANCY SENSOR W / POWER PACK (CEILING / WALL)
OC S	OCCUPANCY SENSOR SWITCH
DL	DAYLIGHTING SENSOR
TC	TIME CLOCK
PC	PHOTOCELL
	EMERGENCY OFF SWITCH WITH COVER
	DUPLEX RECEPTACLE
	DOUBLE DUPLEX RECEPTACLE
	SINGLE RECEPTACLE
	SPECIAL PURPOSE RECEPTACLE, VERIFY NEMA CONFIGURATION WITH EQUIPMENT
	GROUNDING BUSBAR

ELECTRICAL SYMBOLS	
	FURNITURE PARTITION WHIP CONNECTION
	FLOOR SERVICE FITTING WITH OUTLET(S); REFER TO SCHEDULE (X)
	POKE-THRU ASSEMBLY WITH OUTLET(S); REFER TO SCHEDULE (X)
	TELEPOWER POLE WITH OUTLET(S); REFER TO SCHEDULE (X)
	WALL BOX WITH PLATE FOR FURNITURE POWER WITH WHIP CONNECTIONS
	WALL BOX WITH PLATE FOR FURNITURE TELECOMMUNICATIONS WITH WHIP CONNECTIONS
	SURFACE MOUNTED FACTORY PRE-WIRED MULTI-OUTLET RACEWAY
	SURFACE MOUNTED RACEWAY. SEE PLANS OR SCHEDULE FOR QUANTITY OF DEVICES
EHC	ELECTRICAL HEATING CABLE
	SWITCH LEG WIRING
	CONTROL WIRING
XXX	WIRING - REFER TO ABBREVIATION LIST (XXX)
	CIRCUIT BREAKER SIZE
	HOME RUN
	PANEL DESIGNATION
	PANEL DESIGNATION 20A-1P HOME RUN (TYPICAL)
	HOME RUN
	PANEL DESIGNATION POLES/AMPERAGE
	HOME RUN
	PANEL DESIGNATION CIRCUIT NUMBERS
	HOME RUN
	SURFACE ELECTRICAL PANEL, 208Y/120 OR 208 VOLT
	SURFACE SPECIAL-PURPOSE PANEL OR CABINET
	FLUSH ELECTRICAL PANEL, 208Y/120 VOLT
	FLUSH SPECIAL-PURPOSE PANEL OR CABINET
	ENCLOSED SWITCH
	ELECTRIC MOTOR
	JUNCTION BOX
	FIRE ALARM CONTROL PANEL
	FIRE ALARM REMOTE ANNUNCIATOR
	SMOKE DETECTOR
	COMBINATION SMOKE/CARBON MONOXIDE DETECTOR
	HEAT DETECTOR
	REMOTE INDICATOR
	FIRE ALARM MANUAL PULL STATION
	FIRE ALARM HORN / STROBE
	FIRE ALARM STROBE
	FIRE ALARM CEILING-MOUNTED SPEAKER
	PROGRAM BELL
	PUSH PLATE
	DOOR OPERATOR
	CALL-FOR-AID SWITCH W/ CORD
	CALL-FOR-AID LIGHT AND BUZZER
	MAGNETIC DOOR LOCK

COMMUNICATIONS SYMBOLS	
	VOICE OUTLET(S); REFER TO ABBREVIATIONS (X)
	DATA AND VOICE OUTLET(S); REFER TO ABBREVIATIONS (X)
	DATA OUTLET(S); REFER TO ABBREVIATIONS (X)
	SPECIALTY OUTLET(S); REFER TO ABBREVIATIONS (X)
	TELEVISION CATV OUTLET
SECURITY SYMBOLS	
ACCESS CONTROL	
	INTERCOM STATION
	DOOR OPERATOR
	PUSH PLATE
	MAGNETIC DOOR LOCK
	ELECTRONIC DOOR STRIKE
	ELECTRONIC DOOR LATCH RETRACTION
	CARD READER
	REQUEST TO EXIT
	MASTER INTERCOM STATION
	ELECTRONIC DOOR HARDWIRING
INTRUSION DETECTION	
	AUDIBLE SIREN/HORN
	INTRUSION DETECTION PANEL
	GLASS BREAK ALARM
	KEYPAD
	DOOR CONTACT SWITCH
	MOTION DETECTOR
	SOUND DETECTOR

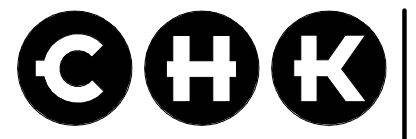

CLOHESSY HARRIS & KAISER LLC

GREYSTONE COURT WEST  
575 HOPKINS STREET  
PO BOX 95  
SIMSBURY, CT 06070-0095  
860-651-3777  
Fax 860-651-7316  
chk@chkarch.com

Consultants



50 Griffin Road South Bloomfield, CT 06002  
Tel: (860) 286-9171 www.bvhis.com

STATE OF CONNECTICUT  
INTERIOR RENOVATIONS AT THE  
OFFICE OF THE PROBATE COURT ADMINISTRATOR

186 NEWINGTON ROAD  
WEST HARTFORD, CT

Revisions	

Date	3/10/2017
Scale	1/8" = 1'-0"
Project Number	17001
Drawn By	DMC / JCK

MEP SYMBOL LIST

MEP002

LUMINAIRE SCHEDULE					
NOTES:					
1. BIDS SHALL BE BASED ON THE LUMINAIRE SCHEDULE BELOW AND THE SPECIFICATIONS. REFER TO THE ELECTRICAL SPECIFICATIONS FOR ADDITIONAL GENERAL REQUIREMENTS.					
TYPE	MANUFACTURER	MODEL	FIXTURE DESCRIPTION	VOLTS	LAMPS
A1	LIGHTOLIER "P6R" OR APPROVED EQUAL	P6RD15NZ10 UVBEM P6RD835 VBP6RDCC SERIES	6" RECESSED LED DOWNLIGHT WITH 0-10V DIMMABLE DRIVER AND 1500 LUMENS. FINISH AND COLOR AS SELECTED BY ARCHITECT.	MVOLT	16 WATTS 1500 LM 3500K LED
A1E	LIGHTOLIER "P6R" OR APPROVED EQUAL	P6RD15NZ10 UVBEM P6RD835 VBP6RDCC SERIES	SAME AS TYPE "A1" EXCEPT WITH MAINTANANCE FREE 90-MINUTE BATTERY BACKUP DRIVER AND INTEGRAL TEST SWITCH AND INDICATOR LIGHT	MVOLT	16 WATTS 1500 LM 3500K LED
B1	LIGHOLIER "C4" OR APPROVED EQUAL	C4RNC4L 158 35WZ10U C4RLWCC SERIES	4" RECESSED LED WALL WASH FIXTURE WITH 0-10V DIMMABLE DRIVER AND 1500 LUMENS. FINISH AND COLOR AS SELECTED BY ARCHITECT.	MVOLT	16 WATTS 1500 LM 3500K LED
B2	LIGHOLIER "C4L" OR APPROVED EQUAL	C4LA15NU Z10VC4L15A 35K9NFC4LACCL SERIES	4" RECESSED, ADJUSTIBLE LED WALL WASH FIXTURE WITH 0-10V DIMMABLE DRIVER AND 1500 LUMENS. FINISH AND COLOR AS SELECTED BY ARCHITECT.	MVOLT	27 WATTS 1500 LM 3500K LED
C1	DAYBRITE "CA" OR APPROVED EQUAL	2CAG34L835-2-DS-UNV-DIM SERIES	2X2 RECESSED INDIRECT/DIRECT LED LUMINAIRE WITH ACRYLIC LINEAR LENS, 0-10V DIMMABLE DRIVER, 3400 LUMENS. FINISH AND COLOR AS SELECTED BY ARCHITECT.	MVOLT	33 WATTS 3400 LM 3500K LED
C1E	DAYBRITE "CA" OR APPROVED EQUAL	2CAG34L835-2-DS-UNV-DIM-EMLED SERIES	SAME AS TYPE "A1" EXCEPT WITH MAINTANANCE FREE 90-MINUTE BATTERY BACKUP DRIVER AND INTEGRAL TEST SWITCH AND INDICATOR LIGHT. PROVIDE DRIVER ENCLOSURE MOUNTED ON TOP OF FIXTURE. PROVIDE ALL INTERCONNECTING WIRING.	MVOLT	33 WATTS 3400 LM 3500K LED
D1	LUMETTA "SMS238" OR APPROVED EQUAL	2CAG34L835-2-DS-UNV-DIM-EMLED SERIES	23" SURFACE MOUNTED DRUM LED LUMINAIRE WITH CHROME FINISH, D66 MT BONE DIFFUSER AND 0-10V DIMMABLE DRIVER. COLOR AND FINISH AS SELECTED BY ARCHITECT	MVOLT	18.9 WATTS 2100 LM 3000K LED
X1	PHILIPS CHLORIDE "CXX" OR APPROVED EQUAL	CXXL3RW SERIES	UNIVERSAL MOUNTING SINGLE FACE LED EXIT SIGN WITH THERMOPLASTIC HOUSING, MAINTANANCE FREE 90-MINUTE BATTERY BACKUP, SELF-TESTING AND SELF-DIAGNOSTIC FEATURE, AND ARROWS AS INDICATED ON PLANS. HOUSING FINISH AND LETTERING COLOR AS SELECTED BY ARCHITECT.	MVOLT	LED
X2	PHILIPS CHLORIDE "CXX" OR APPROVED EQUAL	CXXL3RW SERIES	SAME AS TYPE "A1" EXCEPT WITH DOUBLE FACE	MVOLT	LED

GRILLE AND DIFFUSER SCHEDULE									
CEILING SUPPLY DIFFUSER			DUCTED CEILING RETURN / EXHAUST GRILLE		NON-DUCTED CEILING RETURN / EXHAUST GRILLE		FLEXIBLE DUCT SIZES TO SUPPLY DIFFUSERS		
CFM	SQUARE NECK SIZE	ROUND NECK SIZE	CFM	NECK SIZE	CFM	NECK SIZE	CFM	SIZE	
0-100	6 x 6	6"Ø	0-350	12 x 12	0-350	12 x 12	0-100	6"Ø	
101-250	9 x 9	8"Ø	351-1200	22 x 22	351-1200	22 x 22	101-250	8"Ø	
251-400	12 x 12	10"Ø					251-400	10"Ø	
401-600	15 x 15	12"Ø					401-600	12"Ø	
601-800	18 x 18	14"Ø					601-800	14"Ø	

TYPE	MODEL (TITUS)	DESCRIPTION
A1	TDC	SQUARE LOUVER FACE CEILING SUPPLY DIFFUSER WITH REMOVABLE CORE, LAY-IN, 1-WAY THROW. TRANSITIONAL ADAPTER.
A2	TDC	SQUARE LOUVER FACE CEILING SUPPLY DIFFUSER WITH REMOVABLE CORE, LAY-IN, 2-WAY CORNER THROW. TRANSITIONAL ADAPTER.
A3	TDC	SQUARE LOUVER FACE CEILING SUPPLY DIFFUSER WITH REMOVABLE CORE, LAY-IN, 3-WAY THROW. TRANSITIONAL ADAPTER.
A4	TDC	SQUARE LOUVER FACE CEILING SUPPLY DIFFUSER WITH REMOVABLE CORE, LAY-IN, 4-WAY THROW. TRANSITIONAL ADAPTER.
A5	TDC	SQUARE LOUVER FACE CEILING SUPPLY DIFFUSER WITH REMOVABLE CORE, LAY-IN, 2-WAY OPPOSITE THROW. TRANSITIONAL ADAPTER.
B	355 RL	LOUVER TYPE CEILING/WALL RETURN OR EXHAUST GRILLE, 35° FIXED DEFLECTION, 1/2" SPACING WITH BLADES PARALLEL TO THE LONG DIMENSION.
E	300RS	WALL SUPPLY GRILLE, DOUBLE DEFLECTION WITH ADJUSTABLE VERTICAL FRONT BLADES, 3/4" BLADE SPACING.

NOTES:  
[1] COLOR SELECTION BY ARCHITECT

FIN TUBE RADIATION - ELECTRIC							
TAG	MFR	MODEL NO.	W PER LF	TOTAL KW	LENGTH	MIN. CABINET SIZE W x H	REMARKS
RAD	VULCAN	SBF	150	1.5	SEE PLANS	3" W x 5" H	[1] [2] [3] [4]
ELECTRICAL							
TAG	VOLTS / PHASE	HOME RUN	BRANCH CIRCUIT SIZE		SW / FUSE		
RAD-1	120/1	20A-1P PB	3/4" C - 2 #12 & 1 #12 GND		TOGGLE		
RAD-2	120/1	20A-1P PB	3/4" C - 2 #12 & 1 #12 GND		TOGGLE		
RAD-3	120/1	20A-1P PB	3/4" C - 2 #12 & 1 #12 GND		TOGGLE		

NOTES:  
[1] ENCLOSURE FINISH AS SELECTED BY ARCHITECT  
[2] ENCLOSURE TO BE 14 GAUGE STEEL  
[3] PROVIDE BUILT-IN DISCONNECT SWITCH  
[4] PROVIDE UNIT WITH FRONT INTAKE AND TOP DISCHARGE



CLOHESSY HARRIS & KAISER LLC

GREYSTONE COURT WEST  
575 HOPKINSON STREET  
PO BOX 95  
SIMSBURY, CT 06070-0095  
860-651-3777  
Fax 860-651-7316  
chk@chkarch.com

ARCHITECTURE - INTERIOR DESIGN - FACILITIES PLANNING

Consultants



50 Griffin Road South Bloomfield, CT 06002  
Tel: (860) 286-9171 www.bvhis.com

STATE OF CONNECTICUT  
INTERIOR RENOVATIONS AT THE  
OFFICE OF THE PROBATE COURT ADMINISTRATOR  
186 NEWINGTON ROAD  
WEST HARTFORD, CT

Revisions  
\_\_\_\_\_  
\_\_\_\_\_  
\_\_\_\_\_  
\_\_\_\_\_

Date 3/10/2017  
Scale N.T.S.  
Project Number 17001  
Drawn By DMC / JCK

MEP003

MEP SCHEDULES



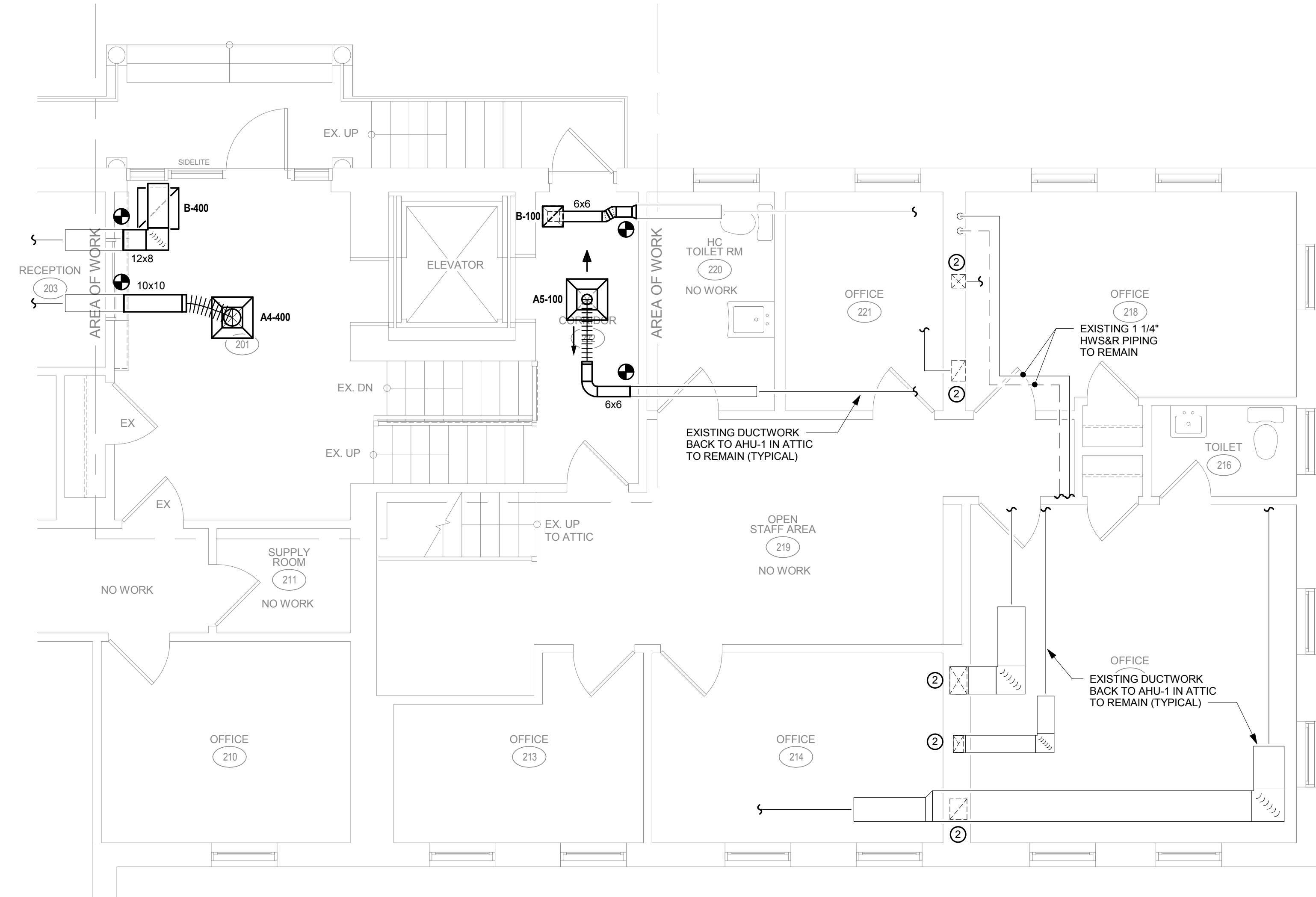
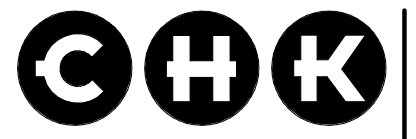

1 UPPER LEVEL HVAC PLAN  
SCALE: 1/4" = 1'-0"

**HVAC SEQUENCES OF OPERATION**  
EXISTING AHU-1 AND AHU-2:  
1. OPERATE ACCORDING TO EXISTING SEQUENCE OF OPERATIONS.  
EXISTING SPLIT SYSTEM AIR CONDITIONERS:  
1. OPERATE ACCORDING TO EXISTING SEQUENCE OF OPERATIONS.  
ELECTRIC BASEBOARD RADIATION:  
1. ROOM TEMPERATURE SENSOR SHALL CYCLE ELECTRIC RADIATION ON AND OFF. COORDINATE SEQUENCES SO THAT SPACE SPLIT SYSTEM OR AIR HANDLING UNIT IS FIRST CALL FOR HEATING.

**GENERAL NOTES**  
1. EXISTING DUCTWORK AND PIPING LAYOUT BASED ON DESIGN DRAWINGS FROM 1991 AND LIMITED FIELD SURVEY. DUCTWORK AND PIPING LAYOUT MAY VARY FROM ROUTING IN FIELD.  
2. PRIOR TO DEMOLITION, MEASURE AND RECORD AIRFLOW VALUES OF ALL DIFFUSERS AND GRILLES WITHIN SCOPE OF WORK AREA. REPORT VALUES TO ENGINEER.  
3. ALL DUCTWORK OPENINGS FROM DEMOLITION SHALL BE PROPERLY CAPPED AND SEALED AIR TIGHT.  
4. EXISTING DUCTWORK, PIPING, GRILLES, DIFFUSERS, MECHANICAL EQUIPMENT, AND CONTROLS TO REMAIN UNLESS NOTED OTHERWISE.

**DRAWING NOTES**  
① BALANCE EXISTING SUPPLY DIFFUSER TO 290 CFM AND EXISTING RETURN GRILLE TO 275 CFM.  
② EXISTING DUCT RISER TO REMAIN.  
③ INSTALL RADIATION UNIT TIGHT TO WALL, COORDINATE WITH MANUFACTURER'S REQUIRED CLEARANCES.

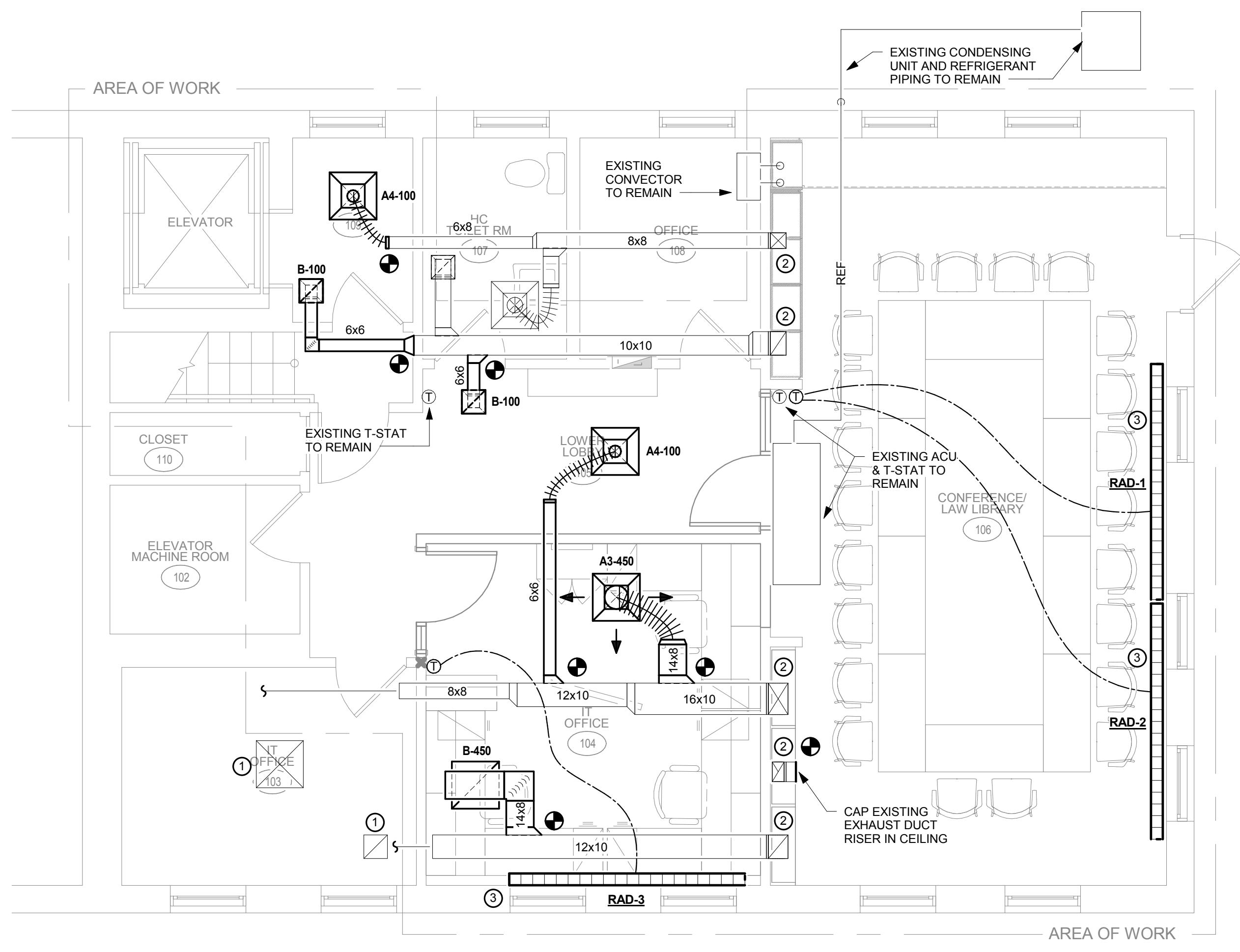

2 LOWER LEVEL HVAC PLAN  
SCALE: 1/4" = 1'-0"

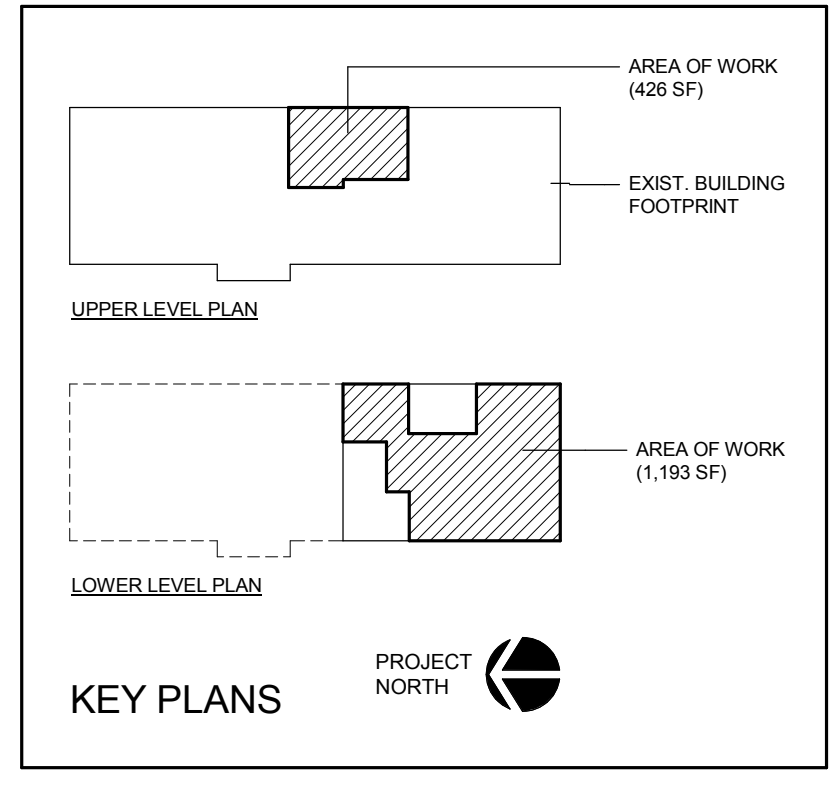

REFER TO MEP DRAWINGS FOR ADDITIONAL INFORMATION.

LOWER LEVEL AND UPPER LEVEL HVAC PLANS

Consultants  
 **BVH** integrated services  
50 Griffin Road South Bloomfield, CT 06002  
Tel: (860) 286-9171 www.bvhis.com

STATE OF CONNECTICUT  
INTERIOR RENOVATIONS AT THE  
OFFICE OF THE PROBATE COURT ADMINISTRATOR  
186 NEWINGTON ROAD  
WEST HARTFORD, CT

Revisions

Date 3/10/2017  
Scale 1/4" = 1'-0"  
Project Number 17001  
Drawn By DMC

H101

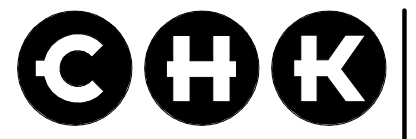

Consultants



50 Griffin Road South Bloomfield, CT 06002  
Tel: (860) 286-9171 www.bvhis.com

STATE OF CONNECTICUT  
INTERIOR RENOVATIONS AT THE  
OFFICE OF THE PROBATE COURT ADMINISTRATOR  
186 NEWINGTON ROAD  
WEST HARTFORD, CT

Revisions	

Date 3/10/2017  
Scale NOT TO SCALE  
Project Number 17001  
Drawn By DMC

HVAC DETAILS

H201

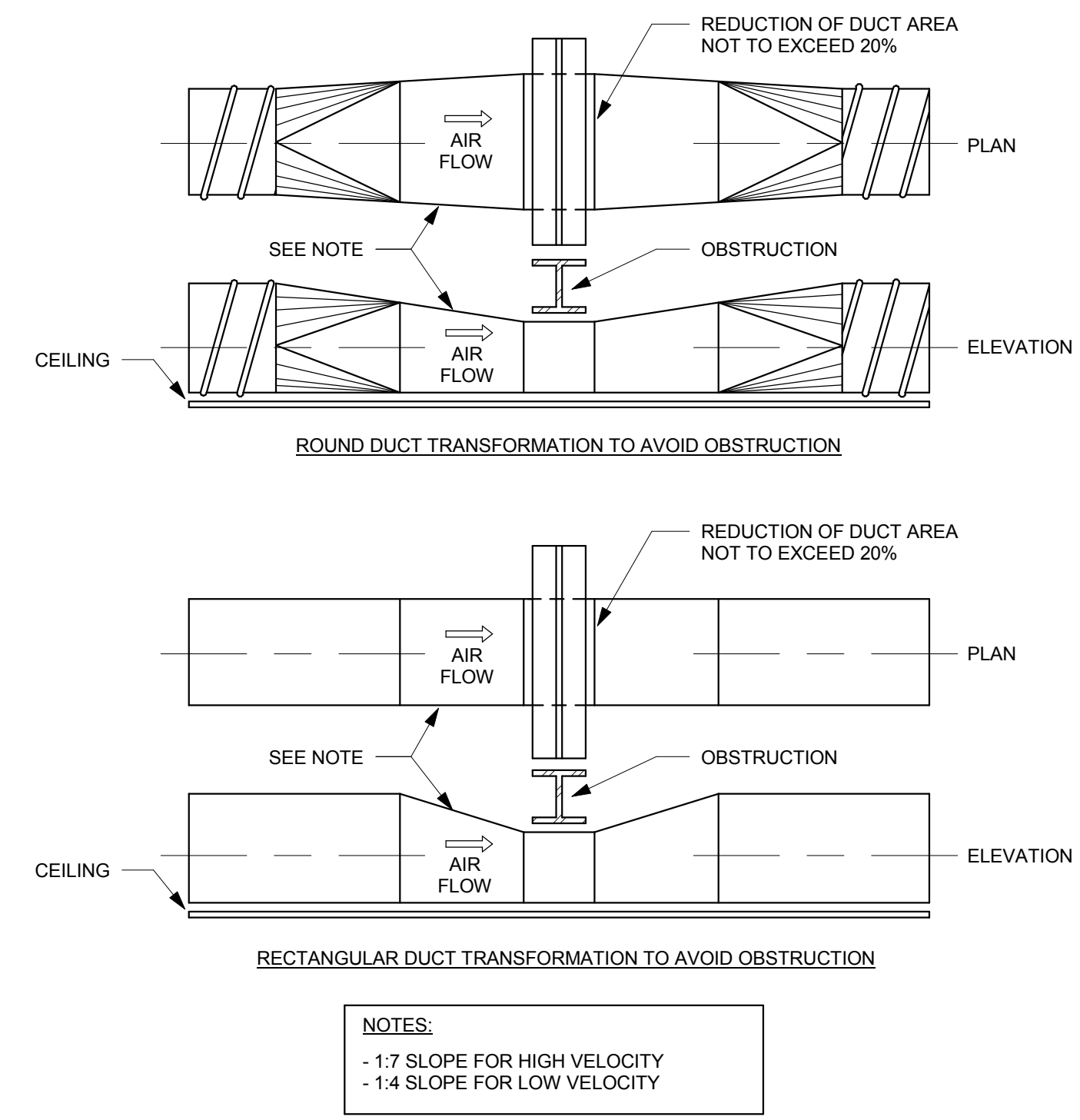

DUCT OBSTRUCTION TRANSFORMATION DETAILS  
NOT TO SCALE

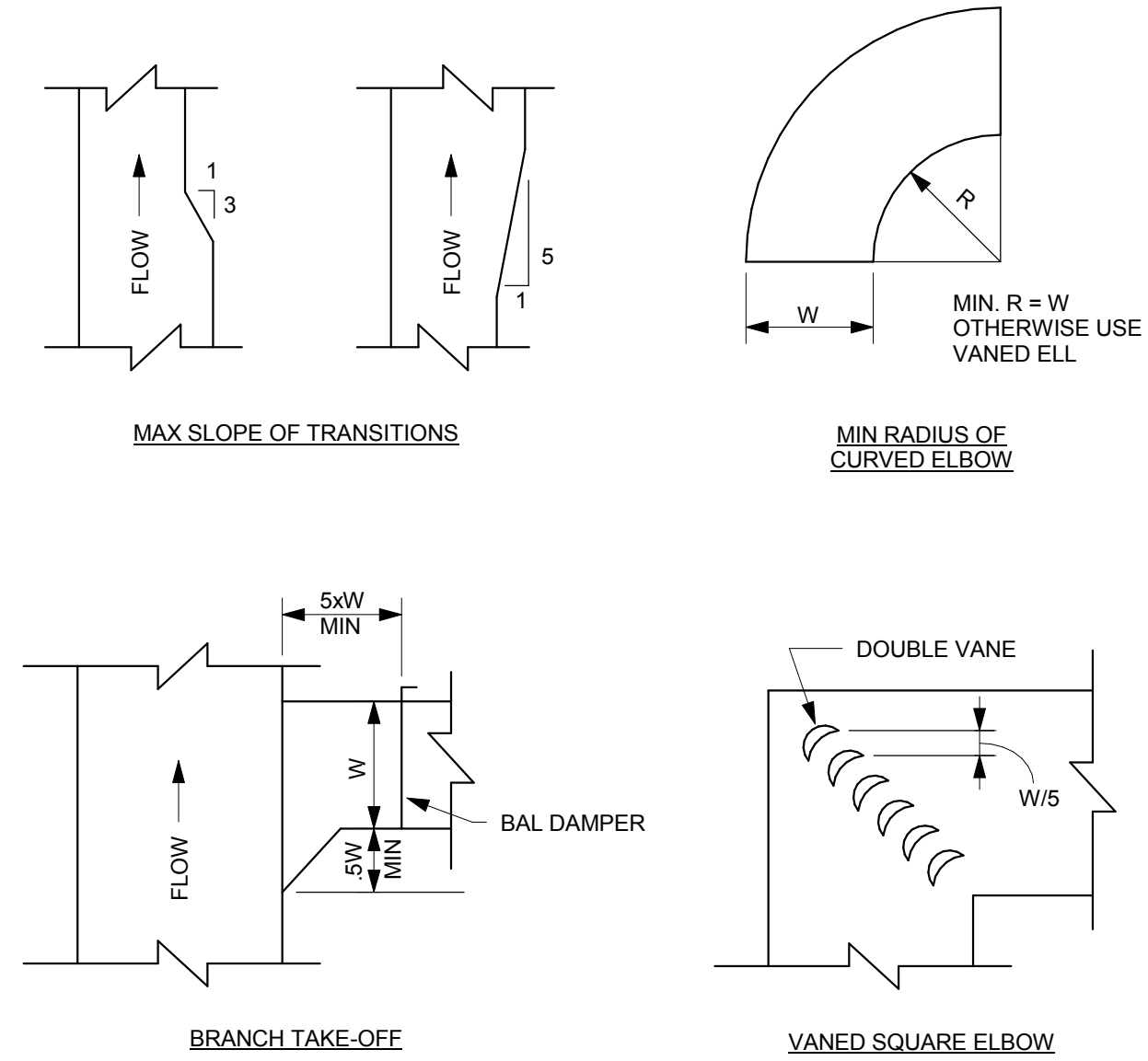

DUCT CONSTRUCTION  
NOT TO SCALE

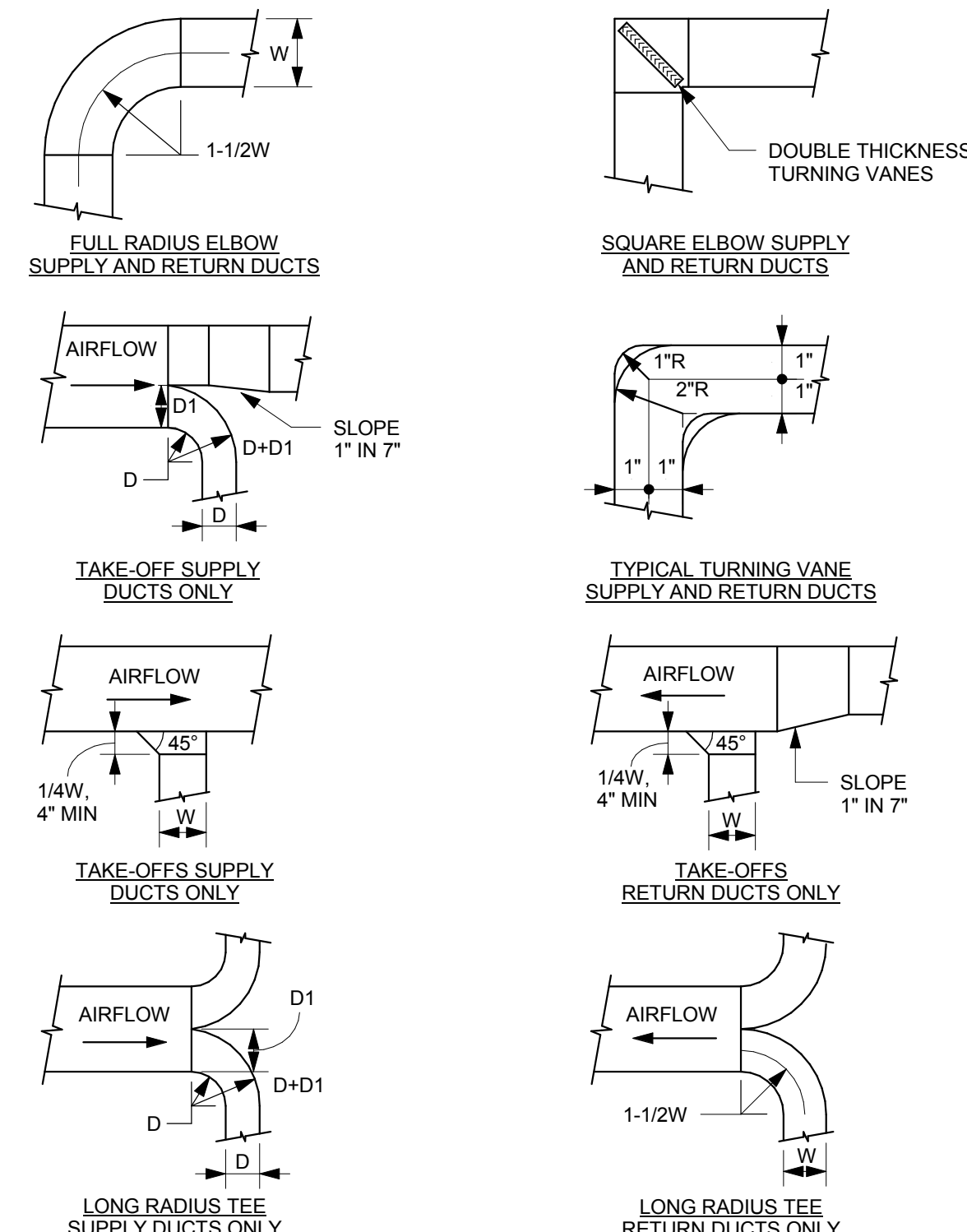

DUCT DETAILS  
NOT TO SCALE

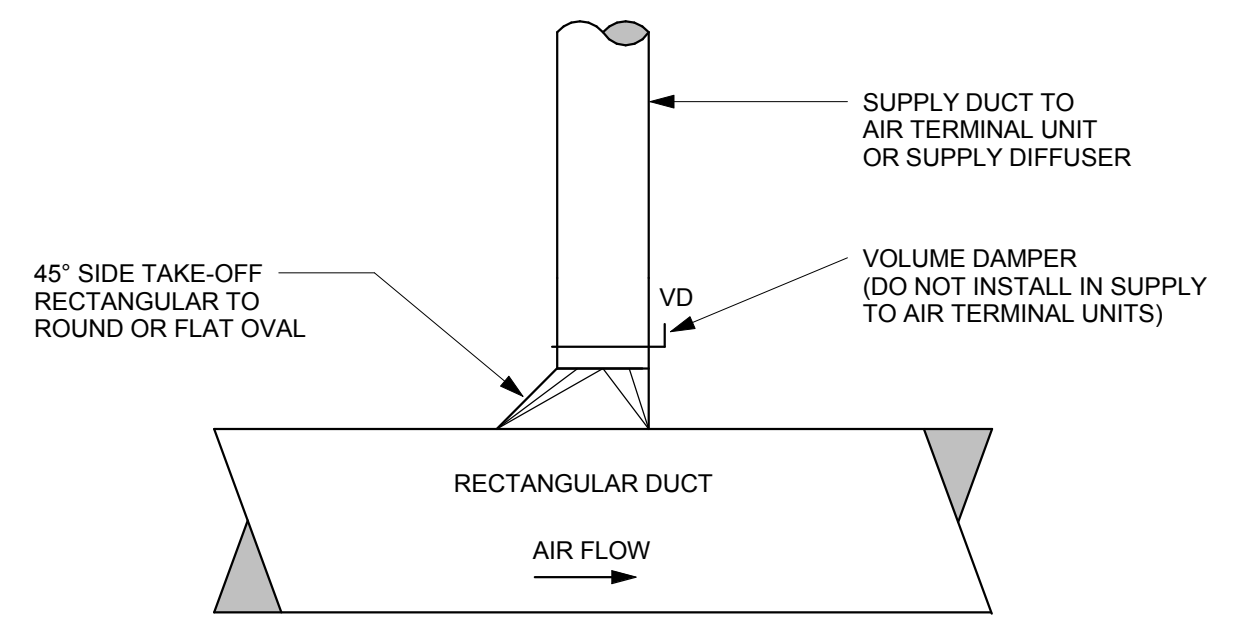

45° SUPPLY AIR TAKEOFF DETAIL  
NOT TO SCALE

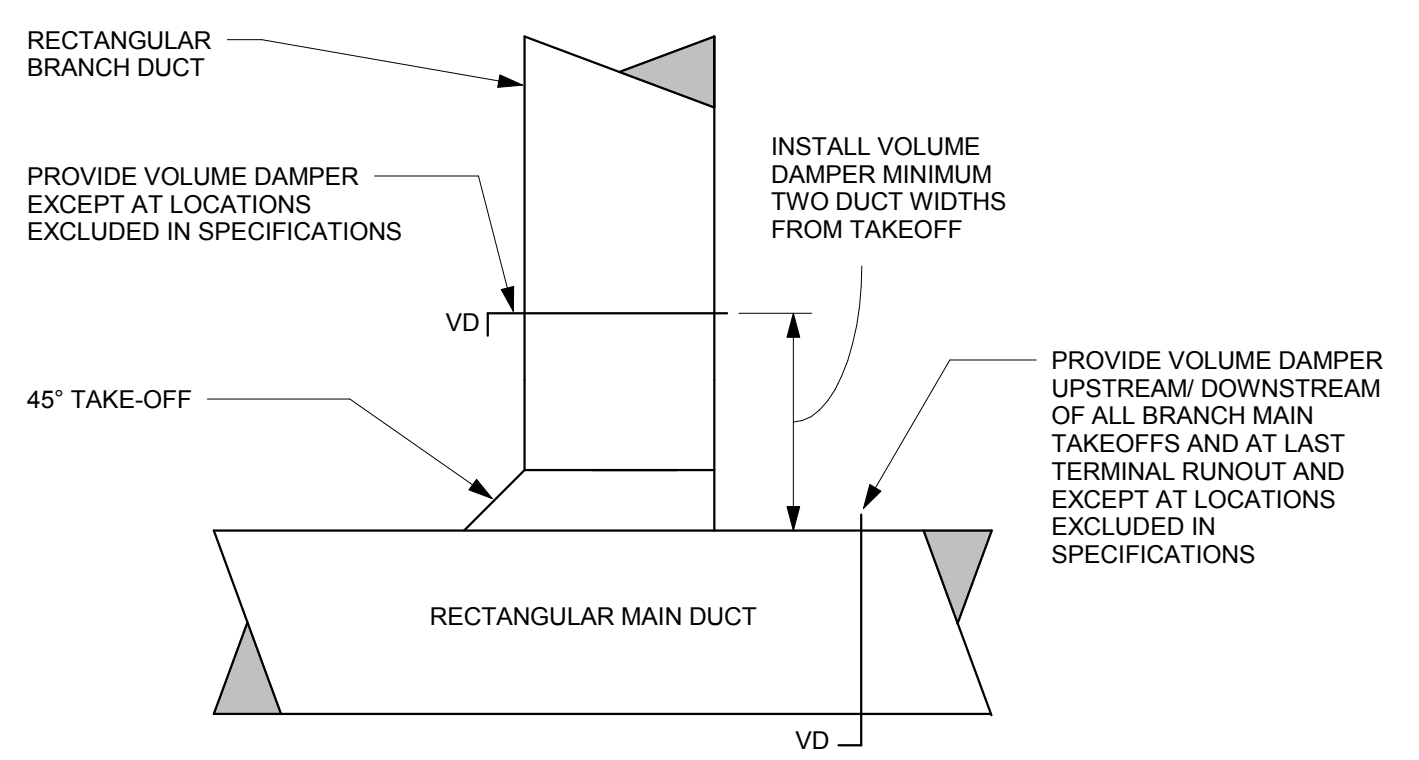

RECTANGULAR BRANCH DUCT TAKEOFF DETAIL  
NOT TO SCALE

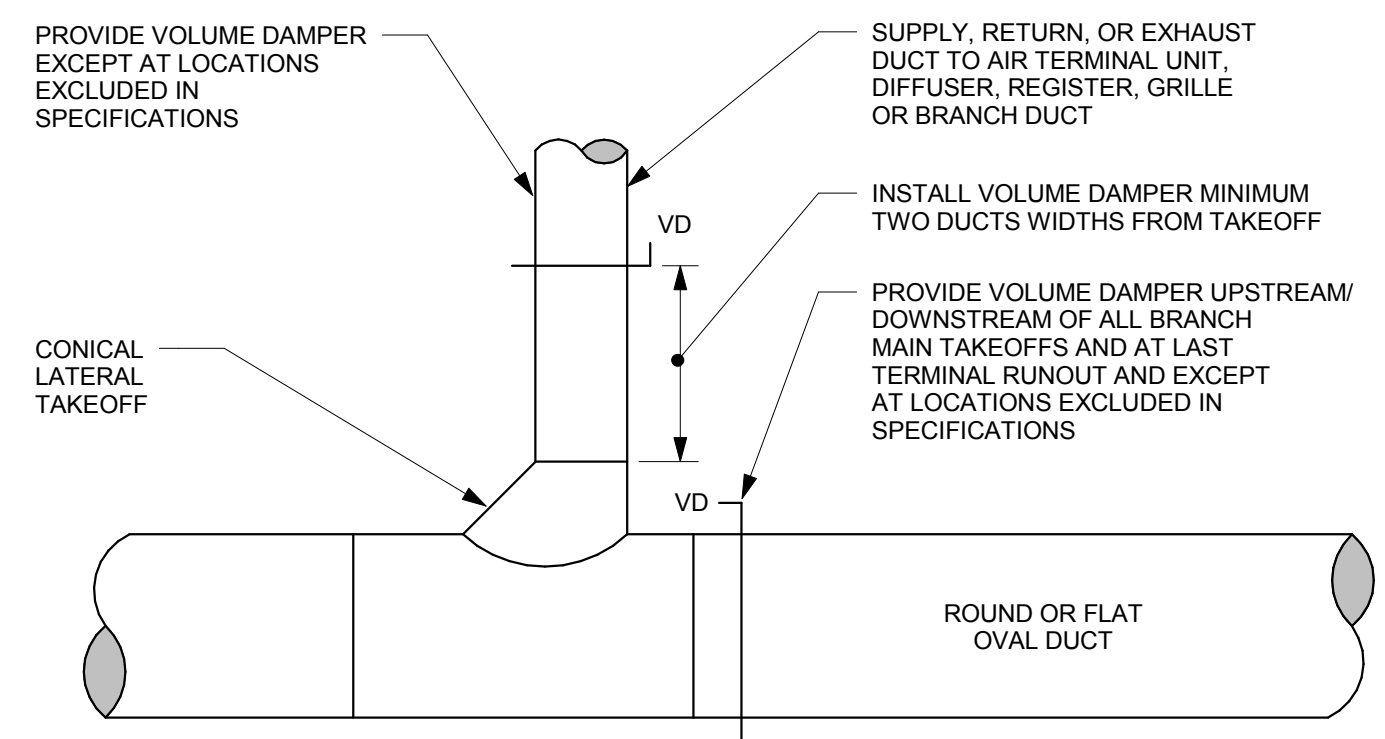

ROUND / FLAT OVAL DUCT TAKEOFF DETAIL  
NOT TO SCALE

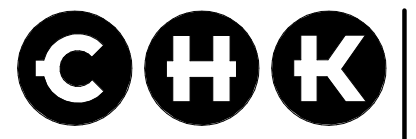

CLOHESSY  
HARRIS &  
KAISER LLC

GREYSTONE COURT WEST  
573 HOPMEADOW STREET  
PO BOX 95  
SIMSBURY, CT 06070-0095  
860-651-3777  
Fax 860-651-7316  
chk@chkarch.com

ARCHITECTURE - INTERIOR DESIGN - FACILITIES PLANNING

Consultants



STATE OF CONNECTICUT  
INTERIOR RENOVATIONS AT THE  
OFFICE OF THE PROBATE COURT ADMINISTRATOR

186 NEWINGTON ROAD  
WEST HARTFORD, CT

Revisions

Date 3/10/2017  
Scale 1/4" = 1'-0"  
Project Number 17001  
Drawn By JCK

ED01

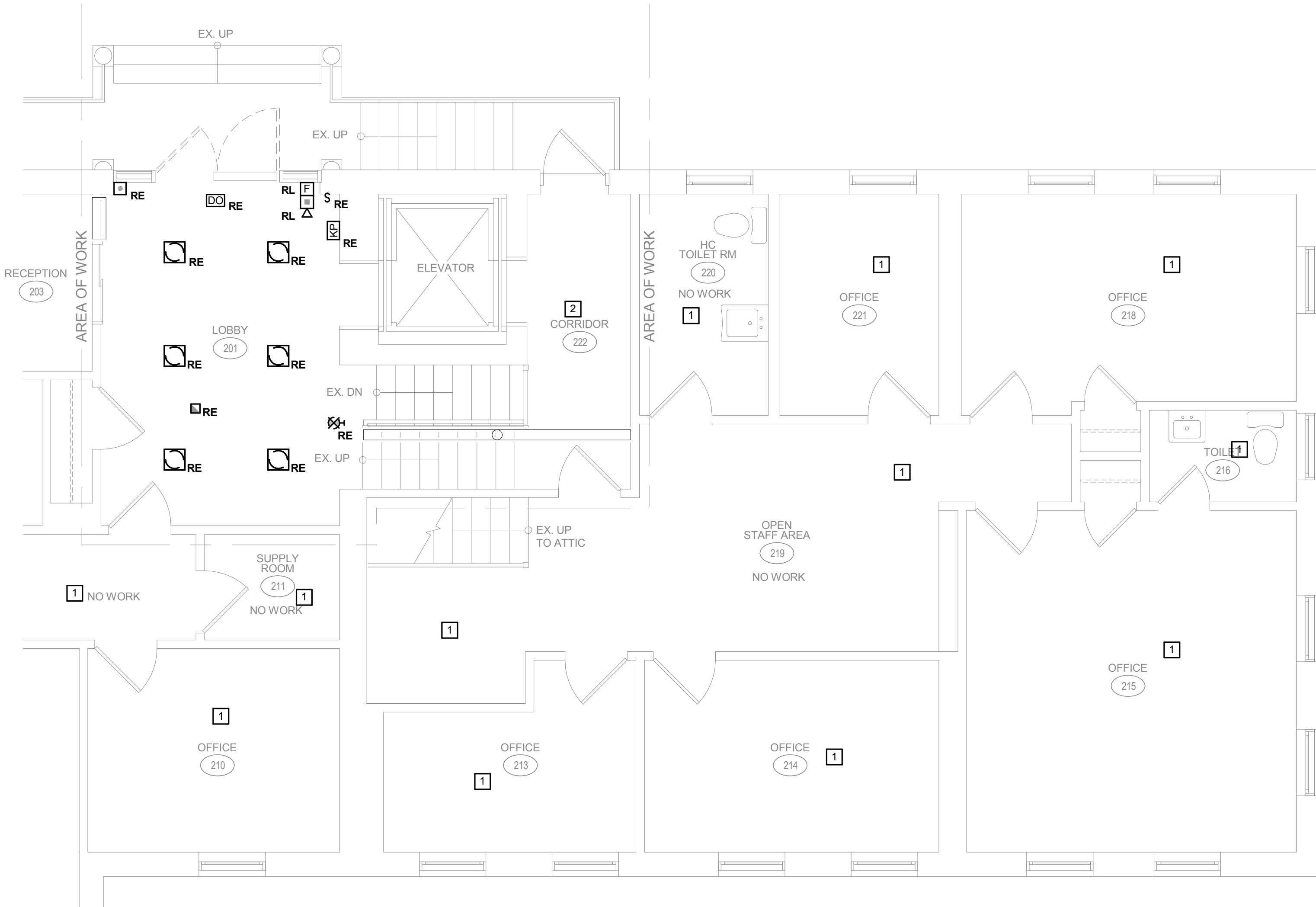

1 UPPER LEVEL ELECTRICAL DEMOLITION PLAN  
SCALE: 1/4" = 1'-0"

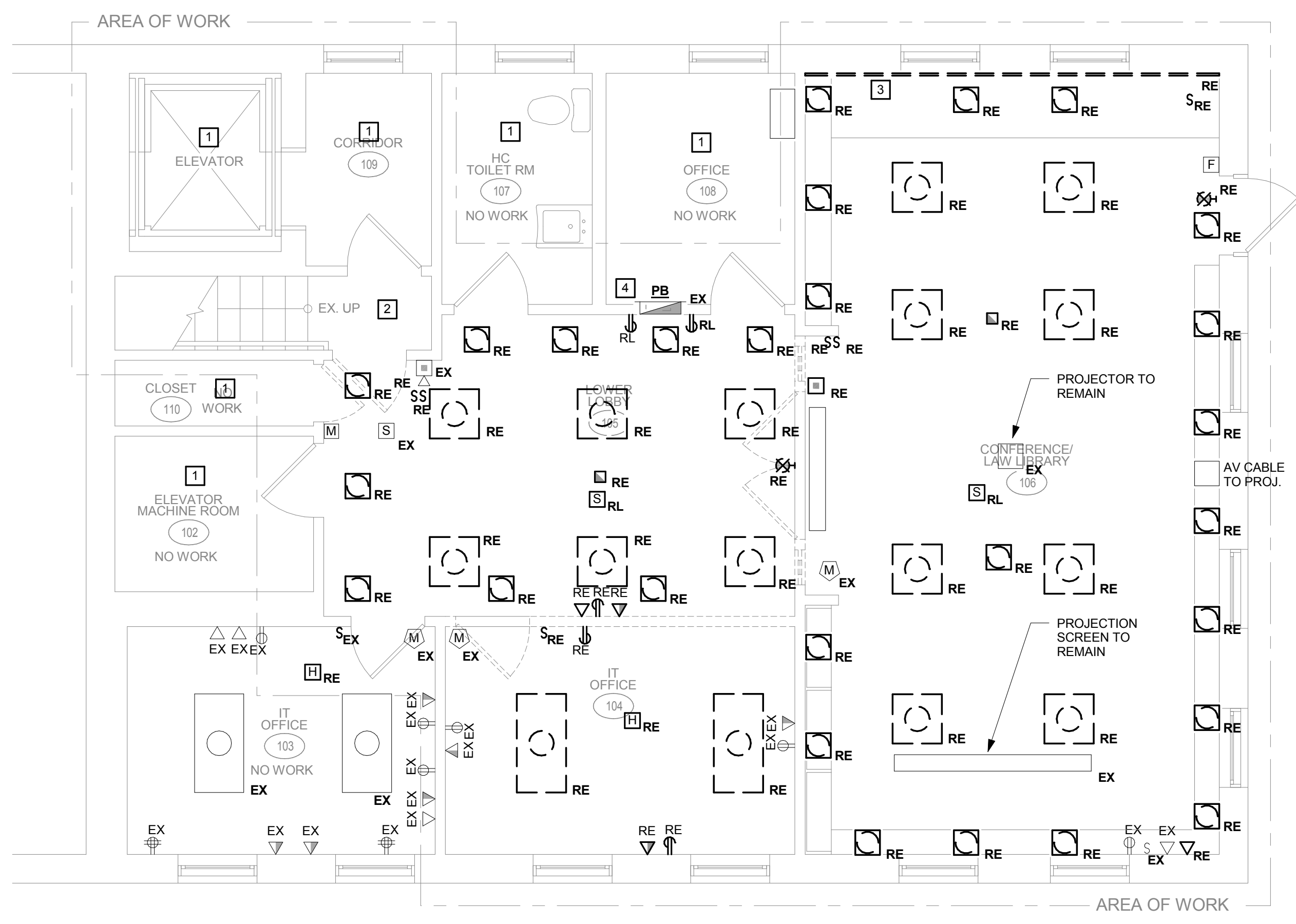

2 LOWER LEVEL ELECTRICAL DEMOLITION PLAN  
SCALE: 1/4" = 1'-0"



- DEMOLITION NOTES**
- 1 EXISTING ELECTRICAL DEVICES AND WIRING IN THIS AREA SHALL REMAIN. MAINTAIN BRANCH CIRCUIT CONTINUITY OF AREAS THAT MAY BE AFFECTED BY DEMOLITION AND/OR SCOPE OF WORK.
  - 2 EXISTING LIGHTING IN THIS AREA TO BE DISCONNECTED AND REMOVED.
  - 3 EXISTING PLUGMOLD TO BE DISCONNECTED AND REMOVED.
  - 4 EXISTING PANEL PB TO REMAIN.

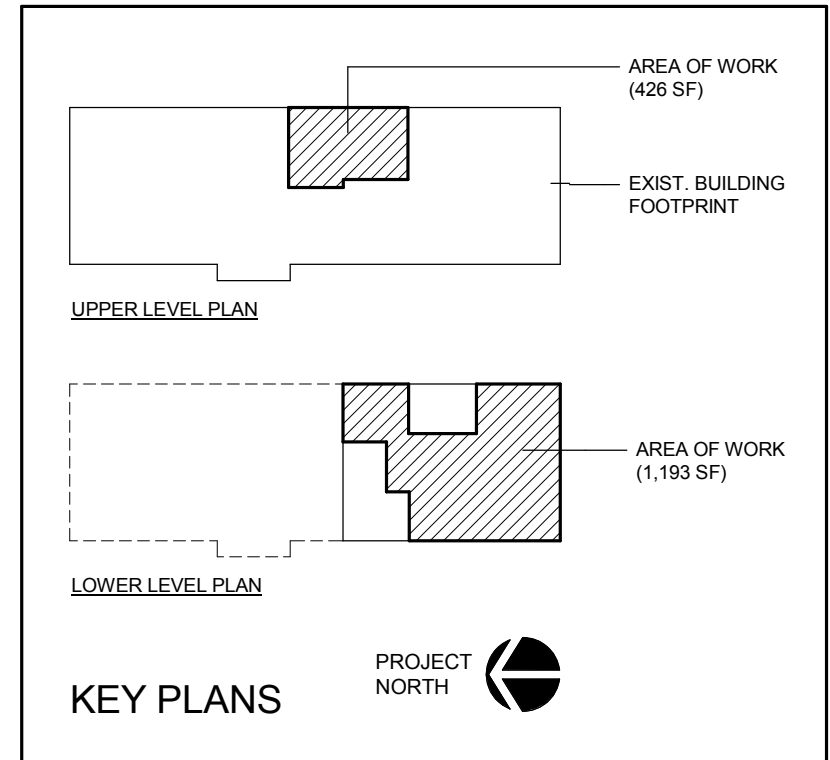

REFER TO MEP DRAWINGS FOR ADDITIONAL INFORMATION.

LOWER LEVEL AND UPPER LEVEL ELECTRICAL DEMOLITION PLANS

16-17-001

3/13/2017 10:10:45 AM



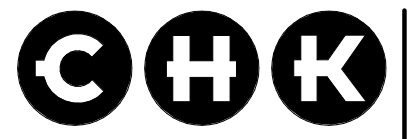

CLOHESSY  
HARRIS &  
KAISER LLC

GREYSTONE COURT WEST  
575 HOPMEADOW STREET  
PO BOX 95  
SIMSBURY, CT 06070-0095  
860-651-3777  
Fax 860-651-7316  
chk@chkarch.com

ARCHITECTURE - INTERIOR DESIGN - FACILITIES PLANNING

Consultants



50 Griffin Road South Bloomfield, CT 06002  
Tel: (860) 286-9171 www.bvhis.com

STATE OF CONNECTICUT  
INTERIOR RENOVATIONS AT THE  
OFFICE OF THE PROBATE COURT ADMINISTRATOR

186 NEWINGTON ROAD  
WEST HARTFORD, CT

LOWER LEVEL AND UPPER LEVEL ELECTRICAL LIGHTING PLANS

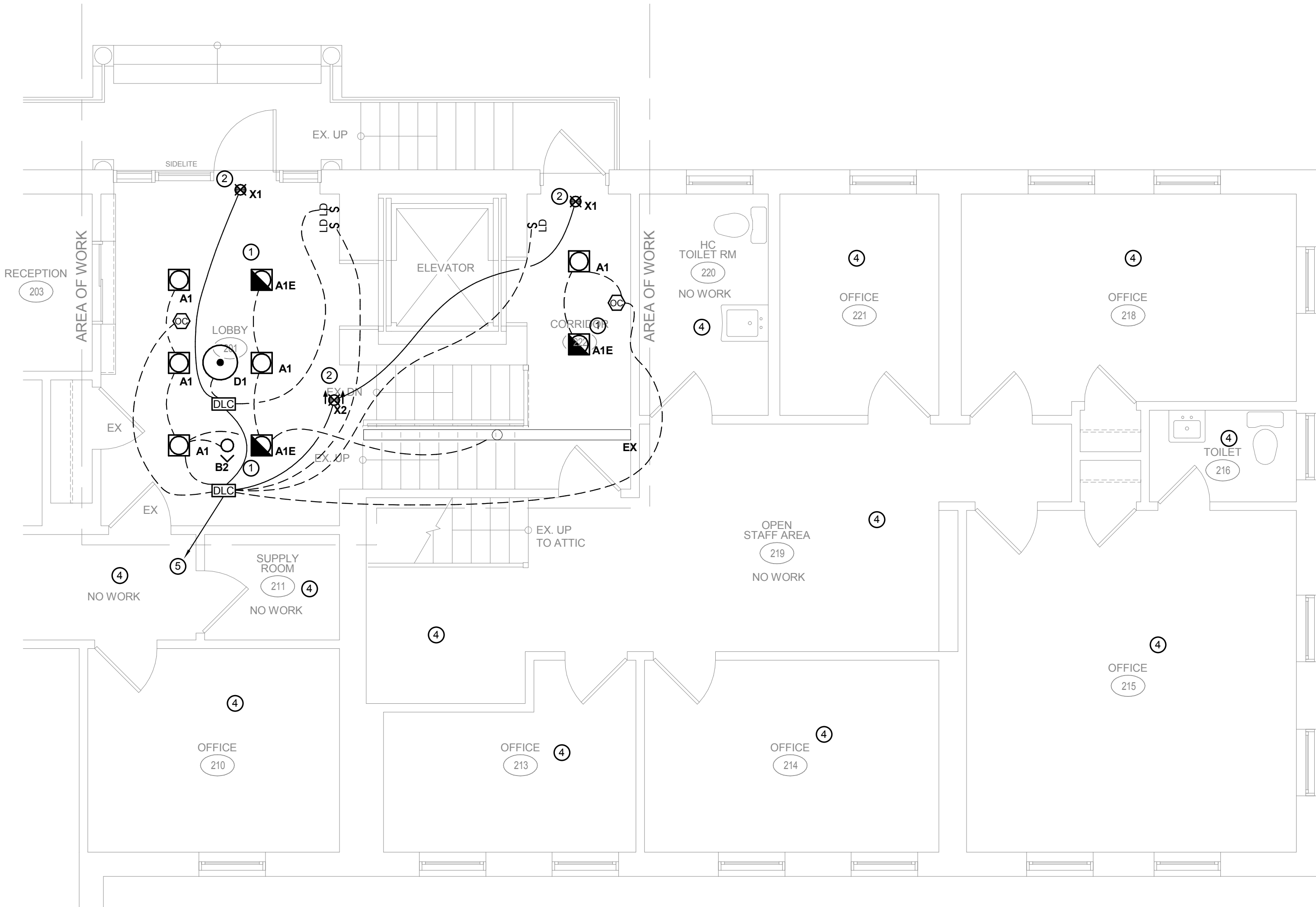

1 UPPER LEVEL ELECTRICAL LIGHTING PLAN  
SCALE: 1/4" = 1'-0"

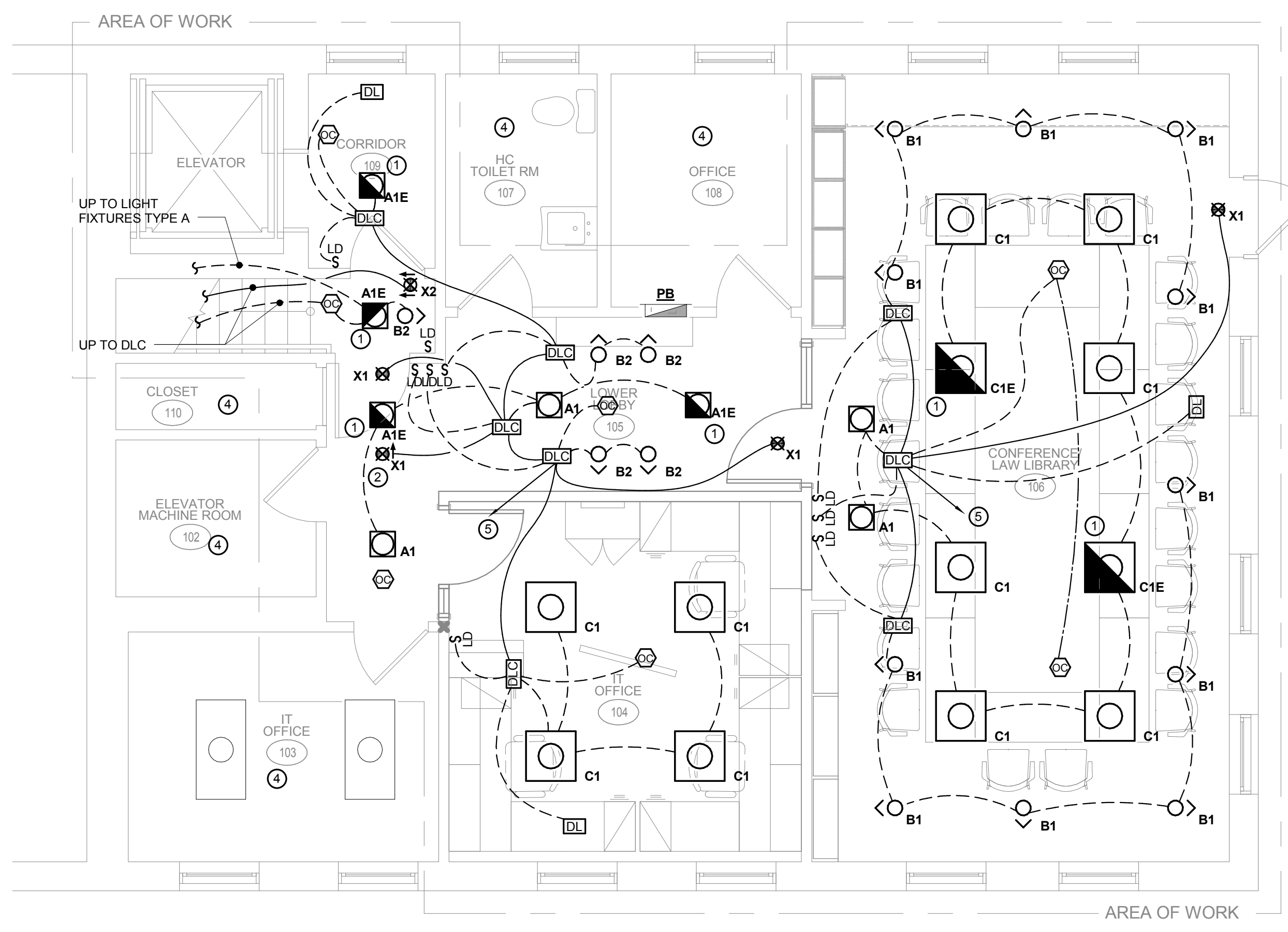

2 LOWER LEVEL ELECTRICAL LIGHTING PLAN  
SCALE: 1/4" = 1'-0"

- DRAWING NOTES**
- 1 EMERGENCY BATTERY DRIVER SHALL BE WIRED AHEAD OF ALL SWITCHING FOR POWER LOSS MONITORING.
  - 2 EXIT SIGN SHALL BE WIRED TO UNSWITCHED LEG OF LOCAL LIGHTING CIRCUIT.
  - 3 3/4"C - 2#10 & 1#10 GND.
  - 4 EXISTING LIGHTING, SWITCHING AND WIRING IN THIS AREA TO REMAIN.
  - 5 INTERCEPT AND REUSE EXISTING LIGHTING CIRCUIT IN THIS AREA TO FEED NEW LIGHTING AS SHOWN.

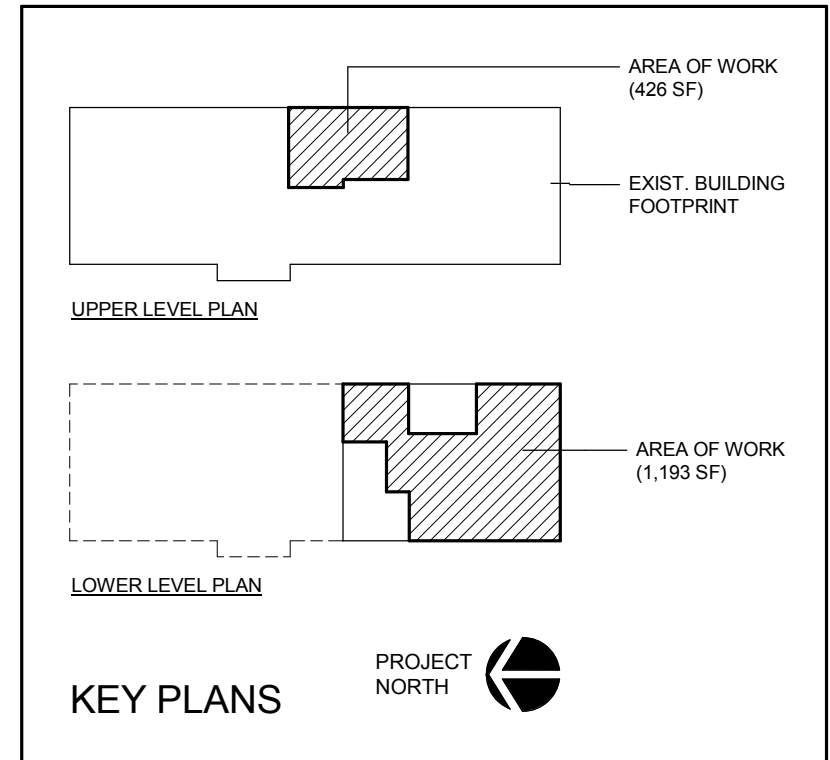

REFER TO MEP DRAWINGS FOR ADDITIONAL INFORMATION.

Revisions

Date: 3/10/2017  
Scale: 1/4" = 1'-0"  
Project Number: 17001  
Drawn By: JCK

EL101

3/13/2017 10:10:46 AM

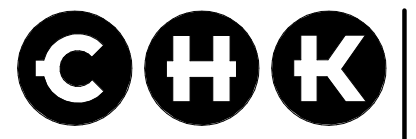

Consultants



50 Griffin Road South Bloomfield, CT 06002  
Tel: (860) 286-9171 www.bvhis.com

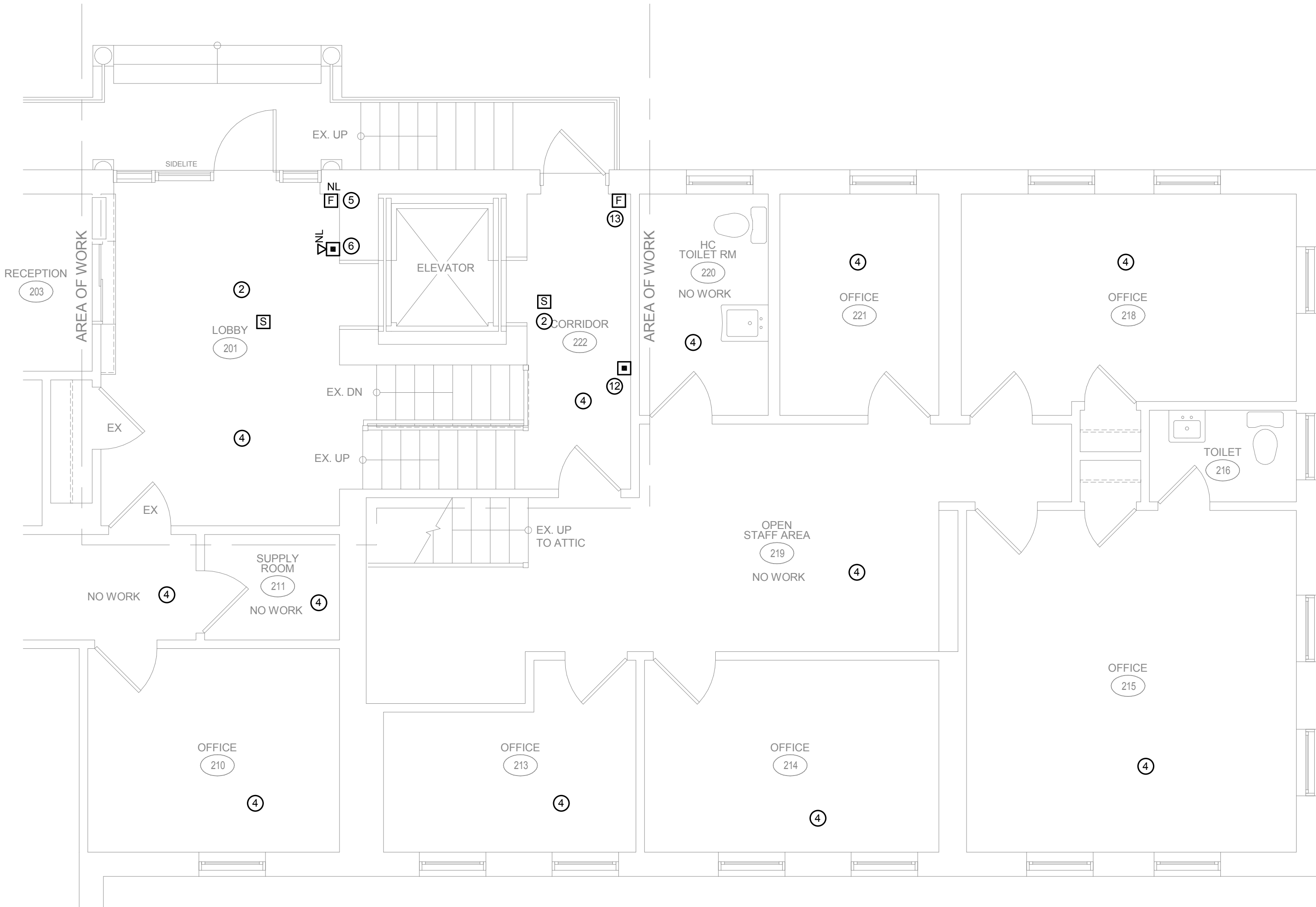

1 UPPER LEVEL ELECTRICAL POWER AND SPECIAL SYSTEMS PLAN  
SCALE: 1/4" = 1'-0"



**GENERAL NOTES**  
1. PROVIDE (2) DATA DROPS FOR SEPARATE DATA NETWORKS AT EACH DATA LOCATION.

- DRAWING NOTES**
- 1 EXISTING ELECTRICAL DEVICES AND WIRING IN THIS AREA SHALL REMAIN. MAINTAIN BRANCH CIRCUIT CONTINUITY OF AREAS THAT MAY BE AFFECTED BY DEMOLITION AND/OR SCOPE OF WORK.
  - 2 NEW SMOKE DETECTOR TO MATCH EXISTING FIRE ALARM SYSTEM. WIRE TO EXISTING FIRE ALARM SYSTEM.
  - 3 RELOCATED SMOKE DETECTOR. EXTEND EXISTING WIRING TO NEW LOCATION.
  - 4 EXISTING POWER AND CIRCUITING TO REMAIN IN THIS AREA UNLESS OTHERWISE NOTED.
  - 5 RELOCATED FIRE ALARM PULL STATION. EXTEND EXISTING WIRING TO NEW LOCATION.
  - 6 RELOCATED FIRE ALARM AUDIO/VISUAL UNIT. EXTEND EXISTING WIRING TO NEW LOCATION.
  - 7 NEW FIRE ALARM AUDIO/VISUAL UNIT TO MATCH EXISTING FIRE ALARM SYSTEM. WIRE TO EXISTING FIRE ALARM SYSTEM.
  - 8 POWER AND TEL/DATA OUTLET MOUNTED IN CABINET FOR A/V EQUIPMENT.
  - 9 FURNISH AND INSTALL (8) 20A-1P CIRCUIT BREAKERS. CIRCUIT BREAKERS ARE TO BE COMPATIBLE WITH EXISTING PANEL MANUFACTURER.
  - 10 MOUNT OUTLETS ABOVE RADIATION.
  - 11 RELOCATED OUTLET. EXTEND EXISTING WIRING TO NEW LOCATION.
  - 12 NEW FIRE ALARM VISUAL UNIT TO MATCH EXISTING FIRE ALARM SYSTEM. WIRE TO EXISTING FIRE ALARM SYSTEM.
  - 13 NEW FIRE ALARM PULL STATION UNIT TO MATCH EXISTING FIRE ALARM SYSTEM. WIRE TO EXISTING FIRE ALARM SYSTEM.
  - 14 POWER AND DATA OUTLET FOR WALL MOUNTED MONITOR PROVIDED BY OWNER. VERIFY MOUNTING HEIGHT.
  - 15 POWER AND TEL/DATA OUTLETS MOUNTED BELOW COUNTERTOP AT FURNITURE SYSTEMS. COORDINATE MOUNTING HEIGHT WITH FURNITURE SYSTEMS LAYOUT AND VERIFY WITH ARCHITECT.

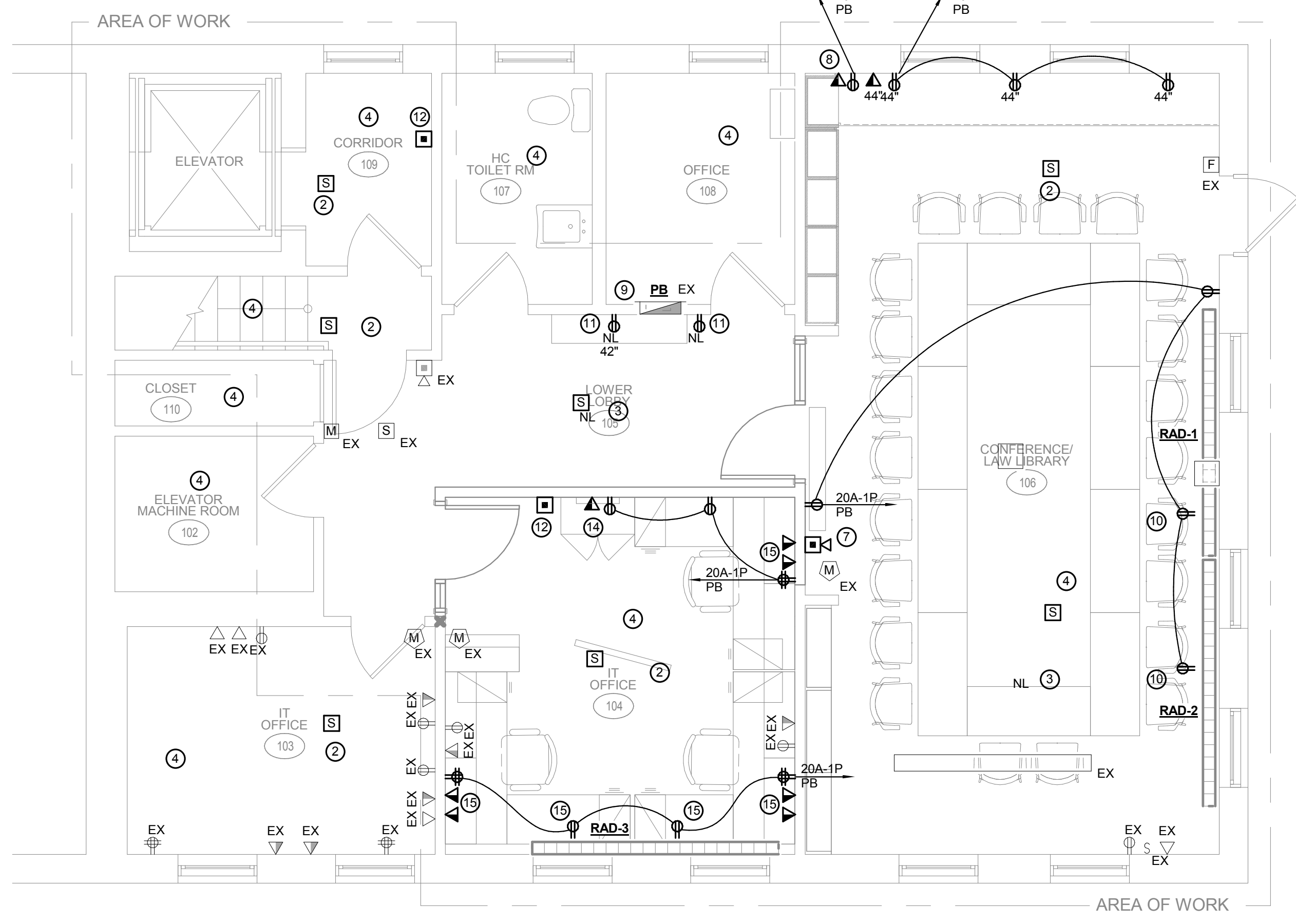

2 LOWER LEVEL ELECTRICAL POWER AND SPECIAL SYSTEMS PLAN  
SCALE: 1/4" = 1'-0"

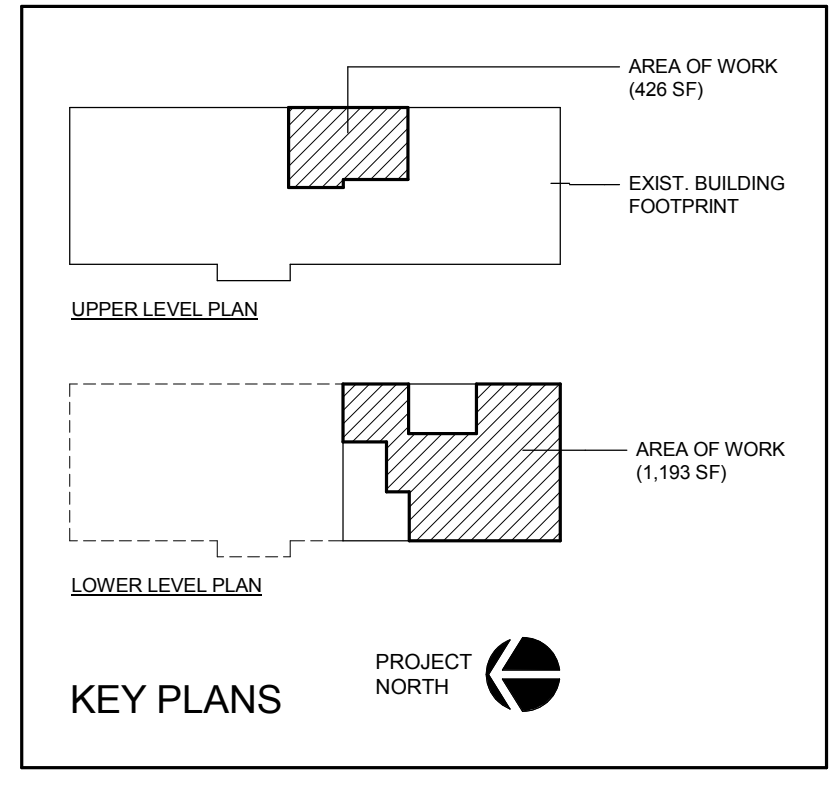

REFER TO MEP DRAWINGS FOR ADDITIONAL INFORMATION.

LOWER LEVEL AND UPPER LEVEL ELECTRICAL POWER AND SPECIAL SYSTEMS PLANS

STATE OF CONNECTICUT  
INTERIOR RENOVATIONS AT THE  
OFFICE OF THE PROBATE COURT ADMINISTRATOR  
186 NEWINGTON ROAD  
WEST HARTFORD, CT

Revisions

Date: 3/10/2017  
Scale: 1/4" = 1'-0"  
Project Number: 17001  
Drawn By: JCK

EPS101



Consultants



50 Griffin Road South Bloomfield, CT 06002  
Tel: (860) 286-9171 www.bvhis.com

STATE OF CONNECTICUT  
INTERIOR RENOVATIONS AT THE  
OFFICE OF THE PROBATE COURT ADMINISTRATOR  
186 NEWINGTON ROAD  
WEST HARTFORD, CT

Revisions	

Date	3/10/2017
Scale	NOT TO SCALE
Project Number	17001
Drawn By	JCK

E201

ELECTRICAL DETAILS

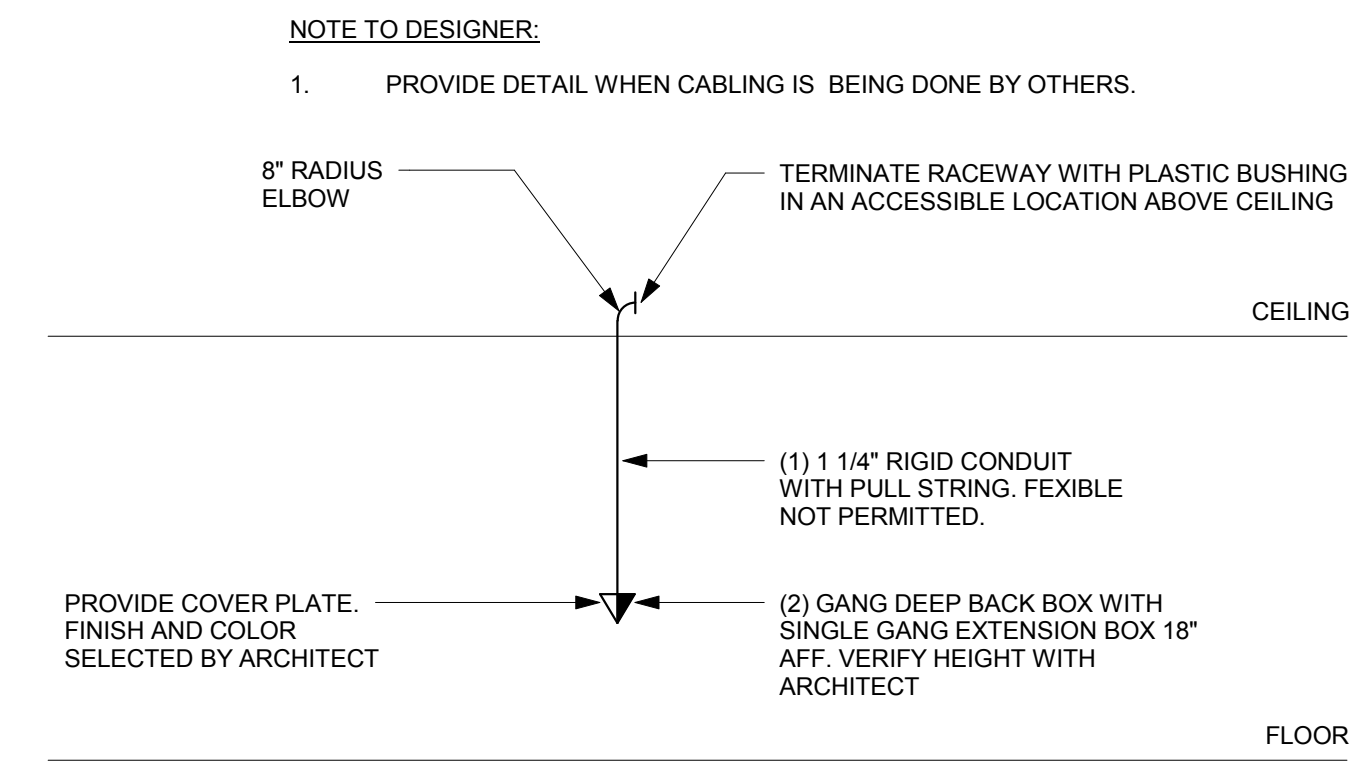

UTILIZE THIS DETAIL WHEN ANY OF THE FOLLOWING SYMBOLS ARE SHOWN ON PLAN: ▼ ▼ ▼

**TELEPHONE/DATA OUTLET DETAIL**  
NOT TO SCALE

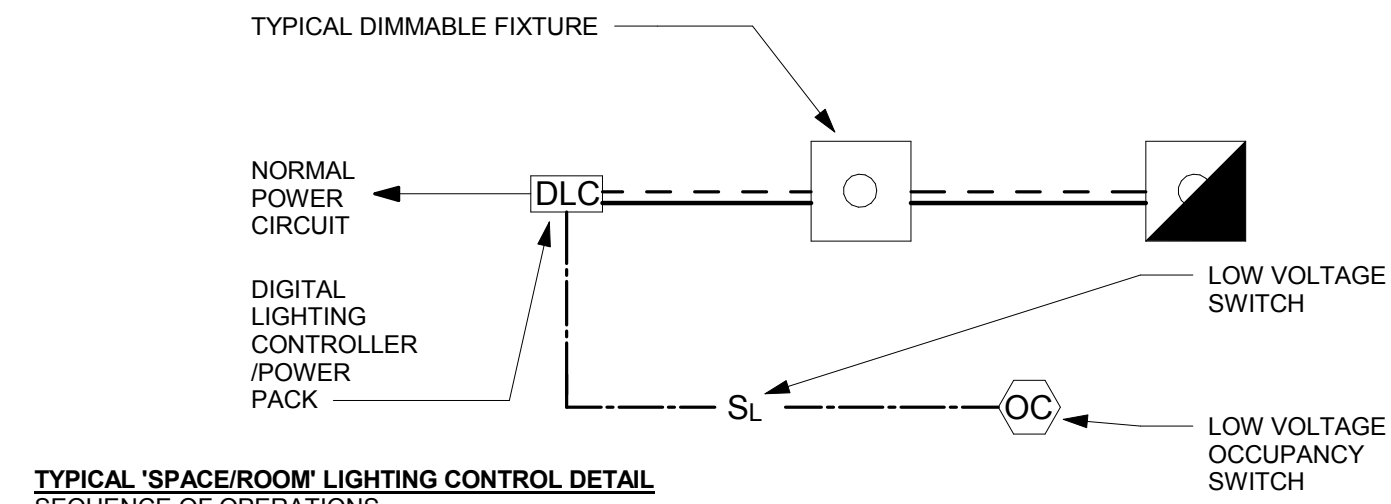

**TYPICAL 'SPACE/ROOM' LIGHTING CONTROL DETAIL**  
SEQUENCE OF OPERATIONS

- NORMAL OPERATION**
- LUMINAIRE(S) TO TURN ON WHEN LOW VOLTAGE SWITCH IS ACTIVATED WHILE LIGHTS ARE OFF.
  - LUMINAIRE(S) TO TURN OFF WHEN LOW VOLTAGE SWITCH IS ACTIVATED WHILE LIGHTS ARE ON OR WHEN VACANCY SENSOR HAS NOT BEEN TRIGGERED FOR 20 MINUTES.
  - DIMMING LEVELS TO BE DETERMINED BY LOW VOLTAGE DIMMING SWITCH CORRESPONDING TO EACH ZONE.

- SWITCHING**
- FOR EACH DEVICE INDICATED ON FLOOR PLANS, PROVIDE LOW VOLTAGE (4) BUTTON WALL STATION WITH THE FOLLOWING FUNCTIONS: FULL LIGHTS, RAISE, LOWER, OFF.

**TYPICAL LIGHTING CONTROLS SPACE/ ROOM DETAIL**  
NOT TO SCALE

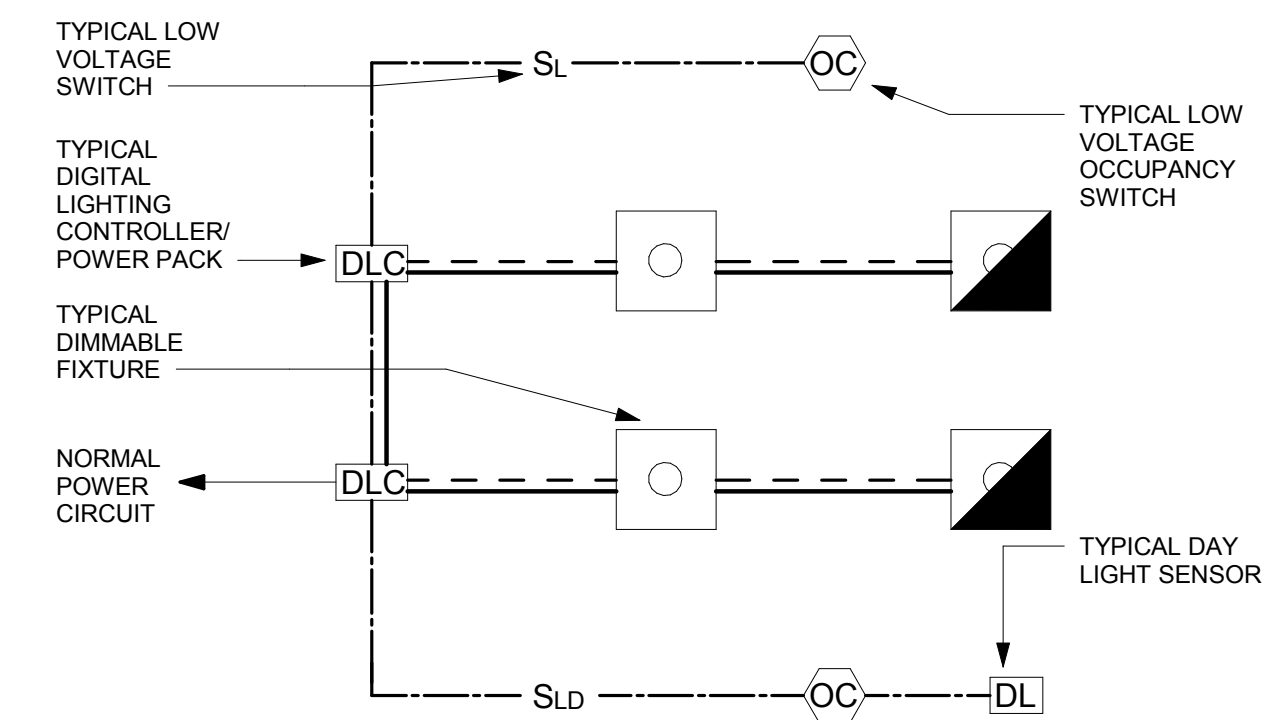

**TYPICAL 'CONFERENCE/ROOM' LIGHTING CONTROL DETAIL**  
SEQUENCE OF OPERATIONS

- NORMAL OPERATION**
- LUMINAIRE(S) TO TURN ON WHEN LOW VOLTAGE SWITCH IS ACTIVATED WHILE LIGHTS ARE OFF.
  - LUMINAIRE(S) TO TURN OFF WHEN LOW VOLTAGE SWITCH IS ACTIVATED WHILE LIGHTS ARE ON OR WHEN VACANCY SENSOR HAS NOT BEEN TRIGGERED FOR 20 MINUTES.

- SWITCHING**
- FOR EACH DEVICE INDICATED ON FLOOR PLANS, PROVIDE LOW VOLTAGE (4) BUTTON WALL STATION WITH THE FOLLOWING FUNCTIONS: FULL LIGHTS, RAISE, LOWER, OFF.

**TYPICAL LIGHTING CONTROLS CONFERENCE/ ROOM DETAIL**  
NOT TO SCALE

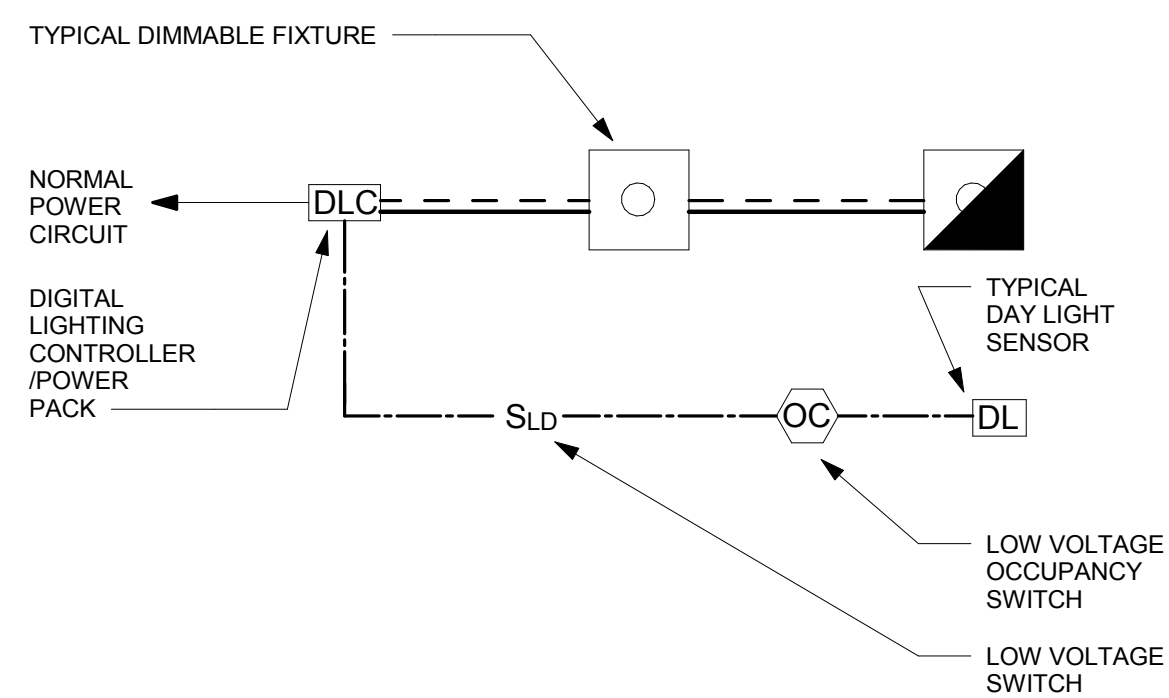

**TYPICAL 'SPACE/ROOM' LIGHTING CONTROL DETAIL**  
SEQUENCE OF OPERATIONS

- NORMAL OPERATION**
- LUMINAIRE(S) TO TURN ON WHEN LOW VOLTAGE SWITCH IS ACTIVATED WHILE LIGHTS ARE OFF.
  - LUMINAIRE(S) TO TURN OFF WHEN LOW VOLTAGE SWITCH IS ACTIVATED WHILE LIGHTS ARE ON OR WHEN VACANCY SENSOR HAS NOT BEEN TRIGGERED FOR 20 MINUTES.
  - DIMMING LEVELS TO BE DETERMINED BY LOW VOLTAGE DIMMING SWITCH CORRESPONDING TO EACH ZONE.

- SWITCHING**
- FOR EACH DEVICE INDICATED ON FLOOR PLANS, PROVIDE LOW VOLTAGE (4) BUTTON WALL STATION WITH THE FOLLOWING FUNCTIONS: FULL LIGHTS, RAISE, LOWER, OFF.

**TYPICAL LIGHTING CONTROLS SPACE/ ROOM DETAIL**  
NOT TO SCALE