

United States Army Warfighting Center
Fort Rucker, Alabama
OCTOBER 2006



STUDENT HANDOUT

TITLE: CH-47D FLIGHT CONTROL HYDRAULIC SYSTEM

FILE NUMBER: 011-2103-3

PROPONENT FOR THIS STUDENT HANDOUT IS:

110th Aviation Brigade
ATTN: ATZQ-ATB-AD
Fort Rucker, Alabama 36362-5000

FOREIGN DISCLOSURE RESTRICTIONS: This product/publication has been reviewed by the product developers in coordination with the Cargo Utility Branch/ Ft. Rucker foreign disclosure authority. This product is releasable to students from all requesting foreign countries without restrictions.

CH-47D FLIGHT CONTROL HYDRAULIC SYSTEM

STUDENT HANDOUT

TERMINAL LEARNING OBJECTIVE (TLO):

Action: Describe components, operational characteristics, functions, and emergency procedures of the CH-47D Flight Control Hydraulic System.

Conditions: In a classroom, given a CH-47D Hydraulic System Trainer and a student handout.

Standards: Correctly answer in writing, without reference, six of eight questions pertaining to components, operational characteristics, functions, and emergency procedures of the CH-47D Flight Control Hydraulic System, In Accordance With (IAW) TM 1-1520-240-10 and the student handout.

Safety Requirements: None.

Risk Assessment Level: Low.

Environmental Considerations: None.

Evaluation: Each student will be evaluated on this block of instruction during the first written examination. This will be a criterion type examination requiring a GO on each scored unit. You will have 90 minutes for the exam.

1. Learning Step/Activity 1-Describe the Flight Control Hydraulic System.

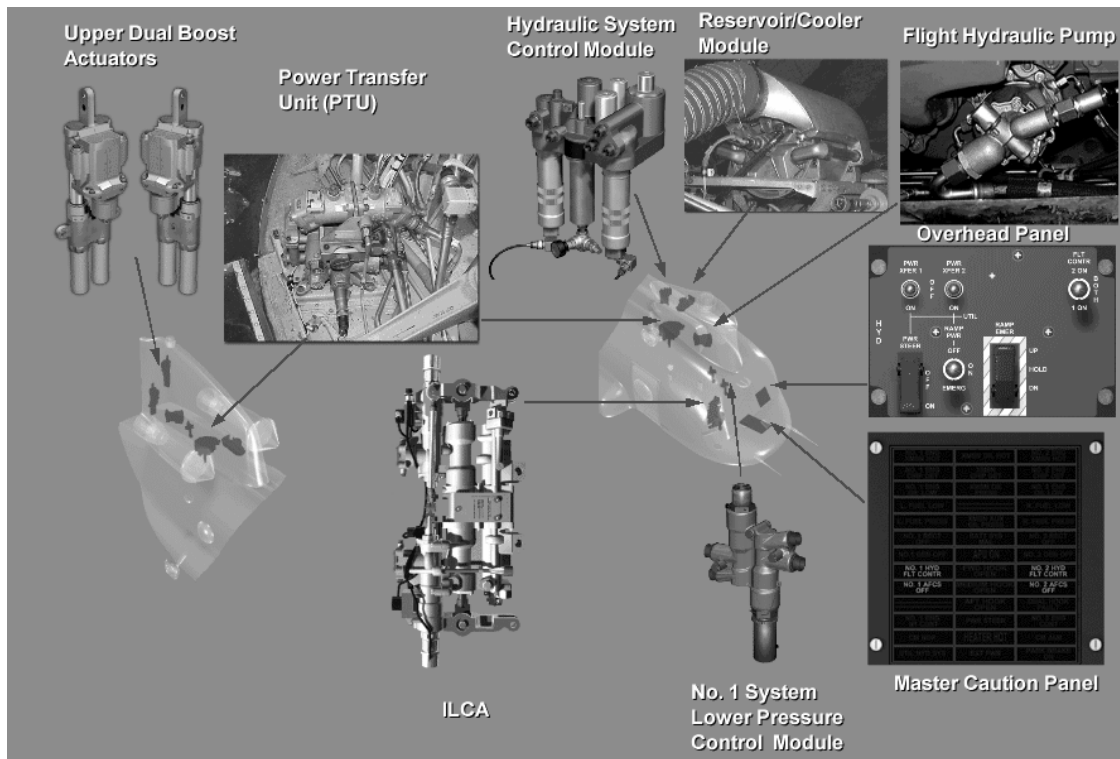

- a. The hydraulic flight control systems consist of two identical systems: No.1 flight control system and the No.2 flight control system. The flight control systems are identical in operation, hydraulically separated, and electrically integrated. They operate at approximately 3,000 psi, reduced to 1,500 psi for the Integrated Lower Control Actuators (ILCA). The flight control systems power four dual upper boost actuators and four dual integrated lower control actuators.
- b. Each system has its own reservoir/cooler assembly, pump, Power Transfer Units (PTU's), and power control modules. Components such as pressure switches, filters, accumulators, and valves are installed in the power control modules.

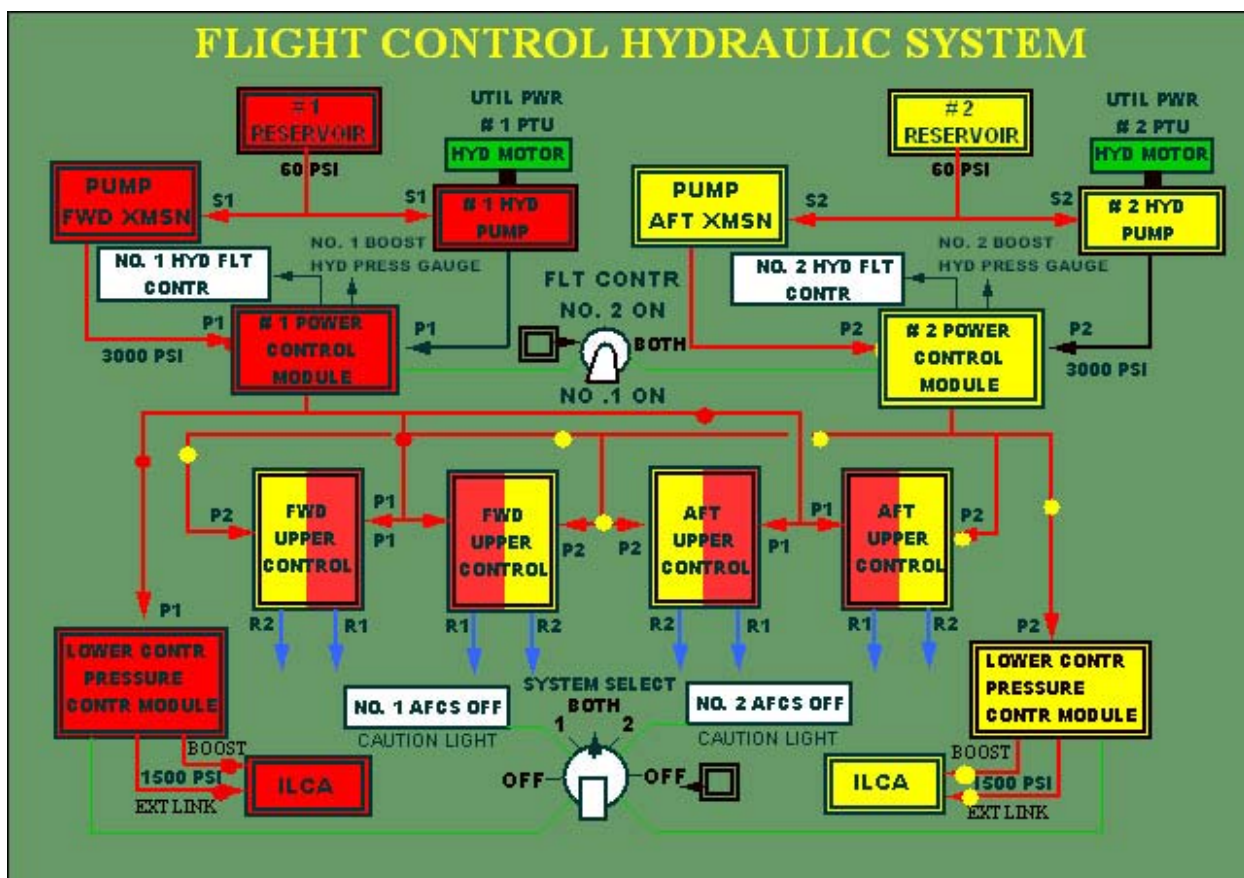

NOTE: Hydraulic assist is required for control movement!

- c. Sources of system pressure.
 - (1) Power Transfer Units (PWR XFR or PTU) pressurize the systems when the rotors are stopped and during some emergencies.
 - (2) Flight control hydraulic pumps pressurize the systems when the rotors are operating.
- d. Type of fluid.
 - (1) MIL-H-83282. Fire retardant.
 - (2) MIL-H-5606. Used when the cold soak temperature is below -46°C.

(3) A -13 entry is required if the types are mixed.

2. Learning Step/Activity 2—Describe the components, operational characteristics, and functions of the Flight Control Hydraulic System.

- a. The No.1 flight control hydraulic components are located in the forward pylon area; reservoir/cooler, PTU, and power control module. The No.1 hydraulic pump is mounted to and driven by the forward transmission.
- b. The No.2 flight control hydraulic components are located in the aft pylon area; reservoir/cooler, PTU, and power control module. The No.2 pump is mounted on the #1 side, and driven by the aft transmission.

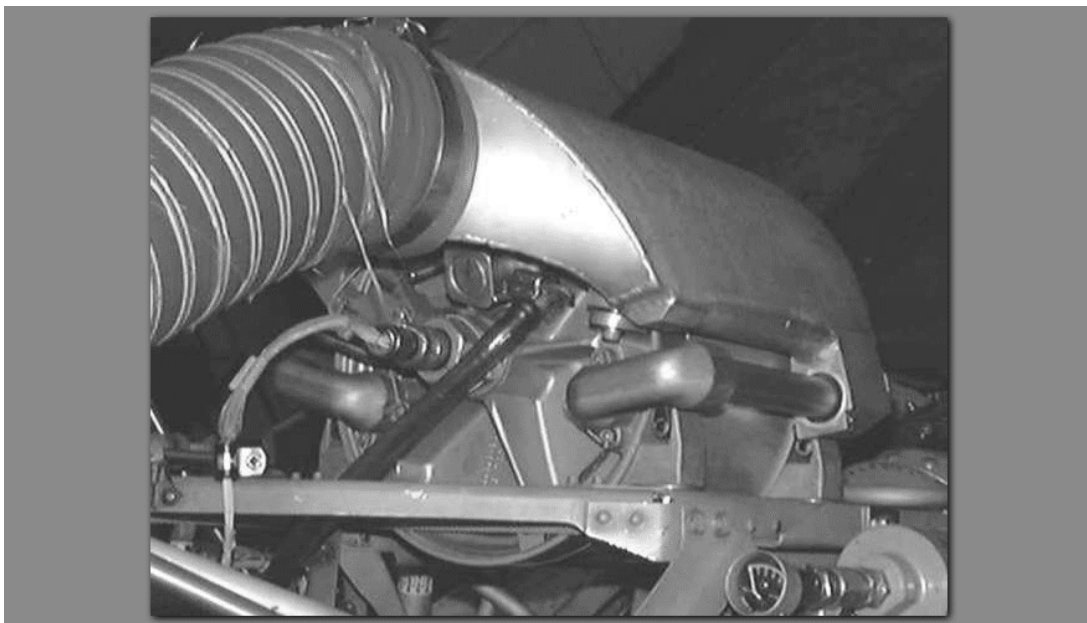

- c. Reservoir/cooler module.
 - (1) No.1 is located in the forward pylon.
 - (2) No.2 is located in the aft pylon.

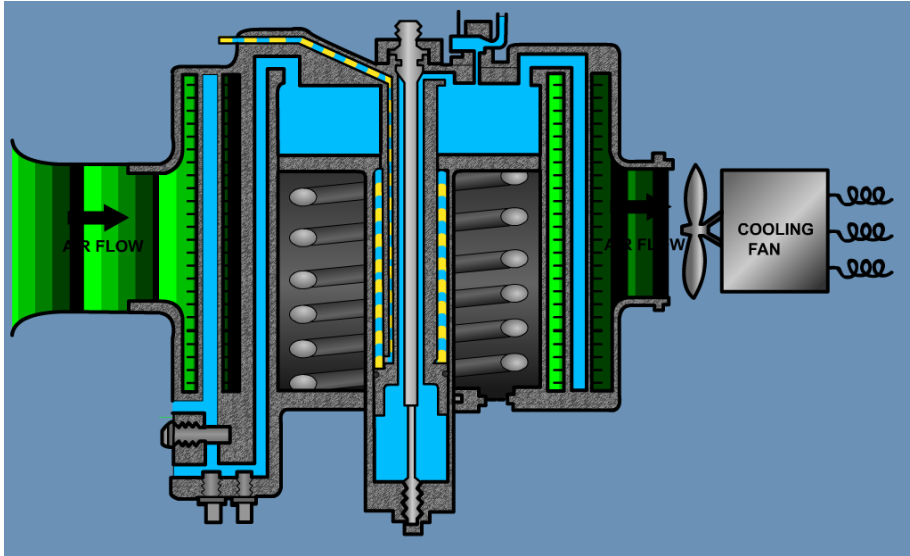

- (3) The reservoir stores fluid under 60 pounds per square inch (psi).
 - (a) A spring exerts pressure to maintain supply fluid pressure when the pump and PTU are OFF.
 - (b) System pressure maintains supply fluid pressure when the pump or PTU is operating.
 - (4) Visual fluid level indication.
 - (5) The cooler cools the fluid prior to the reservoir.
 - (6) Cooler bypass valve allows fluid to bypass if the flow rate exceeds cooler capacity.
 - (7) Bleed/relief valve.
 - (a) Protects the reservoir against excessive pressure.
 - (b) Manually operated to bleed air from the reservoir.
 - (8) Temperature bulb electrically transmits fluid temperature to the indicator on the maintenance panel.
 - (9) Linear Variable Differential Transducer (LVDT) provides fluid level signal to the maintenance panel.
 - (10) A thermal switch controls cooler fan operation.
 - (a) Fan turns on at 63°C.
 - (b) Fan turns off at 54°C.
- d. Cooler fans.

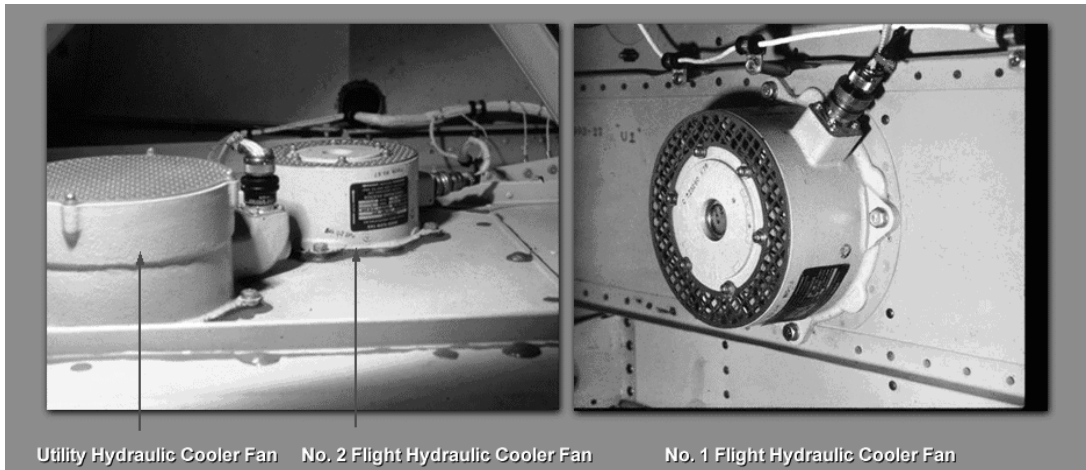

- (1) The No.1 cooler fan is located in the forward pylon and the No.2 cooler fan is located in the aft pylon.
- (2) Two sources of electrical power are required for operation.
 - (a) No.1 system cooler fan uses power from the No.1 AC and DC buses.
 - (b) No.2 system cooler fan uses power from the No.2 AC and DC buses.

e. Hydraulic pumps.

- (1) No.1 is driven by the forward transmission.

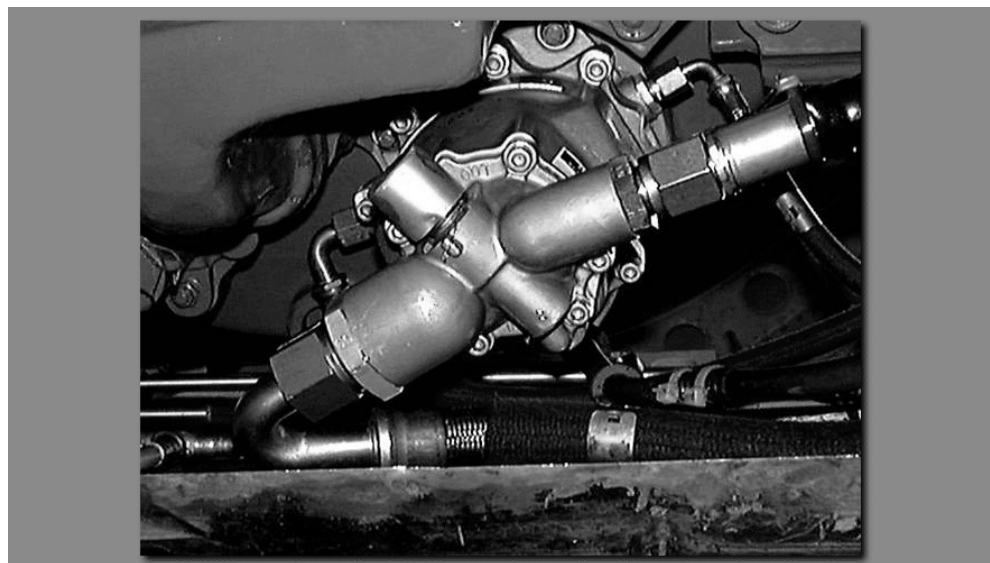

- (2) No.2 is driven by the aft transmission.

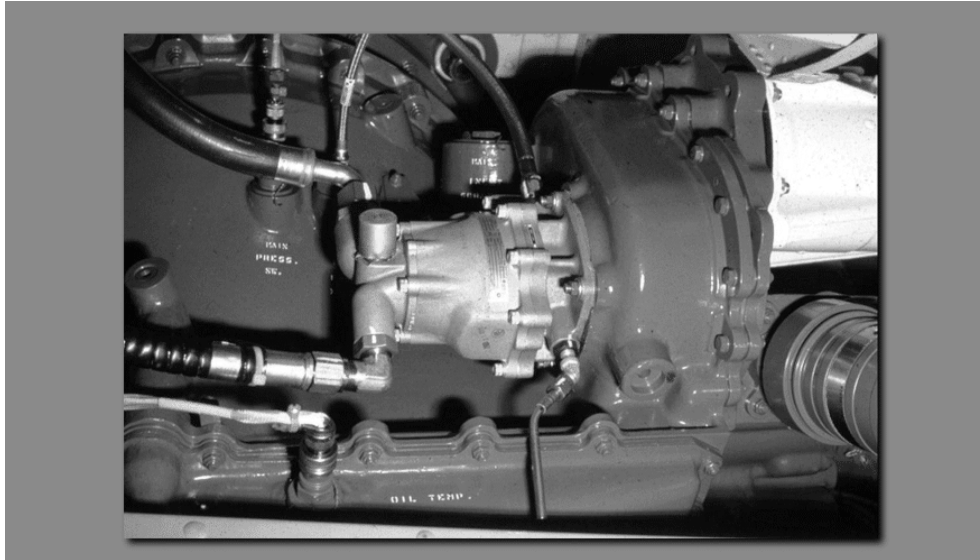

- (3) The pumps provide 3,000 psi for flight control hydraulic actuator operation when the rotors are turning.
- (4) Constant pressure with variable flow rate, 0 to 16.5 gallons per minute (gpm).
- (5) Hydraulic fluid cools and lubricates the pump (case drain).

f. Power control modules.

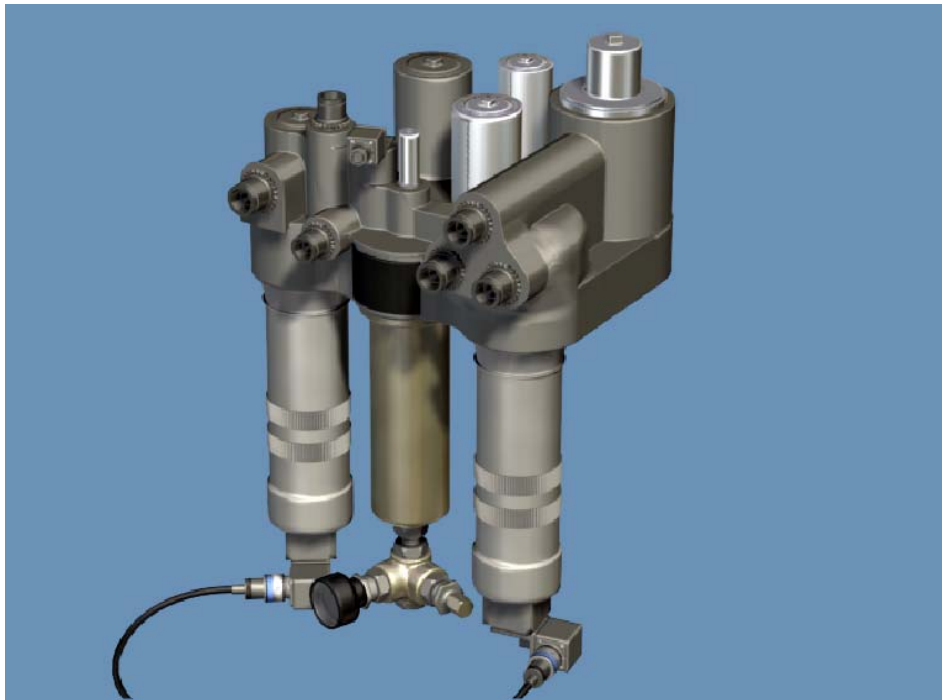

- (1) No.1 is located in the forward pylon and the No.2 is located in the aft pylon.
- (2) Pump/PTU pressure goes directly to the module and then to the actuators.

- (3) Return fluid from the actuators goes to the module and then to the reservoir/cooler.
- (4) Two filters are installed on each module, pressure and return.

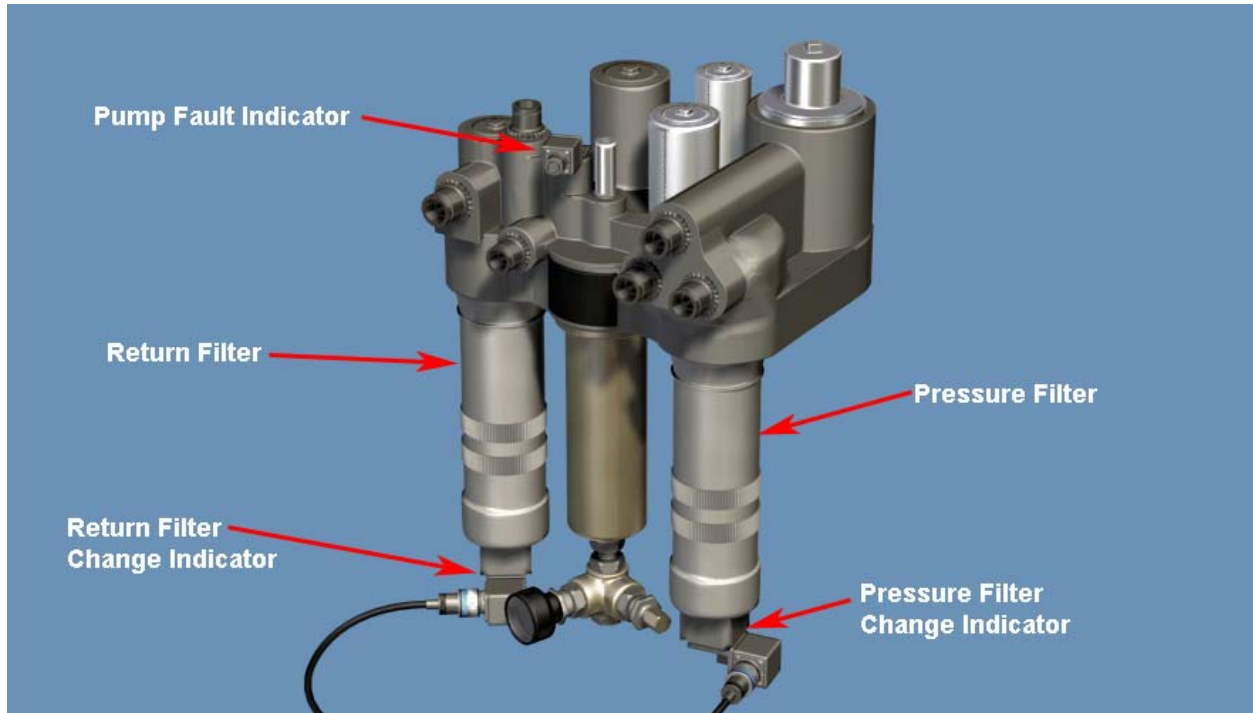

- (a) Differential pressure indicator buttons.
 - 1) Pops out when filter outlet pressure drops below the inlet pressure.
 - 2) Pressure differential may be caused by filter contamination or pressure surges.
- (b) Differential pressure switch activates the FILTER CHANGE light on the maintenance panel when differential pressure occurs.
- (c) If a button is popped and/or the light is on:
 - 1) Reset the button.
 - 2) Cycle controls for 30 seconds.
 - 3) If button pops again, change filter.

- (5) Accumulators.

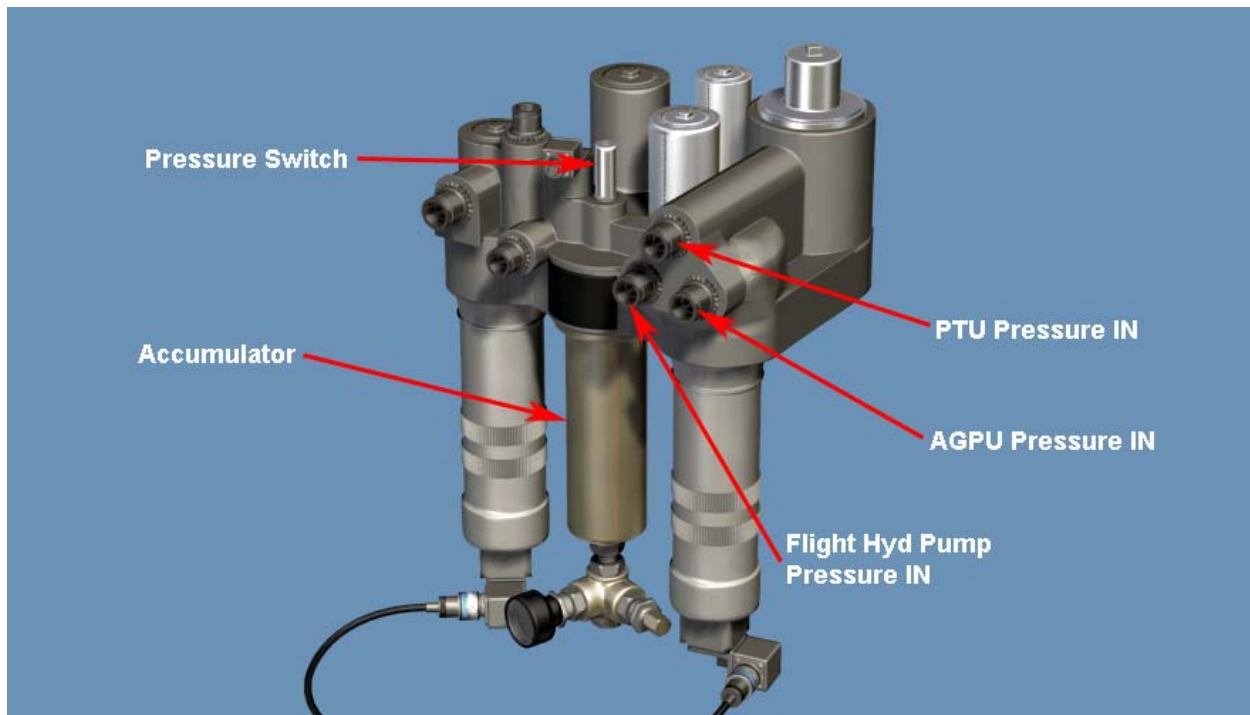

- (a) There is an accumulator on each module. It is a 12 cubic inch accumulator that dampens surges in the system and provides fluid pressure during peak demands. An air pre-charge is stored in the accumulator and the amount of pre-charge pressure is adjusted according to ambient temperature.
- (b) (b) Check for proper pre-charge pressure on preflight.

NOTE: Refer to a current operator's manual or CL.

Pg: 2-15-17

- (6) Pressure switch.
 - (a) When the hydraulic pressure drops below 1,800 psi:
 - 1) The HYD FLT CONTR and AFCS OFF caution lights will illuminate.
 - 2) The FLT CONTR switch **will not** be able to turn off the remaining system.
 - (b) Normal operation resumes when the pressure increases above 2,300 psi.

(7) Control valve.

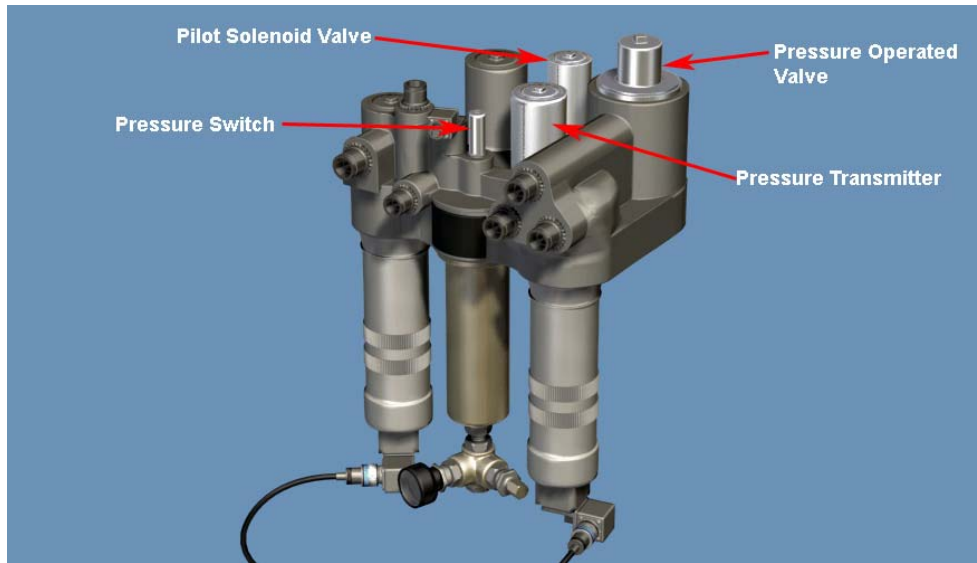

(a) Controls pressure flow to the system actuators.

(b) Electrically controlled, No.2 DC bus.

(c) Hydraulically closed.

(d) Controlled by:

- 1) FLT CONTR switch on the overhead panel.
- 2) Pressure switch of the other system.

(8) The pressure transmitter provides the pressure signal to the indicator on the maintenance panel.

(9) PUMP FAULT indicators.

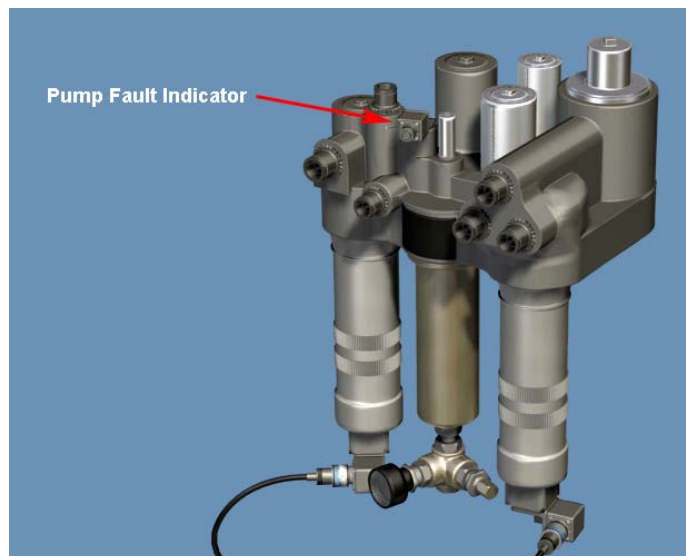

- (a) Pop out buttons.
 - (b) Switch activates the PUMP FAULT light on the maintenance panel.
 - (c) Activated by case drain flow.
 - (d) Indicates impending pump failure.
- g. Lower controls pressure control module. Located in the flight controls closet. No.1 is at STA 105, No.2 at STA 95.

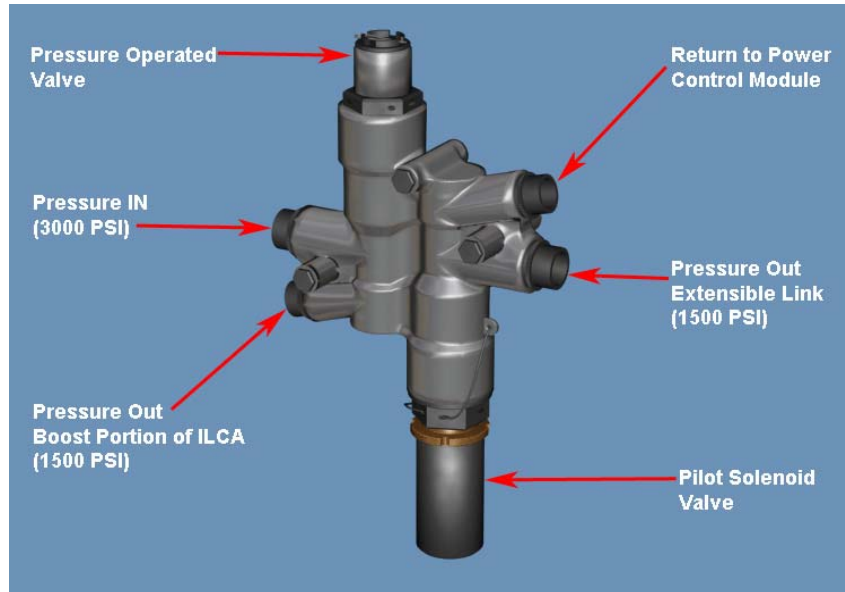

- (1) Reduces system pressure to 1,500 psi for ILCA operation.
- (2) A solenoid valve controls pressure to the extensible link portion of the ILCA's.

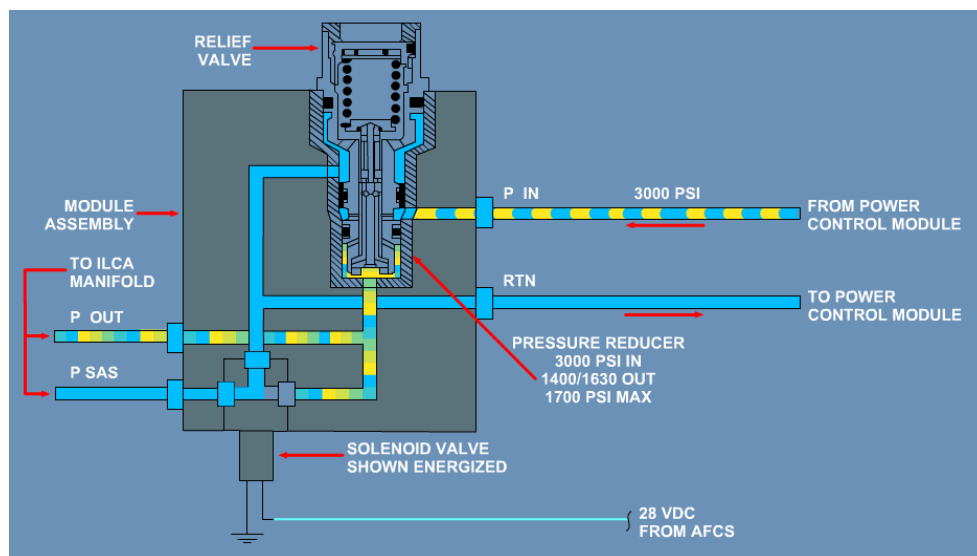

- (a) AFCS ON -Valve is electrically opened.

(b) AFCS OFF –Valve is spring loaded closed.

h. PWR XFR or PTU. The No.1 PTU is located in the forward pylon and the No.2 is in the aft pylon.

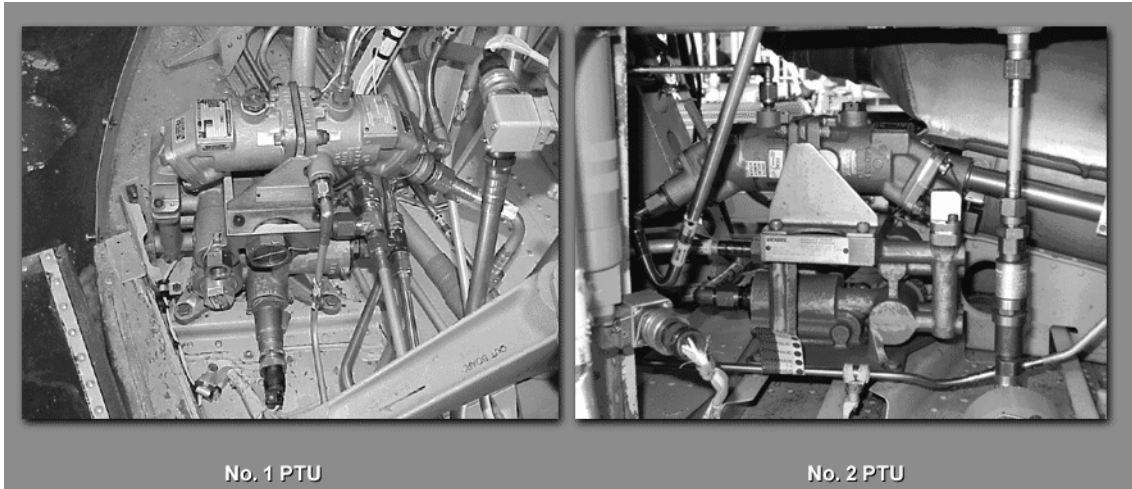

- (1) The PTU's pressurize the flight control hydraulic system during:
 - (a) Ground checks prior to engine start.
 - (b) Engine shutdown.
 - (c) Some in-flight emergencies.

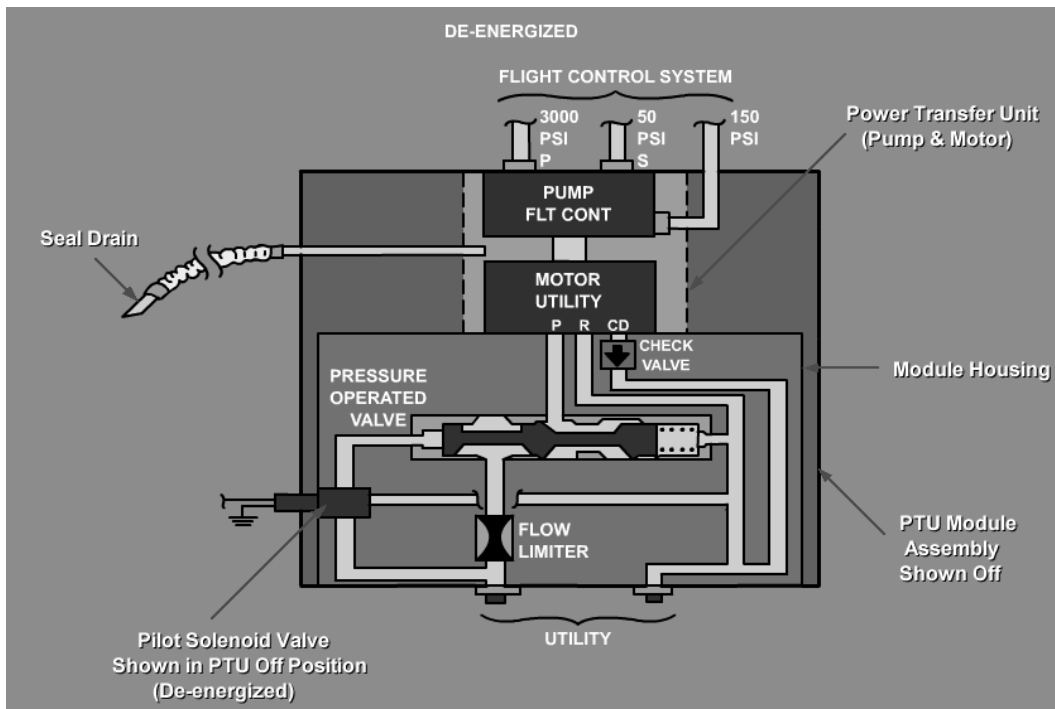

(2) Components.

- (a) Hydraulic motor driven by utility hydraulic system pressure.
- (b) Hydraulic pump that is driven by the hydraulic motor. 3,000 psi at a maximum flow of 3.5 GPM.

OPERATOR'S MANUAL WARNING: The power transfer pumps were designed for ground checkout of the flight control system and have the capacity to pressurize the system in flight for normal maneuvers only. **Pg: 9-1-25**

NOTE: Make normal control inputs only. If the flight controls are moved erratically during the control check, unusual vibrations may be felt.

- (3) PWR XFR No.1 and No.2 switches. These switches are located on the overhead panel. A two position switch, OFF and ON.

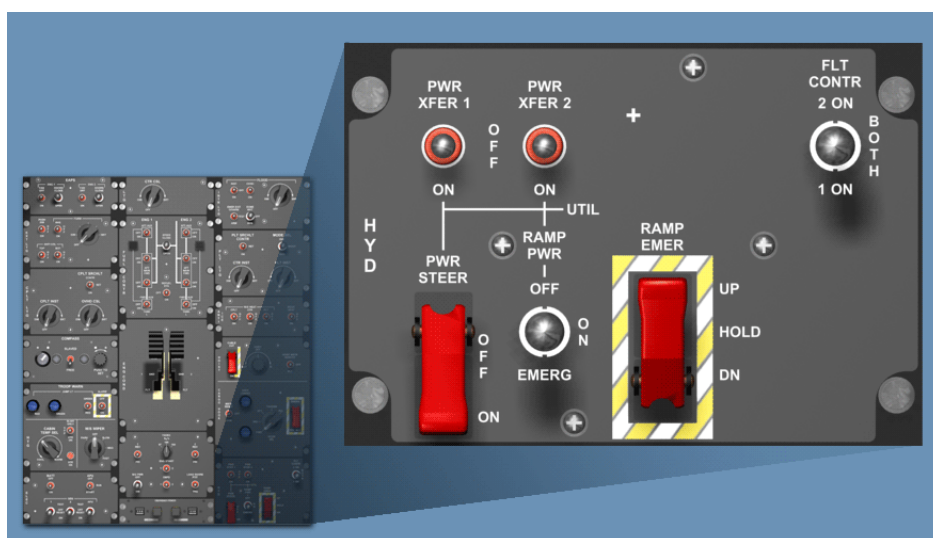

- (a) Electrical power is supplied by the No.2 DC bus.
- (b) Control valves are in the PTU and utility system pressure control module.
- (c) The HYD FLT CONTR caution light must go out within 30 seconds after the PWR XFR switch is placed to ON.
- (d) If the HYD FLT CONTR caution light fails to go out:
 - 1) Turn the PTU OFF.
 - 2) DO NOT FLY THE HELICOPTER!
 - 3) Make a -13 entry.
- i. FLT CONTR switch. Located on the overhead panel.
 - (1) Used to select individual or both systems ON.
 - (2) Switch shall be set to the BOTH position during flight.

- j. (3) Will not turn off a system unless the system that is selected ON is operating. Maintenance panel. Located on the right side of the aft cargo compartment. Provides an indication of system's condition that may require servicing or performance of an emergency procedure.



- (1) Indications for hydraulic systems.
- (a) PRESSURE indicator for each system.
 - 1) Normal pressure: 2,500 to 3,200 psi.
 - 2) Pressure signal is provided by the transmitter on the power control module.
 - 3) Electrical power is from the No.2 DC bus.
 - (b) TEMPERATURE indicator for each system.
 - 1) Caution area: 95^o to 120^oC.
 - 2) Maximum: 120^oC.
 - 3) Temperature signal is provided by a temperature bulb in the reservoir/cooler.
 - 4) Electrical power is from the No.2 DC bus.
 - (c) RESERVOIR LEVEL indicator.
 - 1) One indicator for both systems.
 - 2) FLT CONTR switch is used to select either No.1 or No.2 system.

- 3) LEVEL CHECK switch must be pressed.
 - 4) LVDT in the reservoir provides the signal.
 - 5) Electrical power is from the battery bus.
- (d) FILTER CHANGE lights.
- 1) Activated by the differential pressure switch on the power control module.
 - 2) Electrical power is from the No.2 DC bus.
- (e) PUMP FAULT lights.
- 1) Activated by the pump fault switch on the power control module.
 - 2) Electrical power is from the No.1 DC bus.
- (f) The flight engineer will monitor and notify the pilots when:
- 1) Temperature is showing an abnormal increase or exceeds limits.
 - 2) Pressure is showing an abnormal decrease.
 - 3) Fluid level is decreasing.

- k. Hydraulic system fill module. Located at Sta. 510 on the right side of the aft cargo compartment. Allows crew members to add fluid to any of the three systems, either on the ground or in-flight.

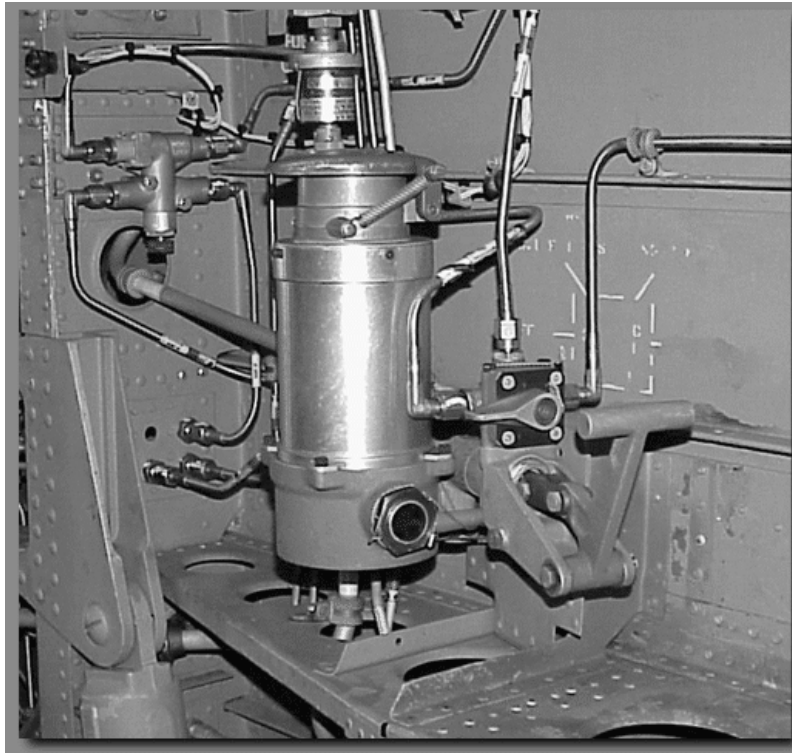

- (1) Selector valve selects the system to be serviced.

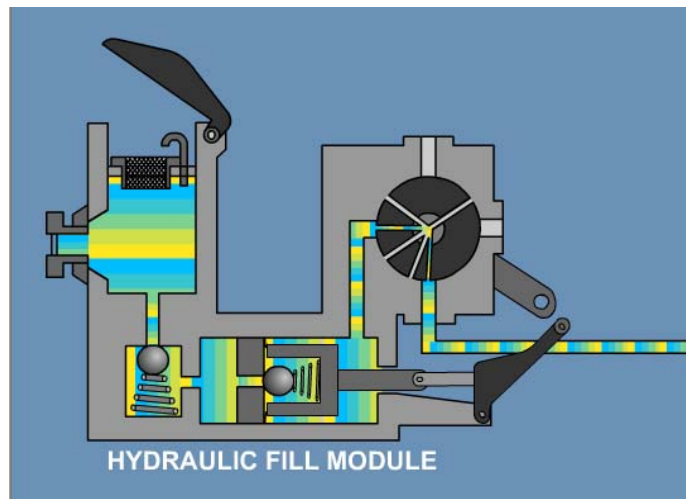

- (2) Fill module reservoir. Do not allow the fluid level to drop below the sight glass.
- (3) The hand pump pumps fluid from the reservoir into the selected system.

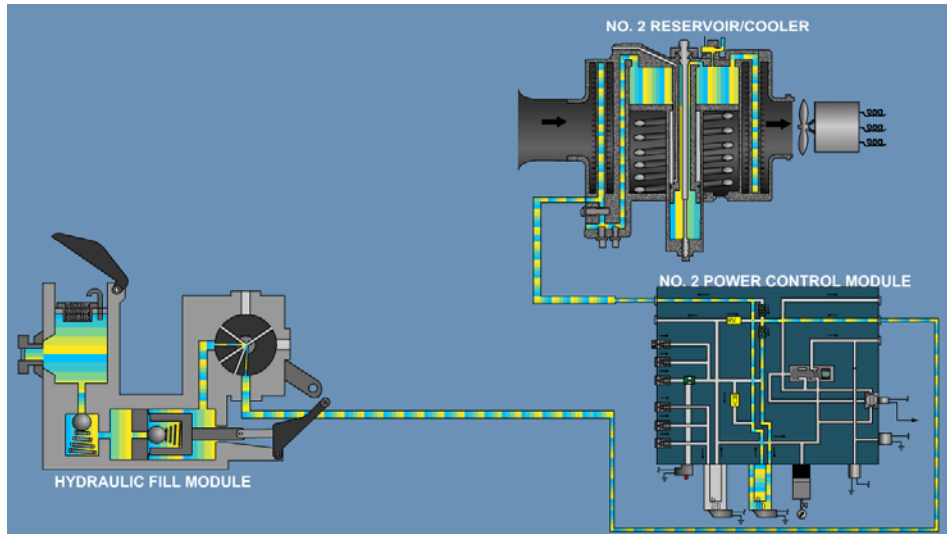

3. Learning Step/Activity 3–Describe emergency procedures for Flight Control Hydraulic Malfunctions.

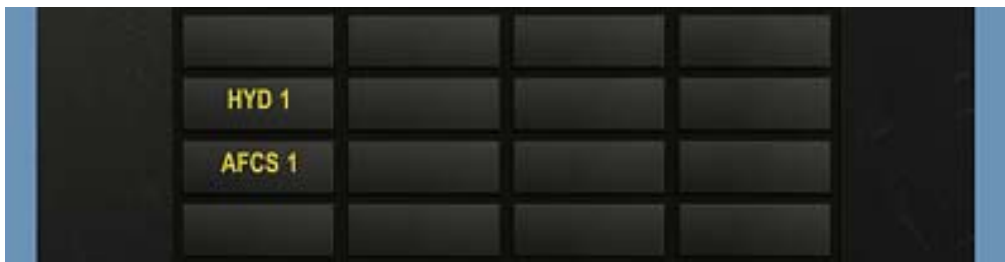

NOTE: The instructor will explain the current operator’s manual procedures.

- a. No.1 or No.2 HYD FLT CONTR. **Pg: 9-26**
 - (1) Fluid loss **is** evident.
 - Land as soon as possible.**
 - (2) Fluid loss **is not** evident.
 - 1. **Land as soon as possible.**
 - 2. **PWR XFER 1 or 2 switch (affected system) – ON.**
 - F 3. **MAINTENANCE PANEL - Monitor**
 - (3) High fluid temperature **is** evident.
 - Land as soon as possible.**

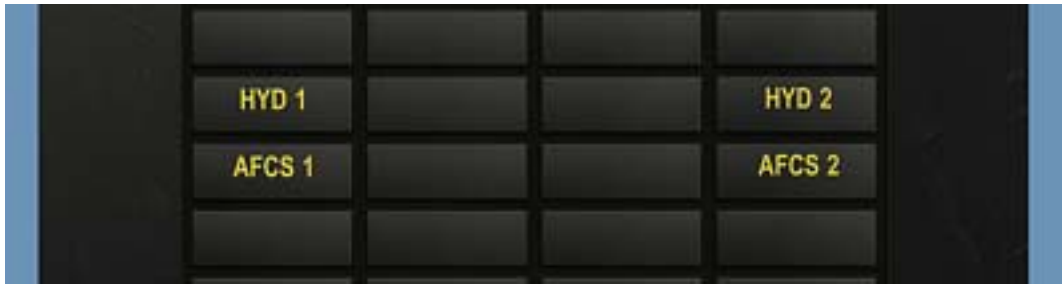

b. No.1 and No.2 HYD FLT CONTR. Pg: 9-26

OPERATORS MANUAL: If both hydraulic systems fail, flight controls cannot be moved. In addition, the No. 1 and No. 2 AFCS-OFF caution will illuminate.

1. **PWR XFER 1 and 2 switches – ON.**
2. **Land as soon as possible.**

Appendix C – Practical Exercises and Solutions

CH-47D FLIGHT CONTROL HYDRAULIC SYSTEM

PRACTICAL EXERCISE

NOTE: This practical exercise covers the instruction you received in this handout. Completion is optional, but strongly encouraged!

1. The normal position for the FLT CONTR switch is _____?
2. What are the two parts of a PTU?
3. What may result if the controls are moved erratically during the controls check on the run-up?
4. What does a PUMP FAULT light on the maintenance panel indicate?
5. The HYD FLT CONTR caution light must go out within _____ after the PWR XFR switch is placed on?
6. What is the emergency procedure No.1 HYD FLT CONTR caution light on and loss fluid is evident?
7. Where are the two places you can check the fluid level of the Flight Control Hydraulics system?
8. The Flight Hydraulic Cooler fan turns on at _____ and then will turn back off at _____ degrees centigrade.
9. What is the emergency procedure for both HYD FLT CONTR caution lights?
10. The Lower Control Pressure Control Module reduces pressure from _____ to _____, for the _____ portion of the ILCA and the _____ link portion of the ILCA.
11. During your preflight you discover a button popped on one of the filters on a power control module. What must be done?
12. When a HYD FLT CONTR caution light comes on, the _____ caution light also comes on.
13. What are three functions of the #1 Power Control Module Pressure Switch?

14. How can you determine if the accumulator pressure on the power control module is correct on your preflight?
15. What are the two sources of pressure for the flight control hydraulic system?
16. Can both flight control hydraulic systems be turned off at the same time?
17. What warning is to be observed when moving the flight controls using PTU pressure?
18. What action should you take if the HYD FLT CONTR caution light fails to go out within 30 seconds after the PTU switch is placed to ON?
19. What are the Minimum and Maximum limits for pressure in the flight control hydraulic systems?
20. What is the emergency procedure for No.2 HYD FLT CONTR caution light on and loss of fluid is **not** evident?

CH-47D FLIGHT CONTROL HYDRAULIC SYSTEM

PRACTICAL EXERCISE SOLUTIONS

1. Both.
2. Pump and Motor
3. Binding or Unusual vibrations.
4. Impending pump failure OR Case drain flow in excess of 1 GPM
5. 30 seconds.
6. Land As Soon as Possible.
7. Maintenance panel / Reservoir using the visual level indicator
8. ON at 63°C and Off at 54°C
9. PWR XFER 1 and 2 switches — ON.
Land As Soon as Possible.
10. 3000/1500 – Boost/Extensible link
11. Reset button, cycle controls for 30 seconds, if button pops –replace filter.
12. Associated AFCS.
13. Turns the #1 HYD FLT CONTR caution light ON or OFF
Sends a signal to the AFCS, a controlling factor in the AFCS caution light
Provides a ground reference single to the opposite system which will prevent turning off the opposite/good system
14. From chart in –10 or CL.
15. PTU and system pump.
16. No
17. Rapid control inputs must be avoided to preclude upper boost actuator stalling (binding) and/ or jam button extensions
18. Turn PTU's off, do not fly the aircraft, and make a –13 entry.
19. 2500 to 3200 PSI
20. PWR XFER 1 or 2 switch (affected system) — ON.
MAINTENANCE PANEL — Monitor.
Land as Soon as Possible

