



BURN-IN SOCKETS

for QFN – TSOP – SOP – LGA – eMMC – BGA

01

Swiss Manufacturing Plant



This building served for the production of Swiss precision watches for a period of 70 years.

In 1984 the facility was purchased, completely renovated and high technology fully automated production equipment was installed for the production of precision interconnection products.

In 1992 the trademark

E-tec

was registered to cover the complete interconnect product range.

As of 1993 a world-wide sales & distribution network was established to offer fast and efficient service regardless of location.

In addition to the interconnection products E-tec also supplies high quality screw machine parts as well as customized injection moulded and machined products. Our innovative approach to new product development allows us to offer the service, quality and competitive prices our customers demand. Whatever your requirement, be it high volume commodity product or low quantity custom special, **E-tec**, the “**Swiss Connection**” will endeavour to satisfy your requirements.

For any further details please contact E-tec or your closest sales office.

INDEX

Part-Number	Type	click on page numbers	Page
BPT-xxx-xx-xx.x/xx	BPT Series BGA PROBE PIN OPEN TOP SOCKET		18~20
MPS-xxx-05-xx.x/xx	MPS Series OPEN TOP eMMC Socket		1 & 2
MPS-xxx-10-xx.x/xx	MPS Series OPEN TOP LGA Socket		3
MPS-xxx-10-xx.x/xx	MPS Series OPEN TOP BGA Socket		4
MPS-xxx-xx-xx.x/xx	MPS Series OPEN TOP BGA SOCKET		5~7
QMC-xxx-xx-xx.x /xx	QMC Series CLAMSHELL QFN SOCKET		16 & 17
QOT-xxx-xx-xx.x /xx	QOT Series OPEN TOP QFN SOCKET		14 & 15
OTZ-xxx-12-xx.x/xx.x/xx.x	OTZ Series SOP SOCKET		8~10
OTZ-xxx-06-xx.x/xx.x/xx.x	OTZ Series SOP SOCKET		11~13

Burn-In Sockets MPS Series

OPEN TOP eMMC SOCKET



Open Top Style. Accommodates Chip Scale Package with 0.5mm pitch.
 Compact size and low actuation force.
 4-point pinch design for enhanced electrical contact.
 Field exchangeable package location plate.
 "U" contact supports any pad or solder ball shape and composition.



Please note, we will always request the chip data to ensure we offer a compatible socket.

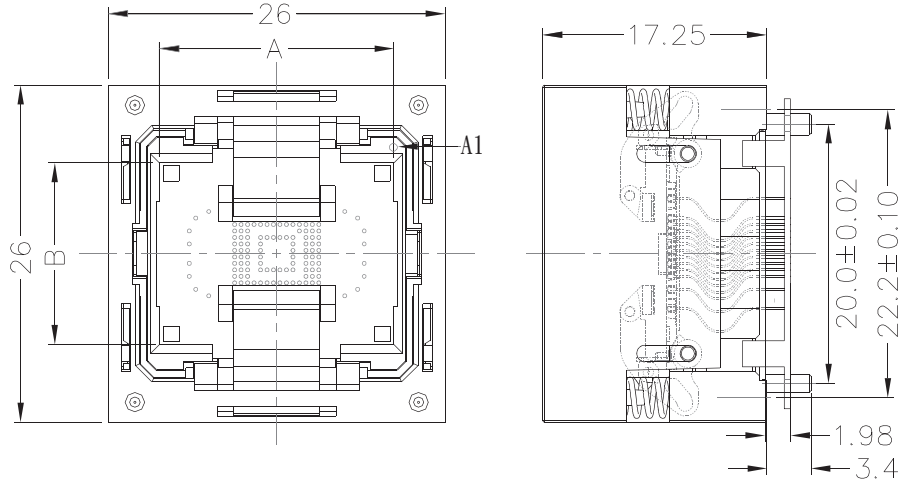
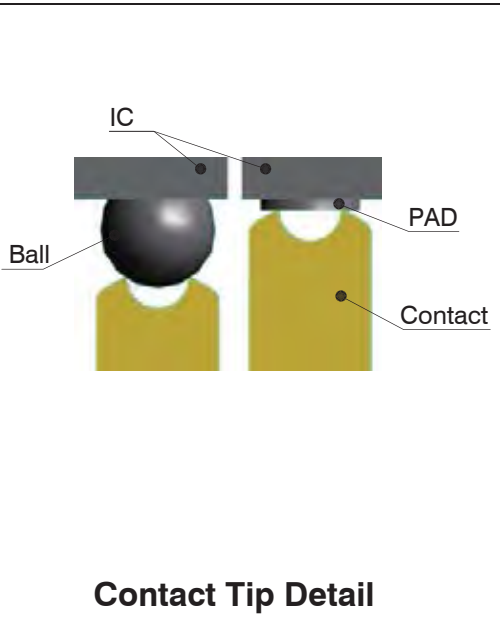

You may request any specific socket dimension from info@e-tec.com
 For top view socket dimension pls. ref. to separate catalog page

Applicable IC	Specifications									
<table border="1"> <tr> <td>A</td> <td>10.00/13.00/16.00/18.00</td> <td>±0.10 mm</td> </tr> <tr> <td>B</td> <td>11.50/12.00/14.00</td> <td>±0.10 mm</td> </tr> <tr> <td>C</td> <td>0.80/1.00/1.50</td> <td>±0.05 mm</td> </tr> </table>	A	10.00/13.00/16.00/18.00	±0.10 mm	B	11.50/12.00/14.00	±0.10 mm	C	0.80/1.00/1.50	±0.05 mm	<p>Mechanical data</p> <p>Contact life: 25,000 cycles Contact Normal Force: 3-5g Per Pin Operation Force: 2.0Kg max.</p> <p>Material</p> <p>Insulator (RoHS compliant): PES, PEI Contact (RoHS compliant): Beryllium Copper Alloy Contact plating: Gold cover Nickel</p> <p>Electrical data</p> <p>Contact resistance: < 30 mΩ Current rating: 1A Insulation resistance at 500V DC: 1,000 mΩ</p> <p>Operating temperature: -55°C to +175°C</p>
A	10.00/13.00/16.00/18.00	±0.10 mm								
B	11.50/12.00/14.00	±0.10 mm								
C	0.80/1.00/1.50	±0.05 mm								

Recommendations:

Solder paste – Please use a solder paste w/o any silver!

Solder profile – Please refer to our website www.e-tec.com

E-tec solderless sockets are adapted to a standard PCB thickness of 1.60mm. For a different PCB thickness, please inform E-tec first!

For high pincount SMT sockets, E-tec recommends the use of a pluggable thru-hole socket mounted into a MiniGrid Adapter (see also page 10, 11 & 12 for more details)

For SMT sockets in general, E-tec recommends the use of locating pegs which can be soldered to the PCB for added mechanical strength.

How to order

MPS - x x x - 05 - xx.x/xx

Nbr of contacts	Pitch	Package Size
169	04 = 0,40mm	11.5/10
153	05 = 0,50mm	11.5/13
	06 = 0,65mm	12.0/16
	07 = 0,75mm	12.0/18
	08 = 0,80mm	12.0/18
		11.5/10
		14.0/18
		for 169 pad count
		for 153 pad count

Burn-In Sockets MPS Series

OPEN TOP eMMC SOCKET



Open Top Style. Accommodates Chip Scale Package with 0.5mm pitch.
 Compact size and low actuation force.
 4-point pinch design for enhanced electrical contact.
 Field exchangeable package location plate.
 "U" contact supports any pad or solder ball shape and composition.



Please note, we will always request the chip data to ensure we offer a compatible socket.

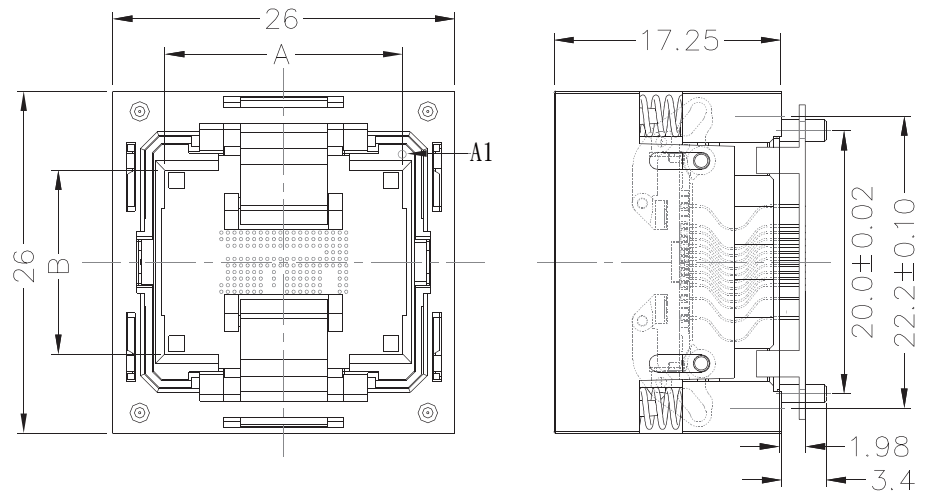
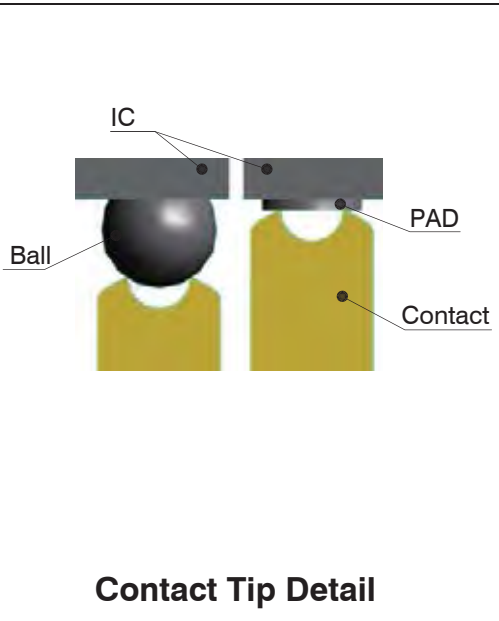

You may request any specific socket dimension from info@e-tec.com
 For top view socket dimension pls. ref. to separate catalog page

Applicable IC	Specifications									
<table border="1"> <tr> <td>A</td> <td>13.00/16.00</td> <td>±0.10 mm</td> </tr> <tr> <td>B</td> <td>11.50/12.00</td> <td>±0.10 mm</td> </tr> <tr> <td>C</td> <td>1.00/1.10/1.20/1.30</td> <td>±0.10 mm</td> </tr> </table>	A	13.00/16.00	±0.10 mm	B	11.50/12.00	±0.10 mm	C	1.00/1.10/1.20/1.30	±0.10 mm	<p>Mechanical data</p> <p>Contact life: 25,000 cycles Contact Normal Force: 3-5g Per Pin Operation Force: 2.0Kg max.</p> <p>Material</p> <p>Insulator (RoHS compliant): PES, PEI Contact (RoHS compliant): Beryllium Copper Alloy Contact plating: Gold cover Nickel</p> <p>Electrical data</p> <p>Contact resistance: < 30 mΩ Current rating: 1A Insulation resistance at 500V DC: 1,000 mΩ</p> <p>Operating temperature: -55°C to +175°C</p>
A	13.00/16.00	±0.10 mm								
B	11.50/12.00	±0.10 mm								
C	1.00/1.10/1.20/1.30	±0.10 mm								

Recommendations:

Solder paste – Please use a solder paste w/o any silver!

Solder profile – Please refer to our website www.e-tec.com

E-tec solderless sockets are adapted to a standard PCB thickness of 1.60mm. For a different PCB thickness, please inform E-tec first!

For high pincount SMT sockets, E-tec recommends the use of a pluggable thru-hole socket mounted into a MiniGrid Adapter (see also page 10, 11 & 12 for more details)

For SMT sockets in general, E-tec recommends the use of locating pegs which can be soldered to the PCB for added mechanical strength.

How to order

MPS - xxx - 05 - xx.x/xx

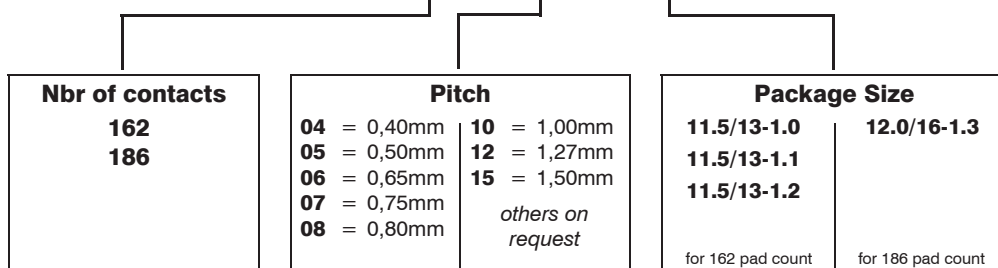

Burn-In Sockets MPS Series

OPEN TOP LGA SOCKET



Open Top Style. Accommodates LGA package with 1.0mm pitch.
 Compact size and low actuation force.
 4-Point pinch design for enhanced electrical contact.
 Field exchangeable package location plate.

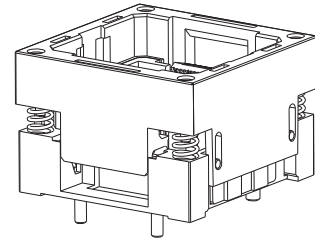

Please note, we will always request the chip data to ensure we offer a compatible socket.

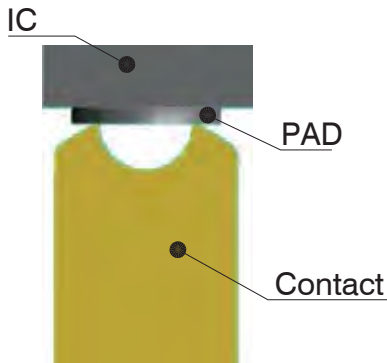

Contact Tip Detail

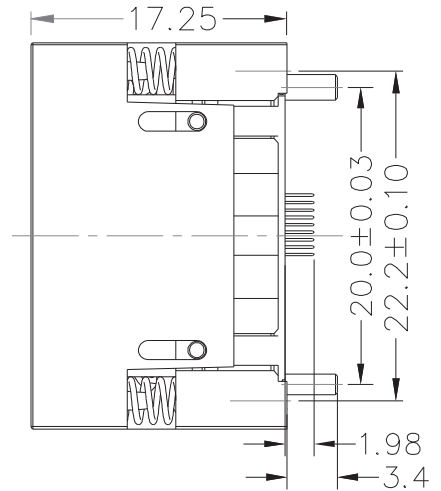
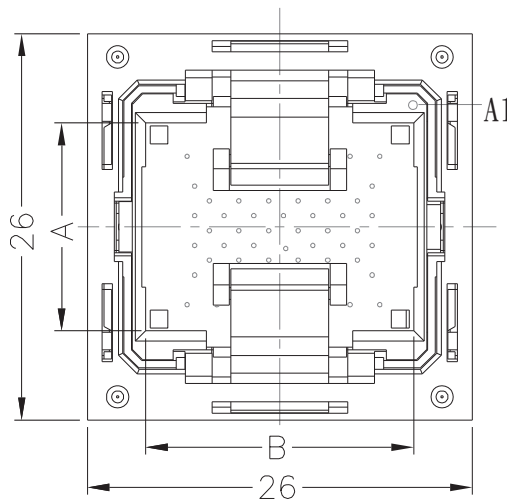

You may request any specific socket dimension from info@e-tec.com

For top view socket dimension pls. ref. to separate catalog page

Applicable IC		Specifications	
		Mechanical data	
		Contact life	25,000 cycles
		Contact Normal Force	3-5g Per Pin
		Operation Force	2.0Kg max.
		Material	
		Insulator (RoHS compliant)	PES, PEI
		Contact (RoHS compliant)	Beryllium Copper Alloy
		Contact plating	Gold cover Nickel
		Electrical data	
		Contact resistance	< 30 mΩ
		Current rating	1A
		Insulation resistance at 500V DC	1,000 mΩ
		Operating temperature	-55°C to +175°C
Recommendations:			
Solder paste – Please use a solder paste w/o any silver!		Solder profile – Please refer to our website www.e-tec.com	
E-tec solderless sockets are adapted to a standard PCB thickness of 1.60mm. For a different PCB thickness, please inform E-tec first!			
For high pincount SMT sockets, E-tec recommends the use of a pluggable thru-hole socket mounted into a MiniGrid Adapter (see also page 10, 11 & 12 for more details)			
For SMT sockets in general, E-tec recommends the use of locating pegs which can be soldered to the PCB for added mechanical strength.			

How to order

MPS - xxx - 10 - xx.x/xx

Nbr of contacts	Pitch	Package Size
052 060	04 = 0,40mm 05 = 0,50mm 06 = 0,65mm 07 = 0,75mm 08 = 0,80mm <i>others on request</i>	14.0/11 17.0/12 17.0/13 18.0/13 18.0/14 20.0/12
	10 = 1,00mm 12 = 1,27mm 15 = 1,50mm	14.0/11 17.0/12 17.0/13 18.0/13 18.0/14 20.0/12
		for 052 pad count for 060 pad count

Burn-In Sockets MPS Series

OPEN TOP BGA SOCKET



Open Top Style. Accommodates Chip Scale package with 1.0mm pitch.
 Compact size and low Actuation Force.
 4-Point pinch design for enhanced electrical contact.
 Field exchangeable package location plate.
 "U" contact supports any type of solder ball shape and composition.

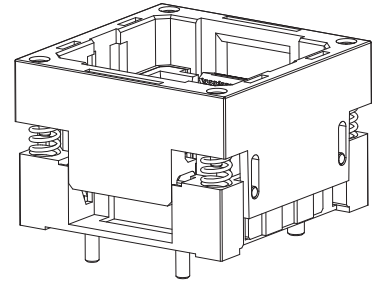

Please note, we will always request the chip data to ensure we offer a compatible socket.

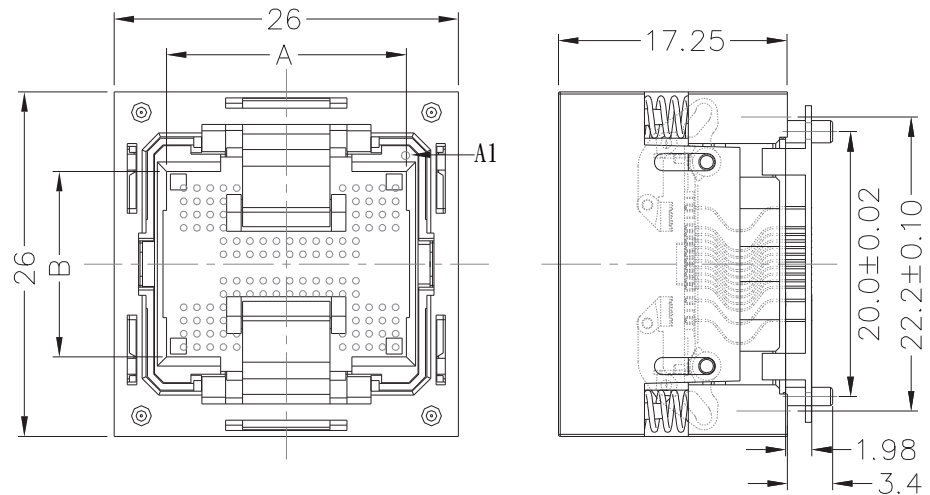
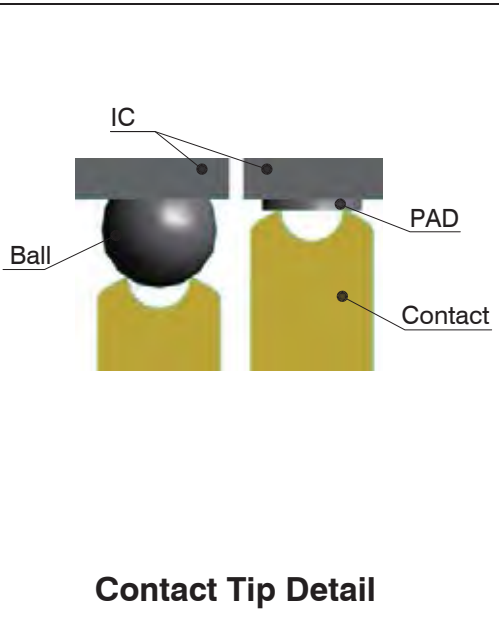

You may request any specific socket dimension from info@e-tec.com
 For top view socket dimension pls. ref. to separate catalog page

Applicable IC	Specifications									
<table border="1"> <tr> <td>A</td> <td>12.00/14.00</td> <td>±0.10 mm</td> </tr> <tr> <td>B</td> <td>16.00/16.50/18.00</td> <td>±0.10 mm</td> </tr> <tr> <td>C</td> <td>0.78/0.98/1.00/1.50</td> <td>±0.05 mm</td> </tr> </table>	A	12.00/14.00	±0.10 mm	B	16.00/16.50/18.00	±0.10 mm	C	0.78/0.98/1.00/1.50	±0.05 mm	<p>Mechanical data</p> <p>Contact life: 25,000 cycles Contact Normal Force: 3-5g Per Pin Operation Force: 2.0Kg max.</p> <p>Material</p> <p>Insulator (RoHS compliant): PES, PEI Contact (RoHS compliant): Beryllium Copper Alloy Contact plating: Gold cover Nickel</p> <p>Electrical data</p> <p>Contact resistance: < 30 mΩ Current rating: 1A Insulation resistance at 500V DC: 1,000 mΩ</p> <p>Operating temperature: -55°C to +175°C</p>
A	12.00/14.00	±0.10 mm								
B	16.00/16.50/18.00	±0.10 mm								
C	0.78/0.98/1.00/1.50	±0.05 mm								

Recommendations:

Solder paste – Please use a solder paste w/o any silver!

Solder profile – Please refer to our website www.e-tec.com

E-tec solderless sockets are adapted to a standard PCB thickness of 1.60mm. For a different PCB thickness, please inform E-tec first!

For high pincount SMT sockets, E-tec recommends the use of a pluggable thru-hole socket mounted into a MiniGrid Adapter (see also page 10, 11 & 12 for more details)

For SMT sockets in general, E-tec recommends the use of locating pegs which can be soldered to the PCB for added mechanical strength.

How to order

MPS - x x x - 10 - xx.x/xx

Nbr of contacts	Pitch	Package Size
088	04 = 0,40mm	12.0/16-0.98 for 088 pad count
132	05 = 0,50mm	14.0/16.5-0.78 for 136 pad count
136	06 = 0,65mm	14.0/16.5-0.98 for 136 pad count
152	07 = 0,75mm	12.0/18-0.78 for 132 pad count
	08 = 0,80mm	12.0/18-0.98 for 132 pad count
	10 = 1,00mm	12.0/18-1.5 for 132 pad count
	12 = 1,27mm	
	15 = 1,50mm	
	others on request	

Burn-In Sockets MPS Series

OPEN TOP BGA SOCKET



Open Top Style. Compact size and low Actuation Force.
 Accommodates BGA chip package with 0.50/0.65/0.80/1.00mm pitch.
 4-Point pinch design for enhanced electrical contact.
 Unique mechanism to eliminate solder ball sticking.
 Field replaceable package location plate.

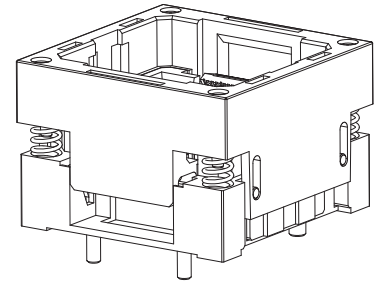

Please note, we will always request the chip data to ensure we offer a compatible socket.

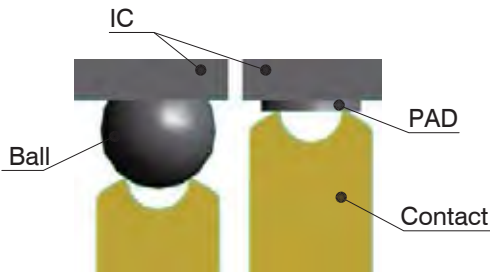

Contact Tip Detail

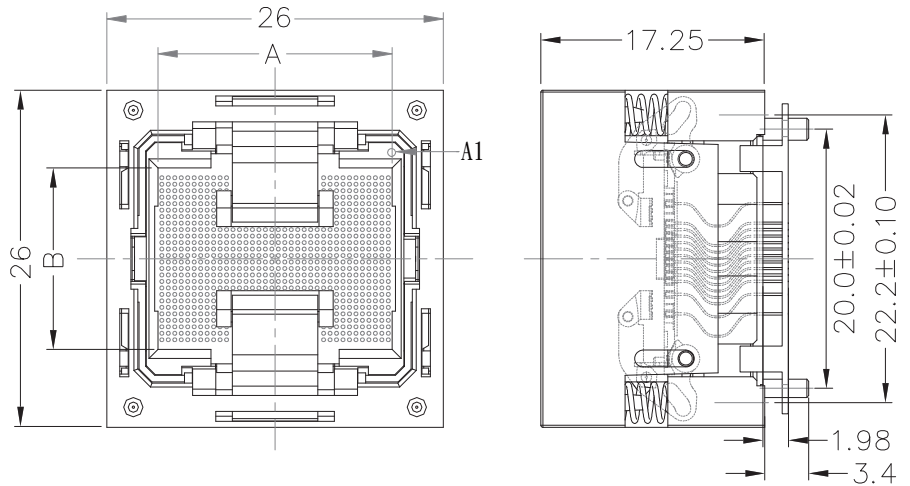

You may request any specific socket dimension from info@e-tec.com

For top view socket dimension pls. ref. to separate catalog page

Specifications

Mechanical data

Contact life 25,000 cycles
 Contact Normal Force 3-5g Per Pin
 Operation Force 2.0kg min.

Material

Insulator (RoHS compliant) PES , PEI
 Contact (RoHS compliant) Beryllium Copper Alloy
 Contact plating Gold cover Nickel

Electrical data

Contact resistance < 30 mΩ
 Current rating 1A
 Insulation resistance at 500V DC 1,000 mΩ

Operating temperature

-55°C to +175°C

Recommendations:

Solder paste – Please use a solder paste w/o any silver!

Solder profile – Please refer to our website www.e-tec.com

E-tec solderless sockets are adapted to a standard PCB thickness of 1.60mm. For a different PCB thickness, please inform E-tec first!

For high pincount SMT sockets, E-tec recommends the use of a pluggable thru-hole socket mounted into a MiniGrid Adapter (see also page 10, 11 & 12 for more details)

For SMT sockets in general, E-tec recommends the use of locating pegs which can be soldered to the PCB for added mechanical strength.

How to order

MPS - xxx - xx - xx.x/xx

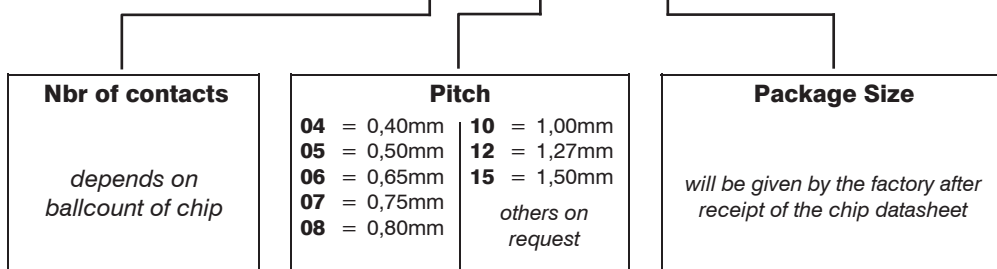

Burn-In Sockets MPS Series

OPEN TOP BGA SOCKET



Open Top Style. Compact size and low Actuation Force.
 Accommodates BGA chip package with 0.50/0.65/0.80/1.00mm pitch.
 4-Point pinch design for enhanced electrical contact.
 Unique mechanism to eliminate solder ball sticking.
 Field replaceable package location plate.

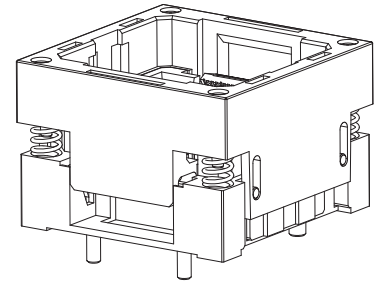

Please note, we will always request the chip data to ensure we offer a compatible socket.

Pitch	No. of Contacts	Package Size(mm)	Part Number
0.5	40	8x9.2	MPS-040-05-8.0/9.2
	48	6x4	MPS-048-05-6.0/4
	56	6x6	MPS-056-05-6.0/6
	64	5x5	MPS-064-05-5.0/5
	84	6x6	MPS-084-05-6.0/6
	88	7x7	MPS-088-05-8.0/8
	105	6x6	MPS-105-05-6.0/6
0.8	141	11.5x13	MPS-141-05-11.5/13
	25	5x5	MPS-025-08-5.0/5
	30	5x5	MPS-030-08-5.0/5
	48	6x10	MPS-048-08-6.0/10
	48	6x11	MPS-048-08-6.0/11
	48	6x8	MPS-048-08-6.0/8
	48	6x9	MPS-048-08-6.0/9
	48	6.15x8.15	MPS-048-08-6.15/8.15
	48	8x10	MPS-048-08-8.0/10
	48	9x11	MPS-048-08-9.0/11
	48	9.5x12	MPS-048-08-9.5/12
	48	10.95x11.95	MPS-048-08-10.95/11.95
	48	11x12	MPS-048-08-11/12
	54	8x8	MPS-054-08-8.0/8
	56	7x9	MPS-056-08-7.0/9
	56	8x10	MPS-056-08-8.0/10
	56	8x11.6	MPS-056-08-8.0/11.6
	56	8x11.6	MPS-056-08-8/11.6
	56	8x13	MPS-056-08-8.0/13
	59	8x11.6	MPS-056-08-8.0/11.6
	60	8x10	MPS-060-08-8.0/10
	60	8x11.6	MPS-060-08-8.0/11.6
	60	11x13	MPS-060-08-11.0/13
	63	7x11	MPS-063-08-7.0/11
	64	7x7	MPS-064-08-7.0/7
	64	8x11	MPS-064-08-8.0/11
64	8.1x11.1	MPS-064-08-8.1/11.1	

Burn-In Sockets MPS Series

OPEN TOP BGA SOCKET



Open Top Style. Compact size and low Actuation Force.
 Accommodates BGA chip package with 0.50/0.65/0.80/1.00mm pitch.
 4-Point pinch design for enhanced electrical contact.
 Unique mechanism to eliminate solder ball sticking.
 Field replaceable package location plate.

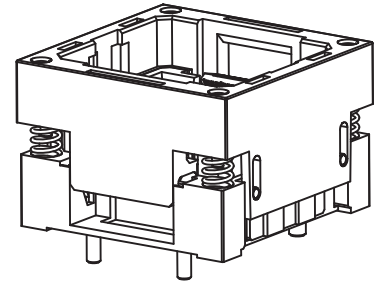

Please note, we will always request the chip data to ensure we offer a compatible socket.

Pitch	No. of Contacts	Package Size(mm)	Part Number
1.0	64	7.95x8.95	MPS-064-10-7.95/8.95
	64	9x9	MPS-064-10-9.0/9
	64	9x11.5	MPS-064-10-9.0/11.5
	64	10.95x11.95	MPS-064-10-10.95/11.95
	66	7.47x11.02	MPS-066-10-7.47/11.02
	72	10x10	MPS-072-10-10.0/10
	80	7x9	MPS-080-10-7.0/09
	80	8x8	MPS-080-10-8.0/08
	80	8x10	MPS-080-10-8.0/10
	80	8x11	MPS-080-10-8.0/11
	80	9x11.5	MPS-080-10-9.0/11.5
	81	8x8	MPS-081-10-8.0/08
	81	14x18	MPS-081-10-14.0/18

Burn-In Sockets OTZ Series

SOP SOCKET



Open top thru-hole style for Small Outline chip Packages.
 Zero Insertion Force designed for automatic loading.
 Highly reliable, dual pinch, pre-loaded contacts.
 Live bug insertion for 0.65/1.27mm pitch packages.
 High force contact version available for Pb-free devices (single beam type).



Please note, we will always request the chip data to ensure we offer a compatible socket.

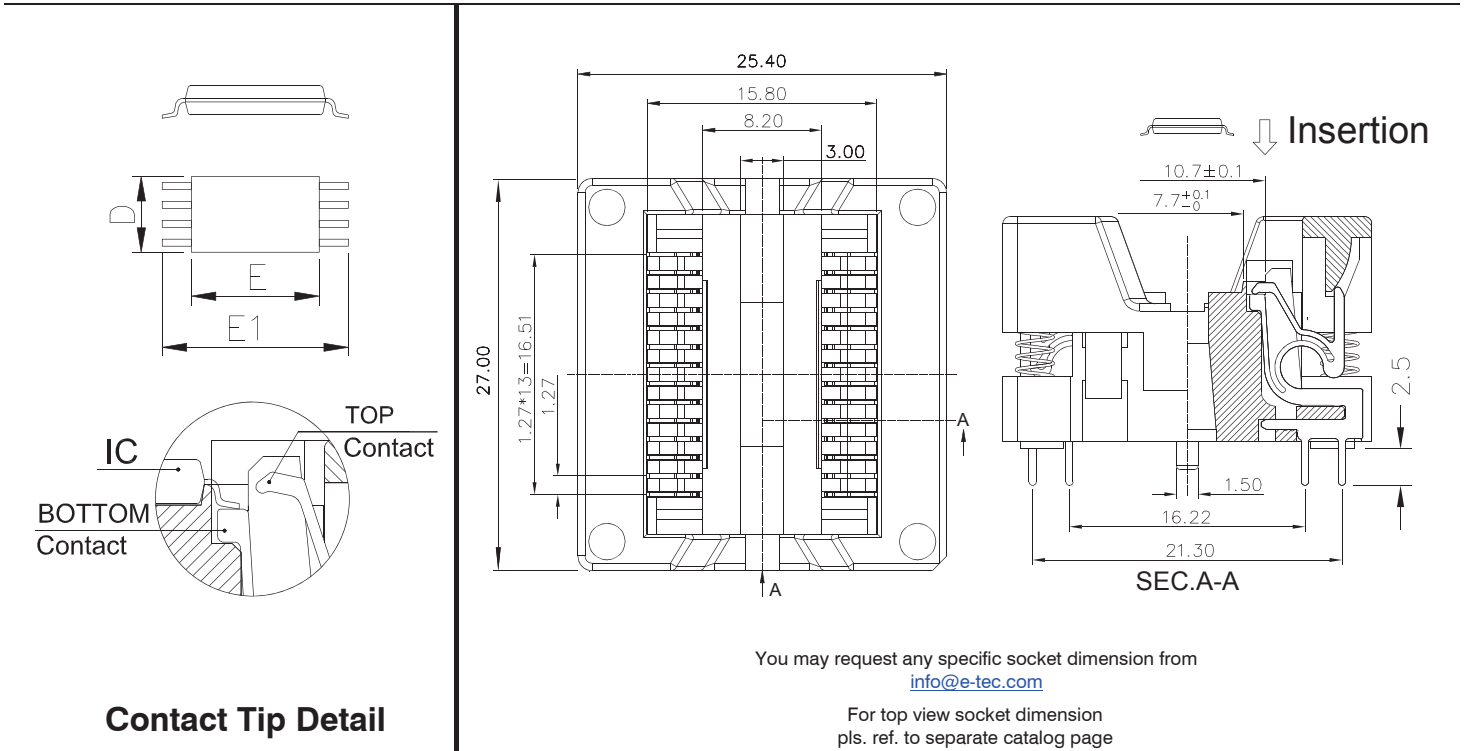

Specifications			
Mechanical data		Electrical data	
Contact life	15,000 cycles	Contact resistance	< 30 mΩ
Contact Normal Force	18g Per Pin	Current rating	10mA
Operation Force	1.0Kg max.	Insulation resistance at 500V DC	1,000 mΩ
Material		Operating temperature	
Insulator (RoHS compliant)	PES , PEI	-55°C to +175°C	
Contact (RoHS compliant)	Beryllium Copper Alloy		
Contact plating	Gold cover Nickel		
Recommendations:			
Solder paste – Please use a solder paste w/o any silver!		Solder profile – Please refer to our website www.e-tec.com	
E-tec solderless sockets are adapted to a standard PCB thickness of 1.60mm. For a different PCB thickness, please inform E-tec first!			
For high pincount SMT sockets, E-tec recommends the use of a pluggable thru-hole socket mounted into a MiniGrid Adapter (see also page 10, 11 & 12 for more details)			
For SMT sockets in general, E-tec recommends the use of locating pegs which can be soldered to the PCB for added mechanical strength.			

How to order

OTZ - x x x - 12 - xx.x/xx.x/xx.x

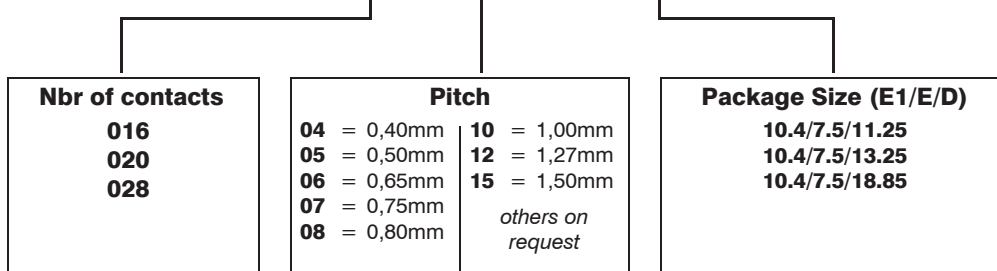

Burn-In Sockets OTZ Series

SOP SOCKET



Open top thru-hole style for Small Outline chip Packages.
 Zero Insertion Force designed for automatic loading.
 Highly reliable, dual pinch, pre-loaded contacts.
 Live bug insertion for 0.65/1.27mm pitch packages.
 High force contact version available for Pb-free devices (single beam type).



Please note, we will always request the chip data to ensure we offer a compatible socket.

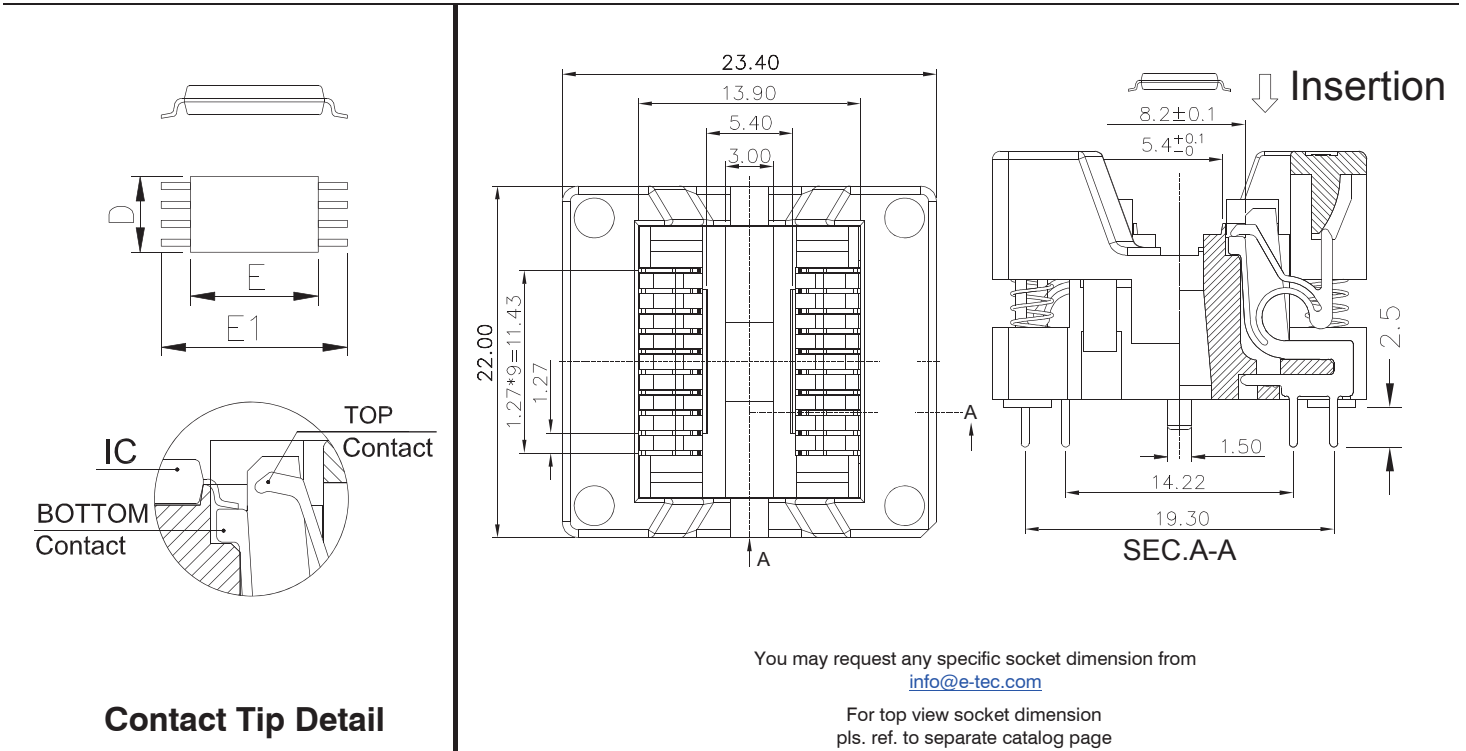

Specifications

Mechanical data

Contact life 15,000 cycles
 Contact Normal Force 18g Per Pin
 Operation Force 1.0Kg max.

Material

Insulator (RoHS compliant) PES , PEI
 Contact (RoHS compliant) Beryllium Copper Alloy
 Contact plating Gold cover Nickel

Electrical data

Contact resistance < 30 mΩ
 Current rating 10mA
 Insulation resistance at 500V DC 1,000 mΩ

Operating temperature

-55°C to +175°C

Recommendations:

Solder paste – Please use a solder paste w/o any silver!

Solder profile – Please refer to our website www.e-tec.com

E-tec solderless sockets are adapted to a standard PCB thickness of 1.60mm. For a different PCB thickness, please inform E-tec first!

For high pincount SMT sockets, E-tec recommends the use of a pluggable thru-hole socket mounted into a MiniGrid Adapter (see also page 10, 11 & 12 for more details)

For SMT sockets in general, E-tec recommends the use of locating pegs which can be soldered to the PCB for added mechanical strength.

How to order

OTZ - x x x - 12 - xx.x/xx.x/xx.x

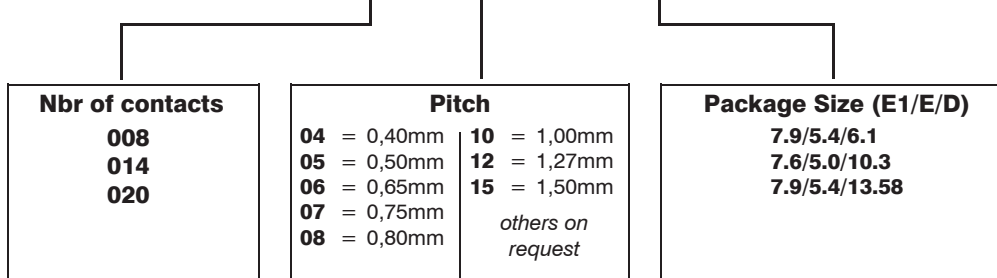

Burn-In Sockets OTZ Series

SOP SOCKET



Open top thru-hole style for Small Outline chip Packages.
 Zero Insertion Force designed for automatic loading.
 Highly reliable, dual pinch, pre-loaded contacts.
 Live bug insertion for 0.65/1.27mm pitch packages.
 High force contact version available for Pb-free devices (single beam type).



Please note, we will always request the chip data to ensure we offer a compatible socket.

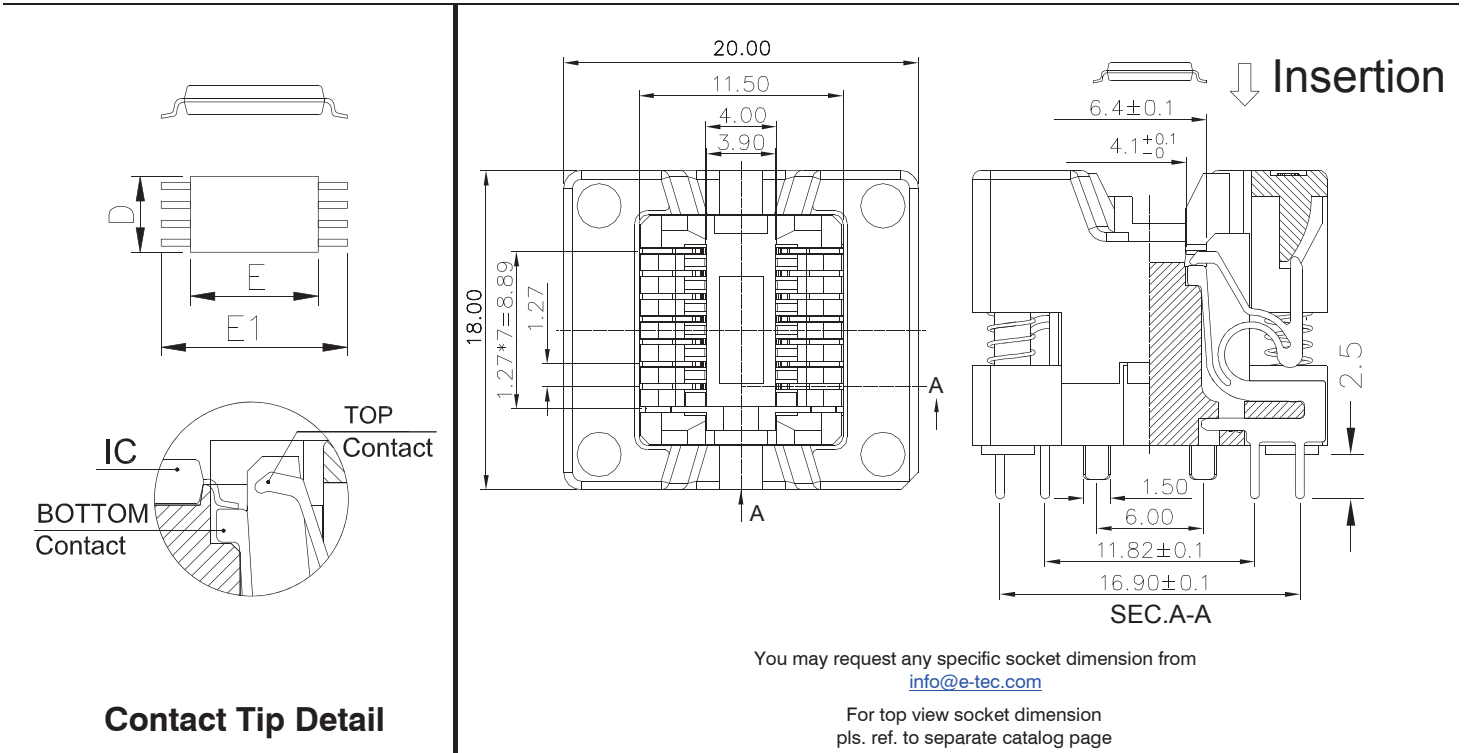

Specifications

Mechanical data

Contact life 15,000 cycles
 Contact Normal Force 18g Per Pin
 Operation Force 1.0Kg max.

Material

Insulator (RoHS compliant) PES , PEI
 Contact (RoHS compliant) Beryllium Copper Alloy
 Contact plating Gold cover Nickel

Electrical data

Contact resistance < 30 mΩ
 Current rating 10mA
 Insulation resistance at 500V DC 1,000 mΩ

Operating temperature

-55°C to +175°C

Recommendations:

Solder paste – Please use a solder paste w/o any silver!

Solder profile – Please refer to our website www.e-tec.com

E-tec solderless sockets are adapted to a standard PCB thickness of 1.60mm. For a different PCB thickness, please inform E-tec first!

For high pincount SMT sockets, E-tec recommends the use of a pluggable thru-hole socket mounted into a MiniGrid Adapter (see also page 10, 11 & 12 for more details)

For SMT sockets in general, E-tec recommends the use of locating pegs which can be soldered to the PCB for added mechanical strength.

How to order

OTZ - x x x - 12 - xx.x/xx.x/xx.x

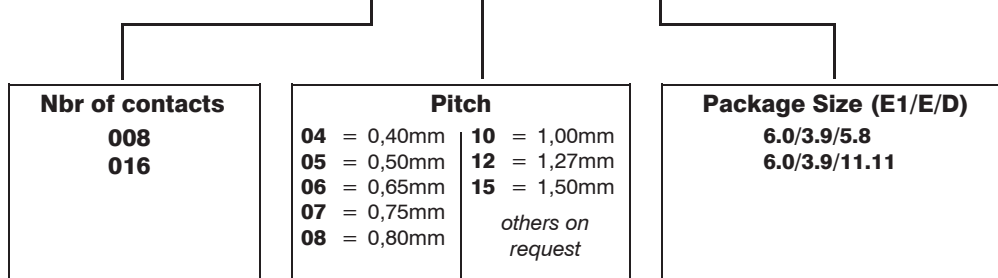

Burn-In Sockets OTZ Series

SOP SOCKET



Open top thru-hole style for Small Outline chip Packages.
 Zero Insertion Force designed for automatic loading.
 Highly reliable, dual pinch, pre-loaded contacts.
 Live bug insertion for 0.65/1.27mm pitch packages.
 High force contact version available for Pb-free devices (single beam type).



Please note, we will always request the chip data to ensure we offer a compatible socket.

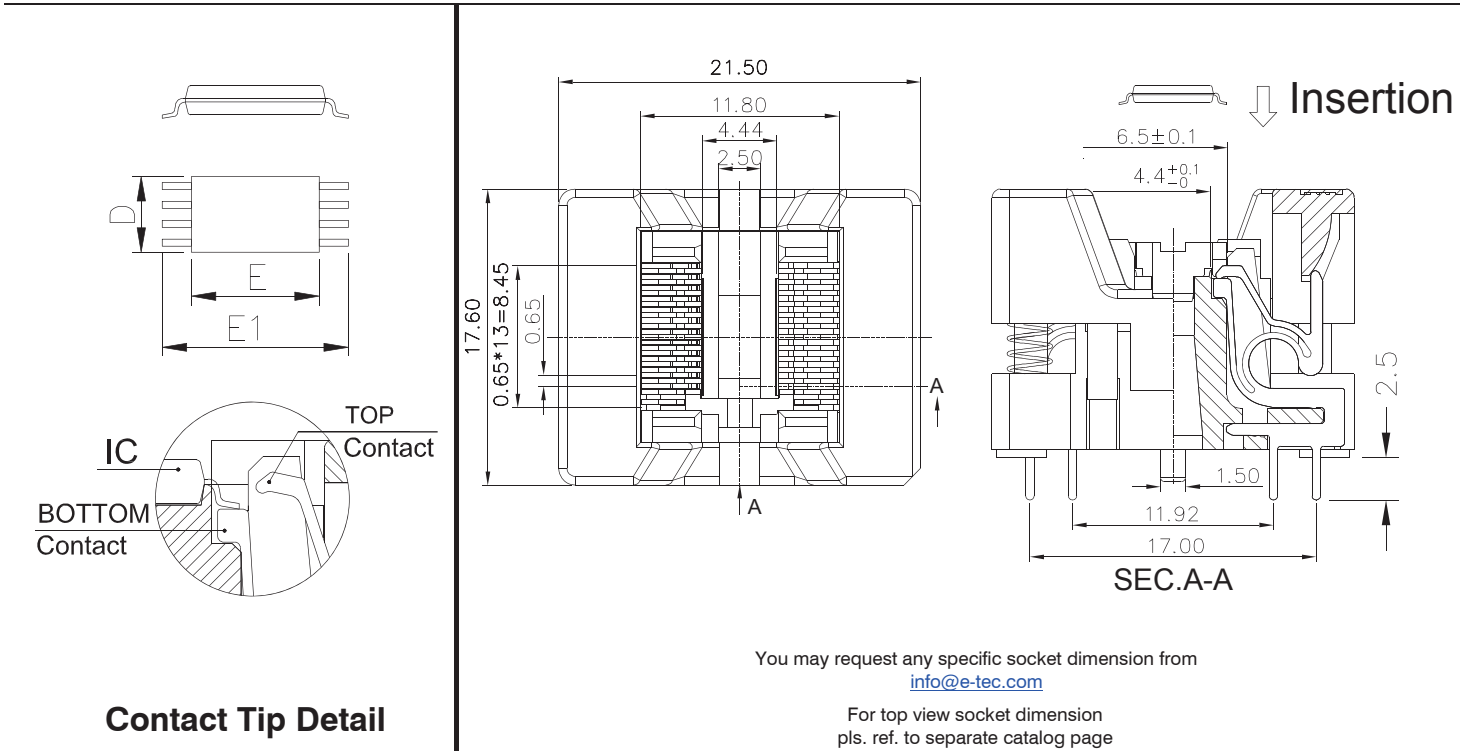

Specifications

Mechanical data

Contact life 15,000 cycles
 Contact Normal Force 18g Per Pin
 Operation Force 1.0Kg max.

Material

Insulator (RoHS compliant) PES , PEI
 Contact (RoHS compliant) Beryllium Copper Alloy
 Contact plating Gold cover Nickel

Electrical data

Contact resistance < 30 mΩ
 Current rating 10mA
 Insulation resistance at 500V DC 1,000 mΩ

Operating temperature

-55°C to +175°C

Recommendations:

Solder paste – Please use a solder paste w/o any silver!

Solder profile – Please refer to our website www.e-tec.com

E-tec solderless sockets are adapted to a standard PCB thickness of 1.60mm. For a different PCB thickness, please inform E-tec first!

For high pincount SMT sockets, E-tec recommends the use of a pluggable thru-hole socket mounted into a MiniGrid Adapter (see also page 10, 11 & 12 for more details)

For SMT sockets in general, E-tec recommends the use of locating pegs which can be soldered to the PCB for added mechanical strength.

How to order

OTZ - x x x - 06 - xx.x/xx.x/xx.x

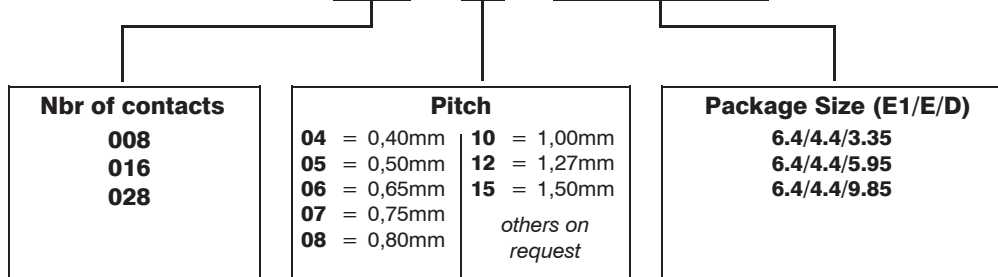

Burn-In Sockets OTZ Series

SOP SOCKET



Open top thru-hole style for Small Outline chip Packages.
 Zero Insertion Force designed for automatic loading.
 Highly reliable, dual pinch, pre-loaded contacts.
 Live bug insertion for 0.65/1.27mm pitch packages.
 High force contact version available for Pb-free devices (single beam type).



Please note, we will always request the chip data to ensure we offer a compatible socket.

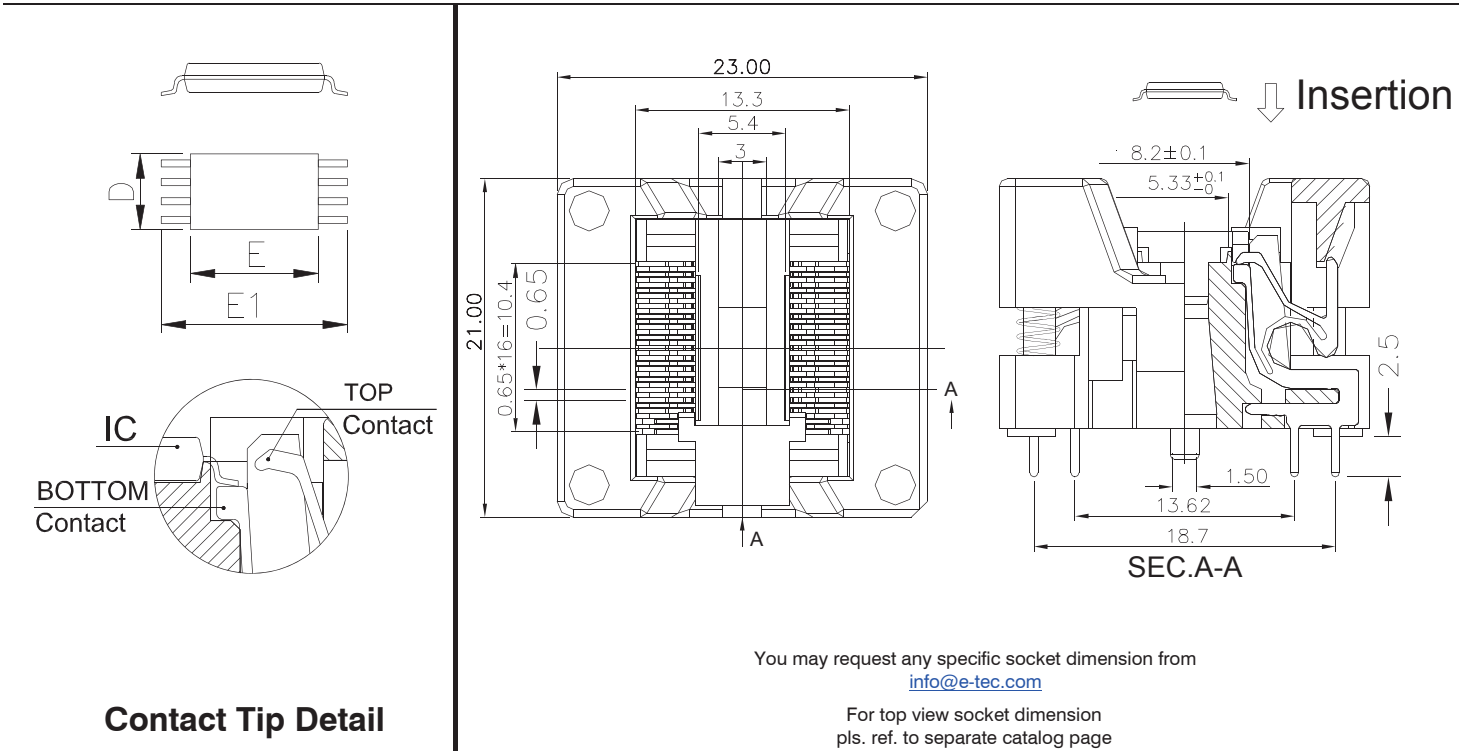

Specifications

Mechanical data

Contact life 15,000 cycles
 Contact Normal Force 18g Per Pin
 Operation Force 1.0Kg max.

Material

Insulator (RoHS compliant) PES , PEI
 Contact (RoHS compliant) Beryllium Copper Alloy
 Contact plating Gold cover Nickel

Electrical data

Contact resistance < 30 mΩ
 Current rating 10mA
 Insulation resistance at 500V DC 1,000 mΩ

Operating temperature

-55°C to +175°C

Recommendations:

Solder paste – Please use a solder paste w/o any silver!

Solder profile – Please refer to our website www.e-tec.com

E-tec solderless sockets are adapted to a standard PCB thickness of 1.60mm. For a different PCB thickness, please inform E-tec first!

For high pincount SMT sockets, E-tec recommends the use of a pluggable thru-hole socket mounted into a MiniGrid Adapter (see also page 10, 11 & 12 for more details)

For SMT sockets in general, E-tec recommends the use of locating pegs which can be soldered to the PCB for added mechanical strength.

How to order

OTZ - x x x - 06 - xx.x/xx.x/xx.x

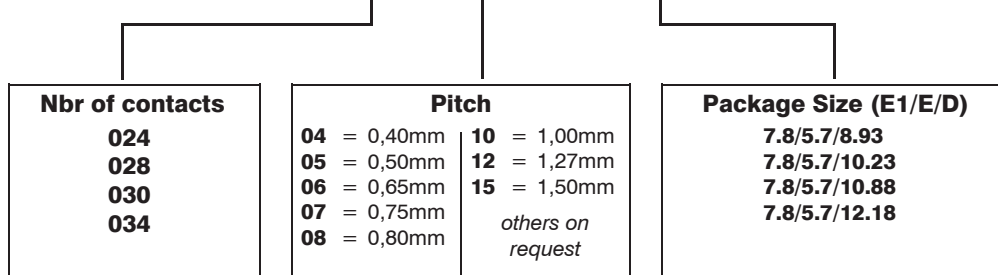

Burn-In Sockets OTZ Series

SOP SOCKET



Open top thru-hole style for Small Outline chip Packages.
 Zero Insertion Force designed for automatic loading.
 Highly reliable, dual pinch, pre-loaded contacts.
 Live bug insertion for 0.65/1.27mm pitch packages.
 High force contact version available for Pb-free devices (single beam type).



Please note, we will always request the chip data to ensure we offer a compatible socket.

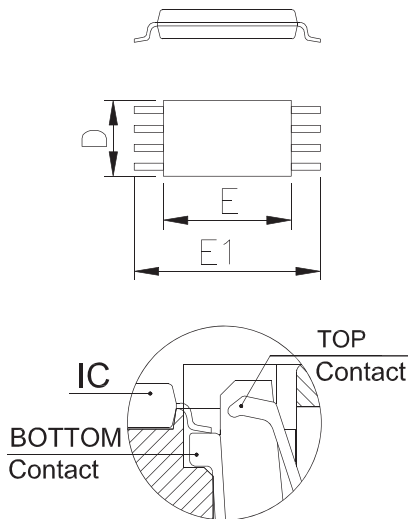

Contact Tip Detail

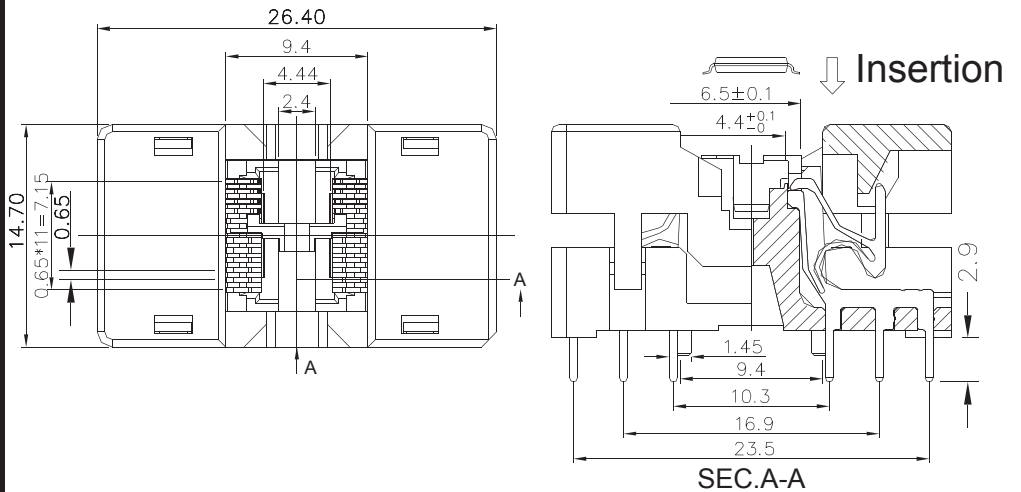

You may request any specific socket dimension from info@e-tec.com

For top view socket dimension pls. ref. to separate catalog page

Specifications

Mechanical data

Contact life 15,000 cycles
 Contact Normal Force 18g Per Pin
 Operation Force 1.0Kg max.

Material

Insulator (RoHS compliant) PES , PEI
 Contact (RoHS compliant) Beryllium Copper Alloy
 Contact plating Gold cover Nickel

Electrical data

Contact resistance < 30 mΩ
 Current rating 10mA
 Insulation resistance at 500V DC 1,000 mΩ

Operating temperature

-55°C to +175°C

Recommendations:

Solder paste – Please use a solder paste w/o any silver!

Solder profile – Please refer to our website www.e-tec.com

E-tec solderless sockets are adapted to a standard PCB thickness of 1.60mm. For a different PCB thickness, please inform E-tec first!

For high pincount SMT sockets, E-tec recommends the use of a pluggable thru-hole socket mounted into a MiniGrid Adapter (see also page 10, 11 & 12 for more details)

For SMT sockets in general, E-tec recommends the use of locating pegs which can be soldered to the PCB for added mechanical strength.

How to order

OTZ - x x x - 06 - xx.x/xx.x/xx.x

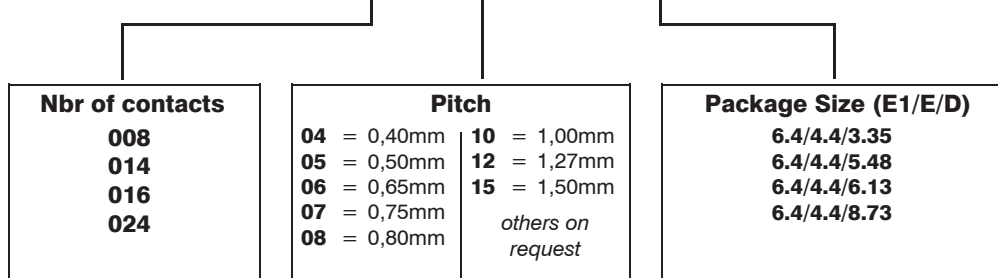

Burn-In Sockets QOT Series

OPEN TOP QFN SOCKET



Universal Open Top Style for Thru-Hole mount
 Individual spring loaded pressure pad per device type
 Inexpensive GP insert accommodates many package sizes
 X-shape stand-off prevents package from sticking
 Accommodate 0.5~1.2mm thick packages
 (See pages 16/17 for ClamShell style)

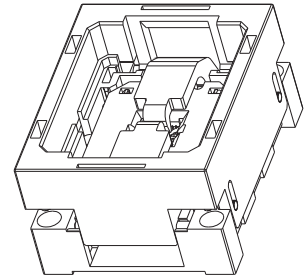

Please note, we will always request the chip data to ensure we offer a compatible socket.

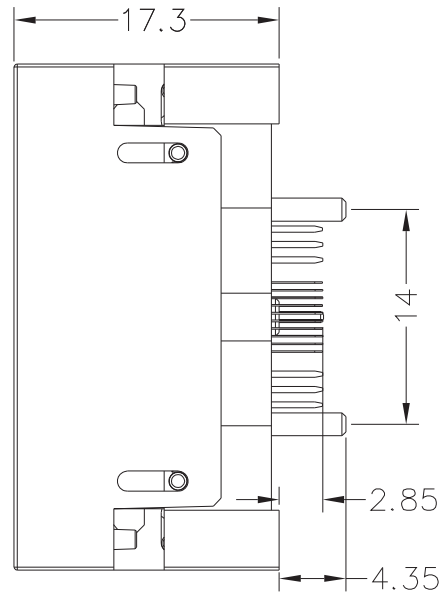
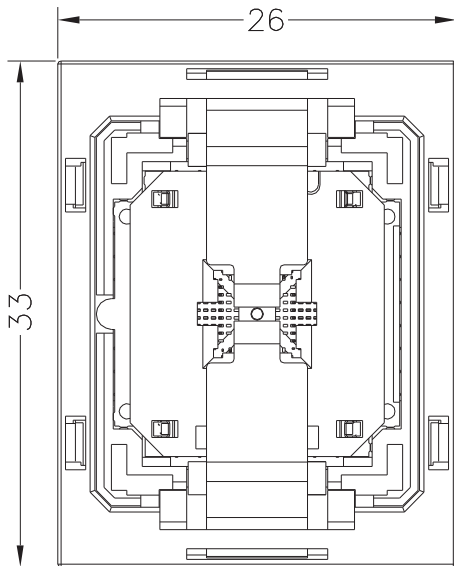

You may request any specific socket dimension from info@e-tec.com

For top view socket dimension pls. ref. to separate catalog page

Specifications

Mechanical data

Contact life 15,000 cycles
 Contact Normal Force 5-8g Per Pin
 Operation Force 2.0Kg max

Material

Insulator (RoHS compliant) PES , PEI
 Contact (RoHS compliant) Beryllium Copper Alloy
 Contact plating Gold cover Nickel

Electrical data

Contact resistance < 30 mΩ
 Current rating 1A
 Insulation resistance at 500V DC 1,000 mΩ

Operating temperature

-55°C to +175°C

Recommendations:

Solder paste – Please use a solder paste w/o any silver!

Solder profile – Please refer to our website www.e-tec.com

E-tec solderless sockets are adapted to a standard PCB thickness of 1.60mm. For a different PCB thickness, please inform E-tec first!

For high pincount SMT sockets, E-tec recommends the use of a pluggable thru-hole socket mounted into a MiniGrid Adapter (see also page 10, 11 & 12 for more details)

For SMT sockets in general, E-tec recommends the use of locating pegs which can be soldered to the PCB for added mechanical strength.

How to order

QOT - XXX - XX - XX.X/XX

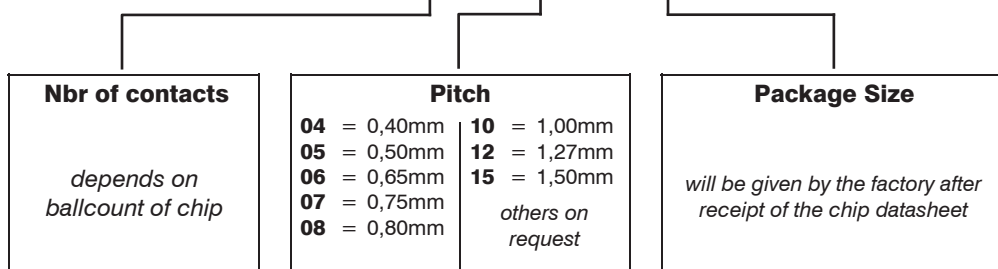

Burn-In Sockets QOT Series

OPEN TOP QFN SOCKET



Universal Open Top Style for Thru-Hole mount
 Individual spring loaded pressure pad per device type
 Inexpensive GP insert accommodates many package sizes
 X-shape stand-off prevents package from sticking
 Accommodate 0.5~1.2mm thick packages
 (See pages 16/17 for ClamShell style)

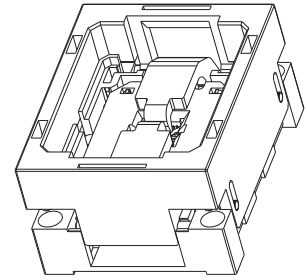

Please note, we will always request the chip data to ensure we offer a compatible socket.

Pitch	No. of Contacts	Pad Matrix	Package Size(mm)	Part Number
0.4	12	odd	2x2	QOT-012-04-2.0/2
	16	even	3x3	QOT-016-04-3.0/3
	20	odd	3x3	QOT-020-04-3.0/3
	24	even	4x4	QOT-024-04-4.0/4
	28	odd	4x4	QOT-028-04-4.0/4
	32	even	5x5	QOT-032-04-5.0/5
	36	odd	5x5	QOT-036-04-5.0/5
	40	even	5x5	QOT-040-04-5.0/5
	44	odd	6x6	QOT-044-04-6.0/6
	48	even	6x6	QOT-048-04-6.0/6
	52	odd	7x7	QOT-052-04-7.0/7
	56	even	7x7	QOT-056-04-7.0/7
	60	odd	8x8	QOT-060-04-8.0/8
	64	even	8x8	QOT-064-04-8.0/8
	76	odd	9x9	QOT-076-04-9.0/9
	80	even	9x9	QOT-080-04-9.0/9
	84	odd	10x10	QOT-084-04-10.0/10
	88	even	10x10	QOT-088-04-10.0/10
104	even	12x12	QOT-104-04-12.0/12	
108	odd	12x12	QOT-108-04-12.0/12	
0.5	12	odd	2x2	QOT-012-05-2.0/2
	16	even	3x3	QOT-016-05-3.0/3
	12	odd	3x3	QOT-012-05-3.0/3
	20	odd	3x3	QOT-020-05-3.0/3
	24	even	4x4	QOT-024-05-4.0/4
	20	odd	4x4	QOT-020-05-4.0/4
	32	even	5x5	QOT-032-05-5.0/5
	28	odd	5x5	QOT-028-05-5.0/5
	40	even	6x6	QOT-040-05-6.0/6
	36	odd	6x6	QOT-036-05-6.0/6
	48	even	7x7	QOT-048-05-7.0/7
	44	odd	7x7	QOT-044-05-7.0/7
	56	even	8x8	QOT-056-05-8.0/8
	52	odd	8x8	QOT-052-05-8.0/8
	64	even	9x9	QOT-064-05-9.0/9
	60	odd	9x9	QOT-060-05-9.0/9
	72	even	10x10	QOT-072-05-10.0/10
	68	odd	10x10	QOT-068-05-10.0/10
88	even	12x12	QOT-088-05-12.0/12	
84	odd	12x12	QOT-084-05-12.0/12	

Burn-In Sockets QMC Series

CLAMSHELL QFN SOCKET



Universal ClamShell Style for Thru-Hole mount
 Individual spring loaded pressure pad per device type
 Inexpensive GP insert accommodates many package sizes
 Opening provided on top for sensor placement
 X-shape stand-off prevents package from sticking
 Accommodate 0.5~1.2mm thick packages
 (See pages 14/15 for Open Top style)

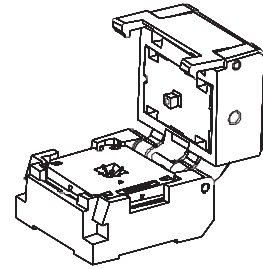

Please note, we will always request the chip data to ensure we offer a compatible socket.

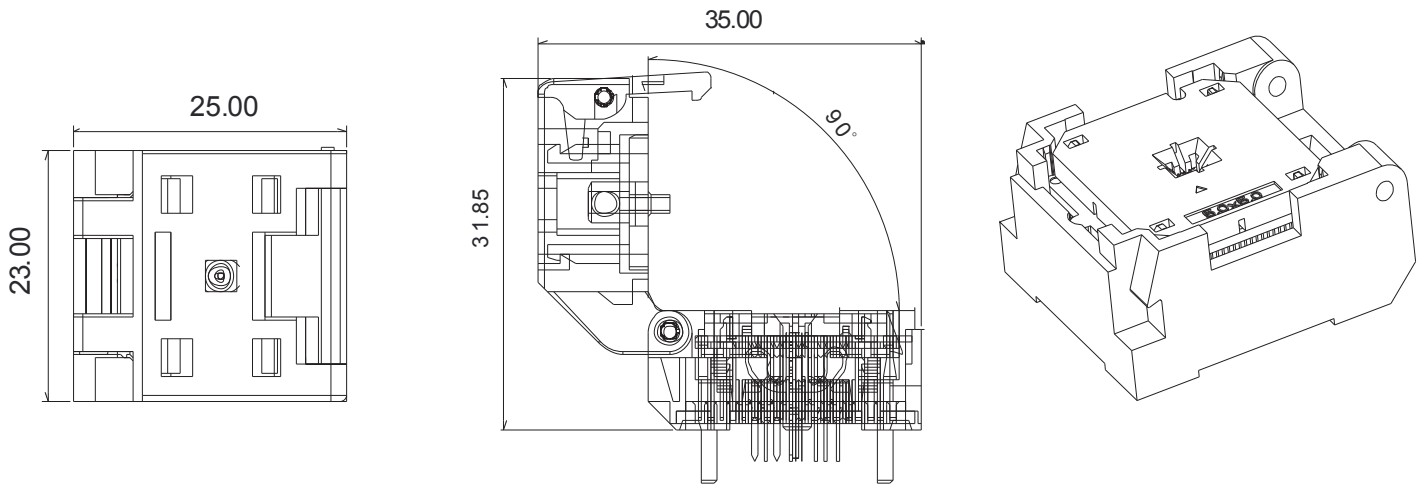

You may request any specific socket dimension from info@e-tec.com

For top view socket dimension pls. ref. to separate catalog page

Specifications

Mechanical data

Contact life 15,000 cycles
 Contact Normal Force 5-8g Per Pin
 Operation Force 2.0Kg max

Material

Insulator (RoHS compliant) PES , PEI
 Contact (RoHS compliant) Beryllium Copper Alloy
 Contact plating Gold cover Nickel

Electrical data

Contact resistance < 30 mΩ
 Current rating 1A
 Insulation resistance at 500V DC 1,000 mΩ

Operating temperature

-55°C to +175°C

Recommendations:

Solder paste – Please use a solder paste w/o any silver!

Solder profile – Please refer to our website www.e-tec.com

E-tec solderless sockets are adapted to a standard PCB thickness of 1.60mm. For a different PCB thickness, please inform E-tec first!

For high pincount SMT sockets, E-tec recommends the use of a pluggable thru-hole socket mounted into a MiniGrid Adapter (see also page 10, 11 & 12 for more details)

For SMT sockets in general, E-tec recommends the use of locating pegs which can be soldered to the PCB for added mechanical strength.

How to order

QMC - xxx - xx - xx.x/xx

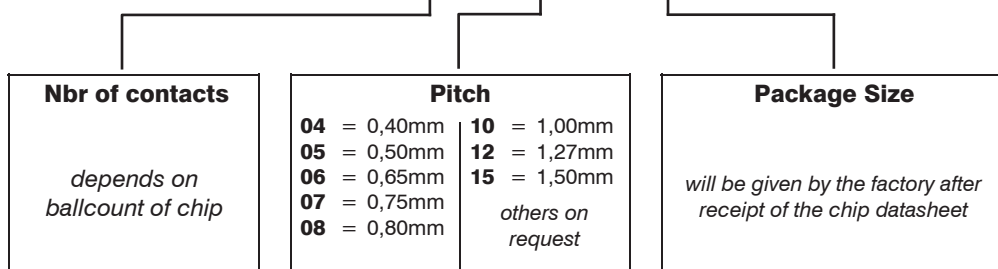

Burn-In Sockets QMC Series

CLAMSHELL QFN SOCKET



Universal ClamShell Style for Thru-Hole mount
 Individual spring loaded pressure pad per device type
 Inexpensive GP insert accommodates many package sizes
 Opening provided on top for sensor placement
 X-shape stand-off prevents package from sticking
 Accommodate 0.5~1.2mm thick packages
 (See pages 14/15 for Open Top style)

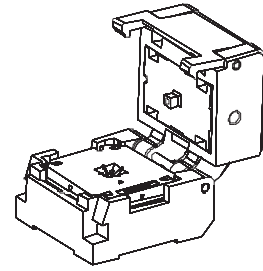

Please note, we will always request the chip data to ensure we offer a compatible socket.

Pitch	No. of Contacts	Pad Matrix	Package Size(mm)	Part Number
0.4	12	odd	2x2	QMC-012-04-2.0/2
	16	even	3x3	QMC-016-04-3.0/3
	20	odd	3x3	QMC-020-04-3.0/3
	24	even	4x4	QMC-024-04-4.0/4
	28	odd	4x4	QMC-028-04-4.0/4
	32	even	5x5	QMC-032-04-5.0/5
	36	odd	5x5	QMC-036-04-5.0/5
	40	even	5x5	QMC-040-04-5.0/5
	44	odd	6x6	QMC-044-04-6.0/6
	48	even	6x6	QMC-048-04-6.0/6
	52	odd	7x7	QMC-052-04-7.0/7
	56	even	7x7	QMC-056-04-7.0/7
	60	odd	8x8	QMC-060-04-8.0/8
	64	even	8x8	QMC-064-04-8.0/8
	76	odd	9x9	QMC-076-04-9.0/9
	80	even	9x9	QMC-080-04-9.0/9
	84	odd	10x10	QMC-084-04-10.0/10
	88	even	10x10	QMC-088-04-10.0/10
104	even	12x12	QMC-104-04-12.0/12	
108	odd	12x12	QMC-108-04-12.0/12	
0.5	12	odd	2x2	QMC-012-05-2.0/2
	16	even	3x3	QMC-016-05-3.0/3
	12	odd	3x3	QMC-012-05-3.0/3
	20	odd	3x3	QMC-020-05-3.0/3
	24	even	4x4	QMC-024-05-4.0/4
	20	odd	4x4	QMC-020-05-4.0/4
	32	even	5x5	QMC-032-05-5.0/5
	28	odd	5x5	QMC-028-05-5.0/5
	40	even	6x6	QMC-040-05-6.0/6
	36	odd	6x6	QMC-036-05-6.0/6
	48	even	7x7	QMC-048-05-7.0/7
	44	odd	7x7	QMC-044-05-7.0/7
	56	even	8x8	QMC-056-05-8.0/8
	52	odd	8x8	QMC-052-05-8.0/8
	64	even	9x9	QMC-064-05-9.0/9
	60	odd	9x9	QMC-060-05-9.0/9
	72	even	10x10	QMC-072-05-10.0/10
	68	odd	10x10	QMC-068-05-10.0/10
88	even	12x12	QMC-088-05-12.0/12	
84	odd	12x12	QMC-084-05-12.0/12	

Burn-In Sockets BPT Series

BGA PROBE PIN OPEN TOP SOCKET



Open Top Style for Solderless Compression mount
 Accommodates pitch sizes of 0.4/0.5/0.65/0.8/1.0/1.27mm
 Compact size and low Actuation Force
 4-Point pinch design for enhanced electrical contact
 Unique mechanism to eliminate solder ball sticking
 Field replaceable package location plate

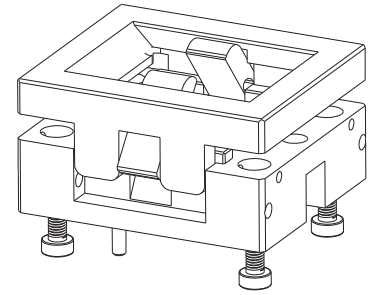

Please note, we will always request the chip data to ensure we offer a compatible socket.

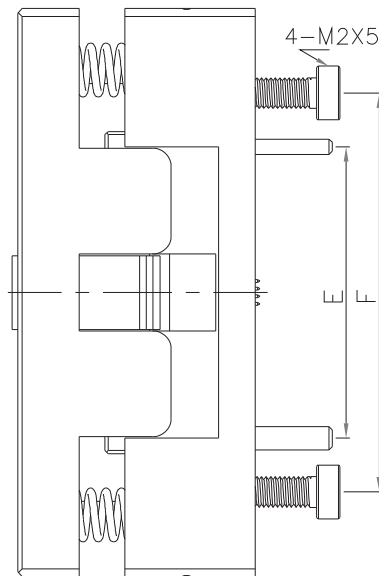
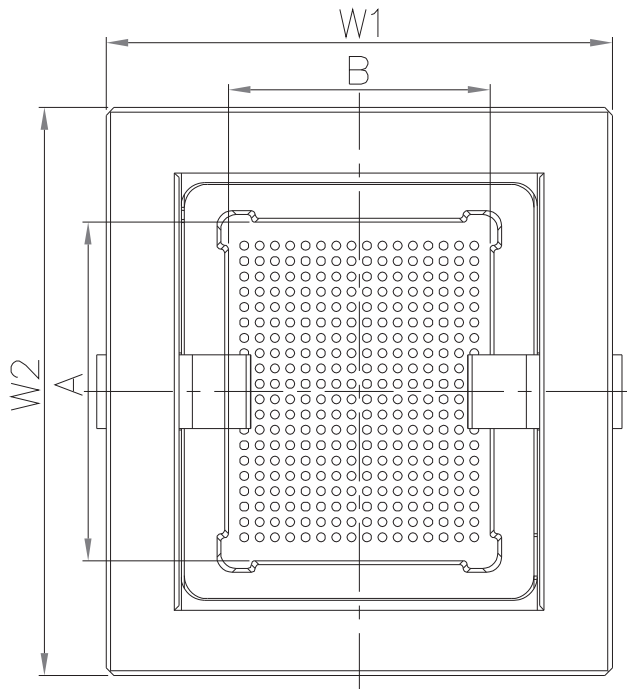

You may request any specific socket dimension from info@e-tec.com

For top view socket dimension pls. ref. to separate catalog page

Specifications

Mechanical data

Contact life 50,000 / 8,000 cycles
 (0.5 / 0.8 pitch)
 Contact Normal Force 25 / 28g Per Pin
 Operation Force 2.0Kg max

Material

Insulator (RoHS compliant) PES , PEI
 Contact (RoHS compliant) Beryllium Copper Alloy
 Contact plating Gold cover Nickel

Electrical data

Contact resistance < 30 mΩ
 Current rating 1A / 2A (0.5 / 0.8 pitch)
 Insulation resistance at 500V DC 1,000 mΩ

Operating temperature

-40°C to +155°C

How to order

BPT - xxx - xx - xx.x/xx

Nbr of contacts

*depends on
ballcount of chip*

Pitch

04 = 0,40mm **10** = 1,00mm
05 = 0,50mm **12** = 1,27mm
06 = 0,65mm **15** = 1,50mm
07 = 0,75mm
08 = 0,80mm
others on request

Package Size

*will be given by the factory after
receipt of the chip datasheet*

Burn-In Sockets BPT Series

BGA PROBE PIN OPEN TOP SOCKET



Open Top Style for Solderless Compression mount
 Accommodates pitch sizes of 0.4/0.5/0.65/0.8/1.0/1.27mm
 Compact size and low Actuation Force
 4-Point pinch design for enhanced electrical contact
 Unique mechanism to eliminate solder ball sticking
 Field replaceable package location plate

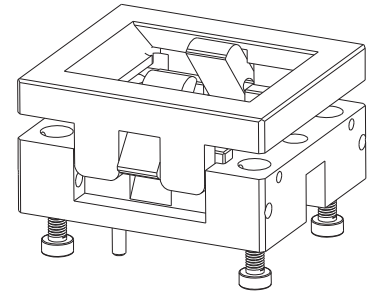

Please note, we will always request the chip data to ensure we offer a compatible socket.

Pitch	No. of Contacts	Package Size(mm)	Part Number
0.4	48	10x12	BPT-048-04-10.0/12
	54	5x5	BPT-054-04-5.0/5
	60	8x10	BPT-060-04-8.0/10
	65	6x8	BPT-065-04-6.0/8
0.5	40	8x9.2	BPT-040-05-8.0/9.2
	48	6x4	BPT-048-05-6.0/4
	56	6x6	BPT-056-05-6.0/6
	64	5x5	BPT-064-05-5.0/5
	105	6x6	BPT-105-05-6.0/6
	141	11.5x13	BPT-141-05-11.5/13
0.65	63	8x10	BPT-063-06-8.0/10
	65	7x11	BPT-065-06-7.0/11
	70	8x8	BPT-070-06-8.0/8
	88	8.1x12	BPT-088-06-8.1/12
0.8	25	5x5	BPT-025-08-5.0/5
	30	5x5	PBT-030-08-5.0/5
	48	9x11	BPT-048-08-9.0/11
	48	9.5x12	BPT-048-08-9.5/12
	54	8x8	BPT-054-08-8.0/8
	56	7x9	BPT-056-08-7.0/9
	56	8x11.6	BPT-056-08-8.0/11.6
	56	8x13	BPT-056-08-8.0/13
	56	8x10	BPT-056-08-8.0/10
	56	8x11.6	BPT-056-08-8.0/11.6
	59	8x11.6	BPT-059-08-8.0/11.6
	60	8x10	BPT-060-08-8.0/10
	60	8x11.6	BPT-060-08-8.0/11.6
	60	11x13	BPT-060-08-11.0/13
	63	7x11	BPT-063-08-7.0/11
	64	7x7	BPT-064-08-7.0/7
64	8x11.6	BPT-064-08-8.0/11.6	
64	8.1x11.1	BPT-064-08-8.1/11.1	

Burn-In Sockets BPT Series

BGA PROBE PIN OPEN TOP SOCKET



Open Top Style for Solderless Compression mount
 Accommodates pitch sizes of 0.4/0.5/0.65/0.8/1.0/1.27mm
 Compact size and low Actuation Force
 4-Point pinch design for enhanced electrical contact
 Unique mechanism to eliminate solder ball sticking
 Field replaceable package location plate

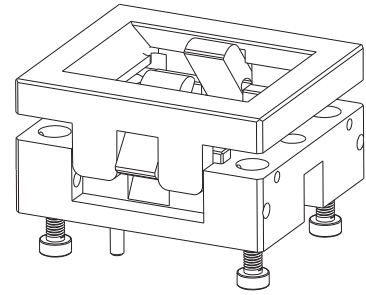

Please note, we will always request the chip data to ensure we offer a compatible socket.

Pitch	No. of Contacts	Package Size(mm)	Part Number
1.0	64	7.95x8.98	BPT-064-10-7.95/8.98
	64	9x9	BPT-064-10-9.0/9
	64	9x11.5	BPT-064-10-9.0/11.5
	64	10.95x11.95	BPT-064-10-10.95/11.95
	66	7.47x11.02	BPT-066-10-7.47/11.02
	72	10x10	BPT-072-10-10.0/10
	80	7x9	BPT-080-10-7.0/9
	80	8x8	BPT-080-10-8.0/8
	80	8x11.6	BPT-080-10-8.0/11.6
	80	8x10	BPT-080-10-8.0/10
	80	9x11.5	BPT-080-10-9.0/11.5
	81	8x8	BPT-081-10-8.0/8
	81	9x9	BPT-081-10-9.0/9
	1.27	36	6x6
64		9x9	BPT-064-12-9.0/9
74		12x12	BPT-074-12-12.0/12
80		11x11	BPT-080-12-11.0/11
96		15x15	BPT-096-12-15.0/15
100		11x11	BPT-100-12-11.0/11

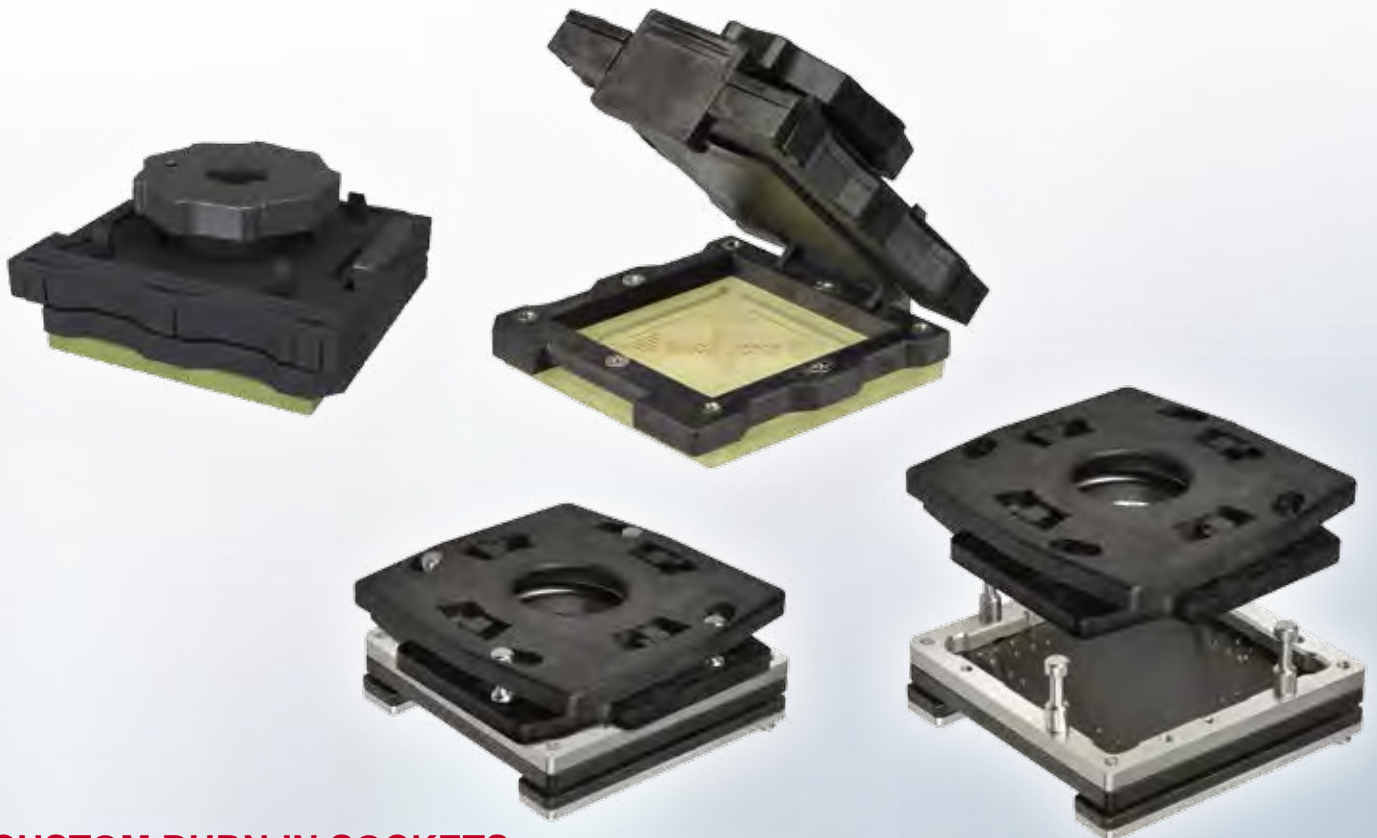

CUSTOM BURN-IN SOCKETS

E-tec Interconnect has over 25 years experience in the design and manufacture of chip test sockets and contactors. This know-how is ideally suited for the fabrication of custom burn-in sockets to satisfy your specific application and we invite you to contact us with your requirements.

Your inquiry will receive our prompt review and response.

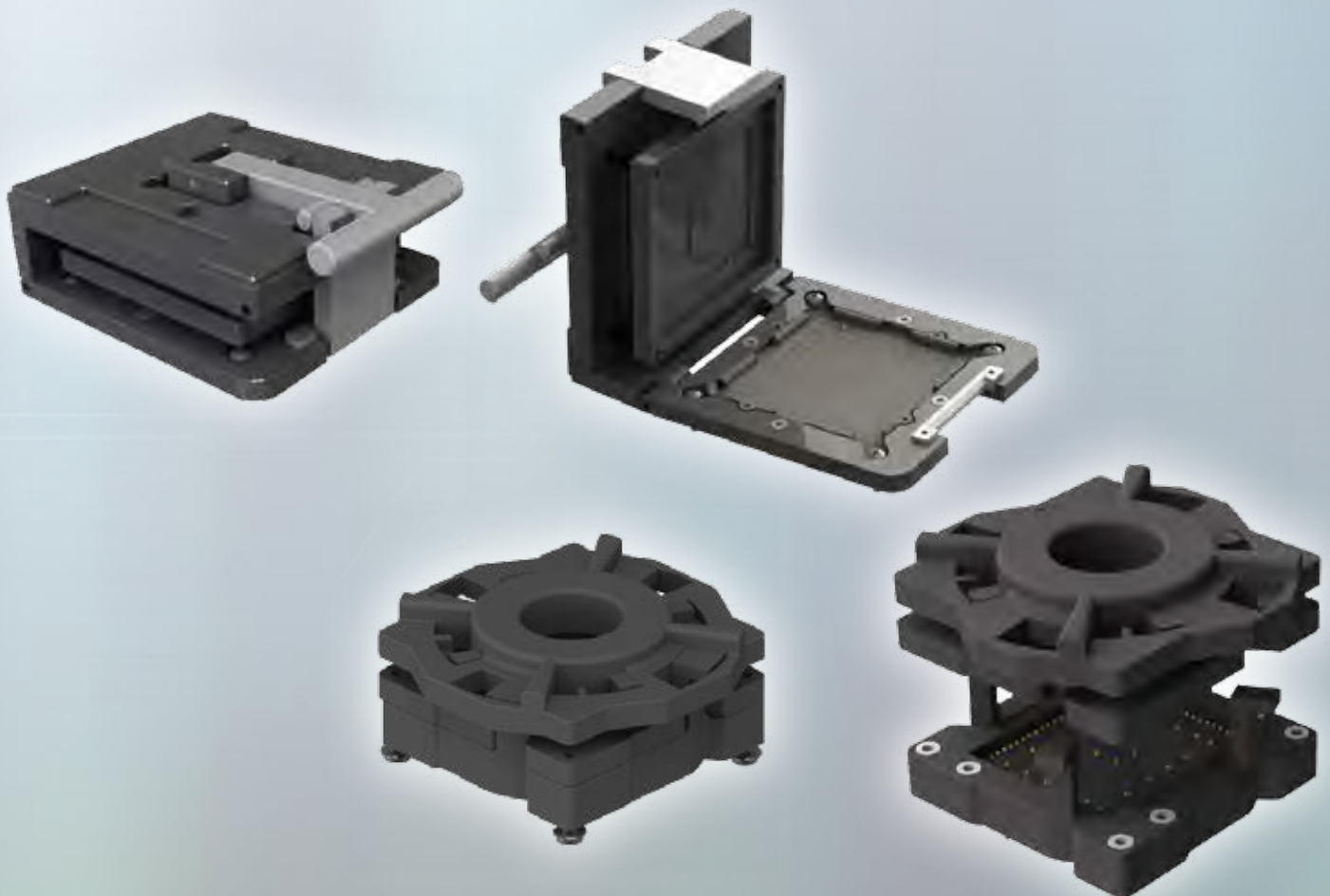

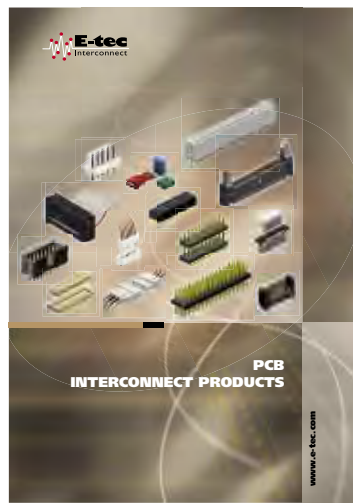
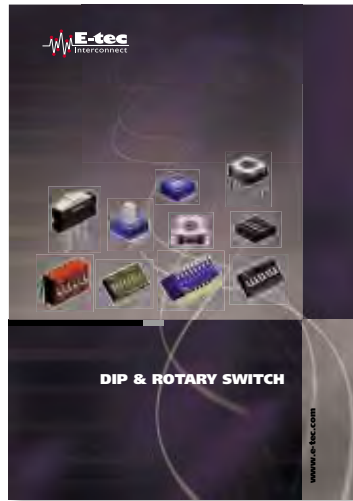

International Sales Headquarters

Switzerland E-tec Interconnect Ltd.
Schweiz Chemin du Grand-Pré 9A
Suisse CH-1510 Moudon/VD
Phone: +41/21/781 08 10
Fax: +41/21/781 08 11
e-mail: info@e-tec.com
www.e-tec.com

Related Sales Headquarters

Deutschland EMC electro mechanical components
Germany Vertriebs GmbH
Allemagne PF. 1160
D-65501 Idstein
Phone: +49/6126/9395-0
Fax: +49/6126/9395-72
e-mail: info@emc-connectors.com
www.emc-connectors.com

France Silfox SA
Frankreich PA des Petits Carreaux
2 bis avenue des Coquelicots
F-94385 Bonneuil
sur Marne Cedex
Phone: +33/1/49 56 04 68
Fax: +33/1/49 56 02 87
e-mail: info@silfox.fr
www.silfox.fr

England E-tec Interconnect (UK) Ltd.
Angleterre Units A5 & A6 Decimus Park
Kingstanding Way
Tunbridge Wells
Kent TN2 3GP
Phone: +44/1892/53 02 60
Fax: +44/1892/51 55 60
e-mail: info@e-tec.co.uk
www.e-tec.co.uk

Factories

Switzerland E-tec AG
Schweiz Friedhofstrasse 1
Suisse CH-2543 Lengnau b. Biel
Phone: +41/32/654 15 50
Fax: +41/32/652 26 93
e-mail: info-ch@e-tec.com
www.e-tec.com

Taiwan E-tec Interconnect Asia Ltd.
10F-2, No. 379, Jhongsan Road
SANCHONG Dist. New Taipei City
Taiwan R.O.C.
Phone: +886/2/29 99 27 26
Fax: +886/2/29 99 52 55
e-mail: info@e-tec-asia.com.tw
www.e-tec-asia.com.tw

YOUR AUTHORISED DISTRIBUTOR
IHR VERTRAGS-DISTRIBUTOR
VOTRE DISTRIBUTEUR OFFICIEL



(www.e-tec.com)

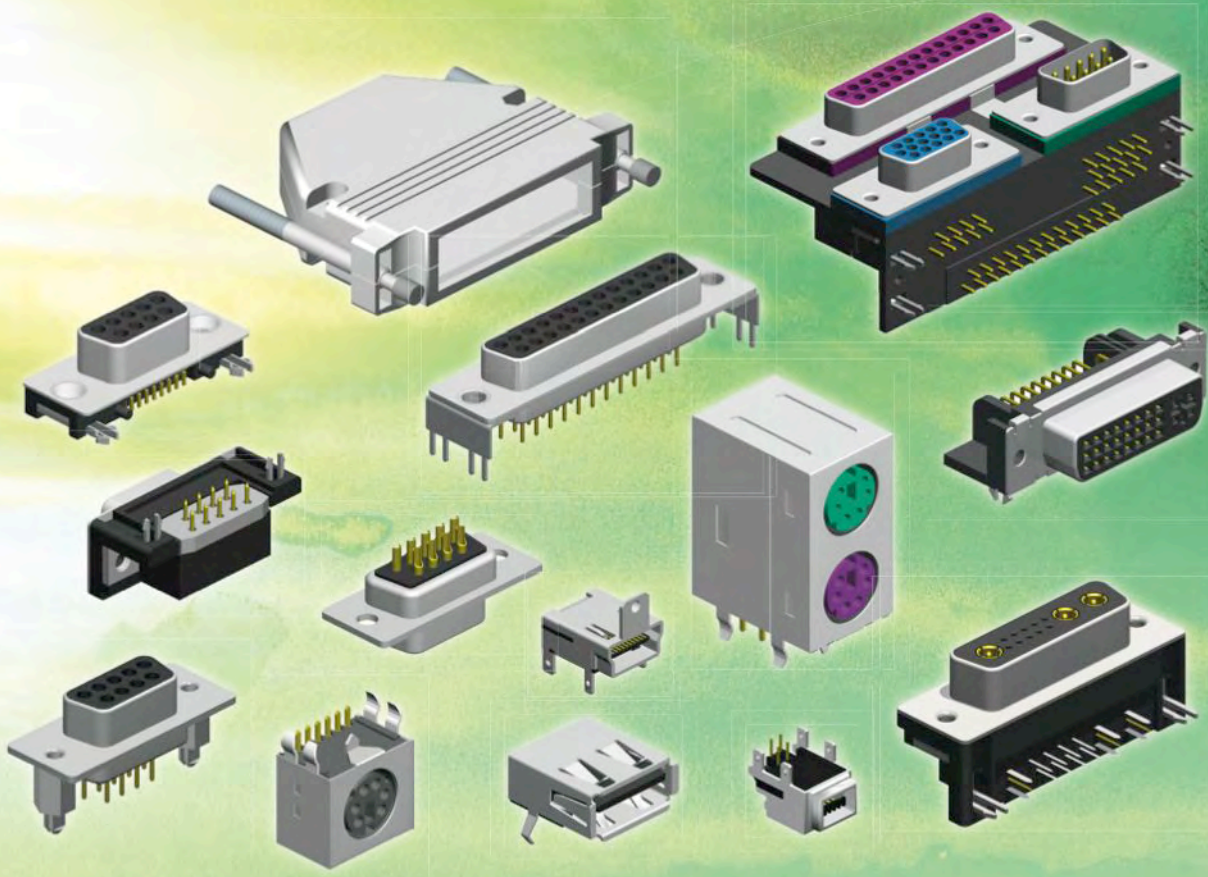

D-SUB & I/O CONNECTORS

INDEX

click on page numbers



Part-Number	Page	Part-Number	Page	Part-Number	Page
DVF-024-NDD1-xx/BB	85	SDD-0909-x-95-FMSNJ	52	SDD-2509-2-95-FMJ	60
DVF-024-NDD1-xx/BBJ	85	SDD-0909-x-95-FN	51	SDD-2509-2-95-FMN	60
DVF-024-NDD1-xx/WB	85	SDD-0909-x-95-FNJ	51	SDD-2509-2-95-FMNJ	60
DVF-024-NDD1-xx/WBJ	85	SDD-0909-x-95-FS	51	SDD-2509-2-95-FN	59
DVF-024-NDD9-xx/BP	84	SDD-0909-x-95-FSJ	51	SDD-2509-2-95-FNJ	59
DVF-024-NDD9-xx/BPJ	84	SDD-0909-x-95-FSN	51	SDD-2509-2-95-M	59
DVF-024-NDD9-xx/WP	84	SDD-0909-x-95-FSNJ	51	SDD-2509-2-95-MF	60
DVF-024-NDD9-xx/WPJ	84	SDD-0909-x-95-M	51	SDD-2509-2-95-MFJ	60
DVF-029-NAD9-xx/BP	84	SDD-0909-x-95-MF	52	SDD-2509-2-95-MFN	60
DVF-029-NAD9-xx/BPJ	84	SDD-0909-x-95-MFJ	52	SDD-2509-2-95-MFNJ	60
DVF-029-NAD9-xx/WP	84	SDD-0909-x-95-MFN	52	SDD-2509-2-95-MJ	59
DVF-029-NAD9-xx/WPJ	84	SDD-0909-x-95-MFNJ	52	SDD-2509-2-95-MN	59
HMR-B19/2-USM1-98/X	96	SDD-0909-x-95-MFS	52	SDD-2509-2-95-MNJ	59
HMR-B19/2-USW1-98/X	96	SDD-0909-x-95-MFSJ	52	SDD-2525-x-95-F	55
HMR-B19-RSK1-98/X	95	SDD-0909-x-95-MFSN	52	SDD-2525-x-95-FJ	55
HMR-B19-RSM1-98/X	95	SDD-0909-x-95-MFSNJ	52	SDD-2525-x-95-FM	56
HMR-B19-SSK1-98/X	94	SDD-0909-x-95-MJ	51	SDD-2525-x-95-FMJ	56
HMR-B19-SSL1-98/X	94	SDD-0909-x-95-MN	51	SDD-2525-x-95-FMN	56
HMR-B19-SSM1-98/X	95	SDD-0909-x-95-MNJ	51	SDD-2525-x-95-FMNJ	56
HMR-B19-SWK1-98/X	94	SDD-0909-x-95-MS	51	SDD-2525-x-95-FMS	56
HMR-B19-SWL1-98/X	94	SDD-0909-x-95-MSJ	51	SDD-2525-x-95-FMSJ	56
HSB-xxx-S101-00Z	71	SDD-0909-x-95-MSN	51	SDD-2525-x-95-FMSN	56
HSB-xxx-S101-45Z	71	SDD-0909-x-95-MSNJ	51	SDD-2525-x-95-FMSNJ	56
HSB-xxx-S102-00Z	71	SDD-0925-x-95-F	61	SDD-2525-x-95-FN	55
HSB-xxx-S102-45Z	71	SDD-0925-x-95-FJ	61	SDD-2525-x-95-FNJ	55
HSC-xxx-S101-00Z	71	SDD-0925-x-95-FN	61	SDD-2525-x-95-FS	55
HSC-xxx-S101-45Z	71	SDD-0925-x-95-FNJ	61	SDD-2525-x-95-FSJ	55
HSC-xxx-S102-00Z	71	SDD-09H15-x-95-F	64	SDD-2525-x-95-FSN	55
HSC-xxx-S102-45Z	71	SDD-09H15-x-95-FJ	64	SDD-2525-x-95-FSNJ	55
HSG-xxx-S101-00Z	71	SDD-09H15-4-95-FM	63	SDD-2525-x-95-M	55
HSG-xxx-S101-45Z	71	SDD-09H15-4-95-FMJ	63	SDD-2525-x-95-MF	56
HSG-xxx-S102-00Z	71	SDD-09H15-4-95-FMN	63	SDD-2525-x-95-MFJ	56
HSG-xxx-S102-45Z	71	SDD-09H15-4-95-FMNJ	63	SDD-2525-x-95-MFN	56
HSM-xxx-S101-00Z	71	SDD-09H15-x-95-FN	64	SDD-2525-x-95-MFNJ	56
HSM-xxx-S101-0RZ	71	SDD-09H15-x-95-FNJ	64	SDD-2525-x-95-MFS	56
HSM-xxx-S101-90Z	71	SDD-09H15-x-95-MF	64	SDD-2525-x-95-MFSJ	56
HSM-xxx-S101-9RZ	71	SDD-09H15-x-95-MFJ	64	SDD-2525-x-95-MFSN	56
HSM-xxx-S102-00Z	71	SDD-09H15-x-95-MFN	64	SDD-2525-x-95-MFSNJ	56
HSM-xxx-S102-0RZ	71	SDD-09H15-x-95-MFNJ	64	SDD-2525-x-95-MJ	55
HSM-xxx-S102-90Z	71	SDD-1515-x-95-F	53	SDD-2525-x-95-MN	55
HSM-xxx-S102-9RZ	71	SDD-1515-x-95-FJ	53	SDD-2525-x-95-MNJ	55
IES-B04-RI01-95	81	SDD-1515-x-95-FM	54	SDD-2525-x-95-MS	55
IES-B04-RIR1-95	81	SDD-1515-x-95-FMJ	54	SDD-2525-x-95-MSJ	55
IES-B04-SI01-95	81	SDD-1515-x-95-FMN	54	SDD-2525-x-95-MSN	55
IES-B06-RIF1-95	80	SDD-1515-x-95-FMNJ	54	SDD-2525-x-95-MSNJ	55
IES-B06-SIF1-95	80	SDD-1515-x-95-FMS	54	SDD-2599-2-95-FM	68
IES-B06-VIF1-95	80	SDD-1515-x-95-FMSJ	54	SDD-2599-2-95-FMJ	68
IES-W06-RIF1-95	80	SDD-1515-x-95-FMSN	54	SDD-2599-2-95-FMN	68
IES-W06-SIF1-95	80	SDD-1515-x-95-FMSNJ	54	SDD-2599-2-95-FMNJ	68
IES-W06-VIF1-95	80	SDD-1515-x-95-FN	53	SDD-2599-2-95-FMF	68
JLP-440-T106-NN	70	SDD-1515-x-95-FNJ	53	SDD-2599-2-95-FMFJ	68
JSR-xxx-Txxx-NN	70	SDD-1515-x-95-FS	53	SDD-2599-2-95-FMFN	68
MDJ-606-DKxx-95	90	SDD-1515-x-95-FSJ	53	SDD-2599-2-95-FMFNJ	68
MDJ-606-DSxx-95	90	SDD-1515-x-95-FSN	53	SDD-25H15-4-95-F	63
MDJ-xxx-RF01-95	88	SDD-1515-x-95-FSNJ	53	SDD-25H15-4-95-FJ	63
MDJ-xxx-RF22-95	88	SDD-1515-x-95-M	53	SDD-25H15-4-95-FN	63
MDJ-xxx-RKLS/x-95	89	SDD-1515-x-95-MF	54	SDD-25H15-4-95-FNJ	63
MDJ-xxx-RKLT/x-95	89	SDD-1515-x-95-MFJ	54	SDD-25L15-2-95-F	62
MDJ-xxx-RN01-AGZ	87	SDD-1515-x-95-MFN	54	SDD-25L15-2-95-FJ	62
MDJ-xxx-RS01-AGZ	88	SDD-1515-x-95-MFNJ	54	SDD-25L15-2-95-FN	62
MDJ-xxx-SN01-AGZ	91	SDD-1515-x-95-MFS	54	SDD-25L15-2-95-FNJ	62
MDJ-xxx-SS01-AGZ	91	SDD-1515-x-95-MFSJ	54	SDD-3737-x-95-F	57
MDP-xxx-FA01-AGZ	92	SDD-1515-x-95-MFSN	54	SDD-3737-x-95-FJ	57
MDP-xxx-MA01-AGZ	92	SDD-1515-x-95-MFSNJ	54	SDD-3737-x-95-FM	58
MDP-xxx-MQ01-55	92	SDD-1515-x-95-MJ	53	SDD-3737-x-95-FMJ	58
SDD-0900-2-95-FN	49	SDD-1515-x-95-MN	53	SDD-3737-x-95-FMN	58
SDD-0900-2-95-FN	49	SDD-1515-x-95-MNJ	53	SDD-3737-x-95-FMNJ	58
SDD-0900-2-95-MN	49	SDD-1515-x-95-MS	53	SDD-3737-x-95-FMS	58
SDD-0900-2-95-MNJ	49	SDD-1515-x-95-MSJ	53	SDD-3737-x-95-FMSJ	58
SDD-0909-x-95-F	51	SDD-1515-x-95-MSN	53	SDD-3737-x-95-FMSN	58
SDD-0909-x-95-FJ	51	SDD-1515-x-95-MSNJ	53	SDD-3737-x-95-FMSNJ	58
SDD-0909-x-95-FM	52	SDD-2500-2-95-FN	50	SDD-3737-x-95-FN	57
SDD-0909-x-95-FMJ	52	SDD-2500-2-95-FNJ	50	SDD-3737-x-95-FNJ	57
SDD-0909-x-95-FMN	52	SDD-2500-2-95-MN	50	SDD-3737-x-95-FS	57
SDD-0909-x-95-FMNJ	52	SDD-2500-2-95-MNJ	50	SDD-3737-x-95-FSJ	57
SDD-0909-x-95-FMS	52	SDD-2509-2-95-F	59	SDD-3737-x-95-FSN	57
SDD-0909-x-95-FMSJ	52	SDD-2509-2-95-FJ	59	SDD-3737-x-95-FSNJ	57
SDD-0909-x-95-FMSN	52	SDD-2509-2-95-FM	60	SDD-3737-x-95-M	57

INDEX

click on page numbers



Part-Number	Page	Part-Number	Page	Part-Number	Page
SDD-3737-x-95-MF	58	SDF-025-N900-95/HJ	26	SDM-015-N900-95/HJ	26
SDD-3737-x-95-MFJ	58	SDF-025-N900-95/N	26	SDM-015-N900-95/N	26
SDD-3737-x-95-MFN	58	SDF-025-N900-95/NJ	26	SDM-015-N900-95/NJ	26
SDD-3737-x-95-MFNJ	58	SDF-025-US91-95/N	9	SDM-025-N900-95/C4	26
SDD-3737-x-95-MFS	58	SDF-025-US91-95/SN	9	SDM-025-N900-95/C4J	26
SDD-3737-x-95-MFSJ	58	SDF-037-N900-95/C4	26	SDM-025-N900-95/H	26
SDD-3737-x-95-MFSN	58	SDF-037-N900-95/C4J	26	SDM-025-N900-95/HJ	26
SDD-3737-x-95-MFSNJ	58	SDF-037-N900-95/H	26	SDM-025-N900-95/N	26
SDD-3737-x-95-MJ	57	SDF-037-N900-95/HJ	26	SDM-025-N900-95/NJ	26
SDD-3737-x-95-MN	57	SDF-037-N900-95/N	26	SDM-037-N900-95/C4	26
SDD-3737-x-95-MNJ	57	SDF-037-N900-95/NJ	26	SDM-037-N900-95/C4J	26
SDD-3737-x-95-MS	57	SDF-xxx-B111-95/BR	20	SDM-037-N900-95/H	26
SDD-3737-x-95-MSJ	57	SDF-xxx-B111-95/BRJ	20	SDM-037-N900-95/HJ	26
SDD-3737-x-95-MSN	57	SDF-xxx-B111-95/FBRx	42	SDM-037-N900-95/N	26
SDD-3737-x-95-MSNJ	57	SDF-xxx-B111-95/FBRxJ	42	SDM-037-N900-95/NJ	26
SDD-H1500-2-95-FN	67	SDF-xxx-B111-95/FBRxJ	46	SDM-xxx-B111-95/BR	21
SDD-H1500-2-95-FNJ	67	SDF-xxx-B111-95/FT	42	SDM-xxx-B111-95/BRJ	21
SDD-H1509-6-95-F	63a	SDF-xxx-B111-95/FT0	42	SDM-xxx-B111-95/FBRx	43
SDD-H1509-6-95-FJ	63a	SDF-xxx-B111-95/FTJ	42	SDM-xxx-B111-95/FBRxJ	43
SDD-H1509-6-95-FN	63a	SDF-xxx-B111-95/T	20	SDM-xxx-B111-95/FT	43
SDD-H1509-6-95-FNJ	63a	SDF-xxx-B111-95/T0	20	SDM-xxx-B111-95/FT0	43
SDD-H1509-7-95-MF	63a	SDF-xxx-B111-95/TJ	20	SDM-xxx-B111-95/FTJ	43
SDD-H1509-7-95-MFJ	63a	SDF-xxx-L900-95/L	28	SDM-xxx-B111-95/T	21
SDD-H1509-7-95-MFN	63a	SDF-xxx-L900-95/LJ	28	SDM-xxx-B111-95/T0	21
SDD-H1509-7-95-MFNJ	63a	SDF-xxx-L900-95/P	28	SDM-xxx-B111-95/TJ	21
SDD-H15H15-4-95-F	65	SDF-xxx-L900-95/PJ	28	SDM-xxx-L900-95/L	28
SDD-H15H15-4-95-FJ	65	SDF-xxx-M900-55/H	27	SDM-xxx-L900-95/LJ	28
SDD-H15H15-x-95-FM	65	SDF-xxx-M900-55/HJ	27	SDM-xxx-L900-95/P	28
SDD-H15H15-x-95-FMJ	65	SDF-xxx-M900-55/N	27	SDM-xxx-L900-95/PJ	28
SDD-H15H15-x-95-FMN	65	SDF-xxx-M900-55/NJ	27	SDM-xxx-M900-55/H	27
SDD-H15H15-x-95-FMNJ	65	SDF-xxx-N900-55/A1T	22	SDM-xxx-M900-55/HJ	27
SDD-H15H15-4-95-FN	65	SDF-xxx-N900-55/A1TJ	22	SDM-xxx-M900-55/N	27
SDD-H15H15-4-95-FNJ	65	SDF-xxx-N900-55/A2T	22	SDM-xxx-M900-55/NJ	27
SDD-H26H26-x-95-F	66	SDF-xxx-N900-55/A2TJ	22	SDM-xxx-N900-55/A1T	22
SDD-H26H26-x-95-FJ	66	SDF-xxx-P150-95/P	30	SDM-xxx-N900-55/A1TJ	22
SDD-H26H26-x-95-FM	66	SDF-xxx-S101-95/T	15	SDM-xxx-N900-55/A2T	22
SDD-H26H26-x-95-FMJ	66	SDF-xxx-S101-95/T0	15	SDM-xxx-N900-55/A2TJ	22
SDD-H26H26-x-95-FMN	66	SDF-xxx-S111-95/BR	18	SDM-xxx-P150-95/P	30
SDD-H26H26-x-95-FMNJ	66	SDF-xxx-S111-95/BRJ	18	SDM-xxx-S101-95/T	15
SDD-H26H26-x-95-FN	66	SDF-xxx-S111-95/BW	18	SDM-xxx-S101-95/T0	15
SDD-H26H26-x-95-FNJ	66	SDF-xxx-S111-95/BWJ	18	SDM-xxx-S111-95/BR	19
SDD-H44H44-x-95-F	67	SDF-xxx-S111-95/FBR	40	SDM-xxx-S111-95/BRJ	19
SDD-H44H44-x-95-FJ	67	SDF-xxx-S111-95/FBRJ	40	SDM-xxx-S111-95/BW	19
SDD-H44H44-x-95-FN	67	SDF-xxx-S111-95/FT	40	SDM-xxx-S111-95/BWJ	19
SDD-H44H44-x-95-FNJ	67	SDF-xxx-S111-95/FT0	40	SDM-xxx-S111-95/FBR	41
SDD-L1525-2-95-F	62	SDF-xxx-S111-95/FTJ	40	SDM-xxx-S111-95/FBRJ	41
SDD-L1525-2-95-FJ	62	SDF-xxx-S111-95/T	18	SDM-xxx-S111-95/FT	41
SDD-L1525-2-95-FN	62	SDF-xxx-S111-95/T0	18	SDM-xxx-S111-95/FT0	41
SDD-L1525-2-95-FNJ	62	SDF-xxx-S111-95/TJ	18	SDM-xxx-S111-95/FTJ	41
SDF-009-N900-95/C4	26	SDF-xxx-T900-55/A1T	22	SDM-xxx-S111-95/T	19
SDF-009-N900-95/C4J	26	SDF-xxx-T900-55/A1TJ	22	SDM-xxx-S111-95/T0	19
SDF-009-N900-95/H	26	SDF-xxx-T900-55/A2T	22	SDM-xxx-S111-95/TJ	19
SDF-009-N900-95/HJ	26	SDF-xxx-T900-55/A2TJ	22	SDM-xxx-T900-55/A1T	22
SDF-009-N900-95/N	26	SDF-xxx-T970-95/H1N	24	SDM-xxx-T900-55/A1TJ	22
SDF-009-N900-95/NJ	26	SDF-xxx-T970-95/H1NJ	24	SDM-xxx-T900-55/A2T	22
SDF-009-US91-95/N	8	SDF-xxx-T970-95/H2N	24	SDM-xxx-T900-55/A2TJ	22
SDF-009-US91-95/SN	8	SDF-xxx-T970-95/H2NJ	24	SDM-xxx-T970-95/H1N	25
SDF-015-N900-95/C4	26	SDM-009-N900-95/C4	26	SDM-xxx-T970-95/H1NJ	25
SDF-015-N900-95/C4J	26	SDM-009-N900-95/C4J	26	SDM-xxx-T970-95/H2N	25
SDF-015-N900-95/H	26	SDM-009-N900-95/H	26	SDM-xxx-T970-95/H2NJ	25
SDF-015-N900-95/HJ	26	SDM-009-N900-95/H1N	23	SDP-2599-2-95-FM	68
SDF-015-N900-95/N	26	SDM-009-N900-95/H1NJ	23	SDP-2599-2-95-FMJ	68
SDF-015-N900-95/NJ	26	SDM-009-N900-95/H2N	23	SDP-2599-2-95-FMN	68
SDF-015-N900-95/YC4	26	SDM-009-N900-95/H2NJ	23	SDP-2599-2-95-FMNJ	68
SDF-015-N900-95/YC4J	26	SDM-009-N900-95/HJ	26	SDP-259H15-4-95-FMF	68
SDF-015-N900-95/YH	26	SDM-009-N900-95/N	26	SDP-259H15-4-95-FMFJ	68
SDF-015-N900-95/YHJ	26	SDM-009-N900-95/NJ	26	SDP-259H15-4-95-FMFN	68
SDF-015-N900-95/YNJ	26	SDM-009-N900-95/TC4	26	SDP-259H15-4-95-FMFNJ	68
SDF-015-US91-95/N	8	SDM-009-N900-95/TC4J	26	SFF-xxx-L900-95/L	45
SDF-015-US91-95/SN	8	SDM-009-N900-95/TH	26	SFF-xxx-L900-95/LJ	45
SDF-025-N900-95/BC4	26	SDM-009-N900-95/THJ	26	SFF-xxx-L900-95/P	45
SDF-025-N900-95/BC4J	26	SDM-009-N900-95/TN	26	SFF-xxx-L900-95/PJ	45
SDF-025-N900-95/BH	26	SDM-009-N900-95/TNJ	26	SFF-xxx-N900-95/H	44
SDF-025-N900-95/BHJ	26	SDM-009-US91-95/N	9	SFF-xxx-N900-95/HJ	44
SDF-025-N900-95/BNJ	26	SDM-009-US91-95/SN	9	SFF-xxx-N900-95/N	44
SDF-025-N900-95/C4	26	SDM-015-N900-95/C4	26	SFF-xxx-N900-95/NJ	44
SDF-025-N900-95/C4J	26	SDM-015-N900-95/C4J	26		
SDF-025-N900-95/H	26	SDM-015-N900-95/H	26		

INDEX

click on page numbers



Part-Number	Page	Part-Number	Page	Part-Number	Page
SFM-xxx-L900-95/L	45	SHM-xxx-B111-95/FBRx	46	UMS-B04-SAS0-95	79
SFM-xxx-L900-95/LJ	45	SHM-xxx-B111-95/FBRxJ	46	UMS-B04-SBS0-95	79
SFM-xxx-L900-95/P	45	SHM-xxx-B111-95/FT	46	UMS-B05-SB01-95	79
SFM-xxx-L900-95/PJ	45	SHM-xxx-B111-95/FT0	46	USC-xxxx-2AMBM-BG/G	82
SFM-xxx-N900-95/H	44	SHM-xxx-B111-95/FTJ	46	USC-xxxx-4AMAM-CH/G	82
SFM-xxx-N900-95/HJ	44	SHM-xxx-F900-55/FH	47	USC-xxxx-4BMBM-CH/G	82
SFM-xxx-N900-95/N	44	SHM-xxx-F900-55/FHJ	47	USC-xxxx-4IMIM-CH/G	82
SFM-xxx-N900-95/NJ	44	SHM-xxx-F900-55/FN	47	USC-xxxx-5BMBM-CH/G	82
SHF-015-F900-95/VN	37	SHM-xxx-F900-55/FNJ	47	USC-xxxx-AMAF-BG/G	82
SHF-015-F900-95/VNJ	37	SHM-xxx-F900-55/H	37	USC-xxxx-AMAM-BG/G	82
SHF-015-US98-95/N	10	SHM-xxx-F900-55/HJ	37	USC-xxxx-BMBM-BG/G	82
SHF-015-US98-95/SN	10	SHM-xxx-F900-55/N	37	USC-xxxx-IM4IM-CH/B	82
SHF-xxx-B111-95/BR	34	SHM-xxx-F900-55/NJ	37	USC-xxxx-IMIM-CH/G	82
SHF-xxx-B111-95/BRJ	34	SHM-xxx-S101-95/T	36	USP-B04-SA01-95	77
SHF-xxx-B111-95/FBRx	46	SHM-xxx-S101-95/T0	36	USP-B04-SA11-95	77
SHF-xxx-B111-95/FT	46	SHM-xxx-S111-95/BR	33	USP-B04-SA21-95	77
SHF-xxx-B111-95/FT0	46	SHM-xxx-S111-95/BRJ	33	USP-B04-SA31-95	77
SHF-xxx-B111-95/FTJ	46	SHM-xxx-S111-95/BW	33	USS-B04-RA01-95	74
SHF-xxx-B111-95/T	34	SHM-xxx-S111-95/BWJ	33	USS-B04-RA02-95	75
SHF-xxx-B111-95/T0	34	SHM-xxx-S111-95/T	33	USS-B04-RB01-95	78
SHF-xxx-B111-95/TJ	34	SHM-xxx-S111-95/T0	33	USS-B04-SA01-95	74
SHF-xxx-F900-55/FH	47	SHM-xxx-S111-95/TJ	33	USS-B04-SB01-95	78
SHF-xxx-F900-55/FHJ	47	SKF-xxx-S201-95/T	16	USS-B04-SBS0-95	78
SHF-xxx-F900-55/FN	47	SKF-xxx-S201-95/T0	16	USS-B04-TA01-95	74
SHF-xxx-F900-55/FNJ	47	SKF-xxx-S202-95/T	17	USS-B04-TB01-95	78
SHF-xxx-F900-55/H	37	SKF-xxx-S202-95/T0	17	USS-B04-UB01-95	78
SHF-xxx-F900-55/HJ	37	SKM-xxx-S201-95/T	16	USS-B04-VA01-95	74
SHF-xxx-F900-55/N	37	SKM-xxx-S201-95/T0	16	USS-B08-TA02-95	75
SHF-xxx-F900-55/NJ	37	SKM-xxx-S202-95/T	17	USS-B12-RA03-95	75
SHF-xxx-S101-95/T	36	SKM-xxx-S202-95/T0	17	USS-BU09-RA31-95	76
SHF-xxx-S101-95/T0	36	SLO-xxx-T106-NN	70	USS-BU18-RA32-95	76
SHF-xxx-S111-95/BR	32	SSF-015-HU98-95/N	13	USS-W04-RA01-95	74
SHF-xxx-S111-95/BRJ	32	SSF-015-HU98-95/R	13	USS-W04-RA02-95	75
SHF-xxx-S111-95/BW	32	SSF-xxx-U908-95/N	11	USS-W04-RB01-95	78
SHF-xxx-S111-95/BWJ	32	SSF-xxx-U908-95/R	11	USS-W04-SAS0-95	74
SHF-xxx-S111-95/T	32	SSM-xxx-U908-95/N	12	USS-W04-SB01-95	78
SHF-xxx-S111-95/T0	32	SSM-xxx-U908-95/R	12	USS-W04-SBS0-95	78
SHF-xxx-S111-95/TJ	32	ULS-B04-RAS0-95	74	USS-W04-TA01-95	74
SHM-xxx-B111-55/BR	35	ULS-B04-RBS0-95	78	USS-W04-TB01-95	78
SHM-xxx-B111-55/BRJ	35	ULS-B04-SAS0-95	74	USS-W04-UB01-95	78
SHM-xxx-B111-55/T	35	ULS-W04-RAS0-95	74	USS-W04-VA01-95	74
SHM-xxx-B111-55/T0	35	ULS-W04-RBS0-95	78	USS-W08-TA02-95	75
SHM-xxx-B111-55/TJ	35	ULS-W04-SAS0-95	74	USS-W12-RA03-95	75

General information concerning the E-tec interconnect products

Specifications

The data contained in this catalog is of general nature and refers to standard products. For example, general tolerances +/- 0.25mm, a „Current rating“ at an ambient temperature of 25° C reflects the value per individual contact. Should you require any further data or test reports, you can obtain this information from your nearest E-tec sales office.

The E-tec connectors conform with signal integrity requirements at high data and frequency rates. However we cannot offer a general information about the max. frequency or data transmission rate. For such a statement, it would require more information about the chosen configuration and pin-out, the length of the cable and/or any other specific requirements regarding the application itself and its related signal integrity. E-tec SMT connectors, male or female, are offered with a coplanarity of max. 0,10mm. They are adapted to all modern SMT soldering processes and they can be handled easily with all currently existing placing techniques. Customers may choose between various packaging options, such as tray, tube and reel.

GENERAL POLICY

All information contained in this catalog, including illustrations, specifications and dimensions are accurate to the best of our knowledge, and reflect the status as at the date of publication. Due to technical progress, it is subject to change without notice. Application information is informational in nature and shall not be construed to warrant suitability of products for any particular purpose as performance may vary depending on the conditions to which a product is subjected. Unless otherwise confirmed at the time of order, all E-tec products are non cancellable and non returnable items (NCNR). E-tec products are warranted for 30 days and the warranty is limited strictly to replacement of products. This warranty does not cover any claims for natural wear and tear, nor for any compensations, such as loss of production, loss of use, loss of orders, loss of profit, nor any other direct or indirect damages.

ULTRA SLIM PROFILE

Standard & HD right angle "solder tail"

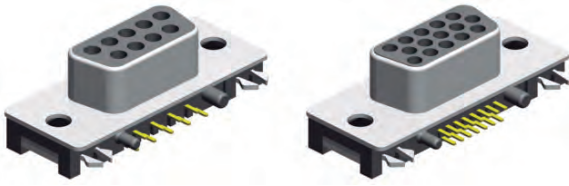

Page 8, 9 & 10

Standard & HD right angle "SMT"



Page 11, 12 & 13

STANDARD VERSION

Hand Solder (solder cup) Type



Page 15

IDC Type



Page 16 & 17

Vertical Solder tail Type

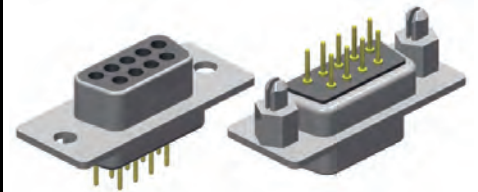

Page 18 & 19

Raised Vertical Solder tail Type

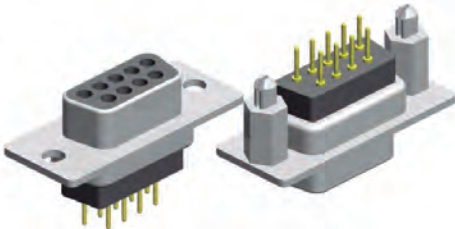

Page 20 & 21

Right Angle "open body" Type



Page 22

Press Fit Type

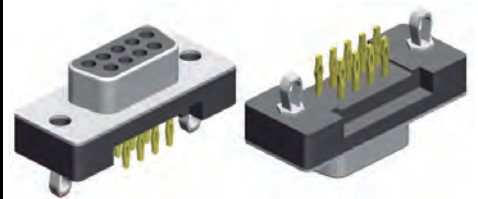

Page 30

Right Angle "open body" Type
6.30mm & 7.30mm centre

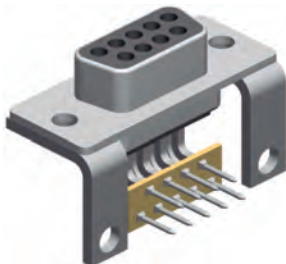

Page 23, 24 & 25

Right Angle "closed body" Type
US Style Footprint 8.08mm

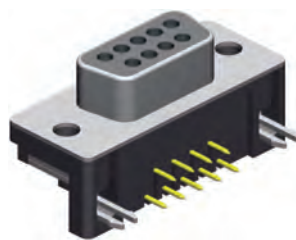

Page 26

Right Angle "closed body" Type
Euro Style Footprint 9.40mm



Page 27

Right Angle "closed body" Type **Long Style** Footprint 15.00mm

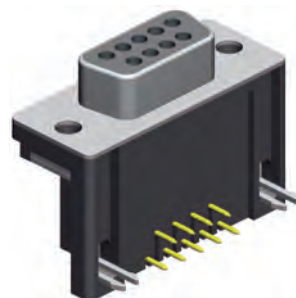

Page 28

HIGH DENSITY

Vertical Solder-tail Type

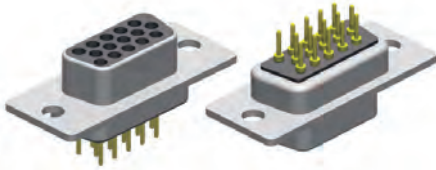

Page 32 & 33

Raised Vertical Solder-tail Type

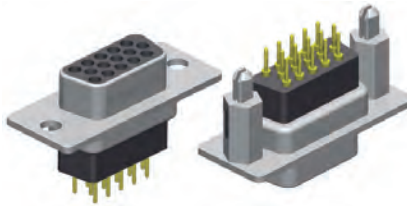

Page 34 & 35

Hand Solder (solder cup) Type

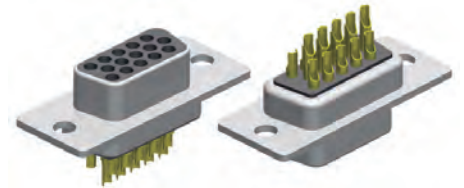

Page 36

Right Angle "closed body" Type

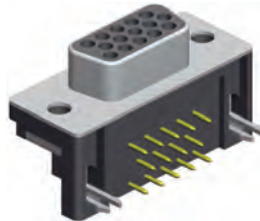

Page 37

D-SUB WITH FERRITE FILTER

Vertical Solder-tail Type

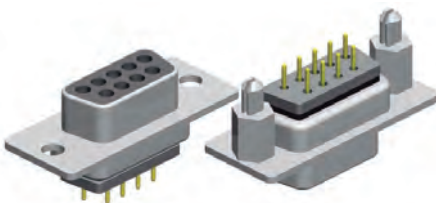

Page 40 & 41

Raised Vertical Solder-tail Type

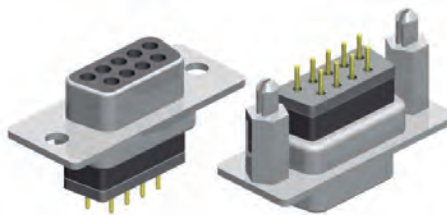

Page 42 & 43

Right Angle "closed body" Type
US Style Footprint 8.08mm



Page 44

Right Angle "closed body" Type
Long Style Footprint 15.00mm



Page 45

"High Density"
Raised Vertical Solder-tail Type

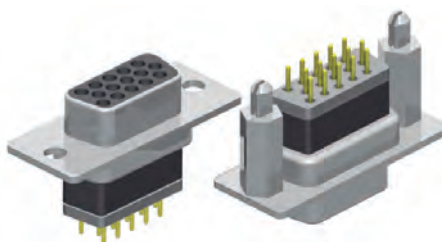

Page 46

"High Density"
Right Angle "closed body" Type



Page 47

Raised & MULTI PORT

Raised Type



Page 49, 50 & 67

Dual Port Type



Page 51 to 67

Triple Port Type

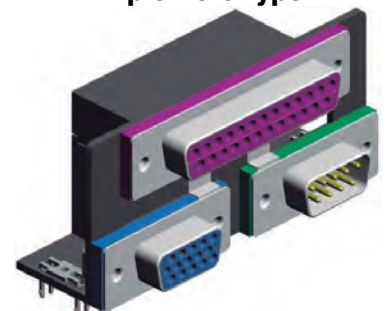

Page 68

PRODUCT OVERVIEW

D-Sub - DVI - HDMI



D-SUB ACCESSORIES

Jack Screws and Slide Locking System



Page 70

Hoods



Page 71

DVI

Analog & Digital 24+4-contact - Right Angle Type



Page 84

Digital 24-contact - Right Angle Type



Page 84

Digital 24-contact - Vertical Type

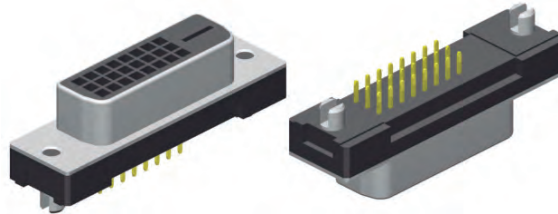

Page 85

HDMI

SMT & Solder Tail without Mounting Flange

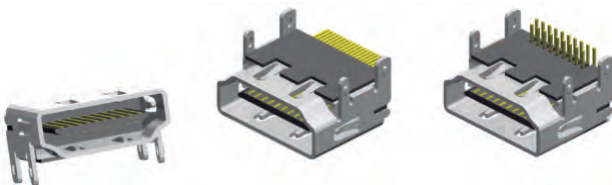

Page 94 & 95

SMT & Solder Tail with "top" Mounting Flange

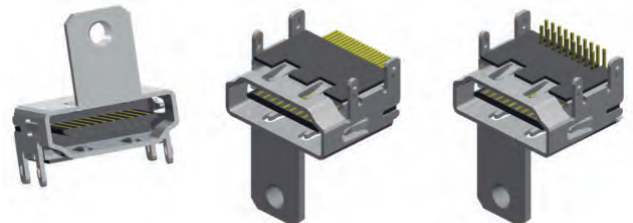







Page 94 & 95

SMT & Solder Tail with "wing" Mounting Flange

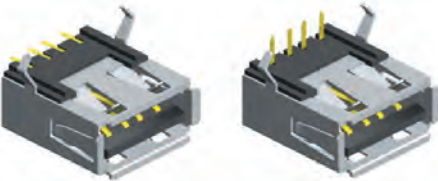

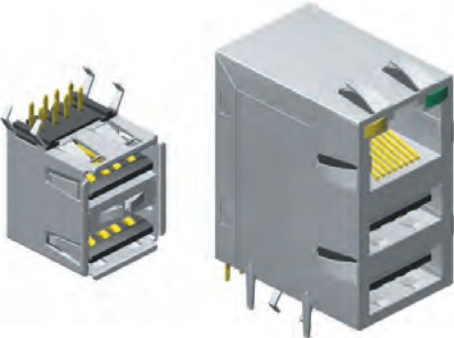
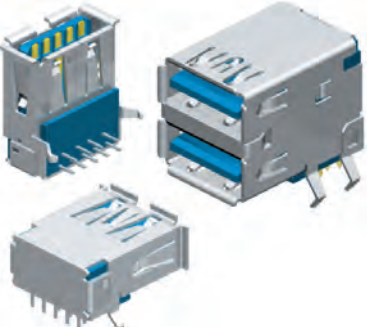

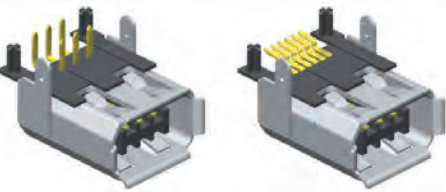
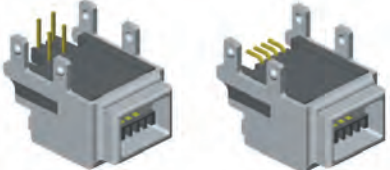

Page 96

USB & IEEE 1394 CONNECTORS

<p>USB Connector Type "A"</p>  <p>Page 74</p>	<p>USB Connector Type "B"</p>  <p>Page 78</p>	<p>Mini USB Connector Type "A" & "B"</p>  <p>Page 79</p>
<p>Multi Port USB Connector Type "A"</p>  <p>Page 75</p>	<p>USB Connector 3.0 Type "A"</p>  <p>Page 76</p>	<p>USB Plug</p>  <p>Page 77</p>
<p>IEEE 1394 Connector 6-Contact Type</p>  <p>Page 80</p>	<p>IEEE 1394 Connector 4-Contact Type</p>  <p>Page 81</p>	<p>USB & IEEE 1394 Connector Cable Assembly</p>  <p>Page 82</p>

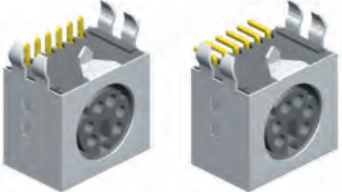
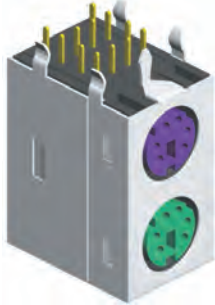
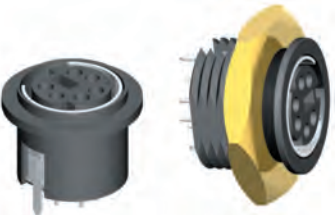
MINI DIN CONNECTORS

<p>Non Shielded Type</p>  <p>Page 87</p>	<p>Shielded Type</p>  <p>Page 88</p>	<p>Low Profile Type Solder-tail & SMT</p>  <p>Page 89</p>
<p>Dual Port Type</p>  <p>Page 90</p>	<p>Straight & Wall Mounting Type</p>  <p>Page 91</p>	<p>Plugs</p>  <p>Page 92</p>

Ultra Slim Profile

D-Sub

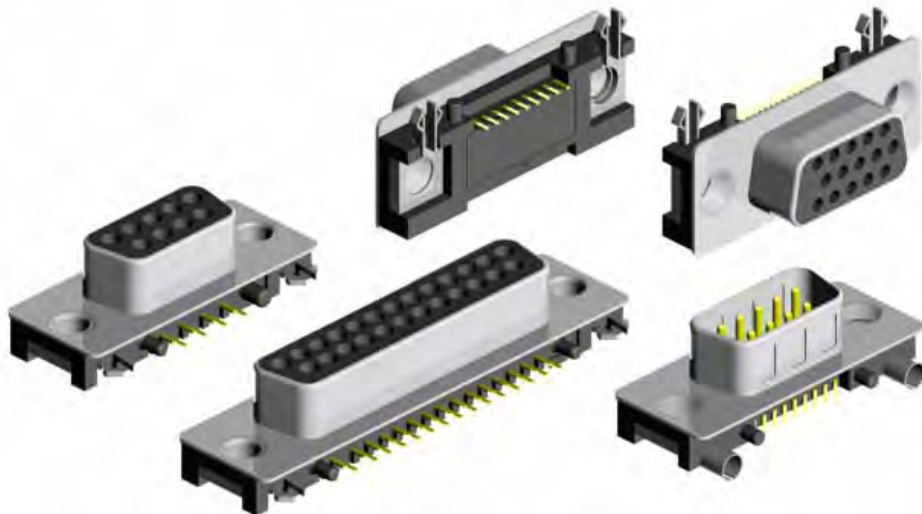

Ultra Slim Profile D-Sub Connectors are designed in order to save space on the PC-Boards.

Standard and High Density versions for through hole “Wave Solder” and “Pin-In-Paste” Technology, as well as regular SMT types, right angle male and female are available.

SD Series - D-Sub 90°
US91 Ultra Slim Profile

"Wave Solder" & "Pin-In-Paste" Technology



female

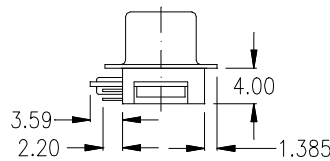
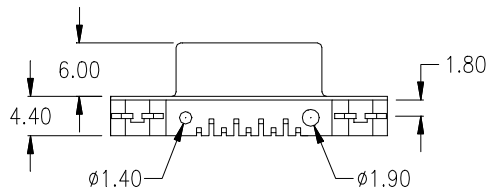
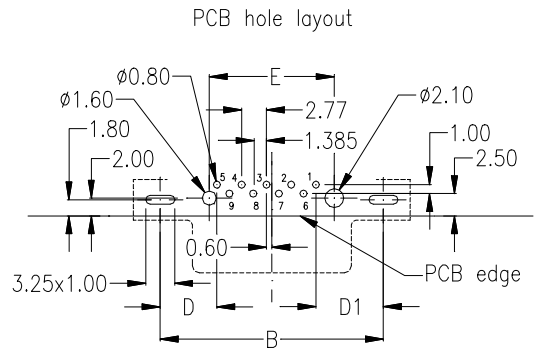
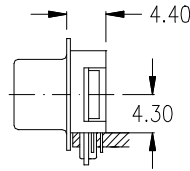
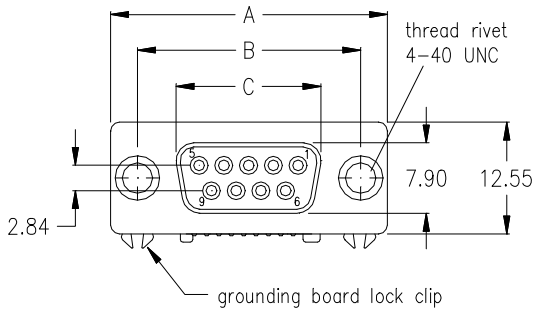

for technical & electrical specification please go to page 72

No. of contacts	Dimension					
	A	B	C	D	D1	E
009	30.81 1.213	24.99 .984	16.33 .643	6.36 .250	7.56 .298	14.00 .551

Ordering Code

for "Wave Solder" Technology

SDF - 009 - US91 - 95 / N

for "Pin-In-Paste" Technology

SDF - 009 - US91 - 95 / SN

Option:

Jack Screw has to be ordered separately.

See page 70

Plating: -95= tin(leadfree)/gold

Special product.

Please ask for availability and minimum order quantity before you consider the article for development, design in or production purposes.

female

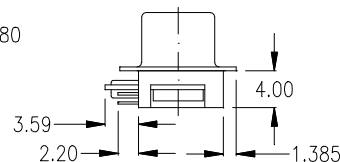
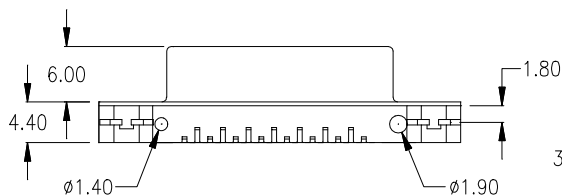
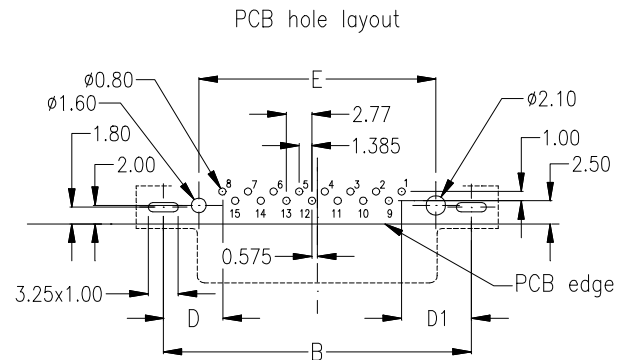
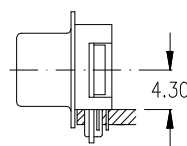
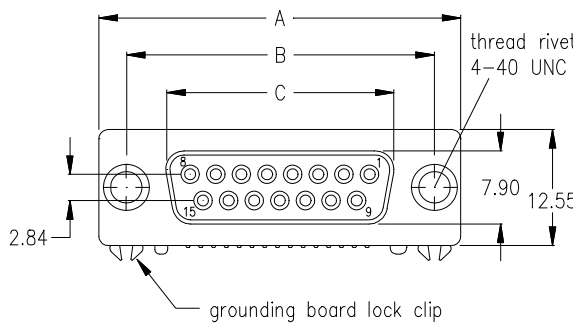

for technical & electrical specification please go to page 72

No. of contacts	Dimension					
	A	B	C	D	D1	E
015	39.14 1.541	33.32 1.312	24.66 .971	6.39 .252	7.54 .297	25.64 1.009

Ordering Code

for "Wave Solder" Technology

SDF - 015 - US91 - 95 / N

for "Pin-In-Paste" Technology

SDF - 015 - US91 - 95 / SN

Option:

Jack Screw has to be ordered separately.

See page 70

Plating: -95= tin(leadfree)/gold

Special product.

Please ask for availability and minimum order quantity before you consider the article for development, design in or production purposes.

SD Series - D-Sub 90° US91 Ultra Slim Profile

"Wave Solder" & "Pin-In-Paste" Technology



female

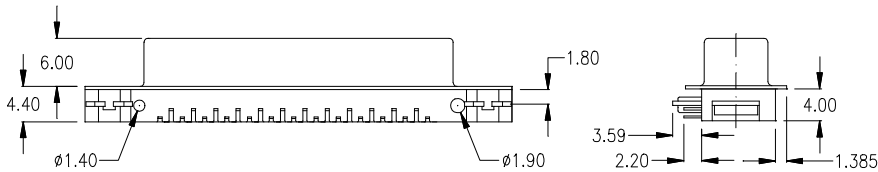
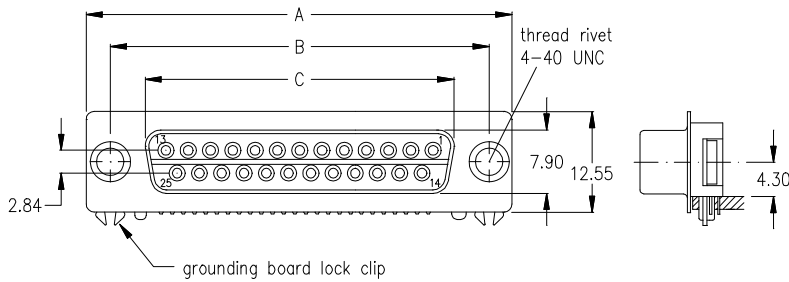

PCB hole layout

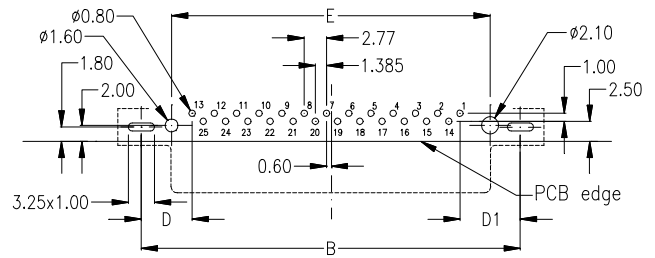

Special product.
Please ask for availability and minimum order quantity before you consider the article for development, design in or production purposes.

for technical & electrical specification please go to page 72

No. of contacts	Dimension					
	A	B	C	D	D1	E
025	53.04 2.088	47.04 1.852	38.38 1.511	6.30 .248	7.50 .295	39.54 1.557

Ordering Code

for "Wave Solder" Technology

SDF - 025 - US91 - 95 / N

for "Pin-In-Paste" Technology

SDF - 025 - US91 - 95 / SN

Option:

Jack Screw has to be ordered separately.

See page 70

Plating: -95= tin(leadfree)/gold

male

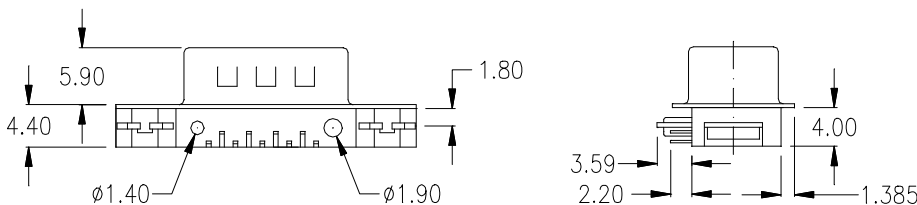
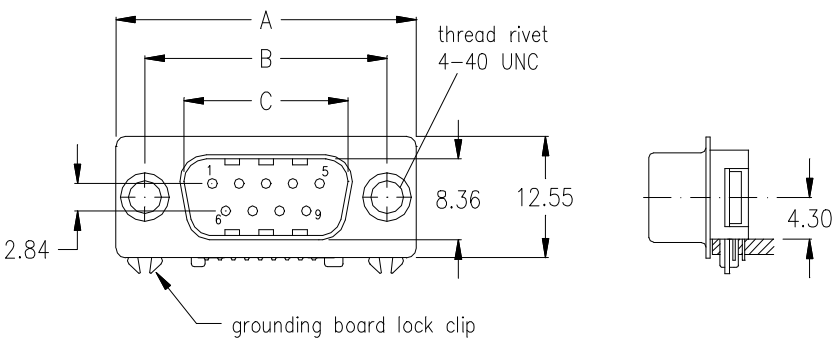

PCB hole layout

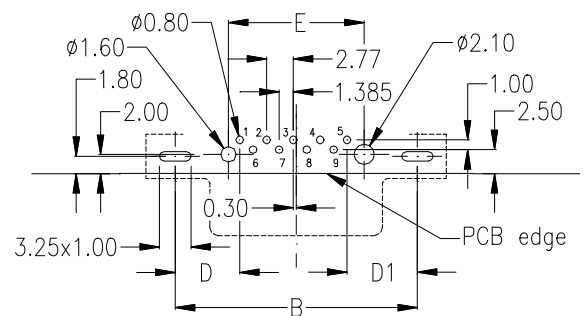

Special product.
Please ask for availability and minimum order quantity before you consider the article for development, design in or production purposes.

for technical & electrical specification please go to page 72

No. of contacts	Dimension					
	A	B	C	D	D1	E
009	30.81 1.213	24.99 .984	16.92 .666	6.66 .262	7.26 .286	14.00 .551

Ordering Code

for "Wave Solder" Technology

SDM - 009 - US91 - 95 / N

for "Pin-In-Paste" Technology

SDM - 009 - US91 - 95 / SN

Option:

Jack Screw has to be ordered separately.

See page 70

Plating: -95= tin(leadfree)/gold

SH Series - High Density D-Sub 90° US98 Ultra Slim Profile

"Wave Solder" & "Pin-In-Paste" Technology



female

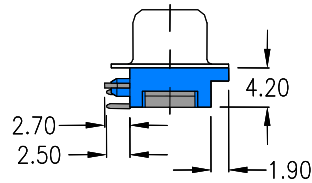
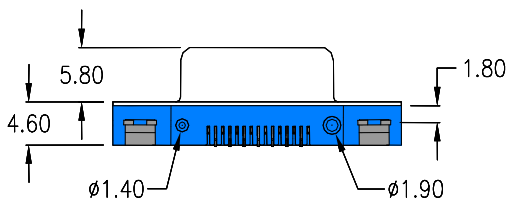
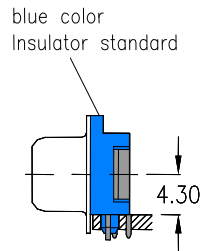
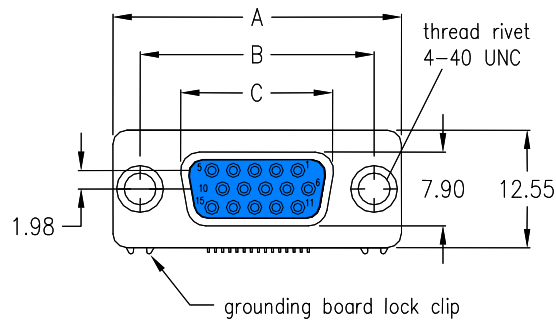

PCB hole layout

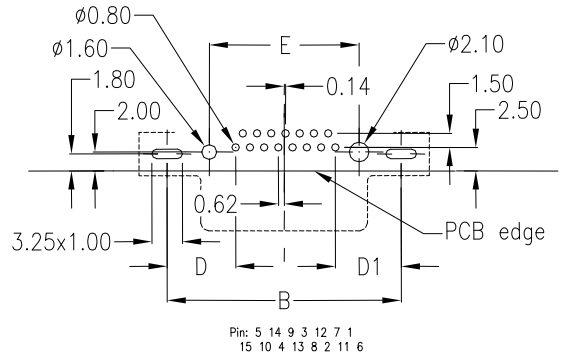

for technical & electrical specification please go to page 72

No. of contacts	Dimension					
	A	B	C	D	D1	E
015	30.81 1.213	24.99 .984	16.33 .643	7.32 .288	7.04 .277	16.00 .630

Ordering Code

for "Wave Solder" Technology

SHF - 015 - US98 - 95 / VN

for "Pin-In-Paste" Technology

SHF - 015 - US98 - 95 / VSN

Option:

Jack Screw
has to
be ordered
separately.

See page 70

Please ask for black color insulator availability

Plating: -95= tin(leadfree)/gold

female - with fork board lock type -

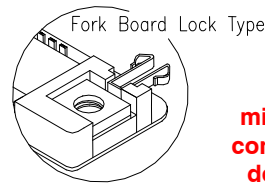
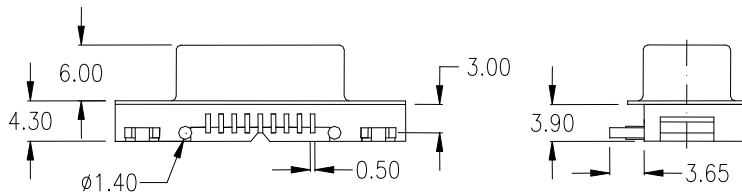
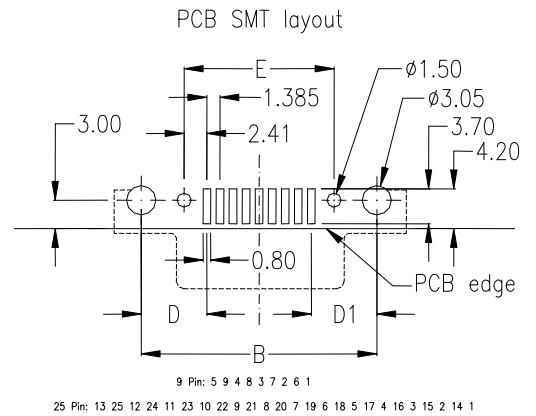
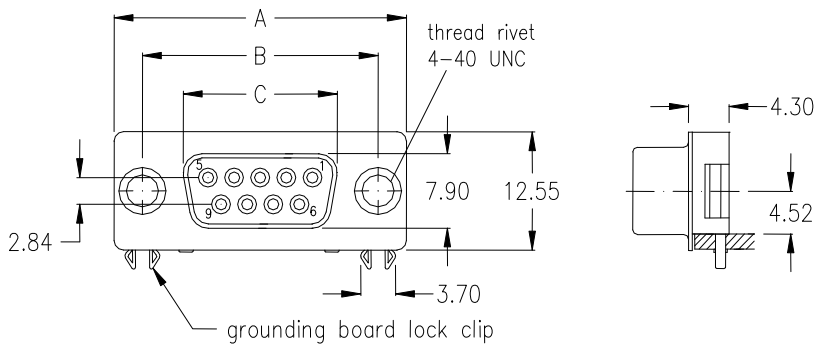

Special product.
Please ask for availability and minimum order quantity before you consider the article for development, design in or production purposes.

for technical & electrical specification please go to page 72

No. of contacts	Dimension					
	A	B	C	D	D1	E
009	30.81 1.213	24.99 .984	16.33 .643	6.96 .274	6.96 .274	15.90 .626
025	53.04 2.088	47.04 1.852	38.38 1.511	6.90 .272	6.90 .272	38.06 1.498

Ordering Code

SSF - xxx - U908 - 95 / N

No. of contacts

Plating: -95= tin(leadfree)/gold

Option:

Jack Screw has to be ordered separately.

See page 70

female - with round board lock type -

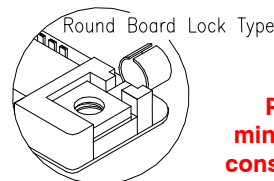
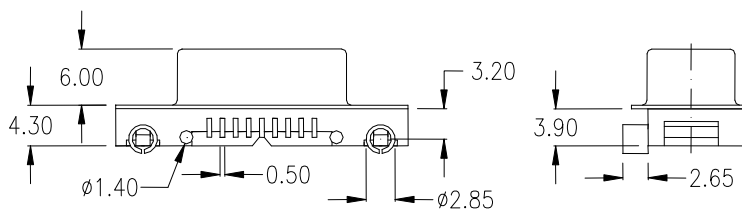
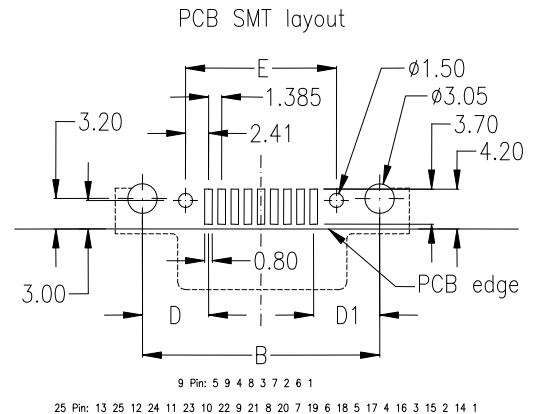
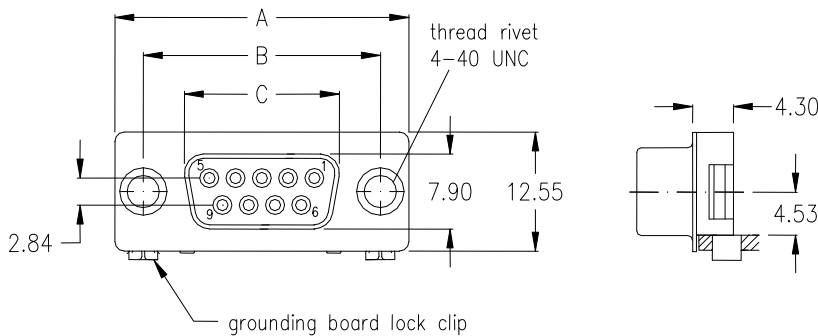

Special product.
Please ask for availability and minimum order quantity before you consider the article for development, design in or production purposes.

for technical & electrical specification please go to page 72

No. of contacts	Dimension					
	A	B	C	D	D1	E
009	30.81 1.213	24.99 .984	16.33 .643	6.96 .274	6.96 .274	15.90 .626
025	53.04 2.088	47.04 1.852	38.38 1.511	6.90 .272	6.90 .272	38.06 1.498

Ordering Code

SSF - xxx - U908 - 95 / R

No. of contacts

Plating: -95= tin(leadfree)/gold

Option:

Jack Screw has to be ordered separately.

See page 70

male - with fork board lock type -

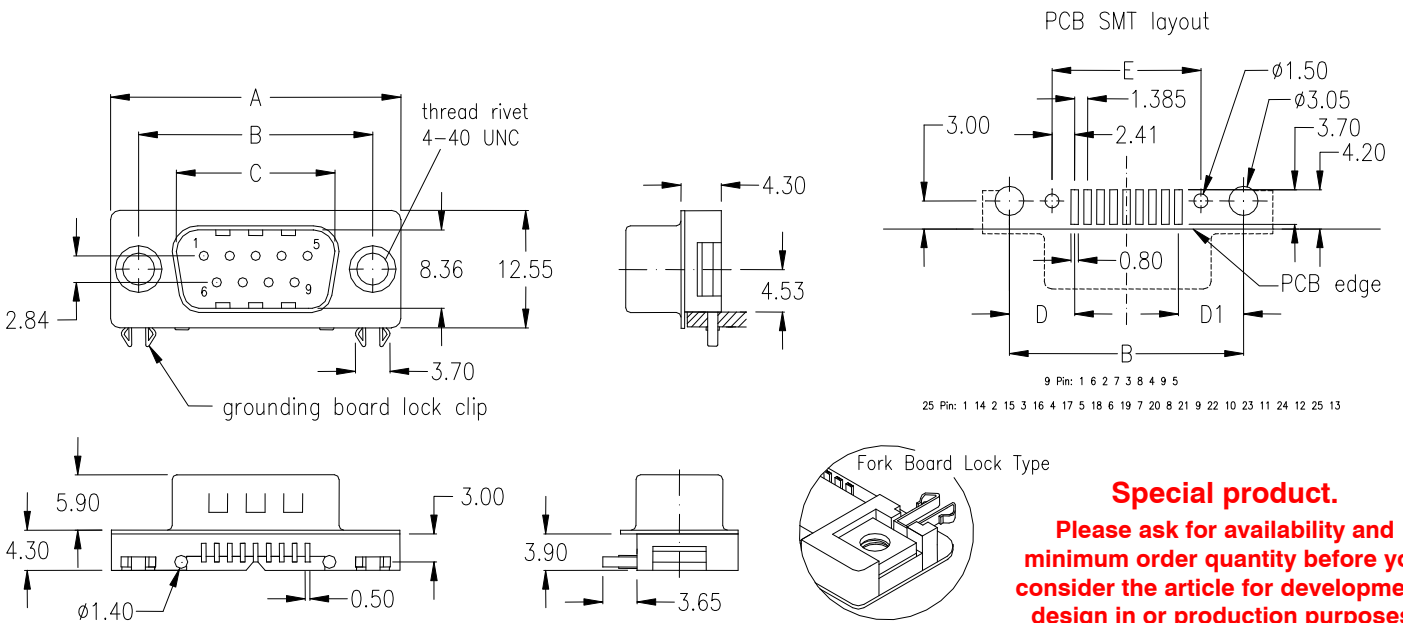

for technical & electrical specification please go to page 72

No. of contacts	Dimension					
	A	B	C	D	D1	E
009	30.81	24.99	16.92	6.96	6.96	15.90
	1.213	.984	.666	.274	.274	.626
025	53.04	47.04	38.96	6.90	6.90	38.06
	2.088	1.852	1.534	.272	.272	1.498

Ordering Code

SSM - xxx - U908 - 95 / N

No. of contacts

Plating: -95= tin(leadfree)/gold

Option:

Jack Screw has to be ordered separately.

See page 70

male - with round board lock type -

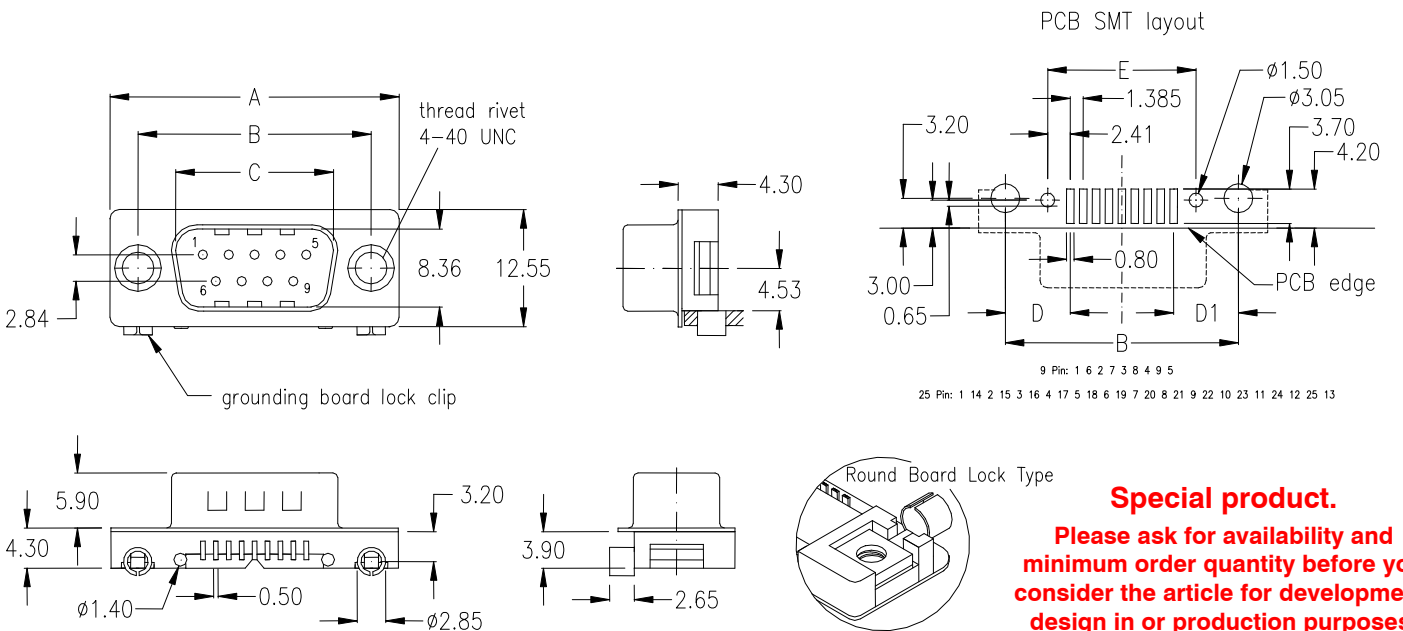

for technical & electrical specification please go to page 72

No. of contacts	Dimension					
	A	B	C	D	D1	E
009	30.81	24.99	16.92	6.96	6.96	15.90
	1.213	.984	.666	.274	.274	.626
025	53.04	47.04	38.96	6.90	6.90	38.06
	2.088	1.852	1.534	.272	.272	1.498

Ordering Code

SSM - xxx - U908 - 95 / R

No. of contacts

Plating: -95= tin(leadfree)/gold

Option:

Jack Screw has to be ordered separately.

See page 70

female – with fork board lock type –

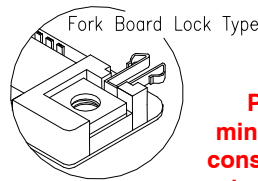
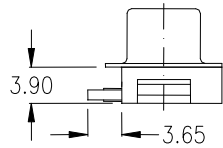
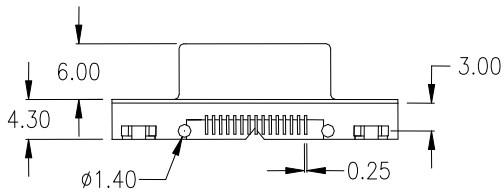
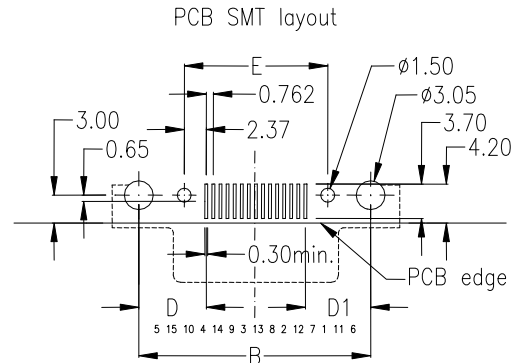
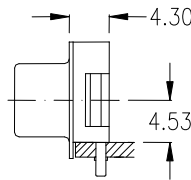
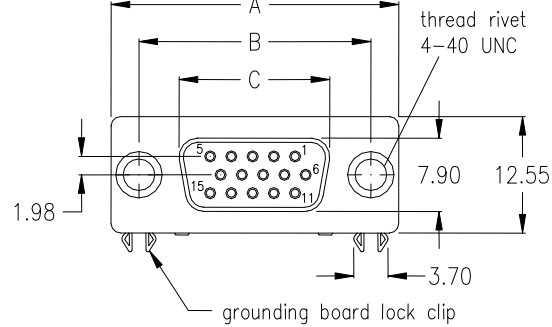

Special product.
Please ask for availability and minimum order quantity before you consider the article for development, design in or production purposes.

for technical & electrical specification please go to page 72

No. of contacts	Dimension					
	A	B	C	D	D1	E
015	30.81 1.213	24.99 .984	16.33 .643	7.296 .287	7.026 .277	15.46 .609

Ordering Code

SSF - 015 - HU98 - 95 / N

Option:

Jack Screw has to be ordered separately.

See page 70

Plating: -95= tin(leadfree)/gold

female – with round board lock type –

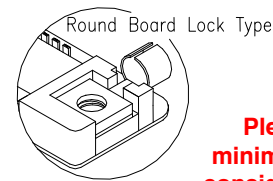
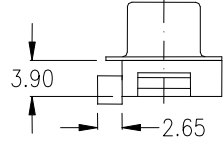
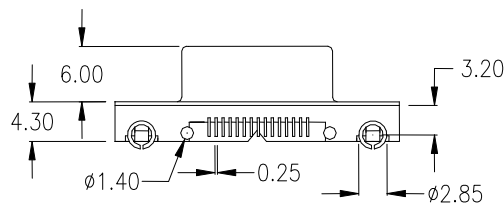
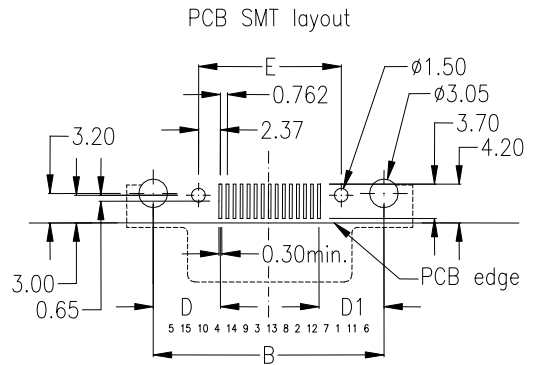
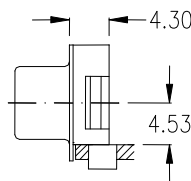
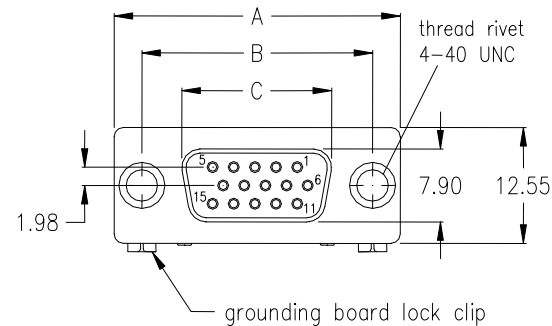

Special product.
Please ask for availability and minimum order quantity before you consider the article for development, design in or production purposes.

for technical & electrical specification please go to page 72

No. of contacts	Dimension					
	A	B	C	D	D1	E
015	30.81 1.213	24.99 .984	16.33 .643	7.296 .287	7.026 .277	15.46 .609

Ordering Code

SSF - 015 - HU98 - 95 / R

Option:

Jack Screw has to be ordered separately.

See page 70

Plating: -95= tin(leadfree)/gold

Standard Version

D-Sub

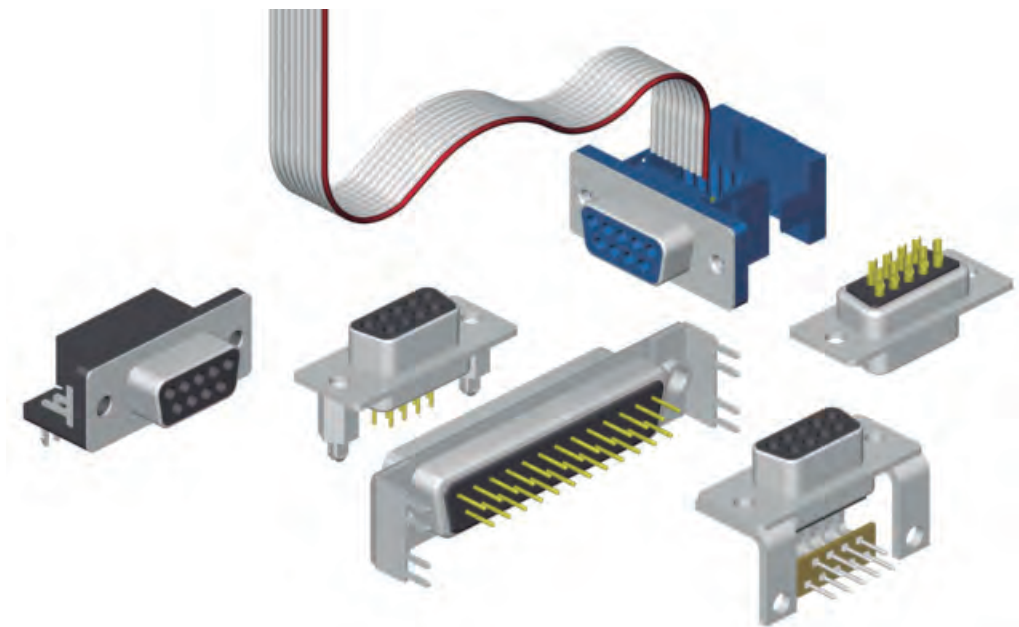

Our D-Sub Connectors conform to industrial specifications and are compatible with DIN 41 652 norms, IEC 48 B, HE 5 etc.....

They are compatible with all other D-Sub Connectors available on the market according to these specifications.

Together with a large variety of accessories, the D-Sub Connectors can be used in most applications, such as industrial electronics, data- and telecommunication and others more.

SD Series - D-Sub
S101 solder cup type



female

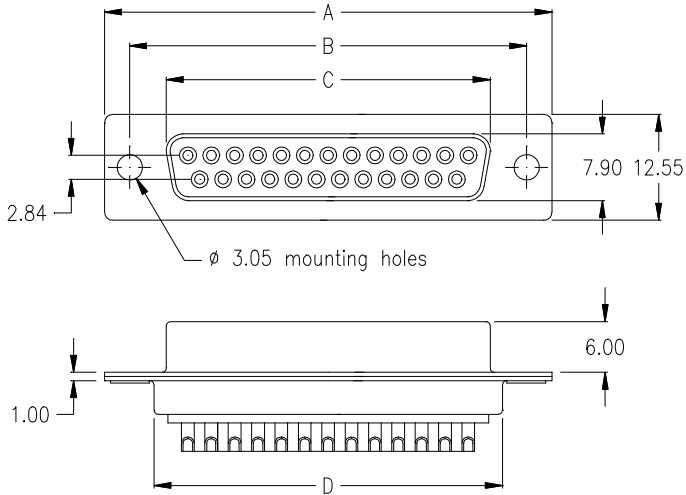

No. of contacts	Dimension			
	A	B	C	D
009	30.81 1.213	24.99 .984	16.33 .643	19.28 .795
015	39.14 1.541	33.32 1.312	24.66 .971	27.51 1.083
025	53.04 2.088	47.04 1.852	38.38 1.511	41.30 1.652
037	69.32 2.729	63.50 2.500	54.84 2.159	57.40 2.272

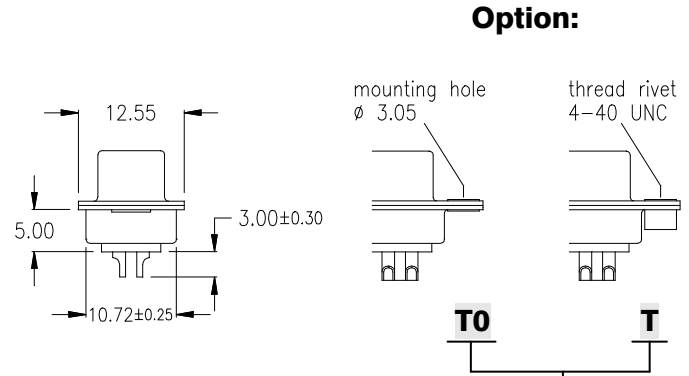

Ordering Code
SDF - xxx - S101 - 95 / XX
No. of contacts Option

General Specification page 72

Plating: -95 = tin(leadfree)/gold

male

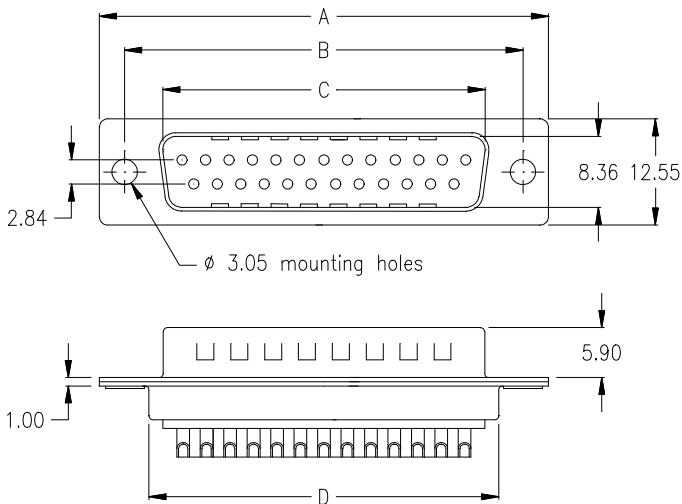

No. of contacts	Dimension			
	A	B	C	D
009	30.81 1.213	24.99 .984	16.92 .666	19.28 .795
015	39.14 1.541	33.32 1.312	25.25 .994	27.51 1.083
025	53.04 2.088	47.04 1.852	38.96 1.534	41.30 1.652
037	69.32 2.729	63.50 2.500	55.42 2.182	57.40 2.272

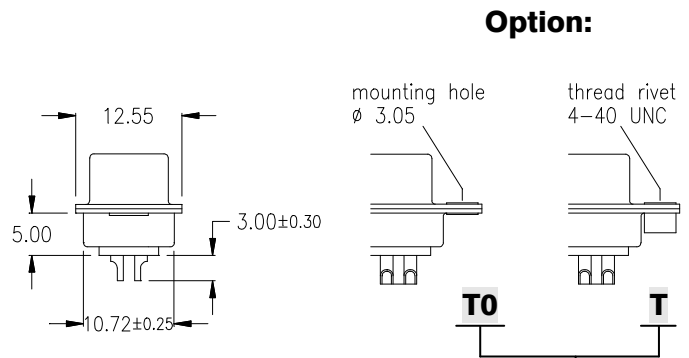

Ordering Code
SDM - xxx - S101 - 95 / XX
No. of contacts Option

General Specification page 72

Plating: -95 = tin(leadfree)/gold



female

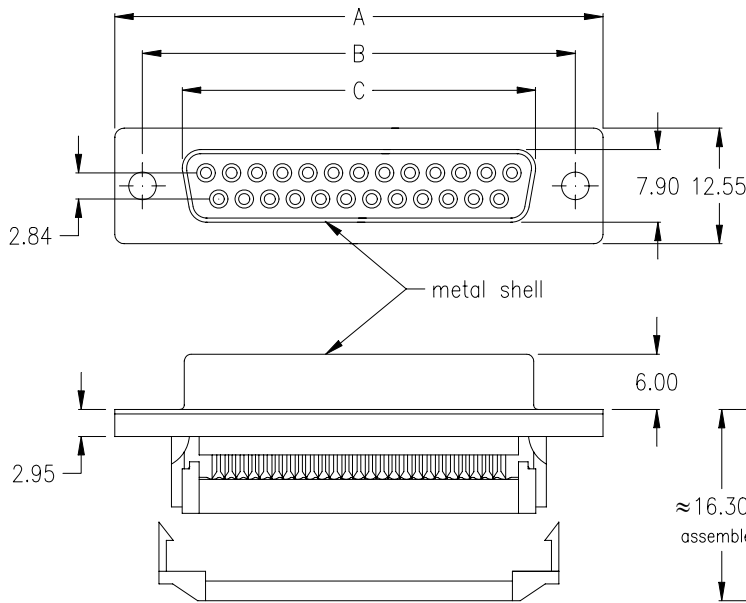

Option:

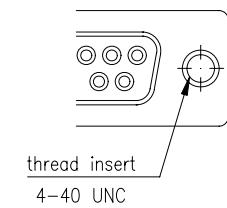
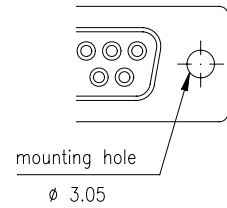

T0

T

No. of contacts	Dimension		
	A	B	C
009	30.81 1.213	24.99 .984	16.33 .643
015	39.14 1.541	33.32 1.312	24.66 .971
025	53.04 2.088	47.04 1.852	38.38 1.511
037	69.32 2.729	63.50 2.500	54.84 2.159

Plating: **-95** = tin(*leadfree*)/gold

General Specification page 72

Ordering Code

SKF - xxx - S201 - 95 / XX

No. of contacts

Option

male

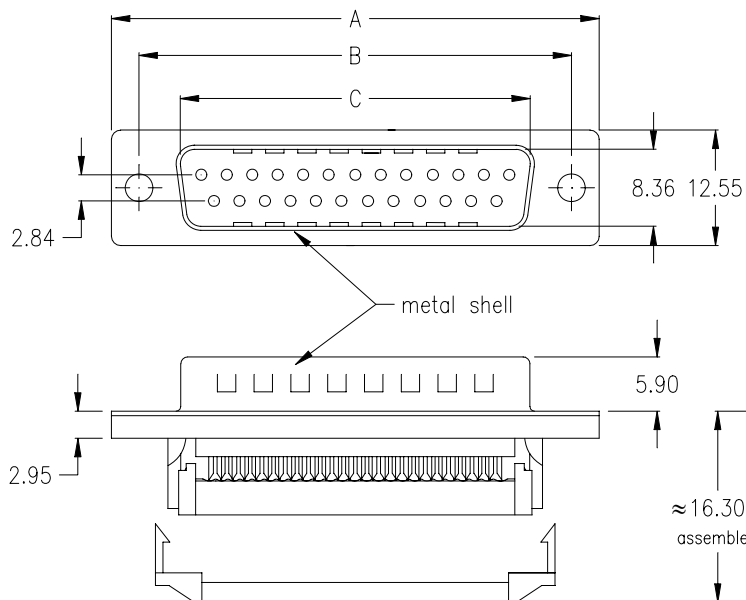

Option:

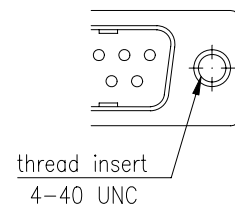
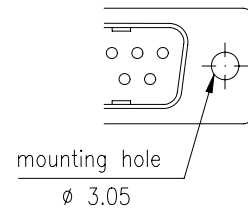

T0

T

No. of contacts	Dimension		
	A	B	C
009	30.81 1.213	24.99 .984	16.92 .666
015	39.14 1.541	33.32 1.312	25.25 .994
025	53.04 2.088	47.04 1.852	38.96 1.534
037	69.32 2.729	63.50 2.500	55.42 2.182

Plating: **-95** = tin(*leadfree*)/gold

General Specification page 72

Ordering Code

SKM - xxx - S201 - 95 / XX

No. of contacts

Option

female

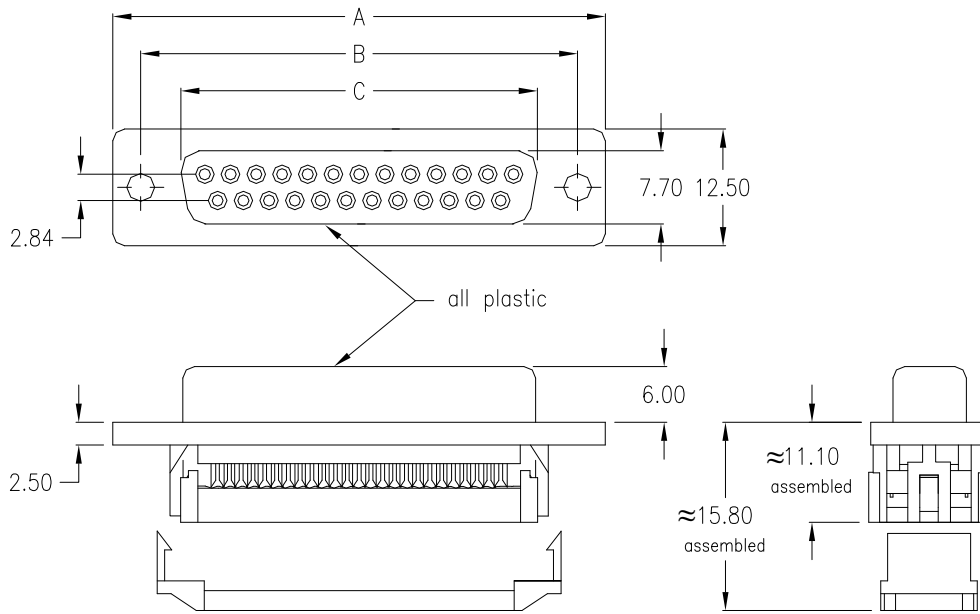

Option:

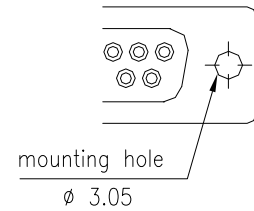

T0

No. of contacts	Dimension		
	A	B	C
009	31.16 1.227	24.99 .984	16.00 .630
015	39.42 1.552	33.32 1.312	24.27 .955
025	53.34 2.100	47.04 1.852	38.22 1.505
037	69.68 2.743	63.50 2.500	54.65 2.152

Plating: **-95** = tin(*leadfree*)/gold

General Specification page 72

Ordering Code

SKF - xxx - S202 - 95 / XX

No. of contacts

Option

male

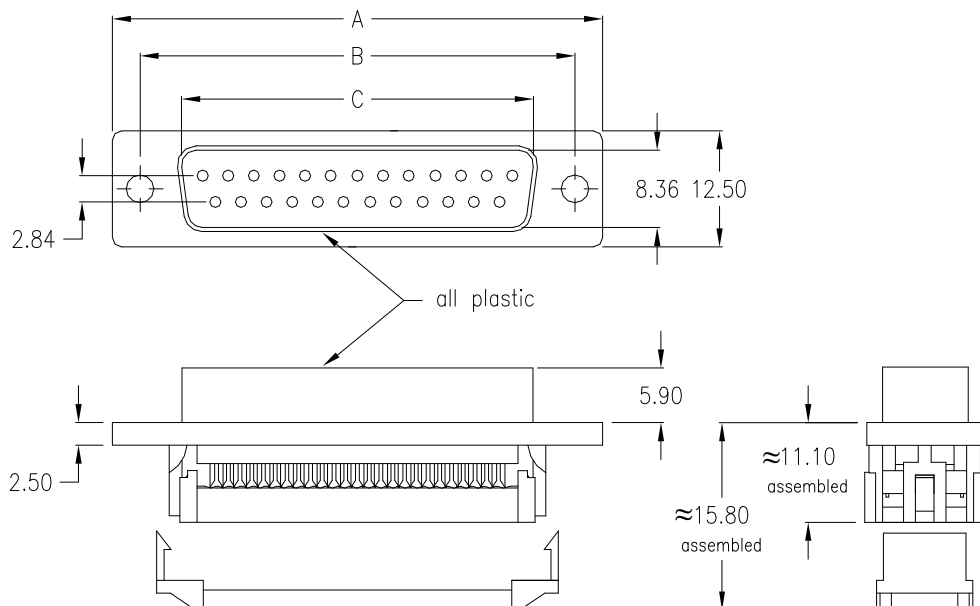

Option:

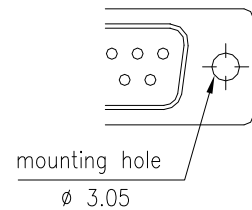

T0

No. of contacts	Dimension		
	A	B	C
009	30.81 1.213	24.99 .984	16.92 .666
015	39.14 1.541	33.32 1.312	25.25 .994
025	53.04 2.088	47.04 1.852	38.96 1.534
037	69.32 2.729	63.50 2.500	55.42 2.182

Plating: **-95** = tin(*leadfree*)/gold

General Specification page 72

Ordering Code

SKM - xxx - S202 - 95 / XX

No. of contacts

Option

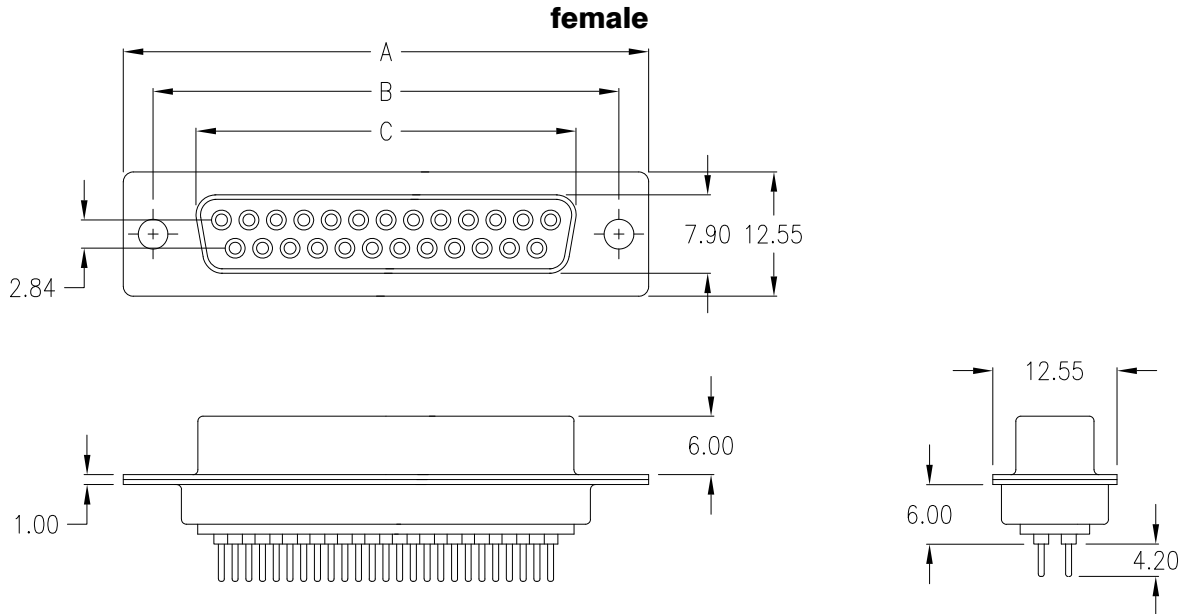

Ordering Code

SDF - xxx - S111 - 95 / XXX

No. of contacts

Option

Plating: -95 = tin(leadfree)/gold

General Specification page 72

No. of contacts	Dimension		
	A	B	C
009	30.81 1.213	24.99 .984	16.33 .643
015	39.14 1.541	33.32 1.312	24.66 .971
025	53.04 2.088	47.04 1.852	38.38 1.511
037	69.32 2.729	63.50 2.500	54.84 2.159

Options

Special product.

Please ask for availability and minimum order quantity before you consider the article for development, design in or production purposes.

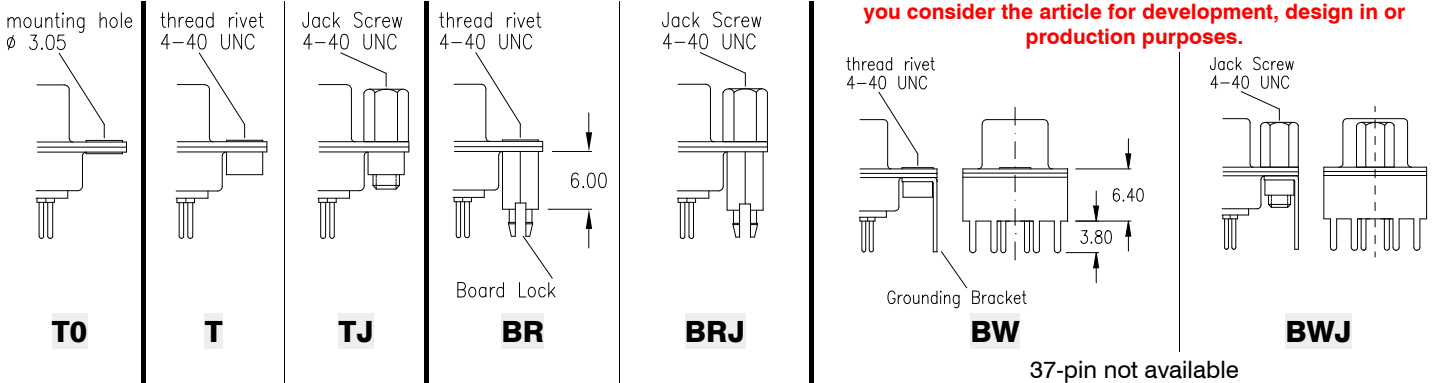

37-pin not available

PCB Layout „female“

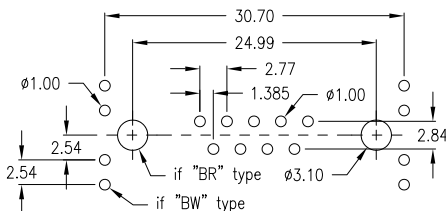

9 pin

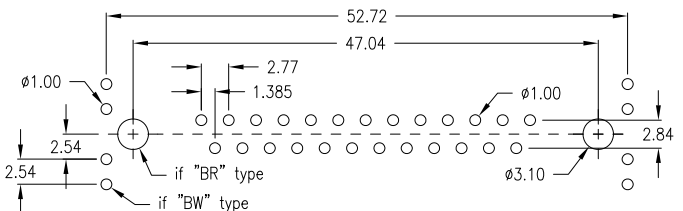

25 pin

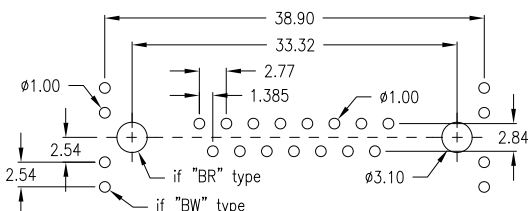

15 pin

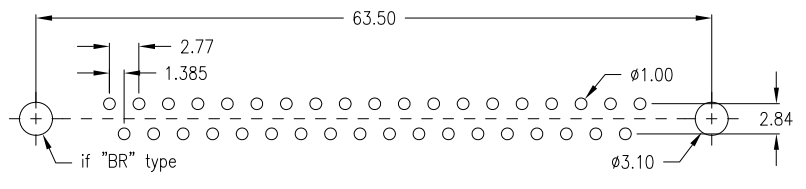

37 pin

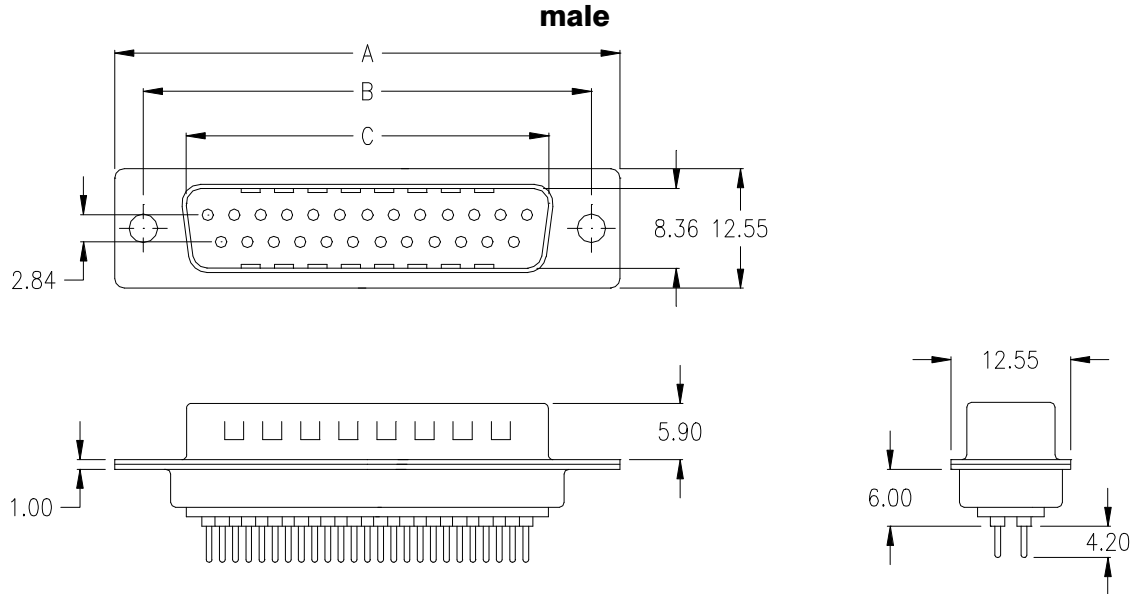

Ordering Code

SDM - xxx - S111 - 95 / XXX

No. of contacts

Option

Plating: -95 = tin(leadfree)/gold

General Specification page 72

No. of contacts	Dimension		
	A	B	C
009	30.81 1.213	24.99 .984	16.92 .666
015	39.14 1.541	33.32 1.312	25.25 .994
025	53.04 2.088	47.04 1.852	38.96 1.534
037	69.32 2.729	63.50 2.500	55.42 2.182

Options

Special product.
Please ask for availability and minimum order quantity before you consider the article for development, design in or production purposes.

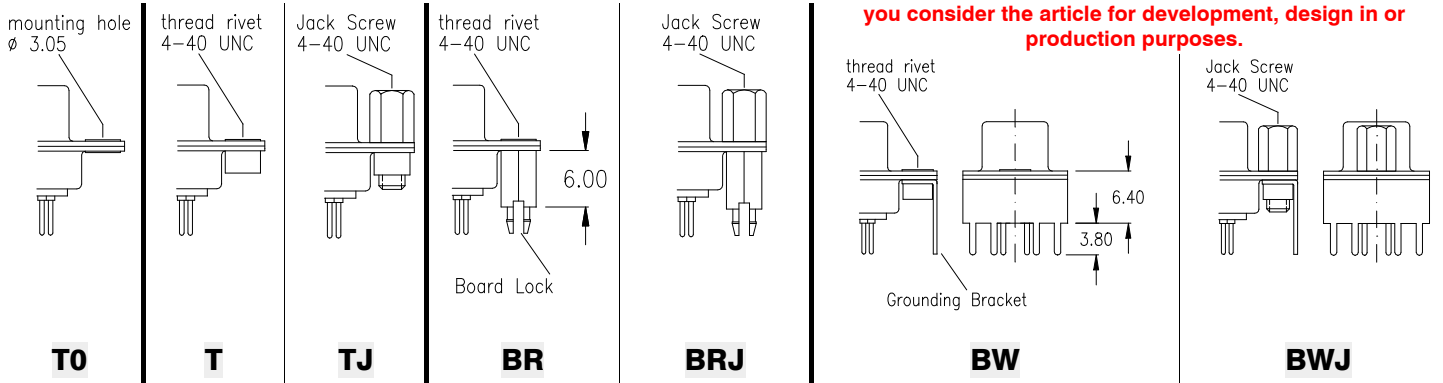

PCB Layout „male“

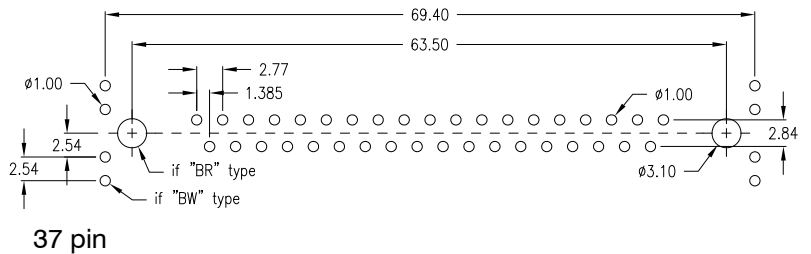
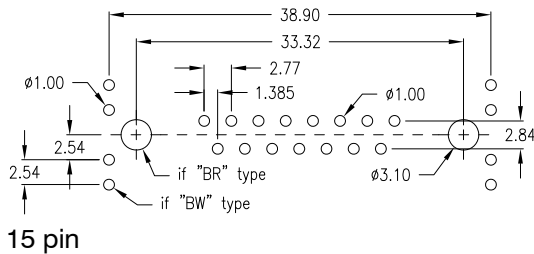
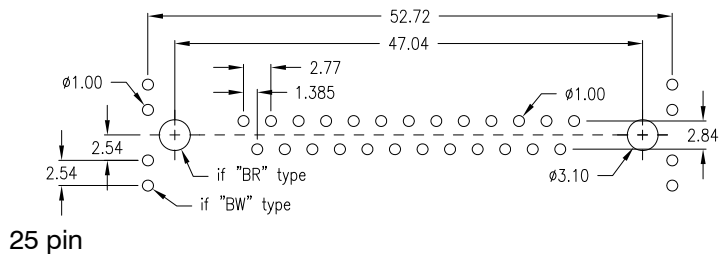
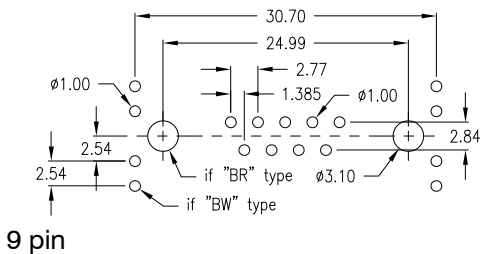

female

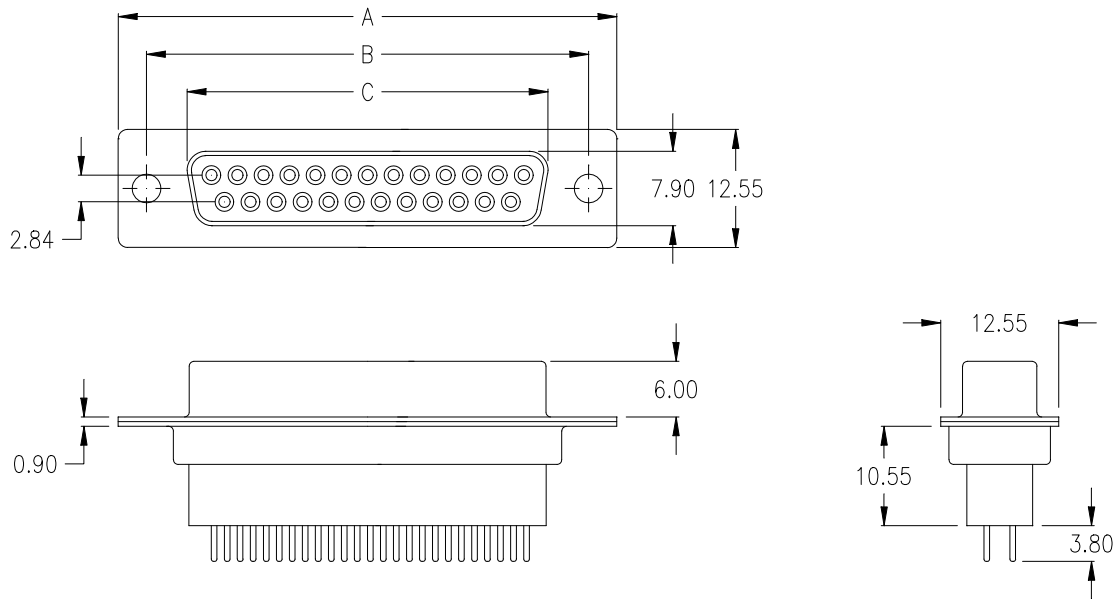

Ordering Code

SDF - xxx - B111 - 95 / XXX

No. of contacts

Option

Plating: -95 = tin(leadfree)/gold

General Specification page 72

No. of contacts	Dimension		
	A	B	C
009	<u>30.81</u> 1.213	<u>24.99</u> .984	<u>16.33</u> .643
015	<u>39.14</u> 1.541	<u>33.32</u> 1.312	<u>24.66</u> .971
025	<u>53.04</u> 2.088	<u>47.04</u> 1.852	<u>38.38</u> 1.511
037	<u>69.32</u> 2.729	<u>63.50</u> 2.500	<u>54.84</u> 2.159

Options

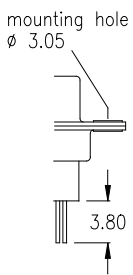

T0

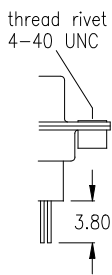

T

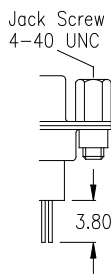

TJ

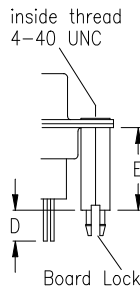

BR

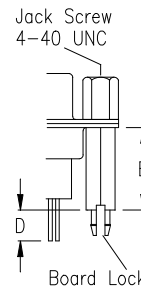

BRJ

D ±0.20	E	Option
3,20	12,70	1
3,50	11,00	2
3,20	14,50	4
4,20	13,50	5

PCB Layout „female“

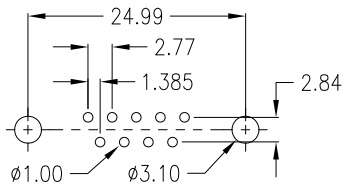

9 pin

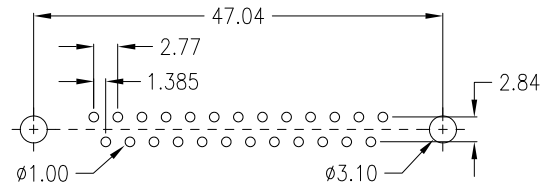

25 pin

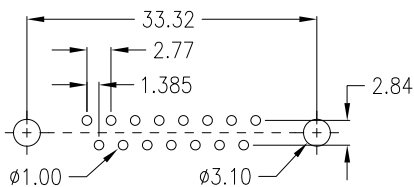

15 pin

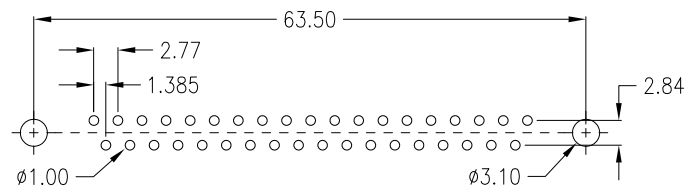

37 pin

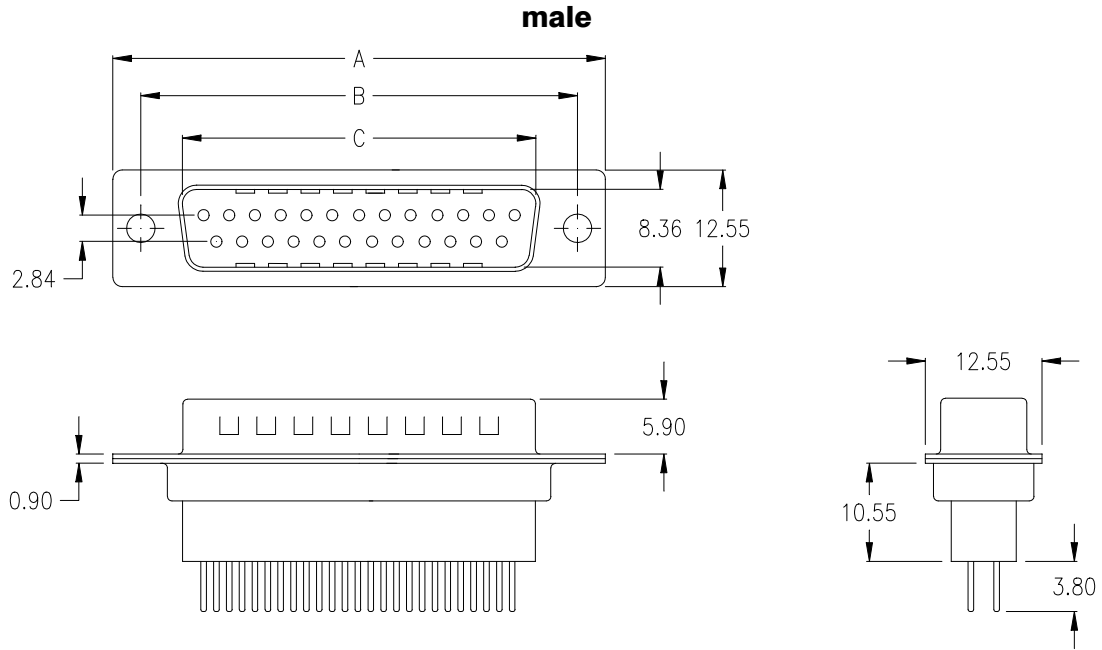

Ordering Code

SDM - xxx - B111 - 95 / XXX

No. of contacts

Option

Plating: -95 = tin(leadfree)/gold

General Specification page 72

No. of contacts	Dimension		
	A	B	C
009	30.81 1.213	24.99 .984	16.92 .666
015	39.14 1.541	33.32 1.312	25.25 .994
025	53.04 2.088	47.04 1.852	38.96 1.534
037	69.32 2.729	63.50 2.500	55.42 2.182

Options

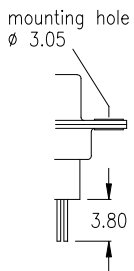

T0

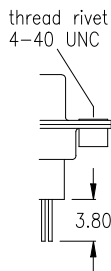

T

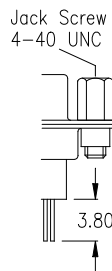

TJ

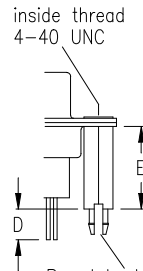

BR

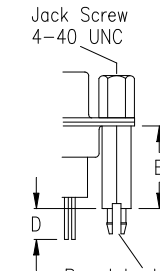

BR_J

D ±0.20	E	Option
3,20	12,70	1
3,50	11,00	2
3,20	14,50	4
4,20	13,50	5

PCB Layout „male“

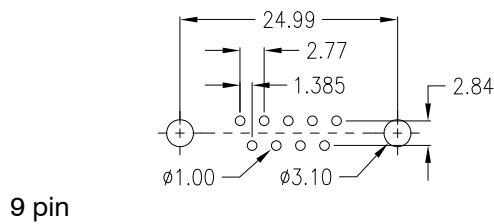

9 pin

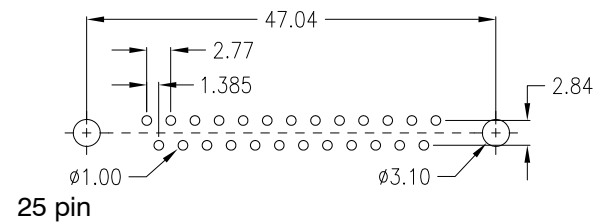

25 pin

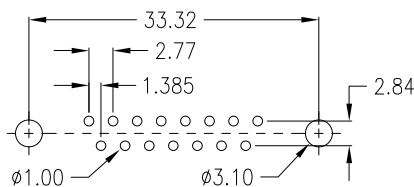

15 pin

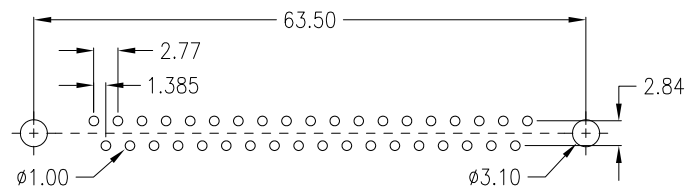

37 pin

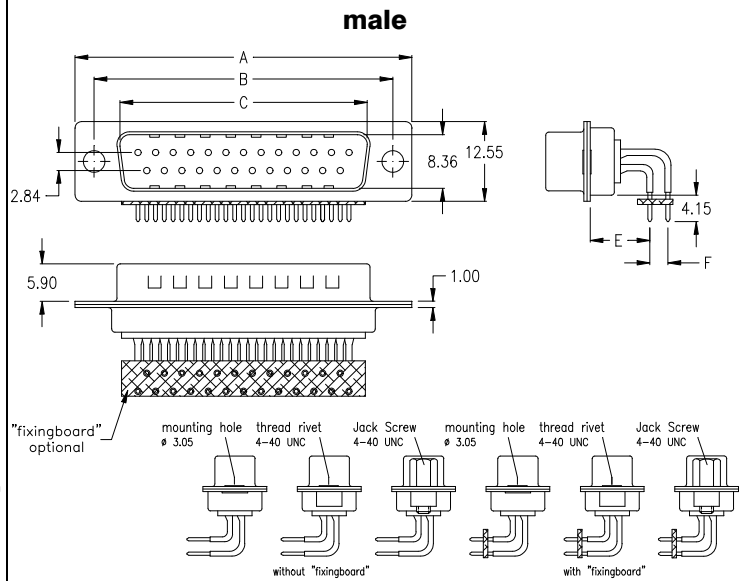
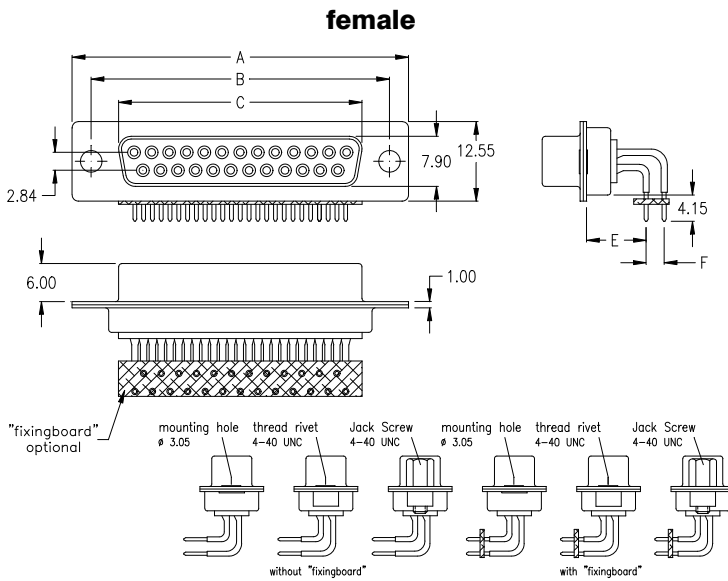

Option: **blank (Standard)** **T** **TJ** **K0** **K** **KJ**

Option: **blank (Standard)** **T** **TJ** **K0** **K** **KJ**

No. of contacts	Dimension			
	A	B	C	E
009	30.81	24.99	16.33	7.20
	1.213	.984	.643	.283
015	39.14	33.32	24.66	7.20
	1.541	1.312	.971	.283
025	53.04	47.04	38.38	9.40
	2.088	1.852	1.511	.370
037	69.32	63.50	54.84	9.40
	2.729	2.500	2.159	.370

No. of contacts	Dimension			
	A	B	C	E
009	30.81	24.99	16.92	7.20
	1.213	.984	.666	.283
015	39.14	33.32	25.25	7.20
	1.541	1.312	.994	.283
025	53.04	47.04	38.96	9.40
	2.088	1.852	1.534	.370
037	69.32	63.50	55.42	9.40
	2.729	2.500	2.182	.370

Ordering Code
SDF - xxx - X xxx - 55 / Xx (XX)

Ordering Code
SDM - xxx - X xxx - 55 / Xx (XX)

No. of contacts

No. of contacts

Dimension "E"	precision contact
7.20 mm	N901-55
9.40 mm	T901-55

Option	Dimension "F"
A1	2.54 mm
A2	2.84 mm

Dimension "E"	precision contact
7.20 mm	N901-55
9.40 mm	T901-55

Option	Dimension "F"
A1	2.54 mm
A2	2.84 mm

-55 = Plating gold all over

PCB Layout

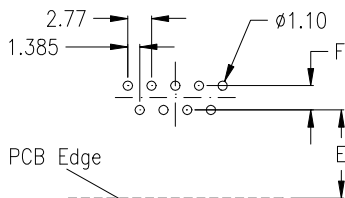

9 pin

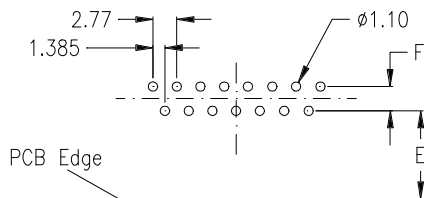

15 pin

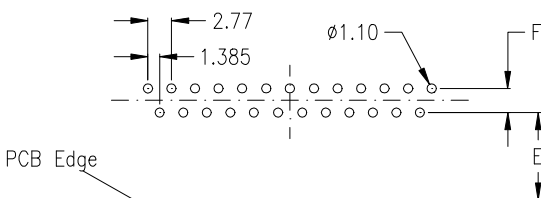

25 pin

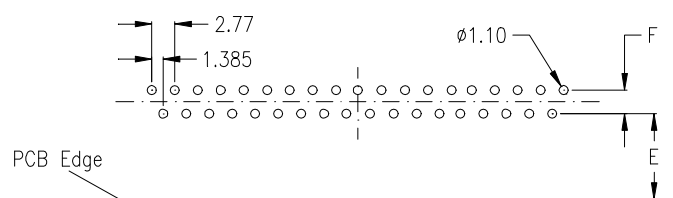

37 pin

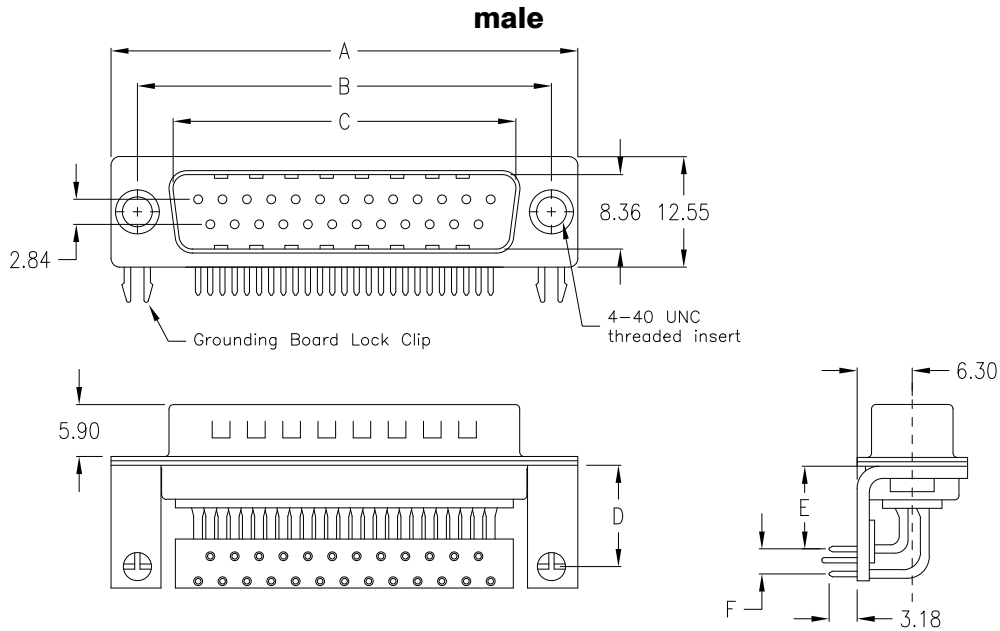

Ordering Code

Special product.

Please ask for availability and minimum order quantity before you consider the article for development, design in or production purposes.

SDM - xxx - N 900 - 95/ XxXX

No. of contacts

Option

Stamped contact

Plating: -95 = tin(leadfree)/gold

No. of contacts	Dimension				
	A	B	C	D if "F"=2,54	D if "F"=2,84
009	30.81 1.213	24.99 .984	16.92 .666	8.47 .333	8.47 .333
015	39.14 1.541	33.32 1.312	25.25 .994	8.47 .333	8.47 .333
025	53.04 2.088	47.04 1.852	38.96 1.534	10.67 .420	10.67 .420
037	69.32 2.729	63.50 2.500	55.42 2.182	10.67 .420	10.67 .420

General Specification page 72

Dimension "E"

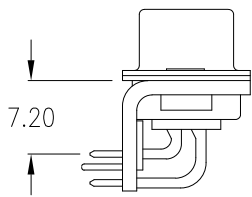

if 9 pin & 15-pin

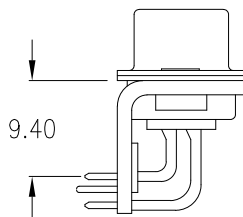

if 25 pin & 37 pin

Options

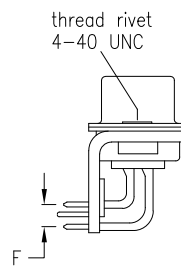

H N

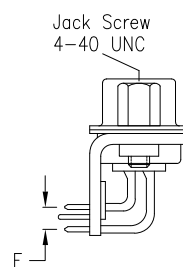

H NJ

Dimension "F"	Option
2,54mm	1
2,84mm	2

PCB Layout „male“

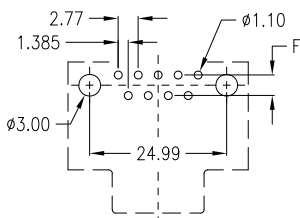

9 pin

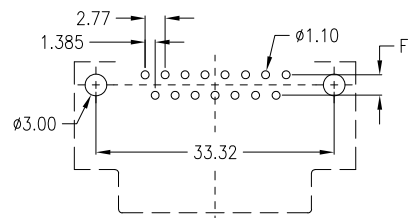

15 pin

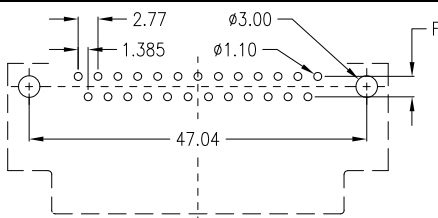

25 pin

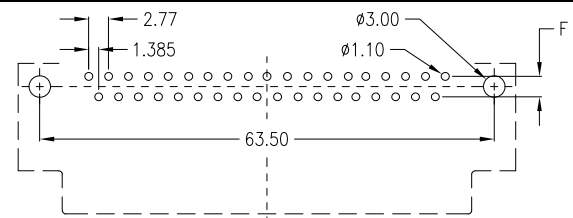

37 pin

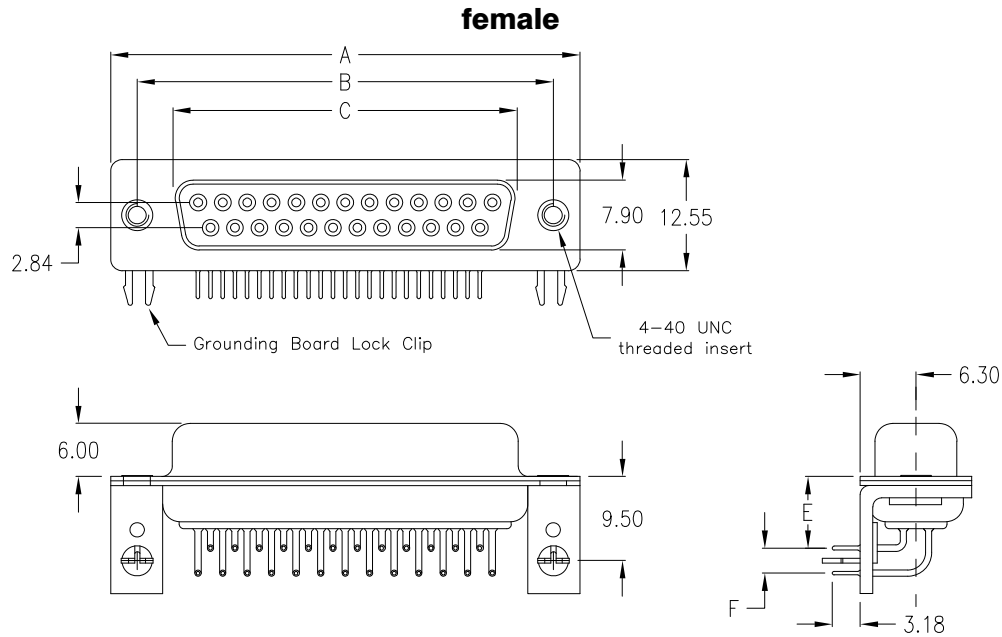

Ordering Code

SDF - xxx - N 901 - 55/ XxXX

No. of contacts

Option

Precision contact

No. of contacts	Dimension		
	A	B	C
009	<u>30.81</u> 1.213	<u>24.99</u> .984	<u>16.33</u> .643
015	<u>39.14</u> 1.541	<u>33.32</u> 1.312	<u>24.66</u> .971
025	<u>53.04</u> 2.088	<u>47.04</u> 1.852	<u>38.38</u> 1.511
037	<u>69.32</u> 2.729	<u>63.50</u> 2.500	<u>54.84</u> 2.159

Plating: -55 = Plating gold all over

General Specification page 72

Dimension "E"

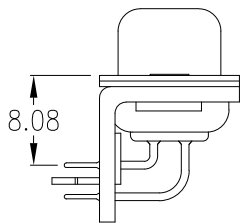

Options

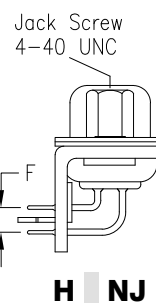
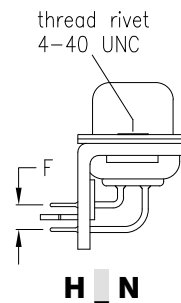

Dimension "F"	Option
2,54mm	1
2,84mm	2

PCB Layout „female“

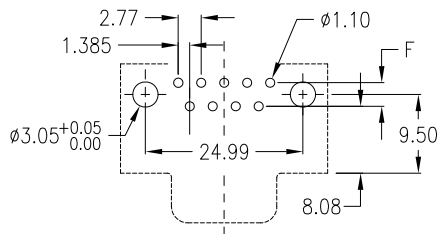

9 pin

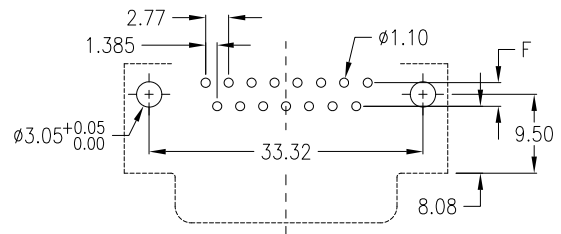

15 pin

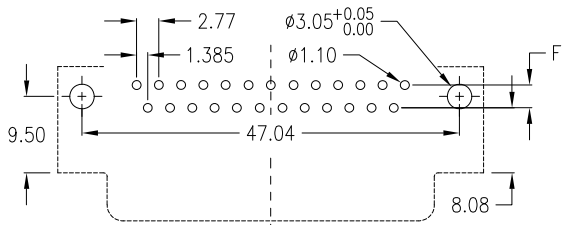

25 pin

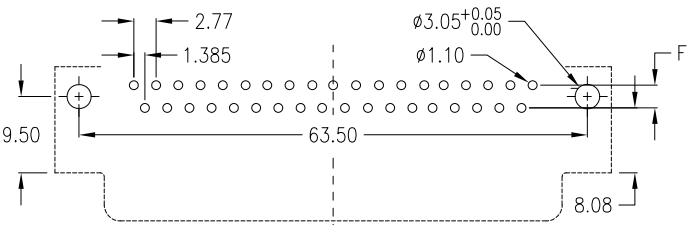

37 pin

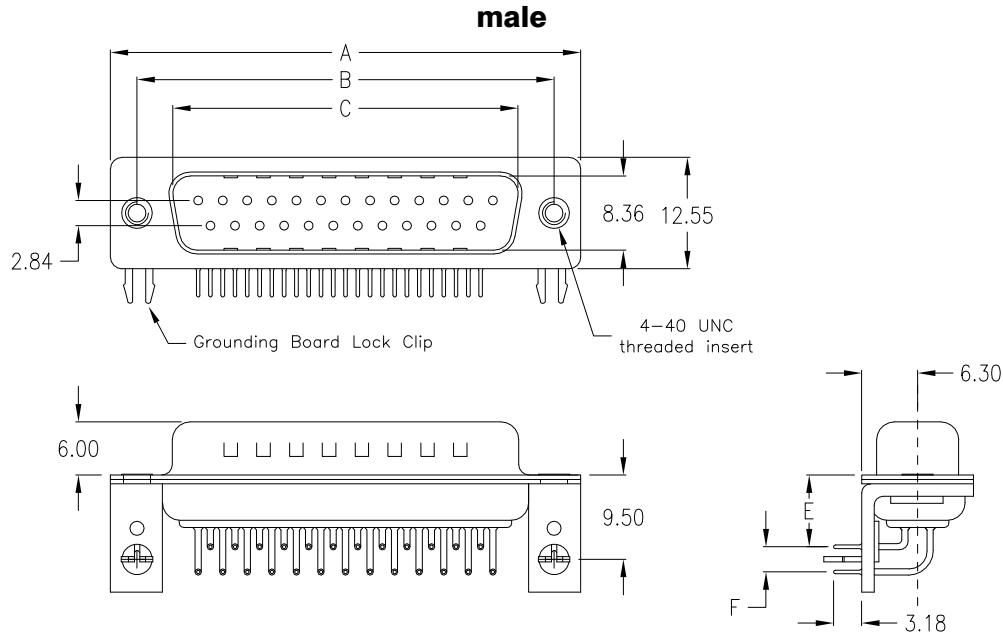

Ordering Code

SDM - xxx - N 901 - 55/ XxXX

No. of contacts

Option

Precision contact

No. of contacts	Dimension		
	A	B	C
009	<u>30.81</u> 1.213	<u>24.99</u> .984	<u>16.92</u> .666
015	<u>39.14</u> 1.541	<u>33.32</u> 1.312	<u>25.25</u> .994
025	<u>53.04</u> 2.088	<u>47.04</u> 1.852	<u>38.96</u> 1.534
037	<u>69.32</u> 2.729	<u>63.50</u> 2.500	<u>55.42</u> 2.182

Plating: -55 = Plating gold all over

General Specification page 72

Dimension "E"

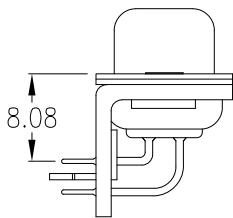

Options

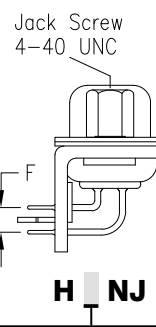
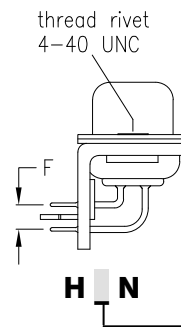

Dimension "F"	Option
2,54mm	1
2,84mm	2

PCB Layout „male“

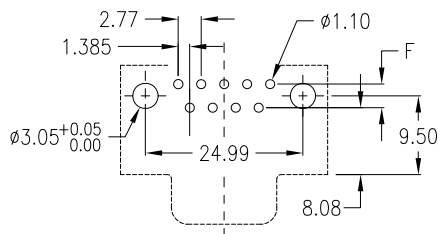

9 pin

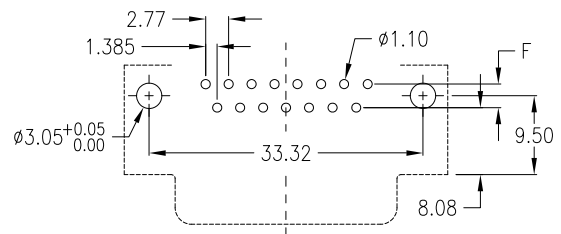

15 pin

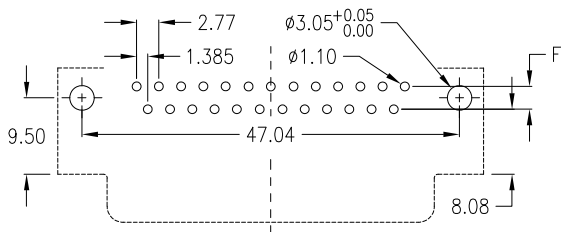

25 pin

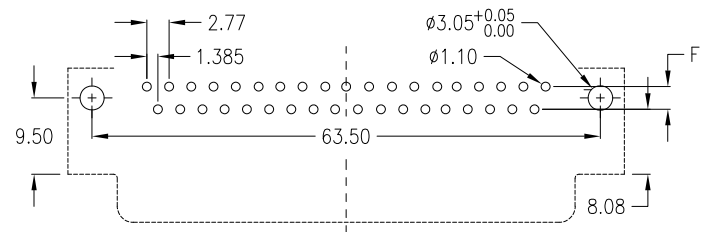

37 pin

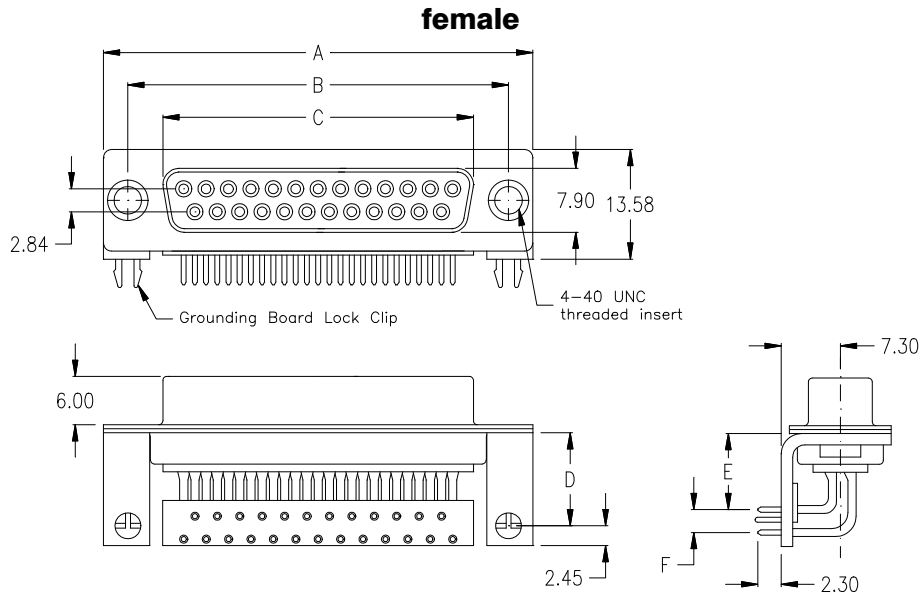

Ordering Code

Special product.

Please ask for availability and minimum order quantity before you consider the article for development, design in or production purposes.

SDF - xxx - T 970 - 55/ XxXX

No. of contacts

Option

Plating: -55 = gold/gold (-95 = tin(leadfree)/gold on request)

No. of contacts	Dimension				
	A	B	C	D if "F"=2,54	D if "F"=2,84
009	30.81 1.213	24.99 .984	16.33 .643	10.07 .396	10.02 .394
015	39.14 1.541	33.32 1.312	24.66 .971	10.07 .396	10.02 .394
025	53.04 2.088	47.04 1.852	38.38 1.511	10.07 .396	10.02 .394
037	69.32 2.729	63.50 2.500	54.84 2.159	10.07 .396	10.02 .394

General Specification page 72

(Dimension "E")

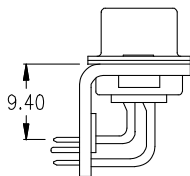

Options

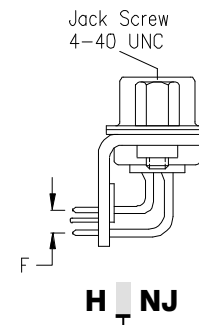
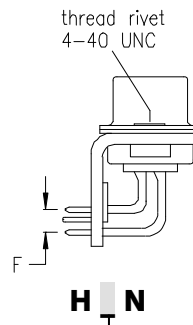

Dimension "F"	Option
2,54mm	1
2,84mm	2

PCB Layout „female“

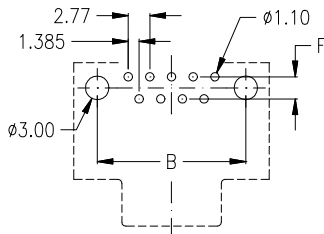

9 pin

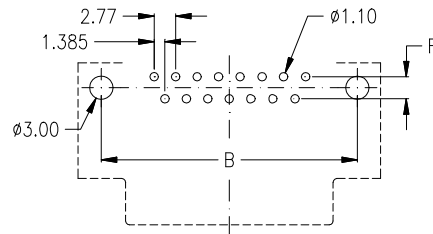

15 pin

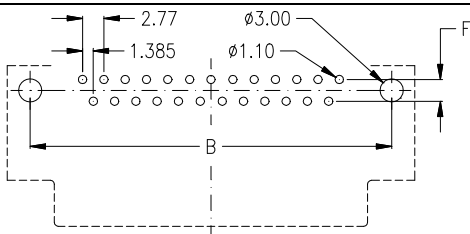

25 pin

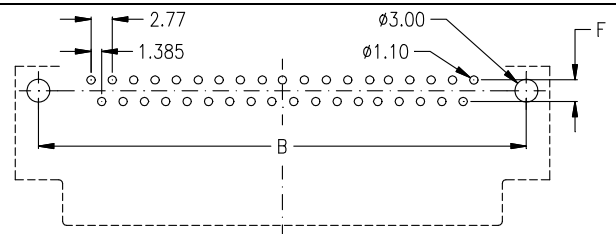

37 pin

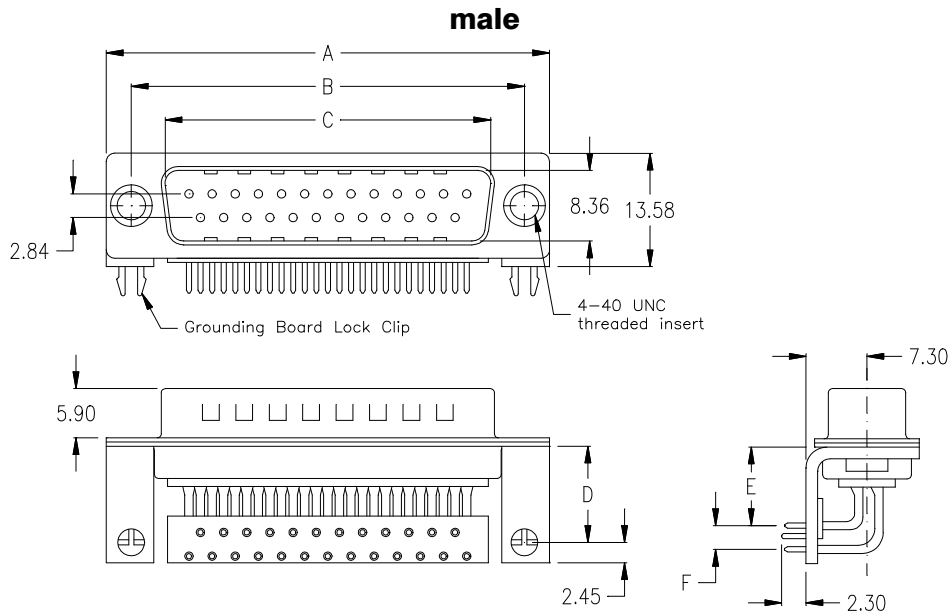

Ordering Code

Special product.

Please ask for availability and minimum order quantity before you consider the article for development, design in or production purposes.

SDM - xxx - T 970 - 55/ Xxxx

No. of contacts

Option

Plating: -55 = gold/gold (-95 = tin(leadfree)/gold on request)

No. of contacts	Dimension				
	A	B	C	D if "F"=2,54	D if "F"=2,84
009	30.81 1.213	24.99 .984	16.92 .666	10.07 .396	10.02 .394
015	39.14 1.541	33.32 1.312	25.25 .994	10.07 .396	10.02 .394
025	53.04 2.088	47.04 1.852	38.96 1.534	10.07 .396	10.02 .394
037	69.32 2.729	69.32 2.729	63.50 2.500	55.42 2.182	10.07 .396

General Specification page 72

(Dimension "E")

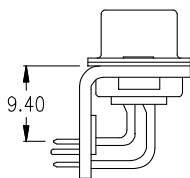

Options

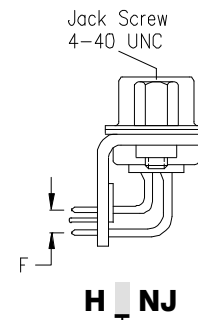
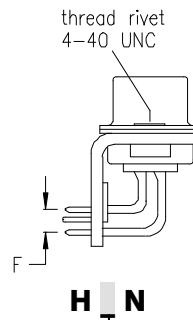

Dimension "F"	Option
2,54mm	1
2,84mm	2

PCB Layout „male“

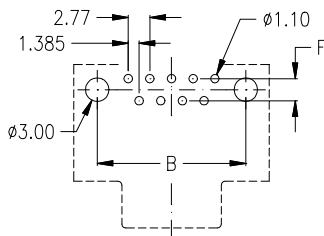

9 pin

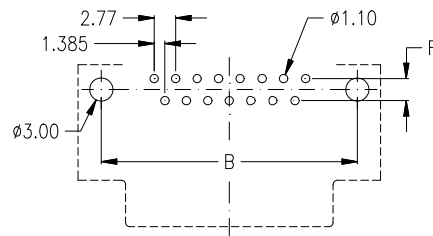

15 pin

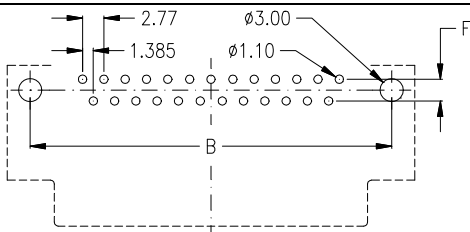

25 pin

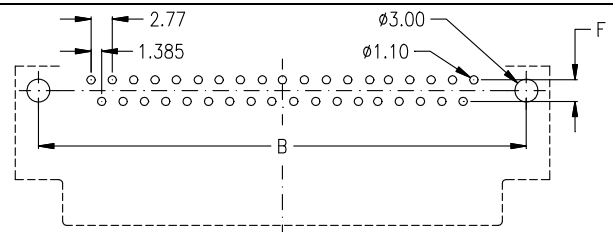

37 pin

SD Series - D-Sub 90°

"Wave Solder" & "Pin-In-Paste" Technology

N900 8,08mm / .318" „US Style“ Footprint



female

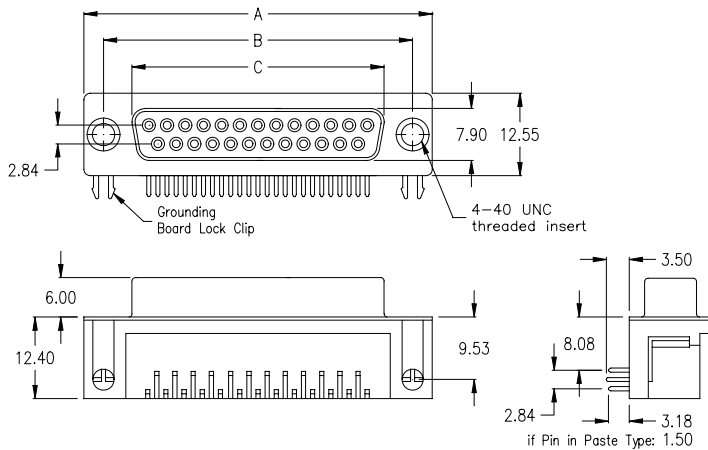

PCB hole layout on page 29

male

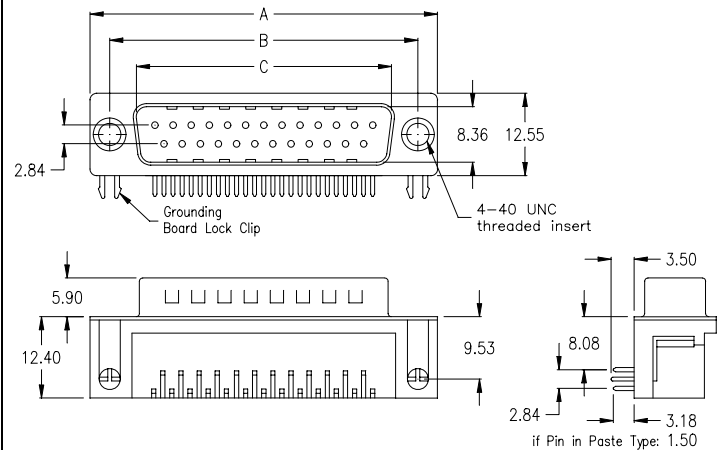

PCB hole layout on page 29

No. of contacts	Dimension			Ordering Code
	A	B	C	
009	30.81 1.213	24.99 .984	16.33 .643	SDF-009-N900-95/ XX
015	39.14 1.541	33.32 1.311	24.66 .971	SDF-015-N900-95/ XX SDF-015-N900-95/Y XX
025	53.04 2.088	47.04 1.852	38.38 1.511	SDF-025-N900-95/ XX SDF-025-N900-95/B XX
037	69.32 2.729	63.50 2.500	54.84 2.159	SDF-037-N900-95/ XX

Plating: **-95** = tin(leadfree)/gold
-55 = gold/gold on request

Option

No. of contacts	Dimension			Ordering Code
	A	B	C	
009	30.81 1.213	24.99 .984	16.92 .666	SDM-009-N900-95/ XX SDM-009-N900-95/T XX
015	39.14 1.541	33.32 1.311	25.25 .994	SDM-015-N900-95/ XX
025	53.04 2.088	47.04 1.852	38.96 1.534	SDM-025-N900-95/ XX
037	69.32 2.729	63.50 2.500	55.42 2.182	SDM-037-N900-95/ XX

Plating: **-95** = tin(leadfree) /gold
-55 = gold/gold on request

Option

SDF - xxx- N900 - 95/Y XX = PC99 type yellowish brown
SDF - xxx- N900 - 95/B XX = PC99 type burgundy

Other colour available on request

SDM - xxx- N900 - 95/T XX = PC99 type teal

Other colour available on request

"Pin-In-Paste" Technology - for availability pls. contact info@e-tec.com

General Specification page 72

Options

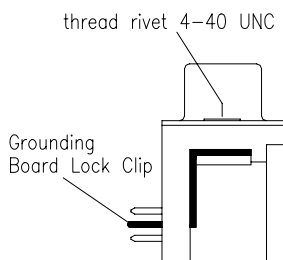

N

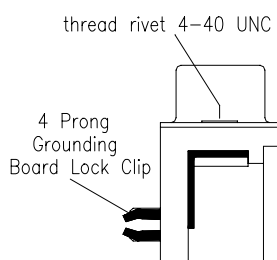

C4

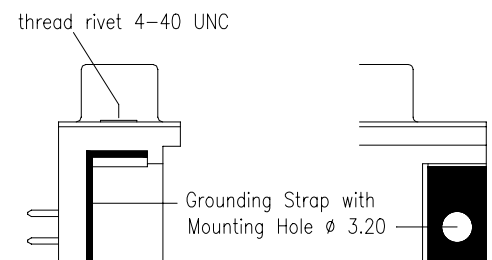

H

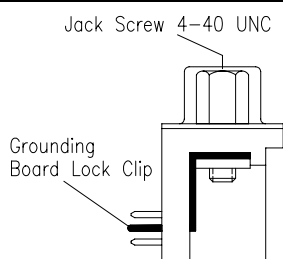

NJ

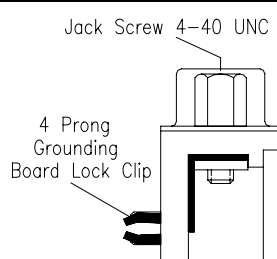

C4J

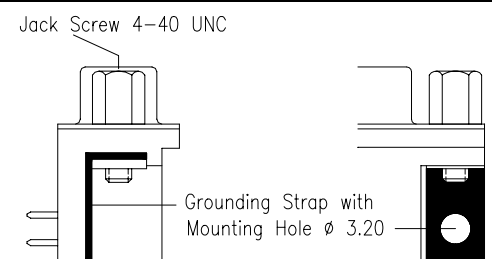

HJ

SD Series - D-Sub 90°
9,40mm / .370" „Euro Style“ Footprint



female

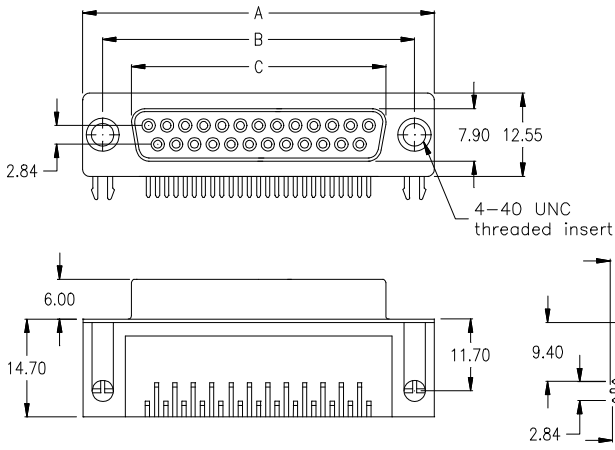

PCB hole layout on page 29

No. of contacts	Dimension		
	A	B	C
009	30.81	24.99	16.33
	1.213	.984	.643
015	39.14	33.32	24.66
	1.541	1.312	.971
025	53.04	47.04	38.38
	2.088	1.852	1.511
037	69.32	63.50	54.84
	2.729	2.500	2.159

Ordering Code

SDF - xxx - M900 - 55 / XX

No. of contacts

Option

male

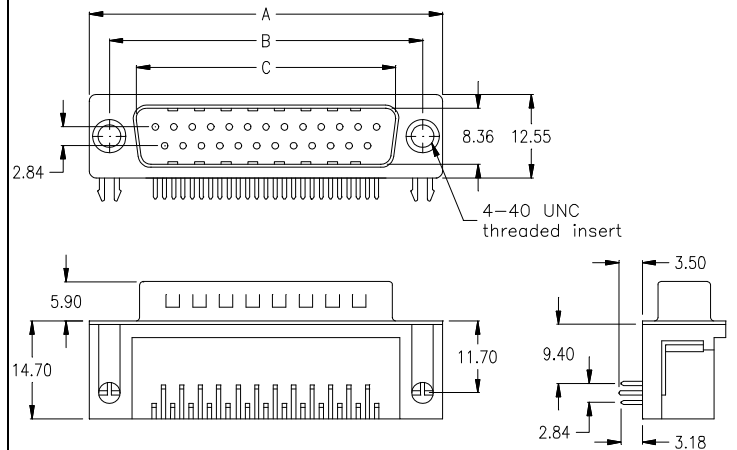

PCB hole layout on page 29

No. of contacts	Dimension		
	A	B	C
009	30.81	24.99	16.92
	1.213	.984	.666
015	39.14	33.32	25.25
	1.541	1.312	.994
025	53.04	47.04	38.96
	2.088	1.852	1.534
037	69.32	63.50	55.42
	2.729	2.500	2.182

Ordering Code

SDM - xxx - M900 - 55 / XX

No. of contacts

Option

Plating: -55 = gold

General Specification page 72

Options

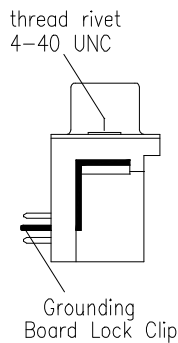

N

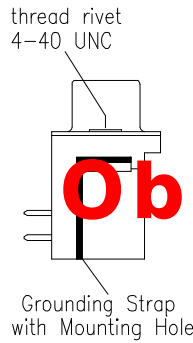

H

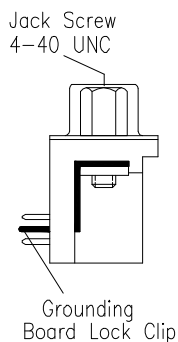
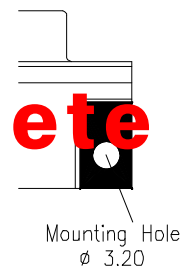

NJ

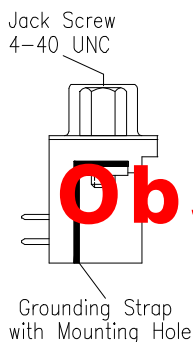

HJ

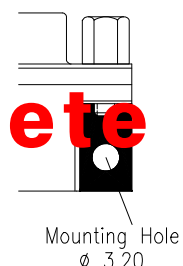

Obsolete

Obsolete

SD Series - D-Sub 90°
15,00mm / .590" „Long Style“ Footprint



female

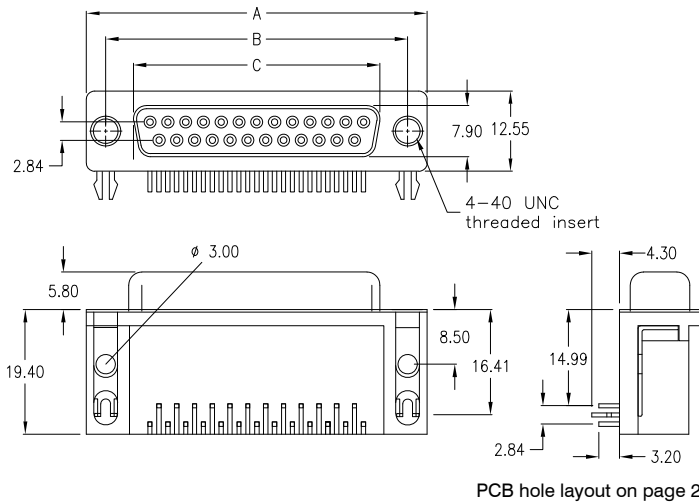

No. of contacts	Dimension		
	A	B	C
009	30.81	24.99	16.33
	1.213	.984	.643
015	39.14	33.32	24.66
	1.541	1.312	.971
025	53.04	47.04	38.38
	2.088	1.852	1.511
037	69.32	63.50	54.84
	2.729	2.500	2.159

Ordering Code

SDF - xxx - L900 - 55 / XX

No. of contacts

Option

Plating: -95 = tin(leadfree)/gold

male

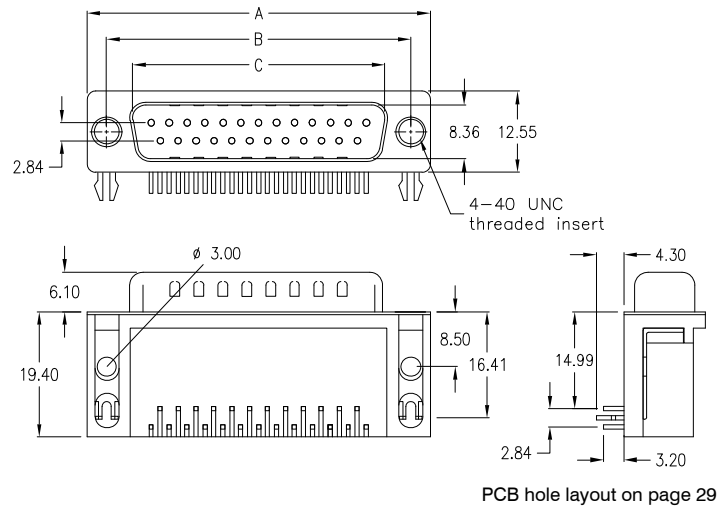

No. of contacts	Dimension		
	A	B	C
009	30.81	24.99	16.92
	1.213	.984	.666
015	39.14	33.32	25.25
	1.541	1.312	.994
025	53.04	47.04	38.96
	2.088	1.852	1.534
037	69.32	63.50	55.42
	2.729	2.500	2.182

Ordering Code

SDM - xxx - L900 - 55 / XX

No. of contacts

Option

Plating: -95 = tin(leadfree)/gold

General Specification page 72

Options

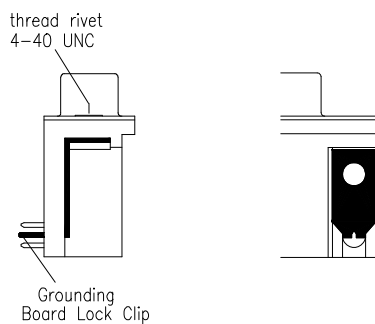

P

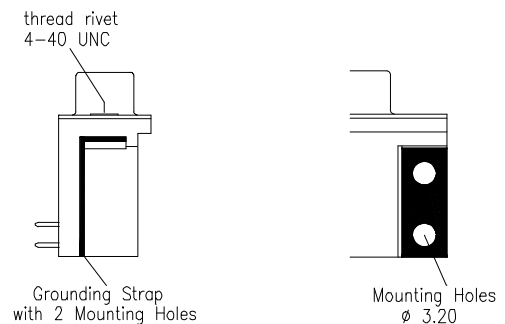

L

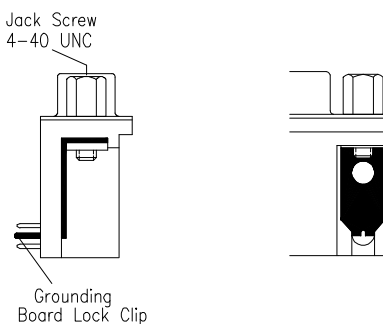

PJ

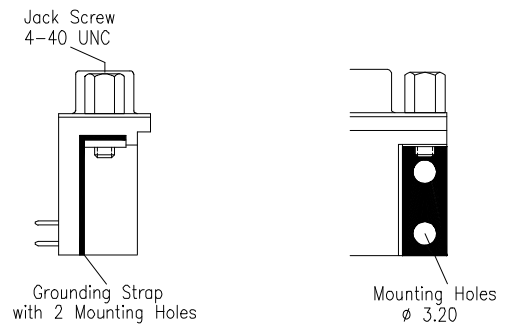

LJ

N900 & M900 Type

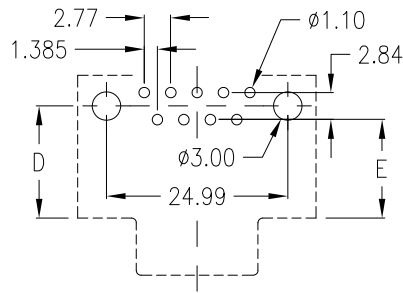

9-pin

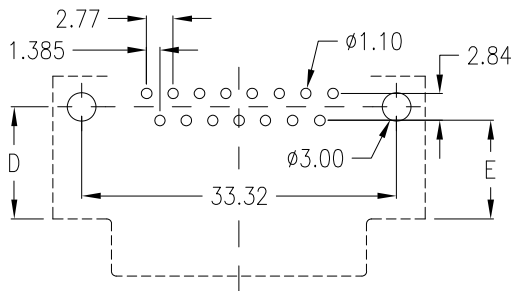

15-pin

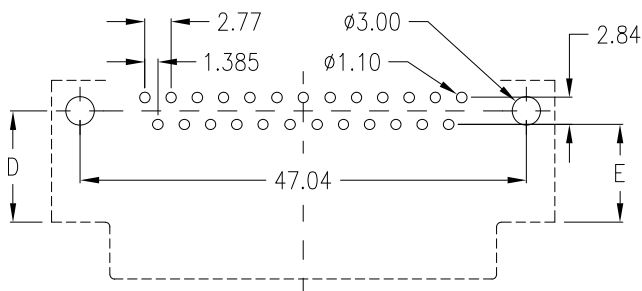

25-pin

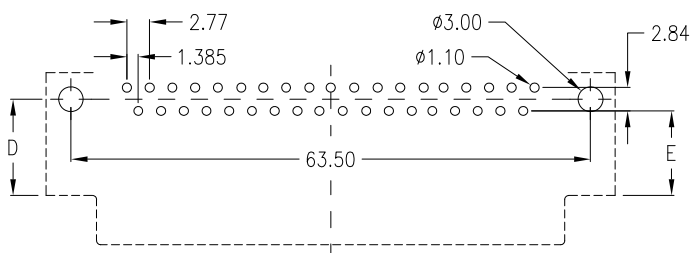

37-pin

L900 Type

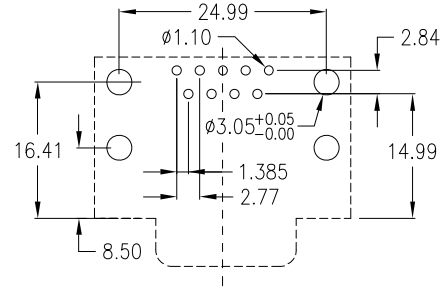

9-pin

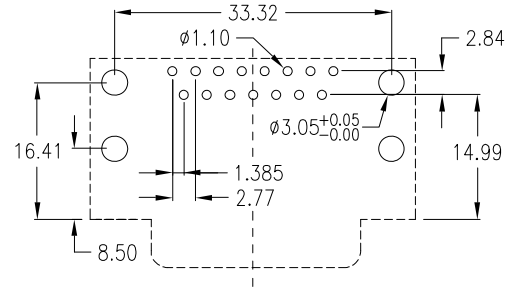

15-pin

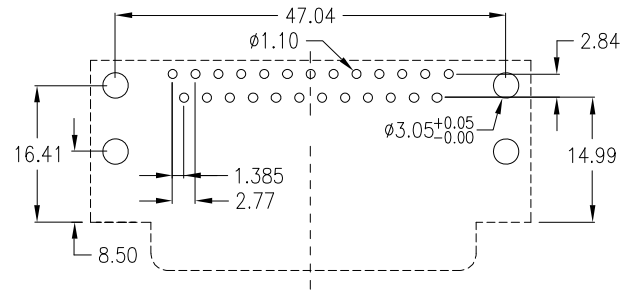

25-pin

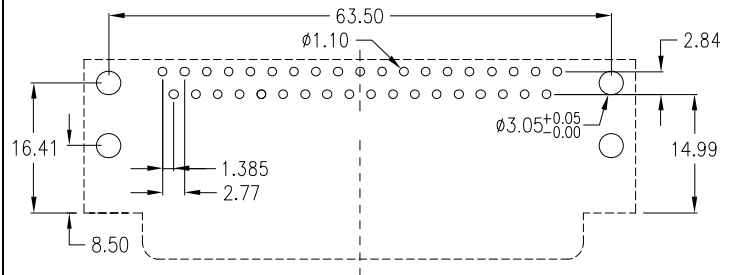

37-pin

D-Sub Type	Dim. "D" ±0.25/±.010	Dim. "E" ±0.25/±.010
N 900	<u>9.50</u> .374	<u>8.08</u> .318
M 900	<u>11.70</u> .461	<u>10.30</u> .406

SD Series - D-Sub

P150 "press fit" type



female

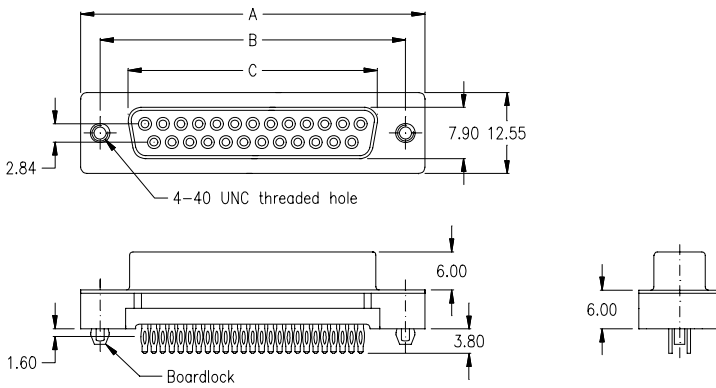

No. of contacts	Dimension			
	A	B	C	E
009	30.81	24.99	16.33	7.20
	1.213	.984	.643	.283
015	39.14	33.32	24.66	7.20
	1.541	1.312	.971	.283
025	53.04	47.04	38.38	9.40
	2.088	1.852	1.511	.370
037	69.32	63.50	54.84	9.40
	2.729	2.500	2.159	.370

Ordering Code

SDF - xxx - P 150 - 95 / P

No. of contacts

if with Jack Screw assemble to the connector: **PJ**

male

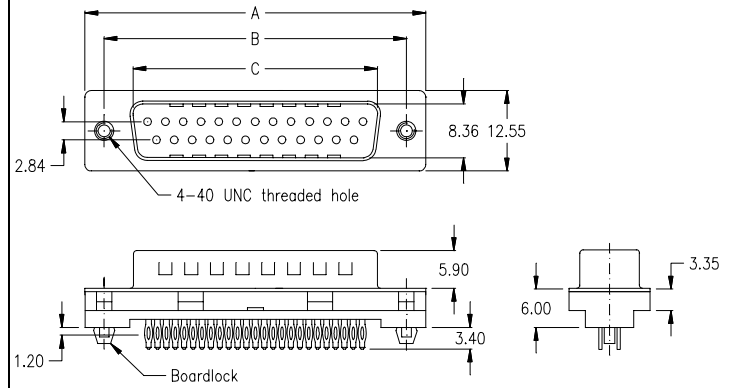

No. of contacts	Dimension			
	A	B	C	E
009	30.81	24.99	16.92	7.20
	1.213	.984	.666	.283
015	39.14	33.32	25.25	7.20
	1.541	1.312	.994	.283
025	53.04	47.04	38.96	9.40
	2.088	1.852	1.534	.370
037	69.32	63.50	55.42	9.40
	2.729	2.500	2.182	.370

Ordering Code

SDM - xxx - P 150 - 95 / P

No. of contacts

if with Jack Screw assemble to the connector: **PJ**

(for Jack Screw dimension etc. pls. see page 70)

PCB - Hole Specification

recommended PCB thickness: 1.60mm

terminal hole		boardlock hole	
drilled hole	1.10mm ± 0.02	drilled hole	3.20mm ± 0.02
finished hole	1.00mm ± 0.05	finished hole	3.10mm ± 0.05
Cu	min. 25 μm	Cu	min. 25 μm
Sn	5 - 15 μm	Sn	5 - 15 μm

General Specification

Current rating	5 A
Contact resistance	30mΩ max.
Insulator resistance	1.000MΩ min. at 500V DC
Withstanding voltage	1.000V AC (rms) for 1 Minute
Contact material	PhBz (RoHS compliant)
Contact plating	tin (leadfree) / gold
Insulator	Nylon 46 (RoHS compliant)
Operating temperature	-55° C to +125° C

PCB Layout

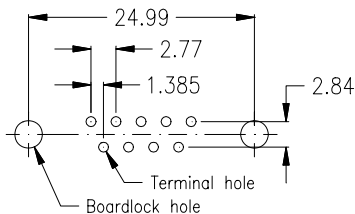

9 pin

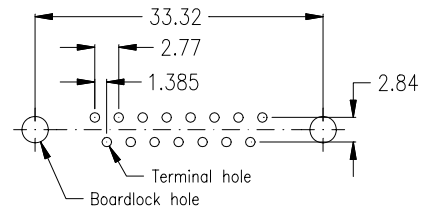

15 pin

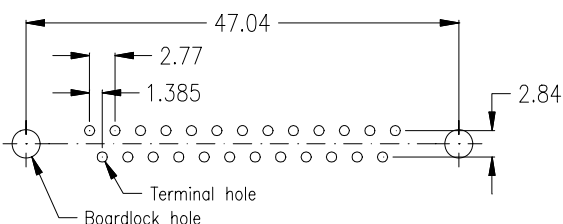

25 pin

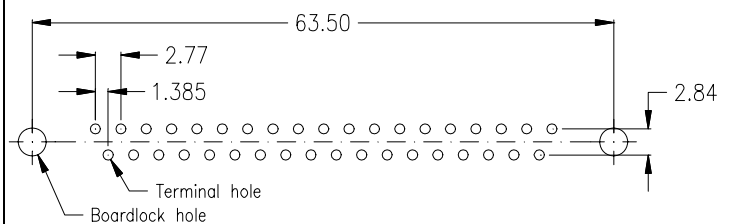

37 pin

High Density D-Sub

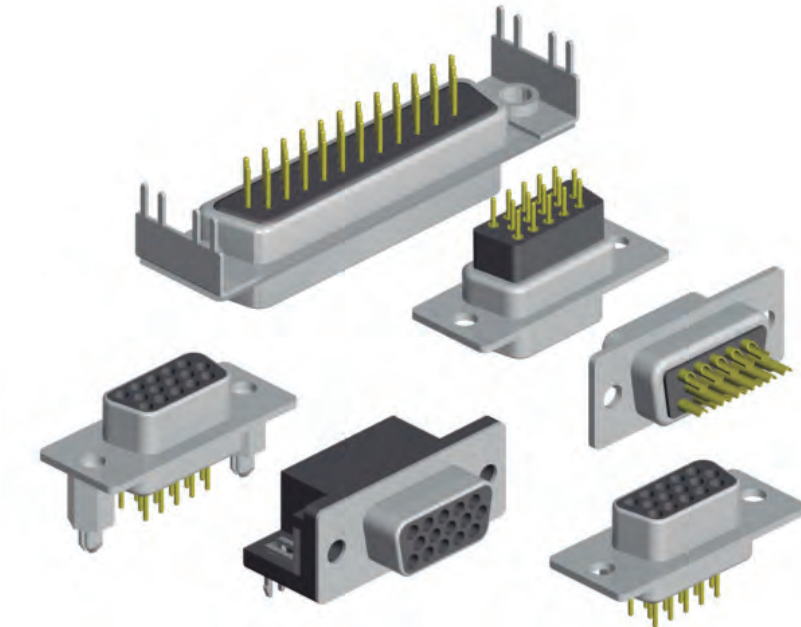

High Density (3 - row) D-Sub family includes hand solder and straight soldertail types.

The right angle types are also available for “Pin-In-Paste” Technology and as “VESA” Type.

A variety of High Density D-Sub Connectors are also available with Ferrite Filter.

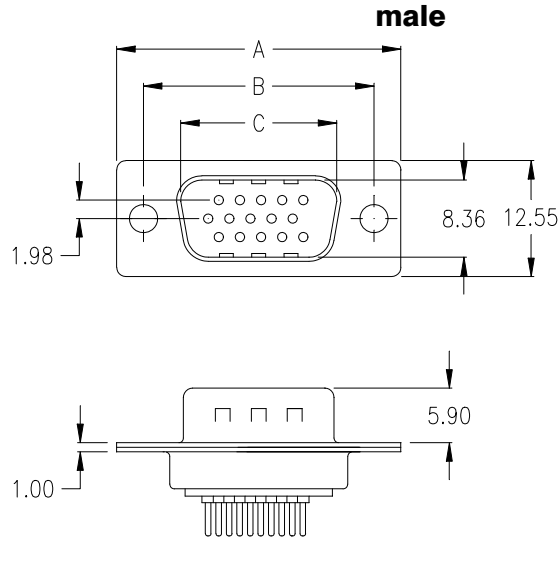

Ordering Code

SHM - xxx - S111 - 95 / XXX

No. of contacts

Option

Plating: -95 = tin(leadfree)/gold

General Specification page 72

No. of contacts	Dimension		
	A	B	C
015	30.81	24.99	16.92
	1.213	.984	.666
026	39.14	33.32	25.25
	1.541	1.312	.994
044	53.04	47.04	38.96
	2.088	1.852	1.534
062	69.32	63.50	55.42
	2.729	2.500	2.182

Options

Special product.
Please ask for availability and minimum order quantity before you consider the article for development, design in or production purposes.

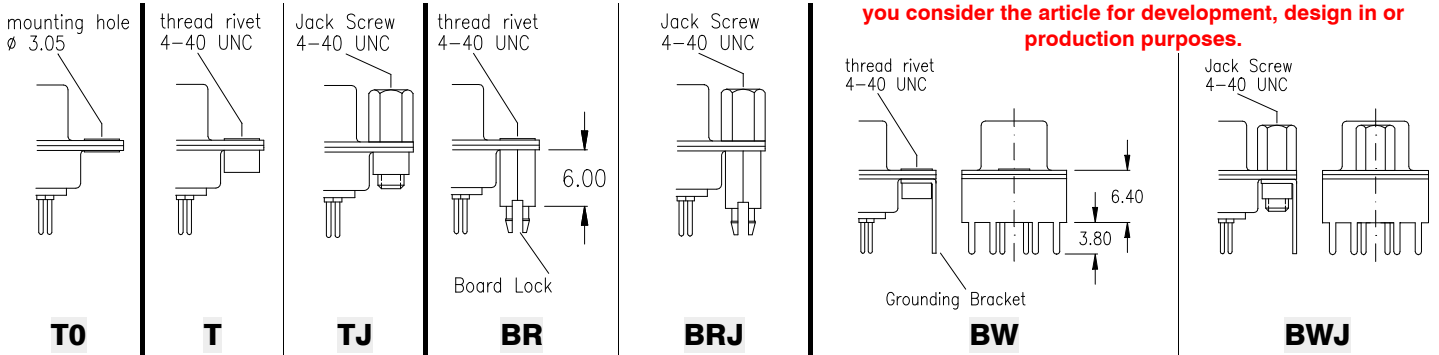

PCB Layout „male“

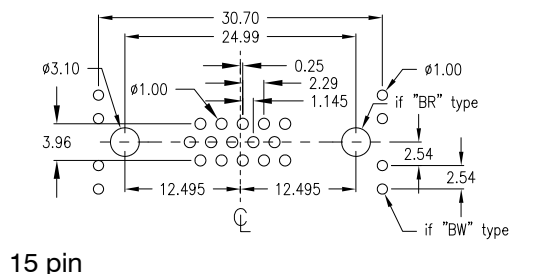

15 pin

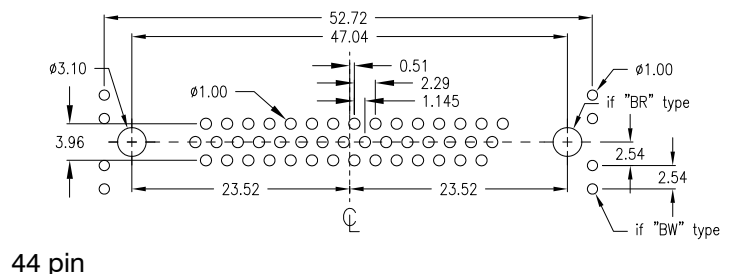

44 pin

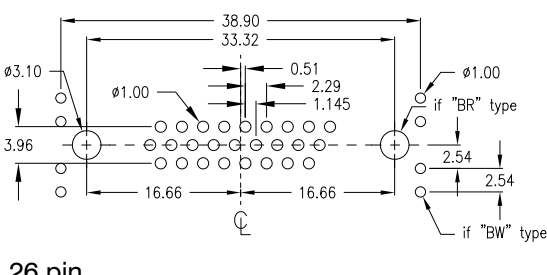

26 pin

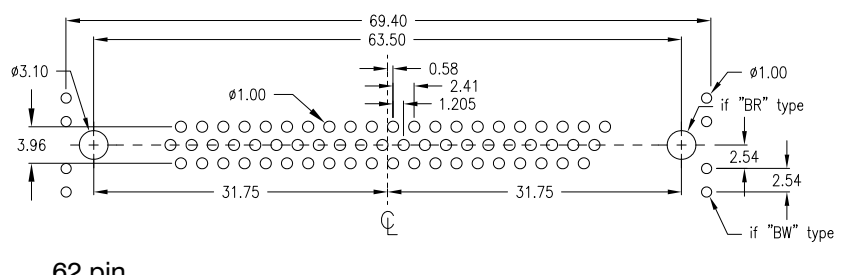

62 pin

SH Series - High Density D-Sub B111 raised soldertail type



female

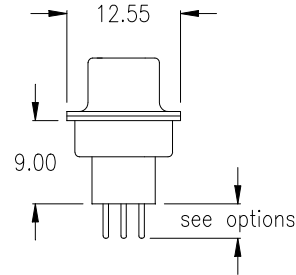
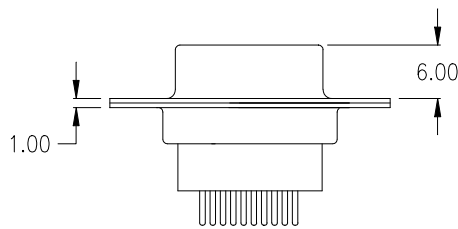
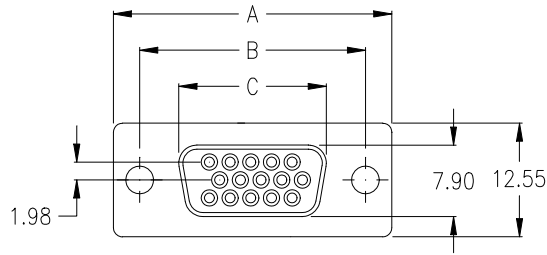

Ordering Code

SHF - xxx - B111 - 95 / XXX

No. of contacts

Option

Plating: -95 = tin (leadfree)/gold

General Specification page 72

No. of contacts	Dimension		
	A	B	C
015	<u>30.81</u> 1.213	<u>24.99</u> .984	<u>16.33</u> .643
026	<u>39.14</u> 1.541	<u>33.32</u> 1.312	<u>24.66</u> .971
044	<u>53.04</u> 2.088	<u>47.04</u> 1.852	<u>38.38</u> 1.511
062	<u>69.32</u> 2.729	<u>63.50</u> 2.500	<u>54.84</u> 2.159

Options

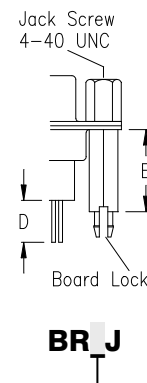
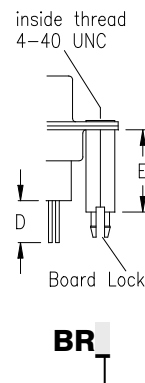
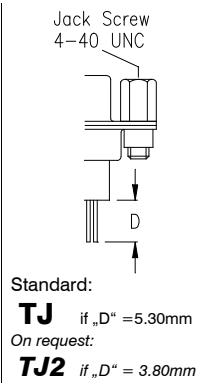
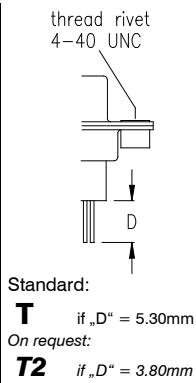
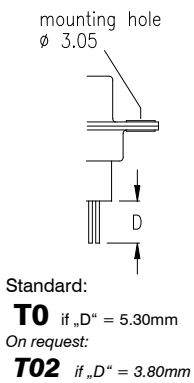

D	E	Option
3,80	9,60	1
5,30	11,00	2
7,20	12,70	3
7,40	13,50	5

PCB Layout „female“

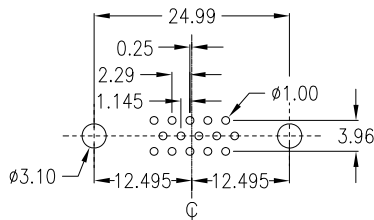

15 pin

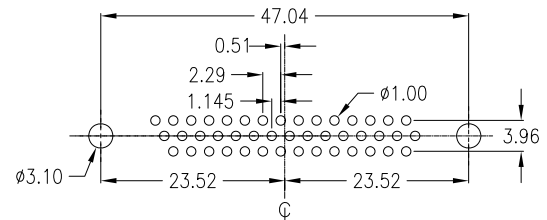

44 pin

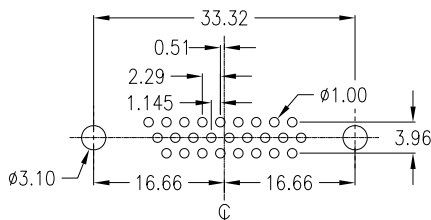

26 pin

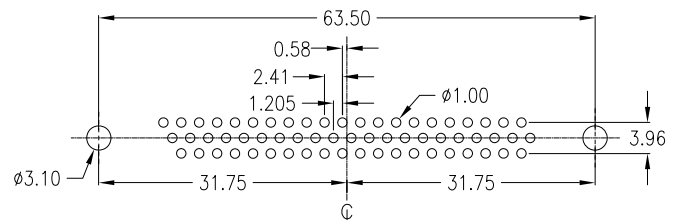

62 pin

SH Series - High Density D-Sub B111 raised soldertail type



male

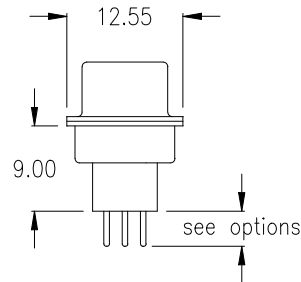
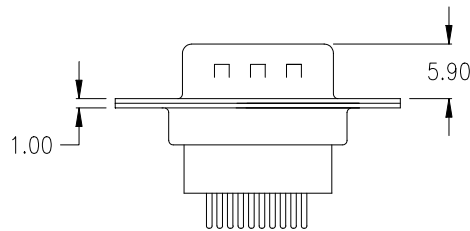
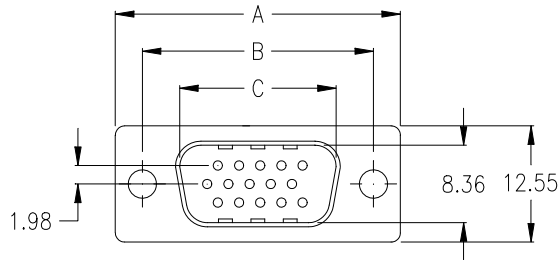

Ordering Code

SHM - xxx - B111 - 55 / XXX

No. of contacts

Option

Plating: **-55** = gold

General Specification page 72

No. of contacts	Dimension		
	A	B	C
015	<u>30.81</u> 1.213	<u>24.99</u> .984	<u>16.92</u> .666
026	<u>39.14</u> 1.541	<u>33.32</u> 1.312	<u>25.25</u> .994
044	<u>53.04</u> 2.088	<u>47.04</u> 1.852	<u>38.96</u> 1.534
062	<u>69.32</u> 2.729	<u>63.50</u> 2.500	<u>55.42</u> 2.182

Options

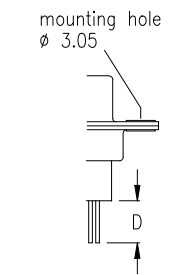

Standard: **T0** if „D“ = 5.30mm
On request: **T02** if „D“ = 3.80mm

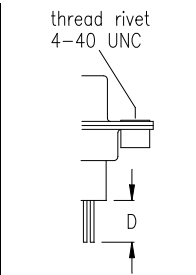

Standard: **T** if „D“ = 5.30mm
On request: **T2** if „D“ = 3.80mm

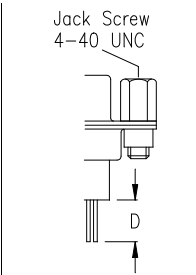

Standard: **TJ** if „D“ = 5.30mm
On request: **TJ2** if „D“ = 3.80mm

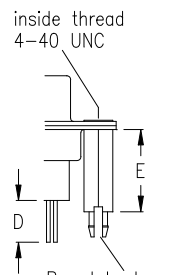

BR

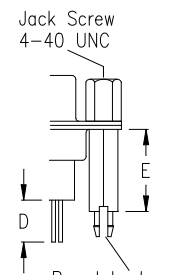

BR J

D	E	Option
3,80	9,60	1
5,30	11,00	2
7,20	12,70	3
7,40	13,50	5

PCB Layout „male“

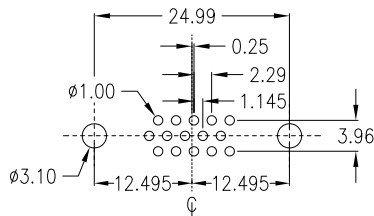

15 pin

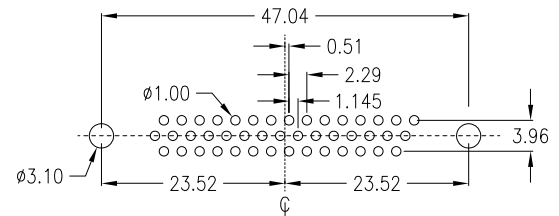

44 pin

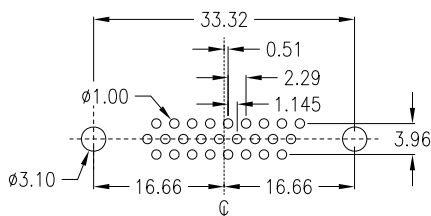

26 pin

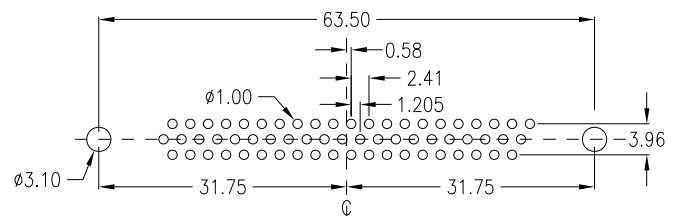

62 pin

female

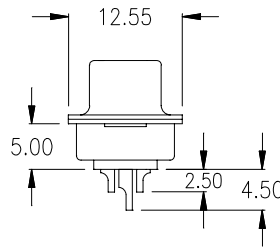
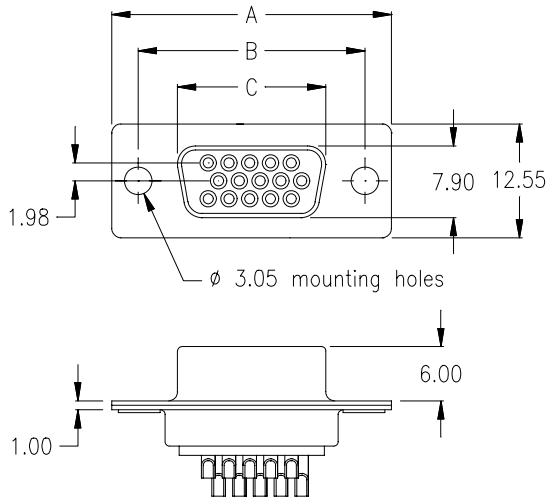

Option:

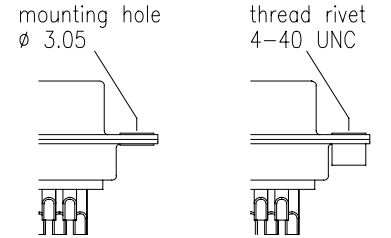

No. of contacts	Dimension		
	A	B	C
015	<u>30.81</u> 1.213	<u>24.99</u> .984	<u>16.33</u> .643
026	<u>39.14</u> 1.541	<u>33.32</u> 1.312	<u>24.66</u> .971
044	<u>53.04</u> 2.088	<u>47.04</u> 1.852	<u>38.38</u> 1.511
062	<u>69.32</u> 2.729	<u>63.50</u> 2.500	<u>54.84</u> 2.159

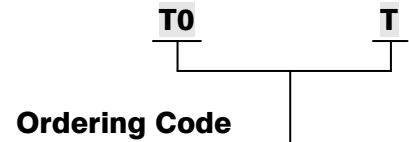

Ordering Code

SHF - xxx - S101 - 95 / XX

No. of contacts

Option

General Specification page 72

Plating: -95 = tin(leadfree)/gold

male

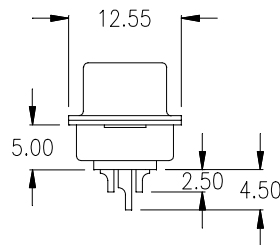
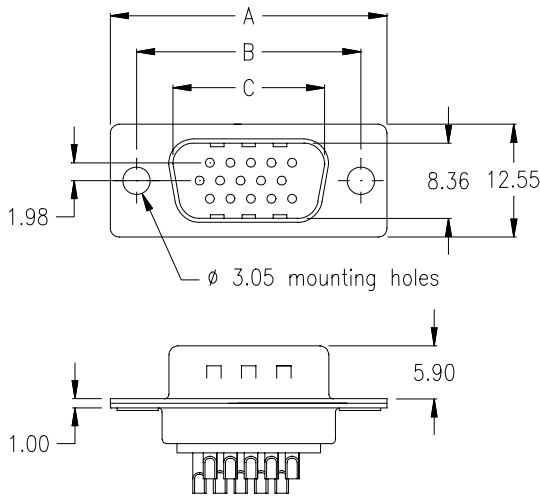

Option:

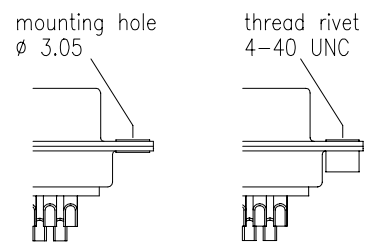

No. of contacts	Dimension		
	A	B	C
015	<u>30.81</u> 1.213	<u>24.99</u> .984	<u>16.92</u> .666
026	<u>39.14</u> 1.541	<u>33.32</u> 1.312	<u>25.25</u> .994
044	<u>53.04</u> 2.088	<u>47.04</u> 1.852	<u>38.96</u> 1.534
062	<u>69.32</u> 2.729	<u>63.50</u> 2.500	<u>55.42</u> 2.182



Ordering Code

SHM - xxx - S101 - 95 / XX

No. of contacts

Option

General Specification page 72

Plating: -95 = tin(leadfree)/gold

SH Series - High Density D-Sub 90°

F900 "Wave Solder" & "Pin-In-Paste" Technology



Female

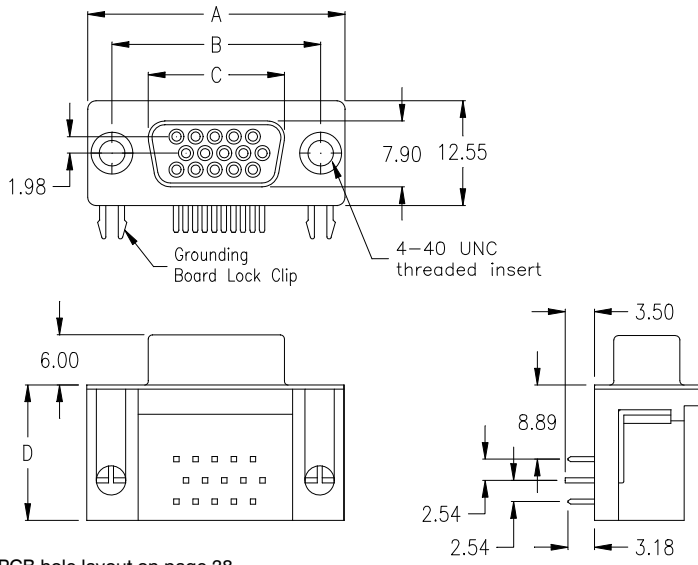

PCB hole layout on page 38

male

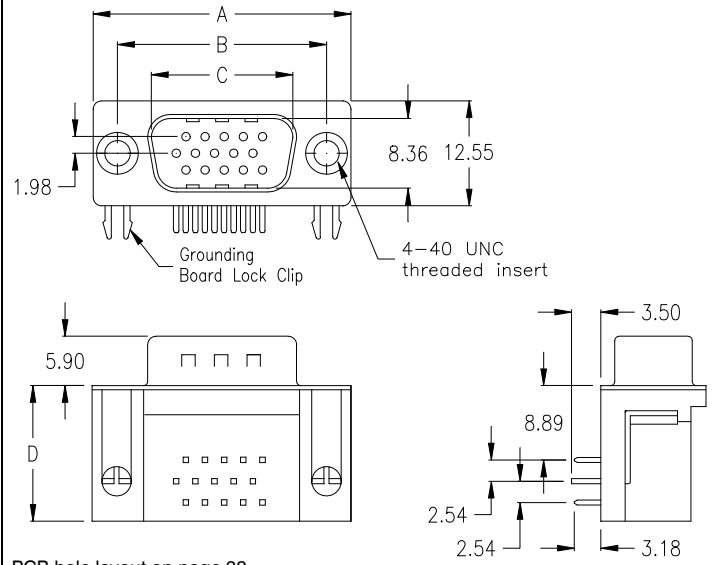

PCB hole layout on page 38

No. of contacts	Dimension				Ordering Code
	A	B	C	D	
015	30.81	24.99	16.33	16.22	SHF-015-F900-55/ XX SHF-015-F900-95/V XX
	1.213	.984	.643	.639	
026	39.14	33.32	24.66	16.22	SHF-026-F900-55/ XX
	1.541	1.311	.971	.639	
044	53.04	47.04	38.38	16.22	SHF-044-F900-55/ XX
	2.088	1.852	1.511	.639	
062	69.32	63.50	54.84	16.22	SHF-062-F900-55/ XX
	2.729	2.500	2.159	.639	

Plating: **-55** = gold/gold (not available for VESA Type)
-95 = tin(leadfree)/gold

Option

No. of contacts	Dimension				Ordering Code
	A	B	C	D	
015	30.81	24.99	16.92	16.22	SHM-015-F900-55/ XX
	1.213	.984	.666	.639	
026	39.14	33.32	25.25	16.22	SHM-026-F900-55/ XX
	1.541	1.311	.994	.639	
044	53.04	47.04	38.96	16.22	SHM-044-F900-55/ XX
	2.088	1.852	1.534	.639	
062	69.32	63.50	55.42	16.22	SHM-062-F900-55/ XX
	2.729	2.500	2.182	.639	

Plating: **-55** = gold/gold
-95 = tin(leadfree)/gold (only on request)

Option

SHF - xxx - F900 - 95/V XX = VESA Type - blue colour insulator
Contact #9 recessed 1.27mm to allow last mate, first break on 5V supply

"Pin-In-Paste" Technology - for availability pls. contact info@e-tec.com

General Specification page 72

Options

Special product.

Please ask for availability and minimum order quantity before you consider the article for development, design in or production purposes.

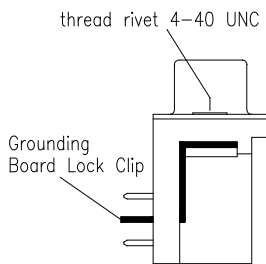

N

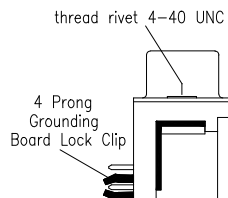

C4

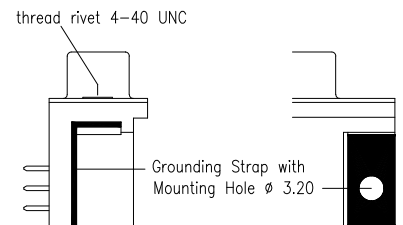

H not available with 78-contact

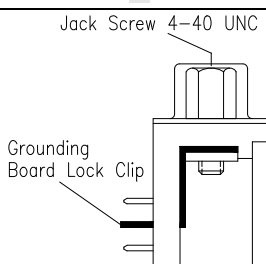

NJ

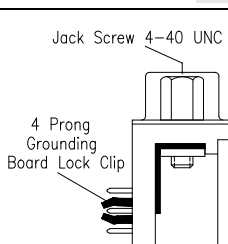

C4J

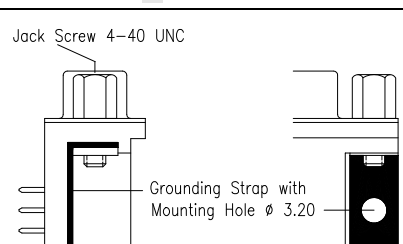

HJ not available with 78-contact

female

male

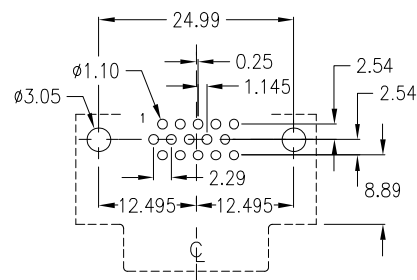
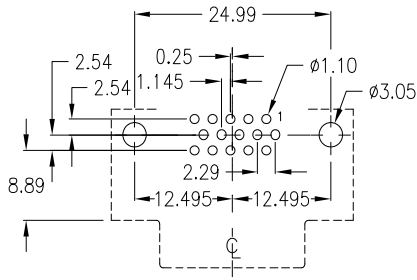

15-pin

15-pin

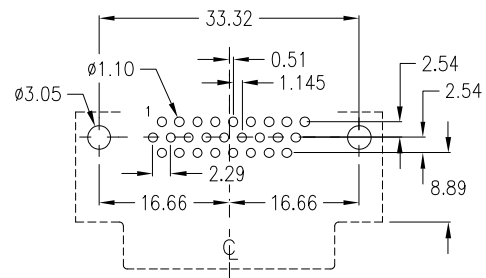
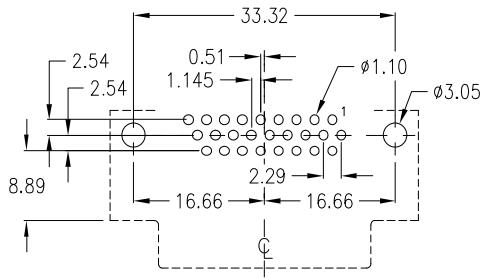

26-pin

26-pin

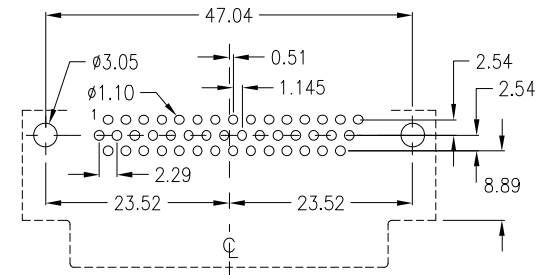
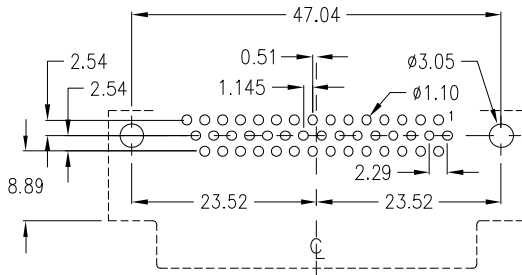

44-pin

44-pin

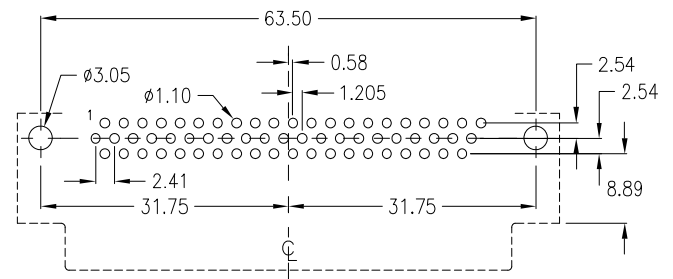
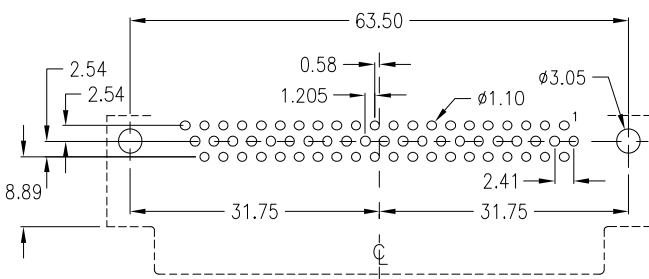

62-pin

62-pin

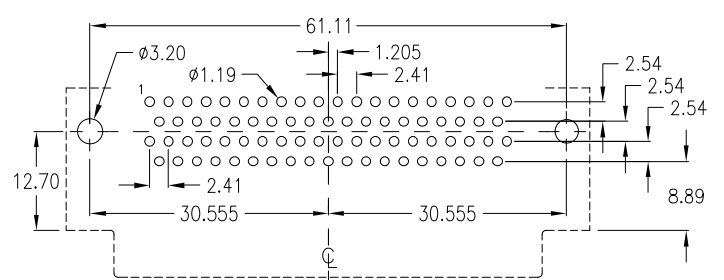
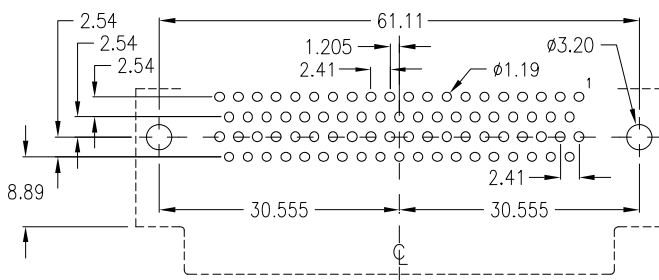

78-pin

78-pin

Ferrite Filter

D-Sub

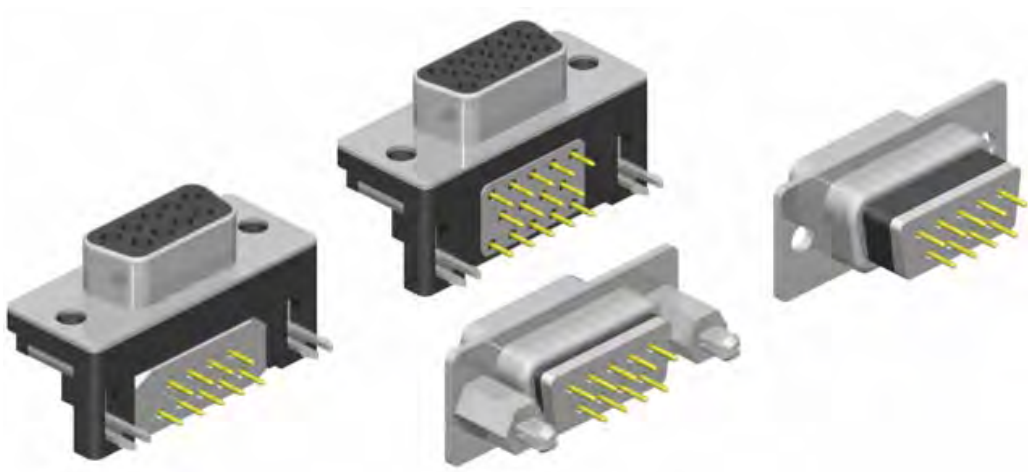

D-Sub Filter Connectors are the ideal solution to reduce or eliminate „electro magnetic interference“ (EMI).

Many different types, straight, right angle single and dual port, as well as High Density versions are available.

Capacitance D-Sub Filter Connectors are available on request.

female

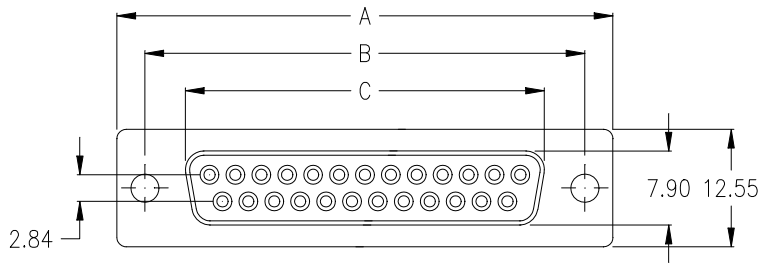

FERRITE SPECIFICATION

No of Contact	Measured Value(OHM)	Test Frequency	Ferrite thickness
009	20 min. 40 min.	25 MHz 100 MHz	1.20mm
015	15 min. 35 min.	25 MHz 100 MHz	
025	15 min. 40 min.	25 MHz 100 MHz	
037	20 min. 50 min.	25 MHz 100 MHz	

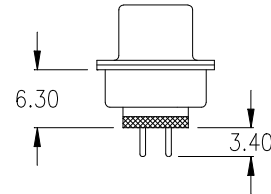
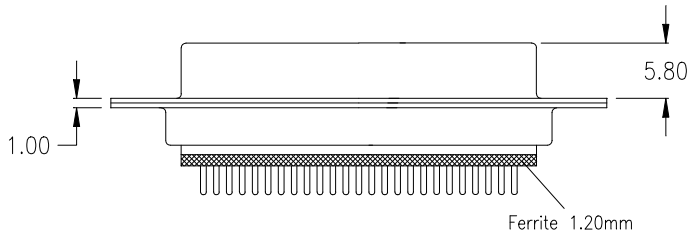

Ordering Code

SDF - xxx - S111 - 95 / F XXX

No. of contacts

Option

Plating: -95= tin(leadfree)/gold

General Specification page 72

No. of contacts	Dimension		
	A	B	C
009	30.81	24.99	16.33
	1.213	.984	.643
015	39.14	33.32	24.66
	1.541	1.312	.971
025	53.04	47.04	38.38
	2.088	1.852	1.511
037	69.32	63.50	54.84
	2.729	2.500	2.159

Options

mounting hole
ø 3.05

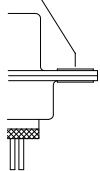

T0

thread rivet
4-40 UNC

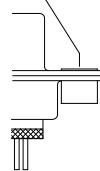

T

Jack Screw
4-40 UNC

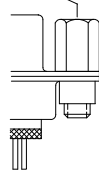

TJ

inside thread
4-40 UNC

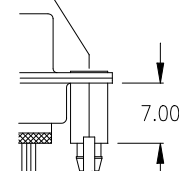

BR

Jack Screw
4-40 UNC

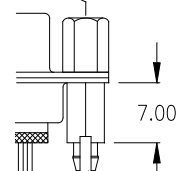

BRJ

PCB Layout „female“

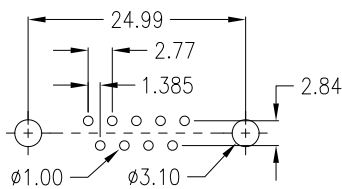

9 pin

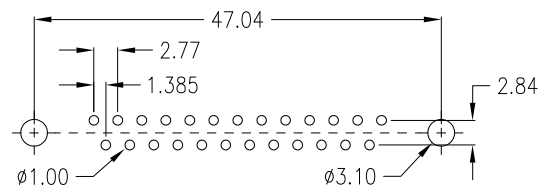

25 pin

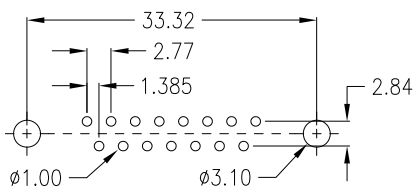

15 pin

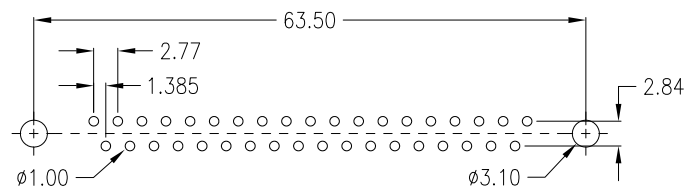

37 pin

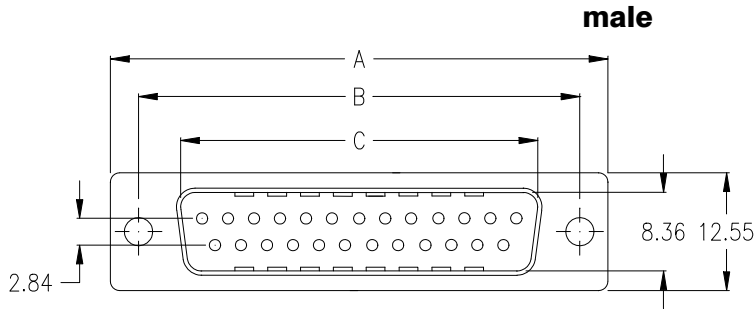

FERRITE SPECIFICATION

No of Contact	Measured Value(OHM)	Test Frequency	Ferrite thickness
009	20 min.	25 MHz	1.20mm
	40 min.	100 MHz	
015	15 min.	25 MHz	
	35 min.	100 MHz	
025	15 min.	25 MHz	
	40 min.	100 MHz	
037	20 min.	25 MHz	
	50 min.	100 MHz	

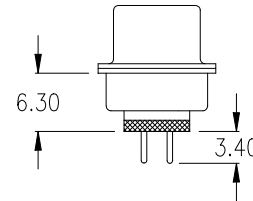
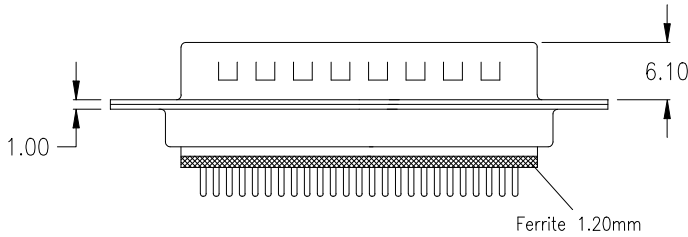

Ordering Code

SDM - xxx - S111 - 95 / F XXX

No. of contacts

Option

Plating: -95 = tin(leadfree)/gold

General Specification page 72

No. of contacts	Dimension		
	A	B	C
009	30.81	24.99	16.92
	1.213	.984	.666
015	39.14	33.32	25.25
	1.541	1.312	.994
025	53.04	47.04	38.96
	2.088	1.852	1.534
037	69.32	63.50	55.42
	2.729	2.500	2.182

Options

mounting hole
ø 3.05

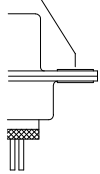

T0

thread rivet
4-40 UNC

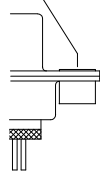

T

Jack Screw
4-40 UNC

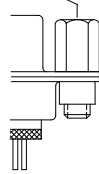

TJ

inside thread
4-40 UNC

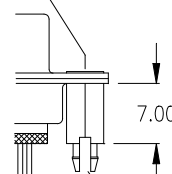

BR

Jack Screw
4-40 UNC

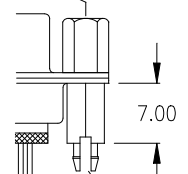

BRJ

PCB Layout „male“

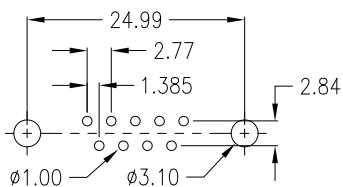

9 pin

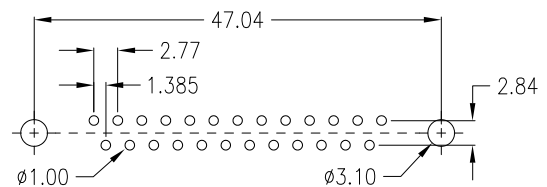

25 pin

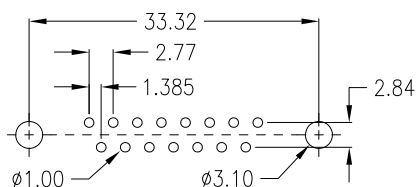

15 pin

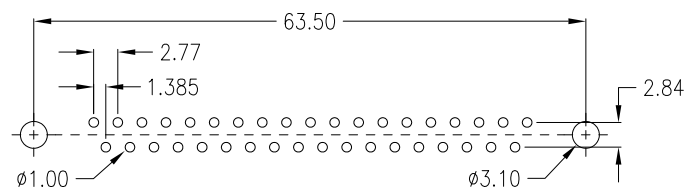

37 pin

female

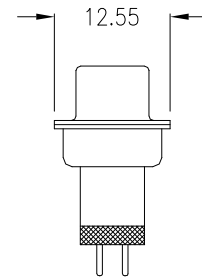
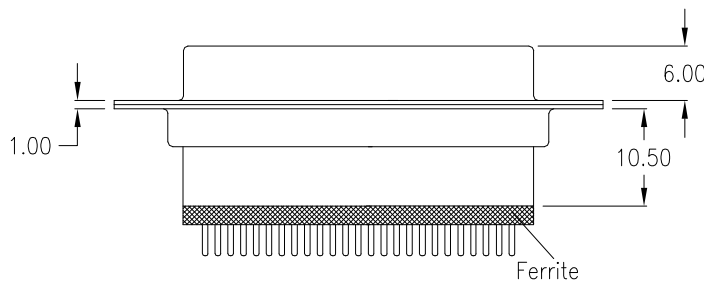
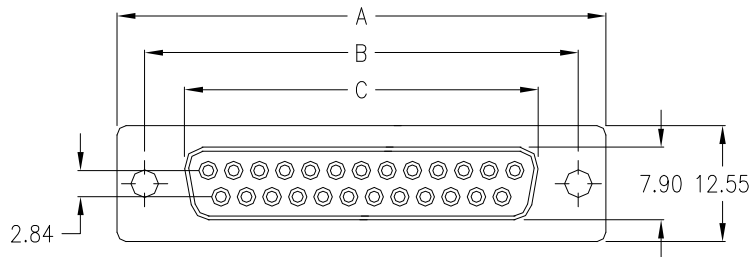

Ordering Code

SDF - xxx - B111 - 95 / F XXX

No. of contacts

Option

Plating: **-95** = tin(leadfree)/gold

General Specification page 72

No. of contacts	Dimension		
	A	B	C
009	30.81 1.213	24.99 .984	16.33 .643
015	39.14 1.541	33.32 1.312	24.66 .971
025	53.04 2.088	47.04 1.852	38.38 1.511
037	69.32 2.729	63.50 2.500	54.84 2.159

Options

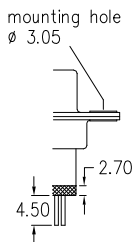

T0

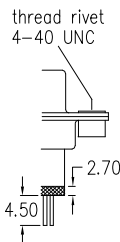

T

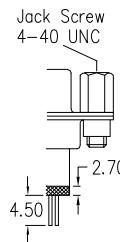

TJ

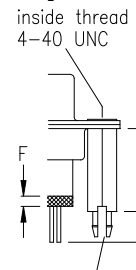

BR

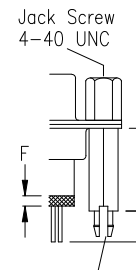

BRJ

D	E	F	Option
3.00	12,70	1.20	3
3.20	14,50	2.70	4

PCB Layout „female“

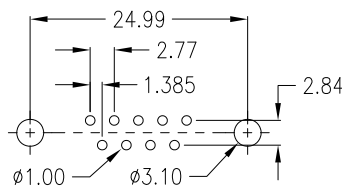

9 pin

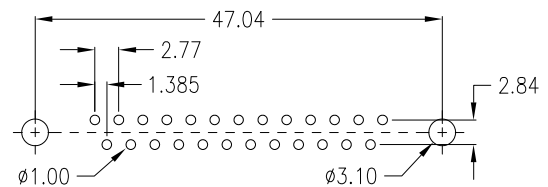

25 pin

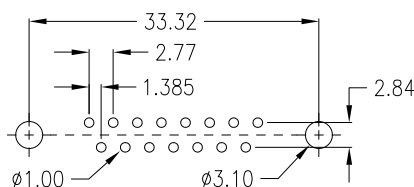

15 pin

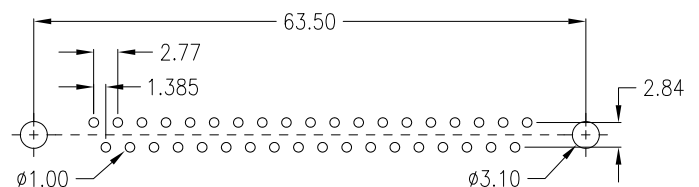

37 pin

male

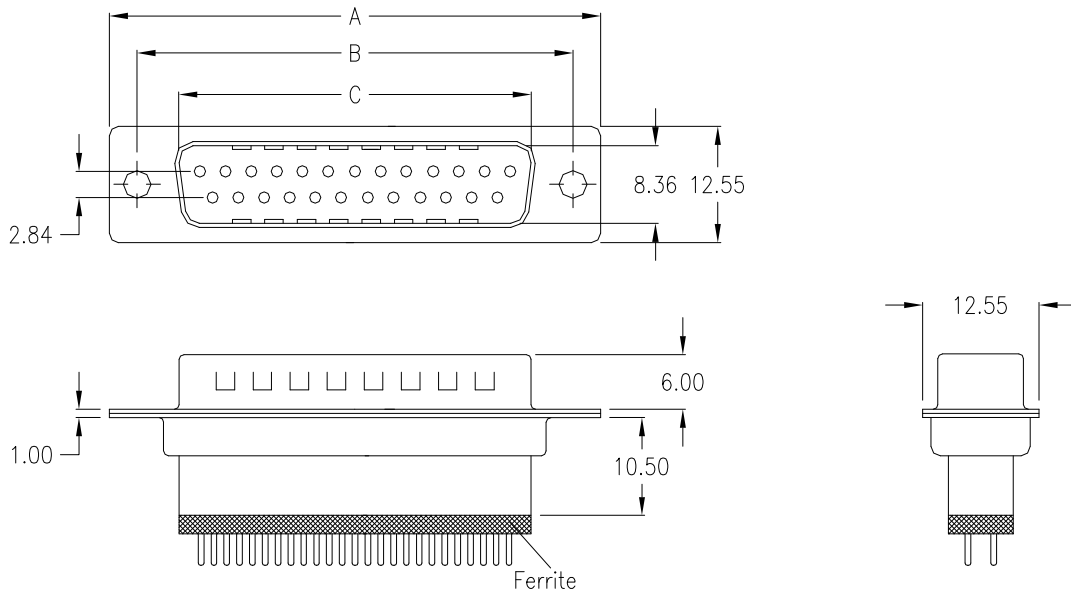

Ordering Code

SDM - xxx - B111 - 95 / F XXX

No. of contacts

Option

Plating: -95 = tin(leadfree)/gold

No. of contacts	Dimension		
	A	B	C
009	30.81	24.99	16.92
	1.213	.984	.666
015	39.14	33.32	25.25
	1.541	1.312	.994
025	53.04	47.04	38.96
	2.088	1.852	1.534
037	69.32	63.50	55.42
	2.729	2.500	2.182

General Specification page 72

Options

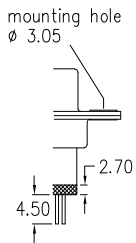

T0

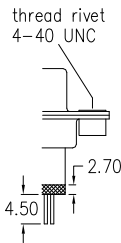

T

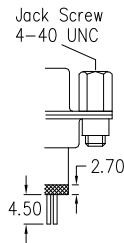

TJ

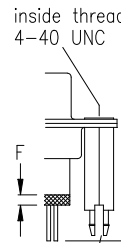

BR

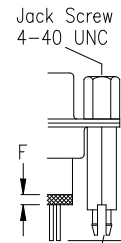

BRJ

D	E	F	Option
3.00	12,70	1.20	3
3.20	14,50	2.70	4

PCB Layout „male“

9 pin

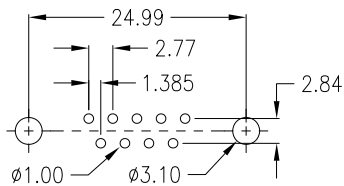

25 pin

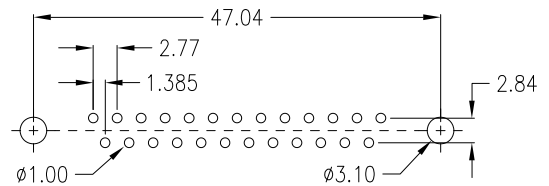

15 pin

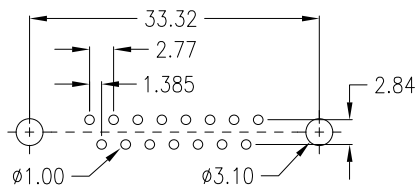

37 pin

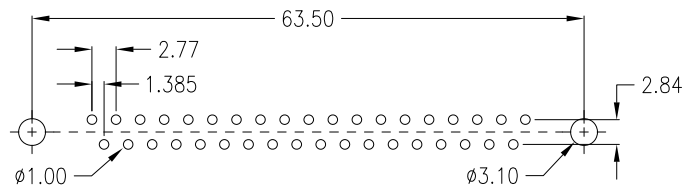



female

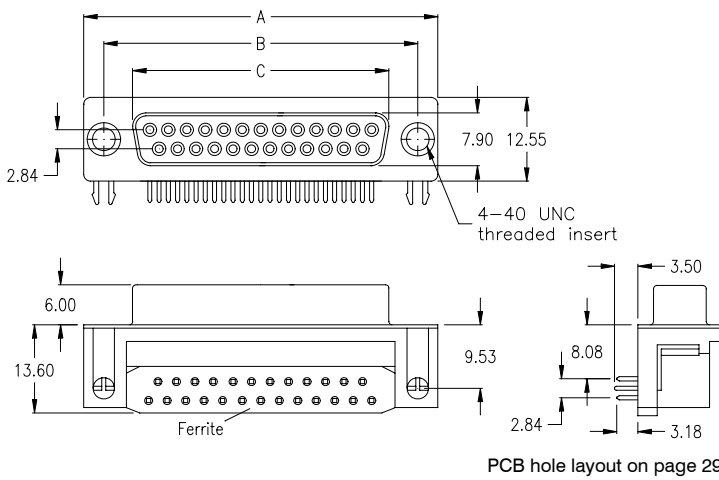

PCB hole layout on page 29

No. of contacts	Dimension		
	A	B	C
009	30.81	24.99	16.33
	1.213	.984	.643
015	39.14	33.32	24.66
	1.541	1.312	.971
025	53.04	47.04	38.38
	2.088	1.852	1.511
037	69.32	63.50	54.84
	2.729	2.500	2.159

Ordering Code

SFF - xxx - N900 - 95 / XX

No. of contacts

Option

male

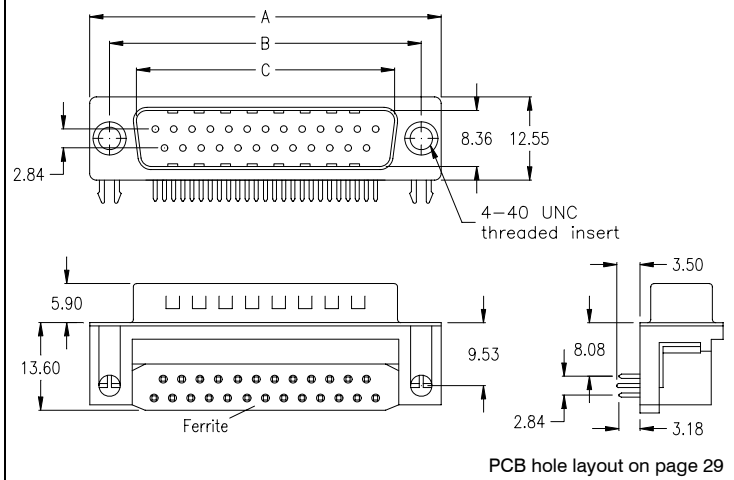

PCB hole layout on page 29

No. of contacts	Dimension		
	A	B	C
009	30.81	24.99	16.92
	1.213	.984	.666
015	39.14	33.32	25.25
	1.541	1.312	.994
025	53.04	47.04	38.96
	2.088	1.852	1.534
037	69.32	63.50	55.42
	2.729	2.500	2.182

Ordering Code

SFM - xxx - N900 - 95 / XX

No. of contacts

Option

Plating: -95 = tin(leadfree)/gold

General Specification page 72

Options

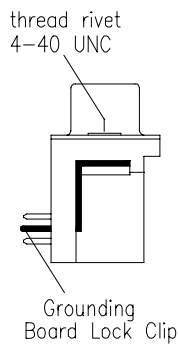

N

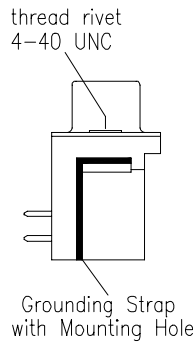

H

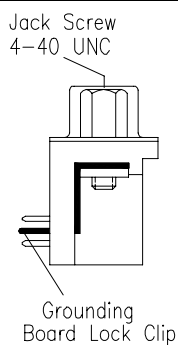
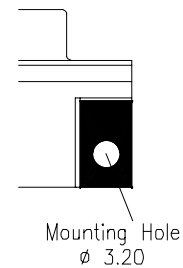

NJ

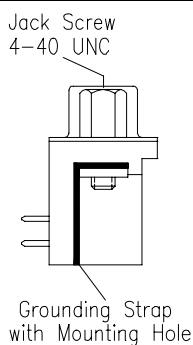

HJ

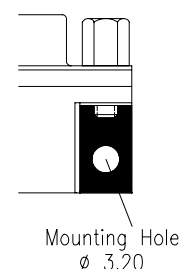



female

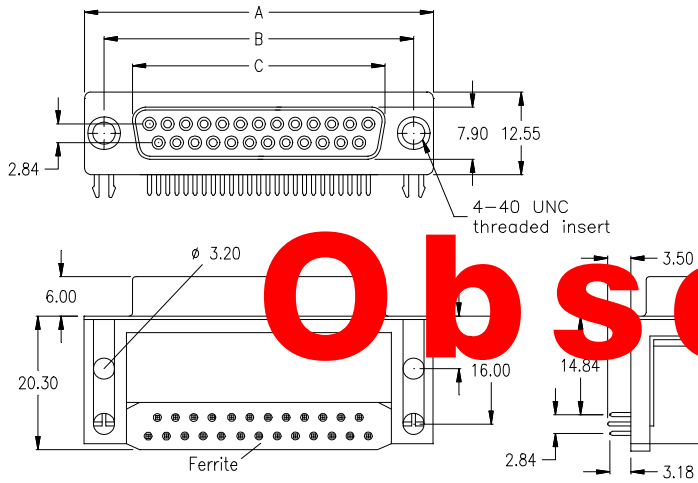

PCB hole layout on page 29

No. of contacts	Dimension		
	A	B	C
009	30.81	24.99	16.33
	1.213	.984	.643
015	39.14	33.32	24.66
	1.541	1.312	.971
025	53.04	47.04	38.38
	2.088	1.852	1.511
037	69.32	63.50	54.84
	2.729	2.500	2.159

Ordering Code

SFF - xxx - L900 - 95 / XX

No. of contacts

Option

Plating: -95 = tin(leadfree)/gold

male

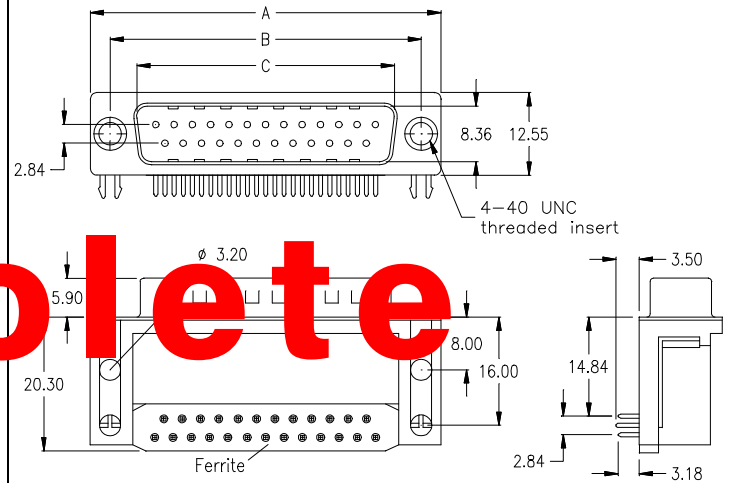

PCB hole layout on page 29

No. of contacts	Dimension		
	A	B	C
009	30.81	24.99	16.92
	1.213	.984	.666
015	39.14	33.32	25.25
	1.541	1.312	.994
025	53.04	47.04	38.96
	2.088	1.852	1.534
037	69.32	63.50	55.42
	2.729	2.500	2.182

Ordering Code

SFM - xxx - L900 - 95 / XX

No. of contacts

Option

General Specification page 72

Options

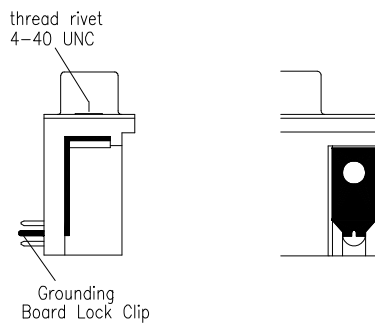

P

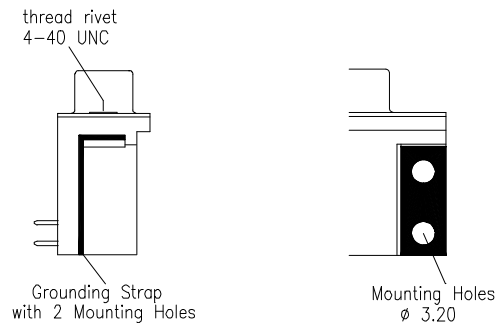

L

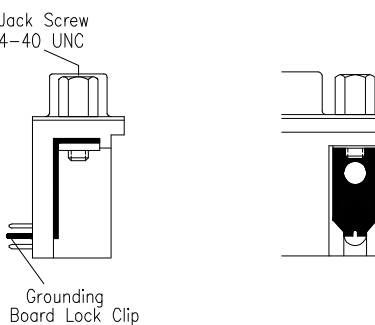

PJ

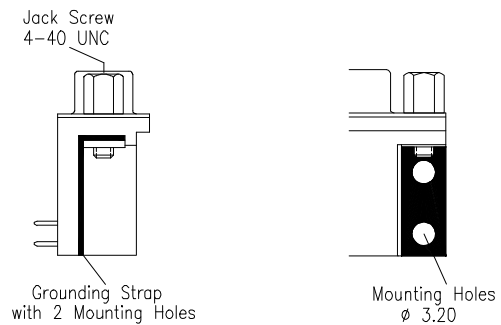

LJ

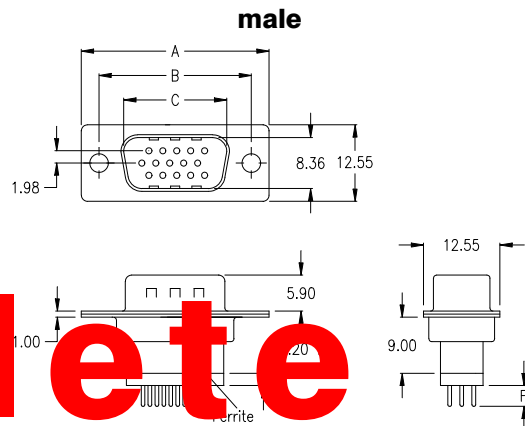
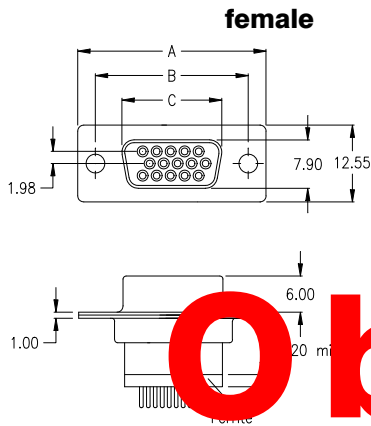

Obsolete

No. of contacts	Dimension		
	A	B	C
015	30.81	24.99	16.33
	1.213	.984	.643
026	39.14	33.32	24.66
	1.541	1.312	.971
044	53.04	47.04	38.38
	2.088	1.852	1.511
062	69.32	63.50	54.84
	2.729	2.500	2.159

No. of contacts	Dimension		
	A	B	C
015	30.81	24.99	16.92
	1.213	.984	.666

Ordering Code
SHF - xxx - B 111 - **95** / F XX

Ordering Code
SHM - 015 - B 111 - **55** / F XX

No. of contacts

Option

No. of contacts

Option

Plating: **-95** = tin(leadfree)/gold **-55** = gold all over

General Specification page 72

Options

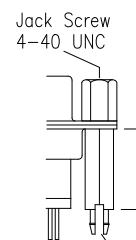
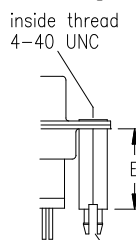
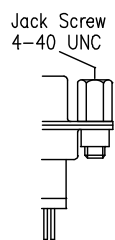
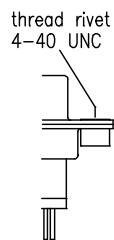
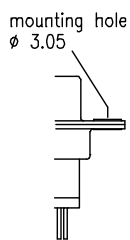

E	F	Option
12,70	4.60	3
14,50	5.20	4

T0

T

TJ

BR

BR J

PCB Layout „female“

PCB Layout „male“

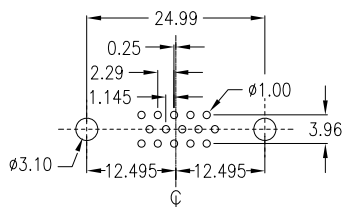

15 pin

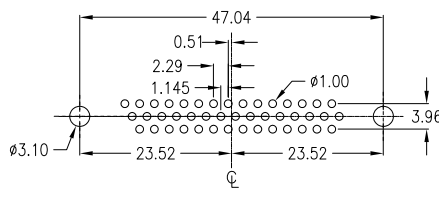

44 pin

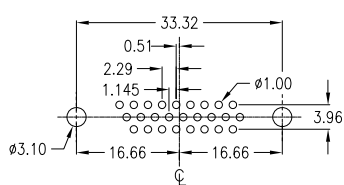

26 pin

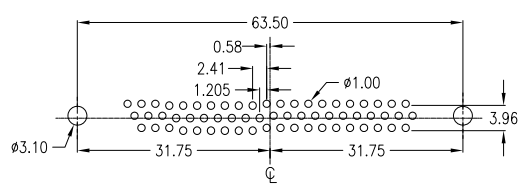

62 pin

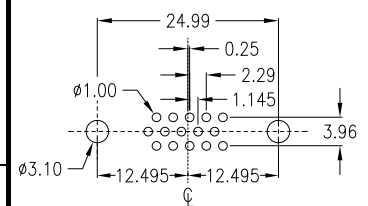

15 pin

SH Series - High Density D-Sub 90° F900 with Ferrite Filter



female

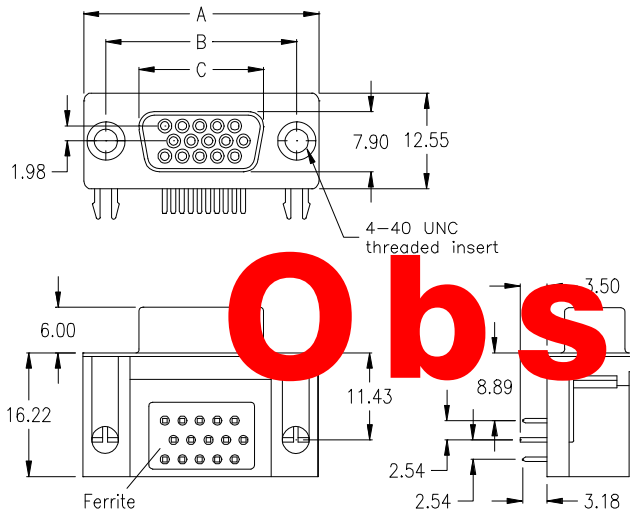

PCB hole layout on page 38

No. of contacts	Dimension		
	A	B	C
015	30.81	24.99	16.33
	1.213	.984	.643
026	39.14	33.32	24.66
	1.541	1.312	.971
044	53.04	47.04	38.38
	2.088	1.852	1.511
062	69.32	63.50	54.84
	2.729	2.500	2.159

Ordering Code

SHF - xxx - F 900 - 95 / F XX

No. of contacts

Option

Plating: -95 = tin(leadfree)/gold

male

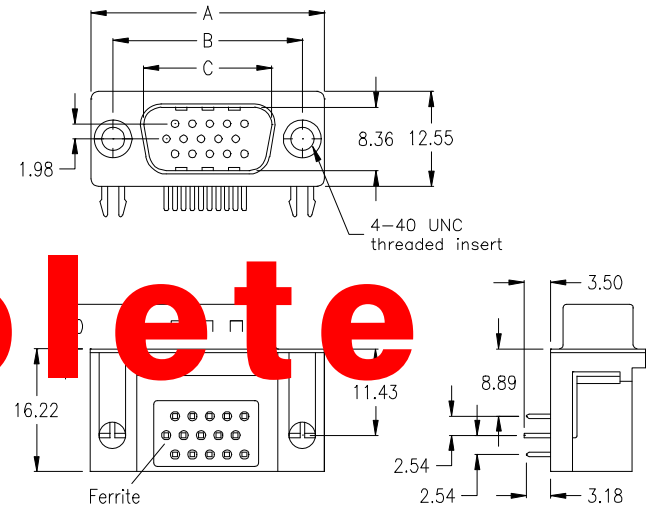

PCB hole layout on page 38

No. of contacts	Dimension		
	A	B	C
015	30.81	24.99	16.92
	1.213	.984	.666
026	39.14	33.32	25.25
	1.541	1.312	.994
044	53.04	47.04	38.96
	2.088	1.852	1.534
062	69.32	63.50	55.42
	2.729	2.500	2.182

Ordering Code

SHM - xxx - F 900 - 95 / F XX

No. of contacts

Option

General Specification page 72

Options

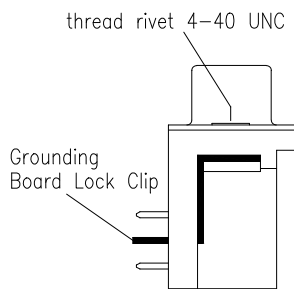

N

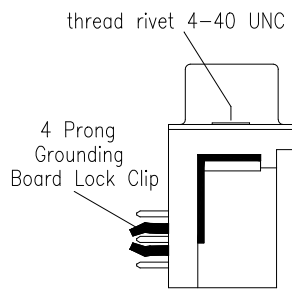

C4

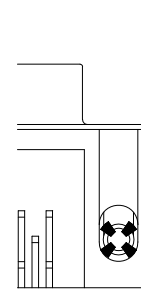

H

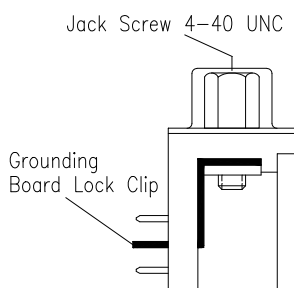
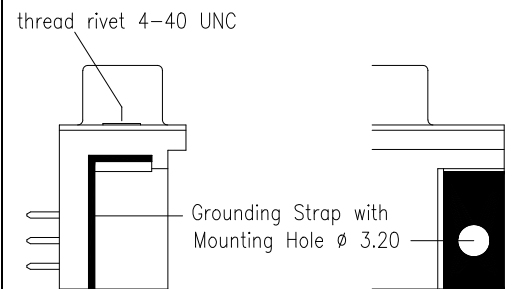

NJ

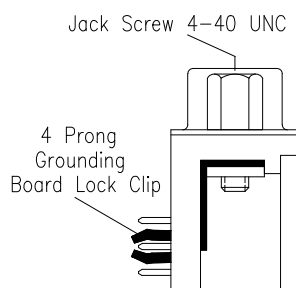

C4J

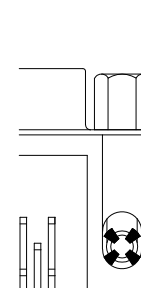

HJ

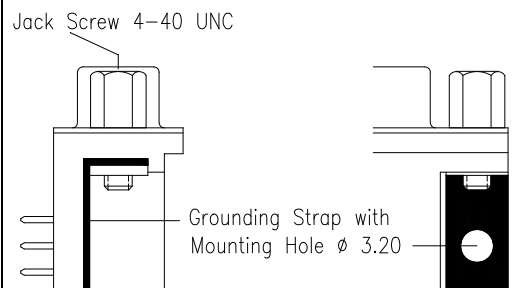

Multi Port

D-Sub

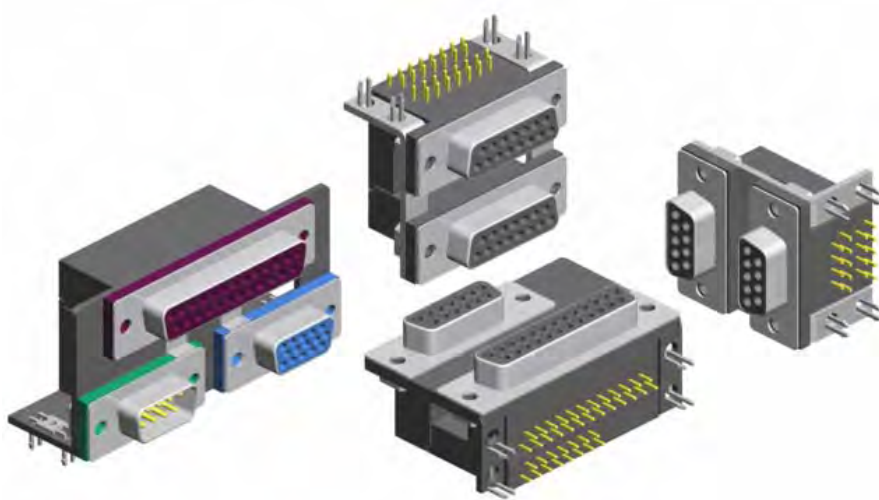

Multi Port D-Sub Connectors are available with a wide combination of different D-Sub types, standard and high density, with and without ferrite filter.

In addition, Triple Port D-Sub's are also available which meet the PC 99 Specification.

These Multi Port D-Sub's can be used on motherboards, as well as for any other electronic design purposes.

Please contact E-tec for any other Multi Port D-Sub Connector styles not shown in the following pages and/or for any other PCB layout styles.

Certain alternative styles can also be viewed on www.e-tec.com

9-pin male raised

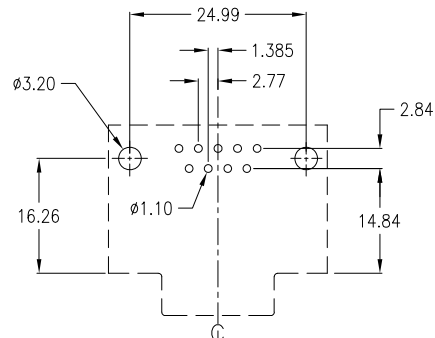
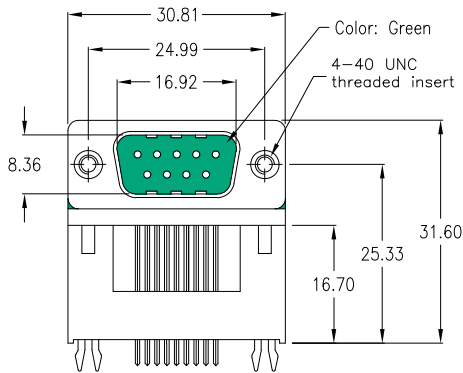

PCB hole layout

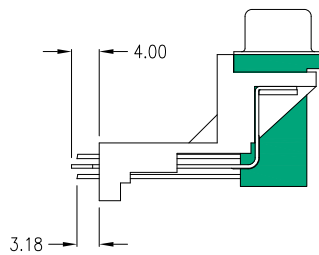
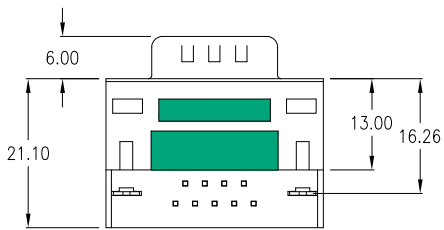

Style "-MN"

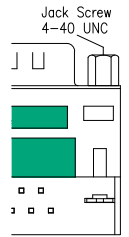

Style "-MNJ"

with 2 grounding clips;
w/o jack screws
Standard
(as above drawing)

SDD-0900-2-95-MN

with 2 grounding clips;
2 jack screws 4-40 UNC
mounted
Option

SDD-0900-2-95-MNJ

9-pin female raised

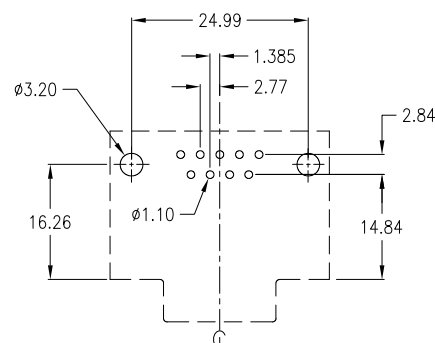
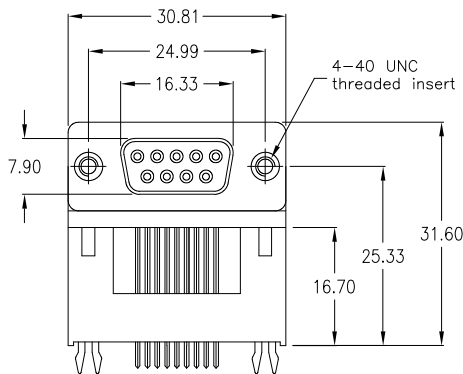

PCB hole layout

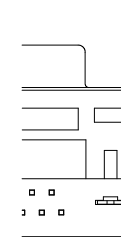
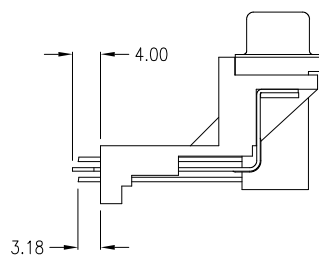
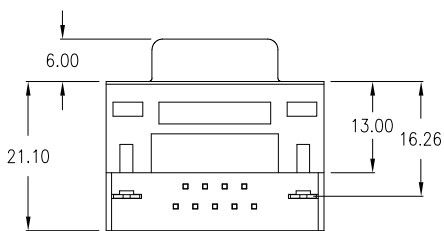

Style "-FN"

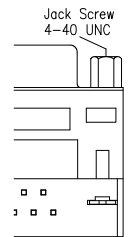

Style "-FNJ"

with 2 grounding clips;
w/o jack screws
Standard
(as above drawing)

SDD-0900-2-95-FN

with 2 grounding clips;
2 jack screws 4-40 UNC
mounted
Option

SDD-0900-2-95-FNJ

25-pin male raised

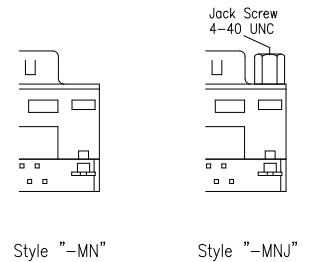
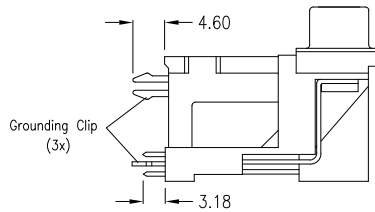
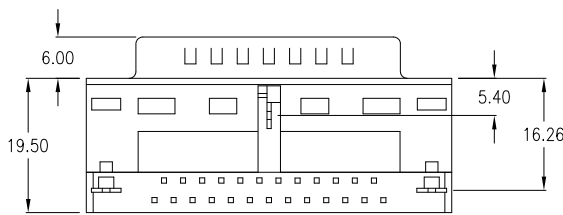
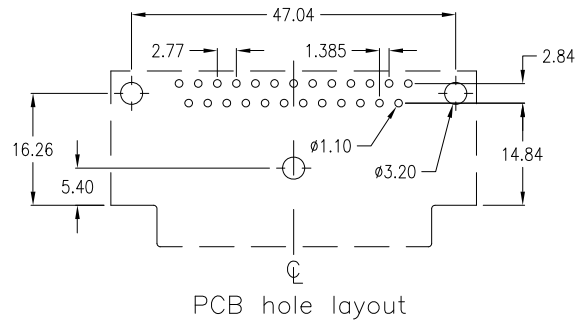
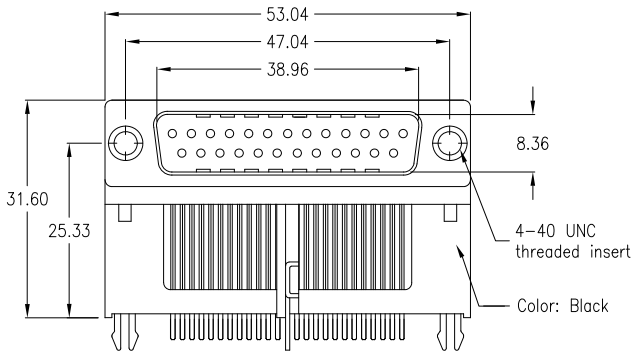

with 3 grounding clips;
w/o jack screws
Standard
(as above drawing)

with 3 grounding clips;
2 jack screws 4-40 UNC
mounted
Option

SDD-2500-2-95-MN

SDD-2500-2-95-MNJ

25-pin female raised

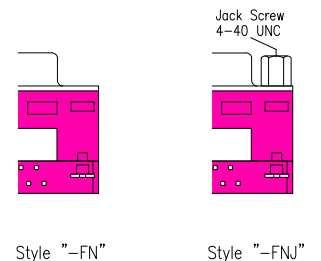
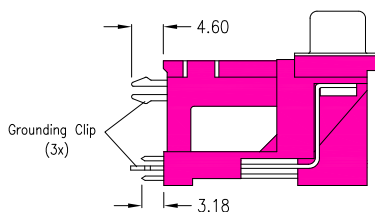
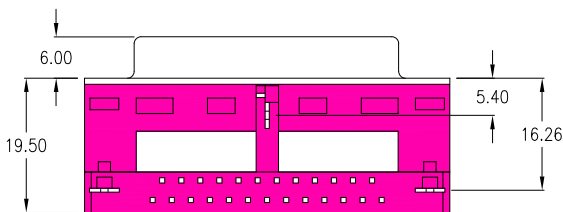
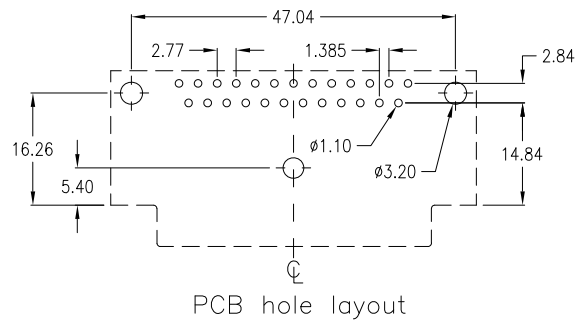
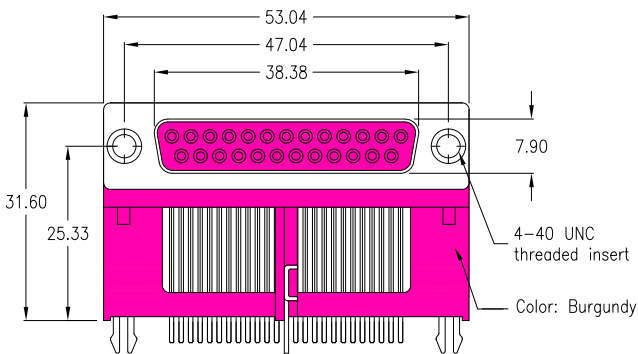

with 3 grounding clips;
w/o jack screws
Standard
(as above drawing)

with 3 grounding clips;
2 jack screws 4-40 UNC
mounted
Option

SDD-2500-2-95-FN

SDD-2500-2-95-FNJ

9-pin female / 9-pin female

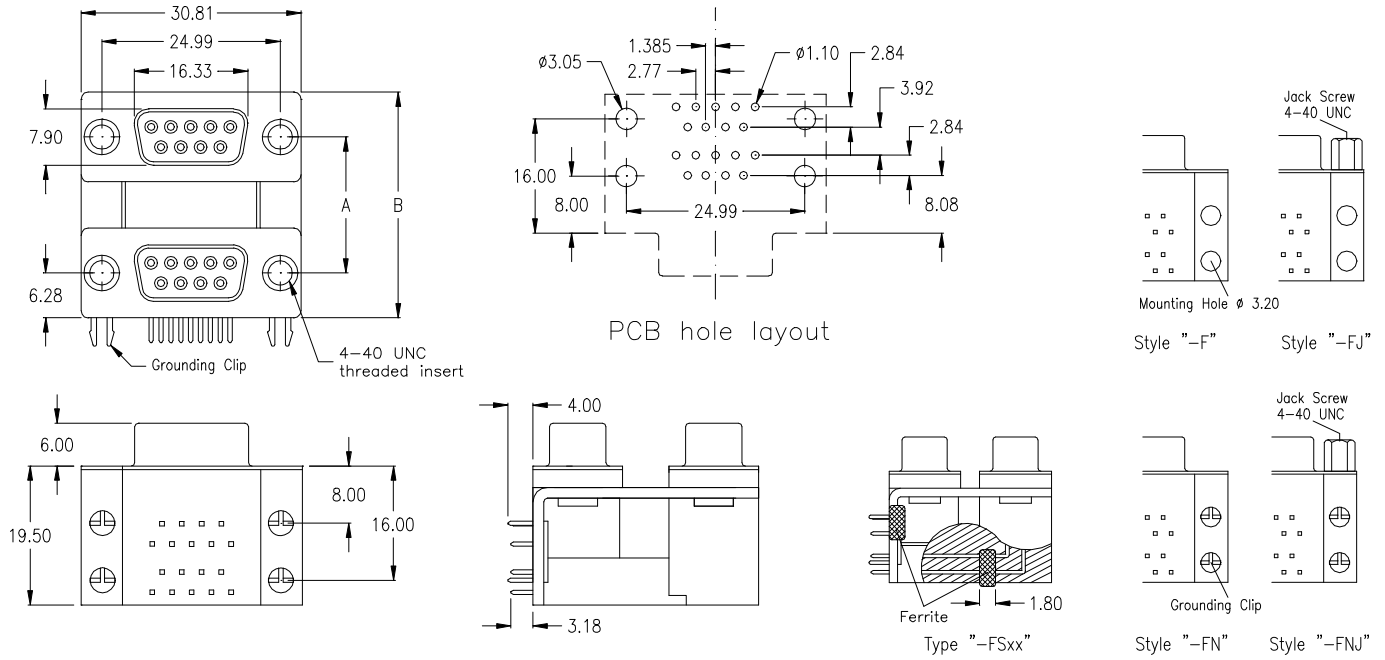

without grounding clips just 4 mounting holes	without grounding clips, just 4 mounting holes; 4 jack screws 4-40 UNC mounted	with 4 grounding clips (as above drawing)	with 4 grounding clips; 4 jack screws 4-40 UNC mounted	Distance Dimensions
SDD-0909-1-95-F	SDD-0909-1-95-FJ	SDD-0909-1-95-FN	SDD-0909-1-95-FNJ	„A“ = 22.86 „B“ = 35.41
SDD-0909-2-95-F	SDD-0909-2-95-FJ	SDD-0909-2-95-FN	SDD-0909-2-95-FNJ	„A“ = 19.05 „B“ = 31.60
SDD-0909-3-95-F	SDD-0909-3-95-FJ	SDD-0909-3-95-FN	SDD-0909-3-95-FNJ	„A“ = 15.87 „B“ = 28.42
if with Ferrite Filter: -FS	if with Ferrite Filter: -FSJ	if with Ferrite Filter: -FSN	if with Ferrite Filter: -FSNJ	

9-pin male / 9-pin male

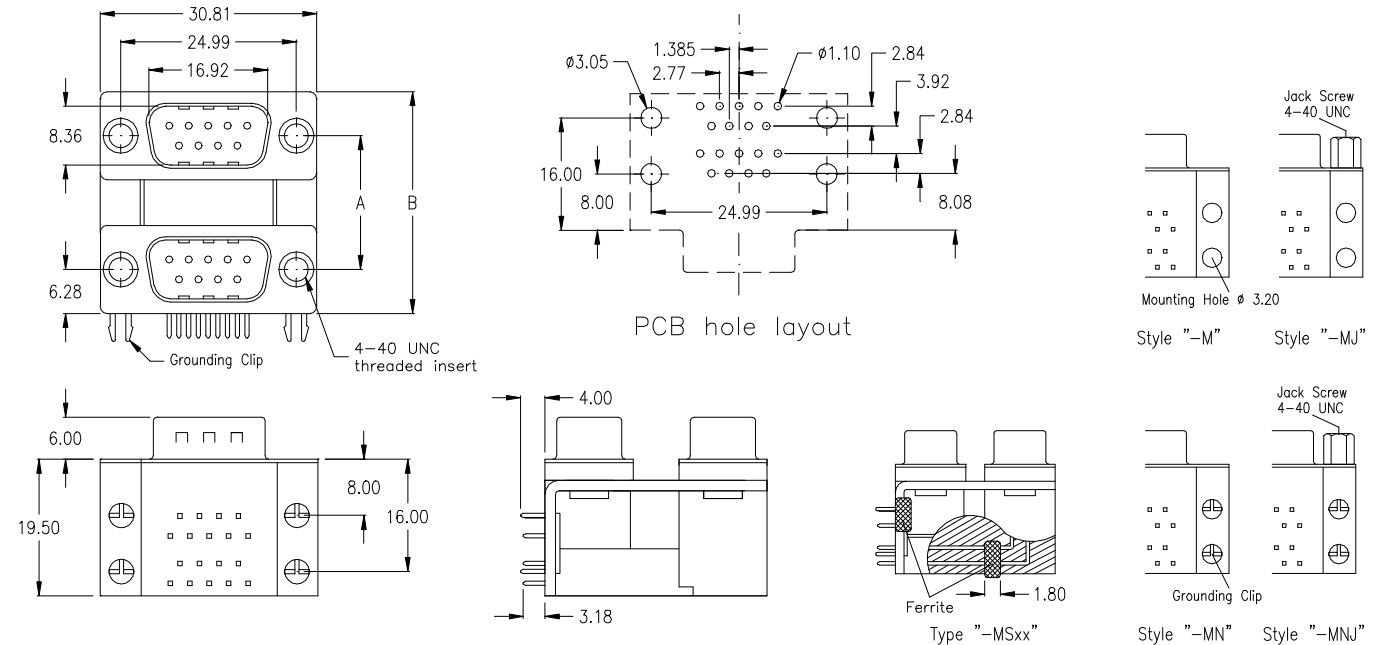

without grounding clips just 4 mounting holes	without grounding clips, just 4 mounting holes; 4 jack screws 4-40 UNC mounted	with 4 grounding clips (as above drawing)	with 4 grounding clips; 4 jack screws 4-40 UNC mounted	Distance Dimensions
SDD-0909-1-95-M	SDD-0909-1-95-MJ	SDD-0909-1-95-MN	SDD-0909-1-95-MNJ	„A“ = 22.86 „B“ = 35.41
SDD-0909-2-95-M	SDD-0909-2-95-MJ	SDD-0909-2-95-MN	SDD-0909-2-95-MNJ	„A“ = 19.05 „B“ = 31.60
SDD-0909-3-95-M	SDD-0909-3-95-MJ	SDD-0909-3-95-MN	SDD-0909-3-95-MNJ	„A“ = 15.87 „B“ = 28.42
if with Ferrite Filter: -MS	if with Ferrite Filter: -MSJ	if with Ferrite Filter: -MSN	if with Ferrite Filter: -MSNJ	

9-pin female / 9-pin male

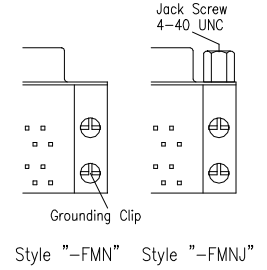
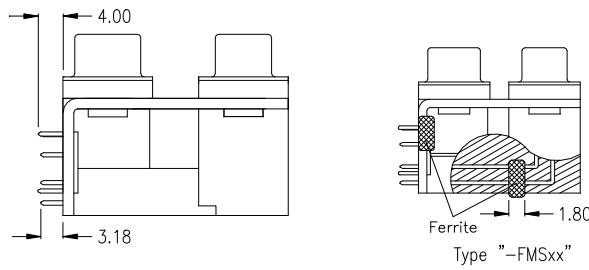
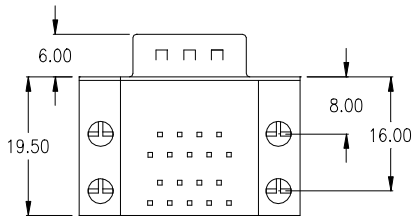
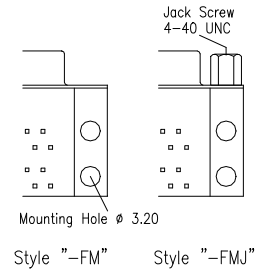
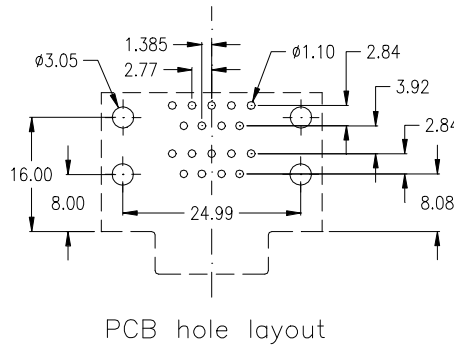
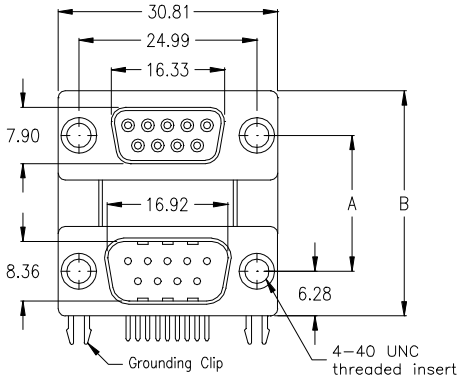

without grounding clips just 4 mounting holes	without grounding clips, just 4 mounting holes; 4 jack screws 4-40 UNC mounted	with 4 grounding clips (as above drawing)	with 4 grounding clips; 4 jack screws 4-40 UNC mounted	Distance Dimensions
SDD-0909-1-95-FM	SDD-0909-1-95-FMJ	SDD-0909-1-95-FMN	SDD-0909-1-95-FMNJ	„A“ = 22.86 „B“ = 35.41
SDD-0909-2-95-FM	SDD-0909-2-95-FMJ	SDD-0909-2-95-FMN	SDD-0909-2-95-FMNJ	„A“ = 19.05 „B“ = 31.60
SDD-0909-3-95-FM	SDD-0909-3-95-FMJ	SDD-0909-3-95-FMN	SDD-0909-3-95-FMNJ	„A“ = 15.87 „B“ = 28.42
if with Ferrite Filter: -FMS	if with Ferrite Filter: -FMSJ	if with Ferrite Filter: -FMSN	if with Ferrite Filter: -FMSNJ	

9-pin male / 9-pin female

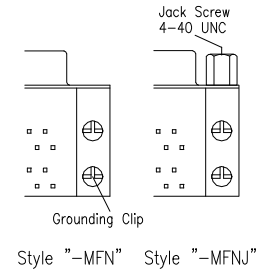
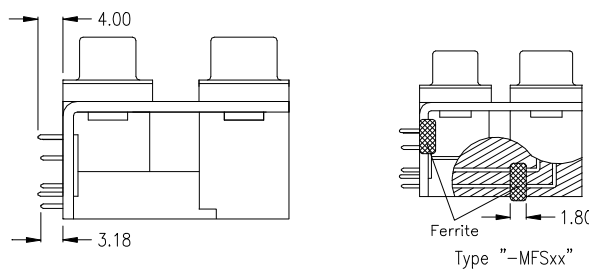
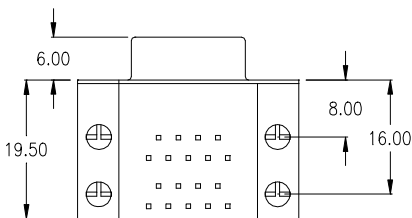
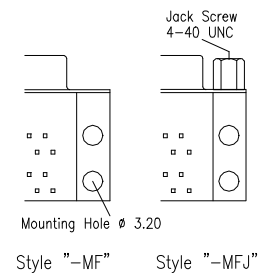
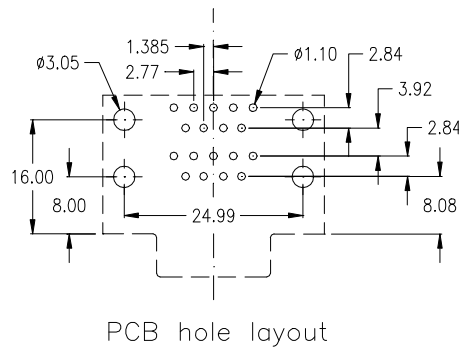
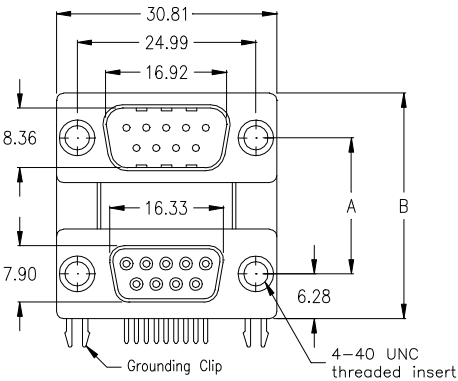

without grounding clips just 4 mounting holes	without grounding clips, just 4 mounting holes; 4 jack screws 4-40 UNC mounted	with 4 grounding clips (as above drawing)	with 4 grounding clips; 4 jack screws 4-40 UNC mounted	Distance Dimensions
SDD-0909-1-95-MF	SDD-0909-1-95-MFJ	SDD-0909-1-95-MFN	SDD-0909-1-95-MFNJ	„A“ = 22.86 „B“ = 35.41
SDD-0909-2-95-MF	SDD-0909-2-95-MFJ	SDD-0909-2-95-MFN	SDD-0909-2-95-MFNJ	„A“ = 19.05 „B“ = 31.60
SDD-0909-3-95-MF	SDD-0909-3-95-MFJ	SDD-0909-3-95-MFN	SDD-0909-3-95-MFNJ	„A“ = 15.87 „B“ = 28.42
if with Ferrite Filter: -MFS	if with Ferrite Filter: -MFSJ	if with Ferrite Filter: -MFSN	if with Ferrite Filter: -MFSNJ	

15-pin female / 15-pin female

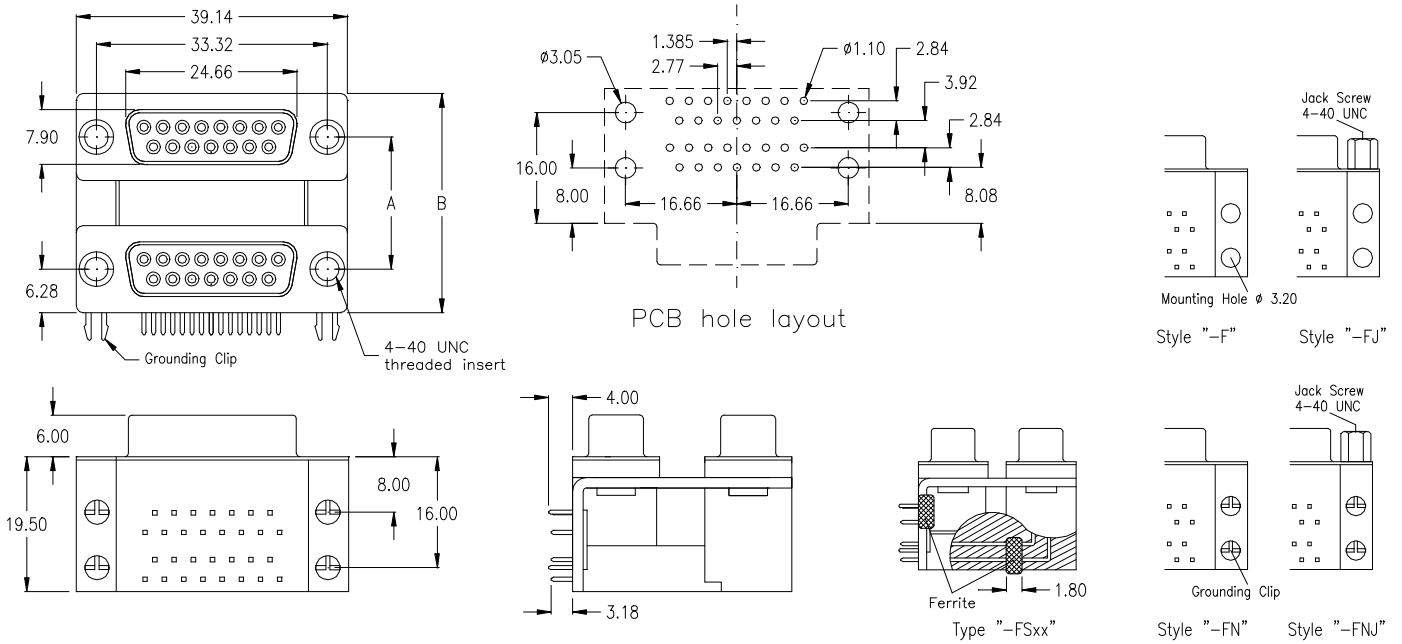

without grounding clips just 4 mounting holes	without grounding clips, just 4 mounting holes; 4 jack screws 4-40 UNC mounted	with 4 grounding clips (as above drawing)	with 4 grounding clips; 4 jack screws 4-40 UNC mounted	Distance Dimensions
SDD-1515-1-95-F	SDD-1515-1-95-FJ	SDD-1515-1-95-FN	SDD-1515-1-95-FNJ	„A“ = 22.86 „B“ = 35.41
SDD-1515-2-95-F	SDD-1515-2-95-FJ	SDD-1515-2-95-FN	SDD-1515-2-95-FNJ	„A“ = 19.05 „B“ = 31.60
SDD-1515-3-95-F	SDD-1515-3-95-FJ	SDD-1515-3-95-FN	SDD-1515-3-95-FNJ	„A“ = 15.87 „B“ = 28.42
if with Ferrite Filter: -FS	if with Ferrite Filter: -FSJ	if with Ferrite Filter: -FSN	if with Ferrite Filter: -FSNJ	

15-pin male / 15-pin male

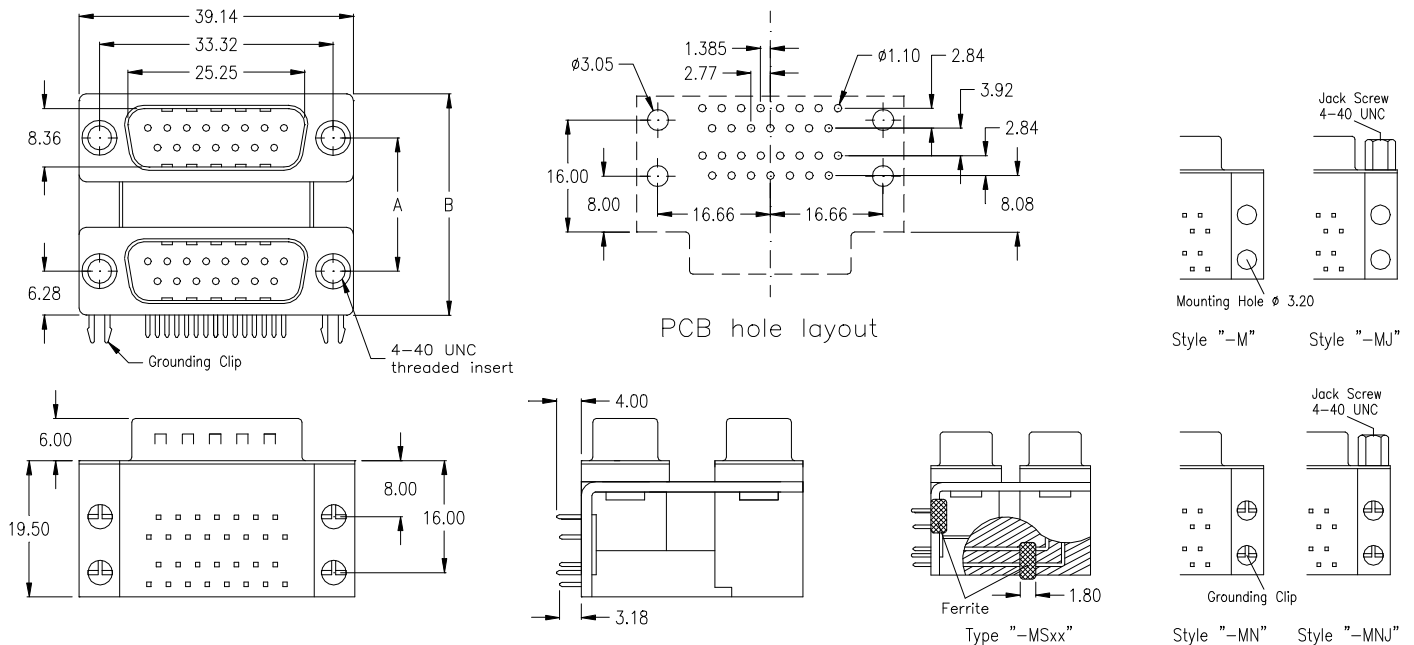

without grounding clips just 4 mounting holes	without grounding clips, just 4 mounting holes; 4 jack screws 4-40 UNC mounted	with 4 grounding clips (as above drawing)	with 4 grounding clips; 4 jack screws 4-40 UNC mounted	Distance Dimensions
SDD-1515-1-95-M	SDD-1515-1-95-MJ	SDD-1515-1-95-MN	SDD-1515-1-95-MNJ	„A“ = 22.86 „B“ = 35.41
SDD-1515-2-95-M	SDD-1515-2-95-MJ	SDD-1515-2-95-MN	SDD-1515-2-95-MNJ	„A“ = 19.05 „B“ = 31.60
SDD-1515-3-95-M	SDD-1515-3-95-MJ	SDD-1515-3-95-MN	SDD-1515-3-95-MNJ	„A“ = 15.87 „B“ = 28.42
if with Ferrite Filter: -MS	if with Ferrite Filter: -MSJ	if with Ferrite Filter: -MSN	if with Ferrite Filter: -MSNJ	

15-pin female / 15-pin male

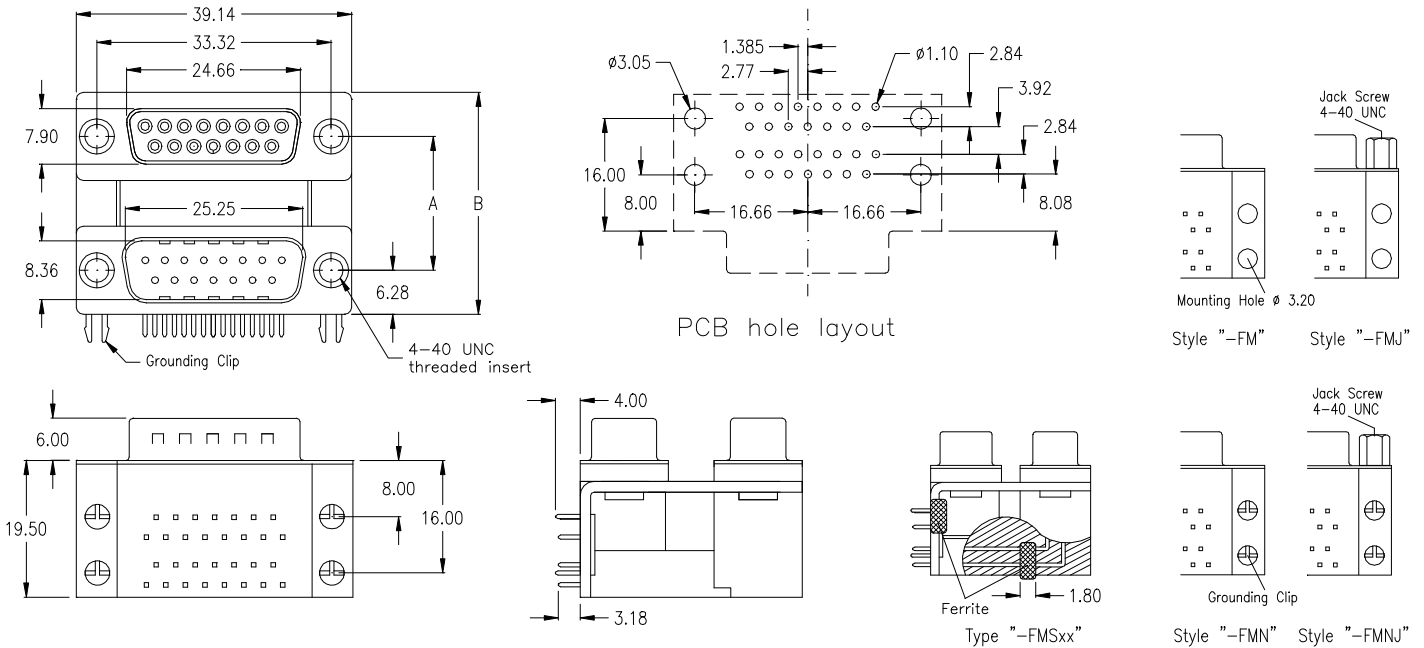

without grounding clips just 4 mounting holes	without grounding clips, just 4 mounting holes; 4 jack screws 4-40 UNC mounted	with 4 grounding clips (as above drawing)	with 4 grounding clips; 4 jack screws 4-40 UNC mounted	Distance Dimensions
SDD-1515-1-95-FM	SDD-1515-1-95-FMJ	SDD-1515-1-95-FMN	SDD-1515-1-95-FMNJ	„A“ = 22.86 „B“ = 35.41
SDD-1515-2-95-FM	SDD-1515-2-95-FMJ	SDD-1515-2-95-FMN	SDD-1515-2-95-FMNJ	„A“ = 19.05 „B“ = 31.60
SDD-1515-3-95-FM	SDD-1515-3-95-FMJ	SDD-1515-3-95-FMN	SDD-1515-3-95-FMNJ	„A“ = 15.87 „B“ = 28.42
if with Ferrite Filter: -FMS	if with Ferrite Filter: -FMSJ	if with Ferrite Filter: -FMSN	if with Ferrite Filter: -FMSNJ	

15-pin male / 15-pin female

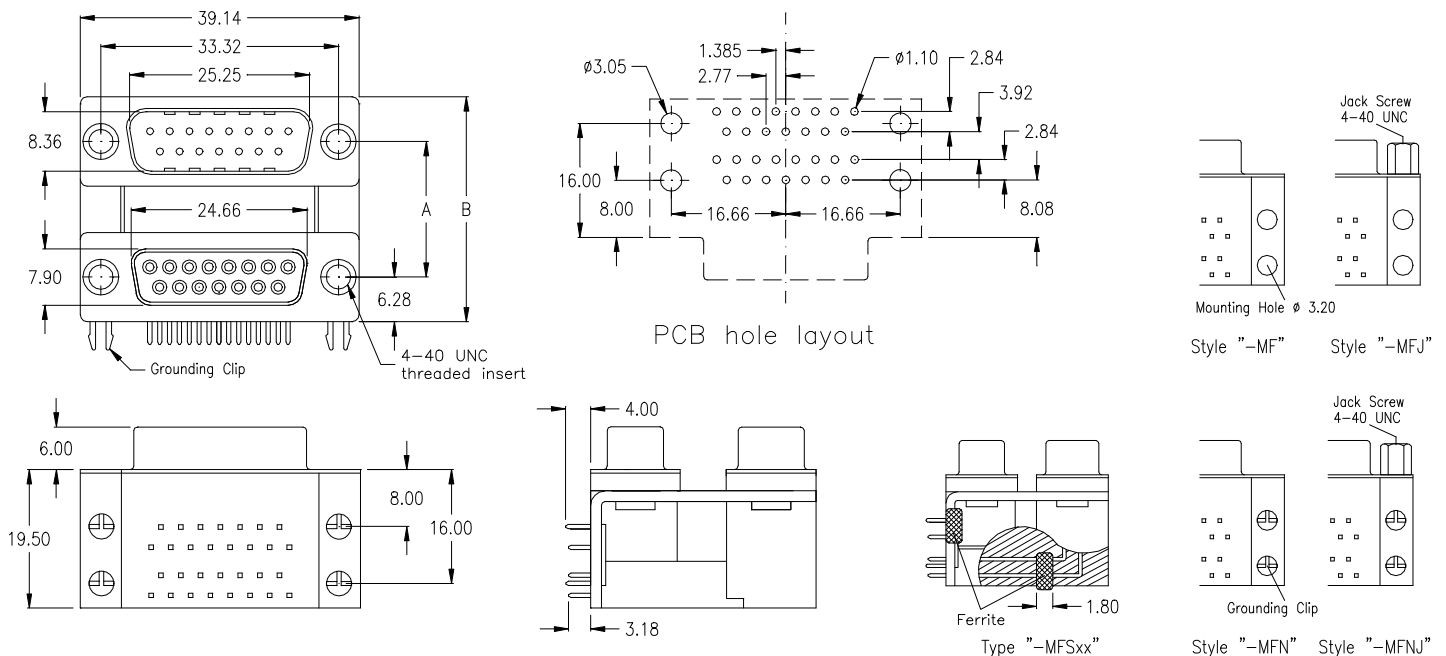

without grounding clips just 4 mounting holes	without grounding clips, just 4 mounting holes; 4 jack screws 4-40 UNC mounted	with 4 grounding clips (as above drawing)	with 4 grounding clips; 4 jack screws 4-40 UNC mounted	Distance Dimensions
SDD-1515-1-95-MF	SDD-1515-1-95-MFJ	SDD-1515-1-95-MFN	SDD-1515-1-95-MFNJ	„A“ = 22.86 „B“ = 35.41
SDD-1515-2-95-MF	SDD-1515-2-95-MFJ	SDD-1515-2-95-MFN	SDD-1515-2-95-MFNJ	„A“ = 19.05 „B“ = 31.60
SDD-1515-3-95-MF	SDD-1515-3-95-MFJ	SDD-1515-3-95-MFN	SDD-1515-3-95-MFNJ	„A“ = 15.87 „B“ = 28.42
if with Ferrite Filter: -MFS	if with Ferrite Filter: -MFSJ	if with Ferrite Filter: -MFSN	if with Ferrite Filter: -MFSNJ	

25-pin female / 25-pin female

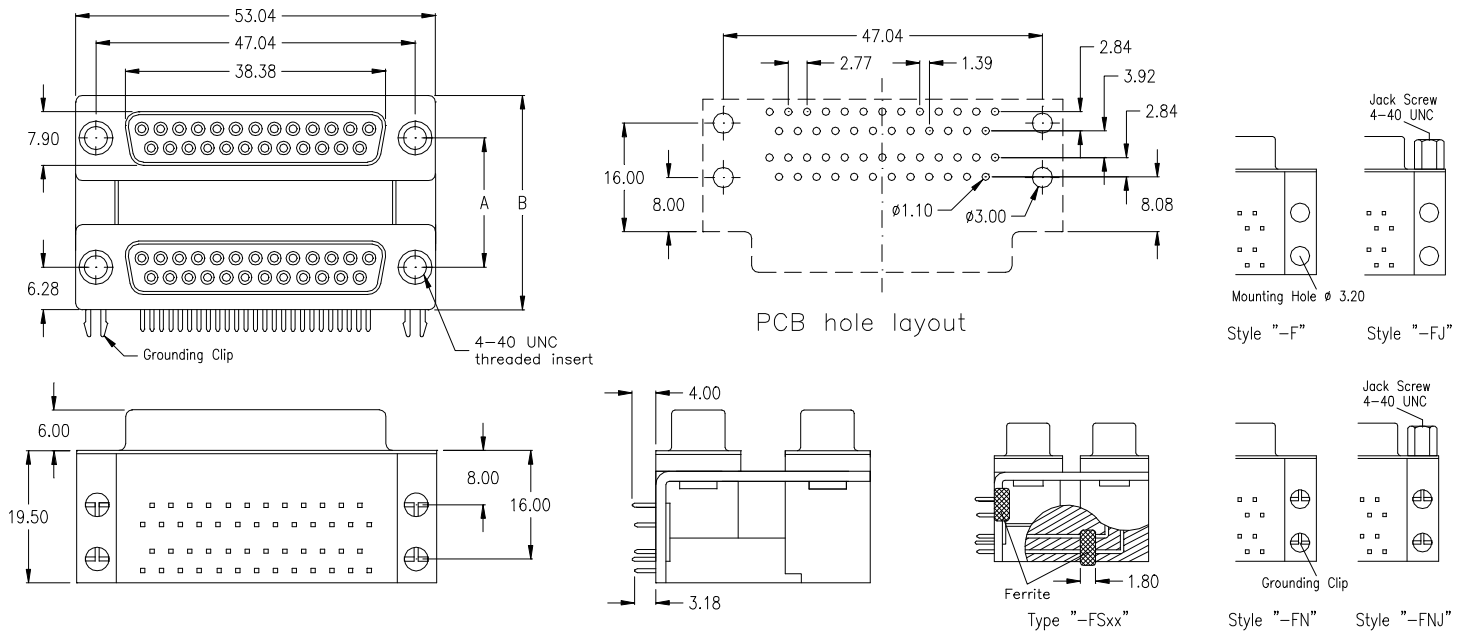

without grounding clips just 4 mounting holes	without grounding clips, just 4 mounting holes; 4 jack screws 4-40 UNC mounted	with 4 grounding clips (as above drawing)	with 4 grounding clips; 4 jack screws 4-40 UNC mounted	Distance Dimensions
SDD-2525-1-95-F	SDD-2525-1-95-FJ	SDD-2525-1-95-FN	SDD-2525-1-95-FNJ	„A“ = 22.86 „B“ = 35.41
SDD-2525-2-95-F	SDD-2525-2-95-FJ	SDD-2525-2-95-FN	SDD-2525-2-95-FNJ	„A“ = 19.05 „B“ = 31.60
SDD-2525-3-95-F	SDD-2525-3-95-FJ	SDD-2525-3-95-FN	SDD-2525-3-95-FNJ	„A“ = 15.87 „B“ = 28.42
if with Ferrite Filter: -FS	if with Ferrite Filter: -FSJ	if with Ferrite Filter: -FSN	if with Ferrite Filter: -FSNJ	

25-pin male / 25-pin male

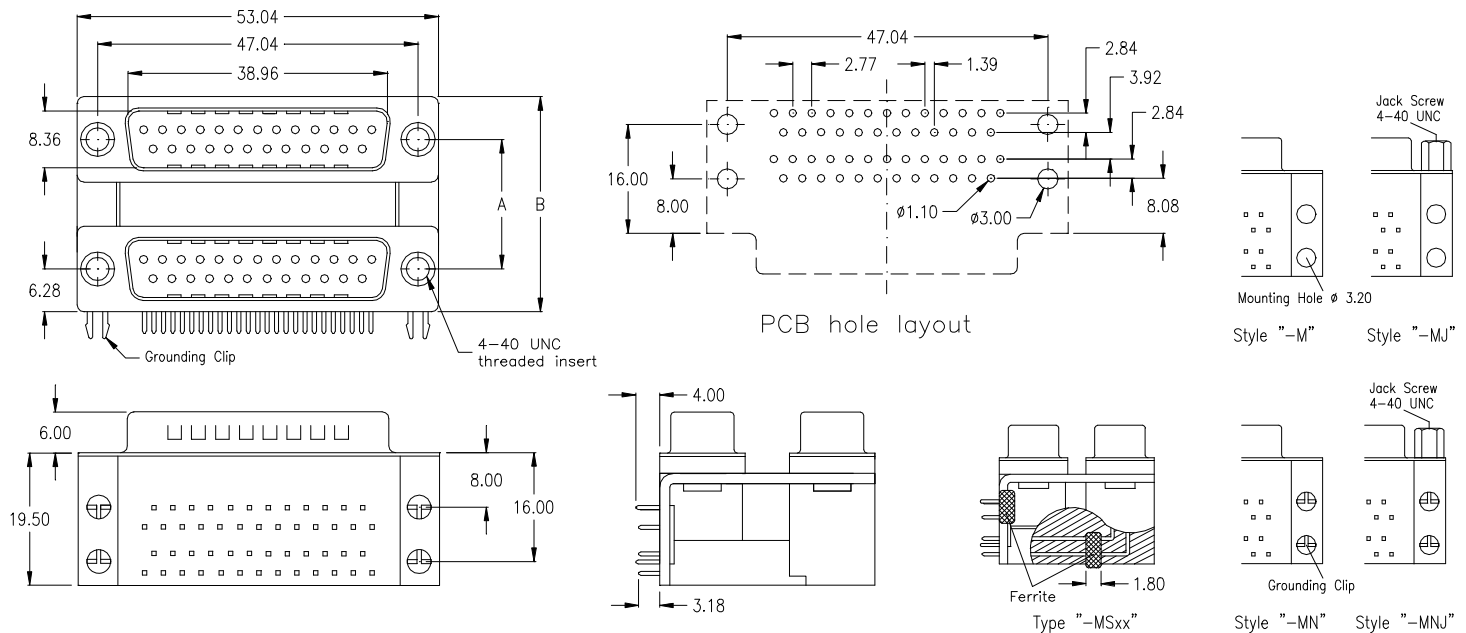

without grounding clips just 4 mounting holes	without grounding clips, just 4 mounting holes; 4 jack screws 4-40 UNC mounted	with 4 grounding clips (as above drawing)	with 4 grounding clips; 4 jack screws 4-40 UNC mounted	Distance Dimensions
SDD-2525-1-95-M	SDD-2525-1-95-MJ	SDD-2525-1-95-MN	SDD-2525-1-95-MNJ	„A“ = 22.86 „B“ = 35.41
SDD-2525-2-95-M	SDD-2525-2-95-MJ	SDD-2525-2-95-MN	SDD-2525-2-95-MNJ	„A“ = 19.05 „B“ = 31.60
SDD-2525-3-95-M	SDD-2525-3-95-MJ	SDD-2525-3-95-MN	SDD-2525-3-95-MNJ	„A“ = 15.87 „B“ = 28.42
if with Ferrite Filter: -MS	if with Ferrite Filter: -MSJ	if with Ferrite Filter: -MSN	if with Ferrite Filter: -MSNJ	

25-pin female / 25-pin male

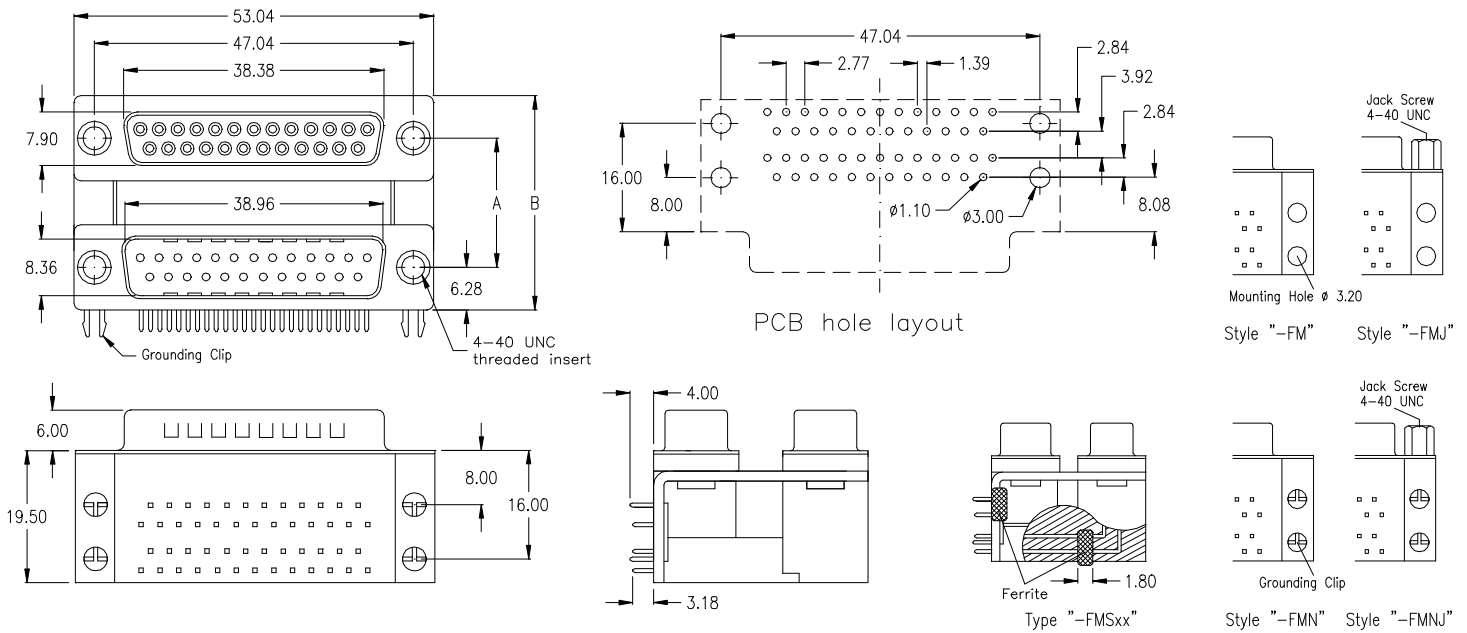

without grounding clips just 4 mounting holes	without grounding clips, just 4 mounting holes; 4 jack screws 4-40 UNC mounted	with 4 grounding clips (as above drawing)	with 4 grounding clips; 4 jack screws 4-40 UNC mounted	Distance Dimensions
SDD-2525-1-95-FM	SDD-2525-1-95-FMJ	SDD-2525-1-95-FMN	SDD-2525-1-95-FMNJ	„A“ = 22.86 „B“ = 35.41
SDD-2525-2-95-FM	SDD-2525-2-95-FMJ	SDD-2525-2-95-FMN	SDD-2525-2-95-FMNJ	„A“ = 19.05 „B“ = 31.60
SDD-2525-3-95-FM	SDD-2525-3-95-FMJ	SDD-2525-3-95-FMN	SDD-2525-3-95-FMNJ	„A“ = 15.87 „B“ = 28.42
if with Ferrite Filter: -FMS	if with Ferrite Filter: -FMSJ	if with Ferrite Filter: -FMSN	if with Ferrite Filter: -FMSNJ	

25-pin male / 25-pin female

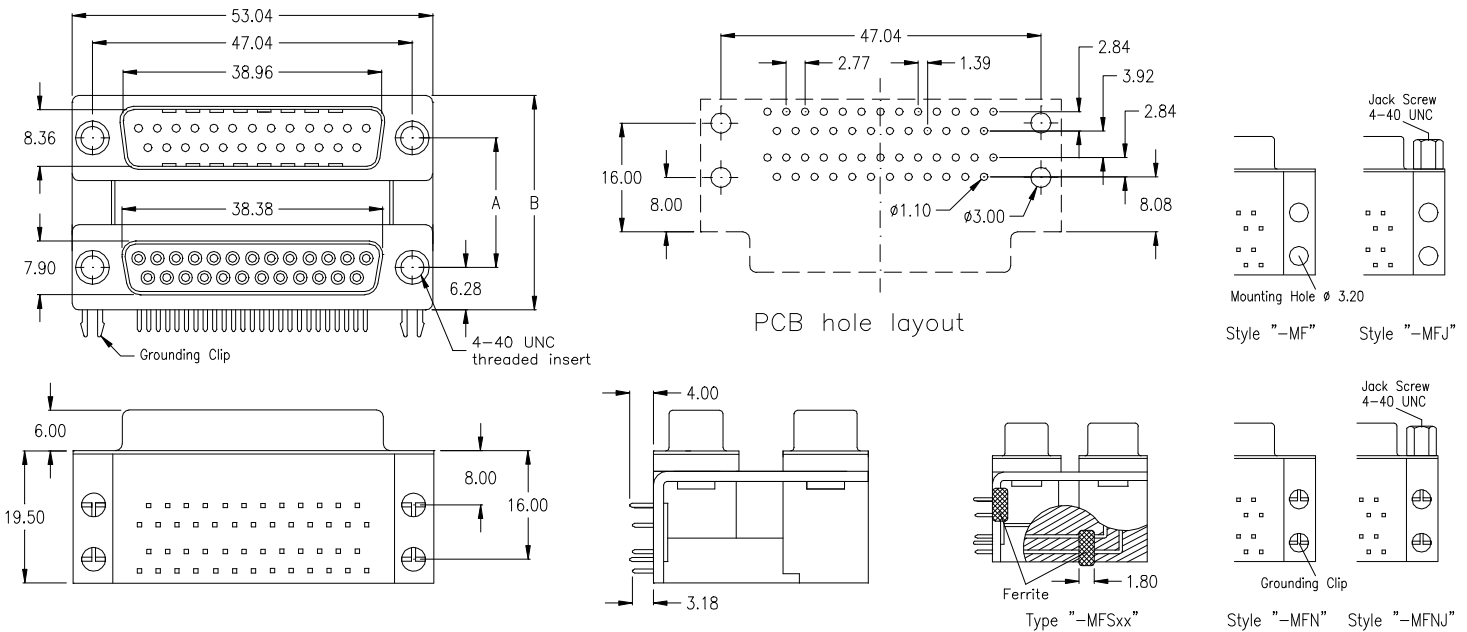

without grounding clips just 4 mounting holes	without grounding clips, just 4 mounting holes; 4 jack screws 4-40 UNC mounted	with 4 grounding clips (as above drawing)	with 4 grounding clips; 4 jack screws 4-40 UNC mounted	Distance Dimensions
SDD-2525-1-95-MF	SDD-2525-1-95-MFJ	SDD-2525-1-95-MFN	SDD-2525-1-95-MFNJ	„A“ = 22.86 „B“ = 35.41
SDD-2525-2-95-MF	SDD-2525-2-95-MFJ	SDD-2525-2-95-MFN	SDD-2525-2-95-MFNJ	„A“ = 19.05 „B“ = 31.60
SDD-2525-3-95-MF	SDD-2525-3-95-MFJ	SDD-2525-3-95-MFN	SDD-2525-3-95-MFNJ	„A“ = 15.87 „B“ = 28.42
if with Ferrite Filter: -MFS	if with Ferrite Filter: -MFSJ	if with Ferrite Filter: -MFSN	if with Ferrite Filter: -MFSNJ	

37-pin female / 37-pin female

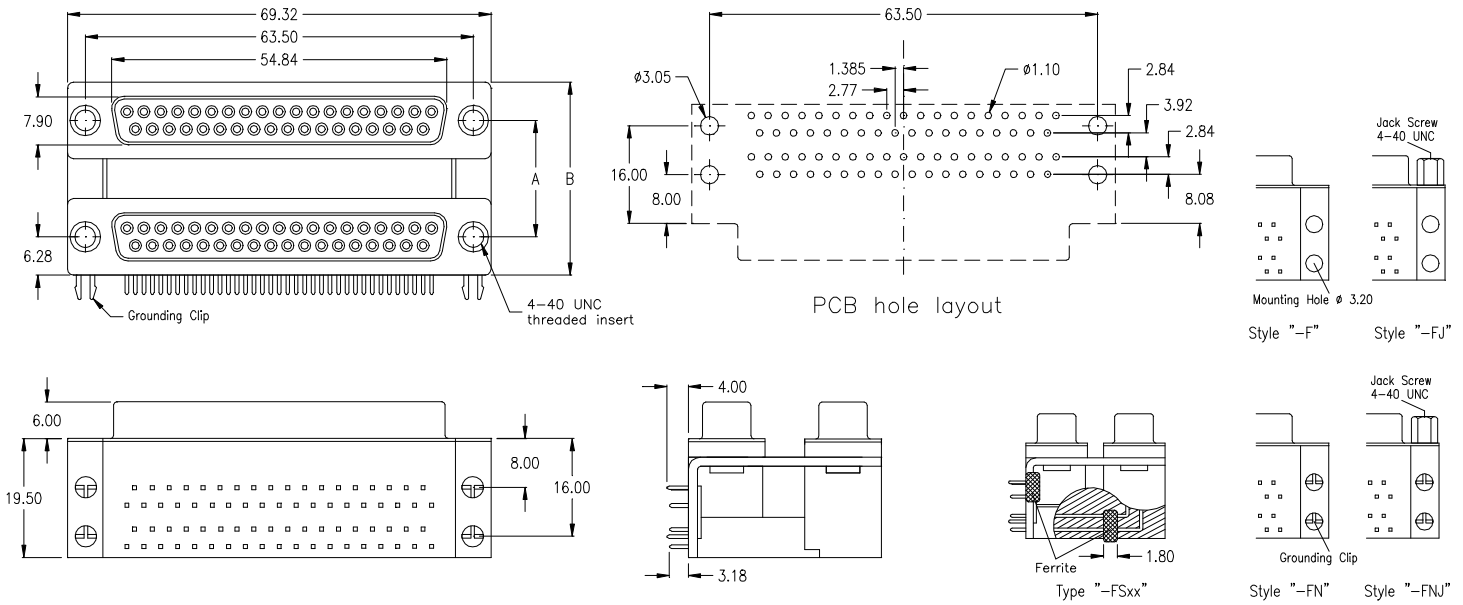

without grounding clips just 4 mounting holes	without grounding clips, just 4 mounting holes; 4 jack screws 4-40 UNC mounted	with 4 grounding clips (as above drawing)	with 4 grounding clips; 4 jack screws 4-40 UNC mounted	Distance Dimensions
SDD-3737-1-95 -F	SDD-3737-1-95 -FJ	SDD-3737-1-95 -FN	SDD-3737-1-95 -FNJ	„A“ = 22.86 „B“ = 35.41
SDD-3737-2-95 -F	SDD-3737-2-95 -FJ	SDD-3737-2-95 -FN	SDD-3737-2-95 -FNJ	„A“ = 19.05 „B“ = 31.60
SDD-3737-3-95 -F	SDD-3737-3-95 -FJ	SDD-3737-3-95 -FN	SDD-3737-3-95 -FNJ	„A“ = 15.87 „B“ = 28.42
if with Ferrite Filter: -FS	if with Ferrite Filter: -FSJ	if with Ferrite Filter: -FSN	if with Ferrite Filter: -FSNJ	

37-pin male / 37-pin male

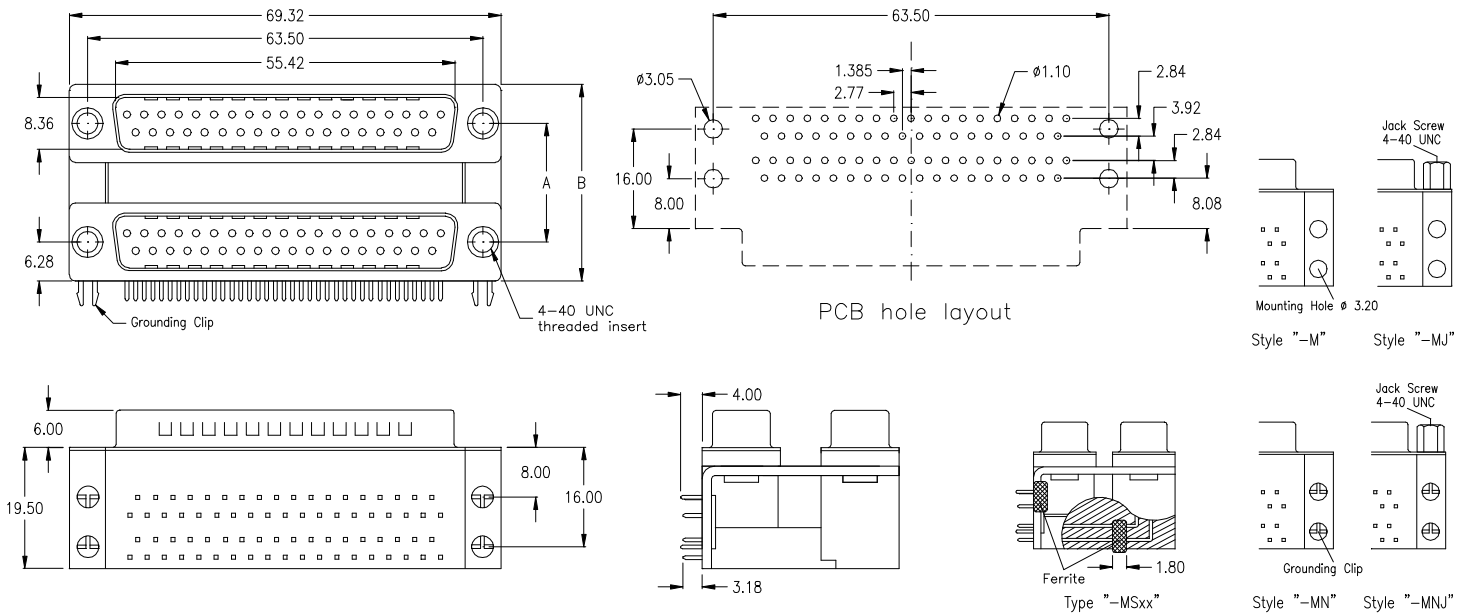

without grounding clips just 4 mounting holes	without grounding clips, just 4 mounting holes; 4 jack screws 4-40 UNC mounted	with 4 grounding clips (as above drawing)	with 4 grounding clips; 4 jack screws 4-40 UNC mounted	Distance Dimensions
SDD-3737-1-95 -M	SDD-3737-1-95 -MJ	SDD-3737-1-95 -MN	SDD-3737-1-95 -MNJ	„A“ = 22.86 „B“ = 35.41
SDD-3737-2-95 -M	SDD-3737-2-95 -MJ	SDD-3737-2-95 -MN	SDD-3737-2-95 -MNJ	„A“ = 19.05 „B“ = 31.60
SDD-3737-3-95 -M	SDD-3737-3-95 -MJ	SDD-3737-3-95 -MN	SDD-3737-3-95 -MNJ	„A“ = 15.87 „B“ = 28.42
if with Ferrite Filter: -MS	if with Ferrite Filter: -MSJ	if with Ferrite Filter: -MSN	if with Ferrite Filter: -MSNJ	

37-pin female / 37-pin male

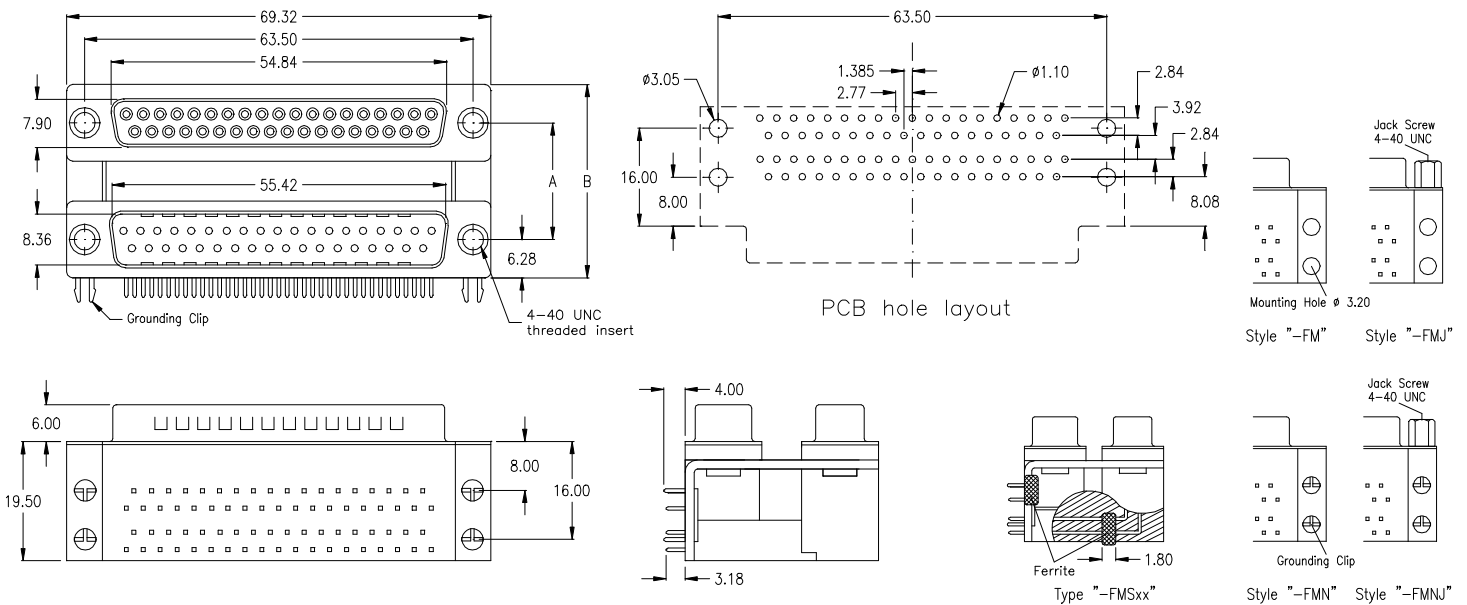

without grounding clips just 4 mounting holes	without grounding clips, just 4 mounting holes; 4 jack screws 4-40 UNC mounted	with 4 grounding clips (as above drawing)	with 4 grounding clips; 4 jack screws 4-40 UNC mounted	Distance Dimensions
SDD-3737-1-95-FM	SDD-3737-1-95-FMJ	SDD-3737-1-95-FMN	SDD-3737-1-95-FMNJ	„A“ = 22.86 „B“ = 35.41
SDD-3737-2-95-FM	SDD-3737-2-95-FMJ	SDD-3737-2-95-FMN	SDD-3737-2-95-FMNJ	„A“ = 19.05 „B“ = 31.60
SDD-3737-3-95-FM	SDD-3737-3-95-FMJ	SDD-3737-3-95-FMN	SDD-3737-3-95-FMNJ	„A“ = 15.87 „B“ = 28.42
if with Ferrite Filter: -FMS	if with Ferrite Filter: -FMSJ	if with Ferrite Filter: -FMSN	if with Ferrite Filter: -FMSNJ	

37-pin male / 37-pin female

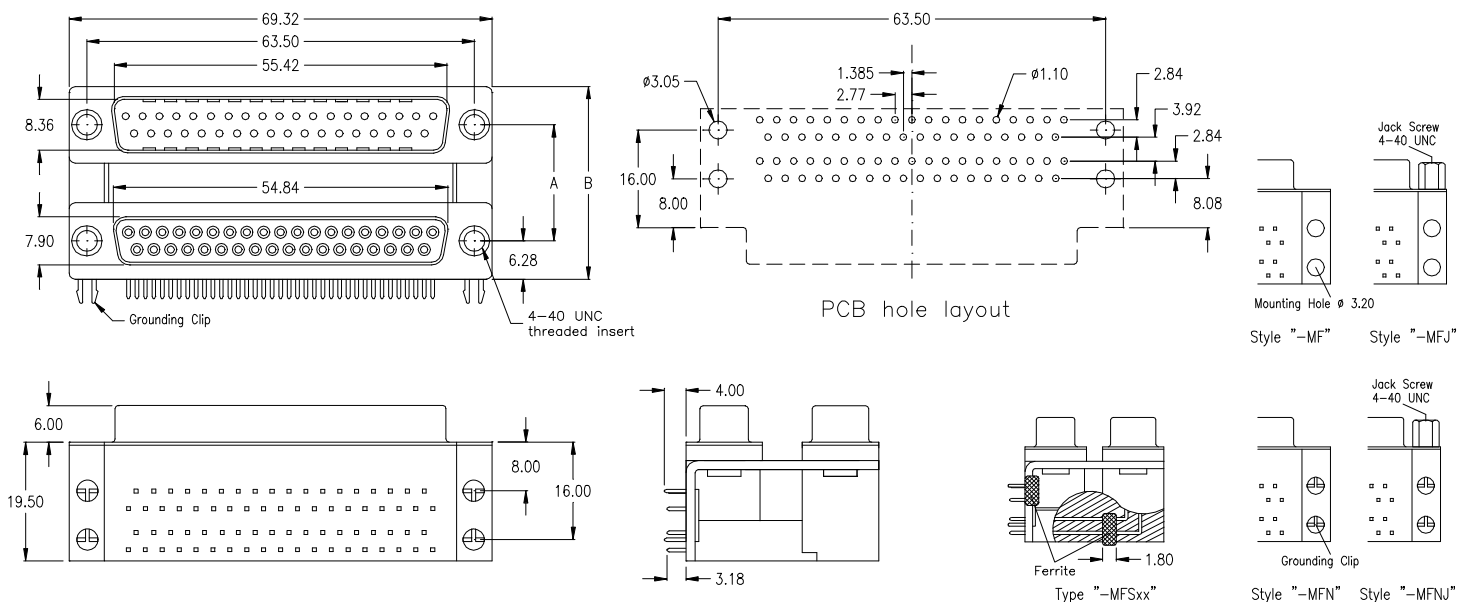

without grounding clips just 4 mounting holes	without grounding clips, just 4 mounting holes; 4 jack screws 4-40 UNC mounted	with 4 grounding clips (as above drawing)	with 4 grounding clips; 4 jack screws 4-40 UNC mounted	Distance Dimensions
SDD-3737-1-95-MF	SDD-3737-1-95-MFJ	SDD-3737-1-95-MFN	SDD-3737-1-95-MFNJ	„A“ = 22.86 „B“ = 35.41
SDD-3737-2-95-MF	SDD-3737-2-95-MFJ	SDD-3737-2-95-MFN	SDD-3737-2-95-MFNJ	„A“ = 19.05 „B“ = 31.60
SDD-3737-3-95-MF	SDD-3737-3-95-MFJ	SDD-3737-3-95-MFN	SDD-3737-3-95-MFNJ	„A“ = 15.87 „B“ = 28.42
if with Ferrite Filter: -MFS	if with Ferrite Filter: -MFSJ	if with Ferrite Filter: -MFSN	if with Ferrite Filter: -MFSNJ	

25-pin female / 9-pin female

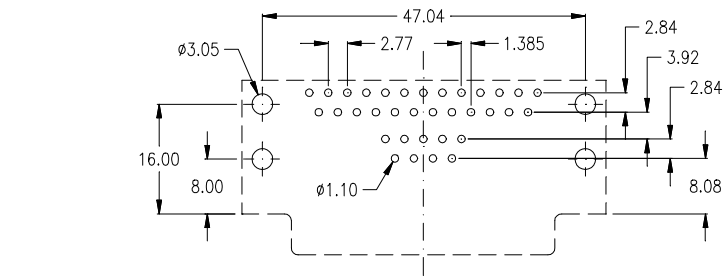
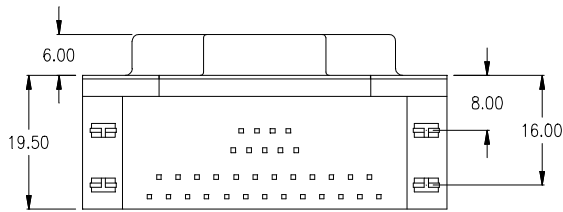
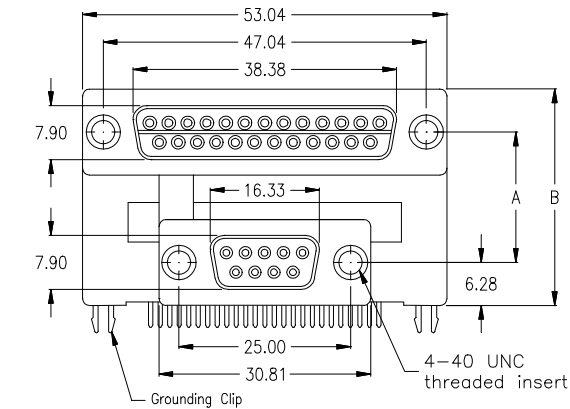

PCB hole layout

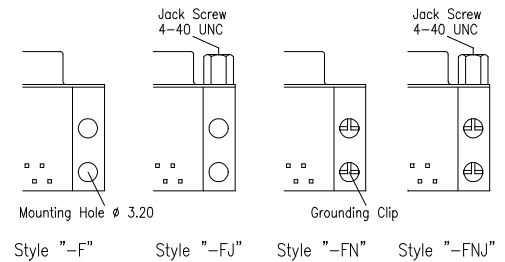
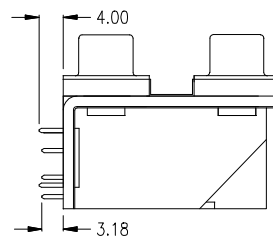

without grounding clips
just 4 mounting holes

without grounding clips,
just 4 mounting holes;
4 jack screws 4-40 UNC
mounted

with 4 grounding clips
(as above drawing)

with 4 grounding clips;
4 jack screws 4-40 UNC
mounted

Distance Dimensions

SDD-2509-2-95-F

SDD-2509-2-95-FJ

SDD-2509-2-95-FN

SDD-2509-2-95-FNJ

„A“ = 19.05 „B“ = 31.60

25-pin male / 9-pin male

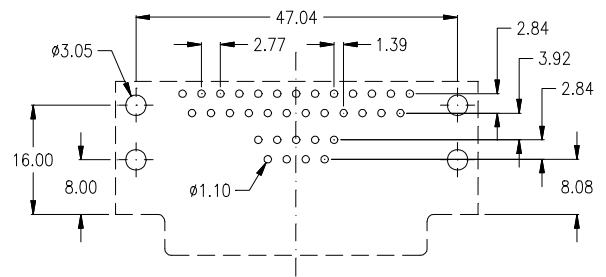
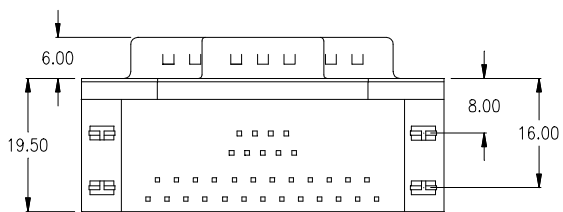
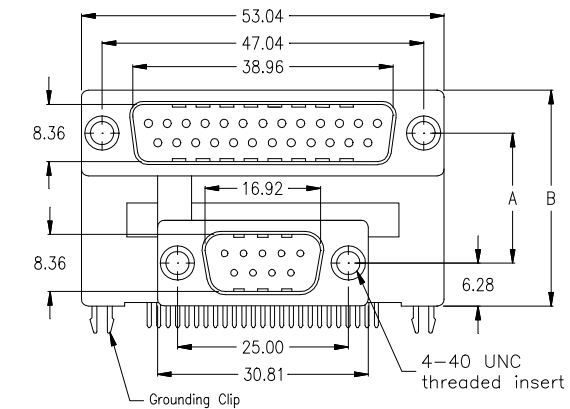

PCB hole layout

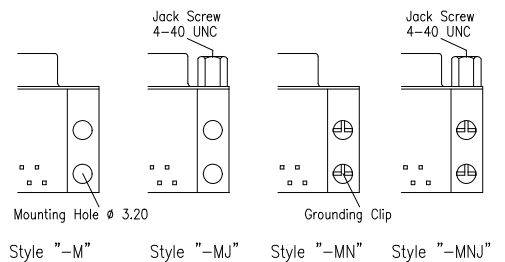
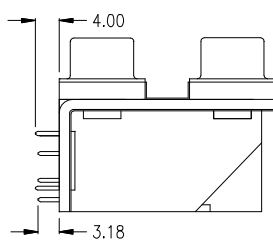

without grounding clips
just 4 mounting holes

without grounding clips,
just 4 mounting holes;
4 jack screws 4-40 UNC
mounted

with 4 grounding clips
(as above drawing)

with 4 grounding clips;
4 jack screws 4-40 UNC
mounted

Distance Dimensions

SDD-2509-2-95-M

SDD-2509-2-95-MJ

SDD-2509-2-95-MN

SDD-2509-2-95-MNJ

„A“ = 19.05 „B“ = 31.60

25-pin female / 9-pin male

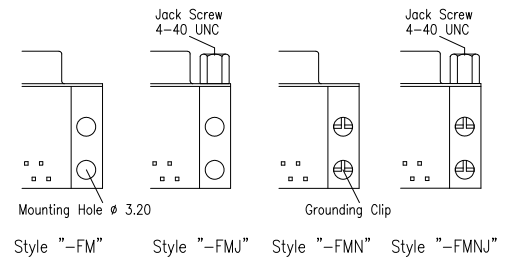
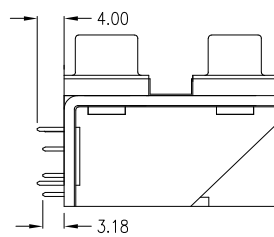
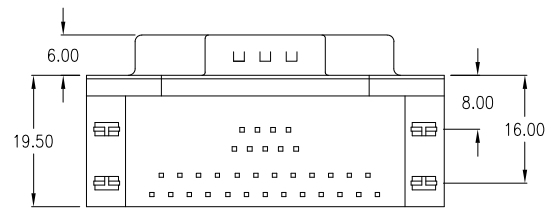
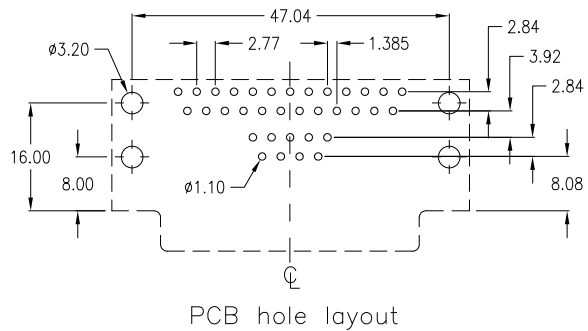
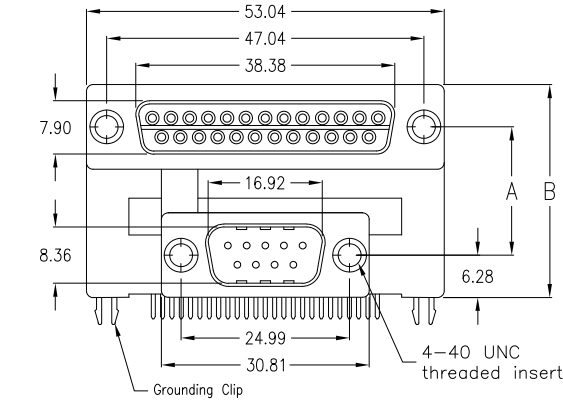

without grounding clips just 4 mounting holes	without grounding clips, just 4 mounting holes; 4 jack screws 4-40 UNC mounted	with 4 grounding clips (as above drawing)	with 4 grounding clips; 4 jack screws 4-40 UNC mounted	Distance Dimensions (mm)	
SDD-2509-2-95-FM	SDD-2509-2-95-FMJ	SDD-2509-2-95-FMN	SDD-2509-2-95-FMNJ	„A“ = 19.05	„B“ = 31.60

25-pin male / 9-pin female

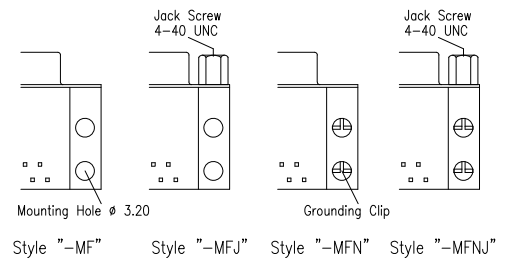
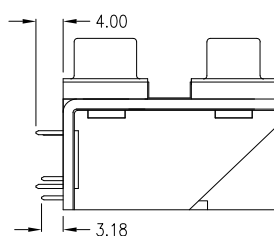
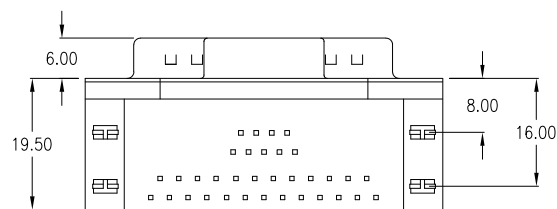
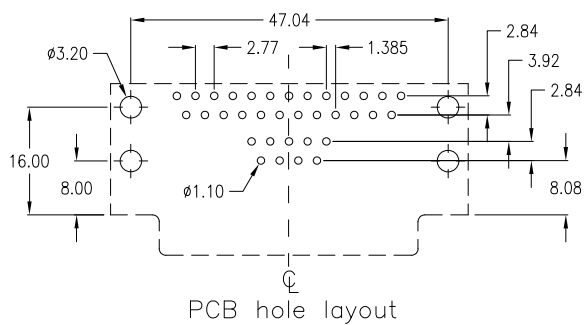
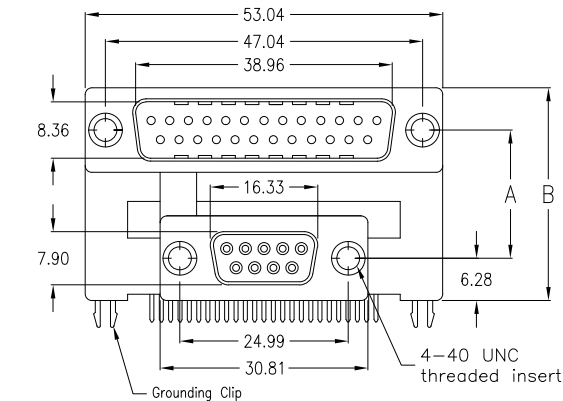

without grounding clips just 4 mounting holes	without grounding clips, just 4 mounting holes; 4 jack screws 4-40 UNC mounted	with 4 grounding clips (as above drawing)	with 4 grounding clips; 4 jack screws 4-40 UNC mounted	Distance Dimensions (mm)	
SDD-2509-2-95-MF	SDD-2509-2-95-MFJ	SDD-2509-2-95-MFN	SDD-2509-2-95-MFNJ	„A“ = 19.05	„B“ = 31.60

9-pin female / 25-pin female

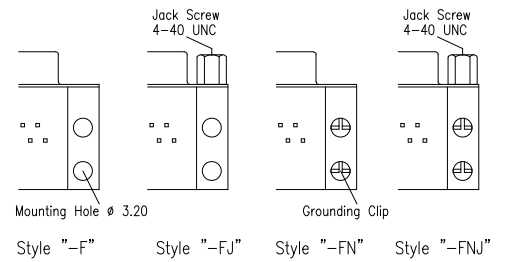
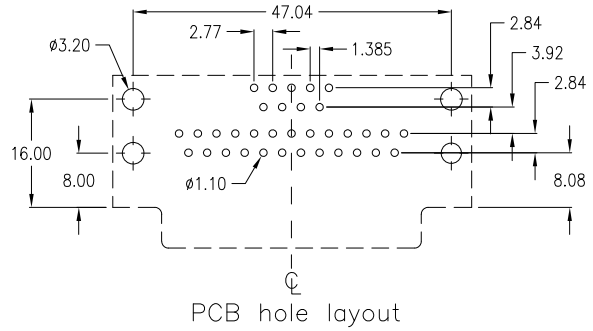
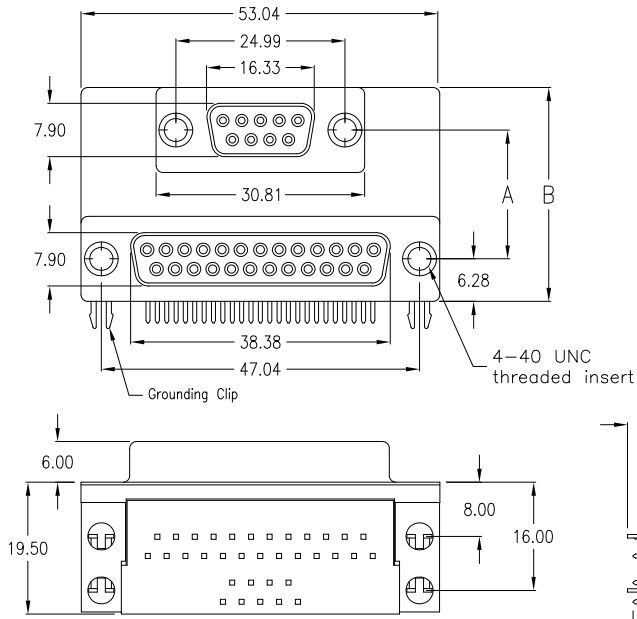

without grounding clips just 4 mounting holes	without grounding clips, just 4 mounting holes; 4 jack screws 4-40 UNC mounted	with 4 grounding clips (as above drawing)	with 4 grounding clips; 4 jack screws 4-40 UNC mounted	Distance Dimensions (mm)	
SDD-0925-2-95-F	SDD-0925-2-95-FJ	SDD-0925-2-95-FN	SDD-0925-2-95-FNJ	„A“ = 19.05	„B“ = 31.60
SDD-0925-3-95-F	SDD-0925-3-95-FJ	SDD-0925-3-95-FN	SDD-0925-3-95-FNJ	„A“ = 15.87	„B“ = 28.42

15-pin female left side / 25-pin female

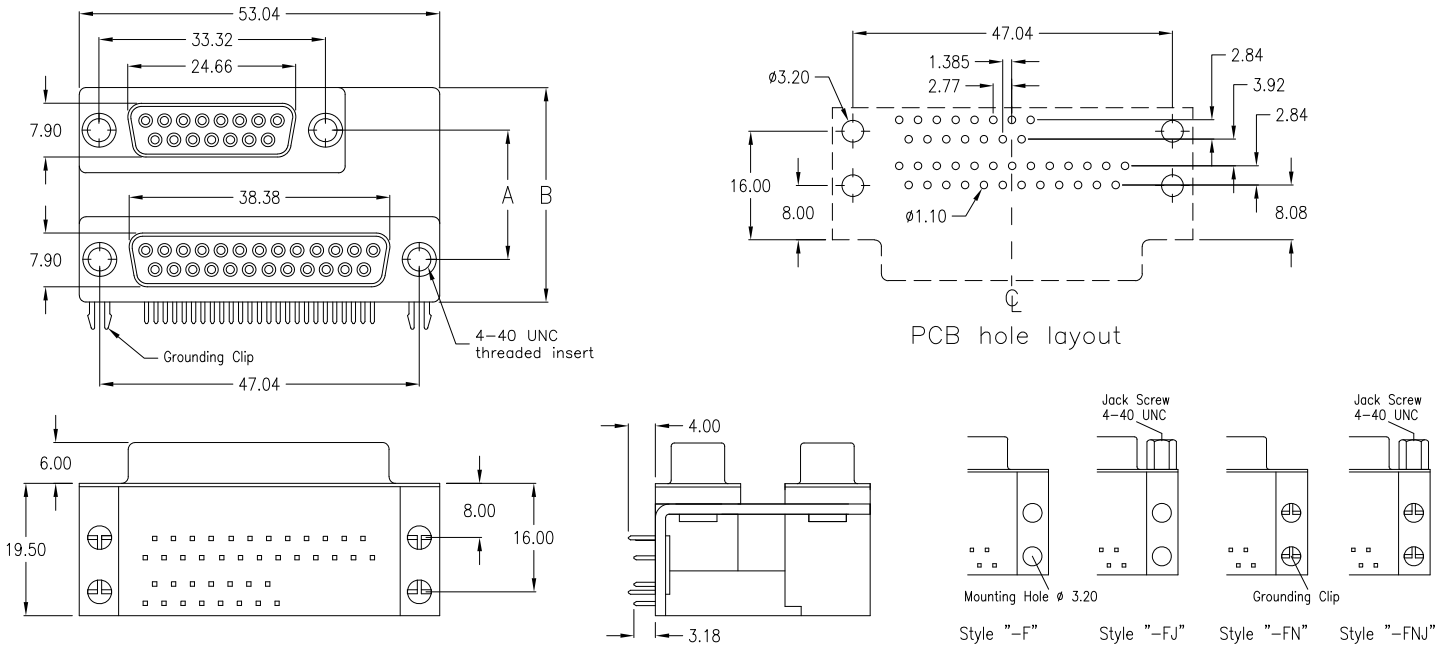

without grounding clips just 4 mounting holes	without grounding clips, just 4 mounting holes; 4 jack screws 4-40 UNC mounted	with 4 grounding clips (as above drawing)	with 4 grounding clips; 4 jack screws 4-40 UNC mounted	Distance Dimensions (mm)	
SDD-L1525-2-95-F	SDD-L1525-2-95-FJ	SDD-L1525-2-95-FN	SDD-L1525-2-95-FNJ	„A“ = 19.05	„B“ = 31.60

25-pin female / 15-pin female left side

Special product.

Please ask for availability and minimum order quantity before you consider the article for development, design in or production purposes.

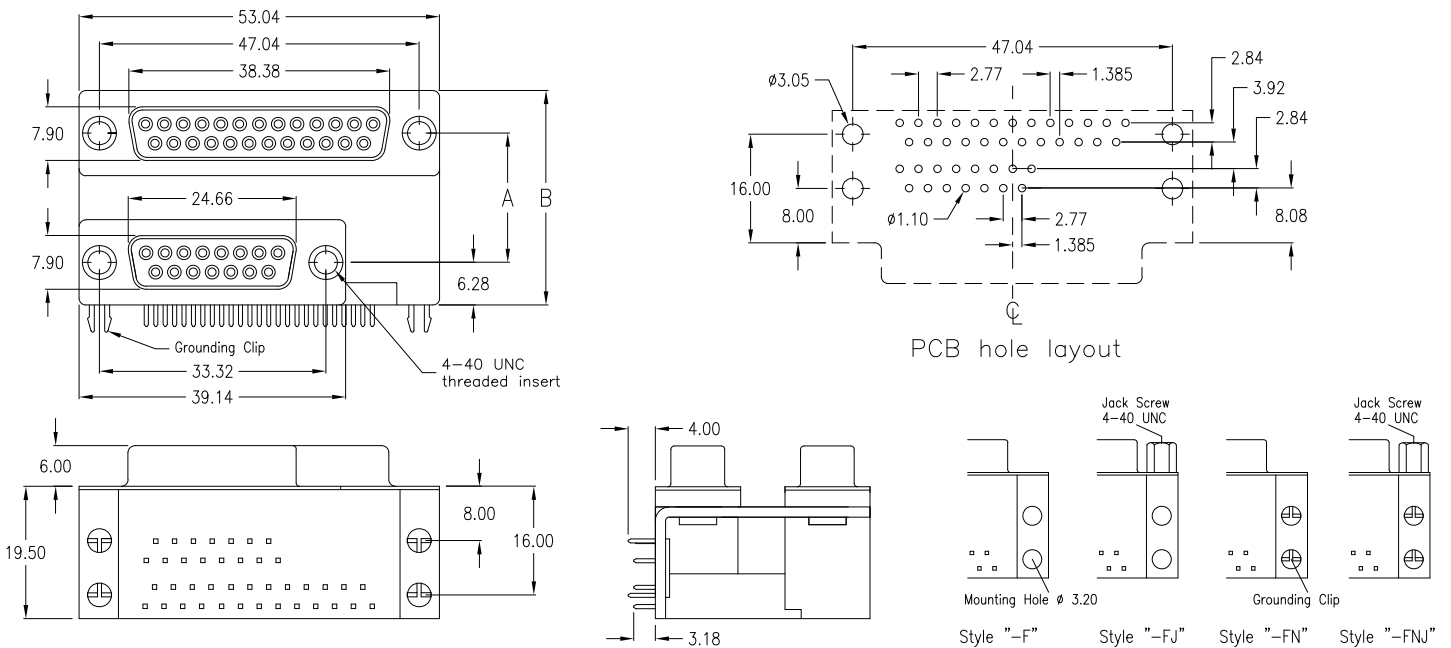

without grounding clips just 4 mounting holes	without grounding clips, just 4 mounting holes; 4 jack screws 4-40 UNC mounted	with 4 grounding clips (as above drawing)	with 4 grounding clips; 4 jack screws 4-40 UNC mounted	Distance Dimensions (mm)	
SDD-25L15-2-95-F	SDD-25L15-2-95-FJ	SDD-25L15-2-95-FN	SDD-25L15-2-95-FNJ	„A“ = 19.05	„B“ = 31.60

25-pin female / 15-pin HD female

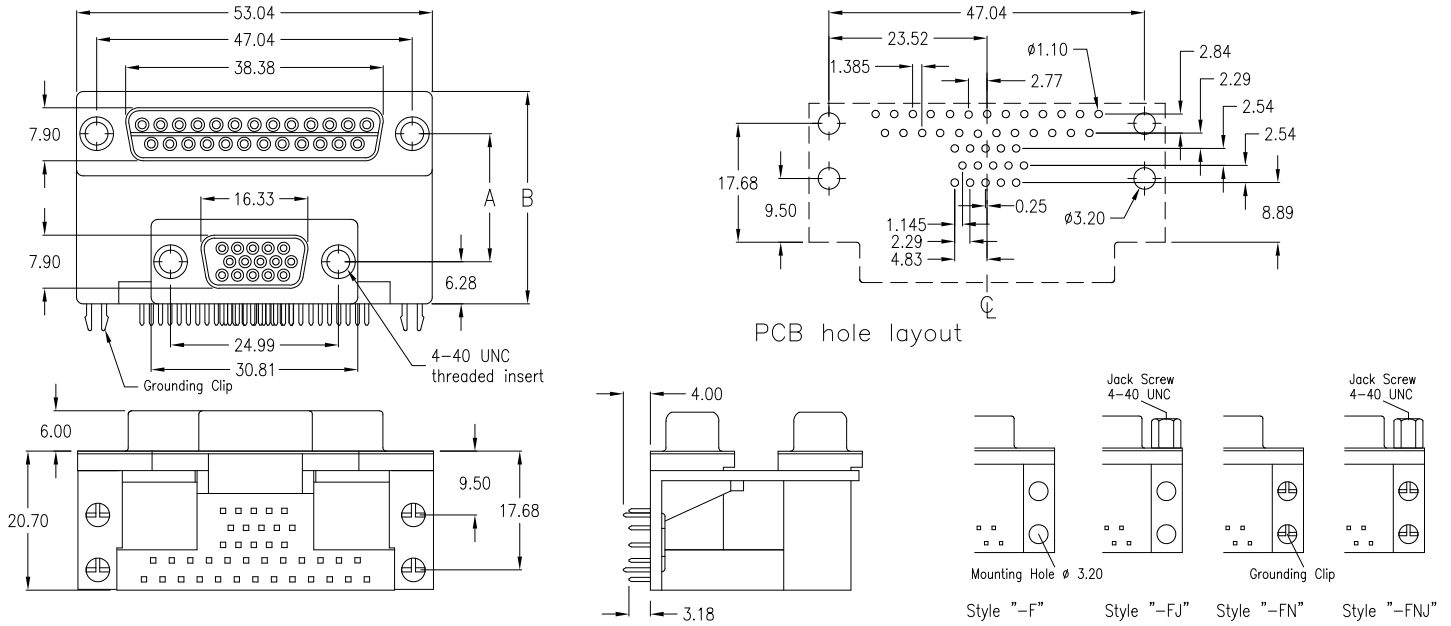

without grounding clips just 4 mounting holes	without grounding clips, just 4 mounting holes; 4 jack screws 4-40 UNC mounted	with 4 grounding clips (as above drawing)	with 4 grounding clips; 4 jack screws 4-40 UNC mounted	Distance Dimensions (mm)	
SDD-25H15-4-95-F	SDD-25H15-4-95-FJ	SDD-25H15-4-95-FN	SDD-25H15-4-95-FNJ	„A“ = 19.05	„B“ = 31.60

9-pin female / 15-pin HD male

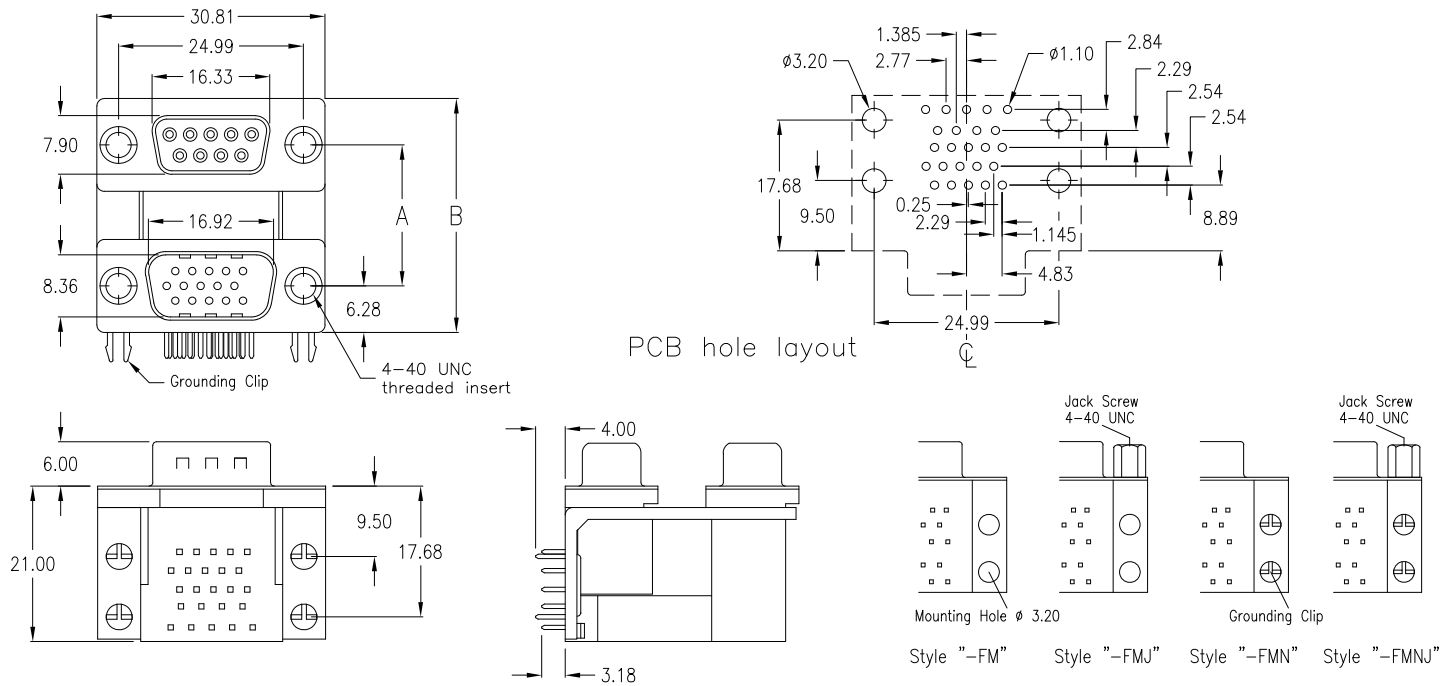

without grounding clips just 4 mounting holes	without grounding clips, just 4 mounting holes; 4 jack screws 4-40 UNC mounted	with 4 grounding clips (as above drawing)	with 4 grounding clips; 4 jack screws 4-40 UNC mounted	Distance Dimensions (mm)	
SDD-09H15-4-95-FM	SDD-09H15-4-95-FMJ	SDD-09H15-4-95-FMN	SDD-09H15-4-95-FMNJ	„A“ = 19.05	„B“ = 31.60

15-pin HD female / 09-pin female

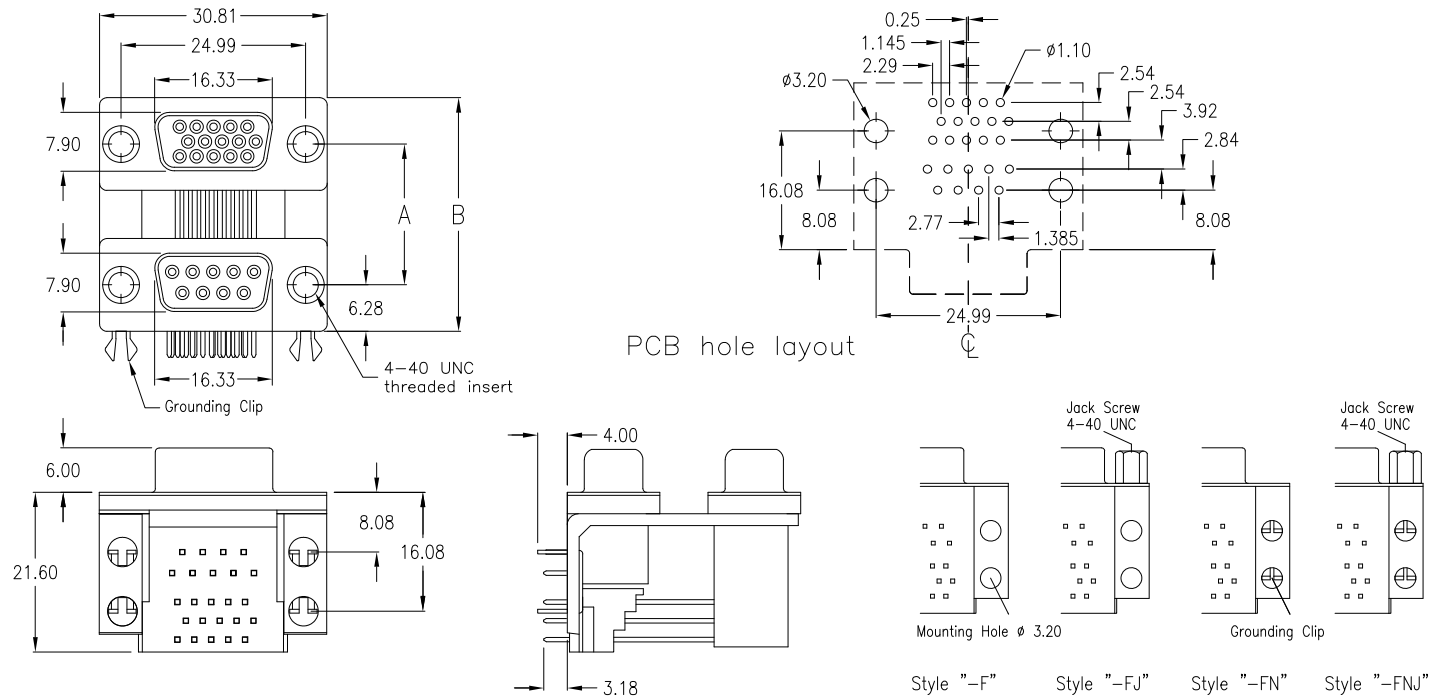

without grounding clips just 4 mounting holes	without grounding clips, just 4 mounting holes; 4 jack screws 4-40 UNC mounted	with 4 grounding clips (as above drawing)	with 4 grounding clips; 4 jack screws 4-40 UNC mounted	Distance Dimensions (mm)	
SDD-H1509-6-95-F	SDD-H1509-6-95-FJ	SDD-H1509-6-95-FN	SDD-H1509-6-95-FNJ	„A“ = 19.05	„B“ = 31.60

15-pin HD male / 09-pin female

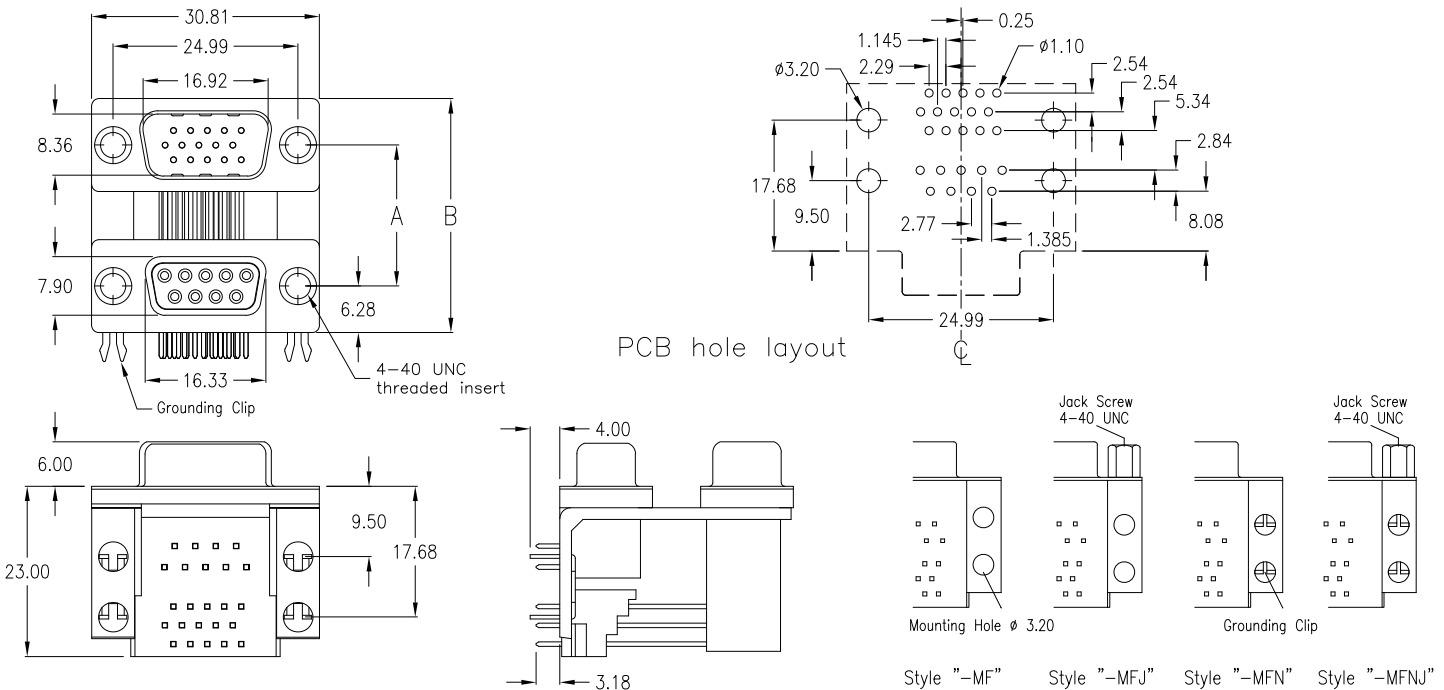

without grounding clips just 4 mounting holes	without grounding clips, just 4 mounting holes; 4 jack screws 4-40 UNC mounted	with 4 grounding clips (as above drawing)	with 4 grounding clips; 4 jack screws 4-40 UNC mounted	Distance Dimensions (mm)	
SDD-H1509-7-95-MF	SDD-H1509-7-95-MFJ	SDD-H1509-7-95-MFN	SDD-H1509-7-95-MFNJ	„A“ = 19.05	„B“ = 31.60

9-pin female / 15-pin HD female

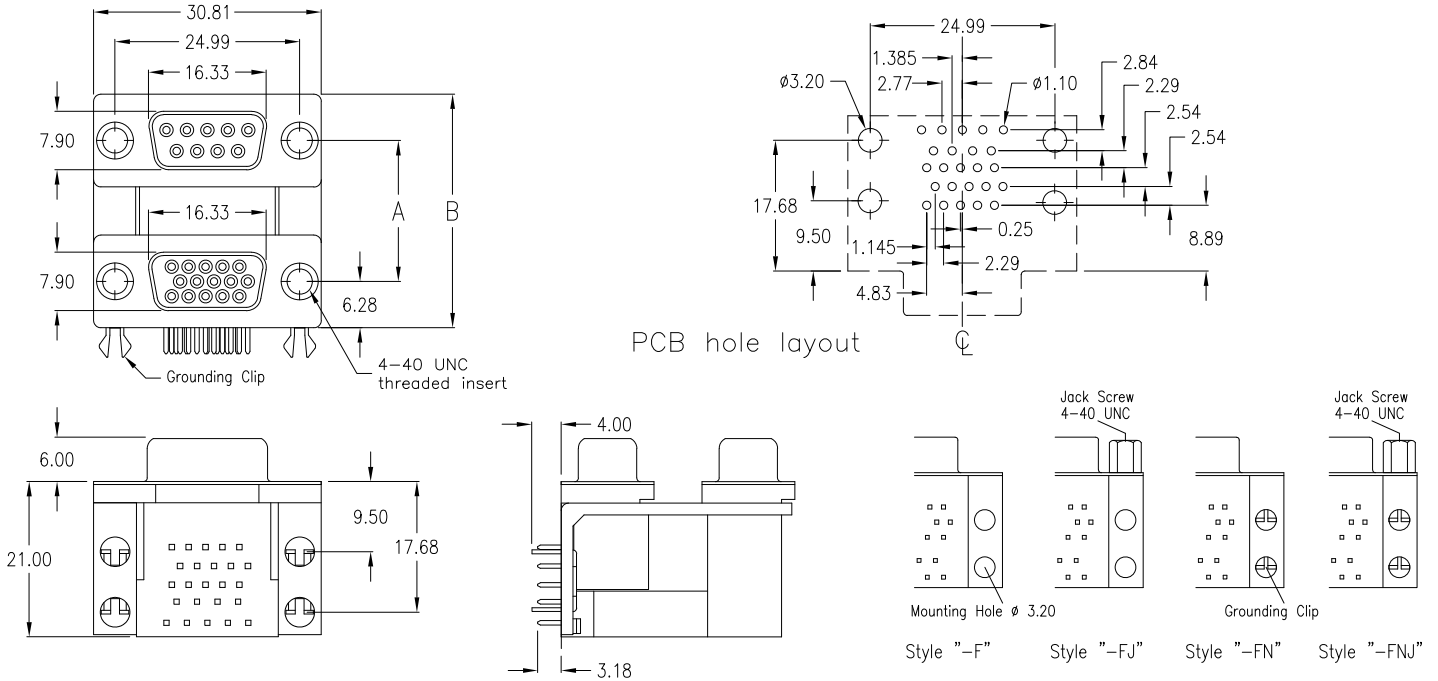

without grounding clips just 4 mounting holes	without grounding clips, just 4 mounting holes; 4 jack screws 4-40 UNC mounted	with 4 grounding clips (as above drawing)	with 4 grounding clips; 4 jack screws 4-40 UNC mounted	Distance Dimensions (mm)	
SDD-09H15-4-95-F	SDD-09H15-4-95-FJ	SDD-09H15-4-95-FN	SDD-09H15-4-95-FNJ	„A“ = 19.05	„B“ = 31.60
SDD-09H15-5-95-F	SDD-09H15-5-95-FJ	SDD-09H15-5-95-FN	SDD-09H15-5-95-FNJ	„A“ = 15.88	„B“ = 28.42

9-pin male / 15-pin HD female

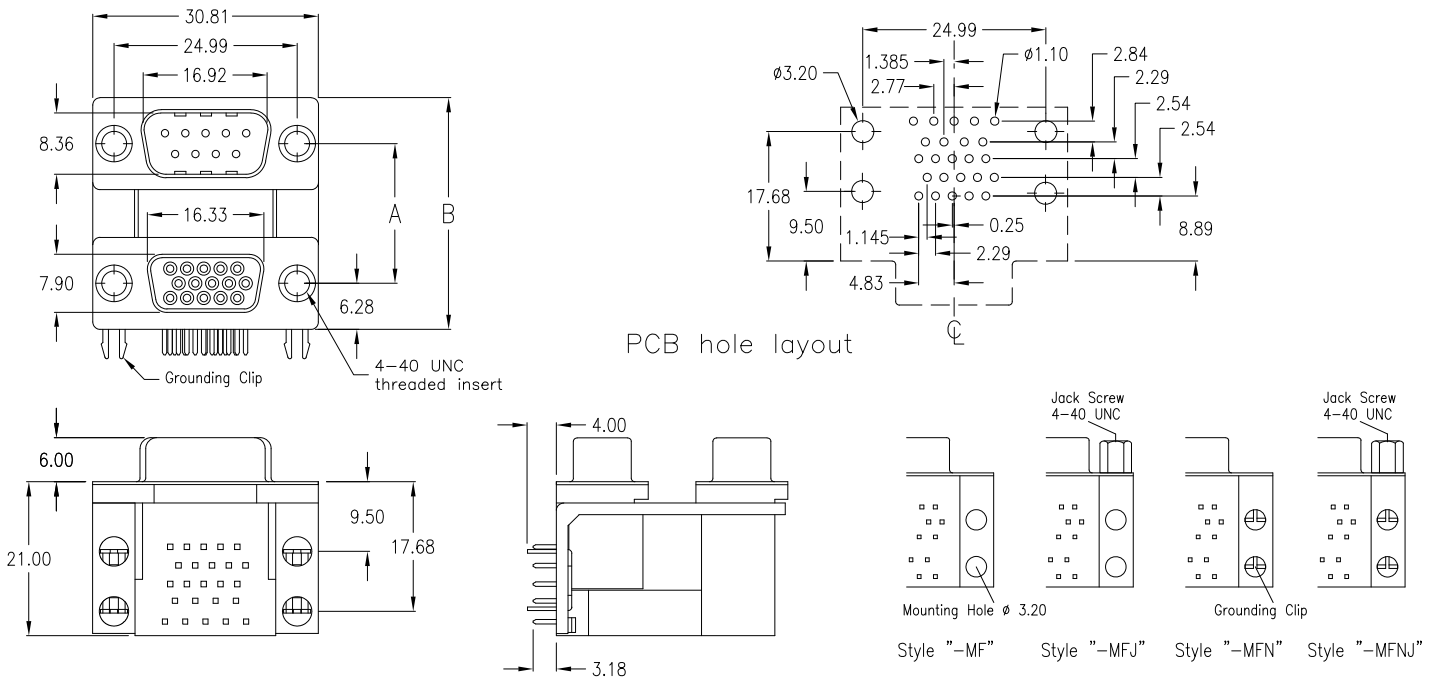

without grounding clips just 4 mounting holes	without grounding clips, just 4 mounting holes; 4 jack screws 4-40 UNC mounted	with 4 grounding clips (as above drawing)	with 4 grounding clips; 4 jack screws 4-40 UNC mounted	Distance Dimensions (mm)	
SDD-09H15-4-95-MF	SDD-09H15-4-95-MFJ	SDD-09H15-4-95-MFN	SDD-09H15-4-95-MFNJ	„A“ = 19.05	„B“ = 31.60
SDD-09H15-5-95-MF	SDD-09H15-5-95-MFJ	SDD-09H15-5-95-MFN	SDD-09H15-5-95-MFNJ	„A“ = 15.88	„B“ = 28.42

15-pin HD female / 15-pin HD male

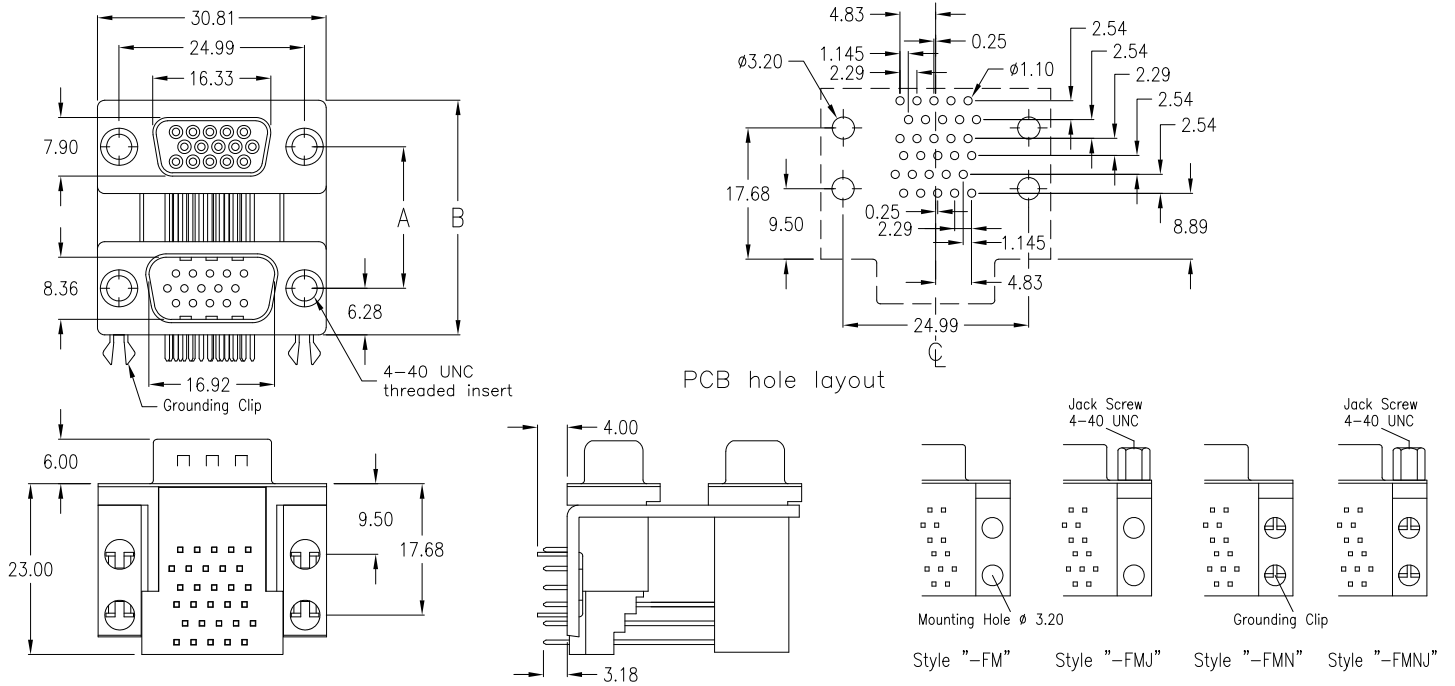

without grounding clips, just 4 mounting holes	without grounding clips, just 4 mounting holes; 4 jack screws 4-40 UNC mounted	with 4 grounding clips (as above drawing)	with 4 grounding clips; 4 jack screws 4-40 UNC mounted	Distance Dimensions (mm)	
SDD-H15H15-4-95-FM	SDD-H15H15-4-95-FMJ	SDD-H15H15-4-95-FMN	SDD-H15H15-4-95-FMNJ	„A“ = 19.05	„B“ = 31.60
SDD-H15H15-5-95-FM	SDD-H15H15-5-95-FMJ	SDD-H15H15-5-95-FMN	SDD-H15H15-5-95-FMNJ	„A“ = 15.88	„B“ = 28.42

15-pin HD female / 15-pin HD female

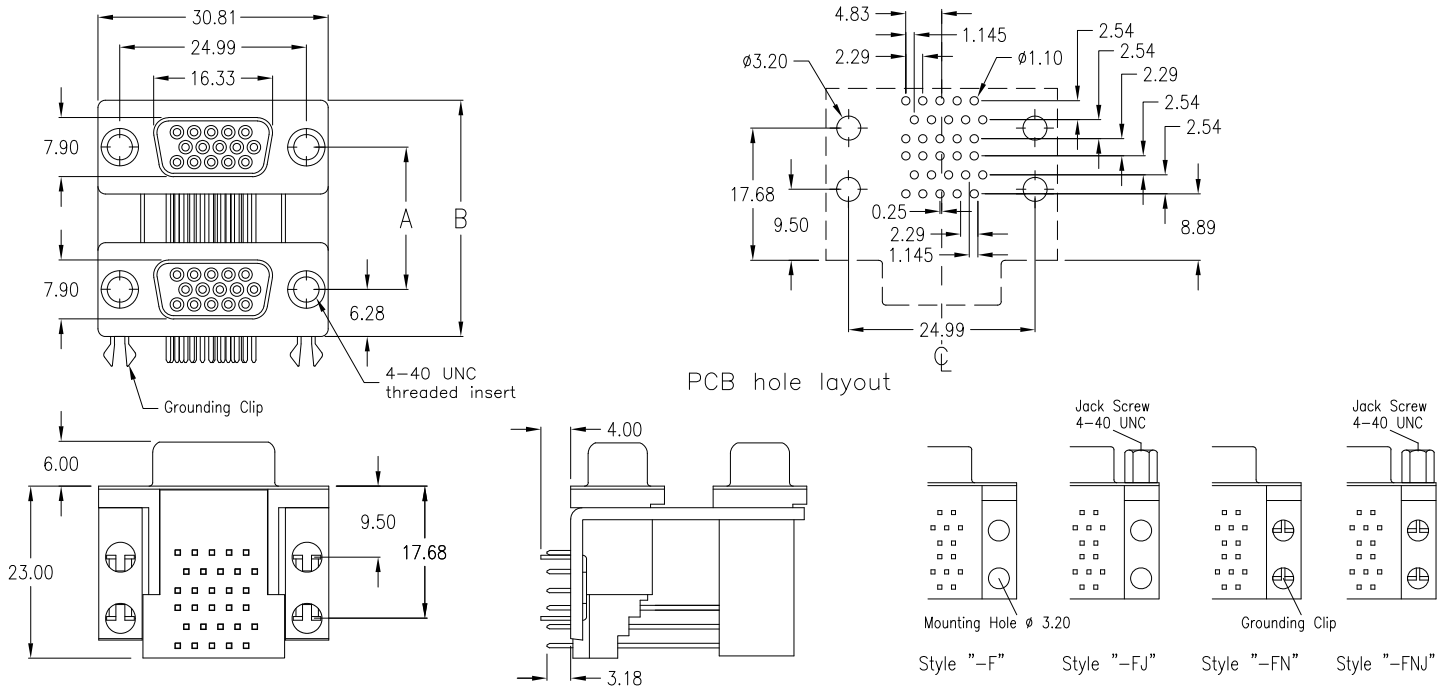

without grounding clips, just 4 mounting holes	without grounding clips, just 4 mounting holes; 4 jack screws 4-40 UNC mounted	with 4 grounding clips (as above drawing)	with 4 grounding clips; 4 jack screws 4-40 UNC mounted	Distance Dimensions (mm)	
SDD-H15H15-4-95-F	SDD-H15H15-4-95-FJ	SDD-H15H15-4-95-FN	SDD-H15H15-4-95-FNJ	„A“ = 19.05	„B“ = 31.60

26-pin HD female / 26-pin HD female

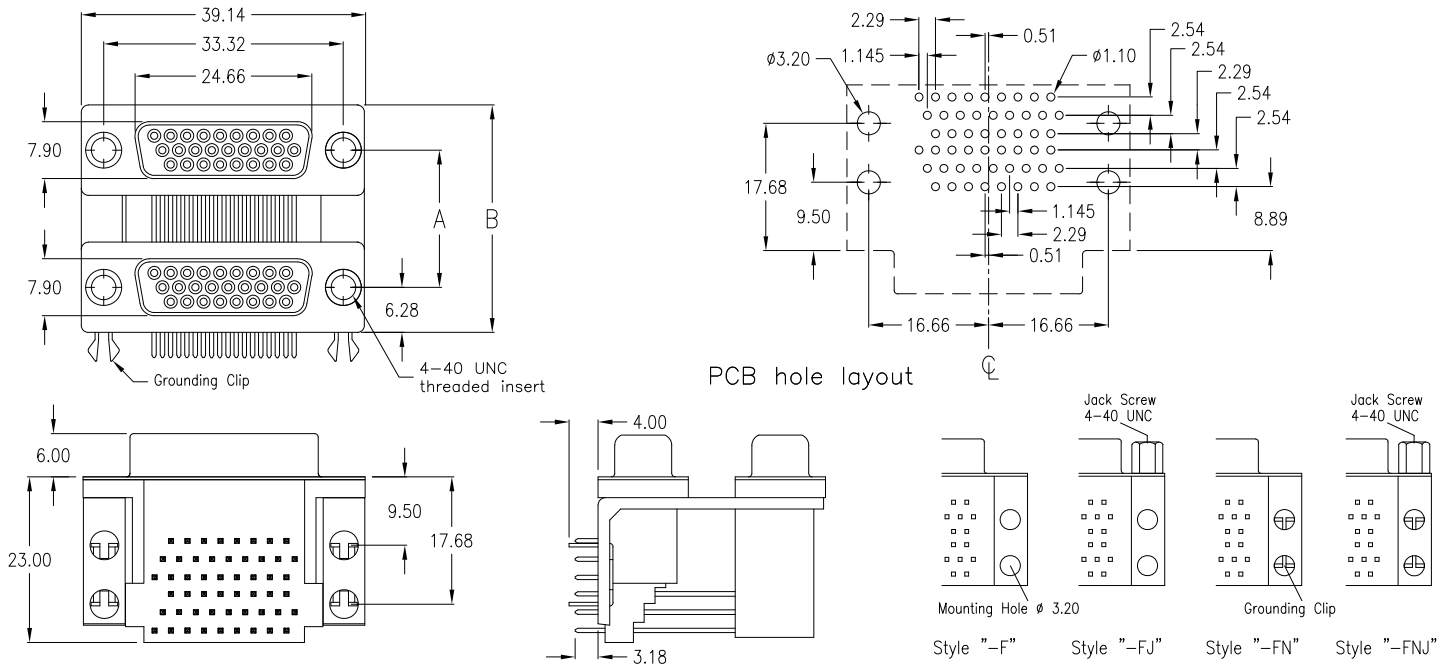

without grounding clips just 4 mounting holes	without grounding clips, just 4 mounting holes; 4 jack screws 4-40 UNC mounted	with 4 grounding clips (as above drawing)	with 4 grounding clips; 4 jack screws 4-40 UNC mounted	Distance Dimensions (mm)	
SDD-H26H26-4-95-F	SDD-H26H26-4-95-FJ	SDD-H26H26-4-95-FN	SDD-H26H26-4-95FNJ	„A“ = 19.05	„B“ = 31.60
SDD-H26H26-5-95-F	SDD-H26H26-5-95-FJ	SDD-H26H26-5-95-FN	SDD-H26H26-5-95FNJ	„A“ = 15.88	„B“ = 28.42

26-pin HD female / 26-pin HD male

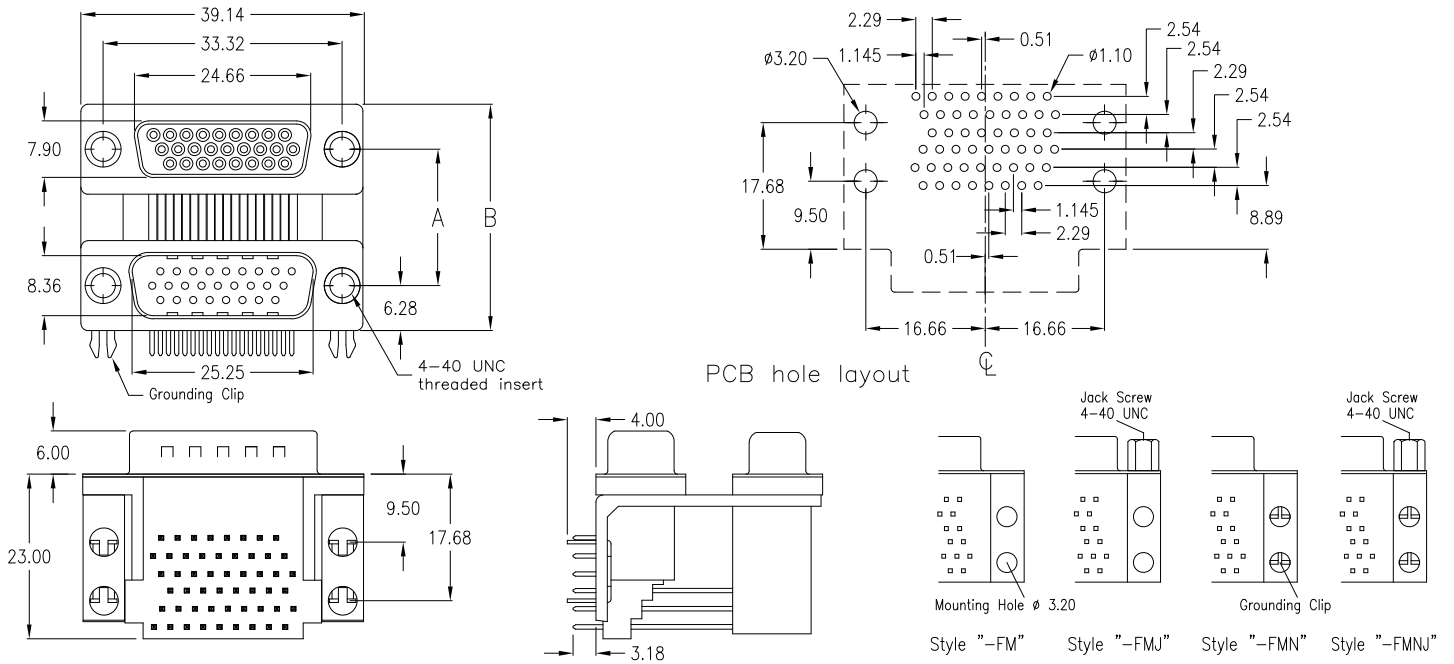

without grounding clips just 4 mounting holes	without grounding clips, just 4 mounting holes; 4 jack screws 4-40 UNC mounted	with 4 grounding clips (as above drawing)	with 4 grounding clips; 4 jack screws 4-40 UNC mounted	Distance Dimensions (mm)	
SDD-H26H26-4-95-FM	SDD-H26H26-4-95-FMJ	SDD-H26H26-4-95-FMN	SDD-H26H26-4-95FMNJ	„A“ = 19.05	„B“ = 31.60
SDD-H26H26-5-95-FM	SDD-H26H26-5-95-FMJ	SDD-H26H26-5-95-FMN	SDD-H26H26-5-95FMNJ	„A“ = 15.88	„B“ = 28.42

44-pin HD female / 44-pin HD female

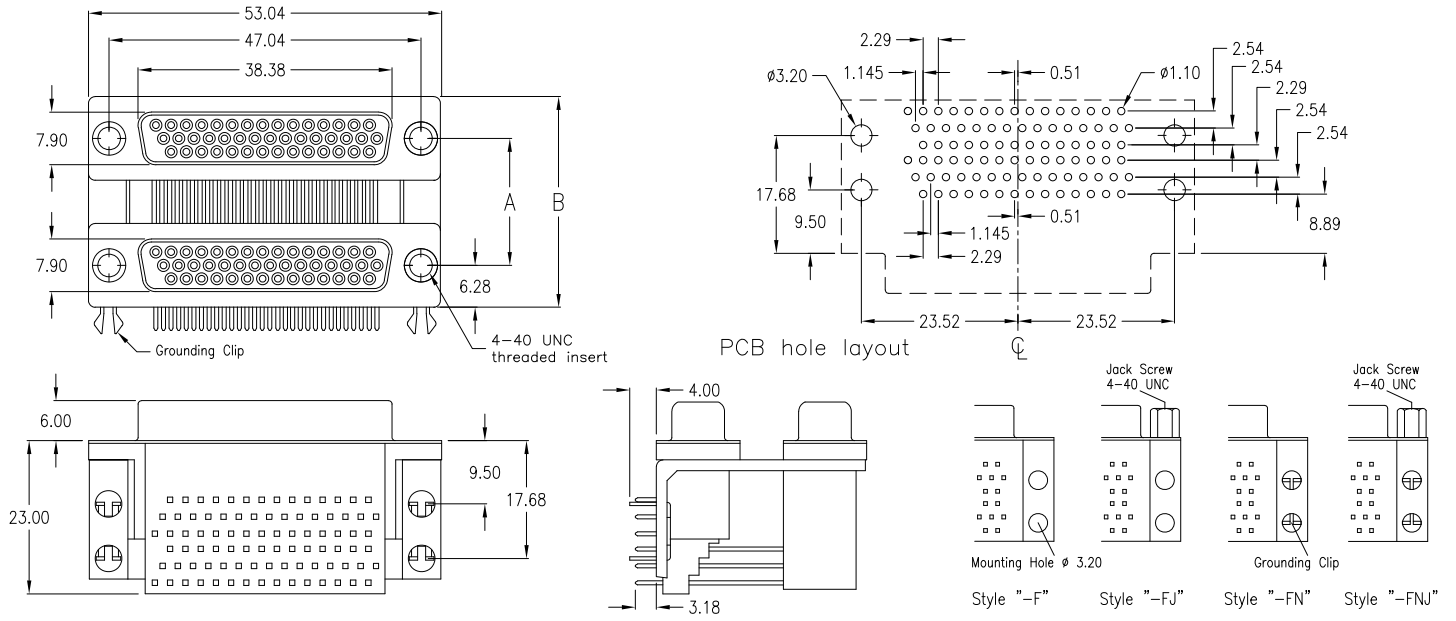

without grounding clips just 4 mounting holes	without grounding clips, just 4 mounting holes; 4 jack screws 4-40 UNC mounted	with 4 grounding clips (as above drawing)	with 4 grounding clips; 4 jack screws 4-40 UNC mounted	Distance Dimensions (mm)	
SDD-H44H44-4-95-F	SDD-H44H44-4-95-FJ	SDD-H44H44-4-95-FN	SDD-H44H44-4-95FNJ	„A“ = 19.05	„B“ = 31.60
SDD-H44H44-5-95-F	SDD-H44H44-5-95-FJ	SDD-H44H44-5-95-FN	SDD-H44H44-5-95FNJ	„A“ = 15.88	„B“ = 28.42

15-pin HD female raised

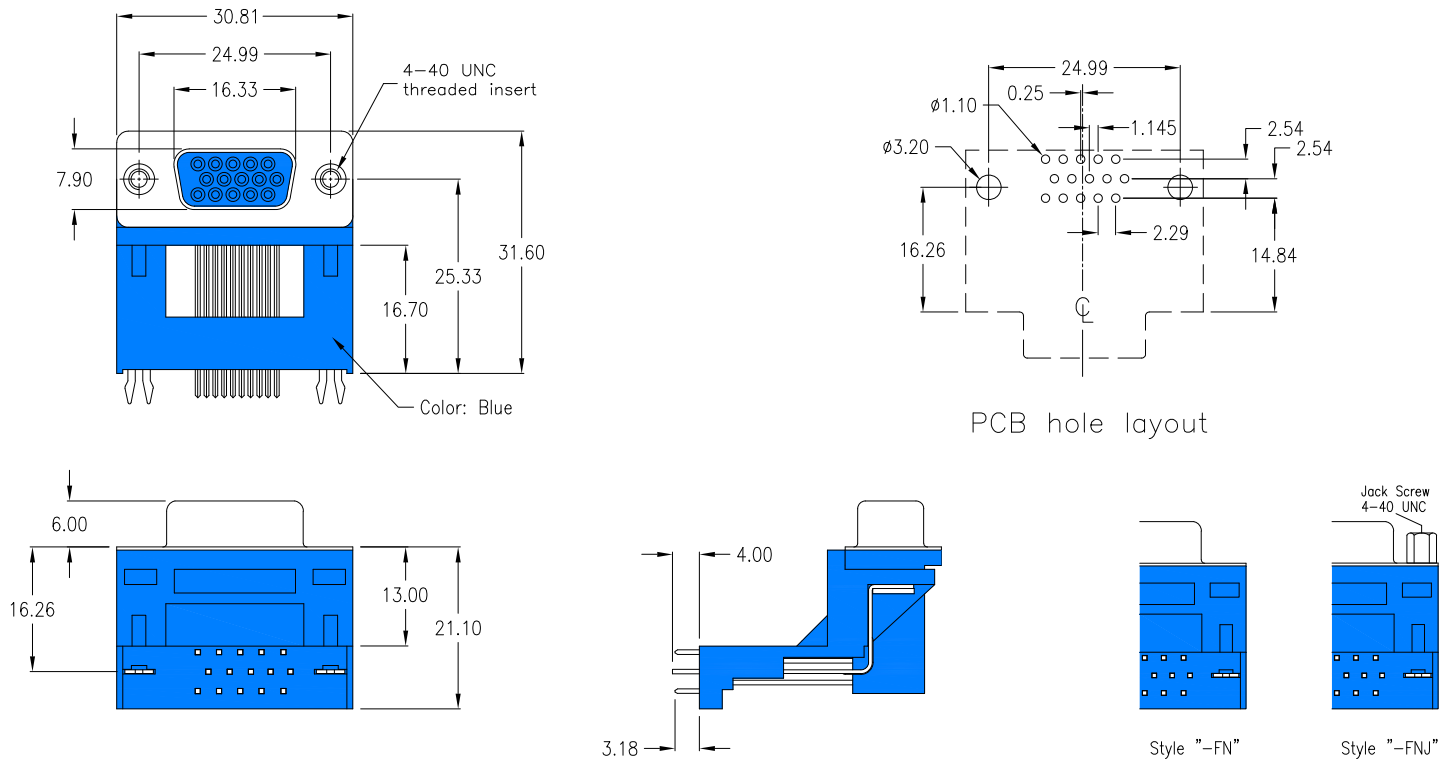

	with 2 grounding clips; w/o jack screws <i>Standard</i> (as above drawing)	with 2 grounding clips; 2 jack screws 4-40 UNC mounted <i>Option</i>	
	SDD-H1500-2-95-FN	SDD-H1500-2-95-FNJ	

D-Sub

Accessories & Technical Data

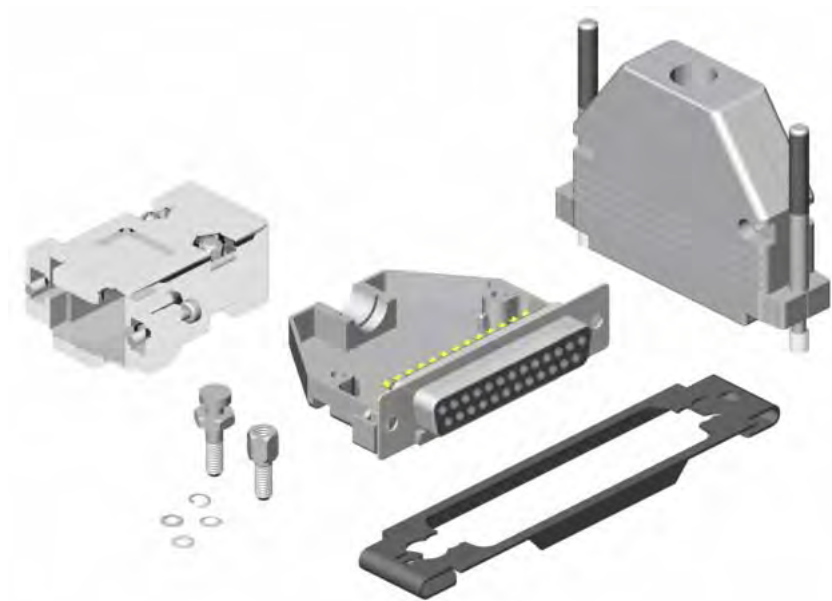

E-tec's D-Sub Connector accessories.

EMI / RFI full metal hoods, plastic and plastic metallized hoods.

Slide lock parts and a variety of jack screws.

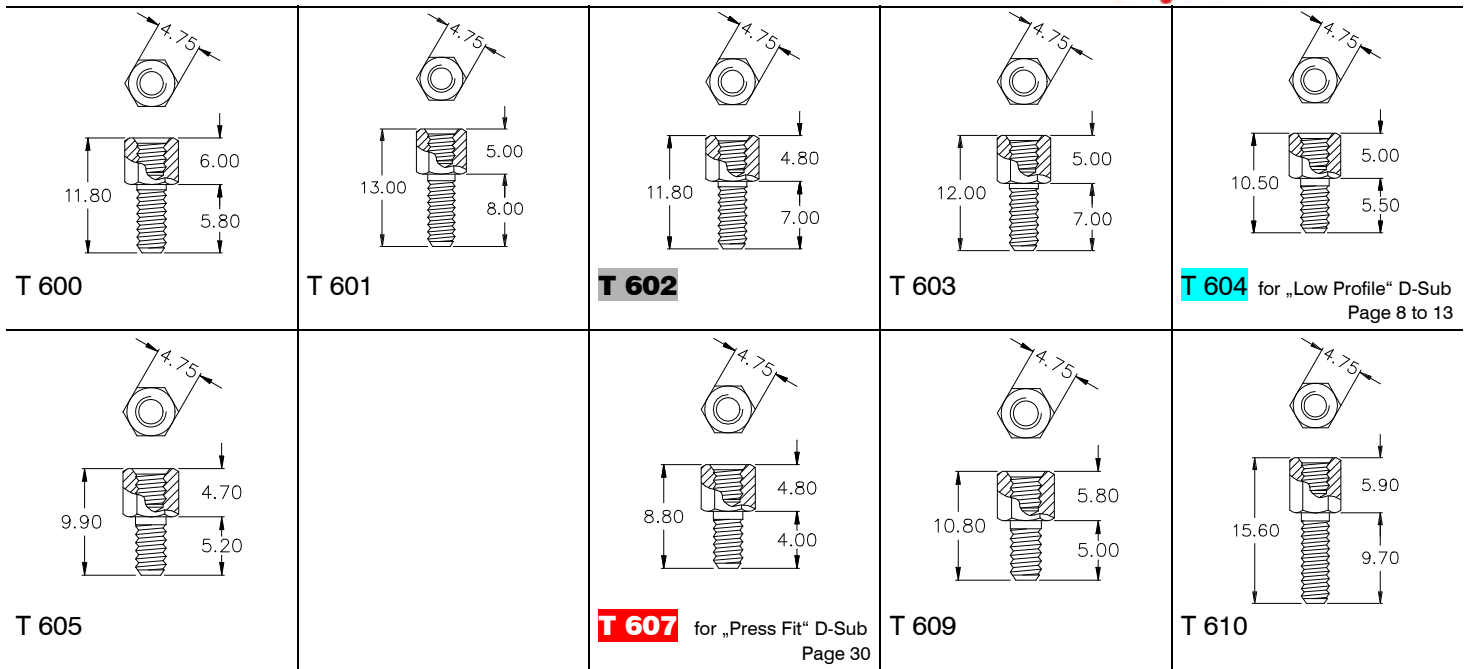

Ordering Code

JSR - xxx - X xxx - NN

thread combination		thread combi-code
inside	outside	
M 2,6	4-40 UNC	244
2-56 UNC	2-56 UNC	256
M 3	M 3	300
M 3	M 2,6	326
M 3	4-40 UNC	344
4-40 UNC	4-40 UNC	440
4-40 UNC	M 3	443

size type

T 600	
T 601	
T 602	standard type
T 603	
T 604	for „Low Profile“ D-Sub; Page 8 to 13
T 605	
T 607	for „press fit“ D-Sub; Page 30
T 609	
T 610	

If you order D-Sub connector assembled with Jack screw, T602 type always will be delivered.

Jack Screws with other dimension, also round head, are available on request.

Slide locking accessories

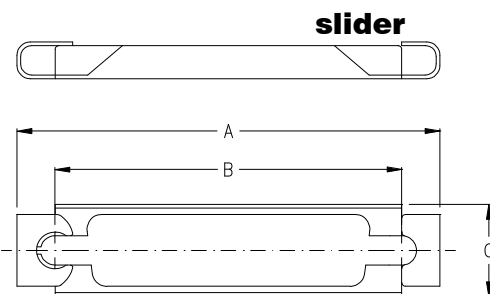

slider

A set of slider consists of:

- * 1 frame
- * 2 screws 4-40 UNC
- * 2 washers
- * 2 nuts 4-40 UNC

Ordering Code

SLO - xxx - T 106 - NN

No. of contacts

009 - 015 - 025 other sizes on request

locking post

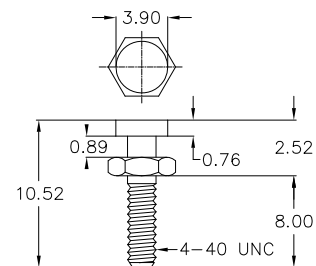

Ordering Code

JLP - 440 - T 106 - NN

If you want to have assembled to the D-Sub connector direct, please ask the nearest E-tec office or Distributor

Jack Screws and Slide locking accessories are Nickel plated

metal hood

materials *RoHS compliant*

hood: zinc alloy Nickel plated

screw: steel

Please ask for detail drawing each type.

Dimension				D-Sub contacts
A	B	C	D	
24.99	31.00	47.00	7.00	009 / 015 (HD)
33.32	40.00	48.20	10.00	015 / 026 (HD)
47.04	53.30	48.70	14.00	025 / 044 (HD)
63.50	69.00	48.60	14.00	037 / 062 (HD)
61.11	67.00	48.30	14.00	050 / 078 (HD)

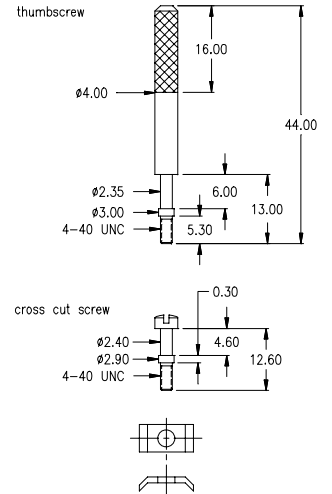
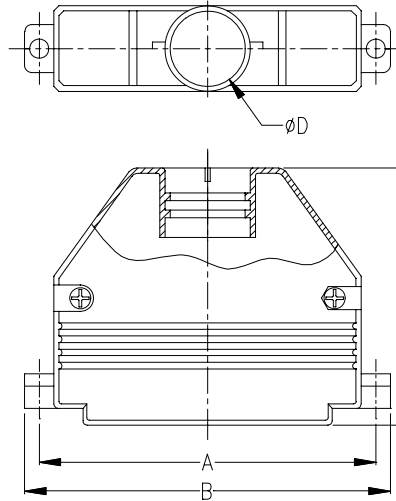

Ordering Code

HSM - xxx - S xxx - xx Z

Size Code	screw type	cable exit
009 = 9-pole Std. / 15-pole HD 015 = 15-pole Std. / 26-pole HD 025 = 25-pole Std. / 44-pole HD 037 = 37-pole Std. / 62-pole HD 050 = 50-pole Std. / 78-pole HD	101 = cross cut screw not available for 90° cable exit 102 = thumbscrew others on request	00 = straight 90 = 90° with Rubber grommet: 0R = straight 9R = 90° 90° cable exit only for size code 009/H15 015/H26 025/H44

plastic hood

materials *RoHS compliant*

hood: PBT UL 94-V0

screw: steel

Please ask for detail drawing each type.

Dimension				D-Sub contacts
A	B	C	D	
24.99	30.80	40.50	7.00	009 / 015 (HD)
33.32	39.70	38.80	9.70	015 / 026 (HD)
47.04	55.00	44.50	14.00	025 / 044 (HD)
63.50	69.00	52.50	14.00	037 / 062 (HD)
61.11	67.00	48.30	14.00	050 / 078 (HD)

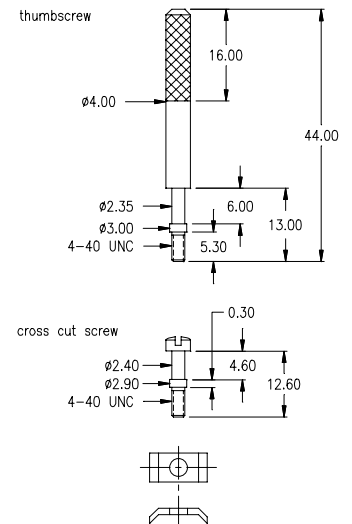
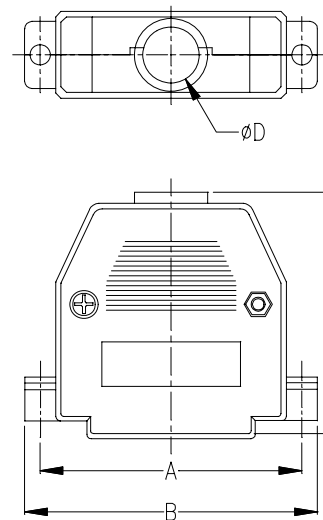

Ordering Code

HS X - xxx - S xxx - xx Z

colour / type	Size Code	screw type	cable exit
B = black G = grey C = chromated others on request	009 = 9-pole Std. / 15-pole HD 015 = 15-pole Std. / 26-pole HD 025 = 25-pole Std. / 44-pole HD 037 = 37-pole Std. / 62-pole HD 050 = 50-pole Std. / 78-pole HD	101 = cross cut screw not available for 45° cable exit 102 = thumbscrew others on request	00 = straight 45 = 45°



mechanical data

Mating force per contact	≤ 3,4 N
Unmating force per contact	≥ 0,2 N
Temperature range	-55° C to +105° C
Processing temperature wave solder (solder bath)	+250°C +0/-5°C for 10sec.
Processing temperature SMT and “pin in paste”	+250°C +0/-5°C for 10sec.
Moisture absorption from air 50% rh	0,10%
IDC Connector types accept AWG 26 or AWG 28 standard wire	

materials and plating (RoHS compliant)

Insulator for wave solder technology, standard black - PC 99 colourful insulator	thermoplastic glassfilled UL 94V – 0 Yellowish brown - Pantone # 131C 15-pos. female Burgundy - Pantone # 235C 25-pos. female Teal - Pantone # 322C 9-pos. male Blue - Pantone # 661C HD 15-pos. female
Insulator for SMT and “Pin-In-Paste”	Nylon UL 94V-0
Shell	Steel, Ni plated
Bracket	Brass, tin plated
Male contact - plating	Copper Alloy (Standard; others on request) -95 = solder side Sn; contact side Au over Ni -55 = solder and contact side Au over Ni
Female contact - plating	Copper Alloy (Standard; others on request) -95 = solder side Sn; contact side Au over Ni -55 = solder and contact side Au over Ni -NN = Ni
D-Sub Accessories (page 70) plating	

electrical data

max. Current rating	5 A/25°C 3 A/70°C (High Density types 3A / IDC types 1A)
Operating voltage	250 V
Test voltage between contacts	1000 V / 50/60 Hz / 1 Minute
Test voltage between shell and contacts	1000 V / 50/60 Hz / 1 Minute
Resistance between mated contacts	< 30 m Ω
Insulation resistance	≥ 1000 MΩ at 500V DC
Dielectric strength	1000 V AC min. for 1 Minute
Volume resistivity	10 ¹⁶ Ω cm (ASTM-D 257)

available performance classes

E-tec D-Sub connectors comply with Performance Class 3 (min. 50 contact cycles).
Please contact E-tec first for availability of Performance Class 2 (min. 200 contact cycles) and 1 (min. 500 contact cycles)

D-Sub with Filter (ferrite)

Frequency range	10 - 300 MHz
Impedance	5 MHz - 15 Ω
	25 MHz - 30 Ω
	100 MHz - 50 Ω
	300 MHz - 75 Ω

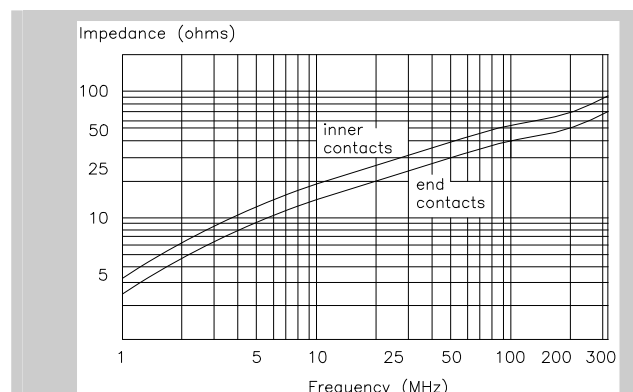

U S B & IEEE 1394 Connectors

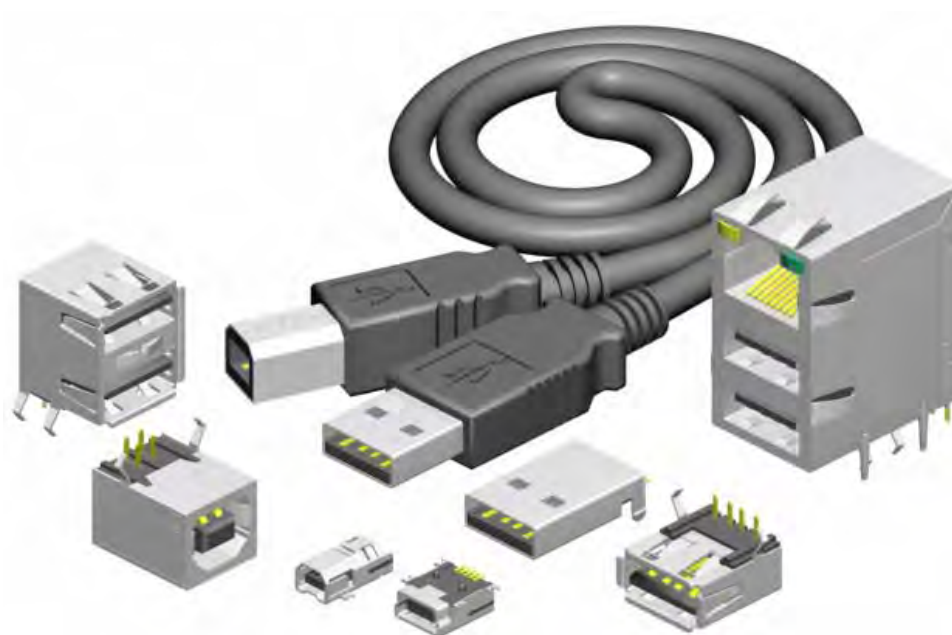

The USB (Universal Serial Bus) connectors allow „plug & play“ connection of peripherals to PC ´s.

Hot plugging and automatic reconfiguration are the main advantages of this technology.

The USB product line comprises SMT and thru-hole PCB mounting connectors, all of which comply to international standards.

USB & IEEE1394 cable assemblies are available on request or please refer to www.e-tec.com for more details.

USS Series

USB Connector Type „A”



single port right angle; soldertail

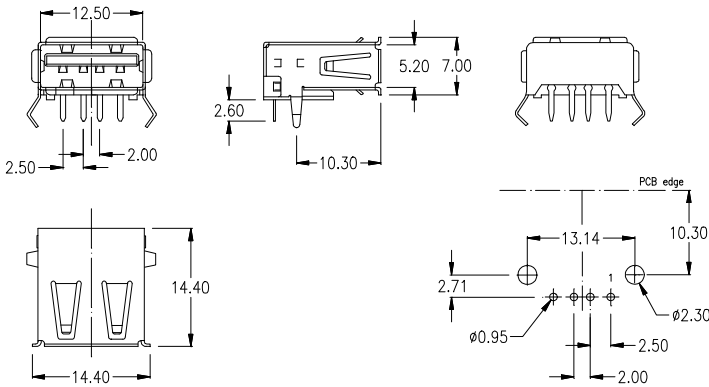

ORDER CODE:
 USB 1.0 corresponding **USS - W04 - RA01 - 95** (- B04 - if black housing)
 USB 2.0 corresponding **USS - W04 - RA21 - 98** (- B04 - if black housing)

“low profile” single port right angle; soldertail

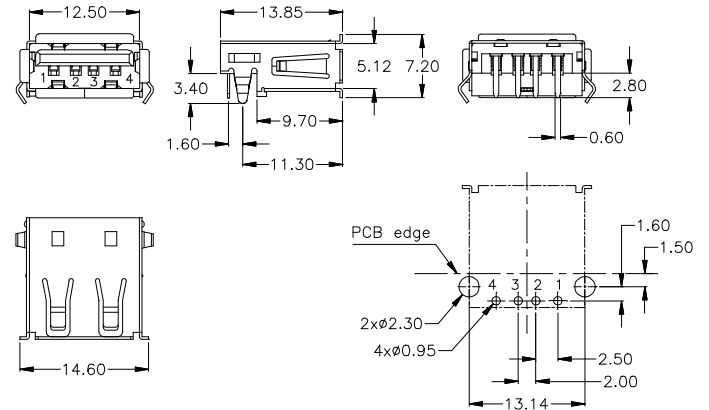

ORDER CODE:
 USB 1.0 corresponding **ULS - W04 - RAS0 - 95** (- B04 - if black housing)
 USB 2.0 corresponding **ULS - W04 - RAS2 - 98** (- B04 - if black housing)

single port right angle; SMT

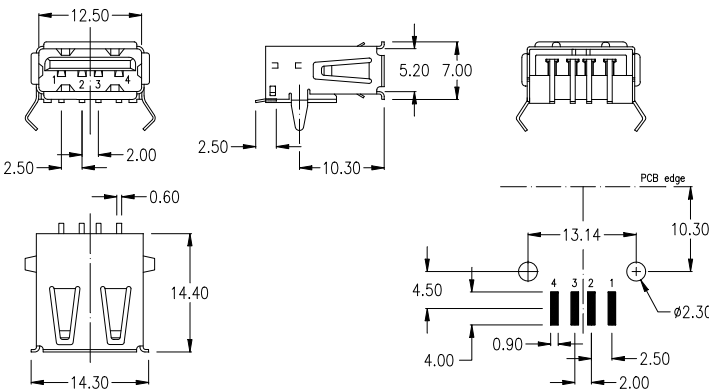

ORDER CODE:
 USB 1.0 corresponding **USS - W04 - SAS0 - 95** (- B04 - if black housing)
 USB 2.0 corresponding **USS - W04 - SAS2 - 98** (- B04 - if black housing)
 Please contact your closest E-tec sales office for order code if reel packaging is required.

“low profile” single port right angle; SMT

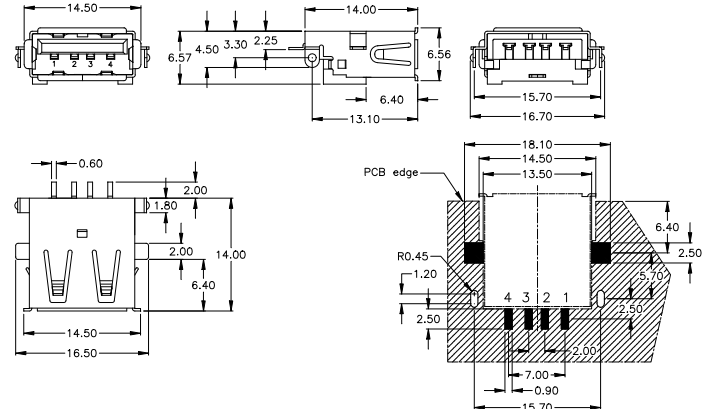

ORDER CODE:
 USB 1.0 corresponding **ULS - W04 - SAS0 - 95** (- B04 - if black housing)
 USB 2.0 corresponding **ULS - W04 - SAS2 - 98** (- B04 - if black housing)
 Please contact your closest E-tec sales office for order code if reel packaging is required.

single port top entry; soldertail

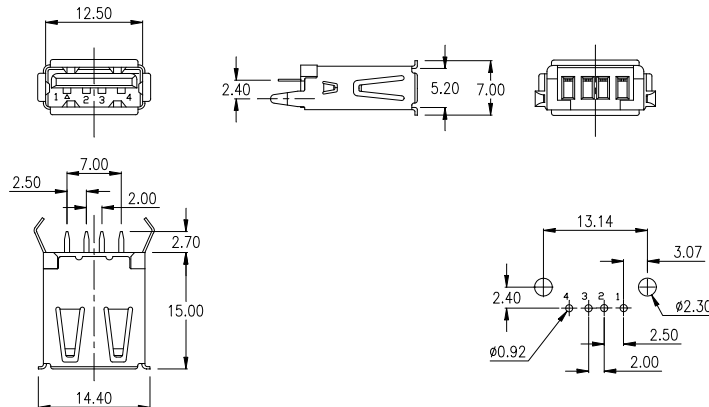

ORDER CODE:
 USB 1.0 corresponding **USS - W04 - TA01 - 95** (- B04 - if black housing)
 USB 2.0 corresponding **USS - W04 - TA21 - 98** (- B04 - if black housing)

single port vertical; soldertail „one line foot”

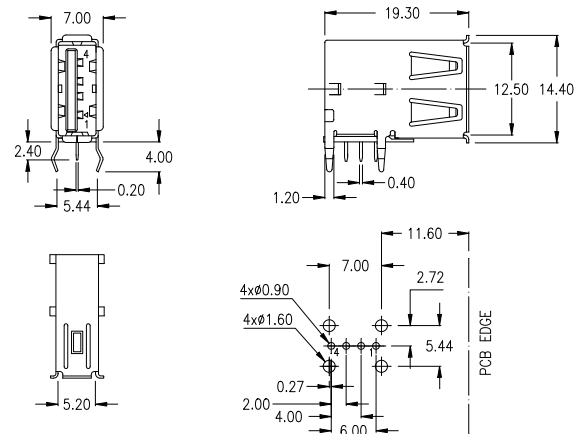

ORDER CODE:
 USB 1.0 corresponding **USS - W04 - VA01 - 95** (- B04 - if black housing)
 USB 2.0 corresponding **USS - W04 - VA21 - 98** (- B04 - if black housing)

Specification

Material

Contact	(RoHS compliant)	Phosphor bronze
Plating:	Contact area	Au flash over Ni (USB 1.0 corresponding) Au 30µ" over Ni (USB 2.0 corresponding)
	Solder area	Sn (leadfree)
Housing	(RoHS compliant)	PBT white UL 94-V0 (PBT black on request)
SMT Housing	(RoHS compliant)	Nylon 9T UL 94-V0
Shell	(RoHS compliant)	brass, 80µ"-120µ" Ni plated

Mechanical

Mating cycles	1.500 min.
---------------	------------

Electrical

Current rating	1,5 A max. 1 Contact (Signal only)
Voltage rating	30V AC (rms)
Withstanding voltage	750V AC (rms) 1 Minute (USB 1.0) 500V AC (rms) 1 Minute (USB 2.0)
Insulation resistance	1.000MΩ min. (500V DC)
Contact resistance	30mΩ max.

Others

Operating temperature	-55° C to +85° C
Processing temp. for SMT type	+260° C for 10 sec. max.

USS Series Multi Port USB Connector Type „A”



dual port right angle; soldertail

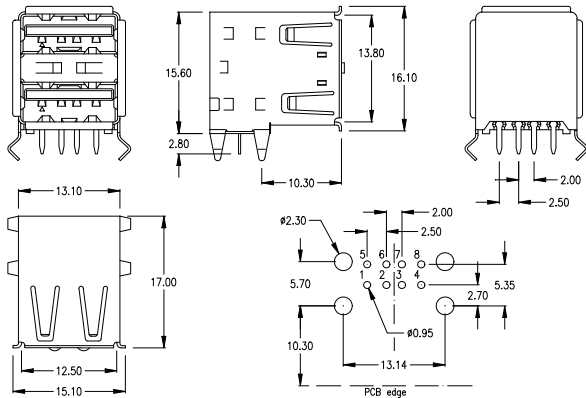

ORDER CODE:

USB 1.0 corresponding **USS - W08 - RA02 - 95** (- B08 - if black housing)
 USB 2.0 corresponding **USS - W08 - RA22 - 98** (- B08 - if black housing)

dual port "low profile" right angle; soldertail

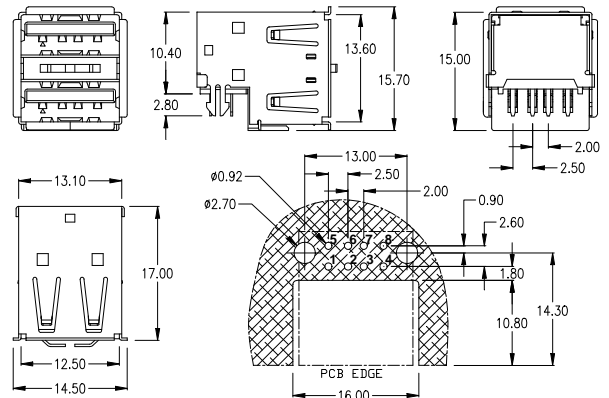

ORDER CODE:

USB 1.0 corresponding **ULS - W08 - RA02 - 95** (- B08 - if black housing)
 USB 2.0 corresponding **ULS - W08 - RA22 - 98** (- B08 - if black housing)

triple port right angle; soldertail

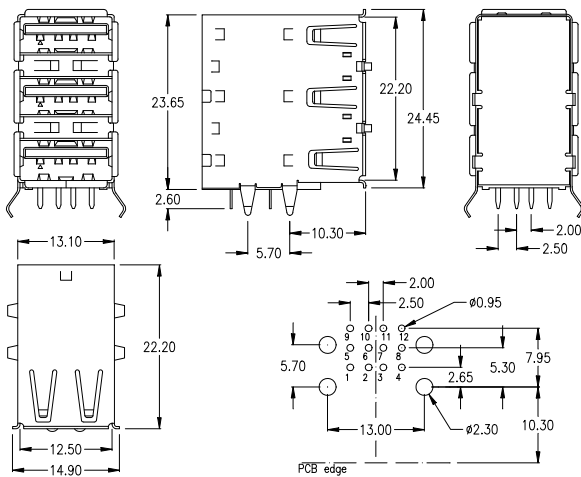

ORDER CODE:

USB 1.0 corresponding **USS - B12 - RA03 - 95** (- W12 - if white housing)
 USB 2.0 corresponding **USS - B12 - RA23 - 98** (- W12 - if white housing)

quad port right angle; soldertail

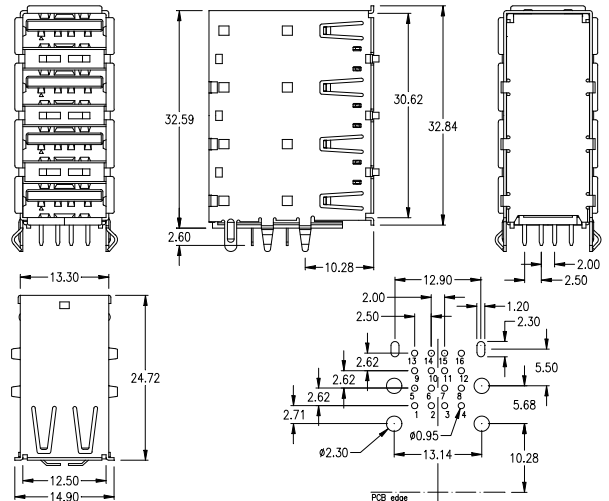

ORDER CODE:

USB 1.0 corresponding **USS - B16 - RA04 - 95** (- W16 - if white housing)
 USB 2.0 corresponding **USS - B16 - RA24 - 98** (- W16 - if white housing)

dual port "top entry"; soldertail

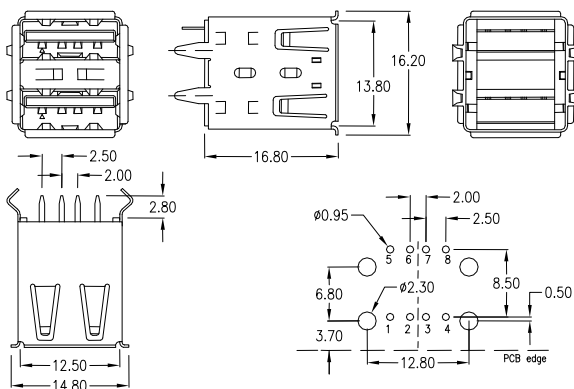

ORDER CODE:

USB 1.0 corresponding **USS - W08 - TA02 - 95** (- B08 - if black housing)
 USB 2.0 corresponding **USS - W08 - TA22 - 98** (- B08 - if black housing)

USB / RJ45 Combi Multi Port

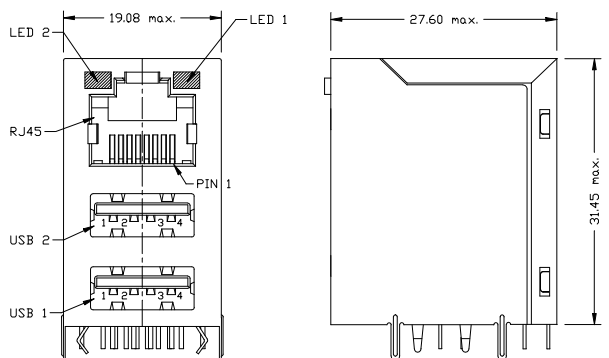

E-tec also offers a USB / RJ45 Combi Multi Port as TX filtered transformer type with integrated LED.
 Datasheets of the different available variations can be obtained on www.e-tec.com or from your closest E-tec sales office.

Specification

Material

Contact	(RoHS compliant) Phosphor Bronze
Plating:	
Contact area	Au flash over Ni (USB 1.0 corresponding) Au 30µ" over Ni (USB 2.0 corresponding)
Solder area	Sn (leadfree)
Housing	(RoHS compliant) PBT UL 94-V0
Shell	(RoHS compliant) Brass, 80µ"-120µ" Ni plated
Mechanical	
Mating cycles	1.500 min.

Electrical

Current rating	1,5 A max. 1 Contact (Signal only)
Voltage rating	30V AC (rms)
Withstanding voltage	750V AC (rms) 1 Minute (USB 1.0) 500V AC (rms) 1 Minute (USB 2.0)
Insulation resistance	1.000MΩ min. (500V DC)
Contact resistance	30mΩ max.

Others

Operating temperature	-55° C to +85° C
-----------------------	------------------

USS Series USB 3.0 Connector Type „A”



single port right angle; soldertail

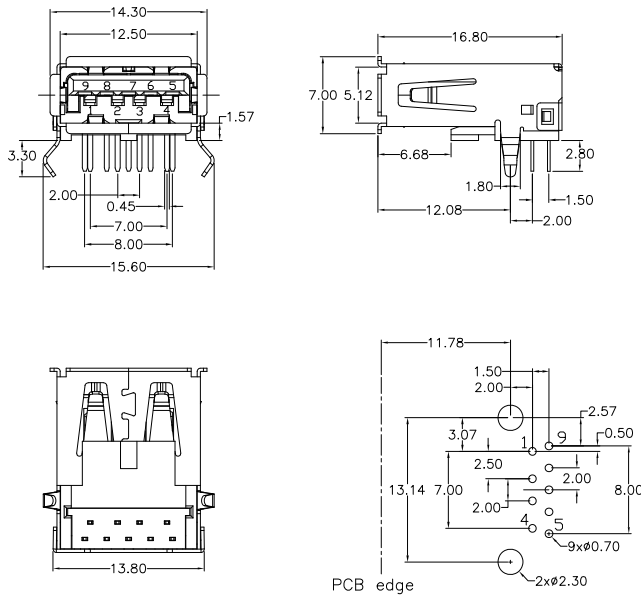

ORDER CODE: **USS - BU09 - RA31 - 98**

dual port right angle; soldertail

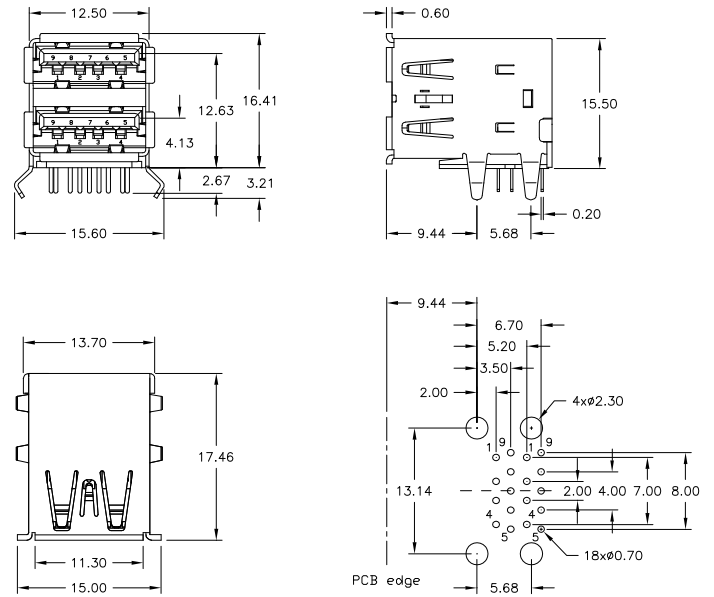

ORDER CODE: **USS - BU18 - RA32 - 98**

Specification

Material

Contact	Phosphor bronze
Plating:	
Contact area	Au 30 μ m over Ni
Solder area	Sn (<i>leadfree</i>)
Housing (Single port)	P.B.T. UL 94-V0 blue
Housing (Dual port)	Nylon 9T UL 94-HB blue
Shell (Single port)	Steel, 80 μ m-120 μ m Ni plated
Shell (Dual port)	Brass, 80 μ m-120 μ m Ni plated

Mechanical

Mating cycles 1.500 min.

Electrical

Current rating 1,8 A max. 1 Contact (Signal only)
 Voltage rating 100V AC (rms)
 Withstanding voltage 500V AC (rms) 1 Minute
 Insulation resistance 100M Ω min. (500V DC)
 Contact resistance 30m Ω max.

Others

Operating temperature -55 $^{\circ}$ C to +85 $^{\circ}$ C

SMT Type

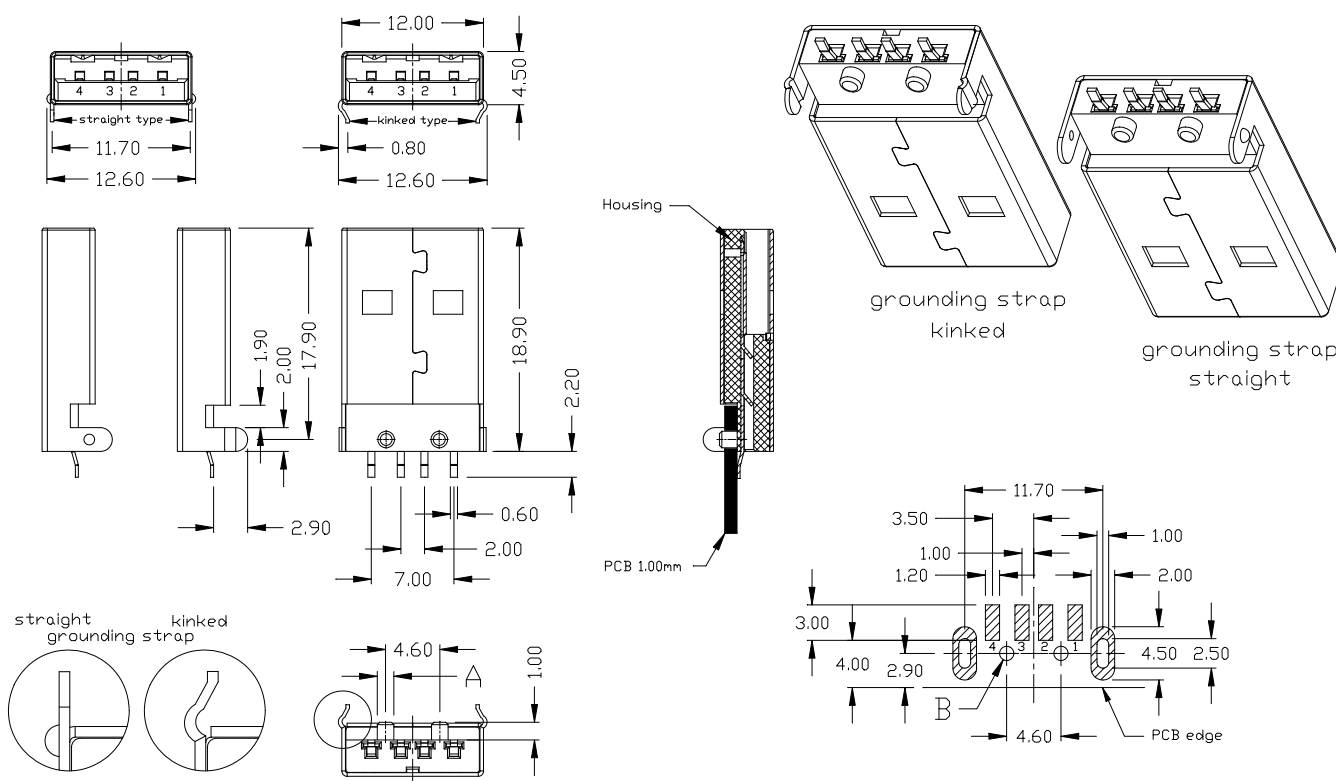

Recommendation:

DIM. "B" = \varnothing 1,20mm if locating peg \varnothing "A"=1,00mm
DIM. "B" = \varnothing 1,60mm if locating peg \varnothing "A"=1,40mm

ORDER CODE

USP - B 04 - SA x x - XX

Housing Colour

Black (Standard) = **B**
others on request

USB Corresponding

- 1 - 95** = USB 1.0 corresponding
- 2 - 98** = USB 2.0 corresponding

Execution

- 0** = kinked grounding pins; locating pegs \varnothing 1.00mm
- 1** = straight grounding pins; locating pegs \varnothing 1.00mm
- 2** = kinked grounding pins; locating pegs \varnothing 1.40mm
- 3** = straight grounding pins; locating pegs \varnothing 1.40mm
(for locating peg dim. pls. go to drawing DIM. "A")

Specification

Material

Contact (RoHS compliant)	Brass
Plating:	
Contact area	Au flash over Ni (USB 1.0 corresponding) Au 30 μ " over Ni (USB 2.0 corresponding)
Solder area	Sn (leadfree)
Housing (RoHS compliant)	Nylon UL 94-V0
Shell (RoHS compliant)	brass, 80 μ "-120 μ " Ni plated

Mechanical

Mating cycles	1.500 min.
SMT coplanarity	0.10mm

Electrical

Current rating	1 A max. 1 Contact (Signal only)
Voltage rating	30V AC (rms)
Withstanding voltage	750V AC (rms) 1 Minute (USB 1.0) 500V AC (rms) 1 Minute (USB 2.0)
Insulation resistance	1.000M Ω min. (500V DC)
Contact resistance	30m Ω max.

Others

Operating temperature	-55° C to +85° C
Processing temperature	+260° C for 10 sec. max.

Mini "A" Type 4 Pin

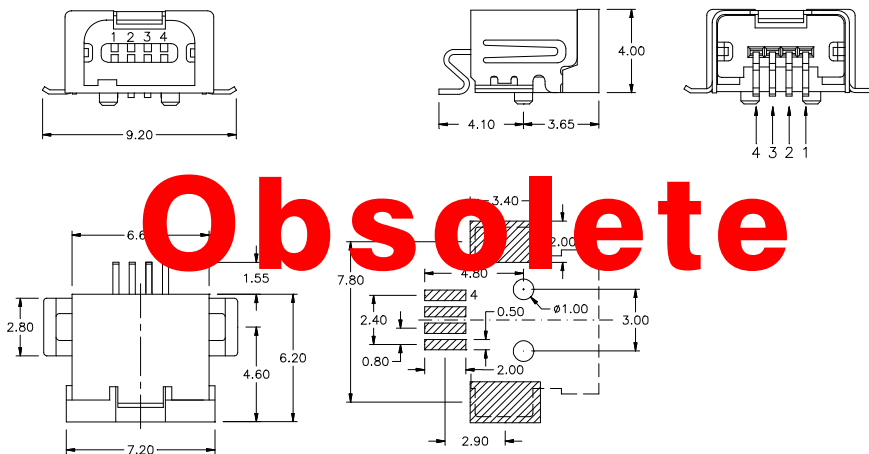

Specification:

Material

Contact (RoHS compliant) PhBz
Plating:
Contact area Au flash over Ni
Solder area Sn (leadfree) over Ni
Housing (RoHS compliant) Nylon 6T black
UL 94-V0
Shell (RoHS compliant) Steel, 80µ"-120µ" Ni plated

Electrical

Current rating 1 A
Voltage rating AC 30V (rms)
Withstanding voltage 100V AC (rms) 1 Minute
Insulation resistance 100MΩ min. (500V DC)
Contact resistance 50mΩ max.

Mechanical

Mating cycles 5.000 min.

Others

Operating temp. -55° C to +85° C
Processing temp. +260° C for 10 sec. max..

ORDER CODE **USB 1.0** corresponding: **UMS - B04 - SAS0 - 95**

Please contact your closest E-tec sales office for order code if reel packaging is required.

Mini "B" Type 4 Pin

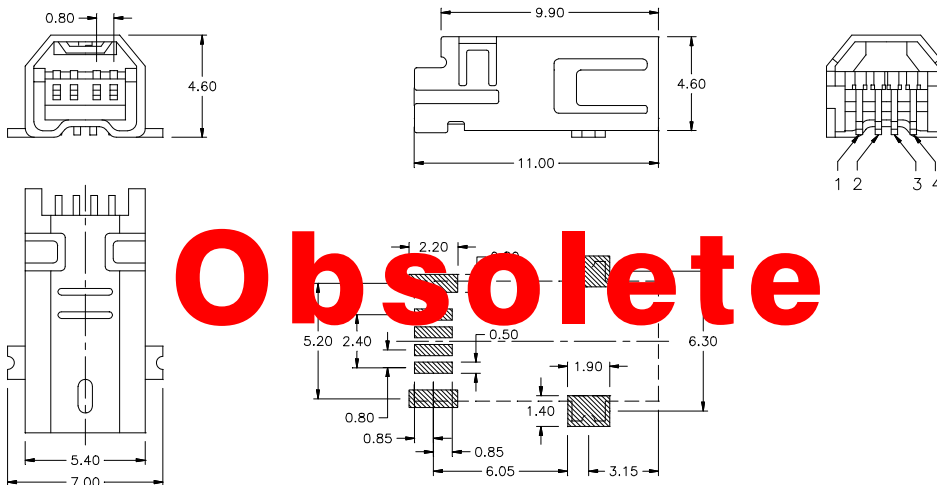

Specification:

Material

Contact (RoHS compliant) PhBz
Plating:
Contact area -95 = Au flash over Ni
-98 = Au 30µ" over Ni
Solder area tin (leadfree) over nickel
Housing (RoHS compliant) Nylon 6T black
UL 94-V0
Shell (RoHS compliant) brass, Sn plated

Electrical

Current rating 1 A
Voltage rating AC 30V (rms)
Withstanding voltage 100V AC (rms) 1 Minute
Insulation resistance 100MΩ min. (500V DC)
Contact resistance 50mΩ max.

Mechanical

Mating cycles 5.000 min.

Others

Operating temp. -55° C to +85° C
Processing temp. +260° C for 10 sec. max.

ORDER CODE **USB 1.0** corresponding: **UMS - B04 - SBS0 - 95**

ORDER CODE **USB 2.0** corresponding: **UMS - B04 - SBS2 - 98**

Please contact your closest E-tec sales office for order code if reel packaging is required.

Mini "B" Type 5 Pin

correspond to USB 2.0

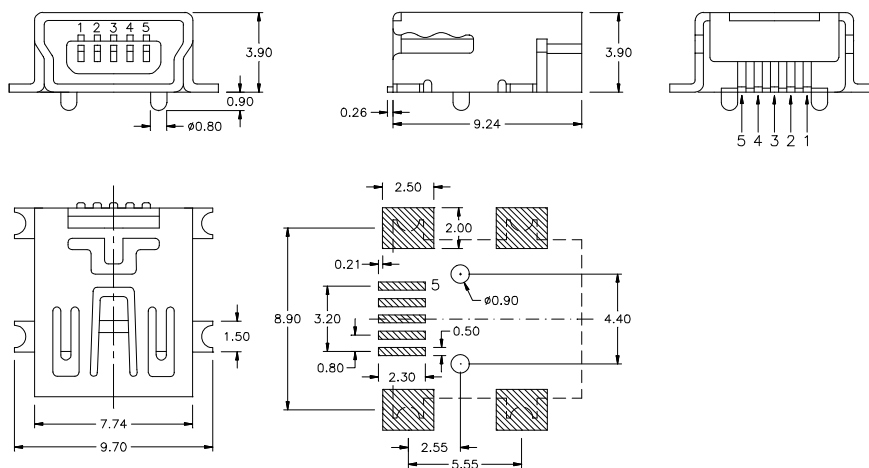

Specification:

Material

Contact (RoHS compliant) PhBz
Plating:
Contact area -98 = Au 30µ" over Ni
Solder area Sn (leadfree) over Ni
Housing (RoHS compliant) Nylon 6T black
UL 94-V0
Shell (RoHS compliant) Steel, 80µ"-120µ" Ni plated

Electrical

Current rating 1 A
Voltage rating AC 30V (rms)
Withstanding voltage 100V AC (rms) 1 Minute
Insulation resistance 100MΩ min. (500V DC)
Contact resistance 50mΩ max.

Mechanical

Mating cycles 5.000 min.

Others

Operating temp. -55° C to +85° C
Processing temp. +260° C for 10 sec. max.

ORDER CODE **USB 2.0** corresponding: **UMS - B05 - SB21 - 98**

Please contact your closest E-tec sales office for order code if reel packaging is required.

IES Series - „IEEE 1394” Connector

6 – Contact Type



single port right angle; SMT “fully shielded” Type

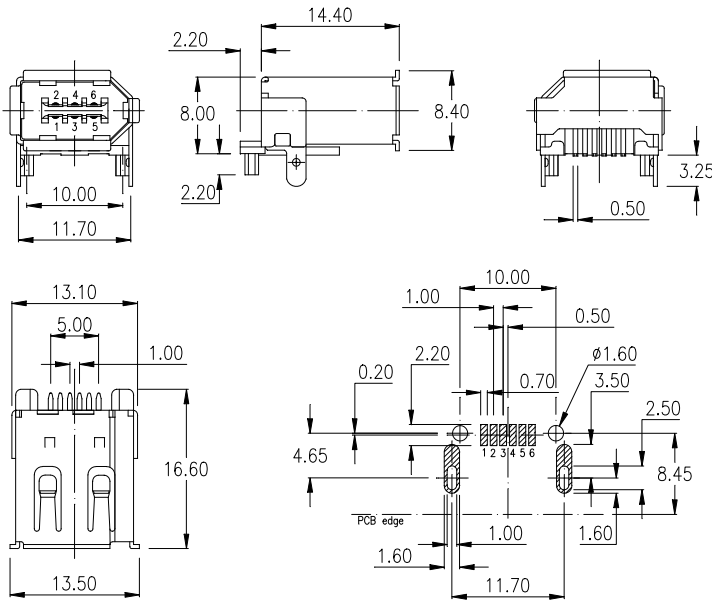

ORDER CODE: **IES - B06 - SIF1 - 98**
(- W06 - if white housing)

single port vertical; soldertail “fully shielded” Type

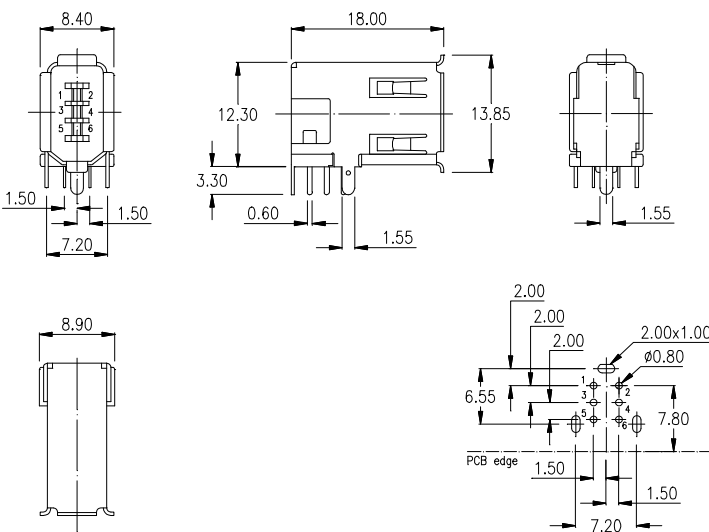

ORDER CODE: **IES - B06 - VIF1 - 98**
(- W06 - if white housing)

single port right angle; soldertail “fully shielded” Type

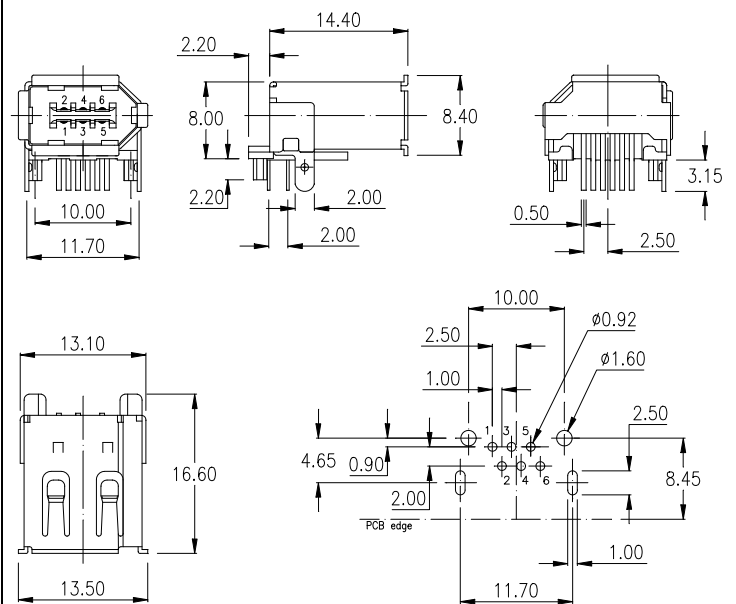

ORDER CODE: **IES - B06 - RIF1 - 98**
(- W06 - if white housing)

Specification

Material

Contact	(RoHS compliant)	Phosphor bronze
Plating:		
Contact area		Au 30μ" over Ni
Solder area		Sn (leadfree)
Housing	(RoHS compliant)	PBT UL 94-V0
SMT housing	(RoHS compliant)	Nylon 9T UL 94-V0
Shell	(RoHS compliant)	brass, 80μ"-120μ" Ni plated

Mechanical

Mating cycles	1.500 min.
---------------	------------

Electrical

Current rating	1,5 A max. 1 Contact (Signal only)
Voltage rating	30V AC (rms)
Withstanding voltage	500V AC (rms) 1 Minute
Insulation resistance	100MΩ min. (500V DC)
Contact resistance	30mΩ max.

Others

Operating temperature	-55° C to +85° C
Processing temp. for SMT type	+260° C for 10 sec. max.

single port right angle

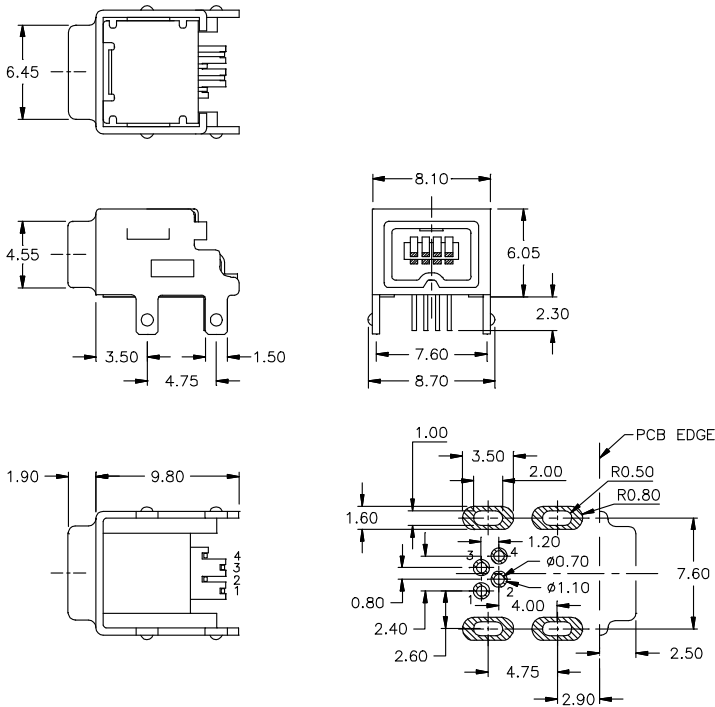

ORDER CODE: **IES - B04 - RI01 - 98**

single port right angle
“reversed” Type

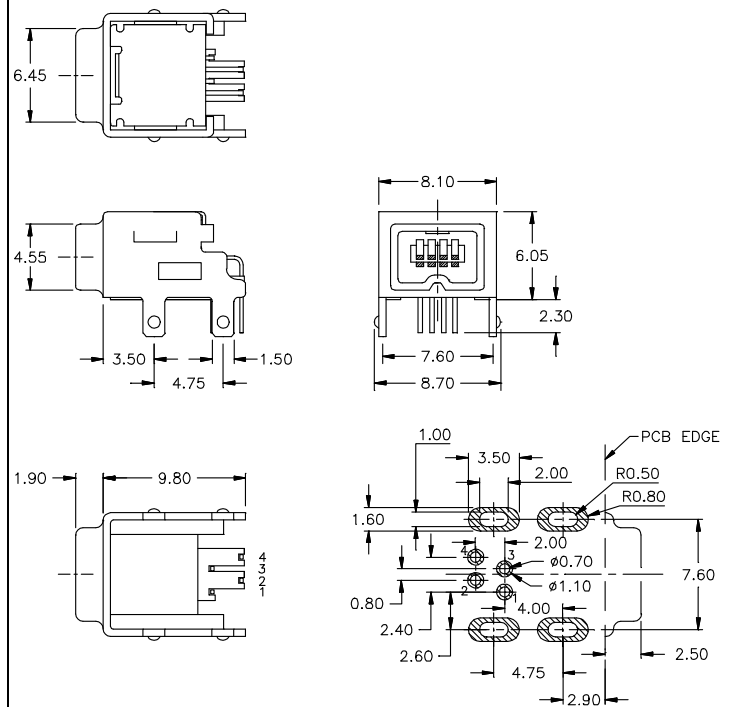

ORDER CODE: **IES - B04 - RIR1 - 98**

single port right angle; SMT

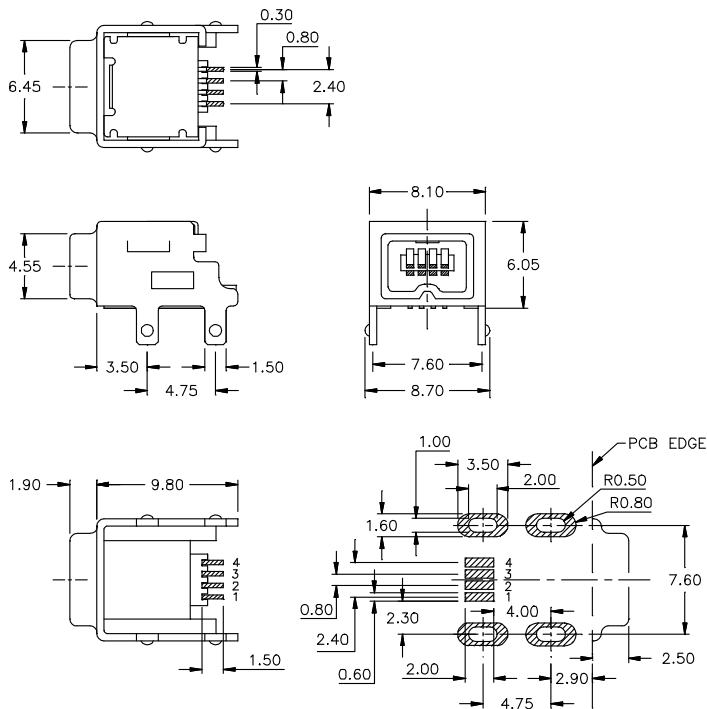

ORDER CODE: **IES - B04 - SI01 - 98**

Specification

Material

Contact	(RoHS compliant) Phosphor bronze
Plating:	
Contact area	Au 30μ" over Ni
Solder area	Sn (leadfree)
Housing	(RoHS compliant) Nylon 9T UL 94-V0 black (standard)
Front Shell	(RoHS compliant) Steel 80μ"-120μ" Ni plated
Rear Shell	(RoHS compliant) Brass 80μ"-120μ" Ni plated

Mechanical

Mating cycles	1.000 min.
---------------	------------

Electrical

Current rating	1,5 A max. 1 Contact (Signal only)
Voltage rating	30V AC (rms)
Withstanding voltage	500V AC (rms) 1 Minute
Insulation resistance	100MΩ min. (500V DC)
Contact resistance	30mΩ max.

Others

Operating temperature	-55° C to +85° C
Processing temp. for SMT type	+260° C for 10 sec. max.

	<p>Order Code: USC-xxxx-AMAM-BG/G</p>
	<p>Order Code: USC-xxxx-AMAF-BG/G</p>
	<p>Order Code: USC-xxxx-2AMBM-BG/G</p>
	<p>Order Code: USC-xxxx-BMBM-BG/G</p>
	<p>Order Code: USC-xxxx-IMIM-CH/G</p>
	<p>Order Code: USC-xxxx-IM4IM-CH/B</p>
	<p>Order Code: USC-xxxx-4IMIM-CH/G</p>
	<p>Order Code: USC-xxxx-4AMAM-CH/G</p>
	<p>Order Code: USC-xxxx-4BMBM-CH/G</p>
	<p>Order Code: USC-xxxx-5BMBM-CH/G</p>

Other Cable and Connector colour on request.

Connector and cable assembly as per Customer specification also possible.

Cable length "L"

Example: **1000** = 1000mm

DVI

Digital Visual Interface

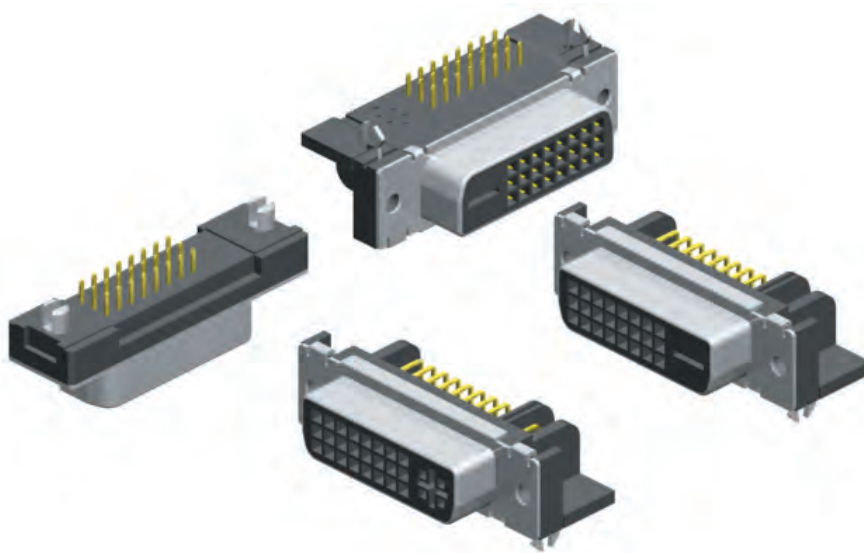

DVI is a video interface standard designed to maximise the visual quality of digital display devices such as flat panel LCD computer displays and digital projectors.

In addition, certain TV's also offer a DVI input connection, which accept digital signals from PC's or DVD players.

Analog & Digital Type

with plastic pegs

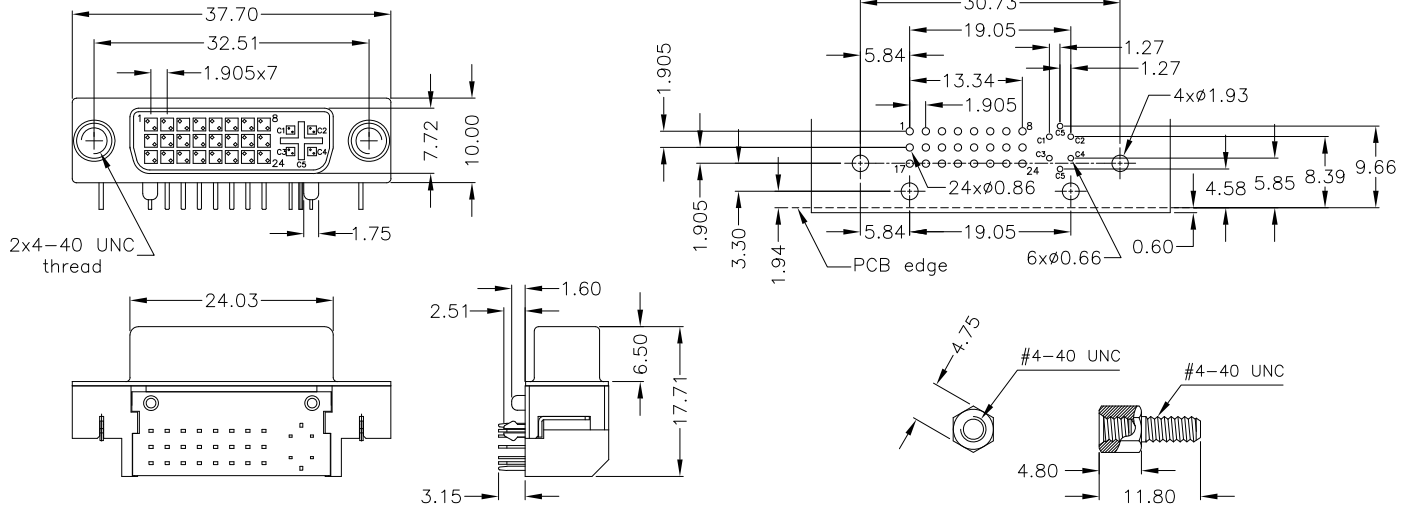

Option: Jack Screw

Specifications

Electrical:	
Current rating	1.5 A min.
Insulator resistance	1000 M Ω min.
Contact resistance	20 m Ω max.
Dielectric strength	1000 V for 1 Min.
Withstanding voltage	500V (rms) AC 1 Min.
Operating temperature	-20° C to +85° C
Mechanical:	
Insertion force	4.5 Kg max.
Withdrawal force	1.0 Kg min.
Durability	100 Cycles
Material:	
Contact	Copper Alloy
Insulator	Hi temp Thermoplastic UL 94V-0
Shell	Steel; Sn (leadfree) over Ni

How to order

DVF - 029 - NAD9 - xx /W P X

Plating	Housing Color	Option
95 = Gold flash / Tin (leadfree) 97 = Gold 15 μ " / Tin (leadfree) 98 = Gold 30 μ " / Tin (leadfree)	W = white (standard) B = black (option)	J 2 Jack Screws 4-40 UNC attached

Digital Type

with plastic pegs

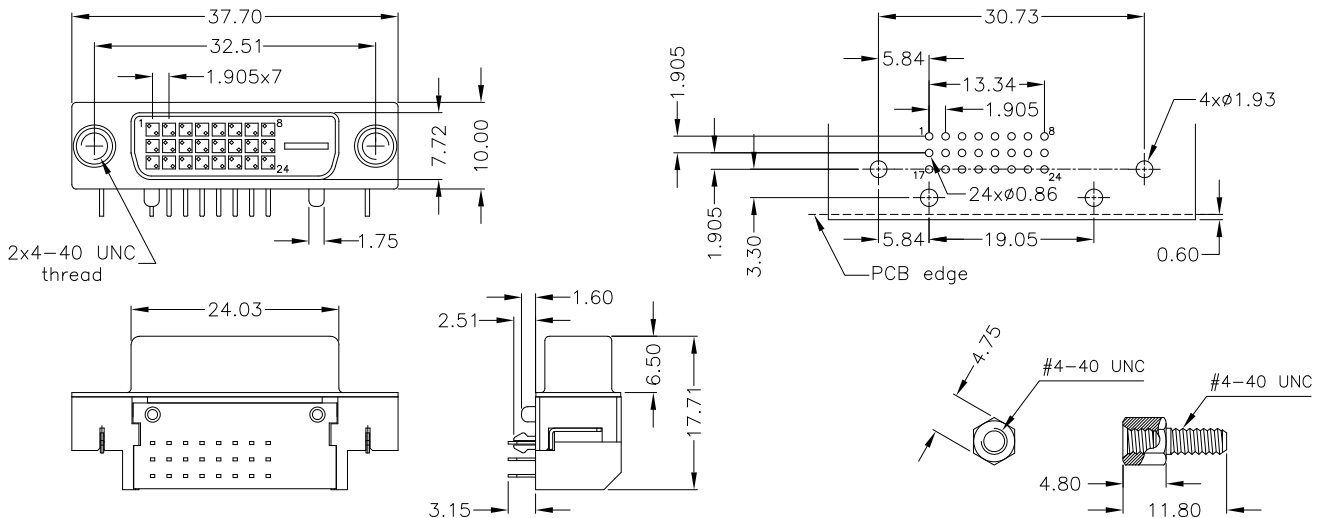

Option: Jack Screw

Specifications

Electrical:	
Current rating	1.5 A min.
Insulator resistance	1000 M Ω min.
Contact resistance	20 m Ω max.
Dielectric strength	1000 V for 1 Min.
Withstanding voltage	500V (rms) AC 1 Min.
Operating temperature	-20° C to +85° C
Mechanical:	
Insertion force	4.5 Kg max.
Withdrawal force	1.0 Kg min.
Durability	100 Cycles
Material:	
Contact	Copper Alloy
Insulator	Hi temp Thermoplastic UL 94V-0
Shell	Steel; Sn (leadfree) over Ni

How to order

DVF - 024 - NDD9 - xx /W P X

Plating	Housing Color	Option
95 = Gold flash / Tin (leadfree) 97 = Gold 15 μ " / Tin (leadfree) 98 = Gold 30 μ " / Tin (leadfree)	W = white (standard) B = black (option)	J 2 Jack Screws 4-40 UNC attached

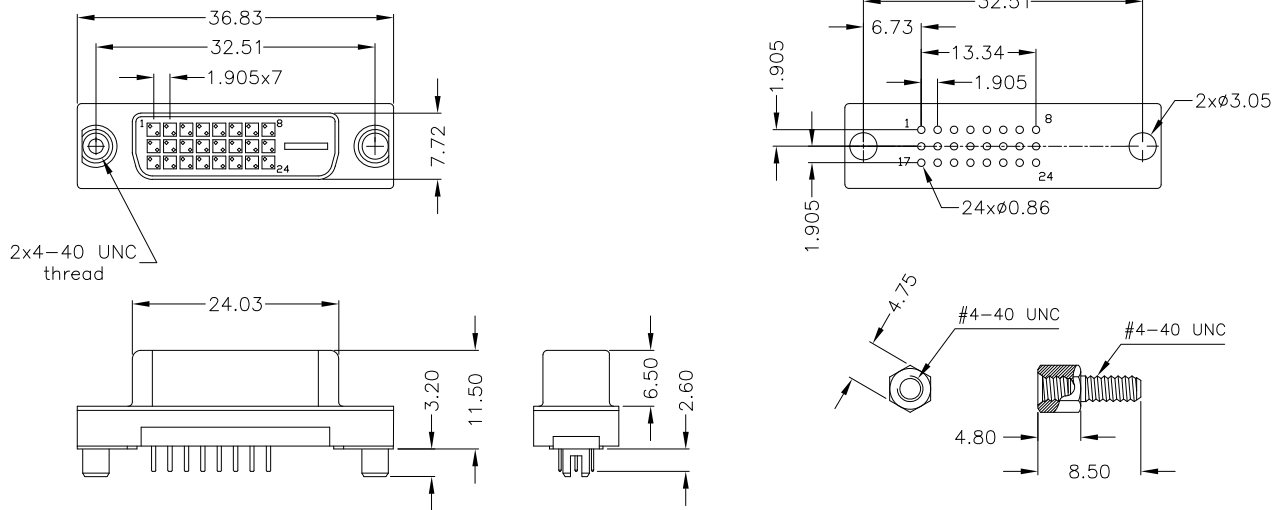

Jack Screw

Specifications

Electrical:	
Current rating	1.5 A min.
Insulator resistance	1000 M Ω min.
Contact resistance	20 m Ω max.
Dielectric strength	1000 V for 1 Min.
Withstanding voltage	500V (rms) AC 1 Min.
Operating temperature	-20° C to +85° C
Mechanical:	
Insertion force	4.5 Kg max.
Withdrawal force	1.0 Kg min.
Durability	100 Cycles
Material:	
Contact	Copper Alloy
Insulator	Hi temp Thermoplastic
Shell	UL 94V-0
	Steel; Sn (<i>leadfree</i>) over Ni

How to order

DVF - 024 - NDD1 - xx /W B J

Plating	
95	= Gold flash / Tin (<i>leadfree</i>)
97	= Gold 15 μ " / Tin (<i>leadfree</i>)
98	= Gold 30 μ " / Tin (<i>leadfree</i>)

Housing Color	
W	= white (standard)
B	= black (option)

J	
2 Jack Screws 4-40 UNC attached	

Mini DIN Connectors

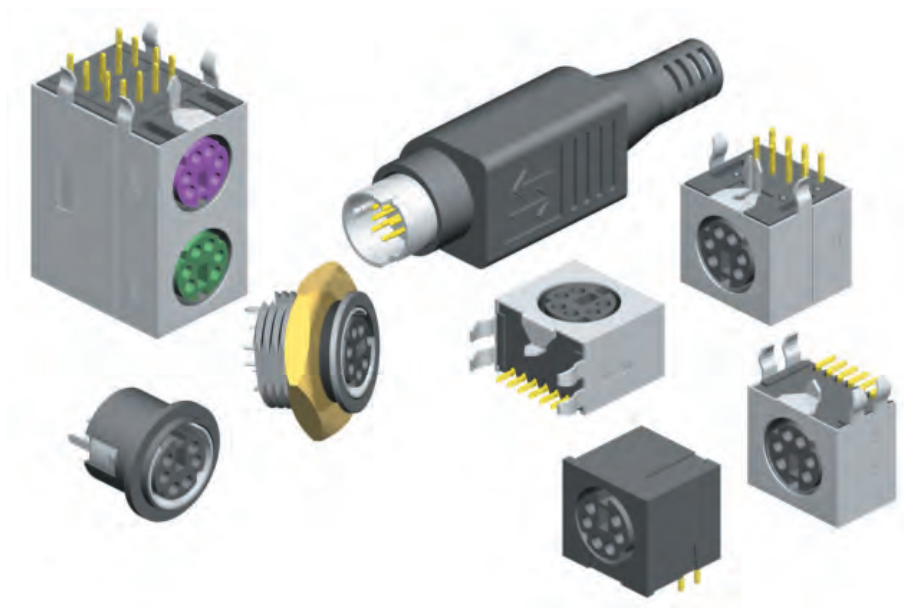

Mini DIN Connectors for Computer, Video, Audio
and Digital Equipment applications.

Single and Dual Port, non shielded and shielded connector versions
are available together with the mating plugs.

Mini DIN Connector - 90° non shielded type



Mini DIN Connectors offered by E-tec have either silver or tin plated contacts. They allow a high number of insertion/extraction cycles and always a save connection to the Plug.

For any other types you may looking for and cannot find specified in this catalog, for example Mini DIN connectors with Filter or switch, please contact the nearest E-tec office or Distributor.

non shielded type

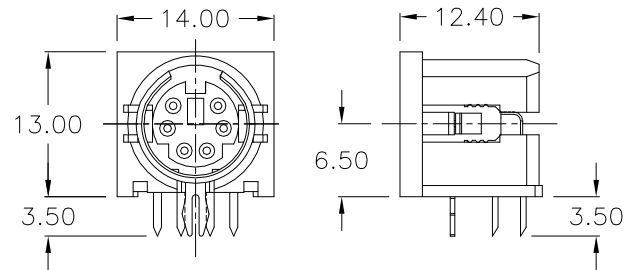

FRONT VIEWS

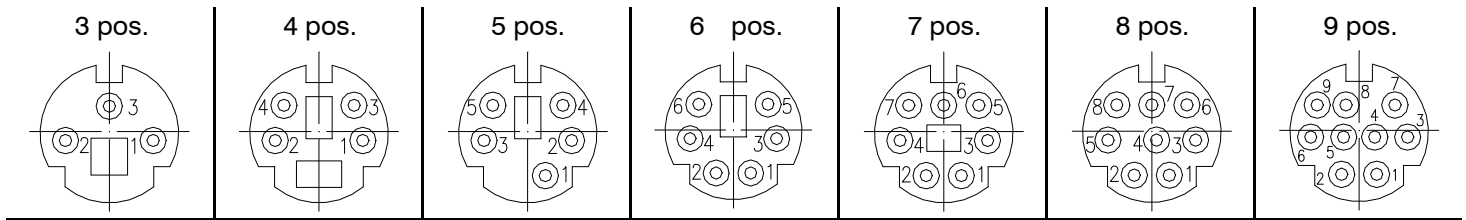

PCB through hole layout

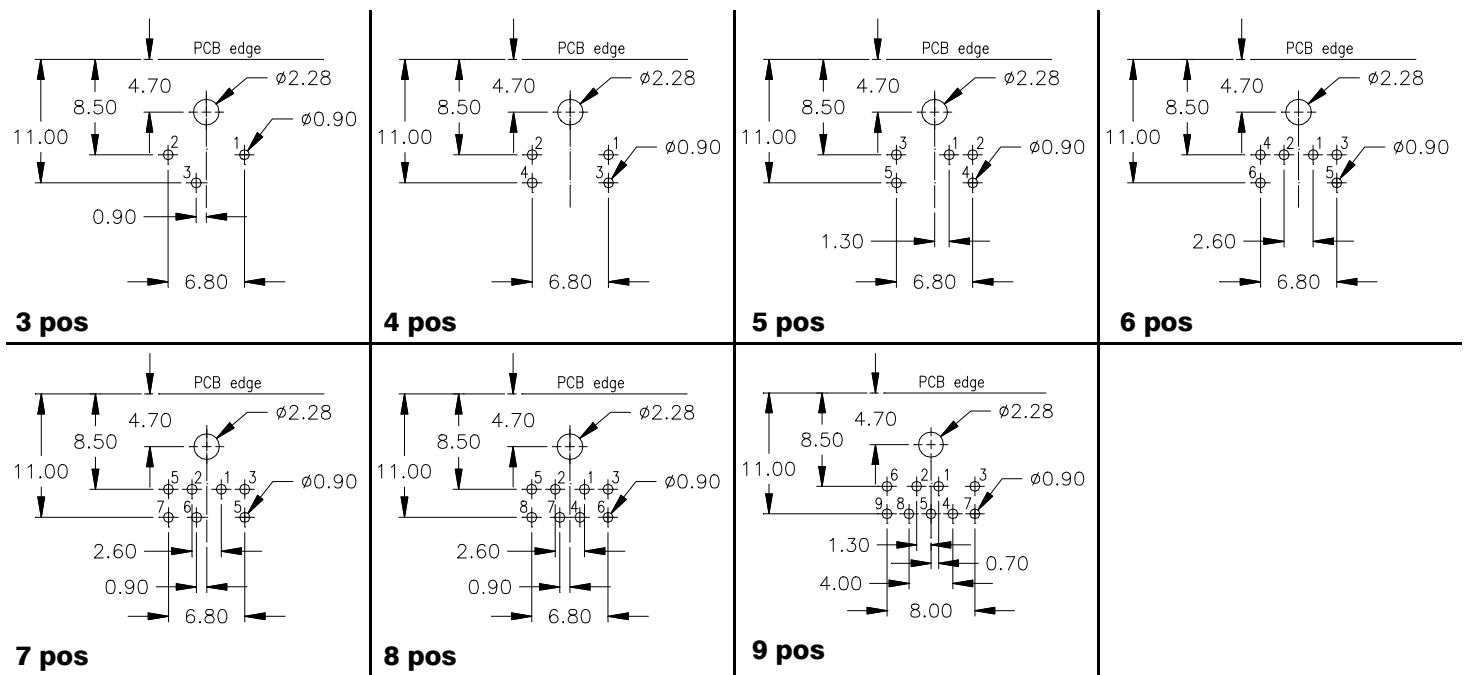

SPECIFICATIONS

Current rating	1 A max. at 100 V AC or 2 A max. at 12 V DC	Contact material <i>(RoHS compliant)</i>	Phosphor bronze
Insulator resistance	50 MΩ min. at 250 V DC	Contact plating	Sn/Au over Ni <i>(Sn leadfree)</i>
Contact resistance	30 mΩ max.	Insulator material <i>(RoHS compliant)</i>	P.B.T. UL 94 V-0
Dielectric withstanding voltage	250 V AC for 1 min.	Insertion force	4.5kg max.
Operating temperature	-55°C to +85°C	Extraction force	0.8kg min.
		Insertion/extraction cycles	500 min.

Ordering Code

MDJ - xxx - RN 01 - 95

Nbr of contacts	
003	to 009

Mini DIN Connector

90° shielded type

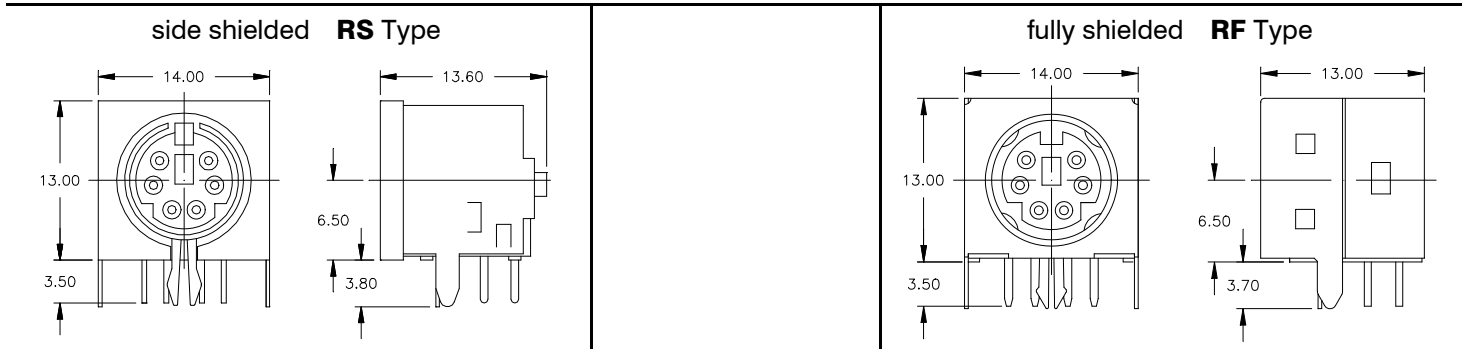

FRONT VIEWS

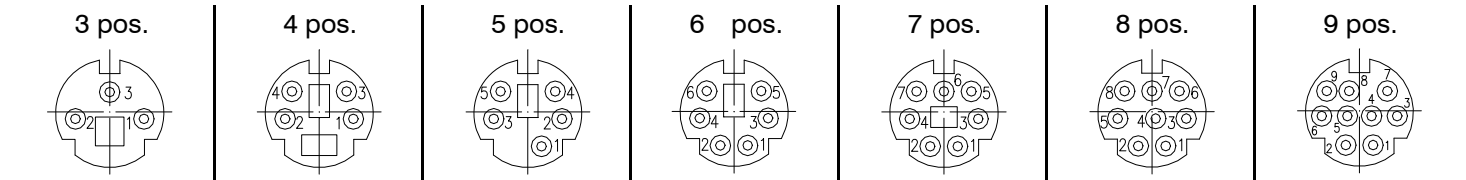

PCB through hole layout

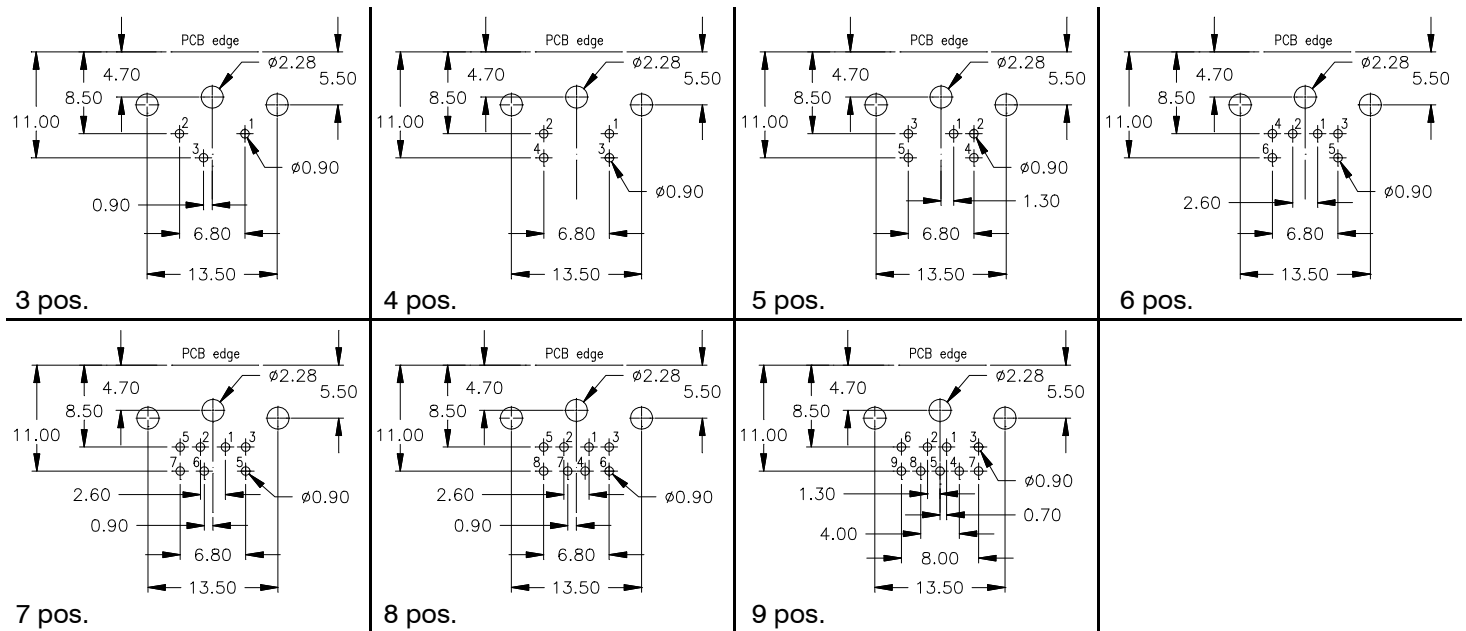

SPECIFICATIONS

Current rating	1 A max. at 100 V AC or 2 A max. at 12 V DC	Contact material	(RoHS compliant) Phosphor bronze
Insulator resistance	50 MΩ min. at 250 V DC	Contact plating	AG, Sn or Sn/Au over Ni (Sn leadfree)
Contact resistance	30 mΩ max.	Insulator material	(RoHS compliant) P.B.T. UL 94 V-0 -black standard -
Dielectric withstanding voltage	250 V AC for 1 min.	Insertion force	4.5kg max.
Operating temperature	-40°C to +105°C	Extraction force	0.8kg min.
		Insertion/extraction cycles	500 min.

Ordering Code

MDJ - xxx - R X xx - xx

Nbr of contacts	Type	Color	Plating
003; 004; 005; 006 007; 008; 009	S = side shielded	01 = black	AGZ = silver
003; 004; 005; 006 007; 008; 009	F = fully shielded	01 = black for all types 22 = purple for 6-contact type only	95 = tin/gold (tin leadfree)

Mini DIN Connector - Low Profile 90° SMT & through hole - fully shielded type -



SMT type

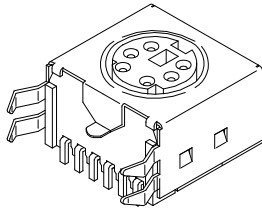

through hole type

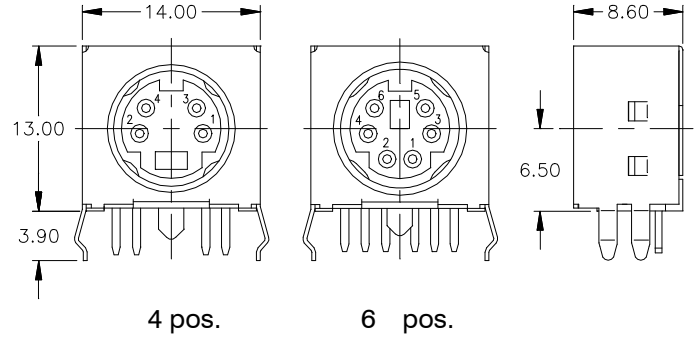
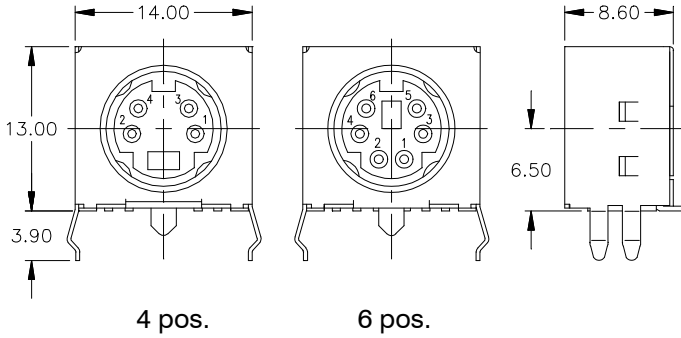
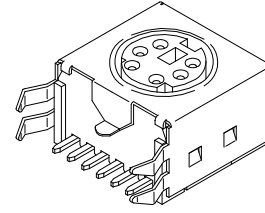

PCB SMT layout

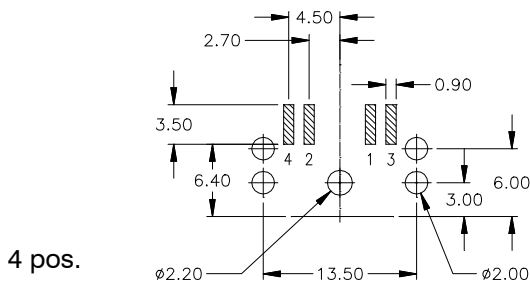

4 pos.

PCB through hole layout

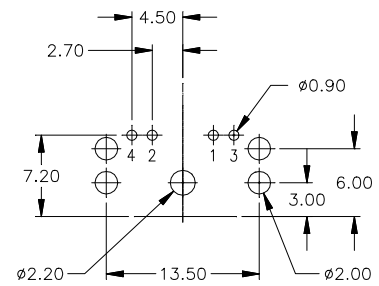

4 pos.

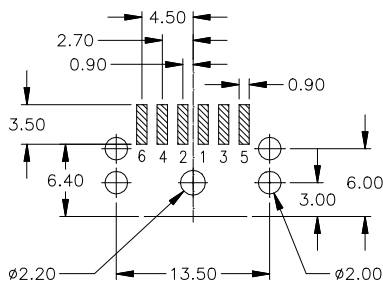

6 pos.

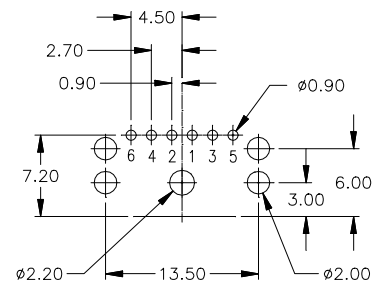

6 pos.

SPECIFICATIONS

Current rating	1 A max. at 100 V AC or 2 A max. at 12 V DC
Insulator resistance	50 MΩ min. at 250 V DC
Contact resistance	30 mΩ max.
Dielectric withstanding voltage	250 V AC for 1 minute
Insertion/extraction cycles	500 min.
Operating temperature	-40°C to +105°C

Insulator material (RoHS compliant)	Nylon 6T UL 94 V-0
Contact material (RoHS compliant)	Phosphor bronze
Contact plating	Sn(leadfree)/Au over Ni
Insertion force	4.5kg max.
Extraction force	0.5kg min.
Reflow soldering temperature:	260° C for 10 sec.

Ordering Code

MDJ - xxx - RKL X / 1 - 95

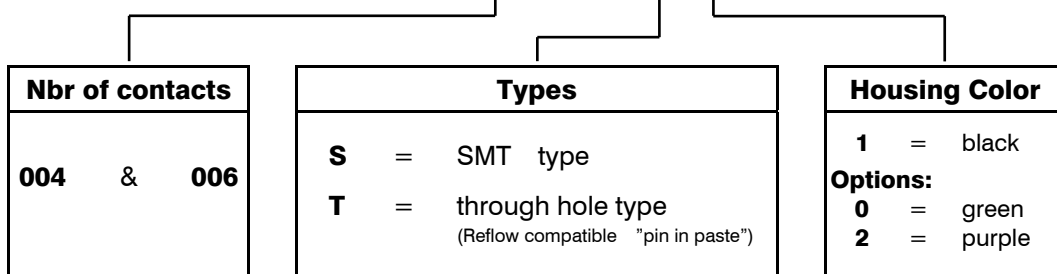

Mini DIN Connector - Dual Port Standard & "PC 99" Type



fully shielded, ground spring & side kink type

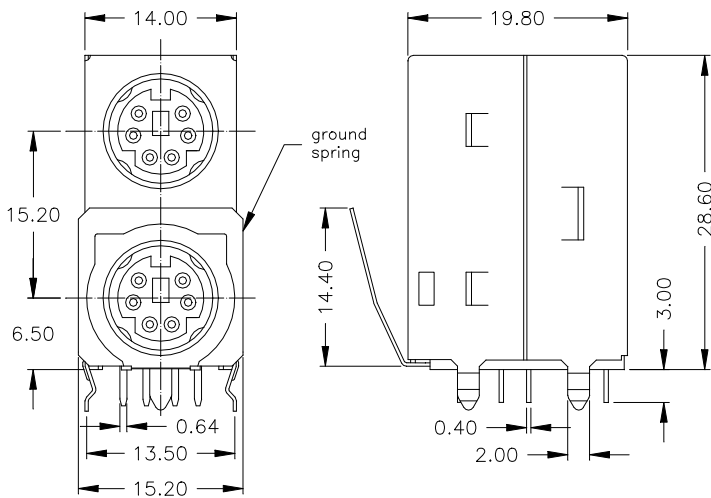

MDJ - 606 - DS xx - 95

fully shielded type

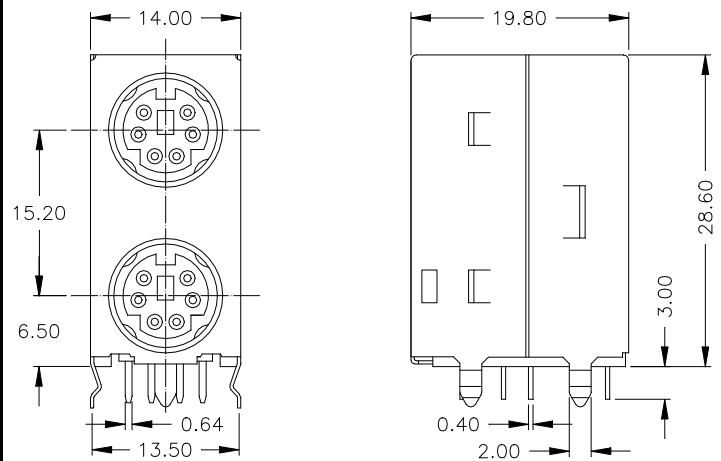

MDJ - 606 - DK xx - 95

front view

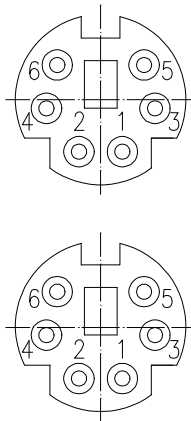

2 x 6 pos.

PCB through hole layout

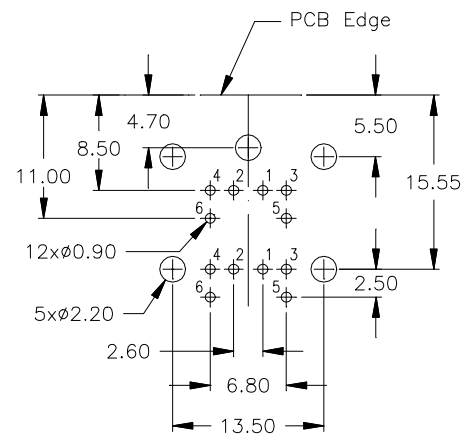

2 x 6 pin = 606

SPECIFICATIONS

Current rating	1 A max. at 100 V AC or 2 A max. at 12 V DC
Insulator resistance	100 MΩ min. at 250 V DC
Contact resistance	30 mΩ max.
Withstanding voltage	250 V AC for 1 min.

Contact material	(RoHS compliant) Phosphor bronze
Insulator material	(RoHS compliant) P.B.T. UL 94 V-0
Shield material	(RoHS compliant) Brass
Shield plating	tin (leadfree)
Insertion/extraction cycles	500 min.
Operating temperature	-40°C to +105°C

Ordering Code

MDJ - 606 - XX xx - 95

Contact Arrangement	Version	Housing Color	Plating
6 top 6 bottom	DS = fully shielded, ground spring & side kink DK = fully shielded & side kink	01 = black top / black bottom 02 = green top / purple bottom	tin/gold <i>(tin leadfree)</i>

Mini DIN Connector

straight & wall mounting type

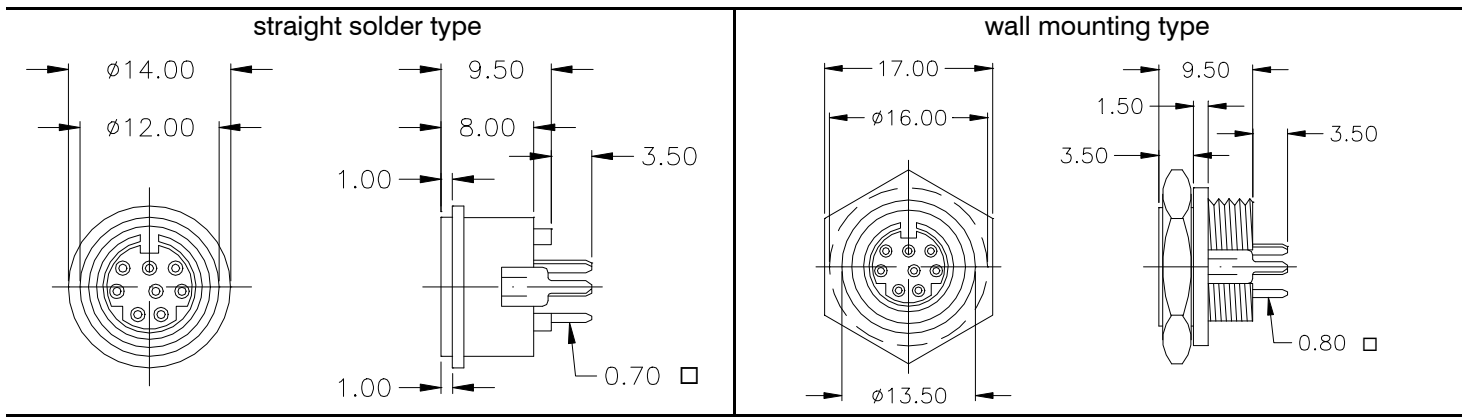

FRONT VIEWS

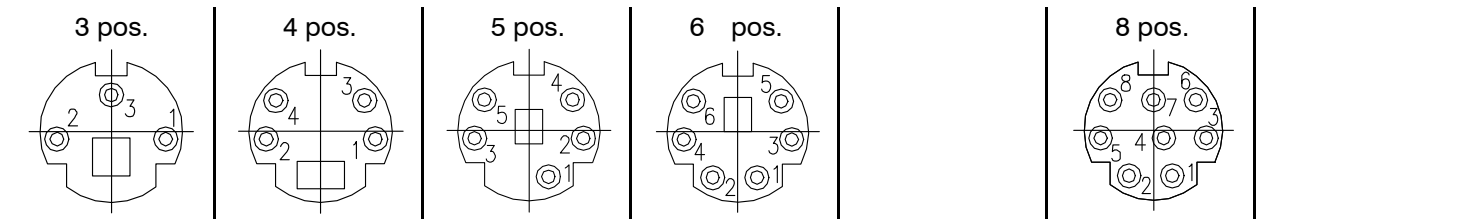

PCB through hole layout

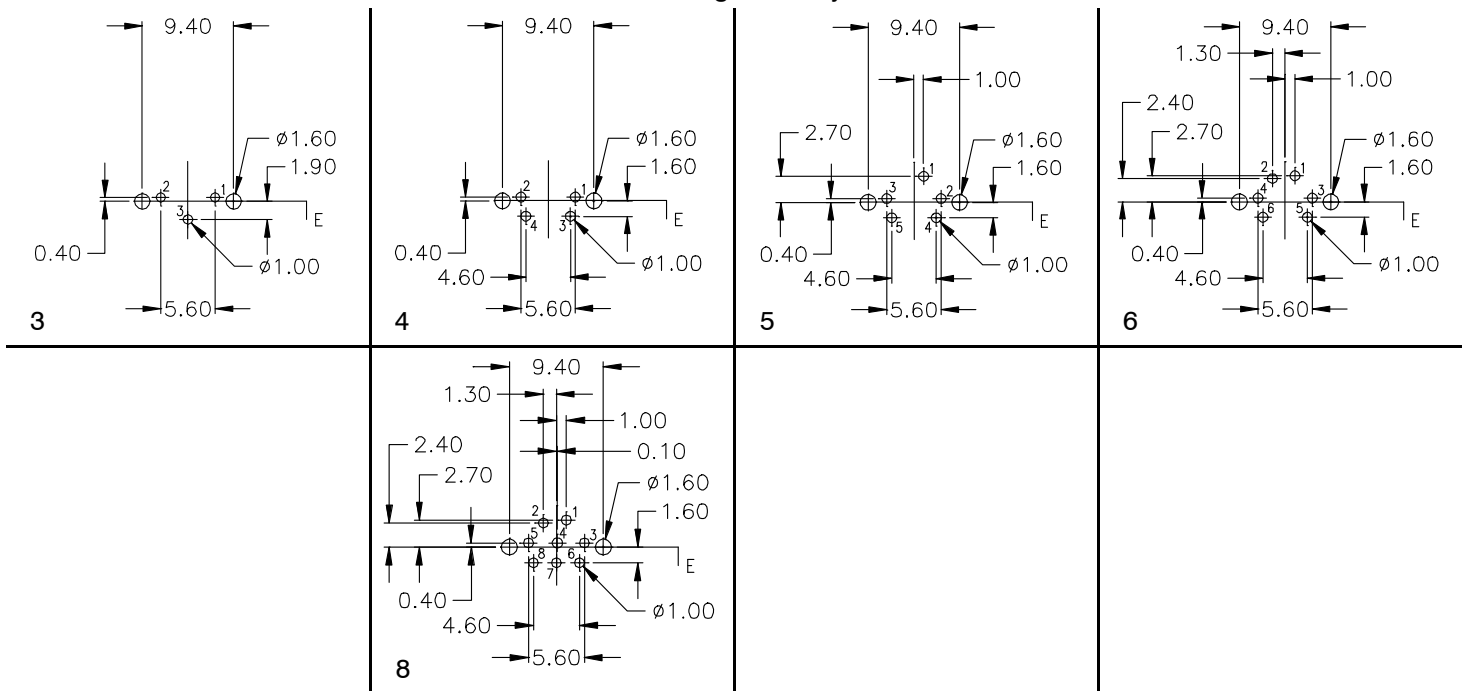

SPECIFICATIONS

Current rating	1 A max. at 100 V AC or 2 A max. at 12 V DC	Contact material (RoHS compliant)	Phosphor bronze
Insulator resistance	50 MΩ min. at 250 V DC	Contact plating	Silver
Contact resistance	30 mΩ max.	Insulator material (RoHS compliant)	P.B.T. UL 94 V-0
Dielectric withstanding voltage	250 V AC for 1 min.	Insertion force	4.5kg max.
Operating temperature	-40°C to +105°C	Extraction force	0.8kg min.
		Insertion/extraction cycles	500 min.

Ordering Code

MDJ - xxx - S X 01 - AGZ

Nbr of contacts
003; 004; 005 006; 008

Types
N = straight solder type S = wall mounting type

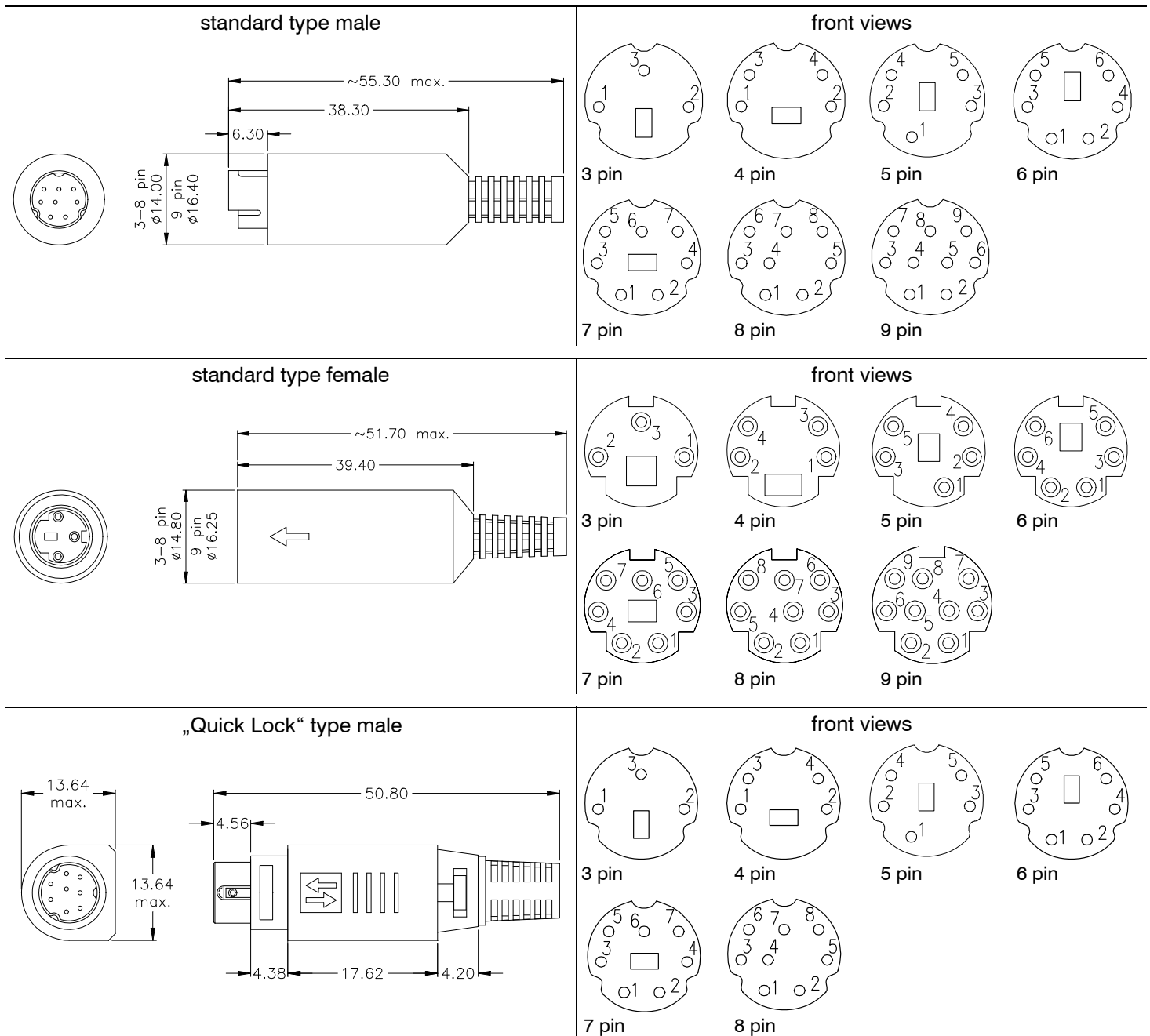

Any cable assembly available on request.
 Connectors at both ends as well as cable length and quality as per your specification possible.
 Please contact the nearest E-tec sales office or Distributor.

SPECIFICATIONS

Current rating	1 A max. at 100 V AC or 2 A max. at 12 V DC	Withstanding voltage	250 V AC for 1 min.	Insulator material (RoHS compliant)	Nylon UL 94 V-0
Insulator resistance	50 MΩ min. at 250 V DC	Operating temperature	-55°C to +85°C	Insertion force	4.5kg max.
Contact resistance	30 mΩ max.	Contact material (RoHS compliant)	Brass	Extraction force	0.8kg min.
		Contact plating	Silver; MQ Type = Gold	Insertion/extraction cycles	500 min.

Ordering Code

MDP - xxx - XX 01 - xx

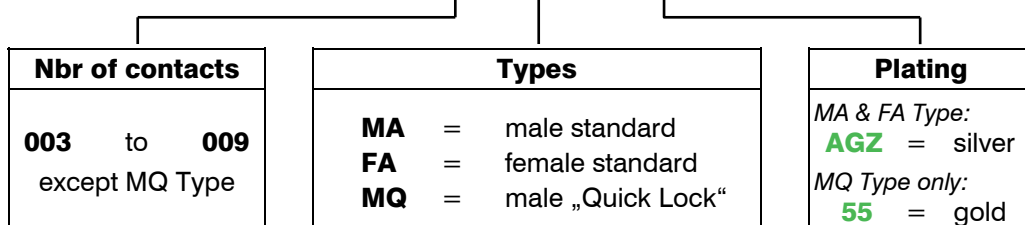

HDMI®

High Definition Multimedia Interface

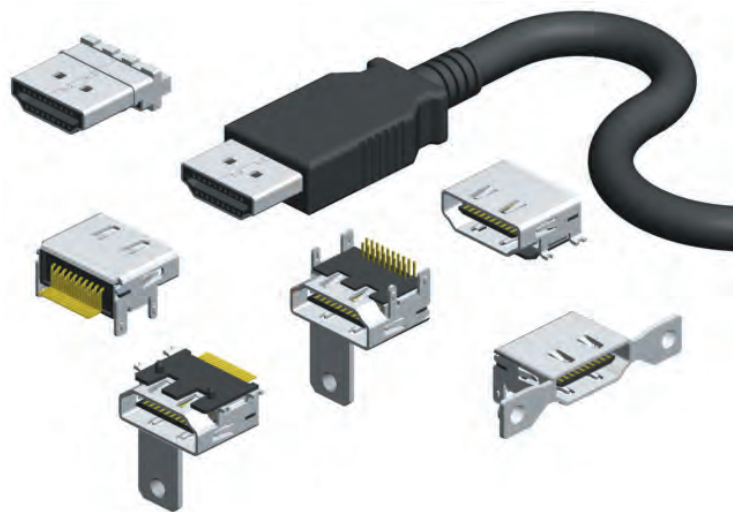

HDMI is an all-digital audio/video interface which was developed in mid 2003 capable of transmitting uncompressed streams. HDMI provides an interface between any compatible digital audio/video source, such as a set-top box, a DVD player, or an AV receiver and a compatible digital audio and/or video monitor, such as a digital television (DTV).

Since June 2006 the version 1.3 has been introduced and these HDMI standards specifically target the home entertainment sector.

SM-Type with "straight" solder pegs

without mounting flange - without locating pins

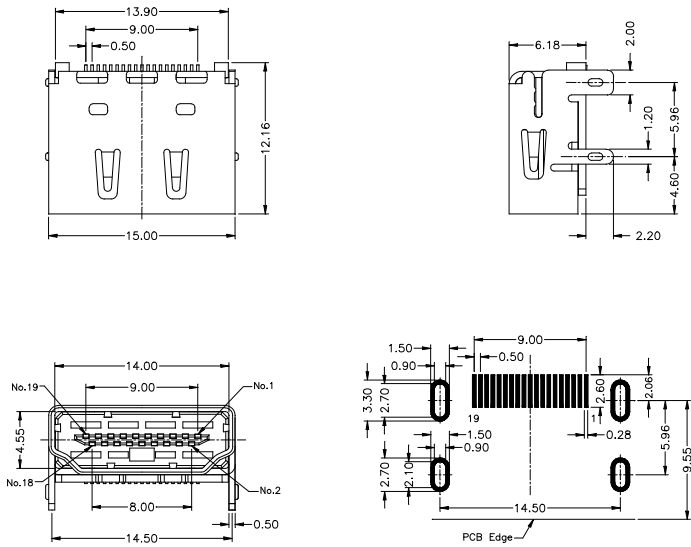

with top mounting flange - without locating pins

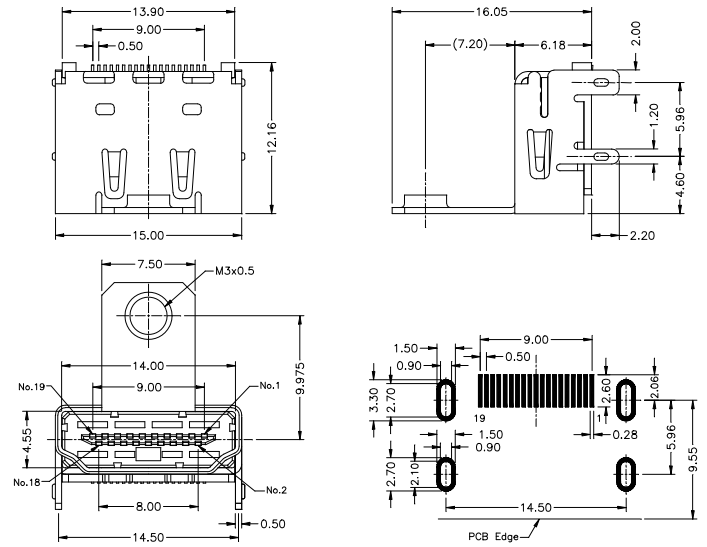

Specifications

Electrical:	
Current rating	0.5 A
Insulator resistance	100 M Ω min. at 150V DC
Contact resistance	30 m Ω max.
Withstanding voltage	500V (rms) AC 1 Min.
Operating temperature	-25° C to +85° C
Mechanical:	
Insertion force	44.1 N max.
Withdrawal force	9.8 N min. / 39.2 N max.
Durability	10,000 Cycles
Material:	
Contact	Copper Alloy
Plating	Sn solderpegs / Au contact
Insulator	Hi temp Thermoplastic black UL 94V-0
Shell	Steel; Sn (leadfree) over Ni

How to order

HMR - B19 - SS X 1 - 98 / X

Style	Plating	Option
K = without mounting flange	95 = Gold flash / Tin (leadfree)	R = reel packing w/o pick up tape
L = with top mounting flange	97 = Gold 15 μ " / Tin (leadfree)	BT = reel packing with pick up tape
	98 = Gold 30 μ " / Tin (leadfree)	

SM-Type with "wing" solder pegs

without mounting flange - with locating pins

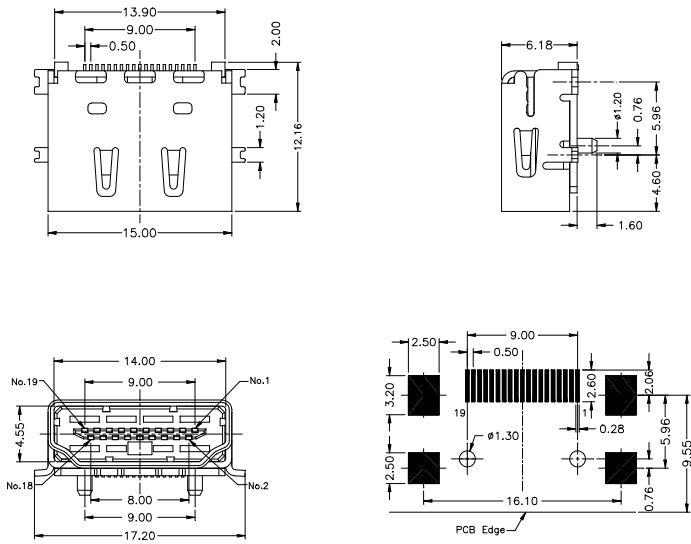

with top mounting flange - with locating pins

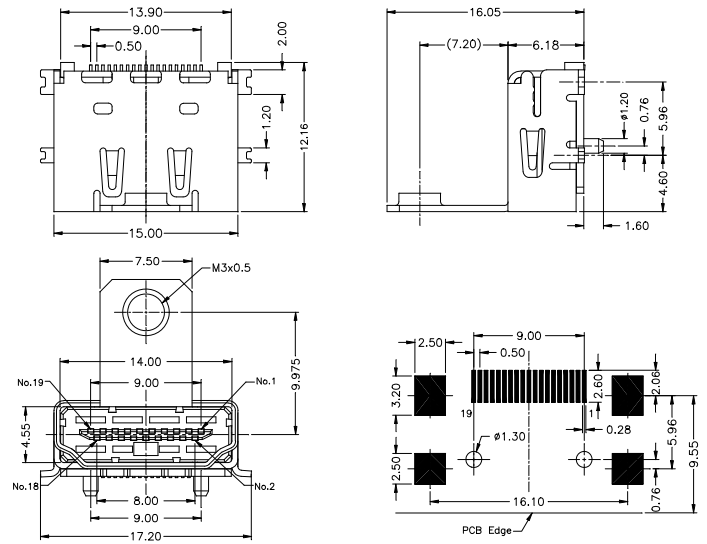

Specifications

Electrical:	
Current rating	0.5 A
Insulator resistance	100 M Ω min. at 150V DC
Contact resistance	30 m Ω max.
Withstanding voltage	500V (rms) AC 1 Min.
Operating temperature	-25° C to +85° C
Mechanical:	
Insertion force	44.1 N max.
Withdrawal force	9.8 N min. / 39.2 N max.
Durability	10,000 Cycles
Material:	
Contact	Copper Alloy
Plating	Sn solderpegs / Au contact
Insulator	Hi temp Thermoplastic black UL 94V-0
Shell	Steel; Sn (leadfree) over Ni

How to order

HMR - B19 - SW X 1 - 98 / X

Style	Plating	Option
K = without mounting flange	95 = Gold flash / Tin (leadfree)	R = reel packing w/o pick up tape
L = with top mounting flange	97 = Gold 15 μ " / Tin (leadfree)	BT = reel packing with pick up tape
	98 = Gold 30 μ " / Tin (leadfree)	

Soldertail Type with "straight" solder pegs - without mounting flange -

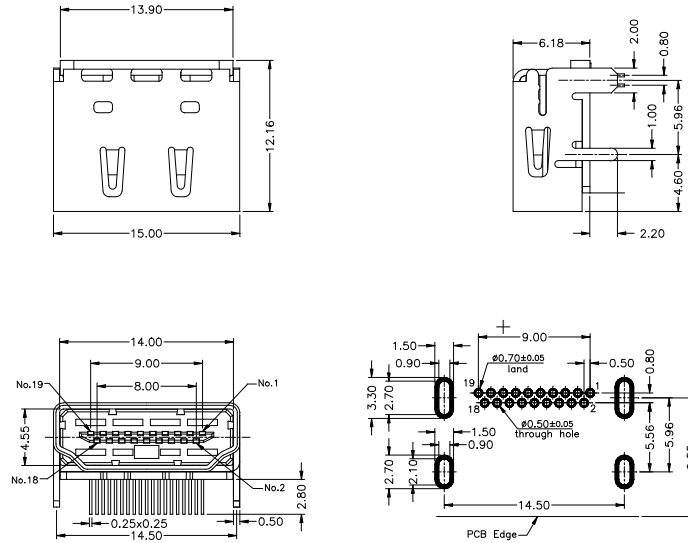

Specifications

Electrical:	
Current rating	0.5 A
Insulator resistance	100 M Ω min. at 150V DC
Contact resistance	30 m Ω max.
Withstanding voltage	500V (rms) AC 1 Min.
Operating temperature	-25° C to +85° C
Mechanical:	
Insertion force	44.1 N max.
Withdrawal force	9.8 N min. / 39.2 N max.
Durability	10.000 Cycles
Material:	
Contact	Copper Alloy
Plating	Sn solderpegs / Au contact
Insulator	Hi temp Thermoplastic black UL 94V-0
Shell	Steel; Sn (leadfree) over Ni

How to order

HMR - B19 - RS X 1 - 98 / X

Style	Plating	Option
K = without mounting flange	95 = Gold flash / Tin (leadfree) 97 = Gold 15 μ " / Tin (leadfree) 98 = Gold 30 μ " / Tin (leadfree)	Blank = tray packing (standard) R = reel packing w/o pick up tape BT = reel packing with pick up tape <i>NOTE: reel packing on request</i>

SM-Type with "straight" solder pegs - with wing mounting flange -

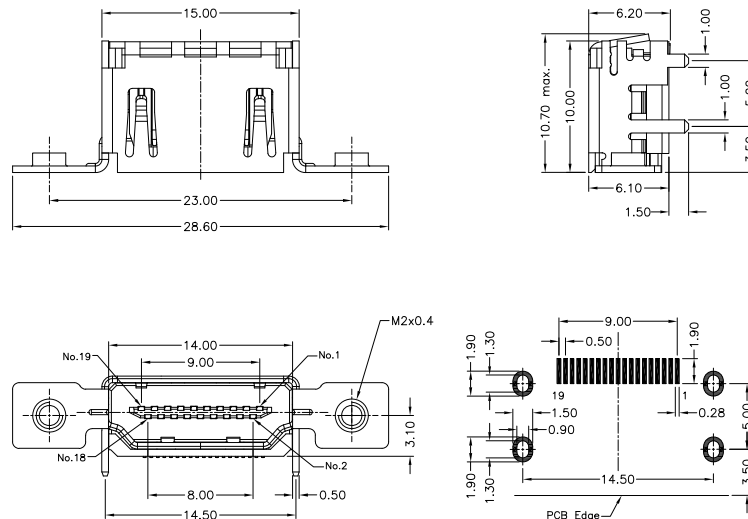

Specifications

Electrical:	
Current rating	0.5 A
Insulator resistance	100 M Ω min. at 150V DC
Contact resistance	30 m Ω max.
Withstanding voltage	500V (rms) AC 1 Min.
Operating temperature	-25° C to +85° C
Mechanical:	
Insertion force	44.1 N max.
Withdrawal force	9.8 N min. / 39.2 N max.
Durability	10.000 Cycles
Material:	
Contact	Copper Alloy
Plating	Sn solderpegs / Aucontact
Insulator	Hi temp Thermoplastic black UL 94V-0
Shell	Steel; Sn (leadfree) over Ni

How to order

HMR - B19 - SS X 1 - 98 / X

Style	Plating	Option
M = with wing mounting flange	95 = Gold flash / Tin (leadfree) 97 = Gold 15 μ " / Tin (leadfree) 98 = Gold 30 μ " / Tin (leadfree)	Blank = tray packing (standard) R = reel packing w/o pick up tape BT = reel packing with pick up tape <i>NOTE: reel packing on request</i>

**-SMT- Top Entry Type with "Wing" mounting flange
and additional 2 Dummy Contacts**

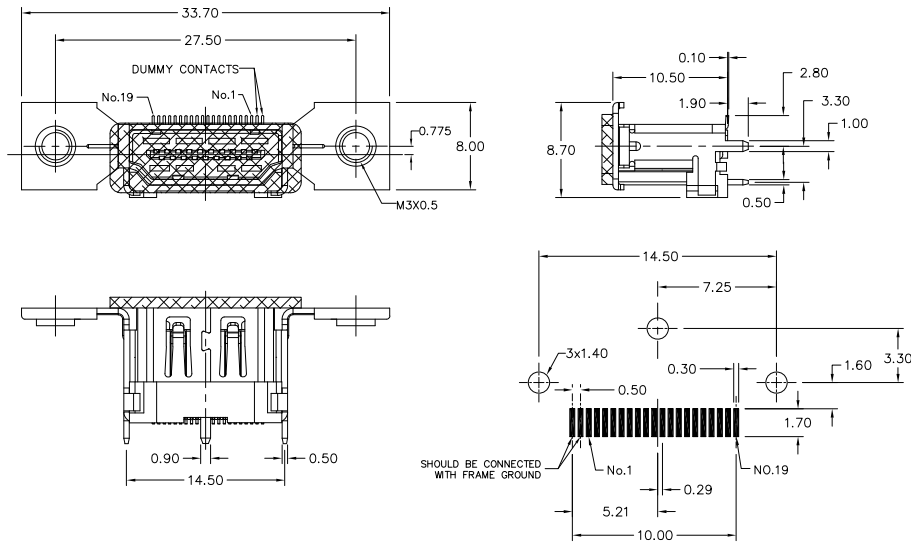

Specifications

Electrical:	
Current rating	0.5 A
Insulator resistance	100 M Ω min. at 150V DC
Contact resistance	30 m Ω max.
Withstanding voltage	500V (rms) AC 1 Min.
Operating temperature	-25° C to +85° C
Mechanical:	
Insertion force	44.1 N max.
Withdrawal force	9.8 N min. / 39.2 N max.
Durability	10,000 Cycles
Material:	
Contact	RoHS compliant Copper Alloy
Plating	Sn solderpegs / Au contact
Insulator	RoHS compliant Hi temp Thermoplastic black UL 94V-0
Shell	Steel; Sn (leadfree) over Ni

How to order

HMR - B19/2 - US M 1 - 98 / X

Style	Plating	Option
M = with wing mounting flange	95 = Gold flash / Tin (leadfree) 97 = Gold 15μ" / Tin (leadfree) 98 = Gold 30μ" / Tin (leadfree)	R = reel packing w/o pick up tape BT = reel packing with pick up tape

**-SMT- Top Entry Type with "L-Wing" mounting flange
and additional 2 Dummy Contacts**

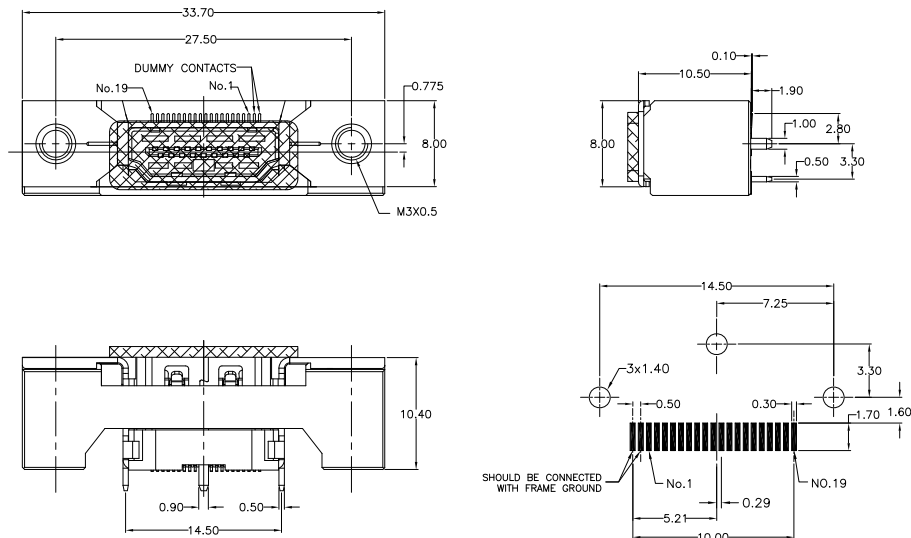

Specifications

Electrical:	
Current rating	0.5 A
Insulator resistance	100 M Ω min. at 150V DC
Contact resistance	30 m Ω max.
Withstanding voltage	500V (rms) AC 1 Min.
Operating temperature	-25° C to +85° C
Mechanical:	
Insertion force	44.1 N max.
Withdrawal force	9.8 N min. / 39.2 N max.
Durability	10,000 Cycles
Material:	
Contact	RoHS compliant Copper Alloy
Plating	Sn solderpegs / Au contact
Insulator	RoHS compliant Hi temp Thermoplastic black UL 94V-0
Shell	Steel; Sn (leadfree) over Ni

How to order

HMR - B19/2 - US W 1 - 98 / X

Style	Plating	Option
W = with "L" wing mounting flange	95 = Gold flash / Tin (leadfree) 97 = Gold 15μ" / Tin (leadfree) 98 = Gold 30μ" / Tin (leadfree)	R = reel packing w/o pick up tape BT = reel packing with pick up tape

Other products from E-tec

Please contact your closest sales office for further information.



Insertion-Extraction Tools



DIMM Sockets



DIP Switch

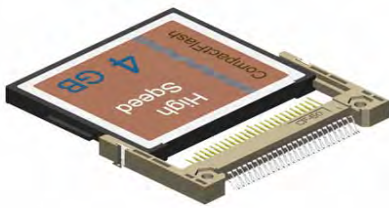

Compact Flash Connector

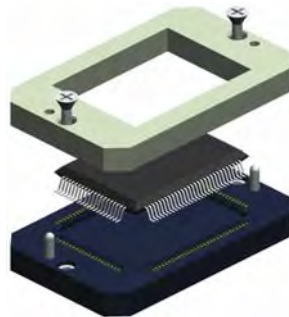

Gullwing Chip Sockets

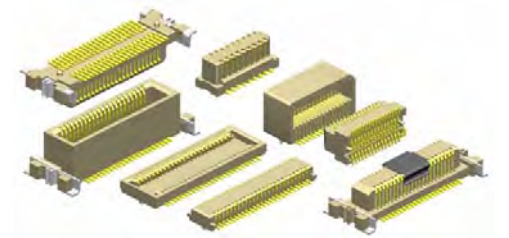

Fine Pitch Board to Board Connectors

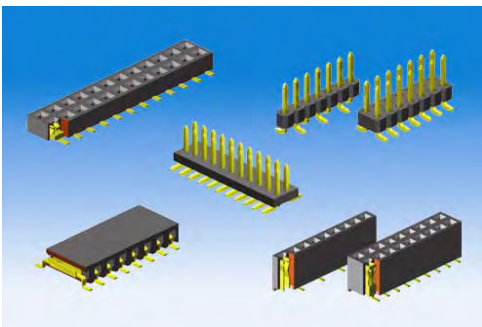

SMT Board to Board Connectors



Flex Cable Connectors

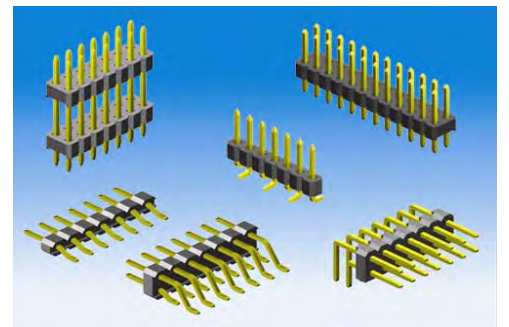

Pin Header



Probe Pin & Probe Pin Connectors

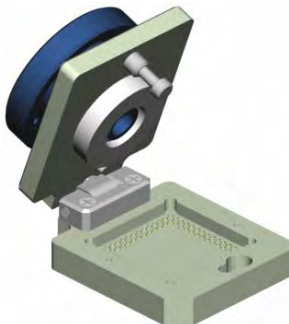

Ball / Land Grid Array Sockets



Multi Media Card Connectors

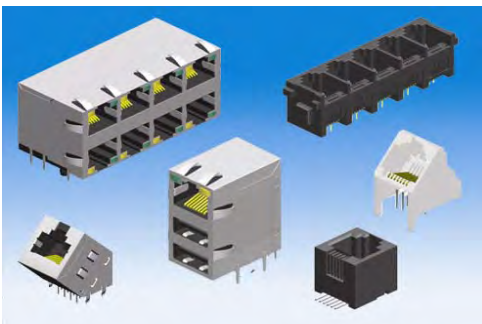

Modular Plugs & Jacks



Phono - & DC - Power Connectors



RF - Connectors

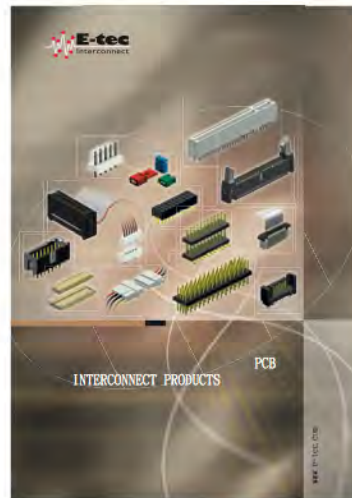
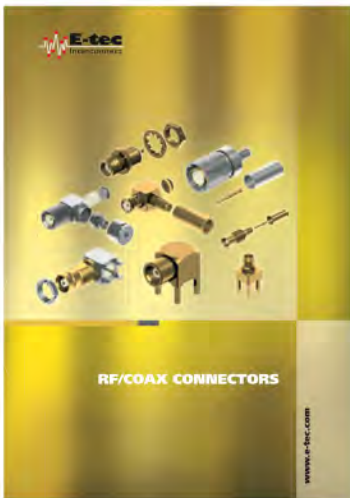

International Sales Headquarters

Switzerland E-tec Interconnect Ltd.
 Schweiz Zone Industrielle C
 Suisse CH-1072 Forel (Lavaux)
 Phone: +41/21/7810810
 Fax: +41/21/7810811
 e-mail: info@e-tec.com
 www.e-tec.com

Related Sales Headquarters

Deutschland EMC electro mechanical components
 Germany Vertriebs GmbH
 Allemagne PF. 1160
 D-65501 Idstein
 Phone: +49/6126/9395-0
 Fax: +49/6126/9395-72
 e-mail: info@emc-connectors.com
 www.emc-connectors.com

France Silfox SA
 Frankreich PA des Petits Carreaux
 2 bis avenue des Coquelicots
 F-94385 BONNEUIL
 SUR MARNE CEDEX
 Phone: +33/1/49560468
 Fax: +33/1/49560287
 e-mail: info@silfox.fr
 www.silfox.fr

England E-tec Interconnect (UK) Ltd.
 Angleterre Units A5 & A6 Decimus Park
 Kingstanding Way
 Tunbridge Wells
 Kent TN2 3GP
 Phone: +44/1892/530260
 Fax: +44/1892/515560
 e-mail: info@e-tec.co.uk
 www.e-tec.co.uk

Factories

Switzerland HAPP AG / E-tec AG
 Schweiz Friedhofstrasse 1
 Suisse CH-2543 Lengnau b. Biel
 Phone: +41/32/6541550
 Fax: +41/32/6522693
 e-mail: info-ch@e-tec.com
 www.e-tec.com

Taiwan HAPP & E-tec Taiwan Ltd.
 10-2F, No. 379, Zhong Shan Road
 San Chong City, Taipei Hsien
 TAIWAN
 Phone: +886/2/2999-2726
 Fax: +886/2/2999-5255
 e-mail: info@happetec.com.tw
 www.happetec.com.tw

YOUR AUTHORISED DISTRIBUTOR
 IHR VERTRAGS-DISTRIBUTOR
 VOTRE DISTRIBUTEUR OFFICIEL

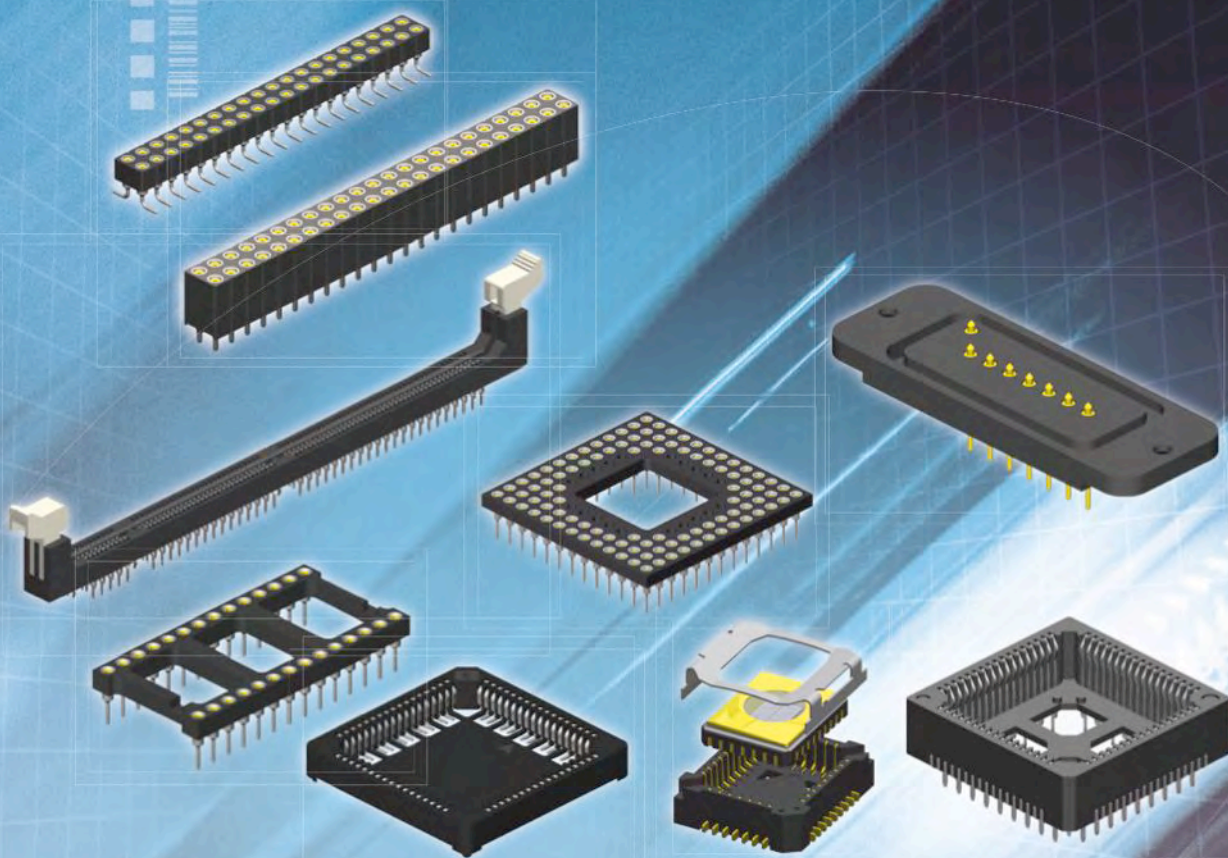

IC-SOCKETS & INTERCONNECT PRODUCTS



This building served for the production of Swiss precision watches for a period of 70 years.

In 1984 the facility was purchased, completely renovated and high technology fully automated production equipment was installed for the production of precision interconnection products.

In 1992 the trademark

E-tec

was registered to cover the complete interconnect product range.

As of 1993 a world-wide sales & distribution network was established to offer fast and efficient service regardless of location.

In addition to the interconnection products E-tec also supplies high quality screw machine parts as well as customized injection moulded and machined products.

Our innovative approach to new product development allows us to offer the service, quality and competitive prices our customers demand.

Whatever your requirement, be it high volume commodity product or low quantity custom special, E-tec, the "Swiss Connection" will endeavour to satisfy your requirements.

For any further details please contact E-tec or your closest sales office.

INDEX

click on page numbers



Part - Number	Page	Part - Number	Page
BL1 - xxx - Axxx - xx	10	PGS - xxx - Exxx - xxX - xx	18
BL1 - xxx - Gxxx - xx	10	PLE - xxx - N115 - xx	34
BL2 - xxx - Axxx - xx	10	PLP - xxx - H100 - 99/x	36
BL2 - xxx - Gxxx - xx	10	PLP - xxx - N110 - 99	35
BS1 - xxx - G560 - xx	12	PLS - xxx - H105 - 99/x	37
BS1 - xxx - G860 - xx	11	POA - xxx - Sxxx - xx	19
BS2 - xxx - G560 - xx	12	POO - xxx - Sxxx - xx	14 & 15
BS2 - xxx - G702 - xx	11	POS - xxx - Sxxx - xx	14 to 16
BS2 - xxx - G860 - xx	11	PSC - xxx - H09x - xx	21
COS - xxx - S001 - xx	25	PSC - xxx - H933 - xx	21
DCA - xxx - Sxxx - xx	20	PSC - xxx - HR94 - xx	21
DCP - xxx - Sxxx - xx	20	PSO - xxx - H09x - xx	21
DIS - 2xx - R9xx - xx	9	PSO - xxx - H933 - xx	21
DIS - 2xx - Fxxx - xx	5 & 6	PSO - xxx - HR94 - xx	21
DIS - 2xx - Sxxx - xx	5 & 7	PUL - xxx	44
DM1 - 100 - VCA9 - 95/1L	39	PUS - xxx	44
DM1 - 168 - RCA9 - 95/1L	42	QIL - 764 - Sxxx - xx	25
DM1 - 168 - SXA8 - 95/1L	41	QIT - xxx - Sxxx - xx	22
DM1 - 168 - VXX9 - 95/1L	40	QIT - xxx - Wxxx - xx	22
DR1 - 184 - VBZ9 - 95/1L	43	SCP - xxx - Sxxx - xx	20
DSP - xxx - Exxx - xx	18	SDC - xxx - Exxx - xx	24
DSP - xxx - Exxx - xx/1	18	SDC - 764 - Sxxx - xx	24
DSP - xxx - Exxx - xx/2	18	SDO - 764 - Sxxx - xx	24
DSS - 2xx - H094 - xx	8	SDS - 232 - Sxxx - xx	24
HCL - xxx	33	SIB - 1xx - Exxx - xx	5 to 7
HCP - xxx	35 & 36	SIB - 1xx - Fxxx - xx	5 & 6
LCC - xxx - Hxxx - xx	33	SIB - 1xx - R9xx - xx	9
LEH - 2xx - Sxxx - xx	26	SIB - 1xx - Sxxx - xx	5 to 7
LEH - 3xx - Sxxx - xx	26	SL1 - xxx - A379 - xx	13
LEH - 4xx - Sxxx - xx	26	SL1 - xxx - G379 - xx	13
LEH - 6xx - Sxxx - xx	26	SL2 - xxx - A379 - xx	13
LEV - 2xx - Sxxx - xx	26	SL2 - xxx - G379 - xx	13
LEV - 3xx - Sxxx - xx	26	SLP - 1xx - S083 - xx	17
LEV - 6xx - Sxxx - xx	26	SM1 - xxx - TS99 - 99/1M	38
LOC - xxx - T051 - 99	23	SM1 - xxx - TV99 - 99/1M	38
LOP - 3xx - S083 - xx	17	SM1 - xxx - TV99 - 99/1MR	38
LOP - 6xx - S083 - xx	17	SSB - 1xx - H094 - xx	8
LSP - xxx - Exxx - xx	18	SSP - xxx - Exxx - xx	18
LSP - xxx - Exxx - xx/1	18	SSP - xxx - Exxx - xx/1	18
LSP - xxx - Exxx - xx/2	18	SSP - xxx - Exxx - xx/2	18
MGS xxxx - Exxx - xx X xx xx	32	TIS - 3xx - Exxx - xx	5 to 7
PCB - xxx - Rxxx - xx/x	28	TOS - 202 - S001 - xx	27
PCL - xxx - Sxxx - xx	14 to 16	TOS - xxx - S118 - xx	27
PGA - xxx - Exxx - xxX - xx	29 to 31	ZZS - xxx - Exxx - xx	18
PGA - xxx - Sxxx - xxX - xx	29 to 31	ZZS - xxx - Exxx - xx/1	18
PGL - xxx - Exxx - xxX - xx	29 to 31	ZZS - xxx - Exxx - xx/2	18
Custom Design	50 & 51	Terminals (loose)	46 to 48
General Specification & Information	49	Test Sockets & Adapter	52
Probe Pins & Probe Pin Connectors	45		

THROUGH HOLE SOCKET STRIPS

Straight Socket Strips
Single-, Dual- & Triple-In-Line



Page 5 to 7

Straight Socket Strips
Low- & Super Low Profile



Page 17 & 18

90° Socket Strips
Single- & Dual-In-Line

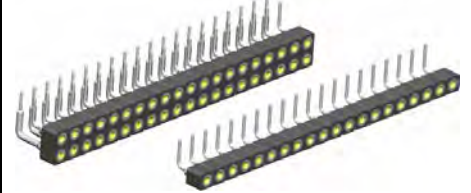

Page 9

Straight Board Stacker Strips
Single-, Dual- & Triple-In-Line

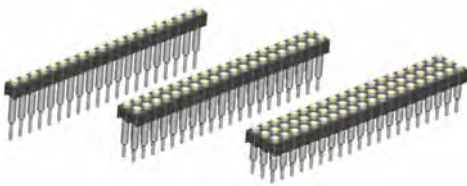

Page 5 & 6

Straight Adapter Strips
Single-, Dual- & Triple-In-Line

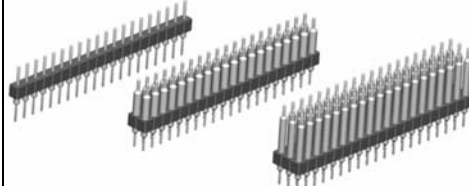

Page 5, 7 & 18

90° Adapter Strips
Single- & Dual-In-Line



Page 9

SMT SOCKET STRIPS

Single- & Dual-In-Line

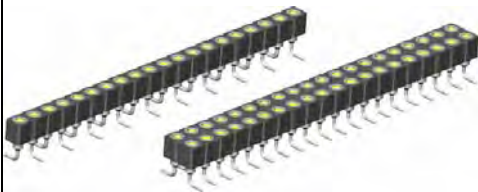

Page 8

Super Low Profile



Page 18

“F” – CONTACT STRIPS



Page 28

JUMBO CONTACT SOCKET & ADAPTER STRIPS

mating with 0,65x0,65mm square pins (Pin Header)

Single- & Dual-In-Line Socket
straight & 90° through hole version

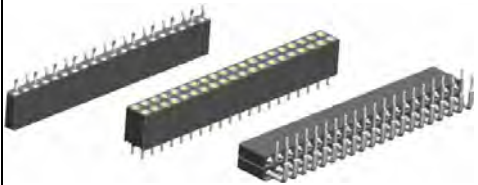

Page 10

Single- & Dual-In-Line Socket
SMT version



Page 11 & 12

Single- & Dual-In-Line Adapter
straight & 90° through hole version



Page 13

Specials

Crystal Oscillator Sockets



Page 25

Sockets for 7-Segment LED Displays





Page 26



Transistor-, TO-Sockets
& Fuse Holders

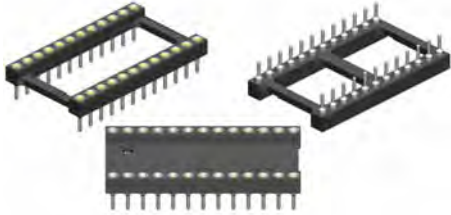
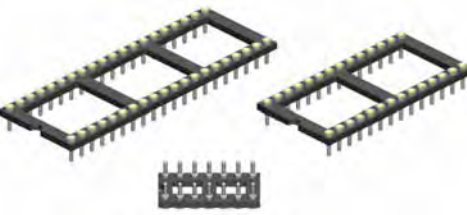
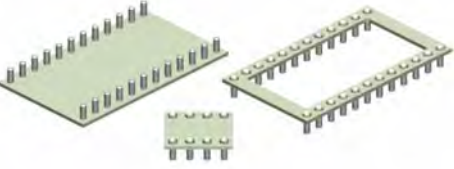
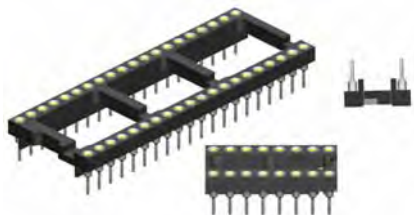
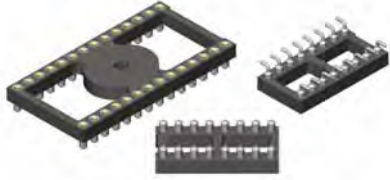
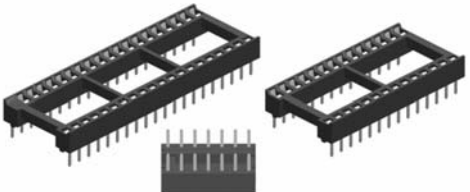
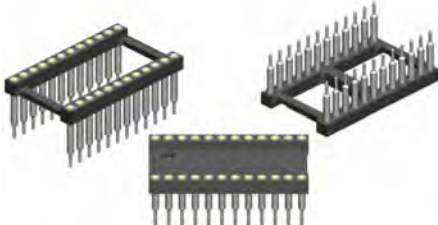
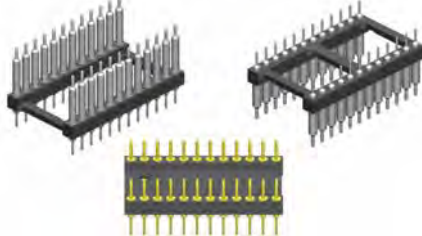

Page 27

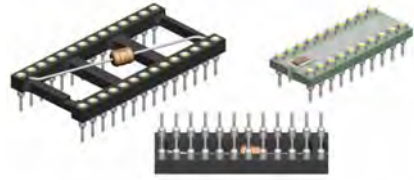
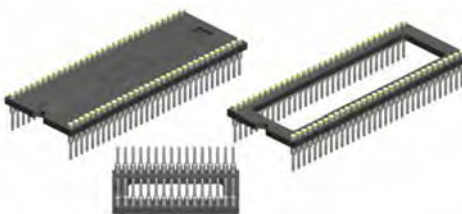
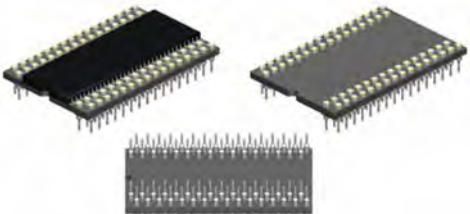
IC DIP SOCKETS THROUGH HOLE STYLE

<p>Precision Contact open & closed frame</p>  <p>Page 14</p>	<p>Precision Contact Low Profile</p>  <p>Page 17</p>	<p>Precision Contact Super Low Profile</p>  <p>Page 18</p>
<p>Precision Contact Socket for automatic insertion</p>  <p>Page 19</p>	<p>SMT Precision Contact</p>  <p>Page 21</p>	<p>Low Cost - stamped Contact</p>  <p>Page 23</p>
<p>Precision Contact Board Stacker open & closed frame</p>  <p>Page 15</p>	<p>Precision Contact Board Spacer open & closed frame</p>  <p>Page 16</p>	<p>Carrier Sockets</p>  <p>Page 20</p>
<p>Capacitor Sockets</p>  <p>Page 22</p>	<p>Shrink Sockets</p>  <p>Page 24</p>	<p>Quad-In-Line Sockets</p>  <p>Page 25</p>

<p>TOOLS</p>	<p>PROBE PINS PROBE PIN CONNECTORS</p>	<p>TERMINALS</p>
 <p>Page 44</p>	 <p>Page 45</p>	 <p>Page 46 to 48</p>

PIN GRID ARRAY SOCKETS & ADAPTERS

MiniGrid Sockets & Adapter
pitch 0.80 – 1.00 – 1.50 – 2.00mm

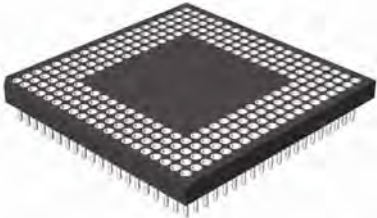

Page 32

Sockets
pitch 1.27 & 2.54mm
and Interstitial (2.54mm/1.27mm)

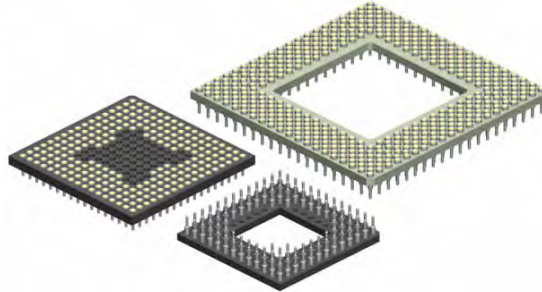

Page 29 to 31

Adapter
pitch 1.27 & 2.54mm
and Interstitial (2.54mm/1.27mm)

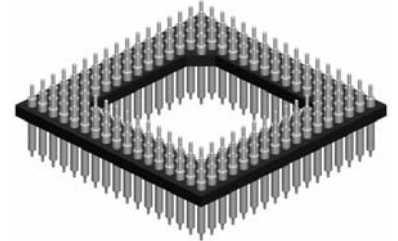

Page 31 & 32

LCC & PLCC SOCKETS

Socket for LCC JEDEC Type “C”



Page 33

Socket for PLCC Chips
through hole “Commercial” Type

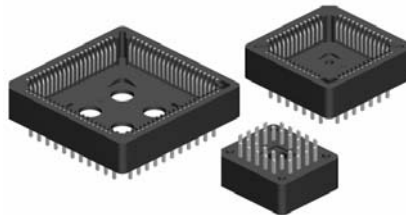

Page 34

Socket for PLCC Chips
through hole “Hi-Rel” Type

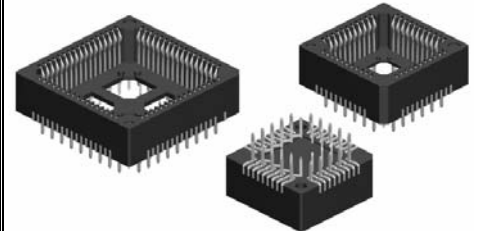

Page 35

Socket for PLCC Chips
SMT “Hi-Rel” Type

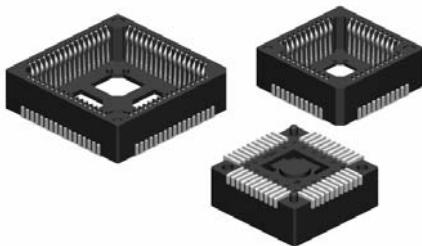

Page 36

Socket for PLCC Chips
SMT “Low Profile” Type

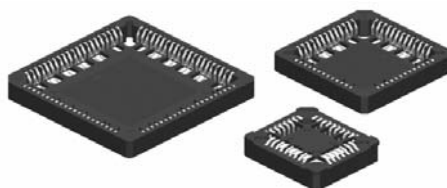

Page 37

Special PLCC Parts
Adapter & Wire Wrap Adapter

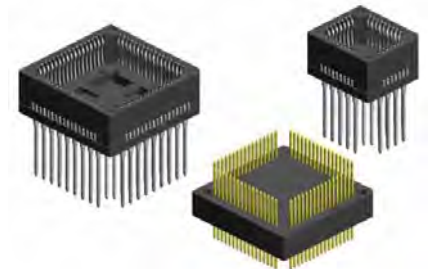

Please ask E-tec for availability

SIMM SOCKETS

Vertical & 26° slanted Type
72- & 80-pin



Page 38

DIMM SOCKETS

Vertical Type
100- , 168- , 184-pin



Page 39, 40 & 43

25° slanted Type
168-pin



Page 41

90° right angle Type
168-pin



Page 42

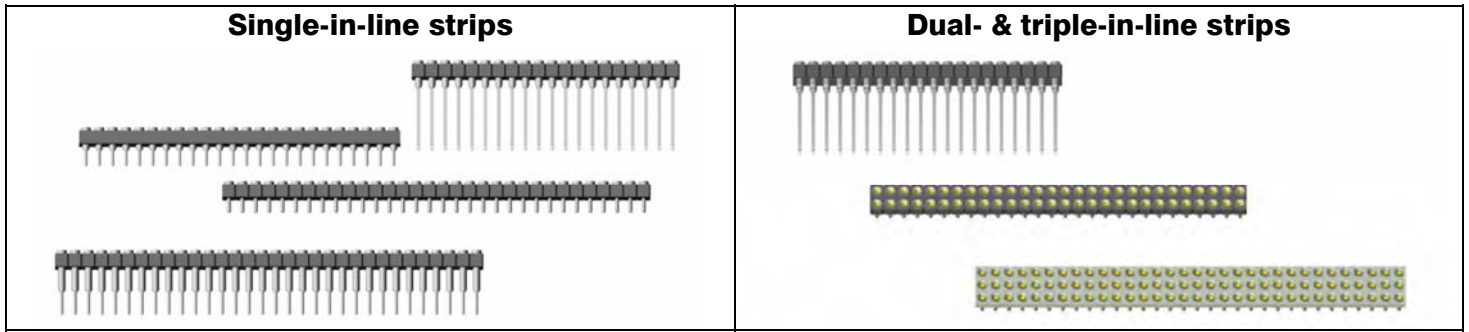

SIB Series
single-in-line Strips
breakable and solid insulator available
Unless otherwise specifically requested, the strips will be delivered either in solid or breakable plastic depending on availability of the insulator bodies.

breakable shown solide shown

2.50

"head flush" "head above"

SIB Series
Standard "head flush"
SIB-1xx-Fxxx-xx

Alternative: "head above"
SIB-1xx-Sxxx-xx

Number of contacts standard breakable sizes
20; 32 and 40

Number of contacts either breakable or solid available
from **02 to 40**

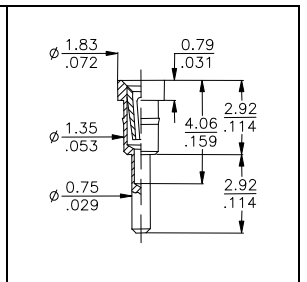
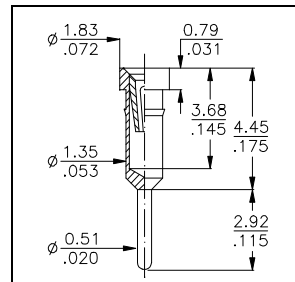

001 Standard terminal

047 Low profile terminal

DIS & TIS Series
dual and triple row 2,54mm grid

2.54 5.00

2.54

DIS Series
DIS-2xx-Fxxx-xx

Number of contacts available
from **04 to 80**

TIS Series
TIS-3xx-Exxx-xx

Number of contacts available
from **06 to 96**

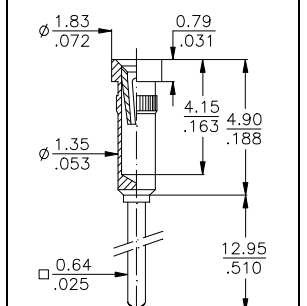
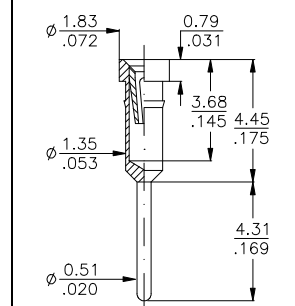

008 long tail terminal

003 3-level w/w

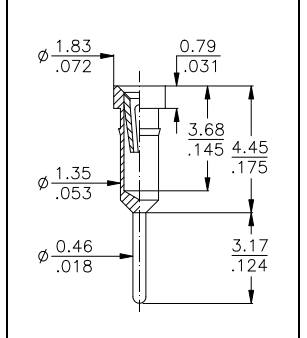
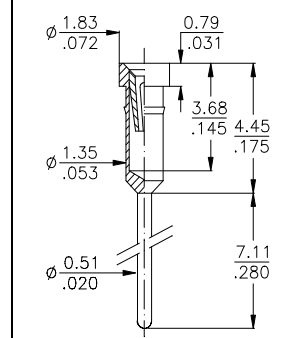

009 extra long tail

010 Carrier terminal

Strips
Other lengths & pin-outs available on request.

Specifications
refer to page 49 of this catalogue

Terminals
For other terminal styles please refer to the pages 46 to 48 of this catalogue or contact your closest sales office.

How to order

XXX - x xx - X xxx - xx

<p>Series</p> <p>SIB = single-in-line strips</p> <p>DIS = dual-in-line strips...</p> <p>TIS = triple-in-line strips...</p>	<p>Rows</p> <p>..... 1</p> <p>..... 2</p> <p>..... 3</p>	<p>Nbr of contacts</p> <p>see above table</p>	<p>Insulator</p> <p>F = head flush</p> <p>S = head above</p> <p>E = Epoxy FR4 TIS Series only</p>	<p>Terminal style</p> <p>see drawings above or refer to pages 46 to 48 of this catalogue for other types.</p>	<p>Plating</p> <p>- 95 = tin/gold</p> <p>- 55 = gold/gold</p> <p>- 99 = tin/tin <i>(tin is leadfree)</i></p>
--	--	--	---	--	--



Board Stacker Terminals

<p>079</p>	<p>623</p>	<p>062</p>
<p>060</p>	<p>063</p>	<p>080</p>
<p>084</p>	<p>085</p>	<p>088</p>
<p>065</p>	<p>Many other terminals and custom specific terminal styles are available on request, or refer to the pages 46 to 48 of this catalogue.</p>	

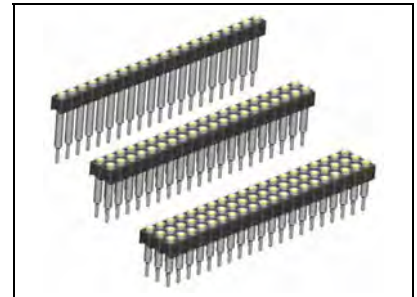

Application Examples

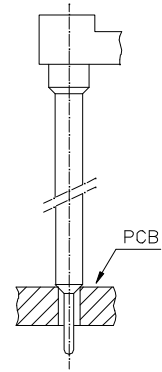

Possible Terminals:

060; 062; 063; 065; 079
080; 084; 085; 088; 623

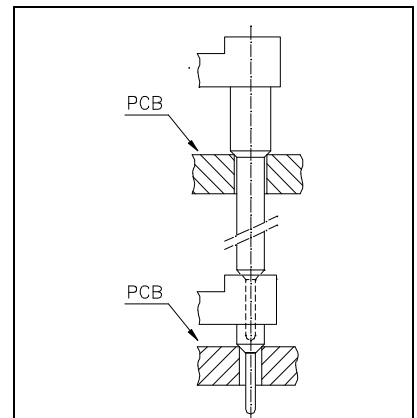

Possible Terminals:

060; 062; 063; 079; 623

Specifications

See page 49 of this catalogue

How to order

XXX - xxx - X xxx - 95

<p>Series SIB = single-in-line strips. DIS = dual-in-line strips... TIS = triple-in-line strips...</p>	<p>Rows 1 2 3</p>	<p>Nbr of contacts 1-row = 02 to 40 2-row = 04 to 80 3-row = 06 to 96</p>	<p>Insulator see socket strip page 5</p>	<p>Terminal style see drawings above or refer to pages 46 to 48 of this catalogue for other types.</p>	<p>Plating - 95 = tin/gold (tin leadfree) other on request</p>
---	--	---	--	--	--



Board to Board Terminals

<p>077</p>	<p>057</p>	<p>037</p>
<p>058</p>	<p>059</p>	<p>056</p>
<p>542</p>	<p>038</p>	<p>353</p>
<p>036</p>	<p>Many other terminals and custom specific terminal styles are available on request, or refer to the pages 46 to 48 of this catalogue.</p>	

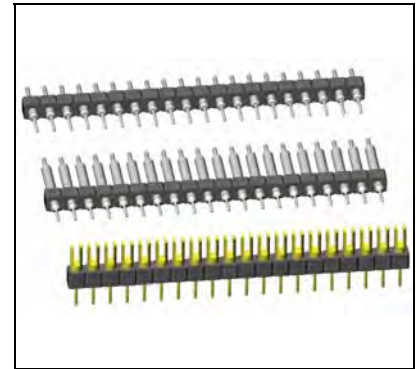

Application Examples

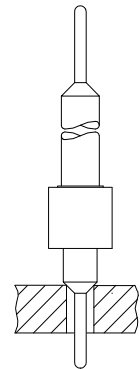

Possible Terminals:
037; 056; 057; 058; 059
077; 220; 542; 544
562; 583; 770

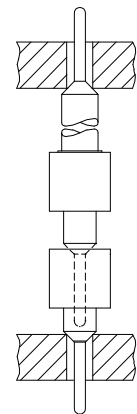

Possible Terminals:
037; 056; 057; 058; 059
077; 078; 542; 544
562; 583; 770

How to order

XXX - x XX - X xxx - xx

<p>Series SIB = single-in-line strips. DIS = dual-in-line strips... TIS = triple-in-line strips..</p>	<p>Rows 1 2 3</p>	<p>Nbr of contacts 1-row = 02 to 40 2-row = 04 to 80 3-row = 06 to 96</p>	<p>Insulator S = Plastic E = Epoxy FR4 (TIS Series only) dimension see socket strip page 5</p>	<p>Terminal style see drawings above or refer to pages 46 to 48 of this catalogue for other types.</p>	<p>Plating - 55 = gold - 99 = tin (leadfree)</p>
--	--	---	---	---	---

The 2,54mm pitch **SMT** socket strips with standard IC-Socket Precision Contacts can also be used in combination with the straight version SIB/DIS strips shown earlier in this catalogue.

The socket strips accept round pins with a diameter of 0,41 to 0,56mm max., as well as square pins of 0,40 x 0,40mm max.

The **SMT** socket strips are available in single and dual row.

The head of the female terminal is completely embedded in the insulator.

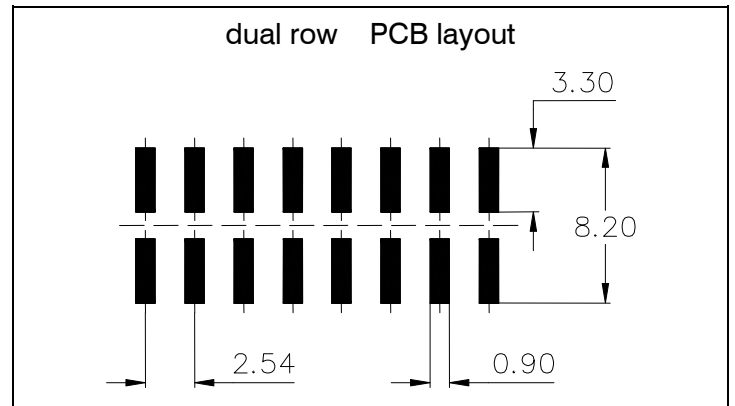
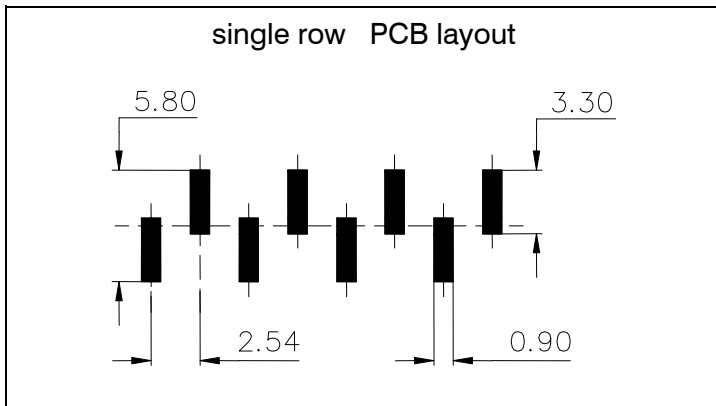
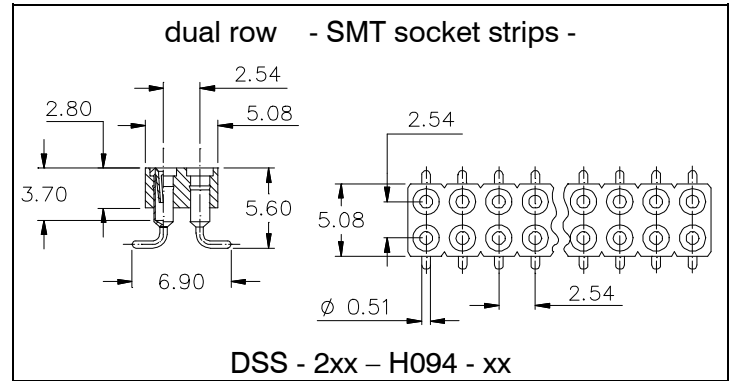
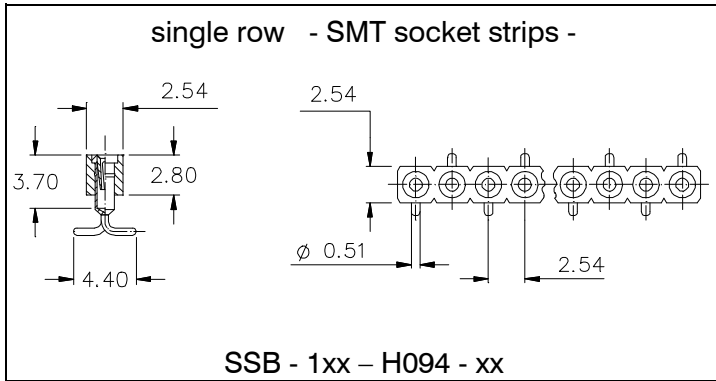
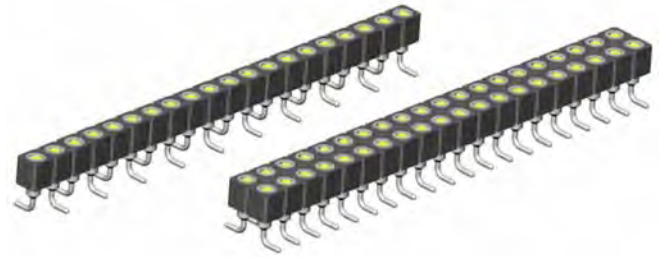

Specifications

Mechanical data

Insertion force contact type 900	1,80 N (avg)
Extraction force contact type 900	0,90 N (avg)
Contact life	> 100 cycles
Operating temperature	-55° C to +125° C
Processing temperature	+250°C +0/-5°C for 20~40sec.

Material

Insulator (RoHS compliant)	high temp plastic UL 94 V-0
Terminal (RoHS compliant)	CuZn
Contact (RoHS compliant)	BeCu

Electrical data

Insulation resistance	5 x 10 ⁹ Ω min.
Breakdown voltage	500 V AC for 1 minute
Contact resistance	4,3 mΩ typ.
Current rating	1 A max., 100V

Insertion depth contact type 900

maximum	3,68mm / .145"
minimum	2,80mm / .110"

How to order

XXX - x xx - H 094 - xx

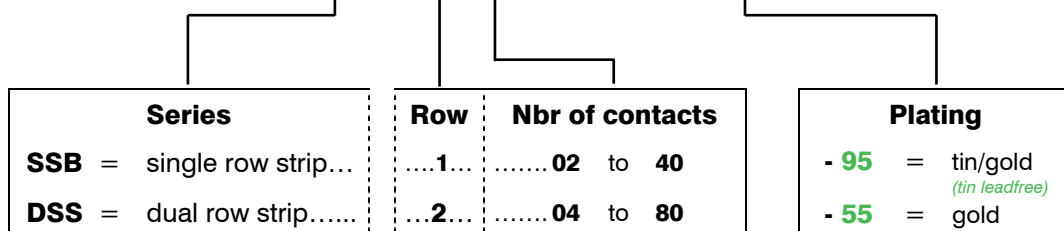

90° Socket Strips & Male Headers

The 2,54mm pitch 90° socket strips and male headers are designed for „board to board“ connections, and can also be used in combination with the straight version SIB/DIS strips shown earlier in this catalogue.

The socket strips accept round pins with a diameter of 0,41 to 0,56mm max., as well as square pins of 0,40 x 0,40mm max.

The socket strips and male headers are stackable and available in any pinout as shown in the below order code.

The head of the female terminal is completely embedded in the insulator.

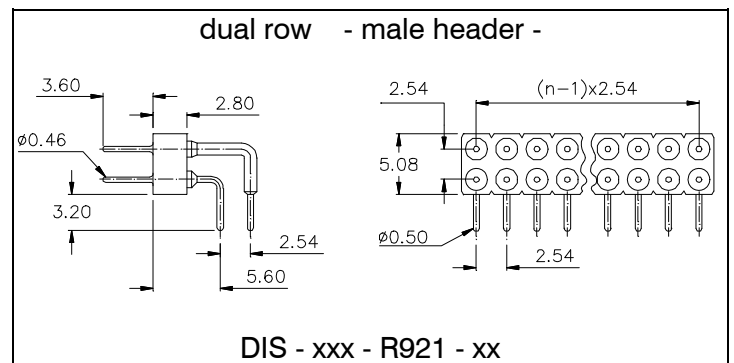
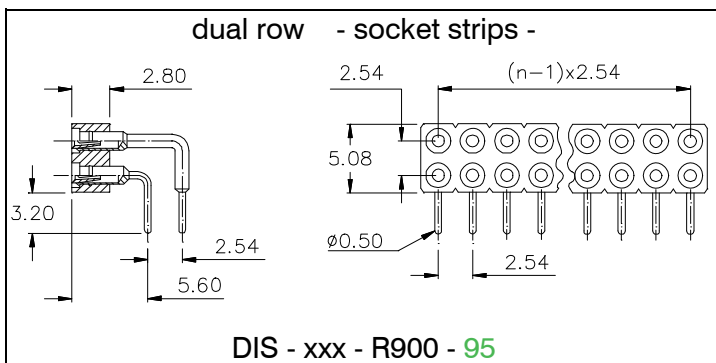
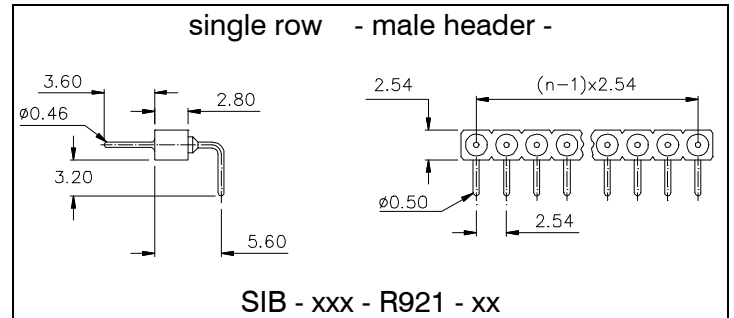
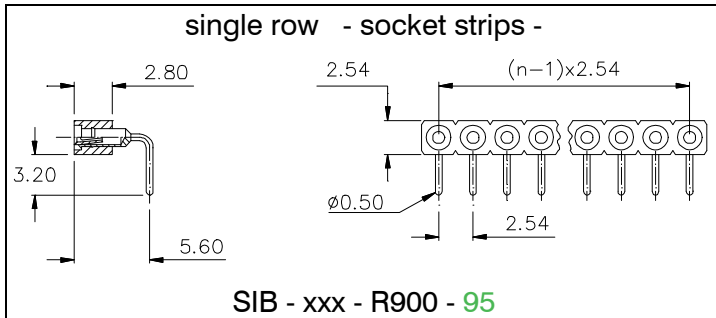
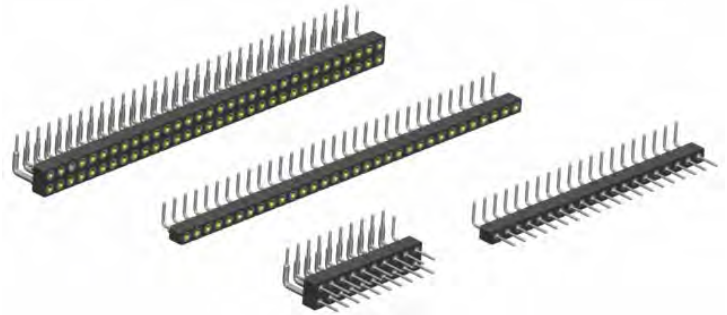

Specifications

Mechanical data

Insertion force contact type 900	1,80 N (avg)
Extraction force contact type 900	0,90 N (avg)
Contact life	> 100 cycles
Operating temperature	-55° C to +125° C
Processing temperature	+250°C +0/-5°C for 20~40sec.

Material

Insulator (RoHS compliant)	high temp plastic UL 94 V-0
Terminal (RoHS compliant)	CuZn
Contact (RoHS compliant)	BeCu

Electrical data

Insulation resistance	5 x 10 ⁹ Ω min.
Breakdown voltage	500 V AC for 1 minute
Contact resistance	4,3 mΩ typ.
Current rating	1 A max., 100V

Insertion depth contact type 900

maximum	3,68mm / .145"
minimum	2,80mm / .110"

How to order

XXX - xxx - R xxx - xx

Series	Row	Nbr of contacts	Contact Type	Plating
SIB = single-in-line strips	... 1	02 to 40 <i>20, 32, 40 Std. breakable sizes</i>	900 = female	Contact type „900“ - 95 = tin/gold (tin leadfree)
DIS = dual-in-line strips...	... 2	04 to 72	921 = male	Contact type „921“ - 99 = tin (tin leadfree) - 55 = gold

BL - Series „Jumbo Contact“

Female Headers 2,54mm pitch



2,54mm pitch female header with precision „Jumbo Contact“ for board to board connections.

Accepts **square pins 0,65 x 0,65mm** max. (Pin Headers), as well as **round pins Ø 0,65 to 0,85mm** max.

7,00mm standard profile, and 4.50mm low profile available, other on request.

The stand-offs underneath the insulator, prevent the header from slanting during soldering.

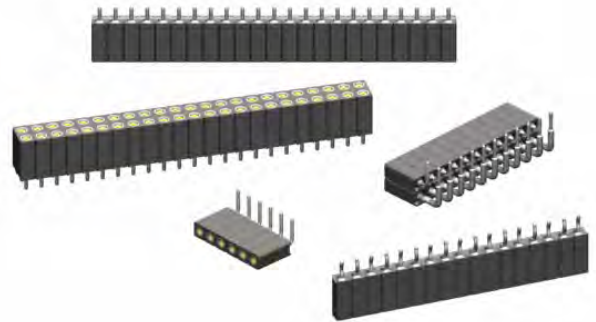

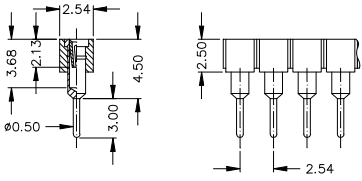
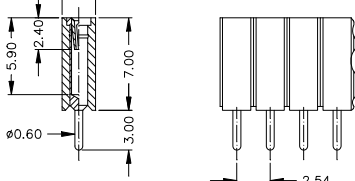
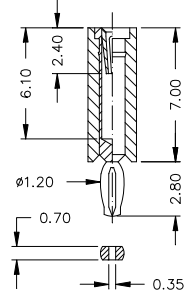
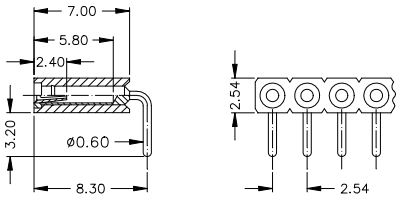
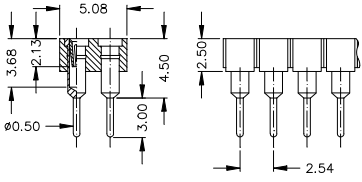
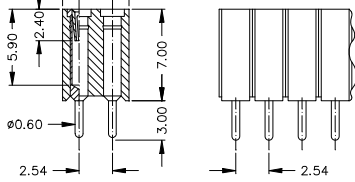
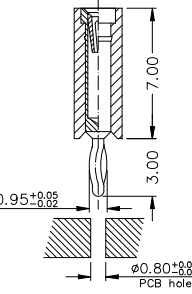
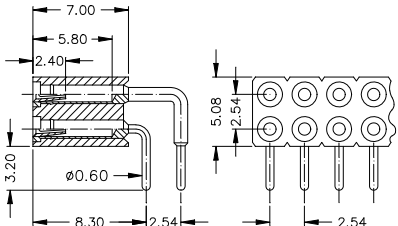
<p>4.50mm Profile single row -straight-</p>  <p>BL1 - xxx - G109 - 95</p>	<p>7.00mm Profile single row -straight-</p>  <p>BL1 - xxx - G700 - 95</p>	<p>Other available Terminals</p>  <p>G065P press fit type For PCB thickness 1.50 to 2.00mm; plated-thru holes: Ø0,94 to 1,09mm</p>	<p>single row -right angle-</p>  <p>BL1 - xxx - A700 - 95</p>
<p>4.50mm Profile dual row -straight-</p>  <p>BL2 - xxx - G109 - 95</p>	<p>7.00mm Profile dual row -straight-</p>  <p>BL2 - xxx - G700 - 95</p>	 <p>G799 Clinched type off G700 only for BL1 Series available</p>	<p>dual row -right angle-</p>  <p>BL2 - xxx - A700 - 95</p>

Specifications

Mechanical data

Insertion force (test probe Ø 0,66) 1,40 N (avg) if A700, G700 & G109
2,00 N (avg) if G065P
3,75 N (avg) if G799

Extraction force (test probe Ø 0,66) 0,25 N (avg) if A700, G700 & G109
1,00 N (avg) if G065P & G799

Contact life > 100 cycles

Operating temperature -55° C to +125° C

Material

Insulator (RoHS compliant) high temp plastic UL 94 V-O

Terminal (RoHS compliant) CuZn

Contact (RoHS compliant) BeCu

Electrical data

Insulation resistance 10⁴ MΩ min.

Breakdown voltage 500 V AC for 1 minute

Contact resistance 30 mΩ / contact max.

Current rating 3 A max., 100V

Insertion depth
maximum depends on the Terminal style
minimum 4,00mm / .157"

How to order

BLx - xxx - X xxx - 95

<p>Series</p> <p>BL1 = single row...</p> <p>BL2 = dual row....</p>	<p>Nbr of contacts</p> <p>.....002 to 050</p> <p>Note: 002 to 040 only available for G109 series</p> <p>.....004 to 100</p> <p>Note: 004 to 080 only available for G109 series</p>	<p>Connector style</p> <p>G = straight</p> <p>A = right angle</p>	<p>Terminal Type</p> <p>pls. ref. to the drawings shown above</p> <p>"press fit" = 065P and "clinched" type = 799 not available for the A = right angle style</p>	<p>Plating</p> <p>- 95 = tin/gold (tin leadfree)</p> <p>others on request</p>
---	---	--	--	---

2,54mm pitch **SMT** female header with precision „Jumbo Contact“ for board to board connections.

Accepts square pins 0,65 x 0,65mm max. (Pin Headers), as well as round pins \varnothing 0,65 to 0,85mm max.

The female headers are available in any number of contacts, up to a maximum of 50 for the single row, and 100 for the double row.

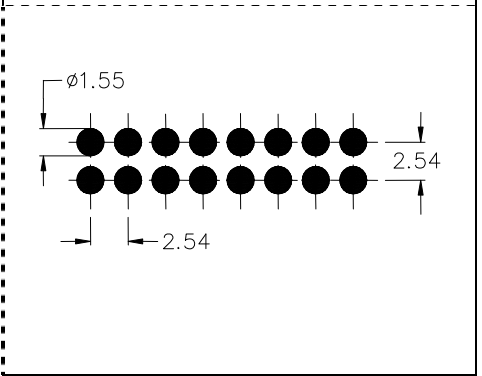
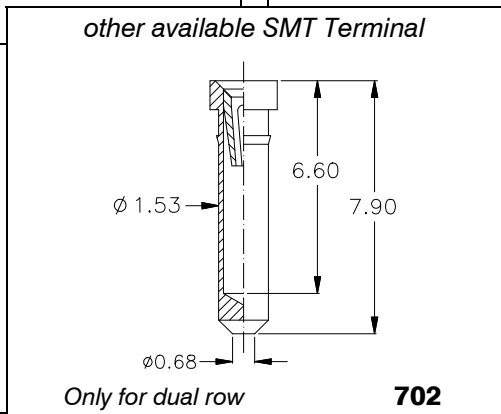
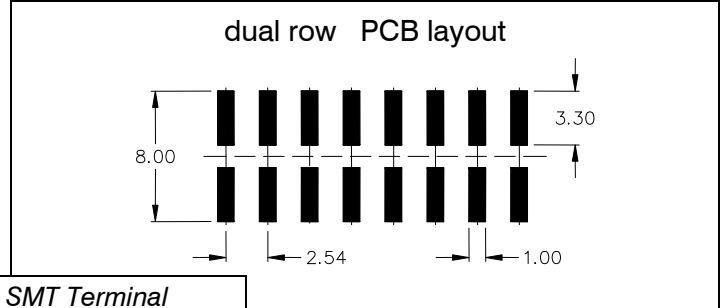
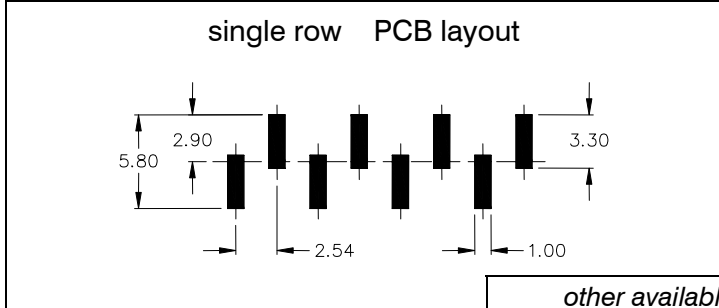
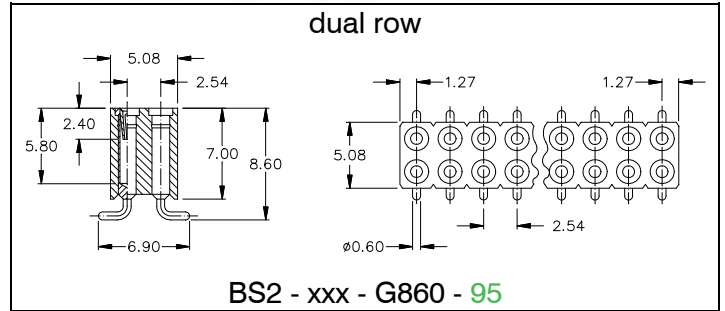
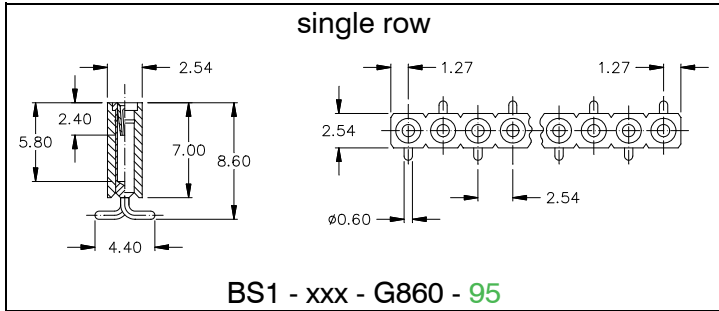
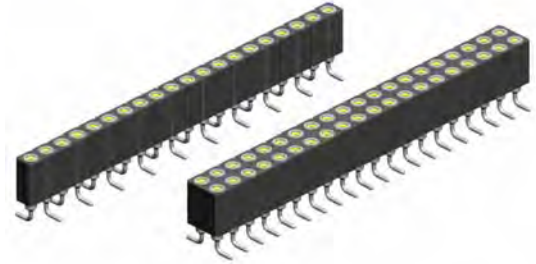

Specifications

Mechanical data

Insertion force (test probe \varnothing 0,66)	2,00 N if Terminal 860
Extraction force (test probe \varnothing 0,66)	1,00 N for all Terminals
Contact life	> 100 cycles
Operating temperature	-55° C to +125° C
Processing Temperature	+250°C +0/-5°C for 20~40sec.

Material

Insulator	(RoHS compliant) high temp plastic UL 94 V-0
Terminal	(RoHS compliant) CuZn
Contact	(RoHS compliant) BeCu

Electrical data

Insulation resistance	10 ⁴ M Ω min.
Breakdown voltage	500 V AC for 1 minute
Contact resistance	30 m Ω / contact max.
Current rating	3 A max., 100V

Insertion depth

maximum	depends on the Terminal style
minimum	4,0mm / .157"

How to order

BSX - xxx - G xxx - xx

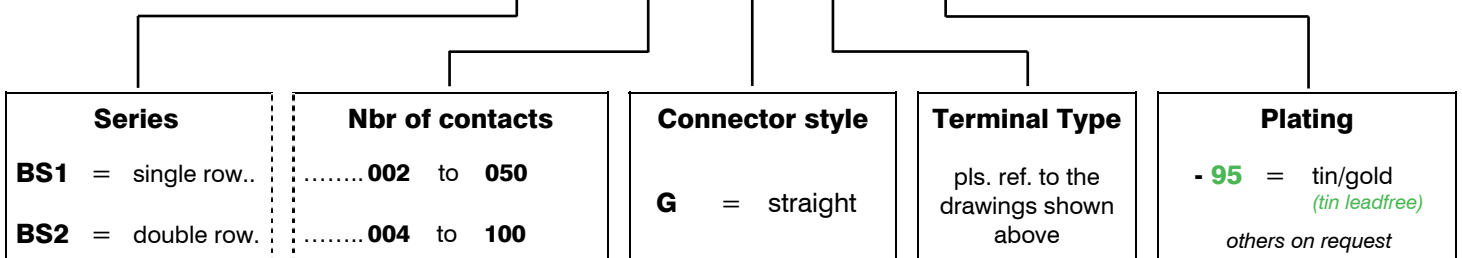

2,54mm pitch “**low profile**” SMT female header with precision „Jumbo Contact“ for board to board connections.

Accepts square pins 0,65 x 0,65mm max. (Pin Headers), as well as round pins \varnothing 0,65 to 0,85mm max.

The female headers are available with 40 contacts max. for the single row, and 80 (2x40) max. for the dual row.

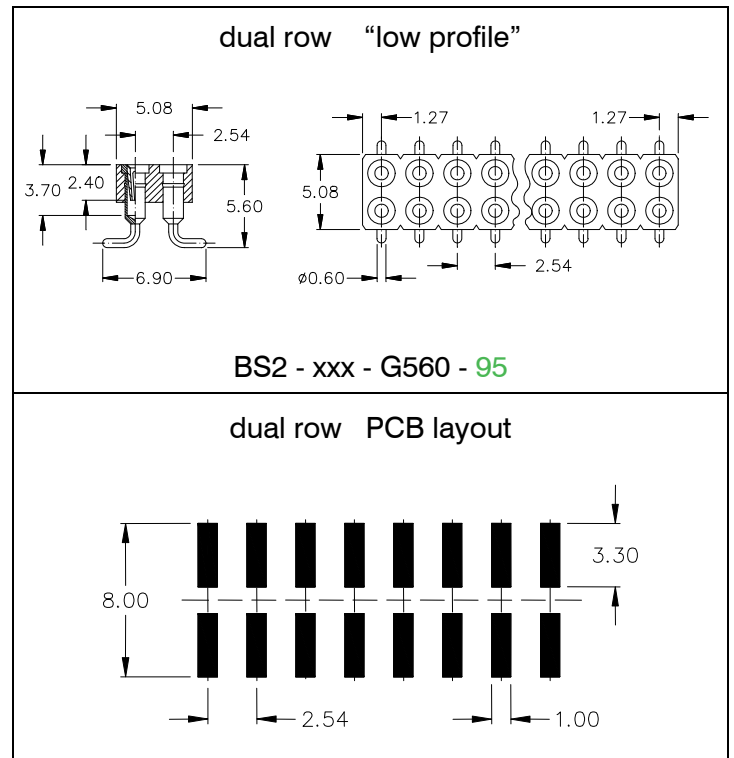
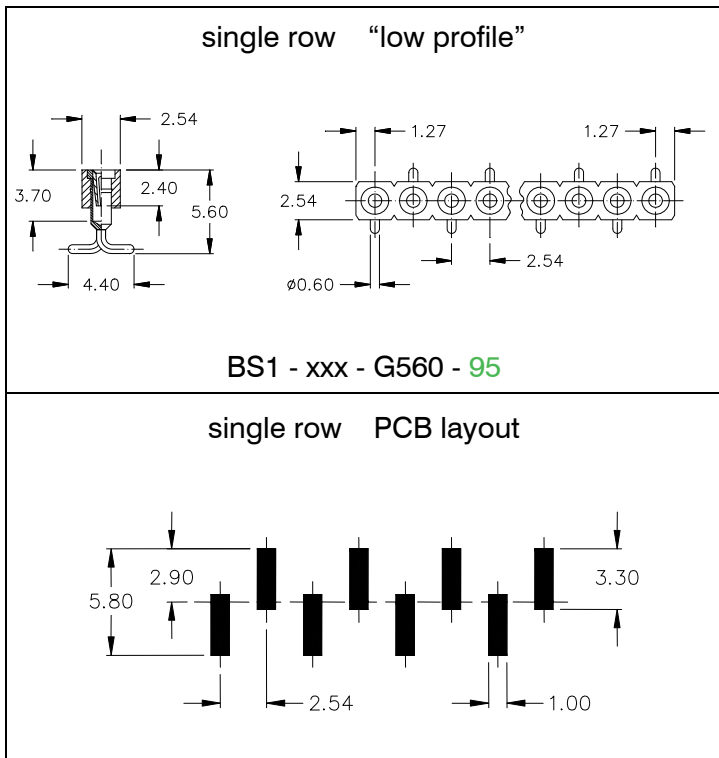
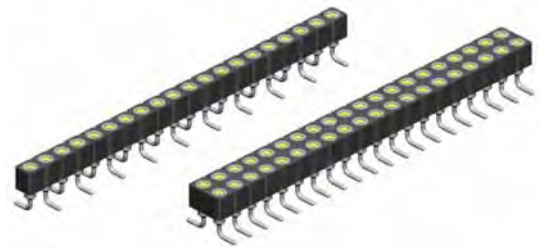

Specifications

Mechanical data

Insertion force	1,40 N (avg) (test probe \varnothing 0,66)
Extraction force	0,25 N (avg) (test probe \varnothing 0,66)
Contact life	> 100 cycles
Operating temperature	-55° C to +125° C
Processing Temperature	+250°C +0/-5°C for 20~40sec.

Material

Insulator	(RoHS compliant) high temp plastic UL 94 V-O
Terminal	(RoHS compliant) CuZn
Contact	(RoHS compliant) BeCu

Electrical data

Insulation resistance	10 ⁴ M Ω min.
Breakdown voltage	500 V AC for 1 minute
Contact resistance	30 m Ω / contact max.
Current rating	3 A max., 100V

Insertion depth

maximum	3.70mm / .146"
minimum	3.00mm / .118"

How to order

BS x - x x x - **G** 5 6 0 - **95**

Series	Nbr of contacts	Connector style	Terminal Type	Plating
BS1 = single row.. 002 to 040	G = straight	pls. ref. to the drawings shown above	- 95 = tin/gold (tin leadfree) others on request
BS2 = dual row.... 004 to 080			

SL - Series „Jumbo“ Male Headers

2,54mm pitch



2,54mm pitch male header with precision turned „Jumbo“ pin, \varnothing 0,76mm / .030“, for board to board connections.

Mates with the „Jumbo Contact“ female headers shown in this catalogue.

The pin headers are stackable and available in single and double row version.

The pins are either completely gold or tin plated.

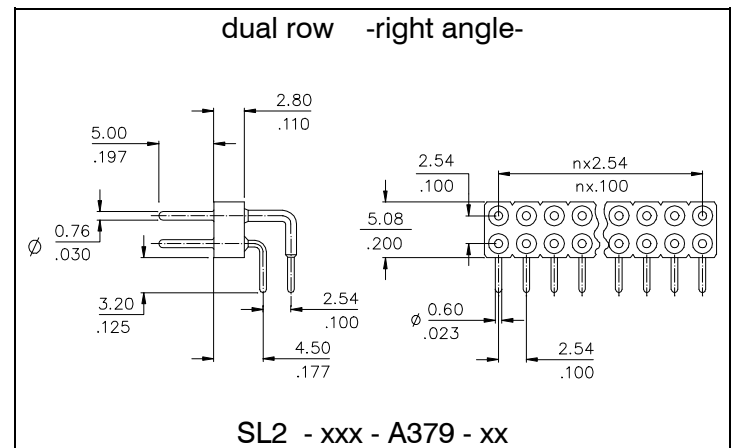
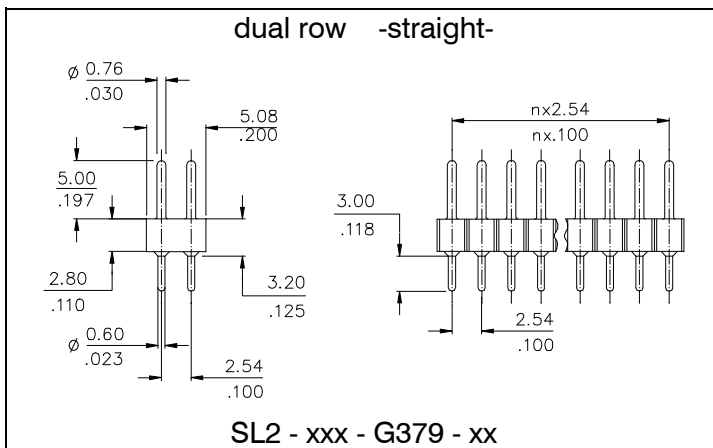
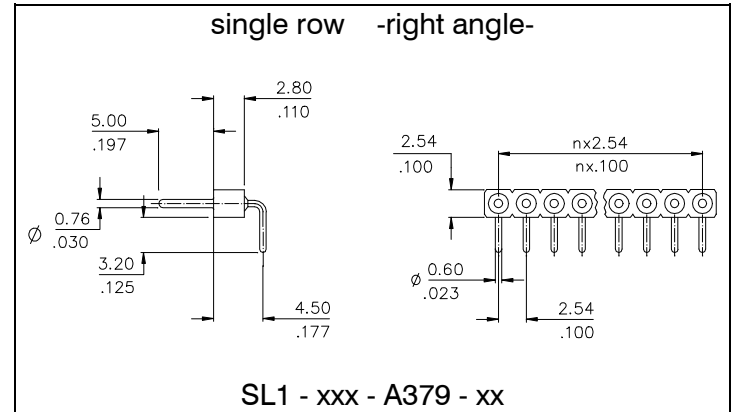
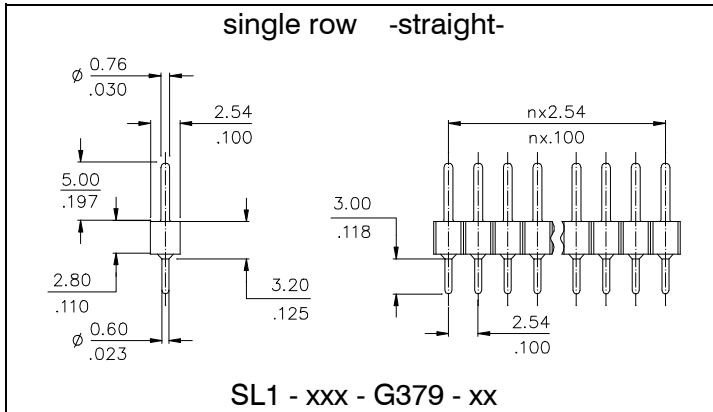
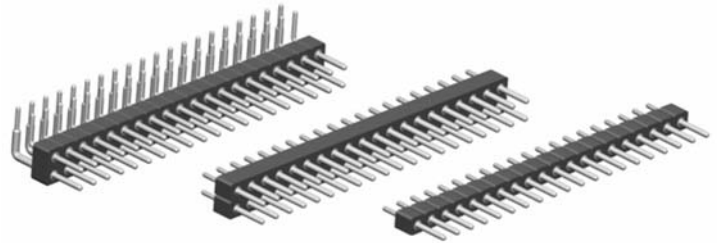

Specifications

Material

Insulator (RoHS compliant) high temp plastic UL 94 V-O
Terminal (RoHS compliant) CuZn

Operating temperature -55° C to +125° C

Electrical data

Insulation resistance 10⁴ M Ω min.
Breakdown voltage 500 V AC for 1 minute
Rated voltage 60 V RMS / 90 V DC
Contact resistance 30 m Ω / contact max.
Current rating 3 A max.

How to order

SLx - xxx - X 379 - xx

Series	
SL1	= single row.....
SL2	= dual row.....

Nbr of contacts	
.....	002 to 040
	064 on request only
.....	004 to 080 (straight style)
.....	004 to 072 (right angle style)

Terminal style	
G	= straight
A	= right angle

Plating	
- 99	= tin (tin leadfree)
- 55	= gold

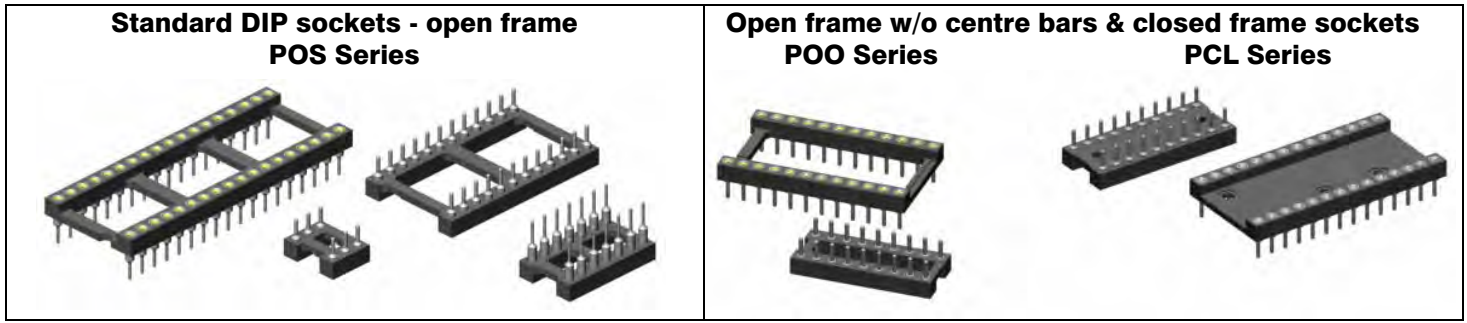

Series POS & POO
- open body with and without centre bars -
If you need all Insulator Dimension pls. ask for customer drawing!

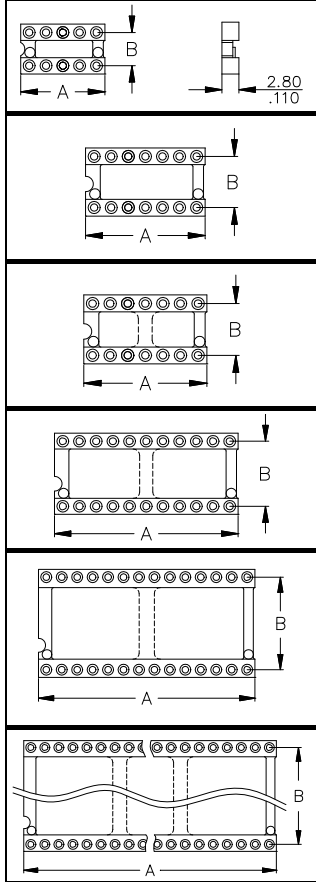

POS sockets in 7,62mm/.300" DIP spacing are either supplied with or without bars in the centre depending on plastic wafer availability. If you need sockets without centre bars, then please always order with POO instead of POS.

Pin	Dimension		Available Pinouts of Series		
	"A"	"B"	POS	POO	PCL
10	12,60	5,08 .200"	-	-	-210-
6	7,60	7,62 .300"	-306-	-	-
8	10,10		-308-	-	-
10	12,60		-310-	-	-
14	17,70		-314-	-314-	-314-
16	20,30		-316-	-316-	-316-
18	22,80	7,62 .300"	-318-	-318-	-318-
20	25,30		-320-	-320-	-320-
22	27,80		on request	on request	-
24	30,40		-324-	-324-	-
28	35,50		-328-	-328-	-
16	20,32	10,16 .400"	on request	on request	on request
22	27,80		on request	on request	on request
24	30,60		on request	on request	on request
24	30,50	15,24 .600"	-624-	-624-	on request
28	35,50		-628-	-628-	-628-
32	40,60		-632-	-632-	-632-
36	45,70		-636-	on request	-
40	50,80		-640-	-640-	-640-
48	60,96		-648-	on request	on request
64	81,26	22,86 .900"	on request	-	-

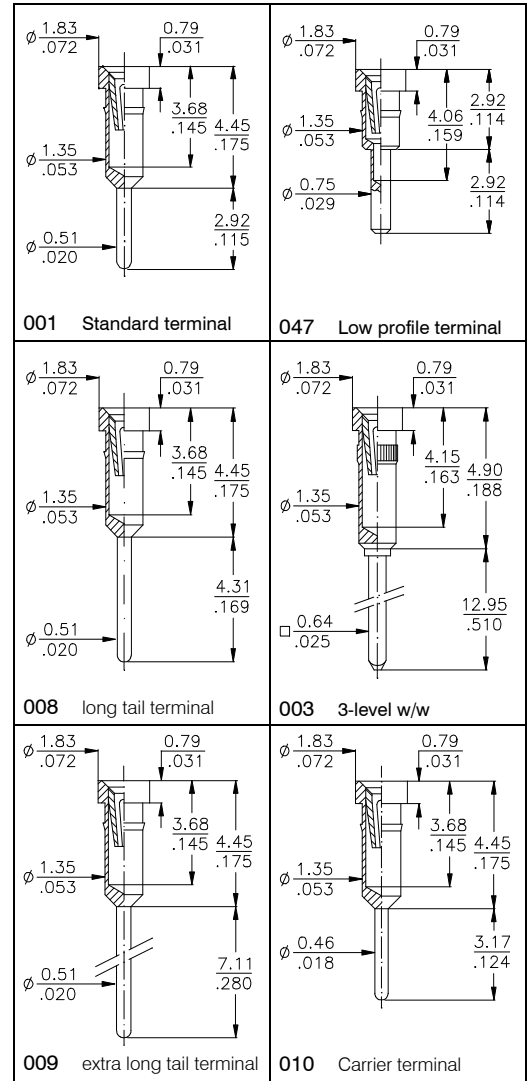

Specifications
PBT and high temp plastic depending on type.
See page 49 of this catalogue and contact factory for more details.

Insulator body
POS series = open insulator - see drawings above
POO series = open insulator w/o centre bars
PCL series = closed insulator body

Terminals
The POS, POO and PCL series are available with many different terminal styles. The most common terminal styles are shown on the right hand side of this page. Many other additional terminals can be found at the end of this catalogue. Custom design terminals are available on request.

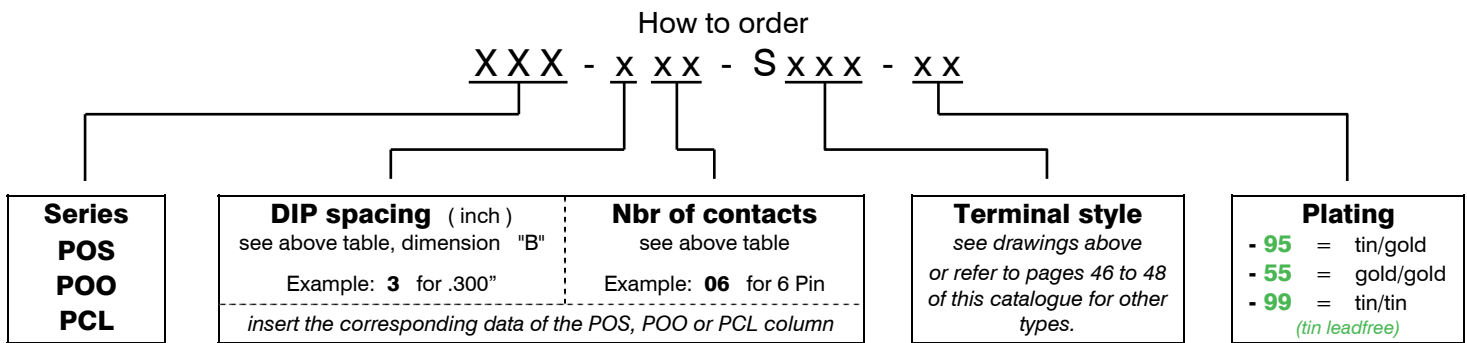



Board Stacker Terminals

<p>079</p>	<p>623</p>	<p>062</p>
<p>060</p>	<p>063</p>	<p>080</p>
<p>084</p>	<p>085</p>	<p>088</p>
<p>065</p>	<p>Many other terminals and custom specific terminal styles are available on request, or refer to the pages 46 to 48 of this catalogue.</p>	

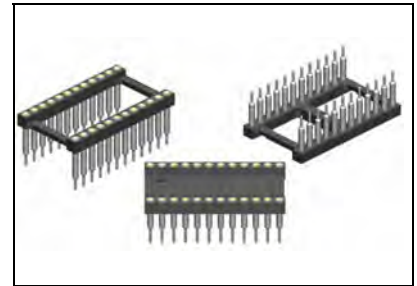

Application Examples

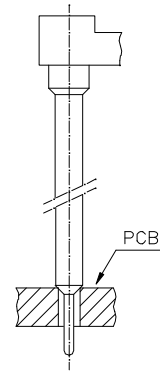

Possible Terminals:

060; 062; 063; 065; 079
080; 084; 085; 088; 623

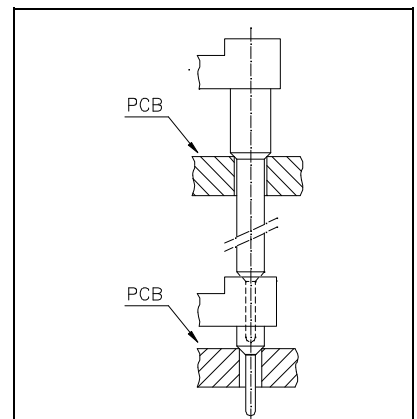

Possible Terminals:

060; 062; 063; 079; 623

Specifications

See page 49 of this catalogue

How to order

XXX - x xx - S xxx - xx

<p>Series POS POO PCL see page 14</p>	<p>DIP spacing in inch refer to table, dimension "B" on page 14 insert the corresponding data of the POS, POO or PCL column</p>	<p>Nbr of contacts refer to table on page 14</p>	<p>Terminal style see drawings above or refer to pages 46 to 48 of this catalogue for other types.</p>	<p>Plating - 95 = tin/gold (tin leadfree) other on request</p>
--	---	---	---	---



Board to Board Terminals

<p>077</p>	<p>057</p>	<p>037</p>
<p>058</p>	<p>059</p>	<p>056</p>
<p>542</p>	<p>038</p>	<p>353</p>
<p>036</p>	<p>Many other terminals and custom specific terminal styles are available on request, or refer to the pages 46 to 48 of this catalogue.</p>	

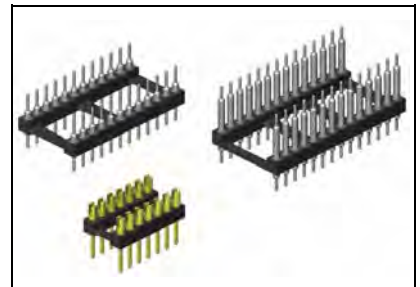

Application Examples

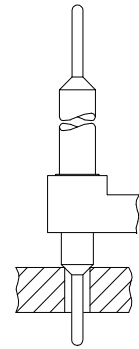

Possible Terminals:

037; 056; 057; 058; 059; 077
220; 221; 542; 543; 544; 562
770

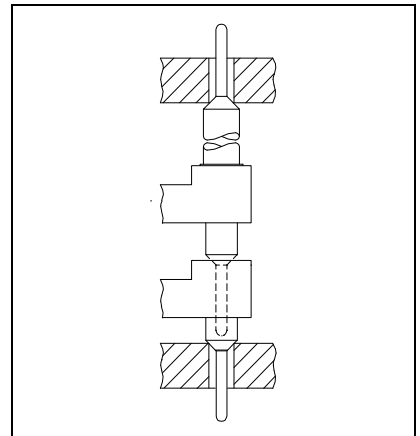

Possible Terminals:

037; 056; 057; 058; 059
077; 542; 544; 562; 770

Specifications

See page 49 of this catalogue

How to order

XXX - xxx - Sxxx - xx

<p>Series POS PCL see page 14</p>	<p>DIP spacing in inch refer to table, dimension "B" on page 14 insert the corresponding data of the POS, POO or PCL column</p>	<p>Nbr of contacts refer to table on page 14</p>	<p>Terminal style see drawings above or refer to pages 46 to 48 of this catalogue for other types.</p>	<p>Plating - 55 = gold - 99 = tin (tin leadfree)</p>
--	---	---	---	---

“low profile“ Sockets & Strips

Low profile DIP sockets LOP Series

height above PCB 2.41mm / .095"

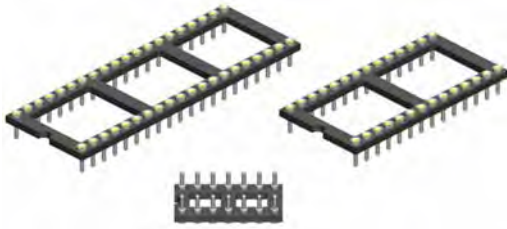

Low profile strips SLP Series

height above PCB 2.41mm / .095"

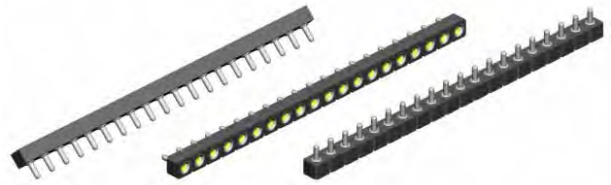

Insulator

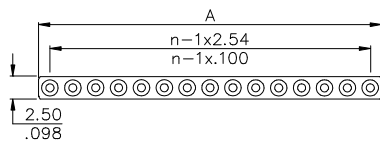
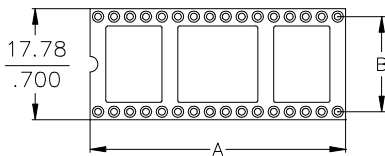
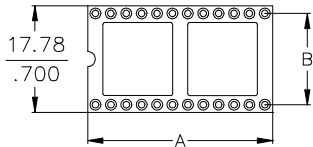
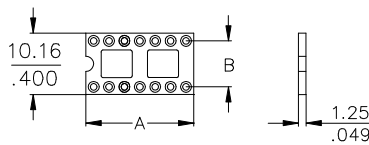

Pin	Dimensions mm/inch		Ordering Code
	"A"	"B"	
14	17,78/.700	7,62 .300	LOP - 314 - S083 - 95
16	20,32/.800		LOP - 316 - S083 - 95
18	22,86/.900		LOP - 318 - S083 - 95
20	25,40/1.000		LOP - 320 - S083 - 95
24	30,48/1.200		LOP - 324 - S083 - 95
		15,24 .600	
24	30,48/1.200		LOP - 624 - S083 - 95
28	35,56/1.400		LOP - 628 - S083 - 95
		15,24 .600	
32	40,64/1.600		LOP - 632 - S083 - 95
40	50,80/2.000		LOP - 640 - S083 - 95
10	25,40/1.000		SLP - 110 - S083 - 95
14	35,56/1.400		SLP - 114 - S083 - 95

Other sizes and flush head version on request

Pin-outs

Other pin-outs available on request.

Despite the very low profile of these sockets the IC legs can be inserted completely.

Recommended PCB Layout

Recommended drilling hole dia Ø 0,8mm/.031"

Low Profile Terminal

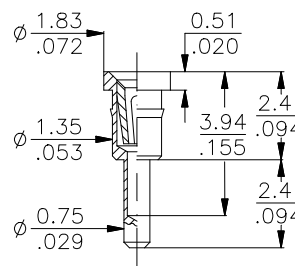

083 2.41mm / .095" over PCB

Plating

Standard:

- **95** = tin/gold
(tin leadfree)

Alternative

- **55** = gold/gold
- **99** = tin/ tin
(leadfree)

Specifications

Mechanical data

Insertion force 1,80 N (avg)
Extraction force 0,90 N (avg)
Contact life > 100 cycles
Solderability as per IEC 60068-2-58
Contact security:
-Vibration as per EN60352-4
-Shock as per EN60352-4

Material

Insulator *(RoHS compliant)* PBT UL 94 V-0
Terminal *(RoHS compliant)* CuZn
Contact *(RoHS compliant)* BeCu

Electrical data

Contact resistance at 1A 4,3 mΩ typ.
Current rating 1A max., 100V
Contact capacitance at 1MHz 2 pF max.
Insulation resistance at 500V DC 5 × 10⁹ Ω min.
Breakdown voltage at 60 Hz 500 V AC
Contact resistance ≤ 7 mΩ

Operating temperature

-55° C to +125° C

Pitch

2,54 mm (.100")

More information, for example about testresult please ref. to page 49 or contact E-tec.

E-tec's super low profile sockets and adapters are designed for use in applications where height above board is most critical.

The sockets have a profile of 0,60mm above board and they can be combined with the adapters to achieve a board to board interconnection height of 2,20mm max.

Also available in this socket range are the ultra low profile SMT sockets with a height above board of only 3,45mm.

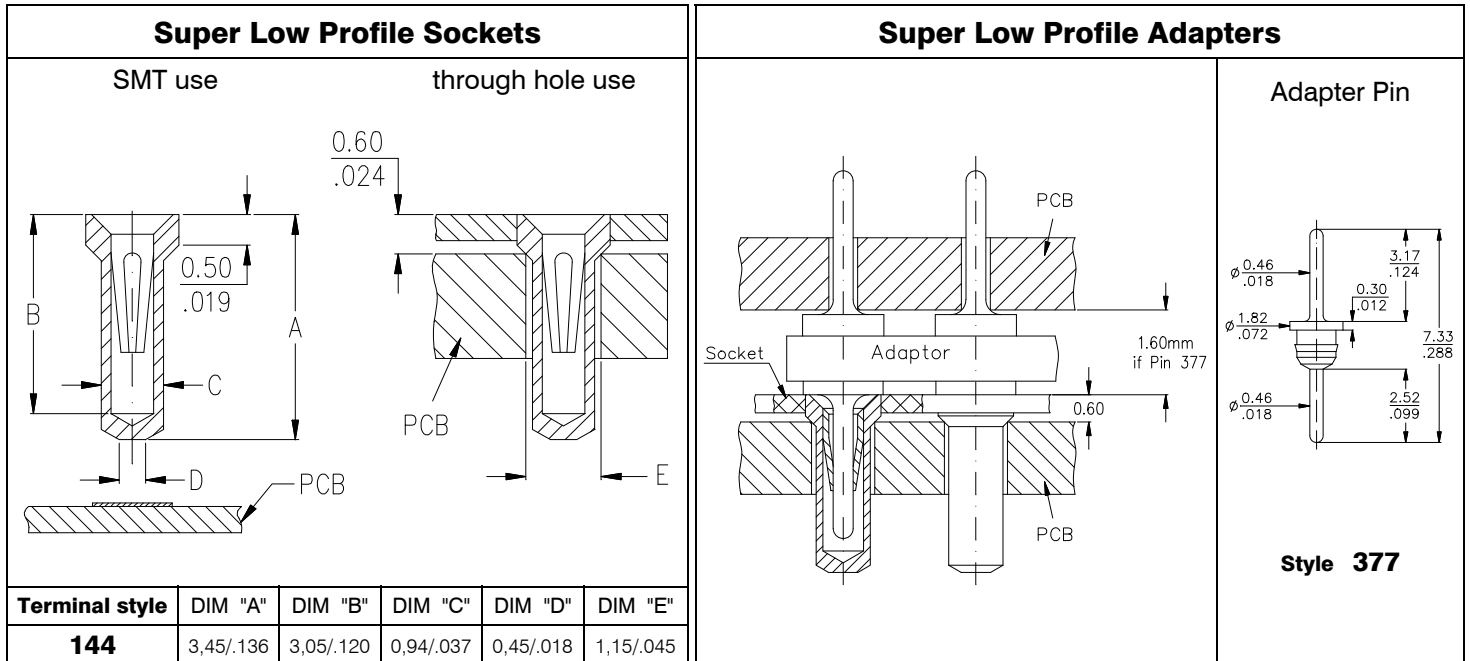
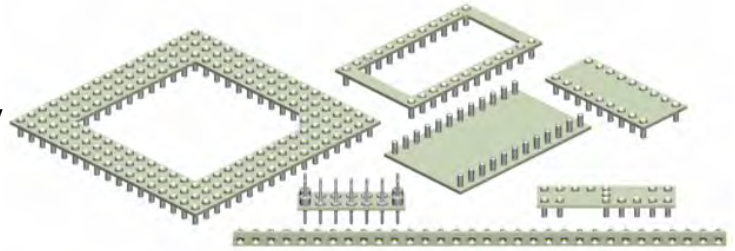

Specifications			
Mechanical data		Electrical data	
Force per contact (avg)	0,70N insertion / 0,25N extraction	Breakdown voltage at 60 Hz	500 V AC
Contact life	>50 cycles min.	Contact resistance at 1A	4,3 mΩ typ
Solderability	as per IEC 60068-2-58	Insulation resistance	5 × 10 ⁹ Ω min.
Material		Current rating	1A max., 100V
Terminal (RoHS compliant)	BeCu	Capacitance	2 pF max.
Insulator (RoHS compliant)	Glass Epoxy FR4	Operating temperature	-55 °C to +125 °C

How to order

XXX - x x x - E x x x (- x x X) - x x (/ x)

Series	DIP spacing	Nbr of contacts	Terminal styles	Plating	Pitch
LSP = DIP sockets SSP = SIP sockets DSP = 2-row SIP's PGS = PGA sockets ZZS = Zig-Zag sockets	see pages for LSP series: for SSP series: for DSP series: for ZZS series:	POS SIB/SIS DIS ZZP	See drawings above for 2,54mm and 2,00mm pitch. For 1,27mm pitch please contact nearest sales office.	- 95 = tin/gold (tin leadfree) (not available for adapter terminals) - 55 = gold/gold - 99 = tin/tin (leadfree)	Complete with 1 = 1,27mm 2 = 2,00mm 2.54mm pitch is standard. Others available on request

Grid size & Configuration code only for PGA sockets

Please refer to PGA socket pages 29 to 31

IC Sockets for Automatic Insertion

The terminals can be bent before and cut after the soldering process.

Open frame sockets with rails under the plastic as required by certain auto-insert machines.

Delivered in tubes with correct orientation.

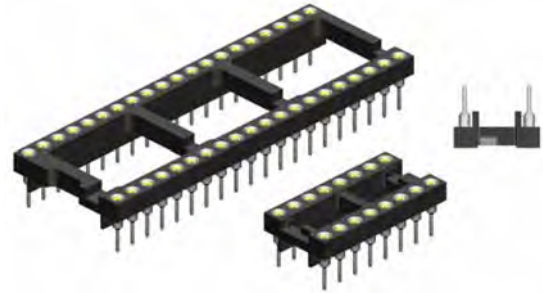

Socket Drawing "top view"		PIN	Dimensions mm/inch			Ordering Code
DIM "B" = 7,62mm / .300"	DIM "B" = 15,24mm / .600"		"A"	"B"	"C"	
		08	10,16 / .400	7,62 .300	4,50 .177	POA-308-Sxxx-95
		14	17,78 / .700			POA-314-Sxxx-95
		16	20,32 / .800			POA-316-Sxxx-95
		18	22,86 / .900			POA-318-Sxxx-95
		20	25,40 / 1.000			POA-320-Sxxx-95
		24	30,48 / 1.200			POA-324-Sxxx-95
		28	35,56 / 1.400			POA-328-Sxxx-95
		24	30,48 / 1.200			15,24 .600
		28	35,56 / 1.400	POA-628-Sxxx-95		
		40	50,80 / 2.000	POA-640-Sxxx-95		

Socket Drawing "side view"	Terminal styles
	<div style="display: flex; justify-content: space-around;"> <div style="text-align: center;"> <p>001</p> </div> <div style="text-align: center;"> <p>010</p> </div> </div>

Specifications			
Mechanical data Insertion force: 1,80 N (avg) Extraction force: 0,90 N (avg) Contact life: > 100 cycles Solderability: as per IEC 60068-2-58 Contact security: -Vibration: as per EN60352-4 -Shock: as per EN60352-4	Electrical data Contact resistance at 1A: 4,3 mΩ typ. Current rating: 1A max., 100V Contact capacitance at 1MHz: 2 pF max. Insulation resistance at 500V DC: 5 × 10 ⁹ Ω min. Breakdown voltage at 60 Hz: 500 V AC Contact resistance: ≤ 7 mΩ	Operating temperature : -55° C to +125° C Pitch : 2,54 mm (.100")	Material Insulator (RoHS compliant): PBT UL 94 V-0 Terminal (RoHS compliant): CuZn Contact (RoHS compliant): BeCu
More information, for example about testresult please ref. to page 49 or contact E-tec.			

How to order

POA - x x x - S x x x - x x

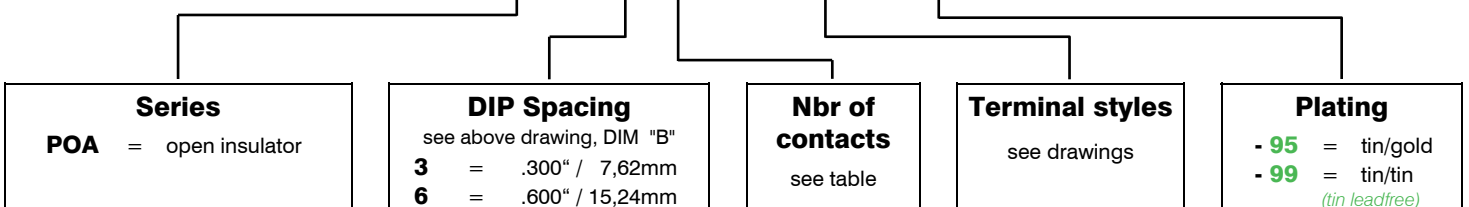

DCA/DCP/SCP - Series

Carrier Sockets & Strips

2,54mm pitch

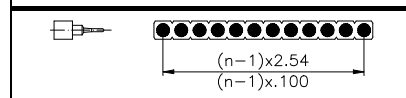
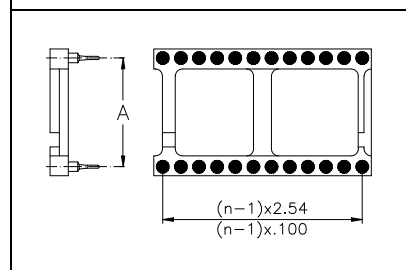
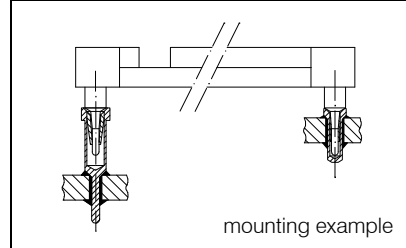
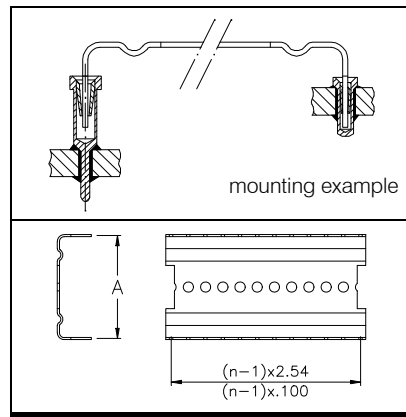
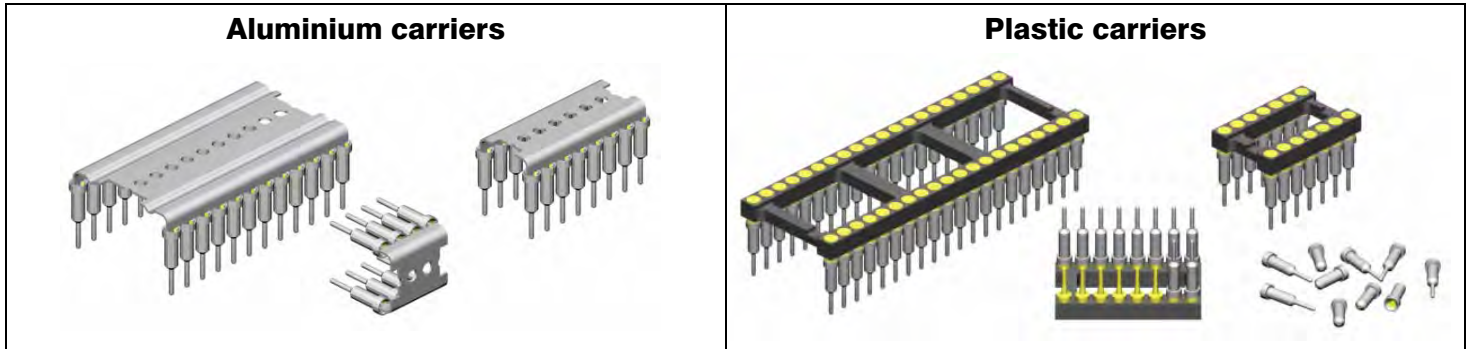

PIN	DIM "A" mm/inch	Ordering Code	
6	7,62/.300	DCA-306-Sxxx-95	
8		DCA-308-Sxxx-95	
14		DCA-314-Sxxx-95	
16		DCA-316-Sxxx-95	
18		DCA-318-Sxxx-95	
20		DCA-320-Sxxx-95	
22	15,24/.600	DCA-322-Sxxx-95	
24		DCA-624-Sxxx-95	
28		DCA-628-Sxxx-95	
40		DCA-640-Sxxx-95	
6		7,62/.300	DCP-306-Sxxx-95
8			DCP-308-Sxxx-95
10	DCP-310-Sxxx-95		
14	DCP-314-Sxxx-95		
16	DCP-316-Sxxx-95		
18	DCP-318-Sxxx-95		
20	15,24/.600	DCP-320-Sxxx-95	
24		DCP-324-Sxxx-95	
28		DCP-328-Sxxx-95	
24		DCP-624-Sxxx-95	
28		DCP-628-Sxxx-95	
32		DCP-632-Sxxx-95	
36	DCP-636-Sxxx-95		
40	DCP-640-Sxxx-95		
48	DCP-648-Sxxx-95		
2 to 32	single strip	SCP-1xx-Sxxx-95	
4 to 80	double strip	SCP-2xx-Sxxx-95	

<p>001</p>	<p>008</p>
<p>012</p>	<p>016</p>
<p>047</p>	<p>083</p>

Specifications
See page 49 of this catalogue

Terminals
For other terminal styles please refer to the pages 46 to 48 of this catalogue or contact your closest sales office.

Carrier Material
DCP & SCP series : PBT or high temp plastic UL 94 V-0 depending on pincount
DCA series : Aluminum

How to order

XXX - x xx - S xxx - 95

Series	
DCA	= DIL Alu Carrier
DCP	= DIL Plastic Carrier
SCP	= SIL Plastic Carrier

Pitch	
1	= only for SCP Series
2	= only for SCP Series
3	= .300" / 7,62mm
4	= .400" / 10,16mm
6	= .600" / 15,24mm
9	= .900" / 22,86mm

Nbr of contacts	
see Ordering Code table above	

Terminal style	
see drawings above	
or refer to pages 46 to 48 of this catalogue for other types.	

Plating	
- 95	= tin/gold (tin leadfree)

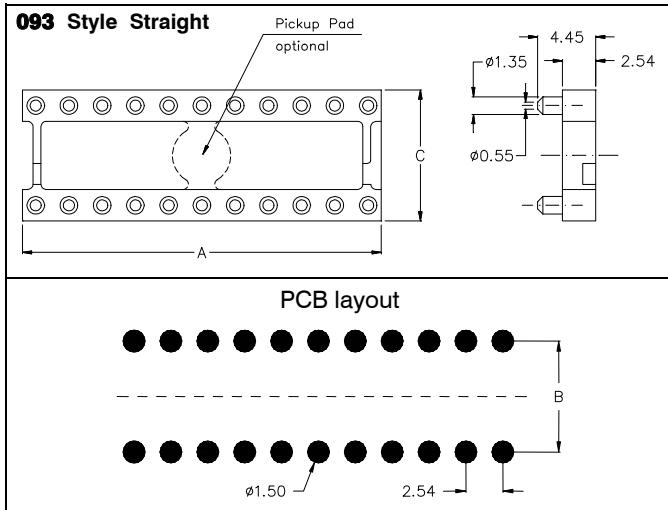
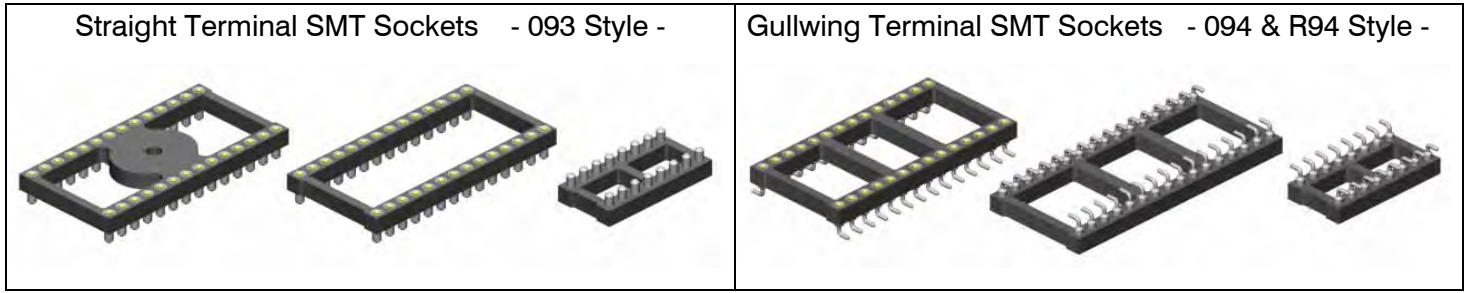

Pin	Dimensions (mm/inch)				Ordering Code
	"A"	"B"	"C"		
6	7,62/.300	7,62 .300	10,16 .400		PSO-306-H093-95
8	10,16/.400			PSO-308-H093-95	
10	12,70/.500			PSO-310-H093-95	
14	17,78/.700			PSO-314-H093-95	
16	20,32/.800			PSO-316-H093-95	
18	22,86/.900			PSO-318-H093-95	
20	25,40/1.000			PSO-320-H093-95	
24	30,48/1.200	15,24 .600	17,78 .700		PSO-624-H093-95
28	35,56/1.400			PSO-628-H093-95	
32	40,64/1.600			PSO-632-H093-95	
36	45,72/1.800			PSO-636-H093-95	
40	50,80/2.000			PSO-640-H093-95	
48	60,96/2.400			PSO-648-H093-95	

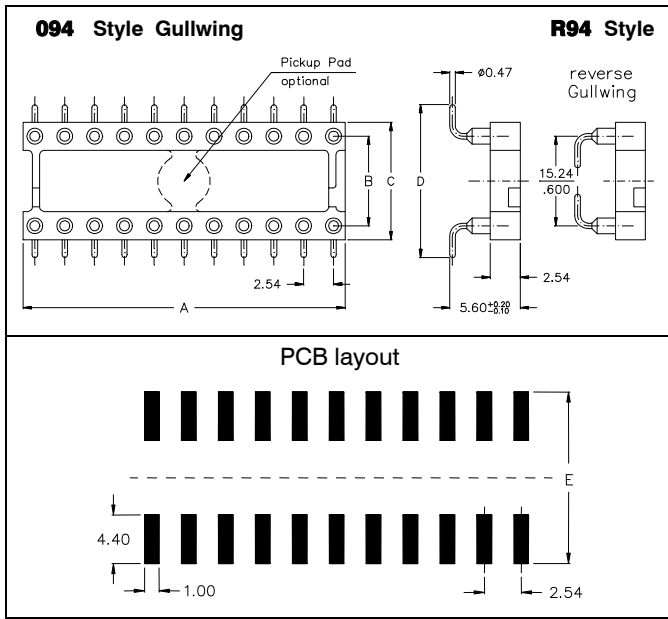

Pin	Dimensions (mm/inch)					Ordering Code	
	"A"	"B"	"C"	"D"	"E" 094 Style		
10	12,70/.500	5,08 .200	7,62 .300	10,46 .412		PSO-210-H094-95	
6	7,62/.300	7,62 .300	10,16 .400	13,00 .512	15,00 .590	PSO-306-H094-95	
8	10,16/.400					PSO-308-H094-95	
10	12,70/.500					PSO-310-H094-95	
14	17,78/.700					PSO-314-H094-95	
16	20,32/.800					PSO-316-H094-95	
18	22,86/.900					PSO-318-H094-95	
20	25,40/1.000					PSO-320-H094-95	
24	30,48/1.20	15,24 .600	17,78 .700	20,70 .815	22,70 .894	16,50 .650	PSO-624-Hxxx-95
28	35,56/1.40						PSO-628-Hxxx-95
32	40,64/1.60						PSO-632-Hxxx-95
40	50,80/2.00						PSO-640-Hxxx-95

<p>Body types</p> <p>Standard = Open frame (PSO Series)</p> <p>Optional = Closed frame (PSC Series)</p>	<p>Insulator</p> <p>high-temp plastic UL 94 V-0 (RoHS compliant)</p> <p>For further technical data refer to page 49</p>	<p>Temperature</p> <p>Operating temp. -55 °C to +125 °C</p> <p>Processing temp. +250°C +/-5°C for 20~40sec.</p>
--	--	--

How to order

PSO - x x x - H x x x - 95 (/P)

if with Pickup Pad only 28- & 32-pin -others on request-

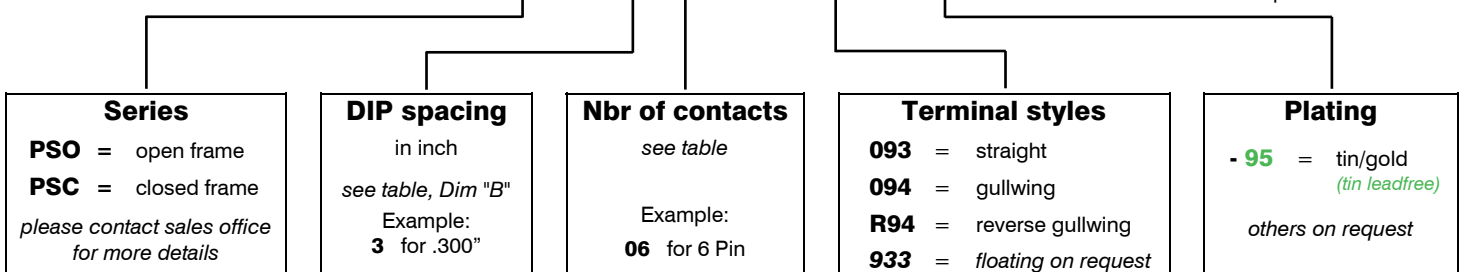

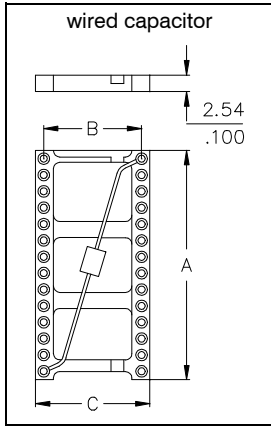
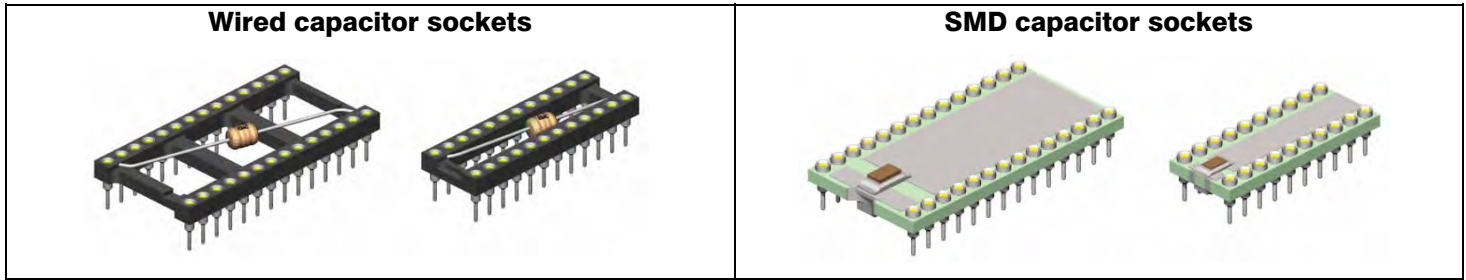

Pin	"A"	"B"	"C"	Ordering code
8	10,16/.400	7.62 .300	10.16 .400	QIT-308-W001-95
14	17,78/.700			QIT-314-W001-95
16	20,32/.800			QIT-316-W001-95
18	22,86/.900			QIT-318-W001-95
20	25,40/1.00			QIT-320-W001-95
24	30,48/1.20			QIT-324-W001-95
28	35,56/1.40	15.24 .600	17.78 .700	Not available
24	30,48/1.20			QIT-624-W001-95
28	35,56/1.40			QIT-628-W001-95
32	40,64/1.60			QIT-632-W001-95
40	50,80/2.00			QIT-640-W001-95

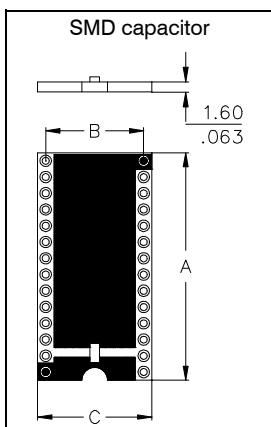
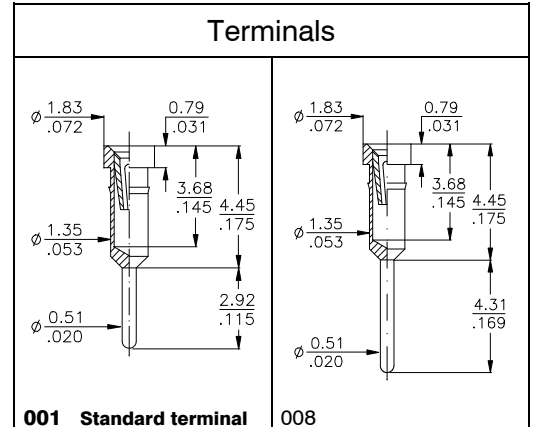

Pin	"A"	"B"	"C"	Ordering code
8	10,16/.400	7.62 .300	10.16 .400	QIT-308-S001-95
14	17,78/.700			QIT-314-S001-95
16	20,32/.800			QIT-316-S001-95
18	22,86/.900			QIT-318-S001-95
20	25,40/1.00			QIT-320-S001-95
24	30,48/1.20			QIT-324-S001-95
28	35,56/1.40	15.24 .600	17.78 .700	QIT-328-S001-95
24	30,48/1.20			QIT-624-S001-95
28	35,56/1.40			QIT-628-S001-95
32	40,64/1.60			QIT-632-S001-95
40	50,80/2.00			QIT-640-S001-95

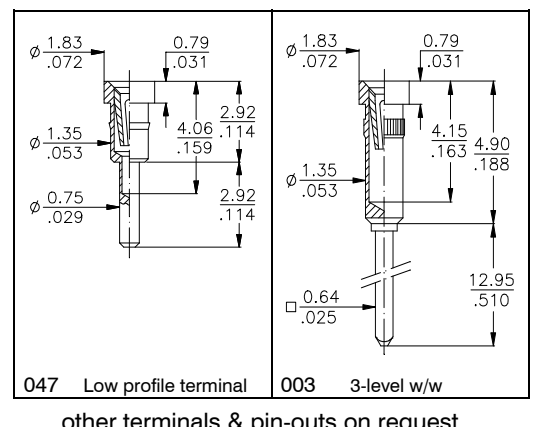

other terminals & pin-outs on request

Socket Specifications			
Mechanical data	Insertion force Extraction force Contact life Solderability Contact security: -Vibration -Shock	1,80 N (avg) 0,90 N (avg) > 100 cycles as per IEC 60068-2-58 as per EN60352-4 as per EN60352-4	Electrical data Contact resistance at 1A Current rating Contact capacitance at 1MHz Insulation resistance at 500V DC Breakdown voltage at 60 Hz Contact resistance
Material	Insulator Terminal Contact	(RoHS compliant) (RoHS compliant) (RoHS compliant)	Hi temp plastic UL 94 V-0 (wired version) Epoxy FR4 if with SMD capacitor CuZn BeCu
Operating temperature			4,3 mΩ typ. 1A max., 100V 2 pF max. 5 × 10 ⁹ Ω min. 500 V AC ≤ 7 mΩ -55° C to +125° C
			Operating temperature Pitch
			2,54 mm (.100")
More information, for example about testresult please ref. to page 49 or contact E-tec.			

Capacitor Specifications			
General data	Ceramic material Voltage	Z5U 50 V	Available capacitor values Standard type Alternatives:
			100nF (0.1 μF) 10nF (0.01 μF)

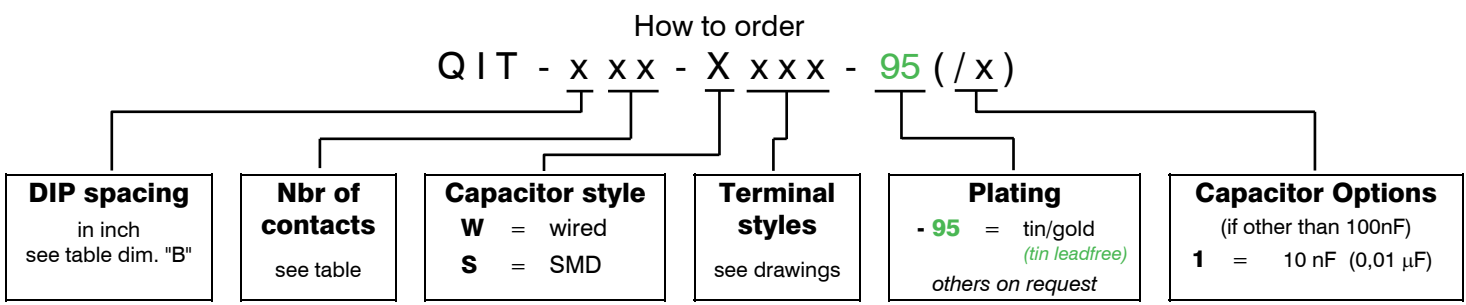

Available in sizes of 6 to 48 pins.

Low profile & dual-beam contact design.

Contact design incorporates anti-overstress feature.

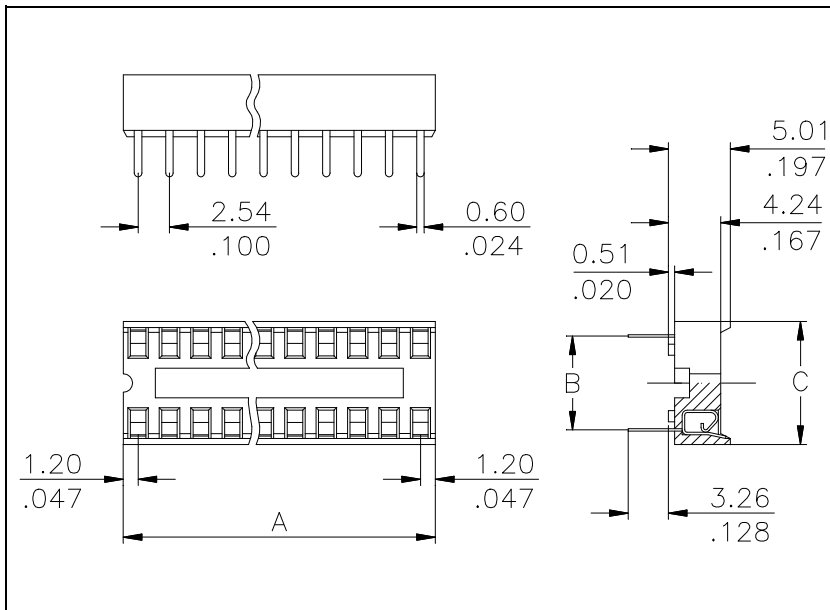
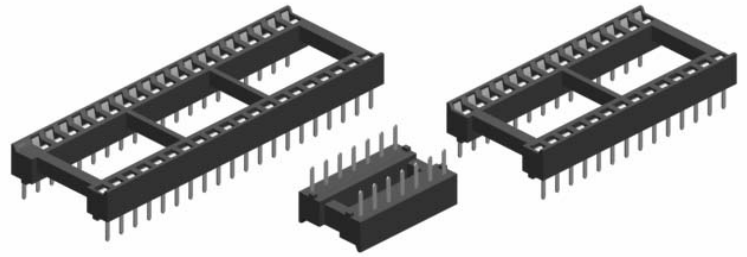

Pin	Dimensions mm/inch			Ordering Code
	"A"	"B"	"C"	
6	7,49/.295	7,62 / .300	10,16 / .400	LOC-306-T051-99
8	10,03/.795			LOC-308-T051-99
14	17,65/.695			LOC-314-T051-99
16	20,19/.795			LOC-316-T051-99
18	22,73/.895			LOC-318-T051-99
20	25,27/.995			LOC-320-T051-99
24	30,35/1.195			LOC-324-T051-99
28	35,43/1.395			LOC-328-T051-99
22	27,81/1.095	10,16 / .400	12,70 / .500	LOC-422-T051-99
24	30,35/1.195	15,24 / .600	17,70 / .700	LOC-624-T051-99
28	35,43/1.395			LOC-628-T051-99
32	40,51/1.595			LOC-632-T051-99
40	50,67/1.995			LOC-640-T051-99
42	53,21/2.095			LOC-642-T051-99
48	60,83/2.395			LOC-648-T051-99

Low Cost DIP are also available with the "Shrink" pitch 1,778mm / .070".
Please request separate datasheets.

Specification

Mechanical data

Insertion force 2 N max.
Extraction force 0,5 N min.
Contact reliability 50 cycles min

Material

Insulator (RoHS compliant) std. temp PBT plastic
UL 94 V-0
Contact (RoHS compliant) Phosphor bronze

Electrical data

Contact resistance 10 mΩ typ.
Current rating 1A max., 100V
Contact capacitance 0,5 pF
Insulation resistance 1000 MΩ min.
Breakdown voltage 1 KV min.

Operating temperature

-50°C to +125°C

How to order

LOC - x xx - T051 - 99

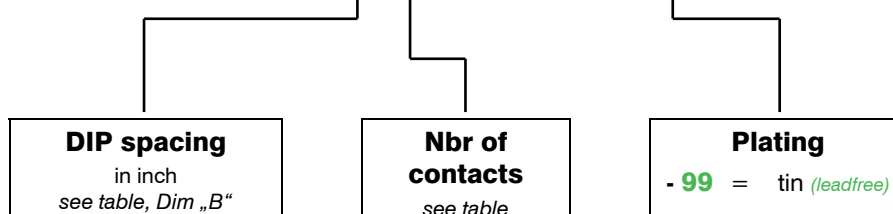

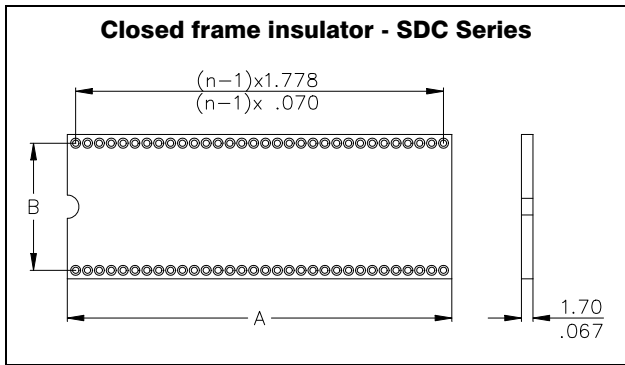
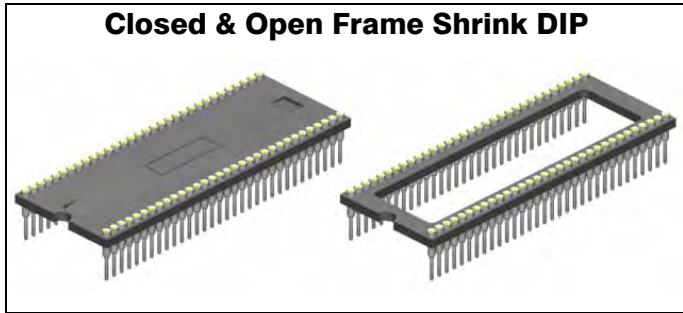

Pin	Dimensions mm/inch		Ordering Code
	"A"	"B"	
24	22,09 / .870	10,16 .400	SDC-424-Exxx-xx
28	25,65 / 1.010		SDC-628-Exxx-xx
40	36,32 / 1.430	15,24 .600	SDC-640-Exxx-xx
42	36,32 / 1.430		SDC-642-Exxx-xx
64	57,65 / 2.270	19,05 .750	SDC-764-Sxxx-xx

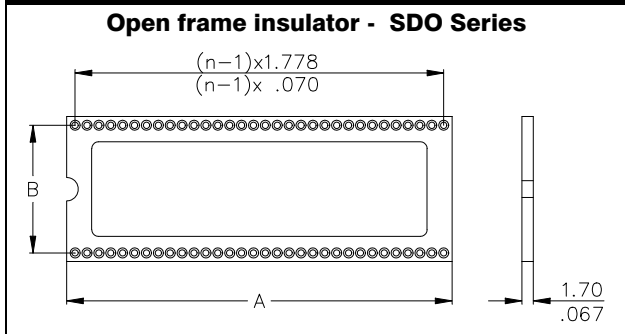
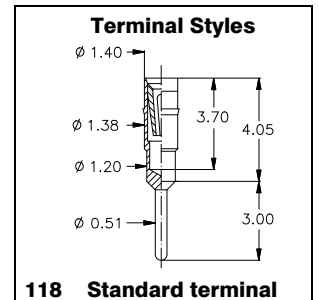

64	57,65 / 2.270	19,05 .750	SDO-764-Sxxx-xx
----	---------------	---------------	------------------------

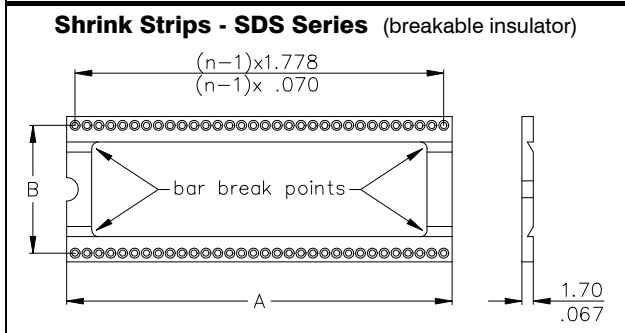
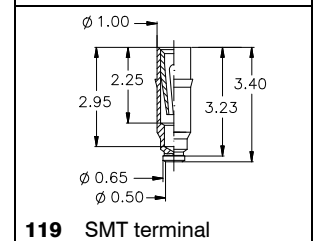

2 x 32	57,65 2.270	19,05 .750	SDS-232-Sxxx-xx
--------	----------------	---------------	------------------------

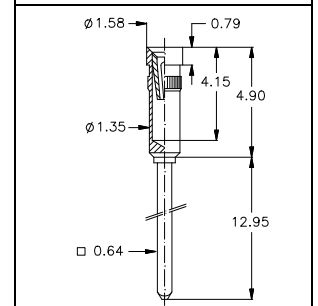

Technical Data :
 Insertion force 0.70 N (avg.)
 Extraction force 0.25 N (avg.)

For further data refer to page 49 in this catalogue.

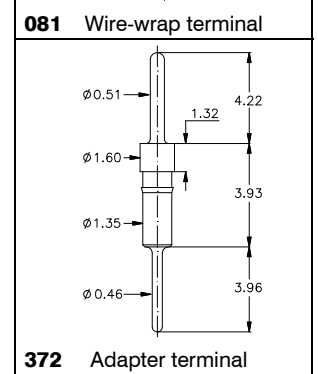

How to order

XXX - xxx - Xxxx - xx

Series
SDC = closed frame
SDO = open frame
SDS = strips

DIP spacing
 Dim "B" in inch
 Example:
6 for ".600"

Nbr of contacts
 see table

Insulator
S = Plastic
E = FR 4 (Epoxy)

Terminal styles
 see drawings
others on request

Plating
- 95 = tin/gold (not for terminal 372)
- 55 = gold/gold
- 99 = tin/tin (tin is leadfree)

Crystal Oscillator and Quad-in-Line Sockets

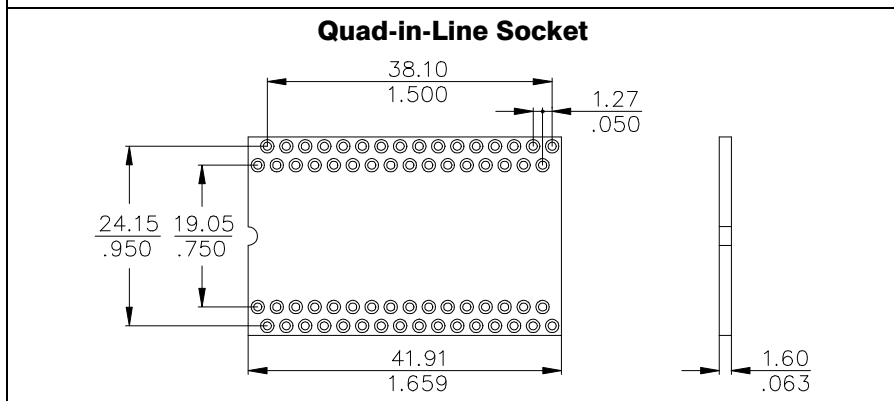
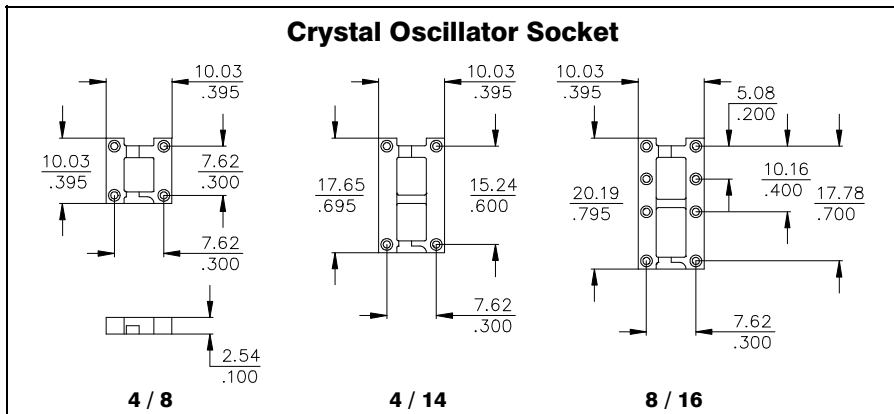
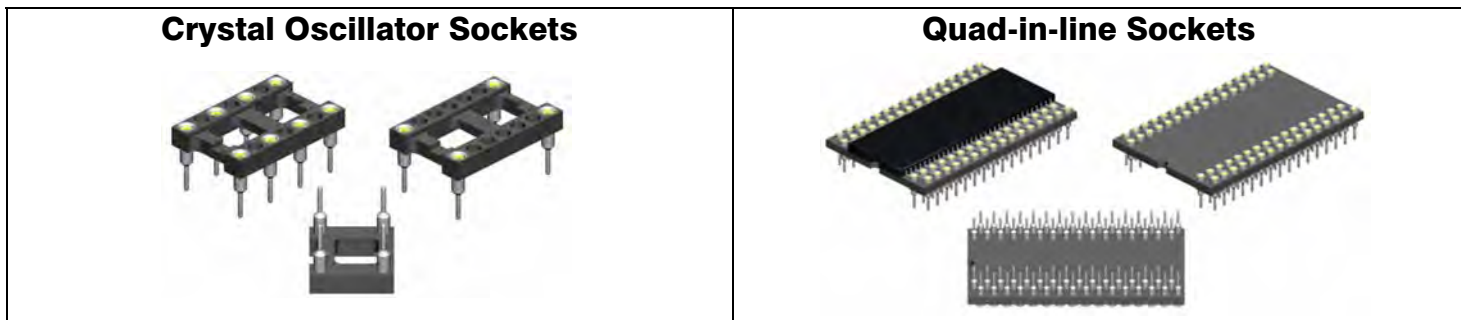

Crystal Oscillator Sockets

Pin	Ordering Code
4 / 8	COS-084-S001-95
4 / 14	COS-144-S001-95
8 / 16	COS-168-S001-95

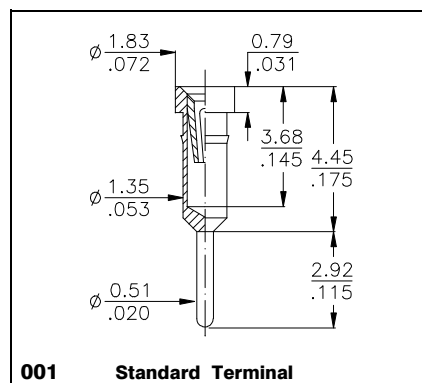

Quad-in-line Socket

Pin	Ordering Code
64	QIL-764-S001-95

for Rockwell & NEC Chip

Other pin-outs available on request.

Specifications			
Mechanical data	Insertion force	1,80 N for COS & 0.70N for QIL	Electrical data
	Extraction force	0,90 N for COS & 0.25N for QIL	
Material	Insulator (RoHS compliant)	COS Series: hi temp plastic UL 94 V-0	Current rating
	Terminal (RoHS compliant)	QIL Series: PBT plastic UL 94 V-0	Contact capacitance at 1MHz
	Contact (RoHS compliant)	CuZn	Insulation resistance at 500V DC
		BeCu	Breakdown voltage at 60 Hz
			Contact resistance
			Operating temperature
			Pitch

4,3 mΩ typ.
1A max., 100V
2 pF max.
5 × 10⁹ Ω min.
500 V AC
≤7 mΩ
-55° C to +125° C
2,54 mm (.100")

More information, for example about testresult please ref. to page 49 or contact E-tec.

How to order

XXX - xxx - S001 - 95

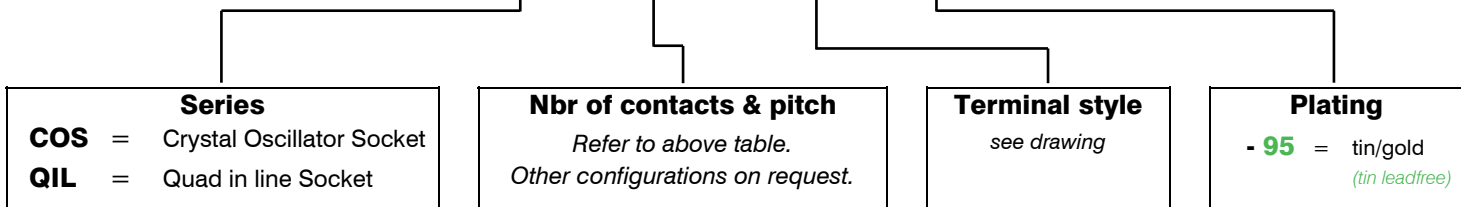

LED socket mounted with precision turned pins ensure perfect contact reliability.

The sockets are available in horizontal and vertical executions.

The contacts are designed to hold many different IC's and LED's with short leads.

The LED sockets are also designed to accept DIP Switches.

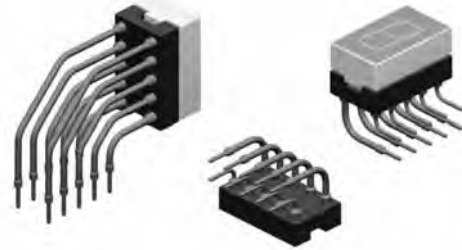

LEH Series - Horizontal -

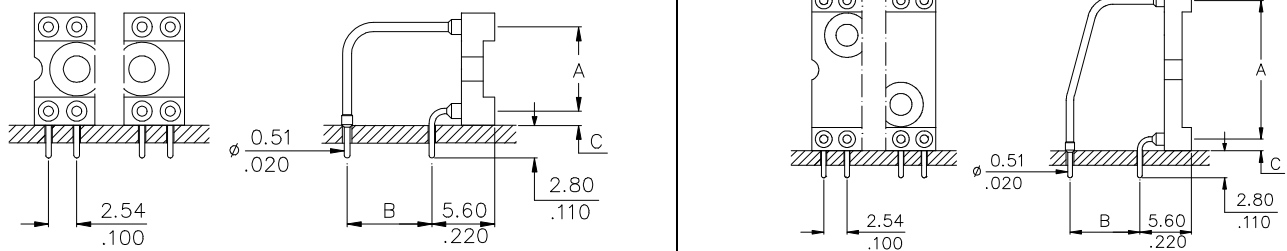

Ordering Code

Dimensions of the various socket types

pin-outs on request	Standard type -900-					all types Dim. "C"
	Dim. "A"	Dim. "B"	Option -901	Option -902	Option -903	
LEH - 2 xx - S xxx - 95	5,08/.200	5,08/.200	2,54/.100	7,62/.300	-	1,27/.050
LEH - 3 xx - S xxx - 95	7,62/.300	7,62/.300	2,54/.100	5,08/.200	-	1,27/.050
LEH - 4 xx - S xxx - 95	10,16/.400	10,16/.400	2,54/.100	5,08/.200	7,62/.300	1,27/.050
LEH - 6 xx - S xxx - 95	15,24/.600	7,62/.300	15,24/.600	-	-	1,27/.050
LEH - 6 xx - S904 - 95	15,24/.600	7,62/.300	-	-	-	2,87/.112

LEV Series - Vertical -

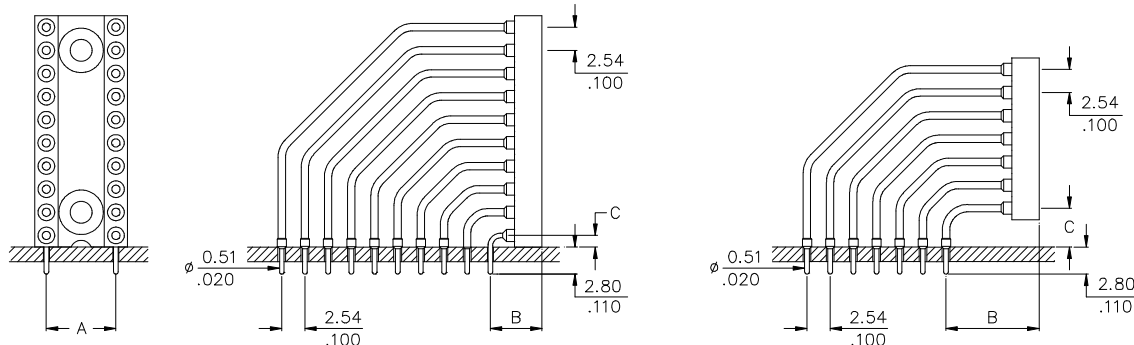

Drawing for standard socket type -910

Drawing for all other options

Ordering Code

Dimensions

pin-outs on request	Options								
	all types "A"	Standard Type -910 "B" "C"		-915 "B" "C"		-916 "B" "C"		-917 "B" "C"	
LEV - 2 xx - S xxx - 95	5,08/.200	5,60/.220	1,27/.050	8,14/.320	3,81/.150	10,68/.420	6,35/.250	13,22/.520	
LEV - 3 xx - S xxx - 95	7,62/.300	5,60/.220	1,27/.050	8,14/.320	3,81/.150	10,68/.420	6,35/.250	13,22/.520	
LEV - 6 xx - S xxx - 95	15,24/.600	5,60/.220	1,27/.050	8,14/.320	3,81/.150	10,68/.420	6,35/.250	13,22/.520	

LEV - 3 xx - S911 - 95 7,62/.300 10,16/.400 4,87/.192

For technical specifications please refer to page 49

How to order

LE X - x xx - S xxx - 95

Execution

H = Horizontal
V = Vertical

DIP spacing

Dim "A" in inch

Nbr of contacts

on request

Socket Type

see above drawings
Other options available on request.

Plating

- **95** = tin/gold
(leadfree)

Sockets for TO-5 and TO-18 packages.

3-pole for transistors

and 2-pole TR-5 Fuse Holders shown on this page.

Embedded terminals prevent shortings.

High contact reliability with the 4-finger clips.

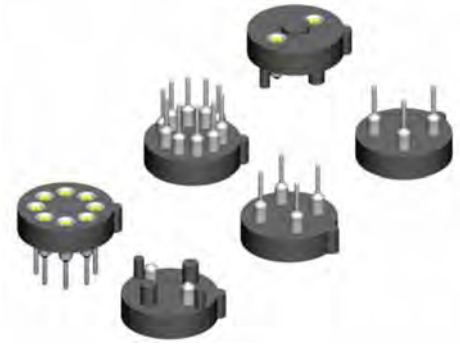

Transistor- & TO-Sockets				
3 - pin	4 - pin	8 - pin	10 - pin	
TOS-503-S118-95	TOS-504-S118-95	TOS-508-S118-95	TOS-610-S118-95	← Order Codes

Specifications

Mechanical data

Insertion force 1,80 N (avg)
 Extraction force 0,90 N (avg)
 Contact life > 100 cycles
 Solderability as per IEC 60068-2-58
 Contact security: as per EN60352-4
 -Vibration as per EN60352-4
 -Shock as per EN60352-4

Material

Insulator (RoHS compliant) PBT UL 94 V-0
 Terminal (RoHS compliant) CuZn
 Plating Sn (leadfree), Ni underplated
 Contact (RoHS compliant) BeCu
 Plating Au, Ni underplated

Electrical data

Contact resistance at 1A 4,3 mΩ typ.
 Current rating 1A max., 100V
 Contact capacitance at 1MHz 2 pF max.
 Insulation resistance at 500V DC 5 × 10⁹ Ω min.
 Breakdown voltage at 60 Hz 500 V AC
 Contact resistance ≤ 7 mΩ

Operating temperature

-55° C to +125° C

More information, for example about testresult please ref. to page 49 or contact E-tec.

Socket for TR 5 Fuses		Specifications
		(vary from the above)
TOS-202-S001-95		<p>Electrical</p> <p>Contact resistance at 1A 4,3 mΩ typ. Current rating at 250 V; 1,6 W 6,3 A max. short time 45 sec. 9 A 15 sec. 11 A 5 sec. 16 A</p> <p>Mechanical</p> <p>Insertion force > 13 N Extraction force < 4 N</p> <p>Probe diam. 0,58 - 0,62mm</p> <p>Material</p> <p>Insulator (RoHS compliant) Stanyl PA 46 Type UL 94 V-0</p> <p>Temperature</p> <p>Operating temperature -55° to +125°C Processing temperature +250°C +0/-5°C for 20-40sec.</p>

2,50mm / 5,00mm / 7,50mm pitch connector
for 90° board-to-board connections.

Compatible with ITT Cannon G09 connectors.

Ultra low profile with only 1.80mm above board.

Used in consumer as well as industrial applications.

Any pincount available between 1 and 27.

Plastic can be easily broken to desired size.

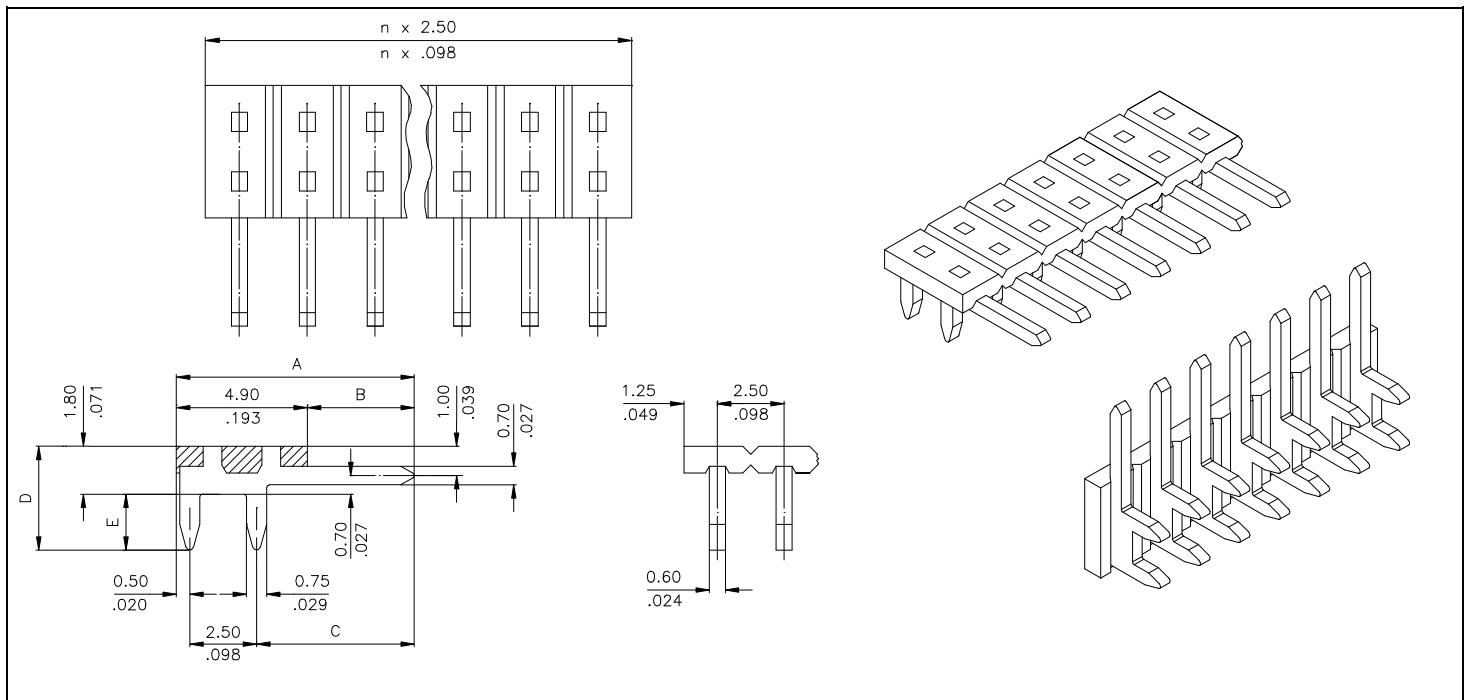
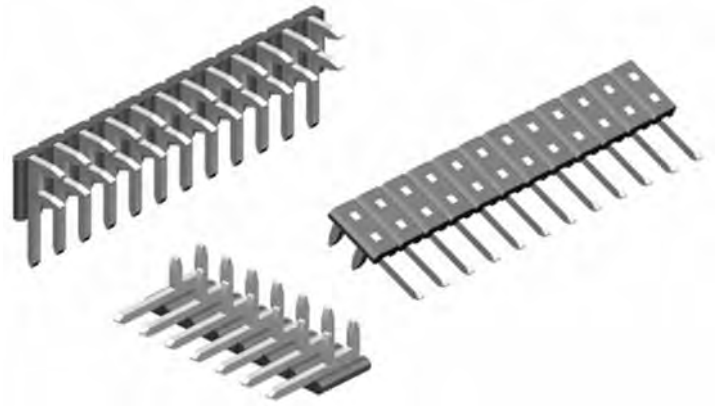

Specifications

Pitch 2,50 / 5,00 / 7,50mm
 Contact material (RoHS compliant) CuZn
 Insulator (RoHS compliant) high temp plastic UL 94 V-0
 Operating temperature -55° C to +125° C

Insulation resistance 5 x 10⁹ MΩ
 Breakdown voltage 600 V AC
 Contact resistance <10 mΩ
 Current rating 3 A max., 250V

How to order

PCB - xxx - Rxxx - 99 / x

Series	Nbr of contacts 001 to 027	Terminal style					Plating - 99 = tin (leadfree)	Pitch 3 = 2,5mm 4 = 5,0mm 5 = 7,5mm
		Dim "A"	Dim "B"	Dim "C"	Dim "D"	Dim "E"		
061		8,9mm	4,0mm	5,9mm	3,9mm	2,1mm		
153		11,4mm	6,5mm	8,4mm	3,9mm	2,1mm		
154		11,4mm	6,5mm	8,4mm	5,0mm	3,2mm		

E-tec offers any configuration.

You may choose between open frame and closed frame socket bodies.

The E-tec PGA sockets with Insulator code "S" will be supplied either in plastic or FR4 Epoxy depending on material availability.

If you wish to receive the sockets in FR4 Epoxy material only, then you need to specify the code "E" in the order code.

If you only accept plastic, then you have to request E-tec for availability first.

All interstitial PGA (PGI) and Mini-Grid sockets (MGS) in any grid size and standard PGA sockets with grid size 19x19 or higher are delivered in FR4 Epoxy only.

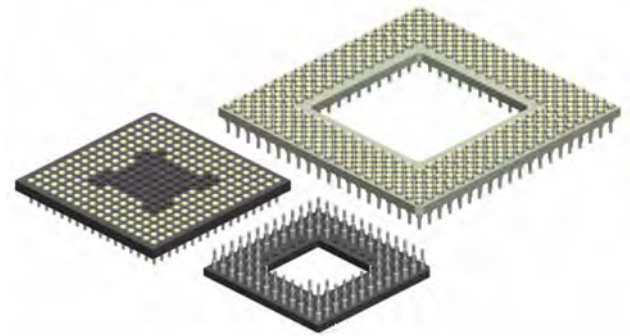

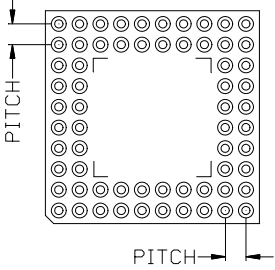
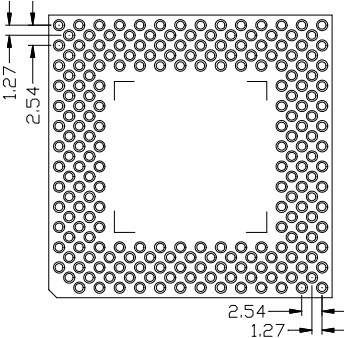
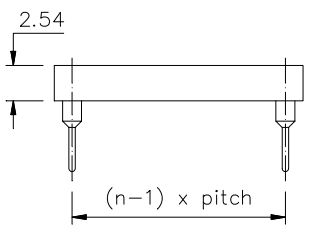
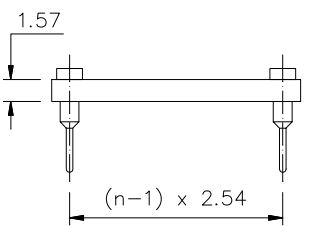
Series PGA & MGS Pitch 1,27mm (.050") or 2,54mm (.100") 	Series PGI Interstitial zig-zag pitch 2,54mm/1,27mm (.100"/.050") 	Plastic insulator dimensions 	Epoxy FR4 insulator dimensions For PGI Sockets generally 
--	---	--	--

Specifications			
Mechanical data Insertion force (avg) 0,70 N for PGA / 0,40 N for PGI Extraction force (standard) 0,25 N for PGA / 0,15 N for PGI Contact life > 100 cycles Solderability as per IEC 60068-2-58 Contact security: -Vibration as per EN60352-4 -Shock as per EN60352-4 Material Insulator: "S" version (RoHS compliant) PBT UL 94 V-0 "E" version (RoHS compliant) Epoxy FR4 Terminal (RoHS compliant) CuZn Contact (RoHS compliant) BeCu		Electrical data Contact resistance at 1A 4,3 mΩ typ. Current rating 1A max., 100V Contact capacitance at 1MHz 2 pF max. Insulation resistance at 500V DC 5 × 10 ⁹ Ω min. Breakdown voltage at 60 Hz 500 V AC Contact resistance ≤7 mΩ Operating temperature -55° C to +125° C	<p style="text-align: center;">More information, for example about testresult please ref. to page 49 or contact E-tec.</p>

How to order

XXX - xxx - X xxx - xx X - xx

Series PGA = Pin Grid Array pitch 2,54mm (.100") PGI = Interstitial PGA pitch 2,54mm / 1,27mm (.100" / .050") MGS = Mini Grid Array pitch 1,27mm (.050") please refer to page 32	Nbr of contacts depends on pincount of chip	Insulator S = Standard for PGA PBT or FR4 Epoxy (Depending on availability) E = Standard for PGI Epoxy FR 4	Terminal styles refer to page 30 & 31	Grid Code : Config Code will be given by the factory after receipt of the chip datasheet Refer also to www.e-tec.com for more information	Plating - 95 = tin/gold (tin leadfree) not available for adapter terminals - 55 = gold/gold - 99 = tin/tin (leadfree)
---	---	---	---	--	---

PGA/PGI - Series Socket Terminal Styles

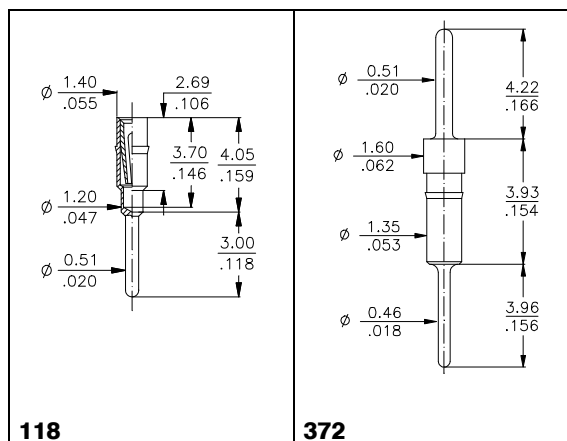
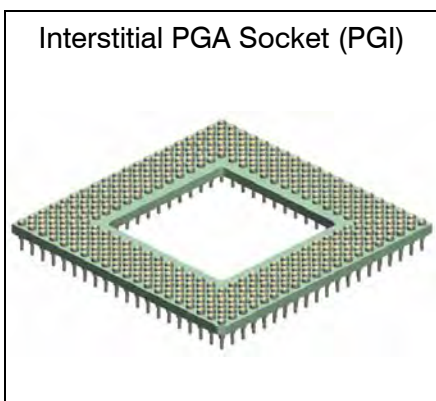
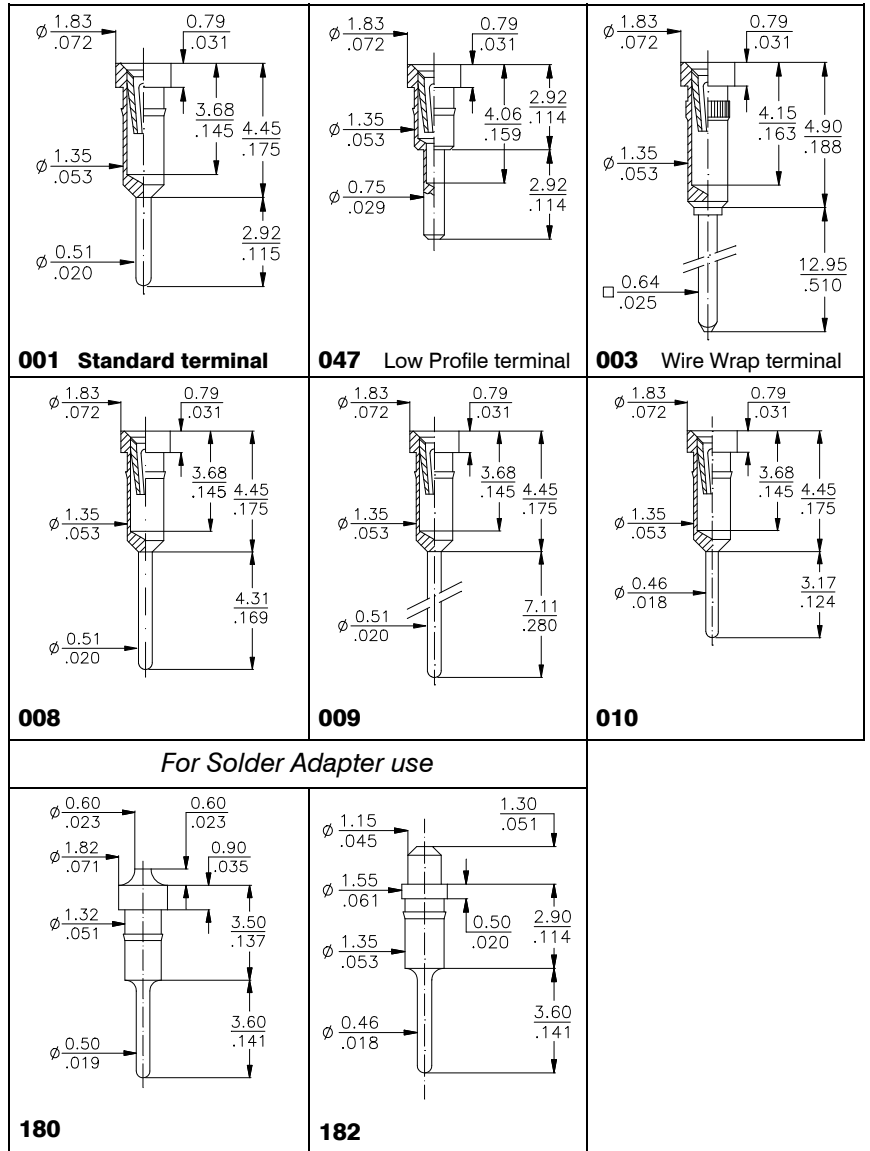
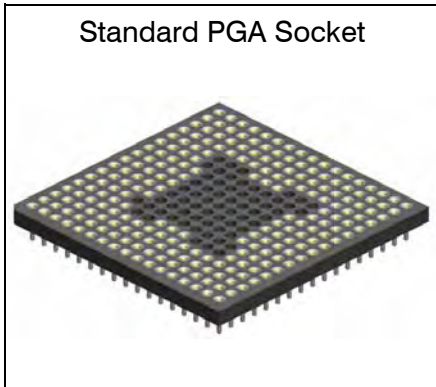

PGA/PGI - Series Adapter Terminal Styles

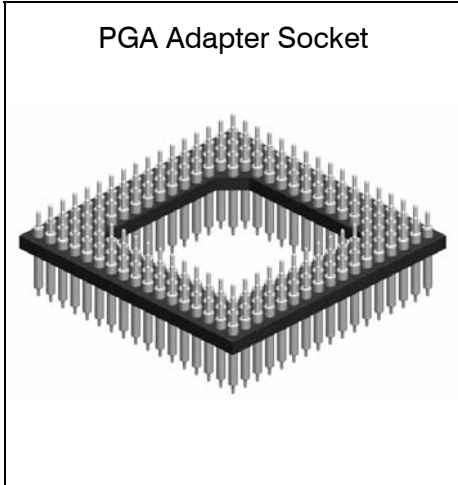

<p>037</p>	<p>054</p>	<p>056</p>
<p>058</p>	<p>059</p>	<p>077</p>
<p>220</p>	<p>543</p>	<p>544</p>
<p>770</p>	<p>PGI Socket Adapter Pin</p> <p>372 (only for PGI Sockets)</p>	

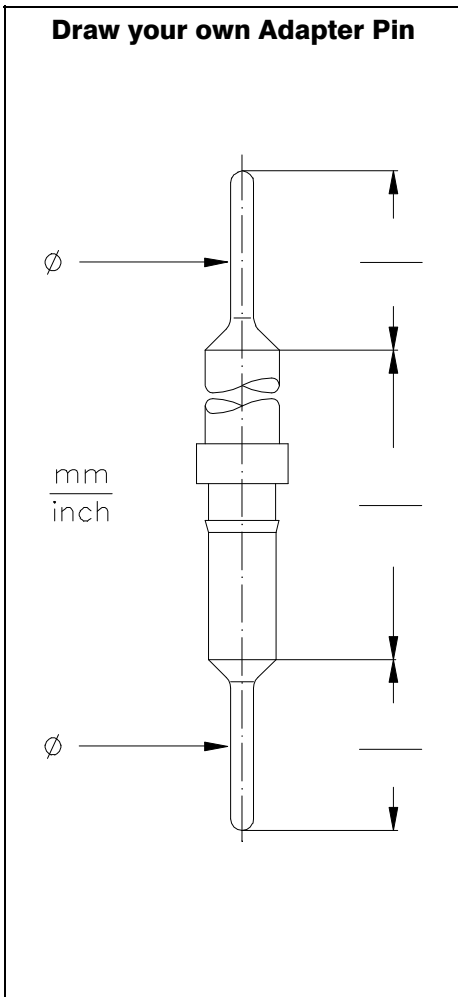

E-tec offers MiniGrid sockets in any pin-out, configuration and grid size adapted to the chip and customer requirements. Open frame socket bodies are also available on request. Special terminal designs are possible on request also.

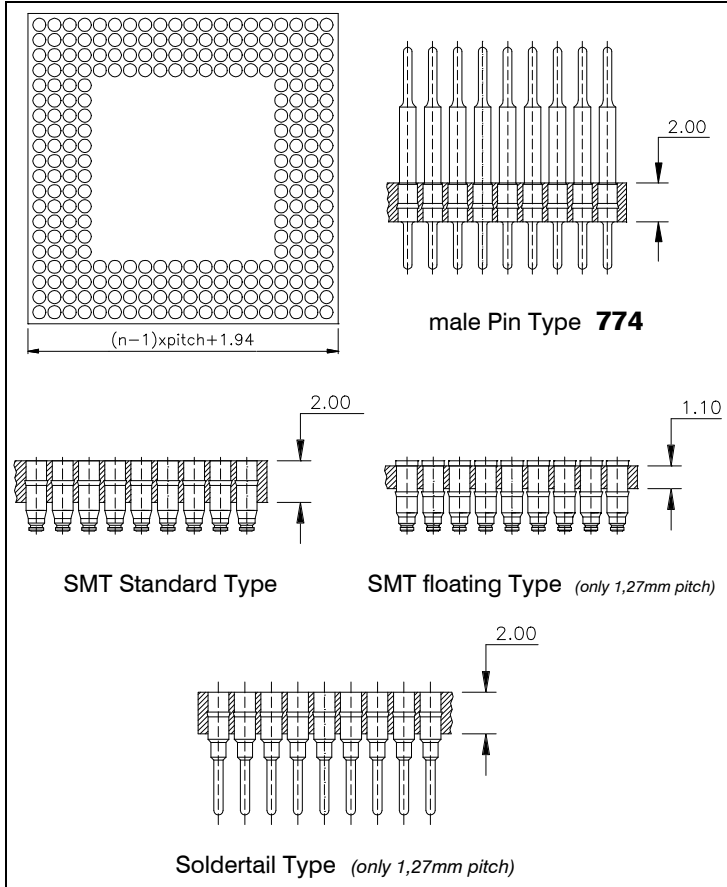
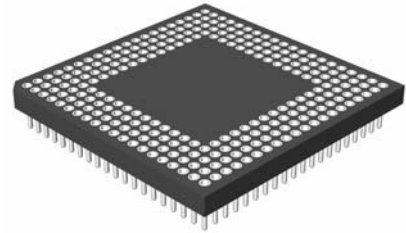

Terminal styles			
 SMT Terminal Type 119 if 1,50 & 2,00mm pitch	 SMT „floating” Terminal Type 120 if 1,50 & 2,00mm pitch	 SMT Terminal Type 167 if 1,27 and 1,00mm pitch	 SMT Terminal Type 169 if 0,80mm pitch
 Solder-tail Terminal Type 117 if 1,50 & 2,00mm pitch	 Solder-tail Terminal Type 172 if 1,27 and 1,00mm pitch	 Solder-tail Terminal Type 174 if 0,80mm pitch	 male pin Type 774 if 1,27 ; 1,50 & 2,00mm pitch

Specifications				
Terminal Type	Material	Plating	Socket & Adapter	Others
774	CuZn	Au over Ni over Cu	Material	Operating Temperature
117, 119, 120, 167 169, 172, 174	Terminal : CuZn Contact clip : BeCu	Sn over Ni over Cu Au over Ni over Cu	FR 4 glass Epoxy UL 94V-0	-55°C to +125°C ; 260°C for 60 sec.

How to order

MGS xxxx - E xxx - xx X 95 xx

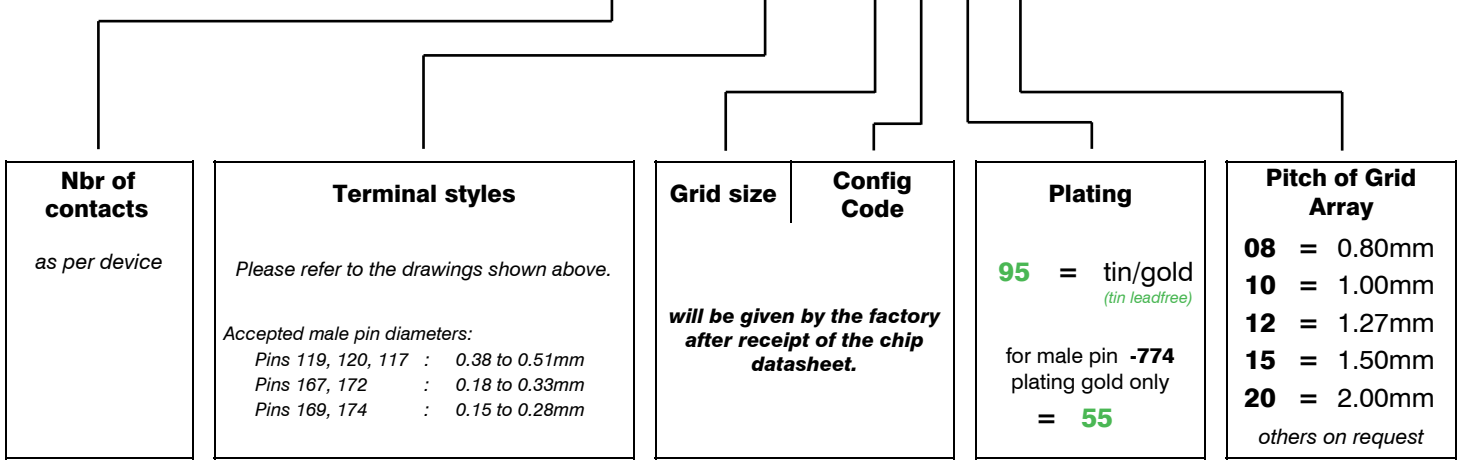

The „commercial“ PLE sockets have very solid solder legs for safe assembly to PCB.

The sockets are designed to accept PLCC Chips according to JEDEC standards.

The sockets are correctly oriented in the tubes for automatic pick and place.

Chips can be easily removed with the Universal extraction tool PUL - 200.

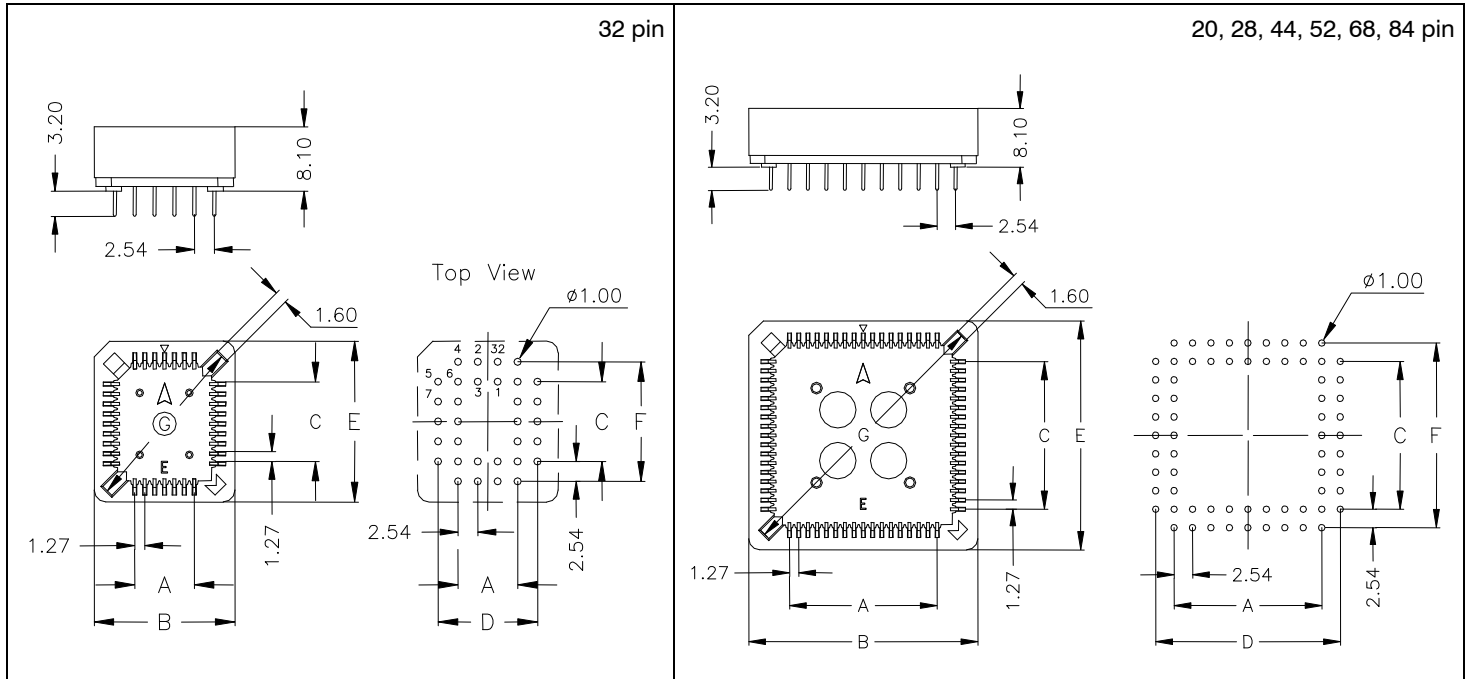
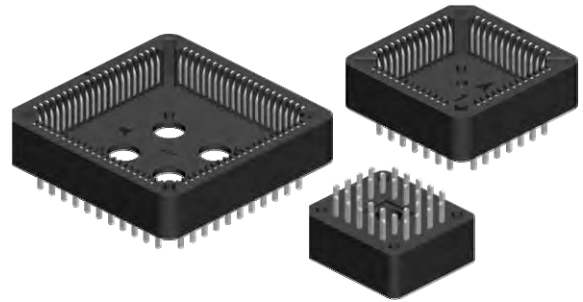

Specifications

Mechanical data

Insulator (RoHS compliant)	High temp plastic UL 94 V-0
Contact (RoHS compliant)	Copper Alloy
Plating	Sn (leadfree) over Ni
Insertion force	0.60N max.
Extraction force	0.15N min.
Mating cycles	50 min.

Electrical data

Withstanding voltage	600 V RMS for 1 Minute
Contact resistance	20 mΩ max.
Insulation resistance	1000 MΩ min.
Current rating	1 A max., 250V AC

Operating temperature

Processing temperature

-40°C to +105°C
260°C ±5°C for 5 Sec.

PIN	Ordering Code	Dimensions (mm)						
	"Commercial" PLCC through hole type	"A"	"B"	"C"	"D"	"E"	"F"	"G"
20	PLE - 020 - N115 - 99	5,08	15,50	5,08	10,16	15,50	10,16	17,06
28	PLE - 028 - N115 - 99	7,62	18,04	7,62	12,70	18,04	12,70	20,70
32	PLE - 032 - N115 - 99 (rectangular)	7,62	18,04	10,16	12,70	20,60	15,24	22,56
44	PLE - 044 - N115 - 99	12,70	23,48	12,70	17,78	23,48	17,78	28,40
52	PLE - 052 - N115 - 99	15,24	25,88	15,24	20,32	25,88	20,32	31,76
68	PLE - 068 - N115 - 99	20,32	31,04	20,32	25,40	31,04	25,40	39,16
84	PLE - 084 - N115 - 99	25,40	36,04	25,40	30,48	36,04	30,48	46,22
PUL -200		Universal extraction tool for all socket sizes (see also page 44)						



E-tec „hi-rel“ soldertail PLCC sockets correspond to JEDEC Norms. Precision stamped contact design provides special „push-down effect“ onto the leads of the chip.

Optional retention clips for very high shock and vibration applications.

Inside polarisation corner prevents wrong insertion of the chips.

Stand-off's under the base prevent solder shorts.

Chips can be easily removed with the Universal extraction tool PUL - 200.

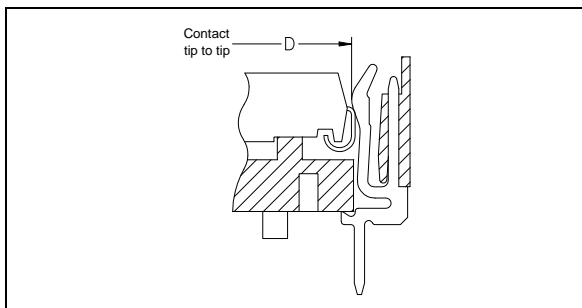
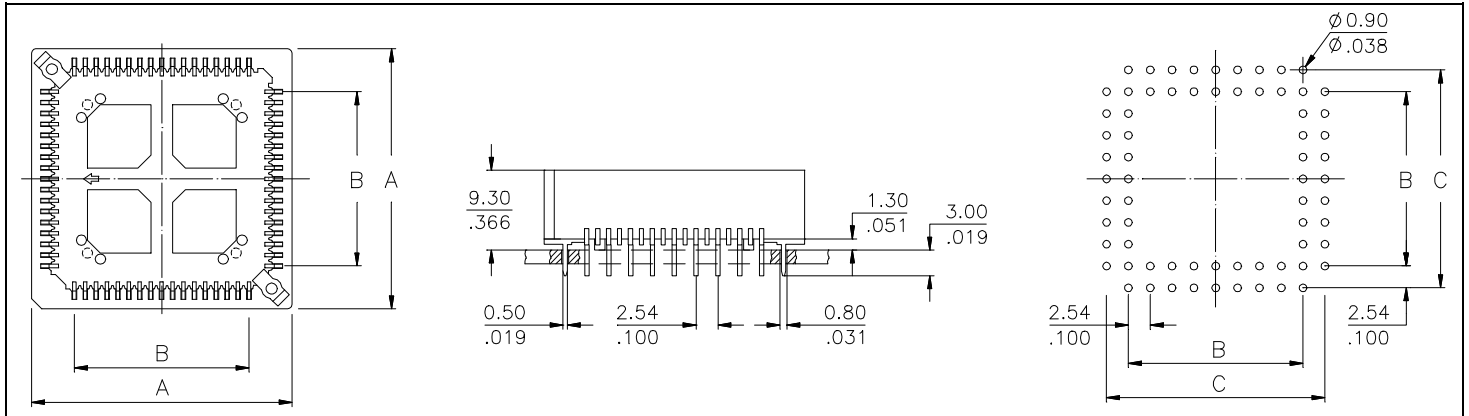
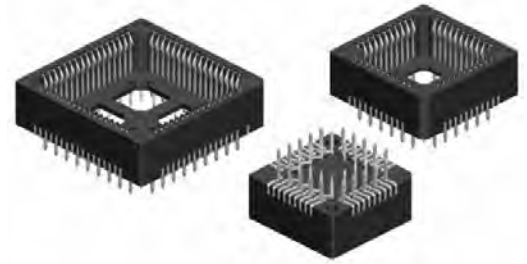

JEDEC Specification for Plastic Leaded Chip Carrier					
		Chip type "A" Chip type "B"			
Jedec Nbr	Nbr of Pins	Dimensions mm/inch			
		"A" min.	"A" max.	„B“ min.	„B“ max.
MO-047 AB	28	12,32 / .485	12,57 / .495	1,37 / .054	2,36 / .093
MO-052 AE	32 rectang.	14,86 x 12,32 .585 x .485	15,11 x 12,57 .595 x .495	1,37 / .054	2,36 / .093
MO-047 AB	44	17,40 / .685	17,65 / .695	1,37 / .054	2,36 / .093
MO-047 AB	52	19,94 / .785	20,19 / .795	1,37 / .054	2,36 / .093
MO-047 AB	68	25,02 / .985	25,27 / .995	1,37 / .054	2,36 / .093
MO-047 AB	84	30,10 / 1.185	30,35 / 1.195	1,37 / .054	2,36 / .093

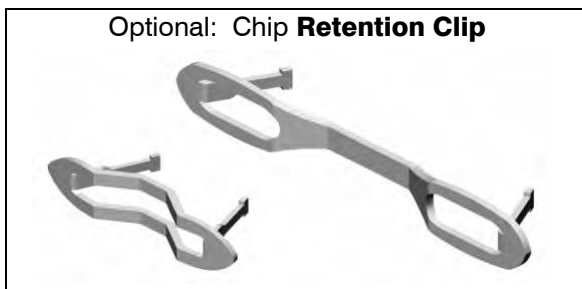

Specifications			
Mechanical data	Plating: Sn (leadfree) over Ni	Temperature	Operating temp. - 55° to +125 °C
Mating cycles: min. 50	Insertion force: max. 1,30N per contact	Material	Insulator (RoHS compliant): high temp plastic UL 94 V-0
Extraction force: min. 0,90N per contact		Contact (RoHS compliant): Phosphor Bronze	Retention Clip: Spring steel
		Electrical data	Operating voltage: 100 V RMS / 150V DC
		Breakdown voltage: >600 V RMS	Contact resistance: <20 mΩ
		Insulation resistance: >5000 MΩ	Current rating: 1 A max., 100V
		Capacitance: <2 pF	

PIN	Ordering Code	Dimensions mm/inch			
		"A"	"B"	"C"	"D"
28	PLP - 028 - N110 - 99	17,60/.693	7,62/.300	12,70/.500	11,50/.453
32	PLP - 032 - N110 - 99 (rectangular)	17,60 x 20,14 .693 x .793	10,16 x 7,62 .400 x .300	12,70 x 15,24 .500 x .600	11,50 x 14,04 .453 x .553
44	PLP - 044 - N110 - 99	22,68/.893	12,70/.500	17,78/.700	16,58/.653
52	PLP - 052 - N110 - 99	25,22/.993	15,24/.600	20,32/.800	19,12/.753
68	PLP - 068 - N110 - 99	30,30/1.193	20,32/.800	25,40/1.000	24,20/.953
84	PLP - 084 - N110 - 99	35,38/1.393	25,40/1.000	30,48/1.200	29,28/1.153

Order Code for optional Retention Clip : HCP - xxx (replace "xxx" with nbr of pins. Example. -028 if for 28-pin Socket)

PUL - 200

Universal extraction tool for all socket sizes (see also page 44)



E-tec „hi-rel“ SMT PLCC sockets correspond to JEDEC Norms. Precision stamped contact design provides special „push-down effect“ onto the leads of the chip.

For very high shock and vibration applications a chip retention clip can be obtained on request.

Inside polarisation corner prevents wrong insertion of the chips.

Stand-off's under the base prevent solder shorts.

Chips can be easily removed with the Universal extraction tool PUL-200.

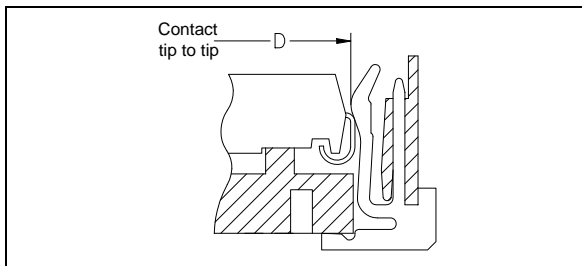
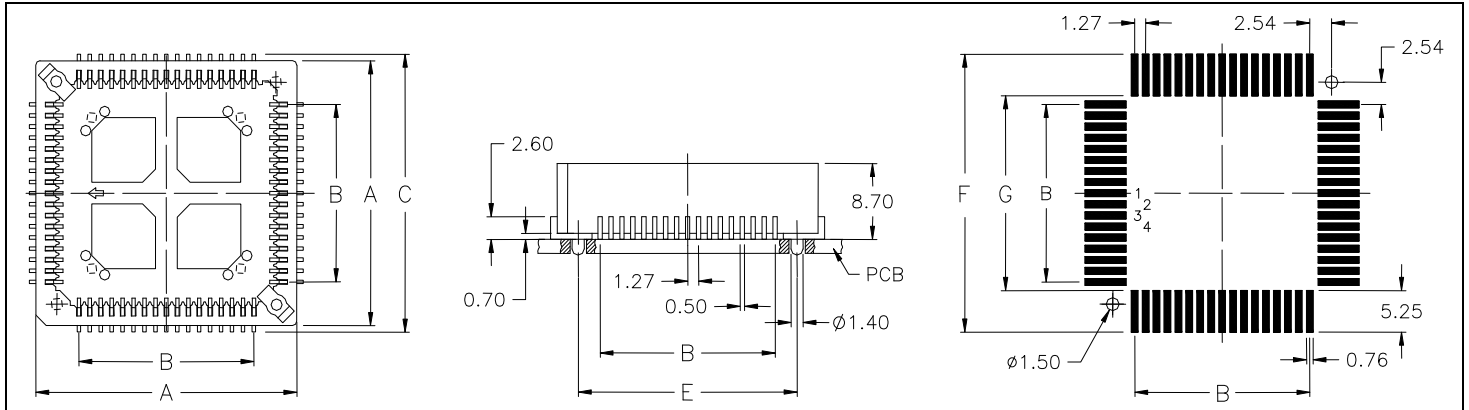
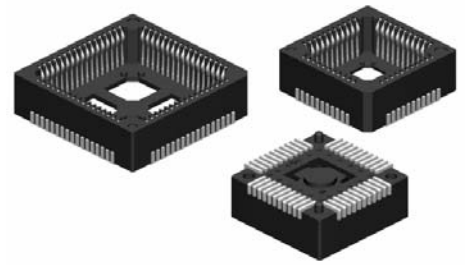

JEDEC Specification for Plastic Leaded Chip Carrier					
Jedec Nbr	Nbr of Pin	Dimensions mm/inch			
		"A" min.	"A" max.	„B“ min.	„B“ max.
MO-047 AB	28	12,32 / .485	12,57 / .495	1,37 / .054	2,36 / .093
MO-052 AE	32 rectang.	14,86 x 12,32 .585 x .485	15,11 x 12,57 .595 x .495	1,37 / .054	2,36 / .093
MO-047 AB	44	17,40 / .685	17,65 / .695	1,37 / .054	2,36 / .093
MO-047 AB	52	19,94 / .785	20,19 / .795	1,37 / .054	2,36 / .093
MO-047 AB	68	25,02 / .985	25,27 / .995	1,37 / .054	2,36 / .093
MO-047 AB	84	30,10 / 1.185	30,35 / 1.195	1,37 / .054	2,36 / .093

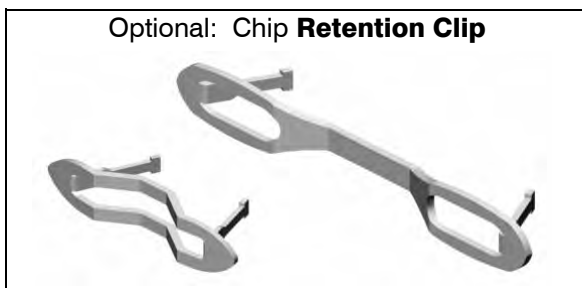

Mechanical data		Temperature		Electrical data	
Plating	Sn (leadfree) over Ni; Au on request	Operating temp.	- 55°C to +125°C	Operating voltage	100 V RMS / 150V DC
Mating cycles	min. 50	Soldering temp.	+250°C +0/-5°C for 20~40 sec.	Breakdown voltage	>600 V RMS
Insertion force	max. 1,30N per contact	Material		Contact resistance	<20 mΩ
Extraction force	min. 0,90N per contact	Insulator (RoHS compliant)	high temp plastic UL 94 V-0	Insulation resistance	>5000 MΩ
		Contact (RoHS compliant)	Phosphor Bronze	Current rating	1 A max., 100V
		Retention Clip	Spring steel	Capacitance	<2 pF

PIN	Ordering Code PLCC SMT Type	Dimensions mm/inch						
		"A" +0,10 -0,20	"B"	"C" +0,10 -0,05	"D"	"E" +0,10 -0,15	"F" +0,05 -0,00	"G" +0,00 -0,05
28	PLP - 028 - H100 - 99 (/x)	17,60/.693	7,62/.300	19,10/.752	11,50/.453	12,70/.500	19,60/.772	9,10/.358
32	PLP - 032 - H100 - 99 (/x) (rectangular)	17,60 x 20,14 .693 x .793	7,62 x 10,16 .300 x .400	19,10 x 21,64 .752 x .852	11,50 x 14,04 .453 x .553	12,70 x 15,24 .500 x .600	19,60 x 22,14 .772 x .872	9,10 x 11,14 .358 x .438
44	PLP - 044 - H100 - 99 (/x)	22,68/.893	12,70/.500	24,18/.952	16,58/.653	17,78/.700	24,68/.972	14,18/.558
52	PLP - 052 - H100 - 99 (/x)	25,22/.993	15,24/.600	26,72/1.052	19,12/.753	20,32/.800	27,22/1.072	16,72/.658
68	PLP - 068 - H100 - 99 (/x)	30,30/1.193	20,32/.800	31,80/1.252	24,20/.953	25,40/1.000	32,30/1.272	21,80/.858
84	PLP - 084 - H100 - 99 (/x)	35,38/1.393	25,40/1.000	36,88/1.452	29,28/1.153	30,48/1.200	37,38/1.472	26,88/1.058

for sockets with index pins please add: /1 = 1 pin in right angle corner /2 = 1 pin in slanted corner /3 = 2 pins diagonal

Order Code for optional Retention Clip : HCP - xxx (replace "xxx" with nbr of pins. Example. -028 if for 28-pin Socket)

PUL - 200 Universal extraction tool for all socket sizes (see also page 44)



Only 4.60mm height above board.
 Identical PCB layout for socket and chip.
 Solder terminals visible for post solder checks.
 Available with index pins under the insulator for correct orientation of the sockets.
 Diagonal slots for easy extraction of the chip with the Universal extraction tool PUL-200.
 Sockets correspond to JEDEC Norms.
 Also available in reel packaging.

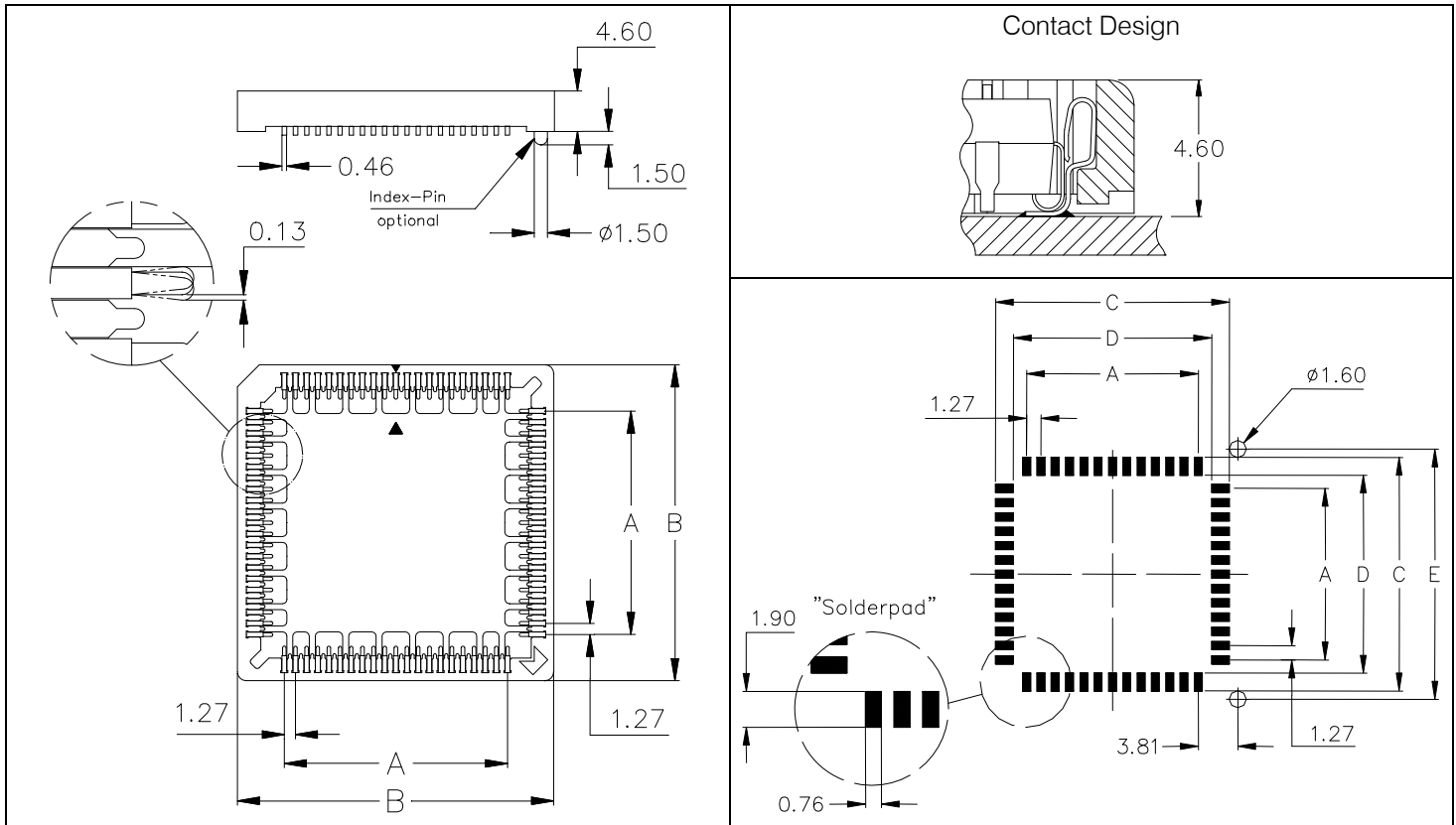
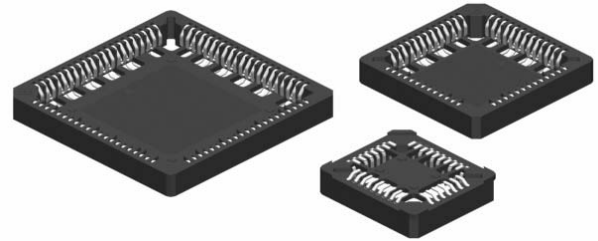

Specifications

Mechanical data

Contact (RoHS compliant) Phosphor bronze
 Plating Sn (leadfree) over Ni
 Insulator (RoHS compliant) High temp plastic black UL 94 V-0
Temperature
 Operating temp. - 40°C to +105°C
 Processing temp. +250°C +0/-5°C for 20~40sec.

Electrical data

Measuring voltage 100 V RMS / 150V DC
 Breakdown voltage >600 V RMS
 Contact resistance <20 mΩ
 Insulation resistance >5000 MΩ
 Current rating 1 A max., 100V
 Capacitance <2 pF

PIN	Ordering Code		Dimensions mm				
	PLCC SMT without index pins	PLCC SMT with index pins	"A"	"B"	"C"	"D"	"E"
20	PLS - 020 - H105 - 99	PLS - 020 - H105 - 99/4	5,08	15,58	10,50	6,70	12,70
28	PLS - 028 - H105 - 99	PLS - 028 - H105 - 99/4	7,62	18,12	12,61	8,81	15,24
32	PLS - 032 - H105 - 99 (rectangular)	PLS - 032 - H105 - 99/4 (rectangular)	7,62 x 10,16	20,66 x 18,12	13,04 x 15,58	9,24 x 11,78	17,78
44	PLS - 044 - H105 - 99	PLS - 044 - H105 - 99/4	12,70	23,20	18,12	14,32	20,32
52	PLS - 052 - H105 - 99	PLS - 052 - H105 - 99/4	15,24	25,74	20,86	17,06	22,86
68	PLS - 068 - H105 - 99	PLS - 068 - H105 - 99/4	20,32	30,82	25,74	21,94	27,94
84	PLS - 084 - H105 - 99	PLS - 084 - H105 - 99/4	25,40	35,90	30,39	26,59	33,02
For reel packing pls. order with - 99/R							
PUL -200			Universal extraction tool for all sizes (see also page 44)				

1,27mm pitch

SIMM sockets are made of hi-temp resistant LCP.

Single row types are available in vertical and slanted version (26°).

Insertion & extraction of the module can be made without any tools.

Positive polarization prevents wrong insertion of the module.

Contacts are designed with an anti-overstress feature.

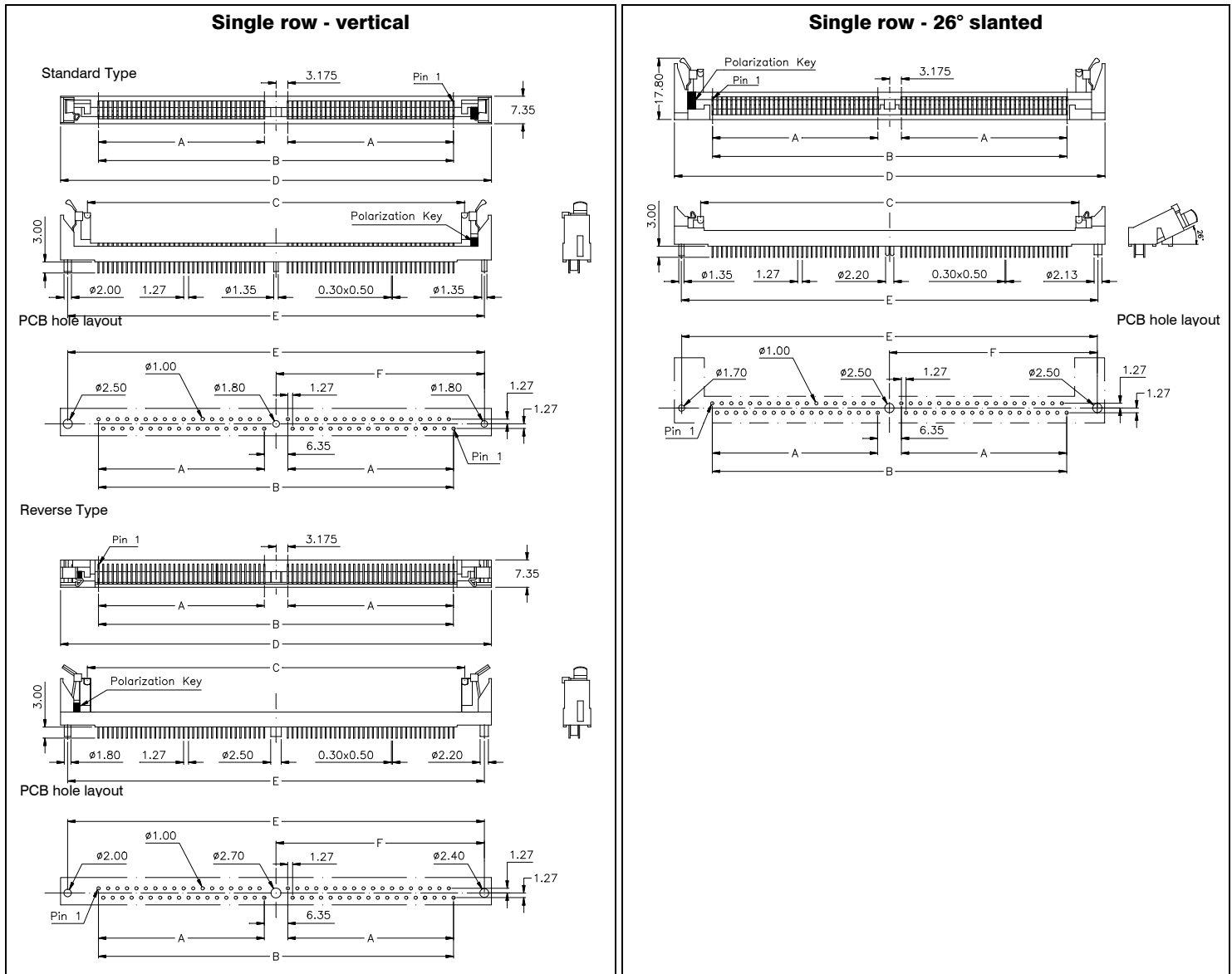

Specifications

Current rating	: 1 A max., 100V
Contact resistance	: 30 mΩ max.
Breakdown voltage	: 1,5 KV RMS max.
Insulation resistance	: 10 ⁴ MΩ min.
Capacitance	: 2 pF max.
Contact force	: 2 N min. (Module: 1.19mm to 1.37mm thick)
Operating temperature	: -55 °C to + 150 °C min.
Insulator (RoHS compliant)	: high temp plastic (ivory) UL 94 V-0
Contact (RoHS compliant)	: Phosphor bronze
Plating	: Sn (leadfree) over Ni

Dimensions for 1,27mm pitch SIMM Modules

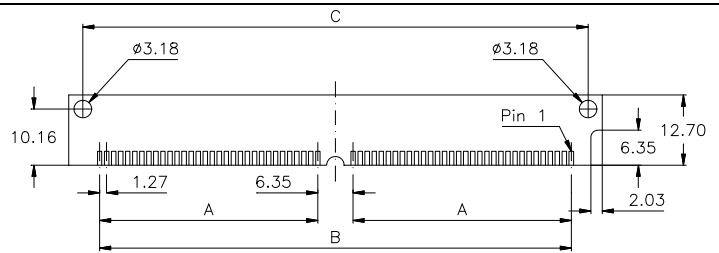

Pin	Execution	Ordering Code		Dimensions mm					
		Standard Type	Reverse Type	"A"	"B"	"C"	"D"	"E"	"F"
72	vertical	SM1 - 072 - TV99 - 99 / 1M	SM1 - 072 - TV99 - 99 / 1MR	44,45	95,25	101,20	115,45	111,56	55,78
80	vertical	SM1 - 080 - TV99 - 99 / 1M	SM1 - 080 - TV99 - 99 / 1MR	49,53	105,40	111,35	125,75	121,80	60,90
72	26° slanted	SM1 - 072 - TS99 - 99 / 1M		44,45	95,25	101,20	115,45	111,56	55,78
80	26° slanted	SM1 - 080 - TS99 - 99 / 1M		49,53	105,40	111,35	125,75	121,80	60,90

DM - Series DIMM Sockets

vertical type 100-pin 4bit



DIMM sockets are only available as long latch type
(Module locking extractors).

Insertion & extraction of the module can be made without any tools.

Positive polarization prevents wrong insertion of the module.

Contacts are designed with an anti-overstress feature for long contact life. Selective Gold/Tin plated. Gold only in contact area.

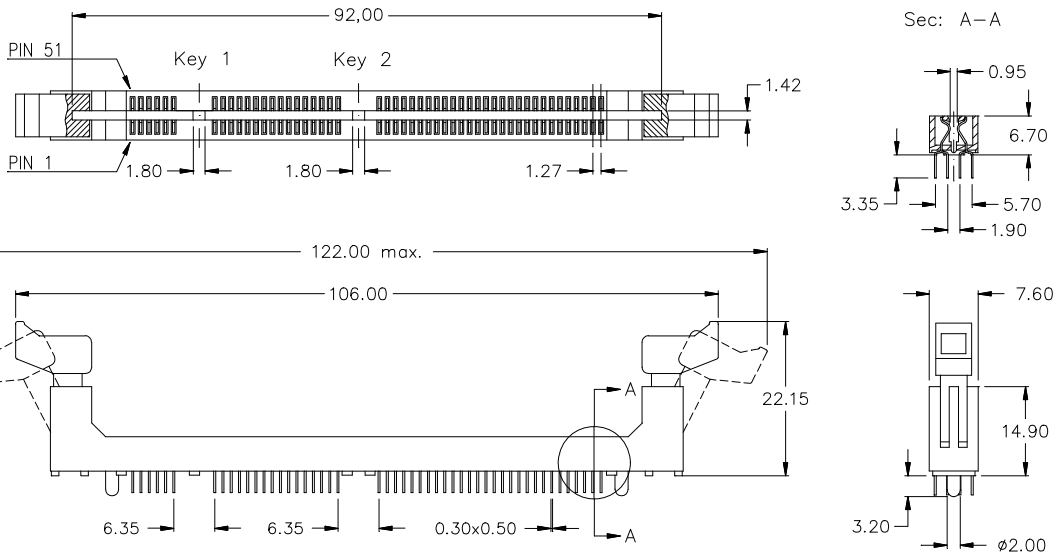

PC Board hole layout

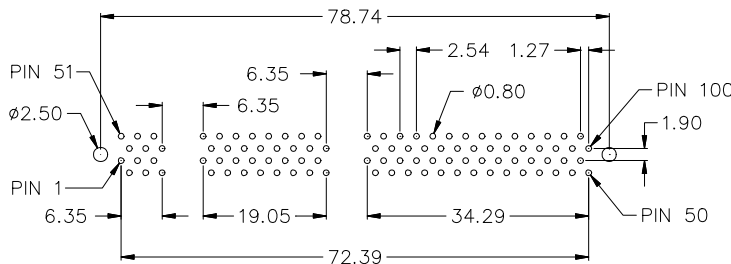

Module keying Type "A"

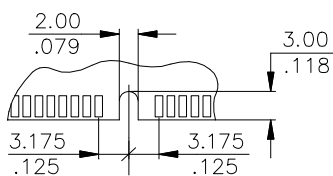

Module keying Type "B"

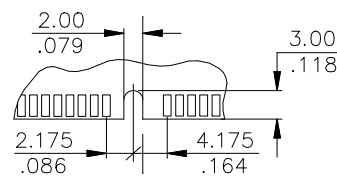

Module keying Type "C"

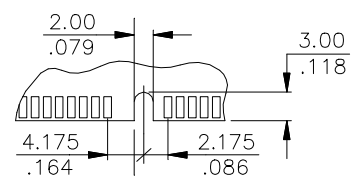

Specification

Current rating	1 A max., 250V AC	Operating temperature	-55° C to +105° C min.
Contact resistance	30 mΩ max.	Insulator (RoHS compliant)	high temp plastic UL 94 V-0
Breakdown voltage	1,5 KV RMS max.	Contact (RoHS compliant)	Copper Alloy
Insulation resistance	10 ⁴ MΩ min.	Plating	Au / Sn (leadfree) over Ni
Capacitance	1 pF max.		

Pin	Socket Type	Key No. 1	Key No. 2	Ordering Code
100 pin	DRAM 5 Volt	Type "A"	Type "B"	Please contact E-tec sales office for availability.
100 pin	SDRAM 5 Volt	Type "B"	Type "B"	Please contact E-tec sales office for availability.
100 pin	UDRAM 5 Volt	Type "C"	Type "B"	Please contact E-tec sales office for availability.
100 pin	DRAM 3,3 Volt	Type "A"	Type "A"	Please contact E-tec sales office for availability.
100 pin	SDRAM 3,3 Volt	Type "B"	Type "A"	Please contact E-tec sales office for availability.
100 pin	UDRAM 3,3 Volt	Type "C"	Type "A"	DM1 - 100 - VCA9 - 95/1L

DM - Series DIMM Sockets

vertical type 168-pin



DIMM sockets are only available as long latch type
(Module locking extractors).

Insertion & extraction of the module can be made without any tools.

Positive polarization prevents wrong insertion of the module.

Contacts are designed with an anti-overstress feature for long contact life. Selective Gold/Tin plated. Gold only in contact area.

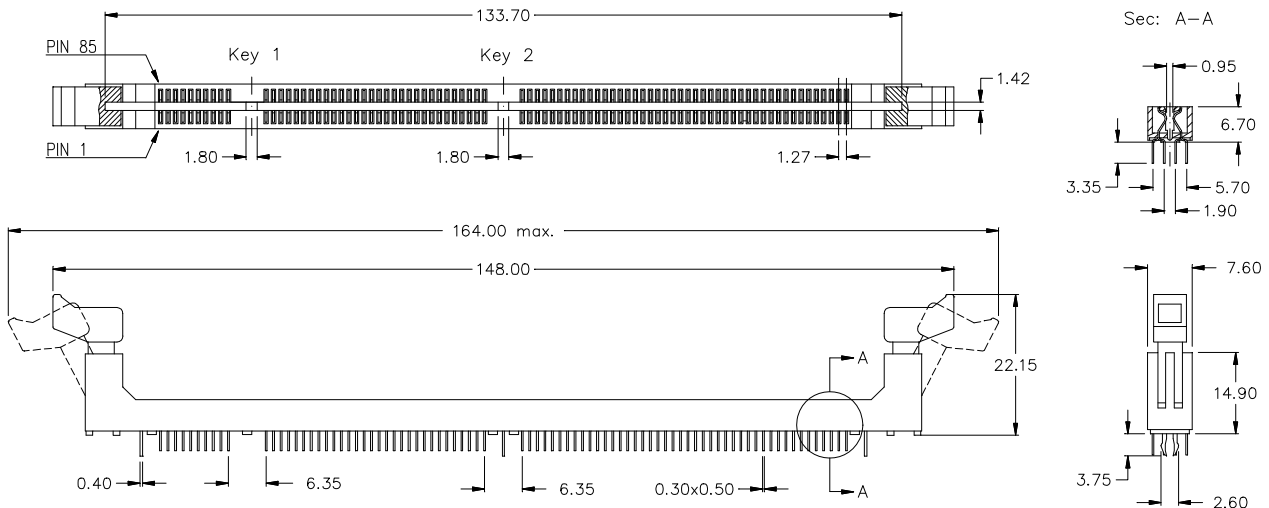

PC Board hole layout

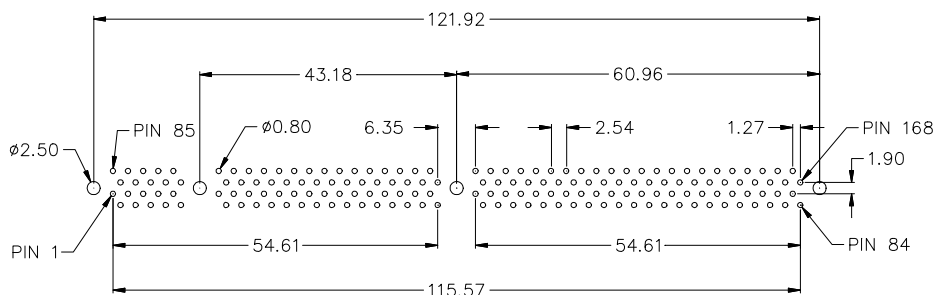

Module keying Type "A"

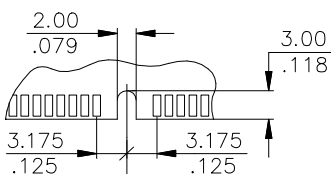

Module keying Type "B"

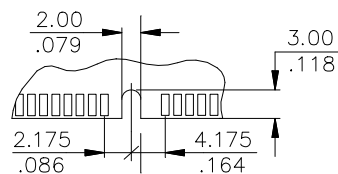

Module keying Type "C"

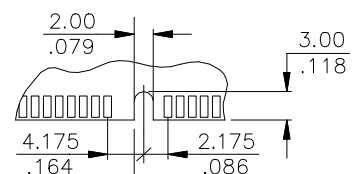

Specification

Current rating	1 A max., 250V AC	Operating temperature	-55° C to +105° C min.
Contact resistance	30 mΩ max.	Insulator (RoHS compliant)	high temp plastic UL 94 V-0
Breakdown voltage	1,5 KV RMS max.	Contact (RoHS compliant)	Copper Alloy
Insulation resistance	10 ⁴ MΩ min.	Plating	Au / Sn (<i>leadfree</i>) over Ni
Capacitance	1 pF max.		

Pin	Socket Type	Key No. 1	Key No. 2	Ordering Code
168 pin	DRAM 5 Volt	Type "A"	Type "B"	DM1 - 168 - VAB9 - 95/1L
168 pin	SDRAM 5 Volt	Type "B"	Type "B"	DM1 - 168 - VBB9 - 95/1L
168 pin	UDRAM 5 Volt	Type "C"	Type "B"	DM1 - 168 - VCB9 - 95/1L
168 pin	DRAM 3,3 Volt	Type "A"	Type "A"	DM1 - 168 - VAA9 - 95/1L
168 pin	SDRAM 3,3 Volt	Type "B"	Type "A"	DM1 - 168 - VBA9 - 95/1L
168 pin	UDRAM 3,3 Volt	Type "C"	Type "A"	DM1 - 168 - VCA9 - 95/1L

DM - Series DIMM Sockets

25° slanted type 168-pin



DIMM sockets are only available as long latch type
(Module locking extractors).

Insertion & extraction of the module can be made without any tools.

Positive polarization prevents wrong insertion of the module.

Contacts are designed with an anti-overstress feature for long contact life. Selective Gold/Tin plated. Gold only in contact area.

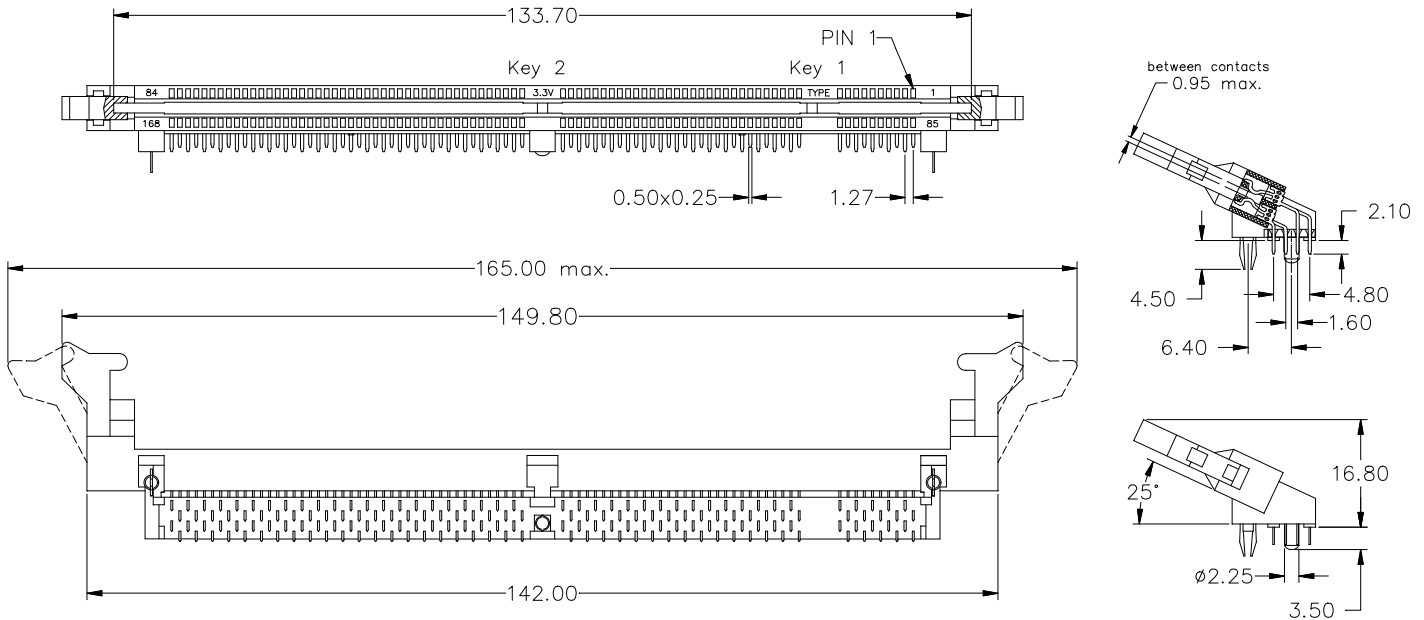

PC Board hole layout

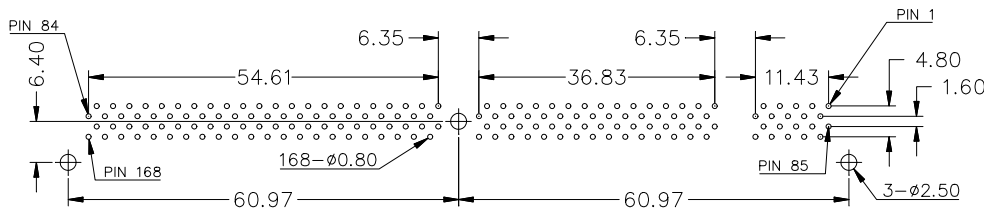

Module keying

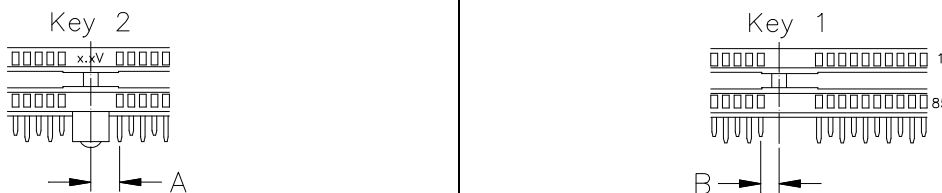

Specification

Current rating	1 A max., 250V AC	Operating temperature	-25° C to +105° C min.
Contact resistance	30 mΩ max.	Insulator (RoHS compliant)	high temp plastic UL 94 V-0
Breakdown voltage	1,5 KV RMS max.	Contact (RoHS compliant)	Copper Alloy
Insulation resistance	1000 MΩ min.	Plating	Au / Sn (leadfree) over Ni
Capacitance	1 pF max.		

Pin	Socket Type	Key No. 1	Key No. 2	Type	Ordering Code
168 pin	DRAM 3,3 Volt	DIM "B" = 3.175 mm	DIM "A" = 3.175 mm	AA	DM1 - 168 - SAA8 - 95/1L
168 pin	SDRAM 3,3 Volt	DIM "B" = 4.175 mm	DIM "A" = 3.175 mm	BA	DM1 - 168 - SBA8 - 95/1L
168 pin	UDRAM 3,3 Volt	DIM "B" = 2.175 mm	DIM "A" = 3.175 mm	CA	DM1 - 168 - SCA8 - 95/1L

DM - Series DIMM Sockets

90° right angle type 168-pin



DIMM sockets are only available as long latch type
(Module locking extractors).

Insertion & extraction of the module can be made without any tools.

Positive polarization prevents wrong insertion of the module.

Contacts are designed with an anti-overstress feature for long contact life. Selective Gold/Tin plated. Gold only in contact area.

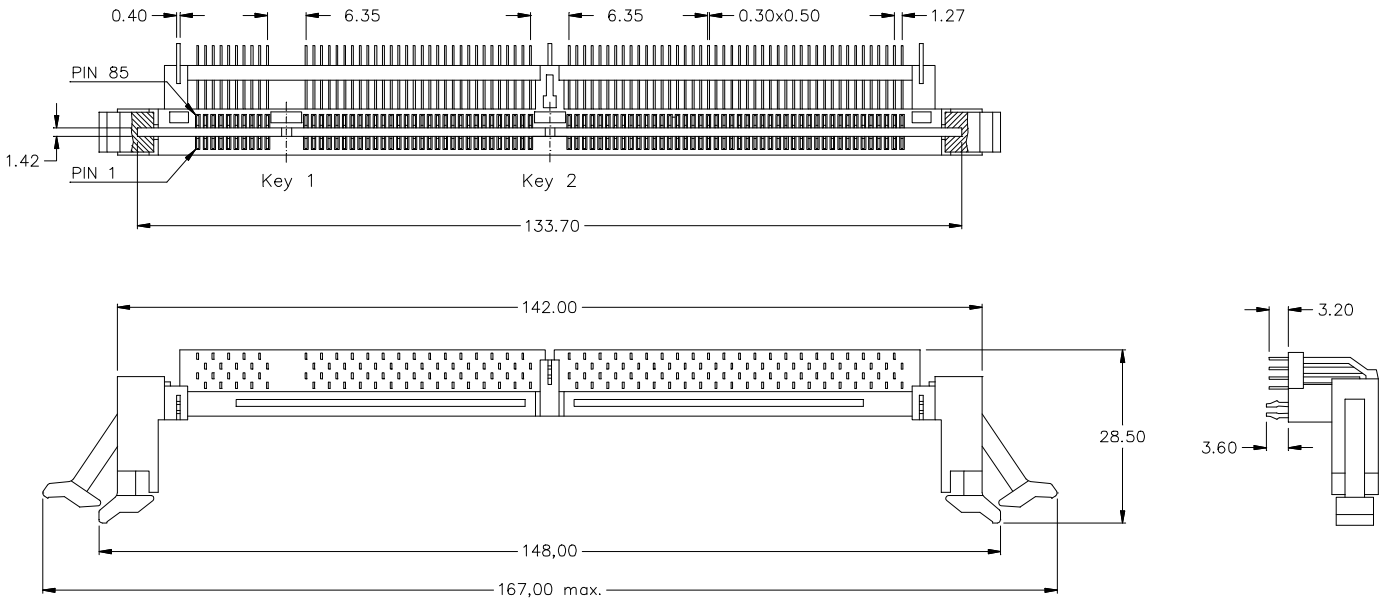

PC Board hole layout

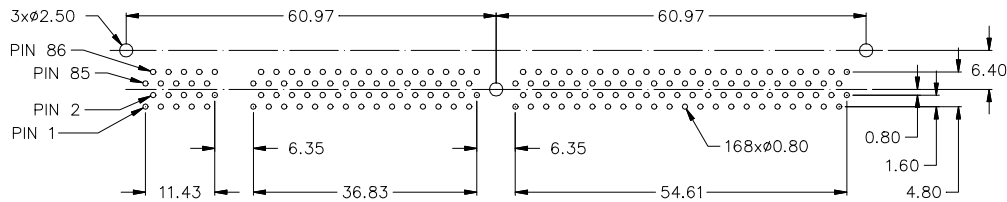

Module keying Type "A"

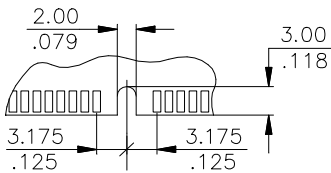

Module keying Type "B"

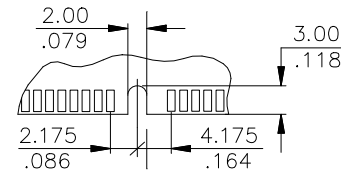

Module keying Type "C"

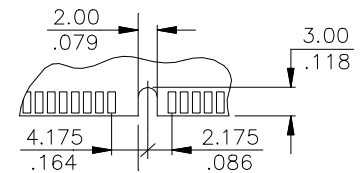

Specification

Current rating: 1 A max., 250V AC
 Contact resistance: 30 mΩ max.
 Breakdown voltage: 1,5 KV RMS max.
 Insulation resistance: 10⁴ MΩ min.
 Capacitance: 1 pF max.

Operating temperature: -55° C to +105° C min.
 Insulator (RoHS compliant): high temp plastic UL 94 V-0
 Contact (RoHS compliant): Copper Alloy
 Plating: Au / Sn (leadfree) over Ni

Pin	Socket Type	Key No. 1	Key No. 2	Ordering Code
168 pin	DRAM 5 Volt	Type "A"	Type "B"	Please contact E-tec sales office for availability.
168 pin	SDRAM 5 Volt	Type "B"	Type "B"	Please contact E-tec sales office for availability.
168 pin	UDRAM 5 Volt	Type "C"	Type "B"	Please contact E-tec sales office for availability.
168 pin	DRAM 3,3 Volt	Type "A"	Type "A"	Please contact E-tec sales office for availability.
168 pin	SDRAM 3,3 Volt	Type "B"	Type "A"	Please contact E-tec sales office for availability.
168 pin	UDRAM 3,3 Volt	Type "C"	Type "A"	DM1 - 168 - RCA9 - 95/1L

DR - Series DIMM Sockets for DDR Module vertical type 184-pin



DIMM sockets for DDR module are only available as long latch type (Module locking extractors).

Insertion & extraction of the module can be made without any tools.

Positive polarization prevents wrong insertion of the module.

Contacts are designed with an anti-overstress feature for long contact life. Selective Gold/Tin plated. Gold only in contact area.

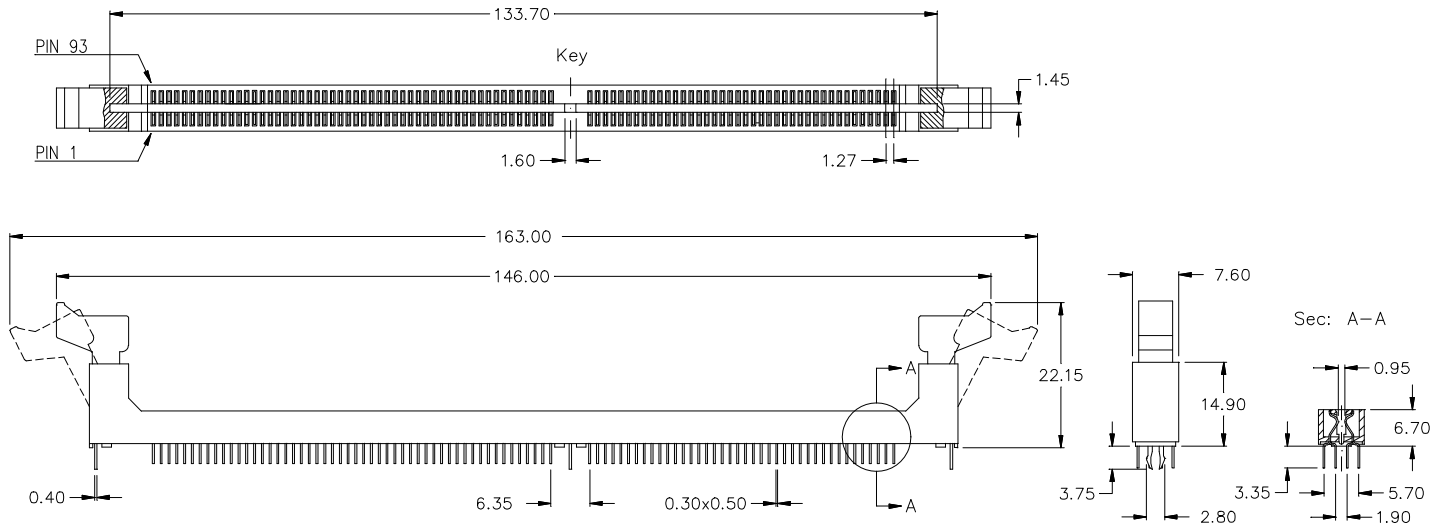

PC Board hole layout

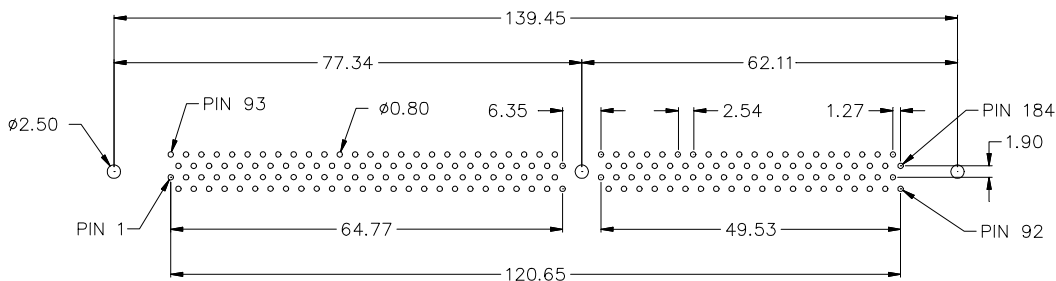

Module keying Type "A"

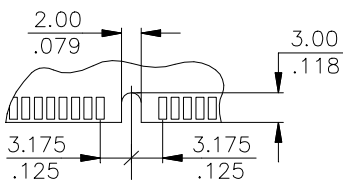

Module keying Type "B"

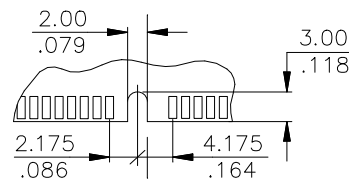

Module keying Type "C"

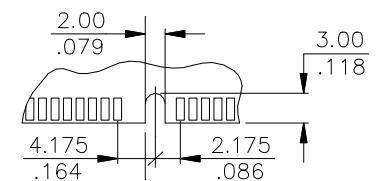

Specification

Current rating 1 A max., 250V AC
Contact resistance 30 mΩ max.
Breakdown voltage 1,5 KV RMS max.
Insulation resistance 10⁴ MΩ min.
Capacitance 1 pF max.

Operating temperature -55° C to +105° C min.
Insulator (RoHS compliant) high temp plastic UL 94 V-0
Contact (RoHS compliant) Copper Alloy
Plating Au / Sn (leadfree) over Ni

Pin	Socket Type	Voltage Key	Ordering Code
184 pin	1,8 Volt	Type "A"	Please contact E-tec sales office for availability.
184 pin	2,5 Volt	Type "B"	DR1 - 184 - VBZ9 - 95/1L
184 pin	3,3 Volt	Type "C"	Please contact E-tec sales office for availability.

DMD Series - SO - DIMM Sockets

200-pin for DDR Module



SO-DIMM sockets for **200-pin DDR Module** are made of hi-temp resistant LCP.

Insertion & extraction of the module can be made without any tools.
Positive polarization prevents wrong insertion of the module.

Contacts are designed with an anti-overstress feature for long contact life.

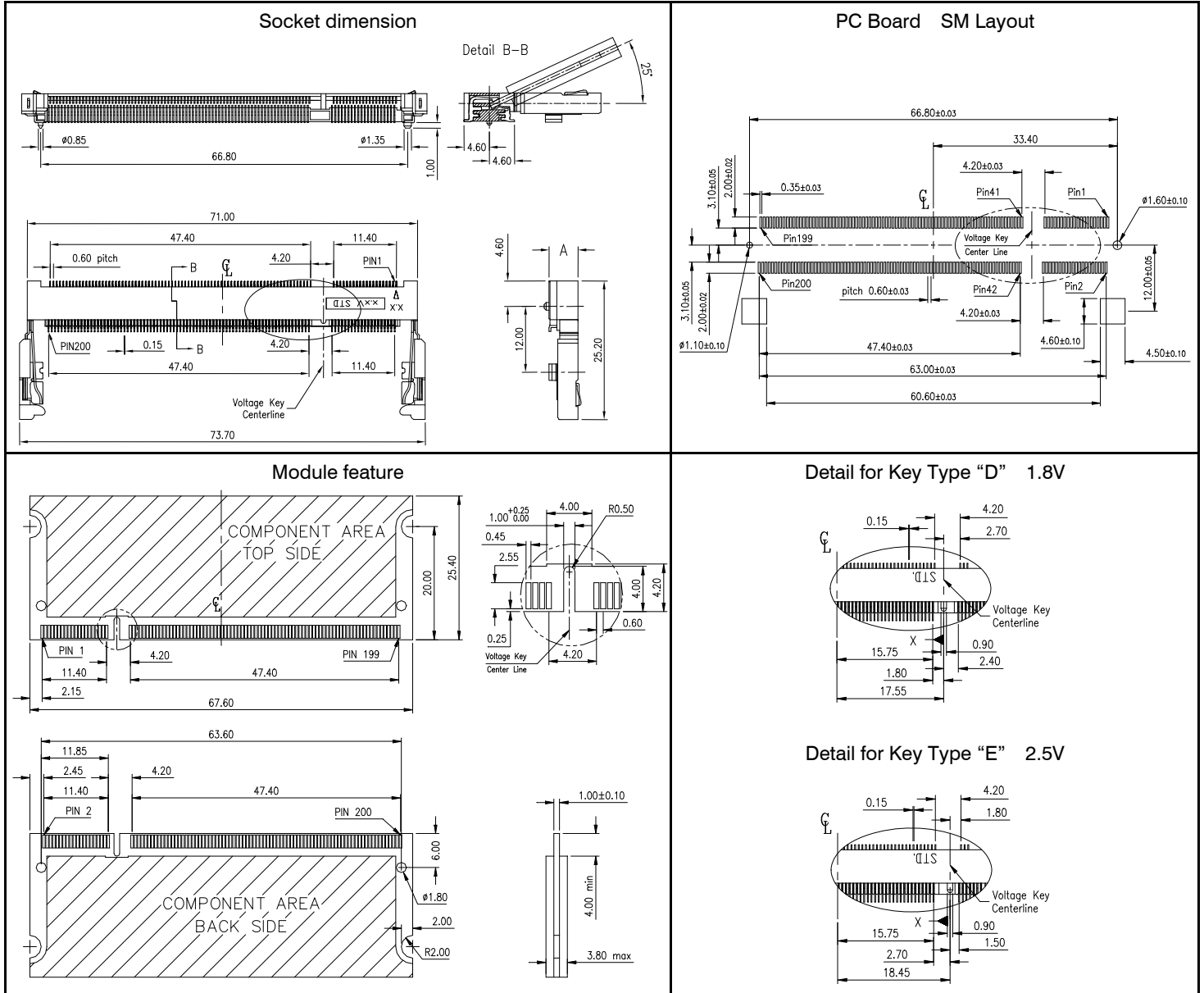

Specification			
Current rating	0.5 A	Insulator	(RoHS compliant) LCP black UL 94 V-0
Voltage rating	50 V AC	Contact	ivory on request
Insulation resistance	500 MΩ min. (initial) 100 MΩ max. (final)	Plating	(RoHS compliant) Au over Ni
Contact resistance	50 mΩ max.	Lifetime	25 cycles min.
Operating temperature	-40°C to +80°C min.	Latch	(RoHS compliant) Stainless Steel, Sn (leadfree) plated
Processing temperature	+250°C +0/-5° for 20~40 Sec.		

Pin	SDRAM "Standard" Socket Type	Connector Dimension "A"	Ordering Code	
			1.8 Volt Key Type "D"	2.5 Volt Key Type "E"
200 pin	Low-Profile	4.00 mm	DMD - 200 - RLD9 - 55	DMD - 200 - RLE9 - 55
200 pin	Standard-Profile	5.20 mm	DMD - 200 - RSD9 - 55	DMD - 200 - RSE9 - 55

DMD Series - SO - DIMM Socket

200-pin for DDR Module "9.20mm height"



This **9.20mm height** SO-DIMM socket for 200-pin DDR Module, made of hi-temp resistant LCP, can be also used in combination with the 4.00mm & 5.20mm height type as **"Piggyback"**.

Insertion & extraction of the module can be made without any tool.
Positive polarization prevents wrong insertion of the module.

Contacts are designed with an anti-overstress feature for long contact life.

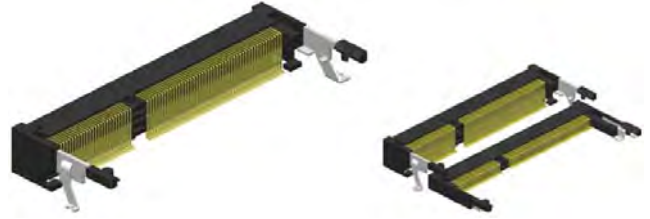

Piggyback application

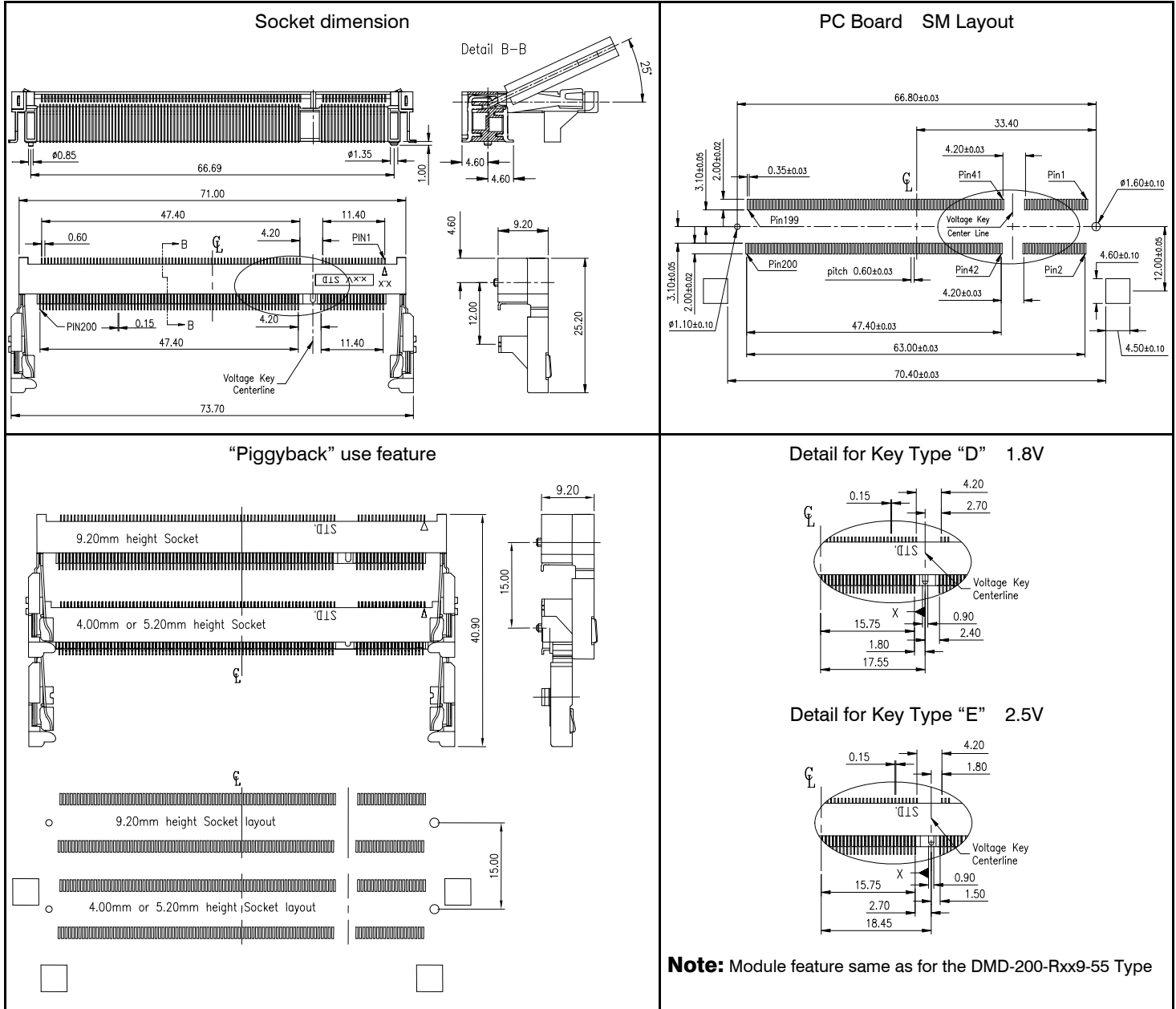

Specification

Current rating	0.5 A	Insulator	(RoHS compliant) LCP black UL 94 V-0
Voltage rating	50 V AC	Contact	ivory on request
Insulation resistance	500 MΩ min. (initial)	Plating	(RoHS compliant) Au over Ni
	100 MΩ max. (final)	Lifetime	25 cycles min.
Contact resistance	50 mΩ max.	Latch	(RoHS compliant) Stainless Steel, Sn (leadfree) plated
Operating temperature	-40°C to +80°C min.		
Processing temperature	+250°C +0/-5° for 20~40 Sec.		

Pin	SDRAM "Standard" Socket Type	Connector Dimension "A"	Ordering Code	
			1.8 Volt Key Type "D"	2.5 Volt Key Type "E"
200 pin	"Piggyback" - Type	9.20 mm	DMD - 200 - RPD9 - 55	DMD - 200 - RPE9 - 55

PGA Extraction Tools

for changing multi-pole PIN-GRID-ARRAYS

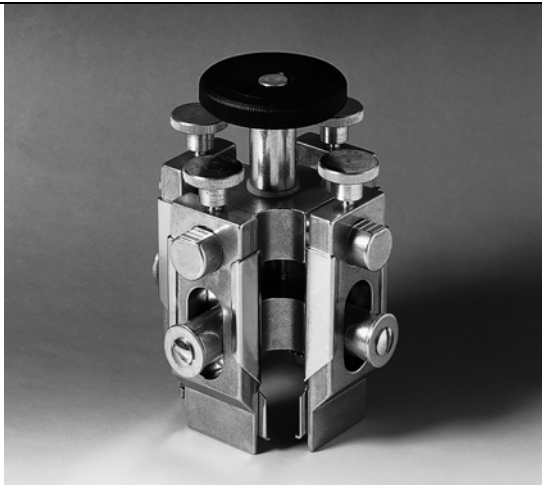

For extraction of PIN-GRID-ARRAYS from sockets with high extraction force, the **four side grip claw type** is recommended in order to prevent damaging the Array.

Order Code: PUL – 2300 – D/26

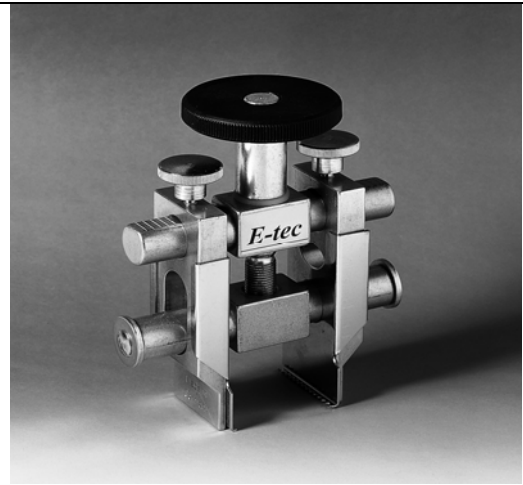

The multi-range tools have spindle actuation and a lifting mechanism with movable support jaws. Solid aluminium crossbars ensure even load distribution during the extraction operation. Their relatively large lift of approx. 15mm also permits safe extraction of arrays with bonded-on heat sinks.

Order Code: PUL – 2300 – S

**PLCC , SOJ & LCC “Universal” Extraction Tool
WHY UNIVERSAL ?**

It only requires ONE tool for extracting PLCC & SOJ chips of all pin configurations and LCC 32- and 44-pin chips (E-PROM's). The plastic arms sit on the side, thus avoiding an extraction force on the socket itself. This is most important for SMD sockets, which would otherwise be torn off the board.

The same tool can be used for all sockets built according to JEDEC standards and having diagonal entry slots.

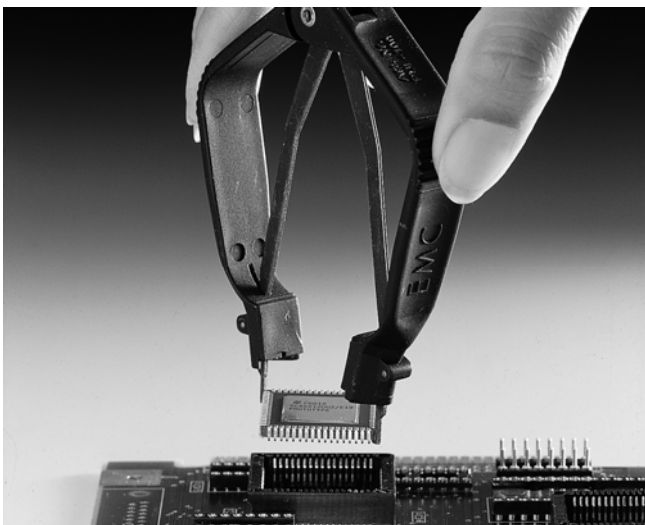

Order Code: PUL – 200

**PGA Insertion Tools
for inserting multi-pole PIN-GRID-ARRAYS**

Inserting multi-pole PGA's into Sockets with precision contacts causes the same difficulties as extracting them.

When inserting a PGA into a corresponding socket, even pressure must be applied to the top of the PGA.

E-tec recommends the use of this PUS-2060 Series in order to avoid tilting and damaging the contact pins.



Please consult your closest sales office for detailed information and order codes.

Spring loaded contacts and connectors can be found in numerous environments for consumer and professional electronic applications in fixed or mobile equipments for communications, automotive, loading stations, SIM card connectors, docking stations, test & measurement instruments, cameras (picture & film), medical apparatus and many more. The probe pin and connector designs are generally specifically adapted to customer requirements.

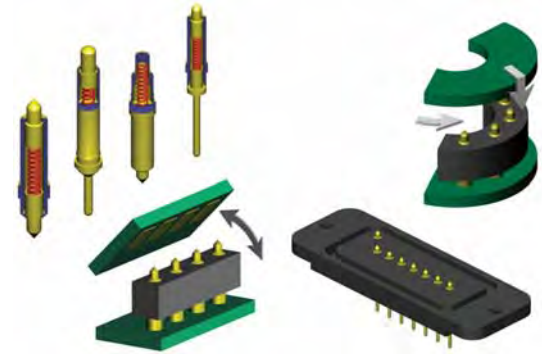

	Plunger tip types (please circle your requirement below)			
	 Single point tip <input type="checkbox"/>	 Crown tip <input type="checkbox"/>	 Convex tip <input type="checkbox"/>	 Concave tip <input type="checkbox"/>
Probe pin types (please circle your requirement below)				
Solderless		SMT		Thru-hole
 Single point tip <input type="checkbox"/>	 Crown tip <input type="checkbox"/>	 Round tip <input type="checkbox"/>	 Flat tip <input type="checkbox"/>	 Solderetail <input type="checkbox"/>

Probe pin and Connectors are generally produced to custom specifications.

Please supply a datasheet or a sketch of the required probe pin and/or connector dimensions and highlight the critical requirements for your application.

The list above and below covers some of the probe pin aspects which need to be determined or which may be critical for your application.

Please complete and/or tick your requirements and send this page to your closest E-tec sales office. If you need any further assistance, please do not hesitate to call.

Overall height DIM. "A"	<input type="text"/>	Plunger travel (stroke) DIM "B"	<input type="text"/>	Pitch	<input type="text"/>
Contact force	<input type="text"/>	Current rating	<input type="text"/>	Mechanical life	<input type="text"/>
Bandwidth	<input type="text"/>	Operating temperature	<input type="text"/>		
Material specs for plunger	<input type="text"/>				
Material specs for spring	<input type="text"/>				
Material specs for barrel	<input type="text"/>				
Material specs for connector body	<input type="text"/>				

Socket Terminals

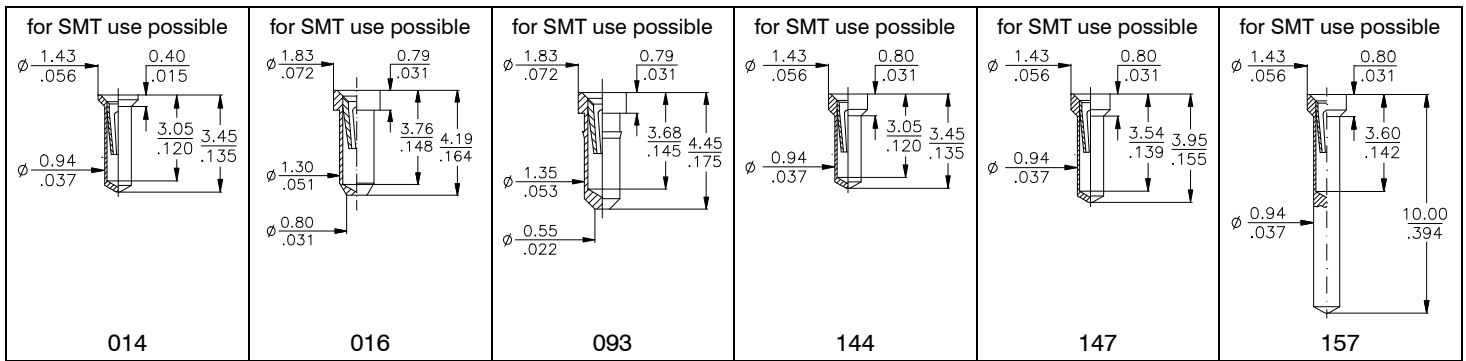
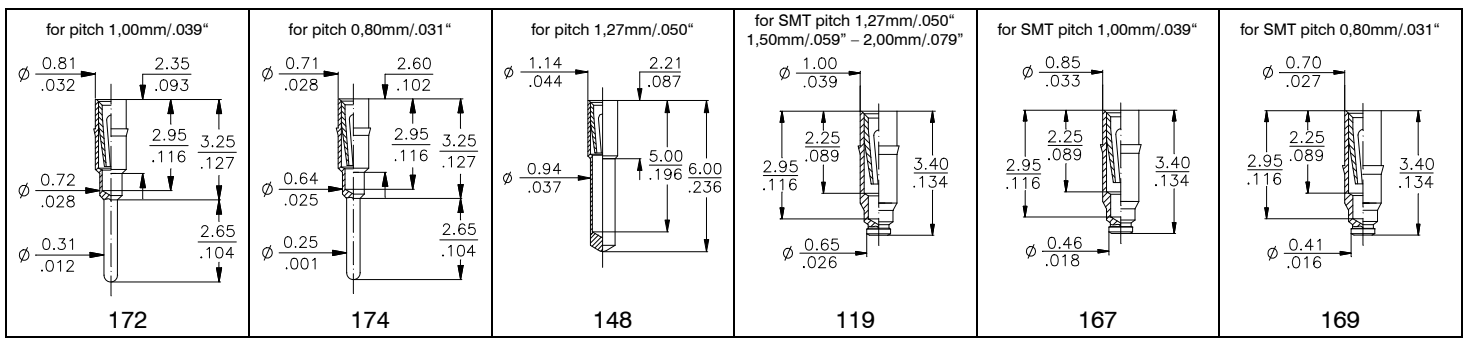
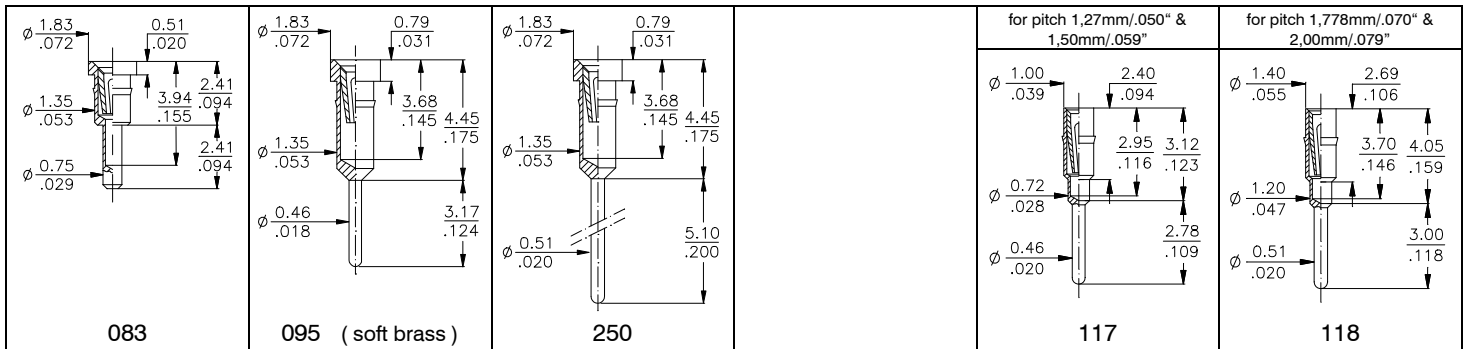
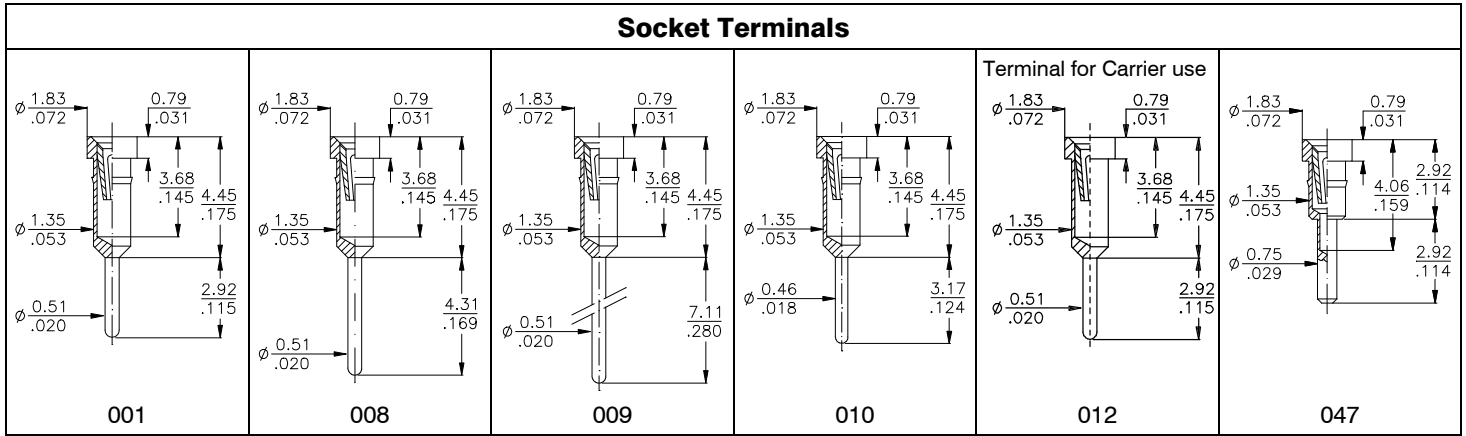

Wire Wrap Terminals

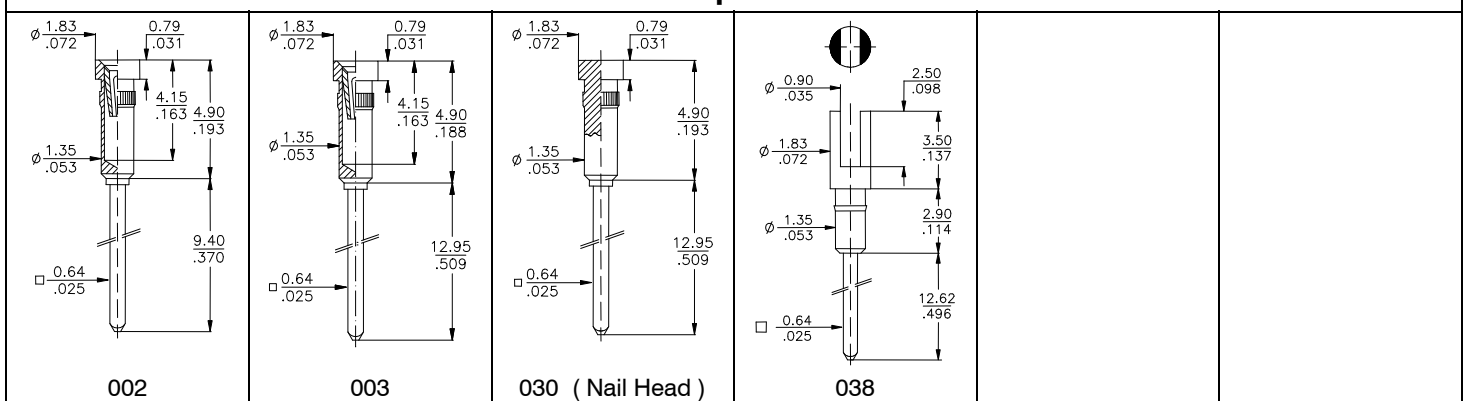

Raised Terminals

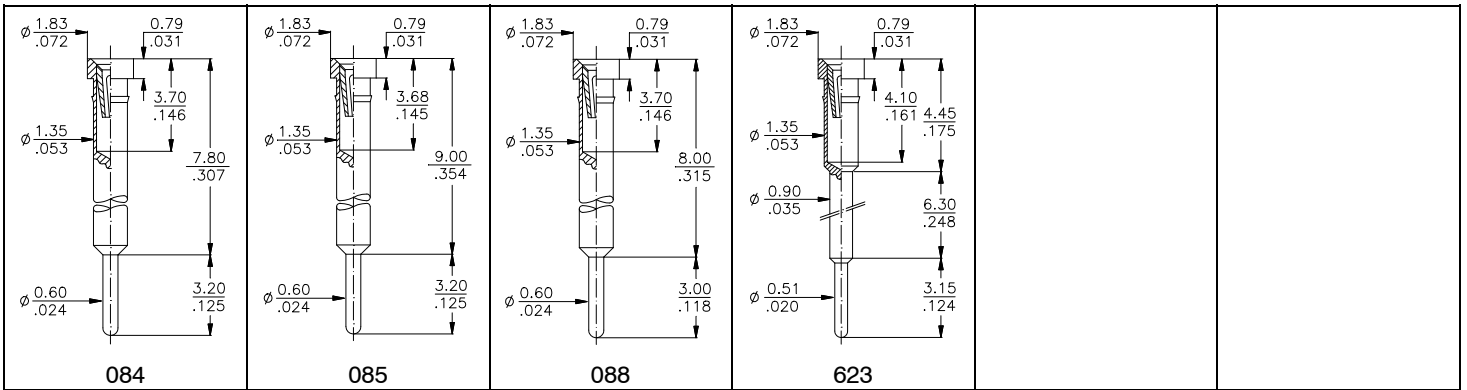
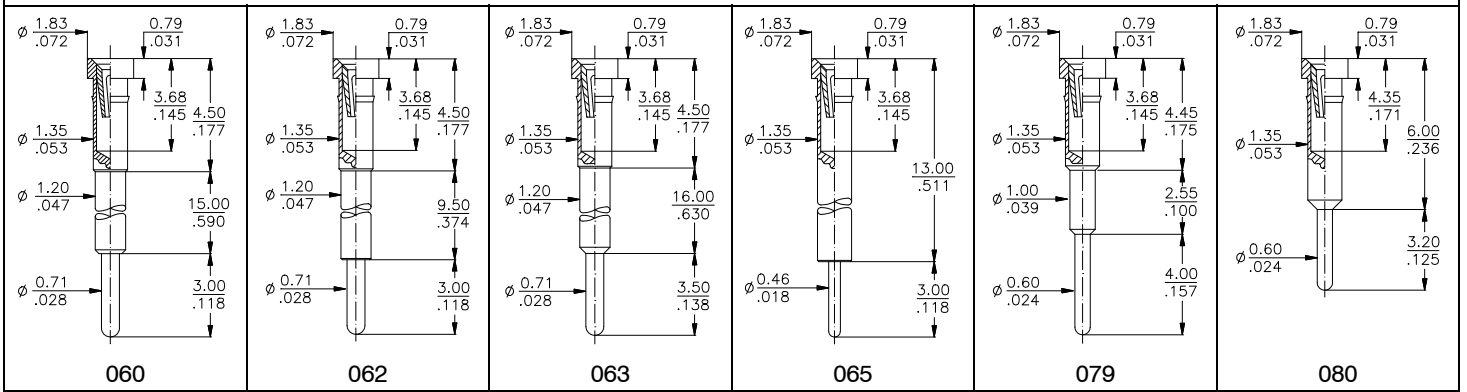

„Jumbo“ Contact & Male Terminals

(Contact accepts 0,64mm/.025" sq. & 0,90mm/.036" dia. Pins)

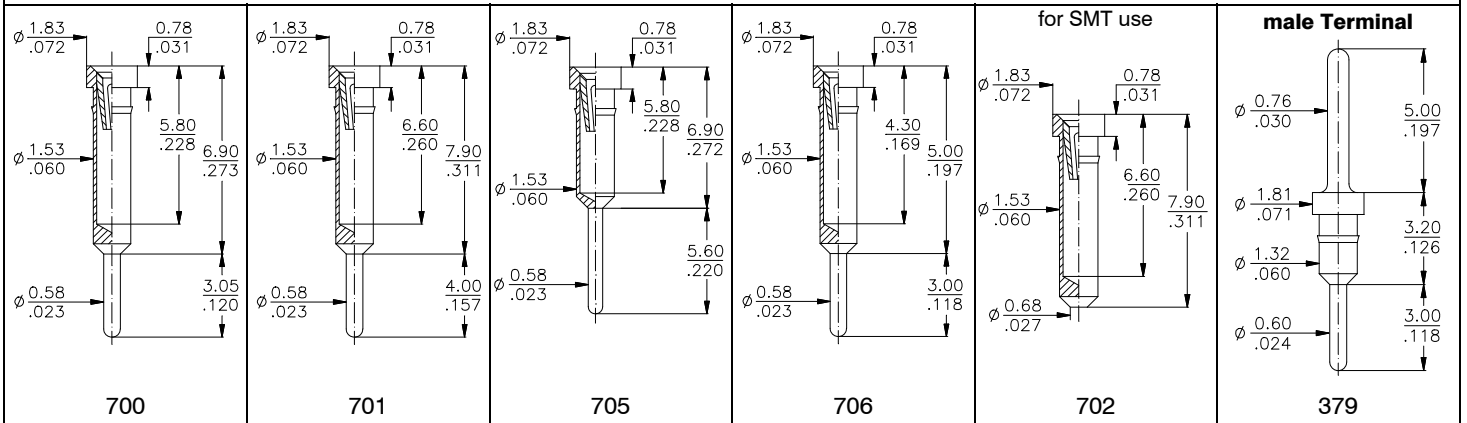

Solder Adapter Terminals

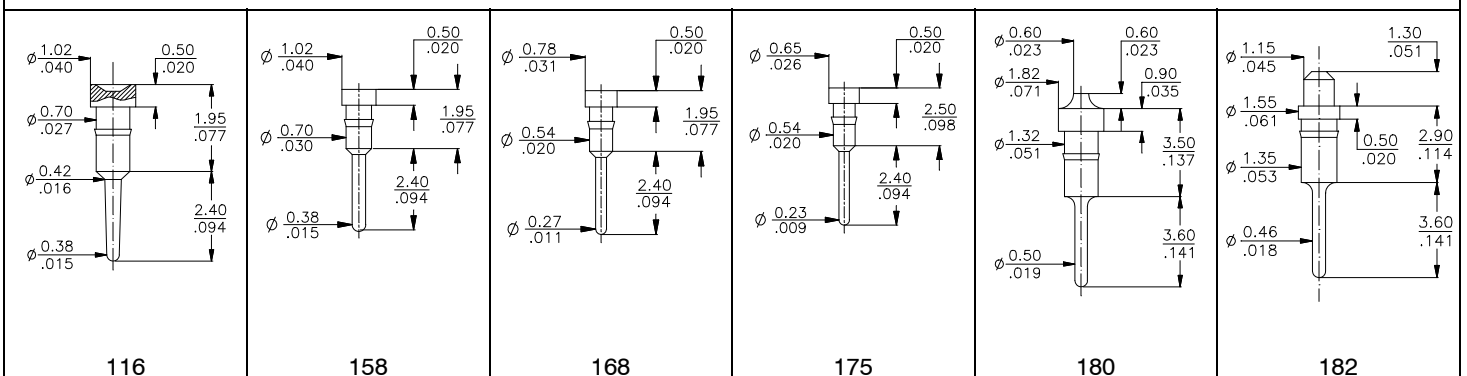

Board to Board Terminals

<p>Terminal 037 dimensions: ϕ 0.64 / .025, 4.22 / .166, ϕ 1.83 / .072, 3.93 / .154, ϕ 1.35 / .053, 3.96 / .156, ϕ 0.46 / .018.</p>	<p>Terminal 056 dimensions: ϕ 0.65 / .025, 4.68 / .184, ϕ 1.52 / .060, 14.82 / .583, ϕ 1.83 / .072, 1.35 / .053, ϕ 0.46 / .018, 3.40 / .134.</p>	<p>Terminal 057 dimensions: ϕ 0.65 / .025, 4.10 / .161, ϕ 1.83 / .072, 3.90 / .153, ϕ 1.35 / .053, 7.19 / .283, ϕ 0.50 / .019.</p>	<p>Terminal 058 dimensions: ϕ 0.46 / .018, 3.56 / .140, ϕ 1.52 / .060, 8.89 / .350, ϕ 1.83 / .072, ϕ 1.35 / .053, ϕ 0.46 / .018, 3.40 / .134.</p>	<p>Terminal 059 dimensions: ϕ 0.46 / .018, 3.56 / .140, ϕ 1.52 / .060, 11.61 / .457, ϕ 1.83 / .053, ϕ 1.35 / .072, ϕ 0.46 / .018, 3.40 / .134.</p>	
<p>Terminal 077 dimensions: ϕ 0.46 / .018, 4.22 / .166, ϕ 1.83 / .072, 3.68 / .144, ϕ 1.35 / .053, 3.96 / .156, ϕ 0.46 / .018.</p>	<p>Terminal 078 dimensions: ϕ 0.64 / .025, 12.95 / .509, ϕ 1.83 / .072, 3.94 / .155, ϕ 1.35 / .053, 3.96 / .155, ϕ 0.46 / .018.</p>	<p>Terminal 220 dimensions: ϕ 0.46 / .018, 4.22 / .166, ϕ 1.83 / .072, 3.34 / .131, ϕ 1.35 / .053, 5.80 / .228, ϕ 0.64 / .025.</p>	<p>Terminal 372 dimensions: ϕ 0.51 / .020, 4.22 / .166, ϕ 1.60 / .062, 3.93 / .154, ϕ 1.35 / .053, 3.96 / .156, ϕ 0.46 / .018.</p>	<p>Terminal 377 dimensions: ϕ 0.46 / .018, 3.17 / .124, ϕ 1.82 / .072, 0.30 / .012, 7.33 / .288, ϕ 0.46 / .018, 2.52 / .099.</p>	
<p>Terminal 542 dimensions: ϕ 0.46 / .018, 2.95 / .116, ϕ 1.48 / .058, 19.05 / .750, ϕ 1.83 / .072, 1.35 / .053, ϕ 0.46 / .018, 3.40 / .133.</p>	<p>Terminal 544 dimensions: ϕ 0.46 / .018, 3.56 / .140, ϕ 1.18 / .046, 10.50 / .413, ϕ 1.83 / .072, ϕ 1.35 / .053, ϕ 0.46 / .018, 3.40 / .133.</p>	<p>Terminal 562 dimensions: ϕ 0.46 / .018, 3.56 / .140, ϕ 1.48 / .058, 14.82 / .583, ϕ 1.83 / .072, ϕ 1.35 / .053, ϕ 0.46 / .018, 3.40 / .133.</p>	<p>Terminal 583 dimensions: ϕ 0.46 / .018, 3.56 / .140, ϕ 1.20 / .047, 5.70 / .224, ϕ 1.83 / .053, ϕ 1.35 / .072, ϕ 0.46 / .018, 2.40 / .094.</p>	<p>Terminal 770 dimensions: ϕ 0.46 / .018, 3.60 / .141, ϕ 1.80 / .070, 3.50 / .138, ϕ 1.35 / .053, ϕ 0.46 / .018, 2.90 / .114.</p>	<p>for pitch 1,27mm/.050"</p> <p>Terminal 774 dimensions: ϕ 0.44 / .017, 2.40 / .094, ϕ 1.00 / .039, 6.05 / .238, ϕ 0.85 / .033, ϕ 0.44 / .017, 2.85 / .112.</p>

Header Terminals

<p>Terminal 036 dimensions: ϕ 0.96 / .038, 3.81 / .150, 3.99 / .157, 12.47 / .491, ϕ 1.60 / .063, 6.58 / .259, ϕ 2.00 / .079, 3.96 / .156, ϕ 1.35 / .053, ϕ 0.46 / .018.</p>	<p>Terminal 353 dimensions: ϕ 0.90 / .035, 2.55 / .100, 4.00 / .157, 3.45 / .135, ϕ 1.80 / .070, ϕ 1.35 / .053, ϕ 0.50 / .019, 3.15 / .124.</p>	<p>Terminal 038 (Wire Wrap) dimensions: ϕ 0.90 / .035, 2.50 / .098, 3.50 / .137, 2.90 / .114, ϕ 1.83 / .072, 12.62 / .496, ϕ 1.35 / .053, ϕ 0.64 / .025.</p>			
--	---	--	--	--	--

General Specifications for Precision Pin Sockets

Mechanical data

Average forces for available clip types:	
Standard type	1.80N insertion / 0.90N extraction
Low force type	0.70N insertion / 0.25N extraction
Super low force type	0.40N insertion / 0.15N extraction
High force type	4.00N insertion / 2.50N extraction
„Jumbo“ contact	1.40N insertion / 0.25N extraction
<i>Other clips and forces available on request</i>	
Contact life	min. 100 cycles
Vibration as per EN60352-4	sinusoidal, 10 to 500 Hz, 10g, 1 octave/min, 10 cycles for each axis
Shock as per EN60352-4	half sine, 50g, 11ms, 3 shocks in 3 axes
Thermal shock as per IEC 60068-2-14	-55°C/+125°C, 5 cycles, 30 minutes
Solderability as per IEC 60068-2-58	245°C to 255°C 5 sec; Sn97Ag3 solder alloy
Dry heat steady state as per IEC 60068-2-2	260°C for 20 sec.
Cold stead state as per IEC 60068-2-1	-55°C, 2h
Damp heat cyclic as per IEC 60068-2-30	55°C, 90-100%rH, 24h
Moisture sensitivity Level (JEDEC J-STD-020C)	2 for PBT & Nylon 1 for all other materials
PCB holes for 2.54mm pitch standard connectors	1.00mm diameter
Coplanarity thru-hole	0.30mm
General tolerances	+/- 0.10mm

Operating temperature (standard)

-55°C to +125°C

Processing temperature

injection molded insulator (high temp)	+250°C +0/-5°C for 20~40 sec. (reflow solder)
injection molded insulator (PBT)	+250°C +0/-5°C for 10 sec. (wave solder only)
Epoxy FR4 (Standard)	+220°C min. for 10 sec.
Epoxy FR4 (hi temp)	+260°C min. for 60 sec.

Electrical data

Contact resistance at 1A	4,3 mΩ typ.
Current rating (except „Jumbo“ contact)	1A max.
„Jumbo“ contact	3A max.
Contact capacitance at 1MHz	2pF max.
Insulation resistance at 500V DC for std & hi-temp	5 × 10 ⁹ Ω min.
Insulation resistance at 500V DC for FR4 Epoxy	> 10 ⁴ MΩ
Breakdown voltage at 60 Hz	500 V AC min.
Contact resistance after 1000 ins./ext. cycles	≤ 7 mΩ

Material (RoHS compliant)

Standard temperature plastic: PBT UL 94 V-0	14, 15, 16, 23, 17, 19, 20, 24 25, 26, 27, 29
High-temp plastic: Nylon, PCT, SPS, PPS, LCP UL 94 V-0	5, 6, 7, 8, 9, 10, 11, 12, 13, 14 15, 16, 21, 22, 20, 25, 26, 27 28, 33, 34, 35, 36, 37, 38, 39 40, 41, 42, 43
Epoxy FR4: UL 94 V-0 & UL 94 V-1	32, 5, 6, 7, 18, 22, 24, 29
PBT, Nylon, PCT, SPS, PPS, LCP & Epoxy FR4	If necessary pls. contact E-tec for Material specification.
Terminal: CuZn	
Contact: BeCu	

Male pin dimensions for standard clip (except „Jumbo Contact“)

(DIN 41 870, IEC 191 for square IC-legs)

DIM	min.	max.
„A“ ∅	0.42 .016"	0.56 .022"
„B“ □	0.36 .014"	0.55 .023"
„C“ □	0.20 .008"	0.30 .014"

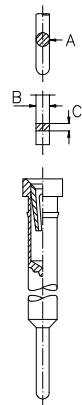

General information concerning the E-tec interconnect products

Plating:

- Standard tin plating:
min. 2.50µm Sn (*leadfree*) over Ni
- Standard gold plating:
flash, max. 0,10µm Au over Ni
- Higher gold platings are offered on request

Specifications:

The data contained in this catalog is of general nature and refers to standard products. For example a „Current rating“ at an ambient temperature of 25° C reflects the value per individual contact. Should you require any further data or test reports, you can obtain this information from your nearest E-tec sales office.

The E-tec connectors conform with signal integrity requirements at high data and frequency rates. However we cannot offer a general information about the max. frequency or data transmission rate. For such a statement, it would require more information about the chosen configuration and pin-out, the length of the cable and/or any other specific requirements regarding the application itself and its related signal integrity.

E-tec SMT connectors, male or female, are offered with a coplanarity of max. 0,10mm. They are adapted to all modern SMT soldering processes and they can be handled easily with all currently existing placing techniques. Customers may choose between various packaging options, such as tray, tube and tape & reel.

GENERAL POLICY

All information contained in this catalog, including illustrations, specifications and dimensions are accurate to the best of our knowledge, and reflect the status as at the date of publication. Due to technical progress, it is subject to change without notice. Application information is informational in nature and shall not be construed to warrant suitability of products for any particular purpose as performance may vary depending on the conditions to which a product is subjected. Unless otherwise confirmed at the time of order, all E-tec products are non cancellable and non returnable items (NCNR). E-tec products are warranted for 30 days and the warranty is limited strictly to replacement of products. This warranty does not cover any claims for natural wear and tear, nor for any compensations, such as loss of production, loss of use, loss of orders, loss of profit, nor any other direct or indirect damages.

Contact your closest office for customized products

Consumer Electronics examples

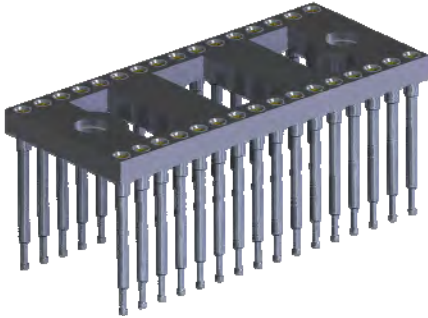

Industrial Electronics examples



Military & Aerospace Electronics examples

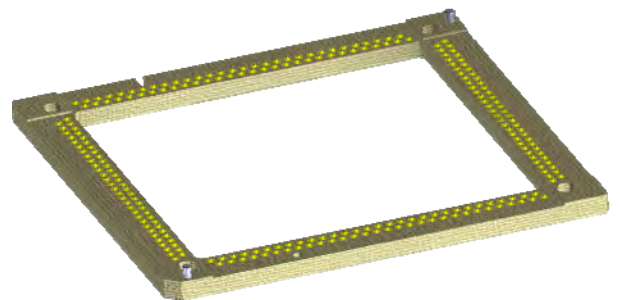
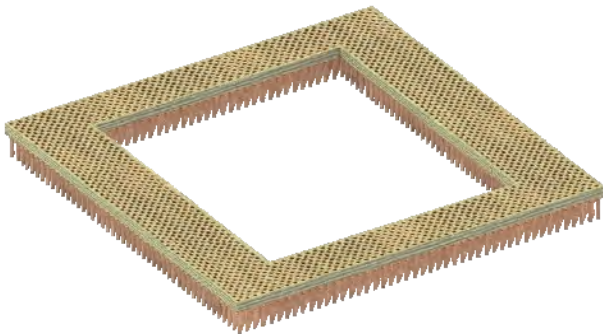

Test- & Measuring Electronics examples

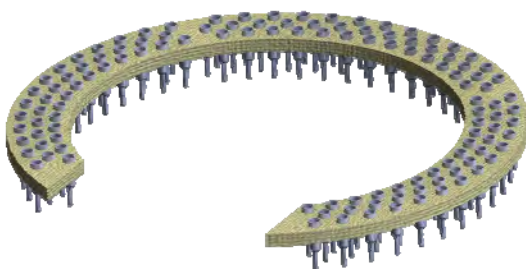

Contact your closest office for customized products

Medical Electronics examples

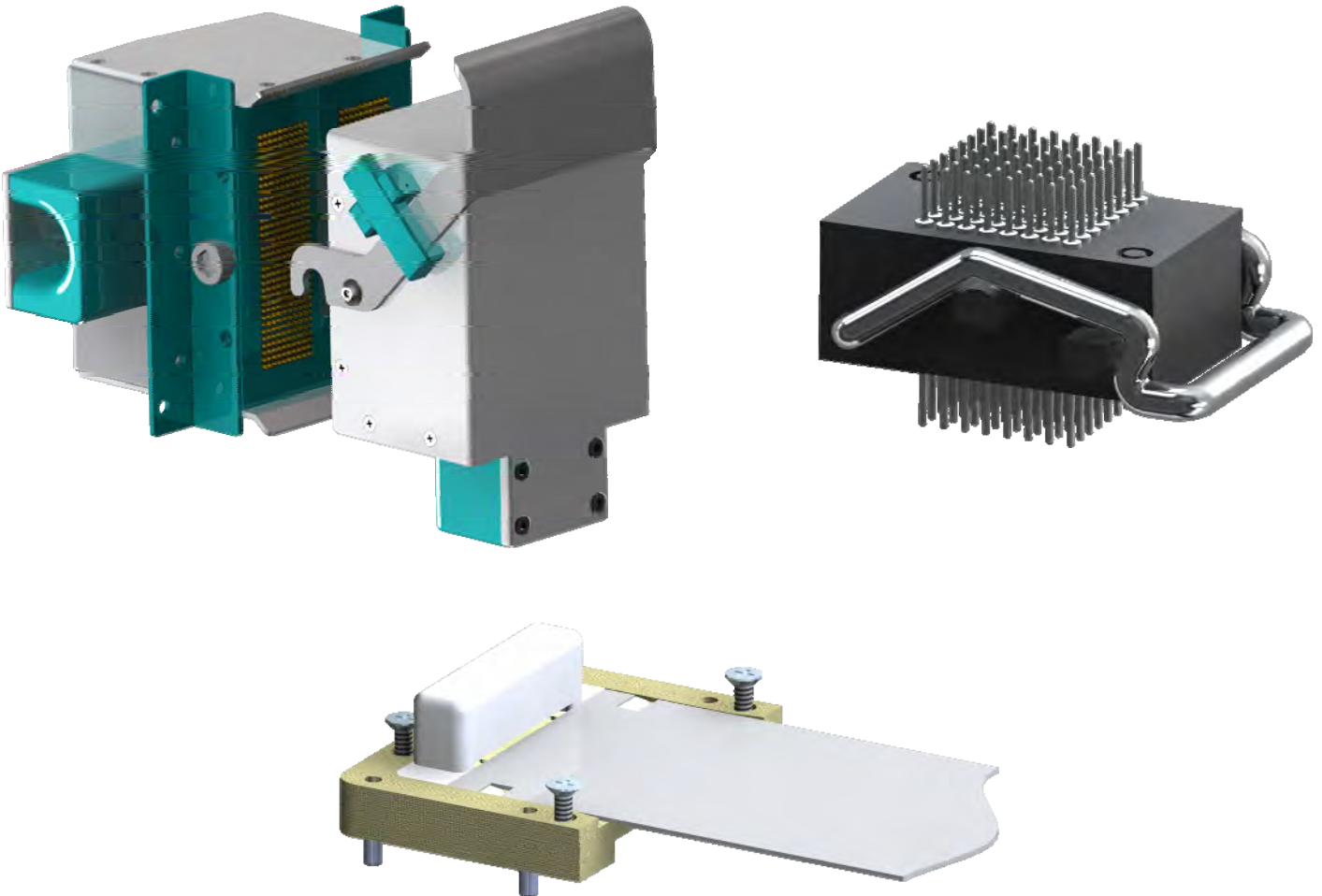

Telecommunication examples

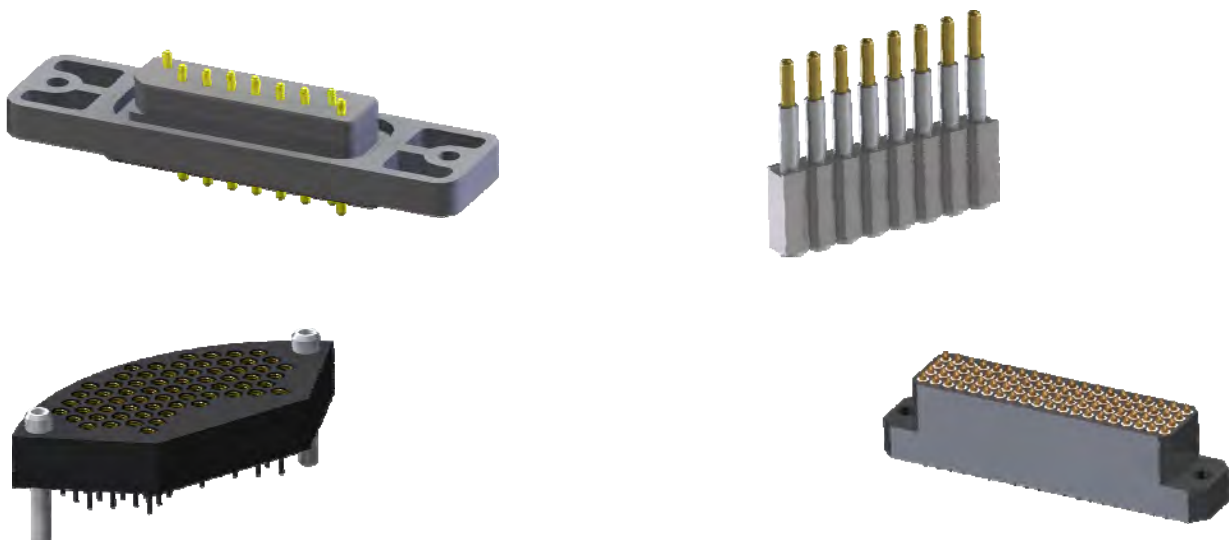

E-tec test sockets are custom made high temperature sockets to test IC packages on a PCB (BGA, LGA, CGA, QFN, GullWing type, etc.).

Generally used for prototyping, pre-production and test & burn-in, the E-tec test sockets allow the customer to insert an IC package into the socket, test it in its original condition and remove it again for final soldering to the PCB after all tests have been completed. The sockets are easily adaptable to customer requirements.

For more information please refer to our Test Socket catalog TS-01

Test Sockets (BGA, LGA, CGA, QFN, GullWing Type) available with a large variety of locking systems

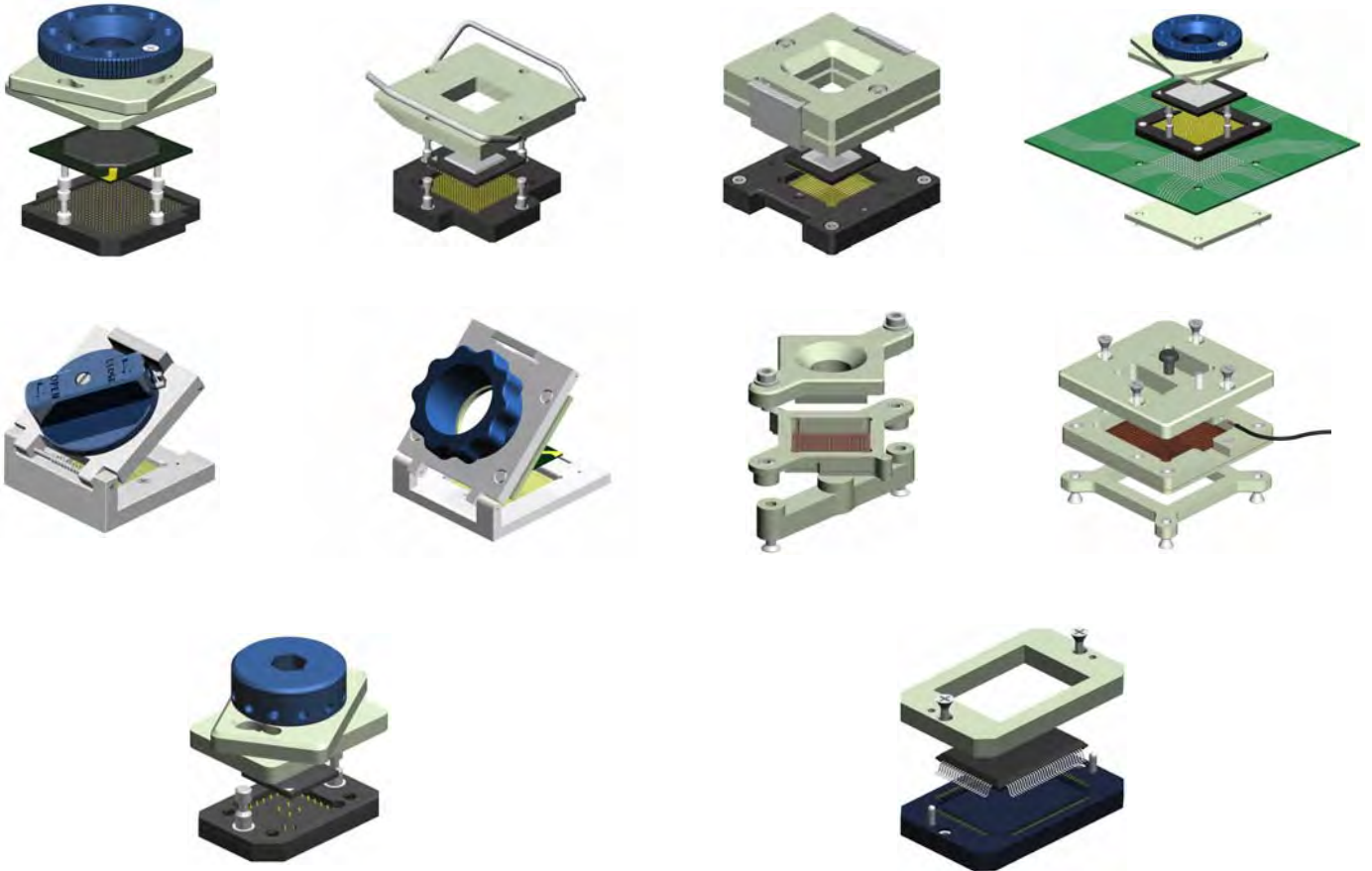

Adapter Solutions

An alternative to direct soldering of test sockets to the PCB.

A light weight SMT adapter is soldered to the PCB first, and then the test socket can be plugged into this adapter and unplugged again.

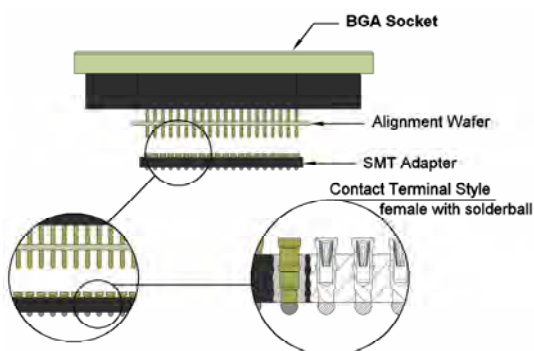

ZIF Test Sockets for Flex Cable

Used for testing components (scanner, membrane switch, etc) which need to be connected via a FFC/FPC cable.

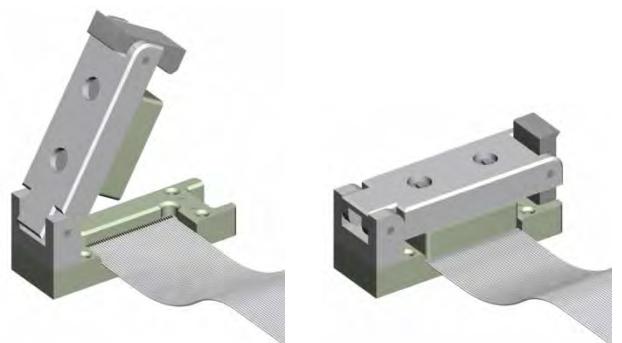

Other products from E-tec

Please contact your closest sales office for further information.



DVI Connectors

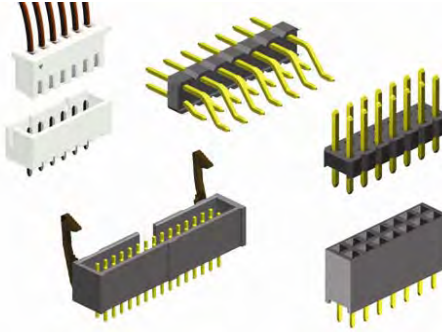

PCB Connectors



DIP Switch



Mini DIN Connectors

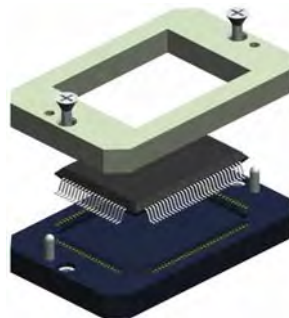

Gullwing Chip Sockets

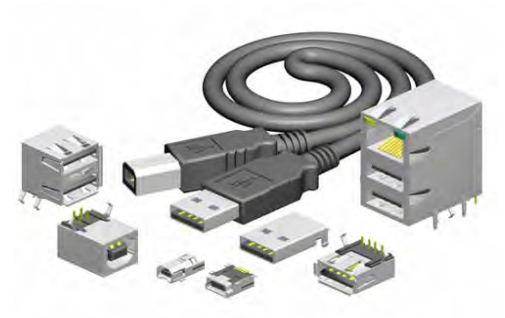

USB & IEEE 1394 Connectors

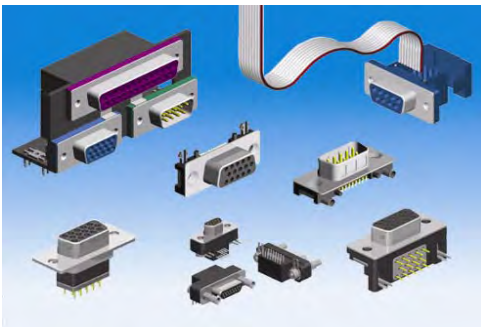

D-Sub Connectors



Flex Cable Connectors



HDMI Connectors

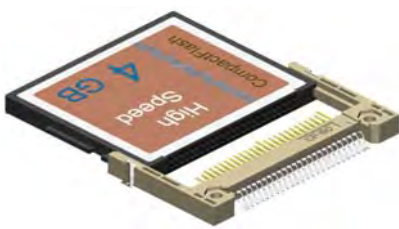

Compact Flash Connector

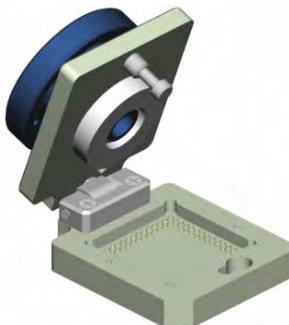

Ball / Land Grid Array Sockets



Multi Media Card Connectors

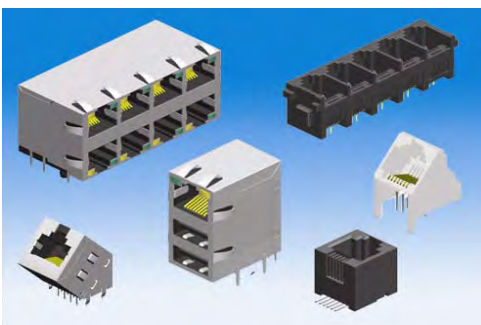

Modular Plugs & Jacks



Phono - & DC - Power Connectors



RF - Connectors

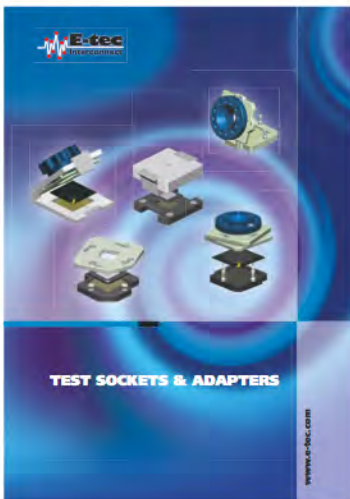
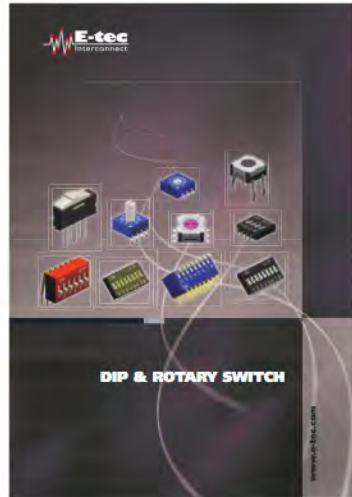

International Sales Headquarters

Switzerland E-tec Interconnect Ltd.
 Schweiz Zone Industrielle C
 Suisse CH-1072 Forel (Lavaux)
 Phone: +41/21/78108 10
 Fax: +41/21/78108 11
 e-mail: info@e-tec.com
 www.e-tec.com

Related Sales Headquarters

Deutschland EMC electro mechanical components
 Germany Vertriebs GmbH
 Allemagne PF. 1160
 D-65501 Idstein
 Phone: +49/6126/9395-0
 Fax: +49/6126/9395-72
 e-mail: info@emc-connectors.com
 www.emc-connectors.com

France Silfox SA
 Frankreich PA des Petits Carreaux
 2 bis avenue des Coquelicots
 F-94385 BONNEUIL
 SUR MARNE CEDEX
 Phone: +33/1/49560468
 Fax: +33/1/49560287
 e-mail: info@silfox.fr
 www.silfox.fr

England E-tec Interconnect (UK) Ltd.
 Angleterre Units A5 & A6 Decimus Park
 Kingstanding Way
 Tunbridge Wells
 Kent TN2 3GP
 Phone: +44/1892/530260
 Fax: +44/1892/515560
 e-mail: info@e-tec.co.uk
 www.e-tec.co.uk

Factories

Switzerland E-tec AG
 Schweiz Friedhofstrasse 1
 Suisse CH-2543 Lengnau b. Biel
 Phone: +41/32/6541550
 Fax: +41/32/6522693
 e-mail: info-ch@e-tec.com
 www.e-tec.com

Taiwan E-tec Interconnect Asia Ltd.
 10F-2, No. 379, Jhongshan Road
 SANCHONG Dist. New Taipei City
 Taiwan R.O.C.
 Phone: +886/2/29992726
 Fax: +886/2/29995255
 e-mail: info@e-tec-asia.com.tw
 www.e-tec-asia.com.tw

YOUR AUTHORISED DISTRIBUTOR
 IHR VERTRAGS-DISTRIBUTOR
 VOTRE DISTRIBUTEUR OFFICIEL



02

LAN Solutions

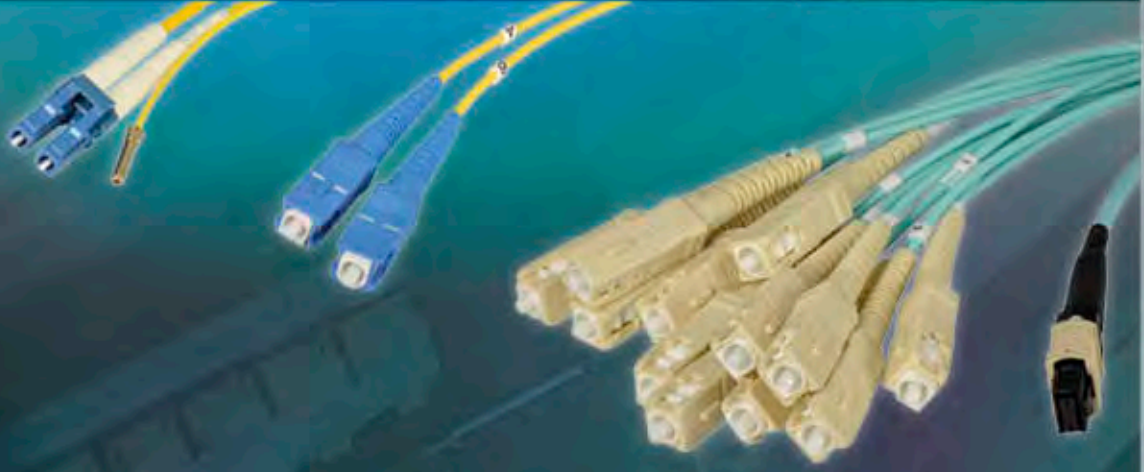

SWISS MANUFACTURING PLANT



HISTORY

- 1973** **E-tec** manufacturing Switzerland was founded as a turned pin manufacturer for the watch and electronics industry.
- 1980** The first private label (OEM) IC socket was produced and the product line was expanded over the following decade to a full range of IC sockets and interconnects products.
- 1984** The facility was purchased, completely renovated and high technology fully automated production equipment was installed for the production of precision interconnection products.
- 1992** The trademark **E-tec** was registered to cover the complete interconnect product range (IC sockets & connectors) and new offices in Switzerland, Germany and France were established.
- 1993** As a world-wide sales & distribution network (**E-tec Asia, UK, and USA** were set-up to promote this new brand name on a world-wide basis) was established to offer fast and efficient service regardless of location. In addition to the interconnection products **E-tec** also supplies high quality screw machine parts as well as customized injection moulded and machined products. Our innovative approach to new product development allows us to offer the service, quality and competitive prices our customers demand.
- 1999** The LAN product line (copper cables, fiber optic cables and LAN accessories) was added to the interconnect product portfolio.
- 2004** **E-tec Interconnect Ltd Switzerland** is ISO 9001:2000 certified
- 2005** The ETEC-LAN was officially allocated to this product line, in order to clearly separate the **E-tec** interconnect product business from the ETEC-LAN cabling business.
- 2006** **E-tec Interconnect Asia Ltd** is ISO 9001:2000 certified
- 2012** **E-tec Interconnect Ltd Switzerland** and **E-tec Interconnect Asia Ltd** are ISO 9001:2008 certified
- 2013** **E-tec Interconnect Ltd** has consolidated the international headquarter and the Swiss factory into one location at Lengnau b. Biel Switzerland and celebrates its 40th anniversary.

Whatever your requirement, be it high volume commodity product or low quantity custom special, **E-tec**, the "**Swiss Connection**" will endeavour to satisfy your requirements.

Please contact our sales office on info@e-tec.com

Company Address:

E-tec Interconnect Ltd, Friedhofstrasse, 1, 2543 Lengnau b. Biel / Switzerland

Tel: +41 (0)32 654 15 50, Fax: +41 (0)32 652 26 93

Visit us online now: www.etec-lan.com

INDEX

Contents	Page No.
FIBER OPTIC	
– Fiber Optic-Patch cords General Information	6 – 10
– FO Reduced Bend Sensitivity (FRB) Patch cords	11
– FO Standard Patch cord Duplex Multimode	12 – 13
– FO Standard Patch cord Duplex Singlemode	14 – 16
– FO Standard Patch cord Simplex Singlemode	17 – 18
– Standard Pigtails Multimode	19
– Standard Pigtails Singlemode	20
– MPO / MIP Fiber Management	21
– MPO / MIP Fan – out Cables	22 – 23
– MPO / MIP Pre – Terminated Trunk Cables	24
– MPO / MIP Standard Patch Panels	25
– MPO / MIP Modular Sliding Patch Module	26 - 27
– Single Loose Tube Fiber Cable (2-24 Fibers)	28
– Tight Buffered Distribution Cable (2-24 Fibers)	29
– Tight Buffered Distribution Cable Multi-Core (36-96 Fibers)	30
– Single Loose Tube steel tape armored (STA) cable	31
– Multi Loose Tube Corrugated steel Tape (CST) cable	32
– Break-Out Fiber cable	33
– Pre-Terminated cable Solutions for Rapid Deployment	34 – 35
– Armored Patch Cords Specifications	36 – 37
– Armored Patch Cords Duplex Multimode	38
– Armored Patch Cords Duplex Singlemode	39 – 40
– Armored Dispatching Cords specifications	41
– Armored Dispatching Cords Multimode	42
– Armored Dispatching Cords Singlemode	43
– Mode Conditioning Patch Cords	44 – 45
TRANSCEIVERS AND ADAPTERS	
– Gigabit Transceivers	46 – 48
– Attenuators for Fiber Optic	49
– Adapters Fiber Optic	50 – 52
– Keystone Jack Adapters	52
PATCH PANELS	
– Sliding Patch Panels Description	53
– Sliding Patch Panels Type 24 Port for FC, ST	54
– Sliding Patch Panels Type 24 Port for E2000, LC, MTRS	55
– Sliding Patch Panels Type 24 Port for SC	56
– Sliding Patch Panels Type 8 Port for LC-Quad of SC Duplex	57
– Sliding Patch Panels Type 12 Port for LC-Quad of SC Duplex	58
– Sliding Patch Panels Type 24 Port for LC-Quad of SC Duplex	59
– Sliding Patch Panels Type 8 Port for E2000, LC, MTRJ, SC	60 – 61
– Sliding Patch Modules Type 3 – Sliding Modules	62
– Sliding Patch Modules Plates	63 – 65
– Universal Dual Plate	66
– Universal Dual Plate accessories	67 – 68
WALL BOXES	
– Lockable Wall Boxes Type 48 Port for FC, ST	69
– Lockable Wall Boxes Type 36 Port LC Quad, SC Duplex	70
– Lockable Wall Boxes Type 24 Port for FC, ST	71
– Lockable Wall Boxes Type 18 Port for E2000 LC, MTRJ of SC	72
– Lockable Wall Boxes Type 12 Port for LC Quad of SC Duplex	73 – 74
– Cable Management Accessories	75 – 77

INDEX

COOPER CABLE and PANELS

– Cable General information	78
– Cat 5e Standard Patch cords	79 – 80
– Cat 5e of Cat 6e Special Patch cords	81
– Cat 6 Standard Patch cords	82 – 85
– Cat 6a Standard Patch cords	84 – 85
– Patch Panels & Accessories	86 – 87

INDEX

Order Code	Description	Page No.
ADC-xx/xx-xx/xx-3xx-xx.xM	Armored Dispatching Cords - Multimode - OM3	42
ADC-xx/xx-xx/xx-4xx-xx.xM	Armored Dispatching Cords - Multimode - OM4	42
ADC-xx/xx-xx/xx-5xx-xx.xM	Armored Dispatching Cords - Multimode - OM2	42
ADC-xx/xx-xx/xx-9xx-xx.xM	Armored Dispatching Cords - Singlemode - OS2 & OS2-APC	43
APC-xx/xx-xx/xx-3xx-xx.xM	Armored Patch Cords - Multimode - OM3	38
APC-xx/xx-xx/xx-4xx-xx.xM	Armored Patch Cords - Multimode - OM4	38
APC-xx/xx-xx/xx-5xx-xx.xM	Armored Patch Cords - Multimode - OM2	38
APC-xx/xx-xx/xx-9xx-xx.xM	Armored Patch Cords - Singlemode - OS2 & OS2-APC	39
BOC-3-xx-xxx.xM	Break-Out Fiber Optic Cable - Multimode - OM3	33
BOC-4-xx-xxx.xM	Break-Out Fiber Optic Cable - Multimode - OM4	33
BOC-5-xx-xxx.xM	Break-Out Fiber Optic Cable - Multimode - OM2	33
BOC-9-xx-xxx.xM	Break-Out Fiber Optic Cable - Singlemode OS2	38
CBL-3-MF/R-xx.xM-xx/xx	Cooper Patch Cords - Cat 5e - Crossed cables - SSTP (shielded)	81
CBL-3-MF-xx.xM-xx/N	Cooper Patch Cords - Cat 5e - Standard - SSTP (shielded)	79
CBL-3-MU/R-xx.xM-xx/xx/N	Cooper Patch Cords - Cat 5e - Crossed cables - UTP (unshielded)	81
CBL-3-MU-xx.xM-xx/N	Cooper Patch Cords - Cat 5e - Standard - UTP (unshielded)	79
CBL-3-MU-xx.xM-xx-2P/N	Cooper Patch Cords - Cat 5e - Special 2-pair style - UTP (unshielded)	81
CBL-6a-MF-xx.xM-xx/LN	Cooper Patch Cords - Cat 6a - Standard - SSTP (shielded) - LSNH	84
CBL-6a-MU-xx.xM-xx/N	Cooper Patch Cords - Cat 6a - Standard - UTP (unshielded)	84
CBL-6-MF-xx.xM-xx/LN	Cooper Patch Cords - Cat 6 - Standard - SSTP (shielded) - LSNH	82
CBL-6-MU/R-xx.xM-xx/xx/N	Cooper Patch Cords - Cat 6 - Crossed cables - UTP (unshielded)	81
CBL-6-MU-xx.xM-xx/N	Cooper Patch Cords - Cat 6 - Standard - UTP (unshielded)	82
CMA-xx-xxxx	Cable Management Accessories	75
CST-3-xx-xxx.xM	Multi Loose Tube CST Fiber Optic Cable - Multimode - OM3	32
CST-4-xx-xxx.xM	Multi Loose Tube CST Fiber Optic Cable - Multimode - OM4	32
CST-5-xx-xxx.xM	Multi Loose Tube CST Fiber Optic Cable - Multimode - OM2	32
CST-9-xx-xxx.xM	Multi Loose Tube CST Fiber Optic Cable - Singlemode OS2	32
FAD-xx/xx-xx/xx-xx-x	Fiber Optic Adapters	50-51 / 52-60 / 67-73
FAD-xx-xx-W	Universal Dual Plate Patch Panels Accessories	67
FAD-xx-xx-x	Keystone Jack Adapters	51
FAT-xx-xx/xx-x	Fiber Optic Attenuators	49
FMC-xx/xx-xx/xx-3x-xx.xM	Mode Conditioning Patch Cords - Multimode - OM3	45
FMC-xx/xx-xx/xx-4x-xx.xM	Mode Conditioning Patch Cords - Multimode - OM4	45
FMC-xx/xx-xx/xx-5x-xx.xM	Mode Conditioning Patch Cords - Multimode - OM2	45
FMF-xx/xx-xx/xx-3y-yy-xxxM	MPO/MTP Fan-out cables Multimode OM3	22
FMF-xx/xx-xx/xx-4y-yy-xxxM	MPO/MTP Fan-out cables Multimode OM4	22
FMF-xx/xx-xx/xx-5y-yy-xxxM	MPO/MTP Fan-out cables Multimode OM2	22
FMF-xx/xx-xx/xx-9y-yy-xxxM	MPO/MTP Fan-out cables Singlemode OS2 & OS2-APC	22
FMP-xx/xx-xx/xx-3-yyy-x-xxxM	MPO/MTP Pre-terminated Trunk cables Multimode OM3	24
FMP-xx/xx-xx/xx-4-yyy-x-xxxM	MPO/MTP Pre-terminated Trunk cables Multimode OM4	24
FMP-xx/xx-xx/xx-5-yyy-x-xxxM	MPO/MTP Pre-terminated Trunk cables Multimode OM2	24
FMP-xx/xx-xx/xx-9-yyy-x-xxxM	MPO/MTP Pre-terminated Trunk cables Singlemode OS2 & OS2-APC	24
FPC -xx/xx-xx/xx-9xS-xx.xM	Standard Fiber Patch Cords Simplex Singlemode OS2 & OS2 APC	17

INDEX

Order Code	Description	Page No.
FPC-xx/xx-xx/xx-3xx-xx.xM	Standard Fiber Patch Cords Duplex Multimode OM3	12
FPC-xx/xx-xx/xx-4xx-xx.xM	Standard Fiber Patch Cords Duplex Multimode OM4	12
FPC-xx/xx-xx/xx-5xx-xx.xM	Standard Fiber Patch Cords Duplex Multimode OM2	12
FPC-xx/xx-xx/xx-9xx-xx.xM	Standard Fiber Patch Cords Duplex Singlemode OS2 & OS2 APC	14
FPT-xx/xx-3MS-xx.xM	Pigtail Multimode OM3	19
FPT-xx/xx-4MS-xx.xM	Pigtail Multimode OM4	19
FPT-xx/xx-5MS-xx.xM	Pigtail Multimode OM2	19
FPT-xx/xx-9SS-xx.xM	Pigtail Singlemode OS2 & OS2-APC	20
FRB-xx/xx-xx/xx-3xx-xx.xM	Reduced Bend Sensitivity Fiber Patch Cords Duplex Multimode OM3	11
FRB-xx/xx-xx/xx-4xx-xx.xM	Reduced Bend Sensitivity Fiber Patch Cords Duplex Multimode OM4	11
FRB-xx/xx-xx/xx-5xx-xx.xM	Reduced Bend Sensitivity Fiber Patch Cords Duplex Multimode OM2	11
FRB-xx/xx-xx/xx-9xS-xx.xM	Reduced Bend Sensitivity Fiber Patch Cords Simplex Singlemode OS2+OS2 APC	17
FRB-xx/xx-xx/xx-9xx-xx.xM	Reduced Bend Sensitivity Fiber Patch Cords Duplex Singlemode OS2+OS2 APC	14
GBIC-GLC-xx-xx-xxx	GBIC Transceivers	46
ILC-x-U-KT-S-B	Patch Panels Copper Accessories - In-line coupler	87
KSJ-x-x-x-D-1-x	Patch Panels Copper Accessories - Keystone Jacks	87
LWB-12-S-xx/xx-xx-ME-xx-G	Lockable Wall Boxes - LC Quad & SC Duplex - Single door style - 12 ports	73
LWB-18-S-xx/xx-xx-ME-xx-G	Lockable Wall Boxes - E2000 - LC - MTRJ - SC - Single door style - 18 ports	72
LWB-24-S-xx/xx-xx-ME-xx-G	Lockable Wall Boxes - FC - ST - Single door style - 24 ports	71
LWB-36-D-xx/xx-xx-ME-xx-G	Lockable Wall Boxes - LC Quad & SC Duplex - Double door style - 36 ports	70
LWB-48-D-xx/xx-xx-ME-xx-G	Lockable Wall Boxes - FC - ST - Double door style - 48 ports	69
MPM-xx-xx-xx/xx-3	MPO/MTP Sliding Patch Modules - Multimode - OM3	27
MPM-xx-xx-xx/xx-4	MPO/MTP Sliding Patch Modules - Multimode - OM4	27
MPM-xx-xx-xx/xx-4	MPO/MTP Sliding Patch Modules - Singlemode - OS2 & OS2-APC	27
MPM-xx-xx-xx/xx-5	MPO/MTP Sliding Patch Modules - Multimode - OM2	27
MPP-xx-x-xx/x-xx	Module Patch Plate for Sliding Patch Panels	63
PLH-x-U-xx-D-0-0-M	Patch Panels Copper - Horizontal dual-type jacks - unshielded type	86
PLK-D-xx-1U-x-M	Universal Dual Plate Patch Panels - Fiber Optic & Cooper	66 / 86
PLV-x-F-xx-D-0-1	Patch Panels Copper - Vertical dual-type jacks - shielded type	86
SLT-3-xx-xxx.xM	Single Loose Tube Fiber Optic Cable (2-24 Fibers) - Multimode - OM3	28
SLT-4-xx-xxx.xM	Single Loose Tube Fiber Optic Cable (2-24 Fibers) - Multimode - OM4	28
SLT-5-xx-xxx.xM	Single Loose Tube Fiber Optic Cable (2-24 Fibers) - Multimode - OM2	28
SLT-9-xx-xxx.xM	Single Loose Tube Fiber Optic Cable (2-24 Fibers) - Singlemode OS2	28
SPM-3-x-ALL-ME-B	MPO/MTP Modular Sliding Module & 3 - Sliding Patch Panels Modules	25 / 62
SPP-08-A-xx/xx-xx-ME-xx-B	Sliding Patch Panels - E2000 - LC - MTRJ - SC - Angled Adapter Position - 8 ports	60
SPP-08-H-xx/xx-xx-ME-xx-B	Sliding Patch Panels-LC Quad & SC Duplex-Horizontal Adapter Position - 8 ports	57
SPP-12-V-xx/xx-xx-ME-xx-B	Sliding Patch Panels-LC Quad & SC Duplex - Vertical Adapter Position - 12 ports	58
SPP-24-N-FC/ST-ME-B	MPO/MTP Standard Patch Panel FC & ST adapter - 24 ports	25
SPP-24-N-xx/xx-xx-ME-xx-B	Sliding Patch Panels - FC - ST - Central Adapter Position - 24 ports	54
SPP-24-V-E2/LC/MT/SC-ME-B	MPO/MTP Standard Patch Panel E2000/LC/MT/SC adapter - 24 ports	25
SPP-24-V-SC/xx-xx-ME-xx-B	Sliding Patch Panels - SC - Vertical Adapter Position - 24 ports	56
SPP-24-V-xx/xx-xx-ME-xx-B	Sliding Patch Panels - E2000 - LC - MTRJ - Vertical Adapter Position - 24 ports	55
SPP-24-V-xx/xx-xx-ME-xx-B	Sliding Patch Panels - LC Quad & SC Duplex - Vertical Adapter Position - 24 ports	59

INDEX

Order Code	Description	Page No.
STA-3-xx-xxx.xM	Single Loose Tube STA Fiber Optic Cable - Multimode - OM3	31
STA-4-xx-xxx.xM	Single Loose Tube STA Fiber Optic Cable - Multimode - OM4	31
STA-5-xx-xxx.xM	Single Loose Tube STA Fiber Optic Cable - Multimode - OM2	31
STA-9-xx-xxx.xM	Single Loose Tube STA Fiber Optic Cable - Singlemode OS2	31
TBC-3-xx-xxx.xM	Tight Buffered Distribution Cable (2-24 Fibers) - Multimode - OM3	29
TBC-3-xx-xxx.xM	Tight Buffered Distribution Cable (36 - 96 Fibers) - Multimode - OM3	30
TBC-4-xx-xxx.xM	Tight Buffered Distribution Cable (2-24 Fibers) - Multimode - OM4	29
TBC-4-xx-xxx.xM	Tight Buffered Distribution Cable (36 - 96 Fibers) - Multimode - OM4	30
TBC-5-xx-xxx.xM	Tight Buffered Distribution Cable (2-24 Fibers) - Multimode - OM2	29
TBC-5-xx-xxx.xM	Tight Buffered Distribution Cable (36 - 96 Fibbers) - Multimode - OM2	30
TBC-9-xx-xxx.xM	Tight Buffered Distribution Cable (2-24 Fibers) - Singlemode - OS2	29
TBC-9-xx-xxx.xM	Tight Buffered Distribution Cable (36 - 96 Fibers) - Singlemode - OS2	30
xx/x-xxx-3xxx-xxx.xM-x-xx/x	Pre-Terminated Cable Solution - Multimode - OM3	34
xx/x-xxx-4xxx-xxx.xM-x-xx/x	Pre-Terminated Cable Solution - Multimode - OM4	34
xx/x-xxx-5xxx-xxx.xM-x-xx/x	Pre-Terminated Cable Solution - Multimode - OM2	34
xx/x-xxx-9xxx-xxx.xM-x-xx/x	Pre-Terminated Cable Solution - Singlemode - OS2	34

FIBER OPTIC GENERAL INFORMATION

Fiber optic connectors

The fiber optic connectors are precision made and produced to very high quality standards. The alignment of the fiber inside the connector is a crucial point in the production process in order to ensure low light loss between the mating connectors. Besides, the ferrule needs to be highly polished also.

The body of the connector will lock the ferrule into an adapter and the ferrule is generally manufactured from ceramic, with the exception of the MTRJ and MPO connectors, which use a polymer ferrule instead.

The connectors are designed for fibers in multimode (enhanced 50/125 μ m or 50/125 μ m) and singlemode (9/125 μ m fiber) versions, which are generally delivered in 900 μ m (pigtailed) and 1.80mm, 2mm or 3mm patch cables.

The first designs of fiber optic connectors (ST, FC) were produced with nickel plated brass bodies but the more recent generation connectors are plastic injection molded designs (SC, LC, MU, MTRJ, E2000).

Fiber optic cable assemblies

Fiber optic cable assemblies consist of a fiber optic cable which is mounted with a connector (on one or both ends). The critical part of the cable assembly is the manufacturing process and this will define the final quality of the cable assembly. The performance can be enhanced by the choice of the cable and the connector style, but the actual manufacturing process is key to a high quality product and which will avoid high insertion & low return losses in a fiber optic network.

Fiber optic adapters

Fiber optic patch cables are connected between each other with a fiber optic adapter and which is generally mounted in a wall box or a panel. This adapter will ensure correct alignment of the ferrules between each other. With the exception of the MTRJ connectors, the adapters generally contain two types of alignment sleeves, which come either in phosphor bronze (for general purpose application) or in ceramic (generally for singlemode only). For the MTRJ, the alignment feature is made with two alignment pins seated inside the connector itself and the adapter only supports and locks the connectors together.

FIBER OPTIC PATCH CABLE ASSEMBLIES

Specifications for Standard Patch Cords



Diagram and Cross Section of Cable

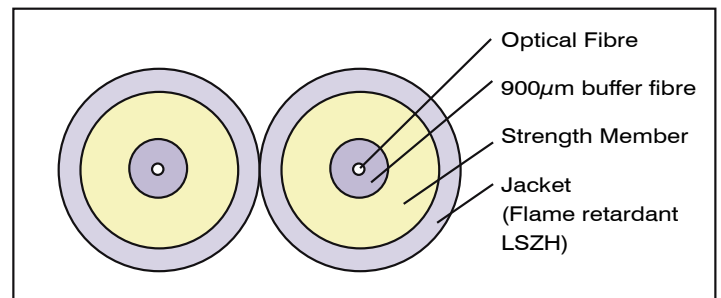
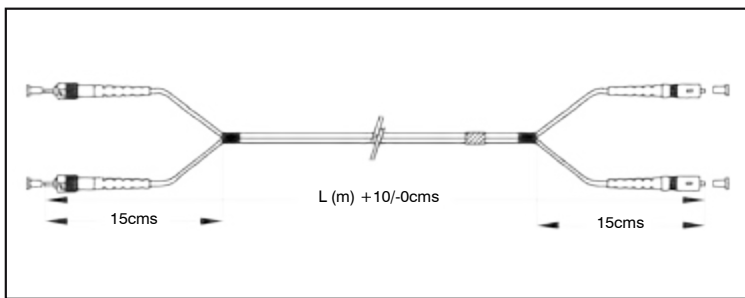

General specifications

- Mating durability: min. 500 cycles
- Operating temperature: -40°C to +70°C
- LSZH cable jacket
- RoHS compliant
- Cable diameters available in 1.80mm (for MTRJ), 2mm (standard for others) and 3mm (option)
- Individual Lot numbers & Test Results delivered per cable
- Cable length tolerances:

less than 0.5 meter	=	+/- 10cm
between 0.5 meter and 5 meter	=	+/- 15cm
over 5 meters	=	+/- 20cm

Specifications for singlemode patch cords (OS2 & OS2-APC style)

- Fiber terminations:

PC = ultra polished style
APC = (angled polished style)
- Connector styles:

PC: available in E2000, FC, LC, MTRJ, MU, SC, ST
APC: available in E2000, FC, LC, SC
- Insertion Loss: 0.3dB max. , for MTRJ: 0.5dB max.
- Return Loss: 50dB min. for PC / 60dB min. for APC
- Standard color: Yellow (others on request)

Specifications for multimode patch cords (OM2, OM3, OM4)

- Fiber types:

OM2 = 50/125µm / OM3 = 50/125µm
OM4 = enhanced 50/125µm (550m/10GbE)
- Fiber termination: PC = ultra polished style
- Connector styles: available in E2000, FC, LC, MTRJ, MU, SC, ST
- Insertion Loss: 0.3dB max.
- Standard colors:

OM2 = orange
OM3 = aqua blue OM4 = magenta
Other colors (on request)

Standard Patch Cords (FPC)

Fiber optic patch cords need to be produced to the highest quality standards in order to guarantee a perfect network performance, which depends on the following three factors:

1. Connector type
2. Cable quality
3. Manufacturing quality

E-tec Interconnect Ltd only chooses the highest quality connector and cable types. Besides we have a very long term experience in manufacturing high quality fiber optic cable assemblies and which are only released after severe final QA control procedures. Each cable is delivered with an individual lot number and the final test result is printed on a sticker which is added on each individual plastic bag.

E-tec Interconnect Ltd offers a full product range adapted to any fiber optic network system, offering cable assemblies including all industry standard connector versions (FC, ST, SC, LC, E2000, MTRJ, MU) and all fiber styles (multimode and singlemode) in simplex and duplex versions.

Please contact E-tec Interconnect Ltd for any fiber optic cable requirement. We will be able to offer a solution to all your requirements.

Reduced Bend Sensitivity (FRB) patch cords and pigtails

FRB patch cords and pigtails are available for multimode (OM3 and OM4) and singlemode (OS2/G.657A1 and G.657A2) based on reduced bend sensitivity fiber cable.

FRB patch cords exhibit much lower optical power loss under bend conditions while remaining compatible with conventional cabling and are made with solid trench assisted optical fiber that is designed to reduce optical loss when the cable is bent.

They provide the same high quality, mechanical features and optical performance as our standard patch cords with the added capability of maintaining optical performance when bent or flexed.

Applications

FRB patch cords and pigtails are used in applications for which low loss in tight radius routing is important:

- When routing cable around corners and in tight spaces is required, for example in FTTH (Fiber to the Home) installations in existing buildings.
- FTTH cabling in Point of Presences, Main Distribution points and subscriber connections.
- Data Centers where network up time is critical. For example, OM4 FRB patch cords will continue to provide data service when pinched by a cabinet door, whereas service would be lost with conventional OM4 patch cords.
- When small radius installation is needed or the cabling may be subject to occasional small radius events.

Specification

General mechanical and optical specifications of FRB patch cords are as per corresponding standard products including IEC and TIA/EIA standards conformance.

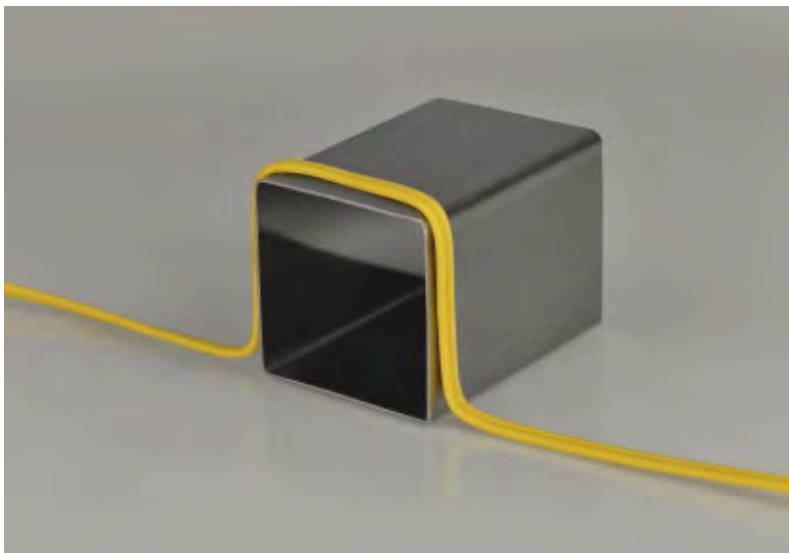

Tight Radius Routing

FIBER OPTIC CABLE ASSEMBLIES

Specifications for FRB singlemode patch cords (OS2 / ITU-T G657A1 and G657A2)

G657A1 Bend performance

- Guideline radius: 15mm radius
- Loss at 1550nm: 15mm radius < 0.25 dB
10mm radius < 0.75 dB

G657A2 Bend performance

- Guideline radius: 7.5mm radius
- Loss at 1550nm: 15mm radius < 0.03 dB
10mm radius < 0.01 dB
7.5mm radius < 0.5 dB

Specifications for multimode patch cords (OM3 and OM4)

OM3 Bend performance

- Guideline radius: 10mm radius
- Loss at 850nm: 15mm radius < 0.1 dB
- Loss at 1300nm: 15mm radius < 0.3 dB

OM4 Bend performance

- Guideline radius: 10mm radius
- Loss at 850nm: 7.5mm radius < 0.2 dB
- Loss at 1300nm: 7.5mm radius < 0.4 dB

Reduced Bend Sensitivity (FRB) Patch Cords

OPTIONS

Cable length:	Replace "xx.x" by cable length in meter (example: 07.0 = 7 meter cable)
Standard cable lengths:	1, 2, 3, 5 & 10 meters (others on demand)
Cable diameter:	standard = 2.00mm (1.80mm for MTRJ) 3.00mm = on request
Color:	OS2 = Yellow (standard) OM2 = Orange (standard) OM3 = Aqua Blue (standard) OM4 = Magenta (standard) Other colors = on request

ORDERING CODE STRUCTURE

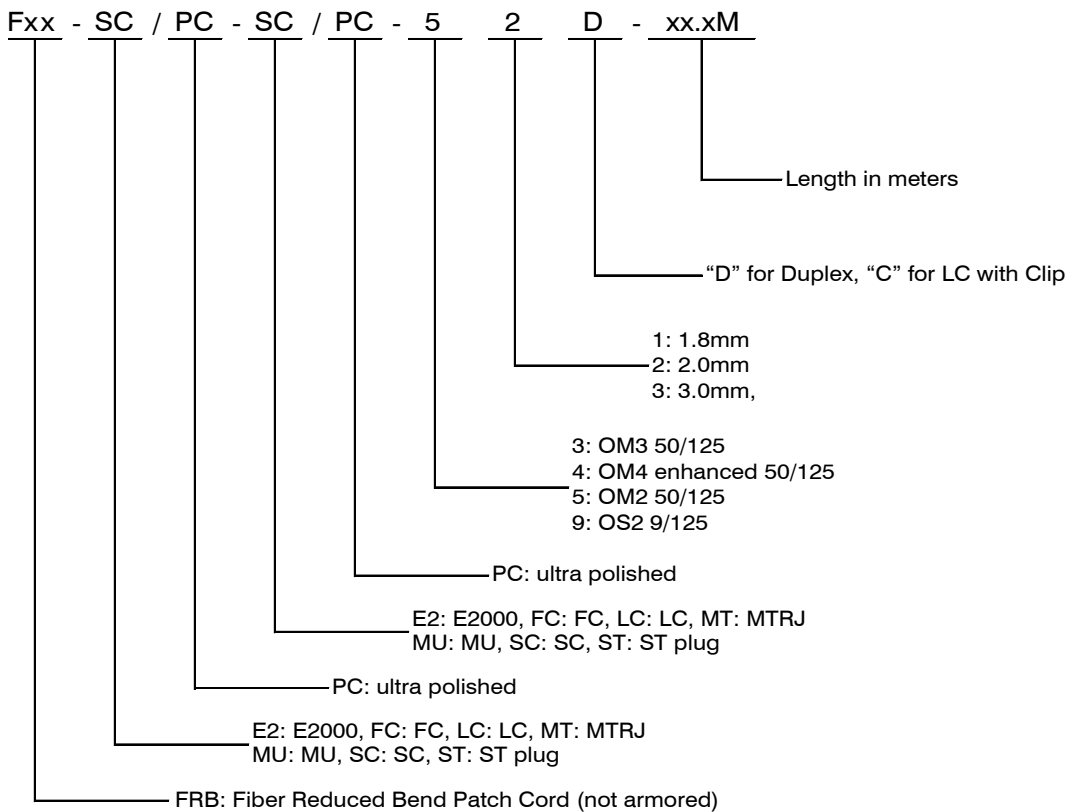

FIBER OPTIC PATCH CABLE ASSEMBLIES

Standard Patch Cords

Duplex Multimode

		OM2 50/125µm orange color	OM3 50/125µm/300m(10GbE) aqua blue color	OM4 enhanced 50/125µm/550m(10GbE) magenta color	
E2000/E2000 	OM2	Fxx-E2/PC-E2/PC-52D-xx.xM	LC/MTRJ 	OM2	Fxx-LC/PC-MT/PC-51C-xx.xM
	OM3	Fxx-E2/PC-E2/PC-32D-xx.xM		OM3	Fxx-LC/PC-MT/PC-31C-xx.xM
	OM4	Fxx-E2/PC-E2/PC-42D-xx.xM		OM4	Fxx-LC/PC-MT/PC-41C-xx.xM
E2000/FC 	OM2	Fxx-E2/PC-FC/PC-52D-xx.xM	LC/SC 	OM2	Fxx-LC/PC-SC/PC-52C-xx.xM
	OM3	Fxx-E2/PC-FC/PC-32D-xx.xM		OM3	Fxx-LC/PC-SC/PC-32C-xx.xM
	OM4	Fxx-E2/PC-FC/PC-42D-xx.xM		OM4	Fxx-LC/PC-SC/PC-42C-xx.xM
E2000/LC 	OM2	Fxx-E2/PC-LC/PC-52C-xx.xM	LC/ST 	OM2	Fxx-LC/PC-ST/PC-52C-xx.xM
	OM3	Fxx-E2/PC-LC/PC-32C-xx.xM		OM3	Fxx-LC/PC-ST/PC-32C-xx.xM
	OM4	Fxx-E2/PC-LC/PC-42C-xx.xM		OM4	Fxx-LC/PC-ST/PC-42C-xx.xM
E2000/MTRJ 	OM2	Fxx-E2/PC-MT/PC-51D-xx.xM	MPO/SC 	OM2	Fxx-MF/PC-SC/PC-52D-xx.xM
	OM3	Fxx-E2/PC-MT/PC-31D-xx.xM		OM3	Fxx-MF/PC-SC/PC-32D-xx.xM
	OM4	Fxx-E2/PC-MT/PC-41D-xx.xM		OM4	Fxx-MF/PC-SC/PC-42D-xx.xM
E2000/SC 	OM2	Fxx-E2/PC-SC/PC-52D-xx.xM	MPO/ST 	OM2	Fxx-MF/PC-ST/PC-52D-xx.xM
	OM3	Fxx-E2/PC-SC/PC-32D-xx.xM		OM3	Fxx-MF/PC-ST/PC-32D-xx.xM
	OM4	Fxx-E2/PC-SC/PC-42D-xx.xM		OM4	Fxx-MF/PC-ST/PC-42D-xx.xM
E2000/ST 	OM2	Fxx-E2/PC-ST/PC-52D-xx.xM	MTRJ/MTRJ 	OM2	Fxx-MT/PC-MT/PC-51D-xx.xM
	OM3	Fxx-E2/PC-ST/PC-32D-xx.xM		OM3	Fxx-MT/PC-MT/PC-31D-xx.xM
	OM4	Fxx-E2/PC-ST/PC-42D-xx.xM		OM4	Fxx-MT/PC-MT/PC-41D-xx.xM
FC/FC 	OM2	Fxx-FC/PC-FC/PC-52D-xx.xM	MTRJ/SC 	OM2	Fxx-MT/PC-SC/PC-51D-xx.xM
	OM3	Fxx-FC/PC-FC/PC-32D-xx.xM		OM3	Fxx-MT/PC-SC/PC-31D-xx.xM
	OM4	Fxx-FC/PC-FC/PC-42D-xx.xM		OM4	Fxx-MT/PC-SC/PC-41D-xx.xM
FC/LC 	OM2	Fxx-FC/PC-LC/PC-52C-xx.xM	MTRJ/ST 	OM2	Fxx-MT/PC-ST/PC-51D-xx.xM
	OM3	Fxx-FC/PC-LC/PC-32C-xx.xM		OM3	Fxx-MT/PC-ST/PC-31D-xx.xM
	OM4	Fxx-FC/PC-LC/PC-42C-xx.xM		OM4	Fxx-MT/PC-ST/PC-41D-xx.xM
FC/MTRJ 	OM2	Fxx-FC/PC-MT/PC-51D-xx.xM	SC/SC 	OM2	Fxx-SC/PC-SC/PC-52D-xx.xM
	OM3	Fxx-FC/PC-MT/PC-31D-xx.xM		OM3	Fxx-SC/PC-SC/PC-32D-xx.xM
	OM4	Fxx-FC/PC-MT/PC-41D-xx.xM		OM4	Fxx-SC/PC-SC/PC-42D-xx.xM
FC/SC 	OM2	Fxx-FC/PC-SC/PC-52D-xx.xM	SC/ST 	OM2	Fxx-SC/PC-ST/PC-52D-xx.xM
	OM3	Fxx-FC/PC-SC/PC-32D-xx.xM		OM3	Fxx-SC/PC-ST/PC-32D-xx.xM
	OM4	Fxx-FC/PC-SC/PC-42D-xx.xM		OM4	Fxx-SC/PC-ST/PC-42D-xx.xM
LC/LC 	OM2	Fxx-LC/PC-LC/PC-52C-xx.xM	ST/ST 	OM2	Fxx-ST/PC-ST/PC-52D-xx.xM
	OM3	Fxx-LC/PC-LC/PC-32C-xx.xM		OM3	Fxx-ST/PC-ST/PC-32D-xx.xM
	OM4	Fxx-LC/PC-LC/PC-42C-xx.xM		OM4	Fxx-ST/PC-ST/PC-42D-xx.xM
LC/MPO 	OM2	Fxx-LC/PC-MF/PC-52C-xx.xM			
	OM3	Fxx-LC/PC-MF/PC-32C-xx.xM			
	OM4	Fxx-LC/PC-MF/PC-42C-xx.xM			

Replace "xx.x" by length in "meters"

FIBER OPTIC PATCH CABLE ASSEMBLIES

Standard Patch Cords

Duplex Multimode

OPTIONS





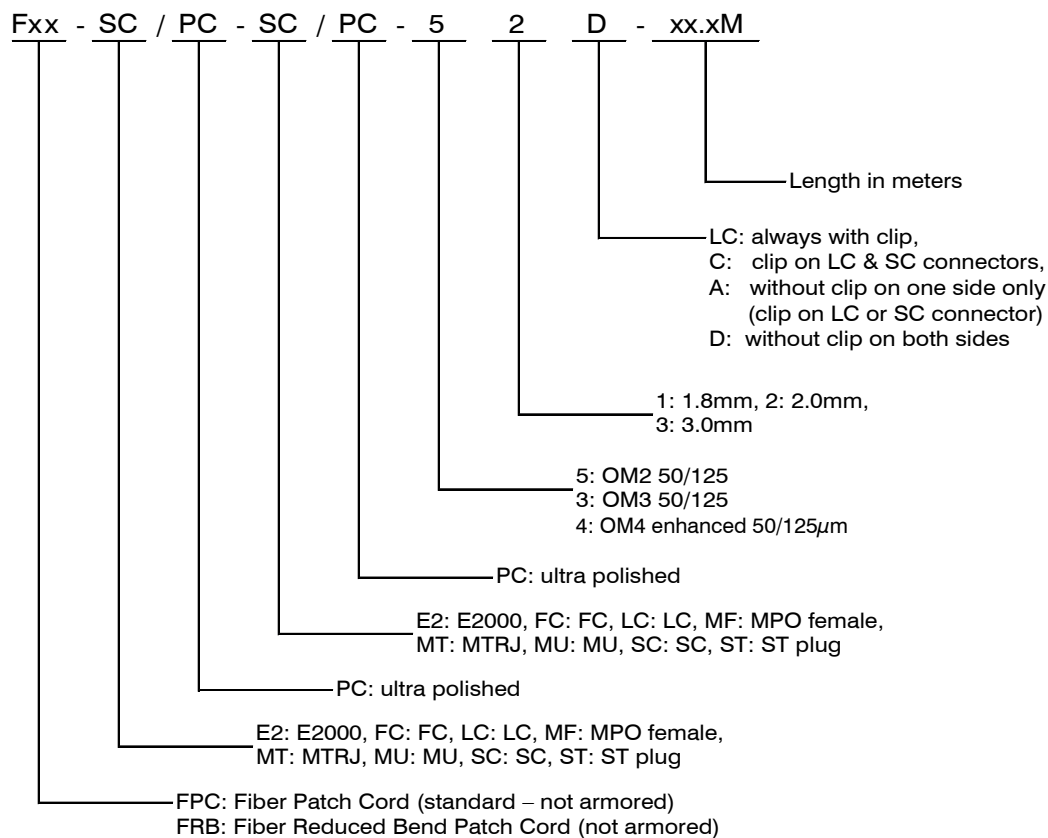













Cable length:	Replace "xx.x" by cable length in meter (example: 07.0 = 7 meter cable)
Standard cable lengths:	1, 2, 3, 5 & 10 meters (others on demand)
Cable diameter:	standard = 2.00mm (1.80mm for MTRJ) 3.00mm = on request
Color:	OM2 = Orange (standard) OM3 = Aqua Blue (standard) OM4 = Magenta (standard) Other colors = on request

ORDERING CODE STRUCTURE



FIBER OPTIC PATCH CABLE ASSEMBLIES









Standard Patch Cords Duplex Singlemode

		OS2 9/125 μ m (PC/PC) Yellow color	OS2-APC 9/125 μ m (APC/APC) Yellow color		Mixed: OS2-APC & OS2 9/125 μ m (APC/PC) Yellow color
E2000/E2000 	OS2	Fxx-E2/PC-E2/PC-92D-xx.xM	FC/MTRJ 	OS2	Fxx-FC/PC-MT/PC-91D-xx.xM
	OS2-APC	Fxx-E2/AP-E2/AP-92D-xx.xM		OS2-APC	
	Mixed	Fxx-E2/AP-E2/PC-92D-xx.xM		Mixed	Fxx-FC/AP-MT/PC-91D-xx.xM
E2000/FC 	OS2	Fxx-E2/PC-FC/PC-92D-xx.xM	FC/MU 	OS2	Fxx-FC/PC-MU/PC-92D-xx.xM
	OS2-APC	Fxx-E2/AP-FC/AP-92D-xx.xM		OS2-APC	
	Mixed	Fxx-E2/AP-FC/PC-92D-xx.xM Fxx-E2/PC-FC/AP-92D-xx.xM		Mixed	Fxx-FC/AP-MU/PC-92D-xx.xM
E2000/LC 	OS2	Fxx-E2/PC-LC/PC-92C-xx.xM	FC/SC 	OS2	Fxx-FC/PC-SC/PC-92D-xx.xM
	OS2-APC	Fxx-E2/AP-LC/AP-92C-xx.xM		OS2-APC	Fxx-FC/AP-SC/AP-92D-xx.xM
	Mixed	Fxx-E2/AP-LC/PC-92C-xx.xM Fxx-E2/PC-LC/AP-92C-xx.xM		Mixed	Fxx-FC/AP-SC/PC-92D-xx.xM Fxx-FC/PC-SC/AP-92D-xx.xM
E2000/MTRJ 	OS2	Fxx-E2/PC-MT/PC-91D-xx.xM	LC/LC 	OS2	Fxx-LC/PC-LC/PC-92C-xx.xM
	OS2-APC			OS2-APC	Fxx-LC/AP-LC/AP-92C-xx.xM
	Mixed	Fxx-E2/AP-MT/PC-91D-xx.xM		Mixed	Fxx-LC/AP-LC/PC-92C-xx.xM
E2000/SC 	OS2	Fxx-E2/PC-SC/PC-92D-xx.xM	LC/MPO 	OS2	Fxx-LC/PC-MF/PC-92C-xx.xM
	OS2-APC	Fxx-E2/AP-SC/AP-92D-xx.xM		OS2-APC	Fxx-LC/AP-MF/AP-92C-xx.xM
	Mixed	Fxx-E2/AP-SC/PC-92D-xx.xM Fxx-E2/PC-SC/AP-92D-xx.xM		Mixed	Fxx-LC/AP-MF/PC-92C-xx.xM Fxx-LC/PC-MF/AP-92C-xx.xM
E2000/ST 	OS2	Fxx-E2/PC-ST/PC-92D-xx.xM	LC/MTRJ 	OS2	Fxx-LC/PC-MT/PC-91C-xx.xM
	OS2-APC			OS2-APC	
	Mixed	Fxx-E2/AP-ST/PC-92D-xx.xM		Mixed	Fxx-LC/AP-MT/PC-91C-xx.xM
FC/FC 	OS2	Fxx-FC/PC-FC/PC-92D-xx.xM	LC/MU 	OS2	Fxx-LC/PC-MU/PC-92C-xx.xM
	OS2-APC	Fxx-FC/AP-FC/AP-92D-xx.xM		OS2-APC	
	Mixed	Fxx-FC/AP-FC/PC-92D-xx.xM		Mixed	Fxx-LC/AP-MU/PC-92C-xx.xM
FC/LC 	OS2	Fxx-FC/PC-LC/PC-92C-xx.xM	LC/SC 	OS2	Fxx-LC/PC-SC/PC-92C-xx.xM
	OS2-APC	Fxx-FC/AP-LC/AP-92C-xx.xM		OS2-APC	Fxx-LC/AP-SC/AP-92C-xx.xM
	Mixed	Fxx-FC/AP-LC/PC-92C-xx.xM Fxx-FC/PC-LC/AP-92C-xx.xM		Mixed	Fxx-LC/AP-SC/PC-92C-xx.xM Fxx-LC/PC-SC/AP-92C-xx.xM
FC/MPO 	OS2	Fxx-FC/PC-MF/PC-92D-xx.xM	LC/ST 	OS2	Fxx-LC/PC-ST/PC-92C-xx.xM
	OS2-APC	Fxx-FC/AP-MF/AP-92D-xx.xM		OS2-APC	
	Mixed	Fxx-FC/AP-MF/PC-92D-xx.xM Fxx-FC/PC-MF/AP-92D-xx.xM		Mixed	Fxx-LC/AP-ST/PC-92C-xx.xM

Replace "xx.x" by length in "meters"

FIBER OPTIC PATCH CABLE ASSEMBLIES

Standard Patch Cords Duplex Singlemode

		OS2 9/125µm (PC/PC) Yellow color	OS2-APC 9/125µm (APC/APC) Yellow color		Mixed: OS2-APC & OS2 9/125µm (APC/PC) Yellow color
MPO/SC 	OS2	Fxx-MF/PC-SC/PC-92D-xx.xM	MTRJ/ST 	OS2	Fxx-MT/PC-ST/PC-91D-xx.xM
	OS2-APC	Fxx-MF/AP-SC/AP-92D-xx.xM		OS2-APC	
	Mixed	Fxx-MF/AP-SC/PC-92D-xx.xM		Mixed	
		Fxx-MF/PC-SC/AP-92D-xx.xM			
MPO/ST 	OS2	Fxx-MF/PC-ST/PC-92D-xx.xM	SC/SC 	OS2	Fxx-SC/PC-SC/PC-92D-xx.xM
	OS2-APC			OS2-APC	Fxx-SC/AP-SC/AP-92D-xx.xM
	Mixed	Fxx-MF/AP-ST/PC-92D-xx.xM		Mixed	Fxx-SC/AP-SC/PC-92D-xx.xM
MTRJ/MTRJ 	OS2	Fxx-MT/PC-MT/PC-91D-xx.xM	SC/ST 	OS2	Fxx-SC/PC-ST/PC-92D-xx.xM
	OS2-APC			OS2-APC	
	Mixed			Mixed	Fxx-SC/AP-ST/PC-92D-xx.xM
MTRJ/SC 	OS2	Fxx-MT/PC-SC/PC-91D-xx.xM	ST/ST 	OS2	Fxx-ST/PC-ST/PC-92D-xx.xM
	OS2-APC			OS2-APC	
	Mixed	Fxx-MT/PC-SC/AP-91D-xx.xM		Mixed	

Replace "xx.x" by length in "meters"

FIBER OPTIC PATCH CABLE ASSEMBLIES

Standard Patch Cords

Duplex Singlemode

OPTIONS





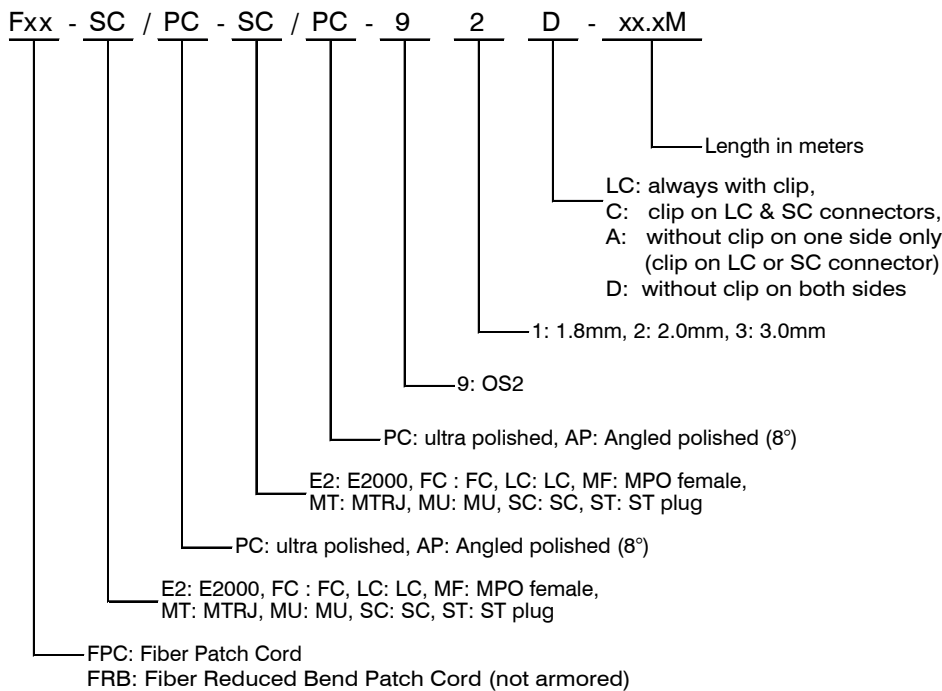











Cable length:	Replace "xx.x" by cable length in meter (example: 07.0 = 7 meter cable)
Standard cable lengths:	1, 2, 3, 5 & 10 meters (others on demand)
Cable diameter:	standard = 2.00mm (1.80mm for MTRJ) 3.00mm = option on request
Ultra polished OS2:	PC
Angled polished OS2-APC:	AP (only for E2000, FC, LC, SC)
Color:	Yellow (standard) Others (on request)

ORDERING CODE STRUCTURE



FIBER OPTIC PATCH CABLE ASSEMBLIES

Standard Patch Cords Simplex Singlemode

		OS2 9/125µm (PC/PC) Yellow color	OS2-APC 9/125µm (APC/APC) Yellow color		Mixed: OS2-APC & OS2 9/125µm (APC/PC) Yellow color
E2000/E2000 	OS2	Fxx-E2/PC-E2/PC-92S-xx.xM	FC/SC 	OS2	Fxx-FC/PC-SC/PC-92S-xx.xM
	OS2-APC	Fxx-E2/AP-E2/AP-92S-xx.xM		OS2-APC	Fxx-FC/AP-SC/AP-92S-xx.xM
	Mixed	Fxx-E2/AP-E2/PC-92S-xx.xM		Mixed	Fxx-FC/AP-SC/PC-92S-xx.xM
		Fxx-FC/PC-SC/AP-92S-xx.xM			
E2000/FC 	OS2	Fxx-E2/PC-FC/PC-92S-xx.xM	LC/LC 	OS2	Fxx-LC/PC-LC/PC-92S-xx.xM
	OS2-APC	Fxx-E2/AP-FC/AP-92S-xx.xM		OS2-APC	Fxx-LC/AP-LC/AP-92S-xx.xM
	Mixed	Fxx-E2/AP-FC/PC-92S-xx.xM		Mixed	Fxx-LC/AP-LC/PC-92S-xx.xM
		Fxx-E2/PC-FC/AP-92S-xx.xM			
E2000/LC 	OS2	Fxx-E2/PC-LC/PC-92S-xx.xM	LC/MU 	OS2	Fxx-LC/PC-MU/PC-92S-xx.xM
	OS2-APC	Fxx-E2/AP-LC/AP-92S-xx.xM		OS2-APC	
	Mixed	Fxx-E2/AP-LC/PC-92S-xx.xM		Mixed	Fxx-LC/AP-MU/PC-92S-xx.xM
		Fxx-E2/PC-LC/AP-92S-xx.xM			
E2000/SC 	OS2	Fxx-E2/PC-SC/PC-92S-xx.xM	LC/SC 	OS2	Fxx-LC/PC-SC/PC-92S-xx.xM
	OS2-APC	Fxx-E2/AP-SC/AP-92S-xx.xM		OS2-APC	Fxx-LC/AP-SC/AP-92S-xx.xM
	Mixed	Fxx-E2/AP-SC/PC-92S-xx.xM		Mixed	Fxx-LC/AP-SC/PC-92S-xx.xM
		Fxx-E2/PC-SC/AP-92S-xx.xM			
E2000/ST 	OS2	Fxx-E2/PC-ST/PC-92S-xx.xM	LC/ST 	OS2	Fxx-LC/PC-ST/PC-92S-xx.xM
	OS2-APC			OS2-APC	
	Mixed	Fxx-E2/AP-ST/PC-92S-xx.xM		Mixed	Fxx-LC/AP-ST/PC-92S-xx.xM
FC/FC 	OS2	Fxx-FC/PC-FC/PC-92S-xx.xM	SC/SC 	OS2	Fxx-SC/PC-SC/PC-92S-xx.xM
	OS2-APC	Fxx-FC/AP-FC/AP-92S-xx.xM		OS2-APC	Fxx-SC/AP-SC/AP-92S-xx.xM
	Mixed	Fxx-FC/AP-FC/PC-92S-xx.xM		Mixed	Fxx-SC/AP-SC/PC-92S-xx.xM
FC/LC 	OS2	Fxx-FC/PC-LC/PC-92S-xx.xM	SC/ST 	OS2	Fxx-SC/PC-ST/PC-92S-xx.xM
	OS2-APC	Fxx-FC/AP-LC/AP-92S-xx.xM		OS2-APC	
	Mixed	Fxx-FC/AP-LC/PC-92S-xx.xM		Mixed	Fxx-SC/AP-ST/PC-92S-xx.xM
		Fxx-FC/PC-LC/AP-92S-xx.xM			
FC/MU 	OS2	Fxx-FC/PC-MU/PC-92S-xx.xM	ST/ST 	OS2	Fxx-ST/PC-ST/PC-92S-xx.xM
	OS2-APC			OS2-APC	
	Mixed	Fxx-FC/AP-MU/PC-92S-xx.xM		Mixed	

Replace "xx.x" by length in "meters"

FIBER OPTIC PATCH CABLE ASSEMBLIES

Standard Patch Cords

Simplex Singlemode

OPTIONS

Cable length:	Replace "xx.x" by cable length in meter (example: 07.0 = 7 meter cable)
Standard cable lengths:	1, 2, 3, 5 & 10 meters (others on demand)
Cable diameter:	standard = 2.00mm 3.00mm = option on request
Ultra polished OS2:	PC
Angled polished OS2-APC:	AP (only for E2000, FC, LC, SC)
Color:	Yellow (standard) Others (on request)



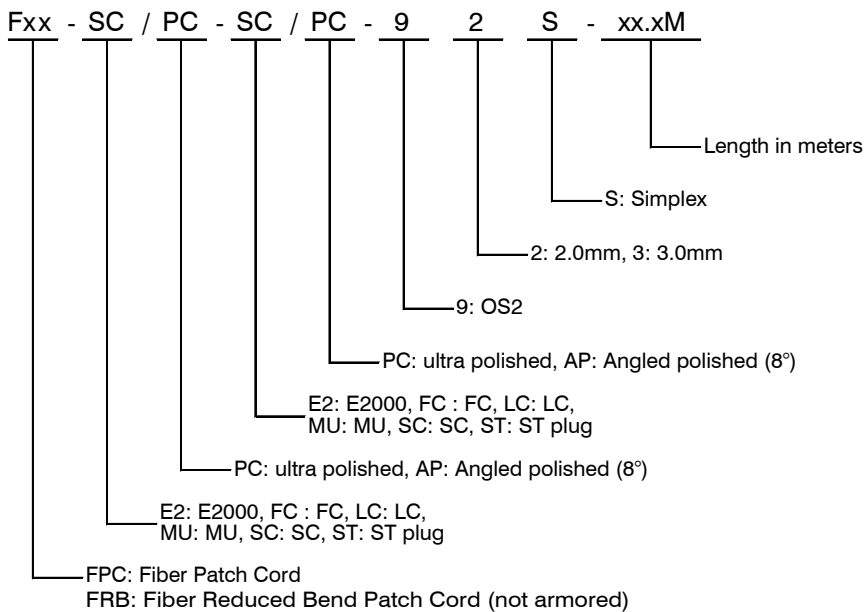

ORDERING CODE STRUCTURE



FIBER OPTIC PATCH CABLE ASSEMBLIES

Standard Pigtails

Pigtails Multimode

	OM2 50/125 μ m	OM3 50/125 μ m	OM4 enhanced 50/125 μ m		
E2000 	OM2	FPT-E2/PC-5MS-xx.xM	SC 	OM2	FPT-SC/PC-5MS-xx.xM
	OM3	FPT-E2/PC-3MS-xx.xM		OM3	FPT-SC/PC-3MS-xx.xM
	OM4	FPT-E2/PC-4MS-xx.xM		OM4	FPT-SC/PC-4MS-xx.xM
FC 	OM2	FPT-FC/PC-5MS-xx.xM	ST 	OM2	FPT-ST/PC-5MS-xx.xM
	OM3	FPT-FC/PC-3MS-xx.xM		OM3	FPT-ST/PC-3MS-xx.xM
	OM4	FPT-FC/PC-4MS-xx.xM		OM4	FPT-ST/PC-4MS-xx.xM
LC 	OM2	FPT-LC/PC-5MS-xx.xM			
	OM3	FPT-LC/PC-3MS-xx.xM			
	OM4	FPT-LC/PC-4MS-xx.xM			

Replace "xx.x" by length in "meters"

OPTIONS

Cable length: Replace "xx.x" by cable length in meter
(example: 02.0 = 2 meter cable)



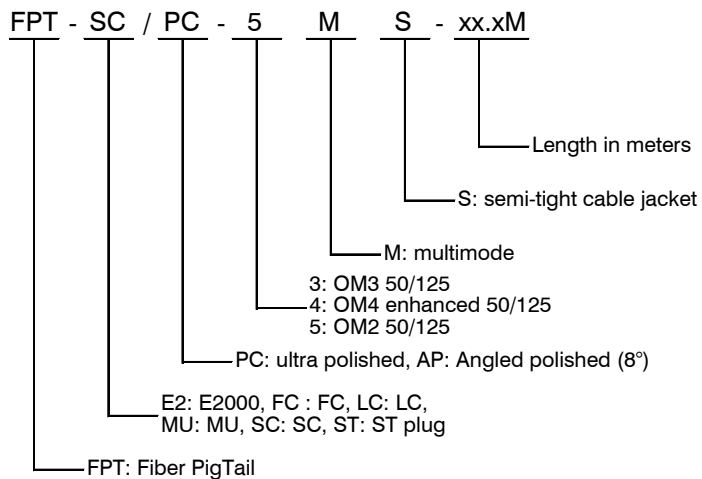



ORDERING CODE STRUCTURE



FIBER OPTIC PATCH CABLE ASSEMBLIES

Standard Pigtails

Pigtails Singlemode

		OS2 9/125µm (PC)			OS2-APC 9/125µm (APC)		
E2000		OS2	FPT-E2/PC-9SS-xx.xM	MU		OS2	FPT-MU/PC-9SS-xx.xM
		OS2-APC	FPT-E2/AP-9SS-xx.xM			OS2-APC	
FC		OS2	FPT-FC/PC-9SS-xx.xM	SC		OS2	FPT-SC/PC-9SS-xx.xM
		OS2-APC	FPT-FC/AP-9SS-xx.xM			OS2-APC	
LC		OS2	FPT-LC/PC-9SS-xx.xM	ST		OS2	FPT-ST/PC-9SS-xx.xM
		OS2-APC	FPT-LC/AP-9SS-xx.xM			OS2-APC	

Replace "xx.x" by length in "meters"

OPTIONS

Cable length: Replace "xx.x" by cable length in meter
(example: 02.0 = 2 meter cable)

ORDERING CODE STRUCTURE

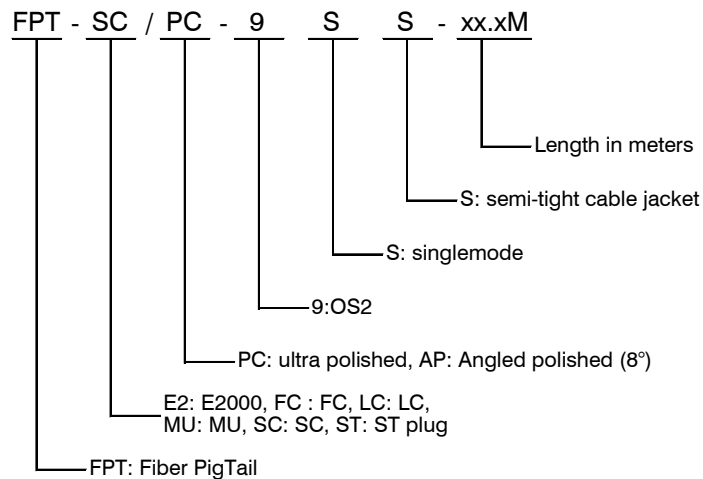

MPO/MTP Cable Assemblies & Patch Panels

MPO/MTP Fiber Management

The MPO/MTP system is the perfect solution for fiber optic installations. The high density fiber optic MPO/MTP connector from “USCONEC” allows simple plug & play of the backbone fiber to the distribution cabinet. Pre-terminated MPO/MTP fiber solutions allows you to prepare the distribution cabinets in your own premises and installed at the site when the installation is ready to go live.

1. System design

The system needs to be designed according to the number of fibers and type of connectors required in the distribution cabinet. SC and MTRJ connectors can accept up to a maximum of 36 fibers, whereas LC connectors can support up to 144 fibers. For lower patch panel density requirements the standard sliding tray patch panel can be an option.

2. Site survey

Measure the total length of the backbone cable required from point A to B and increase this value by another 10% for cable slack, plus a total of 6 meters (2 meters at each end) for termination and management of the cables within the distribution cabinet.

3. Installation

The MPO/MTP cable assembly is laid into position and loosely secured to the cable tray with no bends smaller than 5cm radius. Make sure that the maximum pulling force of the cable will not be exceeded when pulling any fiber optical assembly into the building. Any excess force will damage the cable and the fibers inside. Loop any spare cable under or within the cabinet to ensure a stress free run to the rear of the patch panel. Maintain the dust caps on the MPO/MTP assemblies until final connection. Once the dust caps have been removed, connect the pre-terminated MPO/MTP fiber assembly immediately to the MPO/MTP-fan-out or module.

MPO/MTP Installation

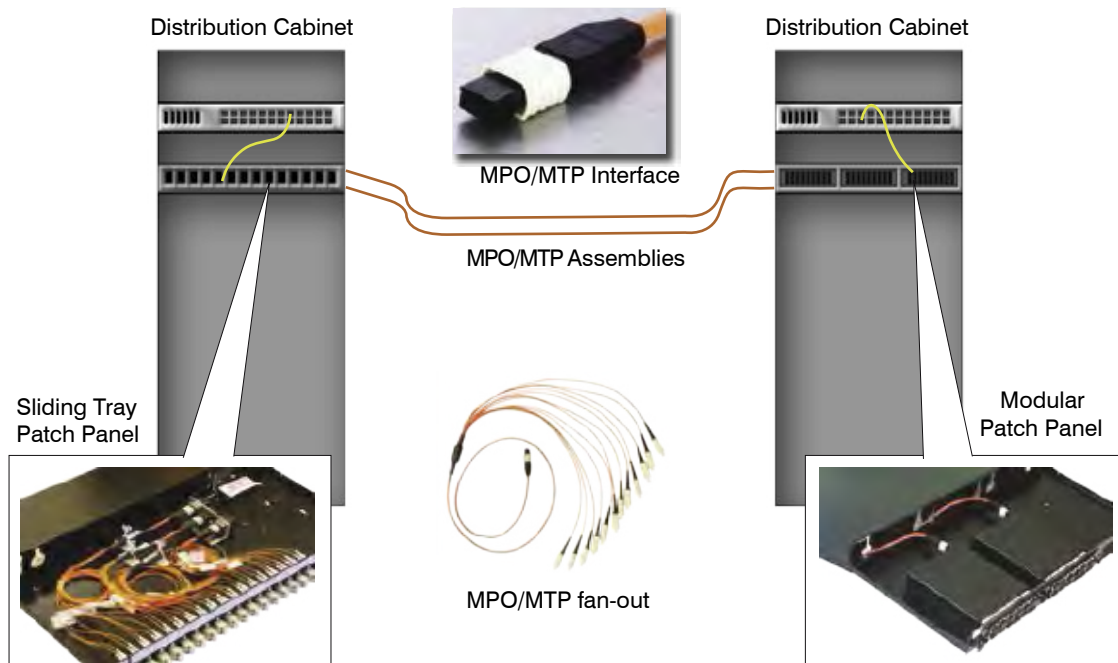

MPO/MTP Cable Assemblies

MPO/MTP Fan-out Cables

The MPO/MTP fan-out cables for direct connections within the communications cabinet. These cables are offered in multimode and singlemode with FC, LC, MTRJ, MU, SC and ST terminations.

Cable style	Connector	2.00mm cable	0.9mm cable
OM2(50/125)	E2000	FMF-SM/PC-E2/PC-52-yy-xxxM	not available
	FC	FMF-SM/PC-FC/PC-52-yy-xxxM	FMF-SM/PC-FC/PC-59-yy-xxxM
	LC	FMF-SM/PC-LC/PC-52-yy-xxxM	FMF-SM/PC-LC/PC-59-yy-xxxM
	MTRJ	FMF-SM/PC-MT/PC-52-yy-xxxM	FMF-SM/PC-MT/PC-59-yy-xxxM
	MU	FMF-SM/PC-MU/PC-52-yy-xxxM	not available
	SC	FMF-SM/PC-SC/PC-52-yy-xxxM	FMF-SM/PC-SC/PC-59-yy-xxxM
	ST	FMF-SM/PC-ST/PC-52-yy-xxxM	FMF-SM/PC-ST/PC-59-yy-xxxM
OM3 (50/125)	E2000	FMF-SM/PC-E2/PC-32-yy-xxxM	not available
	FC	FMF-SM/PC-FC/PC-32-yy-xxxM	FMF-SM/PC-FC/PC-39-yy-xxxM
	LC	FMF-SM/PC-LC/PC-32-yy-xxxM	FMF-SM/PC-LC/PC-39-yy-xxxM
	MTRJ	FMF-SM/PC-MT/PC-32-yy-xxxM	FMF-SM/PC-MT/PC-39-yy-xxxM
	MU	FMF-SM/PC-MU/PC-32-yy-xxxM	not available
	SC	FMF-SM/PC-SC/PC-32-yy-xxxM	FMF-SM/PC-SC/PC-39-yy-xxxM
	ST	FMF-SM/PC-ST/PC-32-yy-xxxM	FMF-SM/PC-ST/PC-39-yy-xxxM
OM4 enhanced (50/125)	E2000	FMF-SM/PC-E2/PC-42-yy-xxxM	not available
	FC	FMF-SM/PC-FC/PC-42-yy-xxxM	FMF-SM/PC-FC/PC-49-yy-xxxM
	LC	FMF-SM/PC-LC/PC-42-yy-xxxM	FMF-SM/PC-LC/PC-49-yy-xxxM
	MTRJ	FMF-SM/PC-MT/PC-42-yy-xxxM	FMF-SM/PC-MT/PC-49-yy-xxxM
	MU	FMF-SM/PC-MU/PC-42-yy-xxxM	not available
	SC	FMF-SM/PC-SC/PC-42-yy-xxxM	FMF-SM/PC-SC/PC-49-yy-xxxM
	ST	FMF-SM/PC-ST/PC-42-yy-xxxM	FMF-SM/PC-ST/PC-49-yy-xxxM
OS2(9/125)	E2000	FMF-SM/PC-E2/PC-92-yy-xxxM	not available
	FC	FMF-SM/PC-FC/PC-92-yy-xxxM	FMF-SM/PC-FC/PC-99-yy-xxxM
	LC	FMF-SM/PC-LC/PC-92-yy-xxxM	FMF-SM/PC-LC/PC-99-yy-xxxM
	MTRJ	FMF-SM/PC-MT/PC-92-yy-xxxM	FMF-SM/PC-MT/PC-99-yy-xxxM
	MU	FMF-SM/PC-MU/PC-92-yy-xxxM	not available
	SC	FMF-SM/PC-SC/PC-92-yy-xxxM	FMF-SM/PC-SC/PC-99-yy-xxxM
	ST	FMF-SM/PC-ST/PC-92-yy-xxxM	FMF-SM/PC-ST/PC-99-yy-xxxM
OS2-APC (9/125 angled)	E2000	FMF-SM/PC-E2/AP-92-yy-xxxM	not available
	FC	FMF-SM/PC-FC/AP-92-yy-xxxM	FMF-SM/PC-FC/AP-99-yy-xxxM
	LC	FMF-SM/PC-LC/AP-92-yy-xxxM	FMF-SM/PC-LC/AP-99-yy-xxxM
	SC	FMF-SM/PC-SC/AP-92-yy-xxxM	FMF-SM/PC-SC/AP-99-yy-xxxM

Replace “yy-xxxM” by number of fibers and length in meters: Examples: -12-002M = 12 fibers / 2 Meters

MPO/MTP Cable Assemblies

MPO/MTP Fan-out Cables



MPO/MTP 2.0mm fan-out cable



MPO/MTP 0.9mm fan-out cable

ORDERING CODE STRUCTURE

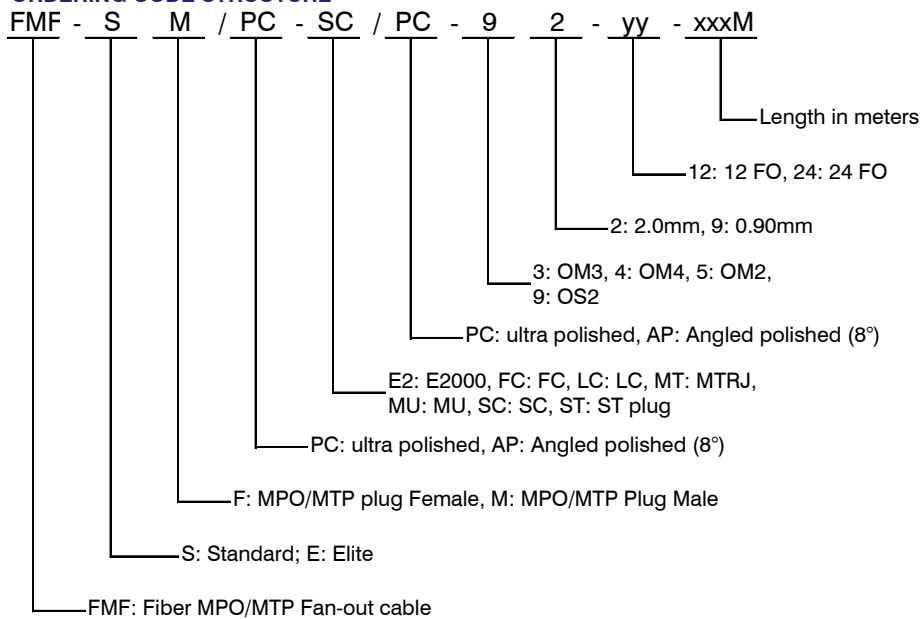

MPO/MTP Cable Assemblies

MPO/MTP Pre-terminated Trunk Cables

Pre-terminated MPO/MTP cable assemblies are offered in multimode and singlemode with female MPO/MTP terminations for installation within the building and connecting to the rear of a MPO/MTP patch panel or to a fan-out cable.

Mode	Optical Fiber	Part Number
Multimode	OM2 (50/125)	FMP-SF/PC-SF/PC-5-yyy-A-xxxM
	OM3 (enhanced 50/125μm)	FMP-SF/PC-SF/PC-3-yyy-A-xxxM
	OM4 (enhanced 50/125μm)	FMP-SF/PC-SF/PC-4-yyy-A-xxxM
Singlemode	OS2(9/125)	FMP-SF/PC-SF/PC-9-yyy-A-xxxM
	OS2-APC(9/125)	FMP-SF/AP-SF/AP-9-yyy-A-xxxM

Replace “yyy-A-xxxM” by number of fibers and length in meters: Examples: -012-A-125M = 12 fibers / 125 Meters

ORDERING CODE STRUCTURE

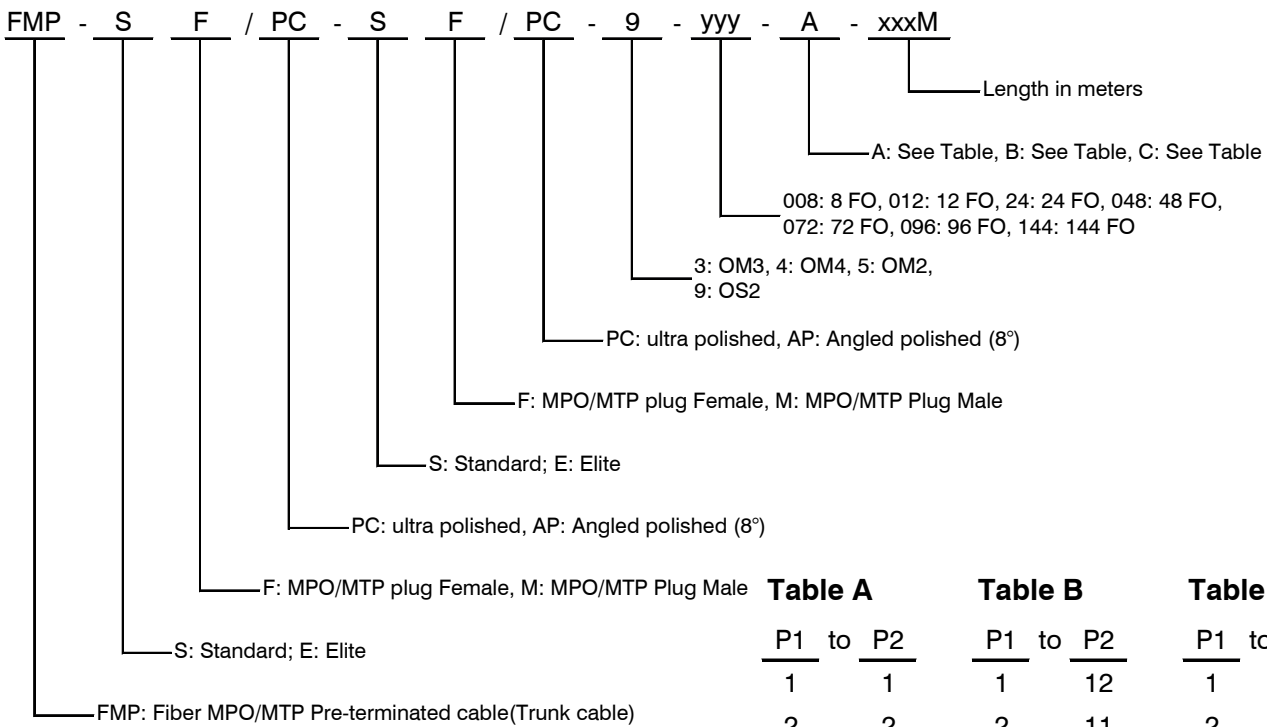

Table A		Table B		Table C	
P1	to P2	P1	to P2	P1	to P2
1	1	1	12	1	2
2	2	2	11	2	1
3	3	3	10	3	4
4	4	4	9	4	3
5	5	5	8	5	6
6	6	6	7	6	5
7	7	7	6	7	8
8	8	8	5	8	7
9	9	9	4	9	10
10	10	10	3	10	9
11	11	11	2	11	12
12	12	12	1	12	11

MPO/MTP Patch Panels

MPO/MTP Standard Patch Panel

19" black sliding tray patch panel pre-loaded for 24 FC, SC, ST and 48 MTRJ or LC connections to MPO/MTP cable assemblies. Contact E-tec Interconnect Ltd for more information & part numbers.

Order Code for empty Sliding Patch Panel:

FC & ST adapter style = **SPP-24-N- FC/ST-ME-B**
 E2000/LC/MT/SC adapter style = **SPP-24-V- E2/LC/MT/SC-ME-B**

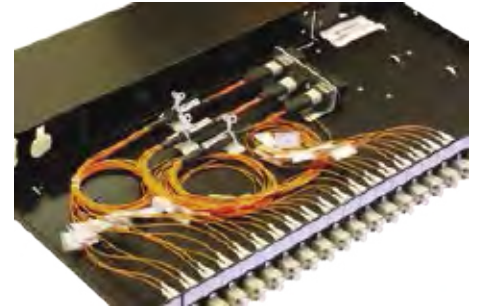

MPO/MTP Modular Sliding Patch Module

19" black sliding tray patch panel for 3 modules supports up to 36 SC connections with 3 MPO/MTP links or 72 LC/MTRJ connections with 6 MPO/MTP Links.



SPM-3-P-ALL-ME-B

ORDERING CODE STRUCTURE

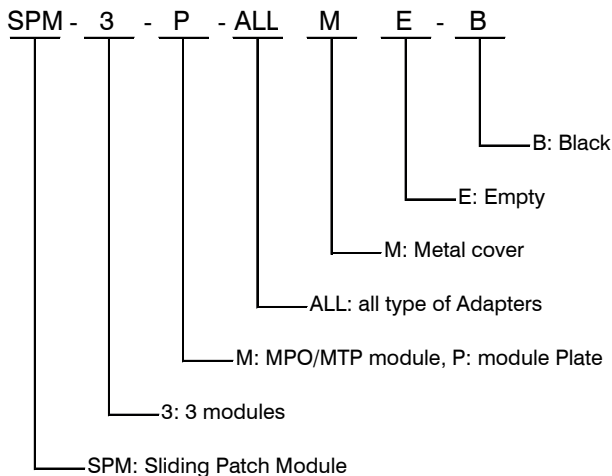

MPO/MTP Patch Panels

MPO/MTP Sliding Modules

The 12 and 24 port sliding modules are designed to fit the MPO/MTP Modular Patch Panel.

Order code information

Cable style	Connector	12 Fibers	24 Fibers
OM2 (50/125)	E2000	MPM-PC-12-E2/PC-5	not available
	FC	MPM-PC-12-FC/PC-5	not available
	LC	MPM-PC-12-LC/PC-5	MPM-PC-24-LC/PC-5
	MTRJ	MPM-PC-12-MT/PC-5	not available
	MU	MPM-PC-12-MU/PC-5	not available
	SC	MPM-PC-12-SC/PC-5	not available
	ST	MPM-PC-12-ST/PC-5	not available
OM3 (50/125)	E2000	MPM-PC-12-E2/PC-3	not available
	FC	MPM-PC-12-FC/PC-3	not available
	LC	MPM-PC-12-LC/PC-3	MPM-PC-24-LC/PC-3
	MTRJ	MPM-PC-12-MT/PC-3	not available
	MU	MPM-PC-12-MU/PC-3	not available
	SC	MPM-PC-12-SC/PC-3	not available
	ST	MPM-PC-12-ST/PC-3	not available
OM4 (enhanced 50/125)	E2000	MPM-PC-12-E2/PC-4	not available
	FC	MPM-PC-12-FC/PC-4	not available
	LC	MPM-PC-12-LC/PC-4	MPM-PC-24-LC/PC-4
	MTRJ	MPM-PC-12-MT/PC-4	not available
	MU	MPM-PC-12-MU/PC-4	not available
	SC	MPM-PC-12-SC/PC-4	not available
	ST	MPM-PC-12-ST/PC-4	not available
OS2 (9/125)	E2000	MPM-PC-12-E2/PC-9	not available
	FC	MPM-PC-12-FC/PC-9	not available
	LC	MPM-PC-12-LC/PC-9	MPM-PC-24-LC/PC-9
	MTRJ	MPM-PC-12-MT/PC-9	not available
	MU	MPM-PC-12-MU/PC-9	not available
	SC	MPM-PC-12-SC/PC-9	not available
	ST	MPM-PC-12-ST/PC-9	not available
OS2-APC (9/125 angled)	E2000	MPM-PC-12-E2/AP-9	not available
	FC	MPM-PC-12-FC/AP-9	not available
	LC	MPM-PC-12-LC/AP-9	MPM-PC-24-LC/AP-9
	SC	MPM-PC-12-SC/AP-9	not available

MPO/MTP Patch Panels

MPO/MTP Sliding Modules



MPO/MTP 12-port SC module
pre-assembled for 12 SC connections



MPO/MTP 24-port LC module
pre-assembled for 24 LC connections

ORDERING CODE STRUCTURE

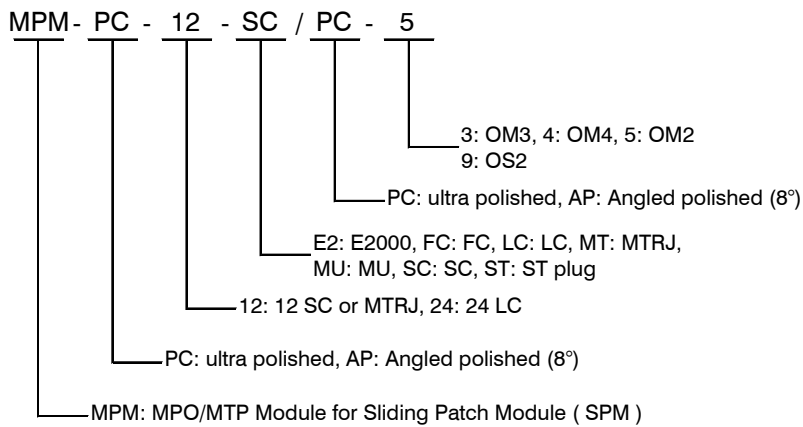

FIBRE OPTIC CABLE

Product Datasheet

Single Loose Tube Fibre Optic Cable (2-24 Fibres)

DESCRIPTION

2 to 24 fibre OM2, OM3, OM4 multimode or OS2 (ITU-T G.652D) singlemode 250µm single loose tube external duct cables with e-glass strenght members and polyethylene (PE) or Low Smoke Zero Halogen (LSZH) jacket.

The single loose tube cables consist of 2 to 24, 250µm optical fibres in a single gel filled loose tube with e-glass non metallic strenght members and black PE or LSZH jacket with ripcord.

FEATURES / BENEFITS

- Choice of fibre types
- Colour coded fibres
- E-glass strenght members for rodent resistance
- Flame retardant LSZH jacket option for enhanced fire performance
- Compact 250µm loose tube construction

APPLICATIONS

- Suitable for internal / external duct applications
- Suitable for environments where rodent resistance is required
- Ideal for intra building links in campus environments

TECHNICAL SPECIFICATIONS

DESCRIPTION		2-12 CORE	14-24 CORE
Outer Diameter	mm	6.5 ±0.3	6.7 ±0.3
Weight	kg/km	40	47
Max. Load (installation)	N	1000	1000
Max. Load (installed)	N	500	500
Min. Bend Radius (installation)	Times diameter	20	20
Min. Bend Radius (installed)	Times diameter	10	10
Fire Performance		LSZH	LSZH
Operating Temp.	°C	-20~+60	-20~+60
Storage Temp.	°C	-20~+60	-20~+60
Installation Temp.	°C	-20~+60	-20~+60
Crush Resistance	N/100mm	1000	1000



ORDERING CODE STRUCTURE

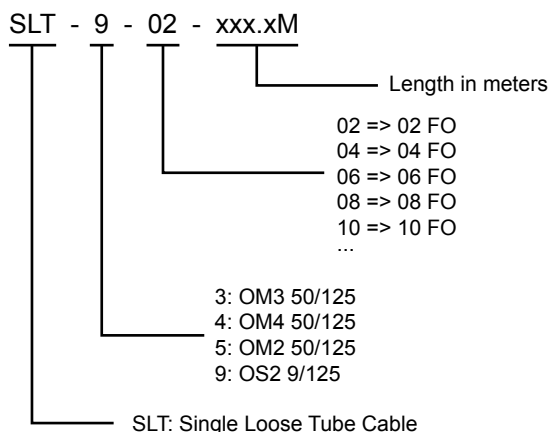

FIBRE OPTIC CABLE

Product Datasheet

Tight Buffered Distribution Cable (2-24 Fibres)

DESCRIPTION

The tight buffered internal distribution cables are constructed of 900µm buffered fibres surrounded by e-glass strength members jacketed in a LSZH outer jacket.

FEATURES / BENEFITS

- Choice of fibre types
- Colour coded fibres
- High strength E-Glass rodent resistant yarn strength members for ease of handling
- LSZH jacket
- Easy to strip

APPLICATIONS

- Internal cable for installation in trunking, under floor or ceiling spaces
- Fibre backbones in riser and horizontal configurations

TECHNICAL SPECIFICATIONS

DESCRIPTION		4-CORE LSZH	8-CORE LSZH	12-CORE LSZH	24-CORE LSZH
Outer Diameter	mm	4.8 ±0.3	5.8 ±0.3	6.5 ±0.3	7.5 ±0.3
Weight	kg/km	26	34	40	61
Max. Load (installation)	N	600	750	750	900
Max. Load (installed)	N	300	375	375	450
Min. Bend Radius (installation)	mm	96	116	130	150
Min. Bend Radius (installed)	mm	48	58	65	75
Fire Performance		LSZH	LSZH	LSZH	LSZH
Operating Temp.	°C	-20~+60	-20~+60	-20~+60	-20~+60
Storage Temp.	°C	-20~+60	-20~+60	-20~+60	-20~+60
Installation Temp.	°C	-20~+60	-20~+60	-20~+60	-20~+60
Crush Resistance		1000	1000	1000	1000



ORDERING CODE STRUCTURE

TBC - 9 - 02 - xxx.xM

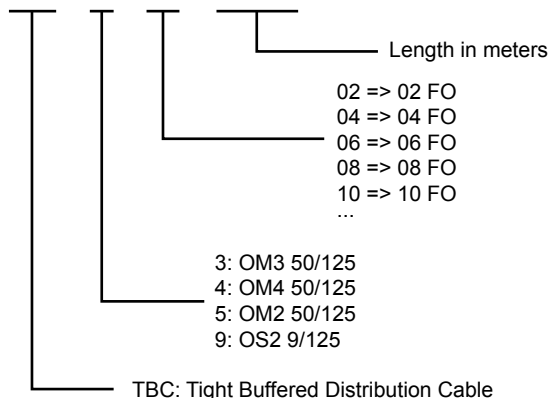

FIBRE OPTIC CABLE

Product Datasheet

Tight Buffered Distribution Cable Multi-Core (36-96 Fibres)

DESCRIPTION

36 to 96 fibre, stranded sub unit rodent resistant internal distribution cables consisting of 4 to 8, 12 fibre sub units and fillers when necessary. Each subunit consists of 12, 900µm tight buffered optical fibres with e-glass non-metallic strength members and LSZH jacket. The individually coloured 6mm outside diameter (OD) sub units are helically stranded around an FRP central strength member with polyester wrapping tape, ripcord and Low Smoke Zero Halogen (LSZH) final jacket.

FEATURES / BENEFITS

- Choice of fibre types
- Colour coded fibres for easy identification
- High strength aramid yarn strength members
- Easy to use
- Lightweight and compact
- LSZH jacket

APPLICATIONS

- Internal cable for horizontal distribution or riser applications

TECHNICAL SPECIFICATIONS

DESCRIPTION		36-CORE LSZH	48-CORE LSZH	72-CORE LSZH	96-CORE LSZH
Outer Diameter	mm	17.4 ±0.5	17.4 ±0.5	21.6 ±0.5	25.5 ±0.5
Weight	kg/km	237	237	397	571
Max. Load (installation)	N	2800	2800	4600	5000
Max. Load (installed)	N	1500	1500	2000	2200
Min. Bend Radius (installation)	mm	350	350	440	500
Min. Bend Radius (installed)	mm	175	175	220	250
Fire Performance		LSZH	LSZH	LSZH	LSZH
Operating Temp.	°C	-20~+60	-20~+60	-20~+60	-20~+60
Storage Temp.	°C	-20~+60	-20~+60	-20~+60	-20~+60
Installation Temp.	°C	-20~+60	-20~+60	-20~+60	-20~+60
Crush Resistance	N/100mm	1500	1500	1500	1500

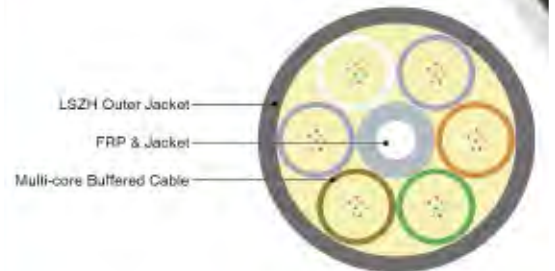

ORDERING CODE STRUCTURE

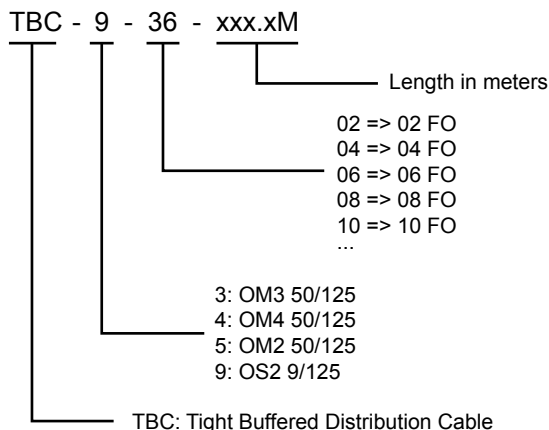

FIBRE OPTIC CABLE

Product Datasheet

Single Loose Tube STA Fiber Optic Cable

DESCRIPTION

Single loose tube corrugated **steel tape armored** cables are constructed of 250µm fibers held in a gel filled central loose tube surrounded by waterblocking tape and corrugated, polyethylene laminated steel tape. The cable features two parallel steel wire strength members embedded in the PE /LSZH outer jacket.

FEATURES / BENEFITS

- Choice of fibre types
- Colour code of fiber
- High water resistance
- PE outer sheath

APPLICATIONS

- Suitable for external applications in ducts.

OPTIONS

- Bend insensitive fibers G657 A/B
- OM4 fibers 10 Gigs at 550 meters
- Any color of cable jacket
- Printing on cable
- OFNP plenum jacket

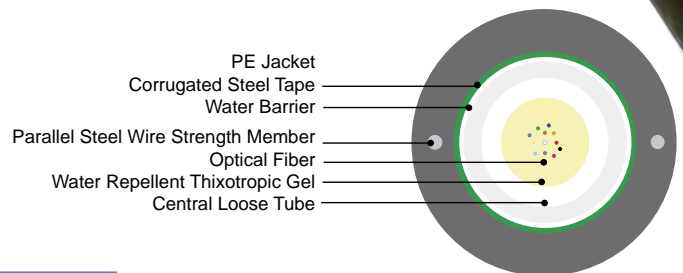

TECHNICAL SPECIFICATIONS

FiBer NumBer	OD	CABLe Weigh T	Drum DimeNSIONS	Drum Weigh T	miN. BeND rAD iuS		mAx. TeNSION (N)		Cru Sh LOADIg (N/100mm)	
					Static	Dynamic	Short terms	Long terms	Short terms	Long terms
	mm	kg/km	mm	kg/pcs						
4	10.1	105	900	54						
8	10.1	105	900	54						
12	10.1	105	900	54	10XD	20XD	1500	600	3000	1000
16	10.1	105	900	54						
24	10.6	105	900	54						



ORDERING CODE STRUCTURE

STA - 9 - 04 - xxx.xM

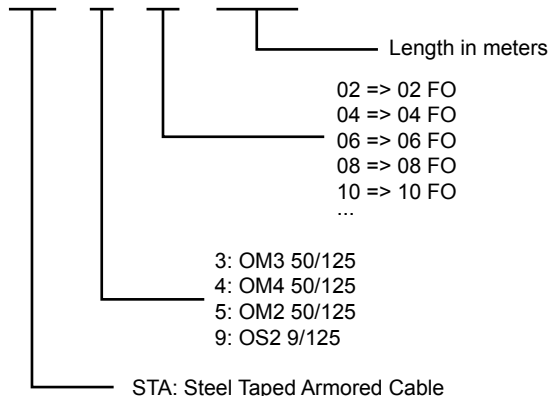

FIBRE OPTIC CABLE

Product Datasheet

Multi Loose Tube CST Fiber Optic Cable

DESCRIPTION

Multi loose tube cable construction consists of up to 12 elements and a maximum of 144, 250 µm optical fibers in 12 fiber gel filled loose tubes with fillers where appropriate, SZ stranded around a jacketed Fiber Reinforced Plastic (FRP) central strength member with waterswellable threads and waterswellable tape. Helically applied waterblocking e-glass non metallic strength members with ripcord. **Corrugated Steel Tape (CST)** armoring and black High Density Polyethylene (HDPE) or Low Smoke Zero Halogen (LSZH) jacket.

FEATURES / BENEFITS

- Choice of fiber type
- Colour code of fiber
- High water resistance
- PE outer sheath

APPLICATIONS

- Suitable for external applications in ducts.

OPTIONS

- Bend insensitive fibers G657 A/B
- OM4 fibers 10 Gigs at 550 meters
- Any color of cable jacket
- Printing on cable
- OFNP plenum jacket

TECHNICAL SPECIFICATIONS

Fiber Number	OD	CABLE Weight	Dru M DiMeNSIONS	Dru M WeiGhT	MiN. BeND rAD iuS		MAx. TeNSiON (N)		Cru Sh LOADiNG (N/100MM)	
					Static	Dynamic	Short terms	Long terms	Short terms	Long terms
24	10.6	105	900	54						
36	11.1	116	1000	67						
48	11.4	135	1000	67						
72	11.9	160	1100	76	10xD	20xD	1500	600	3000	1000
96	12.9	170	1100	95						
144	16.3	260	1300	108						
256	18.7	295	1400	158						

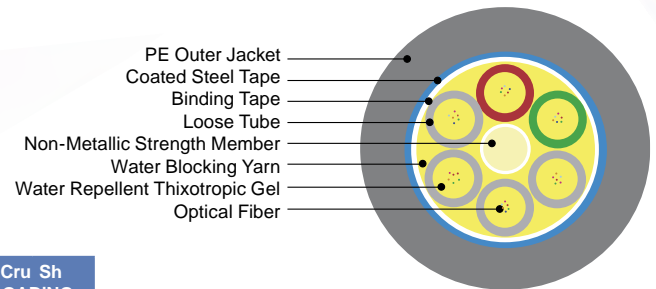

ORDERING CODE STRUCTURE

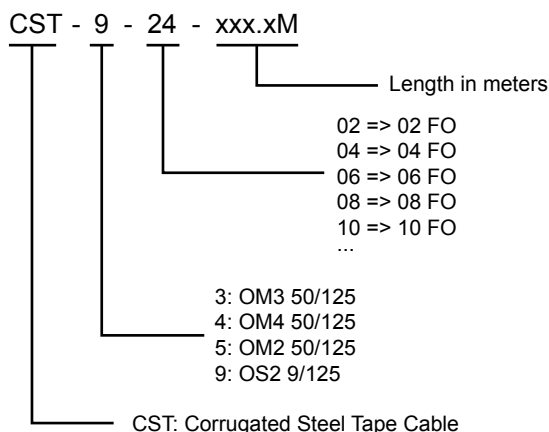

FIBRE OPTIC CABLE

Product Datasheet

Break-Out Fiber Optic Cable

DESCRIPTION

Full OM1, OM2, OM3, OM4 multimode or OS1/OS2 (ITU-TG.652D), ITU-T G.657A1 singlemode Breakout cable consisting of 24, 2.0 mm Low Smoke Zero Halogen (LSZH) Simplex cables each consisting of 1, 900um tight secondary buffered optical fiber with longitudinally applied aramid non metallic strength members and low smoke zero halogen (LSZH) jacket The individually numbered Simplex subunits are helically stranded in two layers around a LSZH jacketed Fiber Reinforced Plastic (FRP) non metallic central strength member with polyester wrapping tape, ripcord and LSZH final jacket.

FEATURES / BENEFITS

- Fire retardant
- Choice of fiber type
- Individual aramid yarn strength members
- Easy to use
- Lightweight and compact
- Choice of outer sheath material
- Choice of outer sheath color

APPLICATIONS

- Internal break-out cable for horizontal distribution

OPTIONS

- Bend insensitive fibers G657 A/B
- OM4 fibers 10 Gigs at 550 meters
- Any color of cable jacket
- Printing on cable
- OFNP plenum jacket

Technical Specifications

FiBer NumBer	OD mm	CABLe WeiGhT kg/km	Drum DimeNsiONs mm	Drum WeiGhT kg/pcs	miN. BeND rAD ius		mAx. Te Nsi ON (N)	
					Static	Dynamic	Short terms	Long terms
4	7.2	54	800	43			500	270
6	8.3	75	900	54			1000	600
8	9.4	100	900	54	10D	20D	1100	700
12	12.2	170	1100	76			1400	800
24	15.6	230	1300	108			2300	1100

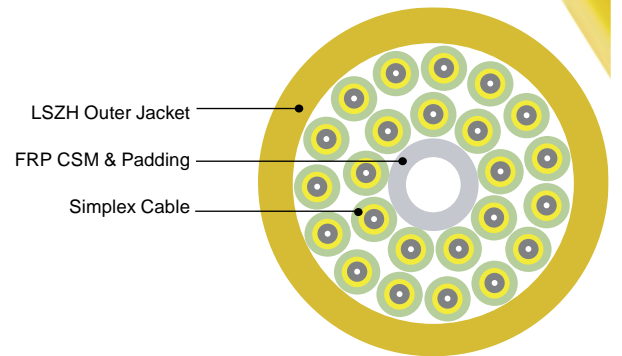

ORDERING CODE STRUCTURE

BOC - 9 - 04 - xxx.xM

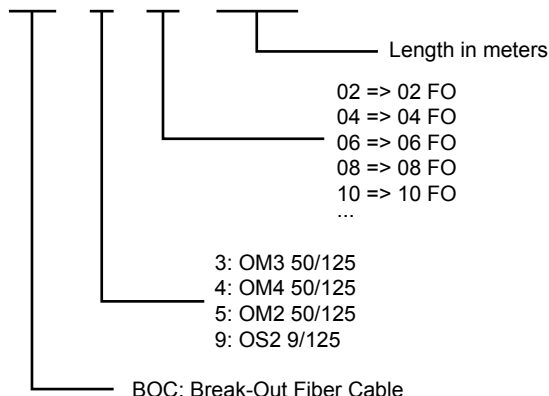

FIBRE OPTIC CABLE

Product Datasheet

Pre-Terminated Cable Solutions for Rapid Deployment



DESCRIPTION

E-tec Interconnect Ltd have established state-of-the-art manufacturing facilities, which provide a rapid turnaround on all of your orders.

The speed and cost of network deployment can be the factors that decide which solution is chosen.

The way to reduce time and cost is to use a Pre-Terminated fibre optic cable solution. Installation can be 65% quicker than traditional methods.

A Pre-Terminated solution consists of a length of cable that is stripped out at each end. The cable is then terminated with connectors, fully tested and fitted with protective sleeving and pulling eye at each end. This will then be delivered to site ready to be installed. Simple!

FEATURES / BENEFITS

- Fast installation time with minimum site disruption.
- Short, reliable lead-time.
- No need for specialized training or special tools and termination kits.
- Less waste to dispose of on site.
- Delivered labelled and fully tested with documentation.
- High precision connectors terminated in a controlled environment deliver a maximum insertion loss of 0.30dB.

Our Pre-Term solutions are totally tailor made to suit your requirements.

APPLICATIONS

- Enterprise premise and campus applications.
- Data Centre: Trunk cables to Equipment Distribution Area (EDA) and Storage Area Network (SAN) applications.
- FTTX.



FIBRE OPTIC CABLE

ORDERING CODE STRUCTURE

Example: PRE - LC/P - S04 - 9SLT - xxx.xM - S - LC/P

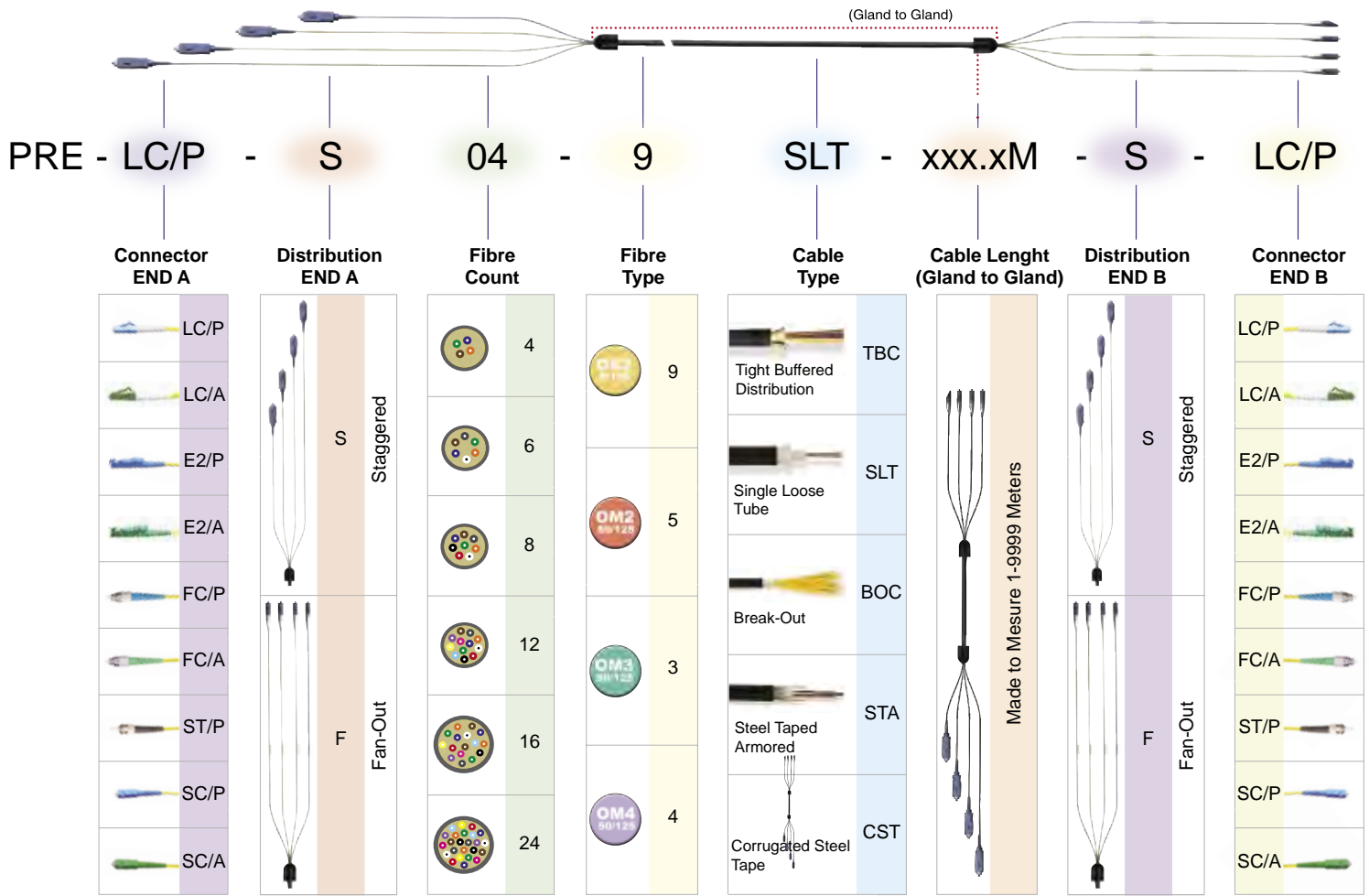

CONNECTOR TYPE CHART

LC/P	LC ultra polished
LC/A	LC angled polished 8°
E2/P	E2 ultra polished
E2/A	E2 angled polished 8°
FC/P	FC ultra polished
FC/A	FC angled polished 8°
ST/P	ST ultra polished
SC/A	SC angled polished 8°
SC/P	SC ultra polished

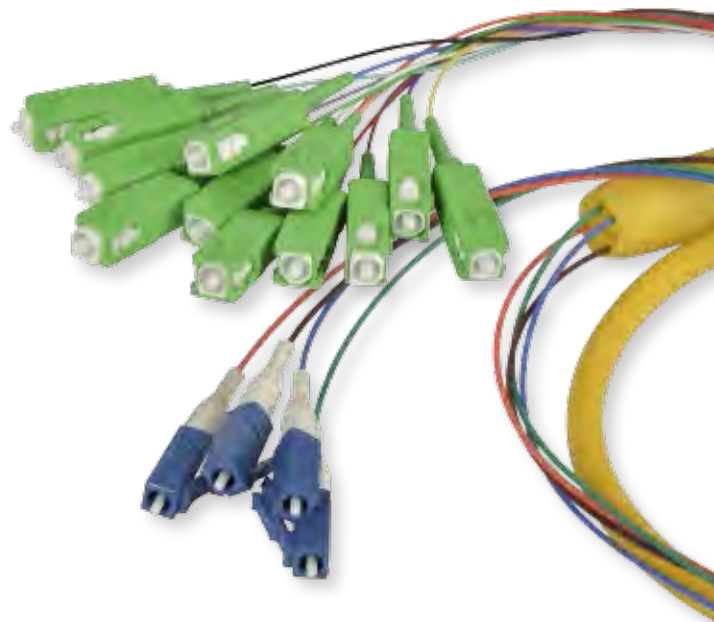

Armored Patch Cords

The armored cables are used in harsh environments and they enhance the stability and safety of the whole network. They are also very popular for covering long distances, since the fibers are protected by a stainless steel flexible tube, which substantially increases the tensile strength, pressure and twist resistance. As a result it greatly increases the yield during the installation phase and thus offers a high cost saving. These cables sustain up to 300 kilo weight which also avoids damage from trampling on the cables. The construction of the armored cable offers high flexibility despite the armored braiding and tubing surrounding the fiber optic cable. It also secures transmission power and avoids extra attenuation compared to standard patch cords, in case of bending/twisting the cables and/or when using cable ties to attach several cables together.

Construction

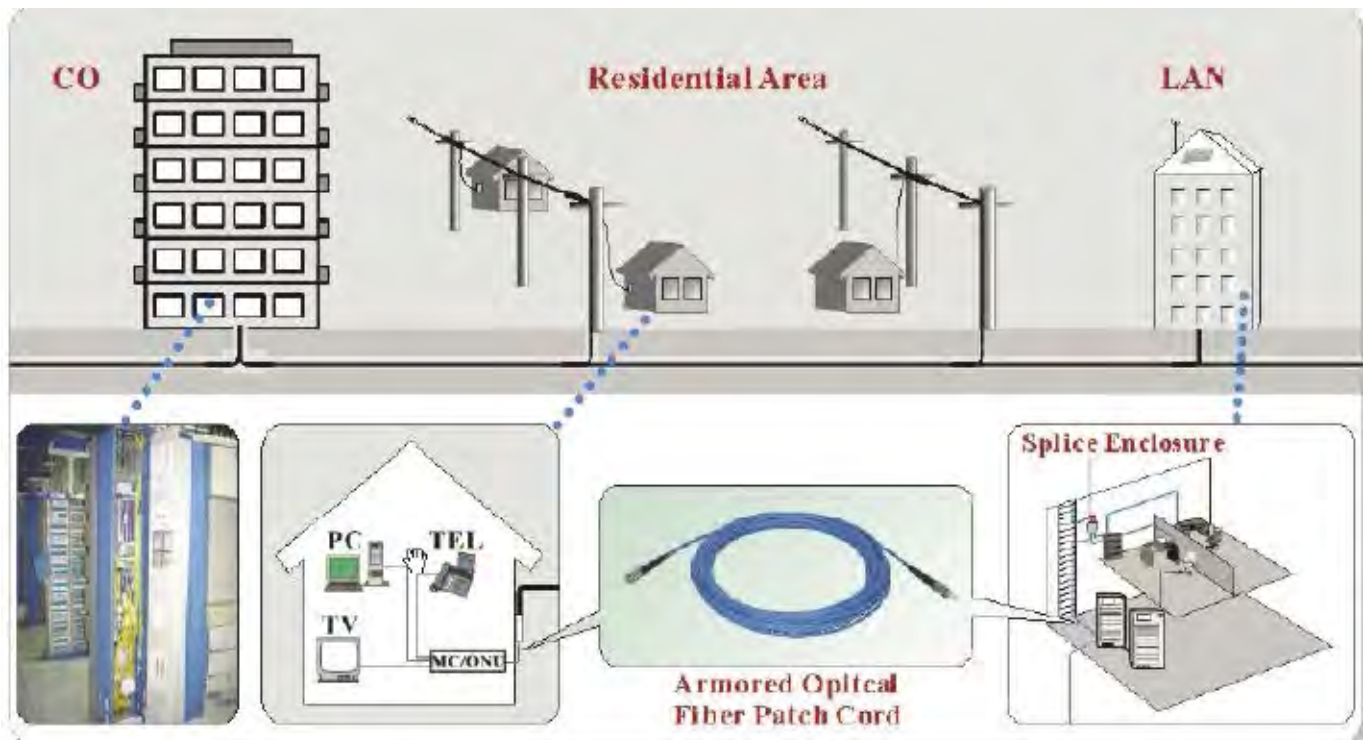
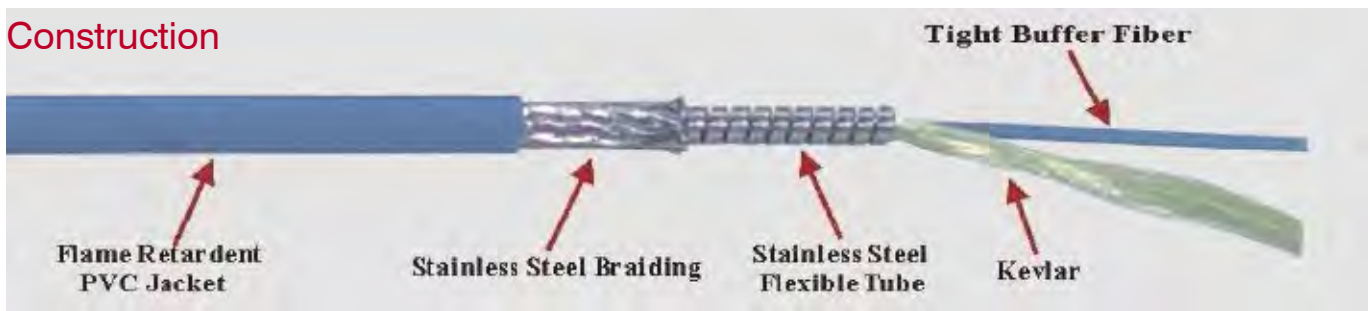

Specifications for Armored Patch Cords

General specifications

- Mating durability: min. 500 cycles
- Operating temperature: -40°C to +85°C
- RoHS compliant
- Pulling force: 20 kilos (pulling velocity 50mm/min)
- Load force: 300 kilos (Tube deformation >50°, FO still functioning)
- Cable diameter: 3mm
- Individual Lot numbers & Test Results delivered per cable
- Cable length tolerances:

less than 0.5 meter	=	+/- 10cm
between 0.5 meter and 5 meter	=	+/- 15cm
over 5 meters	=	+/- 20cm

Specifications for singlemode patch cords (OS2 & OS2-APC style)

- Fiber terminations:

PC = ultra polished style
APC = (8° angled polished style)
- Connector styles:

PC: available in E2000, FC, LC, MTRJ, MU, SC, ST
APC: available in E2000, FC, SC
- Insertion Loss: <0.5dB for MTRJ / <0.3dB (all others)
- Return Loss: >55dB for PC / >60dB for APC
- Standard color: Yellow (others on request)

Specifications for multimode patch cords (OM2, OM3, OM4)

- Fiber types:

OM2 = 50/125µm / OM3 = 50/125µm
OM4 = enhanced 50/125µm
- Fiber termination: PC = ultra polished style
- Connector styles: available in E2000, FC, LC, MTRJ, MU, SC, ST
- Insertion Loss: <0.3dB / typ. 0.2dB
- Standard colors:

OM2 = Orange
OM3 = Blue
OM4 = Magenta
Other colors (on request)

FIBER OPTIC CABLE ASSEMBLIES

Armored Patch Cords Duplex Multimode

	OM2 50/125µm orange color	OM3 50/125µm blue color	OM4 enhanced 50/125µm magenta color
E2000/E2000	APC-E2/PC-E2/PC-53D-xx.xM	APC-E2/PC-E2/PC-33D-xx.xM	APC-E2/PC-E2/PC-43D-xx.xM
E2000/FC	APC-E2/PC-FC/PC-53D-xx.xM	APC-E2/PC-FC/PC-33D-xx.xM	APC-E2/PC-FC/PC-43D-xx.xM
E2000/LC	APC-E2/PC-LC/PC-53C-xx.xM	APC-E2/PC-LC/PC-33C-xx.xM	APC-E2/PC-LC/PC-43C-xx.xM
E2000/MTRJ	APC-E2/PC-MT/PC-53D-xx.xM	APC-E2/PC-MT/PC-33D-xx.xM	APC-E2/PC-MT/PC-43D-xx.xM
E2000/SC	APC-E2/PC-SC/PC-53D-xx.xM	APC-E2/PC-SC/PC-33D-xx.xM	APC-E2/PC-SC/PC-43D-xx.xM
E2000/ST	APC-E2/PC-ST/PC-53D-xx.xM	APC-E2/PC-ST/PC-33D-xx.xM	APC-E2/PC-ST/PC-43D-xx.xM
FC/FC	APC-FC/PC-FC/PC-53D-xx.xM	APC-FC/PC-FC/PC-33D-xx.xM	APC-FC/PC-FC/PC-43D-xx.xM
FC/LC	APC-FC/PC-LC/PC-53C-xx.xM	APC-FC/PC-LC/PC-33C-xx.xM	APC-FC/PC-LC/PC-43C-xx.xM
FC/MTRJ	APC-FC/PC-MT/PC-53D-xx.xM	APC-FC/PC-MT/PC-33D-xx.xM	APC-FC/PC-MT/PC-43D-xx.xM
FC/MU	APC-FC/PC-MU/PC-53D-xx.xM	APC-FC/PC-MU/PC-33D-xx.xM	APC-FC/PC-MU/PC-43D-xx.xM
FC/SC	APC-FC/PC-SC/PC-53D-xx.xM	APC-FC/PC-SC/PC-33D-xx.xM	APC-FC/PC-SC/PC-43D-xx.xM
FC/ST	APC-FC/PC-ST/PC-53D-xx.xM	APC-FC/PC-ST/PC-33D-xx.xM	APC-FC/PC-ST/PC-43D-xx.xM
LC/LC	APC-LC/PC-LC/PC-53C-xx.xM	APC-LC/PC-LC/PC-33C-xx.xM	APC-LC/PC-LC/PC-43C-xx.xM
LC/MPO	APC-LC/PC-MF/PC-53C-xx.xM	APC-LC/PC-MF/PC-33C-xx.xM	APC-LC/PC-MF/PC-43C-xx.xM
LC/MTRJ	APC-LC/PC-MT/PC-53C-xx.xM	APC-LC/PC-MT/PC-33C-xx.xM	APC-LC/PC-MT/PC-43C-xx.xM
LC/MU	APC-LC/PC-MU/PC-53C-xx.xM	APC-LC/PC-MU/PC-33C-xx.xM	APC-LC/PC-MU/PC-43C-xx.xM
LC/SC	APC-LC/PC-SC/PC-53C-xx.xM	APC-LC/PC-SC/PC-33C-xx.xM	APC-LC/PC-SC/PC-43C-xx.xM
LC/ST	APC-LC/PC-ST/PC-53C-xx.xM	APC-LC/PC-ST/PC-33C-xx.xM	APC-LC/PC-ST/PC-43C-xx.xM
MTRJ/MTRJ	APC-MT/PC-MT/PC-53D-xx.xM	APC-MT/PC-MT/PC-33D-xx.xM	APC-MT/PC-MT/PC-43D-xx.xM
MTRJ/SC	APC-MT/PC-SC/PC-53D-xx.xM	APC-MT/PC-SC/PC-33D-xx.xM	APC-MT/PC-SC/PC-43D-xx.xM
MTRJ/ST	APC-MT/PC-ST/PC-53D-xx.xM	APC-MT/PC-ST/PC-33D-xx.xM	APC-MT/PC-ST/PC-43D-xx.xM
MPO/SC	APC-MF/PC-SC/PC-53D-xx.xM	APC-MF/PC-SC/PC-33D-xx.xM	APC-MF/PC-SC/PC-43D-xx.xM
MPO/ST	APC-MF/PC-ST/PC-53D-xx.xM	APC-MF/PC-ST/PC-33D-xx.xM	APC-MF/PC-ST/PC-43D-xx.xM
SC/SC	APC-SC/PC-SC/PC-53D-xx.xM	APC-SC/PC-SC/PC-33D-xx.xM	APC-SC/PC-SC/PC-43D-xx.xM
SC/ST	APC-SC/PC-ST/PC-53D-xx.xM	APC-SC/PC-ST/PC-33D-xx.xM	APC-SC/PC-ST/PC-43D-xx.xM
ST/ST	APC-ST/PC-ST/PC-53D-xx.xM	APC-ST/PC-ST/PC-33D-xx.xM	APC-ST/PC-ST/PC-43D-xx.xM

OPTIONS

Cable length: Replace "xx.x" by cable length in meter
(example: 35.0 = 35 meter cable)

Cable diameter: 3.4mm

Color: OM2 = Orange (other colors on request)
OM3 = Blue (other colors on request)
OM4 = Magenta (other colors on request)

ORDERING CODE STRUCTURE

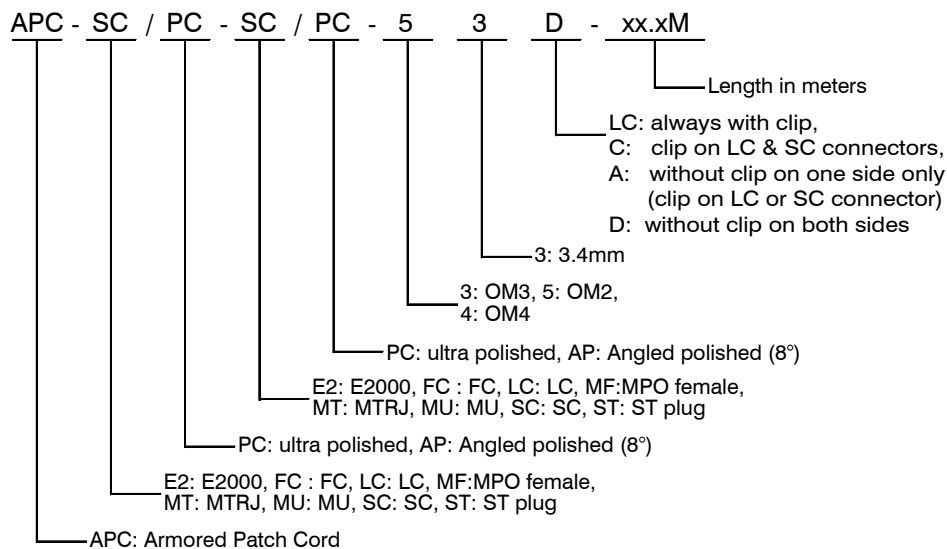

FIBER OPTIC CABLE ASSEMBLIES

Armored Patch Cords

Duplex Singlemode

	OS2 9/125 μ m (PC/PC) Yellow color	OS2-APC 9/125 μ m (APC/APC) Yellow color	Mixed: OS2-APC & OS2 9/125 μ m (APC/APC) Yellow color
E2000/E2000	APC-E2/PC-E2/PC-93D-xx.xM	APC-E2/AP-E2/AP-93D-xx.xM	APC-E2/AP-E2/PC-93D-xx.xM
E2000/FC	APC-E2/PC-FC/PC-93D-xx.xM	APC-E2/AP-FC/AP-93D-xx.xM	APC-E2/AP-FC/PC-93D-xx.xM APC-E2/PC-FC/AP-93D-xx.xM
E2000/LC	APC-E2/PC-LC/PC-93C-xx.xM		APC-E2/AP-LC/PC-93C-xx.xM
E2000/MTRJ	APC-E2/PC-MT/PC-93D-xx.xM		APC-E2/AP-MT/PC-93D-xx.xM
E2000/SC	APC-E2/PC-SC/PC-93D-xx.xM	APC-E2/AP-SC/AP-93D-xx.xM	APC-E2/AP-SC/PC-93D-xx.xM APC-E2/PC-SC/AP-93D-xx.xM
E2000/ST	APC-E2/PC-ST/PC-93D-xx.xM		APC-E2/AP-ST/PC-93D-xx.xM
FC/FC	APC-FC/PC-FC/PC-93D-xx.xM	APC-FC/AP-FC/AP-93D-xx.xM	APC-FC/AP-FC/PC-93D-xx.xM
FC/LC	APC-FC/PC-LC/PC-93C-xx.xM	APC-FC/AP-LC/AP-93C-xx.xM	APC-FC/AP-LC/PC-93C-xx.xM
FC/MPO	APC-FC/PC-MF/PC-93D-xx.xM	APC-FC/AP-MF/AP-93D-xx.xM	APC-FC/AP-MF/PC-93D-xx.xM APC-FC/PC-MF/AP-93D-xx.xM
FC/MTRJ	APC-FC/PC-MT/PC-93D-xx.xM		APC-FC/AP-MT/PC-93D-xx.xM
FC/MU	APC-FC/PC-MU/PC-93D-xx.xM		APC-FC/AP-MU/PC-93D-xx.xM
FC/SC	APC-FC/PC-SC/PC-93D-xx.xM	APC-FC/AP-SC/AP-93D-xx.xM	APC-FC/AP-SC/PC-93D-xx.xM APC-FC/PC-SC/AP-93D-xx.xM
LC/LC	APC-LC/PC-LC/PC-93C-xx.xM		
LC/MPO	APC-LC/PC-MF/PC-93C-xx.xM		APC-LC/PC-MF/AP-93C-xx.xM
LC/MTRJ	APC-LC/PC-MT/PC-93C-xx.xM		
LC/MU	APC-LC/PC-MU/PC-93C-xx.xM		
LC/SC	APC-LC/PC-SC/PC-93C-xx.xM		APC-LC/PC-SC/AP-93C-xx.xM
LC/ST	APC-LC/PC-ST/PC-93C-xx.xM		
MPO/SC	APC-MF/PC-SC/PC-93D-xx.xM	APC-MF/AP-SC/AP-93D-xx.xM	APC-MF/AP-SC/PC-93D-xx.xM APC-MF/PC-SC/AP-93D-xx.xM
MPO/ST	APC-MF/PC-ST/PC-93D-xx.xM		APC-MF/AP-ST/PC-93D-xx.xM
MTRJ/MTRJ	APC-MT/PC-MT/PC-93D-xx.xM		
MTRJ/SC	APC-MT/PC-SC/PC-93D-xx.xM		APC-MT/PC-SC/AP-93D-xx.xM
MTRJ/ST	APC-MT/PC-ST/PC-93D-xx.xM		
SC/SC	APC-SC/PC-SC/PC-93D-xx.xM	APC-SC/AP-SC/AP-93D-xx.xM	APC-SC/AP-SC/PC-93D-xx.xM
SC/ST	APC-SC/PC-ST/PC-93D-xx.xM		APC-SC/AP-ST/PC-93D-xx.xM
ST/ST	APC-ST/PC-ST/PC-93D-xx.xM		

FIBER OPTIC CABLE ASSEMBLIES

Armored Patch Cords Duplex Singlemode

OPTIONS

Cable length:	Replace "xx.x" by cable length in meter (example:35.0 = 35 meter cable)
Cable diameter:	3.4mm
Ultra polished OS2:	PC
Angled polished OS2-APC:	AP (only for E2000, FC, MPO, SC)
Color:	Yellow (standard) Others (on request)

ORDERING CODE STRUCTURE

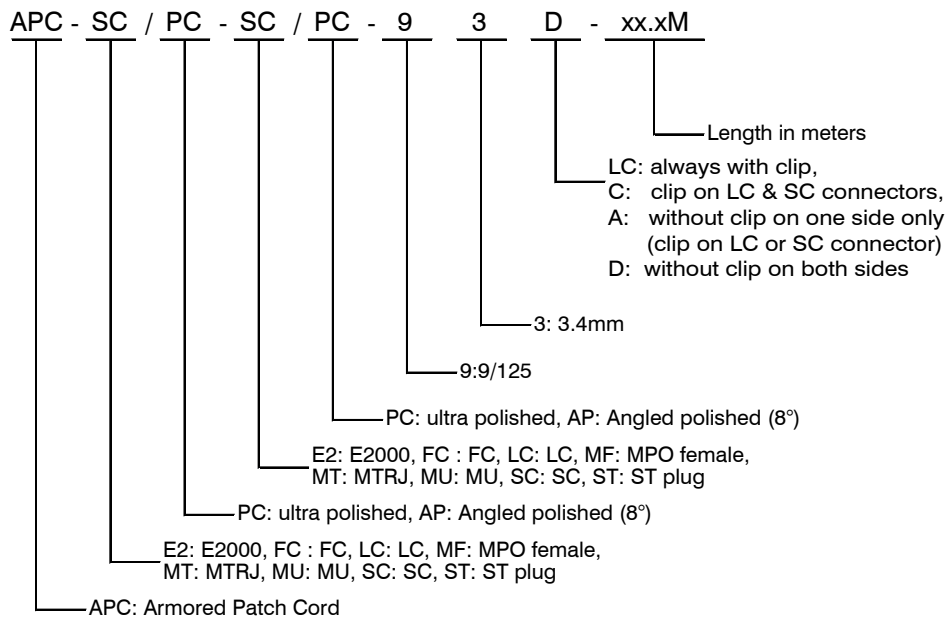

FIBER OPTIC CABLE ASSEMBLIES

Armored Dispatching Cords

The armored dispatching cords are generally used in hard environments and they enhance the stability and safety of the whole network. The fibers are protected by a stainless steel flexible tube, which substantially increases the tensile strength, pressure and twist resistance. As a result it greatly increases the yield during the installation phase and thus offers a high cost saving. The PVC coating of the different branch cords can be offered up to 12 different standard colors (IEC6030) and with a maximum core count of 12. The outer jacket and water retardant belt prevent the fiber from damage due to water and/or humidity.

These cables are mainly used for connecting between floors and multi-core connections to the ODF (Optical Fiber Distribution Frame) and is most suitable for the transmission of the last 100 meters of FTTH (Fiber to the Home).

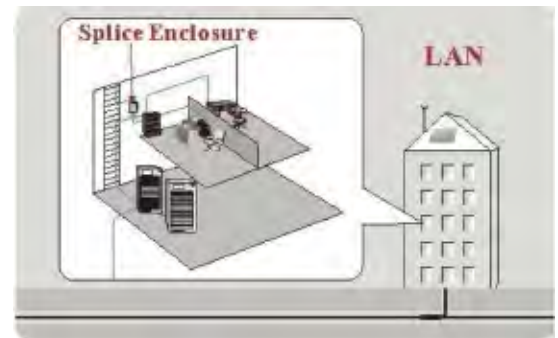
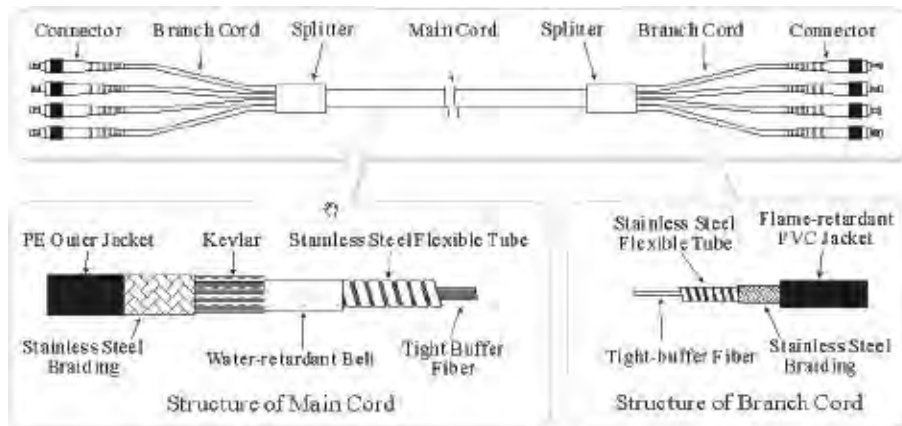

General Specifications

Insertion loss:	SM = 0.2dB max. / MM = 0.3dB max.
Return loss (SM):	45dB min (PC) / 50dB min (UPC) / 60dB min (APC)
Pressure resistance:	≤300 kilos
Tensile resistance:	Main cord: 100 kilos / branch cord: 15 kilos
Operating temperature:	-40°C to +85°C
Cable diameter:	Main cord: 6.0/6.9mm +/- 0.1mm Branch cord: 2.5/3.00mm +/- 0.1mm

FIBER OPTIC CABLE ASSEMBLIES

Armored Dispatching Cords Multimode

	OM2 50/125µm	OM3 50/125µm	OM4 enhanced 50/125µm
E2000/E2000	ADC-E2/PC-E2/PC-5yy-xxxM	ADC-E2/PC-E2/PC-3yy-xxxM	ADC-E2/PC-E2/PC-4yy-xxxM
E2000/FC	ADC-E2/PC-FC/PC-5yy-xxxM	ADC-E2/PC-FC/PC-3yy-xxxM	ADC-E2/PC-FC/PC-4yy-xxxM
E2000/LC	ADC-E2/PC-LC/PC-5yy-xxxM	ADC-E2/PC-LC/PC-3yy-xxxM	ADC-E2/PC-LC/PC-4yy-xxxM
E2000/MTRJ	ADC-E2/PC-MT/PC-5yy-xxxM	ADC-E2/PC-MT/PC-3yy-xxxM	ADC-E2/PC-MT/PC-4yy-xxxM
E2000/SC	ADC-E2/PC-SC/PC-5yy-xxxM	ADC-E2/PC-SC/PC-3yy-xxxM	ADC-E2/PC-SC/PC-4yy-xxxM
E2000/ST	ADC-E2/PC-ST/PC-5yy-xxxM	ADC-E2/PC-ST/PC-3yy-xxxM	ADC-E2/PC-ST/PC-4yy-xxxM
FC/FC	ADC-FC/PC-FC/PC-5yy-xxxM	ADC-FC/PC-FC/PC-3yy-xxxM	ADC-FC/PC-FC/PC-4yy-xxxM
FC/LC	ADC-FC/PC-LC/PC-5yy-xxxM	ADC-FC/PC-LC/PC-3yy-xxxM	ADC-FC/PC-LC/PC-4yy-xxxM
FC/MTRJ	ADC-FC/PC-MT/PC-5yy-xxxM	ADC-FC/PC-MT/PC-3yy-xxxM	ADC-FC/PC-MT/PC-4yy-xxxM
FC/MU	ADC-FC/PC-MU/PC-5yy-xxxM	ADC-FC/PC-MU/PC-3yy-xxxM	ADC-FC/PC-MU/PC-4yy-xxxM
FC/SC	ADC-FC/PC-SC/PC-5yy-xxxM	ADC-FC/PC-SC/PC-3yy-xxxM	ADC-FC/PC-SC/PC-4yy-xxxM
LC/LC	ADC-LC/PC-LC/PC-5yy-xxxM	ADC-LC/PC-LC/PC-3yy-xxxM	ADC-LC/PC-LC/PC-4yy-xxxM
LC/MTRJ	ADC-LC/PC-MT/PC-5yy-xxxM	ADC-LC/PC-MT/PC-3yy-xxxM	ADC-LC/PC-MT/PC-4yy-xxxM
LC/MU	ADC-LC/PC-MU/PC-5yy-xxxM	ADC-LC/PC-MU/PC-3yy-xxxM	ADC-LC/PC-MU/PC-4yy-xxxM
LC/SC	ADC-LC/PC-SC/PC-5yy-xxxM	ADC-LC/PC-SC/PC-3yy-xxxM	ADC-LC/PC-SC/PC-4yy-xxxM
LC/ST	ADC-LC/PC-ST/PC-5yy-xxxM	ADC-LC/PC-ST/PC-3yy-xxxM	ADC-LC/PC-ST/PC-4yy-xxxM
MTRJ/MTRJ	ADC-MT/PC-MT/PC-5yy-xxxM	ADC-MT/PC-MT/PC-3yy-xxxM	ADC-MT/PC-MT/PC-4yy-xxxM
MTRJ/SC	ADC-MT/PC-SC/PC-5yy-xxxM	ADC-MT/PC-SC/PC-3yy-xxxM	ADC-MT/PC-SC/PC-4yy-xxxM
MTRJ/ST	ADC-MT/PC-ST/PC-5yy-xxxM	ADC-MT/PC-ST/PC-3yy-xxxM	ADC-MT/PC-ST/PC-4yy-xxxM
SC/SC	ADC-SC/PC-SC/PC-5yy-xxxM	ADC-SC/PC-SC/PC-3yy-xxxM	ADC-SC/PC-SC/PC-4yy-xxxM
SC/ST	ADC-SC/PC-ST/PC-5yy-xxxM	ADC-SC/PC-ST/PC-3yy-xxxM	ADC-SC/PC-ST/PC-4yy-xxxM
ST/ST	ADC-ST/PC-ST/PC-5yy-xxxM	ADC-ST/PC-ST/PC-3yy-xxxM	ADC-ST/PC-ST/PC-4yy-xxxM

OPTIONS

Cable length: Replace "yy-xxxM", "yy" by number of fibers (04, 06, 08, 12) and "xxx" by length in meters (total cable length, including breakout cables)
 Examples: 12-020M = 12 fibers / 20 Meters
 04-100M = 4 fibers / 100 Meters

Breakout cable length (Branch cords): 1 meters (standard) – others on request

Colors: Main cable: black
 Break-out cables: Individual colors for easy identification

ORDERING CODE STRUCTURE

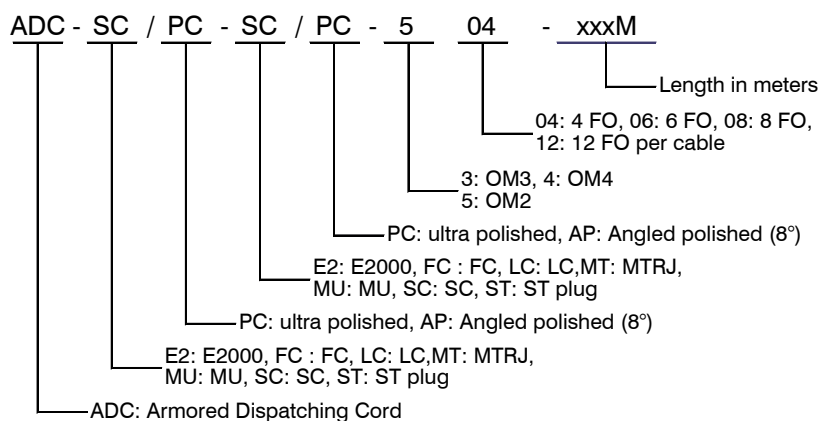

FIBER OPTIC CABLE ASSEMBLIES

Armored Dispatching Cords Singlemode

	OS2 9/125 μ m (PC/PC)	OS2-APC 9/125 μ m (APC/APC)	Mixed: OS2-APC & OS2 9/125 μ m (APC/APC)
E2000/E2000	ADC-E2/PC-E2/PC-9yy-xxxM	ADC-E2/AP-E2/AP-9yy-xxxM	ADC-E2/AP-E2/PC-9yy-xxxM
E2000/FC	ADC-E2/PC-FC/PC-9yy-xxxM	ADC-E2/AP-FC/AP-9yy-xxxM	ADC-E2/AP-FC/PC-9yy-xxxM
E2000/LC	ADC-E2/PC-LC/PC-9yy-xxxM		ADC-E2/AP-LC/PC-9yy-xxxM
E2000/SC	ADC-E2/PC-SC/PC-9yy-xxxM	ADC-E2/AP-SC/AP-9yy-xxxM	ADC-E2/AP-SC/PC-9yy-xxxM
E2000/ST	ADC-E2/PC-ST/PC-9yy-xxxM		ADC-E2/AP-ST/PC-9yy-xxxM
FC/FC	ADC-FC/PC-FC/PC-9yy-xxxM	ADC-FC/AP-FC/AP-9yy-xxxM	ADC-FC/AP-FC/PC-9yy-xxxM
FC/LC	ADC-FC/PC-LC/PC-9yy-xxxM		ADC-FC/AP-LC/PC-9yy-xxxM
FC/MU	ADC-FC/PC-MU/PC-9yy-xxxM		ADC-FC/AP-MU/PC-9yy-xxxM
FC/SC	ADC-FC/PC-SC/PC-9yy-xxxM	ADC-FC/AP-SC/AP-9yy-xxxM	ADC-FC/AP-SC/PC-9yy-xxxM
LC/LC	ADC-LC/PC-LC/PC-9yy-xxxM		
LC/MU	ADC-LC/PC-MU/PC-9yy-xxxM		
LC/SC	ADC-LC/PC-SC/PC-9yy-xxxM		ADC-LC/PC-SC/AP-9yy-xxxM
LC/ST	ADC-LC/PC-ST/PC-9yy-xxxM		
SC/SC	ADC-SC/PC-SC/PC-9yy-xxxM	ADC-SC/AP-SC/AP-9yy-xxxM	ADC-SC/AP-SC/PC-9yy-xxxM
SC/ST	ADC-SC/PC-ST/PC-9yy-xxxM		
ST/ST	ADC-ST/PC-ST/PC-9yy-xxxM		

OPTIONS

Cable length: Replace "yy-xxxM", "yy" by number of fibers (04, 06, 08, 12) and "xxx" by length in meters (total cable length, including breakout cables)
 Examples: 12-020M = 12 fibers / 20 Meters
 04-100M = 4 fibers / 100 Meters

Breakout cable length (Branch cords): 1 meters (standard) – others on request

Colors: Main cable: black
 Break-out cables: Individual colors for easy identification

ORDERING CODE STRUCTURE

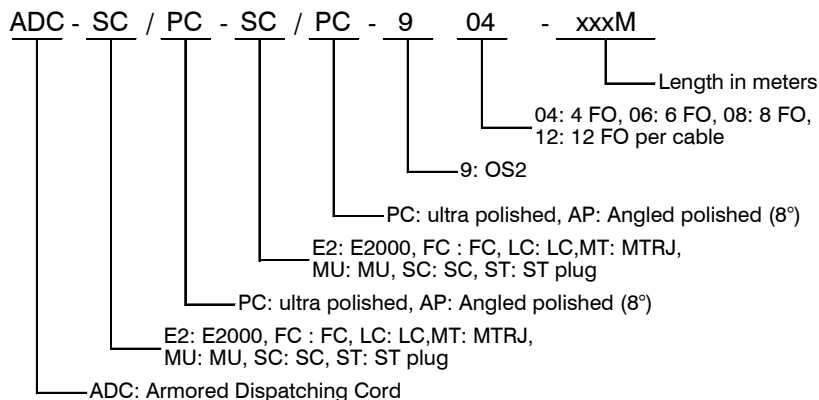

Mode Conditioning Patch Cords

Multimode optical fiber cables which are linked to a laser based transmitter can be limited in bandwidth to values less than half of the over-filled launch bandwidth. The bandwidth is very low in the case of center launch and the E-tec Interconnect Ltd mode conditioning patch cords are designed to transmit your gigabit signals into conventional precision fusion spliced to the multimode fiber to a precise core alignment. The light is launched on to the multimode fiber at a precise angle, giving the cable its mode conditioning properties. The fusion splice of the mode conditioning cable assembly is protected by a black over-wrap and the yellow side of the cable connects to the transmit side of the gigabit equipment.



Mode conditioning cables are generally used when the link distances exceed 300 meters. The E-tec Interconnect Ltd mode conditioning cable assemblies allow long wave length signals at 1310 nm to be transmitted up to 550 meter distances. The Gigabit hubs (VCSEL) are used in gigabit ethernet applications, based on a singlemode launch condition and they operate over both singlemode and multimode fiber. Differential mode delay (DMD) occurs when the transmitter device launches a singlemode laser signal into the center of the multimode fiber, resulting in transmission of multiple signals. Such signals confuse the receiver with resultant limitations on the operating bandwidth and especially the drive distances of the gigabit ethernet. The E-tec Interconnect Ltd mode conditioning cables eliminate this differential mode delay by moving the singlemode launch to an offset position away from the center of the fiber where the impurities are found.

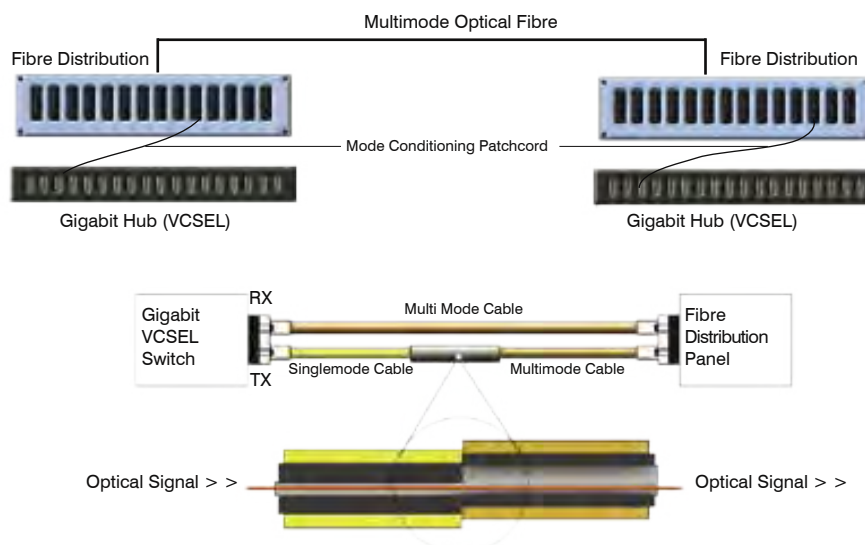

FIBER OPTIC CABLE ASSEMBLIES

Mode Conditioning Patch Cords

Equipment side MM/SM		Cable plant side MM/MM	OM2 50/125 μ m	OM3 50/125 μ m	OM4 enhanced 50/125 μ m
FC	to	FC	FMC-FC/PC-FC/PC-5D-xxxM	FMC-FC/PC-FC/PC-3D-xxxM	FMC-FC/PC-FC/PC-4D-xxxM
FC	to	LC	FMC-FC/PC-LC/PC-5C-xxxM	FMC-FC/PC-LC/PC-3C-xxxM	FMC-FC/PC-LC/PC-4C-xxxM
FC	to	SC	FMC-FC/PC-SC/PC-5D-xxxM	FMC-FC/PC-SC/PC-3D-xxxM	FMC-FC/PC-SC/PC-4D-xxxM
FC	to	ST	FMC-FC/PC-ST/PC-5D-xxxM	FMC-FC/PC-ST/PC-3D-xxxM	FMC-FC/PC-ST/PC-4D-xxxM
LC	to	FC	FMC-LC/PC-FC/PC-5C-xxxM	FMC-LC/PC-FC/PC-3C-xxxM	FMC-LC/PC-FC/PC-4C-xxxM
LC	to	LC	FMC-LC/PC-LC/PC-5C-xxxM	FMC-LC/PC-LC/PC-3C-xxxM	FMC-LC/PC-LC/PC-4C-xxxM
LC	to	SC	FMC-LC/PC-SC/PC-5C-xxxM	FMC-LC/PC-SC/PC-3C-xxxM	FMC-LC/PC-SC/PC-4C-xxxM
LC	to	ST	FMC-LC/PC-ST/PC-5C-xxxM	FMC-LC/PC-ST/PC-3C-xxxM	FMC-LC/PC-ST/PC-4C-xxxM
SC	to	LC	FMC-SC/PC-LC/PC-5C-xxxM	FMC-SC/PC-LC/PC-3C-xxxM	FMC-SC/PC-LC/PC-4C-xxxM
SC	to	SC	FMC-SC/PC-SC/PC-5D-xxxM	FMC-SC/PC-SC/PC-3D-xxxM	FMC-SC/PC-SC/PC-4D-xxxM
SC	to	ST	FMC-SC/PC-ST/PC-5D-xxxM	FMC-SC/PC-ST/PC-3D-xxxM	FMC-SC/PC-ST/PC-4D-xxxM
ST	to	FC	FMC-ST/PC-FC/PC-5D-xxxM	FMC-ST/PC-FC/PC-3D-xxxM	FMC-ST/PC-FC/PC-4D-xxxM
ST	to	LC	FMC-ST/PC-LC/PC-5C-xxxM	FMC-ST/PC-LC/PC-3C-xxxM	FMC-ST/PC-LC/PC-4C-xxxM
ST	to	SC	FMC-ST/PC-SC/PC-5D-xxxM	FMC-ST/PC-SC/PC-3D-xxxM	FMC-ST/PC-SC/PC-4D-xxxM
ST	to	ST	FMC-ST/PC-ST/PC-5D-xxxM	FMC-ST/PC-ST/PC-3D-xxxM	FMC-ST/PC-ST/PC-4D-xxxM

OPTIONS

Cable length: Replace "xx.xM" by cable length in meter
Examples: 25.0M = 25 Meters

ORDERING CODE STRUCTURE

FMC - SC / PC - SC / PC - 5 D - xx.xM

Length in meters

LC: always with clip,
C: clip on LC & SC connectors,
A: without clip on one side only
(clip on LC or SC connector)
D: without clip on both sides

5: OM2 50/125
3: OM3 50/125
4: OM4 enhanced 50/125

PC: ultra polished, AP: Angled polished (8°)

Cable plant side:
FC: FC, LC: LC, SC: SC, ST: ST plug

PC: ultra polished, AP: Angled polished (8°)

Equipment side:
FC: FC, LC: LC, SC: SC, ST: ST

FMC: Fiber Mode Conditioning patch cord

TRANSCEIVER

Gigabit Transceivers

E-tec Interconnect Ltd offers a comprehensive range of Gigabit interface converters (GBIC) compatible with Cisco, 3com, HP, Alcatel, etc., commonly used with Gigabit Ethernet for copper and fiber channel. The GBIC is a hot swappable electrical interface and the long-wavelength SFP transceivers are compatible with the Small Form Factor Multi-Sourcing Agreement (MSA) and comply with the IEEE standards for Gigabit Ethernet applications.



The following Gigabit long-wave SFP Transceiver are available as standard products from E-tec Interconnect Ltd and any other types are available on request:

Ordering Code	Transceiver description
GBIC-GLC-T -SFP	1000Base T (RJ45/100m/ Cat5e) transceiver for CISCO
GBIC-GLC-SX-MM-SFP	1000Base SX (LC/550m/850nm/Multimode) transceiver for CISCO
GBIC-GLC-LH-SM-SFP	1000Base LX (LC/10km/1310nm/singlemode) transceiver for CISCO
GBIC-GLC-ZX-SM-SFP	1000Base ZX (LC/70km/1550nm/singlemode) transceiver for CISCO

General SFP dimensions

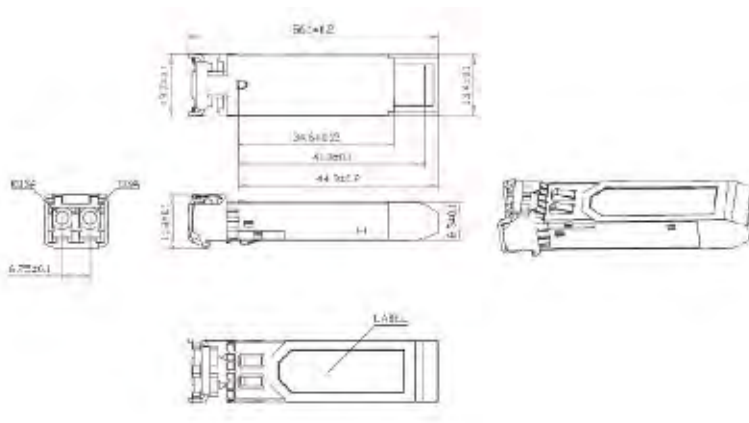

Product features

- Up to 1.25Gb/s bi-directional data links (all others on request)
- Hot pluggable SFP footprint
- 850nm, 1310 & 1550 nm Fabry-Perot laser transmitter
- Duplex LC connector
- Very low jitter
- No Rate Select input required for Fiber Channel 1x/2x Operation
- Up to 70 km on 9/125 μ m SM fiber (depending on GBIC type)
- Metal enclosure for lower EMI
- Single 3.3V power supply
- Low power dissipation <700mW typical
- CWDM is also available

Applications

- Gigabit Ethernet
- 1x Fiber or 1x copper channel
- Switch to Switch interface
- Switched backplane applications
- Router/Server interface
- Other optical transmission systems

Gigabit Transceivers

Technical Specifications

1. Absolute Maximum Ratings

Parameter	Symbol	Min	Typ	Max	Unit	Note
Maximum Supply Voltage	Vcc	0.5		4.5	V	
Storage Temperature	TS	-40		100	°C	
Case Operating Temperature	TOP	-40		85	°C	
Relative Humidity	RH	0		85	%	1

2. Electrical Characteristics (TOP = -40°C to +85°C, VCC 3V to 3.60V)

Parameter	Symbol	Min	Typ	Max	Unit	Note
Supply Voltage	Vcc	3		3.6	V	
Supply Current	Icc		200	300	mA	
Transmitter						
Input differential impedance	Rin		100		Ω	2
Single ended data input swing	Vin,pp	250		1200	mV	
Transmit Disable Voltage	VD	Vcc – 1.3		Vcc	V	
Transmit Enable Voltage	VEN	Vee		Vee+ 0.8	V	3
Transmit Disable Assert Time				10	us	
Receiver						
Single ended data output swing	Vout,pp	300	400	800	mV	4
Data output rise time	tr		100	175	ps	5
Data output fall time	tf		100	175	ps	5
LOS Fault	VLOS fault	Vcc – 0.5		VccHOST	V	6
LOS Normal	VLOS	norm Vee		Vee+0.5	V	6
Power Supply Rejection	PSR	100			mVpp	7
Deterministic Jitter Contribution	RX Δ DJ			51.7	ps	8
Total Jitter Contribution	RX Δ TJ			122.4	ps	

Notes:

1. Non condensing.
2. AC coupled.
3. Or open circuit.
4. Into 100 ohm differential termination.
5. 20 – 80 %
6. LOS is LVTTTL. Logic 0 indicates normal operation; logic 1 indicates no signal detected.
7. All transceiver specifications are compliant with a power supply sinusoidal modulation of 20 Hz to 1.5 MHz up to specified value applied through the power supply filtering network shown on page 23 of the Small Form-factor Pluggable (SFP) Transceiver MultiSource Agreement (MSA), September 14, 2000.
8. Measured with DJ-free data input signal. In actual application, output DJ will be the sum of input DJ and DJ and Δ DJ.

Gigabit Transceivers

3. Optical Characteristics (TOP = 0°C to +70°C, VCC 3V to 3.60V)

Parameter	Symbol	Min	Typ	Max	Unit	Note
Transmitter						
Output Opt. Power	POUT	-8		0	dBm	1
Optical Wavelength	λ	1270	1310	1360	nm	2
Spectral Width	σ			3	nm	2
Optical Modulation Amplitude	OMA	174			μ W	2,3
Optical Rise/Fall Time	tr/ tf		100	160	ps	4
RIN				-120	dB/Hz	
Deterministic Jitter Contribution	TX Δ DJ		20	56.5	ps	5
Total Jitter Contribution	TX Δ TJ		70	119	ps	
Optical Extinction Ratio	ER	9			dB	
Receiver						
Average Rx Sensitivity @ 2.125 Gb/s (2X Fiber Channel)	RSENS1			-21	dBm	6, 7
Average Rx Sensitivity @ 1.25 Gb/s (Gigabit Ethernet)	RSENS2			-22	dBm	6, 7
Average Rx Sensitivity @ 1.06 Gb/s (1X Fiber Channel)	RSENS1			-22	dBm	6, 7
Stressed RX sens. = 1.25 Gb/s			-18	-14.5	dBm	
Average Received Power	RxMAX			0	dBm	
Receiver Elec. 3 dB cutoff freq.				1500	MHz	
Optical Center Wavelength	λ C	1265		1600	nm	
Return Loss		12			dB	
LOS De-Assert	LOSD		-23	-19	dBm	
LOS Assert	LOSA	-30	-25		dBm	
LOS Hysteresis		0.5			dB	

Notes:

1. Class 1 Laser Safety per FDA/CDRH and EN (IEC) 60825 regulations.
2. Also specified to meet curves in FC-PI 13.0 Figures 18 and 19, which allow trade-off between wavelength, spectral width and OMA.
3. Equivalent extinction ratio specification for Fiber Channel. Allows smaller ER at higher average power.
4. Unfiltered, 20-80%. Complies with IEEE 802.3 (Gig. E), FC 1x and 2x eye masks when filtered.
5. Measured with DJ-free data iMeasured with DJ-free data ion, output DJ will be the sum of input DJ and Δ DJ.
6. Measured with conformance signals defined in FC-PI 13.0 specifications.
7. Measured with PRBS 27-1 at 10-12 BER.

Fiber Optic Attenuators

E-tec Interconnect Ltd singlemode attenuators are used in communication systems to reduce the optical power launched onto receivers. These high performance devices give accurate attenuation and they are designed to be plugged directly onto the ends of the fiber optical cable and inserted into the appropriate adapter.

These fiber optical attenuators are available in FC, LC, MU, SC, ST connector styles with PC and APC finish and for a wavelength operation of 1310nm (others on request).



Standard types:

Connector/Cable style

Order code :

FC/PC	FAT-05-FC/PC-1
FC/APC	FAT-05-FC/AP-1
LC/PC	FAT-05-LC/PC-1
MU/PC	FAT-05-MU/PC-1
SC/PC	FAT-05-SC/PC-1
SC/APC	FAT-05-SC/AP-1

ORDERING CODE STRUCTURE

FAT - 05 - SC / PC - 1

1: 1310nm, 2: 1550nm,
3: 1310nm and 1550nm

PC: ultra polished, AP: Angled polished (8°)

E2: E2000, FC : FC, LC: LC
SC: SC, ST: ST plug

05: -5dB, 10: -10db

FAT: Fiber optic Attenuator

Features:

- Plug-in type
- Ultra low back reflection
- Accurate attenuation
- RoHS compliant

Applications:

- Telecommunications Networks
- CATV
- FTTX
- LAN and WAN
- Test & Measurement

Specifications:

Available attenuation:

1.0 to 30 dB with 1.0dB increments

Attenuation tolerance:

up to 5dB = +/- 0.5dB / as of 5dB
= +/- 10% of nominal value

Return Loss:

PC (ultra polished style) >55dB
/ APC (angled polished style) >60dB

Operating wavelength:

1310nm (others on request)

Temperature range:

-40°C to +85°C

FIBER OPTIC ACCESSORIES

Fiber Optic Adapters

The fiber optic adapters are used to mate two connectors together within a distribution panel or wall box. The E-tec Interconnect Ltd fiber optic adapters are precision made to ensure perfect alignment of the connections in order to keep the insertion loss to a minimum. Phosphor bronze sleeves are for general use and the ceramic versions are generally used in singlemode low loss environments. The MTRJ and MPO connectors incorporate two small alignment pins, so that the fiber optic adapter for these two versions simply supports and locks the connectors together.

E2000



Multimode Simplex
Beige color
FAD-E2/PC-E2/PC-MS-F



Singlemode Simplex
Blue color
FAD-E2/PC-E2/PC-SS-F



Singlemode APC Simplex
Green color
FAD-E2/AP-E2/AP-SS-F

FC



Multimode Simplex
Black cap
FAD-FC/PC-FC/PC-MS-D



Singlemode Simplex
Yellow cap
FAD-FC/PC-FC/PC-SS-D



Singlemode APC Simplex
Green cap
FAD-FC/AP-FC/AP-SS-D

LC



Multimode Duplex
Beige color
FAD-LC/PC-LC/PC-MD-F



Singlemode Duplex
Blue color
FAD-LC/PC-LC/PC-SD-F



Singlemode APC Duplex
Green color
FAD-LC/AP-LC/AP-SD-F



Quad Multimode
Beige color
FAD-LC/PC-LC/PC-MQ-F



Quad Singlemode
Blue color
FAD-LC/PC-LC/PC-SQ-F

MTRJ & MPO



Multimode MTRJ Duplex
Black color
FAD-MT/PC-MT/PC-MD-F



Multimode MPO Simplex PC
Black color
FAD-MP/PC-MP/PC-MS-F



Singlemode MPO Simplex APC
Black color
FAD-MP/AP-MP/AP-SS-F

MU



Singlemode
Metal color
FAD-MU/PC-MU/PC-SD-F

FIBER OPTIC ACCESSORIES

Fiber Optic Adapters

SC



Multimode Simplex
Beige color
FAD-SC/PC-SC/PC-MS-F

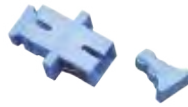

Singlemode Simplex
Blue color
FAD-SC/PC-SC/PC-SS-F



Singlemode APC Simplex
Green color
FAD-SC/AP-SC/AP-SS-F



Multimode Duplex
Beige color
FAD-SC/PC-SC/PC-MD-F



Singlemode Duplex
Blue color
FAD-SC/PC-SC/PC-SD-F



Singlemode APC Duplex
Green color
FAD-SC/AP-SC/AP-SD-F

ST



Multimode Simplex
Black cap
FAD-ST/PC-ST/PC-MS-D



Singlemode Simplex
Yellow cap
FAD-ST/PC-ST/PC-SS-D

Hybrid



SC-ST Multimode Duplex
Beige color
FAD-SC/PC-ST/PC-MD-F



SC-ST Singlemode Duplex
Blue color
FAD-SC/PC-ST/PC-SD-F



SC-FC Singlemode Simplex
Blue color
FAD-SC/PC-FC/PC-SS-F

Keystone Jack adapters



Blank type
White color
FAD-KT-BK-W



LC Duplex/SC type (square)
White color
FAD-KT-SC-W



ST type (round)
White color
FAD-KT-ST-W

FIBER OPTIC ACCESSORIES

Fiber Optic Adapters

ORDERING CODE STRUCTURE

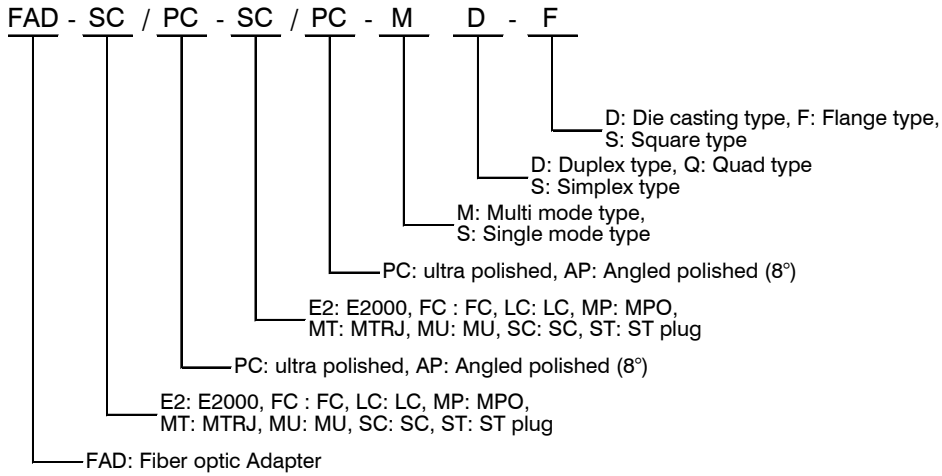

Keystone Jack Adapters

ORDERING CODE STRUCTURE

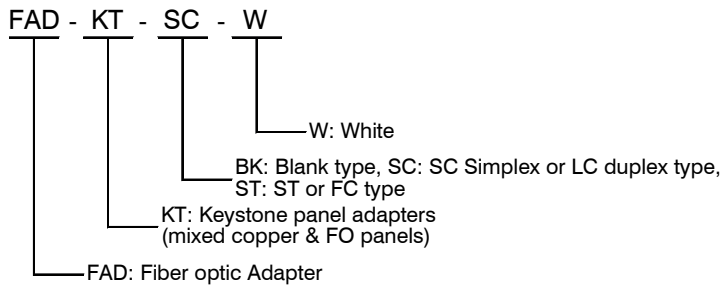

FIBER OPTIC PATCH PANELS

Description Sliding Patch Panels

E-Tec Interconnect Ltd offers an innovative, robust 1U sliding patch panel. This panel has been designed to accept up to 48 fibres housed within a 1U space.

With the ability to use a full array of Adaptor types offering a flexible solution to the end user, enabling them to incorporate a multi functional panel which allow easy access during installation or re-work with no disturbance of the existing cable or fibres.

In the addition to the array of adaptors the panel also offers multiple cable entry solutions, up to 4 standard cable entry points for, loose tube, tight buffer, pre terminated and steel tape armoured cable.

Each panels has integrated strength member tie positions also with the additional removable plate at the rear of the panel allows the installation of steel tape armored cable.



Features / Benefits

- Up to 48 fibres in 1U
- Multiple Adaptor options available
- 24 Adaptor positions
- Individually labelled ports
- 45° open working angle
- Accepts loose tube, distribution and pre terminated cables
- ROHS, REACH SvHC and UL rated
- Fits standard 19"

Applications

- Data centres, premise instalations, telecommunication networks
- Ethernet, fibre Channel, ATM, LAN, MAN, and WAN
- Data communication
- Indoor applications

Technical Specification

Element	Characteristic
U Size	1U (44.4mm)
Width	482mm
Depth	205mm
Net. weight	2.5 kgs
Packaged weight	3 kgs
Packaged dimensions	450mm W X 55mm H x 280mm D
IP rating	IP20
Suitable for Adaptor type	SC Duplex
Number of ports	24
Cable Entry 20mm	2
Cable entry 25mm	2
Mounting Adjustment range	50mm
Material	Cold- rolled steel
Material thickness	1.2mm
Material coating	Powder coating
Colour	RAL 9004
Operating temperature	-40°c to +50°c
Designed in accordance with	TIA/EIA 568 C, ISO/IEC 11801, EN50173, IEC60304, IEC61754, EN297-1
Compliant to	RoHS, Reach/SVHC

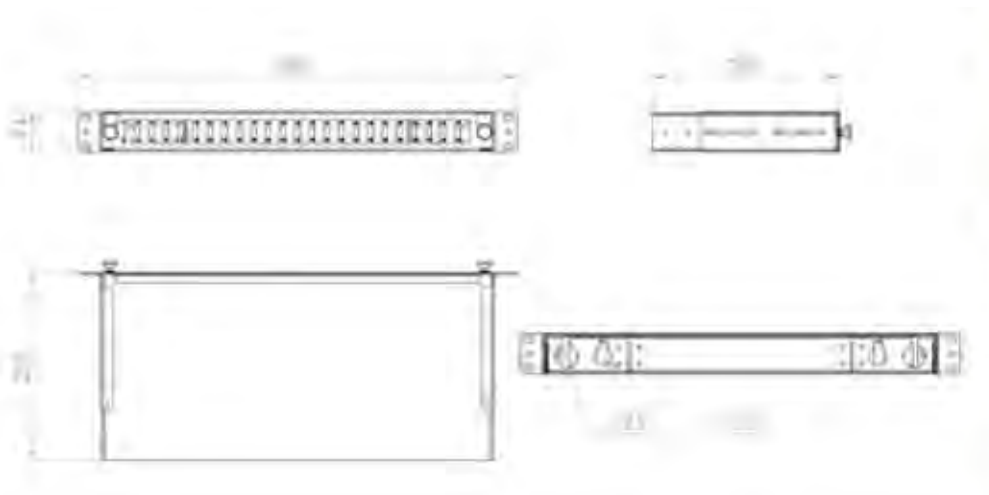

FIBER OPTIC PATCH PANELS

Sliding Patch Panels

FC, ST Patch Panels (Sliding tray style)

24-port



Order Code (empty 24-port patch panel): **SPP-24-N-FC/ST-ME-B**

	With	FC Multimode – 24 Port	FC Singlemode – 24 Port
	4 adapters	SPP-24-N-FC/PC-MS-ME-04-B	SPP-24-N-FC/PC-SS-ME-04-B
	8 adapters	SPP-24-N-FC/PC-MS-ME-08-B	SPP-24-N-FC/PC-SS-ME-08-B
	12 adapters	SPP-24-N-FC/PC-MS-ME-12-B	SPP-24-N-FC/PC-SS-ME-12-B
	16 adapters	SPP-24-N-FC/PC-MS-ME-16-B	SPP-24-N-FC/PC-SS-ME-16-B
	fully loaded	SPP-24-N-FC/PC-MS-ME-24-B	SPP-24-N-FC/PC-SS-ME-24-B
	Adapters only	FAD-FC/PC-FC/PC-MS-D	FAD-FC/PC-FC/PC-SS-D
	With	FC APC Singlemode – 24 Port	
	4 adapters	SPP-24-N-FC/AP-SS-ME-04-B	
	8 adapters	SPP-24-N-FC/AP-SS-ME-08-B	
	12 adapters	SPP-24-N-FC/AP-SS-ME-12-B	
	16 adapters	SPP-24-N-FC/AP-SS-ME-16-B	
	fully loaded	SPP-24-N-FC/AP-SS-ME-24-B	
	Adapters only	FAD-FC/AP-FC/AP-SS-D	
	With	ST Multimode – 24 Port	ST Singlemode – 24 Port
	4 adapters	SPP-24-N-ST/PC-MS-ME-04-B	SPP-24-N-ST/PC-SS-ME-04-B
	8 adapters	SPP-24-N-ST/PC-MS-ME-08-B	SPP-24-N-ST/PC-SS-ME-08-B
	12 adapters	SPP-24-N-ST/PC-MS-ME-12-B	SPP-24-N-ST/PC-SS-ME-12-B
	16 adapters	SPP-24-N-ST/PC-MS-ME-16-B	SPP-24-N-ST/PC-SS-ME-16-B
	fully loaded	SPP-24-N-ST/PC-MS-ME-24-B	SPP-24-N-ST/PC-SS-ME-24-B
	Adapters only	FAD-ST/PC-ST/PC-MS-D	FAD-ST/PC-ST/PC-SS-D

See Cable Management Accessories for further options

FIBER OPTIC PATCH PANELS

Sliding Patch Panels

E2000, LC, MTRJ Patch Panels

(Sliding tray style – vertical adapter position)



24-port

Order Code (empty 24-port patch panel): **SPP-24-V-E2/LC/MT/SC-ME-B**

Adapters

With	E2000 Multimode – 24 Port	E2000 Singlemode – 24 Port
4 adapters	SPP-24-V-E2/PC-MS-ME-04-B	SPP-24-V-E2/PC-SS-ME-04-B
8 adapters	SPP-24-V-E2/PC-MS-ME-08-B	SPP-24-V-E2/PC-SS-ME-08-B
12 adapters	SPP-24-V-E2/PC-MS-ME-12-B	SPP-24-V-E2/PC-SS-ME-12-B
16 adapters	SPP-24-V-E2/PC-MS-ME-16-B	SPP-24-V-E2/PC-SS-ME-16-B
fully loaded	SPP-24-V-E2/PC-MS-ME-24-B	SPP-24-V-E2/PC-SS-ME-24-B
Adapters only	FAD-E2/PC-E2/PC-MS-F	FAD-E2/PC-E2/PC-SS-F
With	E2000 APC Singlemode - 24 Port	MTRJ – 24 Port
4 adapters	SPP-24-V-E2/AP-SS-ME-04-B	SPP-24-V-MT/PC-MD-ME-04-B
8 adapters	SPP-24-V-E2/AP-SS-ME-08-B	SPP-24-V-MT/PC-MD-ME-08-B
12 adapters	SPP-24-V-E2/AP-SS-ME-12-B	SPP-24-V-MT/PC-MD-ME-12-B
16 adapters	SPP-24-V-E2/AP-SS-ME-16-B	SPP-24-V-MT/PC-MD-ME-16-B
fully loaded	SPP-24-V-E2/AP-SS-ME-24-B	SPP-24-V-MT/PC-MD-ME-24-B
Adapters only	FAD-E2/AP-E2/AP-SS-F	FAD-MT/PC-MT/PC-MD-F
With	LC Multimode Duplex– 24 Port	LC Singlemode Duplex– 24 Port
4 adapters	SPP-24-V-LC/PC-MD-ME-04-B	SPP-24-V-LC/PC-SD-ME-04-B
8 adapters	SPP-24-V-LC/PC-MD-ME-08-B	SPP-24-V-LC/PC-SD-ME-08-B
12 adapters	SPP-24-V-LC/PC-MD-ME-12-B	SPP-24-V-LC/PC-SD-ME-12-B
16 adapters	SPP-24-V-LC/PC-MD-ME-16-B	SPP-24-V-LC/PC-SD-ME-16-B
fully loaded	SPP-24-V-LC/PC-MD-ME-24-B	SPP-24-V-LC/PC-SD-ME-24-B
Adapters only	FAD-LC/PC-LC/PC-MD-F	FAD-LC/PC-LC/PC-SD-F

See Cable Management Accessories for further options

FIBER OPTIC PATCH PANELS

Sliding Patch Panels

SC Patch Panels

(Sliding tray style – vertical adapter position)

24-port



Order Code (empty 24-port patch panel): **SPP-24-V-SC-ME-B**

With	SC Multimode Simplex – 24 Port	SC Singlemode Simplex– 24 Port
4 adapters	SPP-24-V-SC/PC-MS-ME-04-B	SPP-24-V-SC/PC-SS-ME-04-B
8 adapters	SPP-24-V-SC/PC-MS-ME-08-B	SPP-24-V-SC/PC-SS-ME-08-B
12 adapters	SPP-24-V-SC/PC-MS-ME-12-B	SPP-24-V-SC/PC-SS-ME-12-B
16 adapters	SPP-24-V-SC/PC-MS-ME-16-B	SPP-24-V-SC/PC-SS-ME-16-B
fully loaded	SPP-24-V-SC/PC-MS-ME-24-B	SPP-24-V-SC/PC-SS-ME-24-B
Adapters only	FAD-SC/PC-SC/PC-MS-F	FAD-SC/PC-SC/PC-SS-F

Adapters

With	SC Singlemode APC Simplex– 24 Port
4 adapters	SPP-24-V-SC/AP-SS-ME-04-B
8 adapters	SPP-24-V-SC/AP-SS-ME-08-B
12 adapters	SPP-24-V-SC/AP-SS-ME-12-B
16 adapters	SPP-24-V-SC/AP-SS-ME-16-B
fully loaded	SPP-24-V-SC/AP-SS-ME-24-B
Adapters only	FAD-SC/AP-SC/AP-SS-F

See Cable Management Accessories for further options

FIBER OPTIC PATCH PANELS

Sliding Patch Panels

LC-Quad & SC Duplex Patch Panels

(Sliding tray style – horizontal adapter position)

8-port



Order Code (empty 8-port patch panel): **SPP-08-H-LCQ/SCD-ME-B**

	With	LC Quad Multimode – 8 Port	LC Quad Singlemode – 8 Port
	2 adapters	SPP-08-H-LC/PC-MQ-ME-02-B	SPP-08-H-LC/PC-SQ-ME-02-B
	4 adapters	SPP-08-H-LC/PC-MQ-ME-04-B	SPP-08-H-LC/PC-SQ-ME-04-B
	fully loaded	SPP-08-H-LC/PC-MQ-ME-08-B	SPP-08-H-LC/PC-SQ-ME-08-B
	Adapters only	FAD-LC/PC-LC/PC-MQ-F	FAD-LC/PC-LC/PC-SQ-F
	With	SC Multimode Duplex – 8 Port	SC Singlemode Duplex – 8 Port
Adapters	2 adapters	SPP-08-H-SC/PC-MD-ME-02-B	SPP-08-H-SC/PC-SD-ME-02-B
	4 adapters	SPP-08-H-SC/PC-MD-ME-04-B	SPP-08-H-SC/PC-SD-ME-04-B
	fully loaded	SPP-08-H-SC/PC-MD-ME-08-B	SPP-08-H-SC/PC-SD-ME-08-B
	Adapters only	FAD-SC/PC-SC/PC-MD-F	FAD-SC/PC-SC/PC-SD-F
		With	SC APC Singlemode Duplex – 8 Port
	2 adapters	SPP-08-H-SC/AP-SD-ME-02-B	
	4 adapters	SPP-08-H-SC/AP-SD-ME-04-B	
	fully loaded	SPP-08-H-SC/AP-SD-ME-08-B	
	Adapters only	FAD-SC/AP-SC/AP-SD-F	

See Cable Management Accessories for further options

FIBER OPTIC PATCH PANELS

Sliding Patch Panels

LC-Quad & SC Duplex Patch Panels
(Sliding tray style – vertical adapter position)

12-port



Order Code (empty 12-port patch panel): **SPP-12-V-LCQ/SCD-ME-B**

	With	LC Quad Multimode – 12 Port	LC Quad Singlemode – 12 Port
	4 adapters	SPP-12-V-LC/PC-MQ-ME-04-B	SPP-12-V-LC/PC-SQ-ME-04-B
	8 adapters	SPP-12-V-LC/PC-MQ-ME-08-B	SPP-12-V-LC/PC-SQ-ME-08-B
	fully loaded	SPP-12-V-LC/PC-MQ-ME-12-B	SPP-12-V-LC/PC-SQ-ME-12-B
	Adapters only	FAD-LC/PC-LC/PC-MQ-F	FAD-LC/PC-LC/PC-SQ-F
	With	SC Multimode Duplex – 12 Port	SC Singlemode Duplex – 12 Port
Adapters	4 adapters	SPP-12-V-SC/PC-MD-ME-04-B	SPP-12-V-SC/PC-SD-ME-04-B
	8 adapters	SPP-12-V-SC/PC-MD-ME-08-B	SPP-12-V-SC/PC-SD-ME-08-B
	fully loaded	SPP-12-V-SC/PC-MD-ME-12-B	SPP-12-V-SC/PC-SD-ME-12-B
	Adapters only	FAD-SC/PC-SC/PC-MD-F	FAD-SC/PC-SC/PC-SD-F
		With	SC APC Singlemode Duplex – 12 Port
	4 adapters	SPP-12-V-SC/AP-SD-ME-04-B	
	8 adapters	SPP-12-V-SC/AP-SD-ME-08-B	
	fully loaded	SPP-12-V-SC/AP-SD-ME-12-B	
	Adapters only	FAD-SC/AP-SC/AP-SD-F	

See Cable Management Accessories for further options

FIBER OPTIC PATCH PANELS

Sliding Patch Panels

LC-Quad & SC Duplex Patch Panels
(Sliding tray style – vertical adapter position)

24-port



Order Code (empty 24-port patch panel): **SPP-24-V-LCQ/SCD-ME-B**

Adapters

With	LC Quad Multimode – 24 Port	LC Quad Singlemode – 24 Port
4 adapters	SPP-24-V-LC/PC-MQ-ME-04-B	SPP-24-V-LC/PC-SQ-ME-04-B
8 adapters	SPP-24-V-LC/PC-MQ-ME-08-B	SPP-24-V-LC/PC-SQ-ME-08-B
12 adapters	SPP-24-V-LC/PC-MQ-ME-12-B	SPP-24-V-LC/PC-SQ-ME-12-B
16 adapters	SPP-24-V-LC/PC-MQ-ME-16-B	SPP-24-V-LC/PC-SQ-ME-16-B
fully loaded	SPP-24-V-LC/PC-MQ-ME-24-B	SPP-24-V-LC/PC-SQ-ME-24-B
Adapters only	FAD-LC/PC-LC/PC-MQ-F	FAD-LC/PC-LC/PC-SQ-F
With	SC Multimode Duplex – 24 Port	SC Singlemode Duplex – 24 Port
4 adapters	SPP-24-V-SC/PC-MD-ME-04-B	SPP-24-V-SC/PC-SD-ME-04-B
8 adapters	SPP-24-V-SC/PC-MD-ME-08-B	SPP-24-V-SC/PC-SD-ME-08-B
12 adapters	SPP-24-V-SC/PC-MD-ME-12-B	SPP-24-V-SC/PC-SD-ME-12-B
16 adapters	SPP-24-V-SC/PC-MD-ME-16-B	SPP-24-V-SC/PC-SD-ME-16-B
fully loaded	SPP-24-V-SC/PC-MD-ME-24-B	SPP-24-V-SC/PC-SD-ME-24-B
Adapters only	FAD-SC/PC-SC/PC-MD-F	FAD-SC/PC-SC/PC-SD-F
With	SC APC Singlemode Duplex – 24 Port	
4 adapters	SPP-24-V-SC/AP-SD-ME-04-B	
8 adapters	SPP-24-V-SC/AP-SD-ME-08-B	
12 adapters	SPP-24-V-SC/AP-SD-ME-12-B	
16 adapters	SPP-24-V-SC/AP-SD-ME-16-B	
fully loaded	SPP-24-V-SC/AP-SD-ME-24-B	
Adapters only	FAD-SC/AP-SC/AP-SD-F	

See Cable Management Accessories for further options

FIBER OPTIC PATCH PANELS

Sliding Patch Panels

E2000, LC, MTRJ, SC Patch Panels
(Sliding tray style – angled adapter position)

8-port



Order Code (empty 8-port patch panel): **SPP-08-A-E2/LC/MT/SC-ME-B**

With	E2000 Multimode – 8 Port	E2000 Singlemode – 8 Port
2 adapters	SPP-08-A-E2/PC-MS-ME-02-B	SPP-08-A-E2/PC-SS-ME-02-B
4 adapters	SPP-08-A-E2/PC-MS-ME-04-B	SPP-08-A-E2/PC-SS-ME-04-B
fully loaded	SPP-08-A-E2/PC-MS-ME-08-B	SPP-08-A-E2/PC-SS-ME-08-B
Adapters only	FAD-E2/PC-E2/PC-MS-F	FAD-E2/PC-E2/PC-SS-F
With	E2000 APC Singlemode - 8 Port	MTRJ – 8 Port
2 adapters	SPP-08-A-E2/AP-SS-ME-02-B	SPP-08-A-MT/PC-MD-ME-02-B
4 adapters	SPP-08-A-E2/AP-SS-ME-04-B	SPP-08-A-MT/PC-MD-ME-04-B
fully loaded	SPP-08-A-E2/AP-SS-ME-08-B	SPP-08-A-MT/PC-MD-ME-08-B
Adapters only	FAD-E2/AP-E2/AP-SS-F	FAD-MT/PC-MT/PC-MD-F
With	LC Multimode Duplex– 8 Port	LC Singlemode Duplex– 8 Port
2 adapters	SPP-08-A-LC/PC-MD-ME-02-B	SPP-08-A-LC/PC-SD-ME-02-B
4 adapters	SPP-08-A-LC/PC-MD-ME-04-B	SPP-08-A-LC/PC-SD-ME-04-B
fully loaded	SPP-08-A-LC/PC-MD-ME-08-B	SPP-08-A-LC/PC-SD-ME-08-B
Adapters only	FAD-LC/PC-LC/PC-MD-F	FAD-LC/PC-LC/PC-SD-F
With	SC Multimode Simplex-8 Port	SC Singlemode Simplex-8 Port
2 adapters	SPP-08-A-SC/PC-MS-ME-02-B	SPP-08-A-SC/PC-SS-ME-02-B
4 adapters	SPP-08-A-SC/PC-MS-ME-04-B	SPP-08-A-SC/PC-SS-ME-04-B
fully loaded	SPP-08-A-SC/PC-MS-ME-08-B	SPP-08-A-SC/PC-SS-ME-08-B
Adapters only	FAD-SC/PC-SC/PC-MS-F	FAD-SC/PC-SC/PC-SS-F
With	SC Singlemode APC Simplex– 8 Port	
2 adapters	SPP-08-A-SC/AP-SS-ME-02-B	
4 adapters	SPP-08-A-SC/AP-SS-ME-04-B	
fully loaded	SPP-08-A-SC/AP-SS-ME-08-B	
Adapters only	FAD-SC/AP-SC/AP-SS-F	

See Cable Management Accessories for further options

FIBER OPTIC PATCH PANELS

Sliding Patch Panels

ORDERING CODE STRUCTURE

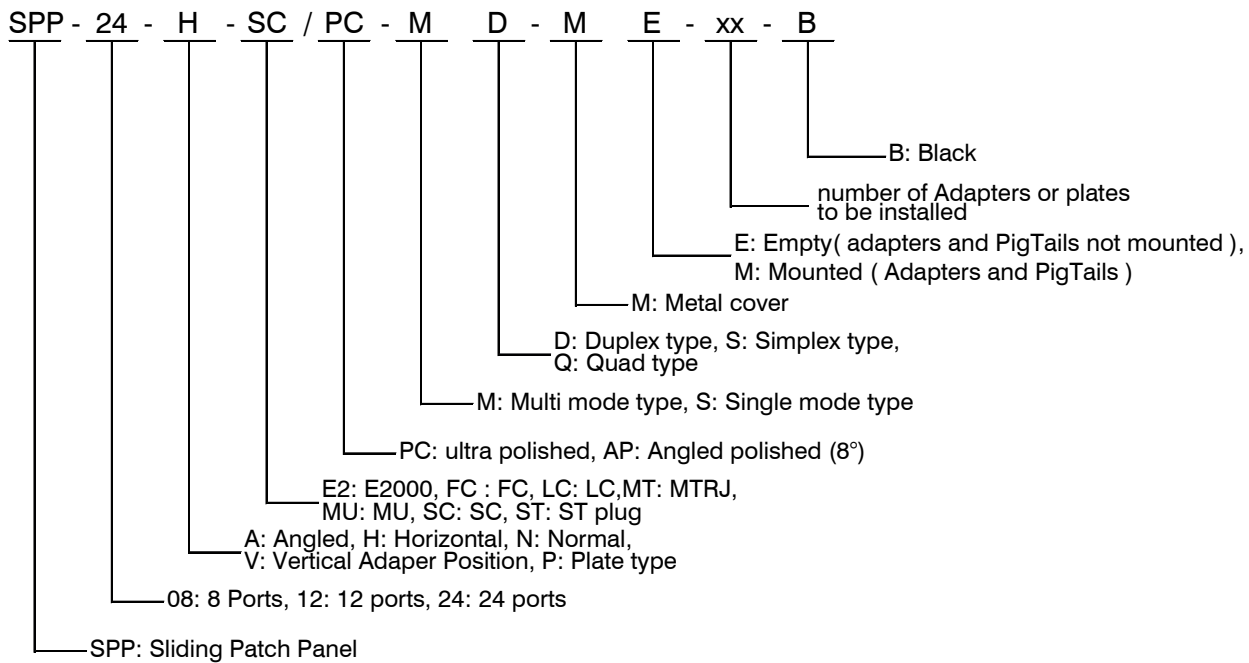

FIBER OPTIC PATCH PANELS

Sliding Patch Panels

Sliding Patch Modules (Sliding tray style)

3-Sliding Patch Module

19" black sliding tray patch panel for 3 modules

Supports up to 36 SC connections with 3 MPO links or 72 LC/MTRJ connections with 6 MPO Links

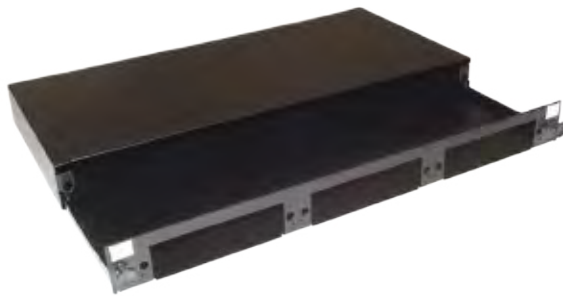

SPM-3-P-ALL-ME-B

ORDERING CODE STRUCTURE

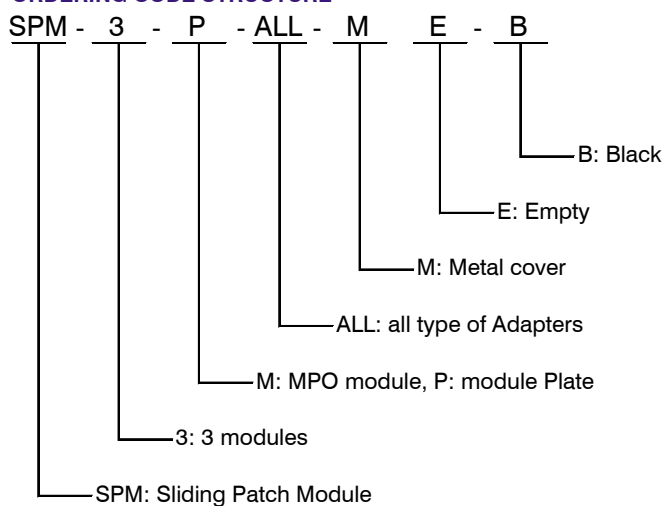

FIBER OPTIC PATCH PANELS

Sliding Patch Panels Module Patch Plate

E2000 Multimode – 8 Port



8 port adapter **MPP-08-V-E2/PC-MS**
Adapters only **FAD-E2/PC-E2/PC-MS-F**

E2000 Singlemode – 8 Port



8 port adapter **MPP-08-V-E2/PC-SS**
Adapters only **FAD-E2/PC-E2/PC-SS-F**

E2000 APC Singlemode – 8 Port



8 port adapter **MPP-08-V-E2/AP-SS**
Adapters only **FAD-E2/AP-E2/AP-SS-F**

MTRJ – 8 Port



8 port adapter **MPP-08-V-MT/PC-MD**
Adapters only **FAD-MT/PC-MT/PC-MD-F**

FC Multimode – 8 Port



8 port adapter **MPP-08-Z-FC/PC-MS**
Adapters only **FAD-FC/PC-FC/PC-MS-D**

FC Singlemode – 8 Port



8 port adapter **MPP-08-Z-FC/PC-SS**
Adapters only **FAD-FC/PC-FC/PC-SS-D**

FC APC Singlemode – 8 Port



8 port adapter **MPP-08-Z-FC/AP-SS**
Adapters only **FAD-FC/AP-FC/AP-SS-D**

LC Multimode Duplex – 8 Port



8 port adapter **MPP-08-V-LC/PC-MD**
Adapters only **FAD-LC/PC-LC/PC-MD-F**

LC Singlemode Duplex – 8 Port



8 port adapter **MPP-08-V-LC/PC-SD**
Adapters only **FAD-LC/PC-LC/PC-SD-F**

LC APC Singlemode Duplex – 8 Port



8 port adapter **MPP-08-V-LC/AP-SD**
Adapters only **FAD-LC/AP-LC/AP-SD-F**

FIBER OPTIC PATCH PANELS

Sliding Patch Panels Module Patch Plate

LC Quad Multimode– 6 Port



6 port adapter
Adapters only

MPP-06-V-LC/PC-MQ
FAD-LC/PC-LC/PC-MQ-F

LC Quad Singlemode – 6 Port



6 port adapter
Adapters only

MPP-06-V-LC/PC-SQ
FAD-LC/PC-LC/PC-SQ-F

SC Multimode Duplex – 6 Port



6 port adapter
Adapters only

MPP-06-H-SC/PC-MD
FAD-SC/PC-SC/PC-MD-F

SC Singlemode Duplex – 6 Port



6 port adapter
Adapters only

MPP-06-H-SC/PC-SD
FAD-SC/PC-SC/PC-SD-F

SC Multimode Simplex – 8 Port



8 port adapter
Adapters only

MPP-08-V-SC/PC-MS
FAD-SC/PC-SC/PC-MS-F

SC Singlemode Simplex – 8 Port



8 port adapter
Adapters only

MPP-08-V-SC/PC-SS
FAD-SC/PC-SC/PC-SS-F

See Cable Management Accessories for further options

FIBER OPTIC PATCH PANELS

Sliding Patch Panels

Module Patch Plate

SC APC Singlemode Simplex – 8 Port



8 port adapter
Adapters only

MPP-08-V-SC/AP-SS
FAD-SC/AP-SC/AP-SS-F

ST Multimode – 8 Port



8 port adapter
Adapters only

MPP-08-Z-ST/PC-MS
FAD-ST/PC-ST/PC-MS-D

ST Singlemode – 8 Port



8 port adapter
Adapters only

MPP-08-Z-ST/PC-SS
FAD-ST/PC-ST/PC-SS-D

Blank Plate



Blank cover plate

MPP-BLANK

See Cable Management Accessories for further options

ORDERING CODE STRUCTURE

MPP - 08 - V - SC / PC - M D

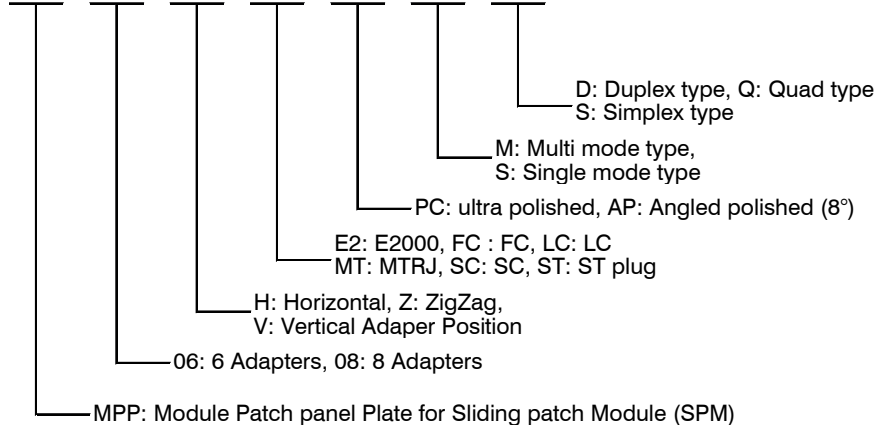

FIBER OPTIC PATCH PANELS

Universal Dual Plate Patch Panels

E2000, FC, LC Duplex, MTRJ, MU, SC Simplex, ST Patch Panels

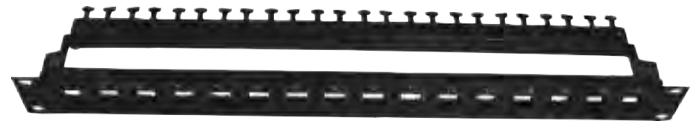
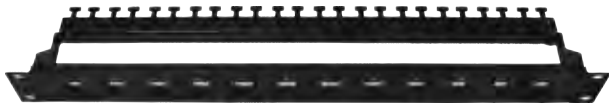

12-port: **PLK-D-12-1U-0-M**

Blank patch panel only / black color
Adapters & jacks to be ordered separately

16-port: **PLK-D-16-1U-0-M**

Blank patch panel only / black color
Adapters & jacks to be ordered separately

Universal patch panel assembly examples:

12-port example:



16-port example



The Universal Dual Plate Patch Panels are assembled first with the « Panel adapters » which allow to use this universal patch panel with the various types of fiber optic adapters

ORDERING CODE STRUCTURE

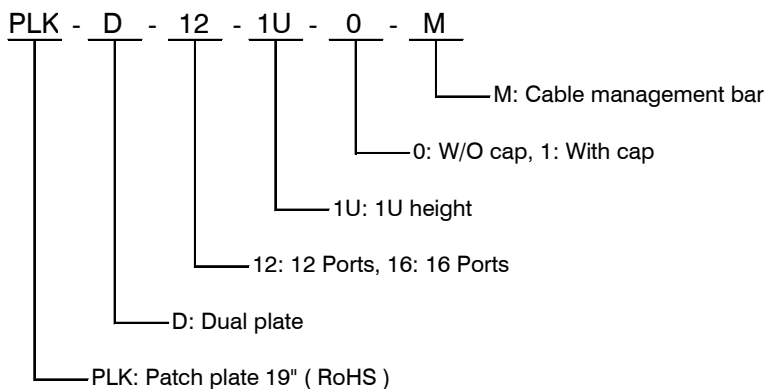

FIBER OPTIC PATCH PANEL ACCESSORIES

Universal Dual Plate Patch Panel Accessories

1. Panel adapters:



FAD-KT-SC-W

Square hole type

Panel adapter for
E2000 Simplex, LC Duplex
MTRJ, MU or SC Simplex
White Color



FAD-KT-ST-W

Round hole type

Panel adapter for
FC or ST
White Color



FAD-KT-BK-W

Blank type

Panel adapter to close
unused holes in patchpanel
White Color

2. Fiber Optic adapters



E2000

Multimode Simplex
Beige color
FAD-E2/PC-E2/PC-MS-F



Singlemode Simplex
Blue color
FAD-E2/PC-E2/PC-SS-F



Singlemode APC Simplex
Green color
FAD-E2/AP-E2/AP-SS-F



FC

Multimode Simplex
Black cap
FAD-FC/PC-FC/PC-MS-D



Singlemode Simplex
Yellow cap
FAD-FC/PC-FC/PC-SS-D



Singlemode APC Simplex
Green cap
FAD-FC/AP-FC/AP-SS-D



LC

Multimode Duplex
Beige color
FAD-LC/PC-LC/PC-MD-F



Singlemode Duplex
Blue color
FAD-LC/PC-LC/PC-SD-F



Singlemode APC Duplex
Green color
FAD-LC/AP-LC/AP-SD-F

MTRJ & MU



Multimode MTRJ Duplex
Black color
FAD-MT/PC-MT/PC-MD-F



MU Singlemode
Blue color
FAD-MU/PC-MU/PC-SD-F

FIBER OPTIC PATCH PANEL ACCESSORIES

Universal Dual Plate Patch Panel Accessories

SC



Multimode Simplex
Beige color
FAD-SC/PC-SC/PC-MS-F



Singlemode Simplex
Blue color
FAD-SC/PC-SC/PC-SS-F



Singlemode APC Simplex
Green color
FAD-SC/AP-SC/AP-SS-F



Multimode Duplex
Beige color
FAD-SC/PC-SC/PC-MD-F



Singlemode Duplex
Blue color
FAD-SC/PC-SC/PC-SD-F



Singlemode APC Duplex
Green color
FAD-SC/AP-SC/AP-SD-F

ST



Multimode Simplex
Black cap
FAD-ST/PC-ST/PC-MS-D



Singlemode Simplex
Yellow cap
FAD-ST/PC-ST/PC-SS-D

ORDERING CODE STRUCTURE

1. Panel Adapters

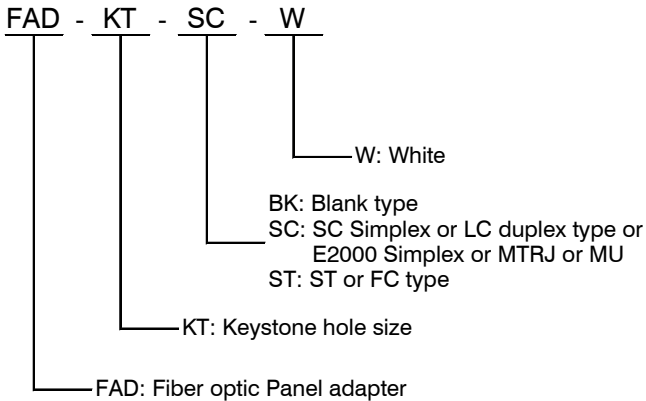

2. Fiber Optic Adapters

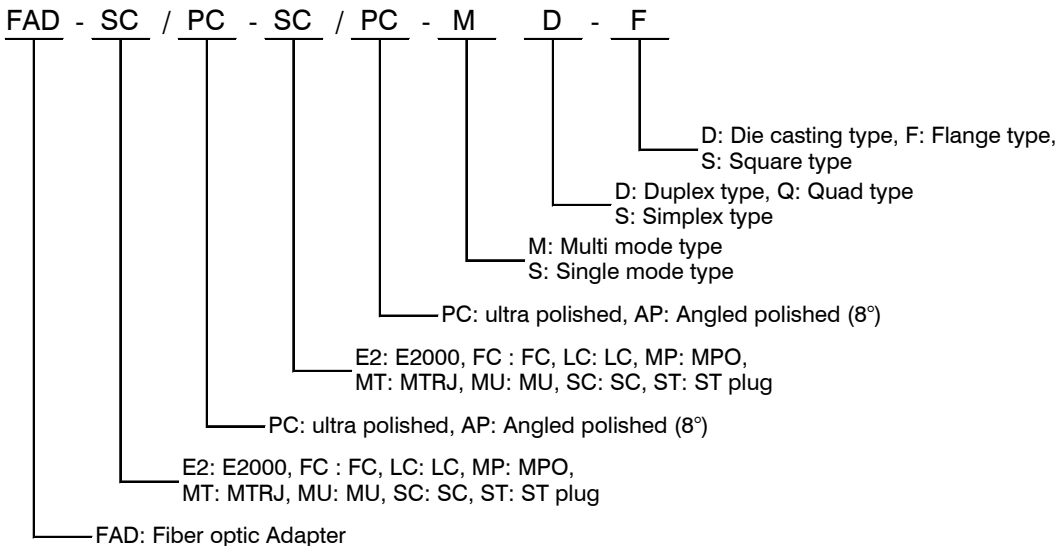

FIBER OPTIC WALL BOXES

Lockable Wall Boxes

FC, ST Wall boxes
(Lockable – Double door style)

48-port



Order Code (empty 48-port wall box): **LWB-48-D-FC/ST-ME-G**

	With	FC Multimode – 48 Port	FC Singlemode – 48 Port
	24 adapters	LWB-48-D-FC/PC-MS-ME-24-G	LWB-48-D-FC/PC-SS-ME-24-G
	36 adapters	LWB-48-D-FC/PC-MS-ME-36-G	LWB-48-D-FC/PC-SS-ME-36-G
	fully loaded	LWB-48-D-FC/PC-MS-ME-48-G	LWB-48-D-FC/PC-SS-ME-48-G
	Adapters only	FAD-FC/PC-FC/PC-MS-D	FAD-FC/PC-FC/PC-SS-D
	With	FC APC Singlemode – 48 Port	
Adapters	24 adapters	LWB-48-D-FC/AP-SS-ME-24-G	
	36 adapters	LWB-48-D-FC/AP-SS-ME-36-G	
	fully loaded	LWB-48-D-FC/AP-SS-ME-48-G	
	Adapters only	FAD-FC/AP-FC/AP-SS-D	
	With	ST Multimode – 48 Port	ST Singlemode – 48 Port
	24 adapters	LWB-48-D-ST/PC-MS-ME-24-G	LWB-48-D-ST/PC-SS-ME-24-G
	36 adapters	LWB-48-D-ST/PC-MS-ME-36-G	LWB-48-D-ST/PC-SS-ME-36-G
	fully loaded	LWB-48-D-ST/PC-MS-ME-48-G	LWB-48-D-ST/PC-SS-ME-48-G
	Adapters only	FAD-ST/PC-ST/PC-MS-D	FAD-ST/PC-ST/PC-SS-D

Specifications:

Dimensions: Width 355mm, Depth 90mm, Height 365mm
Weight: 4.0 kilos (fully loaded), Color: Grey, 4 x 20mm gland holes

See Cable Management Accessories for further options

FIBER OPTIC WALL BOXES

Lockable Wall Boxes

LC Quad, SC Duplex Wall boxes
(Lockable – Double door style)

36-port

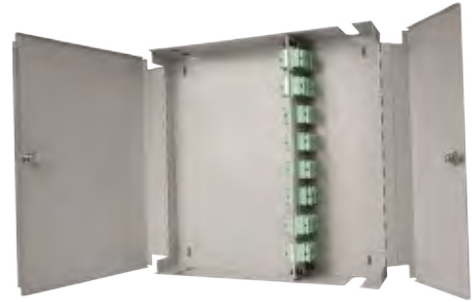

Order Code (empty 36-port wall box): **LWB-36-D-LCQ/SCD-ME-G**

	With	LC Quad Multimode – 36 Port	LC Quad Singlemode – 36 Port
	18 adapters	LWB-36-D-LC/PC-MQ-ME-18-G	LWB-36-D-LC/PC-SQ-ME-18-G
	24 adapters	LWB-36-D-LC/PC-MQ-ME-24-G	LWB-36-D-LC/PC-SQ-ME-24-G
	fully loaded	LWB-36-D-LC/PC-MQ-ME-36-G	LWB-36-D-LC/PC-SQ-ME-36-G
	Adapters only	FAD-LC/PC-LC/PC-MQ-F	FAD-LC/PC-LC/PC-SQ-F
	With	SC Multimode Duplex – 36 Port	SC Singlemode Duplex – 36 Port
Adapters	18 adapters	LWB-36-D-SC/PC-MD-ME-18-G	LWB-36-D-SC/PC-SD-ME-18-G
	24 adapters	LWB-36-D-SC/PC-MD-ME-24-G	LWB-36-D-SC/PC-SD-ME-24-G
	fully loaded	LWB-36-D-SC/PC-MD-ME-36-G	LWB-36-D-SC/PC-SD-ME-36-G
	Adapters only	FAD-SC/PC-SC/PC-MD-F	FAD-SC/PC-SC/PC-SD-F
		With	SC APC Singlemode Duplex – 36 Port
	18 adapters	LWB-36-D-SC/AP-SD-ME-18-G	
	24 adapters	LWB-36-D-SC/AP-SD-ME-24-G	
	fully loaded	LWB-36-D-SC/AP-SD-ME-36-G	
	Adapters only	FAD-SC/AP-SC/AP-SD-F	

Specifications:

Dimensions: Width 355mm, Depth 90mm, Height 365mm

Weight: 4.0 kilos (fully loaded), Color: Grey, 4 x 20mm gland holes

See Cable Management Accessories for further options

FIBER OPTIC WALL BOXES

Lockable Wall Boxes

FC, ST Wall boxes

(Lockable – Single door style)

24-port

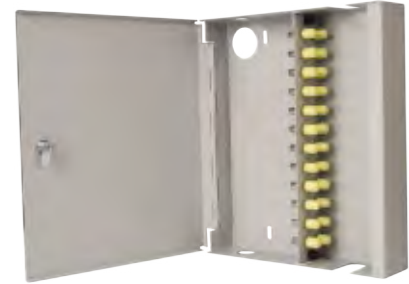

Order Code (empty 24-port wall box): **LWB-24-S-FC/ST-ME-G**

	With	FC Multimode – 24 Port	FC Singlemode – 24 Port
	6 adapters	LWB-24-S-FC/PC-MS-ME-06-G	LWB-24-S-FC/PC-SS-ME-06-G
	12 adapters	LWB-24-S-FC/PC-MS-ME-12-G	LWB-24-S-FC/PC-SS-ME-12-G
	fully loaded	LWB-24-S-FC/PC-MS-ME-24-G	LWB-24-S-FC/PC-SS-ME-24-G
	Adapters only	FAD-FC/PC-FC/PC-MS-D	FAD-FC/PC-FC/PC-SS-D
	With	FC APC Singlemode – 24 Port	
Adapters	6 adapters	LWB-24-S-FC/AP-SS-ME-06-G	
	12 adapters	LWB-24-S-FC/AP-SS-ME-12-G	
	fully loaded	LWB-24-S-FC/AP-SS-ME-24-G	
	Adapters only	FAD-FC/AP-FC/AP-SS-D	
	With	ST Multimode – 24 Port	ST Singlemode – 24 Port
	6 adapters	LWB-24-S-ST/PC-MS-ME-06-G	LWB-24-S-ST/PC-SS-ME-06-G
	12 adapters	LWB-24-S-ST/PC-MS-ME-12-G	LWB-24-S-ST/PC-SS-ME-12-G
	fully loaded	LWB-24-S-ST/PC-MS-ME-24-G	LWB-24-S-ST/PC-SS-ME-24-G
	Adapters only	FAD-ST/PC-ST/PC-MS-D	FAD-ST/PC-ST/PC-SS-D

Specifications:

Dimensions: Width 225mm, Depth 50mm, Height 270mm

Weight: 2.0 kilos (fully loaded), Color: Grey, 2 x 20mm gland holes

See Cable Management Accessories for further options

FIBER OPTIC WALL BOXES

Lockable Wall Boxes

E2000, LC, MTRJ, SC Wall boxes
(Lockable – Single door style)

18-port

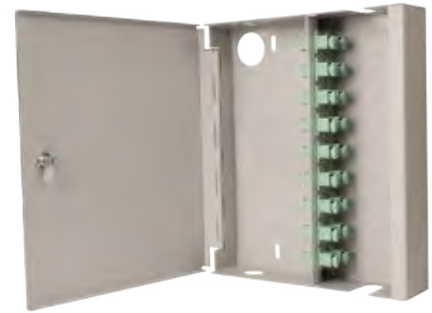

Order Code (empty 18-port wall box): **LWB-18-S-E2/LC/MT/SC-ME-G**

	With	E2000 Multimode – 18 Port	E2000 Singlemode – 18 Port
	4 adapters	LWB-18-S-E2/PC-MS-ME-04-G	LWB-18-S-E2/PC-SS-ME-04-G
	6 adapters	LWB-18-S-E2/PC-MS-ME-06-G	LWB-18-S-E2/PC-SS-ME-06-G
	12 adapters	LWB-18-S-E2/PC-MS-ME-12-G	LWB-18-S-E2/PC-SS-ME-12-G
	fully loaded	LWB-18-S-E2/PC-MS-ME-18-G	LWB-18-S-E2/PC-SS-ME-18-G
	Adapters only	FAD-E2/PC-E2/PC-MS-F	FAD-E2/PC-E2/PC-SS-F
	With	E2000 APC Singlemode - 18 Port	MTRJ – 18 Port
	4 adapters	LWB-18-S-E2/AP-SS-ME-04-G	LWB-18-S-MT/PC-MD-ME-04-G
	6 adapters	LWB-18-S-E2/AP-SS-ME-06-G	LWB-18-S-MT/PC-MD-ME-06-G
	12 adapters	LWB-18-S-E2/AP-SS-ME-12-G	LWB-18-S-MT/PC-MD-ME-12-G
	fully loaded	LWB-18-S-E2/AP-SS-ME-18-G	LWB-18-S-MT/PC-MD-ME-18-G
	Adapters only	FAD-E2/AP-E2/AP-SS-F	FAD-MT/PC-MT/PC-MD-F
	With	LC Multimode Duplex– 18 Port	LC Singlemode Duplex– 18 Port
	4 adapters	LWB-18-S-LC/PC-MD-ME-04-G	LWB-18-S-LC/PC-SD-ME-04-G
	6 adapters	LWB-18-S-LC/PC-MD-ME-06-G	LWB-18-S-LC/PC-SD-ME-06-G
	12 adapters	LWB-18-S-LC/PC-MD-ME-12-G	LWB-18-S-LC/PC-SD-ME-12-G
	fully loaded	LWB-18-S-LC/PC-MD-ME-18-G	LWB-18-S-LC/PC-SD-ME-18-G
	Adapters only	FAD-LC/PC-LC/PC-MD-F	FAD-LC/PC-LC/PC-SD-F
	With	SC Multimode Simplex – 18 Port	SC Singlemode Simplex– 18 Port
	4 adapters	LWB-18-S-SC/PC-MS-ME-04-G	LWB-18-S-SC/PC-SS-ME-04-G
	6 adapters	LWB-18-S-SC/PC-MS-ME-06-G	LWB-18-S-SC/PC-SS-ME-06-G
	12 adapters	LWB-18-S-SC/PC-MS-ME-12-G	LWB-18-S-SC/PC-SS-ME-12-G
	fully loaded	LWB-18-S-SC/PC-MS-ME-18-G	LWB-18-S-SC/PC-SS-ME-18-G
	Adapters only	FAD-SC/PC-SC/PC-MS-F	FAD-SC/PC-SC/PC-SS-F
	With	SC Singlemode APC Simplex– 18 Port	
	4 adapters	LWB-18-S-SC/AP-SS-ME-04-G	
	6 adapters	LWB-18-S-SC/AP-SS-ME-06-G	
	12 adapters	LWB-18-S-SC/AP-SS-ME-12-G	
	fully loaded	LWB-18-S-SC/AP-SS-ME-18-G	
	Adapters only	FAD-SC/AP-SC/AP-SS-F	

Adapters

Specifications:

Dimensions: Width 225mm, Depth 50mm, Height 270mm

Weight: 2.0 kilos (fully loaded), Color: Grey, 2 x 20mm gland holes

See Cable Management Accessories for further options

FIBER OPTIC WALL BOXES

Lockable Wall Boxes

LC-Quad & SC Duplex Wall boxes
(Lockable – Single door style)

12-port

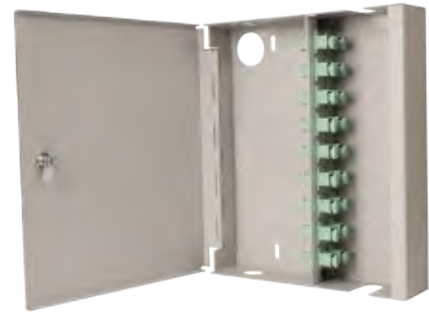

Order Code (empty 12-port wall box): **LWB-12-S-LCQ/SCD-ME-G**

	With	LC Quad Multimode – 12 Port	LC Quad Singlemode – 12 Port
	4 adapters	LWB-12-S-LC/PC-MQ-ME-04-G	LWB-12-S-LC/PC-SQ-ME-04-G
	8 adapters	LWB-12-S-LC/PC-MQ-ME-08-G	LWB-12-S-LC/PC-SQ-ME-08-G
	fully loaded	LWB-12-S-LC/PC-MQ-ME-12-G	LWB-12-S-LC/PC-SQ-ME-12-G
	Adapters only	FAD-LC/PC-LC/PC-MQ-F	FAD-LC/PC-LC/PC-SQ-F
	With	SC Multimode Duplex – 12 Port	SC Singlemode Duplex – 12 Port
Adapters	4 adapters	LWB-12-S-SC/PC-MD-ME-04-G	LWB-12-S-SC/PC-SD-ME-04-G
	8 adapters	LWB-12-S-SC/PC-MD-ME-08-G	LWB-12-S-SC/PC-SD-ME-08-G
	fully loaded	LWB-12-S-SC/PC-MD-ME-12-G	LWB-12-S-SC/PC-SD-ME-12-G
	Adapters only	FAD-SC/PC-SC/PC-MD-F	FAD-SC/PC-SC/PC-SD-F
		With	SC APC Singlemode Duplex – 12 Port
	4 adapters	LWB-12-S-SC/AP-SD-ME-04-G	
	8 adapters	LWB-12-S-SC/AP-SD-ME-08-G	
	fully loaded	LWB-12-S-SC/AP-SD-ME-12-G	
	Adapters only	FAD-SC/AP-SC/AP-SD-F	

Specifications:

Dimensions: Width 225mm, Depth 50mm, Height 270mm
Weight: 2.0 kilos (fully loaded), Color: Grey, 2 x 20mm gland holes

See Cable Management Accessories for further options

Lockable Wall Boxes

ORDERING CODE STRUCTURE

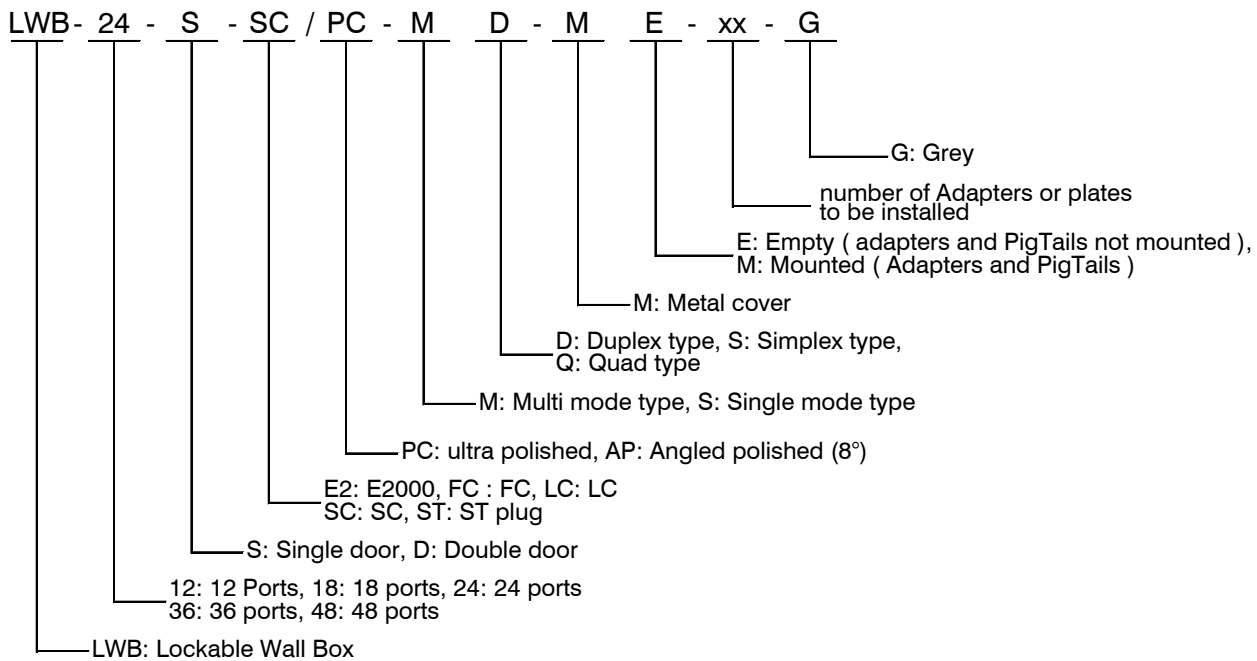

CABLE MANAGEMENT ACCESSORIES

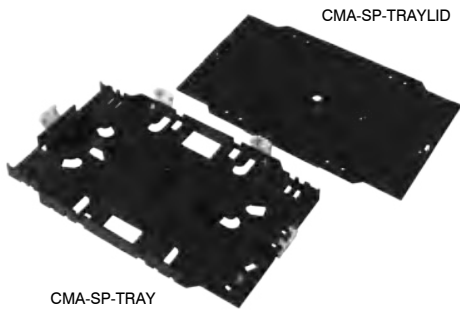

Splice Tray & Lid

Universal splice tray:

Lid for Splice tray:

CMA-SP-TRAY

CMA-SP-TRAYLID



Splice Tray Splice Holders

Splice holder for heatshrink splice:

Splice holder for crimp splice:

CMA-SP-TRAYHOLDER-1

CMA-SP-TRAYHOLDER-2

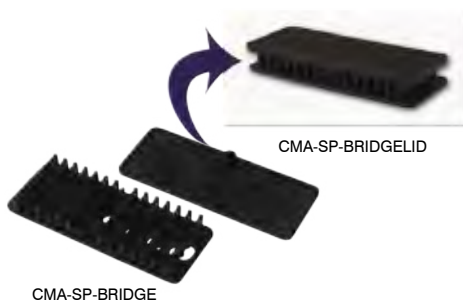

Splice Bridge & Lid

Splice Bridge :

Lid for Splice Bridge:

CMA-SP-BRIDGE

CMA-SP-BRIDGELID



Splice Cassette with Clear Lid

Splice Cassette Base unit :

2x6 way base unit with clear lid

CMA-SP-CASSETTE-BASE-12

Stackable splice cassette:

2x6 way stackable splice
cassette with clear lid

CMA-SP-CASSETTE-ADD-12

CABLE MANAGEMENT ACCESSORIES



Crimp Splice Protector
Metal crimp splice protector

CMA-SP-CRIMP-PROTECT



Blanks for Panels
ST Blank Plug
SC Duplex Blank Plug
SC Simplex Blank Plug

CMA-ST-BLANK
CMA-SC-D-BLANK
CMA-SC-S-BLANK



Cable Gland
Cable Gland

CMA-GLAND-EG13.5

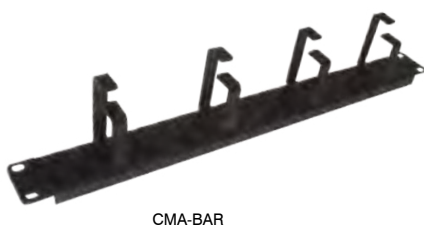

Cable Management Bar
Cable Management Bar

CMA-BAR

CABLE MANAGEMENT ACCESSORIES

Dust Caps

ST Singlemode dust cap (yellow)

CMA-ST-S-YL

ST Multimode dust cap (black)
(delivered in packs of 100 pieces)

CMA-ST-M-BK

SC dust cap (transparent)
(delivered in packs of 1000 pieces)

CMA-SC-TR

SC APC dust cap (green)
(delivered in packs of 1000 pieces)

CMA-SC-GR

LC dust cap (white)

CMA-LC-WH

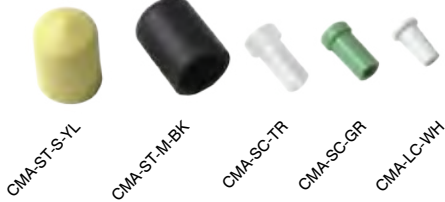

Bunny Clip

Bunny clip for cable management

CMA-B-CLIP



CMA-B-CLIP

Splice Protectors

45mm Splice protector (transparent)

CMA-SP-PROTECT-45

60mm Splice protector (transparent)

CMA-SP-PROTECT-60



CMA-SP-PROTECT-60

Cable Management Kit

Cable Management Kit

CMA-KIT



CMA-KIT

Cable General Information

E-tec Interconnect Ltd offers a full range of Cat 5e and Cat 6 cable assemblies in unshielded and fully shielded versions and which are available in all common colors. LSNH cable coating is also available optionally. These cables correspond to the TIA-EIA-568A and ISO 11801 standards and they exceed the respective Cat 5e and Cat 6 specifications. The individual cable constructions can be found here below:

UTP Cat 5e cable construction

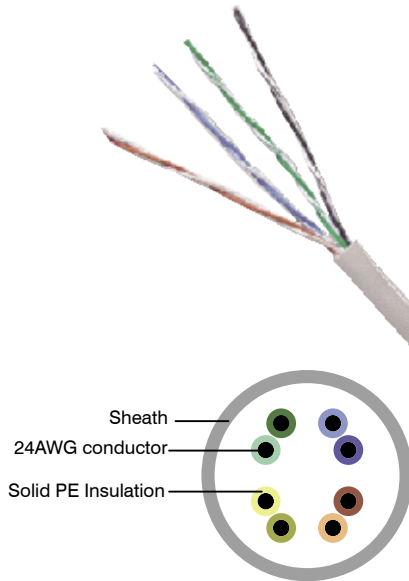

UTP Cat 6/6a cable construction

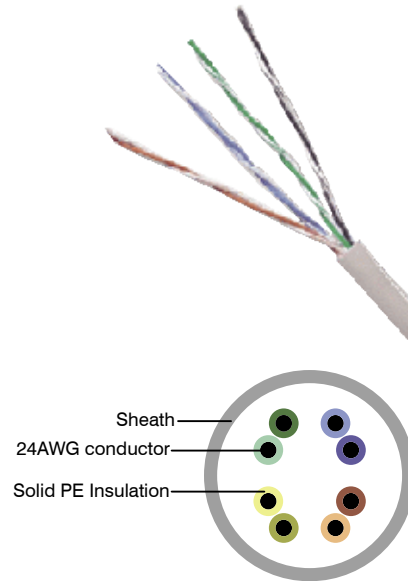

SSTP Cat 5e cable construction

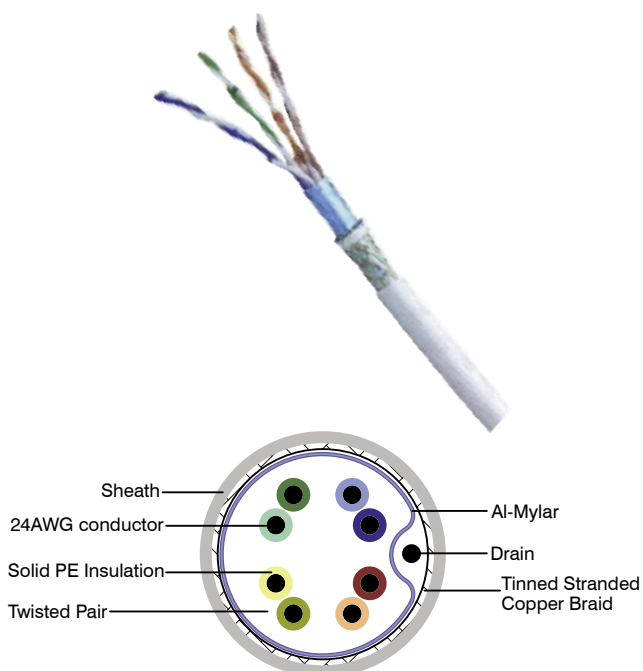

SFTP Cat 6/6a LSNH cable construction

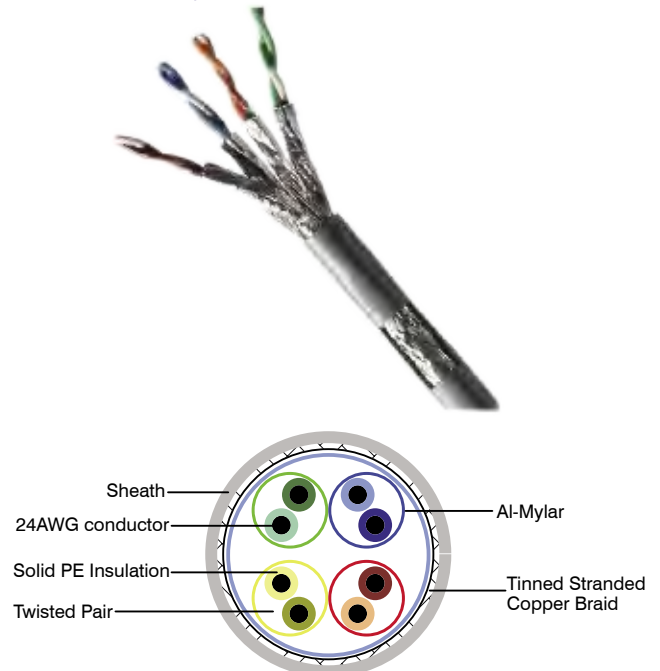

















COPPER CABLE

Cat 5e Standard Patch Cords

E-tec Interconnect Ltd offers the Cat 5e patch cords in a comprehensive range colors and special color requirements are available on request also.



Cat 5e cable ordering codes

		Cat 5e UTP Unshielded patch cable		Cat 5e SFTP Fully shielded patch cable
Grey		CBL-3-MU-xx.xM-GY/N		CBL-3-MF-xx.xM-GY
Red		CBL-3-MU-xx.xM-RD/N		CBL-3-MF-xx.xM-RD
Orange		CBL-3-MU-xx.xM-OR/N		CBL-3-MF-xx.xM-OR
Yellow		CBL-3-MU-xx.xM-YL/N		CBL-3-MF-xx.xM-YL
Green		CBL-3-MU-xx.xM-GN/N		CBL-3-MF-xx.xM-GN
Blue		CBL-3-MU-xx.xM-BU/N		CBL-3-MF-xx.xM-BU
Black		CBL-3-MU-xx.xM-BK/N		CBL-3-MF-xx.xM-BK
White		CBL-3-MU-xx.xM-WH/N		CBL-3-MF-xx.xM-WH

COPPER CABLE

Cat 5e Standard Patch Cords

OPTIONS

- Cable length: Replace "xx.x" by cable length in meter
(example: 01.0 = 1 meter cable)
- Standard cable lengths: 0.3, 0.6, 1, 1.5, 2, 3, 5, 7, 10 & 20 meters (others on request)
- Standard colors: Grey (GY), Red (RD), Orange (OR), Yellow (YL), Green (GN),
Blue (BU), Black (BK), White (WH)
Others on request

ORDERING CODE STRUCTURE

Cat 5e unshielded:

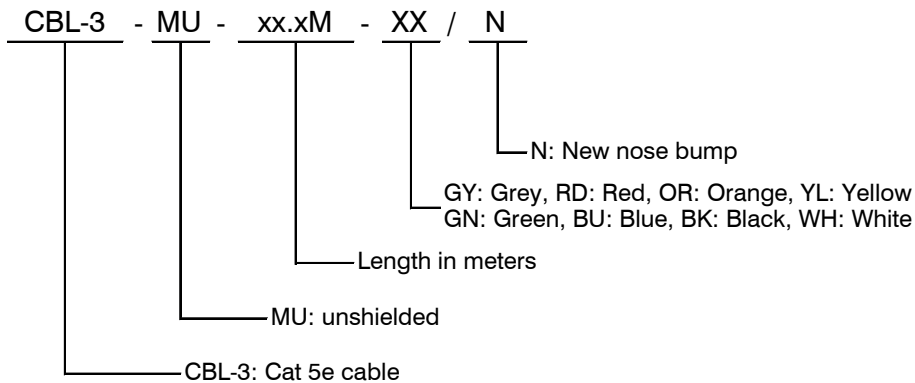

Cat 5e fully shielded:

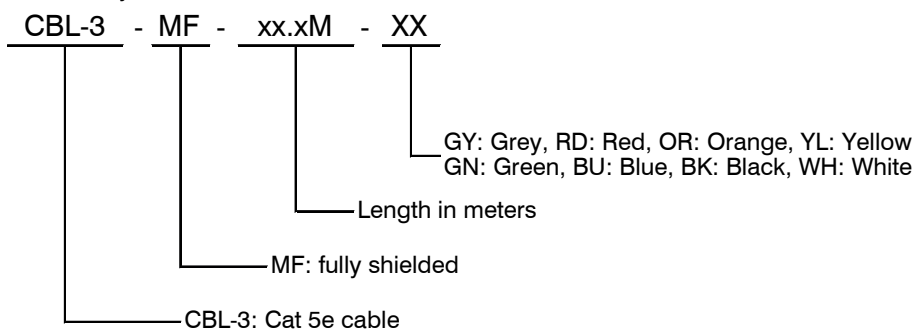

COPPER CABLE

Cat 5e & Cat 6 Special Patch Cords

E-tec Interconnect Ltd also offers special 2-pair cables generally used for telephone installations (standard green color).

We also offer red color crossed cables which are identified by a black overmold on each extremity for UTP cables and grey color crossed cables which are identified by a black overmold on each extremity for SSTP.

Cat 5e – special 2-pair UTP (green color)



Length	Order Code
0.3 meter	CBL-3-MU-00.3M-GN-2P/N
0.6 meter	CBL-3-MU-00.6M-GN-2P/N
1.0 meter	CBL-3-MU-01.0M-GN-2P/N
1.5 meter	CBL-3-MU-01.5M-GN-2P/N
2.0 meter	CBL-3-MU-02.0M-GN-2P/N
3.0 meter	CBL-3-MU-03.0M-GN-2P/N

ORDERING CODE STRUCTURE

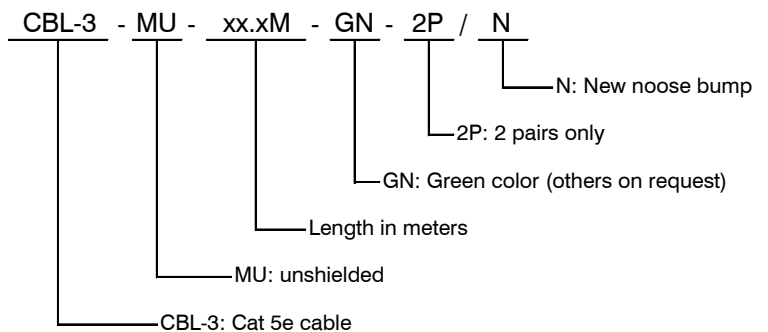

4-pair crossed cables (red color with black overmold)

Cat 5e UTP



Length	Order Code
0.3 meter	CBL-3-MU/R-00.3M-RD/BK/N
0.6 meter	CBL-3-MU/R-00.6M-RD/BK/N
1.0 meter	CBL-3-MU/R-01.0M-RD/BK/N
1.5 meter	CBL-3-MU/R-01.5M-RD/BK/N
2.0 meter	CBL-3-MU/R-02.0M-RD/BK/N
3.0 meter	CBL-3-MU/R-03.0M-RD/BK/N
5.0 meter	CBL-3-MU/R-05.0M-RD/BK/N
7.0 meter	CBL-3-MU/R-07.0M-RD/BK/N
10 meter	CBL-3-MU/R-10.0M-RD/BK/N
20 meter	CBL-3-MU/R-20.0M-RD/BK/N

Cat 5e SSTP



Length	Order Code
0.6 meter	CBL-3-MF/R-00.6M-GY/BK
1.0 meter	CBL-3-MF/R-01.0M-GY/BK
2.0 meter	CBL-3-MF/R-02.0M-GY/BK
3.0 meter	CBL-3-MF/R-03.0M-GY/BK
5.0 meter	CBL-3-MF/R-05.0M-GY/BK
10.0 meter	CBL-3-MF/R-10.0M-GY/BK
20.0 meter	CBL-3-MF/R-20.0M-GY/BK

Cat 6 UTP



Length	Order Code
0.5 meter	CBL-6-MU/R-00.5M-RD/BK/N
1.0 meter	CBL-6-MU/R-01.0M-RD/BK/N
1.5 meter	CBL-6-MU/R-01.5M-RD/BK/N
2.0 meter	CBL-6-MU/R-02.0M-RD/BK/N
3.0 meter	CBL-6-MU/R-03.0M-RD/BK/N
5.0 meter	CBL-6-MU/R-05.0M-RD/BK/N
7.0 meter	CBL-6-MU/R-07.0M-RD/BK/N
10 meter	CBL-6-MU/R-10.0M-RD/BK/N

ORDERING CODE STRUCTURE

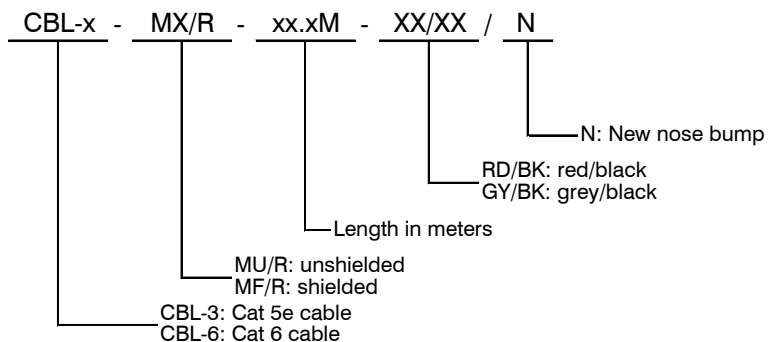

COPPER CABLE

Cat 6 Standard Patch Cords











E-tec Interconnect Ltd offers the Cat 6 patch cables in a comprehensive range colors and special color requirements are available on request also.



Cat 6 cable ordering codes

Cat 6 UTP
Unshielded patchcable

Cat 6 SFTP
Shielded and Foiled
Twisted pairs

	Cat 6 UTP Unshielded patchcable	Cat 6 SFTP Shielded and Foiled Twisted pairs
Grey	 CBL-6-MU-xx.xM-GY/N	 CBL-6-MF-xx.xM-GY/LN
Red	 CBL-6-MU-xx.xM-RD/N	 CBL-6-MF-xx.xM-RD/LN
Yellow	 CBL-6-MU-xx.xM-YL/N	 CBL-6-MF-xx.xM-YL/LN
Green	 CBL-6-MU-xx.xM-GN/N	 CBL-6-MF-xx.xM-GN/LN
Blue	 CBL-6-MU-xx.xM-BU/N	 CBL-6-MF-xx.xM-BU/LN

COPPER CABLE

Cat 6 Standard Patch Cords

OPTIONS

- Cable length: Replace "xx.x" by cable length in meter
(example: 01.0 = 1 meter cable)
- Standard cable lengths: 0.5, 1, 1.5, 2, 3, 5, 7, 10 meters (others on request)
- Standard colors: Grey (GY), Red (RD), Yellow (YL), Green (GN),
Blue (BU)
Others on request

ORDERING CODE STRUCTURE

Cat 6 unshielded:

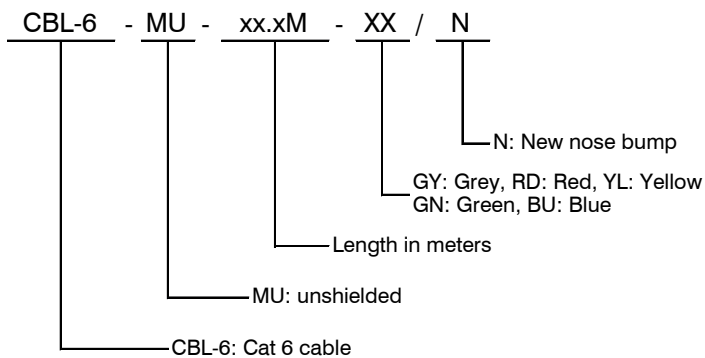

Cat 6 fully shielded:

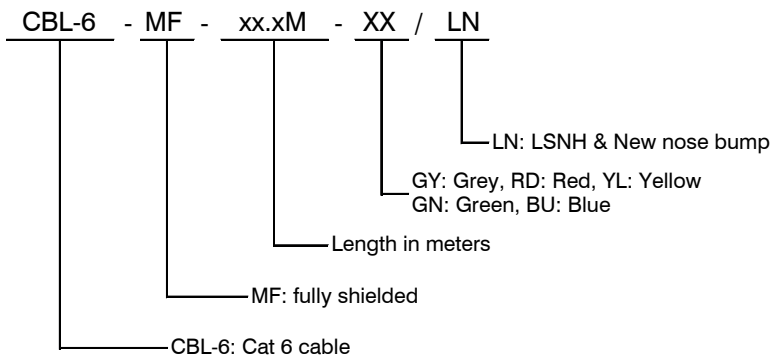

COPPER CABLE

Cat 6a Standard Patch Cords











E-tec Interconnect Ltd offers the Cat 6a patch cables in a comprehensive range colors and special color requirements are available on request also.



Cat 6a cable ordering codes

Cat 6a UTP
Unshielded patchcable

Cat 6a SFTP
Shielded and Foiled
Twisted pairs

		Cat 6a UTP Unshielded patchcable		Cat 6a SFTP Shielded and Foiled Twisted pairs
Grey		CBL-6a-MU-xx.xM-GY/N		CBL-6a-MF-xx.xM-GY/LN
Red		CBL-6a-MU-xx.xM-RD/N		CBL-6a-MF-xx.xM-RD/LN
Yellow		CBL-6a-MU-xx.xM-YL/N		CBL-6a-MF-xx.xM-YL/LN
Green		CBL-6a-MU-xx.xM-GN/N		CBL-6a-MF-xx.xM-GN/LN
Blue		CBL-6a-MU-xx.xM-BU/N		CBL-6a-MF-xx.xM-BU/LN

COPPER CABLE

Cat 6a Standard Patch Cords

OPTIONS

- Cable length: Replace "xx.x" by cable length in meter
(example: 01.0 = 1 meter cable)
- Standard cable lengths: 0.5, 1, 1.5, 2, 3, 5, 7, 10 meters (others on request)
- Standard colors: Grey (GY), Red (RD), Yellow (YL), Green (GN),
Blue (BU)
Others on request

ORDERING CODE STRUCTURE

Cat 6a unshielded:

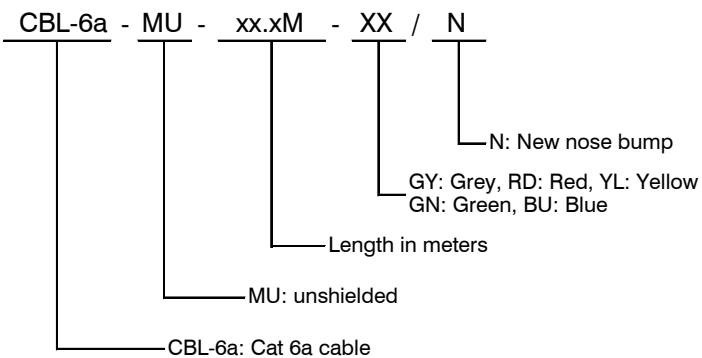

Cat 6a fully shielded:

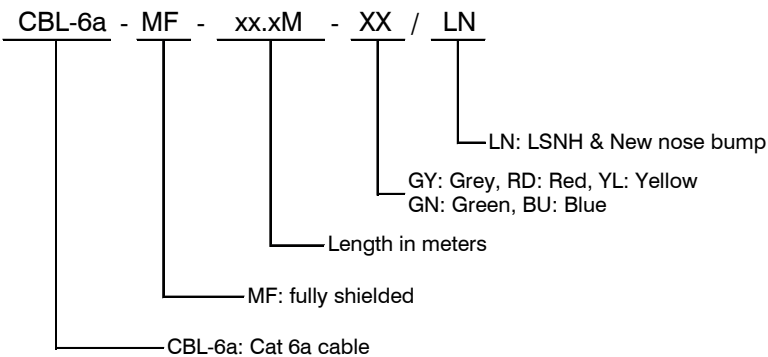

COPPER CABLE PATCH PANELS

Patch Panels

E-tec Interconnect Ltd offers high reliability patch panels for Cat5e and Cat6 requirements for copper cable management, as well as mixed copper & fiber optic patch cable management.

1. Universal dual plate patch panel for keystone jacks & fiber optical adapters (unshielded)

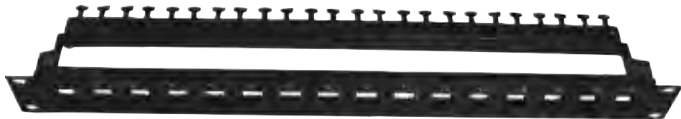

For vertical & horizontal keystone jacks:

12-port: **PLK-D-12-1U-0-M**

16-port: **PLK-D-16-1U-0-M**

Only for slim horizontal keystone jacks & slim inline couplers:

24-port: **PLK-D-24-1U-0-M**

Blank patch panel only / black color
Adapters & jacks to be ordered separately

Universal patch panel assembly examples:

Copper cable assembly



Mixed copper & fiber optic assembly



Fiber optic assembly



2. Horizontal Cat 5e & Cat 6 patch panel (unshielded)



Cat 5e - 24-port: **PLH-5-U-24-D-0-0-M**

Cat 6 - 24-port: **PLH-6-U-24-D-0-0-M**

Mounted with dual type jacks / black color

3. Vertical Cat 5e & Cat 6 patch panel (shielded)



Cat 5e - 24-port: **PLV-5-F-24-D-0-1**

Cat 6 - 24-port: **PLV-6-F-24-D-0-1**

Mounted with dual type jacks / Black color

COPPER CABLE ACCESSORIES

Patch Panel Accessories

- 1 Slim Horizontal Keystone Jacks – Unshielded type for 24-port patch plate (16.3mm)



Cat 5e : **KSJ-5-H-U-D-1-W**

Cat 6: **KSJ-6-H-U-D-1-W**

Keystone jack type: Dual / unshielded / white color

- 2 Slim Horizontal Keystone Jacks –shielded type for 24-port patch plate (16.3mm)

Cat 5e : **KSJ-5-H-S-D-1-M**

Cat 6: **KSJ-6-H-S-D-1-M**

Keystone jack type: Dual / shielded / metal color

- 3 Vertical Keystone Jacks – Unshielded type



Cat 5e : **KSJ-5-V-U-D-1-W**

Cat 6: **KSJ-6-V-U-D-1-W**

Keystone jack type: Dual / unshielded / white color

- 4 Vertical Keystone Jacks –shielded type

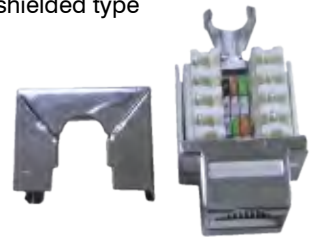

Cat 5e : **KSJ-5-V-S-D-1-M**

Cat 6: **KSJ-6-V-S-D-1-M**

Keystone jack type: Dual / shielded / metal color

- 5 Slim in-line coupler RJ45– unshielded type for 24-port patch plate



Cat 5e : **ILC-5-U-KT-S-B**

Cat 6: **ILC-6-U-KT-S-B**

RJ45 coupler: unshielded / slim type / BLACK color

- 6 Blank plates
(inserts to close holes in patch panel)



Order code: **FAD-KT-BK-W**

Plate type: Blank / white color

ORDERING CODE STRUCTURE

KSJ - 5 - H - U - D - x - W

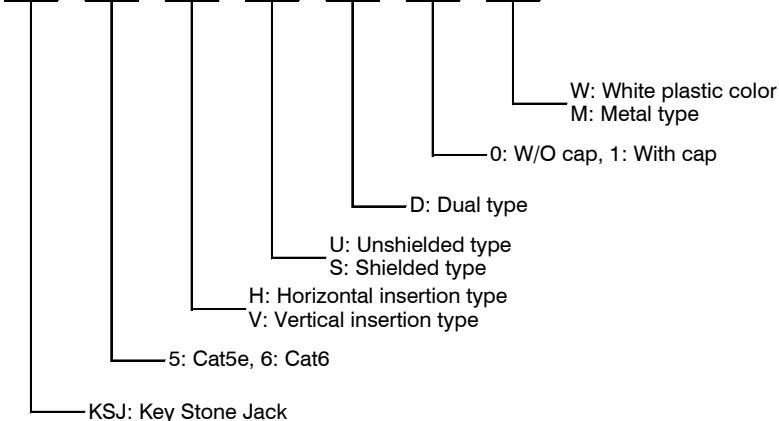

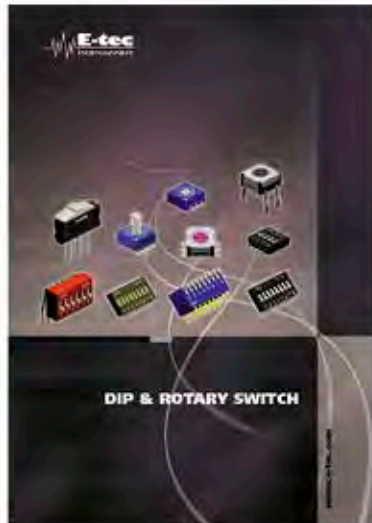

E-tec Interconnect Ltd
Friedhofstrasse 1
CH-2543 Lengnau
Switzerland

Tel.: +41 32 654 15 50
Fax: +41 32 652 26 93

E-mail: info@e-tec.com
Lan products: www.etec-lan.com
Connectors: www.e-tec.com

YOUR AUTHORISED DISTRIBUTOR
IHR VERTRAGS-DISTRIBUTOR
VOTRE DISTRIBUTEUR OFFICIEL



(www.etec-lan.com)

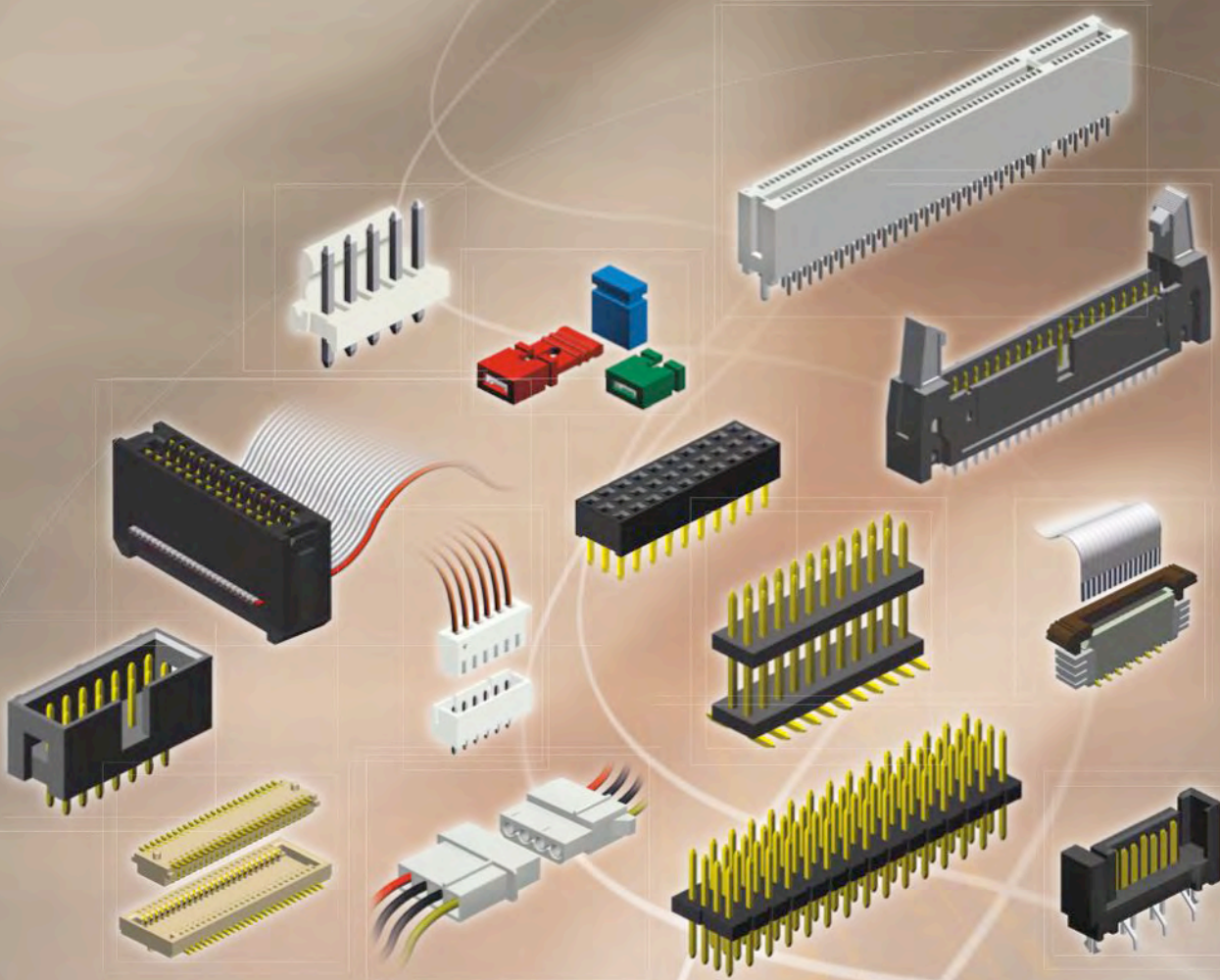

PCB INTERCONNECT PRODUCTS

INDEX

click on page numbers



Part-Number	Page	Part-Number	Page	Part-Number	Page
BB1 - 1 xx - S500 - 55	74	CRF - 1 xx - F250	128	FCL - xxx - S125 - 99	108
BB1 - 5 xx - S500 - 55	74	CRF - 1 xx - F254	129	FCL - xxx - V100 - 99/ xx	103
BB1 - xxx - B850 - 55	73	CRF - 1 xx - G125	124	FCT - x xx - C xxx - xx	114
BB2 - 3 xx - S500 - 55	74	CRF - 1 xx - H200	125	FCT - x xx - S xxx - xx	114
BB2 - 5 xx - S430 - 55/2	52	CRF - 1 xx - H254	129	FCT - x xx - T xxx - xx	114
BB2 - 5 xx - S500 - 55	74	CRF - 1 xx - I250	127	FCZ - xxx - H050 - 99/ x	92
BB2 - 6 xx - S430 - 55/2	52	CRF - 1 xx - L100	123	FCZ - xxx - H051 - 99/ x	92
BB2 - 7 xx - S500 - 55	74	CRF - 1 xx - O200	125	FCZ - xxx - H052 - 99/ x	94
BB2 - xxx - B850 - 55	73	CRF - 1 xx - R250	127	FCZ - xxx - H053 - 99/ x	94
BE1 - xxx - S xxx - 55	72	CRF - 1 xx - S125	124	FCZ - xxx - H058 - 99/ x	95
BE2 - xxx - S xxx - 55	72	CRF - 1 xx - S250	127	FCZ - xxx - H080 - 99	96
BE2 - xxx - S8 xx - 55/2	50	CRF - 104 - P250	128	FCZ - xxx - H081 - 99	96
BE3 - xxx - S xxx - 55	72	CRF - 2 xx - D200	126	FCZ - xxx - H100 - 99/ x	98
BF1 - xxx - R500 - 55	71	CRF - 2 xx - H200	125	FCZ - xxx - H101 - 99/ x	98
BF1 - xxx - S500 - 55	71	CRF - 2 xx - H254	129	FCZ - xxx - H115 - 99/ x	100
BF1 - xxx - S680 - 95	71	CRF - 2 xx - H254/HP	129	FCZ - xxx - H116 - 99/ x	100
BF1 - xxx - S710 - 95	71	CRF - 2 xx - H254/P	129	FCZ - xxx - R100 - 99	102
BF1 - xxx - S850 - 95	71	CRF - 999 - C200 - 99	126	FCZ - xxx - R101 - 99	102
BF2 - xxx - S500 - 55	71	CRF - 999 - D200 - 99	126	FCZ - xxx - R125 - 99	110
BF2 - xxx - S680 - 95	71	CRF - 999 - F250 - 99	128	FCZ - xxx - S100 - 99	101
BF2 - xxx - S710 - 55	71	CRF - 999 - F254 - 99	129	FCZ - xxx - S125 - 99	110
BF2 - xxx - S850 - 55	71	CRF - 999 - G125 - 99	124	FCZ - xxx - SR100 - 99	101
BH1 - xxx - R850 - 55	76	CRF - 999 - H200 - 55	125	FCZ - xxx - V050 - 99/ xx	91
BH2 - xxx - R345 - 55/11	30	CRF - 999 - H254 - 95	129	FCZ - xxx - V052 - 99/ xx	93
BH2 - xxx - R450 - 55/2	53	CRF - 999 - I250 - 99	127	FCZ - xxx - V053 - 99/ xx	93
BH2 - xxx - R850 - 55	76	CRF - 999 - L100 - 99	123	FCZ - xxx - V100 - 99/ xx	97
BL1 - xxx - R430 - 55/2	48	CRF - 999 - O200 - 99	125	FCZ - xxx - V115 - 99/ xx	99
BL1 - xxx - R570 - 55	70	CRF - 999 - P250 - 99	128	FPC - xxx - R254 - 99	112
BL1 - xxx - R842 - 55	69	CRF - 999 - R250 - 99	127	FPC - xxx - S254 - 99	111
BL1 - xxx - S400 - 55/2	48	CRF - 999 - S125 - 99	124	IDC - xxx - W100 - N5	90
BL1 - xxx - S430 - 55/2	48	CRF - 999 - S250 - 99	127	IDD - xxx - L100 - 95	82
BL1 - xxx - S460 - 55/1	29	CRF - 999L - H200 - 55	125	IDD - xxx - S100 - 95	82
BL1 - xxx - S570 - 55	70	CRF - 999L - H254 - 95	129	IDH - xxx - E100 - 95	82
BL1 - xxx - S842 - 55	69	CRF - 1 xx - C200	126	IDH - xxx - W100 - 95	82
BL1 - xxx - S850 - 55/1	29	CRM - 1 xx - B250	128	IDP - xxx - S100 - N5	85
BL1 - xxx - SH635 - 55/2	49	CRM - 999 - B250 - 99	128	IDP - xxx - S200 - N5	84
BL2 - xxx - R430 - 55/11	28	CRM - 999 - H254 - 95	129	IDP - xxx - S300 - 95	85
BL2 - xxx - R570 - 55	70	CRR - 1 xx - C125 - 99/R	124	IDP - xxx - S600 - 95	85
BL2 - xxx - R720 - 55/2	48	CRR - 1 xx - F250 - 99	128	IDP - xxx - T050 - 99	86
BL2 - xxx - R842 - 55	69	CRR - 1 xx - F254 - 99	129	IDS - xxx - S100 - N5/ x	80
BL2 - xxx - S340 - 55/11	28	CRR - 1 xx - G125 - 99	124	IDS - xxx - S200 - 95 / x	58
BL2 - xxx - S400 - 55/2	48	CRR - 1 xx - I250 - 99	127	IDS - xxx - W050 - 55/ x	38
BL2 - xxx - S430 - 55/11	28	CRR - 1 xx - O200 - 99	125	IDS - xxx - W100 - N5/ x	80
BL2 - xxx - S430 - 55/2	48	CRR - 1 xx - R250 - 99	127	IDS - xxx - W200 - 95 / x	58
BL2 - xxx - S460 - 55/1	29	CRR - 1 xx - S125 - 99	124	JPC - 127 - BL - 55	83
BL2 - xxx - S570 - 55	70	CRR - 1 xx - S250 - 99	127	JPC - 200 - BL - 55	83
BL2 - xxx - S842 - 55	69	CRR - 1 xx - SL100 - 99/R	123	JPC - 254 - xx - 55	83
BL2 - xxx - S850 - 55/1	29	CRR - 104 - P250 - 99	128	JPC - 508 - BL - 55	83
BL2 - xxx - SH635 - 55/2	49	CRR - 2xx - C200 - 99	126	JPE - 200 - xx - 55	83
BL3 - xxx - R842 - 55	69	CRR - 2xx - D200 - 99	126	JPE - 254 - xx - 55	83
BL3 - xxx - S842 - 55	69	CRS - 1 xx - C125 - 99/R	124	JPH - 200 - xx - 55	83
BL4 - xxx - S630/ x - 55/2	51	CRS - 1 xx - F250 - 99	128	JPH - 254 - xx - 55	83
BS1 - xxx - B21x - 55/11 xx	35	CRS - 1 xx - F254 - 99	129	JPM - xx - 200 - BL - 55	83
BS1 - xxx - H430 - 55/2 x	54	CRS - 1 xx - G125 - 99	124	JPM - xx - 254 - BL - 55	83
BS1 - xxx - H431 - 55/2 x	54	CRS - 1 xx - I250 - 99	127	JPW - 102 - 55	83
BS1 - xxx - H450 - 55/11 xx	32	CRS - 1 xx - O200 - 99	125	JPW - 254 - 55	83
BS1 - xxx - H451 - 55/11 xx	32	CRS - 1 xx - R250 - 99	127	JPW - 508 - 55	83
BS1 - xxx - H50 x - 55/ x	77	CRS - 1 xx - S125 - 99	124	JPW - 762 - 55	83
BS1 - xxx - H75 x - 55/ x	77	CRS - 1 xx - S250 - 99	127	MFM - xxx - DC50 - 99	115
BS1 - xxx - R390 - 55/ x	79	CRS - 1 xx - SL100 - 99/R	123	MFP - xxx - DC50 - 99	116
BS1 - xxx - T22 x - 55/11 xx	35	CRS - 104 - P250 - 99	128	MMF - xxx - RB50 - 99	121
BS1 - xxx - TB22 - 55/2 x	55	CRS - 1xx - C200 - 99	126	MMF - xxx - SB50 - 99	119
BS2 - xxx - H222 - 55/00 x	14	CRS - 1xx - SC200 - 99/ x	126	MMF - xxx - SL50 - 99	120
BS2 - xxx - H360 - 55/11 x	34	CRS - 2xx - D200 - 99	126	MMF - xxx - HB50 - 99/ x	117
BS2 - xxx - H36A - 55/11 x	34	DHL - xxx - R100 - 55	81	MMF - xxx - HL50 - 99/ x	118
BS2 - xxx - H430 - 55/2 x	54	DHL - xxx - S100 - 55	81	MMM - xxx - SS50 - 99	122
BS2 - xxx - H450 - 55/11 x	33	DHS - xxx - R100 - 55	81	PCC - 1 xx - PM635/ x	136
BS2 - xxx - H45A - 55/11 x	33	DHS - xxx - S100 - 55	81	PCF - 1 xx - F396	131
BS2 - xxx - H45B - 55/11 x	33	DHW - xxx - R100 - 55	81	PCF - 1 xx - F508	134
BS2 - xxx - H45P - 55/11 x	33	DHW - xxx - S100 - 55	81	PCF - 1 xx - P420	132
BS2 - xxx - H500 - 55/ x	77	ECC - 120 - P050 - 95	87	PCF - 1 xx - P635/ x	136
BS2 - xxx - H600 - 55/1 x	31	ECC - 184 - P053 - 95	87	PCF - 1 xx - Q396	131
BS2 - xxx - H750 - 55/ x	77	ECC - 184 - P055 - 95	87	PCF - 104 - I508 - 99	134
BS2 - xxx - R345 - 55/11 x	37	ECC - xxx - R100 - 95	89	PCF - 104 - I508 - 99/C	134
BS2 - xxx - R390 - 55/ x	79	ECC - xxx - S050 - 95/ x	88	PCF - 104 - P508	134
BS2 - xxx - R500 - 55/2 x	57	ECC - xxx - S100 - 95	89	PCF - 106 - L396	131
BS2 - xxx - TB22 - 55/11 x	36	FCA - x xx - X xxx - xxxx - x	113	PCF - 2 xx - P420	133
BS2 - xxx - TB22 - 55/2 x	56	FCZ - xxx - H100 - 99/ x	100	PCF - 2 xx - W300	130
BS2 - xxx - TB28 - 55/2 x	56	FCL - xxx - H125 - 99	107	PCF - 999 - F396 - 99	131
BS2 - xxx - TB365 - 55/ x	78	FCL - xxx - R100 - 99	106	PCF - 999 - F508 - 99	134
BW2 - xxx - R850 - 55/P	75	FCL - xxx - R125 - 99	109	PCF - 999 - L396 - 99	131
BW2 - xxx - S850 - 55/P	75	FCL - xxx - S100 - 99	105	PCF - 999 - P420 - 99	132 & 133

INDEX

click on page numbers



Part-Number	Page	Part-Number	Page	Part-Number	Page
PCF – 999 – P508 – 99	134	SL1 – xxx – RH xxx/xx – xx	60	SLS – xxx – R565/ x – 55/11	25
PCF – 999 – P635 – 99	136	SL1 – xxx – S xxx/xx – 55/1	19	SLS – xxx – R920 – 55	66
PCF – 999 – Q396 – 99	131	SL1 – xxx – S xxx/xx – xx	59	SLS – xxx – S103 – 55/ x	68
PCF – 999 – W300 – 99	130	SL1 – xxx – S088/ xx – xx /2	39	SLS – xxx – S510 – 55/11	27
PCM – 104 – C508	134	SL1 – xxx – SH xxx/xx – xx	59	SLS – xxx – S535 – 55/11	24
PCM – 999 – C508 – 55	134	SL1 – xxx – U xxx/xx – xx	60	SLS – xxx – S562 – 55/2	46
PCM – 999 – P635 – 99	136	SL1 – xxx – UH xxx/xx – xx	60	SLS – xxx – S920 – 55	66
PCR – 1 xx – A420 – 99	132	SL2 – xxx – B096/ xx – xx /2	39	SP1 – xxx – N xxx/ xx – 55/2	42
PCR – 1 xx – F396 – 99	131	SL2 – xxx – K106/ xx – xx /2	39	SP1 – xxx – S xxx/ xx – 55/2	42
PCR – 1 xx – F508 – 99	134	SL2 – xxx – N088/ xx – xx /2	39	SP1 – xxx – S xxx/x – 55 /11	18
PCR – 1 xx – P420 – 99	132	SL2 – xxx – R xxx/xx – xx	60	SP1 – xxx – S xxx/xx – 55/1	19
PCR – 1 xx – Q396 – 99	131	SL2 – xxx – R071/ x – 55/11	17	SP1 – xxx – S xxx/xx – xx	62
PCR – 1 xx – W420 – 99	132	SL2 – xxx – R106/ xx – xx /2	39	SP1 – xxx – SH xxx/xx – xx	62
PCR – 104 – T508 – 99	135	SL2 – xxx – RH xxx/xx – xx	60	SP2 – xxx – H xx/ x – 55/11 x	21
PCR – 2 xx – P420 – 99	133	SL2 – xxx – S xxx/xx – 55/1	19	SP2 – xxx – H065/ x – 55/2 x	44
PCR – 2 xx – W300 – 99	130	SL2 – xxx – S xxx/xx – xx	59	SP2 – xxx – H160/ xx – 55 x	64
PCR – 2 xx – W420 – 99	133	SL2 – xxx – S050/ x – 55/00	11	SP2 – xxx – H220/ x – 55/1 x	23
PCS – 1 xx – F396 – 99	131	SL2 – xxx – S063/ x – 55/11	16	SP2 – xxx – H51/ x – 55/00 x	13
PCS – 1 xx – F508 – 99	134	SL2 – xxx – S064/ x – 55/11	16	SP2 – xxx – N xxx/ xx – 55/2	42
PCS – 1 xx – P420 – 99	132	SL2 – xxx – S081/ x – 55/11	16	SP2 – xxx – S xxx/ xx – 55/2	42
PCS – 1 xx – PF635 – 99/ x	136	SL2 – xxx – S088/ xx – xx /2	39	SP2 – xxx – S xxx/x – 55 /11	18
PCS – 1 xx – PM635 – 99/ x	136	SL2 – xxx – S112/ x – 55/00	11	SP2 – xxx – S xxx/xx – 55/1	19
PCS – 1 xx – PWF635 – 99/ x	136	SL2 – xxx – SH xxx/xx – xx	59	SP2 – xxx – S xxx/xx – xx	62
PCS – 1 xx – PWM635 – 99/ x	136	SL2 – xxx – U xxx/xx – xx	60	SP2 – xxx – SH xxx/xx – xx	62
PCS – 1 xx – Q396 – 99	131	SL2 – xxx – UH xxx/xx – xx	60	SP3 – xxx – S xxx/xx – xx	62
PCS – 104 – T508 – 99	135	SL3 – xxx – R xxx/xx – xx	60	SP3 – xxx – SH xxx/xx – xx	62
PCS – 106 – L396 – 99	131	SL3 – xxx – RH xxx/xx – xx	60	SR1 – xxx – H093/ x – 55/2 x	45
PCS – 106 – L396 – 99/L	131	SL3 – xxx – S xxx/xx – xx	59	SR1 – xxx – H135/ xx – xx x	65
PCS – 2 xx – P420 – 99	133	SL3 – xxx – SH xxx/xx – xx	59	SR2 – xxx – H122/ x – 55/2 x	45
PCS – 2 xx – SC300 – 99/ x	130	SL3 – xxx – U xxx/xx – xx	60	SR2 – xxx – H135/ xx – xx x	65
PCS – 2 xx – SW300 – 99/ x	130	SL3 – xxx – UH xxx/xx – xx	60	SS1 – xxx – H085/ x – 55/2 x	43
PCS – 2 xx – W300 – 99	130	SL4 – xxx – S830/ x – 55/2	41	SS1 – xxx – H14 x /xx – 55 x	63
SE2 – xxx – R430 – xx /2	40	SLS – xxx – D xxx – 55	66	SS1 – xxx – H185/ x – 55/2 x	43
SE2 – xxx – R635 – 55	61	SLS – xxx – D762/ xx – 55/2	46	SS1 – xxx – H380/0 – 55/1 x	22
SE2 – xxx – S400 – xx /2	40	SLS – xxx – H510 – 55/11 x	27	SS1 – xxx – H381/0 – 55/1 x	22
SE2 – xxx – S740 – 55	61	SLS – xxx – H562 – 55/2 x	47	SS1 – xxx – TH14 x /xx – 55 x	63
SL1 – xxx – B083/0 – 55/11	15	SLS – xxx – H610 – 55/11 x	26	SS2 – xxx – H064/ x – 55/2 x	44
SL1 – xxx – B096/ xx – xx /2	39	SLS – xxx – H885 – 55/ x	67	SS2 – xxx – H085/ x – 55/2 x	43
SL1 – xxx – K106/ xx – xx /2	39	SLS – xxx – HP2x – 55/11 x	26	SS2 – xxx – H140/ xx – 55 x	63
SL1 – xxx – N088/ xx – xx /2	39	SLS – xxx – P535/ x – 55/11	24	SS2 – xxx – H18/ x – 55/00 x	12
SL1 – xxx – R xxx/xx – xx	60	SLS – xxx – R103 – 55/ x	68	SS2 – xxx – H380/ x – 55/1 x	22
SL1 – xxx – R071/ x – 55/11	17	SLS – xxx – R510 – 55/11	27	SS2 – xxx – H70/ x – 55/11 x	20
SL1 – xxx – R106/ xx – xx /2	39	SLS – xxx – R562 – 55/2	46	SS2 – xxx – TH140/ xx – 55 x	63

General information concerning the E-tec interconnect products

E-tec **SMT** connectors, male or female, are offered with a coplanarity of max. 0.10mm. They are adapted to all modern SMT soldering process and they can be handled easily with all currently existing placing techniques.

Customers may choose between various packaging options, such as tray, tube and reel.

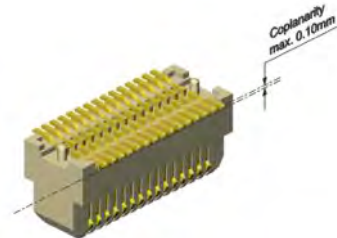

Tolerances:

All dimensions shown in this catalog represent average values. For precise +/- tolerance values please request a specific product datasheet. All pin header dimensions "A" have a general tolerance of +/- 0.25mm, unless otherwise indicated.

Plating:

- 99 = Standard Tin plating over Nickel
 - 55 = Standard Gold plating over Nickel
 - 95 = Standard selective Tin/Gold plating over Nickel
- Other platings are offered on request

Specifications:

The data contained in this catalog is of general nature and refers to standard products. For example a „Current rating“ at an ambient temperature of 25°C reflects the value per individual contact. Should you require any further data or test reports, you can obtain this information from your nearest E-tec sales office. The E-tec connectors conform with signal integrity requirements at high data and frequency rates. However we cannot offer a general information about the max. frequency or data transmission rate. For such a statement, it would require more information about the chosen configuration and pin-out, the length of the cable and/or any other specific requirements regarding the application itself and its related signal integrity.

GENERAL POLICY

All information contained in this catalog, including illustrations, specifications and dimensions are accurate to the best of our knowledge, and reflect the status as at the date of publication. Due to technical progress, it is subject to change without notice. Application information is informational in nature and shall not be construed to warrant suitability of products for any particular purpose as performance may vary depending on the conditions to which a product is subjected. Unless otherwise confirmed at the time of order, all E-tec products are non cancellable and non returnable items (NCNR). E-tec products are warranted for 30 days and the warranty is limited strictly to replacement of products. This warranty does not cover any claims for natural wear and tear, nor for any compensations, such as loss of production, loss of use, loss of orders, loss of profit, nor any other direct or indirect damages.

Fine Pitch Plug Board Connectors

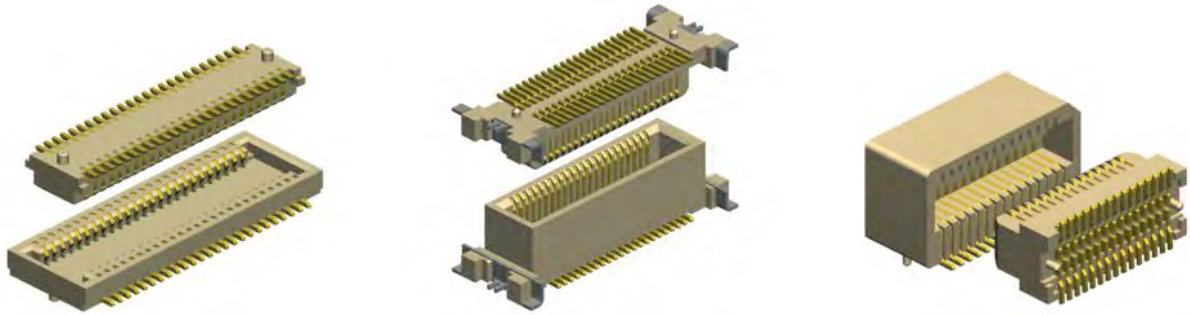

0.50mm - 0.60mm - 0.80mm pitch Page 9

Board to Board & Board to Wire Connectors

PIN HEADER

Straight

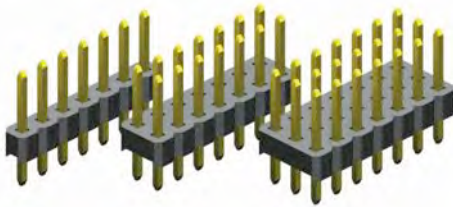

1.00mm pitch: Page 11
 1.27mm pitch: Page 15, 16 & 19
 2.00mm pitch: Page 39
 2.54mm pitch: Page 59

Right Angle

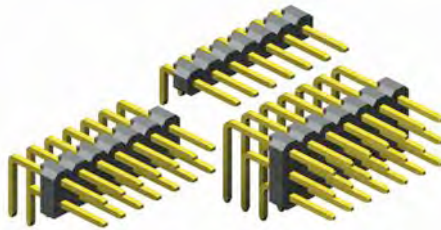

1.27mm pitch: Page 17
 2.00mm pitch: Page 39
 2.54mm pitch: Page 60

Double Plastic Board Spacer

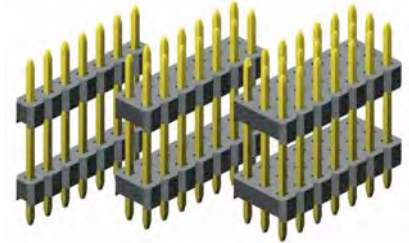

1.27mm pitch: Page 18 & 19
 2.00mm pitch: Page 42
 2.54mm pitch: Page 62

PC 104 Type

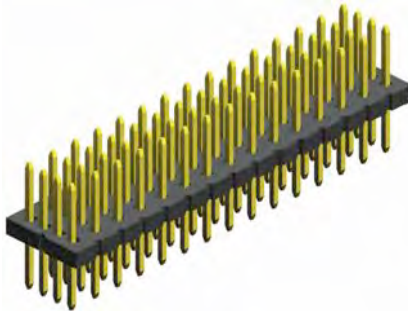

2.00mm pitch: Page 41

High Base "Board To Board"

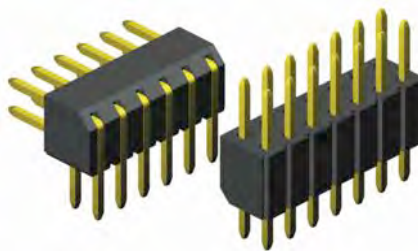

2.00mm pitch: Page 40
 2.54mm pitch: Page 61

SMT straight

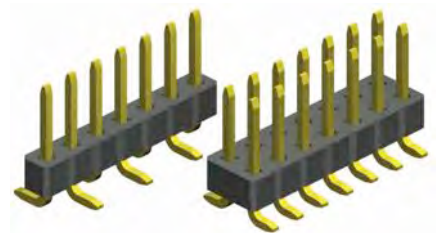

1.00mm pitch: Page 12
 1.27mm pitch: Page 20 & 22
 2.00mm pitch: Page 43 & 44
 2.54mm pitch: Page 63

SMT Double Plastic Board Spacer



1.00mm pitch: Page 13
 1.27mm pitch: Page 21 & 23
 2.00mm pitch: Page 44
 2.54mm pitch: Page 64

SMT "slanted"

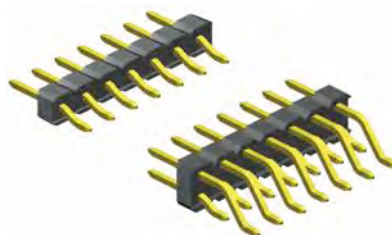

2.00mm pitch: Page 45
 2.54mm pitch: Page 65

Jumper & Shorting Links



1.27mm pitch: Page 83
 2.00mm pitch: Page 83
 2.54mm pitch: Page 83
 5.08mm pitch: Page 83

PRODUCT OVERVIEW

[click on page numbers](#)

BOX HEADER

Straight Box Header

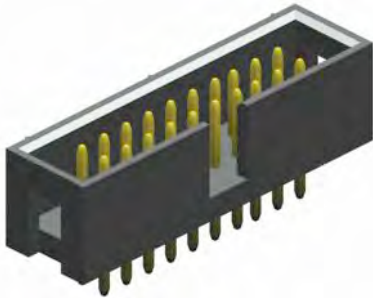

1.27mm pitch: Page 24 & 27
 2.00mm pitch: Page 46
 2.54mm pitch: Page 66

Right Angle Box Header

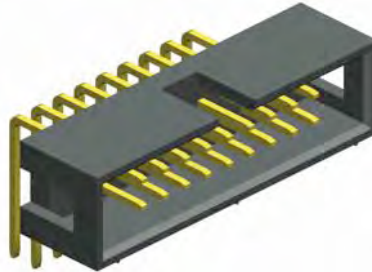

1.27mm pitch: Page 25 & 27
 2.00mm pitch: Page 46
 2.54mm pitch: Page 66

SMT Box Header

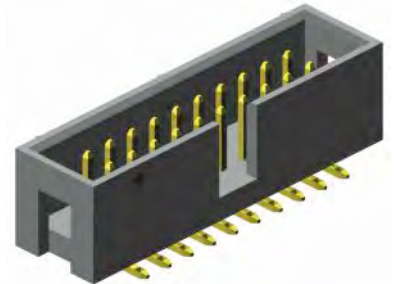

1.27mm pitch: Page 26 & 27
 2.00mm pitch: Page 47
 2.54mm pitch: Page 67

Box Header
with metal ejection latches
straight & right angle



2.54mm pitch: Page 68

Box- & DIN 41 651 HEADER
with plastic ejection latches
straight, right angle & SMT



2.54mm pitch: Page 81

Mini - Flex™ Connectors

IDC Type for Ribbon Cable UL Style 2651

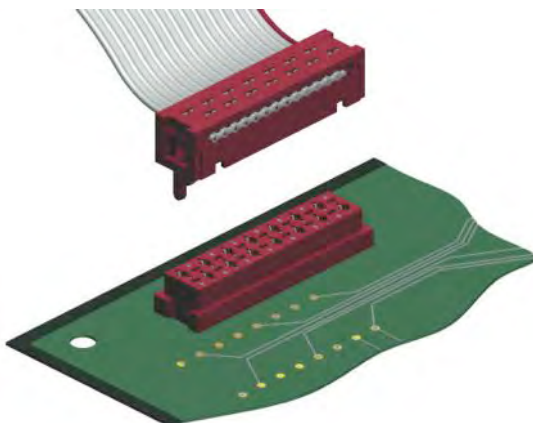

1.27mm pitch: Page 115 & 116

Mini - Mate™ Connectors

SMT & THT Type

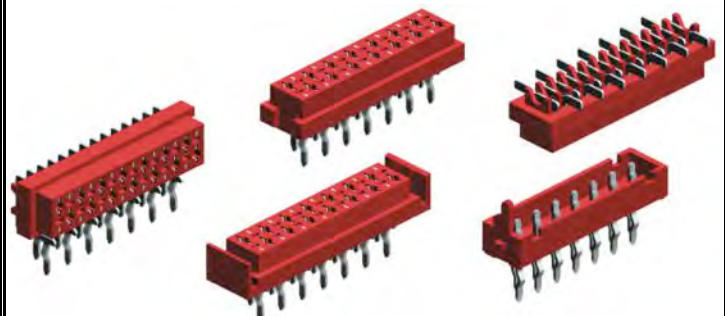

1.27mm pitch: Page 117 to 122

PRODUCT OVERVIEW

[click on page numbers](#)



FEMALE HEADERS

Straight Types single & dual row

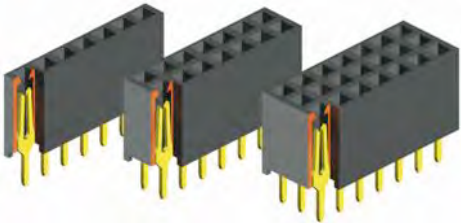

1.27mm pitch: Page 28 & 29
2.00mm pitch: Page 48 & 49
2.54mm pitch: Page 69 to 71

Right Angle Types

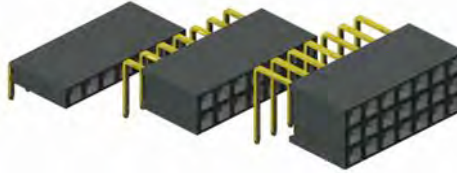

1.27mm pitch: Page 28
2.00mm pitch: Page 48
2.54mm pitch: Page 69 to 71

SMT "standard profile" Types

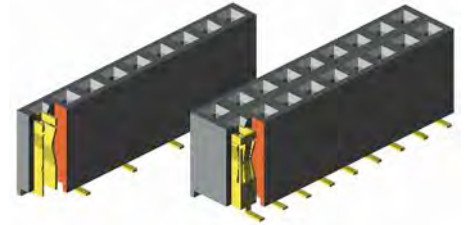

1.27mm pitch: Page 31 to 33
2.00mm pitch: Page 54
2.54mm pitch: Page 77

PC 104+ Type

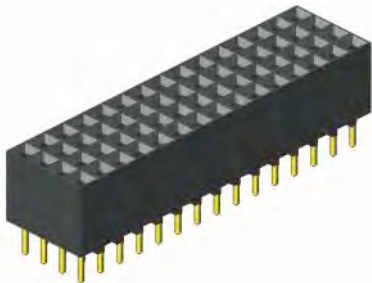

2.00mm pitch: Page 51

Elevated Types

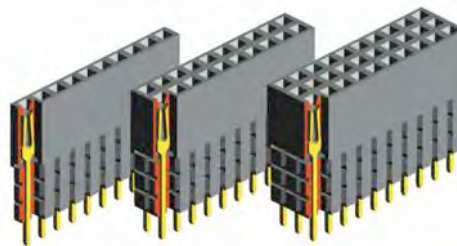

2.00mm pitch: Page 50
2.54mm pitch: Page 72

SMT "low profile" Types



1.00mm pitch: Page 14
1.27mm pitch: Page 34 to 36
2.00mm pitch: Page 55 & 56
2.54mm pitch: Page 78

Dual Entry Types "low profile"

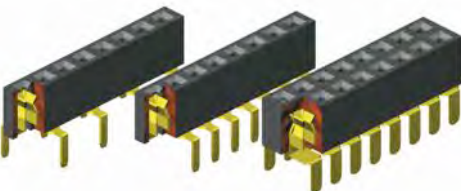

2.00mm pitch: Page 52
2.54mm pitch: Page 74

Dual Entry Type "standard profile"

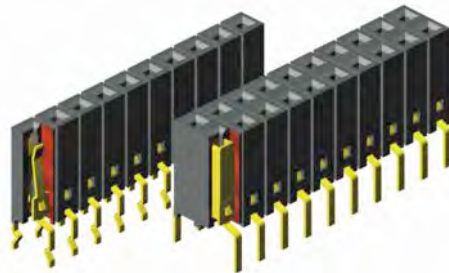

2.54mm pitch: Page 73

Shrouded Mating Types

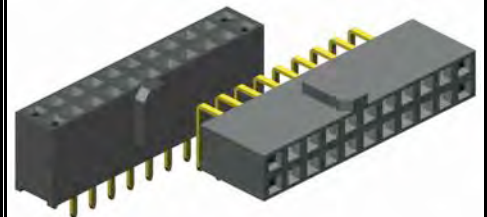

2.54mm pitch: Page 75

Through Hole (THT) Side Entry Types

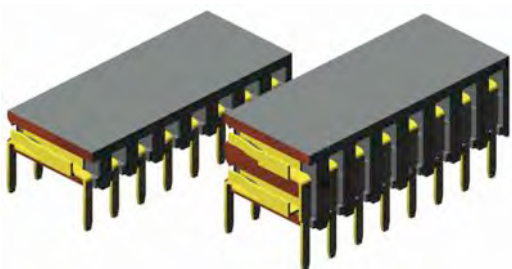

1.27mm pitch: Page 30
2.00mm pitch: Page 53
2.54mm pitch: Page 76

SMT Side Entry Types

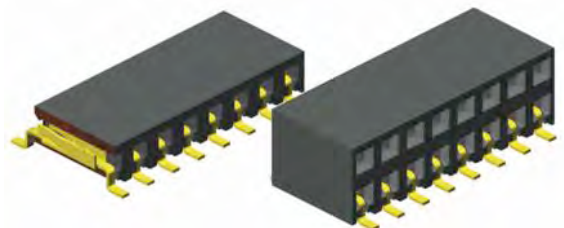

1.27mm pitch: Page 37
2.00mm pitch: Page 57
2.54mm pitch: Page 79

PRODUCT OVERVIEW

[click on page numbers](#)



IDC CONNECTORS

IDC Female Headers



1.27mm pitch: Page 38
2.00mm pitch: Page 58
2.54mm pitch: Page 80

DIP Plugs



2.00mm x 2.00mm
IDC pitch 1.00mm: Page 84
2.54mm
IDC pitch 1.27mm: Page 85

Transition Connectors

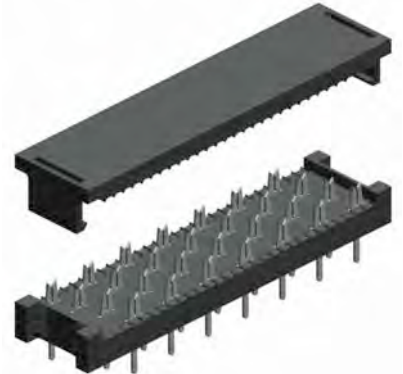

2.54mm
IDC pitch 1.27mm: Page 86

IDC Box Headers

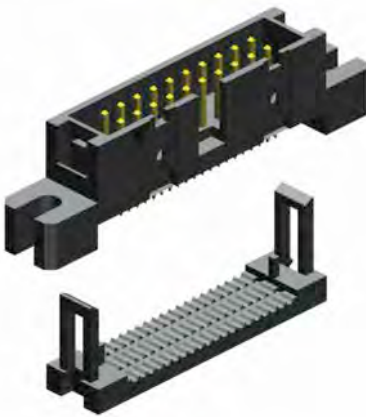

2.54mm pitch: Page 82

IDC DIN Headers DIN 41 651



2.54mm pitch: Page 82

IDC Card Edge Connectors



2.54mm pitch: Page 90

CARD EDGE CONNECTORS

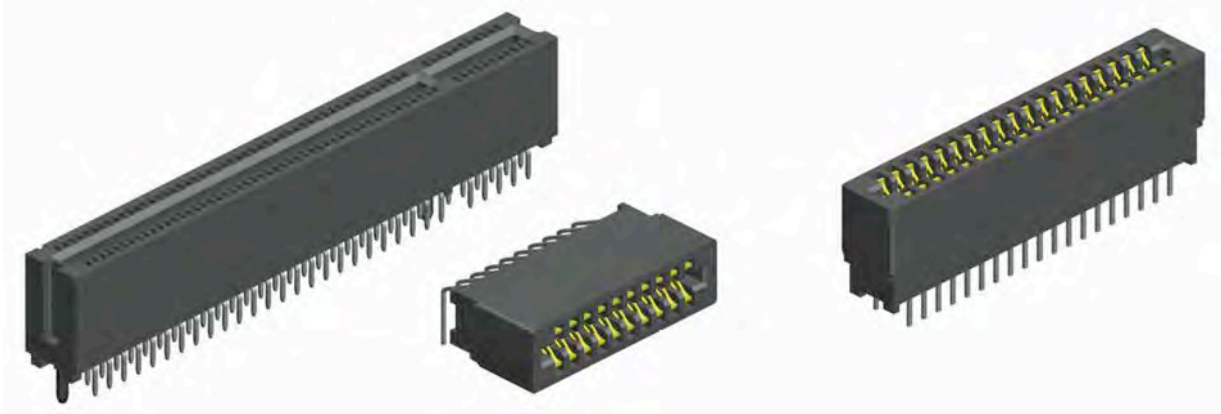

PCI 1.27mm pitch : Page 87
Card Edge 1.27mm pitch : Page 88
Card Edge 2.54mm pitch : Page 89

PRODUCT OVERVIEW

[click on page numbers](#)

FPC/FFC CONNECTORS

ZIF SMT FPC/FFC Type vertical

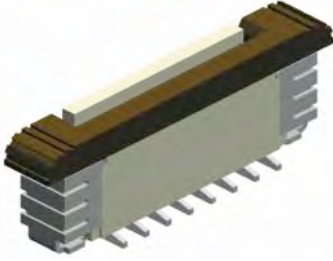

0.50mm pitch: Page 91 & 93
1.00mm pitch: Page 97 & 99

ZIF SMT FPC/FFC Type horizontal

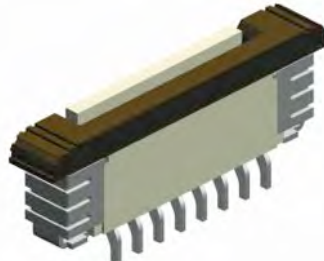

0.50mm pitch: Page 92 & 94
0.80mm pitch: Page 96
1.00mm pitch: Page 98 & 100

ZIF SMT FPC/FFC Type horizontal
"Easy-on" Type

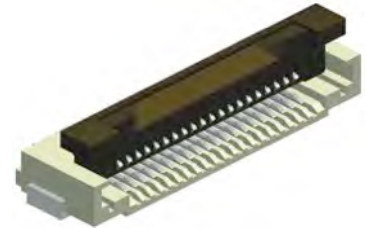

0.50mm pitch: Page 95

ZIF FPC/FFC Type straight

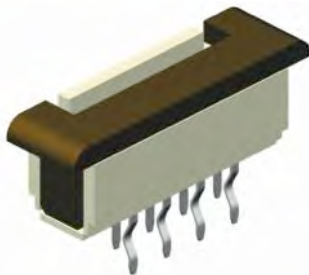

1.00mm pitch: Page 101
1.25mm pitch: Page 110

ZIF FPC/FFC Type right angle

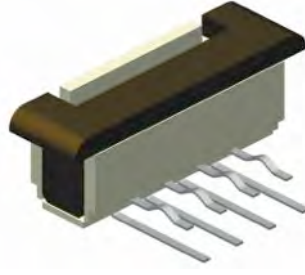

1.00mm pitch: Page 102
1.25mm pitch: Page 110

LIF SMT FPC/FFC Type vertical



1.00mm pitch: Page 103

LIF SMT FPC/FFC Type horizontal



1.00mm pitch: Page 104
1.25mm pitch: Page 107

LIF FPC/FFC Type straight

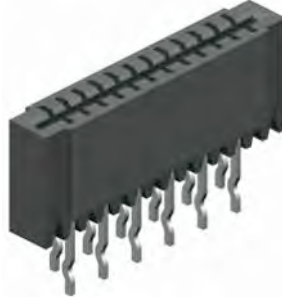

1.00mm pitch: Page 105
1.25mm pitch: Page 108
2.54mm pitch: Page 111

LIF FPC/FFC Type right angle



1.00mm pitch: Page 106
1.25mm pitch: Page 109
2.54mm pitch: Page 112

FLEX CABLE

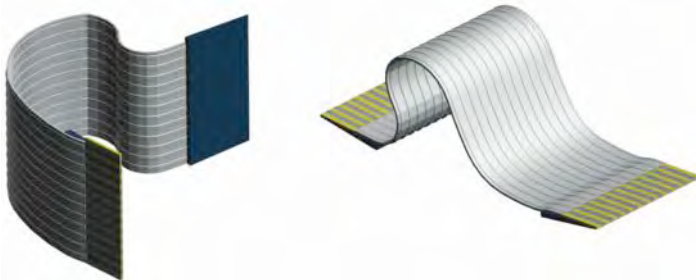

Pitch: 0.50mm - 0.80mm - 1.00mm - 1.25mm -
1.27mm - 2.00mm - 2.54mm Page 113

ZIF Test Sockets for FLEX CABLE



Available for pitch 0.50mm to 2.54mm

Page 114

CRIMP CONNECTORS

1.00mm pitch Types

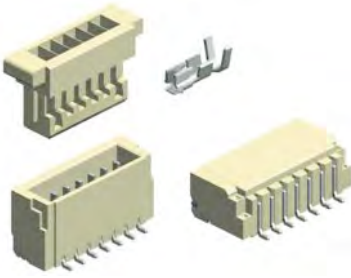

Page 123

1.25mm pitch Types

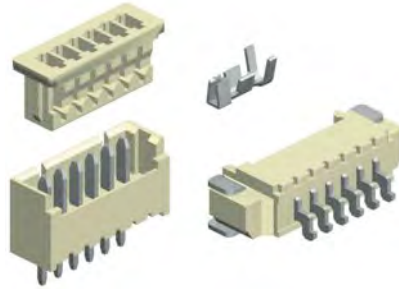

Page 124

2.00mm pitch Types



Page 125 & 126

2.50mm pitch Types

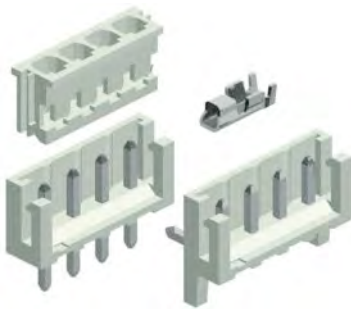

Page 127 & 128

2.54mm Types

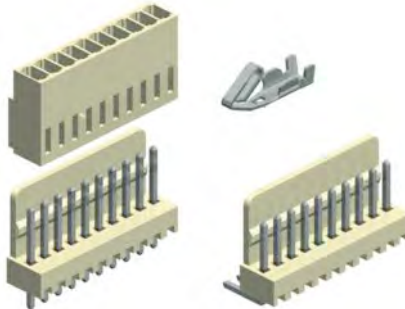

Page 129

POWER CONNECTORS

3.00mm Types



Page 130

3.96mm Types

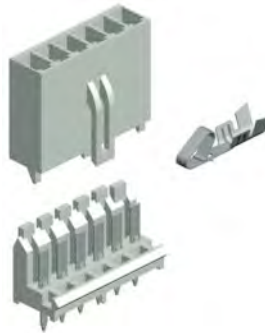

Page 131

4.20mm Types

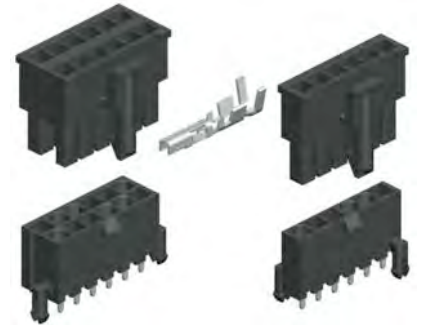

Page 132 & 133

5.08mm Types



Page 134 & 135

6.35mm Types



Page 136

Fine Pitch

Plug-Board Connectors

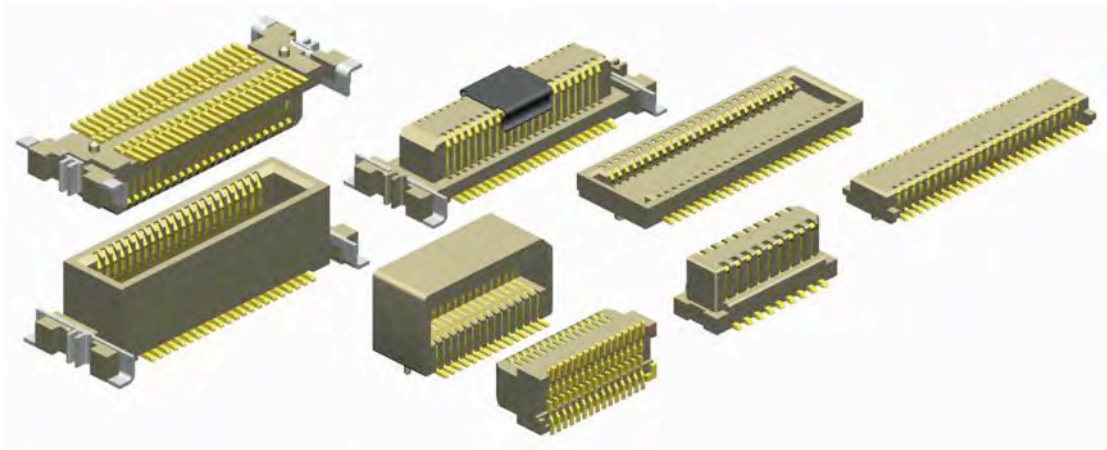

Fine pitch board-to-board connectors allow high density low profile PCB interconnections. These connectors are generally not designed for high insertion/extraction cycles but for one time interconnection, with a possibility to disconnect a limited number of times (around 5 times) during the life time of the product for maintenance purposes only.

Due to the very large variety of design requirements (pincount, board height, pitch, soldertabs, etc) these fine pitch board-to-board connectors are being presented with the following generic E-tec datasheet which allows to highlight the specific project requirements. Based on this information, our production will be able to determine if the current toolings can be adjusted to your requirements and/or if new toolings need to be set-up or if any other close equivalents can be offered as an alternative.

Plug-Board Connector - SMT -

0.50mm - 0.60mm - 0.80mm Pitch



- Fine pitch, super low profile, from 1.50mm to 9.50mm between the boards
- The stamped, solid contacts assure reliable PC Board connections
- Tube or Reel packing available
- Also available with "locating pegs" for easy positioning of the connector during placement
- Some types can also be offered with metal solder tabs, which provide additional mechanical strength to avoid damages to the solder joints during disconnection of the male & female connectors.

Please inform us of your application and precise requirements, so that our product engineers may offer you a suitable solution.

Please indicate your dimensional requirements for the
 0.50mm 0.60mm 0.80mm pitch
 „Plug-Board“ connector.
 Solutions **without** metal solder tabs,
 but with & without locating pegs.

Number of contacts in total

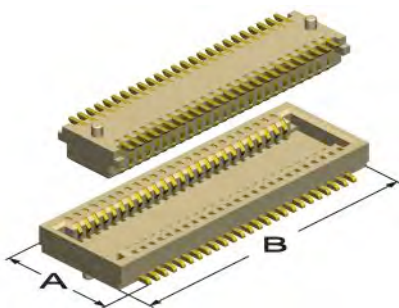

Dimension „A“ (max.):

Dimension „B“ (max.):

Please indicate your dimensional requirements for the
 0.50mm 0.60mm 0.80mm pitch
 „Plug-Board“ connector.
 Solutions **with** metal solder tabs,
 but with & without locating pegs.

Number of contacts in total

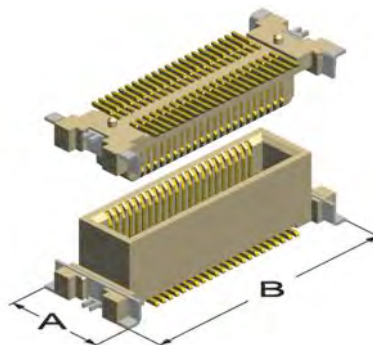

Dimension „A“ (max.):

Dimension „B“ (max.):

Please indicate your dimensional requirements for the
 0.50mm 0.60mm 0.80mm pitch
 right angle type „Plug-Board“ connector.
 Solutions **without** metal solder tabs,
 but with & without locating pegs.

Number of contacts in total

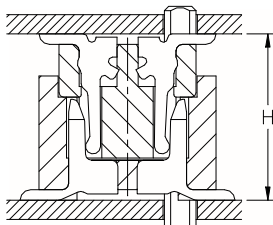
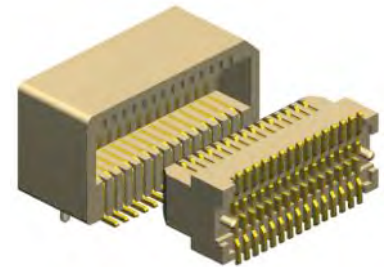

Your board-to-board requirement
 Dimension „H“:

Do you wish to receive this connector
 with or without locating peg?

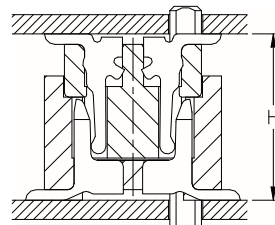

Your board-to-board requirement
 Dimension „H“:

Do you wish to receive this connector
 with or without locating peg?

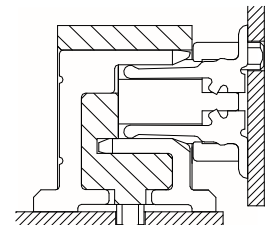

Do you wish to receive this connector
 with or without locating peg?

In addition, please also provide the following information:

For which application do you intend to use our fine pitch „Plug Board“ connector?

.....

.....

Please indicate your quantity requirement for „prototypes“ and **„production“**

Please also indicate the expected „life time“ of your project

Your Company Name & Address:

.....

Your Name, Phone, FAX & e-mail

Please FAX this page to the nearest E-tec sales office and we will get back to you as soon as possible with a solution adapted to your needs.

Specifications for E-tec fine pitch Plug Board Connectors

Current rating	0.3 A	Operating temperature	- 45°C to +125°C
Insulator resistance	500 MΩ min. at 100 V DC	Processing temperature	+230°C for 60 sec. max. +260°C for 10 sec. max.
Contact resistance	50 mΩ max. at 100 mA	Contact material	Phosphor Bronze
Withstanding voltage	150 V AC 1 minute	Insulator material	Nylon UL 94 V-0

Board to Board & Cable to Board Connectors

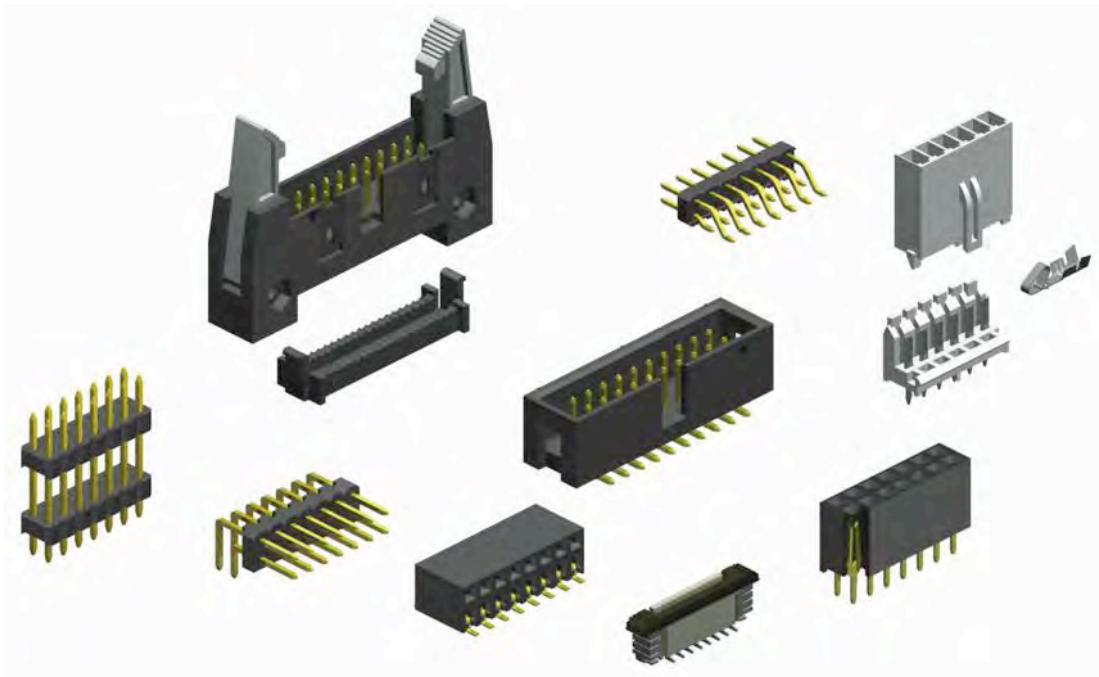

E-tec offers a very large variety of board-to-board and cable-to-board connectors, which take care of nearly all requirements a customer may have in terms of required board connections.

The male/female board-to-board connectors are available in 1.00mm, 1.27mm, 2.00mm and 2.54mm pitch. For the cable-to-board connectors the available pitches start from 0.50mm upwards. The following catalog pages show the standard connector designs, but many other pin lengths or custom designs can be offered on request.

1.00mm pitch Pin Header
 - THT - dual row straight

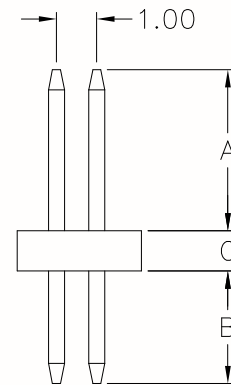
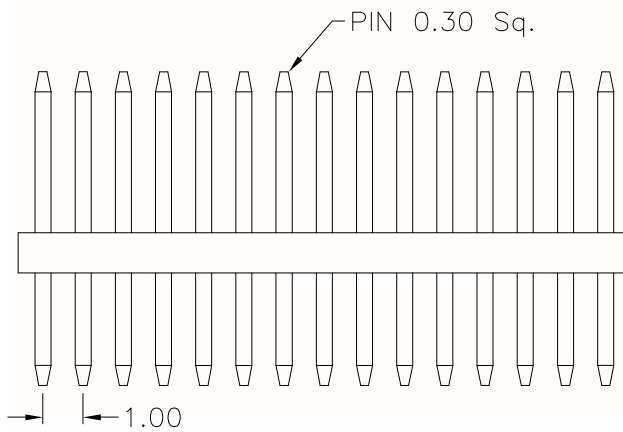
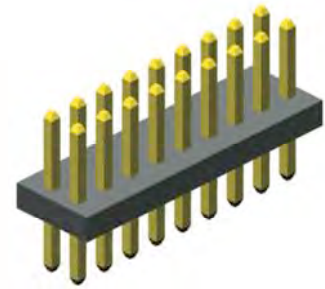
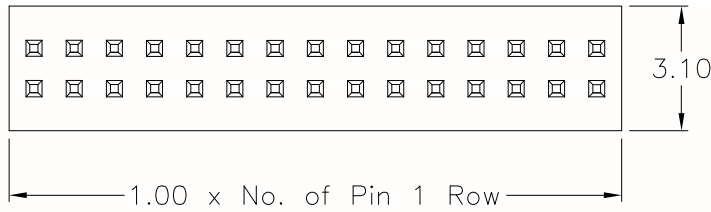

SPECIFICATIONS

Current rating	1 A
Insulator resistance	100 MΩ min.
Withstanding voltage	500 V AC
Operating temperature	- 40°C to +105°C
Contact material	(RoHS compliant) Copper alloy
Insulator material	(RoHS compliant) Nylon or LCP UL 94 V-0

PCB Hole Layout

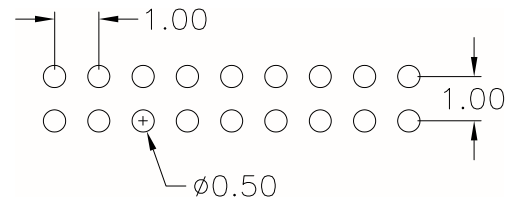

How to order

SL 2 - xxx - S xxx/x - 55 / 00

Nbr of pins
004 to 080

Pin code	DIM "A"	DIM "B"	DIM "C"
050/1	2.00 mm	2.00 mm	1.00 mm
050/2	3.20 mm	2.30 mm	1.00 mm
050/3	3.00 mm	2.30 mm	1.00 mm
112/1	6.50 mm	3.20 mm	1.50 mm
Other dimensions on request			

Plating
55 = gold
Other platings on request

1.00mm pitch Pin Header
 - SMT - low profile dual row

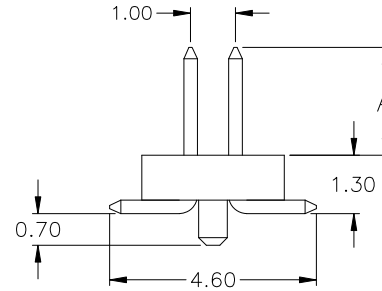
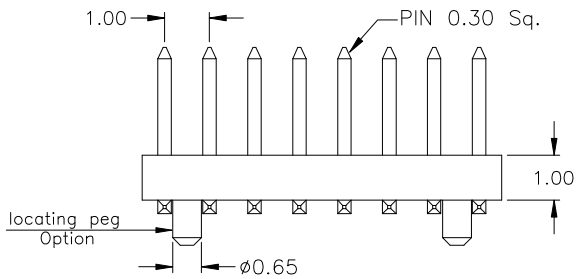
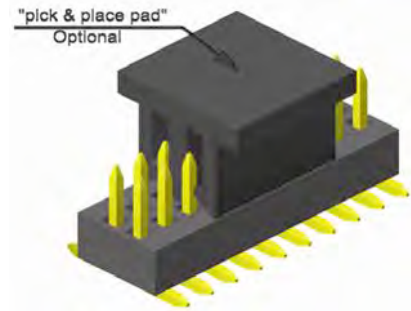
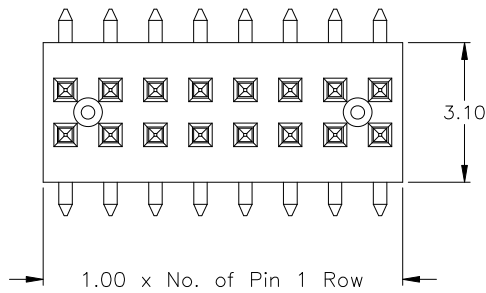

APPLICATION AND FEATURES

- **Standard: tube packing and without "locating pegs"**
- Assures reliable PC Board connections
- Fine pitch, low profile type with 0.30mm square pin
- Mate with female header BS2-xxx-H222-55/00X then "board to board" distance 3.60mm

PCB Surface Mount Layout

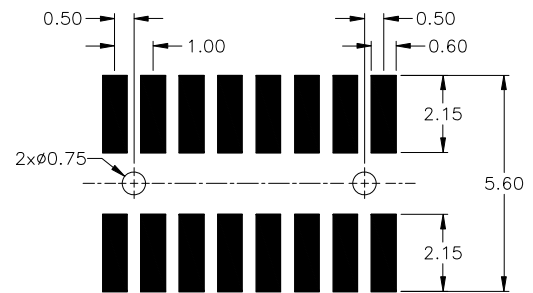

SPECIFICATIONS

Current rating	1 A
Insulator resistance	100 MΩ min.
Withstanding voltage	500 V AC

Operating temperature	- 40°C to +105°C
Processing temperature	+250°C +0/-5°C for 10sec.
Contact material	(RoHS compliant) Copper alloy
Insulator material	(RoHS compliant) Nylon UL 94 V-0

How to order

SS2 - xxx - H 18/x - 55/ 00 X

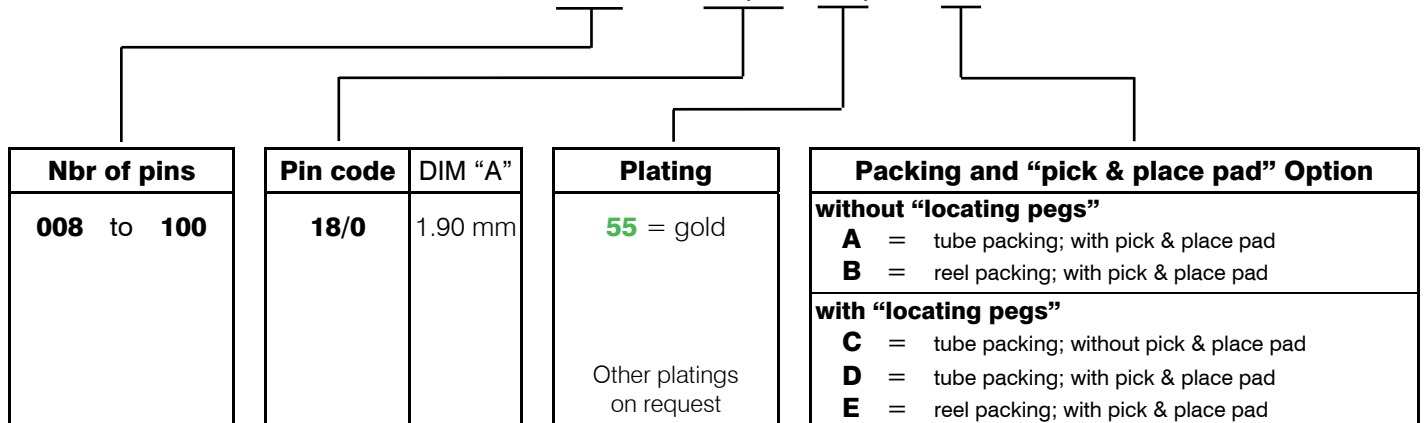

1.00mm pitch Board Spacer

- SMT - dual row

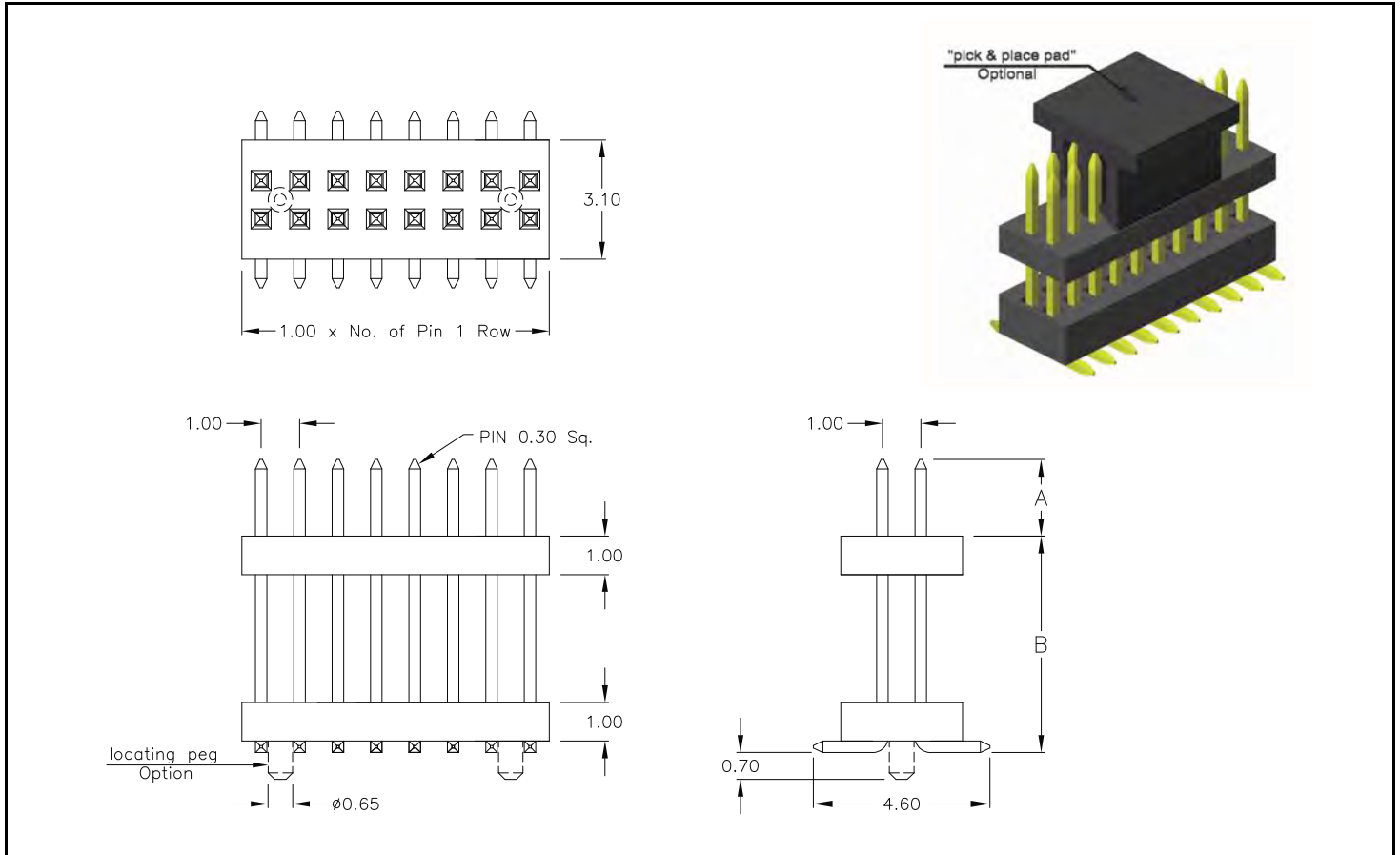

SPECIFICATIONS

Current rating	1 A
Insulator resistance	100 MΩ min.
Withstanding voltage	500 V AC
Operating temperature	- 40°C to +105°C
Processing temperature	+250°C +0/-5°C for 5sec.
Contact material (RoHS compliant)	Copper alloy
Insulator material (RoHS compliant)	Nylon UL 94 V-0

PCB Surface Mount Layout

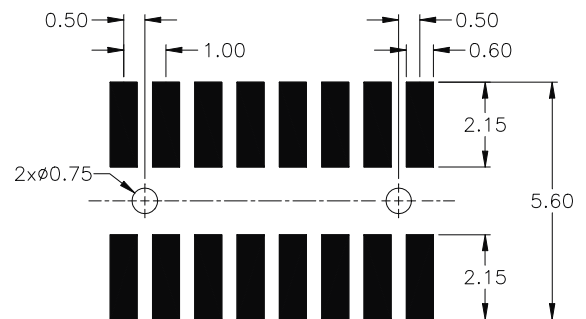

How to order

SP2 - xxx - H 51/x - 55 /00 X

Nbr of pins 008 to 100	Pin code 51/0	DIM "A" 2.00 mm	DIM "B" 7.80 mm	Plating 55 = gold	Packing and "pick & place pad" Option without "locating pegs" A = tube packing; with pick & place pad B = reel packing; with pick & place pad with "locating pegs" C = tube packing; without pick & place pad D = tube packing; with pick & place pad E = reel packing; with pick & place pad
	Other dimensions on request			Other platings on request	

1.00mm pitch Female Header
 - SMT - low profile dual row

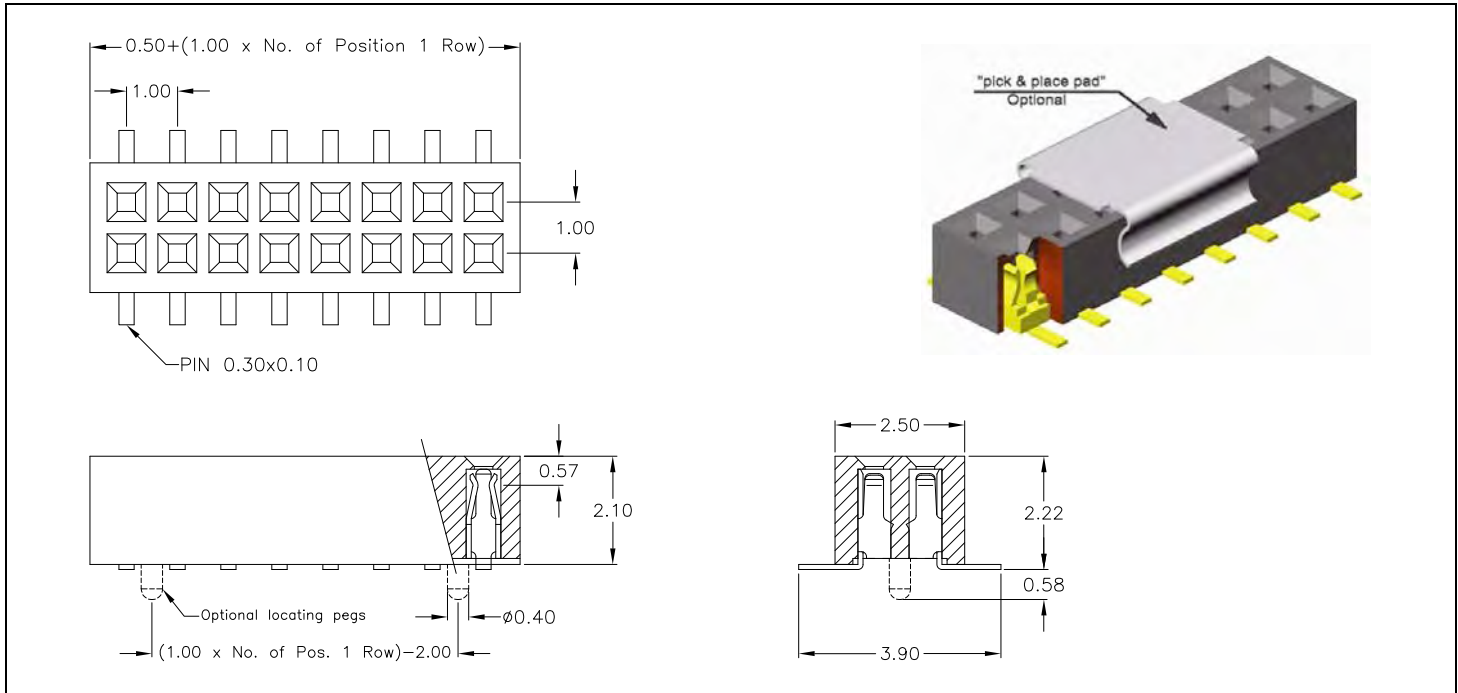

APPLICATION AND FEATURES

- **Standard: tube packing, without "locating pegs" and without "pick & place pad"**
- Assures reliable PC Board connections
- Fine pitch, low profile for space saving Application
- Accept 0.30mm square Pin Header

PCB Surface Mount Layout

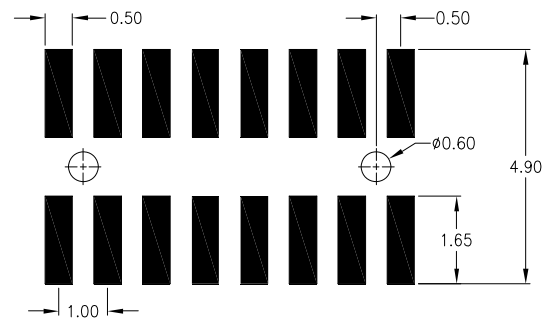

SPECIFICATIONS

Current rating	1 A	Operating temperature	- 40°C to +105°C
Insulator resistance	100 M Ω min.	Processing temperature	+250°C +0/-5°C for 10sec.
Contact resistance	20 m Ω max.	Contact material	Phosphor Bronze (RoHS compliant)
Withstanding voltage	500 V AC	Insulator material	LCP UL 94 V-0 (RoHS compliant)

How to order

BS2 - xxx - H222 - 55 /00 X

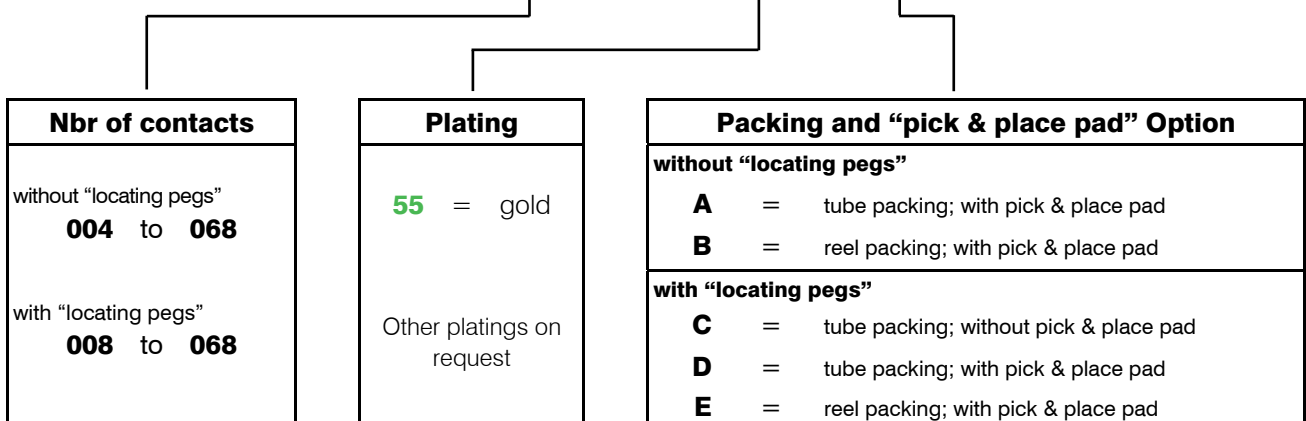

1.27mm pitch Pin Header
 - THT - single row straight

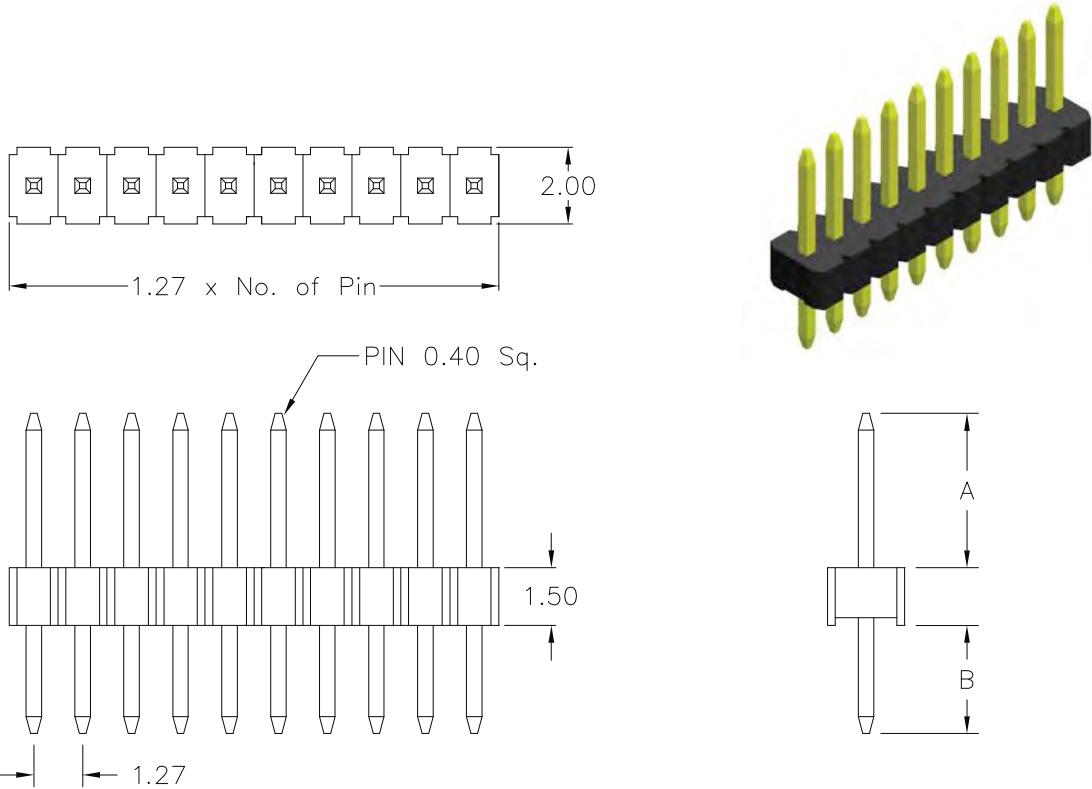

SPECIFICATIONS

Current rating	1 A
Insulator resistance	1000 MΩ min.
Withstanding voltage	500 V AC
Operating temperature	- 40°C to +105°C
Contact material <i>(RoHS compliant)</i>	Copper alloy
Insulator material <i>(RoHS compliant)</i>	Nylon UL 94 V-0

PCB Hole Layout

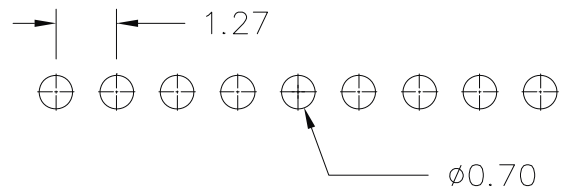

How to order

SL 1 - xxx - B xxx/x - 55 / 11

Nbr of pins
002 to 050

Pin code	DIM "A"	DIM "B"
083/0	4.00 mm	2.80 mm
Other dimensions on request		

Plating
55 = gold
Other platings on request

1.27mm pitch Pin Header

- THT - dual row straight



S063/x & S064/x style

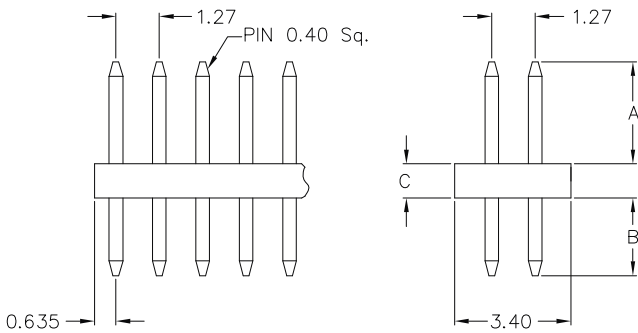
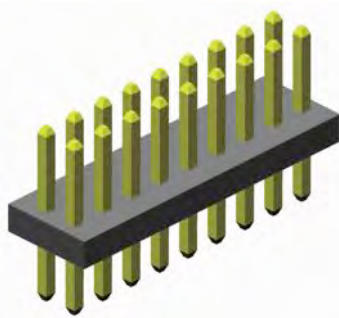

S081/x style

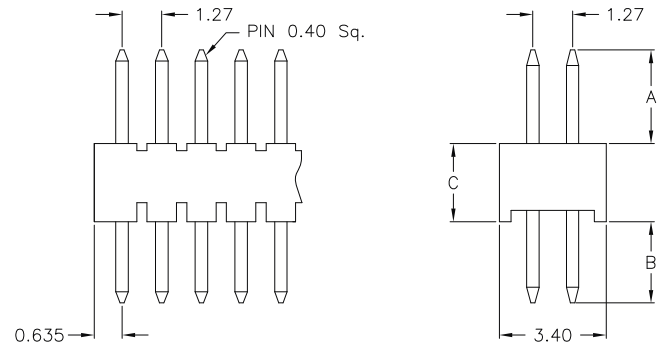
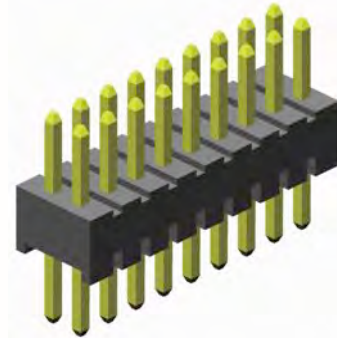

PCB Hole Layout

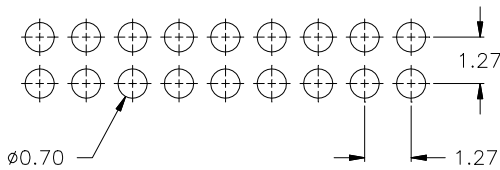

PCB Hole Layout

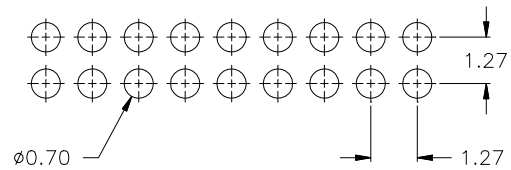

SPECIFICATIONS

Current rating	1 A
Insulator resistance	1000 MΩ min.
Withstanding voltage	500 V AC

Operating temperature	- 40°C to +105°C
Contact material	(RoHS compliant) Copper alloy
Insulator material	(RoHS compliant) Nylon UL 94 V-0

How to order

SL 2 - xxx - S xxx/x - 55 / 11

Nbr of pins
006 to 100

Pin code	DIM "A"	DIM "B"	DIM "C"
063/1	3.00 mm	2.30 mm	1.00 mm
063/2	7.00 mm	2.30 mm	1.00 mm
063/3	5.00 mm	2.30 mm	1.00 mm
063/4	3.10 mm	1.90 mm	1.00 mm
063/5	2.80 mm	2.50 mm	1.00 mm
064/0	7.50 mm	5.00 mm	1.50 mm
Insulator thickness 2.00mm on request.			
081/1	3.00 mm	2.60 mm	2.50 mm
081/2	4.00 mm	2.60 mm	2.50 mm
Other dimensions on request			

Plating
55 = gold
Other platings on request

1.27mm pitch Pin Header

- THT - single & dual row right angle

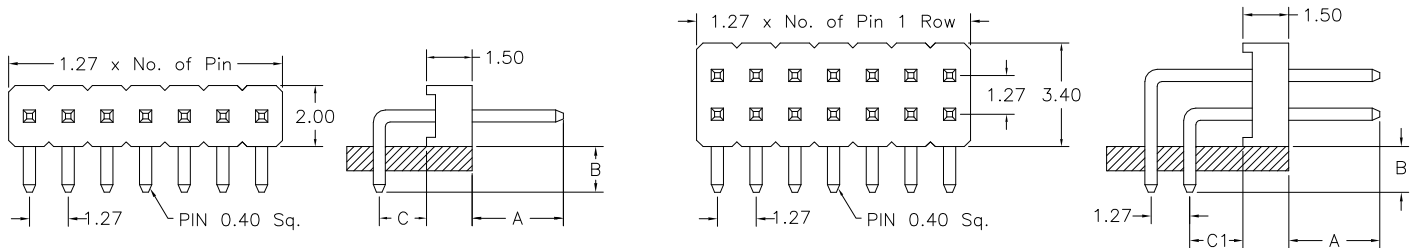
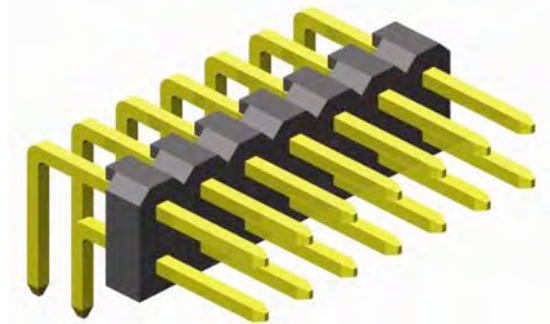
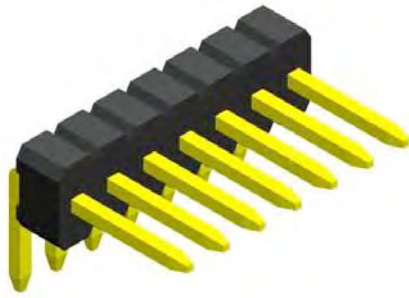

SPECIFICATIONS

Current rating	1 A
Insulator resistance	1000 MΩ min.
Withstanding voltage	500 V AC
Operating temperature	- 40°C to +105°C
Contact material	(RoHS compliant) Copper alloy
Insulator material	(RoHS compliant) Nylon UL 94 V-0

PCB Hole Layout

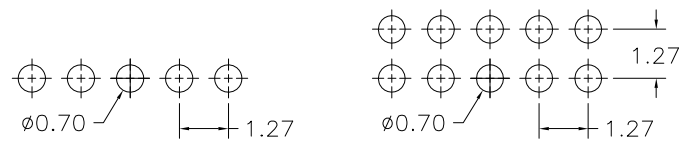

How to order

SL x - xxx - R xxx/x - 55 / 11

Rows	Nbr of pins	Pin code	DIM "A"	DIM "B"	DIM "C" (1 row)	DIM "C1" (2 row)	Plating
1 = single row	002 to 050	071/0	3.80 mm	3.00 mm	1.50 mm	1.70 mm	55 = gold
		071/1	4.80 mm	2.50 mm	0.80 mm	1.00 mm	
		071/2	3.00 mm	3.00 mm	1.50 mm	1.70 mm	
		071/3	3.80 mm	4.50 mm	1.50 mm	1.70 mm	
		071/4	3.80 mm	1.60 mm	1.50 mm	1.70 mm	
		071/5	3.00 mm	2.80 mm	1.50 mm	1.70 mm	
2 = dual row	006 to 100	071/6	4.00 mm	4.00 mm	1.50 mm	1.70 mm	Other platings on request
		Other dimensions on request					

1.27mm pitch Board Spacer
- THT - single & dual row

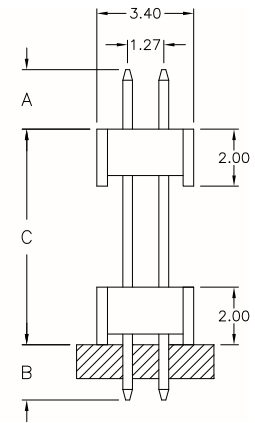
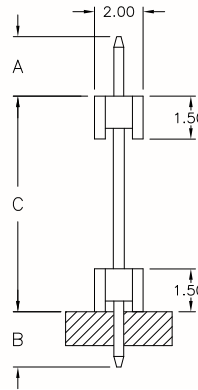
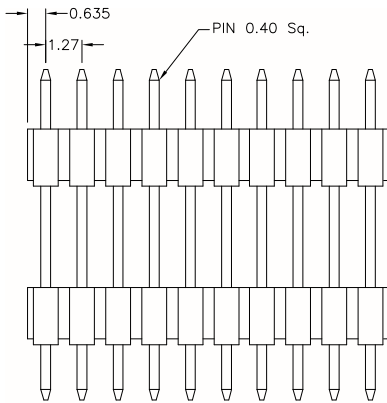

PCB Hole Layout

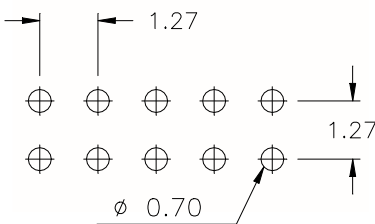
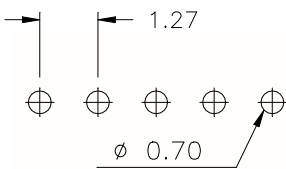

SPECIFICATIONS

Current rating	1 A
Insulator resistance	1000 MΩ min.
Withstanding voltage	500 V AC
Operating temperature	- 40°C to +105°C
Contact material	Copper alloy <i>(RoHS compliant)</i>
Insulator material	Nylon UL 94 V-0 <i>(RoHS compliant)</i>

Pin code	DIM "A"	DIM "B"	DIM "C"
162/1	5.70 mm	5.70 mm	4.80 mm
179/0	5.85 mm	5.85 mm	6.15 mm
130/2	3.70 mm	2.30 mm	7.00 mm
130/3	3.00 mm	3.00 mm	7.00 mm
150/2	4.00 mm	3.00 mm	8.00 mm
127/1	2.20 mm	2.20 mm	8.30 mm
152/2	3.60 mm	2.60 mm	9.00 mm
180/3	4.00 mm	4.00 mm	10.00 mm
205/1	3.00 mm	6.50 mm	11.00 mm
190/1	3.00 mm	3.00 mm	13.00 mm
220/1	6.00 mm	3.00 mm	13.00 mm
200/1	3.00 mm	3.00 mm	14.00 mm
230/1	3.00 mm	6.00 mm	14.00 mm
210/4	3.50 mm	3.00 mm	14.50 mm
230/2	3.00 mm	3.00 mm	17.00 mm
244/2	4.00 mm	3.00 mm	17.40 mm
265/1	4.60 mm	3.00 mm	18.90 mm

Other dimensions on request

How to order

SP x - xxx - S xxx/x - 55 /11

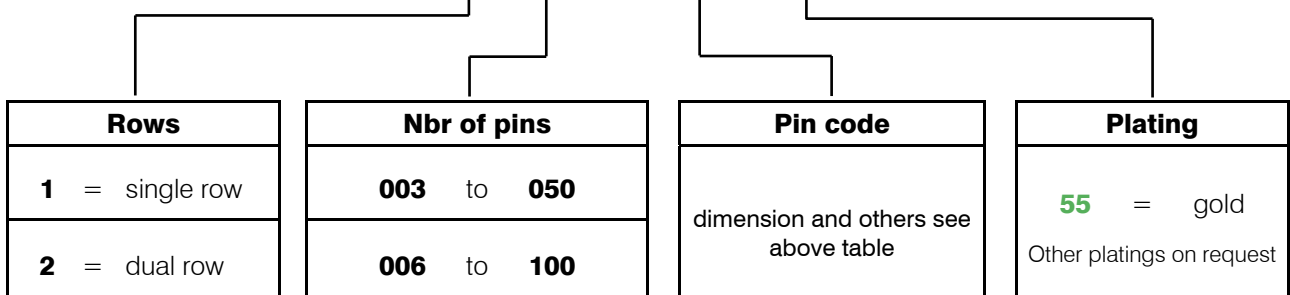

1.27mm Pin Header & Board Spacer
 1.27mm x 2.54mm Board Spacer

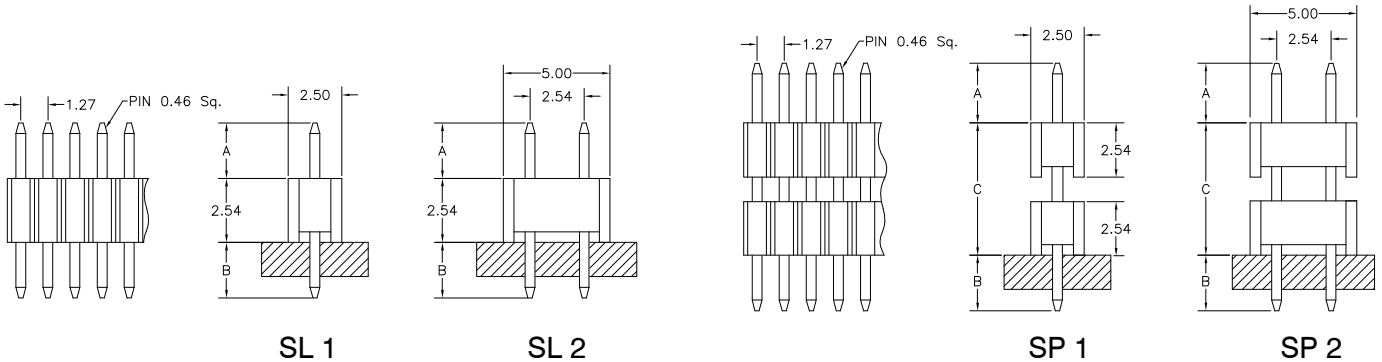
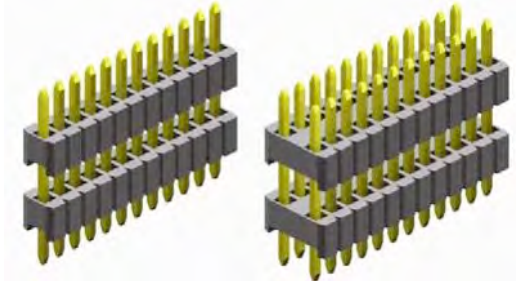
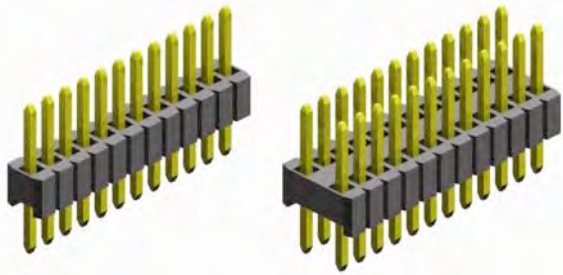

SPECIFICATIONS

Current rating	1 A
Insulator resistance	1000 MΩ min.
Withstanding voltage	500 V AC
Operating temperature	- 40°C to +105°C
Contact material (RoHS compliant)	Copper alloy
Insulator material (RoHS compliant)	Nylon, UL 94 V-0

PCB Hole Layout

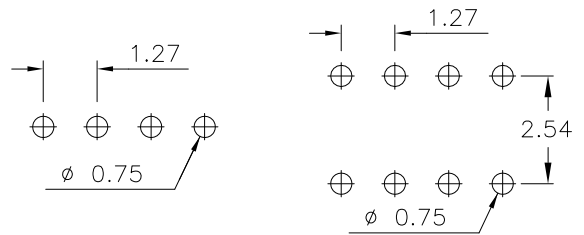

How to order

S xx - xxx - S xxx/xx - 55 /1

Single plastic	Nbr of pins	Pin code	DIM "A"	DIM "B"	Plating
L1 = single row	single row = 003 to 050	079/01	2.80 mm	2.60 mm	55 = gold
L2 = dual row	dual row = 006 to 100	091/01	4.00 mm	2.60 mm	
		111/01	6.00 mm	2.60 mm	
		164/01	2.50 mm	11.40 mm	
		Other dimensions on request			
Double plastic "Boardspacer"	Nbr of pins	Pin code	DIM "A"	DIM "B"	DIM "C"
P1 = single row	single row = 003 to 050	084/01	1.10 mm	1.30 mm	6.00 mm
P2 = dual row	dual row = 006 to 100	116/01	2.80 mm	2.60 mm	6.20 mm
		152/01	6.00 mm	3.00 mm	6.20 mm
		127/01	2.20 mm	2.20 mm	8.30 mm
		137/01	3.00 mm	2.30 mm	8.40 mm
		160/06	3.00 mm	4.00 mm	9.00 mm
		210/06	5.50 mm	2.50 mm	13.00 mm
		218/01	6.00 mm	1.80 mm	14.00 mm
		Other dimensions on request			
					Other platings on request

1.27mm pitch Pin Header
 - SMT - low profile dual row

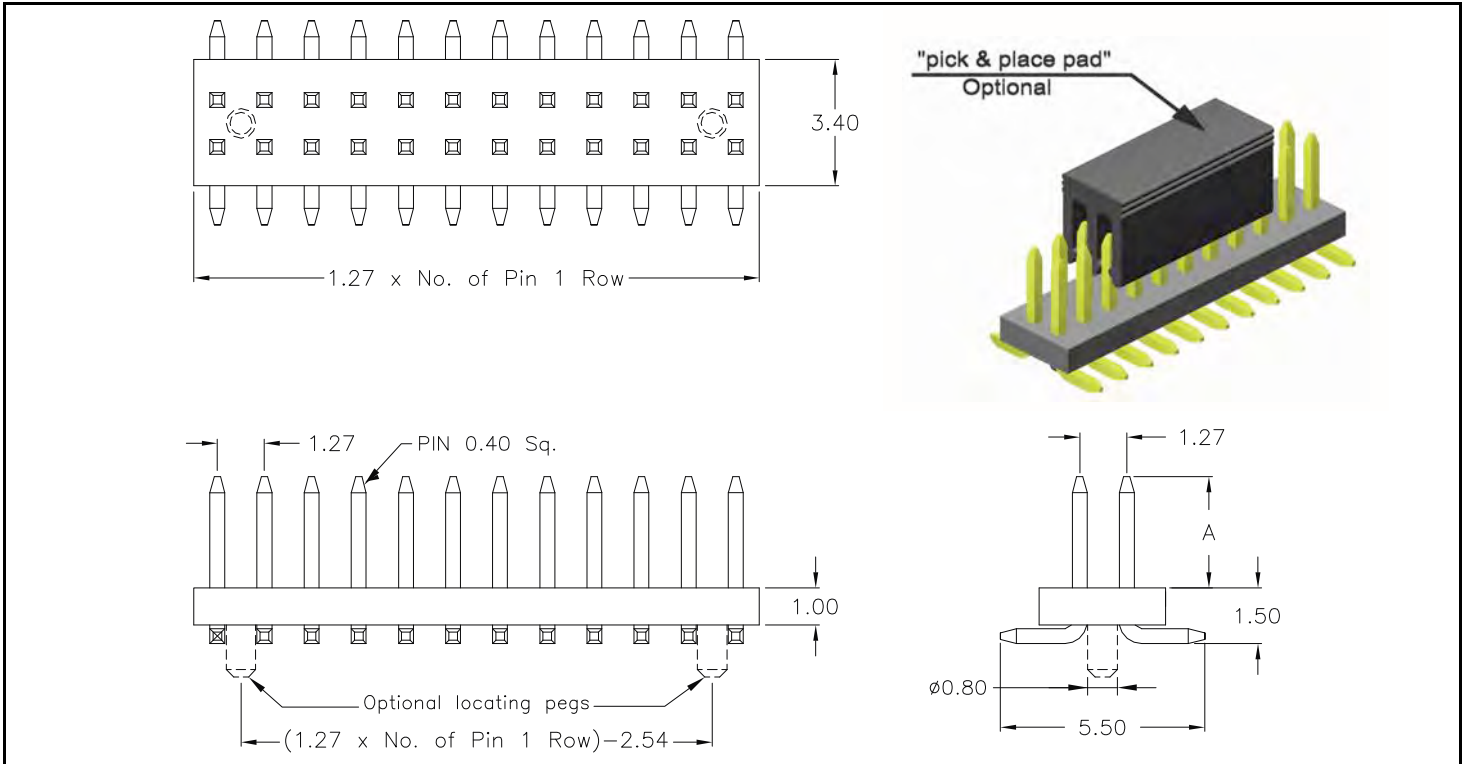

APPLICATION AND FEATURES

- **Standard: tube packing and without "locating pegs"**
- Assures reliable PC Board connections
- Low profile insulator
- Mates with 1.27mm pitch Female Headers

PCB Surface Mount Layout

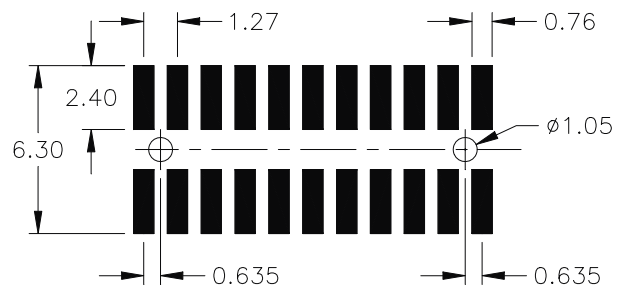

SPECIFICATIONS

Current rating 1 A
 Insulator resistance 1000 MΩ min.
 Withstanding voltage 500 V AC

Operating temperature -40°C to +105°C
 Processing temperature +250°C +0/-5°C for 10sec.

Contact material (RoHS compliant) Copper alloy
 Insulator material (RoHS compliant) Nylon UL 94 V-0

How to order

SS2 - xxx - H xx/x - 55 /11 X

Nbr of pins	Pin code	DIM "A"	Plating	Packing and "pick & place pad" Option
without locating pegs: 006 to 100	70/0	3.00 mm	55 = gold	without "locating pegs" A = tube packing; with pick & place pad B = reel packing; with pick & place pad
with locating pegs: 008 to 100	70/1	10.00 mm	Other platings on request	with "locating pegs" (available only from 008 to 100 pins) C = tube packing; without pick & place pad D = tube packing; with pick & place pad E = reel packing; with pick & place pad
	70/2	6.50 mm		
	Other dimensions on request			

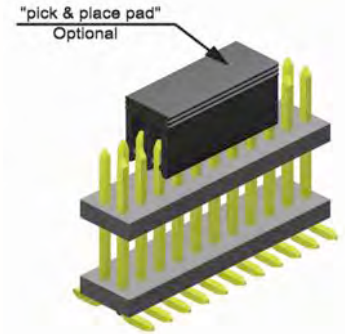
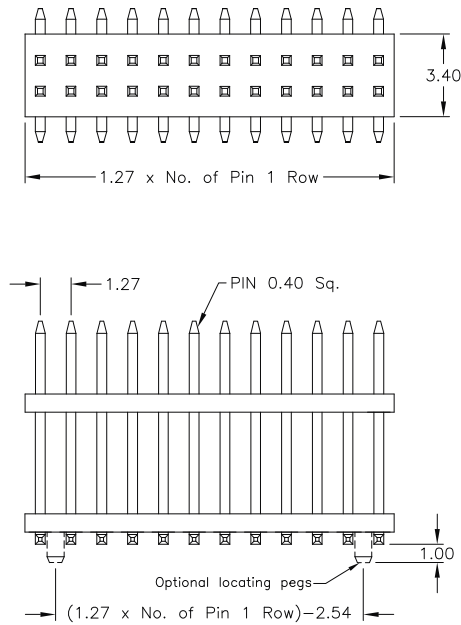

SPECIFICATIONS

Current rating	1 A
Insulator resistance	1000 MΩ min.
Withstanding voltage	500 V AC
Operating temperature	- 40°C to +105°C
Processing temperature	+250°C +0/-5°C for 5sec.
Contact material	Copper alloy (RoHS compliant)
Insulator material	Nylon UL 94 V-0 (RoHS compliant)

PCB Surface Mount Layout

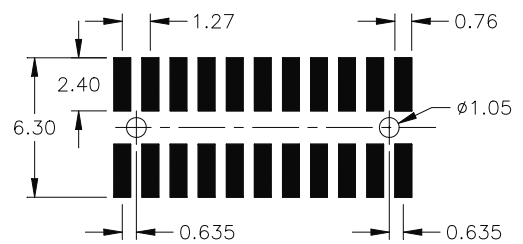

How to order

SP2 - xxx - H xx/x - 55 /11 X

Nbr of pins	Pin code	DIM "A"	DIM "B"	Plating	Packing and "pick & place pad" Option
without "locating pegs"	21/9	4.10 mm	2.90 mm	55 = gold	without "locating pegs" A = tube packing; with pick & place pad B = reel packing; with pick & place pad
006 to 100	22/9	5.20 mm	3.80 mm		
with "locating pegs"	21/1	3.00 mm	4.00 mm	Other platings on request	with "locating pegs" (available only from 008 to 100 pins) C = tube packing; without pick & place pad D = tube packing; with pick & place pad E = reel packing; with pick & place pad
	22/8	1.50 mm	4.40 mm		
	22/3	5.00 mm	4.50 mm		
	21/2	3.00 mm	5.50 mm		
	22/5	6.00 mm	5.50 mm		
	21/0	3.00 mm	6.00 mm		
	22/0	3.00 mm	7.00 mm		
	22/2	4.70 mm	7.10 mm		
	22/4	4.00 mm	7.50 mm		
	21/8	4.80 mm	7.50 mm		
	23/0	6.10 mm	7.50 mm		
	21/3	5.60 mm	8.00 mm		
	21/7	4.00 mm	8.30 mm		
	21/5	3.00 mm	9.00 mm		
	21/4	3.80 mm	9.65 mm		
	22/1	5.10 mm	10.20 mm		
	22/6	3.00 mm	11.50 mm		
	22/7	3.00 mm	14.00 mm		
21/6	3.00 mm	16.00 mm			
Other dimensions on request					

1.27mm - SMT - Pin Header

dual row 1.27mm x 2.54mm

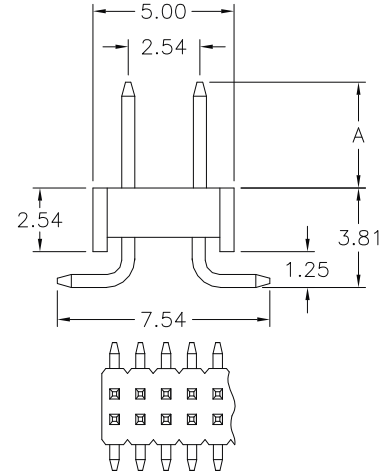
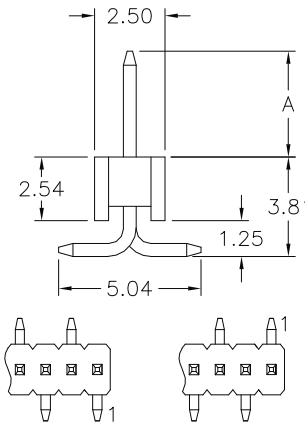
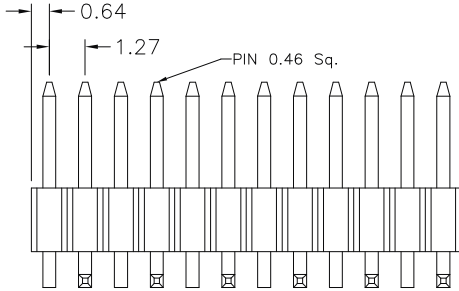
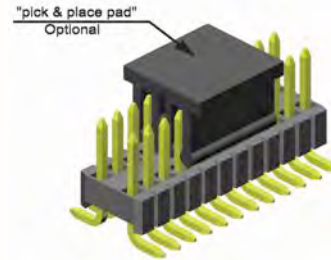
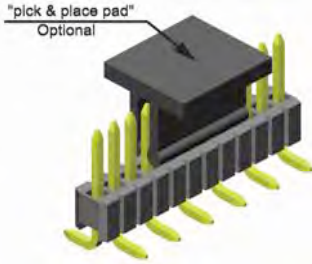

Foot style: **380** **381** **380**

SPECIFICATIONS

Current rating	1 A
Insulator resistance	1000 MΩ min.
Withstanding voltage	500 V AC
Operating temperature	- 40°C to +105°C
Processing temperature	+250°C +0/-5°C for 5sec.
Contact material (RoHS compliant)	Brass
Insulator material (RoHS compliant)	Nylon UL 94 V-0

PCB Surface Mount Layout

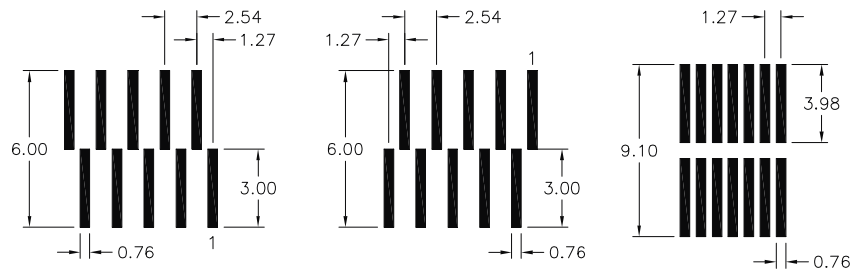

Foot style: **380** (single row) **381** (single row) **380** (dual row)

How to order

SS x - xxx - H xxx / x - 55 / 1 X

Rows	Nbr of pins	Foot style	Pin code	DIM "A"	Plating	Packing and "pick & place pad" Option
1 = single row	003 to 050	380 / 0		2.80 mm	55 = gold	A = tube packing; with pick & place pad B = reel packing; with pick & place pad
		381 / 0		2.80 mm		
2 = dual row	006 to 100	380 / 0		2.80 mm	Other platings on request	
		380 / 1		4.50 mm		
		380 / 2		5.50 mm		
		380 / 3		4.80 mm		
		Other dimensions on request				

1.27mm x 2.54mm Board Spacer

- SMT - dual row

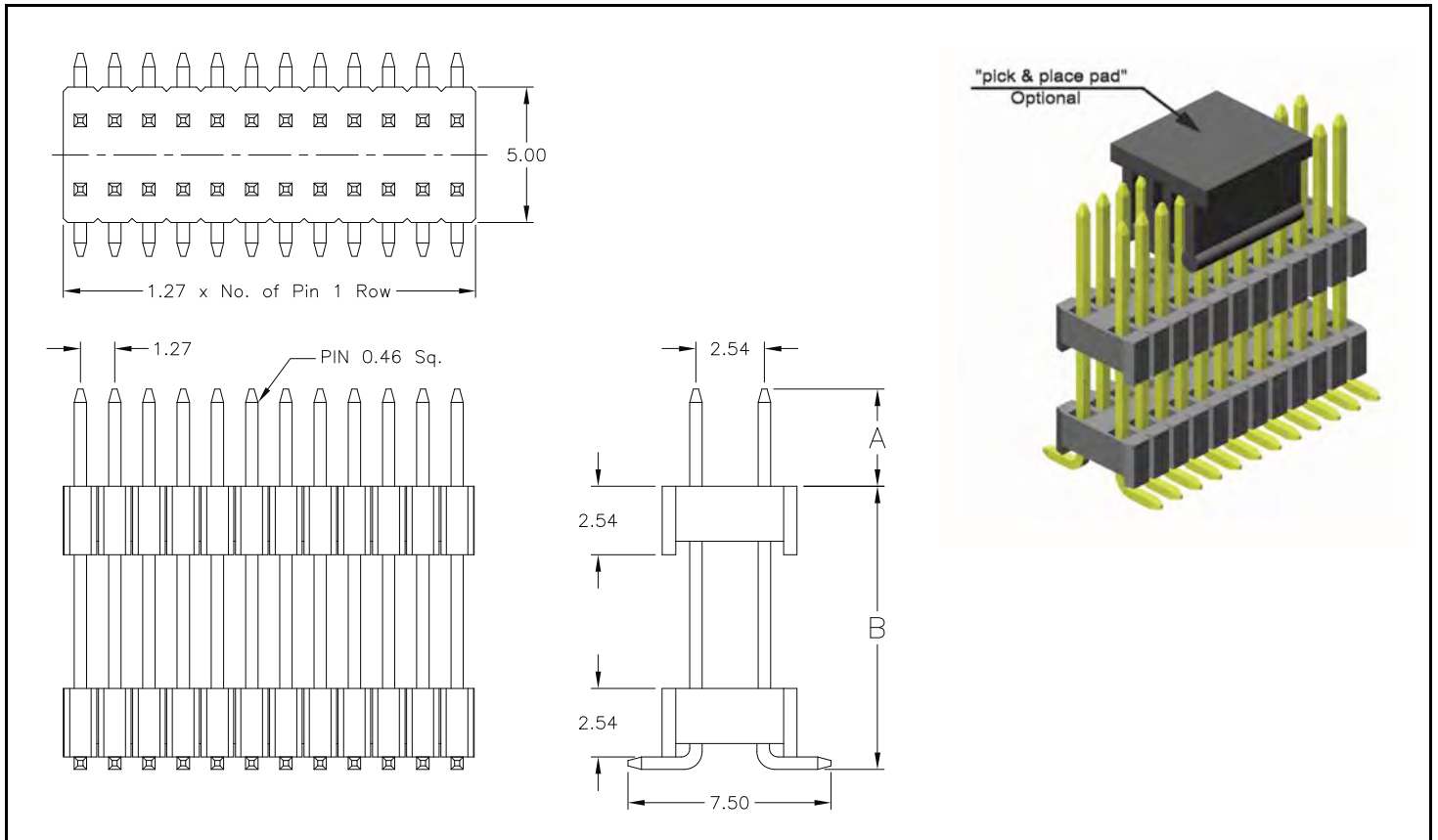

SPECIFICATIONS	
Current rating	1 A
Insulator resistance	1000 MΩ min.
Withstanding voltage	500 V AC
Operating temperature	- 40°C to +105°C
Processing temperature	+250°C +0/-5°C for 5sec.
Contact material (RoHS compliant)	Brass
Insulator material (RoHS compliant)	Nylon UL 94 V-0

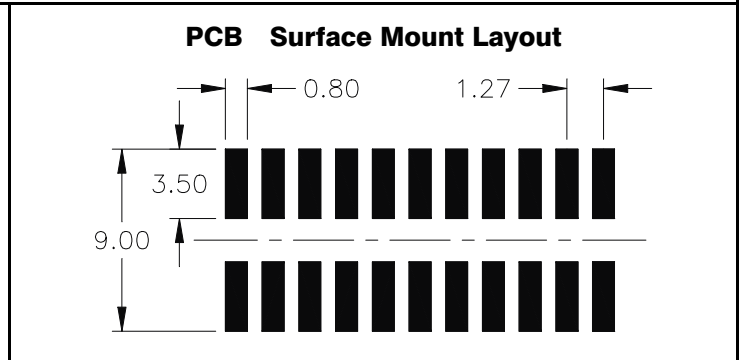

How to order

SP2 - xxx - H 220/x - 55 /1 X

Nbr of pins	Pin code	DIM "A"	DIM "B"	Plating	Packing and "pick & place pad" Option (standard tube packing; without pick & place pad)
006 to 100	220/0	5.60 mm	8.50 mm	55 = gold Other platings on request	A = tube packing; with pick & place pad B = reel packing; with pick & place pad
	220/1	5.60 mm	9.75 mm		
	220/2	3.40 mm	12.20 mm		
		Other dimensions on request			

1.27mm pitch Box Header
 - THT - straight - raised



S 535 Style

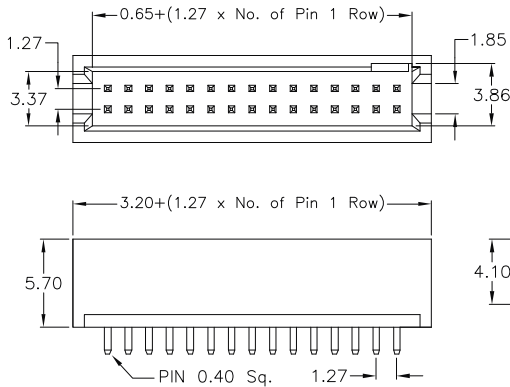
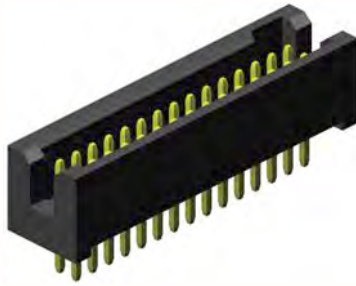

P 535 Style

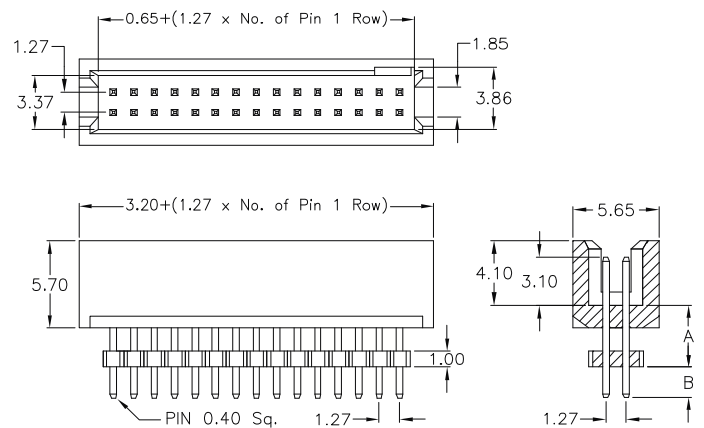

SPECIFICATIONS

Current rating	1 A
Insulator resistance	1000 MΩ min.
Withstanding voltage	500 V AC
Operating temperature	- 40°C to +105°C
Contact material	(RoHS compliant) Copper alloy
Insulator material	(RoHS compliant) Nylon UL 94 V-0

PCB Hole Layout

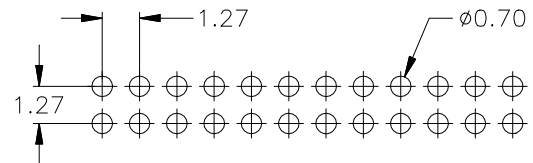

Application and Features

Mating with 1.27mm pitch Female Headers,
 Reliable flat cable to PCB connection, or as "board to board" connection.
 No ejection latches for space saving.

How to order

SLS - xxx - X xxx - 55 /11

Nbr of pins
010 to 100

Style	DIM "A"	DIM "B"
straight standard S 535		2.40 mm
straight raised P 535/0	16.00 mm	2.40 mm
P 535/1	12.40 mm	2.40 mm
Other dimensions on request		

Plating
55 = gold
Other platings on request

1.27mm pitch Box Header

- THT - right angle

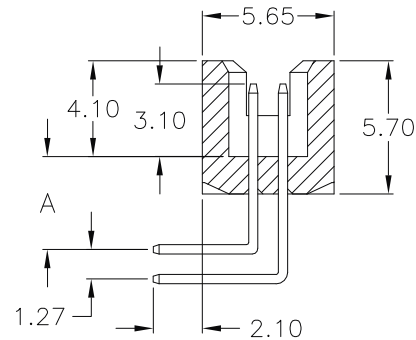
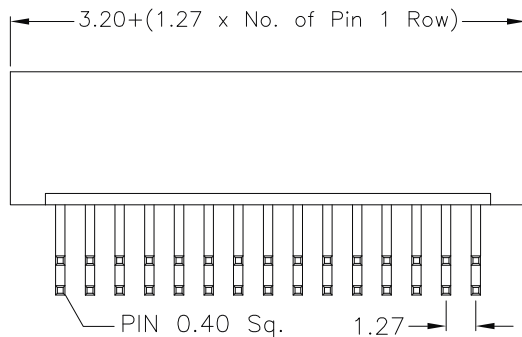
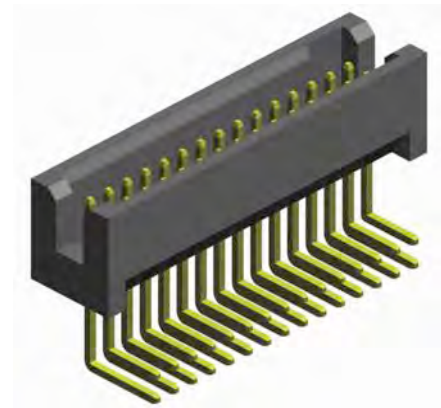
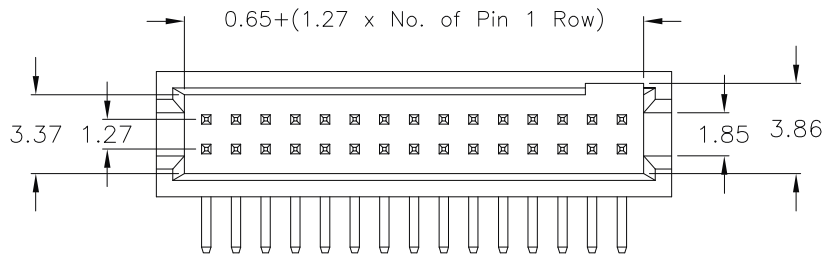

SPECIFICATIONS

Current rating	1 A
Insulator resistance	1000 MΩ min.
Withstanding voltage	500 V AC
Operating temperature	- 40°C to +105°C
Contact material	(RoHS compliant) Copper alloy
Insulator material	(RoHS compliant) Nylon UL 94 V-0

PCB Hole Layout

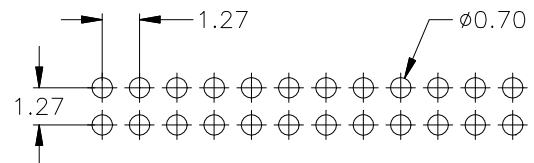

APPLICATION AND FEATURES

Mating with 1.27mm pitch Female Headers,
 Reliable flat cable to PCB connection.
 No ejection latches for space saving.

How to order

SLS - xxx - R xxx/x - 55 /11

Nbr of pins
010 to 100

Pin code	DIM "A"
565/0 (standard)	2.10 mm
565/1	3.70 mm
Other dimensions on request	

Plating
55 = gold
Other platings on request

H 610 Style

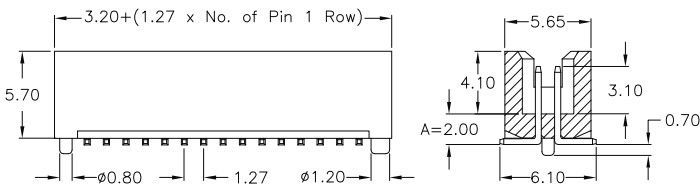
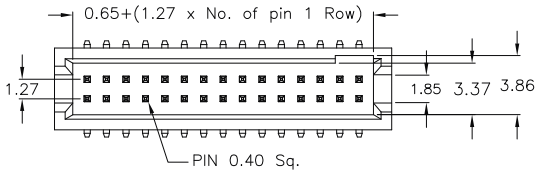

PCB Surface Mount Layout

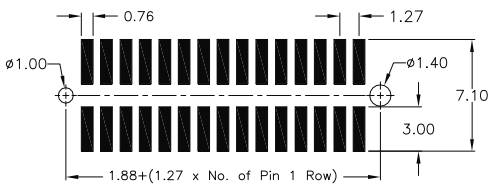

HP xx Style

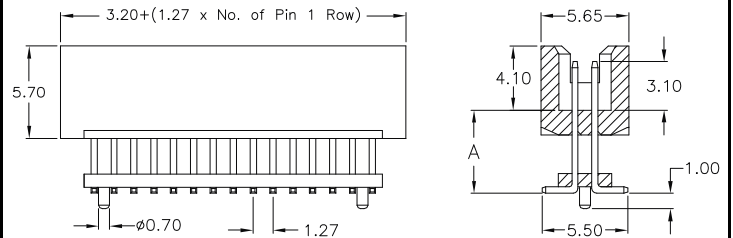
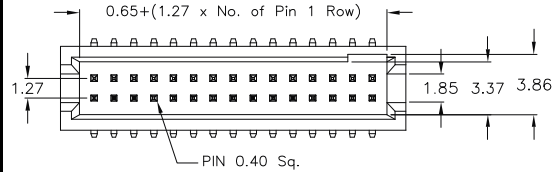
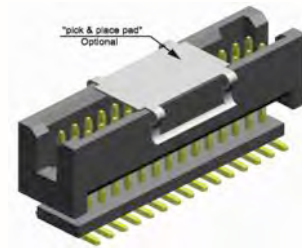

PCB Surface Mount Layout

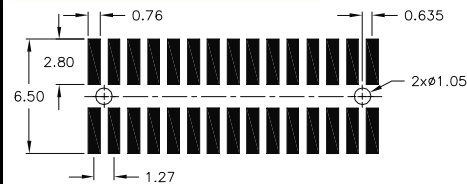

SPECIFICATIONS

Current rating	1 A
Insulator resistance	1000 MΩ min.
Withstanding voltage	500 V AC

Operating temperature	- 40°C to +105°C
Processing temperature	+250°C +0/-5°C for 5sec.
Contact material	(RoHS compliant) Copper alloy
Insulator material	(RoHS compliant) Nylon UL 94 V-0

APPLICATION AND FEATURES

Mating with 1.27mm pitch Female Headers,
 Reliable flat cable to PCB connection, or as "board to board" connection
 No ejection latches for space saving

How to order

SLS - xxx - Xxxx - 55 /11 X

Nbr of pins	Style	Plating	Packing and "pick & place pad" Option
010 to 100	H610 Low Profile DIM "A" = 2.00 mm	55 = gold Other platings on request	A = tube packing; with pick & place pad B = reel packing; with pick & place pad
	Raised Type DIM "A"		
	HP20 15.00 mm (standard)		
	HP21 18.00 mm		
	HP22 8.50 mm		
<i>Other dimensions on request</i>			

1.27mm pitch Box Header

-THT- straight, right angle & - SMT -

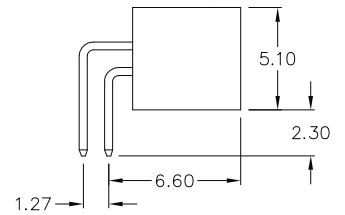
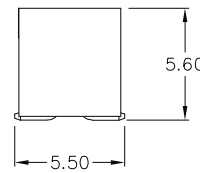
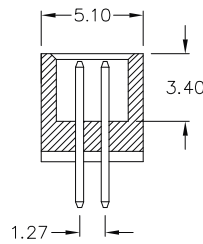
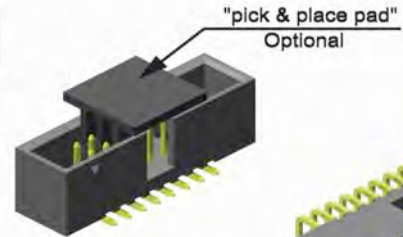
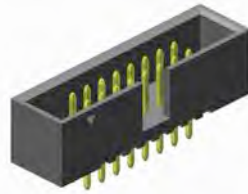
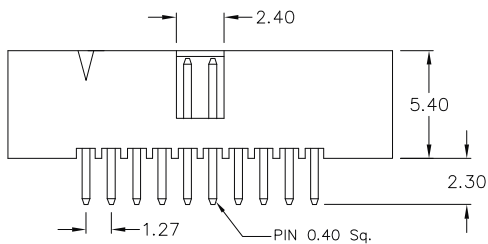
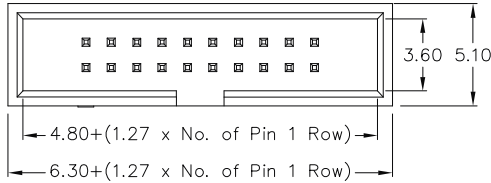

S 510

H 510

R 510

APPLICATION AND FEATURES

- **Standard:**
tray packing for S510 & R510 Style
tube packing for H510 Style
- Designed to mate with IDC female connector IDS-xxx-W050-55/P
- Reliable flat cable to PCB connection
- No ejection latches for space saving

PCB Hole and Surface Mount Layout

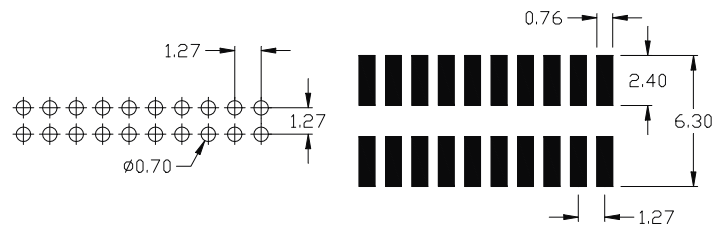

SPECIFICATIONS

Current rating	1 A
Insulator resistance	1000 MΩ min.
Withstanding voltage	500 V AC

Operating temperature	- 40°C to +105°C
Processing temperature (SMT)	+250°C +0/-5°C for 10sec.
Contact material (RoHS compliant)	Copper Alloy
Insulator material (RoHS compliant)	LCP UL 94 V-0

How to order

SLS - xxx - X xxx - 55/11 (X)

Nbr of pins	Pin style	Plating	Option only for - H510 - Style
006; 008; 010; 012 014; 016; 020; 024 026; 030; 034; 036 040; 044; 050; 060 064; 066; 068; 080 100	S 510 = straight R 510 = right angle H 510 = SMT	55 = gold Other platings on request	A = tube packing; with pick & place pad B = reel packing; with pick & place pad

1.27mm pitch Female Header
 - THT - dual row straight & right angle

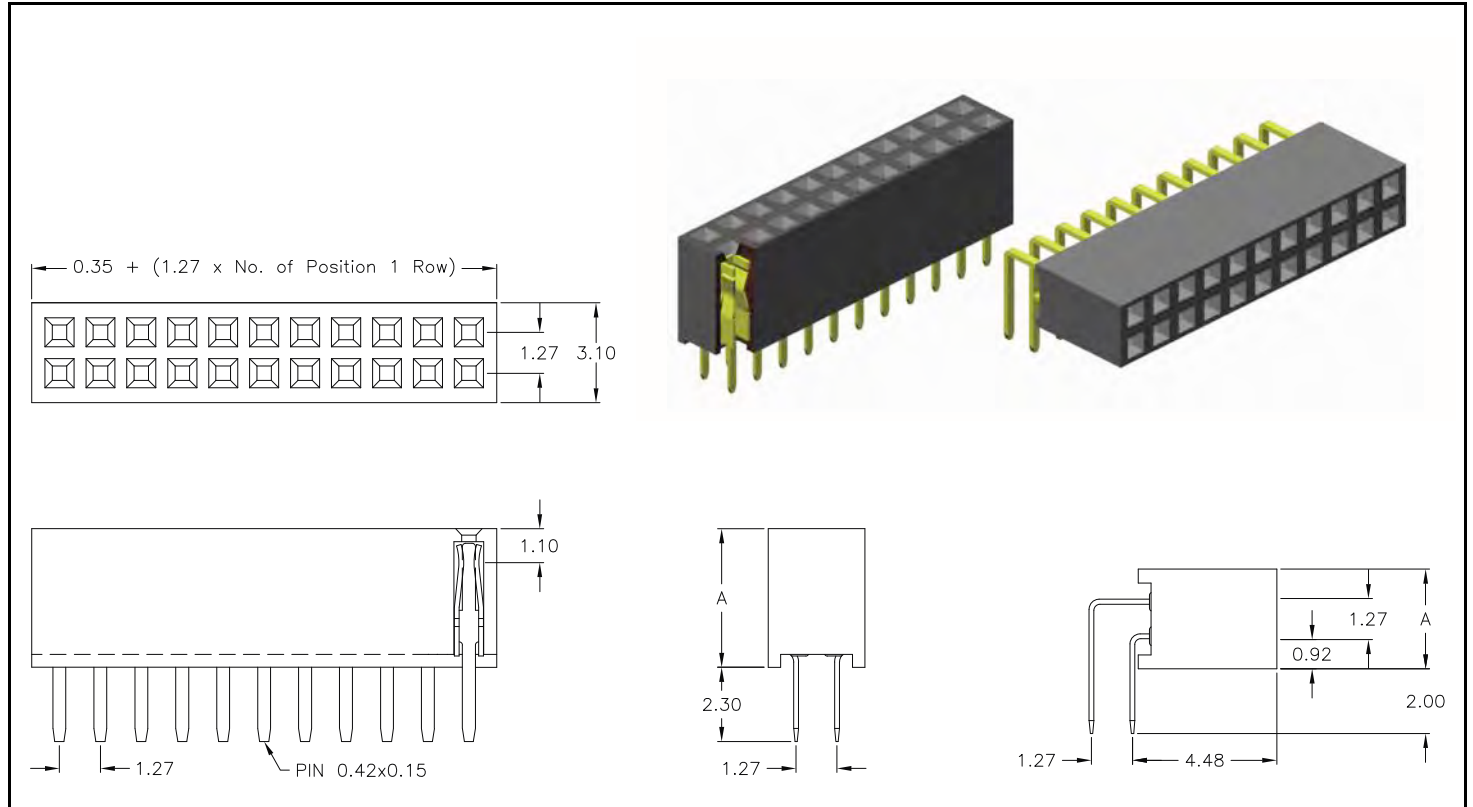

APPLICATION AND FEATURES

- 3.40 or 4.40mm height above board straight type
- Hi-rel dual beam contact assures reliable PC-Board connections
- Accepts 0.40mm square pins
- Stand-off's facilitate post solder cleaning
- Side stackable

PCB Hole Layout

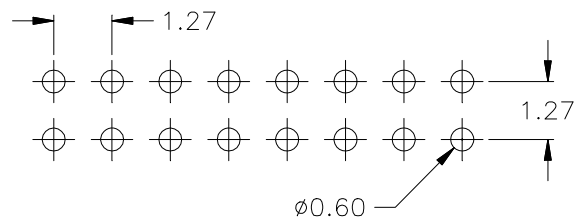

SPECIFICATIONS

Current rating	1 A	Operating temperature	- 40°C to +105°C
Insulator resistance	1000 MΩ min.	Contact material	(RoHS compliant) Phosphor Bronze
Contact resistance	20 mΩ max.	Insulator material	(RoHS compliant) LCP UL 94 V-0
Withstanding voltage	500 V AC		

How to order

BL 2 - xxx - X xxx - 55 / 11

Nbr of contacts	Connector style	DIM "A"	Plating
006 to 100	S340 straight	3.40 mm	55 = gold Other platings on request
004 to 100	S430 straight	4.40 mm	
004 to 100	R430 right angle	3.10 mm	

1.27mm pitch Female Header
 -THT- 1.27mm x 2.54mm dual row

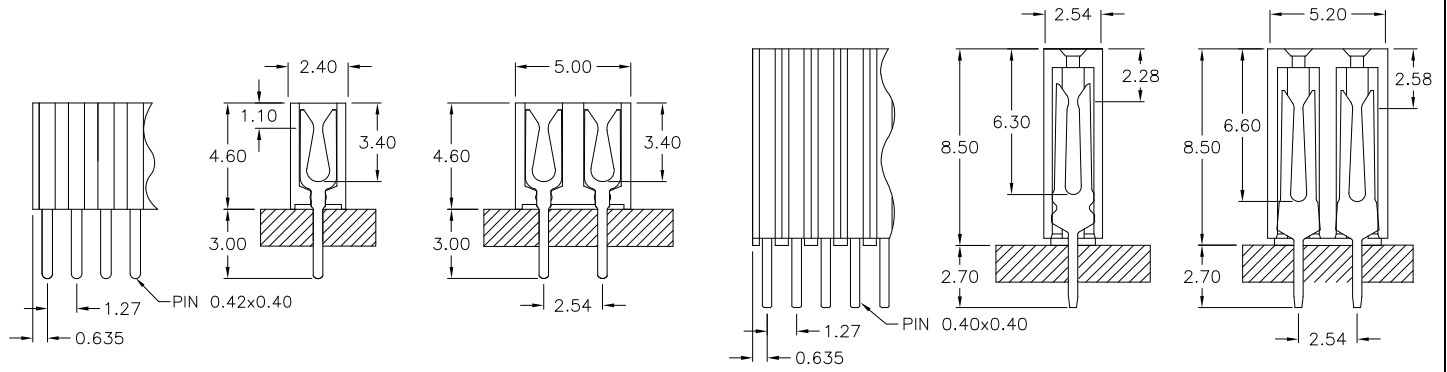
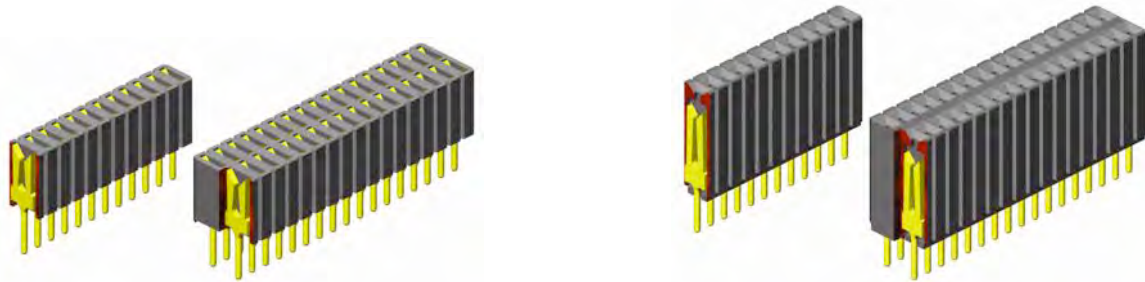

S 460

S 850

SPECIFICATIONS

Current rating	1 A
Insulator resistance	1000 MΩ min.
Contact resistance	20 mΩ max.
Withstanding voltage	500 V AC
Operating temperature	- 40°C to +105°C
Contact material (RoHS compliant)	Phosphor Bronze
Insulator material (RoHS compliant)	LCP UL 94 V-0

PCB Hole Layout

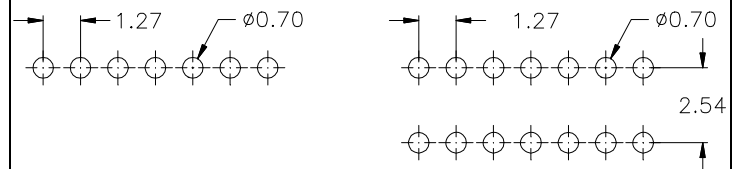

APPLICATION AND FEATURES

- Standard & low profile types
- Hi-rel fork contact design
- Mates with 0.46mm square or round Pin Header

How to order

BL x - xxx - S xxx - 55 /1

Rows	Nbr of contacts	Version (height above board)	Plating
1 = single row 2 = dual row	version 460 single row = 003 to 040 dual row = 006 to 080	460 = 4.60 mm	55 = gold Other platings on request
	version 850 single row = 003 to 035 dual row = 006 to 070	850 = 8.50 mm	

1.27mm pitch Female Header
 - THT- side entry

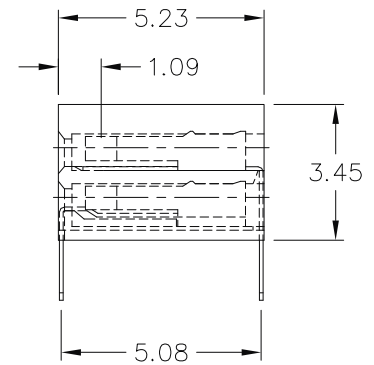
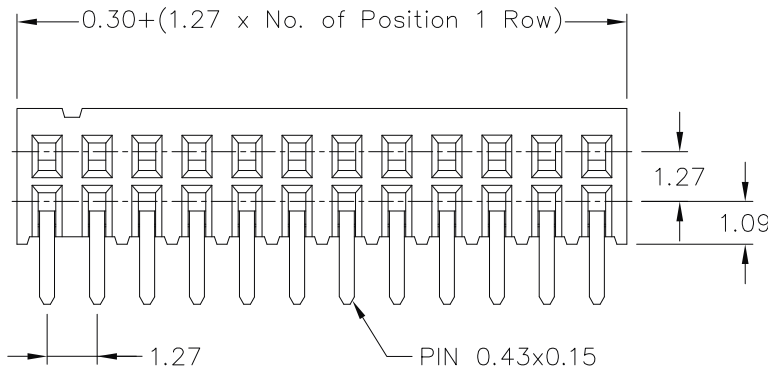
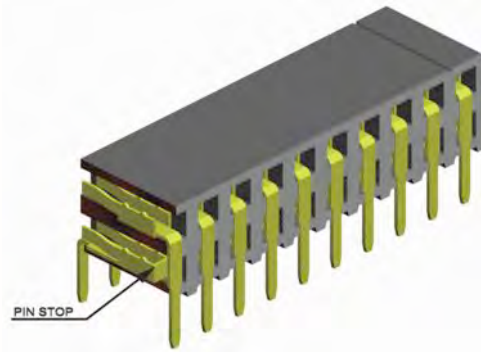
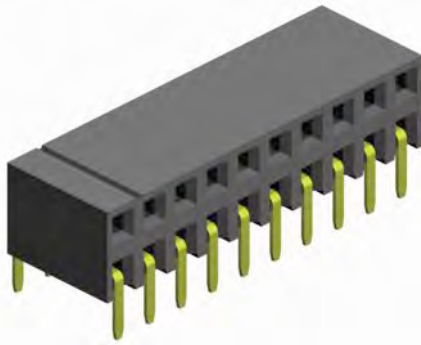

APPLICATION AND FEATURES

- **Standard: tube packing**
- Hi-rel dual beam contact assures reliable PC-Board connections
- Accepts 0.40mm square pins; Pin Header 1.27mm x 1.27mm
- 3.45mm height above board
- Stand-off's facilitate post solder cleaning

PCB Hole Layout

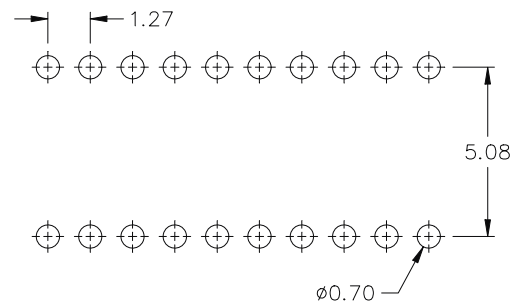

SPECIFICATIONS

Current rating	1 A	Operating temperature	- 40°C to +105°C
Insulator resistance	1000 MΩ min.	Contact material (RoHS compliant)	Phosphor bronze
Contact resistance	20 mΩ max.	Insulator material (RoHS compliant)	Nylon UL 94 V-0
Withstanding voltage	500 V AC		

How to order

BH 2 - xxx - R 345 - 55 /11

Nbr of contacts
006 to 080

Plating
55 = gold
Other platings on request

1.27mm x 2.54mm pitch Female Header

- SMT - dual row 6.00mm profile

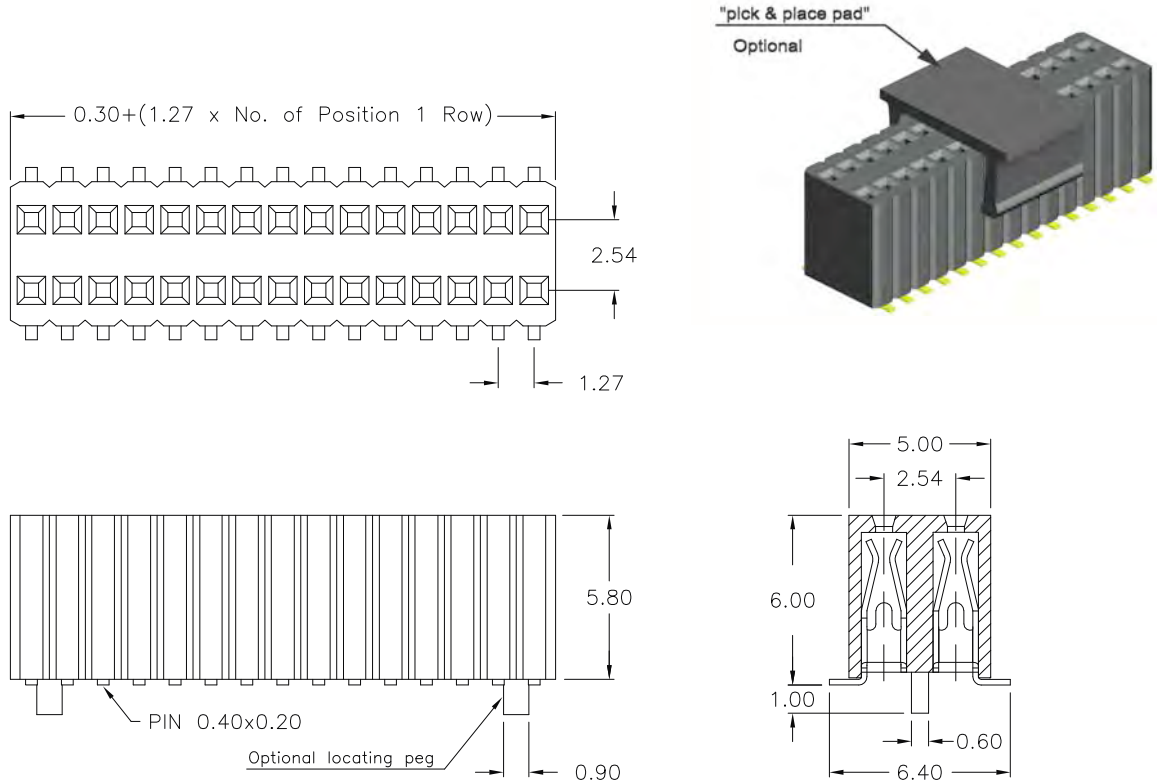

SPECIFICATIONS

Current rating	1 A
Insulator resistance	1000 MΩ min.
Contact resistance	20 mΩ max.
Withstanding voltage	500 V AC
Operating temperature	- 40°C to +105°C
Processing temperature	+250°C +0/-5°C for 10sec.
Contact material	(RoHS compliant) Phosphor Bronze
Insulator material	(RoHS compliant) Nylon UL 94 V-0

PCB Surface Mount & Hole Layout

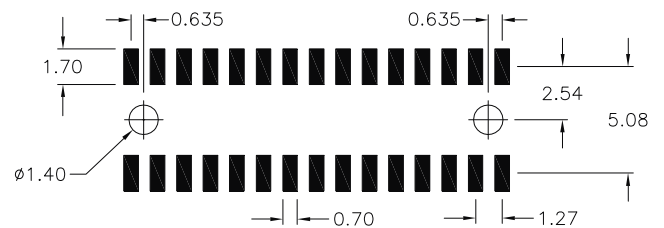

APPLICATION AND FEATURES

Standard: tube packing and without "pick & place pad"
 Hi-rel inner contact design, mates with 0.46mm square pin headers

How to order

BS 2 - xxx - H 600 - 55 /1 X

Rows	Nbr of contacts	Plating	Packing and "pick & place pad" Option
2 = dual row	006 to 100	55 = gold	without "locating pegs" A = tube packing; with pick & place pad B = reel packing; with pick & place pad with "locating pegs" C = tube packing; without pick & place pad D = tube packing; with pick & place pad E = reel packing; with pick & place pad



Foot style

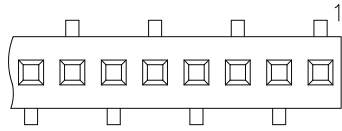

451

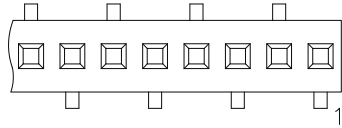

450

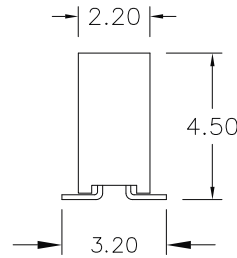
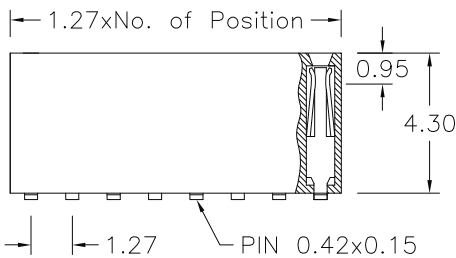

APPLICATION AND FEATURES

- **Standard: tube packing; without pick & place pad.**
- Also available with "pick & place pad" for automatic suck assembly to the PCB
- Low profile, 4.50mm height Type. Hi-rel dual beam contacts.
- Mating with 1.27mm pitch, 0.40mm square pin headers.
- Through Board mating possible

PCB Surface Mount & Hole Layout

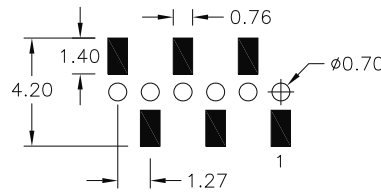

Foot style: 450

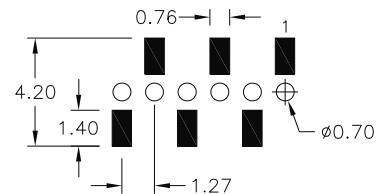

451

SPECIFICATIONS

Current rating	1 A
Insulator resistance	1000 MΩ min.
Contact resistance	20 mΩ max.
Withstanding voltage	500 V AC

Operating temperature	- 40°C to +105°C
Processing temperature	+250°C +0/-5°C for 10sec.
Contact material (RoHS compliant)	Phosphor Bronze
Insulator material (RoHS compliant)	LCP UL 94 V-0

How to order

BS 1 - xxx - H xxx - 55 /11 XX

Nbr of contacts	Foot style	Plating	Packing and "pick & place pad" Option
003 to 050	<p>450 Pls. choose 450 style if odd pin count.</p> <p>451 Foot style see above detail</p>	55 = gold	<p>A = tube packing; with pick & place pad</p> <p>B = reel packing; with pick & place pad</p> <p>AT = tube packing; with film pad</p> <p>BT = reel packing; with film pad</p>

1.27mm pitch Female Header

- SMT - dual row 4.50mm profile

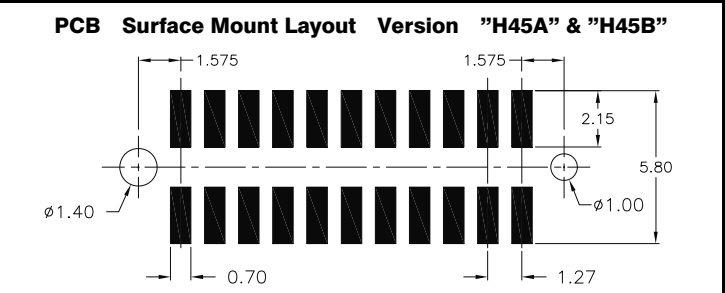
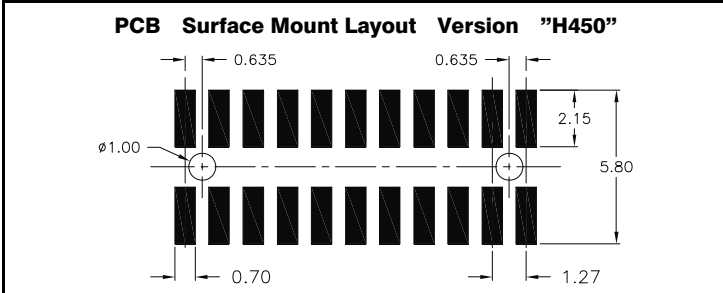
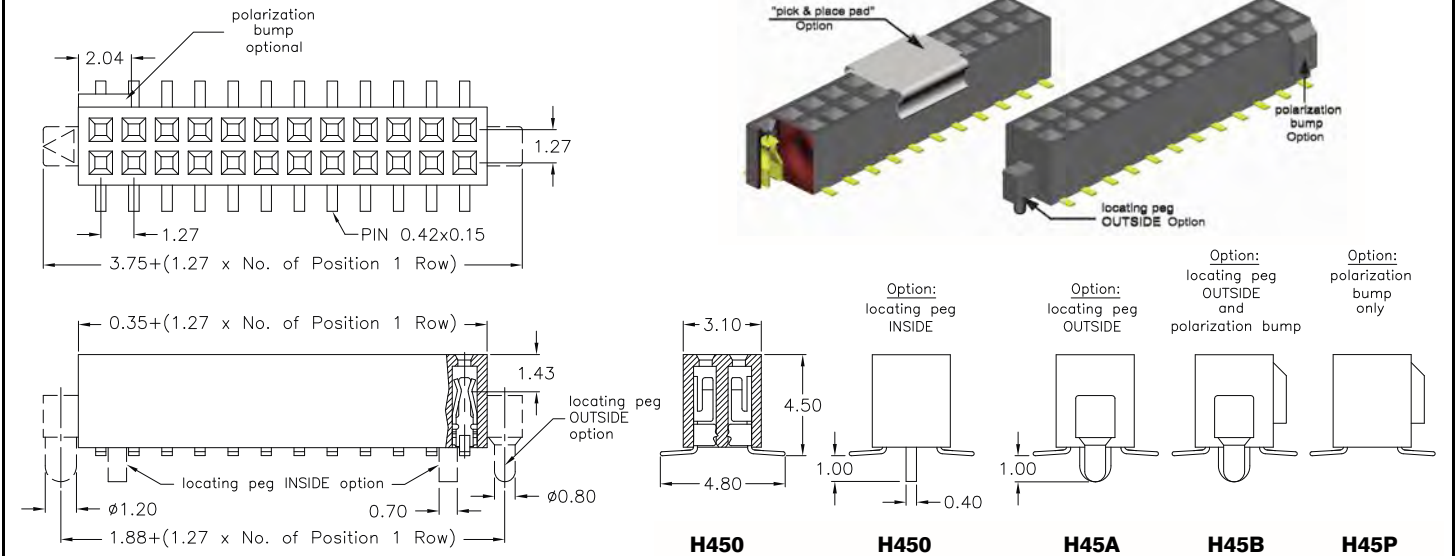

APPLICATION AND FEATURES

- Standard: tube packing without locating pegs and polarization bump
- Also available with "pick & place pad" for automatic suck assembly to the PCB
- Medium profile, 4.50mm height Type. Hi-rel dual beam contacts.
- Mating with 1.27mm x 1.27mm pitch, 0.40mm square or round pin headers.

SPECIFICATIONS

Current rating	1 A	Operating temperature	- 40°C to +105°C
Insulator resistance	1000 MΩ min.	Processing temperature	+250°C +0/-5°C for 10sec.
Contact resistance	20 mΩ max.	Contact material	(RoHS compliant) Phosphor Bronze
Withstanding voltage	500 V AC	Insulator material	(RoHS compliant) LCP UL 94 V-0

How to order

BS2 - xxx - H xxx - 55 / 11 X

Nbr of contacts	Version	Packing and "pick & place pad" Option
008 to 100	450 = without & with inside locating pegs 45A = with outside locating pegs 45B = with outside locating pegs & polarization bump 45P = with polarization bump; without locating pegs	See below
004 to 100		
only BS2-xxx-H450-55/11 BS2-xxx-H450-55/11A BS2-xxx-H450-55/11B		

Order Code Options:

without "locating pegs"	with "locating pegs"
BS2-xxx-H450-55/11 = tube packing; w/o pick & place pad	BS2-xxx-H450-55/11C = tube packing; w/o pick & place pad
BS2-xxx-H45P-55/11 = tube packing; w/o pick & place pad	BS2-xxx-H450-55/11D = tube packing; with pick & place pad
BS2-xxx-H450-55/11A = tube packing; with pick & place pad	BS2-xxx-H45A-55/11D = tube packing; with pick & place pad
BS2-xxx-H45P-55/11A = tube packing; with pick & place pad	BS2-xxx-H45B-55/11D = tube packing; with pick & place pad
BS2-xxx-H450-55/11B = reel packing; with pick & place pad	BS2-xxx-H450-55/11E = reel packing; with pick & place pad
BS2-xxx-H45P-55/11B = reel packing; with pick & place pad	BS2-xxx-H45A-55/11E = reel packing; with pick & place pad
	BS2-xxx-H45B-55/11E = reel packing ;with pick & place pad

1.27mm pitch Female Header
 - SMT - dual row 3.60mm profile

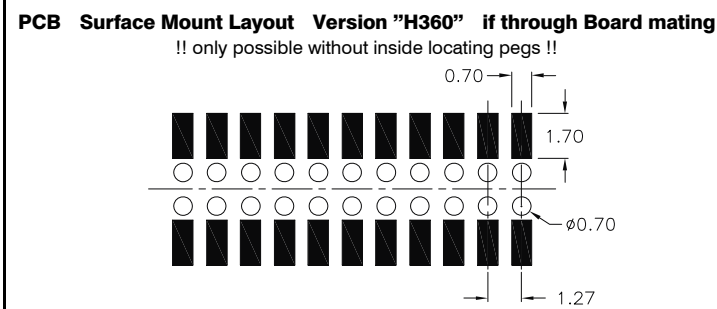
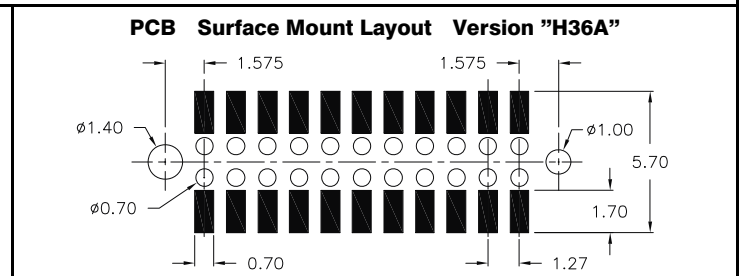
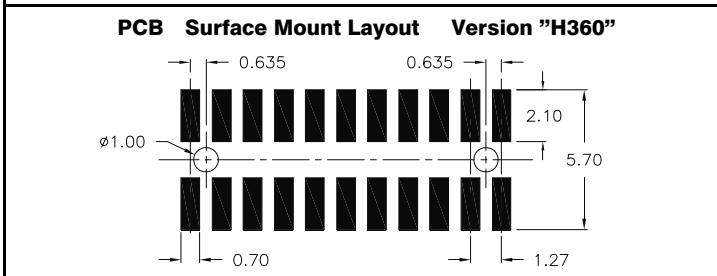
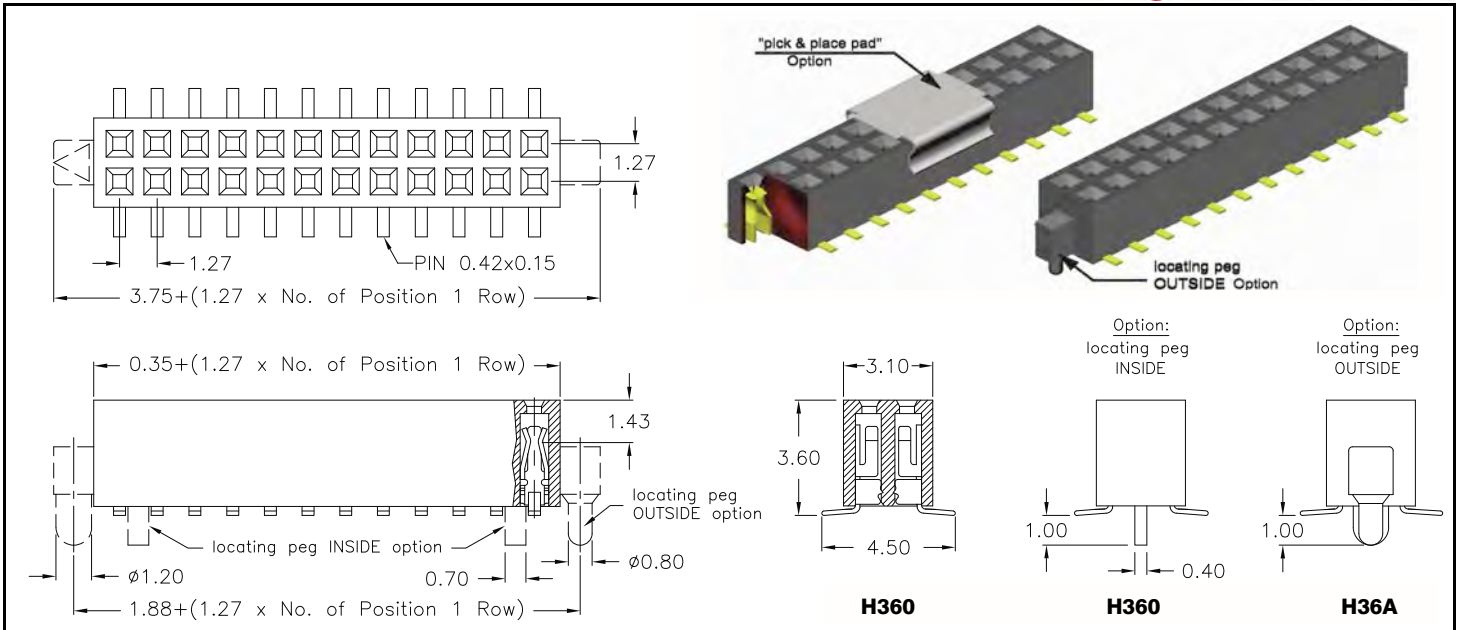

APPLICATION AND FEATURES

- **Standard: tube packing without locating pegs**
- Also available with "pick & place pad" for automatic suck assembly to the PCB
- Low profile, 3.60mm height Type. Hi-rel dual beam contacts.
- Mating with 1.27mm x 1.27mm pitch, 0.40mm square pin headers.
- Through Board mating possible

SPECIFICATIONS

Current rating	1 A	Operating temperature	- 40°C to +105°C
Insulator resistance	1000 MΩ min.	Processing temperature	+250°C +0/-5°C for 10sec.
Contact resistance	20 mΩ max.	Contact material	(RoHS compliant) Phosphor Bronze
Withstanding voltage	500 V AC	Insulator material	(RoHS compliant) LCP UL 94 V-0

How to order

BS2 - xxx - H xxx - 55 / 11 X

Nbr of contacts	Version	Packing and "pick and place pad" Option
006 to 100	360 = without & with inside locating pegs 36A = with outside locating pegs	See below

Order Code Options:

without "locating pegs"	with "locating pegs"
BS2-xxx-H360-55/11 = tube packing; w/o pick & place pad	BS2-xxx-H360-55/11C = tube packing; w/o pick & place pad
BS2-xxx-H360-55/11A = tube packing; with pick & place pad	BS2-xxx-H360-55/11D = tube packing; with pick & place pad
BS2-xxx-H360-55/11B = reel packing; with pick & place pad	BS2-xxx-H36A-55/11D = tube packing; with pick & place pad
	BS2-xxx-H360-55/11E = reel packing; with pick & place pad
	BS2-xxx-H36A-55/11E = reel packing; with pick & place pad

1.27mm pitch Female Header - SMT- single row 2.10 & 2.20mm profile



<p>Top entry</p>	<p>Bottom entry</p>																
<p>Foot style T220</p> <p>T221</p>	<p>Foot style B210</p> <p>B211</p>																
<p>PCB Surface Mount & Hole Layout</p> <p>Foot style: T220 T221</p>	<p>PCB Surface Mount & Hole Layout</p> <p>Foot style: B210 B211</p>																
<p>APPLICATION AND FEATURES</p> <p>Standard: tube packing, without "pick & place pad"</p> <ul style="list-style-type: none"> ■ Also available "reel" packing. ■ Low profile, 2.10 & 2.20mm height. Hi-rel dual beam contacts. ■ Mating with 1.27mm pitch 0.40mm square or round pin headers. ■ Designed for board to board small spacing interconnection. 	<p>SPECIFICATIONS</p> <table style="width:100%; border: none;"> <tr> <td style="width:70%;">Current rating</td> <td>1 A</td> </tr> <tr> <td>Insulator resistance</td> <td>1000 MΩ min</td> </tr> <tr> <td>Contact resistance</td> <td>20 mΩ max.</td> </tr> <tr> <td>Withstanding voltage</td> <td>500 V AC</td> </tr> <tr> <td>Operating temperature</td> <td>- 40°C to +105°C</td> </tr> <tr> <td>Processing temperature</td> <td>+250°C +0/-5°C for 10sec.</td> </tr> <tr> <td>Contact material</td> <td>(RoHS compliant) Phosphor Bronze</td> </tr> <tr> <td>Insulator material</td> <td>(RoHS compliant) Nylon UL 94 V-0</td> </tr> </table>	Current rating	1 A	Insulator resistance	1000 MΩ min	Contact resistance	20 mΩ max.	Withstanding voltage	500 V AC	Operating temperature	- 40°C to +105°C	Processing temperature	+250°C +0/-5°C for 10sec.	Contact material	(RoHS compliant) Phosphor Bronze	Insulator material	(RoHS compliant) Nylon UL 94 V-0
Current rating	1 A																
Insulator resistance	1000 MΩ min																
Contact resistance	20 mΩ max.																
Withstanding voltage	500 V AC																
Operating temperature	- 40°C to +105°C																
Processing temperature	+250°C +0/-5°C for 10sec.																
Contact material	(RoHS compliant) Phosphor Bronze																
Insulator material	(RoHS compliant) Nylon UL 94 V-0																

How to order

BS1 - xxx - X 2xx - 55 / 11 XX

Nbr of contacts	Version	Plating	Packing and "pick & place pad" Option
Top Entry (T22x) 003 to 040	Top Entry T 220 ; T 221 Bottom Entry B 210 ; B 211	55 = gold	A = tube packing; with pick & place pad B = reel packing; with pick & place pad AT = tube packing; with film pad BT = reel packing; with film pad
Bottom Entry(B21x) 003 to 050	Pls. choose T220 or B210 style if odd pin count. Foot style see above detail		

When using this female connector as a bottom entry connector, we recommend that the pinheader pins protrude by around 2.00mm above the surface of the female connector after assembly. This will avoid any risk of separation of the pinheader from the female header during shock and vibration.

1.27mm pitch Female Header - SMT-
Top & Bottom Entry 2.20mm profile

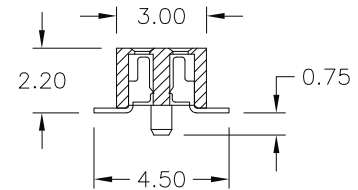
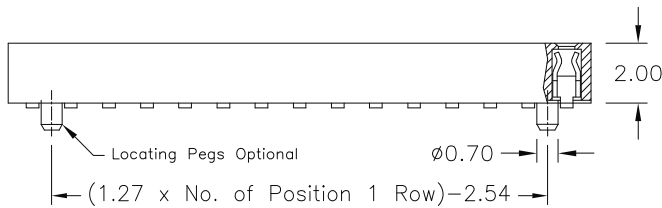
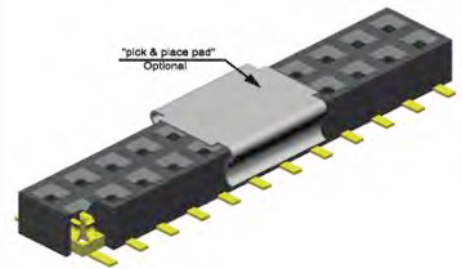
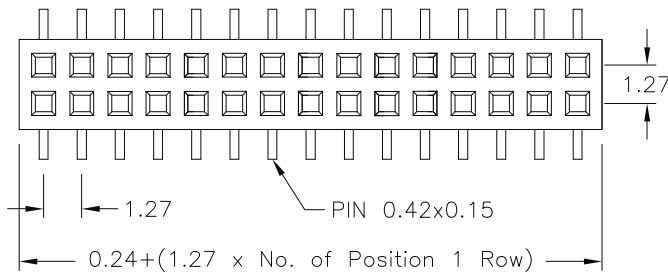

APPLICATION AND FEATURES

- **Standard: tube packing, without locating pegs and without "pick & place pad"**
- Also available "reel" packing.
- Low profile, 2.20mm height. Hi-rel dual beam contacts.
- Mating with 1.27mm x 1.27mm pitch 0.40mm square or round pin headers.
- Designed for board to board small spacing interconnection.

PCB Surface Mount & Hole Layout

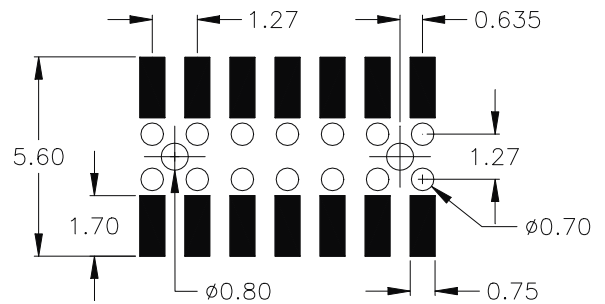

SPECIFICATIONS

Current rating	1 A
Insulator resistance	1000 MΩ min.
Contact resistance	20 mΩ max.
Withstanding voltage	500 V AC

Operating temperature	- 40°C to +105°C
Processing temperature	+250°C +0/-5°C for 10sec.
Contact material	(RoHS compliant) Phosphor Bronze
Insulator material	(RoHS compliant) Nylon UL 94 V-0

How to order

BS2 - xxx - TB 22 - 55 / 11 X

Nbr of contacts	Plating	Packing and "pick & place pad" Option
006 to 080	55 = gold	<p>without "locating pegs"</p> <p>A = tube packing; with pick & place pad</p> <p>B = reel packing; with pick & place pad</p> <p>with "locating pegs"</p> <p>C = tube packing; without pick & place pad</p> <p>D = tube packing; with pick & place pad</p> <p>E = reel packing; with pick & place pad</p>

When using this female connector as a bottom entry connector, we recommend that the pinheader pins protrude by around 2.00mm above the surface of the female connector after assembly. This will avoid any risk of separation of the pinheader from the female header during shock and vibration.

1.27mm pitch Female Header

- SMT- side entry

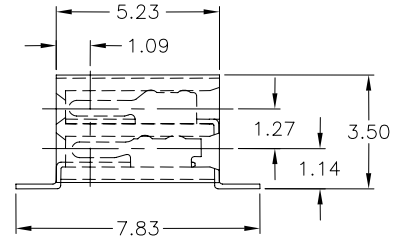
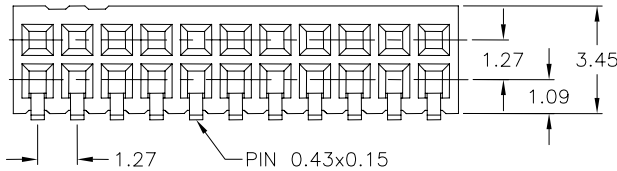
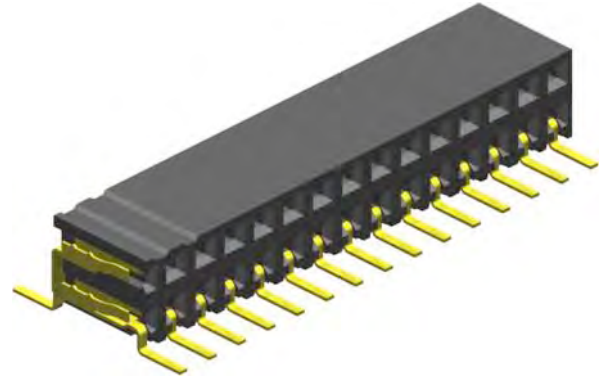
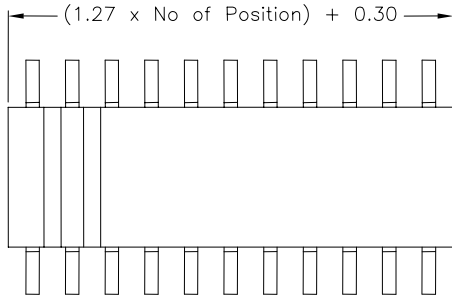

APPLICATION AND FEATURES

- **Standard: tube packing**
- Hi-rel dual beam contact assures reliable PC-Board connections
- Accepts 0.40mm square pins; Pin Header 1.27mm x1.27 mm
- 3.50mm height above board
- Automatic assembly to PCB possible

PCB Surface Mount Layout

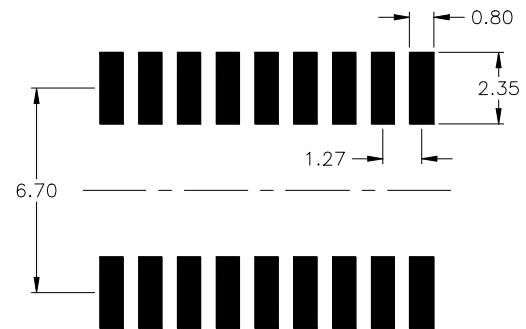

SPECIFICATIONS

Current rating	1 A
Insulator resistance	1000 MΩ min.
Contact resistance	20 mΩ max.
Withstanding voltage	500 V AC

Operating temperature	- 40°C to +105°C
Processing temperature	+250°C +0/-5°C for 10sec.
Contact material	(RoHS compliant) Phosphor Bronze
Insulator material	(RoHS compliant) Nylon 6T UL 94 V-0

How to order

BS 2 - xxx - R 345 - 55 / 11 X

Nbr of contacts	
006	to 080

Plating	
55	= gold
Other platings on request	

Packing Option	
R	= reel packing

1.27mm pitch

IDC – Female Connector

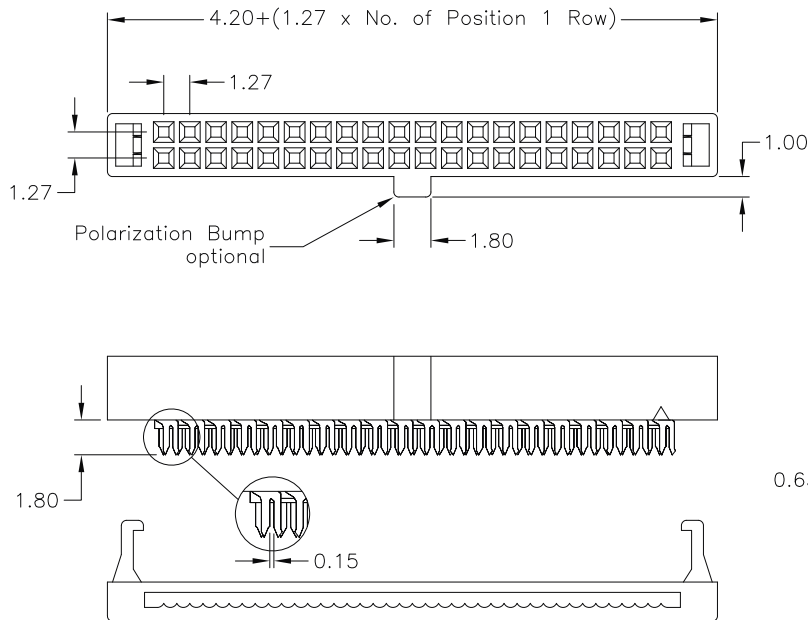

SPECIFICATIONS

Current rating	0.5 A	Operating temperature	- 40°C to +105°C
Contact resistance	30 mΩ max.	Contact material	(RoHS compliant) Phosphor Bronze
Insulation resistance	1000 MΩ min.	Insulator material	(RoHS compliant) P.B.T. black UL 94 V-0
Withstanding voltage	250 V AC		

APPLICATION AND FEATURES

Designed to mate with 0.40mm square pins, box (shrouded) header type
 SLS – xxx – X 510 – 55/11
 High Quality dual beam contacts.
 Accepts 30 AWG 0.635mm pitch flat ribbon cable.

How to order

IDS - xxx - W 050 - 55 / P

Nbr of contacts
006; 008; 010; 012
014; 016; 020; 022
024; 026; 030; 034
036; 040; 044; 050
060; 064; 068; 080

Plating
55 = gold

Option
P
if Polarization bump is requested.

2.00mm pitch Pin Header
 - THT - straight & right angle

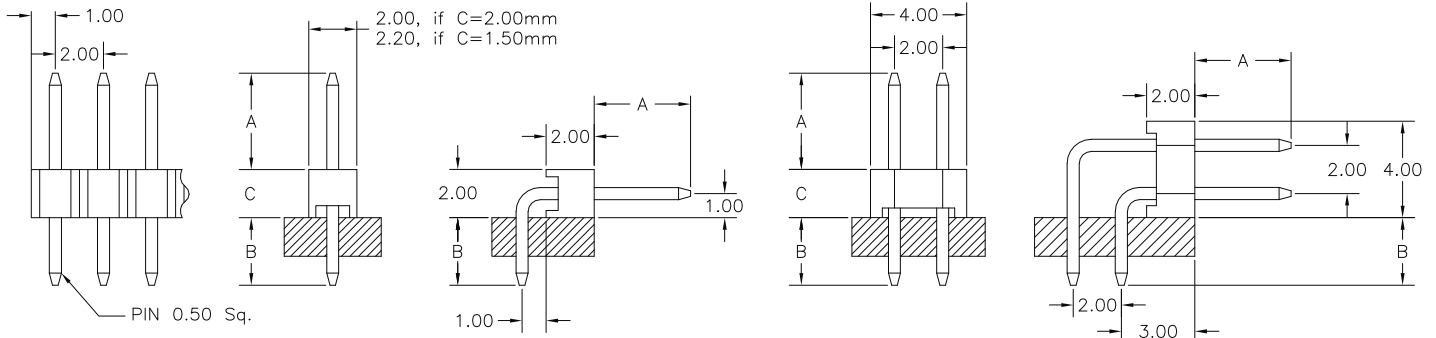

SPECIFICATIONS

Current rating	1 A
Insulator resistance	1000 MΩ min.
Withstanding voltage	500 V AC
Operating temperature	- 40°C to +105°C
Contact material	(RoHS compliant) Copper alloy
Insulator material	(RoHS compliant) P.B.T. or Nylon UL 94 V-0
	Standard : P.B.T.

PCB Hole Layout

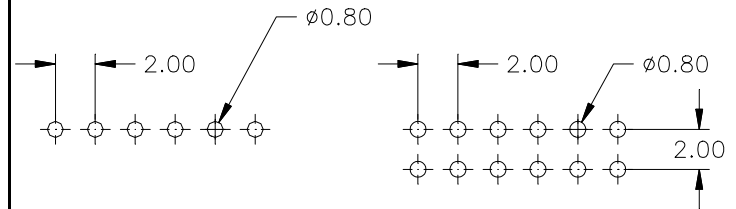

APPLICATION AND FEATURES

Side and end stackable.
 Variable terminal lengths as well as two insulator thicknesses available for the straight type.
 Notches for easy breaking.
 Straight type with standoff's for post solder cleaning.

How to order

SL x - xxx - X xxx/xx - 55 /2

Rows	Nbr of pins	Insulator style	DIM "C"	Code	Pin code	DIM "A"	DIM "B"	Plating
1 = single row	002 to 040	straight	2.00 mm	S = P.B.T. N = Nylon	088/01	4.00 mm	2.80 mm	55 = gold (standard) 99 = tin (leadfree tin) Other platings on request
			1.50 mm	B = Nylon	096/00	4.00 mm	2.80 mm	
2 = dual row	004 to 080	right angle	2.00 mm	R = P.B.T. K = Nylon	088/02	6.00 mm	2.80 mm	
					088/03	6.80 mm	3.00 mm	
					088/04	4.00 mm	4.00 mm	
					088/05	3.70 mm	5.00 mm	
					096/01	6.00 mm	2.10 mm	
					096/02	4.50 mm	4.00 mm	
					096/03	1.70 mm	8.80 mm	
					096/04	4.00 mm	2.30 mm	
096/05	3.20 mm	3.50 mm						
096/06	4.00 mm	4.00 mm						
096/07	7.00 mm	2.20 mm						
096/08	3.60 mm	3.00 mm						
096/09	21.00 mm	2.54 mm						
096/10	5.10 mm	3.00 mm						
					106/00	3.20 mm	3.20 mm	
					106/01	4.00 mm	2.80 mm	
					106/02	10.00 mm	2.80 mm	
					106/03	11.00 mm	2.80 mm	
					106/04	2.50 mm	2.80 mm	
					106/05	5.00 mm	2.80 mm	
					106/06	11.00 mm	2.40 mm	
					106/07	6.00 mm	2.80 mm	
Other dimensions on request								

2.00mm pitch Pin Header
 - THT - high plastic base

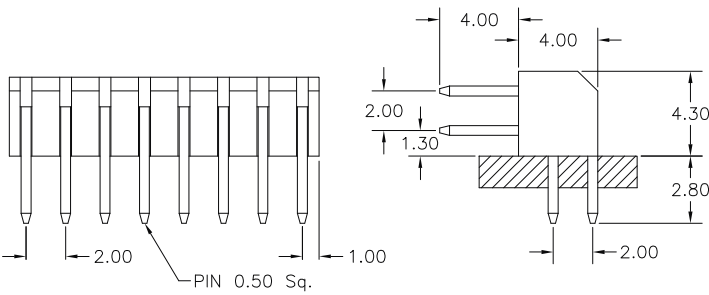
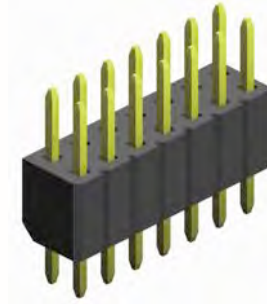
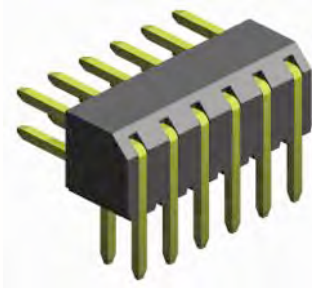

R430

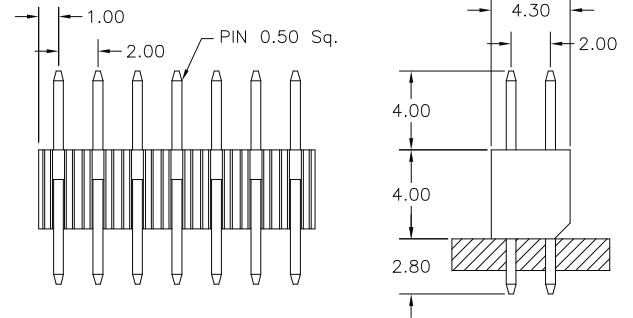

S400

SPECIFICATIONS

Current rating	1 A
Insulator resistance	1000 MΩ min.
Withstanding voltage	500 V AC
Operating temperature	- 40°C to +105°C
Contact material <i>(RoHS compliant)</i>	Copper alloy
Insulator material <i>(RoHS compliant)</i>	Nylon UL 94 V-0

PCB Hole Layout

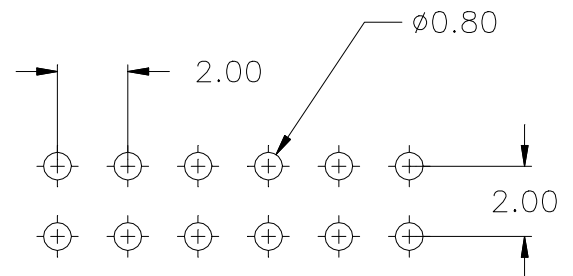

APPLICATION AND FEATURES

- Side stackable
- Mate with 2.00 mm pitch female and shunt connector
- Standoff's facilitate post solder cleaning

How to order

SE 2 - xxx - X xxx - xx / 2

Nbr of pins
004 to 080

Pin style
S400 = straight
R430 = right angle

Plating
55 = gold
95 = tin/gold <i>(tin leadfree)</i>
Other platings on request

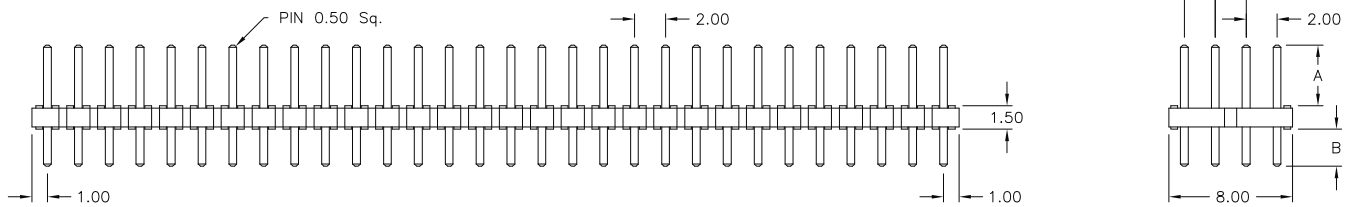
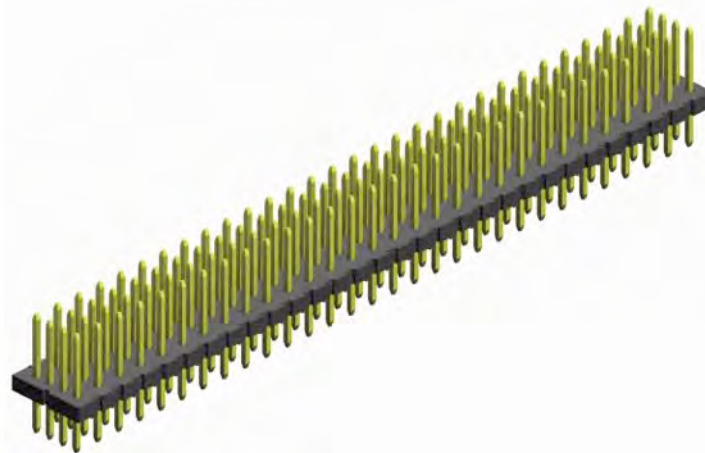

SPECIFICATIONS

Current rating	1 A
Insulator resistance	1000 MΩ min.
Withstanding voltage	500 V AC
Operating temperature	- 40°C to +105°C
Contact material	(RoHS compliant) Copper alloy
Insulator material	(RoHS compliant) Nylon UL 94 V-0

PCB Hole Layout

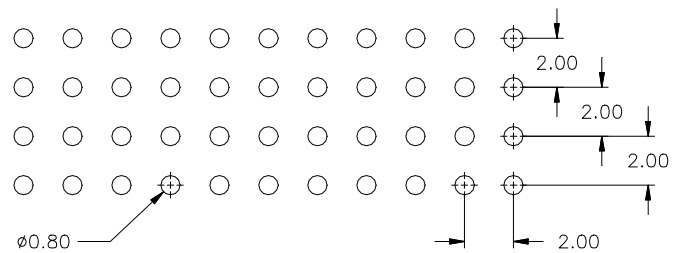

APPLICATION AND FEATURES

Designed for “board to board” small spacing interconnection.

Variable terminal length available.

With standoff's for post solder cleaning.

Mate with female header BL4 - xxx - S630/ x - xx/2

How to order

SL4 - xxx - S xxx/x - 55 /2

Nbr of pins
012 to 120

Pin code	DIM “A”	DIM “B”
830/0	4.40 mm	2.40 mm
830/1	8.60 mm	3.60 mm
830/2	3.20 mm	3.50 mm
830/3	12.00 mm	2.40 mm
830/4	7.40 mm	2.70 mm
Other dimensions on request		

Plating
55 = gold
Other platings on request

2.00mm pitch Board Spacer

- THT - single & dual row

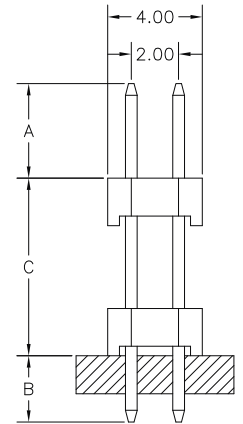
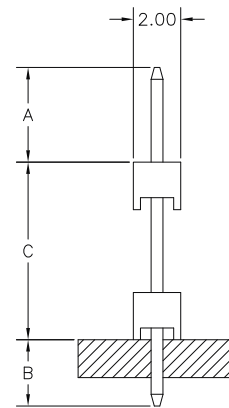
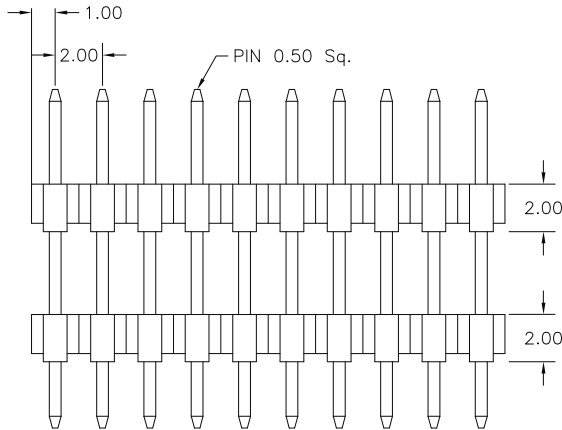
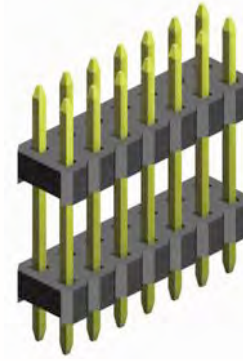
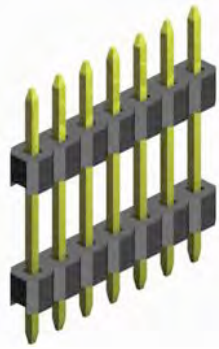

PCB Hole Layout

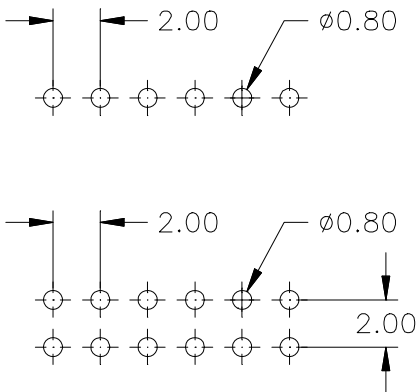

SPECIFICATIONS

Current rating	1 A
Insulator resistance	1000 MΩ min.
Withstanding voltage	500 V AC
Operating temperature	- 40°C to +105°C
Contact material	Copper alloy <i>(RoHS compliant)</i>
Insulator material	P.B.T. or Nylon, UL 94 V-0 <i>(RoHS compliant)</i> Standard : P.B.T.

Pin code	DIM "A"	DIM "B"	DIM "C"
143/02	6.80 mm	2.80 mm	4.70 mm
104/01	2.70 mm	2.70 mm	5.00 mm
136/02	5.30 mm	3.20 mm	5.10 mm
191/01	9.30 mm	4.30 mm	5.50 mm
117/01	2.80 mm	2.80 mm	6.10 mm
143/01	4.00 mm	2.80 mm	7.50 mm
143/03	2.40 mm	3.90 mm	8.00 mm
150/01	4.00 mm	2.50 mm	8.50 mm
163/01	4.00 mm	2.80 mm	9.50 mm
180/03	5.00 mm	3.00 mm	10.00 mm
170/01	3.00 mm	3.00 mm	11.00 mm
180/02	3.00 mm	3.00 mm	12.00 mm
210/01	6.00 mm	3.00 mm	12.00 mm
260/04	9.00 mm	4.00 mm	13.00 mm
220/01	4.00 mm	2.80 mm	15.25 mm
252/02	5.20 mm	4.20 mm	15.80 mm
300/03	10.00 mm	3.00 mm	17.00 mm
225/01	2.50 mm	2.50 mm	17.50 mm
270/02	4.00 mm	3.00 mm	20.00 mm
410/01	9.00 mm	4.00 mm	28.00 mm
432/01	3.20 mm	3.20 mm	36.80 mm

Other dimensions on request

How to order

SP x - xxx - X xxx/xx - 55 /2

Rows	Nbr of pins	Insulator	Pin code	Plating
1 = single row	002 to 040	S = P.B.T. N = Nylon <small>Nylon processing temp.: +250°C +0/-5°C for 5sec.</small>	dimension and others see above table	55 = gold Other platings on request
2 = dual row	004 to 080			

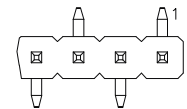
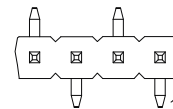
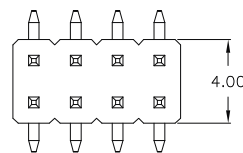
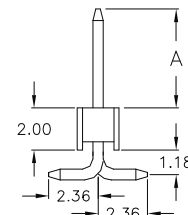
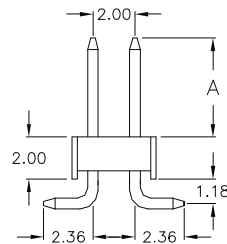
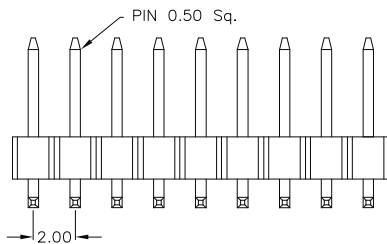
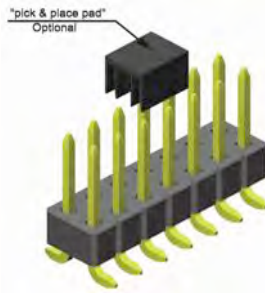

Foot style:

085

085

185

APPLICATION AND FEATURES

- **Standard: tube packing and without "pick & place pad"**
- Low Profile Insulator
- Assures reliable PC Board connections
- Mate with female header 2.00mm x 2.00mm pitch

PCB Surface Mount Layout

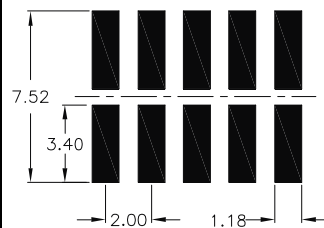

Foot style: **085** (dual row)

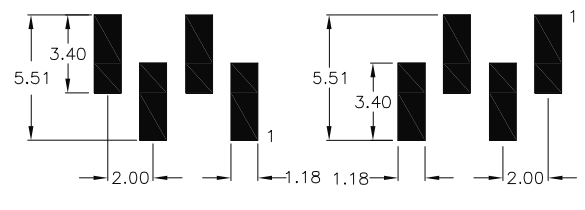

085 (single row)

185 (single row)

SPECIFICATIONS

Current rating	1 A	Operating temperature)	- 40°C to +105°C
Insulator resistance	1000 MΩ min.	Processing temperature	+250°C +0/-5°C for 5sec.
Withstanding voltage	500 V AC	Contact material	(RoHS compliant) Brass
		Insulator material	(RoHS compliant) Nylon UL 94 V-0

How to order

SS x - xxx - H xxx / x - **55** /2 X

Rows	Nbr of pins	Foot style	Pin code	DIM "A"	Plating	Packing and "pick & place pad" Option
1 single row	002 to 040	085 185 Pls. choose 085 style if odd pin count.	0	4.73 mm	55 = gold Other platings on request	A = tube packing; with pick & place pad B = reel packing; with pick & place pad
			1	6.00 mm		
2 dual row	004 to 080	085	2	13.57 mm		
			3	6.50 mm		
			4	8.07 mm		
			5	7.62 mm		
			6	9.10 mm		
			7	10.00 mm		
			Other dimensions on request			

2.00mm pitch

- SMT - Pin Header & Board Spacer

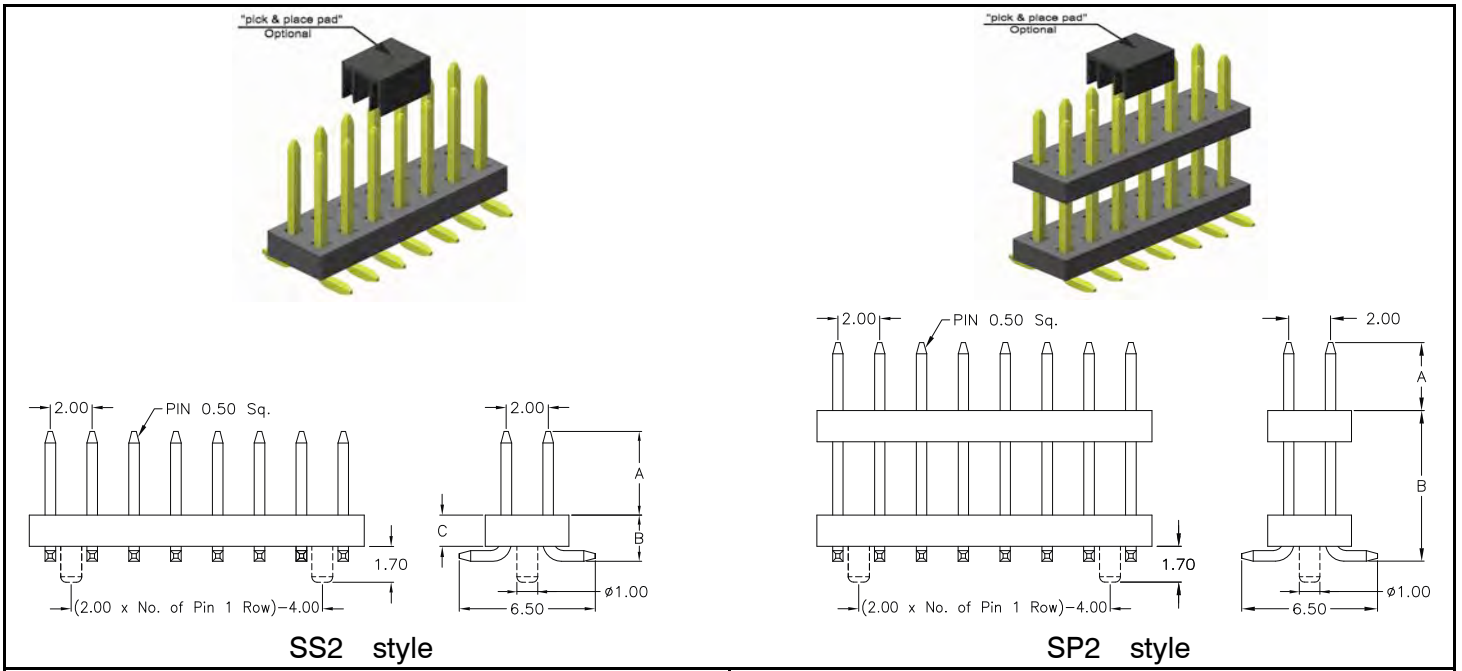

- APPLICATION AND FEATURES**
- **Standard: tube packing, without "locating pegs" and "pick & place pad"**
 - Designed for "board to board" spacing
 - Variable terminal length available
 - Mate with female header 2.00mm x 2.00mm pitch

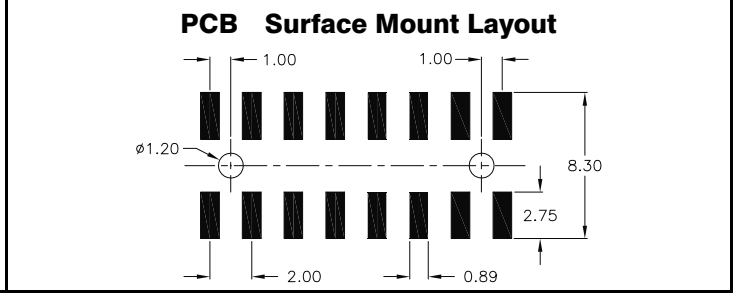

SPECIFICATIONS

Current rating	1 A
Insulator resistance	1000 MΩ min.
Withstanding voltage	500 V AC
Operating temperature	- 40°C to +105°C

SPECIFICATIONS

Processing temperature	+250°C +0/-5°C
	SS2 Style = 250°C for 10sec.
	SP2 Style = 250°C for 5sec.
Contact material	(RoHS compliant) Copper alloy
Insulator material	(RoHS compliant) Nylon UL 94 V-0

How to order

S X 2 - xxx - H xxx/x - 55 / 2 X

Pin style	Nbr of pins	Pin code	DIM "A"	DIM "B"	DIM "C"	Plating	Packing and "pick & place pad" Option
S Low Profile	006 to 050	064/0	6.00 mm	2.20 mm	1.50 mm	55 = gold Other platings on request	without "locating pegs" A = tube packing; with pick & place pad B = reel packing; with pick & place pad with "locating pegs" (if DIM "C" = 1.50mm only) C = tube packing; without pick & place pad D = tube packing; with pick & place pad E = reel packing; with pick & place pad
		064/1	4.00 mm	2.20 mm	1.50 mm		
		064/2	3.50 mm	2.70 mm	2.00 mm		
		064/3	5.80 mm	2.20 mm	1.50 mm		
		064/4	3.20 mm	2.20 mm	1.50 mm		
		064/5	3.60 mm	2.20 mm	1.50 mm		
		064/6	4.00 mm	2.70 mm	2.00 mm		
		064/7	13.50 mm	2.65 mm	2.00 mm		
		064/8	9.50 mm	2.20 mm	1.50 mm		
		064/9	8.00 mm	2.20 mm	1.50 mm		
P Board Spacer	006 to 050	065/0	6.00 mm	6.00 mm			
		065/A	5.40 mm	7.00 mm			
		065/4	3.90 mm	8.00 mm			
		065/7	7.50 mm	8.50 mm			
		065/1	6.00 mm	10.00 mm			
		065/2	6.00 mm	12.00 mm			
		065/6	9.50 mm	12.00 mm			
		065/9	5.00 mm	12.30 mm			
		065/8	4.65 mm	12.70 mm			
		065/3	4.00 mm	13.33 mm			
		065/B	4.50 mm	16.00 mm			
		065/5	4.50 mm	17.00 mm			
Other dimensions on request							

2.00mm pitch Pin Header - slanted -

- SMT - single and dual row

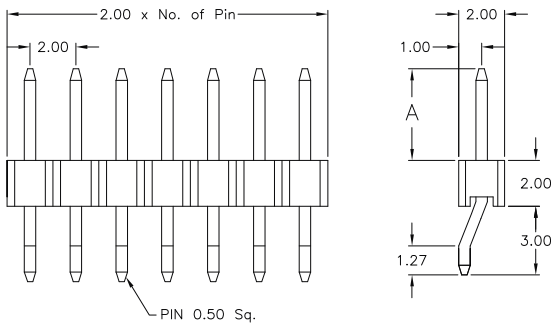
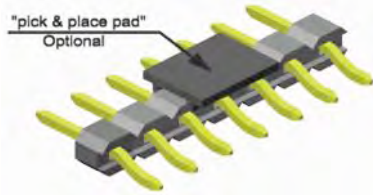

SR1 style

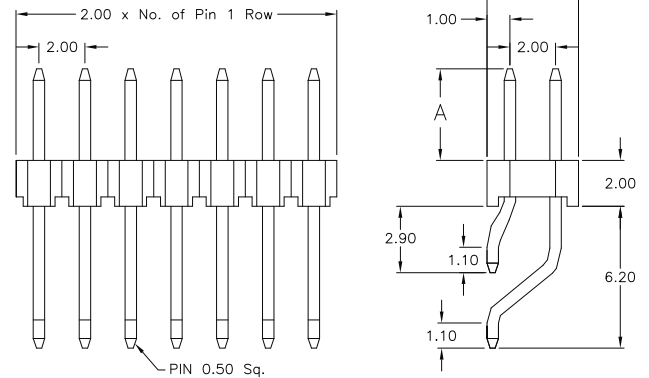

SR2 style

PCB Surface Mount Layout single row

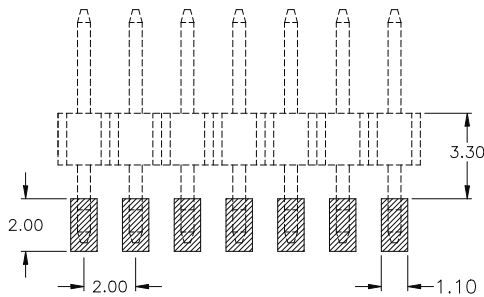

PCB Surface Mount Layout dual row

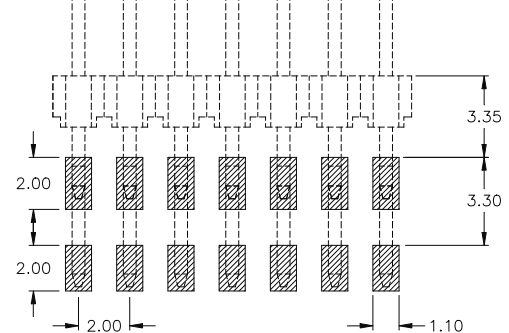

SPECIFICATIONS

Current rating 1 A
 Insulator resistance 1000 MΩ min.
 Withstanding voltage 500 V AC

Operating temperature -40°C to +105°C
 Processing temperature +250°C +0/-5°C for 10sec.
 Contact material (RoHS compliant) Copper alloy
 Insulator material (RoHS compliant) Nylon UL 94 V-0

How to order

SR x - xxx - H xxx/x - 55 / 2 X

Rows	Nbr of pins	Pin code	DIM "A"	Plating	Packing and "pick & place pad" Option
1 = single row	002 to 040	093 / 0 093 / 1 093 / 2 093 / 3	4.00 mm 4.45 mm 3.20 mm 6.00 mm	55 = gold Other platings on request	A = tube packing; with pick & place pad B = reel packing; with pick & place pad
2 = dual row	004 to 080	122 / 0 122 / 1	4.00 mm 6.00 mm		

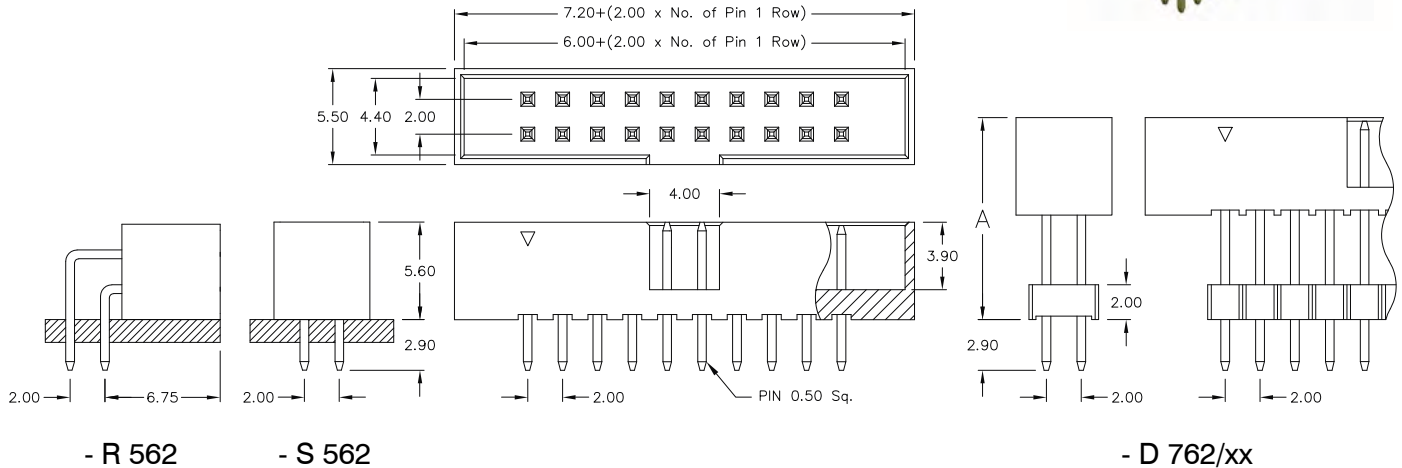
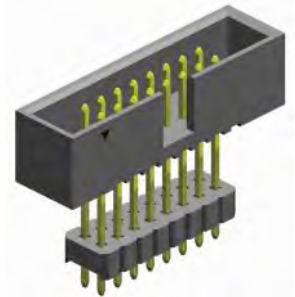
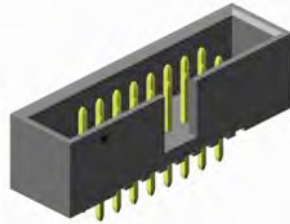
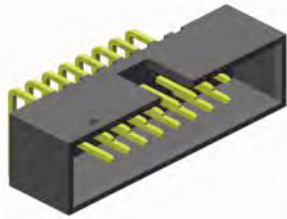

APPLICATION AND FEATURES

- Designed to mate with IDC female connector IDS-xxx-X 200-95/P
- Reliable flat cable to PCB connection
- No ejection latches for space saving

PCB Hole Layout

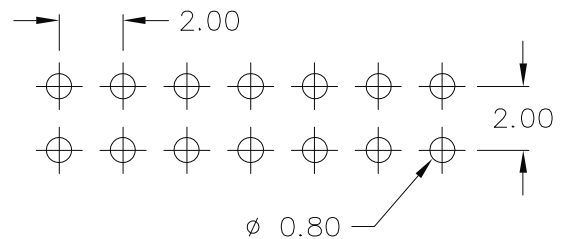

SPECIFICATIONS

Current rating	1 A	Operating temperature	- 40°C to +105°C
Insulator resistance	1000 MΩ min.	Contact material	(RoHS compliant) Copper alloy
Withstanding voltage	500 V AC	Insulator material	(RoHS compliant) Nylon UL 94 V-0

How to order

SLS - xxx - X xxx - 55 /2

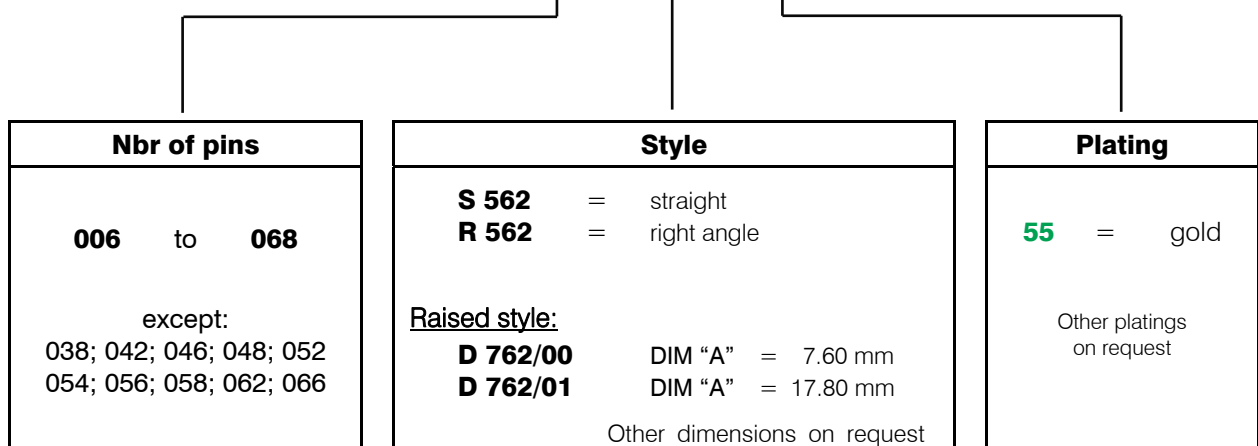

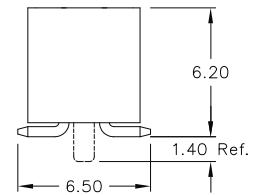
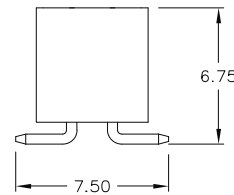
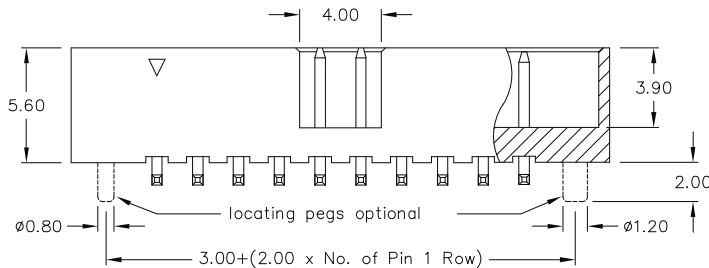
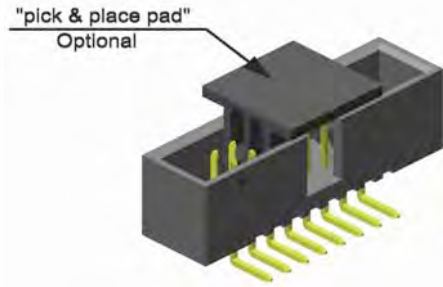
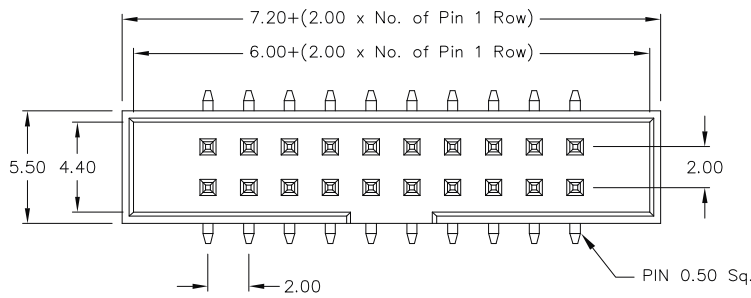

APPLICATION AND FEATURES

- **Standard:**
without locating pegs, tray packing and without "pick & place pad"
- Also available "tape & reel" packing
- Designed to mate with IDC female connector IDS-xxx-X 200-95/P
- Reliable flat cable to PCB connection
- No ejection latches for space saving

PCB Surface Mount Layout

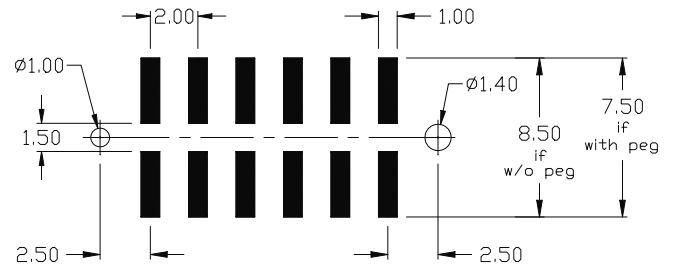

SPECIFICATIONS

Current rating	1 A
Insulator resistance	1000 MΩ min.
Withstanding voltage	500 V AC

Operating temperature	- 40°C to +105°C
Processing temperature	+250°C +0/-5°C for 5sec.
Contact material	(RoHS compliant) Copper Alloy
Insulator material	(RoHS compliant) Nylon UL 94 V-0

How to order

SLS - xxx - H 562 - 55 /2 X

Nbr of pins
without "locating pegs" 006 to 068
except: 038; 042; 046; 048 052; 054; 056; 058 062; 066
with "locating pegs" 008 to 050

Plating
55 = gold
Other platings on request

Packing and "pick & place pad" Option
without "locating pegs"
F = tray packing; with pick & place pad
T = tube packing; without pick & place pad
A = tube packing; with pick & place pad
B = reel packing; with pick & place pad
with "locating pegs"
C = tube packing; without pick & place pad
D = tube packing; with pick & place pad
E = reel packing; with pick & place pad

2.00mm pitch Female Header
 - THT - low profile

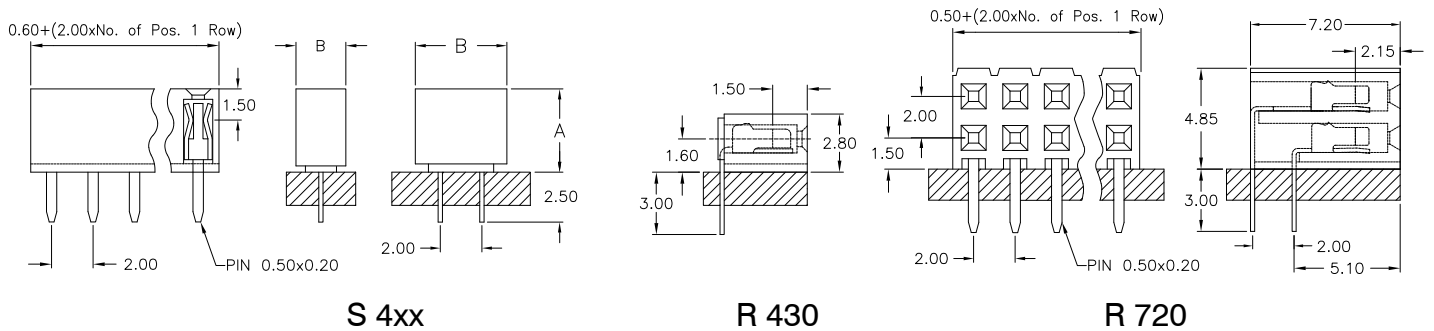
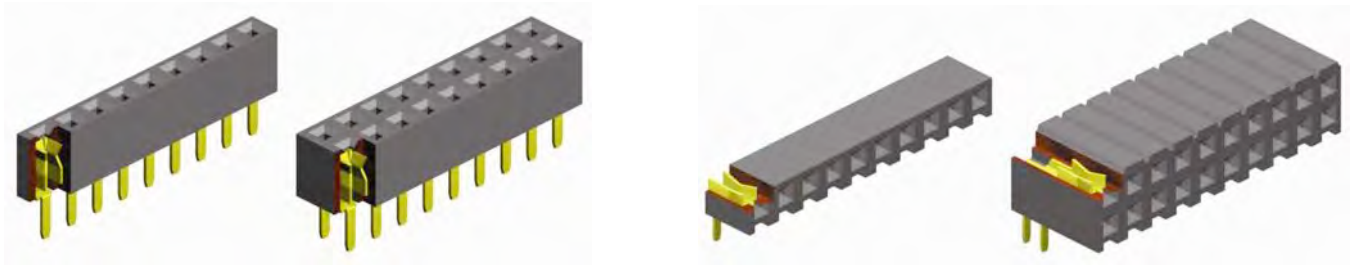

SPECIFICATIONS

Current rating	1 A
Insulator resistance	1000 MΩ min.
Contact resistance	20 mΩ max.
Withstanding voltage	500 V AC
Operating temperature	- 40°C to +105°C
Contact material	Phosphor Bronze (RoHS compliant)
Insulator material	Nylon UL 94 V-0 (RoHS compliant)

PCB Hole Layout

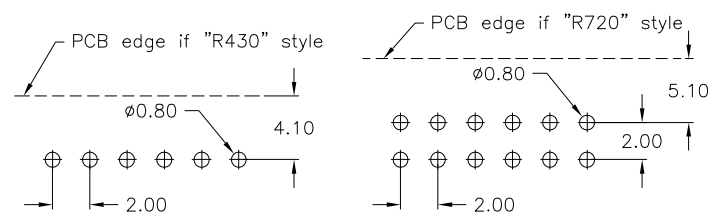

APPLICATION AND FEATURES

Low profile, 4.00mm and 4.30mm height single & dual row straight.
 Designed for board to board small spacing interconnection.
 High quality dual beam contacts mating with 0.50 x 0.50mm Pin Header.

How to order

BL x - xxx - X xxx - 55 / 2

Rows	Nbr of contacts	Version	Plating
1 = single row	S400 & S430 = 002 to 040 R430 = 003 to 025	S 400 = straight – single row : "A"=4.00 mm "B"=2.20 mm straight – dual row : "A"=4.00 mm "B"=4.20 mm S 430 = straight – single row : "A"=4.30 mm "B"=2.40 mm straight – dual row : "A"=4.30 mm "B"=4.60 mm R 430 = right angle – single row R 720 = right angle – dual row	55 = gold Other platings on request
2 = dual row	S400 & S430 = 004 to 080 R720 = 004 to 080		

2.00mm pitch Female Header

- THT - 6.35mm profile

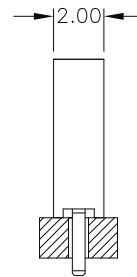
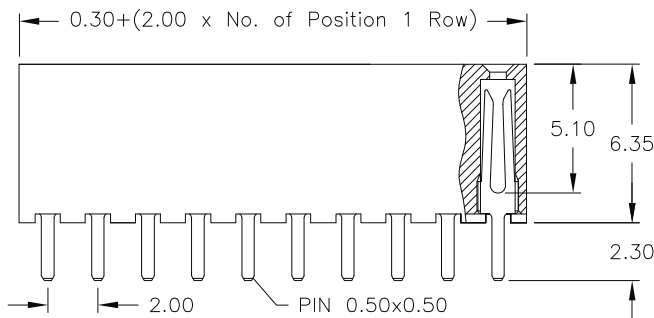
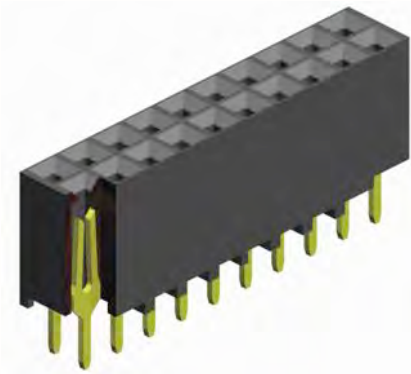
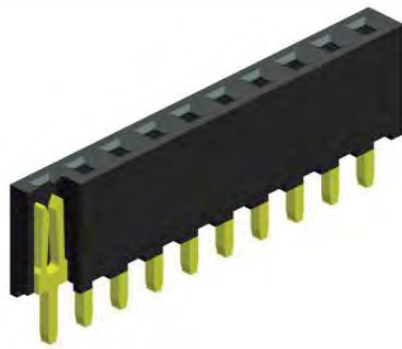

single row

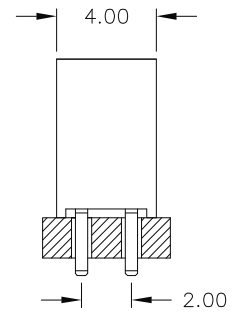

dual row

APPLICATION AND FEATURES

- For board-to-board connections
- Ideal solution for PC/104 Systems
- Accepts 0.50mm square pins
- Hi-rel fork contact design

PCB Hole Layout

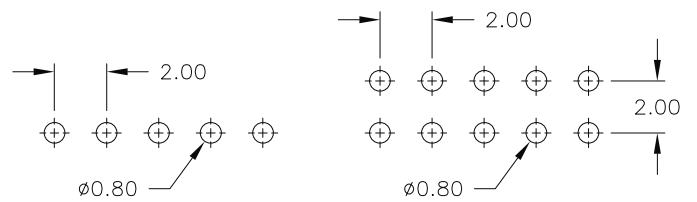

SPECIFICATIONS

Current rating	1 A
Insulator resistance	1000 MΩ min.
Contact resistance	20 mΩ max.
Withstanding voltage	500 V AC

Operating temperature	- 40°C to +105°C
Contact material	(RoHS compliant) Copper Alloy
Insulator material	(RoHS compliant) LCP UL 94 V-0

How to order

BL x - xxx - SH635 - 55 /2

Rows
1 = single row
2 = dual row

Nbr of contacts
single row = 002 to 040
dual row = 004 to 080

Plating
55 = gold
Other platings on request

2.00mm pitch Female Header

- THT - Elevated

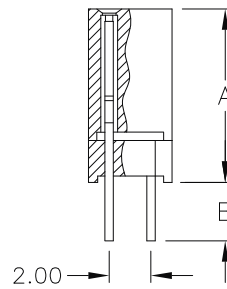
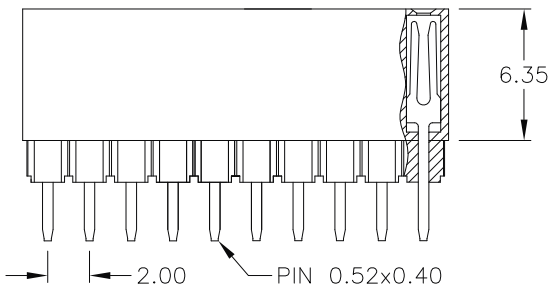
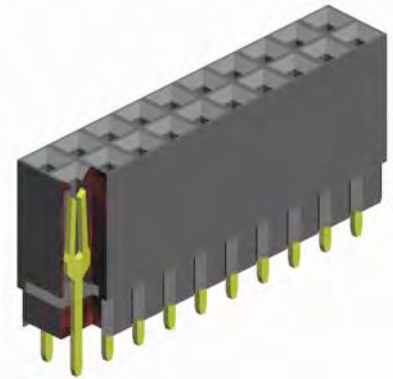
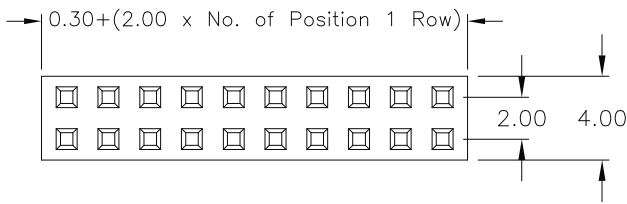

APPLICATION AND FEATURES

- Various heights for board-to-board connections
- Also ideal solution for PC/104 Systems
- Accepts 0.50mm square pins
- Hi-rel fork contact design

PCB Hole Layout

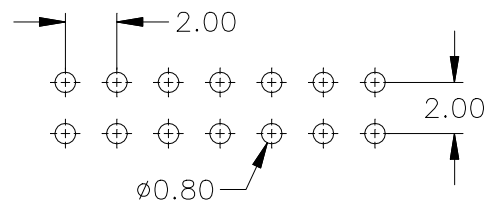

SPECIFICATIONS

Current rating	1 A
Insulator resistance	1000 MΩ min.
Contact resistance	20 mΩ max.
Withstanding voltage	500 V AC

Operating temperature	- 40°C to +105°C
Contact material	(RoHS compliant) Phosphor Bronze
Insulator material	(RoHS compliant) Nylon 6T UL 94 V-0

How to order

BE 2 - xxx - S xxx - 55/2

Nbr of contacts
004 to 080

Version	DIM "A" (mm / inch)	DIM "B" (mm / inch)
831	8.30 / .327	3.40 / .134
835	9.40 / .370	2.30 / .090
836	18.20 / .716	3.40 / .134
837	19.30 / .760	2.30 / .090
838	17.70 / .697	2.80 / .110
839	19.00 / .748	2.50 / .098
840	16.40 / .645	5.20 / .205
841	11.00 / .433	10.60 / .417
843	15.50 / .610	3.50 / .138

Plating
55 = gold
Other platings on request

Other dimensions on request.

Available as standard:

"A" + "B" = 11.70mm & 21.60mm

2.00mm pitch Female Header - THT -
 "PC 104+ Type" Quad Row, 120 contacts max.

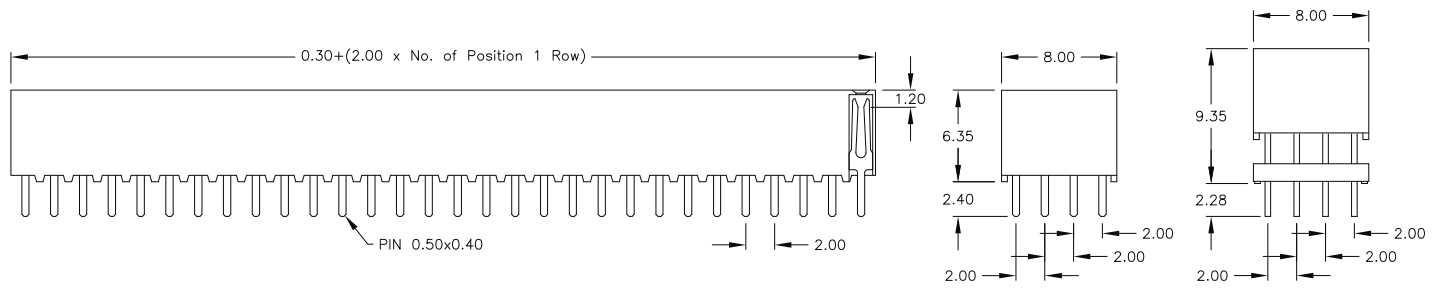
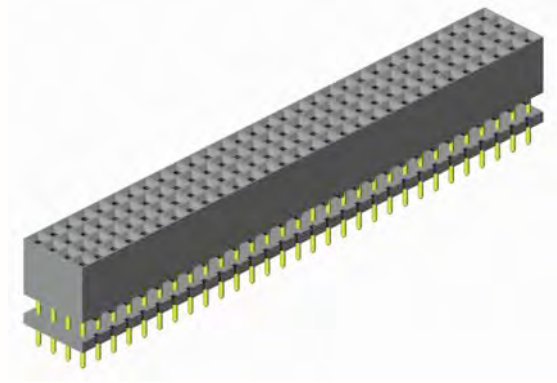
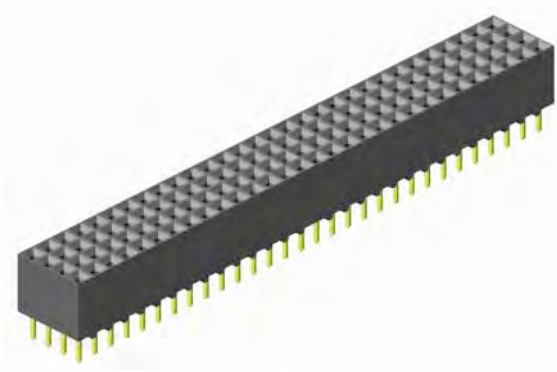

S630/0

S630/1

SPECIFICATIONS

Current rating	1 A
Insulator resistance	1000 MΩ min.
Contact resistance	20 mΩ max.
Withstanding voltage	500 V AC
Operating temperature	- 40°C to +105°C
Contact material <i>(RoHS compliant)</i>	Phosphor Bronze
Insulator material <i>(RoHS compliant)</i>	Nylon UL 94 V-0

PCB Hole Layout

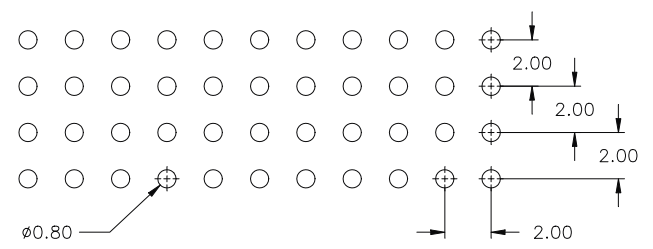

APPLICATION AND FEATURES

Low and high Profile PC/104-Plus Type
 Designed for "board to board" small spacing interconnection
 With standoff's for post solder cleaning
 Mate with pin header SL4 - xxx - S830/x - xx/2

How to order

BL4 - xxx - S xxx/x - 55 /2

Nbr of contacts
012 to 120

Version	Dimension above PCB
630/0	6.35 mm
630/1	9.35 mm
Other dimensions on request	

Plating
55 = gold
Other platings on request

2.00mm pitch Female Header
 - THT - Dual Entry Type

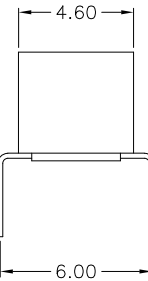
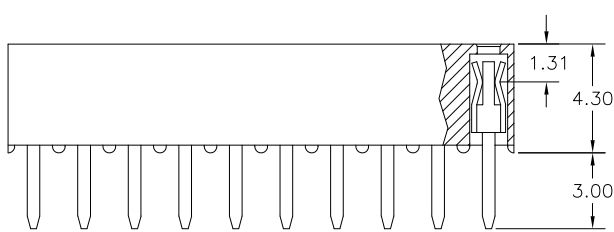
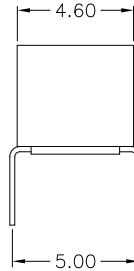
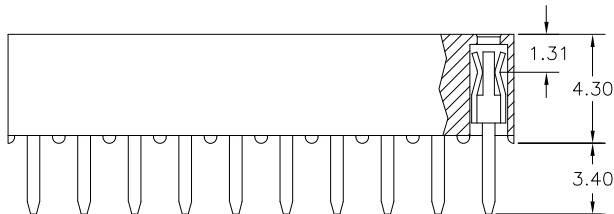
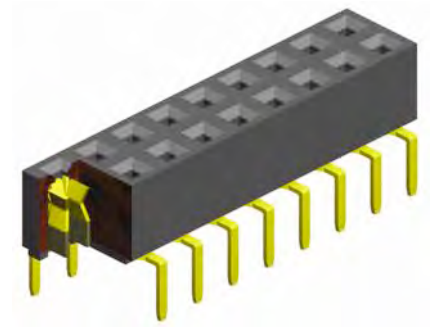
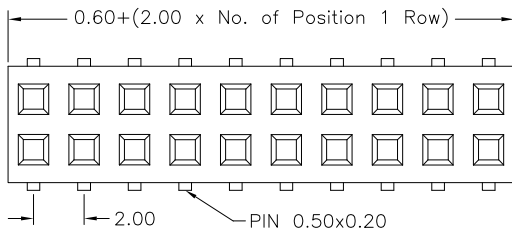

SPECIFICATIONS

Current rating	1 A
Insulator resistance	1000 MΩ min.
Contact resistance	20 mΩ max.
Withstanding voltage	500 V AC
Operating temperature	- 40°C to +105°C
Contact material	(RoHS compliant) Phosphor Bronze
Insulator material	(RoHS compliant) Nylon UL 94 V-0

PCB Hole Layout

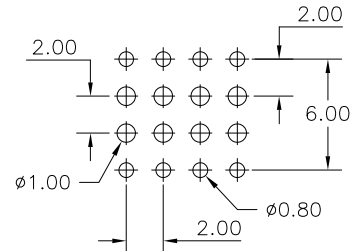
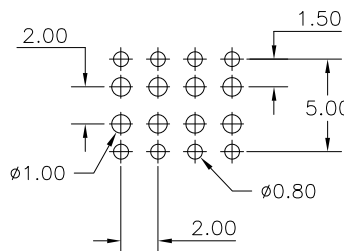

APPLICATION AND FEATURES

Dual entry low profile 4.30mm height
 Designed for parallel and vertical board stacking
 Dual-beam folded contact and low insertion force, mating with 0.50 x 0.50mm Pin Header

How to order

BB2 - x xx - S430 - 55 /2

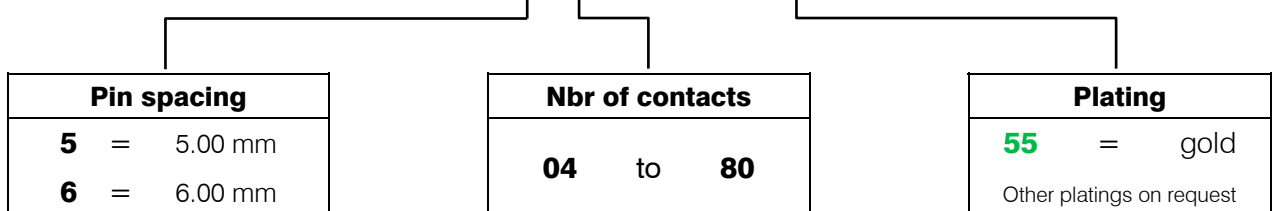

2.00mm pitch Female Header
 - THT - side entry type

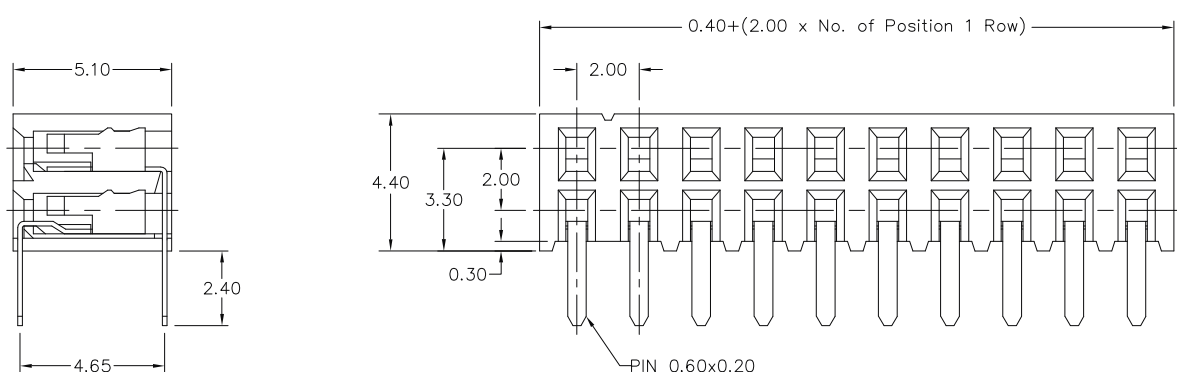
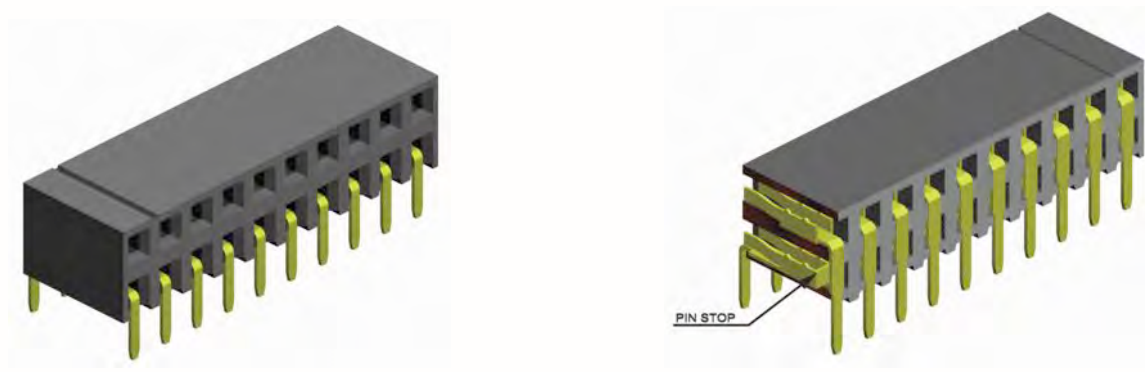

APPLICATION AND FEATURES

- Hi-rel dual beam contact assures reliable PC-Board connections
- Accepts 0.50mm square pins
- 4.40mm height above board
- Stand-off's facilitate post solder cleaning

PCB Hole Layout



SPECIFICATIONS

Current rating	1 A	Operating temperature	- 40°C to +105°C
Insulator resistance	1000 MΩ min.	Contact material	Phosphor bronze (RoHS compliant)
Contact resistance	20 mΩ max.	Insulator material	Nylon (RoHS compliant) UL 94 V-0
Withstanding voltage	500 V AC		

How to order

BH 2 - xxx - R 450 - 55 /2

Nbr of contacts

004 to 050

Plating

55 = gold

Other platings on request

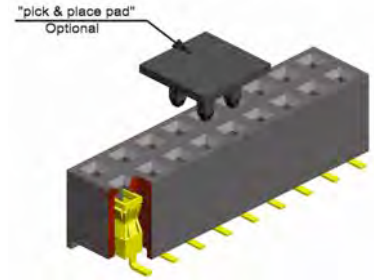
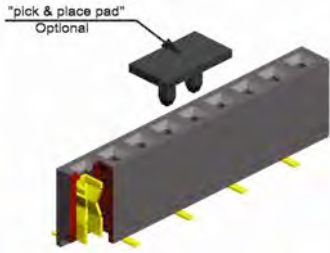

Foot style

430

431

430

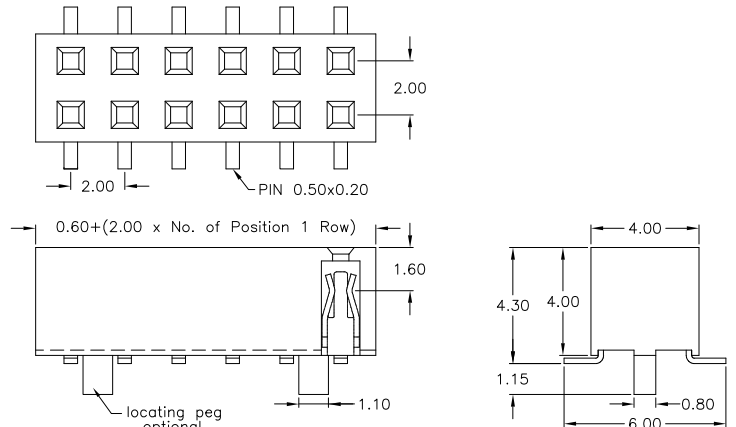
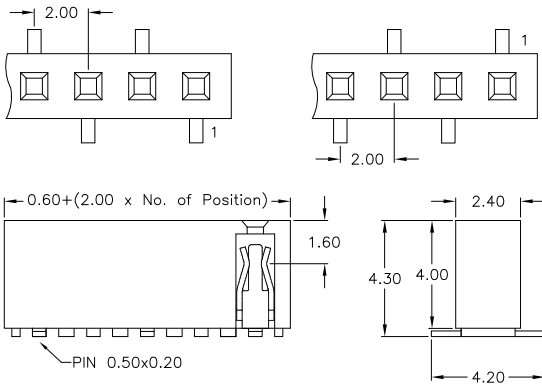

APPLICATION AND FEATURES

- **Standard: tube packing and without "pick & place pad"**
- Low profile, 4.30mm height.
- Hi-rel dual beam contacts
- Mating with 2.00mm pitch, 0.50mm square, or round pin headers

PCB Surface Mount Layout

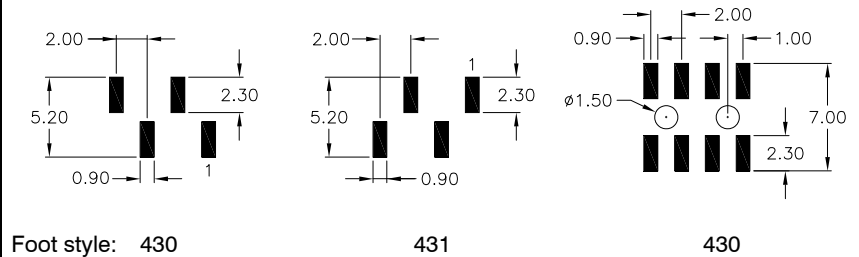

SPECIFICATIONS

Current rating	1 A	Operating temperature	- 40°C to +105°C
Insulator resistance	1000 MΩ min.	Processing temperature	+250°C +0/-5°C for 10sec.
Contact resistance	20 mΩ max.	Contact material	Phosphor Bronze (RoHS compliant)
Withstanding voltage	500 V AC	Insulator material	Nylon UL 94 V-0 (RoHS compliant)

How to order

BS x - xxx - H xxx - 55 / 2 X

Rows	Nbr of contacts	Foot style	Plating	Packing and "pick & place pad" Option
1 single row	003 to 040	430 (standard) 431 (option) Pls. choose 430 style if odd pin count	55 = gold	A = tube packing; with pick & place pad B = reel packing; with pick & place pad
2 dual row	006 to 080	430	Other platings on request	without "locating pegs" A = tube packing; with pick & place pad B = reel packing; with pick & place pad with "locating pegs" C = tube packing; without pick & place pad D = tube packing; with pick & place pad E = reel packing; with pick & place pad

2.00mm pitch Female Header

- SMT - Top & Bottom Entry 2.20mm profile

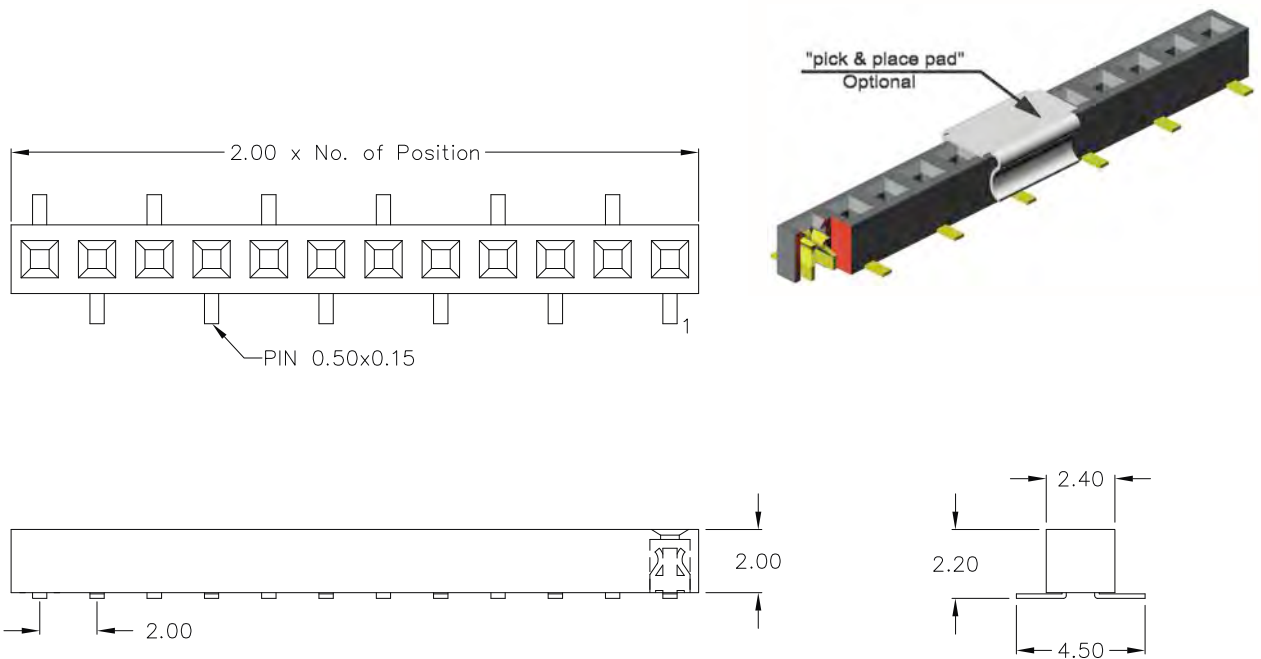

PCB Surface Mount & Hole Layout

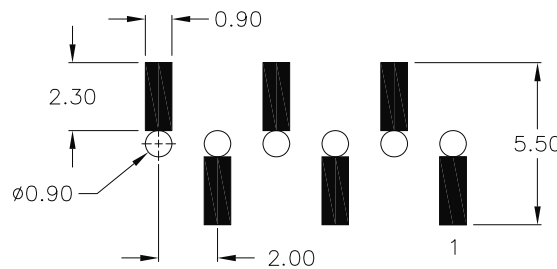

APPLICATION AND FEATURES

- **Standard: tube packing and without "pick & place pad"**
- Low profile, 2.20mm height above PCB available
- Mating with 2.00mm pitch, 0.50mm square, or round pin headers
- Designed for board to board small spacing interconnection

SPECIFICATIONS

Current rating	1 A
Insulator resistance	1000 MΩ min.
Contact resistance	20 mΩ max.
Withstanding voltage	500 V AC
Operating temperature	- 40°C to +105°C
Processing temperature	+250°C +0/-5°C for 10sec.
Contact material (RoHS compliant)	Phosphor Bronze
Insulator material (RoHS compliant)	Nylon UL 94 V-0

How to order

BS 1 - xxx - TB 22 - 55 /2 X

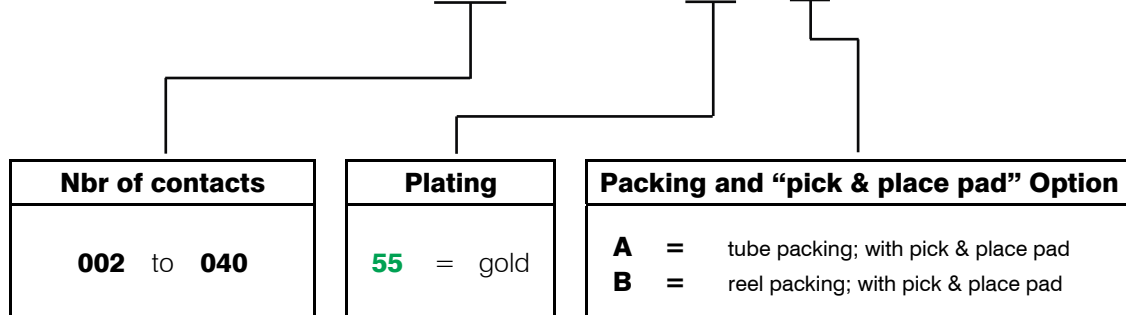

When using this female connector as a bottom entry connector, we recommend that the pin header pins protrude by around 2.00mm above the surface of the female connector after assembly. This will avoid any risk of separation of the pin header from the female header during shock and vibration.

2.00mm pitch Female Header - SMT - Top & Bottom Entry 2.20mm & 2.95mm profile

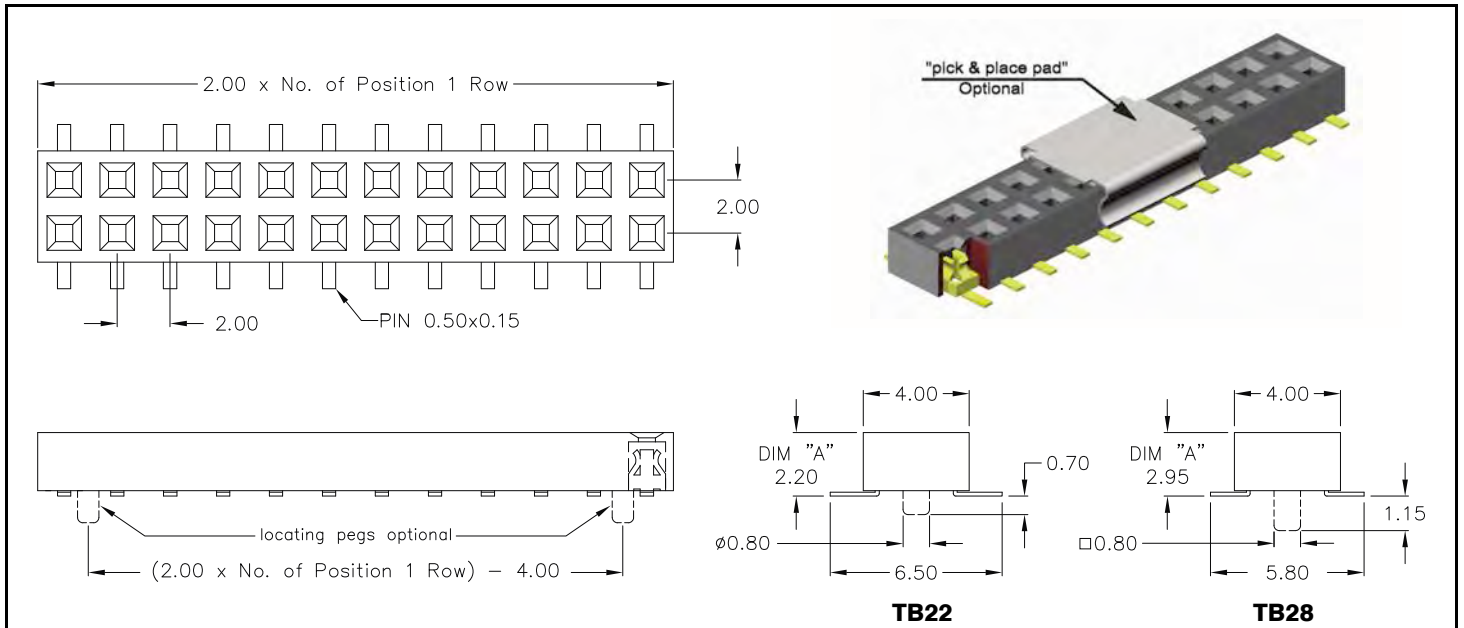

PCB Surface Mount & Hole Layout

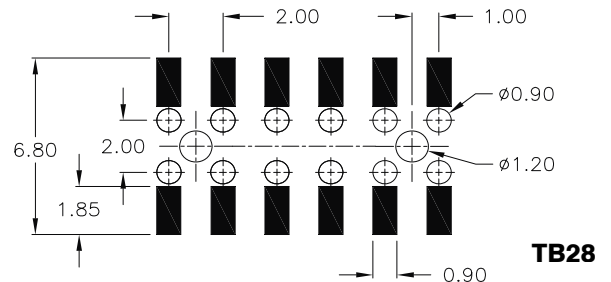
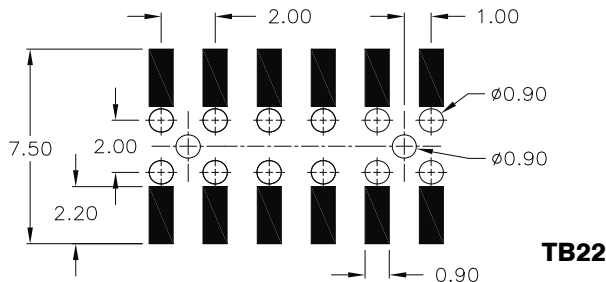

APPLICATION AND FEATURES

- **Standard: tube packing, without "locating pegs" and "pick & place pad"**
- Low profile, 2.20mm and 2.95mm height above PCB available
- Mating with 2.00mm x 2.00mm pitch, 0.50mm square, or round pin headers
- Designed for board to board small spacing interconnection

SPECIFICATIONS

Current rating	1 A
Insulator resistance	1000 MΩ min.
Contact resistance	20 mΩ max.
Withstanding voltage	500 V AC
Operating temperature	- 40°C to +105°C
Processing temperature	+250°C +0/-5°C for 10sec.
Contact material	(RoHS compliant) Phosphor Bronze
Insulator material	(RoHS compliant) Nylon UL 94 V-0

How to order

BS 2 - xxx - TB xx - 55 /2 X

Nbr of contacts	Version		Plating	Packing and "pick & place pad" Option
006 to 080	22	DIM „A“ = 2.20 mm	55 = gold	without "locating pegs"
006 to 070	28	DIM „A“ = 2.95 mm		A = tube packing; with pick & place pad B = reel packing; with pick & place pad
				with "locating pegs"
				C = tube packing; without pick & place pad D = tube packing; with pick & place pad E = reel packing; with pick & place pad

When using this female connector as a bottom entry connector, we recommend that the pin header pins protrude by around 2.00mm above the surface of the female connector after assembly. This will avoid any risk of separation of the pin header from the female header during shock and vibration.

2.00mm pitch Female Header
- SMT- side entry

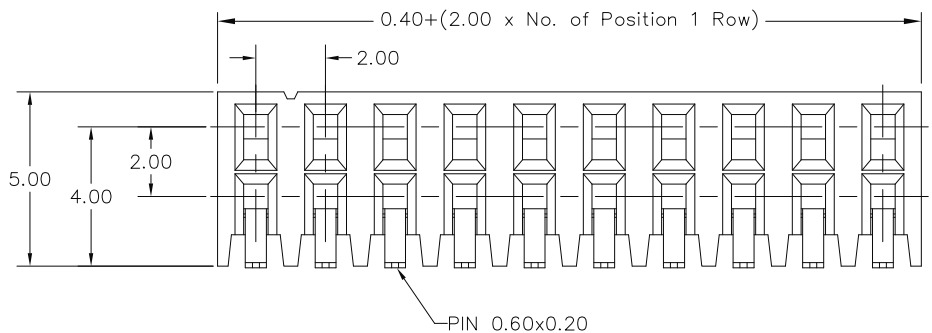
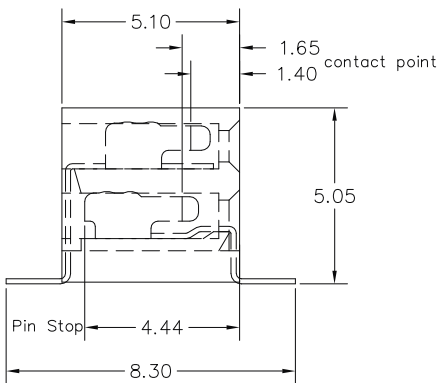
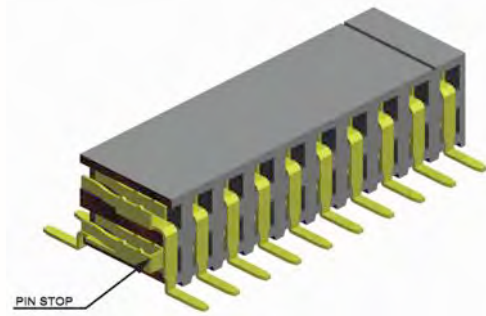
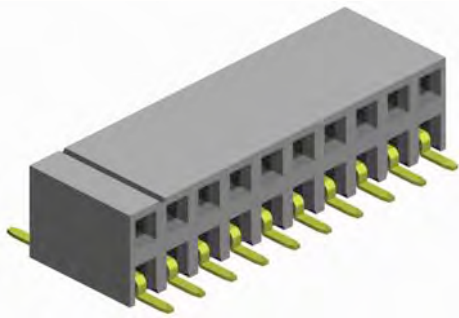

APPLICATION AND FEATURES

- Hi-rel dual beam contact with „Pin Stop“ assures reliable connections
- Accepts 0.50mm square pins
- 5.00mm height above board
- Automatic assembly to PCB possible

PCB Surface Mount Layout

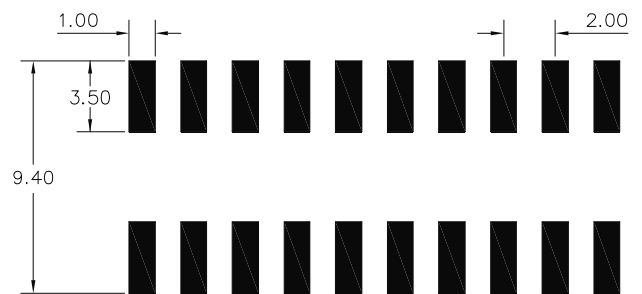

SPECIFICATIONS

Current rating	1 A
Insulator resistance	1000 MΩ min.
Contact resistance	20 mΩ max.
Withstanding voltage	500 V AC

Operating temperature	- 40°C to +105°C
Processing temperature	+250°C +0/-5°C for 10sec.
Contact material (RoHS compliant)	Phosphor Bronze
Insulator material (RoHS compliant)	Nylon UL 94 V-0

How to order

BS 2 - xxx - R 500 - 55 /2 X

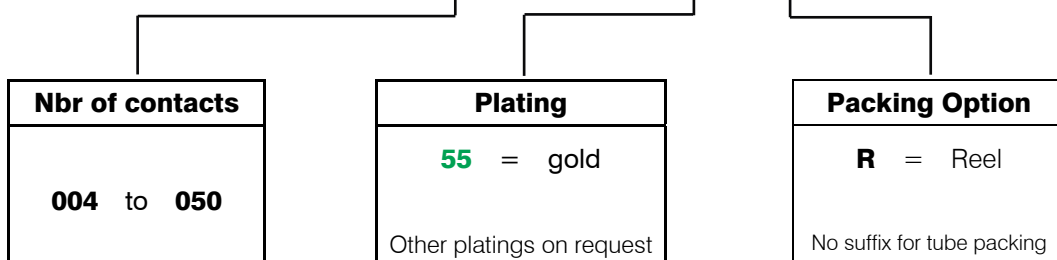

2.00mm pitch

IDC – Female Connector

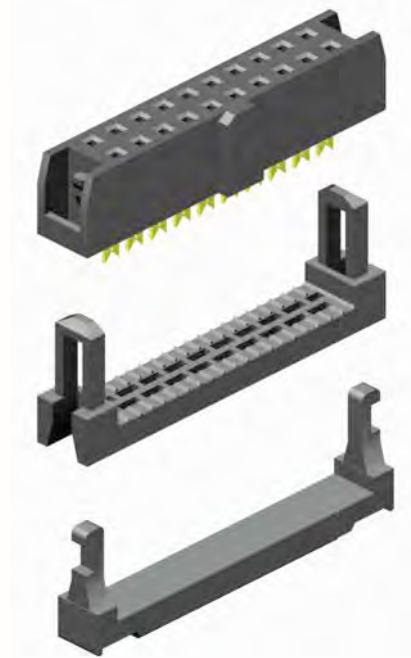
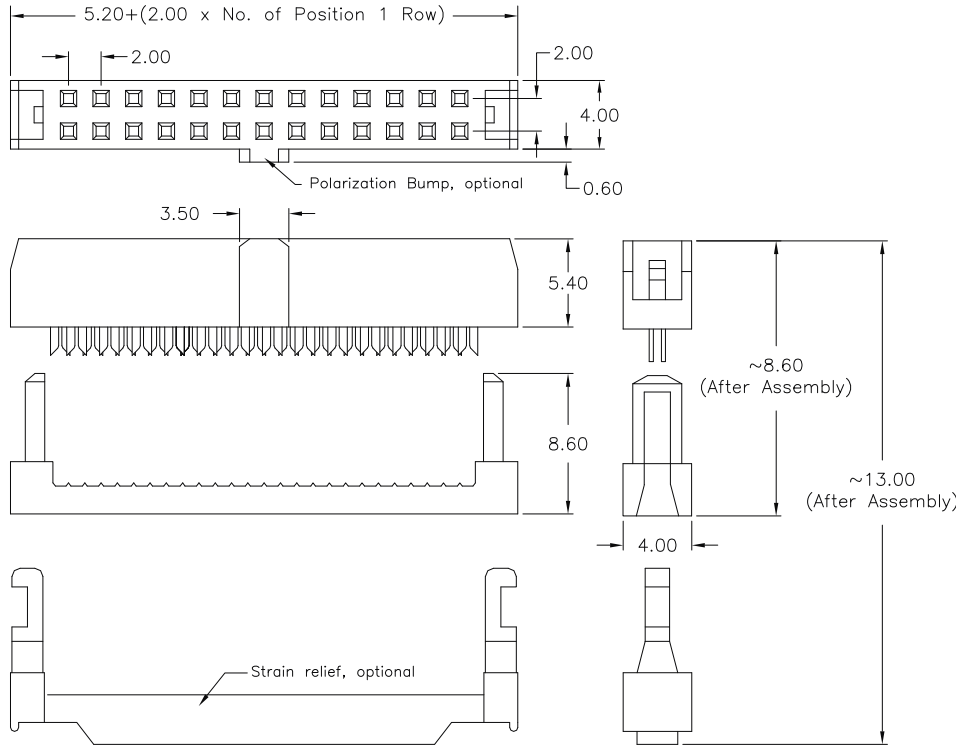

SPECIFICATIONS

Current rating	1 A	Operating temperature	- 40°C to +105°C
Insulator resistance	1000 MΩ min.	Contact material	Phosphor Bronze (RoHS compliant)
Contact resistance	20 mΩ max.	Insulator material	P.B.T. UL 94 V-0 (RoHS compliant)
Withstanding voltage	500 V AC		

APPLICATION AND FEATURES

Designed to mate with 0.50mm square pins Box Header
 High Quality dual beam contacts
 Accepts 26 & 28 AWG 1.00mm flat ribbon cable.

How to order

IDS - xxx - X 200 - 95 (/ P)

Nbr of contacts
available with strain relief: 010; 012; 014; 016; 018; 020 022; 024; 026; 028; 030; 032 034; 040; 044; 050
available without strain relief: 006; 008; 010; 012; 014; 016 018; 020; 022; 024; 026; 028 030; 032; 034; 040; 044; 050 054; 056; 060; 064; 068

Strain relief
S = with W = without

Plating
95 = tin / gold <small>(tin leadfree)</small> Other platings on request

Option
P Polarization bump

2.54mm pitch Pin Header

- THT - straight

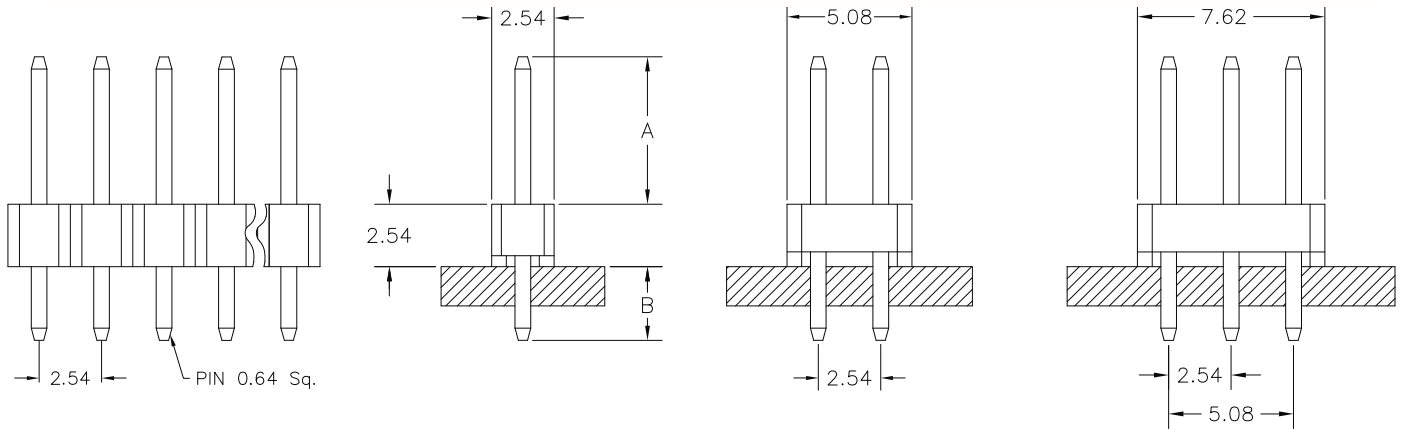
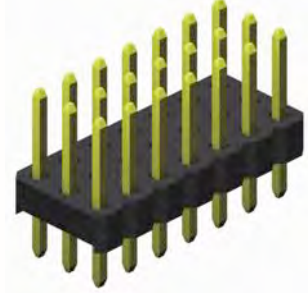
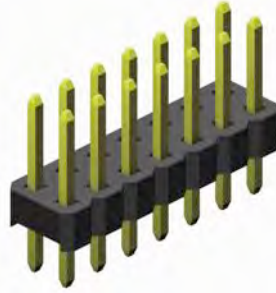
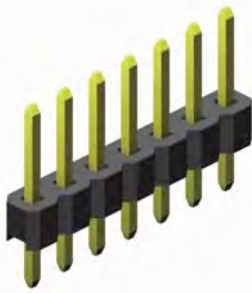

Pin code	DIM "A" mm/inch	DIM "B" mm/inch	Pin code	DIM "A" mm/inch	DIM "B" mm/inch	Pin code	DIM "A" mm/inch	DIM "B" mm/inch
116 / 01	6.00/.236	3.10/.122	105 / 04	6.00/.236	2.00/.079	168 / 01	11.00/.433	3.30/.130
076 / 01	3.40/.124	2.70/.106	108 / 09	6.10/.240	2.16/.085	176 / 02	11.80/.465	3.30/.130
125 / 04	3.30/.123	6.70/.264	147 / 06	6.10/.240	6.10/.240	184 / 10	12.30/.484	3.60/.142
105 / 05	4.20/.165	3.60/.142	147 / 02	7.00/.276	5.11/.201	186 / 01	12.40/.488	3.80/.150
108 / 10	4.30/.169	4.00/.157	125 / 01	7.00/.276	3.00/.118	184 / 02	12.60/.496	3.00/.118
105 / 01	5.00/.197	3.00/.118	125 / 02	7.50/.295	2.54/.100	216 / 07	12.80/.504	6.30/.248
108 / 12	5.00/.197	3.30/.130	135 / 05	8.00/.315	2.80/.110	184 / 01	12.90/.508	3.00/.118
108 / 11	5.50/.216	2.80/.110	140 / 03	8.50/.335	3.00/.118	185 / 04	13.00/.512	3.00/.118
108 / 02	5.70/.224	2.54/.100	140 / 02	9.00/.354	2.54/.100	204 / 01	14.90/.586	3.00/.118
139 / 01	5.70/.224	5.70/.224	155 / 01	9.80/.386	3.15/.124	228 / 01	17.30/.681	3.00/.118
108 / 01	5.80/.228	2.50/.098	184 / 03	10.50/.413	5.11/.201	261 / 01	17.80/.700	5.80/.228
113 / 02	5.80/.228	3.00/.118	155 / 06	10.80/.425	2.20/.087	240 / 02	18.50/.728	3.00/.118
100 / 01	6.00/.236	1.50/.059	159 / 06	10.80/.425	2.54/.100	245 / 01	19.00/.748	3.00/.118

Standard dimension & pin code

Many other dimensions available on request

SPECIFICATIONS

Current rating	3 A	Operating temperature	- 40°C to +105°C
Insulator resistance	1000 MΩ min.	Insulator material (RoHS compliant)	P.B.T. or Nylon UL 94 V-0
Withstanding voltage	500 V AC	Contact material (RoHS compliant)	Standard : P.B.T. Brass
Breakdown voltage	1800 VRMS min.		

How to order

SL x - xxx - S xxx/xx - 55

Rows	Nbr of pins	Insulator	Pin code	Plating
1 = single row 2 = dual row 3 = triple row	single row = 002 to 040 dual row = 004 to 080 triple row = 009 to 120	S = P.B.T. SH = Nylon	See above table	55 = gold (standard) 99 = tin (leadfree) 95 = tin/gold (tin leadfree) Other platings on request

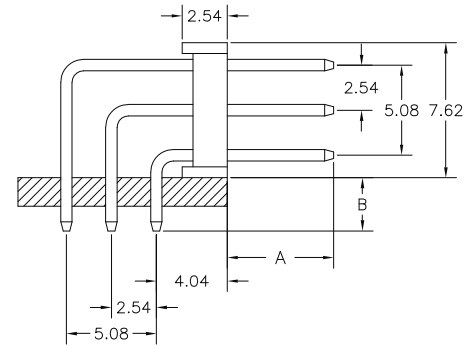
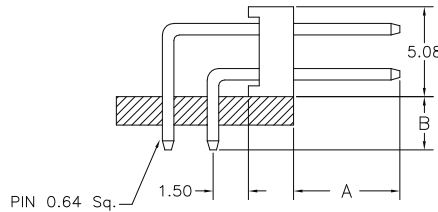
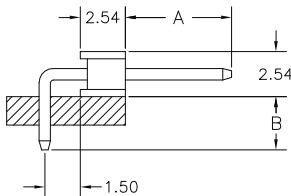
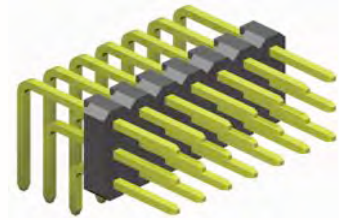
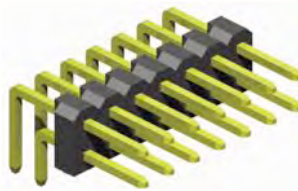
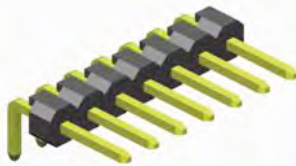

DOWN ANGLE PIN STYLE

Pin code	DIM "A" mm/inch	DIM "B" mm/inch	Pin code	DIM "A" mm/inch	DIM "B" mm/inch	Pin code	DIM "A" mm/inch	DIM "B" mm/inch	Pin code	DIM "A" mm/inch	DIM "B" mm/inch
100/03	2.50/.098	2.50/.098	125/11	5.60/.220	2.10/.083	176/01	7.00/.276	6.00/.236	170/02	8.80/.346	3.30/.130
103/01	2.75/.108	2.75/.108	132/01	5.70/.224	2.50/.098	147/03	7.40/.291	2.54/.100	165/01	9.00/.354	2.54/.100
105/02	2.80/.110	3.00/.118	133/01	5.70/.224	2.85/.112	133/03	7.50/.295	1.50/.059	184/05	9.40/.370	4.60/.181
106/01	2.80/.110	2.80/.110	155/02	5.70/.224	5.11/.201	136/06	7.50/.295	2.54/.100	176/03	9.70/.382	3.15/.124
108/01	3.00/.118	3.00/.118	126/02	5.80/.228	2.30/.091	140/04	7.80/.307	1.50/.059	203/04	9.70/.382	5.80/.228
116/03	3.00/.118	4.00/.157	140/05	5.80/.228	3.60/.142	155/05	7.80/.307	3.00/.118	181/01	9.90/.390	3.20/.126
106/02	3.30/.130	2.30/.090	140/11	5.80/.228	3.00/.118	136/01	8.00/.315	3.60/.142	180/05	9.96/.392	3.30/.130
111/01	3.50/.138	3.00/.118	141/01	5.80/.228	4.80/.189	184/04	8.00/.315	5.80/.228	251/01	10.00/.394	10.00/.394
116/04	3.50/.138	3.50/.138	159/01	5.90/.232	5.11/.201	187/02	8.00/.315	6.00/.236	184/09	10.40/.409	3.30/.130
108/02	3.60/.142	2.50/.098	125/16	6.00/.236	2.00/.079	182/01	8.10/.319	5.10/.201	186/01	10.70/.421	3.30/.130
111/02	3.70/.136	2.75/.108	140/01	6.00/.236	3.00/.118	155/04	8.20/.323	2.54/.100	203/05	12.00/.472	3.30/.130
120/01	4.50/.177	2.50/.098	140/09	6.20/.244	3.15/.124	159/04	8.20/.323	3.00/.118	203/03	12.50/.492	3.00/.118
125/07	4.50/.177	3.30/.130	149/01	6.70/.264	3.20/.126	203/06	8.23/.324	7.00/.276	203/02	13.00/.512	2.54/.100
125/06	4.70/.185	3.15/.124	148/01	6.75/.266	2.90/.114	246/01	8.30/.327	11.70/.461	209/01	13.10/.516	3.00/.118
147/04	4.80/.189	5.11/.201	147/02	6.90/.272	3.30/.130	159/02	8.50/.335	2.54/.100	216/03	13.60/.535	3.30/.130
125/09	5.30/.209	2.54/.100	140/03	7.00/.276	2.00/.079	165/02	8.60/.339	3.30/.130			
133/02	5.30/.209	3.30/.013	147/01	7.00/.276	3.00/.118	169/01	8.60/.339	3.30/.130			

Standard dimension & pin code

Many other dimensions available on request

UP ANGLE PIN STYLE

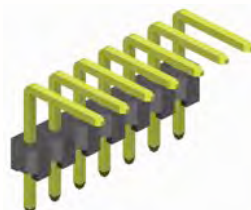
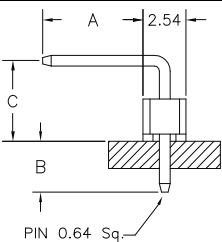

Pin code	DIM "A" mm/inch	DIM "B" mm/inch	DIM "C" mm/inch	Pin code	DIM "A" mm/inch	DIM "B" mm/inch	DIM "C" mm/inch
151/01	3.30/.130	7.00/.276	3.84/.151	160/05	6.00/.236	3.00/.118	6.04/.238
170/01	3.30/.130	8.60/.339	3.84/.151	175/03	6.00/.236	3.00/.118	7.54/.297
190/02	3.30/.130	10.60/.417	3.84/.151	155/03	6.20/.244	2.54/.100	6.30/.248
114/01	4.00/.157	2.60/.102	4.25/.167	130/01	7.00/.276	2.54/.100	3.00/.118
190/01	4.25/.167	3.00/.118	8.00/.315	184/15	7.00/.276	3.00/.118	6.35/.250
155/09	5.10/.201	3.10/.122	6.41/.252	184/06	8.00/.315	3.60/.142	6.30/.248
135/11	6.00/.236	3.00/.118	3.50/.138	149/02	9.70/.382	1.50/.059	2.80/.110
147/07	6.00/.236	3.00/.118	4.80/.189				

Specifications: Refer to straight pin headers

Many other dimensions available on request

How to order

SL x - xxx - X xxx/xx - 55

Rows	Nbr of pins	Pin style & Insulator	Pin code	Plating
<p>1 = single row</p> <p>2 = dual row</p> <p>3 = triple row</p>	<p>single row = 002 to 040</p> <p>dual row = 004 to 080</p> <p>triple row = 009 to 120</p>	<p>R = Down angle (P.B.T. Insulator)</p> <p>RH = Down angle (Nylon Insulator)</p> <p>U = Up angle (P.B.T. Insulator)</p> <p>UH = Up angle (Nylon Insulator)</p>	<p>See above table</p>	<p>55 = gold (standard)</p> <p>99 = tin (leadfree)</p> <p>95 = tin/gold (tin leadfree)</p> <p>Other platings on request</p>

2.54mm pitch Pin Header
 - THT - high plastic base



Straight style - 7.40mm body

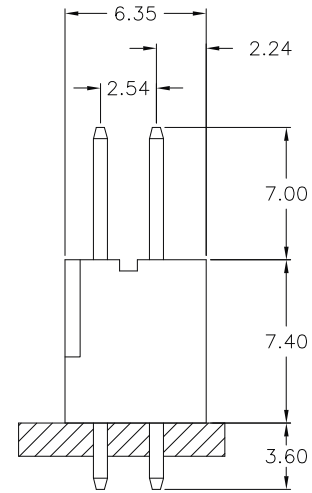
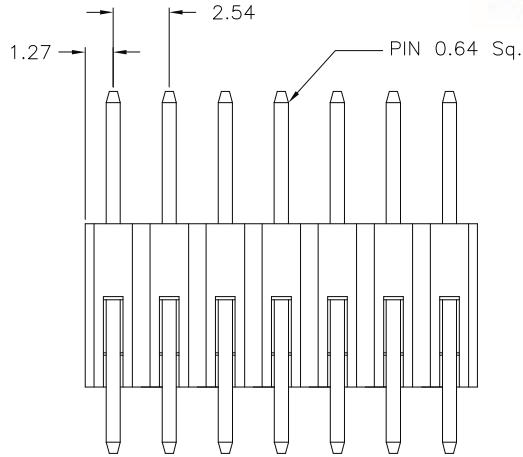
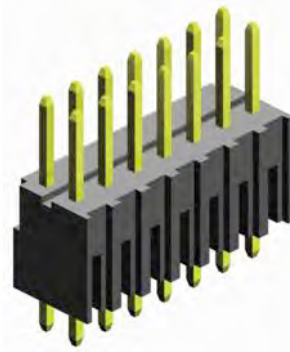

S 740

Right angle style - 6.35mm body

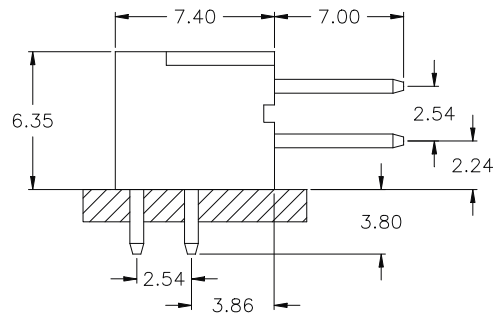

R 635

Specifications

Current rating	3 A
Insulator resistance	1000 MΩ min.
Withstanding voltage	500 V AC
Operating temperature	- 40°C to +105°C
Contact material	Brass
Insulator material	P.B.T. UL 94 V-0

PCB Hole layout

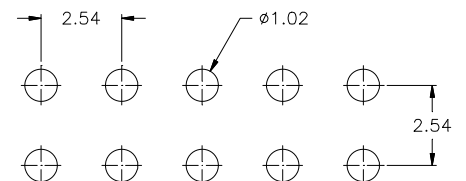

How to order

SE 2 - xxx - X xxx - 55

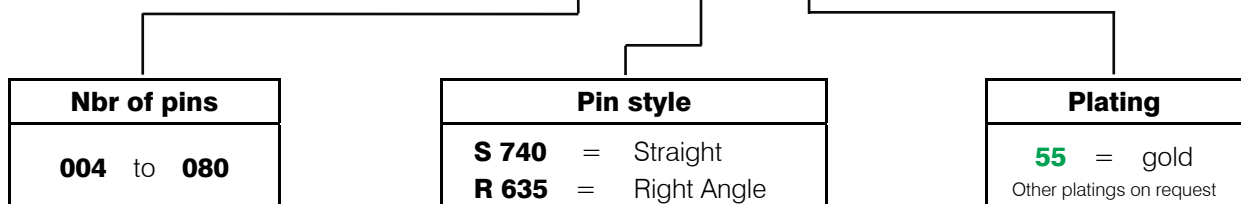

2.54mm pitch Board Spacer

- THT - single, dual & triple row

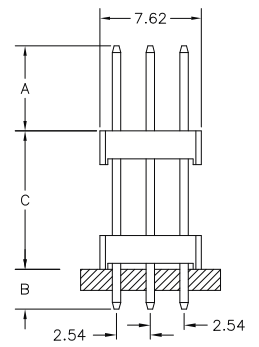
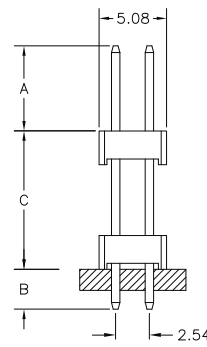
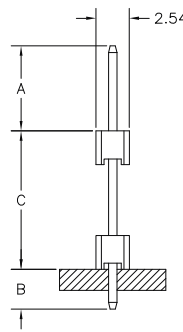
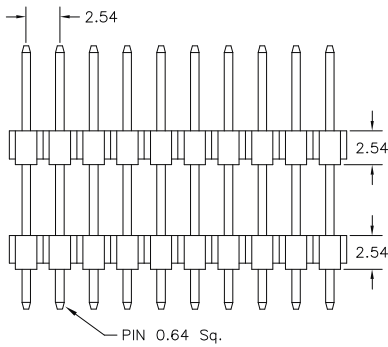
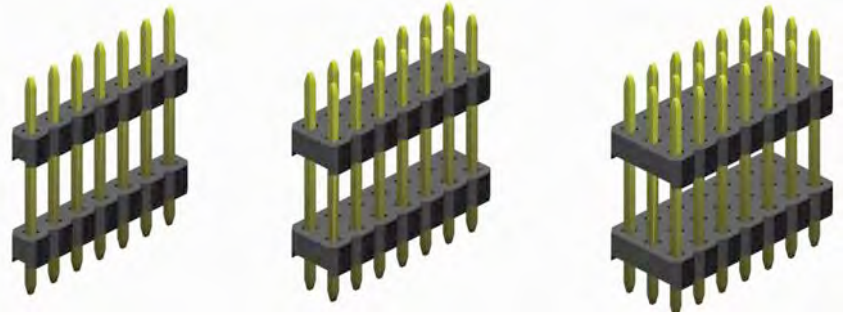

PIN STYLE

Pin code	DIM "A" mm/inch	DIM "B" mm/inch	DIM "C" mm/inch	Pin code	DIM "A" mm/inch	DIM "B" mm/inch	DIM "C" mm/inch
113 / 01	3.00/.118	3.30/.130	5.00/.197	240 / 03	6.00/.236	3.00/.118	15.00/.590
249 / 09	15.00/.590	3.90/.153	6.00/.236	249 / 06	6.00/.236	3.40/.134	15.50/.610
185 / 02	8.50/.335	3.00/.118	7.00/.276	290 / 04	6.50/.256	6.50/.256	16.00/.630
137 / 01	3.00/.118	2.30/.090	8.40/.331	249 / 08	5.30/.209	2.60/.102	17.00/.669
260 / 01	13.90/.547	3.60/.142	8.50/.335	216 / 05	1.95/.077	1.95/.077	17.70/.697
147 / 08	3.00/.118	3.00/.118	8.70/.343	263 / 01	5.50/.216	2.80/.110	18.00/.709
216 / 08	6.30/.248	6.30/.248	9.00/.354	340 / 01	9.00/.354	6.00/.236	19.00/.748
198 / 02	6.00/.236	3.00/.118	10.40/.409	290 / 01	6.50/.256	2.50/.098	20.00/.787
184 / 13	5.30/.209	2.50/.984	10.60/.417	276 / 01	3.20/.126	3.20/.126	21.20/.835
198 / 03	6.50/.256	2.70/.106	10.60/.417	308 / 03	6.00/.236	3.30/.130	21.50/.846
216 / 10	6.50/.256	3.60/.142	11.50/.453	342 / 01	6.10/.240	6.10/.240	22.00/.866
198 / 01	5.50/.217	2.50/.984	11.80/.465	342 / 02	3.00/.118	9.20/.362	22.00/.866
211 / 01	6.00/.236	2.90/.114	12.20/.480	352 / 01	3.00/.118	9.20/.362	23.00/.905
235 / 01	7.00/.275	3.60/.142	12.90/.508	378 / 02	7.30/.287	3.30/.130	27.20/1.071
255 / 01	9.00/.354	3.60/.142	12.90/.508	378 / 01	5.30/.209	2.50/.984	30.00/1.181
249 / 07	8.80/.346	2.50/.984	13.60/.535	408 / 04	5.80/.228	2.50/.984	32.50/1.280
216 / 02	5.30/.209	2.50/.984	13.80/.543	516 / 01	6.80/.268	3.30/.130	41.50/1.634
290 / 08	7.25/.285	7.25/.285	14.50/.571	606 / 01	6.00/.236	3.10/.122	51.50/2.028
238 / 01	5.90/.232	3.20/.126	14.70/.279				

Many other dimensions available on request

SPECIFICATIONS

Current rating	3 A	Operating temperature	- 40°C to +105°C
Insulator resistance	1000 MΩ min.	Insulator material (RoHS compliant)	P.B.T. or Nylon UL 94 V-0
Withstanding voltage	500 V AC	Contact material (RoHS compliant)	Standard : P.B.T.
Breakdown voltage	1800 VRMS min.		Brass

How to order

SP x - xxx - S xxx/xx - xx

Rows	Nbr of pins	Insulator	Pin code	Plating
1 = single row	single row = 002 to 040	S = P.B.T.	See above table	55 = gold (standard)
2 = dual row	dual row = 004 to 080	SH = Nylon		99 = tin (leadfree)
3 = triple row	triple row = 009 to 120			95 = tin/gold (tin leadfree)
				Other platings on request

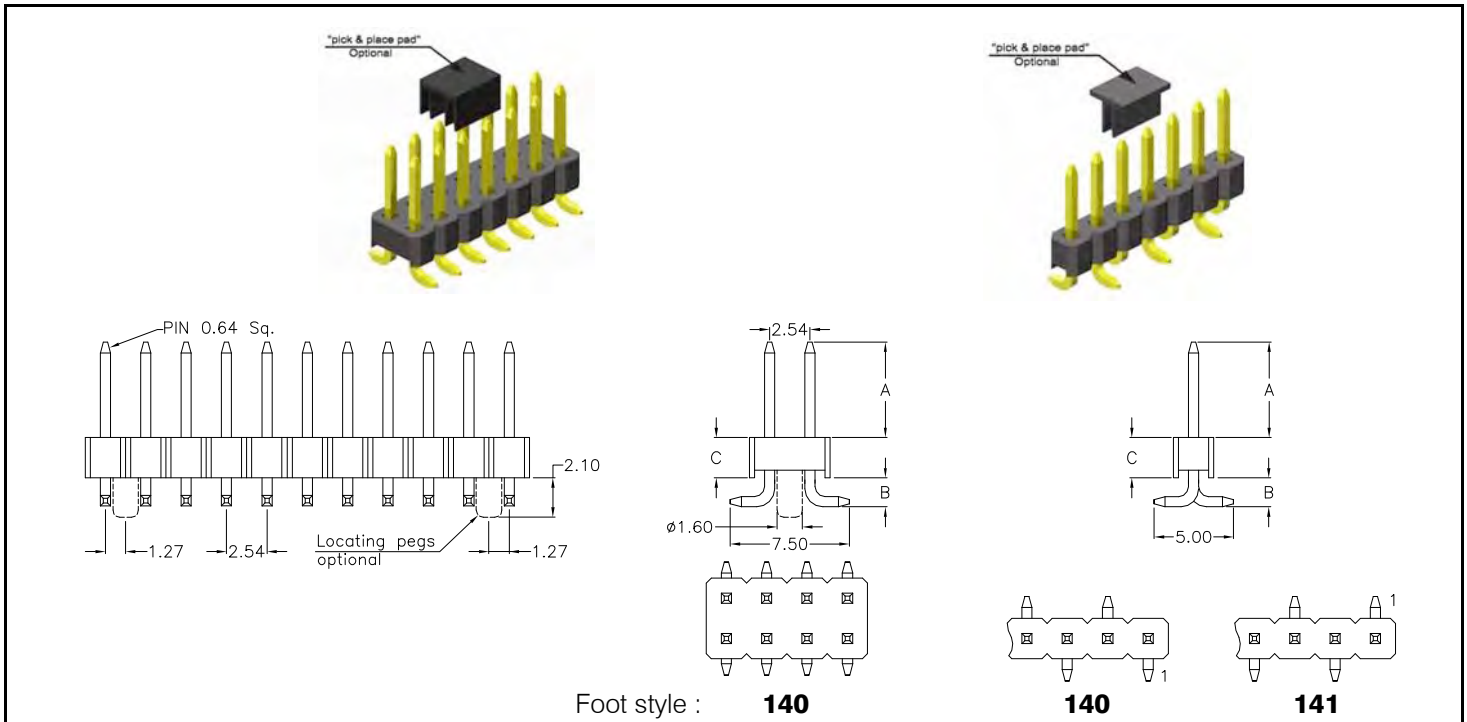

Foot style : **140** **140** **141**

APPLICATION AND FEATURES

- **Standard: tube packing and without "pick & place pad"**
- Standard Pin code **01**, others on request
- Mating with 2.54mm female headers

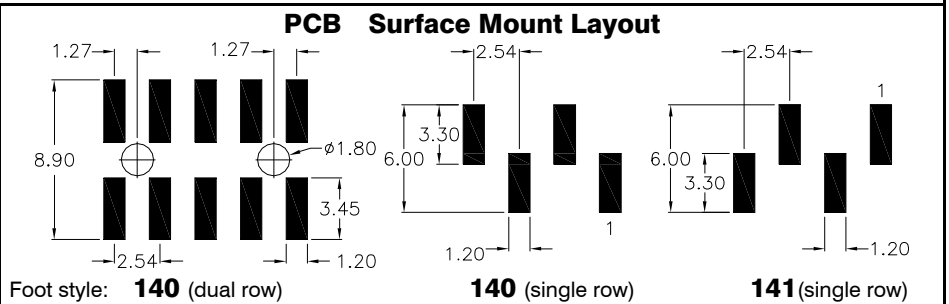

SPECIFICATIONS

Current rating	3 A	Operating temperature	- 40°C to +105°C
Insulator resistance	1000 MΩ min.	Processing temperature	+250°C +0/-5°C for 5sec.
Withstanding voltage	500 V AC	Contact material	(RoHS compliant) Brass
		Insulator material	(RoHS compliant) Nylon UL 94 V-0

How to order

SS x - xxx - H 140 / xx - 55 X

Rows	Nbr of pins	Insulator style	Foot style	Pin code	DIM"A" (mm)	DIM"B" (mm)	DIM"C" (mm)	Plating	Packing and "pick & place pad" Option
1 single row	004 to 040	H (=Standard) if DIM"C"=2.54mm	140 141 <small>Pls. choose 140 style if odd pin count.</small>	00	5.00	1.00	1.50	55 = gold Other platings on request	without "locating pegs" A = tube packing; with pick & place pad B = reel packing; with pick & place pad
				01	6.00	1.82	2.54		
2 dual row	004 to 080	TH if DIM"C"=1.50mm Please note: 1.50mm Insulator is only available without locating peg.	140	02	10.70	1.27	2.54		with "locating pegs" (only available for dual row pin headers) C = tube packing; w/o pick & place pad D = tube packing; with pick & place pad E = reel packing; with pick & place pad
				03	14.20	0.64	2.54		
				04	6.00	0.64	2.54		
				05	10.70	1.82	2.54		
				06	6.00	1.27	2.54		
				07	4.00	1.00	1.50		
				08	9.60	1.90	2.54		
				09	8.13	1.27	2.54		
				10	3.00	1.96	2.54		
				11	8.10	0.72	2.54		
				12	3.23	3.22	2.54		
13	4.85	2.30	2.54						
				Other dimensions on request					

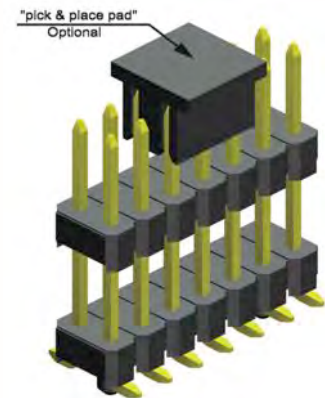
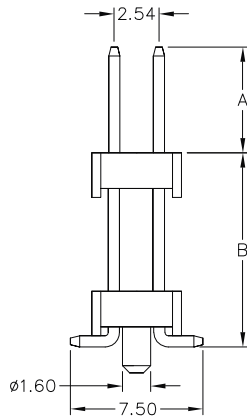
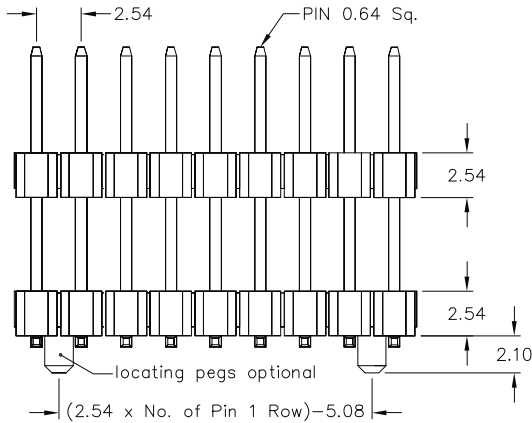
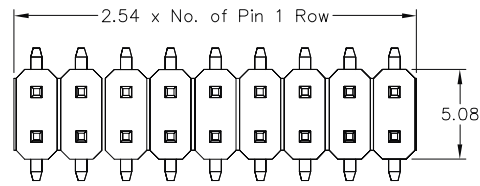

APPLICATION AND FEATURES

- **Standard: tube packing, without "locating pegs" and "pick & place pad"**
- Designed for "board to board" spacing
- Variable terminal length available
- Mate with female header 2.54mm x 2.54mm pitch

PCB Surface Mount Layout

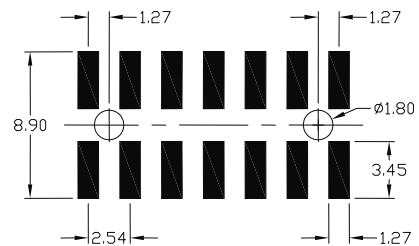

SPECIFICATIONS

Current rating	3 A
Insulator resistance	1000 MΩ min.
Withstanding voltage	500 V AC

Operating temperature	- 40°C to +105°C
Processing temperature	+250°C +0/-5°C for 5sec.
Contact material	(RoHS compliant) Copper alloy
Insulator material	(RoHS compliant) Nylon UL 94 V-0

How to order

SP2 - xxx - H xxx/xx - 55 X

Nbr of pins	Pin code	DIM "A"	DIM "B"	Plating	Packing and "pick & place pad" Option
004 to 080	160/16	3.50 mm	5.30 mm	55 = gold Other platings on request	without "locating pegs" A = tube packing; with pick & place pad B = reel packing; with pick & place pad
	160/03	5.50 mm	6.40 mm		
	160/12	5.50 mm	7.50 mm		with "locating pegs" C = tube packing; without pick & place pad D = tube packing; with pick & place pad E = reel packing; with pick & place pad
	160/04	7.50 mm	9.40 mm		
	160/07	5.90 mm	10.60 mm		
	160/09	3.70 mm	10.70 mm		
	160/01	6.00 mm	11.40 mm		
	160/15	6.90 mm	12.50 mm		
	160/14	8.80 mm	13.60 mm		
	160/06	5.50 mm	14.00 mm		
	160/17	7.00 mm	14.50 mm		
	160/05	6.00 mm	15.50 mm		
	160/13	8.80 mm	16.10 mm		
	160/02	4.50 mm	17.00 mm		
160/08	6.00 mm	28.00 mm			
160/10	2.70 mm	28.30 mm			
160/11	4.00 mm	34.30 mm			
Other dimensions on request					

2.54mm pitch Pin Header - slanted -
- SMT - single and dual row

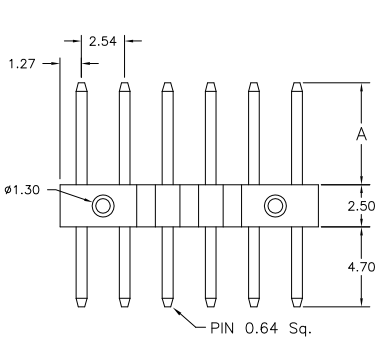
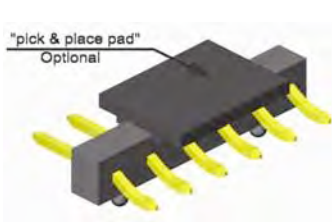

SR1 style

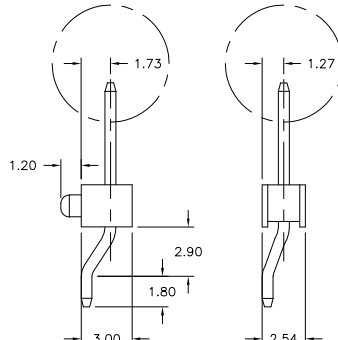

with locating peg
without locating peg

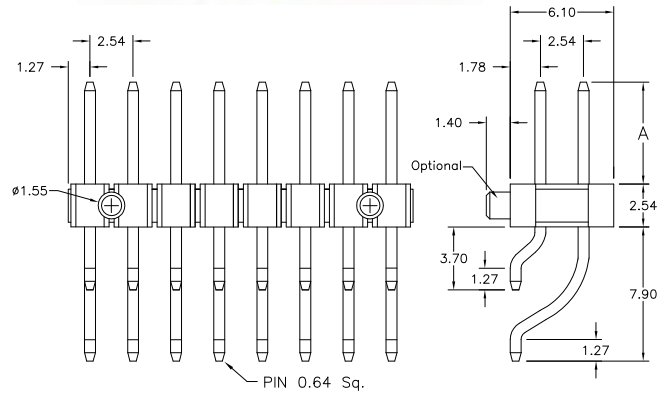

SR2 style

PCB Surface Mount Layout "single row"

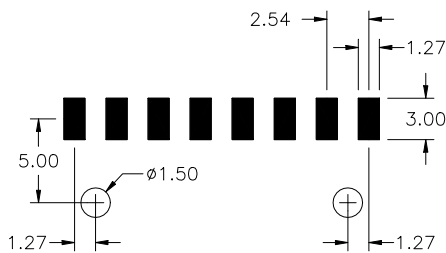

PCB Surface Mount Layout "dual row"

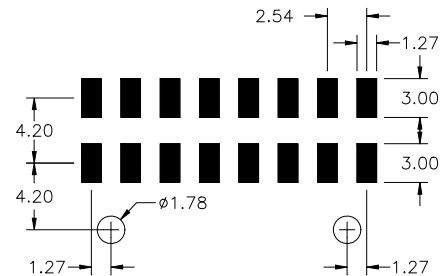

SPECIFICATIONS

Current rating	3 A
Insulator resistance	1000 MΩ min.
Withstanding voltage	500 V AC

Operating temperature	- 40°C to +105°C
Processing temperature	+250°C +0/-5°C for 10sec.
Contact material	(RoHS compliant) Copper alloy
Insulator material	(RoHS compliant) SR1 = Nylon UL 94 V-0 SR2 = LCP UL 94 V-0

How to order

SR x - xxx - H xxx/xx - xx X

Rows	Nbr of pins	Pin code	DIM "A"	Plating	Packing and "pick & place pad" Option (standard: Tube packing and w/o pick & place pad)	
1 single row	without locating pegs 002 to 040	135/00	3.00 mm	55 = gold 95 = tin/gold (tin leadfree) Other platings on request	without "locating pegs"	
	with locating pegs 003 to 030	135/01	3.60 mm		A = tube packing; with pick & place pad	
2 dual row	006 to 080	135/02	6.00 mm		B = reel packing; with pick & place pad	
		135/03	6.80 mm		with "locating pegs"	
		135/04	7.20 mm			C = tube packing; without pick & place pad
		135/05	7.40 mm			D = tube packing; with pick & place pad
		135/06	10.70 mm			E = reel packing; with pick & place pad
		135/07	10.40 mm			
		135/08	5.85 mm			
		135/09	8.15 mm			
		135/10	10.00 mm			
		Other dimensions on request				

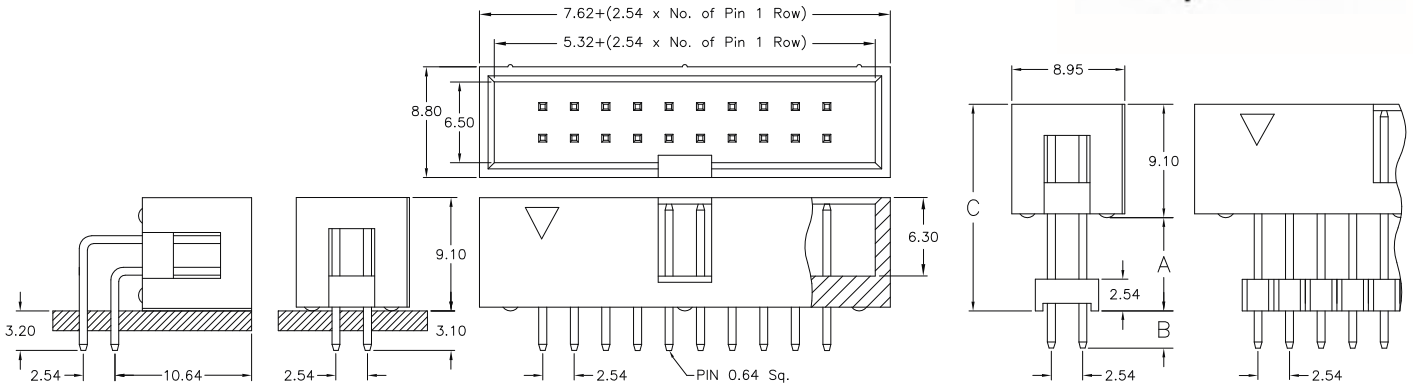
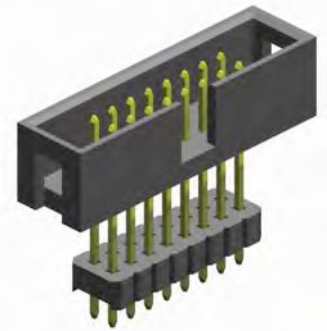
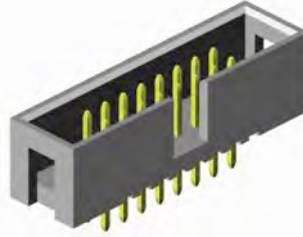

- R 920

- S 920

- "Dxxx" style

APPLICATION AND FEATURES

- Mating devices for female headers, solder tail and IDC Type
- Reliable flat cable to PCB connection
- No ejection latches for space saving

PCB Hole Layout

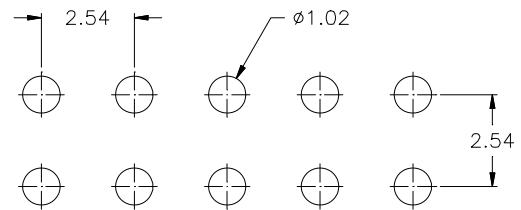

SPECIFICATIONS

Current rating	3 A	Operating temperature	- 40°C to +105°C
Insulator resistance	1000 MΩ min.	Contact material	Brass (RoHS compliant)
Withstanding voltage	500 V AC	Insulator material	P.B.T. (RoHS compliant) UL 94 V-0

How to order

SLS - xxx - X xxx - 55

Nbr of pins	Style	Pin code for "Dxxx" = raised style	DIM "A" (mm)	DIM "B" (mm)	DIM "C" (mm)	Plating
S & R Version: 006; 008; 010; 012; 014; 016 020; 024; 026; 030; 034; 040 044; 050; 060; 064 D Version 006; 008; 010; 012; 014; 016 020; 024; 026; 030; 034; 040 050; 060; 064	S920 = straight R920 = right angle Dxxx = raised style	141 166 232 235	5.00 7.50 14.10 14.40	3.00 3.00 3.00 3.00	14.10 16.60 23.20 23.50	55 = gold Other platings on request
Other dimensions on request						

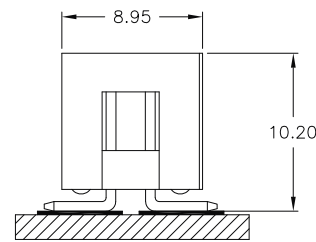
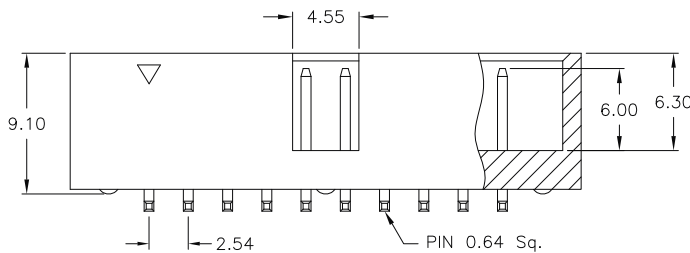
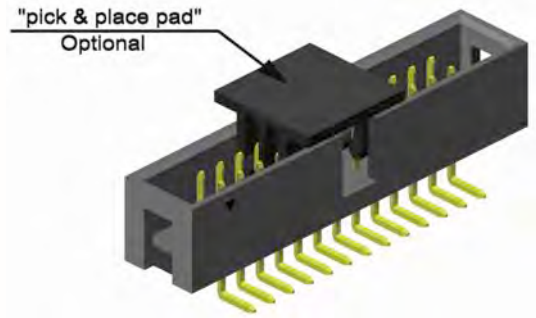
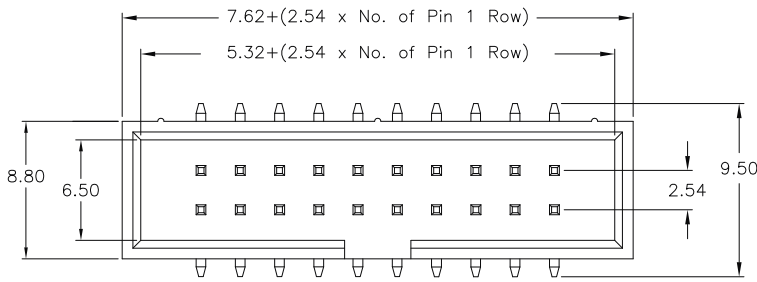

APPLICATION AND FEATURES

- **Standard: tray packing and without "pick & place pad"**
- Also available "reel" packing
- Mating devices for female headers, solder tail and IDC Type
- Reliable flat cable to PCB connection
- No ejector latches for space saving

PCB Surface Mount Layout

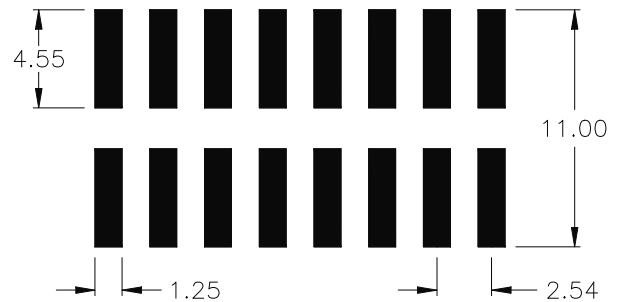

SPECIFICATIONS

Current rating	3 A
Insulator resistance	1000 MΩ min.
Withstanding voltage	500 V AC

Operating temperature	- 40°C to +105°C
Processing temperature	+250°C +0/-5°C for 5sec.
Contact material (RoHS compliant)	Brass
Insulator material (RoHS compliant)	Nylon UL 94 V-0

How to order

SLS - xxx - H 885 - 55 / X

Nbr of pins
006; 008; 010; 012
014; 016; 020; 024
026; 030; 034; 040
044; 050

Plating
55 = gold
Other platings on request

Packing and "pick & place pad" Option
F = tray packing; with pick & place pad
T = tube packing; without pick & place pad
A = tube packing; with pick & place pad
B = reel packing; with pick & place pad

2.54mm pitch Box Header
 - THT - with ejection latches

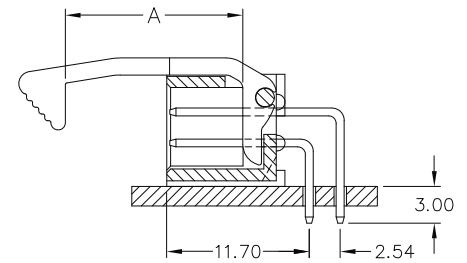
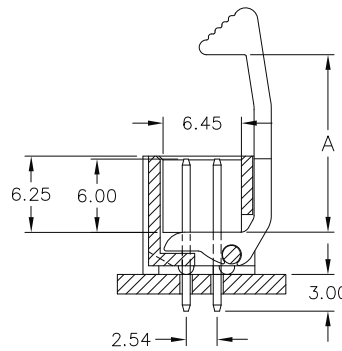
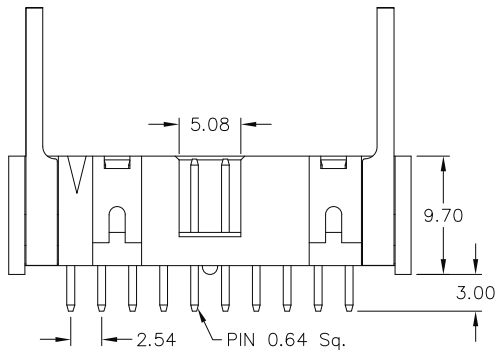
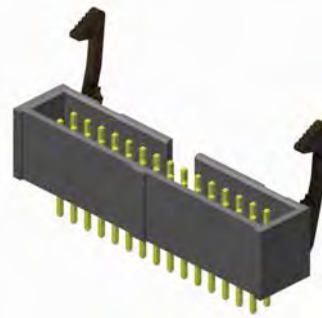
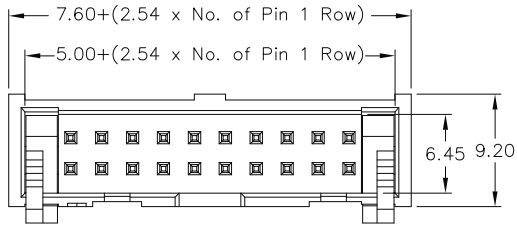

- S103

- R103

APPLICATION AND FEATURES

- Mating devices for female headers IDC Type
- Reliable flat cable to PCB connection
- Ejection latches for easy handling

PCB Hole Layout

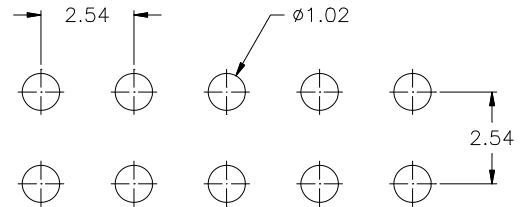

SPECIFICATIONS

Current rating	3 A
Insulator resistance	1000 MΩ min.
Withstanding voltage	500 V AC

Operating temperature	- 40°C to +105°C
Contact material	(RoHS compliant) Copper alloy
Insulator material	(RoHS compliant) P.B.T. UL 94 V-0
	Standard: black

How to order

SLS - xxx - X 103 - 55 / X

Nbr of pins
010; 014; 016
020; 024; 026
030; 034; 040
050; 060; 064

Style
S = straight
R = right angle

Plating
55 = gold
Other platings on request

Latch style
S = short latch DIM "A" = 10.65 mm
L = long latch DIM "A" = 14.55 mm

2.54mm pitch Female Header

- THT - 8.50mm profile

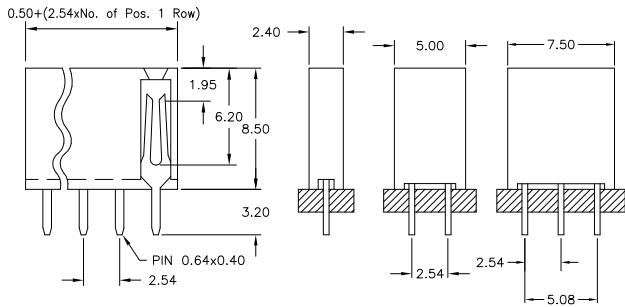
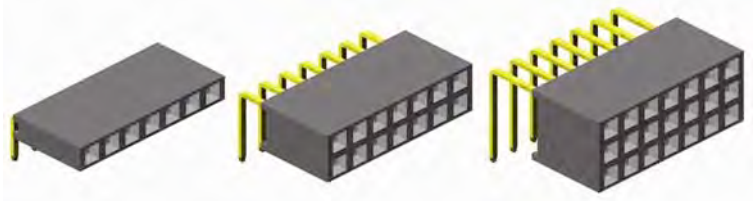
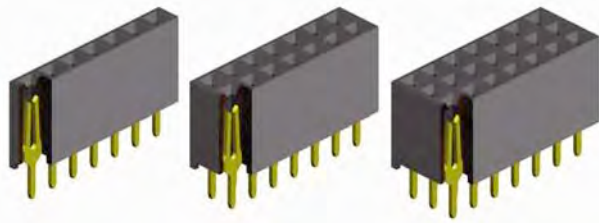

S 842

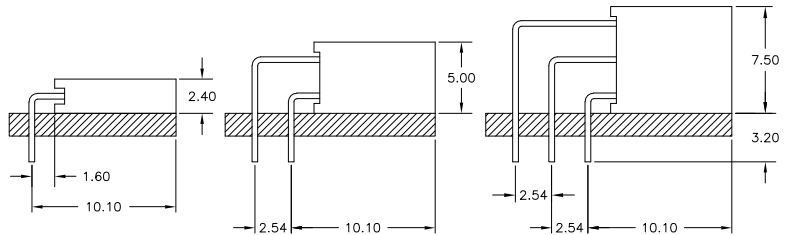

R 842

PCB Hole Layout

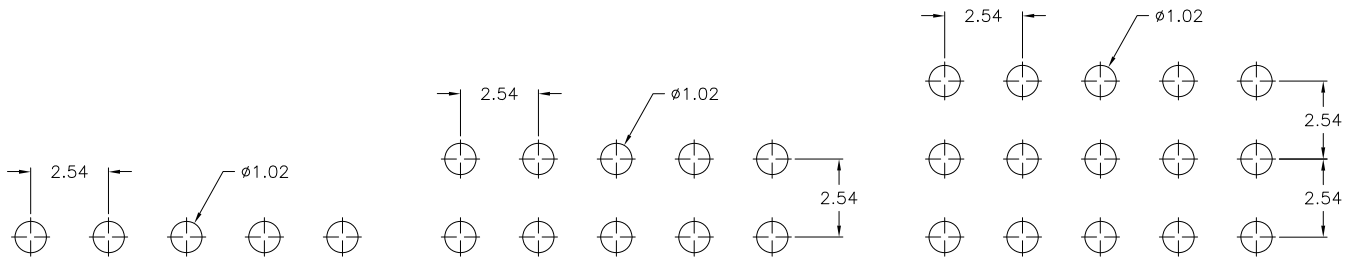

APPLICATION AND FEATURES

Standard profile, 8.50mm height for straight connector style.

Hi-rel fork contacts

Accepts 0.64mm square pins

SPECIFICATIONS

Current rating	3 A
Insulator resistance	1000 MΩ min.
Contact resistance	20 mΩ max.
Withstanding voltage	500 V AC
Operating temperature	- 40°C to +105°C
Contact material (RoHS compliant)	Brass
Insulator material (RoHS compliant)	P.B.T. UL 94 V-0

How to order

BL x - xxx - X 842 - 55

Rows	Nbr of contacts	Connector style	Plating
1 = single row	single row = 002 to 040	S 842 = straight	55 = gold
2 = dual row	dual row = 004 to 080	R 842 = right angle	Other platings on request
3 = triple row	triple row = 009 to 120	Dimensions see drawings above	

2.54mm pitch Female Header

- THT - 8.50mm profile

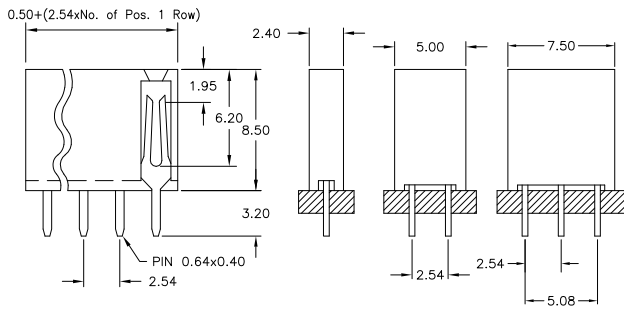
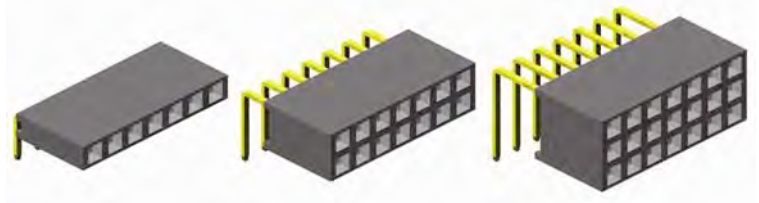
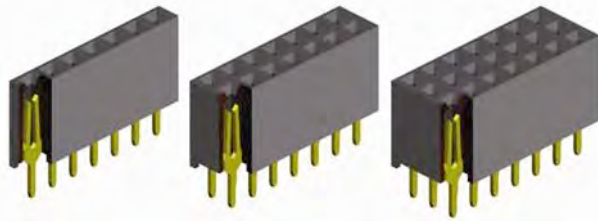

Straight

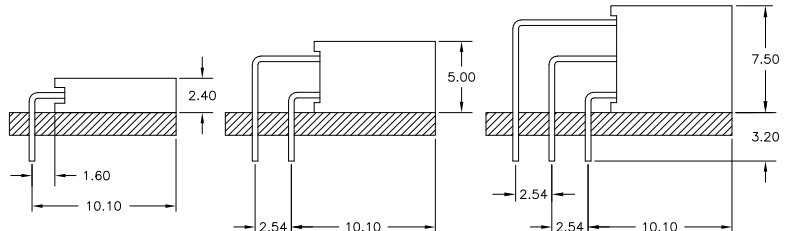

Right angle

PCB Hole Layout

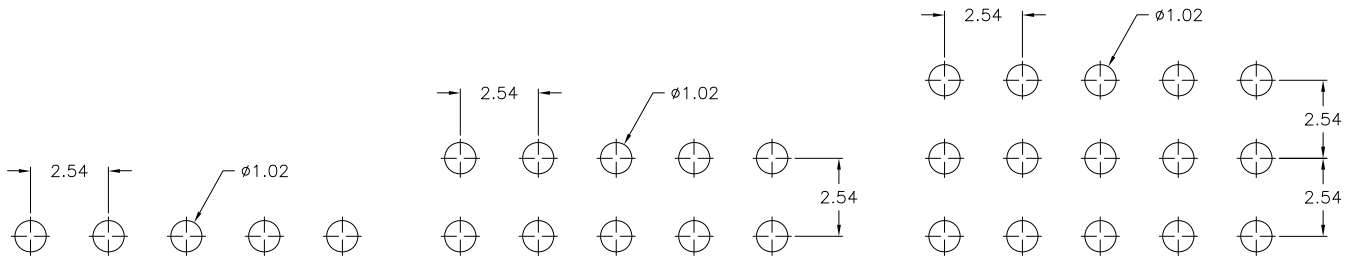

APPLICATION AND FEATURES

Standard profile, 8.50mm height for straight connector style.

Hi-rel fork contacts

Accepts 0.64mm square pins

SPECIFICATIONS

Current rating	3 A
Insulator resistance	1000 MΩ min.
Contact resistance	20 mΩ max.
Withstanding voltage	500 V AC
Operating temperature	- 40°C to +105°C
Contact material (RoHS compliant)	Phosphor Bronze
Insulator material (RoHS compliant)	P.B.T. or Nylon UL 94 V-0

How to order

BL x - xxx - X 842 - 55

Rows	Nbr of contacts	Connector style	Plating
1 = single row	single row = 002 to 040	S 842 = straight (P.B.T. Insulator)	55 = gold
2 = dual row	dual row = 004 to 080	SH 842 = straight (Nylon Insulator)	Other platings on request
3 = triple row	triple row = 009 to 120	R 842 = right angle (P.B.T. Insulator)	
		RH 842 = right angle (Nylon Insulator)	
Dimensions see drawings above			

2.54mm pitch Female Header
 - THT - 5.70mm profile

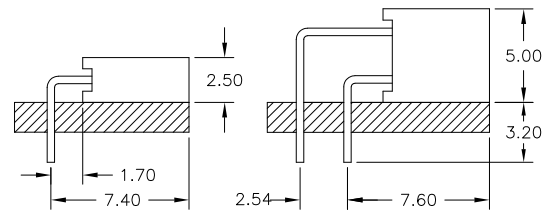
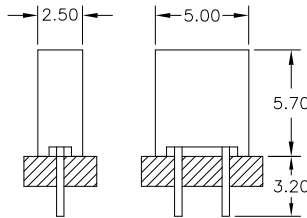
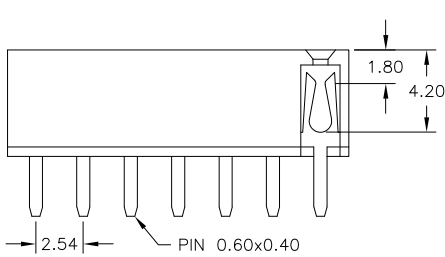
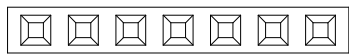
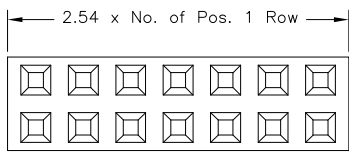
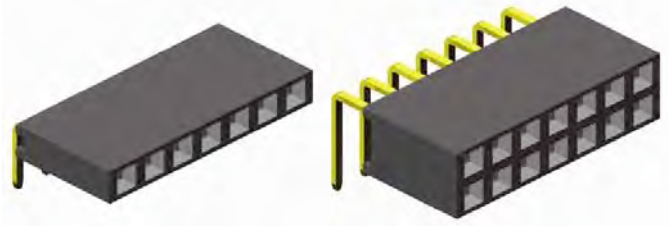
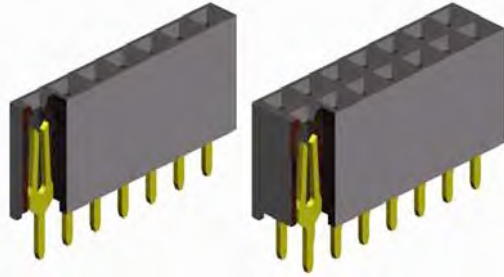

S 570

R 570

SPECIFICATIONS

Current rating	3 A
Insulator resistance	1000 MΩ min.
Contact resistance	20 mΩ max.
Withstanding voltage	500 V AC
Operating temperature	- 40°C to +105°C
Contact material	Brass (RoHS compliant)
Insulator material	P.B.T. UL 94 V-0 (RoHS compliant)

PCB Hole Layout

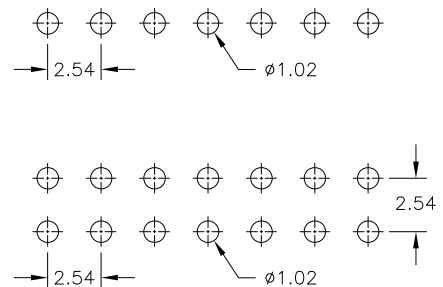

How to order

BL x - xxx - X 570 - 55

Rows	
1	= single row
2	= dual row

Nbr of contacts	
single row	= 002 to 040
dual row	= 004 to 080

Connector style	
S 570	= straight
R 570	= right angle

Plating	
55	= gold
Other platings on request	

2.54mm pitch Female Header

- THT - folded contacts

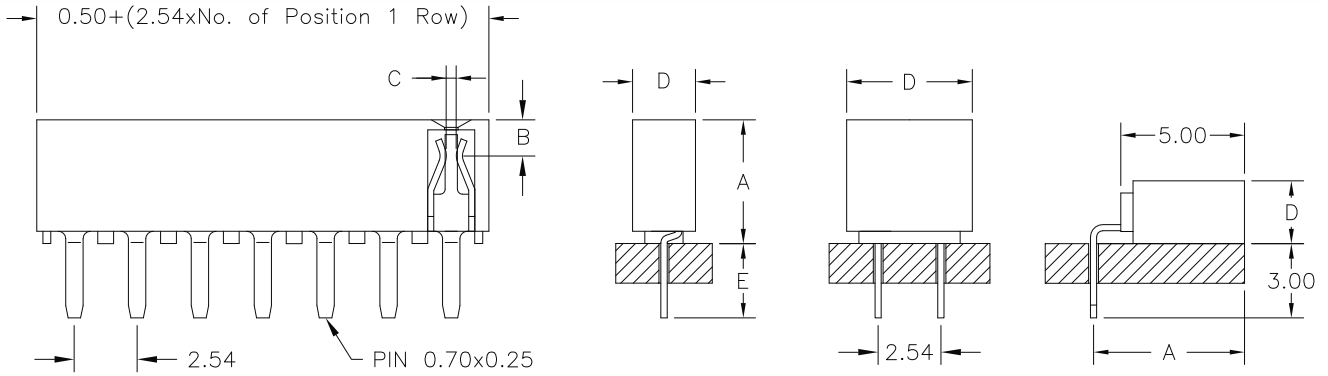
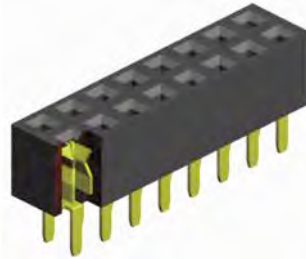
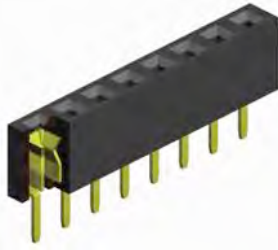

single row

dual row

right angle

PCB Hole Layout

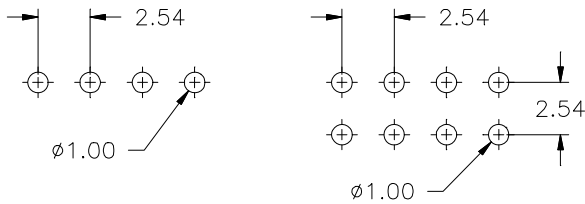

SPECIFICATIONS

Current rating	3 A
Insulator resistance	1000 MΩ min.
Contact resistance	20 mΩ max.
Withstanding voltage	500 V AC
Operating temperature	-40°C to +105°C
Contact material	Phosphor Bronze
Insulator material	P.B.T. UL 94 V-0

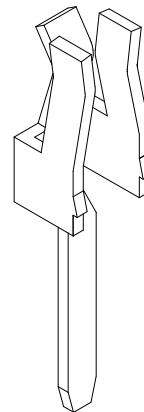

Contact style 1

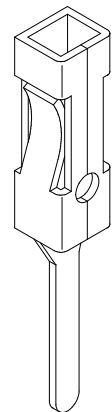

Contact style 2

How to order

BF x - **xxx** - **X** xxx - **55**

Rows	Nbr of contacts	Code	Connector style	Contact style	DIM "A" (mm)	DIM "B" (mm)	DIM "C" (mm)	DIM "D" (mm)	DIM "E" (mm)	Plating
1 = 1 row 2 = 2 rows	002 to 040 (1 row) 004 to 080 (2 rows)	S 500	straight	1	5.00	1.50	0.42	2.50 (1 row) 5.00 (2 rows)	3.20	55 = gold Other platings on request
1 = 1 row	002 to 040 (1 row)	R 500	R/A	1	6.10	1.50	0.42	2.50 (1 row)		
1 = 1 row 2 = 2 rows	002 to 030 (1 row) 004 to 060 (2 rows)	S 680	straight	2	6.80	3.50	0.50	3.50 (1 row) 5.80 (2 rows)	3.50	
1 = 1 row 2 = 2 rows	002 to 040 (1 row) 004 to 080 (2 rows)	S 710	straight	1	7.10	1.50	0.22	2.50 (1 row) 5.00 (2 rows)	3.20	
1 = 1 row	002 to 040 (1 row)	S 850	straight	1	8.50	1.50	0.22	3.00 (1 row)	3.20	
2 = 2 rows	004 to 080 (2 rows)							5.50 (2 rows)		

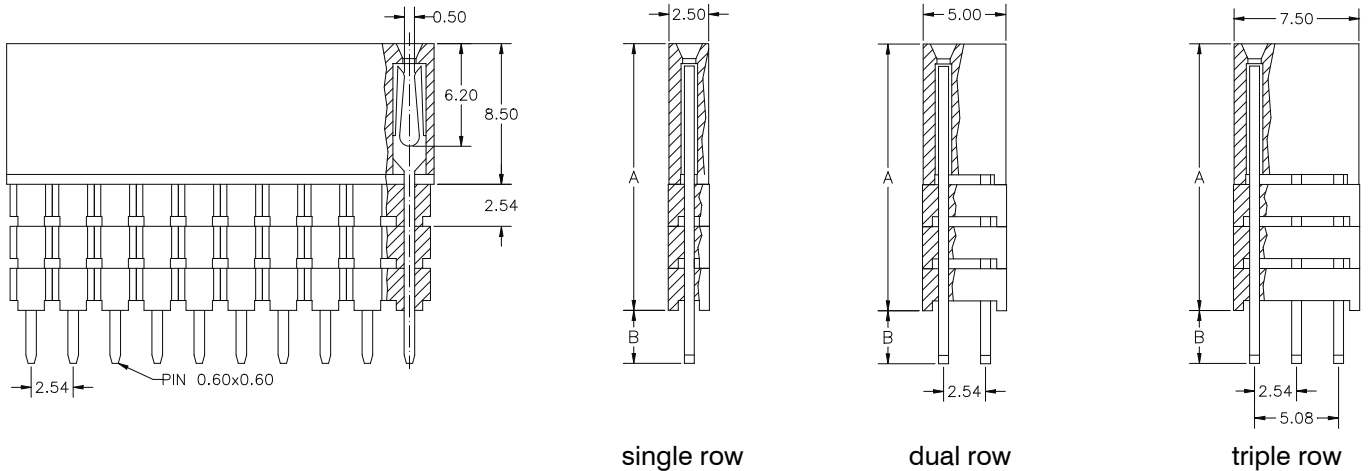
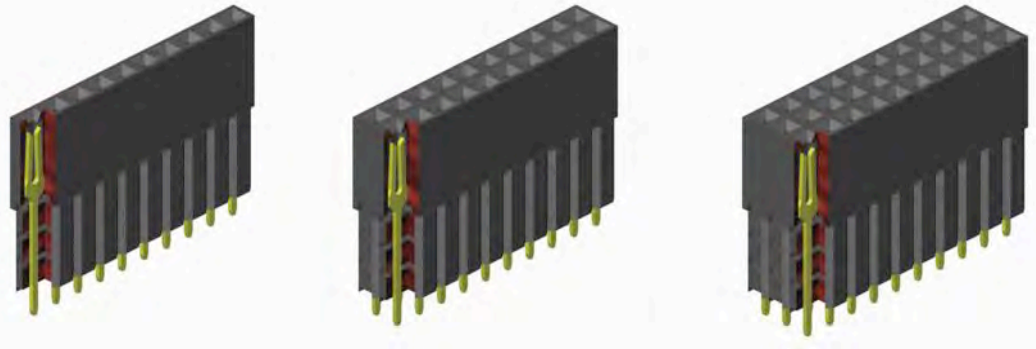

single row

dual row

triple row

APPLICATION AND FEATURES

- Various heights for board-to-board connections
- Ideal solution for PC/104-Plus Systems
- Accepts 0.64mm square pins
- Hi-rel fork contact design

PCB Hole Layout

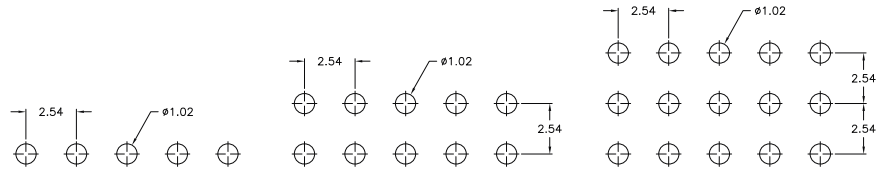

SPECIFICATIONS

Current rating	3 A	Operating temperature	- 40°C to +105°C
Insulator resistance	1000 MΩ min.	Contact material	Phosphor Bronze
Contact resistance	20 mΩ max.	Insulator material	P.B.T. UL 94 V-0
Withstanding voltage	500 V AC		

How to order

BE x - xxx - S xxx - 55

Rows	Nbr of contacts	Version	DIM "A" (mm / inch)	DIM "B" (mm / inch)	Plating
1 = single row	single row = 002 to 040	111	11.05 / .435	2.30 / .091	55 = gold
2 = dual row	dual row = 004 to 080	112	11.05 / .435	7.35 / .289	
3 = triple row	triple row = 006 to 120	113	11.05 / .435	12.20 / .480	Other platings on request
		131	13.59 / .535	4.85 / .191	
		132	13.59 / .535	9.65 / .380	
		161	16.13 / .635	2.30 / .091	
		162	16.13 / .635	7.10 / .280	
		181	18.67 / .735	4.60 / .181	
		Other dimensions on request			

2.54mm pitch Female Header
 - THT - dual entry type 8.50mm profile

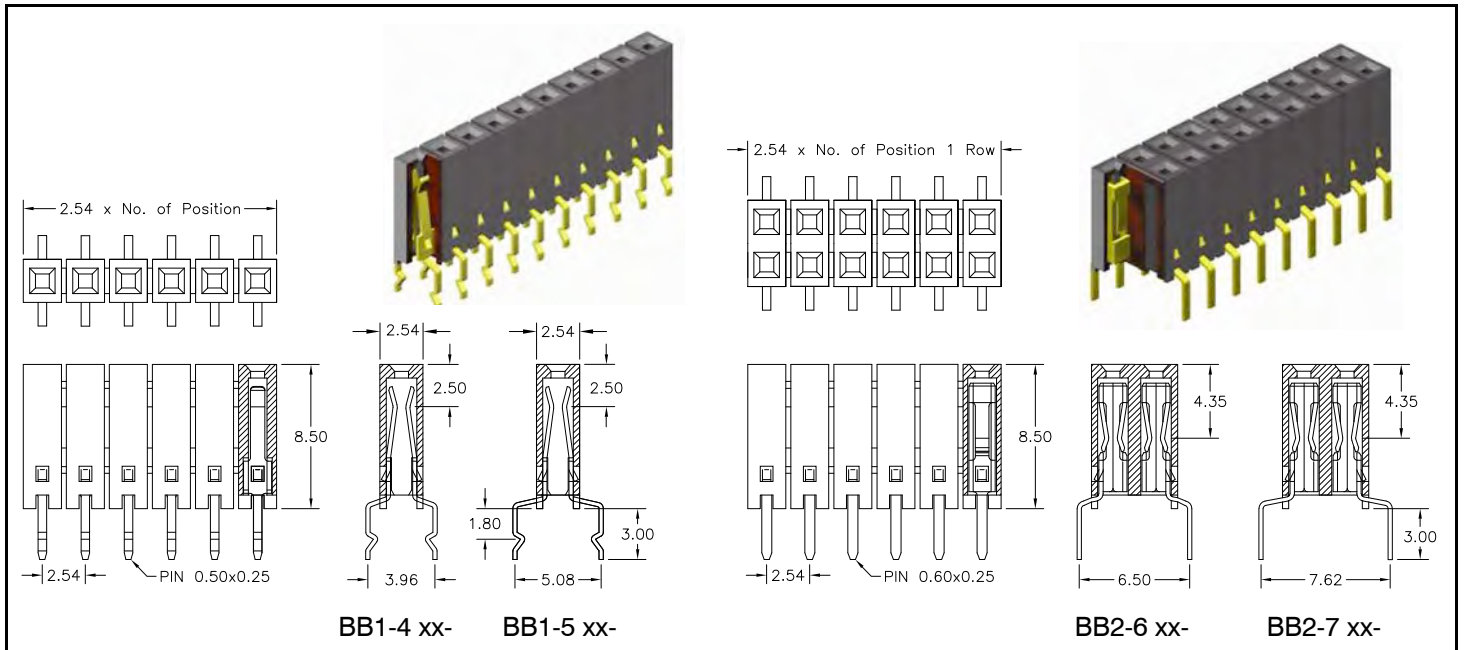

PCB Hole Layout

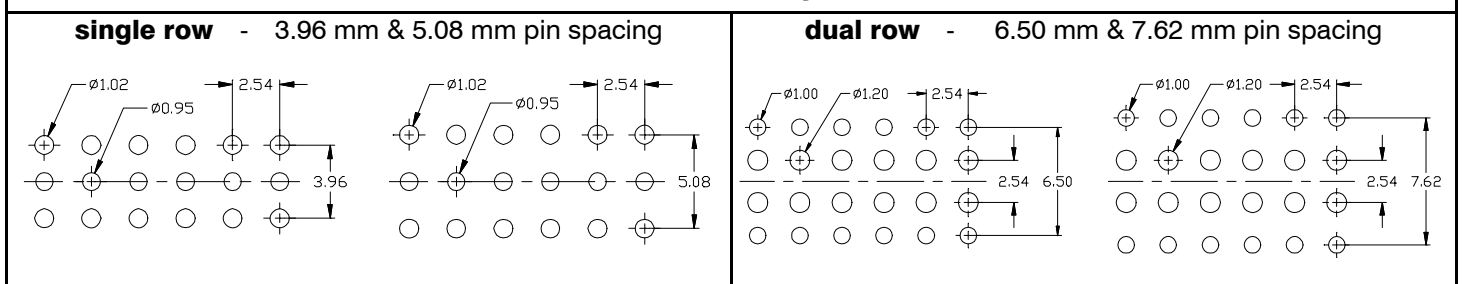

APPLICATION AND FEATURES

- Hi-rel dual beam contact assures reliable PCB connections
- Dual entry design for board stacking
- Accepts 0.64mm square pins
- Stand-off's facilitate post solder cleaning

SPECIFICATIONS

Current rating	3 A
Insulator resistance	1000 MΩ min.
Contact resistance	20 mΩ max.
Withstanding voltage	500 V AC
Operating temperature	- 40°C to +105°C
Contact material (RoHS compliant)	Phosphor Bronze
Insulator material (RoHS compliant)	LCP UL 94 V-0

How to order

BB **x** - **x** **xx** - B850 - **55**

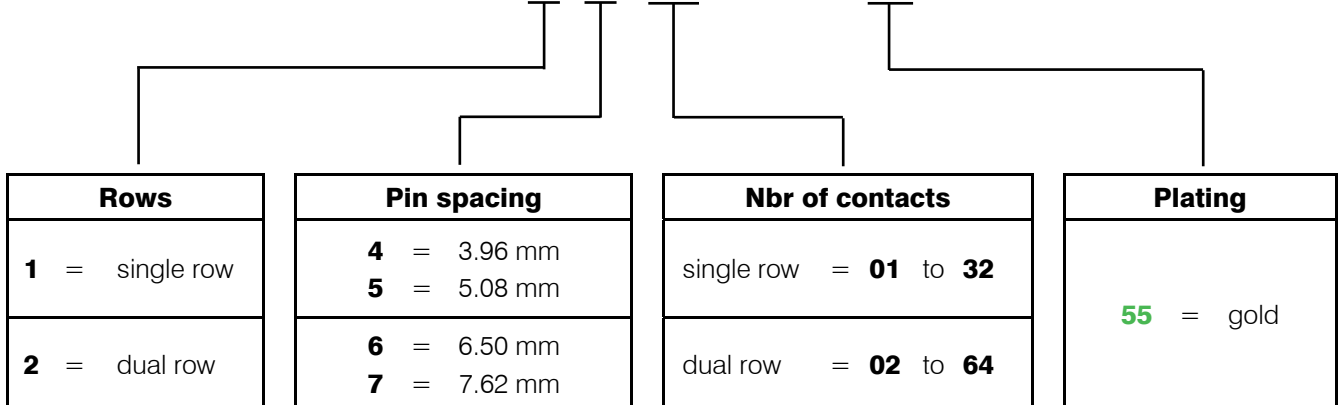

2.54mm pitch Female Header
 - THT - dual entry type low profile

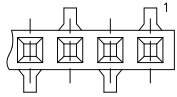
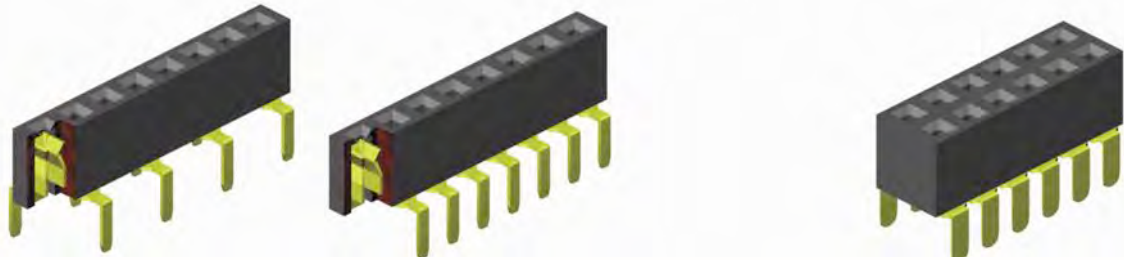

S501 style

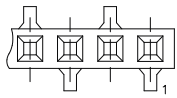

S500 style

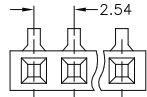

S500 style

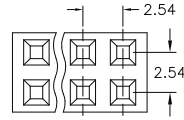

S500 style

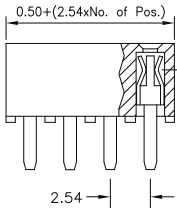

BB1-5xx-

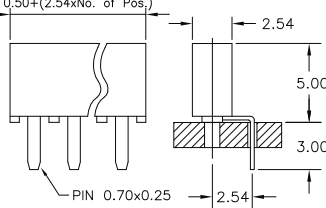

BB1-1xx-

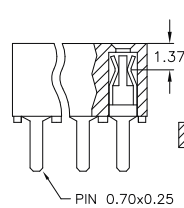

BB2-3xx-

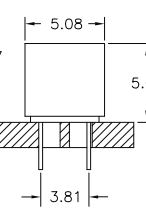

BB2-5xx-

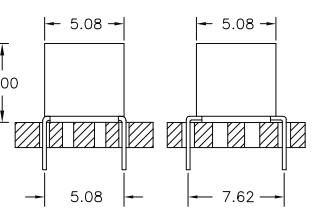

BB2-7xx-

PCB Hole Layout

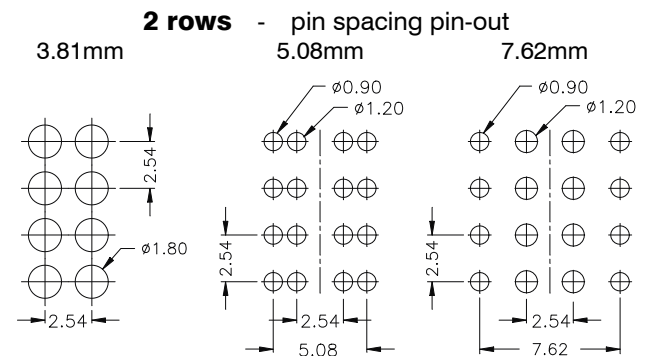
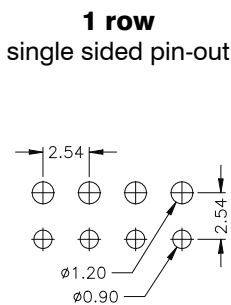
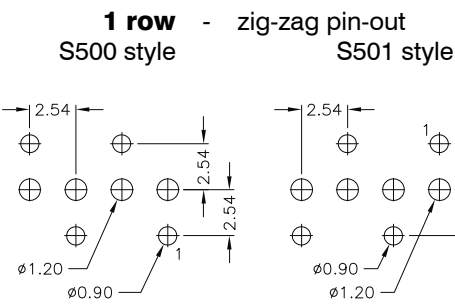

APPLICATION AND FEATURES

- Hi-rel dual beam contact assures reliable PCB connections
- Dual entry design for board stacking
- Accepts 0.64mm square pins
- Stand-off's facilitate post solder cleaning

SPECIFICATIONS

Current rating	3 A
Insulator resistance	1000 MΩ min.
Contact resistance	20 mΩ max.
Withstanding voltage	500 V AC
Operating temperature	- 40°C to +105°C
Contact material (RoHS compliant)	Phosphor Bronze
Insulator material (RoHS compliant)	P.B.T. UL 94 V-0

How to order

BB x - x xx - S xxx - 55

Rows	Pin spacing	Nbr of contacts	Foot Style	Plating
1 = single row	1 = single side only 5 = 5.08mm zig-zag	<i>single row</i> 02 to 40	<i>single row</i> 500 & 501 Pls. choose 500 style if odd pin count.	55 = gold
2 = dual row	3 = 3.81 mm 5 = 5.08 mm 7 = 7.62 mm	<i>dual row</i> 04 to 80	<i>dual row</i> 500	

2.54mm pitch Female Header
 - THT - for "Box Header" mating

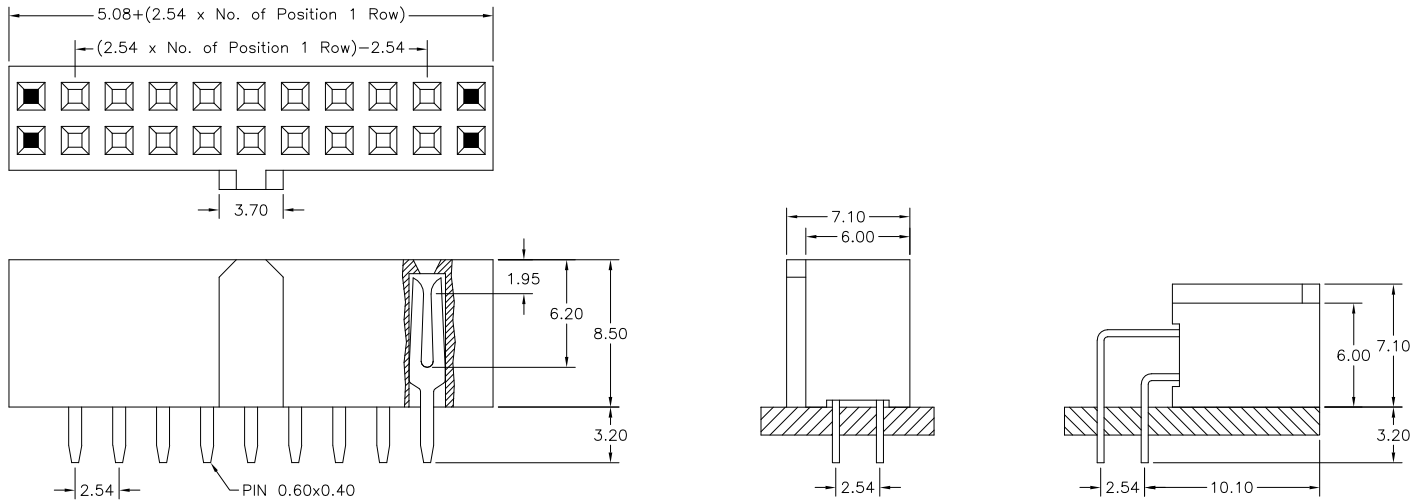

APPLICATION AND FEATURES

Mating with box (shrouded) header 2.54mm pitch

SLS-xxx-S920-xx, SLS-xxx-R920-xx, SLS-xxx-Dxxx-xx & SLS-xxx-H885-xx/X

Standard with polarization bump.

SPECIFICATIONS

Current rating	3 A
Insulator resistance	1000 MΩ min.
Contact resistance	20 mΩ max.
Withstanding voltage	500 V AC
Operating temperature	- 40°C to + 105°C
Contact material (RoHS compliant)	Brass
Insulator Material (RoHS compliant)	P.B.T. UL 94 V-0

PCB Hole Layout

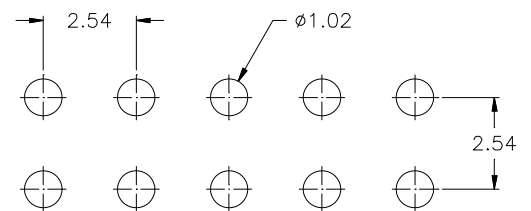

How to order

BW 2 - xxx - X 850 - 55 / P

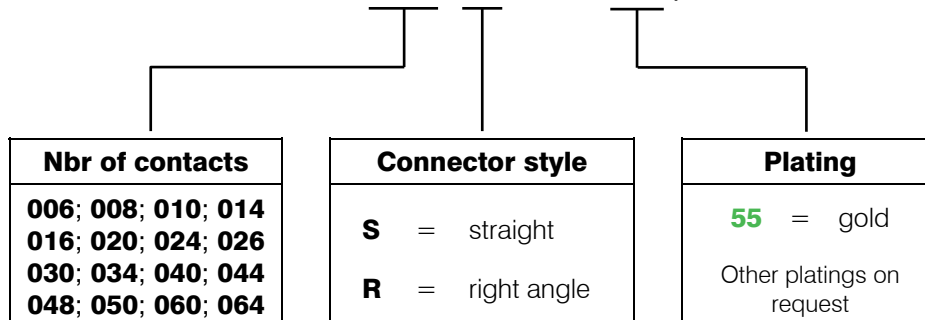

2.54mm pitch Female Header

- THT - side entry type

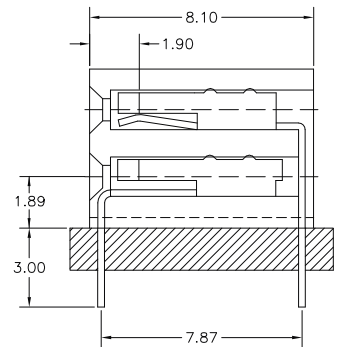
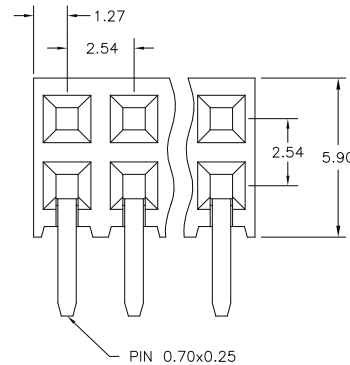
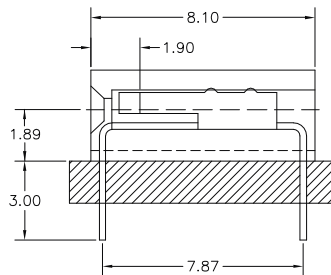
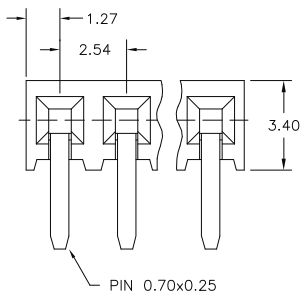
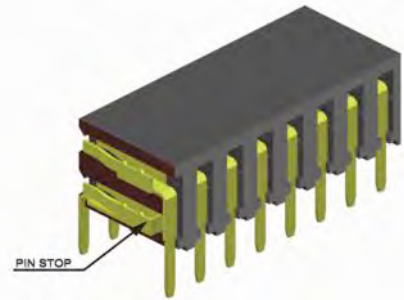
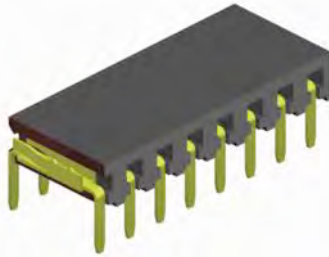

APPLICATION AND FEATURES

- Hi-rel dual beam contact assures reliable PC-board connections
- Accepts 0.64mm square pins
- Stand-off's facilitate post solder cleaning
- 3.40mm and 5.90mm height above board

PCB Hole Layout

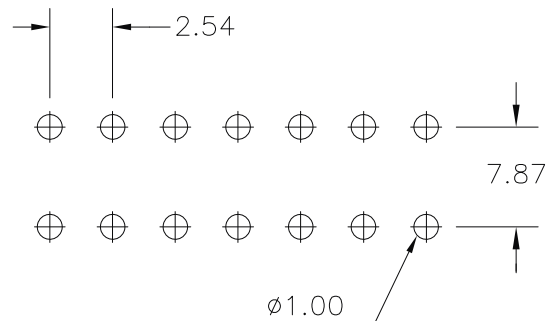

SPECIFICATIONS

Current rating	3 A
Insulator resistance	1000 MΩ min.
Contact resistance	20 mΩ max.
Withstanding voltage	500 V AC

Operating temperature	- 40°C to + 105°C
Contact material	(RoHS compliant) Phosphor Bronze
Insulator material	(RoHS compliant) P.B.T. UL 94 V-0

How to order

BH x - xxx - R850 - 55

Rows	
1	= single row
2	= dual row

Nbr of contacts	
single row	= 003 to 040
dual row	= 004 to 080

Plating	
55	= gold
Other platings on request	

2.54mm pitch Female Header - SMT - Top & Bottom Entry 7.50mm & 5.00mm profile

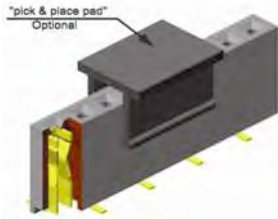

Version and Foot style

500 & 750

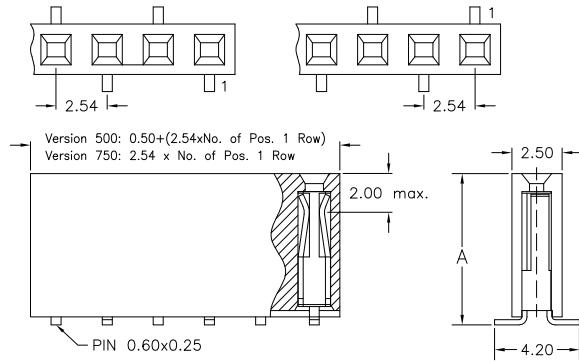

Version 500 & 750

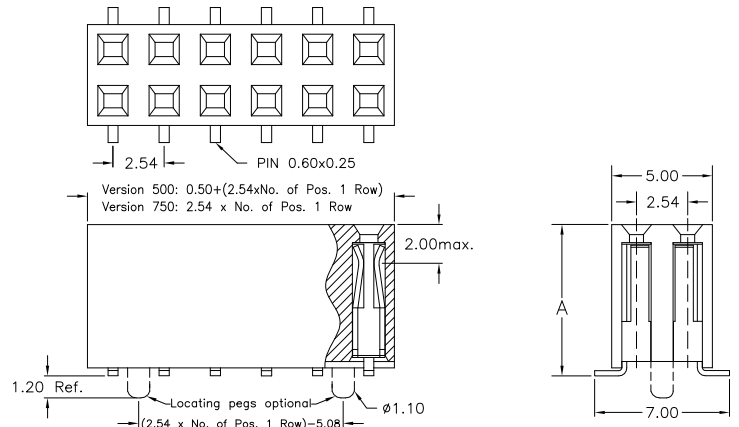

APPLICATION AND FEATURES

- **Standard: tube packing and without "pick & place pad"**
- 5.00mm & 7.50mm height above board. Hi-rel dual beam contacts.
- Mating with 2.54mm pitch, 0.64mm sq. or round pin headers.

PCB Surface Mount & Hole Layout

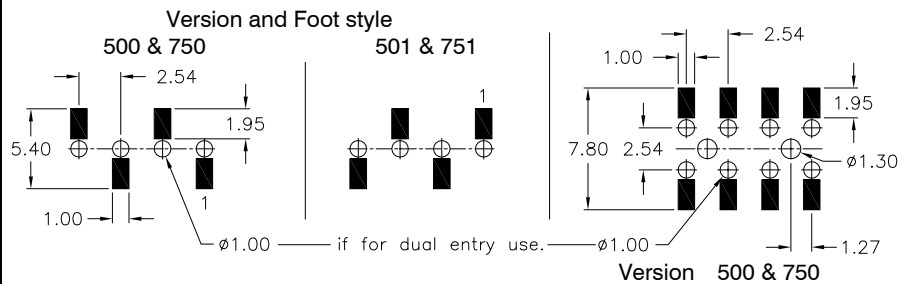

SPECIFICATIONS

Current rating	3 A	Operating temperature	-40° C to +105° C
Insulator resistance	1000 MΩ min.	Processing temperature	+250° C ±0/-5° C for 10sec.
Contact resistance	20 mΩ max.	Contact material	Phosphor Bronze
Withstanding voltage	500 V AC	Insulator material	Nylon UL 94 V-0

How to order

BS x - xxx - H xxx - 55 / X

Rows	Nbr of contacts	Version & Foot style	Plating	Packing and "pick & place pad" Option
1 single row	002 to 040	500 DIM "A" = 5.00 mm 501 (optional foot layout) 750 DIM "A" = 7.50 mm 751 (optional foot layout) Pls. choose 500 or 750 style if odd pin count	55 = gold	A = tube packing; with pick & place pad B = reel packing; with pick & place pad
2 dual row	004 to 080	500 DIM "A" = 5.00 mm 750 DIM "A" = 7.50 mm	Other platings on request	without "locating pegs" A = tube packing; with pick & place pad B = reel packing; with pick & place pad with "locating pegs" C = tube packing; without pick & place pad D = tube packing; with pick & place pad E = reel packing; with pick & place pad

2.54mm pitch Female Header - SMT -
Top & Bottom Entry 3.65mm profile

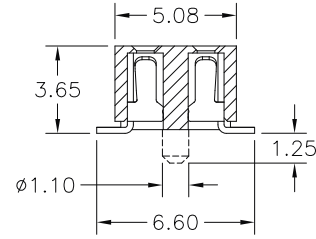
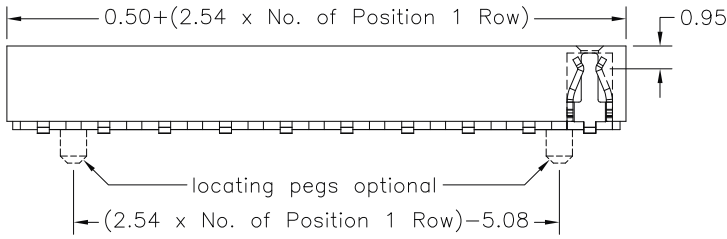
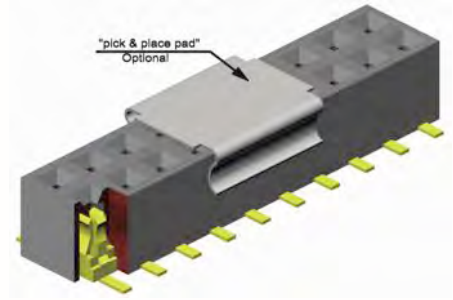
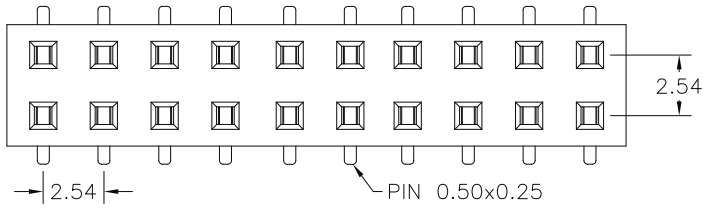

APPLICATION AND FEATURES

- **Standard:**
tube packing and without "pick & place pad"
- 3.65mm height above board.
- Hi-rel dual beam contacts
- Designed for board to board small spacing interconnection
- Mating with 2.54mm pitch, 0.64mm square pin headers

PCB Surface Mount & Hole Layout

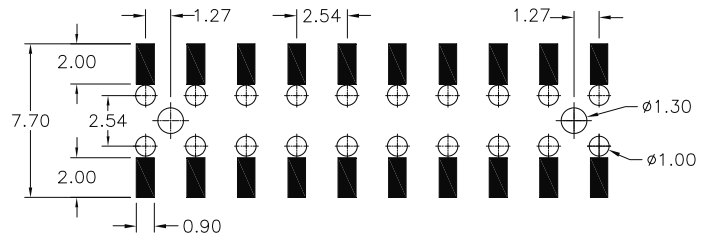

SPECIFICATIONS

Current rating	3 A
Insulator resistance	1000 MΩ min.
Contact resistance	20 mΩ max.
Withstanding voltage	500 V AC

Operating temperature	- 40°C to +105°C
Processing temperature	+250°C +0/-5°C for 10sec.
Contact material	(RoHS compliant) Phosphor Bronze
Insulator material	(RoHS compliant) Nylon UL 94 V-0

How to order

BS2 - xxx - TB 365 - 55 / X

Nbr of contacts

004 to 080

Plating

55 = gold

Other platings on request

Packing and "pick & place pad" Option

without "locating pegs"

- A** = tube packing; with pick & place pad
- B** = reel packing; with pick & place pad

with "locating pegs" (available only from 006 to 080 contacts)

- C** = tube packing; without pick & place pad
- D** = tube packing; with pick & place pad
- E** = reel packing; with pick & place pad

When using this female connector as a bottom entry connector, we recommend that the pinheader pins protrude by around 2.00mm above the surface of the female connector after assembly. This will avoid any risk of separation of the pinheader from the female header during shock and vibration.

2.54mm pitch Female Header
 - SMT - side entry single & dual row

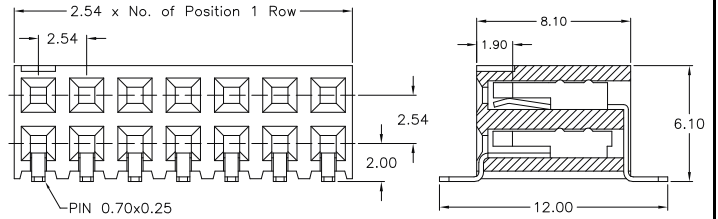
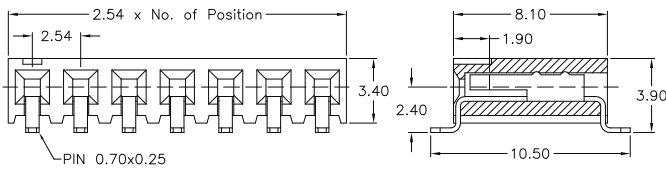

PCB Surface Mount Layout -single row-

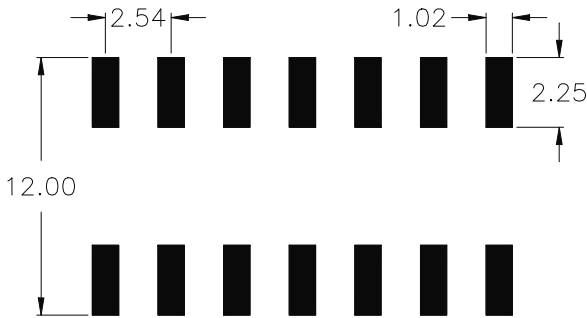

PCB Surface Mount Layout -dual row-

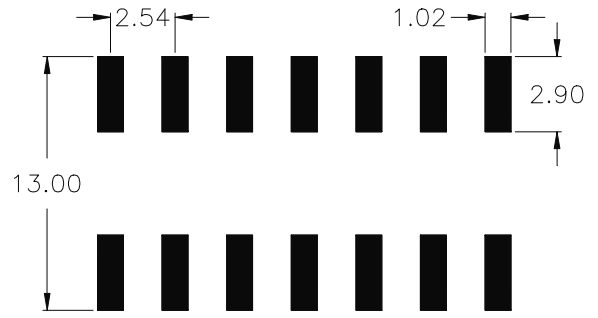

APPLICATION AND FEATURES

- **Standard: tube packing**
- Hi-rel dual beam contact assures reliable PC-board connections
- Accepts 0.64mm square pins
- Stand-off's facilitate post solder cleaning
- Lowest possible profile
- Automatic assembly to PCB possible

SPECIFICATIONS

Current rating	3 A
Insulator resistance	1000 MΩ min.
Contact resistance	20 mΩ max.
Withstanding voltage	500 V AC

Operating temperature	- 40°C to +105°C
Processing temperature	+250°C +0/-5°C for 10sec.
Contact material (RoHS compliant)	Phosphor Bronze
Insulator material (RoHS compliant)	Nylon UL 94 V-0

How to order

BS x - xxx - R390 - 55 / X

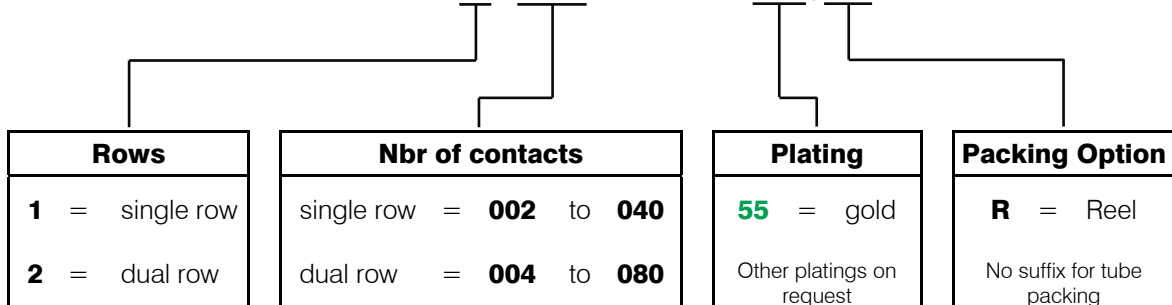

2.54mm pitch

IDC – Female Connector

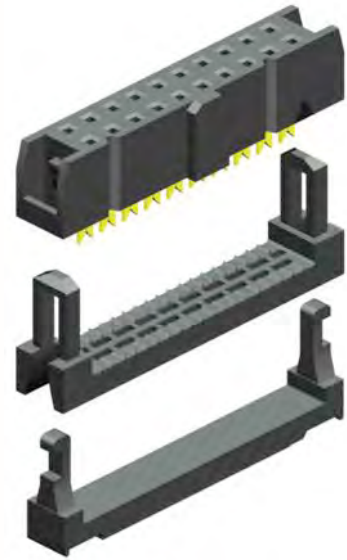
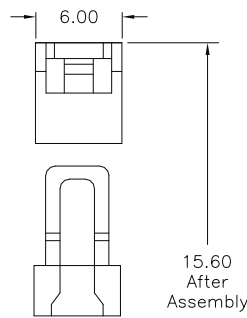
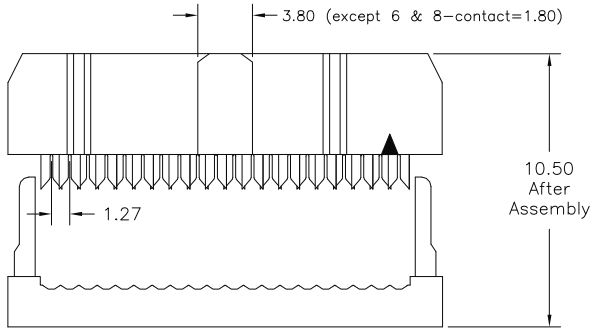
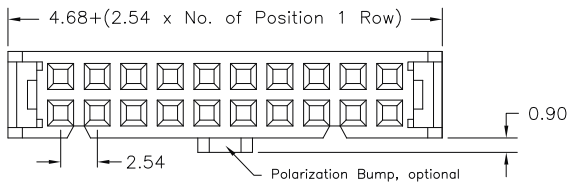

SPECIFICATIONS

Current rating	1 A	Operating temperature	- 40°C to +105°C
Insulator resistance	1000 MΩ min.	Contact material (RoHS compliant)	Brass
Contact resistance	30 mΩ max.	Plating	Nickel; Gold on mating area
Withstanding voltage	500 V AC	Insulator material (RoHS compliant)	P.B.T. black UL 94 V-0 (grey colour on request)

APPLICATION AND FEATURES

Designed to mate with 0.64mm square pins box (shrouded) header

High Quality contacts

Accepts 1.27mm pitch flat ribbon cable AWG 28 (0.20mm) or AWG 30 (0.17mm).

How to order

IDS - xxx - X 100 - N5 (/ P)

Nbr of contacts
006; 008; 010; 012
014; 016; 018; 020
024; 026; 030; 034
036; 040; 050; 060
064

Strain relief
S = With
W = Without

Option
P
if Polarization bump is requested

2.54mm pitch

DIN Header (DIN 41651)

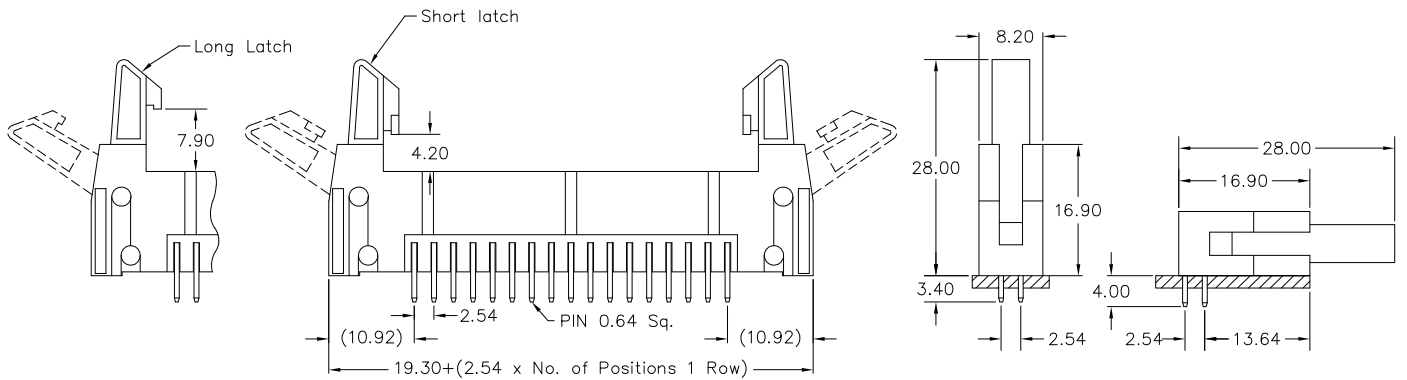

APPLICATION AND FEATURES

Provides fast connection / disconnection of IDC connectors.

Assures reliable flat cable to PC - board assembly.

Optional latching features available.

SPECIFICATIONS

Current rating	3 A	Operating temperature	- 40°C to +105°C
Insulator resistance	1000 MΩ min.	Contact material <i>(RoHS compliant)</i>	Brass
Withstanding voltage	500 V AC	Insulator material <i>(RoHS compliant)</i>	P.B.T. UL 94 V-0 black colour

How to order

DH X - xxx - X 100 - 55

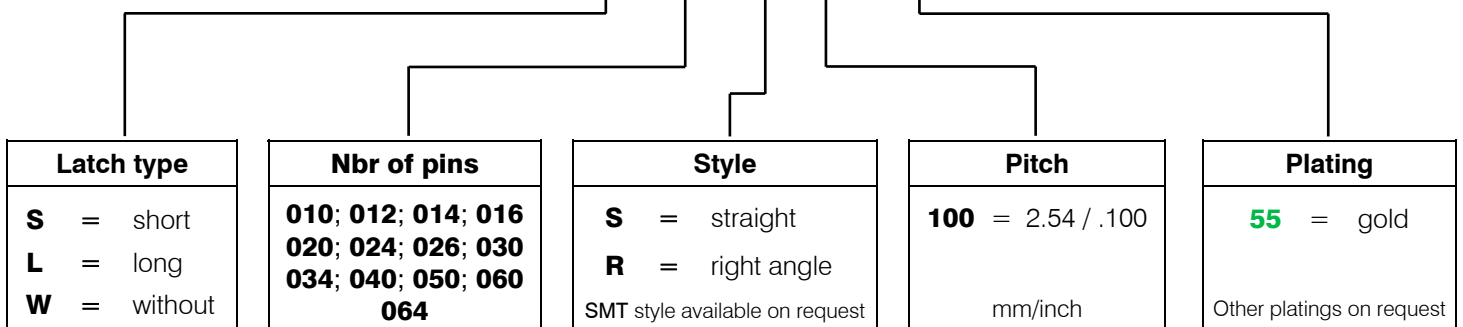

2.54mm pitch

IDC Shrouded Header

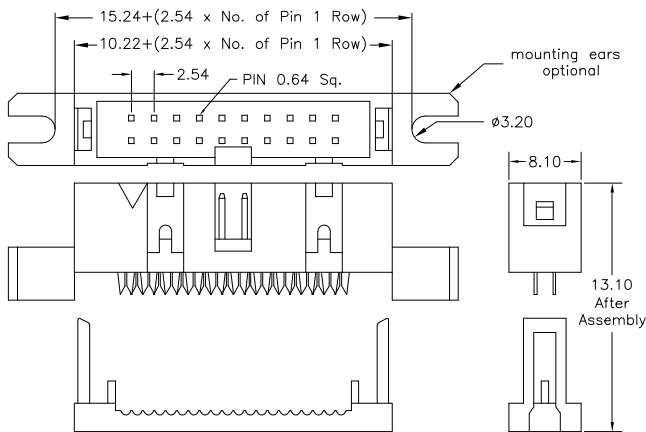
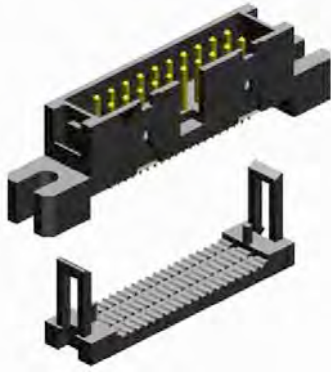

IDH Type

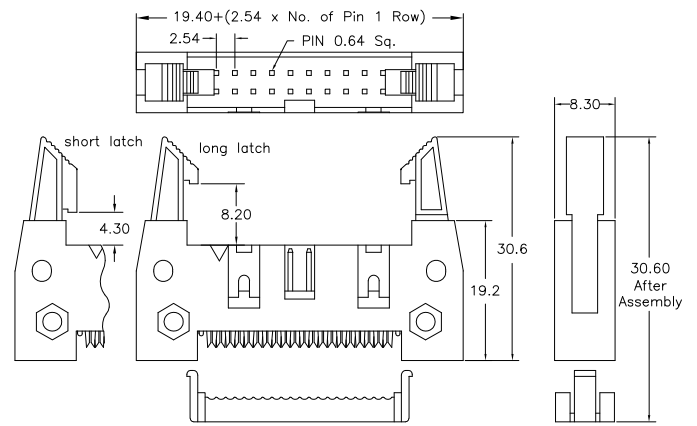

IDD Type

SPECIFICATIONS

Current rating	3 A	Operating temperature	- 40°C to +105°C
Insulator resistance	1000 MΩ min.	Contact material	(RoHS compliant) Phosphor bronze
Withstanding voltage	500 V AC	Insulator material	(RoHS compliant) P.B.T. gray UL 94 V-0

APPLICATION AND FEATURES

Designed to mate with 2.54mm IDC female headers.
 Header type is available with or without mounting ears.
 DIN Header type is available with long & short eject latches.
 Standard Insulator colour gray, other colours on request

How to order

ID X - xxx - X 100 - 95

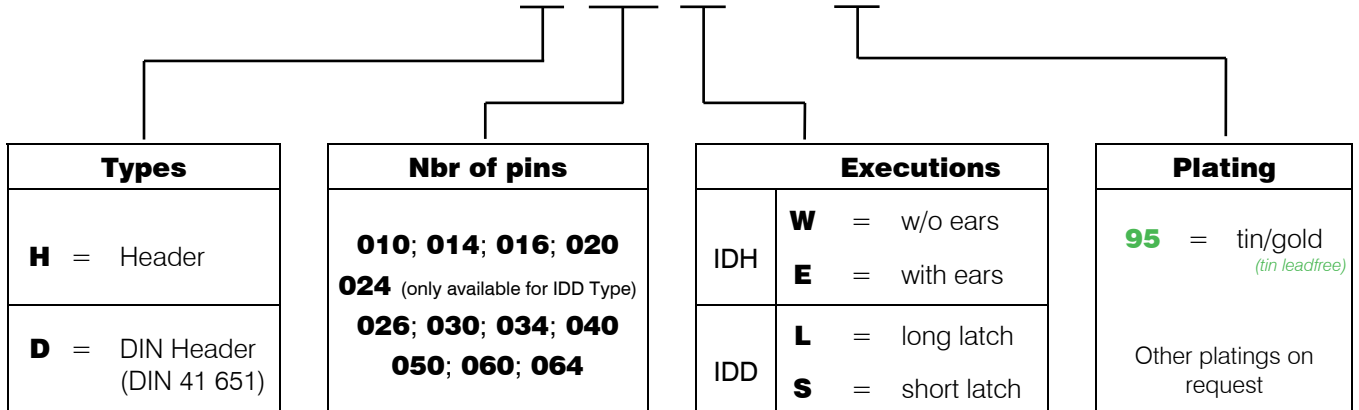

Mini – Jumpers

1.27mm, 2.00mm, 2.54mm & 5.08mm



1.27mm & 2.00mm		Mini - Jumpers	
<p>JPC – type - top closed -</p> <p>Order Code: JPC – 127 – BL – 55</p>	<p>JPE – type - top open -</p> <p>Order Code: JPE – 200 – BL – 55 Other colours: RD, BU, YL</p>	<p>JPC – type - top closed -</p> <p>Order Code: JPC – 200 – BL – 55</p>	<p>JPH – type - with handle -</p> <p>Order Code: JPH – 200 – BL – 55 Other colours: RD, BU, YL & WH</p>

2.54mm & 5.08mm		Mini - Jumpers	
<p>JPE – type top open - commercial type -</p> <p>Order Code: JPE – 254 – BL – 55 Other colours: GR, RD, BU, YL & WH</p>	<p>JPC – type top closed</p> <p>Order Code: JPC – 254 – BL – 55 Other colours: GR, RD, BU, YL & WH</p>	<p>JPH – type with handle</p> <p>Order Code: JPH – 254 – BL – 55 Other colours: GR, RD, BU, YL & WH</p>	<p>JPC – type top closed</p> <p>Order Code: JPC – 508 – BL – 55</p>

2.00mm Multi - Jumper	2.54mm Multi - Jumper
<p>Order Code: JPM – xx – 200 – BL – 55 No. of Jumper : 02 to 11</p>	<p>Order Code: JPM – xx – 254 – BL – 55 No. of Jumper : 02 to 10</p>

Non Insulated Wire Shorting Links			
<p>JPW – type 254</p> <p>Order Code: JPW – 254 – 55</p>	<p>JPW – type 508</p> <p>Order Code: JPW – 508 – 55</p>	<p>JPW – type 762</p> <p>Order Code: JPW – 762 – 55</p>	<p>JPW – type 102</p> <p>Order Code: JPW – 102 – 55</p>

Specifications	
<p>Max. current rating</p> <p>1.27 & 2.00mm pitch : 1 A</p> <p>2.54 & 5.08mm pitch : 3 A</p> <p>Insulator resistance 1000 MΩ min.</p> <p>Contact resistance 20 mΩ max.</p> <p>Withstanding voltage 500 V AC</p> <p>Operating temperature - 40°C to +105°C</p>	<p>Contact material JPC, JPE, JPH & JPM: Phosphor Bronze JPW: Brass; Ø 0.51 +0.25/-0.00</p> <p>Plating Jumper & Wire Shorting Links Au plated</p> <p>Insulator material P.B.T. UL 94 V-0 (RoHS compliant)</p> <p>Colour attributes BL = black for Jumpers <i>Standard</i> RD = red BU = blue GR = green WH = white YL = yellow <i>Other colours on request</i></p>

IDC – DIP Plug 2.00mm x 2.00mm

IDC pitch 1.00mm

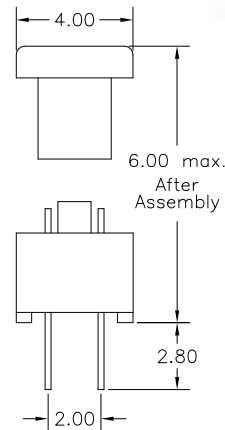
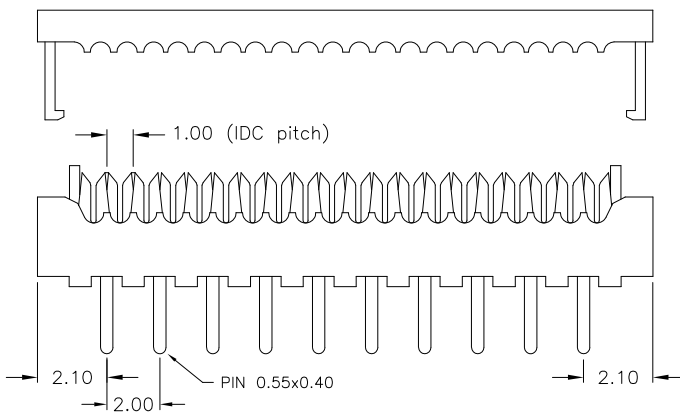

APPLICATION AND FEATURES

- A perfect solution for attaching a 1.00mm pitch flat ribbon cable to a PC-board
- Low-profile, only 6.00mm above board
- Designed for plug into socket or direct soldering to a PC-board

PCB Hole Layout

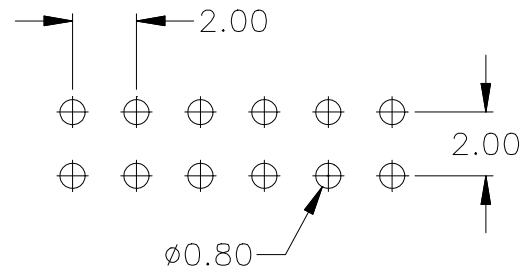

SPECIFICATIONS

Current rating	1 A
Insulator resistance	1000 M Ω min.
Contact resistance	20 m Ω max.
Withstanding voltage	500 V AC

Operating temperature	- 40°C to +105°C
Contact material (RoHS compliant)	Phosphor Bronze
Insulator material (RoHS compliant)	P.B.T. UL 94 V-0

How to order

IDP - xxx - S 200 - N5

Nbr of contacts
<p>006; 008; 010; 012; 014 016; 020; 022; 024; 026 030; 034; 040; 044; 050 060; 068</p>

Plating
<p>N5</p> <p>Ni on IDC area / Au on solder tail</p>

IDC – DIP Plugs 2.54mm

IDC pitch 1.27mm

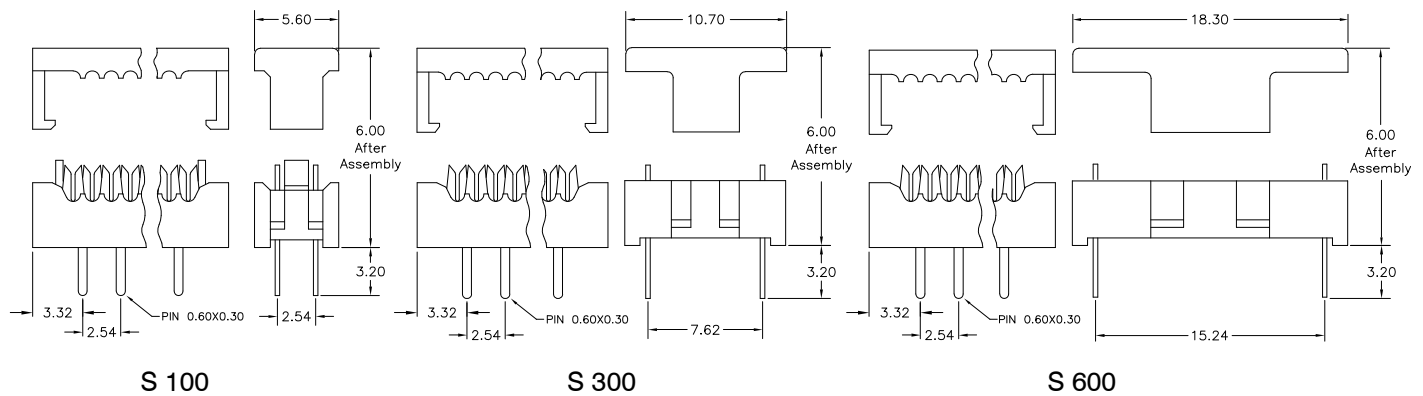
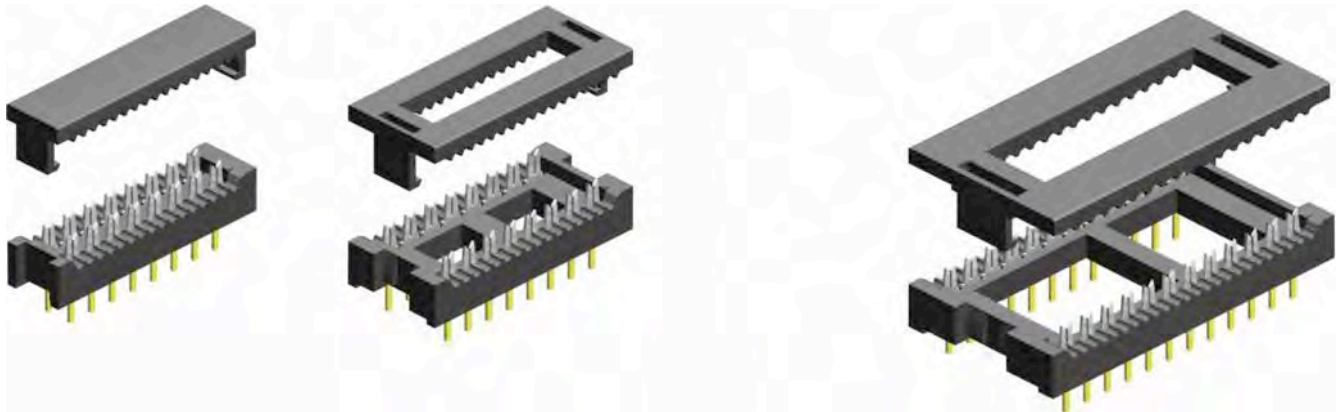

APPLICATION AND FEATURES

- A perfect solution for attaching a 1.27mm flat ribbon cable to a PC-board
- Low-profile, only 6.00mm above board
- Designed for direct soldering to a PC-board

PCB Hole Layout

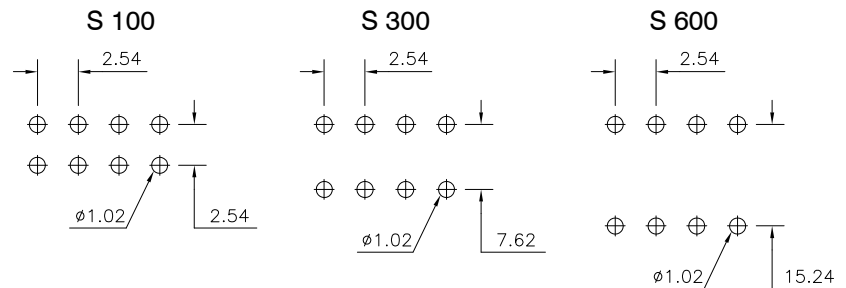

SPECIFICATIONS

Current rating	1 A	Operating temperature	- 40°C to +105°C
Insulator resistance	1000 MΩ min.	Contact material	(RoHS compliant) Phosphor Bronze
Contact resistance	30 mΩ max.	Insulator material	(RoHS compliant) P.B.T. UL 94 V-0
Withstanding voltage	500 V AC		

How to order

IDP - xxx - S xxx - **N5**

Nbr of contacts			DIP Plug style		Plating
S 100 Style	S 300 Style	S 600 Style	Code	Pitch (mm/inch)	
006; 008; 010; 012 014; 016; 020; 024 026; 030; 034; 040 050; 060; 064	008; 010; 014 016; 018; 020 024; 026; 028 034; 040	010; 014; 016 018; 020; 024 026; 028; 032 034; 036; 040	S 100	2.54 / .100	N5 Ni on IDC area/Au on solder tail
			S 300	7.62 / .300	
			S 600	15.24 / .600	

IDC Transition Connector - THT -

IDC pitch 1.27mm

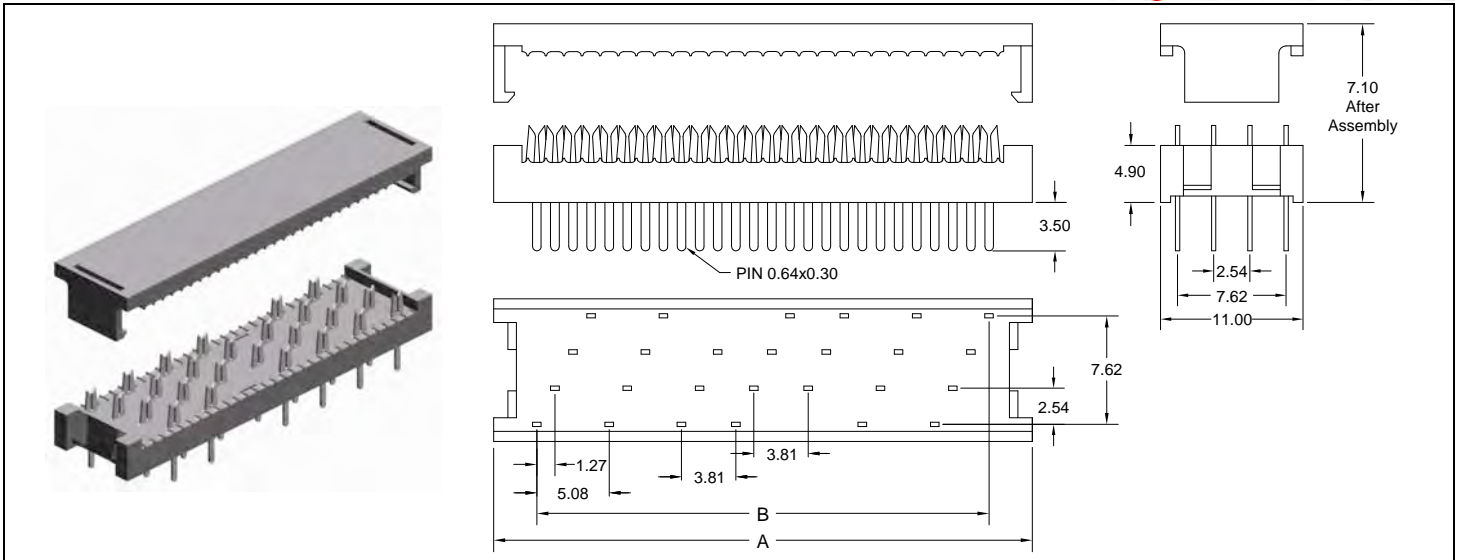

DIMENSIONS (mm/inch)

DIM	10 pos.	16 pos.	20 pos.	26 pos.	34 pos.	40 pos.	50 pos.
A	18.17 / .715	25.79 / 1.015	30.87 / 1.215	38.49 / 1.515	48.65 / 1.915	56.27 / 2.215	68.97 / 2.715
B	11.43 / .450	19.05 / .750	24.13 / .950	31.75 / 1.250	41.91 / 1.650	49.53 / 1.950	62.23 / 2.450

PCB HOLE LAYOUTS

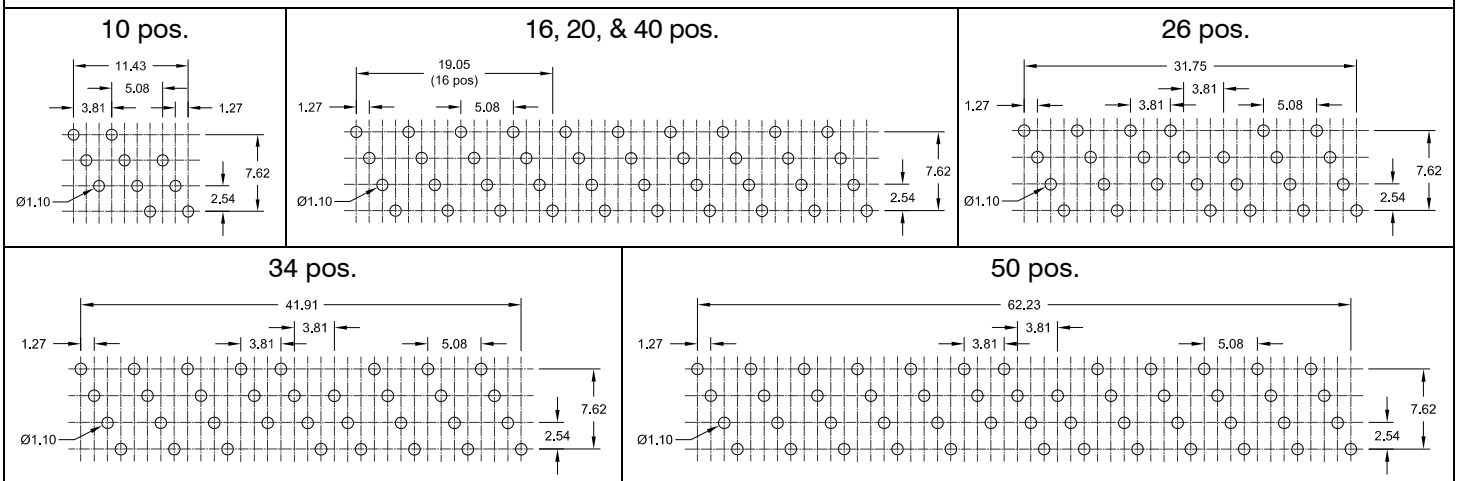

APPLICATION AND FEATURES

Designed for 1.27mm (.050") centre flat ribbon cable.
 Low profile with only 5.80mm above board after assembly.
 Designed for direct soldering to PCB.

SPECIFICATIONS

Current rating	1 A	Operating temperature	- 40°C to +105°C
Insulator resistance	1000 MΩ min.	Contact material (RoHS compliant)	Phosphor Bronze
Contact resistance	30 mΩ max.	Insulator material (RoHS compliant)	P.B.T. UL 94 V-0
Withstanding voltage	500 V AC		

How to order
IDP - xxx - T050 - 99

Nbr of contacts

010; 016; 020; 026
034; 040; 050

Plating

99 = tin (leadfree)
 Other platings on request

PCI Card Edge Connector - THT - 1.27mm pitch



120 pin

Technical drawings for the 120 pin connector. The top view shows a total length of 84.84mm with a 1.27mm pitch. The side view shows a height of 8.89mm. The PCB hole layout shows a 64.77mm wide array of holes with a 1.27mm pitch and a 3.81mm typical spacing between the hole array and the edge. Dimensions include 14.99mm, 63.25mm, 1.78mm, 15.49mm, 3.00mm, 64.77mm, 1.98x2.40mm, 0.60±0.20mm, 1.88mm, 7.62mm, 2.54mm, 1.27mm, 3.81typ., ø1.02±0.08, ø2.44^{+0.05}/_{-0.03}, and Pin 1.

PCI 32bit Order Code: **ECC - 120 - P050 - 95**



184 pin

Technical drawings for the 184 pin connector. The top view shows a total length of 128.02mm with a 1.27mm pitch. The side view shows a height of 8.89mm. The PCB hole layout shows a 64.77mm wide array of holes with a 1.27mm pitch and a 3.81mm typical spacing between the hole array and the edge. Dimensions include 14.99mm, 63.25mm, 41.81mm, 1.78mm, 1.37mm, 15.49mm, 3.00mm, 64.77mm, 1.98x2.40mm, 43.18mm, 1.98x2.40mm, 0.60±0.20mm, 1.88mm, 7.62mm, 2.54mm, 1.27mm, 3.81typ., ø1.02±0.08, ø2.44^{+0.05}/_{-0.03}, and Pin 1.

PCI 64bit 3.3V Order Code: **ECC - 184 - P053 - 95**

184 pin

Technical drawings for the 184 pin connector. The top view shows a total length of 128.02mm with a 1.27mm pitch. The side view shows a height of 8.89mm. The PCB hole layout shows a 64.77mm wide array of holes with a 1.27mm pitch and a 3.81mm typical spacing between the hole array and the edge. Dimensions include 14.99mm, 63.25mm, 41.81mm, 1.78mm, 1.37mm, 15.49mm, 3.00mm, 64.77mm, 1.98x2.40mm, 59.69mm, 1.98x2.40mm, 0.60±0.20mm, 1.88mm, 7.62mm, 2.54mm, 1.27mm, 3.81typ., ø1.02±0.08, ø2.44^{+0.05}/_{-0.03}, and Pin 1.

PCI 64bit 5V Order Code: **ECC - 184 - P055 - 95**

APPLICATION AND FEATURES

1.27mm contact centre pitch.

Hi-rel dual beam contact assures reliable PC Board connections.

Accepts PCB thickness of 1.57mm ±0.18

Recommended Mating Board Dimensions

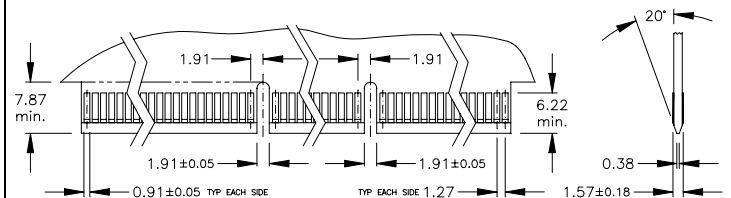

SPECIFICATIONS

Current rating	1 A
Insulation resistance	1000 MΩ min.
Contact resistance	30 mΩ max.
Withstanding voltage	500 V AC rms. 60Hz for 1 Minute
Capacitance	2pF max.
Voltage	250 V AC rms.
Operating temperature	- 55°C to +85°C
Solder temperature	260°C +/-5°C for 10Sec.

Contact material	Copper alloy (RoHS compliant)
Plating	Contact area – Au over Ni Soldertail area – Sn over Ni (tin leadfree)
Insulator material (white colour)	Nylon 66 UL 94 V-0 (RoHS compliant)
Contact retention	460g min. per contact
Insertion force	230g max. per contact pair
Withdrawal force	15g min. per contact pair

Card Edge Connector - THT -

1.27mm pitch

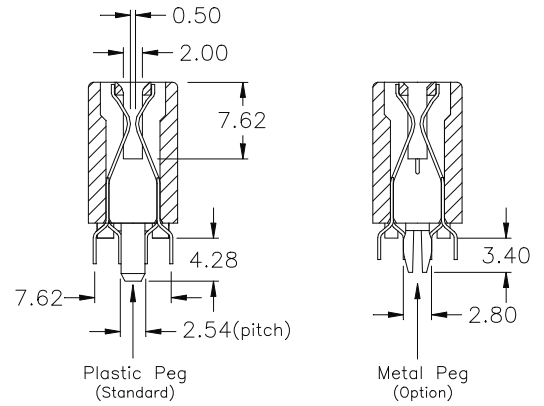
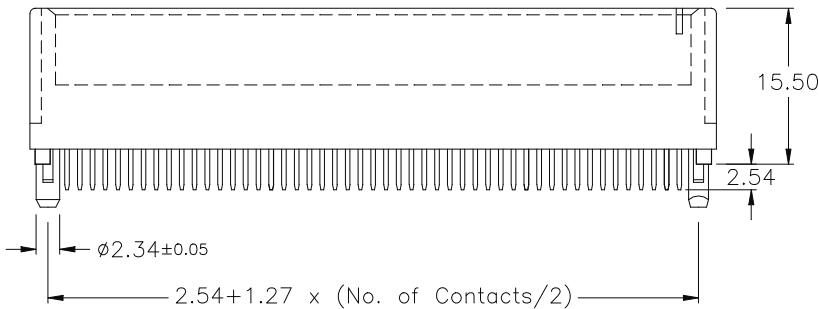
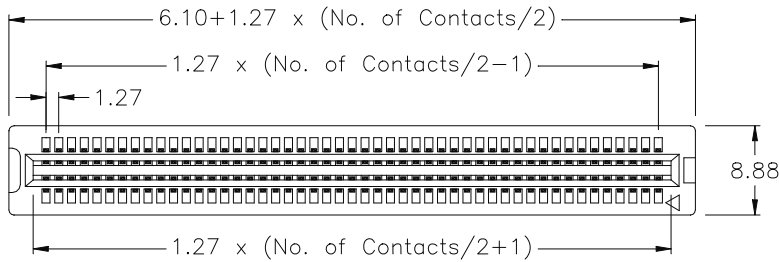

APPLICATION AND FEATURES

Hi-rel dual beam contact assures reliable PC Board connections.
 Accepts PCB thickness of $1.57\text{mm} \pm 0.18$
 1.27mm contact centre pitch.

PCB Hole Layout

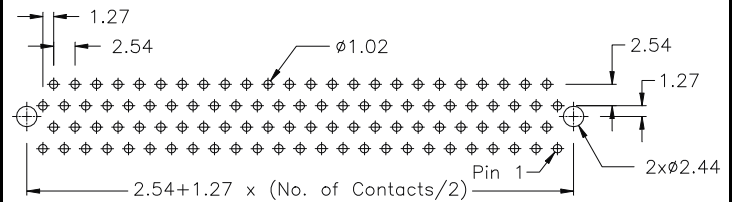

SPECIFICATIONS

Current rating	1 A
Insulation resistance	1000 MΩ min.
Contact resistance	30 mΩ max.
Withstanding voltage	500 V AC
Capacitance	2pF max.
Voltage	250 V

Operating temperature	-55°C to +85°C
Contact material	Copper alloy (RoHS compliant)
Plating	Contact area - Au over Ni Solder tail area - Sn over Ni (tin leadfree)
Insulator material (black colour)	Nylon 66 UL 94 V-0 (RoHS compliant)
Insertion force	230g max. per contact pair
Retention force	460g min. per contact pair

How to order

ECC - xxx - S050 - 95/ X

Nbr of contacts
004; 006; 008; 010; 012; 014; 016; 018; 020
022; 024; 026; 028; 030; 032; 034; 036; 038
040; 042; 044; 046; 048; 050; 052; 054; 056
058; 060; 068; 080; 100; 120; 124; 128
Other contacts on request

Plating
95 = tin/gold (tin leadfree)
Other platings on request

Peg Option
N = metal peg
plastic peg is standard; no Option suffix

Card Edge Connector - THT - 2.54mm pitch "X" Contact Style

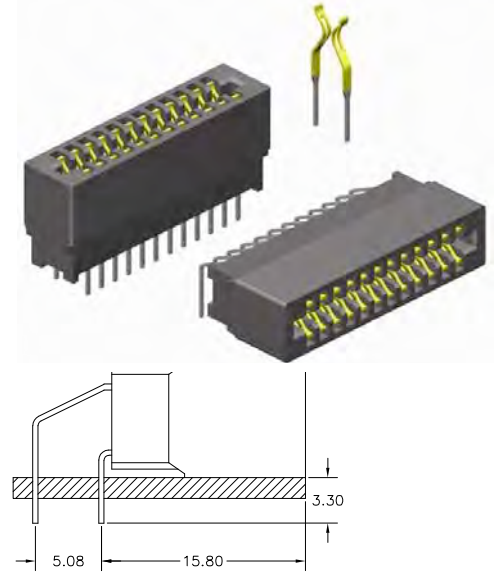
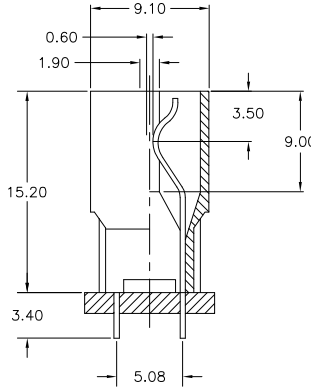
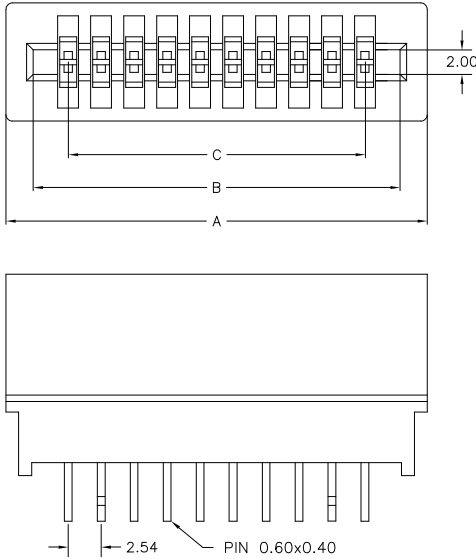

APPLICATION AND FEATURES

Hi-rel dual beam contact assures reliable PC-board connection.
Accepts PC Board thickness of 1.37mm to 1.78mm.
26, 36, 60, 62 and 120 contact type will be delivered with some kinked legs

Connectors with mounting ears or solder eyes are also available.

Please contact your nearest sales office for more details.

"X" Contact Style



PCB Hole Layout

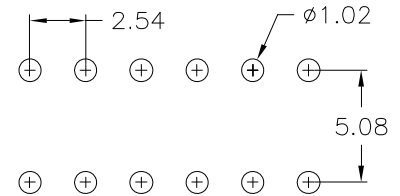

Important:

The PCB Layout is not identical for all pincount's
Individual datasheets are available on request.

SPECIFICATIONS

Current rating 3 A
Insulator resistance 1000 MΩ min.
Contact resistance 20 mΩ max.
Withstanding voltage 500 V AC

Operating temperature -40°C to +105°C
Contact material (RoHS compliant) Brass
Insulator material (RoHS compliant) P.B.T. UL 94 V-0
Insertion force 340g max. / pair
Withdrawal force 28g min. / pair

DIMENSIONS (mm)

Style	No. of Contacts	DIM "A"	DIM "B"	DIM "C"	Style	No. of Contacts	DIM "A"	DIM "B"	DIM "C"	Style	No. of Contacts	DIM "A"	DIM "B"	DIM "C"
S & R	006	14.22	10.16	5.08	S & R	034	49.78	45.72	40.64	S & R	062	85.34	81.28	76.20
S & R	008	16.76	12.70	7.62	S & R	036	52.32	48.26	43.18	S & R	064	87.88	83.82	78.74
S & R	010	19.30	15.24	10.16	S & R	038	54.86	50.80	45.72	S & R	068	92.96	88.90	83.82
S & R	012	21.84	17.78	12.70	S & R	040	57.40	53.34	48.26	S & R	070	95.50	91.44	86.36
S & R	014	24.38	20.32	15.24	S & R	042	59.94	55.88	50.80	S & R	072	98.04	93.98	88.90
S & R	016	26.92	22.86	17.78	S & R	044	62.48	58.42	53.34	S & R	080	108.20	104.14	99.06
S & R	018	29.46	25.40	20.32	S & R	046	65.02	60.96	55.88	S & R	086	115.82	111.76	106.68
S & R	020	32.00	27.94	22.86	S & R	048	67.56	63.50	58.42	S & R	092	123.44	119.38	114.30
S & R	022	34.54	30.48	25.40	S & R	050	70.10	66.04	60.96	S & R	098	131.06	127.00	121.92
S & R	024	37.08	33.02	27.94	S & R	052	72.64	68.58	63.50	S & R	100	133.60	129.54	124.46
S & R	026	39.62	35.56	30.48	S & R	054	75.18	71.12	66.04	S & R	104	138.68	134.62	129.54
S & R	028	42.16	38.10	33.02	S & R	056	77.72	73.66	68.58	S	110	146.30	142.24	137.16
S & R	030	44.70	40.64	35.56	S & R	058	80.26	76.20	71.12	S	120	159.00	154.94	149.86
S & R	032	47.24	43.18	38.10	S & R	060	82.80	78.74	73.66					

How to order

ECC - xxx - X100 - 95

Nbr of contacts
see above table

Connector style
S 100 = straight
R 100 = right angle
Attention high MOQ's
Refer to Connector style SC100 and RC100 on page 89a for a close equivalent

Plating
95 = tin/gold
(tin leadfree)
Other platings on request

Card Edge Connector - THT - 2.54mm pitch "M" Contact Style

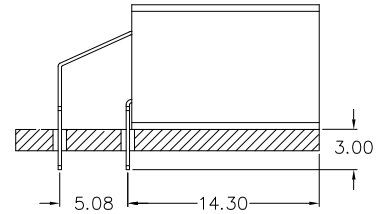
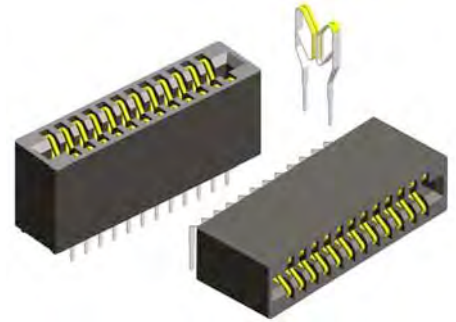
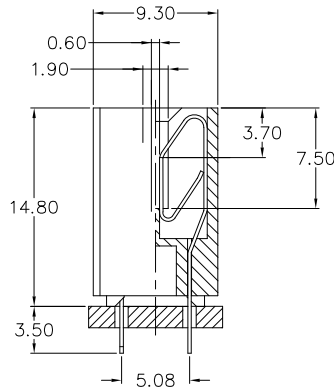
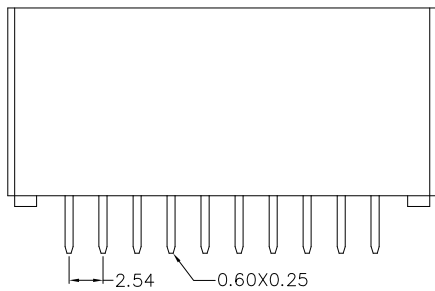
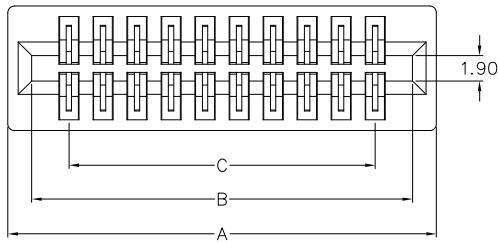

APPLICATION AND FEATURES

Hi-rel dual beam contact assures reliable PC-board connection.
Accepts PC Board thickness of 1.00mm to 1.60mm.

Connectors with mounting ears or solder eyes are also available.

Please contact your nearest sales office for more details.

"M" Contact Style



PCB Hole Layout

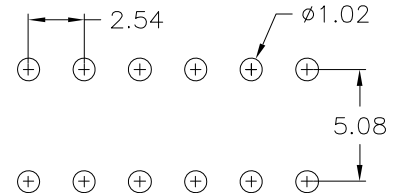

Important:

The PCB Layout is not identical for all pincount's
Individual datasheets are available on request.

SPECIFICATIONS

Current rating 3 A
Insulator resistance 1000 MΩ min.
Contact resistance 20 mΩ max.
Withstanding voltage 1000 V AC

Operating temperature -55°C to +85°C
Contact material (RoHS compliant) Brass
Insulator material (RoHS compliant) P.B.T. UL 94 V-0
Insertion force 340g max. / pair
Withdrawal force 28g min. / pair

DIMENSIONS (mm)

Style	No. of Contacts	DIM "A"	DIM "B"	DIM "C"	Style	No. of Contacts	DIM "A"	DIM "B"	DIM "C"	Style	No. of Contacts	DIM "A"	DIM "B"	DIM "C"
S & R	006	14.22	10.66	5.08	S & R	034	49.78	46.22	40.64	S & R	062	85.34	81.78	76.20
S & R	008	16.76	13.20	7.62	S & R	036	52.32	48.76	43.18	S & R	064	87.88	84.32	78.74
S & R	010	19.30	15.74	10.16	S & R	038	54.86	51.30	45.72	S & R	066	90.42	86.86	81.28
S & R	012	21.84	18.28	12.70	S & R	040	57.40	53.84	48.26	S & R	068	92.96	89.40	83.82
S & R	014	24.38	20.82	15.24	S & R	042	59.94	56.38	50.80	S & R	070	95.50	91.94	86.36
S & R	016	26.92	23.36	17.78	S & R	044	62.48	58.92	53.34	S & R	072	98.04	94.48	88.90
S & R	018	29.46	25.90	20.32	S & R	046	65.02	61.46	55.88	S & R	080	108.20	104.64	99.06
S & R	020	32.00	28.44	22.86	S & R	048	67.56	64.00	58.42	S & R	086	115.82	111.76	106.68
S & R	022	34.54	30.98	25.40	S & R	050	70.10	66.54	60.96	S & R	100	133.60	130.04	124.46
S & R	024	37.08	33.52	27.94	S & R	052	72.64	69.08	63.50	S & R	120	159.00	155.44	149.86
S & R	026	39.62	36.06	30.48	S & R	054	75.18	71.62	66.04					
S & R	028	42.16	38.60	33.02	S & R	056	77.72	74.16	68.58					
S & R	030	44.70	41.14	35.56	S & R	058	80.26	76.70	71.12					
S & R	032	47.24	43.68	38.10	S & R	060	82.80	79.24	73.66					

How to order

ECC - xxx - XC100 - 95

Nbr of contacts

see above table

Connector style

SC 100 = straight
RC 100 = right angle

Plating

95 = tin/gold
(tin leadfree)
Other platings on request

IDC – Card Edge Connector

2.54mm pitch

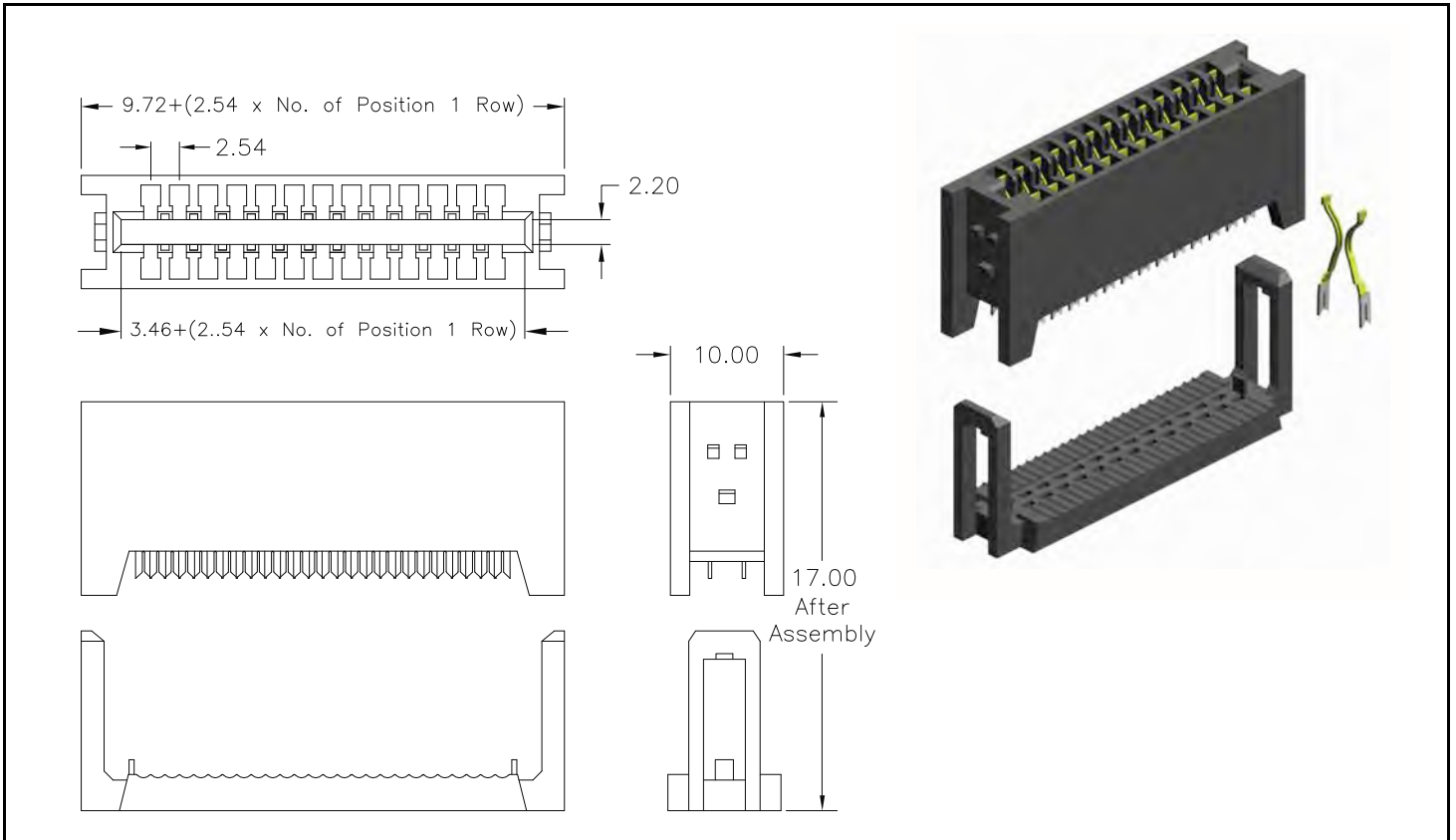

SPECIFICATIONS

Current rating	3 A
Insulator resistance	1000 MΩ min.
Contact resistance	20 mΩ max.
Withstanding voltage	500 V AC
Operating temperature	- 40°C to +105°C
Contact material (RoHS compliant)	Copper alloy
Insulator material (RoHS compliant)	P.B.T. UL 94 V-0

Recommended PCB dimensions

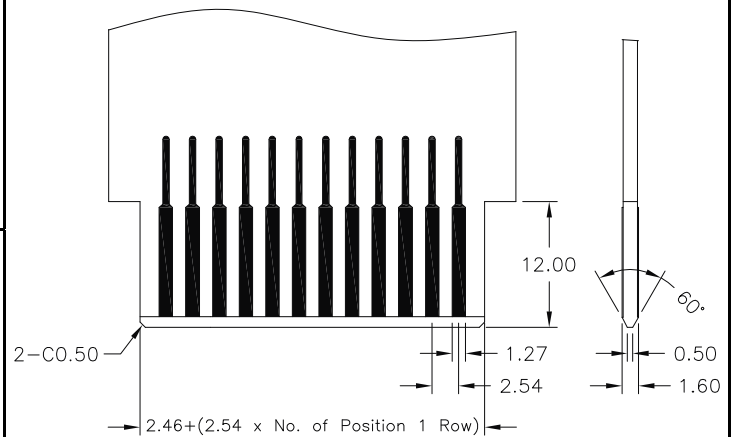

APPLICATION AND FEATURES

Hi-rel dual beam contact for reliable PCB connections.
 Accepts PCB thickness of 1.37 to 1.78mm.
 Insulation displacement termination for 1.27mm flat cable.

How to order

IDC - xxx - W100 - N5

Nbr of contacts

010; 020; 026
034; 040; 050

Plating

N5
 Nickel in crimp & gold in contact area
 Other platings on request

FPC/FFC Connector ZIF Type

- SMT - 0.50mm pitch vertical

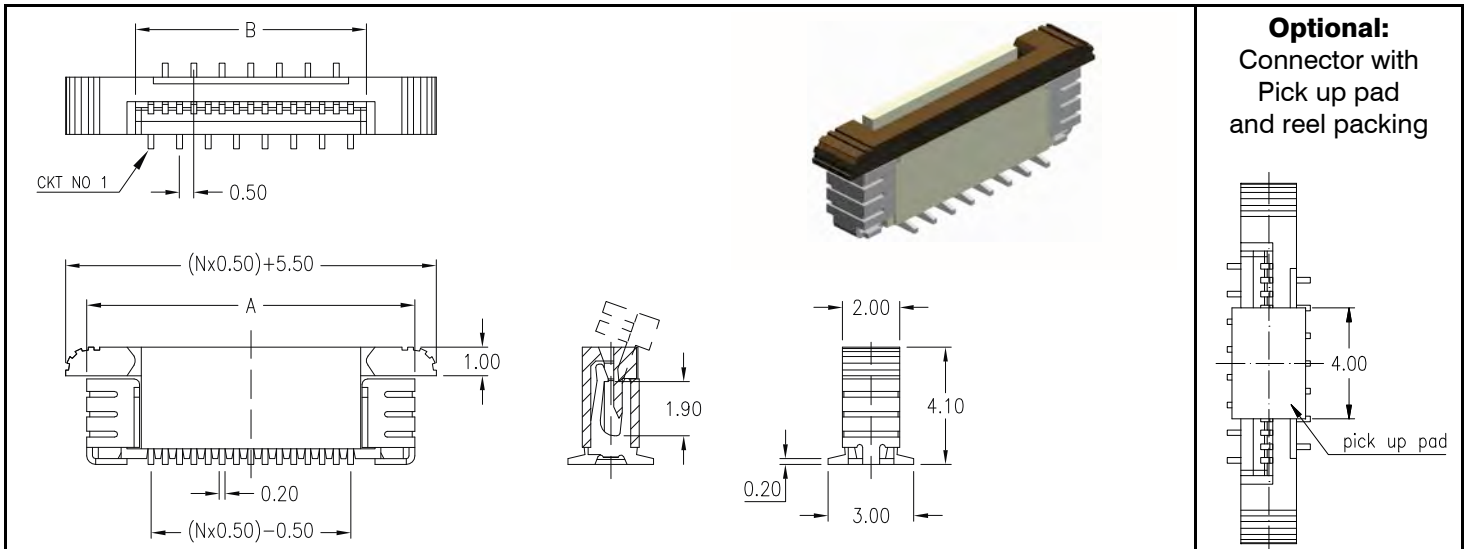

Optional:
Connector with
Pick up pad
and reel packing

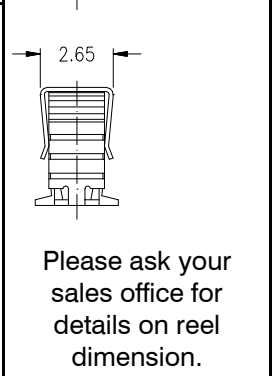
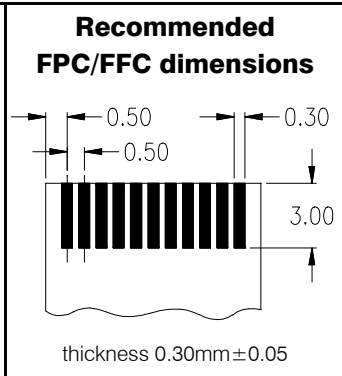
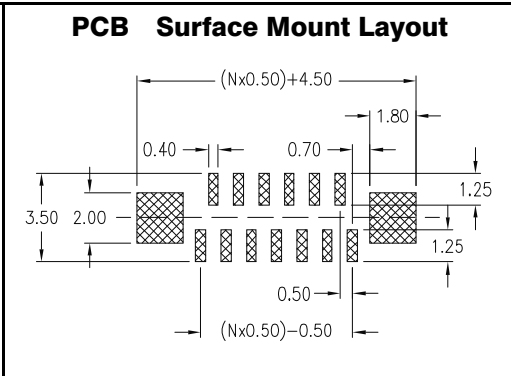
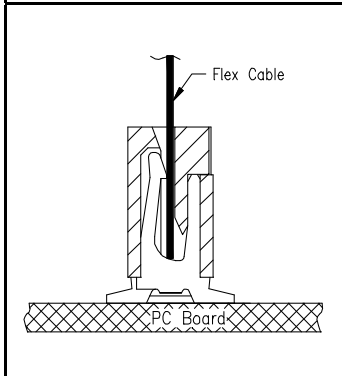

SPECIFICATIONS			
Current rating	0.4 A max.	Operating temperature	- 55°C to +85°C
Insulator resistance	50 MΩ min.	Processing temperature	+250°C +0/-5°C for 3sec.
Contact resistance	30 mΩ max.	Contact material	(RoHS compliant) Phosphor Bronze
Withstanding voltage	250 V AC/1 Min.	Contact plating	Tin (leadfree)
		Insulator material	(RoHS compliant) Nylon UL 94 V-0

Dimensions (mm)											
Contacts	DIM "A"	DIM "B"	Contacts	DIM "A"	DIM "B"	Contacts	DIM "A"	DIM "B"	Contacts	DIM "A"	DIM "B"
004	6.00	2.60	016	12.00	8.60	028	18.00	14.60	040	24.00	20.60
005	6.50	3.10	017	12.50	9.10	029	18.50	15.10	041	24.50	21.10
006	7.00	3.60	018	13.00	9.60	030	19.00	15.60	042	25.00	21.60
007	7.50	4.10	019	13.50	10.10	031	19.50	16.10	043	25.50	22.10
008	8.00	4.60	020	14.00	10.60	032	20.00	16.60	044	26.00	22.60
009	8.50	5.10	021	14.50	11.10	033	20.50	17.10	045	26.50	23.10
010	9.00	5.60	022	15.00	11.60	034	21.00	17.60	046	27.00	23.60
011	9.50	6.10	023	15.50	12.10	035	21.50	18.10	047	27.50	24.10
012	10.00	6.60	024	16.00	12.60	036	22.00	18.60	048	28.00	24.60
013	10.50	7.10	025	16.50	13.10	037	22.50	19.10	049	28.50	25.10
014	11.00	7.60	026	17.00	13.60	038	23.00	19.60	050	29.00	25.60
015	11.50	8.10	027	17.50	14.10	039	23.50	20.10			

How to order

FCZ - xxx - V 050 - 99 / XX

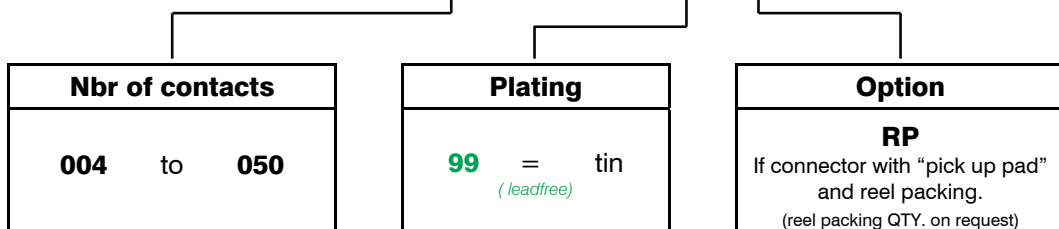

FPC/FFC Connector ZIF Type

- SMT - 0.50mm pitch horizontal

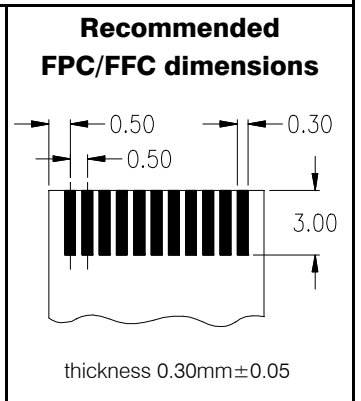
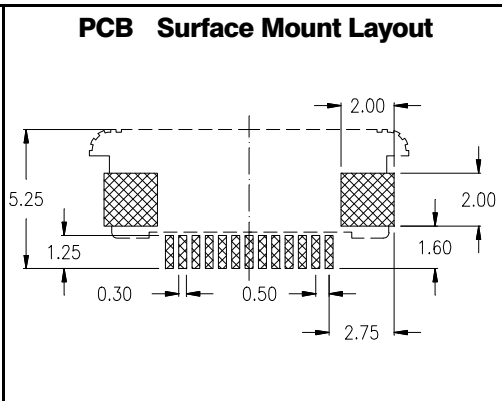
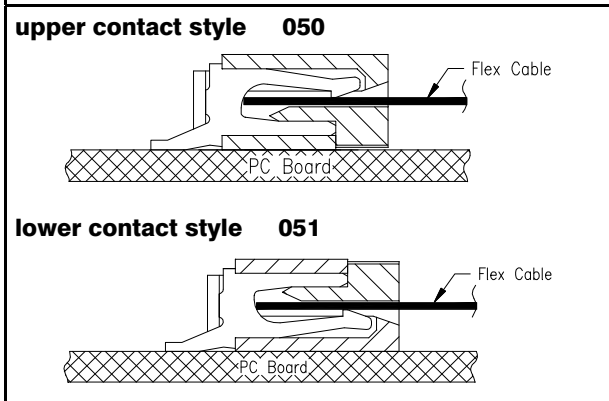
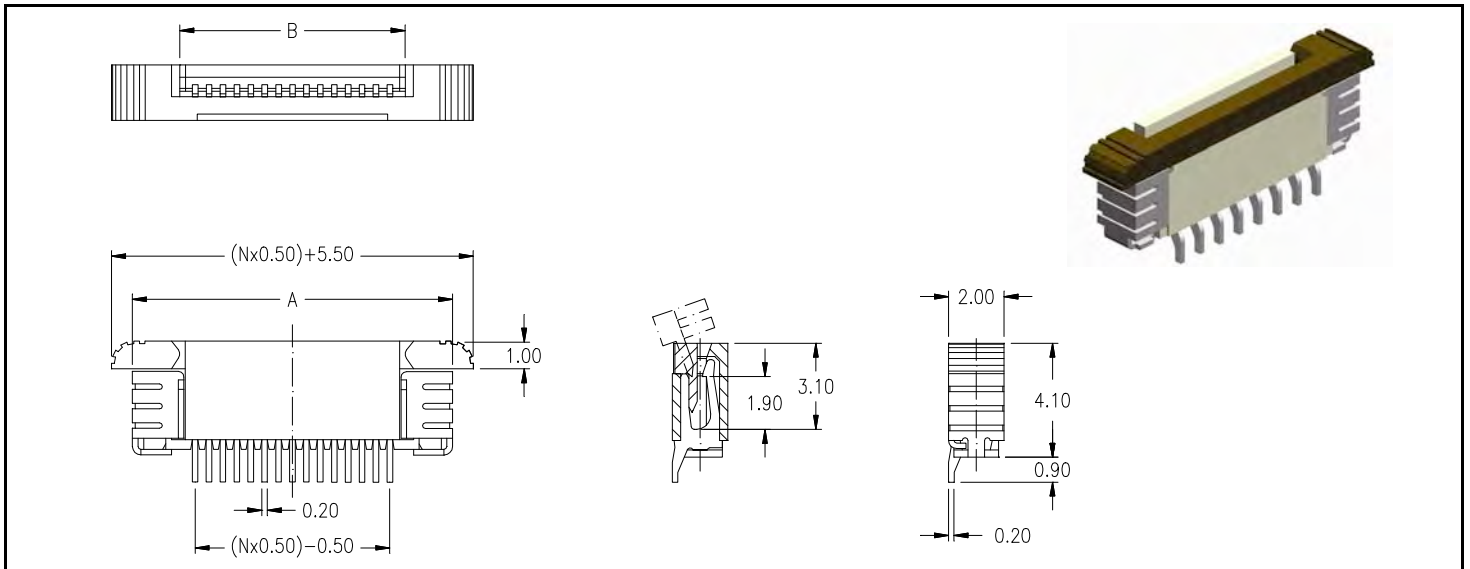

SPECIFICATIONS			
Current rating	0.4 A max.	Operating temperature	- 55°C to +85°C
Insulator resistance	50 MΩ min.	Processing temperature	+250°C +0/-5°C for 3sec.
Contact resistance	30 mΩ max.	Contact material	Phosphor Bronze (RoHS compliant)
Withstanding voltage	250 V AC/1 Min.	Contact plating	Tin (leadfree)
		Insulator material	Nylon (RoHS compliant) UL 94 V-0

Dimensions (mm)											
Contacts	DIM "A"	DIM "B"	Contacts	DIM "A"	DIM "B"	Contacts	DIM "A"	DIM "B"	Contacts	DIM "A"	DIM "B"
004	6.00	2.60	016	12.00	8.60	028	18.00	14.60	040	24.00	20.60
005	6.50	3.10	017	12.50	9.10	029	18.50	15.10	041	24.50	21.10
006	7.00	3.60	018	13.00	9.60	030	19.00	15.60	042	25.00	21.60
007	7.50	4.10	019	13.50	10.10	031	19.50	16.10	043	25.50	22.10
008	8.00	4.60	020	14.00	10.60	032	20.00	16.60	044	26.00	22.60
009	8.50	5.10	021	14.50	11.10	033	20.50	17.10	045	26.50	23.10
010	9.00	5.60	022	15.00	11.60	034	21.00	17.60	046	27.00	23.60
011	9.50	6.10	023	15.50	12.10	035	21.50	18.10	047	27.50	24.10
012	10.00	6.60	024	16.00	12.60	036	22.00	18.60	048	28.00	24.60
013	10.50	7.10	025	16.50	13.10	037	22.50	19.10	049	28.50	25.10
014	11.00	7.60	026	17.00	13.60	038	23.00	19.60	050	29.00	25.60
015	11.50	8.10	027	17.50	14.10	039	23.50	20.10			

How to order

FCZ - xxx - H xxx - 99 / X

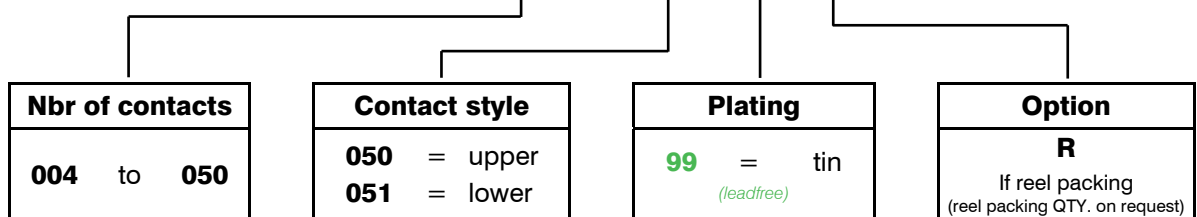

FPC/FFC Connector ZIF Type

- SMT - 0.50mm pitch vertical

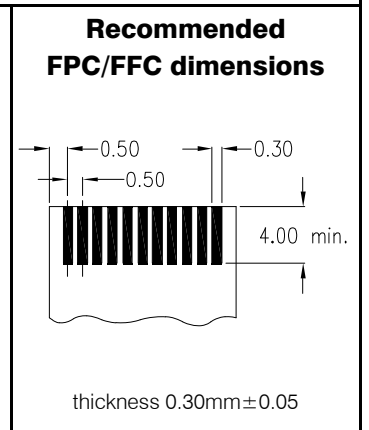
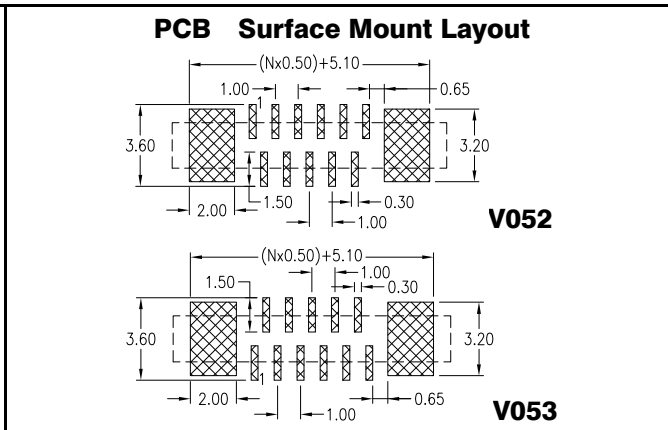
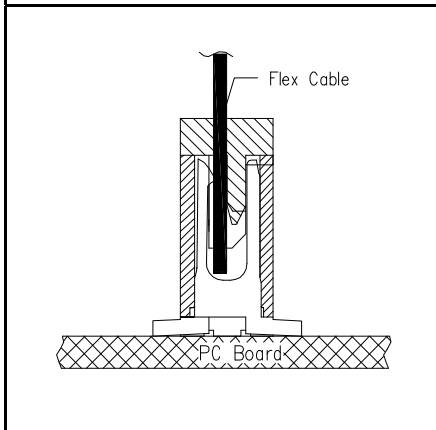
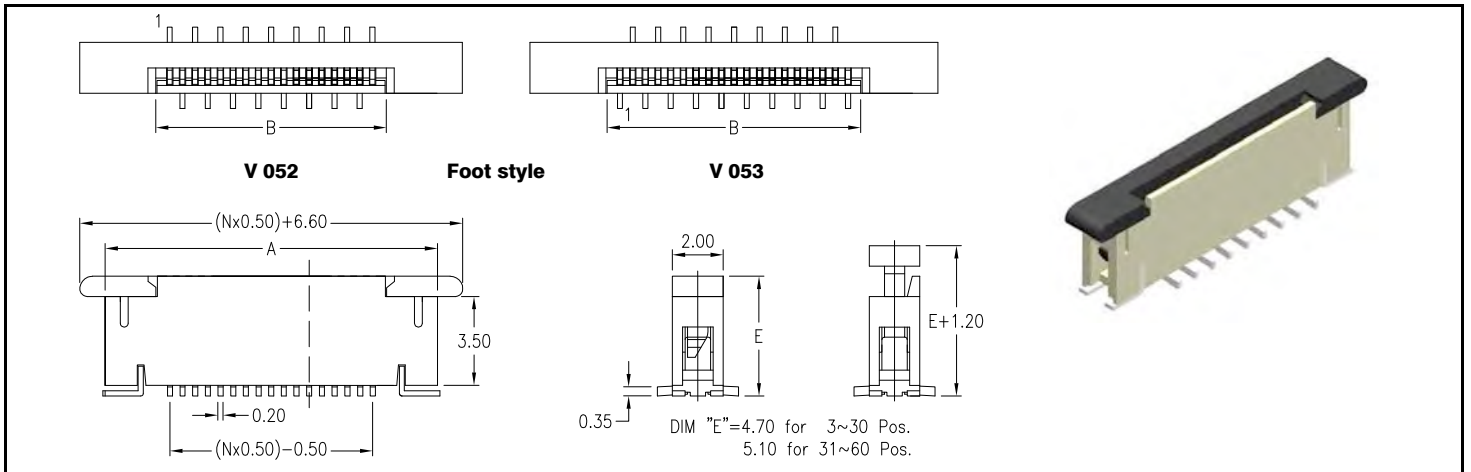

SPECIFICATIONS

Current rating	0.4 A max.	Operating temperature	-20°C to +85°C
Insulator resistance	50 MΩ min.	Processing temperature	+250°C +0/-5°C for 3sec.
Contact resistance	30 mΩ max.	Contact material	Phosphor Bronze (RoHS compliant)
Withstanding voltage	250 V AC/1 Min.	Contact plating	Tin (leadfree)
		Insulator material	LCP (RoHS compliant) UL 94 V-0
		Actuator material	PPA (RoHS compliant) UL 94 V-0

Dimensions (mm)

Contacts	DIM "A"	DIM "B"	Contacts	DIM "A"	DIM "B"	Contacts	DIM "A"	DIM "B"	Contacts	DIM "A"	DIM "B"
003	8.10	2.10	018	15.60	9.60	033	23.10	17.10	048	30.60	24.60
004	8.60	2.60	019	16.10	10.10	034	23.60	17.60	049	31.10	25.10
005	9.10	3.10	020	16.60	10.60	035	24.10	18.10	050	31.60	25.60
006	9.60	3.60	021	17.10	11.10	036	24.60	18.60	051	32.10	26.10
007	10.10	4.10	022	17.60	11.60	037	25.10	19.10	052	32.60	26.60
008	10.60	4.60	023	18.10	12.10	038	25.60	19.60	053	33.10	27.10
009	11.10	5.10	024	18.60	12.60	039	26.10	20.10	054	33.60	27.60
010	11.60	5.60	025	19.10	13.10	040	26.60	20.60	055	34.10	28.10
011	12.10	6.10	026	19.60	13.60	041	27.10	21.10	056	34.60	28.60
012	12.60	6.60	027	20.10	14.10	042	27.60	21.60	057	35.10	29.10
013	13.10	7.10	028	20.60	14.60	043	28.10	22.10	058	35.60	29.60
014	13.60	7.60	029	21.10	15.10	044	28.60	22.60	059	36.10	30.10
015	14.10	8.10	030	21.60	15.60	045	29.10	23.10	060	36.60	30.60
016	14.60	8.60	031	22.10	16.10	046	29.60	23.60			
017	15.10	9.10	032	22.60	16.60	047	30.10	24.10			

How to order

FCZ - xxx - V xxx - 99 / X

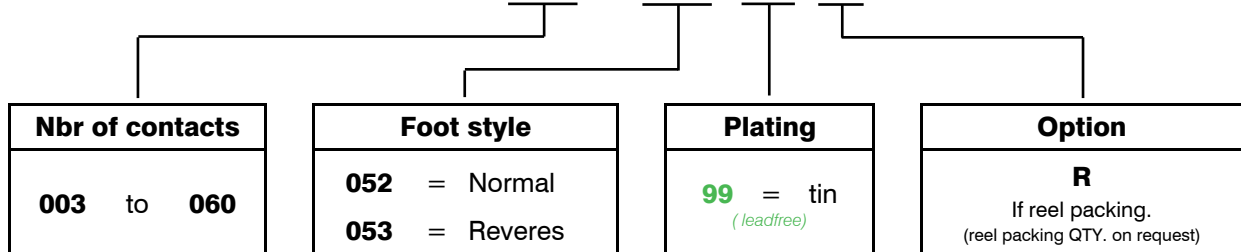

FPC/FFC Connector ZIF Type

- SMT - 0.50mm pitch horizontal

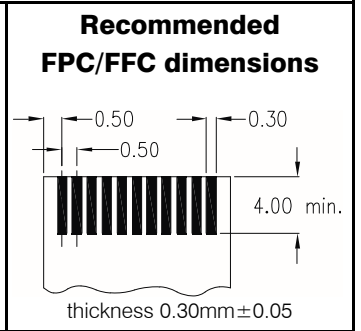
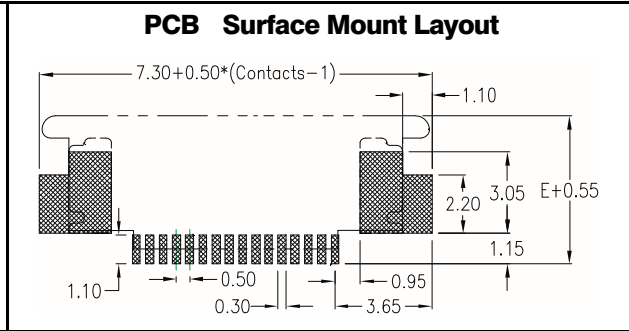
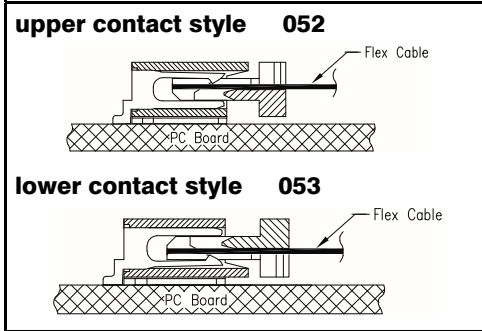
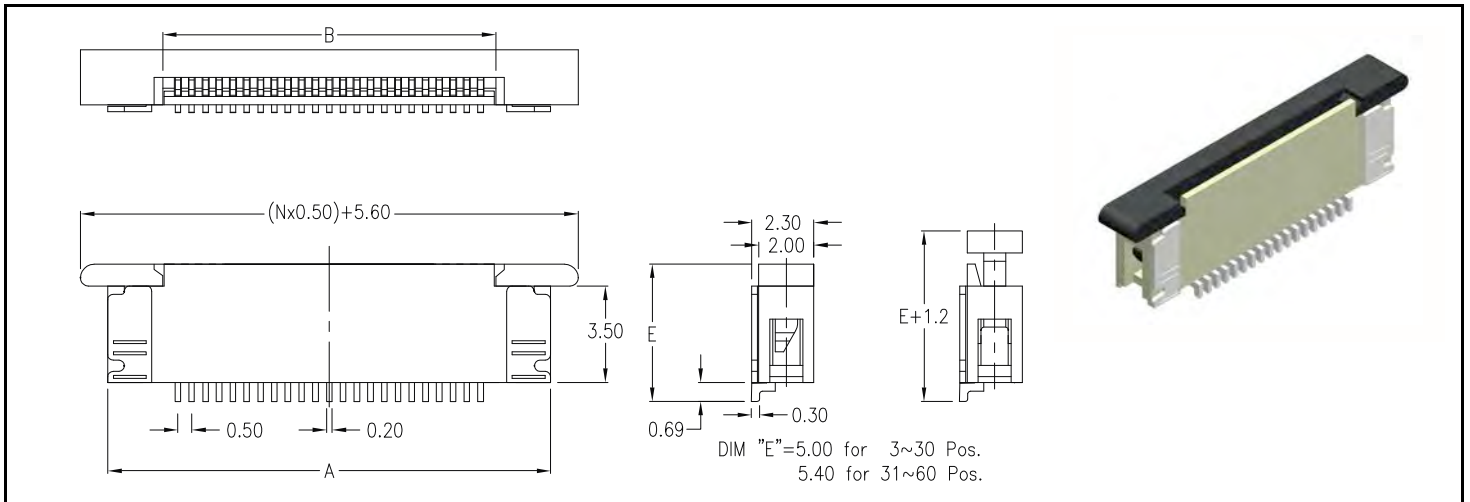

SPECIFICATIONS			
Current rating	0.4 A max.	Operating temperature	-20°C to +85°C
Insulator resistance	50 MΩ min.	Processing temperature	+250°C +0/-5°C for 3sec.
Contact resistance	30 mΩ max.	Contact material	Phosphor Bronze (RoHS compliant)
Withstanding voltage	250 V AC/1 Min.	Contact plating	Tin (leadfree)
		Insulator material	LCP (RoHS compliant) UL 94 V-0
		Actuator material	PPA (RoHS compliant) UL 94 V-0

Dimensions (mm)											
Contacts	DIM "A"	DIM "B"	Contacts	DIM "A"	DIM "B"	Contacts	DIM "A"	DIM "B"	Contacts	DIM "A"	DIM "B"
003	6.10	2.10	018	13.60	9.60	033	21.10	17.10	048	28.60	24.60
004	6.60	2.60	019	14.10	10.10	034	21.60	17.60	049	29.10	25.10
005	7.10	3.10	020	14.60	10.60	035	22.10	18.10	050	29.60	25.60
006	7.60	3.60	021	15.10	11.10	036	22.60	18.60	051	30.10	26.10
007	8.10	4.10	022	15.60	11.60	037	23.10	19.10	052	30.60	26.60
008	8.60	4.60	023	16.10	12.10	038	23.60	19.60	053	31.10	27.10
009	9.10	5.10	024	16.60	12.60	039	24.10	20.10	054	31.60	27.60
010	9.60	5.60	025	17.10	13.10	040	24.60	20.60	055	32.10	28.10
011	10.10	6.10	026	17.60	13.60	041	25.10	21.10	056	32.60	28.60
012	10.60	6.60	027	18.10	14.10	042	25.60	21.60	057	33.10	29.10
013	11.10	7.10	028	18.60	14.60	043	26.10	22.10	058	33.60	29.60
014	11.60	7.60	029	19.10	15.10	044	26.60	22.60	059	34.10	30.10
015	12.10	8.10	030	19.60	15.60	045	27.10	23.10	060	34.60	30.60
016	12.60	8.60	031	20.10	16.10	046	27.60	23.60			
017	13.10	9.10	032	20.60	16.60	047	28.10	24.10			

How to order

FCZ - xxx - H xxx - 99 / X

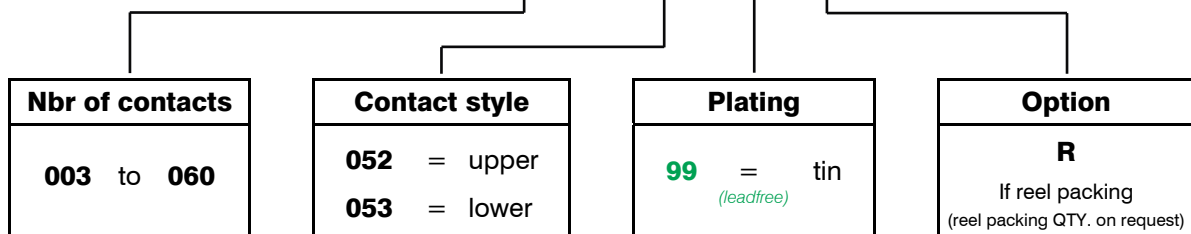

FPC/FFC Connector ZIF "Easy-on" Type

- SMT - 0.50mm pitch horizontal

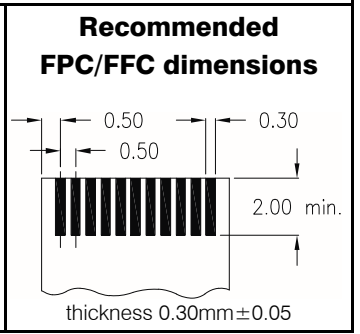
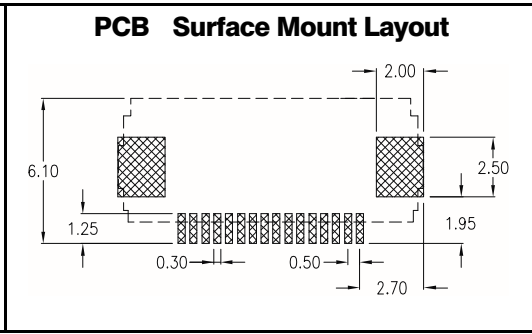
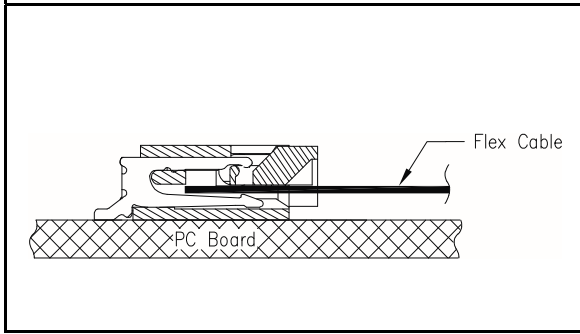
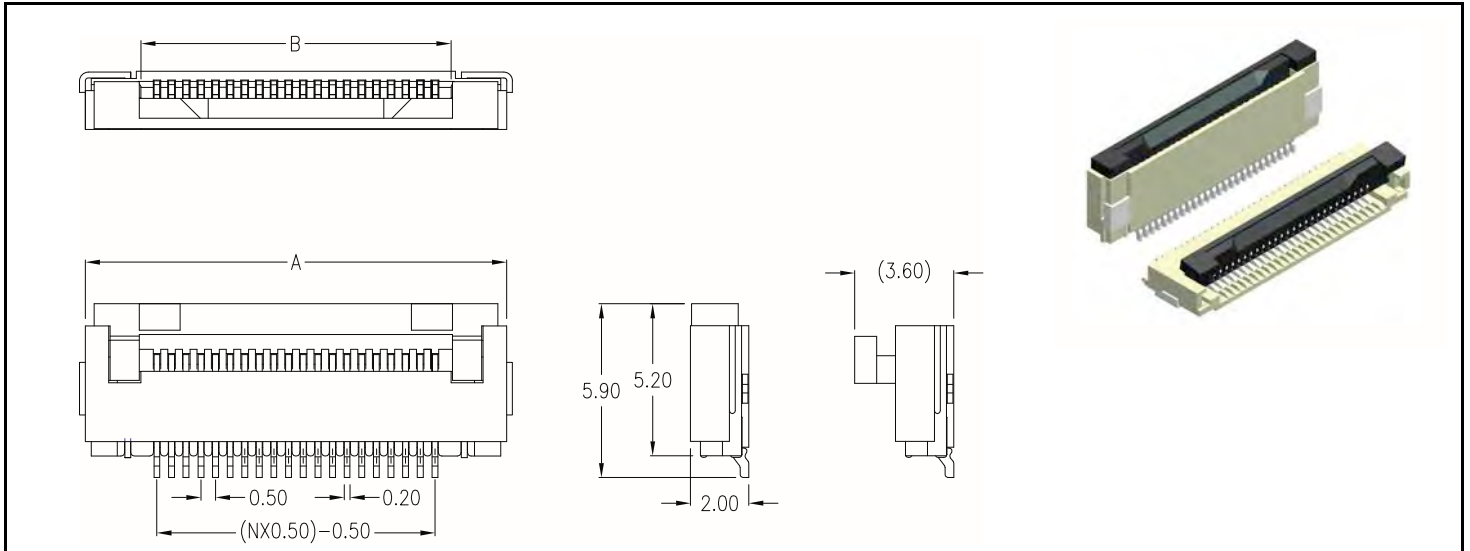

SPECIFICATIONS

Current rating	0.4 A max.	Operating temperature	- 20°C to +85°C
Insulator resistance	50 MΩ min.	Processing temperature	+250°C +0/-5°C for 3sec.
Contact resistance	30 mΩ max.	Contact material	Phosphor Bronze (RoHS compliant)
Withstanding voltage	250 V AC/1 Min.	Contact plating	Tin (leadfree)
		Insulator material	LCP UL 94 V-0 (RoHS compliant)
		Actuator material	PPA UL 94 V-0 (RoHS compliant)

Dimensions (mm)

Contacts	DIM "A"	DIM "B"	Contacts	DIM "A"	DIM "B"	Contacts	DIM "A"	DIM "B"	Contacts	DIM "A"	DIM "B"
006	7.40	3.60	020	14.40	10.60	034	21.40	17.60	048	28.40	24.60
007	7.90	4.10	021	14.90	11.10	035	21.90	18.10	049	28.90	25.10
008	8.40	4.60	022	15.40	11.60	036	22.40	18.60	050	29.40	25.60
009	8.90	5.10	023	15.90	12.10	037	22.90	19.10	051	29.90	26.10
010	9.40	5.60	024	16.40	12.60	038	23.40	19.60	052	30.40	26.60
011	9.90	6.10	025	16.90	13.10	039	23.90	20.10	053	30.90	27.10
012	10.40	6.60	026	17.40	13.60	040	24.40	20.60	054	31.40	27.60
013	10.90	7.10	027	17.90	14.10	041	24.90	21.10	055	31.90	28.10
014	11.40	7.60	028	18.40	14.60	042	25.40	21.60	056	32.40	28.60
015	11.90	8.10	029	18.90	15.10	043	25.90	22.10	057	32.90	29.10
016	12.40	8.60	030	19.40	15.60	044	26.40	22.60	058	33.40	29.60
017	12.90	9.10	031	19.90	16.10	045	26.90	23.10	059	33.90	30.10
018	13.40	9.60	032	20.40	16.60	046	27.40	23.60	060	34.40	30.60
019	13.90	10.10	033	20.90	17.10	047	27.90	24.10			

How to order

FCZ - xxx - H 058 - 99 / X

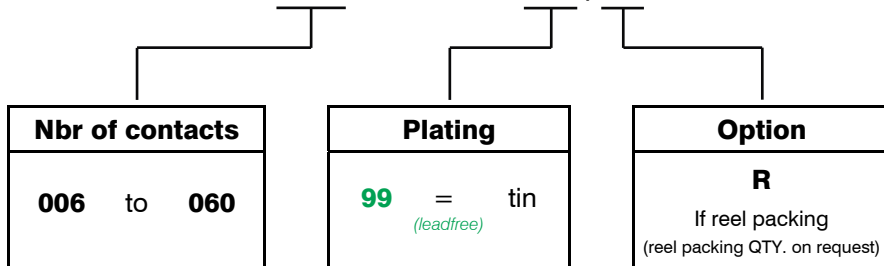

FPC/FFC Connector ZIF Type

- SMT - 0.80mm pitch horizontal

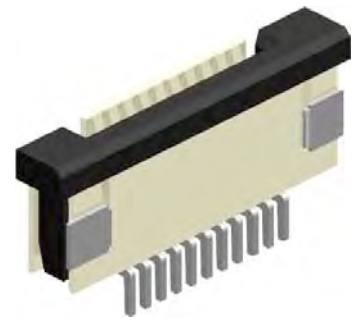
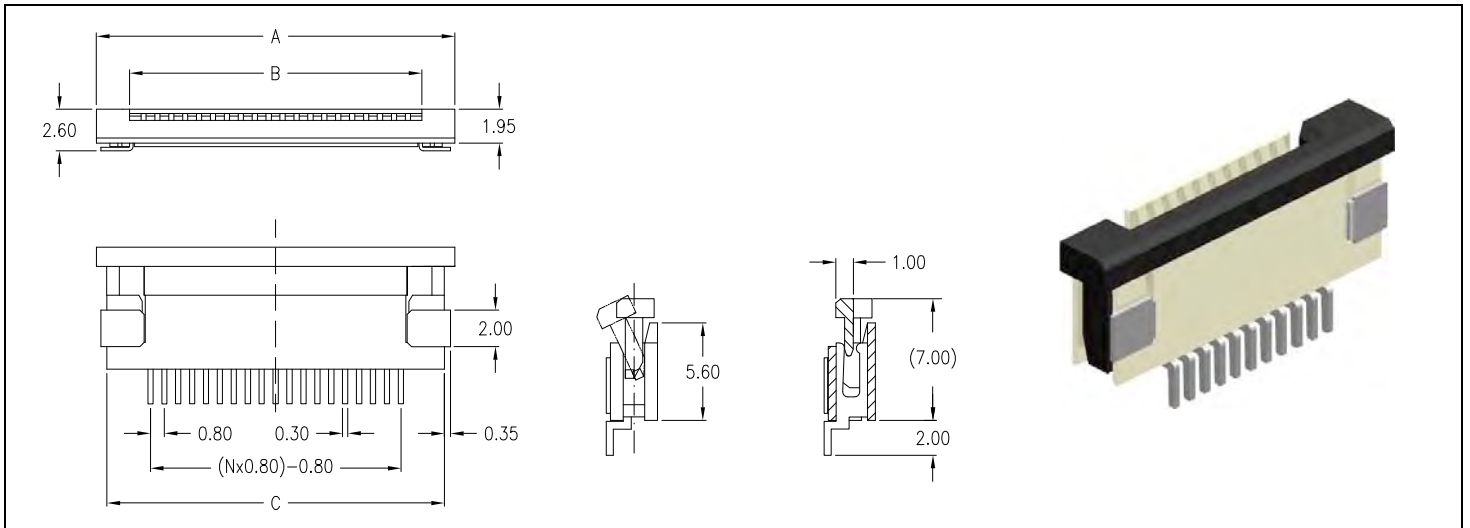

upper contact style 080

lower contact style 081

PCB surface mount layout

Recommended FPC/FFC dimensions

thickness 0.30mm±0.05

SPECIFICATIONS			
Current rating	0.5 A max.	Operating temperature	- 20°C to +105°C
Insulator resistance	100 MΩ min.	Processing temperature	+250°C +0/-5°C for 3 sec.
Contact resistance	20 mΩ max.	Contact material	Phosphor Bronze
Withstanding voltage	500 V AC/1 Min.	Contact plating	Tin (<i>leadfree</i>)
		Insulator material	LCP UL 94 V-0
		Actuator material	PPA UL 94 V-0

Dimensions (mm)															
Contacts	DIM"A"	DIM"B"	DIM"C"	Contacts	DIM"A"	DIM"B"	DIM"C"	Contacts	DIM"A"	DIM"B"	DIM"C"	Contacts	DIM"A"	DIM"B"	DIM"C"
004	9.50	4.25	8.20	011	15.10	9.85	13.80	018	20.70	15.45	19.40	025	26.30	21.05	25.00
005	10.30	5.05	9.00	012	15.90	10.65	14.60	019	21.50	16.25	20.20	026	27.10	21.85	25.80
006	11.10	5.85	9.80	013	16.70	11.45	15.40	020	22.30	17.05	21.00	027	27.90	22.65	26.60
007	11.90	6.65	10.60	014	17.50	12.25	16.20	021	23.10	17.85	21.80	028	28.70	23.45	27.40
008	12.70	7.45	11.40	015	18.30	13.05	17.00	022	23.90	18.65	22.60	029	29.50	24.25	28.20
009	13.50	8.25	12.20	016	19.10	13.85	17.80	023	24.70	19.45	23.40	030	30.30	25.05	29.00
010	14.30	9.05	13.00	017	19.90	14.65	18.60	024	25.50	20.25	24.20				

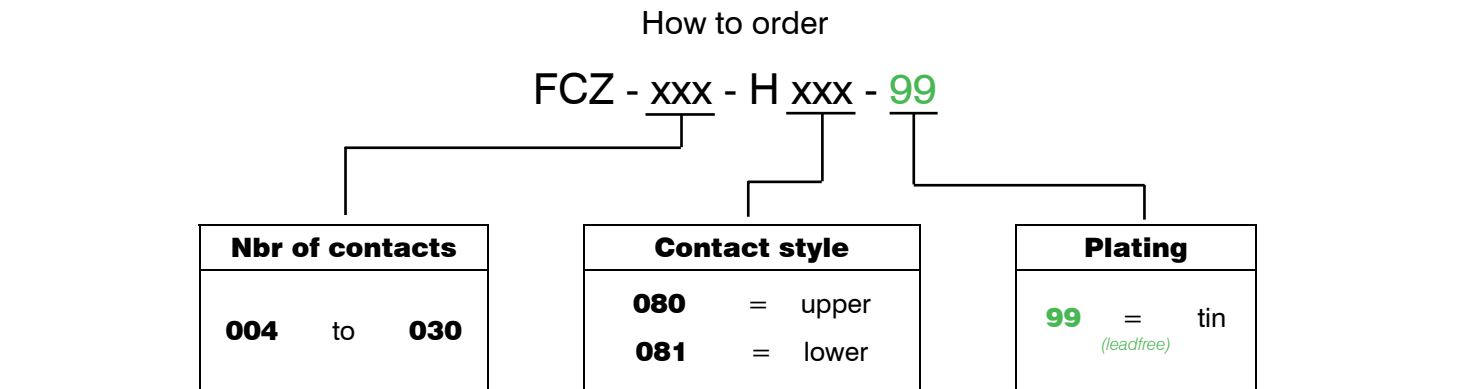

FPC/FFC Connector ZIF Type

- SMT - 1.00mm pitch vertical



Technical drawings showing dimensions: B, A, 1.00, (nx1.00)+6.00, 1.90, 2.00, 4.10, 0.20, 3.00, (nx1.00)-1.00, 0.20, (nx1.00)+5.00, 1.80, 0.40, 1.20, 1.25, 3.50, 2.00, 1.00, (nx1.00)-1.00, 1.25.

Optional:
Connector with Pick up pad and reel packing

pick up pad

2.65

Flex Cable
PC Board

PCB Surface Mount Layout

Recommended FPC/FFC dimensions

thickness 0.30mm±0.05

Please ask your sales office for details on reel dimension.

SPECIFICATIONS			
Current rating	0.4 A max.	Operating temperature	- 55°C to +85°C
Insulator resistance	50 MΩ min.	Processing temperature	+250°C +0/-5°C for 3 sec.
Contact resistance	30 mΩ max.	Contact material	Phosphor Bronze (RoHS compliant)
Withstanding voltage	250 V AC/1 Min.	Contact plating	Tin (leadfree)
		Insulator material	Nylon (RoHS compliant) UL 94 V-0

Dimensions (mm)											
Contacts	DIM "A"	DIM "B"	Contacts	DIM "A"	DIM "B"	Contacts	DIM "A"	DIM "B"	Contacts	DIM "A"	DIM "B"
004	8.50	5.10	010	14.50	11.10	016	20.50	17.10	022	26.50	23.10
005	9.50	6.10	011	15.50	12.10	017	21.50	18.10	023	27.50	24.10
006	10.50	7.10	012	16.50	13.10	018	22.50	19.10	024	28.50	25.10
007	11.50	8.10	013	17.50	14.10	019	23.50	20.10			
008	12.50	9.10	014	18.50	15.10	020	24.50	21.10			
009	13.50	10.10	015	19.50	16.10	021	25.50	22.10			

How to order

FCZ - xxx - V 100 - 99 / XX

Nbr of contacts

004 to 024

Plating

99 = tin
(leadfree)

Option

RP

If connector with "pick up pad" and reel packing.
(reel packing QTY. on request)

FPC/FFC Connector ZIF Type

- SMT - 1.00mm pitch horizontal

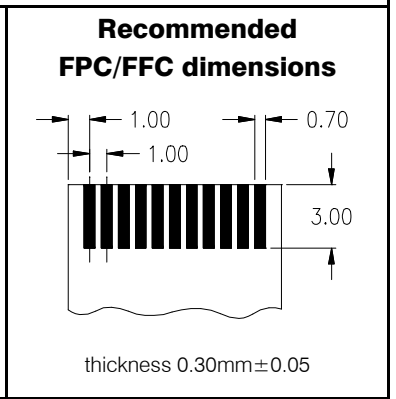
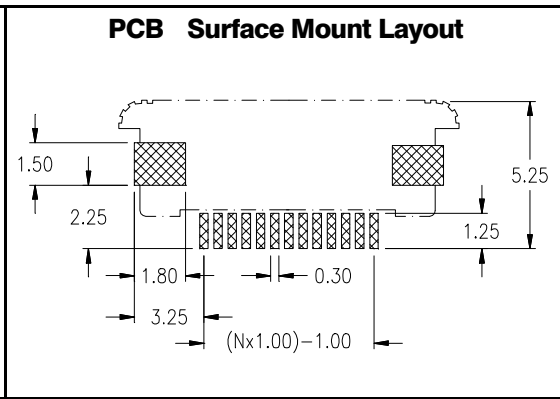
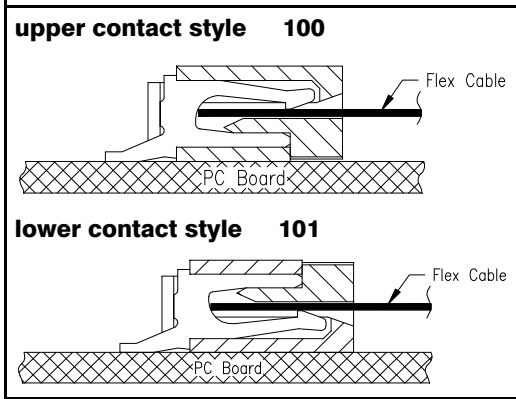
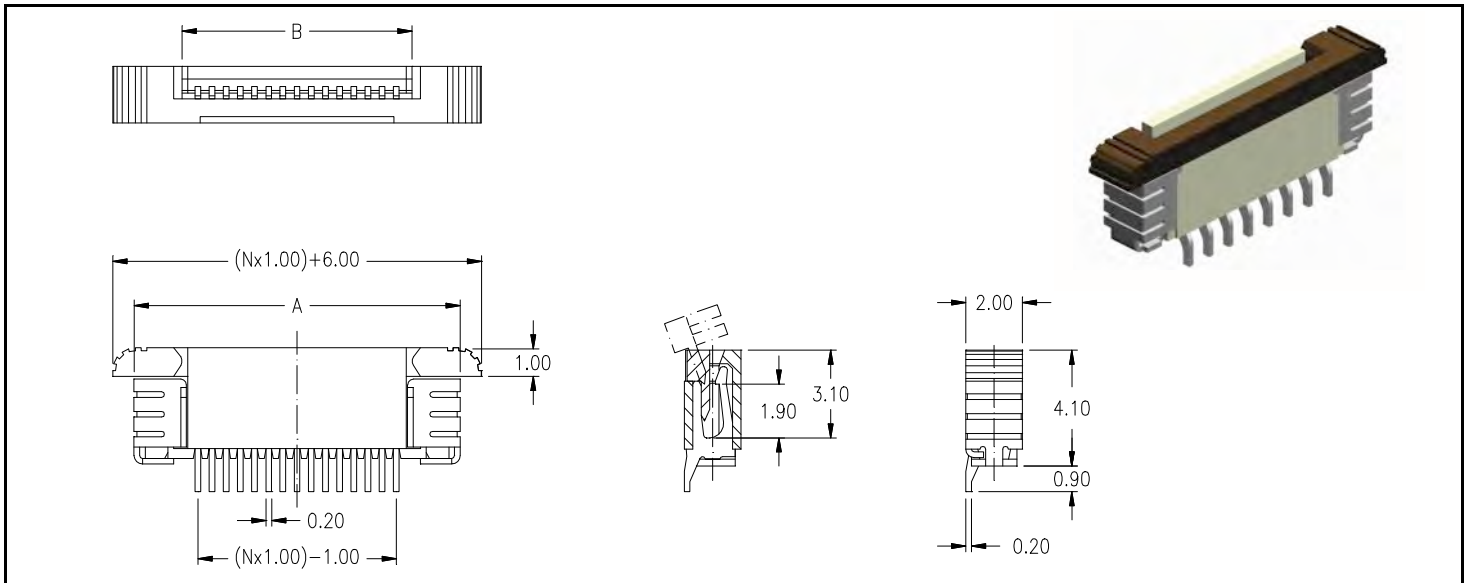

SPECIFICATIONS

Current rating 0.4 A max.
 Insulator resistance 50 MΩ min.
 Contact resistance 30 mΩ max.
 Withstanding voltage 250 V AC/1 Min.

Operating temperature -55°C to +85°C
 Processing temperature +250°C +0/-5°C for 3sec.
 Contact material (RoHS compliant) Phosphor Bronze
 Contact plating Tin (leadfree)
 Insulator material (RoHS compliant) Nylon UL 94 V-0

Dimensions (mm)

Contacts	DIM "A"	DIM "B"	Contacts	DIM "A"	DIM "B"	Contacts	DIM "A"	DIM "B"	Contacts	DIM "A"	DIM "B"
004	8.50	5.10	010	14.50	11.10	016	20.50	17.10	022	26.50	23.10
005	9.50	6.10	011	15.50	12.10	017	21.50	18.10	023	27.50	24.10
006	10.50	7.10	012	16.50	13.10	018	22.50	19.10	024	28.50	25.10
007	11.50	8.10	013	17.50	14.10	019	23.50	20.10			
008	12.50	9.10	014	18.50	15.10	020	24.50	21.10			
009	13.50	10.10	015	19.50	16.10	021	25.50	22.10			

How to order

FCZ - xxx - H xxx - 99 / X

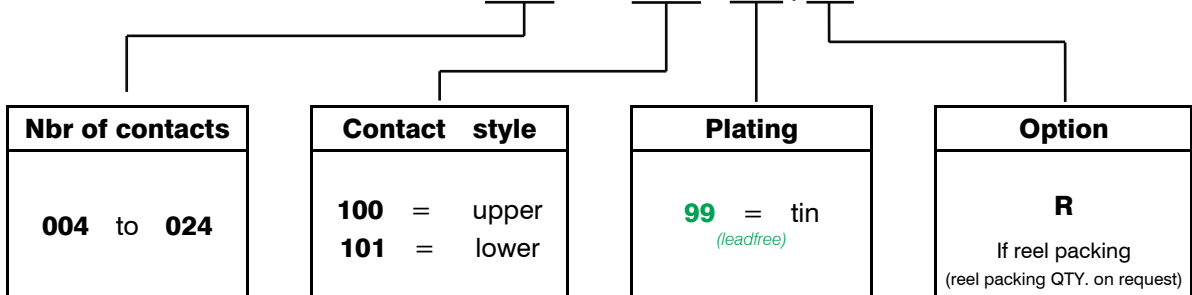

FPC/FFC Connector ZIF Type

- SMT - 1.00mm pitch vertical



Optional:
Connector with Pick up pad and reel packing

PCB Surface Mount Layout

Recommended FPC/FFC dimensions

Please ask your sales office for details on reel dimension.

SPECIFICATIONS

Current rating	0.5 A max.
Insulator resistance	100 MΩ min.
Contact resistance	20 mΩ max.
Withstanding voltage	500 V AC/1 Min.

Operating temperature	- 40°C to +105°C
Processing temperature	+250°C +0/-5°C for 3 sec.
Contact material	Phosphor Bronze (RoHS compliant)
Contact plating	Tin (leadfree)
Insulator material	LCP UL 94 V-0 (RoHS compliant)
Actuator material	PPA UL 94 V-0 (RoHS compliant)

Dimensions (mm)

Contacts	DIM "A"	DIM "B"	Contacts	DIM "A"	DIM "B"	Contacts	DIM "A"	DIM "B"	Contacts	DIM "A"	DIM "B"
003	8.00	4.20	010	15.00	11.20	017	22.00	18.20	024	29.00	25.20
004	9.00	5.20	011	16.00	12.20	018	23.00	19.20	025	30.00	26.20
005	10.00	6.20	012	17.00	13.20	019	24.00	20.20	026	31.00	27.20
006	11.00	7.20	013	18.00	14.20	020	25.00	21.20	027	32.00	28.20
007	12.00	8.20	014	19.00	15.20	021	26.00	22.20	028	33.00	29.20
008	13.00	9.20	015	20.00	16.20	022	27.00	23.20	029	34.00	30.20
009	14.00	10.20	016	21.00	17.20	023	28.00	24.20	030	35.00	31.20

How to order

FCZ - xxx - V 115 - 99 / XX

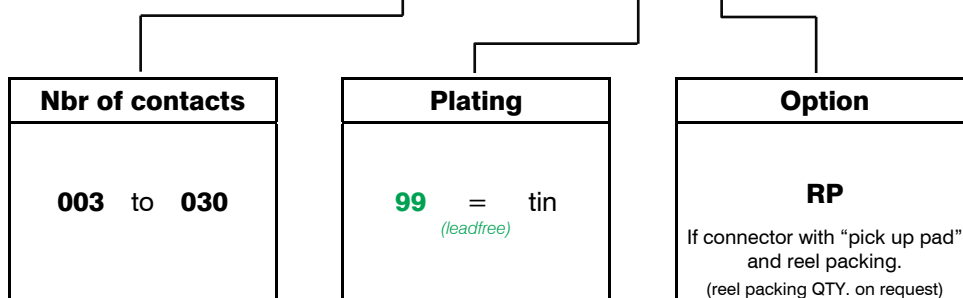

FPC/FFC Connector ZIF Type

- SMT - 1.00mm pitch horizontal

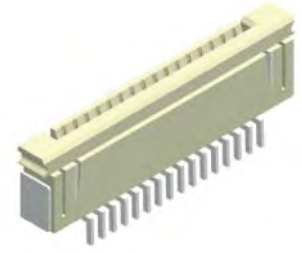
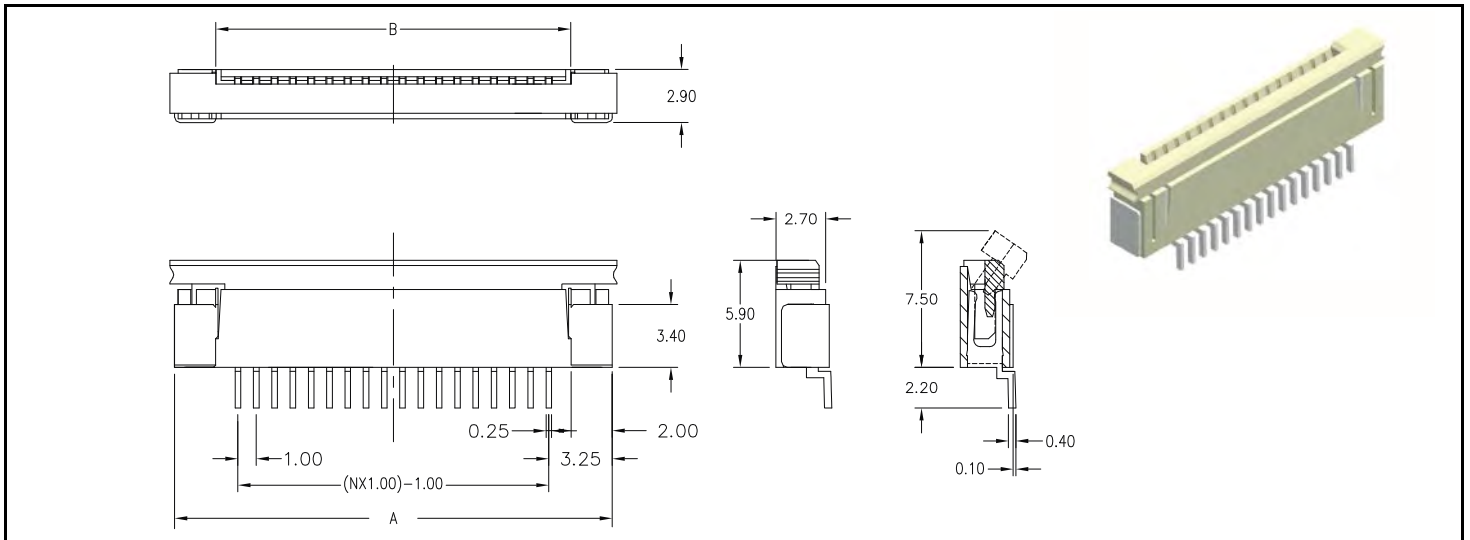

<p>upper contact style 115</p> <p>lower contact style 116</p>	<p>PCB Surface Mount Layout</p>	<p>Recommended FPC/FFC dimensions</p> <p>thickness 0.30mm±0.05</p>
---	--	---

SPECIFICATIONS			
Current rating	0.5 A max.	Operating temperature	- 40°C to +105°C.
Insulator resistance	100 MΩ min.	Processing temperature	+250°C +0/-5°C for 3sec.
Contact resistance	20 mΩ max.	Contact material	Phosphor Bronze (RoHS compliant)
Withstanding voltage	500 V AC/1 Min.	Contact plating	Tin (leadfree)
		Insulator material	LCP UL 94 V-0 (RoHS compliant)
		Actuator material	PPA UL 94 V-0 (RoHS compliant)

Dimensions (mm)											
Contacts	DIM "A"	DIM "B"	Contacts	DIM "A"	DIM "B"	Contacts	DIM "A"	DIM "B"	Contacts	DIM "A"	DIM "B"
003	8.50	4.20	011	16.50	12.20	019	24.50	20.20	027	32.50	28.20
004	9.50	5.20	012	17.50	13.20	020	25.50	21.20	028	33.50	29.20
005	10.50	6.20	013	18.50	14.20	021	26.50	22.20	029	34.50	30.20
006	11.50	7.20	014	19.50	15.20	022	27.50	23.20	030	35.50	31.20
007	12.50	8.20	015	20.50	16.20	023	28.50	24.20	031	36.50	32.20
008	13.50	9.20	016	21.50	17.20	024	29.50	25.20	032	37.50	33.20
009	14.50	10.20	017	22.50	18.20	025	30.50	26.20			
010	15.50	11.20	018	23.50	19.20	026	31.50	27.20			

How to order

FCZ - xxx - H xxx - 99 / X

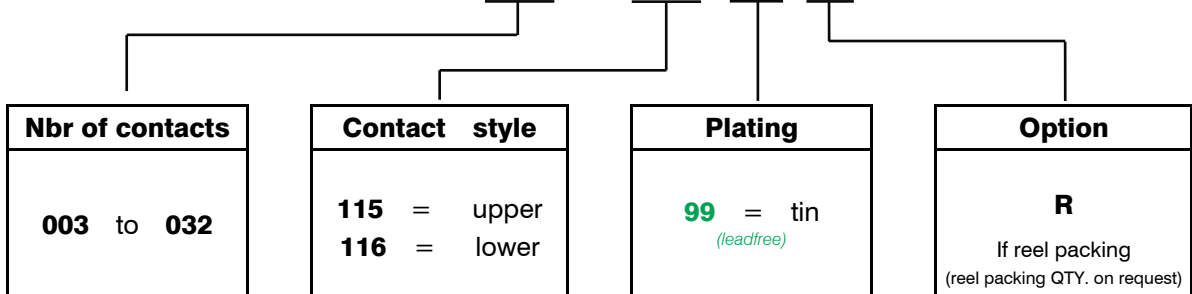

FPC/FFC Connector ZIF Type

- THT - 1.00mm pitch vertical

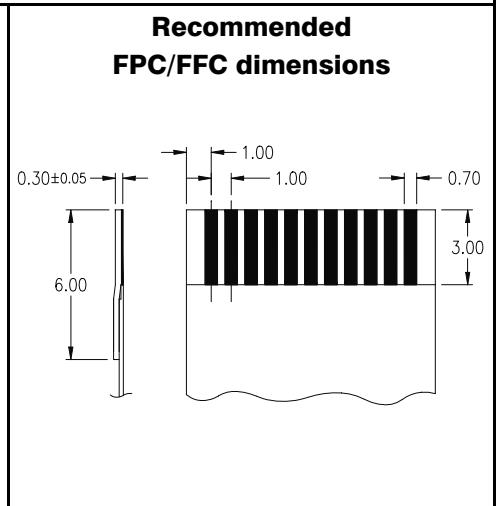
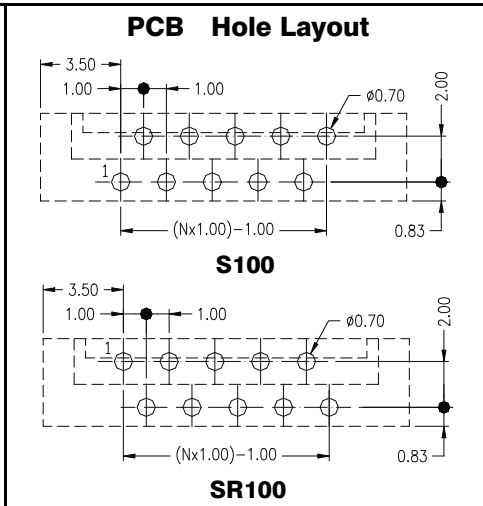
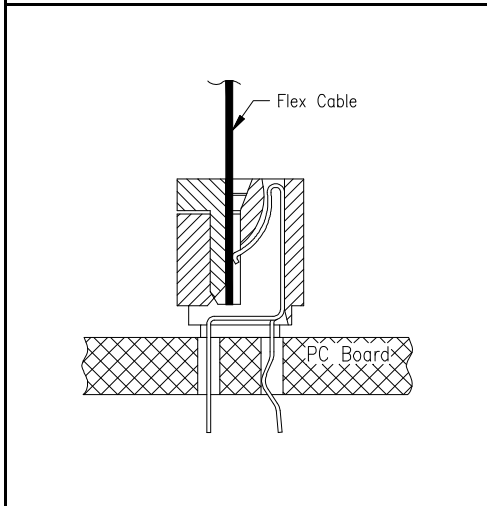
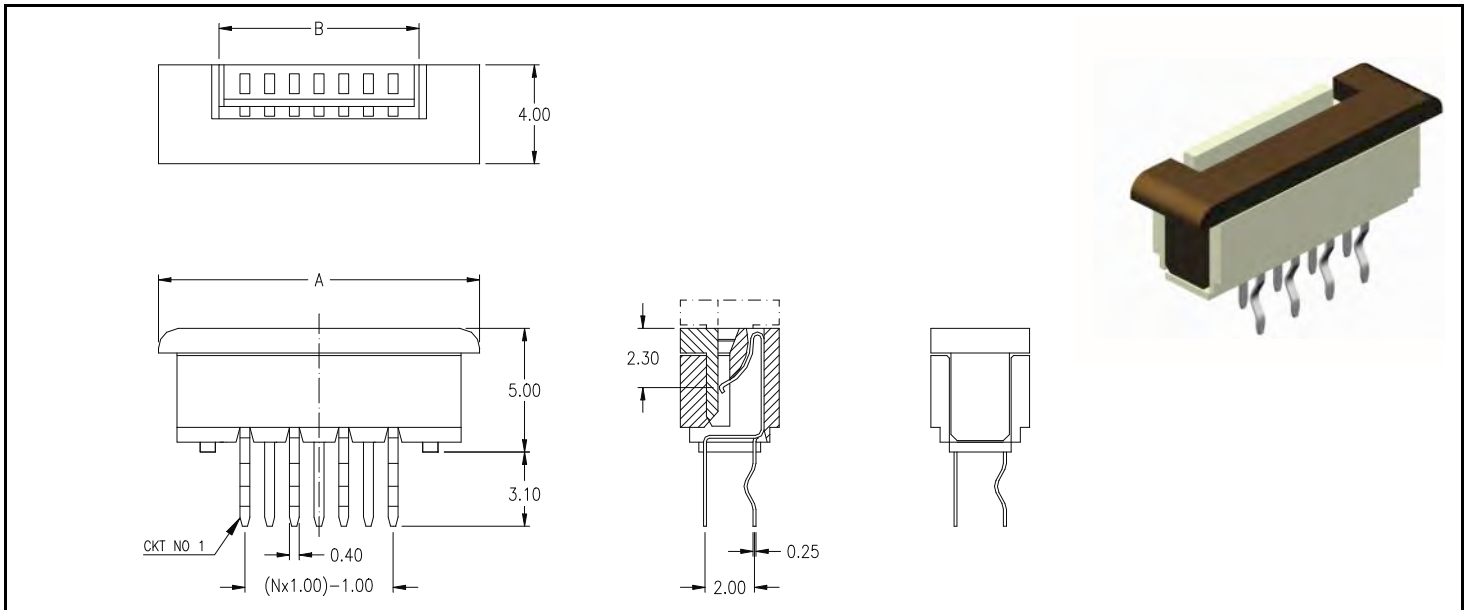

SPECIFICATIONS

Current rating	0.4 A max.	Operating temperature	- 55°C to +85°C
Insulator resistance	50 MΩ min.	Contact material	(RoHS compliant) Phosphor Bronze
Contact resistance	30 mΩ max.	Contact plating	Tin (leadfree)
Withstanding voltage	250 V AC/1 Min.	Insulator material	(RoHS compliant) Nylon UL 94 V-0

Dimensions (mm)

Contacts	DIM "A"	DIM "B"	Contacts	DIM "A"	DIM "B"	Contacts	DIM "A"	DIM "B"	Contacts	DIM "A"	DIM "B"
004	10.00	5.20	012	18.00	13.20	020	26.00	21.20	028	34.00	29.20
005	11.00	6.20	013	19.00	14.20	021	27.00	22.20	029	35.00	30.20
006	12.00	7.20	014	20.00	15.20	022	28.00	23.20	030	36.00	31.20
007	13.00	8.20	015	21.00	16.20	023	29.00	24.20	031	37.00	32.20
008	14.00	9.20	016	22.00	17.20	024	30.00	25.20	032	38.00	33.20
009	15.00	10.20	017	23.00	18.20	025	31.00	26.20			
010	16.00	11.20	018	24.00	19.20	026	32.00	27.20			
011	17.00	12.20	019	25.00	20.20	027	33.00	28.20			

How to order

FCZ - xxx - SX100 - 99

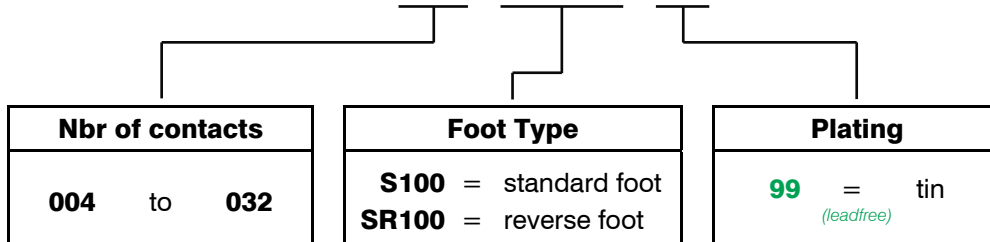

FPC/FFC Connector ZIF Type

- THT - 1.00mm pitch right angle

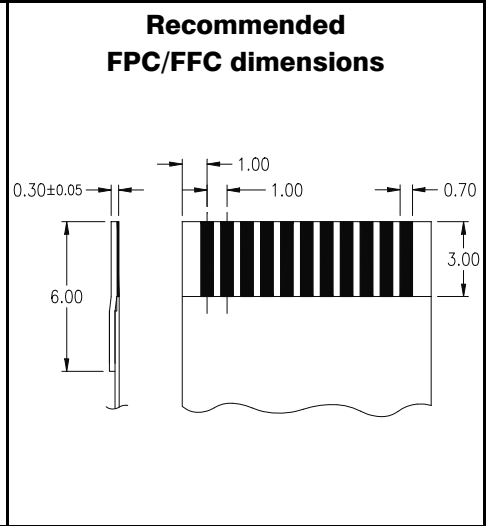
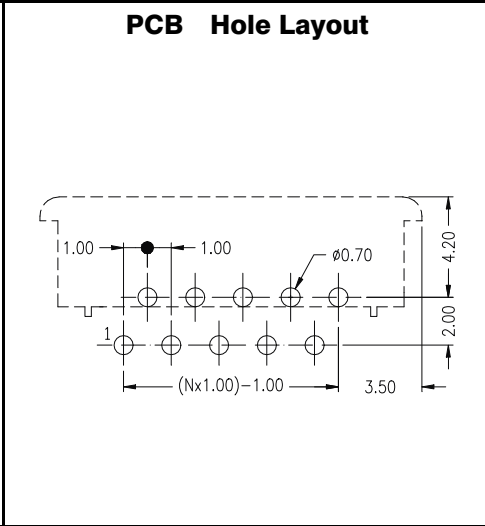
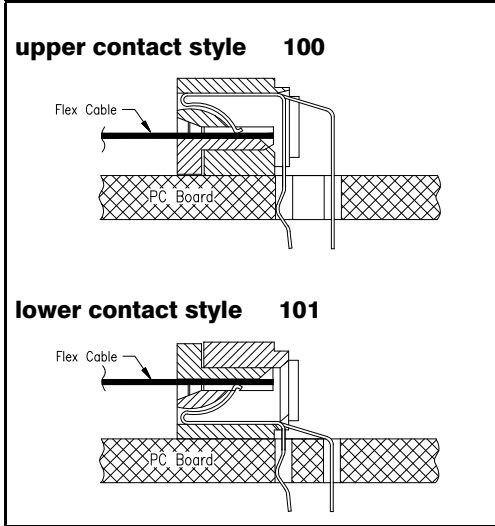
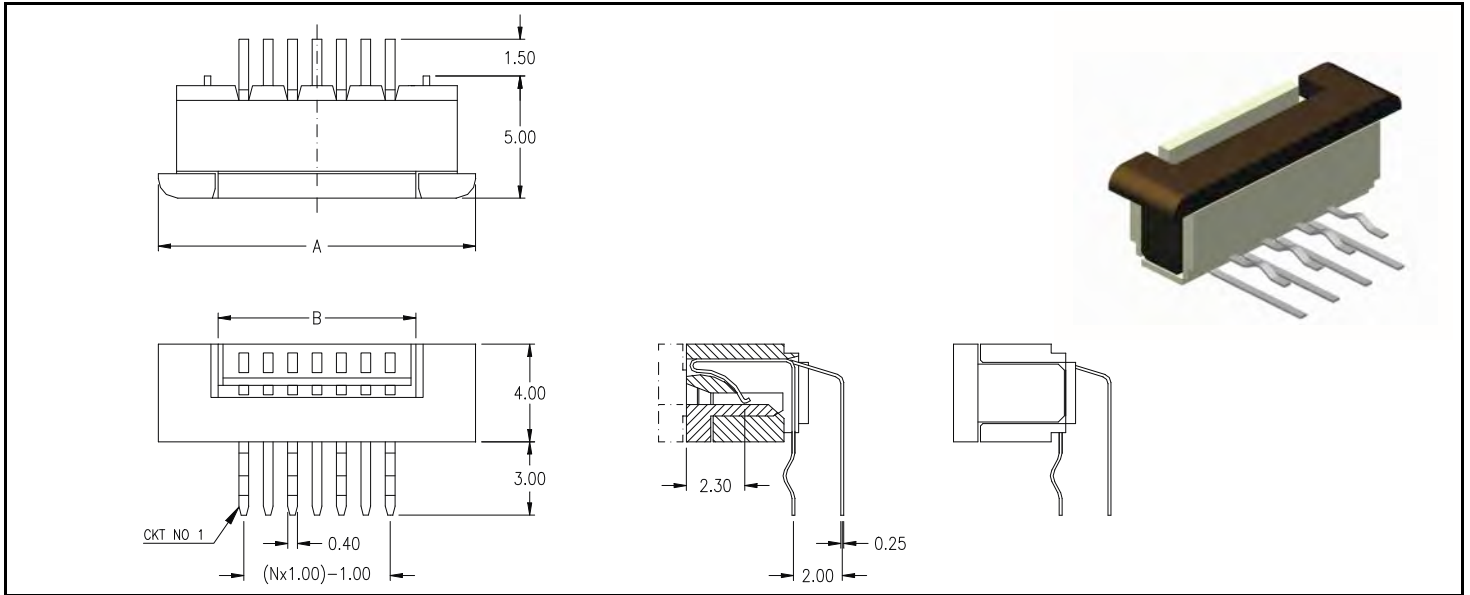

SPECIFICATIONS			
Current rating	0.4 A max.	Operating temperature	- 55°C to +85°C
Insulator resistance	50 MΩ min.	Contact material	(RoHS compliant) Phosphor Bronze
Contact resistance	30 mΩ max.	Contact plating	Tin (leadfree)
Withstanding voltage	250 V AC/1 Min.	Insulator material	(RoHS compliant) Nylon UL 94 V-0

Dimensions (mm)											
Contacts	DIM "A"	DIM "B"	Contacts	DIM "A"	DIM "B"	Contacts	DIM "A"	DIM "B"	Contacts	DIM "A"	DIM "B"
004	10.00	5.20	012	18.00	13.20	020	26.00	21.20	028	34.00	29.20
005	11.00	6.20	013	19.00	14.20	021	27.00	22.20	029	35.00	30.20
006	12.00	7.20	014	20.00	15.20	022	28.00	23.20	030	36.00	31.20
007	13.00	8.20	015	21.00	16.20	023	29.00	24.20	031	37.00	32.20
008	14.00	9.20	016	22.00	17.20	024	30.00	25.20	032	38.00	33.20
009	15.00	10.20	017	23.00	18.20	025	31.00	26.20			
010	16.00	11.20	018	24.00	19.20	026	32.00	27.20			
011	17.00	12.20	019	25.00	20.20	027	33.00	28.20			

How to order

FCZ - xxx - R xxx - 99

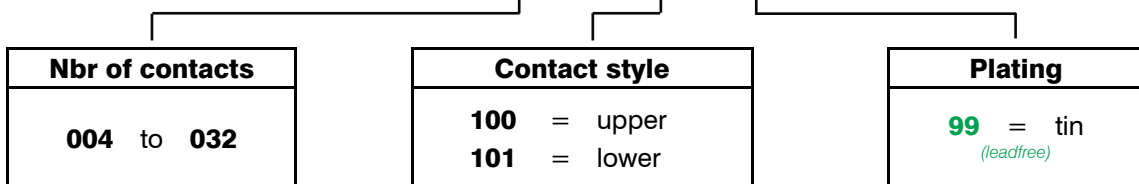

FPC/FFC Connector LIF Type

- SMT - 1.00mm pitch vertical

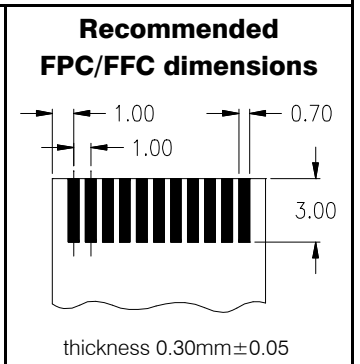
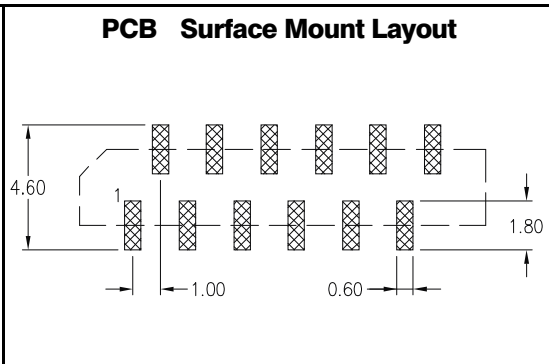
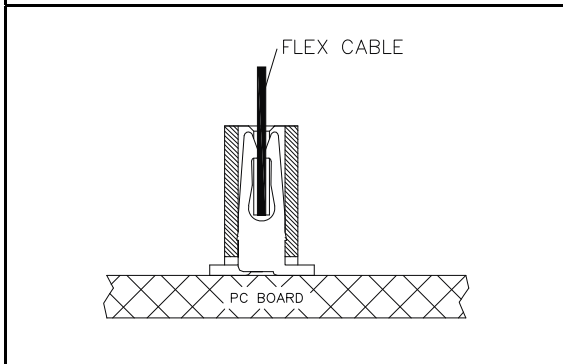
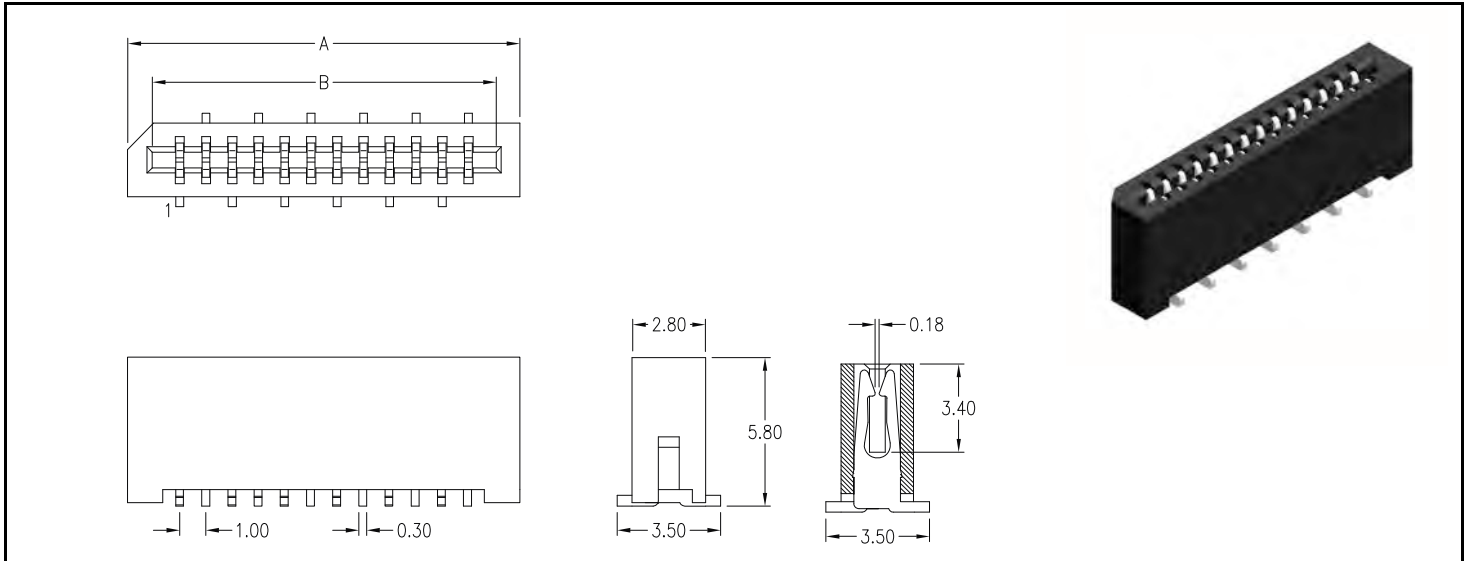

SPECIFICATIONS

Current rating	0.5 A max.	Operating temperature	- 40°C to +105°C
Insulator resistance	100 MΩ min.	Processing temperature	+250°C +0/-5°C for 3 sec.
Contact resistance	20 mΩ max.	Contact material	Phosphor Bronze (RoHS compliant)
Withstanding voltage	500 V AC/1 Min.	Contact plating	Tin (leadfree)
		Insulator material	Nylon (black) UL 94 V-0

Dimensions (mm)

Contacts	DIM "A"	DIM "B"	Contacts	DIM "A"	DIM "B"	Contacts	DIM "A"	DIM "B"	Contacts	DIM "A"	DIM "B"
003	6.00	4.10	012	15.00	13.10	021	24.00	22.10	030	33.00	31.10
004	7.00	5.10	013	16.00	14.10	022	25.00	23.10	031	34.00	32.10
005	8.00	6.10	014	17.00	15.10	023	26.00	24.10	032	35.00	33.10
006	9.00	7.10	015	18.00	16.10	024	27.00	25.10	033	36.00	34.10
007	10.00	8.10	016	19.00	17.10	025	28.00	26.10	034	37.00	35.10
008	11.00	9.10	017	20.00	18.10	026	29.00	27.10	035	38.00	36.10
009	12.00	10.10	018	21.00	19.10	027	30.00	28.10	036	39.00	37.10
010	13.00	11.10	019	22.00	20.10	028	31.00	29.10	037	40.00	38.10
011	14.00	12.10	020	23.00	21.10	029	32.00	30.10	038	41.00	39.10

How to order

FCL - xxx - V 100 - 99 / XX

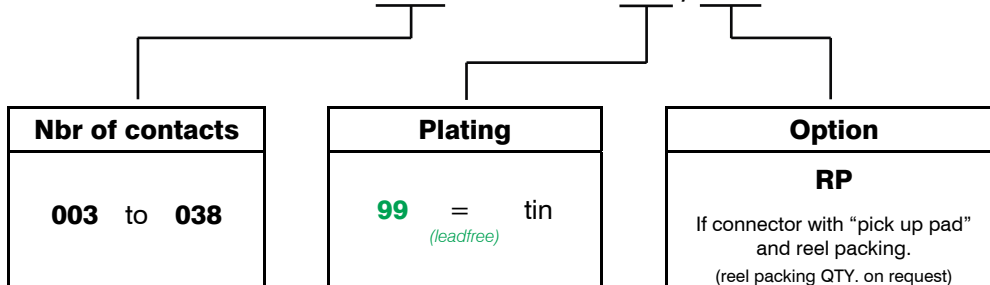

FPC/FFC Connector LIF Type

- SMT - 1.00mm pitch horizontal

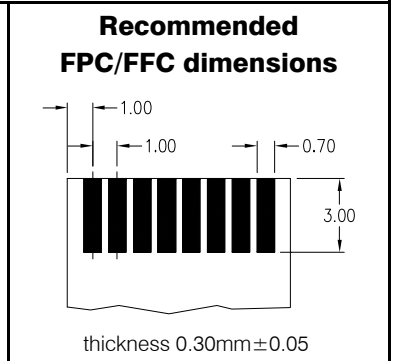
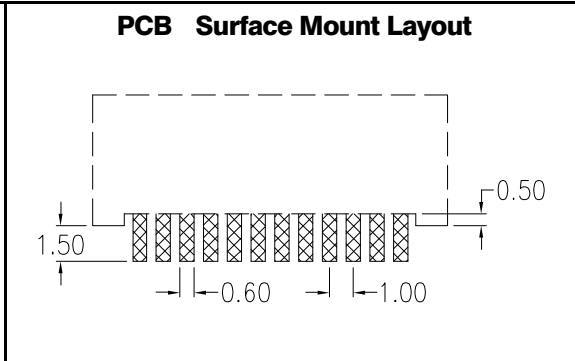
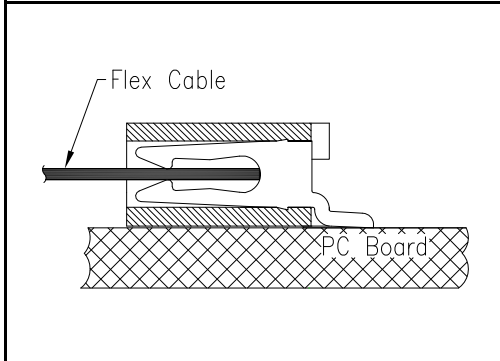
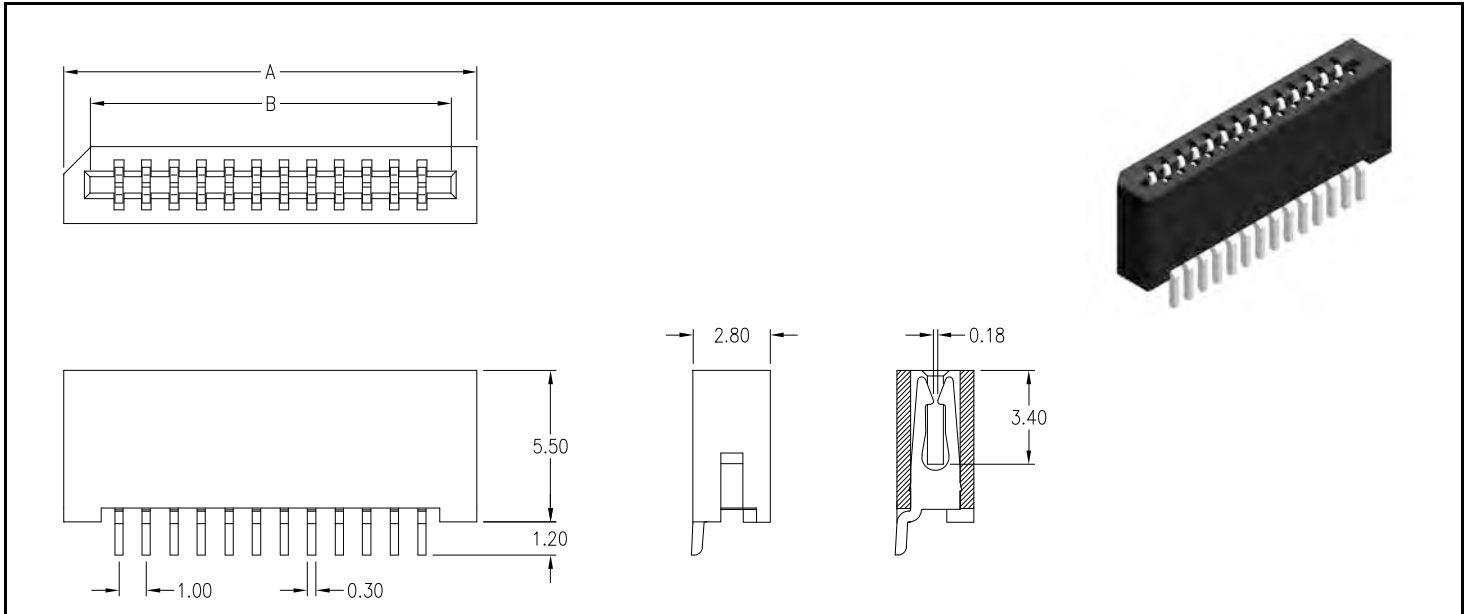

SPECIFICATIONS

Current rating	0.5 A max.	Operating temperature	- 40°C to +105°C
Insulator resistance	100 MΩ min.	Processing temperature	+250°C +0/-5°C for 3 sec.
Contact resistance	20 mΩ max.	Contact material	Phosphor Bronze (RoHS compliant)
Withstanding voltage	500 V AC/1 Min.	Contact plating	Tin (leadfree)
		Insulator material	Nylon (black) UL 94 V-0 (RoHS compliant)

Dimensions (mm)

Contacts	DIM "A"	DIM "B"	Contacts	DIM "A"	DIM "B"	Contacts	DIM "A"	DIM "B"	Contacts	DIM "A"	DIM "B"
003	6.00	4.10	012	15.00	13.10	021	24.00	22.10	030	33.00	31.10
004	7.00	5.10	013	16.00	14.10	022	25.00	23.10	031	34.00	32.10
005	8.00	6.10	014	17.00	15.10	023	26.00	24.10	032	35.00	33.10
006	9.00	7.10	015	18.00	16.10	024	27.00	25.10	033	36.00	34.10
007	10.00	8.10	016	19.00	17.10	025	28.00	26.10	034	37.00	35.10
008	11.00	9.10	017	20.00	18.10	026	29.00	27.10	035	38.00	36.10
009	12.00	10.10	018	21.00	19.10	027	30.00	28.10	036	39.00	37.10
010	13.00	11.10	019	22.00	20.10	028	31.00	29.10	037	40.00	38.10
011	14.00	12.10	020	23.00	21.10	029	32.00	30.10	038	41.00	39.10

How to order

FCL - xxx - H100 - 99 / X

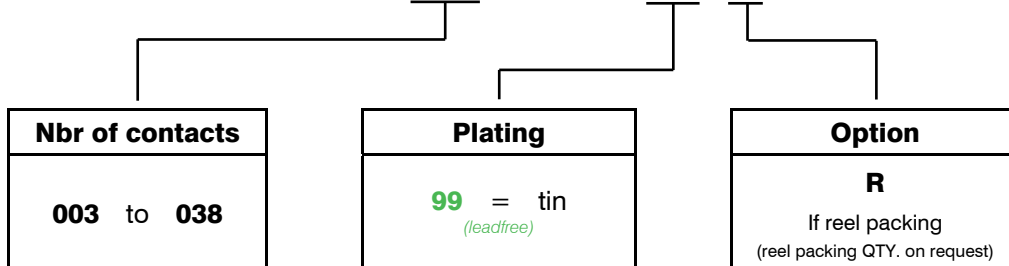

FFC/FPC Connector LIF Type

- THT - 1.00mm pitch vertical

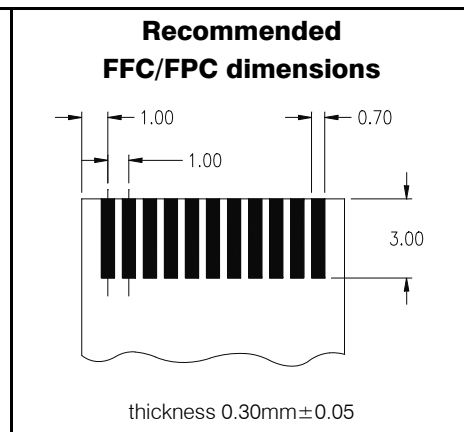
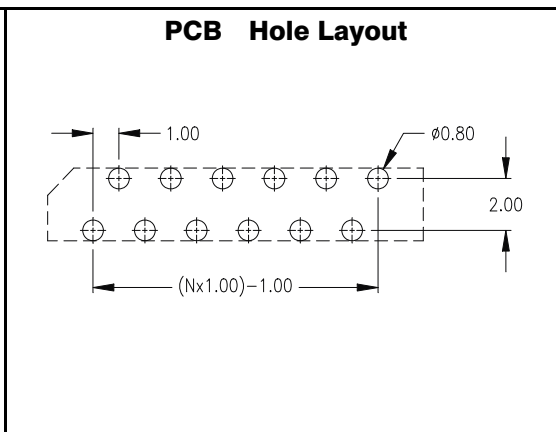
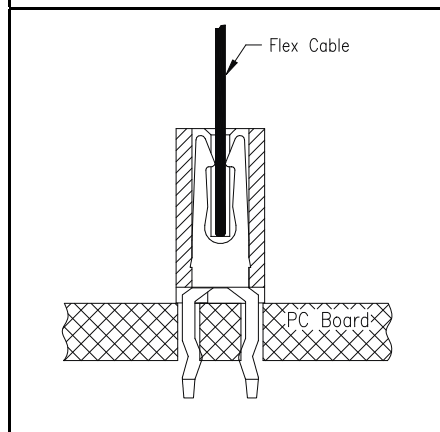
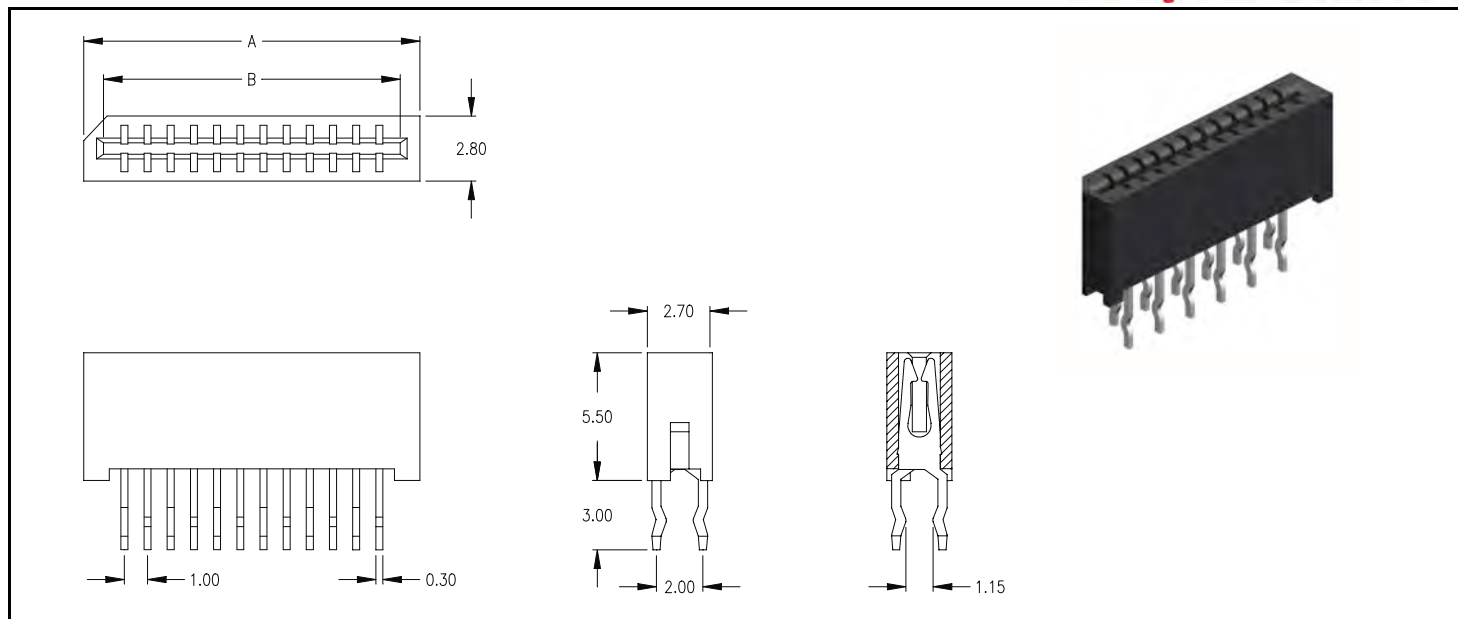

SPECIFICATIONS

Current rating	0.5 A max.	Operating temperature	- 40°C to +105°C
Insulator resistance	100 MΩ min.	Contact material	Phosphor Bronze (RoHS compliant)
Contact resistance	20 mΩ max.	Contact plating	Tin (leadfree)
Withstanding voltage	500 V AC/1 Min.	Insulator material	P.B.T. UL 94 V-0 (RoHS compliant)

Dimensions (mm)

Contacts	DIM "A"	DIM "B"	Contacts	DIM "A"	DIM "B"	Contacts	DIM "A"	DIM "B"	Contacts	DIM "A"	DIM "B"
004	6.50	5.20	012	14.50	13.20	020	22.50	21.20	028	30.50	29.20
005	7.50	6.20	013	15.50	14.20	021	23.50	22.20	029	31.50	30.20
006	8.50	7.20	014	16.50	15.20	022	24.50	23.20	030	32.50	31.20
007	9.50	8.20	015	17.50	16.20	023	25.50	24.20	031	33.50	32.20
008	10.50	9.20	016	18.50	17.20	024	26.50	25.20	032	34.50	33.20
009	11.50	10.20	017	19.50	18.20	025	27.50	26.20			
010	12.50	11.20	018	20.50	19.20	026	28.50	27.20			
011	13.50	12.20	019	21.50	20.20	027	29.50	28.20			

How to order

FCL - xxx - S100 - 99

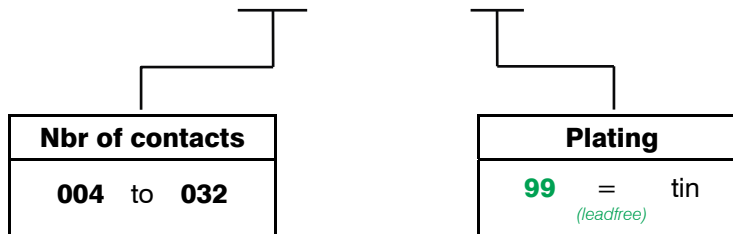

FPC/FFC Connector LIF Type

- THT - 1.00mm pitch right angle

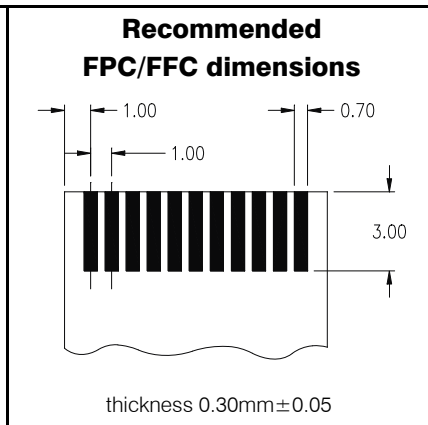
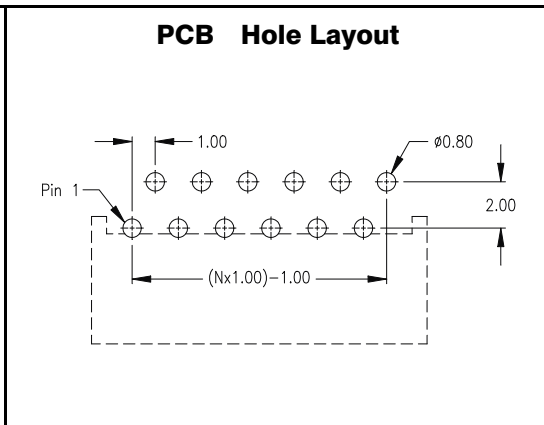
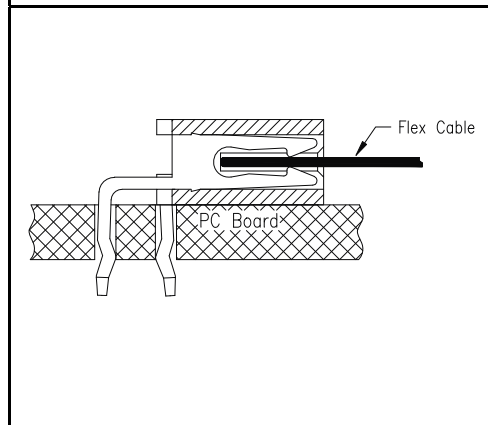
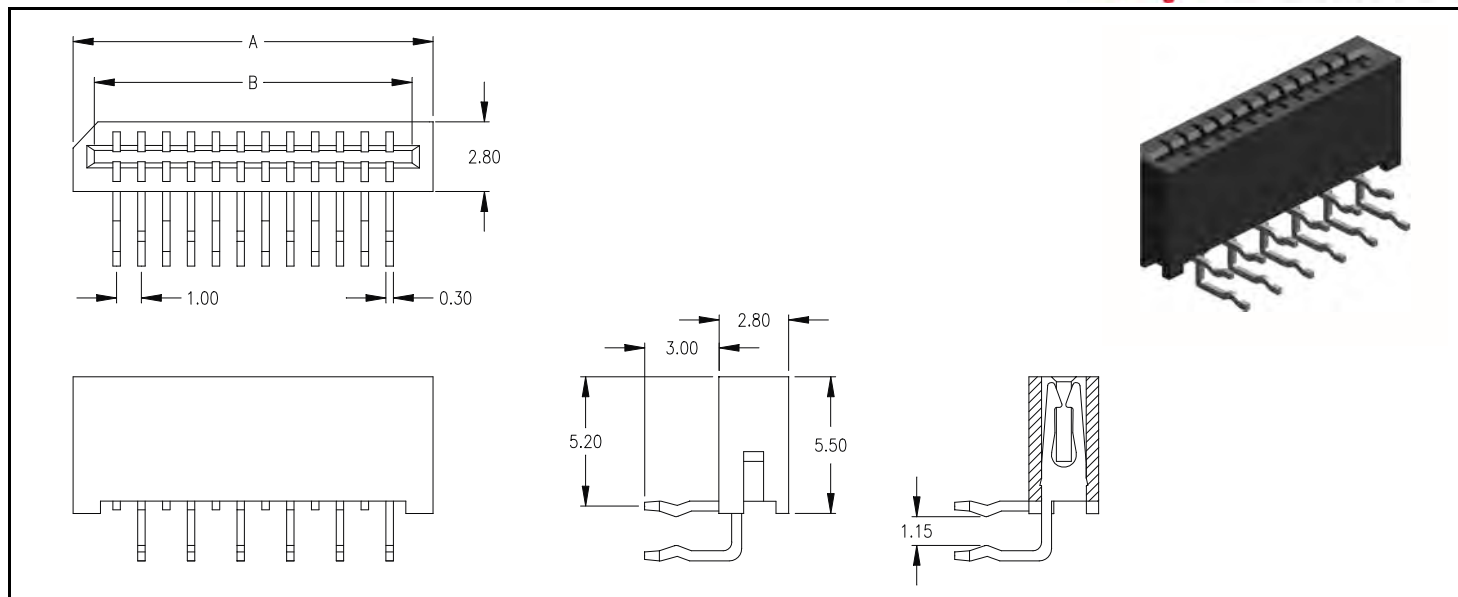

SPECIFICATIONS

Current rating	0.5 A max.	Operating temperature	- 40°C to +105°C
Insulator resistance	100 MΩ min.	Contact material	(RoHS compliant) Phosphor Bronze
Contact resistance	20 mΩ max.	Contact plating	Tin (leadfree)
Withstanding voltage	500 V AC/1 Min.	Insulator material	(RoHS compliant) P.B.T. UL 94 V-0

Dimensions (mm)

Contacts	DIM "A"	DIM "B"	Contacts	DIM "A"	DIM "B"	Contacts	DIM "A"	DIM "B"	Contacts	DIM "A"	DIM "B"
004	6.50	5.20	012	14.50	13.20	020	22.50	21.20	028	30.50	29.20
005	7.50	6.20	013	15.50	14.20	021	23.50	22.20	029	31.50	30.20
006	8.50	7.20	014	16.50	15.20	022	24.50	23.20	030	32.50	31.20
007	9.50	8.20	015	17.50	16.20	023	25.50	24.20	031	33.50	32.20
008	10.50	9.20	016	18.50	17.20	024	26.50	25.20	032	34.50	33.20
009	11.50	10.20	017	19.50	18.20	025	27.50	26.20			
010	12.50	11.20	018	20.50	19.20	026	28.50	27.20			
011	13.50	12.20	019	21.50	20.20	027	29.50	28.20			

How to order

FCL - xxx - R100 - 99

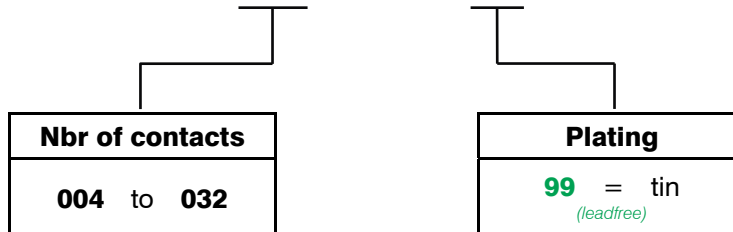

FPC/FFC Connector LIF Type

- SMT - 1.25mm pitch horizontal

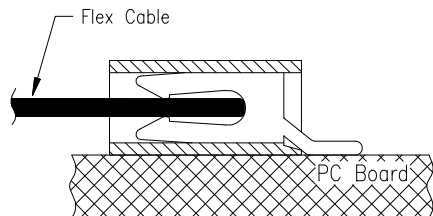
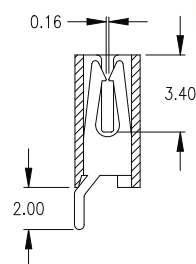
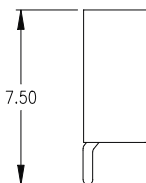
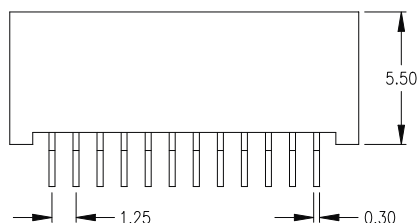
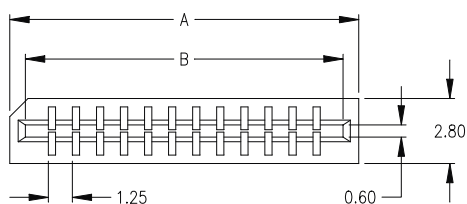

PCB Surface Mount Layout

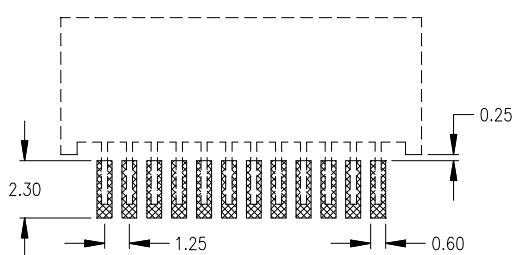

Recommended FPC/FFC dimensions

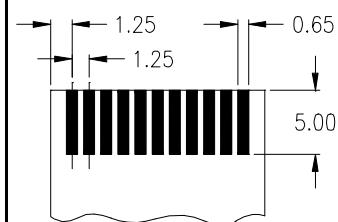

thickness 0.30mm±0.05

SPECIFICATIONS

Current rating	1 A max.
Insulator resistance	500 MΩ min.
Contact resistance	20 mΩ max.
Withstanding voltage	500 V AC/1 Min.

Operating temperature	- 40°C to +105°C
Processing temperature	+250°C +0/-5°C for 3sec.
Contact material	Phosphor Bronze (RoHS compliant)
Contact plating	Tin (leadfree)
Insulator material	Nylon (black) UL 94 V-0 (RoHS compliant)

Dimensions (mm)

Contacts	DIM "A"	DIM "B"	Contacts	DIM "A"	DIM "B"	Contacts	DIM "A"	DIM "B"	Contacts	DIM "A"	DIM "B"
003	7.15	5.05	012	18.40	16.30	021	29.65	27.55	030	40.90	38.80
004	8.40	6.30	013	19.65	17.55	022	30.90	28.80	031	42.15	40.05
005	9.65	7.55	014	20.90	18.80	023	32.15	30.05	032	43.40	41.30
006	10.90	8.80	015	22.15	20.05	024	33.40	31.30	033	44.65	42.55
007	12.15	10.05	016	23.40	21.30	025	34.65	32.55	034	45.90	43.80
008	13.40	11.30	017	24.65	22.55	026	35.90	33.80	035	47.15	45.05
009	14.65	12.55	018	25.90	23.80	027	37.15	35.05	036	48.40	46.30
010	15.90	13.80	019	27.15	25.05	028	38.40	36.30			
011	17.50	15.05	020	28.40	26.30	029	39.65	37.55			

How to order

FCL - xxx - H125 - 99

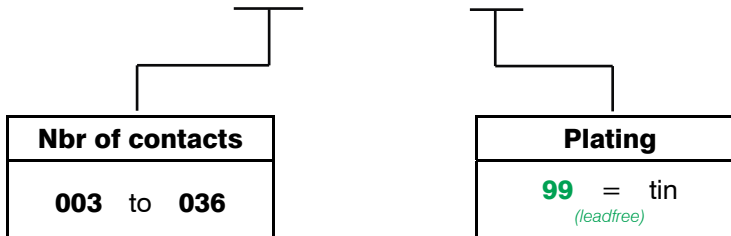

FPC/FFC Connector LIF Type
 - THT - 1.25mm pitch vertical

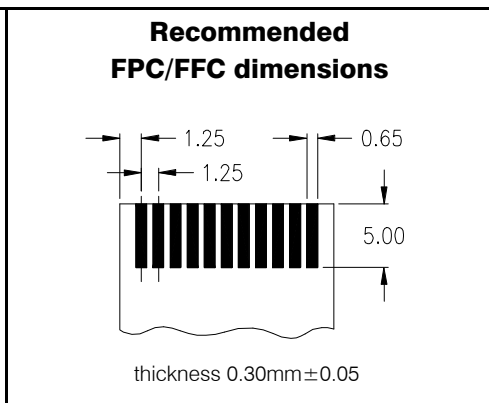
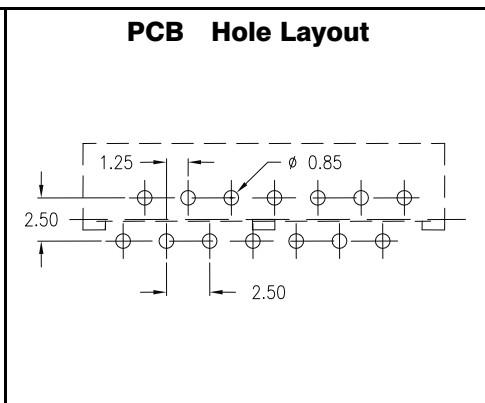
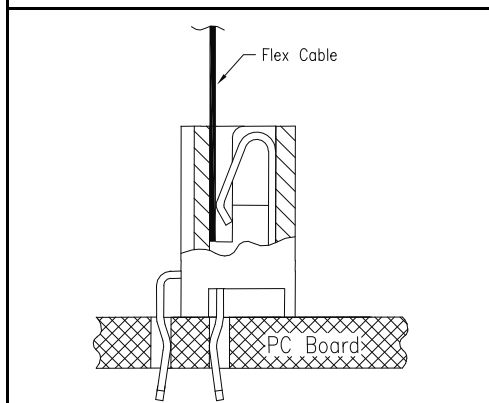
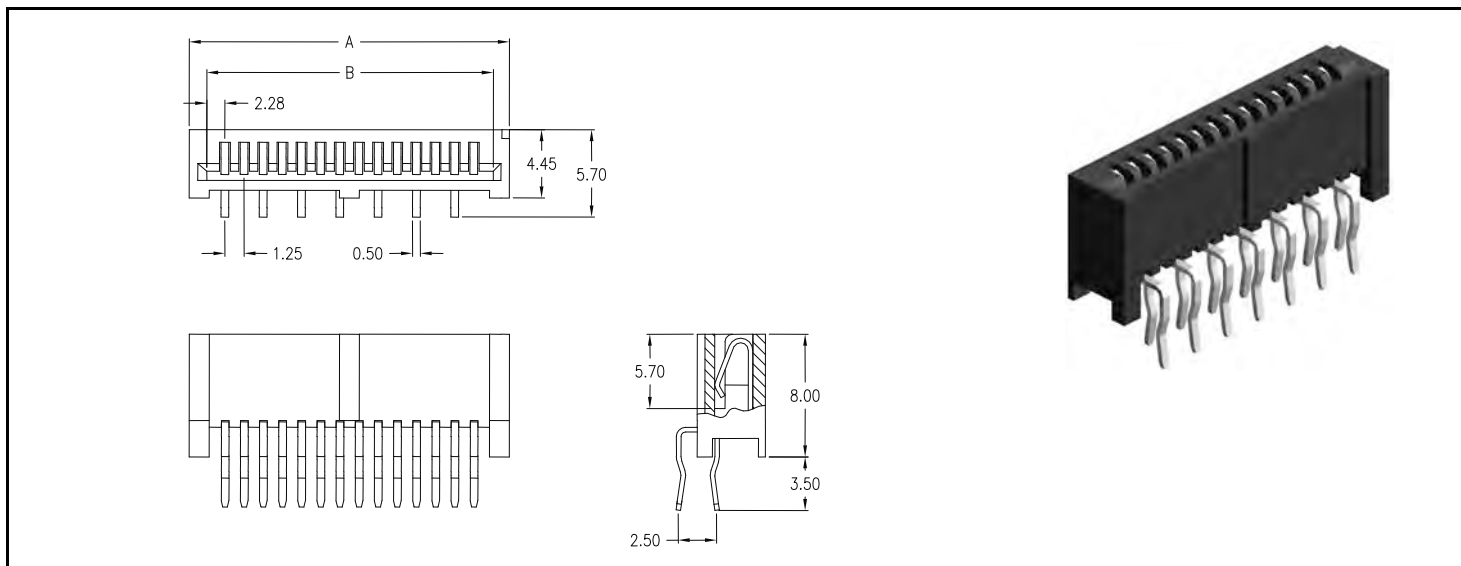

SPECIFICATIONS			
Current rating	1 A max.	Operating temperature	- 40° to +105°C
Insulator resistance	500 MΩ min.	Contact material	(RoHS compliant) Phosphor Bronze
Contact resistance	20 mΩ max.	Contact plating	Tin (leadfree)
Withstanding voltage	500 V AC/1 Min.	Insulator material	(RoHS compliant) Nylon (black) UL 94 V-0

Dimensions (mm)											
Contacts	DIM "A"	DIM "B"	Contacts	DIM "A"	DIM "B"	Contacts	DIM "A"	DIM "B"	Contacts	DIM "A"	DIM "B"
003	7.15	5.10	011	17.15	15.10	019	27.15	25.10	027	37.15	35.10
004	8.40	6.35	012	18.40	16.35	020	28.40	26.35	028	38.40	36.35
005	9.65	7.60	013	19.65	17.60	021	29.65	27.60	029	39.65	37.60
006	10.90	8.85	014	20.90	18.85	022	30.90	28.85	030	40.90	38.85
007	12.15	10.10	015	22.15	20.10	023	32.15	30.10	031	42.15	40.10
008	13.40	11.35	016	23.40	21.35	024	33.40	31.35	032	43.40	41.35
009	14.65	12.60	017	24.65	22.60	025	34.65	32.60	033	44.65	42.60
010	15.90	13.85	018	25.90	23.85	026	35.90	33.85			

How to order

FCL - xxx - S125 - 99

Nbr of contacts
 003 to 033

Plating
 99 = tin
 (leadfree)

FPC/FFC Connector LIF Type
 - THT - 1.25mm pitch right angle

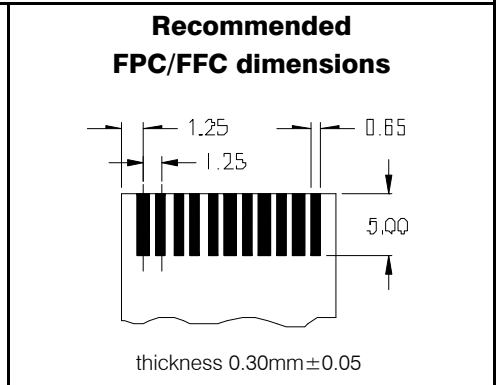
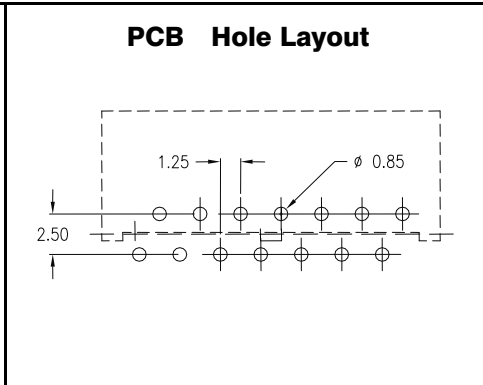
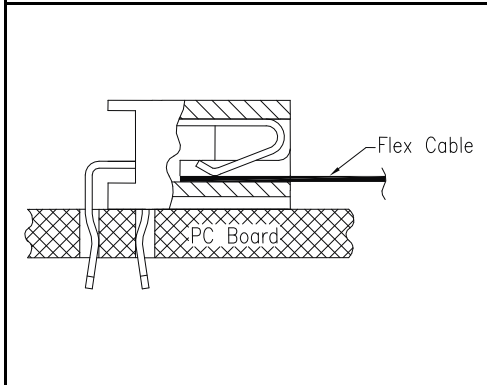
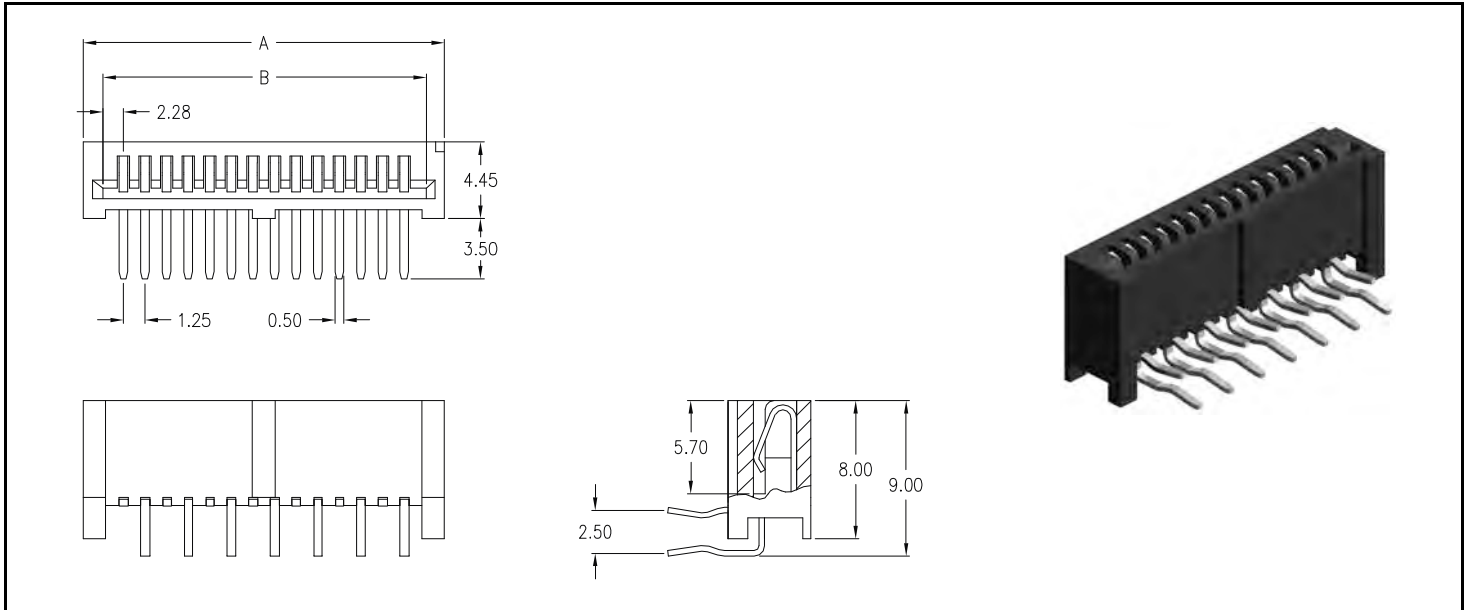

SPECIFICATIONS

Current rating	1 A max.	Operating temperature	- 40° to +105°C
Insulator resistance	500 M Ω min.	Contact material	Phosphor Bronze (RoHS compliant)
Contact resistance	20 m Ω max.	Contact plating	Tin (leadfree)
Withstanding voltage	500 V AC/1 Min.	Insulator material	Nylon (black) UL 94 V-0 (RoHS compliant)

Dimensions (mm)

Contacts	DIM "A"	DIM "B"	Contacts	DIM "A"	DIM "B"	Contacts	DIM "A"	DIM "B"	Contacts	DIM "A"	DIM "B"
003	7.15	5.10	011	17.15	15.10	019	27.15	25.10	027	37.15	35.10
004	8.40	6.35	012	18.40	16.35	020	28.40	26.35	028	38.40	36.35
005	9.65	7.60	013	19.65	17.60	021	29.65	27.60	029	39.65	37.60
006	10.90	8.85	014	20.90	18.85	022	33.90	28.85	030	40.90	38.85
007	12.15	10.10	015	22.15	20.10	023	32.15	30.10	031	42.15	40.10
008	13.40	11.35	016	23.40	21.35	024	33.40	31.35	032	43.40	41.35
009	14.65	12.60	017	24.65	22.60	025	34.65	32.60	033	44.65	42.60
010	15.90	13.85	018	25.90	23.85	026	35.90	33.85			

How to order

FCL - xxx - R125 - 99

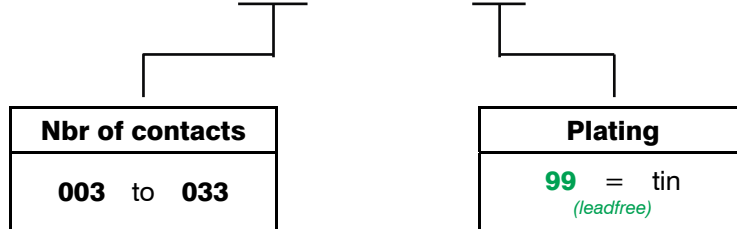

FPC/FFC Connector ZIF Type

- THT - 1.25mm pitch straight & right angle

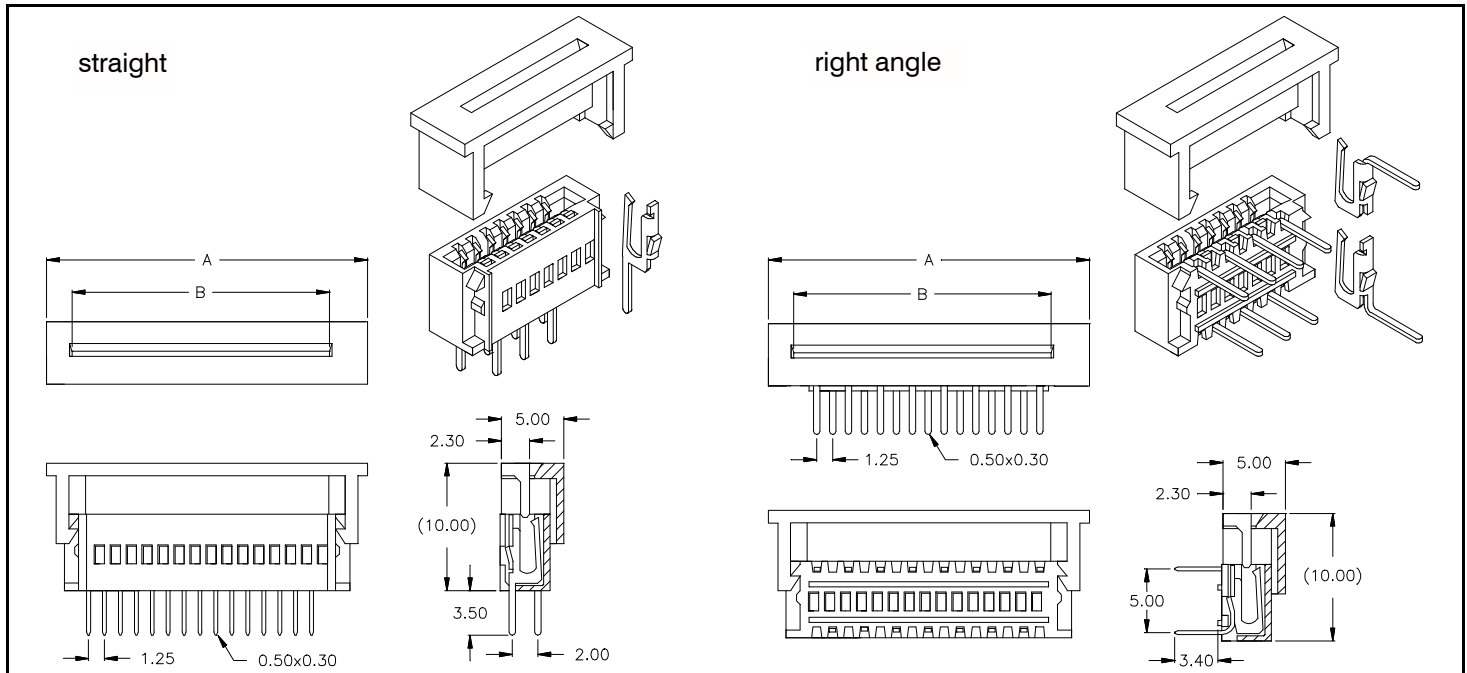

PCB Hole Layout

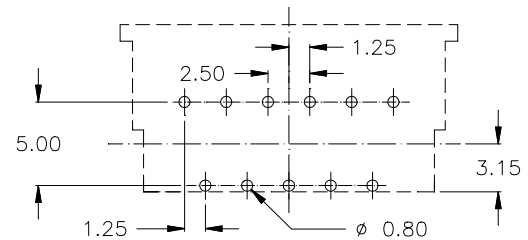
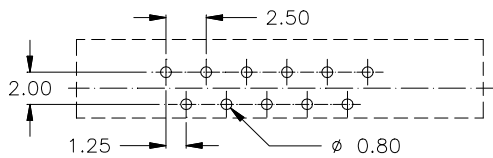

SPECIFICATIONS

Current rating	1 A max.
Insulator resistance	500 MΩ min.
Contact resistance	20 mΩ max.
Withstanding voltage	500 V AC/1 Min.
Operating temperature	-20°C to +85°C
Contact material	Phosphor Bronze (RoHS compliant)
Contact plating	Tin (leadfree)
Insulator material	P.B.T. UL 94 V-0 (RoHS compliant)

Recommended FPC/FFC dimensions

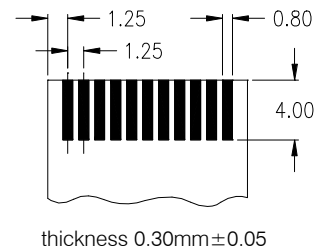

Dimensions (mm)

Contacts	DIM "A"	DIM "B"	Contacts	DIM "A"	DIM "B"	Contacts	DIM "A"	DIM "B"	Contacts	DIM "A"	DIM "B"
003	9.55	5.20	011	19.55	15.20	019	29.55	25.20	027	39.55	35.20
004	10.80	6.45	012	20.80	16.45	020	30.80	26.45	028	40.80	36.45
005	12.05	7.70	013	22.05	17.70	021	32.05	27.70	029	42.05	37.70
006	13.30	8.95	014	23.30	18.95	022	33.30	28.95	030	43.30	38.95
007	14.55	10.20	015	24.55	20.20	023	34.55	30.20	031	44.55	40.20
008	15.80	11.45	016	25.80	21.45	024	35.80	31.45	032	45.80	41.45
009	17.05	12.70	017	27.05	22.70	025	37.05	32.70			
010	18.30	13.95	018	28.30	23.95	026	38.30	33.95			

How to order

FCZ - xxx - X 125 - 99

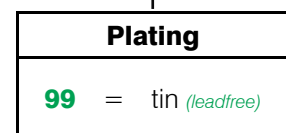
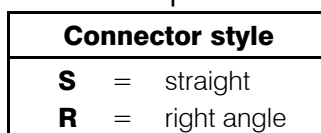
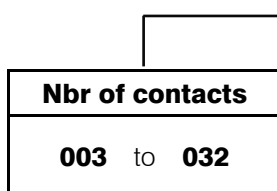

FPC/FFC Connector LIF Type

- THT - 2.54mm pitch vertical

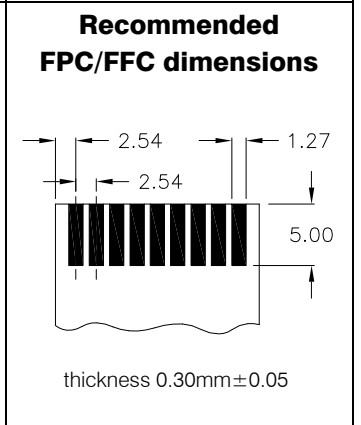
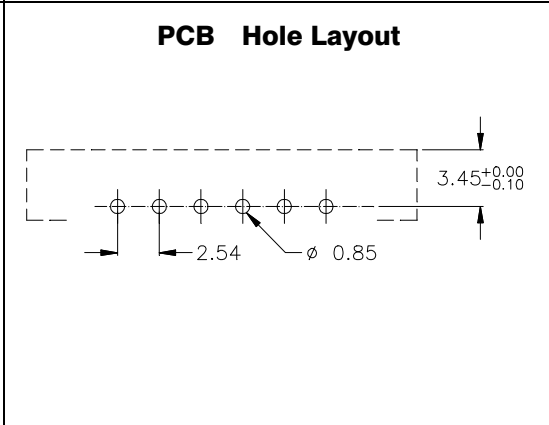
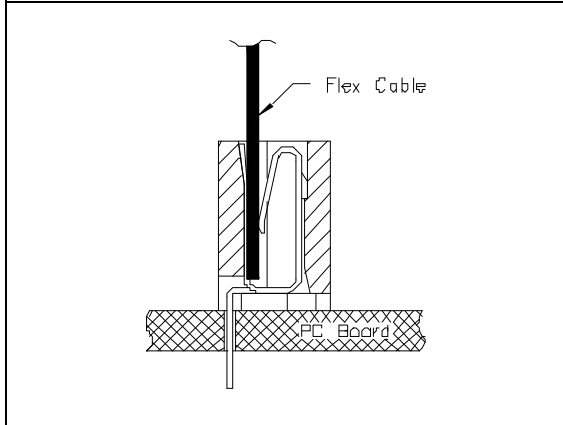
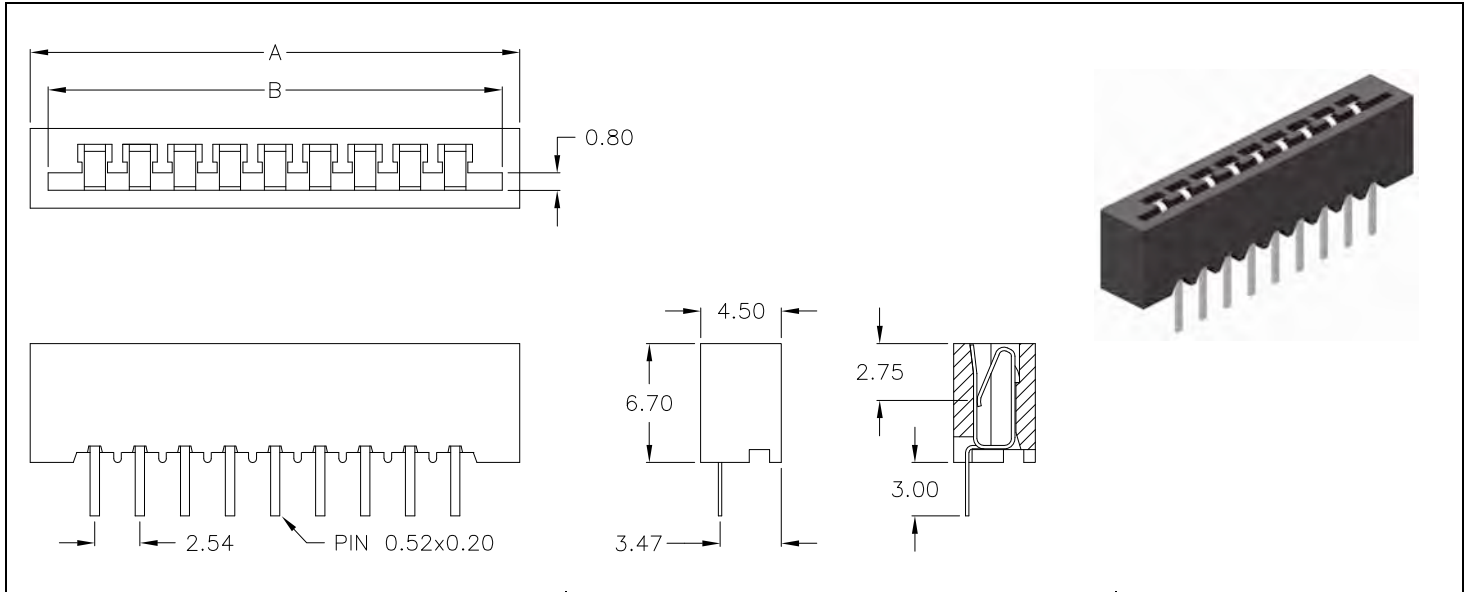

SPECIFICATIONS

Current rating	1 A max.	Operating temperature	- 55°C to +85°C
Insulator resistance	1000 MΩ min.	Contact material	Phosphor Bronze (RoHS compliant)
Contact resistance	25 mΩ max.	Contact plating	Tin (leadfree)
Withstanding voltage	500 V AC	Insulator material	P.B.T. UL 94 V-0 (RoHS compliant)

Dimensions (mm)

Contacts	DIM "A"	DIM "B"	Contacts	DIM "A"	DIM "B"	Contacts	DIM "A"	DIM "B"	Contacts	DIM "A"	DIM "B"
002	10.54	8.43	009	28.32	26.21	016	46.10	43.99	023	63.88	61.77
003	13.08	10.97	010	30.86	28.75	017	48.64	46.53	024	66.42	64.31
004	15.62	13.51	011	33.40	31.29	018	51.18	49.07	025	68.96	66.85
005	18.16	16.05	012	35.94	33.83	019	53.72	51.60	026	71.50	69.39
006	20.70	18.59	013	38.48	36.37	020	56.26	54.15			
007	23.24	21.13	014	41.02	38.91	021	58.80	56.69			
008	25.78	23.67	015	43.56	41.45	022	61.34	59.23			

How to order

FPC - xxx - S254 - 99

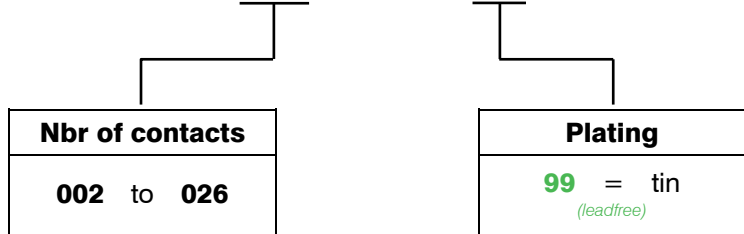

FPC/FFC Connector LIF Type

- THT - 2.54mm pitch right angle

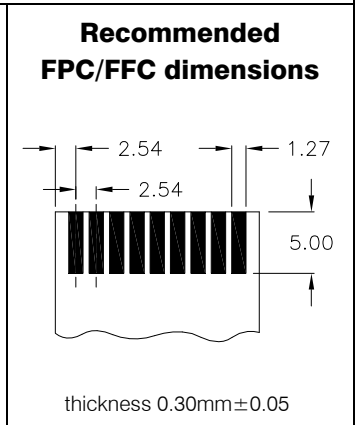
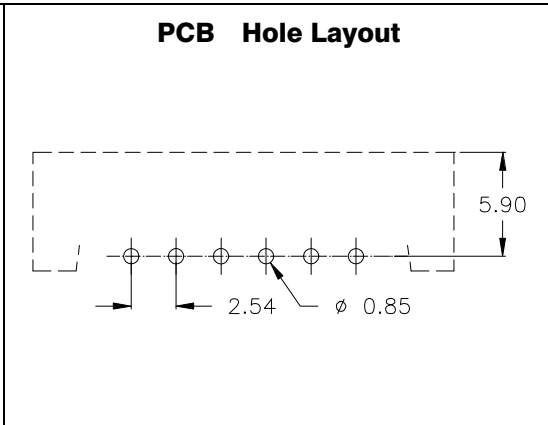
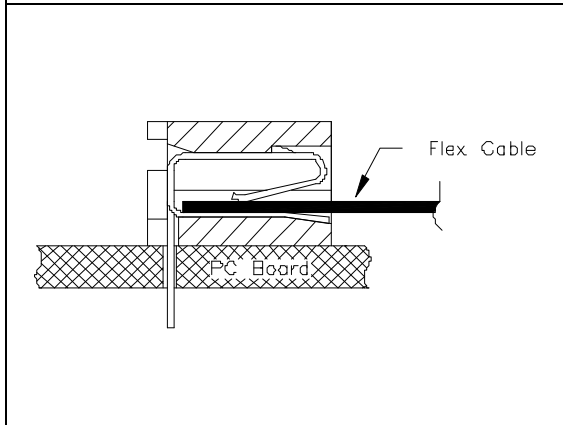
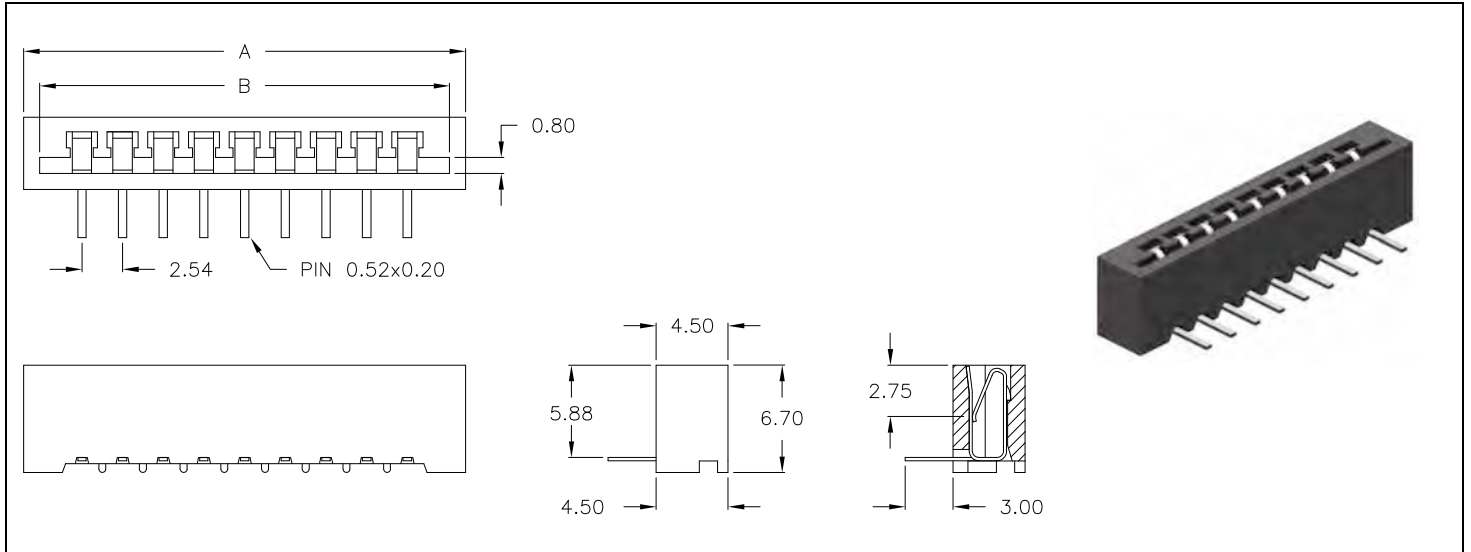

SPECIFICATIONS

Current rating	1 A max.	Operating temperature	- 55°C to +85°C
Insulator resistance	1000 MΩ min.	Contact material	Phosphor Bronze (RoHS compliant)
Contact resistance	25 mΩ max.	Contact plating	Tin (leadfree)
Withstanding voltage	500 V AC	Insulator material	P.B.T. UL 94 V-0 (RoHS compliant)

Dimensions (mm)

Contacts	DIM "A"	DIM "B"	Contacts	DIM "A"	DIM "B"	Contacts	DIM "A"	DIM "B"	Contacts	DIM "A"	DIM "B"
002	10.54	8.43	009	28.32	26.21	016	46.10	43.99	023	63.88	61.77
003	13.08	10.97	010	30.86	28.75	017	48.64	46.53	024	66.42	64.31
004	15.62	13.51	011	33.40	31.29	018	51.18	49.07	025	68.96	66.85
005	18.16	16.05	012	35.94	33.83	019	53.72	51.60	026	71.50	69.39
006	20.70	18.59	013	38.48	36.37	020	56.26	54.15			
007	23.24	21.13	014	41.02	38.91	021	58.80	56.69			
008	25.78	23.67	015	43.56	41.45	022	61.34	59.23			

How to order

FPC - xxx - R254 - 99

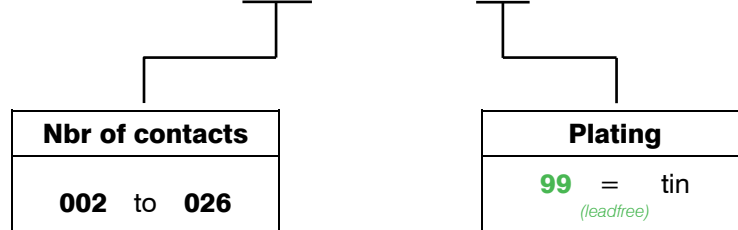

Flex Cable

0.50mm to 2.54mm pitch

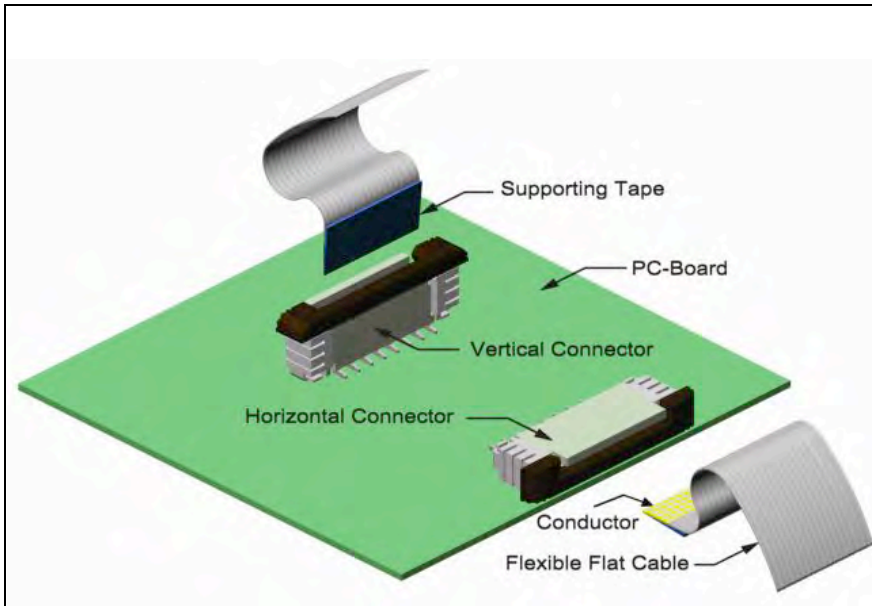

SPECIFICATIONS

Conductor resistance	according to JIS C-C3102 (@ 20°C)
Insulation resistance	> 1000 MΩ/m @ 500 V DC
Dielectric strength	500 V, 0.5Ma / 1 Minute
Operating temperature	-40°C to ~ +80°C
Flame Test	UL Sub, 758 VW-1

Flexing Test

- A) Bending angle: 180°, R=Cable thickness ≥ 20 cycles
- B) 10mmR, 70 cycle/Min., 25mm Reciprocate ≥ 100.000 cycles

Abrasion Test

ø5.0mm, 600g, 60 cycle/Min. ≥ 10.000 cycles

Dimensions

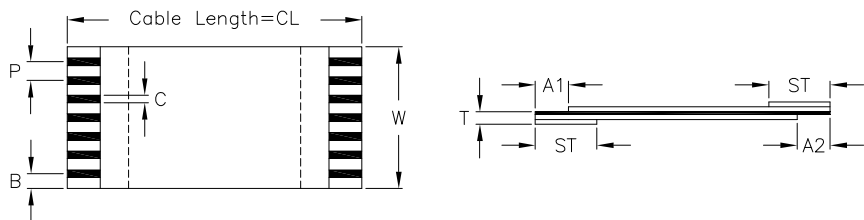

Cable Type



	"P" (Pitch)	"C"	"B"	"W"	"CL"	"T"	"A1"	"A2"	"ST"
Range	0.50 - 2.54	0.30 - 0.80	same as "P"	P×(n+1)	20.00 min.	0.30	3.00 - 6.00	3.00 - 6.00	6.00 - 15.00
Tolerance	±0.05	±0.05	±0.15	±0.10	see Note	±0.05	±1.00	±1.00	±2.00

Note : 20 - 100mm ±2.00mm 101 - 200mm ±3.00mm 201 - 300mm ±4.00mm 301mm ↑ ±5.00mm

How to order

FCA - x xx - X xxx - 4406 - x

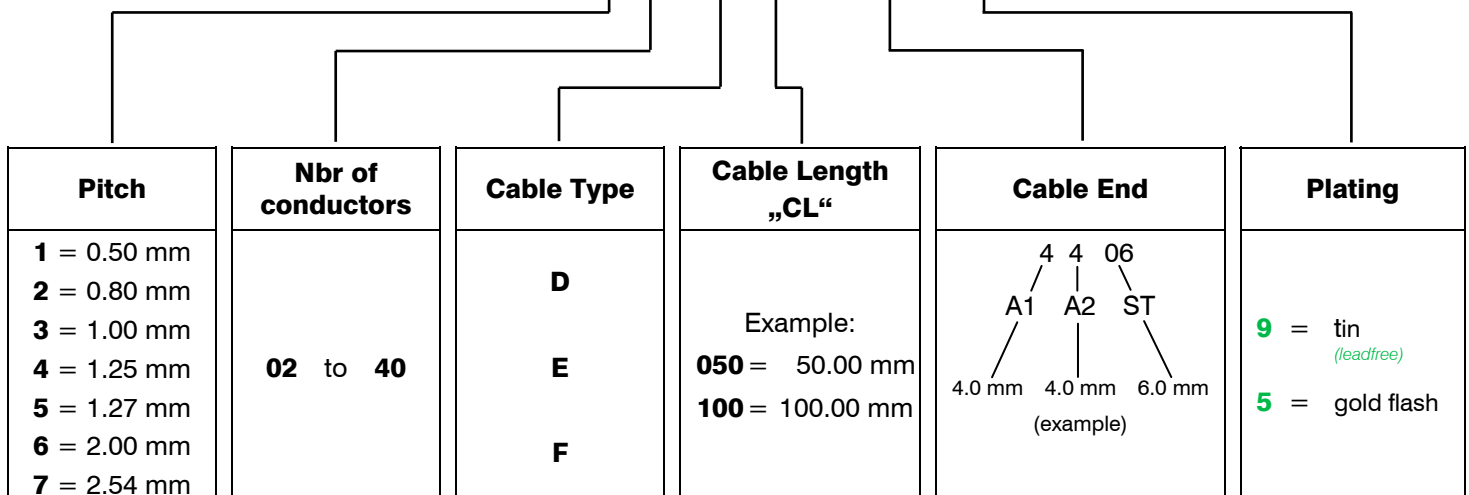

ZIF Test Sockets for Flex Cable

0.50mm to 2.54mm pitch



High cycle ZIF Test Sockets for any kind and pitch of Flex-Cable.

Handles up to 10K cycles with simple open/close ClamShell type retention frame.

Cable Dimensions

In order to be able to offer the correct socket for your cable, we need to know the type of cable you are using and the corresponding dimensions as shown below.

Please send the datasheet of your cable together with your socket request.

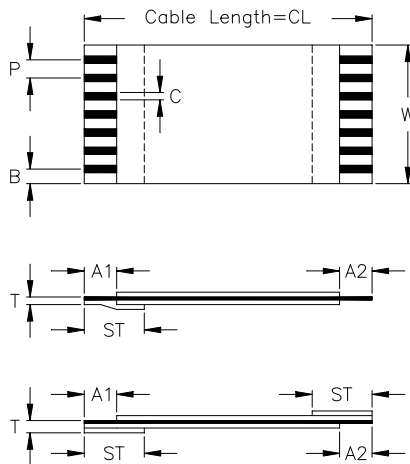

SPECIFICATIONS

<p>Mechanical data Contact life Retention System life Solderability Individual contact force</p> <p>Material Insulator (RoHS compliant) Terminal (RoHS compliant) Spring (RoHS compliant)</p> <p>Electrical data Contact resistance Current rating Insulation resistance at 500V DC Breakdown voltage at 60 Hz Capacitance Inductance</p> <p>Operating temperature</p> <p>Processing temperature</p>	<p>10.000 cycles min. 10.000 cycles min. as per IEC 60068-2-58 40 grams max.</p> <p>High temp plastic or epoxy FR4 Brass BeCu</p> <p>< 100 mΩ 500 mA max. 100 MΩ if 0.50 to 0.80mm pitch 500 MΩ 1.00mm pitch upwards 500V min. < 1 pF < 2 nH</p> <p>-55°C to +125°C</p> <p>260°C for 60sec.</p>
--	---

A detailed socket drawing with the required PCB layout dimensions will be submitted by E-tec for each project.

How to order

FCT - x xx - X xxx - xx

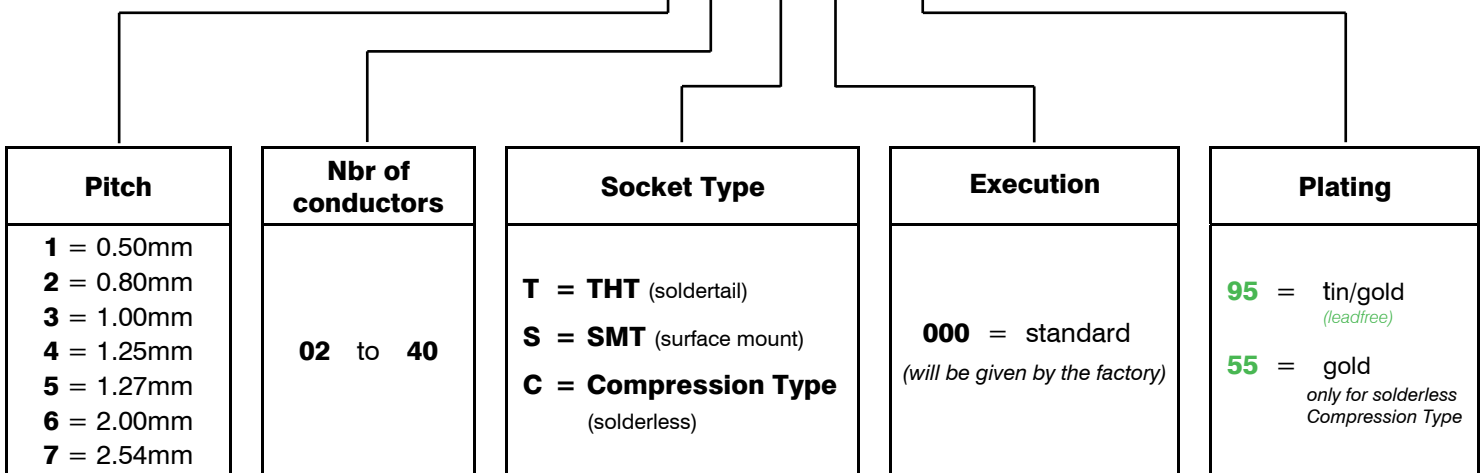

Mini – Flex Connector
 IDC pitch 1,27mm shrouded male

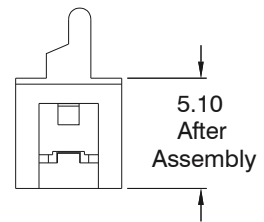
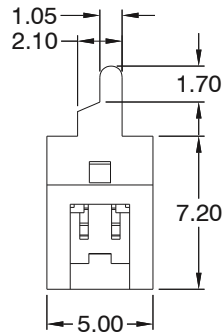
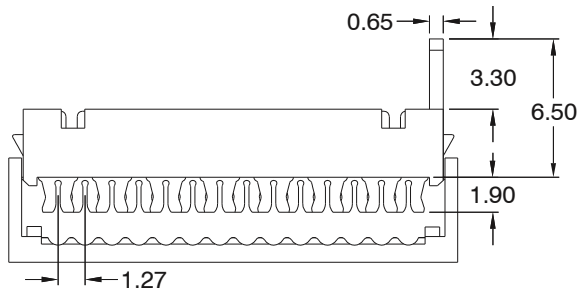
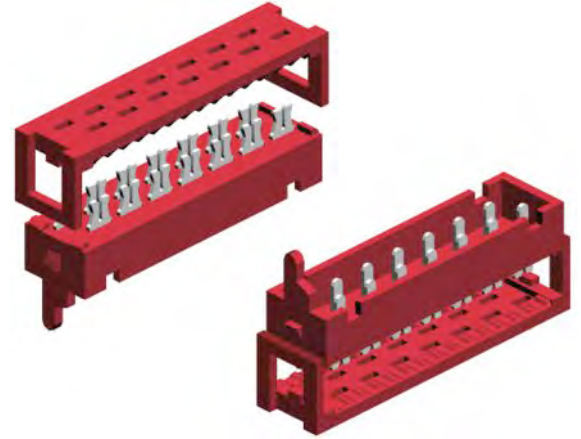
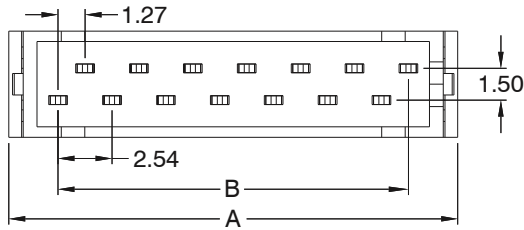

SPECIFICATIONS

Current rating	1.5 A
Nominal rating	230 V
Contact resistance	10 mΩ max.
Insulator resistance	1000 MΩ min.
Withstanding voltage	500 V AC
Operating temperature	-40°C to +105°C
Insulator material	P.B.T. (red) UL 94 V-0
Contact material	Phosphor Bronze

RIBBON CABLE RECOMMENDATION

Cable Type	Ribbon UL Style 2651
Spacing	1.27 mm
Wire range	stranded 0.08-0.09 mm ² AWG28 solid Ø 0.30
Insulation Diameter	0.90 mm

Dimensions (mm)

Contacts	DIM "A"	DIM "B"	Contacts	DIM "A"	DIM "B"	Contacts	DIM "A"	DIM "B"
004	8.45	3.81	012	18.61	13.97	020	28.77	24.13
006	10.99	6.35	014	21.15	16.51			
008	13.53	8.89	016	23.69	19.05			
010	16.07	11.43	018	26.23	21.59			

How to order

MFM - xxx - DC50 - 99

Nbr of contacts
004; 006; 008; 010 012; 014; 016; 018 020

Plating
99 = Tin
Other platings on request

Mini – Flex Connector

IDC pitch 1,27mm - THT - Plug

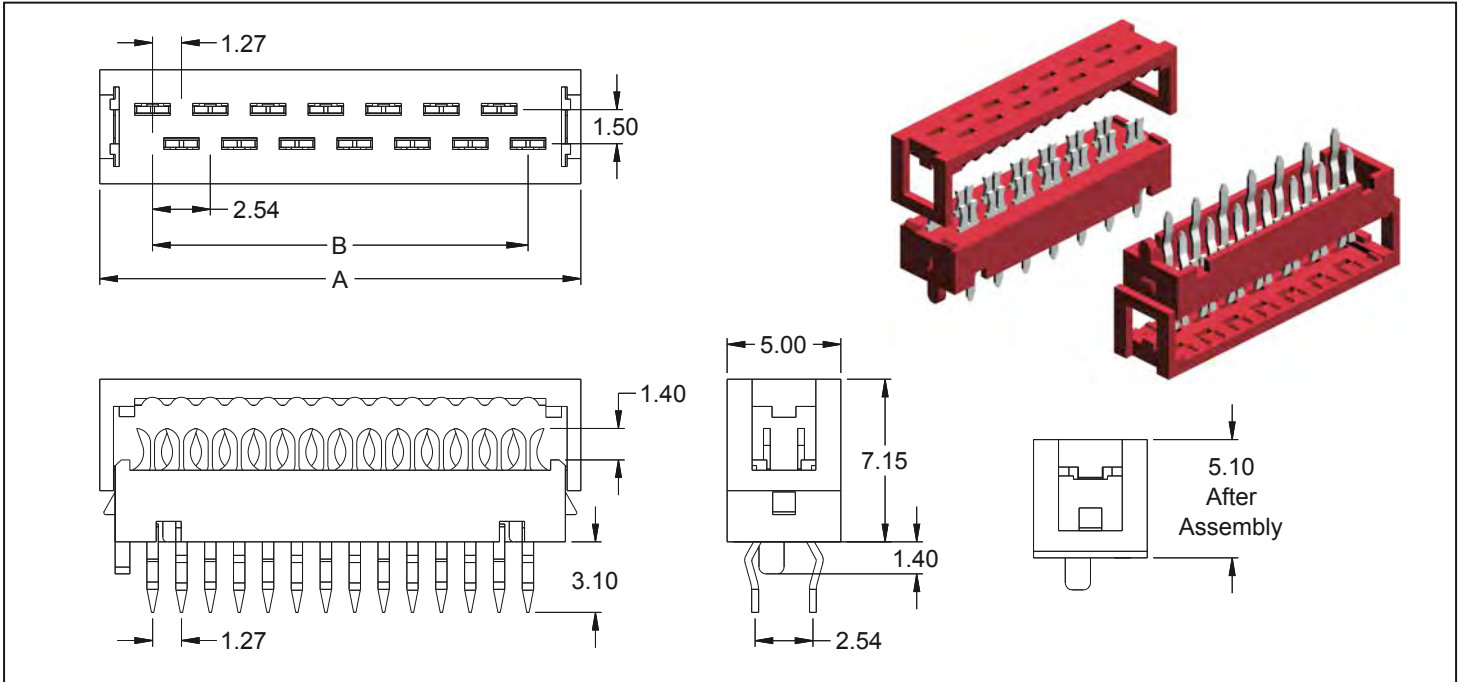

PCB Hole Layout

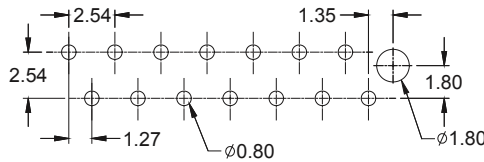

SPECIFICATIONS

Current rating	1.5 A
Nominal rating	230 V
Contact resistance	10 mΩ max.
Insulator resistance	1000 MΩ min.
Withstanding voltage	500 V AC
Operating temperature	-40°C to +105°C
Insulator material	P.B.T. (red) UL 94 V-0
Contact material	Phosphor Bronze

RIBBON CABLE RECOMMENDATION

Cable Type	Ribbon UL Style 2651
Spacing	1.27 mm
Wire range	stranded 0.08-0.09 mm ² AWG28 solid Ø 0.30
Insulation Diameter	0.90 mm

Dimensions (mm)

Contacts	DIM "A"	DIM "B"	Contacts	DIM "A"	DIM "B"	Contacts	DIM "A"	DIM "B"
004	8.45	3.81	012	18.61	13.97	020	28.77	24.13
006	10.99	6.35	014	21.15	16.51			
008	13.53	8.89	016	23.69	19.05			
010	16.07	11.43	018	26.23	21.59			

How to order

MFP - xxx - DC50 - 99

Nbr of contacts
004; 006; 008; 010 012; 014; 016; 018 020

Plating
99 = Tin
Other platings on request

Mini - Mate Connector

- SMT - female Block Shape

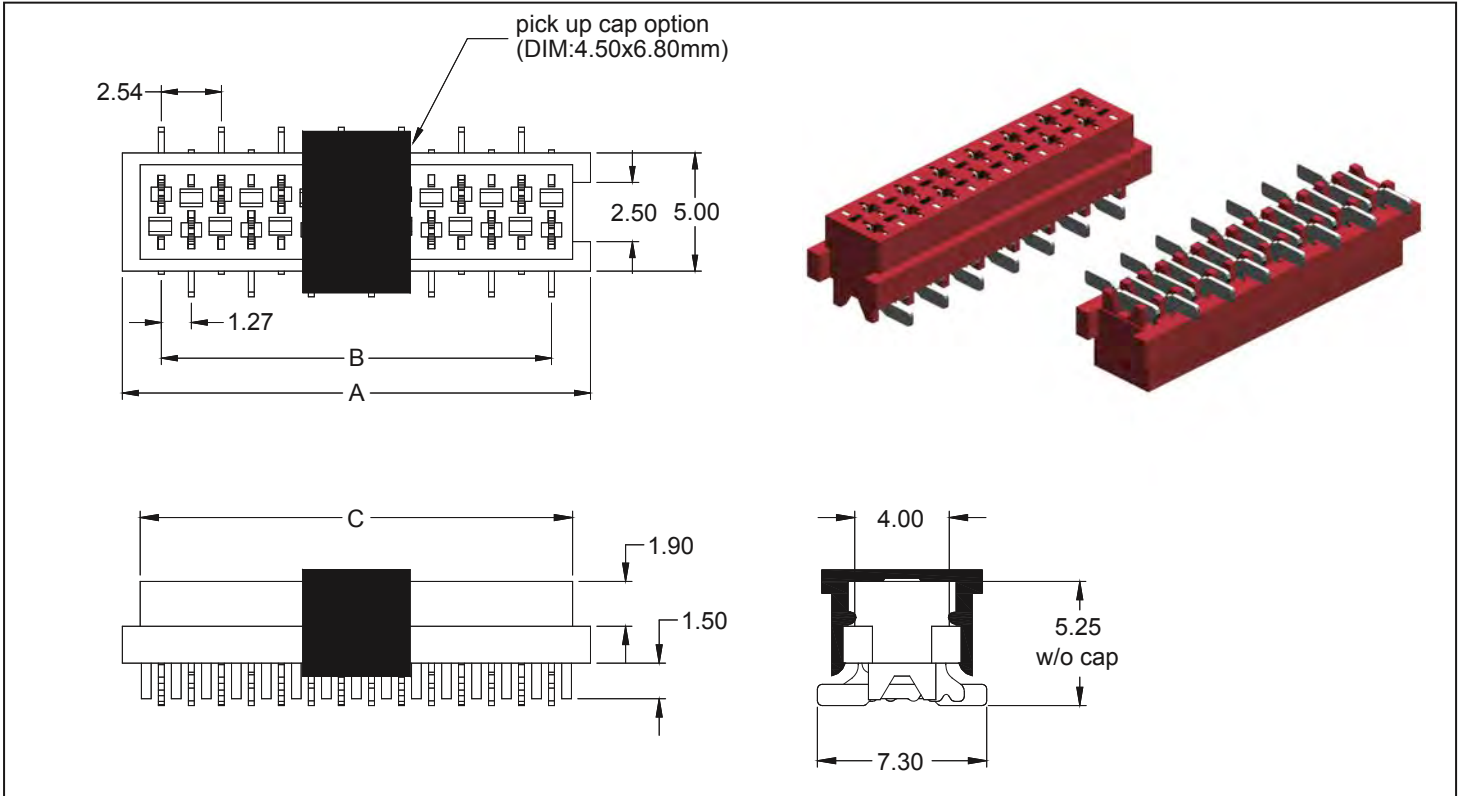

SPECIFICATIONS

Current rating	1 A
Nominal rating	230 V
Contact resistance	10 mΩ max.
Insulator resistance	1000 MΩ min.
Withstanding voltage	500 V AC
Operating temperature	-40°C to +105°C
Processing temperature	+260°C +0/-5°C for 5sec.
Preheating	150°C±10°C/1~2 Min.
Insulator material	Nylon 46 (red) UL 94 V-0
Contact material	Phosphor Bronze

PCB Surface Mount Layout

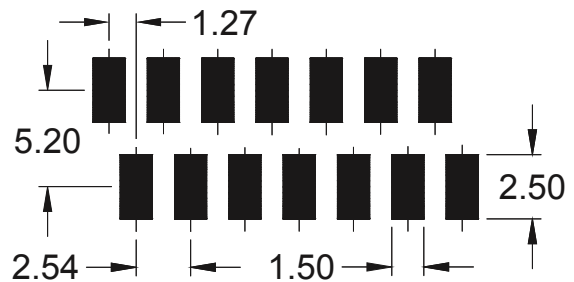

Dimensions (mm)

Contacts	DIM "A"	DIM "B"	DIM "C"	Contacts	DIM "A"	DIM "B"	DIM "C"	Contacts	DIM "A"	DIM "B"	DIM "C"
004	7.00	3.81	5.60	012	17.16	13.97	15.76	020	27.32	24.13	25.92
006	9.54	6.35	8.14	014	19.70	16.51	18.30				
008	12.08	8.89	10.68	016	22.24	19.05	20.84				
010	14.62	11.43	13.22	018	24.78	21.59	23.38				

How to order

MMF - xxx - HB50 - 99 / X

Nbr of contacts
004; 006; 008; 010 012; 014; 016; 018 020

Plating
99 = Tin
Other platings on request

Option
A = tube packing; with pick & place pad
B = reel packing; with pick & place pad
T = tube packing; without pick & place pad

Mini - Mate Connector

- SMT - female Latch Shape

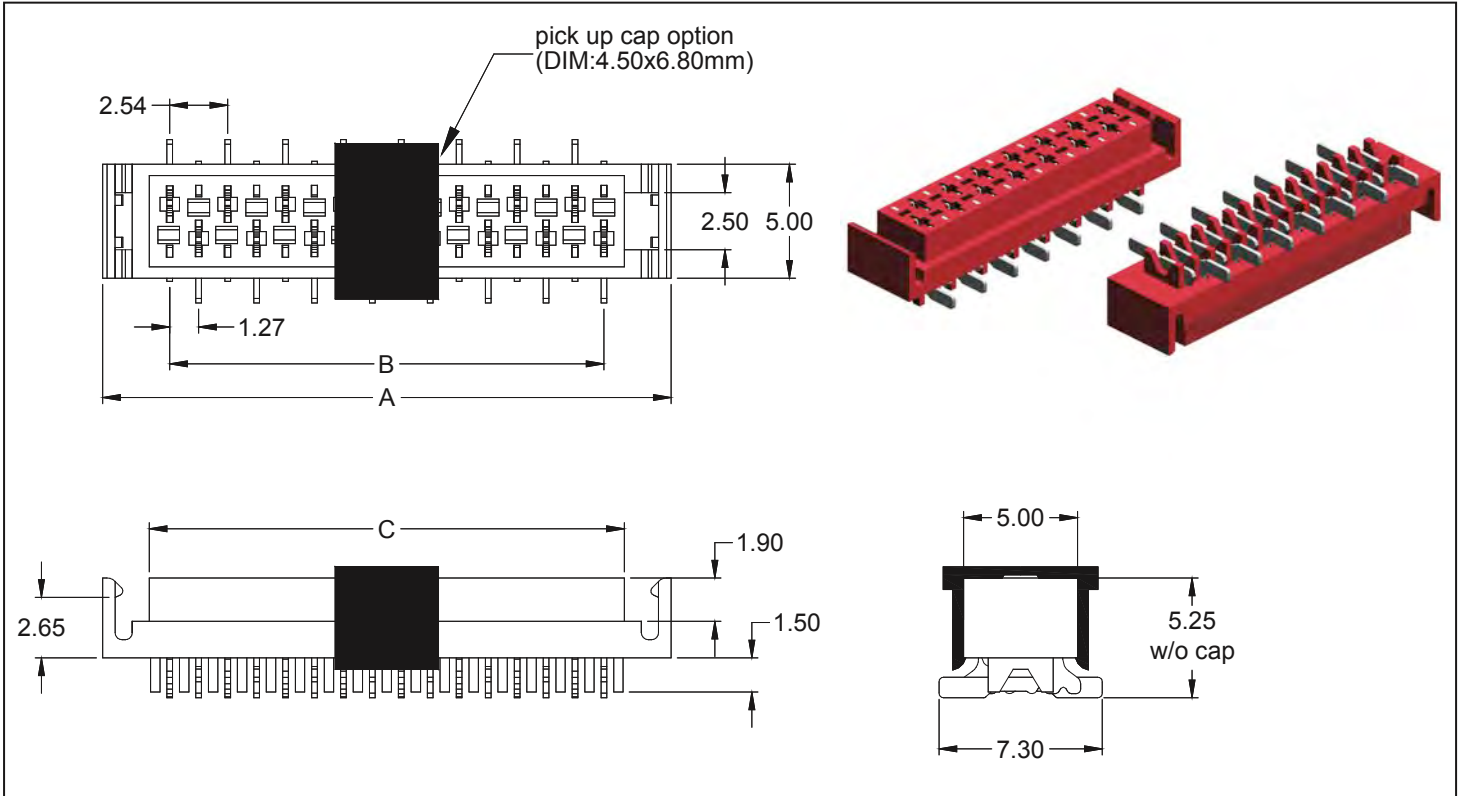

SPECIFICATIONS

Current rating	1 A
Nominal rating	230 V
Contact resistance	10 mΩ max.
Insulator resistance	1000 MΩ min.
Withstanding voltage	500 V AC
Operating temperature	-40°C to +105°C
Processing temperature	+260°C +0/-5°C for 5sec.
Preheating	150°C±10°C/1~2 Min.
Insulator material	Nylon 46 (red) UL 94 V-0
Contact material	Phosphor Bronze

PCB Surface Mount Layout

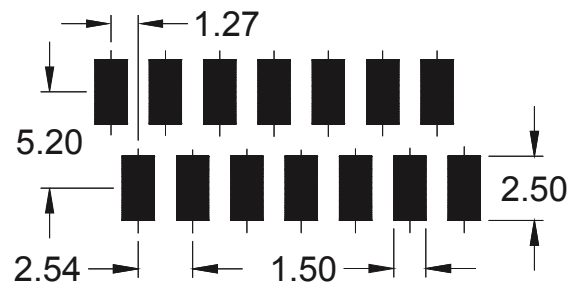

Dimensions (mm)

Contacts	DIM "A"	DIM "B"	DIM "C"	Contacts	DIM "A"	DIM "B"	DIM "C"	Contacts	DIM "A"	DIM "B"	DIM "C"
004	9.70	3.81	5.60	012	19.86	13.97	15.76	020	30.02	24.13	25.92
006	12.24	6.35	8.14	014	22.40	16.51	18.30				
008	14.78	8.89	10.68	016	24.94	19.05	20.84				
010	17.32	11.43	13.22	018	27.48	21.59	23.38				

How to order

MMF - xxx - HL50 - 99 / X

Nbr of contacts
004; 006; 008; 010 012; 014; 016; 018 020

Plating
99 = Tin
Other platings on request

Option
A = tube packing; with pick & place pad
B = reel packing; with pick & place pad
T = tube packing; without pick & place pad

Mini - Mate Connector

- THT - straight female Block Shape

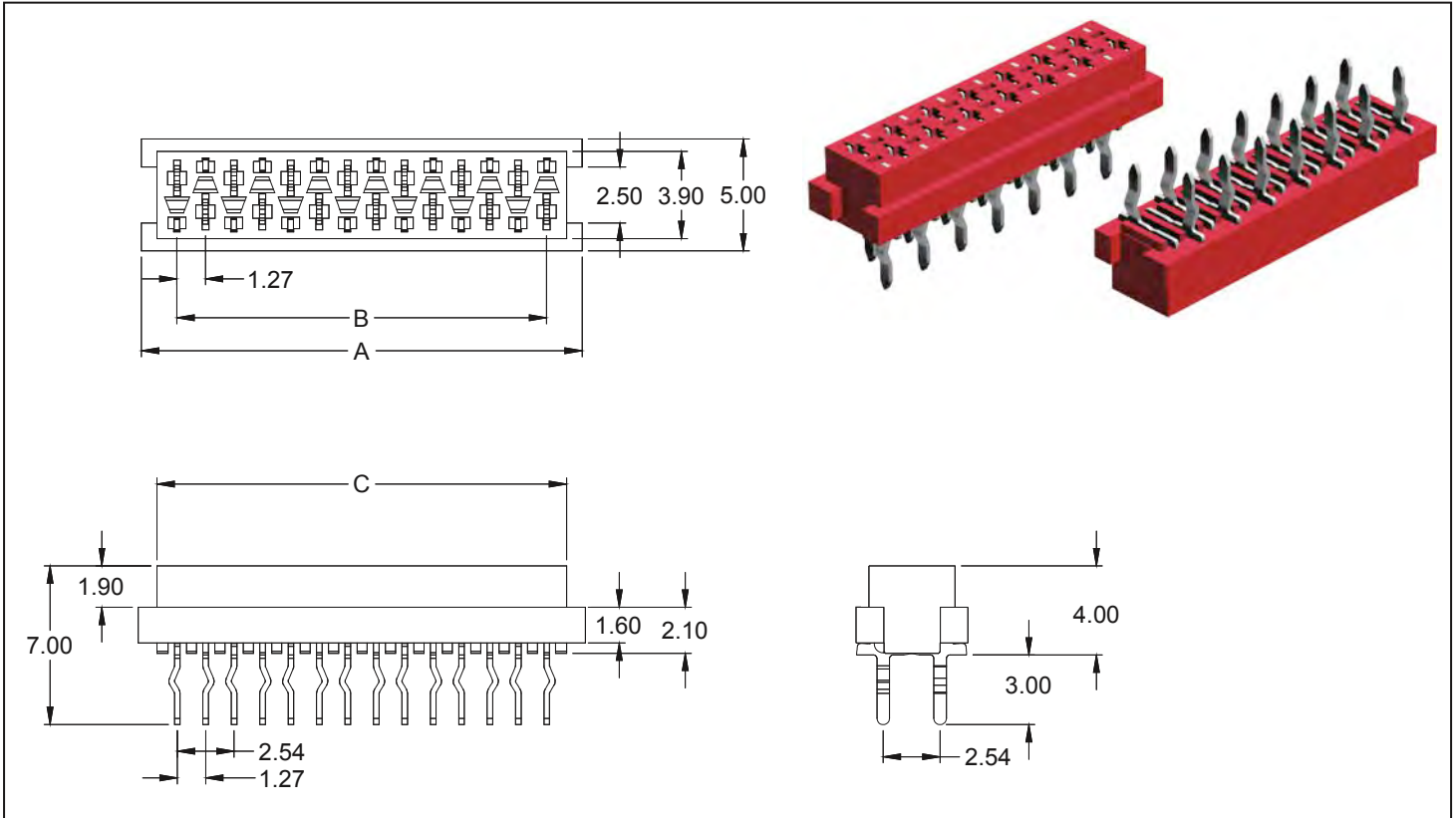

SPECIFICATIONS

Current rating	1 A
Nominal rating	230 V
Contact resistance	10 mΩ max.
Insulator resistance	1000 MΩ min.
Withstanding voltage	500 V AC
Operating temperature	-40°C to +105°C
Insulator material	Nylon 46 (red) UL 94 V-0
Contact material	Phosphor Bronze

PCB Hole Layout

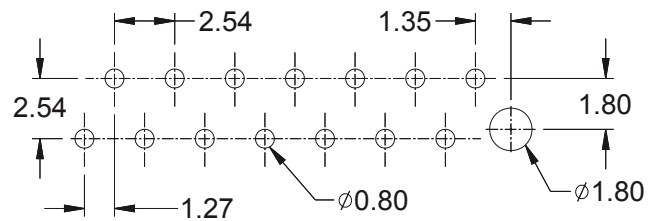

Dimensions (mm)

Contacts	DIM "A"	DIM "B"	DIM "C"	Contacts	DIM "A"	DIM "B"	DIM "C"	Contacts	DIM "A"	DIM "B"	DIM "C"
004	7.00	3.81	5.60	012	17.16	13.97	15.76	020	27.32	24.13	25.92
006	9.54	6.35	8.14	014	19.70	16.51	18.30				
008	12.08	8.89	10.68	016	22.24	19.05	20.84				
010	14.62	11.43	13.22	018	24.78	21.59	23.38				

How to order

MMF - xxx - SB50 - 99

Nbr of contacts
004; 006; 008; 010 012; 014; 016; 018 020

Plating
99 = Tin
Other platings on request

Mini - Mate Connector

- THT - straight female Latch Shape

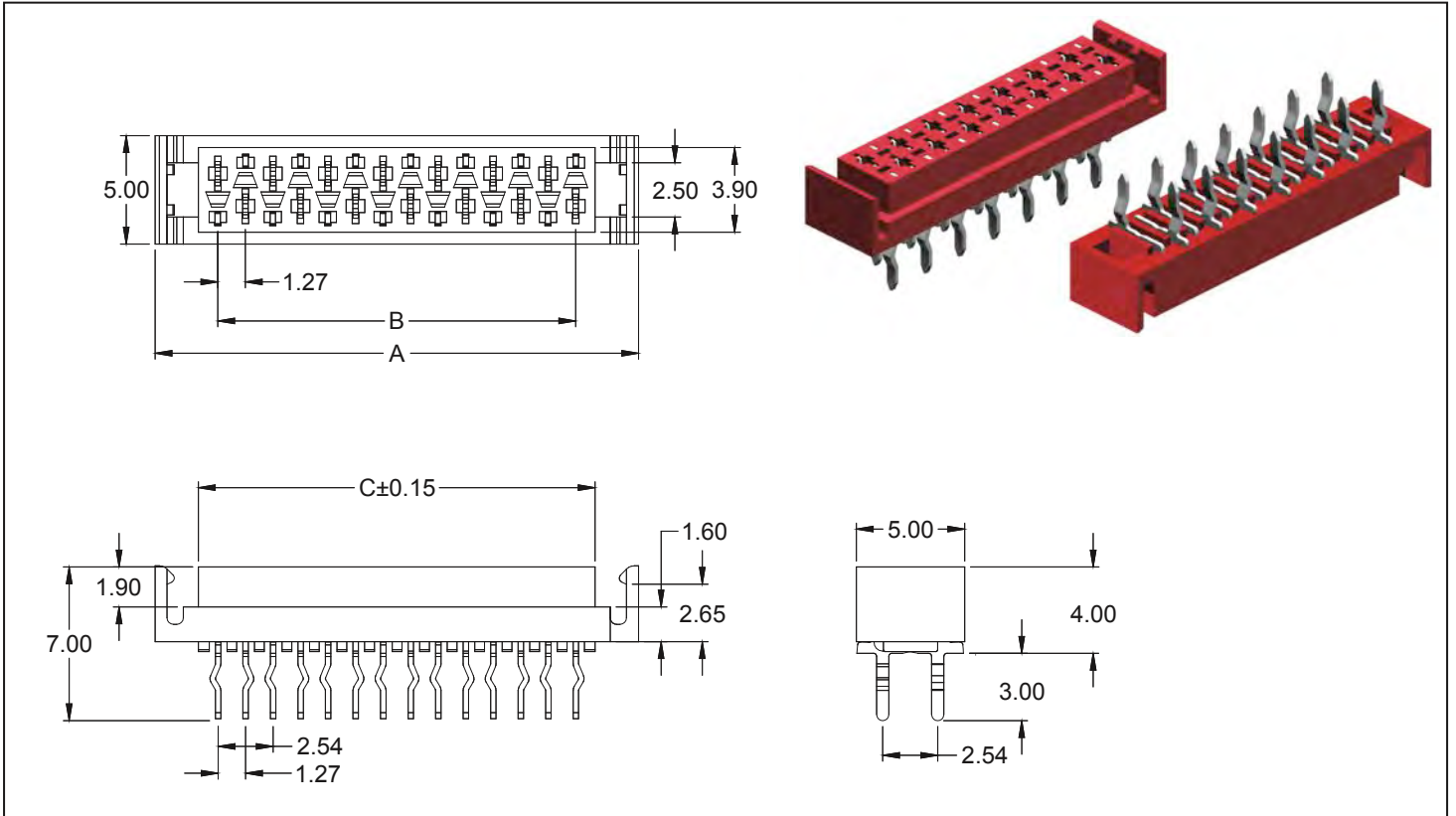

SPECIFICATIONS

Current rating	1 A
Nominal rating	230 V
Contact resistance	10 mΩ max.
Insulator resistance	1000 MΩ min.
Withstanding voltage	500 V AC
Operating temperature	-40°C to +105°C
Insulator material	Nylon 46 (red) UL 94 V-0
Contact material	Phosphor Bronze

PCB Hole Layout

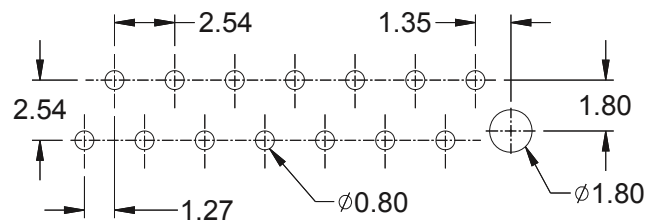

Dimensions (mm)

Contacts	DIM "A"	DIM "B"	DIM "C"	Contacts	DIM "A"	DIM "B"	DIM "C"	Contacts	DIM "A"	DIM "B"	DIM "C"
004	9.70	3.81	5.60	012	19.86	13.97	15.76	020	30.02	24.13	25.92
006	12.24	6.35	8.14	014	22.40	16.51	18.30				
008	14.78	8.89	10.68	016	24.94	19.05	20.84				
010	17.32	11.43	13.22	018	27.48	21.59	23.38				

How to order

MMF - xxx - SL50 - 99

Nbr of contacts
004; 006; 008; 010 012; 014; 016; 018 020

Plating
99 = Tin
Other platings on request

Mini - Mate Connector

- THT - right angle female Block Shape

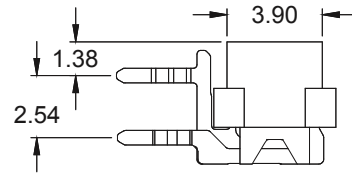
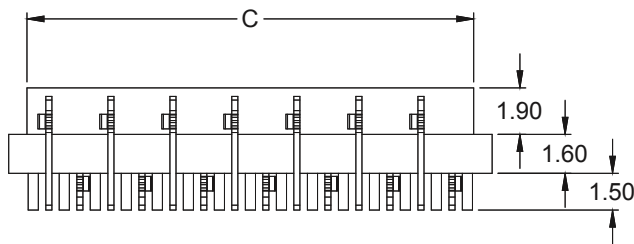
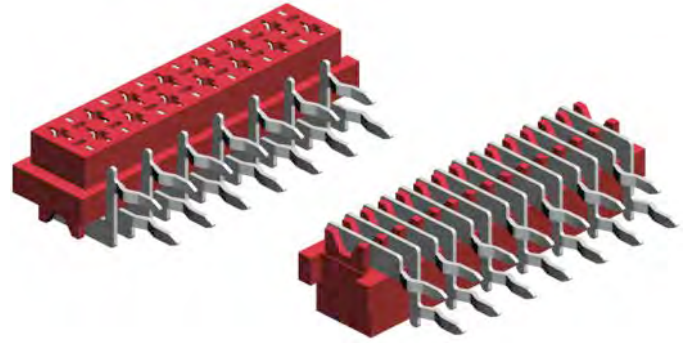
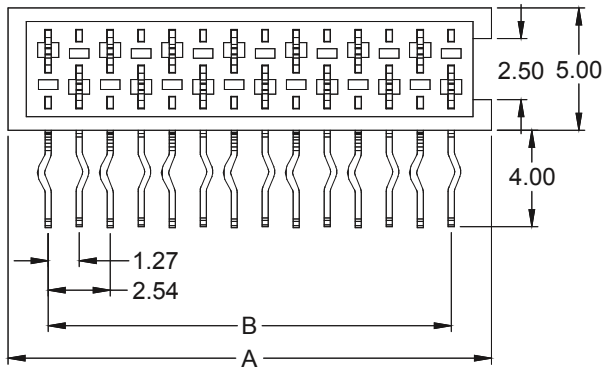

SPECIFICATIONS

Current rating	1 A
Nominal rating	230 V
Contact resistance	10 mΩ max.
Insulator resistance	1000 MΩ min.
Withstanding voltage	500 V AC
Operating temperature	-40°C to +105°C
Insulator material	Nylon 46 (red) UL 94 V-0
Contact material	Phosphor Bronze

PCB Hole Layout

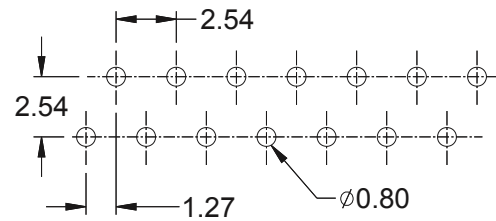

Dimensions (mm)

Contacts	DIM "A"	DIM "B"	DIM "C"	Contacts	DIM "A"	DIM "B"	DIM "C"	Contacts	DIM "A"	DIM "B"	DIM "C"
004	7.00	3.81	5.60	012	17.16	13.97	15.76	020	27.32	24.13	25.92
006	9.54	6.35	8.14	014	19.70	16.51	18.30				
008	12.08	8.89	10.68	016	22.24	19.05	20.84				
010	14.62	11.43	13.22	018	24.78	21.59	23.38				

How to order

MMF - xxx - RB50 - 99

Nbr of contacts
004; 006; 008; 010 012; 014; 016; 018 020

Plating
99 = Tin
Other platings on request

Mini - Mate Connector

- THT - straight male Shrouded

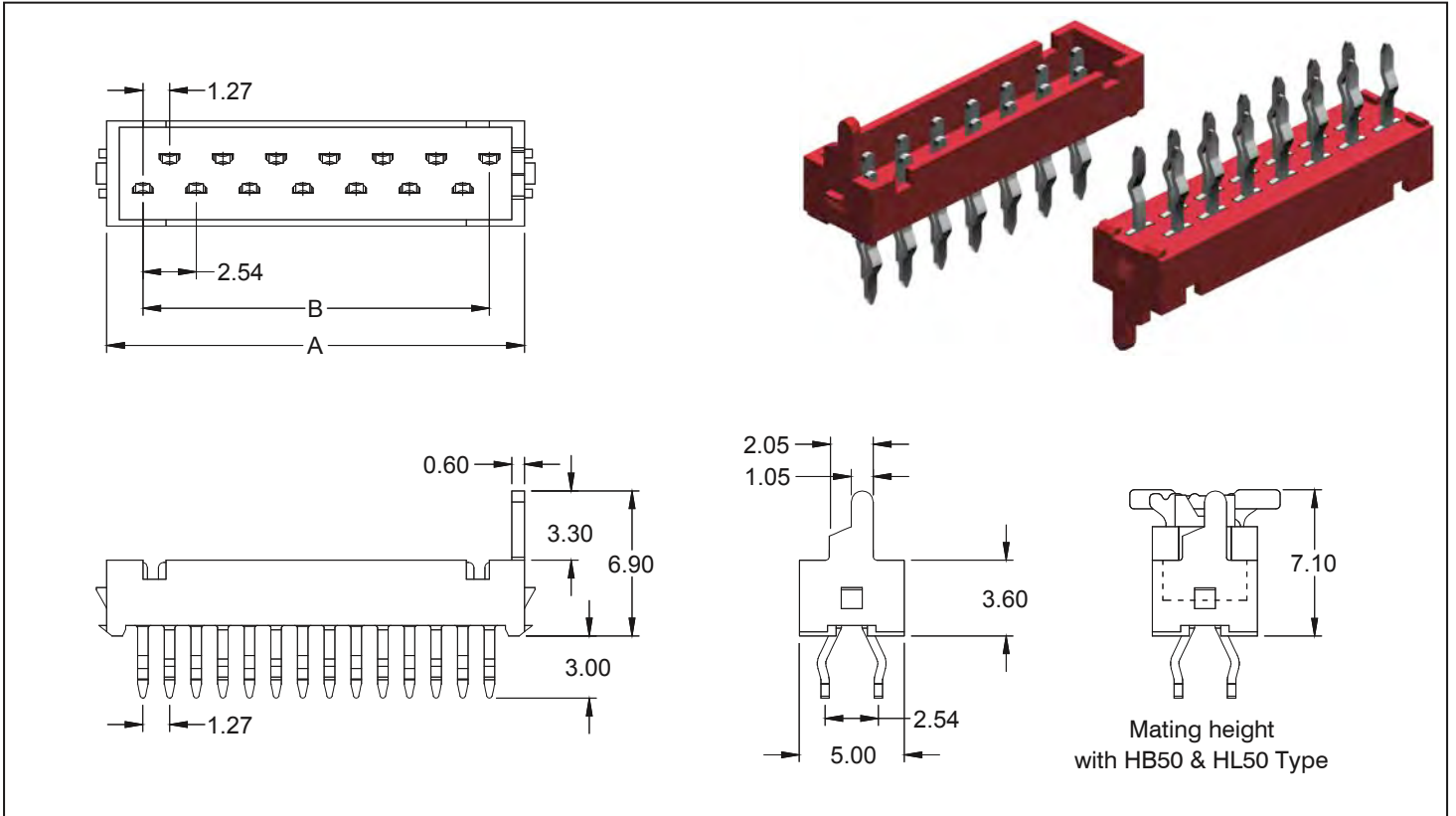

SPECIFICATIONS

Current rating	1 A
Nominal rating	230 V
Contact resistance	10 mΩ max.
Insulator resistance	1000 MΩ min.
Withstanding voltage	500 V AC
Operating temperature	-40°C to +105°C
Insulator material	P.B.T. (red) UL 94 V-0
Contact material	Phosphor Bronze

PCB Hole Layout

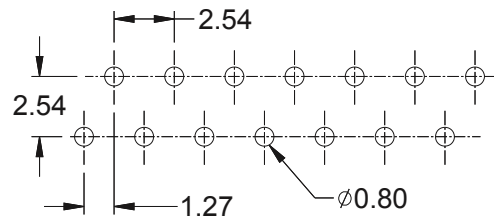

Dimensions (mm)

Contacts	DIM "A"	DIM "B"	Contacts	DIM "A"	DIM "B"	Contacts	DIM "A"	DIM "B"
004	7.20	3.81	012	17.36	13.97	020	27.52	24.13
006	9.74	6.35	014	19.90	16.51			
008	12.28	8.89	016	22.44	19.05			
010	14.82	11.43	018	24.98	21.59			

How to order

MMM - xxx - SS50 - 99

Nbr of contacts
004; 006; 008; 010 012; 014; 016; 018 020

Plating
99 = Tin
Other platings on request

Fully Shrouded

<p>L - Type female plug (AWG 28 to 32)</p> <p>Order Code housing: CRF-1xx-L100 Contact: CRF-999-L100-99</p>	<p>SL - Type -SMT- male (side entry)</p> <p>Order Code: CRR-1xx-SL100-99/X</p>
---	--

Fully Shrouded

<p>SL - Type -SMT- male (top entry)</p> <p>Order Code: CRS-1xx-SL100-99/R</p>	
---	--

SPECIFICATIONS

Current rating	1 A	Contact resistance	20 mΩ max.	Contact material	Copper alloy
Insulator resistance	500 MΩ min.	Withstanding voltage	500 V AC	Insulator material	Nylon UL 94 V-0
Voltage rating	50 V AC max.	Operating temp.	-25°C to +85°C	PCB Thickness	1.60 mm (.063")

How to order

CR X - x xx - X 100 - 99 / X

Type	Rows	Nbr of contacts	Execution	Plating	Option
F = Female R = R/A male S = Straight male	1 = single row 9 = loose contacts	02 - 20 = L, SL - type 99 = loose contacts MOQ: 10K / reel	L = L - type SL = SL - type see dwg above	99 = Tin Other platings on request	R = reel

Shrouded Type

S - Type

female plug

(AWG 28 to 32)

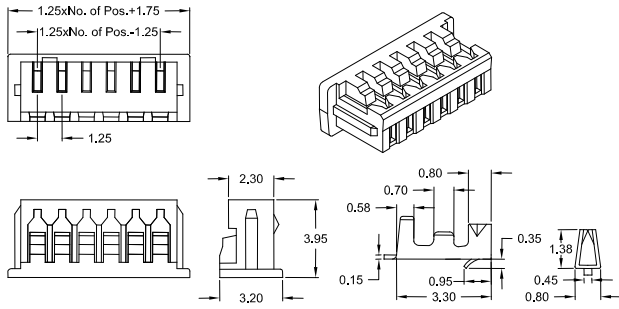

Order Code housing: CRF-1xx-S125

contact: CRF-999-S125-99

S - Type

-THT- male

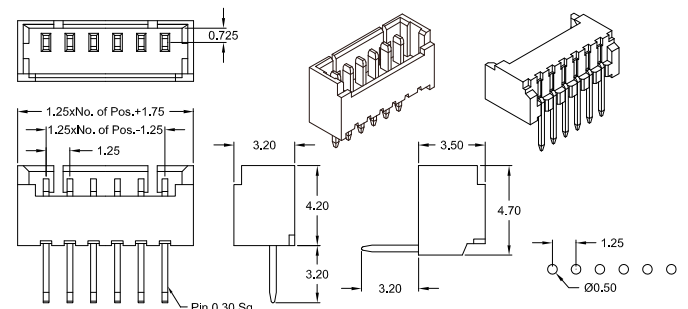

Order Code straight: CRS-1xx-S125-99

right angle: CRR-1xx-S125-99

Shrouded Type

SS - Type

-SMT- male (side entry)

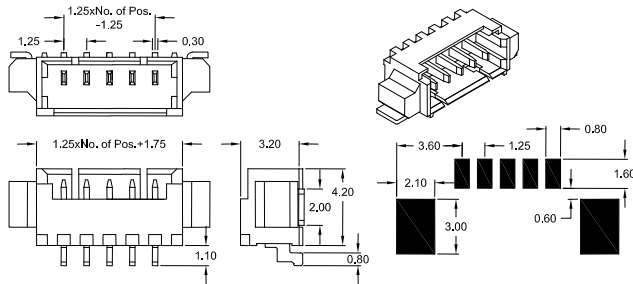

Order Code: CRR-1xx-SS125-99/R

SS - Type

-SMT- male (top entry)

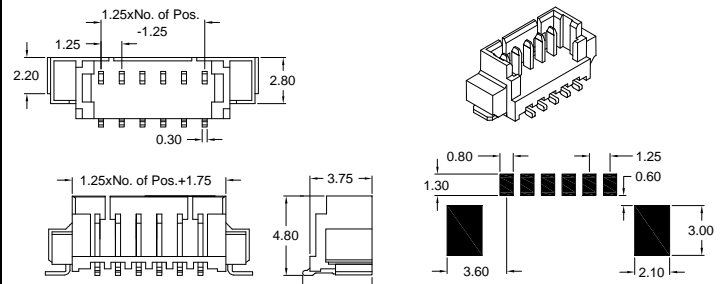

Order Code: CRS-1xx-SS125-99/R

Shrouded Type

G - Type

female plug

(AWG 28 to 32)

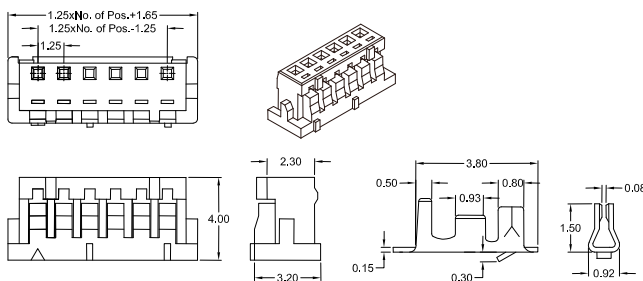

Order Code housing: CRF-1xx-G125

contact: CRF-999-G125-99

G - Type

-THT- male

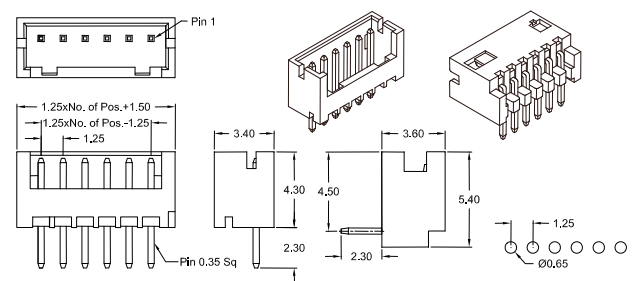

Order Code straight: CRS-1xx-G125-99

right angle: CRR-1xx-G125-99

SPECIFICATIONS

Current rating	1 A	Contact resistance	20 mΩ max.	Contact material	Copper alloy
Insulator resistance	500 MΩ min.	Withstanding voltage	500 V AC	Insulator material	Nylon UL 94 V-0
Voltage rating	50 V AC max.	Operating temp.	-25°C to +85°C	SS125 Type	LCP UL 94 V-0
				PCB Thickness	1.60 mm (.063")

How to order

CR X - x xx - X 125 - 99 / X

Type	Rows	Nbr of contacts	Execution	Plating	Option
F = Female	1 = single row	02 - 15 = S, SS, G - type	S = S - type	99 = tin <i>(leadfree)</i>	R = Reel
R = R/A male	9 = loose contacts	99 = loose contacts MOQ: 10K / reel	SS = SS - type SMT male	Other platings on request	
S = Straight male			G = G - type see dwg above		

Shrouded Type - front open plastic

O - Type

female plug

(AWG 26 to 30)

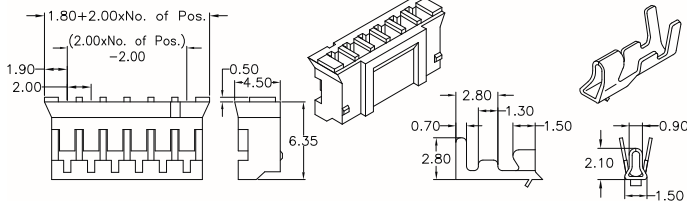

O - Type

-THT- male

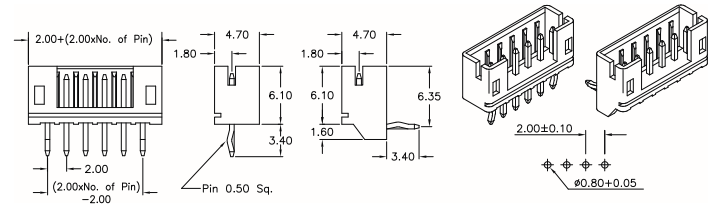

Order Code housing: CRF-1xx-O200

contact: CRF-999-O200-99

Order Code straight: CRS-1xx-O200-99

right angle: CRR-1xx-O200-99

Female Header Type

H - Type

single row

(AWG 26 to 30)

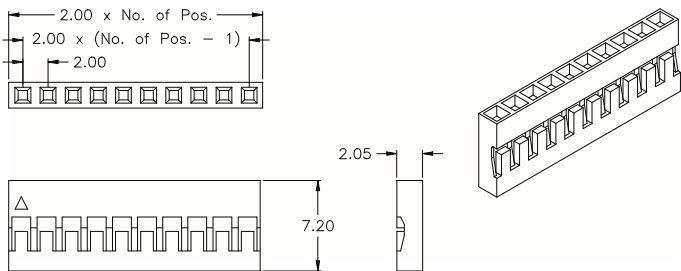

Order Code housing: CRF-1xx-H200

H - Type

dual row

(AWG 26 to 30)

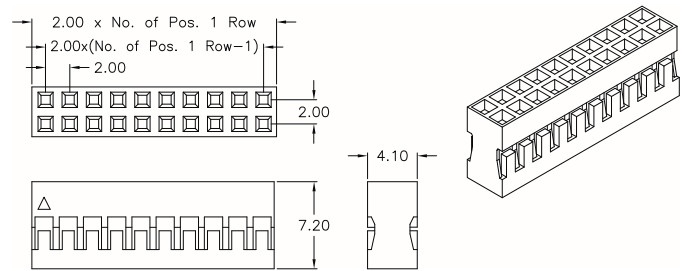

Order Code housing: CRF-2xx-H200

H - Type

female contact

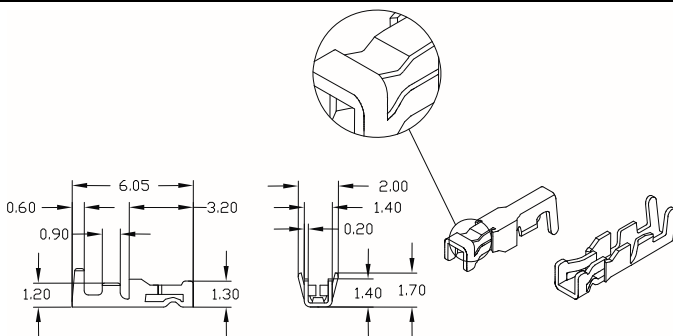

if for single row 01-19 & dual row 04-18 contacts:

Order Code: CRF-999L-H200-55

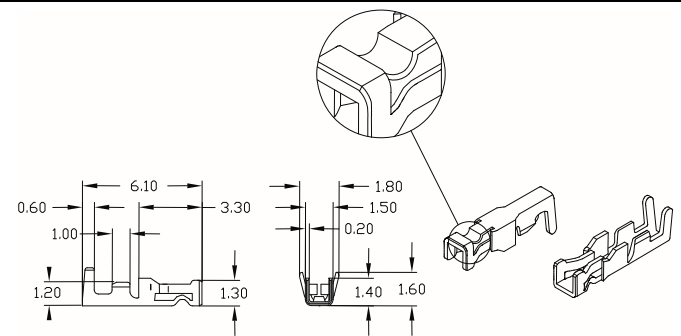

if for single row 20-40 & dual row 20-80 contacts:

Order Code: CRF-999-H200-55

SPECIFICATIONS

Current rating	1 A	Contact resistance	20 mΩ max.	Contact material	Copper alloy
Insulator resistance	1000 MΩ min.	Withstanding voltage	800 V AC	Insulator material	Nylon UL 94 V-0
Voltage rating	100 V AC max.	Operating temp.	-25°C to +90°C	PCB Thickness	1.60 mm (.063")

How to order

CR X - x xx - X 200 - 99

Type	Rows	Nbr of contacts	Execution	Plating
F = Female	1 = single row	02 - 16 = O - type	O = O - type	99 = tin (leadfree)
R = R/A male	2 = double row	01 - 40 = H - type - 1 row	H = H - type	55 = gold
S = Straight male	9 = loose contacts	04 - 80 = H - type - 2 row	Refer to above drawings for details	Other platings on request
		99 = loose contact MOQ: 10K / reel		

Fully Shrouded

<p>D - Type female plug (AWG 22 to 28)</p> <p>Order Code housing: CRF-2xx-D200 Contact: CRF-999-D200-99</p>	<p>D - Type -THT- male</p> <p>Order Code straight: CRS-2xx-D200-99 right angle: CRR-2xx-D200-99</p>
--	--

Single side shrouded

<p>C - Type female plug (AWG 22 to 26)</p> <p>Order Code housing: CRF-1xx-C200 Contact: CRF-999-C200-99</p>	<p>C - Type -THT- male</p> <p>Order Code straight: CRS-1xx-C200-99 right angle: CRR-1xx-C200-99</p>
--	--

Single side shrouded

<p>SC - Type -SMT- male (top entry)</p> <p>Order Code: CRS-1xx-SC200-99/X</p>	
---	--

SPECIFICATIONS

Current rating	2 A	Contact resistance	20 mΩ max.	Contact material	Copper alloy
Insulator resistance	1000 MΩ min.	Withstanding voltage	800 V AC	Insulator material	Nylon UL 94 V-0
Voltage rating	100 V AC max.	Operating temp.	-25°C to +85°C	PCB Thickness	1.60 mm (.063")

How to order

CR X - x xx - X 200 - 99 / X

<p>Type</p> <p>F = Female R = R/A male S = Straight male</p>	<p>Rows</p> <p>1 = single row 2 = dual row 9 = loose contacts</p>	<p>Nbr of contacts</p> <p>04 - 40 = D - type 02 - 12 = C - type 03 - 06 = SC - type 99 = loose contacts MOQ: 10K / reel</p>	<p>Execution</p> <p>D = D - type C = C - type SC = SC - type</p> <p>see dwgs above</p>	<p>Plating</p> <p>99 = Tin</p> <p>Other platings on request</p>	<p>Option</p> <p>A = tube packing; with pick & place pad B = reel packing; with pick & place pad</p>
--	---	--	--	---	---

Fully shrouded

<p>S - Type female plug (AWG 22 to 28)</p> <p>Order Code housing: CRF-1xx-S250 contact: CRF-999-S250-99</p>	<p>S - Type -THT- male</p> <p>Order Code straight: CRS-1xx-S250-99 right angle: CRR-1xx-S250-99</p>
---	---

Fully shrouded with inside ribs

<p>I - Type female plug (AWG 24 to 28)</p> <p>Order Code housing: CRF-1xx-I250 contact: CRF-999-I250-99</p>	<p>I - Type -THT- male</p> <p>Order Code straight: CRS-1xx-I250-99 right angle: CRR-1xx-I250-99</p>
---	---

Single side shrouded with inside ribs

<p>R - Type female plug (AWG 24 to 28)</p> <p>Order Code housing: CRF-1xx-R250 contact: CRF-999-R250-99</p>	<p>R - Type -THT- male</p> <p>Order Code straight: CRS-1xx-R250-99 right angle: CRR-1xx-R250-99</p>
---	---

SPECIFICATIONS

Current rating	3 A	Contact resistance	20 mΩ max.	Contact material	Copper alloy
Insulator resistance	1000 MΩ min.	Withstanding voltage	1000 V AC	Insulator material	Nylon UL 94 V-0
Voltage rating	250 V AC max.	Operating temp.	-25°C to +90°C	PCB Thickness	1.60 mm (.063")

How to order

CR X - x xx - X 250 - 99

<p>Type</p> <p>F = Female</p> <p>R = R/A male</p> <p>S = Straight male</p>	<p>Rows</p> <p>1 = single row</p> <p>9 = loose contacts</p>	<p>Nbr of contacts</p> <p>02 - 20 = S - type</p> <p>02 - 15 = I & R - types</p> <p>99 = loose contacts MOQ: 10K / reel</p>	<p>Execution</p> <p>S = S - type</p> <p>I = I - type</p> <p>R = R - type</p> <p>see dwgs above</p>	<p>Plating</p> <p>99 = tin <i>(leadfree)</i></p> <p>Other platings on request</p>
--	--	--	--	---

Shrouded with polarization feature

<p>P - Type female plug (AWG 20 to 26)</p> <p>Order Code housing: CRF-104-P250 contact: CRF-999-P250-99</p>	<p>P - Type -THT- male</p> <p>Order Code straight: CRS-104-P250-99 right angle: CRR-104-P250-99</p>
--	--

Friction Lock Header

<p>F - Type female plug (AWG 22 to 28)</p> <p>Order Code housing: CRF-1xx-F250 contact: CRF-999-F250-99</p>	<p>F - Type -THT- male</p> <p>Order Code straight: CRS-1xx-F250-99 right angle: CRR-1xx-F250-99</p>
--	--

Board-lock Type

<p>B - Type male (AWG 22 to 28)</p> <p>Order Code housing: CRM-1xx-B250 contact: CRM-999-B250-99</p>	<p>PCB Hole Layout</p> <p>Dimensions: $.098 \pm .002$, 2.50 ± 0.05, $\phi 0.39 + .004$, $\phi 1.00 + 0.10$</p>
---	---

SPECIFICATIONS

Current rating	3 A	Contact resistance	20 mΩ max.	Contact material	Copper alloy
Insulator resistance	1000 MΩ min.	Withstanding voltage	1000 V AC	Insulator material	Nylon UL 94 V-0
Voltage rating	250 V AC max.	Operating temp.	-25°C to +85°C	PCB Thickness	1.60 mm (.063")

How to order

CR X - x xx - X 250 - 99

<p>Type</p> <p>F = Female R = R/A male S = Straight male M = male contact & header</p>	<p>Rows</p> <p>1 = single row 9 = loose contacts</p>	<p>Nbr of contacts</p> <p>04 = P - type 02 - 12 = F - type 02 - 16 = B - type (others on request) 99 = loose contacts MOQ: -P250- & -B250- type = 10K / reel -F250- type = 8K / reel</p>	<p>Execution</p> <p>P = P - type F = F - type B = B - type</p> <p>see dwgs above</p>	<p>Plating</p> <p>99 = tin (leadfree)</p> <p>Other platings on request</p>
--	--	---	--	---

Friction Lock Type

<p>F - Type female plug (AWG 22 to 28)</p> <p>Order Code housing: CRF-1xx-F254 contact: CRF-999-F254-99</p>	<p>F - Type -THT- male</p> <p>Order Code straight: CRS-1xx-F254-99 right angle: CRR-1xx-F254-99</p>
---	---

Female Header Type

<p>H - Type female dual row (AWG 22 to 28) - without bump -</p> <p>Order Code housing: CRF-2xx-H254</p>	<p>H - Type female dual row (AWG 22 to 28) - with low bump -</p> <p>Order Code housing: CRF-2xx-H254/P</p>	<p>H - Type female dual row (AWG 22 to 28) - with high bump -</p> <p>Order Code housing: CRF-2xx-H254/HP</p>
<p>H - Type female single row (AWG 22 to 28) - without bump -</p> <p>Order Code housing: CRF-1xx-H254</p>	<p>H - Type female contact</p> <p>if for single row 01-19 & dual row 04-18 contacts: Order Code: CRF-999L-H254-95</p> <p>if for single row 20-40 & dual row 20-80 contacts: Order Code: CRF-999-H254-95</p>	

SPECIFICATIONS

Current rating	3 A	Operating temp.	-25°C to +90°C
Insulator resistance	1000 MΩ min.	Contact material	Copper alloy
Contact resistance	20 mΩ max.	Insulator material	Nylon UL 94 V-2
Withstanding voltage	1000 V AC	F-Type	P.B.T. UL 94 V-0
Voltage rating	250 V AC max.	H-Type	
		PCB Thickness	1.60 mm (.063")

H - Type male contact

Order Code: **CRM-999-H254-55**

How to order

CR X - x xx - X 254 - 99

<p>Type</p> <p>Header Type: R = R/A male S = Straight male</p> <p>Contact Type: F = Female M = Male</p>	<p>Rows</p> <p>1 = single row 2 = double row 9 = loose contacts</p>	<p>Nbr of contacts</p> <p>02 - 20 = F - type 01 - 40 = H - type - 1 row 04 - 80 = H - type - 2 row 99 = loose contact MOQ: 10K / reel</p>	<p>Execution</p> <p>F = F - type H = H - type</p> <p>Refer to above drawings for details</p>	<p>Plating</p> <p>99 = tin 55 = gold</p> <p>NOTE: for CRF-999-H254 & CRF-999L-H254 only tin/gold plating available</p> <p>Code: 95</p>
--	---	--	--	---

Male Type Fully Shrouded

W - Type

-THT- straight

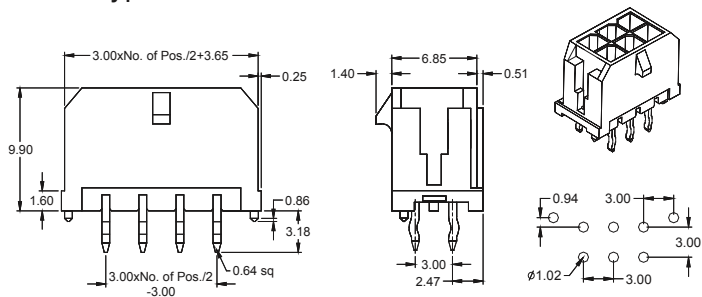

Order Code: PCS-2xx-W300-99

W - Type

-THT- right angle

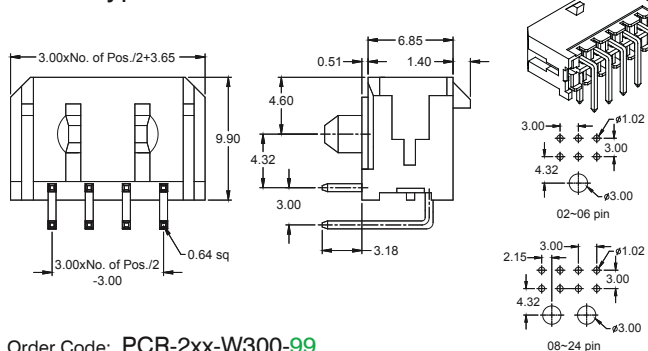

Order Code: PCR-2xx-W300-99

SW - Type

-SMT- straight with solder tabs

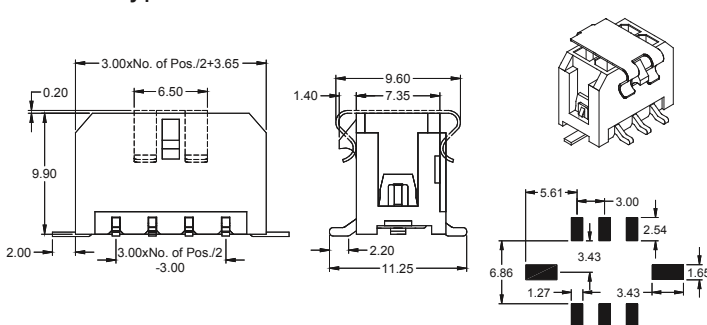

Order Code: PCS-2xx-SW300-99/X

SC - Type

-SMT- straight with solder clips

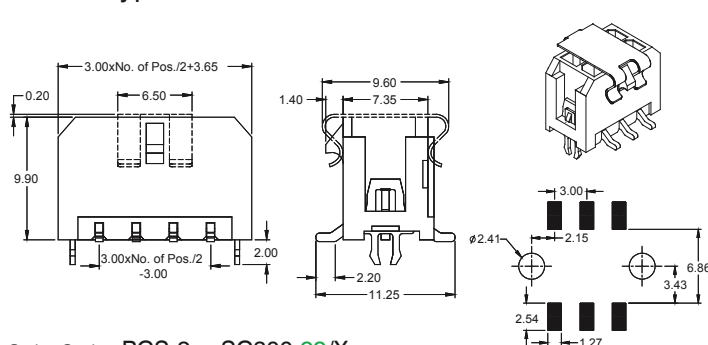

Order Code: PCS-2xx-SC300-99/X

Female Type

W - Type

(AWG 20 to 24)

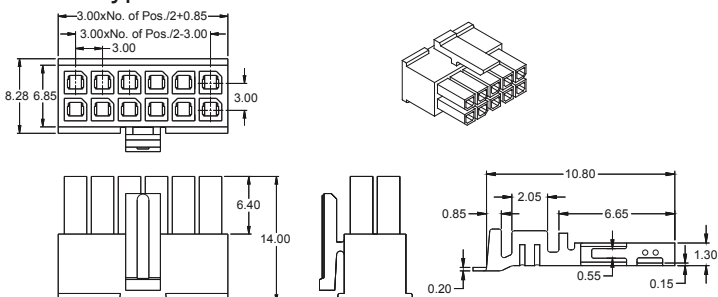

Order Code housing: PCF-2xx-W300

Contact: PCF-999-W300-99

SPECIFICATIONS

Current rating	5 A	Contact resistance	20 m Ω max.	Contact material	Copper alloy
Insulator resistance	1000 M Ω min.	Withstanding voltage	1500V AC	Insulator material	LCP UL 94 V-0(male) Nylon UL 94 V-2(female)
Voltage rating	250V AC max.	Operating temp.	-25°C to +85°C	PCB Thickness	1.60 mm (.063")

How to order

PC X - x xx - X 300 - 99 / X

Type F = Female R = R/A male S = Straight male	Rows 2 = dual row 9 = loose contacts	Nbr of contacts 02 - 24 = W, SW, SC - type 99 = loose contacts MOQ: 10K / reel	Execution W = W - type SW = SW - type SC = SC - type see dwgs above	Plating 99 = Tin Other platings on request	Option A = tube packing; with pick & place pad B = reel packing; with pick & place pad
---	---	--	---	--	---

Friction lock

F - Type

female plug

(AWG 18 to 24)

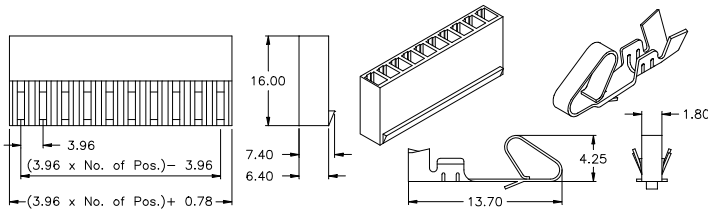

Order Code housing: PCF-1xx-F396

contact: PCF-999-F396-99

F - Type

-THT- male

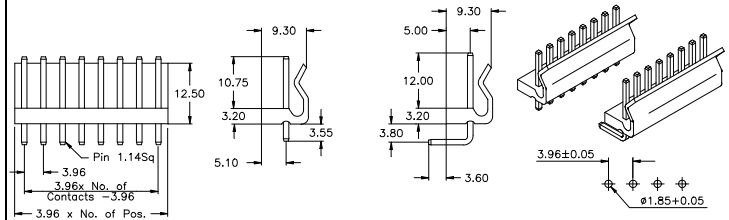

Order Code straight: PCS-1xx-F396-99

right angle: PCR-1xx-F396-99

Latch lock

L - Type

female plug

(AWG 18 to 24)

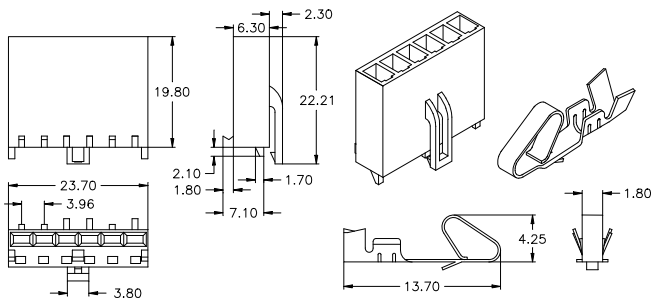

Order Code housing: PCF-106-L396

contact: PCF-999-L396-99

L - Type

-THT- male

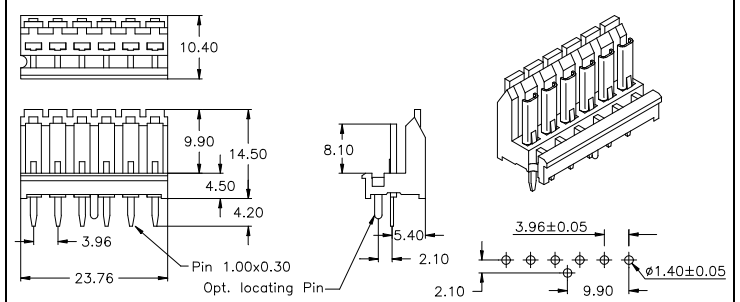

Order Code straight: PCS-106-L396-99

with locating pin: PCS-106-L396-99/L

Quick lock

Q - Type

female plug

(AWG 18 to 22)

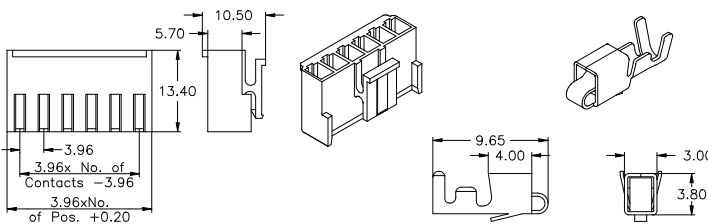

Order Code housing: PCF-1xx-Q396

contact: PCF-999-Q396-99

Q - Type

-THT- male

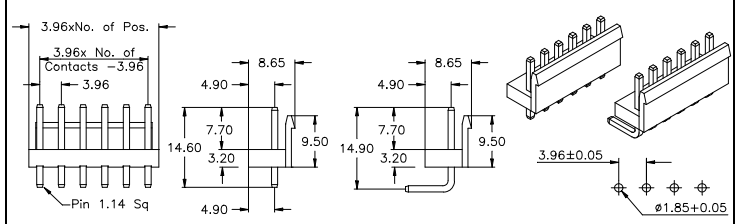

Order Code straight: PCS-1xx-Q396-99

right angle: PCR-1xx-Q396-99

SPECIFICATIONS

Current rating	5 A	Contact resistance	20 mΩ max.	Contact material	Copper alloy
Insulator resistance	1000 MΩ min.	Withstanding voltage	1500 V AC	Insulator material	Nylon UL 94 V-2
Voltage rating	250 V AC max.	Operating temp.	-25°C to +105°C	PCB thickness	Nylon UL 94 V-0 (Q-Type) 1.60 mm (.063")

How to order

PC X - x xx - X 396 - 99

Type

F = Female
R = R/A male
S = Straight male

Rows

1 = single row
9 = loose contacts

Nbr of contacts

02 - 13 = F - type
06 = L - type
02 - 15 = Q - type
99 = loose contacts
MOQ for F396 & L396 = 6K/reel
for Q396 = 4K reel

Execution

F = F - type
L = L - type
Q = Q - type

see dwgs above

Plating

99 = tin
(leadfree)

Other platings
on request

Male Type Fully Shrouded

P - Type

-THT- straight

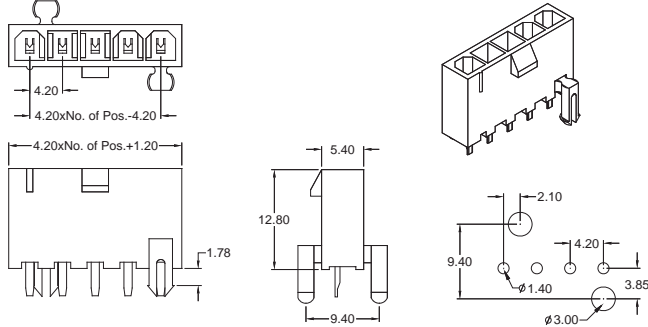

Order Code: PCS-1xx-P420-99

P - Type

-THT- right angle (with board lock clips)

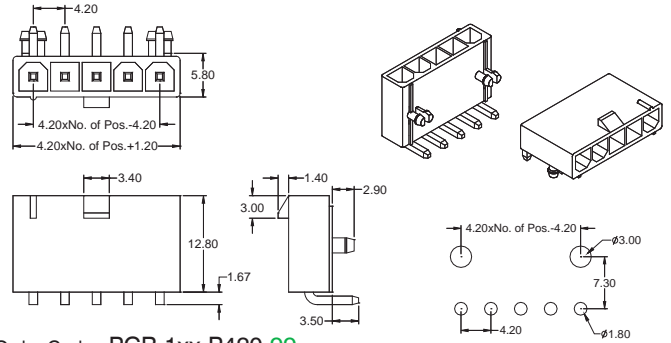

Order Code: PCR-1xx-P420-99

A - Type

-THT- right angle

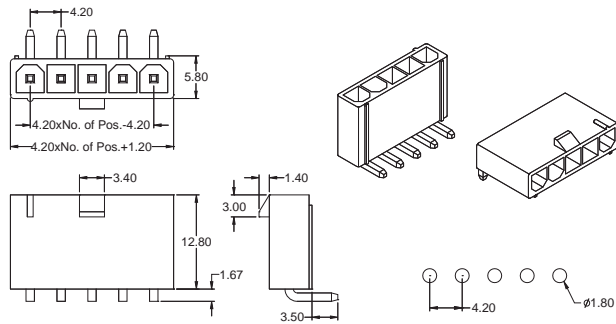

Order Code: PCR-1xx-A420-99

W - Type

-THT- right angle (with mounting ears)

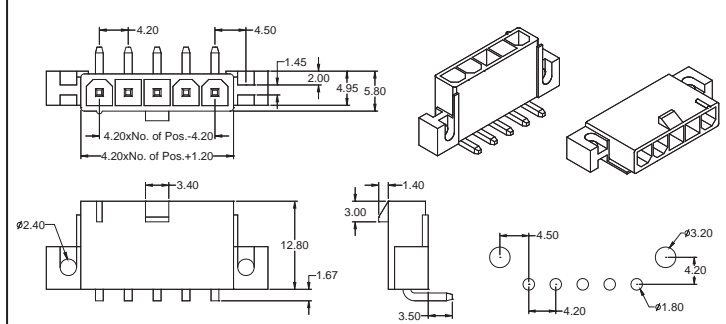

Order Code: PCR-1xx-W420-99

Female Type

P - Type

(AWG 16 to 24)

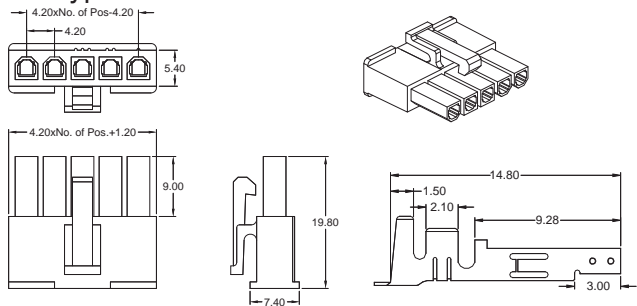

Order Code housing: PCF-1xx-P420

Contact: PCF-999-P420-99

SPECIFICATIONS

Current rating	7 A	Contact resistance	20 mΩ max.	Contact material	Copper alloy
Insulator resistance	1000 MΩ min.	Withstanding voltage	1500 V AC	Insulator material	Nylon UL 94 V-2
Voltage rating	600 V AC max.	Operating temp.	-25°C to +85°C	PCB Thickness	1.60 mm (.063")

How to order

PC X - x xx - X 420 - 99

Type	Rows	Nbr of contacts	Execution	Plating
F = Female R = R/A male S = Straight male	1 = single row 9 = loose contacts	02 - 12 = P, A, W - type 99 = loose contacts MOQ: 10K / reel	P = P - type A = A - type W = W - type see dwgs above	99 = Tin Other platings on request

Male Type Fully Shrouded

P - Type -THT- straight

Order Code: **PCS-2xx-P420-99**

P - Type -THT- right angle (with board lock clips)

Order Code: **PCR-2xx-P420-99**

W - Type -THT- right angle (with mounting ears)

Order Code: **PCR-2xx-W420-99**

Female Type

P - Type (AWG 16 to 24)

Order Code housing: **PCF-2xx-P420** Contact: **PCF-999-P420-99**

SPECIFICATIONS

Current rating	7 A	Contact resistance	20 mΩ max.	Contact material	Copper alloy
Insulator resistance	1000 MΩ min.	Withstanding voltage	1500 V AC	Insulator material	Nylon UL 94 V-2
Voltage rating	600 V AC max.	Operating temp.	-25°C to +85°C	PCB Thickness	1.60 mm (.063")

How to order

PC X - x xx - X 420 - 99

Type
F = Female
R = R/A male
S = Straight male

Rows
2 = dual row
9 = loose contacts

Nbr of contacts
02 - 24 = P, W - type
99 = loose contacts MOQ: 10K / reel

Execution
P = P - type
W = W - type
see dwgs above

Plating
99 = Tin
Other platings on request



Friction lock

F - Type female plug (AWG 18 to 24)

Order Code housing: **PCF-1xx-F508** contact: **PCF-999-F508-99**

F - Type -THT- male

Order Code straight: **PCS-1xx-F508-99** right angle: **PCR-1xx-F508-99**

4 Contact Female Types

P - Type polarized insulator (AWG 18 to 20)

Order Code housing: **PCF-104-P508** contact: **PCF-999-P508-99**

I - Type IDC - Connector (AWG 18 to 20)

Order Code: with standard Cover **PCF-104-I508-99** add /C if type "C" Cover

4 Contact Crimp "shrouded" Male Type

C - Type (AWG 18 to 22)

Order Code housing: **PCM-104-C508** contact: **PCM-999-C508-99**

SPECIFICATIONS

Current rating	7 A	Contact resistance	20 mΩ max.	Contact material	Copper alloy
Insulator resistance	1000 MΩ min.	Withstanding voltage	1500 V AC	Insulator material	Nylon UL 94 V-2
Voltage rating	250 V AC max.	Operating temp.	-25°C to +85°C	PCB Thickness	1.60 mm (.063")

How to order

PC X - x xx - X 508 - 99

<p>Type</p> <p>F = Female R = R/A male S = Straight male M = male contact & header</p>	<p>Rows</p> <p>1 = single row 9 = if contact</p>	<p>Nbr of contacts</p> <p>02 - 12 = F - type 04 = P, I, C - types 99 = loose contacts MOQ: -F508- type = 6K / reel -P508- type = 7K / reel -C508- type = 7K / reel</p>	<p>Execution</p> <p>F = F - type P = P - type I = I - type C = C - type see drawings above</p>	<p>Plating</p> <p>99 = tin (leadfree) Other platings on request</p>
--	--	---	---	---

5.08mm Power Connectors Disk Drive Power Connection System



4 Contact Male - Through Board Solder Types

Straight "T" type

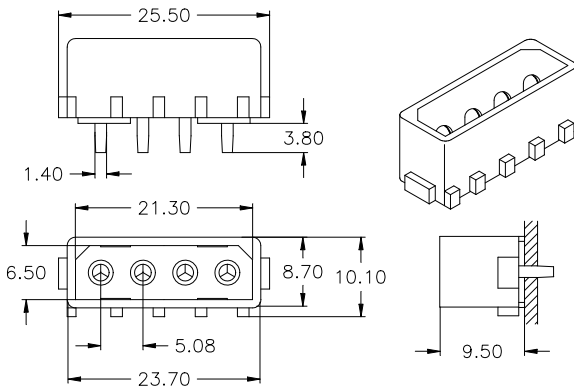

Order Code: **PCS-104-T508-99**

Right angle "T" type

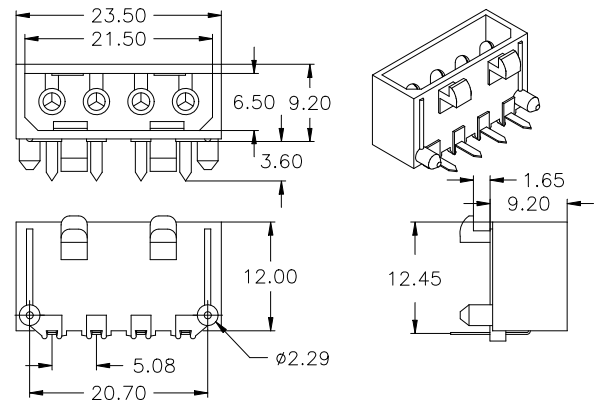

Order Code: **PCR-104-T508-99**

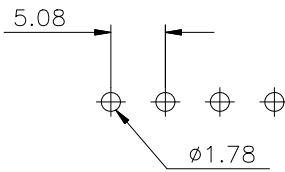

PCB Hole Layout

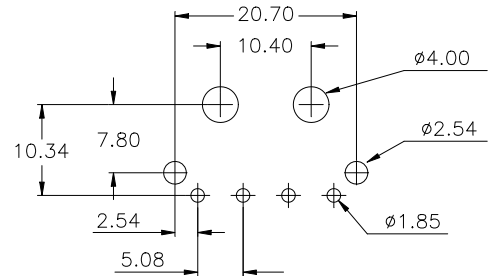

PCB Hole Layout

SPECIFICATIONS

Current rating	7 A	Contact resistance	20 mΩ max.	Contact material	Copper alloy
Insulator resistance	1000 MΩ min.	Withstanding voltage	1500 V AC	Insulator material	Nylon UL 94 V-2
Voltage rating	250 V AC max.	Operating temp.	-25°C to +90°C	PCB Thickness	1.60 mm (.063")

How to order

PC X - 104 - T 508 - 99

Type	
R	= right angle type
S	= straight type

Plating	
99	= tin <i>(leadfree)</i>



Quick Lock

<p>P - Type female</p> <p>Order Code housing: PCF-1xx-P635/X</p>	<p>PM - Type Clutch</p> <p>Order Code housing: PCC-1xx-PM635/X</p>
<p>P - Type female contact (AWG 16 to 20)</p> <p>Order Code contact: PCF-999-P635-99</p>	<p>P - Type male contact (AWG 16 to 20)</p> <p>Order Code contact: PCM-999-P635-99</p>

Fully Shrouded

<p>P - Type -THT- male & female straight</p> <p>Option Contact Type Order Code</p> <p>male PCS-1xx-PM635-99</p> <p>female PCS-1xx-PF635-99</p>	<p>PW - Type -THT- male & female right angle (with mounting ears)</p> <p>Option Contact Type Order Code</p> <p>male PCR-1xx-PWM635-99</p> <p>female PCR-1xx-PWF635-99</p>
---	--

SPECIFICATIONS

Current rating	13 A	Contact resistance	20 mΩ max.	Contact material	Copper alloy
Insulator resistance	1000 MΩ min.	Withstanding voltage	1000 V AC	Insulator material	Nylon
Voltage rating	600 V AC max.	Operating temp.	-55°C to +105°C	PCB Thickness	1.60mm (.063")

How to order

PC X - x xx - X 635 - 99 / X

Type	Rows	Nbr of contacts	Execution	Plating	Option
C = Clutch F = Female M = Male S = Straight R = Right angle	1 = single row 9 = loose contacts	02 - 10 = P, PM, PF, PWM PWF - type 99 = loose contacts MOQ: 10K / reel	P = P-type PM = P-type male PF = P-type female PWM = PW-type male PWF = PW-type female see dwgs above	99 = tin (leadfree) Other platings on request	N = nature colour (UL 94 V-2) W = white colour (UL 94 V-0)

Other products from E-tec

Please contact your closest sales office for further information.



Insertion- Extraxtion Tools



DIMM Sockets



DIP Switch

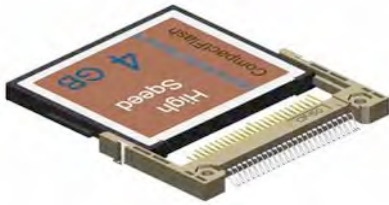

Compact Flash Connector

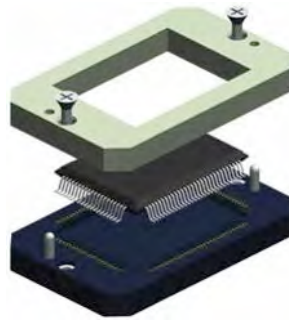

Gullwing Chip Sockets



USB & IEEE 1394 Connectors

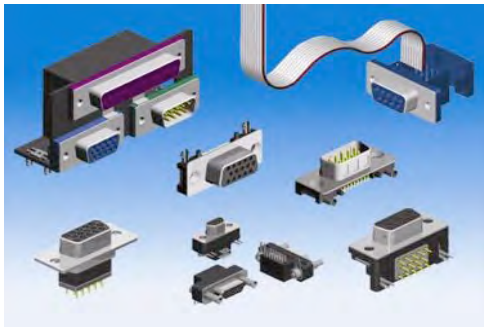

D-Sub Connectors

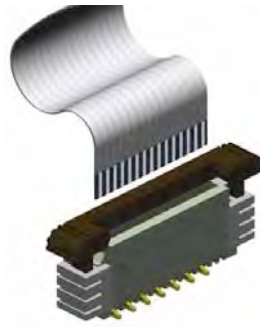

Flex Cable Connectors



HDMI Connectors



Probe Pin & Probe Pin Connectors

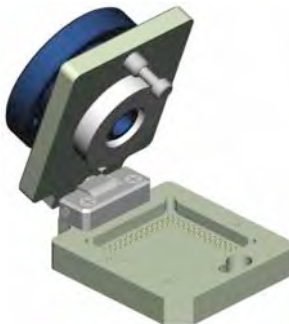

Ball / Land Grid Array Sockets



Multi Media Card Connectors

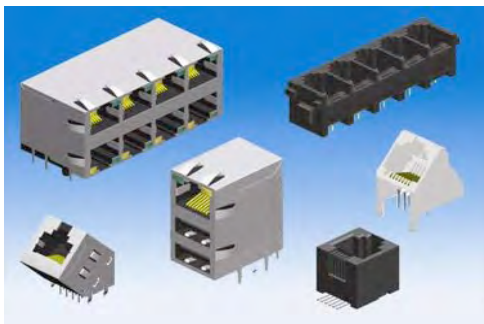

Modular Plugs & Jacks



Phono - & DC - Power Connectors



RF - Connectors

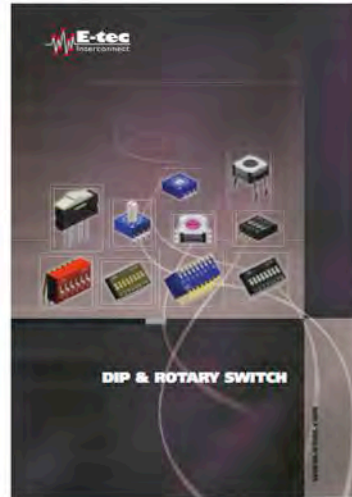

International Sales Headquarters

Switzerland E-tec Interconnect Ltd.
 Schweiz Zone Industrielle C
 Suisse CH-1072 Forel (Lavaux)
 Phone: +41/21/78108 10
 Fax: +41/21/78108 11
 e-mail: info@e-tec.com
 www.e-tec.com

Related Sales Headquarters

Deutschland EMC electro mechanical components
 Germany Vertriebs GmbH
 Allemagne PF. 1160
 D-65501 Idstein
 Phone: +49/61 26/9395-0
 Fax: +49/61 26/9395-72
 e-mail: info@emc-connectors.com
 www.emc-connectors.com

France Silfox SA
 Frankreich PA des Petits Carreaux
 2 bis avenue des Coquelicots
 F-94385 BONNEUIL
 SUR MARNE CEDEX
 Phone: +33/1/49560468
 Fax: +33/1/49560287
 e-mail: info@silfox.fr
 www.silfox.fr

England E-tec Interconnect (UK) Ltd.
 Angleterre Units A5 & A6 Decimus Park
 Kingstanding Way
 Tunbridge Wells
 Kent TN2 3GP
 Phone: +44/1892/530260
 Fax: +44/1892/515560
 e-mail: info@e-tec.co.uk
 www.e-tec.co.uk

Factories

Switzerland HAPP AG / E-tec AG
 Schweiz Friedhofstrasse 1
 Suisse CH-2543 Lengnau b. Biel
 Phone: +41/32/654 15 50
 Fax: +41/32/652 26 93
 e-mail: info-ch@e-tec.com
 www.e-tec.com

Taiwan HAPP & E-tec Taiwan Ltd.
 10-2F, No. 379, Zhong Shan Road
 San Chong City, Taipei Hsien
 TAIWAN
 Phone: +886/2/2999-27 26
 Fax: +886/2/2999-52 55
 e-mail: info@happetec.com.tw
 www.happetec.com.tw

YOUR AUTHORISED DISTRIBUTOR
 IHR VERTRAGS-DISTRIBUTOR
 VOTRE DISTRIBUTEUR OFFICIEL

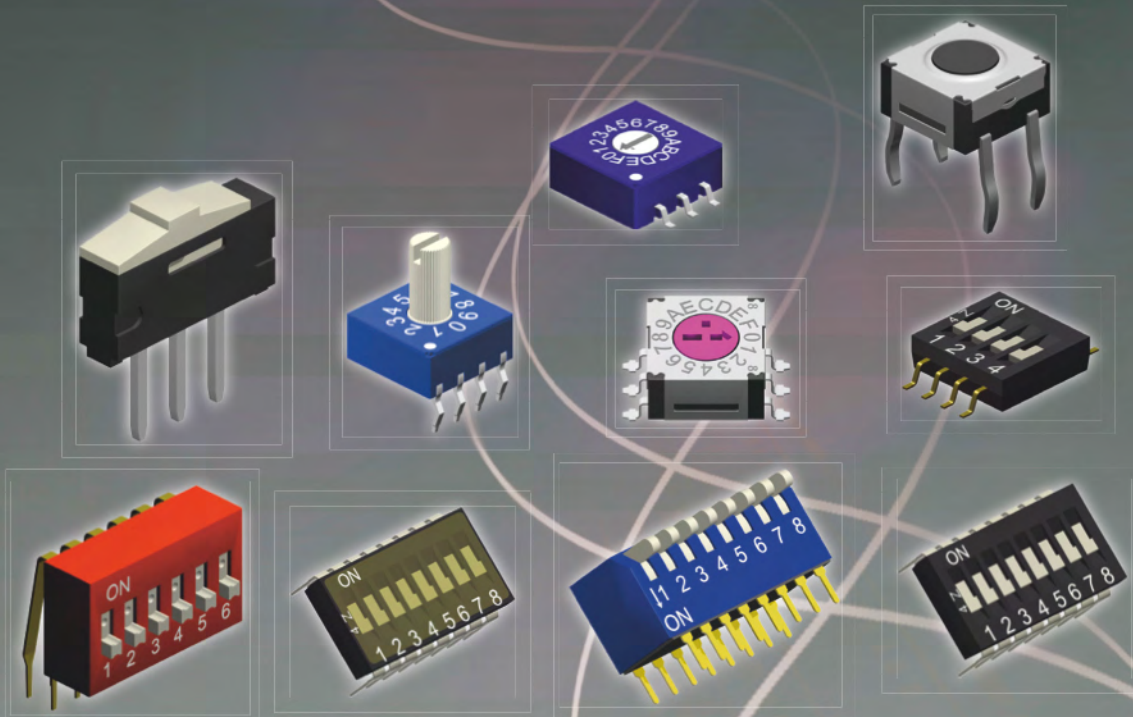

DIP & ROTARY SWITCH

INDEX



Type	click on page numbers	Page
Changeover Slide Switch "DSS" Series	2.54mm Pin to Pin THT & SMT	2
Rotary Switch "DRD" Series	3:3 & 1:4 Pin-out SMT 2.54mm Pin to Pin	3
	3:3 Pin-out straight THT 2.54 x 7.62mm footprint	4
	1:4 Pin-out straight THT 2.54 x 7.62mm footprint	5
	3:3 Pin-out right angle THT 2.54 x 2.54mm footprint	6
	1:4 Pin-out right angle THT 2.54 x 2.54mm footprint	7
	3:3 Pin-out right angle THT 2.54 x 5.08mm footprint	8
	1:4 Pin-out right angle THT 2.54 x 5.08mm footprint	9
Slide Switch "DDG" & "DDS" Series	Standard Profile 2.54mm DIP Type THT	10 & 11
Slide Switch "DAH" Series	Auto Inserting 2.54mm DIP Type THT	12
Slide Switch "DAM" Series	End Stackable 2.54mm DIP Type THT	13
Slide Switch "DSD" & "DSL" Series	End Stackable 2.54mm DIP Type SMT	14
Slide Switch "DHS" Series	HALF PITCH (1.27mm) SMT	15
Slide TRI-STATE Switch "DTD" / "DTA" & "DTS" Series	Standard Profile 2.54mm DIP Type THT & SMT	16
Selector Slide Switch "DSP" Series	Standard 2.54mm DIP Type THT & SMT	17
Piano Switch "DPG" & "DPS" Series	Standard Profile 2.54mm DIP Type THT	18 & 19
Piano Switch "DPH" Series	Low Profile 2.54mm DIP Type THT	20
Piano Switch "DPI" Series	Low Profile, End Stackable 2.54mm DIP Type THT	21
Piano Switch "DPA" Series	Low Profile 2.54mm DIP Type SMT	22
Piano Switch "DPM" Series	Low Profile, End Stackable 2.54mm DIP Type SMT	23

Part-Number	Page	Part-Number	Page	Part-Number	Page	Part-Number	Page
DAH-1xx-E01Z	12	DDS-5xx-SRAZ	11	DPM-1xx-EB11Z	23	DRD-4xx-CRZ	7
DAH-1xx-EZ	12	DDS-5xx-STZ	11	DPM-1xx-LA10Z	23	DRD-4xx-CSZ	5
DAH-1xx-L01Z	12	DDS-5xx-SZ	11	DPM-1xx-LA11Z	23	DRD-4xx-RFZ	9
DAH-1xx-LT01Z	12	DDS-6xx-STZ	10	DPM-1xx-LAT0Z	23	DRD-4xx-RMZ	3
DAH-1xx-LTZ	12	DDS-6xx-SZ	10	DPM-1xx-LAT1Z	23	DRD-4xx-RRZ	7
DAH-1xx-LZ	12	DHS-1xx-LCZ	15	DPM-1xx-LB10Z	23	DRD-4xx-RSZ	5
DAM-1xx-E01Z	13	DHS-1xx-LDZ	15	DPM-1xx-LB11Z	23	DRD-5xx-CFZ	9
DAM-1xx-EZ	13	DHS-1xx-LTZ	15	DPM-1xx-LBT0Z	23	DRD-5xx-CRZ	7
DAM-1xx-L01Z	13	DHS-1xx-LZ	15	DPM-1xx-LBT1Z	23	DRD-5xx-CSZ	5
DAM-1xx-LT01Z	13	DPA-1xx-EA00Z	22	DPS-1xx-ATZ	18	DRD-5xx-RFZ	9
DAM-1xx-LTZ	13	DPA-1xx-EA10Z	22	DPS-1xx-AZ	18	DRD-5xx-RRZ	7
DAM-1xx-LZ	13	DPA-1xx-LA00Z	22	DPS-1xx-BTZ	18	DRD-5xx-RSZ	5
DDG-1xx-LTZ	11	DPA-1xx-LA10Z	22	DPS-1xx-BZ	18	DSD-1xx-EZ	14
DDG-1xx-LZ	11	DPA-1xx-LAT0Z	22	DPS-2xx-ATZ	18	DSD-1xx-LCZ	14
DDG-1xx-SRAZ	11	DPA-1xx-LAT1Z	22	DPS-2xx-AZ	18	DSD-1xx-LDZ	14
DDG-1xx-STZ	11	DPG-1xx-ATZ	18	DPS-2xx-BTZ	18	DSD-1xx-LTZ	14
DDG-1xx-SZ	11	DPG-1xx-AZ	18	DPS-2xx-BZ	18	DSD-1xx-LZ	14
DDG-2xx-STZ	10	DPG-1xx-BTZ	18	DPS-3xx-ATZ	18	DSL-1xx-EZ	14
DDG-2xx-SZ	10	DPG-1xx-BZ	18	DPS-3xx-AZ	18	DSL-1xx-LCZ	14
DDG-3xx-STZ	10	DPG-2xx-ATZ	18	DPS-3xx-BTZ	18	DSL-1xx-LDZ	14
DDG-3xx-SZ	10	DPG-2xx-AZ	18	DPS-3xx-BZ	18	DSL-1xx-LTZ	14
DDG-4xx-LTZ	11	DPG-2xx-BTZ	18	DPS-4xx-ATZ	19	DSL-1xx-LZ	14
DDG-4xx-LZ	11	DPG-2xx-BZ	18	DPS-4xx-AZ	19	DSP-42-E01Z	17
DDG-4xx-SRAZ	11	DPG-3xx-ATZ	18	DPS-4xx-BTZ	19	DSP-42-E02Z	17
DDG-4xx-STZ	11	DPG-3xx-AZ	18	DPS-4xx-BZ	19	DSP-42-EC02Z	17
DDG-4xx-SZ	11	DPG-3xx-BTZ	18	DPS-5xx-ATZ	19	DSP-42-L01Z	17
DDG-5xx-LTZ	11	DPG-3xx-BZ	18	DPS-5xx-AZ	19	DSP-42-L02Z	17
DDG-5xx-LZ	11	DPG-4xx-ATZ	19	DPS-5xx-BTZ	19	DSP-42-LC02Z	17
DDG-5xx-SRAZ	11	DPG-4xx-AZ	19	DPS-5xx-BZ	19	DSP-42-LD02Z	17
DDG-5xx-STZ	11	DPG-4xx-BTZ	19	DPS-6xx-ATZ	19	DSP-42-LT01Z	17
DDG-5xx-SZ	11	DPG-4xx-BZ	19	DPS-6xx-AZ	19	DSP-42-LT02Z	17
DDG-6xx-STZ	10	DPG-5xx-ATZ	19	DPS-6xx-BTZ	19	DSS-1010Z	2
DDG-6xx-SZ	10	DPG-5xx-AZ	19	DPS-6xx-BZ	19	DSS-2010Z	2
DDS-1xx-LTZ	11	DPG-5xx-BTZ	19	DRD-1xx-CFZ	8	DSS-3020Z	2
DDS-1xx-LZ	11	DPG-5xx-BZ	19	DRD-1xx-CMZ	3	DSS-4020KDZ	2
DDS-1xx-SRAZ	11	DPG-6xx-ATZ	19	DRD-1xx-CRZ	6	DSS-4020Z	2
DDS-1xx-STZ	11	DPG-6xx-AZ	19	DRD-1xx-CSZ	4	DTA-1xx-ETZ	16
DDS-1xx-SZ	11	DPG-6xx-BTZ	19	DRD-1xx-RFZ	8	DTA-1xx-EZ	16
DDS-2xx-STZ	10	DPG-6xx-BZ	19	DRD-1xx-RMZ	3	DTA-1xx-LTZ	16
DDS-2xx-SZ	10	DPH-1xx-EAZ	20	DRD-1xx-RRZ	6	DTA-1xx-LZ	16
DDS-3xx-STZ	10	DPH-1xx-LATZ	20	DRD-1xx-RSZ	4	DTD-1xx-ETZ	16
DDS-3xx-SZ	10	DPH-1xx-LAZ	20	DRD-2xx-CFZ	8	DTD-1xx-EZ	16
DDS-4xx-LTZ	11	DPI-1xx-EA10Z	21	DRD-2xx-CRZ	6	DTS-1xx-ETZ	16
DDS-4xx-LZ	11	DPI-1xx-EB10Z	21	DRD-2xx-CSZ	4	DTS-1xx-EZ	16
DDS-4xx-SRAZ	11	DPI-1xx-LA10Z	21	DRD-2xx-RFZ	8	DTS-1xx-LTZ	16
DDS-4xx-STZ	11	DPI-1xx-LB10Z	21	DRD-2xx-RRZ	6	DTS-1xx-LZ	16
DDS-4xx-SZ	11	DPM-1xx-EA10Z	23	DRD-2xx-RSZ	4		
DDS-5xx-LTZ	11	DPM-1xx-EA11Z	23	DRD-4xx-CFZ	9		
DDS-5xx-LZ	11	DPM-1xx-EB10Z	23	DRD-4xx-CMZ	3		

Changeover Slide Switch

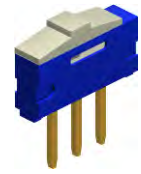
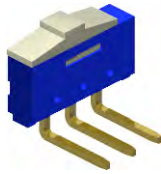

SMT & THT Page 2

Rotary Switch

horizontal SMT

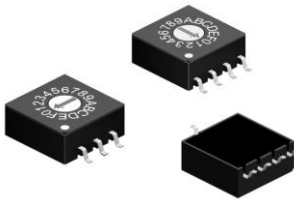

Page 3

horizontal THT

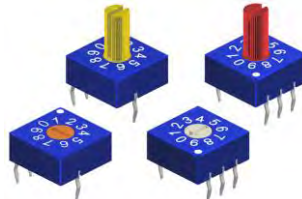

Page 4 & 5

vertical THT

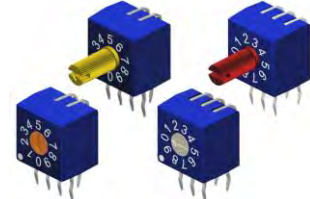

Page 6 to 9

Slide Switch

DIP Package "THT"

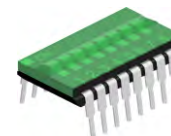
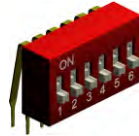
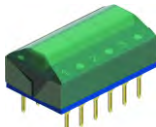

DDG / DDS Series Page 10 & 11

DAH / DAM Series Page 12 & 13

DIP Package "SMT"



DSD / DSL Series Page 14

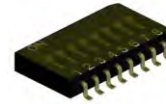

DHS Series Page 15

TRI-State "THT" & "SMT"

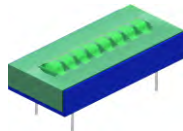
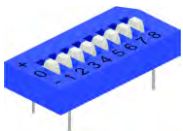

DTD / DTA / DTS Series Page 16

Selector "THT" & "SMT"

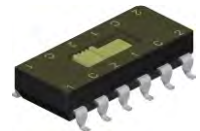

DSP Series Page 17

Piano Switch

DIP Package "THT"



DPG / DPS Series Page 18 & 19

DPH / DPI Series Page 20 & 21

DIP Package "SMT"

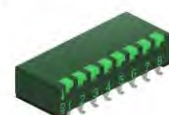

DPA / DPM Series Page 22 & 23

<p>DSS-10xx</p>		<p>Circuit diagram</p>	<p>Switch position</p> <table border="0"> <tr> <td>(B)</td> <td>(A)</td> </tr> <tr> <td>PT</td> <td>PT</td> </tr> <tr> <td>C-1</td> <td>C-2</td> </tr> </table>	(B)	(A)	PT	PT	C-1	C-2	<p>PCB Hole Layout</p>
(B)	(A)									
PT	PT									
C-1	C-2									
<p>DSS-20xx</p>		<p>Circuit diagram</p>	<p>Switch position</p> <table border="0"> <tr> <td>(B)</td> <td>(A)</td> </tr> <tr> <td>PT</td> <td>PT</td> </tr> <tr> <td>C-1</td> <td>C-2</td> </tr> </table>	(B)	(A)	PT	PT	C-1	C-2	<p>PCB Hole Layout</p>
(B)	(A)									
PT	PT									
C-1	C-2									
<p>DSS-30xx</p>		<p>Circuit diagram</p>	<p>Switch position</p> <table border="0"> <tr> <td>(B)</td> <td>(A)</td> </tr> <tr> <td>PT</td> <td>PT</td> </tr> <tr> <td>C-1</td> <td>C-2</td> </tr> </table>	(B)	(A)	PT	PT	C-1	C-2	<p>PCB SMT Layout</p>
(B)	(A)									
PT	PT									
C-1	C-2									
<p>DSS-40xx</p>		<p>Circuit diagram</p>	<p>Switch position</p> <table border="0"> <tr> <td>(B)</td> <td>(A)</td> </tr> <tr> <td>PT</td> <td>PT</td> </tr> <tr> <td>C-1</td> <td>C-2</td> </tr> </table>	(B)	(A)	PT	PT	C-1	C-2	<p>PCB SMT Layout</p>
(B)	(A)									
PT	PT									
C-1	C-2									

SPECIFICATIONS

Electrical data

Contact Rating	
-switching	0.2A, 24V DC / 0.5A, 12V DC
-minimum	1 mA at 10mV
Contact Resistance	50 mΩ max.
-after life test	100 mΩ max.
Insulation Resistance	10000 MΩ min. at 500V DC
Withstanding Voltage	500 V AC for 1 Minute
Capacitance between adjacent switches	1.5 pF max.

Mechanical and Environmental data

Operating Temperature	- 25°C to +70°C
Storage Temperature	- 40°C to +85°C
Soldering Temperature	
-SMT reflow soldering	250°C +0/-5°C for 10 sec. max.
-THT wave soldering	250°C +0/-5°C for 10 sec. max.
Operating force	800 gf max.
Mechanical Life	5000 operations
Vibration	10 Hz – 50 Hz – 10 Hz for 6 hours

FEATURES

- Suitable for signal switching and communication equipments
- All plastics used are UL 94V-0 grade fire retardant
- Gold plated contacts to ensure low contact resistance

- Tropical Version (black color) also for THT straight and right angle type available

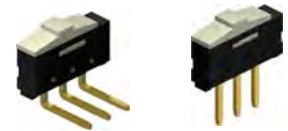

How to order

DSS – xx xx XX Z

Type	
10	= Straight THT
20	= Right angle THT
<i>Tropical version only:</i>	
30	= Vertical SMT
40	= Horizontal SMT

Execution	
10	= Standard version (blue) <i>Material: Nylon 66</i>
20	= Tropical version (black) <i>Material: Nylon 9T</i>

Packing option	
blank	= Tube packing
KD	= Reel packing <i>for DSP-40xx series only</i>

DRD-1 xx-XM Z (3:3 pin-out)



16 POSITIONS

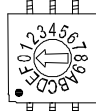

10 POSITIONS

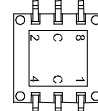
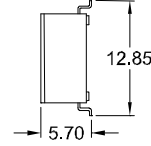
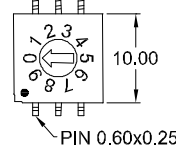

8 POSITIONS

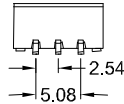
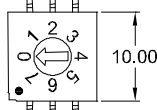

Pin No.	POSITION															
	0	1	2	3	4	5	6	7	8	9	A	B	C	D	E	F
1	○	●	○	○	○	○	○	○	○	○	○	○	○	○	○	○
2	○	○	○	○	○	○	○	○	○	○	○	○	○	○	○	○
4	○	○	○	○	○	○	○	○	○	○	○	○	○	○	○	○
8	○	○	○	○	○	○	○	○	○	○	○	○	○	○	○	○

● Real Code Rotor color: White
○ Complementary Code Rotor color: Red

DRD-4 xx-XM Z (1:4 pin-out)



16 POSITIONS

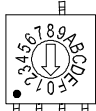

10 POSITIONS

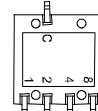
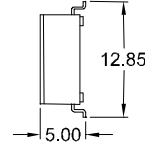
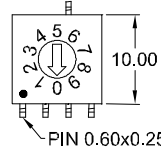

8 POSITIONS

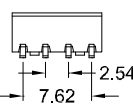
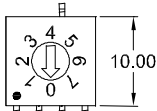

Pin No.	POSITION															
	0	1	2	3	4	5	6	7	8	9	A	B	C	D	E	F
1	○	○	○	○	○	○	○	○	○	○	○	○	○	○	○	○
2	○	○	○	○	○	○	○	○	○	○	○	○	○	○	○	○
4	○	○	○	○	○	○	○	○	○	○	○	○	○	○	○	○
8	○	○	○	○	○	○	○	○	○	○	○	○	○	○	○	○

● Real Code Rotor color: Yellow
○ Complementary Code Rotor color: Orange

Construction

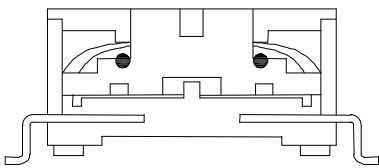

PCB SMT Layout

3:3 PIN-OUT

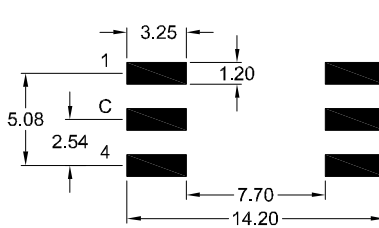

1:4 PIN-OUT

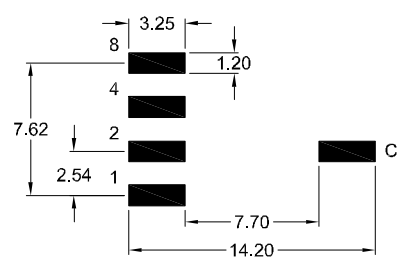

SPECIFICATIONS

Electrical data

Contact Rating	
-switching	25 mA, 24 V DC
-non-switching	100 mA, 50 V DC
Contact Resistance	
-initial	50 mΩ max.
-after life test	100 mΩ max.
Insulation Resistance	1000 MΩ min. at 100 V DC
Withstanding Voltage	250 V AC for 1 Minute

Mechanical and Environmental data

Operating Temperature	- 25°C to +70°C
Storage Temperature	- 40°C to +85°C
Soldering Temperature	
-SMT reflow soldering	250°C +0/-5°C for 10 sec.
Operating Force	500 gf-cm max. (torque)
Mechanical Life	2000 steps per position
Vibration	10 Hz – 50 Hz – 10 Hz for 6 hours

FEATURES

- Molded-in terminals and fully sealed construction
- Standard 2.54mm pin to pin
- All plastics are UL 94V-0 grade fire retardant
- Reliable contact and long-term stability
- Binary decimal (8 or 10 positions) and hexadecimal (16 positions), real and complementary codes available
- Gold plated contacts to ensure low contact resistance. Terminals Tin plated.

How to order

DRD – x xx – XX Z

Rotor	
1	= Flat type (3:3 pin-out)
4	= Flat type (1:4 pin-out)

Nbr of positions	
08; 10; 16	

Code	
RM	= Real
CM	= Complementary

DRD-1 xx-XS Z (Flat Type)

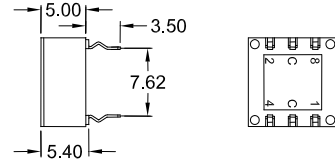
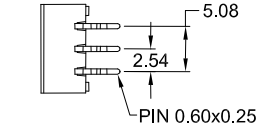
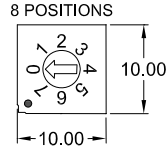
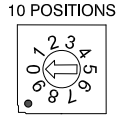
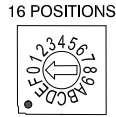
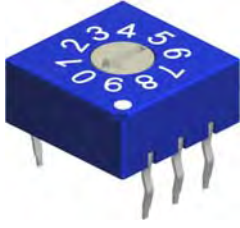

DRD-2 xx-XS Z (Shaft Type)

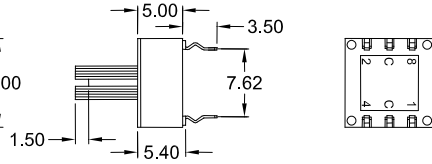
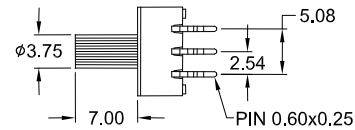
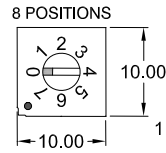
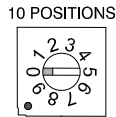
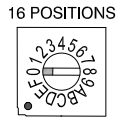
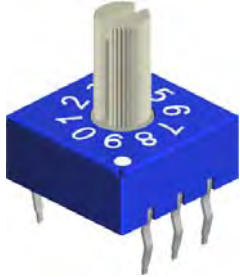

Construction

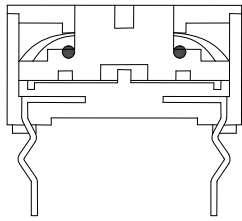

PCB Hole Layout

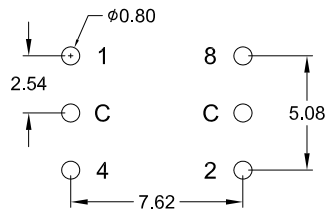

Code

Pin No.	POSITION															
	0	1	2	3	4	5	6	7	8	9	A	B	C	D	E	F
1	○	●	○	○	○	○	○	○	○	○	○	○	○	○	○	○
2	○	○	○	○	○	○	○	○	○	○	○	○	○	○	○	○
4	○	○	○	○	○	○	○	○	○	○	○	○	○	○	○	○
8	○	○	○	○	○	○	○	○	○	○	○	○	○	○	○	○

● Real Code Rotor color: White
○ Complementary Code Rotor color: Red

SPECIFICATIONS

Electrical data

Contact Rating	
-switching	25 mA, 24 V DC
-non-switching	100 mA, 50 V DC
Contact Resistance	
-initial	50 mΩ max.
-after life test	100 mΩ max.
Insulation Resistance	1000 MΩ min. at 100 V DC
Withstanding Voltage	250 V AC for 1 Minute

Mechanical and Environmental data

Operating Temperature	- 25°C to +70°C
Storage Temperature	- 40°C to +85°C
Operating Force	500 gf-cm max. (torque)
Mechanical Life	2000 steps per position
Vibration	10 Hz – 50 Hz – 10 Hz for 6 hours

FEATURES

- Molded-in terminals and fully sealed construction
- Standard 2.54mm pin to pin
- All plastics are UL 94V-0 grade fire retardant
- Reliable contact and long-term stability
- Binary decimal (8 or 10 positions) and hexadecimal (16 positions), real and complementary codes available
- Gold plated contacts to ensure low contact resistance. Terminals Tin plated.

How to order

DRD – x xx – XX Z

Rotor

1	= Flat type
2	= Shaft type

Nbr of positions

08; 10; 16

Code

RS	= Real	7.62mm row space
CS	= Complementary	7.62mm row space

DRD-4 xx-XS Z (Flat Type)

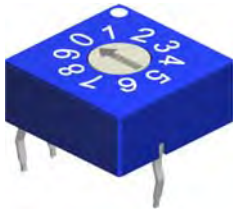

10 POSITIONS



8 POSITIONS

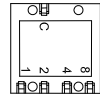
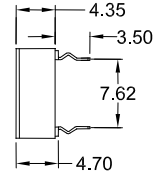
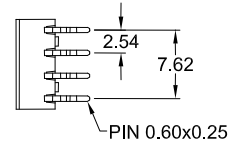
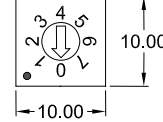

DRD-5 xx-XS Z (Shaft Type)



16 POSITIONS



10 POSITIONS



8 POSITIONS

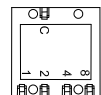
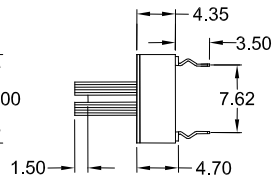
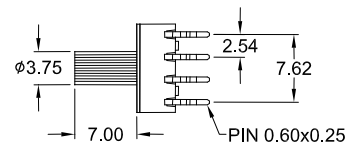
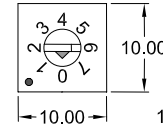

Construction

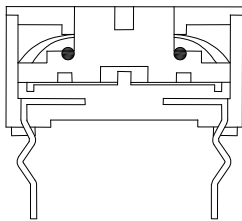

PCB Hole Layout

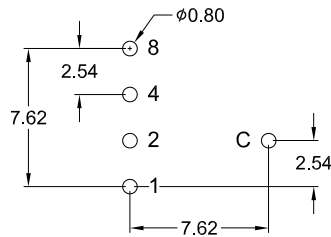

Code

Pin No.	POSITION															
	0	1	2	3	4	5	6	7	8	9	A	B	C	D	E	F
1	○	●	○	●	○	●	○	●	○	●	○	●	○	●	○	●
2	○	○	○	○	○	○	○	○	○	○	○	○	○	○	○	○
4	○	○	○	○	○	○	○	○	○	○	○	○	○	○	○	○
8	○	○	○	○	○	○	○	○	○	○	○	○	○	○	○	○

● Real Code Rotor color: Yellow
 ○ Complementary Code Rotor color: Orange

SPECIFICATIONS

Electrical data

Contact Rating	
-switching	25 mA, 24 V DC
-non-switching	100 mA, 50 V DC
Contact Resistance	
-initial	50 mΩ max.
-after life test	100 mΩ max.
Insulation Resistance	1000 MΩ min. at 100 V DC
Withstanding Voltage	250 V AC for 1 Minute

Mechanical and Environmental data

Operating Temperature	-25°C to +70°C
Storage Temperature	-40°C to +85°C
Operating Force	500 gf-cm max. (torque)
Mechanical Life	2000 steps per position
Vibration	10 Hz – 50 Hz – 10 Hz for 6 hours

FEATURES

- Molded-in terminals and fully sealed construction
- Standard 2.54mm pin to pin
- All plastics are UL 94V-0 grade fire retardant
- Reliable contact and long-term stability
- Binary decimal (8 or 10 positions) and hexadecimal (16 positions), real and complementary codes available
- Gold plated contacts to ensure low contact resistance. Terminals Tin plated.

How to order

DRD - x xx - XX Z

Rotor	
4	= Flat type
5	= Shaft type

Nbr of positions	
08; 10; 16	

Code	
RS	= Real 7.62mm row space
CS	= Complementary 7.62mm row space

DRD-4 xx-XF Z (Flat Type)



16 POSITIONS

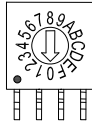

10 POSITIONS

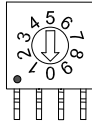

8 POSITIONS

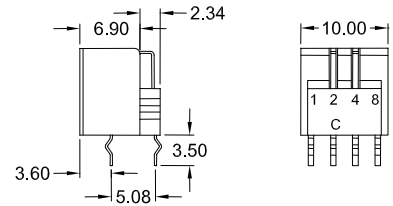
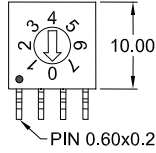

DRD-5 xx-XF Z (Shaft Type)



16 POSITIONS

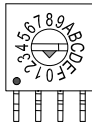

10 POSITIONS

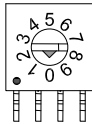

8 POSITIONS

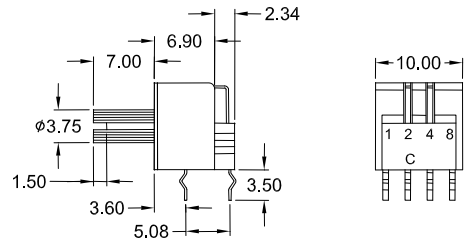
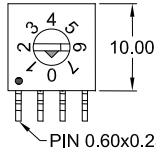

Construction

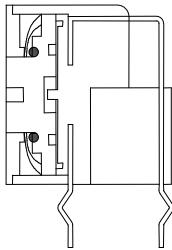

PCB Hole Layout

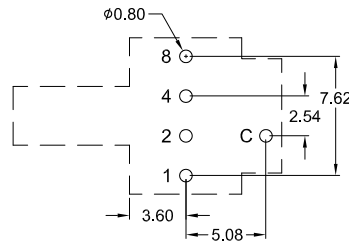

Code

Pin No.	POSITION															
	0	1	2	3	4	5	6	7	8	9	A	B	C	D	E	F
1	○	●	○	●	○	●	○	●	○	●	○	●	○	●	○	●
2	○	○	●	●	○	○	●	●	○	○	●	●	○	○	●	●
4	○	○	○	○	●	●	○	○	○	○	○	○	○	○	○	○
8	○	○	○	○	○	○	○	○	○	○	○	○	○	○	○	○

● Real Code

○ Complementary Code

Rotor color: Yellow

Rotor color: Orange

SPECIFICATIONS

Electrical data

Contact Rating	
-switching	25 mA, 24 V DC
-non-switching	100 mA, 50 V DC
Contact Resistance	
-initial	50 mΩ max.
-after life test	100 mΩ max.
Insulation Resistance	1000 MΩ min. at 100 V DC
Withstanding Voltage	250 V AC for 1 Minute

Mechanical and Environmental data

Operating Temperature	- 25°C to +70°C
Storage Temperature	- 40°C to +85°C
Operating Force	500 gf-cm max. (torque)
Mechanical Life	2000 steps per position
Vibration	10 Hz – 50 Hz – 10 Hz for 6 hours

FEATURES

- Molded-in terminals and fully sealed construction
- Standard 2.54mm pin to pin
- All plastics are UL 94V-0 grade fire retardant
- Reliable contact and long-term stability

- Binary decimal (8 or 10 positions) and hexadecimal (16 positions), real and complementary codes available
- Gold plated contacts to ensure low contact resistance. Terminals Tin plated.

How to order

DRD – x xx – XX Z

Rotor	
4	= Flat type
5	= Shaft type

Nbr of positions	
08; 10; 16	

Code	
RF	= Real 5.08mm row space
CF	= Complementary 5.08mm row space

DDG / DDS Series

SLIDE STANDARD PROFILE "THT" TYPE



DPDT Contact Form

Standard Actuator only!

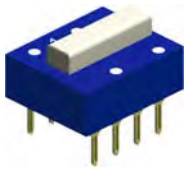

Position	1	2	3
Dim. "A"	11.70	21.70	31.80

Unit: mm

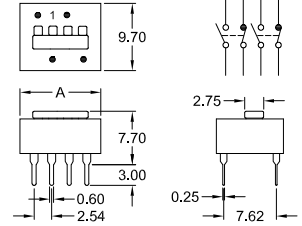

DPST Contact Form

Standard Actuator only!

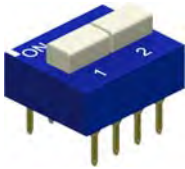

Position	1	2	3	4	5	6
Dim. "A"	6.70	11.70	16.70	21.70	26.70	31.80

Unit: mm

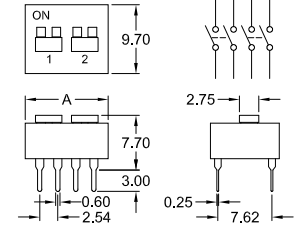

SPDT Contact Form

Standard Actuator only!



Position	1	2	3	4	5	6
Dim. "A"	6.70	11.70	16.70	21.70	26.70	31.80

Unit: mm

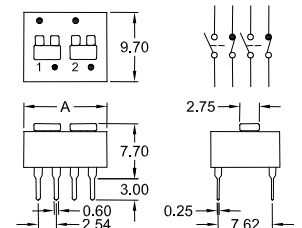

Construction

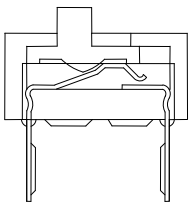

Options

1. Special top and/or side marking available

2. Tape sealed

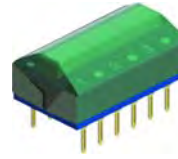
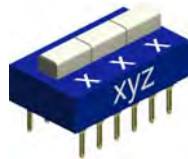

PCB Hole Layout

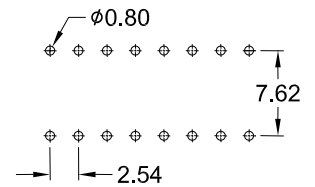

SPECIFICATIONS

Electrical data

Contact Rating	25 mA, 24 V DC
-switching	100 mA, 50 V DC
-non-switching	
Contact Resistance	
-initial	50 mΩ max.
-after life test	100 mΩ max.
Insulation Resistance	1000 MΩ min. at 100 V DC
Withstanding Voltage	500 V AC for 1 Minute
Capacitance between adjacent switches	5 pF max.

Mechanical and Environmental data

Operating temperature	-25°C to +70°C
Storage temperature	-40°C to +85°C
Operating force	800 gf max.
Mechanical life	2000 operations
Vibration	10 Hz – 50 Hz – 10 Hz for 6 hours

FEATURES

- Tactile response is performed directly by larger contact pressure to ensure very stable contact
- All plastics used are UL 94V-0 grade fire retardant
- Bottom epoxy sealed standard
- Contact wiping on make and break
- Gold plated (*gold/gold*) or silver plated (*silver/tin*) contacts to ensure low contact resistance and long mechanical life
- Ideal for Data Processing, Telecommunication, Remote Control and Burglar Alarm System use, where manual programming is required
- Standard packing method Tube

How to order

DDX – x xx – XX Z

Series

- DDG** = Gold plated Contacts
DDS = Silver plated Contacts

Contact Form

- 2** = DPST
3 = SPDT
6 = DPDT

Nbr of positions

see under position/dimension box above

Example:
 1 Position = **01**
 2 Position = **02**
 etc.

Actuator and Sealing

- S** = Standard Actuator
ST = Standard Actuator & Tape sealed

DDG / DDS Series

SLIDE STANDARD PROFILE "THT" TYPE



3PST Contact Form

Standard Actuator only!



Position	1	2	3	4
Dim. "A"	9.20	16.70	24.20	31.80

Unit: mm

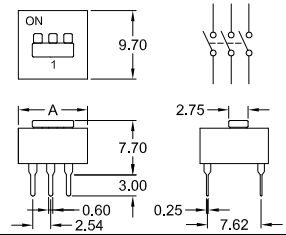

4PST Contact Form

Standard Actuator only!



Position	1	2	3
Dim. "A"	11.70	21.70	31.80

Unit: mm

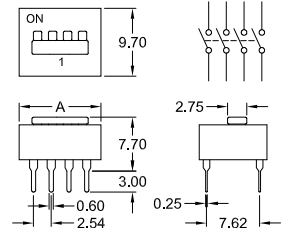

SPST Contact Form

Standard & Low Actuator possible.



Position	1	2	3	4	5	6
Dim. "A"	3.91	6.70	9.20	11.70	14.20	16.70
Position	7	8	9	10	12	15
Dim. "A"	19.20	21.70	24.20	26.70	31.80	39.50

Unit: mm

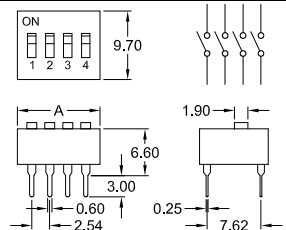

Construction

Options

1. Right Angle for SPST Contact Form; 1 to 15 positions

2. Low profile actuator

3. Tape sealed

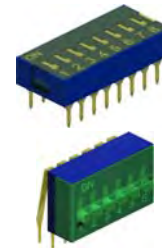
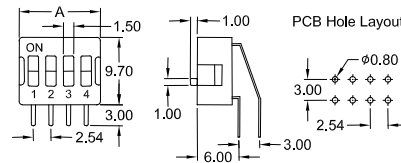
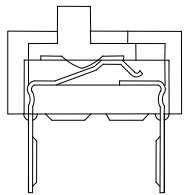

PCB Hole Layout

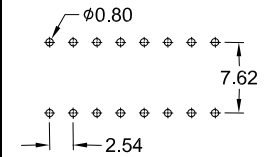

SPECIFICATIONS

Electrical data

Contact Rating	
-switching	25 mA, 24 V DC
-non-switching	100 mA, 50 V DC
Contact Resistance	
-initial	50 mΩ max.
-after life test	100 mΩ max.
Insulation Resistance	1000 MΩ min. at 100 V DC
Withstanding Voltage	500 V AC for 1 Minute
Capacitance between adjacent switches	5 pF max.

Mechanical and Environmental data

Operating temperature	- 25°C to +70°C
Storage temperature	- 40°C to +85°C
Operating force	800 gf max.
Mechanical life	2000 operations
Vibration	10 Hz – 50 Hz – 10 Hz for 6 hours

FEATURES

- Tactile response is performed directly by larger contact pressure to ensure very stable contact
- All plastics used are UL 94V-0 grade fire retardant
- Bottom epoxy sealed standard
- Contact wiping on make and break
- Gold plated (*gold/gold*) or silver plated (*silver/tin*) contacts to ensure low contact resistance and long mechanical life
- Ideal for Data Processing, Telecommunication, Remote Control and Burglar Alarm System use, where manual programming is required
- Standard packing method Tube

How to order

DDX – x xx – XXX Z

Series

DDG = Gold plated Contacts
DDS = Silver plated Contacts

Contact Form

1 = SPST
4 = 3PST
5 = 4PST

Nbr of positions

see under position/dimension box above

Example:
1 Position = **01**
2 Position = **02**
etc.

Actuator and Sealing

S = Standard Actuator
L = Low Profile Actuator
LT = Low Profile Actuator & Tape sealed
ST = Standard Actuator & Tape sealed
SRA = Right Angle Type

all in "ON" position

Extended Actuator

6.40 1.00 0.40 8.50 7.62

DIP Space

Circuit diagram

Low Profile Actuator

6.40 3.40 4.30 8.50 7.62

DIP Space

PCB Hole Layout

φ0.80 7.62 2.54

Position	2	3	4	5	6	7	8	10	12
Dim. "A"	6.68	9.42	11.96	14.50	17.04	19.58	22.12	27.20	32.28

Unit: mm

Construction

Options

- Two kinds of pitch available as attached table
- Special marking and body color available
- Tape sealed

Actuator Type	Pitch(mm)	
	Standard	Option
E	7.62	8.50
L	8.50	7.62

SPECIFICATIONS

Electrical data		Mechanical and Environmental data	
Contact Rating	25 mA, 24 V DC	Operating temperature	- 25°C to +70°C
-switching	100 mA, 50 V DC	Storage temperature	- 40°C to +85°C
Contact Resistance		Operating force	800 gf max.
-initial	50 mΩ max.	Mechanical life	2000 operations
-after life test	100 mΩ max.	Vibration	10 Hz – 50 Hz – 10 Hz for 6 hours
Insulation Resistance	1000 MΩ min. at 100 V DC		
Withstanding Voltage	500 V AC for 1 Minute		
Capacitance between adjacent switches	5 pF max.		

FEATURES

<ul style="list-style-type: none"> Same size as an IC, 7.62mm (.300"), can be assembled by any automatic IC Inserter Smaller size makes better heat convection during PC board wave soldering Tape sealed to withstand solder vapors and board washing 	<ul style="list-style-type: none"> All plastics used are UL 94V-0 grade fire retardant Twin contact design to ensure stable contact Gold plated contacts to ensure low contact resistance, and tin plated terminal to prevent contamination during soldering (<i>gold/tin</i>) Standard packing method Tube
---	---

How to order

DAH – 1 xx – XXxx Z

Contact Form	Nbr of positions	Actuator, Sealing and DIP Space
<p>1 = SPST</p>	<p>see under position/dimension box above</p> <p>Example: 2 Position = 02 3 Position = 03 etc.</p>	<p>L = Low profile Actuator and DIP space 8.50mm</p> <p>LT = Low profile Actuator & Tape sealed & DIP space 8.50mm</p> <p>L01 = Low profile Actuator and DIP space 7.62mm</p> <p>LT01 = Low profile Actuator & Tape sealed & DIP space 7.62mm</p> <p>E = Extended Actuator and DIP space 7.62mm</p> <p>E01 = Extended Actuator and DIP space 8.50mm</p>

DAM Series

SLIDE END STACKABLE "THT" TYPE



all in "ON" position

Extended Actuator

Circuit diagram

Low Profile Actuator

PIN 0.50x0.25

PCB Hole Layout

Position	1	2	3	4	5	6	7	8	9	10	12
Dim. "A"	2.50	5.04	7.58	10.12	12.66	15.20	17.74	20.28	22.82	25.36	30.43

Unit: mm

Construction

Options

- Two kinds of pitch available as attached table
- Special marking and body color available
- Tape sealed

Actuator Type	Pitch (mm)	
	Standard	Option
E	7.62	8.50
L	8.50	7.62

SPECIFICATIONS

Electrical data		Mechanical and Environmental data	
Contact Rating	25 mA, 24 V DC	Operating temperature	- 25°C to +70°C
-switching	100 mA, 50 V DC	Storage temperature	- 40°C to +85°C
-non-switching		Operating force	800 gf max.
Contact Resistance	50 mΩ max.	Mechanical life	2000 operations
-initial	100 mΩ max.	Vibration	10 Hz – 50 Hz – 10 Hz for 6 hours
-after life test	1000 MΩ min. at 100 V DC		
Insulation Resistance	500 V AC for 1 Minute		
Withstanding Voltage	5 pF max.		
Capacitance between adjacent switches			

FEATURES

- End stackable for standard 2.54mm (.100") integrated circuit pitch
- All plastics used are UL 94V-0 grade fire retardant
- Same size as an IC, 7.62mm (.300"), can be assembled by any automatic IC Inserter
- Twin contact design to ensure stable contact
- Tape sealed to withstand solder vapors and board washing
- Gold plated contacts to ensure low contact resistance, and tin plated terminal to prevent contamination during soldering (*gold/tin*)
- Standard packing method Tube

How to order

DAM – 1 xx – XXxx Z

Contact Form	Nbr of positions	Actuator, Sealing and DIP Space																		
1 = SPST	see under position/dimension box above Example: 1 Position = 01 2 Position = 02 etc.	<table style="width: 100%; border-collapse: collapse;"> <tr> <td style="width: 10%;">L</td> <td>=</td> <td>Low profile Actuator and DIP space 8.50mm</td> </tr> <tr> <td>LT</td> <td>=</td> <td>Low profile Actuator & Tape sealed & DIP space 8.50mm</td> </tr> <tr> <td>L01</td> <td>=</td> <td>Low profile Actuator and DIP space 7.62mm</td> </tr> <tr> <td>LT01</td> <td>=</td> <td>Low profile Actuator & Tape sealed & DIP space 7.62mm</td> </tr> <tr> <td>E</td> <td>=</td> <td>Extended Actuator and DIP space 7.62mm</td> </tr> <tr> <td>E01</td> <td>=</td> <td>Extended Actuator and DIP space 8.50mm</td> </tr> </table>	L	=	Low profile Actuator and DIP space 8.50mm	LT	=	Low profile Actuator & Tape sealed & DIP space 8.50mm	L01	=	Low profile Actuator and DIP space 7.62mm	LT01	=	Low profile Actuator & Tape sealed & DIP space 7.62mm	E	=	Extended Actuator and DIP space 7.62mm	E01	=	Extended Actuator and DIP space 8.50mm
L	=	Low profile Actuator and DIP space 8.50mm																		
LT	=	Low profile Actuator & Tape sealed & DIP space 8.50mm																		
L01	=	Low profile Actuator and DIP space 7.62mm																		
LT01	=	Low profile Actuator & Tape sealed & DIP space 7.62mm																		
E	=	Extended Actuator and DIP space 7.62mm																		
E01	=	Extended Actuator and DIP space 8.50mm																		

DSD / DSL Series

SLIDE END STACKABLE "SMT" TYPE



DSD Gull Wing Type

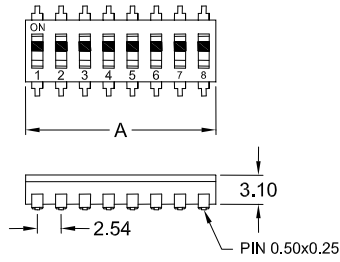

Low Profile Actuator

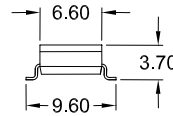

Extended Actuator

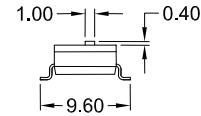

Circuit diagram

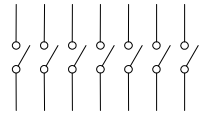

DSL J-Leg Type

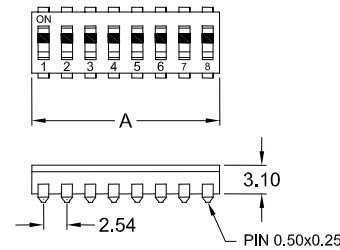

Low Profile Actuator

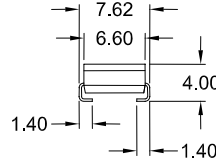

Extended Actuator

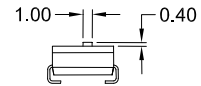

Circuit diagram

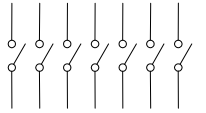

Position	1	2	3	4	5	6	7	8	9	10	12
Dim. "A"	2.50	5.04	7.58	10.12	12.66	15.20	17.74	20.28	22.82	25.36	30.43

DSL Series: 1 position switch is not available

Unit: mm

Construction

DSD

DSL

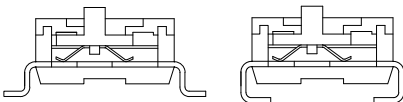

PCB SMT Layout

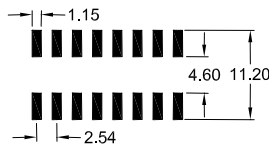

Options

1. Special marking and body color available

2. Tape sealed



SPECIFICATIONS

Electrical data

Contact Rating	
-switching	25 mA, 24 V DC
-non-switching	100 mA, 50 V DC
Contact Resistance	
-initial	50 mΩ max.
-after life test	100 mΩ max.
Insulation Resistance	1000 MΩ min. at 100 V DC
Withstanding Voltage	500 V AC for 1 Minute
Capacitance between adjacent switches	5 pF max.

Mechanical and Environmental data

Operating Temperature	-25°C to +70°C
Storage Temperature	-40°C to +85°C
Soldering Temperature	
-SMT reflow soldering	250°C +0/-5°C for 10 sec.
Operating Force	800 gf max.
Mechanical Life	2000 operations
Vibration	10 Hz – 50 Hz – 10 Hz for 6 hours

FEATURES

- End stackable for standard 2.54mm (.100") integrated circuit pitch
- Tape sealed to withstand solder vapors and board washing
- All plastics used are UL 94V-0 grade fire retardant

- Twin contact design to ensure stable contact
- Gold plated contacts to ensure low contact resistance, and tin plated terminal to prevent contamination during soldering (*gold/tin*)

How to order

DSX – 1 xx – XX Z

Series

DSD = Gull Wing Type
DSL = J-Leg Type

Nbr of positions

see under position/dimension box above

Example:
1 Position = 01
2 Position = 02
etc.

Actuator, Sealing and Packing

L = Low Profile Actuator; Tube packing
LT = Low Profile Actuator & Tape sealed; Tube packing
LC = Low Profile Actuator; Reel packing
LD = Low Profile Actuator & Tape sealed; Reel packing
E = Extended Actuator; Tube packing

DHS Series

SLIDE HALF PITCH (1.27mm) "SMT" TYPE



Circuit diagram

Position	2	4	6	8	10
Dim. "A"	3.70	6.20	8.75	11.30	13.80

Unit: mm

<p>Construction</p>	<p>PCB SMT Layout</p>	<p>Options</p> <div style="display: flex; justify-content: space-around;"> <div style="width: 45%;"> <p>1. Special marking and body color available</p> </div> <div style="width: 45%;"> <p>2. Tape sealed</p> </div> </div>
----------------------------	------------------------------	---

SPECIFICATIONS																																	
<p>Electrical data</p> <table style="width: 100%; border-collapse: collapse;"> <tr> <td style="padding: 2px;">Contact Rating</td> <td style="padding: 2px;">25 mA, 24 V DC</td> </tr> <tr> <td style="padding: 2px;">-switching</td> <td style="padding: 2px;">100 mA, 50 V DC</td> </tr> <tr> <td style="padding: 2px;">-non-switching</td> <td style="padding: 2px;"></td> </tr> <tr> <td style="padding: 2px;">Contact Resistance</td> <td style="padding: 2px;">50 mΩ max.</td> </tr> <tr> <td style="padding: 2px;">-initial</td> <td style="padding: 2px;">100 mΩ max.</td> </tr> <tr> <td style="padding: 2px;">-after life test</td> <td style="padding: 2px;">500 MΩ min. at 100 V DC</td> </tr> <tr> <td style="padding: 2px;">Insulation Resistance</td> <td style="padding: 2px;">300 V AC for 1 Minute</td> </tr> <tr> <td style="padding: 2px;">Withstanding Voltage</td> <td style="padding: 2px;">5 pF max.</td> </tr> <tr> <td style="padding: 2px;">Capacitance between adjacent switches</td> <td style="padding: 2px;"></td> </tr> </table>	Contact Rating	25 mA, 24 V DC	-switching	100 mA, 50 V DC	-non-switching		Contact Resistance	50 mΩ max.	-initial	100 mΩ max.	-after life test	500 MΩ min. at 100 V DC	Insulation Resistance	300 V AC for 1 Minute	Withstanding Voltage	5 pF max.	Capacitance between adjacent switches		<p>Mechanical and Environmental data</p> <table style="width: 100%; border-collapse: collapse;"> <tr> <td style="padding: 2px;">Operating Temperature</td> <td style="padding: 2px;">- 25°C to +70°C</td> </tr> <tr> <td style="padding: 2px;">Storage Temperature</td> <td style="padding: 2px;">- 40°C to +85°C</td> </tr> <tr> <td style="padding: 2px;">Soldering Temperature</td> <td style="padding: 2px;">250°C +0/-5°C for 10 sec.</td> </tr> <tr> <td style="padding: 2px;">-SMT reflow soldering</td> <td style="padding: 2px;"></td> </tr> <tr> <td style="padding: 2px;">Operating Force</td> <td style="padding: 2px;">800 gf max.</td> </tr> <tr> <td style="padding: 2px;">Mechanical Life</td> <td style="padding: 2px;">1000 operations</td> </tr> <tr> <td style="padding: 2px;">Vibration</td> <td style="padding: 2px;">10 Hz – 50 Hz – 10 Hz for 6 hours</td> </tr> </table>	Operating Temperature	- 25°C to +70°C	Storage Temperature	- 40°C to +85°C	Soldering Temperature	250°C +0/-5°C for 10 sec.	-SMT reflow soldering		Operating Force	800 gf max.	Mechanical Life	1000 operations	Vibration	10 Hz – 50 Hz – 10 Hz for 6 hours
Contact Rating	25 mA, 24 V DC																																
-switching	100 mA, 50 V DC																																
-non-switching																																	
Contact Resistance	50 mΩ max.																																
-initial	100 mΩ max.																																
-after life test	500 MΩ min. at 100 V DC																																
Insulation Resistance	300 V AC for 1 Minute																																
Withstanding Voltage	5 pF max.																																
Capacitance between adjacent switches																																	
Operating Temperature	- 25°C to +70°C																																
Storage Temperature	- 40°C to +85°C																																
Soldering Temperature	250°C +0/-5°C for 10 sec.																																
-SMT reflow soldering																																	
Operating Force	800 gf max.																																
Mechanical Life	1000 operations																																
Vibration	10 Hz – 50 Hz – 10 Hz for 6 hours																																

FEATURES	
<ul style="list-style-type: none"> End stackable for standard 1.27mm (.050") integrated circuit pitch Lowest profile DIP Switch, only 1.80mm above PCB Tape sealed to withstand solder vapors and board washing 	<ul style="list-style-type: none"> All plastics used are UL 94V-0 grade fire retardant Gold plated contacts, contact & solder area (<i>gold/gold</i>), to ensure low contact resistance

How to order

DHS – x xx – XX Z

<p>Contact Form</p> <p style="font-size: 1.2em; text-align: center;">1 = SPST</p>	<p>Nbr of positions</p> <p style="text-align: center; font-size: 0.8em;">see under position/dimension box above</p> <p style="font-size: 0.8em;">Example: 1 Position = 02 2 Position = 04 etc.</p>	<p>Actuator, Sealing and Packing</p> <table style="width: 100%; border-collapse: collapse;"> <tr> <td style="padding: 2px;">L</td> <td style="padding: 2px;">= Low Profile Actuator; Tube packing</td> </tr> <tr> <td style="padding: 2px;">LT</td> <td style="padding: 2px;">= Low Profile Actuator & Tape sealed; Tube packing</td> </tr> <tr> <td style="padding: 2px;">LC</td> <td style="padding: 2px;">= Low Profile Actuator; Reel packing</td> </tr> <tr> <td style="padding: 2px;">LD</td> <td style="padding: 2px;">= Low Profile Actuator & Tape sealed; Reel packing</td> </tr> </table>	L	= Low Profile Actuator; Tube packing	LT	= Low Profile Actuator & Tape sealed; Tube packing	LC	= Low Profile Actuator; Reel packing	LD	= Low Profile Actuator & Tape sealed; Reel packing
L	= Low Profile Actuator; Tube packing									
LT	= Low Profile Actuator & Tape sealed; Tube packing									
LC	= Low Profile Actuator; Reel packing									
LD	= Low Profile Actuator & Tape sealed; Reel packing									

DTD / DTA / DTS Series

SLIDE TRI-STATE "THT" & "SMT" TYPE



DTD

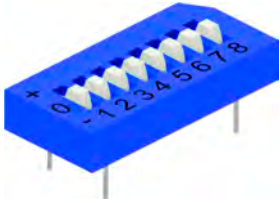

Position	4	5	6	7
Dim. "A"	15.30	17.84	20.38	22.92
Position	8	9	10	
Dim. "A"	25.46	28.00	30.54	

Unit: mm

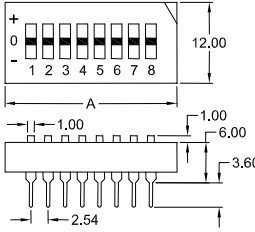
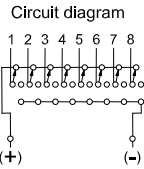



DTA

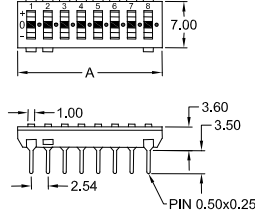
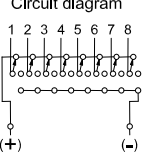

Position	2	3	4	5
Dim. "A"	6.88	9.42	11.96	14.50
Position	6	7	8	9
Dim. "A"	17.04	19.58	22.12	24.66

Unit: mm





DTS

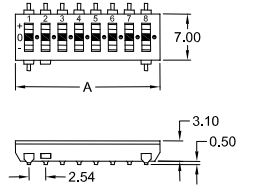
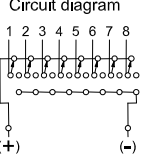

Position	10	12		
Dim. "A"	27.20	32.28		

Unit: mm

<p>Construction</p> 			<p>PCB Hole/SMT Layout</p> 		<p>Options</p> <p>1. Tape sealed</p> <p>2. Reverse PCB Layout available</p> 	
--	--	--	---	--	--	--

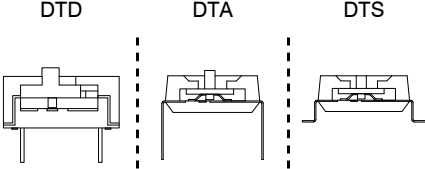
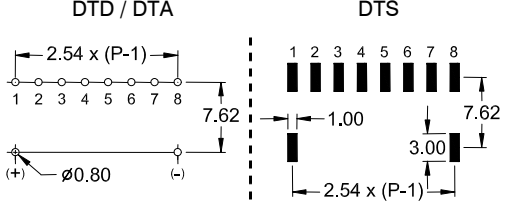
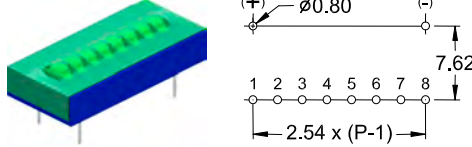
SPECIFICATIONS

<p>Electrical data</p> <p>Contact Rating</p> <ul style="list-style-type: none"> -switching: 25 mA, 24 V DC -non-switching: 100 mA, 50 V DC <p>Contact Resistance</p> <ul style="list-style-type: none"> -initial: 50 mΩ max. -after life test: 100 mΩ max. <p>Insulation Resistance: 1000 MΩ min. at 100 V DC</p> <p>Withstanding Voltage: 500 V AC for 1 Minute</p> <p>Capacitance between adjacent switches: 5 pF max.</p>	<p>Mechanical and Environmental data</p> <p>Operating temperature: -25°C to +70°C</p> <p>Storage temperature: -40°C to +85°C</p> <p>Operating force: 800 gf max.</p> <p>Mechanical life: 2000 operations</p> <p>Vibration: 10 Hz – 50 Hz – 10 Hz for 6 hours</p>
---	---

FEATURES

<ul style="list-style-type: none"> With three state (1-open-0) setting function, especially suitable for encoding/decoding of tri-state encoder/decoder integrated circuit to obtain more security codes than traditional two-state (1-0) operation. For instance, 9 bits with tri-state gets 19,683 (3⁹) codes, while two-state has 512 (2⁹) codes, gains 38 times in former All plastics used are UL 94V-0 grade fire retardant 	<ul style="list-style-type: none"> Gold plated contacts to ensure low contact resistance, and tin plated terminal to prevent contamination during soldering (<i>gold/tin</i>) Twin contacts designed to ensure stable contact Ideal for Telecommunication, Transmitter, Remote Control and Burglar Alarm Systems which use integrated circuits with tri-state coding systems Standard packing method Tube
---	---

How to order

DTX – 1 xx – XX Z

<p>Series</p> <p>DTD = Bottom Epoxy Sealed THT Type</p> <p>DTA = Low Profile THT Type</p> <p>DTS = Low Profile SMT Type</p>	<p>Nbr of positions</p> <p>see under position/dimension box above</p> <p>Example: 2 Position = 02 3 Position = 03 etc.</p>	<p>Actuator and Sealing</p> <p>E = Extended Actuator</p> <p>ET = Extended Actuator & Tape sealed</p> <p><i>Low Profile Actuator for DTA & DTS Series only!</i></p> <p>L = Low Profile Actuator</p> <p>LT = Low Profile Actuator & Tape sealed</p>
---	---	--

DSP-42-XX 01 Z (THT Type)

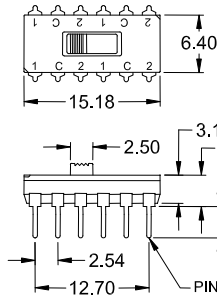

Low Profile Actuator

Extended Actuator

Circuit diagram

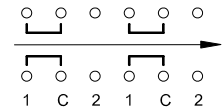

DSP-42-XX 02 Z (SMT Type)

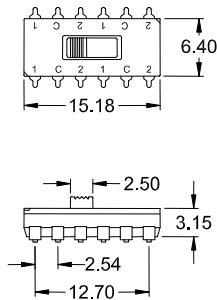

Low Profile Actuator

Extended Actuator

Circuit diagram

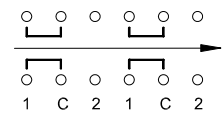

PCB Layout

DSP-42-XX 01 Z (THT Type)

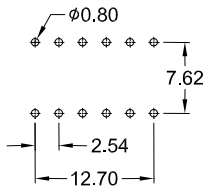

DSP-42-XX 02 Z (SMT Type)

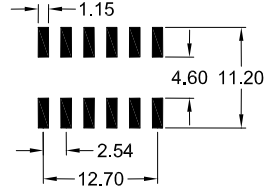

Option

Tape sealed

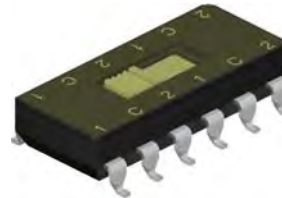

Application

Ideal as Function and Band Selector Switch in Radio-Cassette, Recorder, Office Equipment, TV sets, VCR etc.

SPECIFICATIONS

Electrical data

Contact Rating	25 mA, 24 V DC
-switching	100 mA, 50 V DC
-non-Switching	
Contact Resistance	
-initial	50 mΩ max.
-after life test	100 mΩ max.
Insulation Resistance	1000 MΩ min. at 100 V DC
Withstanding Voltage	500 V AC for 1 Minute
Capacitance between adjacent switches	5 pF max.

Mechanical and Environmental data

Operating Temperature	- 25°C to +70°C
Storage Temperature	- 40°C to +85°C
Soldering Temperature	
-SMT reflow soldering	250°C +0/-5°C for 10 sec. max.
-THT wave soldering	250°C +0/-5°C for 10 sec. max.
Operating Force	100 gf min / 1000 gf max.
Mechanical Life	2000 operations
Vibration	10 Hz – 50 Hz – 10 Hz for 6 hours

FEATURES

- Same size as an IC, 7.62mm (.300"), can be assembled by any automatic IC inserter
- Top tape sealed to withstand solder vapors and board washing
- All plastics used are UL 94V-0 grade fire retardant
- Gold plated contacts to ensure low contact resistance and tin plated terminal to prevent contamination during soldering

How to order

DSP – 42 – XX xx Z

Contact Form
42 = 4PDT

Device Type, Actuator, DIP Space & Packing	
L 01	= THT Type; Low Profile Actuator DIP space 8.50mm; Tube packing
LT 01	= THT Type; Low Profile Actuator DIP space 8.50mm; Top sealed; Tube packing
E 01	= THT Type; Extended Actuator DIP space 7.62mm; Tube packing
L 02	= SMT Type; Low Profile Actuator; Tube packing
LT 02	= SMT Type; Low Profile Actuator; Top sealed; Tube packing
LC 02	= SMT Type; Low Profile Actuator; Reel packing
LD 02	= SMT Type; Low Profile Actuator; Top sealed; Reel packing
E 02	= SMT Type; Extended Actuator; Tube packing
EC 02	= SMT Type; Extended Actuator; Reel packing

SPST Contact Form



Position	2	3	4	5	6
Dim. "A"	6.70	9.20	11.70	14.20	16.70
Position	7	8	9	10	12
Dim. "A"	19.20	21.70	24.20	26.70	31.80

Unit: mm

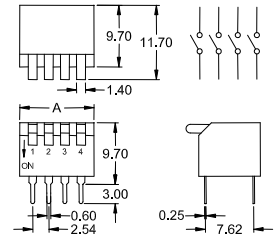

DPST Contact Form



Position	1	2	3	4	5	6
Dim. "A"	6.70	11.70	16.70	21.70	26.70	31.80

Unit: mm

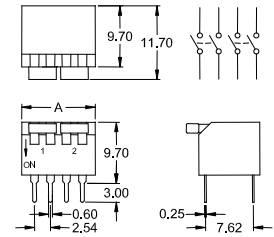

SPDT Contact Form



Position	1	2	3	4	5	6
Dim. "A"	6.70	11.70	16.70	21.70	26.70	31.80

Unit: mm

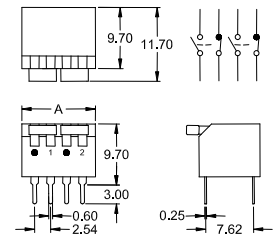

Construction

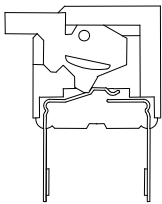

PCB Hole Layout

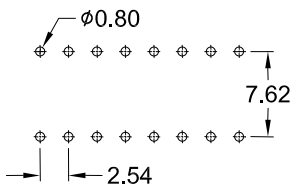

Options

1. Top side "OFF" and "ON" available
2. Black body color available
3. Tape sealed

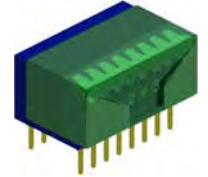

SPECIFICATIONS

Electrical data

Contact Rating	25 mA, 24 V DC
-switching	100 mA, 50 V DC
-non-switching	
Contact Resistance	50 mΩ max.
-initial	100 mΩ max.
-after life test	
Insulation Resistance	1000 MΩ min. at 100 V DC
Withstanding Voltage	500 V AC for 1 Minute
Capacitance between adjacent switches	5 pF max.

Mechanical and Environmental data

Operating temperature	- 25°C to +70°C
Storage temperature	- 40°C to +85°C
Operating force	800 gf max.
Mechanical life	1000 operations
Vibration	10 Hz – 50 Hz – 10 Hz for 6 hours

FEATURES

- Edge actuated (piano type) easy setting on closely racked PCB
- Tactile response is performed directly by larger contact pressure to ensure very stable contact
- All plastic are UL 94V-0 grade fire retardant
- Bottom epoxy sealed standard to ensure free of flux immersion during wave soldering
- Contact wiping on make and break
- Gold plated (gold/gold) or Tin plated contact to ensure low contact resistance and long operation life
- Ideal for Data Processing, Telecommunication, Remote Control and Burglar Alarm System use, where manual programming is required

How to order

DPX – **X** **XX** – **XX** **Z**

Series	Contact Form	Nbr of positions	"ON/OFF" Position and Sealing
DPG = Gold plated Contacts	1 = SPST	see under position/dimension box above	A = Top side OFF
DPS = Tin plated Contacts	2 = DPST	Example: 1 Position = 01 2 Position = 02 etc.	AT = Top side OFF & Tape sealed
	3 = SPDT		B = Top side ON
			BT = Top side ON & Tape sealed

DPDT Contact Form



Position	1	2	3
Dim. "A"	11.70	21.70	31.80

Unit: mm

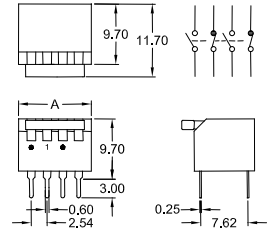

3PST Contact Form

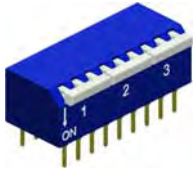

Position	1	2	3	4
Dim. "A"	9.20	16.70	24.20	31.80

Unit: mm

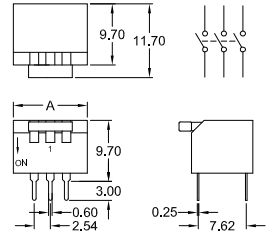

4PST Contact Form

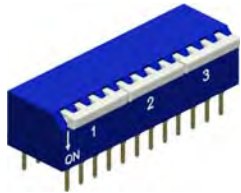

Position	1	2	3
Dim. "A"	11.70	21.70	31.80

Unit: mm

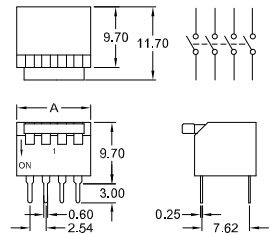

Construction

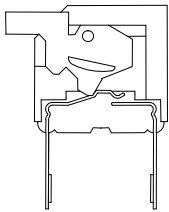

PCB Hole Layout

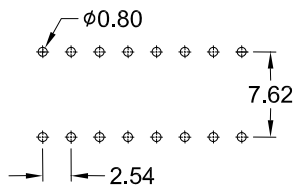

Options

1. Black body color available
2. Tape sealed

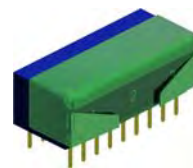

Application

Ideal for Data Processing, Telecommunication, Remote Control and Burglar Alarm System use, where manual programming is required.

SPECIFICATIONS

Electrical data

Contact Rating	25 mA, 24 V DC
-switching	100 mA, 50 V DC
-non-Switching	
Contact Resistance	50 mΩ max.
-initial	100 mΩ max.
-after life test	1000 MΩ min. at 100 V DC
Insulation Resistance	500 V AC for 1 Minute
Withstanding Voltage	5 pF max.
Capacitance between adjacent switches	

Mechanical and Environmental data

Operating temperature	-25°C to +70°C
Storage temperature	-40°C to +85°C
Operating force	800 gf max.
Mechanical life	1000 operations
Vibration	10 Hz – 50 Hz – 10 Hz for 6 hours

FEATURES

- Edge actuated (piano type) easy setting on closely racked PCB
- Tactile response is performed directly by larger contact pressure to ensure very stable contact
- Bottom epoxy sealed standard to ensure free of flux immersion during wave soldering
- Contact wiping on make and break
- All plastics used are UL 94V-0 grade fire retardant
- Gold plated (*gold/gold*) or Tin plated contact to ensure low contact resistance and long operation life

How to order

DPX – x xx – XX Z

Series

- DPG** = Gold plated Contacts
- DPS** = Tin plated Contacts

Contact Form

- 4** = 3PST
- 5** = 4PST
- 6** = DPDT

Nbr of positions

see under position/dimension box above

Example:
1 Position = **01**
2 Position = **02**
etc.

Actuator and Sealing

- A** = Top side OFF
- AT** = Top side OFF & Tape sealed
- B** = Top side ON
- BT** = Top side ON & Tape sealed

DPH Series

PIANO LOW PROFILE "THT" TYPE



Position	2	4	6	8	10
Dim. "A"	6.50	11.60	16.70	21.70	26.70

Unit: mm

<p>Construction</p>	<p>PCB Hole Layout</p>	<p>Option</p> <p>Tape sealed</p>
----------------------------	-------------------------------	---

SPECIFICATIONS	
<p>Electrical data</p> <p>Contact Rating</p> <ul style="list-style-type: none"> -switching 25 mA, 24 V DC -non-Switching 100 mA, 50 V DC <p>Contact Resistance</p> <ul style="list-style-type: none"> -initial 50 mΩ max. -after life test 100 mΩ max. <p>Insulation Resistance 1000 MΩ min. at 100 V DC</p> <p>Withstanding Voltage 500 V AC for 1 Minute</p> <p>Capacitance between adjacent switches 5 pF max.</p>	<p>Mechanical and Environmental data</p> <p>Operating Temperature - 25°C to +70°C</p> <p>Storage Temperature - 40°C to +85°C</p> <p>Operating Force 800 gf max.</p> <p>Mechanical Life 1000 operations</p> <p>Vibration 10 Hz – 50 Hz – 10 Hz for 6 hours</p>

FEATURES	
<ul style="list-style-type: none"> ● Edge actuated (piano type) easy setting on closely racked PCB ● Tactile response is performed directly by larger contact pressure to ensure very stable contact ● All plastic are UL 94V-0 grade fire retardant 	<ul style="list-style-type: none"> ● Twin contact design to ensure stable contact ● Contact wiping on make and break ● Gold plated contacts to ensure low contact resistance, and tin plated terminal to prevent contamination during soldering (<i>gold/tin</i>)

How to order

DPH – 1 xx – XX Z

<p>Nbr of positions</p> <p>see under position/dimension box above</p> <p>Example: 2 Position = 02 4 Position = 04 etc.</p>

<p>Actuator and "ON/OFF" Position</p> <p>LA = Low Profile Actuator EA = Extended Actuator LAT = Low Profile Actuator & Tape sealed</p> <p>the DPH Series is basically "Top Side OFF"</p>

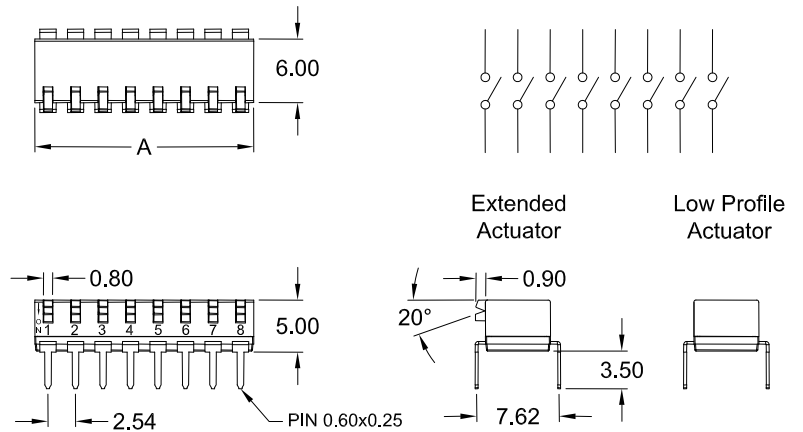

Position	2	4	6	8	10
Dim. "A"	4.98	10.06	15.15	20.22	25.30

Unit: mm

Construction

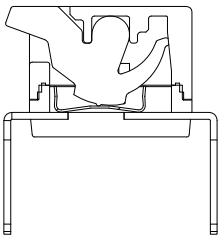

PCB Hole Layout

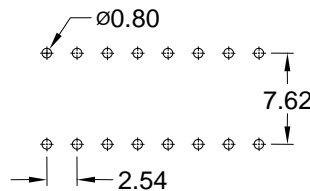

Precautions in Handling

Do not wash the switch!
Washable Type not available.

SPECIFICATIONS

Electrical data

Contact Rating	25 mA, 24 V DC
-switching	100 mA, 50 V DC
-non-switching	
Contact Resistance	
-initial	100 mΩ max.
-after life test	200 mΩ max.
Insulation Resistance	100 MΩ min. at 500 V DC
Withstanding Voltage	500 V AC for 1 Minute
Capacitance between adjacent switches	5 pF max..

Mechanical and Environmental data

Operating Temperature	- 20°C to +85°C
Storage Temperature	- 40°C to +85°C
Operating Force	800 gf max.
Mechanical Life	2000 operations
Vibration	10 Hz – 50 Hz – 10 Hz for 6 hours

FEATURES

- End stackable for standard 2.54mm (.100") integrated circuit pitch
- Twin contact design to ensure stable contact
- All plastics used are UL 94V-0 grade fire retardant
- Gold plated contacts, contact & solder area (*gold/gold*), to ensure low contact resistance

How to order

DPI – 1 xx – XX 1 0 Z

Nbr of positions

see under position/dimension box above

Example:
2 Position = **02**
4 Position = **04**
etc.

Actuator and "ON/OFF" Position

EA	= Extended Actuator; Top side OFF
EB	= Extended Actuator; Top side ON
LA	= Low profile Actuator; Top side OFF
LB	= Low profile Actuator; Top side ON

Packing

0 = Tube packing

Position	2	4	6	8	10
Dim. "A"	6.50	11.60	16.70	21.70	26.70

Unit: mm

Construction	PCB SMT Layout	Option
		Tape sealed

SPECIFICATIONS

Electrical data	Mechanical and Environmental data
Contact Rating -switching 25 mA, 24 V DC -non-Switching 100 mA, 50 V DC Contact Resistance -initial 50 mΩ max. -after life test 100 mΩ max. Insulation Resistance 1000 MΩ min. at 100 V DC Withstanding Voltage 500 V AC for 1 Minute Capacitance between adjacent switches 5 pF max.	Operating Temperature -25°C to +70°C Storage Temperature -40°C to +85°C Soldering Temperature -SMT reflow soldering 250°C +0/-5°C for 10 sec. Operating Force 800 gf max. Mechanical Life 1000 operations Vibration 10 Hz – 50 Hz – 10 Hz for 6 hours

FEATURES

<ul style="list-style-type: none"> ● Edge actuated (piano type) easy setting on closely racked PCB ● Tactile response is performed directly by larger contact pressure to ensure very stable contact ● All plastic are UL 94V-0 grade fire retardant 	<ul style="list-style-type: none"> ● Twin contact design to ensure stable contact ● Contact wiping on make and break ● Gold plated contacts to ensure low contact resistance, and tin plated terminal to prevent contamination during soldering (<i>gold/tin</i>)
---	--

How to order

DPA – 1 xx – XX Xx Z

Nbr of positions	Actuator and "ON/OFF" Position	Packing and Sealing
<p style="text-align: center;">see under position/dimension box above</p> Example: 2 Position = 02 4 Position = 04 etc.	EA = Extended Actuator; Top side OFF LA = Low Profile Actuator; Top side OFF	00 = Tube packing 10 = Reel packing 00 = Tube packing 10 = Reel packing T0 = Tube packing & Tape sealed T1 = Reel packing & Tape sealed

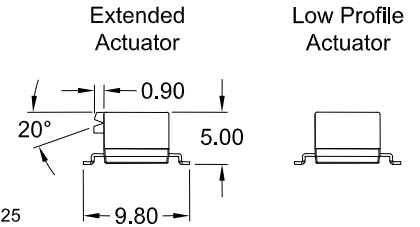
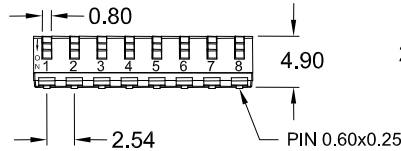
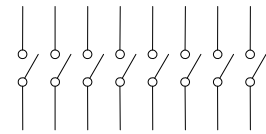
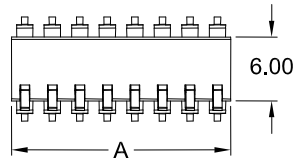

Position	2	4	6	8	10
Dim. "A"	4.98	10.06	15.15	20.22	25.30

Unit: mm

Construction

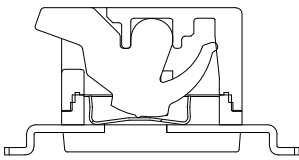

PCB SMT Layout

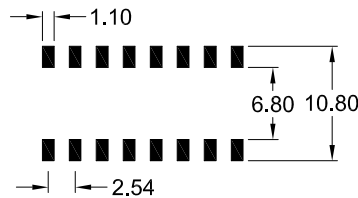

Precautions in Handling

Do not wash the switch!
Washable Type not available.

SPECIFICATIONS

Electrical data

Contact Rating	25 mA, 24 V DC
-switching	100 mA, 50 V DC
-non-switching	
Contact Resistance	
-initial	100 mΩ max.
-after life test	200 mΩ max.
Insulation Resistance	100 MΩ min. at 500 V DC
Withstanding Voltage	500 V AC for 1 Minute
Capacitance between adjacent switches	5 pF max..

Mechanical and Environmental data

Operating Temperature	- 20°C to +85°C
Storage Temperature	- 40°C to +85°C
Soldering Temperature	
-SMT reflow soldering	250°C +0/-5°C for 10 sec.
Operating Force	800 gf max.
Mechanical Life	2000 operations
Vibration	10 Hz – 50 Hz – 10 Hz for 6 hours

FEATURES

- End stackable for standard 2.54mm (.100") integrated circuit pitch
- Twin contact design to ensure stable contact
- All plastics used are UL 94V-0 grade fire retardant
- Gold plated contacts, contact & solder area (*gold/gold*), to ensure low contact resistance

How to order

DPM – 1 xx – XX 1 xx Z

Nbr of positions

see under position/dimension box above

Example:
2 Position = 02
4 Position = 04
etc.

Actuator and "ON/OFF" Position

EA	= Extended Actuator; Top side OFF
EB	= Extended Actuator; Top side ON
LA	= Low profile Actuator; Top side OFF
LB	= Low profile Actuator; Top side ON

Packing

10	= Tube packing
11	= Reel packing
10	= Tube packing
11	= Reel packing
T0	= Tube packing & Tape sealed
T1	= Reel packing & Tape sealed

Other products from E-tec

Please contact your closest sales office for further information.

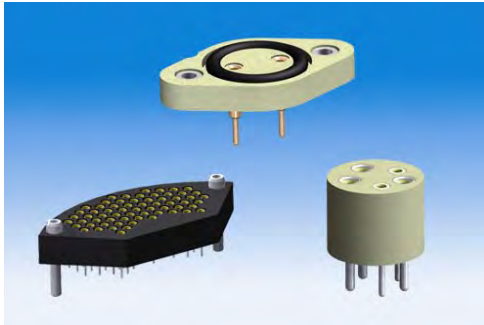

Customized Products

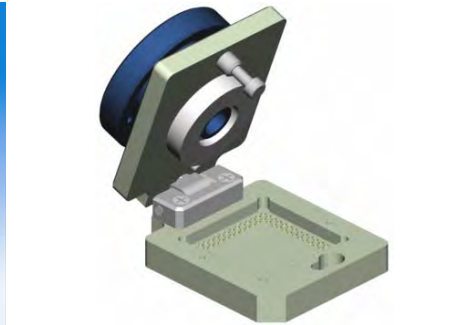

Test Sockets & Adapters

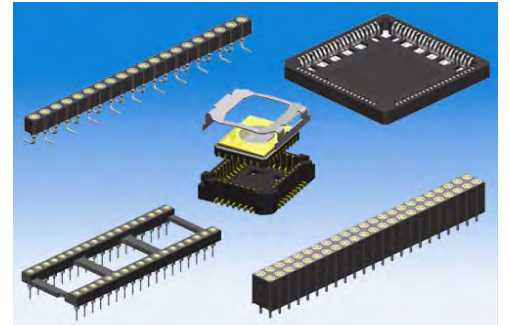

IC - Sockets

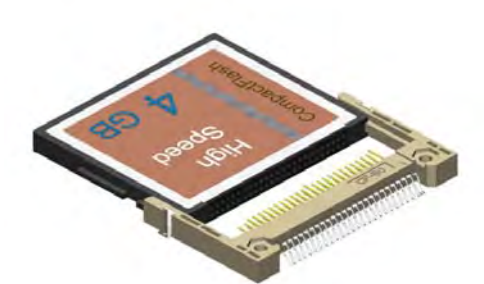

Compact Flash Connectors



USB & IEEE 1394 Connectors



Mini PCI Express Connectors

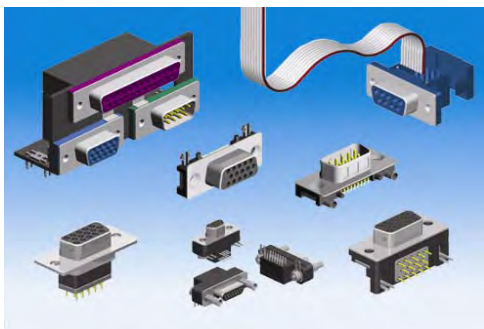

D-Sub Connectors



Flex Cable Connectors



HDMI Connectors



Probe Pin & Probe Pin Connectors

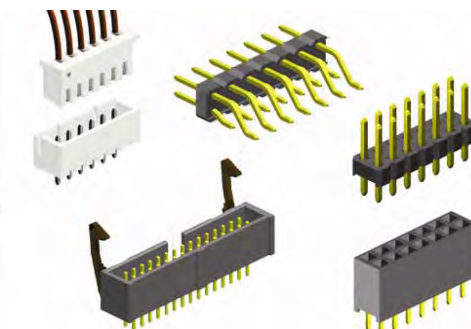

PCB Connectors



Multi Media Card Connectors

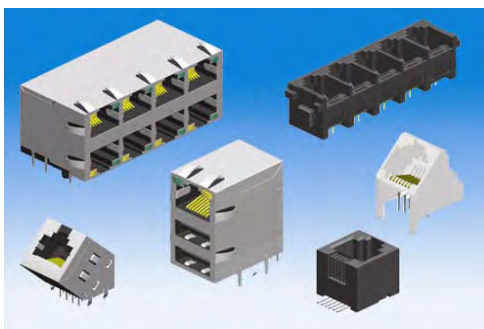

Modular Plugs & Jacks



Phono - & DC - Power Connectors



RF - Connectors



International Sales Headquarters

Switzerland E-tec Interconnect Ltd.
 Schweiz Chemin du Grand-Pré 9A
 Suisse CH-1510 Moudon
 Phone: +41/21/78108 10
 Fax: +41/21/78108 11
 e-mail: info@e-tec.com
 www.e-tec.com

Related Sales Headquarters

Deutschland EMC electro mechanical
 Germany components GmbH
 Allemagne PO Box/Postfach 11 60
 D-65501 Idstein
 Phone: +49/61 26/9395-0
 Fax: +49/61 26/9395-72
 e-mail: info@emc-connectors.com
 www.emc-connectors.com

France Silfox SA
 Frankreich PA des Petits Carreaux
 2 bis avenue des Coquelicots
 F-94385 BONNEUIL
 SUR MARNE CEDEX
 Phone: +33/1/49 56 04 68
 Fax: +33/1/49 56 02 87
 e-mail: info@silfox.fr
 www.silfox.fr

England E-tec Interconnect (UK) Ltd.
 Angleterre Units A5 & A6 Decimus Park
 Kingstanding Way
 Tunbridge Wells
 Kent TN2 3GP
 Phone: +44/1892/530260
 Fax: +44/1892/515560
 e-mail: info@e-tec.co.uk
 www.e-tec.co.uk

Factories

Switzerland E-tec AG
 Schweiz Friedhofstrasse 1
 Suisse CH-2543 Lengnau b. Biel
 Phone: +41/32/654 1550
 Fax: +41/32/652 2693
 e-mail: info@etecag.ch
 www.etecag.ch

Taiwan E-tec Interconnect Asia Ltd.
 10F-2, No. 379, Jhongshan Road
 Sanchong Dist. New Taipei City
 Taiwan R.O.C.
 Phone: +886/2/2 999-2726
 Fax: +886/2/2 999-5255
 e-mail: info@e-tec-asia.com.tw
 www.e-tec-asia.com.tw

YOUR AUTHORISED DISTRIBUTOR
 IHR VERTRAGS-DISTRIBUTOR
 VOTRE DISTRIBUTEUR OFFICIEL

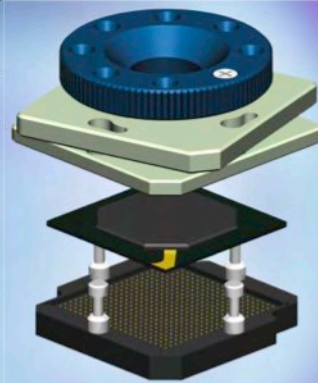
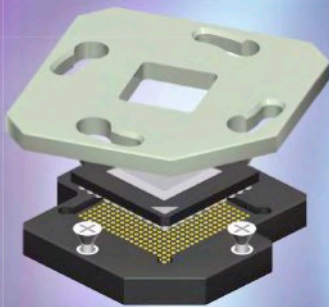
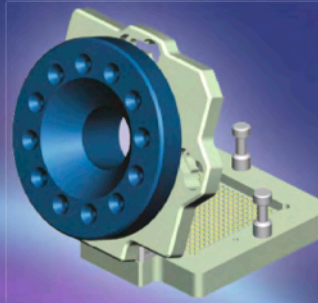
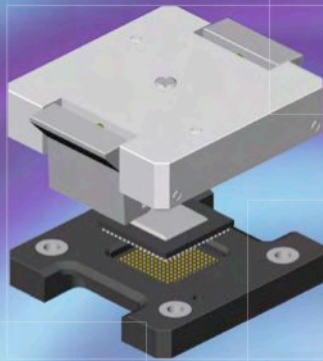
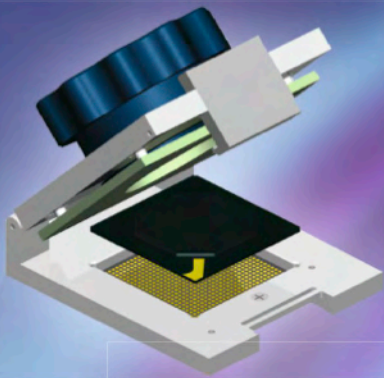

01

TEST SOCKETS & ADAPTERS

Swiss Manufacturing Plant



This building served for the production of Swiss precision watches for a period of 70 years.

In 1984 the facility was purchased, completely renovated and high technology fully automated production equipment was installed for the production of precision interconnection products.

In 1992 the trademark

E-tec

was registered to cover the complete interconnect product range.

As of 1993 a world-wide sales & distribution network was established to offer fast and efficient service regardless of location.

In addition to the interconnection products E-tec also supplies high quality screw machine parts as well as customized injection moulded and machined products. Our innovative approach to new product development allows us to offer the service, quality and competitive prices our customers demand. Whatever your requirement, be it high volume commodity product or low quantity custom special, **E-tec**, the **“Swiss Connection”** will endeavour to satisfy your requirements.

For any further details please contact E-tec or your closest sales office.

INDEX

[click on page number](#)

Part-Number	Type	Page
	About E-tec Test Sockets & Adapters	A
	Available Retention Frames	B
	Adapter & Converter Solutions	B
	Socket & Retention System Selector Guides	C
	General Product Information	D
ABG xxx-Exxx-xx X 55 xx	BGA Solder Adapter	11
BPC xxxx-xx xx-xx XX xx	BGA Socket ClamShell “Professional”	7 & 8
BPE xxxx-xx xx-xx XX xx	BGA Socket ClamShell “Economy”	6 & 8
BPF xxxx-xx xx-xx XX xx	BGA Socket FastLock	1 & 8
BPQ xxxx-xx xx-xx XX xx	BGA Socket QuickLock	4 & 8
BPW xxxx-xx xx-xx XX xx	BGA Socket TwistLock	2 & 8
BPZ xxxx-xx xx-xx XX xx	BGA Socket LeverLock	5 & 8
BUC xxxx-xx xx-xx XX xx	BGA Socket ClamShell “Professional”	7 & 8
BUE xxxx-xx xx-xx XX xx	BGA Socket ClamShell “Economy”	6 & 8
BUF xxxx-xx xx-xx XX xx	BGA Socket FastLock	1 & 8
BUQ xxxx-xx xx-xx XX xx	BGA Socket QuickLock	4 & 8
BUW xxxx-xx xx-xx XX xx	BGA Socket TwistLock	2 & 8
BUZ xxxx-xx xx-xx XX xx	BGA Socket LeverLock	5 & 8
CPC xxxx-xx xx-xx XX xx	Column Grid Socket ClamShell “Professional”	7 & 8
CPE xxxx-xx xx-xx XX xx	Column Grid Socket ClamShell “Economy”	6 & 8
CPF xxxx-xx xx-xx XX xx	Column Grid Socket FastLock	1 & 8
CPQ xxxx-xx xx-xx XX xx	Column Grid Socket QuickLock	4 & 8
CPW xxxx-xx xx-xx XX xx	Column Grid Socket TwistLock	2 & 8
CPZ xxxx-xx xx-xx XX xx	Column Grid Socket LeverLock	5 & 8
EBE xxxx-xx xx-xx XX xx	BGA Socket Elastomer Interposer Type ClamShell “Economy”	9
EBF xxxx-xx xx-xx XX xx	BGA Socket Elastomer Interposer Type FastLock	9
EBQ xxxx-xx xx-xx XX xx	BGA Socket Elastomer Interposer Type QuickLock	9
EBW xxxx-xx xx-xx XX xx	BGA Socket Elastomer Interposer Type TwistLock	9
EGF xxxx-xx xx-xx XX xx	GullWing Chip Socket Elastomer Interposer Type FastLock	9
EGQ xxxx-xx xx-xx XX xx	GullWing Chip Socket Elastomer Interposer Type QuickLock	9
EGW xxxx-xx xx-xx XX xx	GullWing Chip Socket Elastomer Interposer TwistLock	9
ELE xxxx-xx xx-xx XX xx	LGA/QFN Socket Elastomer Interposer Type ClamShell “Economy”	9
ELF xxxx-xx xx-xx XX xx	LGA/QFN Socket Elastomer Interposer Type FastLock	9
ELQ xxxx-xx xx-xx XX xx	LGA/QFN Socket Elastomer Interposer Type QuickLock	9
ELW xxxx-xx xx-xx XX xx	LGA/QFN Socket Elastomer Interposer Type TwistLock	9
FCT xxx-Xxxx-xx	ZIF Test sockets for Flex Cables	16
LPC xxxx-xx xx-xx XX xx	Land Grid Socket ClamShell “Professional”	7 & 8
LPE xxxx-xx xx-xx XX xx	Land Grid Socket ClamShell “Economy”	6 & 8
LPF xxxx-xx xx-xx XX xx	Land Grid Socket FastLock	1 & 8
LPQ xxxx-xx xx-xx XX xx	Land Grid Socket QuickLock	4 & 8
LPW xxxx-xx xx-xx XX xx	Land Grid Socket TwistLock	2 & 8
LPZ xxxx-xx xx-xx XX xx	Land Grid Socket LeverLock	5 & 8
LQE xxxx-xx xx-xx XX xx	QFN/MLF/MLP Socket ClamShell “Economy”	13
LQF xxxx-xx xx-xx XX xx	QFN/MLF/MLP Socket FastLock	13
LQQ xxxx-xx xx-xx XX xx	QFN/MLF/MLP Socket QuickLock	13
LQW xxxx-xx xx-xx XX xx	QFN/MLF/MLP Socket TwistLock	13
MGS xxxx-Exxx-xx X 95 xx	MiniGrid Socket	12
MGS xxxx-SB01-xx X 95 xx	MiniGrid SMT Solder Ball Adapter	10
QFC xxxx-xx xx-xx XX xx	GullWing Chip Socket ClamShell	14
QFF xxxx-xx xx-xx XX xx	GullWing Chip Socket FastLock	14
QFQ xxxx-xx xx-xx XX xx	GullWing Chip Socket QuickLock	14
QFW xxxx-xx xx-xx XX xx	GullWing Chip Socket ScrewLock	14
TOL-7CN-TORQUE	Torque Limiting Screwdriver Kit	15

E-tec test sockets are custom made high temperature sockets to test IC packages on a PCB (BGA, LGA, CGA, QFN, GullWing type, etc.).

Generally used for prototyping, pre-production and test & burn-in, the E-tec test sockets allow the customer to insert an IC package into the socket, test it in its original condition and remove it again for final soldering to the PCB after all tests have been completed. The sockets are easily adaptable to customer requirements.

Main questions on how to choose a socket

- **Which IC package needs to be tested?**
 - **E-tec offers socket solutions for any chip types**
The mechanical dimensions of the IC package are critical for defining the appropriate socket, thus a dimensional drawing always needs to be submitted.
- **Which contact style should be chosen?**
 - **Generally depends on contact durability, operating temperatures and/or frequency.**
Three main contact styles are available:
 - E-tec patented Probe pins (standard) up to 3.4 GHz
 - High Speed Probe pins (up to 30 GHz)
 - Elastomer interposers (up to 30 GHz)
- **How to connect the socket to the PCB?**
 - SMT (standard or raised)
 - Thru-hole
 - Solderless compression (probe pin or elastomer interposer)
- **Which socket retainer style is needed?**
 - Various factors will influence the choice of the retainer solution chosen, such as:
 - How many times will the socket be opened each day?
 - Cost of socket?
 - Is there any space limitation for the socket ?
 - Access required to the die of chip / heat dissipation (open top?)

Options for attaching the socket to the PCB

SMT soldering type
(Low profile, short signal path)

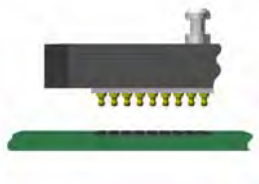

Raised SMT type
(lifts socket above close-by components)



Thru hole soldering type
(Generally for test & burn-in applications)

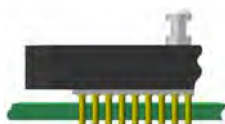

Solderless Compression type
(short signal path, avoids soldering process)

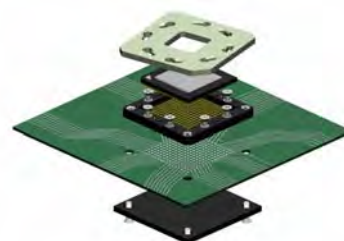

Available Retention frames

FastLock

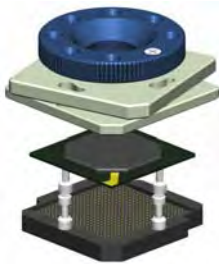

with lever
for high pincount

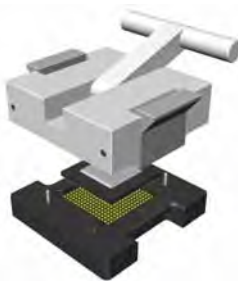

TwistLock

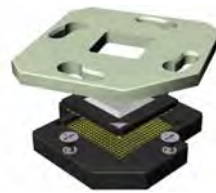

QuickLock

without lever
for low pincount



LeverLock

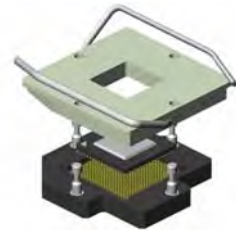

open top
(on request)

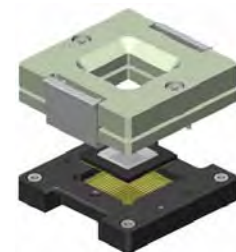

ClamShell

Economy
Open top

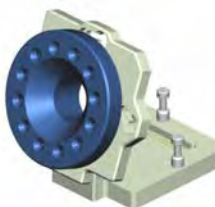

Professional
closed top



Professional
open top (on request)

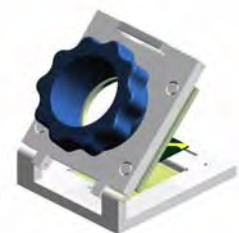

SMT Adapter solution for plugging a test socket

- solderball or solid pin surface mount sockets
- easy to solder (especially high pincount)
- easy plugging of test socket after soldering

Step 1: solder mini-grid socket to PCB
Step 2: plug test socket into mini-grid socket

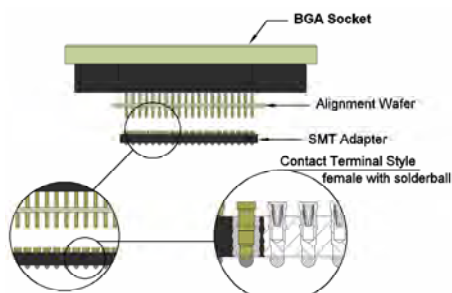

Converter Adapter solution

- generally for high volume requirements
- mini-grid sockets available with solder balls or regular solid pins

Step 1: mini-grid socket soldered to PCB
Step 2: chip soldered to adapter board (converting BGA to PGA)
Step 3: Plug adapter board into mini-grid socket

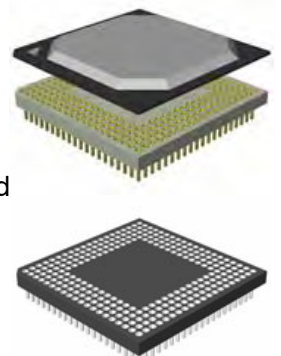

The below Socket & Retention System Selector Guides will help you to make the right choice.

The options indicated refer to standard options. If you should not find what you need or if your specs should vary from the below chart, please contact your closest E-tec office, since we will most likely be able to offer a customized solution also.

Socket Selector Guide

Socket style	Lowest Pitch	Contact interface			Available Temperature range	Chip types						
		Regular Probe pin (up to 3.4 GHz)	High speed (up to 30 GHz)	Replaceable contacts		BGA/CSP	CGA	LGA	QFN	LCC	Gullwing (QFP, TSOP, SSOP, etc)	Others
Surface Mount	0.50mm	Yes	No	No	-55°C to +125°C	Yes	Yes	Yes	Yes	Yes	Yes	on request
Raised Surface Mount	0.50mm	Yes	No	No	-55°C to +125°C	Yes	Yes	Yes	Yes	Yes	Yes	on request
Thru-hole	0.50mm	Yes	No	No	-55°C to +125°C	Yes	Yes	Yes	Yes	Yes	Yes	on request
Solderless Probe pin	0.40mm	Yes	Yes	only high speed probes	-55°C to +125°C	Yes	Yes	Yes	Yes	Yes	Yes	on request
Solderless Elastomer	0.30mm	n/a	Yes	Yes	-35°C to +125°C	Yes	No	Yes	Yes	No	Yes	on request

Retention System Selector Guide

Retention frame style	Socket Cost	Open top	Open/close cycles	Socket size	Socket height above board	Tools required to open/close	Torque tool option	available with integrated heatsink	Recommended for SMT sockets	Accepted chip heights	Accepted max. chip height variations from min to max	Accepted min/max chip size	Available for elastomer sockets	Available for "gullwing chip" sockets	Available for gullwing chips with "tie bar" attached to legs
TwistLock / ScrewLock	Low	Yes	1000	smallest	lowest	Yes	Yes	Yes	Yes	no limit	no limit	min 4x4mm max no limit	Yes	Yes	Yes
FastLock	Low	Yes	10000	small	medium	No	Yes	Yes	Yes, with locating pegs	no limit	2.5mm	min 4x4mm max 52x52mm	Yes	Yes	Yes
Economy ClamShell	Low	Yes	10000	small	medium	No	Yes	Yes	Yes, with locating pegs	no limit	2.5mm	min 7x7mm max 50x50mm	Yes	No	No
LeverLock	Medium	Yes	1000	small	low	No	No	No	Yes, with locating pegs	no limit	0.40mm	min 15x15mm max 40x40mm	Yes	No	No
QuickLock	Medium to High	on request	10000	medium	high	No	No	No	Yes	min 0.5mm max 3.5mm	3.0mm	min 4x4mm max 36x36mm	Yes	Yes	No
Professional ClamShell	High	on request	10000	largest	high	No	No	No	Yes, with locating pegs	min 0.5mm max 4.0mm	3.5mm	min 7x7mm max 40x40mm	Yes	Yes	No
Adapter solution (mini-grid socket & pluggable Test socket)	Depends on retention system	Depends on retention system	Depends on retention system	small adapter base	high	Depends on retention system	Depends on retention system	Depends on retention system	Yes with small size locking systems	Depends on retention system	Depends on retention system	Depends on retention system	Yes	Yes	Yes

General Socket Recommendations

TwistLock Test Socket

1. Use the E-tec torque tool **TOL-7CN-TORQUE** with appropriate torque setting for TwistLock sockets. Generally 7cNm up to 800 pins and 7cNm to 10cNm for higher pin counts.
2. Close the screws of the retainer with light tightening first and then fully tighten the screws one after each other. For sockets with 4 or 8 screws tighten the screws “cross wise” to apply equal forces.

SMT Test Socket

1. Use solder paste without silver or less than 0.5% silver content.
2. Solder profile & socket mounting recommendations are available for download from our homepage www.e-tec.com
3. Whenever possible use locating pegs which are tin plated for soldering to the PCB. This avoids the solder joints from being stressed during handling of the socket. Socket life cycle can be heavily reduced if used without locating pegs.
4. For high pin count sockets, it's preferable to solder a light weight mini-grid adapter to the PCB first and then plug the test socket into that adapter.
5. Choose the raised SMT socket for lifting the socket above close-by components. Special clearances in the socket body can also be offered on request.

Solderless Test Socket

1. Use gold plated PCB pads (hard gold if possible).
2. PCB pads must be flush or higher than the solder mask for reliable interconnection with the socket.
3. Clearance for close-by components or components underneath the PCB can be offered on request.

Test Socket with Mini-Grid SMT Adapter

When inserting the test socket into the mini-grid adapter, make sure that the pin alignment plate has been positioned at the tip of the test socket pins. During insertion, this plate will then be pressed backwards and remain seated in-between the socket and the mini-grid adapter. This pin alignment board ensures correct alignment of the test socket pins onto the pins of the mini-grid adapter and thus reduces the risk of damaging the test socket pins during insertion. If the adapter socket has been removed from the mini-grid socket, then this pin alignment board needs to be pushed back to the tip of the test socket pins prior to reinserting the test socket into the mini-grid adapter.

E-tec Patented Probe Pin Designs

BGA ball grid array contact design
(patented)
standard size solderballs

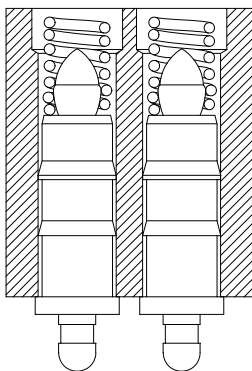

BGA ball grid array contact design
(patented)
small size solderballs

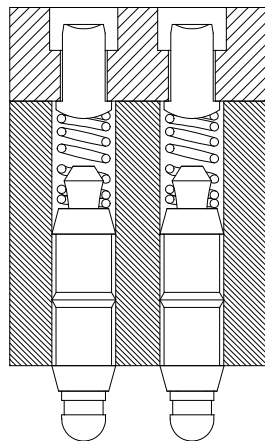

LGA land grid array contact design
(patented)

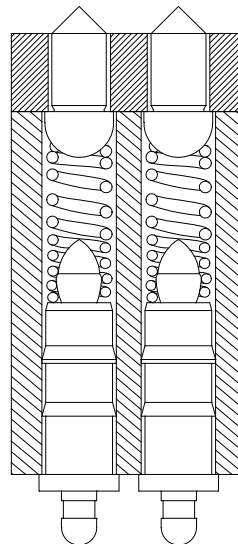

CGA Column grid contact design
(patented)

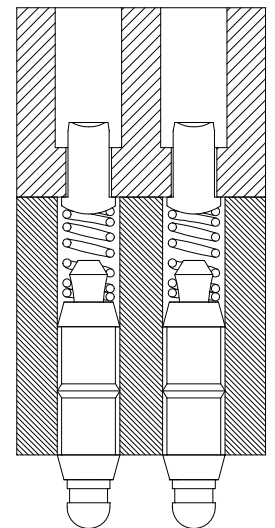

Ball / Land Grid Array Sockets

FastLock Type



E-tec is now the leading BGA socket manufacturer.

EP patents 0829188, 0897655 US patents 6190181, 6249440 Patented in other countries.

FastLock sockets are available for any chip size and grid pattern. The SMT socket is simply placed and reflowed onto the PCB in the same way as the chip and occupies only a small amount of additional board space. The solderless sockets are mounted with 2 or 4 mounting pegs to the PCB depending on the chip size. The FastLock retainer uses a thumbscrew which does not require any tools for opening/closing of the socket. Torque tools or adjustment of pressdown force are available with this locking system also.

We aim to solve your requirements – your custom sets our standards!

Please note, we will always request the chip data to ensure we offer a compatible socket.

FastLock Type

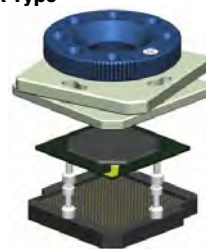

SMT style

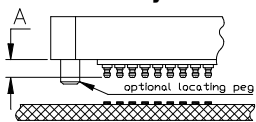

PCB Pad Layout

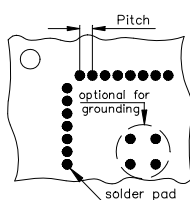

- Ø 0,60mm/.024" if pitch 1,27mm
- Ø 0,50mm/.020" if pitch 1,00mm
- Ø 0,40mm/.016" if pitch 0,80mm
- Ø 0,35mm/.014" if pitch 0,75mm
- Ø 0,35mm/.014" if pitch 0,65mm
- Ø 0,30mm/.012" if pitch 0,50mm

Soldertail style

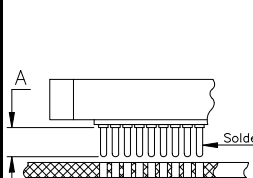

PCB Pad Layout

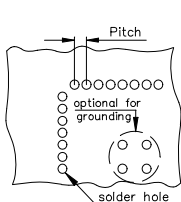

Soldertail dimension:

- Ø 0,42mm/.016" if pitch 1,27mm
- Ø 0,29mm/.011" if pitch 1,00mm
- Ø 0,29mm/.011" if pitch 0,80mm
- Ø 0,27mm/.010" if pitch 0,75mm
- Ø 0,27mm/.010" if pitch 0,65mm
- Ø 0,27mm/.010" if pitch 0,50mm
- Ø 0,17mm/.007" if pitch 0,40mm

PCB solder hole:

- Ø 0,60mm/.024" if pitch 1,27mm
- Ø 0,50mm/.020" if pitch 1,00mm
- Ø 0,40mm/.016" if pitch 0,80mm
- Ø 0,35mm/.014" if pitch 0,75mm
- Ø 0,35mm/.014" if pitch 0,65mm
- Ø 0,35mm/.014" if pitch 0,50mm
- Ø 0,25mm/.010" if pitch 0,40mm

Solderless Compression style

(FastLock Type as example shown)

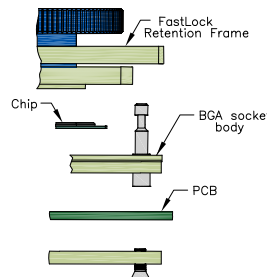

PCB Pad Layout

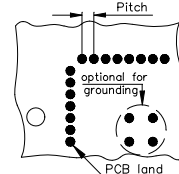

You may request any specific socket dimension from info@e-tec.com

- gold plated pads Ø 0,70mm/.027" if pitch 1,27mm
- gold plated pads Ø 0,60mm/.024" if pitch 1,00mm
- gold plated pads Ø 0,50mm/.020" if pitch 0,80mm
- gold plated pads Ø 0,45mm/.018" if pitch 0,75mm
- gold plated pads Ø 0,40mm/.016" if pitch 0,65mm
- gold plated pads Ø 0,35mm/.012" if pitch 0,50mm
- gold plated pads Ø 0,25mm/.010" if pitch 0,40mm

Solderless Compression Type and other locking systems (on request)

FastLock Type

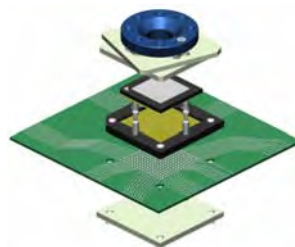

Important Note:

Please check the ball diameters & heights of your chip prior to ordering the standard E-tec BGA (BPC) sockets. Any deviation has to be communicated to E-tec in order to check compatibility with the standard socket design and if necessary to obtain a special order code adapted to your chip dimensions. The standard solderball diameters & heights are the following:

Pitch	ball diameters min/max	ball height min/max
0,50mm	0,25mm 0,35mm	0,20mm 0,30mm
0,65mm	0,25mm 0,45mm	0,20mm 0,30mm
0,75mm	0,25mm 0,45mm	0,20mm 0,40mm
0,80mm	0,40mm 0,55mm	0,25mm 0,45mm
1,00mm	0,50mm 0,70mm	0,30mm 0,50mm
1,27mm & higher	0,60mm 1,00mm	0,50mm 1,00mm

If the minimum ball diameter of a given chip falls below the above indications, then a BUF socket will generally be proposed.

Specifications

Mechanical data

- Contact life 10.000 cycles min.
- Retention system life 10.000 cycles min.
- Solderability as per IEC 60068-2-58
- Individual contact force 40 grams max.

Material

- Insulator (RoHS compliant) High temp plastic or epoxy FR4
- Terminal (RoHS compliant) Brass
- Contact (RoHS compliant) BeCu

Electrical data

- Contact resistance < 100 mΩ
- Current rating 500 mA max.
- Insulation resistance at 500V DC 100 MΩ if 0.50 to 0.80mm pitch
- 500 MΩ 1.00mm pitch upwards
- Breakdown voltage at 60 Hz 500V min.
- Capacitance < 1 pF
- Inductance < 2 nH

Operating temperature

-55°C to +125°C ; 260°C for 60 sec.

Recommendations:

Solder paste – Please use a solder paste w/o any silver!

E-tec solderless sockets are adapted to a standard PCB thickness of 1.60mm. For a different PCB thickness, please inform E-tec first!

SMT FastLock sockets are recommended to be ordered with locating pegs for soldering to the PCB, to avoid the solderjoints from being stressed due to the torque forces applied with this locking system. If used without locating pegs, the life cycle of the socket may be heavily reduced.

For high pincount SMT sockets, E-tec recommends the use of a pluggable thru-hole socket mounted into a MiniGrid Adapter (see also pages 10, 11 & 12 for more details).

How to order

X X F x x x x - x x x x - x x x x x x L ← optional for locating pegs

Device Type

- B** = Ball Grid
- L** = Land Grid
- C** = Column Grid

Socket Type

- P** = socket for LGA, CGA and BGA chips with standard diameter solderballs (see dimensions in table above)
- U** = socket for small diameter solderballs

Pitch

- 04** = 0,40mm
- 05** = 0,50mm
- 06** = 0,65mm
- 07** = 0,75mm
- 08** = 0,80mm
- 10** = 1,00mm
- 12** = 1,27mm
- 15** = 1,50mm
- others on request

Grid Code

Config Code

will be given by the factory after receipt of the chip datasheet

Plating

- 95** = tin/gold (tin leadfree)
- 55** = gold only for Compression Type

Nbr of contacts

depends on ballcount of chip

Contact Type

- 30** = standard SMT... („A“ = 1,20mm if 1,27mm pitch; 0,80mm if 1,00mm pitch, 0,60 if 0,80mm pitch; 0,40mm if <0.80mm pitch)
- 29** = raised SMT... („A“ = 5,00mm if 1,27mm pitch; 3,20mm if 1,00mm pitch; 2,80mm if 0,80mm pitch, 2,30mm if <0.80mm pitch)
- 28** = special raised SMT - only for 1.00 & 0.80mm pitch... („A“ = 4,50mm)
- 70** = standard solder tail... („A“ = 3,30 if 1,27mm pitch, 2,80 if 1,00mm or 0,80mm pitch, 2,30mm if <0.80mm pitch)
- 90 & 91** = compression type (see page 8 for more details)

Ball / Land Grid Array Sockets TwistLock Type



E-tec is now the leading BGA socket manufacturer.

EP patents 0829188, 0897655 US patents 6190181, 6249440 Patented in other countries.

TwistLock sockets are generally chosen when relatively low insertion / extraction cycles are required and when the cost of the socket is a predominant factor. The TwistLock socket extends by around 6.00mm beyond the outer ball row and special clearances can be offered on request.

We aim to solve your requirements - many different terminals and configurations are available.
Your custom sets our standards!

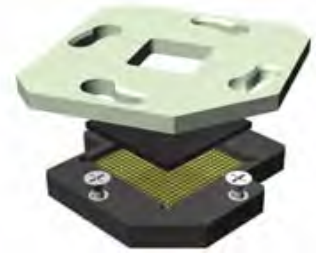

Please note, we will always request the chip data to ensure we offer a compatible socket.

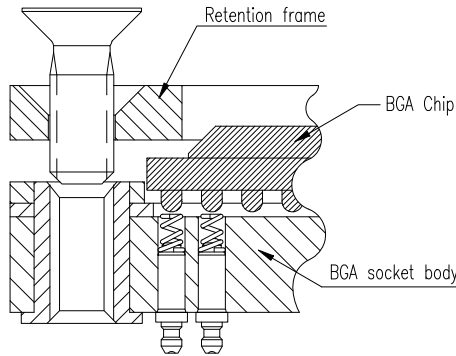
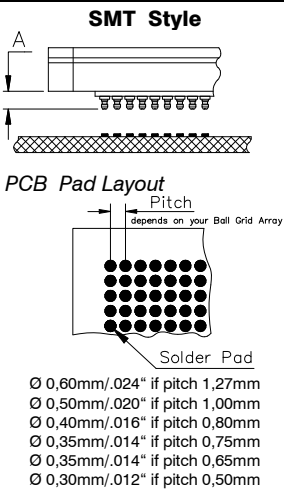

You may request any specific socket dimension from info@e-tec.com

For top view socket dimension pls. ref. to separate catalog page

Important Note:

Please check the ball diameters & heights of your chip prior to ordering the standard E-tec BGA (BPW) sockets. Any deviation has to be communicated to E-tec in order to check compatibility with the standard socket design and if necessary to obtain a special order code adapted to your chip dimensions.

The standard solderball diameters & heights are the following:

Pitch	ball diameters min/max	ball height min/max
0.50mm	0.25mm / 0.35mm	0.20mm / 0.30mm
0.65mm	0.25mm / 0.45mm	0.20mm / 0.30mm
0.75mm	0.25mm / 0.45mm	0.20mm / 0.40mm
0.80mm	0.40mm / 0.55mm	0.25mm / 0.45mm
1.00mm	0.50mm / 0.70mm	0.30mm / 0.50mm
1.27mm & higher	0.60mm / 1.00mm	0.50mm / 1.00mm

If the minimum ball diameter of a given chip falls below the above indications, then a BUW socket will generally be proposed.

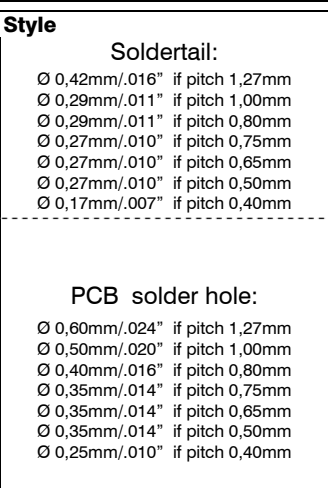
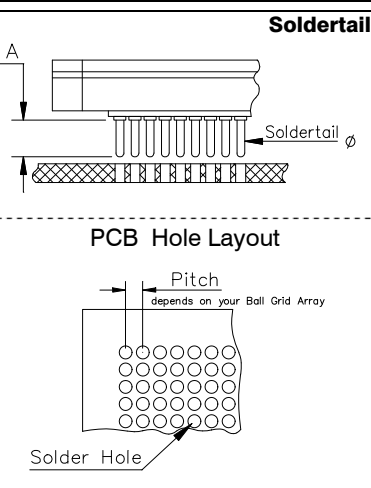

Mechanical data	Specifications
Contact life	10.000 cycles min.
Retention System life	1.000 cycles min.
Solderability	as per IEC 60068-2-58
Individual contact force	40 grams max.
Max. torque for retention screws	up to 800 pins = 7cNm or 10 oz-inch as of 800 pins = 7cNm to 10cNm or 10 oz-inch to 14 oz-inch
Material	
Insulator (RoHS compliant)	High temp plastic or epoxy FR4
Terminal (RoHS compliant)	Brass
Contact (RoHS compliant)	BeCu
Electrical data	
Contact resistance	< 100 mΩ
Current rating	500 mA max.
Insulation resistance at 500V DC	100 MΩ if 0.50mm to 0.80mm pitch 500 MΩ 1.00mm pitch upwards
Breakdown voltage at 60 Hz	500V min.
Capacitance	< 1 pF
Inductance	< 2 nH
Operating temperature	-55°C to +125°C ; 260°C for 60 sec.

Recommendations:

Solder paste – Please use a solder paste w/o any silver!

Solder profile – Please refer to our website www.e-tec.com

E-tec solderless sockets are adapted to a standard PCB thickness of 1.60mm. For a different PCB thickness, please inform E-tec first!

For high pincount SMT sockets, E-tec recommends the use of a pluggable thru-hole socket mounted into a MiniGrid Adapter (see also page 10, 11 & 12 for more details)

For SMT sockets in general, E-tec recommends the use of locating pegs which can be soldered to the PCB for added mechanical strength.

How to order

X X W X X X X - X X X X - X X X X 95 L ← optional for locating pegs

Device Type	Socket Type	Pitch	Grid Code	Config Code	Plating
B = Ball Grid L = Land Grid C = Column Grid	P = socket for LGA, CGA and BGA chips with standard diameter solderballs (see dimensions in table above) U = socket for small diameter solderballs	04 = 0,40mm 05 = 0,50mm 06 = 0,65mm 07 = 0,75mm 08 = 0,80mm 10 = 1,00mm 12 = 1,27mm 15 = 1,50mm others on request	<i>will be given by the factory after receipt of the chip datasheet</i>	<i>will be given by the factory after receipt of the chip datasheet</i>	95 = tin/gold (tin leadfree)

Nbr of contacts



depends on ballcount of chip

Contact Type
30 = standard SMT... („A“ = 1,20mm if 1,27mm pitch; 0,80mm if 1,00mm pitch, 0,60 if 0,80mm pitch; 0,40mm if <0,80mm pitch)
29 = raised SMT.. („A“ = 5,00mm if 1,27mm pitch; 3,20mm if 1,00mm pitch; 2,80mm if 0,80mm pitch, 2,30mm if <0,80mm pitch)
28 = special raised SMT - only for 1.00 & 0.80mm pitch..... („A“ = 4,50mm)
70 = standard solder tail..... („A“ = 3.30 if 1.27mm pitch, 2.80 if 1.00mm or 0.80mm pitch, 2,30mm if <0,80mm pitch)
90 & 91 = compression type (see page 8 for more details)

Ball / Land Grid Array Sockets

Top View for "TwistLock sockets" (through-hole & SMT style only)

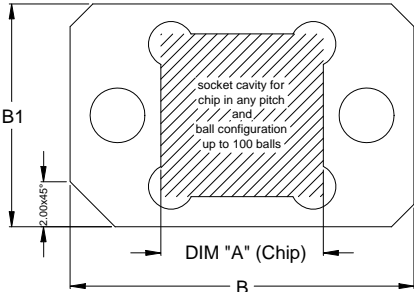
Socket outline for small sized chips up to 100 balls or lands

<p>Note: TwistLock sockets up to 100 pins are produced with 2 screws.</p> 	DIM "A" Chip (sq.)	DIM "B" Socket	DIM "B1" Socket	 <p>up to 100 pins</p>
	6.00mm / .236"	14.77mm / .581"	9.87mm / .389"	
	7.00mm / .276"	16.04mm / .631"	11.14mm / .439"	
	8.00mm / .315"	17.31mm / .681"	12.41mm / .489"	
	9.00mm / .354"	18.58mm / .731"	13.68mm / .539"	
	10.00mm / .394"	19.85mm / .781"	14.95mm / .589"	
	11.00mm / .433"	19.85mm / .781"	14.95mm / .589"	
	12.00mm / .472"	21.12mm / .831"	16.22mm / .639"	
	13.00mm / .512"	22.39mm / .881"	17.49mm / .689"	
	14.00mm / .551"	23.66mm / .931"	18.76mm / .739"	
	15.00mm / .591"	24.93mm / .981"	20.03mm / .789"	
	16.00mm / .630"	26.20mm / 1.031"	21.30mm / .839"	
	17.00mm / .669"	26.20mm / 1.031"	21.30mm / .839"	
	18.00mm / .709"	27.47mm / 1.081"	22.57mm / .889"	
	19.00mm / .748"	27.47mm / 1.081"	22.57mm / .889"	
				 <p>as of 101 pins</p>

Socket outline for standard chips as of 101 balls or lands

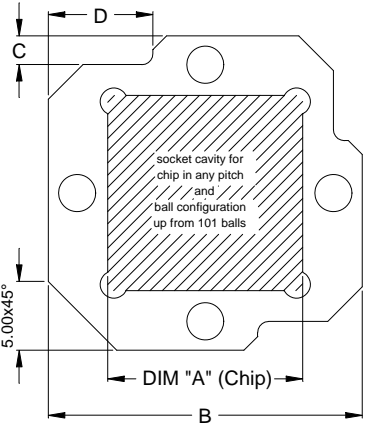
<p>Note: TwistLock sockets from 101 to 600 pins are produced with 4 screws.</p> 	DIM "A" Chip (sq.)	DIM "B" Socket (sq.)	DIM "C" Socket	DIM "D" Socket
	13.00mm / .512"	21.59mm / .850"	2.51mm / .099"	7.62mm / .312"
	14.00mm / .551"	22.86mm / .900"	2.09mm / .082"	7.62mm / .312"
	15.00mm / .591"	24.13mm / .950"	2.81mm / .111"	8.89mm / .350"
	16.00mm / .630"	24.13mm / .950"	2.81mm / .111"	8.89mm / .350"
	17.00mm / .669"	25.40mm / 1.000"	2.84mm / .112"	8.89mm / .350"
	18.00mm / .709"	26.67mm / 1.050"	2.99mm / .118"	8.89mm / .350"
	19.00mm / .748"	27.94mm / 1.100"	2.71mm / .107"	8.91mm / .351"
	20.00mm / .787"	29.21mm / 1.150"	2.70mm / .106"	8.89mm / .350"
	21.00mm / .827"	29.21mm / 1.150"	2.70mm / .106"	8.89mm / .350"
	22.00mm / .866"	30.48mm / 1.200"	2.60mm / .102"	8.89mm / .350"
	23.00mm / .905"	31.75mm / 1.250"	2.88mm / .113"	9.53mm / .375"
	24.00mm / .945"	33.02mm / 1.300"	2.39mm / .094"	8.89mm / .350"
	25.00mm / .984"	33.02mm / 1.300"	2.39mm / .094"	8.89mm / .350"
	26.00mm / 1.024"	34.29mm / 1.350"	2.74mm / .108"	8.89mm / .350"
	27.00mm / 1.063"	35.56mm / 1.400"	2.53mm / .099"	9.53mm / .375"
	28.00mm / 1.102"	36.83mm / 1.450"	2.50mm / .098"	9.53mm / .375"
	29.00mm / 1.142"	38.10mm / 1.500"	2.81mm / .111"	9.53mm / .375"
	30.00mm / 1.181"	38.10mm / 1.500"	2.81mm / .111"	9.53mm / .375"
	31.00mm / 1.220"	39.37mm / 1.550"	2.54mm / .100"	9.53mm / .375"
	32.00mm / 1.260"	40.64mm / 1.600"	2.88mm / .113"	9.53mm / .375"
	32.50mm / 1.279"	40.64mm / 1.600"	2.88mm / .113"	9.53mm / .375"
	33.00mm / 1.299"	41.91mm / 1.650"	2.80mm / .110"	9.53mm / .375"
	34.00mm / 1.339"	43.18mm / 1.700"	2.05mm / .081"	9.53mm / .375"
	34.50mm / 1.358"	43.18mm / 1.700"	2.05mm / .081"	9.53mm / .375"
	35.00mm / 1.378"	43.18mm / 1.700"	2.05mm / .081"	9.53mm / .375"
	36.00mm / 1.358"	44.45mm / 1.750"	3.00mm / .118"	9.53mm / .375"
	37.00mm / 1.457"	45.72mm / 1.800"	2.10mm / .083"	8.26mm / .325"
	37.50mm / 1.476"	45.72mm / 1.800"	2.10mm / .083"	8.26mm / .325"
	38.00mm / 1.496"	46.99mm / 1.850"	3.15mm / .124"	9.53mm / .375"
	39.00mm / 1.535"	48.26mm / 1.900"	2.24mm / .088"	9.53mm / .375"
	40.00mm / 1.575"	48.26mm / 1.900"	2.24mm / .088"	9.53mm / .375"
	41.00mm / 1.641"	49.53mm / 1.950"	3.00mm / .118"	9.53mm / .375"
42.00mm / 1.653"	50.80mm / 2.000"	2.32mm / .091"	9.53mm / .375"	
42.50mm / 1.673"	50.80mm / 2.000"	2.32mm / .091"	9.53mm / .375"	
43.00mm / 1.693"	52.07mm / 2.050"	2.78mm / .109"	9.53mm / .375"	
44.00mm / 1.732"	52.07mm / 2.050"	2.78mm / .109"	9.53mm / .375"	
45.00mm / 1.772"	53.34mm / 2.100"	2.41mm / .095"	9.53mm / .375"	
46.00mm / 1.811"	54.61mm / 2.150"	3.16mm / .124"	9.53mm / .375"	
47.00mm / 1.850"	55.88mm / 2.200"	3.30mm / .130"	9.53mm / .375"	
48.00mm / 1.890"	57.15mm / 2.250"	2.54mm / .100"	9.53mm / .375"	
49.00mm / 1.929"	57.15mm / 2.250"	2.54mm / .100"	9.53mm / .375"	
50.00mm / 1.868"	58.42mm / 2.300"	2.54mm / .100"	9.53mm / .375"	

Note:
TwistLock sockets as of 601 pins are produced with 8 screws.

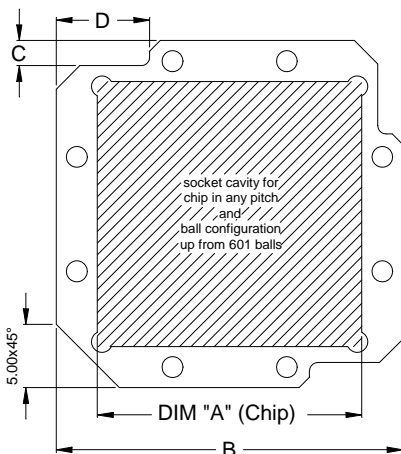

For Solderless, FastLock, LeverLock, QuickLock, ClamShell & other locking systems or larger size outline dimensions, please contact your E-tec sales office for dimensional drawings.

Ball / Land Grid Array Sockets QuickLock Type



E-tec is now the leading BGA socket manufacturer.

EP patents 0829188, 0897655 US patents 6190181, 6249440 Patented in other countries.

QuickLock sockets are available for any chip size and grid pattern. They are available in SMT, thru-hole and solderless compression type versions. The SMT socket is simply placed and reflowed onto the PCB in the same way as the chip and it only requires a small amount of additional board space. A lever is added to the QuickLock retention cover if the pincount exceeds 81 pins which allows the required pressdown forces to be applied easily.

We aim to solve your requirements - many different terminals and configurations are available. Your custom sets our standards!

Please note, we will always request the chip data to ensure we offer a compatible socket.

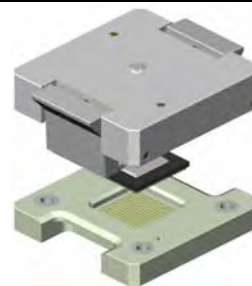

SMT style	Soldertail style	Solderless Compression style
<p>PCB Pad Layout</p> <p>solder pad</p> <p>Ø 0,60mm/.024" if pitch 1,27mm Ø 0,50mm/.020" if pitch 1,00mm Ø 0,40mm/.016" if pitch 0,80mm Ø 0,35mm/.014" if pitch 0,75mm Ø 0,35mm/.014" if pitch 0,65mm Ø 0,30mm/.012" if pitch 0,50mm</p>	<p>PCB Hole Layout</p> <p>solder hole</p> <p>Soldertail dimension: Ø 0,42mm/.016" if pitch 1,27mm Ø 0,29mm/.011" if pitch 1,00mm Ø 0,29mm/.011" if pitch 0,80mm Ø 0,27mm/.010" if pitch 0,75mm Ø 0,27mm/.010" if pitch 0,65mm Ø 0,27mm/.010" if pitch 0,50mm Ø 0,17mm/.007" if pitch 0,40mm</p> <p>PCB solder hole: Ø 0,60mm/.024" if pitch 1,27mm Ø 0,50mm/.020" if pitch 1,00mm Ø 0,40mm/.016" if pitch 0,80mm Ø 0,35mm/.014" if pitch 0,75mm Ø 0,35mm/.014" if pitch 0,65mm Ø 0,35mm/.014" if pitch 0,50mm Ø 0,25mm/.010" if pitch 0,40mm</p>	<p>You may request any specific socket dimension from info@e-tec.com</p> <p>gold plated pads Ø 0,70mm/.027" if pitch 1,27mm gold plated pads Ø 0,60mm/.024" if pitch 1,00mm gold plated pads Ø 0,50mm/.020" if pitch 0,80mm gold plated pads Ø 0,45mm/.018" if pitch 0,75mm gold plated pads Ø 0,40mm/.016" if pitch 0,65mm gold plated pads Ø 0,35mm/.012" if pitch 0,50mm gold plated pads Ø 0,25mm/.010" if pitch 0,40mm</p>

<p>Important Note: Please check the ball diameters & heights of your chip prior to ordering the standard E-tec BGA (BPQ) sockets. Any deviation has to be communicated to E-tec in order to check compatibility with the standard socket design and if necessary to obtain a special order code adapted to your chip dimensions. The standard solderball diameters & heights are the following:</p> <table border="1"> <thead> <tr> <th>Pitch</th> <th>ball diameters min/max</th> <th>ball height min/max</th> </tr> </thead> <tbody> <tr> <td>0.50mm</td> <td>0.25mm / 0.35mm</td> <td>0.20mm / 0.30mm</td> </tr> <tr> <td>0.65mm</td> <td>0.25mm / 0.45mm</td> <td>0.20mm / 0.30mm</td> </tr> <tr> <td>0.75mm</td> <td>0.25mm / 0.45mm</td> <td>0.20mm / 0.40mm</td> </tr> <tr> <td>0.80mm</td> <td>0.40mm / 0.55mm</td> <td>0.25mm / 0.45mm</td> </tr> <tr> <td>1.00mm</td> <td>0.50mm / 0.70mm</td> <td>0.30mm / 0.50mm</td> </tr> <tr> <td>1.27mm & higher</td> <td>0.60mm / 1.00mm</td> <td>0.50mm / 1.00mm</td> </tr> </tbody> </table> <p>If the minimum ball diameter of a given chip falls below the above indications, then a BUQ socket will generally be proposed.</p>	Pitch	ball diameters min/max	ball height min/max	0.50mm	0.25mm / 0.35mm	0.20mm / 0.30mm	0.65mm	0.25mm / 0.45mm	0.20mm / 0.30mm	0.75mm	0.25mm / 0.45mm	0.20mm / 0.40mm	0.80mm	0.40mm / 0.55mm	0.25mm / 0.45mm	1.00mm	0.50mm / 0.70mm	0.30mm / 0.50mm	1.27mm & higher	0.60mm / 1.00mm	0.50mm / 1.00mm	<p>Specifications</p> <p>Mechanical data Contact life: 10.000 cycles min. Retention System life: 10.000 cycles min. Solderability: as per IEC 60068-2-58 Individual contact force: 40 grams max.</p> <p>Material Insulator: (RoHS compliant) Terminal: (RoHS compliant) Contact: (RoHS compliant)</p> <p>Electrical data Contact resistance: < 100 mΩ Current rating: 500 mA max. Insulation resistance at 500V DC: 100 MΩ if 0.50 to 0.80mm pitch, 500 MΩ 1.00mm pitch upwards Breakdown voltage at 60 Hz: 500V min. Capacitance: < 1 pF Inductance: < 2 nH</p> <p>Operating temperature -55°C to +125°C ; 260°C for 60 sec.</p>
Pitch	ball diameters min/max	ball height min/max																				
0.50mm	0.25mm / 0.35mm	0.20mm / 0.30mm																				
0.65mm	0.25mm / 0.45mm	0.20mm / 0.30mm																				
0.75mm	0.25mm / 0.45mm	0.20mm / 0.40mm																				
0.80mm	0.40mm / 0.55mm	0.25mm / 0.45mm																				
1.00mm	0.50mm / 0.70mm	0.30mm / 0.50mm																				
1.27mm & higher	0.60mm / 1.00mm	0.50mm / 1.00mm																				

Recommendations:

Solder paste - Please use a solder paste w/o any silver!

Solder profile - Please refer to our website www.e-tec.com

E-tec solderless sockets are adapted to a standard PCB thickness of 1.60mm. For a different PCB thickness, please inform E-tec first!

For high pincount SMT sockets, E-tec recommends the use of a pluggable thru-hole socket mounted into a MiniGrid Adapter (see also page 10, 11 & 12 for more details)

For SMT sockets in general, E-tec recommends the use of locating pegs which can be soldered to the PCB for added mechanical strength.

How to order

X X Q **x x x x** - **xx** **xx** - **xx** **xx** **xx** **L** ← optional for locating pegs

<p>Device Type</p> <p>B = Ball Grid L = Land Grid C = Column Grid</p>	<p>Socket Type</p> <p>P = socket for LGA, CGA and BGA chips with standard diameter solderballs (see dimensions in table above) U = socket for small diameter solderballs</p>	<p>Pitch</p> <p>04 = 0,40mm 05 = 0,50mm 06 = 0,65mm 07 = 0,75mm 08 = 0,80mm</p> <p>10 = 1,00mm 12 = 1,27mm 15 = 1,50mm others on request</p>	<p>Grid Code Config Code</p> <p>will be given by the factory after receipt of the chip datasheet Chips with dimensions over 36x36mm: please contact E-tec for availability first.</p>	<p>Plating</p> <p>95 = tin/gold (tin leadfree) 55 = gold only for Compression Type</p>
---	---	---	---	---

<p>Nbr of contacts</p> <p>depends on ballcount of chip</p>	<p>Contact Type</p> <p>30 = standard SMT... („A“ = 1,20mm if 1,27mm pitch; 0,80mm if 1,00mm pitch, 0,60 if 0,80mm pitch; 0,40mm if <0.80mm pitch) 29 = raised SMT.. („A“ = 5,00mm if 1,27mm pitch; 3,20mm if 1,00mm pitch; 2,80mm if 0,80mm pitch, 2,30mm if <0.80mm pitch) 28 = special raised SMT - only for 1.00 & 0.80mm pitch..... („A“ = 4,50mm) 70 = standard solder tail..... („A“ = 3.30 if 1.27mm pitch, 2.80 if 1.00mm or 0.80mm pitch, 2.30mm if <0.80mm pitch) 90 & 91 = compression type (see page 8 for more details)</p>
---	---

Ball / Land Grid Array Sockets

LeverLock Type



E-tec is now the leading BGA socket manufacturer.

EP patents 0829188, 0897655 US patents 6190181, 6249440 Patented in other countries.

LeverLock sockets are available for a large variety of chip sizes. The SMT socket is simply placed and reflowed onto the PCB in the same way as the chip and occupies only a small amount of additional board space. The 1.27mm pitch LeverLock socket extends ≈ 6.00mm beyond the outer ball row with no fixing holes required. We aim to solve your requirements – many different terminals and configurations are available. Your custom sets our standards!

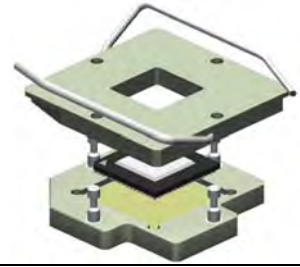

Please note, we will always request the chip data to ensure we offer a compatible socket.

SMT Style

PCB Pad Layout

Pitch depends on your Ball Grid Array

Solder Pad

- Ø 0,60mm/.024" if pitch 1,27mm
- Ø 0,50mm/.020" if pitch 1,00mm
- Ø 0,40mm/.016" if pitch 0,80mm
- Ø 0,35mm/.014" if pitch 0,75mm
- Ø 0,35mm/.014" if pitch 0,65mm
- Ø 0,30mm/.012" if pitch 0,50mm

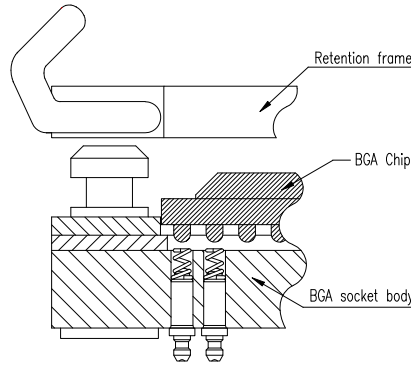

You may request any specific socket dimension from info@e-tec.com

Important Note:

Please check the ball diameters & heights of your chip prior to ordering the standard E-tec BGA (BPZ) sockets. Any deviation has to be communicated to E-tec in order to check compatibility with the standard socket design and if necessary to obtain a special order code adapted to your chip dimensions. The standard solderball diameters & heights are the following:

Pitch	ball diameters min/max	ball height min/max
0.50mm	0.25mm / 0.35mm	0.20mm / 0.30mm
0.65mm	0.25mm / 0.45mm	0.20mm / 0.30mm
0.75mm	0.25mm / 0.45mm	0.20mm / 0.40mm
0.80mm	0.40mm / 0.55mm	0.25mm / 0.45mm
1.00mm	0.50mm / 0.70mm	0.30mm / 0.50mm
1.27mm & higher	0.60mm / 1.00mm	0.50mm / 1.00mm

If the minimum ball diameter of a given chip falls below the above indications, then a BUZ socket will generally be proposed.

Soldertail Style

PCB Hole Layout

Pitch depends on your Ball Grid Array

Solder Hole

Soldertail:

- Ø 0,42mm/.016" if pitch 1,27mm
- Ø 0,29mm/.011" if pitch 1,00mm
- Ø 0,29mm/.011" if pitch 0,80mm
- Ø 0,27mm/.010" if pitch 0,75mm
- Ø 0,27mm/.010" if pitch 0,65mm
- Ø 0,27mm/.010" if pitch 0,50mm
- Ø 0,17mm/.007" if pitch 0,40mm

PCB solder hole:

- Ø 0,60mm/.024" if pitch 1,27mm
- Ø 0,50mm/.020" if pitch 1,00mm
- Ø 0,40mm/.016" if pitch 0,80mm
- Ø 0,35mm/.014" if pitch 0,75mm
- Ø 0,35mm/.014" if pitch 0,65mm
- Ø 0,35mm/.014" if pitch 0,50mm
- Ø 0,25mm/.010" if pitch 0,40mm

Mechanical data

Contact life 10.000 cycles min.
Retention system life 1.000 cycles min.
Solderability as per IEC 60068-2-58
Individual contact force 40 grams max.

Material

Insulator (RoHS compliant) High temp plastic or epoxy FR4
Terminal (RoHS compliant) Brass
Contact (RoHS compliant) BeCu

Electrical data

Contact resistance < 100 mΩ
Current rating 500 mA max.
Insulation resistance at 500V DC 100 MΩ if 0.50 to 0.80mm pitch
500 MΩ 1.00mm pitch upwards
Breakdown voltage at 60 Hz 500V min.
Capacitance < 1 pF
Inductance < 2 nH

Operating temperature

-55°C to +125°C ; 260°C for 60 sec.

Recommendations:

Solder paste – Please use a solder paste w/o any silver!

Solder profile – Please refer to our website www.e-tec.com

E-tec solderless sockets are adapted to a standard PCB thickness of 1.60mm. For a different PCB thickness, please inform E-tec first!

For high pincount SMT sockets, E-tec recommends the use of a pluggable thru-hole socket mounted into a MiniGrid Adapter (see also page 10, 11 & 12 for more details)

For SMT sockets in general, E-tec recommends the use of locating pegs which can be soldered to the PCB for added mechanical strength.

How to order

X X Z **x x x x** - **x x** **x x** - **x x** **X X** **x x** **L** ← optional for locating pegs

Device Type

B = Ball Grid

L = Land Grid

C = Column Grid

Socket Type

P = socket for LGA, CGA and BGA chips with standard diameter solderballs (see dimensions in table above)

U = socket for small diameter solderballs

Pitch

08 = 0,80mm

10 = 1,00mm

12 = 1,27mm

15 = 1,50mm

others on request

Grid Code | **Config Code**

will be given by factory after receipt of the chip datasheet.

Chips with dimensions over 35x35mm: LeverLock not available.

Chips with dimensions below 21x21mm: please contact E-tec for availability first.

Plating

95 = tin/gold (tin leadfree)

55 = gold only for Compression Type

Nbr of contacts

Depends on ballcount of chip. For chips with ballcount < 100 or > 200 please contact E-tec for availability first

Contact Type

30 = standard SMT... („A“ = 1,20mm if 1,27mm pitch; 0,80mm if 1,00mm pitch, 0,60 if 0,80mm pitch; 0,40mm if < 0,80mm pitch)

29 = raised SMT... („A“ = 5,00mm if 1,27mm pitch; 3,20mm if 1,00mm pitch; 2,80mm if 0,80mm pitch, 2,30mm if < 0,80mm pitch)

28 = special raised SMT - only for 1.00 & 0.80mm pitch..... („A“ = 4,50mm)

70 = standard solder tail..... („A“ = 3.30 if 1.27mm pitch, 2.80 if 1.00mm or 0.80mm pitch, 2,30mm if < 0,80mm pitch)

90 & 91 = compression type (see page 8 for more details)

Ball / Land Grid Array Sockets

ClamShell "Economy" Type



E-tec is now the leading BGA socket manufacturer.

EP patents 0829188, 0897655 US patents 6190181, 6249440 Patented in other countries.

Economy ClamShell sockets are available for any chip size and grid pattern. The SMT socket is simply placed and reflowed onto the PCB in the same way as the chip and occupies only a small amount of additional board space. The solderless sockets are mounted with 2 or 4 mounting pegs to the PCB depending on the chip size. The retainer uses a thumbscrew for applying the pressdown forces which does not require any tools for opening/closing of the socket. Stopper screws for setting of the pressdown forces are incorporated in this locking system and the retainer is "open top" for improved heat dissipation.

We aim to solve your requirements - many different terminals and configurations are available. Your custom sets our standards!

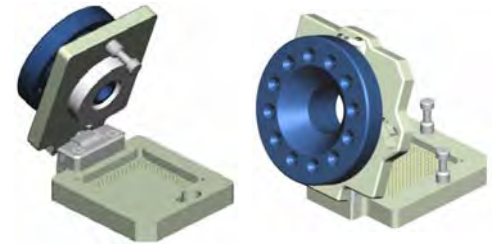

low pincount style high pincount style

Please note, we will always request the chip data to ensure we offer a compatible socket.

SMT style	Soldertail style	Solderless Compression style
<p>PCB Pad Layout</p> <p>solder pad</p> <p>Ø 0,60mm/.024" if pitch 1,27mm Ø 0,50mm/.020" if pitch 1,00mm Ø 0,40mm/.016" if pitch 0,80mm Ø 0,35mm/.014" if pitch 0,75mm Ø 0,35mm/.014" if pitch 0,65mm Ø 0,30mm/.012" if pitch 0,50mm</p>	<p>PCB Hole Layout</p> <p>solder hole</p> <p>Soldertail dimension: Ø 0,42mm/.016" if pitch 1,27mm Ø 0,29mm/.011" if pitch 1,00mm Ø 0,29mm/.011" if pitch 0,80mm Ø 0,27mm/.010" if pitch 0,75mm Ø 0,27mm/.010" if pitch 0,65mm Ø 0,27mm/.010" if pitch 0,50mm Ø 0,17mm/.007" if pitch 0,40mm</p> <p>PCB solder hole: Ø 0,60mm/.024" if pitch 1,27mm Ø 0,50mm/.020" if pitch 1,00mm Ø 0,40mm/.016" if pitch 0,80mm Ø 0,35mm/.014" if pitch 0,75mm Ø 0,35mm/.014" if pitch 0,65mm Ø 0,35mm/.014" if pitch 0,50mm Ø 0,25mm/.010" if pitch 0,40mm</p>	<p>PCB Pad Layout</p> <p>Solder Pad</p> <p>You may request any specific socket dimension from info@e-tec.com</p> <p>gold plated pads Ø 0,70mm/.027" if pitch 1,27mm gold plated pads Ø 0,60mm/.024" if pitch 1,00mm gold plated pads Ø 0,50mm/.020" if pitch 0,80mm gold plated pads Ø 0,45mm/.018" if pitch 0,75mm gold plated pads Ø 0,40mm/.016" if pitch 0,65mm gold plated pads Ø 0,35mm/.012" if pitch 0,50mm gold plated pads Ø 0,25mm/.010" if pitch 0,40mm</p>

Important Note:

Please check the ball diameters & heights of your chip prior to ordering the standard E-tec BGA (BPE) sockets. Any deviation has to be communicated to E-tec in order to check compatibility with the standard socket design and if necessary to obtain a special order code adapted to your chip dimensions.

The standard solderball diameters & heights are the following:

Pitch	ball diameters min/max	ball height min/max
0.50mm	0.25mm / 0.35mm	0.20mm / 0.30mm
0.65mm	0.25mm / 0.45mm	0.20mm / 0.30mm
0.75mm	0.25mm / 0.45mm	0.20mm / 0.40mm
0.80mm	0.40mm / 0.55mm	0.25mm / 0.45mm
1.00mm	0.50mm / 0.70mm	0.30mm / 0.50mm
1.27mm & higher	0.60mm / 1.00mm	0.50mm / 1.00mm

If the minimum ball diameter of a given chip falls below the above indications, then a BUE socket will generally be proposed.

Specifications

Mechanical data

Contact life	10.000 cycles min.
Retention System life	10.000 cycles min.
Solderability	as per IEC 60068-2-58
Individual contact force	40 grams max.

Material

Insulator (RoHS compliant)	High temp plastic or epoxy FR4
Terminal (RoHS compliant)	Brass
Contact (RoHS compliant)	BeCu

Electrical data

Contact resistance	< 100 mΩ
Current rating	500 mA max.
Insulation resistance at 500V DC	100 MΩ if 0.50 to 0.80mm pitch 500 MΩ 1.00mm pitch upwards
Breakdown voltage at 60 Hz	500V min.

Capacitance < 1 pF

Inductance < 2 nH

Operating temperature

-55°C to +125°C; 260°C for 60 sec.

Recommendations:

Solder paste – Please use a solder paste w/o any silver!

Solder profile – Please refer to our website www.e-tec.com

E-tec solderless sockets are adapted to a standard PCB thickness of 1.60mm. For a different PCB thickness, please inform E-tec first!

SMT ClamShell sockets are recommended to be ordered with locating pegs for soldering to the PCB, to avoid the solderjoints from being stressed during the opening/closing of the retainer. If used without locating pegs, the life cycle of the socket may be reduced.

For high pincount SMT sockets, E-tec recommends the use of a pluggable thru-hole socket mounted into a MiniGrid Adapter (see also page 10, 11 & 12 for more details)

How to order

X X E x x x x - x x x x - x x X X x x L ← optional for locating pegs

<p>Device Type</p> <p>B = Ball Grid</p> <p>L = Land Grid</p> <p>C = Column Grid</p>	<p>Socket Type</p> <p>P = socket for LGA, CGA and BGA chips with standard diameter solderballs (see dimensions in table above)</p> <p>U = socket for small diameter solderballs</p>	<p>Pitch</p> <p>04 = 0,40mm 10 = 1,00mm</p> <p>05 = 0,50mm 12 = 1,27mm</p> <p>06 = 0,65mm 15 = 1,50mm</p> <p>07 = 0,75mm others on request</p> <p>08 = 0,80mm</p>	<p>Grid Code Config Code</p> <p>will be given by the factory after receipt of the chip datasheet</p>	<p>Plating</p> <p>95 = tin/gold (tin leadfree)</p> <p>55 = gold only for Compression Type</p>
<p>Nbr of contacts</p> <p>depends on ballcount of chip</p>	<p>Contact Type</p> <p>30 = standard SMT... („A“ = 1,20mm if 1,27mm pitch; 0,80mm if 1,00mm pitch, 0,60 if 0,80mm pitch; 0,40mm if <0.80mm pitch)</p> <p>29 = raised SMT... („A“ = 5,00mm if 1,27mm pitch; 3,20mm if 1,00mm pitch; 2,80mm if 0,80mm pitch, 2,30mm if <0.80mm pitch)</p> <p>28 = special raised SMT - only for 1.00 & 0.80mm pitch..... („A“ = 4,50mm)</p> <p>70 = standard solder tail..... („A“ = 3.30 if 1.27mm pitch, 2.80 if 1.00mm or 0.80mm pitch, 2,30mm if <0.80mm pitch)</p> <p>90 & 91 = compression type (see page 8 for more details)</p>			

Ball / Land Grid Array Sockets

ClamShell "Professional" Type



E-tec is now the leading BGA socket manufacturer.

EP patents 0829188, 0897655 US patents 6190181, 6249440 Patented in other countries.

Professional ClamShell sockets are available for any chip size and grid pattern. They are available in SMT, thru-hole and solderless compression type versions. The SMT socket is simply placed and reflowed onto the PCB in the same way as the chip.

We aim to solve your requirements - many different terminals and configurations are available. Your custom sets our standards!



Please note, we will always request the chip data to ensure we offer a compatible socket.

SMT style	Soldertail style	Solderless Compression style
<p>PCB Pad Layout</p> <p>Pitch</p> <p>solder pad</p> <p> Ø 0,60mm/.024" if pitch 1,27mm Ø 0,50mm/.020" if pitch 1,00mm Ø 0,40mm/.016" if pitch 0,80mm Ø 0,35mm/.014" if pitch 0,75mm Ø 0,35mm/.014" if pitch 0,65mm Ø 0,30mm/.012" if pitch 0,50mm </p>	<p>PCB Hole Layout</p> <p>Pitch</p> <p>solder hole</p> <p> Soldertail dimension: Ø 0,42mm/.016" if pitch 1,27mm Ø 0,29mm/.011" if pitch 1,00mm Ø 0,29mm/.011" if pitch 0,80mm Ø 0,27mm/.010" if pitch 0,75mm Ø 0,27mm/.010" if pitch 0,65mm Ø 0,27mm/.010" if pitch 0,50mm Ø 0,17mm/.007" if pitch 0,40mm </p> <p> PCB solder hole: Ø 0,60mm/.024" if pitch 1,27mm Ø 0,50mm/.020" if pitch 1,00mm Ø 0,40mm/.016" if pitch 0,80mm Ø 0,35mm/.014" if pitch 0,75mm Ø 0,35mm/.014" if pitch 0,50mm Ø 0,25mm/.010" if pitch 0,40mm </p>	<p>Retention Cover</p> <p>BGA Chip</p> <p>BGA socket body</p> <p>PCB</p> <p>Assembly Board</p> <p>mounting screw</p> <p> PCB Pad Layout Pitch Solder Pad </p> <p>You may request any specific socket dimension from info@e-tec.com</p> <p> gold plated pads Ø 0,70mm/.027" if pitch 1,27mm gold plated pads Ø 0,60mm/.024" if pitch 1,00mm gold plated pads Ø 0,50mm/.020" if pitch 0,80mm gold plated pads Ø 0,45mm/.018" if pitch 0,75mm gold plated pads Ø 0,40mm/.016" if pitch 0,65mm gold plated pads Ø 0,35mm/.012" if pitch 0,50mm gold plated pads Ø 0,25mm/.010" if pitch 0,40mm </p>

Important Note:

Please check the ball diameters & heights of your chip prior to ordering the standard E-tec BGA (BPC) sockets. Any deviation has to be communicated to E-tec in order to check compatibility with the standard socket design and if necessary to obtain a special order code adapted to your chip dimensions.

The standard solderball diameters & heights are the following:

Pitch	ball diameters min/max	ball height min/max
0.50mm	0.25mm 0.35mm	0.20mm 0.30mm
0.65mm	0.25mm 0.45mm	0.20mm 0.30mm
0.75mm	0.25mm 0.45mm	0.20mm 0.40mm
0.80mm	0.40mm 0.55mm	0.25mm 0.45mm
1.00mm	0.50mm 0.70mm	0.30mm 0.50mm
1.27mm & higher	0.60mm 1.00mm	0.50mm 1.00mm

If the minimum ball diameter of a given chip falls below the above indications, then a BUC socket will generally be proposed.

Specifications

Mechanical data

Contact life	10.000 cycles min.
Retention System life	10.000 cycles min.
Solderability	as per IEC 60068-2-58
Individual contact force	40 grams max.

Material

Insulator (RoHS compliant)	High temp plastic or epoxy FR4
Terminal (RoHS compliant)	Brass
Contact (RoHS compliant)	BeCu

Electrical data

Contact resistance	< 100 mΩ
Current rating	500 mA max.
Insulation resistance at 500V DC	100 MΩ if 0.50 to 0.80mm pitch 500 MΩ 1.00mm pitch upwards

Breakdown voltage at 60 Hz	500V min.
Capacitance	< 1 pF
Inductance	< 2 nH

Operating temperature

-55°C to +125°C; 260°C for 60 sec.

Recommendations:

Solder paste – Please use a solder paste w/o any silver!

Solder profile – Please refer to our website www.e-tec.com

E-tec solderless sockets are adapted to a standard PCB thickness of 1.60mm. For a different PCB thickness, please inform E-tec first!

SMT ClamShell sockets are recommended to be ordered with locating pegs for soldering to the PCB, to avoid the solderjoints from being stressed during the opening/closing of the retainer. If used without locating pegs, the life cycle of the socket may be heavily reduced.

For high pincount SMT sockets, E-tec recommends the use of a pluggable thru-hole socket mounted into a MiniGrid Adapter (see also page 10, 11 & 12 for more details)

How to order

X X C x x x x - x x x x - x x x x x x L ← optional for locating pegs

Device Type B = Ball Grid L = Land Grid C = Column Grid	Socket Type P = socket for LGA, CGA and BGA chips with standard diameter solderballs (see dimensions in table above) U = socket for small diameter solderballs	Pitch 04 = 0,40mm 05 = 0,50mm 06 = 0,65mm 07 = 0,75mm 08 = 0,80mm 10 = 1,00mm 12 = 1,27mm 15 = 1,50mm others on request	Grid Code Config Code will be given by the factory after receipt of the chip datasheet	Plating 95 = tin/gold (tin leadfree) 55 = gold only for Compression Type
--	---	---	---	---

Nbr of contacts

depends on ballcount of chip

Contact Type

30	= standard SMT... („A“ = 1,20mm if 1,27mm pitch; 0,80mm if 1,00mm pitch, 0,60 if 0,80mm pitch; 0,40mm if <0.80mm pitch)
29	= raised SMT... („A“ = 5,00mm if 1,27mm pitch; 3,20mm if 1,00mm pitch; 2,80mm if 0,80mm pitch, 2,30mm if <0.80mm pitch)
28	= special raised SMT - only for 1.00 & 0.80mm pitch..... („A“ = 4,50mm)
70	= standard solder tail..... („A“ = 3.30 if 1.27mm pitch, 2.80 if 1.00mm or 0.80mm pitch, 2,30mm if <0.80mm pitch)
90 & 91	= compression type (see page 8 for more details)

Ball / Land Grid Array Sockets

ClamShell "Injection Molded" Type



E-tec is now the leading BGA socket manufacturer.

EP patents 0829188, 0897655 US patents 6190181, 6249440 Patented in other countries.

Professional ClamShell sockets "Injection Molded Type" are available for chip size and grid pattern up to 35x35. They are available in SMT, thru-hole and solderless compression type versions. The SMT socket is simply placed and reflowed onto the PCB in the same way as the chip.

We aim to solve your requirements - many different terminals and configurations are available. Your custom sets our standards!

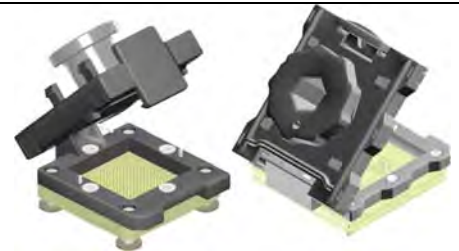

Please note, we will always request the chip data to ensure we offer a compatible socket.

SMT style	Solder tail style	Solderless Compression style
<p>PCB Pad Layout</p> <p>Pitch</p> <p>solder pad</p> <p> \varnothing 0,60mm/.024" if pitch 1,27mm \varnothing 0,50mm/.020" if pitch 1,00mm \varnothing 0,40mm/.016" if pitch 0,80mm \varnothing 0,35mm/.014" if pitch 0,75mm \varnothing 0,35mm/.014" if pitch 0,65mm \varnothing 0,30mm/.012" if pitch 0,50mm </p>	<p>PCB Hole Layout</p> <p>Pitch</p> <p>solder hole</p> <p>Soldertail dimension:</p> <p> \varnothing 0,42mm/.016" if pitch 1,27mm \varnothing 0,29mm/.011" if pitch 1,00mm \varnothing 0,29mm/.011" if pitch 0,80mm \varnothing 0,27mm/.010" if pitch 0,75mm \varnothing 0,27mm/.010" if pitch 0,65mm \varnothing 0,27mm/.010" if pitch 0,50mm \varnothing 0,17mm/.007" if pitch 0,40mm </p> <p>PCB solder hole:</p> <p> \varnothing 0,60mm/.024" if pitch 1,27mm \varnothing 0,50mm/.020" if pitch 1,00mm \varnothing 0,40mm/.016" if pitch 0,80mm \varnothing 0,35mm/.014" if pitch 0,75mm \varnothing 0,35mm/.014" if pitch 0,65mm \varnothing 0,35mm/.014" if pitch 0,50mm \varnothing 0,25mm/.010" if pitch 0,40mm </p>	<p>PCB Pad Layout</p> <p>Pitch</p> <p>solder pad</p> <p> Thumbscrew Retention Cover Retainer BGA Chip BGA socket body PCB Assembly Board Mounting screw </p> <p>You may request any specific socket dimension from info@e-tec.com</p> <p> gold plated pads \varnothing 0,70mm/.027" if pitch 1,27mm gold plated pads \varnothing 0,60mm/.024" if pitch 1,00mm gold plated pads \varnothing 0,50mm/.020" if pitch 0,80mm gold plated pads \varnothing 0,45mm/.018" if pitch 0,75mm gold plated pads \varnothing 0,40mm/.016" if pitch 0,65mm gold plated pads \varnothing 0,35mm/.012" if pitch 0,50mm gold plated pads \varnothing 0,25mm/.010" if pitch 0,40mm </p>

<p>Important Note:</p> <p>Please check the ball diameters & heights of your chip prior to ordering the standard E-tec BGA (BPC) sockets. Any deviation has to be communicated to E-tec in order to check compatibility with the standard socket design and if necessary to obtain a special order code adapted to your chip dimensions.</p> <p>The standard solderball diameters & heights are the following:</p> <table border="1"> <thead> <tr> <th>Pitch</th> <th>ball diameters min/max</th> <th>ball height min/max</th> </tr> </thead> <tbody> <tr> <td>0.50mm</td> <td>0.25mm 0.35mm</td> <td>0.20mm 0.30mm</td> </tr> <tr> <td>0.65mm</td> <td>0.25mm 0.45mm</td> <td>0.20mm 0.30mm</td> </tr> <tr> <td>0.75mm</td> <td>0.25mm 0.45mm</td> <td>0.20mm 0.40mm</td> </tr> <tr> <td>0.80mm</td> <td>0.40mm 0.55mm</td> <td>0.25mm 0.45mm</td> </tr> <tr> <td>1.00mm</td> <td>0.50mm 0.70mm</td> <td>0.30mm 0.50mm</td> </tr> <tr> <td>1.27mm & higher</td> <td>0.60mm 1.00mm</td> <td>0.50mm 1.00mm</td> </tr> </tbody> </table> <p>If the minimum ball diameter of a given chip falls below the above indications, then a BUC socket will generally be proposed.</p>	Pitch	ball diameters min/max	ball height min/max	0.50mm	0.25mm 0.35mm	0.20mm 0.30mm	0.65mm	0.25mm 0.45mm	0.20mm 0.30mm	0.75mm	0.25mm 0.45mm	0.20mm 0.40mm	0.80mm	0.40mm 0.55mm	0.25mm 0.45mm	1.00mm	0.50mm 0.70mm	0.30mm 0.50mm	1.27mm & higher	0.60mm 1.00mm	0.50mm 1.00mm	<p>Specifications</p> <p>Mechanical data</p> <p>Contact life: 10'000 cycles min. Retention System life: 10'000 cycles min. Solderability: as per IEC 60068-2-58 Individual contact force: 40 grams max.</p> <p>Material</p> <p>Insulator (RoHS compliant): High temp plastic or epoxy FR4 Terminal (RoHS compliant): Brass Contact (RoHS compliant): BeCu</p> <p>Electrical data</p> <p>Contact resistance: < 100 mΩ Current rating: 500 mA max. Insulation resistance at 500V DC: 100 MΩ if 0.50 to 0.80mm pitch 500 MΩ 1.00mm pitch upwards Breakdown voltage at 60 Hz: 500V min. Capacitance: < 1 pF Inductance: < 2 nH</p> <p>Operating temperature</p> <p>-55°C to +125°C; 260°C for 60 sec.</p>
Pitch	ball diameters min/max	ball height min/max																				
0.50mm	0.25mm 0.35mm	0.20mm 0.30mm																				
0.65mm	0.25mm 0.45mm	0.20mm 0.30mm																				
0.75mm	0.25mm 0.45mm	0.20mm 0.40mm																				
0.80mm	0.40mm 0.55mm	0.25mm 0.45mm																				
1.00mm	0.50mm 0.70mm	0.30mm 0.50mm																				
1.27mm & higher	0.60mm 1.00mm	0.50mm 1.00mm																				
<p>Recommendations:</p> <p>Solder paste – Please use a solder paste w/o any silver! E-tec solderless sockets are adapted to a standard PCB thickness of 1.60mm. For a different PCB thickness, please inform E-tec first! SMT ClamShell sockets are recommended to be ordered with locating pegs for soldering to the PCB, to avoid the solderjoints from being stressed during the opening/closing of the retainer. If used without locating pegs, the life cycle of the socket may be heavily reduced. For high pincount SMT sockets, E-tec recommends the use of a pluggable thru-hole socket mounted into a MiniGrid Adapter (see also page 10, 11 & 12 for more details)</p>																						

How to order

X X M x x x x - x x x x - x x X X x x L ← optional for locating pegs

<p>Device Type</p> <p>B = Ball Grid L = Land Grid</p>	<p>Socket Type</p> <p>P = socket for LGA, CGA and BGA chips with standard diameter solderballs (see dimensions in table above) U = socket for small diameter solderballs</p>	<p>Pitch</p> <p> 04 = 0,40mm 10 = 1,00mm 05 = 0,50mm 12 = 1,27mm 06 = 0,65mm 15 = 1,50mm 07 = 0,75mm 08 = 0,80mm others on request </p>	<p>Grid Code Config Code</p> <p>will be given by the factory after receipt of the chip datasheet</p>	<p>Plating</p> <p>95 = tin/gold (tin leadfree) 55 = gold only for Compression Type</p>
<p>Nbr of contacts</p> <p>depends on ballcount of chip</p>	<p>Contact Type</p> <p> 30 = standard SMT... („A“ = 1,20mm if 1,27mm pitch; 0,80mm if 1,00mm pitch, 0,60 if 0,80mm pitch; 0,40mm if <0.80mm pitch) 29 = raised SMT... („A“ = 5,00mm if 1,27mm pitch; 3,20mm if 1,00mm pitch; 2,80mm if 0,80mm pitch, 2,30mm if <0.80mm pitch) 28 = special raised SMT - only for 1.00 & 0.80mm pitch..... („A“ = 4,50mm) 70 = standard solder tail..... („A“ = 3,30 if 1.27mm pitch, 2,80 if 1.00mm or 0.80mm pitch, 2,30mm if <0.80mm pitch) 90 & 91 = compression type (see page 8 for more details) </p>			

Ball / Land Grid Array Sockets

Solderless Compression Type



E-tec is now the leading BGA socket manufacturer and offers a solderless socket where board to chip contact is made without the need to solder.

EP patents 0829188, 0897655 US patents 6190181, 6249440 Patented in other countries.

Solderless compression type sockets are available for any chip size and grid pattern.

The solderless socket is easily mounted to the PCB with 4 through hole mounting pegs. The assembly board ensures perfect coplanarity of the socket. Contact reliability is guaranteed with spring loaded gold plated contacts, which are pressed onto gold plated PCB pads. Solderless compression type sockets are available with FastLock, TwistLock, "Economy" ClamShell, QuickLock, LeverLock and "Professional" ClamShell retention systems. We aim to solve your requirements - many different terminals and configurations are available. Your custom sets our standards!

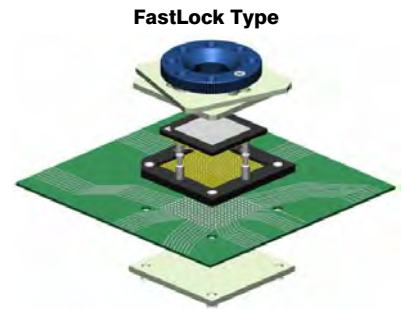

Please note, we will always request the chip data to ensure we offer a compatible socket.

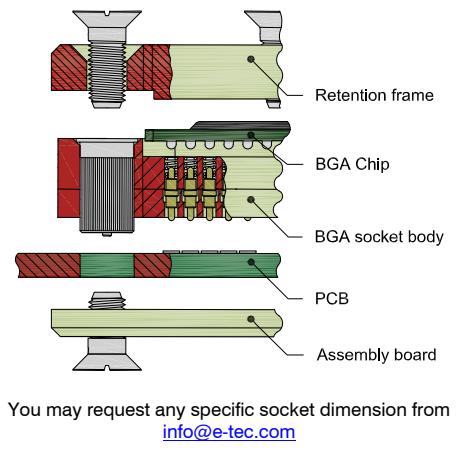

Recommendations:

PCB layout gold plated pads:
 Ø 0,70mm/.027" if pitch 1,27mm
 Ø 0,60mm/.024" if pitch 1,00mm
 Ø 0,50mm/.020" if pitch 0,80mm
 Ø 0,45mm/.018" if pitch 0,75mm
 Ø 0,40mm/.016" if pitch 0,65mm
 Ø 0,35mm/.012" if pitch 0,50mm
 Ø 0,25mm/.010" if pitch 0,40mm

PCB thickness:
 E-tec solderless sockets are adapted to a standard PCB thickness of 1.60mm.
 For a different PCB thickness, please inform E-tec first!

Important Note:
 Please check the ball diameters & heights of your chip prior to ordering the standard E-tec BGA (BPW) sockets. Any deviation has to be communicated to E-tec in order to check compatibility with the standard socket design and if necessary to obtain a special order code adapted to your chip dimensions.
 The standard solderball diameters & heights are the following:

Pitch	ball diameters min/max	ball height min/max
0.50mm	0.25mm / 0.35mm	0.20mm / 0.30mm
0.65mm	0.25mm / 0.45mm	0.20mm / 0.30mm
0.75mm	0.25mm / 0.45mm	0.20mm / 0.40mm
0.80mm	0.40mm / 0.55mm	0.25mm / 0.45mm
1.00mm	0.50mm / 0.70mm	0.30mm / 0.50mm
1.27mm & higher	0.60mm / 1.00mm	0.50mm / 1.00mm

If the minimum ball diameter of a given chip falls below the above indications, then a BUW socket will generally be proposed.

You may request any specific socket dimension from info@e-tec.com

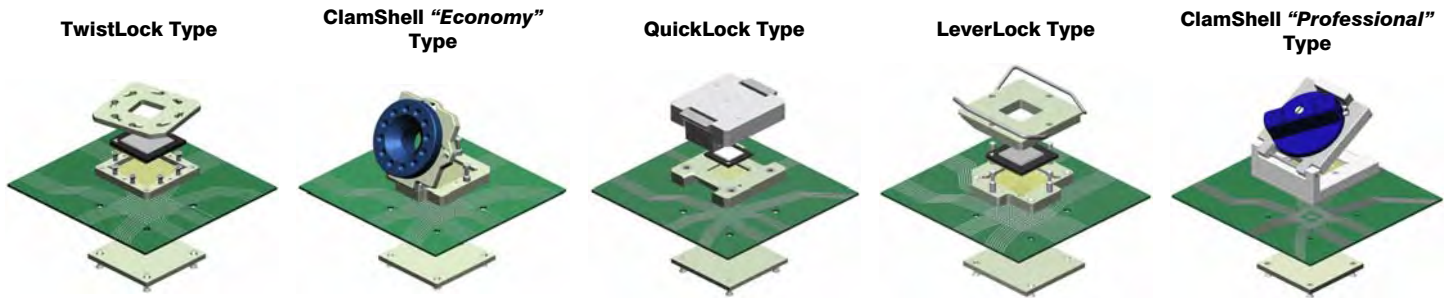

You may request any specific socket dimension from info@e-tec.com

Specifications

Mechanical data	Electrical data
Contact life	Contact resistance
Retention System life	Current rating
Individual contact force	Insulation resistance at 500V DC
Material	Breakdown voltage at 60 Hz
Insulator (RoHS compliant)	Capacitance
Terminal (RoHS compliant)	Inductance
Contact (RoHS compliant)	Operating temperature

How to order

X X W X X X X - X X X X - X X X X 55 L

Device Type B = Ball Grid L = Land Grid C = Column Grid	Socket Type P = socket for LGA, CGA and BGA chips with std diameter solderballs in 0.80mm pitch or higher (see dimensions in table above) U = socket for BGA chips with small diameter solderballs and for all chips with a pitch of 0.75mm or lower	Pitch 04 = 0,40mm 05 = 0,50mm 06 = 0,65mm 07 = 0,75mm 08 = 0,80mm 10 = 1,00mm 12 = 1,27mm 15 = 1,50mm <i>others on request</i>	Grid Code Config Code <i>will be given by the factory after receipt of the chip datasheet</i>	Plating 55 = gold
Locking Type F = FastLock C = ClamShell "Professional" Type E = ClamShell "Economy" Type Q = QuickLock W = TwistLock Z = LeverLock	Nbr of contacts <i>depends on ballcount of chip</i>	Option 90 = standard probes up to 3 GHz 91 = high speed probes exceeding 10 GHz		

E-tec is now the leading BGA socket manufacturer.

These elastomer interposer sockets are available for any chip size and pitch. The standard version is the solderless socket style, which is attached with 2 or 4 screws to the PCB. SMT and thru-hole adapter sockets are available in certain pitches (contact factory for availability first) with these elastomer interposers to allow using this high frequency interposer on PCB's which have already been laid out for SMT or thru-hole sockets. The retainer can be delivered with a center opening for die access and the socket outline will be kept to a minimum and special clearances can be offered to avoid components on the PCB.

We aim to solve your requirements - your custom sets our standards!

Please note, we will always request the chip data to ensure we offer a compatible socket.

BGA/LGA/QFN Chip Socket

GullWing Chip Socket

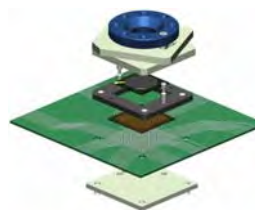

FastLock Type

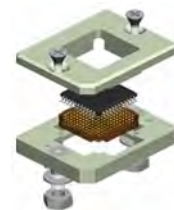

ScrewLock Type

Solderless Compression style Standard Version

(FastLock Type as example only - other locking systems available also)

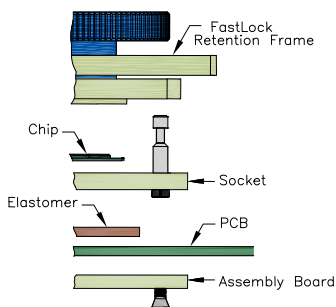
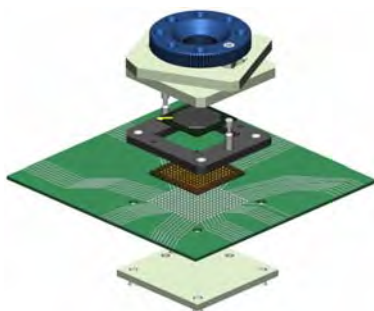

- gold plated pads Ø 0,70mm/.027" if pitch 1,27mm
- gold plated pads Ø 0,60mm/.024" if pitch 1,00mm
- gold plated pads Ø 0,50mm/.020" if pitch 0,80mm
- gold plated pads Ø 0,45mm/.018" if pitch 0,75mm
- gold plated pads Ø 0,40mm/.016" if pitch 0,65mm
- gold plated pads Ø 0,30mm/.012" if pitch 0,50mm

Important Note:

PCB pad height: same or higher than solder mask.
PCB thickness: 1.60mm std. (others: contact E-tec)

Elastomer Specifications

Flammability	UL 94V-0
Current rating at minimum 0.10mm compression depends on solderball size:	
0.30mm dia balls	1A min.
0.60mm dia balls	2A min.
Insulation resistance :	1000 MΩ
Contact resistance :	< 50 mΩ
Capacitance :	< 0.3 pF
Inductance :	< 0.6 nH
Breakdown voltage :	500V DC
Operating temperature :	-35°C to +125°C
Bandwidth	
0.50mm thick elastomer	sinusoidal signals : -1dB at >10 GHz digital signals: 10 GHz min.
1.00mm thick elastomer	sinusoidal signals: -1dB at >10 GHz digital signals: up to 6.5GHz max.
Recommended Compression: 0.10mm min.	
Compression forces	
0.50mm thick elastomer	Solderball diameters 0.50mm = 40 to 50gf @0.20mm 0.60mm = 60 to 80gf @0.20mm 0.75mm = 90 to 120gf @0.20mm
1.00mm thick elastomer	Solderball diameters 0.50mm = 40 to 50gf @0.20mm 0.60mm = 50 to 70gf @0.20mm 0.75mm = 90 to 120gf @0.20mm

Mechanical data

Elastomer life	BGA chips :	1.000 cycles min.
	LGA/QFN chips :	10.000 cycles min.

Dimensions & Tolerances

Pitch of wires	P1 & P2 = 0.05mm x 0.05mm to 0.10mm x 0.10mm (depending on pitch of chip)
Thickness/Offset	T = 0.50mm (±0.05mm)/Offset = 0.25mm (±0.05mm) T = 1.00mm (±0.07mm)/Offset = 0.50mm (±0.07mm)
Width/Length	min. = 3.00mm x 3.00mm (±0.50mm) max. = 49.00mm x 49.00mm (±0.50mm)

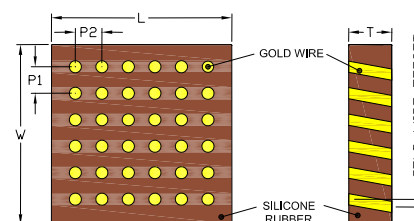

Locking systems overview (not exhaustive)

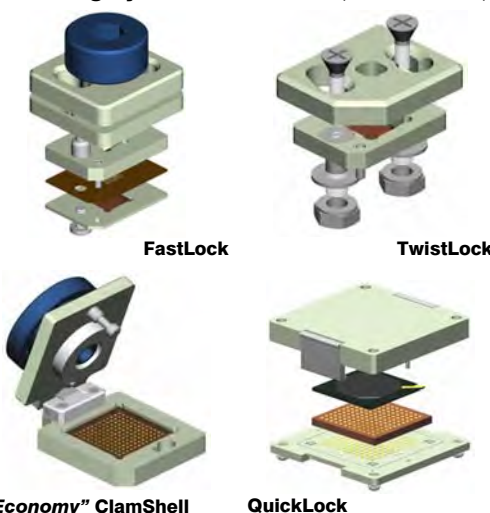

Special Elastomer Adapters (on request)

SMT and THT (Soldertail) Adapter Style on request

(FastLock Type as example only - other locking systems available also)

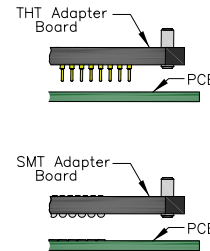
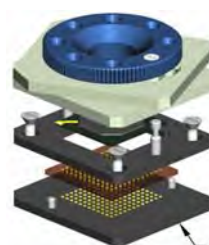

Recommendations for SMT Adapter Boards

Solder paste Please use a solder paste w/o any silver!
Solder profile Please refer to our website www.e-tec.com

How to order

E X X x x x x - x x x x - x x X X x x L ← locating pegs

Device Type	Locking Type	Nbr of contacts	Elastomer or Pitch	Grid Code	Config Code	Plating
B = BGA L = LGA/QFN G = GullWing	W = TwistLock F = FastLock Q = QuickLock E = ClamShell "Economy" Type for BGA/LGA/QFN For GullWing type contact factory. Lifetime: TwistLock 1K cycles min. all others 10K cycles min.	999 if LGA or QFN Ball count if BGA	<i>will be given by the factory after receipt of the chip datasheet</i>	<i>will be given by the factory after receipt of the chip datasheet</i>		55 = gold <hr/> 95 = tin/gold (tin leadfree)

Contact Type

- 90** = Solderless Compression Type; 6.5 GHz performance
- 91** = Solderless Compression Type; 10 GHz performance
others on request
- Solder Adapters (on request only):**
- 30** = SMT..... (with surface mount Adapterboard)
- 70** = THT..... (with soldertail Adapterboard)

BGA emulation adapter allows BGA socket to be inserted.

The SMT adapter is available either with solder ball or with solid pin terminals. This SMT adapter emulates the chip's BGA footprint and is easily installed using standard flux and reflow techniques. The solder ball adapters have the same solder ball types as the IC's they are emulating. You can combine the SMT foot with any of the E-tec socket styles shown in the Test Socket Catalog pages 1 through 7. The corresponding male BGA socket, through hole type, is plugged into the adapter.

We offer any pin-out, configuration and grid size for pitch 0.8mm, 1.00mm and 1.27mm.

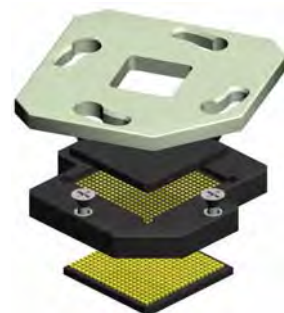

BGA Socket with SMT Adapter

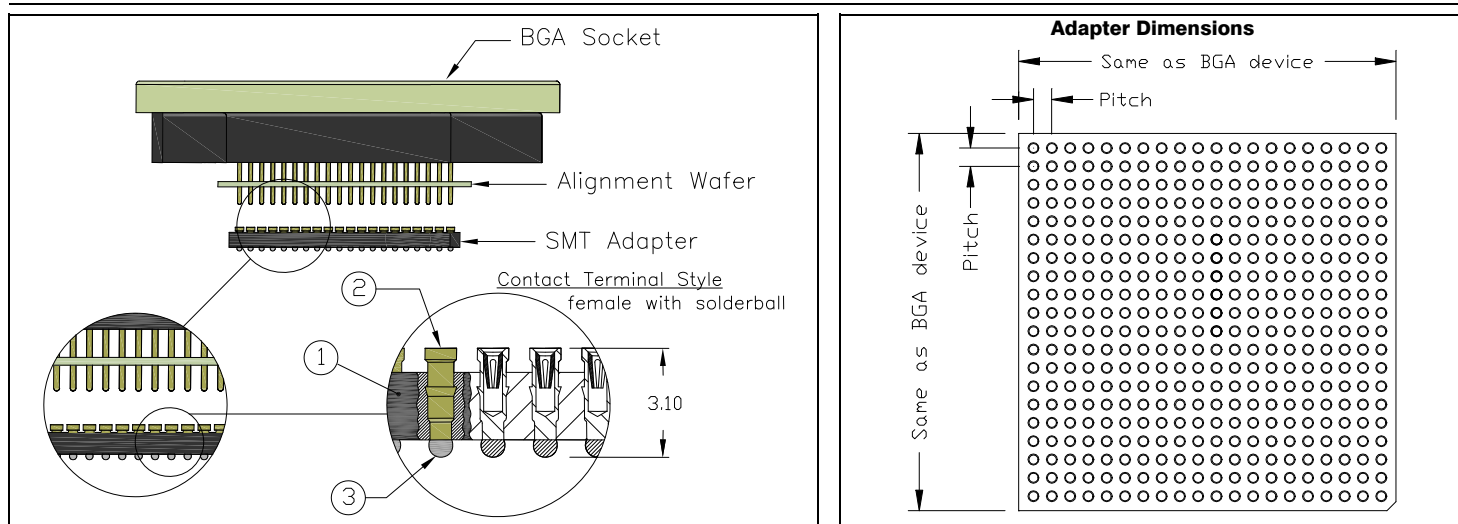

Specifications

1 Insulator (Adapter Wafer)	Material: FR4/G10 or equivalent high temp material (RoHS compliant)
2 Contact (Terminal & Contact Clip) (accepts 0.20mm-0.30mm diameter pins)	Material: Terminal CuZn (RoHS compliant) Contact Clip BeCu (RoHS compliant)
3 Solder Ball	Material: Sn63Pb 37 (NON RoHS compliant) Sn96.5 Ag 3.0 Cu 0.5 (RoHS compliant)

Operating Temperature: -55°C to +125°C

Processing Temperature: 260°C for 60 sec.

Insertion force: 0.45N

Extraction force: 0.25N

How to order

MGS xxxx - SB01 - xx X xx xx

Nbr of contacts/balls as per device	Contact Terminal styles	Grid size	Config Code	Contact Plating & Solder Ball Alloy	Pitch of Grid Array
	<p>Solder Ball Terminal SB01 = standard size (see drawing above)</p> <p>Solid Pin Terminals E119 E167 E169 <small>please refer to the BGA Mini-Grid socket page 12</small></p>				

E-tec will supply the corresponding BGA sockets for plugging into these adapters, which will be delivered with gold plated thru-hole pins and a pin alignment wafer for easy insertion. Please choose the socket style you wish to plug into these adapters from the catalog pages 1 through 7 and request from E-tec the contact style "70" (thru-hole pin), with the plating code to "55" (gold) and with the adder "A" for the alignment plate (XXXxxxx-xx70-xxXX55A). Example: BPW256-1070-16AA55A for a 256-pin TwistLock socket (page 2). For 1.27mm pitch sockets a special thru-hole pin -1272- will be offered. Alternatively the MiniGrid adapters (ABG series - see page 11) can also be supplied together with these SMT BGA emulation adapters.

Please contact E-tec for any further information.

The E-tec BGA Adapter System comprises two elements, the BGA solder adapter onto which the BGA chip is soldered (converting the BGA chip to a PGA), and the MiniGrid Socket which is soldered to the PCB. The solder adapter can then be plugged into the MiniGrid Socket (page 10 or 12).

E-tec offers any pin-out, configuration and grid size.
Special terminal designs are possible on request.

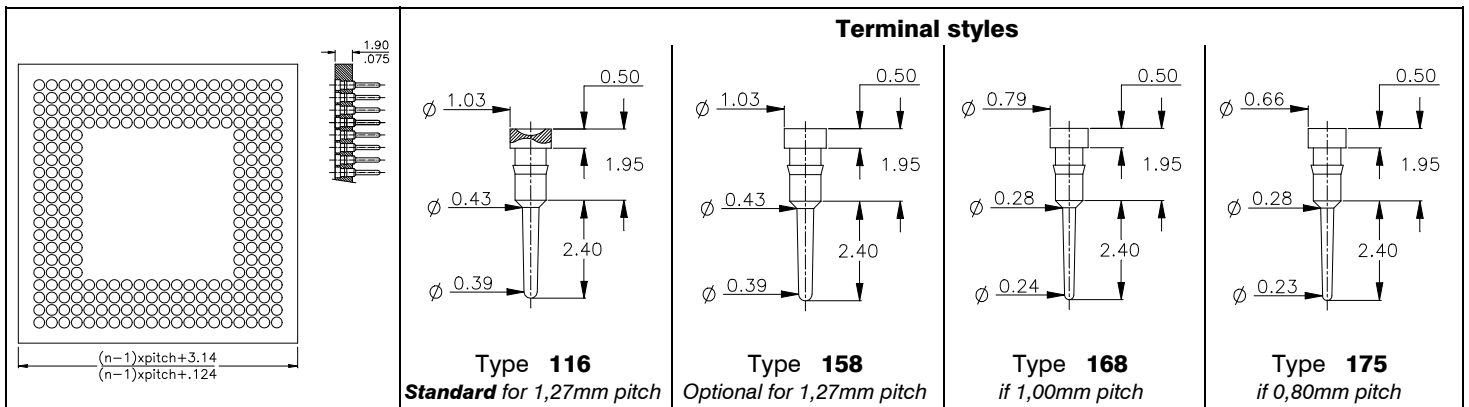
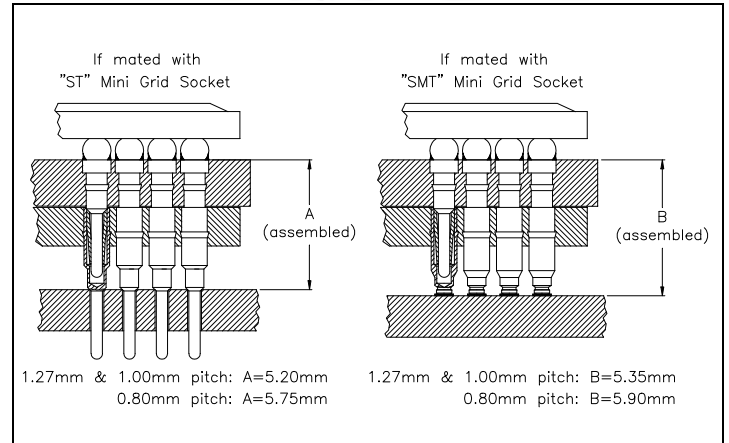
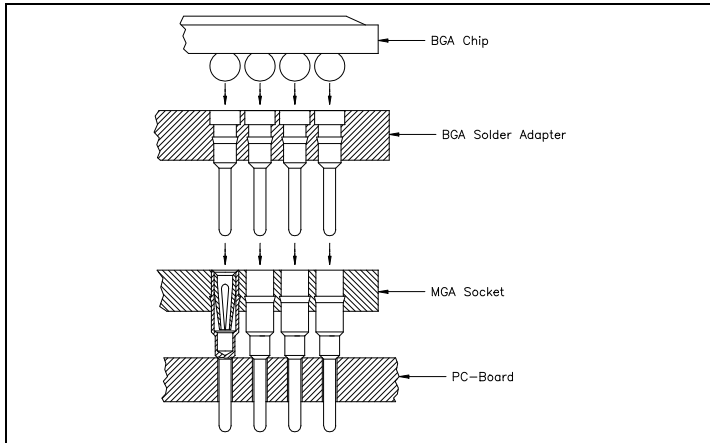
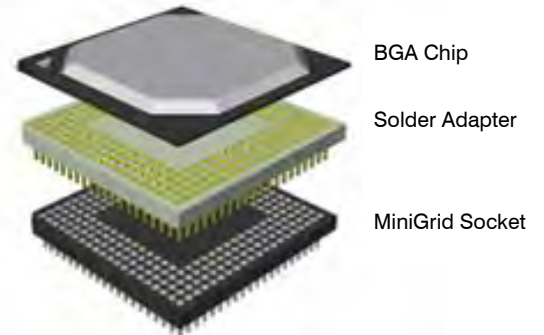

Specifications

Terminal Type	Material	Plating	Adapter	Others
116, 158, 168 & 175	CuZn	Au over Ni over Cu	Material : FR 4 glass Epoxy UL 94V-0	Operating Temperature : -55°C to +125°C ; 260°C for 60 sec.

How to order

ABG xxxx - E xxx - xx X 55 xx

Nbr of contacts / balls

as per device

Terminal style

Please refer to the drawings shown above

Grid size | **Config Code**

will be given by the factory after receipt of the BGA chip datasheet

Plating

55 = gold

Pitch of Grid Array
08 = 0.80mm
10 = 1.00mm
12 = 1.27mm
15 = 1.50mm

others on request

The E-tec MiniGrid Socket is soldered to the target board and is designed to accept the BGA Solder Adapter (where the chip is soldered to the adapter board). As an alternative, this MiniGrid Socket is also designed to accept the “true” through hole BGA Sockets (where the chips can be socketed without soldering).

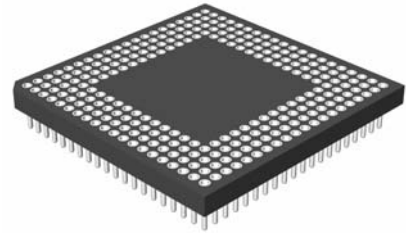

E-tec offers any pin-out, configuration and grid size.
Special terminal designs are possible on request.

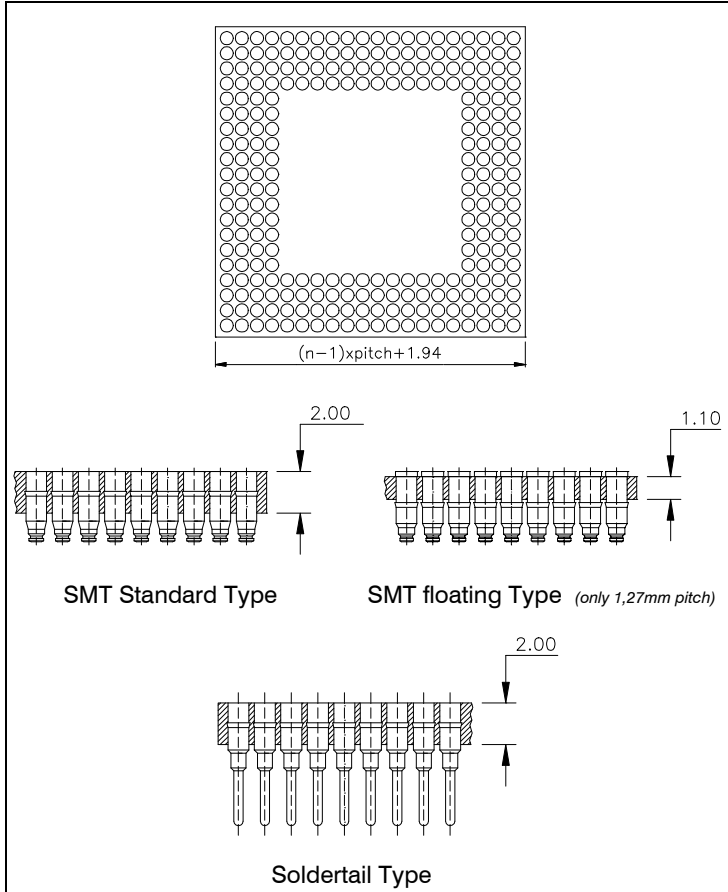

Terminal styles			
 SMT Terminal Type 119 if 1,27 ; 1,50 & 2,00mm pitch	 SMT „floating” Type 120 if 1,27 ; 1,50 & 2,00mm pitch	 SMT Terminal Type 167 if 1,00mm pitch	 SMT Terminal Type 169 if 0,80mm pitch
 Solder-tail Terminal Type 117 if 1,27 ; 1,50 & 2,00mm pitch	 Solder-tail Terminal Type 172 if 1,00mm pitch	 Solder-tail Terminal Type 174 if 0,80mm pitch	

Specifications

Terminal Type	Material	Plating	Socket Material	Others
117, 119, 120, 167, 169, 172, 174	Terminal : CuZn Contact clip : BeCu	Sn over Ni over Cu Au over Ni over Cu	FR 4 glass Epoxy UL 94V-0	Operating Temperature -55°C to +125°C ; 260°C for 60 sec.

How to order

MGS xxxx - E xxx - xx X 95 xx

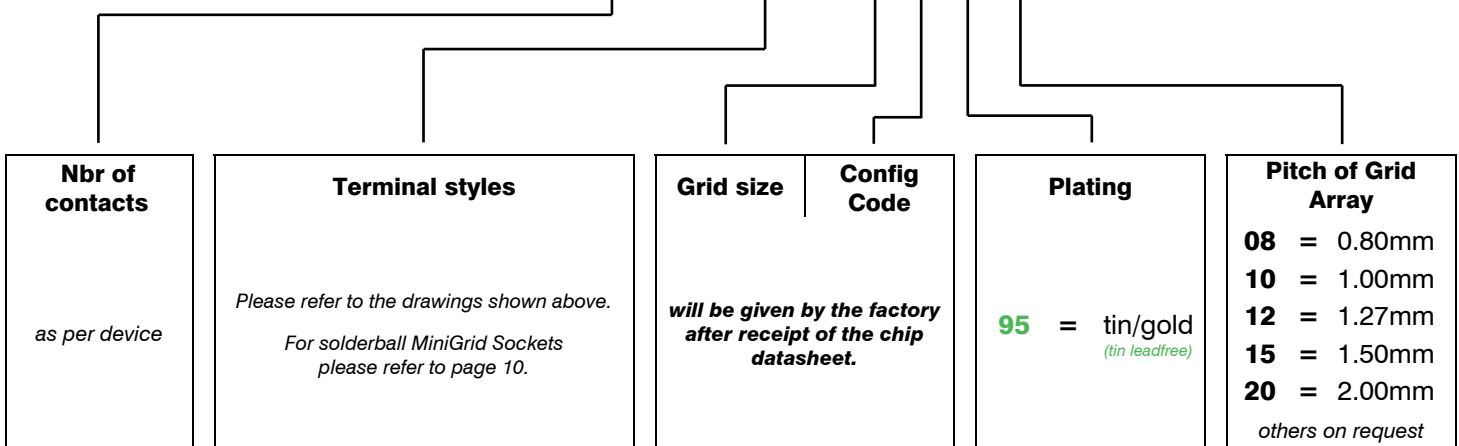

E-tec is now the leading BGA socket manufacturer.

EP patents 0829188, 0897655 US patents 6190181, 6249440 Patented in other countries.

QFN/MLF/MLP sockets are available for any chip size and pitch. They are available in SMT, thru-hole and solderless compression type versions. The SMT socket is simply placed and reflowed onto the PCB in the same way as the chip and it only requires a small amount of additional board space. The retainer can be delivered with a center opening for die access. Additional center grounding pins are offered on request.

We aim to solve your requirements - your custom sets our standards!

Please note, we will always request the chip data to ensure we offer a compatible socket.

FastLock Type

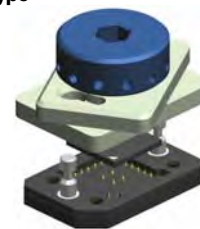

SMT style	Soldertail style	Solderless Compression style (TwistLock Type as example shown)
<p>PCB Pad Layout</p> <p>Pitch</p> <p>optional for grounding</p> <p>solder pad</p> <p>Ø 0,60mm/.024" if pitch 1,27mm Ø 0,50mm/.020" if pitch 1,00mm Ø 0,40mm/.016" if pitch 0,80mm Ø 0,35mm/.014" if pitch 0,75mm Ø 0,35mm/.014" if pitch 0,65mm Ø 0,30mm/.012" if pitch 0,50mm</p>	<p>PCB Pad Layout</p> <p>Pitch</p> <p>optional for grounding</p> <p>solder hole</p> <p>Soldertail dimension:</p> <p>Ø 0,42mm/.016" if pitch 1,27mm Ø 0,29mm/.011" if pitch 1,00mm Ø 0,29mm/.011" if pitch 0,80mm Ø 0,27mm/.010" if pitch 0,75mm Ø 0,27mm/.010" if pitch 0,65mm Ø 0,27mm/.010" if pitch 0,50mm Ø 0,17mm/.007" if pitch 0,40mm</p> <p>PCB solder hole:</p> <p>Ø 0,60mm/.024" if pitch 1,27mm Ø 0,50mm/.020" if pitch 1,00mm Ø 0,40mm/.016" if pitch 0,80mm Ø 0,35mm/.014" if pitch 0,75mm Ø 0,35mm/.014" if pitch 0,65mm Ø 0,35mm/.014" if pitch 0,50mm Ø 0,25mm/.010" if pitch 0,40mm</p>	<p>Retention frame</p> <p>QFN Device</p> <p>Socket body</p> <p>PCB</p> <p>Assembly board</p> <p>PCB Pad Layout</p> <p>Pitch</p> <p>optional for grounding</p> <p>PCB land</p> <p>You may request any specific socket dimension from info@e-tec.com</p> <p>gold plated pads Ø 0,70mm/.027" if pitch 1,27mm gold plated pads Ø 0,60mm/.024" if pitch 1,00mm gold plated pads Ø 0,50mm/.020" if pitch 0,80mm gold plated pads Ø 0,45mm/.018" if pitch 0,75mm gold plated pads Ø 0,40mm/.016" if pitch 0,65mm gold plated pads Ø 0,35mm/.012" if pitch 0,50mm gold plated pads Ø 0,25mm/.010" if pitch 0,40mm</p>

FastLock Solderless Compression Type	TwistLock Solderless Compression Type	ClamShell "Economy" Type	QuickLock Type	Specifications
				<p>Mechanical data</p> <p>Contact life: 10.000 cycles min.</p> <p>Retention System life: TwistLock 1.000 cycles min., ClamShell, Fast- & QuickLock 10.000 cycles min.</p> <p>Solderability: as per IEC 60068-2-58</p> <p>Individual contact force: 40 grams max.</p> <p>Material</p> <p>Insulator (RoHS compliant): High temp plastic or epoxy FR4</p> <p>Terminal (RoHS compliant): Brass</p> <p>Contact (RoHS compliant): BeCu</p> <p>Electrical data</p> <p>Contact resistance: < 100 mΩ</p> <p>Current rating: 500 mA max.</p> <p>Insulation resistance at 500V DC: 100 MΩ if 0.50 to 0.80mm pitch, 500 MΩ 1.00mm pitch upwards</p> <p>Breakdown voltage at 60 Hz: 500V min.</p> <p>Capacitance: < 1 pF</p> <p>Inductance: < 2 nH</p> <p>Operating temperature: -55°C to +125°C ; 260°C for 60 sec.</p>

Recommendations:

Solder paste – Please use a solder paste w/o any silver!

Solder profile – Please refer to our website www.e-tec.com

E-tec solderless sockets are adapted to a standard PCB thickness of 1.60mm. For a different PCB thickness, please inform E-tec first!

SMT sockets are recommended to be ordered with locating pegs for soldering to the PCB, to avoid the solderjoints from being stressed due to the torque forces applied with this locking system. If used without locating pegs, the life cycle of the socket may be heavily reduced.

How to order

L Q X x x x x - x x x x - x x x x x x L ← optional for locating pegs

Locking Type	Nbr of contacts	Pitch	Grid Code	Config Code	Plating
<p>W = TwistLock</p> <p>F = FastLock</p> <p>Q = QuickLock</p> <p>E = ClamShell "Economy" Type</p> <p>Others on request</p>	<p>depends on landcount of chip, plus center grounding pins if required. (generally 4 pins)</p>	<p>04 = 0,40mm 10 = 1,00mm</p> <p>05 = 0,50mm 12 = 1,27mm</p> <p>06 = 0,65mm</p> <p>07 = 0,75mm</p> <p>08 = 0,80mm</p> <p>Others on request</p>	<p>will be given by the factory after receipt of the chip datasheet</p>	<p>will be given by the factory after receipt of the chip datasheet</p>	<p>95 = tin/gold (tin leadfree)</p> <hr/> <p>55 = gold only for solderless Compression Type</p>

Contact Type

- 30** = standard SMT.... („A“ = 1,20mm if 1,27mm pitch; 0,80mm if 1,00mm pitch, 0,60 if 0,80mm pitch; 0,40mm if <0,80mm pitch)
- 29** = raised SMT... („A“ = 5,00mm if 1,27mm pitch; 3,20mm if 1,00mm pitch; 2,80mm if 0,80mm pitch, 2,30mm if <0,80mm pitch)
- 28** = special raised SMT - only for 1.00 & 0.80mm pitch..... („A“ = 4,50mm)
- 70** = standard solder tail..... („A“ = 3.30 if 1.27mm pitch, 2.80 if 1.00mm or 0.80mm pitch, 2.30mm if <0.80mm pitch)
- 90 & 91** = compression type (see page 8 for more details)

"GullWing Chip" Sockets

Screw-, Fast-, QuickLock & ClamShell Type



GullWing sockets are available for any GullWing type chips (QFP, PQFP, SOIC, SO etc.) and lead pattern. The sockets are available for any pin-out and tip-to-tip dimension as of 0.50mm pitch upwards. The SMT socket is simply placed and reflowed onto the PCB in the same way as the chip and it only requires a small amount of additional board space. The standard locking system is the ScrewLock design, but QuickLock and ClamShell locking systems are also available.

We aim to solve your requirements - many different terminals and configurations are available.

Your custom sets our standards!

Please note, we will always request the chip data to ensure we offer a compatible socket.

ScrewLock Type

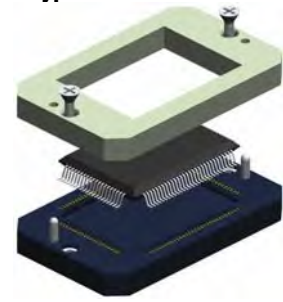

SMT style

PCB Pad Layout

Pitch

solder pad

- Ø 0,50mm/.020" if pitch 1,27mm
- Ø 0,50mm/.020" if pitch 1,00mm
- Ø 0,40mm/.016" if pitch 0,80mm
- Ø 0,35mm/.014" if pitch 0,75mm
- Ø 0,35mm/.014" if pitch 0,65mm
- Ø 0,30mm/.012" if pitch 0,50mm

Soldertail style

PCB Hole Layout

Pitch

solder hole

Soldertail dimension:

- Ø 0,29mm/.011" if pitch 1,27mm
- Ø 0,29mm/.011" if pitch 1,00mm
- Ø 0,29mm/.011" if pitch 0,80mm
- Ø 0,27mm/.010" if pitch 0,75mm
- Ø 0,27mm/.010" if pitch 0,65mm
- Ø 0,27mm/.010" if pitch 0,50mm

PCB solder hole:

- Ø 0,50mm/.020" if pitch 1,27mm
- Ø 0,50mm/.020" if pitch 1,00mm
- Ø 0,40mm/.016" if pitch 0,80mm
- Ø 0,35mm/.014" if pitch 0,75mm
- Ø 0,35mm/.014" if pitch 0,65mm
- Ø 0,35mm/.014" if pitch 0,50mm

Solderless Compression style

You may request any specific socket dimension from info@e-tec.com

- gold plated pads Ø 0,60mm/.024" if pitch 1,27mm
- gold plated pads Ø 0,60mm/.024" if pitch 1,00mm
- gold plated pads Ø 0,50mm/.020" if pitch 0,80mm
- gold plated pads Ø 0,45mm/.018" if pitch 0,75mm
- gold plated pads Ø 0,40mm/.016" if pitch 0,65mm
- gold plated pads Ø 0,35mm/.012" if pitch 0,50mm

<p>Quick Lock Type</p> <p>without lever for low leadcount chips</p>	<p>FastLock Type</p> <p>with lever for high leadcount chips</p>	<p>ClamShell Type</p> <p>adapted to low and high leadcount chips</p>	<p>ClamShell Type</p> <p>with center screw for high leadcount chips</p>
---	---	--	---

Specifications

Mechanical data

- Contact life: 10.000 cycles min.
- Retention System life: 1.000 cycles min.
- ScrewLock ClamShell, Fast- & QuickLock: 10.000 cycles min.
- Solderability: as per IEC 60068-2-58
- Individual contact force: 40 grams max.

Material

- Insulator: (RoHS compliant) High temp plastic or epoxy FR4
- Terminal: (RoHS compliant) Brass
- Contact: (RoHS compliant) BeCu

Electrical data

- Contact resistance: < 100 mΩ
- Current rating: 500 mA max.
- Insulation resistance at 500V DC: 100 MΩ if 0.50 to 0.80mm pitch; 500 MΩ 1.00mm pitch upwards
- Breakdown voltage at 60 Hz: 500V min.
- Capacitance: < 1 pF
- Inductance: < 2 nH

Operating temperature

- 55°C to +125°C ; 260°C for 60 sec.

Recommendations:

- Solder paste – Please use a solder paste w/o any silver!
- Solder profile – Please refer to our website www.e-tec.com

E-tec solderless sockets are adapted to a standard PCB thickness of 1.60mm. For a different PCB thickness, please inform E-tec first!

The SMT sockets are mounted with straight SMT pins (not bent legs), which are adapted to round PCB pads. For rectangular PCB pads, please ensure that the round socket pins will be surface mountable, since E-tec cannot offer any guarantee in such instances.

For SMT sockets in general, E-tec recommends the use of locating pegs, which can be soldered to the PCB for added mechanical strength.

How to order

QF X x x x x - x x x x - x x x x x x L ← optional for locating pegs

Retention Type

- W** = ScrewLock
- F** = FastLock
- Q** = QuickLock
- C** = ClamShell

Nbr of contacts

depends on leadcount of chip

Pitch

05 = 0,50mm	08 = 0,80mm
63 = 0,635mm	10 = 1,00mm
06 = 0,65mm	12 = 1,27mm
07 = 0,75mm	<i>others on request</i>

Grid Code | **Config Code**

will be given by the factory after receipt of the chip datasheet

Plating

- 95** = tin/gold (tin leadfree)
- 55** = gold only for solderless Compression Type

Contact Type

- 30** = standard SMT... („A“ = 0,80mm if 1,27mm pitch or 1,00mm pitch, 0.60 if 0,80mm pitch; 0.40mm if <0.80mm pitch)
- 29** = raised SMT... („A“ = 3,20mm if 1,27mm pitch or 1,00mm pitch; 2,80mm if 0,80mm pitch, 2.30mm if <0.80mm pitch)
- 28** = special raised SMT - only for 1,27, 1.00 & 0.80mm pitch..... („A“ = 4,50mm)
- 70** = standard solder tail..... („A“ = 2,80 if 1.27mm pitch, 1.00mm or 0.80mm pitch; 2,30mm if <0.80mm pitch)
- 90 & 91** = compression type (see page 8 for more details)

Heatsinks for BGA & LGA sockets

Standard & customized Heatsinks (with or without integrated fan) adapted to BGA & LGA sockets are available on request

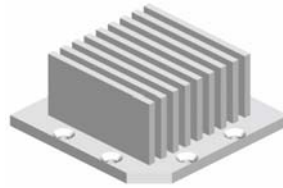
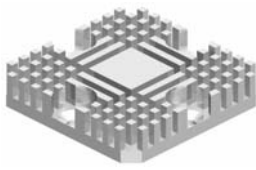

For order code please contact www.e-tec.com

LGA to BGA converter plates

For applications where a chip is tested with & without solderballs the LGA sockets can be delivered with a converter plate to allow socketing BGA chips with an LGA socket.

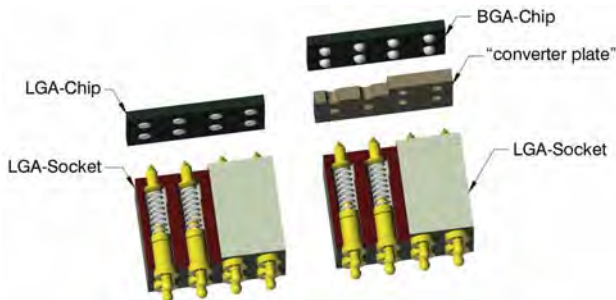

For order code please contact www.e-tec.com

Thermo couple attachment feature

E-tec TwistLock sockets are available with a thermo couple attachment feature on request

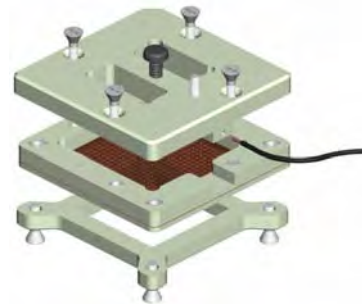

For order code please contact www.e-tec.com

"Torque Limiting Screwdriver Kit" for E-tec BGA "TwistLock Sockets"

E-tec recommends the use of this pre-set adjustable torque screw driver for correct tightening of the E-tec BGA/LGA socket retention frames. Excess tightening can be completely avoided with the use of this screw driver, which comes with a stainless steel shaft and attractive coloured aluminium handle.



The Kit includes:
1 – Torque Limiting Screwdriver
1 – 0 Point Philips Bit 1-15/16"

Order Code:
TOL – 7CN – TORQUE

Special clearances in socket body and stiffener boards

If you need any special clearance for components on the PCB (top side or bottom side), E-tec can easily adapt the socket to your requirements.



Socket body with clearances

Assembly/stiffener board with clearances

For order code please contact www.e-tec.com

"Torque Tool Fixture" for E-tec BGA "FastLock Sockets"



For order code please contact www.e-tec.com

Socket with "interchangeable" chip positioning frames

For chips with same pincount, but different body sizes, E-tec offers interchangeable chip positioning frames to allow the use of one single socket.

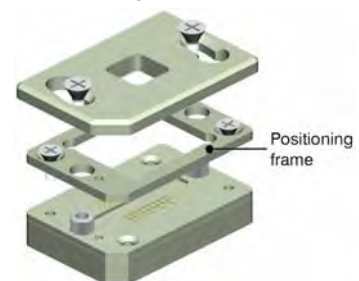

interchangeable positioning frames



For order code please contact www.e-tec.com

Ultra slim socket profile

In case of limited space on the PCB, E-tec can reduce the socket size to a minimum, based on customer request.



For order code please contact www.e-tec.com

Contact E-tec for any other special feature you may require with the sockets. We will attempt to fulfil your needs!

ZIF Test Sockets for Flex Cable

0.50mm to 2.54mm pitch

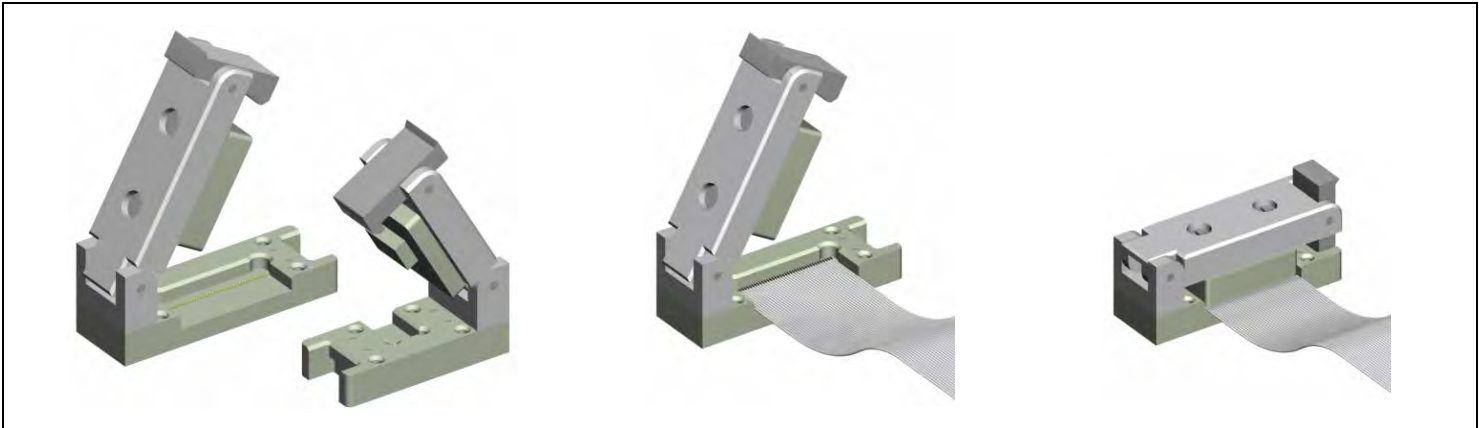

High cycle ZIF Test Sockets for any kind and pitch of Flex-Cable.

Handles up to 10K cycles with simple open/close ClamShell type retention frame.

Cable Dimensions

In order to be able to offer the correct socket for your cable, we need to know the type of cable you are using and the corresponding dimensions as shown below.

Please send the datasheet of your cable together with your socket request.

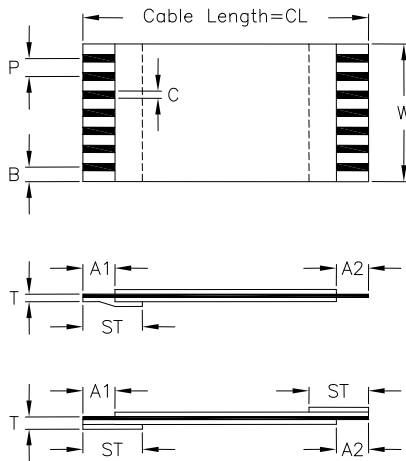

Specifications

Mechanical data

Contact life
Retention System life
Solderability
Individual contact force

10.000 cycles min.
10.000 cycles min.
as per IEC 60068-2-58
40 grams max.

Material

Insulator (RoHS compliant)
Terminal (RoHS compliant)
Spring (RoHS compliant)

High temp plastic or epoxy FR4
Brass
BeCu

Electrical data

Contact resistance
Current rating
Insulation resistance at 500V DC

Breakdown voltage at 60 Hz
Capacitance
Inductance

< 100 mΩ
500 mA max.
100 MΩ if 0.50 to 0.80mm pitch
500 MΩ 1.00mm pitch upwards
500V min.
< 1 pF
< 2 nH

Operating temperature

-55°C to +125°C

Processing temperature

260°C for 60sec.

A detailed socket drawing with the required PCB layout dimensions will be submitted by E-tec for each project.

How to order

FCT - x xx - X xxx - xx

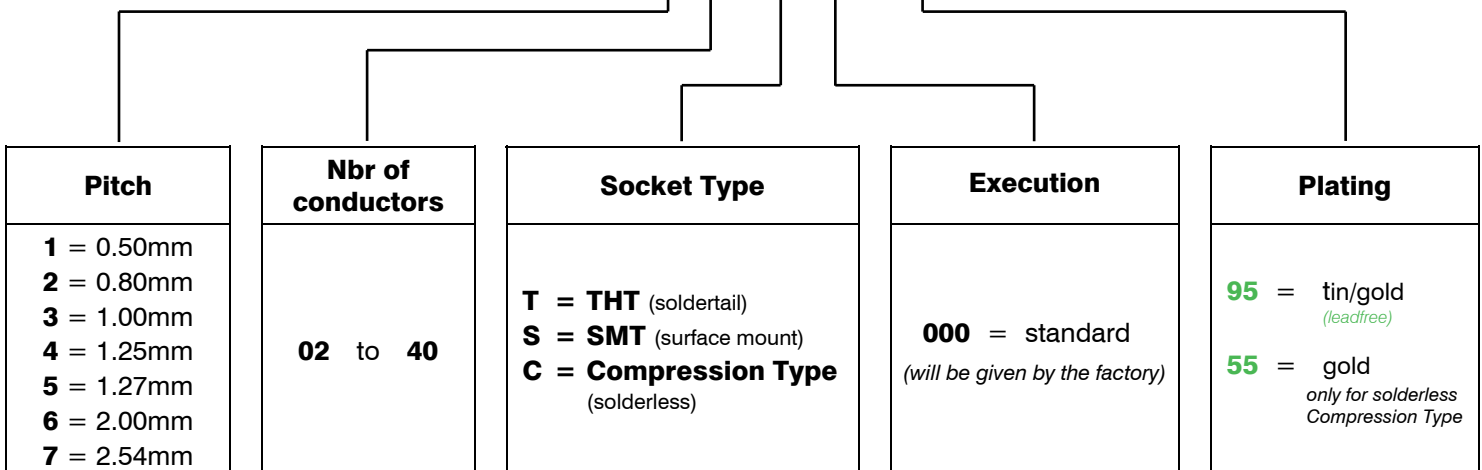

Other products from E-tec

Please contact your closest sales office for further information.



Insertion-Extraction Tools

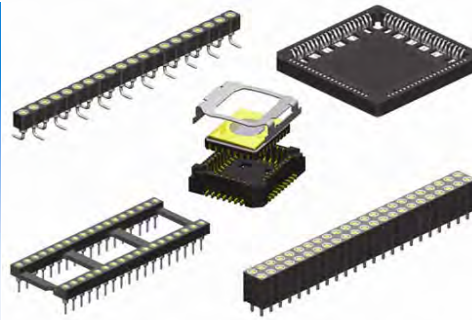

IC - Sockets



Switches

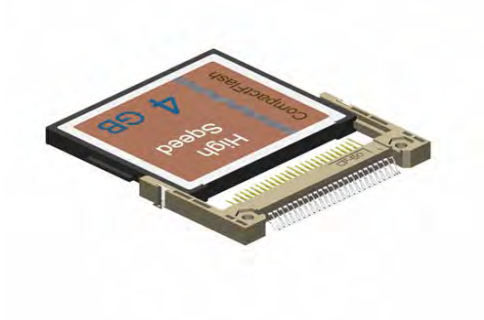

Compact Flash Connectors

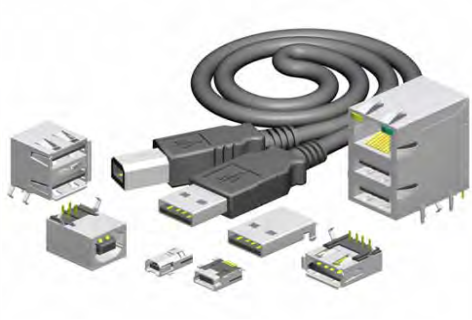

USB & IEEE 1394 Connectors



Mini PCI Express Connectors

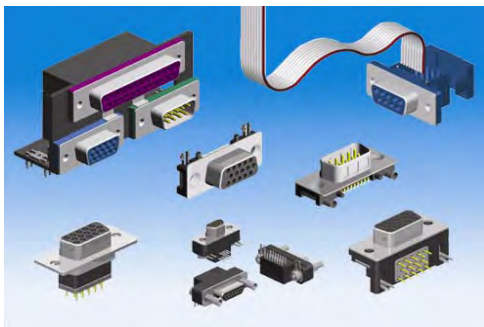

D-Sub Connectors



Flex Cable Connectors



HDMI Connectors



Probe Pin & Probe Pin Connectors

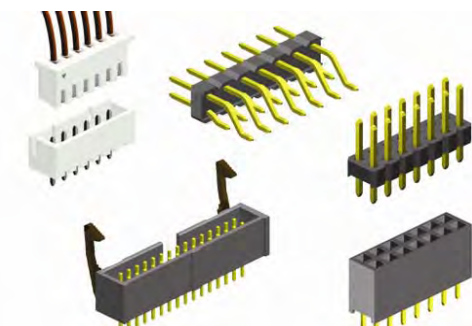

PCB Connectors



Multi Media Card Connectors

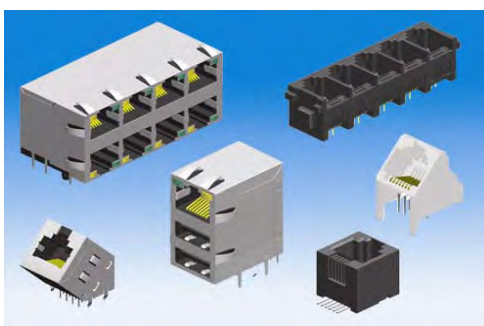

Modular Plugs & Jacks



Phono - & DC - Power Connectors



RF - Connectors



International Sales Headquarters

Switzerland E-tec Interconnect Ltd.
 Schweiz Zone Industrielle C
 Suisse CH-1072 Forel (Lavaux)
 Phone: +41/21/7810810
 Fax: +41/21/7810811
 e-mail: info@e-tec.com
 www.e-tec.com

Related Sales Headquarters

Deutschland EMC electro mechanical components
 Germany Vertriebs GmbH
 Allemagne PF. 1160
 D-65501 Idstein
 Phone: +49/61 26/9395-0
 Fax: +49/61 26/9395-72
 e-mail: info@emc-connectors.com
 www.emc-connectors.com

France Silfox SA
 Frankreich PA des Petits Carreaux
 2 bis avenue des Coquelicots
 F-94385 BONNEUIL
 SUR MARNE CEDEX
 Phone: +33/1/49560468
 Fax: +33/1/49560287
 e-mail: info@silfox.fr
 www.silfox.fr

England E-tec Interconnect (UK) Ltd.
 Angleterre Units A5 & A6 Decimus Park
 Kingstanding Way
 Tunbridge Wells
 Kent TN2 3GP
 Phone: +44/1892/530260
 Fax: +44/1892/515560
 e-mail: info@e-tec.co.uk
 www.e-tec.co.uk

Factories

Switzerland E-tec AG
 Schweiz Friedhofstrasse 1
 Suisse CH-2543 Lengnau b. Biel
 Phone: +41/32/654 15 50
 Fax: +41/32/652 26 93
 e-mail: info-ch@e-tec.com
 www.e-tec.com

Taiwan E-tec Interconnect Asia Ltd.
 10F-2, No. 379, Jhongshan Road
 SANCHONG Dist. New Taipei City
 Taiwan R.O.C.
 Phone: +886 / 2 / 29 99 - 27 26
 Fax: +886 / 2 / 29 99 - 52 55
 e-mail: info@e-tec-asia.com.tw
 www.e-tec-asia.com.tw

YOUR AUTHORISED DISTRIBUTOR
 IHR VERTRAGS-DISTRIBUTOR
 VOTRE DISTRIBUTEUR OFFICIEL