



Filters, Regulators & Lubricators

Particulate Filters B2-B3

F01	B4
F03	B6
F08	B8
F18	B10
F16	B12
F28	B14
F26	B16
F90	B18
F30	B20
F34	B22
F35	B24
F43	B26

Coalescing Filters .. B28-B29

M03	B30
M08	B32
M18	B34
M16	B36
M28	B38
M26	B40
M21	B42
M90	B44
M30	B46
M31	B48
M32	B50
M35	B52
M43	B54
M45	B56
M55	B58

Afterfilters B59

A18	B61
A28	B63

Exhaust Mufflers

F23	B64
F33	B65

Exhaust Silencer

XMC	B66
-----------	-----

Liquid Separators

WSA / WSO	B68
WWSA	B70

External Drains

X01	B71
X02 / XB3	B72
X51	B74

Regulators B77-B79

R03	B80
RB3 / RA3	B82
RA4	B84
R24, R25	B86
R45, R46	B88
R08	B90
R120	B92
R18	B96
R16	B98
R28	B100
R26	B102
R90	B104
R30	B108
R40	B110

Common P1 Regulators B113

R09	B114
R19	B116

Dial-Air™**Regulators B118-B119**

R11	B120
R21	B122
R31	B124
R41	B126

Precision Regulators ... B129

P16	B130
P17	B132
WRA302	B134
WRA102	B136
WRA102BP	B138
WRA171	B140
WEA632	B142
WBA208	B144
WBA45	B146

Lubricators..... B148-B149

L01	B150
L03	B152
L08	B154
L18	B156
L16 / L17	B158
L28	B160
L26 / L27	B162
L90	B164
L30	B166
L31	B168
L32	B170
L40	B172
L41	B174
L42	B176
L50	B178

Filter / Regulators B181-B183

B03	B184
BB3 / BA3	B186
B08	B188
B18	B190
CB6	B192
PC6	B194
B28	B196
B90	B198

Combinations –**2-Unit B200-B201**

D03	B202
D08	B204
CB7	B206
D18	B208
D28	B210
D90	B212

Combinations –**3-Unit B214-B215**

C03	B216
C08	B218
C18	B220
C16	B222
C28	B224
C26	B226
C31	B228
C90	B230

Particulate Filter Numbering System

 = "Most Popular"

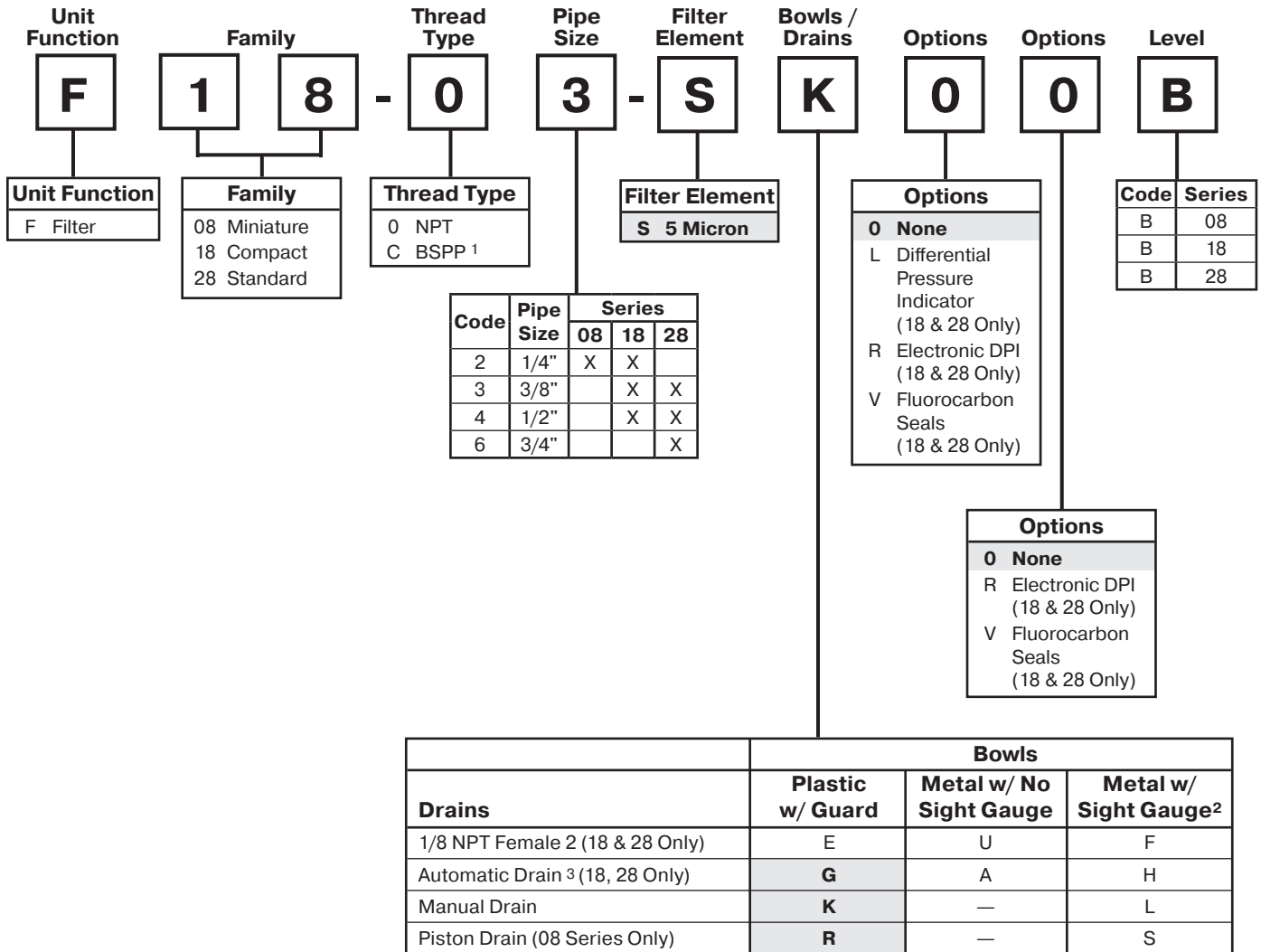

1 ISO, R228 (G Series)

2 F08 Filter has an all Metal Bowl (no sight gauge)

3 Operating range 15 to 250 PSIG (1 to 17 bar)

"F" Series Filters, Type "A" 5 micron elements: All Wilkerson Type "A" 5 micron elements **meet or exceed ISO Class 3** for maximum particle size and concentration of solid contaminants.

NOTE:All classes above refer to International Standards Organization (ISO) standard 8573-1, pertaining to maximum particle size and concentration of solid contaminants, and maximum oil content.

Note: When selecting from the options columns, please enter letters in alphabetical order for positions 7, 8, and 9. For example:

F 1 8 - 0 3 - S K 0 0 B

Particulate Filter Numbering System

 = "Most Popular"

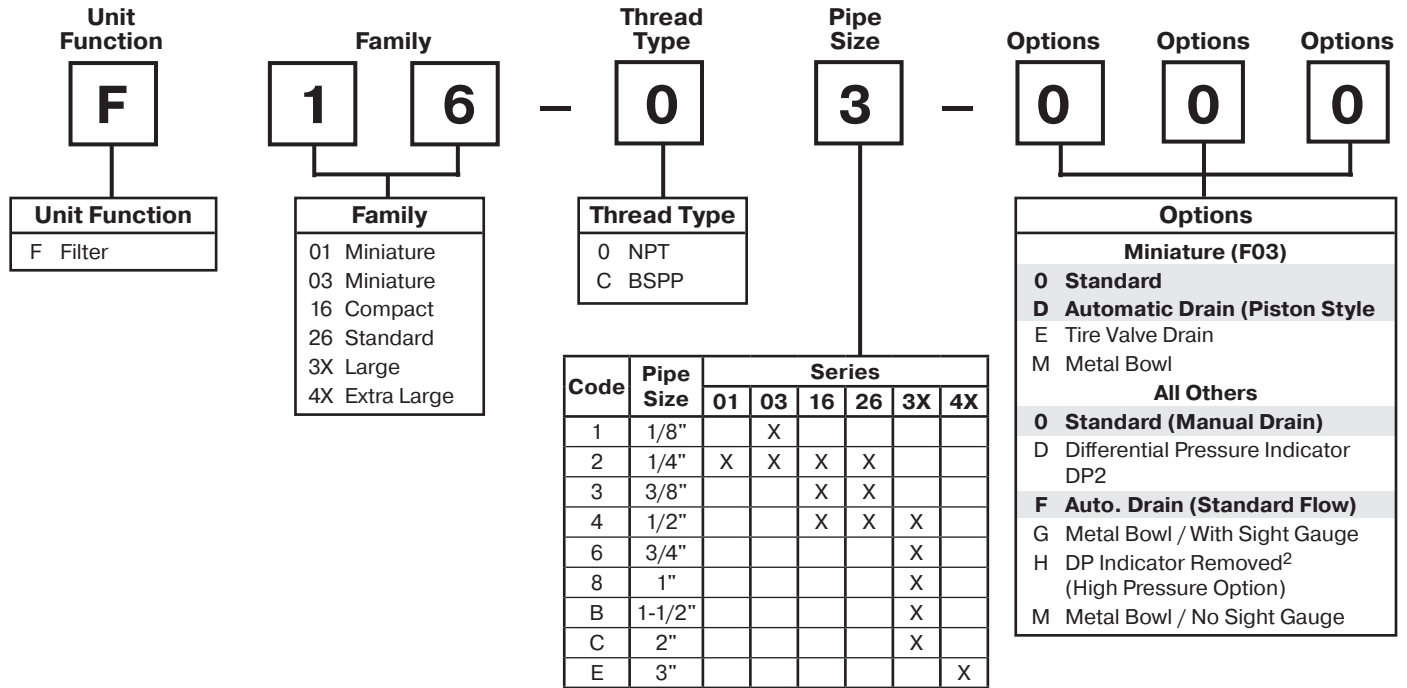

¹ Ports on some units are BSPP-G, others are BSPT-Rc. Consult specific model page for specifications.

² Models F35 & F43.

"F" Series Filters, Type "A" 5 micron elements: All Wilkerson Type "A" micron elements **meet or exceed ISO** Class 3 for maximum particle size and concentration of solid contaminants.

NOTE: All classes above refer to International Standards Organization (ISO) standard 8573-1, pertaining to maximum particle size and concentration of solid contaminants, and maximum oil content.

If more than one option is desired, arrange them in alphabetical order in positions 6, 7, and 8.

NOTE: 000 in position 6, 7, and 8 signifies standard product.

Particulate Filter F01

= "Most Popular"

Specifications

Flow Capacity*	17.0 SCFM (8 dm ³ /s)	
Maximum Supply Pressure	200 PSIG (13.8 bar)	
Operating Temperature	32° to 150°F (0° to 65.5°C)	
Port Size	NPT / BSPT-Rc	1/4
Standard Filtration	5 Micron	
Weight	.13 lb. (.06 kg)	

* Inlet pressure 150 PSIG (10.3 bar). Pressure drop 5 PSIG (0.3 bar).

"F" Series Filters, Type "A" 5 micron elements: All Wilkerson Type "A" 5 micron elements **meet or exceed ISO** Class 3 for maximum particle size and concentration of solid contaminants.

Materials of Construction

Baffle	Aluminum
Body	Aluminum
Filter Element	Sintered Polyethylene
Seals	Nitrile

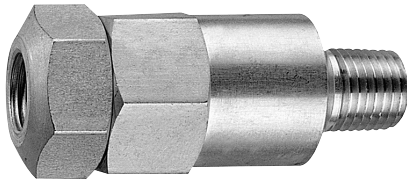
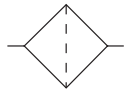

F01-02-000

In-Line Filter

This small, aluminum in-line filter is designed to provide protection for portable pneumatic hand tools. It weighs only 2 ounces with a throw-away filter element rated at 5 microns. Either port may be used as the inlet port. Flow is 17 SCFM (8 dm³/s) at 90 PSIG (6.2 bar) inlet pressure with 5 PSIG (0.3 bar) pressure drop.

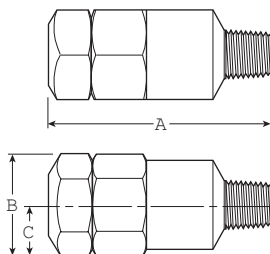

Dimensions

Models	Inches (mm)	A	B	C
Standard Unit F01-02-000		2.50 (63.5)	1.00 (25)	.51 (13)

= "Most Popular"

Replacement Element Kits

Type "A", 5 Micron..... FRP-95-199

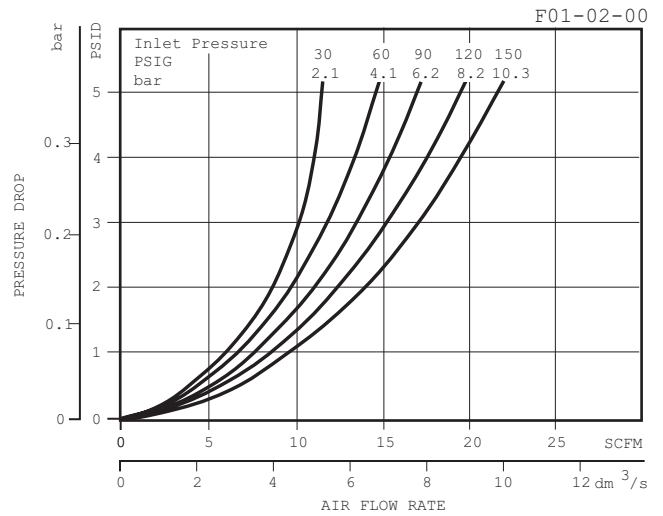

Ordering Information

Model Type	Port Size	Standard Unit
In-Line Filter	1/4	F01-02-000

Options - To order an option supplied with the unit model, add the appropriate coded suffix letter in the designated position of the model number.

Particulate Filter F03

= "Most Popular"

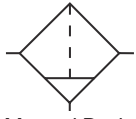

Manual Drain

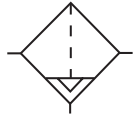

Auto Drain



F03-02-000

Features

- Excellent Water Removal Efficiency
- Unique Deflector Plate that Creates Swirling of the Air Stream Ensuring Maximum Water and Dirt Separation
- Easily Disassembled for Servicing Without the Use of Tools

Specifications

Flow Capacity*	1/8	22.0 SCFM (10 dm ³ /s)
	1/4	24.0 SCFM (11 dm ³ /s)
Maximum Supply Pressure	Polycarbonate Bowl	0 to 150 PSIG (0 to 10.3 bar)
	Metal Bowl	0 to 250 PSIG (0 to 17.2 bar)
	Piston Drain	10 to 250 PSIG (0.7 to 17.2 bar)
Operating Temperature	Polycarbonate Bowl	32°F to 125°F (0°C to 52°C)
	Metal Bowl	32°F to 175°F (0°C to 80°C)
	Piston Drain	32°F to 125°F (0°C to 52°C)
Port Size	NPT	1/8, 1/4
Standard Filtration	5 Micron	
Weight	.41 lb. (.18 kg)	

* Inlet pressure 90 PSIG (6.2 bar). Pressure drop 5 PSID (0.3 bar).

"F" Series Filters, Type "A" 5 micron elements: All Wilkerson Type "A" 5 micron elements **meet or exceed ISO** Class 3 for maximum particle size and concentration of solid contaminants.

Materials of Construction

Body	Zinc	
Bowls	Transparent	Polycarbonate
	Metal (Without Sight Gauge)	Zinc
Deflector, Element Holder & Baffle	Plastic	
Manual Drain	Body & Stem	Plastic
	Seals	Nitrile
Piston Drain	Piston & Seals	Nitrile
	Stem, Seat, Adaptor & Washers	Aluminum
Filter Elements	5 Micron	Plastic
Seals	Nitrile	

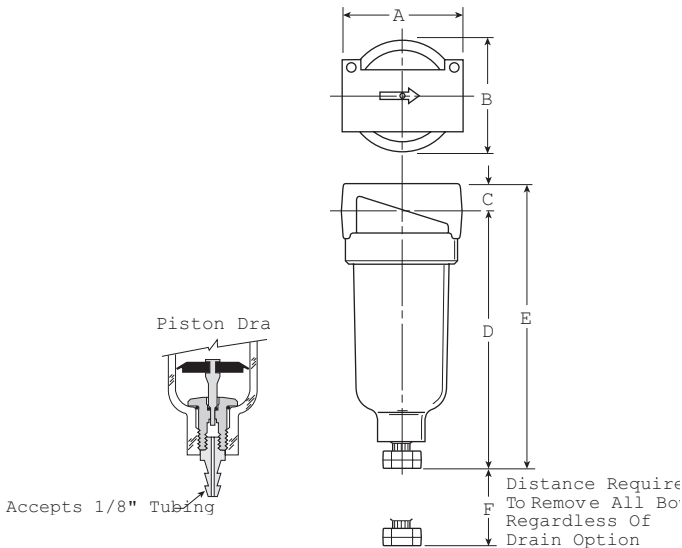

Dimensions

Models	Inches (mm)	A	B	C	D	E	F
Standard Unit F03-XX-000		1.69 (43)	1.53 (39)	.39 (10)	3.82 (97)	4.21 (107)	1.60 (41)
Piston Drain F03-XX-D00		1.69 (43)	1.53 (39)	.39 (10)	3.87 (99)	4.26 (108)	1.60 (41)

= "Most Popular"

Replacement Bowl Kits

- Metal Bowl –
 Manual DrainPS447B
 Piston DrainPS451B

- Plastic Bowl –
 Manual DrainPS404
 Piston DrainPS408B

Replacement Element Kits

- 5 MicronPS403

Accessories

- Filter Element Kit (Bulk Pack, Qty. 12) FRP-96-303
 Mounting Bracket Kit PS417B

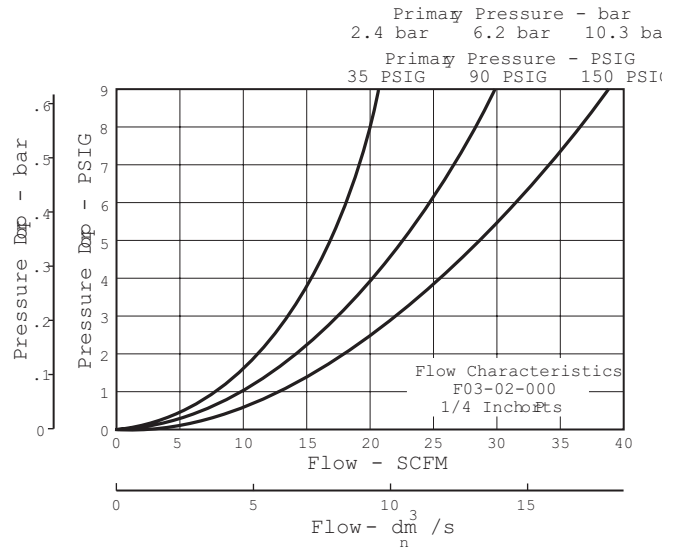
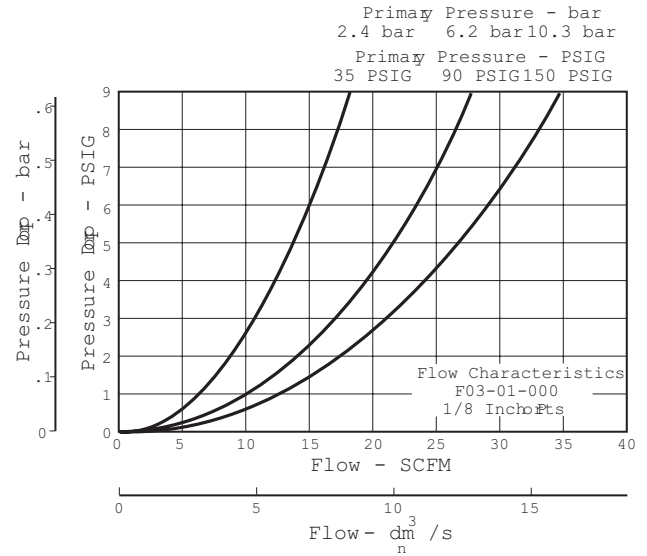

Ordering Information

Model Type	Port Size	Polycarbonate Bowl	Metal Bowl
Manual Drain	1/8	F03-01-000	F03-01-M00
	1/4	F03-02-000	F03-02-M00
Piston Drain	1/8	F03-01-D00	F03-01-DM0
	1/4	F03-02-D00	F03-02-DM0

Options - To order an option supplied with the unit model, add the appropriate coded suffix letter in the designated position of the model number.

Particulate Filter F08

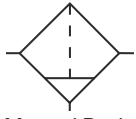

Manual Drain

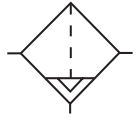

Auto Drain



Features

- Standard 5 Micron Filtration
- Quick-disconnect Bowl
- Bowl Guard
- High Flow Capacity

Specifications

Flow Capacity*	1/4	42 SCFM (20 dm ³ /s, ANR)
Maximum Supply Pressure	Plastic Bowl	150 PSIG (10.3 bar)
	Metal Bowl	250 PSIG (17.2 bar)
Operating Temperature	Plastic Bowl	14° to 125°F (-10° to 52°C)
	Metal Bowl	14° to 150°F (-10° to 65.5°C)
Port Size	NPT / BSPP-G	1/4
Bowl Capacity	0.6 oz	
Standard Filtration	5 Micron	
Weight	0.24 lb. (0.11 kg)	

* Inlet pressure 91.3 psig (6.3 bar). Pressure drop 4.9 psig (0.34 bar).

“F” Series Filters, Type “A” 5 micron elements: All Wilkerson Type “A” 5 micron elements **meet or exceed ISO** Class 3 for maximum particle size and concentration of solid contaminants.

Materials of Construction

Baffle	Acetal	
Body	Aluminum	
Body Cap	ABS	
Bowl	Plastic Bowl	Polycarbonate
	Metal Bowl	Aluminum
Bowl Guard	Nylon	
Element Retainer	Acetal	
Filter Element	Sintered Polyethylene	
Seals	Plastic Bowl	Nitrile
	Metal Bowl	Nitrile

Air quality:

Within ISO 8573-1: 1991 Class 3 (Particulates)
Within ISO 8573-1: 2001 Class 6 (Particulates)

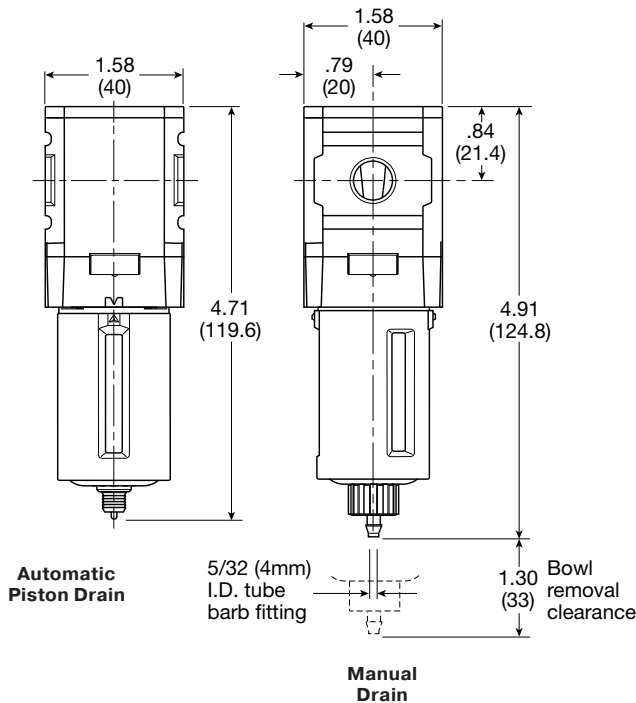

Inches (mm)

= "Most Popular"

Replacement Bowl Kits

- Metal Bowl, Manual Drain GRP-96-714
- Plastic Bowl / Bowl Guard, Manual Drain..... GRP-96-712

Replacement Element Kit and Bowl Seal

- Type "A", 5 Micron.....FRP-96-729

Accessories

- Automatic Piston Drain..... GRP-96-716
- Wall Mounting Bracket –
 - C-Type.....GPA-97-010
 - T-Type GPA-96-737

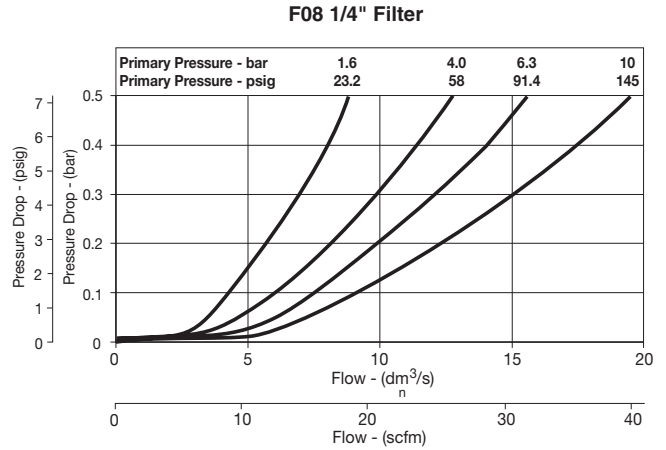

Ordering Information

Model Type	Port Size	Plastic Bowl / Bowl Guard	Metal Bowl (No Sight Gauge)
Manual Drain	1/4	F08-02-SK00B	F08-02-SL00B
Automatic Piston Drain	1/4	F08-02-SR00B	F08-02-SS00B

Options - To order an option supplied with the unit model, Add the appropriate coded suffix letter in the designated position of the model number.

Particulate Filter F18

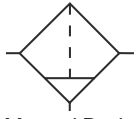

Manual Drain

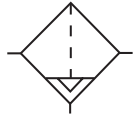

Auto Drain



Features

- Standard 5 Micron Filtration
- High Flow Capacities
- 1/2" NPT / BSPP-G Over-port
- Quick-disconnect Bowl
- Bowl Guard
- Light Weight
- Barbed Manual Drain Connection with Pipe-away

Specifications

Flow Capacity*	1/4	50 SCFM (24 dm ³ /s, ANR)
	3/8	78 SCFM (37 dm ³ /s, ANR)
	1/2	82 SCFM (39 dm ³ /s, ANR)
Maximum Supply Pressure	Plastic Bowl	150 PSIG (10.3 bar)
	Metal Bowl	250 PSIG (17.2 bar)
Operating Temperature	Plastic Bowl	-13° to 125°F (-25° to 52°C)
	Metal Bowl	-13° to 150°F (-25° to 65.5°C)
Port Size	NPT / BSPP-G	1/4, 3/8, 1/2
Bowl Capacity	1.72 oz	
Standard Filtration	5 Micron	
Weight	0.62 lb. (0.28 kg)	

* Inlet pressure 91.3 psig (6.3 bar). Pressure drop 4.9 psig (0.34 bar).

"F" Series Filters, Type "A" 5 micron elements: All Wilkerson Type "A" 5 micron elements **meet or exceed ISO** Class 3 for maximum particle size and concentration of solid contaminants.

Materials of Construction

Body	Aluminum	
Body Cap	ABS	
Bowls	Plastic Bowl	Polycarbonate
	Metal Bowl	Aluminum
Bowl Guard	Nylon	
Deflector	Polypropylene	
Element Retainer / Baffle	Acetal	
Filter Element	Sintered Polyethylene	
Seals	Plastic Bowl	Nitrile
	Metal Bowl	Nitrile
Sight Gauge	Metal Bowl	Polyamide (Nylon)

Air quality:

Within ISO 8573-1: 1991 Class 3 (Particulates)
Within ISO 8573-1: 2001 Class 6 (Particulates)

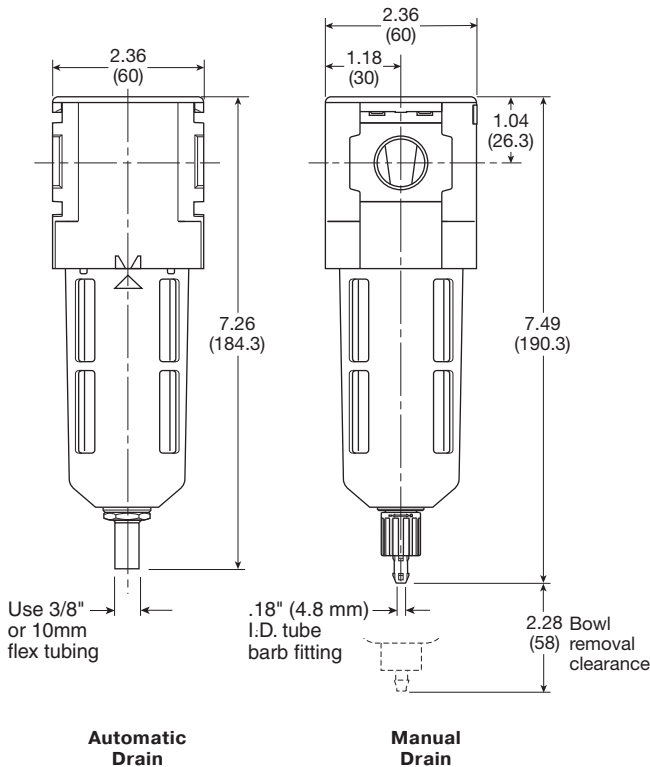

Inches (mm)

= "Most Popular"

Replacement Bowl Kits

- Metal Bowl with Sight Gauge,
Automatic Float Drain GRP-96-637
- Metal Bowl with Sight Gauge, Manual Drain GRP-96-636
- Plastic Bowl –
Bowl Guard, Auto Drain GRP-96-635
- Bowl Guard, Manual Drain GRP-96-634

Replacement Element Kits and Bowl Seal

- Type "A", 5 Micron Element..... FRP-96-639
- Type "A", 5 Micron with Retainer, Deflector,
and Bowl O-ringFRP-96-641

Accessories

- Automatic Drain –
Fluorocarbon GRP-95-981
- Nitrile GRP-95-973
- Manual Drain..... GRP-96-685
- Sight Gauge Kit GRP-96-825
- Wall Mounting Bracket –
L-Type..... GPA-96-604
- T-Type GPA-96-602

F18 1/4" Filter

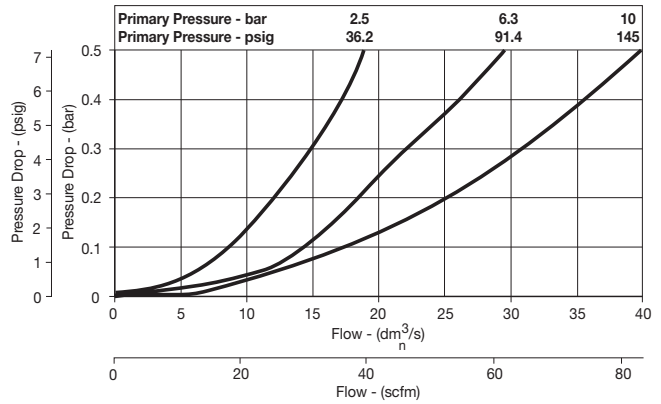

F18 3/8" Filter

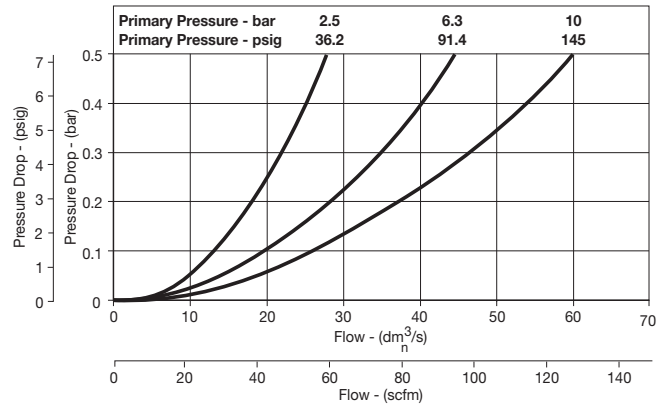

F18 1/2" Filter

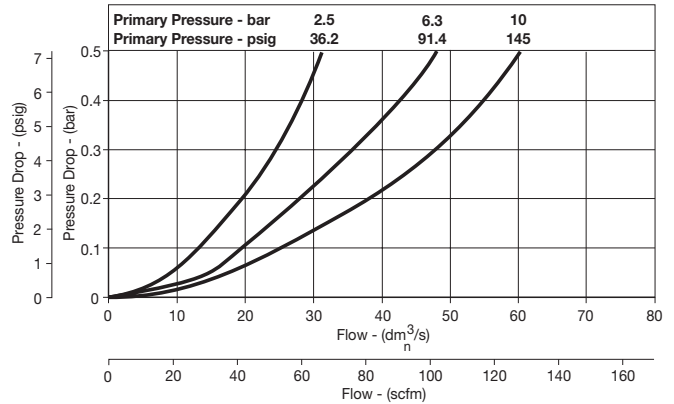

Ordering Information

Model Type	Port Size	Plastic Bowl / Bowl Guard	Metal Bowl / Sight Gauge
Manual Drain	1/4	F18-02-SK00B	F18-02-SL00B
	3/8	F18-03-SK00B	F18-03-SL00B
	1/2	F18-04-SK00B	F18-04-SL00B
Automatic Drain	1/4	F18-02-SG00B	F18-02-SH00B
	3/8	F18-03-SG00B	F18-03-SH00B
	1/2	F18-04-SG00B	F18-04-SH00B

Options - To order an option supplied with the unit model, add the appropriate coded suffix letter in the designated position of the model number.

Particulate Filter F16

= "Most Popular"

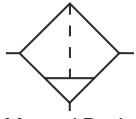

Manual Drain

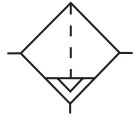

Auto Drain



F16-02-000

Features

- Manual Drain
- 5 Micron Rated Element
- Quick-disconnect Bowl Guard with Integral Plastic Bowl and Safety Latch

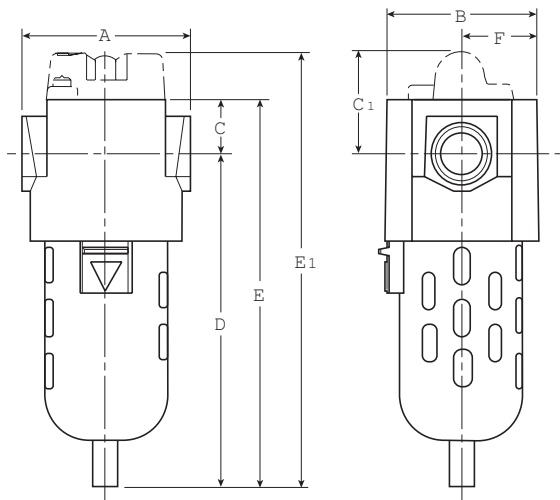

Dimensions

Models	Inches (mm)	A	B	C	C ₁	D	E	E ₁	F
Standard Unit F16-XX-000		3.00 (76)	2.60 (66)	1.00 (25.4)	—	5.50 (139.7)	6.50 (165)	—	1.30 (33)
Differential Pressure Indicator F16-XX-D00		3.00 (76)	2.60 (66)	1.00 (25.4)	1.83 (46.5)	5.50 (139.7)	6.50 (165)	7.33 (186)	1.30 (33)
Automatic Drain F16-XX-F00		3.00 (76)	2.60 (66)	1.00 (25.4)	—	5.50 (139.7)	6.64 (168.7)	—	1.30 (33)
Metal Bowl / Metal Bowl with Sight Gauge F16-XX-G00		3.00 (76)	2.60 (66)	1.00 (25.4)	—	5.50 (139.7)	7.09 (180)	—	1.30 (33)

Specifications

Flow Capacity*	1/4	63.0 SCFM (29.7 dm ³ /s)
	3/8	74.1 SCFM (34.9 dm ³ /s)
	1/2	80.4 SCFM (37.9 dm ³ /s)
Maximum Supply Pressure	Plastic Bowl	150 PSIG (10.3 bar)
	Metal Bowl	200 PSIG (13.8 bar)
Operating Temperature	Plastic Bowl	32° to 125°F (0° to 52°C)
	Metal Bowl	32° to 150°F (0° to 65.5°C)
Port Size	NPT / BSPP-G	1/4, 3/8, 1/2
Bowl Capacity	2.7 oz	
Standard Filtration	5 Micron	
Weight	1.8 lb. (0.8 kg)	

* Inlet pressure 150 PSIG (10.3 bar). Pressure drop 5 PSID (0.3 bar).

"F" Series Filters, Type "A" 5 micron elements: All Wilkerson Type "A" 5 micron elements **meet or exceed ISO** Class 3 for maximum particle size and concentration of solid contaminants.

Materials of Construction

Baffle	Polypropylene	
Body	Zinc	
Bowls	Plastic Bowl	Polycarbonate
	Metal Bowl	Zinc
Deflector	Polypropylene	
Element Retainer	Acetal	
Filter Element	Polyethylene	
Seals	Plastic Bowl	Nitrile
	Metal Bowl	Fluorocarbon
Sight Gauge	Metal Bowl	Polycarbonate

= "Most Popular"

Replacement Bowl Kits

- Metal Bowl –
 Automatic Drain FRP-95-950
 Manual Drain FRP-95-178
 Sight Gauge, Manual Drain GRP-95-133
- Plastic Bowl –
 Bowl Guard, Automatic Drain FRP-95-015
 Bowl Guard, Manual Drain FRP-95-014
 Manual Drain FRP-95-017

Replacement Element Kits

- Type "A", 5 Micron..... FRP-95-160

Accessories

- Automatic Drain, Nitrile GRP-95-973
 L-Bracket GPA-95-016
 Manual Drain..... FRP-95-610
 Sight Gauge Kit GRP-95-079

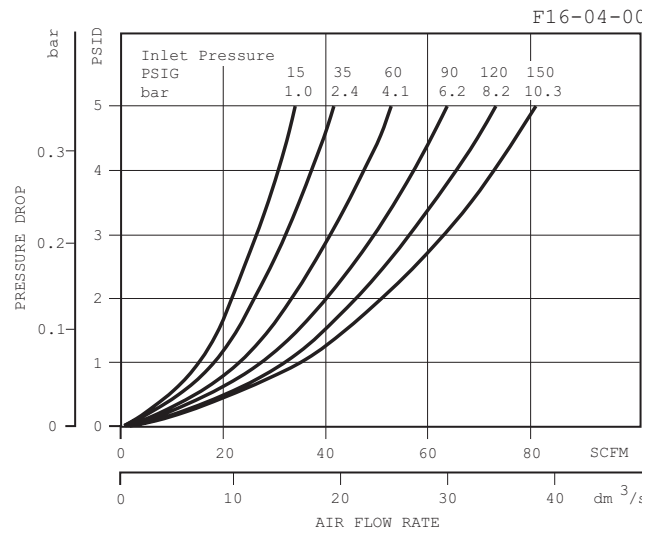
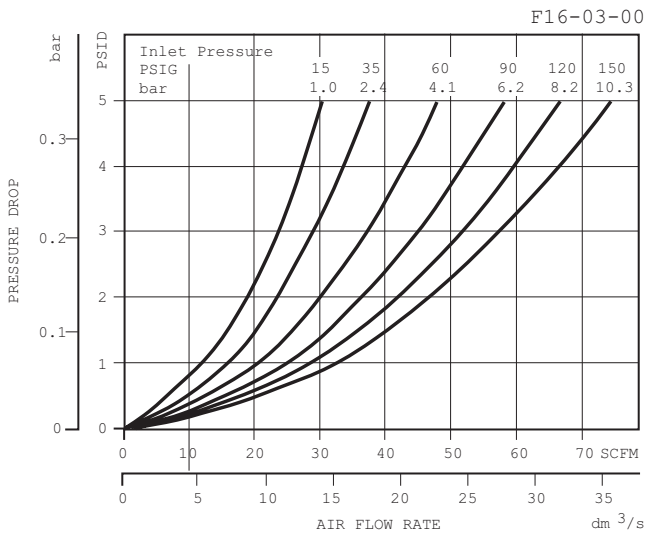
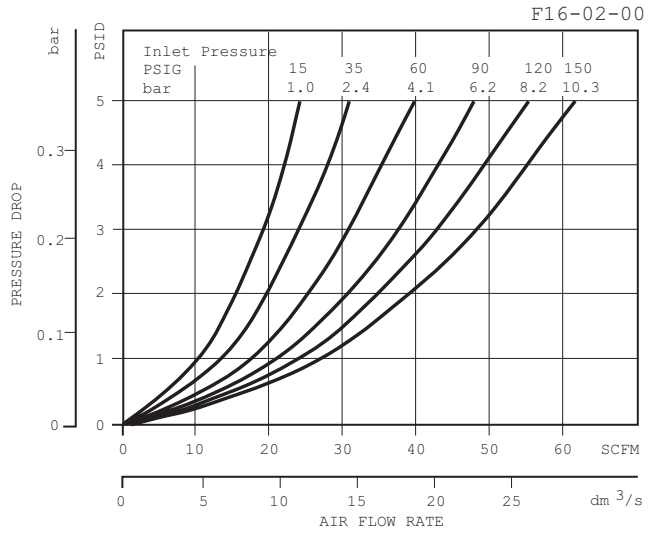

Ordering Information

Model Type	Port Size	Polycarbonate Bowl / Bowl Guard	Metal Bowl	Metal Bowl / Sight Gauge	Polycarbonate Bowl / Bowl Guard / Differential Pressure Indicator
Manual Drain	1/4	F16-02-000	F16-02-M00	F16-02-G00	F16-02-D00
	3/8	F16-03-000	F16-03-M00	F16-03-G00	F16-03-D00
	1/2	F16-04-000	F16-04-M00	F16-04-G00	F16-04-D00
Automatic Drain	1/4	F16-02-F00	F16-02-FM0	F16-02-FG0	F16-02-DF0
	3/8	F16-03-F00	F16-03-FM0	F16-03-FG0	F16-03-DF0
	1/2	F16-04-F00	F16-04-FM0	F16-04-FG0	F16-04-DF0

Options - To order an option supplied with the unit model, add the appropriate coded suffix letter in the designated position of the model number.

Particulate Filter F28

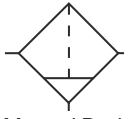

Manual Drain

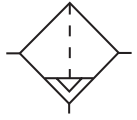

Auto Drain



Features

- Standard 5 Micron Filtration
- High Flow Capacities
- 3/4" NPT / BSPP-G Over-port
- Quick-disconnect Bowl
- Bowl Guard
- Light Weight
- Barbed Manual Drain Connection with Pipe-away

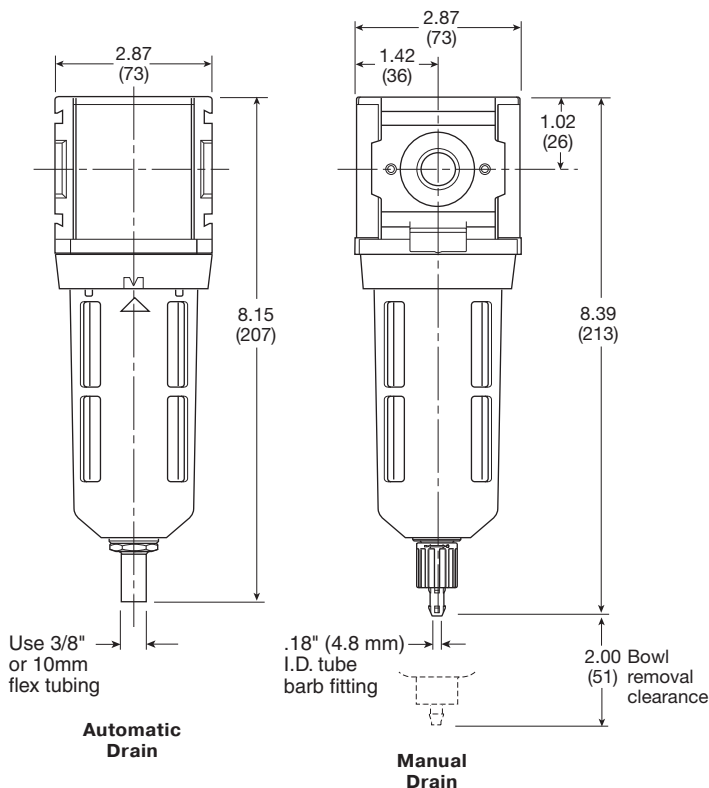

Inches (mm)

Specifications

Flow Capacity*	3/8	115 SCFM (54 dm ³ /s, ANR)
	1/2	120 SCFM (57 dm ³ /s, ANR)
	3/4	145 SCFM (68 dm ³ /s, ANR)
Maximum Supply Pressure	Plastic Bowl	150 PSIG (10.3 bar)
	Metal Bowl	250 PSIG (17.2 bar)
Operating Temperature	Plastic Bowl	-13° to 125°F (-25° to 52°C)
	Metal Bowl	-13° to 150°F (-25° to 65.5°C)
Port Size	NPT / BSPP-G	3/8, 1/2, 3/4
Bowl Capacity	2.87 oz	
Standard Filtration	5 Micron	
Weight	1.01 lb. (0.46 kg)	

* Inlet pressure 91.3 PSIG (6.3 bar). Pressure drop 4.9 PSID (.34 bar).

"F" Series Filters, Type "A" 5 micron elements: All Wilkerson Type "A" 5 micron elements **meet or exceed ISO** Class 3 for maximum particle size and concentration of solid contaminants.

Materials of Construction

Body	Aluminum	
Body Cap	ABS	
Bowls	Plastic Bowl	Polycarbonate
	Metal Bowl	Aluminum
Bowl Guard	Nylon	
Deflector	Polypropylene	
Element Retainer / Baffle	Acetal	
Filter Element	Sintered Polyethylene	
Seals	Plastic Bowl	Nitrile
	Metal Bowl	Nitrile
Sight Gauge	Metal Bowl	Polyamide (Nylon)

Air quality:

Within ISO 8573-1: 1991 Class 3 (Particulates)

Within ISO 8573-1: 2001 Class 6 (Particulates)

= "Most Popular"

Replacement Bowl Kits

- Metal Bowl with Sight Gauge,
Automatic Float Drain GRP-96-645
- Metal Bowl with Sight Gauge, Manual Drain GRP-96-644
- Plastic Bowl –
Bowl Guard, Auto Drain GRP-96-643
- Bowl Guard, Manual Drain GRP-96-642

Replacement Element Kits and Bowl Seal

- Type "A", 5 Micron with Element..... FRP-96-653
- Type "A", 5 Micron with Retainer, Deflector,
and Bowl O-ring FRP-96-283

Accessories

- Automatic Drain –
Fluorocarbon GRP-95-981
- Nitrile GRP-95-973
- Manual Drain GRP-96-685
- Sight Gauge Kit GRP-96-825
- Wall Mounting Bracket –
L-Type GPA-96-605
- T-Type GPA-96-602

F28 3/8" Filter

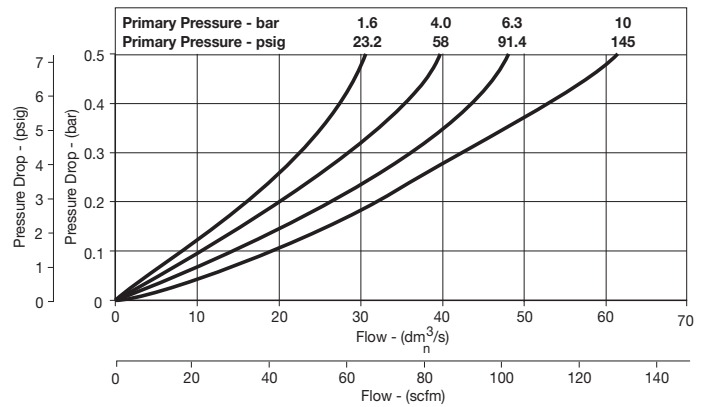

F28 1/2" Filter

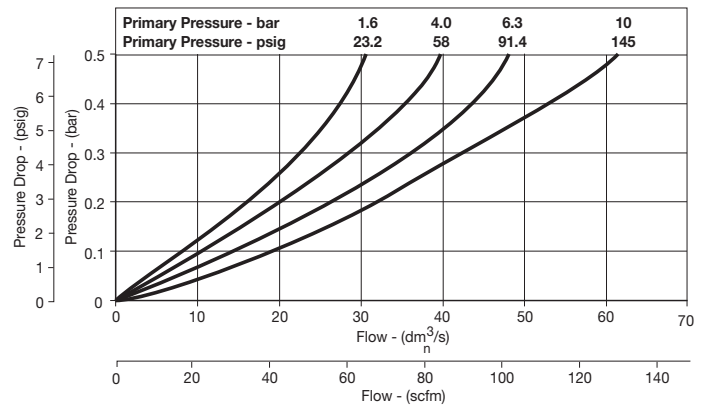

F28 3/4" Filter

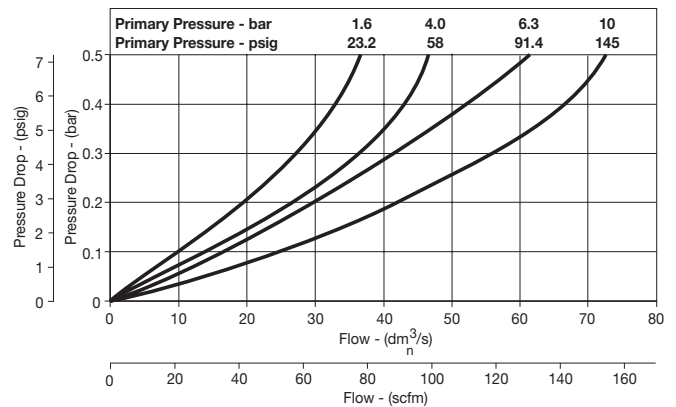

Ordering Information

Model Type	Port Size	Plastic Bowl / Bowl Guard	Metal Bowl / Sight Gauge
Manual Drain	3/8	F28-03-SK00B	F28-03-SL00B
	1/2	F28-04-SK00B	F28-04-SL00B
	3/4	F28-06-SK00B	F28-06-SL00B
Automatic Drain	3/8	F28-03-SG00B	F28-03-SH00B
	1/2	F28-04-SG00B	F28-04-SH00B
	3/4	F28-06-SG00B	F28-06-SH00B

Options - To order an option supplied with the unit model, add the appropriate coded suffix letter in the designated position of the model number.

Particulate Filter F26

= "Most Popular"

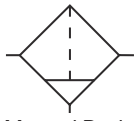

Manual Drain

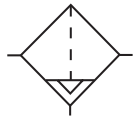

Auto Drain



F26-02-000

Features

- Manual Drain
- 5 Micron Rated Element
- Quick-disconnect Bowl Guard with Integral Plastic Bowl and Safety Latch

Specifications

Flow Capacity*	1/4	81.3 SCFM (28.3 dm ³ /s)
	3/8	117.8 SCFM (55.5 dm ³ /s)
	1/2	149.8 SCFM (70.6 dm ³ /s)
Maximum Supply Pressure	Plastic Bowl	150 PSIG (10,3 bar)
	Metal Bowl	200 PSIG (13,8 bar)
Operating Temperature	Plastic Bowl	32° to 125°F (0° to 52°C)
	Metal Bowl	32° to 150°F (0° to 65.5°C)
Port Size	NPT / BSPP-G	1/4, 3/8, 1/2
Bowl Capacity	3.2 oz	
Standard Filtration	5 Micron	
Weight	2.9 lb. (1.3 kg)	

* Inlet pressure 150 PSIG (10.3 bar). Pressure drop 5 PSID (0.3 bar).

"F" Series Filters, Type "A" 5 micron elements: All Wilkerson Type "A" 5 micron elements **meet or exceed ISO Class 3** for maximum particle size and concentration of solid contaminants.

Materials of Construction

Baffle	Acetal	
Body	Zinc	
Bowls	Plastic Bowl	Polycarbonate
	Metal Bowl	Zinc
Deflector	Polypropylene	
Element Retainer	Acetal	
Filter Element	Polyethylene	
Seals	Plastic Bowl	Nitrile
	Metal Bowl	Fluorocarbon
Sight Gauge	Metal Bowl	Polycarbonate

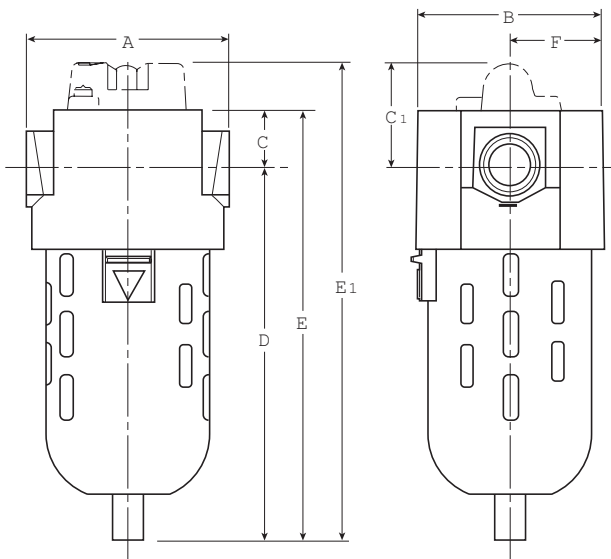

Dimensions

Models	Inches (mm)	A	B	C	C ₁	D	E	E ₁	F
Standard Unit F26-XX-000		3.30 (84)	3.00 (76)	1.00 (25.4)	—	6.40 (162.6)	7.40 (188)	—	1.50 (38)
Differential Pressure Indicator F26-XX-D00		3.30 (84)	3.00 (76)	1.00 (25.4)	1.83 (46.5)	6.40 (162.6)	7.40 (188)	8.23 (209)	1.50 (38)
Automatic Drain F26-XX-F00		3.30 (84)	3.00 (76)	1.00 (25.4)	—	6.40 (162.6)	7.54 (191.5)	—	1.50 (38)
Metal Bowl / Metal Bowl with Sight Gauge F26-XX-G00		3.30 (84)	3.00 (76)	1.00 (25.4)	—	6.40 (162.6)	7.30 (185)	—	1.50 (38)

= "Most Popular"

Replacement Bowl Kits

- Metal Bowl –
 Automatic Drain GRP-95-960
 Manual Drain GRP-95-930
 Sight Gauge, Manual Drain GRP-95-931
- Plastic Bowl –
 Automatic Drain GRP-95-948
 Bowl Guard, Manual Drain GRP-95-935
 Manual Drain GRP-95-929

Replacement Element Kits

- Type "A", 5 Micron..... FRP-95-115

Accessories

- Automatic Drain, Nitrile GRP-95-973
 Manual Drain..... FRP-95-610
 Sight Gauge Kit GRP-95-079
 L-Bracket GPA-95-946

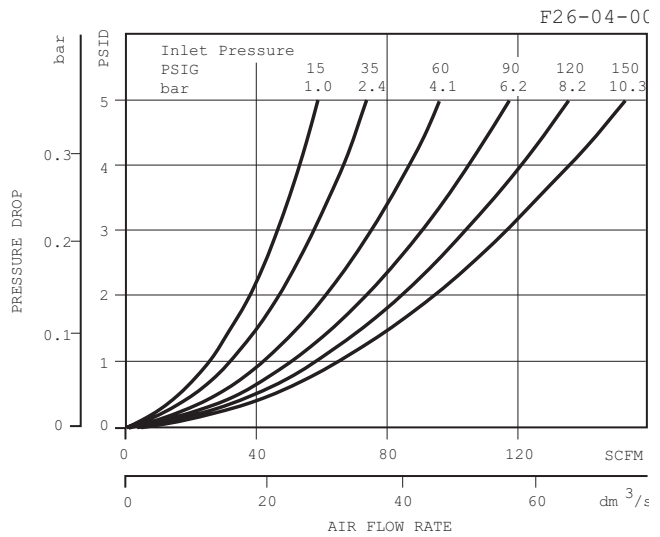
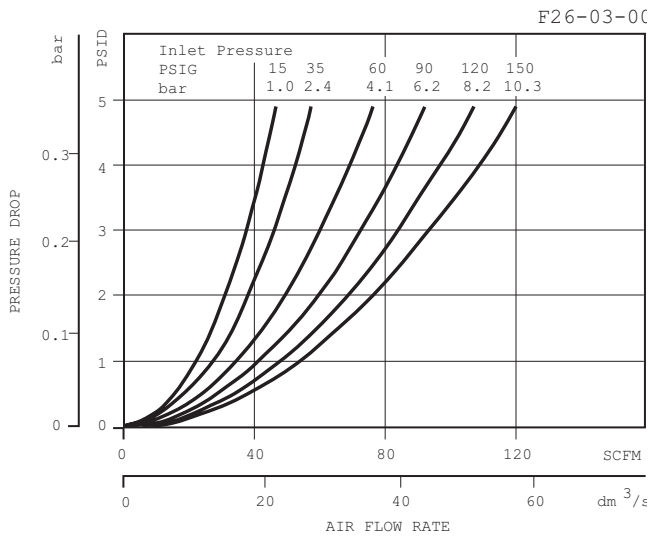
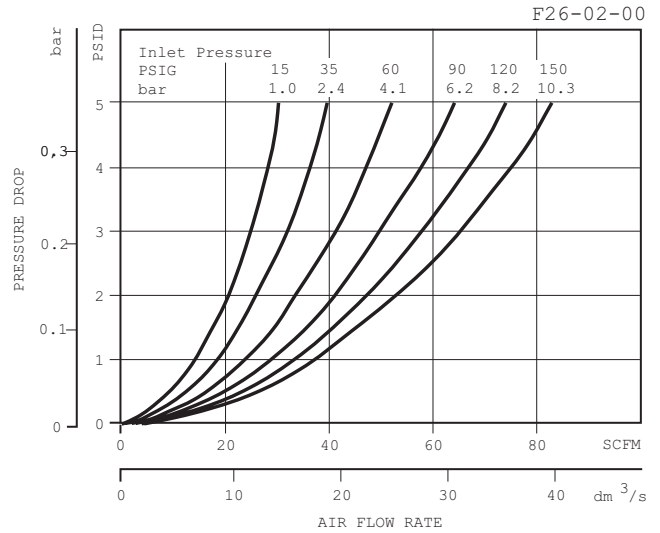

Ordering Information

Model Type	Port Size	Polycarbonate Bowl / Bowl Guard	Metal Bowl	Metal Bowl / Sight Gauge	Polycarbonate Bowl / Bowl Guard / Differential Pressure Indicator
Manual Drain	1/4	F26-02-000	F26-02-M00	F26-02-G00	F26-02-D00
	3/8	F26-03-000	F26-03-M00	F26-03-G00	F26-03-D00
	1/2	F26-04-000	F26-04-M00	F26-04-G00	F26-04-D00
Automatic Drain	1/4	F26-02-F00	F26-02-FM0	F26-02-FG0	F26-02-DF0
	3/8	F26-03-F00	F26-03-FM0	F26-03-FG0	F26-03-DF0
	1/2	F26-04-F00	F26-04-FM0	F26-04-FG0	F26-04-DF0

Options - To order an option supplied with the unit model, add the appropriate coded suffix letter in the designated position of the model number.

Particulate Filter F90

 = "Most Popular"



Symbols

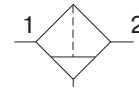

Manual drain

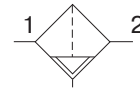

Auto drain

- Integral 3/4" or 1" ports (NPT & BSPP)
- High efficiency particulate element as standard
- Excellent water removal efficiency
- Robust but lightweight aluminum construction
- Low temperature -40° with combined manual / semi-auto drain as standard

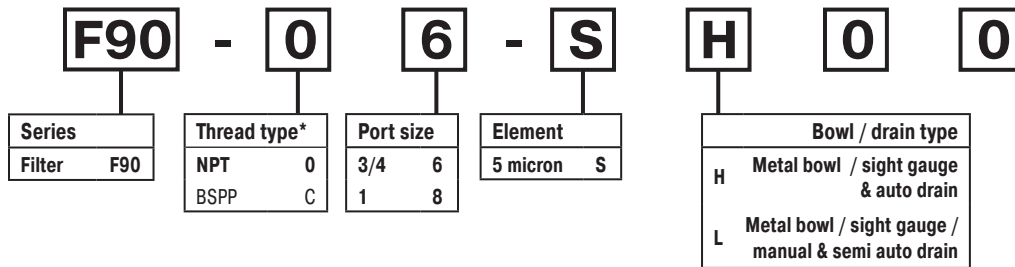

*Note: For 1-1/2" ported unit, please order P3YKA*BCP port block kit separately.
Bold items are most common.

Ordering Information

Port size	Description	Flow [†] scfm	Max. bar (psig)	Min temp °C (°F)	Max temp °C (°F)	Bowl capacity cm ³ (oz)	Height mm (inches)	Width mm (inches)	Depth mm (inches)	Weight kg (lb)	Part number [†]
3/4"	Combined manual / semi auto drain	170	17.5 (254)	-40 (-40)	60 (140)	130 (4.4)	244 (9.6)	90 (3.5)	94 (3.7)	0.9 (1.98)	F90-06-SL00
3/4"	Auto drain	170	17.5 (254)	-10 (14)	60 (140)	130 (4.4)	244 (9.6)	90 (3.5)	94 (3.7)	0.9 (1.98)	F90-06-SH00
1"	Combined manual / semi auto drain	170	17.5 (254)	-40 (-40)	60 (140)	130 (4.4)	244 (9.6)	90 (3.5)	94 (3.7)	0.9 (1.98)	F90-08-SL00
1"	Auto drain	170	17.5 (254)	-10 (14)	60 (140)	130 (4.4)	244 (9.6)	90 (3.5)	94 (3.7)	0.9 (1.98)	F90-08-SH00

[†] Standard part numbers shown in bold. For other models refer to Options chart above.

[‡] Flow with 6.3 bar (91.4 psig) inlet pressure and 0.5 (7.3 psig) pressure drop.

Specifications

Fluid	Compressed air	
Maximum inlet pressure*	17.5 bar (254 psig)	
Temperature range*:		
Auto drain	-10°C to 60°C (14°F to 140°F)	
Combined drain	-40°C to 60°C (-40°F to 140°F)	
Particle removal	5 micron	
Air quality	Within ISO 8573-1: 1991 Class 3 and 5 (particulates) Within ISO 8573-1: 2001 Class 6 and 7 (particulates)	
Typical flow 5 micron element	1" port	170 scfm
6.3 bar (91.4 psig) inlet pressure and		
0.5 bar (7.3 psig) pressure drop		
Manual / semi-auto drain	Closed at 0.8 bar (11.6 psig)	G1/8 thread male
Auto drain bowl pressure to close drain	0.8 bar (11.6 psig)	
Operating range	0.8 bar (11.6 psig) to	
manual override facility	17.5 bar (254 psig)	
Bowl capacity	130 cm ³ (4.4 US oz)	

* Air supply must be dry enough to avoid ice formation at temperatures below 2°C (35.6°F).

Dimensions mm (inches)

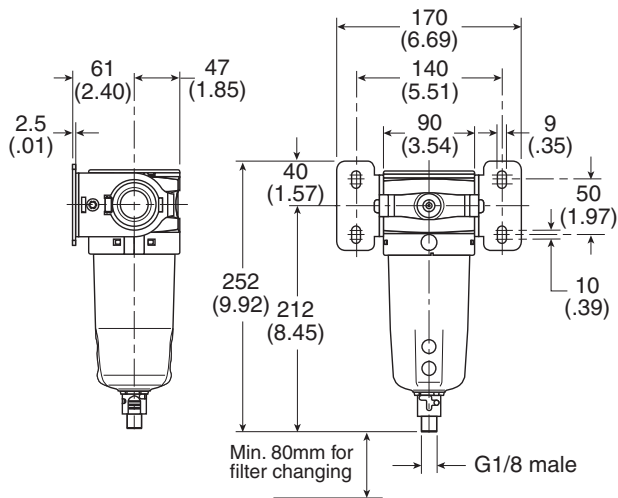

Service kits

- 5 micron element kit P3YKA00ESE
- 40 micron element kit P3YKA00ESG
- Bowl kit with combined manual / semi auto drain..... P3YKA00BSC
- Bowl kit with auto drain P3YKA00BSA

Material specifications

Body	Aluminum	
Sight glass	Polypropylene	
Body cover	ABS	
Element	Sintered P.E.	
Seals	Nitrile NBR	
Drains	Manual / semi-auto:	Acetal
	Automatic:	PA / Ø 10mm brass connection

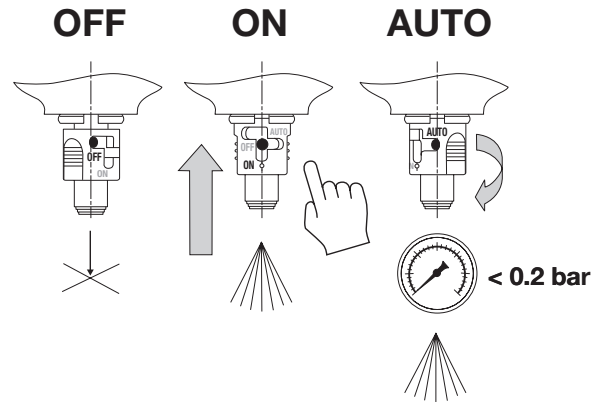

Flow characteristics

(3/4") Filter

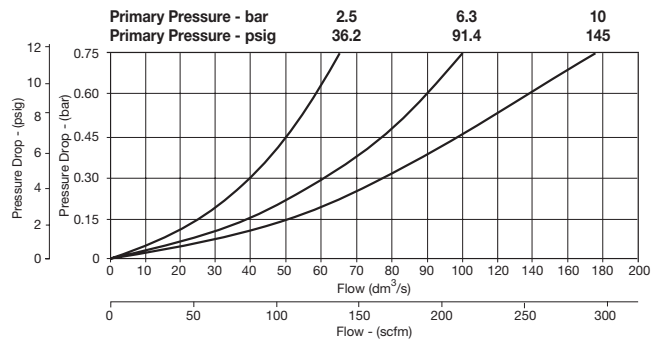

(1") Filter

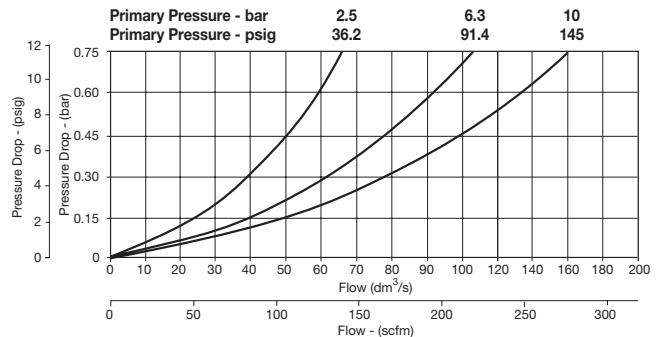

Particulate Filter F30

= "Most Popular"

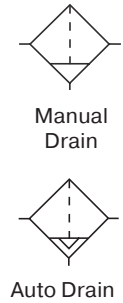

F30-06-000

Features

- Standard Manual Drain
- Standard 5 Micron Rated Element
- Quick-disconnect Clamp Ring for Easy Bowl Removal
- Bowl Guard

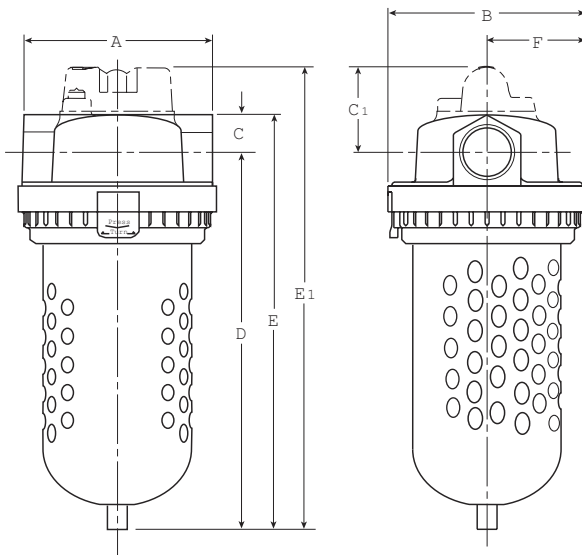

Dimensions

Models	Inches (mm)	A	B	C	C ₁	D	E	E ₁	F
Standard Unit F30-XX-000		4.63 (118)	4.79 (122)	.94 (24)	—	8.96 (228)	9.90 (251)	—	2.40 (61)
Differential Pressure Indicator F30-XX-D00		4.63 (118)	4.79 (122)	.94 (24)	1.89 (48)	8.96 (228)	9.90 (251)	10.73 (272.5)	2.40 (61)
Automatic Drain F30-XX-F00		4.63 (118)	4.79 (122)	.94 (24)	—	8.96 (228)	10.04 (255)	—	2.40 (61)
Metal Bowl F30-XX-M00		4.63 (118)	4.79 (122)	.94 (24)	—	8.96 (228)	10.00 (254)	—	2.40 (61)
Metal Bowl with Sight Gauge F30-XX-G00		4.63 (118)	4.79 (122)	.94 (24)	—	8.96 (228)	9.90 (251)	—	2.40 (61)

Specifications

Flow Capacity*	3/4 1	316 SCFM (149.1 dm ³ /s) 323 SCFM (152.4 dm ³ /s)
Maximum Supply Pressure	Plastic Bowl Metal Bowl	150 PSIG (10.3 bar) 200 PSIG (13.8 bar)
Operating Temperature	Plastic Bowl Metal Bowl	32° to 125°F (0° to 52°C) 32° to 150°F (0° to 65.5°C)
Port Size	NPT / BSPP-G	3/4, 1
Bowl Capacity	2.0 oz	
Standard Filtration	5 Micron	
Weight	5.5 lb. (2.5 kg)	

* Inlet pressure 150 PSIG (10.3 bar). Pressure drop 5 PSID (0.3 bar).

"F" Series Filters, Type "A" 5 micron elements: All Wilkerson Type "A" 5 micron elements **meet or exceed ISO Class 3** for maximum particle size and concentration of solid contaminants.

Materials of Construction

Baffle	Acetal	
Body	Zinc	
Bowls	Plastic Bowl Metal Bowl	Polycarbonate Zinc
Deflector	Aluminum	
Element Retainer	Steel Stud	
Filter Element	Polyethylene	
Seals	Plastic Bowl Metal Bowl	Nitrile Fluorocarbon
Sight Gauge	Metal Bowl	Tempered Glass

= "Most Popular"

Replacement Bowl Kits

- Metal Bowl –**
 Automatic Drain GRP-95-970
 Sight Gauge, Manual Drain GRP-95-676
 Manual Drain FRP-95-593
- Plastic Bowl –**
 Bowl Guard, Automatic Drain FRP-95-775
 Bowl Guard, Manual Drain FRP-95-832
 Manual Drain FRP-96-315

Replacement Element Kits

- Type "A", 5 Micron.....FRP-95-209

Accessories

- Automatic Drain, Nitrile GRP-95-973
 Manual Drain.....FRP-95-610
 Sight Gauge Kit FRP-95-771

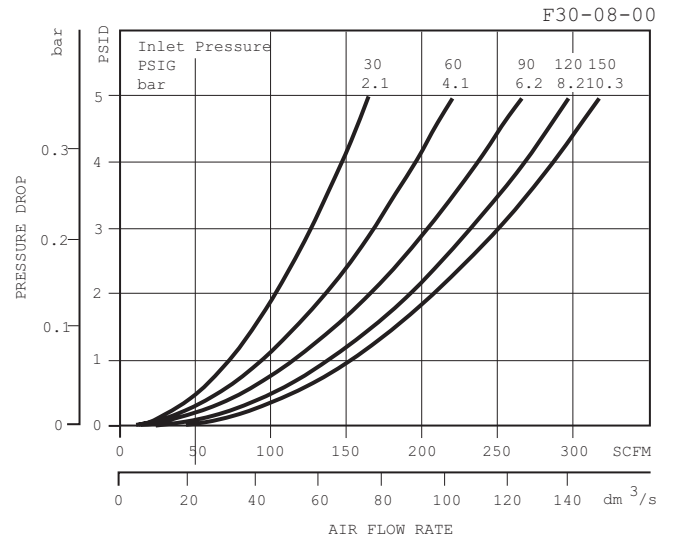
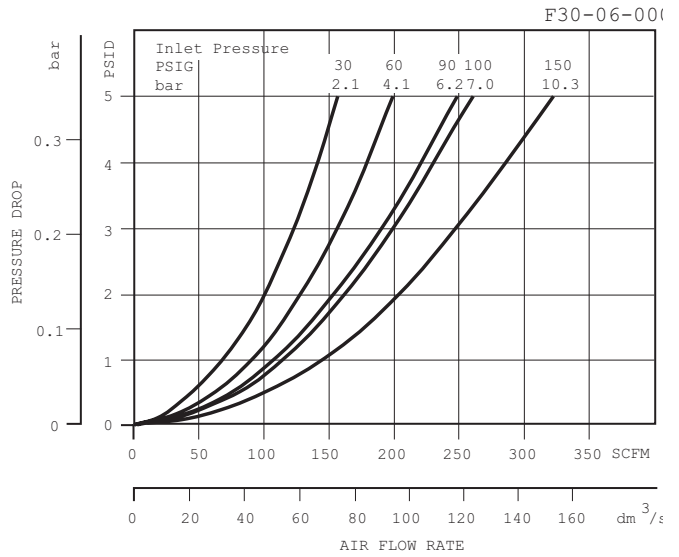

Ordering Information

Model Type	Port Size	Polycarbonate Bowl / Bowl Guard	Metal Bowl	Metal Bowl / Sight Gauge	Polycarbonate Bowl / Bowl Guard / Differential Pressure Indicator
Manual Drain	3/4	F30-06-000	F30-06-M00	F30-06-G00	F30-06-D00
	1	F30-08-000	F30-08-M00	F30-08-G00	F30-08-D00
Automatic Drain	3/4	F30-06-F00	F30-06-FM0	F30-06-FG0	F30-06-DF0
	1	F30-08-F00	F30-08-FM0	F30-08-FG0	F30-08-DF0

Options - To order an option supplied with the unit model, add the appropriate coded suffix letter in the designated position of the model number.

Particulate Filter F35

= "Most Popular"

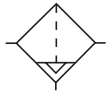

Auto Drain



F35-0B-000

Features

- Heavy-duty Cast Aluminum Housings to Withstand Operating Pressures Up to 250 PSIG*
- Differential Pressure Indicator to Eliminate the Guesswork of Element Replacement
- Differential pressure gauge available, order separately, Kit DP3-01-000
- Unique Drain Mounting Plate Design Offers a Trouble-free Method for Interchanging and Installing External Drains

Specifications

Flow Capacity*	1-1/2 2	1280 SCFM (604 dm ³ /s) 1400 SCFM (660 dm ³ /s)
Maximum Supply Pressure	without DPI and with Pressure Gauge with DPI	250 PSIG (17.2 bar)† 150 PSIG (10.3 bar)
Operating Temperature	32° to 150°F (0° to 65.5°C)	
Port Size	NPT / BSPP-G	1-1/4, 1-1/2, 2
Bowl Capacity	12.5 oz	
Standard Filtration	5 Micron	
Weight	19.3 lb. (8.7 kg)	

* Inlet pressure 150 PSIG (10.3 bar). Pressure drop of 5 PSID (0.3 bar).

** Without pressure indicator – Max. supply pressure is 250 PSIG (17.2 bar).

"F" Series Filters, Type "A" 5 micron elements: All Wilkerson Type "A" 5 micron elements **meet or exceed ISO Class 3** for maximum particle size and concentration of solid contaminants.

Materials of Construction

Baffle	Plated Steel
Body	Aluminum
Bowls	Aluminum
Deflector	Plated Steel
Element Retainer	Plated Steel
Filter Element	Polyethylene
Seals	Fluorocarbon
Stud	Plated Steel

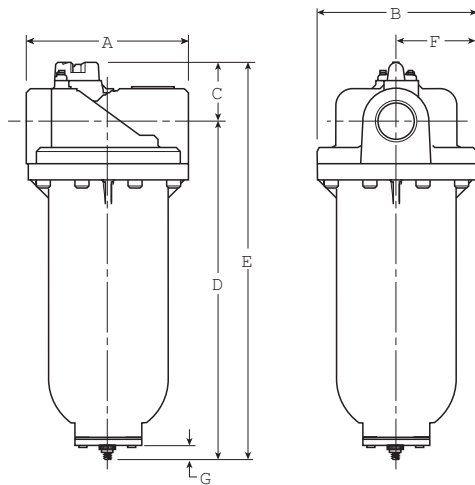

NOTE: Automatic internal float drain shown is included on F35 filters with F00 suffix only. Models with 000 suffix include drain plate with tapped 1/2 NPT / BSPP-G drain port.

Dimensions

Models	Inches (mm)	A	B	C	D	E	F	G
Standard Unit F35-XX-000		7.80 (198)	7.75 (197)	2.81 (71)	16.24 (412.5)	19.07 (484)	3.88 (98.6)	.55 (14)
Automatic Drain F35-XX-F00		7.80 (198)	7.75 (197)	2.81 (71)	15.69 (398.5)	18.52 (470)	3.88 (98.6)	.55 (14)

= "Most Popular"

Replacement Element Kit

Element, F35, 5 Micron, Fluorocarbon O-rings FRP-95-505

Accessories

- Cap, Differential Pressure Indicator –
For pressures over 150 PSIG..... GRP-95-022
- Drain, Automatic, Internal, Fluorocarbon,
1/8 NPT GRP-95-981
- Drain Plate Kit –
1/2 NPT tapped drain port GRP-95-393
5/16 Dia. Drain Port,
For use with Internal Auto Drain..... GRP-95-391
- Gauge, Differential Pressure..... DP3-01-000
- Indicator, Differential Pressure DP2-02-001
- Manual Drain Kit
Includes 1/2" Drain Plate, Manual Drain..... GRP-95-392
- Manual Override for Auto Float Drain –
GRP-05-981 Required GRP-96-001

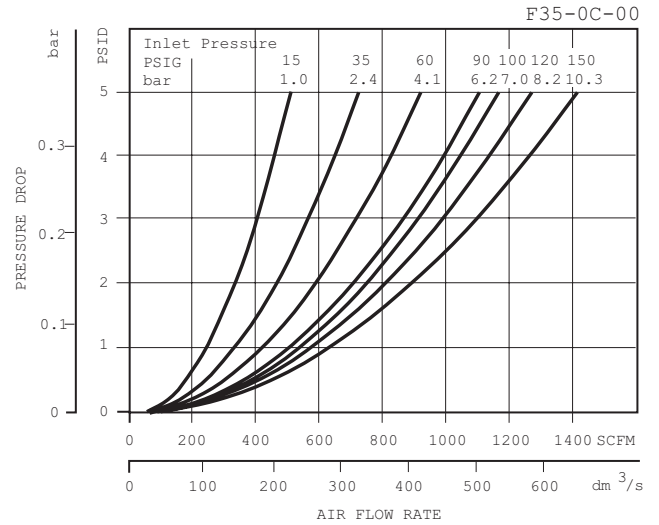
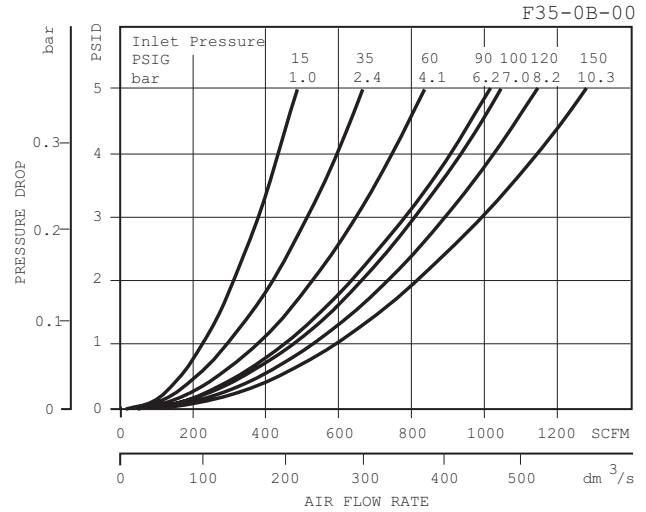

Ordering Information

Model Type	Port Size	Metal Bowl	
Manual Drain	1-1/2	F35-0B-000	(Includes 1/2 NPT / BSPP-G Drain Plate)
	2	F35-0C-000	
Automatic Drain	1-1/2	F35-0B-F00	
	2	F35-0C-F00	

Options - To order an option supplied with the unit model, add the appropriate coded suffix letter in the designated position of the model number.

Particulate Filter WF602

= "Most Popular"

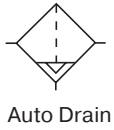

Auto Drain



WF602-12WJ

Features

- Excellent water removal efficiency
- For heavy duty applications with minimum pressure drop requirement
- Unique deflector plate that creates swirling of the air stream ensuring maximum water and dirt separation
- Large filter element surface guarantees low pressure drop and increased element life
- 40 micron filter element standard, 5 micron available
- Metal bowl with sight gauge standard
- Twist drain as standard, optional auto drain
- Large bowl capacity
- Optional high capacity bowl(s) available
- 1-1/2" port, NPT & BSPP

Specifications

Flow Capacity (high flow)*	1-1/2"	450 SCFM (212.4 dm ³ /s)
Maximum Supply Pressure:		
Aluminum (E)		0 to 300 psig (0 to 20.7 bar)
Zinc with gauge (W)		0 to 250 psig (0 to 17.2 bar)
With internal auto drain [R]		20 to 175 psig (1.14 to 11.9 bar)
With external auto drain [Q]		0 to 250 psig (0 to 17.2 bar)
Operating Temperature:		
Aluminum (E)		40°F to 150°F (4.4°C to 65.6°C)
Zinc with gauge (W)		40°F to 150°F (4.4°C to 65.6°C)
With internal auto drain [R]		40°F to 125°F (4.4°C to 52°C)
With external auto drain [Q]		40°F to 150°F (4.4°C to 65.6°C)
Bowl Capacity		
Zinc with gauge (W)		16 oz.
Aluminum (E)		32 oz.
Standard Filtration		5 Micron (G) or 40 Micron (J)
Weight:		
	16 oz.	7.0 lb. (3.18 kg)
	32 oz.	7.7 lb. (3.49 kg)

* Inlet pressure 150 PSIG (10.3 bar). Pressure drop of 5 PSID (0.3 bar).

() Bowl Type, [] Drain Type

Materials of Construction

Body	Zinc
Bowls (E) 32 oz. without sight gauge	Aluminum
Bowl (W) 16 oz. with sight gauge	Zinc
Manual twist drain & overnight	Brass
Drain housing "R"	Acetal
Drain housing "Q"	Bronze
Element	Polypropylene
Seals	Nitrile
Sight gauge	Nylon

Dimensions

Models	Inches (mm)	A	B	C	D	E	F
Manual Drain WF602-12W		5.19 (132)	4.90 (124)	8.18 (208)	9.46 (240)	2.45 (62)	1.28 (32.4)
Automatic Drain WF602-12E		5.19 (132)	4.90 (124)	11.41 (290)	12.69 (322)	2.45 (62)	1.28 (32.4)

= "Most Popular"

Replacement Element Kit

- Element, 5 MicronEK602VB
- Element, 40 MicronEK602B

Accessories

- Aluminum bowl (E) 32 oz.BK603B
- Zinc bowl with sight gauge (W) 16 oz.BK605WB
- External auto drain (E) 32 oz.....SA603D
- External auto drain (W) 16 oz.....SA602D
- Internal auto drain (all)SA602MD
- Manual drain (all)SA600Y7-1
- Semi-automatic (overnight) drainSA602A7
- Deflector, baffle assembly & retaining rod (all)RK602C
- External auto drain (all)RK602D
- Internal auto drain (all)RK602MD
- Metal bowl with sight gauge (W) 16 oz.RKB605WB

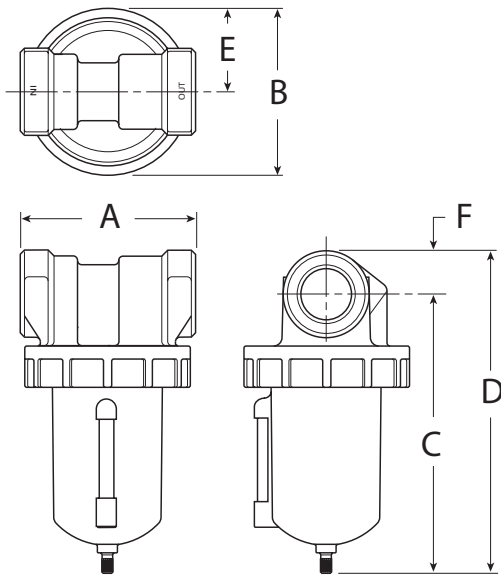
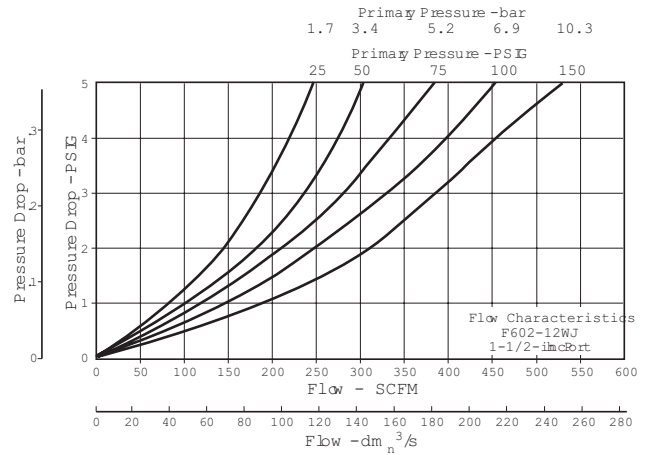

WF602-12W (Hi-Flow)

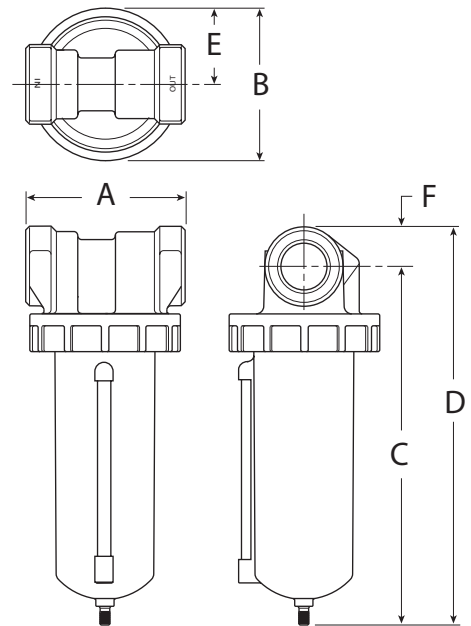

WF602-12E (Hi-Flow)

Ordering Information

Model Type	Port Size	Bowl Capacity	Metal Bowl
Manual Drain	1-1/2	16 oz.	WF602-12WJ
	1-1/2	32 oz.	WF602-12EJ
Automatic Drain	1-1/2	16 oz.	WF602-12WJR
	1-1/2	32 oz.	WF602-12EJR

Options - To order an option supplied with the unit model, add the appropriate coded suffix letter in the designated position of the model number.

Coalescing (Oil Removal) Numbering System

 = "Most Popular"

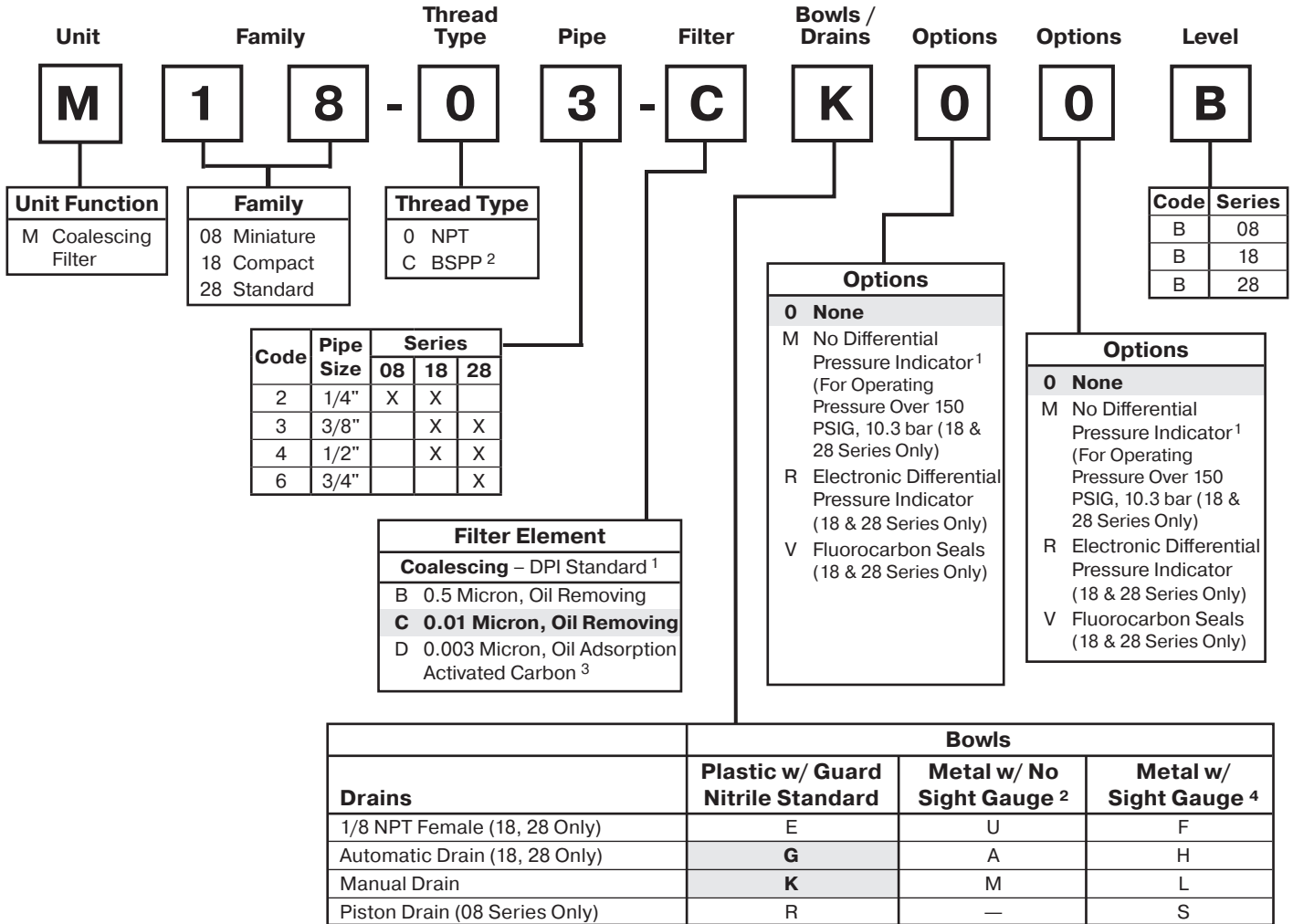

¹ "M" Option not available on 08 Series.

² ISO, R228 (G Series)

³ Only C, D, K, and L bowl / drain configurations available.

⁴ M08 filter has an all metal bowl (no sight gauge).

"M" Series Coalescing Filters, with Type "B" 0.5 micron elements:
 All Wilkerson Type "M" Oil Removal (Coalescing) Filters with Type "B" 0.5 micron elements **exceed ISO** Class 2 for maximum particle size and concentration of solid contaminants, and exceed Class 3 on maximum oil content (ppm/wt).

"M" Series Coalescing Filters, with Type "C" 0.01 micron elements:
 All Wilkerson Type "M" Oil Removal (Coalescing) Filters with Type "C" 0.01 micron elements **exceed ISO** Class 1 for maximum particle size and concentration of solid contaminants, and exceed Class 1 on maximum oil content (ppm/wt).

"M" Series Adsorption Filters, with Type "D" activated carbon elements: All Wilkerson Type "M" adsorption filters with Type "D" 0.003 micron activated carbon elements **exceed ISO** Class 1 on maximum oil content (ppm/wt).

NOTE:All classes above refer to International Standards Organization (ISO) standard 8573-1, pertaining to maximum particle size and concentration of solid contaminants, and maximum oil content.

Note: When selecting from the options columns, please enter letters in alphabetical order for positions 7, 8, and 9. For example:

M 18 - 03 - C K 0 0 B

Coalescing Filter Numbering System

 = "Most Popular"

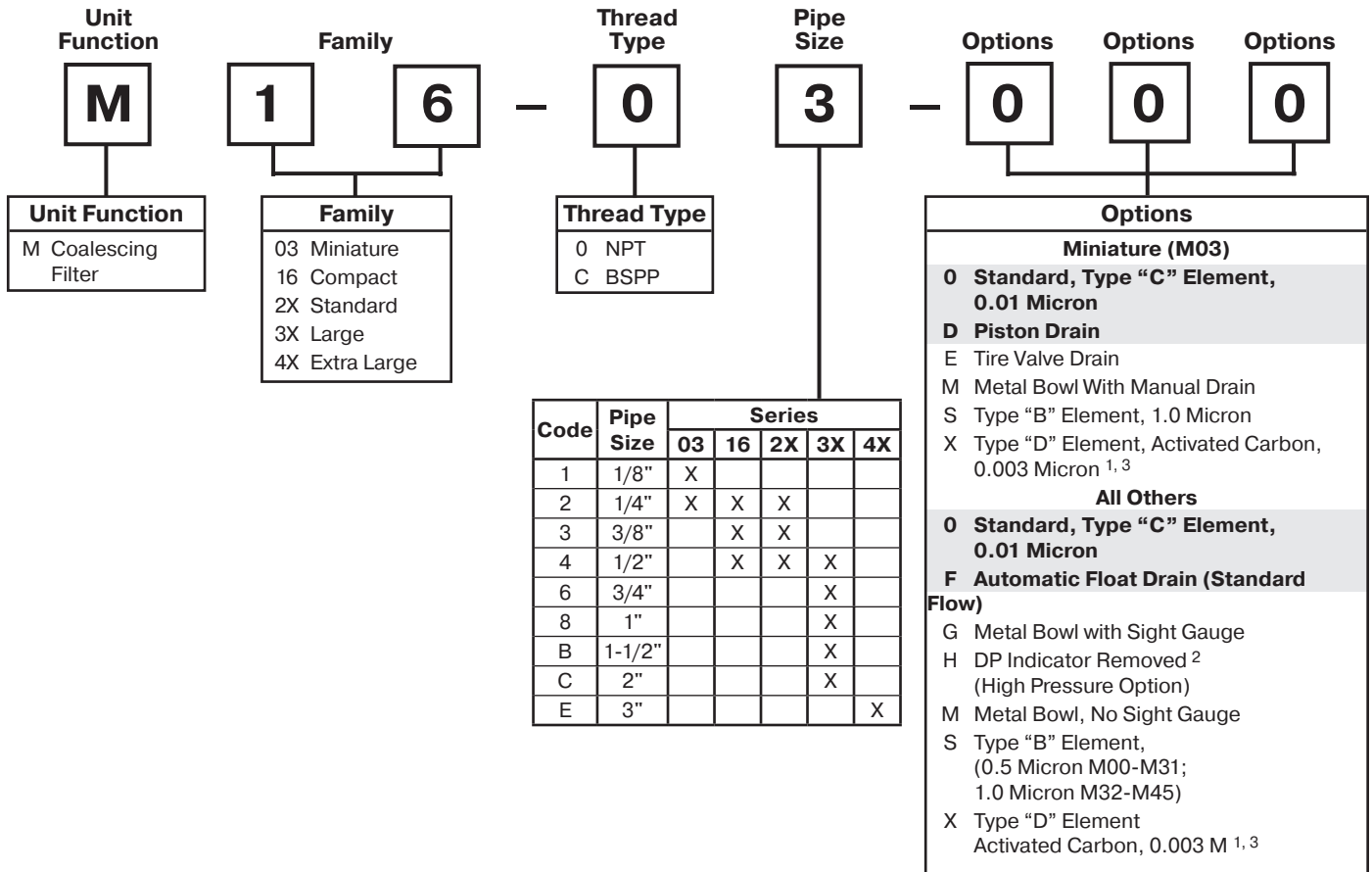

¹ Auto Float Drains not available with M16, M26- units with Type "D" Activated Carbon Elements.

² Except Models M5X.

³ Units with Type "D" element do not contain DP indicator.

"M" Series Coalescing Filters, with Type "B" 0.5 micron elements: All Wilkerson Type "M" Oil Removal (Coalescing) Filters with Type "B" 0.5 micron elements **exceed ISO** Class 2 for maximum particle size and concentration of solid contaminants, and exceed Class 3 on maximum oil content (ppm/wt).

"M" Series Coalescing Filters, with Type "C" 0.01 micron elements: All Wilkerson Type "M" Oil Removal (Coalescing) Filters with Type "C" 0.01 micron elements **exceed ISO** Class 1 for maximum particle size and concentration of solid contaminants, and exceed Class 1 on maximum oil content (ppm/wt).

"M" Series Adsorption Filters, with Type "D" activated carbon elements: All Wilkerson Type "M" adsorption filters with Type "D" activated carbon elements **exceed ISO** Class 1 on maximum oil content (ppm/wt).

NOTE: All classes above refer to International Standards Organization (ISO) standard 8573-1:1991(E), pertaining to maximum particle size and concentration of solid contaminants, and maximum oil content.

If more than one option is desired, arrange them in alphabetical order in positions 6, 7, and 8.

NOTE: 000 in position 6, 7, and 8 signifies standard product.

Coalescing Filter M03

= "Most Popular"

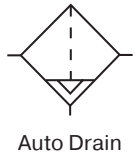
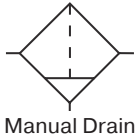

M03-02-000

Features

- Removes Liquid Aerosols and Sub-micron Particles
- Liquids Gravitate to the Bottom of the Element and Will Not Re-enter the Airstream
- Oil Free Air for Critical Applications, such as Air Gauging and Pneumatic Instrumentation and Controls

Specifications

Flow Capacity*	1/8	17.0 SCFM (8 dm ³ /s)
	1/4	20.0 SCFM (9 dm ³ /s)
Maximum Supply Pressure		
Polycarbonate Bowl		0 to 150 PSIG (0 to 10.3 bar)
Metal Bowl		0 to 250 PSIG (0 to 17.2 bar)
Piston Drain		10 to 250 PSIG (0.7 to 17.2 bar)
Operating Temperature		
Polycarbonate Bowl		32°F to 125°F (0°C to 52°C)
Metal Bowl		32°F to 175°F (0°C to 80°C)
Piston Drain		32°F to 125°F (6°C to 52°C)
Port Size	NPT	1/8, 1/4
Standard Filtration	Micron	(B) 1.0, (C) 0.01 (D) 0.003 ppm / wt**
Weight		.41 lb. (.18 kg)

* Inlet pressure 90 PSIG (6.2 bar). Pressure drop 5 PSID (0.3 bar).

**Filtration temperature of 70°F (21°C) @ 100 PSIG (6.9 bar) with typical compressor lubricating oil and protected by Type C filter.

"M" Series Coalescing Filters, with Type "B" 1 micron elements: All Wilkerson Type "M" Oil Removal (Coalescing) Filters with Type "B" 0.5 micron elements **exceed ISO** Class 2 for maximum particle size and concentration of solid contaminants, and exceed Class 3 on maximum oil content (ppm/wt).

"M" Series Coalescing Filters, with Type "C" 0.01 micron elements: All Wilkerson Type "M" Oil Removal (Coalescing) Filters with Type "C" 0.01 micron elements **exceed ISO** Class 1 for maximum particle size and concentration of solid contaminants, and exceed Class 1 on maximum oil content (ppm/wt).

"M" Series Adsorption Filters, with Type "D" 0.003 micron activated carbon elements: All Wilkerson Type "M" adsorption filters with Type "D" 0.003 micron activated carbon elements **exceed ISO** Class 1 on maximum oil content (ppm/wt).

Materials of Construction

Body	Zinc
Bowls – Transparent	Polycarbonate
Metal (Without Sight Gauge)	Zinc
Deflector, Element Holder & Baffle	Plastic
Drains	
Manual Drain – Body & Stem	Plastic
Seals	Nitrile
Piston Drain – Piston & Seals	Nitrile
Stem, Seat, Adaptor & Washers	Aluminum
Filter Element	Plastic
Seals	Nitrile

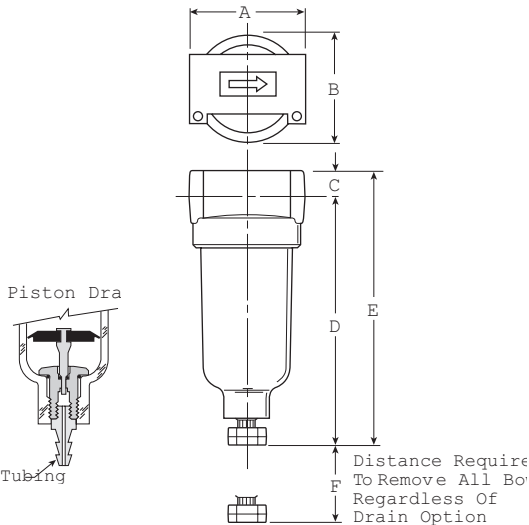

Dimensions

Models	Inches (mm)	A	B	C	D	E	F
Standard Unit M03-XX-000		1.69 (43)	1.53 (39)	.39 (10)	3.82 (97)	4.21 (107)	1.60 (41)
Piston Drain M03-XX-D00		1.69 (43)	1.53 (39)	.39 (10)	3.87 (99)	4.26 (108)	1.60 (41)

= "Most Popular"

Replacement Bowl Kits

- Metal Bowl –
- Manual DrainPS451B
- Piston DrainPS447B

- Plastic Bowl –
- Manual DrainPS404
- Piston DrainPS408B

Replacement Element Kits

- Type "B", 1.0 MicronPS456
- Type "C", 0.01 MicronPS446
- Type "D", Oil Vapor RemovingPS452

Accessories

- Mounting Bracket KitPS417B

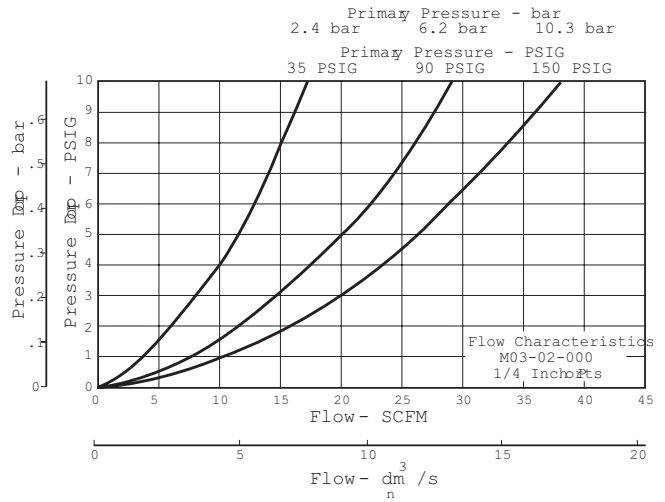
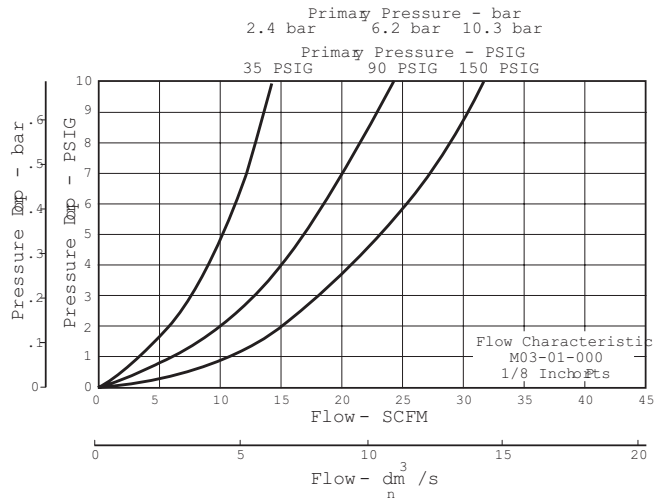

Ordering Information

Model Type	Port Size	Polycarbonate Bowl / "C" Element	Metal Bowl / "C" Element	Polycarbonate Bowl / "B" Micron Element	Polycarbonate Bowl / "D" Element
Manual Drain	1/8	M03-01-000	M03-01-M00	M03-01-S00	M03-01-X00
	1/4	M03-02-000	M03-02-M00	M03-02-S00	M03-02-X00

Options - To order an option supplied with the unit model, add the appropriate coded suffix letter in the designated position of the model number.

Coalescing Filter M08

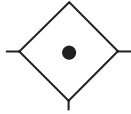

Coalescing Filter



Auto Drain



Features

- High-efficiency Removal of Water, Oil Aerosols, and Solid Particulate Contaminants Down to 0.01 ppm / wt with Minimum Pressure Drop
- Modern Design and Appearance
- Light Weight
- High Flow Capacity
- Bowl Guard
- Quick-disconnect Bowl

Specifications

Flow Capacity*		
1.0 Micron Coalescing		12.0 SCFM (5.5 dm ³ /s, ANR)
0.01 Micron Coalescing		7.5 SCFM (3.6 dm ³ /s, ANR)
Activated Carbon Adsorber		12.7 SCFM (6 dm ³ /s, ANR)
Maximum Supply Pressure		
Plastic Bowl		150 PSIG (10 bar)
Metal Bowl		250 PSIG (17 bar)
Operating Temperature		
Plastic Bowl	14° to 125°F (-10° to 52°C)	
Metal Bowl	14° to 150°F (-10° to 65.5°C)	
Port Size		NPT / BSPP-G 1/4
Bowl Capacity		0.4 oz
Standard Filtration Micron		(B) .5, (C) 0.01 (D) 0.003 ppm wt**
Weight		0.24 lb. (0.11 kg)

* Inlet pressure 91.3 PSIG (6.3 bar). Pressure drop 3 PSIG (0.2 bar).

**Filtration temperature of 70°F (21°C) @ 100 PSIG (6.9 bar) with typical compressor lubricating oil and protected by Type C filter.

“M” Series Coalescing Filters, with Type “B” 0.5 micron elements: All Wilkerson Type “M” Oil Removal (Coalescing) Filters with Type “B” 0.5 micron elements exceed ISO Class 2 for maximum particle size and concentration of solid contaminants, and exceed Class 3 on maximum oil content (ppm/wt).

“M” Series Coalescing Filters, with Type “C” 0.01 micron elements: All Wilkerson Type “M” Oil Removal (Coalescing) Filters with Type “C” 0.01 micron elements exceed ISO Class 1 for maximum particle size and concentration of solid contaminants, and exceed Class 1 on maximum oil content (ppm/wt).

“M” Series Adsorption Filters, with Type “D” 0.003 micron activated carbon elements: All Wilkerson Type “M” adsorption filters with Type “D” 0.003 micron activated carbon elements exceed ISO Class 1 on maximum oil content (ppm/wt).

Materials of Construction

Body	Aluminum	
Body Cap	ABS	
Bowl	Plastic Bowl Metal Bowl	Polycarbonate Aluminum
Filter Element	Type “B”, “C” Type “D”	Borosilicate Cloth Activated Carbon
Seals	Nitrile	

Notes: To optimize the life of the coalescing element, it is advisable to install a pre-filter with a 5 micron element upstream of the coalescing filter.

To optimize the life of the adsorber element, it is advisable to install a coalescing 0.01 micron filter upstream of the adsorber filter.

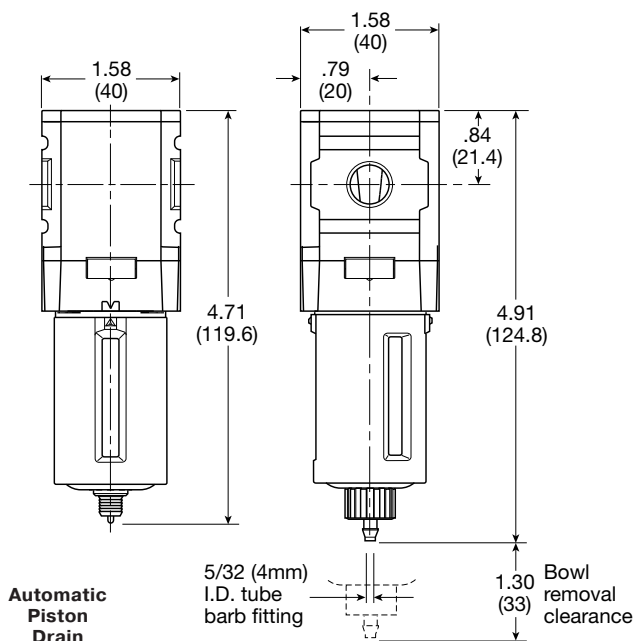

Inches (mm)

= "Most Popular"

Replacement Bowl Kits

- Metal Bowl, Manual Drain GRP-96-714
- Plastic Bowl / Bowl Guard, Manual Drain..... GRP-96-712

Replacement Element Kits

- Type "B", 0.5 Micron MSP-96-732
- Type "C", 0.01 MicronMTP-96-649
- Type "D", 0.003 Micron, Activated Carbon..... MXP-96-222

Accessories

- Automatic Piston Drain..... GRP-96-716
- Wall Mounting Bracket –
- C-Type..... GPA-97-010
- T-Type GPA-96-737

M08 1/4" Filter, 1.0 Micron

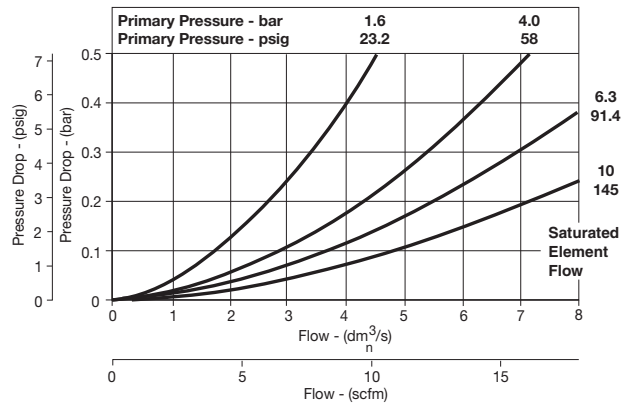

M08 1/4" Filter, 0.01 Micron

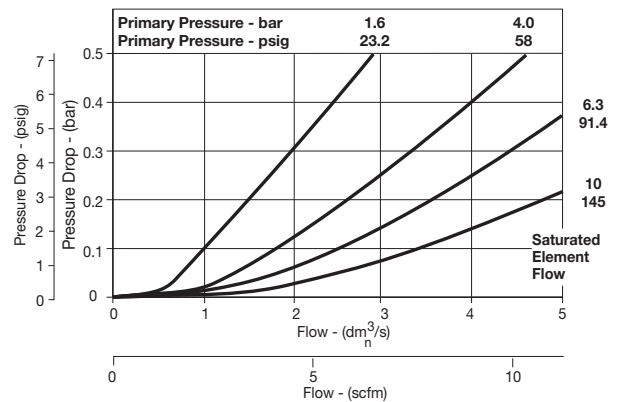

Ordering Information

Model Type	Port Size	Plastic Bowl / Bowl Guard / C Element	Plastic Bowl / Bowl Guard / B Element	Plastic Bowl / Bowl Guard / D Element	Metal Bowl / C Element	Metal Bowl / B Element	Metal Bowl / D Element
Manual Drain	1/4	M08-02-CK00B	M08-02-BK00B	M08-02-DK00B	M08-02-CL00B	M08-02-BL00B	M08-02-DL00B
Automatic Piston Drain	1/4	M08-02-CR00B	M08-02-BR00B	M08-02-DR00B	M08-02-CS00B	M08-02-BS00B	M08-02-DS00B

Options - To order an option supplied with the unit model, add the appropriate coded suffix letter in the designated position of the model number.

Coalescing Filter M18

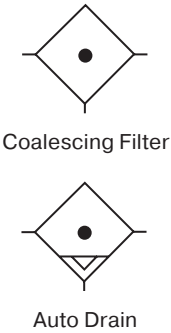

Features

- High-efficiency Removal of Water, Oil Aerosols, and Solid Particulate Contaminants Down to 0.01 ppm / wt with Minimum Pressure Drop
- Modern Design and Appearance
- Light Weight
- High Flow Capacity
- Bowl Guard
- Quick-disconnect Bowl

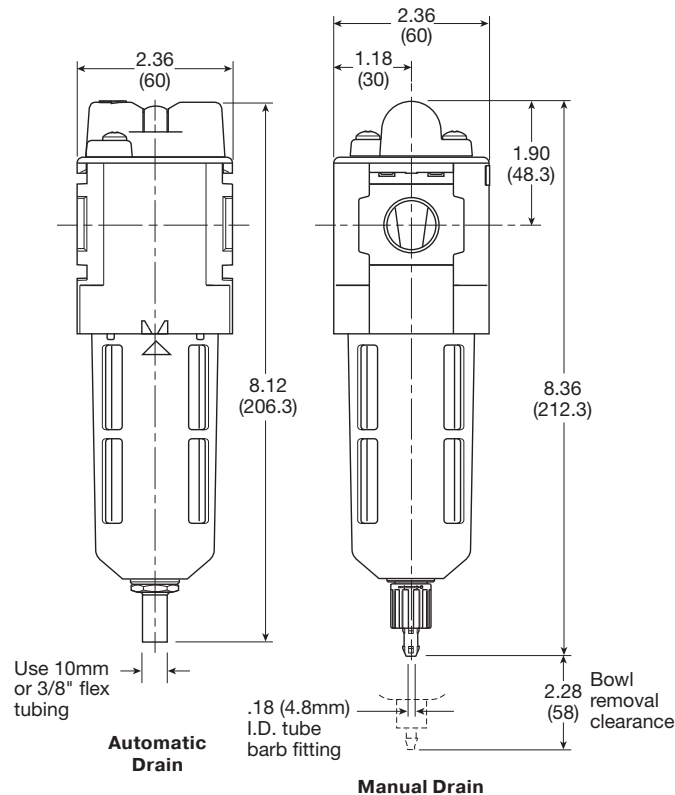

Inches (mm)

Specifications

Flow Capacity*		
1.0 Micron Coalescing		53 SCFM (25 dm ³ /s, ANR)
0.01 Micron Coalescing		36 SCFM (17 dm ³ /s, ANR)
Activated Carbon Adsorber		85 SCFM (40 dm ³ /s, ANR)
Maximum Supply Pressure	Plastic Bowl	150 PSIG (10 bar) [†]
	Metal Bowl w/ DPI	150 PSIG (10 bar) [†]
	Metal Bowl w/o DPI	250 PSIG (17 bar) [†]
Operating Temperature	Plastic Bowl	-13° to 125°F (-25° to 52°C)
	Metal Bowl	-13° to 150°F (-25° to 65.5°C)
Port Size	NPT / BSPP-G	1/4, 3/8, 1/2
Bowl Capacity		1.72 oz
Standard Filtration Micron		(B) 0.5, (C) 0.01
		(D) 0.003 ppm wt**
Weight		0.71 lb (0.32 kg)

* Inlet pressure 91.3 PSIG (6.3 bar). Pressure drop 3 PSIG (0.2 bar).

** Filtration temperature of 70°F (21°C) @ 100 PSIG (6.9 bar) with typical compressor lubricating oil and protected by Type C filter.

† Without pressure indicator — max. supply pressure for metal bowl version is 250 PSIG (17.2 bar).

“M” Series Coalescing Filters, with Type “B” 0.5 micron elements: All Wilkerson Type “M” Oil Removal (Coalescing) Filters with Type “B” 0.5 micron elements **exceed ISO** Class 2 for maximum particle size and concentration of solid contaminants, and exceed Class 3 on maximum oil content (ppm/wt).

“M” Series Coalescing Filters, with Type “C” 0.01 micron elements: All Wilkerson Type “M” Oil Removal (Coalescing) Filters with Type “C” 0.01 micron elements **exceed ISO** Class 1 for maximum particle size and concentration of solid contaminants, and exceed Class 1 on maximum oil content (ppm/wt).

“M” Series Adsorption Filters, with Type “D” 0.003 micron activated carbon elements: All Wilkerson Type “M” adsorption filters with Type “D” 0.003 micron activated carbon elements **exceed ISO** Class 1 on maximum oil content (ppm/wt).

Materials of Construction

Body	Aluminum	
Body Cap	ABS	
Bowl	Plastic Bowl	Polycarbonate
	Metal Bowl	Aluminum
Filter Element	Type “B”, “C”	Borosilicate Cloth
	Type “D”	Activated Carbon
Seals	Nitrile	
Sight Gauge	Metal Bowl	Polyamide (Nylon)

Notes: To optimize the life of the coalescing element, it is advisable to install a pre-filter with a 5 micron element upstream of the coalescing filter.

To optimize the life of the adsorber element, it is advisable to install a coalescing 0.01 micron filter upstream of the adsorber filter.

= "Most Popular"

Replacement Bowl Kits

- Metal Bowl with Sight Gauge,
Automatic Float Drain GRP-96-637
- Metal Bowl with Sight Gauge, Manual Drain GRP-96-636
- Plastic Bowl –
Bowl Guard, Auto Drain GRP-96-635
- Bowl Guard, Manual Drain GRP-96-634

Replacement Element Kits

- Type "B", 0.5 Micron MSP-96-647
- Type "C", 0.01 Micron MTP-96-646
- Type "D", 0.003 Micron Activated Carbon MXP-96-650

Accessories

- Automatic Drain –
Fluorocarbon GRP-95-981
- Nitrile GRP-95-973
- DPI Replacement Kit DP8-01-000
- Electronic DPI Conversion Kit GRP-96-823
(Converts visual DPI to electronic DPI)
- Electronic DPI Replacement Kit GRP-96-824
- Manual Drain GRP-96-685
- Sight Gauge Kit GRP-96-825
- Wall Mounting Bracket –
L-Type GPA-96-604
- T-Type GPA-96-602

M18 1/2" Filter, 1.0 Micron

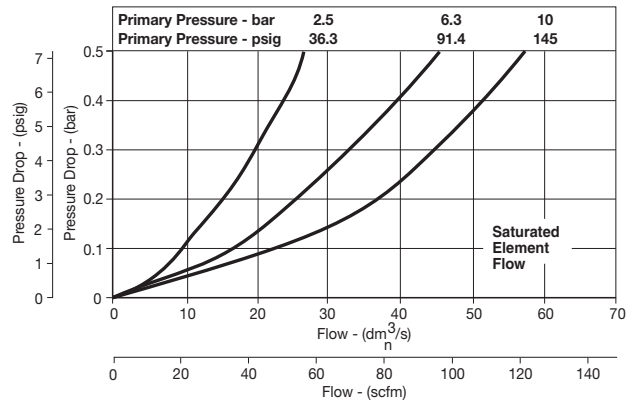

M18 1/4" Filter, 0.01 Micron

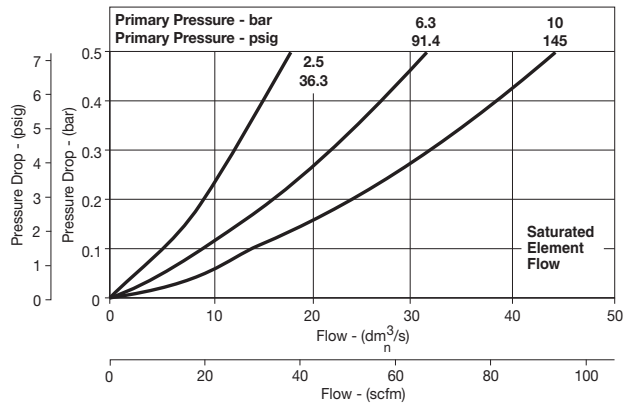

Ordering Information

Model Type	Port Size	Plastic Bowl / Bowl Guard / C Element	Plastic Bowl / Bowl Guard / B Element	Plastic Bowl / Bowl Guard / D Element	Metal Bowl / Sight Gauge / C Element	Metal Bowl / Sight Gauge / B Element	Metal Bowl / Sight Gauge / D Element
Manual Drain	1/4	M18-02-CK00B	M18-02-BK00B	M18-02-DK00B	M18-02-CL00B	M18-02-BL00B	M18-02-DL00B
	3/8	M18-03-CK00B	M18-03-BK00B	M18-03-DK00B	M18-03-CL00B	M18-03-BL00B	M18-03-DL00B
	1/2	M18-04-CK00B	M18-04-BK00B	M18-04-DK00B	M18-04-CL00B	M18-04-BL00B	M18-04-DL00B
Automatic Drain	1/4	M18-02-CG00B	M18-02-BG00B	N/A	M18-02-CH00B	M18-02-BH00B	N/A
	3/8	M18-03-CG00B	M18-03-BG00B	N/A	M18-03-CH00B	M18-03-BH00B	N/A
	1/2	M18-04-CG00B	M18-04-BG00B	N/A	M18-04-CH00B	M18-04-BH00B	N/A

Options - To order an option supplied with the unit model, add the appropriate coded suffix letter in the designated position of the model number.

Coalescing Filter M16

= "Most Popular"



M16-02-000

Features

- Manual Drain
- 0.01 Micron Rated Filter Element
- Quick-disconnect Bowl Guard with Integral Plastic Bowl and Safety Latch
- Differential Pressure Indicator Standard

Specifications

Flow Capacity*	1/4	37.0 SCFM (17.5 dm ³ /s)
	3/8	44.7 SCFM (21.0 dm ³ /s)
	1/2	46.1 SCFM (21.7 dm ³ /s)
Maximum Supply Pressure	Plastic Bowl	150 PSIG (10.3 bar)
	Metal Bowl	200 PSIG (13.8 bar)
Operating Temperature	Plastic Bowl	32° to 125°F (0° to 52°C)
	Metal Bowl	32° to 150°F (0° to 65.5°C)
Port Size	NPT / BSPP-G	1/4, 3/8, 1/2
Bowl Capacity	2.7 oz	
Standard Filtration Micron	(B) 0.5, (C) 0.01	
	(D) 0.003 ppm / wt**	
Weight	1.8 lb.(0.8 kg)	

* Inlet pressure 150 PSIG (10.3 bar). Pressure drop 3 PSID (0.2 bar).

** Filtration temperature of 70°F (21°C) @100 PSIG (6.9 bar) with typical compressor lubricating oil and protected by Type "C" filter.

"M" Series Coalescing Filters, with Type "B" 0.5 micron elements: All Wilkerson Type "M" Oil Removal (Coalescing) Filters with Type "B" 0.5 micron elements **exceed ISO Class 2** for maximum particle size and concentration of solid contaminants, and exceed Class 3 on maximum oil content (ppm/wt).

"M" Series Coalescing Filters, with Type "C" 0.01 micron elements: All Wilkerson Type "M" Oil Removal (Coalescing) Filters with Type "C" 0.01 micron elements **exceed ISO Class 1** for maximum particle size and concentration of solid contaminants, and exceed Class 1 on maximum oil content (ppm/wt).

"M" Series Adsorption Filters, with Type "D" 0.003 micron activated carbon elements: All Wilkerson Type "M" adsorption filters with Type "D" 0.003 micron activated carbon elements **exceed ISO Class 1** on maximum oil content (ppm/wt).

Materials of Construction

Body	Zinc	
Bowls	Plastic Bowl	Polycarbonate
	Metal Bowl	Zinc
Element Retainer	Brass Stud	
Filter Elements	Type "B", "C"	Borosilicate Cloth
	Type "D"	Activated Carbon
Seals	Fluorocarbon	

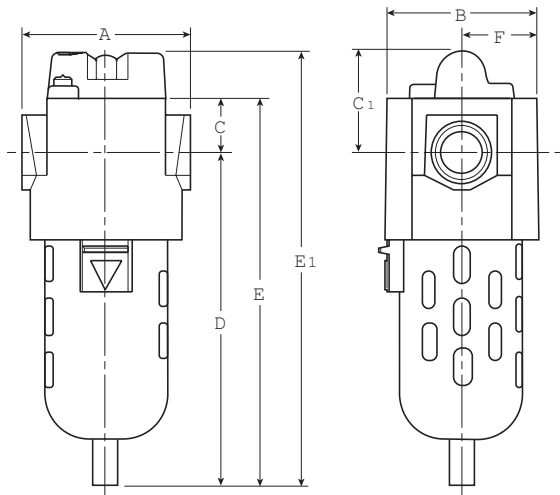

Dimensions

Models	Inches (mm)	A	B	C	C ₁	D	E	E ₁	F
Standard Unit M16-XX-000		3.00 (76)	2.60 (66)	1.00 (25.4)	1.83 (46.5)	5.67 (144)	6.67 (169)	7.50 (190.5)	1.30 (33)
Automatic Drain M16-XX-F00		3.00 (76)	2.60 (66)	1.00 (25.4)	1.83 (46.5)	5.81 (148)	6.81 (173)	7.64 (190.5)	1.30 (33)

= "Most Popular"

Replacement Bowl Kits

- Metal Bowl –**
 Automatic Drain FRP-95-950
 Manual Drain FRP-95-178
- Plastic Bowl –**
 Bowl Guard, Auto Drain FRP-95-015
 Bowl Guard, Manual Drain FRP-95-014
 Manual Drain FRP-95-017

Replacement Element Kits

- Type "B", 0.5 Micron MSP-95-988
 Type "C", 0.01 Micron MTP-95-548
 Type "D", Oil Vapor Removing MXP-95-987

Accessories

- Automatic Mechanical Drain..... GRP-95-973
 Cap, Differential Pressure Indicator –
 For pressures over 150 PSIG..... GRP-95-020
 Differential Pressure Indicator DP2-02-000
 Manual Drain..... FRP-95-610
 Sight Gauge Kit GRP-95-079
 Wall Mounting Bracket, L-Type..... GPA-95-016

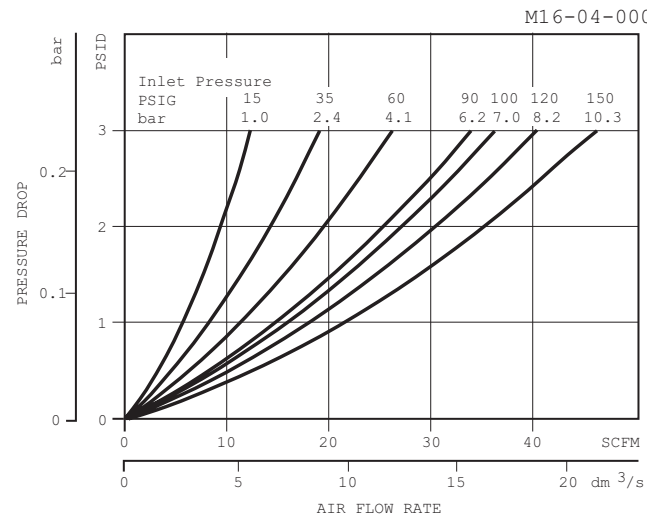
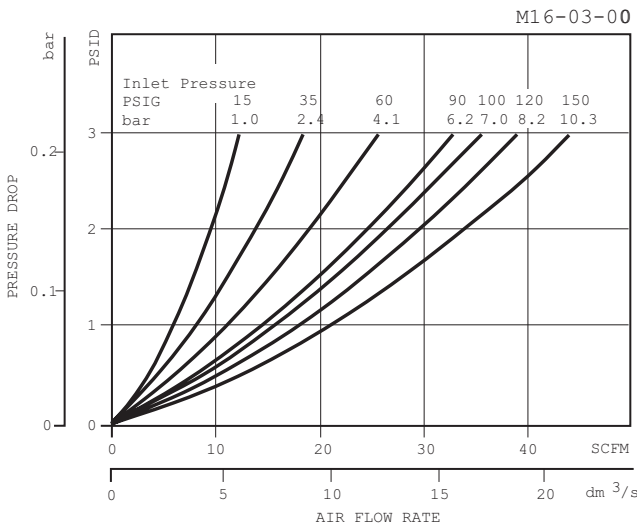
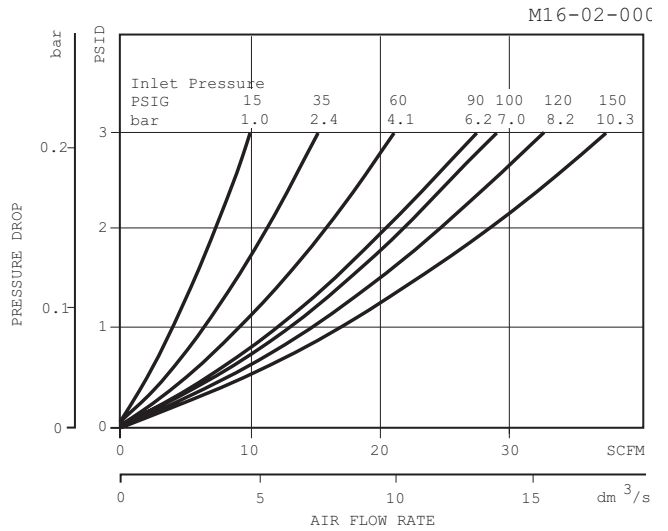

Ordering Information

Model Type	Port Size	Polycarbonate Bowl / Bowl Guard / "C" Element	Metal Bowl / "C" Element	Polycarbonate Bowl / Bowl Guard / "B" Element	Polycarbonate Bowl / Bowl Guard / "D" Element (No DPI)
Manual Drain	1/4	M16-02-000	M16-02-M00	M16-02-S00	M16-02-X00
	3/8	M16-03-000	M16-03-M00	M16-03-S00	M16-03-X00
	1/2	M16-04-000	M16-04-M00	M16-04-S00	M16-04-X00
Automatic Drain	1/4	M16-02-F00	M16-02-FM0	M16-02-FS0	—
	3/8	M16-03-F00	M16-03-FM0	M16-03-FS0	—
	1/2	M16-04-F00	M16-04-FM0	M16-04-FS0	—

Options - To order an option supplied with the unit model, add the appropriate coded suffix letter in the designated position of the model number.

Coalescing Filter M28

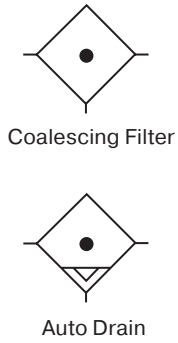

Features

- High-efficiency Removal of Water, Oil Aerosols, and Solid Particulate Contaminants Down to 0.01 ppm / wt with Minimum Pressure Drop
- Modern Design and Appearance
- Light Weight
- High Flow Capacity
- Bowl Guard
- Quick-disconnect Bowl

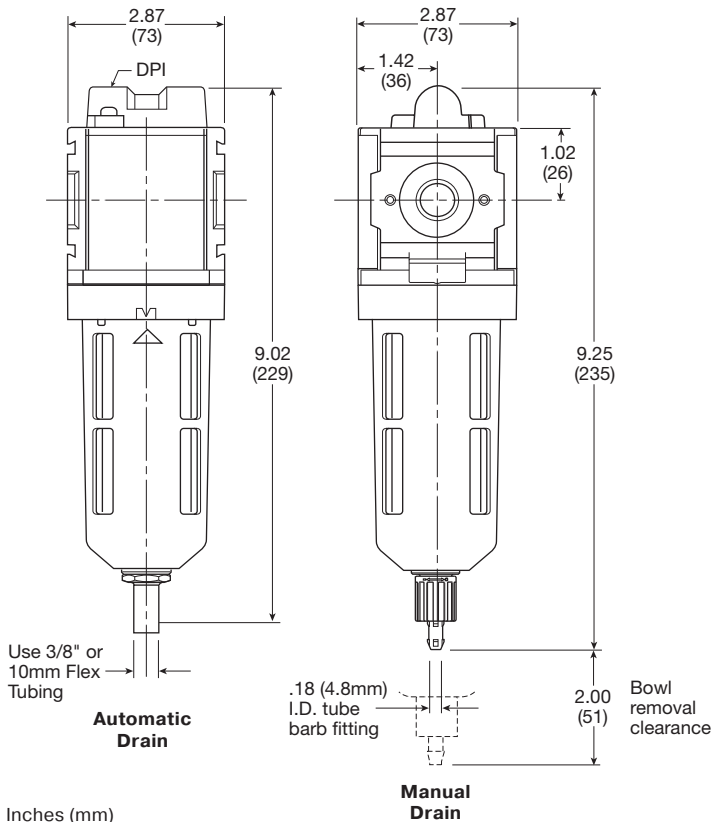

Inches (mm)

Specifications

Flow Capacity*		
1.0 Micron Coalescing		68 SCFM (32 dm ³ /s, ANR)
0.01 Micron Coalescing		42 SCFM (20 dm ³ /s, ANR)
Activated Carbon Adsorber		72 SCFM (34 dm ³ /s, ANR)
Maximum Supply Pressure	Plastic Bowl	150 PSIG (10.3 bar)†
	Metal Bowl	150 PSIG (10.3 bar)†
Operating Temperature	Plastic Bowl	-13° to 125°F (-25° to 52°C)
	Metal Bowl	-13° to 150°F (-25° to 65.5°C)
Port Size	NPT / BSPP-G	3/8, 1/2, 3/4
Bowl Capacity		2.87 oz
Standard Filtration Micron		(B) 0.5, (C) 0.01
		(D) 0.003 ppm wt**
Weight		1.10 lb. (0.5 kg)

* Inlet pressure 91.3 PSIG (6.3 bar). Pressure drop 3 PSIG (0.2 bar).

** Filtration temperature of 70°F (21°C) @ 100 PSIG (6.9 bar) with typical compressor lubricating oil and protected by Type C filter.

† Without pressure indicator — max. supply pressure for metal bowl version is 250 PSIG (17.2 bar)

“M” Series Coalescing Filters, with Type “B” 0.5 micron elements: All Wilkerson Type “M” Oil Removal (Coalescing) Filters with Type “B” 0.5 micron elements **exceed ISO** Class 2 for maximum particle size and concentration of solid contaminants, and exceed Class 3 on maximum oil content (ppm/wt).

“M” Series Coalescing Filters, with Type “C” 0.01 micron elements: All Wilkerson Type “M” Oil Removal (Coalescing) Filters with Type “C” 0.01 micron elements **exceed ISO** Class 1 for maximum particle size and concentration of solid contaminants, and exceed Class 1 on maximum oil content (ppm/wt).

“M” Series Adsorption Filters, with Type “D” 0.003 micron activated carbon elements: All Wilkerson Type “M” adsorption filters with Type “D” 0.003 micron activated carbon elements **exceed ISO** Class 1 on maximum oil content (ppm/wt).

Materials of Construction

Body	Aluminum	
Body Cap	ABS	
Bowls	Plastic Bowl	Polycarbonate
	Metal Bowl	Aluminum
Filter Element	Type “B”, “C”	Borosilicate Cloth
	Type “D”	Activated Carbon
Seals	Nitrile	
Sight Gauge	Metal Bowl	Polyamide (Nylon)

Notes: To optimize the life of the coalescing element, it is advisable to install a pre-filter with a 5 micron element upstream of the coalescing filter.

To optimize the life of the adsorber element, it is advisable to install a coalescing 0.01 micron filter upstream of the adsorber filter.

= "Most Popular"

Replacement Bowl Kits

- Metal Bowl with Sight Gauge,
Automatic Float Drain GRP-96-645
- Metal Bowl with Sight Gauge, Manual Drain GRP-96-644
- Plastic Bowl –
Bowl Guard, Auto Drain GRP-96-643
- Bowl Guard, Manual Drain GRP-96-642

Replacement Element Kits

- Type "B", 0.5 Micron MSP-96-649
- Type "C", 0.01 Micron MTP-96-648
- Type "D", 0.003 Micron Activated Carbon..... MXP-96-651

Accessories

- Automatic Drain –
Fluorocarbon GRP-95-981
- Nitrile GRP-95-973
- DPI Replacement Kit..... DP8-01-000
- Electronic DPI Conversion Kit..... GRP-96-823
(Converts visual DPI to electronic DPI)
- Electronic DPI Replacement Kit..... GRP-96-824
- Manual Drain..... GRP-96-685
- Sight Gauge Kit GRP-96-825
- Wall Mounting Bracket–
L-Type..... GPA-96-605
- T-Type GPA-96-602

M28 3/4" Filter, 1.0 Micron

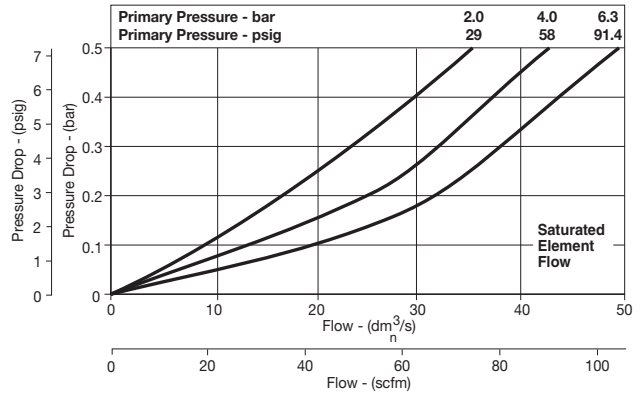

M28 3/4" Filter, 0.01 Micron

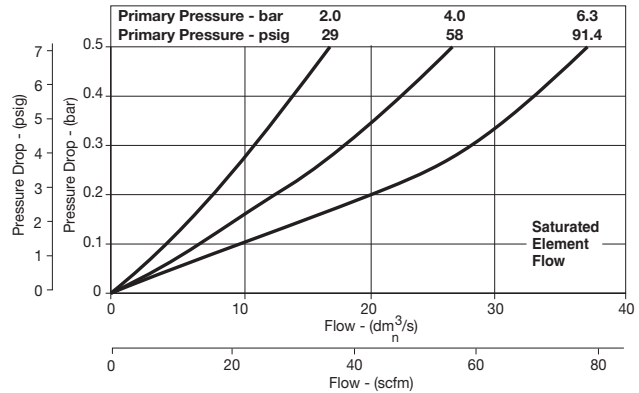

Ordering Information

Model Type	Port Size	Plastic Bowl / Bowl Guard / C Element	Plastic Bowl / Bowl Guard / B Element	Plastic Bowl / Bowl Guard / D Element	Metal Bowl / Sight Gauge / C Element	Metal Bowl / Sight Gauge / B Element	Metal Bowl / Sight Gauge / D Element
Manual Drain	3/8	M28-03-CK00B	M28-03-BK00B	M28-03-DK00B	M28-03-CL00B	M28-03-BL00B	M28-03-DL00B
	1/2	M28-04-CK00B	M28-04-BK00B	M28-04-DK00B	M28-04-CL00B	M28-04-BL00B	M28-04-DL00B
	3/4	M28-06-CK00B	M28-06-BK00B	M28-06-DK00B	M28-06-CL00B	M28-06-BL00B	M28-06-DL00B
Automatic Drain	3/8	M28-03-CG00B	M28-03-BG00B	N/A	M28-03-CH00B	M28-03-BH00B	N/A
	1/2	M28-04-CG00B	M28-04-BG00B	N/A	M28-04-CH00B	M28-04-BH00B	N/A
	3/4	M28-06-CG00B	M28-06-BG00B	N/A	M28-06-CH00B	M28-06-BH00B	N/A

Options - To order an option supplied with the unit model, add the appropriate coded suffix letter in the designated position of the model number.

Coalescing Filter M26

= "Most Popular"



M26-02-000

Features

- Manual Drain
- 0.01 Micron Rated Filter Element
- Quick-disconnect Bowl Guard with Integral Plastic Bowl and Safety Latch
- Differential Pressure Indicator

Specifications

Flow Capacity*	1/4	55.0 SCFM (25.9 dm ³ /s)
	3/8	65.5 SCFM (30.9 dm ³ /s)
	1/2	79.5 SCFM (37.5 dm ³ /s)
Maximum Supply Pressure	Plastic Bowl	150 PSIG (10.3 bar)
	Metal Bowl	200 PSIG (13.8 bar)
Operating Temperature	Plastic Bowl	32° to 125°F (0° to 52°C)
	Metal Bowl	32° to 150°F (0° to 65.5°C)
Standard Filtration	Micron	(B) 0.5, (C) 0.01
		(D) 0.003 ppm / wt**
Port Size	NPT / BSPP-G	1/4, 3/8, 1/2
Bowl Capacity	1.7 oz	
Weight	2.4 lb. (1.1 kg)	

* Inlet pressure 150 PSIG (10.3 bar). Pressure drop of 3 PSID (0.2 bar).

** Filtration temperature of 70°F (21°C) @100 PSIG (6.9 bar) with typical compressor lubricating oil and protected by Type "C" filter.

"M" Series Coalescing Filters, with Type "B" 0.5 micron elements: All Wilkerson Type "M" Oil Removal (Coalescing) Filters with Type "B" 0.5 micron elements **exceed ISO** Class 2 for maximum particle size and concentration of solid contaminants, and exceed Class 3 on maximum oil content (ppm/wt).

"M" Series Coalescing Filters, with Type "C" 0.01 micron elements: All Wilkerson Type "M" Oil Removal (Coalescing) Filters with Type "C" 0.01 micron elements **exceed ISO** Class 1 for maximum particle size and concentration of solid contaminants, and exceed Class 1 on maximum oil content (ppm/wt).

"M" Series Adsorption Filters, with Type "D" 0.003 micron activated carbon elements: All Wilkerson Type "M" adsorption filters with Type "D" 0.003 micron activated carbon elements **exceed ISO** Class 1 on maximum oil content (ppm/wt).

Materials of Construction

Body	Zinc	
Bowls	Plastic Bowl	Polycarbonate
	Metal Bowl	Zinc
Element Retainer	Brass Stud	
Filter Elements	Type "B", "C"	Borosilicate Cloth
	Type "D"	Activated Carbon
Seals	Fluorocarbon	

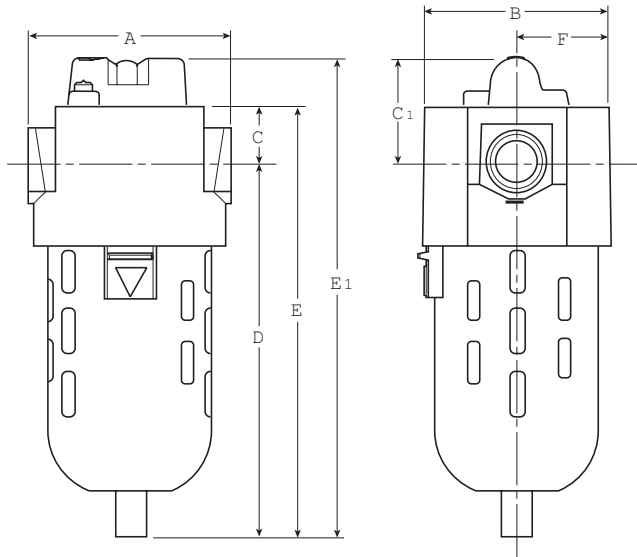

Dimensions

Models	Inches (mm)	A	B	C	C ₁	D	E	E ₁	F
Standard Unit M26-XX-000		3.30 (84)	3.00 (76)	1.00 (25.4)	1.83 (46.5)	6.40 (162.6)	7.40 (188)	8.23 (209)	1.50 (38)
Automatic Drain M26-XX-F00		3.30 (84)	3.00 (76)	1.00 (25.4)	1.83 (46.5)	6.54 (166)	7.54 (191.5)	8.37 (212.5)	1.50 (38)

= "Most Popular"

Replacement Bowl Kits

- Metal Bowl –
- Manual Drain GRP-95-930
- Auto Drain..... GRP-95-960
- Plastic Bowl –
- Manual Drain GRP-95-929
- Bowl Guard, Manual Drain GRP-95-935
- Bowl Guard, Auto Drain GRP-95-948

Replacement Element Kits

- Type "B", 0.5 Micron MSP-95-989
- Type "C", 0.01 Micron MTP-95-549
- Type "D", Oil Vapor Removing MXP-95-540

Accessories

- Automatic Mechanical Drain..... GRP-95-973
- Cap, Differential Pressure Indicator –
- For pressures over 150 PSIG..... GRP-95-020
- Differential Pressure Indicator DP2-02-000
- Manual Flex-Tip FRP-95-610
- Sight Gauge Kit GRP-95-079
- Wall Mounting Bracket, L-Type..... GPA-95-946

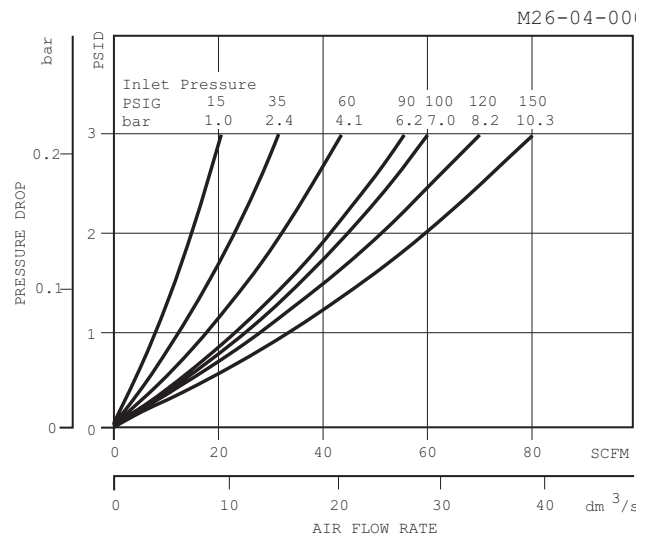
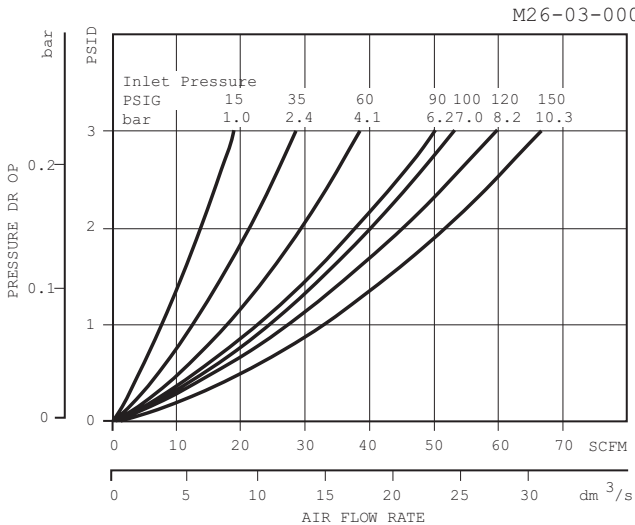
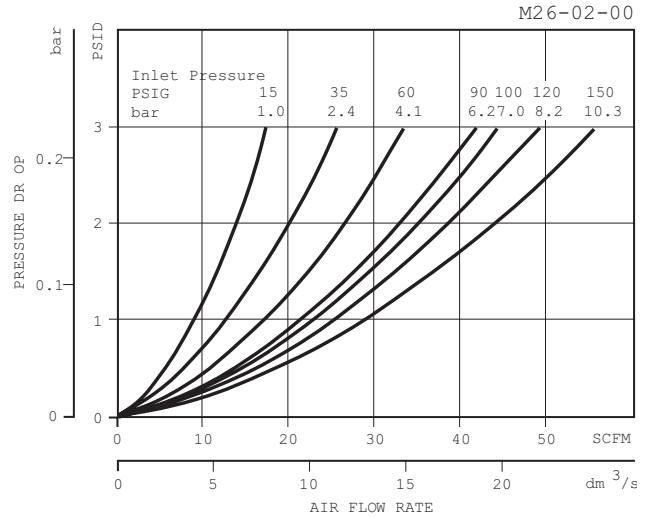

Ordering Information

Model Type	Port Size	Polycarbonate Bowl / Bowl Guard / "C" Element	Metal Bowl / "C" Element	Polycarbonate Bowl / Bowl Guard / "B" Element	Polycarbonate Bowl / Bowl Guard / "D" Element (No DPI)
Manual Drain	1/4	M26-02-000	M26-02-M00	M26-02-S00	M26-02-X00
	3/8	M26-03-000	M26-03-M00	M26-03-S00	M26-03-X00
	1/2	M26-04-000	M26-04-M00	M26-04-S00	M26-04-X00
Automatic Drain	1/4	M26-02-F00	M26-02-FM0	M26-02-FS0	—
	3/8	M26-03-F00	M26-03-FM0	M26-03-FS0	—
	1/2	M26-04-F00	M26-04-FM0	M26-04-FS0	—

Options - To order an option supplied with the unit model, add the appropriate coded suffix letter in the designated position of the model number.

Coalescing Filter M21

= "Most Popular"



M21-03-000

Features

- Manual Drain
- 0.01 Micron Rated Filter Element
- Quick-disconnect Bowl Guard with Integral Plastic Bowl and Safety Latch
- Differential Pressure Indicator

Specifications

Flow Capacity*	3/8	95.4 SCFM (45.0 dm ³ /s)
Maximum Supply Pressure	Plastic Bowl	150 PSIG (10.3 bar)
Operating Temperature	Plastic Bowl	32° to 125°F (0° to 52°C)
Port Size	NPT / BSPP-G	3/8
Bowl Capacity		3.9 oz
Standard Filtration	Micron	(B) 0.5, (C) 0.01 (D) 0.003 ppm / wt**
Weight		3.7 lb. (1.68 kg)

* Inlet pressure 150 PSIG (10.3 bar). Pressure drop of 3 PSID (0.2 bar).

** Filtration temperature of 70°F (21°C) @100 PSIG (6.9 bar) with typical compressor lubricating oil and protected by Type "C" filter.

"M" Series Coalescing Filters, with Type "B" 0.5 micron elements: All Wilkerson Type "M" Oil Removal (Coalescing) Filters with Type "B" 0.5 micron elements **exceed ISO Class 2** for maximum particle size and concentration of solid contaminants, and exceed Class 3 on maximum oil content (ppm/wt).

"M" Series Coalescing Filters, with Type "C" 0.01 micron elements: All Wilkerson Type "M" Oil Removal (Coalescing) Filters with Type "C" 0.01 micron elements **exceed ISO Class 1** for maximum particle size and concentration of solid contaminants, and exceed Class 1 on maximum oil content (ppm/wt).

"M" Series Adsorption Filters, with Type "D" 0.003 micron activated carbon elements: All Wilkerson Type "M" adsorption filters with Type "D" 0.003 micron activated carbon elements **exceed ISO Class 1** on maximum oil content (ppm/wt).

Materials of Construction

Body		Zinc
Bowl		Polycarbonate
Element Retainer		Brass Stud
Filter Elements	Type "B", "C" Type "D"	Borosilicate Cloth Activated Carbon
Seals		Fluorocarbon

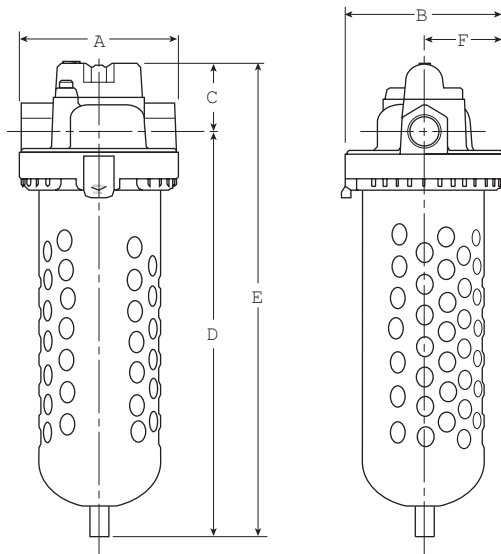

Dimensions

Models	Inches (mm)	A	B	C	D	E	F
Standard Unit M21-03-000		3.70 (94)	3.79 (96.5)	1.70 (43.2)	9.20 (233.7)	10.90 (276.9)	1.89 (48.1)
Automatic Drain M21-03-F00		3.70 (94)	3.79 (96.5)	1.70 (43.2)	9.58 (237)	11.22 (280)	1.89 (48.1)

= "Most Popular"

Replacement Bowl Kits

- Plastic Bowl –
- Bowl Guard, Manual DrainFRP-95-722
- Bowl Guard, Automatic DrainMRP-95-722

Replacement Element Kits

- Type "B", 0.5 MicronMSP-95-990
- Type "C", 0.01 MicronMTP-95-550
- Type "D", Oil Vapor RemovingMXP-95-537

Accessories

- Automatic Drain.....GRP-95-973
- Cap, Differential Pressure Indicator –
- For pressures over 150 PSIG.....GRP-95-020
- Differential Pressure IndicatorDP2-02-000
- Manual Flex-TipFRP-95-610
- Wall Mounting Bracket, U-bolt Pipe ClampGRP-95-734

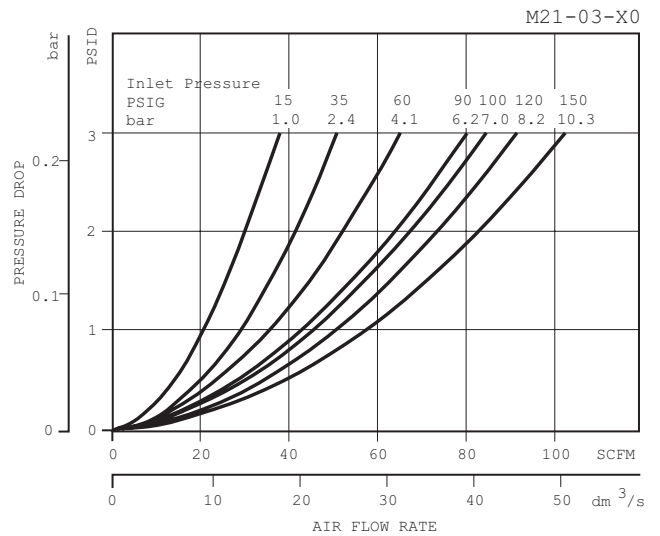
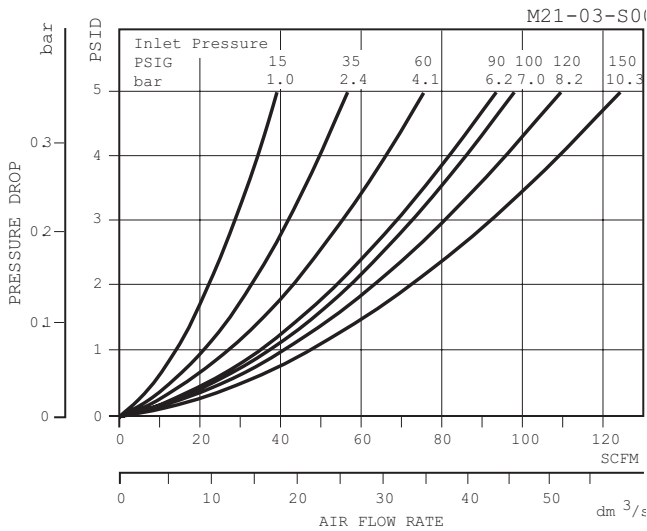
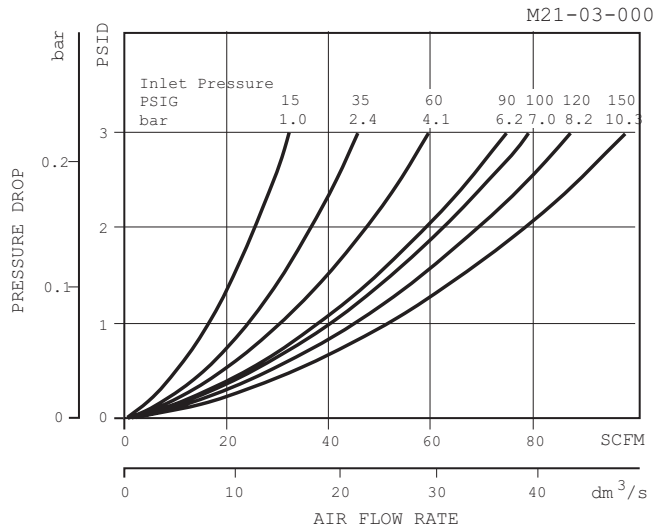

Ordering Information

Model Type	Port Size	Polycarbonate Bowl / Bowl Guard / "C" Element
Manual Drain	3/8	M21-03-000
Automatic Drain	3/8	M21-03-F00

Options - To order an option supplied with the unit model, add the appropriate coded suffix letter in the designated position of the model number.

Coalescing Filter M90

 = "Most Popular"



- Extended high efficiency filter element provides greater filtration surface area.
- Integral 3/4" or 1" ports (BSPP & NPT)
- Removes liquid aerosols and sub micron particles
- Oil free air for critical applications, such as air gauging, pneumatic instrumentation and control
- Adsorber activated carbon element removes oil vapors and most hydrocarbons
- Robust but lightweight aluminum construction

Notes: To optimize the life of the coalescing element, it is advisable to install a F90 pre-filter with a 5 micron element upstream of the coalescing filter.

To optimize the life of the adsorber element, it is advisable to install a 90 Series coalescing 0.01 micron filter upstream of the adsorber filter.

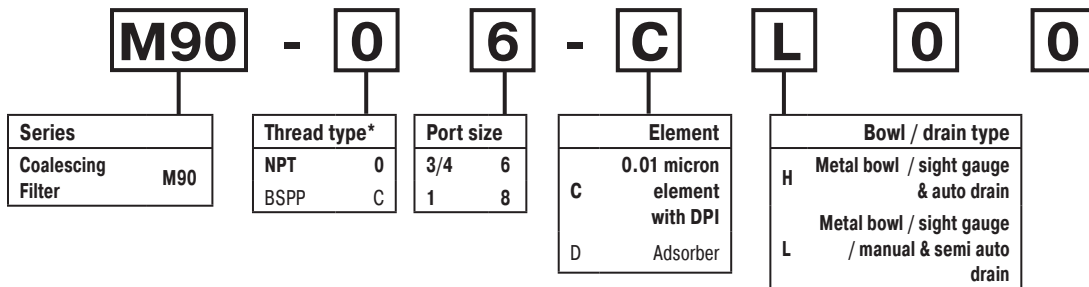

*Note: For 1-1/2" ported unit, please order P3YKA*BCP port block kit separately.
Bold items are most common.

Ordering Information

Port size	Description	Flow† scfm	Max. bar (psig)	Min temp °C (°F)	Max temp °C (°F)	Bowl capacity cm ³ (oz)	Height mm (inches)	Width mm (inches)	Depth mm (inches)	Weight kg (lb)	Part number†
3/4"	Coalescing filter 0.01 micron, combined manual / semi auto drain	275	17.5 (254)	-10 (14)	60 (140)	130 (4.4)	340 (13.4)	90 (3.5)	94 (3.7)	1.6 (3.5)	M90-06-CL00
3/4"	Coalescing filter 0.01 micron, auto drain	275	17.5 (254)	-10 (14)	60 (140)	130 (4.4)	340 (13.4)	90 (3.5)	94 (3.7)	1.6 (3.5)	M90-06-CH00
1"	Coalescing filter 0.01 micron, combined manual / semi auto drain	307	17.5 (254)	-10 (14)	60 (140)	130 (4.4)	340 (13.4)	90 (3.5)	94 (3.7)	1.6 (3.5)	M90-08-CL00
1"	Coalescing filter 0.01 micron, auto drain	307	17.5 (254)	-10 (14)	60 (140)	130 (4.4)	340 (13.4)	90 (3.5)	94 (3.7)	1.6 (3.5)	M90-08-CH00

† Standard part numbers shown in bold. For other models refer to Options chart above.

‡ Flow with 6.3 bar (91.4 psig) inlet pressure and 0.5 (7.3 psig) pressure drop.

Specifications

Fluid	Compressed air
Maximum inlet pressure*	17.5 bar (254 psig)
Temperature range*	-10°C to 60°C (14°F to 140°F)
Media specifications (Coalescer):	
Coalescing efficiency	99.97% (0.3 to 0.6 micron particles)
Max. oil carryover	0.008 mg/m ³
Typical flow element @	
6.3 bar (91.4 psig) inlet pressure and	0.01 micron element
0.5 bar (7.3 psig) pressure drop	1" port 307 scfm
Media specifications (Adsorber):	
Max. oil carryover (PPM w/w)	0.008 mg/m ³
Manual / semi-auto drain	Closed at 0.8 bar (11.6 psig) G1/8 thread male
Auto drain bowl pressure to close drain	0.8 bar (11.6 psig)
Operating range	0.8 bar (11.6 psig) to manual override facility
Bowl capacity	17.5 bar (254 psig) 130 cm ³ (4.4 US oz)

* Air supply must be dry enough to avoid ice formation at temperatures below 2°C (35.6°F).

Dimensions mm (inches)

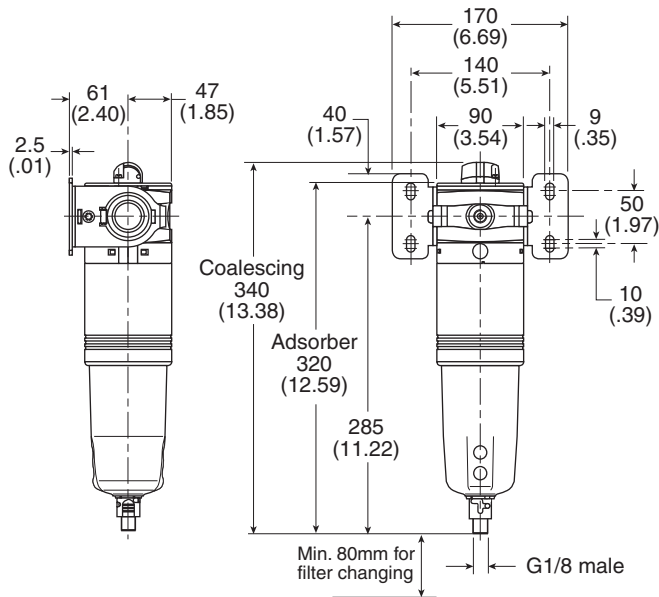

Service kits

0.01 micron element kit.....	P3YKA00ESC
Adsorber element kit	P3YKA00ESA
Bowl kit with combined manual / semi auto drain.....	P3YKA00BSC
Bowl kit with auto drain	P3YKA00BSA
Differential pressure indicator kit	P3YKA00RQ

Material specifications

Body	Aluminum
Sight glass	Polypropylene
Filter cover	ABS
Coalescing element	Borosilicate & nano fibers
Top & bottom end cap (Coalescing)	Aluminum
Adsorber element	Activated carbon
Top & bottom end cap (Adsorber)	Glass filled nylon
Support cylinders	Grade 430 stainless steel
Support media	Polypropylene
Anti re-entrainment barrier	Polyester
Encapsulate	Epoxy resin / hardener
Seals	Nitrile NBR
Drains	Manual / semi-auto: Acetal Automatic: PA / Ø 10mm brass connection
Differential pressure indicator	
Body	Acetal
Internal parts	Acetal
Spring	Stainless steel
Seals	Nitrile NBR
Support plate	ABS
Screws	Steel / zinc plated

Flow characteristics

(3/4") 0.01 Micron Coalescing Filter Saturated

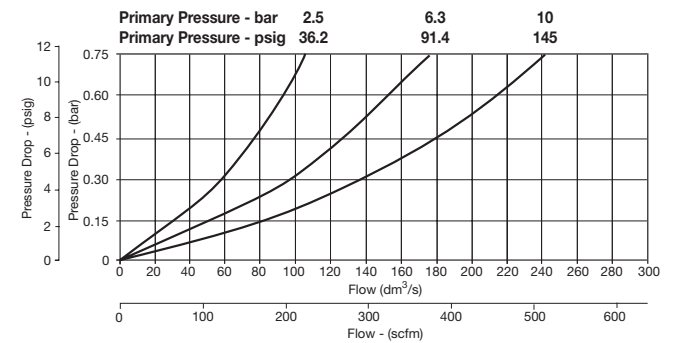

(1") 0.01 Micron Coalescing Filter Saturated

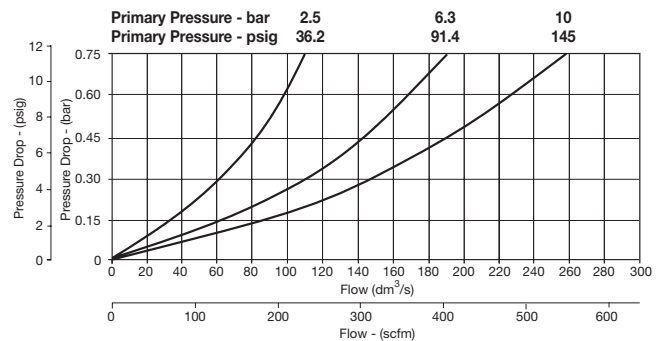

Coalescing Filter M30

= "Most Popular"



M30-04-000

Features

- Manual Drain
- 0.01 Micron Rated Filter Element
- Quick-disconnect Bowl Guard with Integral Plastic Bowl and Safety Latch
- Differential Pressure Indicator

Specifications

Flow Capacity*	1/2	123 SCFM (58.2 dm ³ /s)
	3/4	173 SCFM (81.0 dm ³ /s)
	1	203 SCFM (96.0 dm ³ /s)
Maximum Supply Pressure	Plastic Bowl	150 PSIG (10.3 bar)
	Metal Bowl	200 PSIG (13.8 bar)
Operating Temperature	Plastic Bowl	32° to 125°F (0° to 52°C)
	Metal Bowl	32° to 150°F (0° to 65.5°C)
Port Size	NPT / BSPP-G	1/2, 3/4, 1
Bowl Capacity	2.0 oz	
Standard Filtration Micron	(B) 0.5, (C) 0.01	
	(D) 0.003 ppm / wt**	
Weight	5.4 lb. (2.4 kg)	

* Inlet pressure 150 PSIG (10.3 bar). Pressure drop of 3 PSID (0.2 bar).

** Filtration temperature of 70°F (21°C) @100 PSIG (6.9 bar) with typical compressor lubricating oil and protected by Type "C" filter.

"M" Series Coalescing Filters, with Type "B" 0.5 micron elements: All Wilkerson Type "M" Oil Removal (Coalescing) Filters with Type "B" 0.5 micron elements **exceed ISO Class 2** for maximum particle size and concentration of solid contaminants, and exceed Class 3 on maximum oil content (ppm/wt).

"M" Series Coalescing Filters, with Type "C" 0.01 micron elements: All Wilkerson Type "M" Oil Removal (Coalescing) Filters with Type "C" 0.01 micron elements **exceed ISO Class 1** for maximum particle size and concentration of solid contaminants, and exceed Class 1 on maximum oil content (ppm/wt).

"M" Series Adsorption Filters, with Type "D" 0.003 micron activated carbon elements: All Wilkerson Type "M" adsorption filters with Type "D" 0.003 micron activated carbon elements **exceed ISO Class 1** on maximum oil content (ppm/wt).

Materials of Construction

Body	Zinc	
Bowls	Plastic Bowl	Polycarbonate
	Metal Bowl	Aluminum
Element Retainer	Brass Stud	
Filter Elements	Type "B", "C"	Borosilicate Cloth
	Type "D"	Activated Carbon
Seals	Fluorocarbon	

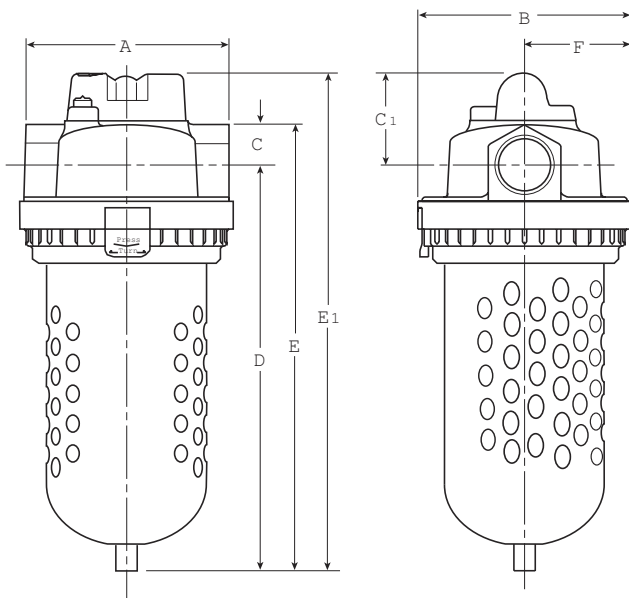

Dimensions

Models	Inches (mm)	A	B	C	C ₁	D	E	E ₁	F
Standard Unit M30-XX-000		4.61 (117)	4.80 (122)	.94 (24)	1.77 (44.9)	9.13 (232)	10.07 (255.8)	10.90 (270)	2.40 (61)
Automatic Drain M30-XX-F00		4.61 (117)	4.80 (122)	.94 (24)	1.77 (44.9)	9.27 (235)	10.21 (259)	11.04 (273.5)	2.40 (61)
Metal Bowl M30-XX-M00		4.61 (117)	4.80 (122)	.94 (24)	1.77 (44.9)	8.73 (221.7)	9.67 (245.6)	10.50 (267)	2.40 (61)

= "Most Popular"

Replacement Bowl Kits

- Metal Bowl –
 Manual Drain FRP-95-593
 Auto Drain..... GRP-95-970
- Plastic Bowl –
 Manual Drain FRP-96-315
 Bowl Guard, Manual Drain FRP-95-832
 Bowl Guard, Auto Drain FRP-95-775

Replacement Element Kits

- Type "B", 0.5 Micron MSP-95-992
 Type "C", 0.01 Micron MTP-95-551
 Type "D", Oil Vapor Removing MXP-95-532

Accessories

- Automatic Mechanical Drain..... GRP-95-973
 Cap, Differential Pressure Indicator –
 For pressures over 150 PSIG..... GRP-95-020
 Differential Pressure Indicator DP2-02-000
 Manual Flex-Tip FRP-95-610
 Sight Gauge Kit LRP-95-771
 Wall Mounting Bracket, U-Bolt Pipe Clamp..... GRP-95-734

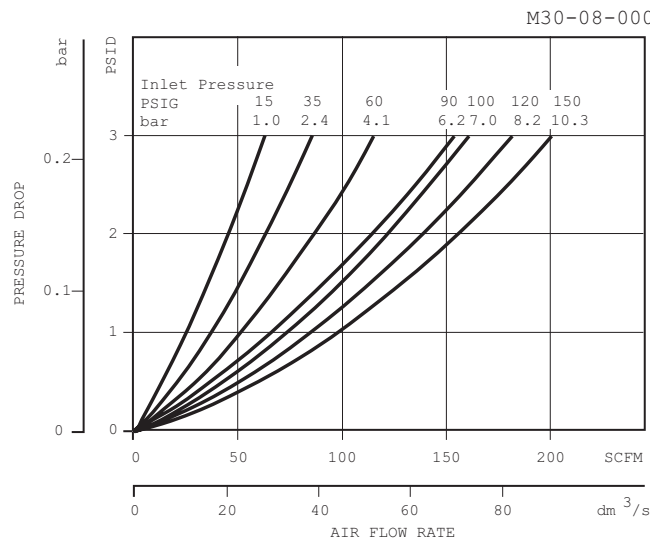
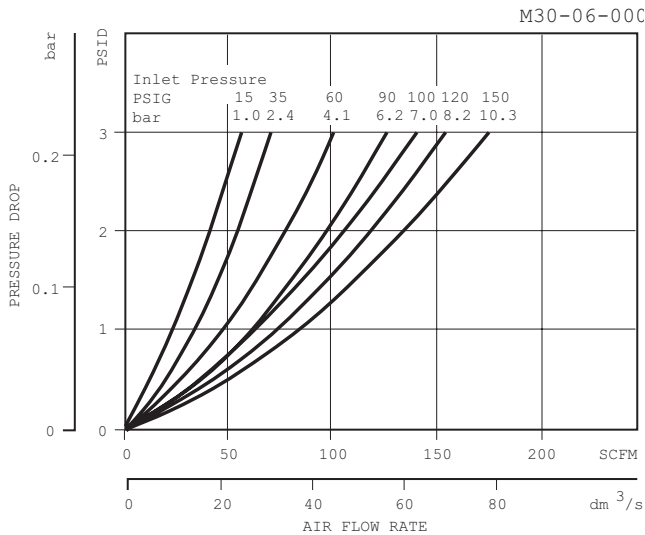
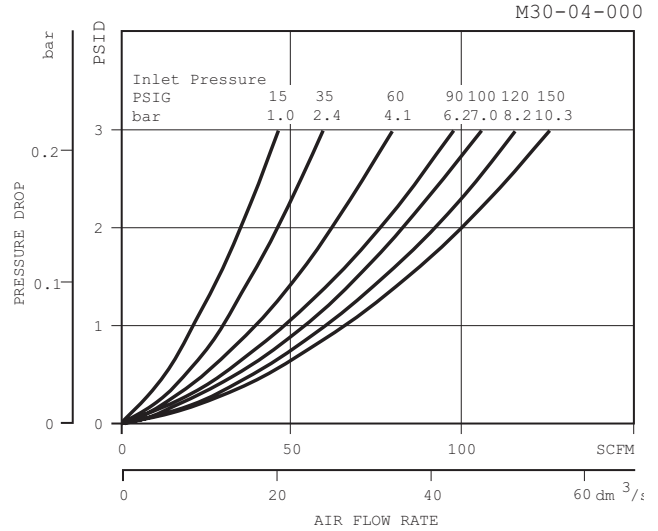

Ordering Information

Model Type	Port Size	Polycarbonate Bowl / Bowl Guard / "C" Element	Metal Bowl / "C" Element	Polycarbonate Bowl / Bowl Guard / "B" Element	Polycarbonate Bowl / Bowl Guard / "D" Element (No DPI)
Manual Drain	1/2	M30-04-000	M30-04-M00	M30-04-S00	M30-04-X00
	3/4	M30-06-000	M30-06-M00	M30-06-S00	M30-06-X00
	1	M30-08-000	M30-08-M00	M30-08-S00	M30-08-X00
Automatic Drain	1/2	M30-04-F00	M30-04-FM0	M30-04-FS0	—
	3/4	M30-06-F00	M30-06-FM0	M30-06-FS0	—
	1	M30-08-F00	M30-08-FM0	M30-08-FS0	—

Options - To order an option supplied with the unit model, add the appropriate coded suffix letter in the designated position of the model number.

Coalescing Filter M35

= "Most Popular"



M35-0B-000

Features

- Heavy-duty Cast Aluminum Housings to Withstand Operating Pressures Up to 250 PSIG †
- Differential Pressure Indicator to Eliminate the Guesswork of Element Replacement
- Differential Pressure Gauge Available, Order Separately, Kit DP3-01-000
- Unique Drain Mounting Plate Design Offers Trouble-free Method for Interchanging and Installing External Drains
- High-flow Filter Elements: Coalescing, 1 Micron and 0.01 Micron

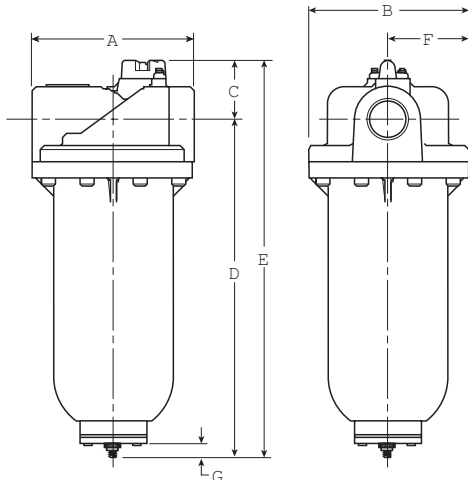

Dimensions

Models	Inches (mm)	A	B	C	D	E	F	G
Standard Unit M35-XX-F00		7.80 (198)	7.75 (197)	2.81 (71)	16.24 (412)	19.07 (484)	3.88 (99)	.55 (14)
Without Automatic Drain M35-XX-000		7.80 (198)	7.75 (197)	2.81 (71)	15.69 (398.5)	18.52 (470)	3.88 (99)	.55 (14)

Specifications

Flow Capacity*	1-1/2 2	710 SCFM (335 dm ³ /s) 710 SCFM (335 dm ³ /s)
Maximum Supply Pressure	without DPI and with Pressure Gauge with DPI	250 PSIG (17.2 bar)† 150 PSIG (10.3 bar)
Operating Temperature	32° to 150°F (0° to 65.5°C)	
Port Size	NPT / BSPP-G	1-1/2, 2
Bowl Capacity	13.9 oz	
Standard Filtration	Micron	(B1) 1.0, (C) 0.01 (D) 0.003 ppm / wt**
Weight	19.3 lb. (8.7 kg)	

* Inlet pressure 150 PSIG (10.3 bar). Pressure drop of 3 PSID (0.2 bar).

** Filtration temperature of 70°F (21°C) @100 PSIG (6.9 bar) with typical compressor lubricating oil and protected by Type "C" filter.

† Without Differential Pressure Indicator – Max. supply pressure is 250 PSIG (17.2 bar).

"M" Series Coalescing Filters, with Type "B1" 1.0 micron elements: All Wilkerson Type "M" Oil Removal (Coalescing) Filters with Type "B1" 1.0 micron elements **exceed ISO** Class 2 for maximum particle size and concentration of solid contaminants, and exceed Class 3 on maximum oil content (ppm/wt).

"M" Series Coalescing Filters, with Type "C" 0.01 micron elements: All Wilkerson Type "M" Oil Removal (Coalescing) Filters with Type "C" 0.01 micron elements **exceed ISO** Class 1 for maximum particle size and concentration of solid contaminants, and exceed Class 1 on maximum oil content (ppm/wt).

"M" Series Adsorption Filters, with Type "D" 0.003 micron activated carbon elements: All Wilkerson Type "M" adsorption filters with Type "D" 0.003 micron activated carbon elements **exceed ISO** Class 1 on maximum oil content (ppm/wt).

Materials of Construction

Body	Aluminum	
Bowls	Aluminum	
Filter Elements	Type "B1", "C" Type "D"	Borosilicate Cloth Activated Carbon
Seals	Fluorocarbon	
Stud	Plated Steel	

NOTE: Automatic internal float drain shown is included on M35 filters with F00 suffix only. Models with 000 suffix include drain plate with tapped 1/2 NPT / BSPP-G drain port.

= "Most Popular"

Replacement Element Kits

- Type "B1", 1.0 Micron.....MSP-95-502
- Type "C", 0.01 MicronMTP-95-502
- Type "D", Oil Vapor Removing.....MXP-95-502

Accessories

- Cap, Differential Pressure Indicator –
(For pressures over 150 PSIG)..... GRP-95-022
- Drain, Automatic, Internal, Fluorocarbon..... GRP-95-981
- Drain Plate Kit –
1/2 NPT Tapped Drain Port GRP-95-393
- Gauge, Differential Pressure..... DP3-01-000
- Indicator, Differential PressureDP2-02-001
- Manual Drain Kit
with 1/2" Drain Plate GRP-95-392

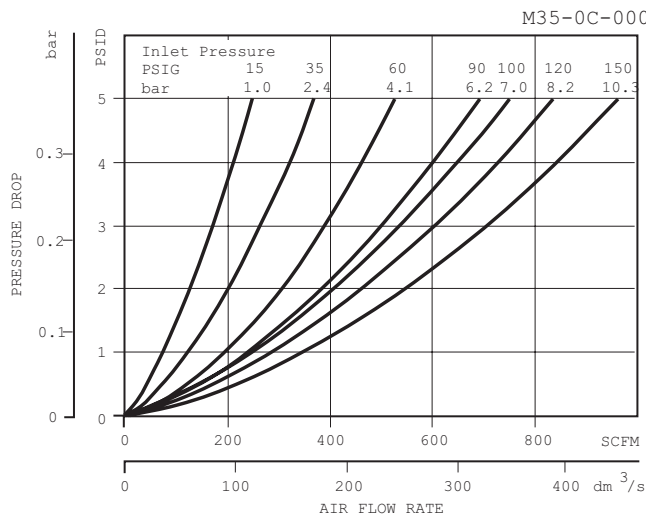
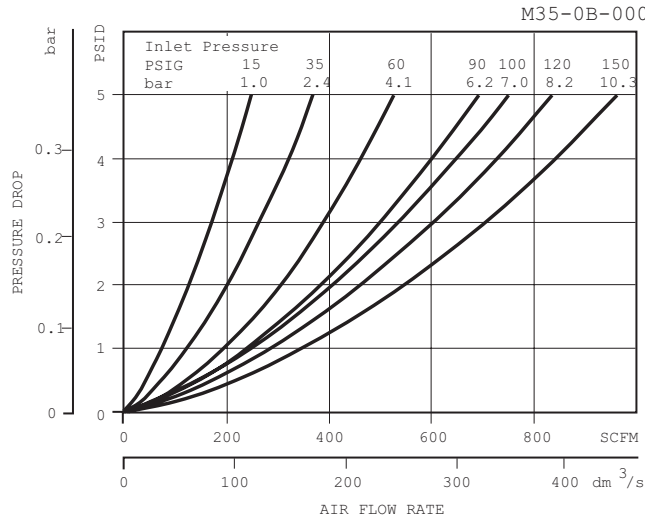

Ordering Information

Model Type	Port Size	Metal Bowl / "C" Element	Metal Bowl / "B1" Element	Metal Bowl / "D" Element
Manual Drain	1-1/2	M35-0B-000	M35-0B-S00	M35-0B-X00 (Includes 1/2 NPT / BSPP-G M35-0C-X00 Drain Plate)
	2	M35-0C-000	M35-0C-S00	
Automatic Drain	1-1/2	M35-0B-F00	M35-0B-FS0	—
	2	M35-0C-F00	M35-0C-FS0	—

Options - To order an option supplied with the unit model, add the appropriate coded suffix letter in the designated position of the model number.

Afterfilter Numbering System

 = "Most Popular"

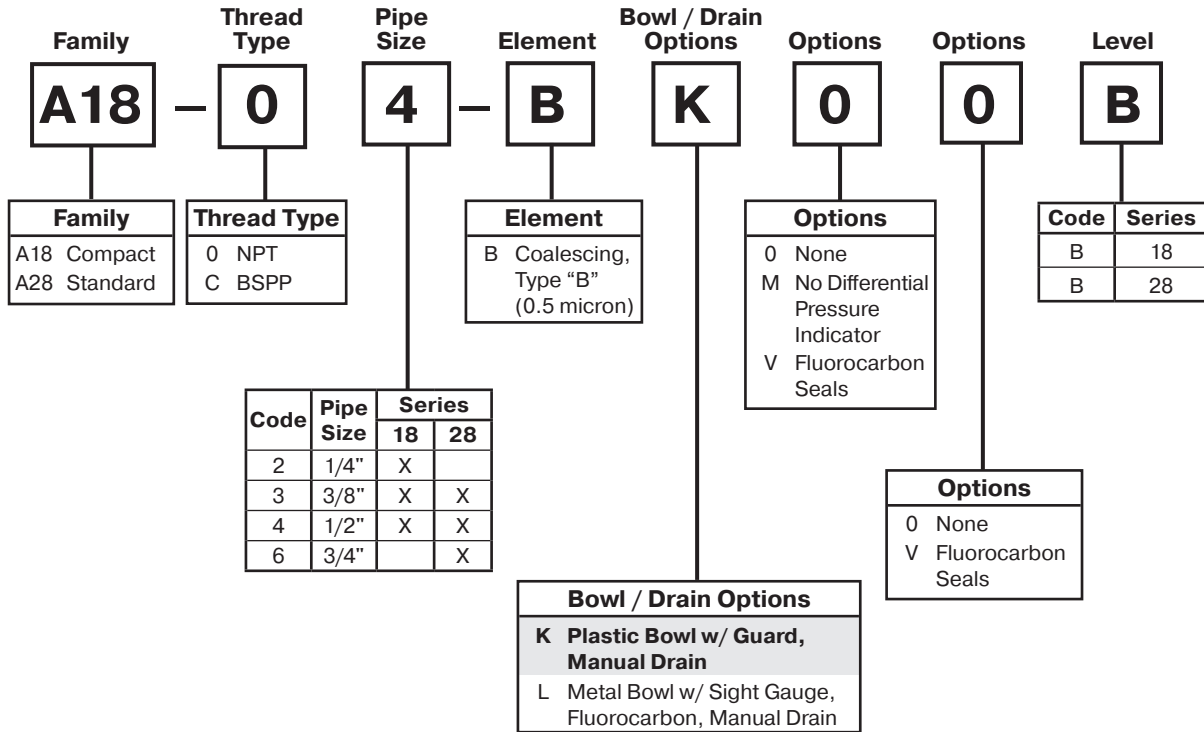

NOTE:All classes above refer to International Standards Organization (ISO) standard 8573-1, pertaining to maximum particle size and concentration of solid contaminants, and maximum oil content.

If more than one option is desired, arrange them in alphabetical order in positions 6, 7, and 8.

Afterfilter A18

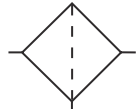

Afterfilter



= "Most Popular"

Specifications

Flow Capacity*	1/4	50 SCFM (23.6 dm ³ /s)
	3/8	60 SCFM (28.3 dm ³ /s)
	1/2	67 SCFM (31.6 dm ³ /s)
Maximum Supply Pressure	Plastic Bowl	150 PSIG (10.3 bar)
	Metal Bowl	250 PSIG (17.2 bar)
Operating Temperature	Plastic Bowl	-13° to 125°F (-25° to 52°C)
	Metal Bowl	-13° to 150°F (-25° to 65.5°C)
Port Size	NPT / BSPP-G	1/4, 3/8, 1/2
Standard Filtration	0.5 Micron	
Weight	0.71 lb. (0.32 kg)	

* Inlet pressure 91.3 PSIG (6.3 bar). Pressure drop 3 PSID (0.2 bar).

"A18" Series Afterfilters, with Type "B" 0.5 micron elements:
All Wilkerson Type "AF" Afterfilters with Type "B" 0.5 micron elements **exceed ISO** Class 2 for maximum particle size and concentration of solid contaminants, and **exceed** Class 3 on maximum oil content (ppm/wt).

Features

- Modern Design and Appearance
- 0.5 Micron Element
- Light Weight
- High Flow Capacity with Minimal Pressure Drop

Materials of Construction

Body	Aluminum	
Body Cap	ABS	
Bowls	Plastic Bowl	Polycarbonate
	Metal Bowl	Aluminum
Filter Element	Type "B"	Borosilicate Fiber
Seals	Nitrile	
Sight Gauge	Metal Bowl	Nylon

Replacement Bowl Kits

- Metal Bowl with Sight Gauge,
Manual Drain GRP-96-636
- Plastic Bowl / Bowl Guard,
Manual Drain GRP-96-634
- Plastic Bowl, Plastic Guard,
No Drain GRP-96-638

Replacement Element Kit

- Type "B", 0.5 Micron MSP-96-647

Accessories

- Wall Mounting Bracket –
L-Type GPA-96-604
T-Type GPA-96-602

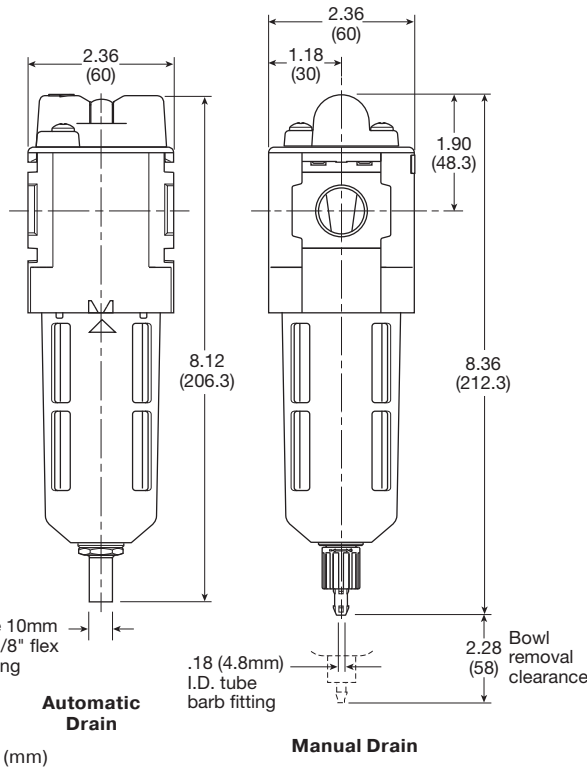

Ordering Information

Model Type	Port Size	Polycarbonate Bowl / Bowl Guard / "B" Element	Metal Bowl / Sight Gauge / "B" Element
Type "B" Element is Standard (Manual Drain)	1/4	A18-02-BK00B	A18-02-BL00B
	3/8	A18-03-BK00B	A18-03-BL00B
	1/2	A18-04-BK00B	A18-04-BL00B

Options - To order an option supplied with the unit model, add the appropriate coded suffix letter in the designated position of the model number.

Afterfilter A28

= "Most Popular"

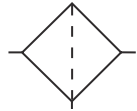

Afterfilter



Features

- Modern Design and Appearance
- 0.5 Micron Element
- Light Weight
- High Flow Capacity with Minimal Pressure Drop
- Bowl Guard
- Quick-Disconnect Bowl

Specifications

Flow Capacity*	3/8	82 SCFM (38.7 dm ³ /s)
	1/2	90 SCFM (42.5 dm ³ /s)
	3/4	98 SCFM (46.3 dm ³ /s)
Maximum Supply Pressure	Plastic Bowl	150 PSIG (10.3 bar)
	Metal Bowl	250 PSIG (17.2 bar)
Operating Temperature	Plastic Bowl	-13° to 125°F (-25° to 52°C)
	Metal Bowl	-13° to 150°F (-25° to 65.5°C)
Port Size	NPT / BSPP-G	3/8, 1/2, 3/4
Standard Filtration	0.5 Micron	
Weight	1.01 lb. (0.46 kg)	

* Inlet pressure 91.3 PSIG (6.3 bar). Pressure drop 3 PSID (0.2 bar).

"A28" Series Afterfilters, with Type "B" 0.5 micron elements:
All Wilkerson Type "AF" Afterfilters with Type "B" 0.5 micron elements **exceed ISO** Class 2 for maximum particle size and concentration of solid contaminants, and **exceed** Class 3 on maximum oil content (ppm/wt).

Materials of Construction

Body	Aluminum	
Body Cap	ABS	
Bowls	Plastic Bowl	Polycarbonate
	Metal Bowl	Aluminum
Filter Element	Type "B"	Borosilicate Fiber
Seals	Nitrile	
Sight Gauge	Metal Bowl	Nylon

Replacement Bowl Kits

- Metal Bowl with Sight Gauge, Manual Drain GRP-96-644
- Plastic Bowl / Bowl Guard, Manual Drain GRP-96-642
- Plastic Bowl, Plastic Guard, No Drain GRP-96-652

Replacement Element Kit

- Type "B", 0.5 Micron MSP-96-649

Accessories

- Wall Mounting Bracket –
 - L-Type GPA-96-605
 - T-Type GPA-96-602

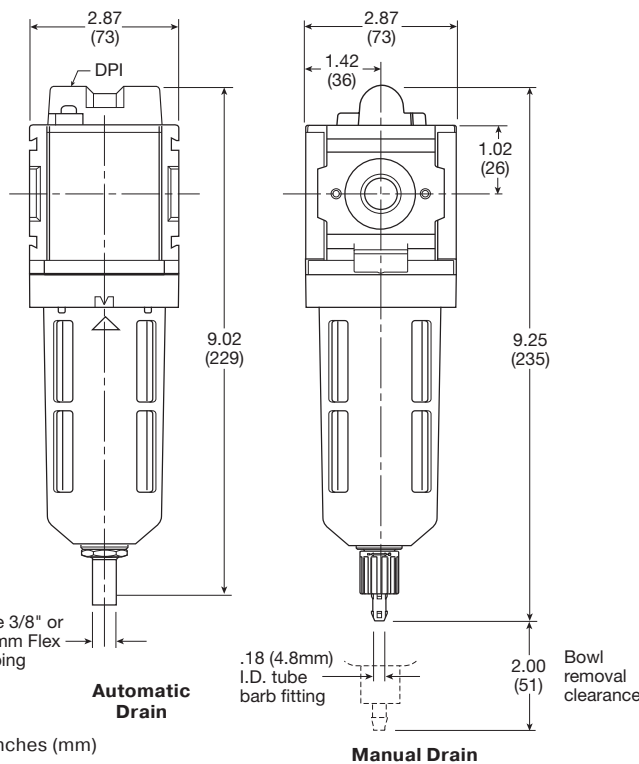

Ordering Information

Model Type	Port Size	Polycarbonate Bowl / Bowl Guard / "B" Element	Metal Bowl / Sight Gauge / "B" Element
Type "B" Element is Standard (Manual Drain)	3/8	A28-03-BK00B	A28-03-BL00B
	1/2	A28-04-BK00B	A28-04-BL00B
	3/4	A28-06-BK00B	A28-06-BL00B

Options - To order an option supplied with the unit model, add the appropriate coded suffix letter in the designated position of the model number.

Exhaust Muffler F23



F23-04-000

Exhaust Muffler Units

Part of an OSHA requirement is to keep sustained noise levels within acceptable specifications: 90 decibels (dBA) or less. Wilkerson's mufflers and oil reclassifiers keep these objectionable exhaust noises (air motors, control valves, etc.) within the OSHA specifications.

These units have only one inlet port.

The contaminants in the exhaust flow are mechanically separated and twice filtered to 5 micron levels. The clean, muffled exhaust flows out of the unit under the metal hood on top.

Features:

- 5 Micron Rated Reusable Elements
- Quick-Disconnect Clamp Ring for Easy Bowl Removal
- Low-Pressure Drop (Back Pressure)
- Removes Oily Aerosols from Exhaust Flows
- Transparent Bowls with Metal Bowl Guards Standard

Replacement Bowl Kits

- Metal Bowl Guard, (for Plastic Bowl) GRP-95-804
- Metal Bowl, Brass Petcock FRP-95-612
- Metal Bowl / Sight Gauge, Brass Petcock GRP-95-613
- Plastic Bowl, Plastic Petcock Drain LRP-96-157
- Plastic Bowl / Bowl Guard, Plastic Petcock Drain. GRP-95-724

Replacement Element Kit

- Type A", 5 Micron (Upper & Lower Elements) FRP-95-169

Replacement Kits

- Clamp Ring Assembly GRP-95-154
- Manual Drain, Brass Petcock GRP-95-182
- O-ring, Bowl, Fluorocarbon (10 per kit) GRP-95-109
- O-ring, Bowl, Nitrile (10 per kit) GRP-95-257

Accessories

- Wall Mounting Bracket, U-Bolt Pipe Clamp GRP-95-734

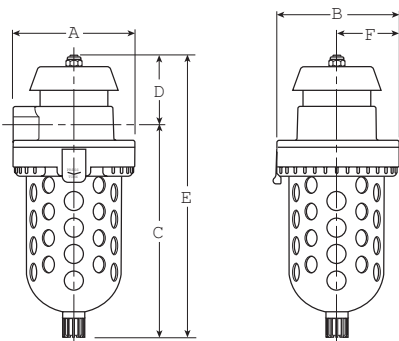

Dimensions

Models	Inches (mm)	A	B	C	D	E	F
Standard Unit F23-04-000		3.83 (97.5)	3.83 (97.5)	6.23 (158.2)	2.06 (52.3)	8.29 (210.6)	1.92 (48.8)

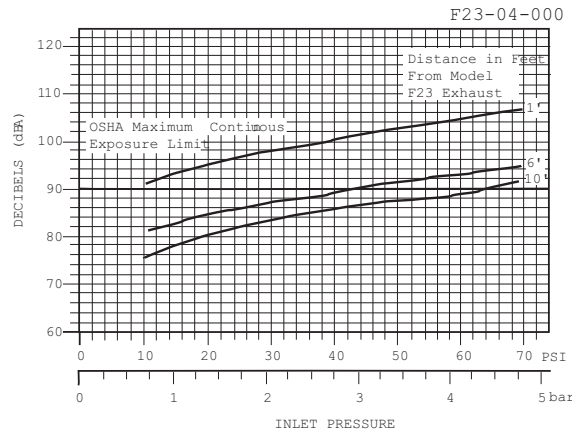
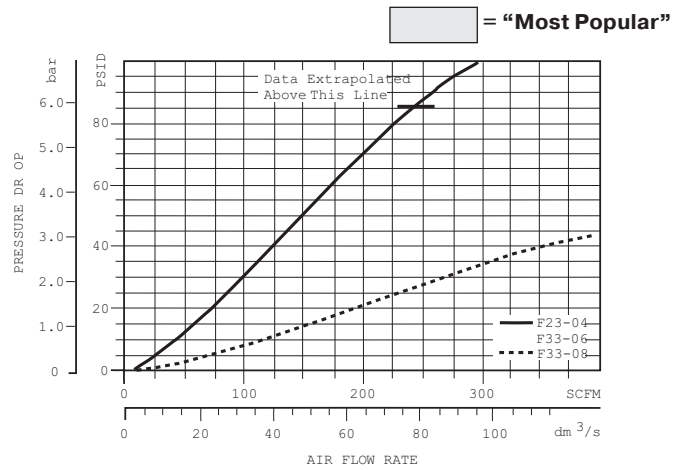

Specifications

Maximum Supply Pressure	150 PSIG (10.3 bar)
Operating Temperature	32° to 125°F (0° to 52°C)
Port Size	NPT / BSPP-G 1/2
Standard Filtration	5 Micron
Weight	3.12 lb. (1.4 kg)

Materials of Construction

Baffle	Acetal	
Body	Zinc	
Bowls	Plastic Bowl Metal Bowl	Polycarbonate Aluminum
Element Retainer	Steel Stud	
Filter Element	Sintered Polyethylene	
Shield	Steel	
Stem	Steel	

Exhaust Muffler F33

Exhaust Muffler Units

Part of an OSHA requirement is to keep sustained noise levels within acceptable specifications: 90 decibels (dBA) or less. Wilkerson's mufflers and oil reclassifiers keep these objectionable exhaust noises (air motors, control valves, etc.) within the OSHA specifications.

These units have only one inlet port. The contaminants in the exhaust flow are mechanically separated and twice filtered to 5 micron levels. The clean, muffled exhaust flows out of the unit under the metal hood on top.



F33-06-000

Features:

- 5 Micron Rated Reusable Elements
- Quick-Disconnect Clamp Ring for Easy Bowl Removal
- Low-Pressure Drop (Back Pressure)
- Removes Oily Aerosols from Exhaust Flows
- Transparent Bowls with Metal Bowl Guards Standard

Replacement Bowl Kits

- Metal Bowl Guard, (for Plastic Bowl) GRP-95-808
- Metal Bowl, Brass Petcock..... FRP-95-593
- Metal Bowl / Sight Gauge, Brass Petcock GRP-95-676
- Plastic Bowl, Plastic Petcock Drain LRP-96-160
- Plastic Bowl / Bowl Guard, Plastic Petcock Drain..LRP-95-830

Replacement Element Kit

- Type "A", 5 Micron..... FRP-95-170

Replacement Kits

- Clamp Ring Assembly GRP-96-404
- Manual Drain, Brass Petcock GRP-95-182
- O-ring, Bowl, Fluorocarbon (10 per kit) GRP-95-942
- O-ring, Bowl, Nitrile (10 per kit)..... GRP-95-256

Accessories

- Wall Mounting Bracket, U-Bolt Pipe Clamp GRP-95-734

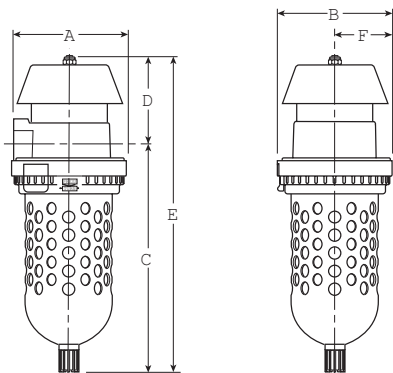

Dimensions

Models	Inches (mm)	A	B	C	D	E	F
Standard Unit F33-06-000 & F33-08-000		4.63 (117.6)	4.63 (117.6)	8.91 (226.3)	3.99 (98.6)	12.79 (324.9)	2.31 (58.7)

= "Most Popular"

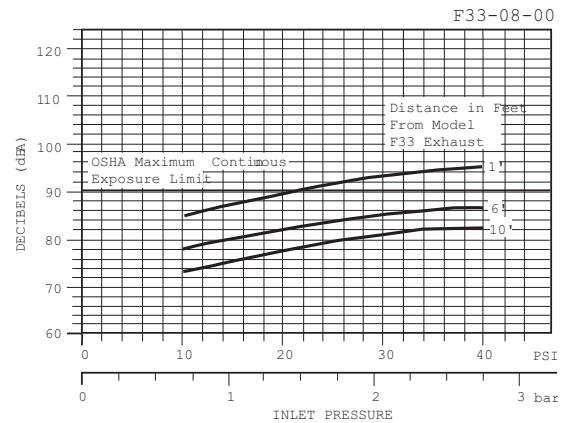
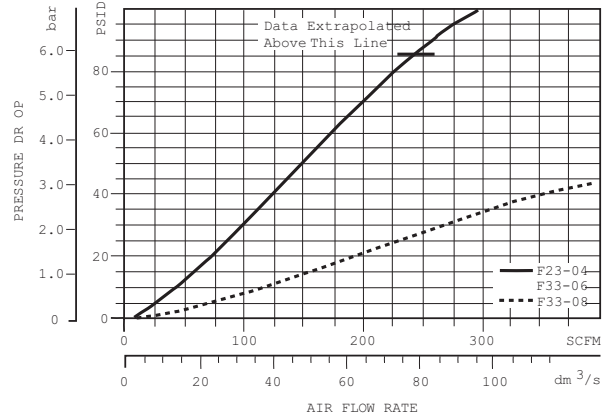

Specifications

Maximum Supply Pressure	150 PSIG (10.3 bar)
Operating Temperature	32° to 125°F (0° to 52°C)
Port Size	NPT / BSPP-G 3/4, 1
Standard Filtration	5 Micron
Weight	6 lb. (2.7 kg)

Materials of Construction

Baffle	Acetal
Body	Zinc
Bowls	Plastic Bowl: Polycarbonate Metal Bowl: Aluminum
Element Retainer	Steel Stud
Filter Element	Sintered Polyethylene
Shield	Steel
Stem	Steel

Exhaust Silencer Mist Eliminator XMC

= "Most Popular"



XMC-08-000

Features

- Port Sizes 1/2", 1" and 1-1/2" NPT
- Liquid Sump with Manual Drain
- Corrosion Resistant Construction
- Compact and Easy to Install
- Low Cost
- Low Back Pressure
- High Density Durable Plastic End Caps

Specifications

	XMC-04-000	XMC-08-000	XMC-0B-000
Air Flow @12 PSIG (0,8 bar)	65 SCFM (30.7 dm ³ /s)	110 SCFM (51.9 dm ³ /s)	200 SCFM (94.4 dm ³ /s)
Back Pressure			
Bowl Capacity	2.2 fl. oz.	5 fl. oz.	5 fl. oz.
Cv	5.5	9.3	16.9
Drain	Manual		
Oil Removal	99.9%		
Operating Temperature	36° to 122°F (2° to 50°C)		
Port Size*	1/2 NPT	1 NPT	1-1/2 NPT
Media	Air		
Noise Reduction	25 dBA		
Weight	0.4 (0,18)		

* Place "C" in position 4 to specify BSPP-G.

Materials of Construction

Corrosion Resistant Threaded End Cap	Nylon
Cover Cap	Plastic
Filter Elements –	
Primary	Borosilicate Cloth
Secondary	PVC Fiber
Oil Drain Cup	Plastic
Outer Support Sleeve	Plastic Mesh Screen

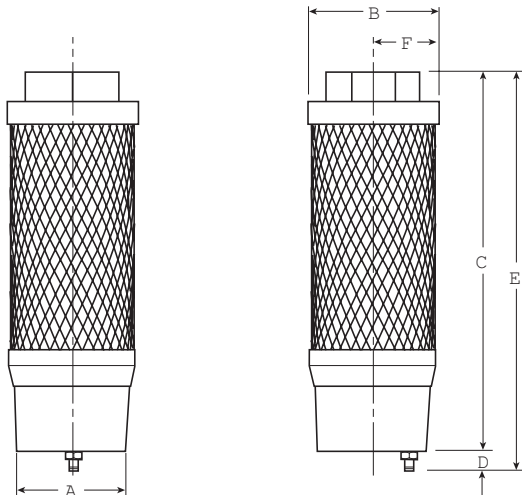

Dimensions

Models	Inches (mm)	Port Size	A	B	C	D	E	F
Standard Unit XMC-04-000		1/2	2.00 (51)	2.36 (60)	3.94 (100)	0.39 (10)	5.94 (150.9)	1.18 (30)
Standard Unit XMC-08-000		1	2.00 (51)	2.36 (60)	5.83 (148)	0.39 (10)	7.83 (198.9)	1.18 (30)
Standard Unit XMC-0B-000		1-1/2	3.00 (76)	3.42 (87)	8.19 (208)	0.42 (11)	11.19 (284)	—

Exhaust Silencer / Mist Eliminator XMC

The XMC Series High Performance Exhaust Silencer / Mist Eliminator is an efficient solution to exhaust air oil mist contamination and excessive noise levels generated by exhaust air at levels generally above acceptable safety standards. The Wilkerson XMC Series Exhaust Silencer / Mist Eliminator solves the following two problems:

Oil and Mist Contamination

Exhaust air from various in-plant pneumatic components, such as valves and cylinders generally contain a significant amount of oil mists, as well as solid particles and other lubricant additives which will pollute the working environment, affect worker's health and the quality of the final product.

Operation

During unit operation, the XMC unit coalesces oil mists, which then collect into an integral drainage cup at the bottom of the element. Depending upon the volume of contamination exhausting into the unit, this may either be drained off periodically by removing the rubber drain plug cap and drain into a container, or continuously by connecting a suitable length of plastic tubing to the drain plug on the unit. The XMC is a disposable unit and should be changed when the back pressure becomes excessive for your particular installation.

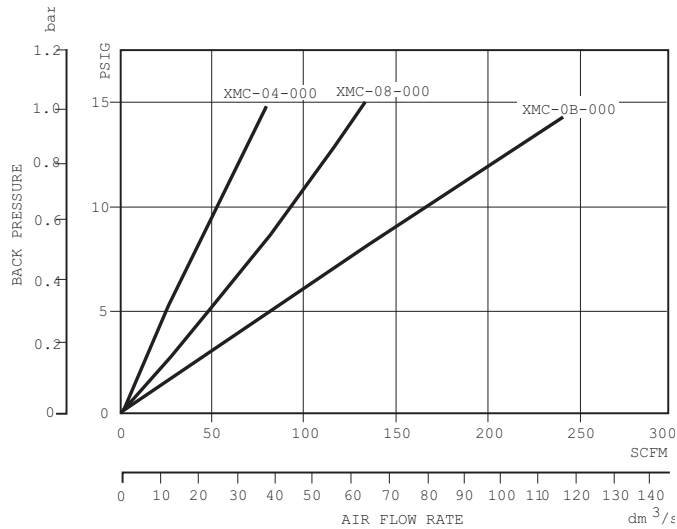

Back Pressure Chart

Unacceptable Noise Levels

The expanding exhaust air also produces both sudden and excessive noise, generally at levels well above the OSHA requirements of 90 decibels (dBA), which makes the working environment both unpleasant and potentially unsafe.

By using a Wilkerson XMC Series unit, oil mist and other contaminants inherent in lubricated air lines are removed thus preventing them from entering the atmosphere. At the same time, the noise level is reduced to meet and exceed the requirements of OSHA standards applicable to environmental conditions. The high performance XMC models remove up to 99.9% of the oil mist from the exhaust air, providing a clean, healthy work environment.

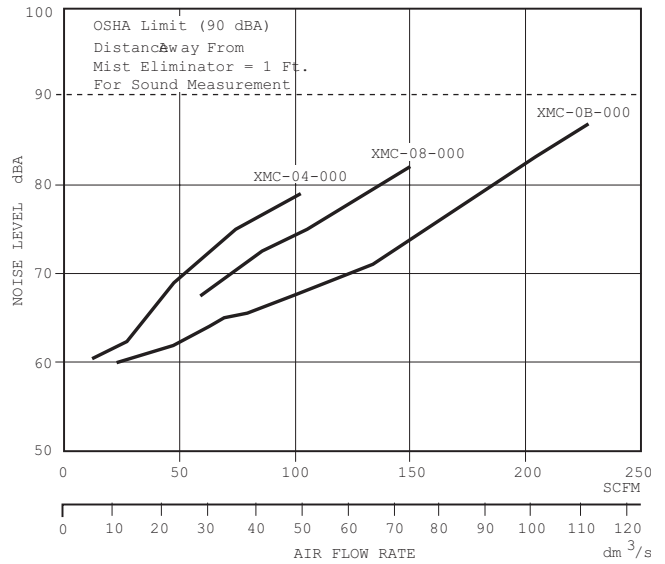

Noise Characteristics Chart

Installation

Wilkerson's XMC Exhaust Silencer / Mist Eliminators can be easily and quickly installed in the exhaust ports of pneumatic valves, air motors and other air operated devices to reduce work area noise and eliminate oil mist from exhaust air. Use of collective piping or manifold where multiple air devices are used makes for easy maintenance and control of oil mist collection and disposal. For manual draining, attach plastic tubing with an inside diameter of 0.25" (6.35 mm) and run tubing from the drain to the collecting container. When installed without plastic tubing, periodically remove rubber drain plug cap and manually drain unit into a proper disposable container.

Liquid Separators WSA / WS0

 = "Most Popular"



Specifications

Maximum Operating Pressure	(WSA)	200 PSIG (13.8 bar)
	(WS0)	232 PSIG (16.0 bar)
Operating Temperature	(WSA)	32° to 150°F (0° to 65.5°C)
	(WS0)	35° to 176°F (1.6° to 80°C)
Pressure Differential at Rated Flow		1.0 PSID (0.07 bar)

Materials of Construction

	WSA	WS0
Housing	Zinc	Aluminum
Seals	Nitrile	Fluorocarbon

Features

- High Flow Rates
- Less than 1 PSIG Differential Pressure
- Lightweight Cast Aluminum Housing with 1" to 3" NPT Connections (WS0)
- Cast Zinc Housings with 1/4" to 1" NPT Connections (WSA)
- External Surfaces Epoxy Painted for Maximum Corrosion Protection
- Standard Equipped with Quick Disconnect Bowls for Ease of Service (WSA)
- Three (3) Optional Automatic Drains Available

Liquid Separators

Our unique design combines the techniques of centrifugal action and other mechanical separation principles (Impingement, Separation, Laminar Flow and Stokes Law) to remove large quantities of liquid and solid contamination.

Typical applications include water separation downstream of aftercoolers, protection of refrigerant and heatless regenerative desiccant dryers, downstream of air receivers, and other liquid / gas separation duties where the volume of water and solids poses a real problem.

Model Number	In / Out NPT Pipe Conn.	Rated Flow (SCFM) @ 100 PSIG*	Approx. Weight lbs.	Recommended Automatic Drain
WSA-02-M00**	1/4"	25	2.2	Optional
WSA-02-FM0	1/4"	25	2.2	Internal
WSA-03-M00**	3/8"	50	2.6	Optional
WSA-03-FM0	3/8"	50	2.6	Internal
WSA-04-M00**	1/2"	50	2.6	Optional
WSA-04-FM0	1/2"	50	2.6	Internal
WSA-06-M00**	3/4"	100	6.0	Optional
WSA-06-FM0	3/4"	100	6.0	Internal
WSA-08-M00**	1"	120	6.0	Optional
WSA-08-FM0	1"	120	6.0	Internal
WS0-08-000B	1"	233	4.8	X02-04-FM0 WDV3-G
WS0-0B-000B	1-1/2"	742	11.2	X02-04-FM0 WDV3-G
WS0-0C-000B	2"	742	11.2	X02-04-FM0 WDV3-G
WS0-0E-000B	3"	1700	22.0	X02-04-FM0 WDV3-G

*1 PSID maximum differential. **Models have petcock.

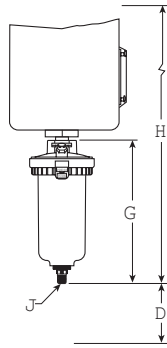

X02

D = Bowl Removal Clearance Dimension

J = External Drain Discharge Port (NPT)

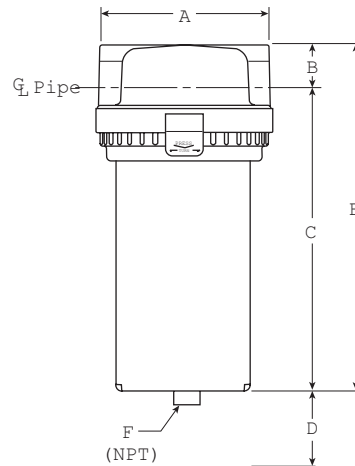

WSA

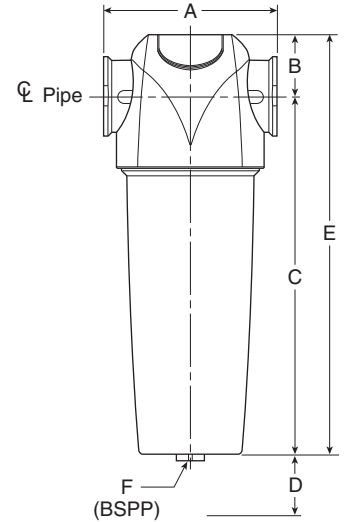

WSO

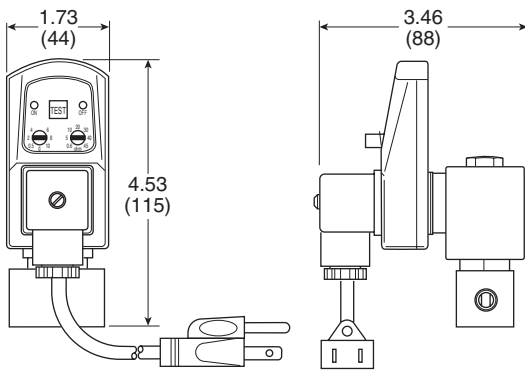

Front View

Side View

WDV3-G

NOTE: MAXIMUM separator efficiency of 98%+ is achieved in the range of 15 to 100% of rated flow in SCFM. At flow rates of <15% or >100%, separator efficiency is reduced considerably. Consult your Wilkerson distributor or contact Wilkerson for assistance in selecting the correct separator model for your application.

Model Number	A	B	C	D	E	NPT F	G	H	NPT J
WSA-02-M00*	3.00	.90	5.51	3.50	6.41	1/8	—	—	—
WSA-02-FM0	3.00	.90	5.51	3.50	6.41	1/8	—	—	—
WSA-03-M00*	3.35	.98	6.36	3.50	7.34	1/8	—	—	—
WSA-03-FM0	3.35	.98	6.36	3.50	7.34	1/8	—	—	—
WSA-04-M00*	3.35	.98	6.36	3.50	7.34	1/8	—	—	—
WSA-04-FM0	3.35	.98	6.36	3.50	7.34	1/8	—	—	—
WSA-06-M00*	4.62	1.00	9.00	3.50	10.00	1/8	—	—	—
WSA-06-FM0	4.62	1.00	9.00	3.50	10.00	1/8	—	—	—
WSA-08-M00*	4.62	1.00	9.00	3.50	10.00	1/8	—	—	—
WSA-08-FM0	4.62	1.00	9.00	3.50	10.00	1/8	—	—	—
WS0-08-000B	5.10	1.60	9.20	3.00	10.80	1/2	5.90	18.00	1/4
WDV3-G	—	—	—	—	—	—	1.62	13.72	—
WS0-0B-000B	6.70	2.00	15.00	4.00	17.00	1/2	5.90	18.00	1/4
WDV3-G	—	—	—	—	—	—	1.62	13.72	—
WS0-0C-000B	6.70	2.00	15.00	4.00	17.00	1/2	5.90	24.50	1/4
WDV3-G	—	—	—	—	—	—	1.62	20.22	—
WS0-0E-000B	8.10	2.40	17.50	4.72	19.90	1/2	5.90	28.90	1/4
WDV3-G	—	—	—	—	—	—	1.62	24.62	—

*Models have petcock.

Bulk Liquid Separators WWSA

 = "Most Popular"



WWSA Series

Features

- Designed in Accordance with ASME and CRN
- Connection Sizes: 4 Inch & 6 Inch
- High Liquid Removal Efficiencies at All Flow Conditions
- Suitable for Variable Flow Compressors
- Works With All Types of Compressor and Compressor Condensate
- External Surface Epoxy Painted for Maximum Corrosion Resistance
- Auto float drain is standard, shipped loose

Specifications

Operating Pressure	232 PSIG (16 bar)
Operating Temperature	35°F to 150°F (1.5°C to 66°C)

Materials of Construction

Baffle	Plated Steel
Body	Steel
Deflector	Plated Steel
Seals	Fluorocarbon
Stud	Plated Steel

Service Kits

Auto Float Drain Kit - 1/2" NPT	HDF-120-NPT-A
---------------------------------	---------------

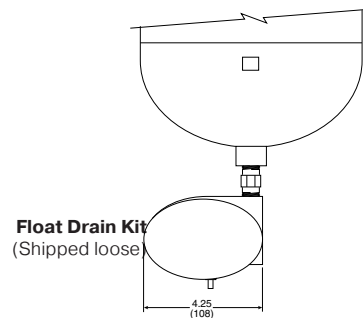

Float Drain Kit
(Shipped loose)

- Designed in Accordance with ASME and CRN
- Connection Sizes: 4 Inch & 6 Inch
- High Liquid Removal Efficiencies at All Flow Conditions
- Suitable for Variable Flow Compressors
- Works With All Types of Compressor and Compressor Condensate
- External Surface Epoxy Painted for Maximum Corrosion Resistance
- Auto float drain is standard, shipped loose

Inlet Air Pressure Correction

PSI	15	29	44	58	73	87	100	116	131	145
bar	1	2	3	4	5	6	7	8	9	10
Factor	2.65	1.87	1.53	1.32	1.18	1.08	1.00	.94	0.88	0.84

For pressures above 232 PSIG (16 bar), use manual drain.

PSI	160	174	189	203	218	232	247	261	275	290
bar	11	12	13	14	15	16	17	18	19	20
Factor	0.80	0.76	0.73	0.71	0.68	0.66	0.64	0.62	0.61	0.59

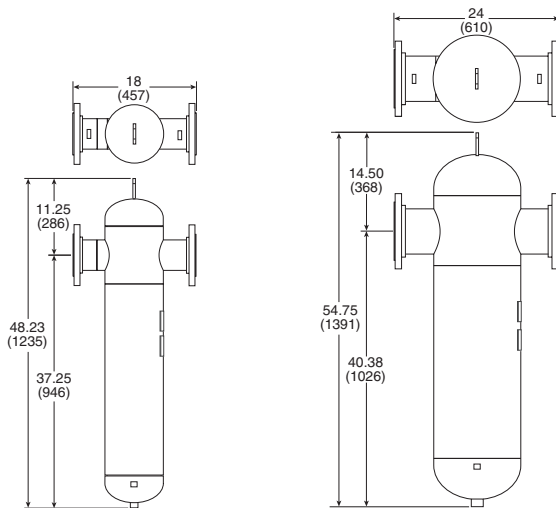

WWSA1000F

WWSA1800F

Ordering Information

Model Type	Port Size	Flow SCFM
WWSA1000F	4" Flange	2119
WWSA1800F	6" Flange	3814

External Drain X01

 = "Most Popular"



X01-04-000

Features

- Fully Automatic Float Operated
- No Electrical Connections
- Easily Installed
- Internal Pilot Operated
- Quick-Disconnected Clamp Ring for Easy Bowl Removal when Servicing
- Transparent Bowl with Metal Bowl Guard Standard

Specifications

Drain Rate	150 GPH @ 100 PSIG (570 l/h @ 6.9 bar)	
Maximum Supply Pressure	Plastic Bowl Metal Bowl	150 PSIG (10.3 bar) 200 PSIG (13.8 bar)
Operating Temperature	Plastic Bowl Metal Bowl	32° to 125°F (0° to 52°C) 32° to 150°F (0° to 65.5°C)
Port Size	NPT / BSPP-G	1/2
Weight	4.6 lb. (2.1 kg)	

Materials of Construction

Body	Zinc
Float Assembly	Plastic with Stainless Steel Internals

Replacement Kits

Bowl Guard, Metal (for Plastic Bowl)	GRP-95-808
Clamp Ring Assembly	GRP-96-404
Plastic Bowl, Auto Drain and Bowl Guard Assembly	XRP-95-747
Metal Bowl and Auto Drain Assembly –	FRP-95-631
O-ring, Bowl –	
Fluorocarbon (10 per kit)	GRP-95-942
Bowl, Nitrile (10 per kit).....	GRP-95-256

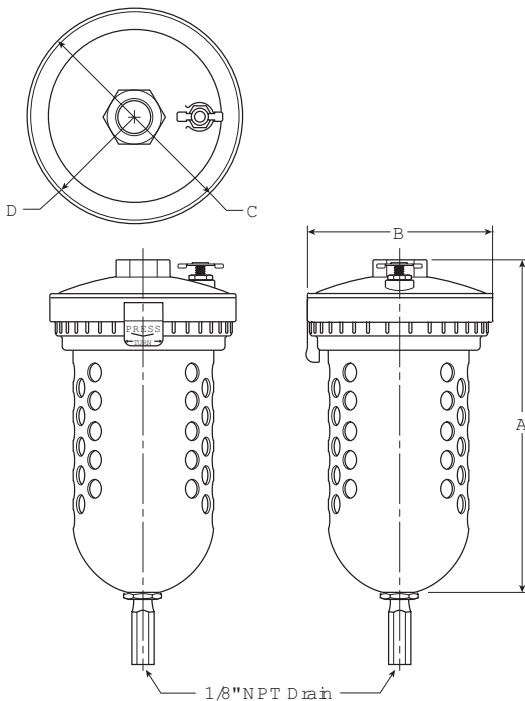

Typical Installations

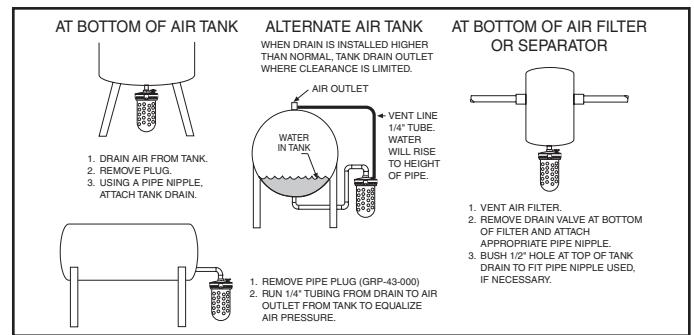

External Drain

As liquid contaminants collect in the bowl, they raise a closed-cell molded float. When the liquid level reaches a given point, the float triggers a mechanism, which pilots line pressure against a large-area diaphragm, which snaps open the drain valve. The contaminants are discharged from the drain orifice at line pressure. As the liquid level falls, the pilot valve closes, line pressure against the diaphragm returns to atmosphere and the drain valve snaps closed.

Dimensions

Models	Inches (mm)	A	B	C	D
Standard Unit X01-04-000		9.66 (245)	4.76 (121)	4.76 (121)	2.36 (60)

External Drain X02 / XB3

= "Most Popular"



X02-04-000



XB3-04-M00

Features

- Available in NPT and BSPP-G Ports
- The Manual Override Allows Drainage at Any Time Without Waiting
- Use of the Manual Override Does Not Interfere with the Normal Operation of the Drain
- To Assist in Compliance with EPA Regulations, a 1/8" Pipe Thread Allows the Liquid Discharge to be Piped Away. The X02 Has No Manual Override for the Automatic Drain.

Specifications

Drain Rate	80 GPH @ 100 PSIG (300 l/h @ 6.9 bar)	
Maximum Supply Pressure	Plastic Bowl	150 PSIG (10.3 bar)
	Metal Bowl	200 PSIG (13.8 bar)
Operating Temperature	Plastic Bowl	32° to 125°F (0° to 52°C)
	Metal Bowl	32° to 150°F (0° to 65.5°C)
Port Size	NPT / BSPP-G 1/2	
Weight	XB3	1.42 lb. (0.6 kg)
	X02	1.26 lb. (0.6 kg)

Materials of Construction

Body	Zinc
Float Assembly	Plastic with Stainless Steel Internals
Manual Override	Brass

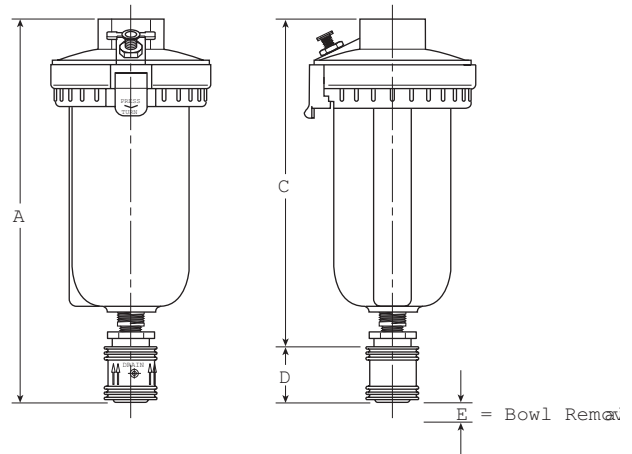
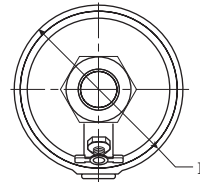

Dimensions

Models	Inches (mm)	A	B	C	D	E
Standard Unit XB3-04-000		7.00 (179)	3.06 (78)	6.00 (152)	1.00 (25)	1.66 (42)
Standard Unit X02-04-F00		5.87 (149)	3.06 (78)	— —	— —	2.88 (73)
Metal Bowl XB3-04-M00		7.50 (190.5)	3.06 (78)	6.50 (165)	1.00 (25)	1.66 (42)
Metal Bowl X02-04-FM0		5.87 (149)	3.06 (78)	— —	— —	2.88 (73)

 = "Most Popular"

External Drain

Wilkerson drains are designed to remove liquid oil and water contaminants from compressed air systems automatically.

Liquid contaminants collected in the bowl cause the float mechanism to rise. When the liquid reaches a specific level the float triggers a mechanism which pilots line pressure against a large-area piston. This action causes the drain orifice to open and evacuate the liquid and particulate contaminants. As the liquid level falls the pilot valve closes, line pressure against the piston returns to atmosphere and the drain valve snaps closed.

Wilkerson's XB3 model automatic drain includes the manual override. The manual override option allows for drainage at times when waiting for the system to drain automatically is not desirable.

Replacement Bowl Kits

- Bowl Guard, Metal (for Plastic Bowls) GRP-95-846
- Metal Bowl –
 - Automatic Float Drain GRP-96-007
 - Brass Petcock..... GRP-95-539
 - Sight Gauge, Brass PetcockLRP-95-673
- Plastic Bowl –
 - Flex Tip Drain FRP-95-017
 - Plastic Petcock Drain LRP-96-543
- Plastic Bowl, Metal Bowl Guard –
 - Automatic Float Drain GRP-95-845
 - Flex Tip DrainFRP-95-847

Accessories

- Auto Float Drain –
 - FluorocarbonGRP-95-981



- Drain, Manual Override For Auto Float Drains –
 - with 1/8 NPT Port GRP-96-001
 - (Use with GRP-95-981 shown above. Order saperately)



- Manual Drain, Flex-TipFRP-95-610

External Piston Drain X51

 = "Most Popular"

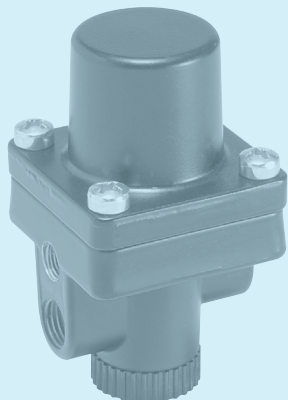

X51-02-0000

Features

- Automatically drains liquid water from compressed air receiver
- Drains Even When System Pressure Decays (20 PSIG)

Specifications

Maximum Supply Pressure	200 PSIG (13.8 bar)	
Minimum Supply Pressure	30 PSIG (2.1 bar)	
Minimum Differential Pressure Required	20 PSIG (1.4 bar)	
Operating Temperature	32° to 150°F (0° to 65.5°C)	
Port Size	NPT / BSPP-G	1/4
Weight	lb. (kg)	.8 (.36)

Materials of Construction

Body	Aluminum
Bottom Cap	Plastic
Check Valve Ball	Chrome Alloy Steel
Piston	Brass
Seals	Fluorocarbon
Springs	Steel

DISCONTINUED

Replacement Piston	XRP-95-512
Maintenance Kit	XRP-95-511

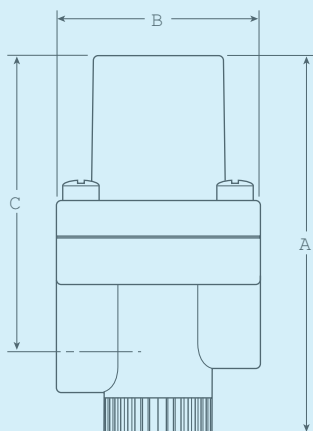

Dimensions

Models	Inches (mm)	A	B	C
Standard Unit X51-02-0000		3.81 (96.8)	2.11 (53.6)	2.93 (74.4)

**Standard Acceptable Installation
(X51 Mounted at Lowest Point in System)**

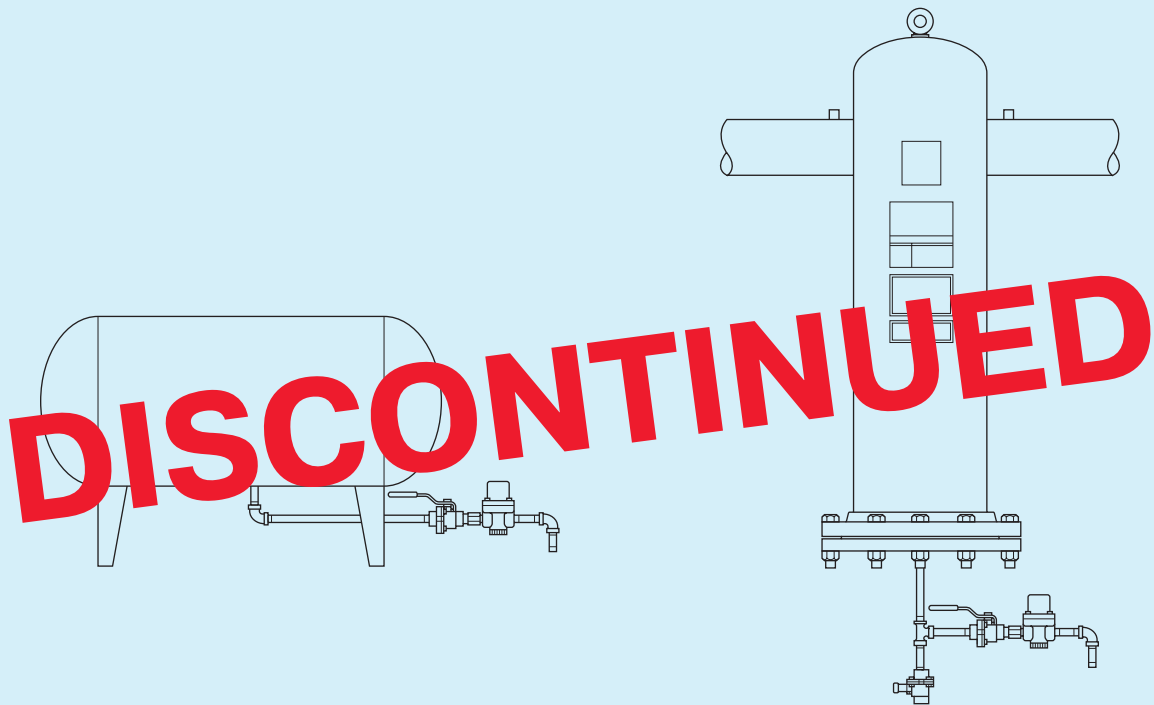

**Unacceptable Installation
(X51 Installed in Piping Above Lowest Point)**

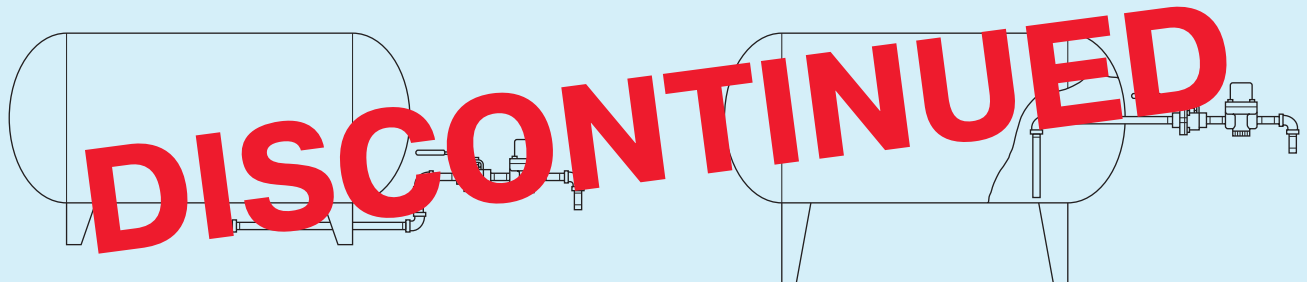

**Proper Installation of Remote Pilot
(X51 Installed Above Lowest Point)**

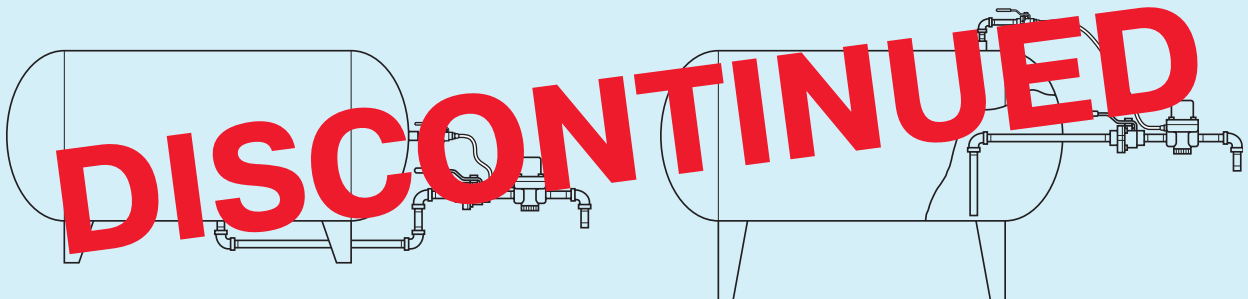

Notes

Regulator Numbering System

 = "Most Popular"

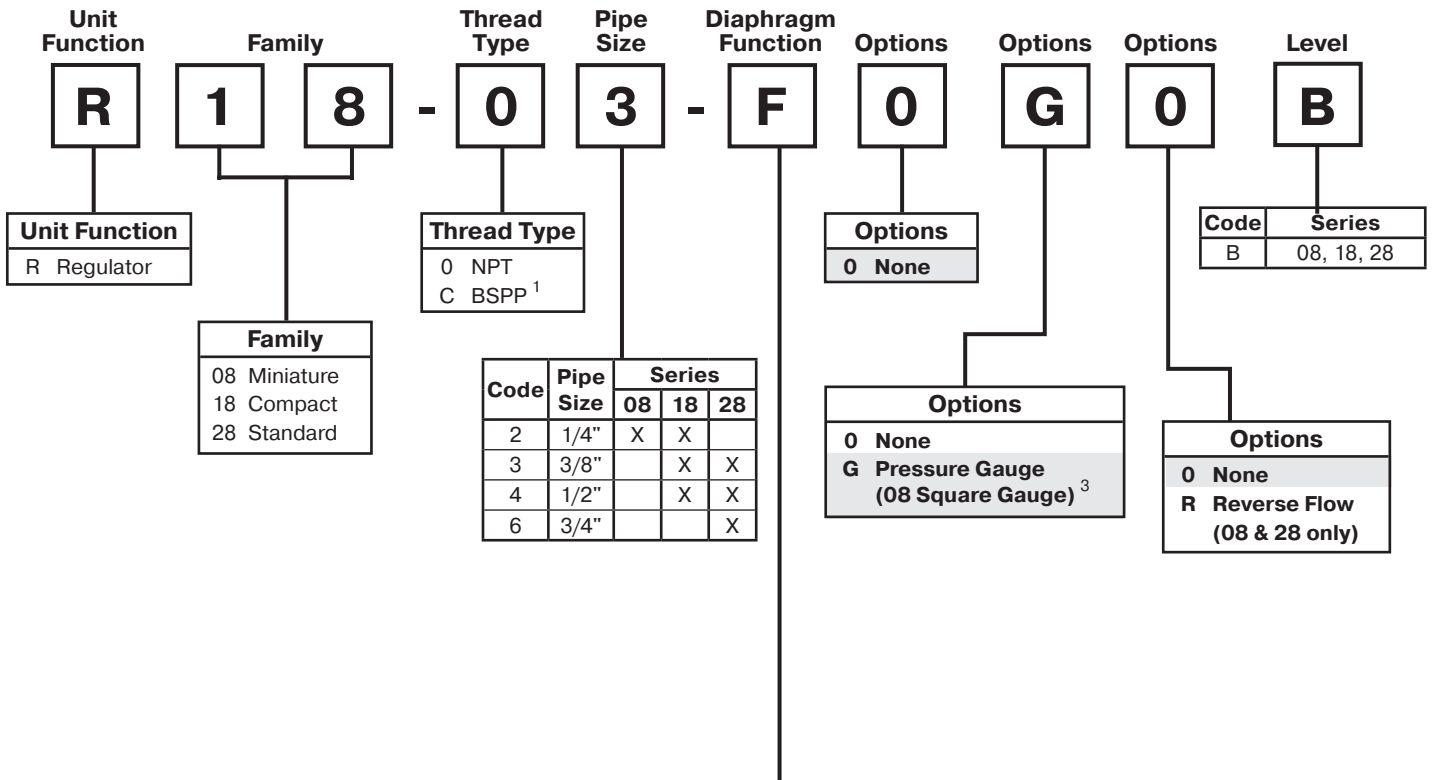

Diaphragm Function	Fluorocarbon (18 & 28 Series Only)	Spring Range			
		0 to 30 PSIG (0 to 2 bar)	0 to 60 PSIG (0 to 4 bar)	0 to 125 PSIG (0 to 8 bar)	0 to 250 PSIG ² (0 to 17 bar)
Relieving	No	C	D	F	G
	Yes	J	K	L	M
Non-relieving	No	P	W	R	S
	Yes	V	X	Y	Z

¹ ISO, R228 (G Series).

² R08 series operating range 0 to 232 PSIG (1 to 16 bar).

³ Square gauge is included with all R08

NOTE: When selecting from the options columns, please enter letters in alphabetical order for positions 7, 8, and 9. For example:

R08-02-F0G0B

RB3 / RA3 Series Regulator Numbering System = "Most Popular"

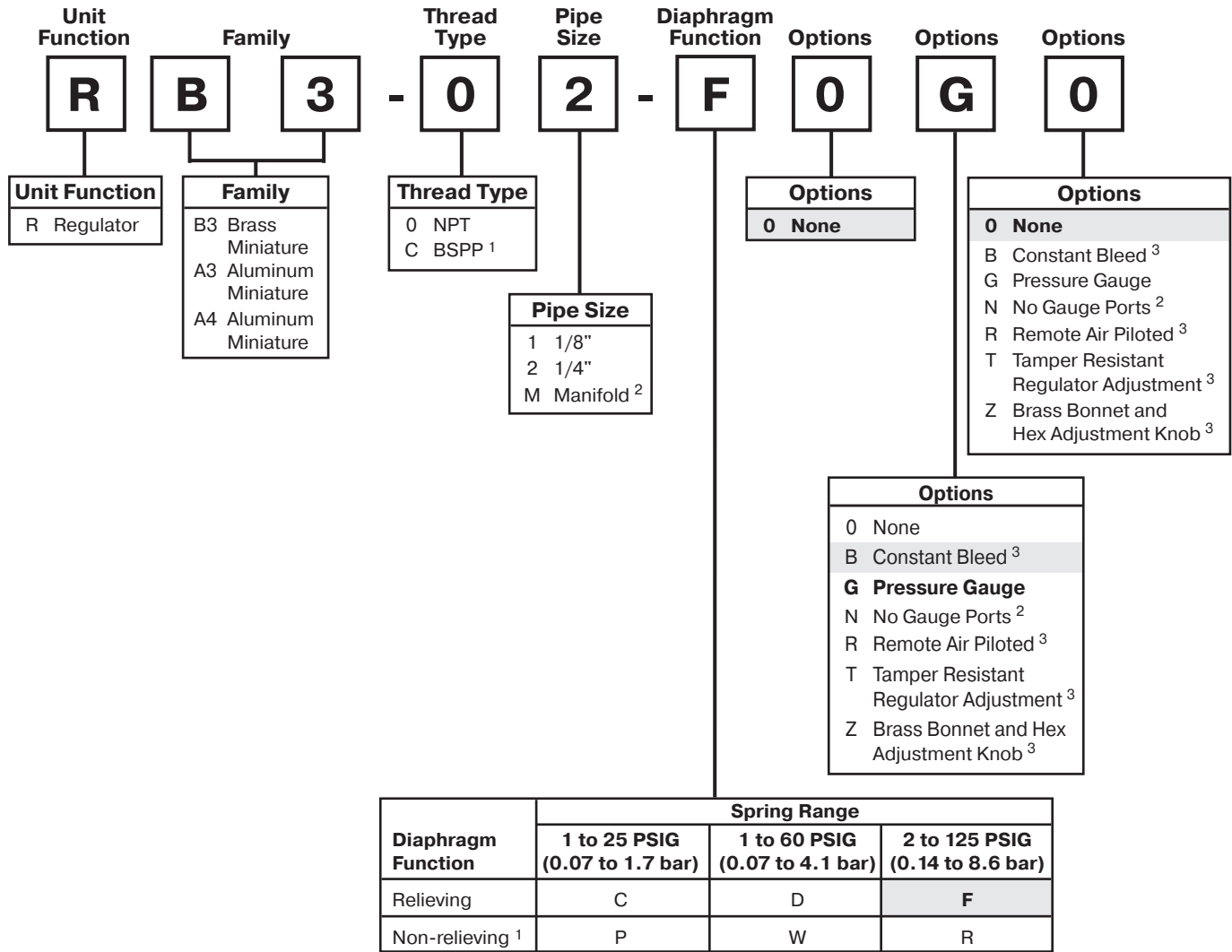

¹ ISO, R228 (G Series)
² RA4 Only
³ Not available on RA4

NOTE: When selecting from the options columns, please enter letters in alphabetical order for positions 8, and 9. For example:

RB3 - 0 2 - F 0 G T

NOTE:Standard pressure adjustment is plastic "snap lock" knob and plastic bonnet with plastic panel mount nut.

Regulator Numbering System

 = "Most Popular"

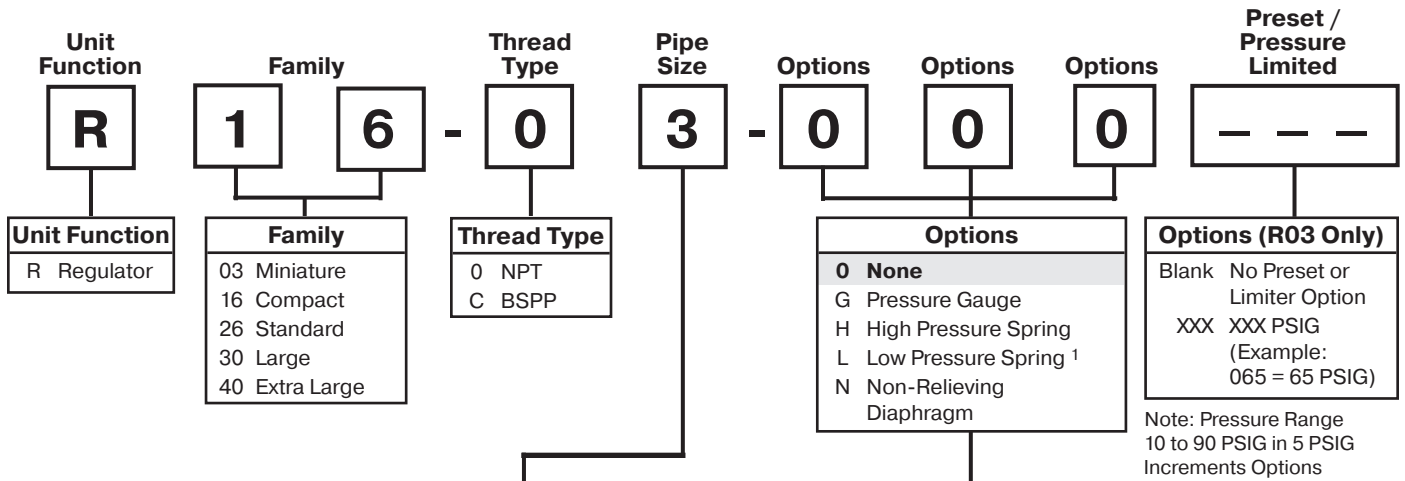

Unit Function
R Regulator

Family
03 Miniature
16 Compact
26 Standard
30 Large
40 Extra Large

Thread Type
0 NPT
C BSPP

Options
0 None
G Pressure Gauge
H High Pressure Spring
L Low Pressure Spring ¹
N Non-Relieving Diaphragm

Options (R03 Only)
Blank No Preset or Limiter Option
XXX XXX PSIG (Example: 065 = 65 PSIG)

Note: Pressure Range 10 to 90 PSIG in 5 PSIG Increments Options

Code	Pipe Size	Series				
		03	16	26	30	40
1	1/8"	X				
2	1/4"	X	X	X		
3	3/8"		X	X		
4	1/2"		X	X		
6	3/4"				X	
8	1"				X	
B	1-1/2"					X
C	2"					X

Options (R03 Only)
0 Standard, 2 to 125 PSI, Relieving
G** Pressure Gauge
J*† Preset, Adjustable
K*† Preset, Non-Adj. / Epoxy
L 1 to 60 PSI, Relieving
M Panel Nut Included
N 2 to 125 PSI, Non-Relieving
P 1 to 30 PSI, Relieving
Q 1 to 15 PSI, Relieving
R*† Pressure Limiter
S 1 to 60 PSI, Non-Relieving
T 1 to 30 PSI, Non-Relieving
U 1 to 15 PSI, Non-Relieving

* Inlet pressure is 100 PSIG. For other pressures, consult factory.
 ** Not available with BSPP thread type.
 † Must specify preset or limited pressure.

Spring Type by Preset / Limited Pressure:
 For Preset / Limited Pressure 10 to 25 use 30 PSI Spring
 For Preset / Limited Pressure 26 to 50 use 60 PSI Spring
 For Preset / Limited Pressure 51 to 90 use 125 PSI Spring

If more than one option is desired, arrange them in alphabetical order in positions 6, 7, and 8.

¹ Not available on R30.

Miniature Regulator R03

 = "Most Popular"

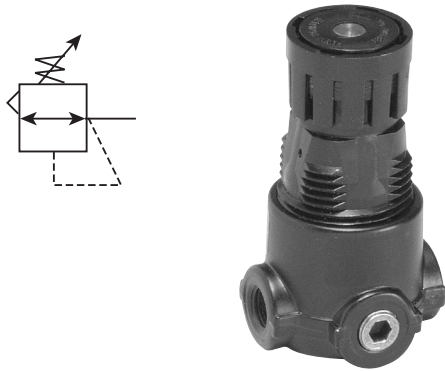

R03-02-000

Features

- Unbalanced Poppet Standard
- Solid Control Piston with Lip Seal for Extended Life
- Non-rising Adjusting Knob
- Compact, 3.08 inch (78mm) High by 1.65 inch (42mm) Wide
- Easily Serviced

Specifications

Flow Capacity*	1/8	13 SCFM (6.14 dm ³ /s)
	1/4	15 SCFM (7.08 dm ³ /s)
Gauge Ports (2)	1/8	
Port Threads	1/8, 1/4 Inch	
Supply Pressure	0 to 300 PSIG (0 to 20.7 bar)	
Operating Temperature	32°F to 125°F (0°C to 52°C)	
Secondary Pressure Ranges –		
Standard Pressure	2 to 125 PSIG (0 to 8.6 bar)	
Medium Pressure	1 to 60 PSIG (0 to 4.1 bar)	
Medium Pressure	1 to 30 PSIG (0 to 2.1 bar)	
Low Pressure	1 to 15 PSIG (0 to 1.0 bar)	
Weight	.3 lb. (.14 kg)	

* Inlet pressure 100 PSIG (6.9 bar). Secondary pressure 90 PSIG (6.2 bar) and 10 PSIG pressure drop.

Materials of Construction

Adjusting Nut	Brass
Adjusting Stem & Spring	Steel
Body	Zinc
Bonnet, Seat, Piston & Valve Poppet	Plastic
Seals	Nitrile

⚠ WARNING

**Product rupture can cause serious injury.
Do not connect regulator to bottled gas.
Do not exceed maximum primary pressure rating.**

CAUTION:

REGULATOR PRESSURE ADJUSTMENT – The working range of knob adjustment is designed to permit outlet pressures within their full range. Pressure adjustment beyond this range is also possible because the knob is not a limiting device. This is a common characteristic of most industrial regulators, and limiting devices may be obtained only by special design.

For best performance, regulated pressure should always be set by increasing the pressure up to the desired setting.

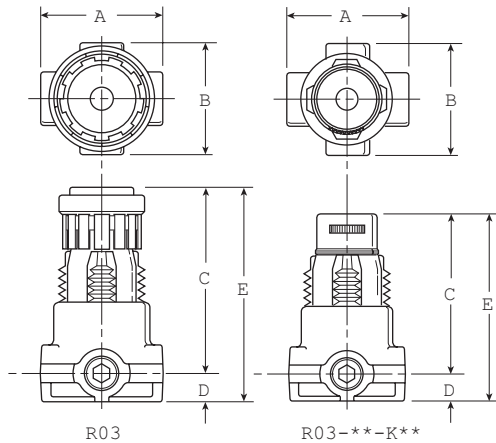

Note: 1.218" dia. (31) mm hole required for panel mounting.

Dimensions

Model	Inches (mm)	A	B	C	D	E
Standard Unit R03-XX-XXX		1.65 (42)	1.56 (39.6)	2.50 (63.5)	.38 (9.6)	2.88 (73)
Preset, Non-Adjustable Unit R03-XX-KXX		1.65 (42)	1.56 (39.6)	2.28 (57.9)	.38 (9.6)	2.66 (67.6)

= "Most Popular"

Replacement Kits

- Poppet / Piston Kits –
 Unbalanced, Non-Relieving PS428P
 Unbalanced, Relieving PS426P
- Springs –
 1-30 PSIG Range..... P01175
 1-60 PSIG Range..... P01174
 2-125 PSIG Range P01173
 1-15 PSIG Range P01176
- Tamperproof Metal Disc.....P01265

Accessories

- Gauge, Pressure –
 30 PSIG, 1/8" NPT (0 to 2.1 bar) K4515N18030
 60 PSIG, 1/8" NPT (0 to 4.1 bar) K4515N18060
 160 PSIG, 1/8" NPT (0 to 11.0 bar)..... K4515N18160
- Mounting Bracket Kit* (Includes Panel Mount Nut) PS417B
- Panel Mount Nuts* –
 Plastic P78652
 Metal.....P01531

*Tighten panel mount nut 2.8 to 3.4 Nm (25 to 30 in-lbs) of torque.

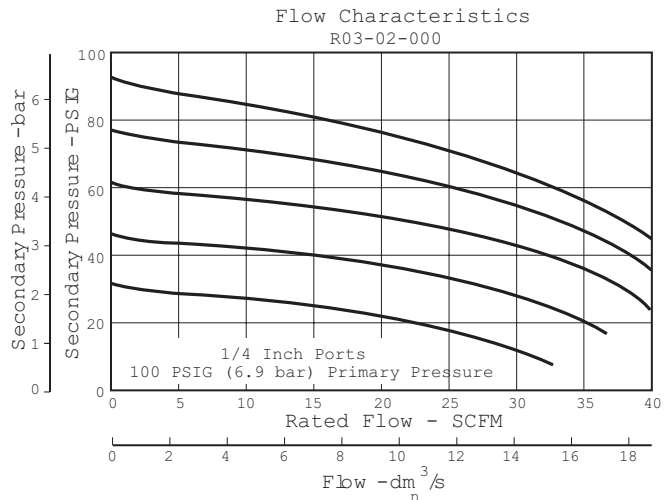
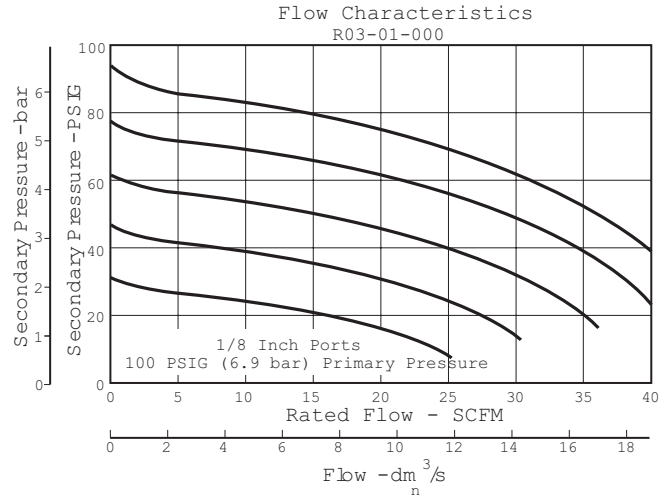

Ordering Information					
Model Type	Port Size	Without Gauge 2 to 125 PSIG (0.2 to 8.6 bar)	Without Gauge 1 to 60 PSIG (0.2 to 4.1 bar)	Without Gauge 1 to 30 PSIG (0.2 to 2.1 bar)	Without Gauge 1 to 15 PSIG (0.2 to 1.0 bar)
Relieving	1/8	R03-01-000	R03-01-L00	R03-01-P00	R03-01-Q00
	1/4	R03-02-000	R03-02-L00	R03-02-P00	R03-02-Q00

Options - To order an option supplied with the unit model, add the appropriate coded suffix letter in the designated position of the model number.

Miniature Regulator

RB3 – Brass

RA3 – Aluminum

= "Most Popular"

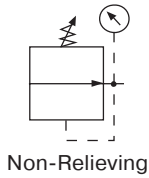
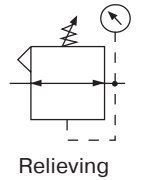

RB3-02-F000

Features

- Brass Body Construction Handles Water and Compressed Air Service
- Large Diaphragm to Valve Area Ratio for Precise Regulation and High Flow Capacity
- Spring Loaded Diaphragm
- High Flow: 1/4" -14 SCFM
- Panel Mount Nut Standard
- Two 1/8" Gauge Ports

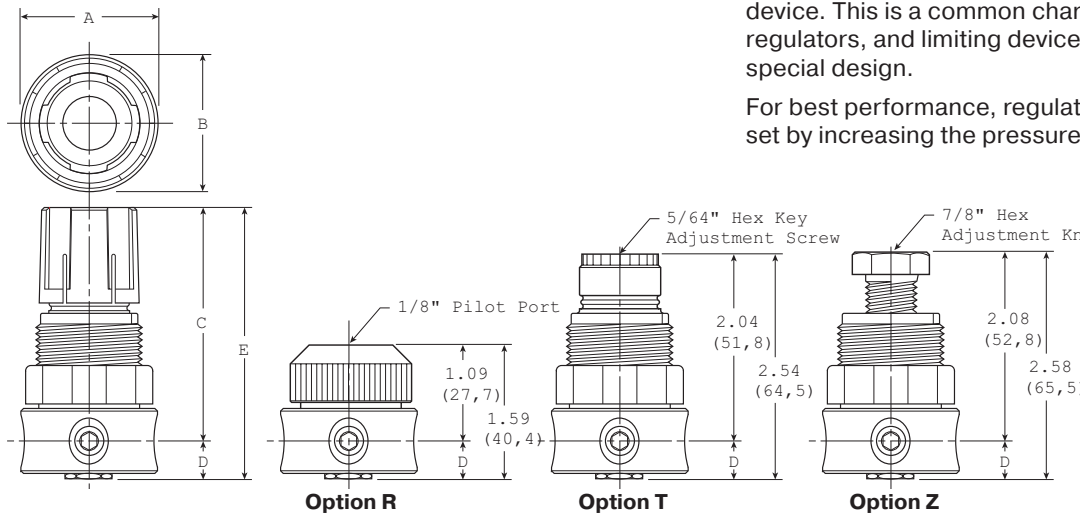

Dimensions

Model	Inches (mm)	A	B	C	D	E
Brass Regulator - Miniature RB3-XX-XXXX		1.56 (39.8)	1.56 (39.8)	2.56 (65)	.50 (12.7)	3.06 (77.7)
Aluminum Regulator - Miniature RA3-XX-XXXX		1.56 (39.8)	1.56 (39.8)	2.56 (65)	.50 (12.7)	3.06 (77.7)

Specifications

Flow Capacity*	1/4	14 SCFM (6.6 dm ³ /s)
Maximum Supply Pressure		300 PSIG (20.7 bar)
Operating Temperature		40° to 125°F (4.4° to 52°C)
Port Size	NPT / BSPP-G	1/8, 1/4
Weight	lb. (kg)	0.5 (0.23)

* Inlet pressure 100 PSIG (6.9 bar). Secondary pressure 90 PSIG (6.2 bar). (flow at 25% pressure drop)

Materials of Construction

Body	RB3 RA3	Brass Aluminum
Bonnet		Acetal
Diaphragm & Seals		Nitrile
Valve Assembly & Bottom Plug		Brass

Note: Panel Nut included, but not shown on dimensional drawing.

Note: 1.19" dia. (30.2) mm hole required for panel mounting.

WARNING

**Product rupture can cause serious injury.
Do not connect regulator to bottled gas.
Do not exceed maximum primary pressure rating.**

CAUTION:

REGULATOR PRESSURE ADJUSTMENT – The working range of knob adjustment is designed to permit outlet pressures within their full range. Pressure adjustment beyond this range is also possible because the knob is not a limiting device. This is a common characteristic of most industrial regulators, and limiting devices may be obtained only by special design.

For best performance, regulated pressure should always be set by increasing the pressure up to the desired setting.

= "Most Popular"

Repair Kits

- Bonnet, Knob, Adjusting Screw Kit RRP-96-821
- Bonnet, Tamper Resistant Adjustment Kit RRP-96-822
- Repair Kit –
- Relieving..... RRP-96-824
- Non-relieving RRP-96-825

Accessories

- Gauge, Pressure –
- 0-160 PSI (0-11,0 bar), 1-1/2" Dial Face,
1/8" NPT, CBM K4515N18160
- 0-60 PSI (0-4,1 bar), 1-1/2" Dial Face,
1/8" NPT K4515N18060
- Panel Mount Nut –
- Aluminum RPA-96-733
- Plastic RPA-96-734
- Wall Mounting Bracket –
- L-Type..... GRP-95-147
- L-Type with Plastic Panel Mount Nut GRP-95-747

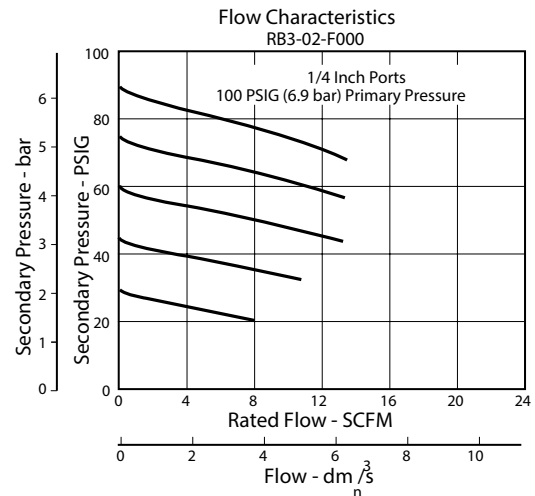
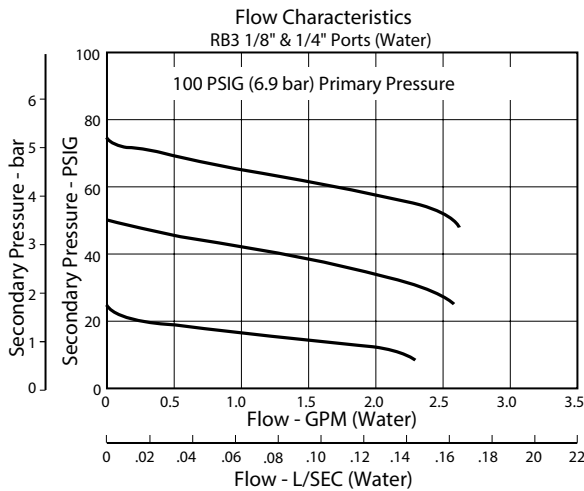
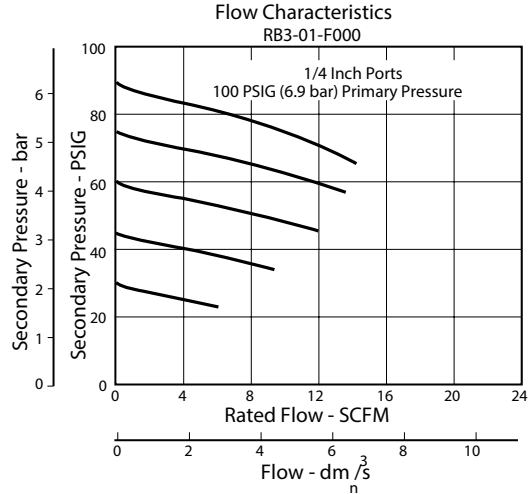

Ordering Information

Model Type	Port Size	Without Gauge 2 to 125 PSI (0.14 to 8.6 bar)	Without Gauge 1 to 60 PSI (0.07 to 4.1 bar)	Without Gauge 1-25 PSI (0.07 to 1.7 bar)
Relieving	1/8"	RB3-01-F000	RB3-01-D000	RB3-01-C000
	1/4"	RB3-02-F000	RB3-02-D000	RB3-02-C000
Non-relieving	1/8"	RB3-01-R000	RB3-01-W000	RB3-01-P000
	1/4"	RB3-02-R000	RB3-02-W000	RB3-02-P000
Relieving	1/8"	RA3-01-F000	RA3-01-D000	RA3-01-C000
	1/4"	RA3-02-F000	RA3-02-D000	RA3-02-C000
Non-relieving	1/8"	RA3-01-R000	RA3-01-W000	RA3-01-P000
	1/4"	RA3-02-R000	RA3-02-W000	RA3-02-P000

Options - To order an option supplied with the unit model, add the appropriate coded suffix letter in the designated position of the model number.

Miniature Regulator RA4

 = "Most Popular"

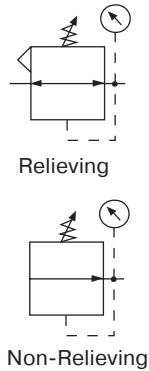

RA4-02-F000 RA4-0M-F000

Features

- Diaphragm Operated for Fast Operation.
- Large Diaphragm to Valve Area Ratio for Precise Regulation and High Flow Capacity.
- Balanced Valve Design for Precise Regulation.
- Available in 2 or 4[†] Port Design.
- Available With a Manifold Mount to Minimize Plumbing.
- Suitable for Low Temperature Applications.
- Non-Rising Adjusting Knob.
- 1/8" - 17 SCFM*
- 1/4" - 19 SCFM*

* SCFM = Standard cubic feet per minute at 100 PSIG inlet, 90 PSIG no flow secondary setting and 10 PSIG pressure drop.

† Not Available with Manifold Mount.

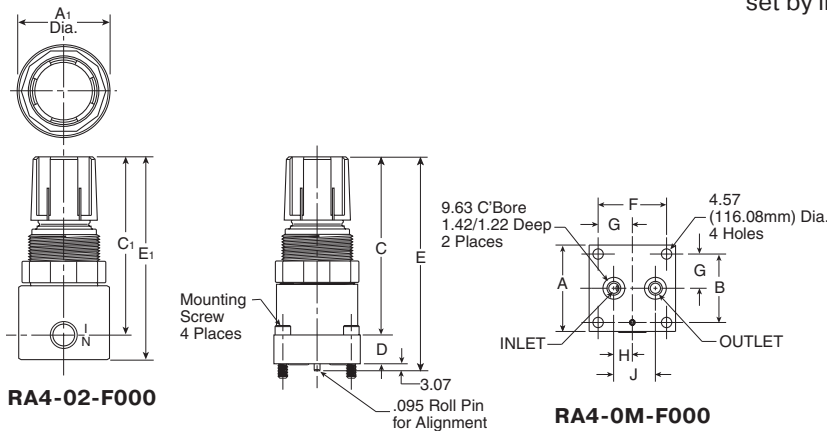

Dimensions

Models	Inches (mm)	A	A ₁	B	B ₁	C	C ₁	D	E	E ₁	F	G	H	J
Brass Regulator - Miniature RA4-XX-XXXX		1.5 (38.1)	1.56 (39.7)	1.188 (30.18)	1.56 (39.7)	2.75 (69.92)	2.7 (68.7)	.5 (12.7)	3.25 (82.62)	3.25 (82.62)	1.188 (30.18)	.6 (15.09)	.32 (8.26)	.73 (18.42)

Specifications

Operating Temperature	-40° F to 150°F (-40° C to 65.5°C)
Supply Pressure	300 PSIG Maximum (20.4 bar)
Port Threads	1/8, 1/4 Inch
Gauge Ports	(2) Std 1/8 Inch (No Gauge Port Version Available)
Weight	.25 lbs. (0.11 kg)

Materials of Construction

Body	Aluminum
Bonnet	Acetal
Diaphragm & Seals	Nitrile
Valve Assembly	Brass
Springs	Steel
Panel Nut	Acetal

WARNING

**Product rupture can cause serious injury.
Do not connect regulator to bottled gas.
Do not exceed maximum primary pressure rating.**

CAUTION:

REGULATOR PRESSURE ADJUSTMENT – The working range of knob adjustment is designed to permit outlet pressures within their full range. Pressure adjustment beyond this range is also possible because the knob is not a limiting device. This is a common characteristic of most industrial regulators, and limiting devices may be obtained only by special design.

For best performance, regulated pressure should always be set by increasing the pressure up to the desired setting.

= "Most Popular"

Replacement Kits

Diaphragm Assembly -

- Non-relievingGRP-96-726
- Relieving.....GRP-96-725

Spring, Regulating -

- 0 to 30 PSIG (0 to 2.1 bar) GRP-95-111
- 0 to 60 PSIG (0 to 4.1 bar) GRP-96-718
- 0 to 125 PSIG (0 to 8.6 bar) GRP-96-717
- Valve AssemblyRRP-96-727
- Valve Spring.....RRP-96-728

Accessories

- Adjusting Knob.....RRP-16-005-000

Panel Mount Nut -

- Aluminum RPA-96-733
- PlasticRPA-96-734

Gauges

- 0 to 60 PSIG (0 to 4.1 bar), 1-1/2" Dial Face,
1/8 NPT, CBM K4515N18060
- 0 to 160 PSIG (0 to 11.0 bar), 1-1/2" Dial Face,
1/8 NPT, CBMK4515N18160
- Tamper Resistant Kit RPA-96-735

Flow Characteristics
RA4-01-F000

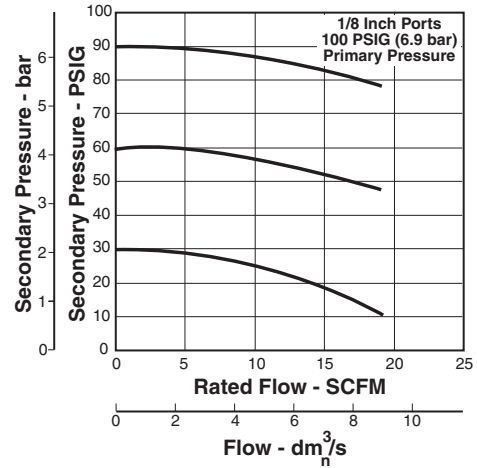

Flow Characteristics
RA4-0M-F000

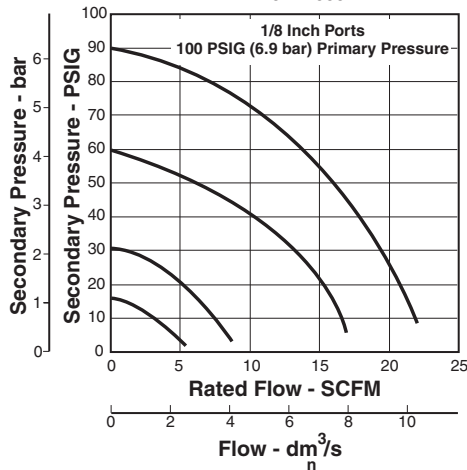

Flow Characteristics
RA4-02-F000

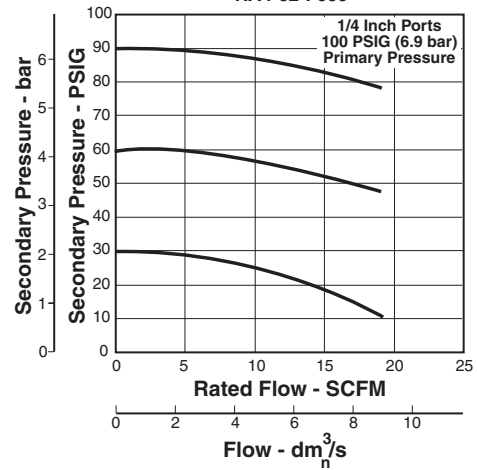

Ordering Information

Model Type	Port Size	Without Gauge 0 to 30 PSIG (0.0 to 2.1 bar)	Without Gauge 0 to 60 PSIG (0.0 to 4.1 bar)	Without Gauge 0 to 125 PSIG (0.0 to 8.6 bar)	With Gauge 0 to 30 PSIG (0.0 to 2.1 bar)	With Gauge 0 to 60 PSIG (0.0 to 4.1 bar)	With Gauge 0 to 125 PSIG (0.0 to 8.6 bar)
Relieving	1/8"	RA4-01-C000	RA4-01-D000	RA4-01-F000	RA4-01-C0G0	RA4-01-D0G0	RA4-01-F0G0
	1/4"	RA4-02-C000	RA4-02-D000	RA4-02-F000	RA4-02-C0G0	RA4-02-D0G0	RA4-02-F0G0
	Manifold Mount	RA4-0M-C000	RA4-0M-D000	RA4-0M-F000			
Non-relieving	1/8"	RA4-01-P000	RA4-01-W000	RA4-01-R000	RA4-01-P0G0	RA4-01-W0G0	RA4-01-R0G0
	1/4"	RA4-02-P000	RA4-02-W000	RA4-02-R000	RA4-02-P0G0	RA4-02-W0G0	RA4-02-R0G0
	Manifold Mount	RA4-0M-P000	RA4-0M-W000	RA4-0M-R000			

Miniature Regulator R24, R25

 = "Most Popular"

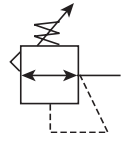

R25-02C

Features

- Lightweight Plastic Body
- Constructed with a Combination of N.S.F. and F.D.A. Approved Materials
- Unbalanced Poppet Standard
- Non-rising, Push-to-lock Adjusting Knob
- Compact, 3.10 inch (79mm) high by 1.60 inch (41mm) wide
- Lightweight
- Diaphragm Operated

Specifications

Maximum Supply Pressure	150 PSIG (10 bar)	
Operating Temperature	40° to 125°F (4.4° to 52°C)	
Gauge Ports (2)	(Can be used for full flow)	1/8 Inch
Port Size	NPT	1/8, 1/4
Weight	lb. (kg)	0.25 (0.11)

Materials of Construction

Adjusting Screw	Steel
Body	Acetal
Bonnet and Seat	Acetal
Diaphragm (R25)	Buna N
Diaphragm (R24)	EPDM
Seals (R25)	Buna N
Seals (R24)	EPDM
Springs	Stainless Steel
Valve Poppet (R25)	Buna N
Valve Poppet (R24)	EPDM

Note: 1.25" dia. (31.8) mm hole required for panel mounting.

WARNING

**Product rupture can cause serious injury.
Do not connect regulator to bottled gas.
Do not exceed maximum primary pressure rating.**

CAUTION:

REGULATOR PRESSURE ADJUSTMENT – The working range of knob adjustment is designed to permit outlet pressures within their full range. Pressure adjustment beyond this range is also possible because the knob is not a limiting device. This is a common characteristic of most industrial regulators, and limiting devices may be obtained only by special design.

For best performance, regulated pressure should always be set by increasing the pressure up to the desired setting.

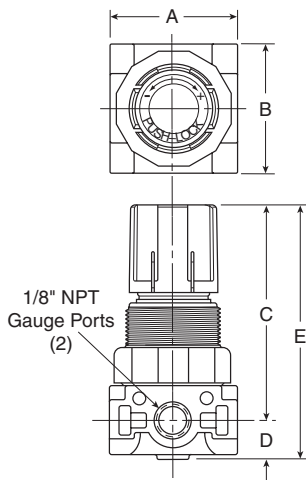

Dimensions

Model	Inches (mm)	A	B	C	D	E
Regulator - Miniature, Air Service R25-XXX		1.60 (41)	1.60 (41)	2.61 (66)	0.49 (13)	3.10 (79)
Regulator - Miniature, Water Service R24-XXX		1.60 (41)	1.60 (41)	2.61 (66)	0.49 (13)	3.10 (79)

= "Most Popular"

Kits and Accessories

Panel Mount Nut –

- PlasticR05X51-P
- AluminumR05X51-A

Mounting Bracket and NutSA161X57

Service Kits –

- Relieving (Buna) RKR25Y
- Non-Relieving (Buna) RKR25KY
- Relieving (EPDM)RKR24Y
- Non-Relieving (EPDM) RKR24KY

Springs –

- 0-25 psig Spring..... SPR-375-1
- 0-60 psig Spring SPR-376
- 0-125 psig Spring SPR-377

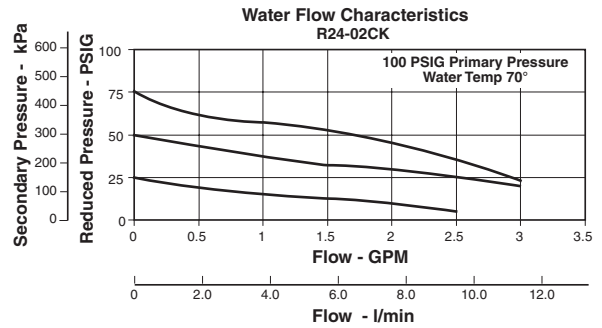
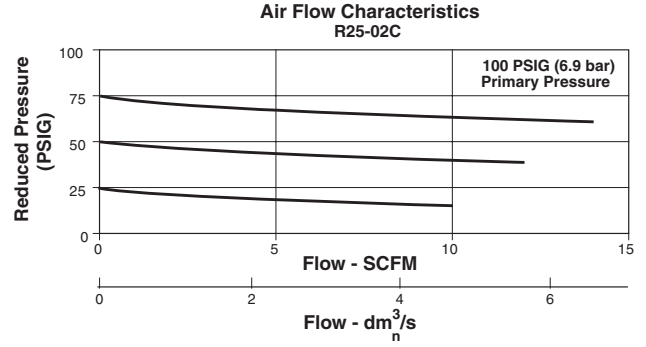

Ordering Information

Model Type	Port Size	Without Gauge 0 to 125 PSI (0 to 8.6 bar)
Air Service Relieving	1/8"	R25-01C
	1/4"	R25-02C
Water Service Non-relieving	1/8"	R24-01CK
	1/4"	R24-02CK

Options - To order an option supplied with the unit model, add the appropriate coded suffix letter in the designated position of the model number.

Miniature Regulator R45, R46

 = "Most Popular"

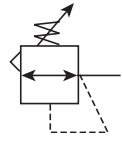

R45-03C

Features

- Lightweight Plastic Body
- Constructed with a Combination of N.S.F. and F.D.A. Approved Materials
- Unbalanced Poppet Standard
- Non-rising, Push-to-lock Adjusting Knob
- Compact, 3.43 inch (87mm) high by 2.06 inch (52.3mm) wide
- Lightweight
- Diaphragm Operated

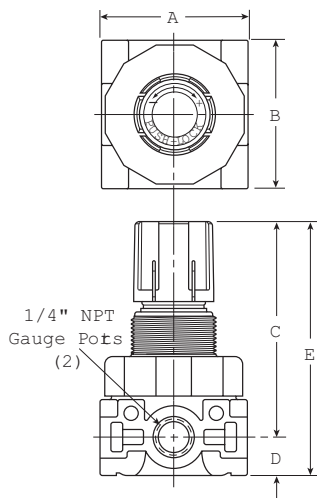

Dimensions

Model	Inches (mm)	A	B	C	D	E
Regulator - Miniature, Air Service R45-XXX		2.06 (52)	2.06 (52)	2.90 (74)	0.53 (143)	3.43 (87)
Regulator - Miniature, Water Service R46-XXX		2.06 (52)	2.06 (52)	2.90 (74)	0.53 (143)	3.43 (87)

Specifications

Maximum Supply Pressure	150 PSIG (10 bar)	
Operating Temperature	40° to 125°F (4.4° to 52°C)	
Gauge Ports (2)	(Can be used for full flow)	1/4 Inch
Port Size	NPT	1/4, 3/8
Weight	lb. (kg)	0.38 (0.17)

Materials of Construction

Adjusting Screw	Steel
Body	Acetal
Bonnet and Seat	Acetal
Diaphragm (R45)	Buna N
Diaphragm (R46)	EPDM
Seals (R45)	Buna N
Seals (R46)	EPDM
Springs	Stainless Steel
Valve Poppet (R45)	Buna N
Valve Poppet (R46)	EPDM

Note: 1.25" dia. (31.8) mm hole required for panel mounting.

WARNING

**Product rupture can cause serious injury.
Do not connect regulator to bottled gas.
Do not exceed maximum primary pressure rating.**

CAUTION:

REGULATOR PRESSURE ADJUSTMENT – The working range of knob adjustment is designed to permit outlet pressures within their full range. Pressure adjustment beyond this range is also possible because the knob is not a limiting device. This is a common characteristic of most industrial regulators, and limiting devices may be obtained only by special design.

For best performance, regulated pressure should always be set by increasing the pressure up to the desired setting.

= "Most Popular"

Kits and Accessories

- Panel Mount Nut –
 - PlasticR05X51-P
 - AluminumR05X51-A
- Mounting Bracket and NutSA161X57
- Service Kits –
 - Relieving (Buna) RKR45Y
 - Non-Relieving (Buna) RKR45KY
- Springs –
 - 0-25 psig Spring.....SPR-46
 - 0-60 psig SpringSPR-47
 - 0-125 psig Spring.....SPR-48

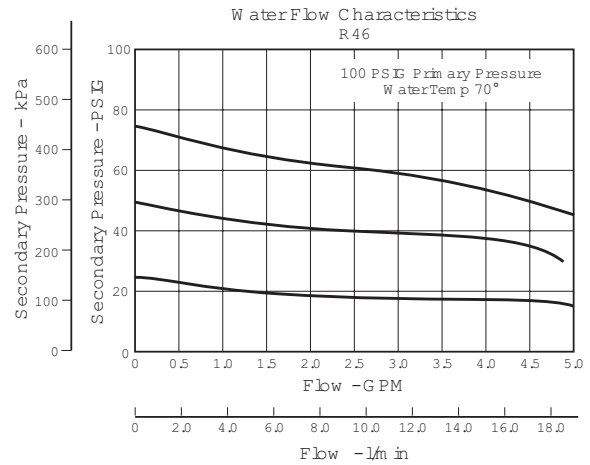
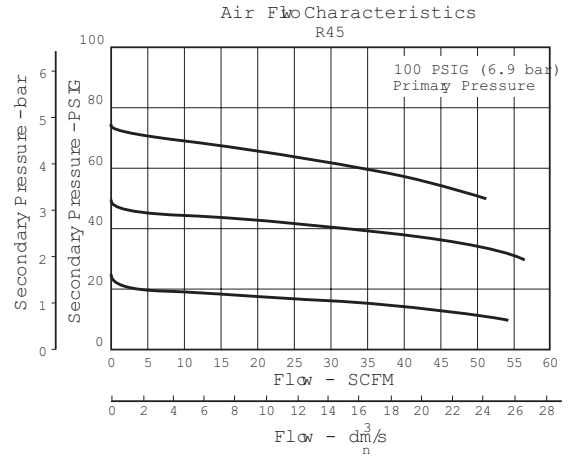

Ordering Information

Model Type	Port Size	Without Gauge 0 to 125 PSI (0 to 8.6 bar)
Air Service Relieving	1/4"	R45-02C
	3/8"	R45-03C
Water Service Non-relieving	1/4"	R46-02CK
	3/8"	R46-03CK

Options - To order an option supplied with the unit model, add the appropriate coded suffix letter in the designated position of the model number.

Regulator R08

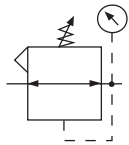

Relieving

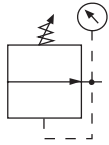

Non-Relieving



Features

- Balanced Valve Design
- Unique Flush-mounted Pressure Gauge
- Light Weight
- Modern Modular Design and Appearance

Specifications

Flow Capacity*	1/4	73 SCFM (34 dm ³ /s, ANR)
Adjusting Range Pressure		0 to 30 PSIG (0 to 2 bar) 0 to 60 PSIG (0 to 4 bar) 0 to 125 PSIG (0 to 8 bar) 0 to 232 PSIG (0 to 16 bar)
Maximum Supply Pressure		300 PSIG (20.7 bar)
Operating Temperature†		-4° to 150°F (-20° to 65.5°C)
Port Size	NPT / BSPP-G	1/4
Weight		0.37 lb. (0.17 kg)

* Inlet pressure 145 psig (10 bar). Secondary pressure 100 psig (6.9 bar) and 14.5 psig (1 bar) pressure drop.

† Units with square gauges: 5°F to 150°F (-15°C to 65.5°C)

Gauge supplied with every part. Gauge can be installed on the front or back of the regulator. If no gauge is installed, both seal screws must be installed.

Materials of Construction

Adjustment Knob	Acetal
Body	Aluminum
Bottom Cap	Glass-filled Nylon
Bonnet	Glass-filled Nylon
Diaphragm Assembly	Stainless Steel / Nitrile
Panel Nut	Acetal
Seals	Nitrile
Springs	Steel
Valve Assembly	Acetal / Nitrile

⚠ WARNING

**Product rupture can cause serious injury.
Do not connect regulator to bottled gas.
Do not exceed maximum primary pressure rating.**

CAUTION:

REGULATOR PRESSURE ADJUSTMENT – The working range of knob adjustment is designed to permit outlet pressures within their full range. Pressure adjustment beyond this range is also possible because the knob is not a limiting device. This is a common characteristic of most industrial regulators, and limiting devices may be obtained only by special design.

For best performance, regulated pressure should always be set by increasing the pressure up to the desired setting.

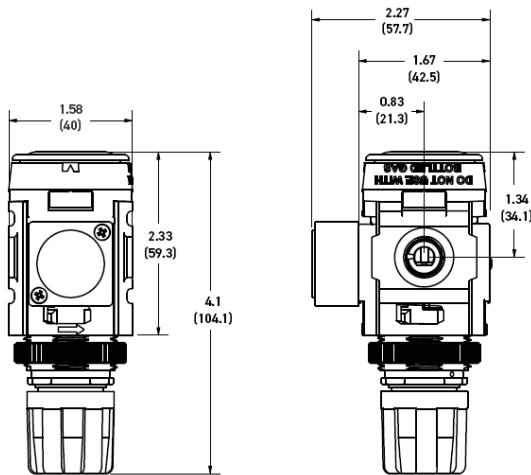

Inches (mm)

NOTE: 1.20 in. (30mm) hole required for panel nut mounting.

Replacement Kits

Adjusting Knob GRP-96-792

= "Most Popular"

Accessories

Panel Mount Nut –

Aluminum RPA-96-773
 Plastic RPA-96-734

Pressure Gauge– (*see note below)

Square flush mount gauge	
0-4 bar	GRP-96-791-04B
0-11 bar	GRP-96-791-11B
0-20 bar	GRP-96-791-20B
0-60 PSIG	GRP-96-791-060
0-160 PSIG.....	GRP-96-791-160
0-290 PSIG	GRP-96-791-290

*For R08/R09 Regulators with date code after November 2023 (4423 Date Code), please use these part numbers when ordering a replacement gauge.

Square flush mount gauge	
0-4 bar	K4511SCR04B
0-11 bar	K4511SCR11B
0-60 PSIG	K4511SCR060
0-160 PSIG.....	K4511SCR160

Square with adapter kit	
0-4 bar	P6G-PR10040
0-11 bar	P6G-PR10110
0-60 PSIG	P6G-PR90060
0-160 PSIG.....	P6G-PR90160

50mm (2") round 1/4" center back mount	
0-30 PSIG / 0-2 bar.....	K4520N14030
0-60 PSIG / 0-4 bar.....	K4520N14060
0-160 PSIG / 0-11 bar	K4520N14160
0-300 PSIG / 0-20 bar	K4520N14300

1-3/4" Digital Round 1/4" NPT	
0 to 160 PSIG	K4517N14160D

Tamperproof Lock and Cover Kit (lock not included).....		RPA-96-736B
--	--	-------------

Wall Mounting Bracket –	
C-Type.....	GPA-97-010
L-Type.....	GPA-96-739
T-Type	GPA-96-737

Ordering Information

Model Type	Port Size	With Gauge 0 to 125 PSIG (0 to 8.6 bar)	With Gauge 0 to 30 PSIG (0 to 2.1 bar)	With Gauge 0 to 60 PSIG (0 to 4.1 bar)
Relieving	1/4	R08-02-F0G0B	R08-02-C0G0B	R08-02-D0G0B

Options - To order an option supplied with the unit model, add the appropriate coded suffix letter in the designated position of the model number.

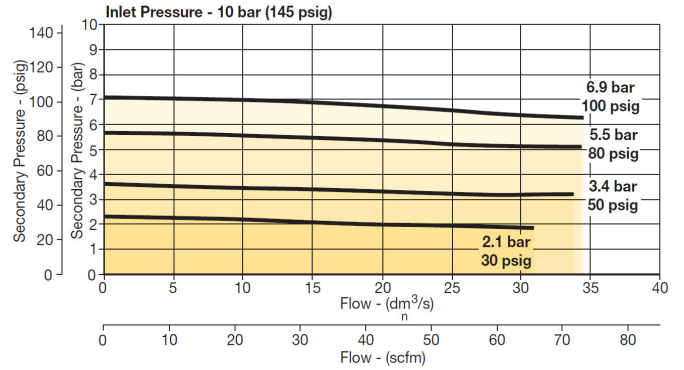

Regulator R120

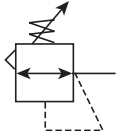

R120-02-000

Features

- High flow performance featuring rugged design for the most demanding applications
- Ideal for those installations calling for constant pressure with wide variation in flow
- Diaphragm operated design with balanced poppet design for quick and accurate regulation
- Secondary aspiration plus balanced poppet provides quick response and accurate pressure regulation
- Heavy duty tee handle adjustment
- Reverse flow version available

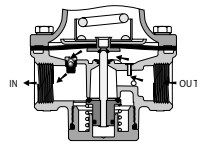
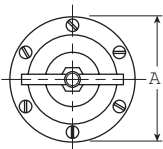

Reverse Flow Option

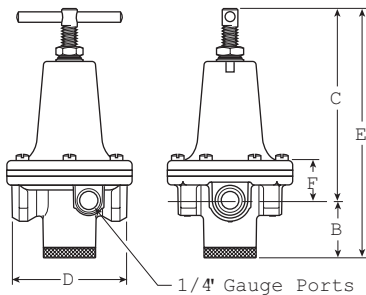

Specifications

Flow Capacity [§]	1/4	100 SCFM (47.2 dm ³ /s)
	3/8	110 SCFM (51.9 dm ³ /s)
	1/2	150 SCFM (70.8 dm ³ /s)
Gauge Port (2 ea.)	NPT / BSPP-G	1/4
Reduced Pressure Range	2 to 125 PSIG (0.15 to 8.5 bar)	
Maximum Supply Pressure	300 PSIG (20.7 bar)	
Operating Temperature	40° to 125°F (4.4° to 52°C)	
Port Size	NPT / BSPP-G	1/4, 3/8, 1/2
Weight		
R120-02, R120-03	1.8 lb. (0.82 kg) / Unit 26 lb. (11.79) / 12-Unit Master Pack	
R120-04	3.2 lb. (1.45 kg) / Unit 27 lb. (12.25) / 8-Unit Master Pack	

§ SCFM = Standard cubic feet per minute at 100 PSIG inlet, 75 PSIG no flow secondary setting, and 20 PSIG pressure drop.

Materials of Construction

Adjustment Screw, Spring	Steel
Body, spring Cage	Zinc
Bottom Plug	Brass
Innervalve	Brass
Seals	Buna N



WARNING

**Product rupture can cause serious injury.
Do not connect regulator to bottled gas.
Do not exceed maximum primary pressure rating.**

CAUTION:

REGULATOR PRESSURE ADJUSTMENT – The working range of knob adjustment is designed to permit outlet pressures within their full range. Pressure adjustment beyond this range is also possible because the knob is not a limiting device. This is a common characteristic of most industrial regulators, and limiting devices may be obtained only by special design.

For best performance, regulated pressure should always be set by increasing the pressure up to the desired setting.

Dimensions

Model	Inches (mm)	A	B	C	D	E	F
Standard Unit, 1/4 & 3/8 Port R120-XX-000		3.00 (76)	1.38 (35)	4.60 (117)	2.74 (70.5)	5.98 (152)	0.96 (24)
Standard Unit, 1/2 Port R120-X4-000		3.56 (90)	1.56 (40)	5.20 (132)	3.25 (83)	6.76 (172)	1.27 (32)

R120 Kits and Accessories

Gauges –

- 2" Dial Size, 1/4" Back Connection
0 to 60 PSIG (0 to 400 kPa) K4520N14060
- 2" Dial Size, 1/4" Back Connection
0 to 160 PSIG (0 to 1100 kPa) K4520N14160
- 2" Dial Size, 1/4" Back Connection
0 to 300 PSIG (0 to 2068 kPa) K4520N14300

Mounting Bracket Kit –

- 1/4", 3/8" WSA15Y57
- 1/2" W18A57

Panel Mount Conversion Kit –

- 1/4", 3/8" W4202
- 1/2" W4204

Repair Kits –

- Non-Relieving Diaphragm,
Valve Assembly (1/4", 3/8"; All PSIG) WRK118Y
- Relieving Diaphragm,
Valve Assembly (1/4", 3/8"; All PSIG) WRK119Y
- Non-Relieving Diaphragm,
Valve Assembly (1/2"; 25, 60, 125 PSIG)..... WRK118A
- Non-Relieving Diaphragm,
Valve Assembly (1/2"; 250 PSIG) WRK118A250
- Relieving Diaphragm,
Valve Assembly (1/2"; 25, 60, 125 PSIG)..... WRK119A
- Relieving Diaphragm,
Valve Assembly (1/2"; 250 PSIG) WRK119A250

For Fluorocarbon Repair Kits, add X64 to Kit Number suffix.

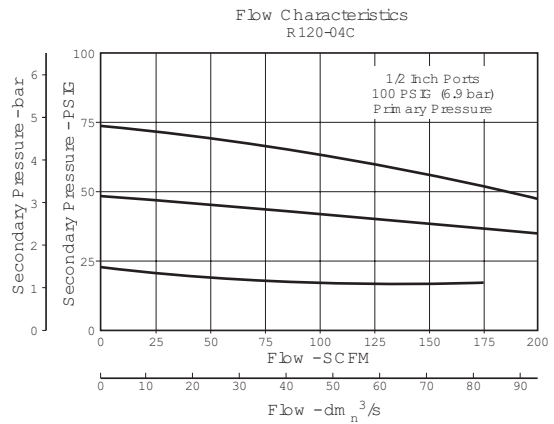
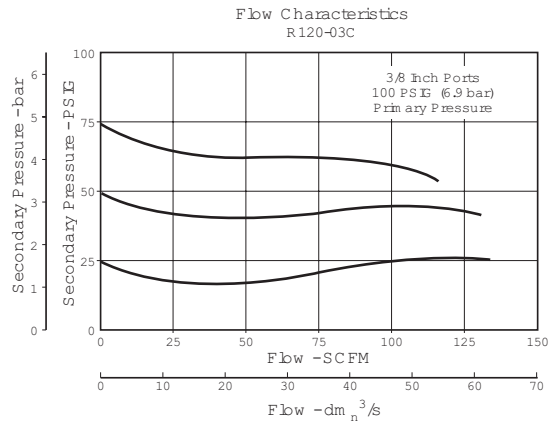
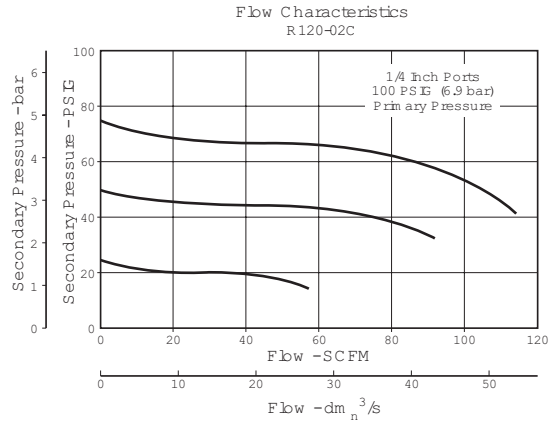

Ordering Information

R120	-	0	2	-	0	0	0
Series		Thread type	Port size		Options †		
Regular R120		NPT 0 BSPP C	2 1/4	3 3/8	G Pressure Gauge	H High Pressure Spring (250 PSI)	L Low Pressure Spring (60 PSI)
			4 1/2		N* Non-Relieving	V All Fluorocarbon	X Reverse Flow

Standard pressure spring is 0 to 125 PSIG

* **Note:** Non-relieving option not available with 250 PSI spring

† For additional options, add to end of model number.
Must be in alphabetical order and up to a total of 5 options.

Regulator R18

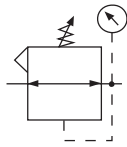

Relieving

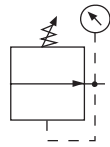

Non-Relieving



Features

- Balanced Valve Design
- Spring-loaded Diaphragm
- 4 Adjusting Pressure Ranges Available
- 1/2" NPT / BSPP-G Over-port
- 2 Gauge Ports
- Regulator will Reverse-flow as Standard

Specifications

Flow Capacity*	1/4	148 SCFM (70 dm ³ /s, ANR)
	3/8	165 SCFM (78 dm ³ /s, ANR)
	1/2	165 SCFM (78 dm ³ /s, ANR)
Adjusting Range Pressure		0 to 30 PSIG (0 to 2 bar)
		0 to 60 PSIG (0 to 4 bar)
		0 to 125 PSIG (0 to 8 bar)
		0 to 250 PSIG (0 to 17 bar)
Gauge Port (2 ea.)	NPT / BSPP-G	1/4
Maximum Supply Pressure		300 PSIG (20.7 bar)
Operating Temperature		-13° to 150°F (-25° to 65.5°C)
Port Size	NPT / BSPP-G	1/4, 3/8, 1/2
Weight		0.90 lb (0.41 kg)

* Inlet pressure 145 psig (10 bar). Secondary pressure 91.3 psig (6.3 bar) and 14.5 psig (1 bar) pressure drop.

Materials of Construction

Adjustment Knob	Acetal
Body	Aluminum
Body Cap	ABS
Bonnet	33% glass-filled nylon
Diaphragm Assembly	
Nitrile / Steel	
Valve Assembly	Brass / Nitrile
Panel Nut	Acetal
Seals	Nitrile
Springs	Main Regulating Valve: Steel Valve: Stainless Steel

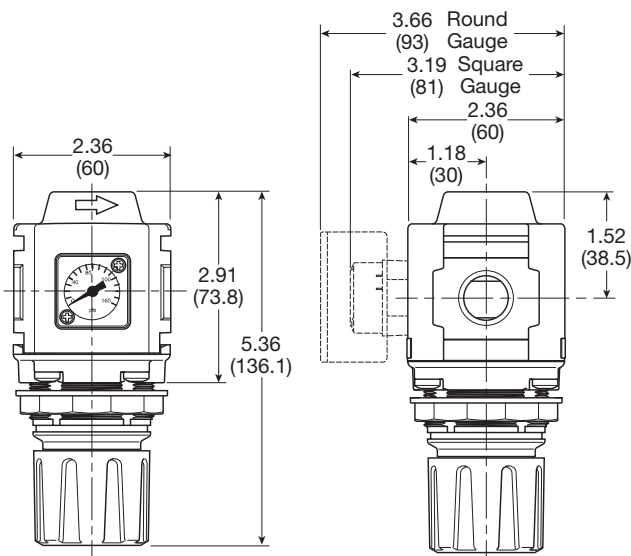

Inches (mm)

NOTE: 1.90 in. (48mm) hole required for panel nut mounting.

WARNING

**Product rupture can cause serious injury.
Do not connect regulator to bottled gas.
Do not exceed maximum primary pressure rating.**

CAUTION:

REGULATOR PRESSURE ADJUSTMENT – The working range of knob adjustment is designed to permit outlet pressures within their full range. Pressure adjustment beyond this range is also possible because the knob is not a limiting device. This is a common characteristic of most industrial regulators, and limiting devices may be obtained only by special design.

For best performance, regulated pressure should always be set by increasing the pressure up to the desired setting.

= "Most Popular"

Replacement Kits

- Adjusting Knob RRP-96-655
- Diaphragm Assembly –
 - Non-relieving RRP-96-657B
 - Relieving RRP-96-656B
- Spring, Regulating –
 - 0 to 30 PSIG (0 to 2.1 bar) RRP-96-659B
 - 0 to 60 PSIG (0 to 4.1 bar) RRP-96-660B
 - 0 to 125 PSIG (0 to 8.6 bar) RRP-96-661B
 - 0 to 250 PSIG (0 to 17.2 bar) RRP-96-662B

Accessories

- Panel Mount Nut –
 - Aluminum RRP-96-673
 - Plastic RRP-96-675B

- Gauge, Pressure –
 - Square flush mount gauge
 - 0-4 bar K4511SCR04B
 - 0-11 bar K4511SCR11B
 - 0-60 PSIG K4511SCR060
 - 0-160 PSIG K4511SCR160

- Square with adapter kit
 - 0-4 bar P6G-PR10040
 - 0-11 bar P6G-PR10110
 - 0-60 PSIG P6G-PR90060
 - 0-160 PSIG P6G-PR90160

- 50mm (2") round 1/4" center back mount
 - 0-30 PSIG / 0-2 bar K4520N14030
 - 0-60 PSIG / 0-4 bar K4520N14060
 - 0-160 PSIG / 0-11 bar K4520N14160
 - 0-300 PSIG / 0-20 bar K4520N14300

- 1-3/4" Digital Round 1/4" NPT
 - 0 to 160 PSIG K4517N14160D

For best performance, regulated pressure should always be set by increasing the pressure up to the desired setting.

- Tamper Resistant Kit RRP-96-671
- Tamperproof Lock and Cover Kit RPA-96-737
- Tamperproof Knob Kit RPA-96-738

- Wall Mounting Bracket –
 - L-Type GPA-96-606
 - T-Type GPA-96-602

R18 1/4" Regulator

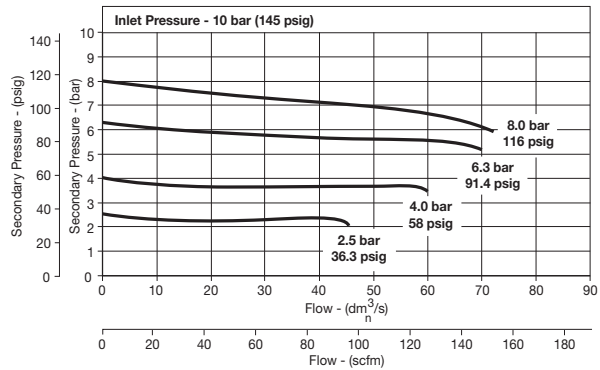

R18 3/8" Regulator

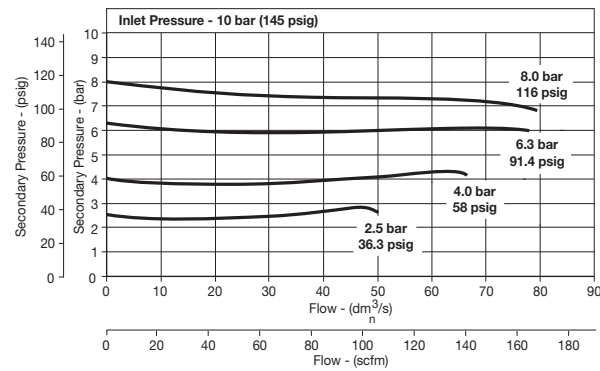

R18 1/2" Regulator

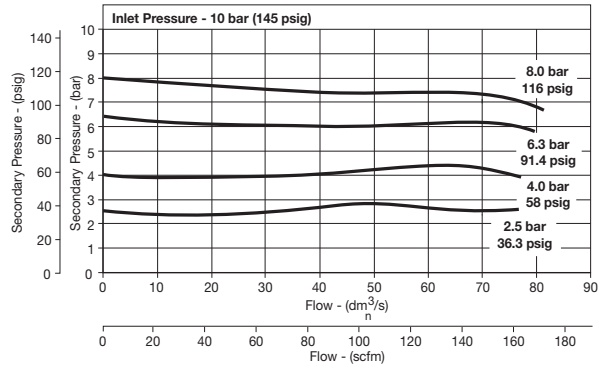

Ordering Information

Model Type	Port Size	With Gauge 5 to 125 PSIG (0.4 to 8.6 bar)	With Gauge 10 to 250 PSIG (0.7 to 17.2 bar)	With Gauge 3 to 60 PSIG (0.2 to 4.1 bar)	Without Gauge 5 to 125 PSIG (0.4 to 8.6 bar)
Relieving	1/4	R18-02-F0G0B	R18-02-G0G0B	R18-02-D0G0B	R18-02-F000B
	3/8	R18-03-F0G0B	R18-03-G0G0B	R18-03-D0G0B	R18-03-F000B
	1/2	R18-04-F0G0B	R18-04-G0G0B	R18-04-D0G0B	R18-04-F000B

Options - To order an option supplied with the unit model, add the appropriate coded suffix letter in the designated position of the model number.

Regulator R16

 = "Most Popular"

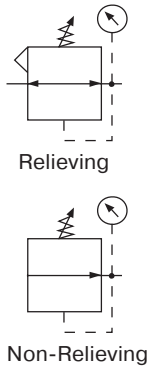

R16-02-000

Features

- Non-Rising Adjustment Knob with Friction Lock Knob
- Standard with Two Full Flow 1/4" NPT / BSPT-Rc Gauge Ports
- Panel Mount Nut
- High Flow Capacity
- Balanced Valve Design for Excellent Regulation Characteristics

Specifications

Flow Capacity*	1/4	71.5 SCFM (33.7 dm ³ /s)
	3/8	80.5 SCFM (38.0 dm ³ /s)
	1/2	88.0 SCFM (41.5 dm ³ /s)
Adjusting Range Pressure		0 to 60 PSIG (0 to 4.1 bar)
		0 to 125 PSIG (0 to 8.6 bar)
		0 to 250 PSIG (0 to 17.2 bar)
Maximum Supply Pressure		300 PSIG (20.7 bar)
Operating Temperature		32° to 150°F (0° to 65.5°C)
Port Size	NPT / BSPP-G	1/4, 3/8, 1/2
Gauge Port (2 ea.)	NPT / BSPT-Rc	1/4
Weight	lb. (kg)	1.7 (0.77)

* Inlet pressure 100 PSIG (6.9 bar). Secondary pressure 90 PSIG (6.2 bar).

Materials of Construction

Body	Zinc
Bonnet	PBT
Diaphragm	Nitrile / Zinc
Panel Nut	Acetal
Seals	Nitrile
Springs	Steel
Valve Assembly	Brass / Nitrile / Acetal

WARNING

**Product rupture can cause serious injury.
Do not connect regulator to bottled gas.
Do not exceed maximum primary pressure rating.**

CAUTION:

REGULATOR PRESSURE ADJUSTMENT – The working range of knob adjustment is designed to permit outlet pressures within their full range. Pressure adjustment beyond this range is also possible because the knob is not a limiting device. This is a common characteristic of most industrial regulators, and limiting devices may be obtained only by special design.

For best performance, regulated pressure should always be set by increasing the pressure up to the desired setting.

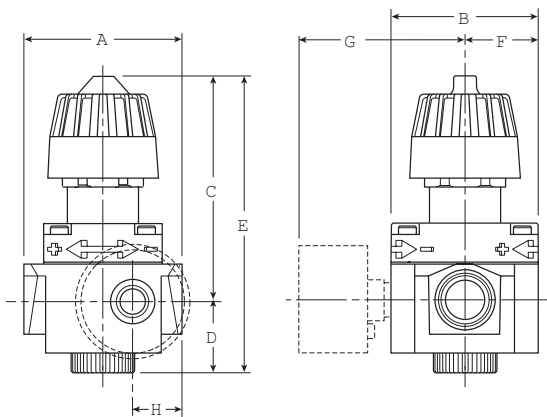

NOTE: 1.31" Dia. (33.3 mm) hole required for panel nut mounting.

Dimensions

Models	Inches (mm)	A	B	C	D	E	F	G	H
Standard Unit R16-XX-000		2.99 (76)	2.59 (66)	3.99 (101.3)	1.20 (30.5)	5.19 (132)	1.29 (33)	— —	1.02 (25.9)
With Gauge R16-XX-G00		2.99 (76)	2.59 (66)	3.99 (101.3)	1.20 (30.5)	5.19 (132)	1.29 (33)	2.80 (71)	1.02 (25.9)

= "Most Popular"

Replacement Kits

- Adjusting Knob RRP-95-023
- Diaphragm Assembly –
 - Non-relieving RRP-96-216
 - Self-relieving.....RRP-96-213
- Spring, Regulating –
 - 0 to 50 PSIG (0 to 3.4 bar) RRP-95-222
 - 0 to 125 PSIG (0 to 8.6 bar) RRP-95-224
 - 0 to 250 PSIG (0 to 17.2 bar).....RRP-95-218
- Valve Assembly –
 - Valve, Valve Spring, Bottom Plug O-ringRRP-96-215

Accessories

- Gauge, Pressure –
 - 0 to 60 PSIG (0 to 4 bar), 2" Dial Face, 1/4 NPT, CBMK4520N14060W
 - 0 to 160 PSIG (0 to 11 bar), 2" Dial Face, 1/4 NPT, CBM K4520N14160W
 - 0 to 300 PSIG (0 to 20 bar), 2" Dial Face, 1/4 NPT, CBMK4520N14300W
 - 0 to 160 PSIG, 1-3/4" Digital Round K4517N14160D
- Panel Mount Nut, Plastic GPA-95-032
- Tamper Resistant Kit, Ring Style..... RPA-95-006
- Wall Mounting Bracket, Gauge Port Adapter, 1/4 NPT RRP-95-590
- Wall Mounting Bracket –
 - L-Type, Heavy Duty..... RPA-95-090
 - L-Type, StandardGPA-95-012
 - L-Type with Plastic Panel Mount NutGPA-95-011

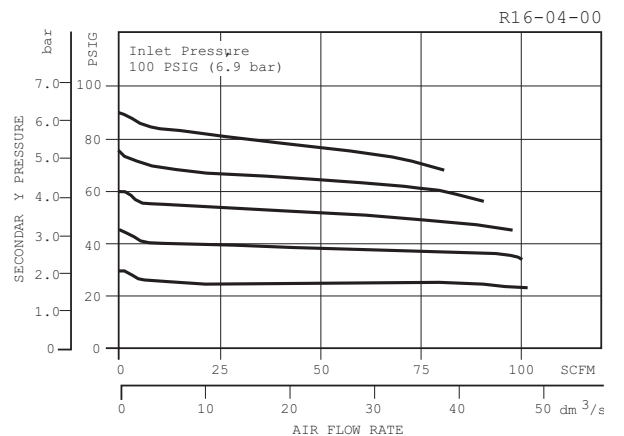
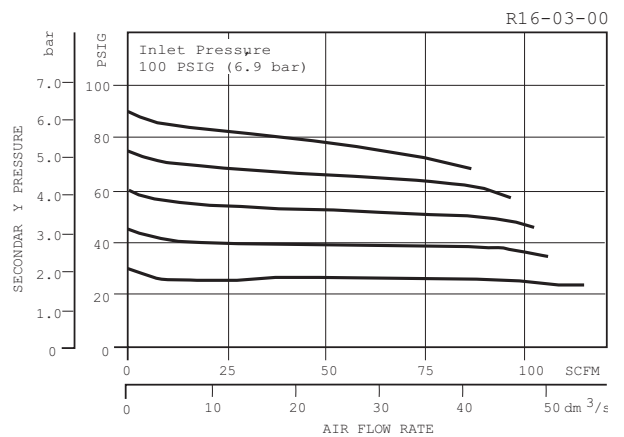
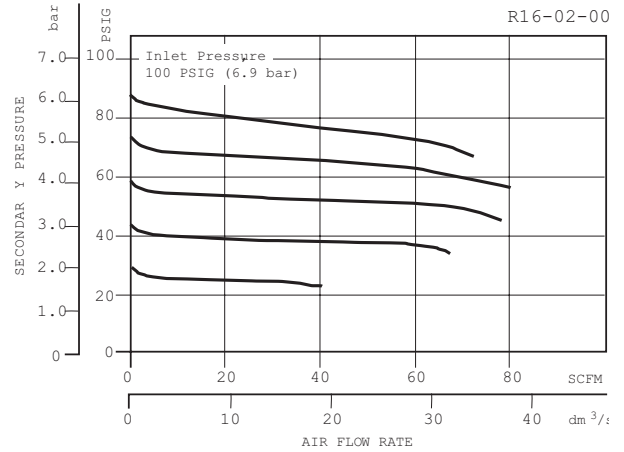

Ordering Information

Model Type	Port Size	Without Gauge 5 to 125 PSIG (0.4 to 8.6 bar)	Without Gauge 10 to 250 PSIG (0.7 to 17.2 bar)	Without Gauge 3 to 60 PSIG (0.2 to 4.1 bar)	With Gauge 5 to 125 PSIG (0.4 to 8.6 bar)	With Gauge 10 to 250 PSIG (0.7 to 17.2 bar)	With Gauge 3 to 60 PSIG (0.2 to 4.1 bar)
Relieving	1/4	R16-02-000	R16-02-H00	R16-02-L00	R16-02-G00	R16-02-GH0	R16-02-GL0
	3/8	R16-03-000	R16-03-H00	R16-03-L00	R16-03-G00	R16-03-GH0	R16-03-GL0
	1/2	R16-04-000	R16-04-H00	R16-04-L00	R16-04-G00	R16-04-GH0	R16-04-GL0
Non-relieving	1/4	R16-02-N00	R16-02-HN0	R16-02-LN0	R16-02-GN0	R16-02-GHN	R16-02-GLN
	3/8	R16-03-N00	R16-03-HN0	R16-03-LN0	R16-03-GN0	R16-03-GHN	R16-03-GLN
	1/2	R16-04-N00	R16-04-HN0	R16-04-LN0	R16-04-GN0	R16-04-GHN	R16-04-GLN

Options - To order an option supplied with the unit model, add the appropriate coded suffix letter in the designated position of the model number.

Regulator R28

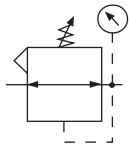

Relieving

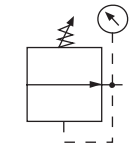

Non-Relieving



Features

- Balanced Valve Design
- Spring-loaded Diaphragm
- 4 Adjusting Pressure Ranges Available
- 3/4" NPT / BSPP-G Over-port
- Reverse-flow Available
- 2 Gauge Ports

Specifications

Flow Capacity*	3/8	228 SCFM (108 dm ³ /s, ANR)
	1/2	233 SCFM (110 dm ³ /s, ANR)
	3/4	233 SCFM (110 dm ³ /s, ANR)
Adjusting Range Pressure		0 to 30 PSIG (0 to 2 bar)
		0 to 60 PSIG (0 to 4 bar)
		0 to 125 PSIG (0 to 8 bar)
		0 to 250 PSIG (0 to 17 bar)
Gauge Port (2 ea.)	NPT / BSPP-G	1/4
Maximum Supply Pressure		300 PSIG (20.7 bar)
Operating Temperature		-13° to 150°F (-25° to 65.5°C)
Port Size	NPT / BSPP-G	3/8, 1/2, 3/4
Weight		1.37 lb. (0.62 kg)

* Inlet pressure 145 psig (10 bar). Secondary pressure 91.3 psig (6.3 bar) and 14.5 psig (1 bar) pressure drop.

Materials of Construction

Adjustment Knob	Acetal
Body	Aluminum
Body Cap	ABS
Bonnet	33% Glass-filled Nylon
Diaphragm Assembly	Nitrile / Zinc
Panel Nut	Acetal
Seals	Nitrile
Springs	Main Regulating Valve: Steel Valve: Stainless Steel
Valve Assembly	Brass / Nitrile / Acetal

⚠ WARNING

**Product rupture can cause serious injury.
Do not connect regulator to bottled gas.
Do not exceed maximum primary pressure rating.**

CAUTION:

REGULATOR PRESSURE ADJUSTMENT – The working range of knob adjustment is designed to permit outlet pressures within their full range. Pressure adjustment beyond this range is also possible because the knob is not a limiting device. This is a common characteristic of most industrial regulators, and limiting devices may be obtained only by special design.

For best performance, regulated pressure should always be set by increasing the pressure up to the desired setting.

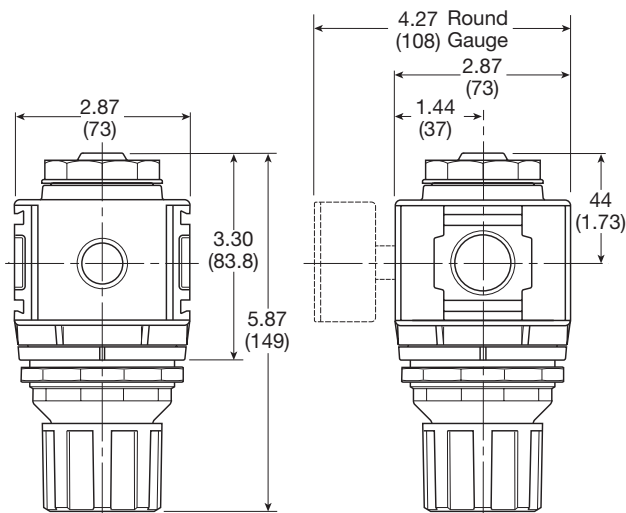

Inches (mm)

NOTE: 2.40 in. (61mm) hole required for panel nut mounting.

= "Most Popular"

Replacement Kits

- Diaphragm Assembly –
 - Non-relieving RRP-96-987
 - Relieving..... RRP-96-986
- Valve Assembly RRP-96-049
- Adjusting Knob RRP-16-341-000
- Spring, Regulating
 - 0 to 30 PSIG (0 to 2.1 bar) RRP-96-163
 - 0 to 60 PSIG (0 to 4.1 bar) RRP-96-164
 - 0 to 125 PSIG (0 to 8.6 bar) RRP-96-165
 - 0 to 250 PSIG (0 to 17.2 bar)..... RRP-96-166

Accessories

- Panel Mount Nut –
 - Aluminum RRP-96-674
 - Plastic RRP-96-676
- Gauge, Pressure –
 - 50mm (2") round 1/4" center back mount
 - 0-30 PSIG / 0-2 bar K4520N14030
 - 0-60 PSIG / 0-4 bar K4520N14060
 - 0-160 PSIG / 0-11 bar K4520N14160
 - 0-300 PSIG / 0-20 bar K4520N14300
 - 0 to 160 PSIG, 1-3/4" Digital Round,
 - 1/4" NPT K4517N14160D
- Tamper Resistant Kit..... RRP-96-672
- Wall Mounting Bracket
 - L-Type..... GPA-96-607
 - T-Type GPA-96-602

R28 3/8" Regulator

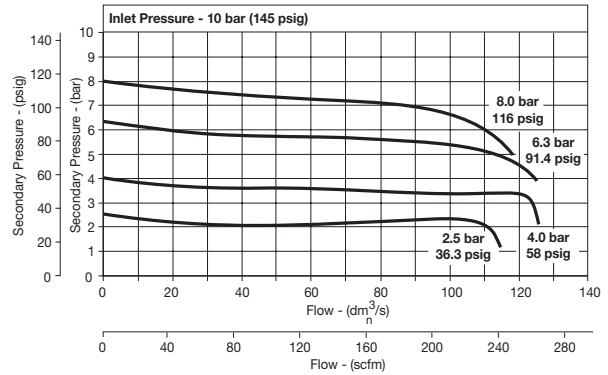

R28 1/2" Regulator

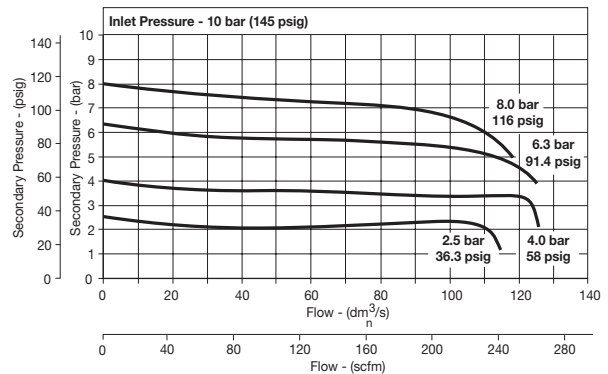

R28 3/4" Regulator

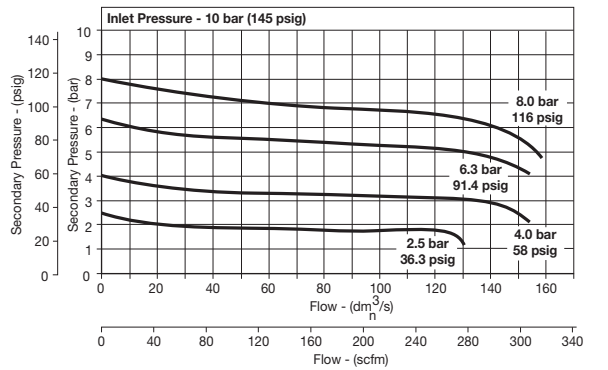

Ordering Information

Model Type	Port Size	With Gauge 5 to 125 PSIG (0.4 to 8.6 bar)	With Gauge 10 to 250 PSIG (0.7 to 17.2 bar)	With Gauge 3 to 60 PSIG (0.2 to 4.1 bar)	Without Gauge 5 to 125 PSIG (0.4 to 8.6 bar)
Relieving	3/8	R28-03-F0G0B	R28-03-G0G0B	R28-03-D0G0B	R28-03-F000B
	1/2	R28-04-F0G0B	R28-04-G0G0B	R28-04-D0G0B	R28-04-F000B
	3/4	R28-06-F0G0B	R28-06-G0G0B	R28-06-D0G0B	R28-06-F000B

Options - To order an option supplied with the unit model, add the appropriate coded suffix letter in the designated position of the model number.

Regulator R26

 = "Most Popular"

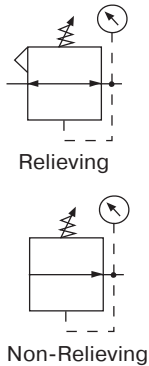

R26-02-000

Features

- Non-Rising Adjustment Knob with Friction Lock Knob
- Standard with Two Full Flow 1/4" NPT / BSPT-Rc Gauge Ports
- Panel Mount Nut
- High Flow Capacity
- Balanced Valve Design for Excellent Regulation Characteristics

Specifications

Flow Capacity*	1/4	112 SCFM (53 dm ³ /s)
	3/8	148 SCFM (70 dm ³ /s)
	1/2	185 SCFM (87 dm ³ /s)
Adjusting Range Pressure	0 to 60 PSIG (0 to 4.1 bar)	
	0 to 125 PSIG (0 to 8.6 bar)	
	0 to 250 PSIG (0 to 17.2 bar)	
Gauge Port (2 ea.)	NPT / BSPT-Rc	1/4
Operating Temperature	32° to 150°F (0° to 65.5°C)	
Maximum Supply Pressure	300 PSIG (21 bar)	
Port Size	NPT / BSPP-G	1/4, 3/8, 1/2
Weight	lb. (kg)	2.5 (1.34)

* Inlet pressure 100 PSIG (6.9 bar). Secondary pressure 90 PSIG (6.2 bar).

Materials of Construction

Body	Zinc
Bonnet	PBT
Diaphragm	Nitrile / Zinc
Panel Nut	Acetal
Seals	Nitrile
Springs	Steel
Valve Assembly	Brass / Nitrile / Acetal

⚠ WARNING

**Product rupture can cause serious injury.
Do not connect regulator to bottled gas.
Do not exceed maximum primary pressure rating.**

CAUTION:

REGULATOR PRESSURE ADJUSTMENT – The working range of knob adjustment is designed to permit outlet pressures within their full range. Pressure adjustment beyond this range is also possible because the knob is not a limiting device. This is a common characteristic of most industrial regulators, and limiting devices may be obtained only by special design.

For best performance, regulated pressure should always be set by increasing the pressure up to the desired setting.

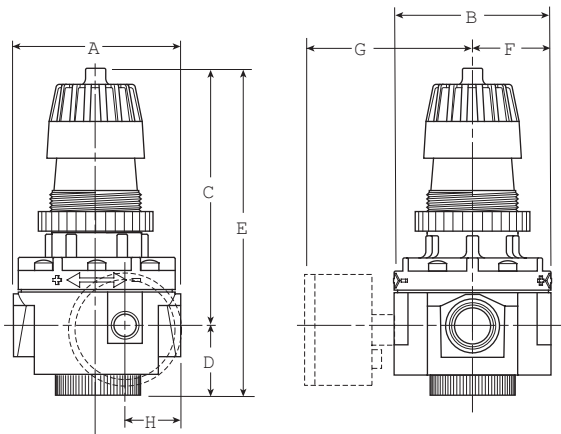

NOTE: 1.88" Dia. (47.8 mm) hole required for panel nut mounting.

Dimensions

Models	Inches (mm)	A	B	C	D	E	F	G	H
Standard Unit R26-XX-000		3.35 (85)	3.10 (79)	5.13 (130.3)	1.35 (34)	6.48 (165)	1.55 (39.4)	— —	1.13 (28.7)
With Gauge R26-XX-G00		3.35 (85)	3.10 (79)	5.13 (130.3)	1.35 (34)	6.48 (165)	1.55 (39.4)	3.13 (79.5)	1.13 (28.7)

= "Most Popular"

Replacement Kits

- Diaphragm Assembly –
 - Non-relieving RRP-96-332
 - Self-relieving..... RRP-96-238
- Knob, Adjusting –
 - Used on Units with Plastic Bonnets..... RRP-95-023
- Spring, Regulating –
 - 0 to 60 PSIG (0 to 4,1 bar) RRP-95-962
 - 0 to 125 PSIG (0 to 8,6 bar) GRP-95-225
 - 0 to 250 PSIG (0 to 17,2 bar)..... RRP-95-219
- Valve Assembly –
 - Valve, Valve Spring, Bottom Plug O-ring RRP-96-294

Accessories

- Gauge, Pressure –
 - 0 to 60 PSIG (0 to 4 bar), 2" Dial Face,
1/4" NPT, CBM K4520N14060W
 - 0 to 160 PSIG (0 to 11 bar), 2" Dial Face,
1/4" NPT, CBM K4520N14160W
 - 0 to 300 PSIG (0 to 20 bar), 2" Dial Face,
1/4" NPT, CBM K4520N14300W
 - 0 to 160 PSIG, 1-3/4" Digital Round
1/4" NPT K4517N14160D
- Nut, Panel Mount, Plastic..... RRP-95-954
- Tamper Resistant Kit –
 - Ring Style used on Plastic Bonnets RPA-95-006
- Wall Mounting Bracket –
 - C-type GPA-95-051
 - C-type RPA-95-947
 - L-Type – Heavy Duty GPA-95-956
- Wall Mounting Bracket, Gauge Port Adapter,
1/4" NPT RRP-95-590

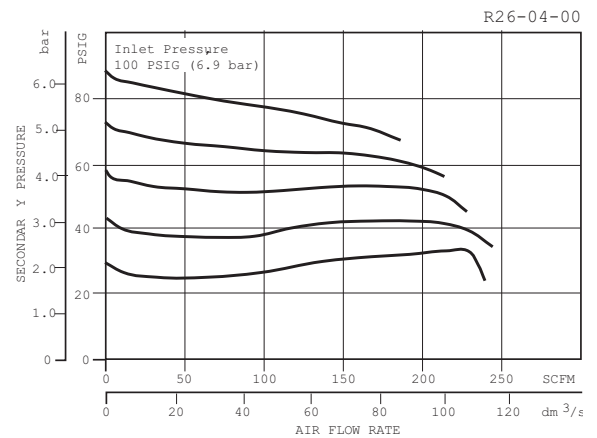
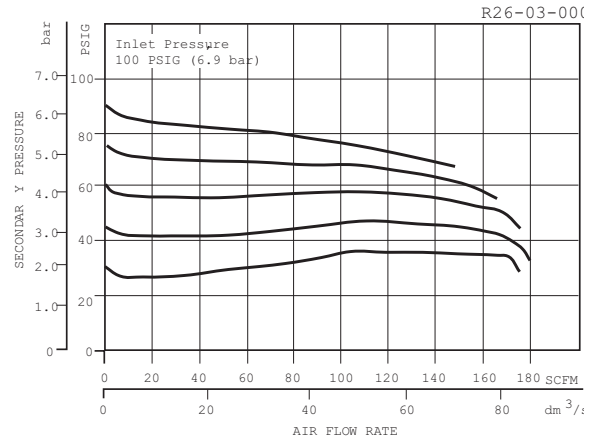
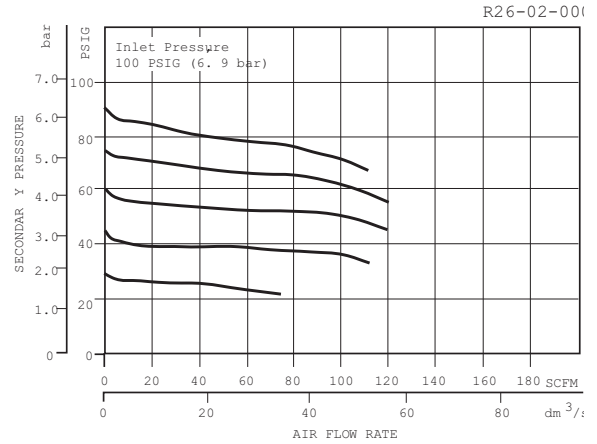

Ordering Information

Model Type	Port Size	Without Gauge 5 to 125 PSIG (0.4 to 8.6 bar)	Without Gauge 10 to 250 PSIG (0.7 to 17.2 bar)	Without Gauge 3 to 60 PSIG (0.2 to 4.1 bar)	With Gauge 5 to 125 PSIG (0.4 to 8.6 bar)	With Gauge 10 to 250 PSIG (0.7 to 17.2 bar)	With Gauge 3 to 60 PSIG (0.2 to 4.1 bar)
Relieving	1/4	R26-02-000	R26-02-H00	R26-02-L00	R26-02-G00	R26-02-GH0	R26-02-GL0
	3/8	R26-03-000	R26-03-H00	R26-03-L00	R26-03-G00	R26-03-GH0	R26-03-GL0
	1/2	R26-04-000	R26-04-H00	R26-04-L00	R26-04-G00	R26-04-GH0	R26-04-GL0
Non-relieving	1/4	R26-02-N00	R26-02-HN0	R26-02-LN0	R26-02-GN0	R26-02-GHN	R26-02-GLN
	3/8	R26-03-N00	R26-03-HN0	R26-03-LN0	R26-03-GN0	R26-03-GHN	R26-03-GLN
	1/2	R26-04-N00	R26-04-HN0	R26-04-LN0	R26-04-GN0	R26-04-GHN	R26-04-GLN

Options - To order an option supplied with the unit model, add the appropriate coded suffix letter in the designated position of the model number.

Regulator R90

 = "Most Popular"



Symbols

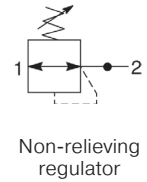
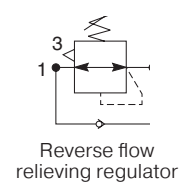
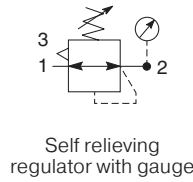

Features

- Integral 3/4" or 1" ports (BSPP & NPT)
- Robust but lightweight aluminum construction
- Secondary pressure ranges 12 and 16 bar
- Rolling diaphragm for extended life
- Secondary aspiration plus rolling diaphragm provides quick response and accurate pressure regulation
- Optional tamperproof regulator padlock
- Reverse flow / relieving option
- Low temperature -40°

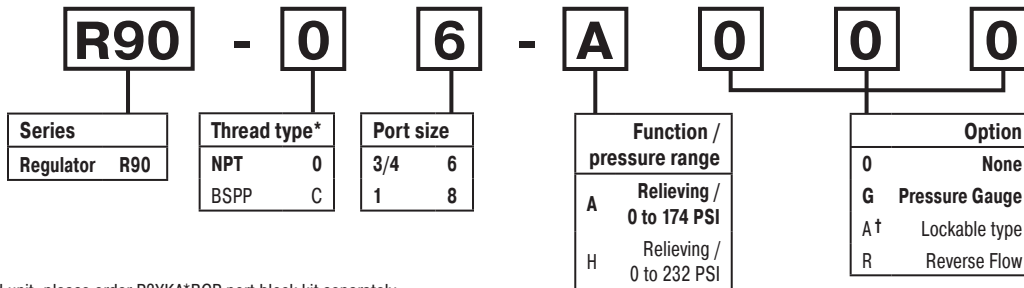

Notes:

* For 1-1/2" ported unit, please order P3YKA*BCP port block kit separately.

† Not field convertible.

Bold items are most common.

Ordering information

Port size	Description	Flow† scfm	Max. bar (psig)	Min temp °C (°F)	Max temp °C (°F)	Height mm (inches)	Width mm (inches)	Depth mm (inches)	Weight kg (lb)	Part number †
3/4"	12 bar relieving	380	17.5 (254)	-40 (-40)	60 (140)	182 (7.2)	90 (3.5)	94 (3.7)	1.08 (2.4)	R90-06-A000
3/4"	12 bar relieving + pressure gauge	380	17.5 (254)	-10 (14)	60 (140)	182 (7.2)	90 (3.5)	94 (3.7)	1.13 (2.5)	R90-06-AG00
1"	12 bar relieving	550	17.5 (254)	-40 (-40)	60 (140)	182 (7.2)	90 (3.5)	94 (3.7)	1.08 (2.4)	R90-08-A000
1"	12 bar relieving + pressure gauge	550	17.5 (254)	-10 (14)	60 (140)	182 (7.2)	90 (3.5)	94 (3.7)	1.19 (2.6)	R90-08-AG00

† Standard part numbers shown in bold. For other models refer to Options chart above.

‡ Flow with 6.3 bar (91.4 psig) inlet pressure and 0.5 (7.3 psig) pressure drop.

Specifications

Fluid	Compressed air
Maximum inlet pressure*	17.5 bar (254 psig)
Temperature range*	-40°C to 60°C (-40°F to 140°F)
Typical flow with 10 bar (145 psig) inlet pressure and 6.3 bar (91 psig) set pressure and 0.5 bar (7.3 psig) pressure drop	1" size 550 scfm
Gauge port (x 2)	1/4"

* Air supply must be dry enough to avoid ice formation at temperatures below 2°C (35.6°F).

Dimensions mm (inches)

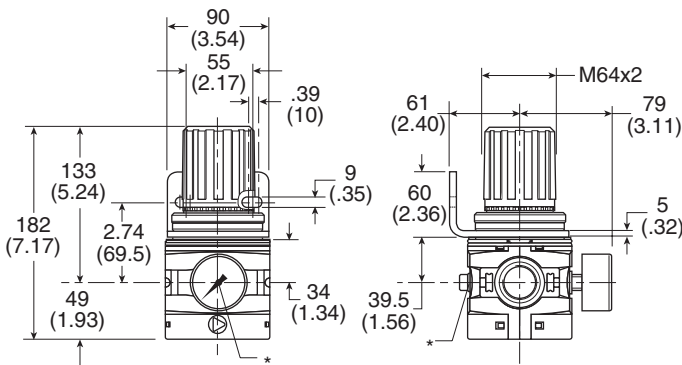

* 1/4" gauge port

Service kits

- Angle bracket + metal lock ring P3YKA00MS
- Panel mounting nut..... P3YKA00MM
- Diaphragm kit (relieving type).....P3YKA00RR
- Diaphragm kit (non-relieving type)..... P3YKA00RN
- Gauge - 1/4" port
- 0 to 10 bar (0 to 160 psig) K4520N14160
- 0 to 20 bar (0 to 300 psig)K4520N14300

⚠ WARNING

**Product rupture can cause serious injury.
Do not connect regulator to bottled gas.
Do not exceed maximum primary pressure rating.**

Material specifications

Body	Aluminum
Bonnet	Glass filled polyamide
Regulator cover	ABS
Control knob	Glass filled polyamide
Valve	Brass / NBR
Seals	Nitrile NBR
Screws	Steel / zinc plated

Flow characteristics

(3/4") Regulator

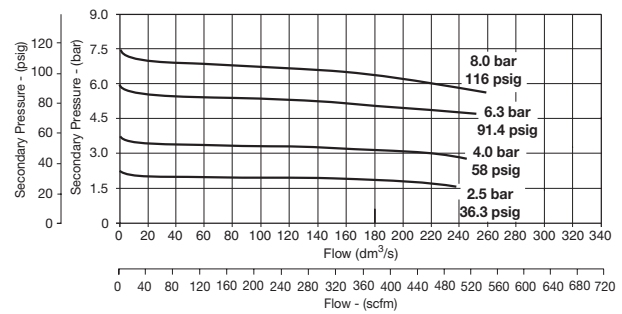

(1") Regulator

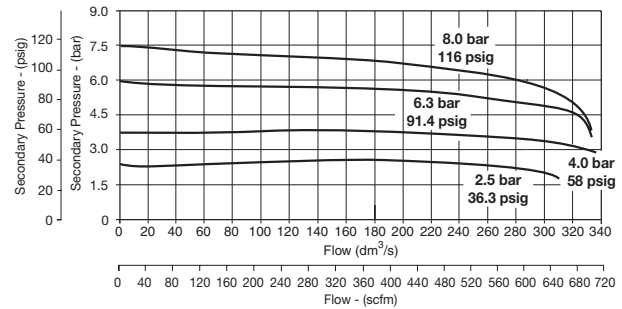

CAUTION:

REGULATOR PRESSURE ADJUSTMENT – The working range of knob adjustment is designed to permit outlet pressures within their full range. Pressure adjustment beyond this range is also possible because the knob is not a limiting device. This is a common characteristic of most industrial regulators, and limiting devices may be obtained only by special design.

For best performance, regulated pressure should always be set by increasing the pressure up to the desired setting.

Pilot Operated Regulator R90

 = "Most Popular"

Symbol

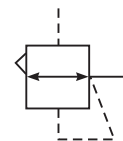

Features

- Integral 3/4" or 1" ports (BSPP & NPT)
- Pilot controlled regulators can be mounted "out of reach" with pilot regulator installed in a convenient location
- Constant pilot bleed control for accurate pressure control
- Balanced poppet provides quick response
- High flow

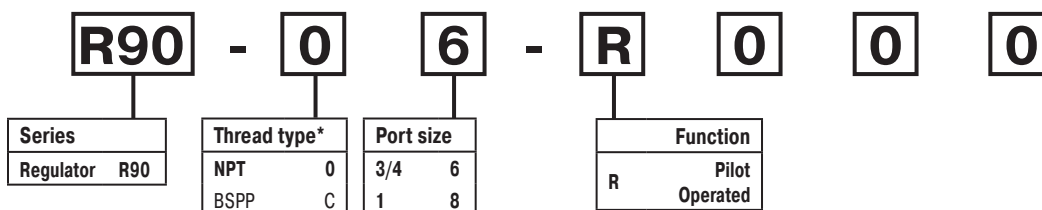

*Note: For 1-1/2" ported unit, please order P3YKA*BCP port block kit separately.
Bold items are most common.

Ordering information

Port size	Description	Flow [‡] scfm	Max. bar (psig)	Min temp °C (°F)	Max temp °C (°F)	Height mm (inches)	Width mm (inches)	Depth mm (inches)	Weight kg (lb)	Part number [†]
3/4"	Pilot operated regulator	550	17.5 (254)	-10 (14)	60 (140)	105.5 (4.15)	90 (3.54)	90 (3.54)	1.2 (2.6)	R90-06-R000
1"	Pilot operated regulator	550	17.5 (254)	-10 (14)	60 (140)	105.5 (4.15)	90 (3.54)	90 (3.54)	1.2 (2.6)	R90-08-R000

[†] Standard part numbers shown in bold. For other models refer to Options chart above.

[‡] Flow with 10 bar (145 psig) inlet pressure, 6.3 bar (91.4 psig) set pressure and 1 bar (14.5 psig) pressure drop.

Specifications

Fluid	Compressed air
Max. pressure air pilot operated	17.5 bar (254 psig)
Operating temperature	-10°C to 60°C (14°F to 140°F)
Weight	3/4" 1.2 kg (2.6 lb)
	1" 1.2 kg (2.6 lb)

Material specifications

Body	Aluminum
Body cover	ABS
Valve	Brass / NBR composite
Pilot valve booster	Aluminum
Seals	Nitrile NBR
Screws	Zinc plated steel

Dimensions mm (inches)

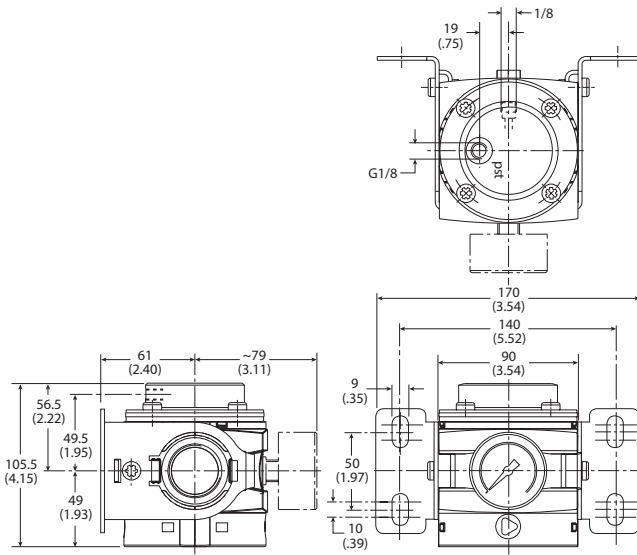

Flow characteristics

3/4" and 1" Pilot Regulator

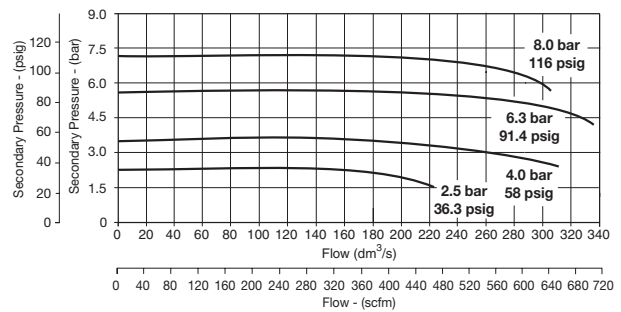

WARNING

**Product rupture can cause serious injury.
Do not connect regulator to bottled gas.
Do not exceed maximum primary pressure rating.**

CAUTION:

REGULATOR PRESSURE ADJUSTMENT – The working range of knob adjustment is designed to permit outlet pressures within their full range. Pressure adjustment beyond this range is also possible because the knob is not a limiting device. This is a common characteristic of most industrial regulators, and limiting devices may be obtained only by special design.

For best performance, regulated pressure should always be set by increasing the pressure up to the desired setting.

Regulator R30

= "Most Popular"

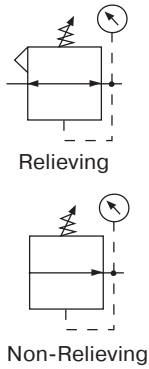

R30-06-000

Features

- Balanced Valve Design
- Standard Self-Relieving
- Two 1/4 NPT / BSPT-Rc Gauge Ports Standard – Can Be Used for Additional Outlet Ports
- Piston Operated
- High Flow Capacity

Specifications

Flow Capacity*	3/4 1	481 SCFM (227 dm ³ /s) 500 SCFM (236 dm ³ /s)
Adjusting Range Pressure		0 to 125 PSIG (0 to 8.6 bar) 0 to 180 PSIG (0 to 12.4 bar)
Gauge Port (2 ea.)	NPT / BSPT-Rc	1/4
Maximum Supply Pressure		300 PSIG (20.7 bar)
Operating Temperature		32° to 150°F (0° to 65.5°C)
Port Size	NPT / BSPP-G	3/4, 1
Weight	lb. (kg)	6 (2.7)

* Inlet pressure 100 PSIG (6.9 bar). Secondary pressure 80 PSIG (5.5 bar).

Materials of Construction

Body	Zinc
Bonnet	Zinc
Piston	Zinc
Seals	Nitrile
Springs	Steel
Valve Assembly	Brass / Nitrile / Steel

WARNING

**Product rupture can cause serious injury.
Do not connect regulator to bottled gas.
Do not exceed maximum primary pressure rating.**

CAUTION:

REGULATOR PRESSURE ADJUSTMENT – The working range of knob adjustment is designed to permit outlet pressures within their full range. Pressure adjustment beyond this range is also possible because the knob is not a limiting device. This is a common characteristic of most industrial regulators, and limiting devices may be obtained only by special design.

For best performance, regulated pressure should always be set by increasing the pressure up to the desired setting.

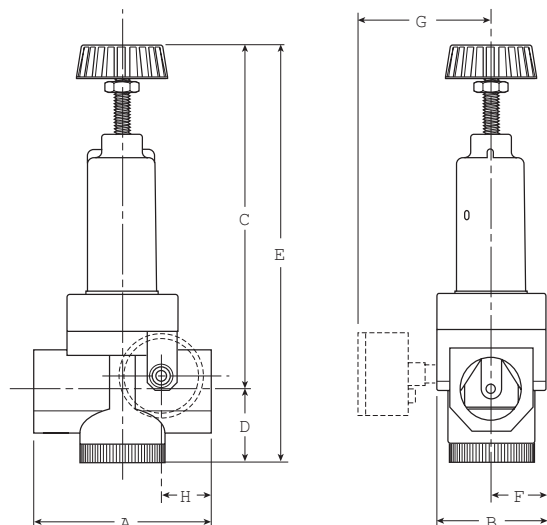

Dimensions

Models	Inches (mm)	A	B	C	D	E	F	G	H
Standard Unit R30-XX-000		4.33 (110)	2.65 (67)	8.62 (218.9)	1.75 (44)	10.37 (263)	1.33 (34)	—	1.23 (31.2)
With Gauge R30-XX-G00		4.33 (110)	2.65 (67)	8.62 (218.9)	1.75 (44)	10.37 (263)	1.33 (34)	2.99 (76)	1.23 (31.2)

= "Most Popular"

Replacement Kits

- Piston Assembly –
 - Non-relieving RRP-95-451
 - Relieving..... RRP-95-964
- Spring, Regulating –
 - 0 to 125 PSIG (0 to 8.6 bar) RRP-95-226
 - 0 to 180 PSIG (0 to 12.4 bar)..... RRP-95-220
- Valve Assembly –
 - Valve, Valve Spring, Bottom Plug O-ring RRP-95-159

Accessories

- Gauge, Pressure –
 - 0 to 160 PSIG (0 to 11 bar), 2" Dial Face,
1/4" NPT, CBM K4520N14160
 - 0 to 300 PSIG (0 to 20 bar), 2" Dial Face,
1/4" NPT, CBMK4520N14300
 - 0 to 160 PSIG, 1-3/4" Digital Round,
1/4" NPT K4517N14160D
- Wall Mounting Bracket –
 - Gauge Port Adapter, 1/4" NPT RRP-95-590
 - U-bolt Pipe Clamp GRP-95-734

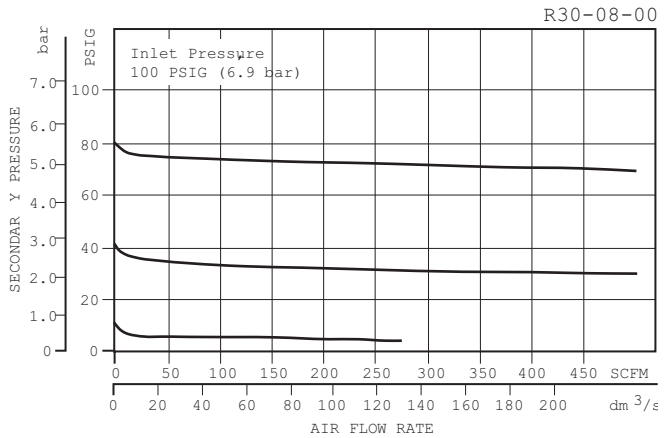
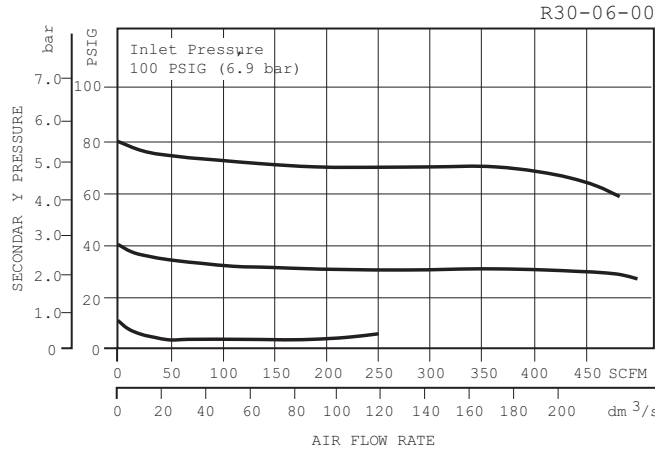

Ordering Information

Model Type	Port Size	Standard Pressure 10 to 125 PSIG (0.7 to 8.6 bar)	High Pressure 10 to 180 PSIG (0.7 to 12.4 bar)
Relieving	3/4	R30-06-000	R30-06-H00
	1	R30-08-000	R30-08-H00
Non-relieving	3/4	R30-06-N00	R30-06-HN0
	1	R30-08-N00	R30-08-HN0

Options - To order an option supplied with the unit model, add the appropriate coded suffix letter in the designated position of the model number.

Regulator R40

 = "Most Popular"

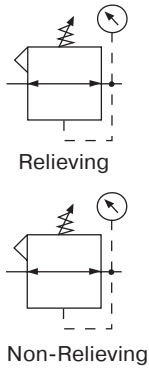

R40-0B-000

Features

- Balanced Valve Design
- Standard Self-Relieving
- Two 1/4 NPT / BSPT-Rc Gauge Ports Standard – Can Be Used for Additional Outlet Ports
- Piston Operated
- High Flow Capacity

Specifications

Flow Capacity*	1-1/2, 2	1200 SCFM (566 dm ³ /s)
Adjusting Range Pressure	0 to 125 PSIG (0 to 8.6 bar)	0 to 180 PSIG (0 to 12.4 bar)
Maximum Supply Pressure	300 PSIG (20.7 bar)	
Operating Temperature	32° to 150°F (0° to 65.5°C)	
Port Size	NPT / BSPP-G	1-1/2, 2
Gauge Port (2 ea.)	NPT / BSPT-Rc	1/4
Weight	lb. (kg)	10.8 (4.9)

* Inlet pressure 100 PSIG (6.9 bar). Secondary pressure 85 PSIG (5.9 bar).

Materials of Construction

Body	Zinc
Bonnet	Zinc
Piston	Zinc
Seals	Nitrile
Springs	Steel
Valve Assembly	Brass / Nitrile / Acetal

WARNING

**Product rupture can cause serious injury.
Do not connect regulator to bottled gas.
Do not exceed maximum primary pressure rating.**

CAUTION:

REGULATOR PRESSURE ADJUSTMENT – The working range of knob adjustment is designed to permit outlet pressures within their full range. Pressure adjustment beyond this range is also possible because the knob is not a limiting device. This is a common characteristic of most industrial regulators, and limiting devices may be obtained only by special design.

For best performance, regulated pressure should always be set by increasing the pressure up to the desired setting.

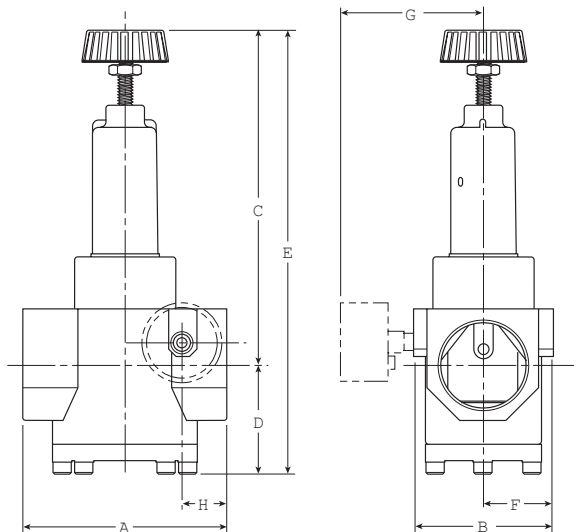

Dimensions

Models	Inches (mm)	A	B	C	D	E	F	G	H
Standard Unit R40-XX-000		5.30 (135)	3.63 (92)	9.05 (230)	2.83 (72)	11.88 (302)	1.82 (43)	— —	1.15 (29.2)
With Gauge (order separately) R40-XX-XXX		5.30 (135)	3.63 (92)	9.05 (230)	2.83 (72)	11.88 (302)	1.82 (43)	4.02 (102)	1.15 (29.2)

= "Most Popular"

Replacement Kits

- Piston Assembly –
 - Non-relieving RRP-95-451
 - Relieving..... RRP-95-964
- Spring, Regulating –
 - 0 to 125 PSIG (0 to 8.6 bar) RRP-95-226
 - 0 to 180 PSIG (0 to 12.4 bar)..... RRP-95-220
- Spring, Valve RRP-95-024
- Valve Assembly (Non-relieving) –
 - Valve, Valve Spring RRP-95-162
- Valve Assembly (Self-relieving) –
 - Valve, Valve Spring, Ret. Ring, O-rings RRP-95-161

Accessories

- Gauge, Pressure –
 - 0 to 160 PSIG (0 to 11 bar), 2" Dial Face, 1/4" NPT, CBM K4520N14160
 - 0 to 300 PSIG (0 to 20 bar), 2" Dial Face, 1/4" NPT, CBM K4520N14300
 - 0 to 160 PSIG, 1-3/4" Digital Round, 1/4" NPT K4517N14160D
- Wall Mounting Bracket, Gauge Port Adapter, 1/4" NPT RRP-95-590

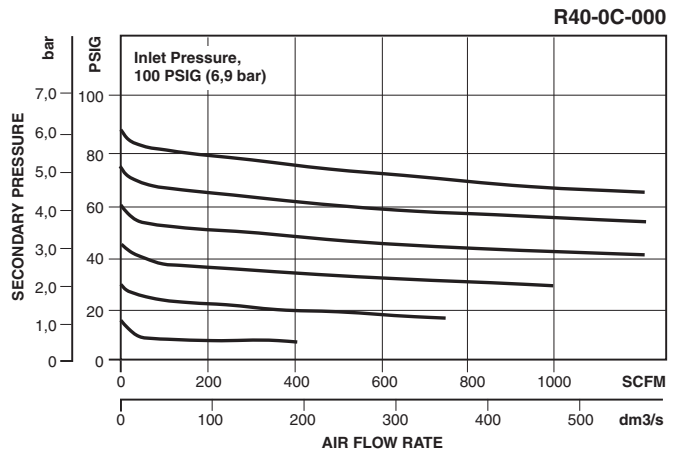
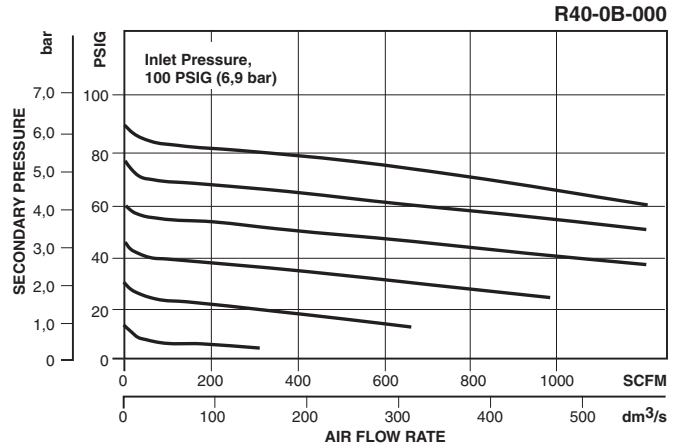

Ordering Information

Model Type	Port Size	Without Gauge 10 to 125 PSIG (0.7 to 8.6 bar)	High Pressure 10 to 180 PSIG (0.7 to 12.4 bar)
Relieving	1-1/2	R40-0B-000	R40-0B-H00
	2	R40-0C-000	R40-0C-H00
Non-relieving	1-1/2	R40-0B-N00	R40-0B-HN0
	2	R40-0C-N00	R40-0C-HN0

Options - To order an option supplied with the unit model, add the appropriate coded suffix letter in the designated position of the model number.

Notes

Common-P1 Regulator Numbering System

 = "Most Popular"

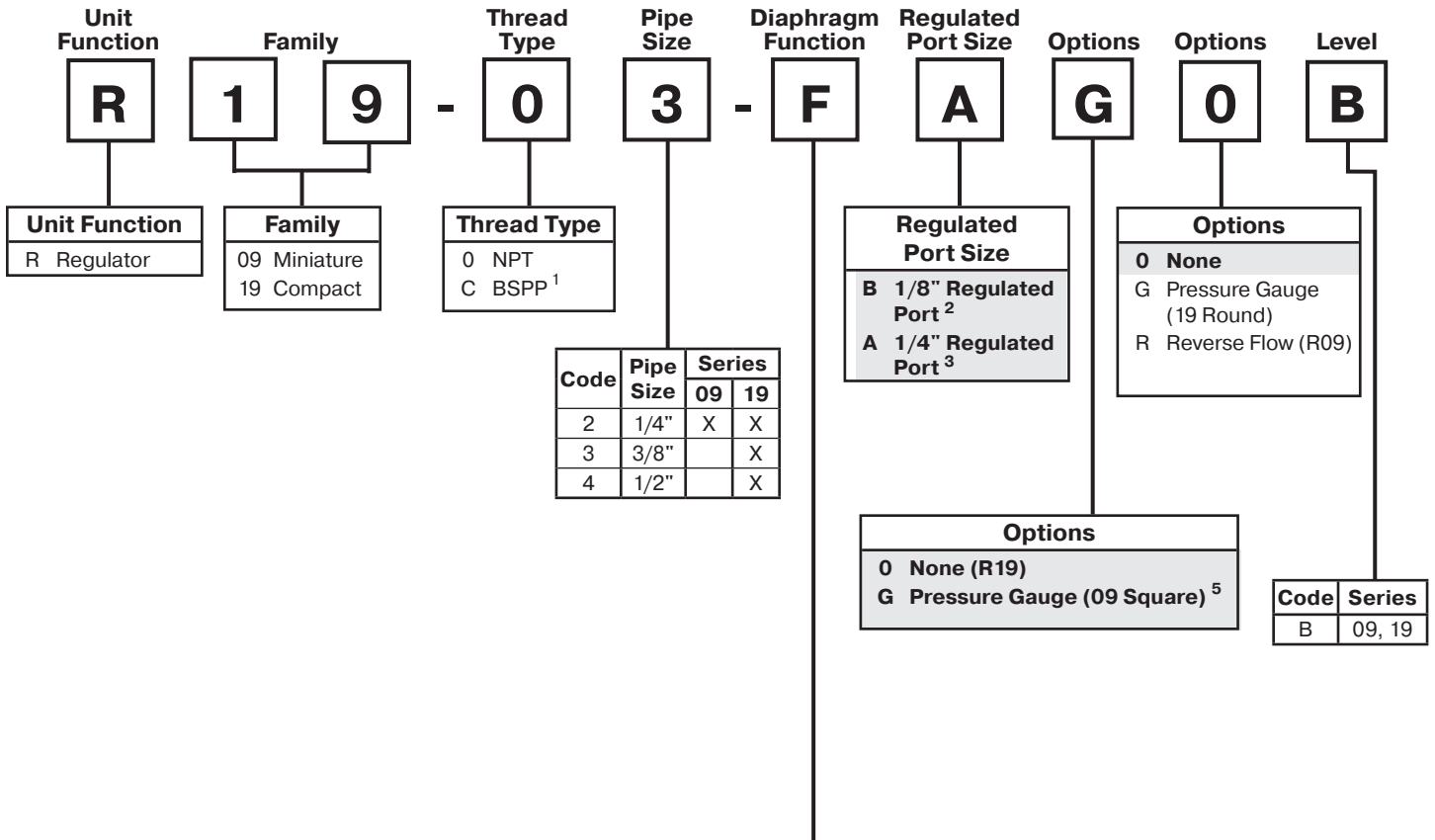

Diaphragm Function	Fluorocarbon (19 Series Only)	Spring Range			
		0 to 30 PSIG (0 to 2.1 bar)	0 to 60 PSIG (0 to 4.1 bar)	0 to 125 PSIG (0 to 8.6 bar)	0 to 250 PSIG ⁴ (0 to 17.2 bar)
Relieving	No	C	D	F	G
	Yes	J	K	L	M
Non-relieving	No	P	W	R	S
	Yes	V	X	Y	Z

1 ISO, R228 (G Series)
 2 Not available on R19
 3 Not available on R09
 4 R09 series operating range 0 to 232 PSIG (1 to 16 bar)
 5 Square gauge is included with all R08

Note: When selecting from the options columns, please enter letters in alphabetical order, for example:

R09-02-FAG0B

Common-P1 Regulator R09

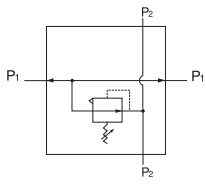

Relieving

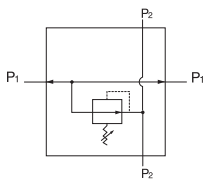

Non-Relieving



Specifications

Flow Capacity*	1/4	42 SCFM (20 dm ³ /s)
Adjusting Range Pressure		0 to 30 PSIG (0 to 2.1 bar)
		0 to 60 PSIG (0 to 4.1 bar)
		0 to 125 PSIG (0 to 8.6 bar)
Maximum Supply Pressure		300 PSIG (20.7 bar)
Operating Temperature		-4° to 150°F (-20° to 65.5°C)
P1 Port Size (Inlet / Outlet)	NPT / BSPP-G	1/4
P2 Regulated Ports (2 ea.)	NPT / BSPP-G	1/8
Weight		0.37 lb (0.17 kg)

* Inlet pressure 145 PSIG (10 bar). Secondary pressure 100 PSIG (6.9 bar).

Gauge supplied with every part. Gauge can be installed on the front or back of the regulator. If no gauge is installed, both seal screws must be installed.

Features

- Balanced Valve Design
- 2 Regulated Ports
- Light Weight
- Modern Modular Design and Appearance

Materials of Construction

Adjustment Knob	Acetal
Body	Aluminum
Bottom Cap	Glass-filled Nylon
Bonnet	Glass-filled Nylon
Diaphragm Assembly	Stainless Steel / Nitrile
Valve Assembly	Acetal / Nitrile

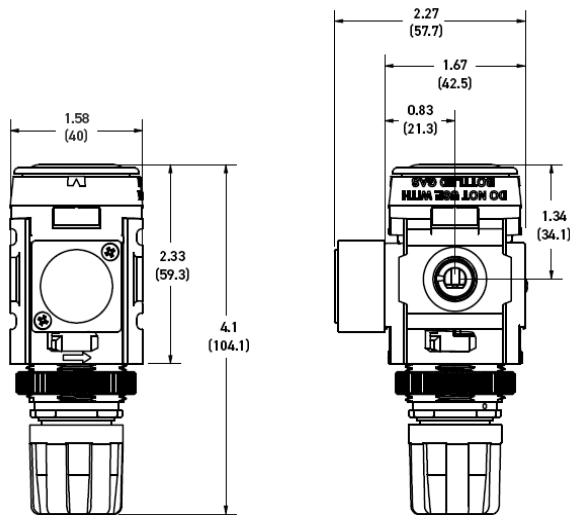

⚠ WARNING

**Product rupture can cause serious injury.
Do not connect regulator to bottled gas.
Do not exceed maximum primary pressure rating.**

CAUTION:

REGULATOR PRESSURE ADJUSTMENT – The working range of knob adjustment is designed to permit outlet pressures within their full range. Pressure adjustment beyond this range is also possible because the knob is not a limiting device. This is a common characteristic of most industrial regulators, and limiting devices may be obtained only by special design.

For best performance, regulated pressure should always be set by increasing the pressure up to the desired setting.

Inches (mm)

NOTE: 1.90 in. (48mm) hole required for panel nut mounting.

= "Most Popular"

Replacement Kits

Adjusting Knob GRP-96-792

Accessories

Panel Mount Nut –
 Aluminum RPA-96-773
 Plastic RPA-96-734

Pressure Gauge– (*see note below)

Square flush mount gauge

0-4 bar	GRP-96-791-04B
0-11 bar	GRP-96-792-11B
0-20 bar	GRP-96-791-20B
0-60 PSIG	GRP-96-791-060
0-160 PSIG.....	GRP-96-791-160
0-290 PSIG	GRP-96-791-290

*For R08/R09 Regulators with date code after November 2023 (4423 Date Code), please use these part numbers when ordering a replacement gauge.

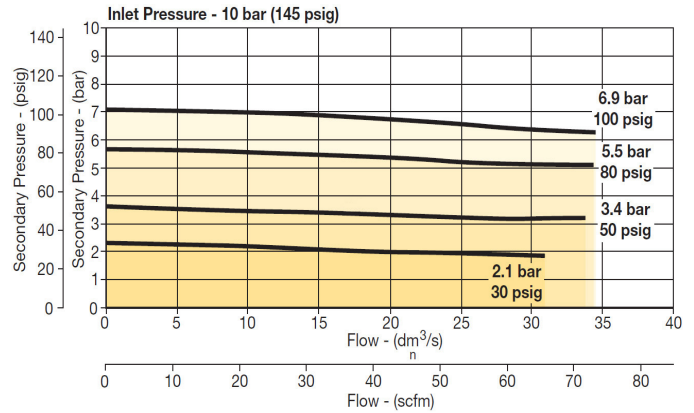

Square flush mount gauge

0-4 bar	K4511SCR04B
0-11 bar	K4511SCR11B
0-60 PSIG	K4511SCR060
0-160 PSIG.....	K4511SCR160

Square with adapter kit

0-4 bar	P6G-PR10040
0-11 bar	P6G-PR10110
0-60 PSIG	P6G-PR90060
0-160 PSIG.....	P6G-PR90160

50mm (2") round 1/4" center back mount

0-30 PSIG / 0-2 bar.....	K4520N14030
0-60 PSIG / 0-4 bar.....	K4520N14060
0-160 PSIG / 0-11 bar.....	K4520N14160
0-300 PSIG / 0-20 bar.....	K4520N14300

1-3/4" Digital Round 1/4" NPT

0 to 160 PSIG	K4517N14160D
---------------------	--------------

Tamperproof Lock and Cover Kit
 (lock not included)..... RPA-96-736B

Wall Mounting Bracket –

C-Type.....	GPA-97-010
L-Type.....	GPA-96-739
T-Type	GPA-96-737



Typical Application

Ordering Information

All P2 Regulated Ports are 1/8" Ports

Model Type	P1 Port Size	Without Gauge 0 to 125 PSIG (0 to 8.6 bar)	Without Gauge 0 to 30 PSIG (0 to 2.1 bar)	Without Gauge 0 to 60 PSIG (0 to 4.1 bar)
Relieving	1/4	R09-02-FB00B	R09-02-CB00B	R09-02-DB00B
Non-relieving	1/4	R09-02-RB00B	R09-02-PB00B	R09-02-WB00B

Options - To order an option supplied with the unit model, add the appropriate coded suffix letter in the designated position of the model number.

Common-P1 Regulator R19

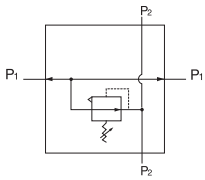

Relieving

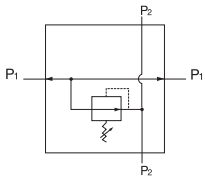

Non-Relieving



Features

- Balanced Valve Design
- Spring-loaded Diaphragm
- 4 Adjusting Pressure Ranges Available
- 1/2" NPT / BSPP-G Over-port
- 2 Regulated Ports

Specifications

Flow Capacity*	1/4, 3/8, 1/2	64.0 SCFM (31 dm ³ /s)
Adjusting Range Pressure		0 to 30 PSIG (0 to 2.1 bar)
		0 to 60 PSIG (0 to 4.1 bar)
		0 to 125 PSIG (0 to 8.6 bar)
		0 to 250 PSIG (0 to 17.2 bar)
Maximum Supply Pressure		300 PSIG (20.7 bar)
Operating Temperature		-13° to 150°F (-25° to 65.5°C)
P1 Port Size (Inlet / Outlet)	NPT / BSPP-G	1/4, 3/8, 1/2
P2 Regulated Ports (2 ea.)	NPT / BSPP-G	1/4
Weight		0.50 lb (0.22 kg)

* Inlet pressure 100 PSIG (6.9 bar). Secondary pressure 90 PSIG (6.2 bar).

Materials of Construction

Adjustment Knob	Acetal
Body	Aluminum
Body Cap	ABS
Bonnet	33% Glass-filled Nylon
Bottom Plug	33% Glass-filled Nylon
Diaphragm Assembly	Nitrile / Steel
Panel Nut	Acetal
Seals	Nitrile
Springs	Main Regulating Valve: Steel Valve: Stainless Steel
Valve Assembly	Brass / Nitrile

⚠ WARNING

**Product rupture can cause serious injury.
Do not connect regulator to bottled gas.
Do not exceed maximum primary pressure rating.**

CAUTION:

REGULATOR PRESSURE ADJUSTMENT – The working range of knob adjustment is designed to permit outlet pressures within their full range. Pressure adjustment beyond this range is also possible because the knob is not a limiting device. This is a common characteristic of most industrial regulators, and limiting devices may be obtained only by special design.

For best performance, regulated pressure should always be set by increasing the pressure up to the desired setting.

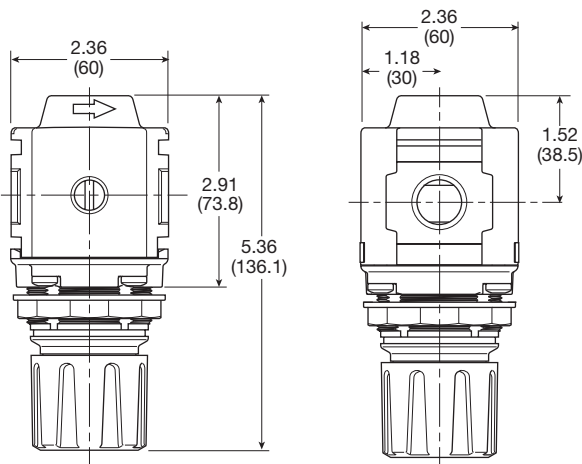

Inches (mm)

NOTE: 1.90 in. (48mm) hole required for panel nut mounting.

Inches (mm)

= "Most Popular"

Replacement Kits

- Diaphragm Assembly –
 - Non-relieving RRP-96-761B
 - Relieving..... RRP-96-760B
- Spring, Regulating–
 - 0 to 30 PSIG (0 to 2.1 bar) RRP-96-659B
 - 0 to 60 PSIG (0 to 4.1 bar) RRP-96-660B
 - 0 to 125 PSIG (0 to 8.6 bar) RRP-96-661B
 - 0 to 250 PSIG (0 to 17.2 bar)..... RRP-96-662B

Accessories

- Gauge, Pressure –
 - 50mm (2") round 1/4" center back mount
 - 0-30 PSIG / 0-2 bar K4520N14030
 - 0-60 PSIG / 0-4 bar K4520N14060
 - 0-160 PSIG / 0-11 bar K4520N14160
 - 0-300 PSIG / 0-20 bar K4520N14300
 - 0 to 160 PSIG, 1-3/4" Digital Round,
 - 1/4" NPT K4517N14160D
- Panel Mount Nut –
 - Aluminum RRP-96-673
 - Plastic RRP-96-675
- Tamper Resistant Kit..... RRP-96-671
- Wall Mounting Bracket –
 - L-Type..... GPA-96-606
 - T-Type GPA-96-603

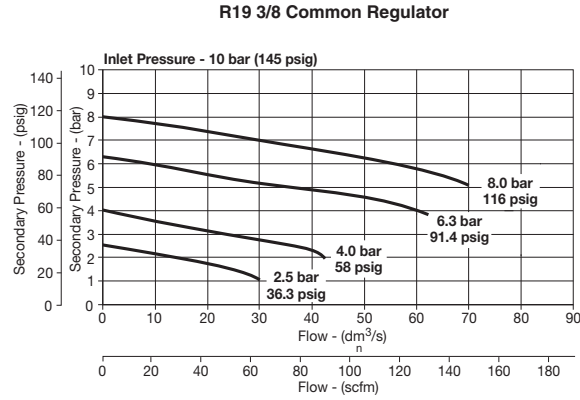

NOTE: Gauge not included, order separately by accessory number.



Typical Application

Ordering Information

All units shown with 1/4" regulated ports.

Model Type	P1 Port Size	5-125 PSIG (0.4 to 8.6 bar)	10-250 PSIG (0.7 to 7.2 bar)	3-60 PSIG (0.2 to 4.1 bar)
Relieving	1/4	R19-02-FA00B	R19-02-GA00B	R19-02-DA00B
	3/8	R19-03-FA00B	R19-03-GA00B	R19-03-DA00B
	1/2	R19-04-FA00B	R19-04-GA00B	R19-04-DA00B
Non-relieving	1/4	R19-02-RA00B	R19-02-SA00B	R19-02-WA00B
	3/8	R19-03-RA00B	R19-03-SA00B	R19-03-WA00B
	1/2	R19-04-RA00B	R19-04-SA00B	R19-04-WA00B

Options - To order an option supplied with the unit model, add the appropriate coded suffix letter in the designated position of the model number.

Principal Regulator (Remote Operated) – R21 / 31 / 41-XX-RXX

Remote-control Dial-Air™ Regulator

Incorporates all the features of the standard Dial-Air™ Regulator plus the additional advantage of remote installation using the R11 model Pilot Regulator. Maximum inlet operating pressure and temperature ratings are 300 PSIG (20.7 bar) and 150°F (65.5°C).

The Remote-control Dial-Air™ Regulators are available in five pipe sizes, with 1/4" NPT connections on the pilot regulator and pilot port of remote-controlled regulators. Typical installation is shown below. For other remote models, see R21, R31 & R41.

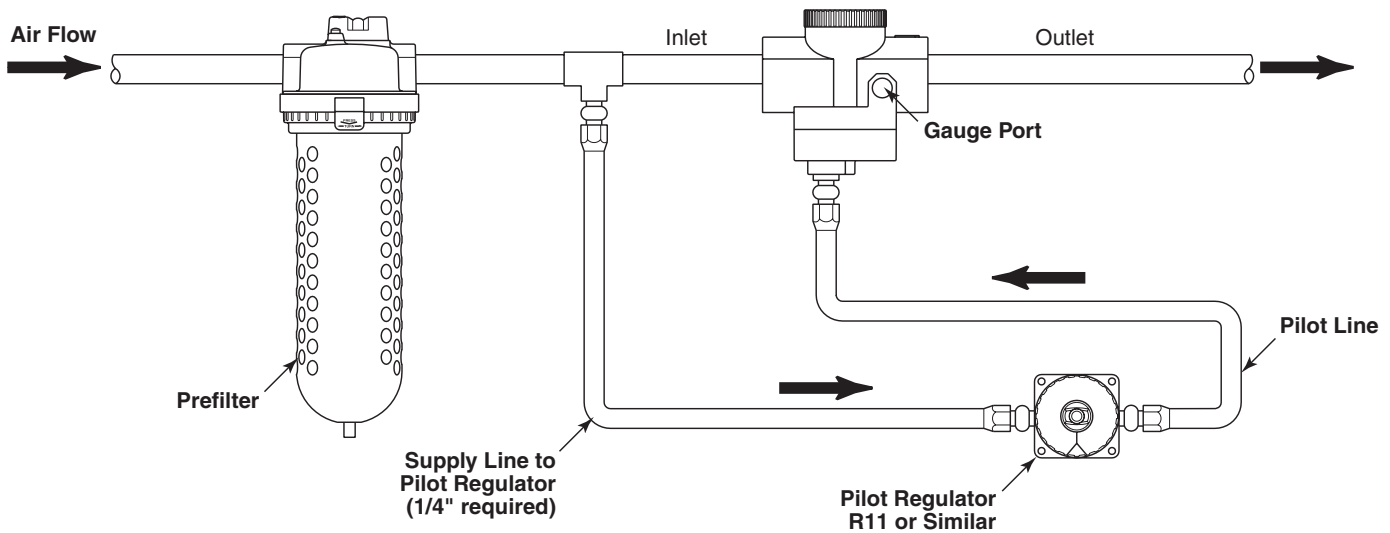

Dial-Air™

Dial-Air™ regulators feature a transparent, pressure-calibrated, non-rising adjustment dial for quick adjustment of secondary pressure. If a gauge (R21, R31, R41) is required for monitoring reasons, two 1/4" gauge ports are provided; however, these are usually used for additional outlet ports. The full reduced pressure range can be dialed in less than 270° of dial rotation. This feature is particularly advantageous if secondary pressure must be changed frequently. The transparent dial can be color or graphics coded for easy reference to required pressure changes. Dial-Air™ regulators can be mounted in any position so dial face is always visible. All Dial-Air™ units have a slight constant air bleed: 0.05 SCFM (0.024 dm³/s), @100 PSIG (6.9 bar) inlet and 90 PSIG (6.2 bar) outlet.

Dial-Air™ Regulator Numbering System

 = "Most Popular"

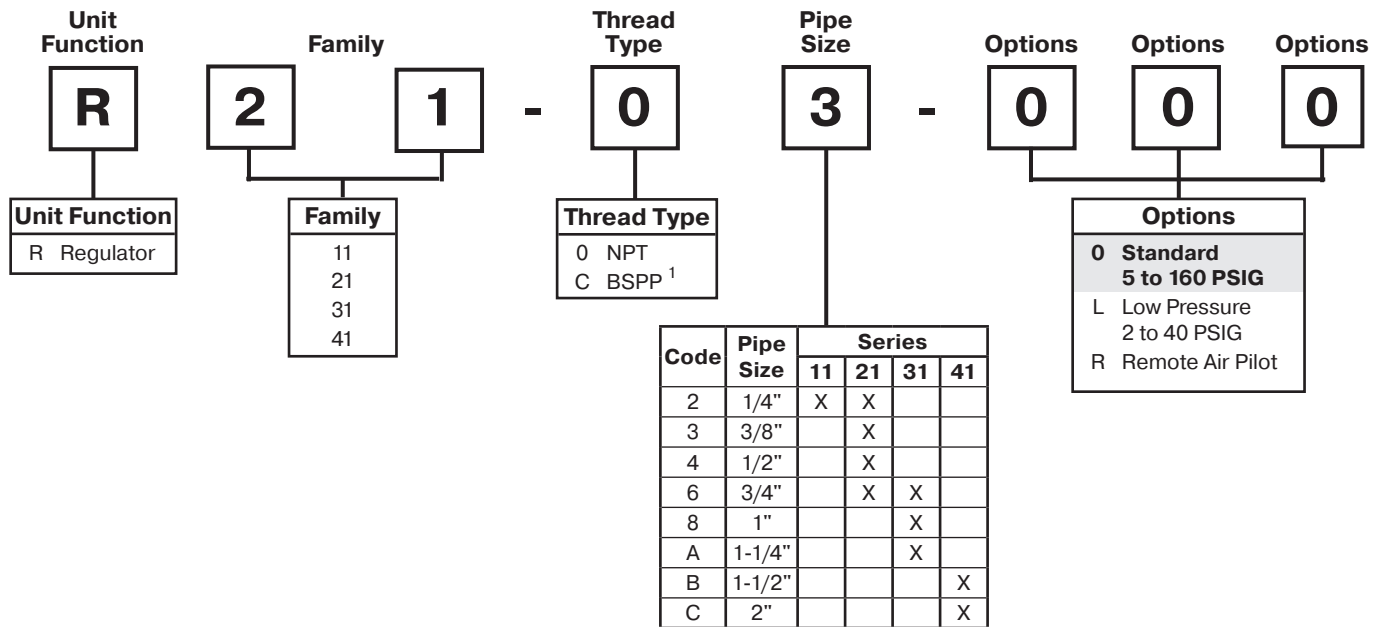

¹ ISO, R228 (G Series)

NOTE: Standard pressure adjustment is plastic "snap lock" knob and plastic bonnet with plastic panel mount nut.

NOTE: When selecting from the options columns, please enter letters in alphabetical order for positions 6, 7, and 8.
For example:

R21 - 0 3 - 0 0 0

Dial-Air™ Regulator R11

 = "Most Popular"

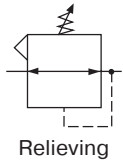

R11-02-000

Features

- Pressure Reference Indicating Dial Face
- Non-rising Pressure Adjustment Knob
- Self-Relieving
- Full Pressure Adjustment in Less Than One Full Turn
- Recommended for Pilot-Air Applications (Low Flow)

Specifications

Flow Capacity*	1/4	0.8 SCFM (0.377 dm ³ /s)
Adjusting Range Pressure	0 to 40 PSIG (0 to 2.8 bar)	0 to 160 PSIG (0 to 11 bar)
Bleed Rate	0.05 SCFM (0.024 dm ³ /s)	
Maximum Supply Pressure	300 PSIG (20.7 bar)	
Operating Temperature	32° to 150°F (0° to 65.5°C)	
Port Size	NPT / BSPP-G	1/4
Weight	lb. (kg)	1.3 (0.5)

* Inlet pressure 100 PSIG (6.9 bar). Secondary pressure 90 PSIG (6.2 bar).

Materials of Construction

Body	Zinc
Bonnet	Zinc / Brass
Piston	Acetal
Seals	Nitrile
Springs	Steel
Valve Assembly	Brass / Nitrile / Acetal

WARNING

**Product rupture can cause serious injury.
Do not connect regulator to bottled gas.
Do not exceed maximum primary pressure rating.**

CAUTION:

REGULATOR PRESSURE ADJUSTMENT – The working range of knob adjustment is designed to permit outlet pressures within their full range. Pressure adjustment beyond this range is also possible because the knob is not a limiting device. This is a common characteristic of most industrial regulators, and limiting devices may be obtained only by special design.

For best performance, regulated pressure should always be set by increasing the pressure up to the desired setting.

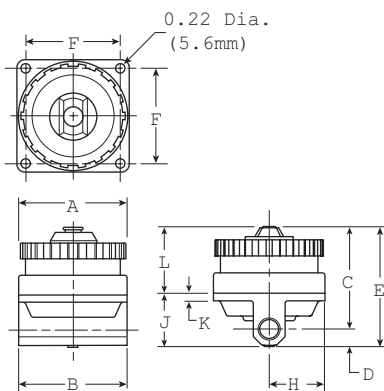

NOTE: Panel mounting requires (2) 11/16" (69mm) diameter holes and (4) 7/32" (5.5mm) screw holes. Unit can be mounted on material up to 1-1/4" (32mm) thick.

Dimensions

Model	Inches (mm)	A	B	C	D	E	F	H	J	K	L
Standard Unit R11-02-000		2.60 (66)	2.60 (66)	2.40 (60.9)	.40 (10)	2.80 (71)	2.20 (55.9)	1.30 (33)	1.25 (31.8)	.18 (4.6)	1.56 (39.6)

= "Most Popular"

Replacement Kits

- Conversion Kit (Series A to Series B) RRP-95-765
- O-ring, Repair Kit GRP-95-260
- Spring, Regulating, Belleville Washer –
 2 to 40 PSIG (0.1 to 3 bar) RRP-95-906
 5 to 160 PSIG (0.4 to 11 bar)..... RRP-95-905
- Valve, Pilot with O-ring and Valve Spring RRP-96-934

Accessories

- Tamper Resistant Kit..... RRP-95-585

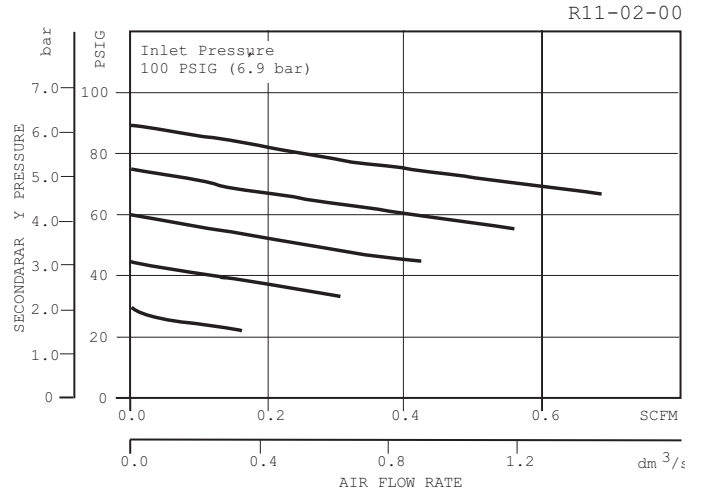

Ordering Information

Model Type	Port Size	Standard Pressure 5 to 160 PSIG (0.4 to 11 bar)	Low Pressure 2 to 40 PSIG (0.1 to 3 bar)
Pilot	1/4	R11-02-000	R11-02-L00

Options - To order an option supplied with the unit model, add the appropriate coded suffix letter in the designated position of the model number.

Dial-Air™ Regulator R21

= "Most Popular"



R21-02-000

Features

- Balanced Valve Design
- Non-Rising Pressure Adjusting Dial
- High-Relief Flow (3/16" Relief Orifice)
- Two 1/4" NPT Gauge Ports, Usually Used for Additional Outlets
- Piston Operated

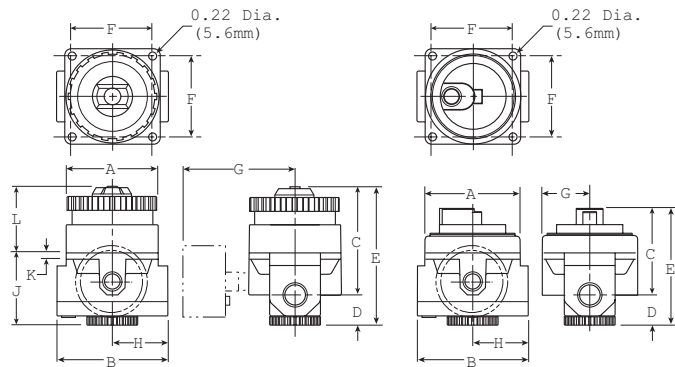

Remote Operated

NOTE: Panel mounting requires (2) 11/16" (69mm) diameter holes and (4) 7/32" (5.5mm) screw holes. Unit can be mounted on material up to 1-1/4" (32mm) thick.

Dimensions

Models	Inches (mm)	A	B	C	D	E	F	G	H	J	K	L
Standard Unit R21-XX-000		2.60 (66)	3.19 (81)	3.14 (79.8)	.95 (24)	4.09 (104)	2.20 (55.9)	—	1.61 (41)	2.08 (52.8)	.18 (4.6)	2.07 (52.6)
With Gauge (order separately) R21-XX-XXX		2.60 (66)	3.19 (81)	3.14 (79.8)	.95 (24)	4.09 (104)	2.20 (55.9)	2.70 (68.5)	1.61 (41)	2.08 (52.8)	.18 (4.6)	2.07 (52.6)
Remote Operated R21-XX-R00		2.60 (66)	3.19 (81)	2.24 (56.9)	.95 (24)	3.19 (81)	2.20 (55.9)	1.33 (33.8)	1.61 (41)	2.08 (52.8)	.18 (4.6)	1.11 (28.2)

Specifications

Flow Capacity*	1/4	117 SCFM (55 dm ³ /s)
	3/8	180 SCFM (85 dm ³ /s)
	1/2	195 SCFM (92 dm ³ /s)
	3/4	220 SCFM (103 dm ³ /s)
Adjusting Range Pressure	0 to 40 PSIG (0 to 2.8 bar) 0 to 160 PSIG (0 to 11 bar)	
Bleed Rate	0.05 SCFM (0.024 dm ³ /s)	
Gauge Port (2 ea.)	NPT / BSPT-Rc	1/4
Maximum Supply Pressure	300 PSIG (20.7 bar)	
Operating Temperature	32° to 150°F (0° to 65.5°C)	
Port Size	NPT / BSPP-G	1/4, 3/8, 1/2, 3/4
Remote Pilot Port Size	1/4	
Weight	lb. (kg)	2.3 (1.04)

* Inlet pressure 100 PSIG (6.9 bar). Secondary pressure (1/4, 1/2 & 3/4) 90 PSIG (6.2 bar); (3/8) 80 PSIG (5.5 bar).

Materials of Construction

Body	Zinc
Bonnet	Zinc / Brass
Piston	Acetal
Seals	Nitrile
Springs	Steel
Valve Assembly	Brass / Nitrile / Acetal

WARNING

**Product rupture can cause serious injury.
Do not connect regulator to bottled gas.
Do not exceed maximum primary pressure rating.**

CAUTION:

REGULATOR PRESSURE ADJUSTMENT – The working range of knob adjustment is designed to permit outlet pressures within their full range. Pressure adjustment beyond this range is also possible because the knob is not a limiting device. This is a common characteristic of most industrial regulators, and limiting devices may be obtained only by special design.

For best performance, regulated pressure should always be set by increasing the pressure up to the desired setting.

= "Most Popular"

Replacement Kits

- Adjustment Dial Knob RRP-16-024-000
- Conversion Kit (Series A to Series B) RRP-95-766
- Cover Kit (Remote) –
 - Bonnet and Nitrile, O-ring (Series B)..... RRP-95-910
 - Bonnet and Fluorocarbon, O-ring (Series B)RRP-95-911
- O-ring, Repair Kit GRP-95-260
- Piston, Bottom and O-ring SealRRP-95-192
- Spring, Regulating, Belleville Washer –
 - 2 to 40 PSIG (0.1 to 3 bar) RRP-95-906
 - 5 to 160 PSIG (0.4 to 11 bar)..... RRP-95-905
- Valve, Main with U-cup Seal RRP-95-151
- Valve, Main with U-cup Seal and Bottom Plug –
 - Nitrile Elastomers..... RRP-95-914
 - Fluorocarbon Elastomers..... RRP-95-915
- Valve, Main (Remote) with U-cup Seal..... RRP-96-952

- Valve, Main (Remote) with U-cup Seal and Bottom Plug –
 - Nitrile Elastomers)..... RRP-95-912
 - Fluorocarbon Elastomers..... RRP-95-913
- Valve, Pilot with O-ring and Valve Spring RRP-96-934

Accessories

- Wall Mounting Bracket, Gauge Port Adapter,
 - 1/4" NPT RRP-95-590
- Gauge, Pressure –
 - 0 to 60 PSIG (0 to 4 bar), 2" Dial Face,
 - 1/4" NPT, CBMK4520N14060
 - 0 to 160 PSIG (0 to 11 bar), 2" Dial Face,
 - 1/4" NPT, CBM K4520N14160
 - 0 to 160 PSIG, 1-3/4" Digital Round,
 - 1/4" NPT K4517N14160D
- Tamper Resistant Kit..... RRP-95-585

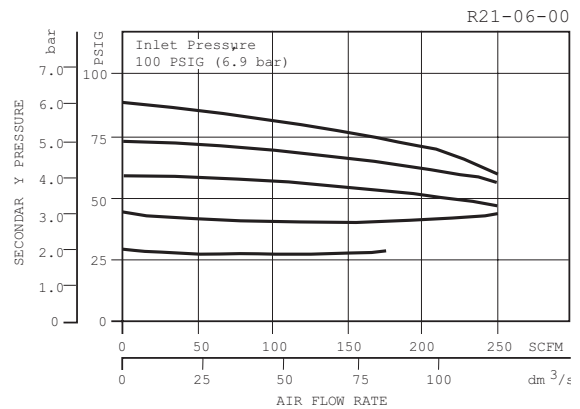
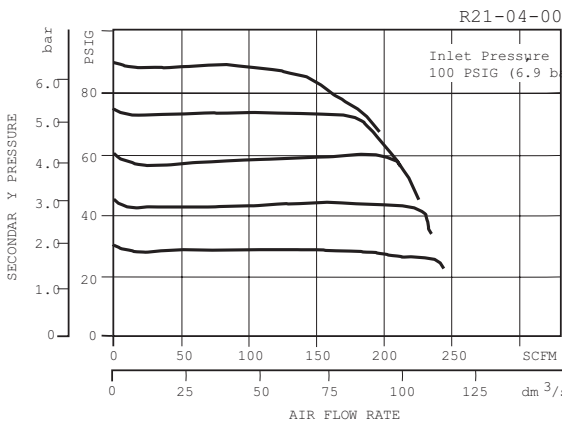
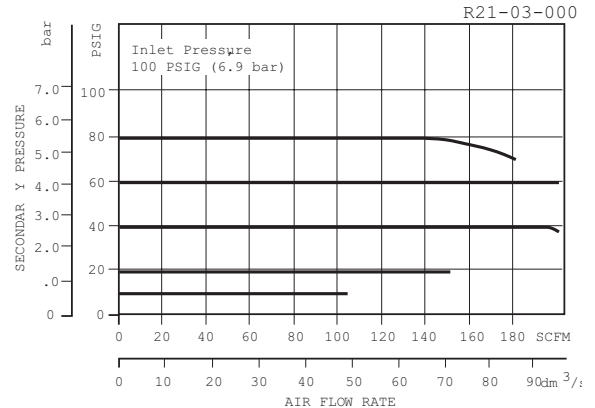
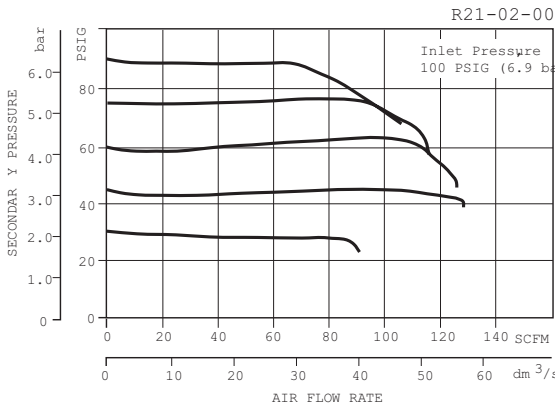

Ordering Information

Model Type	Port Size	High Flow 5 to 160 PSIG (0.4 to 11 bar)	Low Pressure 2 to 40 PSIG (0.1 to 3 bar)	Remote 5 to 160 PSIG (0.4 to 11 bar)
Relieving	1/4	R21-02-000	R21-02-L00	R21-02-R00
	3/8	R21-03-000	R21-03-L00	R21-03-R00
	1/2	R21-04-000	R21-04-L00	R21-04-R00
	3/4	R21-06-000	R21-06-L00	R21-06-R00

Options - To order an option supplied with the unit model, add the appropriate coded suffix letter in the designated position of the model number.

Dial-Air™ Regulator R31

= "Most Popular"

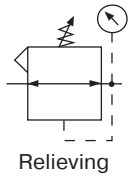

R31-06-000

Features

- Balanced Valve Design
- Non-Rising Pressure Adjusting Dial
- High-Relief Flow (3/16" Relief Orifice)
- Two 1/4" NPT / BSPT-Rc Gauge Ports, Usually Used for Additional Outlets
- Piston Operated

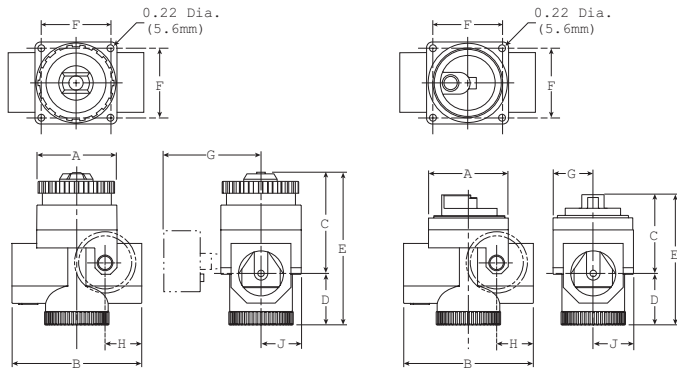

Remote Operated

NOTE: Panel mounting requires (2) 11/16" (69mm) diameter holes and (4) 7/32" (5.5mm) screw holes. Unit can be mounted on material up to 1-1/4" (32mm) thick.

Specifications

Flow Capacity*	3/4	400 SCFM (189 dm ³ /s)
	1	650 SCFM (307 dm ³ /s)
	1-1/4	700 SCFM (330 dm ³ /s)
Adjusting Range Pressure	0 to 40 PSIG (0 to 2.7 bar) 0 to 160 PSIG (0 to 11 bar)	
Bleed Rate	0.05 SCFM (0.024 dm ³ /s)	
Gauge Port (2 ea.)	NPT / BSPT-Rc	1/4
Maximum Supply Pressure	300 PSIG (20.7 bar)	
Operating Temperature	32° to 150°F (0° to 65.5°C)	
Port Size	NPT / BSPP-G	3/4, 1, 1-1/4
Remote Pilot Port Size	1/4	
Weight	lb. (kg)	4.0 (1.8)

* Inlet pressure 100 PSIG (6.9 bar). Secondary pressure 80 PSIG (5.5 bar).

Materials of Construction

Body	Zinc
Bonnet	Zinc / Brass
Piston	Acetal
Seals	Nitrile
Springs	Steel
Valve Assembly	Brass / Nitrile / Acetal

⚠ WARNING

**Product rupture can cause serious injury.
Do not connect regulator to bottled gas.
Do not exceed maximum primary pressure rating.**

CAUTION:

REGULATOR PRESSURE ADJUSTMENT – The working range of knob adjustment is designed to permit outlet pressures within their full range. Pressure adjustment beyond this range is also possible because the knob is not a limiting device. This is a common characteristic of most industrial regulators, and limiting devices may be obtained only by special design.

For best performance, regulated pressure should always be set by increasing the pressure up to the desired setting.

Dimensions

Models	Inches (mm)	A	B	C	D	E	F	G	H	J
Standard Unit R31-XX-000		2.59 (66)	4.29 (109)	3.50 (88.9)	1.69 (43)	5.19 (132)	2.20 (55.9)	—	1.23 (31.2)	1.31 (33.3)
With Gauge (order separately) R31-XX-XXX		2.59 (66)	4.29 (109)	3.50 (88.9)	1.69 (43)	5.19 (132)	2.20 (55.9)	3.00 (76)	1.23 (31.2)	1.31 (33.3)
Remote Operated R31-XX-R00		2.59 (66)	4.29 (109)	2.63 (66.8)	1.69 (43)	4.32 (109.7)	2.20 (55.9)	1.33 (33.7)	1.23 (31.2)	1.31 (33.3)

= "Most Popular"

Replacement Kits

- Adjustment Dial Knob RRP-16-024-000
- Conversion Kit (Series A to Series B) RRP-95-766
- O-ring, Repair Kit GRP-95-261
- Piston, Bottom and O-ring seal.....RRP-95-192
- Spring, Regulating, Belleville Washer –
 2 to 40 PSIG (0.1 to 3 bar) RRP-95-906
 5 to 160 PSIG (0.4 to 11 bar)..... RRP-95-905
- Valve, Main with O-ring Seal.....RRP-95-152
- Valve, Main (Remote) with O-ring Seal RRP-96-950
- Valve, Pilot with O-ring and Valve Spring RRP-96-935

Accessories

- Gauge, Pressure –
 0 to 60 PSIG (0 to 4 bar), 2" Dial Face,
 1/4" NPT, CBMK4520N14060
- 0 to 160 PSIG (0 to 11 bar), 2" Dial Face,
 1/4" NPT, CBM K4520N14160
- 0 to 160 PSIG, 1-3/4" Digital Round,
 1/4" NPT K4517N14160D
- Tamper Resistant Kit..... RRP-95-585
- Wall Mounting Bracket, Gauge Port Adapter,
 1/4" NPT RRP-95-590

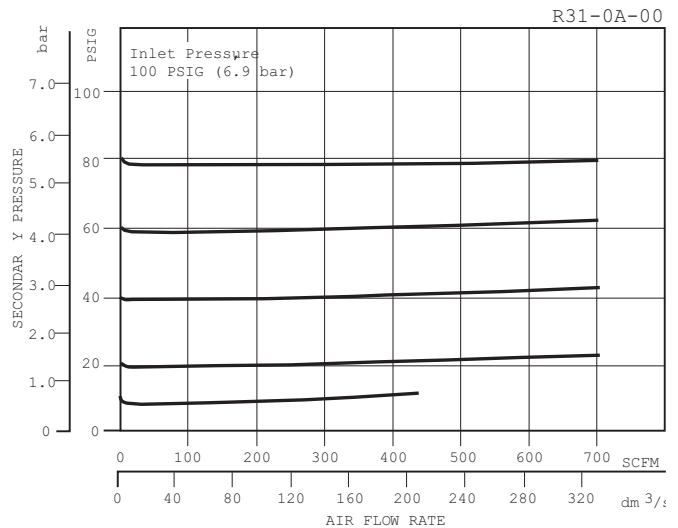
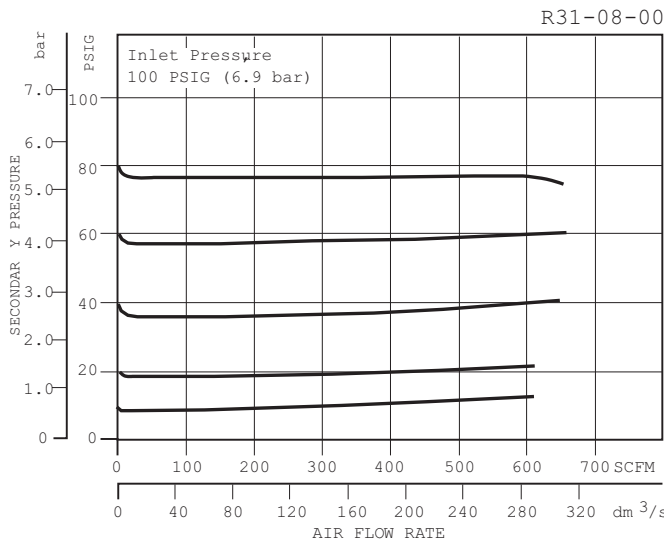
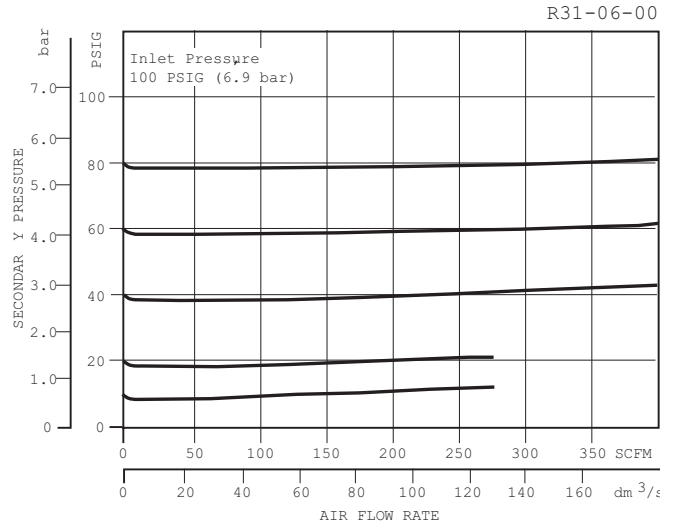

Ordering Information

Model Type	Port Size	High Flow 5 to 160 PSIG (0.4 to 11 bar)	Low Pressure 2 to 40 PSIG (0.1 to 3 bar)	Remote 5 to 160 PSIG (0.4 to 11 bar)
Relieving	3/4	R31-06-000	R31-06-L00	R31-06-R00
	1	R31-08-000	R31-08-L00	R31-08-R00
	1-1/4	R31-0A-000	R31-0A-L00	R31-0A-R00

Options - To order an option supplied with the unit model, add the appropriate coded suffix letter in the designated position of the model number.

Dial-Air™ Regulator R41

= "Most Popular"

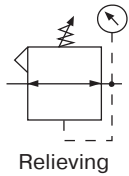

R41-0B-000

Features

- Balanced Valve Design
- Non-Rising Pressure Adjusting Dial
- High-Relief Flow (3/16" Relief Orifice)
- Two 1/4" NPT / BSPT-Rc Gauge Ports, Usually Used for Additional Outlets
- Piston Operated

Specifications

Flow Capacity*	1-1/2, 2	1600 SCFM (755 dm ³ /s)
Adjusting Range Pressure	0 to 160 PSIG (0 to 11 bar)	
Bleed Rate	0.05 SCFM (0,024 dm ³ /s)	
Maximum Supply Pressure	300 PSIG (20.7 bar)	
Operating Temperature	32° to 150°F (0° to 65.5°C)	
Port Size	NPT / BSPP-G	1-1/2, 2
Remote Pilot Port Size	1/4	
Gauge Port (2 ea.)	NPT / BSPT-Rc	1/4
Weight	lb. (kg)	9 (4.1)

* Inlet pressure 100 PSIG (6.9 bar). Secondary pressure 80 PSIG (5.5 bar).

Materials of Construction

Body	Zinc
Bonnet	Zinc / Brass
Piston	Zinc
Seals	Nitrile
Springs	Steel
Valve Assembly	Brass / Nitrile / Acetal

WARNING

**Product rupture can cause serious injury.
Do not connect regulator to bottled gas.
Do not exceed maximum primary pressure rating.**

CAUTION:

REGULATOR PRESSURE ADJUSTMENT – The working range of knob adjustment is designed to permit outlet pressures within their full range. Pressure adjustment beyond this range is also possible because the knob is not a limiting device. This is a common characteristic of most industrial regulators, and limiting devices may be obtained only by special design.

For best performance, regulated pressure should always be set by increasing the pressure up to the desired setting.

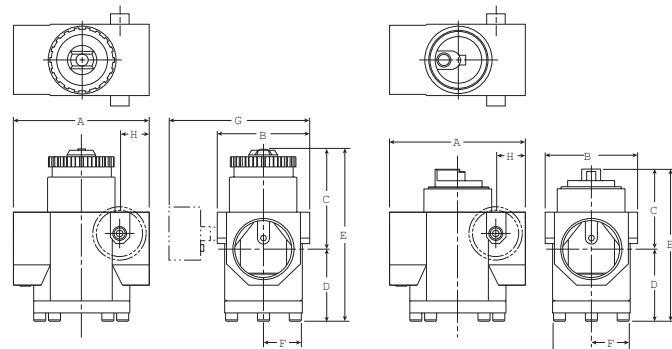

Remote Operated

Dimensions

Models	Inches (mm)	A	B	C	D	E	F	G	H
Standard Unit R41-XX-000		5.31 (135)	3.58 (91)	4.02 (102)	2.79 (71)	6.81 (173)	1.79 (45.7)	— —	1.15 (29.2)
With Gauge (order separately) R41-XX-XXX		5.31 (135)	3.58 (91)	4.02 (102)	2.79 (71)	6.81 (173)	1.79 (45.7)	5.29 (134.6)	1.15 (29.2)
Remote Operated R41-XX-R00		5.31 (135)	3.58 (91)	3.11 (78.9)	2.79 (71)	5.90 (149.8)	1.50 (38)	3.00 (76)	1.15 (29.2)

= "Most Popular"

Replacement Kits

- Adjustment Dial Knob RRP-16-024-000
- Conversion Kit (Series A to Series B) RRP-95-766
- O-ring, Repair Kit GRP-95-262
- Piston, Bottom and O-ring Seal RRP-95-192
- Spring, Regulating, Belleville Washer –
 2 to 40 PSIG (0.1 to 3 bar) RRP-95-906
 5 to 160 PSIG (0.4 to 11 bar) RRP-95-905
- Spring, Valve RRP-95-024
- Valve –
 Main with O-ring Seal RRP-95-153
 Main (Remote) with O-ring Seal RRP-96-951
 Pilot with O-ring and Valve Spring RRP-96-935

Accessories

- Gauge, Pressure –
 0 to 60 PSIG (0 to 4 bar), 2" Dial Face,
 1/4" NPT, CBM K4520N14060
- 0 to 160 PSIG (0 to 11 bar), 2" Dial Face,
 1/4" NPT, CBM K4520N14160
- 0 to 160 PSIG, 1-3/4" Digital Round,
 1/4" NPT K4517N14160D
- Tamper Resistant Kit RRP-95-585
- Wall Mounting Bracket, Gauge Port Adapter,
 1/4" NPT RRP-95-590

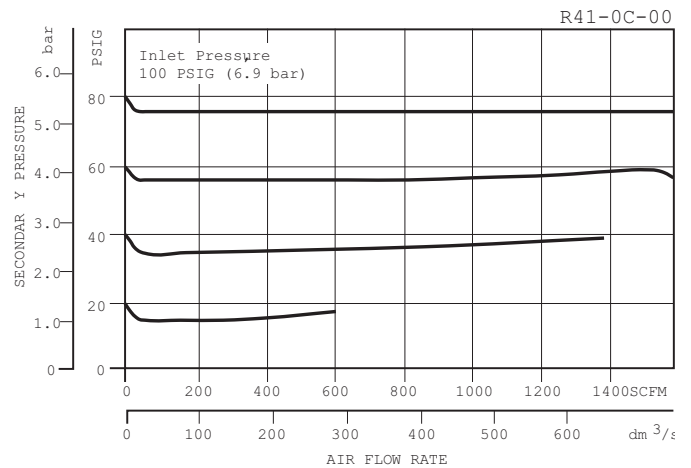
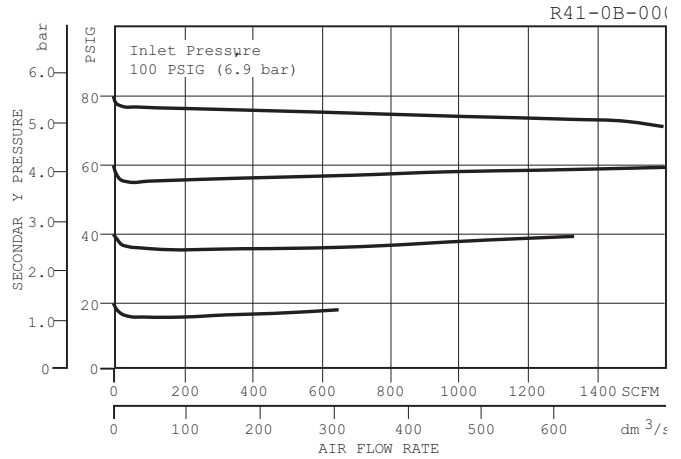

Ordering Information

Model Type	Port Size	High Flow 5 to 160 PSIG (0.4 to 11 bar)	Low Pressure 2 to 40 PSIG (0.1 to 3 bar)	Remote 5 to 160 PSIG (0.4 to 11 bar)
Relieving	1-1/2	R41-0B-000	R41-0B-L00	R41-0B-R00
	2	R41-0C-000	R41-0C-L00	R41-0C-R00

Options - To order an option supplied with the unit model, add the appropriate coded suffix letter in the designated position of the model number.

Notes

Precision Regulator Numbering System (16 Series)

= "Most Popular"

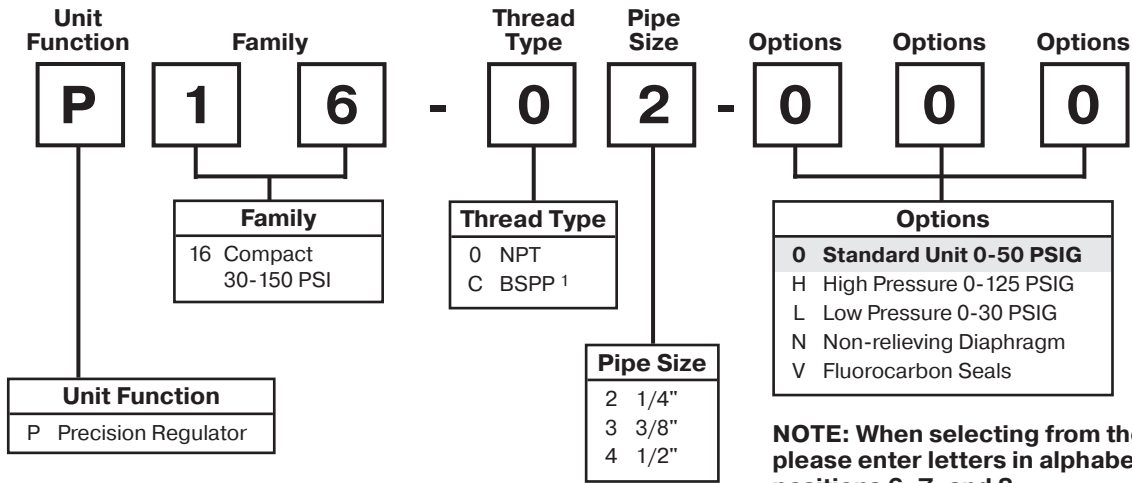

NOTE: When selecting from the options columns, please enter letters in alphabetical order for positions 6, 7, and 8.

For example:

P 1 6 - 0 2 - H 0 0

Precision Regulator P16 (Modular)

 = "Most Popular"

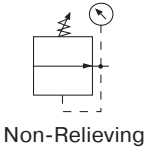
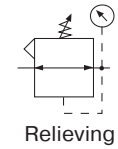

P16-02-000

The P16 models are general purpose regulators specifically designed for applications that require reliable performance and accurate pressure control.

Features

- *Stable Output* – Aspirator Design Minimizes “Droop” at Higher Flow Levels
- *Accuracy* – High Diaphragm-to-Valve-Area Ratio Combined with Unbalanced Valve Provides High Precision with Minimal Initial Pressure Droop
- *Sensitive* – Responds Quickly to the Slightest Change in Downstream Pressure
- *Easy Maintenance* – May be Disassembled and Serviced without Removal from Air Line
- *Modular Design* – Available in a Modular Configuration to Work with Other Wilkerson Modular Units, Accessories and Options

Specifications

Flow Capacity*	P16	22.0 SCFM (10.4 dm ³ /s)
Bleed Rate		0.03 SCFM (0.014 dm ³ /s) max.
Gauge Port (2 ea.)	NPT / BSPT-Rc	1/4
Maximum Supply Pressure		300 PSIG (20.7 bar)
Operating Temperature		32° to 150°F (0° to 65.5°C)
Port Size	NPT / BSPP-G	1/4, 3/8, 1/2
Weight	lb. (kg)	1.66 (0.75)

* Inlet pressure 100 PSIG (6,9 bar). Secondary pressure 45 PSIG (3,1 bar).

Materials of Construction

Body	Zinc
Bonnet	PBT
Diaphragm	Nitrile / Zinc
Panel Nut	Acetal
Seals	Nitrile
Springs	Steel
Valve Assembly	Brass / Nitrile

WARNING

**Product rupture can cause serious injury.
Do not connect regulator to bottled gas.
Do not exceed maximum primary pressure rating.**

CAUTION:

REGULATOR PRESSURE ADJUSTMENT – The working range of knob adjustment is designed to permit outlet pressures within their full range. Pressure adjustment beyond this range is also possible because the knob is not a limiting device. This is a common characteristic of most industrial regulators, and limiting devices may be obtained only by special design.

For best performance, regulated pressure should always be set by increasing the pressure up to the desired setting.

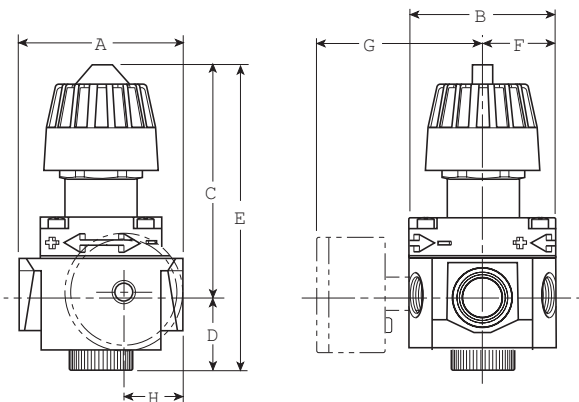

NOTE: 1.31" Dia. (33,3 mm) hole required for panel nut mounting.

Dimensions

Models	Inches (mm)	A	B	C	D	E	F	G	H
Standard Unit P16-XX-000		2.99 (76)	2.59 (66)	3.99 (101.3)	1.20 (30.5)	5.19 (132)	1.29 (33)	—	1.02 (25.9)
With Gauge (order gauge separately) P16-XX-XXX		2.99 (76)	2.59 (66)	3.99 (101.3)	1.20 (30.5)	5.19 (132)	1.29 (33)	2.99 (76)	1.02 (25.9)

= "Most Popular"

Replacement Kits

- Diaphragm Assembly
 - Self-relieving, Fluorocarbon..... PRP-95-073
 - Self-relieving, Nitrile..... PRP-95-960
- Knob, Adjusting (Series A)
 - Used on Units with Plastic Bonnets..... RRP-95-023
- Knob, Adjusting (Prior to Series A)
 - Used on Units with Zinc Bonnets..... RRP-95-007
- Repair Kit, Non-relieving Diaphragm, Valve / Valve Spring, O-rings..... PRP-95-053
- Repair Kit, Self-relieving Diaphragm, Valve / Valve Spring, O-rings..... PRP-95-004
- Spring, Regulating –
 - 0 to 15 PSIG (0 to 1 bar)..... RRP-95-233
 - 0 to 30 PSIG (0 to 2.1 bar)..... RRP-95-916
 - 0 to 50 PSIG (0 to 3.4 bar)..... RRP-95-222
 - 0 to 125 PSIG (0 to 8.6 bar)..... RRP-95-224
- Valve, Fluorocarbon (Valve Only).....PPA-95-067
- Valve Assembly – Valve and Valve Spring..... PRP-95-959

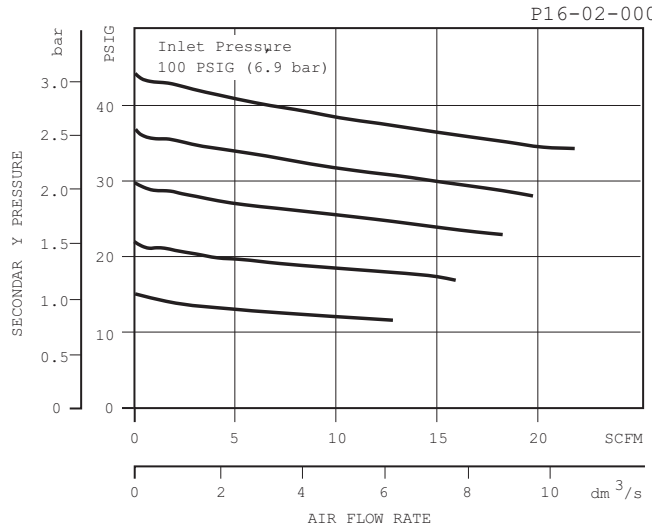

Accessories

- Gauge, Pressure, 2" Dial Face, 1/4 NPT, CBM
 - 0 to 30 PSIG (0 to 2.1 bar).....K4520N14030W
 - 0 to 60 PSIG (0 to 4 bar).....K4520N14060W
 - 0 to 160 PSIG (0 to 11 bar)..... K4520N14160W
 - 0 to 160 PSIG, 1-3/4" Digital Round, 1/4" NPT..... K4517N14160D
- Nut, Panel Nut, Plastic..... GPA-95-032
- Tamper Resistant Kit, Ring Style..... RPA-95-006
- Wall Mounting Bracket
 - Gauge Port Adapter, 1/4 NPT..... RRP-95-590
 - L-Type – Heavy Duty..... RPA-95-090
 - L-Type – Standard.....GPA-95-012
 - L-Type with Plastic Panel Mount Nut..... GPA-95-011

Ordering Information

Model Type	Port Size	Standard Unit 0 to 50 PSIG (0 to 3.4 bar)	High Pressure 0 to 125 PSIG (0 to 8.6 bar)	Low Pressure 0 to 30 PSIG (0 to 2.1 bar)	Fluorocarbon Seals
P16 Relieving	1/4	P16-02-000	P16-02-H00	P16-02-L00	P16-02-V00
	3/8	P16-03-000	P16-03-H00	P16-03-L00	P16-03-V00
	1/2	P16-04-000	P16-04-H00	P16-04-L00	P16-04-V00

Options - To order an option supplied with the unit model, add the appropriate coded suffix letter in the designated position of the model number.

High Precision Regulator

P17

= "Most Popular"



P17-02-F00

Features

- Accurate Pressure Regulation Controls Output Pressure to Within 0.1% Accuracy
- Multi-stage Regulation for Maximum Control and Stability
- Two Full Flow Gauge Ports
- Super Sensitive Relief. Downstream Pressure Buildup, Down to 0.005 PSIG Above the Set Pressure, is Automatically Vented through Internal Relief Valve
- P17 has High Exhaust Relief Capacity

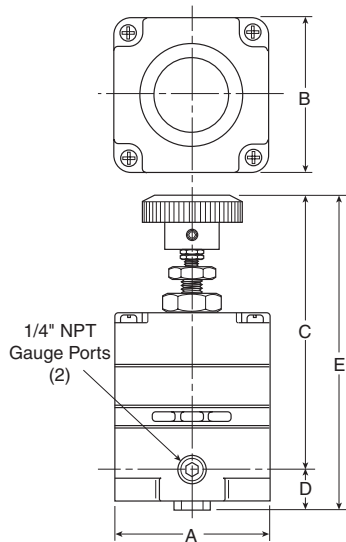

Dimensions

Models	Inches (mm)	A	B	C	D	E
Standard Unit P17-02-F00		2.10 (53)	2.10 (53)	3.82 (97)	0.43 (11)	4.35 (110)

Specifications

Flow Capacity at 100 PSIG (6.89 bar) Supply, 20 PSIG (1.38 bar) Outlet	14 SCFM (25m ³ /hr)	
Constant Bleed Rate (Equals Bleed Rate plus other consumption)	Less than 0.08 SCFM (0.15m ³ /hr)	
Effect of Supply Pressure Variation of 25 PSIG (1.7 bar) on outlet:	Less than 0.005 PSIG (0.0003 bar)	
Exhaust (Relief) Capacity at 5 PSIG (0.34 bar) above 20 PSIG (1.38 bar) Setpoint	Standard Model	3 SCFM (3.4m ³ /hr)
	High-Relief Model	11 SCFM (17m ³ /hr)
Gauge Ports (Can be used as additional full flow 1/4" outlet ports)	1/4" NPTF	
Operating Pressure Range –	PSIG	bar
Primary – Maximum	150	10.34
Secondary – Spring Pressure		
40 PSIG	Minimum 2	0.14
	Maximum 40	2.76
120 PSIG	Minimum 2	0.14
	Maximum 120	8.27
Operating Temperature Range 0°F* to 150°F (-18°C * to 65°C) Temperatures below (0°C) 32°F require moisture free air.		
Port Threads	1/4"	
Repeatability / Sensitivity	0.005 PSIG (0.0003 bar) Inches of Water Column = 1/8"	
Total Air Consumption	6 SCFH (0.21m ³ /hr.)	
Weight	1.4 lb (0.64 kg)	

Materials of Construction

Adjusting Stem & Capsule	Stainless Steel
Body	Zinc
Control Knob	Plastic
Diaphragm(s)	Buna-N
Seals	Buna-N
Springs	Stainless Steel
Valve Poppet	Stainless Steel

The P17 is a high precision, multi-stage pressure regulator. This pressure controller provides the highest level of regulation accuracy and repeatability available and is ideal for applications that call for the utmost in control and maximum stability under variable operating conditions. A stainless steel measuring capsule is used as a sensing element to activate the high gain servo balanced control mechanism in which the main valve is controlled by a pilot valve. This allows for greater accuracy and eliminates many of the problems associated with conventional regulators using range springs and diaphragms.

= "Most Popular"

Regulator Kits

Service Kits

2-40 PSIG	RKR210A*
2-120 PSIG	RKR210C*
2-120 PSIG (High Relieving)	RKR220C*

* Parts in Kit

Accessories

Mounting Bracket Kits

Pipe Mounting	SA200YW57
Right Angle Mounting	446-707-045

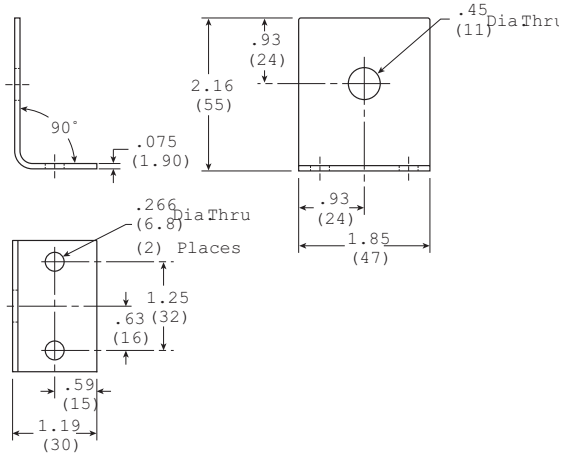

Mounting Bracket: 446-707-045

⚠ WARNING

**Product rupture can cause serious injury.
Do not connect regulator to bottled gas.
Do not exceed maximum primary pressure rating.**

CAUTION:

REGULATOR PRESSURE ADJUSTMENT – The working range of knob adjustment is designed to permit outlet pressures within their full range. Pressure adjustment beyond this range is also possible because the knob is not a limiting device. This is a common characteristic of most industrial regulators, and limiting devices may be obtained only by special design. For best performance, regulated pressure should always be set by increasing the pressure up to the desired setting.

Applications

The P17 regulators are well suited for any process that requires very precise regulation of air pressure in pipes and vessels. These regulators are often used, but not limited to the following applications:

- Air Gauging
- Gas Mixing
- Calibration Standards
- Air Hoists
- Web Tensioning
- Gate Actuators
- Roll Loading
- Valve Operators
- Cylinder Loading

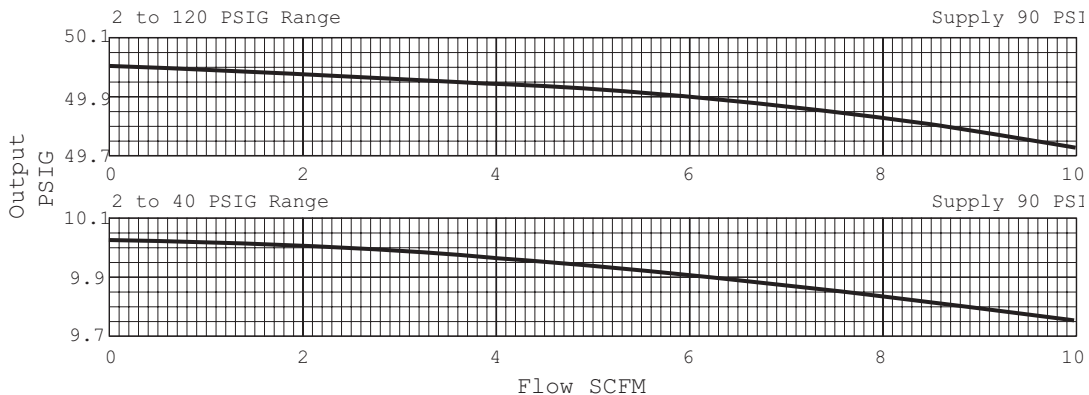

Ordering Information

Relieving		Reduced Pressure Range (PSIG)		
		2 to 40	2 to 120	2 to 120 High Relief
In / Out Ports	1/4"	P17-02-B00	P17-02-F00	P17-02-FH0

Compact High Precision Regulator WRA302

 = "Most Popular"

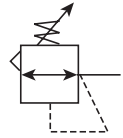

WRA302

Features

- Control Sensitivity of .250" (.63 cm) Water Column Variation Allows Use in Precision Applications
- A Compensating Diaphragm Lets the Regulator Remain Unaffected by Supply Pressure Changes
- Flow of Up to 40 SCFM with 100 PSIG Supply Allows Use in Applications with High Flow Requirements
- An Aspirator Tube Compensates Downstream Pressure Droop Under Flow Conditions
- A Separate Control Chamber Isolates the Diaphragm From the Main Flow to Eliminate Hunting and Buzzing
- Unit Construction Lets You Service the Regulator Without Removing it From the Line

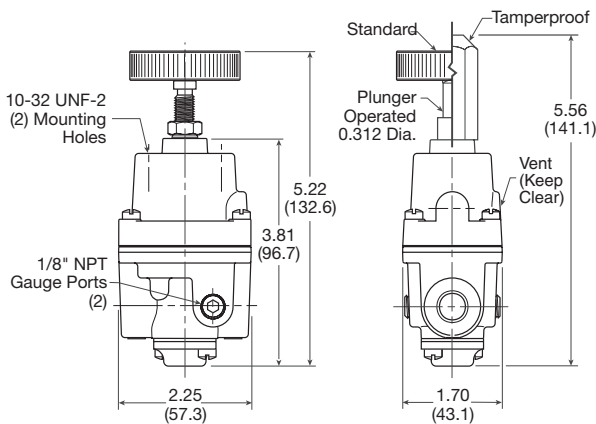

Inches (mm)

Dimensions

Models	Inches (mm)	A	A1	B	C	D	E	E1
Standard Unit WRA302		2.25 (57.3)	1.70 (43.1)	1.25 (31.8)	3.81 (96.7)	0.25 (6.4)	5.22 (132.6)	5.56 (141.1)

Specifications

Supply Pressure 250 PSIG, (17.0 bar), (1700 kPa) Maximum

Flow Capacity –

40 SCFM (68 m³/HR) @ 100 PSIG, (7.0 bar), (700 kPa)
Supply and 20 PSIG, (1.5 bar), (150 kPa) Setpoint

Exhaust Capacity –

2.0 SCFM (3.4 m³/HR) where downstream pressure is
5 PSIG, (.35 bar), (35 kPa) above 20 PSIG, (1.5 bar),
(150 kPa) Setpoint

Supply Pressure Effect –

Less than 0.2 PSIG, (.014 bar), (.14 kPa) for 100 PSIG,
(7.0 bar), (700 kPa) change in Supply Pressure

Sensitivity .250" (.010 PSIG) (.64 cm) Water Column

Ambient Temperature -40°F to +200°F, (-40°C to 93°C)

Hazardous Locations –

Acceptable for use in Zones 1 and 2 for Gas Atmosphere:
Groups IIA and IIB and Zones 21 and 22 for Dust
Atmospheres

Materials of Construction

Body and Housing	Aluminum
Diaphragms	Nitrile on Dacron
Trim	Brass

The WRA302 Regulator is designed for applications that require high capacity and accurate process control in a small package. A poppet valve which is balanced by utilizing a convoluted diaphragm, insures a constant output pressure even during wide supply pressure variations. Stability of regulated pressure is maintained under varying flow conditions through the use of an aspirator tube which adjusts the air supply in accordance with the flow velocity.

= "Most Popular"

WRA302 Kits and Accessories

Service Kits

- 1/2 to 30, 1 to 60, & 2 to 100 PSIG,
Nitrile, Standard.....PS16116-13
- 1/2 to 30, 1 to 60, & 2 to 100 PSIG,
Nitrile, Non-relievingPS16116-14

Tamper Resistant Kit..... PS12163

Mounting Bracket Kit..... PS21667-1

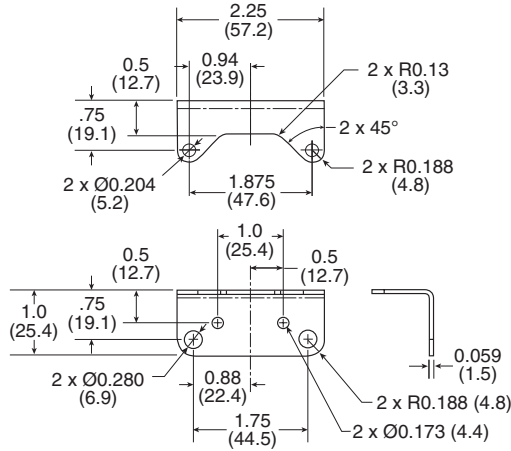

⚠ WARNING

**Product rupture can cause serious injury.
Do not connect regulator to bottled gas.
Do not exceed maximum primary pressure rating.**

CAUTION:

REGULATOR PRESSURE ADJUSTMENT – The working range of knob adjustment is designed to permit outlet pressures within their full range. Pressure adjustment beyond this range is also possible because the knob is not a limiting device. This is a common characteristic of most industrial regulators, and limiting devices may be obtained only by special design. For best performance, regulated pressure should always be set by increasing the pressure up to the desired setting.



Springs
3 0.5 to 30 PSIG
4 1 to 60 PSIG
5 2 to 100 PSIG

Pipe Size
2 1/4" NPT

Options
Blank No Options
H BSPP
N Non-Relieving

Note: Other Spring Ranges, Port Sizes, and Options Available. Please Consult Factory

Ordering Information

Relieving		Reduced Pressure Range (PSIG)		
		0 to 30	0 to 60	0 to 100
In / Out Ports	1/4 Inch	WRA30232	WRA30242	WRA30252

Technical Information

Flow Characteristics
Model WRA302
2-100 PSIG (13.8-690 kPa) Range

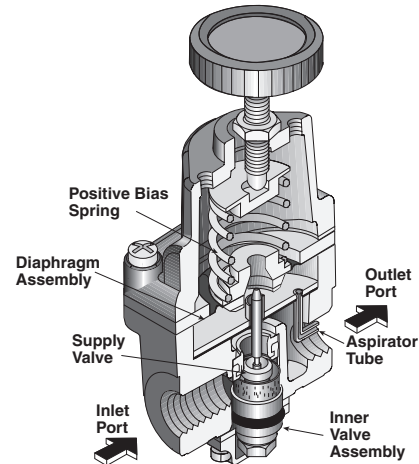
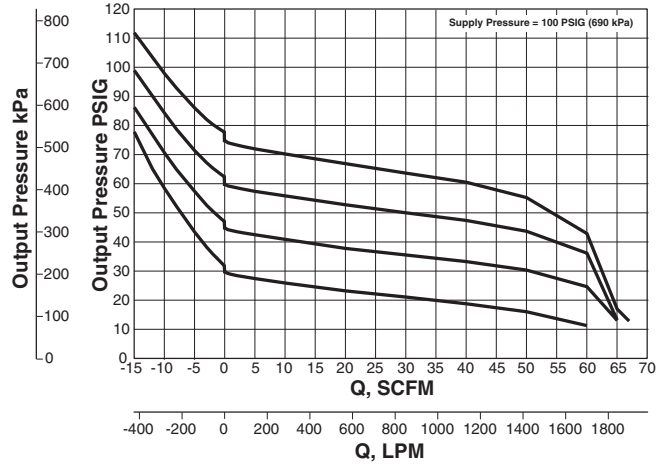

Operating Principles

The WRA302 Regulator uses the force balance principal to control the movement of the valve assembly which in turn controls the output pressure. When the regulator is adjusted for a specific set point, the downward force of the Positive Bias Spring causes the Diaphragm Assembly to move downward. The Supply Valve opens and allows air to pass to the Outlet Port. As the set point is reached, the downward force exerted by the Positive Bias spring is balanced by the upward force of the downstream pressure acting on the bottom of the Diaphragm Assembly. The resultant force moves the supply Valve upward to reduce the flow of air to the Outlet Port. Outlet pressure is maintained as a result of balance between forces acting on the top and bottom of the Diaphragm Assembly.

Standard High Precision Regulator WRA102

= "Most Popular"

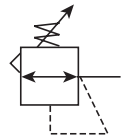

WRA102

Features

- Control Sensitivity of .125" (.32 cm) Water Column Allows Use in Precision Processes
- Pressure Balanced Supply Valve Prevents Supply Pressure Changes From Affecting the Setpoint
- Optional Check Valve Permits Dumping of Downstream Pressure When Supply is Opened to Atmosphere
- Separate Control Chamber Isolates the Diaphragm From the Main Flow to Eliminate Hunting and Buzzing
- An Aspirator Tube Compensates Downstream Pressure Droop Under Flow Conditions

Specifications

Supply Pressure 500 PSIG, (35.0 bar), (3500 kPa) Maximum

Flow Capacity –

40 SCFM (68 m³/HR) @ 100 PSIG, (7.0 bar), (700 kPa) Supply and 20 PSIG, (1.5 bar), (150 kPa) Setpoint

Exhaust Capacity –

5.5 SCFM (9.35 m³/HR) where Downstream Pressure is 5 PSIG, (.35 bar), (35 kPa) above 20 PSIG, (1.5 bar), (150 kPa) Setpoint

Supply Pressure Effect –

Less than 0.1 PSIG, (.007 bar), (.7 kPa) for 100 PSIG, (7.0 bar), (700 kPa) change in Supply Pressure

Sensitivity .125" (.005 PSIG) (.32 cm) Water Column

Ambient Temperature -40°F to +200°F, (-40°C to 93°C)

Hazardous Locations –

Acceptable for use in Zones 1 and 2 for Gas Atmosphere: Groups IIA and IIB and Zones 21 and 22 for Dust Atmospheres

Materials of Construction

Body and Housing	Aluminum
Diaphragms	Buna N on Dacron (Standard Unit Only)
Trim	Brass, Zinc Plated Steel

The WRA102 Regulator is designed for applications that require high capacity and accurate process control. A poppet valve which is balanced by utilizing a rolling diaphragm, insures a constant output pressure even during wide supply pressure variations. Stability of regulated pressure is maintained under varying flow conditions through the use of an aspirator tube which adjusts the air supply in accordance with the flow velocity.

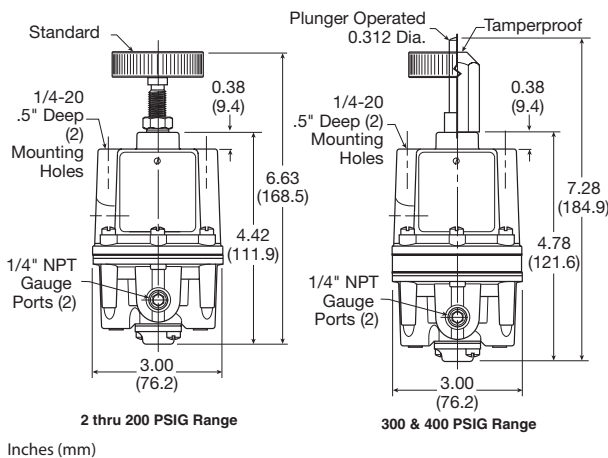

Dimensions

Models	Inches (mm)	A	B	B1	C	C1	D	E	E1
Standard Unit WRA102		3.00 (76.2)	2.22 (56.5)	2.13 (53.9)	4.42 (111.9)	4.78 (121.6)	0.38 (9.4)	6.63 (168.5)	7.28 (184.9)

= "Most Popular"

WRA102 Kits & Accessories

Mounting Bracket Kit –

Zinc Plated Steel..... PS09921

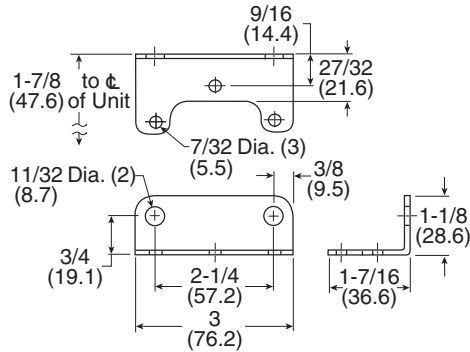

Service Kits

- 0 to 200 PSIG, Relieving PS12125-1
- 0 to 200 PSIG, Non--relieving PS12125-4

Tamper Resistant Kit PS12165

⚠ WARNING

**Product rupture can cause serious injury.
Do not connect regulator to bottled gas.
Do not exceed maximum primary pressure rating.**

CAUTION:

REGULATOR PRESSURE ADJUSTMENT – The working range of knob adjustment is designed to permit outlet pressures within their full range. Pressure adjustment beyond this range is also possible because the knob is not a limiting device. This is a common characteristic of most industrial regulators, and limiting devices may be obtained only by special design. For best performance, regulated pressure should always be set by increasing the pressure up to the desired setting.

Technical Information

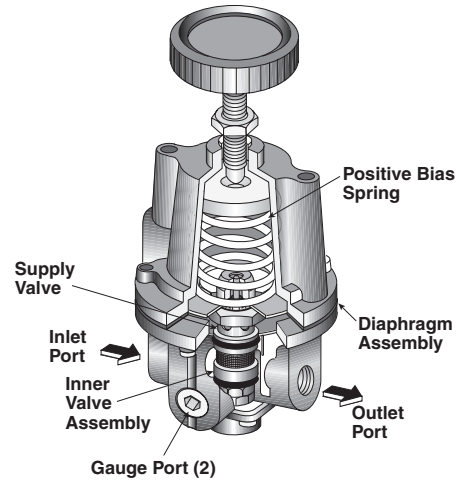
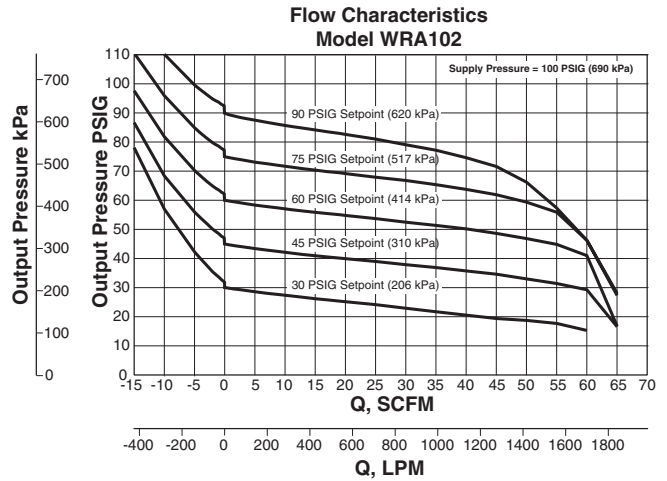

Operating Principles

The WRA102 Series regulator use the force balance principal to control the movement of the Valve Assembly that controls the output pressure. When the regulator is adjusted for a specific set point, the downward force of the Positive Bias Spring moves the Diaphragm Assembly downward. The Supply Valve opens and allows air to pass to the Outlet Port. As the set point is reached, the downward force exerted by the Positive Bias Spring is balanced by the force of the downstream pressure that acts on the Diaphragm Assembly. The resultant force moves the Supply Valve upward to reduce the flow of air to the Outlet Port.

Outlet pressure is maintained as a result of balance between forces acting on the top and bottom of the Diaphragm Assembly.

WRA102		6	2	
Springs	Pipe Size	Options		
3 0.5 to 30 PSIG	2 1/4" NPT	Blank No Options		
4 1 to 60 PSIG		H BSPP		
6 2 to 150 PSIG		N Non-Relieving		

Note: Other Spring Ranges, Port Sizes, and Options Available. Please Consult Factory

Ordering Information

Relieving		Reduced Pressure Range (PSIG)		
		0 to 30	0 to 60	0 to 150
In / Out Ports	1/4 Inch	WRA10232	WRA10242	WRA10262

Compact High Precision Relief Valve

WRA102BP

 = "Most Popular"

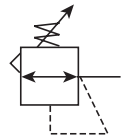

WRA102BP

Features

- Control Sensitivity of .125" (.32 cm) Water Column Allows Use in Precision Applications
- A Separate Control Chamber and Aspirator Tube Isolate the Diaphragm From the Main Flow to Eliminate Hunting and Buzzing
- Unit Construction Lets You Service the WRA102BP Without Removing it From the Line
- Mounting Bracket is Available

Specifications

Set Point Range	System Pressure (Maximum)
2-200 PSIG (0.15-14 bar) (15-1400 kPa)	300 PSIG (21.0 bar) (2100 kPa)
300-400 PSIG (21-28 bar) (2100-2800 kPa)	500 PSIG (35.0 bar) (3500 kPa)

Flow Capacity (SCFM) –
40 (68 m³/HR) @ 100 PSIG, (7.0 bar), (700 kPa) System Pressure

Sensitivity .125" (.005 PSIG) (.32 cm) Water Column

Ambient Temperature -40°F to +200°F, (-40°C to +93°C)

Materials of Construction

Body and Housing	Aluminum
Trim	Zinc Plated Steel, Brass
Nozzle	Nitrile on Dacron

The WRA102BP is a high capacity relief valve that relieves excess pressure in a pneumatic system.

The WRA102BP provides greater accuracy than standard relief valves over a narrow pressure range. The WRA102BP is an excellent choice for a wide range of precision applications.

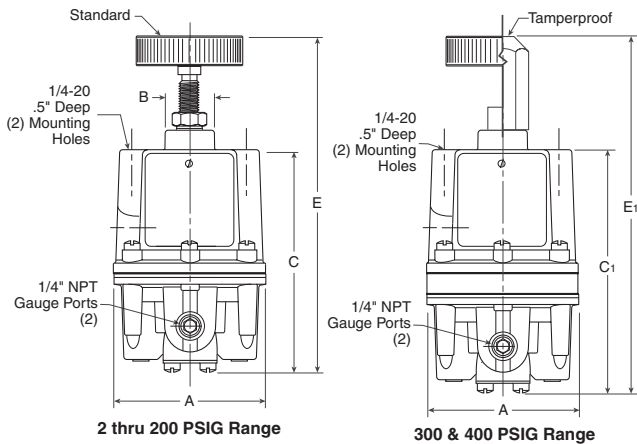

Dimensions

Models	Inches (mm)	A	B	C	C1	E	E1
Standard Unit WRA102BP		3.00 (76.2)	0.97 (24.6)	4.19 (106.4)	4.56 (115.9)	6.31 (160.3)	6.75 (171.4)

= "Most Popular"

WRA102BP Kits & Accessories

Mounting Bracket Kit –

Zinc Plated Steel..... PS09921

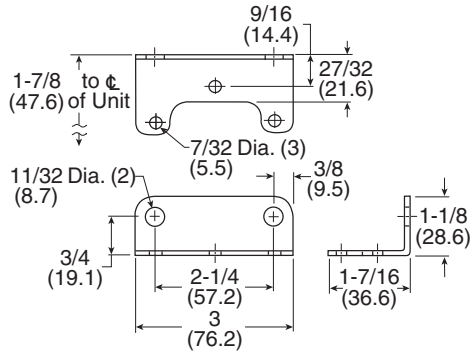

Service Kits

0 to 200 PSIG, Standard..... PS12127-1

Tamper Resistant Kit..... PS12165

⚠ WARNING

**Product rupture can cause serious injury.
Do not connect regulator to bottled gas.
Do not exceed maximum primary pressure rating.**

CAUTION:

REGULATOR PRESSURE ADJUSTMENT – The working range of knob adjustment is designed to permit outlet pressures within their full range. Pressure adjustment beyond this range is also possible because the knob is not a limiting device. This is a common characteristic of most industrial regulators, and limiting devices may be obtained only by special design. For best performance, regulated pressure should always be set by increasing the pressure up to the desired setting.

Technical Information

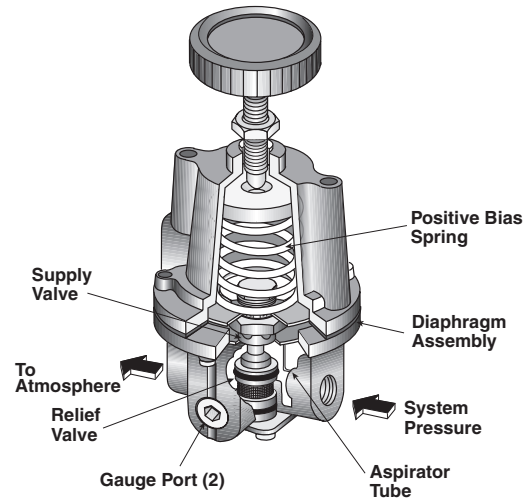
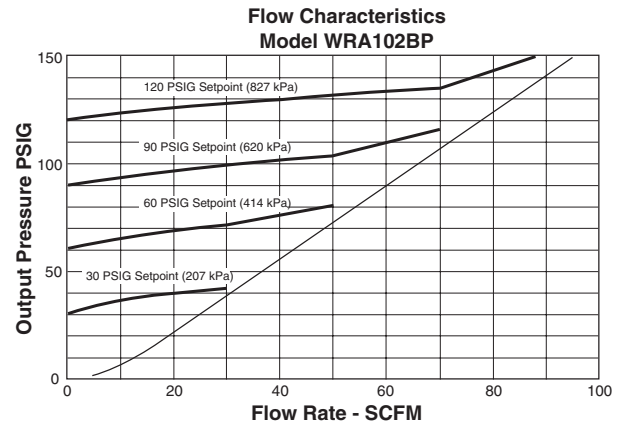

Operating Principles

The WRA102BP Regulator uses the force balance principle to open the Relief Valve and vent system pressure when the set point is exceeded.

Downstream pressure is transmitted through the Aspirator Tube to the bottom of the Diaphragm Assembly. When you adjust the range screw for a specific set point, the Positive Bias Spring compresses and exerts a force on the top of the Diaphragm Assembly. As long as the pressure acting on the bottom of the Diaphragm Assembly produces a force less than the spring force acting on the top of the Diaphragm Assembly, the Relief Valve remains closed. When system pressure increases, the force on the bottom of the Diaphragm Assembly increases until it reaches the set point. When system pressure increases beyond the set point, the assembly moves upward, lifting the Relief Valve from its seat and vents the downstream air.

If downstream pressure decreases below the set point, the assembly moves downward closing the Relief Valve.

WRA102	6	2	BP	
---------------	----------	----------	-----------	--

Springs	
3	0.5 to 30 PSIG
4	1 to 60 PSIG
6	2 to 150 PSIG

Pipe Size	
2	1/4" NPT

Options	
BP	Back Pressure

Options	
Blank	No Options
H	BSP
N	Non-Relieving

Note: Other Spring Ranges, Port Sizes, and Options Available. Please Consult Factory

Ordering Information

Relieving		Reduced Pressure Range (PSIG)		
		0 to 30	0 to 60	0 to 150
In / Out Ports	1/4 Inch	WRA10232BP	WRA10242BP	WRA10262BP

High Precision Vacuum Regulator WRA171

 = "Most Popular"

Specifications

Vacuum Supply (Max)	29.92 Hg (760 torr)
Flow Capacity	3 SCFM @ 650 torr Supply, 250 torr Setpoint
Sensitivity	.125" (.005 PSIG) (.32 cm) Water Column
Ambient Temperature	-40°F to +200°F, (-40°C to +93°C)
Vacuum Supply Effect –	Less than 1 torr for 100 torr (.04 Hg for 3.94 Hg) change in Vacuum Supply

Materials of Construction

Body and Housing	Aluminum
Trim	Zinc Plated Steel, Brass
Elastomers	Nitrile

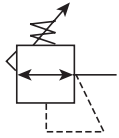

WRA171

Features

- Control Sensitivity of .125" (.32 cm) Water Column Allows Use in Precision Applications
- Balanced Supply Valve Minimizes Effects of Vacuum Variation
- Aspirator Tube Compensates for Downstream Pressure Droop Under Flow Conditions
- Separate Control Chamber Isolates the Diaphragm From the Main Flow to Eliminate Hunting and Buzzing
- Construction Allows Servicing Without Removing From the Line

The WRA171 is a high accuracy vacuum regulator that provides uniform vacuum regulation independent of vacuum supply changes and flow demand.

This unit has a diaphragm assembly with three springs to provide a more balanced loading of the diaphragm.

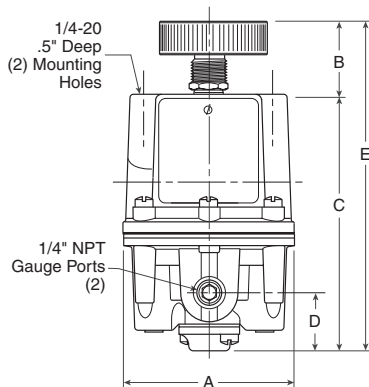

Dimensions

Models	Inches (mm)	A	B	C	D	E
Standard Unit WRA171		3.00 (76.2)	1.13 (28.7)	4.83 (122.6)	1.00 (25.4)	5.96 (151.3)

= "Most Popular"

WRA171 Kits and Accessories

Mounting Bracket PS09921

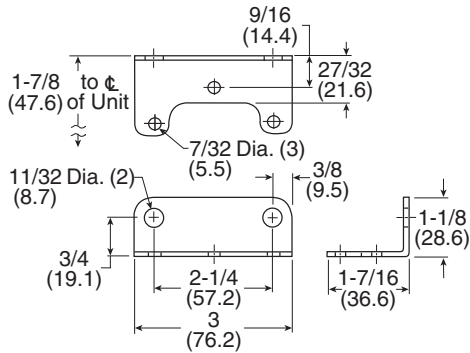

Service Kits

(Includes Diaphragm Assy, Valve Assy, Seat Assy & Gasket) –

0-30" Hg, Nitrile, Nonrelieving..... PS20966-9

Tamper Resistant Kit.....PS20967-1

⚠ WARNING

**Product rupture can cause serious injury.
Do not connect regulator to bottled gas.
Do not exceed maximum primary pressure rating.**

CAUTION:

REGULATOR PRESSURE ADJUSTMENT – The working range of knob adjustment is designed to permit outlet pressures within their full range. Pressure adjustment beyond this range is also possible because the knob is not a limiting device. This is a common characteristic of most industrial regulators, and limiting devices may be obtained only by special design. For best performance, regulated pressure should always be set by increasing the pressure up to the desired setting.

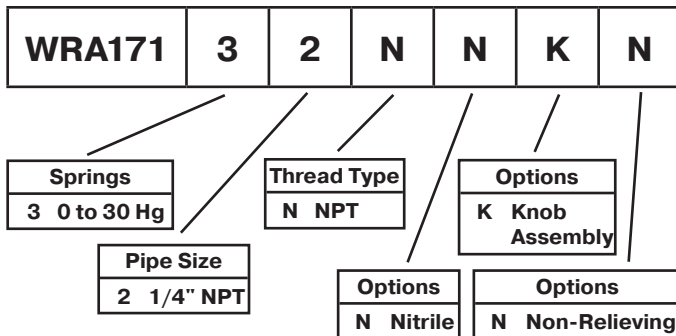

Note: Other Spring Ranges, Port Sizes, and Options Available. Please Consult Factory

Ordering Information

	Relieving	Reduced Pressure Range (PSIG)
		0 to 30
In / Out Ports	1/4 Inch	WRA17132NNKN

Technical Information

Flow Characteristics
Model WRA171

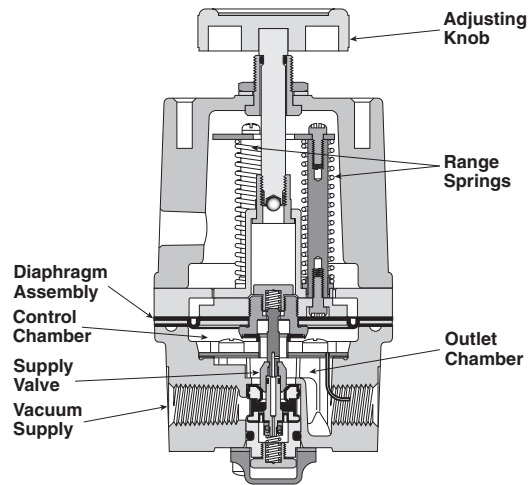
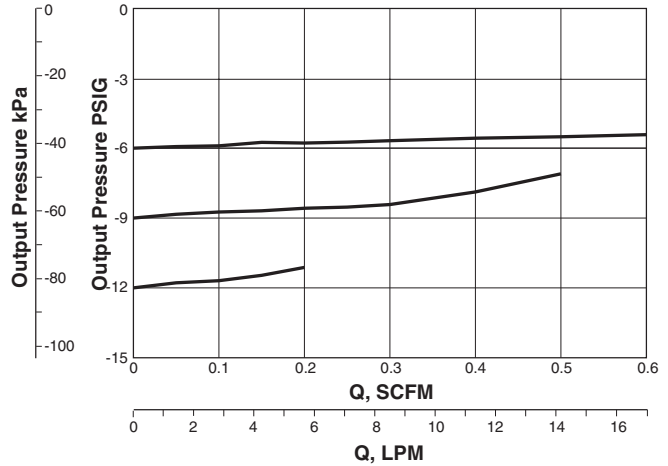

Operating Principles

The Model WRA171 Series vacuum regulator uses the force balance principle to control the movement of the Valve Assembly that controls output vacuum.

When the regulator is adjusted for a specific set point, the upward force of the Range Springs moves the Diaphragm Assembly upward. The Supply Valve opens and allows air to pass to the inlet port. As the set point is reached, the upward force exerted by the Range Springs is balanced by the force of the vacuum that pulls downward on the Diaphragm Assembly. The resultant force moves the Supply Valve downward to reduce the flow of air to the inlet port. Outlet vacuum is maintained as a result of balance between forces acting on the top and bottom of the Diaphragm Assembly.

Precision Filter / Regulator WEA632

= "Most Popular"

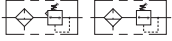

Features

- The No-brass Construction is Well Suited to Harsh Environments
- Internal and External Epoxy Finish for Superior Corrosion Resistance
- Non-Bleed Design to Reduce Consumption.
- Integral Relief Valve
- A Gauge Port Provides Convenient Pressure Gauge Mounting
- The Standard 5-Micron Filter Minimizes Internal Contamination
- The Filter Dripwell Contains a Drain Plug to Easily Drain Trapped Liquids
- Standard Tapped Exhaust
- Soft Relief Seat Minimizes Air Loss.

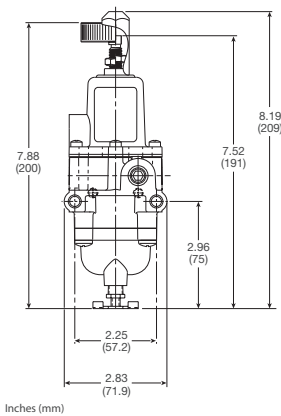

Dimensions

Models	Inches (mm)	A	B	C	D	E	F
Standard Unit WEA632		2.83 (71.9)	2.25 (57.2)	7.88 (200)	2.96 (75)	7.52 (191)	8.19 (209)

Specifications

Supply Pressure	250 PSIG, (17 bar), (1700 kPa) Maximum
Flow Capacity (SCFM) –	25 (42.5 m ³ /HR) @ 100 psig, (7 bar), (700 kPa) supply and 20 PSIG, (1.5 bar), (150 kPa) setpoint
Exhaust Capacity (SCFM) –	0.8 (1.36 m ³ /HR) where downstream pressure is 5 PSIG, (.35 bar), (35 kPa) above 20 PSIG, (1.5 bar), (150 kPa) setpoint. (0.8 SCFM for 120 # unit)
Maximum Supply Pressure	250 PSIG, (14 bar), (1400 kPa)
Consumption	Undetectable
Supply Pressure Effect –	Less than 1.25 PSIG, (.09 bar), (9 kPa) change for 100 psig, (7.0 bar), (700 kPa) change in supply pressure (1.90 psig for 120 # unit)
Sensitivity	1.0" (.036 PSIG) (2.54 cm) Water Column
Temperature Range	-40 ^o F to + 160 ^o F, (-40 ^o C to + 71 ^o C)

Materials of Construction

Body and Housing	Epoxy Coated Aluminum
Trim	Stainless Steel, Nickel Plated Steel
Elastomers	Nitrile

= "Most Popular"

WEA632 Kits & Accessories

Service Kits

1 to 60, 2 to 120 PSIGPS19968-NR

Tamper Resistant Kit PS12165

Technical Information

**Flow Characteristics
Model WEA632**

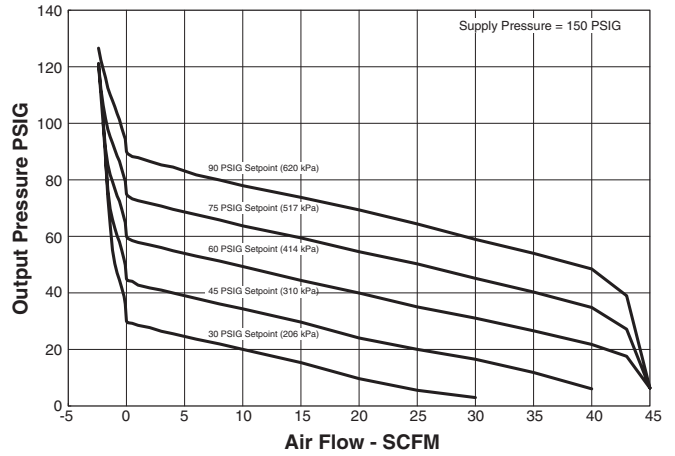

⚠ WARNING

**Product rupture can cause serious injury.
Do not connect regulator to bottled gas.
Do not exceed maximum primary pressure rating.**

CAUTION:

REGULATOR PRESSURE ADJUSTMENT – The working range of knob adjustment is designed to permit outlet pressures within their full range. Pressure adjustment beyond this range is also possible because the knob is not a limiting device. This is a common characteristic of most industrial regulators, and limiting devices may be obtained only by special design. For best performance, regulated pressure should always be set by increasing the pressure up to the desired setting.

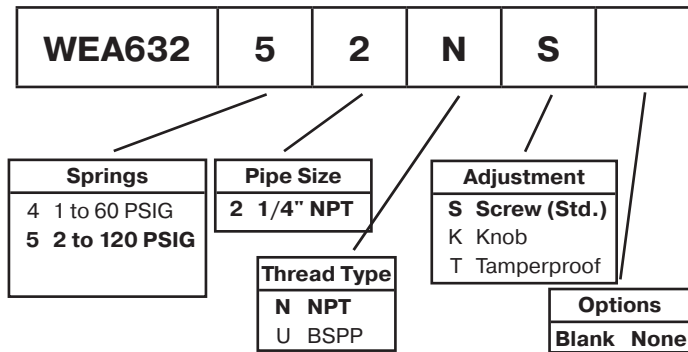

Note: Other Spring Ranges, Port Sizes, and Options Available. Please Consult Factory

Ordering Information

Relieving		Reduced Pressure Range (PSIG)	
		0 to 60	2 to 120
In / Out Ports	1/4 Inch	WEA63242NS	WEA63252NS

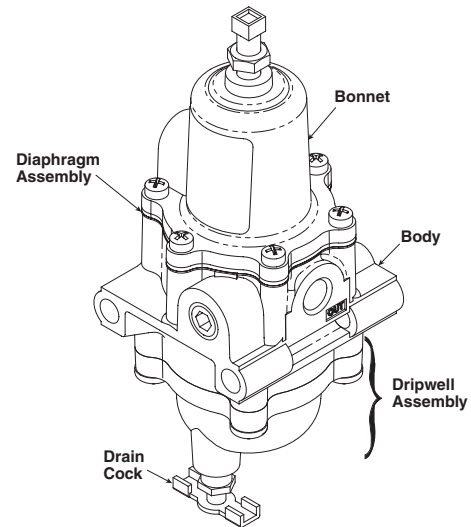

Operating Principles

When you turn the Adjustment Screw to a specific setpoint, the Spring exerts a downward force against the top of the Diaphragm Assembly. This downward force opens the Supply Valve. Output pressure flows through the Outlet Port and the passage to the Control Chamber where it creates an upward force on the bottom of the Diaphragm Assembly.

When the setpoint is reached, the force of the Spring that acts on the top of the Diaphragm Assembly balances with the force of output pressure that acts on the bottom of the Diaphragm Assembly and closes the Supply Valve.

When the output pressure increases above the setpoint, the Diaphragm Assembly moves upward to close the Supply Valve and open the Exhaust Valve. Output pressure flows through the Exhaust Valve and out of the Exhaust Vent on the side of the unit until it reaches the setpoint.

Precision Pneumatic Input Signal Amplifier WBA208

= "Most Popular"



Features

- The WBA208 Uses a Pneumatic Input Signal to Accurately Control Output Pressure Based on a Predetermined Ratio
- A Balanced Supply Valve Minimizes the Effects of Supply Pressure Variation
- An Aspirator Tube Compensates Downstream Pressure Droop Under Flowing Conditions
- A Separate Control Chamber Isolates the Diaphragm From the Main Flow to Eliminate Hunting and Buzzing
- Unit Construction Allows Servicing Without Removal
- Mounting Bracket Available

Specifications

Ratio	Signal:Output		
	1:1	1:2	1:3
Maximum Output Pressure, PSIG (bar)	150 (10.0)	150 (10.0)	150 (10.0)
Maximum Supply Pressure, PSIG (bar)	250 (17.0)	250 (17.0)	250 (17.0)
Flow Capacity SCFM, (m³/HR) 100 PSIG, (7.0 bar) Supply, 20 PSIG, (1.5 bar) Output.	45 (76.5)	45 (76.5)	45 (76.5)
Exhaust Capacity SCFM, (m³/HR) Downstream Pressure 5 PSIG, (.35 bar) Above Output Pressure Set Point of 20 PSIG, (1.5 bar).	11 (18.7)	11 (18.7)	11 (18.7)
Sensitivity (Water Column)	.250" (.64 cm)	.500" (1.27 cm)	.750" (1.9 cm)
Ratio Accuracy % of 100 PSIG, (7.0 bar) Output Span	1.0	1.0	1.0
% of Output Span with (7.0 bar) Input Span	—	—	—
Supply Pressure Effect, PSIG (bar) for change of 100 PSIG, (7.0 bar).	0.10 (.007)	0.20 (.014)	0.30 (.021)
Ambient Temperature, °F (°C)	-40 to +200 (-40 to +93)		

Materials of Construction

Body and Housing	Aluminum
Diaphragm	Nitrile on Dacron Fabric
Trim	Zinc Plated Steel, Brass

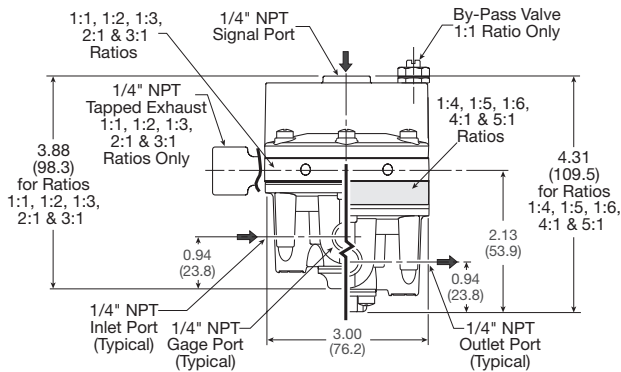

Dimensions

Models	Inches (mm)	A	B	C	C ₁	D	E	E ₁
Standard Unit WBA208		3.00 (76.2)	.94 (23.8)	2.13 (53.9)	.94 (23.8)	.13 (3.2)	3.88 (98.3)	4.31 (109.5)

= "Most Popular"

WBA208 Kits and Accessories

Mounting Bracket PS09921

Service Kits

- 1:1 RatioPS19513-11
- 1:1 Ratio w/ By-Pass Valve PS19513-11I
- 1:2 Ratio PS19513-12
- 1:3 Ratio PS19513-13

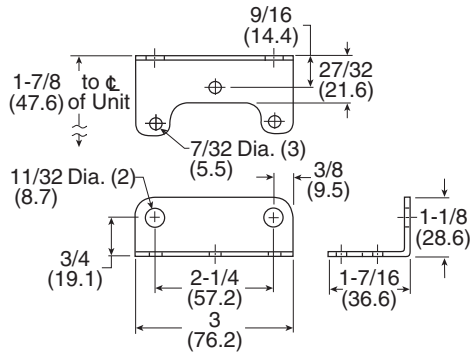

Technical Information

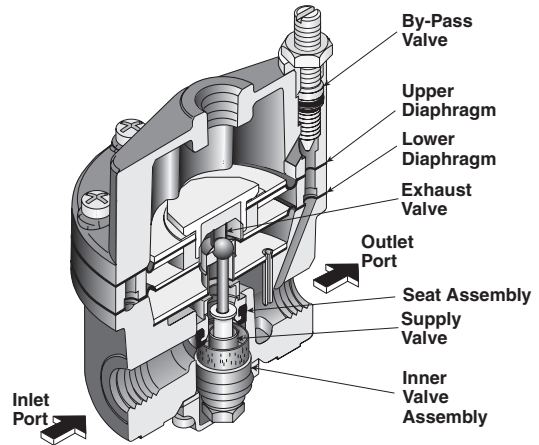
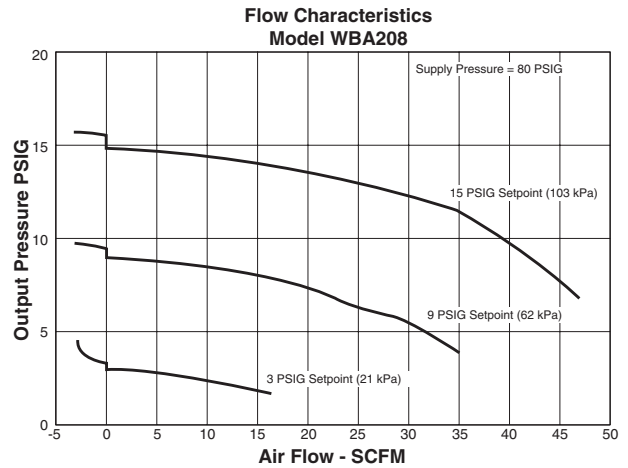

Operating Principles

The WBA208 Input Signal Amplifier is a pneumatic device capable of high flow and exhaust capacity. This device uses a force balance system to control the movement of the supply and exhaust valves.

At set point, the force due to signal pressure that acts on the top of the Upper Diaphragm balances with the force due to output pressure acting on the bottom of the Lower Diaphragm.

WBA208	1	2	
---------------	----------	----------	--

Pilot Ratio	
1	1:1
2	1:2
3	1:3

Pipe Size	
2	1/4" NPT

Options	
Blank	No Options
E	Tapped Exhaust
H	BSPP
I	By-Pass Valve

Note: Other Spring Ranges, Port Sizes, and Options Available. Please Consult Factory

Ordering Information

Relieving		Pilot Ratio		
		1:1	1:2	1:3
In / Out Ports	1/4 Inch	WBA20812	WBA20822	WBA20832

Precision Pneumatic Input Signal Amplifier WBA45

= "Most Popular"



Features

- Five Signal to Output Ratios Meet Most Control Element Requirements
- Control Sensitivity of Water Column Allows Use in Precision Applications
- Large Supply and Exhaust Valves Provide High Forward and Exhaust Flows
- Soft Supply and Exhaust Valve Seats Minimize Air Consumption
- A Balanced Supply Valve Minimizes the Effect of Supply Pressure Variation
- An Aspirator Tube Compensates Downstream Pressure Droop Under Flow Conditions
- A Separate Control Chamber Isolates the Diaphragm From the Main Flow to Eliminate Hunting and Buzzing
- Optional Remote Feedback Port Minimizes Pressure Drop at Final Control Element Under Flow Conditions
- Unit Construction Lets You Service the WBA45 Without Removing it From the Line

Specifications

Ratio	Signal:Output		
	1:1	1:2	1:3
Maximum Output Pressure, PSIG (bar)	150 (10.0)	150 (10.0)	150 (10.0)
Maximum Supply Pressure, PSIG (bar)	250 (17.0)	250 (17.0)	250 (17.0)
Flow Capacity SCFM, (m³/HR) 100 PSIG, (7.0 bar) Supply, 20 PSIG, (1.5 bar) Output	150 (255)	150 (255)	150 (255)
Exhaust Capacity SCFM, (m³/HR) Downstream Pressure 5 PSIG, (.35 bar) Above 20 PSIG, (1.5 bar) Setpoint	40 (62.5)	40 (62.5)	40 (62.5)
Sensitivity (Water Column)	1.0" (2.54 cm)	2.0" (5.08 cm)	3.0" (7.62 cm)
Ratio Accuracy – % of 100 PSIG, (7.0 bar) Output Span	3.0	3.0	3.0
% of Output Span with 100 PSIG (7.0 bar) Input Span	—	—	—
Supply Pressure Effect, PSIG (bar) for change of 100 PSIG, [7.0 bar], (700 kPa).	0.10 (.007)	0.20 (.014)	0.30 (.021)
Ambient Temperature, °F (°C)	-40 to +200 (-40 to +93)		
Hazardous Locations	Acceptable for use in Zones 1 and 2 for gas atmosphere; Groups IIA and IIB and Zones 21 and 22 for dust atmospheres.		

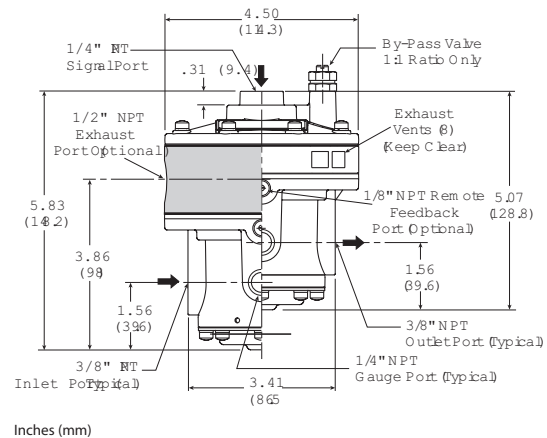

Dimensions

Models	Inches (mm)	A	B	C	C ₁	D	E	E ₁
Standard Unit WBA45		4.50 (114.3)	3.41 (86.5)	3.86 (98)	1.56 (39.6)	.31 (7.9)	5.07 (128.8)	5.83 (148.2)

= "Most Popular"

WBA45 Kits and Accessories

Service Kits

1:1 Ratio	PS19549-1
1:1 Ratio w/ Tapped Exhaust	PS19549-1E
1:3 Ratio	PS19549-3
1:2 Ratio	PS19549-2
1:1 w/ Tapped Exhaust, I Option	PS19549-20E

Materials of Construction

Body and Housing	Aluminum
Diaphragm	Nitrile on Dacron Fabric
Trim	Zinc Plated Steel, Brass

Technical Information

Flow Characteristics
Model WBA45

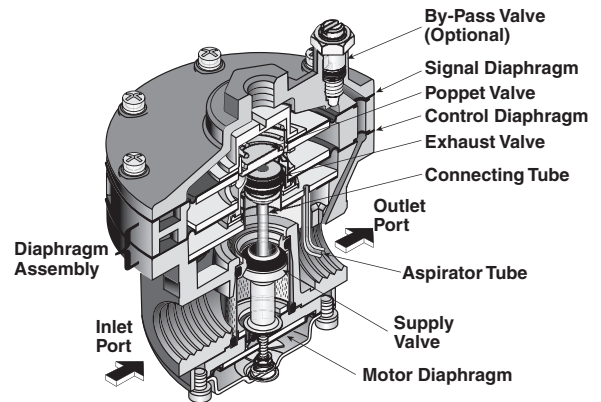
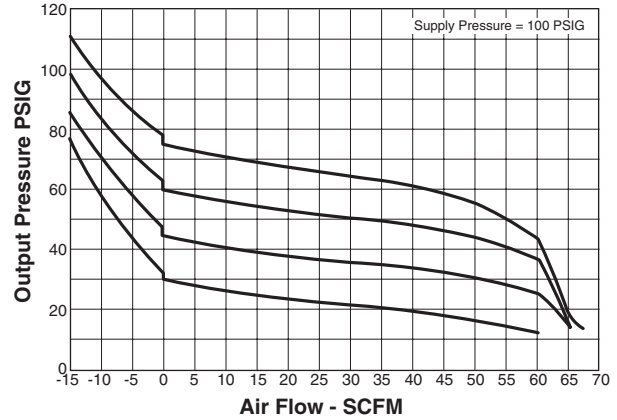

Operating Principles

When signal pressure on the top of the Signal Diaphragm creates a downward force on the Diaphragm Assembly, the Supply Valve opens. Output pressure flows through the Outlet Port and the Aspirator Tube to the Control Chamber to create an upward force on the bottom of the Control Diaphragm. When the setpoint is reached, the force of the signal pressure that acts on the top of the Signal Diaphragm balances with the force of the output pressure that acts on the bottom of the Control Diaphragm to close the Supply Valve.

When the output pressure increases above the signal pressure, the Diaphragm Assembly moves upward to close the Supply Valve and open the Exhaust Valve. Because the Poppet Valve is closed, pressure flows down the Connecting Tube to the bottom of the Motor Diaphragm. This pressure keeps the Supply Valve tightly closed while in the exhaust mode. The Poppet Valve opens and excess output pressure exhausts through the vent in the side of the unit until it reaches the setpoint.

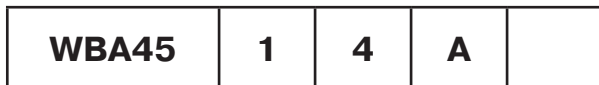

Pilot Ratio	
1	1:1
2	1:2
3	1:3

Pipe Size	
4	1/2" NPT
6	3/4" NPT

Type	
A	45 Series

Options	
Blank	No Options
E	Tapped Exhaust
H	BSPP
I	By-Pass Valve

Note: Other Spring Ranges, Port Sizes, and Options Available. Please Consult Factory

Ordering Information

Relieving		Pilot Ratio		
		1:1	1:2	1:3
In / Out Ports	1/2 Inch	WBA4514A	WBA4524A	WBA4534A
	3/4 Inch	WBA4516A	WBA4526A	WBA4536A

Lubricator Numbering System

 = "Most Popular"

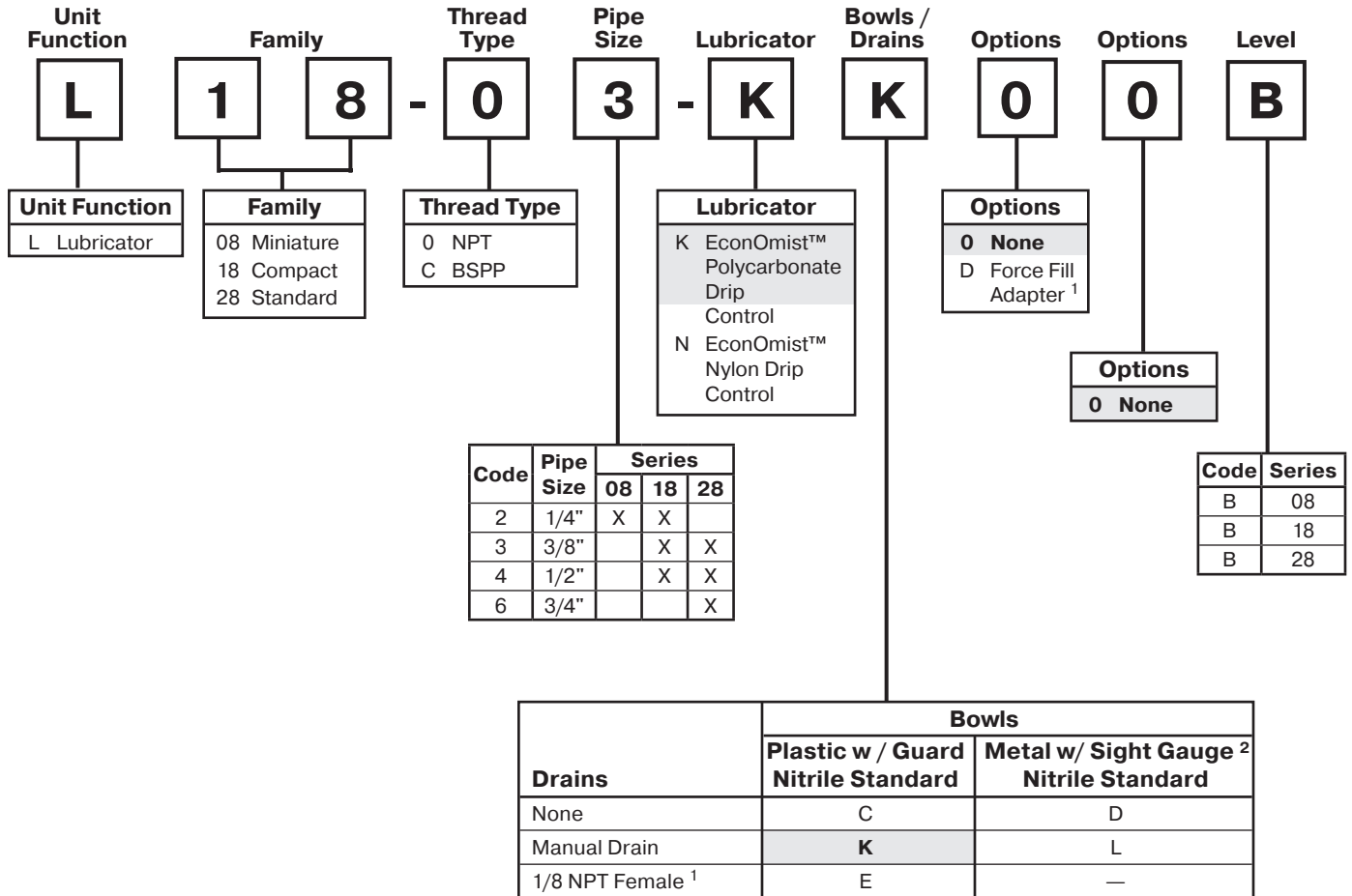

¹ Not available on L08

² No sight gauge on L08

Note: When selecting from the options columns, please enter letters in alphabetical order for positions 7, 8, and 9. For example:

L 18 - 03 - K K 0 0 B

Suggested Lubricant

Airline Oil F442001

Petroleum based oil of 100 to 200 SUS viscosity at 100°F and an aniline point greater than 200°F (DO NOT USE OILS WITH ADDITIVES, COMPOUNDED OILS CONTAINING SOLVENTS, GRAPHITE, DETERGENTS, OR SYNTHETIC OILS.)

Lubricator Numbering System

 = "Most Popular"

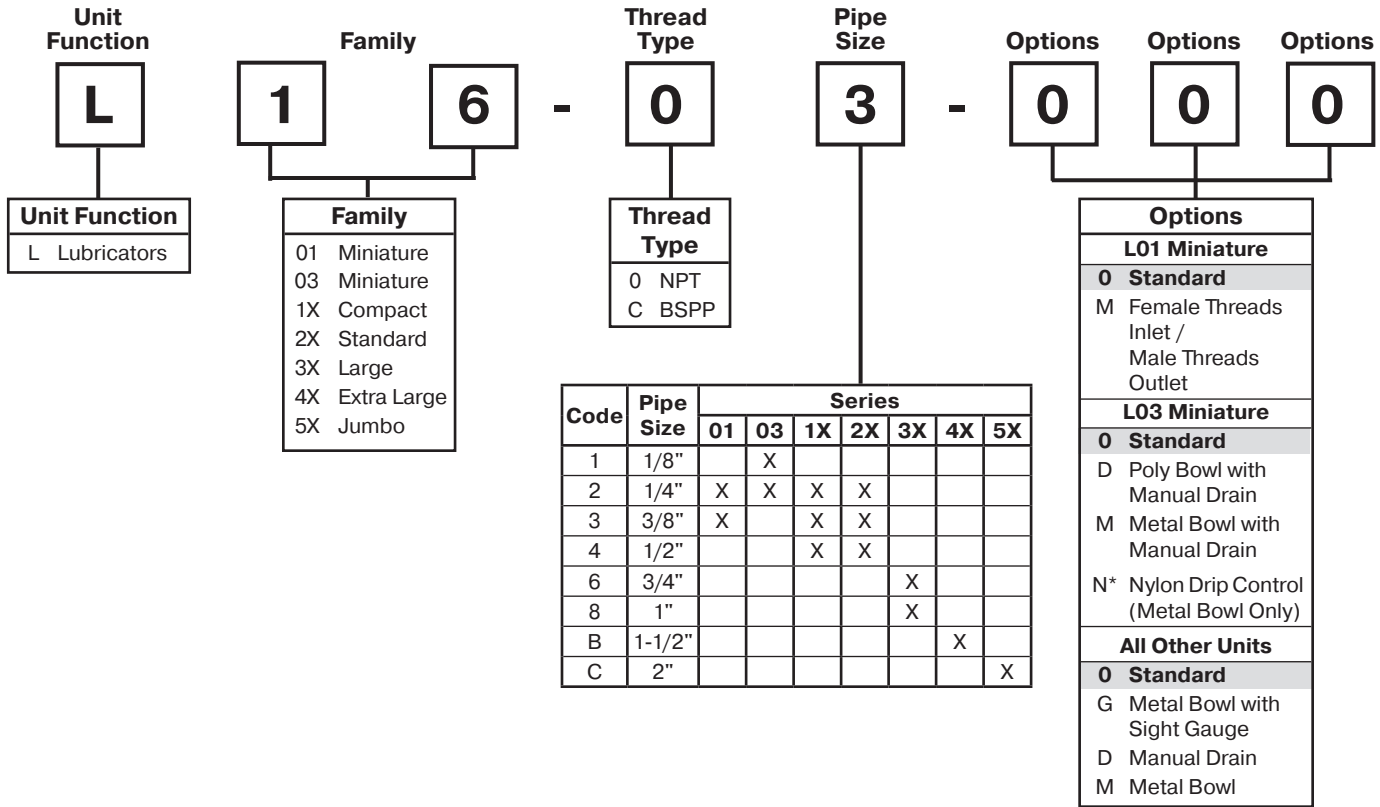

* Available only with Metal Bowl "M".

Note: When selecting from the options columns, please enter letters in alphabetical order for positions 6, 7, and 8. For example:

L16-03-000

Suggested Lubricant

Airline Oil F442001
 Petroleum based oil of 100 to 200 SUS viscosity at 100°F and an aniline point greater than 200°F (DO NOT USE OILS WITH ADDITIVES, COMPOUNDED OILS CONTAINING SOLVENTS, GRAPHITE, DETERGENTS, OR SYNTHETIC OILS.)

Lubricator L01 EconOmist™

 = "Most Popular"



L01-02-000

In-Line Lubricator

In-Line Lubricators assure proper lubrication for small pneumatic hand tools. These in-line lubricators put the oil source right at the tool. Oil capacity is 1/4 oz. (1 ml) enough to last through an average 8-hour shift. This lubricator requires cyclical or intermittent airflow for proper operation, and consequently works best when installed at the tool inlet or on a short hose near the tool.

The L01 cannot be filled under pressure.

Specifications

Flow Capacity*	1/4 3/8	36.0 SCFM (17.0 dm ³ /s) 38.1 SCFM (18.0 dm ³ /s)
Maximum Supply Pressure	200 PSIG (13.8 bar)	
Oil Capacity**	oz. (cm ³)	0.25 (7.4)
Operating Temperature	32° to 150°F (0° to 65.5°C)	
Port Size	NPT / BSPT-Rc	1/4, 3/8
Weight	lb. (kg)	0.2 (0.1)

* Inlet pressure 150 PSIG (10.3 bar). Pressure drop 5 PSID (0.3 bar).

** Oil Capacity refers to usable volume.

Materials of Construction

Body	Aluminum
Seals	Nitrile

Suggested Lubricant

Airline Oil F442001

Petroleum based oil of 100 to 200 SUS viscosity at 100°F and an aniline point greater than 200°F

(DO NOT USE OILS WITH ADDITIVES, COMPOUNDED OILS CONTAINING SOLVENTS, GRAPHITE, DETERGENTS, OR SYNTHETIC OILS.)

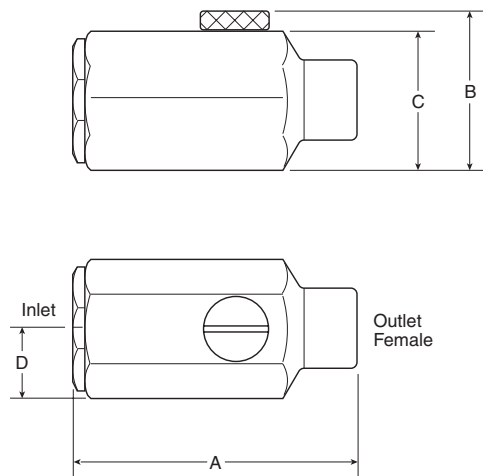

Dimensions

Models	Pipe Size Inlet	Pipe Size Outlet	Inches (mm)	A	B	C	D
Standard Unit	1/4" NPT Female	1/4" NPT Female		2.65 (67)	1.30 (33)	1.12 (28.5)	.65 (16.5)
L01-02-M00	1/4" NPT Female	1/4" NPT Male		2.93 (74)	1.30 (33)	1.12 (28.5)	.65 (16.5)
L01-03-M00	3/8" NPT Female	3/8" NPT Male		3.19 (81)	1.30 (33)	1.12 (28.5)	.65 (16.5)

= "Most Popular"

Replacement Kits

- Fill Plug Kit – Brass Fill Plug and O-ring.....LRP-95-254
- O-ring Repair KitLRP-95-074

Accessories

- Air Line Oil (1 Qt. Bottle).....F442001

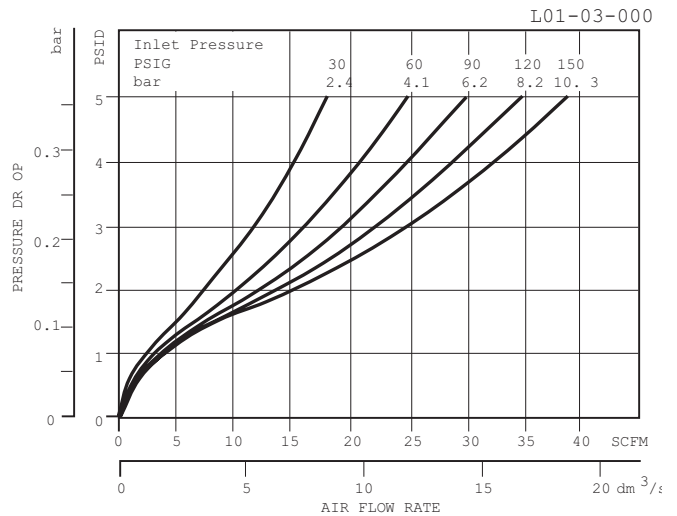
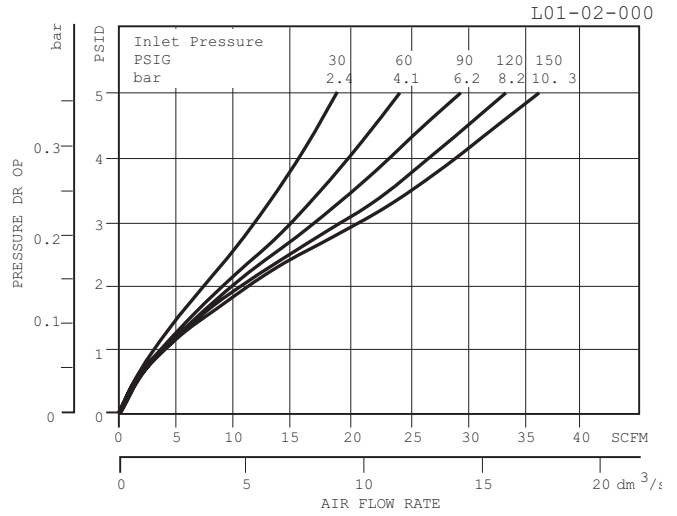

Ordering Information

Model Type	Port Size	Female Threads Inlet / Female Threads Outlet	Female Threads Inlet / Male Threads Outlet
In-Line Lubricator	1/4	L01-02-000	L01-02-M00
	3/8	L01-03-000	L01-03-M00

Options - To order an option supplied with the unit model, add the appropriate coded suffix letter in the designated position of the model number.

Lubricator L03 EconOmist™

= "Most Popular"

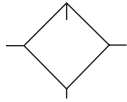

L03-01-000

Features

- Proportional Oil Delivery over a Wide Range of Air Flows
- Precision Needle Valve Assures Repeatable Oil Delivery and Provides Simple Adjustment of Delivery Rate
- Ideal for Low and Light Flow Applications with Changing Air Flow
- Transparent Sight Dome for 360° Visibility

Specifications

Flow Capacity*	1/8	20 SCFM (9.4 dm ³ /s)
	1/4	20 SCFM (9.4 dm ³ /s)
Minimum Flow for Lubrication		0.7 SCFM at 100 PSIG
Port Threads		1/8, 1/4 Inch
Pressure & Temperature Ratings –		
Polycarbonate Bowl –		0 to 150 PSIG (0 to 10.3 bar) 32°F to 125°F (0°C to 52°C)
Metal Bowl –		0 to 250 PSIG (0 to 17.2 bar) 32°F to 175°F (0°C to 80°C)
Weight		.4 lb. (.18 kg)

* Inlet pressure 90 PSIG (6.2 bar). Pressure drop 5 PSID (0.3 bar).

Materials of Construction

Body	Zinc	
Bowls	Plastic Bowl	Polycarbonate
	Metal Bowl (Without Sight Gauge)	Zinc
Drains – Manual – Body & Nut		Plastic
Seals		Nitrile
Sight Dome		Polycarbonate

Suggested Lubricant

Airline Oil F442001

Petroleum based oil of 100 to 200 SUS viscosity at 100°F and an aniline point greater than 200°F
(DO NOT USE OILS WITH ADDITIVES, COMPOUNDED OILS CONTAINING SOLVENTS, GRAPHITE, DETERGENTS, OR SYNTHETIC OILS.)

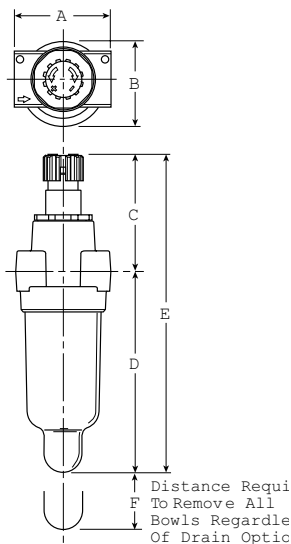

Dimensions

Models	Inches (mm)	A	B	C	D	D†	E	E†	F
Standard Unit L03-XX-000		1.73 (44)	1.56 (40)	2.16 (55)	3.64 (92)	3.78 (96)	5.80 (147)	5.94 (151)	1.60 (41)

† With Twist Drain

Replacement Kits

Bowl Kits –

- Poly Bowl, Manual DrainPS420
- Metal Bowl – Manual Drain (No Sight Gauge).....PS447B
- Poly Bowl – No DrainPS421

Accessories

- Air Line Oil (1 Qt. Bottle).....F442001
- Mounting Bracket Kit PS419

 = “Most Popular”

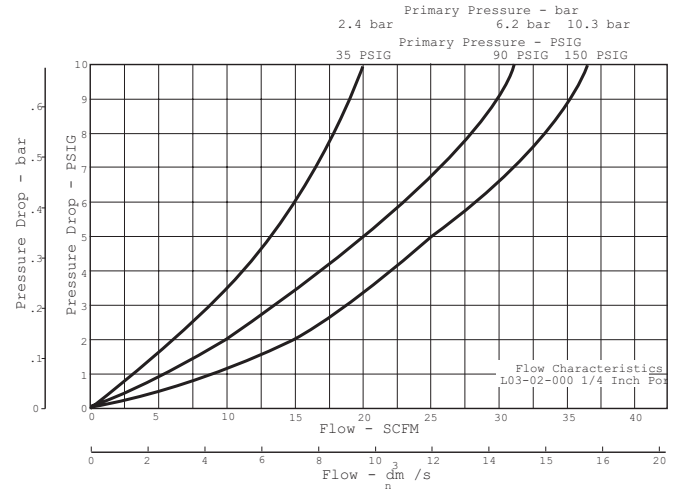
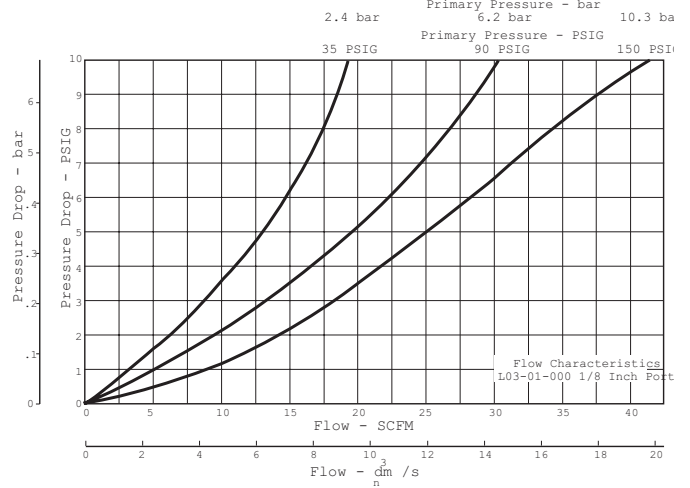

Ordering Information

Model Type	Port Size	Polycarbonate Bowl	Metal Bowl
EconOmist™	1/8	L03-01-000	L03-01-M00
	1/4	L03-02-000	L03-02-M00

Options - To order an option supplied with the unit model, add the appropriate coded suffix letter in the designated position of the model number.

Lubricator L08 EconOmist™

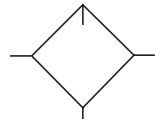

Features

- Integral Sight Dome and Adjustment Knob
- Fill-under Pressure Design
- Modern Design and Appearance
- Light Weight
- High Flow Capacity
- Quick-disconnect Bowl

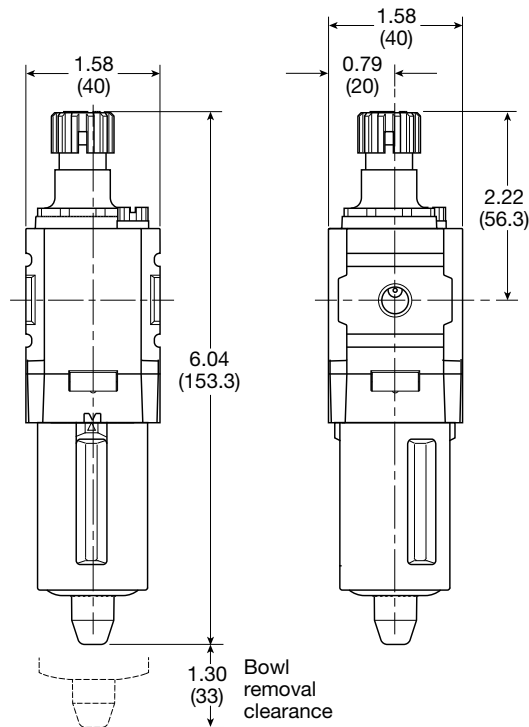

Inches (mm)

Specifications

Flow Capacity*	1/4	52 SCFM (25 dm ³ /s, ANR)
Initial Drip Flow		1.3 SCFM
Maximum Supply Pressure	Plastic Bowl Metal Bowl	150 PSIG (10.3 bar) 250 PSIG (17.2 bar)
Minimum Flow for Lubrication		1.3 SCFM @ 100 PSIG
Operating Temperature	Plastic Bowl Metal Bowl	14° to 125°F (-10° to 52°C) 14° to 150°F (-10° to 65.5°C)
Port Size	NPT / BSPP-G	1/4
Bowl Capacity		0.6 oz
Weight		0.29 lb. (0.13 kg)

* Inlet pressure 91.3 PSIG (6.3 bar). Pressure drop 4.9 PSID (0.34 bar).

Materials of Construction

Body	Aluminum	
Body Cap	ABS	
Bowls	Plastic Bowl Metal Bowl	Polycarbonate Aluminum
Pick-up Filter		Sintered Bronze
Seals	Plastic Bowl Metal Bowl	Nitrile Nitrile
Sight Dome		Polycarbonate

Suggested Lubricant

Airline Oil F442001

Petroleum based oil of 100 to 200 SUS viscosity at 100°F and an aniline point greater than 200°F

(DO NOT USE OILS WITH ADDITIVES, COMPOUNDED OILS CONTAINING SOLVENTS, GRAPHITE, DETERGENTS, OR SYNTHETIC OILS.)

= "Most Popular"

Replacement Bowl Kits

- Metal Bowl –
- Manual Drain GRP-96-714
- No Drain Port GRP-96-715

- Plastic Bowl –
- Bowl Guard, Manual Drain LRP-96-736
- Bowl Guard, No Drain Port LRP-96-713

Replacement Kits

- Bowl O-ring –
- Fluorocarbon GRP-96-711
- Nitrile GRP-96-710

- Fill Plug Kit LRP-96-730

- Sight Dome Assembly –
- Nylon LRP-96-720
- Polycarbonate, L08-XX-**K**XXX LRP-96-725

- Siphon Tube Assembly LRP-96-731

Accessories

- Wall Mounting Bracket –
- C-Type GPA-97-010
- T-Type GPA-96-737

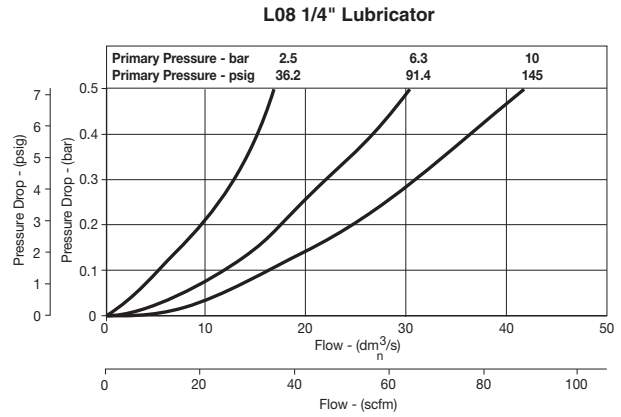

Ordering Information

Model Type	Port Size	Plastic Bowl / Bowl Guard	Metal Bowl / No Sight Gauge
No Drain	1/4	L08-02-KC00B	L08-02-KD00B
Manual Drain	1/4	L08-02-KK00B	L08-02-KL00B

Options - To order an option supplied with the unit model, add the appropriate coded suffix letter in the designated position of the model number.

Lubricator L18 EconOmist™

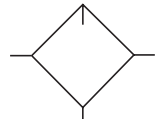

Features

- Integral Sight Dome and Adjustment Knob
- 1/2" NPT / BSPP-G Over-port
- Can be Filled while Under Pressure
- Quick-disconnect Bowl / Bowl Guard
- Manual Drain
- High Flow Capacities

Specifications

Flow Capacity*	1/4	88 SCFM (42 dm ³ /s, ANR)
	3/8	90 SCFM (43 dm ³ /s, ANR)
	1/2	96 SCFM (45 dm ³ /s, ANR)
Initial Drip Flow	0.68 SCFM	
Maximum Supply Pressure	Plastic Bowl	150 PSIG (10.3 bar)
	Metal Bowl	250 PSIG (17.2 bar)
Minimum Flow for Lubrication	.7 SCFM @ 100 PSIG	
Operating Temperature	Plastic Bowl	14° to 125°F (-10° to 52°C)
	Metal Bowl	14° to 150°F (-10° to 65.5°C)
Port Size	NPT / BSPP-G	1/4, 3/8, 1/2
Bowl Capacity	4 oz	
Weight	0.68 lb. (0.31 kg)	

* Inlet pressure 91.3 PSIG (6.3 bar). Pressure drop 4.9 PSID (0.34 bar).

Materials of Construction

Body	Aluminum	
Body Cap	ABS	
Bowls	Plastic Bowl	Polycarbonate
	Metal Bowl	Aluminum
Pick-up Filter	Sintered Bronze	
Seals	Plastic Bowl	Nitrile
	Metal Bowl	Nitrile
Sight Dome	Polycarbonate	
Sight Gauge	Metal Bowl	Polyamide (Nylon)

Suggested Lubricant

Airline Oil F442001
 Petroleum based oil of 100 to 200 SUS viscosity at 100°F and an aniline point greater than 200°F
 (DO NOT USE OILS WITH ADDITIVES, COMPOUNDED OILS CONTAINING SOLVENTS, GRAPHITE, DETERGENTS, OR SYNTHETIC OILS.)

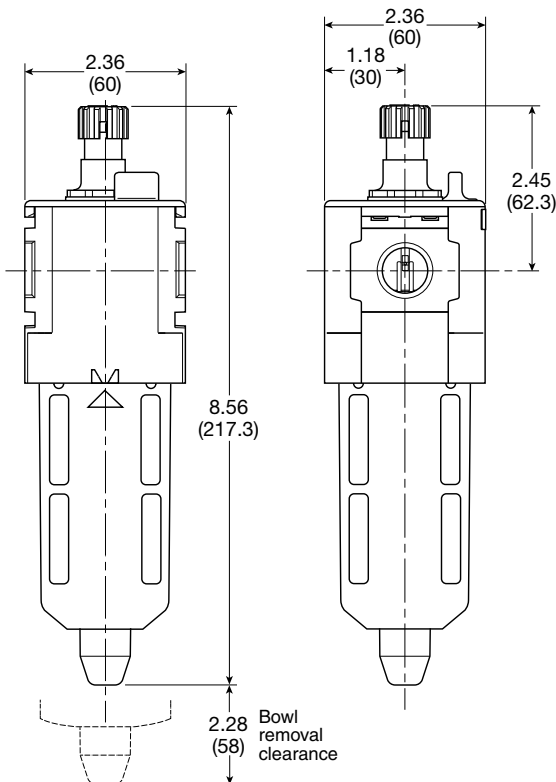

Inches (mm)

= "Most Popular"

Replacement Bowl Kits

- Metal Bowl with Sight Gauge, Manual Drain GRP-96-636
- Plastic Bowl / Bowl Guard, Manual Drain..... LRP-96-701

Replacement Kits

- Bowl O-ring –
 - Fluorocarbon GRP-96-754
 - Nitrile GRP-96-640
- Bypass Assembly LRP-96-678
- Fill Plug Kit LRP-96-679
- Sight Dome Assembly –
 - Nylon..... LRP-96-720
 - Polycarbonate, L18-XX-**KK00** LRP-96-725
- Siphon Tube Assembly..... LRP-96-677

Accessories

- Force Fill Adapter LRP-96-704
- Manual Drain..... GRP-96-685
- Sight Gauge Kit GRP-96-825
- Wall Mounting Bracket –
 - L-Type GPA-96-604
 - T-Type GPA-96-602

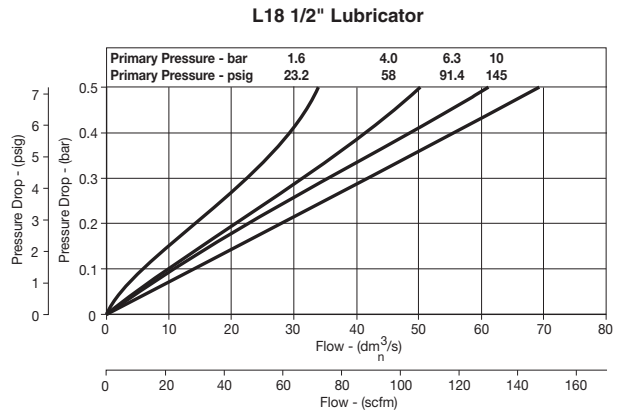
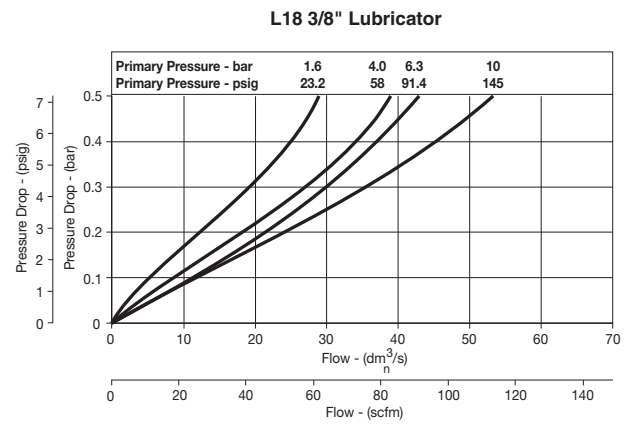
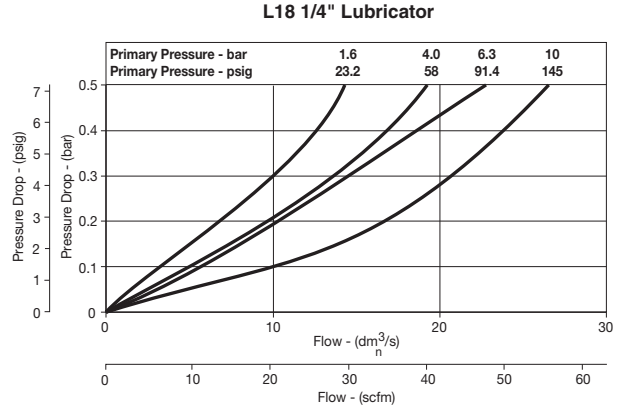

Ordering Information

Model Type	Port Size	Plastic Bowl / Bowl Guard	Metal Bowl / Sight Gauge
No Drain	1/4	L18-02-KC00B	L18-02-KD00B
	3/8	L18-03-KC00B	L18-03-KD00B
	1/2	L18-04-KC00B	L18-04-KD00B
Manual Drain	1/4	L18-02-KK00B	L18-02-KL00B
	3/8	L18-03-KK00B	L18-03-KL00B
	1/2	L18-04-KK00B	L18-04-KL00B

Options - To order an option supplied with the unit model, add the appropriate coded suffix letter in the designated position of the model number.

Lubricator

L16 EconOmist™

L17 AtoMist™

= "Most Popular"

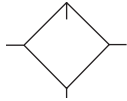

L16 / L17-02-000

Features

- L16 Model Can be Filled with Lubricant while Under Pressure (**L17 AtoMist™ Cannot be Filled Under Pressure**)
- Siphon Tube Filter Provides Clean Lubricant Downstream
- Quick-Disconnect Bowl Guard with Integral Plastic Bowl and Safety Latch
- Adjustable Oil Feed
- Optional Petcock Drain in Polycarbonate Bowl

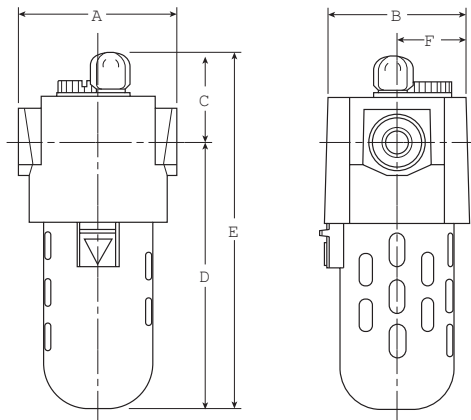

Dimensions

Models	Inches (mm)	A	B	C	D	E	F
Standard Unit L16-XX-000 & L17-XX-000		3.00 (76)	2.62 (66.5)	1.62 (41)	5.03 (128)	6.66 (169)	1.31 (33.3)
Manual Drain L16-XX-D00 & L17-XX-D00		3.00 (76)	2.62 (66.5)	1.62 (41)	5.83 (148)	6.58 (167)	1.31 (33.3)
Metal Bowl with Sight Gauge L16-XX-G00 & L17-XX-G00		3.00 (76)	2.62 (66.5)	1.62 (41)	6.21 (158)	7.80 (198)	1.31 (33.3)

Specifications

Flow Capacity*	1/4	36.1 SCFM (17.0 dm ³ /s)
	3/8	58.5 SCFM (27.6 dm ³ /s)
	1/2	64.0 SCFM (30.2 dm ³ /s)
Initial Drip Flow		.38 - 1.37 SCFM
Maximum Supply Pressure	Plastic Bowl	150 PSIG (10.3 bar)
	Metal Bowl	200 PSIG (13.8 bar)
Minimum Flow for Lubrication		1.4 SCFM @ 100 PSIG
Operating Temperature	Plastic Bowl	32° to 125°F (0° to 52°C)
	Metal Bowl	32° to 150°F (0° to 65.5°C)
Port Size	NPT / BSPP-G	1/4, 3/8, 1/2
Bowl Capacity	L16	5.0 oz
	L17	3.4 oz
Weight		1.8 lb. (0.82 kg)

* Inlet pressure 150 PSIG (10.3 bar). Pressure drop 5 PSID (0.3 bar).

Materials of Construction

Body		Zinc
Bowls	Plastic Bowl	Polycarbonate
	Metal Bowl	Zinc
Seals	Plastic Bowl	Nitrile
	Metal Bowl	Fluorocarbon
Sight Dome		Polycarbonate
Sight Gauge	Metal Bowl	Polycarbonate

Suggested Lubricant

Airline Oil F442001

Petroleum based oil of 100 to 200 SUS viscosity at 100°F and an aniline point greater than 200°F (DO NOT USE OILS WITH ADDITIVES, COMPOUNDED OILS CONTAINING SOLVENTS, GRAPHITE, DETERGENTS, OR SYNTHETIC OILS.)

= "Most Popular"

Replacement Bowl Kits

- Metal Bowl with Sight Gauge, Brass Petcock Drain GRP-95-133
- Plastic Bowl – No Drain Port LRP-96-937
- Plastic Bowl with Plastic Petcock Drain LRP-96-543

Replacement Kits

- Fill Plug Kit – Fill Plug and O-ring LRP-95-253
- Flow Guide – 1/4 NPT / BSPP-G, L16 LRP-95-241
- 3/8 and 1/2 NPT / BSPP-G, L16 LRP-95-242
- 1/4 NPT / BSPP-G, L17 LRP-95-246
- 3/8 and 1/2 NPT / BSPP-G, L17 LRP-95-247
- Sight Dome Kit – Sight Dome and O-ring LRP-95-239
- Tube, Siphon – Tube and Bronze Filter LRP-96-005

Accessories

- Air Line Oil (1 Qt. Bottle) F442001
- Low Level Switch LRP-95-093
- Manual Drain – Brass Petcock GRP-95-182
- Plastic Petcock LRP-95-181
- Tamper Resistant Kit LRP-95-587
- Wall Mounting Bracket, L-Type GPA-95-016

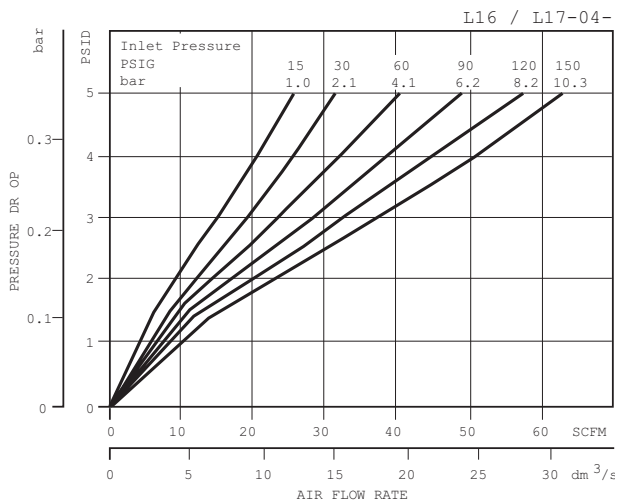
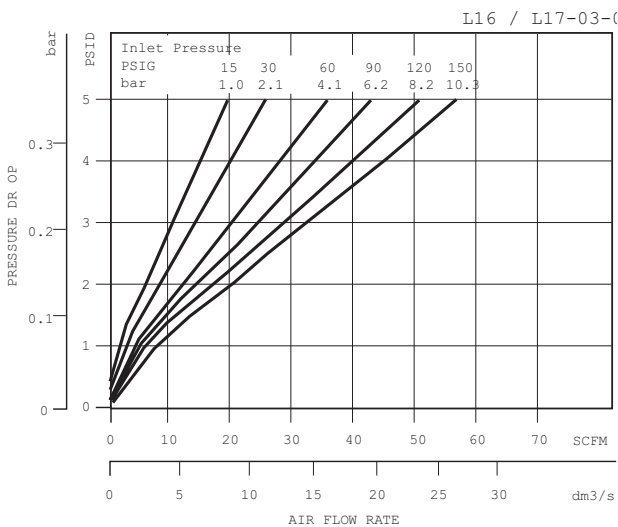
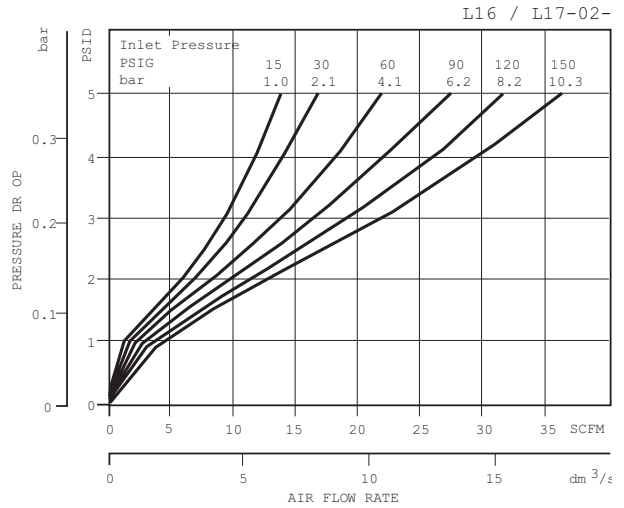

Ordering Information

Model Type	Port Size	Polycarbonate Bowl / Bowl Guard	Polycarbonate Bowl / Bowl Guard with Manual Drain	Metal Bowl / Sight Gauge
EconOmist™	1/4	L16-02-000	L16-02-D00	L16-02-G00
	3/8	L16-03-000	L16-03-D00	L16-03-G00
	1/2	L16-04-000	L16-04-D00	L16-04-G00
AtoMist™	1/4	L17-02-000	L17-02-D00	L17-02-G00
	3/8	L17-03-000	L17-03-D00	L17-03-G00
	1/2	L17-04-000	L17-04-D00	L17-04-G00

Options - To order an option supplied with the unit model, add the appropriate coded suffix letter in the designated position of the model number.

Lubricator L28 EconOmist™

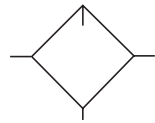

Features

- Integral Sight Dome and Adjustment Knob
- 3/4" NPT / BSPP-G Over-port
- Can be Filled while Under Pressure
- Quick-disconnect Bowl / Bowl Guard
- High Flow Capacities

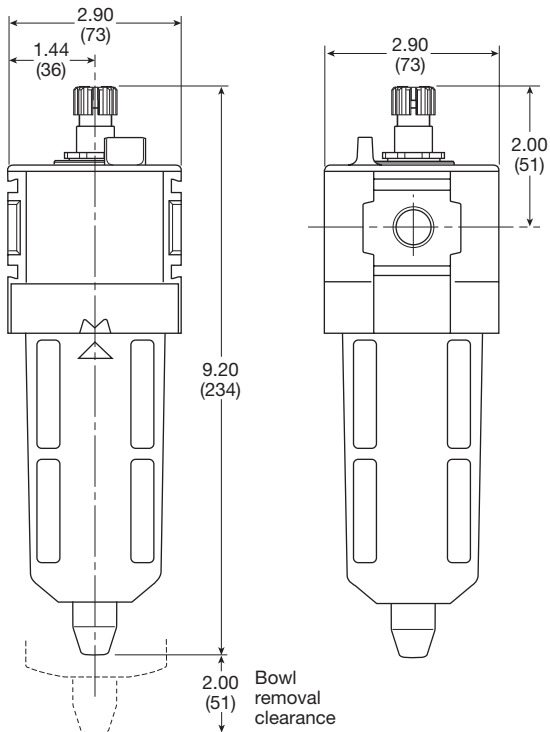

Inches (mm)

Specifications

Flow Capacity*	3/8	110 SCFM (52 dm ³ /s, ANR)
	1/2	110 SCFM (52 dm ³ /s, ANR)
	3/4	150 SCFM (71 dm ³ /s, ANR)
Initial Drip Flow	1.26 SCFM	
Maximum Supply Pressure	Plastic Bowl	150 PSIG (10.3 bar)
	Metal Bowl	250 PSIG (17.2 bar)
Minimum Flow for Lubrication	1.3 SCFM@ 100 PSIG	
Operating Temperature	Plastic Bowl	14° to 125°F (-10° to 52°C)
	Metal Bowl	14° to 150°F (-10° to 65.5°C)
Port Size	NPT / BSPP-G 3/8, 1/2, 3/4	
Bowl Capacity	6 oz	
Weight	1.04 lb. (0.47 kg)	

* Inlet pressure 91.3 PSIG (6.3 bar). Pressure drop 4.9 PSID (0.34 bar).

Materials of Construction

Body	Aluminum	
Body Cap	ABS	
Bowls	Plastic Bowl	Polycarbonate
	Metal Bowl	Aluminum
Pick-up Filter	Sintered Bronze	
Seals	Plastic Bowl	Nitrile
	Metal Bowl	Nitrile
Sight Dome	Polycarbonate	
Sight Gauge	Metal Bowl	Polyamide (Nylon)

Suggested Lubricant

Airline Oil F442001

Petroleum based oil of 100 to 200 SUS viscosity at 100°F and an aniline point greater than 200°F

(DO NOT USE OILS WITH ADDITIVES, COMPOUNDED OILS CONTAINING SOLVENTS, GRAPHITE, DETERGENTS, OR SYNTHETIC OILS.)

= "Most Popular"

Replacement Bowl Kits

- Metal Bowl with Sight Gauge, Manual Drain GRP-96-644
- Plastic Bowl / Bowl Guard, Manual Drain..... LRP-96-702

Replacement Kits

- Bowl O-ring, Nitrile GRP-96-654
- Bowl O-ring, Fluorocarbon GRP-96-755
- Bypass Assembly LRP-96-678
- Fill Plug Kit LRP-96-679
- Sight Dome Assembly –
 - Nylon..... LRP-96-720
 - Polycarbonate, L28-XX-KK00..... LRP-96-725
- Siphon Tube Assembly..... LRP-96-681

Accessories

- Force Fill Adapter LRP-96-704
- Sight Gauge Kit GRP-96-825
- Wall Mounting Bracket –
 - L-Type..... GPA-96-605
 - T-Type GPA-96-602

L28 3/8" Lubricator

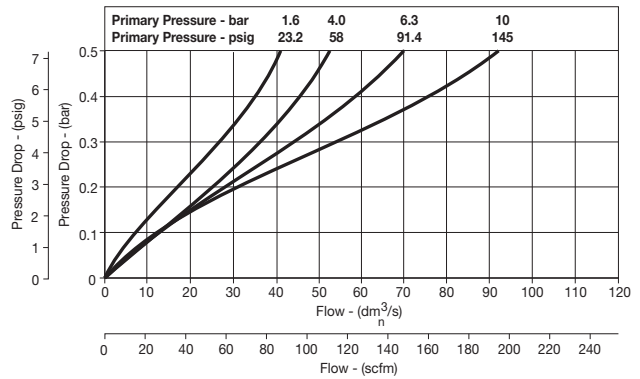

L28 1/2" Lubricator

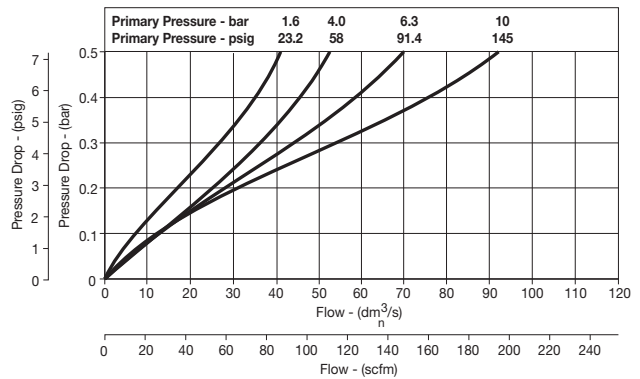

L28 3/4" Lubricator

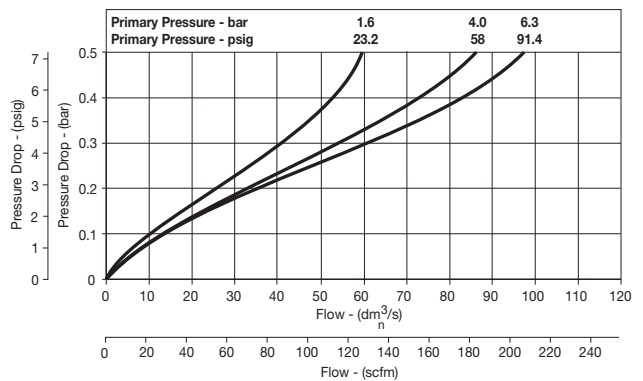

Ordering Information

Model Type	Port Size	Plastic Bowl / Bowl Guard	Metal Bowl / Sight Gauge
No Drain	3/8	L28-03-KC00B	L28-03-KD00B
	1/2	L28-04-KC00B	L28-04-KD00B
	3/4	L28-06-KC00B	L28-06-KD00B
Manual Drain	3/8	L28-03-KK00B	L28-03-KL00B
	1/2	L28-04-KK00B	L28-04-KL00B
	3/4	L28-06-KK00B	L28-06-KL00B

Options - To order an option supplied with the unit model, add the appropriate coded suffix letter in the designated position of the model number.

Lubricator

L26 EconOmist™

L27 AtoMist™

= "Most Popular"



L26 / L27-02-000

Features

- L26 Model Can be Filled with Lubricant while Under Pressure (**L27 AtoMist™ Cannot be Filled Under Pressure**)
- Siphon Tube Filter Provides Clean Lubricant Downstream
- Quick-Disconnect Bowl Guard with Integral Plastic Bowl and Safety Latch
- Adjustable Oil Feed
- Optional Petcock Drain in Polycarbonate Bowl

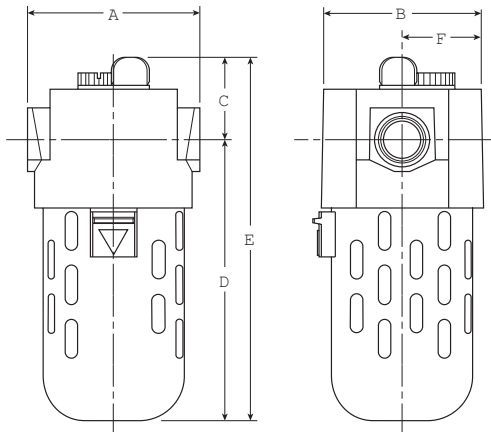

Dimensions

Models	Inches (mm)	A	B	C	D	E	F
Standard Unit L26-XX-000 & L27-XX-000		3.35 (85)	3.06 (78)	1.60 (41)	5.46 (139)	7.06 (179)	1.53 (38.9)
Manual Drain L26-XX-D00 & L27-XX-D00		3.35 (85)	3.06 (78)	1.60 (41)	6.42 (163)	7.76 (197)	1.53 (38.9)
Metal Bowl with Sight Gauge L26-XX-G00 & L27-XX-G00		3.35 (85)	3.06 (78)	1.60 (41)	6.42 (163)	7.80 (198)	1.53 (38.9)

Specifications

Flow Capacity*	1/4	35 SCFM (16.5 dm ³ /s)
	3/8	60 SCFM (28.3 dm ³ /s)
	1/2	128 SCFM (60.4 dm ³ /s)
Maximum Supply Pressure	Plastic Bowl	150 PSIG (10.3 bar)
	Metal Bowl	200 PSIG (13.8 bar)
Operating Temperature	Plastic Bowl	32° to 125°F (0° to 52°C)
	Metal Bowl	32° to 150°F (0° to 65.5°C)
Port Size	NPT / BSPP-G	1/4, 3/8, 1/2
Bowl Capacity	L26	10.0 oz
	L27	6.6 oz
Weight	2.4 lb. (1.07 kg)	

* Inlet pressure 150 PSIG (10.3 bar). Pressure drop 5 PSID (0.3 bar).

Materials of Construction

Body	Zinc	
Bowls	Plastic Bowl	Polycarbonate
	Metal Bowl	Zinc
Seals	Plastic Bowl	Nitrile
	Metal Bowl	Fluorocarbon
Sight Gauge	Metal Bowl	Nylon
Sight Dome	Nylon	

Suggested Lubricant

Airline Oil F442001

Petroleum based oil of 100 to 200 SUS viscosity at 100°F and an aniline point greater than 200°F

(DO NOT USE OILS WITH ADDITIVES, COMPOUNDED OILS CONTAINING SOLVENTS, GRAPHITE, DETERGENTS, OR SYNTHETIC OILS.)

= "Most Popular"

Replacement Bowl Kits

Metal Bowl / Sight Gauge, Brass Petcock Drain .. GRP-95-931

Plastic Bowl –

No Drain PortLRP-96-938

Plastic Petcock DrainLRP-95-958

Plastic Bowl / Guard, Brass Petcock DrainLRP-95-967

Replacement Kits

Fill Plug Kit – Fill Plug and O-ringLRP-95-253

Flow Guide –

1/4 NPT / BSPP-G, L26 LRP-95-241

3/8 NPT / BSPP-G, L26 LRP-95-242

1/2 NPT / BSPP-G, L26..... LRP-95-243

1/4 NPT / BSPP-G, L27..... LRP-95-246

3/8 NPT / BSPP-G, L27 LRP-95-247

1/2 NPT / BSPP-G, L27..... LRP-95-248

Sight Dome Kit – Sight Dome and O-ringLRP-95-239

Tube, Siphon – Tube and Bronze Filter LRP-96-137

Accessories

Air Line Oil (1 Qt. Bottle).....F442001

Auto-Fill™ Adapter Kit.....LRP-95-965

Low Level SwitchLRP-95-093

Manual Drain –

Brass Petcock..... GRP-95-182

Plastic Petcock LRP-95-181

Tamper Resistant Kit.....LRP-95-587

Wall Mounting Bracket, L-Type..... GPA-95-946

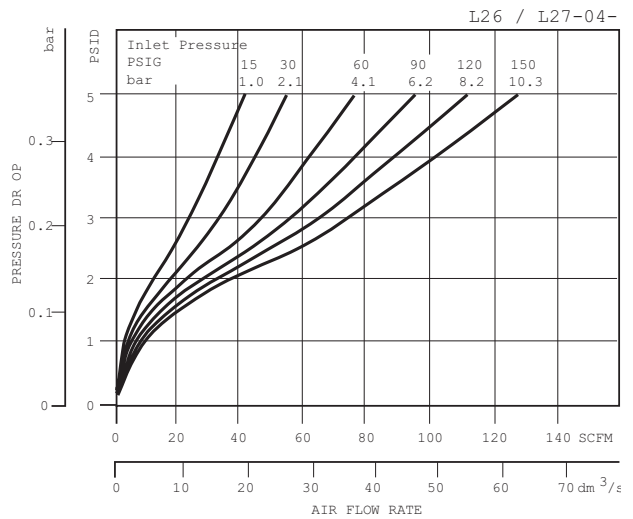
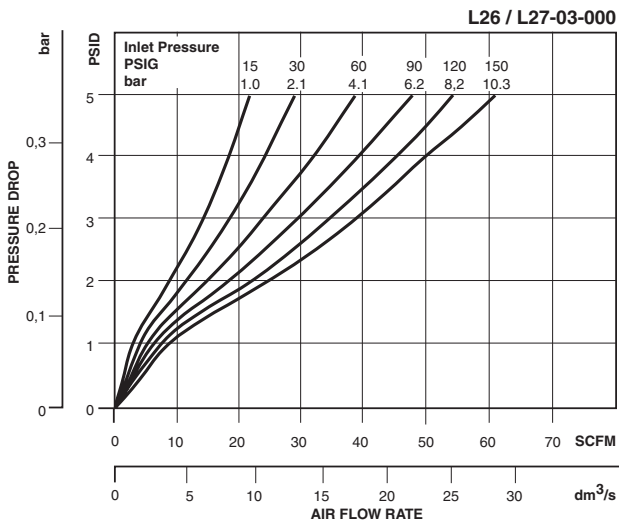
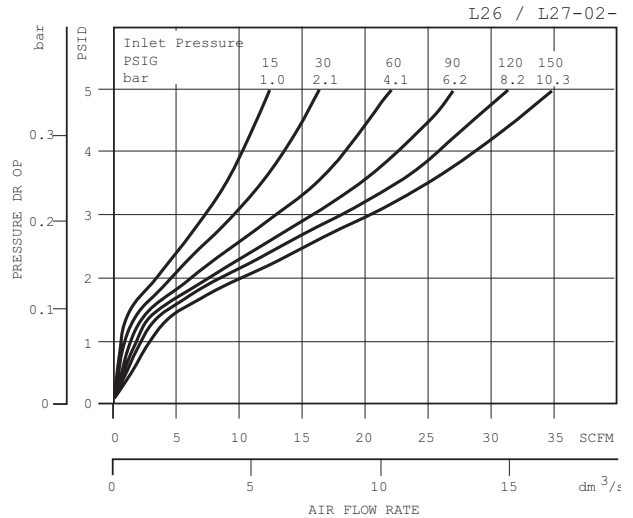

Ordering Information

Model Type	Port Size	Polycarbonate Bowl / Bowl Guard	Polycarbonate Bowl / Bowl Guard with Manual Drain	Metal Bowl / Sight Gauge
EconOmist™	1/4	L26-02-000	L26-02-D00	L26-02-G00
	3/8	L26-03-000	L26-03-D00	L26-03-G00
	1/2	L26-04-000	L26-04-D00	L26-04-G00
AtoMist™	1/4	L27-02-000	L27-02-D00	L27-02-G00
	3/8	L27-03-000	L27-03-D00	L27-03-G00
	1/2	L27-04-000	L27-04-D00	L27-04-G00

Options - To order an option supplied with the unit model, add the appropriate coded suffix letter in the designated position of the model number.

Lubricator L90

 = "Most Popular"



Symbol

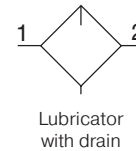

Features

- Integral 3/4" or 1" ports (BSPP & NPT)
- Robust but lightweight aluminum construction
- Proportional oil delivery over a wide range of air flows
- Possible to fill under system pressure eliminating down time
- Large oil reservoir

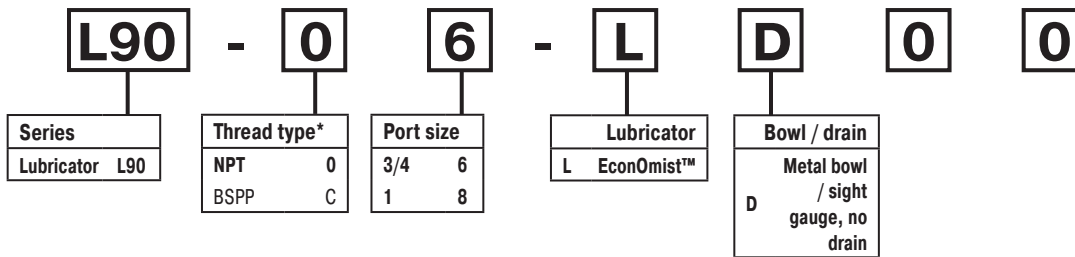

*Note: For 1-1/2" ported unit, please order P3YKA*BCP port block kit separately.
Bold items are most common.

Ordering information

Port size	Description	Flow † scfm	Max. bar (psig)	Min temp °C (°F)	Max temp °C (°F)	Bowl capacity cm³ (oz)	Height mm (inches)	Width mm (inches)	Depth mm (inches)	Weight kg (lb)	Part number †
3/4"	Oil mist, fill under pressure	315	17.5 (254)	-10 (14)	60 (140)	500 (16.9)	247 (9.7)	90 (3.5)	94 (3.7)	0.8 (1.8)	L90-06-LD00
1"	Oil mist, fill under pressure	390	17.5 (254)	-10 (14)	60 (140)	500 (16.9)	247 (9.7)	90 (3.5)	94 (3.7)	0.8 (1.8)	L90-08-LD00

† Standard part numbers shown in bold. For other models refer to Options chart above.

‡ Flow with 6.3 bar (91.4 psig) inlet pressure and 0.5 (7.3 psig) pressure drop.

Specifications

Fluid	Compressed air
Maximum inlet pressure*	17.5 bar (254 psig)
Temperature range*	-10°C to 60°C (14°F to 140°F)

* Air supply must be dry enough to avoid ice formation at temperatures below 2°C (35.6°F).

Low flow start point (lubrication pick-up): at 6.3 bar (91.4 psig) inlet pressure 0.5 dm³/s (1.1 scfm).

Flow with 6.3 bar (91.4 psig) inlet pressure and 0.5 bar (7.3 psig) pressure drop.

Dimensions mm (inches)

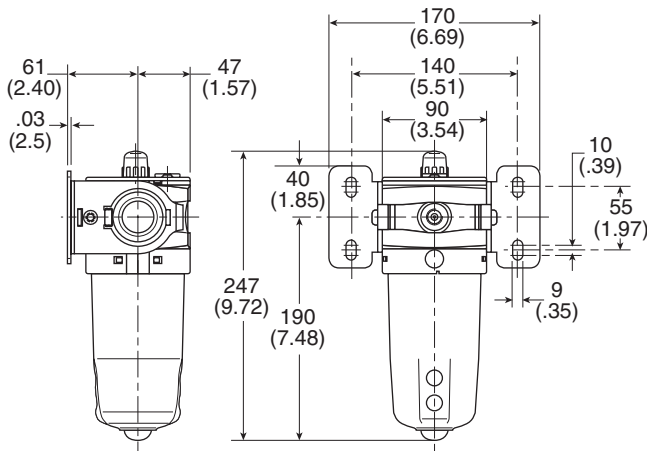

Service kits

Bowl kit.....	P3YKA00BSN
Refill plug.....	P3YKA00PL
Lubricator oil.....	F442002

Material specifications

Body	Aluminum
Sight glass	Polypropylene
Sight dome	Polyamide
Lubricator cover	ABS
Top & bottom end cap	Glass filled nylon
Bayonet support	Nylon
Seals	Nitrile NBR

Suggested Lubricant

Airline Oil F442001

Petroleum based oil of 100 to 200 SUS viscosity at 100°F and an aniline point greater than 200°F

(DO NOT USE OILS WITH ADDITIVES, COMPOUNDED OILS CONTAINING SOLVENTS, GRAPHITE, DETERGENTS, OR SYNTHETIC OILS.)

Flow characteristics

(3/4") Lubricator

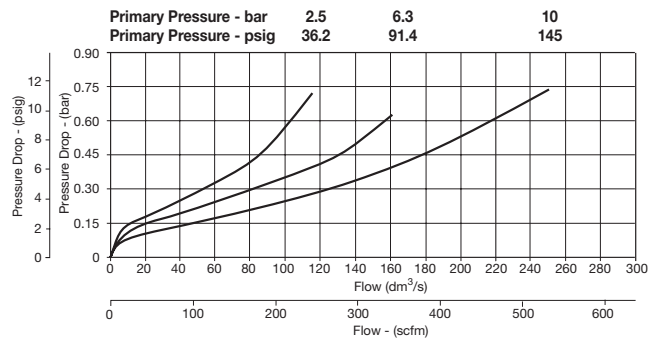

(1") Lubricator

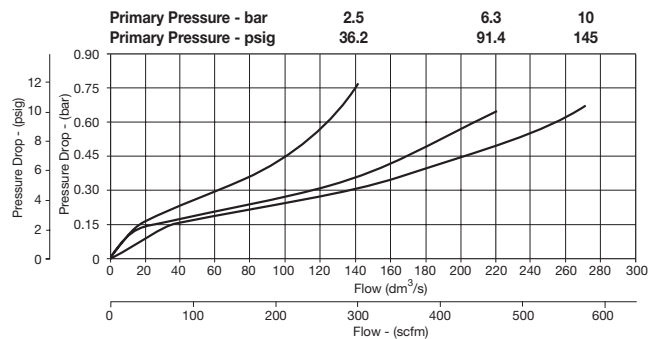

Lubricator L30 EconOmist™

= "Most Popular"

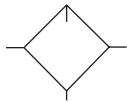

L30-06-000

Features

- Full View Sight Dome
- Siphon Tube Filter Provides Clean Lubricant Downstream
- Quick-Disconnect Clamp Ring for Easy Bowl Removal
- Adjustable Oil Feed
- Standard Transparent Bowl with Metal Bowl Guard
- Optional Petcock in Polycarbonate Bowl
- Can be Filled while Under Pressure

Specifications

Flow Capacity*	3/4 1	196 SCFM (92.4 dm ³ /s) 374 SCFM (176.4 dm ³ /s)
Maximum Supply Pressure	Plastic Bowl Metal Bowl	150 PSIG (10.3 bar) 200 PSIG (13.8 bar)
Operating Temperature	Plastic Bowl Metal Bowl	32° to 125°F (0° to 52°C) 32° to 150°F (0° to 65.5°C)
Port Size	NPT / BSPP-G 3/4, 1	
Bowl Capacity	26.0 oz	
Weight	5.6 lb. (2.54 kg)	

* Inlet pressure 120 PSIG (8.3 bar). Pressure drop 5 PSID (0.3 bar).

Materials of Construction

Body	Zinc	
Bowls	Plastic Bowl Metal Bowl	Polycarbonate Aluminum
Seals	Plastic Bowl Metal Bowl	Nitrile Fluorocarbon
Sight Dome	Nylon	
Sight Gauge	Metal Bowl	Tempered Safety Glass

Suggested Lubricant

Airline Oil F442001

Petroleum based oil of 100 to 200 SUS viscosity at 100°F and an aniline point greater than 200°F

(DO NOT USE OILS WITH ADDITIVES, COMPOUNDED OILS CONTAINING SOLVENTS, GRAPHITE, DETERGENTS, OR SYNTHETIC OILS.)

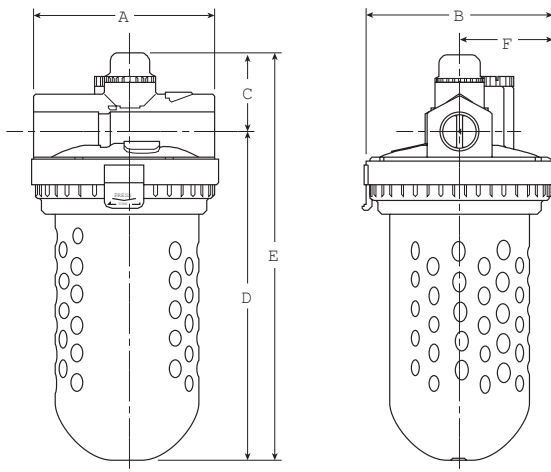

Dimensions

Models	Inches (mm)	A	B	C	D	E	F
Standard Unit L30-XX-000		4.63 (117)	4.79 (122)	1.98 (50)	8.36 (212)	10.38 (264)	2.40 (61)
Manual Drain L30-XX-D00		4.63 (117)	4.79 (122)	1.98 (50)	8.90 (226)	10.90 (277)	2.40 (61)
Metal Bowl with Sight Gauge L30-XX-G00		4.63 (117)	4.79 (122)	1.98 (50)	8.90 (226)	10.95 (278)	2.40 (61)

= "Most Popular"

Replacement Bowl Kits

- Metal Bowl / Sight Gauge, Brass Petcock Drain .. GRP-95-676
- Plastic Bowl –
 - Guard, Plastic Petcock DrainLRP-95-830
 - No Drain Port LRP-96-940
 - Plastic Petcock Drain LRP-96-160

Replacement Kits

- Fill Plug Kit – Fill Plug and O-ringLRP-95-253
- Flow Guide –
 - 3/4 NPT / BSPP-G LRP-95-189
 - 1 NPT / BSPP-G LRP-95-190
- Sight Dome Kit – Sight Dome and O-ringLRP-95-249
- Tube, Siphon – Tube and Bronze Filter LRP-96-182

Accessories

- Air Line Oil (1 Qt.).....F442001
- Air Line Oil (1 Gal.)F442002
- Auto-Fill™ Adapter Kit.....LRP-95-698
- Force Fill Adapter GRP-96-394
- Manual Drain –
 - Brass Petcock..... GRP-95-182
 - Plastic Petcock LRP-95-181
- Sight Gauge Kit LRP-95-771
- Tamper Resistant Kit.....LRP-95-587
- Wall Mounting Bracket, U-Bolt Pipe Clamp..... GRP-95-734

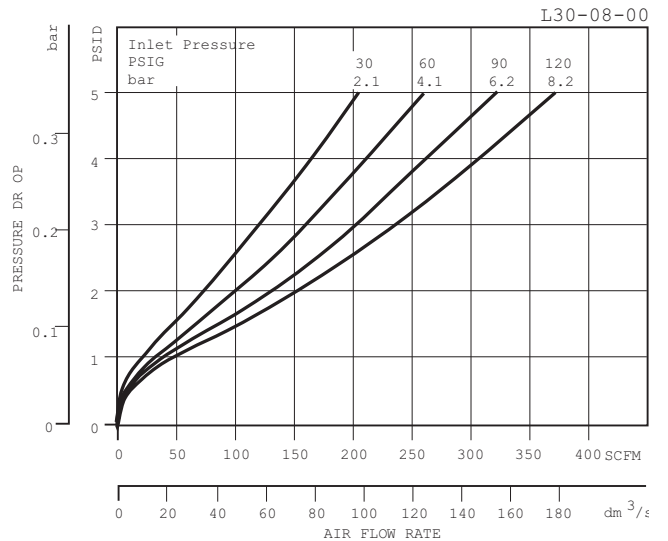
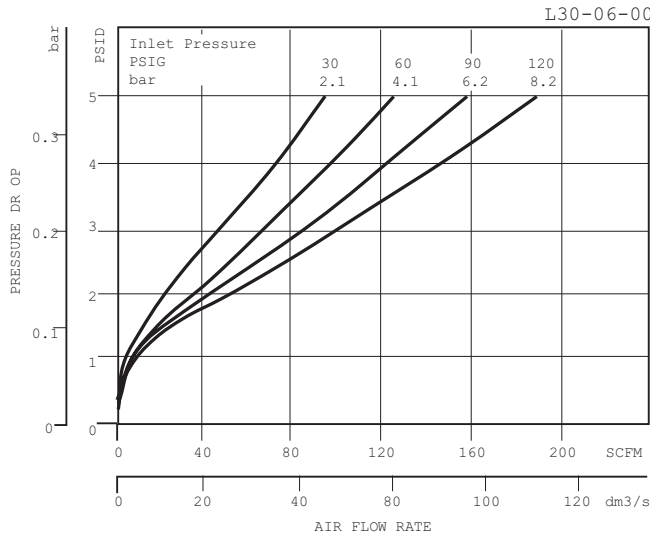

Ordering Information

Model Type	Port Size	Polycarbonate Bowl / Bowl Guard	Polycarbonate Bowl / Bowl Guard with Manual Drain	Metal Bowl / Sight Gauge
EconOmist™	3/4	L30-06-000	L30-06-D00	L30-06-G00
	1	L30-08-000	L30-08-D00	L30-08-G00

Options - To order an option supplied with the unit model, add the appropriate coded suffix letter in the designated position of the model number.

Lubricator L40 EconOmist™

 = "Most Popular"

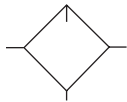

L40-0B-000

Features

- Full View Sight Dome
- Siphon Tube Filter Provides Clean Lubricant Downstream
- Quick-Disconnect Clamp Ring for Easy Bowl Removal
- Adjustable Oil Feed
- Standard Transparent Bowl with Metal Bowl Guard
- Can be Filled while Under Pressure

Specifications

Flow Capacity*	1-1/2	927 SCFM (437 dm ³ /s)
Initial Drip Flow		.95 SCFM
Maximum Supply Pressure		150 PSIG (10.3 bar)
Minimum Flow for Lubrication		1 SCFM @ 100 PSIG
Operating Temperature		32° to 125°F (0° to 52°C)
Port Size	NPT / BSPP-G	1-1/4, 1-1/2
Bowl Capacity		26.0 oz
Weight		9.4 lb. (4.3 kg)

* Inlet pressure 120 PSIG (8.3 bar). Pressure drop 5 PSID (0.3 bar).

Materials of Construction

Body	Zinc
Bowl	Polycarbonate
Seals	Nitrile
Sight Dome	Nylon

Suggested Lubricant

Airline Oil F442001

Petroleum based oil of 100 to 200 SUS viscosity at 100°F and an aniline point greater than 200°F

(DO NOT USE OILS WITH ADDITIVES, COMPOUNDED OILS CONTAINING SOLVENTS, GRAPHITE, DETERGENTS, OR SYNTHETIC OILS.)

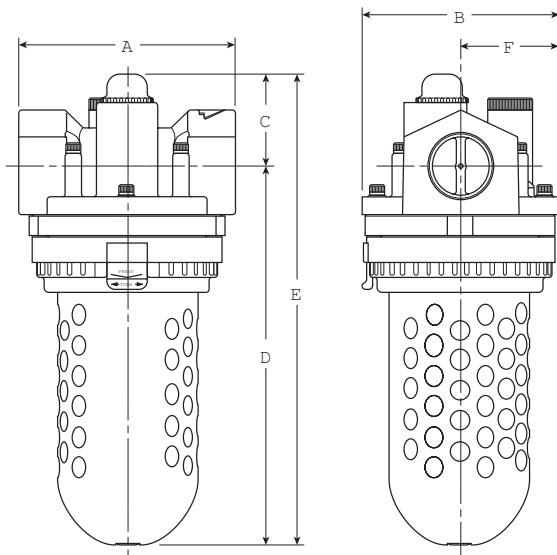

Dimensions

Models	Inches (mm)	A	B	C	D	E	F
Standard Unit L40-XX-000		5.50 (140)	4.79 (122)	2.27 (58)	9.40 (239)	11.67 (296)	2.40 (61)

= "Most Popular"

Replacement Bowl Kits

- Metal Bowl –**
 Brass Petcock Drain FRP-95-593
 Sight Gauge, Brass Petcock Drain..... GRP-95-676
- Plastic Bowl –**
 Plastic Petcock Drain LRP-96-160
 Guard, Plastic Petcock Drain LRP-95-830
 No Drain Port LRP-96-940

Replacement Kits

- Fill Plug Kit – Fill Plug and O-ring LRP-95-250
 Sight Dome Kit – Sight Dome and O-ring LRP-95-249
 Tube, Siphon – Tube and Bronze Filter LRP-96-182

Accessories

- Air Line Oil (1 Qt.)..... F442001
 Air Line Oil (1 Gal.) F442002
 Brass Petcock..... GRP-95-182
 Plastic Petcock LRP-95-181
 Tamper Resistant Kit..... LRP-95-587

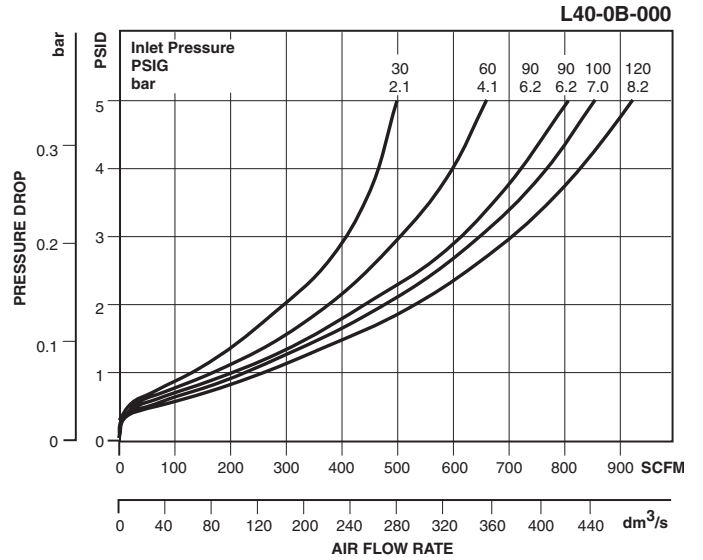

Ordering Information

Model Type	Port Size	Metal Bowl / Sight Gauge / Manual Drain	Polycarbonate Bowl / Bowl Guard	Polycarbonate Bowl / Bowl Guard / Manual Drain
EconOmist™	1-1/2	L40-0B-G00	L40-0B-000	L40-0B-D00

Options - To order an option supplied with the unit model, add the appropriate coded suffix letter in the designated position of the model number.

Notes

Filter / Regulator Numbering System

 = "Most Popular"

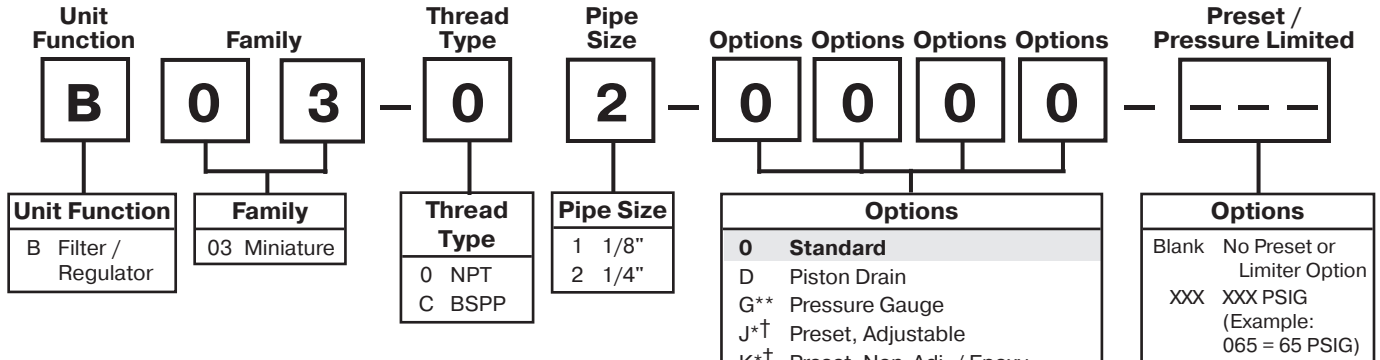

Note: When selecting from the options columns, please enter letters in alphabetical order for positions 6, 7, 8 and 9.
For example: **B 0 3 - 0 1 - D M 0 0**

NOTE: 0000 in position 6, 7, 8 and 9 signifies standard product.
(Poly Bowl, Manual Drain, 2 to 125 PSIG, Relieving)

Spring Type by Preset / Limited Pressure:
For Preset / Limited Pressure 10 to 25 use 30 PSI Spring
For Preset / Limited Pressure 26 to 50 use 60 PSI Spring
For Preset / Limited Pressure 51 to 90 use 125 PSI Spring

* Inlet pressure is 100 PSIG.
For other pressures, consult factory.
** Not available with BSPP thread type.
† Must specify preset or limited pressure.

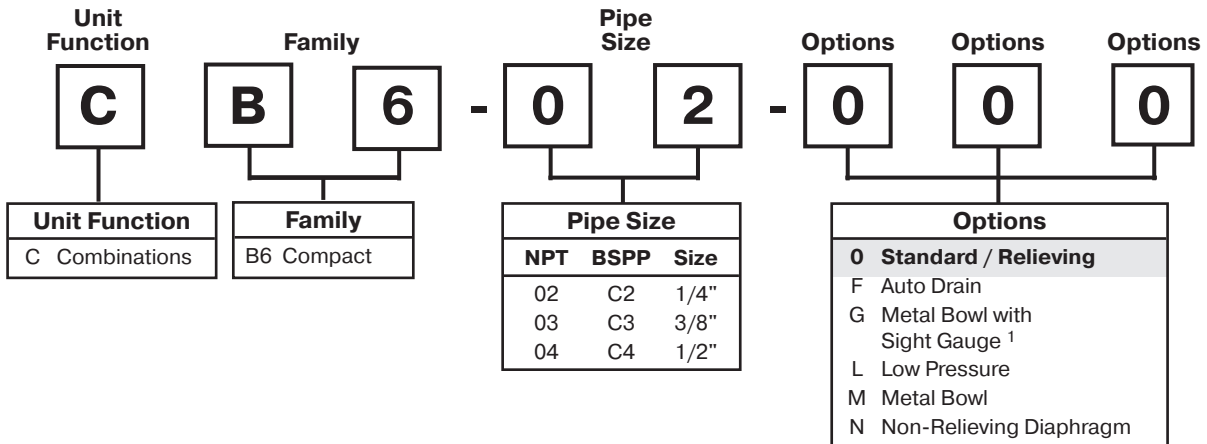

¹ For miniature family units, G option is a pressure gauge.
For compact, G option is a metal bowl with sight gauge.

"F" Series Filters, Type "A" 5 micron elements:
All Wilkerson Type "A" 5 micron elements **meet or exceed ISO Class 3** for maximum particle size and concentration of solid contaminants.

NOTE:All classes above refer to International Standards Organization (ISO) standard 8573-1, pertaining to maximum particle size and concentration of solid contaminants, and maximum oil content.

Note: When selecting from the options columns, please enter letters in alphabetical order for positions 6, 7, and 8.
For example:

CB6-02-0 0 0

Note: 000 in positions 6, 7 and 8 signifies standard product.

Filter / Regulator Numbering System

 = "Most Popular"

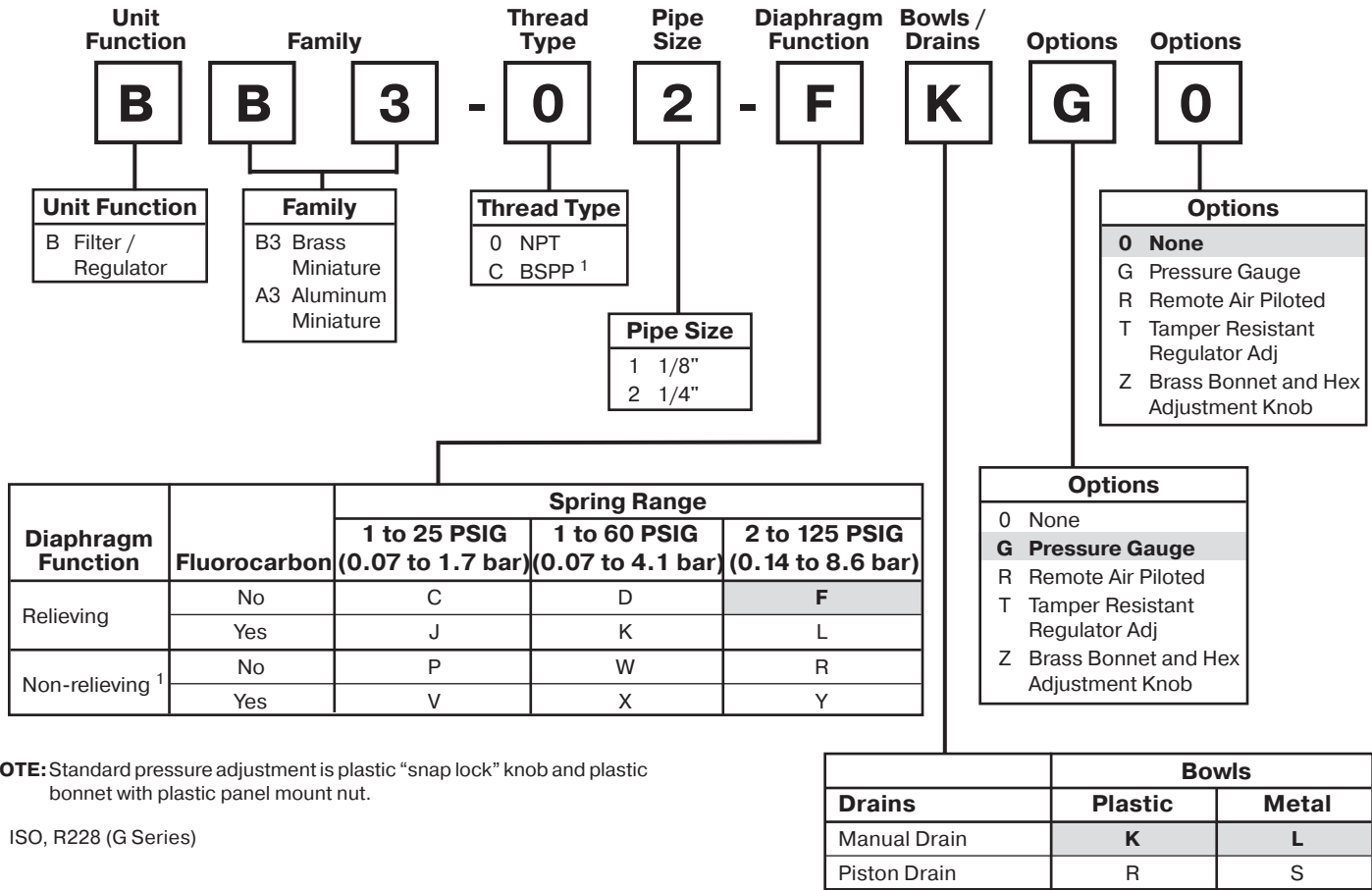

NOTE: Standard pressure adjustment is plastic "snap lock" knob and plastic bonnet with plastic panel mount nut.

¹ ISO, R228 (G Series)

Type "A" 5 micron elements: All Wilkerson Type "A" 5 micron elements **meet or exceed ISO Class 3** for maximum particle size and concentration of solid contaminants.

NOTE: All classes above refer to International Standards Organization (ISO) standard 8573-1, pertaining to maximum particle size and concentration of solid contaminants, and maximum oil content.

Note: When selecting from the options columns, please enter letters in alphabetical order for positions 8 and 9. For example:

BB3-02-F K G T

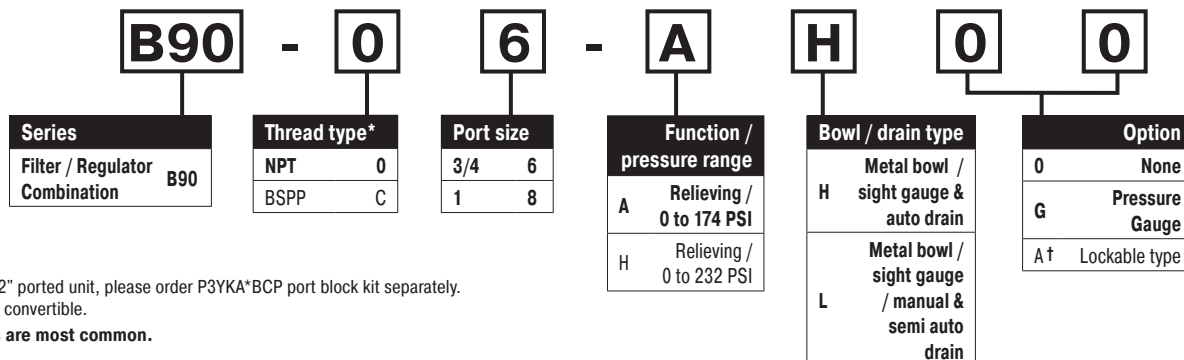

Notes:

* For 1-1/2" ported unit, please order P3YKA*BCP port block kit separately.

† Not field convertible.

Bold items are most common.

Filter / Regulator Numbering System

 = "Most Popular"

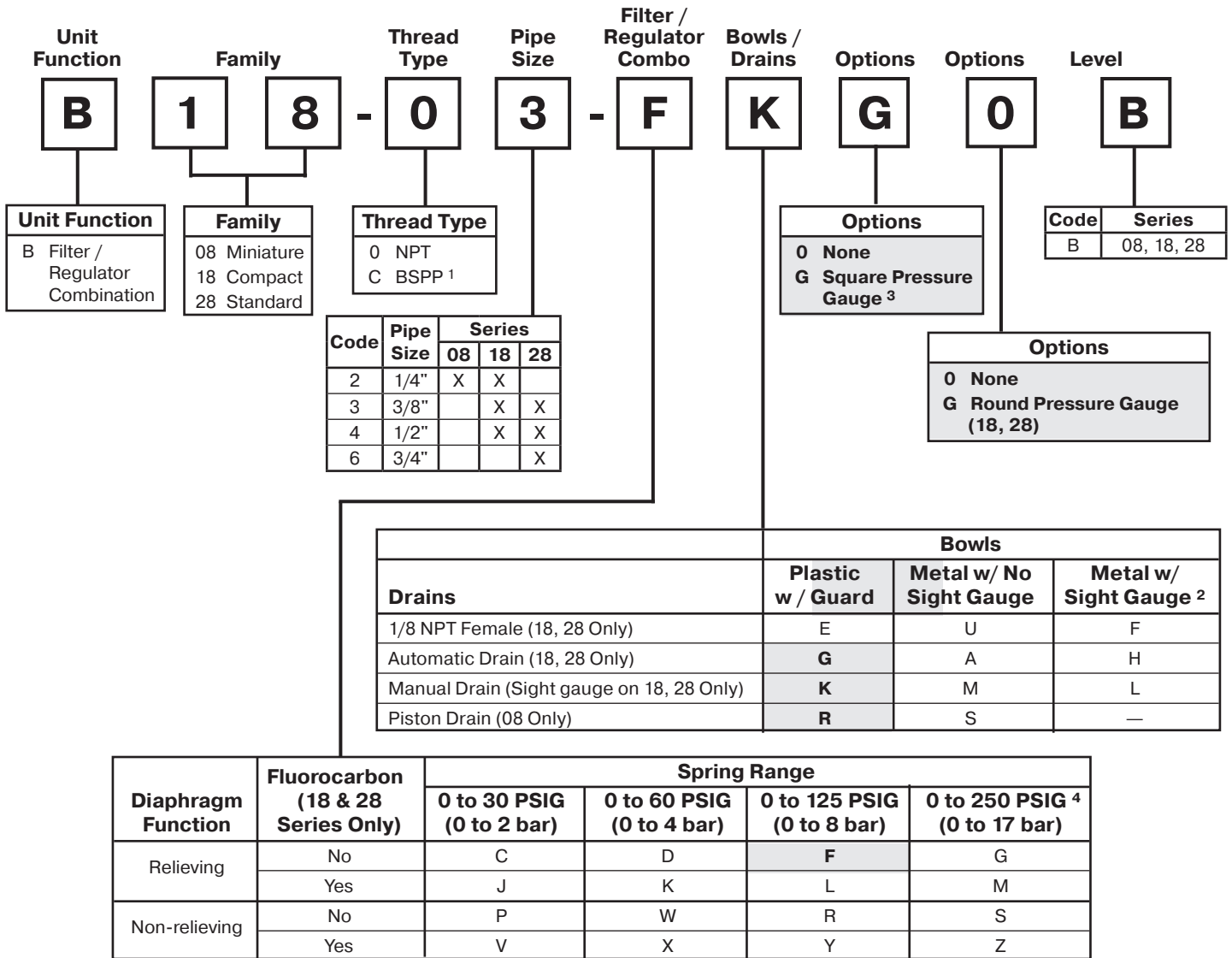

¹ ISO, R228 (G Series)
² B08 Filter / Regulator has an all metal bowl (no sight gauge)
³ Square gauge included with B08
⁴ B08 series operating range 0 to 232 PSIG (1 to 16 bar)

NOTE: When selecting from the options columns, please enter letters in alphabetical order, for positions 7, 8, 9. For example:

B 18-03-F K 0 0 B

"F" Series Filters, Type "A" 5 micron elements: All Wilkerson Type "A" 5 micron elements **meet or exceed ISO Class 3** for maximum particle size and concentration of solid contaminants.

NOTE: All classes above refer to International Standards Organization (ISO) standard 8573-1, pertaining to maximum particle size and concentration of solid contaminants, and maximum oil content.

Filter / Regulator B03

= "Most Popular"

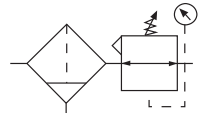

B03-02-0000

Features

- Excellent Water Removal Efficiency
- Unbalanced Poppet Standard
- Solid Control Piston for Extended Life
- Space Saving Package offers both Filter and Regulator features in One Integral Unit
- Non-rising Adjustment Knob
- Two Full Flow 1/8" Gauge Ports

NOTE: 1.218 Dia. (31mm) hole required for panel mounting.

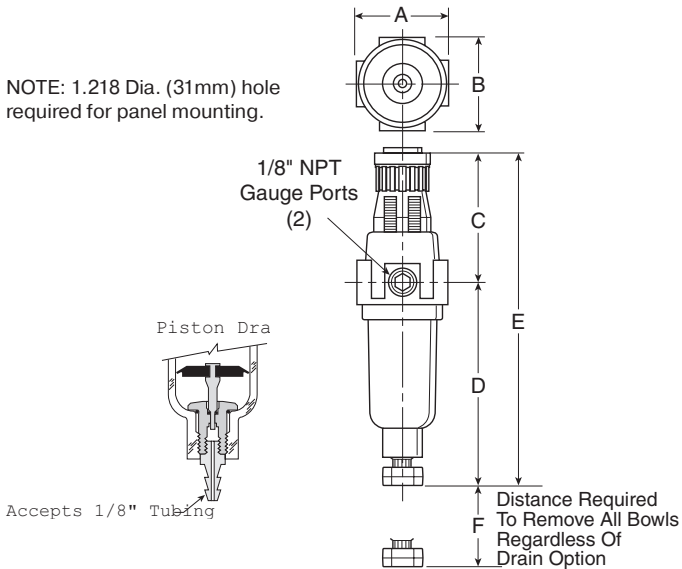

Specifications

Flow Capacity*	1/8	16 SCFM (7.5 dm ³ /s)
	1/4	18 SCFM (8.5 dm ³ /s)
Gauge Ports (2)	1/8 Inch	
Port Threads	1/8, 1/4 Inch	
Pressure & Temperature Ratings –		
Plastic Bowl	0 to 150 PSIG (0 to 10.3 bar) 32°F to 125°F (0°C to 52°C)	
Metal Bowl	0 to 250 PSIG (0 to 17.2 bar) 32°F to 175°F (0°C to 80°C)	
Secondary Pressure Ranges –		
Standard Pressure	2 to 125 PSIG (0 to 8.6 bar)	
Medium Pressure	1 to 60 PSIG (0 to 4.1 bar)	
Medium Pressure	1 to 30 PSIG (0 to 2.1 bar)	
Low Pressure	1 to 15 PSIG (0 to 1.0 bar)	
Weight	.4 lb. (.18 kg)	

* Inlet pressure 100 PSIG (6.9 bar). Secondary pressure 90 PSIG (6.2 bar) and 10 PSIG pressure drop.

Materials of Construction

Adjusting Nut	Brass
Adjusting Stem & Spring	Steel
Body	Zinc
Bonnet, Knob, Seat, Piston, Holder & Deflector	Plastic
Bowls – Transparent	Polycarbonate
Metal (Without Sight Gauge)	Zinc
Filter Elements – 5 Micron (Standard)	Plastic
Manual Drain –	
Body & Stem	Plastic
Seals	Nitrile
Piston Drain –	
Piston & Seals	Nitrile
Stem, Seat, Adaptor & Washers	Aluminum
Seals	Nitrile

Dimensions

Model	Inches (mm)	A	B	C	D	D†	E	E†	F
Standard Unit B03-XX-XXXX		1.62 (41)	1.58 (40)	2.42 (61)	3.79 (96)	3.64 (92)	6.21 (158)	6.06 (154)	1.60 (41)

† With Piston Drain

= "Most Popular"

Replacement Kits

- Filter Element Kit, 5 MicronPS403
- Metal Bowl –
 - Piston Drain PS451B
 - Manual Drain PS447B
- Poly Bowl –
 - Piston DrainPS408B
 - Manual Drain PS404
- Poppet / Piston Kits –
 - Unbalanced, Non-Relieving PS428P
 - Unbalanced, Relieving PS426P

Accessories

- Gauge, Pressure –
 - 30 PSIG (0 to 2.1 bar)..... K4515N18030
 - 60 PSIG (0 to 4.1 bar)..... K4515N18060
 - 160 PSIG (0 to 11.0 bar) K4515N18160
- Mounting Bracket Kit* (Includes Panel Mount Nut) PS417B
- Panel Mount Nut* –
 - Plastic P78652
 - Metal P01531
- Springs –
 - 1 to 15 PSIG Range P01176
 - 1 to 30 PSIG Range P01175
 - 1 to 60 PSIG Range P01174
 - 2 to 125 PSIG Range..... P01173

*Tighten panel mount nut 2.8 to 3.4 Nm (25 to 30 in-lbs) of torque.

WARNING

Product rupture can cause serious injury.
Do not connect regulator to bottled gas.
Do not exceed maximum primary pressure rating.

CAUTION:

REGULATOR PRESSURE ADJUSTMENT – The working range of knob adjustment is designed to permit outlet pressures within their full range. Pressure adjustment beyond this range is also possible because the knob is not a limiting device. This is a common characteristic of most industrial regulators, and limiting devices may be obtained only by special design.

For best performance, regulated pressure should always be set by increasing the pressure up to the desired setting.

Ordering Information

Model Type	Port Size	Plastic Bowl	Metal Bowl
Manual Drain	1/8	B03-01-0000	B03-01-M000
	1/4	B03-02-0000	B03-02-M000

Options - To order an option supplied with the unit model, add the appropriate coded suffix letter in the designated position of the model number.

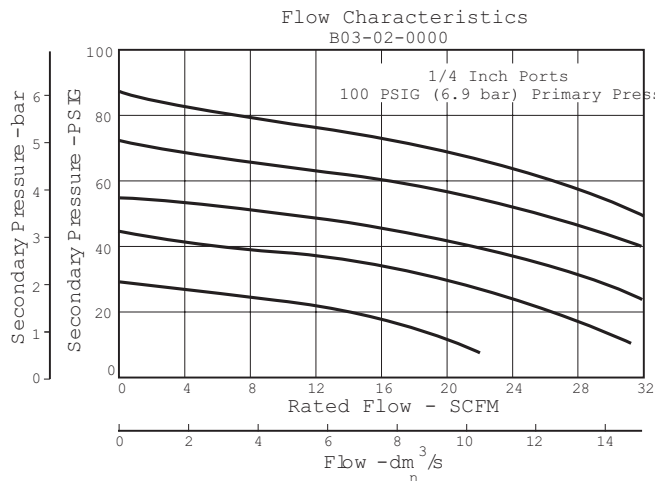
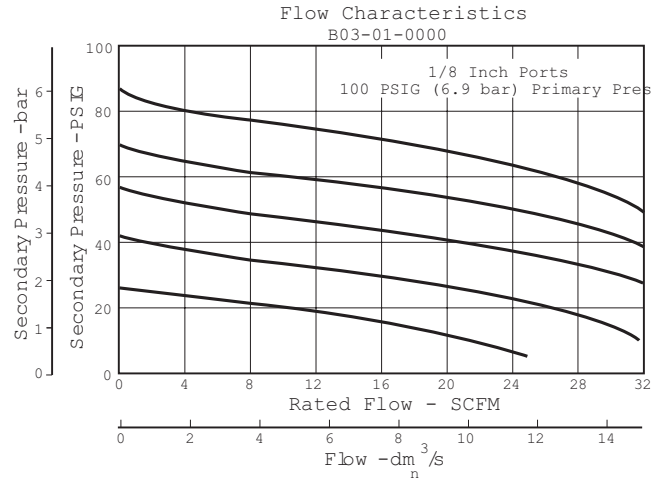

Miniature Filter / Regulator

BB3 – Brass

BA3 – Aluminum

= "Most Popular"

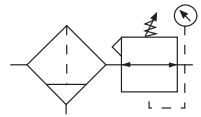

BB3-02-FK00

Features

- Brass Construction Handles Most Corrosive Environments
- Large Diaphragm to Valve Area Ratio for Precise Regulation and High Flow Capacity
- Plastic Bowl or Black Painted Zinc Metal Bowl
- High Flow: 1/4" -16 SCFM
- Fluorocarbon Seals Optional

Specifications

Flow Capacity*	1/4	16 SCFM (7.6 dm ³ /s)
Maximum Supply Pressure		
Polycarbonate Bowl		150 PSIG (10.37 bar)
Metal Bowl		300 PSIG (20.7 bar)
Operating Temperature		40°F to 125°F (4.4°C to 52°C)
Port Size	NPT / BSPP-G	1/8, 1/4
Standard Filtration		5 Micron
Weight		0.8 lb. (0.36 kg)

* Inlet pressure 100 PSIG (6.9 bar). Secondary pressure 75 PSIG (5.2 bar).

Materials of Construction

Body	Brass	
Bowls	Polycarbonate or Zinc - Painted Black	
Manual Drain	Brass	
Diaphragm and Seals	Nitrile	
Element Holder / Deflector / Bonnet	Acetal	
Filter Elements	Type A	Polyethylene
Knob	Acetal	
Springs	Plated Steel	
Valve Assembly and Bottom Plug	Brass	

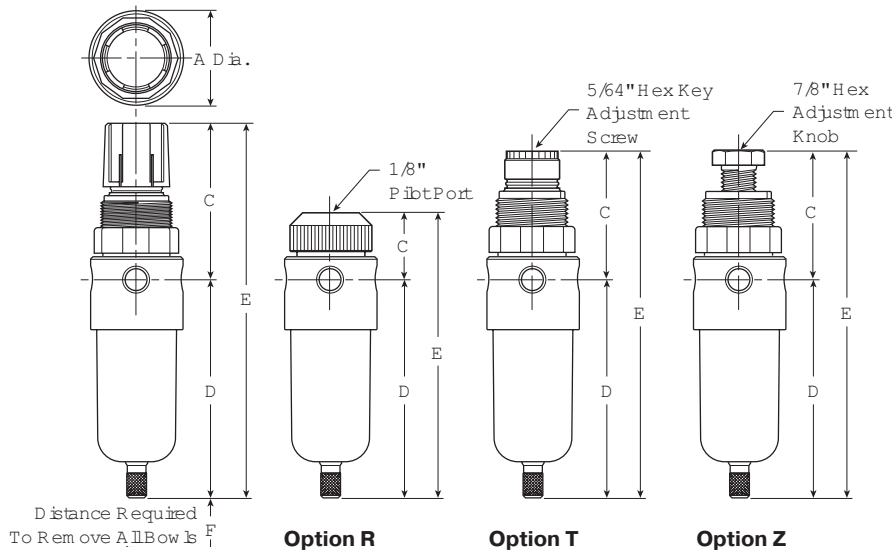

NOTES: Panel Nut included, but not shown on dimensional drawing. 1.19" dia. (30,2) mm hole required for panel mounting.

Dimensions

Model	Inches (mm)	A	C	C			D	E	E			F
				Option R	Option T	Option Z			Option R	Option T	Option Z	
Standard Unit - Brass Body BB3-02-XXXX		1.56 (40)	2.63 (67)	1.09 (27.7)	2.04 (51.8)	2.08 (52.8)	3.63 (92)	6.25 (159)	4.72 (119.9)	5.67 (144.0)	5.71 (145.0)	1.58 (40)
Standard Unit - Aluminum Body BA3-02-XXXX		1.56 (40)	2.63 (67)	1.09 (27.7)	2.04 (51.8)	2.08 (52.8)	3.63 (92)	6.25 (159)	4.72 (119.9)	5.67 (144.0)	5.71 (145.0)	1.58 (40)

= "Most Popular"

Replacement Element and Repair Kits

- 5 Micron Element FRP-96-806
- Bonnet, Knob, Adjusting Screw Kit RRP-96-821
- Bonnet, Tamper Resistant Adjustment Kit RRP-96-822
- Diaphragm and Valve Repair Kit –
 - Relieving RRP-96-819
 - Non-Relieving RRP-96-820
- Plastic Bowl –
 - No Guard, Manual Twist Drain GRP-96-808
 - No Guard, Piston Drain GRP-96-809
- Metal Bowl –
 - Manual Twist Drain GRP-96-810
 - Piston Drain GRP-96-811

Accessories

- Gauge, Pressure –
 - 0 to 60 PSI (0 to 4.1 bar), 1-1/2" Dial Face, 1/8" NPT K4515N18060
 - 0 to 160 PSI (0 to 11.0 bar), 1-1/2" Dial Face, 1/8" NPT, CBM K4515N18160
- Manual Drain GRP-96-812
- Piston Type Drain GRP-96-813
- Panel Mount Nut –
 - Aluminum RPA-96-733
 - Plastic RPA-96-734
- Wall Mounting Bracket –
 - L-Type GRP-95-147
 - L-Type with Plastic Panel Mount Nut GRP-95-747

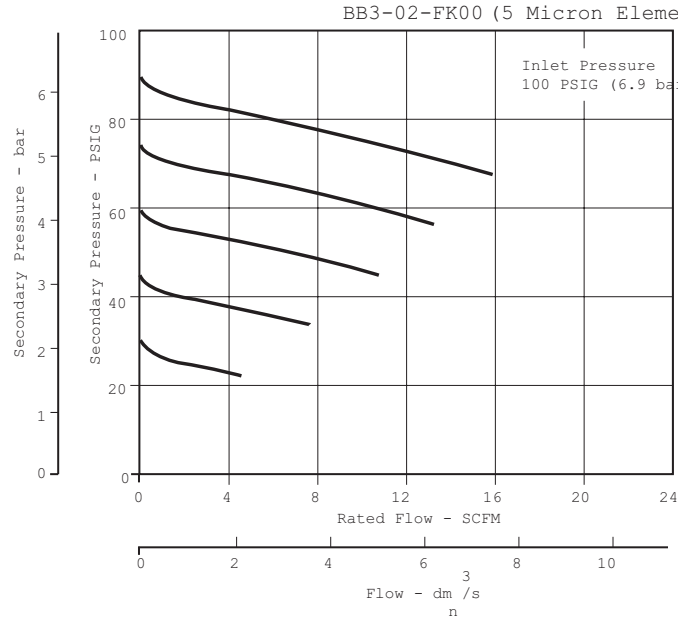

⚠ WARNING

**Product rupture can cause serious injury.
Do not connect regulator to bottled gas.
Do not exceed maximum primary pressure rating.**

CAUTION:

REGULATOR PRESSURE ADJUSTMENT – The working range of knob adjustment is designed to permit outlet pressures within their full range. Pressure adjustment beyond this range is also possible because the knob is not a limiting device. This is a common characteristic of most industrial regulators, and limiting devices may be obtained only by special design.

For best performance, regulated pressure should always be set by increasing the pressure up to the desired setting.

Ordering Information

Model Type	Port Size	Relieving 2 to 125 PSI (0.14 to 8.6 bar)	Relieving 1 to 60 PSI (0.07 to 4.1 bar)	Relieving 1 to 25 PSI (0.07 to 1.7 bar)	Relieving 2 to 125 PSI (0.14 to 8.6 bar)	Relieving 1 to 60 PSI (0.07 to 4.1 bar)	Relieving 1 to 25 PSI (0.07 to 1.7 bar)
		No Bowl Guard	No Bowl Guard	No Bowl Guard	Metal Bowl	Metal Bowl	Metal Bowl
Manual Drain	1/8"	BB3-01-FK00	BB3-01-DK00	BB3-01-CK00	BB3-01-FL00	BB3-01-DL00	BB3-01-CL00
	1/4"	BB3-02-FK00	BB3-02-DK00	BB3-02-CK00	BB3-02-FL00	BB3-02-DL00	BB3-02-CL00
Piston Drain	1/8"	BB3-01-FR00	BB3-01-DR00	BB3-01-CR00	BB3-01-FS00	BB3-01-DS00	BB3-01-CS00
	1/4"	BB3-02-FR00	BB3-02-DR00	BB3-02-CR00	BB3-02-FS00	BB3-02-DS00	BB3-02-CS00
Manual Drain	1/8"	BA3-01-FK00	BA3-01-DK00	BA3-01-CK00	BA3-01-FL00	BA3-01-DL00	BA3-01-CL00
	1/4"	BA3-02-FK00	BA3-02-DK00	BA3-02-CK00	BA3-02-FL00	BA3-02-DL00	BA3-02-CL00
Piston Drain	1/8"	BA3-01-FR00	BA3-01-DR00	BA3-01-CR00	BA3-01-FS00	BA3-01-DS00	BA3-01-CS00
	1/4"	BA3-02-FR00	BA3-02-DR00	BA3-02-CR00	BA3-02-FS00	BA3-02-DS00	BA3-02-CS00

Options - To order an option supplied with the unit model, add the appropriate coded suffix letter in the designated position of the model number.

Filter / Regulator B08

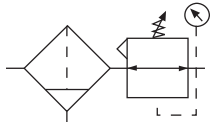

Features

- Space-Saving Integral Filter / Regulator Design
- Unique Flush-mounted Pressure Gauge Available
- Balanced Valve Design
- Modern Design and Appearance
- Light Weight
- High Flow Capacities
- Quick-Disconnect Bowl / Bowl Guard

⚠ WARNING

**Product rupture can cause serious injury.
Do not connect regulator to bottled gas.
Do not exceed maximum primary pressure rating.**

Specifications

Flow Capacity*	1/4	73 SCFM (35 dm ³ /s, ANR)
Adjusting Range Pressure		0 to 30 PSIG (0 to 2 bar)
		0 to 60 PSIG (0 to 4 bar)
		0 to 125 PSIG (0 to 8 bar)
		0 to 232 PSIG (0 to 16 bar)
Gauge Ports (2)**	NPT	1/8
Maximum Supply Pressure	Plastic Bowl	150 PSIG (10.3 bar)
	Metal Bowl	250 PSIG (17.2 bar)
Operating Temperature†	Plastic Bowl	14° to 125°F (-10° to 52°C)
	Metal Bowl	14° to 150°F (-10° to 65.5°C)
Port Size	NPT / BSPP-G	1/4
Bowl Capacity		0.4 oz
Standard Filtration		5 Micron
Weight		0.42 lb. (0.19 kg)

* Inlet pressure 145 psig (10 bar). Secondary pressure 100 psig (6.9 bar) and 14.5 psig (1 bar) pressure drop.

† Units with square gauges: 5°F to 150°F (-15°C to 65.5°C)

"F" Series Filters, Type "A" 5 micron elements: All Wilkerson Type "A" 5 micron elements **meet or exceed ISO Class 3** for maximum particle size and concentration of solid contaminants.

Air quality: Within ISO 8573-1: 1991 Class 3 (Particulates)
Within ISO 8573-1: 2001 Class 6 (Particulates)

Gauge supplied with every part. Gauge can be installed on the front or back of the regulator. If no gauge is installed, both seal screws must be installed.

Materials of Construction

Adjustment Knob	Acetal	
Body	Aluminum	
Bottom Cap	Glass-filled Nylon	
Bonnet	Glass-filled Nylon	
Bowl	Plastic Bowl	Polycarbonate
	Metal Bowl	Aluminum
Bowl Guard	Nylon	
Diaphragm Assembly	Stainless Steel / Nitrile	
Filter Element	Polyethylene	
Panel Nut	Acetal	
Seals	Plastic Bowl	Nitrile
	Metal Bowl	Nitrile
Springs	Steel	
Valve Assembly	Acetal / Nitrile	

CAUTION:

REGULATOR PRESSURE ADJUSTMENT – The working range of knob adjustment is designed to permit outlet pressures within their full range. Pressure adjustment beyond this range is also possible because the knob is not a limiting device. This is a common characteristic of most industrial regulators, and limiting devices may be obtained only by special design.

For best performance, regulated pressure should always be set by increasing the pressure up to the desired setting.

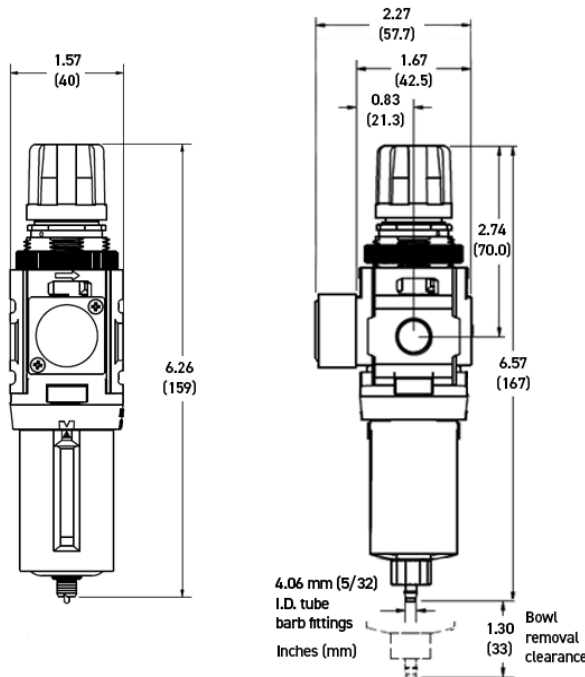

Inches (mm)

Accessories

Automatic Piston Drain..... GRP-96-716

Panel Mount Nut –

AluminumRPA-96-773
 PlasticRPA-96-734

Pressure Gauge– (*see note below)

Square flush mount gauge

0-4 bar GRP-96-791-04B
 0-11 bar GRP-96-792-11B
 0-20 bar GRP-96-791-20B
 0-60 PSIG GRP-96-791-060
 0-160 PSIG..... GRP-96-791-160
 0-290 PSIG GRP-96-791-290

*For B08 Filter Regulators with date code after November 2023 (4423 Date Code), please use these part numbers when ordering a replacement gauge.

Square flush mount gauge

0-4 barK4511SCR04B
 0-11 barK4511SCR11B
 0-60 PSIG K4511SCR060
 0-160 PSIG..... K4511SCR160

Square with adapter kit

0-4 barP6G-PR10040
 0-11 barP6G-PR10110
 0-60 PSIGP6G-PR90060
 0-160 PSIG.....P6G-PR90160

50mm (2") round 1/4" center back mount

0-30 PSIG / 0-2 bar K4520N14030
 0-60 PSIG / 0-4 bar K4520N14060
 0-160 PSIG / 0-11 bar K4520N14160
 0-300 PSIG / 0-20 bar K4520N14300

1-3/4" Digital Round 1/4" NPT

0 to 160 PSIG K4517N14160D

Tamperproof Lock and Cover Kit

(lock not included)..... RPA-96-736B

Wall Mounting Bracket –

C-Type.....GPA-97-010
 L-Type..... GPA-96-739
 T-Type GPA-96-737

= "Most Popular"

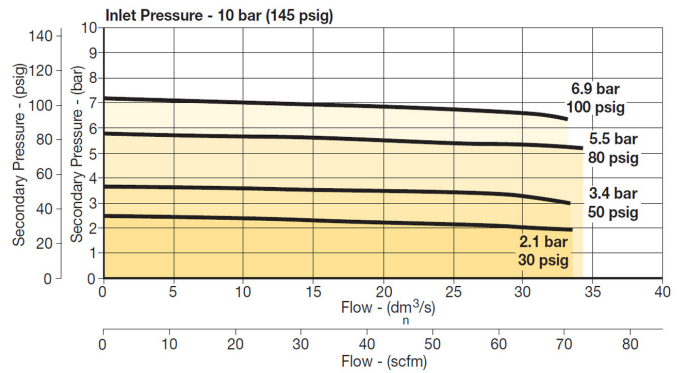

Replacement Bowl Kits

Metal Bowl, Manual Drain GRP-96-714
 Plastic Bowl / Bowl Guard, Manual Drain..... GRP-96-712

Replacement Element Kit

Type "A", 5 Micron.....FRP-96-729

Replacement Kits

Adjusting Knob..... GRP-96-792

Ordering Information

Model Type	Port Size	Plastic Bowl / Bowl Guard / Manual Drain / With Gauge 0 to 125 PSIG (0 to 8.6 bar)	Plastic Bowl / Bowl Guard / Manual Drain / With Gauge 0 to 30 PSIG (0 to 2.0 bar)	Plastic Bowl / Bowl Guard / Automatic Piston / With Gauge 0 to 125 PSIG (0 to 8.6 bar)
Relieving	1/4	B08-02-FKG0B	B08-02-CKG0B	B08-02-FRG0B
Non-relieving	1/4	B08-02-RKG0B	B08-02-PKG0B	B08-02-RRG0B

Options - To order an option supplied with the unit model, add the appropriate coded suffix letter in the designated position of the model number.

Filter / Regulator B18

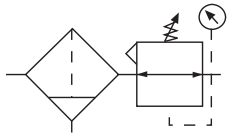

Features

- 5 Micron Filtration
- Balanced Valve Design
- Spring Loaded Diaphragm
- 1/2" NPT / BSPP-G Over-Ported
- Quick-Disconnect Bowl / Bowl Guard
- Light Weight
- High Flow Capacities

⚠ WARNING

**Product rupture can cause serious injury.
Do not connect regulator to bottled gas.
Do not exceed maximum primary pressure rating.**

Specifications

Flow Capacity*	1/4	148 SCFM (70 dm ³ /s, ANR)
	3/8	158 SCFM (75 dm ³ /s, ANR)
	1/2	164 SCFM (77 dm ³ /s, ANR)
Adjusting Range Pressure	0 to 30 PSIG (0 to 2 bar)	
	0 to 60 PSIG (0 to 4 bar)	
	0 to 125 PSIG (0 to 8 bar)	
	0 to 250 PSIG (0 to 17 bar)	
Gauge Port (2)	NPT / BSPP-G	1/4
Maximum Supply Pressure	Plastic Bowl	150 PSIG (10.3 bar)
	Metal Bowl	250 PSIG (17.2 bar)
Operating Temperature	Plastic Bowl	-13° to 125°F (-25° to 52°C)
	Metal Bowl	-13° to 150°F (-25° to 65.5°C)
Port Size	NPT / BSPP-G	1/4, 3/8, 1/2
Bowl Capacity	1.72 oz	
Standard Filtration	5 Micron	
Weight	1.17 lb. (0.53 kg)	

* Inlet pressure 145 psig (10 bar). Secondary pressure 91.3 psig (6.3 bar) and 14.5 psig (1 bar) pressure drop.

"F" Series Filters, Type "A" 5 micron elements: All Wilkerson Type "A" 5 micron elements **meet or exceed ISO Class 3** for maximum particle size and concentration of solid contaminants.

Air quality: Within ISO 8573-1: 1991 Class 3 (Particulates)
Within ISO 8573-1: 2001 Class 6 (Particulates)

Materials of Construction

Adjustment Knob	Acetal	
Body	Aluminum	
Body Cap	ABS	
Bowl	Plastic Bowl	Polycarbonate
	Metal Bowl	Aluminum
Bowl Guard	Nylon	
Diaphragm Assembly	Nitrile / Steel	
Element Retainer / Baffle	Acetal	
Filter Element	Sintered Polyethylene	
Panel Nut	Acetal	
Seals	Plastic Bowl	Nitrile
	Metal Bowl	Nitrile
Sight Gauge	Metal Bowl	Polyamide (Nylon)
Springs	Main Regulating / Valve	Steel / S.S.
Valve Assembly	Brass / Nitrile	

CAUTION:

REGULATOR PRESSURE ADJUSTMENT – The working range of knob adjustment is designed to permit outlet pressures within their full range. Pressure adjustment beyond this range is also possible because the knob is not a limiting device. This is a common characteristic of most industrial regulators, and limiting devices may be obtained only by special design.

For best performance, regulated pressure should always be set by increasing the pressure up to the desired setting.

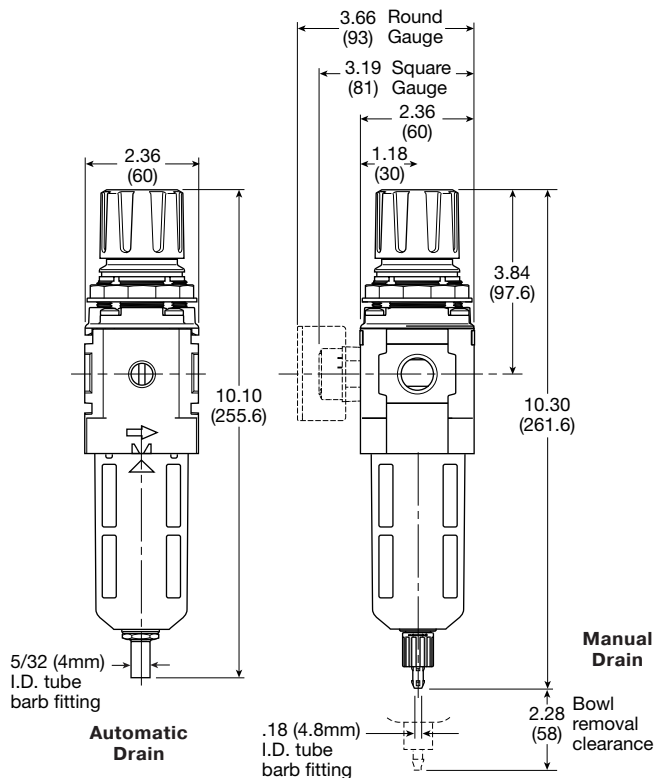

Inches (mm)

= "Most Popular"

Replacement Bowl Kits

- Metal Bowl –
 Sight Gauge, Automatic Drain GRP-96-637
 Sight Gauge, Manual Drain GRP-96-636
- Plastic Bowl –
 Bowl Guard, Automatic Drain GRP-96-635
 Bowl Guard, Manual Drain GRP-96-634

Replacement Element Kits

- Type "A", 5 Micron FRP-96-639
 Retainer, Deflector, and Element Kit FRP-96-641

Replacement Kits

- Adjusting Knob RRP-16-340-000
- Diaphragm Assembly –
 Non-relieving RRP-96-657B
 Relieving RRP-96-656B
- Spring, Regulating –
 0 to 30 PSIG (0 to 2.1 bar) RRP-96-659B
 0 to 60 PSIG (0 to 4.1 bar) RRP-96-660B
 0 to 125 PSIG (0 to 8.6 bar) RRP-96-661B
 0 to 250 PSIG (0 to 17.2 bar) RRP-96-662B

Accessories

- Automatic Drain –
 Fluorocarbon GRP-95-981
 Nitrile GRP-95-973
- Drain, Manual Override GRP-96-000
- Manual Drain GRP-96-685
- Panel Mount Nut –
 Aluminum RRP-96-673
 Plastic RRP-96-675B
- Gauge, Pressure –
 50mm (2") round 1/4" center back mount
 0-30 PSIG / 0-2 bar K4520N14030
 0-60 PSIG / 0-4 bar K4520N14060
 0-160 PSIG / 0-11 bar K4520N14160
 0-300 PSIG / 0-20 bar K4520N14300
 0 to 160 PSIG, 1-3/4" Digital Round,
 1/4" NPT K4517N14160D
- Tamper Resistant Kit RRP-96-671
 Tamperproof Lock & Cover Kit RPA-96-736
 Sight Gauge Kit GRP-96-825
- Wall Mounting Bracket
 L-Type (Body) GPA-96-604
 L-Type (Bonnet) GPA-96-606
 T-Type GPA-96-602

B08 1/4" Filter / Regulator

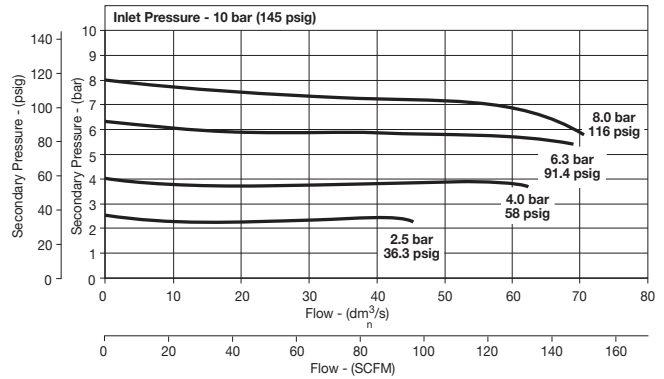

B18 3/8" Filter / Regulator

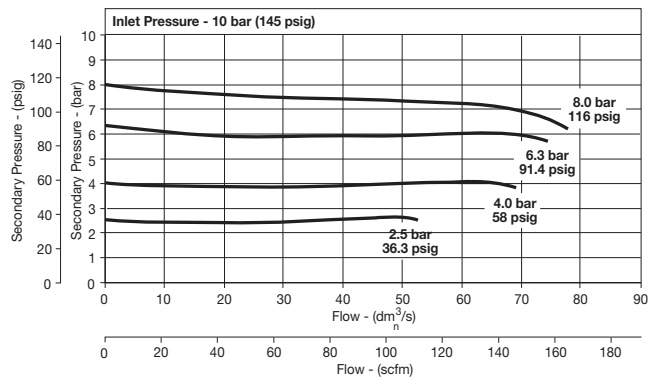

B08 1/2" Filter / Regulator

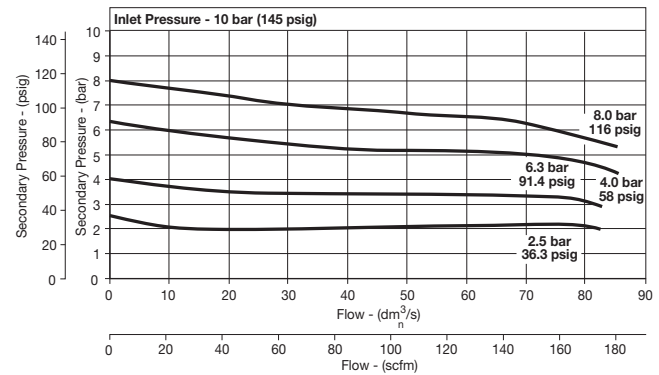

Ordering Information

Model Type	Port Size	Plastic Bowl / Bowl Guard With Gauge 5 to 125 PSIG (0.4 to 8.6 bar)	Metal Bowl / Sight Gauge With Gauge 5 to 125 PSIG (0.4 to 8.6 bar)
Manual Drain	1/4	B18-02-FKG0B	B18-02-FLG0B
	3/8	B18-03-FKG0B	B18-03-FLG0B
	1/2	B18-04-FKG0B	B18-04-FLG0B
Automatic Drain	1/4	B18-02-FGG0B	B18-02-FHG0B
	3/8	B18-03-FGG0B	B18-03-FHG0B
	1/2	B18-04-FGG0B	B18-04-FHG0B

Options - To order an option supplied with the unit model, add the appropriate coded suffix letter in the designated position of the model number.

Filter / Regulator CB6

 = "Most Popular"

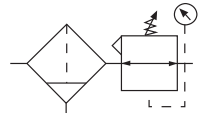

CB6-02-000

Features

- 5 Micron Filtration
- Balanced Valve
- Manual Flex Drain
- Integral Plastic Bowl / Bowl Guard
- Quick-Disconnect Bowl

⚠ WARNING

**Product rupture can cause serious injury.
Do not connect regulator to bottled gas.
Do not exceed maximum primary pressure rating.**

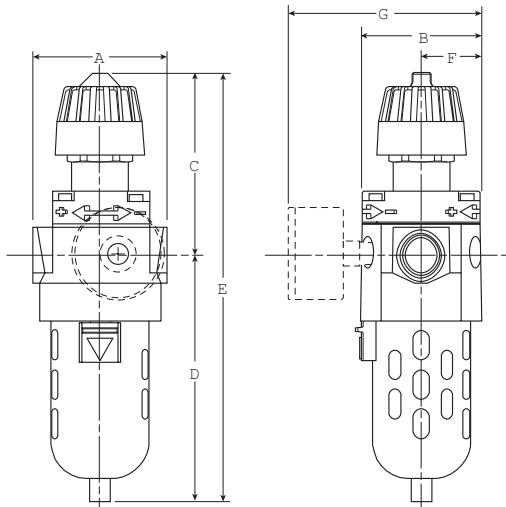

NOTE: 1.31" Dia. (33.3 mm) hole required for panel nut mounting.

Dimensions

Models	Inches (mm)	A	B	C	D	E	F	G
Standard Unit CB6-XX-000		3.00 (76)	2.64 (67)	3.95 (100)	5.43 (137.9)	9.38 (238)	1.34 (34)	4.18 (106)
Automatic Drain CB6-XX-F00		3.00 (76)	2.64 (67)	3.95 (100)	5.55 (140.9)	9.50 (241)	1.34 (34)	4.18 (106)
Metal Bowl CB6-XX-M00		3.00 (76)	2.64 (67)	3.95 (100)	6.05 (153.7)	10.00 (254)	1.34 (34)	4.18 (106)
Metal Bowl with Sight Gauge CB6-XX-G00		3.00 (76)	2.64 (67)	3.95 (100)	6.15 (156)	10.10 (256.5)	1.34 (34)	4.18 (106)

Specifications

Flow Capacity*	1/4	64.0 SCFM (30.2 dm ³ /s)
	3/8	70.0 SCFM (33.0 dm ³ /s)
	1/2	70.0 SCFM (33.0 dm ³ /s)
Adjusting Range Pressure	0 to 50 PSIG (0 to 3.5 bar)	
	0 to 125 PSIG (0 to 8.6 bar)	
Gauge Port (2)	NPT / BSPT-Rc	1/4
Maximum Supply Pressure	Plastic Bowl	150 PSIG (10.3 bar)
	Metal Bowl	200 PSIG (13.8 bar)
Operating Temperature	Plastic Bowl	32° to 125°F (0° to 52°C)
	Metal Bowl	32° to 150°F (0° to 65.5°C)
Port Size	NPT / BSPP-G	1/4, 3/8, 1/2
Standard Filtration	5 Micron	
Weight	2.4 lb. (1.1 kg)	

* Inlet pressure 100 PSIG (6.9 bar). Secondary pressure 90 PSIG (6.2 bar).

"F" Series Filters, Type "A" 5 Micron Elements: All Wilkerson Type "A" 5 micron elements **meet or exceed ISO Class 3** for maximum particle size and concentration of solid contaminants.

Materials of Construction

Body	Zinc	
Bonnet, Knob	PBT	
Bowls	Plastic Bowl	Polycarbonate
	Metal Bowl	Zinc
Diaphragm	Nitrile / Zinc	
Filter Element	Polyethylene	
Panel Nut	Acetal	
Seals	Plastic Bowl	Nitrile
	Metal Bowl	Fluorocarbon
Stem, Element Retainer and Deflector	Acetal	
Springs	Steel	
Valve Assembly	Brass / Nitrile	

CAUTION:

REGULATOR PRESSURE ADJUSTMENT – The working range of knob adjustment is designed to permit outlet pressures within their full range. Pressure adjustment beyond this range is also possible because the knob is not a limiting device. This is a common characteristic of most industrial regulators, and limiting devices may be obtained only by special design.

For best performance, regulated pressure should always be set by increasing the pressure up to the desired setting.

= "Most Popular"

Replacement Bowl Kits

- Metal Bowl –
 - Automatic Float Drain FRP-95-950
 - Brass Petcock Drain FRP-95-178
- Metal Bowl / Sight Gauge, Brass Petcock Drain .. GRP-95-133
- Plastic Bowl, Flex Tip Drain FRP-95-017
- Plastic Bowl / Bowl Guard –
 - Automatic Float Drain FRP-95-015
 - Flex Top Drain FRP-95-014

Replacement Element Kits

- Type "A", 5 Micron w/ Nitrile Bowl O-Ring FRP-95-160

Replacement Kits

- Diaphragm Assembly –
 - Non-relieving RRP-96-216
 - Self-relieving.....RRP-96-213
- Spring, Regulating –
 - 0 to 50 PSIG (0 to 3.4 bar) Blue Color RRP-95-222
 - 0 to 125 PSIG (0 to 8.5 bar) Silver Color RRP-95-224

Accessories

- Automatic Mech. Drain, 1/8" NPT –
 - Fluorocarbon GRP-95-981
 - Nitrile GRP-95-973
 - Manual Flex Tip Drain FRP-95-610
 - Wall Mounting Bracket –
 - Gauge Port Adapter, 1/4" NPT RRP-95-590
 - L-Type.....GPA-95-012
 - Drain, Manual Override for
 - Auto Float Drain, 1/8 NPT.....GRP-96-000
 - Gauge, Pressure, 2" Dial Face, 1/4" NPT CBM –
 - 0 to 60 PSIG (0 to 4.1 bar) K4520N14060W
 - 0 to 160 PSIG (0 to 11.0 bar)..... K4520N14160W
 - 0 to 300 PSIG (0 to 21 bar) K4520N14300W
 - 0 to 160 PSIG, 1-3/4" Digital Round, 1/4" NPT . K4517N14160D
 - Panel Nut, Plastic GPA-95-032
 - Tamper Resistant Kit..... RPA-95-006
- NOTE: Gauge not included, order separately by accessory number.

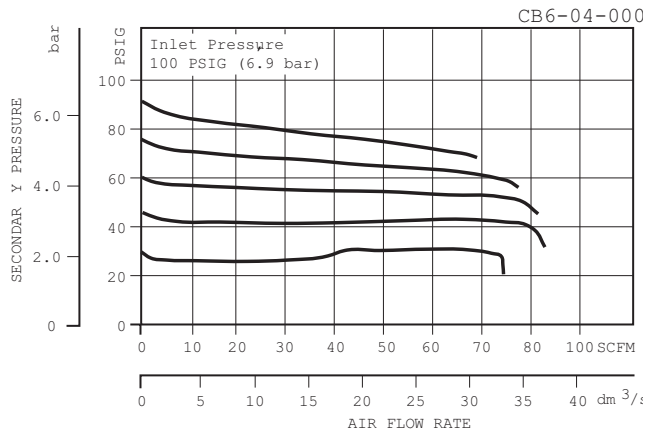
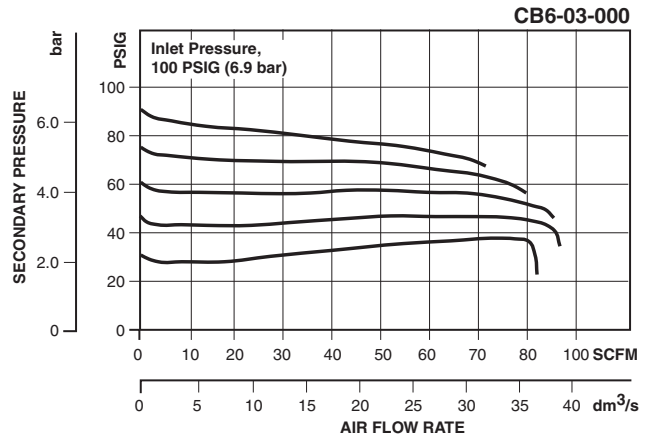
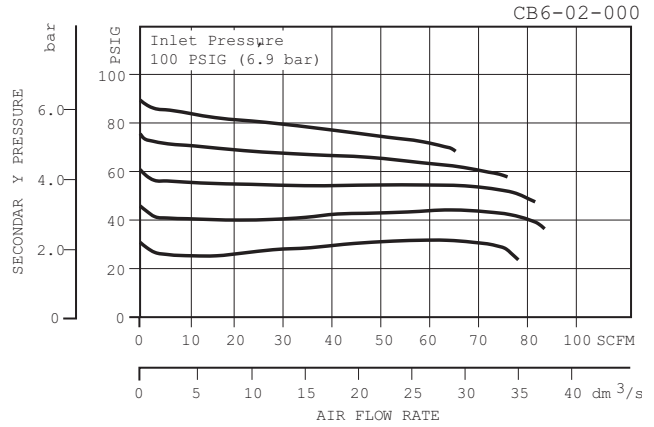

Ordering Information

Model Type	Port Size	Plastic Bowl / Bowl Guard 0 to 125 PSIG (0 to 8.6 bar)	Metal Bowl 0 to 125 PSIG (0 to 8.6 bar)	Metal Bowl w/ Sight Gauge 0 to 125 PSIG (0 to 8.6 bar)	Metal Bowl Low Pressure 0 to 50 PSIG (0 to 3.4 bar)
Manual Drain	1/4	CB6-02-000	CB6-02-M00	CB6-02-G00	CB6-02-LM0
	3/8	CB6-03-000	CB6-03-M00	CB6-03-G00	CB6-03-LM0
	1/2	CB6-04-000	CB6-04-M00	CB6-04-G00	CB6-04-LM0
Automatic Drain	1/4	CB6-02-F00	CB6-02-FM0	CB6-02-FG0	CB6-02-FLM
	3/8	CB6-03-F00	CB6-03-FM0	CB6-03-FG0	CB6-03-FLM
	1/2	CB6-04-F00	CB6-04-FM0	CB6-04-FG0	CB6-04-FLM

Options - To order an option supplied with the unit model, add the appropriate coded suffix letter in the designated position of the model number.

Precision Filter / Regulator PC6

= "Most Popular"

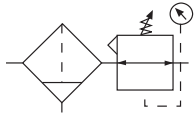

PC6-02-000

Precision Filter / Regulator

The PC6 models are general purpose regulators specifically designed for applications that require reliable performance and accurate pressure control.

Features

- *Stable Output* – Aspirator Design Minimizes “Droop” at Higher Flow Levels
- *Accuracy* – High Diaphragm-to-Valve-Area Ratio Combined with Unbalanced Valve Provides High Precision with Minimal Initial Pressure Droop
- *Quality Air* – 5 Micron Filtration for Superior Protection of Critical Downstream Equipment
- *Easy Maintenance* – May be Disassembled and Serviced without Removal from Air Line
- *Competitive* – Compact, Integral Filter / Regulator Can be Used Where Limited Space or Lower Cost is Required

Specifications

Flow Capacity*	PC6	19.0 SCFM (9.0 dm ³ /s)
Gauge Port (2)	NPT / BSPT-Rc	1/4
Maximum Supply Pressure	Plastic Bowl	150 PSIG (10.3 bar)
	Metal Bowl	200 PSIG (13.8 bar)
Port Size	NPT / BSPP-G	1/4, 3/8, 1/2
Operating Temperature	Plastic Bowl	32° to 125°F (0° to 52°C)
	Metal Bowl	32° to 150°F (0° to 65.5°C)
Weight	2.4 lb. (1.1 kg)	

* Inlet pressure 100 PSIG (6.9 bar).
Secondary pressure PC6, 45 PSIG (3.1 bar).

“F” Series Filters, Type “A” 5 micron elements: All Wilkerson Type “A” 5 micron elements **meet or exceed ISO Class 3** for maximum particle size and concentration of solid contaminants.

Materials of Construction

Body	Zinc	
Bonnet, Knob	PBT	
Bowls	Plastic Bowl	Polycarbonate
	Metal Bowl	Zinc
Diaphragm	Nitrile / Zinc	
Filter Element	Polypropylene	
Panel Nut	Acetal	
Seals	Plastic Bowl	Nitrile
Springs	Steel	
Stem, Element Retainer and Deflector	Acetal	
Valve Assembly	Brass / Nitrile	

⚠ WARNING

**Product rupture can cause serious injury.
Do not connect regulator to bottled gas.
Do not exceed maximum primary pressure rating.**

CAUTION:

REGULATOR PRESSURE ADJUSTMENT – The working range of knob adjustment is designed to permit outlet pressures within their full range. Pressure adjustment beyond this range is also possible because the knob is not a limiting device. This is a common characteristic of most industrial regulators, and limiting devices may be obtained only by special design.

For best performance, regulated pressure should always be set by increasing the pressure up to the desired setting.

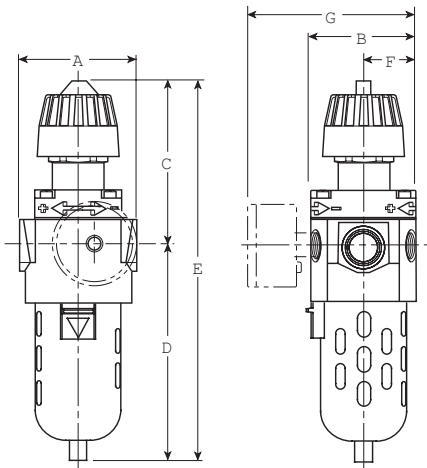

NOTE: 1.31" Dia. (33.3 mm) hole required for panel nut mounting.

Dimensions

Models	Inches (mm)	A	B	C	D	E	F	G
Standard Unit PC6-XX-000		3.00 (76)	2.64 (67)	3.95 (100)	5.43 (137.9)	9.38 (238)	1.34 (34)	4.18 (106)
Automatic Drain PC6-XX-F00		3.00 (76)	2.64 (67)	3.95 (100)	5.55 (140.9)	9.50 (241)	1.34 (34)	4.18 (106)
Automatic Drain PC6-XX-G00		3.00 (76)	2.64 (67)	3.95 (100)	6.15 (156)	10.10 (256.5)	1.34 (34)	4.18 (106)

= "Most Popular"

Replacement Bowl Kits

- Metal Bowl –
 - Automatic Drain PRP-96-006
 - Manual Drain PRP-95-070
- Metal Bowl / Sight Gauge, Brass Petcock Drain .. PRP-95-071
- Plastic Bowl, FlexTip Drain FRP-95-017
- Plastic Bowl / Bowl Guard –
 - Automatic Drain FRP-95-015
 - FlexTip Drain FRP-95-014

Replacement Element Kits

- Type "A", 5 Micron..... FRP-95-160

Replacement Kits

- Diaphragm Assembly –
 - Non-relieving, Nitrile..... PRP-95-055
 - Self-relieving, Nitrile PRP-95-025
- Spring, Regulating –
 - 0 to 15 PSIG (1 bar) RRP-95-233
 - 0 to 30 PSIG (2,1 bar)..... RRP-95-916
 - 0 to 50 PSIG (0 to 3,4 bar)..... RRP-95-222
 - 0 to 125 PSIG (0 to 8,5 bar) RRP-95-224

Accessories

- Automatic Mechanical Drain
 - 1/8 NPT, Fluorocarbon..... GRP-95-981
 - 1/8 NPT, Nitrile..... GRP-95-973
- Drain, Manual Override for
 - Auto Float Drain, 1/8 NPT..... GRP-96-000
- FlexTip Drain FRP-95-610
- Gauge, Pressure, 2" Dial Face, 1/4 NPT, CBM –
 - 0 to 30 PSIG (0 to 2,1 bar) K4520N14030W
 - 0 to 60 PSIG (0 to 4 bar)..... K4520N14060W
 - 0 to 120 PSIG (0 to 8,3 bar) K4520N14160W
 - 0 to 160 PSIG, 1-3/4" Digital Round, 1/4" NPT . K4517N14160D
- Panel Nut, Plastic GPA-95-032
- Tamper Resistant Kit..... RPA-95-006
- Wall Mounting Bracket –
 - Gauge Port Adapter, 1/4 NPT RRP-95-590
 - L-Type w/Panel Mount Nut GPA-95-011

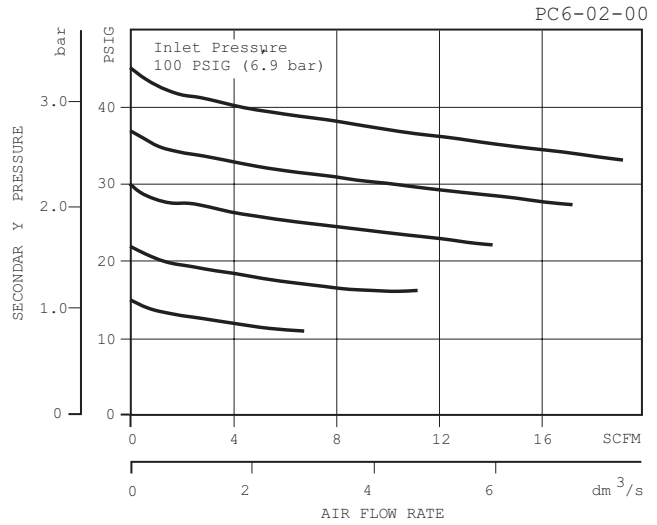

Ordering Information

Model Type	Port Size	Standard Unit 0 to 50 PSIG (0 to 3.4 bar)	Automatic Mechanical Drain	Sight Gauge	High Pressure 0 to 125 PSIG (0 to 8.6 bar)	Low Pressure 0 to 30 PSIG (0 to 2.1 bar)	Metal Bowl	Fluorocarbon Seals
Relieving	1/4	PC6-02-000	PC6-02-F00	PC6-02-G00	PC6-02-H00	PC6-02-L00	PC6-02-M00	PC6-02-V00
	3/8	PC6-03-000	PC6-03-F00	PC6-03-G00	PC6-03-H00	PC6-03-L00	PC6-03-M00	PC6-03-V00
	1/2	PC6-04-000	PC6-04-F00	PC6-04-G00	PC6-04-H00	PC6-04-L00	PC6-04-M00	PC6-04-V00
Non-relieving	1/4	PC6-02-N00	PC6-02-FN0	PC6-02-GN0	PC6-02-HN0	PC6-02-LN0	PC6-02-MN0	PC6-02-VN0
	3/8	PC6-03-N00	PC6-03-FN0	PC6-03-GN0	PC6-03-HN0	PC6-03-LN0	PC6-03-MN0	PC6-03-VN0
	1/2	PC6-04-N00	PC6-04-FN0	PC6-04-GN0	PC6-04-HN0	PC6-04-LN0	PC6-04-MN0	PC6-04-VN0

Options - To order an option supplied with the unit model, add the appropriate coded suffix letter in the designated position of the model number.

Filter / Regulator B28

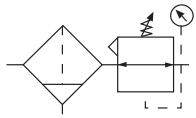

Features

- 5 Micron Filtration
- Balanced Valve Design
- Spring Loaded Diaphragm
- 3/4" NPT / BSPP-G Over-Ported
- Quick-Disconnect Bowl / Bowl Guard
- Light Weight
- High Flow Capacities

⚠ WARNING
Product rupture can cause serious injury. Do not connect regulator to bottled gas. Do not exceed maximum primary pressure rating.

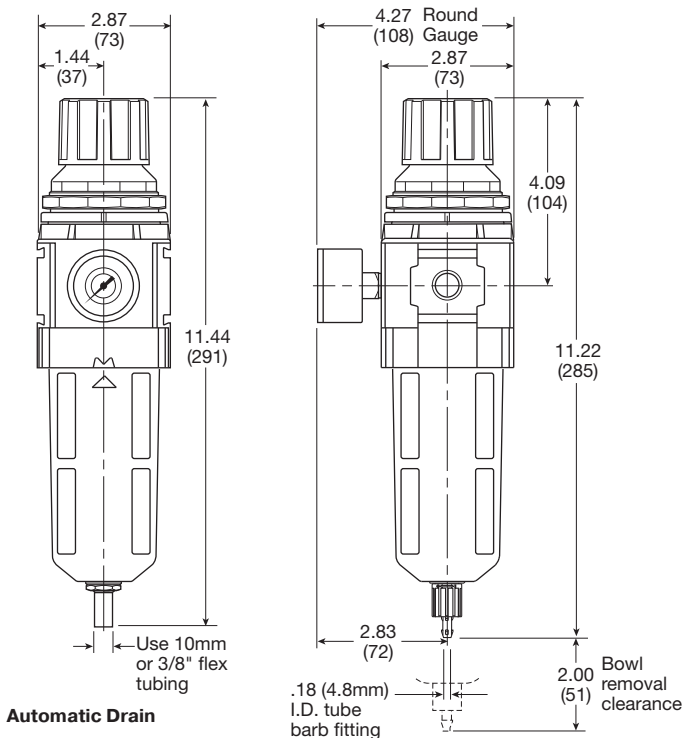

Inches (mm)

Specifications

Flow Capacity*	3/8	200 SCFM (94 dm ³ /s, ANR)
	1/2	200 SCFM (94 dm ³ /s, ANR)
	3/4	235 SCFM (109 dm ³ /s, ANR)
Adjusting Range Pressure		0 to 30 PSIG (0 to 2.1 bar)
		0 to 60 PSIG (0 to 4.1 bar)
		0 to 125 PSIG (0 to 8.6 bar)
		0 to 250 PSIG (0 to 17.2 bar)
Gauge Port (2)	NPT / BSPP-G	1/4
Maximum Supply Pressure	Plastic Bowl	150 PSIG (10.3 bar)
	Metal Bowl	250 PSIG (17.2 bar)
Operating Temperature	Plastic Bowl	-13° to 125°F (-25° to 52°C)
	Metal Bowl	-13° to 150°F (-25° to 65.5°C)
Port Size	NPT / BSPP-G	3/8, 1/2, 3/4
Bowl Capacity		2.87 oz
Standard Filtration		5 Micron
Weight		1.87 lb. (0.85 kg)

* Inlet pressure 145 psig (10 bar). Secondary pressure 91.3 psig (6.3 bar) and 14.5 psig (1 bar) pressure drop.

"F" Series Filters, Type "A" 5 micron elements: All Wilkerson Type "A" 5 micron elements **meet or exceed ISO** Class 3 for maximum particle size and concentration of solid contaminants.

Air quality: Within ISO 8573-1: 1991 Class 3 (Particulates)
Within ISO 8573-1: 2001 Class 6 (Particulates)

Materials of Construction

Adjustment Knob		Acetal
Body		Aluminum
Body Cap		ABS
Bowls	Plastic Bowl	Polycarbonate
	Metal Bowl	Aluminum
Diaphragm Assembly		Nitrile / Zinc
Element Retainer / Baffle		Acetal
Filter Element		Sintered Polyethylene
Panel Nut		Acetal
Seals	Plastic Bowl	Nitrile
	Metal Bowl	Nitrile
Sight Gauge	Metal Bowl	Polyamide (Nylon)
Springs	Main Regulating / Valve	Steel / S.S.
Valve Assembly		Brass / Nitrile

CAUTION:

REGULATOR PRESSURE ADJUSTMENT – The working range of knob adjustment is designed to permit outlet pressures within their full range. Pressure adjustment beyond this range is also possible because the knob is not a limiting device. This is a common characteristic of most industrial regulators, and limiting devices may be obtained only by special design.

For best performance, regulated pressure should always be set by increasing the pressure up to the desired setting.

= "Most Popular"

Replacement Bowl Kits

- Metal Bowl –
 - Sight Gauge, Automatic Drain GRP-96-645
 - Sight Gauge, Manual Drain GRP-96-644
- Plastic Bowl –
 - Bowl Guard, Automatic Drain GRP-96-643
 - Bowl Guard, Manual Drain GRP-96-642

Replacement Element Kits

- Type "A", 5 Micron FRP-96-653
- Element, Deflector, Retainer kit FRP-96-283

Replacement Kits

- Adjusting Knob RRP-16-341-000
- Diaphragm Assembly –
 - Non-relieving RRP-96-987
 - Relieving RRP-96-986
- Spring, Regulating –
 - 0 to 30 PSIG (0 to 2.1 bar) RRP-96-163
 - 0 to 60 PSIG (0 to 4.1 bar) RRP-96-164
 - 0 to 125 PSIG (0 to 8.6 bar) RRP-96-165
 - 0 to 250 PSIG (0 to 17.2 bar) RRP-96-166
- Valve Assembly RRP-96-049

Accessories

- Automatic Drain –
 - Fluorocarbon GRP-95-981
 - Nitrile GRP-95-973
- Manual Drain GRP-96-685
- Panel Mount Nut –
 - Aluminum RRP-96-674
 - Plastic RRP-96-676
- Gauge, Pressure –
 - 50mm (2") round 1/4" center back mount
 - 0-30 PSIG / 0-2 bar K4520N14030
 - 0-60 PSIG / 0-4 bar K4520N14060
 - 0-160 PSIG / 0-11 bar K4520N14160
 - 0-300 PSIG / 0-20 bar K4520N14300
 - 0 to 160 PSIG, 1-3/4" Digital Round, 1/4" NPT K4517N14160D
- Tamper Resistant Kit RRP-96-672
- Sight Gauge Kit GRP-96-825
- Wall Mounting Bracket –
 - L-Type (Body) GPA-96-605
 - L-Type (Bonnet) GPA-96-607
 - T-Type GPA-96-602

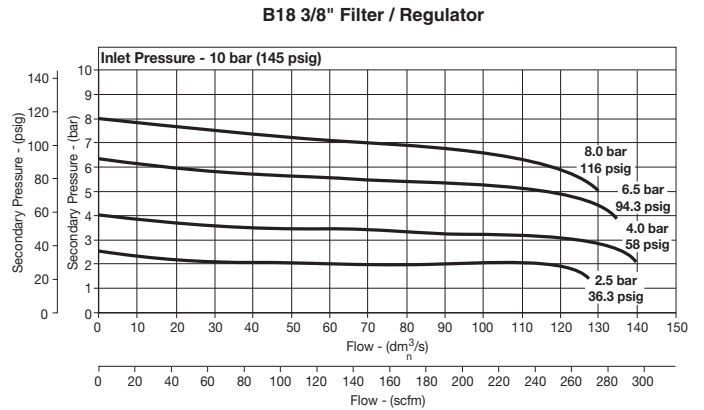
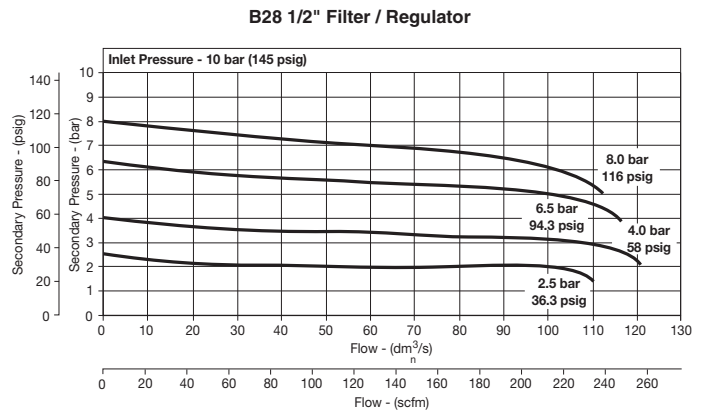
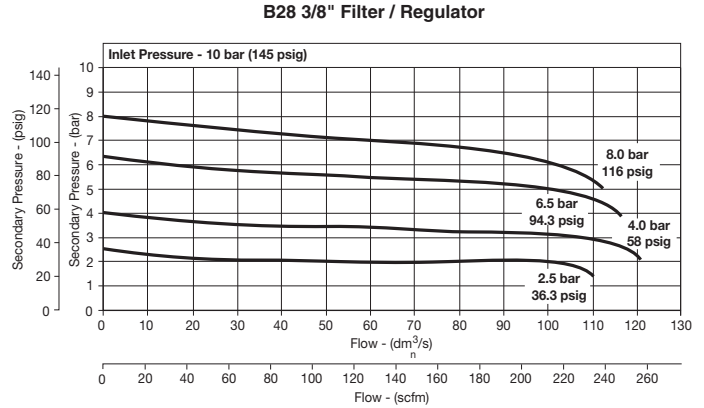

Ordering Information

Model Type	Port Size	Plastic Bowl / Bowl Guard With Gauge 5 to 125 PSIG (0.4 to 8.6 bar)	Metal Bowl / Sight Gauge With Gauge 5 to 125 PSIG (0.4 to 8.6 bar)
Manual Drain	3/8	B28-03-FKG0B	B28-03-FLG0B
	1/2	B28-04-FKG0B	B28-04-FLG0B
	3/4	B28-06-FKG0B	B28-06-FLG0B
Automatic Drain	3/8	B28-03-FGG0B	B28-03-FHG0B
	1/2	B28-04-FGG0B	B28-04-FHG0B
	3/4	B28-06-FGG0B	B28-06-FHG0B

Options - To order an option supplied with the unit model, add the appropriate coded suffix letter in the designated position of the model number.

Filter / Regulator B90

 = "Most Popular"



Symbols

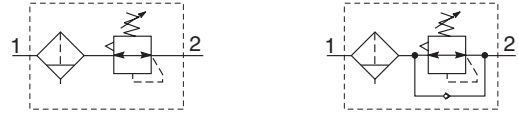

Features

- Integral 3/4" or 1" ports (BSPP or NPT)
- High efficiency element as standard
- Excellent water removal efficiency
- Robust but lightweight aluminum construction
- Secondary pressure ranges 12 and 16 bar
- Rolling diaphragm for extended life
- Secondary aspiration plus balanced poppet provides quick response and accurate pressure regulation
- Reverse flow / relieving option
- Low temperature -40° with combined manual / semi-auto drain as standard

B90	-	0	-	6	-	A	H	0	0
Series		Thread type*		Port size		Function / pressure range	Bowl / drain type	Option	
Filter / Regulator Combination B90		NPT 0 BSPP C		3/4 6 1 8		A Relieving / 0 to 174 PSI H Relieving / 0 to 232 PSI	H Metal bowl / sight gauge & auto drain L Metal bowl / sight gauge / manual & semi auto drain	0 None G Pressure Gauge A† Lockable type	

Notes:
 * For 1-1/2" ported unit, please order P3YKA*BCP port block kit separately.
 † Not field convertible.

Bold items are most common.

Ordering information

Port size	Description	Flow‡ scfm	Max. bar (psig)	Min temp °C (°F)	Max temp °C (°F)	Bowl capacity cm³ (oz)	Height mm (inches)	Width mm (inches)	Depth mm (inches)	Weight kg (lb)	Part number †
3/4"	12 bar, relieving, combined manual / semi auto drain	335	17.5 (254)	-40 (-40)	60 (140)	130 (4.4)	345 (13.5)	90 (3.5)	94 (3.7)	1.5 (3.3)	B90-06-AL00
3/4"	12 bar, relieving, auto drain	335	17.5 (254)	-10 (14)	60 (140)	130 (4.4)	345 (13.5)	90 (3.5)	94 (3.7)	1.5 (3.3)	B90-06-AH00
3/4"	12 bar, relieving, gauge, combined manual / semi auto drain	335	17.5 (254)	-10 (14)	60 (140)	130 (4.4)	345 (13.5)	90 (3.5)	94 (3.7)	1.5 (3.3)	B90-06-ALG0
3/4"	12 bar, relieving, gauge, auto drain	335	17.5 (254)	-10 (14)	60 (140)	130 (4.4)	345 (13.5)	90 (3.5)	94 (3.7)	1.5 (3.3)	B90-06-AHGO
1"	12 bar, relieving, combined manual / semi auto drain	465	17.5 (254)	-40 (-40)	60 (140)	130 (4.4)	345 (13.5)	90 (3.5)	94 (3.7)	1.5 (3.3)	B90-08-AL00
1"	12 bar, relieving, auto drain	465	17.5 (254)	-10 (14)	60 (140)	130 (4.4)	345 (13.5)	90 (3.5)	94 (3.7)	1.5 (3.3)	B90-08-AH00
1"	12 bar, relieving, gauge, combined manual / semi auto drain	465	17.5 (254)	-10 (14)	60 (140)	130 (4.4)	345 (13.5)	90 (3.5)	94 (3.7)	1.5 (3.3)	B90-08-ALG0
1"	12 bar, relieving, gauge, auto drain	465	17.5 (254)	-10 (14)	60 (140)	130 (4.4)	345 (13.5)	90 (3.5)	94 (3.7)	1.5 (3.3)	B90-08-AHGO

† Standard part numbers shown in bold. For other models refer to Options chart above.

‡ Flow with 10 bar (145 psig) inlet pressure, 6.3 bar (91.4 psig) set pressure and 1 bar (14.5 psig) pressure drop.

Lockable regulators will require key lock kit (opposite page).

Specifications

Fluid	Compressed air
Maximum inlet pressure*	17.5 bar (254 psig)
Temperature range*:	
Auto drain	-10°C to 60°C (14°F to 140°F)
Combined drain	-40°C to 60°C (-40°F to 140°F)
Particle removal	5 micron
Air quality	Within ISO 8573-1: 1991 Class 3 and 5 (particulates) Within ISO 8573-1: 2001 Class 6 and 7 (particulates)
Typical flow with 10 bar (145 psig) inlet pressure and 6.3 bar (91 psig) set pressure and 0.5 bar (7.3 psig) pressure drop	1" size 465 scfm
Manual / semi-auto drain	Closed at 0.8 bar (11.6 psig) G1/8 thread male
Auto drain bowl pressure to close drain	0.8 bar (11.6 psig)
Operating range manual override facility	0.8 bar (11.6 psig) to 17.5 bar (254 psig)
Bowl capacity	130 cm ³ (4.4 US oz)
Gauge ports (x2)	1/4"

* Air supply must be dry enough to avoid ice formation at temperatures below 2°C (35.6°F).

Dimensions mm (inches)

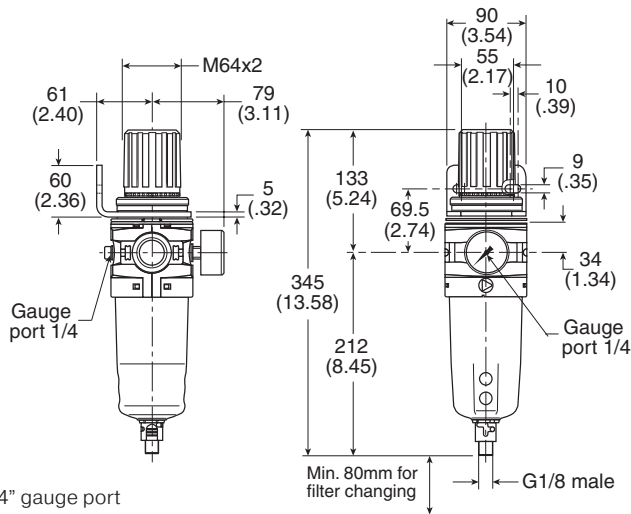

* 1/4" gauge port

Service kits

- 5 micron element kit P3YKA00ESE
- Bowl kit
 - Manual/semi auto drain (combined) P3YKA00BSC
 - Auto drain P3YKA00BSA
- Key lock kit..... P3XKA00AS
- Diaphragm kit
 - Relieving type P3YKA00RR
 - Non-relieving type..... P3YKA00RN
- Angle bracket + metal lock ring P3YKA00MS
- Panel mount nut P3YKA00MM

Material specifications

Body	Aluminum
Sight glass	Polypropylene
Body cover	ABS
Element	Sintered polypropylene
Seals	Nitrile NBR
Drains	Manual / semi-auto: Acetal Automatic: PA / Ø 10mm brass connection
Bonnet	Glass filled polyamide
Control knob	Glass filled polyamide
Valve	Brass / NBR
Screws	Steel / zinc plated

CAUTION:

REGULATOR PRESSURE ADJUSTMENT – The working range of knob adjustment is designed to permit outlet pressures within their full range. Pressure adjustment beyond this range is also possible because the knob is not a limiting device. This is a common characteristic of most industrial regulators, and limiting devices may be obtained only by special design.

For best performance, regulated pressure should always be set by increasing the pressure up to the desired setting.

Flow characteristics

(3/4") 5 Micron Filter / Regulator

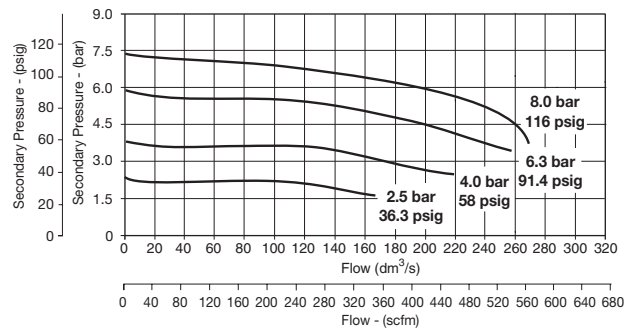

(1") 5 Micron Filter / Regulator

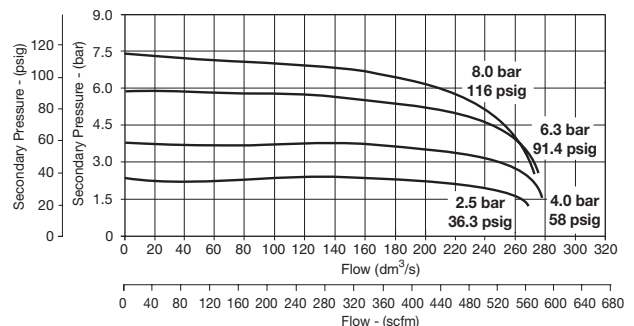

Filter / Regulator-Lubricator Numbering System

 = "Most Popular"

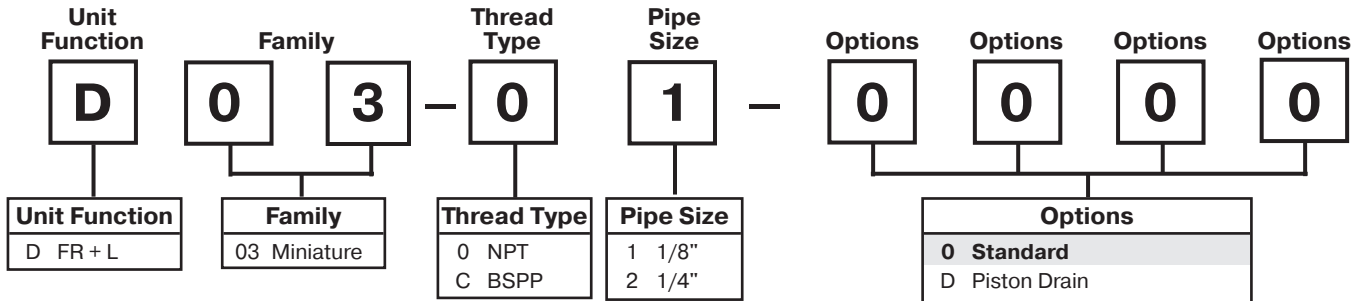

Note: When selecting from the options columns, please enter letters in alphabetical order for positions 6, 7, 8, and 9.
For example: **M 0 3 - 0 1 - D M 0 0**

NOTE: 0000 in position 6, 7, 8 and 9 signifies standard product.
(Poly Bowl, Manual Drain on Filter, no Drain on Lubricator, 2 to 125 PSIG, Relieving)

* Not available with BSPP thread type.

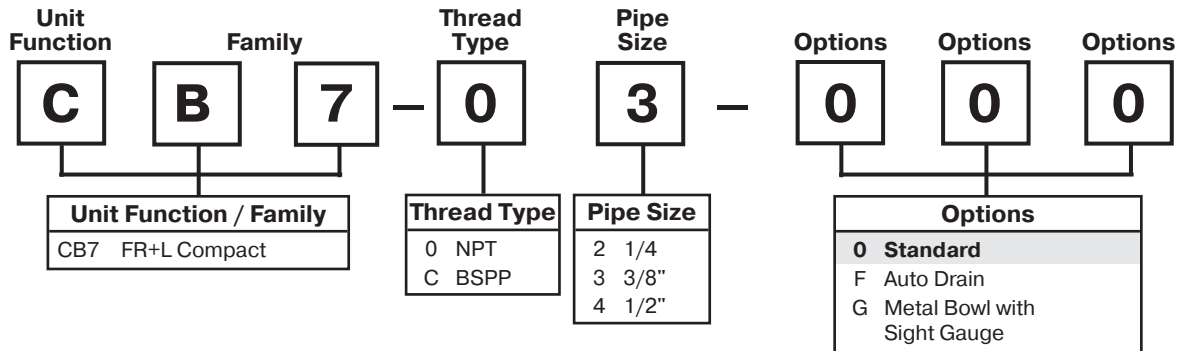

"F" Series Filters, Type "A" 5 micron elements: All Wilkerson Type "A" 5 micron elements **meet or exceed** ISO Class 3 for maximum particle size and concentration of solid contaminants.

Note: All classes above refer to International Standards Organization (ISO) standard 8573-1, pertaining to maximum particle size and concentration of solid contaminants, and maximum oil content.

NOTE: When selecting from the options columns, please enter letters in alphabetical order for positions 6, 7, 8.
For example:

C B 7 - 0 3 - 0 0 0

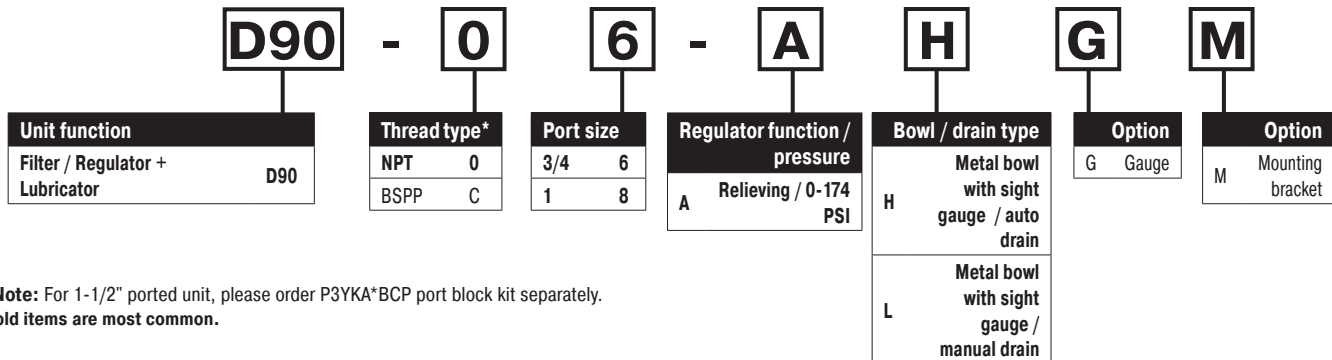

*Note: For 1-1/2" ported unit, please order P3YKA*BCP port block kit separately.
Bold items are most common.

Filter / Regulator-Lubricator Numbering System

 = "Most Popular"

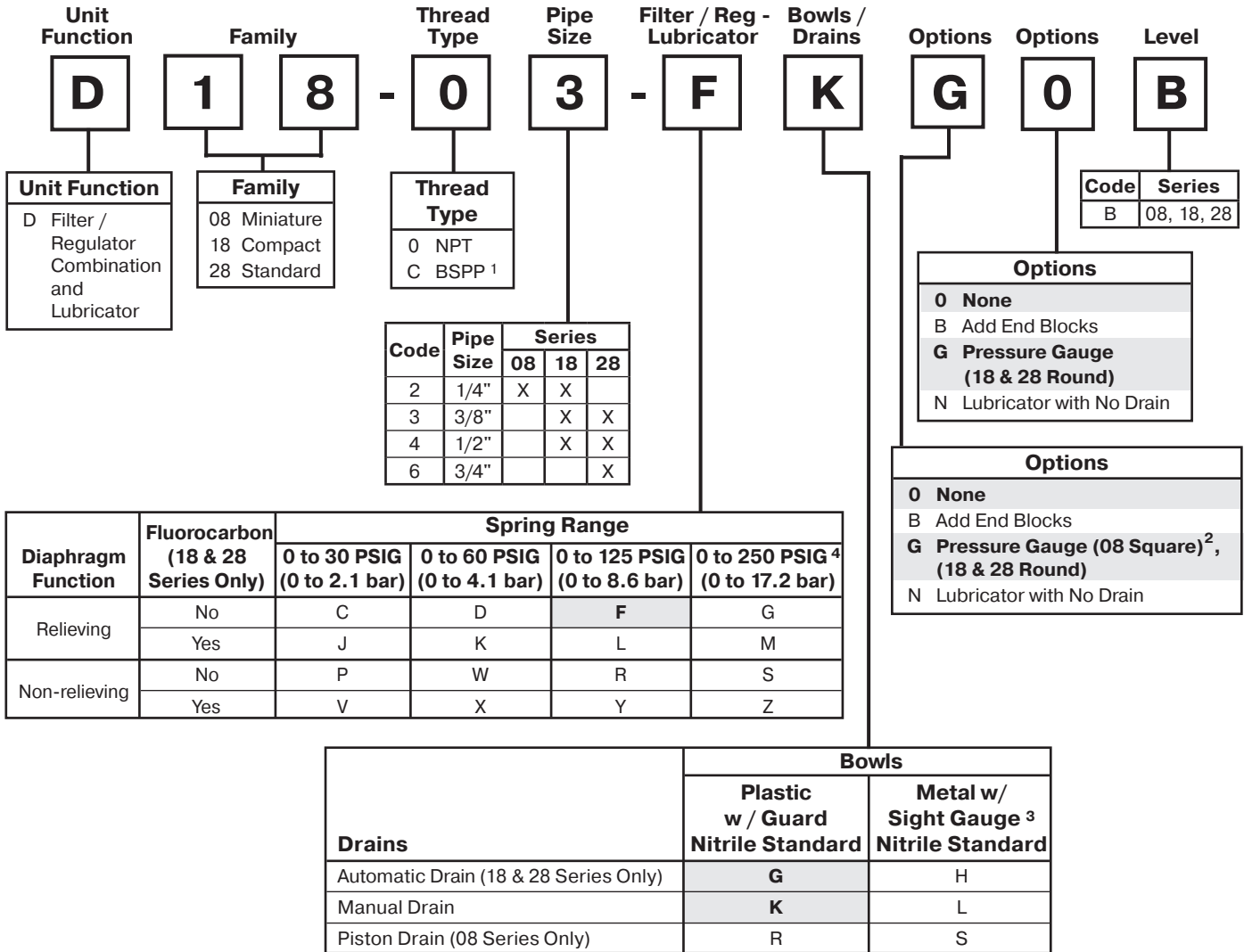

1 ISO, R228 (G Series)
 2 Square gauge included with all D08
 3 08 series has all metal bowl (no sight gauge)
 4 08 series operating range 0 to 232 PSIG (1 to 16 bar)

NOTE: When selecting from the options columns, please enter letters in alphabetical order for positions 7, 8, 9. For example:

D 1 8 - 0 3 - F K G 0 B

"F" Series Filters, Type "A" 5 micron elements: All Wilkerson Type "A" 5 micron elements **meet or exceed ISO Class 3** for maximum particle size and concentration of solid contaminants.

Note: All classes above refer to International Standards Organization (ISO) standard 8573-1, pertaining to maximum particle size and concentration of solid contaminants, and maximum oil content.

Suggested Lubricant

Airline Oil F442001
 Petroleum based oil of 100 to 200 SUS viscosity at 100°F and an aniline point greater than 200°F
 (DO NOT USE OILS WITH ADDITIVES, COMPOUNDED OILS CONTAINING SOLVENTS, GRAPHITE, DETERGENTS, OR SYNTHETIC OILS.)

Combination D03

= "Most Popular"

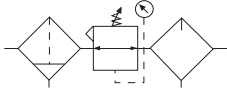

D03-02-0000

Features

- Excellent Water Removal Efficiency
- Unbalanced Poppet Standard
- Solid Control Piston for Extended Life
- Non-rising Adjustment Knob
- Two Full Flow 1/8" Gauge Ports
- Proportional Oil Delivery over a Wide Range of Air Flows
- Precision Needle Valve Assures Repeatable Oil Delivery and Provides Simple Adjustment of Delivery Rate
- Ideal for Low and Light flow Applications with Changing Air Flow
- Transparent Sight Dome for 360° Visibility

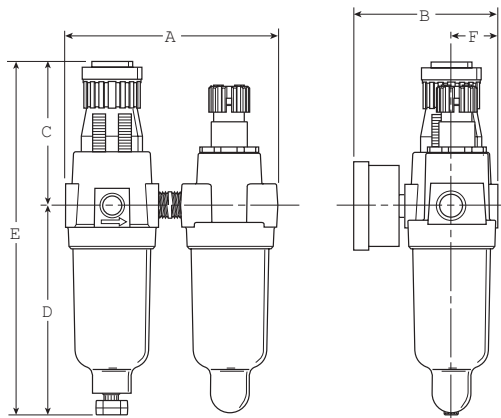

Dimensions

Model	Inches (mm)	A	B	C	D	E	F
Standard Unit D03-XX-XXXX		3.75 (95)	2.83 (71.9)	2.42 (61)	3.79 (96)	6.21 (158)	.79 (20)

Specifications

Flow Capacity*	1/8	20 SCFM (9.4 dm ³ /s)
	1/4	20 SCFM (9.4 dm ³ /s)
Gauge Ports (2)	1/8	
Minimum Flow for Lubrication	0.7 SCFM at 100 PSIG	
Port Threads	1/8, 1/4	
Pressure & Temperature Ratings –		
Plastic Bowl	0 to 150 PSIG (0 to 10.3 bar) 32°F to 125°F (0°C to 52°C)	
Metal Bowl	0 to 250 PSIG (0 to 17.2 bar) 32°F to 175°F (0°C to 80°C)	
Secondary Pressure Ranges –		
Standard Pressure	2 to 125 PSIG (0 to 8.6 bar)	
Medium Pressure	1 to 60 PSIG (0 to 4.1 bar)	
Medium Pressure	1 to 30 PSIG (0 to 2.1 bar)	
Low Pressure	1 to 15 PSIG (0 to 1.0 bar)	
Weight	.9 lb. (.36 kg)	

* Inlet pressure 100 PSIG (6.9 bar). Secondary pressure 90 PSIG (6.2 bar).

"F" Series Filters, Type "A" 5 micron elements: All Wilkerson Type "A" 5 micron elements **meet or exceed ISO** Class 3 for maximum particle size and concentration of solid contaminants.

Materials of Construction

Adjusting Nut	Brass
Adjusting Stem & Spring	Steel
Body	Zinc
Bonnet, Knob, Seat, Piston, Holder & Deflector	Plastic
Bowls –	
Transparent	Polycarbonate
Metal (Without Sight Gauge)	Zinc
Filter Elements – 5 Micron (Standard)	Plastic
Manual Drain –	
Body & Stem	Plastic
Seals	Nitrile
Piston Drain –	
Piston & Seals	Nitrile
Stem, Seat, Adaptor & Washers	Aluminum
Seals	Nitrile
Sight Dome	Polycarbonate
Suggested Lubricant	Airline Oil F442001

 = "Most Popular"

Note: For Kits and Repair Parts, see individual pages for Filters, Regulators, and Lubricators.

 WARNING
<p>Product rupture can cause serious injury. Do not connect regulator to bottled gas. Do not exceed maximum primary pressure rating.</p>

CAUTION:

REGULATOR PRESSURE ADJUSTMENT – The working range of knob adjustment is designed to permit outlet pressures within their full range. Pressure adjustment beyond this range is also possible because the knob is not a limiting device. This is a common characteristic of most industrial regulators, and limiting devices may be obtained only by special design.

For best performance, regulated pressure should always be set by increasing the pressure up to the desired setting.

Ordering Information

Model Type	Port Size	Plastic Bowl with Gauge	Metal Bowl with Gauge
Manual Drain	1/8	D03-01-G000	D03-01-GM00
	1/4	D03-02-G000	D03-02-GM00

Options - To order an option supplied with the unit model, add the appropriate coded suffix letter in the designated position of the model number.

Combination D08

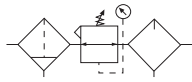

Specifications

Flow Capacity*	1/4	28 SCFM (14 dm ³ /s, ANR)
Gauge Port (2)**	NPT	1/8
Maximum Supply Pressure	Plastic Bowl	150 PSIG (10.3 bar)
	Metal Bowl	250 PSIG (17.2 bar)
Operating Temperature	Plastic Bowl	14° to 125°F (-10° to 52°C)
	Metal Bowl	14° to 150°F (-10° to 65.5°C)
Port Size	NPT / BSPP-G	1/4
Standard Filtration	5 Micron	
Weight	1.43 lb. (0.6 kg)	

* Inlet pressure 145 PSIG (10 bar), Secondary pressure 100 PSIG (6.9 bar), 14.5 PSIG (1 bar) pressure drop.

"F" Series Filters, Type "A" 5 micron elements: All Wilkerson Type "A" 5 micron elements **meet or exceed ISO** Class 3 for maximum particle size and concentration of solid contaminants.

Gauge supplied with every part. Gauge can be installed on the front or back of the regulator. If no gauge is installed, both seal screws must be installed.

Features

- Components Integrated into Single Unit
- Modern Design and Appearance
- Light Weight, Ready-to-Mount Assembly Comes Standard with Flush-Mount Pressure Gauge and Modular T-Bracket / Joiner Assembly
- High Flow Capacity
- Quick-Disconnect Bowl / Bowl Guard

Materials of Construction

Body	Aluminum	
Bonnet	Glass-filled Nylon	
Bowls	Plastic Bowl	Polycarbonate
	Metal Bowl	Aluminum
Diaphragm Assembly	Stainless Steel / Nitrile	
Filter Element	Polyethylene	
Knob	Acetal	
Seals	Plastic Bowl	Nitrile
	Metal Bowl	Nitrile
Sight Dome	Polycarbonate	
Springs	Steel	
Valve	Brass / Nitrile	

Suggested Lubricant

Airline Oil F442001

Petroleum based oil of 100 to 200 SUS viscosity at 100°F and an aniline point greater than 200°F

(DO NOT USE OILS WITH ADDITIVES, COMPOUNDED OILS CONTAINING SOLVENTS, GRAPHITE, DETERGENTS, OR SYNTHETIC OILS.)

Ordering Information

Model	Port Size	Plastic Bowl w / Plastic Bowl Guard 0 to 125 PSI (0 to 8.6 bar) With Gauge	Metal Bowl w / 0 to 125 PSI (0 to 8.6 bar) With Gauge
Manual Drain	1/4	D08-02-FKG0B	D08-02-FLG0B

Options - To order an option supplied with the unit model, add the appropriate coded suffix letter in the designated position of the model number.

 = "Most Popular"

Note: For Kits and Repair Parts, see individual pages for Filters, Regulators, and Lubricators.

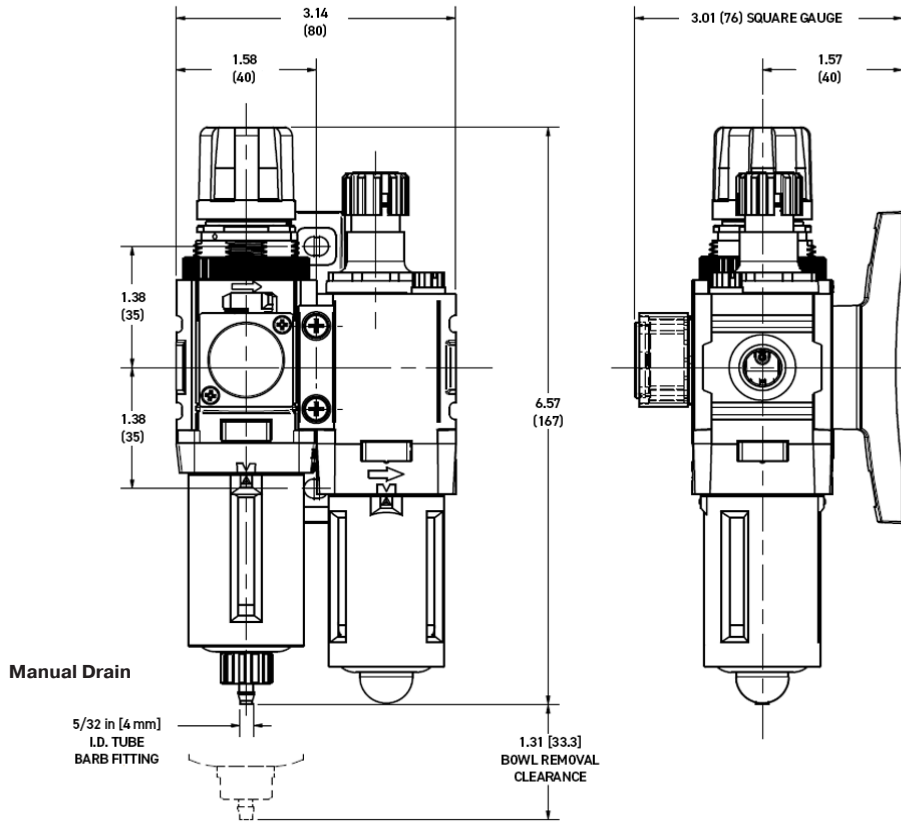

Inches (mm)

 **WARNING**

**Product rupture can cause serious injury.
Do not connect regulator to bottled gas.
Do not exceed maximum primary pressure rating.**

CAUTION:

REGULATOR PRESSURE ADJUSTMENT – The working range of knob adjustment is designed to permit outlet pressures within their full range. Pressure adjustment beyond this range is also possible because the knob is not a limiting device. This is a common characteristic of most industrial regulators, and limiting devices may be obtained only by special design.

For best performance, regulated pressure should always be set by increasing the pressure up to the desired setting.

Combination CB7

= "Most Popular"

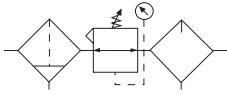

CB7-02-000

Features

- Components Integrated into Single Unit
- Metal Bowl with Sight Gauge Option
- Pressure Gauge Standard
- Integral Plastic Bowl / Bowl Guard
- Quick Disconnect Bowl
- Standard Self-relieving

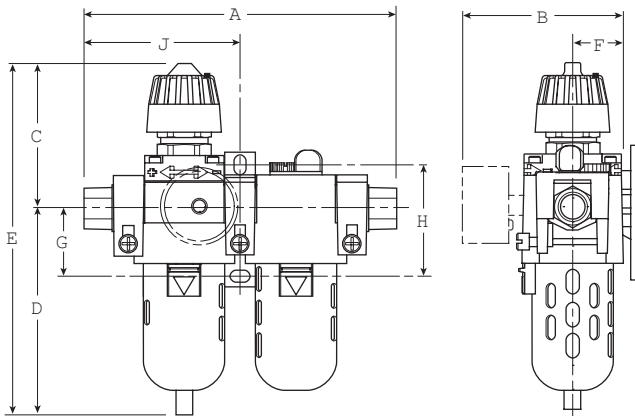

Dimensions

Model	Inches (mm)	A	B	C	D	E	F	G	H	J
Standard Unit With End Blocks CB7-XX-000		8.35 (212)	4.18 (106)	3.95 (44)	5.43 (137.9)	9.38 (238)	1.34 (34)	1.73 (44)	2.98 (75.7)	4.17 (76)

Specifications

Flow Capacity*	1/4	36.1 SCFM (17.0 dm ³ /s)
	3/8	58.5 SCFM (27.6 dm ³ /s)
	1/2	64.0 SCFM (30.2 dm ³ /s)
Gauge Ports (2)	NPT / BSPP-G	1/4
Port Threads	NPT	1/4, 3/8, 1/2
Pressure & Temperature Ratings –		
Plastic Bowl		0 to 150 PSIG (0 to 10.3 bar) 32°F to 125°F (0°C to 52°C)
Metal Bowl		0 to 200 PSIG (0 to 14 bar) 32°F to 175°F (0°C to 80°C)
Weight		5.58 lb. (2.5 kg)

* Inlet pressure 150 PSIG (10.3 bar). Pressure drop 5 PSID (0.3 bar).

"F" Series Filters, Type "A" 5 micron elements: All Wilkerson Type "A" 5 micron elements **meet or exceed ISO Class 3** for maximum particle size and concentration of solid contaminants.

Materials of Construction

Body	Zinc
Bonnet, Knob	PBT
Bowls –	
Transparent	Polycarbonate
Metal	Zinc
Diaphragm	Nitrile / Zinc
Drain Stem	Acetal / Polycarbonate
Filter Elements	Polypropylene
Manual Drain –	
Body & Stem	Plastic
Seals	Nitrile
Piston Drain –	
Piston & Seals	Nitrile
Stem, Seat, Adaptor & Washers	Aluminum
Seals –	
Transparent	Nitrile
Metal	Fluorocarbon
Sight Dome	Nylon
Springs	Steel
Stem, Element Retainer and Deflector	Acetal
Suggested Lubricant	Airline Oil F442001

 = "Most Popular"

Note: For Kits and Repair Parts, see individual pages for Filters, Regulators, and Lubricators.

 WARNING
Product rupture can cause serious injury. Do not connect regulator to bottled gas. Do not exceed maximum primary pressure rating.

CAUTION:

REGULATOR PRESSURE ADJUSTMENT – The working range of knob adjustment is designed to permit outlet pressures within their full range. Pressure adjustment beyond this range is also possible because the knob is not a limiting device. This is a common characteristic of most industrial regulators, and limiting devices may be obtained only by special design.

For best performance, regulated pressure should always be set by increasing the pressure up to the desired setting.

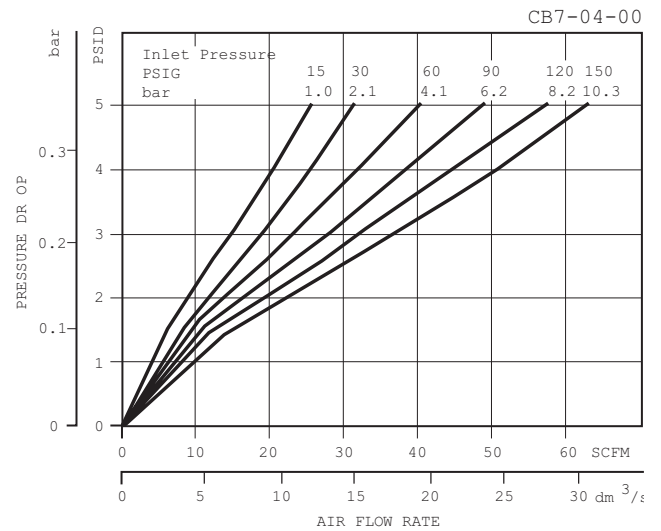
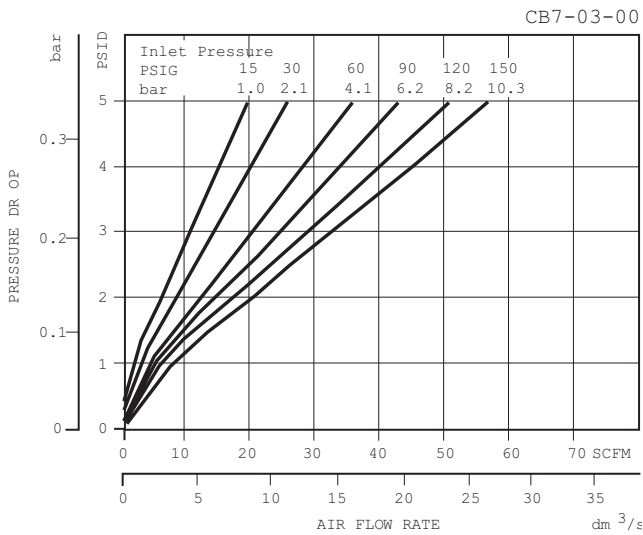
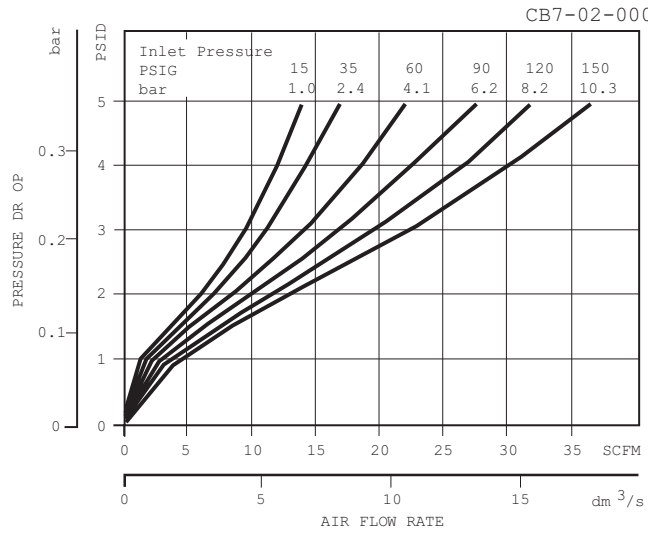

Ordering Information

Model Type	Port Size	Plastic Bowl / Bowl Guard with End Blocks 0 to 125 PSIG (0 to 8.5 bar)	Metal Bowl / Sight Gauge 0 to 125 PSIG (0 to 8.5 bar)	Automatic Drain 0 to 125 PSIG (0 to 8.5 bar)
CB7	1/4	CB7-02-000	CB7-02-G00	CB7-02-F00
	3/8	CB7-03-000	CB7-03-G00	CB7-03-F00
	1/2	CB7-04-000	CB7-04-G00	CB7-04-F00

Options - To order an option supplied with the unit model, add the appropriate coded suffix letter in the designated position of the model number.

Combination D18

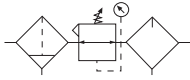

Specifications

Flow Capacity*	1/4	45 SCFM (22 dm ³ /s, ANR)
	3/8	70 SCFM (33 dm ³ /s, ANR)
	1/2	90 SCFM (43 dm ³ /s, ANR)
Gauge Port (2)	NPT / BSPP-G	1/4
Maximum Supply Pressure	Plastic Bowl	150 PSIG (10.3 bar)
	Metal Bowl	250 PSIG (17.2 bar)
Operating Temperature	Plastic Bowl	-13° to 125°F (-25° to 52°C)
	Metal Bowl	-13° to 150°F (-25° to 65.5°C)
Port Size	NPT / BSPP-G	1/4, 3/8, 1/2
Standard Filtration	5 Micron	
Weight	2.98 lb. (1.3 kg)	

* Inlet pressure 145 PSIG (10 bar), Secondary pressure 91.3 PSIG (6.3 bar), 14.5 PSIG (1 bar) pressure drop.

"F" Series Filters, Type "A" 5 micron elements: All Wilkerson Type "A" 5 micron elements **meet or exceed ISO Class 3** for maximum particle size and concentration of solid contaminants.

Features

- Components Integrated into Single Unit
- Modern Design and Appearance
- Light Weight, Ready-to-Mount Assembly Comes Standard with Pressure Gauge and Modular T-Bracket / Joiner Assembly
- High Flow Capacity
- Quick-Disconnect Bowl / Bowl Guard

Materials of Construction

Body	Aluminum	
Body Cap	ABS	
Bonnet / Knob	Nylon / Acetal	
Bowls	Plastic Bowl	Polycarbonate
	Metal Bowl	Aluminum
Diaphragm Assembly	Nitrile / Steel	
Element Retainer / Baffle and Deflector	Acetal Polypropylene	
Filter Element	5 micron	Polyethylene
Seals	Plastic Bowl	Nitrile
	Metal Bowl	Nitrile
Sight Dome	Polycarbonate	
Sight Gauge	Polyamide (Nylon)	
Springs	Main Regulating Valve	Steel Stainless Steel
Suggested Lubricant	Airline Oil F442001	
Valve Assembly	Brass / Nitrile	

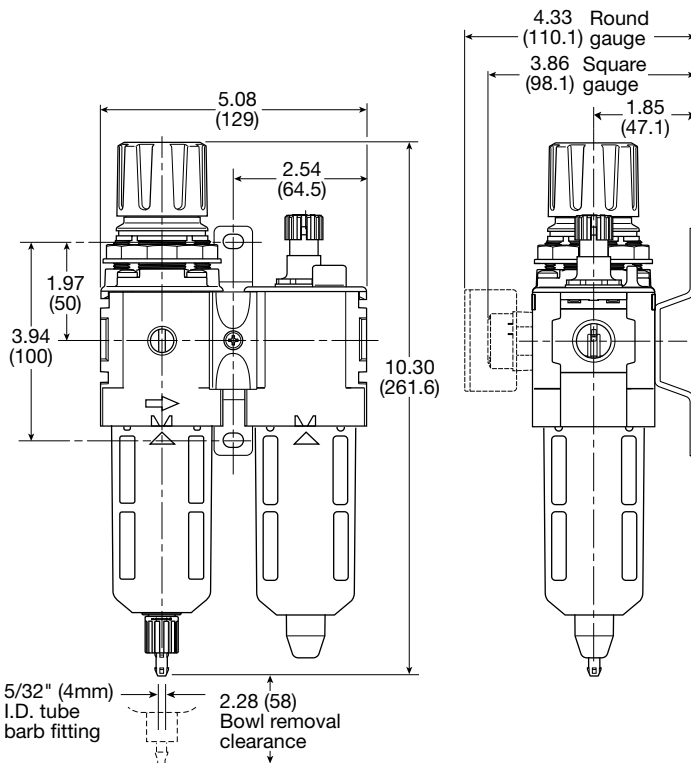

Manual Drain

Inches (mm)

 = "Most Popular"

Note: For Kits and Repair Parts, see individual pages for Filters, Regulators, and Lubricators.

 WARNING
<p>Product rupture can cause serious injury. Do not connect regulator to bottled gas. Do not exceed maximum primary pressure rating.</p>

CAUTION:

REGULATOR PRESSURE ADJUSTMENT – The working range of knob adjustment is designed to permit outlet pressures within their full range. Pressure adjustment beyond this range is also possible because the knob is not a limiting device. This is a common characteristic of most industrial regulators, and limiting devices may be obtained only by special design.

For best performance, regulated pressure should always be set by increasing the pressure up to the desired setting.

Ordering Information

Model Type	Port Size	Plastic Bowl / Bowl Guard Without Gauge 0 to 125 PSI (0 to 8.6 bar)	Plastic Bowl / Bowl Guard With Gauge 0 to 125 PSI (0 to 8.6 bar)
Manual Drain	1/4	D18-02-FK00B	D18-02-FKG0B
	3/8	D18-03-FK00B	D18-03-FKG0B
	1/2	D18-04-FK00B	D18-04-FKG0B
Automatic Drain	1/4	D18-02-FG00B	D18-02-FGG0B
	3/8	D18-03-FG00B	D18-03-FGG0B
	1/2	D18-04-FG00B	D18-04-FGG0B

Options - To order an option supplied with the unit model, add the appropriate coded suffix letter in the designated position of the model number.

Combination D28

= "Most Popular"

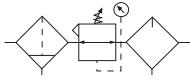

Features

- Components Integrated into Single Unit
- Modern Design and Appearance
- Light Weight, Ready-to-Mount Assembly Comes Standard with Pressure Gauge and Modular T-Bracket / Joiner Assembly
- High Flow Capacity
- Quick-Disconnect Bowl / Bowl Guard

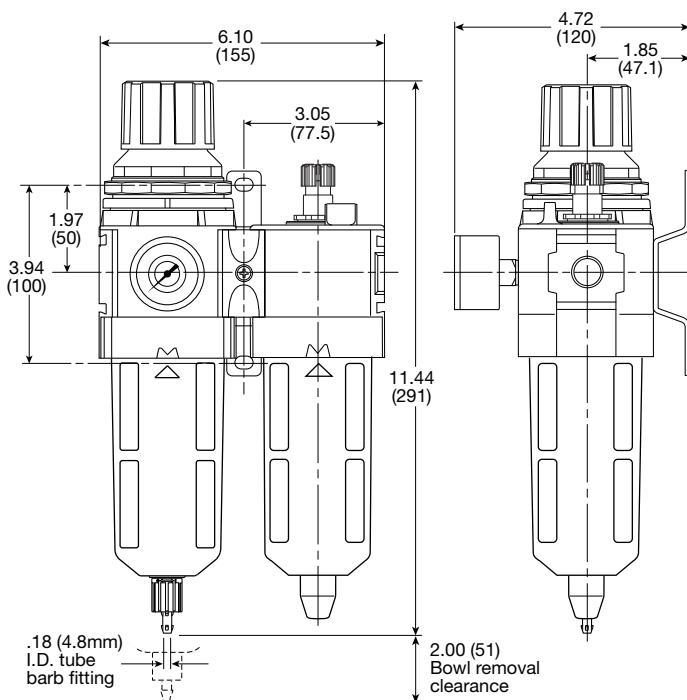

Manual Drain

Inches (mm)

Specifications

Flow Capacity*	3/8	110 SCFM (52 dm ³ /s, ANR)
	1/2	110 SCFM (52 dm ³ /s, ANR)
	3/4	150 SCFM (71 dm ³ /s, ANR)
Maximum Supply Pressure	Plastic Bowl	150 PSIG (10.3 bar)
	Metal Bowl	250 PSIG (17.2 bar)
Operating Temperature	Plastic Bowl	-13° to 125°F (-25° to 52°C)
	Metal Bowl	-13° to 150°F (-25° to 65.5°C)
Port Size	NPT/BSPP-G	3/8, 1/2, 3/4
Standard Filtration	5 Micron	
Weight	4.65 lb. (2.1 kg)	

* Inlet pressure 145 PSIG (10 bar), Secondary pressure 91.3 PSIG (6.3 bar), 14.5 PSIG (1 bar) pressure drop.

"F" Series Filters, Type "A" 5 micron elements: All Wilkerson Type "A" 5 micron elements **meet or exceed ISO Class 3** for maximum particle size and concentration of solid contaminants.

Materials of Construction

Body	Aluminum	
Body Cap	ABS	
Bonnet / Knob	Nylon / Acetal	
Bowls	Plastic Bowl	Polycarbonate
	Metal Bowl	Aluminum
Diaphragm Assembly	Nitrile / Zinc	
Element Retainer / Baffle and Deflector	Acetal Polypropylene	
Filter Element	Polyethylene	
Seals	Plastic Bowl	Nitrile
	Metal Bowl	Nitrile
Sight Dome	Polycarbonate	
Sight Gauge	Metal Bowl	Polyamide (Nylon)
Springs	Main Regulating Valve	Steel
		Stainless Steel
Suggested Lubricant	Airline Oil F442001	
Valve Assembly	Brass / Nitrile / Acetal	

 = "Most Popular"

Note: For Kits and Repair Parts, see individual pages for Filters, Regulators, and Lubricators.

 WARNING
<p>Product rupture can cause serious injury. Do not connect regulator to bottled gas. Do not exceed maximum primary pressure rating.</p>

CAUTION:

REGULATOR PRESSURE ADJUSTMENT – The working range of knob adjustment is designed to permit outlet pressures within their full range. Pressure adjustment beyond this range is also possible because the knob is not a limiting device. This is a common characteristic of most industrial regulators, and limiting devices may be obtained only by special design.

For best performance, regulated pressure should always be set by increasing the pressure up to the desired setting.

Ordering Information

Model Type	Port Size	Plastic Bowl / Bowl Guard With Gauge 0 to 125 PSI (0 to 8.6 bar)	Metal Bowl / Sight Gauge With Gauge 0 to 125 PSI (0 to 8.6 bar)	Plastic Bowl / Bowl Guard With Gauge & End Blocks 0 to 125 PSI(0 to 8.6 bar)
Manual Drain	3/8	D28-03-FKG0B	D28-03-FLG0B	D28-03-FKBGB
	1/2	D28-04-FKG0B	D28-04-FLG0B	D28-04-FKBGB
	3/4	D28-06-FKG0B	D28-06-FLG0B	D28-06-FKBGB
Automatic Drain	3/8	D28-03-FGG0B	D28-03-FHG0B	D28-03-FGBGB
	1/2	D28-04-FGG0B	D28-04-FHG0B	D28-04-FGBGB
	3/4	D28-06-FGG0B	D28-06-FHG0B	D28-06-FGBGB

Options - To order an option supplied with the unit model, add the appropriate coded suffix letter in the designated position of the model number.

Combination D90

= "Most Popular"

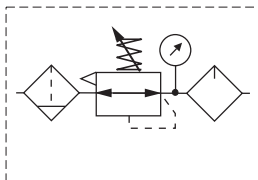

Options

D90	-	0	-	6	-	A	-	H	-	G	-	M
Unit function		Thread type*		Port size		Regulator function / pressure		Bowl / drain type		Option		Option
Filter / Regulator + Lubricator	D90	NPT 0 BSPP C		3/4 6 1 8		A Relieving / 0-174 PSI		H Metal bowl with sight gauge / auto drain L Metal bowl with sight gauge / manual drain		G Gauge		M Mounting bracket

*Note: For 1-1/2" ported unit, please order P3YKA*BCP port block kit separately.
Bold items are most common.

Filter / Regulator + Lubricator Combinations 5 micron element, 12 bar (174 psig) regulator + gauge and wall mounting bracket

Ordering information

Port size	Flow† scfm	Weight kg (lb)	Combined manual / semi-auto drain part number†	Auto drain part number†
3/4"	315	2.8 (6.2)	D90-06-ALGM	D90-06-AHGM
1"	340	2.8 (6.2)	D90-08-ALGM	D90-08-AHGM

† Standard part numbers shown in bold. For other models refer to Options chart below.

‡ Flow with 10 bar (145 psig) inlet pressure, 6.3 bar (91.4 psig) set pressure and 1 bar (14.5 psig) pressure drop.

Note: For Kits and Repair Parts, see individual pages for Filters, Regulators, and Lubricators.

 WARNING
Product rupture can cause serious injury. Do not connect regulator to bottled gas. Do not exceed maximum primary pressure rating.

CAUTION:

REGULATOR PRESSURE ADJUSTMENT – The working range of knob adjustment is designed to permit outlet pressures within their full range. Pressure adjustment beyond this range is also possible because the knob is not a limiting device. This is a common characteristic of most industrial regulators, and limiting devices may be obtained only by special design.

For best performance, regulated pressure should always be set by increasing the pressure up to the desired setting.

Dimensions mm (inches)

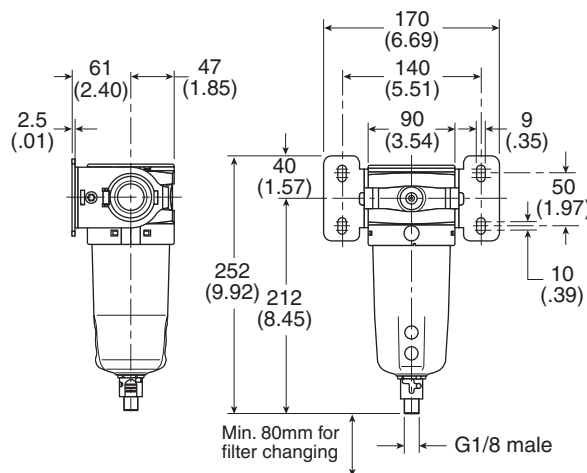
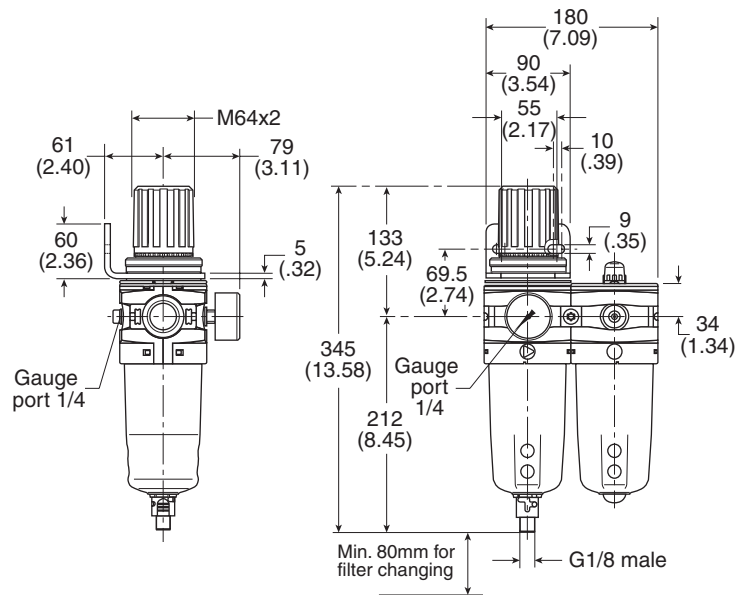

Combination Numbering System

 = "Most Popular"

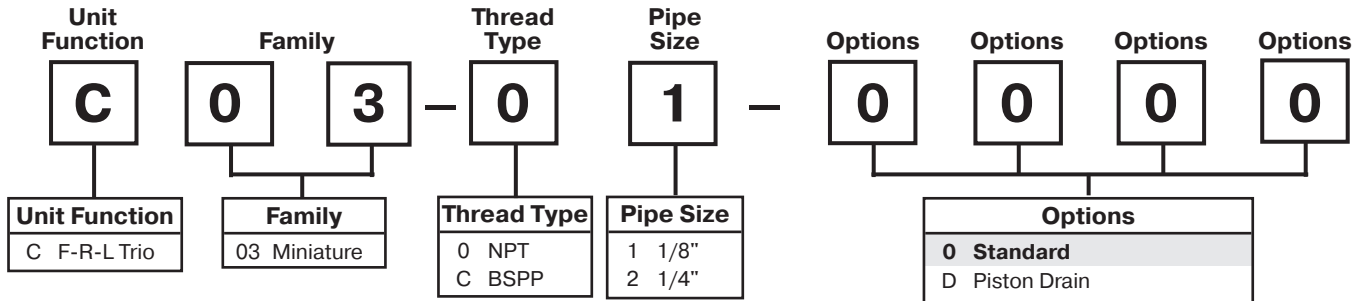

Note: When selecting from the options columns, please enter letters in alphabetical order for positions 6, 7, 8, and 9.
For example: **M03-01-DM00**

NOTE: 0000 in position 6, 7, 8 and 9 signifies standard product.
(Poly Bowl, Manual Drain on Filter, no Drain on Lubricator, 2 to 125 PSIG, Relieving)

* Not available with BSPP thread type.

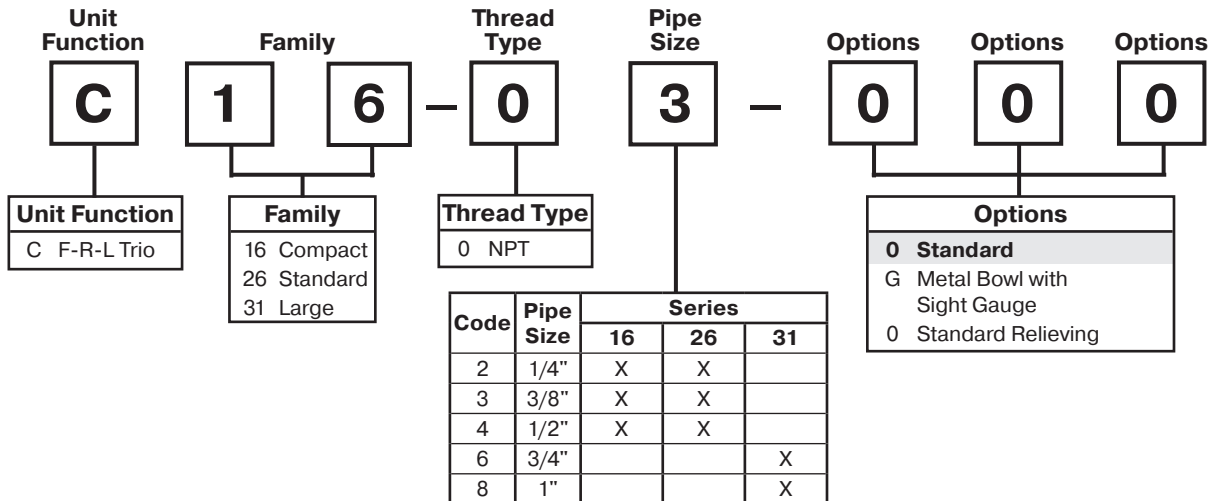

"F" Series Filters, Type "A" 5 micron elements: All Wilkerson Type "A" 5 micron elements meet or exceed ISO Class 3 for maximum particle size and concentration of solid contaminants.

Note: All classes above refer to International Standards Organization (ISO) standard 8573-1, pertaining to maximum particle size and concentration of solid contaminants, and maximum oil content.

NOTE: When selecting from the options columns, please enter letters in alphabetical order for positions 6, 7, 8.
For example:

C16-03-000

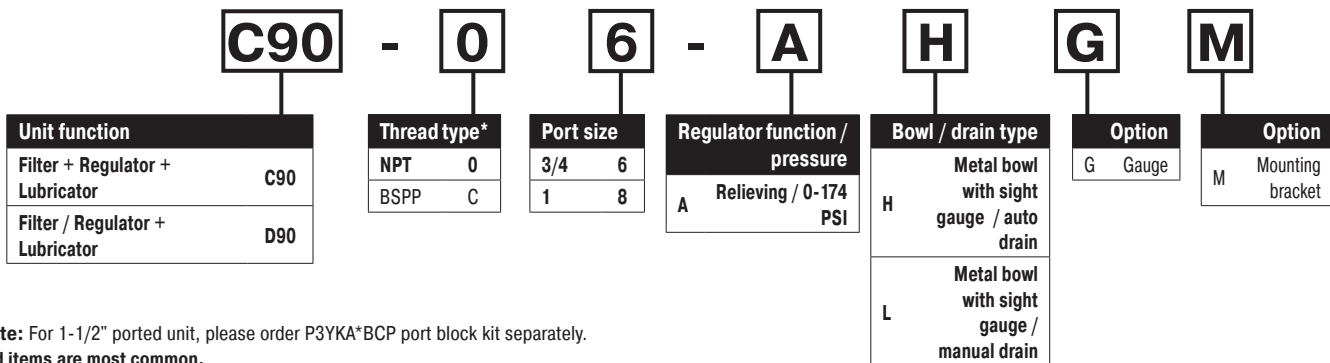

*Note: For 1-1/2" ported unit, please order P3YKA*BCP port block kit separately.
Bold items are most common.

Combination Numbering System

 = "Most Popular"

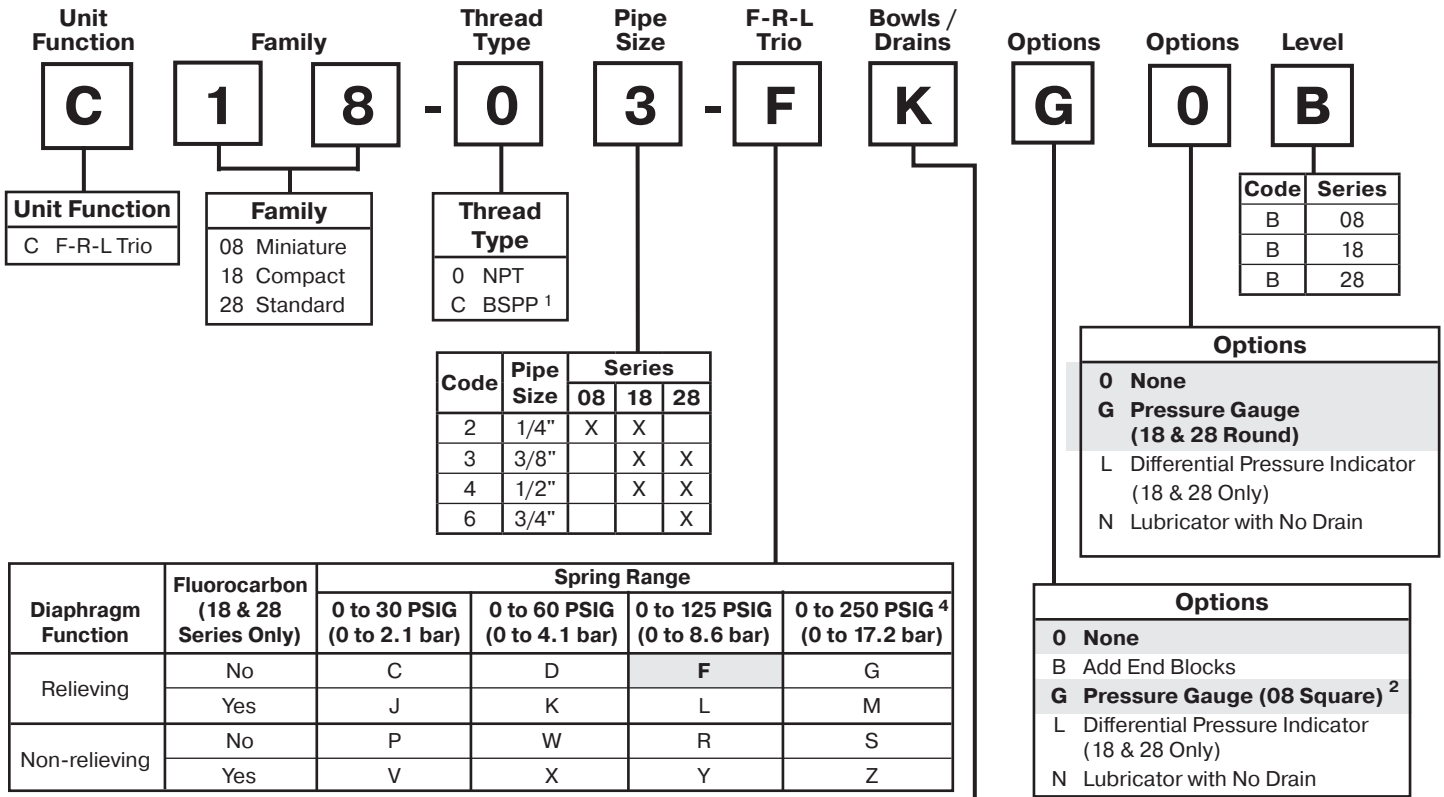

Wilkerson combination models are offered with the T-bracket(s) as standard.

Drains	Bowls	
	Plastic w / Guard Nitrile Standard	Metal w/Sight Gauge ³ Nitrile Standard
Automatic Drain (18 & 28 Series Only)	G	H
Manual Drain	K	L
Piston Drain (08 Series Only)	R	S

- ¹ ISO, R228 (G Series)
- ² Square gauge included with all C08
- ³ 08 series has all metal bowl (no sight gauge).
- ⁴ 08 series operating range 0 to 232 PSIG (1 to 16 bar).

"F" Series Filters, Type "A" 5 micron elements: All Wilkerson Type "A" 5 micron elements meet or exceed ISO Class 3 for maximum particle size and concentration of solid contaminants.

NOTE: All classes above refer to International Standards Organization (ISO) standard 8573-1, pertaining to maximum particle size and concentration of solid contaminants, and maximum oil content.

***Note:** For 1-1/2" ported unit, please order P3YKA*BCP port block kit separately.

NOTE: When selecting from the options columns, please enter letters in alphabetical order for positions 7, 8, 9. For example:

C 1 8 - 0 3 - F K G 0 B

Suggested Lubricant

Airline Oil F442001
 Petroleum based oil of 100 to 200 SUS viscosity at 100°F and an aniline point greater than 200°F
 (DO NOT USE OILS WITH ADDITIVES, COMPOUNDED OILS CONTAINING SOLVENTS, GRAPHITE, DETERGENTS, OR SYNTHETIC OILS.)

Combination C03

= "Most Popular"



C03-02-0000

Features

- Excellent Water Removal Efficiency
- Unbalanced Poppet Standard
- Solid Control Piston for Extended Life
- Non-rising Adjustment Knob
- Two Full Flow 1/8" Gauge Ports
- Proportional Oil Delivery over a Wide Range of Air Flows
- Precision Needle Valve Assures Repeatable Oil Delivery and Provides Simple Adjustment of Delivery Rate
- Ideal for Low and Light flow Applications with Changing Air Flow
- Transparent Sight Dome for 360° Visibility
- Regulator can be mounted with knob in up or down position. (Factory supplied in down position)

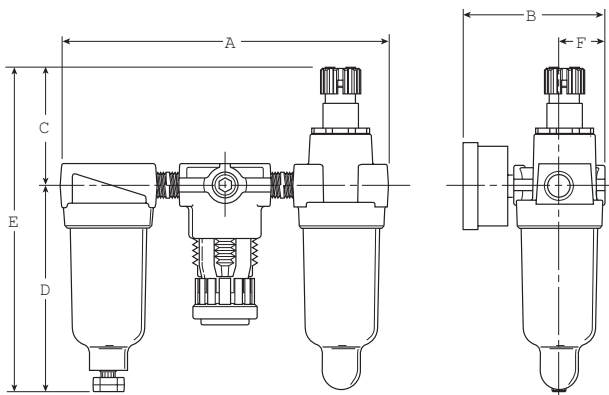

Dimensions

Model	Inches (mm)	A	B	C	D	E	F
Standard Unit C03-XX-XXXX		5.77 (147)	2.83 (71.9)	2.16 (55)	3.82 (97)	5.98 (152)	.79 (20)

Specifications

Flow Capacity*	1/8	20 SCFM (9.4 dm ³ /s)
	1/4	20 SCFM (9.4 dm ³ /s)
Gauge Ports (2)	1/8	
Minimum Flow for Lubrication	0.7 SCFM at 100 PSIG	
Port Threads	1/8, 1/4	
Pressure & Temperature Ratings –		
Plastic Bowl	0 to 150 PSIG (0 to 10.3 bar) 32°F to 125°F (0°C to 52°C)	
Metal Bowl	0 to 250 PSIG (0 to 17.2 bar) 32°F to 175°F (0°C to 80°C)	
Secondary Pressure Ranges –		
Standard Pressure	2 to 125 PSIG (0 to 8.6 bar)	
Medium Pressure	1 to 60 PSIG (0 to 4.1 bar)	
Medium Pressure	1 to 30 PSIG (0 to 2.1 bar)	
Low Pressure	1 to 15 PSIG (0 to 1.0 bar)	
Weight	.9 lb. (.36 kg)	

* Inlet pressure 100 PSIG (6.9 bar). Secondary pressure 90 PSIG (6.2 bar).

"F" Series Filters, Type "A" 5 micron elements: All Wilkerson Type "A" 5 micron elements **meet or exceed ISO Class 3** for maximum particle size and concentration of solid contaminants.

Materials of Construction

Adjusting Nut	Brass
Adjusting Stem & Spring	Steel
Body	Zinc
Bonnet, Knob, Seat, Piston, Holder & Deflector	Plastic
Bowls –	
Transparent	Polycarbonate
Metal (Without Sight Gauge)	Zinc
Filter Elements – 5 Micron (Standard)	Plastic
Manual Drain –	
Body & Stem	Plastic
Seals	Nitrile
Piston Drain –	
Piston & Seals	Nitrile
Stem, Seat, Adaptor & Washers	Aluminum
Seals	Nitrile
Sight Dome	Polycarbonate
Suggested Lubricant	Airline Oil F442001

 = "Most Popular"

Note: For Kits and Repair Parts, see individual pages for Filters, Regulators, and Lubricators.

 WARNING
<p>Product rupture can cause serious injury. Do not connect regulator to bottled gas. Do not exceed maximum primary pressure rating.</p>

CAUTION:

REGULATOR PRESSURE ADJUSTMENT – The working range of knob adjustment is designed to permit outlet pressures within their full range. Pressure adjustment beyond this range is also possible because the knob is not a limiting device. This is a common characteristic of most industrial regulators, and limiting devices may be obtained only by special design.

For best performance, regulated pressure should always be set by increasing the pressure up to the desired setting.

Ordering Information

Model Type	Port Size	Plastic Bowl with Gauge	Plastic Bowl without Gauge	Metal Bowl with Gauge	Metal Bowl without Gauge
Manual Drain	1/8	C03-01-G000	C03-01-0000	C03-01-GM00	C03-01-M000
	1/4	C03-02-G000	C03-02-0000	C03-02-GM00	C03-02-M000

Options - To order an option supplied with the unit model, add the appropriate coded suffix letter in the designated position of the model number.

Combination C08

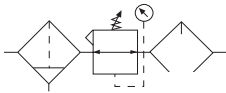

Features

- Components Integrated into Single Unit
- Modern Design and Appearance
- Light Weight, Ready-to-Mount Assembly Comes Standard with Flush-Mount Pressure Gauge and Modular T-bracket / Joiner Assembly
- High Flow Capacity
- Quick-Disconnect Bowl / Bowl Guard

Specifications

Flow Capacity*	1/4	27 SCFM (13 dm ³ /s, ANR)
Gauge Port** (2)	NPT	1/8
Maximum Supply Pressure	Plastic Bowl	150 PSIG (10.3 bar)
	Metal Bowl	250 PSIG (17.2 bar)
Operating Temperature	Plastic Bowl	14° to 125°F (-10° to 52°C)
	Metal Bowl	14° to 150°F (-10° to 65.5°C)
Port Size	NPT / BSPP-G	1/4
Standard Filtration	5 Micron	
Weight	1.96 lb. (0.9 kg)	

* Inlet pressure 145 PSIG (10 bar), Secondary pressure 100 PSIG (6.9 bar), 14.5 PSIG (1 bar) pressure drop.

“F” Series Filters, Type “A” 5 micron elements: All Wilkerson Type “A” 5 micron elements **meet or exceed ISO Class 3** for maximum particle size and concentration of solid contaminants.

Gauge supplied with every part. Gauge can be installed on the front or back of the regulator. If no gauge is installed, both seal screws must be installed.

Materials of Construction

Body	Aluminum	
Bonnet	Glass-filled Nylon	
Bowl	Plastic Bowl	Polycarbonate
	Metal Bowl	Aluminum
Bowl Guard	Nylon	
Diaphragm Assembly	Stainless Steel/ Nitrile	
Filter Element	Polyethylene	
Knob	Acetal	
Seals	Plastic Bowl	Nitrile
	Metal Bowl	Nitrile
Sight Dome	Polycarbonate	
Springs	Steel	
Valve	Brass / Nitrile	

Suggested Lubricant

Airline Oil F442001
 Petroleum based oil of 100 to 200 SUS viscosity at 100°F and an aniline point greater than 200°F
 (DO NOT USE OILS WITH ADDITIVES, COMPOUNDED OILS CONTAINING SOLVENTS, GRAPHITE, DETERGENTS, OR SYNTHETIC OILS.)

Ordering Information

Model Type	Port Size	Plastic Bowl /Bowl Guard / With Gauge 0 to 125 PSI (0 to 8.6 bar)	Metal Bowl /With Gauge 0 to 125 PSI (0 to 8.6 bar)
Manual Drain	1/4	C08-02-FKG0B	C08-02-FLG0B

Options - To order an option supplied with the unit model, add the appropriate coded suffix letter in the designated position of the model number.

 = "Most Popular"

Note: For Kits and Repair Parts, see individual pages for Filters, Regulators, and Lubricators.

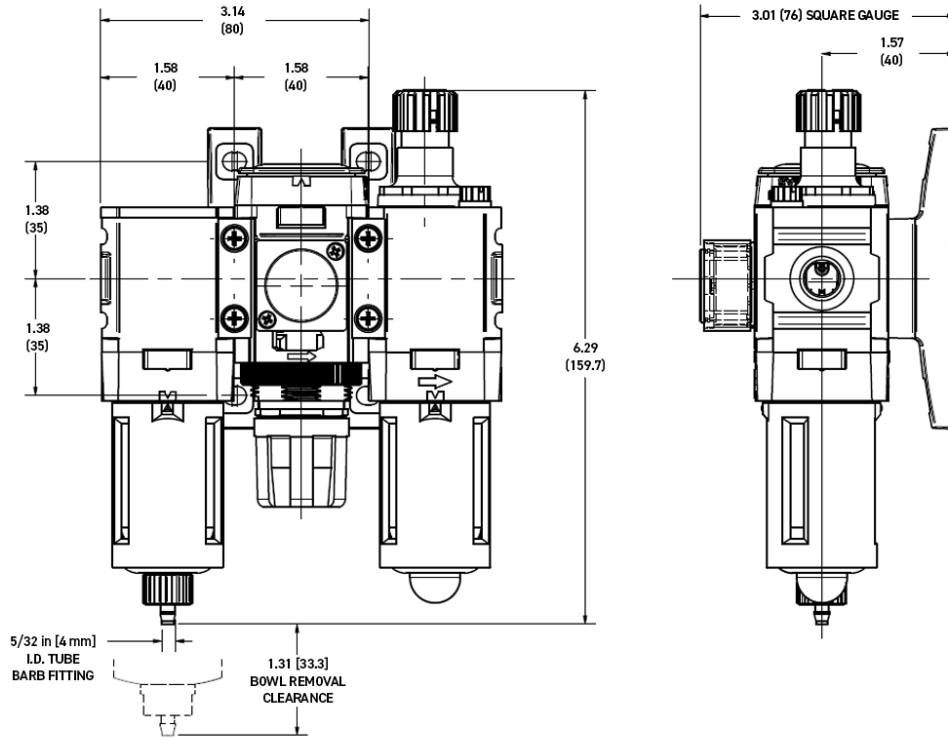

CAUTION:

REGULATOR PRESSURE ADJUSTMENT – The working range of knob adjustment is designed to permit outlet pressures within their full range. Pressure adjustment beyond this range is also possible because the knob is not a limiting device. This is a common characteristic of most industrial regulators, and limiting devices may be obtained only by special design.

For best performance, regulated pressure should always be set by increasing the pressure up to the desired setting.

⚠ WARNING

**Product rupture can cause serious injury.
Do not connect regulator to bottled gas.
Do not exceed maximum primary pressure rating.**

Combination C18

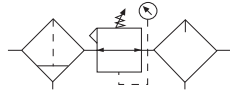

Features

- Components Integrated into Single Unit
- Modern Design and Appearance
- Light Weight, Ready-to-Mount Assembly Comes Standard with Pressure Gauge and Modular T-Bracket / Joiner Assembly
- High Flow Capacity
- Quick-Disconnect Bowl / Bowl Guard

Specifications

Flow Capacity*	1/4	42 SCFM (20 dm ³ /s, ANR)
	3/8	68 SCFM (32 dm ³ /s, ANR)
	1/2	85 SCFM (40 dm ³ /s, ANR)
Gauge Port (2)	NPT / BSPP-G 1/4	
Maximum Supply Pressure	Plastic Bowl	150 PSIG (10.3 bar)
	Metal Bowl	250 PSIG (17.2 bar)
Operating Temperature	Plastic Bowl	-13° to 125°F (-25° to 52°C)
	Metal Bowl	-13° to 150°F (-25° to 65.5°C)
Port Size	NPT / BSPP-G 1/4, 3/8, 1/2	
Standard Filtration	5 Micron	
Weight	4.04 lb. (1.83 kg)	

* Inlet pressure 145 PSIG (10 bar), Secondary pressure 91.3 PSIG (6.3 bar), 14.5 PSIG (1 bar) pressure drop.

"F" Series Filters, Type "A" 5 micron elements: All Wilkerson Type "A" 5 micron elements **meet or exceed ISO Class 3** for maximum particle size and concentration of solid contaminants.

Materials of Construction

Body	Aluminum	
Bonnet / Knob	Nylon / Acetal	
Bowls	Plastic Bowl	Polycarbonate
	Metal Bowl	Aluminum
Diaphragm Assembly	Nitrile / Zinc	
Filter Element	Polyethylene	
Seals	Plastic Bowl	Nitrile
	Metal Bowl	Nitrile
Sight Dome	Polycarbonate	
Sight Gauge	Metal Bowl	Polyamide (Nylon)
Springs	Main Regulating Valve	Steel
		Stainless Steel
Suggested Lubricant	Airline Oil F442001	
Valve	Brass / Nitrile	

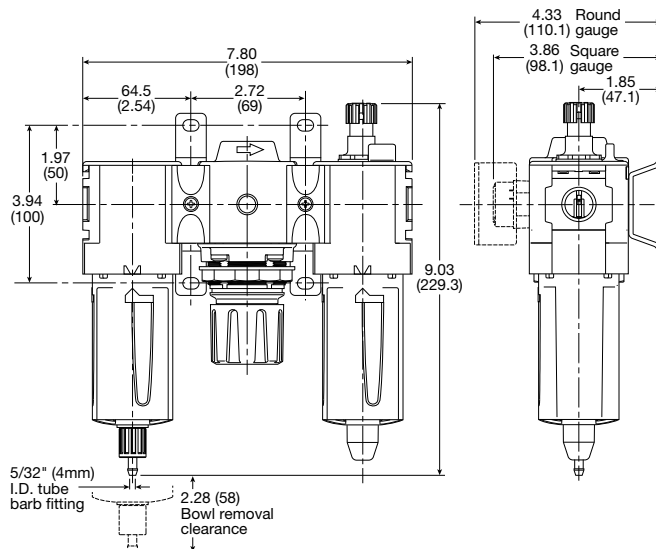

Inches (mm)

Manual Drain

 = "Most Popular"

Note: For Kits and Repair Parts, see individual pages for Filters, Regulators, and Lubricators.

 WARNING
Product rupture can cause serious injury. Do not connect regulator to bottled gas. Do not exceed maximum primary pressure rating.

CAUTION:

REGULATOR PRESSURE ADJUSTMENT – The working range of knob adjustment is designed to permit outlet pressures within their full range. Pressure adjustment beyond this range is also possible because the knob is not a limiting device. This is a common characteristic of most industrial regulators, and limiting devices may be obtained only by special design.

For best performance, regulated pressure should always be set by increasing the pressure up to the desired setting.

Ordering Information

Model Type	Port Size	Plastic Bowl / Bowl Guard / With Gauge 0 to 125 PSI (0 to 8.6 bar)	Metal Bowl / Sight Gauge / With Gauge 0 to 125 PSI (0 to 8.6 bar)	Plastic Bowl / Bowl Guard / With Gauge & End Blocks 0 to 125 PSI (0 to 8.6 bar)
Manual Drain	1/4	C18-02-FKG0B	C18-02-FLG0B	C18-02-FKBGB
	3/8	C18-03-FKG0B	C18-03-FLG0B	C18-03-FKBGB
	1/2	C18-04-FKG0B	C18-04-FLG0B	C18-04-FKBGB
Automatic Drain	1/4	C18-02-FGG0B	C18-02-FHG0B	C18-02-FGBGB
	3/8	C18-03-FGG0B	C18-03-FHG0B	C18-03-FGBGB
	1/2	C18-04-FGG0B	C18-04-FHG0B	C18-04-FGBGB

Options - To order an option supplied with the unit model, add the appropriate coded suffix letter in the designated position of the model number.

Combination C16

= "Most Popular"

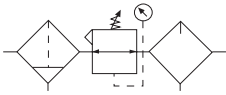

C16-02-000

Features

- Components Integrated into Single Unit
- Metal Bowl with Sight Gauge Option
- Pressure Gauge Standard
- Integral Plastic Bowl / Bowl Guard
- Quick Disconnect Bowl
- Standard Self-relieving

Specifications

Flow Capacity*	1/4	36.1 SCFM (17.0 dm ³ /s)
	3/8	58.5 SCFM (27.6 dm ³ /s)
	1/2	64.0 SCFM (30.2 dm ³ /s)
Gauge Ports (2)	NPT	1/4
Port Threads	NPT	1/4, 3/8, 1/4
Pressure & Temperature Ratings –		
Plastic Bowl	0 to 150 PSIG (0 to 10.3 bar) 32°F to 125°F (0°C to 52°C)	
Metal Bowl	0 to 200 PSIG (0 to 13.8 bar) 32°F to 175°F (0°C to 80°C)	
Standard Filtration	5 Micron	
Weight	7.3 lb. (3.3 kg)	

* Inlet pressure 150 PSIG (10.3 bar). Pressure drop 5 PSID (0.3 bar).

"F" Series Filters, Type "A" 5 micron elements: All Wilkerson Type "A" 5 micron elements **meet or exceed ISO** Class 3 for maximum particle size and concentration of solid contaminants.

Materials of Construction

Body	Zinc
Bonnet, Knob	PBT
Bowls –	
Plastic Bowl	Polycarbonate
Metal Bowl	Zinc
Diaphragm	Nitrile / Zinc
Filter Element	Polypropylene
Seals –	
Plastic Bowl	Nitrile
Metal Bowl	Fluorocarbon
Sight Dome	Nylon
Springs	Steel
Suggested Lubricant	Airline Oil F442001
Valve Assembly	Brass / Nitrile / Acetal

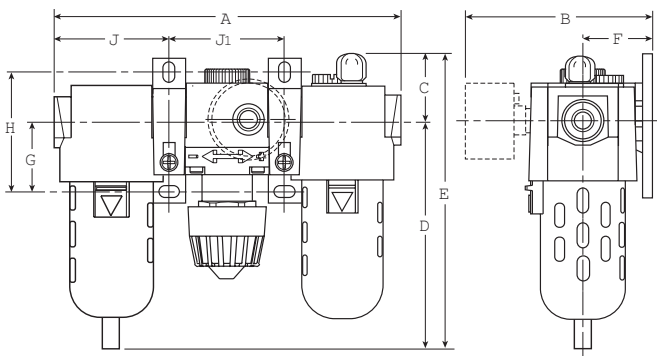

Dimensions

Model	Inches (mm)	A	B	C	D	E	F	G	H	J	J ₁
Standard Unit with End Blocks C16-XX-000		11.30 (287)	4.30 (109)	1.62 (41)	5.50 (139.7)	7.12 (180.8)	1.30 (33)	1.74 (44)	2.98 (75.7)	5.65 (143.5)	2.91 (73.9)

 = "Most Popular"

Note: For Kits and Repair Parts, see individual pages for Filters, Regulators, and Lubricators.

⚠ WARNING
Product rupture can cause serious injury. Do not connect regulator to bottled gas. Do not exceed maximum primary pressure rating.

CAUTION:

REGULATOR PRESSURE ADJUSTMENT – The working range of knob adjustment is designed to permit outlet pressures within their full range. Pressure adjustment beyond this range is also possible because the knob is not a limiting device. This is a common characteristic of most industrial regulators, and limiting devices may be obtained only by special design.

For best performance, regulated pressure should always be set by increasing the pressure up to the desired setting.

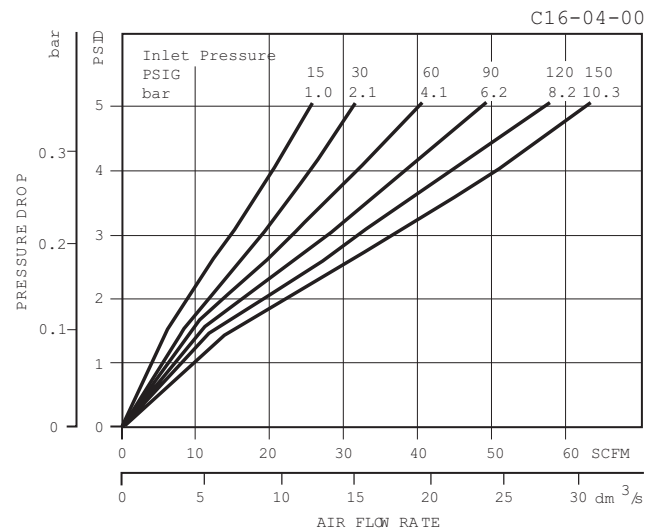
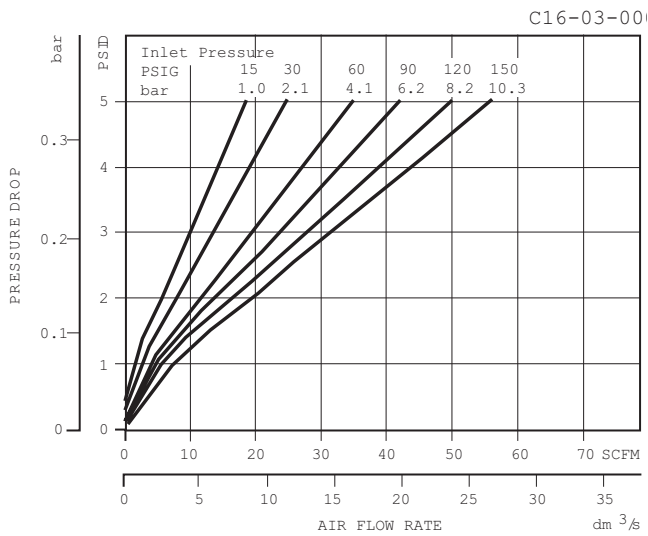
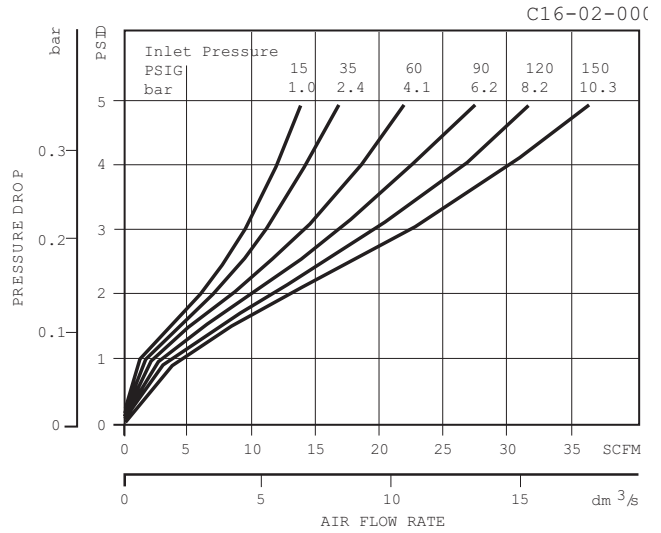

Ordering Information

Model Type	Port Size	Plastic Bowl / Bowl Guard with End Blocks 0 to 125 PSIG (0 to 8.5 bar)	Metal Bowl / Sight Gauge 0 to 125 PSIG (0 to 8.5 bar)
C16	1/4	C16-02-000	C16-02-G00
	3/8	C16-03-000	C16-03-G00
	1/2	C16-04-000	C16-04-G00

Options - To order an option supplied with the unit model, add the appropriate coded suffix letter in the designated position of the model number.

Combination C28

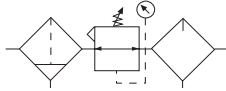

Features

- Components Integrated into Single Unit
- Modern Design and Appearance
- Light Weight, Ready-to-Mount Assembly Comes Standard with Pressure Gauge and Modular T-Bracket / Joiner Assembly
- High Flow Capacity
- Quick-Disconnect Bowl / Bowl Guard

Specifications

Flow Capacity*	3/8	90 SCFM (43 dm ³ /s, ANR)
	1/2	90 SCFM (43 dm ³ /s, ANR)
	3/4	110 SCFM (52 dm ³ /s, ANR)
Gauge Port (2)	NPT / BSPP-G 1/4	
Maximum Supply Pressure	Plastic Bowl	150 PSIG (10.3 bar)
	Metal Bowl	250 PSIG (17.2 bar)
Operating Temperature	Plastic Bowl	-13° to 125°F (-25° to 52°C)
	Metal Bowl	-13° to 150°F (-25° to 65.5°C)
Port Size	NPT / BSPP-G 3/8, 1/2, 3/4	
Standard Filtration	5 micron	
Weight	5.90 lb. (2.6 kg)	

* Inlet pressure 145 PSIG (10 bar), Secondary pressure 91.3 PSIG (6.3 bar), 14.5 PSIG (1 bar) pressure drop.

"F" Series Filters, Type "A" 5 micron elements: All Wilkerson Type "A" 5 micron elements **meet or exceed ISO Class 3** for maximum particle size and concentration of solid contaminants.

Materials of Construction

Body	Aluminum	
Bonnet / Knob	Nylon / Acetal	
Bowls	Plastic Bowl	Polycarbonate
	Metal Bowl	Aluminum
Diaphragm Assembly	Nitrile / Zinc	
Filter Element	Polyethylene	
Seals	Plastic Bowl	Nitrile
	Metal Bowl	Nitrile
Sight Dome	Polycarbonate	
Sight Gauge	Metal Bowl	Polyamide (Nylon)
Springs	Main Regulating Valve	Steel
		Stainless Steel
Suggested Lubricant	Airline Oil F442001	
Valve	Brass / Nitrile / Acetal	

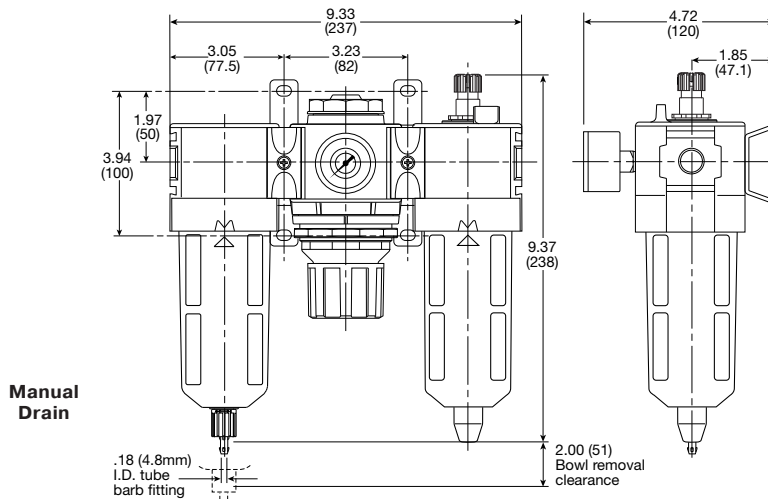

Inches (mm)

 = "Most Popular"

Note: For Kits and Repair Parts, see individual pages for Filters, Regulators, and Lubricators.

 WARNING
<p>Product rupture can cause serious injury. Do not connect regulator to bottled gas. Do not exceed maximum primary pressure rating.</p>

CAUTION:

REGULATOR PRESSURE ADJUSTMENT – The working range of knob adjustment is designed to permit outlet pressures within their full range. Pressure adjustment beyond this range is also possible because the knob is not a limiting device. This is a common characteristic of most industrial regulators, and limiting devices may be obtained only by special design.

For best performance, regulated pressure should always be set by increasing the pressure up to the desired setting.

Ordering Information

Model Type	Port Size	Plastic Bowl / Bowl Guard / With Gauge 0 to 125 PSI (0 to 8.6 bar)	Metal Bowl / Sight Gauge / With Gauge 0 to 125 PSI (0 to 8.6 bar)	Plastic Bowl / Bowl Guard / With Gauge & End Blocks 0 to 125 PSI (0 to 8.6 bar)
Manual Drain	3/8	C28-03-FKG0B	C28-03-FLG0B	C28-03-FKBGB
	1/2	C28-04-FKG0B	C28-04-FLG0B	C28-04-FKBGB
	3/4	C28-06-FKG0B	C28-06-FLG0B	C28-06-FKBGB
Automatic Drain	3/8	C28-03-FGG0B	C28-03-FHG0B	C28-03-FGBGB
	1/2	C28-04-FGG0B	C28-04-FHG0B	C28-04-FGBGB
	3/4	C28-06-FGG0B	C28-06-FHG0B	C28-06-FGBGB

Options - To order an option supplied with the unit model, add the appropriate coded suffix letter in the designated position of the model number.

Combination C26

 = "Most Popular"



C26-02-000

Features

- Components Integrated into Single Unit
- Metal Bowl with Sight Gauge Option
- Pressure Gauge Standard
- Integral Plastic Bowl / Bowl Guard
- Quick Disconnect Bowl
- Standard Self-relieving

Specifications

Flow Capacity*	1/4	35.0 SCFM (16.5 dm ³ /s)
	3/8	60.0 SCFM (28.3 dm ³ /s)
	1/2	128 SCFM (60.4 dm ³ /s)
Gauge Ports (2)	NPT / BSPP-G	1/4
Port Threads	NPT	1/4, 3/8, 1/2
Pressure & Temperature Ratings –		
Plastic Bowl	0 to 150 PSIG (0 to 10.3 bar) 32°F to 125°F (0°C to 52°C)	
Metal Bowl	0 to 200 PSIG (0 to 13.8 bar) 32°F to 175°F (0°C to 80°C)	
Standard Filtration	5 Micron	
Weight	10.5 lb. (4.7 kg)	

* Inlet pressure 150 PSIG (10.3 bar). Pressure drop 5 PSID (0.3 bar).

"F" Series Filters, Type "A" 5 micron elements: All Wilkerson Type "A" 5 micron elements **meet or exceed ISO** Class 3 for maximum particle size and concentration of solid contaminants.

Materials of Construction

Body	Zinc
Bonnet, Knob	PBT
Bowls –	
Plastic Bowl	Polycarbonate
Metal Bowl	Zinc
Diaphragm	Nitrile / Zinc
Filter Element	Polypropylene
Seals –	
Plastic Bowl	Nitrile
Metal Bowl	Fluorocarbon
Sight Dome	Nylon
Springs	Steel
Suggested Lubricant	Airline Oil F442001
Valve Assembly	Brass / Nitrile / Acetal

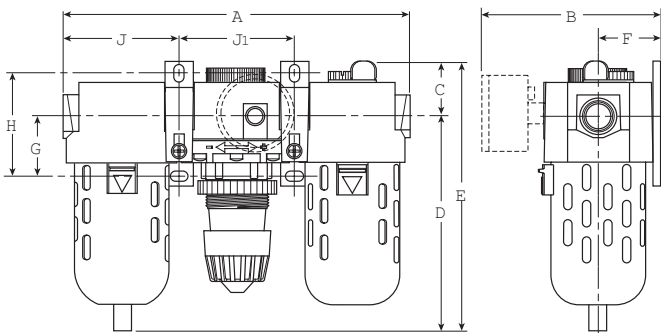

Dimensions

Model	Inches (mm)	A	B	C	D	E	F	G	H	J	J ₁
Standard Unit with End Blocks C26-XX-000		12.35 (314)	4.80 (122)	1.60 (41)	6.40 (162.6)	8.00 (203)	1.50 (38)	1.74 (44)	2.98 (75.7)	6.17 (157)	3.35 (85.1)

 = "Most Popular"

Note: For Kits and Repair Parts, see individual pages for Filters, Regulators, and Lubricators.

 WARNING
Product rupture can cause serious injury. Do not connect regulator to bottled gas. Do not exceed maximum primary pressure rating.

CAUTION:

REGULATOR PRESSURE ADJUSTMENT – The working range of knob adjustment is designed to permit outlet pressures within their full range. Pressure adjustment beyond this range is also possible because the knob is not a limiting device. This is a common characteristic of most industrial regulators, and limiting devices may be obtained only by special design.

For best performance, regulated pressure should always be set by increasing the pressure up to the desired setting.

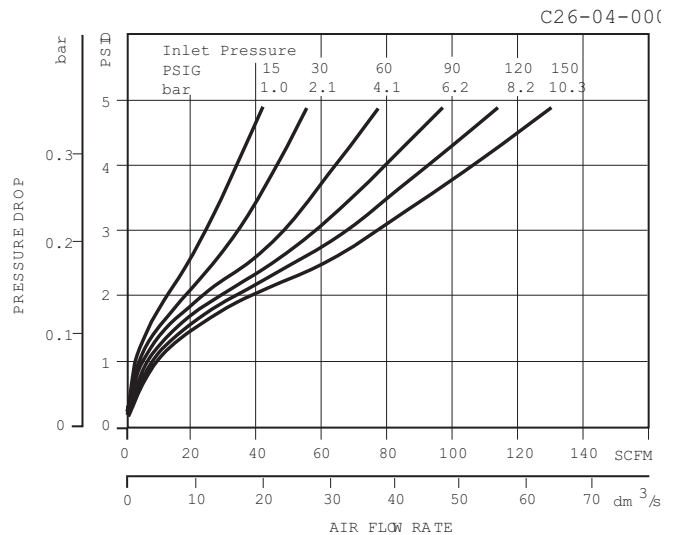
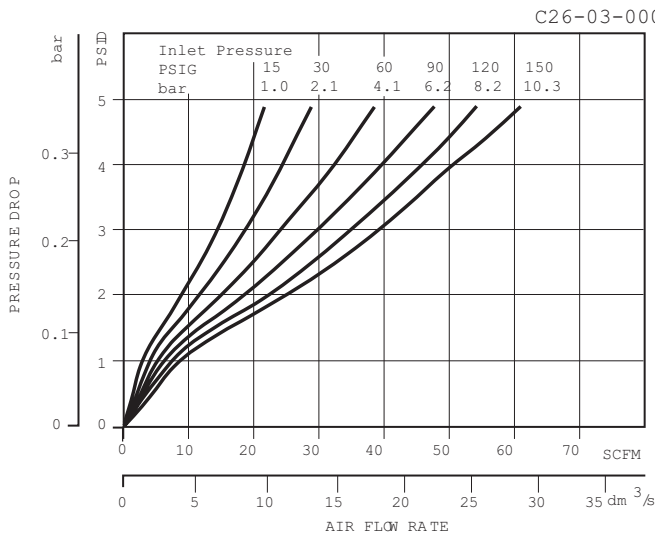
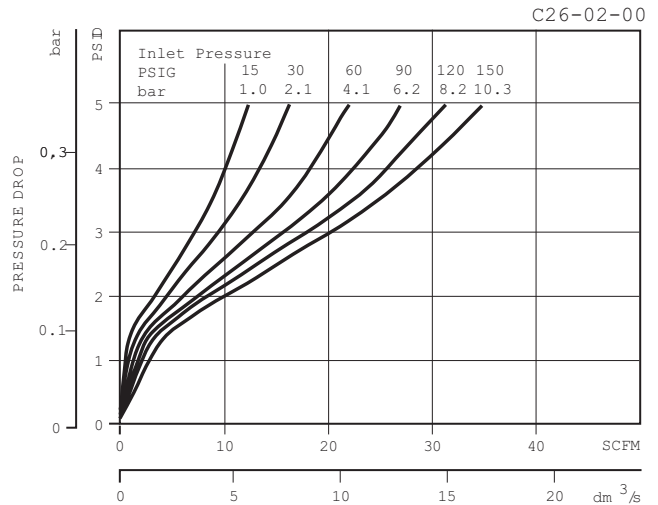

Ordering Information

Model Type	Port Size	Plastic Bowl / Bowl Guard with End Blocks 0 to 125 PSIG (0 to 8.5 bar)	Metal Bowl / Sight Gauge 0 to 125 PSIG (0 to 8.5 bar)
C26	1/4	C26-02-000	C26-02-G00
	3/8	C26-03-000	C26-03-G00
	1/2	C26-04-000	C26-04-G00

Options - To order an option supplied with the unit model, add the appropriate coded suffix letter in the designated position of the model number.

Combination C90

= "Most Popular"

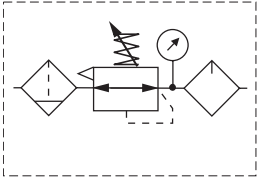

Options

C90	-	0	-	6	-	A	H	G	M																							
<table border="1" style="width: 100%; border-collapse: collapse;"> <tr><th>Unit function</th></tr> <tr><td>Filter + Regulator + Lubricator</td></tr> <tr><td style="text-align: right;">C90</td></tr> </table>	Unit function	Filter + Regulator + Lubricator	C90		<table border="1" style="width: 100%; border-collapse: collapse;"> <tr><th>Thread type*</th></tr> <tr><td>NPT 0</td></tr> <tr><td>BSPP C</td></tr> </table>	Thread type*	NPT 0	BSPP C		<table border="1" style="width: 100%; border-collapse: collapse;"> <tr><th>Port size</th></tr> <tr><td>3/4 6</td></tr> <tr><td>1 8</td></tr> </table>	Port size	3/4 6	1 8		<table border="1" style="width: 100%; border-collapse: collapse;"> <tr><th>Regulator function / pressure</th></tr> <tr><td>Relieving / 0-174 PSI</td></tr> <tr><td>A</td></tr> </table>	Regulator function / pressure	Relieving / 0-174 PSI	A	<table border="1" style="width: 100%; border-collapse: collapse;"> <tr><th>Bowl / drain type</th></tr> <tr><td>Metal bowl with sight gauge / auto drain</td></tr> <tr><td>H</td></tr> <tr><td>Metal bowl with sight gauge / manual drain</td></tr> <tr><td>L</td></tr> </table>	Bowl / drain type	Metal bowl with sight gauge / auto drain	H	Metal bowl with sight gauge / manual drain	L	<table border="1" style="width: 100%; border-collapse: collapse;"> <tr><th>Option</th></tr> <tr><td>Gauge</td></tr> <tr><td>G</td></tr> </table>	Option	Gauge	G	<table border="1" style="width: 100%; border-collapse: collapse;"> <tr><th>Option</th></tr> <tr><td>Mounting bracket</td></tr> <tr><td>M</td></tr> </table>	Option	Mounting bracket	M
Unit function																																
Filter + Regulator + Lubricator																																
C90																																
Thread type*																																
NPT 0																																
BSPP C																																
Port size																																
3/4 6																																
1 8																																
Regulator function / pressure																																
Relieving / 0-174 PSI																																
A																																
Bowl / drain type																																
Metal bowl with sight gauge / auto drain																																
H																																
Metal bowl with sight gauge / manual drain																																
L																																
Option																																
Gauge																																
G																																
Option																																
Mounting bracket																																
M																																

*Note: For 1-1/2" ported unit, please order P3YKA*BCP port block kit separately.
Bold items are most common.

Filter + Regulator + Lubricator Combinations 5 micron element, 12 bar (174 psig) regulator + gauge and wall mounting bracket

Ordering information

Port size	Flow† scfm	Weight kg (lb)	Combined manual / semi-auto drain part number†	Auto drain part number†
3/4"	170	3.3 (7.3)	C90-06-ALGM	C90-06-AHGM
1"	170	3.3 (7.3)	C90-08-ALGM	C90-08-AHGM

† Standard part numbers shown in bold. For other models refer to Options chart below.
 ‡ Flow with 10 bar (145 psig) inlet pressure, 6.3 bar (91.4 psig) set pressure and 1 bar (14.5 psig) pressure drop.

Note: For Kits and Repair Parts, see individual pages for Filters, Regulators, and Lubricators.

 WARNING
Product rupture can cause serious injury. Do not connect regulator to bottled gas. Do not exceed maximum primary pressure rating.

CAUTION:

REGULATOR PRESSURE ADJUSTMENT – The working range of knob adjustment is designed to permit outlet pressures within their full range. Pressure adjustment beyond this range is also possible because the knob is not a limiting device. This is a common characteristic of most industrial regulators, and limiting devices may be obtained only by special design.

For best performance, regulated pressure should always be set by increasing the pressure up to the desired setting.

Dimensions mm (inches)

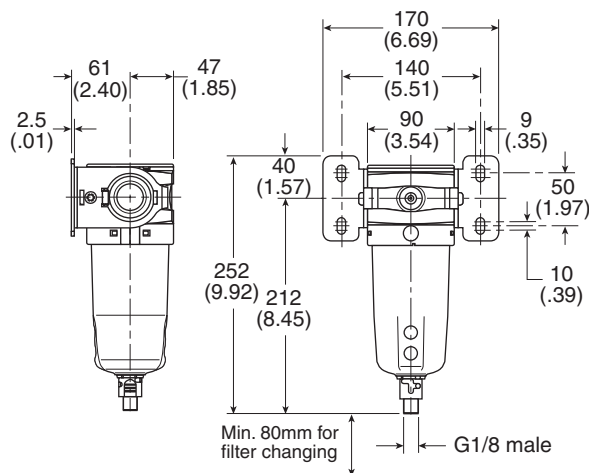
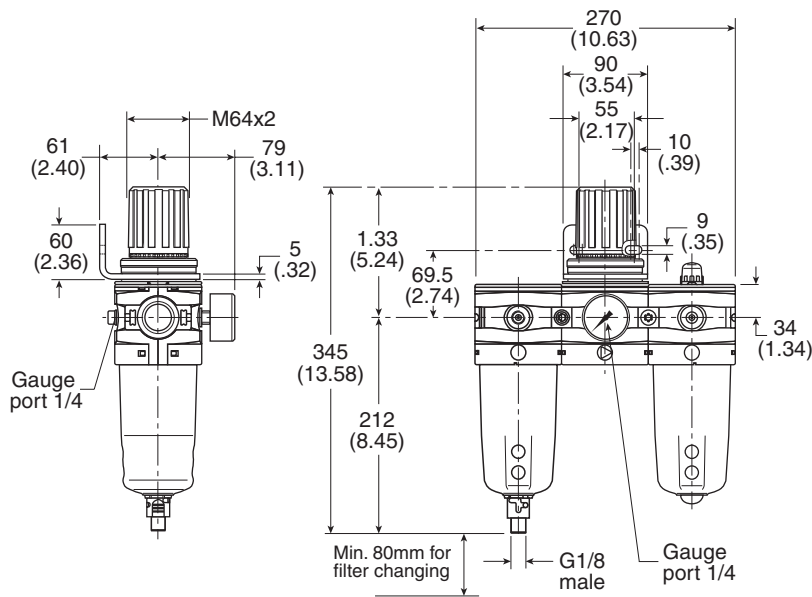

Notes