



**TOWN OF AMHERSTBURG  
COUNCIL MEETING  
AGENDA**

**Tuesday, November 12, 2019**

**6:00 PM**

**Council Chambers**

**271 Sandwich Street South, Amherstburg, ON, N9V 2A5**

For information pertaining to this agenda or to arrange for any additional accessibility needs please contact Tammy Fowkes, Deputy Clerk at [tfowkes@amherstburg.ca](mailto:tfowkes@amherstburg.ca)

Information will be gathered in accordance with the Municipal Freedom of Information and Protection of Privacy Act (MFIPPA). All comments and communications received will become part of the public record unless you expressly request the Town to remove it. If you want to learn more about why and how the Town collects your information, write to the Town Clerk's Office, 271 Sandwich Street South, Amherstburg, ON N9V 2A5 or call 519-736-0012.

---

**1. CALL TO ORDER**

**2. SPECIAL IN-CAMERA COUNCIL MEETING**

That Council move into an In-Camera Meeting of Council at 3:00 pm pursuant to Section 239 of the Municipal Act, 2001, as amended, for the following reasons:

**Item A - Section 239(2)(i)** - A trade secret or scientific, technical, commercial, financial or labour relations information, supplied in confidence to the municipality or local board, which, if disclosed, could reasonably be expected to prejudice significantly the competitive position, or interfere significantly with the contractual or other negotiations of a person, group of persons, or organization; and, **Section 239(2)(k)** - A position, plan, procedure, criteria or instruction to be applied to any negotiations carried on or to be carried on by or on behalf of the municipality or local board.

**Item B - Section 239(3.1)** - Education Session.

3. **DISCLOSURE OF PECUNIARY INTEREST & GENERAL NATURE THEREOF**

*(In-Camera Agenda Meeting Items)*

4. **RECESS FROM SPECIAL IN-CAMERA COUNCIL MEETING**

5. **RESUMPTION OF REGULAR COUNCIL MEETING**

That Council resume Regular session at        p.m.

6. **NATIONAL ANTHEM**

7. **DISCLOSURE OF PECUNIARY INTEREST & GENERAL NATURE THEREOF**

*(Public Council Meeting Agenda Items)*

8. **REPORT OUT FROM IN-CAMERA MEETING - Oct. 28 & Nov.12, 2019**

9. **MINUTES OF PREVIOUS MEETING**

That the minutes **BE ADOPTED** and that those confidential minutes of the closed sessions of Council remain confidential and restricted from public disclosure in accordance with exemptions provided in the Municipal Freedom of Information and Protection of Privacy Act:

9.1 **Special Council Meeting Minutes - August 26, 2019**

9.2 **Special Council Meeting Minutes - Planning - September 9, 2019**

**10. DELEGATIONS**

**10.1 Boblo Island Development Agreement - Cindy Prince, Vice President, AMICO Infrastructure Inc., and Eric Farron, AMICO Legal Counsel**

That the delegation **BE RECEIVED**.

**11. REPORTS – CORPORATE SERVICES**

**11.1 2019 Tax Write-Offs and Rebates**

It is recommended that:

1. The property tax adjustments outlined in the report from the Supervisor of Revenue dated October 18, 2019 regarding 2019 Tax Write-offs and Rebates **BE AFFIRMED**.

**11.2 Asset Management Policy**

It is recommended that:

1. The Asset Management Policy **BE ADOPTED** as presented.

**12. REPORTS – PARKS, FACILITIES, RECREATION AND CULTURE**

There are no reports.

**13. REPORTS – ENGINEERING AND PUBLIC WORKS**

There are no reports.

## 14. REPORTS – PLANNING, DEVELOPMENT AND LEGISLATIVE SERVICES

### 14.1 Transfer of Municipal Lands-Road Allowance at 26 Whelan Drive; Block 52, Plan 12M373 - in front of 26 Whelan Drive (Lot 37 on Plan 12M373)

It is recommended that:

1. **By-law 2019-79** being a by-law to Stop Up, Close and Sell a Portion of the Unimproved Road Allowance described as Block 52 on Plan 12M373 located on the North side of Whelan Avenue be taken as having been read three times and finally passed and the Mayor and Clerk **BE AUTHORIZED** to sign the same; and,
2. The Mayor and Clerk **BE AUTHORIZED** to sign all necessary documents for the transfer prepared in form and content satisfactory to the Director of Planning, Development and Legislative Services.

### 14.2 Zoning By-Law Amendment - WS Concession 4 South

It is recommended that:

1. **By-law 2019-077**, being a by-law to amend Zoning By-law No. 1999-52 for WS Concession 4 South, be taken as having been read three times and finally passed and the Mayor and Clerk **BE AUTHORIZED** to sign same.

### 14.3 Subdivision Agreement for Boblo Developments (South-end) - County of Essex File No. 37-T-14004

It is recommended that:

1. **By-law 2019-091** being a by-law to authorize the signing of a Subdivision Agreement for Boblo Developments (South-end)-County of Essex File No. 37-T-14004, satisfactory in form to the Director of Planning, Development and Legislative Services, in financial content to the Director of Corporate Services, and in technical content to the Manager of Planning Services, be taken as having been read three times and finally passed and the Mayor and Clerk **BE AUTHORIZED** to sign the same.



**15. REPORTS - CAO's OFFICE**

**15.1 2020 Calendar of Council Meetings**

It is recommended that:

1. The rules in the Procedural By-law requiring that regular meetings be held the second and fourth Monday of each month **BE WAIVED** for the months of July, August, and December; and,
2. The 2020 Calendar of Council Meetings **BE APPROVED**, as presented.

**16. INFORMATION REPORTS**

That the following information reports **BE RECEIVED**:

**16.1 Cheque Listing for the Month of October 2019**

**16.2 Kingsbridge Subdivision – Options for Additional Entrance**

**16.3 Monthly Fire Department Report - September 2019**

**17. CONSENT CORRESPONDENCE**

That the following consent correspondence **BE RECEIVED**:

**17.1 Accounts Paid - January 1, 2019 - May 31, 2019**

**17.2 Local Health Care Services - Town of Kingsville Resolution**

**17.3 Transformation of Building Services in Ontario - Municipality of Prescott Resolution**

**17.4 Conservation Authority Board of Directors - Grey Sauble Conservation Authority Resolution**

**17.5 Advertising Rates - 2020 Veterans Day Magazine**

**18. CONSENT OTHER MINUTES**

That the following minutes **BE RECEIVED**:

**18.1 Mayor's Youth Advisory Committee Minutes - October 21, 2019**

**19. OTHER MINUTES**

That the following recommendations from the October 22, 2019, Accessibility Advisory Committee Meeting **BE APPROVED**:

**19.1 Accessibility Advisory Committee Minutes - October 22, 2019**

- The Town of Amherstburg **MATCH** the Accessibility Committee of the Town of Essex in providing an equal portion of \$5,445.47 for the purchase of 5 accessible picnic tables; and,
- The Person First Language (PFL) **BE ADOPTED** as a pilot project at the Accessibility Committee level with further consideration of use in the organization at a later date.

## 19.2 Drainage Board Meeting Minutes - November 5, 2019

It is recommended that:

1. The Drainage Board Meeting Minutes of November 5, 2019 **BE RECEIVED**;
2. **By-law 2019-093** being a by-law to provide for the New Access Culvert on the Dupuis Drain for Bastien based on the Drainage Report by R. Dobbin Engineering BE **PROVISIONALLY ADOPTED** by giving first and second reading and the Mayor and Clerk **BE AUTHORIZED** to sign same;
3. **By-law 2019-095** being a by-law to provide for the John Parks Drain No. 1 Improvements based on the Drainage Report by R. Dobbin Engineering Inc. BE **PROVISIONALLY ADOPTED** by giving first and second reading and the Mayor and Clerk **BE AUTHORIZED** to sign same;
4. The request from Peter Crump for the repair and improvement of the John Parks Drain No. 2 per Section 78 of the Drainage Act **BE ACCEPTED**, as recommended by the Drainage Board;
5. The appointment of the firm of R. Dobbin Engineering Inc. to complete a report for the repair and improvement of the John Parks Drain No. 2 **BE APPROVED**, as recommended by the Drainage Board, and,
6. The assessment adjustments as listed in the engineering report prepared by Rood Engineering Inc. for the Subsequent Connection – Tremblay Drain (Lepera Section 65) **BE APPROVED**, as recommended by the Drainage Board.

## 20. UNFINISHED BUSINESS

### 20.1 Unfinished Business List as at November 12, 2019

## 21. NEW BUSINESS

## 22. NOTICE OF MOTION

*As introduced at the October 28, 2019, Regular Council Meeting*

### 22.1 Climate Change Emergency Declaration - Councillor McArthur

**23. BY-LAWS**

**23.1 By-law 2019-103 - Confirmatory By-law**

That **By-law 2019-103** being a by-law to Confirm all Resolutions of the Municipal Council Meetings held November 4th and 11th, 2019, be taken as having been read three times and finally passed and the Mayor and Clerk **BE AUTHORIZED** to sign same.

**24. RESUMPTION OF SPECIAL IN-CAMERA COUNCIL MEETING**

That Council move back into an In-Camera Meeting of Council after Regular session pursuant to Section 239 of the Municipal Act, 2001, as amended, for the following reason:

**Item C - Section 239(2)(d)** - Labour relations or employee negotiations.

**25. ADJOURNMENT OF SPECIAL IN-CAMERA COUNCIL MEETING**

**26. RESUMPTION OF REGULAR COUNCIL MEETING**

That Council resume Regular session at    p.m.

**27. ADJOURNMENT**

That Council rise and adjourn at    p.m.



**TOWN OF AMHERSTBURG  
SPECIAL COUNCIL MEETING**

**Monday, August 26, 2019  
5:00 PM**

Council Chambers, 271 Sandwich Street South, Amherstburg, ON, N9V 2A5

**MINUTES**

**PRESENT**

Mayor Aldo DiCarlo  
Deputy Mayor Leo Meloche  
Councillor Donald McArthur  
Councillor Michael Prue  
Councillor Marc Renaud  
Councillor Patricia Simone

Giovanni (John) Miceli, CAO  
Tammy Fowkes, Deputy Clerk

**ABSENT**

Councillor Peter Courtney

**CALL TO ORDER**

The Mayor called the meeting to order at 5:00 p.m.

**DISCLOSURE OF PECUNIARY INTEREST & GENERAL NATURE THEREOF**

There were no disclosures of pecuniary interest noted.

**PRESENTATIONS**

**3.1 2019 Development Charges Background Study – Nancy Neale, Watson and Associates Economists Ltd.**

Ms. Neale provided Council with the 2019 Development Charges Background Study and answered Council questions.

The Mayor invited the public to comment. The following were heard:

- Loris Colovino

Resolution # 20190826-425

**Moved By** Deputy Mayor Meloche

**Seconded By** Councillor McArthur

**That the presentation BE RECEIVED.**

The Mayor put the Motion.

**Motion Carried**

Resolution # 20190826-426

**Moved By** Councillor Prue

**Seconded By** Councillor Simone

**That Administration BE DIRECTED to report back to Council at the meeting prior to the 2020 Budget Deliberations and regularly thereafter through 2020 to ensure pertinent deadlines aren't missed for Community Benefit Charges and Community Use By-laws.**

The Mayor put the Motion.

**Motion Carried**

## **CONSENT CORRESPONDENCE**

### **4.1 Ministry of Municipal Affairs and Housing – June 7, 2019**

Resolution # 20190826-427

**Moved By** Councillor McArthur

**Seconded By** Councillor Simone

**That the correspondence BE RECEIVED.**

The Mayor put the Motion.

**Motion Carried**

**ADJOURNMENT**

**Moved By** Councillor Renaud

**Seconded By** Deputy Mayor

**That Council rise and adjourn at 6:08 p.m.**

The Mayor put the Motion.

**Motion Carried**

\_\_\_\_\_  
MAYOR – ALDO DICARLO

\_\_\_\_\_  
DEPUTY CLERK – TAMMY FOWKES



**TOWN OF AMHERSTBURG**  
**SPECIAL COUNCIL MEETING - PLANNING**

**Monday, September 9, 2019**  
**5:00 PM**

Council Chambers, 271 Sandwich Street South, Amherstburg, ON, N9V 2A5

**MINUTES**

**PRESENT**

Mayor Aldo DiCarlo  
Deputy Mayor Leo Meloche  
Councillor Peter Courtney  
Councillor Donald McArthur  
Councillor Michael Prue  
Councillor Marc Renaud  
Councillor Patricia Simone

Giovanni (John) Miceli, CAO  
Paula Parker, Clerk  
Tammy Fowkes, Deputy Clerk  
Frank Garardo, Manager of Planning Services  
Mark Galvin, Director, Planning Development and  
Legislative Services

---

**CALL TO ORDER**

The Mayor called the meeting to order at 5:00 p.m.

**DISCLOSURE OF PECUNIARY INTEREST & GENERAL NATURE THEREOF**

There were no disclosures of pecuniary interest noted.



## **SPECIAL PLANNING REPORTS**

The Manager of Planning Services provided an overview with respect to the Cannabis Production Facilities Zoning By-law Amendment and answered Council questions.

### **3.1 Cannabis Production Facilities Zoning By-law Amendment**

Resolution # 20190909-430

**Moved By** Councillor Simone

**Seconded By** Councillor McArthur

**That:**

- 1. The report from the Manager of Planning Services dated August 23, 2019, regarding a Zoning By-law Amendment for Cannabis Production Facilities BE RECEIVED; and,**
- 2. Comments from the public with respect to the Zoning By-law Amendment, Zoning By-law 2019-075 BE RECEIVED and SUMMARIZED in a future report to Council.**

The Mayor put the Motion.

**Motion Carried**

## **ADJOURNMENT**

**Moved By** Councillor Courtney

**Seconded By** Councillor Prue

**That Council rise and adjourn at 5:28 p.m.**

The Mayor put the Motion.

**Motion Carried**

---

MAYOR – ALDO DICARLO

---

CLERK – PAULA PARKER



## Town of Amherstburg Delegation Request Form

I wish to appear before:

Council

Advisory Committee of Council Specify: \_\_\_\_\_

Date of Meeting: November 12, 2019

Name of Delegate(s): CINDY PRINCE, AMICO legal council, ERIC FARRON

Address: 2199 Blackacre, Oldcastle, ON NOR 1L0

Phone: 519-737-1577 Email: CPRINCE@TELAMICO.COM

Attending as an Individual

Representing a Group/Organization

\_\_\_\_\_  
(Name of Group/Organization/Business)

Have you contacted Administration regarding this matter?

Yes

No

If yes, who? John Miceli

Reason(s) for Delegation Request (subject matter to be discussed):

If the request is in response to an item on the agenda, please specify the item by agenda item #.

Boblo Island development agreement being considered before Council.

Presentation is being prepared.

(Use a separate page if more space is required or attach additional documentation.)

If your request is in response to an agenda item, are you in favour of the recommendation? If not, please provide your reasoning below:

Yes. presentation is being prepared and will be  
forward shortly.

**\*\*Speaking notes and presentation materials must accompany this request.**

Additional documentation attached?  Yes  No

Will a PowerPoint presentation be made?  Yes  No

**Note:** An electronic copy of the PowerPoint presentation is required to be submitted to the Town Clerk no later than 12:00 noon on the Friday before the meeting.

The completed Delegation Request Form is to be submitted to the Town Clerk, Town of Amherstburg, 271 Sandwich Street South, Amherstburg, ON N9V 2A5  
Phone: 519.736.0012 Fax: 519.736.5403 or email [pparker@amherstburg.ca](mailto:pparker@amherstburg.ca).

**For office use only:**

Date request received: Nov. 5/19 Request Received by (initials): TF

Request relates to: Boblo Island Dev. Agmt.

Staff Report: Subdivision Agmt. for Boblo Dev. Staff Name: Frank Garardo

Personal information contained on this form is authorized under Section 5 of the Town of Amherstburg's Procedure By-law, for the purpose of contacting individuals and/or organizations requesting an opportunity to appear as a delegation before Council or an Advisory Committee of Council. The Delegation Request Form may be published in its entirety with the public agenda which is also posted on the Town's website. The Procedure By-law is a requirement of Section 238(2) of the Municipal Act, 2001.

Please note that all meetings are open to the public except where permitted to be closed to the public under legislated authority. Questions regarding collection of the information on this form or additional accessibility requirements may be directed to the Municipal Clerk, 271 Sandwich Street South, Amherstburg, ON N9V 2A5, 519.736.0012.



# *Bob-Lo Island; Amherstburg*







# *Introduction*

## **Topics for Discussion:**

- Bob-Lo Island Past
- Bob-Lo Island Present
- Bob-Lo Island Future
- Bob-Lo Island Facts
- Questions





# Bob-Lo Past

## 2004

- Previous Owner/Developer files for bankruptcy
- Amico was not paid for work it had completed (\$9 million)



## 2005

- Amico works with courts, Receiver and Town to prepare bankruptcy plan transferring ownership to Amico as the largest creditor



## 2006

- Municipality realized it had **no securities** in place
- Started negotiations with Amico to work together. New agreement prepared





## *Bob-Lo Past*

Areas of exposure for the Municipality included:

Item	Amount
Waterline Installation repayment	\$600,000
Operational expenses and ownership transfer for the sewage treatment plant	\$400,000
Outstanding taxes owing to the municipality (2001 – 2004)	\$500,000 plus interest and penalties
Municipal roads on the Island had base coat of asphalt but needed repair and final coat of asphalt applied	\$170,000
Outstanding legal and other invoices	\$40,000



## Bob-Lo Past

Notwithstanding having no legal obligation to do so Amico agreed to pay the municipality the outstanding **\$1.54 million** owing (does not include the roads) in the following priority:

Item	Amount	Notes
Municipal Taxes	\$500,000	Paid in full
Waterline	\$600,000	Paid in full
Sewage and water charges	\$400,000	Paid in full
Outstanding legal and other misc. bills	\$40,000	Paid in full
Roads	\$170,000	Town to pay





## *Bob-Lo Present*

**After approximately 13 years, Amico has:**



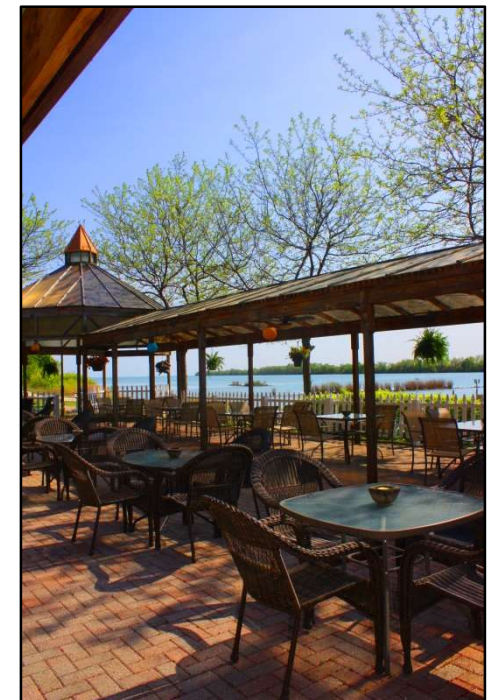
- Prepared and agreed to one development agreement replacing the three agreements that had been in place with the previous owner. That agreement stipulates the rules regarding development of the north end of the island. Amico is in good standing and current on all agreement obligations;
- Zoning that permits development of the entire island;





## *Bob-Lo Present*

- Completed numerous environmental studies in conjunction with ERCA and MNRF to ensure the island's development does not negatively impact the natural environment;
- Pre-paid all costs for the sewage treatment plant and infrastructure on Bob-Lo (1999). Since the Town would normally be responsible for these costs, Amico is being repaid via Development Charge credits.







## Bob-Lo Present

- Permission to create lots on the north end of the island by the consent process. In a decision of the Ontario Municipal Board, it states:
  - “The Board has reviewed the master development agreement and finds it to be comprehensive and similar in its form and content to a subdivision agreement. The Board does **not** accept Mr. Prue’s assertions that these lands should be developed by draft plan of subdivision and that this approach is to be preferred to the consent process followed by the municipality in this case.”
  - “Neither approval process is subservient, the criteria and conditions of approval set out in the Act are similar under both lot creation processes.”





## *Bob-Lo Present*

- The decision reaffirms that Bob-Lo Island has the right to develop by the consent process in the north end and that the municipality has acted properly with respect to overseeing this development through its development agreement. It also confirms that all environmental matters are being addressed responsibly.
- The more recent LPAT decision for the south end of the island, reaffirms this position when it states that the environmental evidence regarding the south end development was unshaken despite Mr. Prue's questioning. The south end development was found to be consistent with the PPS and as such was approved.





## *Bob-Lo Present*

- The other two issues raised at the LPAT Hearing were with respect to the ferry service and First Nations consultation. The decision states that the First Nation representative acknowledged the applicant's efforts and indicated that they have no concerns about the consultation that occurred and are not opposed to the development.
- The municipality was also commended on its Emergency Plan for Boblo and based on expert evidence LPAT concluded that the transportation and emergency solutions are adequate to accommodate the proposed development.







# *Bob-Lo Future-Development Agreement*

- The next step in the process following the LPAT decision is to put a development agreement in place to legally establish LPAT's conditions.
- The purpose of the agreement is to establish the rules under which the development can proceed. If the rules are not followed, the development cannot proceed.
- The agreement protects all parties including the municipality, the developer, the Boblo residents and Amherstburg residents at large.
- Without an agreement, the municipality's requirements and the developer's obligations are not legally established. This legally binding agreement clearly articulates what must be done by everyone and when it must be done.



## *Bob-Lo Future*

- In the past, Amico has enjoyed a respectful working relationship with the Council for Amherstburg.
- It is the goal of Amico, to continue the relationship the two parties have enjoyed while completing the Boblo Master Plan and developing the hotel and riverfront condos.
- A previous Ontario Municipal Board review of planning activities on the island confirmed that both parties are acting responsibly; from both a land use planning perspective and an environmental standpoint.
- Last year's LPAT decision came to the same conclusion. LPAT approved the development for the south end of the island. The LPAT decision establishes the requirement for a development agreement to be prepared and for that agreement to ensure all of the conditions are included.



## *Bob-Lo Future*

- The LPAT decision states “In the event that there are any difficulties ..... the Tribunal may be spoken to”. We much prefer to work with the municipality to get this done.
- In addition to the \$9 million owing to Amico at the time the island’s ownership was transferred there has been an operating loss of approximately \$1.1 million each and every year for 13 years.
- The majority of that loss comes from the ferry operational deficit.
- Amico simply cannot afford to continue on this path any longer.
- Development of the south end has been approved by LPAT after a lengthy hearing. That was over a year ago. It is time to move forward with the process.





# *Questions/Comments*





THE CORPORATION OF THE TOWN OF AMHERSTBURG

OFFICE OF CORPORATE SERVICES

MISSION STATEMENT: Committed to delivering cost-effective and efficient services for the residents of the Town of Amherstburg with a view to improve and enhance their quality of life.

Table with 2 columns: Author's Name, Report Date, Author's Phone, Date to Council, Author's E-mail, Resolution #.

To: Mayor and Members of Town Council

Subject: 2019 Tax Write-Offs and Rebates

1. RECOMMENDATION:

It is recommended that:

- 1. That the property tax adjustments outlined in the report from the Supervisor of Revenue dated October 18, 2019 regarding 2019 Tax Write-offs and Rebates BE AFFIRMED.

2. BACKGROUND:

Property tax write-offs and rebates are applied based on one or more of the following:

- 1. Application under sections 110(17), 357, 358, 361(1), 361(4), 364(1), 365 of the Municipal Act, R.S.O. 2001, c25.
2. Assessment Review Board decisions or Minutes of Settlement.

The mandatory programs complied with by the Municipality:

- Rebates for Charities (Section 361, Municipal Act 2001, as amended) [Every municipality shall have a tax rebate program for eligible charities for the purposes of giving them relief from taxes or amounts paid on account of taxes on eligible property they occupy.] Tax policy under this section is established by the County of Essex under By-law and applies to all of its lower-tier municipalities.
• Write-Offs (Section 354, Municipal Act 2001, as amended) [Municipalities shall not remove unpaid taxes from the roll except in accordance with this section,

which includes write-offs under various sections of the Act or a decision of any court.]

The optional programs applied with by the Municipality are:

- 357 / 358 Reductions (Section 357/358, Municipal Act 2001, as amended) [A Municipality may cancel, reduce or refund all or part of taxes levied on land in the year in respect of which certain criteria is met.] Applications for the cancellation, reduction or refund of taxes are initially made to municipal Council, and can be appealed to the Assessment Review Board.
- Tax relief for low income seniors or low income persons with disabilities (Section 319, Municipal Act 2001, as amended) [A Municipality may pass a by-law providing for deferrals or cancellation of, or other relief in respect of, all or part of a tax increase for 1998 and subsequent years on property in the residential property class for persons assessed as owners who are, or whose spouses are low income seniors as defined in the by-law or low income persons with disabilities as defined in the by-law.
- Tax reduction for heritage property (Section 365.2, Municipal Act 2001, as amended) [A local municipality may establish a program to provide tax reductions or refunds in respect of eligible heritage property.] The Town has adopted By-law 2012-112 to provide 40% rebate on property taxes once every three years for eligible applicants under this program.
- Canada Ontario Affordable Housing Program (COHAP) (Section 110(17)): Under the Canada Ontario Affordable Housing Program, property taxes for rental and supportive housing projects are set at an effective rate equivalent to or lower than the single-residential rate. The Town adopted By-law 2015-35 to provide for agreements under this program for eligible properties.

### **3. DISCUSSION:**

In accordance with past practice and or as required under legislation, property tax adjustments have been processed as outlined in Appendix A to this report and are reported to Council for information (mandatory) or affirmation (optional).

### **4. RISK ANALYSIS:**

The annual budget includes an allowance for property tax write-off expense to mitigate the impact of tax adjustments. These adjustments could relate to multiple taxation years, but the cost is incurred by the Town in the year in which the adjustment is finalized and processed.

Although Administration did receive some Assessment Review Board decisions in 2019 resulting from ARB appeals, a group of appeals remain open. When the outstanding appeals are finalized, Administration will receive notification of tax adjustments which must be issued. Some appeals may have adjustments going back to tax year 2014 and may have a significant financial impact on the Town's finances.

**5. FINANCIAL MATTERS:**

Changes to the returned roll assessment value and/or tax classification, as determined by MPAC, resulted in adjustments to property taxes. Although tax adjustments cover the assessment years 2017 through 2019, the reductions to property taxes were incurred and funded entirely in 2019 as an expense in the non-departmental budget centre. The chart below provides a summary of the adjustments by assessment year and levy type.

Year	Municipal Levy	County Levy	School Boards	Total
2017	\$ (353.21)	\$ (173.07)	\$ (65.97)	\$ (592.25)
2018	\$ (36,072.44)	\$ (17,487.96)	\$ (10,993.42)	\$ (64,553.82)
2019	\$ (39,341.21)	\$ (19,032.95)	\$ (18,579.59)	\$ (76,953.75)
	<b>\$ (75,766.86)</b>	<b>\$ (36,693.98)</b>	<b>\$ (29,638.98)</b>	<b>\$(142,099.82)</b>

As shown above, property tax adjustments for write-offs and rebates processed in 2019 total \$142,099.82.

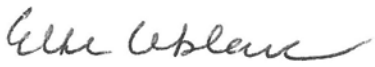
Appendix A to this report provides a detailed listing of the adjustments processed for 2019. Heritage rebates to be processed in 2019 have not been approved at this time, therefore heritage rebates are not included as part of Appendix A.

**6. CONSULTATIONS:**

None

**7. CONCLUSION:**

The property tax write-offs and rebates processed in 2019 were completed in accordance with applicable legislation and policy as outlined in this report.



---

Elke Leblanc  
**Supervisor of Revenue**

## Report Approval Details

Document Title:	2019 Write Offs Issued.docx
Attachments:	- Appendix A 2019 Write Off Summary for Council Report.pdf
Final Approval Date:	Nov 1, 2019

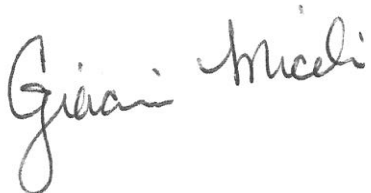
This report and all of its attachments were approved and signed as outlined below:



**Cheryl Horrobin - Oct 30, 2019 - 12:22 PM**



**Mark Galvin - Oct 30, 2019 - 1:39 PM**



**John Miceli - Oct 31, 2019 - 1:57 PM**



**Paula Parker - Nov 1, 2019 - 4:03 PM**

**Appendix A**  
**Write Offs and Rebates Issued in 2019**

Item	Assmt Year	Municipal Levy	County Levy	School Boards	Total	Authority	Description
1	2018	\$ (354.20)	\$ (172.20)	\$ (61.44)	\$ (587.84)	Agricorp	Farm Property Class Tax Rate Program
2	2018	\$ (1,858.19)	\$ (903.35)	\$ (322.32)	\$ (3,083.86)		
3	2018	\$ (5,978.41)	\$ (2,906.39)	\$ (1,037.01)	\$ (9,921.81)		
4	2019	\$ (2,011.11)	\$ (972.95)	\$ (324.32)	\$ (3,308.38)		
5	2019	\$ (2,192.44)	\$ (1,060.68)	\$ (353.57)	\$ (3,606.69)		
6	2019	\$ (363.48)	\$ (175.84)	\$ (58.62)	\$ (597.94)		
7	2019	\$ (25.34)	\$ (12.26)	\$ (4.08)	\$ (41.68)		
8	2019	\$ (753.36)	\$ (364.47)	\$ (121.50)	\$ (1,239.33)		
9	2019	\$ (16.30)	\$ (7.89)	\$ (2.63)	\$ (26.82)		
10	2019	\$ (1,590.47)	\$ (769.46)	\$ (256.49)	\$ (2,616.42)		
11	2019	\$ (1,985.38)	\$ (960.51)	\$ (320.19)	\$ (3,266.08)		
12	2019	\$ (1,225.70)	\$ (592.98)	\$ (197.66)	\$ (2,016.34)		
13	2019	\$ (1,247.27)	\$ (603.42)	\$ (201.15)	\$ (2,051.84)		
14	2018	\$ (9,580.99)	\$ (4,635.23)	\$ -	\$ (14,216.22)	COHAP	By-Law 2010-15
15	2018	\$ (12,249.25)	\$ (5,926.12)	\$ -	\$ (18,175.37)		By-Law 2010-74
16	2019	\$ (3,581.17)	\$ (1,732.54)	\$ (4,003.88)	\$ (9,317.59)	MNRF	Conservation Land Tax Incentive Program
17	2019	\$ (149.15)	\$ (72.16)	\$ (24.06)	\$ (245.37)		
18	2018	\$ (171.51)	\$ (83.38)	\$ (29.75)	\$ (284.64)	Minutes of Settlement (MOS)	Request for Reconsideration (RFR)
19	2019	\$ (594.20)	\$ (287.48)	\$ (95.83)	\$ (977.51)		
20	2017	\$ (112.60)	\$ (55.18)	\$ (21.03)	\$ (188.81)		
21	2018	\$ (122.51)	\$ (59.56)	\$ (21.25)	\$ (203.32)		
22	2019	\$ (132.27)	\$ (64.00)	\$ (21.33)	\$ (217.60)		
23	2019	\$ (59.26)	\$ (28.66)	\$ (9.55)	\$ (97.47)		
24	2019	\$ (1,357.60)	\$ (656.79)	\$ (218.93)	\$ (2,233.32)		
25	2018	\$ (863.32)	\$ (419.71)	\$ (2,527.87)	\$ (3,810.90)		
26	2019	\$ (3,678.87)	\$ (1,779.81)	\$ (593.29)	\$ (6,051.97)		
27	2019	\$ (638.93)	\$ (309.11)	\$ (103.04)	\$ (1,051.08)		
28	2019	\$ (896.75)	\$ (433.85)	\$ (144.61)	\$ (1,475.21)		
29	2019	\$ (284.45)	\$ (137.61)	\$ (45.88)	\$ (467.94)		
30	2019	\$ (522.89)	\$ (252.96)	\$ (84.32)	\$ (860.17)		
31	2017	\$ (39.02)	\$ (19.12)	\$ (7.29)	\$ (65.43)		
32	2018	\$ (161.10)	\$ (78.32)	\$ (27.94)	\$ (267.36)		
33	2018	\$ (477.22)	\$ (232.00)	\$ (595.94)	\$ (1,305.16)		
34	2019	\$ (353.79)	\$ (171.15)	\$ (422.48)	\$ (947.42)		ARB Hearing 720368
35	2019	\$ 919.36	\$ 444.78	\$ (560.26)	\$ 803.88	Property Assessment Notice	Factual Info Change
36	2019	\$ 0.14	\$ 0.07	\$ 0.02	\$ 0.23		
37	2019	\$ 7.52	\$ 3.65	\$ 1.21	\$ 12.38		
38	2019	\$ (107.99)	\$ (52.25)	\$ (17.42)	\$ (177.66)		
39	2018	\$ (65.96)	\$ (32.08)	\$ (11.44)	\$ (109.48)		
40	2019	\$ (451.66)	\$ (218.50)	\$ (72.84)	\$ (743.00)		
41	2019	\$ (81.62)	\$ (39.48)	\$ (13.16)	\$ (134.26)		
42	2019	\$ 137.52	\$ 66.54	\$ 22.18	\$ 226.24		
43	2019	\$ (166.92)	\$ (80.75)	\$ (26.92)	\$ (274.59)		
44	2019	\$ 847.35	\$ 409.94	\$ 69.88	\$ 1,327.17		
45	2018	\$ -	\$ -	\$ (533.75)	\$ (533.75)	SANS	Small Scale On Farm Business
46	2019	\$ (1,982.05)	\$ (958.90)	\$ (841.75)	\$ (3,782.70)		
47	2018	\$ (50.47)	\$ (24.54)	\$ (395.54)	\$ (470.55)		
48	2019	\$ (54.42)	\$ (26.33)	\$ (384.65)	\$ (465.40)		
49	2018	\$ -	\$ -	\$ (533.75)	\$ (533.75)		
50	2019	\$ -	\$ -	\$ (516.25)	\$ (516.25)		
51	2019	\$ (253.88)	\$ (122.83)	\$ (298.93)	\$ (675.64)	Section 354	Doubtful Account
52	2018	\$ 513.64	\$ 249.70	\$ (335.47)	\$ 427.87	Section 357	Demolition
53	2019	\$ (592.02)	\$ (286.42)	\$ (95.48)	\$ (973.92)		
54	2018	\$ (241.66)	\$ (117.48)	\$ (41.91)	\$ (401.05)		
55	2018	\$ (10.52)	\$ (5.11)	\$ (1.82)	\$ (17.45)		
56	2019	\$ (39.93)	\$ (19.32)	\$ (6.44)	\$ (65.69)		
57	2019	\$ (110.55)	\$ (53.49)	\$ (17.83)	\$ (181.87)		
58	2017	\$ (151.31)	\$ (74.14)	\$ (28.27)	\$ (253.72)		
59	2018	\$ (631.46)	\$ (306.99)	\$ (109.53)	\$ (1,047.98)		
60	2019	\$ (661.07)	\$ (319.82)	\$ (106.61)	\$ (1,087.50)		
61	2018	\$ (2.87)	\$ (1.40)	\$ (0.50)	\$ (4.77)		
62	2019	\$ (7.20)	\$ (3.49)	\$ (1.17)	\$ (11.86)		
63	2019	\$ (394.00)	\$ (190.61)	\$ (63.54)	\$ (648.15)		
64	2019	\$ (66.44)	\$ (32.15)	\$ (10.71)	\$ (109.30)		
65	2019	\$ (5.36)	\$ (2.59)	\$ (0.87)	\$ (8.82)		
66	2019	\$ (100.73)	\$ (48.74)	\$ (16.25)	\$ (165.72)		
67	2017	\$ (24.17)	\$ (11.83)	\$ (4.51)	\$ (40.51)		Fire
68	2018	\$ (261.72)	\$ (127.24)	\$ (45.40)	\$ (434.36)		
69	2019	\$ (278.06)	\$ (134.52)	\$ (44.84)	\$ (457.42)		
70	2017	\$ (26.11)	\$ (12.80)	\$ (4.87)	\$ (43.78)		Senior Disabled
71	2018	\$ (53.41)	\$ (25.97)	\$ (9.27)	\$ (88.65)		
72	2018	\$ (706.90)	\$ (346.40)	\$ (924.30)	\$ (1,977.60)	Section 361	Charity Rebate
73	2018	\$ (502.97)	\$ (244.52)	\$ (628.11)	\$ (1,375.60)		
74	2018	\$ (2,241.44)	\$ (1,089.67)	\$ (2,799.11)	\$ (6,130.22)		
75	2019	\$ (6,434.28)	\$ (3,112.86)	\$ (1,037.64)	\$ (10,584.78)	Section 365.2	County # 10-2016
76	2019	\$ (1,034.33)	\$ (500.40)	\$ (1,235.18)	\$ (2,769.91)	Lease Agreement	11-Oct-11
77	2019	\$ (3,042.12)	\$ (1,471.76)	\$ (3,632.83)	\$ (8,146.71)		By-Law 2011-100
78	2019	\$ (1,728.29)	\$ (836.14)	\$ (2,063.90)	\$ (4,628.33)		01-Jun-15
		<b>\$ (75,766.86)</b>	<b>\$ (36,693.98)</b>	<b>\$ (29,638.98)</b>	<b>\$ (142,099.82)</b>		
		<b>MUN</b>	<b>CTY</b>	<b>SCH</b>	<b>Total</b>		



THE CORPORATION OF THE TOWN OF AMHERSTBURG

OFFICE OF CORPORATE SERVICES

**MISSION STATEMENT:** *Committed to delivering cost-effective and efficient services for the residents of the Town of Amherstburg with a view to improve and enhance their quality of life.*

Author's Name: Justin Rousseau and Cheryl Horrobin	Report Date: October 31, 2019
Author's Phone: 519 736-0012 ext. 2259	Date to Council: November 12, 2019
Author's E-mail: <a href="mailto:jrousseau@amherstburg.ca">jrousseau@amherstburg.ca</a>	Resolution #: N/A

To: Mayor and Members of Town Council

Subject: Asset Management Policy

---

1. **RECOMMENDATION:**

It is recommended that:

1. The Asset Management Policy **BE ADOPTED** as presented.

2. **BACKGROUND:**

Ontario Regulation 588/17 – Asset Management Planning for Municipal Infrastructure (Regulation) became effective January 1, 2018, and requires municipalities to outline commitments to best practices and continuous improvement.

The Regulation laid out deliverables/milestones that municipalities are responsible to implement with the intention of improving “the quality and consistency of municipal asset management planning.”

The first mandatory requirement under the Regulation is that all municipalities must adopt an Asset Management Policy by July 1, 2019 that includes various overarching components which will be reviewed, and if necessary updated, at least every five (5) years.

The Town's current Asset Management Policy (AM Policy) (attached) has been in place since February 2013, however that policy does not include the updates required under the new legislation.

### **3. DISCUSSION:**

The recommended AM Policy (attached) is in line with legislative requirements and with best practices as outlined by the Municipal Finance Officers Association (MFOA).

These key principles included in the recommended AM Policy are:

1. Maintenance and enhancement of asset inventories and their related information through condition assessment measures
2. Inclusion of asset inventories which at a minimum meet capitalization thresholds for compliance with Public Sector Accounting Standards
3. Identification, monitoring and reporting of levels of service to ensure strategic objectives of the Town are being met
4. Maintenance and management of infrastructure assets at their defined service levels
5. Development and utilization of optimized lifecycle replacement strategies
6. Ensuring adequate funding to maintain established levels of service
7. Integration of the Town's Asset Management Plan with related corporate plans and strategies
8. Establish organizational accountability and responsibility for asset inventory, condition, use and performance
9. Ensure corporate governance through demonstrable long-term financial planning based upon desired service levels and growth related demand
10. Ongoing assessment of the effects caused by climate change to infrastructure planning and adoption of approaches to mitigate risk when possible
11. An ongoing commitment to continuous improvement of processes which support asset management
12. A commitment to coordinate asset management planning where the Town's infrastructure assets connect or are interrelated with those of the County and neighbouring municipalities
13. A commitment to provide opportunities for residents and other interested parties to provide input in the Town's asset management planning

Additional deliverables/milestones under the Regulation are due in 2021, 2023 and 2024, with ongoing requirements to monitor, maintain and update the Town's Asset Management Plan (AMP).

The next deliverable/milestone, due by July 1, 2021, requires the Town's AMP to include 'core municipal infrastructure assets' (roads, bridges, water, wastewater and stormwater assets). The additional deliverables/milestones require the AMP to include all assets by a July 1, 2023 and proposed levels of service and lifecycle management and financial strategy by July 1, 2024.



Administration has included a recommendation in the draft 2020 Budget – Corporate Services – Finance budget centre for funding toward the purchase of professional services to assist the Town in working toward achieving these legislative requirements. In addition, the 2020 Budget includes a staff resource recommendation in the same budget centre to address workload pressures and assist in meeting the Town’s continuing obligations under this legislation, which cannot be accommodated with existing resources.

Beyond that, additional funding may be required in future for the update of source data (such as the Roads Needs Study, etc.) and other supports (such as technology) to support the required enhancements to the AMP and to maintain the AMP thereafter.

**4. RISK ANALYSIS:**

Adoption of the new Asset Management Policy is recommended in order to bring the Town into compliance with legislation and to avoid the risk of jeopardizing the Town’s ability to access senior government funding.

**5. FINANCIAL MATTERS:**

There are no direct financial implications of adopting the policy; however, as noted above there will be future costs for enhancing the Town’s AMP to achieve and maintain legislative compliance based on further deliverables/milestones required under the Regulation.


The AM Policy supports the enhancement and maintenance of the AMP, which will in turn assist in shaping future financial decisions and plans for the municipality with respect to investment in the Tangible Capital Assets (TCA) that maintain or enhance the Town’s service levels.

**6. CONSULTATIONS:**

MFOA, the Clerk and Policy/Committee Coordinator were consulted on the proposed policy.

**7. CONCLUSION:**

It is recommended that the Asset Management Policy be adopted, which will replace previous policy.

  
\_\_\_\_\_  
Justin Rousseau  
Treasurer

## Report Approval Details

Document Title:	Asset Management Policy .docx
Attachments:	- assetmanagementpolicy.pdf - Asset Management Policy - Draft for Council.docx
Final Approval Date:	Nov 7, 2019

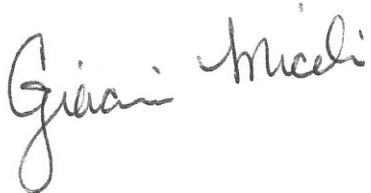
This report and all of its attachments were approved and signed as outlined below:



**Cheryl Horrobin - Nov 1, 2019 - 1:21 PM**



**Mark Galvin - Nov 4, 2019 - 10:40 AM**



**John Miceli - Nov 6, 2019 - 9:09 AM**



**Paula Parker - Nov 7, 2019 - 12:42 PM**



POLICY: Asset Management Policy  
SOURCE: Council Minutes – 2013 02 19  
SECTION: Reports – CAO's Office  
DATE ENACTED: February 19, 2013  
DATE OF AMENDMENT:

---

**SUBJECT:**

**1.0 POLICY STATEMENT**

1.1 Asset Management (AM) is a broad strategic framework that encompasses many disciplines and involves the entire organization. The term asset management, as used in this document, is defined as “the ***application of sound technical, social and economic principles that considers present and future needs of rate payers, and service from the asset***”. To guide the organization, the following policy statements have been developed:

- a) Administration will maintain and manage infrastructure assets at defined levels to support public safety, community well-being and community goals.
- b) Administration will monitor standards and service levels to ensure that they meet / support community and council goals and objectives.
- c) Administration will develop and maintain asset inventories of all its infrastructure and fleet.
- d) Administration will establish infrastructure replacement strategies through the use of full life cycle costing principals.
- e) Council and Administration will plan financially for the appropriate level of maintenance of assets to deliver service levels and extend the useful life of assets.

- f) Council and Administration will plan for and provide stable long term funding to replace and / or renew and / or decommission infrastructure assets.
- g) Administration will report to rate payers regularly on the status and performance of work related to the implementation of the asset management policy.
- h) Where appropriate Council & Administration will consider and incorporate asset management in the Town of Amherstburg corporate plans.

## 2.0 PURPOSE

- 2.1 The basis for our asset related decisions are anchored on the four pillars of sustainability. They are economic, environmental, social and cultural. They support the Town of Amherstburg long-term sustainability goals approved by council.
- 2.2 The objective of this policy is to detail the Asset Management program principals with the purpose of:
  - ❖ Reducing the life cycle costs while maintaining acceptable levels of service
  - ❖ Linking infrastructure investment decisions to service levels
  - ❖ Striving to deliver services at approved levels of service
  - ❖ Improving decision making accountability and transparency
  - ❖ Provides policy statements to guide staff in carrying out the organizations strategic plans and activities.
  - ❖ Better demonstrating the long term consideration of short term decisions

- 2.3 Asset Management is an integrated business approach involving planning, finance, engineering, maintenance and operations geared towards effectively managing existing and new infrastructure to maximize benefits, reduce risk and provide safe and reliable levels of service to community users. This is accomplished in a socially, culturally, environmentally and economically conscious manner.
- 2.4 Asset Management relies on four key organizational components integrating together to achieve the desired service outcomes: well-planned strategies, good physical assets, well trained staff with respects to practices and procedures and integrated business processes. These components supported by appropriate technologies, provide a strong foundation for efficient service delivery.
- 2.5 Where possible and appropriate, Council and Staff will consider this policy and integrate it in the development of corporate documents such as:
- ❖ Business Plan
  - ❖ Corporate Strategic Plan
  - ❖ Corporate Financial Plan
  - ❖ Capital Budget Plan
  - ❖ Operational plans and budgets ( including vehicle and fleet plans and budgets)
  - ❖ Annual Reports
  - ❖ Infrastructure Servicing, management and replacement plans
  - ❖ Parks and Recreation Plans
  - ❖ Facility Plans

### **3.0 SCOPE**

- 3.1 The Asset Management Policy applies to all physical assets of the town including but not limited to roads, sidewalks, bridges, water mains, sewers, storm water ponds, pumping stations, reservoirs, treatment plants, landfills, fleet, IT Systems, buildings, parks and trees.
- 3.2 The Asset Management Program encompasses all aspects of the management of each asset through its lifecycle.
- 3.3 Integrates with the corporate planning framework to complement the strategic plan and objectives of the town, business systems, legislation and regulations.
- 3.4 Creates a framework that establishes the mechanism for collaboration and consistency in developing Asset Management Program while keeping corporate objectives and strategies priority.
- 3.5 Commits to providing levels of service for present and future rate payers and communities in the most effective and efficient manner, through the planning, design, construction, acquisition, operation and maintenance, renewal and disposal of assets.

### **4.0 POLICY DIRECTION**

To meet the goals and objectives of this policy, Senior Management will:

- 4.1 Create and maintain a Comprehensive Asset Management (CAM) governance structure to lead the development of AM tools and practices and to oversee their application across the organization.
- 4.2 Make informed decisions, identifying all revenues and costs (including operation, maintenance, replacement and decommission) associated with infrastructure asset decisions, including additions and deletions.
- 4.3 Establish organizational accountability and responsibility for asset inventory, condition, use and performance.
- 4.4 Define levels of service that balance customer expectations with risk, affordability and timing constraints.

- 4.5 Monitor the performance of the assets and track the effectiveness of AM practices with a view to continuous improvement
- 4.6 Consult with stakeholders where appropriate
- 4.7 Define and articulate service, maintenance and replacement levels and outcomes
- 4.8 Manage assets to be sustainable
- 4.9 Minimize total life cycle costs of assets
- 4.10 Pursue best practices where available
- 4.11 Consider social and sustainability goals
- 4.12 Seek funding and service delivery opportunities to address infrastructure investment pressures.

**5.0 PROCEDURE**

- 5.1 Key roles in managing the Asset Management Policy
- 5.2 All policies are approved by Council. While staff and public may provide input on the nature of the policy, Council retains the authority to approve, update, amend or rescind policies.

Roles	Responsibility
Identification of issues and development of policy updates	Council & Administration
Establish levels of service	Council & Administration
Exercise stewardship of assets, adopt policy and budgets	Council & Administration
Implementation of policy	Administration
Development of guidelines and practices	Administration
On-going review of policies	Council & Administration

Actions	Responsibility
Adopt Asset Management Policy	Council & Administration
Monitor and review infrastructure standards and service levels at established intervals	Council & Administration
Develop and maintain infrastructure strategies including development and service plans	Council & Administration
Develop and maintain asset inventories	Administration
Assess infrastructure condition and service levels	Administration
Establish and monitor infrastructure replacement levels through the use of full life cycle costing principle	Administration
Develop and maintain financial plans for the appropriate level of maintenance, rehabilitation, extension and decommission of assets	Administration
Report to citizens on status of the community's infrastructure Asset Management Program. The channel may include citizen reports, business plans etc.	Administration




## 6.0 ASSET MANAGEMENT DEFINITIONS

The following key strategic CAM documents will be developed, in addition to the long range financial plans that will form part of the town's overall approach to asset management:

- 6.1 ***Comprehensive Asset Management Policy***: This document establishes Council's expectations around the management of the town's physical assets. It is to be approved by Council.
- 6.2 ***Comprehensive Asset Management Strategy***: This document defines Senior Management's commitment and approach to achieving the Council approved policy.
- 6.3 ***Customer Levels of Service***: This document defines the level to which assets are to be maintained to achieve defined levels of service. These are to be approved by Council.
- 6.4 ***Asset Management Plans***: These documents identify how assets are being managed through their lifecycle in support of the delivery of services. These are to be approved at the Departmental Management level for all service areas.
- 6.5 ***State of the Asset Report***: This document provides information on the state of the Town's physical assets which can then be referenced when making infrastructure asset investment decisions as part of the annual budget and long range financial planning processes. This is to be submitted to Council for information.

# POLICY

	Policy:	<b>Asset Management Policy</b>		
	Department:	Corporate Services		
	Division:	Finance	By-law No:	
	Administered by:	Treasurer	Approval Date:	
	Replaces:	Asset Management Policy – February 13, 2013		
	Attachment(s):	N/A		

## 1. POLICY STATEMENT

The Corporation of the Town of Amherstburg (Town) is committed to protecting and enhancing the quality of life of its residents by making the best possible decisions regarding Town assets in a way that provides targeted levels of service and manages risk in a cost effective manner. As such, all asset related decisions are anchored in the Town of Amherstburg’s strategic plans and studies and in accordance with legislation that support the Town’s long term economic growth and prosperity.

## 2. PURPOSE

- 2.1. This policy supports the Town in focusing its infrastructure efforts on managing risks, addressing priorities and meeting short and long term needs within the constraints of funding.
- 2.2. This policy describes the Town’s objective to provide levels of service for present and future ratepayers and the community in the most effective and efficient manner, through the planning, design, construction, acquisition, operation and maintenance, renewal and disposal of assets.
- 2.3. This policy ensures the commitment and intention of the Town to plan, design, construct, acquire, operate, maintain, renew, replace and dispose of the Town’s infrastructure assets in a way that ensures sound stewardship of public assets while balancing levels of service delivery and risk.
- 2.4. This policy ensures compliance required under Provincial regulation (O.Reg. 588/17 - Asset Management Planning for Municipal Infrastructure) that the Town prepare and adopt an Asset Management Policy.

## 3. SCOPE

- 3.1. This policy applies to all Town staff involved in Asset Management.
- 3.2. This policy applies to all Tangible (physical) Capital Assets of the town including but not limited to roads, sidewalks, bridges, water mains, sanitary and storm sewers, storm-water ponds, pumping stations, reservoirs, treatment plants, fleet, equipment, buildings and parks.
- 3.3. This policy shall be reviewed every five (5) years from the date it becomes effective, and/or sooner at the discretion of the CAO (or designate).

#### 4. **DEFINITIONS**

- 4.1. **Asset** is an item, thing or entity that has potential or actual value to an organization.
- 4.2. **Asset Management (AM)** is a combination of management, financial, economic, engineering, and other practices applied to physical assets with the objective of providing the required level of service in the most cost-effective manner at an acceptable level of risk. It involves data-driven decision-making and actions throughout the lifecycle of assets.
- 4.3. **Asset Management Plan** is a plan that documents and specifies how the organizational objectives are to be converted into AM objectives, the approach for developing AM plans and the role of the asset management system in supporting the achievement of AM objectives.
- 4.4. **Asset Management System** is a set of interrelated and interacting elements of an organization, including the AM policy, AM objectives, AM Strategy, AM Plans and the processes to achieve these objectives.
- 4.5. **Capitalization Threshold** is the value of a Town infrastructure asset at or above which the Town will capitalize the value of it and below which it will expense the value of it.
- 4.6. **Green Infrastructure Asset** means an infrastructure asset consisting of natural or human-made elements that provide ecological and hydrological functions and processes and includes natural heritage features and systems, parklands, stormwater management systems, street trees, urban forests, natural channels, permeable surfaces and green roofs.
- 4.7. **Life cycle** in this policy means phases involved in the management of an asset.
- 4.8. **Life cycle data** refers to the cost, performance and risk data collected and managed through business processes required to help make well informed, evidence-based decisions in all phases of an asset's life cycle.
- 4.9. **Level of Service** refers to the parameters which reflect social political environmental and economic outcomes that an organization delivers from their assets.
- 4.10. **Operating Costs** means the aggregate costs, including energy costs, of operating a municipal infrastructure asset over its service life.
- 4.11. **Service Life** means the total period which a municipal infrastructure asset is in use or is available to be used.
- 4.12. **Tangible Capital Asset (TCA)** are non-financial assets having physical substance that are acquired or constructed/developed and used on a continuing basis in the Town's operations, have useful lives greater than one year and are not held for re-sale in the ordinary course of operations.

Other common definitions, acronyms, and terms are available in the Glossary located on the Town's Policies webpage.

#### 5. **INTERPRETATIONS**

Any reference in this policy to any statute or any section of a statute shall, unless expressly stated, be deemed to be reference to the statute as amended, restated or re-enacted from time to time. Any references to a by-law or Town policy shall be deemed to be a reference to the most recent passed policy or by-law and any replacements thereto.

## 6. GENERAL CONDITIONS

The Asset Management approach will strive to develop and maintain an AM System to ensure the right balance of strategy, assets, resources and business processes to deliver established levels of service through an optimized risk-based decision-making approach.

### 6.1. **Guiding Principles**

The Infrastructure for Jobs and Prosperity Act, 2015 sets out principles to guide asset management planning in municipalities in Ontario. The following principles will be incorporated, whenever possible, into the day-to-day operations of the Town:

- **Forward Looking:** The Town shall take a long-term view while considering demographic and economic trends in the region.
- **Budgeting and Planning:** The Town shall take into account any applicable budgets or fiscal plans, such as fiscal plans released under the Fiscal Transparency and Accountability Act, 2004, and the Budgets adopted under Part VII of the Municipal Act, 2001.
- **Prioritizing:** The Town shall clearly identify infrastructure priorities which will drive investment decisions.
- **Economic Development:** The Town shall promote economic competitiveness, productivity, job creation, and training opportunities.
- **Transparency:** The Town shall be evidence-based and transparent. Additionally, subject to any prohibitions under the Act or otherwise law on the collection, use or disclosure of information, the town shall make decisions with respect to infrastructure based on information that is publicly available or made available to the public, and share information with implications on infrastructure and investment decisions with the Government and broader public sector entities.
- **Environmentally Conscious:** The Town shall minimize the impact of infrastructure on the environment by respecting and helping maintain ecological and biological diversity, augmenting resilience to the effects of climate change, and endeavoring to make use of acceptable recycled aggregates.
- **Health and Safety:** The Town shall ensure that the health and safety of workers involved in the construction and maintenance of infrastructure assets is protected.
- **Community Focussed:** The Town shall promote community benefits, being the supplementary social and economic benefits arising from an infrastructure project that are intended to improve the well-being of a community affected by the project, such as local job creation and training opportunities, improvement of public spaces within the community, and promoting accessibility for persons with disabilities.
- **Innovation:** The Town shall strive to create opportunities to make use of innovative technologies, services, and practices, particularly where doing so would utilize technology, techniques and practices developed in Ontario.
- **Integration:** The Town shall where relevant and appropriate, be mindful and consider the principles and content of non-binding provincial or municipal plans and strategies

established under an Act or otherwise, in planning and making decisions surrounding the infrastructure that supports them.

- **Consistency:** The Town shall ensure the continued provision of core public services.

## 6.2. **Asset Management Plan**

- 6.2.1. The Town's Asset Management Plan will support and align with the strategic goals and plans of the Town and outline the approach to continuous improvement and adoption of appropriate practices regarding asset management planning.
- 6.2.2. The AM Plan will be considered in development of the Town's budgets and long-term financial plans..

## 6.3. **Community Planning and Stakeholder Engagement**

The Town recognizes the importance of community planning and stakeholder engagement, as an integral component of a comprehensive asset management approach. Accordingly, the Town will foster informed dialogue with the community and various parties using the best information available and providing opportunities to give input in asset management planning; and coordinating efforts with other infrastructure asset owning agencies such as municipal bodies and regulated utilities. Cross-referencing the Towns Official Plan and the Asset Management Plan will ensure that development occurs within the Town's means through an understanding of current and future asset needs.

## 6.4. **Climate Change**

Climate change will be considered as part of the Town's risk management approach embedded in asset management planning methods. This approach will balance the potential cost of vulnerabilities to climate change impact and other risks with the cost of reducing these vulnerabilities. Actions will be taken in addition to acquiring or modifying assets based on greenhouse gas reduction targets. The Town will make efforts to strike a balance between its organizational capacity, financial and stakeholder support, and the local risks and vulnerabilities related to climate change such as operations and increased maintenance schedules, levels of service and lifecycle management. The Town will continue to work with the Region to support climate change mitigation and adaptation.

## 6.5. **Scope and Capitalization Thresholds**

The service rendered by an asset will be the determining factor in whether or not to include it in asset management plans. It is the assets whose role in service delivery requires deliberate management by the Town that will thus be included in the asset management plan. The threshold used to determine which assets are to be included in the asset management plan, is therefore a guideline for the application of Council-endorsed principles in professional judgement. This qualitative approach is unlike the quantitative and dollar value based methodology prescribed in the tangible asset policy.

## 6.6. **Financial Planning and Budgeting**

The Town will integrate asset management planning into the annual capital budget, operating budget, and its long-term financial plan. The asset management plan will be used as a resource in order to identify all potential revenues and costs (including operating, maintenance, replacement and decommissioning) associated with forthcoming infrastructure asset decisions. The plan will also evaluate the validity and need of each significant new

capital asset, including considering the impact on future operating costs; and incorporate new revenue tools and alternative funding strategies where possible.

**6.7. Annual Review of Asset Management Planning Process**

In accordance with 9.(1) of the Asset Management Planning For Municipal Infrastructure Act, Council shall conduct an annual review of its asset management progress on or before July 1 in each year, starting the year after the Town's asset management plan is completed. The annual review will address the Town's progress in implementing its asset management plan including any factors will impede the Town's ability to implement its asset management plan, and a strategy to address these factors.

**7. RESPONSIBILITIES**

**7.1. Council** has the authority and responsibility to:

- 7.1.1. Approve by resolution the Asset Management Plan and its updates.
- 7.1.2. Adopt policy and strategic plans in support of AM.
- 7.1.3. Maintain the necessary corporate capacity to support the AM System; including but not limited to staff resources, supporting technology systems and equipment and funding.

**7.2. The CAO** has the authority and responsibility to:

- 7.2.1. Maintain compliance with the Asset Management Policy and provincial asset management regulations.
- 7.2.2. Develop and maintain a governance structure to lead the development of asset management tools and practices and to oversee their application across the organization.
- 7.2.3. Implementation of related policies, procedures, guidelines and practices.

**7.3. Directors** have the authority and responsibility to:

- 7.3.1. Identify all revenues and costs (including operation, maintenance, replacement, and decommission) associated with infrastructure asset decisions, including additions and deletions.
- 7.3.2. Establish departmental accountability and responsibility for asset inventory, condition, use and performance.
- 7.3.3. Recommend levels of service that balance customer expectations with risk, affordability and timing constraints
- 7.3.4. Monitor the performance of the assets and track the effectiveness of AM practices with a view to continuous improvement
- 7.3.5. Consult with stakeholders where appropriate through planning processes.
- 7.3.6. Conduct on-going review of related policies.
- 7.3.7. Seek funding and service delivery opportunities to address infrastructure investment pressures.

- 7.4. The **Treasurer** has the authority and responsibility to:
  - 7.4.1. Develop and maintain financial plans for the appropriate level of maintenance, rehabilitation, extension and decommission of assets.
  - 7.4.2. Report on status of the AM Program through budget and financial reporting.
  
- 7.5. **Supervisors and Managers** have the authority and responsibility to:
  - 7.5.1. Develop and maintain asset inventories.
  - 7.5.2. Assess infrastructure condition and service levels.
  - 7.5.3. Recommend and monitor infrastructure replacement requirements.

## **8. REFERENCES AND RELATED DOCUMENTS**

- 8.1. [Asset Management Planning for Municipal Infrastructure, O. Reg. 588/17](#)
- 8.2. [Infrastructure for Jobs and Prosperity Act, 2015, S.O. 2015, c. 15](#)
- 8.3. [Building Together – Guide for Municipal Asset Management Plans](#)
- 8.4. [Town of Amherstburg Emergency Response Plan](#)
- 8.5. [Planning Act, R.S.O. 1990](#)  
[Town Official Plan](#)



## THE CORPORATION OF THE TOWN OF AMHERSTBURG

### OFFICE OF PLANNING, DEVELOPMENT & LEGISLATIVE SERVICES

*MISSION STATEMENT: Committed to delivering cost-effective and efficient services for the residents of the Town of Amherstburg with a view to improve and enhance their quality of life.*

Author's Names: Frank Garardo	Report Date: October 10, 2019
Author's Phone: 519 736-5408 ext. 2124	Date to Council: November 12, 2019
Author's E-mail: <a href="mailto:fgarardo@amherstburg.ca">fgarardo@amherstburg.ca</a>	Resolution #: N/A

**To:** Mayor and Members of Town Council

**Subject:** Transfer of Municipal Lands-Road Allowance at 26 Whelan Drive; Block 52, Plan 12M373 - in front of 26 Whelan Drive (Lot 37 on Plan 12M373)

#### 1. RECOMMENDATION:

It is recommended that:

1. **By-law 2019-79** being a by-law to Stop Up, Close and Sell a Portion of the Unimproved Road Allowance described as Block 52 on Plan 12M373 located on the North side of Whelan Avenue be taken as having been read three times and finally passed and the Mayor and Clerk **BE AUTHORIZED** to sign the same; and,
2. The Mayor and Clerk **BE AUTHORIZED** to sign all necessary documents for the transfer prepared in form and content satisfactory to the Director of Planning, Development and Legislative Services.

#### 2. BACKGROUND:

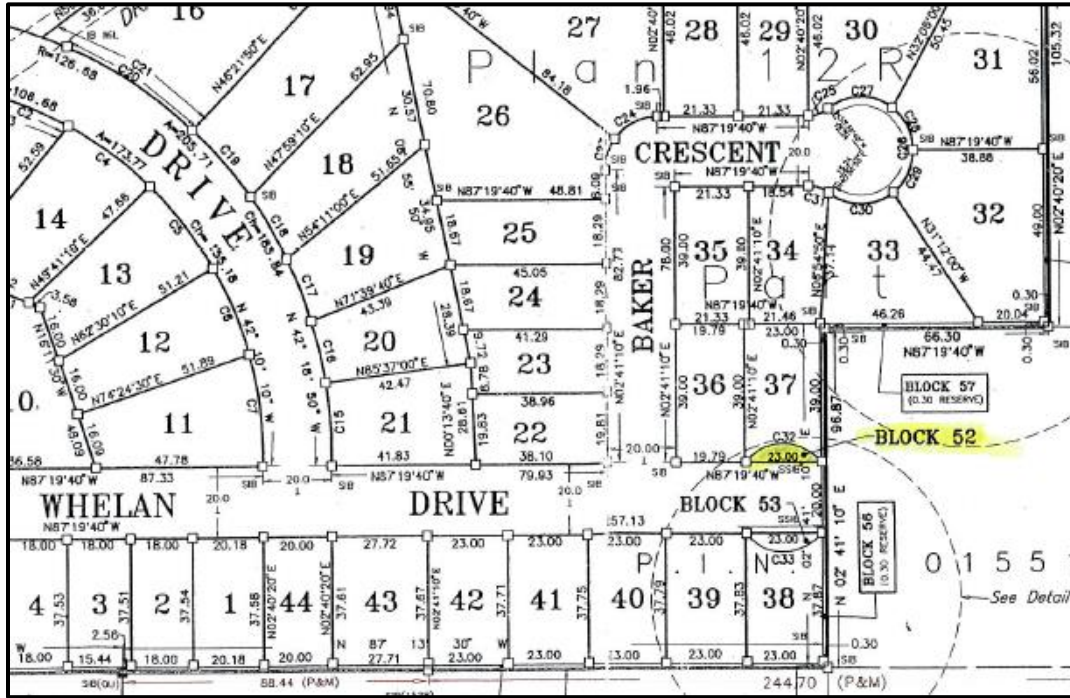
A request was received by the owners of 26 Whelan Drive to convey a semi-circular piece of land identified as Block 52 on Plan 12M373 located between Lot 37 and Whelan drive. Block 52 is registered in the name of the Corporation of the Town of Amherstburg as a result of amalgamation. Block 52 on Plan 12M373 and a corresponding piece of land across the street known as Block 53 on Plan 12M373 appear to have been intended to form part of a temporary cul-de sac at what was previously the end of Whelan Street.

The proponent's solicitor has made a request with regards to acquiring the lands described as Block 52 on Plan 12M373 to provide access and reconfigure the lands described as lot 37 on Plan 12M373.



A similar property across the street known as Block 53 was previously conveyed to the owner of Lot 38 on Plan 12M373. Presumably the intent was to similarly convey Block 52 to the owner of Lot 37, however the transfer was ne completed.

As a result of that request Town staff reviewed the proposal and determined that the subject portion of lands were no longer utilized as a temporary cul-de-sac and no longer required by the Town of Amherstburg.



\*Block 52 is to be transferred to Lot 37 (26 Whelan Drive)  
 Block 53 was transferred to Lot 38 (27 Whelan Drive)



Aerial photo of Lot 37 (26 Whelan Drive).

**3. DISCUSSION:**

The abutting property owners are not affected by the proposal as the portion of municipal lands is located directly abutting 26 Whelan drive and not used as a traveled portion of the street.

The standard right-of-way/road allowance is typically 20 meters wide and the conveyance of Block 52 would not reduce the right-of-way below that standard . The conveyance of block 52 on Plan 12M373 to Lot 37 on Plan 12M373 (26 Whelan Drive) would not impact the traffic flow.

Public Works has identified that they have no requirement for the portion of lands.

**4. RISK ANALYSIS:**

Given the subject parcel of land has not been traveled on from abutting land owners or through traffic, the conveyance of Block 52 on Plan 12M373 presents little risk to the current street and traffic layout. If the Town does not transfer the lands to the abutting property owner then the Town would remain responsible for any maintenance and liability of the lands.

**5. FINANCIAL MATTERS:**

The proponent would be required to cover all costs of the transfer of lands and registration on title. If the lands are included in the Town's asset inventory, the ascribed value would be written off on transfer of the lands.

**6. CONSULTATIONS:**

Public notification was completed in accordance with the policy and procedures of the Town of Amherstburg By-Law 2015-51 Provision of Notice to the Public.

Engineering and Public Works has reviewed the proposed amendment and identified no concerns.

**7. CONCLUSION:**

The lands in Block 52 on Plan 12M373 are no required by the Town. The transfer of those lands to the abutting Lot 37 will eliminate any liability the Town currently has over those lands and will effect a transfer similar to that completed for the parcel across the street when the Town's discontinued use of the lands as a temporary cul-de-sac.



---

Frank Garardo  
**Manager of Planning Services**

**Report Approval Details**

<b>Document Title:</b>	<b>Transfer of Road Allowance at 26 Whelan Drive; Block 52, Plan 12M373 - (Lot 37 on Plan 12M373).docx</b>
<b>Attachments:</b>	<b>- Report to Council-October 15-26 Whelan Dr Sale of Road Allowance-ATTACHMENTS.pdf</b>
<b>Final Approval Date:</b>	<b>Nov 1, 2019</b>

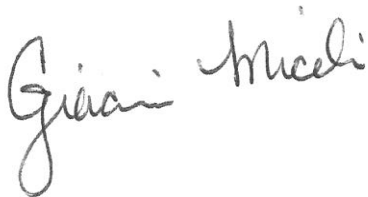
**This report and all of its attachments were approved and signed as outlined below:**



**Mark Galvin - Oct 28, 2019 - 12:47 PM**



**Cheryl Horrobin - Nov 1, 2019 - 8:04 AM**



**John Miceli - Nov 1, 2019 - 10:33 AM**



**Paula Parker - Nov 1, 2019 - 4:12 PM**

**THE CORPORATION OF THE TOWN OF AMHERSTBURG**

**BY-LAW NO. 2019-079**

**A By-law to stop up, close and sell a portion of the unimproved Road Allowance in front of 26 Whelan Drive; Block 52, Plan 12M373**

---

**WHEREAS** the Council of the Corporation deems it expedient to close a portion of the unimproved Road Allowance in front of 26 Whelan Drive; Block 52, Plan 12M373 located on the north side of Whelan Drive described legally as Block 52, Plan 12M373 and to sell the lands to the abutting owners.

**AND WHEREAS** by virtue of the provisions of Section 34 of the Municipal Act 2001, R.S.O. 2001, c 25, as amended, a by-law permanently closing a highway, including a road allowance on a registered plan of subdivision, does not take effect until a certified copy of the by-law is registered in the appropriate Land Registry Office.

**NOW THEREFORE** the Council of the Corporation of the Town of Amherstburg hereby enacts as follows:

1. That a portion of the unimproved Road Allowance between in front of 26 Whelan Drive; described as Block 52, Plan 12M373, in the Town of Amherstburg in the County of Essex be and the same are hereby **stopped up and closed**.
2. It is hereby confirmed the lands described in Section 1 of the By-Law are deemed surplus to the needs of the Corporation.
3. Upon completion of the closing of a portion of the unimproved Road Allowance described as Block 52, Plan 12M373 on the north side of Whelan Drive; described as Block 52, Plan 12M373, that the portion of the unimproved Road Allowance so closed may be transferred to the abutting owner.  
**PROVIDED** that all costs and expenses incurred in connection with this matter be borne by the ratepayers concerned .
4. This By-law shall come into force and take effect after the final passing thereof on the date upon which the By-law is registered in the Land Registry Office in the County of Essex (No.12).

Read a first and second time and finally passed this 12th day of November, 2019.

---

**MAYOR-Aldo DiCarlo**

---

**CLERK- Paula Parker**



C = N00°58'10"E

# THE KING'S HIGHWAY No. 18

See Detail 'A'

PLAN  
1211 373

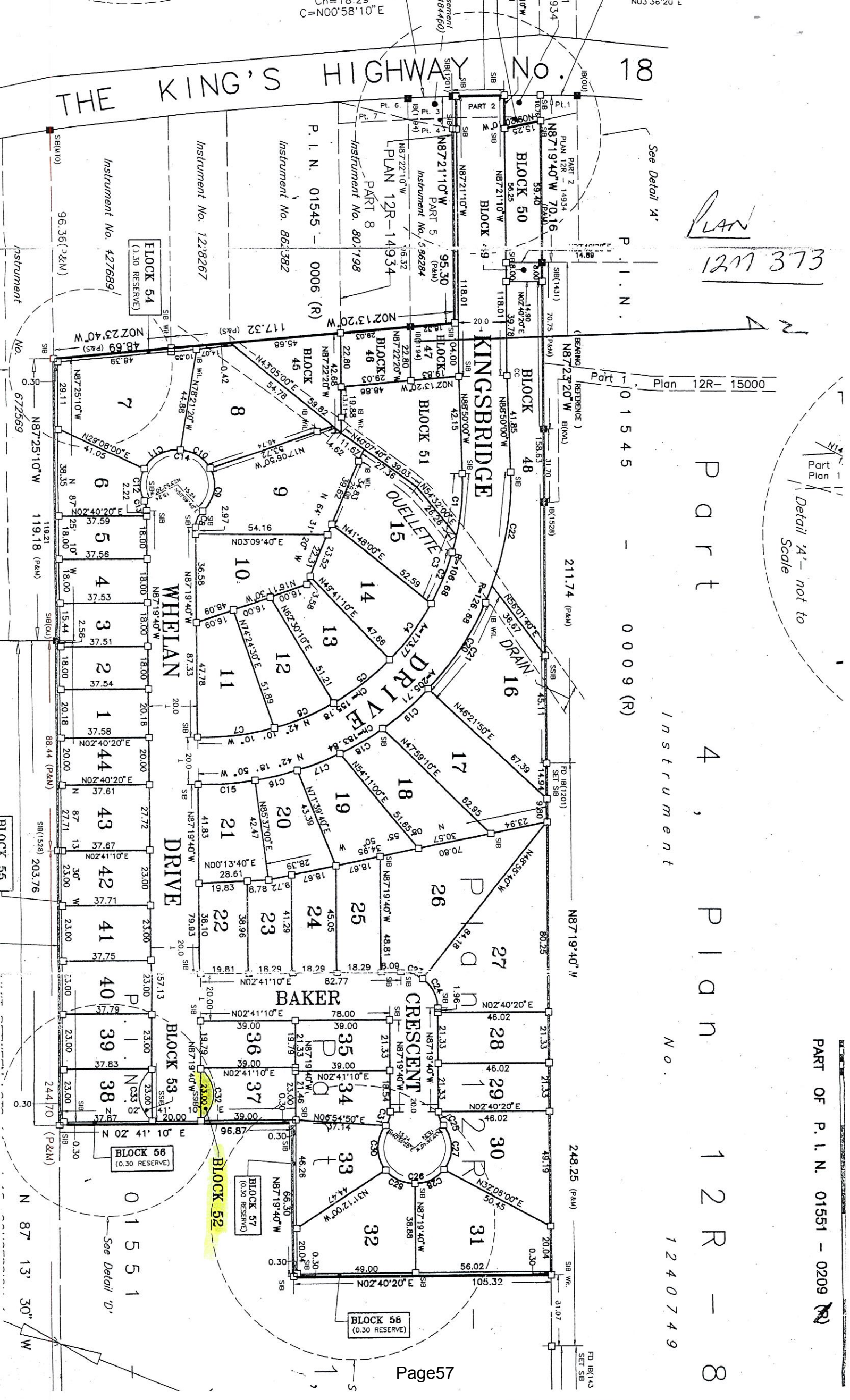
P. I. N. 01545 - 0009 (R)

Instrument No.

## Part 4, Plan 12R - 8

Detail 'A' - not to Scale

PART OF P. I. N. 01551 - 0209 (R)





0 1 5 4 5 - 0 0 0 5 (R)

See Detail 'B'

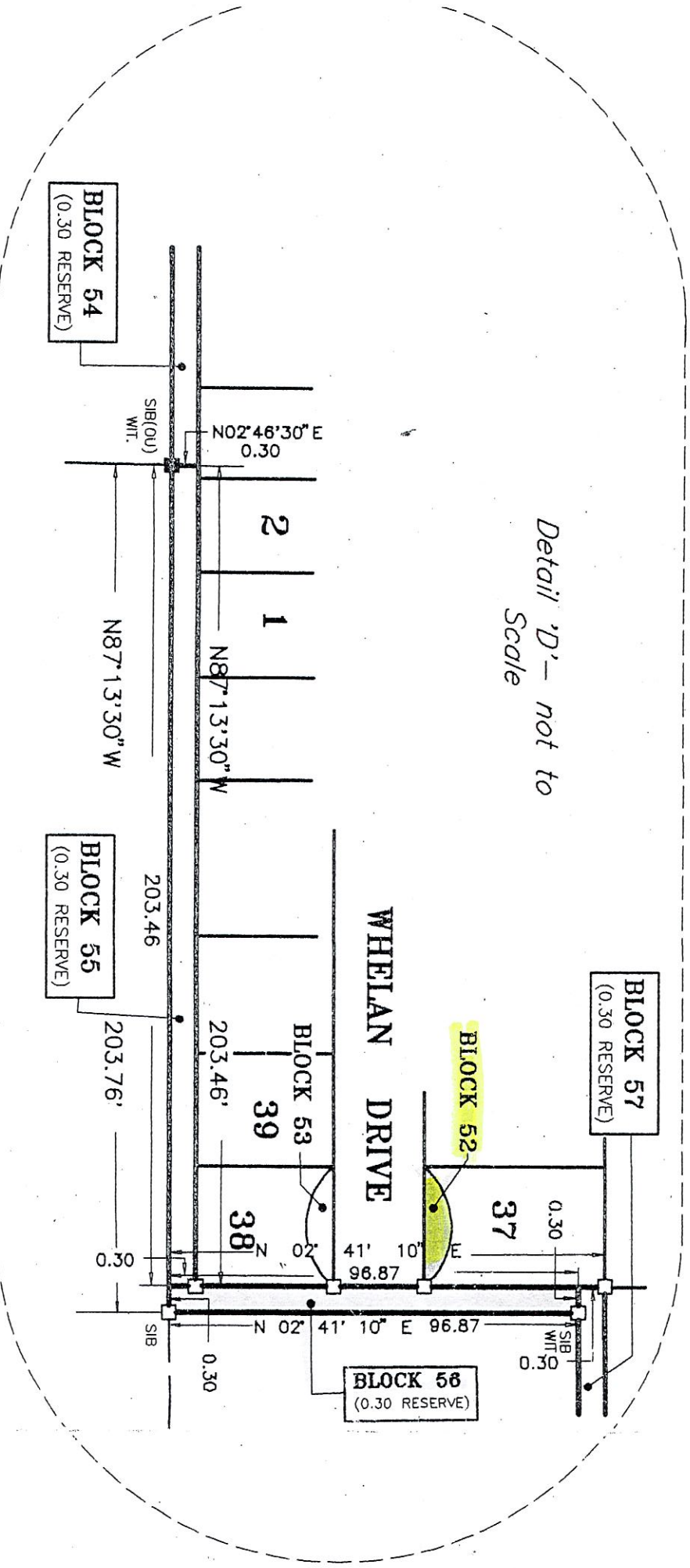
(0.30 RESERVE)

P a r t

P l a n

P . I . N .

Detail 'D' - not to Scale



### LEGEND

- SIB DENOTES 25mm X 25mm X 1.22m STANDARD IRON BAR
- SSIB DENOTES 25mm X 25mm X 0.61m SHORT STANDARD IRON BAR
- IB DENOTES 16mm X 16mm X 0.61m IRON BAR
- IB Ø DENOTES 19mm diameter X 0.61m ROUND IRON BAR
- DENOTES SURVEY MONUMENT FOUND
- DENOTES SURVEY MONUMENT SET AND MARKED 1528

### OWNER'S CERTIFICATE

THIS IS TO CERTIFY  
 1. LOTS 1 TO 44 (including  
 BLOCKS 54 TO 58  
 KINGSBRIDGE DRIVE  
 HAVE BEEN LAIN



## NOTICE OF ROAD CLOSURE AND LAND CONVEYANCE

Please take notice that the Town of Amherstburg intends to pass a by-law to close a portion of the unimproved Road Allowance described as Block 52 on Plan 12M373 to be conveyed by the Town to the abutting Owners of 12M373 lot 37 (known municipally as 26 Whelan Drive).

The Road Allowance is described legally as follows:

*The Road Allowance is located on the north side of Whelan Drive between Baker Crescent and Cambridge Court and described as Block 52 on Plan 12M373.*

Council will hear any person who claims that their land will be prejudicially affected by the By-law at the Public Council Meeting to be held on November 12<sup>th</sup>, 2019 at 6:00 p.m. at the Amherstburg Town Hall, 271 Sandwich Street South. There will be an opportunity for verbal presentation at the meeting.

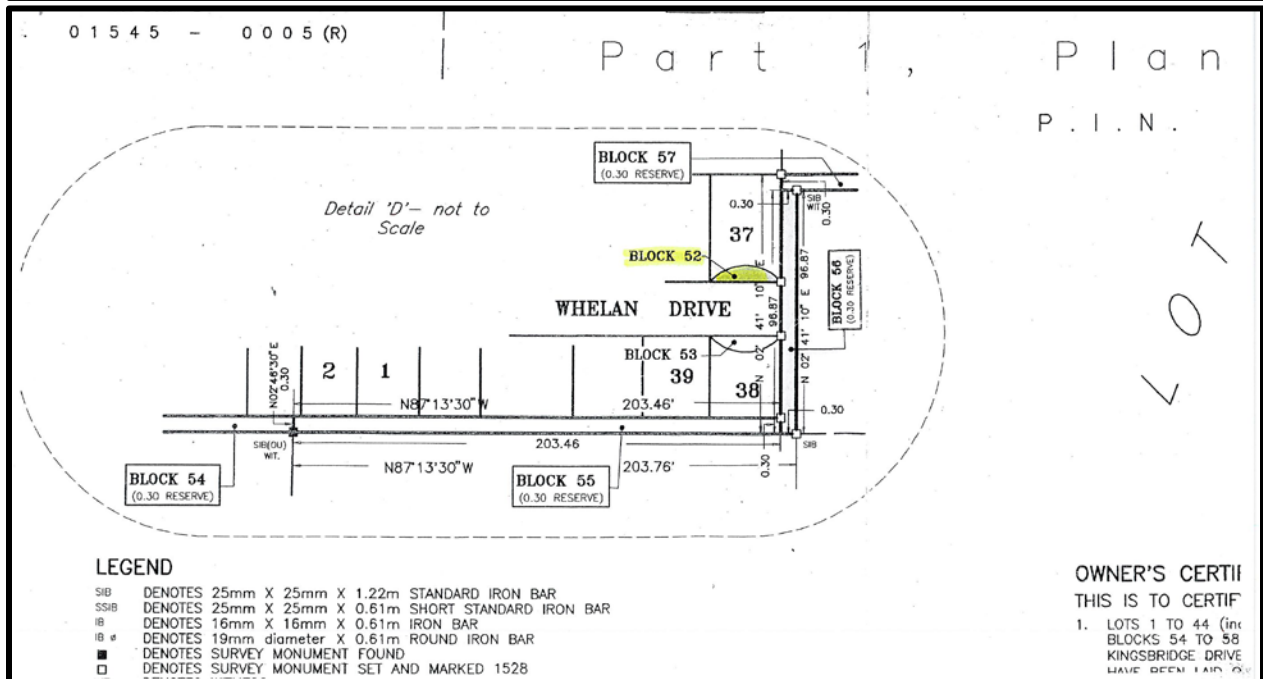
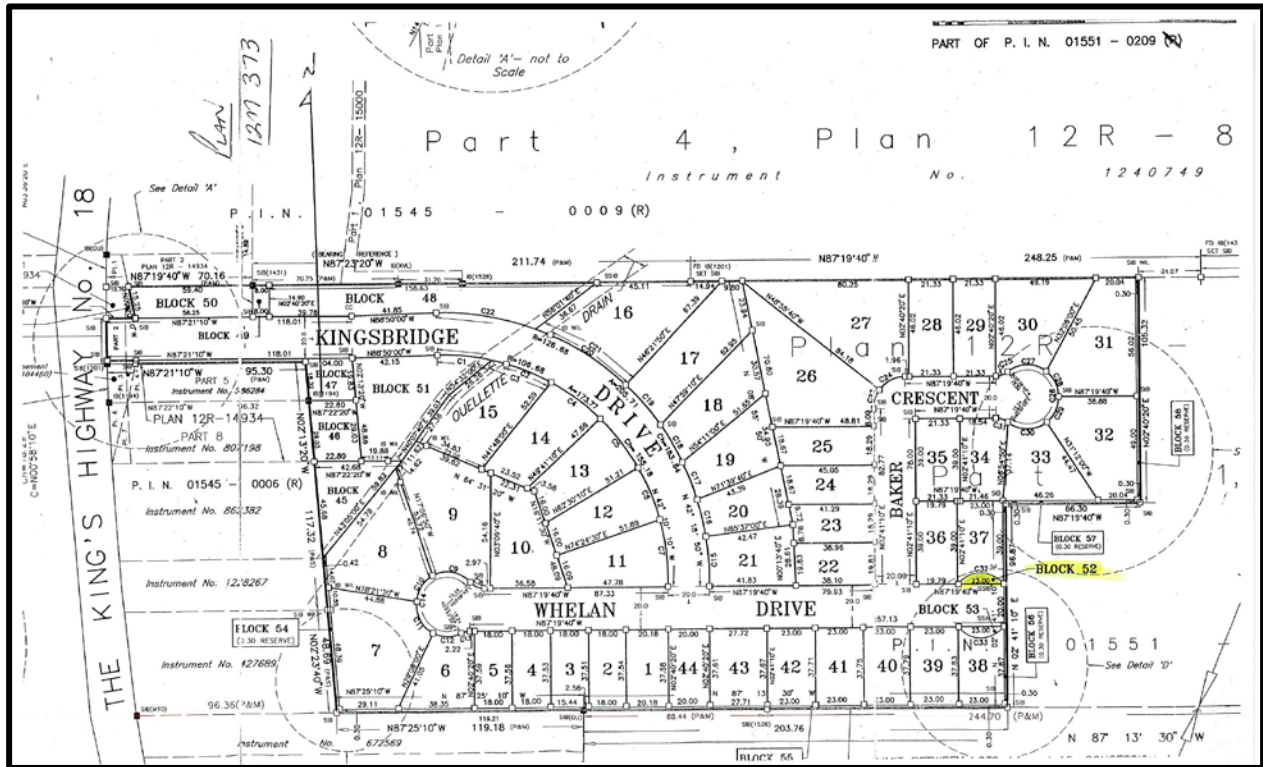
Written submissions should be submitted to the Clerk no later than November 6<sup>th</sup>, 2019 at 12:00 p.m. It is the intention of Council to consider and pass the by-law for closure at the November 12<sup>th</sup>, 2019 Council meeting.

If you have any questions or objections, contact the Clerk. To view the Plan of Survey please visit the News and Public Notices Section at <https://www.amherstburg.ca>.

Paula Parker  
[pparker@amherstburg.ca](mailto:pparker@amherstburg.ca)  
519-736-0012 ext. 2238

---

Information will be gathered in accordance with the Municipal Freedom of Information and Protection of Privacy Act (MFIPPA). All comments and communications received will become part of the public record unless you expressly request the Town to remove it. If you want to learn more about why and how the Town collects your information, write to the Town Clerk's Office, 271 Sandwich Street South, Amherstburg, ON N9V 2A5 or call 519-736-0012.



Information will be gathered in accordance with the Municipal Freedom of Information and Protection of Privacy Act (MFIPPA). All comments and communications received will become part of the public record unless you expressly request the Town to remove it. If you want to learn more about why and how the Town collects your information, write to the Town Clerk's Office, 271 Sandwich Street South, Amherstburg, ON N9V 2A5 or call 519-736-0012.





JEFFREY A. BAKER, LL.B.  
JANICE O. BUSCH, B.Sc., LL.B.

May 22, 2019

41 SANDWICH STREET SOUTH  
AMHERSTBURG, ONTARIO  
CANADA  
N9V 1Z5

TELEPHONE (519) 736-2154  
TELECOPIER (519) 736-2466

Town of Amherstburg  
271 Sandwich Street South  
Amherstburg, ON N9V 2A5  
Attention: Paula Parker, Municipal Clerk

**RE: 26 Whelan Drive being Lot 37 on Plan 12M373, Amherstburg, ON**

Dear Ms. Parker,

I represent William Fetter and Judith Fetter, who purchased the above-referenced property in December of 2016. I enclose a copy of a letter signed by you dated December 1, 2016 in relation to this matter which you provided to Christine Riley, the solicitor for the vendor who sold the above-referenced property to my clients. My title search revealed that a semi-circular piece of land identified as Block 52 on Plan 12M373 is located between Lot 37 and Whelan Drive. I enclose a copy of the relevant parts of Plan 12M373 for your reference. Block 52 is registered in the name of The Corporation of the Township of Anderdon and therefore is now owned by the Corporation of the Town of Amherstburg as a result of amalgamation. Block 52 and a corresponding piece of land across the street known as Block 56 appear to have been intended to form part of a temporary cul-de-sac at what was then the end of Whelan Street. My concern was at the time and continues to be that Block 52 is owned by the municipality and there was no bylaw registered on title dedicating Block 52 as a public right-of-way and it therefore prevents Lot 37 from fronting on a public road or public right-of-way and it prevents a legal right of ingress and egress for Lot 37. I raised this issue with Christine Riley, who then raised it with the Town and you provided the enclosed letter dated December 1, 2018. As you may recall, your letter was intended to provide comfort to my clients and assure them that they may have ingress and egress over Block 52 to access their property and the intention was to rectify this matter within a few weeks and to put the matter before Council if necessary to fix the problem.

My searches indicate the similar property across the street known as Block 56 was conveyed to the owner of Lot 38. Presumably the intent was to similarly convey Block, 52 to the owner of Lot 37 but unfortunately, this has not been done.

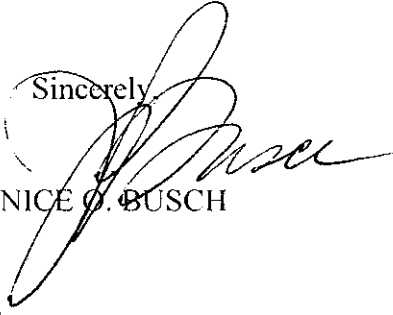
---

WINDSOR, ONTARIO CANADA

Since receipt of your letter enclosed, I have been attempting to follow up on this matter with Rebecca Belanger, the Town's Planner at the time. I enclose copies of my email correspondence with her which repeatedly indicated that she would have to pull the file and look into the matter, the last response from her was dated January 30, 2019 in which she indicated that she would attempt to clean this up before leaving the Town for her new job. On today's date, I did a search of the Land Registry Office records for Block 52 which indicates that nothing has been done to fix this problem. I enclose a copy of the parcel register printout for your reference. It seems to me that the appropriate fix would be for the Town to convey Block 52 to the owners of Lot 37. Had the Town intended to keep Block 52 and Block 56, then depiction of these Blocks on the plan of subdivision would not have been necessary and the land forming Blocks 52 and 56 would have been simply drawn as a permanent part of Whelan Drive. I am writing to ask that you kindly look into this matter and determine whether or not the Town is willing to convey Block 52 to the owners of Lot 37. If the Town is not now inclined to convey Block 52 to the owners of Lot 37, then a bylaw should be passed dedicating Block 52 as a public right-of-way.

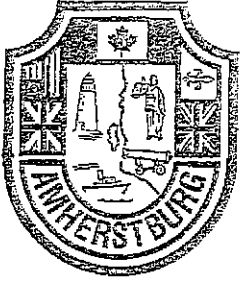
I look forward to hearing from you with regard to this matter.

Sincerely,

  
JANICE O. BUSCH

enclosures

- copy of your letter of December 1, 2016
- relevant parts of Plan 12M373
- copy of email correspondence
- parcel register printout for Block 52, Plan 12M373



The Corporation of The  
Town of Amherstburg

271 SANDWICH ST. SOUTH  
AMHERSTBURG, ONTARIO  
N9V 2A5

December 1, 2016

Bondy, Riley, Koski Barristers,  
Solicitors and Notaries  
Suite 310, 176 University Avenue West,  
Windsor, Ontario,  
N9A 5P1

Attention: Christine A. Riley

Dear Ms. Riley:

Subject: D'Alimonte, Jennifer s/t Fetter- 26 Whelan Drive, Amherstburg  
Your File No.: 4665-002

---

This is in response to your correspondence dated November 29, 2016 wherein you requested to have Block 52 either assumed as part of Whelan Drive, or the transfer of the title to the new purchaser and until that time that either Ms. D'Alimonte or the new purchaser have the ability to cross over and along Block 52 to access Whelan Drive.

We have considered your request for access over and along Block 52 to allow for the ingress and egress for persons, vehicles and things for Ms. D'Alimonte and the new purchaser and can confirm that the Town has no objection to this request for access.

We are presently undertaking a search of our files so that this matter can be rectified and finalized such that legal access and frontage will be created on the assumed Whelan Drive for Lot 37. At this point we cannot confirm whether Block 52 will be assumed as part of Whelan Drive or proposed to be transferred in title to the new purchaser of Lot 37. It is anticipated that the finalization of this matter may require the approval of Council and therefore it may take several weeks to address this request due to the Council meeting schedule.

Kindest Regards,

A handwritten signature in black ink, appearing to read "Paula Parker".

Paula Parker,  
Municipal Clerk

**From:** [Frank Garardo](#)  
**To:** [Katrina DiGiovanni](#)  
**Subject:** FW: 26 Whelan Drive - Correspondence from Janice Busch  
**Date:** Tuesday, October 08, 2019 10:06:49 AM

---

**From:** Frank Garardo  
**Sent:** May-29-19 1:00 PM  
**To:** Todd Hewitt  
**Subject:** RE: 26 Whelan Drive - Correspondence from Janice Busch

Thanks.

---

**From:** Todd Hewitt  
**Sent:** May-29-19 12:37 PM  
**To:** Frank Garardo  
**Subject:** RE: 26 Whelan Drive - Correspondence from Janice Busch

Frank,

We have no reason to own this parcel and require no easements.

Todd

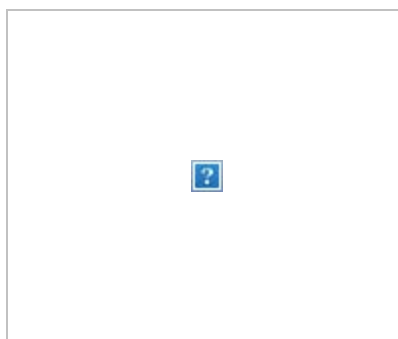
**Todd Hewitt**

*Manager of Engineering and Operations*

Town of Amherstburg

512 Sandwich St South, Amherstburg, ON, N9V 3R2

Tel: 519-736-3664 ext 2313 Fax: 519-736-7080 TTY: 519-736-9860



The information in this e-mail is confidential, privileged and is subject to copyright and authorized solely for the addressee(s) named. The Town of Amherstburg is not responsible for any loss or damage arising from the use of this email or attachments.

---

**From:** Frank Garardo  
**Sent:** May 29, 2019 11:55 AM  
**To:** Todd Hewitt <[thewitt@amherstburg.ca](mailto:thewitt@amherstburg.ca)>  
**Subject:** FW: 26 Whelan Drive - Correspondence from Janice Busch

Hi Todd,

The owners of 26 Whelan would like to proceed with conveying some Town lands to square of the front driveway (block52). Do you see any reasons why the Town would still need the parcel or easements on it?



**Frank Garardo**

*Manager, Planning Services*

Town of Amherstburg - Libro Centre

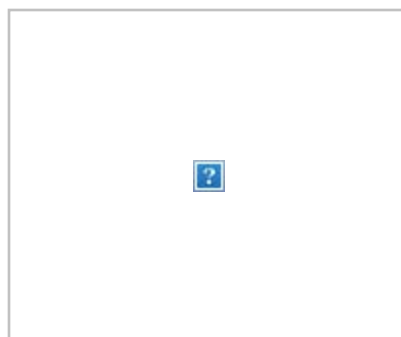
3295 Meloche Rd., Amherstburg, ON, N9V 2Y8

Tel: 519-736-5408 Fax: 519-736-9859 TTY: 519-736-9860



**TALK  
THE  
BURG**

[www.talktheburg.ca](http://www.talktheburg.ca)



The information in this e-mail is confidential, privileged and is subject to copyright and authorized solely for the addressee(s) named. The Town of Amherstburg is not responsible for any loss or damage arising from the use of this email or attachments.

---

**From:** Mark Galvin  
**Sent:** May-28-19 4:15 PM  
**To:** Frank Garardo

**Cc:** Sarah Sinasac; Paula Parker  
**Subject:** FW: 26 Whelan Drive - Correspondence from Janice Busch

Frank – please see matter below and attached.

Mark

**Mark Galvin**

*Director of Planning, Development, and Legislative Services*  
Town of Amherstburg  
3295 Meloche Rd., Amherstburg, ON, N9V 2Y8  
Tel: 519-736-5712 ext Fax: 519-736-7111 TTY: 519-736-9860



The information in this e-mail is confidential, privileged and is subject to copyright and authorized solely for the addressee(s) named. The Town of Amherstburg is not responsible for any loss or damage arising from the use of this email or attachments.

---

**From:** Paula Parker  
**Sent:** May-28-19 4:13 PM  
**To:** Mark Galvin <[mgalvin@amherstburg.ca](mailto:mgalvin@amherstburg.ca)>  
**Subject:** 26 Whelan Drive - Correspondence from Janice Busch

Hey Mark,

Here is a copy of an email stemming from Rebecca with respect to 26 Whelan Drive. I have received correspondence today from Janice Busch regarding this outstanding matter. My involvement in this matter was limited to signing the correspondence. Could you or Frank please follow up and complete this outstanding matter? I will advise Ms. Busch that it has been referred to Planning.

Thank you,  
P

**Paula Parker**  
*Municipal Clerk*  
Town of Amherstburg

**From:** [Frank Garardo](#)  
**To:** [Katrina DiGiovanni](#)  
**Subject:** FW: Block 52, Plan 12M272 - in front of 26 Whelan Drive (Lot 37 on Plan 12M373)  
**Date:** Thursday, October 10, 2019 11:12:57 AM

---

**From:** Baker Busch [mailto:info@bakerbusch.ca]  
**Sent:** October-10-19 11:08 AM  
**To:** Frank Garardo  
**Subject:** RE: Block 52, Plan 12M272 - in front of 26 Whelan Drive (Lot 37 on Plan 12M373)

Thank you Mr. Garardo. It would be appreciated if you or someone from the Town would advise me of the date on which the matter will be scheduled before council, once that date is known.

Janice Busch.  
Barrister & Solicitor  
Baker Busch  
41 Sandwich Street South, Amherstburg, Ontario N9V 1Z5  
phone (519)736-2154; fax (519) 736-2466

CONFIDENTIALITY NOTICE: The information in this e-mail is legally privileged and confidential. It is intended only for use by the addressee named above. If you are not the intended addressee, any disclosure, copying or distribution of the information, or the taking of action in reliance on it is strictly prohibited. If you have received this transmission in error, please advise the sender immediately, by telephone call, fax transmission or e-mail and delete all copies from your computer. Thank you.

---

**From:** Frank Garardo <[fgarardo@amherstburg.ca](mailto:fgarardo@amherstburg.ca)>  
**Sent:** October-10-19 10:49 AM  
**To:** Baker Busch <[info@bakerbusch.ca](mailto:info@bakerbusch.ca)>  
**Subject:** RE: Block 52, Plan 12M272 - in front of 26 Whelan Drive (Lot 37 on Plan 12M373)

Good morning,

I will be bringing a report to Council for consideration of authorizing a by-law to transfer the municipal lands.  
As discussed, the cost of the transfer and registration will be the responsibility of the applicants.

Regards,

**Frank Garardo**

*Manager, Planning Services*  
Town of Amherstburg - Libro Centre  
3295 Meloche Rd., Amherstburg, ON, N9V 2Y8  
Tel: 519-736-5408 Fax: 519-736-9859 TTY: 519-736-9860



**TALK  
THE  
BURG**

[www.talktheburg.ca](http://www.talktheburg.ca)

The information in this e-mail is confidential, privileged and is subject to copyright and authorized solely for the addressee(s) named. The Town of Amherstburg is not responsible for any loss or damage arising from the use of this email or attachments.

---

**From:** Baker Busch [<mailto:info@bakerbusch.ca>]

**Sent:** September-12-19 11:25 AM

**To:** Frank Garardo

**Subject:** Block 52, Plan 12M272 - in front of 26 Whelan Drive (Lot 37 on Plan 12M373)

Dear Mr. Garardo,

You may recall that we spoke in June about this matter. At that time, you indicated that you had determined that the Town of Amherstburg has no need to retain Block 52, Plan 12M272, being part of a temporary cul-de-sac between Lot 37 and Whelan Drive. I understand that you were going to determine the proper procedure for conveyance of the road to my clients, Mr. and Mrs. Fetter, who own Lot 37 so that they will have frontage on Whelan Drive. My clients realize that they will be expected to cover certain costs associated with this process. Presumably the Town will need to declare this land as surplus lands and pass a bylaw that it be conveyed to Mr. and Mrs. Fetter to provide their lot with road frontage and road access. I am wondering what, if any progress has been made in this regard. Please advise and also please let me know if you need anything from me or my clients at this stage.

Best regards,

Janice Busch.

Barrister & Solicitor

Baker Busch

41 Sandwich Street South, Amherstburg, Ontario N9V 1Z5

phone (519)736-2154; fax (519) 736-2466

CONFIDENTIALITY NOTICE: The information in this e-mail is legally privileged and confidential. It is intended only for use by the addressee named above. If you are not the intended addressee, any disclosure, copying or distribution of the information, or the taking of action in reliance on it is strictly prohibited. If you have received this transmission in error, please advise the sender immediately, by telephone call, fax transmission or e-mail and delete all copies from your computer. Thank you.





THE CORPORATION OF THE TOWN OF AMHERSTBURG

OFFICE OF PLANNING, DEVELOPMENT & LEGISLATIVE SERVICES

MISSION STATEMENT: Committed to delivering cost-effective and efficient services for the residents of the Town of Amherstburg with a view to improve and enhance their quality of life.

Table with 2 columns: Author's Name, Report Date, Author's Phone, Date to Council, Author's E-mail, Resolution #.

To: Mayor and Members of Town Council

Subject: Zoning By-Law Amendment - WS Concession 4 South

1. RECOMMENDATION:

It is recommended that:

- 1. By-law 2019-077, being a by-law to amend Zoning By-law No. 1999-52 for WS Concession 4 South, be taken as having been read three times and finally passed and the Mayor and Clerk BE AUTHORIZED to sign same.

2. BACKGROUND:

The Statutory Public Meeting was held at 4:00 p.m., September 23, 2019 to hear public comments on an application for a Zoning By-law Amendment for the WS Concession 4 S. The Zoning By-law Amendment will change the zoning for the subject lands from the "Agricultural (A) Zone" to "Special Provision Agricultural (A-36) Zone".

3. DISCUSSION:

The subject lands affected by the proposed amendment are described as Malden Concession 3 Part of Lot 28; the residence which was the subject of the severance is located at 4380 Concession 4 N is not subject to this rezoning.

The applicant has to severe a parcel of land being 77.1 m (253 ft) ± frontage by 115.82 m (approx. 380 ft) depth with an area of 8,943.55 sq m (approx. 2.21 acres) which includes a single detached dwelling and three (3) accessory structures that are surplus

to the needs of the farming operation. The remaining parcel that is subject of the re-zoning is 41.75m (approx.137 ft) frontage by an irregular depth with an area of 15.21 hectares (37.59 acres) ± is vacant agricultural land.

The Zoning By-law Amendment will allow for general agricultural uses on the subject property and prohibit any new dwelling units on the land.

The application is consistent with the Provincial Policy Statement, specifically Section 2.3.4.1(c) which provides for lot creation for a residence surplus to a farming operation as a result of farm consolidation provided that new residential dwellings are prohibited on any vacant remnant parcel created by the severance. The application is also in conformity with the Town's Official Plan, specifically Section 3.2.2(14), which provides for surplus dwelling severances subject to the remnant parcel being rezoned to ensure no new dwelling units will be permitted. The proposed lot size as well as the intended land use for the subject parcel complies with the zone requirements for the Special Provision Agricultural Zone.

**4. RISK ANALYSIS:**

The recommendation presents little to no risk to the municipality. Should Council not approve the proposed application for Zoning By-law Amendment, the consent which has been approved by the Committee of Adjustment could not be finalized. The home which is surplus to the needs of the farming operation could then not be severed and transferred

**5. FINANCIAL MATTERS:**

All costs associated with the application are the responsibility of the applicant. Support of agricultural operations promotes stability in agricultural assessment base.

**6. CONSULTATIONS:**

No further consultation is required to meet the statutory requirements of the Planning Act regarding this Zoning By-law Amendment.

**7. CONCLUSION:**

It is recommended that Zoning By-law 2019-077 be approved by Council, given three readings and finally passed and the Mayor and Clerk be authorized to sign same.

  
\_\_\_\_\_  
Frank Garardo  
**Manager of Planning Services**

**KD**

### Report Approval Details

Document Title:	Zoning By-Law Amendment-4380 Concession 4 South.docx
Attachments:	- Report to Council- November 12-ZBA- WS Conc 4 S-ATTACHMENTS.pdf
Final Approval Date:	Nov 1, 2019

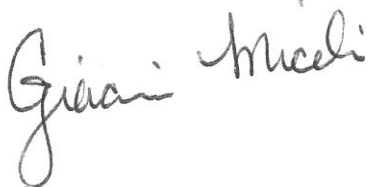
This report and all of its attachments were approved and signed as outlined below:



**Mark Galvin - Oct 30, 2019 - 9:17 AM**



**Cheryl Horrobin - Oct 31, 2019 - 9:29 AM**



**John Miceli - Oct 31, 2019 - 2:08 PM**



**Paula Parker - Nov 1, 2019 - 4:05 PM**

**CORPORATION OF THE TOWN OF AMHERSTBURG  
BY-LAW NO. 2019-077**

**By-law to amend Zoning By-law No. 1999-52  
WS Concession 4 S, Amherstburg**

---

**WHEREAS** By-law 1999-52, as amended, is a land use control by-law regulating the use of lands and the character, location and use of buildings and structures within the Town of Amherstburg;

**AND WHEREAS** the Council of the Town of Amherstburg deems it appropriate and in the best interest of proper planning to amend By-law 1999-52, as herein provided;

**AND WHEREAS** this By-law conforms to the Official Plan for the Town of Amherstburg;

**NOW THEREFORE** the Council of the Corporation of the Town of Amherstburg enacts as follows:

1. Schedule "A", Map 48 of By-law 1999-52, as amended, is hereby amended by changing the zone symbol on those lands shown as "Zone Change from A to A-36" on Schedule "A" attached hereto and forming part of this By-law from "Agricultural (A) Zone" to "Special Provision Agricultural (A-36) Zone".
2. THIS By-law shall take effect from the date of passage by Council and shall come into force in accordance with Sections 34 of the Planning Act, R.S.O. 1990, c.P. 13.

Read a first, second and third time and finally passed this 12<sup>th</sup> day of November, 2019.

---

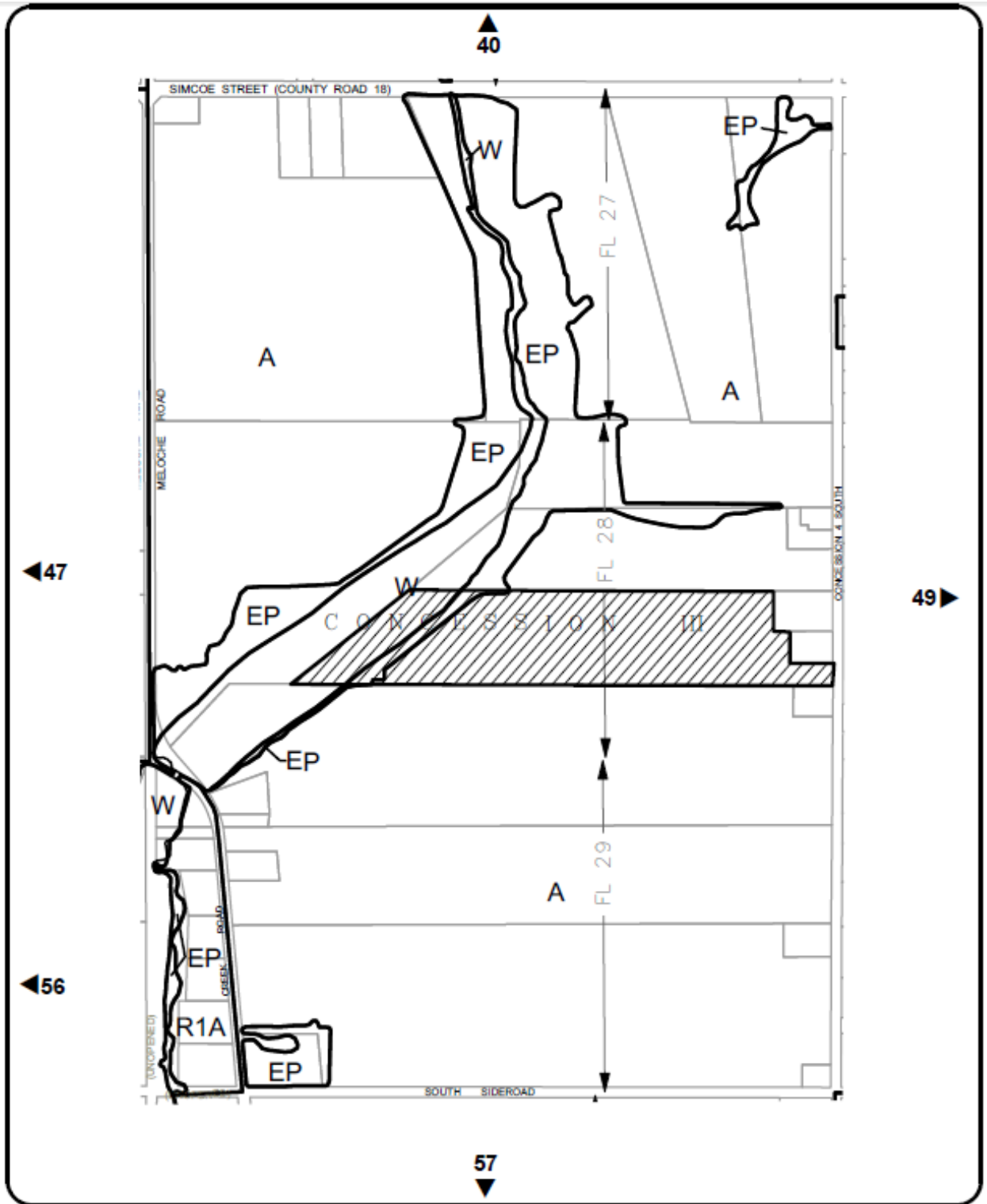
MAYOR- ALDO DICARLO

---


CLERK- PAULA PARKER

**TOWN OF AMHERSTBURG**

SCHEDULE "A" TO BY-LAW No. 2019-077  
 A BY-LAW TO AMEND BY-LAW No. 1999-52



**SCHEDULE 'A'**  
**MAP 48**  
 ZONING BY-LAW NO. 1999-52

A to A-36 

MAYOR- ALDO DICARLO

CLERK- PAULA PARKER

CORPORATION OF THE TOWN OF AMHERSTBURG  
**NOTICE OF PUBLIC MEETING**

**TAKE NOTICE** that the Council of the Corporation of the Town of Amherstburg will hold a public meeting on **Monday, September 23<sup>rd</sup>, 2019 commencing at 4:00 p.m.** in the Town of Amherstburg Council Chambers, 271 Sandwich Street South, Amherstburg, Ontario, to consider a proposed amendment to the Town of Amherstburg Zoning By-law 1999-52 under Section 34 of the Planning Act, RSO 1990 cP.13.

**THE SUBJECT LAND** affected by the proposed amendment is described as Part of Lot 28, Concession 3, municipally known as 4380 Concession 4 South. The property has 137 ft frontage and an irregular depth with a total area of 37.59 acres ± (see key map below).

**THE PURPOSE OF THE AMENDMENT** is to change the zoning of the subject lands noted above from the “**Agricultural (A) Zone**” to “**Special Provision Agricultural (A-36) Zone**”. The parcel is designated Agricultural in the Town’s Official Plan. The lands described above are subject to an application for consent (File B/14/19) to sever a dwelling which is surplus to the needs of a farming operation.

**THE EFFECT OF THE ZONING BY-LAW AMENDMENT** will be to allow for general agricultural use on the subject property and prohibit any new dwelling unit on the land. The “Special Provision Agricultural (A-36) Zone” is established as a site specific zone for the retained agricultural parcel created through consent, to prohibit new residential uses on these lands.

**ANY PERSON** may attend the public meeting and/or make written or verbal representation in support of or in opposition to the proposed Zoning By-law Amendment.

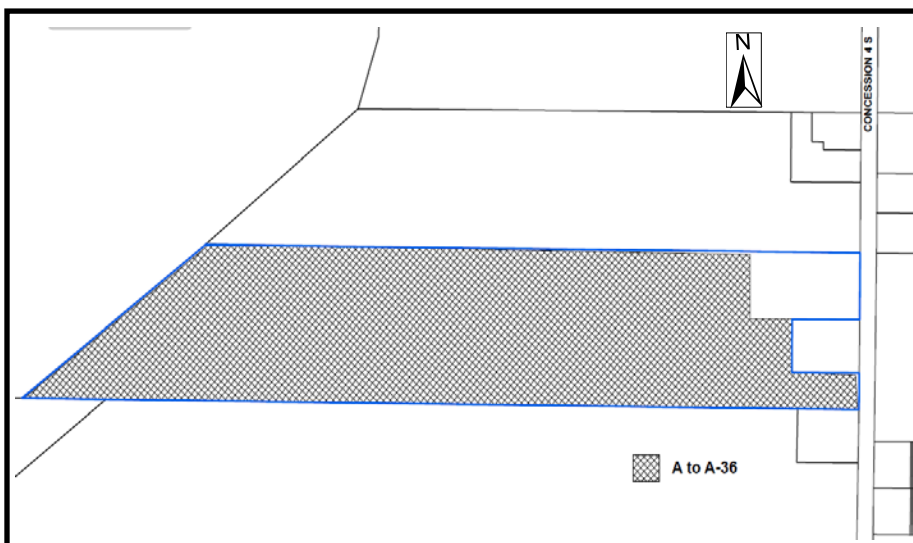
**IF A PERSON OR PUBLIC BODY** would otherwise have an ability to appeal the decision of the Council for the Corporation of the Town of Amherstburg to the Local Planning Appeal Tribunal but the person or public body does not make oral submissions at a public meeting or make written submissions to the Corporation of the Town of Amherstburg before the by-law is passed, the person or public body is not entitled to appeal the decision.

**IF A PERSON OR PUBLIC BODY** does not make oral submissions at a public meeting, or make written submissions to the Corporation of the Town of Amherstburg before the by-law is passed, the person or public body may not be added as a party to the hearing of an appeal before the Local Planning Appeal Tribunal unless, in the opinion of the Tribunal, there is reasonable grounds to do so.

**ADDITIONAL INFORMATION** relating to the proposed Zoning By-law Amendment (File No. ZBA/17/19) is available for inspection at the Town of Amherstburg Planning Offices at the Libro Centre, 3295 Meloche Road, during normal office hours, 8:30 a.m. to 4:30 p.m. or at the Town website [www.amherstburg.ca](http://www.amherstburg.ca). If you wish to be notified of the passage of the proposed by-law you must make a written request to the Town at the address below.

**DATED** at the Town of Amherstburg this 21<sup>st</sup> day of August, 2019.

**KEY MAP**



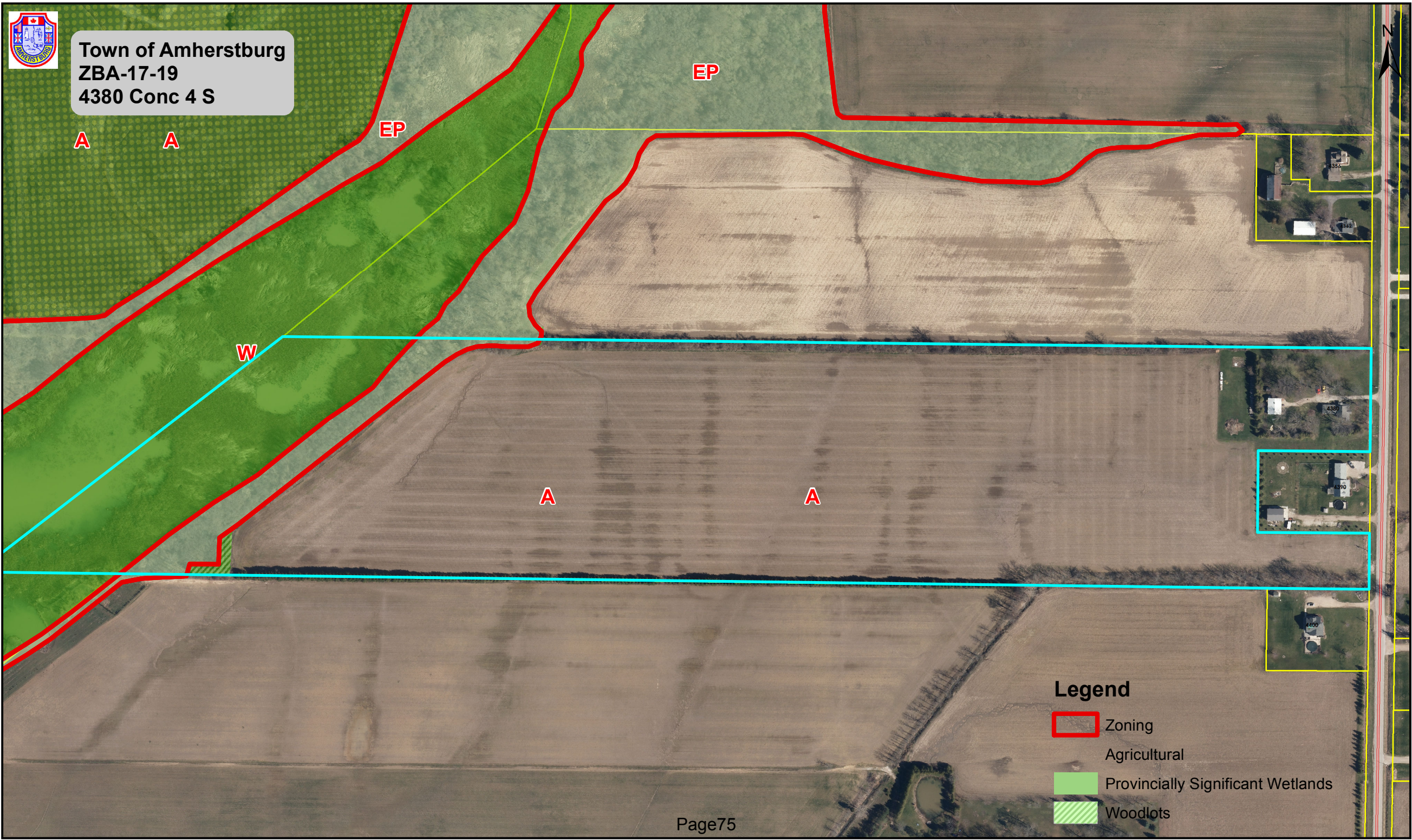
Frank Garardo, MCIP, RPP  
Manager of Planning Services  
Town of Amherstburg  
Libro Centre  
3295 Meloche Road  
Amherstburg, Ontario N9V 2Y8  
Telephone: (519) 736-5408  
Fax No. (519) 736-9859  
Website: [www.amherstburg.ca](http://www.amherstburg.ca)

Information will be gathered in accordance with the Municipal Freedom of Information and Protection of Privacy Act (MFIPPA). All comments and communications received will become part of the public record unless you expressly request the Town to remove it. If you want to learn more about why and how the Town collects your information, write to the Town Clerk's Office, 271 Sandwich Street South, Amherstburg, ON N9V 2A5 or call 519-736-0012.





Town of Amherstburg  
ZBA-17-19  
4380 Conc 4 S



- Legend**
- Zoning
  - Agricultural
  - Provincially Significant Wetlands
  - Woodlots





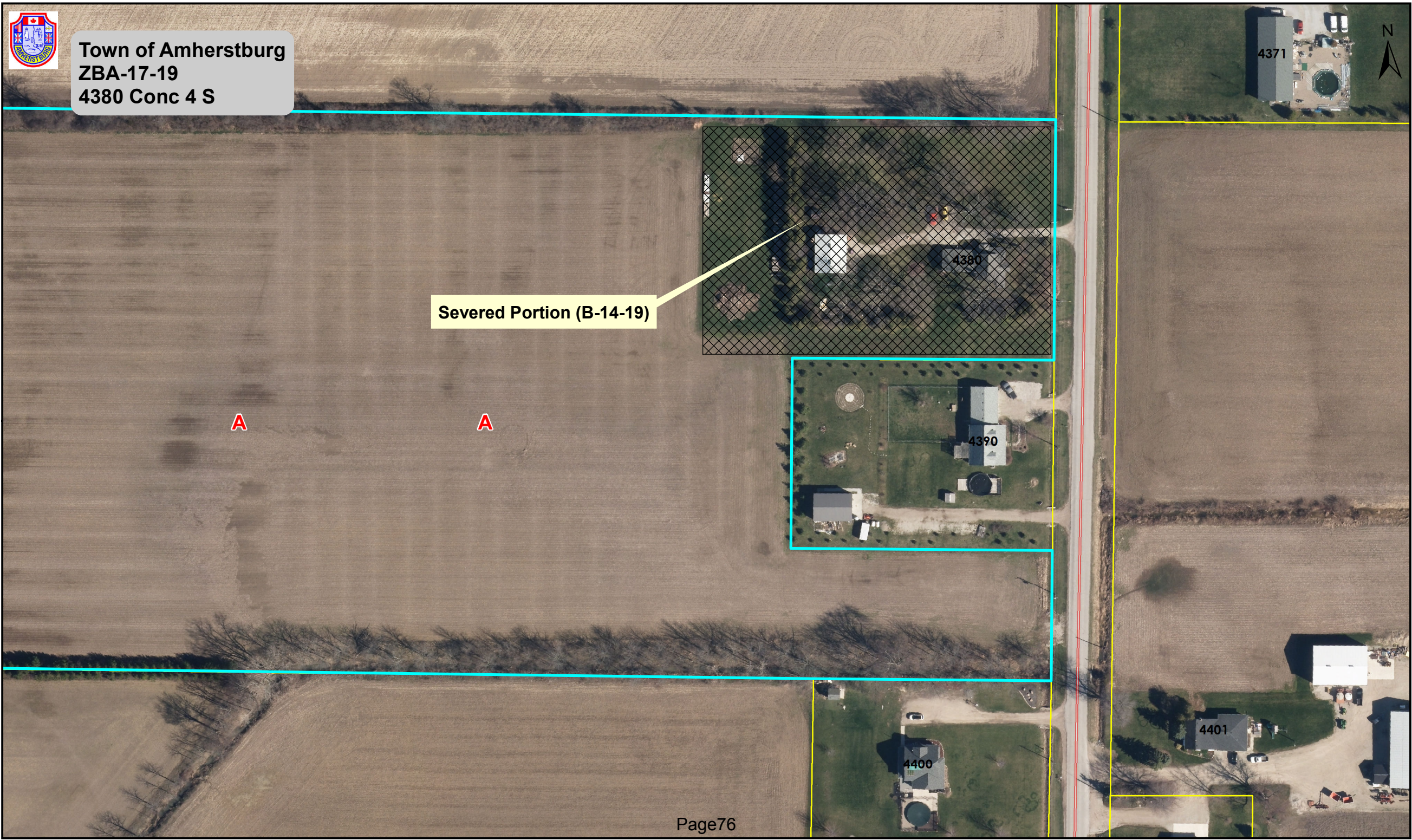
Town of Amherstburg  
ZBA-17-19  
4380 Conc 4 S



Severed Portion (B-14-19)

A

A







planning@erca.org

P.519.776.5209

F.519.776.8688

360 Fairview Avenue West  
Suite 311, Essex, ON N8M 1Y6

August 29, 2019

Mr. Frank Garardo  
Manager of Planning Services  
3925 Meloche Road  
Amherstburg, ON N9V 2Y8

Dear Mr. Garardo:

RE: Zoning By-Law Amendment ZBA-17-19 4380 CONCESSION 4 S  
ARN 372964000002700; PIN:  
Applicant: David & Carol Mailloux

The following is provided as a result of our review of Zoning By-Law Amendment ZBA-17-19. The purpose of this amendment is to change the zoning of the subject lands from "Agricultural (A) Zone" to "Special Provision Agricultural (A-36) Zone" as the property is subject to an application for consent (File B-14-19) to sever a dwelling which is surplus to the needs of the farming operation.

## **DELEGATED RESPONSIBILITY TO REPRESENT PROVINCIAL INTEREST IN NATURAL HAZARDS (PPS, 2014) AND REGULATORY RESPONSIBILITIES OF THE CONSERVATION AUTHORITIES ACT**

The following comments reflect our role as representing the provincial interest in natural hazards encompassed by Section 3.1 of the Provincial Policy Statement of the Planning Act as well as our regulatory role as defined by Section 28 of the Conservation Authorities Act.

The western portion of the above noted lands is subject to our Development, Interference with Wetlands and Alteration to Shorelines and Watercourses Regulation under the *Conservation Authorities Act* (Ontario Regulation No. 158/06). The parcel falls within the regulated area of the Big Creek and Whelan Drain. The property owner will be required to obtain a Permit and/or Clearance from the Essex Region Conservation Authority prior to any construction or site alteration or other activities affected by the regulations.

## **WATERSHED BASED RESOURCE MANAGEMENT AGENCY**

The following comments are provided in an advisory capacity as a public commenting body on matters related to watershed management.

## **SECTION 1.6.6.7 Stormwater Management (PPS, 2014)**

Our office has reviewed the proposal and has no concerns relating to stormwater management.

Mr. Garardo  
August 29, 2019

**PLANNING ADVISORY SERVICE TO MUNICIPALITIES - NATURAL HERITAGE POLICIES OF THE PPS, 2014**

The following comments are provided from our perspective as a service provider to the Municipality on matters related to natural heritage and natural heritage systems. The comments in this section do not necessarily represent the provincial position and are advisory in nature for the consideration of the Municipality as the planning authority.

The western portion of the subject property contains a natural heritage feature that is identified as a significant wetland, significant woodland, significant valleyland, and significant wildlife habitat under the Provincial Policy Statement (PPS, 2014). Our information also indicates that this portion of the property may support habitat of endangered species, threatened species, and potential fish habitat.

Upon review of the circulated application, we acknowledge that the entirety of the natural heritage feature on this site is zoned "Environmental Protection (EP)" which ensures no future development within the EP Zone. As noted in our previous comments for Consent application B-14-19, the surplus dwelling extents will be located well over 120 metres from the natural heritage feature. It is our opinion that a demonstration of no negative impact on the natural heritage feature is not required for this application. We therefore advise the Committee and the Town that this application is consistent with the policies of the PPS.

**FINAL RECOMMENDATION**

We have no objections to this application for Zoning By-law Amendment.

If you have any questions or require any additional information, please contact the undersigned.

Sincerely,



Corinne Chiasson  
Resource Planner  
/cor



**From:** [Ron Meloche](#)  
**To:** [Katrina DiGiovanni](#); [Angelo Avolio](#); [Antonietta Giofu](#); [Antonio Marra](#); [Bruce Montone](#); [Denise Kimmerly](#); ["Executivevp.lawanddevelopment@opg.com"](#); [GECDSB-Planning Officer](#); [Giovanni \(John\) Miceli](#); [kbalallo@countyofessex.ca](#); [Lisa Shepley \(Ishepley@countyofessex.ca\)](#); [Michelle Lavin-Faucher](#); ["ONTUGLLandsINO@uniongas.com"](#); [Paul Acton](#); [Paula Parker](#); [planning@erca.org](#); [Rebecca Belanger](#); [Rob Unis](#); [Todd Hewitt](#)  
**Subject:** RE: Notice for Circulation: ZBA-17-19 4380 Conc 4 S  
**Date:** Thursday, August 22, 2019 1:00:55 PM

---

Fire has no objection to ZBA-17-19

**Ron Meloche**

*Assistant Deputy Chief / Fire Prevention & Inspection Officer*

Town of Amherstburg

271 Sandwich St. South, Amherstburg, ON, N9V 2A5

Tel: 519-736-6500 Fax: 519-736-3683 TTY: 519-736-9860



The information in this e-mail is confidential, privileged and is subject to copyright and authorized solely for the addressee(s) named. The Town of Amherstburg is not responsible for any loss or damage arising from the use of this email or attachments.

---

**From:** Katrina DiGiovanni  
**Sent:** August-21-19 3:55 PM  
**To:** Angelo Avolio; Antonietta Giofu; Antonio Marra; Bruce Montone; Denise Kimmerly; 'Executivevp.lawanddevelopment@opg.com'; GECDSB-Planning Officer; Giovanni (John) Miceli; kbalallo@countyofessex.ca; Lisa Shepley (Ishepley@countyofessex.ca); Michelle Lavin-Faucher; 'ONTUGLLandsINO@uniongas.com'; Paul Acton; Paula Parker; planning@erca.org; Rebecca Belanger; Rob Unis; Ron Meloche; Todd Hewitt  
**Subject:** Notice for Circulation: ZBA-17-19 4380 Conc 4 S

Good Afternoon,

Please find attached the notice for a Zoning By-Law Amendment for 4380 Conc 4 S. Please provide comments by August 30<sup>th</sup>, 2019.

Thanks,

**Katrina DiGiovanni**

*Planning Clerk*

Town of Amherstburg

3295 Meloche Rd., Amherstburg, ON, N9V 2Y8

**PUBLIC MEETING ATTENDANCE RECORD**  
 Date: Monday, September 23<sup>rd</sup> at 4:00 p.m.

**Statutory Public Meeting –Zoning By-law Amendment:**  
 1.) ZBA-15-19: ES Howard Ave  
 2.) ZBA-17-19: 4380 Concession 4 S

NAME (please print clearly)	ADDRESS and PHONE # (please print clearly)	SIGNATURE	Present for Application	
			ZBA-15-19 Howard Ave	ZBA-17-19 Concession 4 S
Sarah Sinasac	[REDACTED]	S. Sinasac	✓	
Joel Bezaire	[REDACTED]	J. Bezaire	✓	
Megan Dragicevic	[REDACTED]	M. Dragicevic	✓	

Personal information on this form is collected under the authority of the Municipal Act, 2011. The information will be used to send you minutes of this meeting, and/or agendas for future meetings/events. Questions about this collection can be directed to Paula Parker, Clerk at 271 Sandwich Street South, Amherstburg, Ontario N9V 2A5, telephone 519-736-0012.

Seconded by J. Mailloux

That application A/1/19 be approved.

- carried-

Reasons of Committee – The Committee, having considered the evidence presented, and having reviewed the plans and correspondence on file, is satisfied that the variance request is minor in nature, will not impact the character of the neighbourhood, and is keeping with the intent of the Official Plan and Zoning By-law. The applicant communicated their intent with ERCA and ERCA is confident that the proposal will be able to satisfy the natural hazard policies of the PPS and the requirements under the Conservation Authorities Act.

(2) **B/14/19** David & Carol Mailloux  
4380 4<sup>th</sup> Conc S  
3729-640-000-02700

Public in Attendance: David Mailloux



The applicant is proposing to sever a parcel of land being 77.1 m (253 ft) ± frontage by 115.82 m (380 ft) ± depth with an area of 8,943.55 sq m (2.21 acres) ± which includes a single detached dwelling and three (3) accessory structures which are surplus to the needs of the farming operation. The remaining parcel being 41.75 (137 ft) ± frontage by an irregular depth with an area of 15.21 hectares (37.59 acres) ± is vacant agricultural land.

The subject property is designated Agricultural, Provincially Significant Wetland and Natural Environment in the Town's Official Plan and zoned Agricultural (A) Zone, Environmental Protection (EP) Zone & Wetland (W) Zone in By-law 1999-52, as amended.

The following correspondence was received from the various agencies and residents circulated:

- (i) Letter dated March 14, 2019 from the Essex Region Conservation Authority: *The above noted lands are subject to our Development, Interference with Wetlands and Alteration to Shorelines and Watercourses Regulation under the Conservation Authorities Act, (Ontario Regulation No. 158/06). The parcel falls within the regulated area of the Big Creek and Whelan Drain. The property owner will be required to obtain a Permit and/or Clearance from the Essex Region Conservation Authority prior to any construction or site alteration or other activities affected by the regulations. We have reviewed this application and can confirm that it is consistent with the natural hazard policies of the PPS and the Conservation Authorities Act.*

*Our office has reviewed the proposal and has no concerns relating to stormwater management.*

*The subject property contains a portion of a natural heritage feature that is identified as a significant wetland, significant woodland, significant valleyland, and significant wildlife habitat under the Provincial Policy Statement (PPS, 2014). Our information also indicates that the subject property may support habitat of endangered species, threatened species, and potential fish habitat.*

*Upon review of the circulated application, we acknowledge that the entire natural heritage feature on this site is zoned "Environmental Protection (EP)" which ensures no future development within the EP Zone. We also understand from the circulation that the surplus dwelling extents will be*

*located well over 120 metres from the natural heritage feature. It is our opinion that a demonstration of no negative impact on the natural heritage feature is not required for this application. We therefore advise the Committee and the Town that this application is consistent with the policies of the PPS.*

*We have no objections to this Application for Consent and Minor Variance.*

- (ii) Email dated March 13, 2019 from the Public Works Department with the following comment:
  - *Drainage apportionments required for the Whelan Drain*
- (iii) Planning Report dated March 15, 2019 from the Town of Amherstburg Planning Department.

Committee Discussion:

Mr. Mailloux presented the concept of the application. He stated that he bought the farm approximately 10 years ago along with the old farm house on the property. His daughter and her husband have been living in the house. He would like to sever the house as a surplus dwelling and continue to farm the retained property. He stated that the entrance on the south side of the farm would remain to provide access to the farm. He agreed with the condition that no new houses would be permitted on the property. Ms. Sinasac read the conditions and Mr. Mailloux acknowledged understanding of the conditions.

The following resolution was put forth:

Moved by D. Shaw  
Seconded by T. Buchanan

That application B/14/19 be approved subject to the following conditions:

1. That a Reference Plan of the subject property satisfactory to the municipality be deposited in the Registry Office; an electronic and paper copy to be provided to the municipality.
2. The applicant to submit to the municipality the deed, in triplicate, acceptable for registration in order that consent may be attached to the original and duplicate and a copy be provided to the municipality.
3. That all property taxes be paid in full.
4. That an assessment apportionment for any and all drains affected by the severance be completed in accordance with the provisions of the Drainage Act and that all costs associated with said apportionment be paid by the applicant.
5. That the retained farmland to be rezoned to ensure that no new dwelling units shall be permitted and the requirement for this non-development be registered against the title of the property.
6. That the applicant obtains a report from a certified designer/installer that the existing private septic system serving the surplus dwelling does not cross the property lines, that the system is in working order and that its operation will not be affected by the severance. Further the Chief Building Official or his designate is to be onsite for inspection purposes when the field investigation is conducted by the designer/installer.
7. That a minor variance be obtained from the provisions of Bylaw 1999-52, as amended, Section 26(3)(a)(i) which requires a minimum lot area of 40 hectares in an Agricultural (A) Zone regarding the retained farm parcel.
8. This consent will be deemed to be refused in accordance with the Planning Act if the above noted conditions are not met within one year from the date of this notice.

- carried -

Reasons of Committee – The request is in conformity with Section 6.1.2 of Amherstburg's Official Plan and is consistent with the Provincial Policy Statement. The severed lot is surplus to a farmer's needs and the retained farmland will be rezoned to

restrict any residential development.

- (3) **A/3/19** David & Carol Mailloux  
4380 4<sup>th</sup> Conc S  
3729-640-000-02700

Public in Attendance: David Mailloux

The applicant is requesting relief from Zoning By-law 1999-52, as amended, Section 26(3)(a)(i), which requires a minimum lot area of 40 hectares in an Agricultural (A) Zone. Subsequent to a severance (File No. B/14/19) from an existing 16.1 hectares (39.8 acres) parcel the retained farm parcel will have an area of 15.21 hectares (37.59 acres). Therefore the amount of relief requested is 24.79 hectares (61.25 acres).

The subject property is designated Agricultural, Provincially Significant Wetland and Natural Environment in the Town's Official Plan and zoned Agricultural (A) Zone, Environmental Protection (EP) Zone & Wetland (W) Zone in By-law 1999-52, as amended.

The following correspondence was received from the various agencies and residents circulated:

- (i) Letter dated March 14, 2019 from the Essex Region Conservation Authority: *The above noted lands are subject to our Development, Interference with Wetlands and Alteration to Shorelines and Watercourses Regulation under the Conservation Authorities Act, (Ontario Regulation No. 158/06). The parcel falls within the regulated area of the Big Creek and Whelan Drain. The property owner will be required to obtain a Permit and/or Clearance from the Essex Region Conservation Authority prior to any construction or site alteration or other activities affected by the regulations. We have reviewed this application and can confirm that it is consistent with the natural hazard policies of the PPS and the Conservation Authorities Act.*

*Our office has reviewed the proposal and has no concerns relating to stormwater management.*

*The subject property contains a portion of a natural heritage feature that is identified as a significant wetland, significant woodland, significant valleyland, and significant wildlife habitat under the Provincial Policy Statement (PPS, 2014). Our information also indicates that the subject property may support habitat of endangered species, threatened species, and potential fish habitat.*

*Upon review of the circulated application, we acknowledge that the entire natural heritage feature on this site is zoned "Environmental Protection (EP)" which ensures no future development within the EP Zone. We also understand from the circulation that the surplus dwelling extents will be located well over 120 metres from the natural heritage feature. It is our opinion that a demonstration of no negative impact on the natural heritage feature is not required for this application. We therefore advise the Committee and the Town that this application is consistent with the policies of the PPS.*

*We have no objections to this Application for Consent and Minor Variance.*

- (i) Email dated March 13, 2019 from the Public Works Department indicating no comments.
- (iv) Planning Report dated March 15, 2019 from the Town of Amherstburg Planning Department.

Committee Discussion:

Mr. Mailloux presented the concept of the application. The minor variance is required as



a condition of Consent File B/14/19. The farm property after the severance will be less than the minimum lot size of 40 hectares.

The following resolution was put forth:

Moved by J. Mailloux  
Seconded by S. Ducedre

That application A/3/19 be approved.

- carried-

Reasons of Committee - The Committee, having considered the evidence presented, and having reviewed the plans and correspondence on file, is satisfied that the variance request is minor in nature, will not impact the character of the neighbourhood, and is keeping with the intent of the Official Plan and Zoning By-law. The farm parcel will be rezoned to restrict any new residential development from occurring on the property.

(4) **B/15/19**

Dino Parete  
277 Sandwich St S  
3729-120-000-05500

Public in Attendance: Dino Parete

The applicant is proposing to sever a parcel of land being 2.8 m (9.18 ft) ± frontage by 8.52 m (28 ft) ± depth with an area of 49.89 sq m (537 sq ft) ± for the purpose of a lot addition to merge with the 151 Gore St. to the east, Roll No. 3729-120-000-05300 for the purpose of enlarging the parking lot and driveway to the commercial property. The two properties are zoned Commercial General (CG) in Zoning By-Law 1999-52, as amended. The proposed retained parcel being 18.28 m (60 ft) ± frontage by irregular depth with an area of 423.9 sq m (4,563 sq ft) ± includes a single detached dwelling and one (1) accessory structure.

The subject property is designated General Commercial in the Town's Official Plan and zoned Commercial General (CG) Zone in By-law 1999-52, as amended.

The following correspondence was received from the various agencies and residents circulated:

- (i) Letter dated March 15, 2019 from the Essex Region Conservation Authority indicating no objections to the application.
- (ii) Email dated March 13, 2019 from the Public Works Department indicating no comments.
- (v) Planning Report dated March 18, 2019 from the Town of Amherstburg Planning Department.

Committee Discussion:

Mr. Parete presented the concept of the application. He stated that he wanted to sever the rear portion of 277 Sandwich Street S to join with 151 Gore St. He owns both properties and is correcting the lot lines so that the properties square off. He stated that the properties were divided oddly years ago and that 151 Gore St only owns half a driveway. The lot addition will place the entire driveway into the ownership of 151 Gore St. There will be no change of use to either property. Ms. Sinasac read the conditions to the applicant. Mr. Parete acknowledged understanding of the conditions.

The following resolution was put forth:



THE CORPORATION OF THE TOWN OF AMHERSTBURG

OFFICE OF PLANNING, DEVELOPMENT & LEGISLATIVE SERVICES

MISSION STATEMENT: Committed to delivering cost-effective and efficient services for the residents of the Town of Amherstburg with a view to improve and enhance their quality of life.

Table with 2 columns: Author's Name, Report Date, Author's Phone, Date to Council, Author's E-mail, Resolution #.

To: Mayor and Members of Town Council

Subject: Subdivision Agreement for Boblo Developments (South-end)-County of Essex File No. 37-T-14004

1. RECOMMENDATION:

It is recommended that:

- 1. By-law 2019-091 being a By-law to authorize the signing of a Subdivision Agreement for Boblo Developments (South-end)-County of Essex File No. 37-T-14004, satisfactory in form to the Director of Planning, Development and Legislative Services, in financial content to the Director of Corporate Services, and in technical content to the Manager of Planning Services, be taken as having been read three times and finally passed and the Mayor and Clerk BE AUTHORIZED to sign the same.

2. BACKGROUND:

The Subdivision Agreement applies to approximately a 32-hectare parcel of land located on the south-end of Bois Blanc Island ('Boblo'). The subdivision includes One hundred and twenty-four (124) lots for single detached residential units; forty-eight (48) lots for ninety-six (96) semi-detached residential units; and four (4) blocks.

A decision of the Local Planning Appeal Tribunal (LPAT) granted draft plan approval subject to a number of conditions including a provision that the applicant enter into a Subdivision Agreement (Agreement) with the municipality to satisfy all the requirements, financial and otherwise, for the provision of services and other matters.

A historical context of the subdivision includes:

- The Town of Amherstburg was notified of an application for draft plan of subdivision located on the south-end of Bois Blanc Island ('Boblo') by Boblo Developments Inc. in January 2013.
- At that time, the County notified the developer that further information was required before it would be processed by the Manager of Planning Services at the County of Essex.
- In 2014, the applicant requested the County to notify the Town to hold the public meeting. The County identified concerns that many reports and studies had not yet been received; the County sent a letter to the Town and directed for the Town to hold the public meeting to obtain public comments.
- The zoning and designation on Boblo Island permits a range of residential uses including the proposed development of single unit and two unit dwellings in the RR/RC Zone. The land area associated with the proposed plan of subdivision is approximately on 32 hectares of land. The plan of subdivision at the time of the public meeting was proposed to be 209 lots and is now proposed to be 172 total lots.
- The proposed subdivision pertains to the plan of subdivision prepared and certified by Brian Coad, O.L.S., dated September 20, 2016 that shows:
  - One hundred and twenty-four (124) lots for single detached residential units;
  - Forty-eight (48) lots for ninety-six (96) semi-detached residential units; and
  - Four (4) blocks;
- The application for subdivision approval was heard by the Local Planning Appeal Tribunal (LPAT) in August of 2018. At the Tribunal Hearing, the County of Essex, the Town of Amherstburg and the successor to the Developer all agreed that in the event the Tribunal approved the plan of subdivision, conditions, as revised and submitted, should be attached to the approval. A decision from the LPAT Hearing was rendered November 29, 2018. The decision of the LPAT and conditions therein are attached to the Agreement as Schedule "A";
- The decision of the LPAT was rendered November 29, 2018 and the conditions presented at the Tribunal Hearing and attached in the Agreement hereto included a provision that the Developer must enter into a Subdivision Agreement with the Town wherein the Developer agrees to satisfy all the requirements, financial and otherwise, of the Town concerning the payment of Development Charges, provision of roads, installation and capacity of services, sanitary sewerage collection system, water distribution system, utilities and stormwater management facilities for the development of the lands within the plan and transportation to and from the island.

### 3. **DISCUSSION:**

#### Provincial Policy Statement (PPS)

The application is consistent with the PPS in that the development promotes the efficient use of existing designated land and promotes cost-effective development patterns and standards to minimize land consumption and servicing costs.

### County Official Plan (COP)

The proposed plan of subdivision is located within a Primary Settlement Area as designated in the County's Official Plan. The application conforms to the policies of the County of Essex Official Plan.

### Town of Amherstburg Official Plan (OP)

Boblo Island is designated Recreational Development Special Policy Area 6 in the Town's Official Plan (the "Town OP"). The Town OP anticipates that the residential component of development will take the form of a combination of dwelling types ranging from single detached dwellings to multi-family dwellings.

Therefore, the proposal conforms to the basic land use policies of the Town OP.

### Town of Amherstburg Zoning By-Law

The subject property is zoned as Resort Residential / Resort Commercial (RR / RC) in the Town's Zoning By-law No. 1999-52, which permits single-unit, two-unit, and multi-unit dwellings.

The County of Essex has prepared a set of draft conditions for the proposed draft plan of subdivision. The draft conditions were sent to the Town administration and ERCA for review and revisions as necessary. Due to the risk involved and lack of control for the direction and outcome of the Local Planning Appeal Tribunal hearing, the County was of the opinion that it would be beneficial to have draft conditions that are prepared for the unique challenges associated with this development, which are implementable and enforceable through preparation of the Agreement. Town administration has participated in the composition of the draft conditions with the County.

The LPAT decision was rendered on November 29, 2018 with thirty-five (35) conditions and amendments to final plan of approval for registration of the subdivision. The conditions from the Tribunal hearing and attached to the Agreement included a provision that the developer must enter into a Subdivision Agreement with the Town. The Agreement ensures compliance with the LPAT conditions of requiring a Subdivision Agreement to outline the requirements with the Municipality as set out in the LPAT notice of decision.

*That the Owner enters into a subdivision agreement with the Municipality wherein the Owner agrees to satisfy all the requirements, financial and otherwise, of the Municipality concerning the payment of development charges, provisions of roads, installation and capacity of services, sanitary sewerage collection system, water distribution system, utilities and stormwater management facilities for the development of the lands within the plan, and transportation to and from the island.*

It is understood and agreed that this subdivision development will not proceed until all necessary approvals are in place.

## Plan of Subdivision

A Plan of Subdivision is a legal survey (M-Plan) that divides a parcel of land into smaller lots or blocks and secures the developer's obligations through a Subdivision Agreement with the Town.

The developer/owner is required to sign a Subdivision Agreement with the Town prior to registration of the plan. Prior to registration of the plan, the owner must also fulfill all conditions provided in the LPAT Notice of Decision. Once the plan is registered, lots in the subdivision can be sold (legally transferred to the purchaser) and building permits issued.

The attached Agreement implements the conditions and amendments to final plan of approval for registration of the subdivision and includes the developer's obligations to the Municipality or County including:

- Provision of performance and maintenance securities to guarantee satisfaction of the developer's obligations under the Agreement;
- The Developer acknowledges that the lands subdivided by this Agreement are subject to Development Charges as established by the Town in its Development Charges By-law and any future Community Benefit Charges under the Planning Act, as applicable.
- Provision of public liability and property insurance during the period of construction;
- Developers responsibilities for installation of all stormwater management measures (including an overland flow route) to the satisfaction the Town and the Essex Region Conservation Authority;
- Developer responsibilities for installation of sanitary sewage conveyance as per the sewage allocation provisions in the Agreement;
- Requirement for the conveyance of easements as may be necessary for drainage and utilities;
- Developers responsibilities regarding damages;
- Provision for parkland dedication in satisfaction of the requirement of the Planning Act with regard to parkland dedication, that the Developer convey cash-in-lieu of up to 5% of the land included in the plan to the Town for park purposes;
- The Agreement outlines the requirements in the purchase and sale agreements;
- The Developer is required to comply with all of the requirements identified within the Boblo Island Residential Subdivision Traffic Impact Study prepared by Dillon Consulting, (dated July 2018) and shall be responsible for constructing any roadway improvements identified in the final report as part of the development of the site;
- The Developer shall comply with the conclusions and recommendations relating to mitigation, implementation and monitoring, as outlined in the Heritage Impact Assessment, prepared by MHBC Planning Limited (dated August 3, 2016);
- Provisions with regard to access to and from Bois Blanc (Boblo Island), as required from the LPAT decision;
- There are conditions that address completion of natural heritage studies, necessary final approvals from the Province in regards to the Endangered Species Act and ERCA, to evaluate and mitigate the potential impacts on natural

features and their ecological functions of the subject lands to the satisfaction of the Town and ERCA;

- The agreement requires that prior to site alteration of any kind, and final approval of any phase by the County of Essex, the Owner shall obtain all required permits from the Province issued under the Endangered Species Act, 2007 (ESA), and complete and implement the recommendations contained in the permit or permits, along with any other letters/authorizations/directions from the Province, and a certified biologist shall confirm in writing that any site alteration has been completed in accordance with the requirements of such permit or permits or any other letters/authorizations/directions issued under the ESA;
- Provisions for Fire and Emergency Management Plans to address matters related to police and fire protection;

#### **4. RISK ANALYSIS:**

The decision of the LPAT was rendered November 29, 2018 and the conditions presented at the Tribunal Hearing and attached hereto included a provision that the Developer must enter into a Subdivision Agreement with the Town wherein the Developer agrees to satisfy all the requirements, financial and otherwise, of the Town concerning the payment of development charges, provision of roads, installation and capacity of services, sanitary sewerage collection system, water distribution system, utilities and stormwater management facilities for the development of the lands within the plan and transportation to and from the island. It is understood and agreed that this subdivision development will not proceed until all necessary approvals are in place.

There is always the potential for a developer to abandon their application, which in this case would possibly mean an abandonment of the Boblo South End Development entirely. If that were to happen the Town would be left with a partially developed island, which originally was intended to have a full build-out in the Official Plan of 1800 residents.

Approval of the Agreement for Boblo South End Development will satisfy one component of the completion requirements for final approval of the subdivision approval process under the *Planning Act*.

#### **5. FINANCIAL MATTERS:**

The cost associated with the applications and planning processes are the responsibility of the Developer. Prior to undertaking servicing and site alteration, the Developer will be required to provide all securities and insurance to the Town.

The future development of the subdivision supports the Town's residential assessment base. The Developer will be responsible to pay applicable charges to the Town, including Development Charges, building permit fees and possibly Community Benefit Charges, which may become applicable under Bill 108, at the time of building permit issuance.

**6. CONSULTATIONS:**

The Engineering and Public Works Department and Director of Corporate Services provided review and participation in the preparation of the Agreement.

**7. CONCLUSION:**

All conditions of draft approval must be met, including the execution of the Agreement, before final approval by the County of Essex can be granted. The subdivision plan must be registered as a 12M-Plan before any lots can be sold or permits issued for construction.

The proposed Agreement complies with the Town's planning documents, incorporates the conditions of draft plan approval as required under the decision rendered from the Local Planning Appeal Tribunal and addresses site servicing details and other issues in accordance with the requirements of the *Planning Act*.

Approval of the Agreement for Boblo South End Development will satisfy one component of the completion of requirements for final approval of the subdivision approval process under the *Planning Act*.



---

Frank Garardo  
**Manager of Planning Services**

**FG/MG**

<b>DEPARTMENTS/OTHERS CONSULTED:</b> Name: Phone #: 519                      ext.
---

<b>NOTIFICATION :</b>				
Name	Address	Email Address	Telephone	FAX



## Report Approval Details

Document Title:	Subdivision Agreement for Boblo Developments (South-end)- County of Essex File No. 37-T-14004.docx
Attachments:	- Report to Council-November 12.-Boblo South End Sub Agreement-ATTACHMENTS.pdf
Final Approval Date:	Nov 7, 2019

This report and all of its attachments were approved and signed as outlined below:



**Mark Galvin - Nov 7, 2019 - 3:41 PM**



**Cheryl Horrobin - Nov 7, 2019 - 4:35 PM**

**No Signature - Task assigned to John Miceli was completed by workflow administrator Paula Parker**

**John Miceli - Nov 7, 2019 - 4:48 PM**



**Paula Parker - Nov 7, 2019 - 4:51 PM**

**CORPORATION OF THE TOWN OF AMHERSTBURG  
BY-LAW NO. 2019-091**

**By-law to authorize the execution of a  
Subdivision Agreement between Boblo Developments Inc. and  
the Corporation of the Town of Amherstburg**

---

**WHEREAS** Boblo Developments Incorporated has proposed the subdivision and servicing of lands owned by it within Part of Bois Blanc Island (Malden Township)('Boblo Island'), Town of Amherstburg;

**AND WHEREAS** the Corporation of the Town of Amherstburg has settled with Boblo South Development Incorporated, the requirements for the provisions of Municipal Services within the area to be subdivided, which requirements are set out in the agreement hereto annexed, and which agreement is ratified and adopted by Boblo South Development Incorporated;

**NOW THEREFORE** the Council of the Corporation of the Town of Amherstburg enacts as follows:

1. THAT the Corporation of the Town of Amherstburg enter into a Subdivision Agreement with Boblo Developments Incorporated in the form annexed hereto, and the Mayor and Clerk be and they are hereby authorized to sign the original and copies thereof and affix the Corporate Seal thereto.
  
2. THAT this By-law shall come into force and effect on the date of final passage hereof.

Read a first, second and third time and finally passed this 12<sup>th</sup> day of November, 2019.

---

MAYOR – ALDO DICARLO

---

CLERK – PAULA PARKER

**Boblo Developments Inc.**  
**SUBDIVISION AGREEMENT**  
**(Boblo South End Development)**

**BOBLO SOUTH END DEVELOPMENT  
(Boblo Developments Inc.)**

**Contents**

1. Recitals .....	5
2. Interpretation .....	5
3. Installation of Services .....	5
4. Certificate of Liability Insurance.....	5
5. Save and Hold Harmless.....	5
6. Drawings and Tenders .....	5
7. Construction of Services by Contractors .....	6
8. Inspection.....	6
9. Approval for Commencement of Work.....	6
10. Work Schedule/Quality of Work.....	6
11. Development Phasing .....	7
12. Developer's Responsibilities Until Final Acceptance .....	7
13. Building Permits .....	8
14. Tree Provisions/Mailbox Requirements .....	8
15. Landscaping Requirements.....	9
16. Registration Requirements.....	9
17. Financial Security.....	9
18. Maintenance Security .....	9
19. Iron Bars .....	9
20. Staking of Bars Prior to Construction.....	10
21. Developers Responsibilities in Regard to Damages.....	10
22. Stormwater Management .....	10
23. Stormwater Management Issues: Catchbasin and Road Maintenance.....	11
24. Design Drawings .....	11
25. Additional Work .....	11
26. Grading of Topsoil.....	11
27. Grading/Dumping/Removal of Material.....	11
28. Grass and Weeds Maintenance .....	11
29. Rear Yard Drainage .....	11
30. Sump Pump Overflow .....	12
31. Municipal Numbers.....	12
32. Interim Acceptance of Services .....	12
33. Final Acceptance of Services .....	12
34. Town's Fees.....	12
35. Easements .....	13
36. Environmental Impact Assessment- Implementation .....	13
37. Post-Construction Report (EIA Requirements).....	13
38. Endangered Species Act Permits/Letter of Advice/ERCA Clearances.....	13
39. Department of Fisheries and Oceans (DFO) .....	13
40. Archaeological Assessment .....	14
41. Traffic Impact Study .....	14
42. Heritage Impact Assessment.....	14
43. Parks Canada .....	14
44. First Nations Consultation .....	14
45. Register Notice of Agreement .....	14
46. Development Charges.....	14
47. Town Engineer .....	15
48. Use of General Terms.....	15
49. Enforcement of Agreement .....	15
50. No Waiver of Rights .....	15
51. Parkland Dedication .....	15
52. Schools .....	16
53. Sidewalks .....	16
54. Access to and From the Island.....	16
55. Emergency Response Plan & Fire Protection.....	17
56. Emergency Management Plan .....	17
57. Streetlights .....	17
58. Street Signs.....	17

59. Sewage Allocation.....	17
60. Sewage Ejector Pumps .....	18
61. Cure Period.....	18
62. Notice.....	18
63. Agreement Binding on Parties.....	19
SCHEDULE "A" .....	20
SCHEDULE "B" .....	25
SCHEDULE "C" .....	26
SCHEDULE "D" .....	27

**SUBDIVISION AGREEMENT**

**THIS AGREEMENT** made in quadruplicate this \_\_\_\_\_ day of \_\_\_\_\_, 2019.

**BETWEEN: Boblo Developments Inc.**

(hereinafter called the "**Developer**")

OF THE FIRST PART;

-and-

**THE CORPORATION OF THE TOWN OF AMHERSTBURG**

(hereinafter called the "**Town**")

OF THE SECOND PART;

**WHEREAS** the Developer proposes the subdivision, development, servicing and sale of lands within Part of Bois Blanc Island (Malden Township)('Boblo Island'), Town of Amherstburg, County of Essex which lands are more particularly illustrated on Schedule "B" annexed hereto;

**AND WHEREAS** this agreement pertains to the plan of subdivision prepared and certified by Brian Coad, O.L.S., dated September 20, 2016 that shows:

1. One hundred and twenty-four (124) lots for single detached residential units;
2. Forty-eight (48) lots for ninety-six (96) semi-detached residential units; and
3. Four (4) blocks;

**AND WHEREAS** the application for subdivision approval was heard by the Local Planning Appeal Tribunal (LPAT) in August of 2018. At the Tribunal Hearing, the County of Essex, the Town of Amherstburg and the Developer all agreed that in the event the Tribunal approved the plan of subdivision, conditions, as revised and submitted, should be attached to the approval. A decision from the LPAT Hearing was rendered November 29, 2018. The decision of the LPAT and conditions therein are attached to this Agreement as Schedule "A";

**AND WHEREAS** the decision of the LPAT was rendered November 29, 2018 and the conditions presented at the Tribunal Hearing and attached hereto included a provision that the Developer must enter into a subdivision agreement with the Town wherein the Developer agrees to satisfy all the requirements, financial and otherwise, of the Town concerning the payment of development charges, community benefit charges (if applicable), provision of roads, installation and capacity of services, sanitary sewerage collection system, water distribution system, utilities and stormwater management facilities for the development of the lands within the plan and transportation to and from the island. It is understood and agreed that this subdivision development will not proceed until all necessary approvals are in place;

**AND WHEREAS** the Developer represents and warrants to the Town that it is the registered owner of all the lands illustrated on Schedule "B" annexed hereto and that all of the right, title and interest of its predecessors in title and all the right and authority to complete the subdivision and to develop the lands is vested in it;

**NOW THEREFORE IN CONSIDERATION** of the premises and of the Town certifying to the County of Essex that the requirements of the Town have been met, the parties hereto agree as follows:



1. **Recitals**

The foregoing Recitals are true in substance and in fact and are hereby incorporated herein by reference.

2. **Interpretation**

The meanings of various terms used within the Agreement are as indicated in the definitions contained with the attached Schedule "C".

3. **Installation of Services**

The Developer will design, construct and install Services at its own expense in the lands in accordance with such design criteria, detailed plans and work schedules to be filed in the office of the Clerk of the Town copying the Town of Amherstburg Engineering and Public Works Department, with good materials, in a good, workmanlike and timely manner, in accordance with good and accepted engineering practices, and to the satisfaction of the Town, and in all cases the Town Engineer. In addition, the road allowances included in the plan shall be shown and dedicated as public highways. Such streets shall be named to the Town's satisfaction and all streets that terminate shall contain a 0.3 metre reserve to be illustrated on the final plan and to be conveyed to the Town.

4. **Certificate of Liability Insurance**

The Developer will provide to the Town, on or before the commencement of any construction and installation of any of the Services called for herein, a certificate of liability insurance satisfactory to the Town, naming the Town as an additional insured party. The insurance shall protect the Developer and the Town against any liability that might arise out of the construction or installation of any of the Services herein referred to, and the said Developer shall continue such insurance in full force and effect so long as any Services are to be constructed or installed, and for a period of two (2) years after completion and Final Acceptance of the last of such Services. The limits of liability for public liability and property damage coverage under such insurance shall not be less than \$5,000,000.00. Before commencement of the installation of the Services, the Developer's consulting engineer shall provide satisfactory evidence to the Town that the said consulting engineer maintains a policy of public liability insurance and errors and omissions insurance satisfactory to the Town, which policy is to be maintained in full force and effect until the Services are completed and Final Acceptance occurs of the last of the Services.

5. **Save and Hold Harmless**

The Developer covenants and agrees to save the Town harmless from any and all claims, demands, loss, costs, or damages, including legal costs on a substantial indemnity basis in any way arising from or related to the subdivision and the proposed development thereof, arising or accruing to anyone up to two years after the completion and Final Acceptance of the last of the Services in the subdivision.

6. **Drawings and Tenders**

The Developer shall submit, in both electronic and hard copy form, all plans, design drawings, grading plans and specification lists, all of which shall carry the seal of the professional engineer who is responsible for such design and be signed by him, to the Town for examination by them and the Town Engineer. In the case of any Services to be constructed by contract, the Developer shall also submit, in both electronic and hard copy form, to the Town a copy of each set of "information for tenders" documents and each proposed contract together with the names of the proposed

contractors and sub-contractors to be engaged. The Developer shall file with the Town work schedules for the construction and installation of all Services, whether by the Developer, the contractors, sub-contractors or others. The Developer shall obtain the approval in writing of the Town to all of the foregoing, except the selection of contractors or sub-contractors before granting any contract or commencing any work. The design criteria contained in Schedule "D" hereto shall constitute the minimum conditions upon which tenders are made, contracts let, or work done. The Developer's consulting engineer or successor thereto, shall continue to be retained by the Developer until the Services are completed and Final Acceptance occurs of the last of the Services.

7. **Construction of Services by Contractors**

In case of construction of Services by contractors, the Developer shall comply with all of the holdback provisions of the Construction Lien Act. In the construction of all services the Developer shall indemnify and save the Town harmless from any and all claims, actions and demands resulting from the construction and installation of Services.

8. **Inspection**

The Town, and its authorized agents, including the Town Engineer, shall have the right at any time and from time to time to inspect all Services during and after construction and to inspect and test all materials proposed to be used in the construction of any of the services. The costs of such inspections and tests shall be paid by the Developer within 15 days of written demand by the Town. If at any time, the construction of any service or material is, in the opinion of the Town Engineer, not in accordance with the plans and specifications or not in accordance with good engineering practices or any of the provisions of this Agreement, the Town Engineer may order the materials to be replaced or the work to be placed in satisfactory condition within such time as he may specify, and in the event of the Developer failing to comply or obtain compliance with such order, the Town Engineer may stop work upon such services, or in his sole discretion upon all services. The Developer shall at all times provide all information requested by the Town, its authorized agents and the Town Engineer in relation to the various materials and services and shall at any time at his expense expose any municipal service for inspection by the Town Engineer. Notwithstanding the generality of the foregoing, the rights of the Town and its authorized agents including the Town Engineer hereunder shall be limited to a period of two years after the initial acceptance of the last of the services within or required to facilitate the servicing of lots where such inspection, testing or other action is proposed.

9. **Approval for Commencement of Work**

No work shall commence without the approval of the Town and any work requiring the approval or consent of any other governmental authority shall not commence until such approval or consent has also been obtained. No watermain, sanitary sewer, storm sewer or hydro line shall be connected to any existing system without the written approval of whichever of the Town or the approval of the Authority which has jurisdiction over such system.

Prior to undertaking construction or site alteration activities, any necessary permits or clearances must be received from the Essex Region Conservation Authority.

10. **Work Schedule/Quality of Work**

The Developer will prepare and submit to the Town, plans for the installation of services for each phase of the development and will request a pre-

construction meeting with the Town and its consultants in order to establish a work schedule acceptable to the Town and shall proceed with reasonable development procedures and in accordance with such work schedule. Subject to Force Majeure, if the Developer fails to proceed with reasonable development procedures and in accordance with the accepted work schedule or if in the opinion of the Town Engineer the Services are not being installed in accordance with the drawings, or specifications approved therefore, or in accordance with good engineering practices in a good, workmanlike manner, using good materials, then the Town shall give the Developer thirty (30) days to Cure any default following which and in addition to any other remedy the Town may have, the Town may, without further notice, enter upon the lands of the Developer and proceed to supply all materials and do all necessary work in connection with the installation of the Services, including the repair or reconstruction of faulty work, and replacement of materials not in accordance with the drawings or specifications and the Town shall charge the cost thereof, including all engineering and other fees to the Developer, who shall forthwith pay the same within thirty (30) days of a written demand therefor by the Town. In the event that the payment is not received within thirty (30) days of the written demand by the Town, the amount expended shall constitute and be a lien and charge upon the lands of the Developer and may be collected as real property taxes in accordance with the Municipal Act as amended from time to time.

11. **Development Phasing**

The Developer will prepare and submit a proposed phasing plan for the Boblo South End Development. The phasing plan shall be reviewed and approved by the Town prior to starting construction. The plan shall also provide information to the Town that estimates timing of anticipated phases within the subdivision.

Prior to final approval of any phase, the Town shall confirm and advise the County of Essex accordingly, that the phase complies with the Zoning By-law in effect and that sewage treatment conveyance capacity and water supply capacity is available for all lots in the proposed phase of development.

12. **Developer's Responsibilities Until Final Acceptance**

Until such time as the Town has finally accepted each of the Services, including roadways herein referred to, the Developer shall be responsible therefor. The responsibility of the Developer prior to Final Acceptance by the Town shall include liability for all types of maintenance in connection therewith. If the Developer should in the opinion of the Town or of its agents or employees fail to maintain any Service including roadways, prior to the Final Acceptance by the Town, the Town may without notice in case of emergency, or in any other case on 30 days' notice, if such default is not Cured by the Developer during the 30 day notice, maintain the same, but in so doing, the Town shall for all purposes be deemed to have acted as agent for the Developer, without in any way being deemed to have finally accepted such Service, or to have incurred any liability for future maintenance, and the Town shall be entitled to reimbursement for the cost of any such maintenance, within thirty (30) days of written demand therefor, and the Town shall further be relieved of liability for damages caused unintentionally, in the course of such maintenance. Snow removal, salting or sanding by the Town shall not constitute acceptance of the roads by maintenance thereof.

The Developer shall also be responsible for the cleaning and flushing of sewers throughout the development until such time as the maintenance period for the construction of the Services has expired. The Town shall

have the right to inspect the said sewers from time to time and, if deemed necessary, may require the Developer to clean and flush same immediately, and the Developer hereby agrees to perform such cleaning and flushing on demand to the entire satisfaction of the Town.

### 13. **Building Permits**

The Developer covenants and agrees on behalf of itself and its successors in title to any lot, not to apply for any building permit for the construction of any building on any lots covered by this agreement until:

- (i) **Initial Acceptance of Services**  
All of the services relating to all of the lots therein have been installed and initially accepted by the Town with the exception of the final asphalt surface course of the roadway.
- (ii) **Model Homes**  
The Developer may apply to the Chief Building Official for model home permits prior to the completion of all services provided the dwelling unit is connected to water, storm, and sanitary services and that the base coat of asphalt and concrete curbs and gutter (where required) have been installed, to the satisfaction of the Town Engineer.

Model home building permits shall not exceed ten (10) dwelling units in any particular phase or ten percent of the total dwelling units in any particular phase and shall adhere to all of the requirements in the Town's development manual.

For additional phases within the subdivision, the application(s) for model home permits by the Developer shall adhere to the Town's Development Manual.

### 14. **Tree Provisions/Mailbox Requirements**

The Developer shall:

- (i) **Tree Provision**  
The Developer will provide to the Town, before the commencement of any construction or installation of any service, an irrevocable letter of credit (self-renewing and without burden of proof), or a certified cheque, satisfactory to the Town, the value of the trees to be planted (i.e. \$300 x the number of lots in the phase). The trees will be installed by the developer on the lots where homes have been constructed and the front and side yards have been seeded and sodded, once per year annually in the fall. The Town will review the number of trees planted annually and refund the tree deposits for those trees planted on a pro rata basis. The trees will be planted in accordance with the Town's Tree By-law on the municipal ROW, and at a minimum of 60 mm in caliper based on the Tree By-law.
- (ii) **Super Mailboxes:**

Contact Canada Post to determine the location of super mailboxes throughout the subdivision and shall provide notice in every agreement of purchase and sale advising purchasers of the location thereof and that mail delivery will be provided via community mailboxes. The location of super mailboxes shall also be to the satisfaction of the Town.

15. **Landscaping Requirements**

(i) **Front and Side Yards**

The front lawn and exterior side yard of each lot shall be sodded, seeded or otherwise landscaped within six months of the construction of a house thereon, and such sodding, seeding or landscaping shall be continued over the unpaved portion of the road allowance, including any lands between a sidewalk and the road, to the back of the curb and gutter in front of such lot. Such sodding, seeding or landscaping shall be maintained in perpetuity. The Developer shall impose a covenant to this effect in the transfer of each lot conveyed by it.

16. **Registration Requirements**

The Developer covenants and agrees to cause the local Land Registrar to register, immediately after registration of the proposed plan of subdivision, as annexed to each lot in the proposed plan of subdivision, a condition of restriction running with the lands, that such lot is not to be built upon unless the provisions of paragraph 13 of this agreement, limiting entitlement to building permits has been complied with.

17. **Financial Security**

The Developer will provide to the Town, before the commencement of any construction or installation of any service, an irrevocable letter of credit (self-renewing and without burden of proof), or a certified cheque to the Town, in an amount equal to 50% of the value set by the Town for all Services to guarantee satisfactory installation of all Services. This value will be established based on the prices in the tender. The Developer must provide the completed tender form from the contractor to the Town. If work is not tendered the Consulting Engineer must provide a tender form that provides an estimate of cost to establish the value of securities. If the provision of Services to the lots requires the construction or installation of any services outside the subdivision, the foregoing provisions as to the security equal to 100% of the value for Services shall extend to and be required in connection with any Service extending outside.

18. **Maintenance Security**

The Developer shall provide to the Town an irrevocable letter of credit, (self-renewing and without burden of proof), or a certified cheque satisfactory to the Town, in an amount equal to 25% of the value set by the Town upon initial acceptance thereof, for all servicing of lots within the subdivision, until Final Acceptance of services after completion and initial acceptance by the Town of the last service provided. If the Town agrees and/or requests that some of the work be delayed, Performance Securities for 100% of the outstanding works would be required in addition to the Maintenance Security.

19. **Iron Bars**

The Developer will file with the Town a surveyor's certificate dated within 30 days before the application for initial acceptance by the Town of asphalt surfacing on roadways, to the effect that all Standard Iron Bars shown upon the plan of subdivision have been located or replaced.

20. **Staking of Bars Prior to Construction**

Before the sale of any lot or the issue of any building permit within the subdivision, the Developer shall stake to the satisfaction of the Town, the locations of all Standard Iron Bars, and shall maintain such staking to the satisfaction of the Town, its respective servants and agents and the Town Engineer, in relation to each lot until the home foundation is installed and all services to the proposed home have been provided. The Developer will provide to the Town on request, and to any proposed builder, all usual information as to grades and levels for each lot within the subdivision.

21. **Developers Responsibilities in Regard to Damages**

The Developer undertakes and agrees to pay for any damage caused to any existing road, road allowance, structure or plant and any costs involved in the relocation of or repair or connection to any existing services arising in any way from or in connection with this agreement or the provision of services called for herein including the changing of grades of existing adjacent roads, and also any taxes or other charges levied or to be levied upon the lands to be subdivided, until such time as the lands have been assessed and entered on the collector's roll according to the proposed and presently registered plans.

22. **Stormwater Management**

The development of the subdivision requires measures to deal with stormwater management. The Developer agrees:

- (i) As part of the development of the site, the developer shall submit a Stormwater Management Plan based on the Windsor/Essex Regional Stormwater Management Standard Manual. The Developer will be required to install all of the stormwater management measures identified in the final approved stormwater management report. This work shall be to the satisfaction of the Town and ERCA.
- (ii) To continue to conduct regular inspections once every two weeks and after each sizeable storm event of all sediment and erosion control measures recommended in the approved stormwater management plan during the construction phase; Results of these inspections must be sent to the Town on a monthly basis.
- (iii) To maintain an inspection log, which shall be made available for review by the Ministry of the Environment, Conservation and Parks and Essex Region Conservation Authority upon request. These inspection logs must be sent to the Town on a monthly basis. The log shall state the name of the inspector, date of inspections and the rectification or replacement measures which were taken to maintain the sediment and erosion control measures. Inspections shall continue until the assumption of services by the Town or until site construction conditions warrant cessation of the visits.
- (vi) It is the intent that a permanent stormwater management pond be conveyed to the Town. A stormwater management facility is proposed to be constructed in the interior portion of the subdivision. The details regarding the pond will be finalized after the Ministry of the Environment, Conservation and Parks issues its permit for the development.
- (vii) That a copy of this Agreement be provided to ERCA to ensure that the wording contained herein is satisfactory to its requirements.

23. **Stormwater Management Issues: Catchbasin and Road Maintenance**

All catchbasins will have filter fabric placed under the lid to catch sediment. It will be the Developer's responsibility to ensure the filter fabric is changed periodically as required to allow drainage through the catchbasins. The Developer will also be responsible for ensuring the roads are kept in a clean manner during house construction.

24. **Design Drawings**

For all the works outlined herein and referred to in this Agreement, the Developer shall provide design drawings, specification lists and tender documents to the Town, in both electronic and hard copy format.

25. **Additional Work**

If at any time prior to Final Acceptance of the last of the services by the Town it is of the reasonable opinion that additional works are proven necessary to provide any of the public services specified in the schedules hereto, which were not reasonably foreseeable at the date of this Agreement then the Developer shall construct, install or perform such additional work at the request of the Town provided that, if the Developer disagrees that such additional works are necessary, the question shall be resolved by a single arbitrator if the parties can agree on one, otherwise by a panel of three arbitrators proceeding under the Arbitrations Act.

26. **Grading of Topsoil**

The Developer covenants and agrees that topsoil excavated for roadways shall be left and leveled within the subdivision, except as provided in paragraph 27 hereof. Any topsoil that is stockpiled shall be neat and sloped in such a manner that weed cutting can be carried out with mechanical equipment by the Developer to the entire satisfaction of the Town.

27. **Grading/Dumping/Removal of Material**

The Developer shall carry out all grading of all lands, in accordance with the grading plans to be filed in the office of the Clerk of the Town of Amherstburg copying the Chief Building Official of the Town, and shall forthwith carry out temporary or permanent drainage work that the Town Engineer may certify to be necessary to eliminate ponding erosion, channeling of underground water or other drainage problems. The Developer shall neither dump nor permit to be dumped any fill or debris, or remove or permit the removal of any soil or fill from any of the lands to be subdivided without the written consent of the Town Engineer. In seeking consent of the Town Engineer to the removal of topsoil the Developer shall establish that when final grades are established for all of the lots and blocks within the subdivision there will be topsoil to a depth of at least four inches (4") over the entire area not covered by buildings, roadways and driveways.

28. **Grass and Weeds Maintenance**

The Developer shall be responsible for the proper maintenance of grass and weeds throughout the subdivision under the direction of the Town until such time as a building permit is issued on a lot or the lot is transferred to a new owner. The Developer is required to place notice on title of this requirement on each lot conveyed by it.

29. **Rear Yard Drainage**

Rear lot drainage shall be installed on each lot, in connection with the construction of a house thereon, and shall be connected to the storm sewer system. The specifications, design and installation of such rear yard



drainage shall be acceptable to, and subject to the approval of the Town Engineer. On an application for a building permit on any lot within the lands to be subdivided, the builder shall produce a plan or sketch satisfactory to the Chief Building Official of the proposed rear yard drainage, which shall be in accordance with the Building Code. The installation of such rear yard drainage shall be subject to the same inspections as foundation drains and the Chief Building Official may issue work orders or stop work orders in relation thereto.

30. **Sump Pump Overflow**

All homes must be designed to include a sump pump overflow.

31. **Municipal Numbers**

The Developer shall ascertain from the Town the appropriate municipal numbers for each lot, and shall provide such numbers to prospective purchasers, builders and lenders.

32. **Interim Acceptance of Services**

The Developer shall apply for initial acceptance of the municipal Services by filing with the Town a certificate under the hand and seal of its project engineer that the construction and/or installation of such Services has been completed in accordance with the design criteria and the plans and specifications therefor approved and filed by the Town before construction, and by filing as-built drawings of such Service. The Town and its authorized agents, including the Town Engineer, shall carry out such inspections as they deem necessary, and such Service shall then be deemed to have received Interim Acceptance after the Town Engineer certifying that such Service has been completed in accordance with this Agreement, providing that all the covenants of this Agreement have been complied with to the date of such certificate.

33. **Final Acceptance of Services**

The Town shall have granted Final Acceptance of the Services in each phase upon the Town Engineer and the Town being satisfied that all covenants under this Agreement have been fully complied with and all repairs and replacement required during the maintenance period have been carried out within such phase, and then authorizing release of the maintenance securities or bonds. Immediately prior to requesting Final Acceptance of the Services, the Developer shall flush clean and camera inspect the sanitary and storm sewer system including all services. The Developer's consulting engineer shall certify that the Services have been inspected and the camera inspection has been reviewed, and that there are no slumps, cracks, blockages or other deficiencies within the system to the entire satisfaction of the Town. A copy of all sewer videos will be provided to the Town for their review.

34. **Town's Fees**

The Developer undertakes, covenants and agrees to pay any planning, engineering, legal, auditing or other fees or disbursements incurred by the Town relating in any way to the proposed subdivision, or the servicing thereof, or to this agreement, including negotiations and preparations prior to its execution and including the entire fees and disbursements of the Town Engineer when acting pursuant to the terms of this agreement, and any clerical or administrative expense of the Town relating in any way to or arising from this agreement, forthwith upon being invoiced therefor. The Developer agrees to deposit with the Town on or before the execution of

this agreement, the sum of \$2,000.00 to be applied against such fees as may be incurred from time to time, with such deposit to be renewed from time to time as used up, when requested by the Town, any unused balance to be returned to the Developer without interest, on the expiry of the maintenance period.

35. **Easements**

The Developer shall convey to Amherstburg or the appropriate authority, without cost and free of encumbrance, any and all easements as may be required by Amherstburg, the applicable hydro authority, the applicable telecommunications, cable TV and internet service provider(s), and any natural gas provider and/ or any other applicable utility provider. Such easements may be through, over or under the appropriate portion of the Subject Lands and may be required for drainage purposes, sewers, hydro, watermains, telephone, cable tv, natural gas or any other purpose as deemed necessary by Amherstburg. Where required by the Town, daylight corners and road reserves shall be shown on the final plan and conveyed in a form satisfactory to the Town.

36. **Environmental Impact Assessment- Implementation**

The Developer shall finalize the Environmental Impact Assessment Report prepared by BioLogic Incorporated, or other consultant working on behalf of the Developer, to evaluate and mitigate the potential impacts on natural features and their ecological functions of the subject lands to the satisfaction of the Town and ERCA. A copy of this Agreement shall be provided to ERCA to ensure that the wording contained herein is satisfactory to its requirements.

37. **Post-Construction Report (EIA Requirements)**

Prior to final approval of any phase of the subdivision, the Developer agrees to have a qualified professional prepare and submit a post-construction report certifying that the mitigation measures and recommendations of the final Environmental Impact Assessment Report have been implemented. The post-construction report will be prepared to the satisfaction of the Town and ERCA. A copy of this Agreement shall be provided to ERCA to ensure that the wording contained herein is satisfactory to its requirements.

38. **Endangered Species Act Permits/Letter of Advice/ERCA Clearances**

Prior to site alteration of any kind, and final approval of any phase by the County of Essex, the Developer shall obtain all required permits from the Province issued under the Endangered Species Act, 2007 (ESA), and complete and implement the recommendations contained in the permit or permits, along with any other letters/authorizations/directions from the Province. The Developer shall hire a certified biologist to confirm in writing that any site alteration has been completed in accordance with the requirements of such permits or any other letters/authorizations/directions issued under the ESA.

Prior to undertaking construction or site alteration activities of any kind the Developer shall also obtain all necessary permits or clearances from ERCA.

39. **Department of Fisheries and Oceans (DFO)**

Prior to site alteration of any kind, and prior to final approval by the County of Essex, the Developer will provide to the Town and the County a clearance letter from the Department of Fisheries and Oceans (DFO) confirming compliance with the requirements of the Fisheries Act and the Species at Risk Act (SARA).

40. **Archaeological Assessment**

The Developer shall comply with and implement the recommendations and conclusions contained in the archaeological assessments completed by Cultural Resource Management Group (CRM) dated March 2016, and the review letters prepared by the Ministry of Tourism, Culture and Sport, including but not necessarily limited to, those dated June 2, 2016, June 7, 2016, May 29, 2017, November 23, 2017 and July 20, 2018.

41. **Traffic Impact Study**

The Developer shall comply with all of the requirements identified within the Boblo Island Residential Subdivision Traffic Impact Study (Updated) prepared by Dillon Consulting, dated July 2018 and shall be responsible for constructing any roadway improvements identified in the final report as part of the development of the site.

42. **Heritage Impact Assessment**

The Developer shall comply with the conclusions and recommendations relating to mitigation, implementation and monitoring, as outlined in the Heritage Impact Assessment, prepared by MHBC Planning Limited (dated August 3, 2016).

43. **Parks Canada**

Prior to site alteration of any kind, and final approval of any phase by the County of Essex, the Developer shall follow, to the satisfaction of the Town, the recommendations contained within the document from Parks Canada entitled "Guiding Principles for the draft plan of subdivision for Bois Blanc Island Lighthouse and Blockhouse NHSC" dated August 7, 2014.

44. **First Nations Consultation**

Prior to site alteration of any kind, and final approval of any phase by the County of Essex, the Developer shall provide written confirmation, to the satisfaction of the Town, that Walpole Island First Nations, the Caldwell First Nations and the Can-Am Indian Friendship Centre have been consulted.

45. **Register Notice of Agreement**

The Developer covenants and agrees to cause the Local Land Registrar to register notice of this agreement against all of the lands affected hereby, immediately after registration of the proposed subdivision, and to obtain acknowledgement, consent and postponement agreements, from any and all encumbrances registered prior to registration of such notice.

46. **Development Charges**

The Developer acknowledges that the lands subdivided by this agreement are subject to Development Charges as established by the Town in its Development Charges By-law which may include community benefit charges. Once established, the said development charge shall be paid prior to the issuance of a building permit for each lot. The Developer undertakes and agrees to provide that all Offers of Purchase and Sale include information that satisfies Subsection 59(4) of the Development Charges Act including development charges for school purposes relating to any such lot pursuant to 59(4) of the Development Charges Act, 1997.

47. **Town Engineer**

Throughout this agreement the term "Town Engineer" shall mean the professional engineer or firm of professional engineers retained by the Town to carry out the duties referred to in this agreement. Notwithstanding the above, the Town may agree to the use of a single engineering firm. However, should any dispute arise and as a result of this agreement, the selected engineering firm shall be responsible to the Town, and the Developer shall be required to retain its own professional engineer.

48. **Use of General Terms**

Throughout this agreement the singular shall be deemed to include the plural, and the masculine, feminine and neuter genders shall be interchangeable as the context and applicable situations may require.

49. **Enforcement of Agreement**

The Developer will not call into question directly or indirectly in any proceeding whatsoever in law or in equity or before any administrative or other tribunal the right of the Town to enter into this agreement and to enforce each and every term, covenant and condition thereof and this provision may be pleaded by the Town in any such action or proceeding as a complete and conclusive estoppel of any denial of such right. If any provision of this agreement shall be found to be or deemed illegal or invalid, the remainder of the agreement shall not be affected thereby.

The rights of the Town to enforce this Agreement are cumulative and include all rights and remedies available in law or equity. Additionally, in the event of default of any payment required by the Developer to the Town, including the payment of the costs of the Town in remedying any default by the Developer, the Town may, after non-payment of the total amount owing continues for thirty (30) days from the date of written notice, register the amount owing on the tax rolls, which amount shall form a lien and charge upon the lands of the Developer and may be collected and have the same priority as municipal real property taxes in accordance with the provisions of the Municipal Act, 2001, or any similar legislation, as amended from time to time.

50. **No Waiver of Rights**

No indulgence or forbearance by the Town shall be deemed to constitute a waiver by the Town of its rights to insist on performance in a full and timely manner of all the covenants contained herein, and any such waiver, in order to be binding, must be in writing and duly authorized by the Town Council. No such waiver of any provisions, conditions or covenants shall be deemed to be a waiver of the right to later require full and timely compliance with the same terms, conditions or covenants, or with any other terms, covenants or conditions of this agreement at any time.

51. **Parkland Dedication**

In satisfaction of the requirement of the Planning Act with regard to parkland dedication, that the Developer convey up to 5% of the land included in the plan to the Town for park purposes, or cash-in-lieu thereof, the Developer covenants and agrees to pay the Town a cash value of 5% of the lands determined by an appraisal authorized by the Town as determined as of the day before the Draft Plan is approved as outlined in Sections 51.1(3) and (4) of the Planning Act.

52. **Schools**

In accordance with the requirements of the Greater Essex County District School Board and the Windsor-Essex Catholic District School Board, the Developer is required to place notice in every agreement of purchase and sale advising purchasers that students may not be able to attend the closest neighborhood school and could be bused to a distant school with available capacity or could be accommodated in temporary space (i.e. portables).

The Developer is further required to place notice in every agreement of purchase and sale advising purchaser that school busses will not be transported to the island and that the School Boards will designate pick up points on the mainland for students to meet the bus.

53. **Sidewalks**

If required, the Developer shall, at their own expense, construct all sidewalks and trails as per the approved engineering drawings. The sidewalks will be constructed in accordance with the approved Municipal Development Standards Manual with the minimum width of sidewalk to be 1.5m and must meet all AODA requirements, including the installation of tactile plates at intersections. The timing of the installation of the required sidewalks will be determined by the Town's Engineering and Public Works Department in conjunction with the Developer.

54. **Access to and From the Island**

Access to and from Bois Blanc Island (Boblo Island) for all residents and/or property owners on Bois Blanc Island (Boblo Island) is the sole responsibility of the Developer and any subsequent Transferees, other than Transferees which are government entities. The Developer, and any subsequent Transferees (other than government entities) shall provide a ferry service to and from Bois Blanc Island (Boblo Island) that meets the requirements of the Ministry of Transportation and the safety standards of Transport Canada, and if the dimension or weight of any vehicle or load exceeds the limits set out in the Highway Traffic Act, then the vehicle operator shall obtain the appropriate oversize/overweight permit.

The Town is not responsible in any way for access to or from Bois Blanc Island (Boblo Island), and the Developer and any subsequent Transferee acknowledge that the Corporation of the Town of Amherstburg will not provide access to Bois Blanc Island (Boblo Island), and the Developer and any subsequent Transferee shall not request or demand that the Town of Amherstburg provide such access.

The Developer and any subsequent Transferees (other than government entities) agree to make a motor vehicle ferry and operator available to the Town, at no cost to the Town, for administrative purposes, maintenance, emergency, police and fire personnel and their equipment, whenever required by the Town. The Developer and any subsequent Transferees (other than government entities) shall provide access to the ferry landing on the Mainland and back for all school children on Bois Blanc Island (Boblo Island).

A provision outlining the above specification shall be contained in every agreement of purchase and sale of any one or more of the lots in the development. The Developer shall provide access to and from Bois Blanc

Island (Boblo Island) from and to a municipal roadway or right of way to the Island and Mainland. The Developer shall provide an easement/right-of-way for access and egress in favour of the Bois Blanc Community Association from and to a municipal roadway or right-of-way, both on Bois Blanc Island (Boblo Island) and on the Mainland.

All of the above requirements for access to and from the Island shall apply for all residents and/or property owners of Bois Blanc Island (Boblo Island) upon such terms and conditions as are agreeable between the Developer and the residents and/or property owners.

**55. Emergency Response Plan & Fire Protection**

Prior to final approval of any phase by the County of Essex, the Developer is required to prepare, to the satisfaction of the Town, an Emergency Management Plan to address matters related to police and fire protection, Emergency Medical Services (EMS), and potential impacts due the proximity of the Fermi II nuclear facility, in all climatic conditions.

The Developer is also required, to the satisfaction of the Town, to notify purchasers in every agreement of purchase and sale to be aware that each residential dwelling shall be equipped with an automatic fire suppression system to the satisfaction of the Town's Fire and Building Departments, along with any other fire monitoring and response requirements deemed necessary by the Town.

**56. Emergency Management Plan**

It is noted that the Town of Amherstburg has an approved Emergency Management Plan that pertains to Boblo Island. The Amherstburg Fire Department strongly recommends that all dwellings be equipped with a residential sprinkler system. If a wet fire sprinkler is not available within the dwelling, at a minimum a dry system or fire extinguishers should be available at appropriate locations within the dwelling. All smoke alarms should be interconnected and monitored by an independent answering service.

**57. Streetlights**

The Developer shall install streetlights in accordance with the present design standards, all to be approved by the Town of Amherstburg. The Town requires the installation of LED fixtures. The Town shall provide specifications to the Developer based on the lighting required.

**58. Street Signs**

The Developer shall request that the Town install street signs at each intersection and where necessary, all to be done in accordance with present standards. If the Town undertakes the work and/or the signs, the Town will invoice the Developer accordingly.

**59. Sewage Allocation**

The Developer acknowledges that the development is within the sanitary sewer service area for the Boblo Sewage Treatment Plant, which is currently nearing its design capacity. The Town and Developer acknowledge that an Environmental Assessment has been completed which provides for the

inclusion of the Boblo Sewage Treatment Plant into the expanded and upgraded Amherstburg Wastewater Treatment Plant (AWWTP). An agreement to construct the required pump station and forcemain to send the sewage from Boblo Island to the AWWTP must be in place prior to or in conjunction with the installation of municipal services. The agreement shall include cost sharing arrangements, construction timing and additional allowable flows to accommodate new builds until the forcemain is constructed.

60. **Sewage Ejector Pumps**

All homes must be designed to include a sewage ejector pump. Gravity flow from the home will not be accepted.

61. **Cure Period**

Throughout this Agreement, where reference is made to the Town undertaking works on behalf of the Developer because of default or some other reason, it is agreed that the Developer will be given thirty (30) days to Cure any such deficiency, default or other problem or commence to Cure default and proceed diligently to remedy same prior to the Town undertaking the required works unless such deficiency, default or other problem is deemed to be an emergency.

62. **Notice**

- (a) Any notice, direction or other instrument required or permitted to be given by any party under this Agreement shall be in writing and shall be sufficiently given if delivered personally, sent by prepaid first-class mail or transmitted by telecopier or other form of electronic communication during transmission of which no indication of failure or receipt is communicated to the sender:

In the case of notice to the Developer:

c/o Dominic Amicone  
Boblo Developments Inc.  
2199 Blackacre Drive  
Oldcastle, ON N0R 1L0

In the case of notice to the Town:

271 Sandwich Street South  
AMHERSTBURG, ON N9V 2A5

Attention: The Clerk  
Fax: (519) 736-5403

Manager of Planning Services  
Fax: (519) 736-7111

Manager of Engineering  
Fax: (519) 736-7080

- (b) Any such notice, direction or other instrument if delivered personally, shall be deemed to have been given and received on the date on which it was received at such address, or, if sent by mail, shall be deemed to have been given and received on the date which is five (5) days after which it was mailed, provided that if either such day is not a Business Day, then the notice shall be deemed to have been given and received on the Business Day next



following such day. Any notice transmitted by telecopier or other form of electronic communication shall be deemed to have been given and received on the date of its transmission provided that if such day is not a Business Day or it is received after the end of normal business hours on the date of its transmission at the place of receipt, then it shall be deemed to have been given and received at the opening of business in the office of the recipient on the first Business Day next following the transmission thereof. If normal mail service, telex, telecopier or other form of electronic communication is interrupted by strike, slowdown, Force Majeure, or other cause, a notice, direction or other instrument sent by the impaired means of communication will not be deemed to be received until actually received, and the party sending the notice shall utilize any other such service which has not been so interrupted to deliver such notice.

63. **Agreement Binding on Parties**

This agreement shall enure to the benefit of, and be binding upon the parties hereto, and their respective heirs, executors, administrators, successors and assigns.

This agreement may be assigned by either party, subject to the written consent of the other party, which shall not be unreasonably withheld.

**IN WITNESS WHEREOF** the Town has hereunto affixed their seals attested by the signatures of their proper signing officers and the Developer has hereunto affixed its seal attested by the signature of its proper signing officer in that regard.

**Boblo Developments Inc.**

Per \_\_\_\_\_  
Dominic Amicone

*I have authority to bind the Corporation*

**THE CORPORATION OF THE  
TOWN OF AMHERSTBURG**

Per \_\_\_\_\_  
Aldo DiCarlo, Mayor

Per \_\_\_\_\_  
Paula Parker, Clerk

*We have authority to bind the Corporation*

**SCHEDULE "A"**  
**DRAFT PLAN CONDITIONS**

The conditions and amendments to final plan of approval for registration of this Subdivision are as follows:

---

**No.      Conditions**

---

1.      That this approval applies to the draft plan of subdivision prepared and certified by Brian Coad, O.L.S., dated September 20, 2016 that shows:
  - One hundred and twenty-four (124) lots for single detached residential units;
  - Forty-eight (48) lots for ninety-six (96) semi-detached residential units; and
  - Four (4) blocks.

The lands comprising the draft plan of subdivision are legally described as Part of Bois Blanc Island (Malden Township), Town of Amherstburg, County of Essex.

2.      That the Owner enters into a subdivision agreement with the Municipality wherein the Owner agrees to satisfy all the requirements, financial and otherwise, of the Municipality concerning the payment of development charges, provisions of roads, installation and capacity of services, sanitary sewerage collection system, water distribution system, utilities and stormwater management facilities for the development of the lands within the plan, and transportation to and from the island.
3.      That the subdivision agreement between the Owner and the Municipality contain a provision requiring the owner to notify in writing each person who first offers to purchase any subdivided lot within the plan of subdivision of all approved development charges, including development charges for school purposes, relating to any such lot pursuant to Section 59(4) of the Development Charges Act, 1997.
4.      That the subdivision agreement between the Owner and the Municipality, where required, contain a provision prepared to the satisfaction of the Municipality, regarding the phasing and timing of the development.
5.      That the subdivision agreement between the Owner and the Municipality be registered against the lands to which it applies prior to the registration of any final plan of subdivision.
6.      That the road allowances included in this draft plan shall be shown and dedicated as public highways.
7.      That the streets shall be named to the satisfaction of the Municipality.
8.      That all terminating streets shall contain a 0.3 metre reserve, to be illustrated on the final plan and be conveyed to the Municipality.
9.      That the Owner convey to the Municipality for park or other recreational purposes up to 5% of the land included in the plan. Alternatively, the Municipality may require cash-in-lieu or some other form of conveyance acceptable to the Municipality, for all or a portion of the requirement.
10.     That prior to final approval of any phase by the County of Essex, the County is to be advised by the Municipality that the proposed subdivision conforms to the Zoning By-law in effect.

11. That the Owner shall provide easements as may be required for services, utility or drainage purposes in a form satisfactory to the Municipality or utility, and where required by the Municipality, daylight corners and road reserves shall be shown on the final plan and conveyed in a form satisfactory to the Municipality.
12. That prior to final approval of any phase, the Municipality shall confirm that sewage treatment conveyance capacity and water supply capacity is available for all lots in the proposed development, or phase of development.
13. That the subdivision agreement between the Owner and the Municipality contain provisions, to the satisfaction of the Municipality and the Essex Region Conservation Authority, that stipulate that the Owner finalize the Stormwater Management Report prepared by Stantec Consulting Inc., or other consultant working on behalf of the Owner, to the satisfaction of the Municipality and the Essex Region Conservation Authority, and install the stormwater management measures as identified in the finalized stormwater management report.
14. That the subdivision agreement between the Owner and the Municipality contain provisions, to the satisfaction of the Municipality and the Essex Region Conservation Authority, that stipulate that the Owner finalize the Environmental Impact Assessment Report prepared by BioLogic Incorporated, or other consultant working on behalf of the Owner, to the satisfaction of the Municipality and the Essex Region Conservation Authority, and implement all recommendations contained in the final report.
15. That the subdivision agreement between the Owner and the Municipality contain provisions, to the satisfaction of the Municipality and the Essex Region Conservation Authority, that prior to final approval of any phase, the Owner agrees to the requirement that a post-construction report be prepared and submitted by the appropriate qualified professional certifying that the mitigation measures and recommendations of the final Environmental Impact Assessment Report have been implemented.
16. That prior to final approval the Essex Region Conservation Authority shall require a copy of the fully executed subdivision agreement between the Owner and the Municipality, in wording acceptable to the Essex Region Conservation Authority, containing provisions to carry out the recommendations of the plans/reports and requirements noted above in Conditions 13, 14 and 15.
17. That prior to undertaking construction or site alteration activities of any kind, any necessary permits or clearances be received from the Essex Region Conservation Authority.
18. That the subdivision agreement between the Owner and the Municipality contain provisions, to the satisfaction of the Greater Essex County District School Board, the Windsor-Essex Catholic District School Board, and the Municipality, requiring notice in every agreement of purchase and sale advising purchasers of lots to be aware that school busses will not be transported to the island and that the School Boards will designate pick up points on the mainland for students to meet the bus.
19. That the subdivision agreement between the Owner and the Municipality contain provisions, to the satisfaction of the Greater Essex County District School Board, the Windsor-Essex Catholic District School Board, and the Municipality, requiring notice in every agreement of purchase and sale advising purchasers of lots to be aware that students may not be able to attend the closest neighbourhood school and could be bussed to a distant school with available capacity.
20. That the subdivision agreement between the Owner and the Municipality contain provisions, to the satisfaction of Canada Post Corporation and the Municipality, requiring notice in every agreement of purchase and sale advising purchasers of

lots to be aware of the locations of any community mailboxes within or serving the plan and that mail delivery will be provided via community mailboxes.

21. That the subdivision agreement between the Owner and the Municipality contain provisions, to the satisfaction of the Municipality and the County, that prior to site alteration of any kind, and final approval of any phase by the County of Essex, the Owner shall obtain all required permits from the Province issued under the Endangered Species Act, 2007 (ESA), and complete and implement the recommendations contained in the permit or permits, along with any other letters/authorizations/directions from the Province, and a certified biologist shall confirm in writing that any site alteration has been completed in accordance with the requirements of such permit or permits or any other letters/authorizations/directions issued under the ESA.
22. That the subdivision agreement between the Owner and the Municipality contain provisions, to the satisfaction of the Municipality and the County, that prior to site alteration of any kind, and prior to final approval by the County of Essex, the Municipality and the County shall be provided with a clearance letter from the Department of Fisheries and Oceans (DFO) confirming compliance with the requirements of the Fisheries Act and the Species at Risk Act (SARA).
23. That the subdivision agreement between the Owner and the Municipality contain provisions, to the satisfaction of the Municipality, that require that the Owner prepare a Traffic Impact Study, to the satisfaction of the Municipality, and to construct any highway improvements identified in the final report as part of the development of the site.
24. That the subdivision agreement between the Owner and the Municipality contain the following provision with regard to access to and from Bois Blanc (Boblo Island), or such other similar provision satisfactory to the Owner and the Municipality:

Access to and from Bois Blanc Island (Boblo Island) for all residents and/or property owners on Bois Blanc Island (Boblo Island) is the sole responsibility of the Owner and any subsequent Transferees, other than Transferees which are government entities. The Owner, and any subsequent Transferees (other than government entities) shall provide a ferry service to and from Bois Blanc Island (Boblo Island) that meets the requirements of the Ministry of Transportation and the safety standards of Transport Canada, and if the dimension or weight of any vehicle or load exceeds the limits set out in the Highway Traffic Act, then the vehicle operator shall obtain the appropriate oversize/overweight permit. The Town is not responsible in any way for access to or from Bois Blanc Island (Boblo Island), and the Owner and any subsequent Transferee acknowledge that the Corporation of the Town of Amherstburg will not provide access to Bois Blanc Island (Boblo Island), and the Owner and any subsequent Transferee shall not request or demand that the Town of Amherstburg provide such access. The Owner and any subsequent Transferees (other than government entities) agree to make a motor vehicle ferry and operator available to the Town, at no cost to the Town, for administrative purposes, maintenance, emergency, police and fire personnel and their equipment, whenever required by the Town. The Owner and any subsequent Transferees (other than government entities) shall provide access to the ferry landing on the Mainland and back for all school children on Bois Blanc Island (Boblo Island). A provision outlining the above specification shall be contained in every agreement of purchase and sale of any one or more of the lots in the development. The Owner shall provide access to and from Bois Blanc Island (Boblo Island) from and to a municipal roadway or right of way to the Island and Mainland. The Owner shall provide an easement/right-of-way for access and egress in favour of the Bois Blanc Community Association from and to a municipal roadway or right-of-way, both on Bois Blanc Island (Boblo Island) and on the Mainland. These requirements for access shall apply for all residents and/or property owners of Bois Blanc Island (Boblo Island) upon such terms and

conditions as are agreeable between the Owner and the residents and/or property owners.

25. That the subdivision agreement between the Owner and the Municipality contain provisions, to the satisfaction of the Municipality, and prior to final approval of any phase by the County of Essex, requiring the Owner to prepare an emergency response plan to address matters related to police and fire protection, Emergency Medical Services (EMS), and potential impacts due the proximity of the Fermi II nuclear facility, in all climatic conditions, and further that the subdivision agreement contain additional provisions, to the satisfaction of the Municipality, requiring notice in every agreement of purchase and sale advising purchasers of lots to be aware that each residential dwelling shall be equipped with an automatic fire suppression system to the satisfaction of the Municipality's Fire and Building Departments, along with any other fire monitoring and response requirements deemed necessary by the Municipality.
26. That the subdivision agreement between the Owner and the Municipality contain provisions, to the satisfaction of the Municipality and the County, requiring that the Owner comply with the recommendations and conclusions contained in the archaeological assessments completed by Cultural Resource Management Group (CRM) dated March 2016, and the review letters prepared by the Ministry of Tourism, Culture and Sport, including but not necessarily limited to, those dated June 2, 2016, June 7, 2016, May 29, 2017, November 23, 2017 and July 20, 2018.
27. That the subdivision agreement between the Owner and the Municipality contain provisions, to the satisfaction of the Municipality, that prior to site alteration of any kind, and final approval of any phase by the County of Essex, that the Owner provide written confirmation, to the satisfaction of the municipality, that Walpole Island First Nations, the Caldwell First Nations and the Can-Am Indian Friendship Centre have been consulted.
28. That the subdivision agreement between the Owner and the Municipality contain provisions, to the satisfaction of the Municipality, that prior to site alteration of any kind, and final approval of any phase by the County of Essex, that the Owner shall undertake to follow the recommendations contained in the document from Parks Canada entitled "Guiding Principles for the draft plan of subdivision for Bois Blanc Island Lighthouse and Blockhouse NHSC" dated August 7, 2014.
29. That the subdivision agreement between the Owner and the Municipality contain provisions, to the satisfaction of the Municipality, that require the Owner to comply with the conclusions and recommendations relating to mitigation, implementation and monitoring, as outlined in the Heritage Impact Assessment, prepared by MHBC Planning Limited (dated August 3, 2016).
30. That prior to final approval by the County of Essex, the Owner shall submit for review and approval by the Municipality and the County, a draft of the final 12M plan.
31. That prior to final approval by the County of Essex, the County is advised in writing by the Municipality how Conditions 1 to 15 inclusive, and 18 to 30 inclusive have been satisfied.
32. That prior to final approval by the County of Essex, the County is advised in writing by the Essex Region Conservation Authority how Conditions 13 to 17 inclusive, have been satisfied.
33. That prior to final approval by the County of Essex, the County is advised in writing by the Greater Essex County District School Board how Conditions 18 and 19 have been satisfied.

34. That prior to final approval by the County of Essex, the County is advised in writing by the Windsor-Essex Catholic District School Board how Conditions 18 and 19 have been satisfied.
35. That prior to final approval by the County of Essex, the County is advised in writing by the Canada Post Corporation how Condition 20 has been satisfied.

**SCHEDULE "B"**  
**SUBJECT LANDS**

Part of Bois Blanc Island (Malden Township), Town of Amherstburg,  
County of Essex.



**SCHEDULE "C"**  
**DEFINITION OF TERMS**

The following definitions shall apply in the interpretation of this Agreement:

**"Cure"** means that the Developer has commenced the works required to address the Event of Default that has been identified and for which notice in accordance with this Agreement has been provided and is proceeding diligently to remedy any deficiency or default.

**"Event of Default"** means if the Developer fails in the performance of an obligation under this Agreement, and the Town issues a notice of such failure or default and a demand for performance, observance or compliance has been given. In such cases, the Town must allow the Developer a minimum of thirty (30) days to Cure the default (Cure as defined herein) unless such default is determined to be an emergency by the Town in which case a minimum less than thirty (30) days can be established for the Developer to Cure the default.

**"Final Acceptance"** means the date, commencing no sooner than the expiry of the maintenance period wherein the Developer's Consulting Engineer has provided a declaration to the Town confirming that the works and Services have been completed in accordance with the terms of this Agreement and the Town Engineer formally accepts the Services in writing.

**"Force Majeure"** means and includes acts of God, terrorist attacks, weather conditions, labour disputes, shortage of labour and materials and any happening, condition or thing beyond the control of a person which could not reasonably have been anticipated and avoided by such person which delays or prevents such person from performing any of its obligations hereunder, financial inability excepted.

**"Improvements"** means modifications to the Town-owned infrastructure that may be reasonably required from time to time.

**"Indemnifiers"** means jointly and severally.

**"Interim Acceptance"** means when Services are placed on maintenance by the Town.

**"Lands"** means those lands as described in Schedule "B" attached hereto.

**"Plan of Subdivision"** means a registered plan of the lands where new, separate parcels of land have been created and can be legally used for the sale of lots.

**"Services"** means the storm sewers, sanitary sewers, waterlines, roads, curbs and hydro services, including those components of infrastructure described in Schedule "C".

**"Substantial Performance"** means the date that the Developer's Consulting Engineer has provided a declaration to the Town confirming that the works are ready for use or are being used for the purposes intended.

**"Town's Infrastructure Work"** means the infrastructure work being undertaken by or on behalf of the Town to the portions of the Lands not designated for private development.

**SCHEDULE “D”**  
**DESIGN CRITERIA**

**FOR SERVICES TO BE PROVIDED IN THE  
BOBLO SOUTH END DEVELOPMENT – Boblo Developments Inc.**

**TOWN OF AMHERSTBURG**

**GENERAL**

Sanitary and storm sewers, watermains, curbs and gutters, sidewalks, street lighting and electric service connections shall be constructed in accordance with plans and specifications prepared by a professional engineer, registered to practice in the Province of Ontario, and acceptable to the Town of Amherstburg. Criteria upon which these services are to be designed, are as described in this schedule.

**STORM DRAINAGE**

Storm sewers, together with catch waterbasins shall be installed in all streets in the development in accordance with the approved engineering drawings and as approved by the Ministry of the Environment, Conservation and Parks, E.R.C.A. and the Corporation. A copy of the design calculations shall be submitted to the Corporation.

Private service connections (including cleanouts) from the storm sewers to the front property line of each building lot shall be provided and the Developer shall install one private service connection for each unit. The minimum size of service connections shall be 150mm (6”) diameter. Each storm sewer shall be provided with a clean out situated at the property line as per clean out detail on the approved engineering drawings. Private storm service connections and clean-outs shall not be constructed under future driveways.

Sewers shall be designed in accordance with the following criteria:

The developer shall submit a Stormwater Management Plan based on the Windsor/Essex Regional Stormwater Management Standard Manual.

Minimum Pipe Size	300 mm dia.
Minimum Velocity	0.76 m/s
Private Drain Connection	150 mm dia.
Minimum Cover	0.9 m
Maximum Manhole Spacing	122 m
Pipe Material	Concrete, PVC or HDPE

Restrictions imposed on the storm sewer outlet by the Town or by the Essex Region Conservation Authority shall be incorporated in the design of the storm sewer system. A stormwater management study shall be completed to the satisfaction of the Town and the Essex Region Conservation Authority. The study shall be in accordance with the Windsor/Essex Regional Stormwater Management Standard Manual. The Developer shall obtain a certificate of approval from the Ministry of the Environment, Conservation and Parks, Design Approval Branch.

**SANITARY SEWERS**

Sanitary sewers together with all necessary appurtenances and service connections from the appropriate sewer to the front property line of each building lot shall be constructed to the approved design of the Ministry of the Environment, Conservation and Parks. and the Corporation. Each building lot

shall be provided with access to an individual sanitary sewer service connection for each unit. The minimum sanitary service connection size shall be (5") 125mm in diameter. Each sanitary service shall be provided with a clean out situated at the property line as per clean out detail on the approved engineering drawings. The Developer shall be responsible for all costs associated with the construction of the system.

Sewers shall be designed in accordance with the following minimum design criteria:

Average Daily Flow	450 L/cap/day
Peaking Factor	Harmon formula
Population Density	3.5 ppl/lot
Minimum Pipe Size	200 mm dia.
Manning Coefficient	0.013
Minimum Cover	1.5 m
Private Drain Connection	125 mm dia.
Maximum Manhole Spacing	122 m
Pipe Material	PVC

The Developer shall obtain a certificate of approval from the Ministry of the Environment, Conservation and Parks, Design Approval Branch.

All homes must be designed to include a sewage ejector pump. Gravity flow from the home will not be accepted.

#### WATERMAINS

The Developer shall construct and install sufficient watermains including hydrants and valves to service the entire subdivision with connections to all lots in accordance with the approved engineering drawings. Each lot shall be serviced by a single water service connected to the mainline.

Minimum Cover	1.5 m
Maximum Hydrant Spacing	150 m
Maximum Valve Spacing	150 m and at intersections
Minimum Pipe Size	150 mm dia.
Lot Connection	19 mm dia.
Pipe Material	PVC
Mainline Services Pipe Material	Copper

Design and installation shall be in accordance with the Town's watermain specification to the satisfaction of the Town of Amherstburg.

#### ROADS

The Developer shall construct and install roadways and curbs and gutters upon all allowances for roads within the draft plan and upon the detail plans of services, in accordance with the following minimum design criteria:

- (a) Roads within the Subdivision

The required road cross section shall be in accordance with the approved construction drawings.

Alignment:	
Minimum Turning Radius	9 m
Minimum Road Grade	0.30%
Cross Fall Grade	2.0% min. and design parameters recommended by the Ministry of Transportation

In general, any trenches crossing under pavement shall be backfilled with granular material acceptable to the Town Engineer and such trenches shall be mechanically compacted as required by the Town Engineer. Boulevards and other unpaved portions of the allowances for roads (except where forming part of the front lawn of residential lots) must be graded and sodded or seeded by the Developer.

### SIDEWALKS

If required, the Developer shall, at their own expense, construct all sidewalks and trails as per the approved engineering drawings. The sidewalks will be constructed in accordance with the approved Municipal Development Standards Manual with the minimum width of sidewalk to be 1.5m and must meet all AODA requirements, including the installation of tactile plates at intersections. The timing of the installation of the required sidewalks will be determined by the Town's Engineering and Public Works Department in conjunction with the Developer.

### STREETLIGHTS

The Developer shall install streetlights in accordance with the Town's Development Manual, all to be approved by the Town of Amherstburg. All new lights shall be LED fixtures. The Town will provide details on the fixtures to be used.

### STREET SIGNS

The Developer shall request that the Town install street signs at each intersection and where necessary, all to be done in accordance with present standards. If the Town undertakes the work and/or the signs, the Town will invoice the Developer accordingly.

### HYDRO SERVICE

The Developer shall construct and install a sufficient hydro distribution system to service the entire subdivision with connections to all lots therein and connect the same to the existing hydro distribution system. Individual lot services, where possible, shall be provided on common lot lines so that residential hydro meters face each other. The hydro distribution system within the subdivision shall be grounded to the water distribution system. All hydro service within the subdivision shall be underground and designed and installed in accordance with the requirements and criteria of the Town of Amherstburg and Hydro One.

### TELEPHONE

The Developer shall arrange to provide underground telephone service to all of the lots within the subdivision. The Developer must confirm that sufficient wire-line communication/telecommunication infrastructure is currently available within the proposed development to provide communication/telecommunication service to the proposed development. In the event that the infrastructure is not available, the developer is hereby advised that the developer may be required to pay for the connection to and/or extension of the existing communication / telecommunication infrastructure.

The Developer will be required to demonstrate to the municipality that sufficient alternative communication/telecommunication facilities are available within the proposed subdivision to enable, at a minimum, the effective delivery of communication/telecommunication services for emergency management services, i.e., 911 Emergency Services.

## GAS

There is no access to natural gas on the island at this time.

## CABLE T.V. SERVICE

The Developer shall, at its' own expense, make satisfactory provisions to accommodate the servicing for future cable T.V service for this development. The Developer shall provide to the Corporation, upon demand, confirmation from the said cable company that such arrangements have been made.

## ADJUSTMENTS

The grade of any and all water service boxes, valve chambers, hydrants, manholes, drains and transformer boxes shall be adjusted by the Developer when and as may be required by the Department of Engineering and Public Works.

## TEMPORARY SERVICES

Upon a connection of any type being made to the hydro or water services, a temporary meter or meters of a type and in a location or locations satisfactory to the Town shall be installed and continuously maintained until all hydro and/or water used within the subdivision, once the same is accepted by the Town, is metered through approved private connections. The Developer shall be responsible for, and will promptly pay or cause to be paid all charges for hydro and water supplied to the subdivision.

## DRIVEWAY APPROACHES

Residential driveways and their approaches shall be constructed to a width that complies with the provisions of the Corporation's Zoning By-Law and the Town Bylaw 2017-81, Regulate Activity on Town Highways, Road Allowances and Right of Ways as amended from time to time. Residential approaches shall consist of 150 mm. (6") Granular "A" stone base with interlocking paving stone, concrete or asphalt paving from the back of the curb to the property line.

It is understood and agreed that under no circumstances will the Developer herein be permitted to install a new residential driveway approach within the corner radii of a curb constructed along any street in this development.

It is further understood and agreed that under no circumstances will the Developer or any other persons be permitted to install a new residential driveway approach over any private service connections from the storm or sanitary sewers or water system except where such connections cross driveways laterally (over the shortest possible distance) to enter the dwelling.

This provision is to be specifically brought to the attention of purchasers of lots at the time of purchase.

## COMMUNITY MAILBOXES

The Developer will be responsible for negotiating specific locations within the subdivision with Canada Post for the location of community mailboxes. These locations must be to the satisfaction of the Engineering and Public Works Department.

It is a requirement to notify purchasers of lots to be aware of the locations of any community mailboxes within or serving the plan and that mail delivery will be provided via community mailboxes.

## EASEMENTS

The Developer agrees that such easements as may be required for utility or drainage purposes shall be granted to the appropriate authority.

## ROAD ALLOWANCES

All road allowances shown on the draft plan shall be dedicated as public highways and shall be not less than 20.00 m. (66') wide and shall be shown on the approved engineering drawings.

## REAR YARD DRAINAGE

Rear yard drainage shall be provided for each building lot in the locations and according to the specifications prescribed by the approved engineering drawings and as approved by the Corporation. Rear yard drainage shall be installed contemporaneously with the construction of dwellings on each building lot. A separate rear yard drainage system, with 300 mm. diameter pre-fabricated polyethylene catch basins in accordance to the rear yard drainage detail shown on the approved engineering drawings, shall be provided for each building lot.

The Developer shall, at its' own expense, prepare a lot grading and rear yard drainage plan for each individual building lot within this development and shall file same with the Corporation. The final elevations of all dwellings and other buildings, minimum opening elevations, where applicable and the final lot grades relating thereto and the rear yard drainage shall conform to the proposed lot grading and rear yard drainage plan filed for that unit. The consulting engineer, or a certified Ontario Land Surveyor, shall certify upon completion of the construction of the dwelling and building on each lot that the said lot grading and rear yard drainage plan has been complied with, in accordance with the approved engineering drawings, and until such time as the said certification has been received by the Corporation.

## SPECIAL SERVICING REQUIREMENTS

The construction of structures shall conform to the following requirements:

- a) Roof or rain water leaders shall **NOT** be connected to the storm sewer. They are to be discharged to ground on splashpads. Weeping tile drains from each respective building must be discharged to a storm sewer. A sump pump connected to the storm sewer must be provided for each building.
- b) Sump pump overflow piping must be installed
- c) Weeping tile drains shall not be connected to the sanitary sewers.
- d) Basement floor drains shall be connected to the sanitary sewers provided for each dwelling.
- e) All homes must be designed to include a sewage ejector pump. Gravity flow from the home will not be accepted.
- f) Rear yard drainage, including 300 mm. diameter pre-fabricated polyethylene catch basins, shall be provided for each building lot in the locations and according to the design and specifications as shown on the approved engineering drawings.
- g) A lot grading plan shall be included in the final set of plans approved for construction of the works. The consulting engineer or a certified land surveyor shall certify, upon completion of the works, that the lot grades

and catch basin elevation are in accordance with the design and that the lands abutting the subdivision are draining adequately. The Developer acknowledges that, until such time as the provisions of this paragraph have been complied with, no final inspection of any building shall be permitted and any and all securities delivered to the Corporation by the Developer herein shall be held to ensure the provisions of this paragraph are complied with.



**BOBLO SOUTH DEVELOPMENT INC.**  
**AGREEMENT OF PURCHASE AND SALE**

**ARTICLE 1 – THE LANDS**

Section 1.1 - Property

The Undersigned, \_\_\_\_\_, hereby offers to purchase from Boblo South Development Inc. (the "Vendor"), Lot(s) \_\_\_\_\_ shown on the plan attached hereto as Schedule "A" at the purchase price shown in Article 3 below.

**ARTICLE 2 - ACCEPTANCE AND AGREEMENT**

Section 2.1 - Acceptance

This Agreement is open for acceptance by the Vendor until 11:59 a.m. on the 10<sup>th</sup> day after the date of execution by the Purchaser as shown in this Agreement, and is irrevocable by the Purchaser until the acceptance by the Vendor. If not accepted before the expiration of such period by the Vendor in writing, this Agreement shall be null and void unless extended by the Purchaser in writing.

Section 2.2 - Agreement

If this agreement is accepted by the Vendor within the time limited for its acceptance, it shall constitute a binding agreement of purchase and sale between the Vendor and Purchaser on the terms and conditions herein set out. Notice of acceptance to the Purchaser's solicitor shall be deemed notice to the Purchaser. The parties hereto agree that Schedules "A", "B", "C" and shall form part of this Agreement of Purchase and Sale and the Purchaser acknowledges receipt and agrees to be bound thereto and accept title to the Property subject to the provisions thereof.

**ARTICLE 3 - THE PURCHASE PRICE AND CLOSING DATE**

Section 3.1 – Purchase Price

The purchase price for the Lot(s) shall be:

\_\_\_\_\_ **Canadian Dollars**  
**(\$ \_\_\_\_\_) + HST.**

Section 3.2 - Payment of Purchase Price

On the execution of this Agreement of Purchase and Sale, the Purchaser shall pay:

- (a) The sum of \_\_\_\_\_ Canadian Dollars (\$ \_\_\_\_\_) by cheque to the Vendor as a first deposit to be held in trust pending completion of the purchase of the Lot(s) by the Purchaser. If for any reason other than a default by the Vendor, the transaction is not completed, the deposit shall be retained by the Vendor; and
- (b) The sum of \_\_\_\_\_ Canadian Dollars (\$ \_\_\_\_\_) by cheque to the Vendor as a second deposit upon commencement of the site servicing, to be held in trust pending completion of the purchase of the lots by the Purchaser; and
- (c) The sum of \_\_\_\_\_ Canadian Dollars (\$ \_\_\_\_\_) by cheque to the Vendor's solicitor on closing, subject to the usual adjustments; and
- (d) The Vendor agrees to hold a vendor take-back first mortgage (the

“Mortgage”) for the balance of the purchase price, for an initial period of twelve (12) months, which sum shall bear zero percent (0%) interest for the first twelve months and eight percent (8%) interest per annum thereafter. The principal and interest may be repaid at any time without notice or bonus. Thereafter, any funds outstanding shall bear interest at the rate of twelve percent (12%) per annum, compounded annually, until the principal and any accrued interest are repaid in full. The Purchaser may repay any funds outstanding at any time without notice or bonus. The Purchaser shall make interest-only payments, calculated monthly on the funds outstanding, on the first day of each month, beginning on the twenty fifth (25<sup>th</sup>) month after the date of the commencement of the Mortgage. The sum secured by the mortgage shall be due in the event of sale of the Lot(s) or upon occupancy of any residential building constructed on the lot(s), and the Purchaser shall pay the registration costs of the mortgage. All other terms of the mortgage shall be determined by the Vendor in its sole discretion, acting reasonably. The mortgagor shall be entitled to obtain partial discharges of the mortgage upon providing ten (ten) days written notice, and paying a discharge fee of Two Hundred and Fifty Dollars (\$250.00) plus GST and disbursements, provided the provisions contained within Section 7.15(a) through (c) have been adhered to by the Purchaser.

Section 3.3 – Closing Date & Extended Closing Date

This Agreement shall be completed on the later of the tenth day following the date upon which the Corporation of the Town of Amherstburg is prepared to issue building permits for the Lot(s) (hereinafter referred to as the “Closing Date”). If the Vendor is unable or unwilling to close the transaction on the scheduled Closing Date for any reason, the Vendor shall have the option to extend the Closing Date one or more times, as the Vendor may require, by three (3) days written notice to the Purchaser, provided that all extensions in the aggregate shall not exceed ( ) days. Any extension of the Closing Date as provided herein shall be upon the same terms and conditions as contained herein, except for Closing Date, and time shall remain of the essence. If the Vendor is unable or unwilling to close the transaction upon the extended Closing Date, this Agreement shall be null and void and the Purchaser’s deposit returned without interest and neither party shall have any claim or entitlement against the other.

The Parties hereto acknowledge that a Plan of Subdivision must be registered on title to the subject lands of the Boblo South End Development, and the parties further acknowledge that the obligations of the Vendor to complete this transaction of Purchase and Sale are conditional upon the registration of said Plan of Subdivision.

Section 3.4 - HST

The Purchaser acknowledges that this transaction is subject to HST and such tax shall be in addition to the Purchase Price(s).

Section 3.5 – Separate Deeds

The Purchaser has the option to request the registration of separate deeds/transfers for each Lot purchased hereunder. Should the Purchaser choose to exercise said option, it shall be required to pay \$125.00 (plus HST) for each deed/transfer, save and except the first deed/transfer, to the Vendor’s solicitor on closing. Such amount shall be included on the Statement of Adjustments as a credit in favor of the Vendor.



**I hereby request the registration of separate deeds/transfers for each Lot purchased herein at a cost of \$125 plus HST for each deed/transfer.**

### Section 3.6 – Bois Blanc Community Association

The Purchaser acknowledges and agrees that upon the registration of a Deed to the Property, he shall be a Member of the Bois Blanc Community Association (the "Association") which shall operate substantially in accordance with the provisions of Schedule "C" hereof. The Purchaser shall be bound by all by-laws, rules and regulations of the Association passed, enacted or promulgated from time to time and agrees to maintain its Membership in good standing in accordance with Schedule "C" and pay Assessments required by the by-laws of the Association and pursuant to the Restrictive Covenants herein described and the Building Scheme.

The Purchaser acknowledges and agrees that the Building Scheme attached as Schedule "C" hereto may be amended by the Vendor and Bois Blanc Community Association to eliminate the payment of fees by the owners of building lots within Bois Blanc Island Community, such amendments shall be in such form as the Vendor and Bois Blanc Community Association may agree.

The Vendor represents and warrants to the Purchaser that Bois Blanc Community Development Association is a non-profit corporation whose members shall be those persons owning property on Bois Blanc Island. It is not intended that the Vendor shall charge any fee which will result in the Vendor earning a profit for providing services to the members; provided that the Vendor may recover its costs incurred to provide such services.

### **ARTICLE 4 - INDEMNITY**

#### Section 4.1 - Indemnity

The Purchaser shall indemnify and save harmless the Vendor from and against any damage caused by the Purchaser or any related party to the Purchaser, with respect to the services in the Subdivision, and with respect to any act or default on the part of the Purchaser or any related party to the Purchaser with respect to the performance of any obligations of the Purchaser under this Agreement.

#### Section 4.2 - Definitions

For the purpose of this Agreement, the following words and expressions shall have the meaning indicated below:

- (a) "Related Party to the Purchaser" shall mean to include any employee, servant, agent, independent agent, contractor, subcontractor of the Purchaser, or any successor in title to the lands of the Purchaser or any successor to the beneficial interest in any of the Lot(s), or any invitee of any of the aforementioned persons;
- (b) "Services" shall mean to include any services installed or to be installed within the Subdivision, by the Vendor or any other person or persons including the Municipality or the Region or any other authority, including, expressly without limiting the generality of the foregoing survey stakes, landscaping, curbs, streets, walkways, sidewalks, street signs, street lighting, surface draining features, sanitary and storm sewers (including lateral connections), water mains (including lateral connections) and all appurtenances relating to any of the foregoing services, any underground hydro service, transformers, gas service, telephone and cable television transmission lines, or any other installations effected for the purpose of public utilities;
- (b) "Subdivision Agreement" shall mean any agreement between the Vendor and the Municipality, in respect of the Subdivision and provision of Services to the Subdivision, which agreement shall be registered on the title to the Lot on or before the Closing Date;

(d) "Transferor" shall mean the Vendor; and

(e) "Transferee" shall mean the Purchaser.

#### Section 4.3 - Insurance

The Purchaser shall carry public liability insurance with an insurance company satisfactory to the Vendor. Such policy shall be issued in the joint names of the Purchaser and Vendor, and a certified copy of the policy shall be delivered to the Vendor on or before the Closing Date. The minimum limit of such policy shall be Two Million (\$2,000,000.00) Dollars, all inclusive. The policy shall be maintained until the Services are transferred to the municipality, failing which the Vendor may, at its option, place such insurance, at the cost of the Purchaser, and any sum due shall be paid by the Purchaser on demand.

#### Section 4.4 – Determination of Damages

The amount of damages caused by the Purchaser or any related party of the Purchaser to the Services shall be determined by the Vendor's Consulting Engineer ("Consulting Engineer"), or such other engineering firm qualified under the laws of Ontario, as may be determined by the Vendor, on the date the Services are transferred to the municipality, and/or any date or dates prior or subsequent thereto. The decision of said Consulting Engineer acting reasonably shall be final and binding upon the parties hereto and the determination of said Consulting Engineer shall be made by him alone and he shall not be obligated to act as an arbitrator in connection therewith nor shall any of the rules normally applicable to arbitrators apply to the determination by the Consulting Engineer.

### **ARTICLE 5 - POSSESSION**

#### Section 5.1 - Possession

After the Closing Date, the Purchaser shall have the right to vacant possession of the Lot(s) or any part thereof subject to the terms of this Agreement respecting entry for certain purposes by the Vendor, Municipality, the County, Public Utilities Commission of the Municipality and others.

### **ARTICLE 6 - VENDOR'S OBLIGATIONS**

#### Section 6.1 - Subdivision Agreement

The Vendor agrees with the Purchaser that the Vendor will construct all of the services as required pursuant to the terms of the Subdivision Agreement entered into between the Vendor and, the Municipality registered against the title to the Lot(s), subject to the provisions of Article 7 hereof and save and except any matters arising out of the act or omission of the Purchaser or a related party to the Purchaser and except any obligations of the Purchaser hereunder.

The Purchaser shall be responsible for all development charges, park fees, levies, impost fees and other charges arising pursuant to the Subdivision Agreement or Municipal by-laws or other applicable legislation.

### **ARTICLE 7 - PURCHASER'S BUILDING COVENANTS**

#### Section 7.1 – Subdivision Agreement

The Purchaser acknowledges that at the time of execution of this Agreement of Purchase and Sale the Subdivision Agreement with respect to the Subdivision may not be registered on the title to the Lot. The Purchaser waives any right that it may have to void this Agreement of Purchase and Sale for reason of delayed registration of the Subdivision Agreement. The Purchaser covenants and agrees that it shall comply with all of the provisions contained in the Subdivision Agreement pertaining to the Lot(s). The Purchaser acknowledges and agrees that they are required to pay

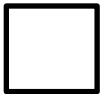
the applicable Development Charges in accordance with the Town of Amherstburg's Development Charges By-Laws. If the Vendor has paid, the full amount or any amount towards the Development Charges for this Lot(s) on or before the closing date, then on the closing date the Purchaser shall pay to the Vendor, as an adjustment to the Purchase Price, the full and current amount of the Development Charges paid by the Vendor as contained within the Town of Amherstburg's Development Charges By-Laws.

#### Section 7.2 - Levies and Fees

The Purchaser shall pay to the Municipality for each building permit issued for each Lot, all municipal development charges, park fees, or such other amount as may be required by the Municipality at the time such building permit is obtained, in accordance with the Municipal By-Laws then applicable from time to time.

#### Section 7.2A – Parkland Contribution

The Purchaser hereby acknowledges that the Vendor has compensated the Corporation of the Town of Amherstburg for public lands and trails contained within this development.



**The Purchaser shall, in turn, pay to the Vendor on closing, a non-refundable amount of [redacted] dollars per lot being purchased and said amount shall form a credit in favour of the Vendor on the Statement of Adjustments.**

#### Section 7.3 - Occupancy of Dwelling

The Purchaser shall not permit any building, dwelling, or any of the Lots to be occupied until:

- (a) the Purchaser has complied with all Municipal by-laws;
- (b) the Purchaser has complied with the Ontario Building Code with respect to the construction of the dwelling;
- (c) the Purchaser has received a Certificate of Compliance of lot grading from Vendor's Consulting Engineer; and
- (d) the Purchaser has received a Certificate of Occupancy.

#### Section 7.4 - Works

Save as provided otherwise in this Agreement and subject to extension of time arising from the usual events of force majeure, the Vendor undertakes to construct the Services in the Subdivision in accordance with the specifications of the Municipality in the streets and to the limit of the Lots(s). The Purchaser undertakes likewise from the limit of the Lot(s) to any dwelling constructed thereon.

#### Section 7.5 - Water Meters and Building Fees

The Purchaser shall pay the cost and obtain all necessary permits for water meters, bulk meters or water service applications (as the case may be), building permit fees, building water used, occupancy permit fees, street opening permits for drain taps, driveway approaches, and sewer taps. The Purchaser shall make and pay for all applications for hydro and other services required, including temporary building services.

#### Section 7.6 - Water Boxes

The Purchaser shall make water boxes and water visible at the time of inspection for transfer of the Services to the Municipality.

#### Section 7.7 - Pumps

The Purchaser shall provide each Lot(s) with a rear yard drainage system with catch basin, basement weeper sump and sump pump with connection by private service connection to the storm sewers.

#### Section 7.8 - Complete Construction

The Purchaser shall complete construction as expeditiously as possible on any dwelling unit once it shall have commenced to construct such dwelling, and shall not at any time during the term of this Agreement, cease constructing once it shall have commenced, subject at all times to force majeure.

#### Section 7.9 - Lands Kept Neat and Tidy

The Purchaser shall keep the Lot(s) in a neat and tidy condition during the course of construction of the building thereon and shall comply with any reasonable request made by the Vendor in respect of the appearance of the Lot(s) during construction as aforesaid. Failure to do so may result in the reduction or complete forfeit of the refundable deposit amount contained in Section 7.18 (c).

#### Section 7.10 - Construction Lien

The Purchaser covenants and agrees that all sums of money due or owing for work done or materials supplied to the Lot(s) or any building erected therein while this Agreement or the VTB Mortgage is in effect, will be duly paid by the Purchaser, save and except such sums which are in dispute by the Purchaser.

Notwithstanding such disputes, the Purchaser shall discharge and/or vacate any construction liens or certificates of action registered against any lot or lots, within ten (10) business days of being notified by the Vendor to do so, failing which the Vendor may, at its option, have such construction liens or certificates of action discharged and/or vacated and the cost of so doing, including all legal costs (as between a solicitor and his own client) shall be added to the principal and form part of the VTB Mortgage and shall be due and payable by the Purchaser to the Vendor immediately, together with interest at the rate stated herein until paid.

#### Section 7.11 - Non-Interference with Services

The Purchaser shall exercise all reasonable care during building operations so as not to interfere with the Services and with the installation by the Vendor of Services and without limiting the generality of the foregoing to keep the total road allowances, including the boulevards in front of or flanking each Lot and/or any easement on, over or under the said Lot, at all times, free from any and all building materials, fill from excavations and/or construction equipment so as not to obstruct in any way the installation of curbs, streets, municipal and utility services, landscaping and use thereof. The Purchaser shall not interfere with the staking of the Lots. The Vendor shall not be required to replace or relocate staking unless the Vendor or his agents damage or remove such stakes.

#### Section 7.12 - Restrictive Covenants

The Purchaser covenants and agrees to comply with the stipulations, restrictive covenants and building scheme set forth in Schedule "B" to this Agreement, and shall obtain a covenant from every subsequent purchaser of the Lot binding such purchaser to the stipulations, restrictive covenants set for in Schedule "B". The covenants contained in this Section 7.12 shall survive the Closing Date and may be registered on title to the Lot(s) at the Vendor's option. The Purchaser acknowledges that the Vendor may amend the restrictive covenants as they apply to any Lot in the Subdivision in its sole discretion.

#### Section 7.13 - Soil

The Vendor shall not be responsible for the condition of the soil of the Lots nor for any loss, damages, expense, injury, claim or action incurred or suffered by the



Purchaser as a result of the condition of the soil.

Section 7.14 – Geotechnical Consultant Review and Recommendations

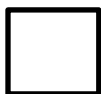
The Purchaser acknowledges that the Vendor or their predecessors in title have placed fill on the lands within Boblo South Development. As a result, the Vendor has engaged the services of a Geotechnical Consultant to review the lands of the Subdivision and the plans for this development and to provide recommendations for the construction of services, roads, dwellings and other structures on the lands of the Subdivision.

The Purchaser agrees that the Vendor or its agents may enter the Lot(s) for the purposes of conducting any required review or to implement any of the recommendations of the Geotechnical Consultant. The Purchaser further agrees to construct the dwelling on the Lot(s) in accordance with the advised recommendations of the Geotechnical Consultant.

Section 7.15 - Architectural Control

- (a) The Purchaser agrees, before commencing any construction or other work on any lot to submit the site plan, building elevations, drawings and specifications to the Vendor for written approval, to ensure compatibility with the stipulations, restrictive covenants and building scheme set forth in Schedule “B”, which approval may not be unreasonably withheld;
- (b) The Purchaser acknowledges that the approval of the Vendor to any submission shall not exonerate the Purchaser from responsibility for compliance with applicable by- laws, other legal requirements and with the applicable provisions of the Subdivision Agreement, and this Agreement. Nor shall the approval of the Vendor to any submission, constitute the Vendor in any way responsible therefore or derogate from the general power of the Vendor to control all phases of architecture, siting, landscaping and grading as required by the Subdivision Agreement or from the right of the Vendor to enforce compliance with the Subdivision Agreement and this Agreement;

- (b) **Failure to obtain written approval as required in section (a) which results in the construction of a building that fails to comply with the stipulations, restrictive covenants set forth in Schedule “B”, will result in a penalty of Ten Thousand (\$10,000.00) Dollars payable to the Vendor by the Purchaser. The mortgage on the land will not be discharged until payment of this penalty is received by the Vendor.**



Section 7.16 – Grading

- (a) The Purchaser acknowledges that the Vendor has notified the Purchaser that an overall grading plan has been prepared by the Vendor’s Consulting Engineer and that this plan has been approved by the Municipality. The Purchaser hereby agrees to grade each of the Lot(s) in compliance with the requirements of the overall drainage plan. Should the Purchaser require any variation to the overall drainage plan, the Purchaser shall first obtain the approval, in writing, of the Vendor’s Consulting Engineer, and the Municipality’s Engineer before carrying out the lot grading;
- (c) The Purchaser agrees that it will accept such grade control and lot drainage as is required by the Vendor or its Consulting Engineer pursuant to the requirements of the Municipality and the Purchaser agrees to allow the Municipality and/or the Vendor to inspect the lot grading.

In the event the slope of any front, side or rear yard does not comply with these requirements, the Purchaser shall be required to install architectural

block retaining walls along those portions of the affected Lot line(s). The said retaining walls shall be installed in the locations determined by the Municipality and shall be completed to the satisfaction of the Municipality.

- (d) The Purchaser agrees that, at the request of the Vendor, the Vendor may, during the maintenance period of the Subdivision by the Municipality enter upon any of the Lots for the purpose of making such modifications for the surface drainage features of the Lots as may be necessary to have the surface drainage features comply with the patterns established by the Municipality.

#### Section 7.17 – Disposal Bins

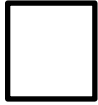
The Purchaser, at the request of the Vendor, shall provide and maintain during the construction period disposal bins on the Lots at locations to be determined by the Vendor to accommodate the proper disposal of refuse and debris, and shall also keep the road allowances adjacent to the Lots clean of debris and dirt.

#### Section 7.18 – Construction Requirements

- (a) The Purchaser agrees to construct any dwelling and any improvements on each Lot in accordance with the site plan, drawings and specifications which have been approved by the Vendor's Engineer or designated agent, and in accordance with all applicable by-laws and other legal requirements including the applicable provisions of the Subdivision Agreement. The Purchaser shall promptly remedy whenever required, any non-compliance with any of the foregoing. Any noncompliance not promptly remedied may be remedied by the Vendor acting reasonably and following five (5) days notice to the Purchase, at the expense of the Purchaser without limiting any other remedies available to the Vendor;
- (b) The Purchaser agrees to reimburse the Vendor for lot grading certifications fees and any other expenses incurred by the Vendor occasioned by the construction of the dwelling and other improvements on the Lot, including without limitation the expense of moving hydrants, curbs, underground transformers, street lighting or utility poles, service boxes, and hydro and water meters, provided such expense was not occasioned by the fault of the Vendor;
- (c) The Purchaser agrees that it will indemnify and reimburse the Vendor and hold it harmless against all injury, damage, and liability arising out of such injury and damage, including the cost of repairs to any Services and any consequential damage including liability to the Municipality, the County or other third parties whether arising from the Vendor's contractual liabilities, or otherwise caused by any act, omission or occurrence arising out of the construction of the house and other improvements on the Lot or other work being done in connection therewith, or for which the Purchaser is in any way responsible, including injury, damage, or liability done by or attributable to the Purchaser or its contractors, employees, or agents and its and their vehicles, materials and equipment to service boxes, hydrants, valve chamber, manholes, grade or survey stakes, utility and communication installations, roadways, gutters, pavements, landscaped areas, curbs or sidewalks, including the cost of replacing contaminated road base; and to likewise indemnify and reimburse the Municipality and the County for an injury or damage done to their respective property or works and for which the Purchaser is in any way responsible as aforesaid.
- (d) The Purchaser is required to take photographs depicting the condition of the curbs, sidewalks, and driveway approaches, for the Lot(s) or abutting the Lot(s) prior to commencement of construction and once again upon completion of construction of the dwelling. If the Purchaser fails to take such photographs any damage to the curbs, sidewalks or driveway approaches of the Lot(s) or abutting the Lot(s) shall be deemed to be the fault of the Purchaser and the Purchaser shall be responsible for the costs

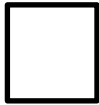
of repairs to same

- (e) The Purchaser acknowledges that appropriate fencing has been constructed within the subdivision as required by the Town of Amherstburg and as a condition of the permit issued by the Ministry of Environment, Conservation and Parks. The Purchaser acknowledges that the fencing constructed shall remain in place in perpetuity and shall not be removed under any circumstances.



**The Purchaser shall, in turn, pay to the Vendor on closing, a non-refundable amount of \_\_\_\_\_ dollars per lot being purchased and said amount shall form a credit in favour of the Vendor on the Statement of Adjustments. These funds will be used to offset the Vendor's costs associated with construction of the fence.**

- (f)



**The Purchaser shall, in addition to the balance due on the Closing Date, deliver to the Vendor the sum of Two Thousand Dollars (\$2,000.00) for each Lot being purchased, to be held by the Vendor as security to ensure the compliance by the Purchaser of the Purchaser's obligations set for herein. The security deposit shall be returned to the Purchaser upon finalization of the building permit for the dwelling to be constructed on the Lot, less any amount required to remedy the Purchaser's breach of its obligations. The Purchaser acknowledges that if the cost to remedy such breach is in excess of the Two Thousand (\$2000.00) Dollars, the Purchaser shall be responsible for same.**

#### Section 7.19 - Sodding

The Purchaser acknowledges that the front lawn and exterior side yard of each lot shall be sodded, seeded or otherwise landscaped within six months of the construction of a house thereon, and such sodding, seeding or landscaping shall be continued over the unpaved portion of the road allowance, including any lands between the property line and the paved portion of the road allowance. Such sodding, seeding or landscaping shall be maintained in perpetuity by the Purchaser and any subsequent transferees.

#### Section 7.20 – Survey Markers

The Purchaser will be responsible for locating the survey markers and will pay to the Vendor on demand the cost of replacing each survey marker for the subject Lots which are damaged, destroyed or removed as a result of any act by the Purchaser, its employees, agents or contractors.

#### Section 7.21 - Driveway Surfaces

The Purchaser acknowledges that residential driveways and their approaches shall be constructed to a width that complies with the provisions of the Corporation's Zoning By-Law and the Town Bylaw 2017-81, Regulate Activity on Town Highways, Road Allowances and Right of Ways as amended from time to time. Residential approaches shall consist of 150 mm. (6") Granular "A" stone base with interlocking paving stone, concrete or asphalt paving from the back of the curb to the property line.

It is understood and agreed that under no circumstances will the Purchaser herein be permitted to install a new residential driveway approach within the corner radii of pavement constructed along any street in this development.

It is further understood and agreed that under no circumstances will the Purchaser or any other persons be permitted to install a new residential driveway approach over any private service connections from the storm or sanitary sewers or water system except where such connections cross driveways laterally (over the shortest possible distance) to enter the dwelling.

#### Section 7.22 - Entry by Vendor

The Purchaser agrees that the Vendor may enter any of the Lot(s) for the purpose of correcting, repairing or installing Services, including without limitation, roads, curbs, sidewalks or utilities, or for any interruption or interference with access to any Lots caused the services. In the event Vendor enters the Lots to install Services, Purchaser agrees that Vendor shall have no liability or responsibility for any damages caused by Vendor's entry on the Lots. However, if Vendor enters such Lots for the purpose of correcting or repairing said Services negligently installed by Vendor, then Vendor agrees to repair at the expense of the Vendor the damages created by Vendor's entry and return the property substantially to the same condition as when it entered the Lot. The Vendor hereby reserves the right to access to the Lot(s) until the Services are transferred to the Municipality.

#### Section 7.23 - Advertising

The Purchaser shall not erect nor cause to be erected any advertising, signs, temporary or permanent, landscaping, posters, banners, flags, lighting, children's play areas, etc. within the Subdivision, save in accordance with drawings showing the proposed design, the location as previously submitted to and approved in writing by the Vendor.

#### Section 7.24 – Multi-Use Path

The Town of Amherstburg has required a multi-use path to be constructed simultaneously with the construction of the internal roadway. No parking will be permitted on the pathway. The multi-use pathway will be constructed continuously through driveway approaches.

### **ARTICLE 8 - NON-ASSIGNMENT & CONSTRUCTION**

#### Section 8.1 - Non-Assignment

The Purchaser shall not assign this Agreement or any part hereof without the prior written consent of the Vendor, which consent may be arbitrarily withheld. If the Purchaser is a corporation, a change in control of the corporation shall be deemed to be an assignment requiring the Vendor's approval, as aforesaid. In addition, the Purchaser shall not transfer, assign, convey or otherwise dispose of any interest which the Purchaser may have in the Agreement or any of the Lot(s) nor shall the Purchaser grant an option to purchaser, acquire or otherwise obtain the interest which the Purchaser had in this Agreement or the Lot(s) at any time prior to the Closing Date, without the written consent of the Vendor, which consent may be arbitrarily withheld.

#### Section 8.2 - Construction

Not later than twenty-four (24) months after the Closing Date, the Purchaser shall obtain the necessary building permits and Substantially Complete the building on each Lot. "Substantially Complete" shall mean either the issuance by the Municipality of an unrestricted occupancy permit or that the building and improvements to each Lot are capable of completion at a cost of not more than twenty (20%) percent of the total cost of construction.

#### Section 8.3 – Option to Repurchase

(a) Subject to the provisions of Section 8.3 (b) hereof, if the Purchaser

named in this Agreement fails to substantially complete the building on the Lot(s) in the manner and within the time limits as required by Section 8.2 hereof and fails within thirty (30) days of notice of such default to substantially complete the building, then for one hundred and twenty (120) days thereafter, the Vendor shall have an irrevocable option to repurchase each Lot on which the Purchaser is in default hereunder for the original purchase price for the Lot(s) less twenty (20%) percent plus the cost of any dwelling constructed thereon as determined by the Vendor's certified appraiser, less any agent's commissions paid or incurred by the Vendor, and deducting any unpaid taxes and charges against the Lot(s) and any monies including interest owing hereunder by the Purchaser to the Vendor and all legal fees (on a solicitor and his own client basis) and expenses incurred by the Vendor in connection with such repurchase. Contemporaneously upon payment to the Purchaser of such price for repurchase and within thirty (30) days of the Vendor's election to repurchase, the Purchaser shall transfer and release all its right, title and interest in the Lot(s) and this Agreement to the Vendor free and clear of all encumbrances and deliver up quiet possession to the Vendor. The provisions of this Article 8 may be included in the transfer to the Purchaser.

- (b) If the completion of construction of either all building footings or substantial completion of the building, as the case may be, as required by Section 8.2 was delayed by cause which in the opinion of the Vendor's Engineer or designated agent were not within the reasonable control of the Purchaser and unavoidable by the exercise of reasonable effort or foresight by the Purchaser (excluding the Purchaser's financial status) or the delay was caused by any default or act of or omission by the Vendor, then the time for completion will be extended by the time of such delay.

#### **ARTICLE 9 - PURCHASER'S UNDERTAKING ON CLOSING**

##### Section 9.1 - Purchaser's Undertaking

At the Vendor's request, the Purchaser shall deliver to the Vendor on the Closing Date the Purchaser's undertaking, covenant and agreement to comply with all provisions of this Agreement of Purchase and Sale including but not limited to Articles 4, 7, 8 and 12. Such undertaking, covenant and agreement shall be in a form satisfactory to the Vendor's solicitor and shall specifically acknowledge that such undertaking, covenant and agreement shall survive the Closing Date and not merge upon registration of the deed.

#### **ARTICLE 10 – TIME OF ESSENCE**

##### Section 10.1 – Time of Essence

The parties expressly declare that time shall be of the essence in all respects hereof.

#### **ARTICLE 11 - TITLE**

##### Section 11.1 - Title and Requisitions

This Agreement shall be subject to title to the Lot(s) being good and free from all encumbrances, except as provided in this Agreement, and except as to local rates and subdivision, development, engineering or similar agreement, any easements referred to in Section 11.2 hereof, any easement for hydro, gas, sewers, water, telephone or like services to the Lot(s) and rights of entry easements, subdivision agreement and licenses referred to in this Agreement and except as to municipal requirements, including building and zoning by-laws and any registered restrictions or covenants that run with the Lot(s), provided that such are complied with. The Vendor shall not be required to furnish any title deeds or abstract of title, proof or evidence or title, or any copies therefore other than those in its possession. **The**

**Purchaser shall be allowed twenty (20) days from the date of acceptance by the Vendor to investigate title to the Lot(s)** at its own expense and if within that time it shall furnish the Vendor in writing with any valid objection to the title which the Vendor shall be unable or unwilling to remove and which the Purchaser will not waive, then, notwithstanding any intermediate negotiation, this Agreement shall be null and void and the deposit returned forthwith to the Purchaser without interest or deduction and the Vendor shall not be liable for any costs or damages.

Save as to any valid objection so made within such time, the Purchaser shall be conclusively deemed to have accepted the title of the Vendor to the Lot(s).

The conveyance or conveyances of the Lot(s) shall be in the usual form prepared by the Vendor and shall be subject to the provisions and restrictions herein provided, to statutory exceptions and qualifications, and to any restrictions imposed by the Municipality, the County or the Region pursuant to the Subdivision Agreement, or any similar agreement entered into pursuant to The Planning Act (as amended from time to time) relating to the Lots and easements in favour of the Municipality, the County, telecommunications, hydro, and other utility or utilities, or any other easement herein provided. The Purchaser agrees to accept and be bound by the restrictive covenants contained in Schedule "B" annexed hereto. The Purchaser shall pay the cost of registration on any conveyance to it. Every transfer to the Purchaser shall contain a covenant to observe and comply with the provisions of Schedule "B" annexed hereto, as well as all of the other stipulations, restrictions, provisions and covenants herein contained on the part of the Purchaser, without limiting the generality of the foregoing, the provisions in Article 7.

#### Section 11.2 – Additional Easements

Where the Town of Amherstburg or other body franchised to provide any public services so requires, title shall also be subject to the right of such body or bodies to install and maintain, and have the appropriate and usual rights and easements for public utilities and services, including catch basins, drains and lines (with their appurtenances) for hydro, telephone and other utilities and communications. Such right is provided for in the Subdivision Agreement, but the Vendor represents that it will provide all such rights and easements as are required as of the Closing Date (none of which shall interfere with the construction of a residential dwelling upon any lot). It is agreed that, if any such further rights or easements are required, they are to be furnished by the Purchaser without abatement or adjustment to the purchase price. If any such right or easement so required is such that it prevents the construction of a residential dwelling on any lot, the Purchaser shall have the right to require the Vendor to repurchase the Lot at the price the Purchaser purchased same from the Vendor together with a reimbursement of interest paid therein.

### **ARTICLE 12 - MISCELLANEOUS**

#### Section 12.1 - Survival of Covenants

All covenants, provisions and terms contained in this Agreement on the part of the Purchaser shall not merge but shall survive the Closing Date and shall not merge upon the delivery of a transfer or transfers of any Lot or Lots by the Vendor to the Purchaser. All covenants, representations and warranties of the Vendor shall merge on closing at the option of the Vendor.

#### Section 12.2 - Non-Waiver

No omission by the Vendor to exercise the right to void this Agreement shall create or operate as a waiver of such right, nor shall a waiver of such right in the case of one or more instances of default create or operate as a waiver of such right in the case of any future or further default.

#### Section 12.3 - Notice

Whenever notice is required, it shall be in writing and shall be given by prepaid

registered mail addressed to the Vendor at 2199 Blackacre Drive, Oldcastle Ontario NOR 1L0 and to the Purchaser at the address stated below or Purchaser's last known address or the Purchaser's solicitor or by delivering it to the Vendor or Purchaser and notice shall be deemed to have been given on the second business day subsequent to the date of mailing of the said notice or delivery of same to the Vendor or Purchaser as aforesaid. In the event of a postal strike or other interference with the mail, notices shall be delivered personally.

#### Section 12.4 - Tender

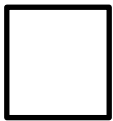
Any tender of documents or money hereunder may be made upon the Vendor or the Purchaser or the solicitor acting for the Vendor or the Purchaser, and money may be tendered by negotiable cheque certified by a chartered bank or trust company.

#### Section 12.5 – Vendor Status

The Vendor represents and warrants that the Vendor is now and shall at the time of closing be a resident of Canada and the Vendor shall deliver on the closing an Affidavit sworn by an officer of the Vendor verifying the representations contained in this paragraph or will deliver a certificate from the Canada Revenue Agency giving clearance under Section 116 of the Income Tax Act.

#### Section 12.6 – Landscaping and Street Trees

The Purchaser acknowledges that street trees shall be planted in accordance with the Town of Amherstburg's requirements. The trees will be planted in accordance with the Town's Tree By-law on the municipal ROW, and at a minimum of 60 mm in caliper based on the Tree By-law. The Purchaser acknowledges that the Vendor will obtain or has obtained the approval of the Municipality as to the type, size and location of the Street Trees. The Purchaser further acknowledges that the Municipality is the owner of the Street Trees and the approval of the Municipality shall be required prior to any maintenance or removal of any Street Tree by any other person other than the Municipality. The Purchaser acknowledges that he or any subsequent owner is required to maintain and/or replace these trees and other landscaping, at their own expense, for a period of two years from the date of planting.



**The Purchaser shall include a clause in all Agreements of Purchase and Sale for the transfer of the Lot(s) that advises the subsequent purchaser of the matters addressed within this paragraph. In addition to the balance due on closing, the Purchaser shall be required to pay a non-refundable Street Tree Levy to the Vendor in the amount of \$500.00 per lot, which shall be added as a credit in favour of the Vendor on the Statement of Adjustments and shall be payable by the Purchaser on the Closing Date.**

#### Section 12.7 – Above Ground Services

The Purchaser acknowledges that above ground services may be constructed or installed within the Subdivision. The location of the above ground services will be or are shown on the plans prepared by the Vendor's Consulting Engineer. The Purchaser is hereby invited to inspect said plans in order to familiarize themselves with the location of the above ground services.

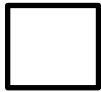
#### Section 12.8 – Canada Post Community Mailbox

The Purchaser acknowledges that Canada Post will not provide mail delivery service directly on the island. Canada Post will be providing delivery to a community mailbox located on the mainland in close proximity to the ferry access.



Section 12.9 - School Board Issues

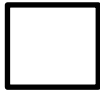
The Purchaser confirms that they have been advised that students may not be able to attend the closest elementary or secondary school and could be bused to a distant school with available capacity and that the present existence of such a school is not a guarantee of its future availability. The Purchaser further acknowledges that school busses will not be transported to the island and that the School Boards will designate pick up points on the mainland for students to meet the bus.



**The Purchaser, its heirs, estate trustees, successors in title and assigns agree to include a special clause regarding this matter in any Agreement of Purchase and Sale they may enter into for the sale of the subject land(s).**

Section 12.10 – Access to and From the Island

The Purchaser acknowledges that access to and from the island for all residents and/or property owners on the island is the sole responsibility of the Vendor and any subsequent Transferees, other than Transferees which are government entities. The Vendor, and any subsequent Transferees (other than government entities) shall provide a ferry service for access to and from the island that meets the requirements of the Ministry of Transportation and the safety standards of Transport Canada. If the dimension or weight of any vehicle or load exceeds the limits set out in the Highway Traffic Act, then the vehicle operator shall obtain the appropriate oversize/overweight permit. The Municipality is not responsible in any way for access to or from the island.



**The Purchaser further acknowledges that the Purchaser's use of the ferry service is subject to a ferry agreement with the Purchaser and the Amherstburg Ferry Company or its successors, transferees and assigns, (the "Resident Ferry Agreement") and that the right to use the ferry is subject to that Resident Ferry Agreement. The Purchaser acknowledges that it will have to pay annually for the limited right to use the ferry as set out in the Resident Ferry Agreement.**



**The Purchaser, its heirs, estate trustees, successors in title and assigns agree to include a special clause regarding this matter in any Agreement of Purchase and Sale they may enter into for the sale of the subject land(s).**

Section 12.11 – Emergency Response Plan and Fire Protection

The Purchaser acknowledges that each residential dwelling shall be equipped with an automatic fire suppression system to the satisfaction of the Town's Fire and Building Departments, along with any other fire monitoring and response requirements deemed necessary by the Town. Fulfilling these obligations will be the requirement of the Purchaser its heirs, estate trustees, successors in title and assigns.

Section 12.12 - No Registration

The Purchaser shall not be entitled to register a copy of this Agreement or notice thereof, or an assignment or notice of an assignment thereof, or caution against the title to the Lot(s) and a breach of this covenant shall be deemed to go to the root of the agreement between the Vendor and the Purchaser entitling the Vendor to terminate this agreement and retain the deposit of the Purchaser paid hereunder.

Section 12.13 - Headings

The headings in this Agreement are inserted for convenience and identification only and are in no way intended to describe, interpret, define, or limit the scope, extent or intent of this Agreement or any provision hereof.

Section 12.14 - Binding on Heirs

This Agreement shall enure to the benefit of and shall be binding upon the successors and assigns of the Vendor and shall enure to the benefit of and shall be binding, upon the permitted successors and assigns of the Purchaser.

Section 12.15 - Gender

This agreement of purchase and sale and its acceptance shall be read with all changes of gender or number as required by the context hereof.

Section 12.16 - Entire Agreement

It is agreed that there is no representation, warranty, collateral agreement or condition affecting this Agreement of the Lot(s) or supported thereby, other than as expressed herein in writing. Any amendment to this Agreement shall be in writing and signed by both Parties.

IN WITNESS WHEREOF the Purchaser has either executed this Agreement or has hereunto affixed its corporate seal under the hands of its proper signing officers duly authorized in that behalf.

DATED at \_\_\_\_\_, Ontario, this \_\_\_\_\_ day of \_\_\_\_\_ 20\_\_\_\_.

SIGNED, SEALED AND DELIVERED

\_\_\_\_\_  
Purchaser

\_\_\_\_\_  
Purchaser

\_\_\_\_\_  
Purchaser's address

THE UNDERSIGNED ACCEPTS THE ABOVE OFFER, SUCH ACCEPTANCE BEING MADE AND DATED THIS \_\_\_\_\_ DAY OF \_\_\_\_\_, 20\_\_\_\_.

SIGNED, SEALED AND DELIVERED

\_\_\_\_\_  
Per:

**Boblo South Development Inc.**

Acknowledgement:

I HEREBY ACKNOWLEDGE RECEIPT OF MY SIGNED COPY OF THIS AGREEMENT OF PURCHASE AND SALE.

\_\_\_\_\_  
Purchaser

PURCHASER'S SOLICITOR

---

VENDOR SOLICITOR

---

Name: Michael Cervi  
Michael Cervi Law Office  
400-1500 Ouellette Avenue  
Windsor, ON N8X 1K7  
Phone: Phone: 519-258-9494  
Fax: 519-258-9985

**SCHEDULE "A"**

**DESCRIPTION OF PROPERTY TO BE PURCHASED**

**Attach Plan**

## SCHEDULE "B"

### RESTRICTIVE COVENANTS

The Purchaser covenants and agrees that the Property, shall be burdened and subject to, and governed by the following restrictions which are to the benefit of other lands owned by the Vendor or its successor or related entities within Bois Blanc Island Community ("Bois Blanc"). The Property shall henceforth be held, transferred, sold, conveyed and occupied subject to the covenants, restrictions, reservations, easements, charges and liens hereinafter set forth without necessity of specific reference hereto. Absence of such specific reference to these Restrictions in any subsequent conveyance or other transfer of the Property shall not excuse the grantee or transferee from full compliance herewith. The Vendor may release, diminish, vary and amend any or all of the restrictive covenants contained herein, in its absolute discretion and shall have no obligation to enforce any restrictive covenant against any other owner of lands within Bois Blanc.

The Purchaser agrees, covenants and acknowledges that it shall own, maintain and operate the Property in conformity with the following requirements and shall do or get in any way contrary to the provisions of these Deed Restrictions, as amended, both before and after the Closing Date.

1. Unless prohibited by the context in which they are used, the following words, when used in these restrictions, shall have the following meanings:

- (a) "Assessment" shall mean the Annual Assessment, Special Assessment and Supplemental Assessment issued by the Association to its Members.
- (b) "Association" shall mean Bois Blanc Community Association, a non-profit corporation.
- (c) "Bois Blanc" means the lands of the Bois Blanc Island Community described in Schedule "A" hereto.
- (d) "Committees" means committees established by the directors of the Association.
- (e) "Common Areas" shall mean all real and personal property (or interest therein) located in Bois Blanc that the Transferor may hereafter convey or transfer lands or property to the Association, or the Town of Amherstburg (formerly the Township of Malden) at the Transferor's discretion, and any buildings or structures erected thereon including but not limited to the community centre, recreational areas and additional landscaping.
- (f) "Owner" shall mean the recorded owner, whether one or more persons or legal entities, of the fee simple title to any of Bois Blanc.
- (g) "Members" shall mean all owners of, or party who has equitable interest in, any part of Bois Blanc.
- (h) "Property" shall mean any subdivision lot, or land and all improvements located thereon, located within Bois Blanc within Plan 12M-\_\_\_\_\_.
- (i) "Transferor" shall mean Boblo Developments Inc.;
- (j) "Transferee" shall mean the Purchaser of any lot or other lands forming part of Bois Blanc.

2. The Transferee shall not let its Membership in the Association lapse or otherwise fault or fail to be in good standing and shall not fail to pay any Assessment levied against the Property when required by the Association By-laws. The Transferee shall not waive its obligation to pay the Assessments based on forfeiting use or reduction of use of the Commons Areas.

3. The Transferee shall not act contrary to all rules, provisions, obligations and stipulations of the Association, as amended, from time to time both before and after the Closing Date.

4. The Transferee shall not fail to pay any Assessment levied by the Association in monthly, annual, or such other instalments as prescribed by the Association, within thirty (30) days of the Association's establishment of its annual budget.

5. The Transferee shall not challenge or dispute the right of the Association to perform the following:

- (a) operate, maintain, manage and improve the Common Areas, upgrade and maintain the landscaping and any boardwalk, if built, in Bois Blanc, operate an architectural control committee, or all other functions which are determined appropriate by its directors;
- (b) set a budget and levy annual maintenance assessments from each of the landowners within Bois Blanc;

- (c) establish annual maintenance assessments and special assessments and take collection procedures and action, including, but not limited to, the registration of liens on the Property;
- (d) assess interest on late payments, bring a lawsuit or take such other action against landowners who fail to pay Assessments in a timely fashion;
- (e) register or enforce a lien against the Property of such owners within Bois Blanc who fail to promptly pay Assessments.

6. The Property shall not be used for the purpose of any profession, trade, or employment service, manufacture or business of any description, nor as a school, hospital or other charitable institution, nor as a hotel, rooming house, or other public resort nor for any sport (other than such games as are usually played in connection with the occupation of a private residence), nor for any other purpose, (other than a private dwelling house erected thereon) which shall be a nuisance to the occupants of any neighbouring lands or buildings.

7. The Purchaser shall not obtain or use the services of any contractor to construct a residential dwelling upon the Property other than Island Cove Development Ltd.

8. No more than one residential dwelling shall be constructed on the Property.

9. No dwelling other than single family dwellings shall be constructed on the Property

10. Residential dwellings shall not be erected on the Property except as follows:

(a) **Lots X - Y**

- (i) two storey houses must have a minimum main floor area of 1,400 square feet;
- (ii) one and one-half storey houses must have a minimum main floor area of 1,800 square feet;
- (iii) one storey houses must have a minimum main floor area of 2,200 square feet; and,
- (iv) no dwelling, including garages and porches, shall be erected closer than:
  - (1) 30 feet from the front lot line;
  - (2) 10 feet from the side lot lines;
  - (3) 50 feet from the rear lot line; and,
  - (4) maximum lot coverage of thirty-five (35%) per cent;

(b) **Lots X - Y**

- (i) two storey houses must have a minimum main floor area of 1,100 square feet;
- (ii) one and one-half storey houses must have a minimum main floor area of 1,400 square feet;
- (iii) one storey houses must have a minimum main floor area of 2,000 square feet; and,
- (iv) no dwelling, including garages and porches, shall be erected closer than:
  - (1) 30 feet from the front lot line;
  - (2) 5 feet from the side lot lines and total side yards of not less than fifteen (15) feet;
  - (3) 30 feet from the rear lot line; and,
  - (4) maximum lot coverage of thirty-five (35%) per cent;

(c) It is the intent of these guidelines to avoid locating driveways side by side on adjacent lots. The first choice shall be governed by the order of approval of the building plans by the Vendor;

(d) It is the intent of these guidelines to locate dwellings on the rear setback line;

(e) For the purposes of this Schedule, the following definitions shall apply:

- (i) Floor Area shall mean the area occupied by the dwelling house exclusive of any open or closed porch, patio, garage, carpet or breezeway;
- (ii) Main Floor shall mean the floor area occupied by the first floor, or intermediate floors lower than the ceiling of the first floor and completely above the finished grade at the front of the dwelling house;
- (iii) Second Floor shall mean the floor area occupied immediately above the main floor or intermediate floor;
- (iv) Half Storey shall mean the floor area occupied within the roof space, provided it is completely finished as living quarters and completely connected to the main floor by a finished stair; and,
- (v) Front of the House shall mean the side of the house facing the street on the narrowest face of the Property.

11. The dwellings constructed on the Property shall not have:

- (a) less than an attached garage for one (1) motor vehicle;
- (b) more than two (2) driveway approaches;

- (c) swimming pools which are constructed above grade;
  - (d) swimming pools which have been constructed of materials not previously approved by the Vendor in writing; and,
  - (e) satellite dishes in excess of eighteen (18") inches in diameter.
12. Fencing:
- (a) No fence shall be constructed on the Property unless the fencing design, location, and material are approved by the Transferor, in its absolute discretion;
  - (b) No fence shall be constructed on the perimeter of the Property which extends beyond the front or rear wall of the primary dwelling unit (except around swimming pools);
  - (c) No fence shall be constructed along street frontages; and,
  - (e) No fence shall be constructed in the front yard of the Property.
13. Except in a fully enclosed garage, no boats, campers, recreational vehicles, commercial vehicles, buses, jet-skis, personal watercraft, go-carts, motor bikes, dirt bikes, motor scooters, motorcycles, trucks, or any other vehicle that is powered by an internal combustion engine, shall be stored or parked on any of the Property or on any public rights-of-way except for automobiles and non-combustion powered vehicles.
14. No boat lifts shall be constructed, and no boats or other watercraft shall be moored, anchored, or tied down except at a marina.
15. The Transferee shall not permit motorized vehicles or motorized crafts of any kind on any bodies of water within Bois Blanc.
16. The Transferee shall use no other garbage or refuse container except containers approved by the Transferor.
17. No poultry or livestock, other than dogs, cats and/or caged birds shall be kept or maintained on any parcel within Bois Blanc, and such dogs, cats and/or caged birds shall not be raised or maintained on the Property for commercial purposes. No rags, junk or other objectionable materials shall be placed or stored on the Property. No tandem trucks or trailers or commercial vehicles shall be stored, garaged, parked, maintained or repaired within Bois Blanc, except as may be required during construction purposes to which it is appurtenant. The Transferee shall not permit a motor vehicle that is not in working order to remain on the Property or on any street including both public and private rights-of-way; provided that such motor vehicle may be parked in a wholly enclosed garage.
18. No open fires shall be allowed. Construction debris, branches, and leaves shall not be stored or kept on the Property.
19. No signs, billboards, notices or other advertising matter of any kind (except the usual signs for residential dwellings offering the parcel and buildings thereon for sale or rent), shall be placed on the Property or upon any buildings or on any fence or tree on the Property except as approved by the Transferor.
20. No above ground utility lines shall be placed on the Property.
21. No trees, shrubs, or plantings shall be cut down or removed from the Property and no trees, shrubs or plantings shall be installed on the Property without prior approval by the Transferor, in its discretion.
22. No lawns or gardens shall be installed or maintained by using pesticides, herbicides or fertilizers unless these substances are approved by the Transferor, acting in its absolute discretion.
23. No beach area shall be constructed on the Property.
24. No debris or litter shall be allowed to remain on beach area abutting the Property.
25. No topsoil or beach sand shall be removed or spread beyond the boundaries of the beach areas and no alteration of the beach areas shall be permitted.
26. No alteration or removal any material forming a water erosion barrier shall be permitted.
27. No dock, raft or permanent float of any kind shall be installed out into the Detroit River.
28. No aquatic vegetation of any kind shall be installed either along the shoreline or out into the Detroit River, on parcels abutting on the Detroit River except by authorized persons or statutory authorities.



29. No aquatic vegetation shall be removed from Detroit River on parcels abutting onto the River, with the exception of dead vegetation found deposited along the shoreline or floating near the shore except by authorized persons or statutory authorities.
30. No waterfowl, water life or wildlife shall be harassed or interfered with in any way, nor shall they be fed nor shall feeding stations be established along shorelines except by authorities having jurisdiction.
31. No waterfowl, wildlife or fish shall be permitted to be introduced to the Detroit River except by authorities having jurisdiction.
32. No alteration, excavation or dredging of the Detroit River bottom or hydrosol or removal of River water shall be permitted.
33. No grade alterations shall be permitted within fifty (50') feet of a lot line abutting onto the Detroit River.
34. No site planning shall occur which requires changes to the existing topography of the Property.
35. The Transferee shall permit no construction of multiple structures on the Property which is not designed in a unified, architectural and spatial manner to the satisfaction of the Transferor.
36. The Transferee shall not restrict, impede or object to the Transferor, or the Association entering onto the Property for the purposes of maintenance, repair, landscaping services, and snow or litter removal to or from the Property.
37. The Transferee shall not permit any soil, sand, silt, snow, ice, or other substance to build up or accumulate in the culvert constructed by the Transferor on the Property, nor shall the Transferee alter, maintain or place objects upon the swale constructed by the Transferor from the edge of the paved portion of the road to the Property line except as specified by the Town of Amherstburg, which requirements include cutting the grass and the replacement of dead or damaged grass.
38. The Transferee shall not object to or interfere with the placement, access, or operations of any above ground services which may be located on the Property or in the Bois Blanc Island Community, and shall not remove, damage, deface, or otherwise interfere with same. Above ground services includes, but is not limited to, super mailboxes, cable television pedestals, lighting standards, fire hydrants, hydro boxes, hydro transformers and its concrete pad, Bell Canada pedestals, and venting pipes.
39. To assist in maintaining a consistent standard in the Bois Blanc Island Community, the Transferee shall not obtain or use the services of any contractor to construct a residential dwelling on the Property other than Island Cove Development Ltd.
40. The Transferee shall not object to or interfere with the placement or use of any super mail boxes.
41. The Transferee shall not dispose of construction material as refuse to be collected and disposed of by the Town of Amherstburg, and shall only utilize garbage containers approved by the Vendor.
42. The Transferee shall install, utilize, and maintain a fire sprinkler system and shall not fail to install a fire sprinkler system of such a type and form as approved by the Town of Amherstburg after Engineering drawings are delivered to the Town of Amherstburg.
43. The Transferee shall not disrupt or interfere with the rear yard drainage, including underground drainage and sewer lines, and shall not alter the grading or drainage of the Property from the lot grading and rear yard drainage plan approved and certified by the Town of Amherstburg.
44. No driveway approaches shall be constructed over any servicing connections from the storm or sanitary system servicing Bois Blanc.
45. No sump pumps are to discharge anywhere on the Property except in the rear yard drainage system.
46. Discharge from downspouts shall not be directed into the storm drainage system, nor shall any discharge from the downspouts be directed on the Property except through the use of splash pads.
47. The Transferee acknowledges that The Corporation of The Town of Amherstburg is under no obligation to provide water or potable water to the property, and the Transferee shall not request or demand that the Town of Amherstburg or the Association provide such water or potable water.
48. The Transferee acknowledges that the Transferor may develop the remainder of its lands on Bob-Lo Island for single and multiple residential, commercial and marine uses, including, but not limited to, a hotel, motel, restaurants, marina and gaming uses and the Transferee hereby consents to the same and shall not object to or solicit an objection from any other person, firm or corporation to such uses.
49. The Transferee acknowledges that The Corporation of The Town of Amherstburg shall not provide

access to Bob-Lo Island, and the Association may, but shall not be obligated to, at the cost of all Members, provide the same, and the Transferee shall not request or demand that the Town of Amherstburg or the Association, provide such access. If the Transferee wishes to use the ferry to access the Island, the Transferee acknowledges that it will enter into a Resident Ferry Agreement with the Amherstburg Ferry Company or its successor or assigns that requires an annual payment for use of the ferry in an amount to be determined by the Amherstburg Ferry Company, its successors or assigns.

50. These Restrictions, as amended and supplemented from time to time as herein provided, shall be deemed to run with the title to the Property, and shall remain in full force and effect for the benefit of the Property designated by the Transferor.

51. These Restrictions shall be binding upon the Transferee and their heirs, executors, administrators, successors and assigns and shall continue in full force and effect in perpetuity from the date hereof. These Restrictions are for the benefit of each and every Owner of the Property and their respective owners from time to time.

52. The construction, validity, and enforcement of these Restrictions shall be determined according to the laws of the Province of Ontario. The venue of any action or suit brought in connection with these Restrictions shall be in Essex County, in the Province of Ontario. Any action or suit brought by or against all Owners who are Members of Association may be brought or defended by such Owners in the name of the Association, and any process, notice of motion or hearing, or other application to any court or judge thereof that is served upon Association in connection therewith shall be binding upon such Owners for all purposes without necessity of individual service upon such Owners.

53. Wherever the covenants, restrictions and conditions herein contain are in conflict with the provisions of any applicable, federal, provincial, or municipal by-law, regulation or ordinance, those provisions contained herein or in such by-law, regulation or ordinance which is the most onerous or which places the greatest restrictive burden on the use of the Property shall be applicable.

54. Failure of the Transferor or Association to insist upon strict performance of any provision of these Restrictions with respect to land within Bois Blanc shall not be deemed to be a waiver of such provision as to such Land unless the Transferor or Association has executed in writing a waiver thereof. Any such written waiver of any provision of these Restrictions by the Transferor or Association with respect to any Property shall not constitute a waiver of such provision as to any other land within Bois Blanc.

55. The amendment or invalidation of any provision or provisions of these Restrictions by lawful court order shall not affect or modify any of the other provisions of these Restrictions, which other provisions shall remain in full force and effect. The parties agree that an Ontario Court shall have the right to amend these Restrictions.

56. Whenever used herein, the singular number shall include the plural and the plural the singular, and the use of any gender shall include all genders or neuters.

57. The Transferor reserves the right to amend these Restrictions as reasonably required, in its sole discretion.

## SCHEDULE "C"

### **BUILDING SCHEME - BOIS BLANC COMMUNITY ASSOCIATION**

The Purchaser acknowledges that the title to the Property shall be subject to a building scheme (the "Building Scheme") to be registered on the title to all lands within Bois Blanc Island Community ("Bois Blanc") and agrees to take title to the Property and be bound by the provisions thereof. The following is a summary only of the most relevant terms, covenants and agreements contained in such building scheme and is not represented to be accurate or comprehensive. The Purchaser acknowledges the opportunity to review the Letters Patent, By-laws of the Association as well as all other documents which comprise the Building Scheme and agrees to be bound thereto. The Vendor reserves the right prior to the registration of the Building Scheme, to amend, vary, expand or alter the Building Scheme to conform to the general purpose of the Building Scheme set out below and the Purchaser agrees to the same.

#### 1. DEFINITIONS

In the Building Scheme, the following words and terms shall have the meanings ascribed to them as follows:

- (a) "Assessment" means the Annual Assessment, Special Assessments and Supplemental Assessments levied by the Association upon the Members pursuant to this Building Scheme;
- (b) "Association" shall mean Bois Blanc Community Association, a corporation not for profit;
- (c) "Block" means any portions of the Bois Blanc that have not been subdivided into building lots;
- (d) "Bois Blanc" means all of the lands of the Bois Blanc Island Community described in Schedule "A" hereto and other lands of the Transferor situate on Bob-Lo Island as the same may be subdivided, conveyed or partitioned from time to time;
- (e) "Building Lot" means a part of Bois Blanc which has been designated on a reference plan or subdivision plan deposited on the title to Bois Blanc and for which a building permit is or will be available for construction of a single unit dwelling;
- (f) "Common Areas" means all real and personal property (or interest therein) located in Bois Blanc that the Developer may hereafter convey or transfer to the Association or to the Township of Malden including any buildings or structures to be erected thereon, for a community centre, recreational area and areas for landscaping if any;
- (g) "Developer" or "Vendor" means Boblo Developments Inc. and its successors, beneficiaries or assigns, if any;
- (h) "Director" means a member of the Board of Directors of the Association;
- (i) "Directors" means the Board of Directors of the Association elected by the Members in accordance with this By-law;
- (j) "Members" shall mean all owners of, or party who has equitable interest in, any part of Bois Blanc; and,
- (k) "Property" shall mean the property of the Vendor.

#### 2. PURPOSE OF THE ASSOCIATION

The Association and all of its business and other activities are to be operated and conducted in the promotion of its non-profitable objects and purposes as specified in its Letters Patent; and in the conduct of its affairs the management shall at all times be mindful of these non-profitable objects and purposes.

In addition to the objects and purposes set out in the Letters Patent, the purpose of the Association is to enhance the quality of life within Bois Blanc and maintain property values for all residents and may include:

- (a) providing services within Bois Blanc and on or to the Common Areas;
- (b) acquiring and paying for such casualty, liability and other insurance coverage as the Association may deem necessary or desirable;
- (c) providing for engineering, administration, and accounting services, legal services, and such other professional and employee services as may be deemed appropriate by the Association or its Directors;
- (d) paying all taxes assessed against Common Areas of Bois Blanc owned by the Association, and against any and all personal property which may hereafter be acquired by the Association;

- (e) paying any other taxes assessed against or payable by the Association;
- (f) paying all expenses required for the operation, management, repair, maintenance, improvement and replacement of the Common Areas including without limitation, landscaping, horticultural improvements, and any community centre, or recreational daycare or educational facilities, if any;
- (g) paying all expenses required for services to Bois Blanc Island and the operation, maintenance, and repair of the ferry docks and the island access points or any water filtration plants, sewage treatment plants, maintenance of roads, sewers and electrical lines serving the Members of the Association, whether or not owned by the Association or the Developer;
- (h) providing a reasonable contingency fund for the ensuing year and to provide a reasonable annual reserve for anticipated major capital repairs, maintenance and improvement, and capital replacements for any property of the Association;
- (i) paying the operating expenses of the Association, and reimbursement of actual expenses incurred by officers and Directors, if authorized by the Directors, and to pay Developer's administration costs;
- (j) repaying any funds borrowed by the Association for any of its lawful purposes, including interest thereon;
- (k) maintaining the culvert and swale located on any Member's Building Lot in accordance with the requirements of the restrictive covenants registered on the title of the said Building Lot, in the event that Member should fail to maintain same, and all costs incurred by the Association shall be recovered by the levy of a Supplementary Assessment against the said Building Lot;
- (l) assess Members for fees and levies and making such expenditures as may be deemed necessary or desirable by the Director for the purpose of accomplishing the intent, purposes and objectives set forth in this Building Scheme; and

### 3. **MEMBERSHIP**

- (a) There shall be one class of Members. The owners of each Building Lot shall be entitled to one (1) Membership in the Association.
- (b) Members shall continue as Members for as long as they continue to hold title to a Building Lot. When a person ceases to hold such title, the Membership shall automatically pass to the transferee, voluntary or involuntary, of such title.
- (c) Subject to the provisions of subparagraph (g) of this Section 3 hereof, Members shall have the right to vote for the election of Directors. No Member shall be entitled to share in the distribution of corporate assets upon the dissolution of the Association.
- (d) Annual meetings and special meetings of the Members of the Association shall be held on or at such time or place as may be determined by the Directors or the President or five (5%) percent of the Members of the Association.
- (e) Persons entitled to vote at a meeting of the Members may do so only in person or by proxy.
- (f) At every meeting of the Members, each Member shall be entitled to one (1) vote per Building Lot, or ten (10) votes for each acre within Bois Blanc. Elections for Directors shall be by majority vote and there shall be no right of cumulative voting for Directors. Only one (1) joint tenant, or one (1) tenant-in-common, of a Building Lot may vote.
- (g) A Member's right to vote as hereinbefore provided may be suspended on the following conditions:
  - (i) The affirmative vote of a majority of the Board of Directors present at a duly called and held meeting; and,
  - (ii) If the Member has failed to pay its Annual Assessment or Special Assessment and such failure has continued for a period greater than fifteen (15) days.
- (h) No Member of the Association, as such, shall be personally liable for the debts, liabilities or obligations of the Association.
- (i)
  - (i) It is the onus of each Member to ascertain from the Association the amount of the Annual Assessment payable by such Member. Failure to ascertain the said amount shall not excuse any Member from payment of any Assessment when due. The Member shall pay quarter-yearly the Annual Assessment allocated to their lot.
  - (ii) The Association may levy Special Assessments in the event that the Budget originally adopted for any fiscal year is insufficient to pay the costs and expenses of operation,

maintenance, and management during such fiscal year; in the event of emergency, or in the event the Association reserves are insufficient to cover expenditure for capital improvements or replacements, the Member must make payment in full of any special Assessment in the same manner as payment for the Annual Assessment.

- (j) All Members of the Association covenant and agree as follows:
- (i) They shall not restrict, impede or object to the Vendor or the Association entering onto the Property for purposes of maintenance, repair, landscaping services, and snow or litter removal, to or from the Property.
  - (ii) To obtain insurance policies for the Property which indicate the Association as an additional named insured party on all policies of insurance covering or insuring the Property and the in amounts satisfactory to the Association.

#### 4. BOARD OF DIRECTORS

(a) Subject to any limitation set forth in the Letters Patent and the By-laws of the Association, this Building Scheme or applicable laws of the Province of Ontario, the Directors shall manage and control all the operations of the Association and the conduct of its affairs and activities. The Directors shall establish corporate policies for the direction and guidance of the Association, its Committees, if any and the officers, and the management of the Association, and formulate the basic rules and regulations governing the operation and management of the Association. Without limiting the generality of the foregoing, the Directors shall have the following powers:

- (i) To elect and remove all officers, agents and employees of the Association, prescribe such powers and duties for them as may not be inconsistent with law, with the Letters Patent and By-laws of the Association, fix their compensation and require from them security for faithful service.
  - (ii) To conduct, manage and control the affairs and business of the Association, and to make such rules and regulations therefor not inconsistent with law, with the Letters Patent and By-laws of the Association as they may deem best.
  - (iii) To levy and collect Annual Assessment and Special Assessments as described herein. All issues, matters and decisions shall be made by the vote of a majority of the Directors.
  - (iv) To change the principal office for the transaction of the business of the Association from one location to another within the same county; to designate any place within or without the Province of Ontario for the holding of any Directors' or Members' meetings; and to adopt, make and use a corporate seal and to alter the form thereof from time to time as in their judgment they may deem best, provided such seal shall at all times comply with the provisions of law.
  - (v) To borrow money and incur indebtedness for the purposes of the Association, and to cause to be executed and delivered therefor, in the corporate name, promissory notes, bonds, debentures, deeds of trust, mortgages, pledges, hypothecations or other evidence of debt and securities therefor.
  - (vi) To establish and operate Committees as may be required for the successful operation of the Association.
  - (vii) To prepare a budget to provide for payment of all expenses incurred by the Association in performing its duties herein set forth.
- (b) The authorized number of Directors shall not be less than six (6) nor more than nine (9) unless and until changed by amendment of the Letters Patent of the Association, or by amendment of by-laws if the Association. The exact number of Directors shall be fixed, within the limits specified, by resolution of the Directors.
- (c) The President of the Association shall occupy automatically a position on the Board of Directors by virtue of his or her office. Such person shall continue to serve as a Director for so long as he or she holds the position by virtue of which he or she becomes or is elected as a director, unless sooner removed in accordance with the By-laws.
- (d) The Directors other than those serving pursuant to Subparagraph (c) of this Section 4, shall serve for a term of three (3) years or until their respective successors are elected and take office.
- (e) Directors shall not be required to be Members of the Association or otherwise resident or own, beneficially or legally, any property in Bois Blanc.
- (f) Directors, shall be elected at the tri-annual meeting of the Members by a vote of the Members. Annual meetings shall be held, but if such annual meeting is not held, or the Directors not elected at the meeting, the Directors may be elected at a special meeting of the Members called for that purpose.

(g) A Director may be removed from office by an affirmative vote of two-thirds (2/3rds) of the Directors. A Director may be removed for any reason if such removal is approved by the Members at a duly called and held meeting or by written consent pursuant to the by-laws of the Association.

(h) The Directors may create, by resolution one or more committees, to serve at the pleasure of the Board of Directors, to delegate to such committee any of the authority of the Directors except with respect to:

- (i) The approval of any action for which the Corporations Act requires approval of the Members or a majority of the Members;
- (ii) The filling of vacancies on the Board of Directors or in any committee;
- (iii) The amendment or repeal of by-laws or the adoption of new by-laws;
- (iv) The amendment or repeal of any resolution of the Board of Directors which by its express terms is not so amendable or repealable;
- (v) The appointment of other committees of the Directors or the Members thereof;
- (vi) Committee membership may consist of Directors only, Directors and non-Directors, or non-directors only, or Members or non-members. The chairman and members of committees shall be appointed by the Directors of the Association. The Board of Directors may appoint, in the same manner, alternate members of any committee who may replace any absent member at any meeting of the committee. The Directors shall have the power to prescribe the manner in which proceedings of any such committee shall be conducted. In the absence of any such prescription, such committee shall have the power to prescribe the manner in which its proceedings shall be conducted. Unless the Directors or such committee shall otherwise provide, the regular and special meetings and other actions of any such committee shall be governed by the provisions of the Association's By-laws applicable to meetings and actions of the Directors. Minutes shall be kept of each meeting of each committee.
- (vii) Committees shall have no legal authority to act for the Association, but shall report their findings and recommendations to the Directors who shall determine, by majority vote, the issue before them.
- (viii) Committees may include, but not be limited to, the following:
  - (A) Grounds and Maintenance Committee - responsible for all landscaping, ensuring proper maintenance of the grounds within the public rights of way, the planting of flowers, shrubs, greenery, maintenance of walking trails, parks entering into contracts for other services and all other functions assigned to it by the Directors;
  - (B) Architectural Committee - shall review and issue directives and/or specifications regarding all fences and construction of single unit residences within Bois Blanc including satellite dishes, accessory buildings and structures and all other mandates assigned to it by the Directors;
  - (C) Environmental Committee - responsible to promulgate rules and regulations within Bois Blanc regarding environmental issues and needs including designation of authorized fertilizers, garbage disposal and all other mandates assigned to it by the Board of Directors;
  - (D) Finance Committee - responsible for directing all budget and financial issues within the Association including assignment of auditors, reviewing and proposing budgets, establishing Assessments and all other purposes assigned to it by the Directors;

(i) The Directors shall receive no compensation for their services as Directors.

## 5. OFFICERS

(a) The officers of the Association shall be a President, Vice-President, Secretary and Treasurer and others designated by the Directors. Such officers shall be chosen by, and hold office at the pleasure of the Directors, subject to the rights, if any, of any officer under any contract of employment. A person need not be a Member of the Association in order to be an officer, provided, that the person elected President shall automatically serve as a Director of the Association. One person may hold two or more offices except neither the Secretary nor the Treasurer may concurrently serve as the President.

(b) The Officers of the Association shall be elected annually by the Directors and each shall hold office until his or her successor shall be elected and qualified to serve, or until he or she shall resign or shall be removed or disqualified to serve.

- (c) (i) Any officer may be removed, either with or without cause, by the Directors at any time or, except in the case of an officer chosen by the Directors, by any officer upon whom such power of removal may be conferred by the Directors. Any such removal shall be without prejudice to the rights, if any, of the officer under any contract of employment of the officer.
- (ii) Any officer may resign at any time by giving written notice to the Association, but without prejudice to the rights, if any, of the Association under any contract to which the officer is a part. Any such resignation shall take effect at the date of the receipt of the notice or at any later time specified in the notice and, unless otherwise specified in the notice, the acceptance of such resignation shall not be necessary to make it effective.
- (d) A vacancy in any office because of death, resignation, removal, disqualification or any other cause shall be filled in the manner prescribed in these by-laws for regular election or appointment to such office, provided that such vacancies shall be filled as they occur and not on an annual basis.

## 6. ASSESSMENTS

- (a) All expenses of the Association incurred to fulfil the Association's purposes set out in Section 2 of this Schedule "E" shall be charged to and payable by Assessments against the Building Lots owned by each Member. The Association shall establish and adopt a Budget for each fiscal year and thereupon levy an Assessment against each Building Lot included within Bois Blanc. The Budget and Assessment shall be in such amount as shall be deemed sufficient in the judgement of the Directors to enable it to carry out the Association's purposes.
- (b) All Building Lots shall be subject to Assessment by the Association. The Association shall have the power and duty to levy Annual Assessments as hereinafter referred to, and to enforce collection thereof in the manner herein provided. An Annual Assessment shall be levied against each Building Lot in Bois Blanc. Assessments shall be based on the Assessment Share of each such lot as described herein.
- (c) Procedures for the collection of Annual Assessments including due date, delinquency charges, and interest shall be as follows:
  - (i) Notice of Assessment - Within thirty (30) days of having established the Budget, the Association shall notify each Member of the Annual Assessment by prepaid mail to the last known address, of the amount of such Member's Annual Assessment for the next fiscal year.
    - (A) In the event that the Association shall fail to notify any Member of the Annual Assessment on or before the time specified above, the levy and lien of said Assessment shall not be invalidated or otherwise affected, but the time for payment of such Assessment shall be extended by the number of days the said notice is delinquent. Failure to receive any notice given by the Association shall not excuse any owner from payment of any Assessment when due.
    - (B) It is the duty of each Member to ascertain from the Association the amount of Annual Assessment payable by such Member.
  - (ii) All Members shall pay their Assessments when due in accordance with the provisions herein set forth, the full amount of the Annual Assessment allocated to their Building Lot.
- (d) The Association may levy Special Assessments in the event the Budget originally adopted for any fiscal year is insufficient to pay the costs and expenses of operation, maintenance, and management during each such fiscal year in the event of emergency or in the event that the Association reserves are insufficient to cover expenditures for capital improvements and replacements. The Association may levy Supplementary Assessments against any particular Building Lot in the event the Association undertakes to remedy any failure of any Member to comply with the restrictive covenants registered on the title of the said Building Lot in order to recover the costs which may be incurred by the Association. Notices of any Special Assessment and Supplementary Assessment shall be given in the same manner as notices for the Annual Assessment and shall be payable within thirty (30) days after establishing same. Special Assessments may be payable in instalments according to a schedule approved by the Board of Directors, if the Board of Directors so determine.
- (e) Supplementary matters regarding Annual Assessments, Special Assessments and Supplementary Assessments - The following provision shall apply to all Assessments:
  - (i) Delinquency Charge and Interest - Any Assessment not paid when due shall bear interest from the date of delinquency until paid at the rate of twenty-four percent (24%) per annum, being two (2%) percent per month.
  - (ii) Obligation of Member - Subject to the lien of Assessment which shall be binding upon subsequent purchasers and encumbrances, every Assessment shall be the obligation of the Member. If any Assessment is not paid within thirty (30) days after the same is due,



then the Association may bring suit against the Member and there shall be added to the amount of such Assessment the aforementioned interest and all costs incurred by the Association, including legal fees on the solicitor and his own client basis.

- (iii) Proof of Payment of Assessment - Upon the request of any Member or mortgagee, and upon payment of a prescribed fee, the Association shall furnish a certificate in writing signed by an Officer of the Association showing the amount of unpaid Assessment, if any, against any lot in which the Member or mortgagee has an interest, the period for which any such unpaid Assessments were assessed and levied, and any interest or other charges owing thereon. Such certificate in the absence of fraud, shall be conclusive evidence of the payment of any Assessment therein stated to have been paid.

(f) Expenses for each Building Lot shall include but not be limited to, accounting, auditing, legal fees, landscaping maintenance and any supplements, repairs and maintenance to buildings and structures and improvements owned by the Association.

(g) The amount of Assessment and percentage to be paid by each Building Lot owner shall be determined annually, or more frequently, in the absolute discretion of the Directors after considering the following factors:

- (i) the number of Building Lots developed within Bois Blanc at the time of such Assessment;
- (ii) the number of Building Lots under development and to be placed for sale in the next twelve (12) months;
- (iii) the actual and estimated costs to be incurred during the subject twelve (12) month period for the Building Lots;
- (iv) the establishment of a reserve account;
- (v) any other criteria deemed desirable by the Directors from time to time.

The Directors shall not be required to follow any criteria, but merely to consider the same.

(h) When all Building Lots within Bois Blanc have been developed or constructed by the Developer, the percentage of Assessment payable by each Building Lot owner shall be fixed by the Directors based upon the number of Building Lots in existence on that date.

(i) In order to provide an additional means to enforce the collection of Annual Assessments, Special Assessments and Supplementary Assessments, the Association shall have a lien against all lots subject to such Assessment in Bois Blanc, together with all improvements thereon, as follows:

- (i) Creation of Lien - The lien of every Assessment, together with interest charges thereon and the cost of collection thereof, shall attach and become a charge on the Property, and all improvements thereon, against which such Assessment is made upon the recording of these restrictions.
- (ii) Enforcement of Lien - In the event any Assessment is not paid within thirty (30) days after the same is due, the Association shall have the right to file a claim for lien in the Land Titles Division of the Registry Office in the County of Essex. Said Assessment lien may be enforced by the Association by foreclosure suit in the same manner as a mortgage foreclosure or in such other manner as is permitted by law. The Association is hereby granted the power-of-attorney for each Member to take action for all collection matters relating to the lien of Assessment. In the event the Association files a claim of lien against any Building Lot, it shall be entitled to recover from the owner of such property before noted interest and all costs, including legal fees on a solicitor and his own client basis.
- (iii) Priority of Lien - It is the intent hereof that the aforesaid Assessment lien against property shall be subordinate and inferior only to lien of real property taxes levied by the municipality, and not to the lien of a mortgagee or construction lien claimants or any other encumbrances registered on the title to each Building Lot.

(j) In the event of any conflict between any restrictive covenant registered on any Member's Building Lot and the building scheme, the restrictions registered on each Member's title to his Building Lot shall govern. The provisions of this By-law shall be supplemental to any restrictive covenant or building scheme, if not in conflict therewith.

## 7. ANNUAL REPORT AND FISCAL YEAR END

(a) The Directors shall cause an annual report to be prepared and sent to the Members no later than one hundred and twenty (120) days after the end of the Association's fiscal year. Such annual report shall be prepared in conformity with the requirements of the Corporations Act, R.S.O. 1990 and as it may

hereafter be amended.

(b) The fiscal year of the Association shall be such date determined by the Directors.

**8. TRANSFER OF TITLE TO ASSOCIATION**

From time to time hereafter, Developer may transfer title to portions of the Common Areas to the Association, which transfer of title may be subject to such easements, reservations, restrictions and limitations upon usage of said property as Developer deems appropriate, and to taxes for the year in which conveyance is made.

**9. TERM**

The Building Scheme described herein this Schedule "G" shall be binding upon all Owners of Property and shall continue in full force and effect for a period of forty (40) years from the date hereof.

**10. GOVERNING LAW**

The construction, validity, and enforcement of this Building Scheme shall be determined according to the laws of the Province of Ontario. The venue of any action or suit brought in connection with this Building Scheme shall be in Essex County, in the Province of Ontario. Any action or suit brought by or against all Members of the Association may be brought or defended by such Owners in the name of Association, and any process, notice of motion or hearing, or other application to any court or judge thereof that is served upon Association in connection therewith shall be binding upon such Members for all purposes without necessity of individual service upon such Members.

**11. WAIVER**

Failure of Developer or Association to insist upon strict performance of any provision of the Building Scheme with respect to any Property shall not be deemed to be a waiver of such provision as to such Property unless Developer or Association has executed in writing a waiver thereof. Any such written waiver of any provision of this Building Scheme by Developer or Association with respect to any Property if effective shall not constitute a waiver of such provision as to any other Property.

**12. INVALIDATION**

The invalidation of any provision or provisions of this Building Scheme by lawful court order shall not affect or modify any of the other provisions of this Building Scheme, which other provisions shall remain in full force and effect.

**13. USAGE**

Whenever used herein, the singular number shall include the plural and the plural the singular, and the use of any gender shall include all genders.

**14. AMENDMENTS**

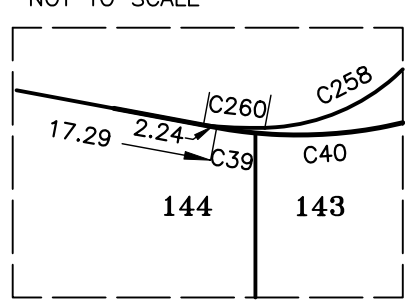
The Developer reserves the right to amend this Building Scheme, prior to registration, as reasonably required.

**15. DOCUMENTS**

Copies of the Letters Patent and By-laws of the Association are available from the Vendor.



DETAIL NOT TO SCALE



INTEGRATION DATA

Table with 2 columns: POINT ID and COORDINATES. It lists various points (CRP-A, CRP-B, CRP-C) and their corresponding coordinates in UTM Zone 17.

Table with 2 columns: LINE SCHEDULE. It lists line numbers (L1 to L20) with their respective bearings and distances.

LEGEND AND NOTES

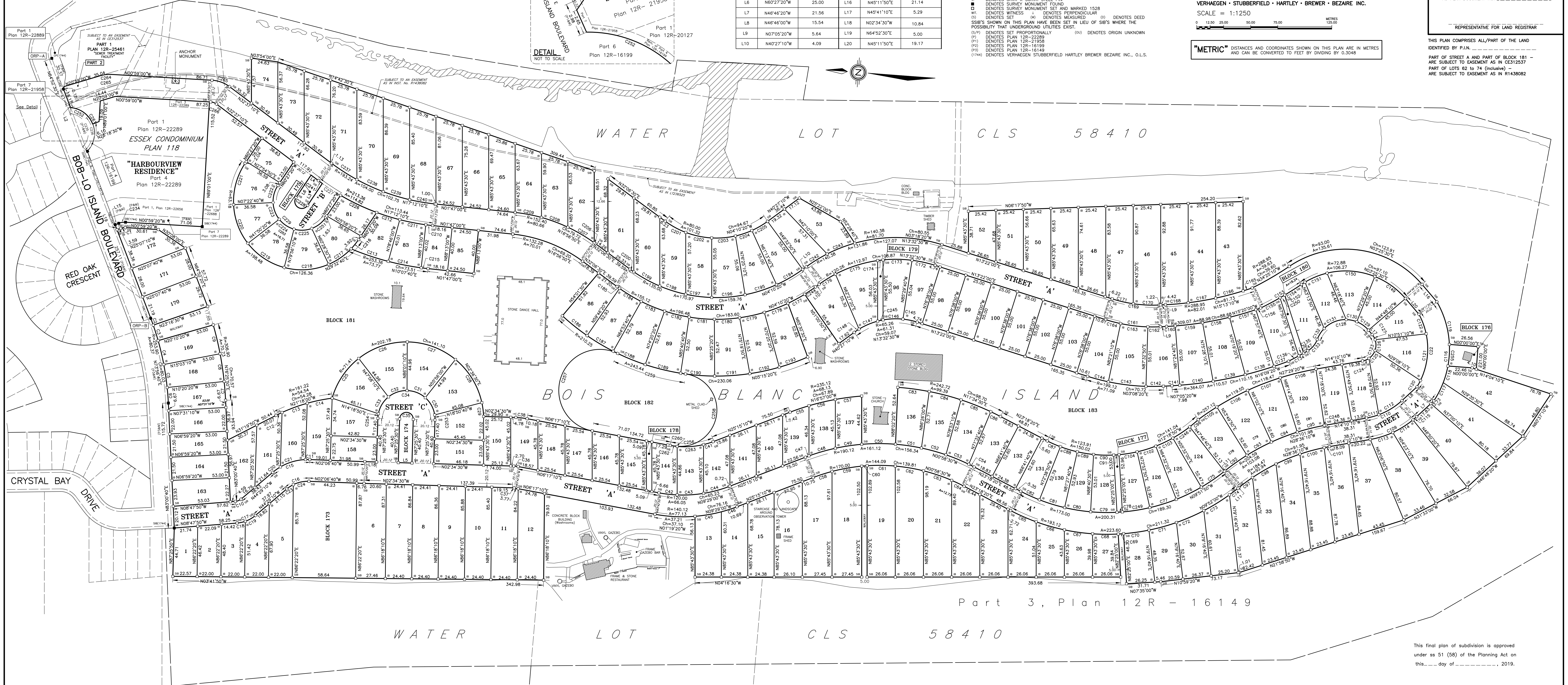
LEGEND AND NOTES: BEARINGS ARE UTM GRID DERIVED FROM OBSERVED REFERENCE POINTS 'A' AND 'B' BY REAL TIME NETWORK OBSERVATIONS. DISTANCES ON THIS PLAN ARE GROUND AND CAN BE CONVERTED TO GRID BY MULTIPLYING BY THE COMBINED SCALE FACTOR OF 0.9999658.

DRAFT PLAN OF SUBDIVISION OF PART OF BOIS BLANC ISLAND (BOB-LO ISLAND) GEOGRAPHIC TOWNSHIP OF MALDEN NOW IN THE TOWN OF AMHERSTBURG COUNTY OF ESSEX, ONTARIO

VERHAEGEN • STUBBERFIELD • HARTLEY • BREWER • BEZARE INC. SCALE = 1:1250 REPRESENTATIVE FOR LAND REGISTRAR

PLAN 12M-

I CERTIFY THAT THIS PLAN IS REGISTERED IN THE LAND REGISTRY OFFICE FOR THE LAND TITLES DIVISION OF ESSEX (12) AT ... O'CLOCK ON THE ... DAY OF ... AND ENTERED IN THE PARCEL REGISTER FOR PROPERTY IDENTIFIER ... AND REQUIRED CONSENTS ARE REGISTERED AS PLAN DOCUMENT NO. ... REPRESENTATIVE FOR LAND REGISTRAR



Multiple tables of CURVE SCHEDULE data. Each table lists curve number, radius, arc, chord, and bearing. The tables are organized by block and street, providing detailed geometric information for the subdivision.

OWNER'S CERTIFICATE: THIS IS TO CERTIFY THAT 1. LOTS 1 TO 172 (inclusive), BLOCKS 173 TO 183 (inclusive), AND THE STREETS NAMED STREET 'A', STREET 'B' AND STREET 'C' HAVE BEEN Laid OUT IN ACCORDANCE WITH OUR INSTRUMENTS. 2. THE STREETS ARE HEREBY DEDICATED TO THE CORPORATION OF THE TOWN OF AMHERSTBURG AS A PUBLIC HIGHWAY.

SURVEYOR'S CERTIFICATE: I CERTIFY THAT: 1. THIS SURVEY AND PLAN ARE CORRECT AND IN ACCORDANCE WITH THE SURVEYORS ACT, THE SURVEYORS REGULATION, THE LAND TITLES ACT AND THE REGULATIONS MADE UNDER THEM. 2. THIS SURVEY WAS COMPLETED ON THE ... DAY OF ...

DATE: JULY 23, 2019. REBECCA BELANGER, M.C.P., R.P.P. Manager, Planning Services County of Essex. DOMINIC AMONE 'I HAVE AUTHORITY TO BIND THE CORPORATION'. SURVEYOR'S CERTIFICATE: BRIAN COYD ONTARIO LAND SURVEYOR FOR VERHAEGEN • STUBBERFIELD • HARTLEY • BREWER • BEZARE INC. WINDSOR ONTARIO. LEAMINGTON ONTARIO. VERHAEGEN • STUBBERFIELD • HARTLEY • BREWER • BEZARE INC. 187 Talbot Street East, Windsor, ON N9A 1B8. Fax: (519) 252-2875. www.vshburys.com. ONTARIO LAND SURVEYORS INC. 19-48-059-03.dwg CAD File: 19-48-059-03.dwg PLAN FILE NO. J-32









Town of Amherstburg  
Boblo Island-South End



**Legend**

-  Zoning
-  Natural Environment
-  Recreational Development
-  Woodlots

RE

6

RR/RC

h-RR/RC

h-RR/RC

EP

EP CG RH CG CH-13  
 RM2 RM2-1 CH-12 RM2  
 CH-8/RM2-4 CH-8 R1  
 CH-14 CH-14 CG  
 CH CH  
 RMH  
 CH  
 I-1  
 I  
 R3 RM1  
 EP EP  
 R3-1 R3 CG 8  
 EP  
 R1 CH  
 R2-2  
 R3 RM1-2  
 RM1/I  
 EP EP A  
 RM1-3 R1A EP-4W  
 CG-9 EP-4W  
 CG-9 RM2-5  
 h-RM2-5 EP  
 RE-2 A



**Local Planning Appeal Tribunal**  
Tribunal d'appel de l'aménagement  
local



**ISSUE DATE:** November 29, 2018

**CASE NO(S):** PL170798

The Ontario Municipal Board (the “OMB”) is continued under the name Local Planning Appeal Tribunal (the “Tribunal”), and any reference to the Ontario Municipal Board or Board in any publication of the Tribunal is deemed to be a reference to the Tribunal.

**PROCEEDING COMMENCED UNDER** subsection 51(34) of the *Planning Act*, R.S.O. 1990, c. P.13, as amended

Applicant and Appellant:	Boblo Developments Inc.
Subject:	Proposed Plan of Subdivision – Failure of the County of Essex to make a decision
Purpose:	To permit the approval for a draft plan of subdivision for 206 lots and 6 blocks creating 209 building lots on the south end of Boblo Island
Property Address/Description:	Part of Bois Blanc Island
Municipality:	Town of Amherstburg
Municipality File No.:	37-T-14004
OMB Case No.:	PL170798
OMB File No.:	PL170798
OMB Case Name:	Boblo Developments Inc. v. Essex (County)

**Heard:** August 20 - 22, 2018 in Amherstburg, Ontario

**APPEARANCES:**

**Parties**

**Counsel\*/Representative**

Boblo Developments Inc.

C. Lyons\*

County of Essex

C. Riley\*

Town of Amherstburg

T. Porter\*

**Applicant:** Boblo Developments Inc.  
**File No.:** 37-T-14004  
**Municipality:** Town of Amherstburg  
**Location:** Part of Bois Blanc Island (Malden)

**Date of Decision:** DRAFT  
**Date of Notice:**  
**Last Date of Appeal:**  
**Lapsing Date:**

---

## ATTACHMENT 1

The conditions and amendments to final plan of approval for registration of this Subdivision are as follows

---

### No. Conditions

---

1. That this approval applies to the draft plan of subdivision prepared and certified by Brian Coad, O.L.S., dated September 20, 2016 that shows:
  - One hundred and twenty-four (124) lots for single detached residential units;
  - Forty-eight (48) lots for ninety-six (96) semi-detached residential units; and
  - Four (4) blocks.

The lands comprising the draft plan of subdivision are legally described as Part of Bois Blanc Island (Malden Township), Town of Amherstburg, County of Essex.

2. That the Owner enters into a subdivision agreement with the Municipality wherein the Owner agrees to satisfy all the requirements, financial and otherwise, of the Municipality concerning the payment of development charges, provisions of roads, installation and capacity of services, sanitary sewerage collection system, water distribution system, utilities and stormwater management facilities for the development of the lands within the plan, and transportation to and from the island.
3. That the subdivision agreement between the Owner and the Municipality contain a provision requiring the owner to notify in writing each person who first offers to purchase any subdivided lot within the plan of subdivision of all approved development charges, including development charges for school purposes, relating to any such lot pursuant to Section 59(4) of the Development Charges Act, 1997.
4. That the subdivision agreement between the Owner and the Municipality, where required, contain a provision prepared to the satisfaction of the Municipality, regarding the phasing and timing of the development.
5. That the subdivision agreement between the Owner and the Municipality be registered against the lands to which it applies prior to the registration of any final plan of subdivision.

**Applicant:** Boblo Developments Inc.  
**File No.:** 37-T-14004  
**Municipality:** Town of Amherstburg  
**Location:** Part of Bois Blanc Island (Malden)

**Date of Decision:** DRAFT  
**Date of Notice:**  
**Last Date of Appeal:**  
**Lapsing Date:**

---

6. That the road allowances included in this draft plan shall be shown and dedicated as public highways.
7. That the streets shall be named to the satisfaction of the Municipality.
8. That all terminating streets shall contain a 0.3 metre reserve, to be illustrated on the final plan and be conveyed to the Municipality.
9. That the Owner convey to the Municipality for park or other recreational purposes up to 5% of the land included in the plan. Alternatively, the Municipality may require cash-in-lieu or some other form of conveyance acceptable to the Municipality, for all or a portion of the requirement.
10. That prior to final approval of any phase by the County of Essex, the County is to be advised by the Municipality that the proposed subdivision conforms to the Zoning By-law in effect.
11. That the Owner shall provide easements as may be required for services, utility or drainage purposes in a form satisfactory to the Municipality or utility, and where required by the Municipality, daylight corners and road reserves shall be shown on the final plan and conveyed in a form satisfactory to the Municipality.
12. That prior to final approval of any phase, the Municipality shall confirm that sewage treatment conveyance capacity and water supply capacity is available for all lots in the proposed development, or phase of development.
13. That the subdivision agreement between the Owner and the Municipality contain provisions, to the satisfaction of the Municipality and the Essex Region Conservation Authority, that stipulate that the Owner finalize the Stormwater Management Report prepared by Stantec Consulting Inc., or other consultant working on behalf of the Owner, to the satisfaction of the Municipality and the Essex Region Conservation Authority, and install the stormwater management measures as identified in the finalized stormwater management report.
14. That the subdivision agreement between the Owner and the Municipality contain provisions, to the satisfaction of the Municipality and the Essex Region Conservation Authority, that stipulate that the Owner finalize the Environmental Impact Assessment Report prepared by BioLogic Incorporated, or other consultant working on behalf of the Owner, to the satisfaction of the Municipality and the Essex Region Conservation Authority, and implement all recommendations contained in the final report.



**Applicant:** Boblo Developments Inc.  
**File No.:** 37-T-14004  
**Municipality:** Town of Amherstburg  
**Location:** Part of Bois Blanc Island (Malden)

**Date of Decision:** DRAFT  
**Date of Notice:**  
**Last Date of Appeal:**  
**Lapsing Date:**

---

15. That the subdivision agreement between the Owner and the Municipality contain provisions, to the satisfaction of the Municipality and the Essex Region Conservation Authority, that prior to final approval of any phase, the Owner agrees to the requirement that a post-construction report be prepared and submitted by the appropriate qualified professional certifying that the mitigation measures and recommendations of the final Environmental Impact Assessment Report have been implemented.
16. That prior to final approval the Essex Region Conservation Authority shall require a copy of the fully executed subdivision agreement between the Owner and the Municipality, in wording acceptable to the Essex Region Conservation Authority, containing provisions to carry out the recommendations of the plans/reports and requirements noted above in Conditions 13, 14 and 15.
17. That prior to undertaking construction or site alteration activities of any kind, any necessary permits or clearances be received from the Essex Region Conservation Authority.
18. That the subdivision agreement between the Owner and the Municipality contain provisions, to the satisfaction of the Greater Essex County District School Board, the Windsor-Essex Catholic District School Board, and the Municipality, requiring notice in every agreement of purchase and sale advising purchasers of lots to be aware that school busses will not be transported to the island and that the School Boards will designate pick up points on the mainland for students to meet the bus.
19. That the subdivision agreement between the Owner and the Municipality contain provisions, to the satisfaction of the Greater Essex County District School Board, the Windsor-Essex Catholic District School Board, and the Municipality, requiring notice in every agreement of purchase and sale advising purchasers of lots to be aware that students may not be able to attend the closest neighbourhood school and could be bussed to a distant school with available capacity.
20. That the subdivision agreement between the Owner and the Municipality contain provisions, to the satisfaction of Canada Post Corporation and the Municipality, requiring notice in every agreement of purchase and sale advising purchasers of lots to be aware of the locations of any community mailboxes within or serving the plan and that mail delivery will be provided via community mailboxes.
21. That the subdivision agreement between the Owner and the Municipality contain provisions, to the satisfaction of the Municipality and the County, that prior to site

**Applicant:** Boblo Developments Inc.  
**File No.:** 37-T-14004  
**Municipality:** Town of Amherstburg  
**Location:** Part of Bois Blanc Island (Malden)

**Date of Decision:** DRAFT  
**Date of Notice:**  
**Last Date of Appeal:**  
**Lapsing Date:**

---

- alteration of any kind, and final approval of any phase by the County of Essex, the Owner shall obtain all required permits from the Province issued under the Endangered Species Act, 2007 (ESA), and complete and implement the recommendations contained in the permit or permits, along with any other letters/authorizations/directions from the Province, and a certified biologist shall confirm in writing that any site alteration has been completed in accordance with the requirements of such permit or permits or any other letters/authorizations/directions issued under the ESA.
22. That the subdivision agreement between the Owner and the Municipality contain provisions, to the satisfaction of the Municipality and the County, that prior to site alteration of any kind, and prior to final approval by the County of Essex, the Municipality and the County shall be provided with a clearance letter from the Department of Fisheries and Oceans (DFO) confirming compliance with the requirements of the Fisheries Act and the Species at Risk Act (SARA).
23. That the subdivision agreement between the Owner and the Municipality contain provisions, to the satisfaction of the Municipality, that require that the Owner prepare a Traffic Impact Study, to the satisfaction of the Municipality, and to construct any highway improvements identified in the final report as part of the development of the site.
24. That the subdivision agreement between the Owner and the Municipality contain the following provision with regard to access to and from Bois Blanc (Boblo Island), or such other similar provision satisfactory to the Owner and the Municipality:

Access to and from Bois Blanc Island (Boblo Island) for all residents and/or property owners on Bois Blanc Island (Boblo Island) is the sole responsibility of the Owner and any subsequent Transferees, other than Transferees which are government entities. The Owner, and any subsequent Transferees (other than government entities) shall provide a ferry service to and from Bois Blanc Island (Boblo Island) that meets the requirements of the Ministry of Transportation and the safety standards of Transport Canada, and if the dimension or weight of any vehicle or load exceeds the limits set out in the Highway Traffic Act, then the vehicle operator shall obtain the appropriate oversize/overweight permit. The Town is not responsible in any way for access to or from Bois Blanc Island (Boblo Island), and the Owner and any subsequent Transferee acknowledge that the Corporation of the Town of Amherstburg will not provide access to Bois Blanc Island (Boblo Island), and the Owner and any subsequent Transferee shall not request or demand that the Town of Amherstburg provide such access. The Owner and any subsequent Transferees (other than government entities) agree

**Applicant:** Boblo Developments Inc.  
**File No.:** 37-T-14004  
**Municipality:** Town of Amherstburg  
**Location:** Part of Bois Blanc Island (Malden)

**Date of Decision:** DRAFT  
**Date of Notice:**  
**Last Date of Appeal:**  
**Lapsing Date:**

---

- to make a motor vehicle ferry and operator available to the Town, at no cost to the Town, for administrative purposes, maintenance, emergency, police and fire personnel and their equipment, whenever required by the Town. The Owner and any subsequent Transferees (other than government entities) shall provide access to the ferry landing on the Mainland and back for all school children on Bois Blanc Island (Boblo Island). A provision outlining the above specification shall be contained in every agreement of purchase and sale of any one or more of the lots in the development. The Owner shall provide access to and from Bois Blanc Island (Boblo Island) from and to a municipal roadway or right of way to the Island and Mainland. The Owner shall provide an easement/right-of-way for access and egress in favour of the Bois Blanc Community Association from and to a municipal roadway or right-of-way, both on Bois Blanc Island (Boblo Island) and on the Mainland. These requirements for access shall apply for all residents and/or property owners of Bois Blanc Island (Boblo Island) upon such terms and conditions as are agreeable between the Owner and the residents and/or property owners.
25. That the subdivision agreement between the Owner and the Municipality contain provisions, to the satisfaction of the Municipality, and prior to final approval of any phase by the County of Essex, requiring the Owner to prepare an emergency response plan to address matters related to police and fire protection, Emergency Medical Services (EMS), and potential impacts due the proximity of the Fermi II nuclear facility, in all climatic conditions, and further that the subdivision agreement contain additional provisions, to the satisfaction of the Municipality, requiring notice in every agreement of purchase and sale advising purchasers of lots to be aware that each residential dwelling shall be equipped with an automatic fire suppression system to the satisfaction of the Municipality's Fire and Building Departments, along with any other fire monitoring and response requirements deemed necessary by the Municipality.
26. That the subdivision agreement between the Owner and the Municipality contain provisions, to the satisfaction of the Municipality and the County, requiring that the Owner comply with the recommendations and conclusions contained in the archaeological assessments completed by Cultural Resource Management Group (CRM) dated March 2016, and the review letters prepared by the Ministry of Tourism, Culture and Sport, including but not necessarily limited to, those dated June 2, 2016, June 7, 2016, May 29, 2017, November 23, 2017 and July 20, 2018.
27. That the subdivision agreement between the Owner and the Municipality contain provisions, to the satisfaction of the Municipality, that prior to site alteration of any kind, and final approval of any phase by the County of Essex, that the Owner

**Applicant:** Boblo Developments Inc.  
**File No.:** 37-T-14004  
**Municipality:** Town of Amherstburg  
**Location:** Part of Bois Blanc Island (Malden)

**Date of Decision:** DRAFT  
**Date of Notice:**  
**Last Date of Appeal:**  
**Lapsing Date:**

---

provide written confirmation, to the satisfaction of the municipality, that Walpole Island First Nations, the Caldwell First Nations and the Can-Am Indian Friendship Centre have been consulted.

28. That the subdivision agreement between the Owner and the Municipality contain provisions, to the satisfaction of the Municipality, that prior to site alteration of any kind, and final approval of any phase by the County of Essex, that the Owner shall undertake to follow the recommendations contained in the document from Parks Canada entitled "Guiding Principles for the draft plan of subdivision for Bois Blanc Island Lighthouse and Blockhouse NHSC" dated August 7, 2014.
29. That the subdivision agreement between the Owner and the Municipality contain provisions, to the satisfaction of the Municipality, that require the Owner to comply with the conclusions and recommendations relating to mitigation, implementation and monitoring, as outlined in the Heritage Impact Assessment, prepared by MHBC Planning Limited (dated August 3, 2016).
30. That prior to final approval by the County of Essex, the Owner shall submit for review and approval by the Municipality and the County, a draft of the final 12M plan.
31. That prior to final approval by the County of Essex, the County is advised in writing by the Municipality how Conditions 1 to 15 inclusive, and 18 to 30 inclusive have been satisfied.
32. That prior to final approval by the County of Essex, the County is advised in writing by the Essex Region Conservation Authority how Conditions 13 to 17 inclusive, have been satisfied.
33. That prior to final approval by the County of Essex, the County is advised in writing by the Greater Essex County District School Board how Conditions 18 and 19 have been satisfied.
34. That prior to final approval by the County of Essex, the County is advised in writing by the Windsor-Essex Catholic District School Board how Conditions 18 and 19 have been satisfied.
35. That prior to final approval by the County of Essex, the County is advised in writing by the Canada Post Corporation how Condition 20 has been satisfied.

**Applicant:** Boblo Developments Inc.  
**File No.:** 37-T-14004  
**Municipality:** Town of Amherstburg  
**Location:** Part of Bois Blanc Island (Malden)

**Date of Decision:** DRAFT  
**Date of Notice:**  
**Last Date of Appeal:**  
**Lapsing Date:**

---

### **NOTES TO DRAFT APPROVAL**

1. It is the applicant's responsibility to fulfill the conditions of draft approval and to ensure that the required clearance letters are forwarded by the appropriate agencies to the County of Essex, quoting the file number "**37-T-14004**".
2. It is suggested that you make yourself aware of section 144 of the Land Titles Act and subsection 78(10) of the Registry Act.

Subsection 144(1) of the Land Titles Act requires that a plan of subdivision of land that is located in a land titles division be registered under the Land Titles Act. Exceptions to this provision are set out in subsection 144(2).

Subsection 78(10) of the Registry Act requires that a plan of subdivision of land that is located only in a registry division cannot be registered under the Registry Act unless that title of the owner of the land has been certified under the Certification of Titles Act. Exceptions to this provision are set out in clauses (b) and (c) of subsection 78(10).

3. Inauguration or extension of a piped water supply, a sewage system or a storm drainage system is subject to the approval of the Ministry of Environment under Section 23 and Section 24 of the Ontario Water Resources Act, R.S.O. 1980.
4. The Ministry of the Environment did not review this subdivision with respect to any groundwater, soil or soil atmosphere testing to fully discount the possibility that waste materials and/or other contaminants are present within or in close proximity to this subdivision. If either the Municipality or the Owner requires this assurance before proceeding any further with this plan of subdivision, a consultant(s) should be engaged to conduct the necessary investigations.
5. The Ministry of the Environment must be advised immediately should waste materials or other contaminants be discovered during the development of this plan of subdivision. If waste materials or contaminants are discovered, a further approval under Section 46 of the Environmental Protection Act may be required from that Ministry.
6. The costs of any relocations or revisions to Hydro One Networks Inc. (HONI) facilities or any other local electrical utility that are necessary to accommodate the subdivision will be borne by the developer.

**Applicant:** Boblo Developments Inc.  
**File No.:** 37-T-14004  
**Municipality:** Town of Amherstburg  
**Location:** Part of Bois Blanc Island (Malden)

**Date of Decision:** DRAFT  
**Date of Notice:**  
**Last Date of Appeal:**  
**Lapsing Date:**

---

7. Any easement rights of Hydro One Networks Inc. (HONI) or any other local electrical utility are to be respected.
8. The developer should contact the local Hydro One Networks Inc. Services office or any other local electrical utility to verify if any low voltage distribution lines may be affected by this proposal.
9. The developer is hereby advised that prior to commencing any work within the plan, the developer must confirm that sufficient wire-line communication/telecommunication infrastructure is currently available within the proposed development to provide communication/telecommunication service to the proposed development. In the event that such infrastructure is not available, the developer is hereby advised that the developer may be required to pay for the connection to and/or extension of the existing communication/telecommunication infrastructure. If the developer elects not to pay for such connection to and/or extension of the existing communication/telecommunication infrastructure, the developer shall be required to demonstrate to the municipality that sufficient alternative communication/telecommunication facilities are available within the proposed development to enable, at a minimum, the effective delivery of communication/telecommunication services for emergency management services, i.e., 911 Emergency Services.
10. The Municipality must register the subdivision agreement as provided by subsection 51(26) of the Planning Act, R.S.O. 1990 against the land to which it applies, as notice to prospective purchasers.
11. Clearances are required from the following agencies:

Ms. Rebecca Belanger  
Town of Amherstburg  
271 Sandwich Street South  
Amherstburg, ON N9V 2Z3

Mr. Mike Nelson  
Essex Region Conservation Authority  
360 Fairview Avenue West  
Essex, ON N8M 1Y6

Greater Essex District School Board  
451 Park Street West  
P.O. Box 210

**Applicant:** Boblo Developments Inc.  
**File No.:** 37-T-14004  
**Municipality:** Town of Amherstburg  
**Location:** Part of Bois Blanc Island (Malden)

**Date of Decision:** DRAFT  
**Date of Notice:**  
**Last Date of Appeal:**  
**Lapsing Date:**

---

Windsor, ON N9A 6K1

Windsor-Essex Catholic District School Board  
1325 California Avenue  
Windsor, ON N9B 3Y6

Mr. Bruno DeSando  
Canada Post Corporation  
955 Highbury Avenue North  
London, ON N5Y 1A3

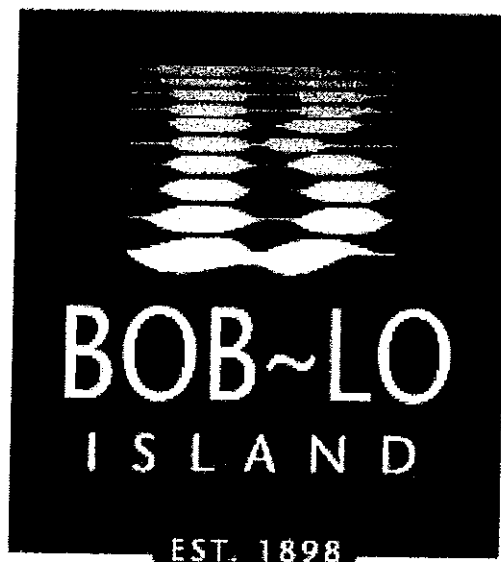
If the agency's clearance concerns a condition in the subdivision agreement, a copy of the agreement should be sent to them. This will expedite clearance of the final plan. The County of Essex does not require a copy of the agreement.

12. All measurements in subdivision and condominium final plans must be presented in metric units.
13. The approval of the draft plan will lapse on \_\_\_\_\_. It is the responsibility of the applicant to request an extension of the draft approval if one is needed.

A request for extension should be made at least 60 days before the approval lapses because no extension can be given after the lapsing date. The request should include the reasons why an extension is needed and a resolution in support of the extension from the Town of Amherstburg.



# BOB-LO SOUTH TRAFFIC STUDY



A MARINA RESORT  
COMMUNITY

## Bob-Lo Island

### Traffic Study Summary

**Prepared by:** Dillon Consulting Ltd.

This study is aimed to understand the demand on the ferry to and from Bob-Lo Island, and to identify the ability of the ferry service and associated groundside infrastructure to accommodate increased demand as the remainder of planned residential units on the island are built.

There are two ferries that can be operated, although only one is used in regular service. The larger ferry has a capacity of approximately 11 conventional vehicles and 1 heavy vehicle (truck, bus, trailer). The smaller ferry has a capacity of approximately 8 conventional vehicles. A round trip can be made in approximately 10 minutes in light-traffic situations.

In general, the average arrival rates of vehicles at the ferry loading location is 0.25 to 0.35 vehicles per minute. The maximum arrival rates are in the order of 0.65 vehicles per minute.

#### Future Conditions

Future ferry demand was estimated by increasing the existing ferry demand proportionally to the level of future development growth. The number of residential units is ultimately expected to be 3.3 times existing levels, and the demand for ferry crossings was similarly assumed to be 3.3 times existing levels.

#### Review of Ferry Operations

The capacity of the crossing is based on the number of ferries in use, number of vehicles that can fit on each ferry and the amount of ferry departures per hour. If the demand is warranted, both ferries could be put into service.

#### **Total Crossing Capacity:**

*Existing Capacity* – 36 vehicles per hour per direction (departures every 20 minutes)

*Future Capacity* – 48 vehicles per hour per direction (departures every 15 minutes)  
(one ferry in service)

*Future Capacity* – 80 vehicles per hour per direction (departures every 7.5 minutes combined)  
(both ferries in service)

Assuming that both existing ferries are in use, and operating at the minimum feasible headways, there would be sufficient capacity to accommodate crossing demand during the weekday AM and PM peak hours. However, the ferry would experience periods of capacity deficiency island-bound during the weekday mid-day peak period, and in both directions during the Saturday afternoon peak period.

There may be an opportunity to reduce the crossing time component by approximately 25%. Engines are currently set below full power as the current schedule and level of ferry demand does not require faster speeds. If engines were set to permit higher crossing speeds, it is estimated that a round trip could be made in approximately 13 minutes.

## **Recommended Mitigation**

*Short Term* – Operate at increased frequency when necessary.

*Medium Term* – Bring the second ferry into service during periods of higher demand, and operate them at the maximum frequency possible.

*Long Term* – Plan to obtain a larger ferry to increase crossing capacity. The smallest ferry would be retired from service, but could be maintained as a backup ferry.

## **Ferry Queues and Queue Lane**

Based on existing activity, the queue should accommodate 16 queued vehicles. Under future long-term conditions, the calculated 95<sup>th</sup> percentile queue is calculated at 19 vehicles.

There is not sufficient area to accommodate longer-term queues under unconstrained conditions, and measures would need to be undertaken to modify the mainland ferry plaza and/or to manage queues differently using existing infrastructure. Possible measures may include:

- Managing queues differently by designating a larger storage area for residents to queue.
- Closing the Discovery Centre driveways if conflicts between queued and circulating traffic become either operational or safety issues.
- Closing the slip-off lane from southbound Dalhousie Street, and widening the main ferry access road to accommodate more than one lane of queued traffic.

Attendants should be provided on-site, to direct traffic and manage queues during peak times.

Attendants will ensure motorists use both lanes, and encourage tighter spacing between queued vehicles to maximize the available storage capacity.

## **What's Next? Recommendations**

To better manage the future vehicle queues on the mainland side, it is recommended that the driveway extending north from the ferry access road be used as a storage area for resident vehicles to queue. If more space is required to store these vehicles, the southbound channelized right turn lane on Dalhousie Street at the access road could be closed to create additional storage space. Similarly, the westernmost driveway to the Discovery Centre could be closed to allow for more queuing space.

On the island side, the current space available to queue up vehicles is nearly sufficient to accommodate the peak period of future queues. That is because there is sufficient space for two storage lanes in the area defined by a median island on Bob-Lo Island Boulevard. Some line painting should be done in this area to properly define two storage lanes, to ensure that vehicles can be queued up to maximize the space. During peak times it is recommended to have an attendant on site to direct vehicles and encourage tighter spacing while queuing up. In the long term, queues should be monitored to ensure that they do not spill back to the proposed traffic circle at Bob-Lo Island Boulevard and Gold Coast Drive. If queues become problematic, consideration should be given to converting this intersection traffic control, to from a traffic circle to stop control. Additionally, some consideration should be given to providing an area near the ferry dock to stage/queue trucks and larger vehicles.

# BOB-LO SOUTH ARCHAEOLOGICAL ASSESSMENT



A MARINA RESORT  
COMMUNITY

## **Bob-Lo Island Archaeological Study Summary**

In the spring of 1994, Stage 2 and limited Stage 3 archaeological assessments were conducted on Bob-Lo Island by Dillon Consulting Limited on behalf of Northern Capital, the then developer of record for Bob-Lo Island at the time. The archeological assessments resulted in the identification of 10 areas of potential archaeological sensitivity spread across the island. As a result, 10,000 test excavations were installed and 75% of the Bob-Lo Island Partnership property was included in these assessments. The methodology involved shovel test pits, soil stripping and cataloguing of found items. As a result of the work undertaken, five of the ten sites were cleared for development.

In the spring of 2015, Cultural Resource Management Group (CRM) was retained by Amico Properties Inc. (Amico) to undertake a further archaeological assessment of the five remaining sites believed to have potential for archaeological significance. The results of the previous work, the outstanding sites and the proposed methodology for studying the remaining five sites (all situated in the south end of the island) were all confirmed by the Archeology Programs Unit of the Ministry of Tourism, Culture and Sport. The results of the various studies are detailed below.

### **1. Western Shore Historic Site (AaHs-36)**

A Stage 3 Archeological Assessment was conducted by CRM in the spring of 2016. This assessment resulted in the recovery of a number of artifacts, the majority of which were diagnostic to post-contact domestic occupation dating to post-1830. The site was defined as a blockhouse constructed by 1840, which was then developed into a private home before being used as the superintendent's building for the Bob-Lo Island Amusement Park.

Based upon the findings of this site as being a domestic archeological site dating after 1830 with cultural heritage value or interest, Stage 4 mitigation was recommended by CRM. There are three options available when a Stage 4 mitigation is recommended. The first is "Permanent Avoidance and Protection", the second is "Excavation" which includes many procedural requirements and the third is "Temporary Avoidance and Short-term Protection Plan". Temporary Avoidance and Short-term Protection requires protective measures being put in place for the site during any construction activities and prior to the establishment of a permanent plan.

It is the intention of Amico to implement "Temporary Avoidance and Short-term Protection" which requires that the site be temporarily protected through avoidance and protection strategies which will include fencing once construction starts. The draft plan of subdivision has been altered to show this area as a block (to be protected). In effect, this area has been excluded from development. It is understood that a Stage 4 study will be required if this area is to be developed.

### **2. Additional Flake Cluster (AaHs-42)**

A Stage 3 Archeological Assessment was conducted by CRM in the spring of 2015. This assessment resulted in the recovery of 11 Precontact artifacts, none of which were diagnostic as to a specific temporal or cultural period. No diagnostic artifacts or Aboriginal ceramics were recovered.

The Ministry of Tourism, Culture and Sport (MTCS), by virtue of their letter dated June 2, 2016, has considered the site free of further archeological concern and as such no further archeological assessment is required. Accordingly, it has been included in the area to be developed.

### **3. Western Shore Precontact (AaHs 37)**

A Stage 3 Archeological Assessment was conducted by CRM in the spring of 2015. This assessment resulted in a low yield of Precontact Aboriginal artifacts, consisting exclusively of unmodified chipping detritus. None of these artifacts are diagnostic as to a specific temporal or cultural period, save for being Precontact Aboriginal. No diagnostic artifacts or Aboriginal ceramics were recovered.

The Ministry of Tourism, Culture and Sport (MTCS), by virtue of their letter dated June 7, 2016, has considered the site free of further archeological concern and as such no further archeological assessment is required. Accordingly, it has been included in the area to be developed.

### **4. South Blockhouse (AaHs-38)**

A Stage 3 Archeological Assessment was conducted by CRM in the spring of 2016. The assessment included 33 test areas of which only one site yielded in excess of twenty or more historic artifacts. These artifacts included pearlware, refined white earthenware, cut nails and military uniform decorations. The majority of these artifacts identify the site as a domestic archaeological site dating after 1830 (military).

A secondary Stage 3 investigation was conducted on the remaining one site and the overall site of concern was reduced significantly and a ten meter buffer zone was prescribed around the one positive shove test area.

Based upon the final findings of this site, a recommendation for Stage 4 mitigation was recommended for this reduced site. Once again, there are three options available when a Stage 4 mitigation is recommended. The first is "Permanent Avoidance and Protection", the second is "Excavation" which includes many procedural requirements and the third is "Temporary Avoidance and Short-term Protection Plan". Temporary Avoidance and Short-term Protection requires protective measures being put in place for the site during any construction activities and prior to the establishment of a permanent plan.

Because this is in the location of the Block House, which Amico agreed to have restored to its original form, it has been decided to implement "Permanent Avoidance and Protection" which requires that the site be left intact and protected through avoidance and protection strategies. The draft plan of subdivision has been altered to shorten the proposed street so that this area will be on the same side of the street as the historic lighthouse. It is believed that this area now presents as a heritage site with both the restored Block House and the protected Lighthouse. The site has been

permanently removed from the development boundary and title to the site is to be gratuitously conveyed to the appropriate government agency.

#### **5. Eastern Shore Site**

A Stage 3 Archeological Assessment was conducted by CRM in the Spring of 2016. This assessment resulted in the recovery of over 350 Precontact artifacts. A sherd of Precontact pottery recovered from the site displays both dentate and punctate decoration – forms of decoration that date to the Middle Woodland period.

Given this period identification, Stage 4 mitigation was recommended for an area of the site measuring approximately 30 metres by 25 metres. Once again, there are three options available when a Stage 4 mitigation is recommended. The first is “Permanent Avoidance and Protection”, the second is “Excavation” which includes many procedural requirements and the third is “Temporary Avoidance and Short-term Protection Plan”. Temporary Avoidance and Short-term Protection requires protective measures being put in place for the site during any construction activities and prior to the establishment of a permanent plan.

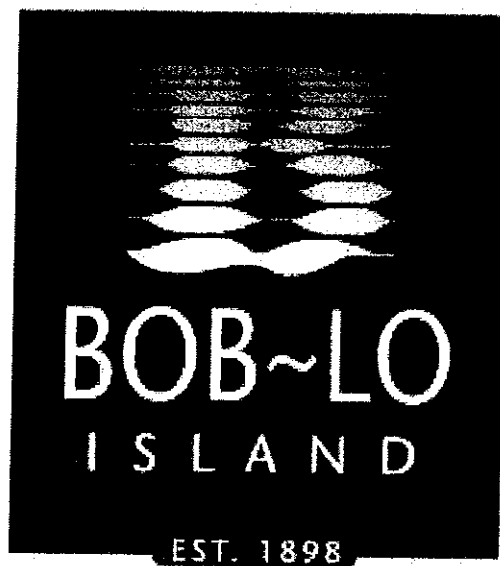
It is the intention of Amico to implement “Temporary Avoidance and Short-term Protection” which requires that the site be temporarily protected through avoidance and protection strategies which will include fencing once construction starts. The draft plan of subdivision has been altered to show this area as three lots to be protected. In effect, this area has been temporarily excluded from development. It is understood that a Stage 4 study will be required if this area is to be developed.

For all sites noted above, Walpole Island First Nations were invited to have a First Nations monitor attend the island and oversee and participate in the Stage 3 and 4 work.



# BOB-LO SOUTH

## EIA



A MARINA RESORT  
COMMUNITY

## Bob-Lo Island

### Environmental Impact Assessment Summary

**Prepared by:** BioLogic, May 28<sup>th</sup> 2014

This EIA is in support of an application for plan of subdivision under the Planning Act for the southern portion of Bob-lo Island. In addition, this EIA identifies existing and potential direct and indirect impacts to natural heritage features, as well as provides recommendations for avoidance, protection, rehabilitation, mitigation, and monitoring.

Following the submission of this EIA, further correspondence with the Ministry of Natural Resources will be required as part of the permitting process under the Endangered Species Act (2007) for impacts to the endangered Eastern Foxsnake.

#### Land Use Setting

The subject lands are zoned Resort Residential/Resort Commercial, with a holding provision on the southern third. The holding provision is to ensure the orderly development of lands and the adequate provision of municipal services and can be lifted as development and site plan agreements are in place and servicing is provided to the satisfaction of the town.

Portions of the subject land are regulated and any development within these regulated lands will require a permit from ERCA.

#### Description of The Natural Environment

The vegetation communities found on the subject lands are predominantly Agriculture, interspersed with Cultural Savannah. The shoreline of the island is composed of a shrubby mix of native and exotic species best described as a Cultural Thicket community.

The nearshore areas of Bob-Lo Island may provide habitat for one or more of the following at-risk-fish species; Channel Darter, Eastern Sand Darter, Lake Chubsucker, Northern Madtom, Pugnose Shiner, and Spotted Gar. The area may also provide the following at-risk mussel species with habitat; Kidneyshell, Northern Riffleshell, Rayed Bean, Round Hickorynut, and Round Pigtoe.

There are 29 provincially ranked floral species within 1km of the legal parcel. Of these species, 4, including Swamp Rose Mallow, Shumard Oak, Honey Locust, and Burning Bush, were indicated as potentially being in the vicinity of the subject lands.

There are eight provincially significant faunal habitats and/or species within 1km of the subject lands. These species include Bald Eagle, Barn Swallow, Chimney Swift, Eastern Foxsnake, Butler's Gartersnake, Eastern Ribbonsnake, Queensnake, Northern Map Turtle, and Elusive Clubtail.

#### Natural Heritage Policy Considerations

Policies that pertain to this cite include:

- The Provincial Policy Statement from MAH, 2014, section 2.1
- The Town Of Amherstburg Official Plan, Section 3

- ERCA Regulations

### Environmental Management Strategy/Opportunities

The woodlot and Natural Environment areas in the southeastern part of the island are noted as natural heritage features in the Amherstburg Official Plan and are protected through the Zoning By-law. A minimum buffer/setback of 10m is proposed from the woodlot feature.

Based on existing habitat and the results of the 2013 coverboard study, the south-eastern shoreline is the most important of the shoreline habitats. This area is closest to the preserved woodlot and natural environment area. As a result, a natural area buffer of 25m is recommended to protect the existing habitats along the southeastern shoreline and to provide expanded grassland habitat nearshore.

It is important for shoreline habitats to be connected to the remainder of the island to facilitate the natural flow of wildlife through the island. To accomplish this, the connection/movement areas recommended in the EMS join both shorelines and the Woodlot to each other through a central naturalized area.

Naturalization of the swale through planting native wetland species, as well as incorporating a wetland adjacent to the Stormwater management pond, would create a habitat that has high value for wildlife and is currently lacking on the island. A shoreline wetland will slow Stormwater flow as well as create a needed wildlife habitat.

It is recommended that Common Reed on the tablelands and shoreline should be removed to prevent viable seed from blowing into the development area. For the area in the southern part of the island, a controlled burn followed by grading/removal of rhizomes should be considered pre-construction to prevent spreading Common Reed seeds throughout the island.

### Environmental Management Strategy

The Environmental Management Strategy as developed in Section 6 has been incorporated into the development [Figure 10] as follows:

- An area of Open Space through the centre of the island for habitat and linkage opportunities
- Shoreline protection
- Multiple lots removed to create wildlife corridors to connect important habitats
- A naturalized swale and Stormwater management facilities to create wildlife habitat
- Tree preservation

### Development Impacts and Mitigation

The following features may be impacted by this development proposal:

- Habitat of Endangered and Threatened Species
- Significant Woodlands/Locally Significant Sites Designated for Protection in Local Official Plans (Woodlot)
- Significant Wildlife Habitat (habitat of species of conservation concern)
- Fish Habitat
- Hazard Land

### **Direct Impacts**

Development is proposed in subject lands that will impact Category 2 Regulated Habitat for Eastern Foxsnake and will require an Overall Benefit permit under the ESA to proceed.

**Recommendation 1:** An application for an Overall Benefit Permit under clause 17(2)(c) of the Endangered Species Act (2007) will be submitted to MNR for development on the subject lands.

Shumard Oak, has been recorded within the subject lands.

**Recommendation 1:** A tree preservation plan should be completed for the subject lands and service. Where possible building locations should be adjusted to preserve healthy trees.

**Recommendation 2:** Shumard Oak and Pin Oak should be considered for planting as a landscape tree within the subject lands, in both naturalized and maintained settings. Trees should be sourced from existing Boblo Island individuals and grown in a nursery setting until they reach a suitable size for transplanting.

### **Indirect Impacts**

Indirect impacts related to the development are limited to those associated with the presence of the Eastern Foxsnake in the vicinity of the subject lands.

**Recommendation 1:** Installing a barrier fence during construction to exclude snakes from the construction area, as well as inspecting equipment during the species active season.

**Recommendation 2:** To prevent or reduce snake/vehicle interactions, high-quality basking features located away from roadways and landscaping should be considered.

**Recommendation 3:** A homeowner education package regarding Eastern Foxsnakes will be developed to inform new residents about the species, how to encourage/discourage wildlife from using their property and the laws that protect wildlife.

There is a municipally identified Woodlot adjacent to the subject lands. This feature is protected from development by a Natural Environment Designation.

**Recommendation 1:** A minimum buffer of 10m from the woodlot should be created and maintained post-development.

**Recommendation 2:** To encourage responsible use of the woodland by residents and visitors educational signage should be erected at trailheads on the developer-owned portions of the island.

**Recommendation 3:** Construction barrier fence should be installed along the edge of the development footprint to exclude construction equipment and debris from being stored on and thus impacting the buffer area or woodland.

The subject lands are immediately adjacent to fish habitat, however, potential impacts to fish habitat as a result of this development are indirect as development will be occurring away from the shoreline on the tablelands.

**Recommendation 1:** Stormwater facilities should be designed to reduce nutrient input to the adjacent fish habitat by including wetland habitats as part of the Stormwater management system.

**Recommendation 2:** Stormwater facilities should be designed to reduce sediment input to adjacent fish habitat through the use of energy-dissipating structures near the outlets to the Detroit River.

**Recommendation 3:** Appropriate sediment and erosion controls should be used to control overland flow during construction.

**Recommendation 4:** Sediment and erosion controls should remain in place post-construction until vegetation has re-established.

Lands within approximately 40m of the Bob-Lo Shoreline are within the limit of Ontario Regulation 158/6.

**Recommendation 1:** A permit from ERCA will be required.

### **Next Steps**

#### **Prior to Construction:**

- Sediment and erosion control measures
- Tree protection fencing for trees that are slated for preservation (inspected) by an Arborist
- Detailed grading plans with regulated areas and adjacent to woodland
- Obtain Fisheries Act Approval/Letter of Intent for SWM outlet works
- Obtain C permit under the ESA for impacts to Eastern Foxsnake habitat

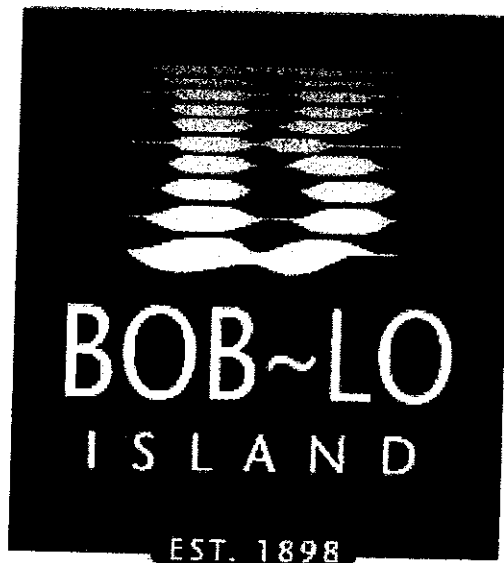
#### **During Construction:**

- Daily site inspections for Eastern Foxsnake individuals within construction area
- Inspection of sediment and erosion control fencing
- Material stockpiles should be limited. Any necessary stockpiles will be located within sediment and erosion/wildlife barrier fenced areas and at least 30m from identified natural heritage features and shorelines
- Ensure site activities comply with the C permit

#### **Post Construction:**

- Re-seed areas of disturbance to maximize erosion protection and minimize invasion of the site by exotic species
- Prior to removal of any sediment and erosion control measures, a qualified ecological consultant should confirm that adequate re-vegetation and site stabilization has occurred
- Distribution of site-specific information material to new residents
- Maintain an Open Space area as prescribed in the C permit

# BOB-LO SOUTH SERVICING DESIGN BRIEF



A MARINA RESORT  
COMMUNITY

## Bob-Lo Island

### Servicing Design Brief Summary

**Prepared by:** Stantec Consulting Ltd.

The proposed development will encompass the remainder of the developable portion of the island or approximately the southern half. The following Design Brief is intended to demonstrate how the development will be serviced, including any necessary temporary measures, in conformity with the Town of Amherstburg Zoning By-Law, Official Plan and other relevant ordinances.

#### Roadways

A minor network of local roads is present where the recent development has progressed. The primary component of the proposed development's road network will consist of a single meandering "U" shaped drive travelling the length of the southern portion of the island. Two crescents are proposed that will be connected to the main road. A service lane is proposed for access purposes in the multi-family residential component.

With the exception of the service lane, the local road system is proposed to be constructed within a standard twenty metre right-of-way. The local roads will be constructed to a semi-urban cross-section composed of seven metres of asphalt pavement. Flush curbs will be provided as well as roadside swales used to collect Stormwater runoff. The main "U" shaped roadway will be provided with an additional 2.5 metre asphalt lane, delineated for use as an active trail.

#### Parklands, Greenways, and Natural Corridors

The proposed development incorporates substantial greenspace and parkland. Gaps in the proposed lot layout ensure that connectivity will be maintained and extended throughout the island. The extent of pathways through green areas and connection corridors have yet to be determined, however, they shall be designed to maximize the ability of residents and visitors to traverse the entire island.

It is proposed that a larger portion of the interior of the island will serve as central parkland. Stormwater management channels and a wet pond for quality treatment, will be incorporated into that space.

#### Stormwater Management

As previously noted, it is proposed that Stormwater management will be provided by the construction of a Stormwater quality wet pond. It will be capable of storing runoff from a 25mm storm event, and allow for a release rate that will result in a minimum detention time of 24 hours. The pond is proposed to be located and incorporated into the central parkland, in the interior of the island between the legs of the main loop road.

#### Sanitary Sewers

The island is currently serviced by local sewers within the developed area that convey sanitary sewage to a local package sewage treatment plant located near the ferry dock on the east side of the island. The existing treatment plant was originally designed to support the operation of two rotating biological



contractor (RBC) units. Provisions were incorporated in the design to accommodate future expansions, each comprising of an additional two RBCs each to a total of six units. The second tank constructed as part of the existing treatment plant is currently empty and unused. It is proposed that this second unit be installed and commissioned to facilitate development of the southern portion of the island.

Of the 218 lots available, homes have been constructed and connected to the sanitary sewer system on approximately 104 of the lots. In total the existing treatment plant should be capable of supporting approximately 215 building units with an assumed population density of three and a half people per unit.

It is proposed that the existing treatment facility be expanded to incorporate a second RBC unit to provide the capacity for the development of the south half of the island. The second RBC unit would be capable of supporting an additional 215 units, which exceeds the proposed 210 units.

As per recommendations outlined in the "Environmental Study Report for the Town of Amherstburg Pollution Control Plant Class Environmental Assessment Study", additional expansion of the existing treatment plant will not be considered. It is proposed to provide a sanitary forcemain, from the island to the mainland, in order to connect the island's sanitary sewage collection with the mainland's sanitary sewer system, which will convey the flows to the Town's primary treatment plant.

### Storm Sewers

The roadways are proposed to be a semi-urban section with drainage depressions on either side of the right-of-way. These low areas will generally be located between driveways, and will drain into a catch basin. The roadway and the front half of the fronting lots will sheet flow Stormwater runoff to these depressions.

The storm sewers will convey the runoff to control structures. The control structures will divert flows to the Stormwater quality wet pond. The rear of the lots exterior to the main loop road, backing onto the Detroit River will sheet flow runoff directly to the river. The rear of the lots interior to the main loop road will sheet flow runoff to the interior of the island to the central parkland.

### Watermains

It is proposed that the watermain network consist of a 200mm diameter main running the length of the main road and be connected to the existing system's 300mm main at Bob-Lo Island Boulevard. The proposed crescents and alleyway will be serviced with 155mm mains. No upsizing of the existing feedermain or any new feedermain to the island is required for the proposed development.

Service connections for each lot and local mains will be provided for the entire site and will be connected to the existing system's trunk line or feedermain. Watermain looping will be included in the design and will be in accordance with the Town of Amherstburg standards. Valves and hydrants will be provided as required to provide adequate fire protection while conforming to good engineering practice and Town of Amherstburg standards.

### Electrical

Hydro One provides electrical servicing to the island. A new line was recently bored from the mainland to the island. This feederline and associated equipment on the island is anticipated to be sufficient to support the entire proposed development.

### Natural Gas

Natural gas service is not currently available on the island. Union Gas is currently reviewing their system and the possibility of installing a main from the mainland to the island. Union Gas' ability and disposition to service the island will be based on the outcome of their business case analysis and whether capacity is available on the mainland to direct to the island.

Should Union Gas elect not to service the island, provisions can be made for trucking and storage of propane on the island, as is the current practice.

### Telecommunications and Television

Bell Canada provides television, telephone and data services to the island. MNSi and Cogeco have both expressed interest in servicing the island. Each is currently reviewing their system and business case.

### Conclusion/Next Steps

It is proposed that the existing sanitary sewage treatment plant on the island be expanded through the addition of a second rotating biological disk to be installed and commissioned in the existing and currently unused RBC unit. This expansion would provide the treatment capacity necessary due to the proposed development.

The amount of proposed development may be required to be restricted in order to prevent the island's treatment plant's capacity being exceeded. As the expanded existing treatment plant's capacity is being approached. It is proposed to provide a sanitary forcemain from the island to the mainland, in order to connect the island's sanitary sewage collection with the mainland's sanitary sewer system. This will convey the flows of the island to the Town's primary treatment plant.

# BOB-LO SOUTH HERITAGE IMPACT ASSESSMENT



A MARINA RESORT  
COMMUNITY

# Boblo Heritage Impact Assessment

## Summary

Prepared by: MHBC April 6<sup>th</sup> 2016

This Heritage Impact Assessment (HIA) has been prepared at the request of the Ministry of Tourism, Culture & Sport and the Town of Amherstburg. This HIA includes an assessment of the existing structures on Bob-Lo Island to determine their cultural heritage value or interest, and an assessment of the impacts of the proposed Draft Plan of Subdivision on any cultural heritage resources or heritage attributes.

### **Individual Building Histories**

#### *Dance Hall*

In 1912, the owners of the park decided to build a bigger dance hall to replace their existing, overcrowded building. The building is of stone, iron and steel construction and was four times bigger than the previous dance hall. The dance hall was completed in June 1913, and for several decades was a popular fixture of the park. The building was repurposed as an “international pavilion” by the 1970’s and 80’s.

#### *Roller Rink*

The building was constructed beginning in 1905. It is a two storey building built of cut stone and was originally constructed to house the carousel. It allowed for both active and passive recreation, as the balcony overlooking the rink allowed spectators to view the rink floor and draw potential new skaters.

#### *Power House*

The building was constructed in 1906 to provide electricity for the horses and lights on the Carousel. The power house remained in operation until the 1950’s, providing power to the entire park. The power house stopped operating in 1958, when Ontario Hydro brought electricity to the Island by a submarine cable.

#### *Washrooms*

The building was designed to complement the appearance of the dance hall and the previous stone buildings on the Island.

#### *Lighthouse*

The lighthouse is designated as a National Historic Site of Canada and is located on land owned by Parks Canada. The lighthouse was constructed in 1836, as the third lighthouse constructed during the 1830’s to improve navigation on Lake Erie.

### *Blockhouse*

The blockhouse is designated as a National Historic Site of Canada, but it is not located on Parks Canada land. The blockhouse is the only remainder of three similar structures that were constructed in 1839. It is a two storey timber structure, built to a square plan with a low pitched hip roof with wood shingles. The blockhouse is constructed with interlocking squared timbers. The blockhouse sits on a concrete slab foundation, and the roof structure is a replacement, with plywood visible under the eaves.

### *Other Structures*

There are four other structures on site that were assessed and photographed during the site visit, including: the former Amherstburg/Gilbralter ferry dock, the bumper car ride, picnic pavilion and space tower. There was little information available regarding these structures.

### **Evaluation under Regulation 9/06 of the Ontario Heritage Act**

Evaluation of site features:

#### *Dance Hall*

<b>Design or Physical Value - The Property...</b>	
is a rare, unique, representative or early example of a style, type, expression, material or construction method	✓
displays a high degree of craftsmanship or artistic merit	✓
demonstrates a high degree of technical or scientific achievement	X
<b>Historical or Associative Value - the property...</b>	
has direct associations with a theme, event, belief, person, activity, organization or institution that is significant to a community	✓
yields, or has the potential to yield, information that contributes to an understanding of a community or culture	X
demonstrates or reflects the work or ideas of an architect, artist, builder, designer or theorist who is significant to a community	✓
<b>Contextual Value - the property...</b>	
is important in defining, maintaining or supporting the character of an area	✓
is physically, functionally, visually or historically linked to its surroundings	✓
is a landmark	✓

*Roller Rink*

<b>Design or Physical Value - The Property...</b>	
is a rare, unique, representative or early example of a style, type, expression, material or construction method	✓
displays a high degree of craftsmanship or artistic merit	✓
demonstrates a high degree of technical or scientific achievement	X
<b>Historical or Associative Value - the property...</b>	
has direct associations with a theme, event, belief, person, activity, organization or institution that is significant to a community	✓
yields, or has the potential to yield, information that contributes to an understanding of a community or culture	X
demonstrates or reflects the work or ideas of an architect, artist, builder, designer or theorist who is significant to a community	X
<b>Contextual Value - the property...</b>	
is important in defining, maintaining or supporting the character of an area	✓
is physically, functionally, visually or historically linked to its surroundings	✓
is a landmark	✓

*Washrooms*

<b>Design or Physical Value - The Property...</b>	
is a rare, unique, representative or early example of a style, type, expression, material or construction method	✓
displays a high degree of craftsmanship or artistic merit	✓
demonstrates a high degree of technical or scientific achievement	X
<b>Historical or Associative Value - the property...</b>	

has direct associations with a theme, event, belief, person, activity, organization or institution that is significant to a community	✓
yields, or has the potential to yield, information that contributes to an understanding of a community or culture	X
demonstrates or reflects the work or ideas of an architect, artist, builder, designer or theorist who is significant to a community	✓
<b>Contextual Value - the property...</b>	
is important in defining, maintaining or supporting the character of an area	✓
is physically, functionally, visually or historically linked to its surroundings	✓
is a landmark	X

*Power House*

<b>Design or Physical Value - The Property...</b>	
is a rare, unique, representative or early example of a style, type, expression, material or construction method	✓
displays a high degree of craftsmanship or artistic merit	✓
demonstrates a high degree of technical or scientific achievement	X
<b>Historical or Associative Value - the property...</b>	
has direct associations with a theme, event, belief, person, activity, organization or institution that is significant to a community	✓
yields, or has the potential to yield, information that contributes to an understanding of a community or culture	X
demonstrates or reflects the work or ideas of an architect, artist, builder, designer or theorist who is significant to a community	X
<b>Contextual Value - the property...</b>	
is important in defining, maintaining or supporting the character of an area	✓
is physically, functionally, visually or historically linked to its surroundings	✓
is a landmark	✓



*Blockhouse and Lighthouse*

<b>Design or Physical Value - The Property...</b>	
is a rare, unique, representative or early example of a style, type, expression, material or construction method	X
displays a high degree of craftsmanship or artistic merit	X
demonstrates a high degree of technical or scientific achievement	X
<b>Historical or Associative Value - the property...</b>	
has direct associations with a theme, event, belief, person, activity, organization or institution that is significant to a community	✓
yields, or has the potential to yield, information that contributes to an understanding of a community or culture	X
demonstrates or reflects the work or ideas of an architect, artist, builder, designer or theorist who is significant to a community	X
<b>Contextual Value - the property...</b>	
is important in defining, maintaining or supporting the character of an area	✓
is physically, functionally, visually or historically linked to its surroundings	✓
is a landmark	✓

*Ferry Dock*

<b>Design or Physical Value - The Property...</b>	
is a rare, unique, representative or early example of a style, type, expression, material or construction method	X
displays a high degree of craftsmanship or artistic merit	X
demonstrates a high degree of technical or scientific achievement	X
<b>Historical or Associative Value - the property...</b>	

has direct associations with a theme, event, belief, person, activity, organization or institution that is significant to a community	✓
yields, or has the potential to yield, information that contributes to an understanding of a community or culture	X
demonstrates or reflects the work or ideas of an architect, artist, builder, designer or theorist who is significant to a community	X
<b>Contextual Value - the property...</b>	
is important in defining, maintaining or supporting the character of an area	✓
is physically, functionally, visually or historically linked to its surroundings	✓
is a landmark	✓

*Sky Tower*

<b>Design or Physical Value - The Property...</b>	
is a rare, unique, representative or early example of a style, type, expression, material or construction method	X
displays a high degree of craftsmanship or artistic merit	X
demonstrates a high degree of technical or scientific achievement	X
<b>Historical or Associative Value - the property...</b>	
has direct associations with a theme, event, belief, person, activity, organization or institution that is significant to a community	✓
yields, or has the potential to yield, information that contributes to an understanding of a community or culture	X
demonstrates or reflects the work or ideas of an architect, artist, builder, designer or theorist who is significant to a community	X
<b>Contextual Value - the property...</b>	
is important in defining, maintaining or supporting the character of an area	✓
is physically, functionally, visually or historically linked to its surroundings	✓
is a landmark	✓

The proposed development of the remaining portion of the subject lands for residential land uses will not have any direct impacts on the early 19<sup>th</sup> century buildings located onsite, as no loss or removal of these resources is proposed. The blockhouse will be retained on a large open space block as parkland. There are no impacts to the lighthouse. The context of the subject lands have evolved over time, and this will continue with the proposed development. This is considered a neutral impact.

### **Alternative Development Approaches**

#### *Do Nothing*

This alternative would result in no loss or removal of any built heritage or landscape features of the subject property. The onsite historic buildings would continue to remain vacant and may result in indirect adverse impacts of continued deterioration over time. This option is not recommended.

#### *Relocate Structures*

Relocation is generally not considered to be a preferred approach by heritage conservation best practices unless there is no other means to conserve a cultural heritage resource. It may be possible to relocate some of the smaller buildings, but it is unlikely that the larger dance hall and roller rink could be moved. This option is not recommended.

#### *Develop Site as Proposed*

With this option, the proposed Draft Plan of Subdivision would proceed. The early 19<sup>th</sup> and 20<sup>th</sup> century structures would be retained. The later 20<sup>th</sup> century structures, including the dodgems/bumper car ride, ferry dock and Sky Tower would be removed. These structures have modest heritage value, and documentation and commemoration of the structures to be removed is recommended. This option is recommended.

### **Implementation and Monitoring**

The following actions are recommended related to implementation and monitoring:

- A conservation plan/maintenance plan should be prepared prior to development proceeding. Such a report would assess the condition of the various buildings on the property, recommend measures to secure the buildings, and identify short, medium, and long-term repairs that are required. This requirement could be integrated as a condition of approval associated with the Draft Plan of Subdivision.
- Any critical repairs and maintenance identified as part of the conservation plan/maintenance plan should be completed prior to development occurring on the property. This will ensure that the buildings are stabilized.
- On-going efforts to secure buildings against vandals and pests should continue, in order to ensure that their integrity is not compromised and that public safety is taken into account.

- Documentation of buildings and an interpretive plan for buildings to be removed should be completed and provided to the Town of Amherstburg (as appropriate) prior to demolition occurring.
- Site interpretation and commemoration for the retained and removed buildings should be integrated into the Plan of Subdivision.
- The future use and adaptive re-use of retained buildings is encouraged, and could include a variety of uses complementary to the ongoing residential development of the site.



THE CORPORATION OF THE TOWN OF AMHERSTBURG

OFFICE OF THE CAO

MISSION STATEMENT: Committed to delivering cost-effective and efficient services for the residents of the Town of Amherstburg with a view to improve and enhance their quality of life.

Table with 2 columns: Author's Name, Report Date, Author's Phone, Date to Council, Author's E-mail, Resolution #.

To: Mayor and Members of Town Council

Subject: 2020 Calendar of Council Meetings

1. RECOMMENDATION:

It is recommended that:

- 1. The rules in the Procedural By-law requiring that regular meetings be held the second and fourth Monday of each month BE WAIVED for the months of July, August, and December; and,
2. The 2020 Calendar of Council Meetings BE APPROVED, as presented.

2. BACKGROUND:

The proposed 2020 Calendar of Council Meetings allows the municipality to conduct its business in an open and transparent manner while ensuring that there is an appropriate level of public notice for the regular cycle of meetings.

3. DISCUSSION:

A 2020 Calendar of Council Meetings is attached for review and approval. As per Procedural By-law 2014-91, Section 4.2 states;

“Prior to the first meeting in January of each year, the Clerk, or designate, shall post on the home page of the Town website, the Council approved schedule for all regular meetings for the calendar year.”

This calendar addresses regular Council meetings, on the 2nd and 4th Monday of each month. For the summer months of July and August, only one regular Council meeting

has been scheduled per month as per past practice. For the month of December, only one regular Council meeting has been scheduled due to Town Hall being closed for the holidays on the 2<sup>nd</sup> Monday. For these months an exception to the Procedural By-law is required, as per past practice, to allow for only one meeting to be held in the month.

Where a Monday meeting date falls on a statutory holiday or on a day where Town Hall is closed, the meeting is scheduled on the Tuesday, in accordance with the Procedural By-law, as noted for the months of April and October.

Two special Council meetings have been “tentatively” scheduled; one in July and one in August to address urgent Planning matters that may require Council’s consideration prior to the next regular Council meeting. In the event there are no Planning matters requiring Council’s approval, the meeting will be cancelled. In addition, special Council meetings have been scheduled in November for tabling and deliberation of the 2021 Budget.

This schedule does not preclude the Mayor from calling a special Council meeting as deemed necessary and in accordance with Section 3.1.1 of the Town of Amherstburg Procedural By-law 2014-91.

As per the Council approved Local Boards/Committees-Terms of Reference, committee meetings will be quarterly unless otherwise approved by the Clerk.

The 2020 Calendar of Council Meetings will be posted on the Town’s website prior to the first meeting in January 2020, and will be made available to members of Council, Administration and the public.

**4. RISK ANALYSIS:**

Provisions provided for in Procedural By-law 2014-91, call for approval of regular Council meetings prior to the upcoming year. Following procedure allows for proper notice to constituents and promotes an open and transparent government.

**5. FINANCIAL MATTERS:**

There are no financial matters associated with this report.

**6. CONSULTATIONS:**

The Municipal Clerk was consulted and concurs with the recommendations of the report.

7. **CONCLUSION:**

The Council calendar is approved each year to ensure accountability and transparency to the public with a set schedule of Council meetings and assists Council and Administration in setting timelines for the day to day operations of the Corporation.



---

Tammy Fowkes  
**Deputy Clerk**



---

Paula Parker  
**Municipal Clerk**



## Report Approval Details

Document Title:	2020 Calendar of Council Meetings.docx
Attachments:	- DRAFT - 2020 Calendar of Council Meetings.doc
Final Approval Date:	Nov 1, 2019

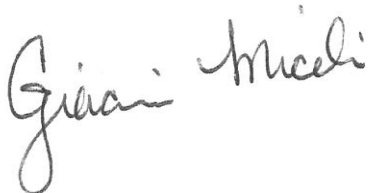
This report and all of its attachments were approved and signed as outlined below:



**Mark Galvin - Oct 30, 2019 - 9:26 AM**



**Cheryl Horrobin - Oct 30, 2019 - 11:36 AM**



**John Miceli - Oct 30, 2019 - 1:20 PM**



**Paula Parker - Nov 1, 2019 - 4:20 PM**

## 2020 SCHEDULE AMHERSTBURG COUNCIL MEETINGS

J A N							F E B							M A R						
S	M	T	W	T	F	S	S	M	T	W	T	F	S	S	M	T	W	T	F	S
			1	2	3	4							1	1	2	3	4	5	6	7
5	6	7	8	9	10	11	2	3	4	5	6	7	8	8	9	10	11	12	13	14
12	13	14	15	16	17	18	9	10	11	12	13	14	15	15	16	17	18	19	20	21
19	20	21	22	23	24	25	16	17	18	19	20	21	22	22	23	24	25	26	27	28
26	27	28	29	30	31		23	24	25	26	27	28	29	29	30	31				
A P R							M A Y							J U N						
S	M	T	W	T	F	S	S	M	T	W	T	F	S	S	M	T	W	T	F	S
			1	2	3	4						1	2		1	2	3	4	5	6
5	6	7	8	9	10	11	3	4	5	6	7	8	9	7	8	9	10	11	12	13
12	13	14	15	16	17	18	10	11	12	13	14	15	16	14	15	16	17	18	19	20
19	20	21	22	23	24	25	17	18	19	20	21	22	23	21	22	23	24	25	26	27
26	27	28	29	30			24	25	26	27	28	29	30	28	29	30				
							31													
J U L							A U G							S E P						
S	M	T	W	T	F	S	S	M	T	W	T	F	S	S	M	T	W	T	F	S
			1	2	3	4							1			1	2	3	4	5
5	6	7	8	9	10	11	2	3	4	5	6	7	8	6	7	8	9	10	11	12
12	13	14	15	16	17	18	9	10	11	12	13	14	15	13	14	15	16	17	18	19
19	20	21	22	23	24	25	16	17	18	19	20	21	22	20	21	22	23	24	25	26
26	27	28	29	30	31		23	24	25	26	27	28	29	27	28	29	30			
							30	31												
O C T							N O V							D E C						
S	M	T	W	T	F	S	S	M	T	W	T	F	S	S	M	T	W	T	F	S
				1	2	3	1	2	3	4	5	6	7 PC			1	2	3	4	5
4	5	6	7	8	9	10	8	9	10	11	12	13	14	6	7	8	9	10	11	12
11	12	13	14	15	16	17	15	16	17	18	19	20	21	13	14	15	16	17	18	19
18	19	20	21	22	23	24	22	23	24	25	26	27	28	20	21	22	23	24	25	26
25	26	27	28	29	30	31	29	30						27	28	29	30	31	Jan 1	Jan 2
	<b>Statutory Holiday (Town Hall Closed)</b>							<b>Regular Council Meetings</b>							<b>Town Hall Closed</b>					
	<b>March Break</b>							<b>Tentative - Special Council Meeting - Planning</b>												
	<b>2021 Budget:</b> <b>Special Council Meetings:</b> Nov. 2, 2020 – Table Budget /Presentation Nov. 17, 2020 – Budget Deliberations 6 pm - 10 pm Nov. 18, 2020 – Budget Deliberations 9 am - 5:30 pm Nov. 19, 2020 – Budget Deliberations 1pm - 7 pm (if required) <b>Public Engagement Session:</b> Nov. 7, 2020 – Public Engagement Session 1 pm - 3 pm																			



## THE CORPORATION OF THE TOWN OF AMHERSTBURG

### OFFICE OF CORPORATE SERVICES

*MISSION STATEMENT: Committed to delivering cost-effective and efficient services for the residents of the Town of Amherstburg with a view to improve and enhance their quality of life.*

Author's Name: Justin Rousseau	Report Date: October 25, 2019
Author's Phone: 519 736-0012 ext. 2259	Date to Council: November 12, 2019
Author's E-mail: <a href="mailto:jrousseau@amherstburg.ca">jrousseau@amherstburg.ca</a>	Resolution #: N/A

To: Mayor and Members of Town Council

Subject: Cheque Listing for the Month of October 2019

---

#### 1. RECOMMENDATION:

It is recommended that:

1. The report from the Treasurer dated October 25, 2019, regarding Cheque Listing for the Month of October 2019 **BE RECEIVED** for information.

#### 2. BACKGROUND:

On June 24 2019, Council adopted the following resolution:

*"That the Accounts Payable reports be re-added to the agenda."*

It is noted that the report is actually a transmittal of the listing of cheques issued for the subject month.

#### 3. DISCUSSION:

The list of cheques issued in the month of October 2019 is attached for information. The cheques are issued by the Town to satisfy Town commitments or obligations as a result of services rendered, goods purchased and received or contractual obligations in accordance with Council approved operating or capital budgets and/or the Council approved Procurement Policy.

**4. RISK ANALYSIS:**

N/A

**5. FINANCIAL MATTERS:**


There is no financial impact from the recommendation in this report.

**6. CONSULTATIONS:**

N/A

**7. CONCLUSION:**

This report is provided for information.

  
\_\_\_\_\_  
Justin Rousseau  
Treasurer

<b>NOTIFICATION :</b>				
Name	Address	Email Address	Telephone	FAX

## Report Approval Details

Document Title:	Cheque Listing for the Month of October 2019.docx
Attachments:	- Accounts paid October 1 - October 31 2019.pdf
Final Approval Date:	Oct 30, 2019

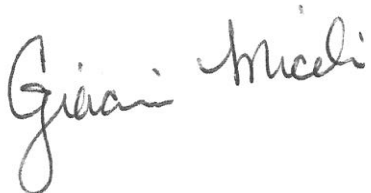
This report and all of its attachments were approved and signed as outlined below:



**Cheryl Horrobin - Oct 30, 2019 - 11:28 AM**



**Mark Galvin - Oct 30, 2019 - 11:55 AM**



**John Miceli - Oct 30, 2019 - 12:04 PM**



**Paula Parker - Oct 30, 2019 - 12:27 PM**



Vendor : CAT038 To ZUL180

Batch : All

Department : All

Cheque Print Date : 01-Oct-2019 To 31-Oct-2019

Bank : 1 To 99

Class : All

Vendor Invoice	Vendor Name Description	Batch	Inv Date	Inv Due Date	Amount
G.L. Account	CC1 CC2 CC3 GL Account Name				
<b>DEPARTMENT 0000000</b>	GENERAL				
<b>A1D169</b>	<b>A-1 DRIVEWAY GROUP</b>				
2019-060	RETURN OF INDEMNITY DEPOSIT FOR 48 BALACLAVA ST	1167	27-Aug-2019	27-Aug-2019	
10-2-0000000-2135	INDEMNITY FEE - RIGHT OF WAY				1,000.00
2019-161	RETURN OF INDEMNITY DEPOSIT FOR 14 FRYER ST	1084	30-Sep-2019	30-Sep-2019	
10-2-0000000-2135	INDEMNITY FEE - RIGHT OF WAY				1,000.00
<b>AGO713</b>	<b>AGO INDUSTRIES INC</b>				
8864645	TRAFFIC SAFETY SHIRT	1133	19-Sep-2019	19-Sep-2019	
80-5-0000000-0161	CLOTHING				39.29
<b>AMH001</b>	<b>AMHERSTBURG PROFESSIONAL FIREFIGHTERS ASSOC</b>				
SEPTEMBER 2 DUES FOR THE MONTH OF SEPTEMBER 2019		1113	30-Sep-2019	30-Sep-2019	
10-2-0000000-1156	A/P - PAYROLL DED. - FIRE				420.96
<b>BAS10</b>	<b>BASTIEN RAYMOND</b>				
2019-143	RETURN OF INDEMNITY DEPOSIT FOR 3828 CONCESSION 3N	1078	26-Sep-2019	26-Sep-2019	
10-2-0000000-2135	INDEMNITY FEE - RIGHT OF WAY				1,000.00
OCTOBER 10, REFUND DUE TO CREDIT BALANCE ON ACCT DUE TO WRITE OFF PROCESSED OCT 3, 2019		1146	10-Oct-2019	10-Oct-2019	
10-1-0000000-2138	A/R PROP TAX REFUND OWING				16.63
<b>BEN260</b>	<b>BENSON TIRE</b>				
12973152	UNIT VM-09	1056	20-Jun-2019	20-Jun-2019	
80-5-0000000-0402	VEHICLE & EQUIPMENT MTCE.				818.69
12974081	UNIT 102	1056	04-Sep-2019	04-Sep-2019	
80-5-0000000-0402	VEHICLE & EQUIPMENT MTCE.				124.30
<b>BER174</b>	<b>BERTHIAUME JOE</b>				
229710	RETURN OF INDEMNITY DEPOSIT FOR 174 RYAN STREET, 2019-122	1127	01-Oct-2019	01-Oct-2019	
10-2-0000000-2140	INDEMNITY FEES				500.00
<b>BON168</b>	<b>BONDY MARK</b>				
OCTOBER 4, 2 SEWER TAP APPLICATION FEE		1133	04-Oct-2019	04-Oct-2019	
80-5-0000000-0815	BACKFLOW - PREVENTION				3,000.00
<b>BOR255</b>	<b>BORDENUIK A.J.</b>				
2019-136	RETURN OF INDEMNITY DEPOSIT FOR 255 MEADOVIEW	1070	19-Sep-2019	19-Sep-2019	
10-2-0000000-2135	INDEMNITY FEE - RIGHT OF WAY				1,000.00
<b>CAN380</b>	<b>CANADIAN TIRE STORE #281</b>				
JULY 2019	JULY 2019 PURCHASES	1078	31-Jul-2019	31-Jul-2019	
80-5-0000000-0850	HYDRANT MAINTENANCE				58.45
80-5-0000000-0850	HYDRANT MAINTENANCE				29.36
80-5-0000000-0810	WATER - MAIN MAINTENANCE				73.39
80-5-0000000-0810	WATER - MAIN MAINTENANCE				73.33
<b>CIP738</b>	<b>CIPKAR LICIA</b>				
226007	RETURN OF INDEMNITY DEPOSIT FOR 7380 COLLISON SIDE ROAD, 2018-415	1167	16-Oct-2019	16-Oct-2019	
10-2-0000000-2140	INDEMNITY FEES				1,000.00
<b>COM046</b>	<b>COM PETERS INC</b>				
4614	SOFTWARE AS A MONTHLY SERVICE	1133	03-Sep-2019	03-Sep-2019	
80-5-0000000-0810	WATER - MAIN MAINTENANCE				395.50
<b>COM355</b>	<b>COMPETERS YOUR SOFTWARE TEAM</b>				
4652	SOFTWARE AS A SERVICES	1133	01-Oct-2019	01-Oct-2019	
80-5-0000000-0755	WATER SERVICE MAINTENANCE				395.50
<b>DER755</b>	<b>DEROSE THERESA</b>				
213147	RETURN OF INDEMNITY DEPOSIT FOR 7085 CONCESSION 7S, 2017-216	1127	22-Sep-2019	22-Sep-2019	
10-2-0000000-2140	INDEMNITY FEES				1,000.00
<b>DES112</b>	<b>DESANTIS JOHN</b>				
OCTOBER 10, REFUND DUE TO CREDIT BALANCE ON ACCT DUE TO WRITE OFF PROCESSED OCT 3, 2019		1146	10-Oct-2019	10-Oct-2019	



Vendor : CAT038 To ZUL180  
 Batch : All  
 Department : All

Cheque Print Date : 01-Oct-2019 To 31-Oct-2019  
 Bank : 1 To 99  
 Class : All

Vendor Invoice	Vendor Name Description	Batch	Inv Date	Inv Due Date	Amount
G.L. Account	CC1 CC2 CC3 GL Account Name				
<b>DEPARTMENT 0000000</b>	GENERAL				
10-1-0000000-2138	A/R PROP TAX REFUND OWING				936.84
<b>DOW547 DOWLER KARN</b>					
34749523 AME CYLINDER RENTAL (HST NOT CHARGED CHARGED ON ORIGINAL INVOICE)		1078	30-Apr-2019	30-Apr-2019	
10-1-0000000-2002	A/R - GST INPUT TAX CR.				3.25
<b>EMC530 EMCO CORPORATION</b>					
37595922-00 BACKFLOW SUPPLIES		1133	04-Jun-2019	04-Jun-2019	
80-5-0000000-0815	BACKFLOW - PREVENTION				831.68
<b>ESS273 ESSEX POWERLINES CORPORATION</b>					
JC7974 WATER BILLING AND COLLECTING CHARGES FOR THE MONTH OF SEPTEMBER 20		1150	30-Sep-2019	30-Sep-2019	
80-5-0000000-0504	COLLECTION EXPENSE				16,272.97
<b>EST672 ESTATE OF PUZZUOLI DOMINIC ANTONIO PUZZUOLI</b>					
OCTOBER 10, REFUND DUE TO CREDIT BALANCE ON ACCT DUE TO WRITE OFF PROCESSED OC		1146	10-Oct-2019	10-Oct-2019	
3, 2019					
10-1-0000000-2138	A/R PROP TAX REFUND OWING				49.08
OCTOBER 10, REFUND DUE TO CREDIT BALANCE ON ACCT DUE TO WRITE OFF PROCESSED OC		1146	10-Oct-2019	10-Oct-2019	
3, 2019					
10-1-0000000-2138	A/R PROP TAX REFUND OWING				811.21
<b>EXP407 407 EXPRESS TOLL ROUTE</b>					
SEP 21, 2019 AUG 21 TO SEP 20, 2019		1133	21-Sep-2019	21-Sep-2019	
80-5-0000000-0249	TRAINING				17.62
<b>GRE05 GREATER ESSEX COUNTY DISTRICT SCHOOL BOARD</b>					
SEPTEMBER 2 SEPTEMBER 2019 PUB SCHOOL BOARD DEVELOPMENT		1084	30-Sep-2019	30-Sep-2019	
10-2-0000000-0112	A/P - PUB SCH BRD. DEV CHARGE				7,860.00
<b>GRE330 GREAT LAKES SAFETY PRODUCTS</b>					
00325879 SUPPLIES		1056	18-Sep-2019	18-Sep-2019	
80-5-0000000-0420	EQUIPMENT MAINTENANCE				159.82
00325880 SUPPLIES		1056	18-Sep-2019	18-Sep-2019	
80-5-0000000-0420	EQUIPMENT MAINTENANCE				155.13
00326462 SUPPLIES		1150	30-Sep-2019	30-Sep-2019	
80-5-0000000-0755	WATER SERVICE MAINTENANCE				79.90
<b>GSP636 G&amp;S EQUIPMENT RENTALS</b>					
1848 GRASS CUTTING		1070	02-Sep-2019	02-Sep-2019	
10-1-0000000-2066	A/R - CLEARING				768.40
<b>HEA693 HEATON SANITATION</b>					
38164 VACTOR FLUSHERS		1056	19-Sep-2019	19-Sep-2019	
80-5-0000000-0810	WATER - MAIN MAINTENANCE				1,220.40
38681 VACTOR FLUSHER		1171	08-Oct-2019	08-Oct-2019	
80-5-0000000-0810	WATER - MAIN MAINTENANCE				1,808.00
38682 VACTOR FLUSHER		1171	09-Oct-2019	09-Oct-2019	
80-5-0000000-0755	WATER SERVICE MAINTENANCE				2,034.00
38683 VACTOR FLUSHER		1171	10-Oct-2019	10-Oct-2019	
80-5-0000000-0810	WATER - MAIN MAINTENANCE				1,695.00
38758 VACTOR FLUSHER		1056	16-Sep-2019	16-Sep-2019	
80-5-0000000-0755	WATER SERVICE MAINTENANCE				2,260.00
38759 VACTOR FLUSHER		1056	19-Sep-2019	19-Sep-2019	
80-5-0000000-0840	VALVE MAINTENANCE				1,921.00
38760 VACTOR FLUSHER		1056	18-Sep-2019	18-Sep-2019	
80-5-0000000-0755	WATER SERVICE MAINTENANCE				1,130.00
38761 VACTOR FLUSHER		1056	19-Sep-2019	19-Sep-2019	
80-5-0000000-0840	VALVE MAINTENANCE				2,034.00
<b>HOL149 HOLDEN LARRY</b>					
2019-159 RETURN OF INDEMNITY DEPOSIT FOR 149 FRASER AVE		1084	30-Sep-2019	30-Sep-2019	
10-2-0000000-2135	INDEMNITY FEE - RIGHT OF WAY				1,000.00



Vendor : CAT038 To ZUL180

Batch : All

Department : All

Cheque Print Date : 01-Oct-2019 To 31-Oct-2019

Bank : 1 To 99

Class : All

Vendor Invoice	Vendor Name Description	Batch	Inv Date	Inv Due Date	Amount
G.L. Account	CC1 CC2 CC3 GL Account Name				
<b>DEPARTMENT 0000000</b>	GENERAL				
<b>IBE01</b>	<b>IBEW - LOCAL 636</b>				
SEPTEMBER 2 SEPTEMBER 2019 MONTHLY DUES		1113	01-Sep-2019	01-Sep-2019	
10-2-0000000-1145	A/P - PAYROLL DED. - UNIO				3,480.31
<b>JON433</b>	<b>JONES ROBERT</b>				
231902 PERMIT CANCELLATION		1167	05-Sep-2019	05-Sep-2019	
10-2-0000000-2140	INDEMNITY FEES				1,000.00
<b>KAL132</b>	<b>KAL TIRE 837 - WINDSOR</b>				
837152633 WM-09		1056	30-Jul-2019	30-Jul-2019	
80-5-0000000-0402	VEHICLE & EQUIPMENT MTCE.				2,450.20
<b>KEL117</b>	<b>KELCOM TELEMESSAGING</b>				
1910-06702 ANSWERING SERVICES		1167	01-Oct-2019	01-Oct-2019	
80-5-0000000-0316	UTILITIES				49.38
<b>KEL198</b>	<b>KELCOM RADIO DIVISION</b>				
80011117 RADIO AIRTIME		1150	16-Sep-2019	16-Sep-2019	
80-5-0000000-0404	VEHICLE & RADIO LICENCES				1,726.02
<b>KNM541</b>	<b>KNM YARD CARE</b>				
1560 GRASS CUTTING FOR SEPTEMBER 2019		1153	01-Oct-2019	01-Oct-2019	
80-5-0000000-0331	GENERAL MAINTENANCE				734.50
80-5-0000000-0331	GENERAL MAINTENANCE				706.25
<b>KTI033</b>	<b>KTI LIMITED</b>				
INV120281 NS PROPAGATION STUDY		1133	18-Sep-2019	18-Sep-2019	
80-5-0000000-0328	ENGINEERING FEES				904.00
<b>LAF110</b>	<b>LAFONTAINE GHISLAINE</b>				
OCTOBER 10, REFUND DUE TO CREDIT BALANCE ON ACCT DUE TO WRITE OFF PROCESSED OCT 3, 2019		1146	10-Oct-2019	10-Oct-2019	
10-1-0000000-2138	A/R PROP TAX REFUND OWING				1,374.20
<b>LAF308</b>	<b>LAFERTE SARAH ELIZABETH</b>				
OCTOBER 10, REFUND DUE TO CREDIT BALANCE ON ACCT DUE TO WRITE OFF PROCESSED OCT 3, 2019		1146	10-Oct-2019	10-Oct-2019	
10-1-0000000-2138	A/R PROP TAX REFUND OWING				812.49
<b>LAS702</b>	<b>LASALLE BACKHOE SERVICE</b>				
2019-112 RETURN OF INDEMNITY DEPOSIT FOR 2019-112 AT 43 SCOTT DRIVE		1127	03-Oct-2019	03-Oct-2019	
10-2-0000000-2135	INDEMNITY FEE - RIGHT OF WAY				1,000.00
<b>LIG108</b>	<b>LIGHTPATH UTILITIES INC.</b>				
375 DIRECTIONAL DRILL FOR WATER SERVICES		1056	19-Sep-2019	19-Sep-2019	
80-5-0000000-0755	WATER SERVICE MAINTENANCE				948.64
376 DIRECTIONAL DRILL FOR WATER SERVICE		1133	19-Sep-2019	19-Sep-2019	
80-5-0000000-0755	WATER SERVICE MAINTENANCE				536.19
<b>LIO033</b>	<b>LIOVAS HOMES</b>				
215337 RETURN OF INDEMNITY DEPOSIT FOR 51 SHAW DRIVE, 2017-179		1146	04-Sep-2019	04-Sep-2019	
10-2-0000000-2140	INDEMNITY FEES				1,000.00
<b>MAC110</b>	<b>MAC COATINGS</b>				
167867 YELLOW QUICK DRY ENAMEL		1056	10-Sep-2019	10-Sep-2019	
80-5-0000000-0850	HYDRANT MAINTENANCE				110.74
<b>MAL448</b>	<b>MALCOLM JAQUELINE ANNE</b>				
OCTOBER 10, REFUND DUE TO CREDIT BALANCE ON ACCT DUE TO WRITE OFF PROCESSED OCT 3, 2019		1146	10-Oct-2019	10-Oct-2019	
10-1-0000000-2138	A/R PROP TAX REFUND OWING				265.08
<b>MAX04</b>	<b>MAXEY COREY</b>				
SEPTEMBER 5 SEWER VIDEO		1056	05-Sep-2019	05-Sep-2019	
80-5-0000000-0815	BACKFLOW - PREVENTION				506.24
<b>MEA01</b>	<b>THE MEARIE GROUP</b>				





Vendor : CAT038 To ZUL180  
 Batch : All  
 Department : All

Cheque Print Date : 01-Oct-2019 To 31-Oct-2019  
 Bank : 1 To 99  
 Class : All

Vendor Invoice	Vendor Name Description	Batch	Inv Date	Inv Due Date	Amount
G.L. Account	CC1 CC2 CC3 GL Account Name				
<b>DEPARTMENT 0000000</b>	GENERAL				
30,368	SEPTEMBER 2019 BENEFITS	1133	26-Sep-2019	26-Sep-2019	
80-5-0000000-0211	BENEFITS - ESSEX POWER - WATER DEPARTMEN				765.49
<b>MEL189 MELVIN ORR TRUCKING LTD.</b>					
162165511	TRIAXLE	1150	30-Sep-2019	30-Sep-2019	
80-5-0000000-0810	WATER - MAIN MAINTENANCE				226.00
162165514	TRIAXLE	1150	30-Sep-2019	30-Sep-2019	
80-5-0000000-0755	WATER SERVICE MAINTENANCE				406.80
<b>MIK315 MIKE'S COMPUTER SHOP</b>					
WIN-303474	HYDRANT TESTING RECORDER - INTERFACE CABLE	1133	29-Aug-2019	29-Aug-2019	
80-5-0000000-0301	OFFICE SUPPLIES				31.01
<b>NAG202 NAGELEISEN ELISA</b>					
OCTOBER 10,	REFUND DUE TO CREDIT BALANCE ON ACCT DUE TO WRITE OFF PROCESSED OC	1146	10-Oct-2019	10-Oct-2019	
3, 2019					
10-1-0000000-2138	A/R PROP TAX REFUND OWING				16.15
<b>NIC306 NICKLESON CHARLES</b>					
230819	RETURN OF INDEMNITY DEPOSIT FOR 306 CRYSTAL BAY DRIVE, 2019-092	1167	16-Oct-2019	16-Oct-2019	
10-2-0000000-2140	INDEMNITY FEES				1,000.00
<b>ONT001 ONTARIO CLEAN WATER AGENCY</b>					
INV000113971	ADDITIONAL SERVICES	1056	21-Jun-2019	21-Jun-2019	
80-5-0000000-0612	GENERAL MAINTENANCE - AWWTP				247.73
INV000113972	ADDITIONAL SERVICES	1056	21-Jun-2019	21-Jun-2019	
80-5-0000000-0612	GENERAL MAINTENANCE - AWWTP				4,781.70
INV000116155	ADDITIONAL SERVICES	1171	19-Sep-2019	19-Sep-2019	
80-5-0000000-0612	GENERAL MAINTENANCE - AWWTP				529.15
INV000116157	ADDITIONAL SERVICES	1171	19-Sep-2019	19-Sep-2019	
80-5-0000000-0612	GENERAL MAINTENANCE - AWWTP				1,321.86
INV000116158	ADDITIONAL SERVICES	1171	19-Sep-2019	19-Sep-2019	
80-5-0000000-0612	GENERAL MAINTENANCE - AWWTP				361.83
INV000116160	ADDITIONAL SERVICES	1171	19-Sep-2019	19-Sep-2019	
80-5-0000000-0612	GENERAL MAINTENANCE - AWWTP				196.78
INV000116162	ADDITIONAL SERVICES	1171	19-Sep-2019	19-Sep-2019	
80-5-0000000-0612	GENERAL MAINTENANCE - AWWTP				4,003.91
INV000116163	ADDITIONAL SERVICES	1171	19-Sep-2019	19-Sep-2019	
80-5-0000000-0612	GENERAL MAINTENANCE - AWWTP				357.30
INV000116165	ADDITIONAL SERVICES	1171	19-Sep-2019	19-Sep-2019	
80-5-0000000-0612	GENERAL MAINTENANCE - AWWTP				508.04
INV000116166	ADDITIONAL SERVICES	1171	19-Sep-2019	19-Sep-2019	
80-5-0000000-0612	GENERAL MAINTENANCE - AWWTP				188.98
INV000116167	ADDITIONAL SERVICES	1171	19-Sep-2019	19-Sep-2019	
80-5-0000000-0680	LIFE CYCLE EXPENSES				5,037.12
INV000116169	ADDITIONAL SERVICES	1171	19-Sep-2019	19-Sep-2019	
80-5-0000000-0680	LIFE CYCLE EXPENSES				7,689.82
INV000116372	OPERATIONS AND MAINTENANCE	1153	01-Oct-2019	01-Oct-2019	
80-5-0000000-0604	CONTRACT COSTS - AWWTP				52,241.42
<b>ONT104 ONTARIO ONE CALL LTD</b>					
201904327	PHONE CALLS	1150	30-Sep-2019	30-Sep-2019	
80-5-0000000-0810	WATER - MAIN MAINTENANCE				328.82
<b>ONT5264 1583921 ONTARIO INC</b>					
OCTOBER 15,	BELLEVUE MORTGAGE PAYMENT	1167	15-Oct-2019	15-Oct-2019	
10-2-0000000-1341	MONTHLY PRINCIPAL DEBT PAYMENT - GENERAL				200,000.00
<b>ORC01 ORCHARD MICHAEL</b>					
OCTOBER 10,	REFUND DUE TO CREDIT BALANCE ON ACCT DUE TO WRITE OFF PROCESSED OC	1146	10-Oct-2019	10-Oct-2019	
3, 2019					



Vendor : CAT038 To ZUL180  
 Batch : All  
 Department : All

Cheque Print Date : 01-Oct-2019 To 31-Oct-2019  
 Bank : 1 To 99  
 Class : All

Vendor Invoice	Vendor Name Description				Batch Invc Date	Invc Due Date	Amount
G.L. Account	CC1	CC2	CC3	GL Account Name			
<b>DEPARTMENT 0000000</b>		GENERAL					
10-1-0000000-2138				A/R PROP TAX REFUND OWING			462.41
<b>PAR46</b>	<b>PARKS CHRISTINE</b>						
OCTOBER 10,	REFUND DUE TO CREDIT BALANCE ON ACCT DUE TO WRITE OFF PROCESSED OC				1146 10-Oct-2019	10-Oct-2019	
	3, 2019						
10-1-0000000-2138				A/R PROP TAX REFUND OWING			840.29
<b>PEA954</b>	<b>PEARCE JAMES</b>						
OCTOBER 10,	REFUND DUE TO CREDIT BALANCE ON ACCT DUE TO WRITE OFF PROCESSED OC				1146 10-Oct-2019	10-Oct-2019	
	3, 2019						
10-1-0000000-2138				A/R PROP TAX REFUND OWING			47.53
<b>PET031</b>	<b>PETTYPIECE LES</b>						
2019-078	RETURN OF INDEMNITY DEPOSIT FOR 31 FRYER ST				1084 30-Sep-2019	30-Sep-2019	
10-2-0000000-2135				INDEMNITY FEE - RIGHT OF WAY			1,000.00
<b>PIS870</b>	<b>PISCIUNERI CONSTRUCTION</b>						
2019-032	RETURN OF INDEMNITY DEPOSIT FOR 277 MULLEN				1084 30-Sep-2019	30-Sep-2019	
10-2-0000000-2135				INDEMNITY FEE - RIGHT OF WAY			1,000.00
2019-152	2018 - 152 - RETURN OF INDEMNITY DEPOSIT FOR 285 MULLEN				1084 30-Sep-2019	30-Sep-2019	
10-2-0000000-2135				INDEMNITY FEE - RIGHT OF WAY			1,000.00
<b>PRE148</b>	<b>PREVIEW INSPECTIONS AND CONSULTING</b>						
0819	ADMINISTRATION OF CROSS-CONNECTION CONTROL PROGRAM FOR AUGUST 20				1056 10-Sep-2019	10-Sep-2019	
80-5-0000000-0815				BACKFLOW - PREVENTION			2,147.00
0919	ADMINISTRATION OF CROSS-CONNECTION CONTROL PROGRAM FOR SEPT 2019				1150 01-Oct-2019	01-Oct-2019	
80-5-0000000-0815				BACKFLOW - PREVENTION			2,147.00
<b>PUR700</b>	<b>PUROLATOR INC.</b>						
442313332	COURIER				1078 23-Aug-2019	23-Aug-2019	
10-1-0000000-1503				TAX REG. - REGISTRATION C			4.53
<b>REU248</b>	<b>REUPER CRAIG</b>						
2019-164	RETURN OF INDEMNITY DEPOSIT FOR ROW PERMIT 2019-164, 248 MEADOWVIEW				1167 16-Oct-2019	16-Oct-2019	
	AVE						
10-2-0000000-2135				INDEMNITY FEE - RIGHT OF WAY			1,000.00
<b>ROB090</b>	<b>ROBINSON JANICE</b>						
2019-145	RETURN OF INDEMNITY DEPOSIT FOR 2019-145, 90 PARK STREET				1127 03-Oct-2019	03-Oct-2019	
10-2-0000000-2135				INDEMNITY FEE - RIGHT OF WAY			1,000.00
<b>RTT067</b>	<b>RIVER TOWN TIMES</b>						
2515	ADVERTISING				1127 21-Aug-2019	21-Aug-2019	
10-1-0000000-1503				TAX REG. - REGISTRATION C			141.01
<b>SCG015</b>	<b>SCG FLOWMETRIC TECHNICAL SERVICES INC.</b>						
2600695	METER REPLACEMENT AT MOBILE HOME SUBDIVISION IN MCGREGOR				1133 31-Jul-2019	31-Jul-2019	
80-5-0000000-0833				WATER METER REPAIRS & MTNCE			6,928.64
<b>SMI151</b>	<b>SMIT GEORGE</b>						
2019-158	RETURN OF INDEMNITY DEPOSIT FOR 151 FORT ST.				1084 30-Sep-2019	30-Sep-2019	
10-2-0000000-2135				INDEMNITY FEE - RIGHT OF WAY			1,000.00
<b>SOB083</b>	<b>SOBEYS AMHERSTBURG</b>						
JULY 2019	PURCHASES MADE IN JULY 2019				1146 30-Jul-2019	30-Jul-2019	
80-5-0000000-0755				WATER SERVICE MAINTENANCE			8.37
<b>SPE045</b>	<b>SPEEDPRINT</b>						
41661	WATER WORK ORDER BOOKS				1056 10-Sep-2019	10-Sep-2019	
80-5-0000000-0301				OFFICE SUPPLIES			290.96
<b>SUT431</b>	<b>SUTTON BILL</b>						
2019-134	RETURN OF INDEMNITY DEPOSIT FOR 431 OLD COLONY TRAIL				1078 04-Sep-2019	04-Sep-2019	
10-2-0000000-2135				INDEMNITY FEE - RIGHT OF WAY			1,000.00
<b>THE08</b>	<b>THE INCORPORATED SYNOD OF THE DIOCESE OF HURON</b>						
OCTOBER 10,	REFUND DUE TO CREDIT BALANCE ON ACCT DUE TO WRITE OFF PROCESSED OC				1146 10-Oct-2019	10-Oct-2019	



Vendor : CAT038 To ZUL180  
 Batch : All  
 Department : All

Cheque Print Date : 01-Oct-2019 To 31-Oct-2019  
 Bank : 1 To 99  
 Class : All

Vendor Invoice	Vendor Name Description	Batch	Inv Date	Inv Due Date	Amount
G.L. Account	CC1 CC2 CC3 GL Account Name				
<b>DEPARTMENT 0000000</b>	GENERAL				
	3, 2019				
10-1-0000000-2138	A/R PROP TAX REFUND OWING				460.92
<b>TOT060</b>	<b>TOTALLYONE CORPORATE OFFICE</b>				
25440	PHONE RENEWAL		1084 09-Sep-2019	09-Sep-2019	
80-5-0000000-0345	CELL PHONE				611.29
25444	PHONE RENEWALS		1084 09-Sep-2019	09-Sep-2019	
80-5-0000000-0345	CELL PHONE				334.20
<b>TOW595</b>	<b>TOWN OF LASALLE</b>				
3014	FLUSHING TECHNIQUES TRAINING		1167 25-Jun-2019	25-Jun-2019	
80-5-0000000-0249	TRAINING				508.80
<b>TRI003</b>	<b>TRI-TARGET INC</b>				
224	TRI-TARGET ADVERTISING		1146 08-Oct-2019	08-Oct-2019	
10-1-0000000-1503	TAX REG. - REGISTRATION C				875.75
<b>TRO104</b>	<b>TROY LIFE &amp; FIRE SAFETY LTD.</b>				
1000153761	INSPECTION SERVICE		1056 16-Sep-2019	16-Sep-2019	
80-5-0000000-0850	HYDRANT MAINTENANCE				4,820.58
1000153764	INSPECTION SERVICE		1056 16-Sep-2019	16-Sep-2019	
80-5-0000000-0850	HYDRANT MAINTENANCE				2,411.42
<b>UNI300</b>	<b>UNITED WAY OF WINDSOR-ESSEX COUNTY</b>				
JUL -SEPTEME 3RD QUARTER DEDUCTIONS FOR 2019			1113 30-Sep-2019	30-Sep-2019	
10-2-0000000-1147	A/P - PAYROLL DED. - UNIT				1,276.00
<b>WAC575</b>	<b>WACHS CANADA LTD</b>				
INV19842	PRETZEL HYDRANT		1171 01-Oct-2019	01-Oct-2019	
80-5-0000000-0845	BLOWOFF REPAIRS, UPGRADES, NEW INSTALLS				1,803.80
<b>WAL101</b>	<b>WALKER AGGREGATES</b>				
285902	SUPPLIES		1171 06-Jul-2019	06-Jul-2019	
80-5-0000000-0755	WATER SERVICE MAINTENANCE				704.55
286824	SUPPLIES		1171 03-Aug-2019	03-Aug-2019	
80-5-0000000-0755	WATER SERVICE MAINTENANCE				475.13
<b>WIG018</b>	<b>WIGLE KAREN</b>				
2019-144	RETURN OF INDEMNITY DEPOSIT FOR 2019-144, 18 FRYER ST		1127 30-Sep-2019	30-Sep-2019	
10-2-0000000-2135	INDEMNITY FEE - RIGHT OF WAY				1,000.00
<b>WIG035</b>	<b>WIGLE HOME HARDWARE BUILDING CENTRE</b>				
132471	SUPPLIES		1133 17-Jul-2019	17-Jul-2019	
80-5-0000000-0420	EQUIPMENT MAINTENANCE				21.46
134326	SUPPLIES		1056 13-Sep-2019	13-Sep-2019	
80-5-0000000-0755	WATER SERVICE MAINTENANCE				162.64
134710	SUPPLIES		1150 26-Sep-2019	26-Sep-2019	
80-5-0000000-0755	WATER SERVICE MAINTENANCE				60.95
135067	SUPPLIES		1171 08-Oct-2019	08-Oct-2019	
80-5-0000000-0755	WATER SERVICE MAINTENANCE				60.95
135250	SUPPLIES		1171 15-Oct-2019	15-Oct-2019	
80-5-0000000-0755	WATER SERVICE MAINTENANCE				60.95
<b>WIL07</b>	<b>WILEY WILLIAM</b>				
2019-098	RETURN OF INDEMNITY DEPOSIT FOR 41 WHELAN DRIVE		1070 19-Sep-2019	19-Sep-2019	
10-2-0000000-2135	INDEMNITY FEE - RIGHT OF WAY				1,000.00
<b>WIN270</b>	<b>WINDSOR DISPOSAL SERVICES LTD</b>				
0000967749	MONTHLY BASIC COLLECTION		1167 01-Oct-2019	01-Oct-2019	
10-1-0000000-2066	A/R - CLEARING				385.85
<b>WOL533</b>	<b>WOLSELEY CANADA INC</b>				
8504865	RED STAKE FLAGS		1056 10-Sep-2019	10-Sep-2019	
80-5-0000000-0810	WATER - MAIN MAINTENANCE				84.75



Vendor : CAT038 To ZUL180

Batch : All

Department : All

Cheque Print Date : 01-Oct-2019 To 31-Oct-2019

Bank : 1 To 99

Class : All

Vendor Invoice	Vendor Name Description	Batch	Inv Date	Inv Due Date	Amount
G.L. Account	CC1 CC2 CC3 GL Account Name				
<b>DEPARTMENT 0000000 GENERAL</b>					
8542292	SUPPLIES	1150	19-Sep-2019	19-Sep-2019	
80-5-0000000-0420	EQUIPMENT MAINTENANCE				169.50
8542293	SUPPLIES	1150	19-Sep-2019	19-Sep-2019	
80-5-0000000-0420	EQUIPMENT MAINTENANCE				1,118.70
8542294	SUPPLIES	1150	19-Sep-2019	19-Sep-2019	
80-5-0000000-0755	WATER SERVICE MAINTENANCE				747.24
8542295	SUPPLIES	1150	19-Sep-2019	19-Sep-2019	
80-5-0000000-0420	EQUIPMENT MAINTENANCE				38.22
8574344	SUPPLIES	1150	19-Sep-2019	19-Sep-2019	
80-5-0000000-0755	WATER SERVICE MAINTENANCE				4,025.46
8632006	SUPPLIES	1171	19-Oct-2019	19-Oct-2019	
80-5-0000000-0755	WATER SERVICE MAINTENANCE				627.15
<b>WOR415 WORK AUTHORITY</b>					
563063	SUPPLIES	1171	13-Oct-2019	13-Oct-2019	
80-5-0000000-0161	CLOTHING				81.35
<b>Department Totals :</b>					<b>396,783.20</b>

<b>DEPARTMENT 1001012 COUNCIL - DEPUTY MAYOR</b>					
<b>TOW17 CORPORATION OF THE TOWN OF KINGSVILLE</b>					
G1109	MAYOR'S INAUGURAL GOLF TOURNAMENT	1127	11-Jul-2019	11-Jul-2019	
10-5-1001012-0340	18DEPU DEP MAYOR - PUBLIC RECEPTIONS, ETC.				150.00
<b>Department Totals :</b>					<b>150.00</b>

<b>DEPARTMENT 1001013 COUNCIL - COUNCILLOR 1</b>					
<b>TOW17 CORPORATION OF THE TOWN OF KINGSVILLE</b>					
G1109	MAYOR'S INAUGURAL GOLF TOURNAMENT	1127	11-Jul-2019	11-Jul-2019	
10-5-1001013-0340	18COU1 COUNCILLOR 1 -PUBLIC RECEPTIONS, ETC.				150.00
<b>Department Totals :</b>					<b>150.00</b>

<b>DEPARTMENT 1001015 ELECTION</b>					
<b>DAT040 DATAFIX</b>					
8213	ELECTION RESERVE	1070	30-Aug-2019	30-Aug-2019	
10-5-1001015-0312	INAUGU ELECTION EXPENSES				2,401.25
<b>Department Totals :</b>					<b>2,401.25</b>

<b>DEPARTMENT 1001016 COUNCIL - COUNCILLOR 3</b>					
<b>TOW17 CORPORATION OF THE TOWN OF KINGSVILLE</b>					
G1109	MAYOR'S INAUGURAL GOLF TOURNAMENT	1127	11-Jul-2019	11-Jul-2019	
10-5-1001016-0340	18COU3 COUNCILLOR 3- PUBLIC RECEPTIONS, ETC.				150.00
<b>Department Totals :</b>					<b>150.00</b>

<b>DEPARTMENT 1001017 COUNCIL - COUNCILLOR 4</b>					
<b>TOW17 CORPORATION OF THE TOWN OF KINGSVILLE</b>					
G1109	MAYOR'S INAUGURAL GOLF TOURNAMENT	1127	11-Jul-2019	11-Jul-2019	
10-5-1001017-0340	18COU4 COUNCILLOR 4 - PUBLIC RECEPTIONS, ETC.				40.00
<b>Department Totals :</b>					<b>40.00</b>

<b>DEPARTMENT 1001018 COUNCIL - COUNCILLOR 5</b>					
<b>TOW17 CORPORATION OF THE TOWN OF KINGSVILLE</b>					
G1109	MAYOR'S INAUGURAL GOLF TOURNAMENT	1127	11-Jul-2019	11-Jul-2019	
10-5-1001018-0340	18COU5 COUNCILLOR 5 - PUBLIC RECEPTIONS, ETC.				150.00

Council/Board Report By Dept-(Computer)



Vendor : CAT038 To ZUL180

Batch : All

Department : All

Cheque Print Date : 01-Oct-2019 To 31-Oct-2019

Bank : 1 To 99

Class : All

Vendor Invoice	Vendor Name Description	Batch	Inv Date	Inv Due Date	Amount
G.L. Account	CC1 CC2 CC3 GL Account Name				

DEPARTMENT 1001018 COUNCIL - COUNCILLOR 5

Department Totals : 150.00

DEPARTMENT 1001020 ADMINISTRATION

ADV329 ADVANCE BUSINESS SYSTEMS

678276	INK FOR PWD POSTAGE MACHINE	1084	09-Aug-2019	09-Aug-2019	
10-5-1001020-0304	POSTAGE & COURIER				256.51
682662	INK FOR TOWN HALL POSTAGE MACHINE	1084	23-Sep-2019	23-Sep-2019	
10-5-1001020-0304	POSTAGE & COURIER				284.20

CAN380 CANADIAN TIRE STORE #281

JULY 2019	JULY 2019 PURCHASES	1078	31-Jul-2019	31-Jul-2019	
40-7-1001020-0012	320COM ST. BERNARD'S 320 RICHMOND				22.58
40-7-1001020-0012	320LIH ST. BERNARD'S 320 RICHMOND				259.89
40-7-1001020-0012	320ACS ST. BERNARD'S 320 RICHMOND				259.89

DEL060 DELINE'S POWERWASH & PEST CONTROL

047843	320 RICHMOND	1167	15-Oct-2019	15-Oct-2019	
40-7-1001020-0012	320COM ST. BERNARD'S 320 RICHMOND				452.00

EMC530 EMCO CORPORATION

127152-00	320 COM CREDIT	1084	26-Sep-2019	26-Sep-2019	
40-7-1001020-0012	320COM ST. BERNARD'S 320 RICHMOND				-720.45
127153-00	CREDIT	1113	26-Sep-2019	26-Sep-2019	
40-7-1001020-0012	320ACS ST. BERNARD'S 320 RICHMOND				-231.09
37503429-00	NURSE PRACTITIONER FOR CLINIC	1113	29-Jul-2019	29-Jul-2019	
40-7-1001020-0012	320LIH ST. BERNARD'S 320 RICHMOND				445.01
375034687-00	320 RICHMOND	1113	29-Jul-2019	29-Jul-2019	
40-7-1001020-0012	320LIH ST. BERNARD'S 320 RICHMOND				73.54
37503525-00	PLUMBING MAT	1070	30-Jul-2019	30-Jul-2019	
40-7-1001020-0012	320LIH ST. BERNARD'S 320 RICHMOND				91.44
37503755-00	320 RICHMOND	1113	02-Aug-2019	02-Aug-2019	
40-7-1001020-0012	320LIH ST. BERNARD'S 320 RICHMOND				83.33
37504627-00	320 LIH	1070	12-Aug-2019	12-Aug-2019	
40-7-1001020-0012	320LIH ST. BERNARD'S 320 RICHMOND				19.37
37504628-00	320 RICHMOND	1146	12-Aug-2019	12-Aug-2019	
40-7-1001020-0012	320ACS ST. BERNARD'S 320 RICHMOND				69.95
37505335-00	PLUMBING MAT	1070	20-Aug-2019	20-Aug-2019	
40-7-1001020-0012	320COM ST. BERNARD'S 320 RICHMOND				403.77
37506165-00	SUPPLIES	1070	28-Aug-2019	28-Aug-2019	
40-7-1001020-0012	320ACS ST. BERNARD'S 320 RICHMOND				886.42
37506338-00	320ACS	1070	29-Aug-2019	29-Aug-2019	
40-7-1001020-0012	320ACS ST. BERNARD'S 320 RICHMOND				24.86
37506562-00	320 ACS	1078	04-Sep-2019	04-Sep-2019	
40-7-1001020-0012	320ACS ST. BERNARD'S 320 RICHMOND				69.43
37506699-00	320 ACS	1078	05-Sep-2019	05-Sep-2019	
40-7-1001020-0012	320ACS ST. BERNARD'S 320 RICHMOND				143.48
37507026-00	320 ACS	1078	10-Sep-2019	10-Sep-2019	
40-7-1001020-0012	320ACS ST. BERNARD'S 320 RICHMOND				305.01
37507278-00	320 ACS	1078	11-Sep-2019	11-Sep-2019	
40-7-1001020-0012	320ACS ST. BERNARD'S 320 RICHMOND				40.02
37508252-01	320 RICHMOND	1113	26-Sep-2019	26-Sep-2019	
40-7-1001020-0012	320COM ST. BERNARD'S 320 RICHMOND				405.31
37508313-00	320 COM	1084	23-Sep-2019	23-Sep-2019	
40-7-1001020-0012	320COM ST. BERNARD'S 320 RICHMOND				3,147.20
37508700-00	320 RICHMOND	1113	26-Sep-2019	26-Sep-2019	
40-7-1001020-0012	320COM ST. BERNARD'S 320 RICHMOND				115.72



Vendor : CAT038 To ZUL180

Batch : All

Department : All

Cheque Print Date : 01-Oct-2019 To 31-Oct-2019

Bank : 1 To 99

Class : All

Vendor Invoice	Vendor Name Description	Batch	Inv Date	Inv Due Date	Amount
G.L. Account	CC1 CC2 CC3 GL Account Name				
<b>DEPARTMENT 1001020 ADMINISTRATION</b>					
37508788-00	320 RICHMOND		1113 26-Sep-2019	26-Sep-2019	
40-7-1001020-0012	320COM ST. BERNARD'S 320 RICHMOND				90.15
37508792-00	320 RICHMOND		1113 26-Sep-2019	26-Sep-2019	
40-7-1001020-0012	320COM ST. BERNARD'S 320 RICHMOND				55.68
37508885-00	320 RICHMOND		1113 29-Sep-2019	29-Sep-2019	
40-7-1001020-0012	320COM ST. BERNARD'S 320 RICHMOND				250.24
37509456-00	320 RICHMOND		1146 02-Oct-2019	02-Oct-2019	
40-7-1001020-0012	320COM ST. BERNARD'S 320 RICHMOND				560.49
3750948-00	320 RICHMOND		1146 03-Oct-2019	03-Oct-2019	
40-7-1001020-0012	320COM ST. BERNARD'S 320 RICHMOND				221.54
37509887-00	320 RICHMOND		1146 08-Oct-2019	08-Oct-2019	
40-7-1001020-0012	320COM ST. BERNARD'S 320 RICHMOND				1,054.50
<b>ENC113 ENCORE MECHANICAL AND BUILDING SERVICES INC</b>					
127036	WORK PERFORMED 320 RICHMOND		1167 10-Sep-2019	10-Sep-2019	
40-7-1001020-0012	320ACS ST. BERNARD'S 320 RICHMOND				8,927.00
127037	COMMUNITY HUB PROJECT EXTRA - STORM DRAIN RELOCATION IN ACS PORTION PROJECT BUILD OUT		1167 30-Aug-2019	30-Aug-2019	
40-7-1001020-0012	320ACS ST. BERNARD'S 320 RICHMOND				3,156.09
<b>MOU001 MOUSSEAU DELUCA McPHERSON PRINCE</b>					
60344	PROFESSIONAL FEES		1084 30-Aug-2019	30-Aug-2019	
40-7-1001020-0003	320RIC CAPITAL - ADMINISTRATION				494.50
60345	PROFESSIONAL FEES		1084 30-Aug-2019	30-Aug-2019	
40-7-1001020-0003	1-CENT CAPITAL - ADMINISTRATION				206.92
<b>NEO150 NEOPOST LEASING SERVICES CANADA LTD</b>					
SEPTEMBER 2	POSTAGE METER REFILL-LIBRO CENTRE, ACCT NO 2565538		1078 20-Sep-2019	20-Sep-2019	
10-5-1001020-0304	POSTAGE & COURIER				565.00
<b>PAR372 PARRLINE ELECTRICAL WHOLESALE</b>					
83484	MAINTENANCE		1167 03-Jul-2019	03-Jul-2019	
40-7-1001020-0012	320COM ST. BERNARD'S 320 RICHMOND				210.52
<b>PIN247 PINCHIN LTD.</b>					
1474248	FOLLOW UP AIR QUALITY TESTING - ONG REG COMPLIANCE COMMON ACS		1167 31-Jul-2019	31-Jul-2019	
40-7-1001020-0012	320ACS ST. BERNARD'S 320 RICHMOND				847.50
<b>PUR700 PUROLATOR INC.</b>					
442497213	COURIER		1078 13-Sep-2019	13-Sep-2019	
10-5-1001020-0304	POSTAGE & COURIER				24.85
442629011	SHIPPING		1167 27-Sep-2019	27-Sep-2019	
10-5-1001020-0304	POSTAGE & COURIER				13.56
442695662	SHIPPING		1167 04-Oct-2019	04-Oct-2019	
10-5-1001020-0304	POSTAGE & COURIER				33.63
<b>REN217 RENE ROY GROUP INC.</b>					
1959	NURSE PRACTITIONER CENTER		1084 27-Sep-2019	27-Sep-2019	
40-7-1001020-0012	320LIH ST. BERNARD'S 320 RICHMOND				23,863.19
40-7-1001020-0012	320ACS ST. BERNARD'S 320 RICHMOND				22,117.11
40-7-1001020-0012	320COM ST. BERNARD'S 320 RICHMOND				12,222.61
<b>RTT067 RIVER TOWN TIMES</b>					
2515	ADVERTISING		1127 21-Aug-2019	21-Aug-2019	
10-5-1001020-0307	ADVERTISING				174.52
2690	ADVERTISING		1078 18-Sep-2019	18-Sep-2019	
10-5-1001020-0307	ADVERTISING				174.52
10-5-1001020-0307	ADVERTISING				141.02
2718	ADVERTISING		1084 25-Sep-2019	25-Sep-2019	
10-5-1001020-0307	ADVERTISING				174.52
10-5-1001020-0307	ADVERTISING				174.52





Vendor : CAT038 To ZUL180

Batch : All

Department : All

Cheque Print Date : 01-Oct-2019 To 31-Oct-2019

Bank : 1 To 99

Class : All

Vendor Invoice	Vendor Name Description	Batch	Inv Date	Inv Due Date	Amount
G.L. Account	CC1 CC2 CC3 GL Account Name				
<b>DEPARTMENT 1001020 ADMINISTRATION</b>					
10-5-1001020-0307	ADVERTISING				141.02
10-5-1001020-0307	ADVERTISING				141.01
2801	ADVERTISING	1127	02-Oct-2019	02-Oct-2019	
10-5-1001020-0307	ADVERTISING				174.52
10-5-1001020-0307	ADVERTISING				87.26
10-5-1001020-0307	ADVERTISING				276.17
10-5-1001020-0307	ADVERTISING				276.16
2849	ADVERTISING	1167	09-Oct-2019	09-Oct-2019	
10-5-1001020-0307	ADVERTISING				174.51
10-5-1001020-0307	ADVERTISING				276.17
10-5-1001020-0307	ADVERTISING				276.17
<b>VIL417 VILLA CONSTRUCTION</b>					
7029	MAINTENANCE	1070	27-Aug-2019	27-Aug-2019	
40-7-1001020-0012	320COM ST. BERNARD'S 320 RICHMOND				2,333.52
7030	MAINTENANCE	1070	28-Aug-2019	28-Aug-2019	
40-7-1001020-0012	320COM ST. BERNARD'S 320 RICHMOND				2,136.11
7049	320 RICHMOND	1167	24-Sep-2019	24-Sep-2019	
40-7-1001020-0012	320COM ST. BERNARD'S 320 RICHMOND				1,741.10
7053	320 RICHMOND	1167	30-Sep-2019	30-Sep-2019	
40-7-1001020-0012	320COM ST. BERNARD'S 320 RICHMOND				17,232.08
<b>WIG035 WIGLE HOME HARDWARE BUILDING CENTRE</b>					
134380	SUPPLIES	1078	16-Sep-2019	16-Sep-2019	
40-7-1001020-0012	320LIH ST. BERNARD'S 320 RICHMOND				11.84
134432	SINGLE KEY CUT	1113	17-Sep-2019	17-Sep-2019	
40-7-1001020-0012	320COM ST. BERNARD'S 320 RICHMOND				6.76
134451	SUPPLIES	1078	18-Sep-2019	18-Sep-2019	
40-7-1001020-0012	320COM ST. BERNARD'S 320 RICHMOND				15.06
134740	SUPPLIES	1113	27-Sep-2019	27-Sep-2019	
40-7-1001020-0012	320ACS ST. BERNARD'S 320 RICHMOND				20.32
135065	320 RICHMOND	1167	08-Oct-2019	08-Oct-2019	
40-7-1001020-0012	320COM ST. BERNARD'S 320 RICHMOND				9.58
135107	320 RICHMOND	1167	09-Oct-2019	09-Oct-2019	
40-7-1001020-0012	320COM ST. BERNARD'S 320 RICHMOND				5.97
<b>WIN210 WINDSOR FACTORY SUPPLY LTD</b>					
5097517	320COM	1070	06-Sep-2019	06-Sep-2019	
40-7-1001020-0012	320COM ST. BERNARD'S 320 RICHMOND				411.33
5100084	320 ACS	1070	10-Sep-2019	10-Sep-2019	
40-7-1001020-0012	320ACS ST. BERNARD'S 320 RICHMOND				508.88
5100107	320 COM	1070	10-Sep-2019	10-Sep-2019	
40-7-1001020-0012	320COM ST. BERNARD'S 320 RICHMOND				364.26
5100984	320 COM	1070	11-Sep-2019	11-Sep-2019	
40-7-1001020-0012	320COM ST. BERNARD'S 320 RICHMOND				73.34
5101290	320 COM	1070	12-Sep-2019	12-Sep-2019	
40-7-1001020-0012	320COM ST. BERNARD'S 320 RICHMOND				186.70
5101783	320 COM	1070	12-Sep-2019	12-Sep-2019	
40-7-1001020-0012	320COM ST. BERNARD'S 320 RICHMOND				415.30
5101829	320 ACS	1070	12-Sep-2019	12-Sep-2019	
40-7-1001020-0012	320ACS ST. BERNARD'S 320 RICHMOND				125.77
5102001	320 COM	1070	13-Sep-2019	13-Sep-2019	
40-7-1001020-0012	320COM ST. BERNARD'S 320 RICHMOND				-126.92
5102637	320 COM	1070	13-Sep-2019	13-Sep-2019	
40-7-1001020-0012	320COM ST. BERNARD'S 320 RICHMOND				63.05
5102999	CREDIT	1146	16-Sep-2019	16-Sep-2019	
40-7-1001020-0012	320ACS ST. BERNARD'S 320 RICHMOND				-276.54



Vendor : CAT038 To ZUL180  
 Batch : All  
 Department : All

Cheque Print Date : 01-Oct-2019 To 31-Oct-2019  
 Bank : 1 To 99  
 Class : All

Vendor Invoice	Vendor Name Description	Batch	Inv Date	Inv Due Date	Amount
G.L. Account	CC1 CC2 CC3 GL Account Name				
<b>DEPARTMENT 1001020 ADMINISTRATION</b>					
5103000 320COM		1070	16-Sep-2019	16-Sep-2019	
40-7-1001020-0012 320COM	ST. BERNARD'S 320 RICHMOND				-368.91
5103798 320COM		1078	16-Sep-2019	16-Sep-2019	
40-7-1001020-0012 320COM	ST. BERNARD'S 320 RICHMOND				96.40
5104033 320COM		1078	17-Sep-2019	17-Sep-2019	
40-7-1001020-0012 320COM	ST. BERNARD'S 320 RICHMOND				1,639.52
5106571 320 RICHMOND		1146	19-Sep-2019	19-Sep-2019	
40-7-1001020-0012 320ACS	ST. BERNARD'S 320 RICHMOND				213.90
5108068 320 COM		1084	23-Sep-2019	23-Sep-2019	
40-7-1001020-0012 320COM	ST. BERNARD'S 320 RICHMOND				52.88
5117155 320 RICHMOND		1146	04-Oct-2019	04-Oct-2019	
40-7-1001020-0012 320COM	ST. BERNARD'S 320 RICHMOND				310.00
5119211 320 RICHMOND		1146	08-Oct-2019	08-Oct-2019	
40-7-1001020-0012 320COM	ST. BERNARD'S 320 RICHMOND				158.55
5119412 PLUMBING MATERIALS		1167	09-Oct-2019	09-Oct-2019	
40-7-1001020-0012 320LIH	ST. BERNARD'S 320 RICHMOND				4,385.08
5122464 320 RICHMOND		1167	15-Oct-2019	15-Oct-2019	
40-7-1001020-0012 320ACS	ST. BERNARD'S 320 RICHMOND				1,989.73
5122816 320 RICHMOND		1167	15-Oct-2019	15-Oct-2019	
40-7-1001020-0012 320ACS	ST. BERNARD'S 320 RICHMOND				233.82
<b>Department Totals :</b>					<b>118,453.04</b>
-----					
<b>DEPARTMENT 1001021 TREASURY</b>					
<b>FIR350 FIRST STOP SERVICES</b>					
4719 SHREDDING SERVICES		1127	30-Sep-2019	30-Sep-2019	
10-5-1001021-0301 OFFICE SUPPLIES					46.66
<b>MON183 MONARCH OFFICE SUPPLY LTD</b>					
167219 PURCHASES MADE FOR THE MONTH OF AUGUST 2019		1078	29-Aug-2019	29-Aug-2019	
10-5-1001021-0301 OFFICE SUPPLIES					389.38
<b>PUR663 PURE WATER BRAND</b>					
SEPTEMBER 2 000332669, 000335046, 000337466 SEPTEMBER 2019		1146	30-Sep-2019	30-Sep-2019	
10-5-1001021-0301 OFFICE SUPPLIES					20.77
<b>Department Totals :</b>					<b>456.81</b>
-----					
<b>DEPARTMENT 1001022 CLERKS</b>					
<b>ADV329 ADVANCE BUSINESS SYSTEMS</b>					
681405 OFFICE SUPPLIES		1127	09-Sep-2019	09-Sep-2019	
10-5-1001022-0301 OFFICE SUPPLIES					121.98
<b>CLA508 CLAIMSPRO INC.</b>					
33620-684717 INSURANCE DEDUCTIBLE		1127	01-Oct-2019	01-Oct-2019	
10-5-1001022-0506 INSURANCE DEDUCTIBLE					483.00
<b>FIR350 FIRST STOP SERVICES</b>					
4719 SHREDDING SERVICES		1127	30-Sep-2019	30-Sep-2019	
10-5-1001022-0301 OFFICE SUPPLIES					46.67
<b>MCT455 MCTAGUE LAW FIRM</b>					
302939 PROFESSIONAL SERVICES		1084	11-Jun-2019	11-Jun-2019	
10-5-1001022-0327 PROFESSIONAL FEES - CLERKS					4,433.56
<b>MON183 MONARCH OFFICE SUPPLY LTD</b>					
162631 PURCHASES MADE FOR THE MONTH OF JULY 2019		1078	30-Jul-2019	30-Jul-2019	
10-5-1001022-0301 OFFICE SUPPLIES					118.07
167219 PURCHASES MADE FOR THE MONTH OF AUGUST 2019		1078	29-Aug-2019	29-Aug-2019	
10-5-1001022-0301 OFFICE SUPPLIES					51.82





Vendor : CAT038 To ZUL180

Batch : All

Department : All

Cheque Print Date : 01-Oct-2019 To 31-Oct-2019

Bank : 1 To 99

Class : All

Vendor Invoice	Vendor Name Description				Batch Invc Date	Invc Due Date	Amount
G.L. Account	CC1	CC2	CC3	GL Account Name			
<b>DEPARTMENT 1001022</b>				CLERKS			
<b>PUR663</b>	<b>PURE WATER BRAND</b>						
SEPTEMBER 2 000332669, 000335046, 000337466				SEPTEMBER 2019	1146 30-Sep-2019	30-Sep-2019	
10-5-1001022-0301				OFFICE SUPPLIES			20.77
<b>Department Totals :</b>							<b>5,275.87</b>
-----							
<b>DEPARTMENT 1001023</b>				C.A.O.			
<b>FIR350</b>	<b>FIRST STOP SERVICES</b>						
4719	SHREDDING SERVICES				1127 30-Sep-2019	30-Sep-2019	
10-5-1001023-0301				OFFICE SUPPLIES			46.67
<b>MON183</b>	<b>MONARCH OFFICE SUPPLY LTD</b>						
162631	PURCHASES MADE FOR THE MONTH OF JULY 2019				1078 30-Jul-2019	30-Jul-2019	
10-5-1001023-0301				OFFICE SUPPLIES			3.93
167219	PURCHASES MADE FOR THE MONTH OF AUGUST 2019				1078 29-Aug-2019	29-Aug-2019	
10-5-1001023-0301				OFFICE SUPPLIES			19.30
<b>MON610</b>	<b>MONTEITH BROWN PLANNING CONSULTANTS</b>						
14442	PROFESSIONAL FEES				1167 15-Oct-2019	15-Oct-2019	
10-5-1001023-0327				PROFESSIONAL FEES			1,932.50
<b>PUR663</b>	<b>PURE WATER BRAND</b>						
SEPTEMBER 2 000332669, 000335046, 000337466				SEPTEMBER 2019	1146 30-Sep-2019	30-Sep-2019	
10-5-1001023-0301				OFFICE SUPPLIES			20.77
<b>Department Totals :</b>							<b>2,023.17</b>
-----							
<b>DEPARTMENT 1001024</b>				HUMAN RESOURCES			
<b>BER067</b>	<b>BERRN CONSULTING LTD./AED4LIFE.CA</b>						
20195778	PHYSIO-CONTROL LIFEPAK QUICK-COMBO ELECTRODES				1146 03-Oct-2019	03-Oct-2019	
10-5-1001024-0250				HEALTH AND SAFETY - HUMAN RESOURCES			118.56
<b>CAN558</b>	<b>CANADA MUNICIPAL JOBS INC.</b>						
4592	ONTARIO MUNICIPAL JOBS - JOB ADS				1146 10-Aug-2019	10-Aug-2019	
10-5-1001024-0372				RECRUITMENT EXPENSES			163.85
<b>EDG002</b>	<b>EDGE SAFETY TRAINING SOLUTIONS A DIVISION OF</b>						
2019-0055	CORPORATE TRAINING				1070 13-Sep-2019	13-Sep-2019	
10-5-1001024-0249				CORPORATE TRAINING			683.65
<b>FSE177</b>	<b>FAMILY SERVICES WINDSOR-ESSEX</b>						
20021	QUARTERLY INSTALLMENT OF EAP SEPT 1 - NOV 30, 2019				1146 30-Sep-2019	30-Sep-2019	
10-5-1001024-0215				BENEFITS - EAP			1,163.70
<b>MED200</b>	<b>MEDIATION SERVICES C/O MRS. P.A. PATTERSON</b>						
AUGUST 2019	PROFESSIONAL SERVICES				1084 14-Aug-2019	14-Aug-2019	
10-5-1001024-0327				PROFESSIONAL FEES			591.00
<b>MON183</b>	<b>MONARCH OFFICE SUPPLY LTD</b>						
162631	PURCHASES MADE FOR THE MONTH OF JULY 2019				1078 30-Jul-2019	30-Jul-2019	
10-5-1001024-0250				HEALTH AND SAFETY - HUMAN RESOURCES			406.78
167219	PURCHASES MADE FOR THE MONTH OF AUGUST 2019				1078 29-Aug-2019	29-Aug-2019	
10-5-1001024-0250				HEALTH AND SAFETY - HUMAN RESOURCES			281.89
170938	OFFICE SUPPLIES				1084 19-Sep-2019	19-Sep-2019	
10-5-1001024-0250				HEALTH AND SAFETY - HUMAN RESOURCES			474.46
<b>PUR700</b>	<b>PUROLATOR INC.</b>						
442617807	COURIER				1146 27-Sep-2019	27-Sep-2019	
10-5-1001024-0301				OFFICE SUPPLIES			9.23
<b>RTT067</b>	<b>RIVER TOWN TIMES</b>						
2515	ADVERTISING				1127 21-Aug-2019	21-Aug-2019	
10-5-1001024-0372				RECRUITMENT EXPENSES			87.26

Council/Board Report By Dept-(Computer)



Vendor : CAT038 To ZUL180  
 Batch : All  
 Department : All

Cheque Print Date : 01-Oct-2019 To 31-Oct-2019  
 Bank : 1 To 99  
 Class : All

Vendor Invoice	Vendor Name Description	Batch	Inv Date	Inv Due Date	Amount
G.L. Account	CC1 CC2 CC3 GL Account Name				
<b>DEPARTMENT 1001024 HUMAN RESOURCES</b>					
10-5-1001024-0372	RECRUITMENT EXPENSES				87.26
2801	ADVERTISING	1127	02-Oct-2019	02-Oct-2019	
10-5-1001024-0372	RECRUITMENT EXPENSES				87.26
2849	ADVERTISING	1167	09-Oct-2019	09-Oct-2019	
10-5-1001024-0372	RECRUITMENT EXPENSES				87.26
10-5-1001024-0372	RECRUITMENT EXPENSES				87.26
<b>TOT060 TOTALLYONE CORPORATE OFFICE</b>					
25440	PHONE RENEWAL	1084	09-Sep-2019	09-Sep-2019	
10-5-1001024-0345	CELL PHONE				620.32
<b>Department Totals :</b>					<b>4,949.74</b>

<b>DEPARTMENT 1001025 INFORMATION TECHNOLOGY</b>					
<b>APP302 APPLIED COMPUTER SOLUTIONS INC</b>					
45699	TELEPHONE REPAIR AND MAINTENANCE	1084	30-Aug-2019	30-Aug-2019	
10-5-1001025-0315	TELEPHONE				353.13
10-5-1001025-0310	COMPUTER MAINTENANCE				282.50
<b>DIR572 DIRECTDIAL.COM</b>					
IN688698	PRINTER USAGE AND MAINTENANCE	1084	28-Aug-2019	28-Aug-2019	
10-5-1001025-0308	PHOTOCOPIES				298.50
<b>ESO651 ESOLUTIONS GROUP LIMITED</b>					
120889	WEBSITE DESIGN UPDATE	1084	17-Sep-2019	17-Sep-2019	
10-5-1001025-0311	WEBSITE DEVELOPMENT & SOFTWARE				197.75
120948	WEBSITE DESIGN AND UPDATE	1084	25-Sep-2019	25-Sep-2019	
10-5-1001025-0311	WEBSITE DEVELOPMENT & SOFTWARE				169.50
<b>KEL117 KELCOM TELEMESSAGING</b>					
1909-06702	AFTER HOURS ANSWERING SERVICE -PWD	1084	01-Sep-2019	01-Sep-2019	
10-5-1001025-0315	TELEPHONE				144.97
1910-06702	ANSWERING SERVICES	1167	01-Oct-2019	01-Oct-2019	
10-5-1001025-0315	TELEPHONE				82.29
<b>SHI03 SHI CANADA ULC c/o T9981</b>					
CB00305100	ANNUAL MAINTENANCE	1084	02-Aug-2019	02-Aug-2019	
10-5-1001025-0310	COMPUTER MAINTENANCE				24,359.25
<b>STA444 STAPLES ADVANTAGE (MIS C/O T04446C</b>					
51483080	BATTERIES	1084	23-Sep-2019	23-Sep-2019	
10-5-1001025-0301	OFFICE SUPPLIES				86.86
<b>THI235 THINK! WIRELESS SOLUTIONS INC.</b>					
0000014286	GPS	1084	06-Sep-2019	06-Sep-2019	
10-5-1001025-0406	GPS				1,196.61
<b>THI740 THINKTEL COMMUNICATIONS - A DIVISION OF DISTRIBUTE</b>					
1206529	TELEPHONE LANDLINE ACCESS	1084	06-Sep-2019	06-Sep-2019	
10-5-1001025-0315	TELEPHONE				375.05
<b>TOS075 TOSHIBA BUISNESS SOLUTIONS; A DIVISION OF</b>					
AR3798243	COPIER - RECORDS RETENTION - USAGE AND MAINTENANCE	1084	23-Sep-2019	23-Sep-2019	
10-5-1001025-0308	PHOTOCOPIES				1.68
AR3798244	COPIER USAGE AND MAINTENANCE	1084	23-Sep-2019	23-Sep-2019	
10-5-1001025-0308	PHOTOCOPIES				3,052.20
<b>Department Totals :</b>					<b>30,600.29</b>

<b>DEPARTMENT 1001029 RECORDS RETENTION</b>					
<b>BOO022 BOOKSHELF BINDERY LTD</b>					
43907	RECORDS MANAGEMENT	1167	17-Oct-2019	17-Oct-2019	
10-5-1001029-0317	BUILDING MAINTENANCE - RECORDS RETENTION				321.37

Council/Board Report By Dept-(Computer)



Vendor : CAT038 To ZUL180  
 Batch : All  
 Department : All

Cheque Print Date : 01-Oct-2019 To 31-Oct-2019  
 Bank : 1 To 99  
 Class : All

Vendor Invoice	Vendor Name Description	Batch	Inv Date	Inv Due Date	Amount
G.L. Account	CC1 CC2 CC3 GL Account Name				

**DEPARTMENT 1001029 RECORDS RETENTION**

**MON183 MONARCH OFFICE SUPPLY LTD**

167219	PURCHASES MADE FOR THE MONTH OF AUGUST 2019	1078	29-Aug-2019	29-Aug-2019	
10-5-1001029-0317	BUILDING MAINTENANCE - RECORDS RETENTION				102.91
<b>Department Totals :</b>					<b>424.28</b>

**DEPARTMENT 1002000 COMMITTEES**

**MOU001 MOUSSEAU DELUCA McPHERSON PRINCE**

60282	HERITAGE COMMITTEE EXPENSE	1146	31-Aug-2019	31-Aug-2019	
10-5-1002000-0368	HERITAGE COMMITTEE				4,525.59
<b>Department Totals :</b>					<b>4,525.59</b>

**DEPARTMENT 1008030 UNFINANCED DRAINS**

**BAR221 BART DIGIOVANNI CONSTRUCTION**

12-040	HOLDB LEO BEAUDOIN DRAIN HOLDBACK	1167	21-Oct-2019	21-Oct-2019	
10-1-1008030-9010	LEO BEAUDOIN DRAIN IMPROVEMENTS				14,454.96
SEPTEMBER 1	LEO BEAUDOIN CHECK VALVE	1070	13-Sep-2019	13-Sep-2019	
10-5-1008030-0764	DRAIN CONSTRUCTION				2,260.00

**D&D100 D & D EXCAVATING & DRAINAGE**

376	STORM CLEAN UP NEAR OMG DRAIN	1084	20-Sep-2019	20-Sep-2019	
10-5-1008030-0765	DRAIN MAINTENANCE				847.50
378	CONSTRUCTION COST FOR NEW BRIDGE	1146	25-Sep-2019	25-Sep-2019	
10-1-1008030-9043	WHELAN DRAIN-HUTCHINS BRIDGE				15,283.25
E09-2018-022	PPC # 1	1146	03-Oct-2019	03-Oct-2019	
10-1-1008030-8400	HOWIE DRAIN				14,409.20

**DIL426 DILLON CONSULTING**

206629	ENGINEERING FEES	1146	30-Sep-2019	30-Sep-2019	
10-1-1008030-9048	PARKS DRAIN - S.4 PETITION				704.78
206633	ENGINEERING FEES	1167	30-Sep-2019	30-Sep-2019	
10-1-1008030-9040	LEMAY-COOKSON DRAIN - REQ FOR IMPROVEMEN				4,597.86

**KNM541 KNM YARD CARE**

1560	GRASS CUTTING FOR SEPTEMBER 2019	1153	01-Oct-2019	01-Oct-2019	
10-1-1008030-8965	WILLOW BEACH PUMP				101.70
10-1-1008030-8675	MICKLE PARK AVE PUMP				84.75

**PAR372 PARRLINE ELECTRICAL WHOLESALE**

84808	SOFT STARTER FOR ESSEX BLVD PUMP	1084	27-Aug-2019	27-Aug-2019	
10-1-1008030-8125	BAR POINT PUMP (ESSEX BLVD PUMP)				2,050.27

**RDO421 R DOBBIN ENGINEERING INC**

176.19	ENGINEERING FEES FOR REPORT PREP	1084	24-Sep-2019	24-Sep-2019	
10-1-1008030-9047	DUPUIS DRAIN - BASTIEN BRIDGE				17,017.80
<b>Department Totals :</b>					<b>71,812.07</b>

**DEPARTMENT 2010000 FIRE DEPARTMENT**

**AJS141 A.J. STONE CO LTD**

0000148781	FIRE FIGHTING EQUIP FOR ENGINE 18	1084	25-Sep-2019	25-Sep-2019	
10-5-2010000-0420	FIREFIGHTING EQUIPMENT				33,912.43
0000148784	HEALTH AND SAFETY ISSUE EQUIP MOUNTING IN ENGINE 1	1084	25-Sep-2019	25-Sep-2019	
10-5-2010000-0420	FIREFIGHTING EQUIPMENT				1,354.87
0000148832	FFING EQUIP	1084	27-Sep-2019	27-Sep-2019	
10-5-2010000-0420	FIREFIGHTING EQUIPMENT				403.78

**BEN260 BENSON TIRE**

20455971	TIRE MAINTENANCE	1167	25-Sep-2019	25-Sep-2019	
10-5-2010000-0402	VEHICLE & EQUIPMENT MTCE.				12.64

Council/Board Report By Dept-(Computer)



Vendor : CAT038 To ZUL180  
 Batch : All  
 Department : All

Cheque Print Date : 01-Oct-2019 To 31-Oct-2019  
 Bank : 1 To 99  
 Class : All

Vendor Invoice	Vendor Name Description	Batch	Inv Date	Inv Due Date	Amount
G.L. Account	CC1 CC2 CC3 GL Account Name				

**DEPARTMENT 2010000 FIRE DEPARTMENT**

**BIZ772 BIZ X MAGAZINE**

SEPTEMBER & FIRE PREVENTION ADS  
 10-5-2010000-0251 FIRE PREVENTION & TRAININ 1084 08-Sep-2019 08-Sep-2019 593.25

**CAN380 CANADIAN TIRE STORE #281**

JULY 2019 JULY 2019 PURCHASES 1078 31-Jul-2019 31-Jul-2019  
 10-5-2010000-0318 JANITORIAL 237.27  
 10-5-2010000-0318 JANITORIAL 67.78  
 10-5-2010000-0254 FIRE FIGHTER TRAINING 315.19  
 10-5-2010000-0420 FIREFIGHTING EQUIPMENT 76.04  
 10-5-2010000-0252 UNIFORMS 105.44

**CAR645 CARRIER CENTERS**

04PS414598 REPAIRS TO L1 1113 04-Aug-2019 04-Aug-2019  
 10-5-2010000-0402 VEHICLE & EQUIPMENT MTCE. 136.65  
 04S414598 REPAIRS TO L1 1084 04-Aug-2019 04-Aug-2019  
 10-5-2010000-0402 VEHICLE & EQUIPMENT MTCE. 136.65  
 05S503362 2019 LADDER - 1 ANNUAL INSPECTION AND SERVICE 1167 30-Sep-2019 30-Sep-2019  
 10-5-2010000-0402 VEHICLE & EQUIPMENT MTCE. 3,231.62  
 05S503364 E 2 REPAIR 1167 03-Oct-2019 03-Oct-2019  
 10-5-2010000-0402 VEHICLE & EQUIPMENT MTCE. 80.17

**FOR053 FORT GARRY FIRE TRUCKS LTD.**

31574 ENGINE 1B 1070 10-Sep-2019 10-Sep-2019  
 10-5-2010000-0402 VEHICLE & EQUIPMENT MTCE. 613.59

**FRO400 FRONTLINE OUTFITTERS**

0000044016 UNIFORMS 1070 13-Sep-2019 13-Sep-2019  
 10-5-2010000-0252 UNIFORMS 1,851.14  
 0000044162 CLASS B SHIRTS 1084 23-Sep-2019 23-Sep-2019  
 10-5-2010000-0252 UNIFORMS 284.15

**KAL132 KAL TIRE 837 - WINDSOR**

837154561 TIRE SERVICE 1167 25-Sep-2019 25-Sep-2019  
 10-5-2010000-0402 VEHICLE & EQUIPMENT MTCE. 132.38  
 837154562 TIRE REPAIR 1167 25-Sep-2019 25-Sep-2019  
 10-5-2010000-0402 VEHICLE & EQUIPMENT MTCE. 79.67

**KEL198 KELCOM RADIO DIVISION**

80011113 PAGING/RADIO AIRTIME 1070 16-Sep-2019 16-Sep-2019  
 10-5-2010000-0319 COMMUNICATION EQUIP MAINTENANCE 3,742.56

**MLS149 M&L SUPPLY FIRE & SAFETY - 3635112**

0000157012 PILOT GUAGE 1084 20-Sep-2019 20-Sep-2019  
 10-5-2010000-0251 FIRE PREVENTION & TRAININ 949.40

**MON183 MONARCH OFFICE SUPPLY LTD**

162631 PURCHASES MADE FOR THE MONTH OF JULY 2019 1078 30-Jul-2019 30-Jul-2019  
 10-5-2010000-0327 PROFESSIONAL FEES 504.13  
 167219 PURCHASES MADE FOR THE MONTH OF AUGUST 2019 1078 29-Aug-2019 29-Aug-2019  
 10-5-2010000-0327 PROFESSIONAL FEES 1,886.33

**SAN107 SANIGEAR**

3100 PPE MAINTENANCE 1078 16-Sep-2019 16-Sep-2019  
 10-5-2010000-0423 PERSONAL PROTECTIVE EQUIPMENT 274.48  
 3233 PPE MAINTENANCE 1167 08-Oct-2019 08-Oct-2019  
 10-5-2010000-0423 PERSONAL PROTECTIVE EQUIPMENT 234.25  
 3242 PPE MAINTENANCE 1167 10-Oct-2019 10-Oct-2019  
 10-5-2010000-0423 PERSONAL PROTECTIVE EQUIPMENT 397.53

**SKY232 SKY MOBILE**

SKY01N2713 BEACONS 1167 01-Oct-2019 01-Oct-2019  
 10-5-2010000-0345 FIRE - CELL PHONE EXPENSE 404.54

Council/Board Report By Dept-(Computer)



Vendor : CAT038 To ZUL180  
 Batch : All  
 Department : All

Cheque Print Date : 01-Oct-2019 To 31-Oct-2019  
 Bank : 1 To 99  
 Class : All

Vendor Invoice	Vendor Name Description	Batch	Inv Date	Inv Due Date	Amount
G.L. Account	CC1 CC2 CC3 GL Account Name				
<b>DEPARTMENT 2010000 FIRE DEPARTMENT</b>					
<b>STA444</b>	<b>STAPLES ADVANTAGE (MIS C/O T04446C</b>				
51515205	BATTERIES	1084	26-Sep-2019	26-Sep-2019	
10-5-2010000-0402	VEHICLE & EQUIPMENT MTCE.				152.41
<b>SUN293</b>	<b>SUNSET ENTERPRIZE &amp; WELDING</b>				
318246	TRUCK CLEANING SUPPLIES	1078	11-Sep-2019	11-Sep-2019	
10-5-2010000-0318	JANITORIAL				169.43
<b>THA150</b>	<b>THAMES COMMUNICATIONS</b>				
CHA20IN1005C	PAGER REPAIR	1113	06-Sep-2019	06-Sep-2019	
10-5-2010000-0319	COMMUNICATION EQUIP MAINTENANCE				94.92
<b>VEH188</b>	<b>VEHICLE VENTURE</b>				
204671	WORKER CENTER TRAILER	1070	30-Aug-2019	30-Aug-2019	
10-5-2010000-0800	EMERGENCY OPERATIONS CENTRE EXPENSES				3,626.80
<b>WIN101</b>	<b>WINDSOR SPRING &amp; ALIGNMENT</b>				
6825	PARTS FOR SUTPHEN	1167	07-Oct-2019	07-Oct-2019	
10-5-2010000-0402	VEHICLE & EQUIPMENT MTCE.				304.32
<b>WOR415</b>	<b>WORK AUTHORITY</b>				
557676	WORK BOOTS	1070	15-Sep-2019	15-Sep-2019	
10-5-2010000-0252	UNIFORMS				150.00
560567	WORK BOOTS	1113	29-Sep-2019	29-Sep-2019	
10-5-2010000-0252	UNIFORMS				150.00
				<b>Department Totals :</b>	<b>56,665.81</b>

<b>DEPARTMENT 2020000 POLICE DEPARTMENT</b>					
<b>APP302</b>	<b>APPLIED COMPUTER SOLUTIONS INC</b>				
45699	TELEPHONE REPAIR AND MAINTENANCE	1084	30-Aug-2019	30-Aug-2019	
10-5-2020000-0315	TELEPHONE				141.25
<b>JAN268</b>	<b>JANI SAFE INC.</b>				
193239	JANITORIAL SUPPLIES	1070	15-Aug-2019	15-Aug-2019	
10-5-2020000-0318	JANITORIAL				68.09
<b>KEL198</b>	<b>KELCOM RADIO DIVISION</b>				
80010993	POLICE RADIO LOCAL INFRASTRUCTURE CONTRACT	1084	15-Aug-2019	15-Aug-2019	
10-5-2020000-0319	RADIO MAINTENANCE				571.78
80010994	POLICE RADIO BACKHAUL MAINTENANCE CONTRACT	1084	15-Aug-2019	15-Aug-2019	
10-5-2020000-0319	RADIO MAINTENANCE				197.75
80011115	POLICE RADIO LOCAL INFRASTRUCTURE SERVICE CONTRACT	1084	16-Sep-2019	16-Sep-2019	
10-5-2020000-0319	RADIO MAINTENANCE				571.78
80011116	POLICE READIO BACKHAUL MAINTENANCE CONTRACT	1084	16-Sep-2019	16-Sep-2019	
10-5-2020000-0319	RADIO MAINTENANCE				197.75
<b>KEL363</b>	<b>KEL COMMUNICATIONS LTD</b>				
RC00004572	TOWER LEASE - CALDWELL NORTH	1084	01-Sep-2019	01-Sep-2019	
10-5-2020000-0319	RADIO MAINTENANCE				444.06
<b>MET052</b>	<b>METRO KING PEST CONTROL INC.</b>				
2152	MONTHLY SERVICE AT VARIOUS LOCATIONS FOR THE MONTH OF JULY 2019	1078	31-Jul-2019	31-Jul-2019	
10-5-2020000-0317	BUILDING MAINTENANCE				33.90
2153	MONTHLY SERVICES AT VARIOUS LOCATIONS	1078	31-Aug-2019	31-Aug-2019	
10-5-2020000-0317	BUILDING MAINTENANCE				33.90
<b>MOU001</b>	<b>MOUSSEAU DELUCA McPHERSON PRINCE</b>				
60320	LEGAL FEES	1078	31-Aug-2019	31-Aug-2019	
10-5-2020000-0324	DISPATCHING - POLICE				926.60
<b>TUR070</b>	<b>TURRIS SITES DEVELOPMENT CORP.</b>				
503798	TOWER LEASE - MCGREGOR	1084	01-Sep-2019	01-Sep-2019	
10-5-2020000-0319	RADIO MAINTENANCE				620.20

TOWN OF AMHERSTBURG  
 Council/Board Report By Dept-(Computer)



AP5130 Page : 17  
 Date : Oct 25, 2019 Time : 9:03 am

Vendor : CAT038 To ZUL180  
 Batch : All  
 Department : All

Cheque Print Date : 01-Oct-2019 To 31-Oct-2019  
 Bank : 1 To 99  
 Class : All

Vendor Invoice	Vendor Name Description				Batch Invc Date	Invc Due Date	Amount
G.L. Account	CC1	CC2	CC3	GL Account Name			
<b>DEPARTMENT 2020000 POLICE DEPARTMENT</b>							
504524	TOWER LEASE - MCGREGOR				1084 10-Jan-2019	10-Jan-2019	
10-5-2020000-0319				RADIO MAINTENANCE			620.20
<b>Department Totals :</b>							<b>4,427.26</b>
-----							
<b>DEPARTMENT 2043010 BUILDING DEPARTMENT</b>							
<b>JON433 JONES ROBERT</b>							
231902	PERMIT CANCELLATION				1167 05-Sep-2019	05-Sep-2019	
10-4-2043010-2115		BS0003		BUILD DEPT - BUILDING PERMITS			500.00
<b>MAL256 MALDEN AUTOMOTIVE</b>							
5294-198898	UNIT BP-02				1078 06-Sep-2019	06-Sep-2019	
10-5-2043010-0402				VEHICLE & EQUIPMENT MTCE.			8.95
<b>MON183 MONARCH OFFICE SUPPLY LTD</b>							
162631	PURCHASES MADE FOR THE MONTH OF JULY 2019				1078 30-Jul-2019	30-Jul-2019	
10-5-2043010-0301				OFFICE SUPPLIES			58.40
<b>SUN419 SUN PARLOUR CHAPTER OBOA</b>							
2019-006	MEMBERSHIP RENEWAL				1078 05-Jul-2019	05-Jul-2019	
10-5-2043010-0350				MEMBERSHIPS			100.00
<b>TOT060 TOTALLYONE CORPORATE OFFICE</b>							
25442	PHONE REPLACEMENT - CBO				1084 09-Sep-2019	09-Sep-2019	
10-5-2043010-0345				BLDG. - CELL PHONE EXPENSE			624.89
<b>Department Totals :</b>							<b>1,292.24</b>
-----							
<b>DEPARTMENT 2043015 LICENSING AND ENFORCEMENT</b>							
<b>AMH220 AMHERSTBURG ANIMAL CLINIC</b>							
SEPTEMBER 2	SPAY/NEUTER				1127 26-Sep-2019	26-Sep-2019	
10-5-2043015-0904				ANIMAL CONTROL - OTHER			50.00
<b>KEL198 KELCOM RADIO DIVISION</b>							
80011118	MONTHLY CONTRACT				1084 16-Sep-2019	16-Sep-2019	
10-5-2043015-0420				SMALL EQUIPMENT			118.48
<b>MIN087 MINISTRY OF TRANSPORTATION</b>							
SEPTEMBER 2	ARIS AGREEMENT SERVICE FEE				1146 30-Sep-2019	30-Sep-2019	
10-4-2043015-5800				BYLAW - PARKING TICKETS			8.25
<b>MON183 MONARCH OFFICE SUPPLY LTD</b>							
167219	PURCHASES MADE FOR THE MONTH OF AUGUST 2019				1078 29-Aug-2019	29-Aug-2019	
10-5-2043015-0301				OFFICE SUPPLIES			81.64
<b>PUR663 PURE WATER BRAND</b>							
SEPTEMBER 2	000332669, 000335046, 000337466			SEPTEMBER 2019	1146 30-Sep-2019	30-Sep-2019	
10-5-2043015-0301				OFFICE SUPPLIES			20.77
<b>PUR700 PUROLATOR INC.</b>							
442617807	COURIER				1146 27-Sep-2019	27-Sep-2019	
10-5-2043015-0301				OFFICE SUPPLIES			23.06
<b>SOU725 SOUTH HOWARD ANIMAL CLINIC; A DIVISION OF</b>							
253406	SOUTH HOWARD ANIMAL CLINIC				1078 06-Sep-2019	06-Sep-2019	
10-5-2043015-0904				ANIMAL CONTROL - OTHER			100.00
<b>TER04 TERANET INC.</b>							
OCTOBER 10,	FUNDS FOR TITLE SEARCH, ACCOUNT # TV009494				1167 10-Oct-2019	10-Oct-2019	
10-5-2043015-0327				PROFESSIONAL FEES - L&E			1,000.00
<b>WIN137 WINDSOR-ESSEX COUNTY HUMANE SOCIETY</b>							
AUGUST 31,	21 SPAY AND NEUTER VOUCHER PROGRAM				1084 31-Aug-2019	31-Aug-2019	
10-5-2043015-0904				ANIMAL CONTROL - OTHER			250.00
JULY 2019	MONTHLY CONTRACT FOR DOG CONTROL FOR THE MONTH OF JULY 2019				1084 31-Jul-2019	31-Jul-2019	



Council/Board Report By Dept-(Computer)



Vendor : CAT038 To ZUL180  
 Batch : All  
 Department : All

Cheque Print Date : 01-Oct-2019 To 31-Oct-2019  
 Bank : 1 To 99  
 Class : All

Vendor Invoice	Vendor Name Description	Batch	Inv Date	Inv Due Date	Amount
G.L. Account	CC1 CC2 CC3 GL Account Name				
<b>DEPARTMENT 2043015 LICENSING AND ENFORCEMENT</b>					
10-5-2043015-0903	ANIMAL CONTROL - CONTRACT				2,500.00
SEPTEMBER 1 CAT INTAKE PROGRAM					
		1070	10-Sep-2019	10-Sep-2019	
10-5-2043015-0904	ANIMAL CONTROL - OTHER				125.00
SEPTEMBER € ANIMAL CONTROL FOR THE MONTH OF SEPTEMBER 2019					
		1070	06-Sep-2019	06-Sep-2019	
10-5-2043015-0904	ANIMAL CONTROL - OTHER				2,500.00
<b>Department Totals :</b>					<b>6,777.20</b>

<b>DEPARTMENT 3010000 PUBLIC WORKS</b>					
<b>ACK297 ACKLANDS-GRAINGER INC</b>					
9307388901	ROAD STOCK		1146	27-Sep-2019	27-Sep-2019
10-5-3010000-0402	VEHICLE & EQUIPMENT MTCE.				22.83
<b>BEN260 BENSON TIRE</b>					
12974085	UNIT 407-19		1070	04-Sep-2019	04-Sep-2019
10-5-3010000-0402	VEHICLE & EQUIPMENT MTCE.				1,017.72
20456085	UNIT 205		1167	26-Sep-2019	26-Sep-2019
10-5-3010000-0402	VEHICLE & EQUIPMENT MTCE.				222.32
20456086	UNIT 205		1167	26-Sep-2019	26-Sep-2019
10-5-3010000-0402	VEHICLE & EQUIPMENT MTCE.				56.71
20456187	UNIT 308		1167	27-Sep-2019	27-Sep-2019
10-5-3010000-0402	VEHICLE & EQUIPMENT MTCE.				164.70
<b>BEN262 BENSON AUTO PARTS</b>					
20453753	SHOP USE		1070	22-Aug-2019	22-Aug-2019
10-5-3010000-0402	VEHICLE & EQUIPMENT MTCE.				56.27
20454479	CREDIT		1070	03-Sep-2019	03-Sep-2019
10-5-3010000-0402	VEHICLE & EQUIPMENT MTCE.				-102.42
20454611	ROADS STOCK		1070	05-Sep-2019	05-Sep-2019
10-5-3010000-0402	VEHICLE & EQUIPMENT MTCE.				32.24
20454713	UNIT 510		1070	06-Sep-2019	06-Sep-2019
10-5-3010000-0402	VEHICLE & EQUIPMENT MTCE.				285.87
20455068	UNIT 209		1070	12-Sep-2019	12-Sep-2019
10-5-3010000-0402	VEHICLE & EQUIPMENT MTCE.				42.85
20455330	UNIT 209		1146	16-Sep-2019	16-Sep-2019
10-5-3010000-0402	VEHICLE & EQUIPMENT MTCE.				76.70
20455946	SHOP TOOLS		1146	24-Sep-2019	24-Sep-2019
10-5-3010000-0402	VEHICLE & EQUIPMENT MTCE.				408.24
20456053	UNIT 116		1146	25-Sep-2019	25-Sep-2019
10-5-3010000-0402	VEHICLE & EQUIPMENT MTCE.				244.41
20456056	UNIT 116		1146	25-Sep-2019	25-Sep-2019
10-5-3010000-0402	VEHICLE & EQUIPMENT MTCE.				34.10
<b>CAN160 CANADIAN BEARINGS LTD</b>					
20154610-00	SS-1		1070	11-Sep-2019	11-Sep-2019
10-5-3010000-0402	VEHICLE & EQUIPMENT MTCE.				555.51
<b>CAN380 CANADIAN TIRE STORE #281</b>					
JULY 2019	JULY 2019 PURCHASES		1078	31-Jul-2019	31-Jul-2019
10-5-3010000-0402	VEHICLE & EQUIPMENT MTCE.				15.00
10-5-3010000-0420	EQUIPMENT				12.42
10-5-3010000-0420	EQUIPMENT				11.96
10-5-3010000-0301	OFFICE SUPPLIES				39.50
<b>CAR645 CARRIER CENTERS</b>					
04P457868	UNIT 116		1070	28-Aug-2019	28-Aug-2019
10-5-3010000-0402	VEHICLE & EQUIPMENT MTCE.				675.84
04P457891	UNIT 116		1070	29-Aug-2019	29-Aug-2019
10-5-3010000-0402	VEHICLE & EQUIPMENT MTCE.				163.04



Vendor : CAT038 To ZUL180  
 Batch : All  
 Department : All

Cheque Print Date : 01-Oct-2019 To 31-Oct-2019  
 Bank : 1 To 99  
 Class : All

Vendor Invoice	Vendor Name Description	Batch	Inv Date	Inv Due Date	Amount
G.L. Account	CC1 CC2 CC3 GL Account Name				
<b>DEPARTMENT 3010000</b>	<b>PUBLIC WORKS</b>				
04P458258 UNIT209 10-5-3010000-0402	VEHICLE & EQUIPMENT MTCE.	1070	12-Sep-2019	12-Sep-2019	1,779.84
04P458905 UNIT 116 10-5-3010000-0402	VEHICLE & EQUIPMENT MTCE.	1146	25-Sep-2019	25-Sep-2019	241.71
04P458911 UNIT 116 10-5-3010000-0402	VEHICLE & EQUIPMENT MTCE.	1146	25-Sep-2019	25-Sep-2019	14.78
04P458929 UNIT 205 10-5-3010000-0402	VEHICLE & EQUIPMENT MTCE.	1146	26-Sep-2019	26-Sep-2019	266.70
<b>COL115 COLUMBIA UTILITY SERVICES INC.</b>					
1632 TREE REMOVAL 10-5-3010000-0765	MUNICIPAL DRAIN EXPENSE	1167	11-Oct-2019	11-Oct-2019	2,712.00
10-5-3010000-0650 T-REMO	TREE MAINTENANCE				3,955.00
<b>COL128 COLONIAL COFFEE CO. LTD.</b>					
781579 COFFEE 10-5-3010000-0301	OFFICE SUPPLIES	1146	19-Sep-2019	19-Sep-2019	48.94
782858 COFFEE 10-5-3010000-0301	OFFICE SUPPLIES	1167	03-Oct-2019	03-Oct-2019	46.94
<b>COL286 COLBRO EQUIPMENT RENTAL</b>					
120969-0 CHAIN SAWS 10-5-3010000-0402	VEHICLE & EQUIPMENT MTCE.	1070	30-Aug-2019	30-Aug-2019	43.53
121490-0 SHOP STOCK 10-5-3010000-0402	VEHICLE & EQUIPMENT MTCE.	1070	17-Sep-2019	17-Sep-2019	122.22
<b>DEL545 DELTA POWER EQUIPMENT</b>					
P44687 DISC MOWER 10-5-3010000-0402	VEHICLE & EQUIPMENT MTCE.	1070	23-Aug-2019	23-Aug-2019	2,006.21
P45086 SUPPLIES 10-5-3010000-0402	VEHICLE & EQUIPMENT MTCE.	1070	04-Sep-2019	04-Sep-2019	220.28
<b>DIA850 DIAMOND MOWERS LLC</b>					
0158427-IN MOWER REPAIRS 10-5-3010000-0402	VEHICLE & EQUIPMENT MTCE.	1146	15-May-2019	15-May-2019	1,482.79
0161658-IN MOWER REPAIRS 10-5-3010000-0402	VEHICLE & EQUIPMENT MTCE.	1146	09-Jul-2019	09-Jul-2019	440.23
<b>ESS959 ESSEX LINEN SUPPLY LTD</b>					
21638 MATTS AND RAGS 10-5-3010000-0301	OFFICE SUPPLIES	1167	03-Oct-2019	03-Oct-2019	100.58
<b>GRE330 GREAT LAKES SAFETY PRODUCTS</b>					
00322914 HEALTH AND SAFETY EQUIPMENT 10-5-3010000-0420	EQUIPMENT	1127	10-Jul-2019	10-Jul-2019	61.35
<b>GRE679 GREG BAILEY LTD</b>					
0000052911 POWER WASHER REPAIR 10-5-3010000-0402	VEHICLE & EQUIPMENT MTCE.	1070	28-Aug-2019	28-Aug-2019	71.18
<b>JOE055 JOE MELOCHE FORD SALES LTD</b>					
IJ03960 TH-1 10-5-3010000-0402	VEHICLE & EQUIPMENT MTCE.	1070	04-Sep-2019	04-Sep-2019	579.15
<b>JOE252 JOE JOHNSON EQUIPMENT</b>					
P05805 UNIT SS-1 10-5-3010000-0402	VEHICLE & EQUIPMENT MTCE.	1070	05-Sep-2019	05-Sep-2019	1,020.01
P06746 UNIT SS-1 10-5-3010000-0402	VEHICLE & EQUIPMENT MTCE.	1167	03-Oct-2019	03-Oct-2019	282.41
<b>KAL132 KAL TIRE 837 - WINDSOR</b>					
837153116 UNIT 308 10-5-3010000-0402	VEHICLE & EQUIPMENT MTCE.	1070	12-Aug-2019	12-Aug-2019	66.67



Council/Board Report By Dept-(Computer)



Vendor : CAT038 To ZUL180

Batch : All

Department : All

Cheque Print Date : 01-Oct-2019 To 31-Oct-2019

Bank : 1 To 99

Class : All

Vendor Invoice	Vendor Name Description	Batch	Inv Date	Inv Due Date	Amount
G.L. Account	CC1 CC2 CC3 GL Account Name				
<b>DEPARTMENT 3010000</b>	<b>PUBLIC WORKS</b>				
<b>KUC134</b>	<b>KUCERA CONSTRUCTION EQUIPMENT</b>				
CW22004	UNIT 308	1070	19-Aug-2019	19-Aug-2019	
10-5-3010000-0402	VEHICLE & EQUIPMENT MTCE.				137.68
CW22142	UNIT 208	1146	26-Sep-2019	26-Sep-2019	
10-5-3010000-0402	VEHICLE & EQUIPMENT MTCE.				1,342.96
CW22149	UNIT 308	1167	30-Sep-2019	30-Sep-2019	
10-5-3010000-0402	VEHICLE & EQUIPMENT MTCE.				1,545.30
<b>LAW731</b>	<b>LAWSON PRODUCTS INC</b>				
9306976161	ROADS STOCK	1070	28-Aug-2019	28-Aug-2019	
10-5-3010000-0402	VEHICLE & EQUIPMENT MTCE.				1,022.35
9307026485	ROADS STOCK	1146	18-Sep-2019	18-Sep-2019	
10-5-3010000-0402	VEHICLE & EQUIPMENT MTCE.				787.17
9307077179	ROADS STOCK	1167	08-Oct-2019	08-Oct-2019	
10-5-3010000-0402	VEHICLE & EQUIPMENT MTCE.				251.38
<b>LKQ176</b>	<b>LKQ CANADA AUTO PARTS INC</b>				
INV-109665925	UNIT 510	1070	03-Sep-2019	03-Sep-2019	
10-5-3010000-0402	VEHICLE & EQUIPMENT MTCE.				101.70
<b>MAL256</b>	<b>MALDEN AUTOMOTIVE</b>				
5294-197510	UNIT 407	1070	15-Aug-2019	15-Aug-2019	
10-5-3010000-0402	VEHICLE & EQUIPMENT MTCE.				9.29
5294-197738	ROADS DEPARTMENT	1070	20-Aug-2019	20-Aug-2019	
10-5-3010000-0402	VEHICLE & EQUIPMENT MTCE.				41.34
5294-197825	PW-01	1070	21-Aug-2019	21-Aug-2019	
10-5-3010000-0402	VEHICLE & EQUIPMENT MTCE.				238.62
5294-197831	CREDIT	1070	21-Aug-2019	21-Aug-2019	
10-5-3010000-0402	VEHICLE & EQUIPMENT MTCE.				-40.68
5294-197929	ROADS STOCK	1070	22-Aug-2019	22-Aug-2019	
10-5-3010000-0402	VEHICLE & EQUIPMENT MTCE.				51.75
5294-197940	SHOP STOCK	1070	22-Aug-2019	22-Aug-2019	
10-5-3010000-0402	VEHICLE & EQUIPMENT MTCE.				13.51
5294-197977	ROAD STOCK	1070	22-Aug-2019	22-Aug-2019	
10-5-3010000-0402	VEHICLE & EQUIPMENT MTCE.				33.09
5294-198277	RS-2	1078	27-Aug-2019	27-Aug-2019	
10-5-3010000-0402	VEHICLE & EQUIPMENT MTCE.				67.38
5294-198329	UNIT HB-01	1078	28-Aug-2019	28-Aug-2019	
10-5-3010000-0402	VEHICLE & EQUIPMENT MTCE.				22.19
5294-198673	ROADS STOCK	1078	04-Sep-2019	04-Sep-2019	
10-5-3010000-0402	VEHICLE & EQUIPMENT MTCE.				141.83
5294-198887	UNIT 110	1078	06-Sep-2019	06-Sep-2019	
10-5-3010000-0402	VEHICLE & EQUIPMENT MTCE.				398.46
5294-198888	ROADS STOCK	1078	06-Sep-2019	06-Sep-2019	
10-5-3010000-0402	VEHICLE & EQUIPMENT MTCE.				40.33
5294-198937	ROAD STOCK	1078	07-Sep-2019	07-Sep-2019	
10-5-3010000-0402	VEHICLE & EQUIPMENT MTCE.				8.80
5294-199368	ROADS CREDIT	1167	13-Sep-2019	13-Sep-2019	
10-5-3010000-0402	VEHICLE & EQUIPMENT MTCE.				-61.74
5294-199689	UNIT 209	1146	18-Sep-2019	18-Sep-2019	
10-5-3010000-0402	VEHICLE & EQUIPMENT MTCE.				13.00
5294-199778	UNIT 209	1146	19-Sep-2019	19-Sep-2019	
10-5-3010000-0402	VEHICLE & EQUIPMENT MTCE.				36.30
5294-200154	ROADS STOCK	1167	25-Sep-2019	25-Sep-2019	
10-5-3010000-0402	VEHICLE & EQUIPMENT MTCE.				8.61
5294-200211	ROADS STOCK	1167	26-Sep-2019	26-Sep-2019	



Vendor : CAT038 To ZUL180  
 Batch : All  
 Department : All

Cheque Print Date : 01-Oct-2019 To 31-Oct-2019  
 Bank : 1 To 99  
 Class : All

Vendor Invoice	Vendor Name Description	Batch	Inv Date	Inv Due Date	Amount
G.L. Account	CC1 CC2 CC3 GL Account Name				
<b>DEPARTMENT 3010000</b>	<b>PUBLIC WORKS</b>				
10-5-3010000-0402	VEHICLE & EQUIPMENT MTCE.				14.85
<b>MCG870</b>	<b>MCGRAIL FARM EQUIPMENT</b>				
124474	407	1167	01-Oct-2019	01-Oct-2019	
10-5-3010000-0402	VEHICLE & EQUIPMENT MTCE.				635.60
<b>MES193</b>	<b>MESSER CANADA INC.</b>				
2101342555	TANKS FOR TORCHES	1167	27-Sep-2019	27-Sep-2019	
10-5-3010000-0402	VEHICLE & EQUIPMENT MTCE.				799.14
2101378533	TANKS FOR TORCHES	1167	27-Sep-2019	27-Sep-2019	
10-5-3010000-0402	VEHICLE & EQUIPMENT MTCE.				9.04
<b>MKR140</b>	<b>M.K. RITTENHOUSE &amp; SONS LIMITED</b>				
IN0346375	SU-1	1078	10-Jul-2019	10-Jul-2019	
10-5-3010000-0402	VEHICLE & EQUIPMENT MTCE.				244.43
<b>MON183</b>	<b>MONARCH OFFICE SUPPLY LTD</b>				
162631	PURCHASES MADE FOR THE MONTH OF JULY 2019	1078	30-Jul-2019	30-Jul-2019	
10-5-3010000-0301	OFFICE SUPPLIES				122.98
167219	PURCHASES MADE FOR THE MONTH OF AUGUST 2019	1078	29-Aug-2019	29-Aug-2019	
10-5-3010000-0301	OFFICE SUPPLIES				171.27
<b>NOR156</b>	<b>NORTRAX CANADA INC.</b>				
1293735	ROADS STOCK	1146	04-Sep-2019	04-Sep-2019	
10-5-3010000-0402	VEHICLE & EQUIPMENT MTCE.				292.89
<b>PUR700</b>	<b>PUROLATOR INC.</b>				
442189117	COURIER	1078	09-Aug-2019	09-Aug-2019	
10-5-3010000-0402	VEHICLE & EQUIPMENT MTCE.				26.74
442247208	COURIER	1078	16-Aug-2019	16-Aug-2019	
10-5-3010000-0402	VEHICLE & EQUIPMENT MTCE.				5.96
442437024	COURIER	1078	06-Sep-2019	06-Sep-2019	
10-5-3010000-0402	VEHICLE & EQUIPMENT MTCE.				18.24
442497215	COURIER	1078	13-Sep-2019	13-Sep-2019	
10-5-3010000-0402	VEHICLE & EQUIPMENT MTCE.				14.01
<b>SAF01</b>	<b>SAFETY-KLEEN CANADA INC</b>				
81041904	OIL AND LIQUID DISPOSAL	1167	13-Sep-2019	13-Sep-2019	
10-5-3010000-0402	VEHICLE & EQUIPMENT MTCE.				676.52
<b>SOB083</b>	<b>SOBEYS AMHERSTBURG</b>				
JULY 2019	PURCHASES MADE IN JULY 2019	1146	30-Jul-2019	30-Jul-2019	
10-5-3010000-0301	OFFICE SUPPLIES				8.37
<b>SOU370</b>	<b>SOUTHPOINT EQUIPMENT; DIV OF CL BENNINGER EQUIPMEN</b>				
IE00918	UNIT 607	1078	10-Sep-2019	10-Sep-2019	
10-5-3010000-0402	VEHICLE & EQUIPMENT MTCE.				108.71
<b>STE366</b>	<b>STERLING FUELS</b>				
0080393	FUEL FOR VECHILES	1146	25-Sep-2019	25-Sep-2019	
10-5-3010000-0401	GASOLINE				3,853.30
0080398	NORTH YARD - FEL FOR TRUCKS	1146	25-Sep-2019	25-Sep-2019	
10-5-3010000-0401	GASOLINE				324.31
0080400	MAIN YARD - FUEL FOR TRUCKS	1146	25-Sep-2019	25-Sep-2019	
10-5-3010000-0401	GASOLINE				1,477.93
0080401	MAIN YARD - FUEL FOR EQUIPMENT	1146	25-Sep-2019	25-Sep-2019	
10-5-3010000-0401	GASOLINE				1,121.25
0080801	FUEL FOR VECHILES	1167	09-Oct-2019	09-Oct-2019	
10-5-3010000-0401	GASOLINE				2,999.03
0080807	FUEL FOR TRUCKS	1167	09-Oct-2019	09-Oct-2019	
10-5-3010000-0401	GASOLINE				382.22
0080810	FUEL FOR EQUIPMENT	1167	09-Oct-2019	09-Oct-2019	

Council/Board Report By Dept-(Computer)



Vendor : CAT038 To ZUL180  
 Batch : All  
 Department : All

Cheque Print Date : 01-Oct-2019 To 31-Oct-2019  
 Bank : 1 To 99  
 Class : All

Vendor Invoice	Vendor Name Description	Batch	Inv Date	Inv Due Date	Amount
G.L. Account	CC1 CC2 CC3 GL Account Name				
<b>DEPARTMENT 3010000</b>	<b>PUBLIC WORKS</b>				
10-5-3010000-0402	VEHICLE & EQUIPMENT MTCE.				1,015.53
0080811	FUEL FOR TRUCKS	1167	09-Oct-2019	09-Oct-2019	
10-5-3010000-0402	VEHICLE & EQUIPMENT MTCE.				997.26
<b>STE615 STEVENS STEEL PRODUCTS INC</b>					
294995	607	1167	12-Sep-2019	12-Sep-2019	
10-5-3010000-0402	VEHICLE & EQUIPMENT MTCE.				180.80
295021	UNIT 205	1167	30-Sep-2019	30-Sep-2019	
10-5-3010000-0402	VEHICLE & EQUIPMENT MTCE.				143.51
<b>TEA795 TEAM TRUCK CENTRES</b>					
05W0510827P	UNIT 305	1167	27-Sep-2019	27-Sep-2019	
10-5-3010000-0402	VEHICLE & EQUIPMENT MTCE.				544.90
<b>TRA689 TRACTION WINDSOR</b>					
396318723	ROADS STOCK	1070	05-Sep-2019	05-Sep-2019	
10-5-3010000-0402	VEHICLE & EQUIPMENT MTCE.				938.98
396318805	ROADS STOCK	1070	06-Sep-2019	06-Sep-2019	
10-5-3010000-0402	VEHICLE & EQUIPMENT MTCE.				96.75
396318807	ROADS STOCK	1070	06-Sep-2019	06-Sep-2019	
10-5-3010000-0402	VEHICLE & EQUIPMENT MTCE.				19.01
396318808	ROADS RESTOCK	1070	06-Sep-2019	06-Sep-2019	
10-5-3010000-0402	VEHICLE & EQUIPMENT MTCE.				126.88
396318809	UNIT 206	1070	06-Sep-2019	06-Sep-2019	
10-5-3010000-0402	VEHICLE & EQUIPMENT MTCE.				92.89
396318818	ROADS CREDIT	1070	06-Sep-2019	06-Sep-2019	
10-5-3010000-0402	VEHICLE & EQUIPMENT MTCE.				-3.04
396319326	ROADS STOCK	1070	12-Sep-2019	12-Sep-2019	
10-5-3010000-0402	VEHICLE & EQUIPMENT MTCE.				180.78
396319371	ROADS STOCK	1070	13-Sep-2019	13-Sep-2019	
10-5-3010000-0402	VEHICLE & EQUIPMENT MTCE.				43.73
396319633	ROADS STOCK	1167	17-Sep-2019	17-Sep-2019	
10-5-3010000-0402	VEHICLE & EQUIPMENT MTCE.				804.56
396319662	ROADS	1167	18-Sep-2019	18-Sep-2019	
10-5-3010000-0402	VEHICLE & EQUIPMENT MTCE.				1,977.95
396319694	UNIT 209	1167	18-Sep-2019	18-Sep-2019	
10-5-3010000-0402	VEHICLE & EQUIPMENT MTCE.				542.40
396319843	ROADS STOCK	1167	19-Sep-2019	19-Sep-2019	
10-5-3010000-0402	VEHICLE & EQUIPMENT MTCE.				408.59
396319861	ROADS STOCK	1167	20-Sep-2019	20-Sep-2019	
10-5-3010000-0402	VEHICLE & EQUIPMENT MTCE.				817.42
396320272	UNIT 116	1146	25-Sep-2019	25-Sep-2019	
10-5-3010000-0402	VEHICLE & EQUIPMENT MTCE.				193.46
396320288	ROADS STOCK	1146	25-Sep-2019	25-Sep-2019	
10-5-3010000-0402	VEHICLE & EQUIPMENT MTCE.				128.73
396320289	ROADS STOCK	1146	25-Sep-2019	25-Sep-2019	
10-5-3010000-0402	VEHICLE & EQUIPMENT MTCE.				34.80
396320449	ROADS STOCK	1146	27-Sep-2019	27-Sep-2019	
10-5-3010000-0402	VEHICLE & EQUIPMENT MTCE.				129.41
396320490	UNIT 205	1146	28-Sep-2019	28-Sep-2019	
10-5-3010000-0402	VEHICLE & EQUIPMENT MTCE.				23.80
396321429	ROADS STOCK	1167	10-Oct-2019	10-Oct-2019	
10-5-3010000-0402	VEHICLE & EQUIPMENT MTCE.				446.89
396321431	UNIT 205	1167	10-Oct-2019	10-Oct-2019	
10-5-3010000-0402	VEHICLE & EQUIPMENT MTCE.				159.24
396321432	UNIT 205	1167	10-Oct-2019	10-Oct-2019	



Vendor : CAT038 To ZUL180

Batch : All

Department : All

Cheque Print Date : 01-Oct-2019 To 31-Oct-2019

Bank : 1 To 99

Class : All

Vendor Invoice	Vendor Name Description	Batch	Inv Date	Inv Due Date	Amount
G.L. Account	CC1 CC2 CC3 GL Account Name				
<b>DEPARTMENT 3010000 PUBLIC WORKS</b>					
10-5-3010000-0402					24.19
396321515	UNIT 205		1167 10-Oct-2019	10-Oct-2019	
10-5-3010000-0402					17.94
<b>TRU429 401 TRUCKSOURCE INC.</b>					
90532226	UNIT 209		1070 09-Sep-2019	09-Sep-2019	
10-5-3010000-0402					739.21
90532228	UNIT 205		1070 09-Sep-2019	09-Sep-2019	
10-5-3010000-0402					285.21
90532419	UNIT 209		1070 10-Sep-2019	10-Sep-2019	
10-5-3010000-0402					972.09
90532600	UNIT 209		1070 11-Sep-2019	11-Sep-2019	
10-5-3010000-0402					75.39
90533036	CREDIT		1146 13-Sep-2019	13-Sep-2019	
10-5-3010000-0402					-423.75
90533172	UNIT 209		1146 14-Sep-2019	14-Sep-2019	
10-5-3010000-0402					790.80
90533322	UNIT 209		1146 16-Sep-2019	16-Sep-2019	
10-5-3010000-0402					68.09
90533903	CREDIT		1146 19-Sep-2019	19-Sep-2019	
10-5-3010000-0402					-38.01
<b>VIK426 VIKING CIVES LTD</b>					
2685801	UNIT 209		1146 20-Sep-2019	20-Sep-2019	
10-5-3010000-0402					296.81
<b>WIG035 WIGLE HOME HARDWARE BUILDING CENTRE</b>					
134257	KEY BOX		1070 11-Sep-2019	11-Sep-2019	
10-5-3010000-0301					50.80
134515	SHOP USE		1146 20-Sep-2019	20-Sep-2019	
10-5-3010000-0402					33.74
<b>WIN100 WINDSOR ESSEX COUNTY HEALTH UNIT</b>					
009 (2019)	WEST NILE MAY, JUNE, JULY AND AUGUST 2019		1167 18-Sep-2019	18-Sep-2019	
10-5-3010000-0736					1,401.05
<b>WUR01 WURTH CANADA LIMITED</b>					
23648304	PARTS CLEANER		1070 05-Sep-2019	05-Sep-2019	
10-5-3010000-0402					129.58
<b>Department Totals :</b>					<b>53,584.11</b>

<b>DEPARTMENT 3015010 MECHANIC</b>					
<b>BEN262 BENSON AUTO PARTS</b>					
20455392	SHOP TOOL		1146 18-Sep-2019	18-Sep-2019	
10-5-3015010-0420					336.12
<b>TRA689 TRACTION WINDSOR</b>					
396317086	SHOP TOOLS		1084 12-Aug-2019	12-Aug-2019	
10-5-3015010-0420					34.86
396317169	SHOP TOOLS		1070 12-Aug-2019	12-Aug-2019	
10-5-3015010-0420					25.38
396318346	SHOP TOOLS		1070 29-Aug-2019	29-Aug-2019	
10-5-3015010-0420					201.61
<b>Department Totals :</b>					<b>597.97</b>

<b>DEPARTMENT 3020000 ROADS</b>					
<b>CAN380 CANADIAN TIRE STORE #281</b>					
JULY 2019	JULY 2019 PURCHASES		1078 31-Jul-2019	31-Jul-2019	

Council/Board Report By Dept-(Computer)



Vendor : CAT038 To ZUL180  
 Batch : All  
 Department : All

Cheque Print Date : 01-Oct-2019 To 31-Oct-2019  
 Bank : 1 To 99  
 Class : All

Vendor Invoice	Vendor Name Description	Batch	Inv Date	Inv Due Date	Amount
G.L. Account	CC1 CC2 CC3 GL Account Name				
<b>DEPARTMENT 3020000 ROADS</b>					
10-5-3020000-0757	STORM SEWER CLEANING & FLUSHING				63.21
<b>ESS160 ESSEX TERMINAL RAILWAY CO</b>					
0021279-IN	RAILWAY MAINTENANCE COST	1167	01-Oct-2019	01-Oct-2019	
10-5-3020000-0720	RAILWAY CROSSINGS				304.30
<b>KNM541 KNM YARD CARE</b>					
1560	GRASS CUTTING FOR SEPTEMBER 2019	1153	01-Oct-2019	01-Oct-2019	
10-5-3020000-0725	ROADS MAINTENANCE - GENERAL				141.25
10-5-3020000-0725	ROADS MAINTENANCE - GENERAL				197.75
10-5-3020000-0725	ROADS MAINTENANCE - GENERAL				113.00
10-5-3020000-0725	ROADS MAINTENANCE - GENERAL				802.30
10-5-3020000-0725	ROADS MAINTENANCE - GENERAL				237.30
10-5-3020000-0725	ROADS MAINTENANCE - GENERAL				237.30
10-5-3020000-0757	STORM SEWER CLEANING & FLUSHING				113.00
10-5-3020000-0757	STORM SEWER CLEANING & FLUSHING				847.50
10-5-3020000-0757	STORM SEWER CLEANING & FLUSHING				282.50
10-5-3020000-0757	STORM SEWER CLEANING & FLUSHING				423.75
10-5-3020000-0725	ROADS MAINTENANCE - GENERAL				129.95
<b>MOR172 MORTON INDUSTRIAL SALES &amp; SERVICE LTD.</b>					
IN284484	INLET AND OUTLET PIPES FOR 6 IN DIESEL PUMP	1167	08-Oct-2019	08-Oct-2019	
10-5-3020000-0757	STORM SEWER CLEANING & FLUSHING				3,950.69
<b>MRC031 MR CLEENZ MOBILE POWERWASH &amp; DETAILING</b>					
544	CLEAN GRAFFITI FROM BRIDGE	1146	21-Sep-2019	21-Sep-2019	
10-5-3020000-0725	ROADS MAINTENANCE - GENERAL				275.00
<b>NAS514 NASCI CONSTRUCTION SERVICES LTD.</b>					
4619	ROAD REPAIRS TENDER	1167	04-Oct-2019	04-Oct-2019	
10-5-3020000-0725	ROADS MAINTENANCE - GENERAL				173,185.92
<b>PAR372 PARRLINE ELECTRICAL WHOLESALE</b>					
83562	ELECTRICAL FOR PUMP STATION	1146	10-Jul-2019	10-Jul-2019	
10-5-3020000-0757	STORM SEWER CLEANING & FLUSHING				372.59
<b>SOU100 SOUTHWESTERN SALES CORP</b>					
IN222606	COLD PATCH	1146	09-Sep-2019	09-Sep-2019	
10-5-3020000-0725	ROADS MAINTENANCE - GENERAL				1,652.63
<b>WIG035 WIGLE HOME HARDWARE BUILDING CENTRE</b>					
134423	TEMPORARY SIGN POST PAINT	1146	17-Sep-2019	17-Sep-2019	
10-5-3020000-0725	ROADS MAINTENANCE - GENERAL				20.32
134594	TEMPORARY FENCING	1146	23-Sep-2019	23-Sep-2019	
10-5-3020000-0725	ROADS MAINTENANCE - GENERAL				56.49
134716	TEMPORARY FENCING	1146	27-Sep-2019	27-Sep-2019	
10-5-3020000-0725	ROADS MAINTENANCE - GENERAL				169.47
<b>Department Totals :</b>					<b>183,576.22</b>
-----					
<b>DEPARTMENT 3022016 ROADS CAPTIAL</b>					
<b>JJL440 J&amp;J LEPERA INFRASTRUCTURES INC</b>					
SW-2013-020 # PPC # 10		1124	30-Aug-2019	30-Aug-2019	
40-7-3022016-0001	MELOCHE RD				11,300.00
<b>Department Totals :</b>					<b>11,300.00</b>
-----					
<b>DEPARTMENT 3022017 ROADS CAPITAL</b>					
<b>KIN840 KING LUMINAIRE COMPANY INC</b>					
I-KCA-1907175 LED STREET LIGHTS		1084	31-Jul-2019	31-Jul-2019	
40-7-3022017-0008	LED STREET LIGHTING UPGRADE PRG				1,120.96
<b>Department Totals :</b>					<b>1,120.96</b>



Vendor : CAT038 To ZUL180  
 Batch : All  
 Department : All

Cheque Print Date : 01-Oct-2019 To 31-Oct-2019  
 Bank : 1 To 99  
 Class : All

Vendor Invoice	Vendor Name Description	Batch	Inv Date	Inv Due Date	Amount
G.L. Account	CC1 CC2 CC3 GL Account Name				

**DEPARTMENT 3022018 ROADS CAPITAL**

**JEF296 JEFF SHEPLEY EXCAVATING LTD**

M424B #7 PPC #7 1124 30-Sep-2019 30-Sep-2019

40-7-3022018-0003 CREEK RD RECONSTRUCTION 33,470.54

**Department Totals : 33,470.54**

**DEPARTMENT 3022019 ROADS CAPITAL**

**WOO4090 WOOD ENVIRONMENTAL & INFRASTRUCTURE SOLUTIONS**

GS7606 PROFESSIONAL SERVICES 1146 06-Sep-2019 06-Sep-2019

40-7-3022019-0016 WALNUT ST (MCCURDY TO HAWTHORN) 1,064.80

**Department Totals : 1,064.80**

**DEPARTMENT 3050000 STREET LIGHTING**

**HIC441 HICKS ELECTRIC**

10033 STREET LIGHT REPAIR 1167 03-Oct-2019 03-Oct-2019

10-5-3050000-0331 GENERAL MAINTENANCE 2,340.23

10035 STREET LIGHT MAINTENANCE 1167 03-Oct-2019 03-Oct-2019

10-5-3050000-0331 GENERAL MAINTENANCE 762.19

10036 STREET LIGHT REPAIR 1167 10-Mar-2019 10-Mar-2019

10-5-3050000-0331 GENERAL MAINTENANCE 164.75

10037 STREET LIGHT REPAIR 1167 03-Oct-2019 03-Oct-2019

10-5-3050000-0331 GENERAL MAINTENANCE 91.53

10038 STREET LIGHT REPAIR 1167 03-Oct-2019 03-Oct-2019

10-5-3050000-0331 GENERAL MAINTENANCE 153.68

**Department Totals : 3,512.38**

**DEPARTMENT 3250000 TRAFFIC CONTROL**

**HIC441 HICKS ELECTRIC**

10061 POLE MAINTENANCE 1167 15-Oct-2019 15-Oct-2019

10-5-3250000-0740 TRAFFIC SIGNS 815.86

**WIG035 WIGLE HOME HARDWARE BUILDING CENTRE**

134591 PLYWOOD SIGN INSTALLS 1146 23-Sep-2019 23-Sep-2019

10-5-3250000-0741 TRAFFIC SIGNS & DEVICES 223.67

**Department Totals : 1,039.53**

**DEPARTMENT 4010000 SANITARY SEWERS**

**ONT001 ONTARIO CLEAN WATER AGENCY**

INV000116184 ADDITIONAL SERVICES 1173 19-Sep-2019 19-Sep-2019

10-5-4010000-0680 LIFE CYCLE EXPENSES 3,187.34

**Department Totals : 3,187.34**

**DEPARTMENT 4017720 MCGREGOR SEWERS**

**KNM541 KNM YARD CARE**

1560 GRASS CUTTING FOR SEPTEMBER 2019 1153 01-Oct-2019 01-Oct-2019

10-5-4017720-0612 MAINTENANCE ITEMS - OCWA 209.05

**ONT001 ONTARIO CLEAN WATER AGENCY**

INV000116126 ADDITIONAL SERVICES 1172 19-Sep-2019 19-Sep-2019

10-5-4017720-0612 MAINTENANCE ITEMS - OCWA 122.11

INV000116151 ADDITIONAL SERVICES 1172 19-Sep-2019 19-Sep-2019

10-5-4017720-0612 MAINTENANCE ITEMS - OCWA 1,620.53

INV000116372 OPERATIONS AND MAINTENANCE 1153 01-Oct-2019 01-Oct-2019

10-5-4017720-0604 CONTRACT O.C.W.A. 13,530.13



TOWN OF AMHERSTBURG  
**Council/Board Report By Dept-(Computer)**



AP5130 Page : 26  
 Date : Oct 25, 2019 Time : 9:03 am

Vendor : CAT038 To ZUL180  
 Batch : All  
 Department : All

Cheque Print Date : 01-Oct-2019 To 31-Oct-2019  
 Bank : 1 To 99  
 Class : All

Vendor Invoice	Vendor Name Description	Batch	Inv Date	Inv Due Date	Amount
G.L. Account	CC1 CC2 CC3 GL Account Name				
<b>DEPARTMENT 4017720</b>	<b>MCGREGOR SEWERS</b>				
INV000116554	ADDITIONAL SERVICES	1173	27-Sep-2019	27-Sep-2019	
10-5-4017720-0613	OCWA UNEXPECTED ITEMS				385.00
<b>Department Totals :</b>					<b>15,866.82</b>

Vendor Invoice	Vendor Name Description	Batch	Inv Date	Inv Due Date	Amount
G.L. Account	CC1 CC2 CC3 GL Account Name				
<b>DEPARTMENT 4017730</b>	<b>EDGEWATER SEWERS</b>				
<b>KNM541</b>	<b>KNM YARD CARE</b>				
1560	GRASS CUTTING FOR SEPTEMBER 2019	1153	01-Oct-2019	01-Oct-2019	
10-5-4017730-0612	OCWA MAINTENANCE ITEMS				141.25
10-5-4017730-0612	OCWA MAINTENANCE ITEMS				141.25
10-5-4017730-0612	OCWA MAINTENANCE ITEMS				113.00
10-5-4017730-0612	OCWA MAINTENANCE ITEMS				96.05
10-5-4017730-0612	OCWA MAINTENANCE ITEMS				226.00
10-5-4017730-0612	OCWA MAINTENANCE ITEMS				113.00
10-5-4017730-0612	OCWA MAINTENANCE ITEMS				101.70
10-5-4017730-0612	OCWA MAINTENANCE ITEMS				113.00
<b>ONT001</b>	<b>ONTARIO CLEAN WATER AGENCY</b>				
INV000116170	ADDITIONAL SERVICES	1172	19-Sep-2019	19-Sep-2019	
10-5-4017730-0612	OCWA MAINTENANCE ITEMS				1,005.39
INV000116171	ADDITIONAL SERVICES	1172	19-Sep-2019	19-Sep-2019	
10-5-4017730-0612	OCWA MAINTENANCE ITEMS				7,869.10
INV000116172	ADDITIONAL SERVICES	1172	19-Sep-2019	19-Sep-2019	
10-5-4017730-0771	OCWA - MEYERS PUMP STATIONS				2,025.09
INV000116372	OPERATIONS AND MAINTENANCE	1153	01-Oct-2019	01-Oct-2019	
10-5-4017730-0604	CONTRACT O.C.W.A.				14,018.54
INV000116562	ADDITIONAL SERVICES	1174	27-Sep-2019	27-Sep-2019	
10-5-4017730-0613	OCWA UNEXPECTED ITEMS				760.00
<b>Department Totals :</b>					<b>26,723.37</b>

Vendor Invoice	Vendor Name Description	Batch	Inv Date	Inv Due Date	Amount
G.L. Account	CC1 CC2 CC3 GL Account Name				
<b>DEPARTMENT 4017740</b>	<b>AMHERSTBURG SEWERS</b>				
<b>BOY024</b>	<b>BOYKO DANNY</b>				
OCTOBER 11,	SUMP PUMP OVERFLOW SUBSIDY	1153	11-Oct-2019	11-Oct-2019	
10-5-4017740-0766	I&I MAINTENANCE				300.00
<b>COL286</b>	<b>COLBRO EQUIPMENT RENTAL</b>				
122300-0	SUPPLIES	1172	09-Oct-2019	09-Oct-2019	
10-5-4017740-0759	SERVICE CONNECTION REPAIR & MTCE.				213.62
<b>ESS273</b>	<b>ESSEX POWERLINES CORPORATION</b>				
JC7973	SEWER BILLING AND COLLECTING CHARGES FOR THE MONTH OF SEPTEMBER 20	1153	30-Sep-2019	30-Sep-2019	
10-5-4017740-0504	COLLECTION EXPENSE				1,159.24
<b>ESS360</b>	<b>ESSEX WINDSOR SOLID WASTE AUTH</b>				
28606	DISPOSAL FEES	1153	30-Sep-2019	30-Sep-2019	
10-5-4017740-0602	LANDFILL CHARGES				6,945.48
<b>HEA693</b>	<b>HEATON SANITATION</b>				
38760	VACTOR FLUSHER	1056	18-Sep-2019	18-Sep-2019	
10-5-4017740-0750	SEWER FLUSHING				791.00
<b>HOS421</b>	<b>HOSKIN SCIENTIFIC LIMITED</b>				
69565	I & I PROGRAM - WEATHER STATIONS	1153	03-Sep-2019	03-Sep-2019	
10-5-4017740-0766	I&I MAINTENANCE				5,245.46
<b>KEL117</b>	<b>KELCOM TELEMESSAGING</b>				
1910-06702	ANSWERING SERVICES	1167	01-Oct-2019	01-Oct-2019	
10-5-4017740-0316	UTILITIES - SEWERS				32.92
<b>KNM541</b>	<b>KNM YARD CARE</b>				
1560	GRASS CUTTING FOR SEPTEMBER 2019	1153	01-Oct-2019	01-Oct-2019	



Vendor : CAT038 To ZUL180

Batch : All

Department : All

Cheque Print Date : 01-Oct-2019 To 31-Oct-2019

Bank : 1 To 99

Class : All

Vendor Invoice	Vendor Name Description	Batch	Inv Date	Inv Due Date	Amount
G.L. Account	CC1 CC2 CC3 GL Account Name				
<b>DEPARTMENT 4017740</b>	AMHERSTBURG SEWERS				
10-5-4017740-0331	GENERAL MAINTENANCE				197.75
<b>LAU027 LAURIE ANDREW</b>					
OCTOBER 11, BACKWATER VALVE INSTALLATION AND SUMP PUMP OVERFLOW SUBSIDY		1153	11-Oct-2019	11-Oct-2019	
10-5-4017740-0766	I&I MAINTENANCE				1,300.00
<b>ONT001 ONTARIO CLEAN WATER AGENCY</b>					
INV000116173 ADDITIONAL SERVICES		1173	19-Sep-2019	19-Sep-2019	
10-5-4017740-0612	OCWA MAINTENANCE ITEMS				980.82
INV000116174 ADDITIONAL SERVICES		1173	19-Sep-2019	19-Sep-2019	
10-5-4017740-0612	OCWA MAINTENANCE ITEMS				995.21
INV000116175 ADDITIONAL SERVICES		1173	19-Sep-2019	19-Sep-2019	
10-5-4017740-0612	OCWA MAINTENANCE ITEMS				832.40
INV000116176 ADDITIONAL SERVICES		1173	19-Sep-2019	19-Sep-2019	
10-5-4017740-0612	OCWA MAINTENANCE ITEMS				4,182.34
INV000116177 ADDITIONAL SERVICES		1173	19-Sep-2019	19-Sep-2019	
10-5-4017740-0612	OCWA MAINTENANCE ITEMS				1,012.51
INV000116178 ADDITIONAL SERVICES		1173	19-Sep-2019	19-Sep-2019	
10-5-4017740-0612	OCWA MAINTENANCE ITEMS				1,780.80
INV000116180 ADDITIONAL SERVICES		1173	19-Sep-2019	19-Sep-2019	
10-5-4017740-0612	OCWA MAINTENANCE ITEMS				610.56
INV000116187 ADDITIONAL SERVICES		1173	19-Sep-2019	19-Sep-2019	
10-5-4017740-0612	OCWA MAINTENANCE ITEMS				390.76
INV000116372 OPERATIONS AND MAINTENANCE		1153	01-Oct-2019	01-Oct-2019	
10-5-4017740-0604	CONTRACT O.C.W.A.				28,411.56
INV000116563 ADDITIONAL SERVICES		1174	27-Sep-2019	27-Sep-2019	
10-5-4017740-0613	OCWA UNEXPECTED ITEMS				3,158.50
<b>ORK584 ORKIN CANADA CORPORATION</b>					
IN-9649836 PEST CONTROL		1153	30-Sep-2019	30-Sep-2019	
10-5-4017740-0331	GENERAL MAINTENANCE				119.78
<b>WOL533 WOLSELEY CANADA INC</b>					
8147188 SUPPLIES		1172	19-Jun-2019	19-Jun-2019	
10-5-4017740-0331	GENERAL MAINTENANCE				596.91
8563461 SUPPLIES		1153	19-Sep-2019	19-Sep-2019	
10-5-4017740-0331	GENERAL MAINTENANCE				108.57
<b>Department Totals :</b>					<b>59,366.19</b>

**DEPARTMENT 4017750 BIG CREEK RBC SEWER**

<b>KNM541 KNM YARD CARE</b>					
1560 GRASS CUTTING FOR SEPTEMBER 2019		1153	01-Oct-2019	01-Oct-2019	
10-5-4017750-0612	OCWA MAINTENANCE ITEMS				197.75
10-5-4017750-0612	OCWA MAINTENANCE ITEMS				113.00
10-5-4017750-0612	OCWA MAINTENANCE ITEMS				113.00
10-5-4017750-0612	OCWA MAINTENANCE ITEMS				452.00
<b>ONT001 ONTARIO CLEAN WATER AGENCY</b>					
INV000116131 ADDITIONAL SERVICES		1172	19-Sep-2019	19-Sep-2019	
10-5-4017750-0612	OCWA MAINTENANCE ITEMS				244.22
INV000116152 ADDITIONAL SERVICES		1172	19-Sep-2019	19-Sep-2019	
10-5-4017750-0612	OCWA MAINTENANCE ITEMS				186.68
INV000116153 ADDITIONAL SERVICES		1172	19-Sep-2019	19-Sep-2019	
10-5-4017750-0612	OCWA MAINTENANCE ITEMS				499.20
INV000116372 OPERATIONS AND MAINTENANCE		1153	01-Oct-2019	01-Oct-2019	
10-5-4017750-0604	CONTRACT O.C.W.A.				9,739.16
INV000116561 ADDITIONAL SERVICES		1174	27-Sep-2019	27-Sep-2019	
10-5-4017750-0613	OCWA UNEXPECTED ITEMS				769.00





Vendor : CAT038 To ZUL180

Batch : All

Department : All

Cheque Print Date : 01-Oct-2019 To 31-Oct-2019

Bank : 1 To 99

Class : All

Vendor Invoice	Vendor Name Description	Batch	Inv Date	Inv Due Date	Amount
G.L. Account	CC1 CC2 CC3 GL Account Name				

**DEPARTMENT 4017750 BIG CREEK RBC SEWER**

**Department Totals : 12,314.01**

**DEPARTMENT 4017755 MCLEOD SBR SEWER**

**ONT001 ONTARIO CLEAN WATER AGENCY**

INV000116127	ADDITIONAL SERVICES	1172	19-Sep-2019	19-Sep-2019	
10-5-4017755-0612	OCWA MAINTENANCE ITEMS				3,388.61
INV000116130	ADDITIONAL SERVICES	1172	19-Sep-2019	19-Sep-2019	
10-5-4017755-0612	OCWA MAINTENANCE ITEMS				301.84
INV000116372	OPERATIONS AND MAINTENANCE	1153	01-Oct-2019	01-Oct-2019	
10-5-4017755-0604	CONTRACT OCWA				15,251.63
INV000116559	ADDITIONAL SERVICES	1174	27-Sep-2019	27-Sep-2019	
10-5-4017755-0613	OCWA UNEXPECTED ITEMS				819.50

**Department Totals : 19,761.58**

**DEPARTMENT 4017760 BOBLO SEWER**

**ONT001 ONTARIO CLEAN WATER AGENCY**

INV000116154	ADDITIONAL SERVICES	1172	19-Sep-2019	19-Sep-2019	
10-5-4017760-0612	OCWA MAINTENANCE ITEMS				177.51
INV000116372	OPERATIONS AND MAINTENANCE	1153	01-Oct-2019	01-Oct-2019	
10-5-4017760-0604	CONTRACT OCWA - BOBLO				7,752.13

**Department Totals : 7,929.64**

**DEPARTMENT 4057710 GARBAGE COLLECTION**

**WIN270 WINDSOR DISPOSAL SERVICES LTD**

0000967749	MONTHLY BASIC COLLECTION	1167	01-Oct-2019	01-Oct-2019	
10-5-4057710-0602	GARBAGE COLLECTION				48,363.48
0000967750	EXTRA BIN PICK UP	1146	01-Oct-2019	01-Oct-2019	
10-5-4057710-0602	GARBAGE COLLECTION				88.75
0000967752	EXTRA BIN PICK UP	1146	01-Oct-2019	01-Oct-2019	
10-5-4057710-0602	GARBAGE COLLECTION				59.17
0000967761	WTP	1146	01-Oct-2019	01-Oct-2019	
10-5-4057710-0602	GARBAGE COLLECTION				47.12
0000967787	LIBRO CENTRE CARDBOARD COLLECTION	1146	01-Oct-2019	01-Oct-2019	
10-5-4057710-0602	GARBAGE COLLECTION				67.54
0000968477	GARBAGE COLLECTION	1167	30-Sep-2019	30-Sep-2019	
10-5-4057710-0602	GARBAGE COLLECTION				56.50
0000969002	WTP	1167	01-Oct-2019	01-Oct-2019	
10-5-4057710-0602	GARBAGE COLLECTION				27.53

**Department Totals : 48,710.09**

**DEPARTMENT 4067715 GARBAGE DISPOSAL**

**ESS360 ESSEX WINDSOR SOLID WASTE AUTH**

28680	LANDFILL CHARGES	1167	30-Sep-2019	30-Sep-2019	
10-5-4067715-0602	LANDFILL CHARGES				21,805.09
28687	YARDWASTE LANDFILL CHARGES	1167	30-Sep-2019	30-Sep-2019	
10-5-4067715-0601	YARDWASTE LANDFILL TIPPING				4,288.83

**WIN270 WINDSOR DISPOSAL SERVICES LTD**

0000967749	MONTHLY BASIC COLLECTION	1167	01-Oct-2019	01-Oct-2019	
10-5-4067715-0603	YARD WASTE - HAULING TO LANDFILL				9,542.47
0000967757	SOUTH YARD CLEAN UP	1146	01-Oct-2019	01-Oct-2019	
10-5-4067715-0607	PWD YARD CLEAN UP EXPENSES				36.44
0000968153	NEXEN YARD CLEAN UP	1146	21-Sep-2019	21-Sep-2019	

## Council/Board Report By Dept-(Computer)



Vendor : CAT038 To ZUL180

Batch : All

Department : All

Cheque Print Date : 01-Oct-2019 To 31-Oct-2019

Bank : 1 To 99

Class : All

Vendor Invoice	Vendor Name Description				Batch Invc Date	Invc Due Date	Amount
G.L. Account	CC1	CC2	CC3	GL Account Name			
<b>DEPARTMENT 4067715 GARBAGE DISPOSAL</b>							
10-5-4067715-0607				PWD YARD CLEAN UP EXPENSES			186.45
0000968476	NEXEN YARD CLEAN UP				1167 30-Sep-2019	30-Sep-2019	
10-5-4067715-0607				PWD YARD CLEAN UP EXPENSES			372.90
<b>Department Totals :</b>							<b>36,232.18</b>
-----							
<b>DEPARTMENT 7010000 PARKS AND RECREATION PROGRAMMING</b>							
<b>AMH179 AMHERSTBURG COMMUNITY SERVICES</b>							
AUG/19	AQUATICS PROGRAMMING TRANSPORTATION				1084 31-Aug-2019	31-Aug-2019	
10-5-7010000-0773				SWIM PROGRAM			1,400.00
JUL/19	AQUATICS PROGRAM				1084 31-Jul-2019	31-Jul-2019	
10-5-7010000-0773				SWIM PROGRAM			1,800.00
<b>BRA065 BRATT AMY</b>							
SEPTEMBER 2	REBATE FOR SWIMMING LESSONS				1078 27-Sep-2019	27-Sep-2019	
10-5-7010000-0773				SWIM PROGRAM			151.20
<b>BRA103 BRAUSS JENNIFER</b>							
SEPTEMBER 2	REBATE FOR SWIM LESSONS				1078 27-Sep-2019	27-Sep-2019	
10-5-7010000-0773				SWIM PROGRAM			75.60
<b>BRE497 BRENNER PACKERS LTD.</b>							
58967	CONCESSION PURCHASE				1084 06-Sep-2019	06-Sep-2019	
10-5-7010000-0384				CONCESSION PRODUCT			250.00
59283	CONCESSION PURCHASE				1084 20-Sep-2019	20-Sep-2019	
10-5-7010000-0384				CONCESSION PRODUCT			250.00
<b>CAR362 CARDINAL SERVICE GROUP</b>							
0575918	CONCESSION MAINTENCE				1146 02-Oct-2019	02-Oct-2019	
10-5-7010000-0422				CONCESSION EQUIP MAINTENANCE			220.00
<b>COL128 COLONIAL COFFEE CO. LTD.</b>							
781504	CONCESSION PURCHASE				1084 06-Sep-2019	06-Sep-2019	
10-5-7010000-0384				CONCESSION PRODUCT			121.30
781855	CONCESSION PURCHASE				1084 26-Sep-2019	26-Sep-2019	
10-5-7010000-0384				CONCESSION PRODUCT			307.30
<b>COL154 COLBURN MICHELLE</b>							
SEPTEMBER 2	REBAT FOR SWIM PROGRAM				1078 27-Sep-2019	27-Sep-2019	
10-5-7010000-0773				SWIM PROGRAM			75.60
<b>GOR299 GORDON FOOD SERVICE CAN. LTD. - ONTARIO DIVISION</b>							
3739411	CONCESSION PURCHASE CREDIT				1084 18-Jul-2019	18-Jul-2019	
10-5-7010000-0384				CONCESSION PRODUCT			-282.74
3869809	CONCESSION PURCHASE				1084 04-Sep-2019	04-Sep-2019	
10-5-7010000-0384				CONCESSION PRODUCT			2,882.38
3875487	CONCESSION PURCHASE CREDIT				1084 05-Sep-2019	05-Sep-2019	
10-5-7010000-0384				CONCESSION PRODUCT			-167.00
3889652	CONCESSION PURCHASE				1084 11-Sep-2019	11-Sep-2019	
10-5-7010000-0384				CONCESSION PRODUCT			961.81
3909366	CONCESSION PURCHASE				1084 18-Sep-2019	18-Sep-2019	
10-5-7010000-0384				CONCESSION PRODUCT			419.86
3914845	CONCESSION PURCHASE CREDIT				1113 19-Sep-2019	19-Sep-2019	
10-5-7010000-0384				CONCESSION PRODUCT			-176.01
3914846	CONCESSION PURCHASE CREDIT				1113 19-Sep-2019	19-Sep-2019	
10-5-7010000-0384				CONCESSION PRODUCT			-83.49
3929227	CONCESSION PURCHASE				1113 25-Sep-2019	25-Sep-2019	
10-5-7010000-0384				CONCESSION PRODUCT			918.33
<b>KIN069 KING MISTY</b>							
SEPTEMBER 2	REBATE FOR SWIM LESSONS				1078 27-Sep-2019	27-Sep-2019	



Vendor : CAT038 To ZUL180

Batch : All

Department : All

Cheque Print Date : 01-Oct-2019 To 31-Oct-2019

Bank : 1 To 99

Class : All

Vendor Invoice	Vendor Name Description	Batch	Inv Date	Inv Due Date	Amount
G.L. Account	CC1 CC2 CC3 GL Account Name				
<b>DEPARTMENT 7010000</b>	PARKS AND RECREATION PROGRAMMING				
10-5-7010000-0773	SWIM PROGRAM				151.20
<b>MCM948 M.C.M. SNACK FOODS</b>					
37413 CONCESSION PURCHASE		1084	05-Sep-2019	05-Sep-2019	
10-5-7010000-0384	CONCESSION PRODUCT				200.68
<b>MEL271 MELOCHE JANICE</b>					
SEPTEMBER 2 REBATE FOR SWIM LESSONS		1078	27-Sep-2019	27-Sep-2019	
10-5-7010000-0773	SWIM PROGRAM				75.60
<b>NAP110 NAPLES PIZZA</b>					
340 REC PROGRAMMING		1084	14-Sep-2019	14-Sep-2019	
10-5-7010000-0420	RECREATION EXPENSES				23.00
342 REC PROGRAMMING		1084	15-Sep-2019	15-Sep-2019	
10-5-7010000-0420	RECREATION EXPENSES				41.00
343 REC PROGRAMMING		1084	22-Sep-2019	22-Sep-2019	
10-5-7010000-0420	RECREATION EXPENSES				59.00
345 REC PROGRAMMING		1084	28-Sep-2019	28-Sep-2019	
10-5-7010000-0420	RECREATION EXPENSES				41.00
347 REC PROGRAMMING		1084	22-Sep-2019	22-Sep-2019	
10-5-7010000-0420	RECREATION EXPENSES				41.00
<b>NUC146 NUCCELLI'S FROZEN YOGURT</b>					
13037 CONCESSION PURCHASE		1084	23-Sep-2019	23-Sep-2019	
10-5-7010000-0384	CONCESSION PRODUCT				303.74
<b>OUE456 OUELLETTE BRITTANY</b>					
SEPTEMBER 2 REBATE FOR SWIM LESSONS		1078	27-Sep-2019	27-Sep-2019	
10-5-7010000-0773	SWIM PROGRAM				75.60
<b>POS236 POST-GAME BREWING COMPANY</b>					
3437 CONCESSION PURCHASE		1084	17-Sep-2019	17-Sep-2019	
10-5-7010000-0384	CONCESSION PRODUCT				372.00
<b>RTT067 RIVER TOWN TIMES</b>					
2515 ADVERTISING		1127	21-Aug-2019	21-Aug-2019	
10-5-7010000-0307	ADVERTISING				141.02
2690 ADVERTISING		1078	18-Sep-2019	18-Sep-2019	
10-5-7010000-0307	ADVERTISING				174.52
<b>SHA567 SHARP BUS LINES LIMITED</b>					
WIN238587 AQUATICS PROGRAM TRANSPORTATION		1084	22-Aug-2019	22-Aug-2019	
10-5-7010000-0773	SWIM PROGRAM				192.10
WIN239493 SUMMER DAY CAMP TRIP		1084	28-Aug-2019	28-Aug-2019	
10-5-7010000-0776	ESSEX POWER YOUTH IN COMM FD				242.95
<b>SMI037 SMITH NELLIE</b>					
SEPTEMBER 2 REBATE FOR SWIM LESSONS		1078	27-Sep-2019	27-Sep-2019	
10-5-7010000-0773	SWIM PROGRAM				75.60
<b>SOB083 SOBEYS AMHERSTBURG</b>					
AUGUST 2019 PURCHASES MADE IN AUGUST 2019		1113	31-Aug-2019	31-Aug-2019	
10-5-7010000-0384	CONCESSION PRODUCT				52.28
10-5-7010000-0384	CONCESSION PRODUCT				121.76
10-5-7010000-0384	CONCESSION PRODUCT				15.43
10-5-7010000-0384	CONCESSION PRODUCT				229.39
10-5-7010000-0384	CONCESSION PRODUCT				66.53
10-5-7010000-0384	CONCESSION PRODUCT				248.40
10-5-7010000-0384	CONCESSION PRODUCT				56.86
10-5-7010000-0384	CONCESSION PRODUCT				36.20
10-5-7010000-0420	RECREATION EXPENSES				34.17
10-5-7010000-0420	RECREATION EXPENSES				75.58
10-5-7010000-0420	RECREATION EXPENSES				4.97
10-5-7010000-0420	RECREATION EXPENSES				12.97



Vendor : CAT038 To ZUL180

Batch : All

Department : All

Cheque Print Date : 01-Oct-2019 To 31-Oct-2019

Bank : 1 To 99

Class : All

Vendor Invoice	Vendor Name Description	Batch	Inv Date	Inv Due Date	Amount
G.L. Account	CC1 CC2 CC3 GL Account Name				
<b>DEPARTMENT 7010000 PARKS AND RECREATION PROGRAMMING</b>					
10-5-7010000-0420	RECREATION EXPENSES				54.97
10-5-7010000-0420	RECREATION EXPENSES				6.77
10-5-7010000-0420	RECREATION EXPENSES				15.04
10-5-7010000-0420	RECREATION EXPENSES				44.67
JULY 2019	PURCHASES MADE IN JULY 2019	1146	30-Jul-2019	30-Jul-2019	
10-5-7010000-0384	CONCESSION PRODUCT				83.61
10-5-7010000-0384	CONCESSION PRODUCT				71.68
10-5-7010000-0384	CONCESSION PRODUCT				92.00
10-5-7010000-0384	CONCESSION PRODUCT				55.15
10-5-7010000-0384	CONCESSION PRODUCT				100.80
10-5-7010000-0384	CONCESSION PRODUCT				169.82
10-5-7010000-0420	RECREATION EXPENSES				19.74
10-5-7010000-0420	RECREATION EXPENSES				137.91
10-5-7010000-0384	CONCESSION PRODUCT				60.23
10-5-7010000-0384	CONCESSION PRODUCT				40.73
10-5-7010000-0384	CONCESSION PRODUCT				90.16
10-5-7010000-0384	CONCESSION PRODUCT				68.21
JUNE 2019	PURCHASES FOR THE MONTH OF JUNE 2019	1084	30-Jun-2019	30-Jun-2019	
10-5-7010000-0420	RECREATION EXPENSES				39.32
10-5-7010000-0420	RECREATION EXPENSES				39.00
10-5-7010000-0420	RECREATION EXPENSES				517.92
10-5-7010000-0420	RECREATION EXPENSES				43.49
10-5-7010000-0771	SPECIAL EVENTS				240.57
10-5-7010000-0384	CONCESSION PRODUCT				4.00
10-5-7010000-0384	CONCESSION PRODUCT				93.28
10-5-7010000-0384	CONCESSION PRODUCT				292.61
10-5-7010000-0384	CONCESSION PRODUCT				257.14
10-5-7010000-0384	CONCESSION PRODUCT				188.87
10-5-7010000-0384	CONCESSION PRODUCT				97.28
10-5-7010000-0384	CONCESSION PRODUCT				48.30
10-5-7010000-0384	CONCESSION PRODUCT				309.41
10-5-7010000-0384	CONCESSION PRODUCT				71.60
<b>STA036 STARK-HELKIE LAURA</b>					
JULY 31, 2019	REBATE FOR SWIMMING LESSONS	834	31-Jul-2019	31-Jul-2019	
10-5-7010000-0773	SWIM PROGRAM				173.80
SEPTEMBER 2	REBATE FOR SWIM LESSONS	1078	27-Sep-2019	27-Sep-2019	
10-5-7010000-0773	SWIM PROGRAM				162.50
<b>VOL382 CORPORATION OF THE TOWN OF LASALLE DEPARTMENT OF</b>					
2222	AQUATICS PROGRAM	1084	18-Sep-2019	18-Sep-2019	
10-5-7010000-0773	SWIM PROGRAM				2,003.00
<b>WHI125 WHITE JANE</b>					
SEPTEMBER 2	REBATE FOR SWIM LESSONS	1078	27-Sep-2019	27-Sep-2019	
10-5-7010000-0773	SWIM PROGRAM				128.60
<b>Department Totals :</b>					<b>18,110.87</b>

<b>DEPARTMENT 7017000 PARKS MAINTENANCE</b>					
<b>AGR835 AGRIS CO-OPERATIVE LTD</b>					
130034120	SEED MIX	1070	18-Sep-2019	18-Sep-2019	
10-5-7017000-0322	GENERAL SUPPLIES - PARKS & REC				1,871.49
130034138	SEEDS	1070	20-Sep-2019	20-Sep-2019	
10-5-7017000-0322	GENERAL SUPPLIES - PARKS & REC				3,390.00
<b>BEN262 BENSON AUTO PARTS</b>					
20453564	PARKS STOCK	1070	20-Aug-2019	20-Aug-2019	
10-5-7017000-0402	VEHICLE & EQUIPMENT MAINTENANCE PARKS				26.88
20453600	PARKS CREDIT	1070	21-Aug-2019	21-Aug-2019	
10-5-7017000-0402	VEHICLE & EQUIPMENT MAINTENANCE PARKS				-108.13

Council/Board Report By Dept-(Computer)



Vendor : CAT038 To ZUL180  
 Batch : All  
 Department : All

Cheque Print Date : 01-Oct-2019 To 31-Oct-2019  
 Bank : 1 To 99  
 Class : All

Vendor Invoice	Vendor Name Description	Batch	Inv Date	Inv Due Date	Amount
G.L. Account	CC1 CC2 CC3 GL Account Name				
<b>DEPARTMENT 7017000 PARKS MAINTENANCE</b>					
20453618	UNIT RM-01	1070	21-Aug-2019	21-Aug-2019	
10-5-7017000-0402	VEHICLE & EQUIPMENT MAINTENANCE PARKS				148.64
20455212	PG-01	1146	13-Sep-2019	13-Sep-2019	
10-5-7017000-0402	VEHICLE & EQUIPMENT MAINTENANCE PARKS				417.91
20455300	PG-01	1146	16-Sep-2019	16-Sep-2019	
10-5-7017000-0402	VEHICLE & EQUIPMENT MAINTENANCE PARKS				43.38
20455322	PARKS CREDIT	1146	16-Sep-2019	16-Sep-2019	
10-5-7017000-0402	VEHICLE & EQUIPMENT MAINTENANCE PARKS				-294.87
20455845	PARKS STOCK	1146	23-Sep-2019	23-Sep-2019	
10-5-7017000-0402	VEHICLE & EQUIPMENT MAINTENANCE PARKS				75.33
<b>CAN160 CANADIAN BEARINGS LTD</b>					
20154825-00	507 REPAIR	1167	25-Sep-2019	25-Sep-2019	
10-5-7017000-0402	VEHICLE & EQUIPMENT MAINTENANCE PARKS				40.57
<b>CAN236 CANADIAN FENCE CONTRACTORS - 1954812</b>					
365	REPAIRS FROM STORM DAMAGE	1167	19-Sep-2019	19-Sep-2019	
10-5-7017000-0336	CONTRACTED SERVICES				2,172.99
<b>CAN380 CANADIAN TIRE STORE #281</b>					
JULY 2019	JULY 2019 PURCHASES	1078	31-Jul-2019	31-Jul-2019	
10-5-7017000-0322	GENERAL SUPPLIES - PARKS & REC				15.80
10-5-7017000-0322	GENERAL SUPPLIES - PARKS & REC				381.19
<b>CHA134 CHATHAM OUTDOOR POWER</b>					
1670	UNIT PG-13	1070	21-Aug-2019	21-Aug-2019	
10-5-7017000-0402	VEHICLE & EQUIPMENT MAINTENANCE PARKS				475.46
1842	UNIT PG-43	1146	17-Sep-2019	17-Sep-2019	
10-5-7017000-0402	VEHICLE & EQUIPMENT MAINTENANCE PARKS				419.89
<b>COL286 COLBRO EQUIPMENT RENTAL</b>					
121456-0	PARKS EQUIPMENT	1070	16-Sep-2019	16-Sep-2019	
10-5-7017000-0402	VEHICLE & EQUIPMENT MAINTENANCE PARKS				95.59
<b>COU132 COUNTY TOWING INC.</b>					
19-01592	UNIT 507	1167	20-Sep-2019	20-Sep-2019	
10-5-7017000-0402	VEHICLE & EQUIPMENT MAINTENANCE PARKS				282.50
<b>DON360 DON'S MARINE; MARINE &amp; OUTDOOR POWER EQUIPMENT</b>					
60130528	UNIT PG-43	1146	16-Sep-2019	16-Sep-2019	
10-5-7017000-0402	VEHICLE & EQUIPMENT MAINTENANCE PARKS				28.51
60130533	PARKS STOCK	1167	17-Sep-2019	17-Sep-2019	
10-5-7017000-0402	VEHICLE & EQUIPMENT MAINTENANCE PARKS				32.76
<b>ELE290 ELECTROZAD SUPPLY CO LTD</b>					
S3481990.001	SUPPLIES	1146	20-Sep-2019	20-Sep-2019	
10-5-7017000-0322	GENERAL SUPPLIES - PARKS & REC				131.25
S3481990.002	SUPPLIES	1146	20-Sep-2019	20-Sep-2019	
10-5-7017000-0322	GENERAL SUPPLIES - PARKS & REC				808.65
S3490438.001	HEALTH & SAFETY	1167	09-Oct-2019	09-Oct-2019	
10-5-7017000-0322	GENERAL SUPPLIES - PARKS & REC				378.26
<b>EMC530 EMCO CORPORATION</b>					
37503906-00	SUPPLIES	1146	02-Aug-2019	02-Aug-2019	
10-5-7017000-0322	GENERAL SUPPLIES - PARKS & REC				30.68
<b>GUA009 GUARDIAN FENCE</b>					
8364	MAINTENANCE	1146	26-Sep-2019	26-Sep-2019	
10-5-7017000-1300	CO-AN PARK EXPENSES				1,042.42
<b>HER247 HERITAGE TIRE SALES INC.</b>					
AIN0003217	PARKS TR3	1070	19-Aug-2019	19-Aug-2019	
10-5-7017000-0402	VEHICLE & EQUIPMENT MAINTENANCE PARKS				169.56



Vendor : CAT038 To ZUL180

Batch : All

Department : All

Cheque Print Date : 01-Oct-2019 To 31-Oct-2019

Bank : 1 To 99

Class : All

Vendor Invoice	Vendor Name Description	Batch	Inv Date	Inv Due Date	Amount
G.L. Account	CC1 CC2 CC3 GL Account Name				

<b>DEPARTMENT 7017000</b>	<b>PARKS MAINTENANCE</b>				
AIN0003257	PARKS TR3		1070 19-Aug-2019	19-Aug-2019	
10-5-7017000-0402	VEHICLE & EQUIPMENT MAINTENANCE PARKS				169.56
AIN0003334	PARKS TR2		1070 19-Aug-2019	19-Aug-2019	
10-5-7017000-0402	VEHICLE & EQUIPMENT MAINTENANCE PARKS				169.56
AIN0003590	PG-1		1146 19-Sep-2019	19-Sep-2019	
10-5-7017000-0402	VEHICLE & EQUIPMENT MAINTENANCE PARKS				33.90
AIN0003640	TR-2		1167 23-Sep-2019	23-Sep-2019	
10-5-7017000-0402	VEHICLE & EQUIPMENT MAINTENANCE PARKS				169.56
<b>HIC441 HICKS ELECTRIC</b>					
10040	BANNER INSTALLATION		1146 06-Oct-2019	06-Oct-2019	
10-5-7017000-0336	CONTRACTED SERVICES				847.50
<b>JOE055 JOE MELOCHE FORD SALES LTD</b>					
IJ03951	TH-1		1070 03-Sep-2019	03-Sep-2019	
10-5-7017000-0402	VEHICLE & EQUIPMENT MAINTENANCE PARKS				31.38
IJ04027	UNIT PG-3		1146 20-Sep-2019	20-Sep-2019	
10-5-7017000-0402	VEHICLE & EQUIPMENT MAINTENANCE PARKS				67.75
<b>KEL198 KELCOM RADIO DIVISION</b>					
80011114	RADIO AIRTIME		1070 16-Sep-2019	16-Sep-2019	
10-5-7017000-0404	RADIO AIR TIME				304.59
<b>KNM541 KNM YARD CARE</b>					
1561	PARKS GRASS CUTTING FOR SEPTEMBER 2019		1146 01-Oct-2019	01-Oct-2019	
10-5-7017000-0336	CONTRACTED SERVICES				3,813.75
<b>MAL256 MALDEN AUTOMOTIVE</b>					
5294-197649	UNIT 710		1070 19-Aug-2019	19-Aug-2019	
10-5-7017000-0402	VEHICLE & EQUIPMENT MAINTENANCE PARKS				69.26
5294-197838	RM-01		1070 21-Aug-2019	21-Aug-2019	
10-5-7017000-0402	VEHICLE & EQUIPMENT MAINTENANCE PARKS				19.73
5294-198089	UNIT 507		1078 24-Aug-2019	24-Aug-2019	
10-5-7017000-0402	VEHICLE & EQUIPMENT MAINTENANCE PARKS				31.05
5294-198257	PARKS TR-5		1078 27-Aug-2019	27-Aug-2019	
10-5-7017000-0402	VEHICLE & EQUIPMENT MAINTENANCE PARKS				14.62
5294-198583	UNIT 507		1078 03-Sep-2019	03-Sep-2019	
10-5-7017000-0402	VEHICLE & EQUIPMENT MAINTENANCE PARKS				57.63
5294-199130	OG-43		1084 10-Sep-2019	10-Sep-2019	
10-5-7017000-0402	VEHICLE & EQUIPMENT MAINTENANCE PARKS				89.06
5294-199244	PG-33		1084 12-Sep-2019	12-Sep-2019	
10-5-7017000-0402	VEHICLE & EQUIPMENT MAINTENANCE PARKS				104.05
5294-199354	PG-43		1084 13-Sep-2019	13-Sep-2019	
10-5-7017000-0402	VEHICLE & EQUIPMENT MAINTENANCE PARKS				8.42
5294-199517	UNIT PG-01		1146 16-Sep-2019	16-Sep-2019	
10-5-7017000-0402	VEHICLE & EQUIPMENT MAINTENANCE PARKS				61.97
5294-200503	PG-1		1167 01-Oct-2019	01-Oct-2019	
10-5-7017000-0402	VEHICLE & EQUIPMENT MAINTENANCE PARKS				252.34
5294-200506	CREDIT		1167 01-Oct-2019	01-Oct-2019	
10-5-7017000-0402	VEHICLE & EQUIPMENT MAINTENANCE PARKS				-114.57
5294-200528	PARKS PG - 1		1167 01-Oct-2019	01-Oct-2019	
10-5-7017000-0402	VEHICLE & EQUIPMENT MAINTENANCE PARKS				162.08
<b>MER975 MERCHANTS PAPER CO</b>					
167596	GARBAGE BAGS		1078 18-Sep-2019	18-Sep-2019	
40-7-7017000-0002	MALDEN PARK - BALL DIAMOND FENCING/BACKS				312.90
<b>MIC117 MICHELIN NORTH AMERICA (CANADA) INC c/o</b>					
DA0007251161	UNIT 210		1078 13-Aug-2019	13-Aug-2019	
10-5-7017000-0402	VEHICLE & EQUIPMENT MAINTENANCE PARKS				172.66





Vendor : CAT038 To ZUL180

Batch : All

Department : All

Cheque Print Date : 01-Oct-2019 To 31-Oct-2019

Bank : 1 To 99

Class : All

Vendor Invoice	Vendor Name Description				Batch Invc Date	Invc Due Date	Amount
G.L. Account	CC1	CC2	CC3	GL Account Name			
<b>DEPARTMENT 7017000</b>				<b>PARKS MAINTENANCE</b>			
<b>NOR156</b>	<b>NORTRAX CANADA INC.</b>						
1290630	PARK UNIT 208				1078 29-Aug-2019	29-Aug-2019	
10-5-7017000-0402				VEHICLE & EQUIPMENT MAINTENANCE PARKS			349.55
<b>PAR372</b>	<b>PARRLINE ELECTRICAL WHOLESAL</b>						
83430	ELECTRICAL SUPPLIES				1078 26-Jul-2019	26-Jul-2019	
10-5-7017000-0322				GENERAL SUPPLIES - PARKS & REC			369.20
83836	ELECTRICAL SUPPLIES				1078 27-Jul-2019	27-Jul-2019	
10-5-7017000-0322				GENERAL SUPPLIES - PARKS & REC			44.30
83969	ELECTRICAL SUPPLIES				1078 30-Jul-2019	30-Jul-2019	
10-5-7017000-0322				GENERAL SUPPLIES - PARKS & REC			77.07
<b>PLA02</b>	<b>PLAYPOWER LT CANADA</b>						
60020937	PLAY EQUIPMENT PARTS FOR TODDY JONES PARK				1167 25-Sep-2019	25-Sep-2019	
10-5-7017000-0322				GENERAL SUPPLIES - PARKS & REC			793.85
<b>RAC462</b>	<b>RACICOT CHRYSLER</b>						
58206	PG-1				1167 18-Sep-2019	18-Sep-2019	
10-5-7017000-0402				VEHICLE & EQUIPMENT MAINTENANCE PARKS			257.64
58304	PG-1				1167 01-Oct-2019	01-Oct-2019	
10-5-7017000-0402				VEHICLE & EQUIPMENT MAINTENANCE PARKS			58.59
CCCS258580	PG-1				1167 17-Sep-2019	17-Sep-2019	
10-5-7017000-0402				VEHICLE & EQUIPMENT MAINTENANCE PARKS			451.32
<b>SOB083</b>	<b>SOBEYS AMHERSTBURG</b>						
JULY 2019	PURCHASES MADE IN JULY 2019				1146 30-Jul-2019	30-Jul-2019	
10-5-7017000-0322				GENERAL SUPPLIES - PARKS & REC			61.34
10-5-7017000-0322				GENERAL SUPPLIES - PARKS & REC			29.67
10-5-7017000-0322				GENERAL SUPPLIES - PARKS & REC			11.96
10-5-7017000-0322				GENERAL SUPPLIES - PARKS & REC			11.96
10-5-7017000-0322				GENERAL SUPPLIES - PARKS & REC			31.82
<b>SOU370</b>	<b>SOUTHPOINT EQUIPMENT; DIV OF CL BENNINGER EQUIPMEN</b>						
IE00813	UNIT 507				1078 23-Aug-2019	23-Aug-2019	
10-5-7017000-0402				VEHICLE & EQUIPMENT MAINTENANCE PARKS			142.54
IE00838	UNIT 507				1078 27-Aug-2019	27-Aug-2019	
10-5-7017000-0402				VEHICLE & EQUIPMENT MAINTENANCE PARKS			38.42
IE00857	UNIT 507				1078 28-Aug-2019	28-Aug-2019	
10-5-7017000-0402				VEHICLE & EQUIPMENT MAINTENANCE PARKS			208.85
IE01019	UNIT 507				1167 23-Sep-2019	23-Sep-2019	
10-5-7017000-0402				VEHICLE & EQUIPMENT MAINTENANCE PARKS			997.98
<b>STE01</b>	<b>STEWART GILBERT LTD</b>						
125326	SUPPLIES				1167 30-Sep-2019	30-Sep-2019	
10-5-7017000-0336				CONTRACTED SERVICES			393.48
125327	SUPPLIES				1167 30-Sep-2019	30-Sep-2019	
10-5-7017000-0336				CONTRACTED SERVICES			472.18
125328	SUPPLIES				1167 30-Sep-2019	30-Sep-2019	
10-5-7017000-0336				CONTRACTED SERVICES			393.49
125329	SUPPLIES				1167 30-Sep-2019	30-Sep-2019	
10-5-7017000-0336				CONTRACTED SERVICES			83.95
125330	SUPPLIES				1167 30-Sep-2019	30-Sep-2019	
10-5-7017000-0336				CONTRACTED SERVICES			157.40
<b>TOW595</b>	<b>TOWN OF LASALLE</b>						
3046	TOWN'S CONTRIBUTION				1167 24-Sep-2019	24-Sep-2019	
10-5-7017000-1310				RIVER CANARD PARK EXPENSES			5,000.00
<b>TRA689</b>	<b>TRACTION WINDSOR</b>						
396319954	UNIT 507				1146 21-Sep-2019	21-Sep-2019	
10-5-7017000-0402				VEHICLE & EQUIPMENT MAINTENANCE PARKS			37.28





Vendor : CAT038 To ZUL180  
 Batch : All  
 Department : All

Cheque Print Date : 01-Oct-2019 To 31-Oct-2019  
 Bank : 1 To 99  
 Class : All

Vendor Invoice	Vendor Name Description	Batch	Inv Date	Inv Due Date	Amount
G.L. Account	CC1 CC2 CC3 GL Account Name				

DEPARTMENT	7017000	PARKS MAINTENANCE			
<b>TSC401</b>	<b>TSC STORES LTD</b>				
SEPTEMBER 2 TRN3702 CUSTOMER # 4904, SUPPLIES			1084	24-Sep-2019	24-Sep-2019
10-5-7017000-0322		GENERAL SUPPLIES - PARKS & REC			56.50
<b>WIG035</b>	<b>WIGLE HOME HARDWARE BUILDING CENTRE</b>				
134378	SUPPLIES		1070	16-Sep-2019	16-Sep-2019
10-5-7017000-0402		VEHICLE & EQUIPMENT MAINTENANCE PARKS			12.25
134566	SUPPLIES		1084	22-Sep-2019	22-Sep-2019
10-5-7017000-0420		PARKS MAINTENANCE EQUIPMENT			9.59
134651	SUPPLIES		1084	25-Sep-2019	25-Sep-2019
10-5-7017000-0322		GENERAL SUPPLIES - PARKS & REC			26.41
134657	SUPPLIES		1084	25-Sep-2019	25-Sep-2019
10-5-7017000-0322		GENERAL SUPPLIES - PARKS & REC			10.85
134835	SUPPLIES		1167	01-Oct-2019	01-Oct-2019
10-5-7017000-0322		GENERAL SUPPLIES - PARKS & REC			95.54
134959	SUPPLIES		1167	04-Oct-2019	04-Oct-2019
10-5-7017000-0322		GENERAL SUPPLIES - PARKS & REC			31.93
135192	SUPPLIES		1167	11-Oct-2019	11-Oct-2019
10-5-7017000-0322		GENERAL SUPPLIES - PARKS & REC			98.25
<b>Department Totals :</b>					<b>29,740.62</b>

DEPARTMENT	7017002	FACILITIES			
<b>ACC134</b>	<b>ACCESS DOORS N MORE</b>				
40727	SERVICE BAY DOOR		1167	07-Oct-2019	07-Oct-2019
10-5-7017002-0317	PWD	FACILITIES - BUILDING MAINTENANCE			90.40
<b>BET358</b>	<b>BETTER LOCKSMITHS INC</b>				
24669A	LOCKSMITHS REPAIR		1070	08-Jul-2019	08-Jul-2019
10-5-7017002-0317	GORDOI	FACILITIES - BUILDING MAINTENANCE			107.35
<b>CAN380</b>	<b>CANADIAN TIRE STORE #281</b>				
JULY 2019	JULY 2019 PURCHASES		1078	31-Jul-2019	31-Jul-2019
10-5-7017002-0317	TOWN	FACILITIES - BUILDING MAINTENANCE			24.71
<b>COX03</b>	<b>COXON'S SALES &amp; RENTALS LTD.</b>				
77334	PWD		1167	24-Sep-2019	24-Sep-2019
10-5-7017002-0317	PWD	FACILITIES - BUILDING MAINTENANCE			480.25
<b>DEL060</b>	<b>DELINE'S POWERWASH &amp; PEST CONTROL</b>				
047841	POWERWASH GORDON HOUSE		1113	26-Sep-2019	26-Sep-2019
10-5-7017002-0317	GORDOI	FACILITIES - BUILDING MAINTENANCE			1,017.00
047842	CARPET CLEANING #1 & #2		1167	03-Oct-2019	03-Oct-2019
10-5-7017002-0317	FIRE	FACILITIES - BUILDING MAINTENANCE			621.50
<b>EMC530</b>	<b>EMCO CORPORATION</b>				
37505952-00	PLUMBING MATS		1070	27-Aug-2019	27-Aug-2019
10-5-7017002-0317	TOWN	FACILITIES - BUILDING MAINTENANCE			20.26
<b>ESS959</b>	<b>ESSEX LINEN SUPPLY LTD</b>				
14681	RENTAL MATS		1070	25-Jul-2019	25-Jul-2019
10-5-7017002-0317	GORDOI	FACILITIES - BUILDING MAINTENANCE			22.49
17443	MAINTENANCE MATERIALS		1084	22-Aug-2019	22-Aug-2019
10-5-7017002-0317	GORDOI	FACILITIES - BUILDING MAINTENANCE			22.49
20243	MAINTENANCE MATERIALS		1084	19-Sep-2019	19-Sep-2019
10-5-7017002-0317	GORDOI	FACILITIES - BUILDING MAINTENANCE			22.49
<b>GUA929</b>	<b>GUARDIAN FIRE PROTECTION</b>				
1153	FIRE EXTINGUISHER REPAIR		1070	14-Aug-2019	14-Aug-2019
10-5-7017002-0317	PWD	FACILITIES - BUILDING MAINTENANCE			92.10
<b>HOL459</b>	<b>HOLLAND CLEANING SOLUTIONS LTD</b>				



Vendor : CAT038 To ZUL180  
 Batch : All  
 Department : All

Cheque Print Date : 01-Oct-2019 To 31-Oct-2019  
 Bank : 1 To 99  
 Class : All

Vendor Invoice	Vendor Name Description	Batch	Inv Date	Inv Due Date	Amount
G.L. Account	CC1 CC2 CC3 GL Account Name				
<b>DEPARTMENT 7017002 FACILITIES</b>					
490381	JANITORIAL MAINTENANCE	1070	23-Aug-2019	23-Aug-2019	
10-5-7017002-0318	JANITORIAL - GLOBAL				169.50
490398	JANITORIAL SUPPLIES	1070	23-Aug-2019	23-Aug-2019	
10-5-7017002-0318	JANITORIAL - GLOBAL				1,012.86
492561	REPAIRS TO JANITORIAL EQUIPMENT	1070	18-Sep-2019	18-Sep-2019	
10-5-7017002-0318	JANITORIAL - GLOBAL				146.90
493717	JANITORIAL SUPPLIES	1146	30-Sep-2019	30-Sep-2019	
10-5-7017002-0318	JANITORIAL - GLOBAL				716.21
<b>IND181 INDOOR ENVIRONMENTAL SPECIALIST</b>					
C3721	ASBESTOS BULK SAMPLING, COURIER AND REPORTING	1113	06-Jun-2019	06-Jun-2019	
10-5-7017002-0317	GORDOI FACILITIES - BUILDING MAINTENANCE				355.95
<b>JAN268 JANI SAFE INC.</b>					
193238	JANITORIAL	1084	15-Aug-2019	15-Aug-2019	
10-5-7017002-0318	JANITORIAL - GLOBAL				1,925.00
193238-1	JANITORIAL	1084	23-Aug-2019	23-Aug-2019	
10-5-7017002-0318	JANITORIAL - GLOBAL				112.37
193907	JANITORIAL SUPPLIES	1070	12-Sep-2019	12-Sep-2019	
10-5-7017002-0318	JANITORIAL - GLOBAL				2,077.73
193908	JANITORIAL SUPPLIES	1070	12-Sep-2019	12-Sep-2019	
10-5-7017002-0318	JANITORIAL - GLOBAL				165.71
194484	JANITORIAL SUPPLIES	1146	04-Oct-2019	04-Oct-2019	
10-5-7017002-0318	JANITORIAL - GLOBAL				1,149.52
<b>MCG880 MCGEE'S PLUMBING SOLUTIONS</b>					
156	EEL WORK	1078	10-Sep-2019	10-Sep-2019	
10-5-7017002-0317	TOWN FACILITIES - BUILDING MAINTENANCE				224.87
<b>MET052 METRO KING PEST CONTROL INC.</b>					
2152	MONTHLY SERVICE AT VARIOUS LOCATIONS FOR THE MONTH OF JULY 2019	1078	31-Jul-2019	31-Jul-2019	
10-5-7017002-0317	TOWN FACILITIES - BUILDING MAINTENANCE				39.55
10-5-7017002-0317	PWD FACILITIES - BUILDING MAINTENANCE				39.55
10-5-7017002-0317	GORDOI FACILITIES - BUILDING MAINTENANCE				28.25
10-5-7017002-0317	ACS FACILITIES - BUILDING MAINTENANCE				33.90
10-5-7017002-0317	99THOM FACILITIES - BUILDING MAINTENANCE				28.25
10-5-7017002-0317	FIRE FACILITIES - BUILDING MAINTENANCE				28.25
10-5-7017002-0317	PARKBL FACILITIES - BUILDING MAINTENANCE				28.25
10-5-7017002-0317	PWD FACILITIES - BUILDING MAINTENANCE				28.25
10-5-7017002-0317	FIRE FACILITIES - BUILDING MAINTENANCE				28.25
2153	MONTHLY SERVICES AT VARIOUS LOCATIONS	1078	31-Aug-2019	31-Aug-2019	
10-5-7017002-0317	TOWN FACILITIES - BUILDING MAINTENANCE				39.55
10-5-7017002-0317	PWD FACILITIES - BUILDING MAINTENANCE				39.55
10-5-7017002-0317	GORDOI FACILITIES - BUILDING MAINTENANCE				28.25
10-5-7017002-0317	ACS FACILITIES - BUILDING MAINTENANCE				33.90
10-5-7017002-0317	99THOM FACILITIES - BUILDING MAINTENANCE				28.25
10-5-7017002-0317	FIRE FACILITIES - BUILDING MAINTENANCE				28.25
10-5-7017002-0317	PARKBL FACILITIES - BUILDING MAINTENANCE				28.25
10-5-7017002-0317	PWD FACILITIES - BUILDING MAINTENANCE				28.25
10-5-7017002-0317	PWD FACILITIES - BUILDING MAINTENANCE				28.25
10-5-7017002-0317	PARKBL FACILITIES - BUILDING MAINTENANCE				28.25
10-5-7017002-0317	FIRE FACILITIES - BUILDING MAINTENANCE				28.25
<b>REC09 RECEIVER GENERAL - CANADA REVENUE AGENCY TECHNOLOG</b>					
14905	BUILDING MAINTENANCE	1070	07-Apr-2019	07-Apr-2019	
10-5-7017002-0317	CARNEC FACILITIES - BUILDING MAINTENANCE				152.55
<b>ROO367 ROOFCRAFT INCORPORATED</b>					
3645	GORDON HOUSE REPAIRING ROOF	1113	24-Sep-2019	24-Sep-2019	
10-5-7017002-0317	GORDOI FACILITIES - BUILDING MAINTENANCE				46,872.40
<b>SAV085 SAVARIA SIS</b>					



Vendor : CAT038 To ZUL180

Batch : All

Department : All

Cheque Print Date : 01-Oct-2019 To 31-Oct-2019

Bank : 1 To 99

Class : All

Vendor Invoice	Vendor Name Description				Batch Invc Date	Invc Due Date	Amount
G.L. Account	CC1	CC2	CC3	GL Account Name			
<b>DEPARTMENT 7017002 FACILITIES</b>							
IN0000000477	REPAIRS TO ELEVATOR				1078 20-Aug-2019	20-Aug-2019	
10-5-7017002-0317	CARNEC			FACILITIES - BUILDING MAINTENANCE			1,557.99
IN0000000490	MAINTENANCE ELEVATOR REPAIR				1167 09-Oct-2019	09-Oct-2019	
10-5-7017002-0317	CARNEC			FACILITIES - BUILDING MAINTENANCE			3,333.50
<b>TEC01 TECHNICAL STANDARDS AND SAFETY AUTHORITY</b>							
6519947	ELEVATOR LICENSE RENEWAL				1070 18-Aug-2019	18-Aug-2019	
10-5-7017002-0317	CARNEC			FACILITIES - BUILDING MAINTENANCE			108.00
<b>TOT060 TOTALLYONE CORPORATE OFFICE</b>							
25444	PHONE RENEWALS				1084 09-Sep-2019	09-Sep-2019	
10-5-7017002-0345				CELL PHONE			858.10
<b>WIG035 WIGLE HOME HARDWARE BUILDING CENTRE</b>							
134078	SUPPLIES				1113 06-Sep-2019	06-Sep-2019	
10-5-7017002-0317	FIRE			FACILITIES - BUILDING MAINTENANCE			12.97
134443	SUPPLIES				1078 18-Sep-2019	18-Sep-2019	
10-5-7017002-0317	GORDOI			FACILITIES - BUILDING MAINTENANCE			72.39
134917	SUPPLIES				1146 03-Oct-2019	03-Oct-2019	
10-5-7017002-0317	TOWN			FACILITIES - BUILDING MAINTENANCE			5.38
134923	SUPPLIES				1167 03-Oct-2019	03-Oct-2019	
10-5-7017002-0317	PWD			FACILITIES - BUILDING MAINTENANCE			49.01
<b>Department Totals :</b>							<b>64,221.45</b>
<hr/>							
<b>DEPARTMENT 7017300 LIBRO</b>							
<b>AMH435 AMHERSTBURG ADMIRALS JR. C HOCKEY CLUB</b>							
368	WASHING MACHINE				1167 15-Oct-2019	15-Oct-2019	
10-5-7017300-0317				BUILDING MAINTENANCE			423.19
<b>BEN262 BENSON AUTO PARTS</b>							
20454106	RS-4				1070 27-Aug-2019	27-Aug-2019	
10-5-7017300-0402				VEHICLE & EQUIPMENT MTCE.			63.79
20455505	UNIT FM-04				1146 18-Sep-2019	18-Sep-2019	
10-5-7017300-0402				VEHICLE & EQUIPMENT MTCE.			237.62
<b>CAN380 CANADIAN TIRE STORE #281</b>							
JULY 2019	JULY 2019 PURCHASES				1078 31-Jul-2019	31-Jul-2019	
10-5-7017300-0317				BUILDING MAINTENANCE			247.35
10-5-7017300-0317				BUILDING MAINTENANCE			60.95
10-5-7017300-0317				BUILDING MAINTENANCE			13.53
10-5-7017300-0317				BUILDING MAINTENANCE			30.01
10-5-7017300-0317				BUILDING MAINTENANCE			161.61
<b>CEN859 CENTENNIAL LOCK &amp; SAFE LIMITED</b>							
25745	TRIP CHARGE				1167 30-Sep-2019	30-Sep-2019	
10-5-7017300-0317				BUILDING MAINTENANCE			158.20
<b>CIN177 CINTAS</b>							
847408847	MAT EXCHANGE				1078 20-Sep-2019	20-Sep-2019	
10-5-7017300-0336				CONTRACTED SERVICES			100.06
847409856	MAT EXCHANGE				1113 27-Sep-2019	27-Sep-2019	
10-5-7017300-0336				CONTRACTED SERVICES			100.06
847410918	MAT EXCHANGE				1167 04-Oct-2019	04-Oct-2019	
10-5-7017300-0336				CONTRACTED SERVICES			100.06
847411961	MAT EXCHANGE				1167 11-Oct-2019	11-Oct-2019	
10-5-7017300-0336				CONTRACTED SERVICES			100.06
<b>CUL391 CULLIGAN WATER</b>							
2615835	COOLER RENTAL WATER				1084 31-Aug-2019	31-Aug-2019	
10-5-7017300-0336				CONTRACTED SERVICES			81.24



Vendor : CAT038 To ZUL180  
 Batch : All  
 Department : All

Cheque Print Date : 01-Oct-2019 To 31-Oct-2019  
 Bank : 1 To 99  
 Class : All

Vendor Invoice	Vendor Name Description	Batch	Inv Date	Inv Due Date	Amount
G.L. Account	CC1 CC2 CC3 GL Account Name				
<b>DEPARTMENT 7017300</b>	LIBRO				
2626956	RENTAL WATER COOLERS				
10-5-7017300-0336	CONTRACTED SERVICES	1146	30-Sep-2019	30-Sep-2019	81.24
<b>DOW547 DOWLER KARN</b>					
115370	REFILL CYLINDER				
10-5-7017300-0401	GASOLINE / PROPANE	1078	27-Jun-2019	27-Jun-2019	77.63
33904051	CYLINDER RENTAL				
10-5-7017300-0401	GASOLINE / PROPANE	1078	30-Jun-2019	30-Jun-2019	28.25
34412436	CYLINDER RENTAL				
10-5-7017300-0401	GASOLINE / PROPANE	1078	27-Sep-2019	27-Sep-2019	28.25
34980747	PROPANE				
10-5-7017300-0401	GASOLINE / PROPANE	1070	31-Jul-2019	31-Jul-2019	28.25
936761	PROPANE				
10-5-7017300-0401	GASOLINE / PROPANE	1070	04-Sep-2019	04-Sep-2019	388.14
939350	PROPANE				
10-5-7017300-0401	GASOLINE / PROPANE	1070	11-Sep-2019	11-Sep-2019	129.39
941927	PROPANE				
10-5-7017300-0401	GASOLINE / PROPANE	1146	18-Sep-2019	18-Sep-2019	207.00
944423	PROPANE				
10-5-7017300-0401	GASOLINE / PROPANE	1146	25-Sep-2019	25-Sep-2019	155.25
<b>EMC530 EMCO CORPORATION</b>					
37506615-00	PLUMBING MATERIALS				
10-5-7017300-0317	BUILDING MAINTENANCE	1070	09-Sep-2019	09-Sep-2019	189.84
37507398-00	MAINTENANCE MATERIALS				
10-5-7017300-0317	BUILDING MAINTENANCE	1070	20-Sep-2019	20-Sep-2019	4,164.41
9125933-00	CREDIT				
10-5-7017300-0331	REFRIGERATION MAINTENANCE	1078	30-Aug-2019	30-Aug-2019	-146.90
<b>FCF160 FCFP</b>					
INV135171	ANNUAL FIRE SUPPRESSION INSPECTION				
10-5-7017300-0317	BUILDING MAINTENANCE	1070	23-Sep-2019	23-Sep-2019	1,788.06
<b>FIRE001 FIREHORSE LEADERSHIP ORGANIZATION</b>					
OCTOBER 10,					
10-4-7017300-1425	LIBRO - ROOM RENTALS	1146	10-Oct-2019	10-Oct-2019	198.69
<b>GRE679 GREG BAILEY LTD</b>					
0000052918	SUPPLIES				
10-5-7017300-0317	BUILDING MAINTENANCE	1078	29-Aug-2019	29-Aug-2019	4.46
<b>GRY115 GRYPHON GLASS</b>					
13195	GLASS REPLACEMENT				
10-5-7017300-0317	BUILDING MAINTENANCE	1167	07-Oct-2019	07-Oct-2019	919.55
<b>JAC351 JACK SMITH FUELS LTD</b>					
IN354616	EXTENDED LIFE ANTIFREEZE 50/50				
10-5-7017300-0331	REFRIGERATION MAINTENANCE	1078	30-Aug-2019	30-Aug-2019	1,593.30
IN355767	EXTENDED LIFE ANTIFREEZE 50/50				
10-5-7017300-0331	REFRIGERATION MAINTENANCE	1078	16-Sep-2019	16-Sep-2019	1,593.30
IN356336	EXTENDED LIFE ANTIFREEZE 50/50				
10-5-7017300-0331	REFRIGERATION MAINTENANCE	1113	23-Sep-2019	23-Sep-2019	1,593.30
<b>JET109 JET ICE</b>					
104632	JET ICE WHITE PAINT FOR ICE				
10-5-7017300-0317	BUILDING MAINTENANCE	1146	21-May-2019	21-May-2019	3,176.50
<b>MAL256 MALDEN AUTOMOTIVE</b>					
5294-197399	RS-10				
10-5-7017300-0402	VEHICLE & EQUIPMENT	1070	14-Aug-2019	14-Aug-2019	17.91
5294-199651	UNIT FM-4				
		1146	18-Sep-2019	18-Sep-2019	



Vendor : CAT038 To ZUL180  
 Batch : All  
 Department : All

Cheque Print Date : 01-Oct-2019 To 31-Oct-2019  
 Bank : 1 To 99  
 Class : All

Vendor Invoice	Vendor Name Description	Batch	Inv Date	Inv Due Date	Amount
G.L. Account	CC1 CC2 CC3 GL Account Name				
<b>DEPARTMENT 7017300</b>	LIBRO				
10-5-7017300-0402	VEHICLE & EQUIPMENT MTCE.				114.57
5294-199705 UNIT FM 4		1146	18-Sep-2019	18-Sep-2019	
10-5-7017300-0402	VEHICLE & EQUIPMENT MTCE.				55.64
5294-199726 CREDIT		1167	18-Sep-2019	18-Sep-2019	
10-5-7017300-0402	VEHICLE & EQUIPMENT MTCE.				-55.64
5294-199954 RS-2		1167	23-Sep-2019	23-Sep-2019	
10-5-7017300-0402	VEHICLE & EQUIPMENT MTCE.				32.68
5294-199987 CREDIT		1167	23-Sep-2019	23-Sep-2019	
10-5-7017300-0402	VEHICLE & EQUIPMENT MTCE.				-32.68
5294-200556 FM-1		1167	01-Oct-2019	01-Oct-2019	
10-5-7017300-0402	VEHICLE & EQUIPMENT MTCE.				161.07
<b>MET052 METRO KING PEST CONTROL INC.</b>					
2152 MONTHLY SERVICE AT VARIOUS LOCATIONS FOR THE MONTH OF JULY 2019		1078	31-Jul-2019	31-Jul-2019	
10-5-7017300-0317 BUILDING MAINTENANCE					45.20
10-5-7017300-0317 BUILDING MAINTENANCE					28.25
2153 MONTHLY SERVICES AT VARIOUS LOCATIONS		1078	31-Aug-2019	31-Aug-2019	
10-5-7017300-0317 BUILDING MAINTENANCE					45.20
10-5-7017300-0317 BUILDING MAINTENANCE					28.25
<b>MIC097 MICHAEL CHARBONNEAU GRAPHICS &amp; DESIGN</b>					
2019-3236 SIGN		1078	08-Sep-2019	08-Sep-2019	
10-5-7017300-0960 OUTDOOR SOCCER (NAT TURF)					446.35
<b>NEL277 NELLA CUTLERY (HAMILTON) INC</b>					
IN2386766 ICE RESURFACING BLADE SHARPENING		1084	12-Sep-2019	12-Sep-2019	
10-5-7017300-0401 GASOLINE / PROPANE					67.80
IN2386768 ICE RESURFACING BLADE SHARPENING		1078	12-Sep-2019	12-Sep-2019	
10-5-7017300-0401 GASOLINE / PROPANE					67.80
<b>PAR372 PARRLINE ELECTRICAL WHOLESALE</b>					
84715 MAINTENANCE MATERIALS		1167	12-Sep-2019	12-Sep-2019	
10-5-7017300-0317 BUILDING MAINTENANCE					373.80
<b>THY410 THYSSENKRUPP ELEVATOR (CANADA) LIMITED</b>					
1644334 MAINTENANCE ELEVATOR		1070	01-Oct-2019	01-Oct-2019	
10-5-7017300-0336 CONTRACTED SERVICES					1,206.57
<b>VIL417 VILLA CONSTRUCTION</b>					
7019 MAINTENANCE		1078	14-Aug-2019	14-Aug-2019	
10-5-7017300-0317 BUILDING MAINTENANCE					2,819.35
<b>WIG035 WIGLE HOME HARDWARE BUILDING CENTRE</b>					
134161 SUPPLIES		1078	09-Sep-2019	09-Sep-2019	
10-5-7017300-0317 BUILDING MAINTENANCE					41.27
134209 SUPPLIES		1078	10-Sep-2019	10-Sep-2019	
10-5-7017300-0317 BUILDING MAINTENANCE					35.32
134270 SUPPLIES		1078	12-Sep-2019	12-Sep-2019	
10-5-7017300-0317 BUILDING MAINTENANCE					12.98
134314 SUPPLIES		1078	13-Sep-2019	13-Sep-2019	
10-5-7017300-0317 BUILDING MAINTENANCE					85.12
134327 SUPPLIES		1078	13-Sep-2019	13-Sep-2019	
10-5-7017300-0317 BUILDING MAINTENANCE					7.59
134664 SUPPLIES		1113	25-Sep-2019	25-Sep-2019	
10-5-7017300-0317 BUILDING MAINTENANCE					69.04
134980 SUPPLIES		1167	04-Oct-2019	04-Oct-2019	
10-5-7017300-0317 BUILDING MAINTENANCE					9.03
135087 SUPPLIES		1167	09-Oct-2019	09-Oct-2019	
10-5-7017300-0317 BUILDING MAINTENANCE					72.01
<b>WIN1506 WINMECH LTD</b>					

Council/Board Report By Dept-(Computer)



Vendor : CAT038 To ZUL180

Batch : All

Department : All

Cheque Print Date : 01-Oct-2019 To 31-Oct-2019

Bank : 1 To 99

Class : All

Vendor Invoice	Vendor Name Description	Batch	Inv Date	Inv Due Date	Amount
G.L. Account	CC1 CC2 CC3 GL Account Name				
<b>DEPARTMENT 7017300 LIBRO</b>					
INV-0121	MAINTENANCE		1167 05-Oct-2019	05-Oct-2019	
10-5-7017300-0331	REFRIGERATION MAINTENANCE				1,118.70
INV-0122	MAINTENANCE		1167 05-Oct-2019	05-Oct-2019	
10-5-7017300-0331	REFRIGERATION MAINTENANCE				5,451.12
INV-0124	MAINTENANCE		1146 08-Oct-2019	08-Oct-2019	
10-5-7017300-0331	REFRIGERATION MAINTENANCE				4,666.90
INV-0125	MAINTENANCE		1167 10-Oct-2019	10-Oct-2019	
10-5-7017300-0331	REFRIGERATION MAINTENANCE				966.15
<b>WIN210 WINDSOR FACTORY SUPPLY LTD</b>					
5104574	MAINTENANCE MATERIAL		1078 17-Sep-2019	17-Sep-2019	
10-5-7017300-0962	PREMIER BASEBALL FIELD				463.36
5105692	MAINTENANCE MATERIAL		1078 18-Sep-2019	18-Sep-2019	
10-5-7017300-0317	BUILDING MAINTENANCE				364.03
5106162	MAINTENANCE MATERIAL		1078 19-Sep-2019	19-Sep-2019	
10-5-7017300-0962	PREMIER BASEBALL FIELD				26.81
5111164	MAINTENANCE MATERIAL		1084 26-Sep-2019	26-Sep-2019	
10-5-7017300-0317	BUILDING MAINTENANCE				814.64
5112374	BASEBALL MAINTENANCE		1146 30-Sep-2019	30-Sep-2019	
10-5-7017300-0962	PREMIER BASEBALL FIELD				-116.28
<b>WIN270 WINDSOR DISPOSAL SERVICES LTD</b>					
0000962927	CARDBOARD COLLECTION		1070 01-Sep-2019	01-Sep-2019	
10-5-7017300-0336	CONTRACTED SERVICES				67.54
<b>ZAM038 ZAMBONI COMPANY LTD</b>					
101837	ZAMBONI PARTS		1070 16-Aug-2019	16-Aug-2019	
10-5-7017300-0402	VEHICLE & EQUIPMENT MTCE.				1,356.00
101958	ZAMBONI PARTS		1070 23-Aug-2019	23-Aug-2019	
10-5-7017300-0402	VEHICLE & EQUIPMENT MTCE.				855.78
102113	ZAMBONI PARTS		1070 05-Sep-2019	05-Sep-2019	
10-5-7017300-0402	VEHICLE & EQUIPMENT MTCE.				616.69
102334	ZAMBONI PARTS		1084 23-Sep-2019	23-Sep-2019	
10-5-7017300-0402	VEHICLE & EQUIPMENT MTCE.				90.95
102403	ZAMBONI PARTS		1113 26-Sep-2019	26-Sep-2019	
10-5-7017300-0402	VEHICLE & EQUIPMENT MTCE.				148.30
<b>Department Totals :</b>					<b>40,720.81</b>

<b>DEPARTMENT 7017313 LIBRO CAPITAL</b>					
<b>ZAM038 ZAMBONI COMPANY LTD</b>					
101235	EDGER		1084 26-Jun-2019	26-Jun-2019	
40-7-7017313-0012	ZAMBONI - 2019				6,198.05
<b>Department Totals :</b>					<b>6,198.05</b>

<b>DEPARTMENT 8010000 PLANNING &amp; LEGISLATIVE SERVICES</b>					
<b>MCT455 MCTAGUE LAW FIRM</b>					
303281	LEGAL FEES		1070 30-Jun-2019	30-Jun-2019	
10-5-8010000-0367	GLOBAL LEGAL FEES				174.02
303282	LEGAL FEES		1070 30-Jun-2019	30-Jun-2019	
10-5-8010000-0367	GLOBAL LEGAL FEES				1,288.57
303826	LEGAL FEES		1070 12-Aug-2019	12-Aug-2019	
10-5-8010000-0367	GLOBAL LEGAL FEES				828.86
303981	LEGAL FEES		1070 12-Aug-2019	12-Aug-2019	
10-5-8010000-0367	GLOBAL LEGAL FEES				3,141.23
304214	PROFESSIONAL SERVICES		1070 05-Sep-2019	05-Sep-2019	





Vendor : CAT038 To ZUL180

Batch : All

Department : All

Cheque Print Date : 01-Oct-2019 To 31-Oct-2019

Bank : 1 To 99

Class : All

Vendor Invoice	Vendor Name Description	Batch	Inv Date	Inv Due Date	Amount
G.L. Account	CC1 CC2 CC3 GL Account Name				
<b>DEPARTMENT 8010000</b>	PLANNING & LEGISLATIVE SERVICES				
10-5-8010000-0367	GLOBAL LEGAL FEES				43.51
304275	LEGAL FEES	1070	05-Sep-2019	05-Sep-2019	
10-5-8010000-0367	GLOBAL LEGAL FEES				503.42
304276	LEGAL FEES	1070	05-Sep-2019	05-Sep-2019	
10-5-8010000-0367	GLOBAL LEGAL FEES				1,025.48
<b>MON183</b>	<b>MONARCH OFFICE SUPPLY LTD</b>				
167219	PURCHASES MADE FOR THE MONTH OF AUGUST 2019	1078	29-Aug-2019	29-Aug-2019	
10-5-8010000-0301	OFFICE SUPPLIES				449.18
<b>MON610</b>	<b>MONTEITH BROWN PLANNING CONSULTANTS</b>				
13772	PROFESSIONAL FEES - CIP	1167	15-Oct-2019	15-Oct-2019	
10-5-8010000-0379	CIP INCENTIVE PROGRAM				16,511.25
<b>MOU001</b>	<b>MOUSSEAU DELUCA McPHERSON PRINCE</b>				
59535	LEGAL FEES	1084	30-Aug-2019	30-Aug-2019	
10-5-8010000-0367	GLOBAL LEGAL FEES				568.39
59673	LEGAL FEES	1084	31-May-2019	31-May-2019	
10-5-8010000-0325	LEGAL FEES				639.00
60266	LEGAS FEES	1084	31-Aug-2019	31-Aug-2019	
10-5-8010000-0325	LEGAL FEES				626.96
60267	LEGAL FEES	1084	31-Aug-2019	31-Aug-2019	
10-5-8010000-0325	LEGAL FEES				639.39
60314	LEGAL FEES	1078	31-Aug-2019	31-Aug-2019	
10-5-8010000-0367	GLOBAL LEGAL FEES				452.00
60315	LEGAL FEES	1078	27-Sep-2019	27-Sep-2019	
10-5-8010000-0367	GLOBAL LEGAL FEES				429.40
60316	LEGAL FEES	1078	31-Aug-2019	31-Aug-2019	
10-5-8010000-0367	GLOBAL LEGAL FEES				406.80
60317	LEGAL FEES	1078	31-Aug-2019	31-Aug-2019	
10-5-8010000-0367	GLOBAL LEGAL FEES				813.60
60319	LEGAL FEES	1078	31-Aug-2019	31-Aug-2019	
10-5-8010000-0367	GLOBAL LEGAL FEES				211.88
60346	LEGAL FEES	1084	30-Aug-2019	30-Aug-2019	
10-5-8010000-0367	GLOBAL LEGAL FEES				1,119.88
60347	LEGAL FEES	1084	30-Aug-2019	30-Aug-2019	
10-5-8010000-0367	GLOBAL LEGAL FEES				610.20
<b>SHI251</b>	<b>SHIBLEY RIGHTON LLP</b>				
194510	LEGAL FEES	1127	25-Jul-2019	25-Jul-2019	
10-5-8010000-0367	GLOBAL LEGAL FEES				2,728.95
195636	LEGAL FEES	1127	31-Aug-2019	31-Aug-2019	
10-5-8010000-0367	GLOBAL LEGAL FEES				988.75
<b>THO199</b>	<b>THOMSON REUTERS CANADA</b>				
6130336951	OFFICE SUPPLIES	1078	09-Sep-2019	09-Sep-2019	
10-5-8010000-0301	OFFICE SUPPLIES				126.00
6130337391	OFFICE SUPPLIES	1078	11-Sep-2019	11-Sep-2019	
10-5-8010000-0301	OFFICE SUPPLIES				227.85
<b>WAT10</b>	<b>WATSON &amp; ASSOCIATES ECONOMISTS LTD.</b>				
0025539	PROFESSIONAL SERVICES	1084	31-Jul-2019	31-Jul-2019	
10-5-8010000-0327	PROFESSIONAL FEES				19,952.69
0025578	PROFESSIONAL SERVICES	1084	31-Aug-2019	31-Aug-2019	
10-5-8010000-0327	PROFESSIONAL FEES				2,586.68
<b>Department Totals :</b>					<b>57,093.94</b>





Vendor : CAT038 To ZUL180

Batch : All

Department : All

Cheque Print Date : 01-Oct-2019 To 31-Oct-2019

Bank : 1 To 99

Class : All

Vendor Invoice	Vendor Name Description	Batch	Inv Date	Inv Due Date	Amount
G.L. Account	CC1 CC2 CC3 GL Account Name				
<b>DEPARTMENT 8020000</b>	<b>TOURISM VISITOR INFORMATION CENTRE</b>				
<b>ALL180 ALLEGRA MARKETING PRINT MAIL</b>					
113740 AMHERSTBURG UNCOMMON		1113	24-Sep-2019	24-Sep-2019	
10-5-8020000-0307 UNCOMI	ADVERTISING				1,079.15
<b>AOR373 AOR RISK SOLUTIONS INC.</b>					
INV-116 AMHERSTBURG UNCOMMON		1070	26-Sep-2019	26-Sep-2019	
10-5-8020000-0340 UNCOMI	COMMUNITY EVENTS				1,527.22
<b>BIZ772 BIZ X MAGAZINE</b>					
15043 HOUSE TOURS		1167	12-Oct-2019	12-Oct-2019	
10-5-8020000-0307 HOUSTC	ADVERTISING				1,356.00
<b>CID164 CKLW-AM WINDSOR/DETROIT</b>					
1434090-1 AMHERSTBURG UNCOMMON		1167	29-Sep-2019	29-Sep-2019	
10-5-8020000-0307 UNCOMI	ADVERTISING				1,711.95
<b>COO840 COOL BUS INC.</b>					
1017 AMHERSTBURG UNCOMMON		1113	27-Sep-2019	27-Sep-2019	
10-5-8020000-0340 UNCOMI	COMMUNITY EVENTS				1,300.00
<b>DEL091 DELISLE SIGNS</b>					
292 AMHERSTBURG UNCOMMON		1084	25-Sep-2019	25-Sep-2019	
10-5-8020000-0307 UNCOMI	ADVERTISING				1,126.61
<b>ELE400 ELECTRICAL SAFETY AUTHORITY</b>					
97929515 COMMUNITY EVENTS		1113	24-Sep-2019	24-Sep-2019	
10-5-8020000-0340 UNCOMI	COMMUNITY EVENTS				402.28
97932749 COMMUNITY EVENTS		1113	26-Sep-2019	26-Sep-2019	
10-5-8020000-0340 UNCOMI	COMMUNITY EVENTS				517.54
<b>ESS115 ESSEX FREE PRESS</b>					
68252 AMHERSTBURG UNCOMMON		1127	24-Sep-2019	24-Sep-2019	
10-5-8020000-0307 UNCOMI	ADVERTISING				609.57
<b>GSP636 G&amp;S EQUIPMENT RENTALS</b>					
1930 AMHERSTBURG UNCOMMON		1167	28-Sep-2019	28-Sep-2019	
10-5-8020000-0340 UNCOMI	COMMUNITY EVENTS				1,259.95
<b>JON531 JONES CORINE</b>					
SEPTEMBER 3 AMHERSTBURG UNCOMMON		1167	30-Sep-2019	30-Sep-2019	
10-5-8020000-0340 UNCOMI	COMMUNITY EVENTS				121.63
<b>LEC171 LECOURS MICHELLE</b>					
SEPTEMBER 3 AMHERSTBURG UNCOMMON		1167	30-Sep-2019	30-Sep-2019	
10-5-8020000-0340 UNCOMI	COMMUNITY EVENTS				67.68
<b>MAG569 MAGNETSIGNS WINDSOR SOUTH</b>					
3536 AMHERSTBURG UNCOMMON		1127	04-Sep-2019	04-Sep-2019	
10-5-8020000-0307 UNCOMI	ADVERTISING				168.37
<b>MON183 MONARCH OFFICE SUPPLY LTD</b>					
162631 PURCHASES MADE FOR THE MONTH OF JULY 2019		1078	30-Jul-2019	30-Jul-2019	
10-5-8020000-0301	OFFICE SUPPLIES				16.89
<b>ONT842 ONTARIO'S SOUTH WEST</b>					
987 GENERAL		1084	24-Sep-2019	24-Sep-2019	
10-5-8020000-0307 GENER/	ADVERTISING				5,000.00
<b>RIV164 CIDR-FM BELL MEDIA INC.</b>					
1434080-1 AMHERSTBURG UNCOMMON		1167	29-Sep-2019	29-Sep-2019	
10-5-8020000-0307 UNCOMI	ADVERTISING				830.55
1461160-1 AMHERSTBURG UNCOMMON		1167	29-Sep-2019	29-Sep-2019	
10-5-8020000-0307 UNCOMI	ADVERTISING				847.50
<b>ROY281 ROYAL CANADIAN LEGION BRANCH 157</b>					
SEPTEMBER 1 EVENT DEPOSIT REFUND		1078	16-Sep-2019	16-Sep-2019	
10-4-8020000-1306	EVENT REVENUE				327.40

Council/Board Report By Dept-(Computer)



Vendor : CAT038 To ZUL180  
 Batch : All  
 Department : All

Cheque Print Date : 01-Oct-2019 To 31-Oct-2019  
 Bank : 1 To 99  
 Class : All

Vendor Invoice	Vendor Name Description	Batch	Inv Date	Inv Due Date	Amount
G.L. Account	CC1 CC2 CC3 GL Account Name				
<b>DEPARTMENT 8020000 TOURISM VISITOR INFORMATION CENTRE</b>					
<b>RTT067 RIVER TOWN TIMES</b>					
2690	ADVERTISING	1078	18-Sep-2019	18-Sep-2019	
10-5-8020000-0301	OFFICE SUPPLIES				141.02
10-5-8020000-0301	OFFICE SUPPLIES				141.02
10-5-8020000-0301	OFFICE SUPPLIES				276.16
<b>SOB083 SOBEYS AMHERSTBURG</b>					
CANADA DAY : CANADA DAY FESTIVITIES					
10-5-8020000-0150	TOURISM COMMITTEE	1146	01-Jul-2019	01-Jul-2019	695.82
JUNE 2019 PURCHASES FOR THE MONTH OF JUNE 2019					
10-5-8020000-0355	GENER/ PRINTED MATERIAL\PROMOTIONAL PRODUCTS	1084	30-Jun-2019	30-Jun-2019	21.54
<b>SOU977 SOUNDS PLUS</b>					
S+43739-8320 AMHERSTBURG UNCOMMON					
10-5-8020000-0340	UNCOMI COMMUNITY EVENTS	1127	01-Oct-2019	01-Oct-2019	6,022.90
<b>STI016 STILES LISA</b>					
0911 AMHERSTBURG UNCOMMON					
10-5-8020000-0340	UNCOMI COMMUNITY EVENTS	1070	11-Sep-2019	11-Sep-2019	295.00
<b>THE247 THE HOUSE YOUTH CENTRE</b>					
OCTOBER 1, 2 AMHERSTBURG UNCOMMON					
10-5-8020000-0340	UNCOMI COMMUNITY EVENTS	1127	01-Oct-2019	01-Oct-2019	750.00
<b>TOU333 TOURISM WINDSOR ESSEX PELEE ISLAND</b>					
4507 ADVERTISING - GOOGLE ADS					
10-5-8020000-0307	UNCOMI ADVERTISING	1127	30-Sep-2019	30-Sep-2019	1,500.00
<b>WIG035 WIGLE HOME HARDWARE BUILDING CENTRE</b>					
134506 COMMUNITY EVENTS					
10-5-8020000-0340	UNCOMI COMMUNITY EVENTS	1113	19-Sep-2019	19-Sep-2019	88.11
134533 SUPPLIES					
10-5-8020000-0340	UNCOMI COMMUNITY EVENTS	1113	20-Sep-2019	20-Sep-2019	23.76
134588 COMMUNITY EVENTS					
10-5-8020000-0340	UNCOMI COMMUNITY EVENTS	1113	23-Sep-2019	23-Sep-2019	12.40
<b>Department Totals :</b>					<b>28,238.02</b>

Computer Paid Total : 1,471,189.31

Council/Board Report By Dept-(EFT)



Vendor : CAT038 To ZUL180  
 Batch : All  
 Department : All

EFT Paid Date : 01-Oct-2019 To 31-Oct-2019  
 Bank : 1 To 99  
 Class : All

Vendor Code Invoice No.	Vendor Name Description	Batch	Inv Date	Inv Due Date	Amount
G.L. Account	CC1 CC2 CC3 GL Account Name				
<b>DEPARTMENT 0000000 GENERAL</b>					
<b>AMH19 AMHERSTBURG PAYROLL-TOWN OF</b>					
PP#40-2019	PP#40-2019 PAYROLL TRANSFER	1130	03-Oct-2019	03-Oct-2019	
10-1-0000000-0302	WFCU-PAYROLL 6429187				103,898.53
PP#42-2019	PP#42-2019 PAYROLL TRANSFER	1176	17-Oct-2019	17-Oct-2019	
10-1-0000000-0302	WFCU-PAYROLL 6429187				101,492.52
PP#41-2019	PP#41-2019 PAYROLL TRANSFER	1154	10-Oct-2019	10-Oct-2019	
10-1-0000000-0302	WFCU-PAYROLL 6429187				101,608.90
<b>GRE03 GREEN SHIELD CANADA</b>					



Vendor : CAT038 To ZUL180

Batch : All

Department : All

EFT Paid Date : 01-Oct-2019 To 31-Oct-2019

Bank : 1 To 99

Class : All

Vendor Code	Vendor Name				Batch	Inv Date	Inv Due Date	Amount
Invoice No.	Description							
G.L. Account	CC1	CC2	CC3	GL Account Name				
<b>DEPARTMENT 0000000</b>	<b>GENERAL</b>							
OCT 2019	OCTOBER 2019 BENEFITS				1134	01-Oct-2019	01-Oct-2019	
10-1-0000000-2068				A/R - EMPLOYEE BENEFITS REGULAR				84.53
10-1-0000000-2064				A/R - EMPLOYEE BENEFITS				1,217.10
80-5-0000000-0205				BENEFITS - GREENSHIELD				4,145.71
80-5-0000000-0206				BENEFITS - GREENSHIELD RE - WATER DEPART				1,707.15
<b>REC04</b>	<b>RECEIVER GENERAL</b>							
PP#2019-40 FU	PP#2019-40 FULL TIME PAYROLL TAXES				1186	03-Oct-2019	03-Oct-2019	
10-2-0000000-1141				A/P - PAYROLL DED. - INC.				25,200.78
10-2-0000000-1142				A/P - PAYROLL DED. - CPP				4,425.70
10-2-0000000-1143				A/P - PAYROLL DED. - E.I.				1,576.44
PP#2019-40 PA	PP#2019-40 PART TIME PAYROLL TAXES				1186	03-Oct-2019	03-Oct-2019	
10-2-0000000-1143				A/P - PAYROLL DED. - E.I.				849.26
10-2-0000000-1142				A/P - PAYROLL DED. - CPP				1,873.78
10-2-0000000-1141				A/P - PAYROLL DED. - INC.				3,964.40
PP#2019-41 FU	PP#2019-41 FULL TIME PAYROLL TAXES				1144	10-Oct-2019	10-Oct-2019	
10-2-0000000-1141				A/P - PAYROLL DED. - INC.				24,486.36
10-2-0000000-1142				A/P - PAYROLL DED. - CPP				4,344.16
10-2-0000000-1143				A/P - PAYROLL DED. - E.I.				1,460.53
PP#2019-41 PA	PP#2019-41 PART TIME PAYROLL TAXES				1144	10-Oct-2019	10-Oct-2019	
10-2-0000000-1143				A/P - PAYROLL DED. - E.I.				794.44
10-2-0000000-1142				A/P - PAYROLL DED. - CPP				1,725.60
10-2-0000000-1141				A/P - PAYROLL DED. - INC.				3,616.32
PP#2019-42 FU	PP#2019-42 FULL TIME PAYROLL TAXES				1177	17-Oct-2019	17-Oct-2019	
10-2-0000000-1141				A/P - PAYROLL DED. - INC.				24,906.58
10-2-0000000-1142				A/P - PAYROLL DED. - CPP				4,394.22
10-2-0000000-1143				A/P - PAYROLL DED. - E.I.				1,435.82
PP#2019-42 PA	PP#2019-42 PART TIME PAYROLL TAXES				1177	17-Oct-2019	17-Oct-2019	
10-2-0000000-1143				A/P - PAYROLL DED. - E.I.				758.45
10-2-0000000-1142				A/P - PAYROLL DED. - CPP				1,680.40
10-2-0000000-1141				A/P - PAYROLL DED. - INC.				3,452.60
<b>Department Totals :</b>								<b>425,100.28</b>

<b>DEPARTMENT 1001020</b>	<b>ADMINISTRATION</b>							
<b>GRE03</b>	<b>GREEN SHIELD CANADA</b>							
OCT 2019	OCTOBER 2019 BENEFITS				1134	01-Oct-2019	01-Oct-2019	
10-5-1001020-0206				BENEFITS - GREENSHIELD RE				5,559.75
<b>ZHO010</b>	<b>ZHONGSHAN IDESSIC LIGHTING FACTORY</b>							
SEPTEMBER 2019	PURCHASE OF CHRISTMAS ORNAMENTS FOR RIVER LIGHTS				1098	26-Sep-2019	26-Sep-2019	
10-5-1001020-0502				INTEREST EXPENSE				50.00
<b>Department Totals :</b>								<b>5,609.75</b>

<b>DEPARTMENT 1001021</b>	<b>TREASURY</b>							
<b>GRE03</b>	<b>GREEN SHIELD CANADA</b>							
OCT 2019	OCTOBER 2019 BENEFITS				1134	01-Oct-2019	01-Oct-2019	
10-5-1001021-0205				BENEFITS - GREENSHIELD				3,663.52
<b>Department Totals :</b>								<b>3,663.52</b>

<b>DEPARTMENT 1001022</b>	<b>CLERKS</b>							
<b>GRE03</b>	<b>GREEN SHIELD CANADA</b>							
OCT 2019	OCTOBER 2019 BENEFITS				1134	01-Oct-2019	01-Oct-2019	
10-5-1001022-0205				BENEFITS - GREENSHIELD - CLERKS				1,204.50
10-5-1001022-0205				BENEFITS - GREENSHIELD - CLERKS				429.23
<b>Department Totals :</b>								<b>1,633.73</b>



Vendor : CAT038 To ZUL180  
 Batch : All  
 Department : All

EFT Paid Date : 01-Oct-2019 To 31-Oct-2019  
 Bank : 1 To 99  
 Class : All

Vendor Code	Vendor Name	Batch	Inv Date	Inv Due Date	Amount
Invoice No.	Description				
G.L. Account	CC1 CC2 CC3 GL Account Name				
<b>DEPARTMENT 1001023 C.A.O.</b>					
<b>GRE03</b>	<b>GREEN SHIELD CANADA</b>				
OCT 2019	OCTOBER 2019 BENEFITS	1134	01-Oct-2019	01-Oct-2019	
10-5-1001023-0205	BENEFITS - GREENSHIELD - C.A.O.				1,204.50
<b>Department Totals :</b>					<b>1,204.50</b>
<b>DEPARTMENT 1001024 HUMAN RESOURCES</b>					
<b>GRE03</b>	<b>GREEN SHIELD CANADA</b>				
OCT 2019	OCTOBER 2019 BENEFITS	1134	01-Oct-2019	01-Oct-2019	
10-5-1001024-0205	BENEFITS - GREENSHIELD - HUMAN RESOURCES				803.00
<b>Department Totals :</b>					<b>803.00</b>
<b>DEPARTMENT 1001025 INFORMATION TECHNOLOGY</b>					
<b>BEL01</b>	<b>BELL CANADA</b>				
SEP 2019	SEPTEMBER 2019 MONTHLY CHARGES	1079	18-Sep-2019	18-Sep-2019	
10-5-1001025-0315	TELEPHONE				32.92
10-5-1001025-0315	TELEPHONE				59.10
<b>GRE03</b>	<b>GREEN SHIELD CANADA</b>				
OCT 2019	OCTOBER 2019 BENEFITS	1134	01-Oct-2019	01-Oct-2019	
10-5-1001025-0205	BENEFITS - GREENSHIELD				974.55
<b>Department Totals :</b>					<b>1,066.57</b>
<b>DEPARTMENT 1008030 DRAINAGE</b>					
<b>GRE03</b>	<b>GREEN SHIELD CANADA</b>				
OCT 2019	OCTOBER 2019 BENEFITS	1134	01-Oct-2019	01-Oct-2019	
10-5-1008030-0205	BENEFITS GREENSHIELD				401.50
<b>Department Totals :</b>					<b>401.50</b>
<b>DEPARTMENT 2010000 FIRE DEPARTMENT</b>					
<b>GRE03</b>	<b>GREEN SHIELD CANADA</b>				
OCT 2019	OCTOBER 2019 BENEFITS	1134	01-Oct-2019	01-Oct-2019	
10-5-2010000-0205	BENEFITS - GREENSHIELD - FIRE				3,512.75
10-5-2010000-0206	BENEFITS - GREENSHIELD RE				2,298.64
<b>HYD02</b>	<b>HYDRO ONE NETWORKS</b>				
SEP 2019	EMER 2S CONC LOT 20, SIRENS	1046	14-Sep-2019	14-Sep-2019	
10-5-2010000-0800	EMERGENCY OPERATIONS CENTRE EXPENSES				44.43
SEP EMERG 2N CONC LOT 10, SIRENS		1082	19-Sep-2019	19-Sep-2019	
10-5-2010000-0800	EMERGENCY OPERATIONS CENTRE EXPENSES				44.43
<b>Department Totals :</b>					<b>5,900.25</b>
<b>DEPARTMENT 2020000 POLICE DEPARTMENT</b>					
<b>CIT350</b>	<b>CITY OF WINDSOR</b>				
OCTOBER 2019	WPS CONTRACT FOR OCTOBER 2019	1097	01-Oct-2019	01-Oct-2019	
10-5-2020000-0605	SERVICE CONTRACT -WPS				406,068.92
SEPTEMBER 2019	3RD PAYMENT CSPT PROGRAM	1099	26-Sep-2019	26-Sep-2019	
10-4-2020000-1022	POLICE - PROVINCIAL COURT SERVICE UPLOAD				13,011.46
<b>GRE03</b>	<b>GREEN SHIELD CANADA</b>				
OCT 2019	OCTOBER 2019 BENEFITS	1134	01-Oct-2019	01-Oct-2019	
10-5-2020000-0206	BENEFITS - GREENSHIELD RE				9,647.85
10-5-2020000-0205	BENEFITS - GREENSHIELD				1,120.25
<b>Department Totals :</b>					<b>429,848.48</b>
<b>DEPARTMENT 2043010 BUILDING DEPARTMENT</b>					



Vendor : CAT038 To ZUL180

Batch : All

Department : All

EFT Paid Date : 01-Oct-2019 To 31-Oct-2019

Bank : 1 To 99

Class : All

Vendor Code	Vendor Name	Batch	Inv Date	Inv Due Date	Amount
Invoice No.	Description				
G.L. Account	CC1 CC2 CC3 GL Account Name				
<b>DEPARTMENT 2043010</b>	<b>BUILDING DEPARTMENT</b>				
<b>GRE03</b>	<b>GREEN SHIELD CANADA</b>				
OCT 2019	OCTOBER 2019 BENEFITS	1134	01-Oct-2019	01-Oct-2019	
10-5-2043010-0205	BENEFITS - GREENSHIELD				1,027.98
10-5-2043010-0206	BENEFITS - GREENSHIELD RE				2,191.92
<b>Department Totals :</b>					<b>3,219.90</b>
<b>DEPARTMENT 2043015</b>	<b>LICENSING AND ENFORCEMENT</b>				
<b>GRE03</b>	<b>GREEN SHIELD CANADA</b>				
OCT 2019	OCTOBER 2019 BENEFITS	1134	01-Oct-2019	01-Oct-2019	
10-5-2043015-0205	BENEFITS - GREENSHIELD				1,401.28
<b>Department Totals :</b>					<b>1,401.28</b>
<b>DEPARTMENT 3010000</b>	<b>PUBLIC WORKS</b>				
<b>GRE03</b>	<b>GREEN SHIELD CANADA</b>				
OCT 2019	OCTOBER 2019 BENEFITS	1134	01-Oct-2019	01-Oct-2019	
10-5-3010000-0205	BENEFITS - GREENSHIELD				5,441.34
10-5-3010000-0206	BENEFITS - GREENSHIELD RE				8,403.96
<b>Department Totals :</b>					<b>13,845.30</b>
<b>DEPARTMENT 7010000</b>	<b>PARKS AND RECREATION PROGRAMMING</b>				
<b>GRE03</b>	<b>GREEN SHIELD CANADA</b>				
OCT 2019	OCTOBER 2019 BENEFITS	1134	01-Oct-2019	01-Oct-2019	
10-5-7010000-0205	BENEFITS - GREENSHIELD				915.26
<b>Department Totals :</b>					<b>915.26</b>
<b>DEPARTMENT 7017000</b>	<b>PARKS MAINTENANCE</b>				
<b>GRE03</b>	<b>GREEN SHIELD CANADA</b>				
OCT 2019	OCTOBER 2019 BENEFITS	1134	01-Oct-2019	01-Oct-2019	
10-5-7017000-0205	BENEFITS - GREENSHIELD - PARKS & GROUNDS				2,395.62
<b>Department Totals :</b>					<b>2,395.62</b>
<b>DEPARTMENT 7017002</b>	<b>FACILITIES</b>				
<b>GRE03</b>	<b>GREEN SHIELD CANADA</b>				
OCT 2019	OCTOBER 2019 BENEFITS	1134	01-Oct-2019	01-Oct-2019	
10-5-7017002-0205	BENEFITS - GREENSHIELD - FACILITIES				858.45
<b>Department Totals :</b>					<b>858.45</b>
<b>DEPARTMENT 7017300</b>	<b>LIBRO</b>				
<b>GRE03</b>	<b>GREEN SHIELD CANADA</b>				
OCT 2019	OCTOBER 2019 BENEFITS	1134	01-Oct-2019	01-Oct-2019	
10-5-7017300-0206	BENEFITS - GREENSHIELD RE				2,360.39
10-5-7017300-0205	BENEFITS - GREENSHIELD				1,027.51
<b>Department Totals :</b>					<b>3,387.90</b>
<b>DEPARTMENT 8010000</b>	<b>PLANNING &amp; LEGISLATIVE SERVICES</b>				
<b>GRE03</b>	<b>GREEN SHIELD CANADA</b>				
OCT 2019	OCTOBER 2019 BENEFITS	1134	01-Oct-2019	01-Oct-2019	
10-5-8010000-0205	BENEFITS - GREENSHIELD				1,002.28
10-5-8010000-0206	BENEFITS - GREENSHIELD RETIREES				1,006.86
<b>Department Totals :</b>					<b>2,009.14</b>



Vendor : CAT038 To ZUL180

Batch : All

Department : All

EFT Paid Date : 01-Oct-2019 To 31-Oct-2019

Bank : 1 To 99

Class : All

Vendor Code	Vendor Name	Description			Batch	Inv Date	Inv Due Date	Amount
Invoice No.		CC1	CC2	CC3	GL Account Name			
G.L. Account								
<b>DEPARTMENT 8020000</b>					<b>TOURISM VISITOR INFORMATION CENTRE</b>			
<b>GRE03</b>	<b>GREEN SHIELD CANADA</b>							
OCT 2019	OCTOBER 2019 BENEFITS					1134 01-Oct-2019	01-Oct-2019	
10-5-8020000-0205					BENEFITS - GREENSHIELD - TOURISM			1,606.00
<b>ZHO010</b>	<b>ZHONGSHAN IDESSIC LIGHTING FACTORY</b>							
SEPTEMBER 21	PURCHASE OF CHRISTMAS ORNAMENTS FOR RIVER LIGHTS					1098 26-Sep-2019	26-Sep-2019	
40-7-8020000-0002	LIGHT DISPLAYS							23,982.50
<b>Department Totals :</b>								<b>25,588.50</b>

**EFT Paid Total : 928,852.93**

Total Unpaid for Approval :	0.00
Total Manually Paid for Approval :	0.00
Total Computer Paid for Approval :	1,471,189.31
Total EFT Paid for Approval :	928,852.93
<b>Grand Total ITEMS for Approval :</b>	<b>2,400,042.24</b>



## THE CORPORATION OF THE TOWN OF AMHERSTBURG

### OFFICE OF ENGINEERING AND PUBLIC WORKS

*MISSION STATEMENT: Committed to delivering cost-effective and efficient services for the residents of the Town of Amherstburg with a view to improve and enhance their quality of life.*

Author's Name: Todd Hewitt	Report Date: October 15, 2019
Author's Phone: 519 736-3664 ext. 2313	Date to Council: November 12, 2019
Author's E-mail: <a href="mailto:thewitt@amherstburg.ca">thewitt@amherstburg.ca</a>	Resolution #: 20190225-165

To: Mayor and Members of Town Council

Subject: Kingsbridge Subdivision – Options for Additional Entrance

---

#### 1. RECOMMENDATION:

It is recommended that:

1. The report from the Manager of Engineering dated October 15, 2019, regarding the Kingsbridge Subdivision – Options for Additional Entrance **BE RECEIVED for Information**

#### 2. BACKGROUND:

Kingsbridge is a residential subdivision located north of Texas Road, just east of County Road 20.

Council, at its meeting of February 25, 2019, made the following resolution:

“That Administration BE DIRECTED to investigate another option for entry and exit into the Kingsbridge Subdivision and to work with the developer in regards to the options cost and location ideas.”

#### 3. DISCUSSION:

In 2019, the developer (1072817 Ontario Ltd.) hired the consulting firm of BairdAE to update the Traffic Impact Study (TIS) for the development. The original TIS for the subdivision was completed in 1998 at the outset of the development. The TIS was updated based on the homes currently built, future build out projections as well as updated traffic counts that were completed. The study completed a review of the main intersections associated with the subdivision and determined that all intersections,



including the intersections of County Road 20 / Kingsbridge Drive and County Road 20 / Texas Road, will operate within acceptable levels of service until 2033, well beyond the projected development buildout. Subsequent to the submission by BairdAE the Town contracted Dillon Consulting to complete a peer review of the study to confirm the findings and recommendations.

Administration contacted the County of Essex to request comments on the potential for an additional entrance into Kingsbridge. The County has indicated that they would not be supportive of a 3<sup>rd</sup> entrance due to the fact that the TIS indicates that the existing network is sufficient to handle the generated traffic.

Although the County has indicated that they would not support the addition of a third entrance onto County Road 20, Administration further investigated possible locations and potential costing for the purposes of this report. The estimates included in this report are very preliminary and were created to provide Council with a basic concept of the cost and impact that would be involved.

### **Potential Costs**

<b>Activity</b>	<b>Cost</b>
Land Acquisition (Front Road)	\$500,000
Land Acquisition (Kingsbridge)	\$75,000
Road Installation	\$750,000
Intersection Improvements (signals)	\$200,000
Road Upgrades	\$250,000
Engineering	\$200,000
<b>Total</b>	<b>\$1,975,000</b>

Land Acquisition (Front Road) - Property would need to be acquired on County Road 20 to facilitate an additional entrance. These are extremely deep lots (500ft +/-) with homes and a view of the water. Many are large homes as well. We have used a preliminary value of \$500,000 for this report but that value would vary significantly depending on property that was identified.

Land Acquisition (Kingsbridge) - Property would be required within the subdivision, resulting in the loss of a building lot. A value of \$75,000 was used for this unserved lot.

Road Installation – Cost estimated to install 350m of roadway from County Road 20 to the subdivision.

Intersection Improvements (Signals) – Costs associated with the installation of traffic signals at County Road 20

Road Upgrades – Preliminary estimate of cost associated with upgrading roads within the subdivision to collector, including additional width. This is assuming the roads have not yet been constructed. Once they are constructed the cost to upgrade them would increase significantly.

Engineering – Costs associated with engineering design and installation.

**4. RISK ANALYSIS:**

N/A

**5. FINANCIAL MATTERS:**

There are no direct costs associated with this report. As there is no justification for a 3<sup>rd</sup> entrance in the Traffic Impact Study there would be no justification for the developer to provide the entrance at their cost. Therefore, any costs associated with the installation of a 3<sup>rd</sup> entrance would be the responsibility of the Town.

**6. CONSULTATIONS:**

The Engineering Technician for the County of Essex and the Kingsbridge developer were consulted.

**7. CONCLUSION:**

It is recommended that this report be received for information.



---

Todd Hewitt  
**Manager of Engineering**

<b>NOTIFICATION :</b>				
Name	Address	Email Address	Telephone	FAX

## Report Approval Details

Document Title:	2019 11 12 Kingsbridge - Review of Additional Entrance.docx
Attachments:	N/A
Final Approval Date:	Nov 1, 2019

This report and all of its attachments were approved and signed as outlined below:



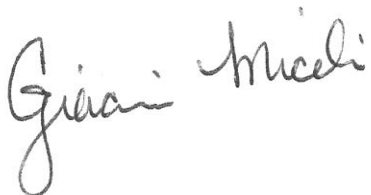
**Antonietta Giofu - Oct 29, 2019 - 10:48 AM**



**Mark Galvin - Oct 30, 2019 - 9:23 AM**



**Cheryl Horrobin - Oct 30, 2019 - 1:05 PM**



**John Miceli - Oct 31, 2019 - 1:44 PM**



**Paula Parker - Nov 1, 2019 - 3:51 PM**



## THE CORPORATION OF THE TOWN OF AMHERSTBURG

### OFFICE OF THE CAO

*MISSION STATEMENT: Committed to delivering cost-effective and efficient services for the residents of the Town of Amherstburg with a view to improve and enhance their quality of life.*

Author's Name: Bruce Montone	Report Date: October 18, 2019
Author's Phone: 519- 737-6500 ext. 2241	Date to Council: November 12, 2019
Author's E-mail: <a href="mailto:bmontone@Amherstburg.ca">bmontone@Amherstburg.ca</a>	Resolution #: 20160411-145

To: Mayor and Members of Town Council

Subject: Monthly Fire Department Report - September 2019

---

#### 1. RECOMMENDATION:

It is recommended that:

1. The report from the Fire Chief dated October 18, 2019 regarding the Monthly Fire Department Activity Report – September 2019 **BE RECEIVED for information.**

#### 2. BACKGROUND:

On April 11, 2016, Council adopted the following:

“That Administration BE DIRECTED to provide monthly activity reports within the Building department, Fire department, and Police Services.”

#### 3. DISCUSSION:

The goal of the Amherstburg Fire Department is to provide fire protection services through a range of programs designed to protect the lives and property of the inhabitants from the adverse effects of fire, sudden medical emergencies or exposure to dangerous conditions created by man or nature.

To achieve this goal the Amherstburg Fire Department utilizes fire suppression and rescue activities, fire inspections, fire investigation, public fire safety education and other fire protection programs as defined by the Fire Protection and Prevention Act, R.S.O.1997. and the Town of Amherstburg, Establishing and Regulating By-Law # 2017 – 67. The attached, represents activities and program information for the month of September 2019.

**4. RISK ANALYSIS:**

N/A

**5. FINANCIAL MATTERS:**

N/A

**6. CONSULTATIONS:**

N/A

**7. CONCLUSION:**

As directed by Council, the Amherstburg Fire Department will continue to provide monthly activity reports.



Bruce Montone  
**Fire Chief**

<b>NOTIFICATION :</b>				
Name	Address	Email Address	Telephone	FAX

## Report Approval Details

Document Title:	Monthly Fire department Activity Report - September 2019.docx
Attachments:	- Monthly Dashboard Report September 19.pdf
Final Approval Date:	Oct 30, 2019

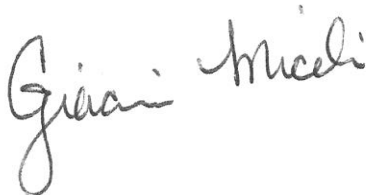
This report and all of its attachments were approved and signed as outlined below:



**Mark Galvin - Oct 28, 2019 - 12:32 PM**



**Cheryl Horrobin - Oct 30, 2019 - 9:21 AM**



**John Miceli - Oct 30, 2019 - 12:02 PM**



**Paula Parker - Oct 30, 2019 - 12:03 PM**



## FIRE SERVICES DASHBOARD

1 - SERVICE LEVEL DELIVERY		2018	YTD 2019	Sep-18	Sep-19
<b>INCIDENTS</b>		436	240	36	38
Inident Types	OFM codes				
Fire	01 - 29	56	43	7	6
False Fire Alarms	31 - 39	112	73	11	12
Public Hazard	41 - 59	47	36	1	8
Rescues	601 - 69	72	47	6	4
Medical	701 - 899	72	31	4	7
Others	91 - 99	77	10	7	1

Number of calls by station		2018	YTD 2019	Sep-18	Sep-19
Station # 1		153	79	10	11
Station # 2		90	78	9	12
Station # 3		45	28	5	9
Duty Officer		153	55	12	6

3 - AVERAGE RESPONSE Targets		2018	YTD 2019	SEP-19 AVG	Sep-19
Alarm Transfer Time	95th Percentile	Not Currently Available			
Alarm Answering Time	95th Percentile	Not Currently Available			
Alarm Processing Time	90th Percentile	0:03:14	0:03:27	0:01:21	0:02:01
Alarm Handling Time	90th Percentile	Not Currently Available			
Turnout Time	90th Percentile	0:07:11	0:07:36	0:02:49	0:06:13
Travel Time	90th Percentile	0:09:07	0:08:35	0:05:17	0:10:33
Intervention Time	90th Percentile	Not Currently Available			
Total Response Time	90th Percentile	Not Currently Available			

3 - OTHER STATISTICS		2018	YTD 2019	Sep-18	Sep-19
Total Training Session		173	161	17	19
Total Training Session (Station 1)		47	35	4	4
Total Training Session (Station 2)		47	33	5	4
Total Training Session (Station 3)		51	34	4	5
Total Training Session (Extra)		36	59	4	6
Total Routine Station Maintenance & Inspection		146	109	12	11
Fire Prevention Inspections		48	59	3	6
Business Licenese Inspections		19	15	1	1
Fire Prevention Program Activities (i.e. Lockbox, Special Event)		106	91	10	17
Fire Safety Plan Reviews (Emergency Plans, Fire Safety Plans)		53	116	8	31
Vulnerable Occupancy Annual Inspections		12	24	3	10
Smoke and CO Alarm Install		14	11	1	3
Fire Permits Issued		347	427	15	14
Fire Permit Inspections		567	230	21	21

4 - COMMUNITY IMPACT		2018	YTD 2019	Sep-18	Sep-19
Total \$ Loss (Estimate)		291,950	523,000	5,150	135,000
Total \$ Saved (Estimate)		1,120,000	460,000	0	460,000
Residential Fire Related Injuries (Entire)		1	0	0	0
Fire Fighter		0	0	0	0
Public		1	0	0	0
Residential Fire Related Fatalities (Entire)		0	1	0	0
Fire Fighter		0	0	0	0
Public		0	1	0	0





## FIRE SERVICES

### DASHBOARD

#### **5 - CHIEF'S COMMENTS**

Met with our Local MPP Taras Natyshak to further our Nuclear Preparedness file with the Province, as a result we were contacted by Minister Jones (Solicitor General) on September 9<sup>th</sup> which resulted in an meeting with OFMEM (Province) on September 19<sup>th</sup> regarding the Lack of Progress on Nuclear Preparedness File.

Met with Fire Service Partners to establish future Radio System Requirements for 2020 future and beyond.

Three Recruitment Orientation Sessions were conducted as first stage of the Volunteer Fire Fighter Recruitment process.

Captain qualifying classes began for 13 Firefighters who expressed interest in qualifying. It should be noted that all are participating in the classroom training without remuneration, (approximately 20 hours of classroom training), they shall complete NFPA Fire Officer I (60hrs) and Fire Instructor I certification (24 hrs) within an agreed upon timeline, they shall complete occupational health and safety training for supervisors on line program (45min.)prior to acting, and complete the Blue Card command certification (86 hrs)within an agreed upon timeline.

30-Sep-19



Vendor : CAT038 To ZUL180

Batch : All

Department : All

Cheque Print Date : 01-Jan-2019 To 31-May-2019

Bank : 1 To 99

Class : All

Vendor Invoice	Vendor Name Description	Batch	Inv Date	Inv Due Date	Amount
G.L. Account	CC1 CC2 CC3 GL Account Name				
<b>DEPARTMENT 0000000</b>	GENERAL				
<b>215114</b>	<b>2156567 ONTARIO LTD</b>				
218201	RETURN OF INDEMNITY DEPOSIT FOR 281 RICHMOND STREET, 2018-018	280	07-Mar-2019	07-Mar-2019	
10-2-0000000-2140	INDEMNITY FEES				1,000.00
<b>ACC334</b>	<b>ACCURATE CREATIONS SPORTS &amp; PROMO GEAR</b>				
1165	CLOTHING	409	20-Mar-2019	20-Mar-2019	
80-5-0000000-0161	CLOTHING				388.72
<b>ACT456</b>	<b>ACTION SIGNS &amp; DESIGNS INC.</b>				
11113	STICKERS FOR ENVIRONMENTAL SERVICES	283	18-Mar-2019	18-Mar-2019	
80-5-0000000-0402	VEHICLE & EQUIPMENT MTCE.				67.80
<b>AGO713</b>	<b>AGO INDUSTRIES INC</b>				
834933	CLOTHING	283	25-Feb-2019	25-Feb-2019	
80-5-0000000-0161	CLOTHING				3,888.54
836315	CLOTHING	283	06-Mar-2019	06-Mar-2019	
80-5-0000000-0161	CLOTHING				193.82
842688	TRAFFIC SAFETY BIB OVERALL	513	22-Apr-2019	22-Apr-2019	
80-5-0000000-0161	CLOTHING				121.50
<b>ALL622</b>	<b>ALLIED FIRE &amp; SAFETY</b>				
AF5521	GATE VALVE AND REDUCER FOR NEW HYDRANT HOOKUP BOX	1555	12-Nov-2018	12-Nov-2018	
80-5-0000000-0810	WATER - MAIN MAINTENANCE				1,221.51
<b>AMH001</b>	<b>AMHERSTBURG PROFESSIONAL FIREFIGHTERS ASSOC</b>				
APRIL 2019	DUES FOR THE MONTH OF APRIL 2019	481	30-Apr-2019	30-Apr-2019	
10-2-0000000-1156	A/P - PAYROLL DED. - FIRE				420.96
DECEMBER 20	DUES FOR THE MONTH OF DECEMBER 2018	1523	31-Dec-2018	31-Dec-2018	
10-2-0000000-1156	A/P - PAYROLL DED. - FIRE				408.80
FEBRUARY 20	DUES FOR THE MONTH OF FEBRUARY 2019	252	28-Feb-2019	28-Feb-2019	
10-2-0000000-1156	A/P - PAYROLL DED. - FIRE				426.96
JANUARY 2019	DUES FOR THE MONTH OF JANUARY 2019	177	31-Jan-2019	31-Jan-2019	
10-2-0000000-1156	A/P - PAYROLL DED. - FIRE				526.20
MARCH 2019	DUES FOR THE MONTH OF MARCH 2019	389	31-Mar-2019	31-Mar-2019	
10-2-0000000-1156	A/P - PAYROLL DED. - FIRE				414.96
<b>AMH29</b>	<b>AMHERSTBURG FIREMAN'S ASSOCIATION</b>				
2018 DUES	2018 DUES COVERS JUNE 1 TO DEC 1, 2018	1523	31-Dec-2018	31-Dec-2018	
10-2-0000000-1156	A/P - PAYROLL DED. - FIRE				50.00
10-2-0000000-1145	A/P - PAYROLL DED. - UNIO				2,875.00
<b>AMH43</b>	<b>AMHERSTBURG PUBLIC WORKS PETTY CASH</b>				
FEBRUARY 1,	PUBLIC WORK PETTY CASH FOR FEBRUARY 2019	134	31-Jan-2019	31-Jan-2019	
80-5-0000000-0161	CLOTHING				28.24
80-5-0000000-0420	EQUIPMENT MAINTENANCE				46.21
<b>AMI02</b>	<b>AMICO DESIGN BUILD</b>				
174242	RETURN OF INDEMNITY DEPOSIT FOR 91 BOBLO ISLAND BLVD, 2014-095	280	07-Mar-2019	07-Mar-2019	
10-2-0000000-2140	INDEMNITY FEES				1,000.00
191653 - 69	RE RETURN OF INDEMNITY DEPOSIT FOR 69 RED OAK CRESCENT, 2015-199	34	14-Jan-2019	14-Jan-2019	
10-2-0000000-2140	INDEMNITY FEES				1,000.00
191653 - 67	RE RETURN OF INDEMNITY DEPOSIT FOR 67 RED OAK DRIVE, 2015-198	481	30-Apr-2019	30-Apr-2019	
10-2-0000000-2140	INDEMNITY FEES				1,000.00
213132	RETURN OF INDEMNITY DEPOSIT FOR 51 RED OAK CRESCENT, 2017-089	481	24-Apr-2019	24-Apr-2019	
10-2-0000000-2140	INDEMNITY FEES				1,000.00
213138	RETURN OF INDEMNITY DEPOSIT FEE 61 RED OAK DRIVE, 2017-196	296	07-Mar-2019	07-Mar-2019	
10-2-0000000-2140	INDEMNITY FEES				1,000.00
213139	RETURN OF INDEMNITY DEPOSIT FOR 63 RED OAK CRESCENT, 2017-197	481	24-Apr-2019	24-Apr-2019	
10-2-0000000-2140	INDEMNITY FEES				1,000.00

Council/Board Report By Dept-(Computer)



Vendor : CAT038 To ZUL180

Batch : All

Department : All

Cheque Print Date : 01-Jan-2019 To 31-May-2019

Bank : 1 To 99

Class : All

Vendor Invoice	Vendor Name Description	Batch	Inv Date	Inv Due Date	Amount
G.L. Account	CC1 CC2 CC3 GL Account Name				
<b>DEPARTMENT 0000000</b>	GENERAL				
2019-023	RETURN OF INDEMNITY DEPOSIT FROM ROW PERMIT	525	16-May-2019	16-May-2019	
10-2-0000000-2135	INDEMNITY FEE - RIGHT OF WAY				1,000.00
<b>BAN435</b>	<b>BANKS JAMAL</b>				
APRIL26, 2019	RETURN OF INDEMNITY DEPOSIT FROM ROW PERMIT	436	26-Apr-2019	26-Apr-2019	
10-2-0000000-2135	INDEMNITY FEE - RIGHT OF WAY				1,000.00
<b>BAR221</b>	<b>BART DIGIOVANNI CONSTRUCTION</b>				
PW-SW-09-02C	SEWER RETURN OF CONTRACTOR DEPOSIT	135	11-Feb-2019	11-Feb-2019	
10-2-0000000-2145	DEPOSIT - SEWER CONTRACTO				2,000.00
<b>BAT156</b>	<b>BATES LYNN</b>				
2018-129	RETURN OF INDEMNITY DEPOSIT FROM ROW PERMIT	1523	19-Dec-2018	19-Dec-2018	
10-2-0000000-2135	INDEMNITY FEE - RIGHT OF WAY				1,000.00
2223873	RETURN OF INDEMNITY DEPOSIT AVENUE, 2018-323	280	03-Mar-2019	03-Mar-2019	
10-2-0000000-2140	INDEMNITY FEES				500.00
<b>BEL152</b>	<b>BELLAVANCE LANDSCAPING &amp; LAWNCARE</b>				
2225531	RETURN OF INDEMNITY DEPOSIT FOR 6136 CONCESSION 6N, 2018-299	34	14-Jan-2019	14-Jan-2019	
10-2-0000000-2140	INDEMNITY FEES				500.00
<b>BEN293</b>	<b>BENETEAU TOM</b>				
MARCH 22, 20	SEWER VIDEO	297	22-Mar-2019	22-Mar-2019	
80-5-0000000-0815	BACKFLOW - PREVENTION				506.24
<b>BLA145</b>	<b>BLAIS CONSTRUCTION</b>				
204304	RETURN OF INDEMNITY DEPOSIT FOR 2451 COUNTY ROAD 10, 2017-296	481	30-Apr-2019	30-Apr-2019	
10-2-0000000-2140	INDEMNITY FEES				1,000.00
<b>BOD549</b>	<b>BODCHIN KRIS</b>				
2226647	RETURN OF INDEMNITY DEPOSIT FOR 390 BENETEAU DRIVE, 2019-002	481	29-Apr-2019	29-Apr-2019	
10-2-0000000-2140	INDEMNITY FEES				1,000.00
<b>BON355</b>	<b>BONIFERRO STEPHEN</b>				
APRIL 26, 2019	RETURN OF INDEMNITY DEPOSIT FROM ROW PERMIT	436	26-Apr-2019	26-Apr-2019	
10-2-0000000-2135	INDEMNITY FEE - RIGHT OF WAY				1,000.00
<b>BON365</b>	<b>BONDY KRISTOPHER</b>				
2220861	RETURN OF INDEMNITY DEPOSIT FOR 3654 CONCESSION 3 N, 2018-127	280	07-Mar-2019	07-Mar-2019	
10-2-0000000-2140	INDEMNITY FEES				500.00
<b>CAN380</b>	<b>CANADIAN TIRE STORE #281</b>				
DECEMBER 20	DECEMBER 2018 PURCHASES	104	31-Jan-2019	31-Jan-2019	
80-5-0000000-0420	EQUIPMENT MAINTENANCE				7.44
80-5-0000000-0420	EQUIPMENT MAINTENANCE				-3.72
80-5-0000000-0833	WATER METER REPAIRS & MTNCE				28.24
80-5-0000000-0402	VEHICLE & EQUIPMENT MTCE.				-44.06
FEBRUARY 20	FEBRUARY 2019 PURCHASES	280	28-Feb-2019	28-Feb-2019	
80-5-0000000-0833	WATER METER REPAIRS & MTNCE				10.83
80-5-0000000-0833	WATER METER REPAIRS & MTNCE				73.39
JANUARY 2019	JANUARY 2019 PURCHASES	389	31-Jan-2019	31-Jan-2019	
80-5-0000000-0402	VEHICLE & EQUIPMENT MTCE.				31.63
80-5-0000000-0402	VEHICLE & EQUIPMENT MTCE.				16.94
80-5-0000000-0420	EQUIPMENT MAINTENANCE				64.06
80-5-0000000-0420	EQUIPMENT MAINTENANCE				21.46
80-5-0000000-0420	EQUIPMENT MAINTENANCE				169.49
80-5-0000000-0833	WATER METER REPAIRS & MTNCE				194.34
MARCH 2019	MARCH 2019 PURCHASES	345	31-Mar-2019	31-Mar-2019	
80-5-0000000-0833	WATER METER REPAIRS & MTNCE				46.75
NOVEMBER 20	NOVEMBER 2018 PURCHASES	133	31-Jan-2019	31-Jan-2019	
80-5-0000000-0835	SAMPLE STATION - REPAIRS, UPGRADES ETC.				58.53
80-5-0000000-0405	VEHICLE MTCE. - TIRE				41.80
80-5-0000000-0850	HYDRANT MAINTENANCE				125.61
80-5-0000000-0845	BLOWOFF REPAIRS, UPGRADES, NEW INSTALLS				15.57



Vendor : CAT038 To ZUL180

Batch : All

Department : All

Cheque Print Date : 01-Jan-2019 To 31-May-2019

Bank : 1 To 99

Class : All

Vendor Invoice	Vendor Name Description				Batch Invc Date	Invc Due Date	Amount
G.L. Account	CC1	CC2	CC3	GL Account Name			
<b>DEPARTMENT 0000000</b>		GENERAL					
80-5-0000000-0845				BLOWOFF REPAIRS, UPGRADES, NEW INSTALLS			7.44
OCTOBER 201	OCTOBER 2018	INVOICES			1554 31-Oct-2018	31-Oct-2018	
80-5-0000000-0420				EQUIPMENT MAINTENANCE			177.26
80-5-0000000-0420				EQUIPMENT MAINTENANCE			67.77
80-5-0000000-0420				EQUIPMENT MAINTENANCE			6.77
80-5-0000000-0420				EQUIPMENT MAINTENANCE			282.39
80-5-0000000-0420				EQUIPMENT MAINTENANCE			-282.39
80-5-0000000-0420				EQUIPMENT MAINTENANCE			17.56
80-5-0000000-0420				EQUIPMENT MAINTENANCE			46.83
80-5-0000000-0331				GENERAL MAINTENANCE			26.02
<b>CAR002</b>	<b>CARMGAR LIMITED</b>						
224912	RETURN OF INDEMNITY DEPOSIT FOR 274 DALHOUSIE ST, UNIT 106, 2018-347				511 29-Apr-2019	29-Apr-2019	
10-2-0000000-2140	INDEMNITY FEES						1,000.00
<b>CAR645</b>	<b>CARRIER CENTERS</b>						
04P449021	CREDIT				389 18-Apr-2019	18-Apr-2019	
80-5-0000000-0850	HYDRANT MAINTENANCE						-65.09
<b>CHA446</b>	<b>CHAPPELL EDWARD</b>						
223414	RETURN OF INDEMNITY DEPOSIT FOR 4461 NORTH SIDEROAD, 2018-288				296 07-Mar-2019	07-Mar-2019	
10-2-0000000-2140	INDEMNITY FEES						500.00
<b>CHA846</b>	<b>CHARRON RUSTY</b>						
APRIL 26, 2019	CULVERT INSTALLATION				436 26-Apr-2019	26-Apr-2019	
10-2-0000000-2135	INDEMNITY FEE - RIGHT OF WAY						1,000.00
<b>COM046</b>	<b>COM PETERS INC</b>						
4386	LOCATES SERVICE				178 01-Feb-2019	01-Feb-2019	
80-5-0000000-0755	WATER SERVICE MAINTENANCE						395.50
4416	LOCATES				283 01-Mar-2019	01-Mar-2019	
80-5-0000000-0755	WATER SERVICE MAINTENANCE						395.50
<b>CON672</b>	<b>CONTE MARC</b>						
183968	RETURN OF INDEMNITY DEPOSIT FOR 672 2ND CONCESSION N, 2015-016				280 08-Mar-2019	08-Mar-2019	
10-2-0000000-2140	INDEMNITY FEES						1,000.00
<b>COR408</b>	<b>ICONIX WATERWORKS LIMITED PARTNERSHIP</b>						
10916022527	BATERIES FOR METER				386 27-Mar-2019	27-Mar-2019	
80-5-0000000-0833	WATER METER REPAIRS & MTNCE						174.59
10916036271	MAINTENANCE				526 26-Apr-2019	26-Apr-2019	
80-5-0000000-0833	WATER METER REPAIRS & MTNCE						81.36
<b>COS340</b>	<b>COSTA RICK</b>						
APRIL 26, 2019	RETURN OF INDEMNITY DEPOSIT FROM ROW PERMIT				436 26-Apr-2019	26-Apr-2019	
10-2-0000000-2135	INDEMNITY FEE - RIGHT OF WAY						1,000.00
<b>COU248</b>	<b>COURTNEY PETER</b>						
MAY 24, 2019	REFUND FOR 2018 AMHERSTBURG VOTE				525 24-May-2019	24-May-2019	
10-2-0000000-2260	DEPOSITS - ELECTIONS						100.00
<b>CUR334</b>	<b>CURRY REPROGRAPHICS LTD.</b>						
1035794					386 20-Mar-2019	20-Mar-2019	
80-5-0000000-0328	ENGINEERING FEES						815.97
<b>DAL009</b>	<b>D'ALIMONTE AGOSTINO</b>						
2223306	RETURN OF INDEMNITY DEPOSIT FOR 9 OXFORD CRESCENT, 2018-264				296 07-Mar-2019	07-Mar-2019	
10-2-0000000-2140	INDEMNITY FEES						500.00
<b>DAN067</b>	<b>DAN 1ST CLASS ROOFING</b>						
2228037	RETURN OF INDEMNITY DEPOSIT FOR 465 FRONT RD N, 2019-035				481 30-Apr-2019	30-Apr-2019	
10-2-0000000-2140	INDEMNITY FEES						1,000.00
<b>DAN535</b>	<b>DANIHER TOP SOIL</b>						
43468	TOP SOIL				409 03-Apr-2019	03-Apr-2019	
80-5-0000000-0810	WATER - MAIN MAINTENANCE						452.00



Vendor : CAT038 To ZUL180

Batch : All

Department : All

Cheque Print Date : 01-Jan-2019 To 31-May-2019

Bank : 1 To 99

Class : All

Vendor Invoice	Vendor Name Description				Batch Invc Date	Invc Due Date	Amount
G.L. Account	CC1	CC2	CC3	GL Account Name			
<b>DEPARTMENT 0000000</b>		GENERAL					
<b>DIC11</b>	<b>DICARLO ALDO</b>						
MAY 24, 2019	REFUND FOR 2018 VOTE AMHERSTBURG				525 24-May-2019	24-May-2019	
10-2-0000000-2260				DEPOSITS - ELECTIONS			200.00
<b>DIG877</b>	<b>DIGIOVANNI DONATO</b>						
215427	RETURN OF THE INDEMNITY DEPOSIT FOR 8770 8TH CONCESSION N, 2017-274				280 07-Mar-2019	07-Mar-2019	
10-2-0000000-2140				INDEMNITY FEES			1,000.00
<b>ELE171</b>	<b>ELECTION SYSTEMS &amp; SOFTWARE CANADA</b>						
104743	RECOUNT				1523 28-Nov-2018	28-Nov-2018	
10-1-0000000-2007				A/R - HST (JULY 1, 2010)			514.41
<b>EMC530</b>	<b>EMCO CORPORATION</b>						
125840-00	HYDRANT HOOK UP BOXES				109 31-Jan-2019	31-Jan-2019	
80-5-0000000-0850				HYDRANT MAINTENANCE			-46.59
37579259-00	HYDRANT HOOK UP BOXES (OCT 24, 2018)				109 31-Jan-2019	31-Jan-2019	
80-5-0000000-0850				HYDRANT MAINTENANCE			615.26
37579298-00	HYDRANT BOX # 2 (OCT 24, 2018)				109 31-Jan-2019	31-Jan-2019	
80-5-0000000-0850				HYDRANT MAINTENANCE			77.27
37585672-00	REPLACE FROZEN BFP				178 15-Jan-2019	15-Jan-2019	
80-5-0000000-0833				WATER METER REPAIRS & MTNCE			711.90
37587954-00	HYDRANT BOX PART				178 07-Feb-2019	07-Feb-2019	
80-5-0000000-0850				HYDRANT MAINTENANCE			14.79
<b>ERI147</b>	<b>ERIE ACCENT POOLS &amp; SPAS</b>						
223026	RETURN OF INDEMNITY DEPOSIT FOR 122 GOLFWOOD DRIVE, 2018-295				250 12-Feb-2019	12-Feb-2019	
10-2-0000000-2140				INDEMNITY FEES			1,000.00
223728	RETURN OF INDEMNITY DEPOSIT FOR 486 WELSH AVENUE, 2018-355				481 01-May-2019	01-May-2019	
10-2-0000000-2140				INDEMNITY FEES			1,000.00
<b>ESL338</b>	<b>ESL UTILITY &amp; MUNICIPAL PRODUCTS</b>						
0000157148	CHLORINE DPD STRIPS				68 18-Jan-2019	18-Jan-2019	
80-5-0000000-0833				WATER METER REPAIRS & MTNCE			238.71
<b>ESS273</b>	<b>ESSEX POWERLINES CORPORATION</b>						
JC7554	COLLECTION (OCT 31, 2018)				109 31-Jan-2019	31-Jan-2019	
80-5-0000000-0504				COLLECTION EXPENSE			16,272.97
JC7590	WATER BILLING & COLLECTING FOR THE MONTH OF NOVEMBER 2018				1555 30-Nov-2018	30-Nov-2018	
80-5-0000000-0504				COLLECTION EXPENSE			16,272.97
JC7600	WATER BILLING & COLLECTING CHARGES				1555 31-Dec-2018	31-Dec-2018	
80-5-0000000-0504				COLLECTION EXPENSE			16,272.97
JC7673	WATER BILLING				178 31-Jan-2019	31-Jan-2019	
80-5-0000000-0504				COLLECTION EXPENSE			16,272.97
JC7696	WATER BILLING & COLLECTING GHARGES FOR THE MONTH OF FEBRUARY 2019				297 28-Feb-2019	28-Feb-2019	
80-5-0000000-0504				COLLECTION EXPENSE			16,272.97
JC7720	WATER BILLING AND COLLECTING CHARGES FOR THE MONTH OF MARCH 2019				409 31-Mar-2019	31-Mar-2019	
80-5-0000000-0504				COLLECTION EXPENSE			16,272.97
JC7768	WATER BILLING AND COLLECTING CHARGES FOR THE MONTH OF APRIL 2019				513 30-Apr-2019	30-Apr-2019	
80-5-0000000-0504				COLLECTION EXPENSE			16,272.97
<b>ESS53</b>	<b>ESSEX REGION CONSERVATION AUTHORITY</b>						
14622	AMHERSTBURG RISK MANAGEMENT SERVICES OCT 1 - DEC 31/18				208 31-Dec-2018	31-Dec-2018	
80-2-0000000-2160				SOURCE PROTECTION MUNICIPAL FUND			1,262.08
IN000014242	RISK MANAGEMENT SERVICES (SEPT 30, 2018)				133 31-Jan-2019	31-Jan-2019	
80-2-0000000-2160				SOURCE PROTECTION MUNICIPAL FUND			113.72
IN000014620	1ST QUARTER GENERAL LEVY INSTALLMENT				280 03-Jan-2019	03-Jan-2019	
80-5-0000000-0550				E.R.C.A. LEVY CW~GS			15,521.00
IN000015070					436 01-Apr-2019	01-Apr-2019	
80-5-0000000-0550				E.R.C.A. LEVY CW~GS			15,521.00

## Council/Board Report By Dept-(Computer)



Vendor : CAT038 To ZUL180

Batch : All

Department : All

Cheque Print Date : 01-Jan-2019 To 31-May-2019

Bank : 1 To 99

Class : All

Vendor Invoice	Vendor Name Description	Batch	Inv Date	Inv Due Date	Amount
G.L. Account	CC1 CC2 CC3 GL Account Name				
<b>DEPARTMENT 0000000</b>	GENERAL				
<b>ESS609</b>	<b>ESSEX REGION CHILDREN'S WATER FESTIVAL</b>				
MAY 2019	WATER FESTIVAL	485	01-May-2019	01-May-2019	
80-5-0000000-0951	WATER CONSERVATION PROGRAM				1,500.00
<b>EVE782</b>	<b>EVERJONGE HOMES</b>				
2018-087	RETURN OF INDEMNITY DEPOSIT FROM ROW PERMIT 193 DAVIS	436	26-Apr-2019	26-Apr-2019	
10-2-0000000-2135	INDEMNITY FEE - RIGHT OF WAY				1,000.00
2018-089	RETURN OF INDEMNITY DEPOSIT FROM ROW PERMIT 356 LAVERS	436	26-Apr-2019	26-Apr-2019	
10-2-0000000-2135	INDEMNITY FEE - RIGHT OF WAY				1,000.00
2019-020	RETURN OF INDEMNITY DEPOSIT FROM ROW PERMIT 394 WELSH	436	26-Apr-2019	26-Apr-2019	
10-2-0000000-2135	INDEMNITY FEE - RIGHT OF WAY				1,000.00
202388	RETURN OF INDEMNITY DEPOSIT FOR 504 COLONY COURT 2016-132	34	11-Jan-2019	11-Jan-2019	
10-2-0000000-2140	INDEMNITY FEES				1,000.00
213859	RETURN OF INDEMNITY DEPOSIT FOR 330 WELSH, 2017-239	34	14-Jan-2019	14-Jan-2019	
10-2-0000000-2140	INDEMNITY FEES				1,000.00
215433	RETURN OF INDEMNITY DEPOSIT FOR 334 WELSH AVENUE 2017-316	34	14-Jan-2019	14-Jan-2019	
10-2-0000000-2140	INDEMNITY FEES				1,000.00
218336	RETURN OF INDEMNITY DEPOSIT FOR 350 WELSH AVENUE, 2018-024	34	14-Jan-2019	14-Jan-2019	
10-2-0000000-2140	INDEMNITY FEES				1,000.00
218340	RETURN OF INDEMNITY DEPOSIT FOR 346 WELSH AVENUE	34	14-Jan-2019	14-Jan-2019	
10-2-0000000-2140	INDEMNITY FEES				1,000.00
218708	RETURN OF INDEMNITY DEPOSIT FOR 382 WELSH AVENUE	34	15-Jan-2019	15-Jan-2019	
10-2-0000000-2140	INDEMNITY FEES				1,000.00
219095	RETURN OF INDEMNITY DEPOSIT FOR 358 WELSH AVENUE 2018-043	34	14-Jan-2019	14-Jan-2019	
10-2-0000000-2140	INDEMNITY FEES				1,000.00
219096	RETURN OF INDEMNITY DEPOSIT FOR 354 WELSH AVENUE, 2017-044	34	14-Jan-2019	14-Jan-2019	
10-2-0000000-2140	INDEMNITY FEES				1,000.00
220167	RETURN OF INDEMNITY DEPOSIT FOR 295 WELSH AVENUE 2018-071	34	15-Jan-2019	15-Jan-2019	
10-2-0000000-2140	INDEMNITY FEES				1,000.00
<b>FAR404</b>	<b>FARACI JILLIAN</b>				
2019-041	RETURN OF INDEMNITY DEPOSIT FROM ROW PERMIT	525	16-May-2019	16-May-2019	
10-2-0000000-2135	INDEMNITY FEE - RIGHT OF WAY				1,000.00
<b>FAS860</b>	<b>FASTENAL CANADA</b>				
ONW1191157	HARDWARE	68	21-Jan-2019	21-Jan-2019	
80-5-0000000-0840	VALVE MAINTENANCE				432.76
<b>FER688</b>	<b>FERGUSON ROB</b>				
193491	RETURN OF INDEMNITY DEPOSIT FOR 688 FRONT RD N, 2015-267	34	14-Jan-2019	14-Jan-2019	
10-2-0000000-2140	INDEMNITY FEES				500.00
<b>FIR418</b>	<b>FIRST ELEMENTS INC.</b>				
AMH-006	WORKING AT HEIGHTS TRAINING	439	12-Apr-2019	12-Apr-2019	
80-5-0000000-0249	TRAINING				406.80
<b>FRY04</b>	<b>FRYER RICK</b>				
MAY 24, 2019	REFUND FOR 2018 AMHERSTBURG VOTE	525	24-May-2019	24-May-2019	
10-2-0000000-2260	DEPOSITS - ELECTIONS				100.00
<b>GEM113</b>	<b>GEMMELL PAULINE</b>				
MAY 24, 2019	REFUND FOR 2018 AMHERSTBURG VOTE	525	24-May-2019	24-May-2019	
10-2-0000000-2260	DEPOSITS - ELECTIONS				100.00
<b>GGC033</b>	<b>G &amp; G CONTRACTING 1078262 ONTARIO LTD</b>				
151068	RETURN OF INDEMNITY DEPOSIT FOR 88 SHAW, 2012-282	345	28-Mar-2019	28-Mar-2019	
10-2-0000000-2140	INDEMNITY FEES				1,000.00
151068 (86 SH.	RETURN OF INDEMNITY DEPOSIT FOR 86 SHAW DRIVE, 212-281	345	28-Mar-2019	28-Mar-2019	
10-2-0000000-2140	INDEMNITY FEES				1,000.00
151068 (92 SH.	RETURN OF INDEMNITY DEPOSIT FOR 92 SHAW, 2012-284	345	28-Mar-2019	28-Mar-2019	



Council/Board Report By Dept-(Computer)



Vendor : CAT038 To ZUL180

Batch : All

Department : All

Cheque Print Date : 01-Jan-2019 To 31-May-2019

Bank : 1 To 99

Class : All

Vendor Invoice	Vendor Name Description	Batch	Inv Date	Inv Due Date	Amount
G.L. Account	CC1 CC2 CC3 GL Account Name				
<b>DEPARTMENT 0000000</b>	<b>GENERAL</b>				
10-2-0000000-2140	INDEMNITY FEES				1,000.00
177454	RETURN OF INDEMNITY DEPOSIT FOR 74 SHAW DRIVE, 2014-200	280	06-Mar-2019	06-Mar-2019	
10-2-0000000-2140	INDEMNITY FEES				1,000.00
177454 (76 SH. RETURN OF INDEMNITY DEPOSIT FOR 76 SHAW DRIVE, 2014-201		280	06-Mar-2019	06-Mar-2019	
10-2-0000000-2140	INDEMNITY FEES				1,000.00
187995	RETURN OF INDEMNITY DEPOSIT FOR 68 SHAW, 2015-151	280	06-Mar-2019	06-Mar-2019	
10-2-0000000-2140	INDEMNITY FEES				1,000.00
190969 (60 SH. RETURN OF INDEMNITY DEPOSIT FOR 60 SHAW DRIVE 2015-219		345	28-Mar-2019	28-Mar-2019	
10-2-0000000-2140	INDEMNITY FEES				1,000.00
202391 - 14 SF RETURN OF INDEMNITY DEPOSIT FOR 14 SHAW DRIVE, 2016-147		35	14-Jan-2019	14-Jan-2019	
10-2-0000000-2140	INDEMNITY FEES				1,000.00
202391 - 16 SF RETURN OF INDEMNITY DEPOSIT FOR 16 SHAW DRIVE, 2016-148		34	11-Jan-2019	11-Jan-2019	
10-2-0000000-2140	INDEMNITY FEES				1,000.00
202391 - 26 SF RETURN OF INDEMNITY DEPOSIT FOR 26 SHAW DRIVE 2016-149		34	11-Jan-2019	11-Jan-2019	
10-2-0000000-2140	INDEMNITY FEES				1,000.00
202391 - 28 SF RETURN OF INDEMNITY DEPOSIT FOR 28 SHAW DRIVE		35	14-Jan-2019	14-Jan-2019	
10-2-0000000-2140	INDEMNITY FEES				1,000.00
202391 - 30 SF RETURN OF INDEMNITY DEPOSIT FOR 30 SHAW DRIVE, 2016-151		35	14-Jan-2019	14-Jan-2019	
10-2-0000000-2140	INDEMNITY FEES				1,000.00
202391 - 32 SF RETURN OF INDEMNITY DEPOSIT FOR 32 SHAW DRIVE, 2016-152		35	14-Jan-2019	14-Jan-2019	
10-2-0000000-2140	INDEMNITY FEES				1,000.00
202391 - 34 SF RETURN OF INDEMNITY DEPOSIT FOR 34 SHAW DRIVE 2016 - 153		34	11-Jan-2019	11-Jan-2019	
10-2-0000000-2140	INDEMNITY FEES				1,000.00
202391 - 36 SF RETURN OF INDEMNITY DEPOSIT FOR 36 SHAW DRIVE 2016-154		34	11-Jan-2019	11-Jan-2019	
10-2-0000000-2140	INDEMNITY FEES				1,000.00
202391 - 38 SF RETURN OF INDEMNITY DEPOSIT FOR 38 SHAW DRIVE, 2016-155		34	11-Jan-2019	11-Jan-2019	
10-2-0000000-2140	INDEMNITY FEES				1,000.00
202391 - 40 SF RETURN OF INDEMNITY DEPOSIT FOR 40 SHAW DRIVE, 2016-156		34	11-Jan-2019	11-Jan-2019	
10-2-0000000-2140	INDEMNITY FEES				1,000.00
202391 - 42 SF RETURN OF INDEMNITY DEPOSIT FOR 42 SHAW DRIVE, 2016-157		34	11-Jan-2019	11-Jan-2019	
10-2-0000000-2140	INDEMNITY FEES				1,000.00
202391 - 44 SF RETURN OF INDEMNITY DEPOSIT FOR 44 SHAW DRIVE, 2016-158		34	11-Jan-2019	11-Jan-2019	
10-2-0000000-2140	INDEMNITY FEES				1,000.00
202391 - 46 SF RETURN OF INDEMNITY DEPOSIT FOR 46 SHAW DRIVE, 2016-159		34	11-Jan-2019	11-Jan-2019	
10-2-0000000-2140	INDEMNITY FEES				1,000.00
202391 - 48 SF RETURN OF INDEMNITY DEPOSIT FOR 48 SHAW DRIVE, 2016-160		35	11-Jan-2019	11-Jan-2019	
10-2-0000000-2140	INDEMNITY FEES				1,000.00
202391 - 50 SF RETURN OF INDEMNITY DEPOSIT FOR 50 SHAW DRIVE, 2016-161		34	11-Jan-2019	11-Jan-2019	
10-2-0000000-2140	INDEMNITY FEES				1,000.00
202391 - 52 SF RETURN OF INDEMNITY DEPOSIT FOR 52 SHAW DRIVE, 2016-162		35	11-Jan-2019	11-Jan-2019	
10-2-0000000-2140	INDEMNITY FEES				1,000.00
213268	RETURN OF INDEMNITY DEPOSIT FOR 208 ADAMS AVENUE, 2017-171	280	06-Mar-2019	06-Mar-2019	
10-2-0000000-2140	INDEMNITY FEES				1,000.00
213271	RETURN OF INDEMNITY DEPOSIT FOR 2 SHAW DRIVE, 2017-158	35	14-Jan-2019	14-Jan-2019	
10-2-0000000-2140	INDEMNITY FEES				1,000.00
213277	RETURN OF INDEMNITY DEPOSIT FOR 96 SHAW DRIVE, 2017-157	35	14-Jan-2019	14-Jan-2019	
10-2-0000000-2140	INDEMNITY FEES				1,000.00
213278	RETURN OF INDEMNITY DEPOSIT FOR 11 SHAW DRIVE, 2017-163	280	06-Mar-2019	06-Mar-2019	
10-2-0000000-2140	INDEMNITY FEES				1,000.00
213281	RETURN OF INDEMNITY DEPOSIT FOR 9 SHAW DRIVE, 2017-162	35	14-Jan-2019	14-Jan-2019	
10-2-0000000-2140	INDEMNITY FEES				1,000.00
213282	RETURN OF INDEMNITY DEPOSIT FOR 202 ADAMS AVENUE, 2017-164	280	06-Mar-2019	06-Mar-2019	
10-2-0000000-2140	INDEMNITY FEES				1,000.00



Council/Board Report By Dept-(Computer)



Vendor : CAT038 To ZUL180

Batch : All

Department : All

Cheque Print Date : 01-Jan-2019 To 31-May-2019

Bank : 1 To 99

Class : All

Vendor Invoice	Vendor Name Description	Batch	Inv Date	Inv Due Date	Amount
G.L. Account	CC1 CC2 CC3 GL Account Name				
<b>DEPARTMENT 0000000</b>	<b>GENERAL</b>				
213285	RETURN OF INDEMNITY DEPOSIT FOR 201 ADAMS, 2017-166	35	14-Jan-2019	14-Jan-2019	
10-2-0000000-2140	INDEMNITY FEES				1,000.00
213286	RETURN OF INDEMNITY DEPOSIT FOR 72 SHAW DRIVE, 2014-203	280	06-Mar-2019	06-Mar-2019	
10-2-0000000-2140	INDEMNITY FEES				1,000.00
<b>GRA593 GRASSHOPPER SOLAR CORP</b>					
214048	RETURN OF INDEMNITY DEPOSIT FOR 7022 EAGLE CRESCENT, 2017-266	481	25-Apr-2019	25-Apr-2019	
10-2-0000000-2140	INDEMNITY FEES				1,000.00
214219	RETURN OF INDEMNITY DEPOSIT FOR 244 FORT STREET, 2017-293	481	29-Apr-2019	29-Apr-2019	
10-2-0000000-2140	INDEMNITY FEES				1,000.00
<b>GRE05 GREATER ESSEX COUNTY DISTRICT SCHOOL BOARD</b>					
APRIL 2019	APRIL 2019 PUB SCHOOL BOARD DEVELOPMENT CHARGE	436	30-Apr-2019	30-Apr-2019	
10-2-0000000-0112	A/P - PUB SCH BRD. DEV CHARGE				2,440.00
DECEMBER 20	DECEMBER 2018 PUB SCHOOL BOARD DEVELOPMENT	1523	31-Dec-2018	31-Dec-2018	
10-2-0000000-0112	A/P - PUB SCH BRD. DEV CHARGE				1,525.00
FEBRUARY 20	FEBRUARY 2019 PUB SCHOOL BOARD DEVELOPMENT CHARGES	204	28-Feb-2019	28-Feb-2019	
10-2-0000000-0112	A/P - PUB SCH BRD. DEV CHARGE				610.00
JANUARY 2019	JANUARY 2019 PUB SCHOOL BOARD DEVELOPMENT	106	31-Jan-2019	31-Jan-2019	
10-2-0000000-0112	A/P - PUB SCH BRD. DEV CHARGE				1,220.00
MARCH 2019	MARCH 2019 PUB SCHOOL BOARD DEVELOPMENT CHARGE	345	31-Mar-2019	31-Mar-2019	
10-2-0000000-0112	A/P - PUB SCH BRD. DEV CHARGE				1,830.00
<b>GRE330 GREAT LAKES SAFETY PRODUCTS</b>					
00316948		178	05-Feb-2019	05-Feb-2019	
80-5-0000000-0755	WATER SERVICE MAINTENANCE				340.77
00318438	SUPPLIES	386	21-Mar-2019	21-Mar-2019	
80-5-0000000-0755	WATER SERVICE MAINTENANCE				28.48
316872	MAINTENANCE	208	01-Feb-2019	01-Feb-2019	
80-5-0000000-0840	VALVE MAINTENANCE				203.40
317556	LINEMEN GLOVES	208	25-Feb-2019	25-Feb-2019	
80-5-0000000-0755	WATER SERVICE MAINTENANCE				79.90
<b>GRE679 GREG BAILEY LTD</b>					
0000050376	PARTS FOR SMALL ENGINE PUMPS	283	18-Mar-2019	18-Mar-2019	
80-5-0000000-0420	EQUIPMENT MAINTENANCE				27.09
0000051592	FITTINGS FOR PUMP	68	15-Jan-2019	15-Jan-2019	
80-5-0000000-0850	HYDRANT MAINTENANCE				56.56
0000051631	PUMP PARTS	178	01-Feb-2019	01-Feb-2019	
80-5-0000000-0850	HYDRANT MAINTENANCE				138.58
<b>HAL153 HALLER MECHANICAL CONTRACTORS INC.</b>					
J026483	METER REPLACEMENT	1555	17-Dec-2018	17-Dec-2018	
80-5-0000000-0833	WATER METER REPAIRS & MTNCE				96.05
<b>HEA693 HEATON SANITATION</b>					
333180	SERVICE BREAK VAC TRUCK	208	24-Feb-2019	24-Feb-2019	
80-5-0000000-0755	WATER SERVICE MAINTENANCE				1,864.50
33351	VAC TRUCK	297	12-Mar-2019	12-Mar-2019	
80-5-0000000-0755	WATER SERVICE MAINTENANCE				1,243.00
33357	VACTOR FLUSHER	320	19-Mar-2019	19-Mar-2019	
80-5-0000000-0755	WATER SERVICE MAINTENANCE				1,017.00
35028	VAC TRUCK	283	01-Mar-2019	01-Mar-2019	
80-5-0000000-0755	WATER SERVICE MAINTENANCE				1,808.00
35236	VAC TRUCK	68	26-Jan-2019	26-Jan-2019	
80-5-0000000-0755	WATER SERVICE MAINTENANCE				813.60
35903	VAC TRUCK	526	25-Apr-2019	25-Apr-2019	
80-5-0000000-0850	HYDRANT MAINTENANCE				1,808.00
36882	WATER SERVICE	68	15-Jan-2019	15-Jan-2019	

## Council/Board Report By Dept-(Computer)



Vendor : CAT038 To ZUL180

Batch : All

Department : All

Cheque Print Date : 01-Jan-2019 To 31-May-2019

Bank : 1 To 99

Class : All

Vendor Invoice	Vendor Name Description	Batch	Inv Date	Inv Due Date	Amount
G.L. Account	CC1 CC2 CC3 GL Account Name				
<b>DEPARTMENT 0000000</b>	GENERAL				
80-5-0000000-0755					
	WATER SERVICE MAINTENANCE				1,582.00
37305	VAC TRUCK	386	26-Mar-2019	26-Mar-2019	
80-5-0000000-0755					
	WATER SERVICE MAINTENANCE				904.00
37680	HYDRANT REPAIR - INSURANCE CLAIM FROM ACCIDENT	283	23-Feb-2019	23-Feb-2019	
80-5-0000000-0850					
	HYDRANT MAINTENANCE				1,243.00
<b>HLH102</b>	<b>H.L. HAMILTON INSURANCE LTD.</b>				
DECEMBER 20 RENEWAL		1554	31-Dec-2018	31-Dec-2018	
10-1-0000000-3000					
	PREPAIDS				799,205.28
<b>HOL500</b>	<b>HOLDEN MIKE</b>				
223289	RETURN OF INDEMNITY DEPOSIT FOR 500 SIMCOE STREET, 2018-276	280	12-Mar-2019	12-Mar-2019	
10-2-0000000-2140					
	INDEMNITY FEES				500.00
<b>IAN02</b>	<b>IANNUCCI ALDO</b>				
0000116549	RETURN OF SANITARY & STORM DEPOSIT	135	11-Feb-2019	11-Feb-2019	
10-2-0000000-2134					
	DEPOSITS - SANITARY & STORM SEWER TAP				1,500.00
<b>IBEW01</b>	<b>IBEW - LOCAL 636</b>				
APRIL 2019	APRIL 2019 MONTHLY DUES	481	01-Apr-2019	01-Apr-2019	
10-2-0000000-1145					
	A/P - PAYROLL DED. - UNIO				3,281.46
DECEMBER 20	DECEMBER 2018 MONTHLY DUES	1523	01-Dec-2018	01-Dec-2018	
10-2-0000000-1145					
	A/P - PAYROLL DED. - UNIO				3,384.10
FEBRUARY 20	FEBRUARY 2019 MONTHLY DUES	252	01-Feb-2019	01-Feb-2019	
10-2-0000000-1145					
	A/P - PAYROLL DED. - UNIO				3,322.33
JANUARY 2019	JANUARY 2019 MONTHLY DUES	177	01-Jan-2019	01-Jan-2019	
10-2-0000000-1145					
	A/P - PAYROLL DED. - UNIO				4,180.85
MARCH 2019	MARCH 2019 MONTHLY DUES	389	01-Mar-2019	01-Mar-2019	
10-2-0000000-1145					
	A/P - PAYROLL DED. - UNIO				3,353.95
<b>JIA096</b>	<b>JIANU RADU</b>				
228495	RETURN OF INDEMNITY DEPOSIT FOR 96 SHAW DRIVE 2019-048	481	01-May-2019	01-May-2019	
10-2-0000000-2140					
	INDEMNITY FEES				500.00
<b>JOH633</b>	<b>JOHNSTON MATTHEW</b>				
227949	RETURN OF INDEMNITY DEPOSIT FOR 267 DALHOUSIE 2019-020	481	25-Apr-2019	25-Apr-2019	
10-2-0000000-2140					
	INDEMNITY FEES				1,000.00
<b>KEE579</b>	<b>KEENAN ELIZABETH</b>				
MAY 24, 2019	REFUND FOR 2018 AMHERSTBURG VOTE	525	24-May-2019	24-May-2019	
10-2-0000000-2260					
	DEPOSITS - ELECTIONS				100.00
<b>KEL117</b>	<b>KELCOM TELEMESSAGING</b>				
1902-06702	CALL CENTRE SERVICES	135	01-Feb-2019	01-Feb-2019	
80-5-0000000-0316					
	UTILITIES				41.75
1903-06702	ANSWERING SERVICE	280	01-Mar-2019	01-Mar-2019	
80-5-0000000-0316					
	UTILITIES				42.68
1904-06702	ANSWERING SERVICES	347	01-Apr-2019	01-Apr-2019	
80-5-0000000-0316					
	UTILITIES				35.38
1905-06702	ANSWERING SERVICE	511	01-May-2019	01-May-2019	
80-5-0000000-0316					
	UTILITIES				53.02
W78745-0119	ANSWERING SERVICE	34	02-Jan-2019	02-Jan-2019	
80-5-0000000-0316					
	UTILITIES				29.48
<b>KEL198</b>	<b>KELCOM RADIO DIVISION</b>				
80010115	RADIO	1523	19-Dec-2018	19-Dec-2018	
10-1-0000000-2070					
	PREPAID EXPENSES				3,742.56
<b>KEN211</b>	<b>KEN LAPAIN &amp; SONS LTD</b>				
IN00109800	ANNUAL INSPECTION # WM-08	1555	20-Dec-2018	20-Dec-2018	
80-5-0000000-0402					
	VEHICLE & EQUIPMENT				1,670.03
<b>KOP130</b>	<b>KOPCHEK DAVID</b>				

## Council/Board Report By Dept-(Computer)



Vendor : CAT038 To ZUL180

Batch : All

Department : All

Cheque Print Date : 01-Jan-2019 To 31-May-2019

Bank : 1 To 99

Class : All

Vendor Invoice	Vendor Name Description				Batch Invc Date	Invc Due Date	Amount
G.L. Account	CC1	CC2	CC3	GL Account Name			
<b>DEPARTMENT 0000000</b>		GENERAL					
2019-040				RETURN OF INDEMNITY DEPOSIT FROM ROW PERMIT	525 16-May-2019	16-May-2019	
10-2-0000000-2135				INDEMNITY FEE - RIGHT OF WAY			1,000.00
<b>KOR721</b>	<b>KOREN PHARMACY INC O/A HEALTH FIRST PHARMACY</b>						
216139				RETURN OF INDEMNITY DEPOSIT FOR 721 FRONT ROAD S, 2017-339	280 07-Mar-2019	07-Mar-2019	
10-2-0000000-2140				INDEMNITY FEES			1,000.00
<b>KPM434</b>	<b>KPMG LLP T4348</b>						
8002226514				PROFESSIONAL FEES (SEPT 26, 2018)	109 31-Jan-2019	31-Jan-2019	
80-5-0000000-0328				ENGINEERING FEES			5,014.75
<b>KRZ015</b>	<b>KRZNARICH JACENTA</b>						
229705				RETURN OF INDEMNITY DEPOSIT FOR 15 BALACLAVA ST N, 20109-120	525 17-May-2019	17-May-2019	
10-2-0000000-2140				INDEMNITY FEES			1,000.00
<b>KTI033</b>	<b>KTI LIMITED</b>						
114426				TOUCHPADS	1555 26-Nov-2018	26-Nov-2018	
80-5-0000000-0833				WATER METER REPAIRS & MTNCE			565.00
115066				PIT METERS	1597 21-Dec-2018	21-Dec-2018	
80-5-0000000-0833				WATER METER REPAIRS & MTNCE			1,810.94
115440				METERS	178 10-Jan-2019	10-Jan-2019	
80-5-0000000-0833				WATER METER REPAIRS & MTNCE			7,005.46
115822				METERS	208 06-Feb-2019	06-Feb-2019	
80-5-0000000-0833				WATER METER REPAIRS & MTNCE			6,588.35
116124				TOUCH COUPLERS	283 26-Feb-2019	26-Feb-2019	
80-5-0000000-0833				WATER METER REPAIRS & MTNCE			12,177.46
116474				MAINTENANCE	297 12-Mar-2019	12-Mar-2019	
80-5-0000000-0833				WATER METER REPAIRS & MTNCE			6,588.35
116596				SOFTWARE SUPPORT	386 19-Mar-2019	19-Mar-2019	
80-5-0000000-0833				WATER METER REPAIRS & MTNCE			3,256.19
117239				MAINTENANCE	439 17-Apr-2019	17-Apr-2019	
80-5-0000000-0833				WATER METER REPAIRS & MTNCE			2,387.35
<b>LAS447</b>	<b>LASSALINE RON</b>						
2019-021				RETURN OF INDEMNITY DEPOSIT FROM ROW PERMIT 447 OLD COLONY TRAIL	436 26-Apr-2019	26-Apr-2019	
10-2-0000000-2135				INDEMNITY FEE - RIGHT OF WAY			1,000.00
<b>LAS702</b>	<b>LASALLE BACKHOE SERVICE</b>						
205942				RETURN OF INDEMNITY DEPOSIT FOR 6906 6TH CONCESSION 6N, 2016-351	481 30-Apr-2019	30-Apr-2019	
10-2-0000000-2140				INDEMNITY FEES			1,000.00
<b>LAZ224</b>	<b>LAZANJA LENA</b>						
MAY 24, 2019				REFUND FOR 2018 AMHERSTBURG VOTE	525 24-May-2019	24-May-2019	
10-2-0000000-2260				DEPOSITS - ELECTIONS			100.00
<b>LIO033</b>	<b>LIOVAS HOMES</b>						
152635				RETURN OF INDEMNITY DEPOSIT FOR 82 SHAW DRIVE 2013-007	481 24-Apr-2019	24-Apr-2019	
10-2-0000000-2140				INDEMNITY FEES			1,000.00
213266				RETURN OF INDEMNITY DEPOSIT FOR 206 ADAMS AVENUE, 2017-170	481 29-Apr-2019	29-Apr-2019	
10-2-0000000-2140				INDEMNITY FEES			1,000.00
213270				RETURN OF INDEMNITY DEPOSIT FOR 205 ADAMS 2017-168	481 29-Apr-2019	29-Apr-2019	
10-2-0000000-2140				INDEMNITY FEES			1,000.00
213275				RETURN OF INDEMNITY DEPOSIT FOR 87 SHAW DRIVE, 2017-161	481 30-Apr-2019	30-Apr-2019	
10-2-0000000-2140				INDEMNITY FEES			1,000.00
213284				RETURN OF INDEMNITY DEPOSIT FOR 203 ADAMS AVENUE, 2017-159	481 29-Apr-2019	29-Apr-2019	
10-2-0000000-2140				INDEMNITY FEES			1,000.00
213289				RETURN OF INDEMNITY DEPOSIT FOR 210 ADAMS AVENUE, 2017-172	481 29-Apr-2019	29-Apr-2019	
10-2-0000000-2140				INDEMNITY FEES			1,000.00
231272				RETURN OF INDEMNITY DEPOSIT FOR 4 SHAW DRIVE 2017-155	481 29-Apr-2019	29-Apr-2019	
10-2-0000000-2140				INDEMNITY FEES			1,000.00

Council/Board Report By Dept-(Computer)



Vendor : CAT038 To ZUL180

Batch : All

Department : All

Cheque Print Date : 01-Jan-2019 To 31-May-2019

Bank : 1 To 99

Class : All

Vendor Invoice	Vendor Name Description	Batch	Inv Date	Inv Due Date	Amount
G.L. Account	CC1 CC2 CC3 GL Account Name				
<b>DEPARTMENT 0000000</b>	GENERAL				
<b>LUC170</b>	<b>LUCIER GLOVE &amp; SAFETY PRODUCTS</b>				
33827	CLOTHING	320	19-Mar-2019	19-Mar-2019	
80-5-0000000-0161	CLOTHING				762.65
33996	CREDIT	511	28-Mar-2019	28-Mar-2019	
80-5-0000000-0161	CLOTHING				-762.65
<b>MAC024</b>	<b>MACRI RINALDO</b>				
199685 (2019)	RETURN OF INDEMNITY DEPOSIT FOR 24 SHAW DRIVE 2016-089	250	28-Feb-2019	28-Feb-2019	
10-2-0000000-2140	INDEMNITY FEES				1,000.00
<b>MAC287</b>	<b>MACKINNON ROBERT</b>				
220170	RETURN OF INDEMNITY DEPOSIT FOR 287 LAKEWOOD DRIVE 2018-076	34	14-Jan-2019	14-Jan-2019	
10-2-0000000-2140	INDEMNITY FEES				1,000.00
<b>MAL256</b>	<b>MALDEN AUTOMOTIVE</b>				
5294-179980	CREDIT	1606	31-Oct-2018	31-Oct-2018	
80-5-0000000-0402	VEHICLE & EQUIPMENT MTCE.				-23.73
5294-180454	VEHICLE MAINTENANCE	1606	07-Nov-2018	07-Nov-2018	
80-5-0000000-0402	VEHICLE & EQUIPMENT MTCE.				258.02
5294-180560	VEHICLE MAINTENANCE	1606	08-Nov-2018	08-Nov-2018	
80-5-0000000-0402	VEHICLE & EQUIPMENT MTCE.				70.99
<b>MAN505</b>	<b>MANCINI MICHELE</b>				
203449	RETURN OF INDEMNITY DEPOSIT FOR 505 ALMA STREET 2016-268	481	24-Apr-2019	24-Apr-2019	
10-2-0000000-2140	INDEMNITY FEES				1,000.00
<b>MAR08</b>	<b>MAROTTE DIDIER</b>				
MAY 24, 2019	REFUND FOR 2018 AMHERSTBURG VOTE	525	24-May-2019	24-May-2019	
10-2-0000000-2260	DEPOSITS - ELECTIONS				100.00
<b>MCA09</b>	<b>MARTHUR DONALD</b>				
MAY 24, 2019	REFUND FOR 2018 AMHERSTBURG VOTE	525	24-May-2019	24-May-2019	
10-2-0000000-2260	DEPOSITS - ELECTIONS				100.00
<b>MCG453</b>	<b>MCGOWAN JAMES</b>				
2227651	RETURN OF INDEMNITY DEPOSIT FOR 453 WELSH AVENUE 2019-023	481	29-Apr-2019	29-Apr-2019	
10-2-0000000-2140	INDEMNITY FEES				1,000.00
<b>MCG684</b>	<b>MCGUIRE FARMS INC</b>				
0715	MAINTENANCE	253	10-Jan-2019	10-Jan-2019	
80-5-0000000-0755	WATER SERVICE MAINTENANCE				738.51
0723	MAINTENANCE	439	03-Apr-2019	03-Apr-2019	
80-5-0000000-0755	WATER SERVICE MAINTENANCE				652.33
<b>MEA01</b>	<b>THE MEARIE GROUP</b>				
29,257	DECEMBER 2018 BENEFITS	1555	31-Dec-2018	31-Dec-2018	
80-5-0000000-0211	BENEFITS - ESSEX POWER - WATER DEPARTMEN				740.90
29,380	JANUARY 2019 BENEFITS	68	31-Jan-2019	31-Jan-2019	
80-5-0000000-0211	BENEFITS - ESSEX POWER - WATER DEPARTMEN				752.61
29,502	FEBRUARY 2019 BENEFITS	253	28-Feb-2019	28-Feb-2019	
80-5-0000000-0211	BENEFITS - ESSEX POWER - WATER DEPARTMEN				752.61
29,614	MARCH 2019 BENEFITS	386	31-Mar-2019	31-Mar-2019	
80-5-0000000-0211	BENEFITS - ESSEX POWER - WATER DEPARTMEN				752.61
29,751	APRIL 2019 BENEFITS	485	30-Apr-2019	30-Apr-2019	
80-5-0000000-0211	BENEFITS - ESSEX POWER - WATER DEPARTMEN				752.61
<b>MEL189</b>	<b>MELVIN ORR TRUCKING LTD.</b>				
162165160	MAINTENANCE	439	04-Apr-2019	04-Apr-2019	
80-5-0000000-0810	WATER - MAIN MAINTENANCE				361.60
<b>MEL42</b>	<b>MELOCHE LEO</b>				
MAY 24, 2019	REFUND FOR 2018 AMHERSTBURG VOTE	525	24-May-2019	24-May-2019	
10-2-0000000-2260	DEPOSITS - ELECTIONS				100.00



Vendor : CAT038 To ZUL180  
 Batch : All  
 Department : All

Cheque Print Date : 01-Jan-2019 To 31-May-2019  
 Bank : 1 To 99  
 Class : All

Vendor Invoice	Vendor Name Description	Batch	Inv Date	Inv Due Date	Amount
G.L. Account	CC1 CC2 CC3 GL Account Name				
<b>DEPARTMENT 0000000 GENERAL</b>					
<b>MEN08 MENNA JOHN</b>					
MAY 24, 2019	REFUND FOR 2018 AMHERSTBURG VOTE	525	24-May-2019	24-May-2019	
10-2-0000000-2260	DEPOSITS - ELECTIONS				100.00
<b>MOR26 MORNEAU SHEPELL LTD.</b>					
APRIL 2019	953243, 953244, 953245, 953246 APRIL 2019	347	01-Apr-2019	01-Apr-2019	
80-5-0000000-0207	BENEFITS - LIFE & DISABILITY				83.20
FEBRUARY 20	921007, 921008, 921009, 921010 FEBRUARY 2019	135	01-Feb-2019	01-Feb-2019	
80-5-0000000-0207	BENEFITS - LIFE & DISABILITY				83.20
JANUARY 2019	902738, 902739, 902740, 902741 JANUARY 2019	62	02-Jan-2019	02-Jan-2019	
80-5-0000000-0207	BENEFITS - LIFE & DISABILITY				83.21
MARCH 2019	936899, 936900, 936901, 936902 MARCH 2019	280	01-Mar-2019	01-Mar-2019	
80-5-0000000-0207	BENEFITS - LIFE & DISABILITY				83.20
MAY 2019	970411, 970412, 970413, 970414 MAY 2019	511	01-May-2019	01-May-2019	
80-5-0000000-0207	BENEFITS - LIFE & DISABILITY				83.21
<b>MOR373 MOORE GREGORY</b>					
MAY 24, 2019	REFUND FOR 2018 AMHERSTBURG VOTE	525	24-May-2019	24-May-2019	
10-2-0000000-2260	DEPOSITS - ELECTIONS				100.00
<b>NOR100 NOR-BUILT CONSTRUCTION</b>					
213715	RETURN OF INDEMNITY DEPOSIT FOR 14 BERTRAND STREET 2017-224	481	30-Apr-2019	30-Apr-2019	
10-2-0000000-2140	INDEMNITY FEES				1,000.00
<b>NSF150 NSF INTERNATIONAL STRATEGIC REGISTRATIONS</b>					
4039452	DWQMS SYSTEM AUDIT	439	22-Mar-2019	22-Mar-2019	
80-5-0000000-0920	DWQMS MAINTENANCE				1,921.00
<b>OHA438 O'HARA JENNIFER</b>					
2221860	RETURN OF INDEMNITY DEPOSIT FOR 438 MCLEAOD AVENUE, 2018-218	252	07-Mar-2019	07-Mar-2019	
10-2-0000000-2140	INDEMNITY FEES				1,000.00
<b>OKT366 OK TIRE STORE - SANTING</b>					
0000179210	OIL SPRAY	178	29-Jan-2019	29-Jan-2019	
80-5-0000000-0850	HYDRANT MAINTENANCE				91.53
<b>ONT001 ONTARIO CLEAN WATER AGENCY</b>					
INV000106448	REPLACE CHLORINE GAS SUPPLY	1555	20-Sep-2018	20-Sep-2018	
80-5-0000000-0612	GENERAL MAINTENANCE - AWWTP				1,242.71
INV000108320	CADUCEON ENTERPRISES INC	1555	22-Nov-2018	22-Nov-2018	
80-5-0000000-0612	GENERAL MAINTENANCE - AWWTP				641.09
INV000108321	QUINN ROOFING SOLUTIONS	1555	22-Nov-2018	22-Nov-2018	
80-5-0000000-0612	GENERAL MAINTENANCE - AWWTP				691.97
INV000108322	ADDITIONAL SERVICES	386	17-Apr-2019	17-Apr-2019	
80-5-0000000-0612	GENERAL MAINTENANCE - AWWTP				506.76
INV000108323	SUNSET ENTERPRIZE WLEDING	1555	22-Nov-2018	22-Nov-2018	
80-5-0000000-0612	GENERAL MAINTENANCE - AWWTP				267.12
INV000108412	OPERATIONS AND MAINTENANCE	1556	01-Dec-2018	01-Dec-2018	
80-5-0000000-0604	CONTRACT COSTS - AWWTP				51,945.93
INV000108834	JOHN BROOKS COMPANY LIMITED & WFS	1555	06-Dec-2018	06-Dec-2018	
80-5-0000000-0612	GENERAL MAINTENANCE - AWWTP				450.44
INV000108867	VOLLMER INC	1555	06-Dec-2018	06-Dec-2018	
80-5-0000000-0612	GENERAL MAINTENANCE - AWWTP				1,222.69
INV000108882	REPAIRS AND MAINTENANCE	1555	07-Dec-2018	07-Dec-2018	
80-5-0000000-0612	GENERAL MAINTENANCE - AWWTP				1,064.18
INV000109923	FILTER AID PUMP	1597	30-Dec-2018	30-Dec-2018	
80-5-0000000-0612	GENERAL MAINTENANCE - AWWTP				903.46
INV000109924	LAB ANALYSIS	1597	30-Dec-2018	30-Dec-2018	
80-5-0000000-0612	GENERAL MAINTENANCE - AWWTP				418.56

Council/Board Report By Dept-(Computer)



Vendor : CAT038 To ZUL180

Batch : All

Department : All

Cheque Print Date : 01-Jan-2019 To 31-May-2019

Bank : 1 To 99

Class : All

Vendor Invoice	Vendor Name Description	Batch	Inv Date	Inv Due Date	Amount
G.L. Account	CC1 CC2 CC3 GL Account Name				
<b>DEPARTMENT 0000000 GENERAL</b>					
INV000110028	LABOUR & BENEFITS	1597	11-Dec-2018	11-Dec-2018	
80-5-0000000-0612	GENERAL MAINTENANCE - AWWTP				361.00
INV000110052	OPERATIONS AND MAINTENANCE	108	02-Jan-2019	02-Jan-2019	
80-5-0000000-0604	CONTRACT COSTS - AWWTP				52,241.42
INV000110552	CHEMICAL AND DIESEL RECONSILIATION	387	24-Jan-2019	24-Jan-2019	
80-5-0000000-0612	GENERAL MAINTENANCE - AWWTP				-307.01
INV000110639	OPERATIONS AND MAINTENANCE	179	01-Feb-2019	01-Feb-2019	
80-5-0000000-0604	CONTRACT COSTS - AWWTP				52,241.42
INV000111061	MAINTENANCE ITEMS	283	25-Feb-2019	25-Feb-2019	
80-5-0000000-0612	GENERAL MAINTENANCE - AWWTP				2,818.74
INV000111062	MAINTENANCE ITEM	283	25-Feb-2019	25-Feb-2019	
80-5-0000000-0612	GENERAL MAINTENANCE - AWWTP				96.67
INV000111179	OPERATIONS AND MAINTENANCE	285	01-Mar-2019	01-Mar-2019	
80-5-0000000-0604	CONTRACT COSTS - AWWTP				52,241.42
INV000111553	ADDITIONAL CHARGES	386	18-Jan-2019	18-Jan-2019	
80-5-0000000-0612	GENERAL MAINTENANCE - AWWTP				1,964.98
INV000111554	ADDITIONAL SERVICES	386	18-Mar-2019	18-Mar-2019	
80-5-0000000-0612	GENERAL MAINTENANCE - AWWTP				1,931.96
INV000111802	OPERATIONS AND MAINTENANCE	437	01-Apr-2019	01-Apr-2019	
80-5-0000000-0604	CONTRACT COSTS - AWWTP				52,241.42
INV000112382	ADDITIONAL SERVICES	439	10-Apr-2019	10-Apr-2019	
80-5-0000000-0612	GENERAL MAINTENANCE - AWWTP				533.54
INV000112383	ADDITIONAL SERVICES	439	10-Apr-2019	10-Apr-2019	
80-5-0000000-0612	GENERAL MAINTENANCE - AWWTP				141.19
INV000112384	ADDITIONAL SERVICES	439	10-Apr-2019	10-Apr-2019	
80-5-0000000-0612	GENERAL MAINTENANCE - AWWTP				1,726.79
INV000112581	OPERATIONS AND MAINTENANCE	527	01-May-2019	01-May-2019	
80-5-0000000-0604	CONTRACT COSTS - AWWTP				52,241.42
INV00011561	ADDITIONAL SERVICES	386	18-Jan-2019	18-Jan-2019	
80-5-0000000-0612	GENERAL MAINTENANCE - AWWTP				363.98
<b>ONT104 ONTARIO ONE CALL LTD</b>					
201996938	SERVICE LOCATES	283	31-Jan-2019	31-Jan-2019	
80-5-0000000-0755	WATER SERVICE MAINTENANCE				313.28
201998774	PHONE CALLS	439	31-Mar-2019	31-Mar-2019	
80-5-0000000-0755	WATER SERVICE MAINTENANCE				310.17
CN4404	CREIDT	283	14-Jan-2019	14-Jan-2019	
80-5-0000000-0810	WATER - MAIN MAINTENANCE				-500.00
<b>ONT5264 1583921 ONTARIO INC</b>					
DECEMBER 31	BELLEVUE MORTGAGE PAYMENT	1523	31-Dec-2018	31-Dec-2018	
10-2-0000000-1341	MONTHLY PRINCIPAL DEBT PAYMENT - GENERAL				200,000.00
<b>PAC03 PACITTI CONTRACTING</b>					
219348	RETURN OF INDEMNITY DEPOSIT FOR 355 FOREST HILL COURT, 2017-048	280	08-Mar-2019	08-Mar-2019	
10-2-0000000-2140	INDEMNITY FEES				1,000.00
<b>PAR372 PARRLINE ELECTRICAL WHOLESALE</b>					
80125	MATERIALS	208	22-Jan-2019	22-Jan-2019	
80-5-0000000-0755	WATER SERVICE MAINTENANCE				81.53
81966	ELECTRICAL SUPPLIES	526	16-Apr-2019	16-Apr-2019	
80-5-0000000-0833	WATER METER REPAIRS & MTNCE				735.78
<b>PIT565 PITTAO'S AUTO CARE INC</b>					
054995	REPAIR UNIT WM-08	283	28-Feb-2019	28-Feb-2019	
80-5-0000000-0402	VEHICLE & EQUIPMENT MTCE				257.98
055055	MAINTENANCE WM-1	386	15-Mar-2019	15-Mar-2019	
80-5-0000000-0402	VEHICLE & EQUIPMENT MTCE.				2,192.90





Vendor : CAT038 To ZUL180

Batch : All

Department : All

Cheque Print Date : 01-Jan-2019 To 31-May-2019

Bank : 1 To 99

Class : All

Vendor Invoice	Vendor Name Description				Batch Invc Date	Invc Due Date	Amount
G.L. Account	CC1	CC2	CC3	GL Account Name			
<b>DEPARTMENT 0000000</b>		GENERAL					
055074		MAINTENANCE WM-07			386 19-Mar-2019	19-Mar-2019	
80-5-0000000-0402				VEHICLE & EQUIPMENT MTCE.			2,725.61
54924		MAINTENANCE TO SM-01 - SEWER TRUCK			208 08-Feb-2019	08-Feb-2019	
80-5-0000000-0402				VEHICLE & EQUIPMENT MTCE.			538.96
54953		SERVICE ON WM-08			208 15-Feb-2019	15-Feb-2019	
80-5-0000000-0402				VEHICLE & EQUIPMENT MTCE.			357.83
<b>POU01</b>	<b>POUGET DIANE</b>						
MAY 24, 2019		REFUND FOR 2018 AMHERSTBURG VOTE			525 24-May-2019	24-May-2019	
10-2-0000000-2260				DEPOSITS - ELECTIONS			100.00
<b>PRE148</b>	<b>PREVIEW INSPECTIONS AND CONSULTING</b>						
0219		BPP			283 07-Mar-2019	07-Mar-2019	
80-5-0000000-0815				BACKFLOW - PREVENTION			2,147.00
0319		ADMINSTRATION OF CROSS CONNECTION CONTROL PROGRAM FOR MARCH 2019			439 02-Apr-2019	02-Apr-2019	
80-5-0000000-0815				BACKFLOW - PREVENTION			2,147.00
1118		CROSS CONNECTION PROGRAM			1597 11-Dec-2018	11-Dec-2018	
80-5-0000000-0815				BACKFLOW - PREVENTION			2,147.00
119		BACKFLOW PP			208 07-Feb-2019	07-Feb-2019	
80-5-0000000-0815				BACKFLOW - PREVENTION			2,147.00
1218		CROSS-CONNECTION CONTROL PROGRAM			36 04-Jan-2019	04-Jan-2019	
80-5-0000000-0815				BACKFLOW - PREVENTION			2,147.00
<b>PRU01</b>	<b>PRUE MICHAEL</b>						
MAY 24, 2019		REFUND FOR 2018 AMHERSTBURG VOTE			525 24-May-2019	24-May-2019	
10-2-0000000-2260				DEPOSITS - ELECTIONS			100.00
<b>PUR700</b>	<b>PURULATOR INC.</b>						
440907751		COURIER			345 22-Mar-2019	22-Mar-2019	
10-1-0000000-2066				A/R - CLEARING			16.29
441108564		COURIER			526 12-Apr-2019	12-Apr-2019	
80-5-0000000-0850				HYDRANT MAINTENANCE			7.91
441164438		COURIER			526 19-Apr-2019	19-Apr-2019	
80-5-0000000-0402				VEHICLE & EQUIPMENT MTCE.			23.17
441234392		COURIER			526 26-Apr-2019	26-Apr-2019	
80-5-0000000-0402				VEHICLE & EQUIPMENT MTCE.			5.02
441304366		COURIER			526 03-May-2019	03-May-2019	
80-5-0000000-0850				HYDRANT MAINTENANCE			77.55
<b>RCH120</b>	<b>R. CHITTLE WOOD PRODUCTS &amp; SERVICES</b>						
933		WOOD WEDGES			526 10-May-2019	10-May-2019	
80-5-0000000-0755				WATER SERVICE MAINTENANCE			276.85
<b>REN45</b>	<b>RENAUD MARC</b>						
MAY 24, 2019		REFUND FOR 2018 AMHERSTBURG VOTE			525 24-May-2019	24-May-2019	
10-2-0000000-2260				DEPOSITS - ELECTIONS			100.00
<b>RIV440</b>	<b>RIVAS KRISTY</b>						
2223309		RETURN OF INDEMNITY DEPOSIT FOR 4400 CONCESSION 4 S, 2018-279			34 17-Jan-2019	17-Jan-2019	
10-2-0000000-2140				INDEMNITY FEES			500.00
<b>ROZ01</b>	<b>ROZANKOVIC ROBERT</b>						
MAY 24, 2019		REFUND FOR 2018 AMHERSTBURG VOTE			525 24-May-2019	24-May-2019	
10-2-0000000-2260				DEPOSITS - ELECTIONS			100.00
<b>RTT067</b>	<b>RIVER TOWN TIMES</b>						
1548		ADVERTISING			345 27-Mar-2019	27-Mar-2019	
80-5-0000000-0307				ADVERTISING			87.26
1688		ADVERTISING			347 03-Apr-2019	03-Apr-2019	
80-5-0000000-0307				ADVERTISING			141.02
<b>RUD01</b>	<b>RUDAK EXCAVATING INC.</b>						





Vendor : CAT038 To ZUL180  
 Batch : All  
 Department : All

Cheque Print Date : 01-Jan-2019 To 31-May-2019  
 Bank : 1 To 99  
 Class : All

Vendor Invoice	Vendor Name Description				Batch Invc Date	Invc Due Date	Amount
G.L. Account	CC1	CC2	CC3	GL Account Name			
<b>DEPARTMENT 0000000</b>	<b>GENERAL</b>						
000119817				RETURN OF CONTRACTOR SEWER DEPOSIT	135 11-Feb-2019	11-Feb-2019	
10-2-0000000-2145				DEPOSIT - SEWER CONTRACTO			2,000.00
<b>RUS02</b>	<b>RUSSCO TRAINING SERVICES</b>						
4233				TRAINING CONFINED SPACES	436 27-Mar-2019	27-Mar-2019	
80-5-0000000-0249				TRAINING			1,695.00
<b>S&amp;CC237</b>	<b>S&amp;C CONSTRUCTION CONSULTANTS &amp; RENTALS</b>						
2384				DIRECTIONAL DRILL	1555 10-Dec-2018	10-Dec-2018	
80-5-0000000-0755				WATER SERVICE MAINTENANCE			1,469.00
<b>SEC01</b>	<b>SECURITY ONE ALARM SYSTEM</b>						
758674				RADIOS	36 02-Jan-2019	02-Jan-2019	
80-5-0000000-0404				VEHICLE & RADIO LICENCES			497.52
<b>SHE05</b>	<b>SHEA BROS. DRAINAGE</b>						
000132721				PW-SW-09-020 RETURN OF SEWER CONTRACTOR DEPOSITS	135 11-Feb-2019	11-Feb-2019	
10-2-0000000-2145				DEPOSIT - SEWER CONTRACTO			2,000.00
<b>SIL02</b>	<b>SILVER SPRINGS CONSTRUCTION</b>						
215629				RETURN OF INDEMNITY DEPOSIT FOR 6862 COUNTY ROAD 50, 2017-325	34 14-Jan-2019	14-Jan-2019	
10-2-0000000-2140				INDEMNITY FEES			1,000.00
2220455				RETURN OF INDEMNITY DEPOSIT FOR 30 LAIRD AVENUE N, 2018-102	34 14-Jan-2019	14-Jan-2019	
10-2-0000000-2140				INDEMNITY FEES			1,000.00
<b>SIM13</b>	<b>SIMONE PATRICIA</b>						
MAY 24, 2019				REFUND FOR 2018 AMHERSTBURG VOTE	525 24-May-2019	24-May-2019	
10-2-0000000-2260				DEPOSITS - ELECTIONS			100.00
<b>SIN527</b>	<b>SINASAC TIM</b>						
2224922				RETURN OF INDEMNITY DEPOSIT FOR 5275 CONC 5 N, 2018-361	280 07-Mar-2019	07-Mar-2019	
10-2-0000000-2140				INDEMNITY FEES			500.00
<b>SMI818</b>	<b>SMITH BEVERLIE</b>						
MAY 13, 2019				REFUND OF DOUBLE PAYMENT OF APRIL 2019 INSTALLMENT ON PROPERTY TAXE:	511 13-May-2019	13-May-2019	
10-1-0000000-2138				A/R PROP TAX REFUND OWING			1,792.00
<b>SPE045</b>	<b>SPEEDPRINT</b>						
40260				WATER WORK ORDER BOOKS	526 26-Apr-2019	26-Apr-2019	
80-5-0000000-0835				SAMPLE STATION - REPAIRS, UPGRADES ETC.			290.96
<b>STP110</b>	<b>ST PIERRE JESS</b>						
194666				RETURN OF INDEMNITY DEPOSIT FOR 1109 FRONT ROAD N, 2016-007	347 01-Apr-2019	01-Apr-2019	
10-2-0000000-2140				INDEMNITY FEES			1,000.00
<b>SUN293</b>	<b>SUNSET ENTERPRIZE &amp; WELDING</b>						
318204				SUPPLIES	386 11-Mar-2019	11-Mar-2019	
80-5-0000000-0402				VEHICLE & EQUIPMENT MTCE.			644.34
<b>SUT01</b>	<b>SUTHERLAND RON</b>						
MAY 24, 2019				REFUND FOR 2018 AMHERSTBURG VOTE	525 24-May-2019	24-May-2019	
10-2-0000000-2260				DEPOSITS - ELECTIONS			100.00
<b>SWI401</b>	<b>SWINTON GLENN</b>						
MAY 24, 2019				REFUND FOR 2018 AMHERSTBURG VOTE	525 24-May-2019	24-May-2019	
10-2-0000000-2260				DEPOSITS - ELECTIONS			200.00
<b>TAN070</b>	<b>TANNOUS HANNA</b>						
2009-163, 1241				RETURN OF SANITARY STORM AND SEWER DEPOSIT	135 11-Feb-2019	11-Feb-2019	
10-2-0000000-2134				DEPOSITS - SANITARY & STORM SEWER TAP			3,000.00
<b>THO033</b>	<b>THOMPSON RON</b>						
2019-020				CANCEL PERMIT - AMOUNT REFUNDED	345 26-Mar-2019	26-Mar-2019	
10-2-0000000-2140				INDEMNITY FEES			998.75
<b>THR251</b>	<b>THRASHER SALES &amp; LEASING LTD</b>						
228245				BLOCK HEATER REPLACEMENT WM-08	1555 10-Dec-2018	10-Dec-2018	
80-5-0000000-0402				VEHICLE & EQUIPMENT MTCE.			499.12

Council/Board Report By Dept-(Computer)



Vendor : CAT038 To ZUL180

Batch : All

Department : All

Cheque Print Date : 01-Jan-2019 To 31-May-2019

Bank : 1 To 99

Class : All

Vendor Invoice	Vendor Name Description	Batch	Inv Date	Inv Due Date	Amount
G.L. Account	CC1 CC2 CC3 GL Account Name				
<b>DEPARTMENT 0000000</b>	GENERAL				
228356	OIL CHANGE - VM-07	1555	13-Dec-2018	13-Dec-2018	
80-5-0000000-0402	VEHICLE & EQUIPMENT MTCE.				93.10
228885	REPLACE HEADLIGHT WM 08	68	18-Jan-2019	18-Jan-2019	
80-5-0000000-0402	VEHICLE & EQUIPMENT MTCE.				138.93
228894	WM-05 REPAIR	68	18-Jan-2019	18-Jan-2019	
80-5-0000000-0402	VEHICLE & EQUIPMENT MTCE.				123.86
<b>TOM015</b>	<b>TOMLIN JENNIFER</b>				
2019-048	RETURN OF INDEMNITY DEPOSIT FROM ROW PERMIT	481	07-May-2019	07-May-2019	
10-2-0000000-2135	INDEMNITY FEE - RIGHT OF WAY				1,000.00
<b>TRI132</b>	<b>TRICKEY ET AL TAX TEAM INC.</b>				
12416	PREPARE FINAL NOTICES	1523	17-Dec-2018	17-Dec-2018	
10-1-0000000-1503	TAX REG. - REGISTRATION C				395.50
12462	PREPARE FINAL NOTICES	62	17-Jan-2019	17-Jan-2019	
10-1-0000000-1503	TAX REG. - REGISTRATION C				565.00
12463	PREPARE FINAL NOTICES	62	17-Jan-2019	17-Jan-2019	
10-1-0000000-1503	TAX REG. - REGISTRATION C				423.75
12464	PREPARE FINAL NOTICES	62	17-Jan-2019	17-Jan-2019	
10-1-0000000-1503	TAX REG. - REGISTRATION C				593.25
12465	PREPARE FINAL NOTICES	62	17-Jan-2019	17-Jan-2019	
10-1-0000000-1503	TAX REG. - REGISTRATION C				621.50
12473	NOTICES SIGNED AND MAILED TO TAX TEAM	105	18-Jan-2019	18-Jan-2019	
10-1-0000000-1503	TAX REG. - REGISTRATION C				316.40
12474	NOTICES SIGNED AND MAILED TO TAX TEAM	105	18-Jan-2019	18-Jan-2019	
10-1-0000000-1503	TAX REG. - REGISTRATION C				316.40
12475	NOTICES SIGNED AND MAILED TO TAX TEAM	105	18-Jan-2019	18-Jan-2019	
10-1-0000000-1503	TAX REG. - REGISTRATION C				316.40
12476	NOTICES SIGNED AND MAILED TO TAX TEAM	105	18-Jan-2019	18-Jan-2019	
10-1-0000000-1503	TAX REG. - REGISTRATION C				316.40
12478	NOTICES SIGNED AND MAILED TO TAX TEAM	105	18-Jan-2019	18-Jan-2019	
10-1-0000000-1503	TAX REG. - REGISTRATION C				316.40
12479	NOTICES SIGNED AND MAILED TO TAX TEAM	106	18-Jan-2019	18-Jan-2019	
10-1-0000000-1503	TAX REG. - REGISTRATION C				316.40
12480	NOTICES SIGNED AND MAILED TO TAX TEAM	106	18-Jan-2019	18-Jan-2019	
10-1-0000000-1503	TAX REG. - REGISTRATION C				406.80
12481	NOTICES SIGNED AND MAILED TO TAX TEAM	106	18-Jan-2019	18-Jan-2019	
10-1-0000000-1503	TAX REG. - REGISTRATION C				316.40
12483	NOTICES SIGNED AND MAILED TO TAX TEAM	105	18-Jan-2019	18-Jan-2019	
10-1-0000000-1503	TAX REG. - REGISTRATION C				316.40
12484	NOTICES SIGNED AND MAILED TO TAX TEAM	105	18-Jan-2019	18-Jan-2019	
10-1-0000000-1503	TAX REG. - REGISTRATION C				406.80
12485	NOTICES SIGNED AND MAILED TO TAX TEAM	105	18-Jan-2019	18-Jan-2019	
10-1-0000000-1503	TAX REG. - REGISTRATION C				406.80
12486	NOTICES SIGNED AND MAILED TO TAX TEAM	105	18-Jan-2019	18-Jan-2019	
10-1-0000000-1503	TAX REG. - REGISTRATION C				316.40
12517	TITLE SEARCH	106	29-Jan-2019	29-Jan-2019	
10-1-0000000-1503	TAX REG. - REGISTRATION C				508.50
12518	TITLE SEARCH	106	29-Jan-2019	29-Jan-2019	
10-1-0000000-1503	TAX REG. - REGISTRATION C				508.50
12582	REGISTER TAX ARREARS CERTIFICATE	204	12-Feb-2019	12-Feb-2019	
10-1-0000000-1503	TAX REG. - REGISTRATION C				621.50
12583	REGISTER TAX ARREARS CERTIFICATE	204	12-Feb-2019	12-Feb-2019	
10-1-0000000-1503	TAX REG. - REGISTRATION C				593.25
12809	TAX TEAM INVOICE ADDED TO ROLL	250	28-Feb-2019	28-Feb-2019	



Vendor : CAT038 To ZUL180

Batch : All

Department : All

Cheque Print Date : 01-Jan-2019 To 31-May-2019

Bank : 1 To 99

Class : All

Vendor Invoice	Vendor Name Description	Batch	Inv Date	Inv Due Date	Amount
G.L. Account	CC1 CC2 CC3 GL Account Name				
<b>DEPARTMENT 0000000 GENERAL</b>					
10-1-0000000-1503	TAX REG. - REGISTRATION C				56.50
12810	TAX TEAM ADDED TO ROLL	250	28-Feb-2019	28-Feb-2019	
10-1-0000000-1503	TAX REG. - REGISTRATION C				56.50
12811	TAX TEAM INVOICE ADDED TO ROLL	252	28-Feb-2019	28-Feb-2019	
10-1-0000000-1503	TAX REG. - REGISTRATION C				56.50
12812	TAX TEAM INVOICE ADDED TO ROLL	252	01-Mar-2019	01-Mar-2019	
10-1-0000000-1503	TAX REG. - REGISTRATION C				56.50
12932	TAX TEAM INVOICE ADDED TO ROLL	296	21-Mar-2019	21-Mar-2019	
10-1-0000000-1503	TAX REG. - REGISTRATION C				508.50
12933	TAX TEAM INVOICE ADDED TO ROLL	296	21-Mar-2019	21-Mar-2019	
10-1-0000000-1503	TAX REG. - REGISTRATION C				508.50
12934	TAX TEAM INVOICE ADDED TO ROLL	296	21-Mar-2019	21-Mar-2019	
10-1-0000000-1503	TAX REG. - REGISTRATION C				508.50
12935	TAX TEAM INVOICE ADDED TO ROLL	296	21-Mar-2019	21-Mar-2019	
10-1-0000000-1503	TAX REG. - REGISTRATION C				508.50
12936	TAX TEAM INVOICE ADDED TO ROLL	296	21-Mar-2019	21-Mar-2019	
10-1-0000000-1503	TAX REG. - REGISTRATION C				508.50
12937	TAX TEAM INVOICE ADDED TO ROLL	296	21-Mar-2019	21-Mar-2019	
10-1-0000000-1503	TAX REG. - REGISTRATION C				508.50
12938	TAX TEAM INVOICE ADDED TO ROLL	319	21-Mar-2019	21-Mar-2019	
10-1-0000000-1503	TAX REG. - REGISTRATION C				316.40
12966	TAX TEAM INVOICE ADDED TO ROLL	406	26-Mar-2019	26-Mar-2019	
10-1-0000000-1503	TAX REG. - REGISTRATION C				593.25
12967	TAX TEAM INVOICE ADDED TO ROLL	406	26-Mar-2019	26-Mar-2019	
10-1-0000000-1503	TAX REG. - REGISTRATION C				593.25
12968	TAX TEAM INVOICE ADDED TO ROLL	406	26-Mar-2019	26-Mar-2019	
10-1-0000000-1503	TAX REG. - REGISTRATION C				593.25
12969	TAX TEAM INVOICE ADDED TO ROLL	406	26-Mar-2019	26-Mar-2019	
10-1-0000000-1503	TAX REG. - REGISTRATION C				593.25
12970	TAX TEAM INVOICE ADDED TO ROLL	406	26-Mar-2019	26-Mar-2019	
10-1-0000000-1503	TAX REG. - REGISTRATION C				593.25
12971	TAX TEAM INVOICE ADDED TO ROLL	406	26-Mar-2019	26-Mar-2019	
10-1-0000000-1503	TAX REG. - REGISTRATION C				649.75
12980	MAIL FIRST NOTICES	347	29-Mar-2019	29-Mar-2019	
10-1-0000000-1503	TAX REG. - REGISTRATION C				480.25
13101	MAIL FIRST NOTICES	481	23-Apr-2019	23-Apr-2019	
10-1-0000000-1503	TAX REG. - REGISTRATION C				310.75
<b>UNI300 UNITED WAY OF WINDSOR-ESSEX COUNTY</b>					
JANUARY-MAF 1ST QUARTER DEDUCTION FOR 2019		347	31-Mar-2019	31-Mar-2019	
10-2-0000000-1147	A/P - PAYROLL DED. - UNIT				1,340.00
OCTOBER-DEI 4TH QUARTER 2018		1523	27-Dec-2018	27-Dec-2018	
10-2-0000000-1147	A/P - PAYROLL DED. - UNIT				1,241.00
<b>VAI107 VAILLANCOURT PATRICIA</b>					
2224913	RETURN OF INEMNITY DEPOSIT FOR 2360 FRONT ROAD NORTH, 2018-352	296	07-Mar-2019	07-Mar-2019	
10-2-0000000-2140	INDEMNITY FEES				500.00
<b>WAL100 WALKER AGGREGATES INC. C/O PROPERTY</b>					
282957	MAINTENANCE	320	09-Mar-2019	09-Mar-2019	
80-5-0000000-0755	WATER SERVICE MAINTENANCE				199.51
<b>WAL101 WALKER AGGREGATES</b>					
283543	MAINTENANCE	485	06-Apr-2019	06-Apr-2019	
80-5-0000000-0755	WATER SERVICE MAINTENANCE				1,199.50
<b>WIG012 WIGHTMAN LORI</b>					
MAY 24, 2019	REFUND FOR 2018 AMHERSTBURG VOTE	525	24-May-2019	24-May-2019	



Vendor : CAT038 To ZUL180

Batch : All

Department : All

Cheque Print Date : 01-Jan-2019 To 31-May-2019

Bank : 1 To 99

Class : All

Vendor Invoice	Vendor Name Description	Batch	Inv Date	Inv Due Date	Amount
G.L. Account	CC1 CC2 CC3 GL Account Name				
<b>DEPARTMENT 0000000</b>	GENERAL				
10-2-0000000-2260	DEPOSITS - ELECTIONS				100.00
<b>WIG035</b>	<b>WIGLE HOME HARDWARE BUILDING CENTRE</b>				
123902	HYDRANT BOX	1555	25-Oct-2018	25-Oct-2018	
80-5-0000000-0850	HYDRANT MAINTENANCE				13.55
125338	HYDRANT BOXES	1555	04-Dec-2018	04-Dec-2018	
80-5-0000000-0850	HYDRANT MAINTENANCE				431.86
125386	HYDRANT BOX	1555	05-Dec-2018	05-Dec-2018	
80-5-0000000-0850	HYDRANT MAINTENANCE				73.82
125416	HYDRANT BOX	1555	06-Dec-2018	06-Dec-2018	
80-5-0000000-0850	HYDRANT MAINTENANCE				44.23
125431	HYDRANT BOX	1555	07-Dec-2018	07-Dec-2018	
80-5-0000000-0850	HYDRANT MAINTENANCE				66.62
125451	HYDRANT BOX	1555	07-Dec-2018	07-Dec-2018	
80-5-0000000-0850	HYDRANT MAINTENANCE				5.07
126289	MAINTENANCE	68	11-Jan-2019	11-Jan-2019	
80-5-0000000-0833	WATER METER REPAIRS & MTNCE				5.62
126665	MAIN YARD WASH HOSE REPAIR	105	24-Jan-2019	24-Jan-2019	
80-5-0000000-0833	WATER METER REPAIRS & MTNCE				67.78
126690	SAMPLE STATION PARTS	178	24-Jan-2019	24-Jan-2019	
80-5-0000000-0835	SAMPLE STATION - REPAIRS, UPGRADES ETC.				142.56
128368	SUPPLIES	386	21-Mar-2019	21-Mar-2019	
80-5-0000000-0755	WATER SERVICE MAINTENANCE				101.59
128568	SUPPLIES	386	28-Mar-2019	28-Mar-2019	
80-5-0000000-0850	HYDRANT MAINTENANCE				23.72
128718	MAINTENANCE SUPPLIES	439	02-Apr-2019	02-Apr-2019	
80-5-0000000-0402	VEHICLE & EQUIPMENT MTCE.				22.88
129666	SUPPLIES	526	29-Apr-2019	29-Apr-2019	
80-5-0000000-0810	WATER - MAIN MAINTENANCE				41.79
<b>WIN270</b>	<b>WINDSOR DISPOSAL SERVICES LTD</b>				
0000927896	MONTHLY GARBAGE COLLECTION - JANUARY	15	02-Jan-2019	02-Jan-2019	
10-1-0000000-2031	A/R - FLOW THROUGH INVOICES				378.02
0000932083	BASIC COLLECTION - AS PER MONTHLY BREAKDOWN (FEBRUARY 1, 2019)	406	01-Feb-2019	01-Feb-2019	
10-1-0000000-2031	A/R - FLOW THROUGH INVOICES				378.02
0000940656	MONTHLY BASIC COLLECTION	347	01-Apr-2019	01-Apr-2019	
10-1-0000000-2031	A/R - FLOW THROUGH INVOICES				378.02
0000944736	MONTHLY BASIC COLLECTION	511	01-May-2019	01-May-2019	
10-1-0000000-2031	A/R - FLOW THROUGH INVOICES				378.02
<b>WOL533</b>	<b>WOLSELEY CANADA INC</b>				
39518	CREDIT WRONG PRICING	1555	23-Nov-2018	23-Nov-2018	
80-5-0000000-0810	WATER - MAIN MAINTENANCE				-105.37
39519	CREDIT WRONG PRICING	1555	23-Nov-2018	23-Nov-2018	
80-5-0000000-0755	WATER SERVICE MAINTENANCE				-1,159.10
39519 A	SUPPLIES	1555	18-Nov-2018	18-Nov-2018	
80-5-0000000-0833	WATER METER REPAIRS & MTNCE				1,159.10
41339	CREDIT WRONG PRICING	1555	30-Nov-2018	30-Nov-2018	
80-5-0000000-0850	HYDRANT MAINTENANCE				-1,356.00
41339 A	SUPPLIES	1555	18-Nov-2018	18-Nov-2018	
80-5-0000000-0850	HYDRANT MAINTENANCE				1,356.00
7432643	WALKER AND PIKE	1555	15-Nov-2018	15-Nov-2018	
80-5-0000000-0810	WATER - MAIN MAINTENANCE				1,247.96
7613127	METER COUPLINGS AND METER TAILS	68	04-Jan-2019	04-Jan-2019	
80-5-0000000-0833	WATER METER REPAIRS & MTNCE				1,020.39
7613128	MAINTENANCE	68	19-Jan-2019	19-Jan-2019	



Vendor : CAT038 To ZUL180

Batch : All

Department : All

Cheque Print Date : 01-Jan-2019 To 31-May-2019

Bank : 1 To 99

Class : All

Vendor Invoice	Vendor Name Description	Batch	Inv Date	Inv Due Date	Amount
G.L. Account	CC1 CC2 CC3 GL Account Name				
<b>DEPARTMENT 0000000 GENERAL</b>					
80-5-0000000-0755	WATER SERVICE MAINTENANCE				134.78
7662032	CONTROL VAL FOR HYDRANT BOX	178	19-Jan-2019	19-Jan-2019	
80-5-0000000-0850	HYDRANT MAINTENANCE				927.26
7683595	SERVICE LINE FOR 1800 COUNTY ROAD 8	178	19-Jan-2019	19-Jan-2019	
80-5-0000000-0755	WATER SERVICE MAINTENANCE				1,197.80
7743023	METER SETTERS	253	19-Feb-2019	19-Feb-2019	
80-5-0000000-0833	WATER METER REPAIRS & MTNCE				2,417.41
7743024	SAMPLE STATION REBUILD KITS	253	19-Feb-2019	19-Feb-2019	
80-5-0000000-0835	SAMPLE STATION - REPAIRS, UPGRADES ETC.				96.28
7763245	HYDRANT	253	19-Feb-2019	19-Feb-2019	
80-5-0000000-0810	WATER - MAIN MAINTENANCE				6,351.96
7772988	BEVELING TOOL	253	19-Feb-2019	19-Feb-2019	
80-5-0000000-0810	WATER - MAIN MAINTENANCE				1,124.35
7772989	METER PIT COVERS	283	19-Feb-2019	19-Feb-2019	
80-5-0000000-0755	WATER SERVICE MAINTENANCE				1,640.76
7798997	MAINTENANCE	283	19-Feb-2019	19-Feb-2019	
80-5-0000000-0810	WATER - MAIN MAINTENANCE				1,358.81
7898806	MAINTENANCE SUPPLIES	439	19-Mar-2019	19-Mar-2019	
80-5-0000000-0755	WATER SERVICE MAINTENANCE				2,679.93
7898807	MAINTENANCE SUPPLIES	439	19-Mar-2019	19-Mar-2019	
80-5-0000000-0810	WATER - MAIN MAINTENANCE				1,056.11
7898808	MAINTENANCE SUPPLIES	439	19-Mar-2019	19-Mar-2019	
80-5-0000000-0755	WATER SERVICE MAINTENANCE				609.93
7943096	MAINTENANCE SUPPLIES	439	19-Apr-2019	19-Apr-2019	
80-5-0000000-0755	WATER SERVICE MAINTENANCE				2,473.14
7943097	MAINTENANCE SUPPLIES	439	19-Apr-2019	19-Apr-2019	
80-5-0000000-0755	WATER SERVICE MAINTENANCE				530.96
7943098	MAINTENANCE SUPPLIES	439	19-Apr-2019	19-Apr-2019	
80-5-0000000-0755	WATER SERVICE MAINTENANCE				843.64
7972476	MAINTENANCE SUPPLIES	526	19-Apr-2019	19-Apr-2019	
80-5-0000000-0833	WATER METER REPAIRS & MTNCE				762.75
7982497	SUPPLIES	526	17-Apr-2019	17-Apr-2019	
80-5-0000000-0833	WATER METER REPAIRS & MTNCE				1,661.10
7982499	SUPPLIES	526	17-Apr-2019	17-Apr-2019	
80-5-0000000-0755	WATER SERVICE MAINTENANCE				997.48
7982500	SUPPLIES	526	17-Apr-2019	17-Apr-2019	
80-5-0000000-0810	WATER - MAIN MAINTENANCE				95.44
8016734	SUPPLIES	526	29-Apr-2019	29-Apr-2019	
80-5-0000000-0850	HYDRANT MAINTENANCE				4,498.80
JANUARY 29 C CREDIT		253	29-Jan-2019	29-Jan-2019	
80-5-0000000-0833	WATER METER REPAIRS & MTNCE				-3,839.34
<b>W00065 WOODLAND CONSULTING</b>					
0000206058	RETURN OF SANITARY & STORM DEPOSIT	135	11-Feb-2019	11-Feb-2019	
10-2-0000000-2134	DEPOSITS - SANITARY & STORM SEWER TAP				1,500.00
<b>WOR415 WORK AUTHORITY</b>					
511355	BOOTS	280	10-Feb-2019	10-Feb-2019	
80-5-0000000-0161	CLOTHING				2,107.38
512799	CLOTHING	250	17-Feb-2019	17-Feb-2019	
80-5-0000000-0161	CLOTHING				473.73
512800	CLOTHING CREDIT	250	17-Feb-2019	17-Feb-2019	
80-5-0000000-0161	CLOTHING				-467.80
521862	CLOTHING	389	31-Mar-2019	31-Mar-2019	
80-5-0000000-0161	CLOTHING				175.20



Vendor : CAT038 To ZUL180

Batch : All

Department : All

Cheque Print Date : 01-Jan-2019 To 31-May-2019

Bank : 1 To 99

Class : All

Vendor Invoice	Vendor Name Description				Batch Invc Date	Invc Due Date	Amount
G.L. Account	CC1	CC2	CC3	GL Account Name			
<b>DEPARTMENT 000000 GENERAL</b>							
<b>WRI037 WRIGHT JAMES</b>							
2223137				RETURN OF INDEMNITY DEPOSIT FOR 37 BALTIC, 2018-267	34	11-Jan-2019	11-Jan-2019
10-2-0000000-2140				INDEMNITY FEES			500.00
<b>WRI083 WRIGHT MIKE</b>							
2019-050				RETURN OF INDEMNITY DEPOSIT FROM ROW PERMIT	525	16-May-2019	16-May-2019
10-2-0000000-2135				INDEMNITY FEE - RIGHT OF WAY			1,000.00
<b>Department Totals :</b>							<b>1,787,114.11</b>
<hr/>							
<b>DEPARTMENT 1001010 COUNCIL</b>							
<b>AMH20 AMHERSTBURG TREASURY PETTY CASH</b>							
FEBRUARY 20				FEBRUARY 2019 PETTY CASH	204	26-Feb-2019	26-Feb-2019
10-5-1001010-0342				COUNCIL MEETINGS			30.50
<b>CIB048 CIBC SECURITIES</b>							
2018 RRSP				2018 RRSP CONTRIBUTION	250	11-Jan-2019	11-Jan-2019
10-5-1001010-0214				BENEFITS - RRSP CONTRIBUTION COUNCIL			98.50
<b>ESS110 ESSEX COUNTY STEAM &amp; GAS ENGINE MUSEUM INC</b>							
MARCH 22, 20				COUNCIL DONATIONS	319	22-Mar-2019	22-Mar-2019
10-5-1001010-0348				DONATIONS			115.00
<b>MON183 MONARCH OFFICE SUPPLY LTD</b>							
133006				JANUARY 2018 PURCHASES	176	30-Jan-2019	30-Jan-2019
10-5-1001010-0301				OFFICE SUPPLIES - COUNCIL			116.58
143523				MARCH 2019 PURCHASES	406	29-Mar-2019	29-Mar-2019
10-5-1001010-0301				OFFICE SUPPLIES - COUNCIL			77.72
<b>OMF470 OMFPOA PUBLICATIONS</b>							
19054NK				COUNCIL DONATIONS	250	22-Jan-2019	22-Jan-2019
10-5-1001010-0348				DONATIONS			435.05
<b>ROY805 THE ROYAL CANADIAN LEGION - PROJECT OFFICE</b>							
FEB 12, 2019				COUNCIL DONATIONS	204	12-Feb-2019	12-Feb-2019
10-5-1001010-0348				DONATIONS			730.00
<b>SOB083 SOBEYS AMHERSTBURG</b>							
FEB/MAR 2019				FEBRUARY MARCH 2019 PURCHASES	511	31-Mar-2019	31-Mar-2019
10-5-1001010-0342				COUNCIL MEETINGS			256.43
10-5-1001010-0342				COUNCIL MEETINGS			40.67
<b>TRI249 TRI GRAPHICS</b>							
5356				BUSINESS CARDS	345	27-Mar-2019	27-Mar-2019
10-5-1001010-0301				OFFICE SUPPLIES - COUNCIL			58.76
10-5-1001010-0301				OFFICE SUPPLIES - COUNCIL			58.76
10-5-1001010-0301				OFFICE SUPPLIES - COUNCIL			58.76
10-5-1001010-0301				OFFICE SUPPLIES - COUNCIL			58.76
10-5-1001010-0301				OFFICE SUPPLIES - COUNCIL			58.76
10-5-1001010-0301				OFFICE SUPPLIES - COUNCIL			58.76
10-5-1001010-0301				OFFICE SUPPLIES - COUNCIL			58.76
<b>Department Totals :</b>							<b>2,311.77</b>
<hr/>							
<b>DEPARTMENT 1001011 COUNCIL - MAYOR</b>							
<b>AMH268 AMHERSTBURG CHAMBER COMMERCE</b>							
33655				BUISNESS EXCELLENCE AWARDS DINNER TICKETS	436	28-Feb-2019	28-Feb-2019
10-5-1001011-0340				18MAYO MAYOR - PUBLIC RECEPTIONS, ETC.			120.00
<b>CIB001 CIBPA THE CANADIAN ITALIAN BUISNESS AND</b>							
2019 CIBPA GC				2019 CIBPA GOLF CLASSIC SEPTEMBER 5, 2019	525	22-May-2019	22-May-2019
10-5-1001011-0340				18MAYO MAYOR - PUBLIC RECEPTIONS, ETC.			150.00



Council/Board Report By Dept-(Computer)



Vendor : CAT038 To ZUL180

Batch : All

Department : All

Cheque Print Date : 01-Jan-2019 To 31-May-2019

Bank : 1 To 99

Class : All

Vendor Invoice	Vendor Name Description	Batch	Inv Date	Inv Due Date	Amount
G.L. Account	CC1 CC2 CC3 GL Account Name				
<b>DEPARTMENT 1001011 COUNCIL - MAYOR</b>					
<b>Department Totals :</b>					<b>270.00</b>
-----					
<b>DEPARTMENT 1001012 COUNCIL - DEPUTY MAYOR</b>					
<b>AMH268</b>	<b>AMHERSTBURG CHAMBER COMMERCE</b>				
3655	BUISNESS EXCELLENCE AWARDS DINNER TICKETS	436	28-Feb-2019	28-Feb-2019	
10-5-1001012-0340	18DEPU DEP MAYOR - PUBLIC RECEPTIONS, ETC.				120.00
<b>Department Totals :</b>					<b>120.00</b>
-----					
<b>DEPARTMENT 1001013 COUNCIL - COUNCILLOR 1</b>					
<b>AMH268</b>	<b>AMHERSTBURG CHAMBER COMMERCE</b>				
3655	BUISNESS EXCELLENCE AWARDS DINNER TICKETS	436	28-Feb-2019	28-Feb-2019	
10-5-1001013-0340	18COU1 COUNCILLOR 1 -PUBLIC RECEPTIONS, ETC.				60.00
<b>Department Totals :</b>					<b>60.00</b>
-----					
<b>DEPARTMENT 1001014 COUNCIL - COUNCILLOR 2</b>					
<b>AMH268</b>	<b>AMHERSTBURG CHAMBER COMMERCE</b>				
3655	BUISNESS EXCELLENCE AWARDS DINNER TICKETS	436	28-Feb-2019	28-Feb-2019	
10-5-1001014-0340	18COU2 COUNCILLOR 2 - PUBLIC RECEPTIONS, ETC.				60.00
<b>Department Totals :</b>					<b>60.00</b>
-----					
<b>DEPARTMENT 1001015 ELECTION</b>					
<b>AMH20</b>	<b>AMHERSTBURG TREASURY PETTY CASH</b>				
DECEMBER 2018	DECEMBER 2018 PETTY CASH	1554	31-Dec-2018	31-Dec-2018	
10-5-1001015-0312	INAUGU ELECTION EXPENSES				45.00
FEBRUARY 2019	FEBRUARY 2019 PETTY CASH	204	26-Feb-2019	26-Feb-2019	
10-5-1001015-0312	GENER/ ELECTION EXPENSES				150.00
<b>AMH60</b>	<b>AMHERSTBURG CLERKS PETTY CASH</b>				
JANUARY 2019	CLERKS PETTY CASH REPLENISHMENT	99	28-Jan-2019	28-Jan-2019	
10-5-1001015-0312	GENER/ ELECTION EXPENSES				42.25
<b>CAN380</b>	<b>CANADIAN TIRE STORE #281</b>				
OCTOBER 2018	OCTOBER 2018 INVOICES	1554	31-Oct-2018	31-Oct-2018	
10-5-1001015-0312	GENER/ ELECTION EXPENSES				45.19
10-5-1001015-0312	GENER/ ELECTION EXPENSES				203.32
<b>GIL120</b>	<b>GILMORE DOCULINK</b>				
53604	ELECTION EXPENSES	319	29-Mar-2019	29-Mar-2019	
10-5-1001015-0312	ELECTION EXPENSES				5,184.69
<b>SOB083</b>	<b>SOBEYS AMHERSTBURG</b>				
NOVEMBER 2018	NOVEMBER 2018 PURCHASES	1608	30-Nov-2018	30-Nov-2018	
10-5-1001015-0312	INAUGU ELECTION EXPENSES				176.76
10-5-1001015-0312	INAUGU ELECTION EXPENSES				211.05
<b>STE124</b>	<b>STEWART WALT</b>				
444942	INAUGURATION	62	18-Jan-2019	18-Jan-2019	
10-5-1001015-0312	INAUGU ELECTION EXPENSES				28.25
<b>TOW06</b>	<b>TOWN OF TECUMSEH</b>				
3553	ELECTION EXPENSES	250	21-Feb-2019	21-Feb-2019	
10-5-1001015-0312	GENER/ ELECTION EXPENSES				228.84
<b>Department Totals :</b>					<b>6,315.35</b>
-----					
<b>DEPARTMENT 1001017 COUNCIL - COUNCILLOR 4</b>					
<b>AMH268</b>	<b>AMHERSTBURG CHAMBER COMMERCE</b>				
3655	BUISNESS EXCELLENCE AWARDS DINNER TICKETS	436	28-Feb-2019	28-Feb-2019	





Vendor : CAT038 To ZUL180

Batch : All

Department : All

Cheque Print Date : 01-Jan-2019 To 31-May-2019

Bank : 1 To 99

Class : All

Vendor Invoice	Vendor Name Description				Batch Invc Date	Invc Due Date	Amount
G.L. Account	CC1	CC2	CC3	GL Account Name			
<b>DEPARTMENT 1001017</b>				COUNCIL - COUNCILLOR 4			
10-5-1001017-0340				18COU4 COUNCILLOR 4 - PUBLIC RECEPTIONS, ETC.			120.00
<b>Department Totals :</b>							<b>120.00</b>
<b>DEPARTMENT 1001020</b>				ADMINISTRATION			
<b>ACT456 ACTION SIGNS &amp; DESIGNS INC.</b>							
11227				SIGNAGE	177 31-Jan-2019	31-Jan-2019	
40-7-1001020-0012	320RIC			ST. BERNARD'S 320 RICHMOND			560.48
<b>ADV329 ADVANCE BUSINESS SYSTEMS</b>							
657777				POSTAGE MACHINE - SERVICE CALL	134 17-Jan-2019	17-Jan-2019	
10-5-1001020-0304				POSTAGE & COURIER			69.56
<b>AMC610 AMCTO</b>							
13675				JOB AD	105 25-Jan-2019	25-Jan-2019	
10-5-1001020-0307				ADVERTISING			587.60
13761				JOB AD	280 04-Mar-2019	04-Mar-2019	
10-5-1001020-0307				ADVERTISING			587.60
<b>AMH179 AMHERSTBURG COMMUNITY SERVICES</b>							
MARCH 26, 20 GRANT					319 26-Mar-2019	26-Mar-2019	
10-5-1001020-0353				GRANTS TO ORGANIZATIONS			7,000.00
<b>AMH214 AMHERSTBURG HISTORIC SITES ASSOCIATION</b>							
MARCH 26, 20 GRANT					319 26-Mar-2019	26-Mar-2019	
10-5-1001020-0353				GRANTS TO ORGANIZATIONS			8,500.00
<b>AMH277 AMHERSTBURG FREEDOM MUSEUM</b>							
MARCH 26, 21 GRANT					319 26-Mar-2019	26-Mar-2019	
10-5-1001020-0353				GRANTS TO ORGANIZATIONS			6,500.00
<b>AMH298 AMHERSTBURG FOOD &amp; FELLOWSHIP MISSION</b>							
MARCH 26, 20 GRANT					319 26-Mar-2019	26-Mar-2019	
10-5-1001020-0353				GRANTS TO ORGANIZATIONS			2,500.00
<b>BIO110 BIOLOGIG AQUATIC AND TERRESTRIAL ECOSYSTEM</b>							
190219				CONSULTING	296 28-Feb-2019	28-Feb-2019	
40-7-1001020-0006		CONSUL		DUFFY'S PROPERTY			3,683.80
<b>CHR317 CHRIST ANGLICAN CHURCH</b>							
MARCH 26, 20 GRANT					319 26-Mar-2019	26-Mar-2019	
10-5-1001020-0353				GRANTS TO ORGANIZATIONS			750.00
<b>COU360 COUNTY OF ESSEX</b>							
IN000013500	C.E.R.B. - 911 SERVICE JANUARY 1 - JUNE 30, 2018				345 16-Feb-2019	16-Feb-2019	
10-5-1001020-0337	911 SERVICE						6,023.57
IN000014650	C.E.R.B - 911 SERVICE JANUARY 1 - JUNE 30, 2019				345 06-Feb-2019	06-Feb-2019	
10-5-1001020-0337	911 SERVICE						6,023.57
<b>EMP481 EMPIRE ROOFING CORPORATION</b>							
29952	ROOF REPLACEMENT (DEC 28, 2018)				104 31-Jan-2019	31-Jan-2019	
40-7-1001020-0001	TOWN HALL RENOVATIONS						73,450.00
<b>ERA010 E.R.A. ARCHITECTS INC.</b>							
26710	BELLEVUE - PROFESSIONAL FEES				1595 13-Nov-2018	13-Nov-2018	
40-7-1001020-0005	BELLEVUE PROPERTY						714.73
<b>ESS53 ESSEX REGION CONSERVATION AUTHORITY</b>							
IN000014620	1ST QUARTER GENERAL LEVY INSTALLMENT				280 03-Jan-2019	03-Jan-2019	
10-5-1001020-0550	CONSERVATON AUTHORITY LEVY						32,353.00
IN000015070					436 01-Apr-2019	01-Apr-2019	
10-5-1001020-0550	CONSERVATON AUTHORITY LEVY						32,353.00
<b>GOL452 GOLDER ASSOCIATES LTD</b>							
1000459	WATERFRONT EA				204 13-Feb-2019	13-Feb-2019	
40-7-1001020-0006	GRELIG			DUFFY'S PROPERTY			4,911.10



Vendor : CAT038 To ZUL180

Batch : All

Department : All

Cheque Print Date : 01-Jan-2019 To 31-May-2019

Bank : 1 To 99

Class : All

Vendor Invoice	Vendor Name Description	Batch	Inv Date	Inv Due Date	Amount
G.L. Account	CC1 CC2 CC3 GL Account Name				
<b>DEPARTMENT 1001020</b>	ADMINISTRATION				
1008033	PROFESSIONAL SERVICES	319	19-Mar-2019	19-Mar-2019	
40-7-1001020-0006	CONSUL DUFFY'S PROPERTY				6,998.94
963249	CONSULTING FEES	1606	09-Dec-2018	09-Dec-2018	
40-7-1001020-0006	DUFFY'S PROPERTY				4,680.32
986333	PROFESSIONAL FEES - WATERFRONT	1554	12-Dec-2018	12-Dec-2018	
40-7-1001020-0006	DUFFY'S PROPERTY				8,082.64
996775	PROFESSIONAL SERVICES FOR DEC 31, 2018	133	31-Jan-2019	31-Jan-2019	
40-7-1001020-0006	GENER/ DUFFY'S PROPERTY				1,357.13
<b>LAN228 LANDMARK ENGINEERS</b>					
17-025-03	WATERFRONT	389	11-Mar-2019	11-Mar-2019	
40-7-1001020-0006	CONSUL DUFFY'S PROPERTY				52,390.90
<b>MAS170 MASTER MAILERS</b>					
23443	2019 INTERIM TAX NOTICES	99	21-Jan-2019	21-Jan-2019	
10-5-1001020-0304	POSTAGE & COURIER				7,499.65
<b>MGS306 M.G.S. REAL ESTATE CONSULTING INC</b>					
FEB 17, 2019	1632/1640 PARK	204	17-Feb-2019	17-Feb-2019	
40-7-1001020-0003	1632/4 CAPITAL - ADMINISTRATION				515.00
FEB 2019	7860 CTY RD 20	204	17-Feb-2019	17-Feb-2019	
40-7-1001020-0003	7860CT CAPITAL - ADMINISTRATION				1,740.00
<b>MIN25 MINISTER OF FINANCE PAYMENT PROCESSING CENTRE</b>					
3553511	INTEREST ON LATE PAYMENT	345	28-Feb-2019	28-Feb-2019	
10-5-1001020-0502	INTEREST EXPENSE				20.30
<b>MON183 MONARCH OFFICE SUPPLY LTD</b>					
125447	TABLE FOR MEETING ROOM	1607	13-Dec-2018	13-Dec-2018	
40-7-1001020-0001	TOWN HALL RENOVATIONS				260.10
<b>MOU001 MOUSSEAU DELUCA McPHERSON PRINCE</b>					
58558	LEGAL FEES - SALE 7860 CTY RD 20 PART 1	1557	30-Nov-2018	30-Nov-2018	
40-7-1001020-0003	CAPITAL - ADMINISTRATION				2,792.85
58696	LEGAL FEES	1606	31-Dec-2018	31-Dec-2018	
40-7-1001020-0003	CAPITAL - ADMINISTRATION				3,464.64
59125 B	LEGAL FEES	280	28-Feb-2019	28-Feb-2019	
40-7-1001020-0006	GENER/ DUFFY'S PROPERTY				1,231.70
<b>NEO150 NEOPOST LEASING SERVICES CANADA LTD</b>					
2430782	NEOPOST POSTAGE MACHINE LEASE	280	27-Feb-2019	27-Feb-2019	
10-5-1001020-0304	POSTAGE & COURIER				1,118.02
6203542	POSTAGE MACHINE LEASE (LEASE # C16101067)	135	01-Feb-2019	01-Feb-2019	
10-5-1001020-0304	POSTAGE & COURIER				663.25
6204558	POSTAGE METER LEASE	250	15-Feb-2019	15-Feb-2019	
10-5-1001020-0304	POSTAGE & COURIER				503.58
6209089	POSTAGE MACHINE LEASE	481	01-May-2019	01-May-2019	
10-5-1001020-0304	POSTAGE & COURIER				663.25
FEBRUARY 4, DPOC ACCOUNT 232920	POSTAGE REFILL	105	04-Feb-2019	04-Feb-2019	
10-5-1001020-0304	POSTAGE & COURIER				4,520.00
MARCH 12, 20	POSTAGE METRE REFILL LIBO ACCT # 2565538	280	12-Mar-2019	12-Mar-2019	
10-5-1001020-0304	POSTAGE & COURIER				1,000.00
MAY 14, 2019	POSTAGE METRE REFILL - LIBRO CENTRE - ACCT NO 2565538	511	14-May-2019	14-May-2019	
10-5-1001020-0304	POSTAGE & COURIER				1,000.00
<b>PAR372 PARRLINE ELECTRICAL WHOLESALE</b>					
82213	ELECTRICAL SUPPLIES	511	01-May-2019	01-May-2019	
40-7-1001020-0012	320ACS ST. BERNARD'S 320 RICHMOND				164.38
82214	ELECTRICAL SUPPLIES	511	01-May-2019	01-May-2019	
40-7-1001020-0012	320LIH ST. BERNARD'S 320 RICHMOND				155.69

## Council/Board Report By Dept-(Computer)



Vendor : CAT038 To ZUL180

Batch : All

Department : All

Cheque Print Date : 01-Jan-2019 To 31-May-2019

Bank : 1 To 99

Class : All

Vendor Invoice	Vendor Name Description				Batch Invc Date	Invc Due Date	Amount
G.L. Account	CC1	CC2	CC3	GL Account Name			
<b>DEPARTMENT 1001020 ADMINISTRATION</b>							
82394	ELECTRICAL SUPPLIES				511 06-May-2019	06-May-2019	
40-7-1001020-0012	320ACS			ST. BERNARD'S 320 RICHMOND			402.66
<b>PIN247 PINCHIN LTD.</b>							
1464088	DESIGNATED SUBSTANCE SURVEY AND SPECIFICATIONS AT 320 RICHMOND				481 29-Apr-2019	29-Apr-2019	
40-7-1001020-0012	320LEA			ST. BERNARD'S 320 RICHMOND			7,096.40
<b>POST740 POSTMEDIA</b>							
81086	JOB AD				1608 31-Dec-2018	31-Dec-2018	
10-5-1001020-0307				ADVERTISING			1,038.12
<b>PUR700 PUROLATOR INC.</b>							
438660221	COURIER (JUL 20, 2018)				250 28-Feb-2019	28-Feb-2019	
10-5-1001020-0304				POSTAGE & COURIER			14.04
439160407	COURIER				250 28-Feb-2019	28-Feb-2019	
10-5-1001020-0304				POSTAGE & COURIER			4.43
439977235	COURIER CHARGES (DEC 7, 2018)				250 28-Feb-2019	28-Feb-2019	
10-5-1001020-0304				POSTAGE & COURIER			14.01
439977236	COURIER				1523 07-Dec-2018	07-Dec-2018	
10-5-1001020-0304				POSTAGE & COURIER			52.14
440114020	COURIER				1554 21-Dec-2018	21-Dec-2018	
10-5-1001020-0304				POSTAGE & COURIER			4.53
440219861	COURIER				34 04-Jan-2019	04-Jan-2019	
10-5-1001020-0304				POSTAGE & COURIER			29.35
440270613	COURIER				105 11-Jan-2019	11-Jan-2019	
10-5-1001020-0304				POSTAGE & COURIER			19.36
440401192	COURIER				105 25-Jan-2019	25-Jan-2019	
10-5-1001020-0304				POSTAGE & COURIER			13.59
440401193	COURIER				105 25-Jan-2019	25-Jan-2019	
10-5-1001020-0304				POSTAGE & COURIER			7.29
440466353	COURIER				177 01-Feb-2019	01-Feb-2019	
10-5-1001020-0304				POSTAGE & COURIER			23.06
440579512	COURIER				250 15-Feb-2019	15-Feb-2019	
10-5-1001020-0304				POSTAGE & COURIER			4.53
440655211	COURIER				250 22-Feb-2019	22-Feb-2019	
10-5-1001020-0304				POSTAGE & COURIER			18.54
440783100	COURIER				347 08-Mar-2010	08-Mar-2010	
10-5-1001020-0304				POSTAGE & COURIER			4.53
440783103	SHIPPING				389 08-Mar-2019	08-Mar-2019	
10-5-1001020-0304				POSTAGE & COURIER			15.07
440845167	SHIPPING				389 15-Mar-2019	15-Mar-2019	
10-5-1001020-0304				POSTAGE & COURIER			7.75
441008566	SHIPPING PPE				389 29-Mar-2019	29-Mar-2019	
10-5-1001020-0304				POSTAGE & COURIER			33.31
441045799	COURIER				347 05-Apr-2019	05-Apr-2019	
10-5-1001020-0304				POSTAGE & COURIER			9.03
441108562	COURIER				481 12-Apr-2019	12-Apr-2019	
10-5-1001020-0304				POSTAGE & COURIER			33.68
441304364	COURIER				511 03-May-2019	03-May-2019	
10-5-1001020-0304				POSTAGE & COURIER			24.13
<b>RAY273 RAY BOWER APPRAISAL SERVICES INC.</b>							
18121004	APPRAISAL REPORT - 320 RICHMOND				34 14-Jan-2019	14-Jan-2019	
40-7-1001020-0003				CAPITAL - ADMINISTRATION			3,014.00
<b>ROB166 ROBERTSON RESTORATION; 818185 ONTARIO INC.</b>							
007-19	ROOF RESTORATION				134 31-Jan-2019	31-Jan-2019	
40-7-1001020-0005				BELLEVUE PROPERTY			5,593.50



Vendor : CAT038 To ZUL180

Batch : All

Department : All

Cheque Print Date : 01-Jan-2019 To 31-May-2019

Bank : 1 To 99

Class : All

Vendor Invoice	Vendor Name Description	Batch	Inv Date	Inv Due Date	Amount
G.L. Account	CC1 CC2 CC3 GL Account Name				
<b>DEPARTMENT 1001020 ADMINISTRATION</b>					
009-19	ROOF RESTORATION	407	31-Jan-2019	31-Jan-2019	
40-7-1001020-0005	BELLEVUE PROPERTY				42,190.25
0100-18	BELLEVUE ROOF RESTORATION	104	31-Jan-2019	31-Jan-2019	
40-7-1001020-0005	BELLEVUE PROPERTY				165,226.91
<b>ROL324 ROLAND'S SIGN &amp; LIGHTING DIVISION OF GP HOLDINGS</b>					
3039	SUPPLY & INSTALL 2 GALAXY 16MM FULL COLOUR ELECTRONIC DISPLAYS	1595	18-Dec-2018	18-Dec-2018	
40-7-1001020-0011	DIGITAL & PROGRAMMABLE SIGNS				46,293.28
<b>RTT067 RIVER TOWN TIMES</b>					
00097795	ADVERTISING	1554	12-Dec-2018	12-Dec-2018	
10-5-1001020-0307	ADVERTISING				174.52
10-5-1001020-0307	ADVERTISING				87.26
10-5-1001020-0307	ADVERTISING				87.26
10-5-1001020-0307	ADVERTISING				141.02
00097859	ADVERTISING	1554	18-Dec-2018	18-Dec-2018	
10-5-1001020-0307	ADVERTISING				174.52
10-5-1001020-0307	ADVERTISING				87.26
10-5-1001020-0307	ADVERTISING				141.02
10-5-1001020-0307	ADVERTISING				141.02
10-5-1001020-0307	ADVERTISING				141.02
10-5-1001020-0307	ADVERTISING				276.18
00097926	ADVERTISING	1554	27-Dec-2018	27-Dec-2018	
10-5-1001020-0307	ADVERTISING				174.52
10-5-1001020-0307	ADVERTISING				161.09
10-5-1001020-0307	ADVERTISING				141.02
00097977	ADVERTISING	15	14-Jan-2019	14-Jan-2019	
10-5-1001020-0307	ADVERTISING				174.51
10-5-1001020-0307	ADVERTISING				80.55
1006	ADVERTISING	34	10-Jan-2019	10-Jan-2019	
10-5-1001020-0307	ADVERTISING				174.63
10-5-1001020-0307	ADVERTISING				87.24
10-5-1001020-0307	ADVERTISING				141.00
10-5-1001020-0307	ADVERTISING				276.15
1034	ADVERTISING	62	16-Jan-2019	16-Jan-2019	
10-5-1001020-0307	ADVERTISING				141.02
10-5-1001020-0307	ADVERTISING				174.60
10-5-1001020-0307	ADVERTISING				87.25
10-5-1001020-0307	ADVERTISING				87.25
10-5-1001020-0307	ADVERTISING				141.00
10-5-1001020-0307	ADVERTISING				276.12
1073	ADVERTISING	105	23-Jan-2019	23-Jan-2019	
10-5-1001020-0307	ADVERTISING				174.62
10-5-1001020-0307	ADVERTISING				87.24
10-5-1001020-0307	ADVERTISING				87.24
10-5-1001020-0307	ADVERTISING				141.00
10-5-1001020-0307	ADVERTISING				276.12
1097	ADVERTISING	134	30-Jan-2019	30-Jan-2019	
10-5-1001020-0307	ADVERTISING				174.60
10-5-1001020-0307	ADVERTISING				87.25
10-5-1001020-0307	ADVERTISING				87.25
10-5-1001020-0307	ADVERTISING				276.14
1185	ADVERTISING	177	06-Feb-2019	06-Feb-2019	
10-5-1001020-0307	ADVERTISING				174.51
10-5-1001020-0307	ADVERTISING				87.26
10-5-1001020-0307	ADVERTISING				87.26
1233	ADVERTISING	176	13-Feb-2019	13-Feb-2019	
10-5-1001020-0307	ADVERTISING				174.60
10-5-1001020-0307	ADVERTISING				87.25

Council/Board Report By Dept-(Computer)



Vendor : CAT038 To ZUL180

Batch : All

Department : All

Cheque Print Date : 01-Jan-2019 To 31-May-2019

Bank : 1 To 99

Class : All

Vendor Invoice	Vendor Name Description	Batch	Inv Date	Inv Due Date	Amount
G.L. Account	CC1 CC2 CC3 GL Account Name				
<b>DEPARTMENT 1001020 ADMINISTRATION</b>					
10-5-1001020-0307	ADVERTISING				87.25
10-5-1001020-0307	ADVERTISING				141.00
10-5-1001020-0307	ADVERTISING				194.90
1280	ADVERTISING	204	20-Feb-2019	20-Feb-2019	
10-5-1001020-0307	ADVERTISING				174.51
10-5-1001020-0307	ADVERTISING				87.26
10-5-1001020-0307	ADVERTISING				87.26
1397	ADVERTISING	204	25-Feb-2019	25-Feb-2019	
10-5-1001020-0307	ADVERTISING				468.95
1411	ADVERTISING	250	27-Feb-2019	27-Feb-2019	
10-5-1001020-0307	ADVERTISING				174.52
10-5-1001020-0307	ADVERTISING				87.26
10-5-1001020-0307	ADVERTISING				87.26
10-5-1001020-0307	ADVERTISING				151.99
10-5-1001020-0307	ADVERTISING				276.16
1415	FOOD SERVICES JOB AD/FACEBOOK POST	250	27-Feb-2019	27-Feb-2019	
10-5-1001020-0307	ADVERTISING				16.95
1486	ADVERTISING	252	06-Mar-2019	06-Mar-2019	
10-5-1001020-0307	ADVERTISING				174.51
10-5-1001020-0307	ADVERTISING				87.26
10-5-1001020-0307	ADVERTISING				87.26
10-5-1001020-0307	ADVERTISING				141.02
10-5-1001020-0307	ADVERTISING				141.02
1513	ADVERTISING	481	13-Mar-2019	13-Mar-2019	
10-5-1001020-0307	ADVERTISING				174.51
10-5-1001020-0307	ADVERTISING				87.26
10-5-1001020-0307	ADVERTISING				87.26
10-5-1001020-0307	ADVERTISING				247.24
10-5-1001020-0307	ADVERTISING				173.46
10-5-1001020-0307	ADVERTISING				173.46
1530	ADVERTISING	481	20-Mar-2019	20-Mar-2019	
10-5-1001020-0307	ADVERTISING				174.52
10-5-1001020-0307	ADVERTISING				141.01
1548	ADVERTISING	345	27-Mar-2019	27-Mar-2019	
10-5-1001020-0307	ADVERTISING				174.51
10-5-1001020-0307	ADVERTISING				87.26
1688	ADVERTISING	347	03-Apr-2019	03-Apr-2019	
10-5-1001020-0307	ADVERTISING				174.52
10-5-1001020-0307	ADVERTISING				87.26
10-5-1001020-0307	ADVERTISING				87.26
10-5-1001020-0307	ADVERTISING				141.02
10-5-1001020-0307	ADVERTISING				141.02
10-5-1001020-0307	ADVERTISING				276.16
1718	ADVERTISING	347	10-Apr-2019	10-Apr-2019	
10-5-1001020-0307	ADVERTISING				174.51
10-5-1001020-0307	ADVERTISING				87.26
1798	ADVERTISING	406	17-Apr-2019	17-Apr-2019	
10-5-1001020-0307	ADVERTISING				174.51
10-5-1001020-0307	ADVERTISING				276.17
1825	ADVERTISING	436	24-Apr-2019	24-Apr-2019	
10-5-1001020-0307	ADVERTISING				174.51
10-5-1001020-0307	ADVERTISING				276.17
10-5-1001020-0307	ADVERTISING				276.17
1921	ADVERTISING	481	01-May-2019	01-May-2019	
10-5-1001020-0307	ADVERTISING				174.51
10-5-1001020-0307	ADVERTISING				87.26
10-5-1001020-0307	ADVERTISING				87.26



Vendor : CAT038 To ZUL180

Batch : All

Department : All

Cheque Print Date : 01-Jan-2019 To 31-May-2019

Bank : 1 To 99

Class : All

Vendor Invoice	Vendor Name Description	Batch	Inv Date	Inv Due Date	Amount
G.L. Account	CC1 CC2 CC3 GL Account Name				
<b>DEPARTMENT 1001020 ADMINISTRATION</b>					
1950	ADVERTISING	525	08-May-2019	08-May-2019	
10-5-1001020-0307	ADVERTISING				174.51
10-5-1001020-0307	ADVERTISING				87.26
1983	ADVERTISING	525	15-May-2019	15-May-2019	
10-5-1001020-0307	ADVERTISING				174.52
10-5-1001020-0307	ADVERTISING				174.51
2007	ADVERTISING	525	22-May-2019	22-May-2019	
10-5-1001020-0307	ADVERTISING				174.52
10-5-1001020-0307	ADVERTISING				87.26
10-5-1001020-0307	ADVERTISING				276.17
10-5-1001020-0307	ADVERTISING				276.17
<b>SFE01 SFERA ARCHITECTURAL ASSOCIATES INC.</b>					
17107	PROFESSIONAL SERVICES	511	18-Apr-2019	18-Apr-2019	
40-7-1001020-0012	320LIH ST. BERNARD'S 320 RICHMOND				83,872.89
40-7-1001020-0012	320ACS ST. BERNARD'S 320 RICHMOND				47,937.90
40-7-1001020-0012	320COM ST. BERNARD'S 320 RICHMOND				15,645.06
<b>SKA04 SKATE AMHERSTBURG</b>					
MARCH 26, 20	GRANT	319	23-Mar-2019	23-Mar-2019	
10-5-1001020-0353	GRANTS TO ORGANIZATIONS				1,069.44
<b>VER944 VERHAEGEN STUBBERFIELD HARTLEY</b>					
00001069		280	15-Mar-2019	15-Mar-2019	
40-7-1001020-0006	GENER/ DUFFY'S PROPERTY				1,687.41
00001070	DUFFY'S	280	15-Mar-2019	15-Mar-2019	
40-7-1001020-0006	GENER/ DUFFY'S PROPERTY				1,369.89
00001278	PROFESSIONAL SERVICES	250	14-Feb-2019	14-Feb-2019	
40-7-1001020-0012	320RIC ST. BERNARD'S 320 RICHMOND				760.78
<b>WIG035 WIGLE HOME HARDWARE BUILDING CENTRE</b>					
130107	NURSE PRACTITIONER CLINIC	511	10-May-2019	10-May-2019	
40-7-1001020-0012	320LIH ST. BERNARD'S 320 RICHMOND				16.94
<b>WIN137 WINDSOR-ESSEX COUNTY HUMANE SOCIETY</b>					
DECEMBER 3( STRAY CAT INTAKE		1608	30-Dec-2018	30-Dec-2018	
10-5-1001020-0361	CONTINGENCY ALLOWANCE				50.00
DECEMBER 4, STRAY CATS		1554	04-Dec-2018	04-Dec-2018	
10-5-1001020-0361	CONTINGENCY ALLOWANCE				25.00
NOVEMBER 3( SNAP & CATS VOUCHERS/ SPAY AND NEUTER PROGRAM		1554	30-Nov-2018	30-Nov-2018	
10-5-1001020-0361	CONTINGENCY ALLOWANCE				450.00
<b>WOO4090 WOOD ENVIRONMENTAL &amp; INFRASTRUCTURE SOLUTIONS</b>					
GS6500		250	01-Feb-2019	01-Feb-2019	
40-7-1001020-0003	1-CENT CAPITAL - ADMINISTRATION				3,418.25
GS6501	SOIL TESTING	250	01-Feb-2019	01-Feb-2019	
40-7-1001020-0003	1-CENT CAPITAL - ADMINISTRATION				26,950.50
<b>Department Totals :</b>					<b>755,634.47</b>

**DEPARTMENT 1001021 TREASURY****AMH20 AMHERSTBURG TREASURY PETTY CASH**

MARCH 2019	MARCH 2019 PETTY CASH	252	01-Mar-2019	01-Mar-2019	
10-5-1001021-0301	OFFICE SUPPLIES				8.50
10-5-1001021-0301	OFFICE SUPPLIES				10.25
10-5-1001021-0301	OFFICE SUPPLIES				11.25
10-5-1001021-0301	OFFICE SUPPLIES				12.25
10-5-1001021-0351	TRAINING & CONFERENCES				20.00

**AON145 AON CONSULTING INC**

M31-0173439	AUDIT FEES	436	14-Apr-2019	14-Apr-2019	
-------------	------------	-----	-------------	-------------	--





Vendor : CAT038 To ZUL180

Batch : All

Department : All

Cheque Print Date : 01-Jan-2019 To 31-May-2019

Bank : 1 To 99

Class : All

Vendor Invoice	Vendor Name Description	Batch	Inv Date	Inv Due Date	Amount
G.L. Account	CC1 CC2 CC3 GL Account Name				
<b>DEPARTMENT 1001021</b>	TREASURY				
10-5-1001021-0326	AUDIT FEES - FINANCE				3,729.00
<b>ASS148 OMTRA ONTARIO MUNICIPAL TAX AND REVENUE</b>					
2019*1053	MEMBERSHIP FEE	62	02-Jan-2019	02-Jan-2019	
10-5-1001021-0351	TRAINING & CONFERENCES				248.60
<b>CAN250 CANADIAN PAYROLL ASSOCIATION</b>					
168243 2019	CPA PROFESSIONAL MEMBERSHIP RENEWAL	204	26-Feb-2019	26-Feb-2019	
10-5-1001021-0350	MEMBERSHIPS				271.20
<b>CIT350 CITY OF WINDSOR</b>					
0000176138	CORPORATE TRAINING	525	10-Apr-2019	10-Apr-2019	
10-5-1001021-0351	TRAINING & CONFERENCES				563.59
<b>COU360 COUNTY OF ESSEX</b>					
IN000013573	UPDATE & CONSOLIDATE TAX ROLL	1523	03-Feb-2018	03-Feb-2018	
10-5-1001021-0327	PROFESSIONAL FEES				2,658.48
<b>FIR350 FIRST STOP SERVICES</b>					
3731	SHRED IT SERVICES	1554	31-Dec-2018	31-Dec-2018	
10-5-1001021-0301	OFFICE SUPPLIES				23.33
4034	SHRED IT SERVICES	177	31-Jan-2019	31-Jan-2019	
10-5-1001021-0301	OFFICE SUPPLIES				23.33
4106	SHREDDING SERVICES	250	28-Feb-2019	28-Feb-2019	
10-5-1001021-0301	OFFICE SUPPLIES				46.66
4174	SHREDDING SERVICES	347	31-Mar-2019	31-Mar-2019	
10-5-1001021-0301	OFFICE SUPPLIES				23.33
4242	OFFICE SUPPLIES	525	30-Apr-2019	30-Apr-2019	
10-5-1001021-0301	OFFICE SUPPLIES				46.66
<b>KPM434 KPMG LLP T4348</b>					
8002314780	AUDIT FEES	345	31-Mar-2019	31-Mar-2019	
10-5-1001021-0326	AUDIT FEES - FINANCE				5,650.00
8002344316	PROFESSIONAL FEES	345	08-Jan-2019	08-Jan-2019	
10-5-1001021-0326	AUDIT FEES - FINANCE				2,373.00
8002436438	PROFESSIONAL SERVICES	525	13-Mar-2019	13-Mar-2019	
10-5-1001021-0326	AUDIT FEES - FINANCE				16,950.00
<b>LAS200 LAS - LOCAL AUTHORITY SERVICES</b>					
EPT001408	ENERGY PLANNING TOOL (EPT) SUBSCRIPTION FOR 2019	345	01-Feb-2019	01-Feb-2019	
10-5-1001021-0327	PROFESSIONAL FEES				282.50
<b>MON183 MONARCH OFFICE SUPPLY LTD</b>					
122755	NOVEMBER 2018 PURCHASES	1606	29-Nov-2018	29-Nov-2018	
10-5-1001021-0301	OFFICE SUPPLIES				444.22
127289	DECEMBER 2018 PURCHASES	1607	31-Dec-2018	31-Dec-2018	
10-5-1001021-0301	OFFICE SUPPLIES				119.05
133006	JANUARY 2018 PURCHASES	176	30-Jan-2019	30-Jan-2019	
10-5-1001021-0301	OFFICE SUPPLIES				1,485.61
138007	FEBRUARY 2019 PURCHASE	319	27-Feb-2019	27-Feb-2019	
10-5-1001021-0301	OFFICE SUPPLIES				261.08
143523	MARCH 2019 PURCHASES	406	29-Mar-2019	29-Mar-2019	
10-5-1001021-0301	OFFICE SUPPLIES				248.40
<b>MOR26 MORNEAU SHEPELL LTD.</b>					
APRIL 2019	953243, 953244, 953245, 953246 APRIL 2019	347	01-Apr-2019	01-Apr-2019	
10-5-1001021-0207	BENEFITS - LIFE & DISABILITY				83.20
FEBRUARY 20	921007, 921008, 921009, 921010 FEBRUARY 2019	135	01-Feb-2019	01-Feb-2019	
10-5-1001021-0207	BENEFITS - LIFE & DISABILITY				83.20
JANUARY 2019	902738, 902739, 902740, 902741 JANUARY 2019	62	02-Jan-2019	02-Jan-2019	
10-5-1001021-0207	BENEFITS - LIFE & DISABILITY				83.20





Vendor : CAT038 To ZUL180  
 Batch : All  
 Department : All

Cheque Print Date : 01-Jan-2019 To 31-May-2019  
 Bank : 1 To 99  
 Class : All

Vendor Invoice	Vendor Name Description	Batch	Inv Date	Inv Due Date	Amount
G.L. Account	CC1 CC2 CC3 GL Account Name				
<b>DEPARTMENT 1001021 TREASURY</b>					
MACH 2019 936899, 936900, 936901, 936902	MARCH 2019 BENEFITS - LIFE & DISABILITY	280	01-Mar-2019	01-Mar-2019	83.20
10-5-1001021-0207					
MAY 2019 970411, 970412, 970413, 970414	MAY 2019 BENEFITS - LIFE & DISABILITY	511	01-May-2019	01-May-2019	83.20
10-5-1001021-0207					
<b>MUN200 MUNICIPAL EMPLOYER PENSION CENTRE OF ONTARIO</b>					
MC004654	MEPCO 2019 EMPLOYEE CONTRIBUTION MEMBERSHIPS	15	02-Jan-2019	02-Jan-2019	54.31
10-5-1001021-0350					
<b>PUR663 PURE WATER BRAND</b>					
APRIL 2019 000310283, 00310968, 000312832	APRIL 2019 OFFICE SUPPLIES	481	30-Apr-2019	30-Apr-2019	25.15
10-5-1001021-0301					
DECEMBER 2018 000294792, 000296431, 000298138	DECEMBER 2018 OFFICE SUPPLIES	1557	31-Dec-2018	31-Dec-2018	19.52
10-5-1001021-0301					
FEBRUARY 2019 000302606, 000304141, 000305160	FEBRUARY 2019 OFFICE SUPPLIES	252	28-Feb-2019	28-Feb-2019	28.90
10-5-1001021-0301					
JANUARY 2019 000299244, 000301010, 000301825	JANUARY 2019 OFFICE SUPPLIES	134	31-Jan-2019	31-Jan-2019	33.27
10-5-1001021-0301					
<b>PUR700 PUROLATOR INC.</b>					
441108561	COURIER OFFICE SUPPLIES	525	12-Apr-2019	12-Apr-2019	4.53
10-5-1001021-0301					
<b>RUN598 RUNNING COUNT INC.</b>					
C190587	OFFICE SUPPLIES OFFICE SUPPLIES	347	09-Apr-2019	09-Apr-2019	271.75
10-5-1001021-0301					
<b>VER140 VERSABANK</b>					
418545014-86E	AUDIT FEES AUDIT FEES - FINANCE	177	06-Feb-2019	06-Feb-2019	25.00
10-5-1001021-0326					
<b>Department Totals :</b>					<b>36,388.72</b>

<b>DEPARTMENT 1001022 CLERKS</b>					
<b>AIG153 AIG INSURANCE COMPANY OF CANADA</b>					
133262	LEGAL FEES INSURANCE DEDUCTIBLE	1523	05-Nov-2018	05-Nov-2018	655.00
10-5-1001022-0506					
<b>AMH20 AMHERSTBURG TREASURY PETTY CASH</b>					
FEBRUARY 2019	FEBRUARY 2019 PETTY CASH MEETINGS	204	26-Feb-2019	26-Feb-2019	38.90
10-5-1001022-0342					
MARCH 2019	MARCH 2019 PETTY CASH CLAIMS COSTS - CLERKS	252	01-Mar-2019	01-Mar-2019	14.50
10-5-1001022-0507					
<b>AMH60 AMHERSTBURG CLERKS PETTY CASH</b>					
JANUARY 2019	CLERKS PETTY CASH REPLENISHMENT OFFICE SUPPLIES	99	28-Jan-2019	28-Jan-2019	16.89
10-5-1001022-0301					
10-5-1001022-0301	OFFICE SUPPLIES				13.51
<b>AZZ244 AZZOPARDI EMMANUEL</b>					
MFIBBA 2019	MFIPPA FEES ADMINISTRATIVE CHARGES - CLERKS	481	08-Jan-2019	08-Jan-2019	90.00
10-4-1001022-1015					
<b>BEA477 BEAULIEU NORM</b>					
MARCH 22, 2019	INSURANCE DEDUCTIBLE INSURANCE DEDUCTIBLE	296	22-Mar-2019	22-Mar-2019	802.75
10-5-1001022-0506					
<b>CIT350 CITY OF WINDSOR</b>					
0000174770	TRAINING TRAINING & CONFERENCES - CLERKS	1523	07-Dec-2018	07-Dec-2018	920.72
10-5-1001022-0351					
<b>CLA508 CLAIMSPRO INC.</b>					
33620-632897	INSURANCE DEDUCTIBLE INSURANCE DEDUCTIBLE	296	22-Mar-2019	22-Mar-2019	1,575.50
10-5-1001022-0506					



Vendor : CAT038 To ZUL180

Batch : All

Department : All

Cheque Print Date : 01-Jan-2019 To 31-May-2019

Bank : 1 To 99

Class : All

Vendor Invoice	Vendor Name Description	Batch	Inv Date	Inv Due Date	Amount
G.L. Account	CC1 CC2 CC3 GL Account Name				
<b>DEPARTMENT 1001022 CLERKS</b>					
33620-647348	INSURANCE DEDUCTIBLE	1554	13-Dec-2018	13-Dec-2018	
10-5-1001022-0506	INSURANCE DEDUCTIBLE				69.00
33620-651519	INSURANCE	525	04-May-2019	04-May-2019	
10-5-1001022-0506	INSURANCE DEDUCTIBLE				195.50
33620-654746	INSURANCE DEDUCTIBLE	176	07-Feb-2019	07-Feb-2019	
10-5-1001022-0506	INSURANCE DEDUCTIBLE				1,260.00
33620-655082	INSURANCE DEDUCTIBLE	177	11-Feb-2019	11-Feb-2019	
10-5-1001022-0506	INSURANCE DEDUCTIBLE				345.00
33620-655344	INSURANCE DEDUCTIBLE	176	12-Feb-2019	12-Feb-2019	
10-5-1001022-0506	INSURANCE DEDUCTIBLE				840.00
33620-657440	INSURANCE DEDUCTIBLE	250	28-Feb-2019	28-Feb-2019	
10-5-1001022-0506	INSURANCE DEDUCTIBLE				1,441.60
33620-657532	INSURANCE DEDUCTIBLE	250	28-Feb-2019	28-Feb-2019	
10-5-1001022-0506	INSURANCE DEDUCTIBLE				1,327.10
33620-659659	INSURANCE DEDUCTIBLE	296	18-Mar-2019	18-Mar-2019	
10-5-1001022-0506	INSURANCE DEDUCTIBLE				310.50
33620-662038	INSURANCE DEDUCTIBLE	406	02-Apr-2019	02-Apr-2019	
10-5-1001022-0506	INSURANCE DEDUCTIBLE				414.00
33620-663273	INSURANCE DEDUCTIBLE	347	15-Apr-2019	15-Apr-2019	
10-5-1001022-0506	INSURANCE DEDUCTIBLE				1,210.10
33620-666304	INSURANCE	525	07-May-2019	07-May-2019	
10-5-1001022-0506	INSURANCE DEDUCTIBLE				156.00
33620.662937	INSURANCE DEDUCTIBLE	347	10-Apr-2019	10-Apr-2019	
10-5-1001022-0506	INSURANCE DEDUCTIBLE				241.50
36610-019846	INSURANCE DEDUCTABLE	319	27-Mar-2019	27-Mar-2019	
10-5-1001022-0506	INSURANCE DEDUCTIBLE				395.27
36610-020069	INSURANCE DEDUCTIBLE	436	24-Apr-2019	24-Apr-2019	
10-5-1001022-0506	INSURANCE DEDUCTIBLE				473.84
36610-020071	INSURANCE DEDUCTIBLE	436	24-Apr-2019	24-Apr-2019	
10-5-1001022-0506	INSURANCE DEDUCTIBLE				808.34
36610-020072	INSURANCE DEDUCTIBLE	436	24-Apr-2019	24-Apr-2019	
10-5-1001022-0506	INSURANCE DEDUCTIBLE				819.56
<b>CMS010 CMS CONSULTING</b>					
798-25	TRAINING & PROFESSIONAL DEVELOPMENT	511	09-May-2019	09-May-2019	
10-5-1001022-0351	TRAINING & CONFERENCES - CLERKS				412.45
<b>CUS128 CUSTOM CREATIONS</b>					
204130	OFFICE SUPPLIES	481	01-May-2019	01-May-2019	
10-5-1001022-0301	OFFICE SUPPLIES				160.00
<b>EXP407 407 EXPRESS TOLL ROUTE</b>					
APR 21, 2019	MAR 21 TO APR 20, 2019 ACCT# 858 994 736	406	21-Apr-2019	21-Apr-2019	
10-5-1001022-0402	VEHICLE & EQUIP MAINTENANCE				4.46
DEC 21, 2018	NOV 21 TO DEC 20, 2018	1523	21-Dec-2018	21-Dec-2018	
10-5-1001022-0402	VEHICLE & EQUIP MAINTENANCE				4.48
FEB 21, 2019	JAN 21 TO FEB 20, 2019 ACCT # 858 994 736	250	21-Feb-2019	21-Feb-2019	
10-5-1001022-0402	VEHICLE & EQUIP MAINTENANCE				4.46
JAN 21, 2019	DEC 21 TO JAN 20, 2019	62	21-Jan-2019	21-Jan-2019	
10-5-1001022-0402	VEHICLE & EQUIP MAINTENANCE				4.46
MAR 21, 2019	FEB 21 TO MAR 20, 2019 ACCT# 858 994 736	319	21-Mar-2019	21-Mar-2019	
10-5-1001022-0402	VEHICLE & EQUIP MAINTENANCE				4.46
<b>FIR350 FIRST STOP SERVICES</b>					
3731	SHRED IT SERVICES	1554	31-Dec-2018	31-Dec-2018	
10-5-1001022-0301	OFFICE SUPPLIES				23.33
4034	SHRED IT SERVICES	177	31-Jan-2019	31-Jan-2019	

## Council/Board Report By Dept-(Computer)



Vendor : CAT038 To ZUL180

Batch : All

Department : All

Cheque Print Date : 01-Jan-2019 To 31-May-2019

Bank : 1 To 99

Class : All

Vendor Invoice	Vendor Name Description	Batch	Inv Date	Inv Due Date	Amount
G.L. Account	CC1 CC2 CC3 GL Account Name				
<b>DEPARTMENT 1001022</b>	CLERKS				
10-5-1001022-0301	OFFICE SUPPLIES				23.33
4106	SHREDDING SERVICES	250	28-Feb-2019	28-Feb-2019	
10-5-1001022-0301	OFFICE SUPPLIES				46.66
4174	SHREDDING SERVICES	347	31-Mar-2019	31-Mar-2019	
10-5-1001022-0301	OFFICE SUPPLIES				23.33
4242	OFFICE SUPPLIES	525	30-Apr-2019	30-Apr-2019	
10-5-1001022-0301	OFFICE SUPPLIES				46.66
<b>KAT508 KATZMAN WYLUPEK LLP</b>					
33620-1225027	INSURANCE DEDUCTIBLE	130	24-Jan-2019	24-Jan-2019	
10-5-1001022-0506	INSURANCE DEDUCTIBLE				150.00
<b>LAF090 LAFRAMBOISE DIANA</b>					
DECEMBER 11	CLAIM PAYOUT	1595	11-Dec-2018	11-Dec-2018	
10-5-1001022-0506	INSURANCE DEDUCTIBLE				65.00
<b>MON183 MONARCH OFFICE SUPPLY LTD</b>					
122755	NOVEMBER 2018 PURCHASES	1606	29-Nov-2018	29-Nov-2018	
10-5-1001022-0301	OFFICE SUPPLIES				383.81
127289	DECEMBER 2018 PURCHASES	1607	31-Dec-2018	31-Dec-2018	
10-5-1001022-0301	OFFICE SUPPLIES				111.25
133006	JANUARY 2018 PURCHASES	176	30-Jan-2019	30-Jan-2019	
10-5-1001022-0301	OFFICE SUPPLIES				255.64
138007	FEBRUARY 2019 PURCHASE	319	27-Feb-2019	27-Feb-2019	
10-5-1001022-0301	OFFICE SUPPLIES				102.18
143523	MARCH 2019 PURCHASES	406	29-Mar-2019	29-Mar-2019	
10-5-1001022-0301	OFFICE SUPPLIES				52.24
<b>MOR26 MORNEAU SHEPELL LTD.</b>					
APRIL 2019	953243, 953244, 953245, 953246 APRIL 2019	347	01-Apr-2019	01-Apr-2019	
10-5-1001022-0207	BENEFITS - LIFE & DISABIL - CLERKS				16.65
FEBRUARY 20	921007, 921008, 921009, 921010 FEBRUARY 2019	135	01-Feb-2019	01-Feb-2019	
10-5-1001022-0207	BENEFITS - LIFE & DISABIL - CLERKS				16.64
JANUARY 2019	902738, 902739, 902740, 902741 JANUARY 2019	62	02-Jan-2019	02-Jan-2019	
10-5-1001022-0207	BENEFITS - LIFE & DISABIL - CLERKS				16.64
MARCH 2019	936899, 936900, 936901, 936902 MARCH 2019	280	01-Mar-2019	01-Mar-2019	
10-5-1001022-0207	BENEFITS - LIFE & DISABIL - CLERKS				16.64
MAY 2019	970411, 970412, 970413, 970414 MAY 2019	511	01-May-2019	01-May-2019	
10-5-1001022-0207	BENEFITS - LIFE & DISABIL - CLERKS				16.64
<b>MUN200 MUNICIPAL EMPLOYER PENSION CENTRE OF ONTARIO</b>					
MC004654	MEPCO 2019 EMPLOYEE CONTRIBUTION	15	02-Jan-2019	02-Jan-2019	
10-5-1001022-0350	MEMBERSHIPS - CLERKS				54.31
<b>PUR663 PURE WATER BRAND</b>					
APRIL 2019	000310283, 00310968, 000312832 APRIL 2019	481	30-Apr-2019	30-Apr-2019	
10-5-1001022-0301	OFFICE SUPPLIES				25.14
DECEMBER 2018	000294792, 000296431, 000298138	1557	31-Dec-2018	31-Dec-2018	
10-5-1001022-0301	OFFICE SUPPLIES				19.52
FEBRUARY 2019	000302606, 000304141, 000305160 FEBRUARY 2019	252	28-Feb-2019	28-Feb-2019	
10-5-1001022-0301	OFFICE SUPPLIES				28.89
JANUARY 2019	000299244, 000301010, 000301825 JANUARY 2019	134	31-Jan-2019	31-Jan-2019	
10-5-1001022-0301	OFFICE SUPPLIES				33.27
MARCH 2019	000305973, 000307456, 000308278 MARCH 2019	345	31-Mar-2019	31-Mar-2019	
10-5-1001022-0301	OFFICE SUPPLIES				34.52
10-5-1001022-0301	OFFICE SUPPLIES				34.52
<b>STE124 STEWART WALT</b>					
204129	OFFICE SUPPLIES	319	27-Mar-2019	27-Mar-2019	
10-5-1001022-0301	OFFICE SUPPLIES				65.00



Vendor : CAT038 To ZUL180

Batch : All

Department : All

Cheque Print Date : 01-Jan-2019 To 31-May-2019

Bank : 1 To 99

Class : All

Vendor Invoice	Vendor Name Description	Batch	Inv Date	Inv Due Date	Amount
G.L. Account	CC1 CC2 CC3 GL Account Name				
<b>DEPARTMENT 1001022 CLERKS</b>					
<b>STE150 STERLING MARKING PRODUCTS</b>					
7163711	OFFICE SUPPLIES	134	21-Jan-2019	21-Jan-2019	
10-5-1001022-0301	OFFICE SUPPLIES				48.92
<b>THO150 THOMAS GOLD PETTINGILL</b>					
157899	INSURANCE	525	31-Mar-2019	31-Mar-2019	
10-5-1001022-0506	INSURANCE DEDUCTIBLE				2,311.70
<b>THR251 THRASHER SALES &amp; LEASING LTD</b>					
228194	VEHICLE MAINTENANCE	1554	07-Dec-2018	07-Dec-2018	
10-5-1001022-0402	VEHICLE & EQUIP MAINTENANCE				1,470.21
<b>TRI249 TRI GRAPHICS</b>					
5338	OFFICE SUPPLIES	105	18-Jan-2019	18-Jan-2019	
10-5-1001022-0301	OFFICE SUPPLIES				216.95
5356	BUSINESS CARDS	345	27-Mar-2019	27-Mar-2019	
10-5-1001022-0301	OFFICE SUPPLIES				58.76
<b>Department Totals :</b>					<b>20,798.20</b>
<hr/>					
<b>DEPARTMENT 1001023 C.A.O.</b>					
<b>AMH20 AMHERSTBURG TREASURY PETTY CASH</b>					
MARCH 2019	MARCH 2019 PETTY CASH	252	01-Mar-2019	01-Mar-2019	
10-5-1001023-0342	MEETING EXPENSES - C.A.O.				75.30
10-5-1001023-0351	CONVENTIONS & SEMINARS - C.A.O.				20.00
<b>AMH268 AMHERSTBURG CHAMBER COMMERCE</b>					
3655	BUISNESS EXCELLENCE AWARDS DINNER TICKETS	436	28-Feb-2019	28-Feb-2019	
10-5-1001023-0351	CONVENTIONS & SEMINARS - C.A.O.				60.00
<b>ASS200 ASSOCIATION OF MUN OF ONTARIO</b>					
MEM006720	2019 MEMBERSHIPS	15	02-Jan-2019	02-Jan-2019	
10-5-1001023-0350	MEMBERSHIPS - C.A.O.				6,828.00
<b>CIB001 CIBPA THE CANADIAN ITALIAN BUISNESS AND</b>					
2019 CIBPA GC	2019 CIBPA GOLF CLASSIC SEPTEMBER 5, 2019	525	22-May-2019	22-May-2019	
10-5-1001023-0342	MEETING EXPENSES - C.A.O.				150.00
<b>DIL426 DILLON CONSULTING</b>					
193907	PROFESSIONAL FEES	345	31-Mar-2019	31-Mar-2019	
10-5-1001023-0327	PROFESSIONAL FEES				1,666.75
<b>FIR350 FIRST STOP SERVICES</b>					
3731	SHRED IT SERVICES	1554	31-Dec-2018	31-Dec-2018	
10-5-1001023-0301	OFFICE SUPPLIES				23.33
4034	SHRED IT SERVICES	177	31-Jan-2019	31-Jan-2019	
10-5-1001023-0301	OFFICE SUPPLIES				23.33
4106	SHREDDING SERVICES	250	28-Feb-2019	28-Feb-2019	
10-5-1001023-0301	OFFICE SUPPLIES				46.66
4174	SHREDDING SERVICES	347	31-Mar-2019	31-Mar-2019	
10-5-1001023-0301	OFFICE SUPPLIES				23.33
4242	OFFICE SUPPLIES	525	30-Apr-2019	30-Apr-2019	
10-5-1001023-0301	OFFICE SUPPLIES				46.66
<b>IAT100 IATONNA MANAGEMENT INC</b>					
FEBRUARY 9,	PROFESSIONAL FEES	177	09-Feb-2019	09-Feb-2019	
10-5-1001023-0327	PROFESSIONAL FEES				1,282.50
<b>IPR571 IPROMOTEU CANADA INC</b>					
120149ZAY	PROFESSIONAL FEES	1523	19-Dec-2018	19-Dec-2018	
10-5-1001023-0327	PROFESSIONAL FEES				797.66
<b>MON183 MONARCH OFFICE SUPPLY LTD</b>					
122755	NOVEMBER 2018 PURCHASES	1606	29-Nov-2018	29-Nov-2018	



Vendor : CAT038 To ZUL180

Batch : All

Department : All

Cheque Print Date : 01-Jan-2019 To 31-May-2019

Bank : 1 To 99

Class : All

Vendor Invoice	Vendor Name Description	Batch	Inv Date	Inv Due Date	Amount
G.L. Account	CC1 CC2 CC3 GL Account Name				
<b>DEPARTMENT 1001023</b>	C.A.O.				
10-5-1001023-0301	OFFICE SUPPLIES				207.65
127289	DECEMBER 2018 PURCHASES	1607	31-Dec-2018	31-Dec-2018	
10-5-1001023-0301	OFFICE SUPPLIES				49.90
133006	JANUARY 2018 PURCHASES	176	30-Jan-2019	30-Jan-2019	
10-5-1001023-0301	OFFICE SUPPLIES				33.01
138007	FEBRUARY 2019 PURCHASE	319	27-Feb-2019	27-Feb-2019	
10-5-1001023-0301	OFFICE SUPPLIES				23.03
<b>MOR26 MORNEAU SHEPELL LTD.</b>					
APRIL 2019 953243, 953244, 953245, 953246	APRIL 2019	347	01-Apr-2019	01-Apr-2019	
10-5-1001023-0207	BENEFITS - LIFE & DISABIL - C.A.O.				24.96
FEBRUARY 20 921007, 921008, 921009, 921010	FEBRUARY 2019	135	01-Feb-2019	01-Feb-2019	
10-5-1001023-0207	BENEFITS - LIFE & DISABIL - C.A.O.				24.96
JANUARY 2019 902738, 902739, 902740, 902741	JANUARY 2019	62	02-Jan-2019	02-Jan-2019	
10-5-1001023-0207	BENEFITS - LIFE & DISABIL - C.A.O.				24.96
MARCH 2019 936899, 936900, 936901, 936902	MARCH 2019	280	01-Mar-2019	01-Mar-2019	
10-5-1001023-0207	BENEFITS - LIFE & DISABIL - C.A.O.				24.96
MAY 2019 970411, 970412, 970413, 970414	MAY 2019	511	01-May-2019	01-May-2019	
10-5-1001023-0207	BENEFITS - LIFE & DISABIL - C.A.O.				24.96
<b>MUN200 MUNICIPAL EMPLOYER PENSION CENTRE OF ONTARIO</b>					
MC004654	MEPCO 2019 EMPLOYEE CONTRIBUTION	15	02-Jan-2019	02-Jan-2019	
10-5-1001023-0350	MEMBERSHIPS - C.A.O.				54.31
<b>MUN428 MUNICIPAL WORLD INC</b>					
275020	SUBSCRIPTION & PUBLICATION	347	12-Apr-2019	12-Apr-2019	
10-5-1001023-0251	MEMBERSHIPS AND SUB. - CAO				46.40
<b>OMA02 OMAA- ONTARIO MUNICIPAL ADMINISTRATORS</b>					
2019-086	2019 MEMBERSHIP	106	02-Jan-2019	02-Jan-2019	
10-5-1001023-0350	MEMBERSHIPS - C.A.O.				440.70
<b>PUB04 PUBLIC SECTOR DIGEST INC.</b>					
11367	SUBSCRIPTIONS	34	16-Jan-2019	16-Jan-2019	
10-5-1001023-0351	CONVENTIONS & SEMINARS - C.A.O.				503.41
<b>PUR663 PURE WATER BRAND</b>					
APRIL 2019 000310283, 000310968, 000312832	APRIL 2019	481	30-Apr-2019	30-Apr-2019	
10-5-1001023-0301	OFFICE SUPPLIES				25.14
DECEMBER 2018 000294792, 000296431, 000298138	DECEMBER 2018	1557	31-Dec-2018	31-Dec-2018	
10-5-1001023-0301	OFFICE SUPPLIES				19.52
FEBRUARY 2019 000302606, 000304141, 000305160	FEBRUARY 2019	252	28-Feb-2019	28-Feb-2019	
10-5-1001023-0301	OFFICE SUPPLIES				28.89
JANUARY 2019 000299244, 000301010, 000301825	JANUARY 2019	134	31-Jan-2019	31-Jan-2019	
10-5-1001023-0301	OFFICE SUPPLIES				33.27
MARCH 2019 000305973, 000307456, 000308278	MARCH 2019	345	31-Mar-2019	31-Mar-2019	
10-5-1001023-0301	OFFICE SUPPLIES				34.52
<b>PUR700 PUROLATOR INC.</b>					
441367493	COURIER	525	10-May-2019	10-May-2019	
10-5-1001023-0301	OFFICE SUPPLIES				4.53
<b>STE150 STERLING MARKING PRODUCTS</b>					
7163711	OFFICE SUPPLIES	134	21-Jan-2019	21-Jan-2019	
10-5-1001023-0301	OFFICE SUPPLIES				48.93
<b>TRI249 TRI GRAPHICS</b>					
5356	BUSINESS CARDS	345	27-Mar-2019	27-Mar-2019	
10-5-1001023-0301	OFFICE SUPPLIES				58.76



Vendor : CAT038 To ZUL180  
 Batch : All  
 Department : All

Cheque Print Date : 01-Jan-2019 To 31-May-2019  
 Bank : 1 To 99  
 Class : All

Vendor Invoice	Vendor Name Description	Batch	Inv Date	Inv Due Date	Amount
G.L. Account	CC1 CC2 CC3 GL Account Name				
<b>DEPARTMENT 1001024 HUMAN RESOURCES</b>					
<b>AMC610 AMCTO</b>					
1543	MEMBERSHIPS	319	18-Jan-2019	18-Jan-2019	
10-5-1001024-0350	MEMBERSHIPS - HUMAN RESOURCES				447.48
<b>AMH60 AMHERSTBURG CLERKS PETTY CASH</b>					
JANUARY 2019	CLERKS PETTY CASH REPLENISHMENT	99	28-Jan-2019	28-Jan-2019	
10-5-1001024-0342	MEETING EXPENSES				157.07
10-5-1001024-0342	MEETING EXPENSES				5.73
<b>CIT350 CITY OF WINDSOR</b>					
0000174770	TRAINING	1523	07-Dec-2018	07-Dec-2018	
10-5-1001024-0351	TRAINING & CONFERENCES - HUMAN RESOURCES				920.72
<b>GRE330 GREAT LAKES SAFETY PRODUCTS</b>					
00317508	FIRST AID SUPPLIES	319	22-Feb-2019	22-Feb-2019	
10-5-1001024-0250	HEALTH AND SAFETY - HUMAN RESOURCES				302.96
<b>MAI336 MAITRE CONSULTING</b>					
235	H&S TRAINING	436	10-Apr-2019	10-Apr-2019	
10-5-1001024-0250	HEALTH AND SAFETY - HUMAN RESOURCES				1,017.00
<b>MAR006 MARIANNE LOVE CONSULTING INC.</b>					
02.19	PROFESSIONAL FEES	177	08-Feb-2019	08-Feb-2019	
10-5-1001024-0327	PROFESSIONAL FEES				3,633.56
193.18	PROFESSIONAL FEES	1557	05-Dec-2018	05-Dec-2018	
10-5-1001024-0327	PROFESSIONAL FEES				4,661.25
58.19	PROFESSIONAL FEES	525	07-Apr-2019	07-Apr-2019	
10-5-1001024-0327	PROFESSIONAL FEES				466.13
<b>MON183 MONARCH OFFICE SUPPLY LTD</b>					
122755	NOVEMBER 2018 PURCHASES	1606	29-Nov-2018	29-Nov-2018	
10-5-1001024-0301	OFFICE SUPPLIES				66.30
127289	DECEMBER 2018 PURCHASES	1607	31-Dec-2018	31-Dec-2018	
10-5-1001024-0301	OFFICE SUPPLIES				7.77
133006	JANUARY 2018 PURCHASES	176	30-Jan-2019	30-Jan-2019	
10-5-1001024-0250	HEALTH AND SAFETY - HUMAN RESOURCES				90.80
138007	FEBRUARY 2019 PURCHASE	319	27-Feb-2019	27-Feb-2019	
10-5-1001024-0250	HEALTH AND SAFETY - HUMAN RESOURCES				326.57
<b>MOR26 MORNEAU SHEPELL LTD.</b>					
APRIL 2019	953243, 953244, 953245, 953246 APRIL 2019	347	01-Apr-2019	01-Apr-2019	
10-5-1001024-0207	BENEFITS - LIFE & DISABIL - HUMAN RESOUR				16.64
FEBRUARY 20	921007, 921008, 921009, 921010 FEBRUARY 2019	135	01-Feb-2019	01-Feb-2019	
10-5-1001024-0207	BENEFITS - LIFE & DISABIL - HUMAN RESOUR				16.64
JANUARY 2019	902738, 902739, 902740, 902741 JANUARY 2019	62	02-Jan-2019	02-Jan-2019	
10-5-1001024-0207	BENEFITS - LIFE & DISABIL - HUMAN RESOUR				16.64
MARCH 2019	936899, 936900, 936901, 936902 MARCH 2019	280	01-Mar-2019	01-Mar-2019	
10-5-1001024-0207	BENEFITS - LIFE & DISABIL - HUMAN RESOUR				16.64
MAY 2019	970411, 970412, 970413, 970414 MAY 2019	511	01-May-2019	01-May-2019	
10-5-1001024-0207	BENEFITS - LIFE & DISABIL - HUMAN RESOUR				16.64
<b>MUN200 MUNICIPAL EMPLOYER PENSION CENTRE OF ONTARIO</b>					
MC004654	MEPCO 2019 EMPLOYEE CONTRIBUTION	15	02-Jan-2019	02-Jan-2019	
10-5-1001024-0350	MEMBERSHIPS - HUMAN RESOURCES				54.31
<b>OMH304 OMHRA</b>					
12894	MEMBERSHIP FEES	177	04-Feb-2019	04-Feb-2019	
10-5-1001024-0350	MEMBERSHIPS - HUMAN RESOURCES				141.25
<b>POS740 POSTMEDIA</b>					
103137	JOB AD	296	28-Feb-2019	28-Feb-2019	
10-5-1001024-0372	RECRUITMENT EXPENSES				1,757.87





Vendor : CAT038 To ZUL180  
 Batch : All  
 Department : All

Cheque Print Date : 01-Jan-2019 To 31-May-2019  
 Bank : 1 To 99  
 Class : All

Vendor Invoice	Vendor Name Description	Batch	Inv Date	Inv Due Date	Amount
G.L. Account	CC1 CC2 CC3 GL Account Name				
<b>DEPARTMENT 1001024 HUMAN RESOURCES</b>					
114598	RECRUITMENT	389	31-Mar-2019	31-Mar-2019	
10-5-1001024-0372	RECRUITMENT EXPENSES				1,217.29
131049	JOB AD	525	30-Apr-2019	30-Apr-2019	
10-5-1001024-0372	RECRUITMENT EXPENSES				503.98
<b>PUB495 PUBLIC SERVICES HEALTH &amp; SAFETY ASSOCIATION</b>					
56994	CERTIFICATION PART 1 HEALTH AND SAFETY TRAINING	15	02-Jan-2019	02-Jan-2019	
10-5-1001024-0250	HEALTH AND SAFETY - HUMAN RESOURCES				791.00
57047	CERTIFICATION PART 1 HEALTH AND SAFETY TRAINING	15	02-Jan-2019	02-Jan-2019	
10-5-1001024-0250	HEALTH AND SAFETY - HUMAN RESOURCES				791.00
<b>TRI249 TRI GRAPHICS</b>					
5356	BUSINESS CARDS	345	27-Mar-2019	27-Mar-2019	
10-5-1001024-0301	OFFICE SUPPLIES				58.76
<b>Department Totals :</b>					<b>17,502.00</b>

<b>DEPARTMENT 1001025 INFORMATION TECHNOLOGY</b>					
<b>APP302 APPLIED COMPUTER SOLUTIONS INC</b>					
43156	NETWORK MONITORING	1607	17-Dec-2018	17-Dec-2018	
10-5-1001025-0310	COMPUTER MAINTENANCE				446.35
43362	SERVER SUPPORT	62	03-Jan-2019	03-Jan-2019	
10-5-1001025-0310	COMPUTER MAINTENANCE				565.00
43442	WEB FILTER AND EMAIL SECURITY/ARCHIVE LICENSING	134	19-Jan-2019	19-Jan-2019	
10-5-1001025-0310	COMPUTER MAINTENANCE				11,520.36
43995	PHONE SYSTEM TROUBLE SHOOTING	280	19-Feb-2019	19-Feb-2019	
10-5-1001025-0315	TELEPHONE				423.75
44094	NETWORK & SERVER MONITORING	296	13-Mar-2019	13-Mar-2019	
10-5-1001025-0310	COMPUTER MAINTENANCE				4,909.85
44283	ROUTER & FIREWALL CHANGES	481	19-Mar-2019	19-Mar-2019	
10-5-1001025-0310	COMPUTER MAINTENANCE				105.94
44316	VMWARE LICENSING	406	19-Mar-2019	19-Mar-2019	
10-5-1001025-0310	COMPUTER MAINTENANCE				1,846.37
<b>CEN100 VADIM COMPUTER MGMT GROUP A CENTRALSQUARE COMPANY;</b>					
230062	TIME ENTRY TRAINING	347	20-Mar-2019	20-Mar-2019	
10-5-1001025-0310	GENER/ COMPUTER MAINTENANCE				728.85
233618	TE SETUP	481	23-Apr-2019	23-Apr-2019	
10-5-1001025-0310	COMPUTER MAINTENANCE				546.64
<b>CIT913 CITYVIEW A DIVISION OF N HARRIS COMPUTER CORP</b>					
CT040152	CITY VIEW IMPLEMENTATION	1523	09-Nov-2018	09-Nov-2018	
40-7-1001025-0008	FINANCIAL SYSTEMS				22,466.11
CT040483	CITY VIEW IMPLEMENTATION	1523	07-Dec-2018	07-Dec-2018	
40-7-1001025-0008	FINANCIAL SYSTEMS				9,978.47
<b>COU360 COUNTY OF ESSEX</b>					
IN000014023	2018 ERSI END USER AGREEMENT	389	01-Apr-2019	01-Apr-2019	
10-5-1001025-0310	COMPUTER MAINTENANCE				17,029.79
IN000014530	ESRI USER AGREEMENT	250	14-Jan-2019	14-Jan-2019	
10-5-1001025-0310	COMPUTER MAINTENANCE				18,690.62
IN00013282	GEOCORTEX ANALYTICS AND ESSENTIALS LICENSES	1523	14-Dec-2018	14-Dec-2018	
10-5-1001025-0310	COMPUTER MAINTENANCE				618.77
IN00014409	GEOCORTEX ESSENTIAL AND OPTIMIZER MAINTENANCE	1523	30-Nov-2018	30-Nov-2018	
10-5-1001025-0310	COMPUTER MAINTENANCE				734.96
IN00014673	WESBISTE HOSTING FEES	250	14-Feb-2019	14-Feb-2019	
10-5-1001025-0311	WEBSITE DEVELOPMENT SOFTWARE				4,391.10
<b>DEL155 DELL CANADA INC-ACCTS.REC ASAP</b>					



Council/Board Report By Dept-(Computer)



Vendor : CAT038 To ZUL180

Batch : All

Department : All

Cheque Print Date : 01-Jan-2019 To 31-May-2019

Bank : 1 To 99

Class : All

Vendor Invoice	Vendor Name Description	Batch	Inv Date	Inv Due Date	Amount
G.L. Account	CC1 CC2 CC3 GL Account Name				
<b>DEPARTMENT 1001025 INFORMATION TECHNOLOGY</b>					
1014402526	SPEAKERS FOR NEW HIRE	481	17-Apr-2019	17-Apr-2019	
10-5-1001025-0310	COMPUTER MAINTENANCE				44.28
1014416071	MONITORS FOR NEW HIRE	481	17-Apr-2019	17-Apr-2019	
10-5-1001025-0310	COMPUTER MAINTENANCE				451.98
<b>DIR572 DIRECTDIAL.COM</b>					
IN571307	NAS REPLACEMENT FOR GORDON HOUSE	481	16-Apr-2019	16-Apr-2019	
10-5-1001025-0310	COMPUTER MAINTENANCE				396.63
IN652612	LAPTOP CASES - COUNCIL	1554	07-Dec-2018	07-Dec-2018	
10-5-1001025-0310	COMPUTER MAINTENANCE				303.97
IN655697	PRINTER USAGE AND MAINTENANCE	347	01-Mar-2019	01-Mar-2019	
10-5-1001025-0308	PHOTOCOPIES				155.34
IN660933	REPLACEMENT LAPTOP TOUCH-POINTS	250	05-Feb-2019	05-Feb-2019	
10-5-1001025-0310	COMPUTER MAINTENANCE				129.95
IN664267	PRINTER USAGE AND MAINTENANCE	280	27-Feb-2019	27-Feb-2019	
10-5-1001025-0308	PHOTOCOPIES				159.79
IN664353	UPS NETWORK RACK - REPLACED PREMATURE FAILURE	296	28-Feb-2019	28-Feb-2019	
40-7-1001025-0002	COMPUTER HARDWARE				1,215.88
IN668272	PRINTER USAGE AND MAINTENANCE	389	26-Mar-2019	26-Mar-2019	
10-5-1001025-0308	PHOTOCOPIES				86.91
IN672723	PRINTER USAGE AND MAINTENANCE	481	26-Apr-2019	26-Apr-2019	
10-5-1001025-0308	PHOTOCOPIES				80.89
<b>ESC060 ESCRIBE SOFTWARE LTD</b>					
1937	ESCRIBE ANNUAL LICENSE & DATA STORAGE COSTS	481	02-Apr-2019	02-Apr-2019	
10-5-1001025-0310	COMPUTER MAINTENANCE				5,301.62
<b>ESO651 ESOLUTIONS GROUP LIMITED</b>					
119027	WEBSITE SEARCH ENGINE	481	16-Apr-2019	16-Apr-2019	
10-5-1001025-0311	WEBSITE DEVELOPMENT & SOFTWARE				754.61
<b>INN291 INNOSOFT CANADA INC</b>					
SUP1001012	RECREATION SOFTWARE LICENSE	135	01-Mar-2019	01-Mar-2019	
10-5-1001025-0310	COMPUTER MAINTENANCE				20,837.20
<b>KEL117 KELCOM TELEMESSAGING</b>					
1902-06702	CALL CENTRE SERVICES	135	01-Feb-2019	01-Feb-2019	
10-5-1001025-0315	TELEPHONE				69.58
1903-06702	ANSWERING SERVICE	280	01-Mar-2019	01-Mar-2019	
10-5-1001025-0315	TELEPHONE				71.12
1904-06702	ANSWERING SERVICES	347	01-Apr-2019	01-Apr-2019	
10-5-1001025-0315	TELEPHONE				58.97
1905-06702	ANSWERING SERVICE	511	01-May-2019	01-May-2019	
10-5-1001025-0315	TELEPHONE				88.36
W78745-0119	ANSWERING SERVICE	34	02-Jan-2019	02-Jan-2019	
10-5-1001025-0315	TELEPHONE				49.12
<b>MIC409 MICROSOFT</b>					
E030074HFN	EMAI; MAILBOX LICENSING	1523	08-Dec-2018	08-Dec-2018	
10-5-1001025-0310	COMPUTER MAINTENANCE				10,298.82
E03007AZLN	SHAREPOINT LICENSING	34	05-Jan-2019	05-Jan-2019	
10-5-1001025-0310	COMPUTER MAINTENANCE				2,169.60
E03007FZEZ	EMAIL HOSTING	250	26-Jan-2019	26-Jan-2019	
10-5-1001025-0310	COMPUTER MAINTENANCE				10,719.18
E03007J70X	EMAIL HOSTING CREDIT	250	08-Feb-2019	08-Feb-2019	
10-5-1001025-0310	COMPUTER MAINTENANCE				-8,493.00
<b>MIK315 MIKE'S COMPUTER SHOP</b>					
WIN-24422	LAPTOPS DOCKS, UPS CONTROLLER CARD	1554	11-Dec-2018	11-Dec-2018	
10-5-1001025-0310	COMPUTER MAINTENANCE				2,872.35



Vendor : CAT038 To ZUL180  
 Batch : All  
 Department : All

Cheque Print Date : 01-Jan-2019 To 31-May-2019  
 Bank : 1 To 99  
 Class : All

Vendor Invoice	Vendor Name Description	Batch	Inv Date	Inv Due Date	Amount
G.L. Account	CC1 CC2 CC3 GL Account Name				
<b>DEPARTMENT 1001025</b>	<b>INFORMATION TECHNOLOGY</b>				
WIN-245037	UPS REPLACEMENT FOR CAMERA SERVICE & REPLACEMENT KVM FOR LIBRO SERVERS	1554	13-Dec-2018	13-Dec-2018	
10-5-1001025-0310	COMPUTER MAINTENANCE				944.31
WIN-269815	LAPTOPS WATER TANKS - LIFECYCLE REPLACEMENTS	389	28-Mar-2019	28-Mar-2019	
40-7-1001025-0002	COMPUTER HARDWARE				4,514.58
<b>MOR26 MORNEAU SHEPELL LTD.</b>					
APRIL 2019 953243, 953244, 953245, 953246	APRIL 2019	347	01-Apr-2019	01-Apr-2019	
10-5-1001025-0207	BENEFITS - LIFE & DISABILITY				33.28
FEBRUARY 20 921007, 921008, 921009, 921010	FEBRUARY 2019	135	01-Feb-2019	01-Feb-2019	
10-5-1001025-0207	BENEFITS - LIFE & DISABILITY				33.28
JANUARY 2019 902738, 902739, 902740, 902741	JANUARY 2019	62	02-Jan-2019	02-Jan-2019	
10-5-1001025-0207	BENEFITS - LIFE & DISABILITY				33.28
MARCH 2019 936899, 936900, 936901, 936902	MARCH 2019	280	01-Mar-2019	01-Mar-2019	
10-5-1001025-0207	BENEFITS - LIFE & DISABILITY				33.29
MAY 2019 970411, 970412, 970413, 970414	MAY 2019	511	01-May-2019	01-May-2019	
10-5-1001025-0207	BENEFITS - LIFE & DISABILITY				33.28
<b>MUN200 MUNICIPAL EMPLOYER PENSION CENTRE OF ONTARIO</b>					
MC004654	MEPCO 2019 EMPLOYEE CONTRIBUTION	15	02-Jan-2019	02-Jan-2019	
10-5-1001025-0350	MEMBERSHIPS				54.30
<b>PUB04 PUBLIC SECTOR DIGEST INC.</b>					
10048	CITY WIDE CAPITAL PLANNING & ANALYSIS	525	03-Apr-2019	03-Apr-2019	
40-7-1001025-0008	FINANCIAL SYSTEMS				4,236.70
10370	ANNUAL SOFTWARE SUPPORT, AND LICENSING RENEWAL JUN 2018 - MAY 2019	525	01-May-2019	01-May-2019	
40-7-1001025-0008	FINANCIAL SYSTEMS				4,741.06
<b>SER102 SERENIC SOFTWARE A SYLOGIST COMPANY</b>					
SI-4984	SERVICE REQUEST MANAGER	1595	17-Dec-2018	17-Dec-2018	
10-5-1001025-0310	COMPUTER MAINTENANCE				4,203.25
<b>SHI03 SHI CANADA ULC c/o T9981</b>					
CB00273712D	ADOBE LICENSING	1554	21-Sep-2018	21-Sep-2018	
10-5-1001025-0310	COMPUTER MAINTENANCE				2,570.75
<b>STA444 STAPLES ADVANTAGE (MIS C/O T04446C)</b>					
49583708	PAPER ROLLS FOR PLOTTER	250	30-Jan-2019	30-Jan-2019	
10-5-1001025-0301	OFFICE SUPPLIES				135.72
<b>SUP711 SUPPORT WAREHOUSE</b>					
0000019101	WARRANTY SERVICE ON LIBRO SAN	347	18-Feb-2019	18-Feb-2019	
10-5-1001025-0310	COMPUTER MAINTENANCE				1,259.95
<b>TEX600 TEXTHELP INC.</b>					
34642	ACCESSIBLE SCREEN READING FEATURE FOR WEBSITE	250	08-Feb-2019	08-Feb-2019	
10-5-1001025-0311	WEBSITE DEVELOPMENT & SOFTWARE				2,932.35
<b>THI235 THINK! WIRELESS SOLUTIONS INC.</b>					
0000012685	GPS	250	03-Jan-2019	03-Jan-2019	
10-5-1001025-0406	GPS				1,077.53
0000012920	GPS	250	01-Feb-2019	01-Feb-2019	
10-5-1001025-0406	GPS				1,162.71
0000013065	GPS	280	04-Mar-2019	04-Mar-2019	
10-5-1001025-0406	GPS				1,162.71
0000013266	GPS	389	01-Apr-2019	01-Apr-2019	
10-5-1001025-0406	GPS				1,162.71
<b>THI740 THINKTEL COMMUNICATIONS - A DIVISION OF DISTRIBUTE</b>					
1184636	TELEPHONE LANDLINE ACCESS	1523	06-Dec-2018	06-Dec-2018	
10-5-1001025-0315	TELEPHONE				354.49
1187049	PHONE SYSTEM LANDLINE ACCESS	134	07-Jan-2019	07-Jan-2019	

## Council/Board Report By Dept-(Computer)



Vendor : CAT038 To ZUL180

Batch : All

Department : All

Cheque Print Date : 01-Jan-2019 To 31-May-2019

Bank : 1 To 99

Class : All

Vendor Invoice	Vendor Name Description				Batch Invc Date	Invc Due Date	Amount
G.L. Account	CC1	CC2	CC3	GL Account Name			
<b>DEPARTMENT 1001025 INFORMATION TECHNOLOGY</b>							
10-5-1001025-0315				TELEPHONE			346.75
1189515	PHONE SYSTEM LANDLINE ACCESS				250 06-Feb-2019	06-Feb-2019	
10-5-1001025-0315				TELEPHONE			334.97
1191922	PHONE SYSTEM LANDLINE ACCESS				280 06-Mar-2019	06-Mar-2019	
10-5-1001025-0315				TELEPHONE			348.97
1194382	PHONE SYSTEM LANDLINE ACCESS				347 04-Apr-2019	04-Apr-2019	
10-5-1001025-0315				TELEPHONE			341.27
1196826	PHONE SYSTEM LANDLINE ACCESS				511 07-May-2019	07-May-2019	
10-5-1001025-0315				TELEPHONE			362.76
<b>TOT060 TOTALLYONE CORPORATE OFFICE</b>							
18427	CELL PHONE REPLACEMENT SERVICE AND SUPPORT TECHNOLOGIST				250 28-Feb-2019	28-Feb-2019	
10-5-1001025-0345				CELL PHONE			428.26
<b>Department Totals :</b>							<b>175,668.59</b>
-----							
<b>DEPARTMENT 1001029 RECORDS RETENTION</b>							
<b>CEN859 CENTENNIAL LOCK &amp; SAFE LIMITED</b>							
25500	MAINTENANCE				389 18-Apr-2019	18-Apr-2019	
10-5-1001029-0317				BUILDING MAINTENANCE - RECORDS RETENTION			1,229.38
<b>FIR350 FIRST STOP SERVICES</b>							
3731-A	RECORDS MANGEMENT				1554 31-Dec-2018	31-Dec-2018	
10-5-1001029-0317				BUILDING MAINTENANCE - RECORDS RETENTION			50.00
4019	RECORDS MANAGEMENT				204 20-Feb-2019	20-Feb-2019	
10-5-1001029-0317				BUILDING MAINTENANCE - RECORDS RETENTION			756.28
<b>Department Totals :</b>							<b>2,035.66</b>
-----							
<b>DEPARTMENT 1002000 COMMITTEES</b>							
<b>AMH276 MIRACLE LEAGUE OF AMHERSTBURG</b>							
MARCH 22, 20	MEMORIAL DONATON IN HONOUR OF KEN HOUSTON				296 22-Mar-2019	22-Mar-2019	
10-5-1002000-0360				COMMITTEE MEETINGS - SUNDRIES			75.00
<b>COM024 COMMUNITY HERITAGE ONTARIO</b>							
2019 MEMBER	2019 MEMBERSHIP RENEWAL				296 22-Mar-2019	22-Mar-2019	
10-5-1002000-0368				HERITAGE COMMITTEE			106.00
<b>MAR235 MARSH COLLECTION SOCIETY</b>							
MARCH 5, 201	PROPERTY RESEARCH				296 05-Mar-2019	05-Mar-2019	
10-5-1002000-0368				HERITAGE COMMITTEE			25.00
<b>MOU001 MOUSSEAU DELUCA McPHERSON PRINCE</b>							
58499	HERITAGE COMMITTEE				1607 30-Nov-2018	30-Nov-2018	
10-5-1002000-0368				HERITAGE COMMITTEE			175.78
<b>REI082 REINER MEG</b>							
APRIL 17, 201	HERITAGE COMMITTEE EXPENSE				436 17-Apr-2019	17-Apr-2019	
10-5-1002000-0368				HERITAGE COMMITTEE			330.00
<b>Department Totals :</b>							<b>711.78</b>
-----							
<b>DEPARTMENT 1008030 UNFINANCED DRAINS</b>							
<b>COL115 COLUMBIA UTILITY SERVICES INC.</b>							
1494	COMMERCIAL TREE SERVICES				296 07-Mar-2019	07-Mar-2019	
10-1-1008030-8020				4th CONC RD DRAIN			7,012.66
<b>DIL426 DILLON CONSULTING</b>							
193702	LEMAY COOKSON DRAIN (DEC 13, 2018)				175 31-Jan-2019	31-Jan-2019	
10-1-1008030-9040				LEMAY-COOKSON DRAIN FOR IMPROVEMEN			4,563.17
195651	DRAINAGE IMPROVEMENT PROJECT				177 24-Jan-2019	24-Jan-2019	
10-1-1008030-9040				LEMAY-COOKSON DRAIN - REQ FOR IMPROVEMEN			3,328.87



Vendor : CAT038 To ZUL180

Batch : All

Department : All

Cheque Print Date : 01-Jan-2019 To 31-May-2019

Bank : 1 To 99

Class : All

Vendor Invoice	Vendor Name Description	Batch	Inv Date	Inv Due Date	Amount
G.L. Account	CC1 CC2 CC3 GL Account Name				
<b>DEPARTMENT 1008030</b>	<b>UNFINANCED DRAINS</b>				
198067	ENGINEERING FEES	345	21-Mar-2019	21-Mar-2019	
10-1-1008030-9048	PARKS DRAIN - S.4 PETITION				1,463.35
199395	ENGINEERING FEES	481	24-Apr-2019	24-Apr-2019	
10-1-1008030-9048	PARKS DRAIN - S.4 PETITION				9,766.25
<b>ESS53</b>	<b>ESSEX REGION CONSERVATION AUTHORITY</b>				
14727	PERMIT APPLICATIONS FOR DRAINAGE WORKS	204	15-Feb-2019	15-Feb-2019	
10-1-1008030-9043	WHELAN DRAIN-HUTCHINS BRIDGE				150.00
10-1-1008030-9037	ODETTE DRAIN-S. 4 PETITION-BASTIEN ENCL				800.00
10-1-1008030-9044	5TH CONC DRAIN S. - VANDENBRINK BRIDGE				150.00
IN000014462	ERCA PERMIT	1557	13-Dec-2018	13-Dec-2018	
10-1-1008030-8400	HOWIE DRAIN				200.00
INV000014414	SHUELL CREEK DRAIN	1554	19-Dec-2018	19-Dec-2018	
10-1-1008030-8850	SHUELL CREEK DRAIN				200.00
<b>GOO460</b>	<b>GOODREAU EXCAVATING LTD</b>				
24445	DRAIN MAINTENANCE (NOV 30, 2018)	175	31-Jan-2019	31-Jan-2019	
10-1-1008030-8860	SINASAC DRAIN				18,543.30
25018	DITCHING (DEC 10, 2018)	175	31-Jan-2019	31-Jan-2019	
10-1-1008030-8860	SINASAC DRAIN				1,073.50
<b>HUR693</b>	<b>HURRICANE SMS INC</b>				
16796	REBIDOUX DRAIN	1554	06-Dec-2018	06-Dec-2018	
10-1-1008030-8780	REBIDOUX DRAIN				771.23
18080	DRAIN MAINTENANCE	177	23-Jan-2019	23-Jan-2019	
10-1-1008030-8780	REBIDOUX DRAIN				2,147.00
18081	DRAIN MAINTENANCE	177	23-Jan-2019	23-Jan-2019	
10-1-1008030-8780	REBIDOUX DRAIN				661.05
18111	DRAIN MAINTENANCE	204	25-Jan-2019	25-Jan-2019	
10-1-1008030-8780	REBIDOUX DRAIN				4,237.50
<b>NJP045</b>	<b>N.J. PERALTA ENGINEERING LTD</b>				
18-237	DOLPHIS MELOCHE DRAIN	1554	18-Dec-2018	18-Dec-2018	
10-1-1008030-9588	DOLPHIS MELOCHE DRAIN - ACCESS CULVERTS				6,085.05
18-239	CORNWALL DRAIN - NEW MAINTENANCE SCHEDULE	1554	18-Dec-2018	18-Dec-2018	
10-1-1008030-9593	CORNWALL DRAIN-MAINTENANCE				4,039.75
18-246	COOK DRAIN - NEW BRIDGE FOR RENAUD	1554	18-Dec-2018	18-Dec-2018	
10-1-1008030-9594	COOK DRAIN- NEW BRIDGE FOR RENAUD				8,695.35
18-258	6TH CONCESSION ROAD DRAIN - BRIDGE FOR KRYWAY	1554	18-Dec-2018	18-Dec-2018	
10-1-1008030-9045	6TH CONC RD DRAIN - KRYWAY BRIDGE				3,378.70
19-042	ENGINEERING FEES	481	25-Apr-2019	25-Apr-2019	
10-1-1008030-9045	6TH CONC RD DRAIN - KRYWAY BRIDGE				10,124.80
<b>ONT654</b>	<b>806574 ONTARIO INC.</b>				
JANUARY 17, ; ALLOWANCE PAYMENT DRAIN IMPROVEMENT		34	17-Jan-2019	17-Jan-2019	
10-1-1008030-9015	8TH CONC RD DRAIN S;QUESNEL IMPROVEMENTS				4,273.00
<b>PIT565</b>	<b>PITTAO'S AUTO CARE INC</b>				
055034	REPLACED WINDSHIELD	347	12-Mar-2019	12-Mar-2019	
10-5-1008030-0402	VEHICLE & EQUIP MAINTENANCE				415.28
<b>PUR700</b>	<b>PUROLATOR INC.</b>				
440845168	DOCUMENT SHIPPING	345	15-Mar-2019	15-Mar-2019	
10-1-1008030-9049	CHARLES SHEPLEY DRAIN				9.81
<b>REG742</b>	<b>REG CLARK TRUCKING LTD</b>				
1819-169	DRAIN MAINTENANCE CONCSTRUCTION COSTS	1554	30-Nov-2018	30-Nov-2018	
10-1-1008030-8315	GEORGE ANDERSON DRAIN				31,972.22
1819-242	BANK STABILIZATION WORK BY RCT	481	03-May-2019	03-May-2019	
10-1-1008030-8635	McKEE DRAIN				6,552.59
<b>RIV260</b>	<b>RIVARD EXCAVATING LTD</b>				

## Council/Board Report By Dept-(Computer)



Vendor : CAT038 To ZUL180

Batch : All

Department : All

Cheque Print Date : 01-Jan-2019 To 31-May-2019

Bank : 1 To 99

Class : All

Vendor Invoice	Vendor Name Description	Batch	Inv Date	Inv Due Date	Amount
G.L. Account	CC1 CC2 CC3 GL Account Name				
<b>DEPARTMENT 1008030</b>	<b>UNFINANCED DRAINS</b>				
1635	BRIDGE OVER RENAUD DRAIN FOR SCHWAB CONSTRUCTION COST	1557	21-Dec-2018	21-Dec-2018	
10-1-1008030-9038	RENAUD DRAIN-ACCESS BRIDGE FOR SCHWAB				17,406.52
<b>ROO009</b>	<b>ROOD ENGINEERING INC.</b>				
REI-2019040	ENGINEERING FEES - DRAINAGE REPORT	296	05-Mar-2019	05-Mar-2019	
10-1-1008030-9041	LANGLOIS DRAIN-ACCESS DRAIN VANRAAY				8,794.79
REI-2019044	ENGINEERING FEES	345	18-Mar-2019	18-Mar-2019	
10-1-1008030-9042	SAM PAQUETTE DRAI-ACCESS BRIDGE BERGERON				10,460.41
REI-2019047	ENGINEERING AND ENVIRONMENTAL CONSULTANT FEES	389	01-Apr-2019	01-Apr-2019	
10-1-1008030-9013	BONDY BASTIEN DRAIN IMPROVEMENTS				3,733.92
<b>TOW033</b>	<b>TOWN OF ESSEX</b>				
931	SUCKER CREEK DRAIN	1523	03-Dec-2018	03-Dec-2018	
10-1-1008030-8875	SUCKER CREEK DRAIN				4,171.36
931 A	SUCKER CREEK DRAIN	1523	03-Dec-2018	03-Dec-2018	
10-1-1008030-8875	SUCKER CREEK DRAIN				413.91
931 B	SUCKER CREEK DRAIN	1523	03-Dec-2018	03-Dec-2018	
10-1-1008030-8875	SUCKER CREEK DRAIN				3,264.95
SALES000000	DRAIN MAINTENANCE	296	22-Mar-2019	22-Mar-2019	
10-5-1008030-0765	DRAIN MAINTENANCE				233.00
<b>WIS04</b>	<b>WISMER BROTHERS LTD. DARAFARMS INC.</b>				
APRIL 18, 2019	REIMBURSEMENT OF DRAINAGE APPOINTMENT	406	18-Apr-2019	18-Apr-2019	
10-4-1008030-1910	DRAINAGE APPORTIONMENTS				500.00
<b>Department Totals :</b>					<b>179,593.29</b>
<b>DEPARTMENT 2010000</b>	<b>FIRE DEPARTMENT</b>				
<b>882116</b>	<b>882865 ONTARIO LIMITED O/A K&amp;H DISTRIBUTING</b>				
20197	FIREWORKS COURSE	406	12-Apr-2019	12-Apr-2019	
10-5-2010000-0254	FIRE FIGHTER TRAINING				56.50
<b>ACK297</b>	<b>ACKLANDS-GRAINGER INC</b>				
9032080294	SALT - RETURNED CREDIT SUBMITTED	1607	13-Dec-2018	13-Dec-2018	
10-5-2010000-0420	FIREFIGHTING EQUIPMENT				168.82
9055351416	CREDIT FOR INVOICE ACK9032080294	204	15-Jan-2019	15-Jan-2019	
10-5-2010000-0420	FIREFIGHTING EQUIPMENT				-168.82
9074742173	ABSORBAL	204	31-Jan-2019	31-Jan-2019	
10-5-2010000-0420	FIREFIGHTING EQUIPMENT				61.19
9089879879	ABSORBAL	204	15-Feb-2019	15-Feb-2019	
10-5-2010000-0420	FIREFIGHTING EQUIPMENT				269.17
9165619488	SAFETY EQUIPMENT	481	03-May-2019	03-May-2019	
10-5-2010000-0420	FIREFIGHTING EQUIPMENT				160.78
<b>ADV329</b>	<b>ADVANCE BUSINESS SYSTEMS</b>				
661656	OFFICE EQUIPMENT	319	27-Feb-2019	27-Feb-2019	
10-5-2010000-0420	FIREFIGHTING EQUIPMENT				282.50
<b>AJS141</b>	<b>A.J. STONE CO LTD</b>				
0000140181	HOSE STRAP RETURN	1523	19-Jun-2018	19-Jun-2018	
10-5-2010000-0420	FIREFIGHTING EQUIPMENT				-142.38
0000141484	WATER RESCUE EQUIPMENT	1523	29-Aug-2018	29-Aug-2018	
10-5-2010000-0431	FIRE TRAINING SIMULATOR				125.32
0000143631	EDUCTORS	1523	21-Dec-2018	21-Dec-2018	
10-5-2010000-0402	VEHICLE & EQUIPMENT MTCE.				1,968.66
0000143922	GATED INTAKE FOR ENGINE 1	34	11-Jan-2019	11-Jan-2019	
10-5-2010000-0420	FIREFIGHTING EQUIPMENT				1,560.53
0000143999	FIRE FOAM	62	16-Jan-2019	16-Jan-2019	
10-5-2010000-0420	FIREFIGHTING EQUIPMENT				2,047.56



Vendor : CAT038 To ZUL180

Batch : All

Department : All

Cheque Print Date : 01-Jan-2019 To 31-May-2019

Bank : 1 To 99

Class : All

Vendor Invoice	Vendor Name Description	Batch	Inv Date	Inv Due Date	Amount
G.L. Account	CC1 CC2 CC3 GL Account Name				
<b>DEPARTMENT 2010000 FIRE DEPARTMENT</b>					
0000144467	EQUIPMENT FOR ENGINE 1	177	11-Feb-2019	11-Feb-2019	
10-5-2010000-0420	FIREFIGHTING EQUIPMENT				797.24
0000145126	BUNKER GEAR, CUSTOM NAME PLATE	345	19-Mar-2019	19-Mar-2019	
10-5-2010000-0423	PERSONAL PROTECTIVE EQUIPMENT				101.70
0000145183	EQUIPMENT	319	21-Mar-2019	21-Mar-2019	
10-5-2010000-0420	FIREFIGHTING EQUIPMENT				4,722.27
0000145658	BUNKER GEAR	406	17-Apr-2019	17-Apr-2019	
10-5-2010000-0423	PERSONAL PROTECTIVE EQUIPMENT				20,611.20
144533	FIRE EQUIPMENT PPV	204	14-Feb-2019	14-Feb-2019	
10-5-2010000-0420	FIREFIGHTING EQUIPMENT				3,315.05
<b>ALL020 ALLIED MEDICAL</b>					
157868	BVM/MEDICAL SUPPLIES	280	25-Feb-2019	25-Feb-2019	
10-5-2010000-0420	FIREFIGHTING EQUIPMENT				76.54
159396	N95 MASKS	525	06-May-2019	06-May-2019	
10-5-2010000-0423	PERSONAL PROTECTIVE EQUIPMENT				175.70
<b>ALP009 ALPINE SPECIALTY CHEMICALS LTD</b>					
0000514547	EXTRACTOR DETERGENT	62	10-Jan-2019	10-Jan-2019	
10-5-2010000-0318	JANITORIAL				263.09
<b>AND110 ANDERSON ROGER</b>					
771867	ENGINE 1 B	280	28-Feb-2019	28-Feb-2019	
10-5-2010000-0402	VEHICLE & EQUIPMENT MTCE.				210.75
771868	ENGINE 2	280	04-Mar-2019	04-Mar-2019	
10-5-2010000-0402	VEHICLE & EQUIPMENT MTCE.				146.90
771871	L1 SERVICE ISSUES/REPAIRS	280	06-Mar-2019	06-Mar-2019	
10-5-2010000-0402	VEHICLE & EQUIPMENT MTCE.				336.18
<b>AND601 ANDY CAP TRUCK STUFF</b>					
293815	CHIEF 3 VEHICLE REPAIR	481	07-Mar-2019	07-Mar-2019	
10-5-2010000-0402	VEHICLE & EQUIPMENT MTCE.				205.66
<b>BAI223 BAILEY SUZANNE</b>					
527701	TARPS FOR ENGINES	345	27-Mar-2019	27-Mar-2019	
10-5-2010000-0402	VEHICLE & EQUIPMENT MTCE.				439.12
<b>BAR240 BARRETTE'S SMALL ENGINES INC. - OLDCASTLE</b>					
555111	HONDA GENERATOR REPAIR	280	12-Mar-2019	12-Mar-2019	
10-5-2010000-0420	FIREFIGHTING EQUIPMENT				1,460.51
555396	SMALL PORTABLE PUMP REPAIR	389	11-Mar-2019	11-Mar-2019	
10-5-2010000-0402	VEHICLE & EQUIPMENT MTCE.				107.02
555455	SMALL ENGINE REPAIR	280	12-Mar-2019	12-Mar-2019	
10-5-2010000-0402	VEHICLE & EQUIPMENT MTCE.				94.73
<b>BRO291 BROOKER MARY ANNE</b>					
10	UNIFORM ALTERATIONS	204	26-Feb-2019	26-Feb-2019	
10-5-2010000-0252	UNIFORMS				15.00
21	PATCH SEWN ON	1607	15-Nov-2018	15-Nov-2018	
10-5-2010000-0252	UNIFORMS				3.00
25	UNIFORM REPAIR	280	27-Feb-2019	27-Feb-2019	
10-5-2010000-0252	UNIFORMS				10.00
31 (2019)	UNIFORM ALTERATIONS	406	22-Apr-2019	22-Apr-2019	
10-5-2010000-0252	UNIFORMS				30.00
41 (2019)	UNIFORM ALTERATION	511	25-Apr-2019	25-Apr-2019	
10-5-2010000-0252	UNIFORMS				10.00
51	ALTERATIONS	511	30-Apr-2019	30-Apr-2019	
10-5-2010000-0252	UNIFORMS				10.00
<b>CAN380 CANADIAN TIRE STORE #281</b>					





Vendor : CAT038 To ZUL180

Batch : All

Department : All

Cheque Print Date : 01-Jan-2019 To 31-May-2019

Bank : 1 To 99

Class : All

Vendor Invoice	Vendor Name Description	Batch	Inv Date	Inv Due Date	Amount
G.L. Account	CC1 CC2 CC3 GL Account Name				
<b>DEPARTMENT 2010000 FIRE DEPARTMENT</b>					
FEBRUARY 2019 FEBRUARY 2019 PURCHASES					
10-5-2010000-0322	GENERAL SUPPLIES	280	28-Feb-2019	28-Feb-2019	-16.93
10-5-2010000-0322	GENERAL SUPPLIES				-33.88
10-5-2010000-0322	GENERAL SUPPLIES				23.80
10-5-2010000-0318	JANITORIAL				67.77
10-5-2010000-0318	JANITORIAL				52.69
10-5-2010000-0318	JANITORIAL				231.22
10-5-2010000-0420	FIREFIGHTING EQUIPMENT				28.22
10-5-2010000-0420	FIREFIGHTING EQUIPMENT				41.87
10-5-2010000-0420	FIREFIGHTING EQUIPMENT				57.81
JANUARY 2019 JANUARY 2019 PURCHASES					
10-5-2010000-0402	VEHICLE & EQUIPMENT MTCE.	389	31-Jan-2019	31-Jan-2019	153.59
10-5-2010000-0420	FIREFIGHTING EQUIPMENT				225.89
10-5-2010000-0420	FIREFIGHTING EQUIPMENT				35.88
MARCH 2019 MARCH 2019 PURCHASES					
10-5-2010000-0322	GENERAL SUPPLIES	345	31-Mar-2019	31-Mar-2019	76.22
10-5-2010000-0322	GENERAL SUPPLIES				220.33
10-5-2010000-0402	VEHICLE & EQUIPMENT MTCE.				76.82
NOVEMBER 2018 NOVEMBER 2018 PURCHASES					
10-5-2010000-0800	EMERGENCY OPERATIONS CENTRE EXPENSES	133	31-Jan-2019	31-Jan-2019	57.61
10-5-2010000-0318	JANITORIAL				15.27
10-5-2010000-0318	JANITORIAL				29.90
10-5-2010000-0800	EMERGENCY OPERATIONS CENTRE EXPENSES				18.24
10-5-2010000-0420	FIREFIGHTING EQUIPMENT				6.77
OCTOBER 2018 OCTOBER 2018 INVOICES					
10-5-2010000-0420	FIREFIGHTING EQUIPMENT	1554	31-Oct-2018	31-Oct-2018	62.99
10-5-2010000-0301	OFFICE SUPPLIES				35.88
10-5-2010000-0420	FIREFIGHTING EQUIPMENT				65.48
10-5-2010000-0402	VEHICLE & EQUIPMENT MTCE.				55.34
<b>CAR13 CARPENTER DAVE</b>					
100101	FITNESS EQUIPMENT	389	04-Apr-2019	04-Apr-2019	
10-5-2010000-0322	GENERAL SUPPLIES				1,500.00
<b>CAR645 CARRIER CENTERS</b>					
05P502451	ELECTRICAL REPAIRS FOR KUSSAMUAL SYSTEMS	177	08-Feb-2019	08-Feb-2019	
10-5-2010000-0402	VEHICLE & EQUIPMENT MTCE.				214.75
05S502504.02	LADDER 1 AERIAL HYDRAULIC LINE REPAIRS (DEC 13, 2018)	137	31-Jan-2019	31-Jan-2019	
10-5-2010000-0402	VEHICLE & EQUIPMENT MTCE.				954.87
05S502505	E2 REPAIRS FROM 2018	389	18-Apr-2019	18-Apr-2019	
10-5-2010000-0402	VEHICLE & EQUIPMENT MTCE.				1,590.63
05S502553	VECHILE REPAIR	389	18-Apr-2019	18-Apr-2019	
10-5-2010000-0402	VEHICLE & EQUIPMENT MTCE.				145.77
<b>CHA260 CHAMPION PRODUCTS CORP.</b>					
1312296	MEDICAL CLEANING SUPPLIES	389	29-Mar-2019	29-Mar-2019	
10-5-2010000-0322	GENERAL SUPPLIES				148.10
<b>CIT1560 CITY OF CLARENCE-ROCKLAND</b>					
110381	EOC SPENDING	481	06-May-2019	06-May-2019	
10-5-2010000-0800	EMERGENCY OPERATIONS CENTRE EXPENSES				59,664.00
<b>CIT350 CITY OF WINDSOR</b>					
0000175946	FOAM	389	27-Mar-2019	27-Mar-2019	
10-5-2010000-0420	FIREFIGHTING EQUIPMENT				1,475.72
0000176108	ACCOUNTABLITY BOARD	406	09-Apr-2019	09-Apr-2019	
10-5-2010000-0318	JANITORIAL				640.84
175266	MLFTU MAINTENANCE	204	31-Dec-2018	31-Dec-2018	
10-5-2010000-0402	VEHICLE & EQUIPMENT MTCE.				271.20
<b>CLA231 CLARE'S MOBILE MARINE INC</b>					



## Council/Board Report By Dept-(Computer)



Vendor : CAT038 To ZUL180

Batch : All

Department : All

Cheque Print Date : 01-Jan-2019 To 31-May-2019

Bank : 1 To 99

Class : All

Vendor Invoice	Vendor Name Description				Batch Invc Date	Invc Due Date	Amount
G.L. Account	CC1	CC2	CC3	GL Account Name			
<b>DEPARTMENT 2010000</b>				FIRE DEPARTMENT			
1105				BOAT REPAIR	406 17-Apr-2019	17-Apr-2019	
10-5-2010000-0432				WATER RESCUE EQUIP/PROGRAM			282.50
<b>COL275 COLENUTT SIGNS LIMITED</b>							
3694				AFD WINDOW IDS	204 19-Feb-2019	19-Feb-2019	
10-5-2010000-0340				RECEPTIONS & AWARDS			508.50
<b>COU132 COUNTY TOWING INC.</b>							
18-00091				AUTO X	1523 19-Dec-2018	19-Dec-2018	
10-5-2010000-0402				VEHICLE & EQUIPMENT MTCE.			339.00
18-00092				AUTO X CARS	1523 19-Dec-2018	19-Dec-2018	
10-5-2010000-0402				VEHICLE & EQUIPMENT MTCE.			339.00
<b>COX123 COXON'S TOWING INC</b>							
19-00386				TRAINING AND PROF	406 19-Feb-2019	19-Feb-2019	
10-5-2010000-0351				TRAINING & PROF.DEVELOPMENT			282.50
<b>D&amp;D100 D &amp; D EXCAVATING &amp; DRAINAGE</b>							
364				EXCAVATION FOR FIRE INVESTIGATION	436 26-Mar-2019	26-Mar-2019	
10-5-2010000-0360				OFM INVESTIGATION			678.00
<b>DEL091 DELISLE SIGNS</b>							
3				SIGN	204 25-Feb-2019	25-Feb-2019	
10-5-2010000-0402				VEHICLE & EQUIPMENT MTCE.			146.90
<b>DIR572 DIRECTDIAL.COM</b>							
IN674213				PRESENTATION EQUIPMEMT	525 07-May-2019	07-May-2019	
10-5-2010000-0327				PROFESSIONAL FEES			1,109.66
<b>DON592 DONE-RIGHT SERVICES</b>							
13524				E2 AIR TANK REPAIR	250 08-Feb-2019	08-Feb-2019	
10-5-2010000-0402				VEHICLE & EQUIPMENT MTCE.			463.97
13655				L1 CHARGER REPLACEMENT	282 27-Feb-2019	27-Feb-2019	
10-5-2010000-0402				VEHICLE & EQUIPMENT MTCE.			2,626.71
14011				REPAIR TO BOAT TRAILER	525 29-Apr-2019	29-Apr-2019	
10-5-2010000-0402				VEHICLE & EQUIPMENT MTCE.			1,636.51
<b>DOW547 DOWLER KARN</b>							
475901				PROPANE REFILL	177 07-Feb-2019	07-Feb-2019	
10-5-2010000-0431				FIRE TRAINING SIMULATOR			41.73
868020				PROPANE	319 11-Mar-2019	11-Mar-2019	
10-5-2010000-0431				FIRE TRAINING SIMULATOR			267.89
<b>DRA755 DRAGER SAFETY CANADA LTD C/O TH1294C</b>							
907032603				DRAGER PARTS	62 07-Jan-2019	07-Jan-2019	
10-5-2010000-0420				FIREFIGHTING EQUIPMENT			392.68
907032630				DRAGER PARTS	62 08-Jan-2019	08-Jan-2019	
10-5-2010000-0402				VEHICLE & EQUIPMENT MTCE.			55.36
<b>DRF118 DR. FEDORUK'S PAIN CLINIC</b>							
104				MEDICALS - RECRUIT	204 23-Jan-2019	23-Jan-2019	
10-5-2010000-0254				FIRE FIGHTER TRAINING			600.00
<b>ERB168 E.R. (BILL) VOLLANS LTD.</b>							
46779				SAW REPAIR	406 28-Mar-2019	28-Mar-2019	
10-5-2010000-0402				VEHICLE & EQUIPMENT MTCE.			2,377.41
<b>EVE740 EVERBRIDGE INC.</b>							
M41942				EVERBRIDGE	319 28-Feb-2019	28-Feb-2019	
10-5-2010000-0800				EMERGENCY OPERATIONS CENTRE EXPENSES			9,831.00
<b>FCF160 FCFP</b>							
INV128318				EXTINGUISHER	406 15-Apr-2019	15-Apr-2019	
10-5-2010000-0402				VEHICLE & EQUIPMENT MTCE.			273.46
<b>FIR100 FIRE MARSHALL'S PUBLIC FIRE SAFETY COUNCIL</b>							

## Council/Board Report By Dept-(Computer)



Vendor : CAT038 To ZUL180

Batch : All

Department : All

Cheque Print Date : 01-Jan-2019 To 31-May-2019

Bank : 1 To 99

Class : All

Vendor Invoice	Vendor Name Description				Batch Invc Date	Invc Due Date	Amount
G.L. Account	CC1	CC2	CC3	GL Account Name			
<b>DEPARTMENT 2010000</b>	<b>FIRE DEPARTMENT</b>						
IN004848	PUBLIC SAFETY COUNCIL				62 11-Jan-2019	11-Jan-2019	
10-5-2010000-0350				MEMBERSHIPS			100.00
IN154303	PUBLIC EDUCATION MATERIAL				511 25-Apr-2019	25-Apr-2019	
10-5-2010000-0251				FIRE PREVENTION & TRAININ			1,152.60
<b>FIR530</b>	<b>FIREHALL BOOKSTORE A DIV. OF ANNEX BUSINESS MEDIA</b>						
BK0000072	EXAM PREP				280 01-Mar-2019	01-Mar-2019	
10-5-2010000-0254				FIRE FIGHTER TRAINING			90.19
BK0000770	TRAINING MANUALS				319 25-Feb-2019	25-Feb-2019	
10-5-2010000-0254				FIRE FIGHTER TRAINING			814.91
<b>FRO400</b>	<b>FRONTLINE OUTFITTERS</b>						
0000038818	PANTS				1523 15-Oct-2018	15-Oct-2018	
10-5-2010000-0252				UNIFORMS			724.02
0000040116	UNIFORMS				62 07-Jan-2019	07-Jan-2019	
10-5-2010000-0252				UNIFORMS			646.80
0000041809	UNIFORMS				406 23-Apr-2019	23-Apr-2019	
10-5-2010000-0252				UNIFORMS			3,030.16
<b>GRE330</b>	<b>GREAT LAKES SAFETY PRODUCTS</b>						
00318758	MAINTENANCE				389 28-Mar-2019	28-Mar-2019	
10-5-2010000-0402				VEHICLE & EQUIPMENT MTCE.			31.54
<b>HOG140</b>	<b>HOGAN'S PRINTING</b>						
27718	UNIFORM SHIRTS				1523 11-Oct-2018	11-Oct-2018	
10-5-2010000-0252				UNIFORMS			258.48
30286	UNIFORM COATS				1523 19-Dec-2018	19-Dec-2018	
10-5-2010000-0252				UNIFORMS			334.36
30287	UNIFORMS				1523 19-Dec-2018	19-Dec-2018	
10-5-2010000-0252				UNIFORMS			1,300.23
30528	COAT				204 19-Feb-2019	19-Feb-2019	
10-5-2010000-0252				UNIFORMS			167.18
<b>INT321</b>	<b>INTEGRITY INDUSTRIAL ABSORBENT PRODUCTS</b>						
3765	CONTAINMENT POOL				62 18-Jan-2019	18-Jan-2019	
10-5-2010000-0420				FIREFIGHTING EQUIPMENT			221.13
<b>ISL244</b>	<b>ISLAND VIEW MARINA</b>						
188289	BOAT REPAIR				406 06-Apr-2019	06-Apr-2019	
10-5-2010000-0432				WATER RESCUE EQUIP/PROGRAM			2,564.37
188772	MUSTANG SUITS				406 22-Apr-2019	22-Apr-2019	
10-5-2010000-0432				WATER RESCUE EQUIP/PROGRAM			1,589.12
189254	BOAT REPAIRS				511 01-May-2019	01-May-2019	
10-5-2010000-0402				VEHICLE & EQUIPMENT MTCE.			1,336.89
<b>KAL132</b>	<b>KAL TIRE 837 - WINDSOR</b>						
837140088	2 CUT TIRES ON ENGINE 2 - OUT OF SERVICE (DEC 13, 2018)				175 31-Jan-2019	31-Jan-2019	
10-5-2010000-0402				VEHICLE & EQUIPMENT MTCE.			2,850.61
837142966	STATION 3 ENGINE TIRE ISSUE AFTER HOURS				177 07-Jan-2019	07-Jan-2019	
10-5-2010000-0402				VEHICLE & EQUIPMENT MTCE.			346.01
837144183	E2 MAINTENANCE				204 16-Jan-2019	16-Jan-2019	
10-5-2010000-0402				VEHICLE & EQUIPMENT MTCE.			146.56
<b>KEL198</b>	<b>KELCOM RADIO DIVISION</b>						
80010161	RADIO AIR TIME				62 15-Jan-2019	15-Jan-2019	
10-5-2010000-0319				COMMUNICATION EQUIP MAINTENANCE			3,742.56
80010281	RADIO AIRTIME				204 15-Feb-2019	15-Feb-2019	
10-5-2010000-0324				DISPATCHING			3,742.56
80010398	PAGER SYSTEM				319 15-Mar-2019	15-Mar-2019	
10-5-2010000-0324				DISPATCHING			3,742.56



Vendor : CAT038 To ZUL180

Batch : All

Department : All

Cheque Print Date : 01-Jan-2019 To 31-May-2019

Bank : 1 To 99

Class : All

Vendor Invoice	Vendor Name Description	Batch	Inv Date	Inv Due Date	Amount
G.L. Account	CC1 CC2 CC3 GL Account Name				
<b>DEPARTMENT 2010000</b>	FIRE DEPARTMENT				
80010515	RADIO AIRTIME	406	15-Apr-2019	15-Apr-2019	
10-5-2010000-0319	COMMUNICATION EQUIP MAINTENANCE				3,742.56
<b>KEN122 KENT COMPRESSOR CO</b>					
029542	COMPRESSOR REPAIR	1554	18-Dec-2018	18-Dec-2018	
10-5-2010000-0402	VEHICLE & EQUIPMENT MTCE.				6,969.30
28836	COMPRESSOR MAINTENANCE	204	17-Sep-2018	17-Sep-2018	
10-5-2010000-0402	VEHICLE & EQUIPMENT MTCE.				721.13
29047	COMPRESSOR MAINTENANCE	204	17-Oct-2018	17-Oct-2018	
10-5-2010000-0402	VEHICLE & EQUIPMENT MTCE.				325.39
<b>MED100 MEDAL MOUNTING SERVICE</b>					
1864	MEDAL MOUNTING	250	20-Feb-2019	20-Feb-2019	
10-5-2010000-0340	RECEPTIONS & AWARDS				71.19
<b>MIN25 MINISTER OF FINANCE PAYMENT PROCESSING CENTRE</b>					
110904191133C	FIRE COLLEGE	406	09-Apr-2019	09-Apr-2019	
10-5-2010000-0254	FIRE FIGHTER TRAINING				390.00
111801191309C	FIRE COLLEGE FEES	177	18-Jan-2019	18-Jan-2019	
10-5-2010000-0254	FIRE FIGHTER TRAINING				195.00
<b>MLS149 M&amp;L SUPPLY FIRE &amp; SAFETY - 3635112</b>					
0000151922	RETURN - CLIPS SCBA	1523	20-Sep-2018	20-Sep-2018	
10-5-2010000-0420	FIREFIGHTING EQUIPMENT				-378.55
0000153331	PPE - GLOVES	1523	27-Dec-2018	27-Dec-2018	
10-5-2010000-0423	PERSONAL PROTECTIVE EQUIPMENT				2,215.13
0000153376	EQUIPMENT REPAIR	34	04-Jan-2019	04-Jan-2019	
10-5-2010000-0402	VEHICLE & EQUIPMENT MTCE.				33.35
153839	SMALL ENGINE REPAIR	204	12-Feb-2019	12-Feb-2019	
10-5-2010000-0402	VEHICLE & EQUIPMENT MTCE.				32.25
<b>MON183 MONARCH OFFICE SUPPLY LTD</b>					
122755	NOVEMBER 2018 PURCHASES	1606	29-Nov-2018	29-Nov-2018	
10-5-2010000-0251	FIRE PREVENTION & TRAININ				395.07
127289	DECEMBER 2018 PURCHASES	1607	31-Dec-2018	31-Dec-2018	
10-5-2010000-0251	FIRE PREVENTION & TRAININ				98.97
133006	JANUARY 2018 PURCHASES	176	30-Jan-2019	30-Jan-2019	
10-5-2010000-0420	FIREFIGHTING EQUIPMENT				1,796.34
138007	FEBRUARY 2019 PURCHASE	319	27-Feb-2019	27-Feb-2019	
10-5-2010000-0254	FIRE FIGHTER TRAINING				60.00
143523	MARCH 2019 PURCHASES	406	29-Mar-2019	29-Mar-2019	
10-5-2010000-0301	OFFICE SUPPLIES				139.70
<b>MOR26 MORNEAU SHEPELL LTD.</b>					
APRIL 2019 953243, 953244, 953245, 953246	APRIL 2019	347	01-Apr-2019	01-Apr-2019	
10-5-2010000-0207	BENEFITS - LIFE & DISABIL				507.54
FEBRUARY 20 921007, 921008, 921009, 921010	FEBRUARY 2019	135	01-Feb-2019	01-Feb-2019	
10-5-2010000-0207	BENEFITS - LIFE & DISABIL				507.54
JANUARY 2019 902738, 902739, 902740, 902741	JANUARY 2019	62	02-Jan-2019	02-Jan-2019	
10-5-2010000-0207	BENEFITS - LIFE & DISABIL				507.54
MARCH 2019 936899, 936900, 936901, 936902	MARCH 2019	280	01-Mar-2019	01-Mar-2019	
10-5-2010000-0207	BENEFITS - LIFE & DISABIL				507.54
MAY 2019 970411, 970412, 970413, 970414	MAY 2019	511	01-May-2019	01-May-2019	
10-5-2010000-0207	BENEFITS - LIFE & DISABIL				507.54
<b>MUN200 MUNICIPAL EMPLOYER PENSION CENTRE OF ONTARIO</b>					
MC004654	MEPCO 2019 E MPLOYEE CONTRIBUTION	15	02-Jan-2019	02-Jan-2019	
10-5-2010000-0350	MEMBERSHIPS				54.31
<b>NUC206 NUCLEAR SERVICES CANADA</b>					



Vendor : CAT038 To ZUL180  
 Batch : All  
 Department : All

Cheque Print Date : 01-Jan-2019 To 31-May-2019  
 Bank : 1 To 99  
 Class : All

Vendor Invoice	Vendor Name Description	Batch	Inv Date	Inv Due Date	Amount
G.L. Account	CC1 CC2 CC3 GL Account Name				
<b>DEPARTMENT 2010000</b>	FIRE DEPARTMENT				
1526	METER CALIBRATION LUDLUMS	389	03-Apr-2019	03-Apr-2019	
10-5-2010000-0800	EMERGENCY OPERATIONS CENTRE EXPENSES				734.50
<b>OFC066</b>	<b>OFCAAA C/O GREATER NAPANEE EMERGENCY SERVICE</b>				
FEBRUARY 20 MEMBERSHIP RENEWAL 2019		250	28-Feb-2019	28-Feb-2019	
10-5-2010000-0350	MEMBERSHIPS				45.00
<b>OKT366</b>	<b>OK TIRE STORE - SANTING</b>				
0000179059	TRUCK CLEANER	62	17-Jan-2019	17-Jan-2019	
10-5-2010000-0318	JANITORIAL				84.75
<b>OTW045</b>	<b>O-TWO MEDICAL TECHNOLOGIES INC</b>				
INV-009828	OR REGULATORS	345	07-Feb-2019	07-Feb-2019	
10-5-2010000-0420	FIREFIGHTING EQUIPMENT				841.31
<b>PRI100</b>	<b>PRINCESS AUTO</b>				
1154267	ACCOUNTABILITY EQUIPMENT	481	24-Apr-2019	24-Apr-2019	
10-5-2010000-0420	FIREFIGHTING EQUIPMENT				144.56
<b>RTT067</b>	<b>RIVER TOWN TIMES</b>				
1006	ADVERTISING	34	10-Jan-2019	10-Jan-2019	
10-5-2010000-0307	ADVERTISING				141.00
1034	ADVERTISING	62	16-Jan-2019	16-Jan-2019	
10-5-2010000-0307	ADVERTISING				141.00
1921	ADVERTISING	481	01-May-2019	01-May-2019	
10-5-2010000-0800	EMERGENCY OPERATIONS CENTRE EXPENSES				141.02
1950	ADVERTISING	525	08-May-2019	08-May-2019	
10-5-2010000-0800	EMERGENCY OPERATIONS CENTRE EXPENSES				87.26
<b>SAN107</b>	<b>SANIGEAR</b>				
1554	GEAR CLEANING	62	14-Jan-2019	14-Jan-2019	
10-5-2010000-0423	PERSONAL PROTECTIVE EQUIPMENT				311.20
1986	PPE ANNUAL	389	30-Mar-2019	30-Mar-2019	
10-5-2010000-0423	PERSONAL PROTECTIVE EQUIPMENT				219.67
2074	GEAR REPAIR	406	11-Apr-2019	11-Apr-2019	
10-5-2010000-0423	PERSONAL PROTECTIVE EQUIPMENT				523.30
2206	PPE	511	08-May-2019	08-May-2019	
10-5-2010000-0423	PERSONAL PROTECTIVE EQUIPMENT				536.41
2231	PPE MAINTENANCE	511	10-May-2019	10-May-2019	
10-5-2010000-0423	PERSONAL PROTECTIVE EQUIPMENT				220.35
<b>SKY232</b>	<b>SKY MOBILE</b>				
AR11385	TELEMATICS	406	05-Apr-2019	05-Apr-2019	
10-5-2010000-0424	COMMUNICATON EQUIPMENT				5,841.54
SKY01N1718	FLEET TRACKING SKY MOBILE	511	03-May-2019	03-May-2019	
10-5-2010000-0424	COMMUNICATON EQUIPMENT				203.40
SKY01N1523	FLEET TRACKING	511	01-May-2019	01-May-2019	
10-5-2010000-0424	COMMUNICATON EQUIPMENT				398.89
<b>STA444</b>	<b>STAPLES ADVANTAGE (MIS C/O T04446C</b>				
49931440	BATTERIES	406	12-Mar-2019	12-Mar-2019	
10-5-2010000-0318	JANITORIAL				157.94
<b>STR045</b>	<b>STRYKER CA LP</b>				
72247	MAINTENANCE	280	27-Feb-2019	27-Feb-2019	
10-5-2010000-0402	VEHICLE & EQUIPMENT MTCE.				245.89
<b>SUN16</b>	<b>SUN PARLOUR CHAPTER OBOA</b>				
JANUARY 25, FIRE ALARM SYSTEM COURSE FEB 11 AND 12, 2019		62	25-Jan-2019	25-Jan-2019	
10-5-2010000-0251	FIRE PREVENTION & TRAININ				400.00
<b>SUN293</b>	<b>SUNSET ENTERPRIZE &amp; WELDING</b>				
318189	CURTAINS FOR PROTECTION FOR PPE	34	04-Jan-2019	04-Jan-2019	

Council/Board Report By Dept-(Computer)



Vendor : CAT038 To ZUL180

Batch : All

Department : All

Cheque Print Date : 01-Jan-2019 To 31-May-2019

Bank : 1 To 99

Class : All

Vendor Invoice	Vendor Name Description	Batch	Inv Date	Inv Due Date	Amount
G.L. Account	CC1 CC2 CC3 GL Account Name				
<b>DEPARTMENT 2010000</b>	<b>FIRE DEPARTMENT</b>				
10-5-2010000-0420	FIREFIGHTING EQUIPMENT				2,332.32
<b>THA150 THAMES COMMUNICATIONS</b>					
CHA20IN9662 PAGER REPAIR		34	11-Jan-2019	11-Jan-2019	
10-5-2010000-0319	COMMUNICATION EQUIP MAINTENANCE				71.19
CHA20IN9665 PAGER REPAIR		105	25-Jan-2019	25-Jan-2019	
10-5-2010000-0319	COMMUNICATION EQUIP MAINTENANCE				71.19
CHA20IN9715 PAGER CLIPS		252	01-Mar-2019	01-Mar-2019	
10-5-2010000-0324	DISPATCHING				169.50
CHA20IN9815 PAGER REPAIR		406	18-Apr-2019	18-Apr-2019	
10-5-2010000-0319	COMMUNICATION EQUIP MAINTENANCE				85.15
<b>THO03 THOMAS R MORAND MARINE SERVICES</b>					
217330 MARINE INSPECTION/SURVEY OF BOAT		250	26-Feb-2019	26-Feb-2019	
10-5-2010000-0432	WATER RESCUE EQUIP/PROGRAM				375.41
<b>THR251 THRASHER SALES &amp; LEASING LTD</b>					
228898 OIL CHANGE		62	18-Jan-2019	18-Jan-2019	
10-5-2010000-0402	VEHICLE & EQUIPMENT MTCE.				47.01
229075 MINVAN SERVICE		177	30-Jan-2019	30-Jan-2019	
10-5-2010000-0402	VEHICLE & EQUIPMENT MTCE.				73.62
<b>ULI350 ULINE CANADA CORPORATION</b>					
5032750 SCENE SUPPLIES		62	10-Jan-2019	10-Jan-2019	
10-5-2010000-0318	JANITORIAL				427.00
5146878 JANITORIAL		406	15-Feb-2019	15-Feb-2019	
10-5-2010000-0318	JANITORIAL				939.06
5220725 JANITORIAL SUPPLIES		319	12-Mar-2019	12-Mar-2019	
10-5-2010000-0318	JANITORIAL				517.88
5324780 VELCRO		406	11-Apr-2019	11-Apr-2019	
10-5-2010000-0318	JANITORIAL				147.50
5351657 VELCRO		481	22-Apr-2019	22-Apr-2019	
10-5-2010000-0318	JANITORIAL				200.30
5356718 CONES		481	23-Apr-2019	23-Apr-2019	
10-5-2010000-0318	JANITORIAL				292.06
5392061 FF EQUIPMENT		511	03-May-2019	03-May-2019	
10-5-2010000-0420	FIREFIGHTING EQUIPMENT				274.88
<b>VAL104 VALLEN CANADA INC</b>					
29280516-00 COMPRESSOR MAINTENANCE		204	24-Jan-2019	24-Jan-2019	
10-5-2010000-0402	VEHICLE & EQUIPMENT MTCE.				2,018.85
<b>WEB122 WEBPLANET.CA</b>					
FB004380 2 BALANCE OWING		1523	30-Jul-2018	30-Jul-2018	
10-5-2010000-0307	ADVERTISING				2,260.00
FB004886 WEPLANET PHASE 2		1607	17-Dec-2018	17-Dec-2018	
10-5-2010000-0307	ADVERTISING				3,390.00
FB005039 SUPPORT AND MANAGING WEBSITE YEARLY FEES		176	01-Feb-2019	01-Feb-2019	
10-5-2010000-0307	ADVERTISING				791.00
<b>WIG035 WIGLE HOME HARDWARE BUILDING CENTRE</b>					
121143 MAINTENANCE SUPPLIES		1595	30-Jul-2018	30-Jul-2018	
10-5-2010000-0402	VEHICLE & EQUIPMENT MTCE.				13.36
121343 MISC EQUIPMENT		1595	07-Aug-2018	07-Aug-2018	
10-5-2010000-0402	VEHICLE & EQUIPMENT MTCE.				3.16
122655 COMMUNICATION EQUIPMENT		1595	18-Sep-2018	18-Sep-2018	
10-5-2010000-0424	COMMUNICATON EQUIPMENT				219.74
126000 FUEL STABILIZER		1523	28-Dec-2018	28-Dec-2018	
10-5-2010000-0402	VEHICLE & EQUIPMENT MTCE.				10.16
126122 STATION SUPPLIES		62	04-Jan-2019	04-Jan-2019	



Vendor : CAT038 To ZUL180

Batch : All

Department : All

Cheque Print Date : 01-Jan-2019 To 31-May-2019

Bank : 1 To 99

Class : All

Vendor Invoice	Vendor Name Description	Batch	Inv Date	Inv Due Date	Amount
G.L. Account	CC1 CC2 CC3 GL Account Name				
<b>DEPARTMENT 2010000 FIRE DEPARTMENT</b>					
10-5-2010000-0318	JANITORIAL				29.37
127001	MISC REPAIRS	176	03-Feb-2019	03-Feb-2019	
10-5-2010000-0402	VEHICLE & EQUIPMENT MTCE.				46.84
127003	CREDIT	176	03-Feb-2019	03-Feb-2019	
10-5-2010000-0420	FIREFIGHTING EQUIPMENT				-12.98
127176	NOZZLES FOR STATION 3	176	08-Feb-2019	08-Feb-2019	
10-5-2010000-0420	FIREFIGHTING EQUIPMENT				45.18
127295	STATION SUPPLIES	204	12-Feb-2019	12-Feb-2019	
10-5-2010000-0318	JANITORIAL				11.29
127386	KEYS FOR MLFTU	204	14-Feb-2019	14-Feb-2019	
10-5-2010000-0431	FIRE TRAINING SIMULATOR				16.57
127387	JANITORIAL SUPPLIES	204	14-Feb-2019	14-Feb-2019	
10-5-2010000-0318	JANITORIAL				21.10
127495	CLEANING SUPPLIES	204	20-Feb-2019	20-Feb-2019	
10-5-2010000-0318	JANITORIAL				24.84
127614	MISC REPAIRS TO MLFTU	250	25-Feb-2019	25-Feb-2019	
10-5-2010000-0431	FIRE TRAINING SIMULATOR				18.40
127904	SUPPLIES	280	06-Mar-2019	06-Mar-2019	
10-5-2010000-0420	FIREFIGHTING EQUIPMENT				73.88
127934	VALVE FOR MLFTU	280	07-Mar-2019	07-Mar-2019	
10-5-2010000-0431	FIRE TRAINING SIMULATOR				16.94
128349	STEP LADDER FOR ENFINE 1	389	20-Mar-2019	20-Mar-2019	
10-5-2010000-0420	FIREFIGHTING EQUIPMENT				73.44
128770	GENERAL HARDWARE SUPPLIES	389	03-Apr-2019	03-Apr-2019	
10-5-2010000-0402	VEHICLE & EQUIPMENT MTCE.				20.45
129920	FF EQUIPMENT	511	06-May-2019	06-May-2019	
10-5-2010000-0420	FIREFIGHTING EQUIPMENT				6.77
<b>WIN101 WINDSOR SPRING &amp; ALIGNMENT</b>					
3356	E1	1523	01-Oct-2018	01-Oct-2018	
10-5-2010000-0402	VEHICLE & EQUIPMENT MTCE.				345.51
4485	LADDER 1 NOT CHARGING	176	23-Jan-2019	23-Jan-2019	
10-5-2010000-0402	VEHICLE & EQUIPMENT MTCE.				230.34
5046	WINDSOR SPRING E 1 ANNUAL	389	01-Apr-2019	01-Apr-2019	
10-5-2010000-0402	VEHICLE & EQUIPMENT MTCE.				3,600.54
5082	SAFETY SUPPORT 2	406	05-Apr-2019	05-Apr-2019	
10-5-2010000-0402	VEHICLE & EQUIPMENT MTCE.				152.78
5145	SAFETY SUPPORT 3	406	11-Apr-2019	11-Apr-2019	
10-5-2010000-0402	VEHICLE & EQUIPMENT MTCE.				152.78
5400	TANKER 3 INSPECTION	525	13-May-2019	13-May-2019	
10-5-2010000-0402	VEHICLE & EQUIPMENT MTCE.				1,685.03
<b>WIN210 WINDSOR FACTORY SUPPLY LTD</b>					
4950885	BURN GEL PACK ENGINE 1	176	29-Jan-2019	29-Jan-2019	
10-5-2010000-0420	FIREFIGHTING EQUIPMENT				326.57
5008997	SAWZALL BLADES	481	24-Apr-2019	24-Apr-2019	
10-5-2010000-0420	FIREFIGHTING EQUIPMENT				104.41
<b>WIN380 WINDSOR TIRE INC.</b>					
W081922	VALVE TIRE EXTENSIONS	1523	18-Dec-2018	18-Dec-2018	
10-5-2010000-0402	VEHICLE & EQUIPMENT MTCE.				50.85
<b>WOR415 WORK AUTHORITY</b>					
477851	WORK BOOTS	389	09-Feb-2019	09-Feb-2019	
10-5-2010000-0252	UNIFORMS				150.00
500772	WORK BOOTS	1523	16-Dec-2018	16-Dec-2018	
10-5-2010000-0420	FIREFIGHTING EQUIPMENT				150.00





Vendor : CAT038 To ZUL180

Batch : All

Department : All

Cheque Print Date : 01-Jan-2019 To 31-May-2019

Bank : 1 To 99

Class : All

Vendor Invoice	Vendor Name Description	Batch	Inv Date	Inv Due Date	Amount
G.L. Account	CC1 CC2 CC3 GL Account Name				
<b>DEPARTMENT 2010000 FIRE DEPARTMENT</b>					
507185	SAFETY BOOTS	62	20-Jan-2019	20-Jan-2019	
10-5-2010000-0252	UNIFORMS				225.08
508774	SAFETY SHOES	105	27-Jan-2019	27-Jan-2019	
10-5-2010000-0423	PERSONAL PROTECTIVE EQUIPMENT				187.57
512177	WORK BOOTS	204	10-Feb-2019	10-Feb-2019	
10-5-2010000-0252	UNIFORMS				146.89
516633	CLOTHING	252	03-Mar-2019	03-Mar-2019	
10-5-2010000-0252	UNIFORMS				300.00
519619	WORK BOOTS	319	17-Mar-2019	17-Mar-2019	
10-5-2010000-0252	UNIFORMS				150.00
522627	WORK BOOTS	389	31-Mar-2019	31-Mar-2019	
10-5-2010000-0252	UNIFORMS				150.00
528718	SAFETY BOOTS	406	21-Apr-2019	21-Apr-2019	
10-5-2010000-0252	UNIFORMS				168.81
535191	PPE	525	19-May-2019	19-May-2019	
10-5-2010000-0423	PERSONAL PROTECTIVE EQUIPMENT				206.33
<b>Department Totals :</b>					<b>213,335.52</b>
-----					
<b>DEPARTMENT 2012018 CAPITAL</b>					
<b>DOW547 DOWLER KARN</b>					
474316	PROPANE	1523	22-Aug-2018	22-Aug-2018	
40-7-2012018-0004	TRAINING SIMULATOR				339.52
<b>Department Totals :</b>					<b>339.52</b>
-----					
<b>DEPARTMENT 2020000 POLICE DEPARTMENT</b>					
<b>ACC134 ACCESS DOORS N MORE</b>					
39464	SUPPLY & INSTALL VARIOUS DOORS - POLICE	204	05-Dec-2018	05-Dec-2018	
10-5-2020000-0317	BUILDING MAINTENANCE				3,333.50
<b>ADT615 ADT SECURITY SERVICES CANADA INC.</b>					
9025790	ALARM MONITORING	62	02-Jan-2019	02-Jan-2019	
10-5-2020000-0317	BUILDING MAINTENANCE				161.67
<b>AGR835 AGRIS CO-OPERATIVE LTD</b>					
600055871	GASOLINE	1606	11-Dec-2018	11-Dec-2018	
10-5-2020000-0401	GASOLINE				991.99
600056210	GASOLINE	1606	31-Dec-2018	31-Dec-2018	
10-5-2020000-0401	GASOLINE				293.20
<b>CAN380 CANADIAN TIRE STORE #281</b>					
MARCH 2019	MARCH 2019 PURCHASES	345	31-Mar-2019	31-Mar-2019	
10-5-2020000-0317	BUILDING MAINTENANCE				6.20
NOVEMBER 2018	NOVEMBER 2018 PURCHASES	133	31-Jan-2019	31-Jan-2019	
10-5-2020000-0317	BUILDING MAINTENANCE				25.96
OCTOBER 2018	OCTOBER 2018 INVOICES	1554	31-Oct-2018	31-Oct-2018	
10-5-2020000-0402	VEHICLE & EQUIPMENT MTCE.				372.89
10-5-2020000-0360	MISCELLANEOUS EXPENSES				33.89
<b>CAN762 CANADIAN AMMUNITION DISPOSAL SERVICES</b>					
C-181105-B	DISPOSAL OF NARCOTICS (NOV 13, 2018)	104	02-Jan-2019	02-Jan-2019	
10-5-2020000-0334	INVESTIGATION EXPENSE				1,412.50
<b>CAN890 CANADIAN POLICE COLLEGE; ATTN: FINANCE</b>					
191165096		345	31-Mar-2019	31-Mar-2019	
10-5-2020000-0254	POLICE TRAINING				3,445.07
<b>CIT350 CITY OF WINDSOR</b>					
0000174740	4TH QUARTER BILLING AS PER ESSEX COUNTY JOINT FORCES COURT SERVICES	1606	06-Dec-2018	06-Dec-2018	





Vendor : CAT038 To ZUL180

Batch : All

Department : All

Cheque Print Date : 01-Jan-2019 To 31-May-2019

Bank : 1 To 99

Class : All

Vendor Invoice	Vendor Name Description				Batch Invc Date	Invc Due Date	Amount
G.L. Account	CC1	CC2	CC3	GL Account Name			
<b>DEPARTMENT 2020000</b>				POLICE DEPARTMENT			
10-5-2020000-0323				JOINT COURT COSTS			6,250.00
0000174869				WINDSOR/AMHERSTBURG DISPATCH ANNUAL FEE	1606 20-Dec-2018	20-Dec-2018	
10-5-2020000-0324				DISPATCHING - POLICE			71,500.00
<b>COR251</b>				<b>THE CORPORATION OF THE CITY OF WINDSOR -</b>			
FEB 19, 2019				OVERESTIMATED FUNDS - QUARTER 1	204 19-Feb-2019	19-Feb-2019	
10-4-2020000-0750				PROVINCIAL OFFENCES REVENUE			14,091.04
<b>DEL060</b>				<b>DELINE'S POWERWASH &amp; PEST CONTROL</b>			
234102				PESTICIDE APPLICATION	406 13-Apr-2019	13-Apr-2019	
10-5-2020000-0317				BUILDING MAINTENANCE			226.00
<b>DIR572</b>				<b>DIRECTDIAL.COM</b>			
IN659293				PRINTER MAINTENANCE AND USAGE	134 25-Jan-2019	25-Jan-2019	
10-5-2020000-0308				PHOTOCOPIER SUPPLIES			72.85
<b>EMC530</b>				<b>EMCO CORPORATION</b>			
126503-00				PLUMBING REPAIRS	389 26-Mar-2019	26-Mar-2019	
10-5-2020000-0317				BUILDING MAINTENANCE			-293.80
37591318-00				MAINTENANCE	389 19-Mar-2019	19-Mar-2019	
10-5-2020000-0317				BUILDING MAINTENANCE			15.39
37591385-00				MAINTENANCE	389 21-Mar-2019	21-Mar-2019	
10-5-2020000-0317				BUILDING MAINTENANCE			137.41
37591413-00				MAINTENANCE	389 21-Mar-2019	21-Mar-2019	
10-5-2020000-0317				BUILDING MAINTENANCE			309.52
37591950-00				MAINTENANCE SUPPLIES	436 26-Mar-2019	26-Mar-2019	
10-5-2020000-0317				BUILDING MAINTENANCE			438.44
<b>FUN710</b>				<b>FUNDEX INVESTMENTS</b>			
JANUARY 21, ; RRSP AGF 40523118					38 21-Jan-2019	21-Jan-2019	
10-5-2020000-0360				MISCELLANEOUS EXPENSES			40,137.00
<b>G4S405</b>				<b>G4S SECURE SOLUTIONS (CANADA) LTD</b>			
10213970				PRISON GUARDS	1606 08-Dec-2018	08-Dec-2018	
10-5-2020000-0371				PRISONER EXPENSES			113.00
<b>HEC021</b>				<b>CONVERGINT TECHNOLOGIES LTD</b>			
W670906				BUILDING MAINTENANCE	436 30-Apr-2019	30-Apr-2019	
10-5-2020000-0317				BUILDING MAINTENANCE			2,280.00
<b>HER247</b>				<b>HERITAGE TIRE SALES INC.</b>			
118204				CAR MAINTENANCE	1606 04-Sep-2018	04-Sep-2018	
10-5-2020000-0405				VEHICLE MTCE. - TIRES			45.20
AIN0001061				MAINTENANCE	1606 10-Dec-2018	10-Dec-2018	
10-5-2020000-0405				VEHICLE MTCE. - TIRES			84.75
<b>INT409</b>				<b>INTEGRYS LIMITED LOCKBOX T9009</b>			
SI102740				MAINTENANCE SUPPLIES	1607 19-Nov-2018	19-Nov-2018	
10-5-2020000-0310				COMPUTER MAINTENANCE			576.30
SI102815				BODY WORN CAMERA REPLACEMENT	1607 06-Dec-2018	06-Dec-2018	
10-5-2020000-0310				COMPUTER MAINTENANCE			288.15
<b>JAN268</b>				<b>JANI SAFE INC.</b>			
190958				JANITORIAL SUPPLIES WINDSOR POLICE	525 16-May-2019	16-May-2019	
10-5-2020000-0318				JANITORIAL			139.20
<b>JOH441</b>				<b>JOHNSTONE &amp; COWLING MANAGEMENT INC</b>			
2002984				LEGAL FEES	1607 07-Dec-2018	07-Dec-2018	
10-5-2020000-0325				LEGAL FEES			39,940.42
2002988				LEGAL FEES	1607 06-Dec-2018	06-Dec-2018	
10-5-2020000-0325				LEGAL FEES			34,428.28
<b>KEL198</b>				<b>KELCOM RADIO DIVISION</b>			
80010117				MAINTENANCE CONTRACT	1606 19-Dec-2018	19-Dec-2018	



Vendor : CAT038 To ZUL180

Batch : All

Department : All

Cheque Print Date : 01-Jan-2019 To 31-May-2019

Bank : 1 To 99

Class : All

Vendor Invoice	Vendor Name Description	Batch	Inv Date	Inv Due Date	Amount
G.L. Account	CC1 CC2 CC3 GL Account Name				
<b>DEPARTMENT 2020000 POLICE DEPARTMENT</b>					
10-5-2020000-0319					
	RADIO MAINTENANCE				571.78
80010118	MAINTENANCE CONTRACT	1606	19-Dec-2018	19-Dec-2018	
10-5-2020000-0319					
	RADIO MAINTENANCE				197.75
80010163	MAINTENANCE CONTRACT	62	15-Jan-2019	15-Jan-2019	
10-5-2020000-0319					
	RADIO MAINTENANCE				571.78
80010164	MAINTENANCE CONTRACT	62	15-Jan-2019	15-Jan-2019	
10-5-2020000-0319					
	RADIO MAINTENANCE				197.75
80010283	MAINTENANCE CONTRACT	345	15-Feb-2019	15-Feb-2019	
10-5-2020000-0319					
	RADIO MAINTENANCE				571.78
80010284	MAINTENANCE CONTRACT	345	15-Feb-2019	15-Feb-2019	
10-5-2020000-0319					
	RADIO MAINTENANCE				197.75
80010400	POLICE RADIO LOCAL INFRASTRUCTURE SERVICES CONTRACT	511	15-Mar-2019	15-Mar-2019	
10-5-2020000-0319					
	RADIO MAINTENANCE				571.78
80010401	POLICE RADIO BACKHAUL MAINTENANCE CONTRACT	511	15-Mar-2019	15-Mar-2019	
10-5-2020000-0319					
	RADIO MAINTENANCE				197.75
80010517	POLICE RADIO LOCAL INFRASTRUCTURE SERVICE CONTRACT	511	15-Apr-2019	15-Apr-2019	
10-5-2020000-0319					
	RADIO MAINTENANCE				571.78
80010518	POLICE RADIO BACKHAUL MAINTENANCE CONTRACT	511	15-Apr-2019	15-Apr-2019	
10-5-2020000-0319					
	RADIO MAINTENANCE				197.75
<b>KEL363 KEL COMMUNICATIONS LTD</b>					
RC00004359	CALDWELL SITE TOWER LEASE	511	01-Jan-2019	01-Jan-2019	
10-5-2020000-0319					
	RADIO MAINTENANCE				435.10
RC00004387	CALDWELL SITE TOWER LEASE	511	01-Feb-2019	01-Feb-2019	
10-5-2020000-0319					
	RADIO MAINTENANCE				444.06
RC00004413	CALDWELL TOWER LEASE	511	01-Mar-2019	01-Mar-2019	
10-5-2020000-0319					
	RADIO MAINTENANCE				444.06
RC00004439	CALDWELL SITE TOWER LEASE	511	01-Apr-2019	01-Apr-2019	
10-5-2020000-0319					
	RADIO MAINTENANCE				444.06
RC00004467	CALDWELL SITE TOWER LEASE	511	01-May-2019	01-May-2019	
10-5-2020000-0319					
	RADIO MAINTENANCE				444.06
<b>LIB174 LIBRO CREDIT UNION</b>					
JANUARY 21, ; RRSP VARIABLE #1 3003233		38	21-Jan-2019	21-Jan-2019	
10-5-2020000-0360					
	MISCELLANEOUS EXPENSES				64,200.00
<b>LUC289 LUCAS WORKS! (WINDSOR) INC.</b>					
115932	BOARD SECRETARY	1606	31-Dec-2018	31-Dec-2018	
10-5-2020000-0327					
	PROFESSIONAL FEES				4,771.26
115950	BOARD SECRETARY	1606	31-Dec-2018	31-Dec-2018	
10-5-2020000-0327					
	PROFESSIONAL FEES				126.65
<b>LUM131 LUMED MANAGEMENT</b>					
4446	VEHICLE MAINTENANCE	1606	30-Nov-2018	30-Nov-2018	
10-5-2020000-0402					
	VEHICLE & EQUIPMENT MTCE.				187.11
4539	VEHICLE MAINTENANCE	1606	31-Dec-2018	31-Dec-2018	
10-5-2020000-0402					
	VEHICLE & EQUIPMENT MTCE.				143.08
<b>MAL256 MALDEN AUTOMOTIVE</b>					
5294-180339	VEHICLE REPAIR	1607	06-Nov-2018	06-Nov-2018	
10-5-2020000-0402					
	VEHICLE & EQUIPMENT MTCE.				7.51
5294-180869	VEHICLE MAINTENANCE	1607	13-Nov-2018	13-Nov-2018	
10-5-2020000-0402					
	VEHICLE & EQUIPMENT MTCE.				239.97
<b>MAN225 MANULIFE SECURITIES</b>					
JANUARY 21, ; ACCOUNT # N88-1032-R - RRSP		38	21-Jan-2019	21-Jan-2019	
10-5-2020000-0360					
	MISCELLANEOUS EXPENSES				108,742.00
<b>MAS108 MASTER CLEANERS</b>					
7873	UNIFORM CLEANING	1606	30-Nov-2018	30-Nov-2018	



Vendor : CAT038 To ZUL180

Batch : All

Department : All

Cheque Print Date : 01-Jan-2019 To 31-May-2019

Bank : 1 To 99

Class : All

Vendor Invoice	Vendor Name Description				Batch Invc Date	Invc Due Date	Amount
G.L. Account	CC1	CC2	CC3	GL Account Name			
<b>DEPARTMENT 2020000</b>				POLICE DEPARTMENT			
10-5-2020000-0253				CLEANING			48.82
7905				UNIFORM CLEANING	1606 31-Dec-2018	31-Dec-2018	
10-5-2020000-0253				CLEANING			15.26
<b>MET052 METRO KING PEST CONTROL INC.</b>							
2145				MONTHLY SERVICE AT VARIOUS LOCATIONS	1606 30-Nov-2018	30-Nov-2018	
10-5-2020000-0317				BUILDING MAINTENANCE			33.90
2147				MONTHLY SERVICE AT VARIOUS LOCATIONS	345 28-Feb-2019	28-Feb-2019	
10-5-2020000-0317				BUILDING MAINTENANCE			33.90
2148				MONTHLY SERVICE AT VARIOUS LOCATIONS	345 31-Mar-2019	31-Mar-2019	
10-5-2020000-0317				BUILDING MAINTENANCE			33.90
<b>MIK315 MIKE'S COMPUTER SHOP</b>							
WIN-245037				UPS REPLACEMENT FOR CAMERA SERVICE & REPLACEMENT KVM FOR LIBRO SERVERS	1554 13-Dec-2018	13-Dec-2018	
10-5-2020000-0310				COMPUTER MAINTENANCE			200.10
<b>MIN107 MINISTER OF FINANCE ONTARIO POLICE COLLEGE</b>							
084187				POLICE COURSE	1606 21-Nov-2018	21-Nov-2018	
10-5-2020000-0254				POLICE TRAINING			60.00
084271				POLICE COURSE	1606 27-Nov-2018	27-Nov-2018	
10-5-2020000-0254				POLICE TRAINING			2,770.00
084514				POLICE COURSE	1606 11-Dec-2018	11-Dec-2018	
10-5-2020000-0254				POLICE TRAINING			960.00
<b>MIN25 MINISTER OF FINANCE PAYMENT PROCESSING CENTRE</b>							
110712181046				OPTIC 4TH QUARTER 2018	1606 07-Dec-2018	07-Dec-2018	
10-5-2020000-0329				OPTIC MAINTENANCE			7,380.29
114128				GENERAL MAINTENANCE	62 11-Jan-2019	11-Jan-2019	
10-5-2020000-0317				BUILDING MAINTENANCE			1,544.52
<b>MON183 MONARCH OFFICE SUPPLY LTD</b>							
122755				NOVEMBER 2018 PURCHASES	1606 29-Nov-2018	29-Nov-2018	
10-5-2020000-0301				OFFICE SUPPLIES			331.38
127289				DECEMBER 2018 PURCHASES	1607 31-Dec-2018	31-Dec-2018	
10-5-2020000-0301				OFFICE SUPPLIES			278.43
<b>MOR26 MORNEAU SHEPELL LTD.</b>							
APRIL 2019 953243, 953244, 953245, 953246				APRIL 2019	347 01-Apr-2019	01-Apr-2019	
10-5-2020000-0207				BENEFITS - LIFE & DISABIL			41.61
FEBRUARY 20 921007, 921008, 921009, 921010				FEBRUARY 2019	135 01-Feb-2019	01-Feb-2019	
10-5-2020000-0207				BENEFITS - LIFE & DISABIL			41.61
JANUARY 2019 902738, 902739, 902740, 902741				JANUARY 2019	62 02-Jan-2019	02-Jan-2019	
10-5-2020000-0207				BENEFITS - LIFE & DISABIL			282.90
MARCH 2019 936899, 936900, 936901, 936902				MARCH 2019	280 01-Mar-2019	01-Mar-2019	
10-5-2020000-0207				BENEFITS - LIFE & DISABIL			41.61
MAY 2019 970411, 970412, 970413, 970414				MAY 2019	511 01-May-2019	01-May-2019	
10-5-2020000-0207				BENEFITS - LIFE & DISABIL			41.61
<b>MOU001 MOUSSEAU DELUCA McPHERSON PRINCE</b>							
59124				LEGAL FEES	296 28-Feb-2019	28-Feb-2019	
10-5-2020000-0325				LEGAL FEES			576.30
<b>MSJ355 MSJ AUTOMOTIVE SERVICE LTD</b>							
105445				MAINTENANCE	1607 26-Oct-2018	26-Oct-2018	
10-5-2020000-0402				VEHICLE & EQUIPMENT MTCE.			640.06
<b>PAR372 PARRLINE ELECTRICAL WHOLESALE</b>							
80145				ELECTRICAL SUPPLIES	177 14-Jan-2019	14-Jan-2019	
10-5-2020000-0317				BUILDING MAINTENANCE			364.03
<b>PUR700 PUROLATOR INC.</b>							



Vendor : CAT038 To ZUL180  
 Batch : All  
 Department : All

Cheque Print Date : 01-Jan-2019 To 31-May-2019  
 Bank : 1 To 99  
 Class : All

Vendor Invoice	Vendor Name Description	Batch	Inv Date	Inv Due Date	Amount
G.L. Account	CC1 CC2 CC3 GL Account Name				
<b>DEPARTMENT 2020000 POLICE DEPARTMENT</b>					
439949297	COURIER	1606	07-Dec-2018	07-Dec-2018	
10-5-2020000-0306	COURIER & EXPRESS				9.06
440015538	COURIER	1606	14-Dec-2018	14-Dec-2018	
10-5-2020000-0306	COURIER & EXPRESS				4.53
440152033	COURIER	1606	28-Dec-2018	28-Dec-2018	
10-5-2020000-0306	COURIER & EXPRESS				4.53
<b>RAC462 RACICOT CHRYSLER</b>					
CCCS252689	MAINTENANCE	1606	14-Dec-2018	14-Dec-2018	
10-5-2020000-0402	VEHICLE & EQUIPMENT MTCE.				491.47
<b>REC06 RECEIVER GENERAL-INDUSTRY CANADA</b>					
20190047711	RADIO MAINTENANCE	481	09-Feb-2019	09-Feb-2019	
10-5-2020000-0319	RADIO MAINTENANCE				2,135.00
<b>SHR157 SHRED-IT INTERNATIONAL ULC</b>					
8100647944	YEAR END SHREDDING	204	31-Jan-2019	31-Jan-2019	
10-5-2020000-0360	MISCELLANEOUS EXPENSES				355.84
8100673006	YEAR END DESTRUCTION OF APS UNIFORMS	296	28-Feb-2019	28-Feb-2019	
10-5-2020000-0252	UNIFORMS				2,921.05
<b>TRO104 TROY LIFE &amp; FIRE SAFETY LTD.</b>					
1000073156	MAINTENANCE	1606	27-Dec-2018	27-Dec-2018	
10-5-2020000-0317	BUILDING MAINTENANCE				289.96
<b>TUR070 TURRIS SITES DEVELOPMENT CORP.</b>					
467215	MCGREGOR SITE TOWER LEASE	436	30-Apr-2019	30-Apr-2019	
10-5-2020000-0319	RADIO MAINTENANCE				606.26
470962	MCGREGOR SITE TOWER LEASE	436	01-Jan-2019	01-Jan-2019	
10-5-2020000-0319	RADIO MAINTENANCE				606.26
478033	MCGREGOR SITE TOWER LEASE	436	01-Feb-2019	01-Feb-2019	
10-5-2020000-0319	RADIO MAINTENANCE				606.26
481712	MCGREGOR SITE TOWER LEASE	436	01-Mar-2019	01-Mar-2019	
10-5-2020000-0319	RADIO MAINTENANCE				634.14
481938	MCGREGOR SITE TOWER LEASE	436	01-Apr-2019	01-Apr-2019	
10-5-2020000-0319	RADIO MAINTENANCE				620.20
485714	MCGREGOR SITE TOWER LEASE	436	01-May-2019	01-May-2019	
10-5-2020000-0319	RADIO MAINTENANCE				620.20
489404	MCGREGOR SITE TOWER LEASE	511	01-Jun-2019	01-Jun-2019	
10-5-2020000-0319	RADIO MAINTENANCE				620.20
<b>WIG035 WIGLE HOME HARDWARE BUILDING CENTRE</b>					
126611	PAINT & SUPPLIES FOR INTERIOR WALLS AT POLICE STATION	134	22-Jan-2019	22-Jan-2019	
10-5-2020000-0317	BUILDING MAINTENANCE				180.91
<b>WOR415 WORK AUTHORITY</b>					
501592	WORK CLOTHING RETURNED	1607	23-Dec-2018	23-Dec-2018	
10-5-2020000-0252	UNIFORMS				-158.19
501593	UNIFORMS	1607	23-Dec-2018	23-Dec-2018	
10-5-2020000-0252	UNIFORMS				316.38
<b>Department Totals :</b>					<b>431,916.88</b>

<b>DEPARTMENT 2043010 BUILDING DEPARTMENT</b>					
<b>AMH432 AMHERSTBURG CHEVEROLET-BUICK-GMC</b>					
48826	VEHICLE EXPENSE	34	16-Jan-2019	16-Jan-2019	
10-5-2043010-0402	VEHICLE & EQUIPMENT MTCE.				152.54
<b>CAI413 CATHIM INC</b>					
4431/3/4	OFFICE SUPPLIES	389	03-Apr-2019	03-Apr-2019	
10-5-2043010-0301	OFFICE SUPPLIES				49.31

Council/Board Report By Dept-(Computer)



Vendor : CAT038 To ZUL180  
 Batch : All  
 Department : All

Cheque Print Date : 01-Jan-2019 To 31-May-2019  
 Bank : 1 To 99  
 Class : All

Vendor Invoice	Vendor Name Description	Batch	Inv Date	Inv Due Date	Amount
G.L. Account	CC1 CC2 CC3 GL Account Name				
<b>DEPARTMENT 2043010 BUILDING DEPARTMENT</b>					
<b>CAN380 CANADIAN TIRE STORE #281</b>					
DECEMBER 2018 DECEMBER 2018 PURCHASES					
10-5-2043010-0301	OFFICE SUPPLIES	104	31-Jan-2019	31-Jan-2019	25.78
10-5-2043010-0301	OFFICE SUPPLIES				22.59
JANUARY 2019 JANUARY 2019 PURCHASES					
10-5-2043010-0301	OFFICE SUPPLIES	389	31-Jan-2019	31-Jan-2019	33.89
10-5-2043010-0301	OFFICE SUPPLIES				-33.89
NOVEMBER 2018 NOVEMBER 2018 PURCHASES					
10-5-2043010-0301	OFFICE SUPPLIES	133	31-Jan-2019	31-Jan-2019	76.82
<b>HER247 HERITAGE TIRE SALES INC.</b>					
TIRE REPAIR					
10-5-2043010-0402	VEHICLE & EQUIPMENT MTCE.	105	15-Jan-2019	15-Jan-2019	45.20
<b>LEX123 LEXISNEXIS CANADA INC.</b>					
OFFICE SUPPLIES					
10-5-2043010-0301	OFFICE SUPPLIES	1607	27-Nov-2018	27-Nov-2018	137.29
<b>MON183 MONARCH OFFICE SUPPLY LTD</b>					
DECEMBER 2018 DECEMBER 2018 PURCHASES					
10-5-2043010-0301	OFFICE SUPPLIES	1607	31-Dec-2018	31-Dec-2018	479.00
MARCH 2019 MARCH 2019 PURCHASES					
10-5-2043010-0301	OFFICE SUPPLIES	406	29-Mar-2019	29-Mar-2019	116.58
<b>MOR26 MORNEAU SHEPELL LTD.</b>					
APRIL 2019 953243, 953244, 953245, 953246 APRIL 2019					
10-5-2043010-0207	BENEFITS - LIFE & DISABIL	347	01-Apr-2019	01-Apr-2019	24.96
FEBRUARY 2019 921007, 921008, 921009, 921010 FEBRUARY 2019					
10-5-2043010-0207	BENEFITS - LIFE & DISABIL	135	01-Feb-2019	01-Feb-2019	24.96
JANUARY 2019 902738, 902739, 902740, 902741 JANUARY 2019					
10-5-2043010-0207	BENEFITS - LIFE & DISABIL	62	02-Jan-2019	02-Jan-2019	24.96
MARCH 2019 936899, 936900, 936901, 936902 MARCH 2019					
10-5-2043010-0207	BENEFITS - LIFE & DISABIL	280	01-Mar-2019	01-Mar-2019	24.96
MAY 2019 970411, 970412, 970413, 970414 MAY 2019					
10-5-2043010-0207	BENEFITS - LIFE & DISABIL	511	01-May-2019	01-May-2019	24.96
<b>MUN200 MUNICIPAL EMPLOYER PENSION CENTRE OF ONTARIO</b>					
MEPCO 2019 EMPLOYEE CONTRIBUTION					
10-5-2043010-0350	MEMBERSHIPS	15	02-Jan-2019	02-Jan-2019	54.30
<b>ONT022 ONTARIO PLUMBING INSPECTORS ASSOCIATION</b>					
2019 MEMBERSHIPS					
10-5-2043010-0350	MEMBERSHIPS	15	02-Jan-2019	02-Jan-2019	70.00
<b>POL104 POLAR PIN</b>					
UNIFORMS					
10-5-2043010-0252	UNIFORMS	135	05-Feb-2019	05-Feb-2019	349.17
<b>STE150 STERLING MARKING PRODUCTS</b>					
OFFICE SUPPLIES					
10-5-2043010-0301	OFFICE SUPPLIES	15	03-Jan-2019	03-Jan-2019	109.69
<b>SUN419 SUN PARLOUR CHAPTER OBOA</b>					
2018 ANNUAL ANNUAL FEE (JAN 01, 2018 TRHU TO DEC 31, 2018)					
10-5-2043010-0350	MEMBERSHIPS	104	31-Jan-2019	31-Jan-2019	100.00
<b>TRI249 TRI GRAPHICS</b>					
BUSINESS CARDS					
10-5-2043010-0301	OFFICE SUPPLIES	406	24-Apr-2019	24-Apr-2019	88.14

Department Totals : 2,001.21



Vendor : CAT038 To ZUL180  
 Batch : All  
 Department : All

Cheque Print Date : 01-Jan-2019 To 31-May-2019  
 Bank : 1 To 99  
 Class : All

Vendor Invoice	Vendor Name Description	Batch	Inv Date	Inv Due Date	Amount
G.L. Account	CC1 CC2 CC3 GL Account Name				
<b>DEPARTMENT 2043015 LICENSING AND ENFORCEMENT</b>					
<b>AMH60 AMHERSTBURG CLERKS PETTY CASH</b>					
JANUARY 2019 CLERKS PETTY CASH REPLENISHMENT 99 28-Jan-2019 28-Jan-2019					
10-5-2043015-0252	UNIFORMS - BYLAW ENFORCEMENT				25.00
10-5-2043015-0252	UNIFORMS - BYLAW ENFORCEMENT				15.00
<b>BOU681 BOUCHARD GARDENS</b>					
APRIL 30, 2019 REFUND OF BUSINESS LICENSING FEE 481 30-Apr-2019 30-Apr-2019					
10-4-2043015-2155	BUSINESS LICENCES				375.00
<b>COU132 COUNTY TOWING INC.</b>					
0437 POLICE OCCURANCE - BYLAW ENFORMCEMTN TRUCK GAS TAN TAMPHERED WITH 345 08-Jan-2019 08-Jan-2019					
10-5-2043015-0402	VEHICLE & EQUIPMENT MAINTENANCE				3,267.04
<b>GRA115 GRAPHIC EMPORIUM</b>					
1946 TAXI STICKERS 406 23-Apr-2019 23-Apr-2019					
10-5-2043015-0301	OFFICE SUPPLIES				42.38
1947 TAXI DECALS 2021 406 23-Apr-2019 23-Apr-2019					
10-5-2043015-0301	OFFICE SUPPLIES				42.38
<b>JOE055 JOE MELOCHE FORD SALES LTD</b>					
RJ15568 MISCHIEF TO BYLAW ENFORMCEMENT VECHILE 319 08-Jan-2019 08-Jan-2019					
10-5-2043015-0402	VEHICLE & EQUIPMENT MAINTENANCE				2,275.91
<b>KEL198 KELCOM RADIO DIVISION</b>					
80010119 KELCOM RADIOS 1554 19-Dec-2018 19-Dec-2018					
10-5-2043015-0420	SMALL EQUIPMENT				118.48
80010166 KELCOM RADIOS 62 15-Jan-2019 15-Jan-2019					
10-5-2043015-0420	SMALL EQUIPMENT				118.48
80010286 RADIO AIRTIME 436 15-Feb-2019 15-Feb-2019					
10-5-2043015-0420	SMALL EQUIPMENT				118.48
80010403 MONTHLY RADIO CONTACT 319 15-Mar-2019 15-Mar-2019					
10-5-2043015-0420	SMALL EQUIPMENT				118.48
80010521 RADIO AIRTIME 436 15-Apr-2019 15-Apr-2019					
10-5-2043015-0420	SMALL EQUIPMENT				118.48
<b>MDC15301 MDC LAW ENFORCEMENT &amp; MILITARY EQUIPMENT</b>					
4000188 UNIFORMS 62 08-Jan-2019 08-Jan-2019					
10-5-2043015-0252	UNIFORMS - BYLAW ENFORCEMENT				292.87
4000461 UNIFORMS 62 17-Jan-2019 17-Jan-2019					
10-5-2043015-0252	UNIFORMS - BYLAW ENFORCEMENT				31.29
4000737 UNIFORMS 134 29-Jan-2019 29-Jan-2019					
10-5-2043015-0252	UNIFORMS - BYLAW ENFORCEMENT				240.17
<b>MIN087 MINISTRY OF TRANSPORTATION</b>					
FEBRUARY 26 PARKING REVENUE 250 26-Feb-2019 26-Feb-2019					
10-4-2043015-5800	BYLAW - PARKING TICKETS				16.50
<b>MON183 MONARCH OFFICE SUPPLY LTD</b>					
122755 NOVEMBER 2018 PURCHASES 1606 29-Nov-2018 29-Nov-2018					
10-5-2043015-0301	OFFICE SUPPLIES				24.97
127289 DECEMBER 2018 PURCHASES 1607 31-Dec-2018 31-Dec-2018					
10-5-2043015-0301	OFFICE SUPPLIES				8.46
128635 KEYS FOR FILE CABINETS 15 08-Jan-2019 08-Jan-2019					
10-5-2043015-0301	OFFICE SUPPLIES				20.34
<b>MOR26 MORNEAU SHEPELL LTD.</b>					
APRIL 2019 953243, 953244, 953245, 953246 APRIL 2019 347 01-Apr-2019 01-Apr-2019					
10-5-2043015-0207	BENEFITS - LIFE & DISABILITY				24.96
FEBRUARY 20 921007, 921008, 921009, 921010 FEBRUARY 2019 135 01-Feb-2019 01-Feb-2019					
10-5-2043015-0207	BENEFITS - LIFE & DISABILITY				24.96
JANUARY 2019 902738, 902739, 902740, 902741 JANUARY 2019 62 02-Jan-2019 02-Jan-2019					



## Council/Board Report By Dept-(Computer)



Vendor : CAT038 To ZUL180

Batch : All

Department : All

Cheque Print Date : 01-Jan-2019 To 31-May-2019

Bank : 1 To 99

Class : All

Vendor Invoice	Vendor Name Description	Batch	Inv Date	Inv Due Date	Amount
G.L. Account	CC1 CC2 CC3 GL Account Name				
<b>DEPARTMENT 2043015</b>	LICENSING AND ENFORCEMENT				
10-5-2043015-0207	BENEFITS - LIFE & DISABILITY				33.28
MACH 2019 936899, 936900, 936901936902 MARCH 2019		280	01-Mar-2019	01-Mar-2019	
10-5-2043015-0207	BENEFITS - LIFE & DISABILITY				24.96
MAY 2019 970411,970412,970413, 970414 MAY 2019		511	01-May-2019	01-May-2019	
10-5-2043015-0207	BENEFITS - LIFE & DISABILITY				24.96
<b>MOU001 MOUSSEAU DELUCA McPHERSON PRINCE</b>					
58412	LEGAL FEES	1554	30-Nov-2018	30-Nov-2018	
10-4-2043015-2157	ENCROACHMENT FEES				476.64
<b>MUN200 MUNICIPAL EMPLOYER PENSION CENTRE OF ONTARIO</b>					
MC004654	MEPCO 2019 E MPLOYEE CONTRIBUTION	15	02-Jan-2019	02-Jan-2019	
10-5-2043015-0350	MEMBERSHIPS				54.30
<b>ONT100- ONTARIO ASSOCIATION OF PROPERTY STANDARDS</b>					
2019-02	PROPERTY STANDARDS COMMITTEE STAFF/TRAINING	319	07-Mar-2019	07-Mar-2019	
10-5-2043015-0351	TRAINING AND CONFERENCES				1,697.00
<b>PUR663 PURE WATER BRAND</b>					
APRIL 2019 000310283,00310968, 000312832 APRIL 2019		481	30-Apr-2019	30-Apr-2019	
10-5-2043015-0301	OFFICE SUPPLIES				25.15
DECEMBER 20 DECEMBER 2018 000294792, 000296431, 000298138		1557	31-Dec-2018	31-Dec-2018	
10-5-2043015-0301	OFFICE SUPPLIES				19.52
FEBRUARY 20 000302606, 000304141, 000305160 FEBRUARY 2019		252	28-Feb-2019	28-Feb-2019	
10-5-2043015-0301	OFFICE SUPPLIES				28.90
JANUARY 2019 000299244, 000301010, 000301825 JANUARY 2019		134	31-Jan-2019	31-Jan-2019	
10-5-2043015-0301	OFFICE SUPPLIES				33.27
MARCH 2019 000305973, 000307456, 000308278 MARCH 2019		345	31-Mar-2019	31-Mar-2019	
10-5-2043015-0301	OFFICE SUPPLIES				34.52
<b>VER944 VERHAEGEN STUBBERFIELD HARTLEY</b>					
00000989	PROFESSIONAL FEES	1523	12-Nov-2018	12-Nov-2018	
10-5-2043015-0327	PROFESSIONAL FEES - L&E				654.49
<b>WIG035 WIGLE HOME HARDWARE BUILDING CENTRE</b>					
126787	VEHICLE & EQUIPMENT MAINTENANCE	134	28-Jan-2019	28-Jan-2019	
10-5-2043015-0402	VEHICLE & EQUIPMENT MAINTENANCE				11.29
<b>WIN137 WINDSOR-ESSEX COUNTY HUMANE SOCIETY</b>					
APRIL 10, 2019 REIMBURSEMENT OF STRAY CATS		406	10-Apr-2019	10-Apr-2019	
10-5-2043015-0904	ANIMAL CONTROL - OTHER				25.00
APRIL 8, 2019 ANIMAL CONTROL SERVICES FOR THE MONTH OF APRIL 2019		406	08-Apr-2019	08-Apr-2019	
10-5-2043015-0903	ANIMAL CONTROL - CONTRACT				2,500.00
DECEMBER 20 ANIMAL CONTROL SERVICES FOR THE MONTH OF DECEMBER 2018		1554	31-Dec-2018	31-Dec-2018	
10-5-2043015-0903	ANIMAL CONTROL - CONTRACT				3,333.33
DECEMBER 31 SPAY & NEUTRE PROGRAM		1608	31-Dec-2018	31-Dec-2018	
10-5-2043015-0904	ANIMAL CONTROL - OTHER				50.00
FEBRUARY 20 MONTHLY CONTRACT FEE FOR DOG CONTROL FEBRUARY 2019		204	27-Feb-2019	27-Feb-2019	
10-5-2043015-0903	ANIMAL CONTROL - CONTRACT				2,500.00
JANUARY 2019 MONTHLY CONTRACT FEE FOR DOG CONTROL JANUARY 2019		204	31-Jan-2019	31-Jan-2019	
10-5-2043015-0903	ANIMAL CONTROL - CONTRACT				2,500.00
MARCH 1, 2019 STRAY CATS REIMBURSEMENT FOR THE MONTH OF FEBRUARY 2019		296	01-Mar-2019	01-Mar-2019	
10-5-2043015-0904	ANIMAL CONTROL - OTHER				125.00
MARCH 5, 2019 MONTHLY DOG CONTROL CONTRACT		319	05-Mar-2019	05-Mar-2019	
10-5-2043015-0903	ANIMAL CONTROL - CONTRACT				2,500.00
NOVEMBER 30 SNAP & CATS VOUCHERS/ SPAY AND NEUTER PROGRAM		1554	30-Nov-2018	30-Nov-2018	
10-5-2043015-0904	ANIMAL CONTROL - OTHER				100.00
<b>WOR415 WORK AUTHORITY</b>					
515934	FULL TIME BY LAW OFFICER ANNUAL BOOT ALLOWANCE	319	03-Mar-2019	03-Mar-2019	
10-5-2043015-0252	UNIFORMS - BYLAW ENFORCEMENT				244.07





Vendor : CAT038 To ZUL180

Batch : All

Department : All

Cheque Print Date : 01-Jan-2019 To 31-May-2019

Bank : 1 To 99

Class : All

Vendor Invoice	Vendor Name Description	Batch	Inv Date	Inv Due Date	Amount
G.L. Account	CC1 CC2 CC3 GL Account Name				

DEPARTMENT 2043015 LICENSING AND ENFORCEMENT

Department Totals : 24,315.31

DEPARTMENT 3010000 PUBLIC WORKS

ACC334 ACCURATE CREATIONS SPORTS & PROMO GEAR

1168 EMBROIDERY FOR UNION CLOTHING 347 08-Apr-2019 08-Apr-2019  
 10-5-3010000-0161 CLOTHING 189.84

ACT456 ACTION SIGNS & DESIGNS INC.

11248 REMOVED DECALS FROM POLICE VEHICLE 250 22-Feb-2019 22-Feb-2019  
 10-5-3010000-0402 VEHICLE & EQUIPMENT MTCE. 762.75

ADV329 ADVANCE BUSINESS SYSTEMS

655930 COPIER LEASE 15 02-Jan-2019 02-Jan-2019  
 10-5-3010000-0301 OFFICE SUPPLIES 678.00

AGO713 AGO INDUSTRIES INC

834830 CLOTHING FOR OUTSIDE UNION WORKERS 280 22-Feb-2019 22-Feb-2019  
 10-5-3010000-0161 CLOTHING 2,070.63

841932 JACKET

10-5-3010000-0161 CLOTHING 511 15-Apr-2019 15-Apr-2019 103.42

ALT565 ALTERNATE SOLUTIONS INC

10069 FUEL TRACKING SYSTEM MAINTENANCE 204 25-Feb-2019 25-Feb-2019  
 10-5-3010000-0401 GASOLINE 1,220.86

9965 EXTRA KEYS FOR GAS TRACKING SYSTEM

10-5-3010000-0401 GASOLINE 1557 08-Nov-2018 08-Nov-2018 403.10

AMH43 AMHERSTBURG PUBLIC WORKS PETTY CASH

FEBRUARY 1, PUBLIC WORK PETTY CASH FOR FEBRUARY 2019 134 31-Jan-2019 31-Jan-2019  
 10-5-3010000-0402 VEHICLE & EQUIPMENT MTCE. 5.00  
 10-5-3010000-0301 OFFICE SUPPLIES 6.50  
 10-5-3010000-0301 OFFICE SUPPLIES 4.98  
 10-5-3010000-0301 OFFICE SUPPLIES 2.26  
 10-5-3010000-0301 OFFICE SUPPLIES 4.52  
 10-5-3010000-0301 OFFICE SUPPLIES 3.02

ARA105 ARAMARK REFRESHMENT

644009 COFFEE SUPPLIES (NOV 04,2018) 104 02-Jan-2019 02-Jan-2019  
 10-5-3010000-0301 OFFICE SUPPLIES 38.99

713276 COFFEE SUPPLIES

10-5-3010000-0301 OFFICE SUPPLIES 105 14-Jan-2019 14-Jan-2019 29.38

ASS129 ASSOC. OF ONT. ROAD SUPERVISORS

18762 SNOW PLOW TRAINING - NEW PUBLIC WORK STAFF 1523 13-Dec-2018 13-Dec-2018  
 10-5-3010000-0351 TRAINING & CONFERENCES 602.81

BON201 BONDY AUTO & TRUCK CENTRE

28756 REPAIR TRACTOR (JULY 18, 2018) 133 31-Jan-2019 31-Jan-2019  
 10-5-3010000-0402 VEHICLE & EQUIPMENT MTCE. 470.19

CAN380 CANADIAN TIRE STORE #281

DECEMBER 20 DECEMBER 2018 PURCHASES 104 31-Jan-2019 31-Jan-2019  
 10-5-3010000-0420 EQUIPMENT 49.66  
 10-5-3010000-0420 EQUIPMENT 146.84  
 10-5-3010000-0420 EQUIPMENT 25.97

FEBRUARY 20 FEBRUARY 2019 PURCHASES 280 28-Feb-2019 28-Feb-2019

10-5-3010000-0301 OFFICE SUPPLIES 20.32  
 10-5-3010000-0420 EQUIPMENT 45.18  
 10-5-3010000-0420 EQUIPMENT 29.37  
 10-5-3010000-0420 EQUIPMENT 27.11

JANUARY 2019 JANUARY 2019 PURCHASES 389 31-Jan-2019 31-Jan-2019

10-5-3010000-0420 EQUIPMENT 45.19



Vendor : CAT038 To ZUL180

Batch : All

Department : All

Cheque Print Date : 01-Jan-2019 To 31-May-2019

Bank : 1 To 99

Class : All

Vendor Invoice	Vendor Name Description	Batch	Inv Date	Inv Due Date	Amount
G.L. Account	CC1 CC2 CC3 GL Account Name				
<b>DEPARTMENT 3010000 PUBLIC WORKS</b>					
10-5-3010000-0420	EQUIPMENT				60.99
10-5-3010000-0420	EQUIPMENT				-36.15
10-5-3010000-0301	OFFICE SUPPLIES				72.29
10-5-3010000-0402	VEHICLE & EQUIPMENT MTCE.				96.00
10-5-3010000-0402	VEHICLE & EQUIPMENT MTCE.				156.80
10-5-3010000-0402	VEHICLE & EQUIPMENT MTCE.				112.99
10-5-3010000-0402	VEHICLE & EQUIPMENT MTCE.				47.98
MARCH 2019 MARCH 2019 PURCHASES		345	31-Mar-2019	31-Mar-2019	
10-5-3010000-0420	EQUIPMENT				79.09
NOVEMBER 2018 NOVEMBER 2018 PURCHASES		133	31-Jan-2019	31-Jan-2019	
10-5-3010000-0402	VEHICLE & EQUIPMENT MTCE.				32.16
10-5-3010000-0420	EQUIPMENT				39.49
10-5-3010000-0420	EQUIPMENT				67.78
10-5-3010000-0420	EQUIPMENT				39.50
10-5-3010000-0420	EQUIPMENT				79.02
10-5-3010000-0420	EQUIPMENT				50.68
10-5-3010000-0420	EQUIPMENT				238.77
10-5-3010000-0420	EQUIPMENT				45.19
10-5-3010000-0420	EQUIPMENT				82.41
10-5-3010000-0420	EQUIPMENT				21.46
10-5-3010000-0420	EQUIPMENT				-104.51
10-5-3010000-0420	EQUIPMENT				-21.46
10-5-3010000-0420	EQUIPMENT				250.27
10-5-3010000-0420	EQUIPMENT				133.18
10-5-3010000-0420	EQUIPMENT				54.10
10-5-3010000-0420	EQUIPMENT				54.19
OCTOBER 2018 OCTOBER 2018 INVOICES		1554	31-Oct-2018	31-Oct-2018	
10-5-3010000-0402	VEHICLE & EQUIPMENT MTCE.				30.97
10-5-3010000-0765	MUNICIPAL DRAIN EXPENSE				56.49
10-5-3010000-0420	EQUIPMENT				11.29
10-5-3010000-0420	EQUIPMENT				23.49
10-5-3010000-0420	EQUIPMENT				33.88
10-5-3010000-0420	EQUIPMENT				225.99
10-5-3010000-0420	EQUIPMENT				31.03
<b>CAR645 CARRIER CENTERS</b>					
04P435176 METER ODOMETER RETURN		389	09-Mar-2019	09-Mar-2019	
10-5-3010000-0402	VEHICLE & EQUIPMENT MTCE.				-549.91
04P446532 PARTS FOR REPAIRS		62	04-Jan-2019	04-Jan-2019	
10-5-3010000-0402	VEHICLE & EQUIPMENT MTCE.				29.33
04P448920 BACKHOE MAINTENANCE		105	22-Jan-2019	22-Jan-2019	
10-5-3010000-0402	VEHICLE & EQUIPMENT MTCE.				65.09
04P449168 DEF FLUID FOR DIESEL VEHICLES		105	28-Jan-2019	28-Jan-2019	
10-5-3010000-0402	VEHICLE & EQUIPMENT MTCE.				87.37
04P449265 DEF FLUID		134	29-Jan-2019	29-Jan-2019	
10-5-3010000-0402	VEHICLE & EQUIPMENT MTCE.				73.16
04P452739 REPAIR 205		525	24-Apr-2019	24-Apr-2019	
10-5-3010000-0402	VEHICLE & EQUIPMENT MTCE.				358.31
04P452741 REPAIR 205		525	25-Apr-2019	25-Apr-2019	
10-5-3010000-0402	VEHICLE & EQUIPMENT MTCE.				19.12
04P452781 WRONG PART		525	24-Apr-2019	24-Apr-2019	
10-5-3010000-0402	VEHICLE & EQUIPMENT MTCE.				25.82
04P453016 CREDIT WRONG PART		525	30-Apr-2019	30-Apr-2019	
10-5-3010000-0402	VEHICLE & EQUIPMENT MTCE.				-25.82
04P453223 CREDIT FOR WRONG PART		525	04-May-2019	04-May-2019	
10-5-3010000-0402	VEHICLE & EQUIPMENT MTCE.				-213.11
04P453242 REPAIR TO SS1		525	06-May-2019	06-May-2019	



Vendor : CAT038 To ZUL180

Batch : All

Department : All

Cheque Print Date : 01-Jan-2019 To 31-May-2019

Bank : 1 To 99

Class : All

Vendor Invoice	Vendor Name Description	Batch	Inv Date	Inv Due Date	Amount
G.L. Account	CC1 CC2 CC3 GL Account Name				
<b>DEPARTMENT 3010000</b>	<b>PUBLIC WORKS</b>				
10-5-3010000-0402	VEHICLE & EQUIPMENT MTCE.				571.76
05P502374 CREDIT		137	31-Jan-2019	31-Jan-2019	
10-5-3010000-0402	VEHICLE & EQUIPMENT MTCE.				-145.77
05P502462 LUBRICANT		250	08-Feb-2019	08-Feb-2019	
10-5-3010000-0402	VEHICLE & EQUIPMENT MTCE.				192.24
<b>CHI120 R. CHITTLE WOOD PRODUCTS &amp; SERVICES</b>					
876 WOOD STAKES FOR LOCATING		1557	11-Sep-2018	11-Sep-2018	
10-5-3010000-0420	EQUIPMENT				96.05
<b>CIT350 CITY OF WINDSOR</b>					
0000174770 TRAINING		1523	07-Dec-2018	07-Dec-2018	
10-5-3010000-0351	TRAINING & CONFERENCES				920.73
<b>COL115 COLUMBIA UTILITY SERVICES INC.</b>					
1433 REFORESTATION CAPITAL 2018		280	18-Jan-2019	18-Jan-2019	
10-5-3010000-0650 T-TRIM	TREE MAINTENANCE				8,136.00
<b>COL286 COLBRO EQUIPMENT RENTAL</b>					
115151-0 SAW BLADE		436	25-Apr-2019	25-Apr-2019	
10-5-3010000-0420	EQUIPMENT				330.86
<b>COU132 COUNTY TOWING INC.</b>					
18-00081 TOWING COST		345	31-Mar-2019	31-Mar-2019	
10-5-3010000-0402	VEHICLE & EQUIPMENT MTCE.				127.13
18-00096 TOWING COST		345	31-Mar-2019	31-Mar-2019	
10-5-3010000-0402	VEHICLE & EQUIPMENT MTCE.				186.45
19-00256 MOVING EQUIPMENT		204	22-Jan-2019	22-Jan-2019	
10-5-3010000-0402	VEHICLE & EQUIPMENT MTCE.				211.88
<b>DLM470 D.L.M. EMISSIONS TESTING</b>					
8282 EMISSIONS TEST FOR PLATES		1606	07-Dec-2018	07-Dec-2018	
10-5-3010000-0402	VEHICLE & EQUIPMENT MTCE.				420.00
<b>DON592 DONE-RIGHT SERVICES</b>					
13530 REPAIR UNIT 206		345	08-Feb-2019	08-Feb-2019	
10-5-3010000-0402	VEHICLE & EQUIPMENT MTCE.				806.65
13531 REPAIR UNIT 220		280	08-Feb-2019	08-Feb-2019	
10-5-3010000-0402	VEHICLE & EQUIPMENT MTCE.				739.08
13532 REPAIR TO UNIT 116		280	08-Feb-2019	08-Feb-2019	
10-5-3010000-0402	VEHICLE & EQUIPMENT MTCE.				629.91
13533 REPAIR UNIT 306		280	08-Feb-2019	08-Feb-2019	
10-5-3010000-0402	VEHICLE & EQUIPMENT MTCE.				781.51
13534 REPAIR PG-53 SIDEWALK PLOW		280	08-Feb-2019	08-Feb-2019	
10-5-3010000-0402	VEHICLE & EQUIPMENT MTCE.				551.51
13535 REPAIR UNIT 305		280	08-Feb-2019	08-Feb-2019	
10-5-3010000-0402	VEHICLE & EQUIPMENT MTCE.				500.25
13536 REPAIR UNIT 108		280	08-Feb-2019	08-Feb-2019	
10-5-3010000-0402	VEHICLE & EQUIPMENT MTCE.				1,663.76
13537 REPAIR UNIIT 206		280	08-Feb-2019	08-Feb-2019	
10-5-3010000-0402	VEHICLE & EQUIPMENT MTCE.				4,605.09
13540 REPAIR UNIT 205 SALTER		280	08-Feb-2019	08-Feb-2019	
10-5-3010000-0402	VEHICLE & EQUIPMENT MTCE.				1,011.07
13556 REPAIR UNIT 209		280	08-Feb-2019	08-Feb-2019	
10-5-3010000-0402	VEHICLE & EQUIPMENT MTCE.				643.61
13557 REPAIR UNIT 206		280	08-Feb-2019	08-Feb-2019	
10-5-3010000-0402	VEHICLE & EQUIPMENT MTCE.				507.25
13566 REPAIR 306 BEACON		250	11-Feb-2019	11-Feb-2019	
10-5-3010000-0402	VEHICLE & EQUIPMENT MTCE.				255.71
13583 REPAIR UNIT 208		250	14-Feb-2019	14-Feb-2019	



Vendor : CAT038 To ZUL180

Batch : All

Department : All

Cheque Print Date : 01-Jan-2019 To 31-May-2019

Bank : 1 To 99

Class : All

Vendor Invoice	Vendor Name Description				Batch Invc Date	Invc Due Date	Amount
G.L. Account	CC1	CC2	CC3	GL Account Name			
<b>DEPARTMENT 3010000 PUBLIC WORKS</b>							
10-5-3010000-0402				VEHICLE & EQUIPMENT MTCE.			396.58
13590	REPAIR 209				250 14-Feb-2019	14-Feb-2019	
10-5-3010000-0402				VEHICLE & EQUIPMENT MTCE.			241.00
13632	REPAIR UNIT # 306				282 25-Feb-2019	25-Feb-2019	
10-5-3010000-0402				VEHICLE & EQUIPMENT MTCE.			680.08
13637	ERPAIR ON UNIT # 116				282 25-Feb-2019	25-Feb-2019	
10-5-3010000-0402				VEHICLE & EQUIPMENT MTCE.			1,845.09
13640	REPAIR ON UNIT 220				282 25-Feb-2019	25-Feb-2019	
10-5-3010000-0402				VEHICLE & EQUIPMENT MTCE.			1,591.58
13681	REPAIR ON UNIT 305				282 04-Mar-2019	04-Mar-2019	
10-5-3010000-0402				VEHICLE & EQUIPMENT MTCE.			192.16
13682	REPAIR				282 04-Mar-2019	04-Mar-2019	
10-5-3010000-0402				VEHICLE & EQUIPMENT MTCE.			2,425.03
13688	REPAIR ON UNIT 209				282 04-Mar-2019	04-Mar-2019	
10-5-3010000-0402				VEHICLE & EQUIPMENT MTCE.			965.31
13721	REPAIR UNIT 206				345 11-Mar-2019	11-Mar-2019	
10-5-3010000-0402				VEHICLE & EQUIPMENT MTCE.			1,542.96
13765	REPAIR UNIT 103				345 20-Mar-2019	20-Mar-2019	
10-5-3010000-0402				VEHICLE & EQUIPMENT MTCE.			548.04
13777	REPAIR UNIT SM-01				345 20-Mar-2019	20-Mar-2019	
10-5-3010000-0402				VEHICLE & EQUIPMENT MTCE.			469.85
13795	REPAIR UNIT 205				345 21-Mar-2019	21-Mar-2019	
10-5-3010000-0402				VEHICLE & EQUIPMENT MTCE.			478.77
13836	REPAIR UNIT 206				345 25-Mar-2019	25-Mar-2019	
10-5-3010000-0402				VEHICLE & EQUIPMENT MTCE.			2,281.28
13922	REPAIR UNIT 209				406 10-Apr-2019	10-Apr-2019	
10-5-3010000-0402				VEHICLE & EQUIPMENT MTCE.			1,981.16
13990	SWEEPER MAINTENANCE				511 24-Apr-2019	24-Apr-2019	
10-5-3010000-0402				VEHICLE & EQUIPMENT MTCE.			3,994.28
<b>ESS53 ESSEX REGION CONSERVATION AUTHORITY</b>							
IN000014531	FINAL TRANSFER PAYMENT STORM WATER GUIDELINES STUDY 2016-2018 (DEC 31, 2018)				104 31-Jan-2019	31-Jan-2019	
10-5-3010000-0328				ENGINEERING FEES			4,454.82
<b>ESS959 ESSEX LINEN SUPPLY LTD</b>							
465825	RAGS & MATS				105 24-Jan-2019	24-Jan-2019	
10-5-3010000-0301				OFFICE SUPPLIES			68.70
468966	RAGS & MATS				250 21-Feb-2019	21-Feb-2019	
10-5-3010000-0301				OFFICE SUPPLIES			68.70
<b>FEE256 THE FEED STORE</b>							
1000201873	NEW PUSH MOWER				511 03-May-2019	03-May-2019	
10-5-3010000-0420				EQUIPMENT			439.57
<b>FIR350 FIRST STOP SERVICES</b>							
4174	SHREDDING SERVICES				347 31-Mar-2019	31-Mar-2019	
10-5-3010000-0301				OFFICE SUPPLIES			23.33
10-5-3010000-0301				OFFICE SUPPLIES			23.33
10-5-3010000-0301				OFFICE SUPPLIES			23.33
<b>FLU1650 FLUID BASICS INC</b>							
41955	INSTALLING GPS UNITS				62 07-Jan-2019	07-Jan-2019	
10-5-3010000-0402				VEHICLE & EQUIPMENT MTCE.			1,252.81
41959	GPS UNIT INSTALL & HYDRAULIC REPAIRS				105 28-Jan-2019	28-Jan-2019	
10-5-3010000-0402				VEHICLE & EQUIPMENT MTCE.			4,892.23
41963	REPAIRS 205 HYDRAULICS				250 07-Feb-2019	07-Feb-2019	
10-5-3010000-0404				VEHICLE & RADIO LICENCES			335.61



Vendor : CAT038 To ZUL180

Batch : All

Department : All

Cheque Print Date : 01-Jan-2019 To 31-May-2019

Bank : 1 To 99

Class : All

Vendor Invoice	Vendor Name Description	Batch	Inv Date	Inv Due Date	Amount
G.L. Account	CC1 CC2 CC3 GL Account Name				
<b>DEPARTMENT 3010000</b>	<b>PUBLIC WORKS</b>				
41972	REPAIR WINTER EQUIPMENT	345	13-Mar-2019	13-Mar-2019	
10-5-3010000-0402	VEHICLE & EQUIPMENT MTCE.				751.45
<b>GAT290</b>	<b>GATA INDUSTRIAL SERVICES INC.</b>				
0327-12059	ANNUAL STRAPS AND CHAINS INSPECTION	347	27-Mar-2019	27-Mar-2019	
10-5-3010000-0402	VEHICLE & EQUIPMENT MTCE.				2,531.20
<b>GRE330</b>	<b>GREAT LAKES SAFETY PRODUCTS</b>				
00311758	SAFETY EQUIPMENT	1554	12-Sep-2018	12-Sep-2018	
10-5-3010000-0420	EQUIPMENT				582.33
00316431	SAFETY EQUIPMENT	105	21-Jan-2019	21-Jan-2019	
10-5-3010000-0420	EQUIPMENT				28.17
00317672	SAFETY EQUIPMENT	319	27-Mar-2019	27-Mar-2019	
10-5-3010000-0420	EQUIPMENT				22.93
00319836	SAFETY EQUIPMENT	481	25-Apr-2019	25-Apr-2019	
10-5-3010000-0420	EQUIPMENT				169.66
<b>GRE679</b>	<b>GREG BAILEY LTD</b>				
0000051705	REPAIR POWER WASHER	280	06-Mar-2019	06-Mar-2019	
10-5-3010000-0402	VEHICLE & EQUIPMENT MTCE.				179.40
<b>HEA693</b>	<b>HEATON SANITATION</b>				
36879	MUNICIPAL DRAIN OPERATIONAL NORBURY REPAIR	34	10-Jan-2019	10-Jan-2019	
10-5-3010000-0765	MUNICIPAL DRAIN EXPENSE				2,147.00
<b>HKR216</b>	<b>H. KROEKER LAWN CARE &amp; LANDSCAPING</b>				
1118	TREE MAINTENANCE PROGRAM - 2018 TREE PLANTING	319	29-Mar-2019	29-Mar-2019	
10-5-3010000-0650	T-PLAN TREE MAINTENANCE				7,593.60
<b>HRY172</b>	<b>HRYCAY CONSULTING ENGINEERS INC.</b>				
M420.01	PROFESSIONAL SERVICES DEC 31, 2018	133	16-Jan-2019	16-Jan-2019	
10-5-3010000-0328	ENGINEERING FEES				3,215.42
M422.01	PROFESSIONAL SERVICES DEC 31, 2018	133	16-Jan-2019	16-Jan-2019	
10-5-3010000-0328	ENGINEERING FEES				1,292.16
<b>INT321</b>	<b>INTEGRITY INDUSTRIAL ABSORBENT PRODUCTS</b>				
3760	FUEL SPILL EQUIPMENT	62	14-Jan-2019	14-Jan-2019	
10-5-3010000-0420	EQUIPMENT				625.04
<b>KEL198</b>	<b>KELCOM RADIO DIVISION</b>				
80010165	RADIO AIR TIME	105	15-Jan-2019	15-Jan-2019	
10-5-3010000-0404	VEHICLE & RADIO LICENCES				1,726.02
8001020	AIR TIME	1554	19-Dec-2018	19-Dec-2018	
10-5-3010000-0404	VEHICLE & RADIO LICENCES				1,726.02
80010285	RADIO AIRTIME	280	15-Feb-2019	15-Feb-2019	
10-5-3010000-0404	VEHICLE & RADIO LICENCES				1,726.02
80010402	RADIO AIRTIME	345	15-Mar-2019	15-Mar-2019	
10-5-3010000-0404	VEHICLE & RADIO LICENCES				1,726.02
80010520	RADIO AIR TIME	511	15-Apr-2019	15-Apr-2019	
10-5-3010000-0404	VEHICLE & RADIO LICENCES				1,726.02
<b>KEN211</b>	<b>KEN LAPAIN &amp; SONS LTD</b>				
IN00109679	AN ANNUAL INSPECTION - UNIT 116	481	09-May-2019	09-May-2019	
10-5-3010000-0402	VEHICLE & EQUIPMENT MTCE.				6,348.24
IN00109708	REPAIRS TO 103	1606	13-Dec-2018	13-Dec-2018	
10-5-3010000-0402	VEHICLE & EQUIPMENT MTCE.				2,095.04
IN00109759	REPAIR UNIT 112	280	01-Mar-2019	01-Mar-2019	
10-5-3010000-0402	VEHICLE & EQUIPMENT MTCE.				751.30
IN00109769	REPAIR UNIT 206	280	01-Mar-2019	01-Mar-2019	
10-5-3010000-0402	VEHICLE & EQUIPMENT MTCE.				1,599.90
IN00109799	AN REPAIR UNIT 103	481	09-May-2019	09-May-2019	

## Council/Board Report By Dept-(Computer)



Vendor : CAT038 To ZUL180

Batch : All

Department : All

Cheque Print Date : 01-Jan-2019 To 31-May-2019

Bank : 1 To 99

Class : All

Vendor Invoice	Vendor Name Description				Batch Invc Date	Invc Due Date	Amount
G.L. Account	CC1	CC2	CC3	GL Account Name			
<b>DEPARTMENT 3010000</b>				<b>PUBLIC WORKS</b>			
10-5-3010000-0402				VEHICLE & EQUIPMENT MTCE.			678.16
IN00110099	REPAIR TO UNIT 206				105 17-Jan-2019	17-Jan-2019	
10-5-3010000-0402				VEHICLE & EQUIPMENT MTCE.			270.17
<b>KUC134</b>	<b>KUCERA CONSTRUCTION EQUIPMENT</b>						
CW20125	MATERIAL FOR BACKHOE REPAIRS				1554 16-Apr-2018	16-Apr-2018	
10-5-3010000-0402				VEHICLE & EQUIPMENT MTCE.			118.46
CW20126	MATERIAL FOR EQUIPMENT REPAIR				1554 16-Apr-2018	16-Apr-2018	
10-5-3010000-0402				VEHICLE & EQUIPMENT MTCE.			7.89
RW08383	REAPIR UNIT 308				1554 06-Dec-2018	06-Dec-2018	
10-5-3010000-0402				VEHICLE & EQUIPMENT MTCE.			951.64
RW08384	REPAIR TO UNIT 108				1554 06-Dec-2018	06-Dec-2018	
10-5-3010000-0402				VEHICLE & EQUIPMENT MTCE.			317.81
RW08422	REPAIR TO 108				1554 31-Dec-2018	31-Dec-2018	
10-5-3010000-0402				VEHICLE & EQUIPMENT MTCE.			1,345.21
RW08458	SERVICE TO 108				62 09-Jan-2019	09-Jan-2019	
10-5-3010000-0402				VEHICLE & EQUIPMENT MTCE.			754.58
RW08459	SERVICE 308				62 09-Jan-2019	09-Jan-2019	
10-5-3010000-0402				VEHICLE & EQUIPMENT MTCE.			1,389.43
RW08518	REPAIR 308				250 08-Feb-2019	08-Feb-2019	
10-5-3010000-0402				VEHICLE & EQUIPMENT MTCE.			2,794.35
RW08519	REPAIR UNIT 108				345 07-Mar-2019	07-Mar-2019	
10-5-3010000-0402				VEHICLE & EQUIPMENT MTCE.			6,970.52
RW08583	REPAIR 108				347 29-Mar-2019	29-Mar-2019	
10-5-3010000-0402				VEHICLE & EQUIPMENT MTCE.			482.92
<b>LAN231</b>	<b>LAND IMPROVEMENT CONTRACTORS OF ONTARIO</b>						
2019	REGISTRATION DUES FOR 2019 LICO CONFERENCE JAN 23 & 24				15 02-Jan-2019	02-Jan-2019	
10-5-3010000-0351	TRAINING & CONFERENCES						576.30
<b>LAR256</b>	<b>LARRY RENAUD FORD SALES</b>						
28856	E-TEST				1554 06-Dec-2018	06-Dec-2018	
10-5-3010000-0402				VEHICLE & EQUIPMENT MTCE.			84.75
<b>MAL256</b>	<b>MALDEN AUTOMOTIVE</b>						
5294-179866	WARRANTY BATTERY REPLACEMENT				1607 29-Oct-2018	29-Oct-2018	
10-5-3010000-0402				VEHICLE & EQUIPMENT MTCE.			-20.34
5294-180395	BRAKES				1606 06-Nov-2018	06-Nov-2018	
10-5-3010000-0402				VEHICLE & EQUIPMENT MTCE.			231.88
5294-180985	FUEL FILTER				1607 15-Nov-2018	15-Nov-2018	
10-5-3010000-0402				VEHICLE & EQUIPMENT MTCE.			46.16
5294-180987	BEARINGS				1607 15-Nov-2018	15-Nov-2018	
10-5-3010000-0402				VEHICLE & EQUIPMENT MTCE.			56.00
5294-181061	BULB REPLACEMENT				1606 15-Nov-2018	15-Nov-2018	
10-5-3010000-0402				VEHICLE & EQUIPMENT MTCE.			15.66
5294-181105	VEHICLE MAINTENANCE				1607 16-Nov-2018	16-Nov-2018	
10-5-3010000-0402				VEHICLE & EQUIPMENT MTCE.			4.97
5294-181123	WIPER BLADE				1606 16-Nov-2018	16-Nov-2018	
10-5-3010000-0402				VEHICLE & EQUIPMENT MTCE.			31.23
5294-182576	REPAIRS TO VENTRAX				1606 11-Dec-2018	11-Dec-2018	
10-5-3010000-0402				VEHICLE & EQUIPMENT MTCE.			39.14
5294-184321	BATTERIES FOR 110				105 15-Jan-2019	15-Jan-2019	
10-5-3010000-0402				VEHICLE & EQUIPMENT MTCE.			178.28
5294-184618	EQUIPMENT REPAIR				105 18-Jan-2019	18-Jan-2019	
10-5-3010000-0402				VEHICLE & EQUIPMENT MTCE.			16.05
5294-184780	BATTERIES FOR PW-01				105 22-Jan-2019	22-Jan-2019	
10-5-3010000-0402				VEHICLE & EQUIPMENT MTCE.			383.41





Vendor : CAT038 To ZUL180  
 Batch : All  
 Department : All

Cheque Print Date : 01-Jan-2019 To 31-May-2019  
 Bank : 1 To 99  
 Class : All

Vendor Invoice	Vendor Name Description	Batch	Inv Date	Inv Due Date	Amount
G.L. Account	CC1 CC2 CC3 GL Account Name				
<b>DEPARTMENT 3010000</b>	<b>PUBLIC WORKS</b>				
5294-185081	WINDSHIELD WASHER FLUID	105	28-Jan-2019	28-Jan-2019	
10-5-3010000-0402	VEHICLE & EQUIPMENT MTCE.				85.43
<b>MIC117 MICHELIN NORTH AMERICA (CANADA) INC c/o</b>					
DA000687667C	NEW TIRES	1554	16-Nov-2018	16-Nov-2018	
10-5-3010000-0402	VEHICLE & EQUIPMENT MTCE.				1,095.20
DA0006920973	NEW TIRES - UNIT TH-02	1554	29-Nov-2018	29-Nov-2018	
10-5-3010000-0402	VEHICLE & EQUIPMENT MTCE.				865.36
<b>MIN27 MINISTER OF FINANCE/MTO</b>					
MAY 1, 2019	TECHNICIAN	436	01-May-2019	01-May-2019	
10-5-3010000-0350	MEMBERSHIPS				14.00
<b>MON183 MONARCH OFFICE SUPPLY LTD</b>					
122755	NOVEMBER 2018 PURCHASES	1606	29-Nov-2018	29-Nov-2018	
10-5-3010000-0301	OFFICE SUPPLIES				22.99
127289	DECEMBER 2018 PURCHASES	1607	31-Dec-2018	31-Dec-2018	
10-5-3010000-0301	OFFICE SUPPLIES				286.53
133006	JANUARY 2018 PURCHASES	176	30-Jan-2019	30-Jan-2019	
10-5-3010000-0301	OFFICE SUPPLIES				277.35
138007	FEBRUARY 2019 PURCHASE	319	27-Feb-2019	27-Feb-2019	
10-5-3010000-0301	OFFICE SUPPLIES				44.74
143523	MARCH 2019 PURCHASES	406	29-Mar-2019	29-Mar-2019	
10-5-3010000-0301	OFFICE SUPPLIES				59.51
<b>MOR26 MORNEAU SHEPELL LTD.</b>					
APRIL 2019	953243, 953244, 953245, 953246 APRIL 2019	347	01-Apr-2019	01-Apr-2019	
10-5-3010000-0207	BENEFITS - LIFE & DISABIL				108.16
FEBRUARY 20	921007, 921008, 921009, 921010 FEBRUARY 2019	135	01-Feb-2019	01-Feb-2019	
10-5-3010000-0207	BENEFITS - LIFE & DISABIL				108.16
MACH 2019	936899, 936900, 936901, 936902 MARCH 2019	280	01-Mar-2019	01-Mar-2019	
10-5-3010000-0207	BENEFITS - LIFE & DISABIL				108.16
MAY 2019	970411, 970412, 970413, 970414 MAY 2019	511	01-May-2019	01-May-2019	
10-5-3010000-0207	BENEFITS - LIFE & DISABIL				108.16
<b>MUN200 MUNICIPAL EMPLOYER PENSION CENTRE OF ONTARIO</b>					
MC004654	MEPCO 2019 E MPLOYEE CONTRIBUTION	15	02-Jan-2019	02-Jan-2019	
10-5-3010000-0350	MEMBERSHIPS				54.31
<b>MWH215 M.W.H. PETROLEUM EQUIPMENT LTD</b>					
60283	REPAIR TO NORTH YARD FUEL TRACKING SYSTEM	345	12-Mar-2019	12-Mar-2019	
10-5-3010000-0401	GASOLINE				330.36
<b>OAC05 OACETT</b>					
1403400	2019 MEMBERSHIP FEES	105	02-Jan-2019	02-Jan-2019	
10-5-3010000-0350	MEMBERSHIPS				249.12
<b>OKT366 OK TIRE STORE - SANTING</b>					
0000179660	VECHILE WASH MATERIAL	345	18-Mar-2019	18-Mar-2019	
10-5-3010000-0402	VEHICLE & EQUIPMENT MTCE.				84.75
0000179674	VECHILE WASH MATERIAL	345	19-Mar-2019	19-Mar-2019	
10-5-3010000-0404	VEHICLE & RADIO LICENCES				237.30
0000179980	WASH SOAP AND PENATRATING OIL	481	11-Apr-2019	11-Apr-2019	
10-5-3010000-0402	VEHICLE & EQUIPMENT MTCE.				131.87
<b>ONT270 1732077 ONTARIO LIMITED O/A TIM WHITES TOTAL TIRE</b>					
93612	TIRE REPAIR	177	28-Jan-2019	28-Jan-2019	
10-5-3010000-0402	VEHICLE & EQUIPMENT MTCE.				243.52
<b>PIO561 PIONEER RESEARCH CORPORATION</b>					
255202	DE-SALTING MATERIAL FOR VEHICLE	250	04-Feb-2019	04-Feb-2019	
10-5-3010000-0402	VEHICLE & EQUIPMENT MTCE.				403.74





Vendor : CAT038 To ZUL180  
 Batch : All  
 Department : All

Cheque Print Date : 01-Jan-2019 To 31-May-2019  
 Bank : 1 To 99  
 Class : All

Vendor Invoice	Vendor Name Description	Batch	Inv Date	Inv Due Date	Amount
G.L. Account	CC1 CC2 CC3 GL Account Name				
<b>DEPARTMENT 3010000</b>	<b>PUBLIC WORKS</b>				
<b>PIT565</b>	<b>PITTAO'S AUTO CARE INC</b>				
055106	REPAIR UNIT 410	347	25-Mar-2019	25-Mar-2019	
10-5-3010000-0402	VEHICLE & EQUIPMENT MTCE.				4,147.69
<b>POW372</b>	<b>POWER DISTRIBUTION SUPPLY</b>				
1901	PARTS FOR ELECTRICAL REPAIR	280	22-Feb-2019	22-Feb-2019	
10-5-3010000-0420	EQUIPMENT				11.30
<b>POW509</b>	<b>POWER</b>				
430201901	WHEEL WEIGHTS	481	30-Apr-2019	30-Apr-2019	
10-5-3010000-0402	VEHICLE & EQUIPMENT MTCE.				3,781.58
<b>PRI100</b>	<b>PRINCESS AUTO</b>				
1067617	PLOW MAINTENANCE FOR TRUCKS	177	21-Jan-2019	21-Jan-2019	
10-5-3010000-0402	VEHICLE & EQUIPMENT MTCE.				197.71
1072001	SUPPLIES	134	25-Jan-2019	25-Jan-2019	
10-5-3010000-0402	VEHICLE & EQUIPMENT MTCE.				11.15
1099362	POST HOLE DRIVER	280	27-Feb-2019	27-Feb-2019	
10-5-3010000-0420	EQUIPMENT				451.99
1156609	POST DRIVER	481	26-Apr-2019	26-Apr-2019	
10-5-3010000-0420	EQUIPMENT				28.85
<b>PUB100</b>	<b>PUBLIC SAFETY SERVICES</b>				
2944	SAFETY LIGHTS FOR NEW VECHILES	1554	10-Dec-2018	10-Dec-2018	
10-5-3010000-0402	VEHICLE & EQUIPMENT MTCE.				1,670.03
<b>PUR700</b>	<b>PURULATOR INC.</b>				
440270614	GPS SYSTEM	105	11-Jan-2019	11-Jan-2019	
10-5-3010000-0402	VEHICLE & EQUIPMENT MTCE.				4.53
440783105	MAIL MEMORY BACK TO ASI FLUIDS	280	08-Mar-2019	08-Mar-2019	
10-5-3010000-0402	VEHICLE & EQUIPMENT MTCE.				4.53
<b>RAC462</b>	<b>RACICOT CHRYSLER</b>				
57532	BATTERIES FOR FOBS	525	30-Apr-2019	30-Apr-2019	
10-5-3010000-0402	VEHICLE & EQUIPMENT MTCE.				33.90
<b>ROO009</b>	<b>ROOD ENGINEERING INC.</b>				
REI-2019033	ENGINEERING	204	04-Feb-2019	04-Feb-2019	
10-5-3010000-0765	MUNICIPAL DRAIN EXPENSE				2,876.98
REI-2019046	ENGINEERING SERVICES	345	25-Mar-2019	25-Mar-2019	
10-5-3010000-0328	ENGINEERING FEES				1,801.22
<b>RTT067</b>	<b>RIVER TOWN TIMES</b>				
1718	ADVERTISING	347	10-Apr-2019	10-Apr-2019	
10-5-3010000-0738	NUISANCE MOSQUITO PROGRAM				87.26
<b>RUS02</b>	<b>RUSSCO TRAINING SERVICES</b>				
4233	TRAINING CONFINED SPACES	436	27-Mar-2019	27-Mar-2019	
10-5-3010000-0351	TRAINING & CONFERENCES				1,412.50
<b>SAF01</b>	<b>SAFETY-KLEEN CANADA INC</b>				
79077528	HYDRAULIC FLUID	204	31-Jan-2019	31-Jan-2019	
10-5-3010000-0402	VEHICLE & EQUIPMENT MTCE.				778.18
<b>STE366</b>	<b>STERLING FUELS</b>				
0071455	FUEL FOR VEHCILES	1554	05-Dec-2018	05-Dec-2018	
10-5-3010000-0401	GASOLINE				2,235.08
0071461	NORTH YARD FUEL FOR TRUCKS	1554	05-Dec-2018	05-Dec-2018	
10-5-3010000-0401	GASOLINE				385.12
0071463	SOUTH YARD - FUEL FOR EQUIPMENT	1554	05-Dec-2018	05-Dec-2018	
10-5-3010000-0401	GASOLINE				211.97
0071466	MAIN YARD FUEL FOR EQUIPMENT	1554	05-Dec-2018	05-Dec-2018	
10-5-3010000-0401	GASOLINE				479.75



Vendor : CAT038 To ZUL180

Batch : All

Department : All

Cheque Print Date : 01-Jan-2019 To 31-May-2019

Bank : 1 To 99

Class : All

Vendor Invoice	Vendor Name Description	Batch	Inv Date	Inv Due Date	Amount
G.L. Account	CC1 CC2 CC3 GL Account Name				
<b>DEPARTMENT 3010000</b>	<b>PUBLIC WORKS</b>				
0071468	FUEL FOR TRUCKS	1554	05-Dec-2018	05-Dec-2018	
10-5-3010000-0401	GASOLINE				609.95
0071995	MAIN YARD FUEL FOR VECHILES	1554	19-Dec-2018	19-Dec-2018	
10-5-3010000-0401	GASOLINE				2,195.70
0072002	NORTH YARD FUEL FOR TRUCKS	1554	19-Dec-2018	19-Dec-2018	
10-5-3010000-0401	GASOLINE				639.00
0072004	SOUTH YARD FUEL FOR TRUCKS	1554	19-Dec-2018	19-Dec-2018	
10-5-3010000-0401	GASOLINE				615.01
0072007	MAIN YARD FUEL FOR EQUIPMENT	1554	19-Dec-2018	19-Dec-2018	
10-5-3010000-0401	GASOLINE				394.43
0072008	MAIN YARD FUEL FOR TRUCKS	1554	19-Dec-2018	19-Dec-2018	
10-5-3010000-0401	GASOLINE				926.88
0072364	FUEL FOR VECHILES	105	02-Jan-2019	02-Jan-2019	
10-5-3010000-0401	GASOLINE				787.61
0072833	NOTH YARD - FUEL FOR EQUIPMENT	134	17-Jan-2019	17-Jan-2019	
10-5-3010000-0401	GASOLINE				197.44
0072834	NORTH YARD - FUEL FOR TRUCKS	134	17-Jan-2019	17-Jan-2019	
10-5-3010000-0401	GASOLINE				683.58
0072861	MAIN YARD - FUEL FOR VEHICLES	134	18-Jan-2019	18-Jan-2019	
10-5-3010000-0401	GASOLINE				2,836.32
0072868	MAIN YARD - FUEL FOR TRUCKS	134	18-Jan-2019	18-Jan-2019	
10-5-3010000-0401	GASOLINE				969.91
0072869	MAIN YARD - FUEL FOR EQUIPMENT	134	18-Jan-2019	18-Jan-2019	
10-5-3010000-0401	GASOLINE				712.57
0073434	MAIN YARD - FUEL FOR VECHILE	250	13-Feb-2019	13-Feb-2019	
10-5-3010000-0401	GASOLINE				2,006.07
0073439	NORTH YARD - FUEL FOR TRUCKS	250	13-Feb-2019	13-Feb-2019	
10-5-3010000-0401	GASOLINE				660.49
0073440	SOUTH YARD - FUEL FOR TRUCKS	250	13-Feb-2019	13-Feb-2019	
10-5-3010000-0401	GASOLINE				482.51
0073441	SOUTH YARD - FUEL FOR EQUIPMENT	250	13-Feb-2019	13-Feb-2019	
10-5-3010000-0401	GASOLINE				433.91
0073444	MAIN YARD- FUEL FOR EQUIPMENT	250	13-Feb-2019	13-Feb-2019	
10-5-3010000-0401	GASOLINE				309.28
0073445	MAIN YARD - FUEL FOR TRUCKS	250	13-Feb-2019	13-Feb-2019	
10-5-3010000-0401	GASOLINE				569.52
0073806	MAIN YARD - FUEL FOR VECHILES	280	27-Feb-2019	27-Feb-2019	
10-5-3010000-0401	GASOLINE				2,164.20
0073812	NORTH YARD FUEL FOR TRUCKS	280	27-Feb-2019	27-Feb-2019	
10-5-3010000-0401	GASOLINE				385.12
0073813	SOUTH YARD - FUEL FOR TRUCKS	280	27-Feb-2019	27-Feb-2019	
10-5-3010000-0401	GASOLINE				499.76
0073816	MAIN YARD FUEL FOR EQUIPMENT	280	27-Feb-2019	27-Feb-2019	
10-5-3010000-0401	GASOLINE				367.14
0073817	MAIN YARD - FUEL FOR TRUCKS	280	27-Feb-2019	27-Feb-2019	
10-5-3010000-0401	GASOLINE				885.99
0074184	FUEL FOR VEHICLES	345	13-Mar-2019	13-Mar-2019	
10-5-3010000-0401	GASOLINE				2,465.86
0074193	FUEL FOR TRUCKS	345	13-Mar-2019	13-Mar-2019	
10-5-3010000-0401	GASOLINE				562.01
0074196	FUEL FOR EQUIPMENT	345	13-Mar-2019	13-Mar-2019	
10-5-3010000-0401	GASOLINE				340.21
0074197	FUEL FOR TRUCKS	345	13-Mar-2019	13-Mar-2019	

Council/Board Report By Dept-(Computer)



Vendor : CAT038 To ZUL180

Batch : All

Department : All

Cheque Print Date : 01-Jan-2019 To 31-May-2019

Bank : 1 To 99

Class : All

Vendor Invoice	Vendor Name Description	Batch	Inv Date	Inv Due Date	Amount
G.L. Account	CC1 CC2 CC3 GL Account Name				
<b>DEPARTMENT 3010000 PUBLIC WORKS</b>					
10-5-3010000-0401					867.09
0074605	MAIN YARD - FUEL FOR VEHICLES	347	27-Mar-2019	27-Mar-2019	
10-5-3010000-0401					2,428.52
0074611	NORTH YARD FUEL FOR EQUIPMENT	347	27-Mar-2019	27-Mar-2019	
10-5-3010000-0401					357.11
0074612	NORTH YARD FUEL FOR TRUCKS	347	27-Mar-2019	27-Mar-2019	
10-5-3010000-0401					450.76
0074615	MAIN YARD - FUEL FOR EQUIPMENT	347	27-Mar-2019	27-Mar-2019	
10-5-3010000-0401					1,062.89
0074616	MAIN YARD FUEL FOR TRUCKS	347	27-Mar-2019	27-Mar-2019	
10-5-3010000-0401					662.94
0075137	SOUTH YARD FUEL FOR EQUIPMENT	481	11-Apr-2019	11-Apr-2019	
10-5-3010000-0401					869.30
0075138	SOUTH YARD FUEL FOR TRUCKS	481	11-Apr-2019	11-Apr-2019	
10-5-3010000-0401					432.04
0075140	MAIN YARD FUEL FOR EQUIPMENT	481	11-Apr-2019	11-Apr-2019	
10-5-3010000-0401					1,219.90
0075143	MAIN YARD FUEL FOR VEHICLES	511	11-Apr-2019	11-Apr-2019	
10-5-3010000-0401					3,591.80
0075447	OIL FOR PUMP STATION	481	24-Apr-2019	24-Apr-2019	
10-5-3010000-0402	VEHICLE & EQUIPMENT MTCE.				168.32
0075508	MAIN YARD FUEL FOR VEHICLE	511	24-Apr-2019	24-Apr-2019	
10-5-3010000-0401					2,541.21
0075512	NORTH YARD FUEL FOR TRUCKS	511	24-Apr-2019	24-Apr-2019	
10-5-3010000-0401					740.32
0075513	SOUTH YARD FUEL FOR EQUIPMENT	511	24-Apr-2019	24-Apr-2019	
10-5-3010000-0401					305.18
0075515	MAIN YARD - FUEL FOR TRUCKS	511	24-Apr-2019	24-Apr-2019	
10-5-3010000-0401					850.01
0075516	MAIN YARD FUEL FOR EQUIPMENT	511	24-Apr-2019	24-Apr-2019	
10-5-3010000-0401					1,068.70
73087	FUEL FOR VEHICLES	204	31-Jan-2019	31-Jan-2019	
10-5-3010000-0401					3,226.43
73096	MAIN YARD - FUEL FOR EQUIPMENT	204	31-Jan-2019	31-Jan-2019	
10-5-3010000-0401					967.68
73097	MAIN YARD - FUEL FOR TRUCKS	204	31-Jan-2019	31-Jan-2019	
10-5-3010000-0401					2,635.04
73099	NORTH YARD - FUEL FOR EQUIPMENT	204	31-Jan-2019	31-Jan-2019	
10-5-3010000-0401					276.62
73100	NORTH YARD - FUEL FOR TRUCKS	204	31-Jan-2019	31-Jan-2019	
10-5-3010000-0401					1,486.56
73101	FUEL FOR TRUCKS - SOUTH YARD	204	31-Jan-2019	31-Jan-2019	
10-5-3010000-0402	VEHICLE & EQUIPMENT MTCE.				2,138.46
73102	FUEL FOR EQUIPMENT	204	31-Jan-2019	31-Jan-2019	
10-5-3010000-0401					787.82
<b>SUN293 SUNSET ENTERPRIZE &amp; WELDING</b>					
318190	BACKHOE REPAIRS	105	10-Jan-2019	10-Jan-2019	
10-5-3010000-0402	VEHICLE & EQUIPMENT MTCE.				802.27
318191	PLOW MAINTENANCE - UNIT 116	105	10-Jan-2019	10-Jan-2019	
10-5-3010000-0402	VEHICLE & EQUIPMENT MTCE.				3,023.30
318199	EQUIPMENT REPAIR	345	20-Feb-2019	20-Feb-2019	
10-5-3010000-0402	VEHICLE & EQUIPMENT MTCE.				1,208.16
318200	REPAIR PLOW	345	20-Feb-2019	20-Feb-2019	



Vendor : CAT038 To ZUL180

Batch : All

Department : All

Cheque Print Date : 01-Jan-2019 To 31-May-2019

Bank : 1 To 99

Class : All

Vendor Invoice	Vendor Name Description				Batch Invc Date	Invc Due Date	Amount
G.L. Account	CC1	CC2	CC3	GL Account Name			
<b>DEPARTMENT 3010000</b>				<b>PUBLIC WORKS</b>			
10-5-3010000-0402				VEHICLE & EQUIPMENT MTCE.			1,043.49
<b>THR251</b>				<b>THRASHER SALES &amp; LEASING LTD</b>			
228146				E-TEST	1557 03-Dec-2018	03-Dec-2018	
10-5-3010000-0402				VEHICLE & EQUIPMENT MTCE.			109.30
228316				VECHILE MAINTENANCE 510	1554 12-Dec-2018	12-Dec-2018	
10-5-3010000-0402				VEHICLE & EQUIPMENT MTCE.			822.65
228319				REPAIR HEADLIGHT 111	1606 20-Dec-2018	20-Dec-2018	
10-5-3010000-0402				VEHICLE & EQUIPMENT MTCE.			135.78
228342				REPAIR UNIT 111	1554 13-Dec-2018	13-Dec-2018	
10-5-3010000-0402				VEHICLE & EQUIPMENT MTCE.			1,038.46
228829				E-TEST FOR UNIT 111	106 15-Jan-2019	15-Jan-2019	
10-5-3010000-0402				VEHICLE & EQUIPMENT MTCE.			19.78
228952				REPAIR M-2	105 22-Jan-2019	22-Jan-2019	
10-5-3010000-0402				VEHICLE & EQUIPMENT MTCE.			268.10
229502				VEHICLE REPAIR	280 26-Feb-2019	26-Feb-2019	
10-5-3010000-0402				VEHICLE & EQUIPMENT MTCE.			81.87
<b>THU01</b>				<b>THUNDER ROAD HARLEY-DAVIDSON BUELL</b>			
178768				REMOVE ALL POLICE EQUIPMENT FROM BIKE	436 05-Apr-2019	05-Apr-2019	
10-5-3010000-0402				VEHICLE & EQUIPMENT MTCE.			1,129.30
<b>TRA689</b>				<b>TRACTION WINDSOR</b>			
396309842				TRAILER EQUIPMENT	525 02-May-2019	02-May-2019	
10-5-3010000-0402				VEHICLE & EQUIPMENT MTCE.			25.15
<b>TRU429</b>				<b>401 TRUCKSOURCE INC.</b>			
90488200				REPAIRING M-2	1554 13-Nov-2018	13-Nov-2018	
10-5-3010000-0402				VEHICLE & EQUIPMENT MTCE.			2,655.50
90499400				VECHILE REPAIR	176 31-Jan-2019	31-Jan-2019	
10-5-3010000-0402				VEHICLE & EQUIPMENT MTCE.			1,342.61
<b>TSC401</b>				<b>TSC STORES LTD</b>			
JANUARY 25, ; HITCH PINS, CUSTOMER NUMBER 4904					105 25-Jan-2019	25-Jan-2019	
10-5-3010000-0402				VEHICLE & EQUIPMENT MTCE.			22.58
<b>TUR200</b>				<b>TURF CARE PRODUCTS CANADA LIMITED LES PRODUITS TUR</b>			
70703244-00				CONVERTING TORRO UNITS TO POLAR TRAX	1554 12-Dec-2018	12-Dec-2018	
10-5-3010000-0402				VEHICLE & EQUIPMENT MTCE.			810.21
70703252-00				MATERIAL FOR TORRO CONVERSION TO WINTER	62 10-Jan-2019	10-Jan-2019	
10-5-3010000-0402				VEHICLE & EQUIPMENT MTCE.			41.75
70703401-00				CHANGE OVER SIDEWALK MOWING MACHINE	525 22-Apr-2019	22-Apr-2019	
10-5-3010000-0402				VEHICLE & EQUIPMENT MTCE.			1,035.08
<b>WIG035</b>				<b>WIGLE HOME HARDWARE BUILDING CENTRE</b>			
122236				PAINT BRUSHES FOR BARRICADES	1606 05-Sep-2018	05-Sep-2018	
10-5-3010000-0402				VEHICLE & EQUIPMENT MTCE.			60.93
126277				PICK HANDLE	105 10-Jan-2019	10-Jan-2019	
10-5-3010000-0420				EQUIPMENT			16.94
126468				HOSE NOZZLE & COUPLING	105 16-Jan-2019	16-Jan-2019	
10-5-3010000-0420				EQUIPMENT			25.96
126487				2L WINDEX GLASS CLEANER	105 17-Jan-2019	17-Jan-2019	
10-5-3010000-0402				VEHICLE & EQUIPMENT MTCE.			10.72
126729				LOCK DE-ICER	105 25-Jan-2019	25-Jan-2019	
10-5-3010000-0402				VEHICLE & EQUIPMENT MTCE.			4.05
126911				MATERIALS	204 31-Jan-2019	31-Jan-2019	
10-5-3010000-0301				OFFICE SUPPLIES			47.45
127240				NUMBERS TO LABLE FUEL TANKS	280 11-Feb-2019	11-Feb-2019	
10-5-3010000-0401				GASOLINE			7.64
128037				EQUIPMENT	280 11-Mar-2019	11-Mar-2019	



Vendor : CAT038 To ZUL180  
 Batch : All  
 Department : All

Cheque Print Date : 01-Jan-2019 To 31-May-2019  
 Bank : 1 To 99  
 Class : All

Vendor Invoice	Vendor Name Description	Batch	Inv Date	Inv Due Date	Amount
G.L. Account	CC1 CC2 CC3 GL Account Name				
<b>DEPARTMENT 3010000 PUBLIC WORKS</b>					
10-5-3010000-0420	EQUIPMENT				29.36
128584	SHELVING FOR SIGN ROOM	406	28-Mar-2019	28-Mar-2019	
10-5-3010000-0420	EQUIPMENT				49.40
128815	GARBAGE CANS FOR SHOPS	406	04-Apr-2019	04-Apr-2019	
10-5-3010000-0420	EQUIPMENT				42.92
<b>WIN156 WINDSOR STAR; A DIVISION OF POSTMEDIA NETWORK INC.</b>					
360466 2019	12 MONTH SUBSCRIPTION RENEWAL ACCOUNT NO. 360466	481	10-May-2019	10-May-2019	
10-5-3010000-0301	OFFICE SUPPLIES				378.00
<b>WIN380 WINDSOR TIRE INC.</b>					
W081335	UNIT 220 TIRE REPAIR	105	21-Jan-2019	21-Jan-2019	
10-5-3010000-0402	VEHICLE & EQUIPMENT MTCE.				231.65
W084232	UNIT 305 SERVICED	345	22-Mar-2019	22-Mar-2019	
10-5-3010000-0402	VEHICLE & EQUIPMENT MTCE.				145.11
<b>WIS4094 WISMER JACKIE</b>					
001	STRAW BALE FOR DUFFY'S SITE - EROSION PROTECTION	1523	06-Dec-2018	06-Dec-2018	
10-5-3010000-0420	EQUIPMENT				140.00
<b>WOL533 WOLSELEY CANADA INC</b>					
5728615	UPSIDE DOWN PAINT MARKING PAINT (JULY 2017)	1554	31-Dec-2018	31-Dec-2018	
10-5-3010000-0420	EQUIPMENT				444.77
<b>WOR415 WORK AUTHORITY</b>					
511355	BOOTS	280	10-Feb-2019	10-Feb-2019	
10-5-3010000-0161	CLOTHING				427.12
511356	BOOTS	204	10-Feb-2019	10-Feb-2019	
10-5-3010000-0161	CLOTHING				381.93
512799	CLOTHING	250	17-Feb-2019	17-Feb-2019	
10-5-3010000-0161	CLOTHING				223.73
518803	CLOTHING	345	17-Mar-2019	17-Mar-2019	
10-5-3010000-0161	CLOTHING				246.32
521862	CLOTHING	389	31-Mar-2019	31-Mar-2019	
10-5-3010000-0161	CLOTHING				203.39
<b>Department Totals :</b>					<b>217,264.45</b>

<b>DEPARTMENT 3020000 ROADS</b>					
<b>BAR221 BART DIGIOVANNI CONSTRUCTION</b>					
DECEMBER 12	PHRAGMITE	1554	12-Dec-2018	12-Dec-2018	
10-5-3020000-0338	PHRAGMITE				678.00
<b>COU132 COUNTY TOWING INC.</b>					
64993	SPILLS CLEAN UP	347	09-Jan-2019	09-Jan-2019	
10-5-3020000-0757	STORM SEWER CLEANING & FLUSHING				7,460.45
<b>COU360 COUNTY OF ESSEX</b>					
IN000014473	ROAD PATROL ANNUAL COST	105	07-Jan-2019	07-Jan-2019	
10-5-3020000-0725	ROADS MAINTENANCE - GENERAL				6,105.60
<b>D&amp;D100 D &amp; D EXCAVATING &amp; DRAINAGE</b>					
359	CLEANING DITCH	1523	15-Oct-2018	15-Oct-2018	
10-5-3020000-0756	DITCHING				5,763.00
360	CLEANING DITCH	1523	15-Oct-2018	15-Oct-2018	
10-5-3020000-0756	DITCHING				4,910.56
<b>ESS160 ESSEX TERMINAL RAILWAY CO</b>					
0020034-IN	RAILWAY CROSSING MAINTENANCE - TEXAS ROAD	1554	01-Dec-2018	01-Dec-2018	
10-5-3020000-0720	RAILWAY CROSSINGS				304.30
0020136-IN	SHARE OF RAILWAY MAINTENANCE	105	02-Jan-2019	02-Jan-2019	
10-5-3020000-0720	RAILWAY CROSSINGS				304.30

Council/Board Report By Dept-(Computer)



Vendor : CAT038 To ZUL180

Batch : All

Department : All

Cheque Print Date : 01-Jan-2019 To 31-May-2019

Bank : 1 To 99

Class : All

Vendor Invoice	Vendor Name Description	Batch	Inv Date	Inv Due Date	Amount
G.L. Account	CC1 CC2 CC3 GL Account Name				
<b>DEPARTMENT 3020000</b>	<b>ROADS</b>				
0020412-IN	MAINTENANCE OF TEXAS ROAD CROSSING	389	01-Mar-2019	01-Mar-2019	
10-5-3020000-0720	RAILWAY CROSSINGS				304.30
0020563-IN	TOWN'S PORTION OF RAILWAY MAINTENANCE	481	01-Apr-2019	01-Apr-2019	
10-5-3020000-0720	RAILWAY CROSSINGS				304.30
20260-IN	TEXAS ROAD - RAILWAY MAINTENANCE	204	01-Feb-2019	01-Feb-2019	
10-5-3020000-0720	RAILWAY CROSSINGS				304.30
<b>GOO460 GOODREAU EXCAVATING LTD</b>					
25018	DITCHING (DEC 10, 2018)	175	31-Jan-2019	31-Jan-2019	
10-5-3020000-0756	DITCHING				4,051.05
<b>HEA693 HEATON SANITATION</b>					
37243	CLEANING CATCH BASINS	481	20-Apr-2019	20-Apr-2019	
10-5-3020000-0757	STORM SEWER CLEANING & FLUSHING				813.60
<b>HET208 HETEK SOLUTIONS INC</b>					
INV0030689	STORM SEWER CLEANING & FLUSHING	37	02-Jan-2019	02-Jan-2019	
10-5-3020000-0757	STORM SEWER CLEANING & FLUSHING				2,247.71
<b>HIC441 HICKS ELECTRIC</b>					
9698	WEATHER STATION MAINTENANCE	1554	20-Dec-2018	20-Dec-2018	
10-5-3020000-0757	STORM SEWER CLEANING & FLUSHING				145.77
9704	WEATHER STATION MAINTENANCE	1554	27-Dec-2018	27-Dec-2018	
10-5-3020000-0757	STORM SEWER CLEANING & FLUSHING				145.77
9787	REPAIR WEATHER STATION	345	11-Mar-2019	11-Mar-2019	
10-5-3020000-0757	STORM SEWER CLEANING & FLUSHING				153.68
<b>HOS421 HOSKIN SCIENTIFIC LIMITED</b>					
64344	REPAIR WEATHER STATION	1554	10-Dec-2018	10-Dec-2018	
10-5-3020000-0757	STORM SEWER CLEANING & FLUSHING				318.66
64866	COVER TO WEATHER STATION	105	18-Jan-2019	18-Jan-2019	
10-5-3020000-0757	STORM SEWER CLEANING & FLUSHING				117.52
<b>KIN840 KING LUMINAIRE COMPANY INC</b>					
I-KCA-1811129	STREET LIGHT MAINTENANCE	1557	07-Nov-2018	07-Nov-2018	
10-5-3020000-0725	ROADS MAINTENANCE - GENERAL				789.87
<b>NAS514 NASCI CONSTRUCTION SERVICES LTD.</b>					
4444	CATCH BASIN REPAIR - VICTORIA STREET	511	02-May-2019	02-May-2019	
10-5-3020000-0757	STORM SEWER CLEANING & FLUSHING				5,237.55
<b>RIV500 RIVERTOWN GROUNDS COMPANY LTD</b>					
10194	REPAIR BOULEVARD	511	12-Apr-2019	12-Apr-2019	
10-5-3020000-0725	ROADS MAINTENANCE - GENERAL				440.70
<b>SAF01 SAFETY-KLEEN CANADA INC</b>					
78390886	GUN WASH STATION	347	17-Apr-2019	17-Apr-2019	
10-5-3020000-0726	ROADS MAINTENANCE - LINE PAINTING				186.45
<b>SOU100 SOUTHWESTERN SALES CORP</b>					
IN211308	COLD PATCH FOR POTHOLE REPAIRS	1554	26-Nov-2018	26-Nov-2018	
10-5-3020000-0725	ROADS MAINTENANCE - GENERAL				834.79
IN212568	COLD PATCH REPAIRS	105	07-Jan-2019	07-Jan-2019	
10-5-3020000-0725	ROADS MAINTENANCE - GENERAL				1,786.81
IN212623	COLD PATCH FOR ROAD REPAIRS	105	14-Jan-2019	14-Jan-2019	
10-5-3020000-0725	ROADS MAINTENANCE - GENERAL				1,791.05
IN213379	COLD PATCH	347	25-Mar-2019	25-Mar-2019	
10-5-3020000-0725	ROADS MAINTENANCE - GENERAL				1,371.54
<b>TOP811 TOP-IT ASPHALT MAINTENANCE INC</b>					
14367	FILLING IN RUMBLE STRIPS AS PER COUNCIL (OCT 4, 2018)	104	31-Jan-2019	31-Jan-2019	
10-5-3020000-0725	ROADS MAINTENANCE - GENERAL				6,930.73
14559	PAINTING LINES - RAMSEY/BATHURST PARKING SPACES	1554	20-Dec-2018	20-Dec-2018	



Council/Board Report By Dept-(Computer)



Vendor : CAT038 To ZUL180

Batch : All

Department : All

Cheque Print Date : 01-Jan-2019 To 31-May-2019

Bank : 1 To 99

Class : All

Vendor Invoice	Vendor Name Description	Batch	Inv Date	Inv Due Date	Amount
G.L. Account	CC1 CC2 CC3 GL Account Name				

DEPARTMENT	3020000	ROADS				
10-5-3020000-0726			ROADS MAINTENANCE - LINE PAINTING			1,113.05
<b>TRA003</b>	<b>TRAFFIC LOGIX CORPORATION</b>					
SIN03784			TRAFFIC RADAR SIGNS - ANNUAL FEES	406 28-Mar-2019	28-Mar-2019	
10-5-3020000-0725			ROADS MAINTENANCE - GENERAL			452.00
<b>WAL100</b>	<b>WALKER AGGREGATES INC. C/O PROPERTY</b>					
282592			GRAVEL FOR ROADS	250 09-Feb-2019	09-Feb-2019	
10-5-3020000-0725			ROADS MAINTENANCE - GENERAL			257.50
283209			GRAVEL FOR ROADS	406 23-Mar-2019	23-Mar-2019	
10-5-3020000-0725			ROADS MAINTENANCE - GENERAL			438.41
283537			GRAVEL FOR ROADS	406 06-Apr-2019	06-Apr-2019	
10-5-3020000-0725			ROADS MAINTENANCE - GENERAL			1,959.62
<b>WAL101</b>	<b>WALKER AGGREGATES</b>					
282190			STONE FOR ROAD WORK	1557 22-Dec-2018	22-Dec-2018	
10-5-3020000-0715			STONE			1,997.63
284114			GRAVEL FOR SHOULDERING	511 30-Apr-2019	30-Apr-2019	
10-5-3020000-0725			ROADS MAINTENANCE - GENERAL			1,016.03
<b>WIG035</b>	<b>WIGLE HOME HARDWARE BUILDING CENTRE</b>					
121712			POST FOR TRAFFIC SIGN REPAIRS	1557 17-Aug-2018	17-Aug-2018	
10-5-3020000-0725			ROADS MAINTENANCE - GENERAL			1,157.80
123869			SCREWS FOR SIGN REPAIRS	1557 24-Oct-2018	24-Oct-2018	
10-5-3020000-0725			ROADS MAINTENANCE - GENERAL			3.15
<b>WOL533</b>	<b>WOLSELEY CANADA INC</b>					
5418554			STORM AND SEWER DRAINS (APRIL 2017)	1554 31-Dec-2018	31-Dec-2018	
10-5-3020000-0757			STORM SEWER CLEANING & FLUSHING			30.83
6036117			STORM COST FOR NEW STAFF PARKING LOT	1588 17-Oct-2018	17-Oct-2018	
10-5-3020000-0757			STORM SEWER CLEANING & FLUSHING			5,783.18
7613129			STORM REPAIR	134 19-Jan-2019	19-Jan-2019	
10-5-3020000-0757			STORM SEWER CLEANING & FLUSHING			17.52
8001776			STORM SEWER REPAIR - MCCURDY	511 19-Apr-2019	19-Apr-2019	
10-5-3020000-0757			STORM SEWER CLEANING & FLUSHING			1,869.45
8001777			CONCRETE CATCH BASIN	511 19-Apr-2019	19-Apr-2019	
10-5-3020000-0757			STORM SEWER CLEANING & FLUSHING			201.86
<b>Department Totals :</b>						<b>70,100.39</b>

DEPARTMENT	3022016	ROADS CAPTIAL				
<b>HRY172</b>	<b>HRYCAY CONSULTING ENGINEERS INC.</b>					
M416.09			MELOCHE ROAD RECONSTRUCTION	204 29-Jan-2019	29-Jan-2019	
40-7-3022016-0001			MELOCHE RD			13,451.52
<b>Department Totals :</b>						<b>13,451.52</b>

DEPARTMENT	3022017	ROADS CAPITAL				
<b>ANC200</b>	<b>ANCHOR HYDRO</b>					
101589			LED STREET LIGHTING UPGRADES	436 11-Apr-2019	11-Apr-2019	
40-7-3022017-0008			LED STREET LIGHTING UPGRADE PRG			1,983.15
T01-2017-002			LED STREETLIGHT CONVERSION	62 21-Jan-2019	21-Jan-2019	
40-7-3022017-0008			LED STREET LIGHTING UPGRADE PRG			160,307.81
<b>HRY172</b>	<b>HRYCAY CONSULTING ENGINEERS INC.</b>					
M411.05			PROFESSIONAL SERVICES (DEC 31, 2018)	133 16-Jan-2019	16-Jan-2019	
40-7-3022017-0005			PICKERING DR. RESURFACING			9,806.71
<b>LED115</b>	<b>LED ROADWAY LIGHTING LTD</b>					
030538			LED STREET LIGHTING UPGRADE	250 15-Feb-2019	15-Feb-2019	
40-7-3022017-0008			LED STREET LIGHTING UPGRADE PRG			3,748.71



## Council/Board Report By Dept-(Computer)



Vendor : CAT038 To ZUL180

Batch : All

Department : All

Cheque Print Date : 01-Jan-2019 To 31-May-2019

Bank : 1 To 99

Class : All

Vendor Invoice	Vendor Name Description	Batch	Inv Date	Inv Due Date	Amount
G.L. Account	CC1 CC2 CC3 GL Account Name				
<b>DEPARTMENT 3022017</b>	<b>ROADS CAPITAL</b>				
030539	LED STREET LIGHTING UPGRADE	250	15-Feb-2019	15-Feb-2019	
40-7-3022017-0008	LED STREET LIGHTING UPGRADE PRG				4,696.19
<b>STA310</b>	<b>STANTEC CONSULTING LTD</b>				
1330932	REHABILITATION OF BOWSTRING ARCH BRIDGE ON 2NC CONCESSION N OVER RIVER CANARD	1554	21-Nov-2018	21-Nov-2018	
40-7-3022017-0001	2017 ENGINEERING PROJECTS				732.24
<b>Department Totals :</b>					<b>181,274.81</b>
<b>DEPARTMENT 3022018</b>	<b>ROADS CAPITAL</b>				
<b>A1D169</b>	<b>A-1 DRIVEWAY GROUP</b>				
1893	CRACK SEAL VARIOUS STREETS WITHIN THE TOWN	1523	20-Dec-2018	20-Dec-2018	
40-7-3022018-0005	CRACK SEAL PROGRAM				32,885.03
<b>DAN991</b>	<b>DAN'S TREE SERVICES</b>				
1899	REFORESTATION CAPITAL PROGRAM	1554	10-Dec-2018	10-Dec-2018	
40-7-3022018-0012	REFORESTATION CAPITAL PROGRAM				24,769.60
<b>GIO275</b>	<b>GIORGI BROS (1994) INC</b>				
10590	EXCAVATE & INSTALL CONCRETE SIDEWALK (JUL 6, 2018)	104	31-Jan-2019	31-Jan-2019	
40-7-3022018-0006	INTERLOCKING SIDEWALK REPLACEMENT				16,215.50
<b>HRY172</b>	<b>HRYCAY CONSULTING ENGINEERS INC.</b>				
M411.06	PROFESSIONAL SERVICES (DEC 31, 20108)	133	16-Jan-2019	16-Jan-2019	
40-7-3022018-0004	PICKERING DR RESURF KING TO FRYER				35,345.04
M424.01	PROFESSIONAL SERVICES DEC 31, 2018	133	16-Jan-2019	16-Jan-2019	
40-7-3022018-0003	CREEK RD RECONSTRUCTION				87,738.74
M424.02	PROFESSIONAL SERVICES DEC 31, 2018	133	16-Jan-2019	16-Jan-2019	
40-7-3022018-0003	CREEK RD RECONSTRUCTION				5,146.02
<b>JEF296</b>	<b>JEFF SHEPLEY EXCAVATING LTD</b>				
M424B #3	PPC # 3	1523	04-Dec-2018	04-Dec-2018	
40-7-3022018-0003	CREEK RD RECONSTRUCTION				783,005.04
M424B #4	PPC # 4 HOLDBACK	177	12-Feb-2019	12-Feb-2019	
40-7-3022018-0003	CREEK RD RECONSTRUCTION				113,721.93
<b>POW509</b>	<b>POWER</b>				
426201901	2018 CAPITAL	481	26-Apr-2019	26-Apr-2019	
40-7-3022018-0010	NEW TRACTOR				117,782.52
<b>RUT01</b>	<b>RUTHVEN NURSERY &amp; GARDEN CENTR</b>				
22196/22200	REFORESTATION	105	31-Jan-2019	31-Jan-2019	
40-7-3022018-0012	REFORESTATION CAPITAL PROGRAM				10,407.30
<b>SLR626</b>	<b>SLR CONTRACTING GROUP INC.</b>				
M411C #4	PPC # 4 HOLDBACK RELEASE	177	08-Feb-2019	08-Feb-2019	
40-7-3022018-0004	PICKERING DR RESURF KING TO FRYER				87,081.88
<b>UNI01</b>	<b>UNION GAS LTD</b>				
636-1719 203-7	636-1719 203-7105 (512 SANDWICH ST S) SOUTH RIVERVIEW ROAD CROSSING CULVERT	1557	31-Dec-2018	31-Dec-2018	
40-7-3022018-0015	SOUTH RIVERVIEW RD CROSSING CULVERT				9,422.15
<b>WOL533</b>	<b>WOLSELEY CANADA INC</b>				
7432642	CAPITAL DRAIN ACCOUNT	1523	15-Nov-2018	15-Nov-2018	
40-7-3022018-0008	2019 DRAIN MAINTENANCE PRG				1,282.35
<b>WOO4090</b>	<b>WOOD ENVIRONMENTAL &amp; INFRASTRUCTURE SOLUTIONS</b>				
GS6257	CREEK ROAD REHABILITATION GEOTECHNIC	1557	22-Nov-2018	22-Nov-2018	
40-7-3022018-0003	CREEK RD RECONSTRUCTION				2,888.61
GS6433	CREED ROAD RECONSTRUCTION (DEC 14, 2018)	104	31-Jan-2019	31-Jan-2019	
40-7-3022018-0003	CREEK RD RECONSTRUCTION				255.85
GS6434	PROFESSIONAL SERVICES FOR DEC 7, 2018	133	31-Jan-2019	31-Jan-2019	



Vendor : CAT038 To ZUL180  
 Batch : All  
 Department : All

Cheque Print Date : 01-Jan-2019 To 31-May-2019  
 Bank : 1 To 99  
 Class : All

Vendor Invoice	Vendor Name Description				Batch Invc Date	Invc Due Date	Amount
G.L. Account	CC1	CC2	CC3	GL Account Name			
<b>DEPARTMENT 3022018</b>		ROADS CAPITAL					
40-7-3022018-0004				PICKERING DR RESURF KING TO FRYER			123.37
<b>Department Totals :</b>							<b>1,328,070.93</b>
<b>DEPARTMENT 3022019</b>		ROADS CAPITAL					
<b>FEE256</b>	<b>THE FEED STORE</b>						
1000202314				CAPITAL EXPENSES	525 08-May-2019	08-May-2019	
40-7-3022019-0003				42" MOWER WITH BAGGER			19,208.87
<b>WOR055</b>	<b>WORK EQUIPMENT LTD.</b>						
046814				NEW TRACKLESS 14' ROTARY MOWER	406 11-Apr-2019	11-Apr-2019	
40-7-3022019-0017				14" ROTARY MOWER			25,854.40
<b>Department Totals :</b>							<b>45,063.27</b>
<b>DEPARTMENT 3030000</b>		WINTER CONTROL					
<b>BAL364</b>	<b>BALTZER BERNIE</b>						
FEBRUARY 25				MAILBOX REPLACEMENT	250 25-Feb-2019	25-Feb-2019	
10-5-3030000-0710				WINTER CONTROL			75.00
<b>DUR03</b>	<b>DUROCHER JASON</b>						
FEBRUARY 25				MAILBOX REPLACEMENT	250 25-Feb-2019	25-Feb-2019	
10-5-3030000-0710				WINTER CONTROL			75.00
<b>ELE290</b>	<b>ELECTROZAD SUPPLY CO LTD</b>						
S3391952.001				LIGHT FOR SALT SHED	99 21-Jan-2019	21-Jan-2019	
10-5-3030000-0710				WINTER CONTROL			432.26
<b>FAS630</b>	<b>FASAN RANDY</b>						
FEBRUARY 28				MAILBOX REPLACEMENT	250 28-Feb-2019	28-Feb-2019	
10-5-3030000-0710				WINTER CONTROL			282.50
<b>JEF296</b>	<b>JEFF SHEPLEY EXCAVATING LTD</b>						
10886				HAULING SALT	1523 30-Nov-2018	30-Nov-2018	
10-5-3030000-0710				WINTER CONTROL			658.78
10923				COST OF HAULING SALT	177 31-Jan-2019	31-Jan-2019	
10-5-3030000-0710				WINTER CONTROL			8,386.74
10931				SALT DELIVERY	250 15-Feb-2019	15-Feb-2019	
10-5-3030000-0710				WINTER CONTROL			1,773.63
10943				HAULING SALT TO YARDS	280 28-Feb-2019	28-Feb-2019	
10-5-3030000-0710				WINTER CONTROL			506.75
<b>KHA613</b>	<b>KHALIFA ALDIN</b>						
FEBRUARY 27				MAILBOX REPLACEMENT	250 27-Feb-2019	27-Feb-2019	
10-5-3030000-0710				WINTER CONTROL			75.00
<b>KSW113</b>	<b>K&amp;S WINDSOR SALT LTD.</b>						
5300395677				SALT FOR WINTER CONTROL	1595 09-Nov-2018	09-Nov-2018	
10-5-3030000-0710				WINTER CONTROL			15,369.75
5300395961				SALT FOR WINTER CONTROL	1595 12-Nov-2018	12-Nov-2018	
10-5-3030000-0710				WINTER CONTROL			6,451.74
5300398142				SALT FOR WINTER CONTROL	1595 20-Nov-2018	20-Nov-2018	
10-5-3030000-0710				WINTER CONTROL			13,156.84
5300416937				SALT FOR WINTER CONTROL	345 21-Jan-2019	21-Jan-2019	
10-5-3030000-0710				WINTER CONTROL			3,202.70
5300417359				SALT FOR WINTER CONTROL	345 22-Jan-2019	22-Jan-2019	
10-5-3030000-0710				WINTER CONTROL			12,621.14
5300417982				SALT FOR WINTER CONTROL	345 23-Jan-2019	23-Jan-2019	
10-5-3030000-0710				WINTER CONTROL			8,746.25
5300418533				SALT FOR WINTER CONTROL	345 24-Jan-2019	24-Jan-2019	
10-5-3030000-0710				WINTER CONTROL			8,587.10



Vendor : CAT038 To ZUL180  
 Batch : All  
 Department : All

Cheque Print Date : 01-Jan-2019 To 31-May-2019  
 Bank : 1 To 99  
 Class : All

Vendor Invoice	Vendor Name Description	Batch	Inv Date	Inv Due Date	Amount
G.L. Account	CC1 CC2 CC3 GL Account Name				
<b>DEPARTMENT 3030000 WINTER CONTROL</b>					
5300419266	SALT FOR WINTER CONTROL	345	25-Jan-2019	25-Jan-2019	
10-5-3030000-0710	WINTER CONTROL				8,385.59
5300420011	SALT FOR WINTER CONTROL	345	28-Jan-2019	28-Jan-2019	
10-5-3030000-0710	WINTER CONTROL				6,669.75
5300420656	SALT FOR WINTER CONTROL	105	29-Jan-2019	29-Jan-2019	
10-5-3030000-0710	WINTER CONTROL				1,753.53
5300420657	SALT FOR WINTER CONTROL	105	29-Jan-2019	29-Jan-2019	
10-5-3030000-0710	WINTER CONTROL				10,263.79
5300421391	SALT FOR WINTER CONTROL	105	30-Jan-2019	30-Jan-2019	
10-5-3030000-0710	WINTER CONTROL				13,633.68
5300423969	SALT FOR WINTER CONTROL	177	05-Feb-2019	05-Feb-2019	
10-5-3030000-0710	WINTER CONTROL				9,583.90
5300424603	SALT FOR ROADS	177	06-Feb-2019	06-Feb-2019	
10-5-3030000-0710	WINTER CONTROL				12,133.33
5300427874	SALT FOR WINTER CONTROL	345	13-Feb-2019	13-Feb-2019	
10-5-3030000-0710	WINTER CONTROL				5,007.24
5300429620	SALT FOR WINTER CONTROL	345	19-Feb-2019	19-Feb-2019	
10-5-3030000-0710	WINTER CONTROL				3,147.81
5300430196	SALT FOR WINTER CONTROL	345	20-Feb-2019	20-Feb-2019	
10-5-3030000-0710	WINTER CONTROL				1,624.91
<b>PAR372 PARRLINE ELECTRICAL WHOLESALE</b>					
79943	ELECTRICAL SUPPLIES DEC 2018	133	31-Jan-2019	31-Jan-2019	
10-5-3030000-0710	WINTER CONTROL				1,329.56
80193	MATERIAL FOR LIGHT INSTALL AT SALT SHED	134	16-Jan-2019	16-Jan-2019	
10-5-3030000-0710	WINTER CONTROL				473.27
<b>SIM5356 SIMON MIKE</b>					
FEBRUARY 26 MAILBOX REPLACEMENT		250	26-Feb-2019	26-Feb-2019	
10-5-3030000-0710	WINTER CONTROL				75.00
<b>WIG035 WIGLE HOME HARDWARE BUILDING CENTRE</b>					
127811	MAILBOX REPAIR	280	04-Mar-2019	04-Mar-2019	
10-5-3030000-0710	WINTER CONTROL				24.85
128133	MAILBOX REPAIR	345	14-Mar-2019	14-Mar-2019	
10-5-3030000-0710	WINTER CONTROL				99.39
<b>WIS406 WISMER ROBERT</b>					
FEBRUARY 25 MAILBOX REPLACEMENT		250	25-Feb-2019	25-Feb-2019	
10-5-3030000-0710	WINTER CONTROL				75.00
<b>Department Totals :</b>					<b>154,681.78</b>

<b>DEPARTMENT 3050000 STREET LIGHTING</b>					
<b>ESS219 ESSEX POWER SERVICES CORP</b>					
JC10264	REPAIR STREET LIGHT	1554	31-Oct-2018	31-Oct-2018	
10-5-3050000-0331	GENERAL MAINTENANCE				411.21
JC10265	ST LIGHT REPAIR	1554	31-Oct-2018	31-Oct-2018	
10-5-3050000-0331	GENERAL MAINTENANCE				306.41
<b>ESS273 ESSEX POWERLINES CORPORATION</b>					
JC7659	REPAIR UNDERGROUND STREET LIGHT ISSUES (DEC 30, 2018)	104	31-Jan-2019	31-Jan-2019	
10-5-3050000-0331	GENERAL MAINTENANCE				4,016.16
<b>HEA693 HEATON SANITATION</b>					
37043	HYDR VAC FOR POLE REPLACEMENTS	1595	13-Dec-2018	13-Dec-2018	
10-5-3050000-0331	GENERAL MAINTENANCE				1,017.00
<b>HIC441 HICKS ELECTRIC</b>					
9509	SERVICE REQUEST FOR STREET LIGHTING REPAIR	1557	24-Jul-2018	24-Jul-2018	



Vendor : CAT038 To ZUL180

Batch : All

Department : All

Cheque Print Date : 01-Jan-2019 To 31-May-2019

Bank : 1 To 99

Class : All

Vendor Invoice	Vendor Name Description				Batch Invc Date	Invc Due Date	Amount
G.L. Account	CC1	CC2	CC3	GL Account Name			
<b>DEPARTMENT 3050000</b>				<b>STREET LIGHTING</b>			
10-5-3050000-0331				GENERAL MAINTENANCE			723.38
9638	INSTALL SHROUDS				1523 20-Nov-2018	20-Nov-2018	
10-5-3050000-0331				GENERAL MAINTENANCE			291.54
9717	TRAFFIC STREET LIGHT MAINTENANCE				1554 28-Dec-2018	28-Dec-2018	
10-5-3050000-0331				GENERAL MAINTENANCE			1,158.25
9723	REPAIRING STREET LIGHT POST				1523 30-Dec-2018	30-Dec-2018	
10-5-3050000-0331				GENERAL MAINTENANCE			2,953.82
9740	STREET LIGHT MAINTENANCE				105 21-Jan-2019	21-Jan-2019	
10-5-3050000-0331				GENERAL MAINTENANCE			960.50
9772	GROUND BOX MAINTENANCE				280 06-Mar-2019	06-Mar-2019	
10-5-3050000-0331				GENERAL MAINTENANCE			183.06
<b>HYD03</b>	<b>HYDRO ONE</b>						
301791099	CONNECTIONS				1523 08-Nov-2018	08-Nov-2018	
10-5-3050000-0331				GENERAL MAINTENANCE			246.54
301792291	CONNECTIONS				1523 08-Nov-2018	08-Nov-2018	
10-5-3050000-0331				GENERAL MAINTENANCE			246.54
301792321	CONNECTIONS				1523 08-Nov-2018	08-Nov-2018	
10-5-3050000-0331				GENERAL MAINTENANCE			246.54
<b>KIN840</b>	<b>KING LUMINAIRE COMPANY INC</b>						
I-KCA-1902095	STREET LIGHT REPLACEMENT - MVA SANDWICH AND DALHOUSIE				204 22-Feb-2019	22-Feb-2019	
10-5-3050000-0331				GENERAL MAINTENANCE			4,508.70
I-KCA-1903155	MAINTENANCE				345 13-Mar-2019	13-Mar-2019	
10-5-3050000-0331				GENERAL MAINTENANCE			5,644.35
<b>Department Totals :</b>							<b>22,914.00</b>
<b>DEPARTMENT 3250000</b>				<b>TRAFFIC CONTROL</b>			
<b>ACT456</b>	<b>ACTION SIGNS &amp; DESIGNS INC.</b>						
11156	SANTA CLAUS PARADE SIGN (NOV 20, 2018)				104 31-Jan-2019	31-Jan-2019	
10-5-3250000-0741				TRAFFIC SIGNS & DEVICES			90.40
11242	REPLACEMENT SIGNS				204 12-Feb-2019	12-Feb-2019	
10-5-3250000-0741				TRAFFIC SIGNS & DEVICES			146.90
<b>CED150</b>	<b>CEDAR SIGNS</b>						
54448	SIGNS FOR DEVELOPMENT				105 18-Jan-2019	18-Jan-2019	
10-5-3250000-0741				TRAFFIC SIGNS & DEVICES			406.66
55214	TRAFFIC SIGNS AND BRACKETS				436 05-Apr-2019	05-Apr-2019	
10-5-3250000-0741				TRAFFIC SIGNS & DEVICES			722.73
55318	TRAFFIC SIGNS				436 12-Apr-2019	12-Apr-2019	
10-5-3250000-0741				TRAFFIC SIGNS & DEVICES			261.28
55563	TRAFFIC SIGNS AND DEVICES				511 29-Apr-2019	29-Apr-2019	
10-5-3250000-0741				TRAFFIC SIGNS & DEVICES			712.17
<b>COU360</b>	<b>COUNTY OF ESSEX</b>						
IN000012977	TRAFFIC LIGHT MAINTENANCE AND IMPROVEMENTS (SEPTEMBER 2017)				250 15-Feb-2019	15-Feb-2019	
10-5-3250000-0740				TRAFFIC SIGNS			15,826.00
IN000014461	SIGNS FOR REPAIRS (DEC 31, 2018)				104 31-Jan-2019	31-Jan-2019	
10-5-3250000-0741				TRAFFIC SIGNS & DEVICES			8,608.60
IN000014521	SIGN AND SIGNAL IMPROVEMENTS AS PER COUNCIL (DEC 31, 2018)				104 31-Jan-2019	31-Jan-2019	
10-5-3250000-0741				TRAFFIC SIGNS & DEVICES			10,015.66
<b>HEA693</b>	<b>HEATON SANITATION</b>						
33358	HYDRO VAC FOR SIGN REPLACEMENT				345 19-Mar-2019	19-Mar-2019	
10-5-3250000-0741				TRAFFIC SIGNS & DEVICES			452.00
37036	HYDRO VAC HOLSE FOR SIGN INSTALLS				1554 04-Dec-2018	04-Dec-2018	
10-5-3250000-0741				TRAFFIC SIGNS & DEVICES			2,034.00

Council/Board Report By Dept-(Computer)



Vendor : CAT038 To ZUL180  
 Batch : All  
 Department : All

Cheque Print Date : 01-Jan-2019 To 31-May-2019  
 Bank : 1 To 99  
 Class : All

Vendor Invoice	Vendor Name Description	Batch	Inv Date	Inv Due Date	Amount
G.L. Account	CC1 CC2 CC3 GL Account Name				
<b>DEPARTMENT 3250000 TRAFFIC CONTROL</b>					
37686	VAC TRUCK	207	20-Feb-2019	20-Feb-2019	
10-5-3250000-0741	TRAFFIC SIGNS & DEVICES				452.00
37687	HYDRO VAC HOLES FOR SIGN INSTALLS	280	20-Feb-2019	20-Feb-2019	
10-5-3250000-0741	TRAFFIC SIGNS & DEVICES				339.00
37697	HYDRO VAC HOLES FOR SIGN INSTALLS	280	07-Mar-2019	07-Mar-2019	
10-5-3250000-0741	TRAFFIC SIGNS & DEVICES				2,034.00
<b>SUN293 SUNSET ENTERPRIZE &amp; WELDING</b>					
318203	SIGN BRACKETS	345	11-Mar-2019	11-Mar-2019	
10-5-3250000-0741	TRAFFIC SIGNS & DEVICES				325.17
318209	REPAIR	511	25-Mar-2019	25-Mar-2019	
10-5-3250000-0741	TRAFFIC SIGNS & DEVICES				198.30
<b>TOW056 TOWNE SHOPPE</b>					
21	CROSSING GUARDS UNIFORMS	250	29-Jan-2019	29-Jan-2019	
10-5-3250000-0252	UNIFORMS				248.57
22	CROSSING GUARDS	319	05-Feb-2019	05-Feb-2019	
10-5-3250000-0252	UNIFORMS				550.26
APRIL 18, 2019	CROSSING GUARDS UNIFORMS	406	18-Apr-2019	18-Apr-2019	
10-5-3250000-0252	UNIFORMS				206.01
<b>WIG035 WIGLE HOME HARDWARE BUILDING CENTRE</b>					
127481	HARDWARE FOR SIGN INSTALLS	250	20-Feb-2019	20-Feb-2019	
10-5-3250000-0741	TRAFFIC SIGNS & DEVICES				24.32
127662	POST FOR SIGN INSTALLS	280	26-Feb-2019	26-Feb-2019	
10-5-3250000-0741	TRAFFIC SIGNS & DEVICES				118.59
127663	POST FOR SIGN INSTALLS	280	26-Feb-2019	26-Feb-2019	
10-5-3250000-0741	TRAFFIC SIGNS & DEVICES				502.62
129467	POST FOR SIGN INSTALLATION	511	23-Apr-2019	23-Apr-2019	
10-5-3250000-0741	TRAFFIC SIGNS & DEVICES				735.38
129514	HARDWARE FOR SIGN INSTALLATION	511	24-Apr-2019	24-Apr-2019	
10-5-3250000-0741	TRAFFIC SIGNS & DEVICES				9.85
129791	PLYWOOD FOR LARGE SIGNS	511	02-May-2019	02-May-2019	
10-5-3250000-0741	TRAFFIC SIGNS & DEVICES				63.26
<b>Department Totals :</b>					<b>45,083.73</b>

<b>DEPARTMENT 4010000 SANITARY SEWERS</b>					
<b>ONT001 ONTARIO CLEAN WATER AGENCY</b>					
110930	ADDITIONAL SERVICES	207	04-Jan-2019	04-Jan-2019	
10-5-4010000-2001	TRANSFER TO CAPITAL - WASTEWATER				20,333.17
110931	ADDITIONAL SERVICES	207	04-Jan-2019	04-Jan-2019	
10-5-4010000-2001	TRANSFER TO CAPITAL - WASTEWATER				15,214.34
INV000108312	ADDITIONAL SERVICES (NOV 22, 2018)	107	31-Jan-2019	31-Jan-2019	
10-5-4010000-0680	LIFE CYCLE EXPENSES				2,066.53
INV000108332	REPLACE RSP # 1	1602	22-Nov-2018	22-Nov-2018	
10-5-4010000-0680	LIFE CYCLE EXPENSES				5,738.10
INV000108831	LIFE CYCLE REPLACEMENT	1599	06-Dec-2018	06-Dec-2018	
10-5-4010000-0680	LIFE CYCLE EXPENSES				3,770.89
INV000108871	REBUILD BLOWER	1598	06-Dec-2018	06-Dec-2018	
10-5-4010000-0680	LIFE CYCLE EXPENSES				5,245.59
INV000108872	REBUILD BLOWER	1598	06-Dec-2018	06-Dec-2018	
10-5-4010000-0680	LIFE CYCLE EXPENSES				5,898.88
INV000109921	BACKWAASH PUMP REPLACEMENT	1598	30-Dec-2018	30-Dec-2018	
10-5-4010000-0680	LIFE CYCLE EXPENSES				5,828.05
INV000109922	CLARIFIER PUMP REPLACEMENT	1598	30-Dec-2018	30-Dec-2018	
10-5-4010000-0680	LIFE CYCLE EXPENSES				14,495.35



Vendor : CAT038 To ZUL180

Batch : All

Department : All

Cheque Print Date : 01-Jan-2019 To 31-May-2019

Bank : 1 To 99

Class : All

Vendor Invoice	Vendor Name Description	Batch	Inv Date	Inv Due Date	Amount
G.L. Account	CC1 CC2 CC3 GL Account Name				
<b>DEPARTMENT 4010000 SANITARY SEWERS</b>					
INV000110295	ADDITIONAL SERVICES	108	08-Jan-2019	08-Jan-2019	
10-5-4010000-0680	LIFE CYCLE EXPENSES				1,062.71
INV000111058	ADDITIONAL SERVICES	284	25-Feb-2019	25-Feb-2019	
10-5-4010000-0680	LIFE CYCLE EXPENSES				341.61
INV000111059	BLOCK HEATER FOR GENERATOR	286	25-Feb-2019	25-Feb-2019	
10-5-4010000-0680	LIFE CYCLE EXPENSES				469.28
INV000111060	EXPLOSION SWITCH REPAIR & COVER	286	25-Feb-2019	25-Feb-2019	
10-5-4010000-0680	LIFE CYCLE EXPENSES				727.88
INV000111152	ADDITIONAL SERVICES	387	18-Mar-2019	18-Mar-2019	
10-5-4010000-0680	LIFE CYCLE EXPENSES				3,016.18
INV000112387	ADDITIONAL SERVICES	437	10-Apr-2019	10-Apr-2019	
10-5-4010000-0680	LIFE CYCLE EXPENSES				6,491.76
<b>Department Totals :</b>					<b>90,700.32</b>

<b>DEPARTMENT 4012006 SANITARY SEWER CAPITAL</b>					
<b>CH2154 CH2M HILL CANADA LIMITED</b>					
388574CH-03	AWWTP POST CONSTRUCTION COSTS	1524	26-Nov-2018	26-Nov-2018	
40-7-4012006-0056	AWWTP - ABURG WASTEWATER PLANT & ENV. AS				3,186.60
388574CH-06	AWWTP POST CONSTRUCTION COSTS ENGINEERING SUPPORT	1556	18-Dec-2018	18-Dec-2018	
40-7-4012006-0056	AWWTP - ABURG WASTEWATER PLANT & ENV. AS				949.20
388574CH-07	AWWTP POST CONSTRUCTION COSTS	139	25-Jan-2019	25-Jan-2019	
40-7-4012006-0056	AWWTP - ABURG WASTEWATER PLANT & ENV. AS				5,943.80
<b>MOU001 MOUSSEAU DELUCA McPHERSON PRINCE</b>					
58597	LEGAL FEES	1554	30-Nov-2018	30-Nov-2018	
40-7-4012006-0056	AWWTP - ABURG WASTEWATER PLANT & ENV. AS				2,474.40
59005	LEGAL FEES	254	31-Jan-2019	31-Jan-2019	
40-7-4012006-0056	AWWTP - ABURG WASTEWATER PLANT & ENV. AS				440.70
59158	LEGAL FEES	296	28-Feb-2019	28-Feb-2019	
40-7-4012006-0056	AWWTP - ABURG WASTEWATER PLANT & ENV. AS				406.80
59346	LEGAL FEES	410	31-Mar-2019	31-Mar-2019	
40-7-4012006-0056	AWWTP - ABURG WASTEWATER PLANT & ENV. AS				1,683.81
<b>Department Totals :</b>					<b>15,085.31</b>

<b>DEPARTMENT 4012011 WASTEWATER CAPITAL</b>					
<b>CH2154 CH2M HILL CANADA LIMITED</b>					
388574CH-11	PROFESSIONAL SERVICES	284	28-Feb-2019	28-Feb-2019	
40-7-4012011-0003	AMHERST. PCP PS NO.2 UPGRADE				1,062.20
<b>MAP266 MAPLE REINDERS CONSTRUCTORS LTD</b>					
PWD-SW-10-0: PPC # 13		1556	10-Dec-2018	10-Dec-2018	
40-7-4012011-0003	AMHERST. PCP PS NO.2 UPGRADE				108,787.09
<b>Department Totals :</b>					<b>109,849.29</b>

<b>DEPARTMENT 4012013 WASTEWATER CAPITAL</b>					
<b>CH2154 CH2M HILL CANADA LIMITED</b>					
388574CH-04	EDGEWATER FORCEMAIN	1524	26-Nov-2018	26-Nov-2018	
40-7-4012013-0003	NEW FORCEMAIN & PUMP STATION				60,105.27
388574CH-05	ENGINEERING SERVICES	1556	18-Dec-2018	18-Dec-2018	
40-7-4012013-0003	NEW FORCEMAIN & PUMP STATION				40,470.95
388574CH-08	PROFESSIONAL FEES FOR EDGEWATER LAGOONS SERVICE AREA	139	25-Jan-2019	25-Jan-2019	
40-7-4012013-0003	NEW FORCEMAIN & PUMP STATION				40,653.16
388574CH-09	LEGAL FEES	284	25-Feb-2019	25-Feb-2019	
40-7-4012013-0003	NEW FORCEMAIN & PUMP STATION				24,973.00



## Council/Board Report By Dept-(Computer)



Vendor : CAT038 To ZUL180

Batch : All

Department : All

Cheque Print Date : 01-Jan-2019 To 31-May-2019

Bank : 1 To 99

Class : All

Vendor Invoice	Vendor Name Description	Batch	Inv Date	Inv Due Date	Amount
G.L. Account	CC1 CC2 CC3 GL Account Name				
<b>DEPARTMENT 4012013 WASTEWATER CAPITAL</b>					
388574CH-10	PROFESSIONAL SERVICES	284	25-Feb-2019	25-Feb-2019	
40-7-4012013-0003	NEW FORCEMAIN & PUMP STATION				13,198.40
388574CH-12	ENGINEERING SERVICES	352	20-Mar-2019	20-Mar-2019	
40-7-4012013-0003	NEW FORCEMAIN & PUMP STATION				24,153.75
388574CH-13	ENGINEERING SERVICES	352	20-Mar-2019	20-Mar-2019	
40-7-4012013-0003	NEW FORCEMAIN & PUMP STATION				9,088.03
388574CH-14	ENGINEERING SERVICES	437	23-Apr-2019	23-Apr-2019	
40-7-4012013-0003	NEW FORCEMAIN & PUMP STATION				53,641.10
388574CH-15	ENGINEERING SERVICES	437	23-Apr-2019	23-Apr-2019	
40-7-4012013-0003	NEW FORCEMAIN & PUMP STATION				19,791.95
<b>GOL452 GOLDER ASSOCIATES LTD</b>					
1004791	PROFESSIONAL SERVICES	284	05-Mar-2019	05-Mar-2019	
40-7-4012013-0003	NEW FORCEMAIN & PUMP STATION				2,975.63
1012897	PROFESSIONAL SERVICES	437	12-Apr-2019	12-Apr-2019	
40-7-4012013-0003	NEW FORCEMAIN & PUMP STATION				5,220.43
983051	EDGEWATER FORCEMAIN	1524	04-Dec-2018	04-Dec-2018	
40-7-4012013-0003	NEW FORCEMAIN & PUMP STATION				4,903.30
993123	GEOTECHNICAL INSPECTIONS	108	16-Jan-2019	16-Jan-2019	
40-7-4012013-0003	NEW FORCEMAIN & PUMP STATION				305.78
<b>JJL440 J&amp;J LEPERA INFRASTRUCTURES INC</b>					
388574 #3	PPC # 3	1524	30-Nov-2018	30-Nov-2018	
40-7-4012013-0003	NEW FORCEMAIN & PUMP STATION				240,016.86
388574 #4	PPC # 4	284	06-Mar-2019	06-Mar-2019	
40-7-4012013-0003	NEW FORCEMAIN & PUMP STATION				823,422.91
SW-2013-020 # PPC # 5		388	12-Apr-2019	12-Apr-2019	
40-7-4012013-0003	NEW FORCEMAIN & PUMP STATION				529,912.44
<b>WOL533 WOLSELEY CANADA INC</b>					
7952804	MAINTENANCE SUPPLIES	437	19-Apr-2019	19-Apr-2019	
40-7-4012013-0003	NEW FORCEMAIN & PUMP STATION				764.72
7982496	MAINTENANCE SUPPLIES	437	19-Apr-2019	19-Apr-2019	
40-7-4012013-0003	NEW FORCEMAIN & PUMP STATION				198.88
<b>Department Totals :</b>					<b>1,893,796.56</b>

<b>DEPARTMENT 4012015 WASTEWATER CAPITAL</b>					
<b>CIV330 CIVICA INFRASTRUCTURE INC</b>					
102879	ENGINEERING SERVICES	284	22-Feb-2019	22-Feb-2019	
40-7-4012015-0001	AWWTP-INFLOW & INFILTRATION ENGINEERING				10,774.55
102978	ENGINEERING	437	08-Apr-2019	08-Apr-2019	
40-7-4012015-0001	AWWTP-INFLOW & INFILTRATION ENGINEERING				5,188.96
<b>REV200 REVOLUTION ENVIRONMENTAL SOLUTIONS LP A TERRAPURE</b>					
165601361	PPC # 3	254	04-Mar-2019	04-Mar-2019	
40-7-4012015-0005	MCGREGOR LAGOON CLEANING CELL 1,2,3				15,834.23
<b>Department Totals :</b>					<b>31,797.74</b>

<b>DEPARTMENT 4012017 WASTEWATER CAPITAL</b>					
<b>BOR430 BORG JAMES</b>					
FEB 2019	SUBSIDY - BACKWATER VALVE INSTALLATION	207	28-Feb-2019	28-Feb-2019	
40-7-4012017-0004	I&I PRG SANITARY SEWER RENEW & REPAIR				1,300.00
<b>CIV330 CIVICA INFRASTRUCTURE INC</b>					
102644	INFLOW AND INFILTRATION - REPAIRS	1524	26-Nov-2018	26-Nov-2018	
40-7-4012017-0003	INFLOW & INFILTRATION STUDY - ENG				62,647.77
102721	L&L INVESTIGATIONS	1556	17-Dec-2018	17-Dec-2018	





Vendor : CAT038 To ZUL180

Batch : All

Department : All

Cheque Print Date : 01-Jan-2019 To 31-May-2019

Bank : 1 To 99

Class : All

Vendor Invoice	Vendor Name Description	Batch	Inv Date	Inv Due Date	Amount
G.L. Account	CC1 CC2 CC3 GL Account Name				
<b>DEPARTMENT 4012017 WASTEWATER CAPITAL</b>					
40-7-4012017-0003	INFLOW & INFILTRATION STUDY - ENG				50,953.87
102814	AWWTP I&I PROGRAM REPAIRS	108	15-Jan-2019	15-Jan-2019	
40-7-4012017-0004	I&I PRG SANITARY SEWER RENEW & REPAIR				38,931.20
102909	ENGINEERING SERVICES	352	06-Mar-2019	06-Mar-2019	
40-7-4012017-0003	INFLOW & INFILTRATION STUDY - ENG				5,234.16
<b>FRA351 FRANK RICHARD</b>					
DECEMBER 31	BACKWATER SUBSIDY & SUMP PUMP SUBSIDY	1556	31-Dec-2018	31-Dec-2018	
40-7-4012017-0004	I&I PRG SANITARY SEWER RENEW & REPAIR				1,300.00
<b>LAJ001 LAJOIE JENNY</b>					
DECEMBER 31	BACKWATER & SUMP PUMP SUBSIDY	1556	31-Dec-2018	31-Dec-2018	
40-7-4012017-0004	I&I PRG SANITARY SEWER RENEW & REPAIR				1,300.00
<b>MAR432 MARSHALL DAVE</b>					
DECEMBER 31	BACKWATER & SUMP PUMP SUBSIDY	1556	31-Dec-2018	31-Dec-2018	
40-7-4012017-0004	I&I PRG SANITARY SEWER RENEW & REPAIR				1,300.00
<b>NJP045 N.J. PERALTA ENGINEERING LTD</b>					
19-029	SEWER REPAIR	437	10-Apr-2019	10-Apr-2019	
40-7-4012017-0004	I&I PRG SANITARY SEWER RENEW & REPAIR				570.65
<b>OCO434 O'CONNOR SHARON</b>					
APRIL 30, 2019	BACKWATER VALVE INSTALLATION & SUMP PUMP OVERFLOW SUBSIDY	437	30-Apr-2019	30-Apr-2019	
40-7-4012017-0004	I&I PRG SANITARY SEWER RENEW & REPAIR				1,300.00
<b>ORC326 ORCHARD GLENN</b>					
DECEMBER 31	SUMP PUMP AND FOUNDATION DRAIN DISCONNECTION SUBSIDY	1556	31-Dec-2018	31-Dec-2018	
40-7-4012017-0004	I&I PRG SANITARY SEWER RENEW & REPAIR				1,300.00
<b>OUE274 OUELLETTE BRANDON</b>					
MAY 10, 2019	RETURN OF BACKWATER VALVE INSTALLATION	486	10-May-2019	10-May-2019	
40-7-4012017-0004	I&I PRG SANITARY SEWER RENEW & REPAIR				1,000.00
<b>RID142 RIDSDALE NICOLE</b>					
DECEMBER 31	BACKWATER & SUMP PUMP SUBSIDY	1556	31-Dec-2018	31-Dec-2018	
40-7-4012017-0004	I&I PRG SANITARY SEWER RENEW & REPAIR				1,300.00
<b>SAV04 SAVO MICHAEL</b>					
JANUARY 31, ;	BACKWATER VALV & SUMP PUMP SUBSIDY	108	31-Jan-2019	31-Jan-2019	
40-7-4012017-0004	I&I PRG SANITARY SEWER RENEW & REPAIR				1,300.00
<b>SMI151 SMIT GEORGE</b>					
JANUARY 31, ;	BACK WATER VALVE SUBSIDY	108	31-Jan-2019	31-Jan-2019	
40-7-4012017-0004	I&I PRG SANITARY SEWER RENEW & REPAIR				1,000.00
<b>SOU144 SOUTH SHORE CONTRACTING OF ESSEX COUNTY INC.</b>					
226	SEWER SEPARATION - BATHURST & GORE	1556	20-Dec-2018	20-Dec-2018	
40-7-4012017-0004	I&I PRG SANITARY SEWER RENEW & REPAIR				78,987.00
<b>TAG448 MARCHAND BROOKE</b>					
JANUARY 18, ;	BACKWATER AND SUMP PUMP SUBSIDY	37	18-Jan-2019	18-Jan-2019	
40-7-4012017-0004	I&I PRG SANITARY SEWER RENEW & REPAIR				1,300.00
<b>WIG193 WIGGINS JEFFERSON</b>					
DECEMBER 31	BACKWATER & SUMP PUMB SUBSIDY	1556	31-Dec-2018	31-Dec-2018	
40-7-4012017-0004	I&I PRG SANITARY SEWER RENEW & REPAIR				1,300.00
<b>Department Totals :</b>					<b>252,324.65</b>

**DEPARTMENT 4012018 WASTEWATER CAPITAL**

<b>RTT067 RIVER TOWN TIMES</b>					
1006	ADVERTISING	34	10-Jan-2019	10-Jan-2019	
40-7-4012018-0001	SE QUADRANT CLASS EA				276.15
1034	ADVERTISING	62	16-Jan-2019	16-Jan-2019	
40-7-4012018-0001	SE QUADRANT CLASS EA				276.16

Council/Board Report By Dept-(Computer)



Vendor : CAT038 To ZUL180

Batch : All

Department : All

Cheque Print Date : 01-Jan-2019 To 31-May-2019

Bank : 1 To 99

Class : All

Vendor Invoice	Vendor Name Description	Batch	Inv Date	Inv Due Date	Amount
G.L. Account	CC1 CC2 CC3 GL Account Name				
<b>DEPARTMENT 4012018 WASTEWATER CAPITAL</b>					
<b>STA310 STANTEC CONSULTING LTD</b>					
1330790	SE QUADRANT EA	1524	21-Nov-2018	21-Nov-2018	
40-7-4012018-0001	SE QUADRANT CLASS EA				14,247.13
1341264	SE QUADRANT EA (DEC 18, 2108)	104	31-Jan-2019	31-Jan-2019	
40-7-4012018-0001	SE QUADRANT CLASS EA				2,549.74
1347091	ENGINEERING SERVICES	139	16-Jan-2019	16-Jan-2019	
40-7-4012018-0001	SE QUADRANT CLASS EA				1,556.93
1358324	SE QUADRANT CLASS FA	298	26-Feb-2019	26-Feb-2019	
40-7-4012018-0001	SE QUADRANT CLASS EA				9,910.56
1365388	PROFESSIONAL SERVICES	437	19-Mar-2019	19-Mar-2019	
40-7-4012018-0001	SE QUADRANT CLASS EA				3,681.34
1368464	ENGINEERING SERVICES	388	27-Mar-2019	27-Mar-2019	
40-7-4012018-0001	SE QUADRANT CLASS EA				4,653.39
<b>Department Totals :</b>					<b>37,151.40</b>

<b>DEPARTMENT 4017720 MCGREGOR SEWERS</b>					
<b>ONT001 ONTARIO CLEAN WATER AGENCY</b>					
INV000108303	LAGOON MAINTENANCE	1601	22-Nov-2018	22-Nov-2018	
10-5-4017720-0612	MAINTENANCE ITEMS - OCWA				1,221.12
INV000108304	MAINTENANCE EQUIPMENT	1601	22-Nov-2018	22-Nov-2018	
10-5-4017720-0612	MAINTENANCE ITEMS - OCWA				472.14
INV000108306	INSULATION	1601	22-Nov-2018	22-Nov-2018	
10-5-4017720-0612	MAINTENANCE ITEMS - OCWA				3,097.09
INV000108307	ALARM REPAIRS	1601	22-Nov-2018	22-Nov-2018	
10-5-4017720-0612	MAINTENANCE ITEMS - OCWA				111.92
INV000108308	WELDING	1601	22-Nov-2018	22-Nov-2018	
10-5-4017720-0612	MAINTENANCE ITEMS - OCWA				2,287.56
INV000108412	OPERATIONS AND MAINTENANCE	1556	01-Dec-2018	01-Dec-2018	
10-5-4017720-0604	CONTRACT O.C.W.A.				13,453.60
INV000108869	VAC TRUCK	1599	06-Dec-2018	06-Dec-2018	
10-5-4017720-0612	MAINTENANCE ITEMS - OCWA				368.88
INV000109080	LABOUR & BENEFITS	1556	17-Dec-2018	17-Dec-2018	
10-5-4017720-0613	OCWA UNEXPECTED ITEMS				1,137.00
INV000110025	LAGOON TREATMENT	1603	31-Dec-2018	31-Dec-2018	
10-5-4017720-0613	OCWA UNEXPECTED ITEMS				372.00
INV000110052	OPERATIONS AND MAINTENANCE	108	02-Jan-2019	02-Jan-2019	
10-5-4017720-0604	CONTRACT O.C.W.A.				13,530.13
INV000110552	CHEMICAL AND DIESEL RECONSILIATION	387	24-Jan-2019	24-Jan-2019	
10-5-4017720-0612	MAINTENANCE ITEMS - OCWA				13,617.44
INV000110639	OPERATIONS AND MAINTENANCE	179	01-Feb-2019	01-Feb-2019	
10-5-4017720-0604	CONTRACT O.C.W.A.				13,530.13
INV000111052	OCWA MAINTENANCE	284	25-Feb-2019	25-Feb-2019	
10-5-4017720-0612	MAINTENANCE ITEMS - OCWA				371.40
INV000111053	WEED CONTROL	284	25-Feb-2019	25-Feb-2019	
10-5-4017720-0612	MAINTENANCE ITEMS - OCWA				1,088.83
INV000111148	ADDITIONAL SERVICES	285	26-Feb-2019	26-Feb-2019	
10-5-4017720-0613	OCWA UNEXPECTED ITEMS				390.00
INV000111179	OPERATIONS AND MAINTENANCE	285	01-Mar-2019	01-Mar-2019	
10-5-4017720-0604	CONTRACT O.C.W.A.				13,530.13
INV000111548	ADDITIONAL SERVICES	387	18-Mar-2019	18-Mar-2019	
10-5-4017720-0612	MAINTENANCE ITEMS - OCWA				652.81
INV000111549	ADDITIONAL SERVICES	387	18-Mar-2019	18-Mar-2019	
10-5-4017720-0613	OCWA UNEXPECTED ITEMS				167.89

Council/Board Report By Dept-(Computer)



Vendor : CAT038 To ZUL180

Batch : All

Department : All

Cheque Print Date : 01-Jan-2019 To 31-May-2019

Bank : 1 To 99

Class : All

Vendor Invoice	Vendor Name Description	Batch	Inv Date	Inv Due Date	Amount
G.L. Account	CC1 CC2 CC3 GL Account Name				
<b>DEPARTMENT 4017720 MCGREGOR SEWERS</b>					
INV000111584	ADDITIONAL SERVICES	388	18-Mar-2019	18-Mar-2019	
10-5-4017720-0613	OCWA UNEXPECTED ITEMS				372.50
INV000111802	OPERATIONS AND MAINTENANCE	437	01-Apr-2019	01-Apr-2019	
10-5-4017720-0604	CONTRACT O.C.W.A.				13,530.13
INV000112376	ADDITIONAL SERVICES	437	10-Apr-2019	10-Apr-2019	
10-5-4017720-0612	MAINTENANCE ITEMS - OCWA				169.73
INV000112378	ADDITIONAL SERVICES	437	10-Apr-2019	10-Apr-2019	
10-5-4017720-0612	MAINTENANCE ITEMS - OCWA				325.85
INV000112416	ADDITIONAL SERVICES	438	11-Apr-2019	11-Apr-2019	
10-5-4017720-0613	OCWA UNEXPECTED ITEMS				1,495.00
INV000112581	OPERATIONS AND MAINTENANCE	527	01-May-2019	01-May-2019	
10-5-4017720-0604	CONTRACT O.C.W.A.				13,530.13
<b>Department Totals :</b>					<b>108,823.41</b>

<b>DEPARTMENT 4017730 EDGEWATER SEWERS</b>					
<b>ONT001 ONTARIO CLEAN WATER AGENCY</b>					
INV000108324	MEYERS UPGRADE	1601	22-Nov-2018	22-Nov-2018	
10-5-4017730-0612	OCWA MAINTENANCE ITEMS				1,053.22
INV000108327	ADDITIONAL SERVICES (NOV 22, 2018)	107	31-Jan-2019	31-Jan-2019	
10-5-4017730-0612	OCWA MAINTENANCE ITEMS				610.56
INV000108329	MEYERS PUMP	1602	22-Nov-2018	22-Nov-2018	
10-5-4017730-0771	OCWA - MEYERS PUMP STATIONS				829.44
INV000108412	OPERATIONS AND MAINTENANCE	1556	01-Dec-2018	01-Dec-2018	
10-5-4017730-0604	CONTRACT O.C.W.A.				13,939.25
INV000108608	CALLOUTS	1602	29-Nov-2018	29-Nov-2018	
10-5-4017730-0613	OCWA UNEXPECTED ITEMS				1,098.00
INV000108679	CHEMTRADE CHEMICALS CANADA LTD	1556	29-Nov-2018	29-Nov-2018	
10-5-4017730-0609	LAGOON TREATMENT				17,002.34
INV000108679	ADDITIONAL SERVICES	1609	29-Nov-2018	29-Nov-2018	
10-5-4017730-0609	LAGOON TREATMENT				600.00
INV000108835	MEYERS STATION	1599	06-Dec-2018	06-Dec-2018	
10-5-4017730-0771	OCWA - MEYERS PUMP STATIONS				610.56
INV000108837	CALLOUTS	1599	06-Dec-2018	06-Dec-2018	
10-5-4017730-0771	OCWA - MEYERS PUMP STATIONS				2,829.59
INV000108841	VAC TRUCK	1599	06-Dec-2018	06-Dec-2018	
10-5-4017730-0612	OCWA MAINTENANCE ITEMS				737.76
INV000109082	LABOUR & BENEFITS	1556	17-Dec-2018	17-Dec-2018	
10-5-4017730-0771	OCWA - MEYERS PUMP STATIONS				1,052.19
INV000109084	LABOUR	1556	17-Dec-2018	17-Dec-2018	
10-5-4017730-0613	OCWA UNEXPECTED ITEMS				725.00
INV000109925	MYERS UPGRADE	1598	30-Dec-2018	30-Dec-2018	
10-5-4017730-0771	OCWA - MEYERS PUMP STATIONS				712.85
INV000109926	TROUBLESHOOT AND REPLACE CONTROL PANEL, MEYERS PUMP STATION	1600	30-Dec-2018	30-Dec-2018	
10-5-4017730-0771	OCWA - MEYERS PUMP STATIONS				2,905.25
INV000109927	MYERS PUMP STATION PANEL UPGRADE	1600	30-Dec-2018	30-Dec-2018	
10-5-4017730-0771	OCWA - MEYERS PUMP STATIONS				2,487.01
INV000109928	MEYERS STATION PANEL UPGRADE	1600	30-Dec-2018	30-Dec-2018	
10-5-4017730-0771	OCWA - MEYERS PUMP STATIONS				158.75
INV000109929	LIFT ASSIST INSTALL	1600	30-Dec-2018	30-Dec-2018	
10-5-4017730-0612	OCWA MAINTENANCE ITEMS				2,820.79
INV000109930	GUIDE RAIL PS5	1600	30-Dec-2018	30-Dec-2018	
10-5-4017730-0612	OCWA MAINTENANCE ITEMS				1,345.78
INV000109931	LABWORK	1600	30-Dec-2018	30-Dec-2018	



Vendor : CAT038 To ZUL180  
 Batch : All  
 Department : All

Cheque Print Date : 01-Jan-2019 To 31-May-2019  
 Bank : 1 To 99  
 Class : All

Vendor Invoice	Vendor Name Description	Batch	Inv Date	Inv Due Date	Amount
G.L. Account	CC1 CC2 CC3 GL Account Name				
<b>DEPARTMENT 4017730 EDGEWATER SEWERS</b>					
10-5-4017730-0612	OCWA MAINTENANCE ITEMS				247.28
INV000110052	OPERATIONS AND MAINTENANCE	108	02-Jan-2019	02-Jan-2019	
10-5-4017730-0604	CONTRACT O.C.W.A.				14,018.54
INV000110299	ADDITIONAL SERVICES	108	08-Jan-2019	08-Jan-2019	
10-5-4017730-0612	OCWA MAINTENANCE ITEMS				1,880.52
INV000110552	CHEMICAL AND DIESEL RECONSILIATION	387	24-Jan-2019	24-Jan-2019	
10-5-4017730-0609	LAGOON TREATMENT				59.62
INV000110639	OPERATIONS AND MAINTENANCE	179	01-Feb-2019	01-Feb-2019	
10-5-4017730-0604	CONTRACT O.C.W.A.				14,018.54
INV000111064	ADDITIONAL SERVICES	286	25-Feb-2019	25-Feb-2019	
10-5-4017730-0771	OCWA - MEYERS PUMP STATIONS				720.35
INV000111065	ADDITIONAL SERVICES	286	27-Feb-2019	27-Feb-2019	
10-5-4017730-0612	OCWA MAINTENANCE ITEMS				111.94
INV000111179	OPERATIONS AND MAINTENANCE	285	01-Mar-2019	01-Mar-2019	
10-5-4017730-0604	CONTRACT O.C.W.A.				14,018.54
INV000111555	ADDITIONAL SERVICES	387	18-Mar-2019	18-Mar-2019	
10-5-4017730-0612	OCWA MAINTENANCE ITEMS				516.94
INV000111586	ADDITIONAL SERVICES	388	18-Mar-2019	18-Mar-2019	
10-5-4017730-0613	OCWA UNEXPECTED ITEMS				1,107.50
INV000111802	OPERATIONS AND MAINTENANCE	437	01-Apr-2019	01-Apr-2019	
10-5-4017730-0604	CONTRACT O.C.W.A.				14,018.54
INV000112406	ADDITIONAL SERVICES	438	10-Apr-2019	10-Apr-2019	
10-5-4017730-0612	OCWA MAINTENANCE ITEMS				3,002.51
INV000112413	ADDITIONAL SERVICES	438	10-Apr-2019	10-Apr-2019	
10-5-4017730-0609	LAGOON TREATMENT				35,246.54
INV000112581	OPERATIONS AND MAINTENANCE	527	01-May-2019	01-May-2019	
10-5-4017730-0604	CONTRACT O.C.W.A.				14,018.54
<b>Department Totals :</b>					<b>164,504.24</b>

<b>DEPARTMENT 4017740 AMHERSTBURG SEWERS</b>					
<b>AMH43 AMHERSTBURG PUBLIC WORKS PETTY CASH</b>					
FEBRUARY 1, PUBLIC WORK PETTY CASH FOR FEBRUARY 2019		134	31-Jan-2019	31-Jan-2019	
10-5-4017740-0759	SERVICE CONNECTION REPAIR & MTCE.				10.95
<b>CAN380 CANADIAN TIRE STORE #281</b>					
JANUARY 2019 JANUARY 2019 PURCHASES		389	31-Jan-2019	31-Jan-2019	
10-5-4017740-0760	MANHOLE CLEANING & MTCE.				61.00
MARCH 2019 MARCH 2019 PURCHASES		345	31-Mar-2019	31-Mar-2019	
10-5-4017740-0760	MANHOLE CLEANING & MTCE.				101.67
10-5-4017740-0760	MANHOLE CLEANING & MTCE.				44.04
<b>COM046 COM PETERS INC</b>					
4318 LOCATE SOFTWARE SERVICE		1556	06-Dec-2018	06-Dec-2018	
10-5-4017740-0759	SERVICE CONNECTION REPAIR & MTCE.				395.50
4349 LOCATE SERVICE SOFTWARE		37	04-Jan-2019	04-Jan-2019	
10-5-4017740-0759	SERVICE CONNECTION REPAIR & MTCE.				395.50
4450 LOCATE SERVICE		387	01-Apr-2019	01-Apr-2019	
10-5-4017740-0759	SERVICE CONNECTION REPAIR & MTCE.				395.50
4481 SOFTWARE MONTHLY SERVICE		512	01-May-2019	01-May-2019	
10-5-4017740-0759	SERVICE CONNECTION REPAIR & MTCE.				395.50
<b>ESS273 ESSEX POWERLINES CORPORATION</b>					
JC7591 BILLING COLLECTION		1556	30-Nov-2018	30-Nov-2018	
10-5-4017740-0504	COLLECTION EXPENSE				1,159.24
JC7601 COLLECTION		1556	31-Dec-2018	31-Dec-2018	
10-5-4017740-0504	COLLECTION EXPENSE				1,159.24

Council/Board Report By Dept-(Computer)



Vendor : CAT038 To ZUL180

Batch : All

Department : All

Cheque Print Date : 01-Jan-2019 To 31-May-2019

Bank : 1 To 99

Class : All

Vendor Invoice	Vendor Name Description				Batch Invc Date	Invc Due Date	Amount
G.L. Account	CC1	CC2	CC3	GL Account Name			
<b>DEPARTMENT 4017740 AMHERSTBURG SEWERS</b>							
JC7674	WASTEWATER COLLECTION				179 31-Jan-2019	31-Jan-2019	
10-5-4017740-0504				COLLECTION EXPENSE			1,159.24
JC7697	SEWER BILLING AND COLLECTING CHARGES FOR THE MONTH OF FEBRUARY 20				298 28-Feb-2019	28-Feb-2019	
10-5-4017740-0504				COLLECTION EXPENSE			1,159.24
JC7721	SEWER BILLING AND COLLECTING CHARGES FOR THE MONTH OF MARCH 2019				410 31-Mar-2019	31-Mar-2019	
10-5-4017740-0504				COLLECTION EXPENSE			1,159.24
JC7769	SEWER BILLING AND COLLECTING CHARGES FOR THE MONTH OF APRIL 2019				512 30-Apr-2019	30-Apr-2019	
10-5-4017740-0504				COLLECTION EXPENSE			1,159.24
<b>ESS360 ESSEX WINDSOR SOLID WASTE AUTH</b>							
27354	SLUDGE REMOVAL FROM AWWTP CENTRIFUGE				1556 30-Nov-2018	30-Nov-2018	
10-5-4017740-0602				LANDFILL CHARGES			3,622.60
27489	LANDFILL (DEC 31, 2018)				107 31-Jan-2019	31-Jan-2019	
10-5-4017740-0602				LANDFILL CHARGES			5,401.45
27611	SLUDGE				207 31-Jan-2019	31-Jan-2019	
10-5-4017740-0602				LANDFILL CHARGES			6,474.66
27714	LANDFILL				284 28-Feb-2019	28-Feb-2019	
10-5-4017740-0602				LANDFILL CHARGES			4,605.54
27810	LANDFILL CHARGES				437 31-Mar-2019	31-Mar-2019	
10-5-4017740-0602				LANDFILL CHARGES			7,521.32
<b>FEE256 THE FEED STORE</b>							
1000199889	GRASS SEED MIXTURE				410 05-Apr-2019	05-Apr-2019	
10-5-4017740-0331				GENERAL MAINTENANCE			280.24
<b>FIN328 FINE LINE INSTRUMENTS</b>							
4507	MAINTENANCE				512 25-Apr-2019	25-Apr-2019	
10-5-4017740-0760				MANHOLE CLEANING & MTCE.			920.95
<b>GRE330 GREAT LAKES SAFETY PRODUCTS</b>							
00314695	GLOVES				1524 26-Nov-2018	26-Nov-2018	
10-5-4017740-0331				GENERAL MAINTENANCE			460.14
00315188	SAFETY REPAIR				1556 07-Dec-2018	07-Dec-2018	
10-5-4017740-0759				SERVICE CONNECTION REPAIR & MTCE.			189.59
00315423	SAFETY BIB				1556 13-Dec-2018	13-Dec-2018	
10-5-4017740-0759				SERVICE CONNECTION REPAIR & MTCE.			130.76
00315922	SAFETY EQUIPMENT				37 04-Jan-2019	04-Jan-2019	
10-5-4017740-0331				GENERAL MAINTENANCE			160.27
00316430	SAFETY EQUIPMENT				108 21-Jan-2019	21-Jan-2019	
10-5-4017740-0750				SEWER FLUSHING			181.07
00318437	MAINTENANCE SUPPLIES				352 21-Mar-2019	21-Mar-2019	
10-5-4017740-0331				GENERAL MAINTENANCE			28.48
00319428	GLOVES				437 15-Apr-2019	15-Apr-2019	
10-5-4017740-0750				SEWER FLUSHING			14.92
<b>HEA693 HEATON SANITATION</b>							
33365	VAC TRUCK				387 25-Mar-2019	25-Mar-2019	
10-5-4017740-0759				SERVICE CONNECTION REPAIR & MTCE.			1,695.00
33370	VAC TRUCK				387 28-Mar-2019	28-Mar-2019	
10-5-4017740-0759				SERVICE CONNECTION REPAIR & MTCE.			1,356.00
33430	VAC TRUCK				410 04-Apr-2019	04-Apr-2019	
10-5-4017740-0750				SEWER FLUSHING			1,582.00
33436	VAC TRUCK				410 09-Apr-2019	09-Apr-2019	
10-5-4017740-0759				SERVICE CONNECTION REPAIR & MTCE.			2,260.00
33443	VAC TRUCK				437 16-Apr-2019	16-Apr-2019	
10-5-4017740-0750				SEWER FLUSHING			1,921.00
35407	SANITARY FLUSHING				284 15-Feb-2019	15-Feb-2019	
10-5-4017740-0750				SEWER FLUSHING			813.60





Vendor : CAT038 To ZUL180  
 Batch : All  
 Department : All

Cheque Print Date : 01-Jan-2019 To 31-May-2019  
 Bank : 1 To 99  
 Class : All

Vendor Invoice	Vendor Name Description	Batch	Inv Date	Inv Due Date	Amount
G.L. Account	CC1 CC2 CC3 GL Account Name				
<b>DEPARTMENT 4017740 AMHERSTBURG SEWERS</b>					
35912	VAC TRUCK	527	03-May-2019	03-May-2019	
10-5-4017740-0750	SEWER FLUSHING				2,034.00
36878	SEWER REPAIR	37	09-Jan-2019	09-Jan-2019	
10-5-4017740-0759	SERVICE CONNECTION REPAIR & MTCE.				2,147.00
36897	VACTOR FLUSHER	179	04-Feb-2019	04-Feb-2019	
10-5-4017740-0750	SEWER FLUSHING				2,034.00
36898	FLUSHING	207	05-Feb-2019	05-Feb-2019	
10-5-4017740-0750	SEWER FLUSHING				452.00
36899	VAC TRUCK	254	05-Feb-2019	05-Feb-2019	
10-5-4017740-0331	GENERAL MAINTENANCE				1,243.00
36900	FLUSHER	207	06-Feb-2019	06-Feb-2019	
10-5-4017740-0750	SEWER FLUSHING				2,034.00
36946	SEWER REPAIR	37	03-Jan-2019	03-Jan-2019	
10-5-4017740-0759	SERVICE CONNECTION REPAIR & MTCE.				2,260.00
37030	VAC TRUCK	1556	28-Nov-2018	28-Nov-2018	
10-5-4017740-0759	SERVICE CONNECTION REPAIR & MTCE.				1,921.00
37040	FLUSHING	1556	07-Dec-2018	07-Dec-2018	
10-5-4017740-0750	SEWER FLUSHING				678.00
37042	VAC TRUCK FLUSHING	1556	11-Dec-2018	11-Dec-2018	
10-5-4017740-0750	SEWER FLUSHING				1,243.00
37137	VAC TRUCK	410	01-Apr-2019	01-Apr-2019	
10-5-4017740-0750	SEWER FLUSHING				678.00
37676	FLUSHER	207	08-Feb-2019	08-Feb-2019	
10-5-4017740-0750	SEWER FLUSHING				2,034.00
37677	FLUSHING	207	08-Feb-2019	08-Feb-2019	
10-5-4017740-0750	SEWER FLUSHING				1,921.00
37678	SANITARY FLUSHING	284	11-Feb-2019	11-Feb-2019	
10-5-4017740-0750	SEWER FLUSHING				2,034.00
37679	FLUSHING	207	12-Feb-2019	12-Feb-2019	
10-5-4017740-0750	SEWER FLUSHING				1,582.00
37685	VAC SEWER REPAIR	207	19-Feb-2019	19-Feb-2019	
10-5-4017740-0759	SERVICE CONNECTION REPAIR & MTCE.				1,808.00
37686	VAC TRUCK	207	20-Feb-2019	20-Feb-2019	
10-5-4017740-0759	SERVICE CONNECTION REPAIR & MTCE.				1,356.00
37691	VAC TRUCK	254	26-Feb-2019	26-Feb-2019	
10-5-4017740-0750	SEWER FLUSHING				1,921.00
<b>HET208 HETEK SOLUTIONS INC</b>					
INV0030689	STORM SEWER CLEANING & FLUSHING	37	02-Jan-2019	02-Jan-2019	
10-5-4017740-0760	MANHOLE CLEANING & MTCE.				2,247.70
<b>HIC441 HICKS ELECTRIC</b>					
9813	SERVICE REQUEST	527	20-Apr-2019	20-Apr-2019	
10-5-4017740-0331	GENERAL MAINTENANCE				1,281.42
<b>HYD04 HYDRO ONE NETWORKS INC. ACCOUNTS RECEIVABLE UNIT</b>					
3000257396	DEC 2018 HYDRO ONE WAS CALLED IN TO HOLD THE POLE WHILE WE DID THE REPAIR TO A HYDRO BOX	284	18-Mar-2019	18-Mar-2019	
10-5-4017740-0759	SERVICE CONNECTION REPAIR & MTCE.				1,826.05
<b>KEL117 KELCOM TELEMESSAGING</b>					
1902-06702	CALL CENTRE SERVICES	135	01-Feb-2019	01-Feb-2019	
10-5-4017740-0316	UTILITIES - SEWERS				27.83
1903-06702	ANSWERING SERVICE	280	01-Mar-2019	01-Mar-2019	
10-5-4017740-0316	UTILITIES - SEWERS				28.45
1904-06702	ANSWERING SERVICES	347	01-Apr-2019	01-Apr-2019	
10-5-4017740-0316	UTILITIES - SEWERS				23.59



Vendor : CAT038 To ZUL180

Batch : All

Department : All

Cheque Print Date : 01-Jan-2019 To 31-May-2019

Bank : 1 To 99

Class : All

Vendor Invoice	Vendor Name Description	Batch	Inv Date	Inv Due Date	Amount
G.L. Account	CC1 CC2 CC3 GL Account Name				
<b>DEPARTMENT 4017740 AMHERSTBURG SEWERS</b>					
1905-06702	ANSWERING SERVICE	511	01-May-2019	01-May-2019	
10-5-4017740-0316	UTILITIES - SEWERS				35.34
W78745-0119	ANSWERING SERVICE	34	02-Jan-2019	02-Jan-2019	
10-5-4017740-0316	UTILITIES - SEWERS				19.65
<b>KT1033 KTI LIMITED</b>					
116643	MAINTENANCE SUPPLIES	410	21-Mar-2019	21-Mar-2019	
10-5-4017740-0750	SEWER FLUSHING				941.40
<b>LEV287 LEVITT-SAFETY LIMITED</b>					
1639705-00	CALIBRATION	437	05-Apr-2019	05-Apr-2019	
10-5-4017740-0331	GENERAL MAINTENANCE				536.75
<b>MCV001 MCVITTY SHANE</b>					
APRIL 18, 2015	BACKWATER VALVE INSTALLATION & SUMP PUMP OVERFLOW	388	18-Apr-2019	18-Apr-2019	
10-5-4017740-0766	I&I MAINTENANCE				1,300.00
<b>MEL271 MELOCHE JANICE</b>					
APRIL 17, 2015	SUMP PUMP OVERFLOW SUBSIDY	387	17-Apr-2019	17-Apr-2019	
10-5-4017740-0766	I&I MAINTENANCE				300.00
<b>MON183 MONARCH OFFICE SUPPLY LTD</b>					
148092	OFFICE SUPPLIES	527	25-Apr-2019	25-Apr-2019	
10-5-4017740-0331	GENERAL MAINTENANCE				910.88
<b>OND245 ONDEJKO JAMIE</b>					
APRIL 18, 2015	BACKWATER VALVE INSTALLATION	388	18-Apr-2019	18-Apr-2019	
10-5-4017740-0766	I&I MAINTENANCE				1,000.00
<b>ONT001 ONTARIO CLEAN WATER AGENCY</b>					
INV000108333	UV REBUILD KITS, MULTIMETER AND FILTER BELT	1602	22-Nov-2018	22-Nov-2018	
10-5-4017740-0612	OCWA MAINTENANCE ITEMS				244.16
INV000108334	MULTIRANGER	1602	26-Nov-2018	26-Nov-2018	
10-5-4017740-0612	OCWA MAINTENANCE ITEMS				3,131.49
INV000108336	PARTS	1602	22-Nov-2018	22-Nov-2018	
10-5-4017740-0612	OCWA MAINTENANCE ITEMS				121.16
INV000108337	UV AND GEN PARTS	1602	22-Nov-2018	22-Nov-2018	
10-5-4017740-0612	OCWA MAINTENANCE ITEMS				308.56
INV000108340	GEN PARTS	1602	22-Nov-2018	22-Nov-2018	
10-5-4017740-0612	OCWA MAINTENANCE ITEMS				416.23
INV000108412	OPERATIONS AND MAINTENANCE	1556	01-Dec-2018	01-Dec-2018	
10-5-4017740-0604	CONTRACT O.C.W.A.				28,247.85
INV000108609	CALLOUTS	1599	29-Nov-2018	29-Nov-2018	
10-5-4017740-0613	OCWA UNEXPECTED ITEMS				2,922.50
INV000108842	FIRE HOSE (DEC 2018)	284	18-Mar-2019	18-Mar-2019	
10-5-4017740-0612	OCWA MAINTENANCE ITEMS				498.35
INV000108844	PARTS	1599	06-Dec-2018	06-Dec-2018	
10-5-4017740-0612	OCWA MAINTENANCE ITEMS				4,648.43
INV000108873	VAC TRUCK	1598	06-Dec-2018	06-Dec-2018	
10-5-4017740-0612	OCWA MAINTENANCE ITEMS				368.88
INV000109085	CALL OUTS	1556	17-Dec-2018	17-Dec-2018	
10-5-4017740-0613	OCWA UNEXPECTED ITEMS				1,476.50
INV000109932	BLOWER MAINTENANCE	1600	30-Dec-2018	30-Dec-2018	
10-5-4017740-0612	OCWA MAINTENANCE ITEMS				451.14
INV000109933	CANADIAN BEARINGS	1600	30-Dec-2018	30-Dec-2018	
10-5-4017740-0612	OCWA MAINTENANCE ITEMS				1,552.58
INV000109934	INSTALLED LIFT ASSIST	1600	30-Dec-2018	30-Dec-2018	
10-5-4017740-0612	OCWA MAINTENANCE ITEMS				1,758.41
INV000109935	CHANGED WATERING TANK DISCHARGE LINE	1600	30-Dec-2018	30-Dec-2018	
10-5-4017740-0612	OCWA MAINTENANCE ITEMS				940.26





Vendor : CAT038 To ZUL180  
 Batch : All  
 Department : All

Cheque Print Date : 01-Jan-2019 To 31-May-2019  
 Bank : 1 To 99  
 Class : All

Vendor Invoice	Vendor Name Description	Batch	Inv Date	Inv Due Date	Amount
G.L. Account	CC1 CC2 CC3 GL Account Name				
<b>DEPARTMENT 4017740</b>	<b>AMHERSTBURG SEWERS</b>				
INV000109936	LABWORK	1603	30-Dec-2018	30-Dec-2018	
10-5-4017740-0612	OCWA MAINTENANCE ITEMS				225.91
INV000110021	LABWORK	1603	31-Dec-2018	31-Dec-2018	
10-5-4017740-0612	OCWA MAINTENANCE ITEMS				50.88
INV000110022	ELECTRICAL WORK	1603	31-Dec-2018	31-Dec-2018	
10-5-4017740-0612	OCWA MAINTENANCE ITEMS				1,057.12
INV000110029	CALLOUTS	1603	31-Dec-2018	31-Dec-2018	
10-5-4017740-0613	OCWA UNEXPECTED ITEMS				360.00
INV000110044	CALLOUTS	37	02-Jan-2019	02-Jan-2019	
10-5-4017740-0613	OCWA UNEXPECTED ITEMS				720.00
INV000110052	OPERATIONS AND MAINTENANCE	108	02-Jan-2019	02-Jan-2019	
10-5-4017740-0604	CONTRACT O.C.W.A.				28,411.56
INV000110301	CREDIT ADDITIONAL SERVICES	108	08-Jan-2019	08-Jan-2019	
10-5-4017740-0612	OCWA MAINTENANCE ITEMS				-518.98
INV000110552	CHEMICAL AND DIESEL RECONSILIATION	387	24-Jan-2019	24-Jan-2019	
10-5-4017740-0612	OCWA MAINTENANCE ITEMS				34,243.22
INV000110639	OPERATIONS AND MAINTENANCE	179	01-Feb-2019	01-Feb-2019	
10-5-4017740-0604	CONTRACT O.C.W.A.				28,411.56
INV000111066	GARAGE DOOR SERVICES	286	25-Feb-2019	25-Feb-2019	
10-5-4017740-0612	OCWA MAINTENANCE ITEMS				172.99
INV000111067	WINDOW REPLACEMENT	286	25-Feb-2019	25-Feb-2019	
10-5-4017740-0612	OCWA MAINTENANCE ITEMS				1,658.69
INV000111068	MOTOR INSTALL FOR AIR MAKE-UP	286	25-Feb-2019	25-Feb-2019	
10-5-4017740-0612	OCWA MAINTENANCE ITEMS				531.22
INV000111069	HEATING PUMP REPAIR	286	25-Feb-2019	25-Feb-2019	
10-5-4017740-0612	OCWA MAINTENANCE ITEMS				2,488.66
INV000111070	NEW KEYPAD FOR PS5 CONTROL PANEL	286	25-Feb-2019	25-Feb-2019	
10-5-4017740-0612	OCWA MAINTENANCE ITEMS				254.38
INV000111071	REPLACEMENT PARTS FOR DISCHARGE VALVE	285	25-Feb-2019	25-Feb-2019	
10-5-4017740-0612	OCWA MAINTENANCE ITEMS				778.97
INV000111072	NEW STRAINERS FOR SAMPLE SUCTION TUBE	285	25-Feb-2019	25-Feb-2019	
10-5-4017740-0612	OCWA MAINTENANCE ITEMS				316.31
INV000111111	REPLACE ROPE SEAL	285	25-Feb-2019	25-Feb-2019	
10-5-4017740-0612	OCWA MAINTENANCE ITEMS				673.40
INV000111112	INSTALLED RECIRC PUMP	285	25-Feb-2019	25-Feb-2019	
10-5-4017740-0612	OCWA MAINTENANCE ITEMS				167.93
INV000111179	OPERATIONS AND MAINTENANCE	285	01-Mar-2019	01-Mar-2019	
10-5-4017740-0604	CONTRACT O.C.W.A.				28,411.56
INV000111403	BILLINGS	285	01-Mar-2019	01-Mar-2019	
10-5-4017740-0613	OCWA UNEXPECTED ITEMS				545.00
INV000111562	ADDITIONAL SERVICES	387	18-Mar-2019	18-Mar-2019	
10-5-4017740-0612	OCWA MAINTENANCE ITEMS				148.32
INV000111563	ADDITIONAL SERVICES	388	18-Mar-2019	18-Mar-2019	
10-5-4017740-0612	OCWA MAINTENANCE ITEMS				406.38
INV000111564	ADDITIONAL SERVICES	388	18-Mar-2019	18-Mar-2019	
10-5-4017740-0331	GENERAL MAINTENANCE				331.74
INV000111802	OPERATIONS AND MAINTENANCE	437	01-Apr-2019	01-Apr-2019	
10-5-4017740-0604	CONTRACT O.C.W.A.				28,411.56
INV000112385	ADDITIONAL SERVICES	437	10-Apr-2019	10-Apr-2019	
10-5-4017740-0612	OCWA MAINTENANCE ITEMS				190.80
INV000112386	ADDITIONAL SERVICES	437	10-Apr-2019	10-Apr-2019	
10-5-4017740-0612	OCWA MAINTENANCE ITEMS				703.85
INV000112407	ADDITIONAL SERVICES	438	11-Apr-2019	11-Apr-2019	



Vendor : CAT038 To ZUL180  
 Batch : All  
 Department : All

Cheque Print Date : 01-Jan-2019 To 31-May-2019  
 Bank : 1 To 99  
 Class : All

Vendor Invoice	Vendor Name Description	Batch	Inv Date	Inv Due Date	Amount
G.L. Account	CC1 CC2 CC3 GL Account Name				
<b>DEPARTMENT 4017740</b>	AMHERSTBURG SEWERS				
10-5-4017740-0331	GENERAL MAINTENANCE				366.34
INV000112420	ADDITIONAL SERVICES	438	11-Apr-2019	11-Apr-2019	
10-5-4017740-0613	OCWA UNEXPECTED ITEMS				1,117.50
INV000112581	OPERATIONS AND MAINTENANCE	527	01-May-2019	01-May-2019	
10-5-4017740-0604	CONTRACT O.C.W.A.				28,411.56
INV0010302	ADDITIONAL SERVICES	108	08-Jan-2019	08-Jan-2019	
10-5-4017740-0612	OCWA MAINTENANCE ITEMS				610.56
INV00109090	CALL OUTS	1556	17-Dec-2018	17-Dec-2018	
10-5-4017740-0613	OCWA UNEXPECTED ITEMS				847.50
INV111587	ADDITIONAL SERVICES	388	18-Mar-2019	18-Mar-2019	
10-5-4017740-0613	OCWA UNEXPECTED ITEMS				1,097.50
<b>ONT104 ONTARIO ONE CALL LTD</b>					
201895098	LOCATES	1556	30-Nov-2018	30-Nov-2018	
10-5-4017740-0759	SERVICE CONNECTION REPAIR & MTCE.				267.97
201896018	LOCATES	1556	31-Dec-2018	31-Dec-2018	
10-5-4017740-0759	SERVICE CONNECTION REPAIR & MTCE.				249.32
201997856	ON1 CALL	283	28-Feb-2019	28-Feb-2019	
10-5-4017740-0758	SERVICE CONNECTION INSPECTION & CAMERA				331.93
201999694	PHONE CALLS	527	30-Apr-2019	30-Apr-2019	
10-5-4017740-0759	SERVICE CONNECTION REPAIR & MTCE.				319.50
<b>PUR700 PUROLATOR INC.</b>					
441046290	COURIER	437	05-Apr-2019	05-Apr-2019	
10-5-4017740-0758	SERVICE CONNECTION INSPECTION & CAMERA				236.49
8303704657	COURIER	527	17-Apr-2019	17-Apr-2019	
10-5-4017740-0758	SERVICE CONNECTION INSPECTION & CAMERA				398.01
<b>REA209 REAUME JODY</b>					
MAY 17, 2019	CUT IN SANITARY CLEAN OUT AT PROPERTY LINE	512	17-May-2019	17-May-2019	
10-5-4017740-0759	SERVICE CONNECTION REPAIR & MTCE.				482.51
<b>SEW124 SEWER TECHNOLOGIES INC.</b>					
12708	SERVICE CONNECTION	352	08-Feb-2019	08-Feb-2019	
10-5-4017740-0758	SERVICE CONNECTION INSPECTION & CAMERA				1,582.00
<b>SMI151 SMIT GEORGE</b>					
APRIL 18, 2019	SUMP PUMP OVERFLOW SUBSIDY	388	18-Apr-2019	18-Apr-2019	
10-5-4017740-0766	I&I MAINTENANCE				1,300.00
<b>TOP811 TOP-IT ASPHALT MAINTENANCE INC</b>					
14551	RESTORATION	1556	17-Dec-2018	17-Dec-2018	
10-5-4017740-0759	SERVICE CONNECTION REPAIR & MTCE.				3,796.80
<b>VIV041 VIVAX CORPORATION - CANADA</b>					
12582	SERVICE CONNECTION	527	30-Apr-2019	30-Apr-2019	
10-5-4017740-0758	SERVICE CONNECTION INSPECTION & CAMERA				762.75
<b>WAL029 WALACH RICHARD</b>					
APRIL 18, 2019	BACKWATER VALVE INSTALATION	388	18-Apr-2019	18-Apr-2019	
10-5-4017740-0766	I&I MAINTENANCE				1,000.00
<b>WAL101 WALKER AGGREGATES</b>					
282027	RESTORATION	1556	15-Dec-2018	15-Dec-2018	
10-5-4017740-0759	SERVICE CONNECTION REPAIR & MTCE.				133.89
282328	AGGREGATES	108	12-Jan-2019	12-Jan-2019	
10-5-4017740-0759	SERVICE CONNECTION REPAIR & MTCE.				2,691.81
<b>WIG035 WIGLE HOME HARDWARE BUILDING CENTRE</b>					
128489	SUPPLIES	387	26-Mar-2019	26-Mar-2019	
10-5-4017740-0331	GENERAL MAINTENANCE				32.18
128825	MAINTENANCE SUPPLIES	437	04-Apr-2019	04-Apr-2019	



Vendor : CAT038 To ZUL180

Batch : All

Department : All

Cheque Print Date : 01-Jan-2019 To 31-May-2019

Bank : 1 To 99

Class : All

Vendor Invoice	Vendor Name Description	Batch	Inv Date	Inv Due Date	Amount
G.L. Account	CC1 CC2 CC3 GL Account Name				
<b>DEPARTMENT 4017740 AMHERSTBURG SEWERS</b>					
10-5-4017740-0766	I&I MAINTENANCE				7.33
129242	MAINTENANCE SUPPLIES	437	16-Apr-2019	16-Apr-2019	
10-5-4017740-0331	GENERAL MAINTENANCE				237.24
129800	SUPPLIES	527	02-May-2019	02-May-2019	
10-5-4017740-0759	SERVICE CONNECTION REPAIR & MTCE.				14.86
<b>WOL533 WOLSELEY CANADA INC</b>					
7540388	INVENTORY	1556	18-Dec-2018	18-Dec-2018	
10-5-4017740-0759	SERVICE CONNECTION REPAIR & MTCE.				258.52
7613130		108	04-Jan-2019	04-Jan-2019	
10-5-4017740-0759	SERVICE CONNECTION REPAIR & MTCE.				415.81
7683596	PARTS NEEDED FOR 184 BALACLAVA	179	23-Jan-2019	23-Jan-2019	
10-5-4017740-0759	SERVICE CONNECTION REPAIR & MTCE.				770.19
7689047	MH GROUT	179	24-Jan-2019	24-Jan-2019	
10-5-4017740-0760	MANHOLE CLEANING & MTCE.				142.22
7705372	SEWER SUPPLIES/LOCATE PAINT	179	29-Jan-2019	29-Jan-2019	
10-5-4017740-0760	MANHOLE CLEANING & MTCE.				397.00
7798998	MAINTENANCE	284	25-Feb-2019	25-Feb-2019	
10-5-4017740-0760	MANHOLE CLEANING & MTCE.				411.95
7878704	MAINTENANCE	388	19-Mar-2019	19-Mar-2019	
10-5-4017740-0760	MANHOLE CLEANING & MTCE.				2,340.82
7943099	MAINTENANCE SUPPLIES	437	19-Apr-2019	19-Apr-2019	
10-5-4017740-0760	MANHOLE CLEANING & MTCE.				954.85
7972477	SUPPLIES	527	15-Apr-2019	15-Apr-2019	
10-5-4017740-0331	GENERAL MAINTENANCE				679.40
8011709	SUPPLIES	527	26-Apr-2019	26-Apr-2019	
10-5-4017740-0759	SERVICE CONNECTION REPAIR & MTCE.				240.66
<b>Department Totals :</b>					<b>347,380.25</b>
<hr/>					
<b>DEPARTMENT 4017750 BIG CREEK RBC SEWER</b>					
<b>ONT001 ONTARIO CLEAN WATER AGENCY</b>					
INV000108313	METER	1601	22-Nov-2018	22-Nov-2018	
10-5-4017750-0612	OCWA MAINTENANCE ITEMS				105.83
INV000108412	OPERATIONS AND MAINTENANCE	1556	01-Dec-2018	01-Dec-2018	
10-5-4017750-0604	CONTRACT O.C.W.A.				9,684.07
INV000108607	CALLOUTS	1602	29-Nov-2018	29-Nov-2018	
10-5-4017750-0613	OCWA UNEXPECTED ITEMS				508.75
INV000110052	OPERATIONS AND MAINTENANCE	108	02-Jan-2019	02-Jan-2019	
10-5-4017750-0604	CONTRACT O.C.W.A.				9,739.16
INV000110639	OPERATIONS AND MAINTENANCE	179	01-Feb-2019	01-Feb-2019	
10-5-4017750-0604	CONTRACT O.C.W.A.				9,739.16
INV000111179	OPERATIONS AND MAINTENANCE	285	01-Mar-2019	01-Mar-2019	
10-5-4017750-0604	CONTRACT O.C.W.A.				9,739.16
INV000111802	OPERATIONS AND MAINTENANCE	437	01-Apr-2019	01-Apr-2019	
10-5-4017750-0604	CONTRACT O.C.W.A.				9,739.16
INV000112418	ADDITIONAL SERVICES	438	11-Apr-2019	11-Apr-2019	
10-5-4017750-0613	OCWA UNEXPECTED ITEMS				755.00
INV000112581	OPERATIONS AND MAINTENANCE	527	01-May-2019	01-May-2019	
10-5-4017750-0604	CONTRACT O.C.W.A.				9,739.16
<b>Department Totals :</b>					<b>59,749.45</b>



Vendor : CAT038 To ZUL180

Batch : All

Department : All

Cheque Print Date : 01-Jan-2019 To 31-May-2019

Bank : 1 To 99

Class : All

Vendor Invoice	Vendor Name Description	Batch	Inv Date	Inv Due Date	Amount
G.L. Account	CC1 CC2 CC3 GL Account Name				
<b>DEPARTMENT 4017755</b>	<b>MCLEOD SBR SEWER</b>				
INV000108311	VOLTAGE REGULATOR	1601	22-Nov-2018	22-Nov-2018	
10-5-4017755-0612	OCWA MAINTENANCE ITEMS				983.45
INV000108412	OPERATIONS AND MAINTENANCE	1556	01-Dec-2018	01-Dec-2018	
10-5-4017755-0604	CONTRACT OCWA				15,165.36
INV000108606	CALLOUTS	1602	29-Nov-2018	29-Nov-2018	
10-5-4017755-0613	OCWA UNEXPECTED ITEMS				745.50
INV000108870	VAC TRUCK	1599	06-Dec-2018	06-Dec-2018	
10-5-4017755-0612	OCWA MAINTENANCE ITEMS				1,106.64
INV000109919	NEW PUMP TROUBLE SHOOTING	1598	10-Dec-2018	10-Dec-2018	
10-5-4017755-0612	OCWA MAINTENANCE ITEMS				1,831.68
INV000109920	ADDITIONAL SERVICES (DEC 30, 2018)	107	31-Jan-2019	31-Jan-2019	
10-5-4017755-0612	OCWA MAINTENANCE ITEMS				317.49
INV000110026	CALLOUTS	1603	31-Dec-2018	31-Dec-2018	
10-5-4017755-0613	OCWA UNEXPECTED ITEMS				377.00
INV000110027	CALLOUTS	1603	31-Dec-2018	31-Dec-2018	
10-5-4017755-0613	OCWA UNEXPECTED ITEMS				382.50
INV000110042	CALLOUTS	37	02-Jan-2019	02-Jan-2019	
10-5-4017755-0613	OCWA UNEXPECTED ITEMS				360.00
INV000110052	OPERATIONS AND MAINTENANCE	108	02-Jan-2019	02-Jan-2019	
10-5-4017755-0604	CONTRACT OCWA				15,251.63
INV000110294	ADDITIONAL SERVICES	108	08-Jan-2019	08-Jan-2019	
10-5-4017755-0612	OCWA MAINTENANCE ITEMS				3,638.94
INV000110552	CHEMICAL AND DIESEL RECONSILIATION	387	24-Jan-2019	24-Jan-2019	
10-5-4017755-0612	OCWA MAINTENANCE ITEMS				1,570.18
INV000110639	OPERATIONS AND MAINTENANCE	179	01-Feb-2019	01-Feb-2019	
10-5-4017755-0604	CONTRACT OCWA				15,251.63
INV000111054	VAC TRUCK	284	25-Feb-2019	25-Feb-2019	
10-5-4017755-0612	OCWA MAINTENANCE ITEMS				2,198.02
INV000111055	ELECTRICAL	284	25-Feb-2019	25-Feb-2019	
10-5-4017755-0612	OCWA MAINTENANCE ITEMS				254.40
INV000111057	WEED CONTROL	284	25-Feb-2019	25-Feb-2019	
10-5-4017755-0612	OCWA MAINTENANCE ITEMS				264.58
INV000111179	OPERATIONS AND MAINTENANCE	285	01-Mar-2019	01-Mar-2019	
10-5-4017755-0604	CONTRACT OCWA				15,251.63
INV000111550	ADDITIONAL SERVICES	387	20-Mar-2019	20-Mar-2019	
10-5-4017755-0612	OCWA MAINTENANCE ITEMS				710.75
INV000111551	ADDITIONAL SERVICES	387	18-Mar-2019	18-Mar-2019	
10-5-4017755-0612	OCWA MAINTENANCE ITEMS				901.59
INV000111585	ADDITIONAL SERVICES	388	18-Mar-2019	18-Mar-2019	
10-5-4017755-0613	OCWA UNEXPECTED ITEMS				705.00
INV000111802	OPERATIONS AND MAINTENANCE	437	01-Apr-2019	01-Apr-2019	
10-5-4017755-0604	CONTRACT OCWA				15,251.63
INV000112379	ADDITIONAL SERVICES	437	10-Apr-2019	10-Apr-2019	
10-5-4017755-0612	OCWA MAINTENANCE ITEMS				447.74
INV000112380	ADDITIONAL SERVICES	437	10-Apr-2019	10-Apr-2019	
10-5-4017755-0612	OCWA MAINTENANCE ITEMS				292.05
INV000112417	ADDITIONAL SERVICES	438	11-Apr-2019	11-Apr-2019	
10-5-4017755-0613	OCWA UNEXPECTED ITEMS				1,125.00
INV000112581	OPERATIONS AND MAINTENANCE	527	01-May-2019	01-May-2019	
10-5-4017755-0604	CONTRACT OCWA				15,251.63

Department Totals : **109,636.02**



Vendor : CAT038 To ZUL180  
 Batch : All  
 Department : All

Cheque Print Date : 01-Jan-2019 To 31-May-2019  
 Bank : 1 To 99  
 Class : All

Vendor Invoice	Vendor Name Description	Batch	Inv Date	Inv Due Date	Amount
G.L. Account	CC1 CC2 CC3 GL Account Name				
<b>DEPARTMENT 4017760 BOBLO SEWER</b>					
<b>ONT001 ONTARIO CLEAN WATER AGENCY</b>					
INV000108315	GRATING	1601	22-Nov-2018	22-Nov-2018	
10-5-4017760-0612	OCWA MAINTENANCE ITEMS				386.61
INV000108316	GRATING	1601	22-Nov-2018	22-Nov-2018	
10-5-4017760-0612	OCWA MAINTENANCE ITEMS				1,899.23
INV000108412	OPERATIONS AND MAINTENANCE	1556	01-Dec-2018	01-Dec-2018	
10-5-4017760-0604	CONTRACT OCWA - BOBLO				7,708.28
INV000108832	AIRLIFT UPGRADE	1599	06-Dec-2018	06-Dec-2018	
10-5-4017760-0612	OCWA MAINTENANCE ITEMS				323.47
INV000110052	OPERATIONS AND MAINTENANCE	108	02-Jan-2019	02-Jan-2019	
10-5-4017760-0604	CONTRACT OCWA - BOBLO				7,752.13
INV000110298	ADDITIONAL SERVICES	284	13-Feb-2019	13-Feb-2019	
10-5-4017760-0613	OCWA UNEXPECTED ITEMS				967.50
INV000110639	OPERATIONS AND MAINTENANCE	179	01-Feb-2019	01-Feb-2019	
10-5-4017760-0604	CONTRACT OCWA - BOBLO				7,752.13
INV000111179	OPERATIONS AND MAINTENANCE	285	01-Mar-2019	01-Mar-2019	
10-5-4017760-0604	CONTRACT OCWA - BOBLO				7,752.13
INV000111802	OPERATIONS AND MAINTENANCE	437	01-Apr-2019	01-Apr-2019	
10-5-4017760-0604	CONTRACT OCWA - BOBLO				7,752.13
INV000112381	ADDITIONAL SERVICES	437	10-Apr-2019	10-Apr-2019	
10-5-4017760-0612	OCWA MAINTENANCE ITEMS				146.38
INV000112419	ADDITIONAL SERVICES	438	11-Apr-2019	11-Apr-2019	
10-5-4017760-0613	OCWA UNEXPECTED ITEMS				2,280.25
INV000112422	ADDITIONAL SERVICES	438	11-Apr-2019	11-Apr-2019	
10-5-4017760-0612	OCWA MAINTENANCE ITEMS				117.02
INV000112581	OPERATIONS AND MAINTENANCE	527	01-May-2019	01-May-2019	
10-5-4017760-0604	CONTRACT OCWA - BOBLO				7,752.13
<b>Department Totals :</b>					<b>52,589.39</b>

<b>DEPARTMENT 4057710 GARBAGE COLLECTION</b>					
<b>ESS360 ESSEX WINDSOR SOLID WASTE AUTH</b>					
IN000010173	WHITE GOODS COLLECTION COST (DEC 31, 2018)	104	31-Jan-2019	31-Jan-2019	
10-5-4057710-0603	WHITE GOODS				1,740.10
IN000010310	WHITE GOODS PICK UP	481	04-Apr-2019	04-Apr-2019	
10-5-4057710-0603	WHITE GOODS				1,430.75
<b>WIG035 WIGLE HOME HARDWARE BUILDING CENTRE</b>					
126672	REPLACE GARBAGE BIN	105	24-Jan-2019	24-Jan-2019	
10-5-4057710-0602	GARBAGE COLLECTION				169.49
<b>WIN270 WINDSOR DISPOSAL SERVICES LTD</b>					
0000920192	GARBAGE COLLECTION	250	28-Feb-2019	28-Feb-2019	
10-5-4057710-0602	GARBAGE COLLECTION				88.75
0000920194	GARBAGE COLLECTION (NOV 1, 2018)	250	28-Feb-2019	28-Feb-2019	
10-5-4057710-0602	GARBAGE COLLECTION				59.17
0000920202	WATER TREATMENT PLANT (NOV 1, 2018)	406	31-Jan-2019	31-Jan-2019	
10-5-4057710-0602	GARBAGE COLLECTION				12.46
0000923404	GARBAGE COLLECTION (DEC 1, 2018)	250	28-Feb-2019	28-Feb-2019	
10-5-4057710-0602	GARBAGE COLLECTION				88.75
0000924677	GARBAGE COLLECTION (DEC 1, 2018)	250	28-Feb-2019	28-Feb-2019	
10-5-4057710-0602	GARBAGE COLLECTION				88.75
0000924679	GARBAGE COLLECTION (DEC 1, 2018)	250	28-Feb-2019	28-Feb-2019	
10-5-4057710-0602	GARBAGE COLLECTION				59.17
0000924686	GARBAGE COLLECTION (DEC 1, 2018)	250	28-Feb-2019	28-Feb-2019	
10-5-4057710-0602	GARBAGE COLLECTION				181.51





Vendor : CAT038 To ZUL180

Batch : All

Department : All

Cheque Print Date : 01-Jan-2019 To 31-May-2019

Bank : 1 To 99

Class : All

Vendor Invoice	Vendor Name Description				Batch Invc Date	Invc Due Date	Amount
G.L. Account	CC1	CC2	CC3	GL Account Name			
<b>DEPARTMENT 4057710</b>				<b>GARBAGE COLLECTION</b>			
0000924688	WTP (DEC 1, 2019)				406 29-Jan-2019	29-Jan-2019	
10-5-4057710-0602				GARBAGE COLLECTION			41.53
0000927896	MONTHLY GARBAGE COLLECTION - JANUARY				15 02-Jan-2019	02-Jan-2019	
10-5-4057710-0602				GARBAGE COLLECTION			46,231.42
0000927897	BIN SERVICES - 286 VICTORIA				15 02-Jan-2019	02-Jan-2019	
10-5-4057710-0602				GARBAGE COLLECTION			133.13
0000927899	BIN SERVICE - 301 VICTORIA				15 02-Jan-2019	02-Jan-2019	
10-5-4057710-0602				GARBAGE COLLECTION			88.75
0000927908	WTP GARBAGE COLLECTION				15 02-Jan-2019	02-Jan-2019	
10-5-4057710-0602				GARBAGE COLLECTION			35.18
0000929037	ADDITIONAL PICK UP - 286 VICTORIA				34 02-Jan-2019	02-Jan-2019	
10-5-4057710-0602				GARBAGE COLLECTION			88.75
0000929039	ADDITIONAL PICK UPS - 301 VICTORIA				34 02-Jan-2019	02-Jan-2019	
10-5-4057710-0602				GARBAGE COLLECTION			59.17
0000929041	EXTRA PICK UP				105 02-Jan-2019	02-Jan-2019	
10-5-4057710-0602				GARBAGE COLLECTION			1.58
0000929047	WTP PICK UPS				34 02-Jan-2019	02-Jan-2019	
10-5-4057710-0602				GARBAGE COLLECTION			9.08
0000932083	BASIC COLLECTION - AS PER MONTHLY BREAKDOWN (FEBRUARY 1, 2019)				406 01-Feb-2019	01-Feb-2019	
10-5-4057710-0602				GARBAGE COLLECTION			46,231.42
0000932084	EXTRA PICK UP - 286 VICTORIA				105 01-Feb-2019	01-Feb-2019	
10-5-4057710-0602				GARBAGE COLLECTION			88.75
0000932086	EXTRA BIN PICK UPS - 301 VICTORIA ST				105 01-Feb-2019	01-Feb-2019	
10-5-4057710-0602				GARBAGE COLLECTION			59.17
0000933421	286 VICTORIA EXTRA PICK UP				406 01-Feb-2019	01-Feb-2019	
10-5-4057710-0602				GARBAGE COLLECTION			88.75
0000933423	301 VICTORIA - EXTRA COLLECTION				406 01-Feb-2019	01-Feb-2019	
10-5-4057710-0602				GARBAGE COLLECTION			59.17
0000936524	EXTRA WEEKLY BIN PICK UPS				252 01-Mar-2019	01-Mar-2019	
10-5-4057710-0602				GARBAGE COLLECTION			133.13
0000936535	GARBAGE PICK UP				252 01-Mar-2019	01-Mar-2019	
10-5-4057710-0602				GARBAGE COLLECTION			64.05
0000937551	EXTRA PICK UP 301 VICTORIA				280 01-Mar-2019	01-Mar-2019	
10-5-4057710-0602				GARBAGE COLLECTION			29.58
0000940656	MONTHLY BASIC COLLECTION				347 01-Apr-2019	01-Apr-2019	
10-5-4057710-0602				GARBAGE COLLECTION			46,231.42
0000940657	EXTRA GARBAGE COLLECTION				347 01-Apr-2019	01-Apr-2019	
10-5-4057710-0602				GARBAGE COLLECTION			88.75
0000940659	EXTRA GARBAGE COLLECTION				347 01-Apr-2019	01-Apr-2019	
10-5-4057710-0602				GARBAGE COLLECTION			59.17
0000941052	GARBAGE COLLECTION NEXEN				511 23-Mar-2019	23-Mar-2019	
10-5-4057710-0602				GARBAGE COLLECTION			789.79
0000941354	GARBAGE COLLECTION NEXEN				511 31-Mar-2019	31-Mar-2019	
10-5-4057710-0602				GARBAGE COLLECTION			1,089.93
0000941843	286 VICTORIA ST - EXTRA COLLECTION				406 01-Apr-2019	01-Apr-2019	
10-5-4057710-0602				GARBAGE COLLECTION			88.75
0000941845	301 VICTORIA - EXTRA PICK UP				406 01-Apr-2019	01-Apr-2019	
10-5-4057710-0602				GARBAGE COLLECTION			59.17
0000941853	WTP				406 01-Apr-2019	01-Apr-2019	
10-5-4057710-0602				GARBAGE COLLECTION			14.85
0000944736	MONTHLY BASIC COLLECTION				511 01-May-2019	01-May-2019	
10-5-4057710-0602				GARBAGE COLLECTION			46,231.42
0000944743	GARBAGE COLLECTION LIBRO				511 01-May-2019	01-May-2019	

## Council/Board Report By Dept-(Computer)



Vendor : CAT038 To ZUL180

Batch : All

Department : All

Cheque Print Date : 01-Jan-2019 To 31-May-2019

Bank : 1 To 99

Class : All

Vendor Invoice	Vendor Name Description	Batch	Inv Date	Inv Due Date	Amount
G.L. Account	CC1 CC2 CC3 GL Account Name				
<b>DEPARTMENT 4057710 GARBAGE COLLECTION</b>					
10-5-4057710-0602	GARBAGE COLLECTION				4.10
0000944774	GARBAGE COLLECTION LIBRO	511	01-May-2019	01-May-2019	
10-5-4057710-0602	GARBAGE COLLECTION				67.90
0000944818	GARBAGE COLLECTION SOUTH YARD	511	06-Apr-2019	06-Apr-2019	
10-5-4057710-0602	GARBAGE COLLECTION				404.54
933431	WATER TREATMENT PLANT	207	01-Feb-2019	01-Feb-2019	
10-5-4057710-0602	GARBAGE COLLECTION				16.56
<b>Department Totals :</b>					<b>192,507.86</b>
<hr/>					
<b>DEPARTMENT 4067715 GARBAGE DISPOSAL</b>					
<b>ESS360 ESSEX WINDSOR SOLID WASTE AUTH</b>					
10203	JANUARY 2019 MONTHLY FIXED COST	204	31-Jan-2019	31-Jan-2019	
10-5-4067715-0602	LANDFILL CHARGES				35,423.00
27425	REFUSE TIPPING FEES	1554	30-Nov-2018	30-Nov-2018	
10-5-4067715-0602	LANDFILL CHARGES				22,661.30
27432	YARD WASTE TIPPING FEES	1554	30-Nov-2018	30-Nov-2018	
10-5-4067715-0601	YARDWASTE LANDFILL TIPPING				8,634.60
27553	REFUSE - TIPPING FEE (DEC 31, 2018)	104	31-Jan-2019	31-Jan-2019	
10-5-4067715-0602	LANDFILL CHARGES				20,012.45
27560	YARD WASTE TIPPING FEES (DEC 31, 2018)	104	31-Jan-2019	31-Jan-2019	
10-5-4067715-0601	YARDWASTE LANDFILL TIPPING				1,409.85
27660	REFUSE TIPPING FEES	204	31-Jan-2019	31-Jan-2019	
10-5-4067715-0602	LANDFILL CHARGES				20,212.20
27667	YARD WASTE TIPPING FEE	204	31-Jan-2019	31-Jan-2019	
10-5-4067715-0601	YARDWASTE LANDFILL TIPPING				363.87
27755	REFUSE LANDFILL CHARGES	280	01-Feb-2019	01-Feb-2019	
10-5-4067715-0602	LANDFILL CHARGES				16,766.43
27866	REFUSE LANDFILL CHARGES	481	31-Mar-2019	31-Mar-2019	
10-5-4067715-0602	LANDFILL CHARGES				18,469.25
27873	YARD WASTE TIPPING FEE	481	31-Mar-2019	31-Mar-2019	
10-5-4067715-0601	YARDWASTE LANDFILL TIPPING				415.74
IN000010091	FIXED COST - LAND FILL TIPPING FEES	1554	30-Nov-2018	30-Nov-2018	
10-5-4067715-0602	LANDFILL CHARGES				35,625.00
IN000010154	REFUSES TIPPING FESS FIXED COST	104	31-Jan-2019	31-Jan-2019	
10-5-4067715-0602	LANDFILL CHARGES				35,623.00
IN000010245	LANDFILL CHARGES -	280	28-Feb-2019	28-Feb-2019	
10-5-4067715-0602	LANDFILL CHARGES				35,423.00
IN000010298	LANDFILL FIXED CHARGES	481	31-Jan-2019	31-Jan-2019	
10-5-4067715-0602	LANDFILL CHARGES				35,423.00
<b>MSM051 MSM RECYCLERS</b>					
INV10W3	TIRE DISPOSAL	481	27-Mar-2019	27-Mar-2019	
10-5-4067715-0607	PWD YARD CLEAN UP EXPENSES				45.20
INV9	DISPOSAL OF TIRES FOUND ALONG ROADWAY (DEC 10, 2018)	133	31-Jan-2019	31-Jan-2019	
10-5-4067715-0607	PWD YARD CLEAN UP EXPENSES				937.90
<b>MUN276 MUNICIPAL MEDIA INC.</b>					
5453	COLLECTION CALENDARS	1554	17-Dec-2018	17-Dec-2018	
10-5-4067715-0307	COLLECTION CALENDAR EXPENSES				621.50
<b>WIN270 WINDSOR DISPOSAL SERVICES LTD</b>					
0000927896	MONTHLY GARBAGE COLLECTION - JANUARY	15	02-Jan-2019	02-Jan-2019	
10-5-4067715-0603	YARD WASTE - HAULING TO LANDFILL				9,121.74
0000932083	BASIC COLLECTION - AS PER MONTHLY BREAKDOWN (FEBRUARY 2019)	406	01-Feb-2019	01-Feb-2019	
10-5-4067715-0603	YARD WASTE - HAULING TO LANDFILL				9,121.74
0000940656	MONTHLY BASIC COLLECTION	347	01-Apr-2019	01-Apr-2019	





Vendor : CAT038 To ZUL180

Batch : All

Department : All

Cheque Print Date : 01-Jan-2019 To 31-May-2019

Bank : 1 To 99

Class : All

Vendor Invoice	Vendor Name Description	Batch	Inv Date	Inv Due Date	Amount
G.L. Account	CC1 CC2 CC3 GL Account Name				
<b>DEPARTMENT 4067715 GARBAGE DISPOSAL</b>					
10-5-4067715-0603	YARD WASTE - HAULING TO LANDFILL				9,121.74
0000941051	PUBLIC WORKS BIN - SOUTH YARD	406	23-Mar-2019	23-Mar-2019	
10-5-4067715-0607	PWD YARD CLEAN UP EXPENSES				84.75
0000944736	MONTHLY BASIC COLLECTION	511	01-May-2019	01-May-2019	
10-5-4067715-0603	YARD WASTE - HAULING TO LANDFILL				9,121.74
<b>Department Totals :</b>					<b>324,639.00</b>
<hr/>					
<b>DEPARTMENT 7010000 PARKS AND RECREATION PROGRAMMING</b>					
<b>CAT038</b>	<b>CRISTOFARO CATHERINE</b>				
038	BALLROOM DANCING	104	28-Jan-2019	28-Jan-2019	
10-5-7010000-0420	RECREATION EXPENSES				500.00
<b>APC145</b>	<b>PARE ASHLEY</b>				
2018-12-07	WINTER/SPRING ACTIVITY GUIDE 2019	1523	07-Dec-2018	07-Dec-2018	
10-5-7010000-0349	MARKETING				350.00
<b>ATE460</b>	<b>A TEAM ROBOTIC</b>				
FEBRUARY 20	ESSEX POWER YOUTH IN COMMUNITY FUND	177	01-Feb-2019	01-Feb-2019	
10-5-7010000-0776	ESSEX POWER YOUTH IN COMM FD				1,000.00
<b>ATH554</b>	<b>ATHLETICA SPORT SYSTEMS</b>				
312676	MINI NETS FOR ICE RINK	406	04-Mar-2019	04-Mar-2019	
10-5-7010000-0420	RECREATION EXPENSES				3,384.35
<b>BRE497</b>	<b>BRENNER PACKERS LTD.</b>				
53972	CONCESSION PURCHASE	389	27-Mar-2019	27-Mar-2019	
10-5-7010000-0384	CONCESSION PRODUCT				250.00
54212	CONCESSION PURCHASE	1523	30-Nov-2018	30-Nov-2018	
10-5-7010000-0384	CONCESSION PRODUCT				250.00
54591	CONCESION PURCHASE	1557	21-Dec-2018	21-Dec-2018	
10-5-7010000-0384	CONCESSION PRODUCT				250.00
54598	CONCESSION PURCHASE	1557	28-Dec-2018	28-Dec-2018	
10-5-7010000-0384	CONCESSION PRODUCT				500.00
54990	CONCESSION PURCHASE	406	05-Apr-2019	05-Apr-2019	
10-5-7010000-0384	CONCESSION PRODUCT				250.00
56405	CONCESSION PURCHASE	62	18-Jan-2019	18-Jan-2019	
10-5-7010000-0384	CONCESSION PRODUCT				250.00
56712	CONCESSION PURCHASE	389	15-Feb-2019	15-Feb-2019	
10-5-7010000-0384	CONCESSION PRODUCT				500.00
56774	CONCESSION PURCHASE	204	22-Feb-2019	22-Feb-2019	
10-5-7010000-0384	CONCESSION PRODUCT				500.00
<b>CAR238</b>	<b>CARSCADDEN AMANDA</b>				
DECEMBER 2, BREAKFAST WITH SANTA COST		1523	02-Dec-2018	02-Dec-2018	
10-5-7010000-0384	CONCESSION PRODUCT				400.00
<b>CEN859</b>	<b>CENTENNIAL LOCK &amp; SAFE LIMITED</b>				
25577	SUPPLIES	250	25-Feb-2019	25-Feb-2019	
10-5-7010000-0421	CONCESSION EQUIPMENT				666.70
<b>COL128</b>	<b>COLONIAL COFFEE CO. LTD.</b>				
766491	CONCESSION PURCHASE	1523	29-Nov-2018	29-Nov-2018	
10-5-7010000-0384	CONCESSION PRODUCT				186.30
768069	CONCESSION PURCHASE	389	17-Jan-2019	17-Jan-2019	
10-5-7010000-0384	CONCESSION PRODUCT				147.30
768230	CONCESSION PURCHASE	1557	20-Dec-2018	20-Dec-2018	
10-5-7010000-0384	CONCESSION PRODUCT				202.30
769888	CONCESSION PURCHASE	34	10-Jan-2019	10-Jan-2019	
10-5-7010000-0384	CONCESSION PRODUCT				183.30

Council/Board Report By Dept-(Computer)



Vendor : CAT038 To ZUL180

Batch : All

Department : All

Cheque Print Date : 01-Jan-2019 To 31-May-2019

Bank : 1 To 99

Class : All

Vendor Invoice	Vendor Name Description	Batch	Inv Date	Inv Due Date	Amount
G.L. Account	CC1 CC2 CC3 GL Account Name				
<b>DEPARTMENT 7010000</b>	<b>PARKS AND RECREATION PROGRAMMING</b>				
770508	CONCESSION PURCHASE	204	14-Feb-2019	14-Feb-2019	
10-5-7010000-0384	CONCESSION PRODUCT				203.65
771086	CONCESSION PURCHASE	389	21-Mar-2019	21-Mar-2019	
10-5-7010000-0384	CONCESSION PRODUCT				147.30
772361	CONCESSION PURCHASE	389	04-Apr-2019	04-Apr-2019	
10-5-7010000-0384	CONCESSION PRODUCT				108.30
<b>COL155 COLASANTI TROPICAL GARDENS</b>					
E10813	MARCH BREAK EXPENSES	389	13-Mar-2019	13-Mar-2019	
10-5-7010000-0420	RECREATION EXPENSES				244.04
<b>DIL581 DILIGENT COMMUNICATIONS INC.</b>					
9426	CAMERA AND SOUND SYSTEM REPAIR	406	30-Jan-2019	30-Jan-2019	
10-5-7010000-0349	MARKETING				1,244.45
<b>FAL686 FALLS WHOLESALE LIMITED</b>					
061640	CONCESSION PURCHASE	1523	06-Dec-2018	06-Dec-2018	
10-5-7010000-0384	CONCESSION PRODUCT				1,287.37
061641	CONCESSION PURCHASE	1557	06-Dec-2018	06-Dec-2018	
10-5-7010000-0384	CONCESSION PRODUCT				1,416.83
062198	CONCESSION PURCHASE	62	18-Jan-2019	18-Jan-2019	
10-5-7010000-0384	CONCESSION PRODUCT				1,296.33
062199	CONCESSION PURCHASE	62	18-Jan-2019	18-Jan-2019	
10-5-7010000-0384	CONCESSION PRODUCT				1,828.67
063018	CONCESSION PURCHASE	389	15-Mar-2019	15-Mar-2019	
10-5-7010000-0384	CONCESSION PRODUCT				688.33
063019	CONCESSION PURCHASE	481	15-Mar-2019	15-Mar-2019	
10-5-7010000-0384	CONCESSION PRODUCT				869.52
62548	CONCESSION PURCHASE	204	13-Feb-2019	13-Feb-2019	
10-5-7010000-0384	CONCESSION PRODUCT				626.34
62549	CONCESSION PURCHASE	204	13-Feb-2019	13-Feb-2019	
10-5-7010000-0420	RECREATION EXPENSES				827.58
<b>FRA589 FRAZER MCPHERSON ALYSON</b>					
NOVEMBER 28 DECORATING FOR CHRISTMAS AT THE LIBRO		1523	28-Nov-2018	28-Nov-2018	
10-5-7010000-0420	RECREATION EXPENSES				345.00
<b>GOR299 GORDON FOOD SERVICE CAN. LTD. - ONTARIO DIVISION</b>					
3081348	CONCESSION PURCHASE	204	07-Nov-2018	07-Nov-2018	
10-5-7010000-0384	CONCESSION PRODUCT				1,569.99
3135954	CONCESSION PURCHASE	1523	28-Nov-2018	28-Nov-2018	
10-5-7010000-0384	CONCESSION PRODUCT				3,497.42
3154957	CONCESSION PURCHASE	1523	05-Dec-2018	05-Dec-2018	
10-5-7010000-0384	CONCESSION PRODUCT				1,183.15
3167147	CONCESSION PURCHASE	1557	10-Dec-2018	10-Dec-2018	
10-5-7010000-0384	CONCESSION PRODUCT				364.10
3180685	CONCESSION PURCHASE	1557	14-Dec-2018	14-Dec-2018	
10-5-7010000-0384	CONCESSION PRODUCT				1,138.32
3192499	CONCESSION PURCHASE	1557	19-Dec-2018	19-Dec-2018	
10-5-7010000-0384	CONCESSION PRODUCT				2,528.09
3211276	CONCESSION PURCHASE	1557	28-Dec-2018	28-Dec-2018	
10-5-7010000-0384	CONCESSION PRODUCT				1,590.47
32238354	CONCESSION PURCHASE	62	09-Jan-2019	09-Jan-2019	
10-5-7010000-0384	CONCESSION PRODUCT				1,625.20
3255724	CONCESSION PURCHASE	62	16-Jan-2019	16-Jan-2019	
10-5-7010000-0384	CONCESSION PRODUCT				1,132.61
3272804	CONCESSION PURCHASE	106	23-Jan-2019	23-Jan-2019	
10-5-7010000-0421	CONCESSION EQUIPMENT				820.23



Vendor : CAT038 To ZUL180

Batch : All

Department : All

Cheque Print Date : 01-Jan-2019 To 31-May-2019

Bank : 1 To 99

Class : All

Vendor Invoice	Vendor Name Description	Batch	Inv Date	Inv Due Date	Amount
G.L. Account	CC1 CC2 CC3 GL Account Name				
<b>DEPARTMENT 7010000</b>	<b>PARKS AND RECREATION PROGRAMMING</b>				
3307105	CONCESSION PURCHASE	204	06-Feb-2019	06-Feb-2019	
10-5-7010000-0384	CONCESSION PRODUCT				1,639.41
3313232	CONCESSION PURCHASE	204	08-Feb-2019	08-Feb-2019	
10-5-7010000-0384	CONCESSION PRODUCT				387.84
3324530	CONCESSION PURCHASE	204	13-Feb-2019	13-Feb-2019	
10-5-7010000-0384	CONCESSION PRODUCT				1,444.37
3347572	CONCESSION PURCHASE	204	22-Feb-2019	22-Feb-2019	
10-5-7010000-0384	CONCESSION PRODUCT				2,399.96
3376305	CONCESSION PURCHASE	389	06-Mar-2019	06-Mar-2019	
10-5-7010000-0384	CONCESSION PRODUCT				1,102.25
3412388	CONCESSION PURCHASE	389	20-Mar-2019	20-Mar-2019	
10-5-7010000-0384	CONCESSION PRODUCT				693.18
3430217	CONCESSION PURCHASE	389	27-Mar-2019	27-Mar-2019	
10-5-7010000-0384	CONCESSION PRODUCT				1,128.98
3448630	CONCESSION PURCHASE	347	03-Apr-2019	03-Apr-2019	
10-5-7010000-0384	CONCESSION PRODUCT				2,561.17
3455225	CONCESSION PURCHASE	347	05-Apr-2019	05-Apr-2019	
10-5-7010000-0384	CONCESSION PRODUCT				893.05
3503276	CONCESSION PURCHASE	481	24-Apr-2019	24-Apr-2019	
10-5-7010000-0384	CONCESSION PRODUCT				513.18
<b>HOL560 HOLZEL RYAN</b>					
MARCH 21, 20	YOUTH DANCE EXPENSE	389	21-Mar-2019	21-Mar-2019	
10-5-7010000-0420	RECREATION EXPENSES				200.00
<b>KOZ001 KOZMA BONNIE</b>					
001	BREAKFAST WITH SANTA	1523	01-Dec-2018	01-Dec-2018	
10-5-7010000-0420	RECREATION EXPENSES				350.00
<b>LAC345 LACASSE PRINTING CO LTD</b>					
90947	GUIDE PRINTING	62	10-Jan-2019	10-Jan-2019	
10-5-7010000-0307	ADVERTISING				4,406.79
<b>LOB898 LOBLAW'S INC</b>					
2018 RECEIPT PURCHASES MADE IN 2018		175	31-Jan-2019	31-Jan-2019	
10-5-7010000-0384	CONCESSION PRODUCT				89.70
<b>MAR131 MARIA'S RESTAURANT</b>					
APRIL 27, 2019	SPECIAL EVENTS AMHA BANQUET	481	27-Apr-2019	27-Apr-2019	
10-5-7010000-0771	SPECIAL EVENTS				2,458.87
APRIL 9, 2019	TRAVEL HOCKEY BANQUET FOOD	406	09-Apr-2019	09-Apr-2019	
10-5-7010000-0771	SPECIAL EVENTS				1,447.50
MARCH 9, 201	SPECIAL EVENT - WOMEN'S BANQUET	389	09-Mar-2019	09-Mar-2019	
10-5-7010000-0771	SPECIAL EVENTS				499.63
<b>MCM948 M.C.M. SNACK FOODS</b>					
37002	CONCESSION PURCHASE	1523	01-Dec-2018	01-Dec-2018	
10-5-7010000-0384	CONCESSION PRODUCT				243.36
37029	CONCESSION PURCHASE	1557	18-Dec-2018	18-Dec-2018	
10-5-7010000-0384	CONCESSION PRODUCT				348.04
37066	CONCESSION PURCHASE	62	15-Jan-2019	15-Jan-2019	
10-5-7010000-0384	CONCESSION PRODUCT				284.04
37106	CONCESSION PURCHASE	204	14-Feb-2019	14-Feb-2019	
10-5-7010000-0384	CONCESSION PRODUCT				336.22
37162	CONCESSION PURCHASE	389	27-Mar-2019	27-Mar-2019	
10-5-7010000-0384	CONCESSION PRODUCT				284.04
<b>MOR26 MORNEAU SHEPELL LTD.</b>					
APRIL 2019	953243, 953244, 953245, 953246	347	01-Apr-2019	01-Apr-2019	
10-5-7010000-0207	BENEFITS - LIFE & DISABILITY				58.24



Vendor : CAT038 To ZUL180  
 Batch : All  
 Department : All

Cheque Print Date : 01-Jan-2019 To 31-May-2019  
 Bank : 1 To 99  
 Class : All

Vendor Invoice	Vendor Name Description	Batch	Inv Date	Inv Due Date	Amount
G.L. Account	CC1 CC2 CC3 GL Account Name				
<b>DEPARTMENT 7010000 PARKS AND RECREATION PROGRAMMING</b>					
10-5-7010000-0207	BENEFITS - LIFE & DISABILITY				74.88
FEBRUARY 20 921007, 921008, 921009, 921010 FEBRUARY 2019					
10-5-7010000-0207	BENEFITS - LIFE & DISABILITY	135	01-Feb-2019	01-Feb-2019	58.24
JANUARY 2019 902738, 902739, 902740, 902741 JANUARY 2019					
10-5-7010000-0207	BENEFITS - LIFE & DISABILITY	62	02-Jan-2019	02-Jan-2019	108.16
10-5-7010000-0207	BENEFITS - LIFE & DISABILITY				58.24
10-5-7010000-0207	BENEFITS - LIFE & DISABILITY				74.88
MARCH 2019 936899, 936900, 936901, 936902 MARCH 2019					
10-5-7010000-0207	BENEFITS - LIFE & DISABILITY	280	01-Mar-2019	01-Mar-2019	58.24
MAY 2019 970411, 970412, 970413, 970414 MAY 2019					
10-5-7010000-0207	BENEFITS - LIFE & DISABILITY	511	01-May-2019	01-May-2019	58.24
<b>MUN200 MUNICIPAL EMPLOYER PENSION CENTRE OF ONTARIO</b>					
MC004654	MEPCO 2019 E MPLOYEE CONTRIBUTION	15	02-Jan-2019	02-Jan-2019	
10-5-7010000-0350	MEMBERSHIPS				54.30
<b>MUS550 MUSCEDERE MIRNA</b>					
016	PROGRAMMING COSTS	1523	19-Nov-2018	19-Nov-2018	
10-5-7010000-0420	RECREATION EXPENSES				625.00
016	DECEMBE REC EVENT	1607	12-Dec-2018	12-Dec-2018	
10-5-7010000-0420	RECREATION EXPENSES				500.00
<b>NAN202 NANTAIS ATHLETIC INC.</b>					
207	MARKETING	1523	27-Nov-2018	27-Nov-2018	
10-5-7010000-0349	MARKETING				143.51
<b>NAN329 NANTAIS ATHLETIC INC (LIBRO)</b>					
3427	PARTICIPANT SHIRTS	15	02-Jan-2019	02-Jan-2019	
10-5-7010000-0420	RECREATION EXPENSES				812.92
534	UNIFORMS	481	31-Mar-2019	31-Mar-2019	
10-5-7010000-0420	RECREATION EXPENSES				248.49
538	CONCESSION PURCHASE	481	31-Mar-2019	31-Mar-2019	
10-5-7010000-0421	CONCESSION EQUIPMENT				761.76
<b>NAP110 NAPLES PIZZA</b>					
1	(DECEMBER HOSPICE TOURNAMENT	1557	28-Dec-2018	28-Dec-2018	
10-5-7010000-0771	SPECIAL EVENTS				4,463.30
295	BIRTHDAY PARTY EXPENSE	1557	19-Dec-2018	19-Dec-2018	
10-5-7010000-0420	RECREATION EXPENSES				41.00
296	BIRTHDAY PARTY EXPENSE	15	27-Jan-2019	27-Jan-2019	
10-5-7010000-0420	RECREATION EXPENSES				41.00
297	BIRTHDAY PARTY EXPENSE	15	02-Feb-2019	02-Feb-2019	
10-5-7010000-0420	RECREATION EXPENSES				41.00
300	BDAY PARTY EXPENSE	62	20-Jan-2019	20-Jan-2019	
10-5-7010000-0420	RECREATION EXPENSES				41.00
302	BIRTHDAY PARTY PROGRAM	204	23-Feb-2019	23-Feb-2019	
10-5-7010000-0420	RECREATION EXPENSES				41.00
303	BIRTHDAY PARTY PROGRAM	204	23-Feb-2019	23-Feb-2019	
10-5-7010000-0420	RECREATION EXPENSES				41.00
304	BDAY PARTY PROGRAM	252	02-Mar-2019	02-Mar-2019	
10-5-7010000-0420	RECREATION EXPENSES				41.00
305	BDAY PARTY PROGRAM	252	02-Mar-2019	02-Mar-2019	
10-5-7010000-0420	RECREATION EXPENSES				41.00
306	BDAY PARTY PROGRAM	252	06-Apr-2019	06-Apr-2019	
10-5-7010000-0420	RECREATION EXPENSES				41.00
307	BDAY PARTY EXPENSES	389	27-Apr-2018	27-Apr-2018	
10-5-7010000-0420	RECREATION EXPENSES				41.00
308	BDAY PARTY EXPENSES	389	13-Apr-2019	13-Apr-2019	



Vendor : CAT038 To ZUL180

Batch : All

Department : All

Cheque Print Date : 01-Jan-2019 To 31-May-2019

Bank : 1 To 99

Class : All

Vendor Invoice	Vendor Name Description	Batch	Inv Date	Inv Due Date	Amount
G.L. Account	CC1 CC2 CC3 GL Account Name				
<b>DEPARTMENT 7010000</b>	<b>PARKS AND RECREATION PROGRAMMING</b>				
10-5-7010000-0420	RECREATION EXPENSES				41.00
311	BDAY PARTY EXPENSE	481	20-Apr-2019	20-Apr-2019	
10-5-7010000-0420	RECREATION EXPENSES				64.27
313	BDAY PARTY EXPENSE	481	04-May-2019	04-May-2019	
10-5-7010000-0420	RECREATION EXPENSES				41.00
314	BDAY PARTY EXPENSE	481	05-May-2019	05-May-2019	
10-5-7010000-0384	CONCESSION PRODUCT				41.00
315	BDAY PARTY EXPENSE	481	26-May-2019	26-May-2019	
10-5-7010000-0420	RECREATION EXPENSES				41.00
316	BDAY PARTY EXPENSE	481	11-May-2019	11-May-2019	
10-5-7010000-0420	RECREATION EXPENSES				41.00
<b>NUC146</b>	<b>NUCELLI'S FROZEN YOGURT</b>				
12623	CONCESSION PURCHASE	1523	30-Nov-2018	30-Nov-2018	
10-5-7010000-0384	CONCESSION PRODUCT				227.81
12648	CONCESSION PURCHASE	1557	14-Dec-2018	14-Dec-2018	
10-5-7010000-0384	CONCESSION PRODUCT				227.81
12657	CONCESSION PURCHASE	1607	05-Dec-2018	05-Dec-2018	
10-5-7010000-0384	CONCESSION PRODUCT				227.81
12690	CONCESSION PURCHASE	204	22-Jan-2019	22-Jan-2019	
10-5-7010000-0384	CONCESSION PRODUCT				227.81
12718	CONCESSION PURCHASE	204	06-Feb-2019	06-Feb-2019	
10-5-7010000-0384	CONCESSION PRODUCT				265.77
12742	CONCESSION PURCHASE	204	23-Feb-2019	23-Feb-2019	
10-5-7010000-0384	CONCESSION PRODUCT				227.81
<b>ROS436</b>	<b>ROSE CITY GYMNASTICS</b>				
JANUARY 14, ; GYMNASTICS INSTRUCTION		62	14-Jan-2019	14-Jan-2019	
10-5-7010000-0420	RECREATION EXPENSES				1,880.00
<b>RTT067</b>	<b>RIVER TOWN TIMES</b>				
00097859	ADVERTISING	1554	18-Dec-2018	18-Dec-2018	
10-5-7010000-0307	ADVERTISING				87.26
00097926	ADVERTISING	1554	27-Dec-2018	27-Dec-2018	
10-5-7010000-0307	ADVERTISING				284.40
00097977	ADVERTISING	15	14-Jan-2019	14-Jan-2019	
10-5-7010000-0307	ADVERTISING				80.55
10-5-7010000-0307	ADVERTISING				141.02
1034	ADVERTISING	62	16-Jan-2019	16-Jan-2019	
10-5-7010000-0307	ADVERTISING				141.00
10-5-7010000-0307	ADVERTISING				284.40
1097	ADVERTISING	134	30-Jan-2019	30-Jan-2019	
10-5-7010000-0307	ADVERTISING				284.38
1185	ADVERTISING	177	06-Feb-2019	06-Feb-2019	
10-5-7010000-0307	ADVERTISING				141.02
1411	ADVERTISING	250	27-Feb-2019	27-Feb-2019	
10-5-7010000-0307	ADVERTISING				276.17
10-5-7010000-0307	ADVERTISING				284.40
1486	ADVERTISING	252	06-Mar-2019	06-Mar-2019	
10-5-7010000-0307	ADVERTISING				141.02
1530	ADVERTISING	481	20-Mar-2019	20-Mar-2019	
10-5-7010000-0307	ADVERTISING				174.52
1688	ADVERTISING	347	03-Apr-2019	03-Apr-2019	
10-5-7010000-0307	ADVERTISING				284.40
1718	ADVERTISING	347	10-Apr-2019	10-Apr-2019	
10-5-7010000-0307	ADVERTISING				284.40



Vendor : CAT038 To ZUL180  
 Batch : All  
 Department : All

Cheque Print Date : 01-Jan-2019 To 31-May-2019  
 Bank : 1 To 99  
 Class : All

Vendor Invoice	Vendor Name Description	Batch	Inv Date	Inv Due Date	Amount
G.L. Account	CC1 CC2 CC3 GL Account Name				
<b>DEPARTMENT 7010000 PARKS AND RECREATION PROGRAMMING</b>					
1798	ADVERTISING	406	17-Apr-2019	17-Apr-2019	
10-5-7010000-0307	ADVERTISING				87.26
10-5-7010000-0307	ADVERTISING				87.26
10-5-7010000-0307	ADVERTISING				141.02
10-5-7010000-0307	ADVERTISING				141.02
1825	ADVERTISING	436	24-Apr-2019	24-Apr-2019	
10-5-7010000-0307	ADVERTISING				174.52
1950	ADVERTISING	525	08-May-2019	08-May-2019	
10-5-7010000-0307	ADVERTISING				141.02
2007	ADVERTISING	525	22-May-2019	22-May-2019	
10-5-7010000-0307	ADVERTISING				87.26
10-5-7010000-0307	ADVERTISING				284.40
10-5-7010000-0307	ADVERTISING				141.02
10-5-7010000-0307	ADVERTISING				284.40
<b>SHA567 SHARP BUS LINES LIMITED</b>					
WIN226452	MARCH BREAK DAY TRIP TRANSPORTATION	406	13-Mar-2019	13-Mar-2019	
10-5-7010000-0776	ESSEX POWER YOUTH IN COMM FD				316.40
<b>SOB083 SOBEYS AMHERSTBURG</b>					
DECEMBER 2018 DECEMBER 2018 PURCHASES					
10-5-7010000-0384	CONCESSION PRODUCT	1608	31-Dec-2018	31-Dec-2018	391.12
10-5-7010000-0384	CONCESSION PRODUCT				77.77
10-5-7010000-0384	CONCESSION PRODUCT				36.78
10-5-7010000-0384	CONCESSION PRODUCT				95.34
10-5-7010000-0384	CONCESSION PRODUCT				76.75
10-5-7010000-0384	CONCESSION PRODUCT				85.32
10-5-7010000-0384	CONCESSION PRODUCT				200.69
10-5-7010000-0384	CONCESSION PRODUCT				27.72
10-5-7010000-0421	CONCESSION EQUIPMENT				95.96
10-5-7010000-0420	RECREATION EXPENSES				85.42
FEB/MAR 2019 FEBRUARY MARCH 2019 PURCHASES					
10-5-7010000-0384	CONCESSION PRODUCT	511	31-Mar-2019	31-Mar-2019	100.21
10-5-7010000-0384	CONCESSION PRODUCT				99.11
10-5-7010000-0384	CONCESSION PRODUCT				53.07
10-5-7010000-0384	CONCESSION PRODUCT				45.63
10-5-7010000-0384	CONCESSION PRODUCT				70.48
10-5-7010000-0384	CONCESSION PRODUCT				51.08
10-5-7010000-0384	CONCESSION PRODUCT				145.90
10-5-7010000-0384	CONCESSION PRODUCT				69.41
10-5-7010000-0384	CONCESSION PRODUCT				175.36
10-5-7010000-0384	CONCESSION PRODUCT				20.19
10-5-7010000-0384	CONCESSION PRODUCT				124.33
10-5-7010000-0384	CONCESSION PRODUCT				48.34
10-5-7010000-0771	SPECIAL EVENTS				220.93
JANUARY 2019 JANUARY 2019 PURCHASES					
10-5-7010000-0384	CONCESSION PRODUCT	511	31-Jan-2019	31-Jan-2019	86.02
10-5-7010000-0384	CONCESSION PRODUCT				81.19
10-5-7010000-0384	CONCESSION PRODUCT				42.18
10-5-7010000-0384	CONCESSION PRODUCT				27.02
10-5-7010000-0384	CONCESSION PRODUCT				55.74
10-5-7010000-0384	CONCESSION PRODUCT				65.25
10-5-7010000-0384	CONCESSION PRODUCT				25.09
10-5-7010000-0384	CONCESSION PRODUCT				92.14
NOVEMBER 2018 NOVEMBER 2018 PURCHASES					
10-5-7010000-0420	RECREATION EXPENSES	1608	30-Nov-2018	30-Nov-2018	68.27
10-5-7010000-0420	RECREATION EXPENSES				226.76
10-5-7010000-0384	CONCESSION PRODUCT				75.59
10-5-7010000-0384	CONCESSION PRODUCT				48.22





Vendor : CAT038 To ZUL180

Batch : All

Department : All

Cheque Print Date : 01-Jan-2019 To 31-May-2019

Bank : 1 To 99

Class : All

Vendor Invoice	Vendor Name Description	Batch	Inv Date	Inv Due Date	Amount
G.L. Account	CC1 CC2 CC3 GL Account Name				
<b>DEPARTMENT 7010000 PARKS AND RECREATION PROGRAMMING</b>					
10-5-7010000-0384	CONCESSION PRODUCT				11.28
10-5-7010000-0384	CONCESSION PRODUCT				126.91
10-5-7010000-0384	CONCESSION PRODUCT				46.06
10-5-7010000-0384	CONCESSION PRODUCT				24.24
10-5-7010000-0384	CONCESSION PRODUCT				296.29
10-5-7010000-0384	CONCESSION PRODUCT				66.46
10-5-7010000-0384	CONCESSION PRODUCT				46.90
10-5-7010000-0384	CONCESSION PRODUCT				278.16
10-5-7010000-0384	CONCESSION PRODUCT				23.66
10-5-7010000-0384	CONCESSION PRODUCT				75.49
10-5-7010000-0384	CONCESSION PRODUCT				39.50
10-5-7010000-0384	CONCESSION PRODUCT				155.26
10-5-7010000-0384	CONCESSION PRODUCT				40.80
10-5-7010000-0384	CONCESSION PRODUCT				337.72
10-5-7010000-0384	CONCESSION PRODUCT				168.10
10-5-7010000-0384	CONCESSION PRODUCT				161.02
10-5-7010000-0420	RECREATION EXPENSES				56.13
10-5-7010000-0420	RECREATION EXPENSES				55.00
10-5-7010000-0420	RECREATION EXPENSES				73.26
<b>STA444 STAPLES ADVANTAGE (MIS C/O T04446C)</b>					
49286304	OFFICE SUPPLIES	1607	20-Dec-2018	20-Dec-2018	
10-5-7010000-0301	OFFICE SUPPLIES				293.30
49303877	OFFICE SUPPLIES	1557	24-Dec-2018	24-Dec-2018	
10-5-7010000-0301	OFFICE SUPPLIES				163.45
49325975	OFFICE SUPPLIES	15	02-Jan-2019	02-Jan-2019	
10-5-7010000-0301	OFFICE SUPPLIES				42.65
49326731	OFFICE SUPPLIES	62	02-Jan-2019	02-Jan-2019	
10-5-7010000-0384	CONCESSION PRODUCT				150.88
49354711	OFFICE SUPPLIES	15	04-Jan-2019	04-Jan-2019	
10-5-7010000-0301	OFFICE SUPPLIES				409.02
49412899	OFFICE SUPPLIES	62	10-Jan-2019	10-Jan-2019	
10-5-7010000-0301	OFFICE SUPPLIES				205.65
49514832	OFFICE SUPPLIES	62	22-Jan-2019	22-Jan-2019	
10-5-7010000-0384	CONCESSION PRODUCT				28.80
49637831	OFFICE SUPPLIES	204	05-Feb-2019	05-Feb-2019	
10-5-7010000-0301	OFFICE SUPPLIES				220.00
49930736	OFFICE SUPPLIES	389	12-Mar-2019	12-Mar-2019	
10-5-7010000-0301	OFFICE SUPPLIES				170.05
50110010	CONCESSION PURCHASE	406	02-Apr-2019	02-Apr-2019	
10-5-7010000-0301	OFFICE SUPPLIES				752.44
50124382	OFFICE SUPPLIES	389	03-Apr-2019	03-Apr-2019	
10-5-7010000-0301	OFFICE SUPPLIES				34.55
50289094	OFFICE SUPPLIES	481	24-Apr-2019	24-Apr-2019	
10-5-7010000-0301	OFFICE SUPPLIES				371.58
50327180	OFFICE SUPPLIES	481	29-Apr-2019	29-Apr-2019	
10-5-7010000-0301	OFFICE SUPPLIES				81.76
50373537	OFFICE SUPPLIES	481	03-May-2019	03-May-2019	
10-5-7010000-0301	OFFICE SUPPLIES				193.43
<b>SWA142 SWARG; SOUTH WEST AREA RECREATION GUILD</b>					
WE-CIM-2019A	SWARG MEMBERSHIP	204	21-Feb-2019	21-Feb-2019	
10-5-7010000-0350	MEMBERSHIPS				1,000.00
<b>THE121 THE WINDSOR SYMPHONY SOCIETY</b>					
2287	RECREATION EVENT	1557	11-Dec-2018	11-Dec-2018	
10-5-7010000-0420	RECREATION EXPENSES				500.00
<b>VIL04 THE VILLAGE SHOPPE</b>					





Vendor : CAT038 To ZUL180  
 Batch : All  
 Department : All

Cheque Print Date : 01-Jan-2019 To 31-May-2019  
 Bank : 1 To 99  
 Class : All

Vendor Invoice	Vendor Name Description	Batch	Inv Date	Inv Due Date	Amount
G.L. Account	CC1 CC2 CC3 GL Account Name				
<b>DEPARTMENT 7010000 PARKS AND RECREATION PROGRAMMING</b>					
APRIL 18, 2015 EASTER EGG HUNT		389	18-Apr-2019	18-Apr-2019	
10-5-7010000-0420	RECREATION EXPENSES				943.78
<b>WIL215 WILLIAMS FOOD EQUIPMENT</b>					
IN00676547 CONCESSION EQUIPMENT		1557	21-Dec-2018	21-Dec-2018	
10-5-7010000-0421	CONCESSION EQUIPMENT				209.07
IN00687444 CONCESSION EQUIPMENT MAINTENANCE		406	10-Apr-2019	10-Apr-2019	
10-5-7010000-0422	CONCESSION EQUIP MAINTENANCE				647.27
IN00689385 CONCESSION EQUIPMENT		481	30-Apr-2019	30-Apr-2019	
10-5-7010000-0421	CONCESSION EQUIPMENT				520.70
<b>WIN210 WINDSOR FACTORY SUPPLY LTD</b>					
4988244 RECREATION EXPENSES		389	25-Mar-2019	25-Mar-2019	
10-5-7010000-0420	RECREATION EXPENSES				216.96
10-5-7010000-0420	RECREATION EXPENSES				273.37
4999321 TAPE FOR COUNT LINES		406	09-Apr-2019	09-Apr-2019	
10-5-7010000-0420	RECREATION EXPENSES				122.58
<b>Department Totals :</b>					<b>89,886.04</b>
-----					
<b>DEPARTMENT 7010160 LION'S POOL PROGRAMMING</b>					
<b>LOB898 LOBLAW'S INC</b>					
2018 RECEIPT PURCHASES MADE IN 2018		175	31-Jan-2019	31-Jan-2019	
10-5-7010160-0250	HEALTH AND SAFETY				7.76
<b>Department Totals :</b>					<b>7.76</b>
-----					
<b>DEPARTMENT 7012017 CAPITAL</b>					
<b>TOW033 TOWN OF ESSEX</b>					
SALES000000( CO ANN CAPITAL		436	30-Apr-2019	30-Apr-2019	
40-7-7012017-0002	CO AN CAPITAL IMPROVEMENT PRG				5,684.52
<b>Department Totals :</b>					<b>5,684.52</b>
-----					
<b>DEPARTMENT 7012018 CAPITAL</b>					
<b>AMH432 AMHERSTBURG CHEVEROLET-BUICK-GMC</b>					
16835 FLEET - NEW PICK UP		134	30-Jan-2019	30-Jan-2019	
40-7-7012018-0004	REPLACE UNIT 103 - WATERING TRUCK				42,786.40
<b>CAR645 CARRIER CENTERS</b>					
042196 NEW 9 FOOT SALTER AND PLOW FOR TRUCK		137	31-Jan-2018	31-Jan-2018	
40-7-7012018-0005	REPLACE UNIT 115 - 1 TON DUMP TRUCK				21,357.00
<b>VEH188 VEHICLE VENTURE</b>					
199712 ROADS CAPITAL		345	06-Mar-2019	06-Mar-2019	
40-7-7012018-0003	REPLACE UNIT 314 - 1978 CUBE VAN				3,954.55
<b>Department Totals :</b>					<b>68,097.95</b>
-----					
<b>DEPARTMENT 7017000 PARKS MAINTENANCE</b>					
<b>ACC334 ACCURATE CREATIONS SPORTS &amp; PROMO GEAR</b>					
1217 UNIFORM LETTERING		525	19-May-2019	19-May-2019	
10-5-7017000-0161	PARKS - CLOTHING				944.12
<b>ACT456 ACTION SIGNS &amp; DESIGNS INC.</b>					
11240 DECALS FOR NEW PICK UP		204	07-Feb-2019	07-Feb-2019	
10-5-7017000-0402	VEHICLE & EQUIPMENT MAINTENANCE PARKS				118.65
<b>AMH432 AMHERSTBURG CHEVEROLET-BUICK-GMC</b>					
57353 NEW LIGHT COVER ON PG 4		345	25-Mar-2019	25-Mar-2019	
10-5-7017000-0402	VEHICLE & EQUIPMENT MAINTENANCE PARKS				168.97



Vendor : CAT038 To ZUL180  
 Batch : All  
 Department : All

Cheque Print Date : 01-Jan-2019 To 31-May-2019  
 Bank : 1 To 99  
 Class : All

Vendor Invoice	Vendor Name Description	Batch	Inv Date	Inv Due Date	Amount
G.L. Account	CC1 CC2 CC3 GL Account Name				
<b>DEPARTMENT 7017000 PARKS MAINTENANCE</b>					
<b>ATS374 ATS UNDERGROUND SPRINKLERS</b>					
54915	OPENING IMAGINATION SYSTEMS	511	03-May-2019	03-May-2019	
10-5-7017000-0336	CONTRACTED SERVICES				1,130.73
54942	OPEN & FULL SYSTEM CHECK NAVY YARD	525	09-May-2019	09-May-2019	
10-5-7017000-0336	CONTRACTED SERVICES				958.81
<b>CAN236 CANADIAN FENCE CONTRACTORS - 1954812</b>					
307	FIX FENCE INSURANCE CLAIM AT CENTENNIAL WHERE CAR DROVE THUR IN 2018	389	28-Mar-2019	28-Mar-2019	
10-5-7017000-0336	CONTRACTED SERVICES				1,052.90
<b>CAN380 CANADIAN TIRE STORE #281</b>					
FEBRUARY 20 FEBRUARY 2019 PURCHASES					
10-5-7017000-0322	GENERAL SUPPLIES - PARKS & REC	280	28-Feb-2019	28-Feb-2019	147.28
10-5-7017000-0322	GENERAL SUPPLIES - PARKS & REC				69.22
10-5-7017000-0322	GENERAL SUPPLIES - PARKS & REC				30.48
10-5-7017000-0322	GENERAL SUPPLIES - PARKS & REC				51.95
JANUARY 2019 JANUARY 2019 PURCHASES					
10-5-7017000-0322	GENERAL SUPPLIES - PARKS & REC	389	31-Jan-2019	31-Jan-2019	169.43
10-5-7017000-0322	GENERAL SUPPLIES - PARKS & REC				24.84
10-5-7017000-0322	GENERAL SUPPLIES - PARKS & REC				29.36
10-5-7017000-0771	SPECIAL EVENTS				45.18
MARCH 2019 MARCH 2019 PURCHASES					
10-5-7017000-0420	PARKS MAINTENANCE EQUIPMENT	345	31-Mar-2019	31-Mar-2019	73.44
10-5-7017000-0420	PARKS MAINTENANCE EQUIPMENT				56.49
10-5-7017000-0322	GENERAL SUPPLIES - PARKS & REC				14.67
10-5-7017000-0322	GENERAL SUPPLIES - PARKS & REC				205.51
NOVEMBER 2018 NOVEMBER 2018 PURCHASES					
10-5-7017000-0771	SPECIAL EVENTS	133	31-Jan-2019	31-Jan-2019	216.82
10-5-7017000-0771	SPECIAL EVENTS				361.37
10-5-7017000-0771	SPECIAL EVENTS				126.48
10-5-7017000-0771	SPECIAL EVENTS				56.48
10-5-7017000-0771	SPECIAL EVENTS				154.72
10-5-7017000-0771	SPECIAL EVENTS				312.81
10-5-7017000-0771	SPECIAL EVENTS				-101.67
10-5-7017000-0771	SPECIAL EVENTS				84.72
10-5-7017000-0771	SPECIAL EVENTS				84.72
10-5-7017000-0322	GENERAL SUPPLIES - PARKS & REC				135.57
10-5-7017000-0420	PARKS MAINTENANCE EQUIPMENT				14.68
10-5-7017000-0420	PARKS MAINTENANCE EQUIPMENT				67.78
10-5-7017000-0771	SPECIAL EVENTS				11.30
OCTOBER 2018 OCTOBER 2018 INVOICES					
10-5-7017000-0771	SPECIAL EVENTS	1554	31-Oct-2018	31-Oct-2018	534.24
10-5-7017000-0771	SPECIAL EVENTS				250.60
10-5-7017000-0771	SPECIAL EVENTS				-242.84
10-5-7017000-0771	SPECIAL EVENTS				48.57
10-5-7017000-0771	SPECIAL EVENTS				987.19
10-5-7017000-0322	GENERAL SUPPLIES - PARKS & REC				13.31
<b>CAR645 CARRIER CENTERS</b>					
04P452745	TORO MOWERS - OIL ANALYSIS KIT	511	24-Apr-2019	24-Apr-2019	
10-5-7017000-0402	VEHICLE & EQUIPMENT MAINTENANCE PARKS				286.46
04P453035	REPAIR UNIT PG32	525	02-May-2019	02-May-2019	
10-5-7017000-0402	VEHICLE & EQUIPMENT MAINTENANCE PARKS				186.45
04S414426	REPAIR SALTER	250	21-Feb-2019	21-Feb-2019	
10-5-7017000-0402	VEHICLE & EQUIPMENT MAINTENANCE PARKS				142.27
<b>COU132 COUNTY TOWING INC.</b>					
19-00519	TOW 210 TO GARAGE	345	07-Mar-2019	07-Mar-2019	
10-5-7017000-0402	VEHICLE & EQUIPMENT MAINTENANCE PARKS				84.75
<b>DAN991 DAN'S TREE SERVICES</b>					



Vendor : CAT038 To ZUL180

Batch : All

Department : All

Cheque Print Date : 01-Jan-2019 To 31-May-2019

Bank : 1 To 99

Class : All

Vendor Invoice	Vendor Name Description				Batch Invc Date	Invc Due Date	Amount
G.L. Account	CC1	CC2	CC3	GL Account Name			
<b>DEPARTMENT 7017000</b>				<b>PARKS MAINTENANCE</b>			
1924	TREE MAINTENANCE AT MALDEN PARK				436 26-Apr-2019	26-Apr-2019	
10-5-7017000-0650				PARKS FORESTRY			7,797.00
<b>DON592</b>	<b>DONE-RIGHT SERVICES</b>						
13738	REPAIR MINI BACKHOE				345 18-Mar-2019	18-Mar-2019	
10-5-7017000-0402				VEHICLE & EQUIPMENT MAINTENANCE PARKS			695.32
13780	REPAIR UNIT PG-53				345 20-Mar-2019	20-Mar-2019	
10-5-7017000-0402				VEHICLE & EQUIPMENT MAINTENANCE PARKS			545.52
13784	REPAIR UNIT PG-11				345 20-Mar-2019	20-Mar-2019	
10-5-7017000-0402				VEHICLE & EQUIPMENT MAINTENANCE PARKS			662.94
13849	REPAIR UNIT PG-11				345 26-Mar-2019	26-Mar-2019	
10-5-7017000-0402				VEHICLE & EQUIPMENT MAINTENANCE PARKS			414.43
13930	REPAIR PG-11				406 11-Apr-2019	11-Apr-2019	
10-5-7017000-0402				VEHICLE & EQUIPMENT MAINTENANCE PARKS			865.42
<b>EMC530</b>	<b>EMCO CORPORATION</b>						
37579836-00	SUPPLIES KNYP (OCTOBER 10, 2108)				104 31-Jan-2019	31-Jan-2019	
10-5-7017000-0322				GENERAL SUPPLIES - PARKS & REC			273.69
37579836-01	GENERAL SUPPLIES (NOV 2, 2018)				104 31-Jan-2019	31-Jan-2019	
10-5-7017000-0322				GENERAL SUPPLIES - PARKS & REC			7.33
37593043-00	HOOK UP SYSTEM FOR FILLING WATER TANKS AT 99 THOMS				347 05-Apr-2019	05-Apr-2019	
10-5-7017000-0322				GENERAL SUPPLIES - PARKS & REC			206.53
<b>EQU401</b>	<b>EQUINOX INDUSTRIES LTD.</b>						
IN00150267	GENERAL SUPPLIES (APRIL 10, 2018)				104 31-Jan-2019	31-Jan-2019	
10-5-7017000-0322				GENERAL SUPPLIES - PARKS & REC			551.44
<b>ERB168</b>	<b>E.R. (BILL) VOLLANS LTD.</b>						
46938	WIDE AREA MOWER REPAIR				511 11-Apr-2019	11-Apr-2019	
10-5-7017000-0402				VEHICLE & EQUIPMENT MAINTENANCE PARKS			305.10
<b>FEE256</b>	<b>THE FEED STORE</b>						
1000201702	CHALK FOR BASEBALL DIAMONDS				436 01-May-2019	01-May-2019	
10-5-7017000-0322				GENERAL SUPPLIES - PARKS & REC			742.41
1000202200	TRIMMER LINE				511 07-May-2019	07-May-2019	
10-5-7017000-0420				PARKS MAINTENANCE EQUIPMENT			124.19
<b>FES459</b>	<b>FESTIVAL TENT &amp; PARTY RENTALS INC.</b>						
112000	PORTA JOHNS				104 31-Jan-2019	31-Jan-2019	
10-5-7017000-0336				CONTRACTED SERVICES			36.44
<b>FIR418</b>	<b>FIRST ELEMENTS INC.</b>						
AMH-006	WORKING AT HEIGHTS TRAINING				439 12-Apr-2019	12-Apr-2019	
10-5-7017000-0351				TRAINING & CONFERENCES			813.60
<b>FLA364</b>	<b>FLAGS UNLIMITED</b>						
269878	MISC SUPPLIES				204 05-Feb-2019	05-Feb-2019	
10-5-7017000-0322				GENERAL SUPPLIES - PARKS & REC			3,881.50
<b>GRE330</b>	<b>GREAT LAKES SAFETY PRODUCTS</b>						
00316346	H&S SUPPLIES				99 17-Jan-2019	17-Jan-2019	
10-5-7017000-0322				GENERAL SUPPLIES - PARKS & REC			65.37
00319964	H&S SUPPLIES				436 29-Apr-2019	29-Apr-2019	
10-5-7017000-0322				GENERAL SUPPLIES - PARKS & REC			56.07
<b>GRE679</b>	<b>GREG BAILEY LTD</b>						
0000051712	GAS POWERED PRESSURE WASHER				280 07-Mar-2019	07-Mar-2019	
10-5-7017000-0420				PARKS MAINTENANCE EQUIPMENT			1,284.65
<b>GYO693</b>	<b>GYORI FARMS INC.</b>						
2731	SOIL TO REPAIR DAMAGE AT FLAG POLES				345 20-Mar-2019	20-Mar-2019	
10-5-7017000-0322				GENERAL SUPPLIES - PARKS & REC			94.92
2734	GIBSON GALLERY BEACHSTONE				345 20-Mar-2019	20-Mar-2019	



Vendor : CAT038 To ZUL180

Batch : All

Department : All

Cheque Print Date : 01-Jan-2019 To 31-May-2019

Bank : 1 To 99

Class : All

Vendor Invoice	Vendor Name Description				Batch Invc Date	Invc Due Date	Amount
G.L. Account	CC1	CC2	CC3	GL Account Name			
<b>DEPARTMENT 7017000</b>				<b>PARKS MAINTENANCE</b>			
10-5-7017000-0322				GENERAL SUPPLIES - PARKS & REC			106.79
2740				GIBSON GALLERY BEACH STONE	345 21-Mar-2019	21-Mar-2019	
10-5-7017000-0322				GENERAL SUPPLIES - PARKS & REC			177.98
2746				NORTH GATE - SOIL	345 26-Mar-2019	26-Mar-2019	
10-5-7017000-0322				GENERAL SUPPLIES - PARKS & REC			94.92
2754				SOIL FOR PILE	345 27-Mar-2019	27-Mar-2019	
10-5-7017000-0322				GENERAL SUPPLIES - PARKS & REC			522.06
<b>HAL561</b>				<b>HALLMARK MEMORIAL &amp; SIGNS</b>			
20002				RE-DO PLAQUE FROM BED 1 @KNYP	319 04-Mar-2019	04-Mar-2019	
10-5-7017000-0322				GENERAL SUPPLIES - PARKS & REC			621.50
<b>HER247</b>				<b>HERITAGE TIRE SALES INC.</b>			
1531				MATERIALS	204 19-Feb-2019	19-Feb-2019	
10-5-7017000-0402				VEHICLE & EQUIPMENT MAINTENANCE PARKS			313.64
<b>KEL198</b>				<b>KELCOM RADIO DIVISION</b>			
80010116				AIR TIME	1554 19-Dec-2018	19-Dec-2018	
10-5-7017000-0404				RADIO AIR TIME			304.59
80010162				RADIO AIRTIME	99 15-Jan-2019	15-Jan-2019	
10-5-7017000-0404				RADIO AIR TIME			304.59
80010282				RADIO AIR TIME	280 15-Feb-2019	15-Feb-2019	
10-5-7017000-0404				RADIO AIR TIME			304.59
80010399				RADIO AIR TIME	319 15-Mar-2019	15-Mar-2019	
10-5-7017000-0404				RADIO AIR TIME			304.59
80010516				RADIO AIR TIME	406 15-Apr-2019	15-Apr-2019	
10-5-7017000-0404				RADIO AIR TIME			304.59
80010636				RADIO AIRTIME	525 15-May-2019	15-May-2019	
10-5-7017000-0404				RADIO AIR TIME			304.59
<b>KNM541</b>				<b>KNM YARD CARE</b>			
1476				GRASS CONTRACT	525 12-May-2019	12-May-2019	
10-5-7017000-0336				CONTRACTED SERVICES			1,525.50
<b>KUC134</b>				<b>KUCERA CONSTRUCTION EQUIPMENT</b>			
RW08381				REPAIR - UNIT 508	1554 06-Dec-2018	06-Dec-2018	
10-5-7017000-0402				VEHICLE & EQUIPMENT MAINTENANCE PARKS			932.91
RW08454				SERVICE TO 508	62 09-Jan-2019	09-Jan-2019	
10-5-7017000-0402				VEHICLE & EQUIPMENT MAINTENANCE PARKS			693.84
RW08486				REPAIR 508 BACKHOE	105 23-Jan-2019	23-Jan-2019	
10-5-7017000-0402				VEHICLE & EQUIPMENT MAINTENANCE PARKS			690.15
RW08520				REPAIR 508	250 06-Feb-2019	06-Feb-2019	
10-5-7017000-0402				VEHICLE & EQUIPMENT MAINTENANCE PARKS			178.77
RW08586				REPAIR UNIT 708	345 07-Mar-2019	07-Mar-2019	
10-5-7017000-0402				VEHICLE & EQUIPMENT MAINTENANCE PARKS			827.76
<b>LUC170</b>				<b>LUCIER GLOVE &amp; SAFETY PRODUCTS</b>			
33892				UNIFORMS	347 22-Mar-2019	22-Mar-2019	
10-5-7017000-0161				PARKS - CLOTHING			3,106.87
34070				CREDIT UNIFORMS	511 03-Apr-2019	03-Apr-2019	
10-5-7017000-0161				PARKS - CLOTHING			-33.90
34538				UNIFORMS	511 01-May-2019	01-May-2019	
10-5-7017000-0161				PARKS - CLOTHING			1,854.93
34739				H&S SUPPLIES	511 10-May-2019	10-May-2019	
10-5-7017000-0161				PARKS - CLOTHING			149.06
<b>MAI925</b>				<b>MAISONVILLE MARINE</b>			
MAY 2019				INSTALL INTAKE PIPE AT KNYP FOR IRRIGATION	511 01-May-2019	01-May-2019	
10-5-7017000-0336				CONTRACTED SERVICES			1,017.00
<b>MAL256</b>				<b>MALDEN AUTOMOTIVE</b>			



Vendor : CAT038 To ZUL180

Batch : All

Department : All

Cheque Print Date : 01-Jan-2019 To 31-May-2019

Bank : 1 To 99

Class : All

Vendor Invoice	Vendor Name Description	Batch	Inv Date	Inv Due Date	Amount
G.L. Account	CC1 CC2 CC3 GL Account Name				
<b>DEPARTMENT 7017000 PARKS MAINTENANCE</b>					
5294-179428	CREDIT	1606	23-Oct-2018	23-Oct-2018	
10-5-7017000-0402	VEHICLE & EQUIPMENT MAINTENANCE PARKS				-20.34
5294-180048	WARRANTY CREDIT	1607	31-Oct-2018	31-Oct-2018	
10-5-7017000-0402	VEHICLE & EQUIPMENT MAINTENANCE PARKS				-425.19
5294-180179	WARRANTY CREDIT	1606	02-Nov-2018	02-Nov-2018	
10-5-7017000-0402	VEHICLE & EQUIPMENT MAINTENANCE PARKS				-425.19
5294-180597	BALL HITCH	1607	09-Nov-2018	09-Nov-2018	
10-5-7017000-0402	VEHICLE & EQUIPMENT MAINTENANCE PARKS				42.83
5294-180598	BALL MOUNT	1607	09-Nov-2018	09-Nov-2018	
10-5-7017000-0402	VEHICLE & EQUIPMENT MAINTENANCE PARKS				64.35
5294-180687	BALL MOUNT	1607	10-Nov-2018	10-Nov-2018	
10-5-7017000-0402	VEHICLE & EQUIPMENT MAINTENANCE PARKS				135.54
5294-186033	EQUIPMENT	204	13-Feb-2019	13-Feb-2019	
10-5-7017000-0420	PARKS MAINTENANCE EQUIPMENT				221.40
5294-188472	BATTERY FOR 60 MOWER PG 33	345	29-Mar-2019	29-Mar-2019	
10-5-7017000-0402	VEHICLE & EQUIPMENT MAINTENANCE PARKS				129.36
5294-188476	BATTERY FOR 60" MOWER PG33 - CREDIT	345	29-Mar-2019	29-Mar-2019	
10-5-7017000-0402	VEHICLE & EQUIPMENT MAINTENANCE PARKS				-1.49
5294-188491	BATTERY RETURNED	345	29-Mar-2019	29-Mar-2019	
10-5-7017000-0402	VEHICLE & EQUIPMENT MAINTENANCE PARKS				-20.34
5294-190134	REPAIR PARKS EQUIPMENT	525	25-Apr-2019	25-Apr-2019	
10-5-7017000-0402	VEHICLE & EQUIPMENT MAINTENANCE PARKS				89.84
<b>MAR003 MAR-CO CLAY PRODUCTS INC</b>					
79171	CAPITAL UPGRADES TO MALDEN PARK	436	12-Apr-2019	12-Apr-2019	
40-7-7017000-0002	MALDEN PARK - BALL DIAMOND FENCING/BACKS				2,866.55
79197	CREDIT TO INVOICE 79171	436	15-Apr-2019	15-Apr-2019	
40-7-7017000-0002	MALDEN PARK - BALL DIAMOND FENCING/BACKS				-50.00
<b>MER975 MERCHANTS PAPER CO</b>					
146568	SUPPLIES	99	09-Jan-2019	09-Jan-2019	
10-5-7017000-0322	GENERAL SUPPLIES - PARKS & REC				290.65
154565	SUPPLIES	406	17-Apr-2019	17-Apr-2019	
10-5-7017000-0322	GENERAL SUPPLIES - PARKS & REC				324.51
<b>MON183 MONARCH OFFICE SUPPLY LTD</b>					
133006	JANUARY 2018 PURCHASES	176	30-Jan-2019	30-Jan-2019	
10-5-7017000-0301	OFFICE SUPPLIES				100.58
143523	MARCH 2019 PURCHASES	406	29-Mar-2019	29-Mar-2019	
10-5-7017000-0301	OFFICE SUPPLIES				284.81
880600	GENERAL SUPPLIES	252	04-Mar-2019	04-Mar-2019	
10-5-7017000-0301	OFFICE SUPPLIES				87.87
<b>MOR26 MORNEAU SHEPELL LTD.</b>					
APRIL 2019	953243, 953244, 953245, 953246 APRIL 2019	347	01-Apr-2019	01-Apr-2019	
10-5-7017000-0207	BENEFITS - LIFE & DISABIL - PARKS & GRDS				199.69
FEBRUARY 20	921007, 921008, 921009, 921010 FEBRUARY 2019	135	01-Feb-2019	01-Feb-2019	
10-5-7017000-0207	BENEFITS - LIFE & DISABIL - PARKS & GRDS				74.88
MARCH 2019	936899, 936900, 936901, 936902 MARCH 2019	280	01-Mar-2019	01-Mar-2019	
10-5-7017000-0207	BENEFITS - LIFE & DISABIL - PARKS & GRDS				74.88
MAY 2019	970411, 970412, 970413, 970414 MAY 2019	511	01-May-2019	01-May-2019	
10-5-7017000-0207	BENEFITS - LIFE & DISABIL - PARKS & GRDS				74.88
<b>NOR156 NORTRAX CANADA INC.</b>					
1117933	SUPPLIES	1523	07-Dec-2018	07-Dec-2018	
10-5-7017000-0322	GENERAL SUPPLIES - PARKS & REC				46.87
<b>ONT270 1732077 ONTARIO LIMITED O/A TIM WHITES TOTAL TIRE</b>					
93388	TIRE REPAIR	177	29-Jan-2019	29-Jan-2019	



Vendor : CAT038 To ZUL180

Batch : All

Department : All

Cheque Print Date : 01-Jan-2019 To 31-May-2019

Bank : 1 To 99

Class : All

Vendor Invoice	Vendor Name Description				Batch Invc Date	Invc Due Date	Amount
G.L. Account	CC1	CC2	CC3	GL Account Name			
<b>DEPARTMENT 7017000</b>				<b>PARKS MAINTENANCE</b>			
10-5-7017000-0402				VEHICLE & EQUIPMENT MAINTENANCE PARKS			216.96
<b>PAR26</b>	<b>PARKS AND RECREATION ONTARIO</b>						
022019-0214-0	PROFESSIONAL DEVELOPMENT				135 01-Feb-2019	01-Feb-2019	
10-5-7017000-0351				TRAINING & CONFERENCES			823.77
<b>PAR372</b>	<b>PARRLINE ELECTRICAL WHOLESALE</b>						
777298	ELECTRICAL SUPPLIES				1554 09-Aug-2018	09-Aug-2018	
10-5-7017000-0322				GENERAL SUPPLIES - PARKS & REC			3,253.95
<b>PIT565</b>	<b>PITTAO'S AUTO CARE INC</b>						
054988	REPAIR UNIT 710				280 27-Feb-2019	27-Feb-2019	
10-5-7017000-0402				VEHICLE & EQUIPMENT MAINTENANCE PARKS			804.09
055009	VEHICLE MAINTENANCE FOR UNIT # 210				280 04-Mar-2019	04-Mar-2019	
10-5-7017000-0402				VEHICLE & EQUIPMENT MAINTENANCE PARKS			2,534.09
055153	UNIT 210 DIAGNOSTIC REVIEW				347 04-Apr-2019	04-Apr-2019	
10-5-7017000-0402				VEHICLE & EQUIPMENT MAINTENANCE PARKS			115.83
055236	REPAIR 210				511 25-Apr-2019	25-Apr-2019	
10-5-7017000-0402				VEHICLE & EQUIPMENT MAINTENANCE PARKS			2,190.46
<b>POW372</b>	<b>POWER DISTRIBUTION SUPPLY</b>						
1902	AP LOCKS/KEYS				280 01-Mar-2019	01-Mar-2019	
10-5-7017000-0322				GENERAL SUPPLIES - PARKS & REC			183.42
<b>PRA389</b>	<b>PRACTICA LTD</b>						
39955	GENERAL SUPPLIES				34 14-Jan-2019	14-Jan-2019	
10-5-7017000-0322				GENERAL SUPPLIES - PARKS & REC			1,089.79
<b>RAC462</b>	<b>RACICOT CHRYSLER</b>						
56991	EQUIPMENT & TOOLS				15 03-Jan-2019	03-Jan-2019	
10-5-7017000-0420				PARKS MAINTENANCE EQUIPMENT			50.57
<b>RTT067</b>	<b>RIVER TOWN TIMES</b>						
2007	ADVERTISING				525 22-May-2019	22-May-2019	
10-5-7017000-0301				OFFICE SUPPLIES			253.56
<b>RUS02</b>	<b>RUSSCO TRAINING SERVICES</b>						
4233	TRAINING CONFINED SPACES				436 27-Mar-2019	27-Mar-2019	
10-5-7017000-0351				TRAINING & CONFERENCES			1,412.50
<b>SIT504</b>	<b>SITEONE LANDSCAPE SUPPLY LLC</b>						
90482885-001	PARTS FOR KNPY INTAKES				436 29-Apr-2019	29-Apr-2019	
10-5-7017000-0322				GENERAL SUPPLIES - PARKS & REC			187.83
<b>STE01</b>	<b>STEWART GILBERT LTD</b>						
76538	PORTA JOHN				511 30-Apr-2019	30-Apr-2019	
10-5-7017000-0336				CONTRACTED SERVICES			293.80
76539	PORTA JOHN				511 30-Apr-2019	30-Apr-2019	
10-5-7017000-0336				CONTRACTED SERVICES			220.35
76540	PORTA JOHN				511 30-Apr-2019	30-Apr-2019	
10-5-7017000-0336				CONTRACTED SERVICES			220.35
76541	PORTA JOHN				511 30-Apr-2019	30-Apr-2019	
10-5-7017000-0336				CONTRACTED SERVICES			73.45
76542	PORTA JOHN				511 30-Apr-2019	30-Apr-2019	
10-5-7017000-0336				CONTRACTED SERVICES			73.45
<b>THE123</b>	<b>THE SMALL ENGINE DOCTOR</b>						
8568095	REPAIR 2 GAS POWERED HEDGE SHEARS				347 20-Mar-2019	20-Mar-2019	
10-5-7017000-0402				VEHICLE & EQUIPMENT MAINTENANCE PARKS			133.00
<b>THR251</b>	<b>THRASHER SALES &amp; LEASING LTD</b>						
228273	REPAIR MIRROR - RS-1				1554 10-Dec-2018	10-Dec-2018	
10-5-7017000-0402				VEHICLE & EQUIPMENT MAINTENANCE PARKS			116.96
228736	VEHICLE MAINTENANCE				34 10-Jan-2019	10-Jan-2019	





Vendor : CAT038 To ZUL180

Batch : All

Department : All

Cheque Print Date : 01-Jan-2019 To 31-May-2019

Bank : 1 To 99

Class : All

Vendor Invoice	Vendor Name Description				Batch Invc Date	Invc Due Date	Amount
G.L. Account	CC1	CC2	CC3	GL Account Name			
<b>DEPARTMENT 7017000</b>				<b>PARKS MAINTENANCE</b>			
10-5-7017000-0402				VEHICLE & EQUIPMENT MAINTENANCE PARKS			222.84
228738	VEHICLE MAINTENANCE				34 10-Jan-2019	10-Jan-2019	
10-5-7017000-0402				VEHICLE & EQUIPMENT MAINTENANCE PARKS			245.61
228761	VEHICLE MAINTENANCE				34 11-Jan-2019	11-Jan-2019	
10-5-7017000-0402				VEHICLE & EQUIPMENT MAINTENANCE PARKS			345.23
<b>TSC401</b>	<b>TSC STORES LTD</b>						
FEBRUARY 25	NEW COMPRESSOR, CUSTOMER NUMBER 4904				280 25-Feb-2019	25-Feb-2019	
10-5-7017000-0420				PARKS MAINTENANCE EQUIPMENT			870.09
JANUARY 11, 2	GENERAL SUPPLIES, CUSTOMER NUMBER 4904				34 11-Jan-2019	11-Jan-2019	
10-5-7017000-0322				GENERAL SUPPLIES - PARKS & REC			338.98
<b>VEH188</b>	<b>VEHICLE VENTURE</b>						
199679	MAINTENANCE				525 15-Apr-2019	15-Apr-2019	
10-5-7017000-0402				VEHICLE & EQUIPMENT MAINTENANCE PARKS			1,569.95
<b>WIG035</b>	<b>WIGLE HOME HARDWARE BUILDING CENTRE</b>						
118021	SUPPLIES				1607 04-May-2018	04-May-2018	
10-5-7017000-0322				GENERAL SUPPLIES - PARKS & REC			55.36
119707	SUPPLIES				1607 18-Jun-2018	18-Jun-2018	
10-5-7017000-0322				GENERAL SUPPLIES - PARKS & REC			43.36
120553	SUPPLIES				1607 12-Jul-2018	12-Jul-2018	
10-5-7017000-0322				GENERAL SUPPLIES - PARKS & REC			2.62
125319	GENERAL				1523 04-Dec-2018	04-Dec-2018	
10-5-7017000-0322				GENERAL SUPPLIES - PARKS & REC			4.83
125413	SUPPLIES				1554 06-Dec-2018	06-Dec-2018	
10-5-7017000-0322				GENERAL SUPPLIES - PARKS & REC			9.76
125557	SUPPLIES				1523 11-Dec-2018	11-Dec-2018	
10-5-7017000-0420				PARKS MAINTENANCE EQUIPMENT			61.74
125822	GENERAL				1523 19-Dec-2018	19-Dec-2018	
10-5-7017000-0322				GENERAL SUPPLIES - PARKS & REC			5.07
125865	GENERAL				1523 20-Dec-2018	20-Dec-2018	
10-5-7017000-0322				GENERAL SUPPLIES - PARKS & REC			6.66
126092	GENERAL SUPPLIES				15 03-Jan-2019	03-Jan-2019	
10-5-7017000-0322				GENERAL SUPPLIES - PARKS & REC			11.27
126159	GENERAL SUPPLIES				15 07-Jan-2019	07-Jan-2019	
10-5-7017000-0322				GENERAL SUPPLIES - PARKS & REC			24.85
126167	GENERAL SUPPLIES				15 07-Jan-2019	07-Jan-2019	
10-5-7017000-0322				GENERAL SUPPLIES - PARKS & REC			39.52
126449	GENERAL SUPPLIES				106 16-Jan-2019	16-Jan-2019	
10-5-7017000-0322				GENERAL SUPPLIES - PARKS & REC			23.70
126493	GENERAL SUPPLIES				106 17-Jan-2019	17-Jan-2019	
10-5-7017000-0322				GENERAL SUPPLIES - PARKS & REC			12.41
126498	TOOLS & EQUIPMENT				62 17-Jan-2019	17-Jan-2019	
10-5-7017000-0420				PARKS MAINTENANCE EQUIPMENT			14.89
126505	GENERAL				62 17-Jan-2019	17-Jan-2019	
10-5-7017000-0322				GENERAL SUPPLIES - PARKS & REC			19.64
126530	TOOLS & EQUIPMENT				106 18-Jan-2019	18-Jan-2019	
10-5-7017000-0420				PARKS MAINTENANCE EQUIPMENT			32.18
126675	SPECIAL EVENTS				106 24-Jan-2019	24-Jan-2019	
10-5-7017000-0771				SPECIAL EVENTS			64.38
127067	SUPPLIES				135 05-Feb-2019	05-Feb-2019	
10-5-7017000-0420				PARKS MAINTENANCE EQUIPMENT			40.67
127076	SUPPLIES				135 05-Feb-2019	05-Feb-2019	
10-5-7017000-0322				GENERAL SUPPLIES - PARKS & REC			33.79
127143	SUPPLIES				135 07-Feb-2019	07-Feb-2019	





Vendor : CAT038 To ZUL180

Batch : All

Department : All

Cheque Print Date : 01-Jan-2019 To 31-May-2019

Bank : 1 To 99

Class : All

Vendor Invoice	Vendor Name Description				Batch Invc Date	Invc Due Date	Amount
G.L. Account	CC1	CC2	CC3	GL Account Name			
<b>DEPARTMENT 7017000</b>				<b>PARKS MAINTENANCE</b>			
10-5-7017000-0322				GENERAL SUPPLIES - PARKS & REC			27.09
127151	SUPPLIES				135 07-Feb-2019	07-Feb-2019	
10-5-7017000-0322				GENERAL SUPPLIES - PARKS & REC			225.16
127160	SUPPLIES				135 07-Feb-2019	07-Feb-2019	
10-5-7017000-0322				GENERAL SUPPLIES - PARKS & REC			47.78
127177	SUPPLIES				135 08-Feb-2019	08-Feb-2019	
10-5-7017000-0322				GENERAL SUPPLIES - PARKS & REC			47.09
127247	SUPPLIES				204 11-Feb-2019	11-Feb-2019	
10-5-7017000-0322				GENERAL SUPPLIES - PARKS & REC			125.03
127272	SUPPLIES				204 12-Feb-2019	12-Feb-2019	
10-5-7017000-0322				GENERAL SUPPLIES - PARKS & REC			7.11
127365	SUPPLIES				204 14-Feb-2019	14-Feb-2019	
10-5-7017000-0322				GENERAL SUPPLIES - PARKS & REC			7.32
127369	SUPPLIES				204 14-Feb-2019	14-Feb-2019	
10-5-7017000-0322				GENERAL SUPPLIES - PARKS & REC			44.51
127489	GENERAL SUPPLIES				250 20-Feb-2019	20-Feb-2019	
10-5-7017000-0322				GENERAL SUPPLIES - PARKS & REC			23.14
127537	SUPPLIES				250 21-Feb-2019	21-Feb-2019	
10-5-7017000-0322				GENERAL SUPPLIES - PARKS & REC			33.18
127641	SUPPLIES				250 26-Feb-2019	26-Feb-2019	
10-5-7017000-0322				GENERAL SUPPLIES - PARKS & REC			20.92
127712	SUPPLIES				250 28-Feb-2019	28-Feb-2019	
10-5-7017000-0322				GENERAL SUPPLIES - PARKS & REC			25.96
127719	SUPPLIES				252 28-Feb-2019	28-Feb-2019	
10-5-7017000-0322				GENERAL SUPPLIES - PARKS & REC			911.31
127762	SUPPLIES				252 01-Mar-2019	01-Mar-2019	
10-5-7017000-0322				GENERAL SUPPLIES - PARKS & REC			96.57
127819	SUPPLIES				252 04-Mar-2019	04-Mar-2019	
10-5-7017000-0322				GENERAL SUPPLIES - PARKS & REC			47.44
127851	GENERAL SUPPLIES				280 05-Mar-2019	05-Mar-2019	
10-5-7017000-0322				GENERAL SUPPLIES - PARKS & REC			19.06
127897	SUPPLIES TO BUILD STORAGE UNITS IN OIL SHED				280 06-Mar-2019	06-Mar-2019	
10-5-7017000-0322				GENERAL SUPPLIES - PARKS & REC			174.84
128075	MAINTENANCE SUPPLIES				345 12-Mar-2019	12-Mar-2019	
10-5-7017000-0322				GENERAL SUPPLIES - PARKS & REC			20.61
128082	BATTERIES				345 12-Mar-2019	12-Mar-2019	
10-5-7017000-0322				GENERAL SUPPLIES - PARKS & REC			11.85
128179	AIRLINE CABLE TO FIX LIBRO FLAGPOLE				345 15-Mar-2019	15-Mar-2019	
10-5-7017000-0322				GENERAL SUPPLIES - PARKS & REC			363.46
128250	SUPPLIES				319 18-Mar-2019	18-Mar-2019	
10-5-7017000-0301				OFFICE SUPPLIES			5.64
128290	FIX LIBRO PARKING BLOCKS				347 19-Mar-2019	19-Mar-2019	
10-5-7017000-0322				GENERAL SUPPLIES - PARKS & REC			14.11
128356	SUPPLIES				347 21-Mar-2019	21-Mar-2019	
10-5-7017000-0322				GENERAL SUPPLIES - PARKS & REC			25.98
128600	SUPPLIES				347 29-Mar-2019	29-Mar-2019	
10-5-7017000-0322				GENERAL SUPPLIES - PARKS & REC			47.95
128614	SUPPLIES				347 29-Mar-2019	29-Mar-2019	
10-5-7017000-0322				GENERAL SUPPLIES - PARKS & REC			88.12
128623	CLEANING SUPPLIES				347 29-Mar-2019	29-Mar-2019	
10-5-7017000-0322				GENERAL SUPPLIES - PARKS & REC			26.51
128726	SUPPLIES				389 02-Apr-2019	02-Apr-2019	
10-5-7017000-0322				GENERAL SUPPLIES - PARKS & REC			37.88



Vendor : CAT038 To ZUL180

Batch : All

Department : All

Cheque Print Date : 01-Jan-2019 To 31-May-2019

Bank : 1 To 99

Class : All

Vendor Invoice	Vendor Name Description				Batch Invc Date	Invc Due Date	Amount
G.L. Account	CC1	CC2	CC3	GL Account Name			
<b>DEPARTMENT 7017000 PARKS MAINTENANCE</b>							
128774	SUPPLIES				389 03-Apr-2019	03-Apr-2019	
10-5-7017000-0322				GENERAL SUPPLIES - PARKS & REC			4.73
128783	SUPPLIES				389 03-Apr-2019	03-Apr-2019	
10-5-7017000-0322				GENERAL SUPPLIES - PARKS & REC			30.50
128855	SUPPLIES				389 05-Apr-2019	05-Apr-2019	
10-5-7017000-0322				GENERAL SUPPLIES - PARKS & REC			95.88
128858	SUPPLIES				389 05-Apr-2019	05-Apr-2019	
10-5-7017000-0322				GENERAL SUPPLIES - PARKS & REC			24.02
129269	SUPPLIES				511 16-Apr-2019	16-Apr-2019	
10-5-7017000-0322				GENERAL SUPPLIES - PARKS & REC			10.88
129350	SUPPLIES				511 18-Apr-2019	18-Apr-2019	
10-5-7017000-0322				GENERAL SUPPLIES - PARKS & REC			8.46
129778	SUPPLIES				511 02-May-2019	02-May-2019	
10-5-7017000-0322				GENERAL SUPPLIES - PARKS & REC			147.98
129843	SUPPLIES				511 03-May-2019	03-May-2019	
10-5-7017000-0322				GENERAL SUPPLIES - PARKS & REC			36.77
130099	SUPPLIES				511 10-May-2019	10-May-2019	
10-5-7017000-0322				GENERAL SUPPLIES - PARKS & REC			54.23
130187	SUPPLIES				525 13-May-2019	13-May-2019	
10-5-7017000-0322				GENERAL SUPPLIES - PARKS & REC			16.23
130281	SUPPLIES				525 15-May-2019	15-May-2019	
10-5-7017000-0420				PARKS MAINTENANCE EQUIPMENT			27.65
130309	SUPPLIES				525 16-May-2019	16-May-2019	
10-5-7017000-0322				GENERAL SUPPLIES - PARKS & REC			15.80
130536	MAINTENANCE SUPPLIES				525 22-May-2019	22-May-2019	
10-5-7017000-0322				GENERAL SUPPLIES - PARKS & REC			16.94
<b>WIN380 WINDSOR TIRE INC.</b>							
W084236	REPAIR TO 30 GENIE BOOM				345 22-Mar-2019	22-Mar-2019	
10-5-7017000-0402				VEHICLE & EQUIPMENT MAINTENANCE PARKS			711.08
<b>WOL533 WOLSELEY CANADA INC</b>							
7928342	WATER SET UP AT 90 THOMAS RD				436 19-Apr-2019	19-Apr-2019	
10-5-7017000-0322				GENERAL SUPPLIES - PARKS & REC			159.17
<b>WOR055 WORK EQUIPMENT LTD.</b>							
046885	MAINTENANCE ON TRACKLESS UNIT				525 24-Apr-2019	24-Apr-2019	
10-5-7017000-0402				VEHICLE & EQUIPMENT MAINTENANCE PARKS			785.95
046894	MOWER ATTACHMENT FOR TRACKLESS UNIT				511 25-Apr-2019	25-Apr-2019	
10-5-7017000-0402				VEHICLE & EQUIPMENT MAINTENANCE PARKS			376.45
<b>WOR415 WORK AUTHORITY</b>							
511357	CLOTHING				250 10-Feb-2019	10-Feb-2019	
10-5-7017000-0161				PARKS - CLOTHING			203.39
<b>Department Totals :</b>							<b>70,906.25</b>

<b>DEPARTMENT 7017002 FACILITIES</b>							
<b>ACC134 ACCESS DOORS N MORE</b>							
39496	SERVICE GARAGE DOOR (DEC 10,2018)				175 31-Jan-2019	31-Jan-2019	
10-5-7017002-0317	FIRE			FACILITIES - BUILDING MAINTENANCE			216.96
39831	SERVICE OVERHEAD DOOR				204 19-Feb-2019	19-Feb-2019	
10-5-7017002-0317	PWD			FACILITIES - BUILDING MAINTENANCE			394.37
39832	PARKS BUILDINGS				204 20-Feb-2019	20-Feb-2019	
10-5-7017002-0317	PARKBL			FACILITIES - BUILDING MAINTENANCE			344.65
39833	SERVICE GARAGE DOOR OPENER				204 20-Feb-2019	20-Feb-2019	
10-5-7017002-0317	99THOM			FACILITIES - BUILDING MAINTENANCE			90.40



Vendor : CAT038 To ZUL180

Batch : All

Department : All

Cheque Print Date : 01-Jan-2019 To 31-May-2019

Bank : 1 To 99

Class : All

Vendor Invoice	Vendor Name Description	Batch	Inv Date	Inv Due Date	Amount
G.L. Account	CC1 CC2 CC3 GL Account Name				
<b>DEPARTMENT 7017002 FACILITIES</b>					
39965	SERVICE	319	20-Mar-2019	20-Mar-2019	
10-5-7017002-0317	TOWN FACILITIES - BUILDING MAINTENANCE				762.75
40167	SERVICE MAIN YARD, NORTH SIDE GARAGE DOOR	511	13-May-2019	13-May-2019	
10-5-7017002-0317	PWD FACILITIES - BUILDING MAINTENANCE				246.34
<b>BET358 BETTER LOCKSMITHS INC</b>					
23903A	SECURITY CODES CHANGES	525	24-Apr-2019	24-Apr-2019	
10-5-7017002-0317	FIRE FACILITIES - BUILDING MAINTENANCE				152.55
<b>CAN380 CANADIAN TIRE STORE #281</b>					
DECEMBER 2018	DECEMBER 2018 PURCHASES	104	31-Jan-2019	31-Jan-2019	
10-5-7017002-0317	GORDOI FACILITIES - BUILDING MAINTENANCE				144.62
10-5-7017002-0317	99THOM FACILITIES - BUILDING MAINTENANCE				5.98
FEBRUARY 2019	FEBRUARY 2019 PURCHASES	280	28-Feb-2019	28-Feb-2019	
10-5-7017002-0318	JANITORIAL - GLOBAL				71.80
10-5-7017002-0317	PWD FACILITIES - BUILDING MAINTENANCE				4.51
10-5-7017002-0317	PWD FACILITIES - BUILDING MAINTENANCE				5.27
10-5-7017002-0317	GORDOI FACILITIES - BUILDING MAINTENANCE				10.16
10-5-7017002-0318	JANITORIAL - GLOBAL				58.77
JANUARY 2019	JANUARY 2019 PURCHASES	389	31-Jan-2019	31-Jan-2019	
10-5-7017002-0317	32ORIC FACILITIES - BUILDING MAINTENANCE				40.59
10-5-7017002-0318	JANITORIAL - GLOBAL				22.58
10-5-7017002-0318	JANITORIAL - GLOBAL				57.62
10-5-7017002-0318	JANITORIAL - GLOBAL				38.94
MARCH 2019	MARCH 2019 PURCHASES	345	31-Mar-2019	31-Mar-2019	
10-5-7017002-0318	JANITORIAL - GLOBAL				12.41
10-5-7017002-0318	JANITORIAL - GLOBAL				22.74
10-5-7017002-0317	TOWN FACILITIES - BUILDING MAINTENANCE				74.52
10-5-7017002-0317	PARKBL FACILITIES - BUILDING MAINTENANCE				9.58
NOVEMBER 2018	NOVEMBER 2018 PURCHASES	133	31-Jan-2019	31-Jan-2019	
10-5-7017002-0317	GORDOI FACILITIES - BUILDING MAINTENANCE				79.09
10-5-7017002-0317	TOWN FACILITIES - BUILDING MAINTENANCE				38.33
10-5-7017002-0318	JANITORIAL - GLOBAL				33.89
OCTOBER 2018	OCTOBER 2018 INVOICES	1554	31-Oct-2018	31-Oct-2018	
10-5-7017002-0318	JANITORIAL - GLOBAL				54.18
10-5-7017002-0318	JANITORIAL - GLOBAL				74.52
10-5-7017002-0318	JANITORIAL - GLOBAL				15.00
10-5-7017002-0318	JANITORIAL - GLOBAL				137.60
<b>CEN859 CENTENNIAL LOCK &amp; SAFE LIMITED</b>					
25444	MAINTENANCE	1606	31-Aug-2018	31-Aug-2018	
10-5-7017002-0317	TOWN FACILITIES - BUILDING MAINTENANCE				2,106.01
25496	CUT KEYS	1523	03-Dec-2018	03-Dec-2018	
10-5-7017002-0317	TOWN FACILITIES - BUILDING MAINTENANCE				229.39
25583	SUPPLIES	250	21-Feb-2019	21-Feb-2019	
10-5-7017002-0317	TOWN FACILITIES - BUILDING MAINTENANCE				120.00
10-5-7017002-0317	PARKBL FACILITIES - BUILDING MAINTENANCE				138.00
25626	MAINTENANCE	481	02-May-2019	02-May-2019	
10-5-7017002-0317	PARKBL FACILITIES - BUILDING MAINTENANCE				562.51
<b>COX01 COXON'S TOWING SERVICE (2000) LTD</b>					
72356	PWD TRAILER RENTAL	204	01-Jan-2019	01-Jan-2019	
10-5-7017002-0317	PWD FACILITIES - BUILDING MAINTENANCE				1,440.75
72357	PWD TRAILER RENTAL	204	24-Jan-2019	24-Jan-2019	
10-5-7017002-0317	PWD FACILITIES - BUILDING MAINTENANCE				480.25
<b>COX03 COXON'S SALES &amp; RENTALS LTD.</b>					
72941	PUBLIC WORKS OFFICE TRAILER	280	26-Feb-2019	26-Feb-2019	
10-5-7017002-0317	PWD FACILITIES - BUILDING MAINTENANCE				960.50
73559	PW OFFICER TRAILER	347	27-Mar-2019	27-Mar-2019	



Vendor : CAT038 To ZUL180

Batch : All

Department : All

Cheque Print Date : 01-Jan-2019 To 31-May-2019

Bank : 1 To 99

Class : All

Vendor Invoice	Vendor Name Description	Batch	Inv Date	Inv Due Date	Amount
G.L. Account	CC1 CC2 CC3 GL Account Name				
<b>DEPARTMENT 7017002 FACILITIES</b>					
10-5-7017002-0317	PWD FACILITIES - BUILDING MAINTENANCE				480.25
74098	OFFICE TRAILER RENTAL	481	24-Apr-2019	24-Apr-2019	
10-5-7017002-0317	PWD FACILITIES - BUILDING MAINTENANCE				480.25
<b>ELE290 ELECTROZAD SUPPLY CO LTD</b>					
S3405751.001	MAINTENANCE MATERIAL	280	28-Feb-2019	28-Feb-2019	
10-5-7017002-0317	PARKBL FACILITIES - BUILDING MAINTENANCE				432.26
S3405753.001	MAINTENANCE MATERIAL	280	28-Feb-2019	28-Feb-2019	
10-5-7017002-0317	FIRE FACILITIES - BUILDING MAINTENANCE				317.20
<b>ELE400 ELECTRICAL SAFETY AUTHORITY</b>					
97571916	MAINTENANCE (NOV 5, 2018)	133	31-Jan-2019	31-Jan-2019	
10-5-7017002-0317	PWD FACILITIES - BUILDING MAINTENANCE				178.54
<b>EMC530 EMCO CORPORATION</b>					
37574751-00	SUPPLIES TO REPAIR WATER TAP - AUGUST 30, 2018	133	31-Jan-2019	31-Jan-2019	
10-5-7017002-0317	PWD FACILITIES - BUILDING MAINTENANCE				11.50
37579211-00	TEST EQUIPMENT BACKFLOW	1607	23-Oct-2018	23-Oct-2018	
10-5-7017002-0317	PWD FACILITIES - BUILDING MAINTENANCE				208.41
37583355-00	MAINTENANCE	1606	11-Dec-2018	11-Dec-2018	
10-5-7017002-0317	TOWN FACILITIES - BUILDING MAINTENANCE				154.66
37583747-00	MAINTENANCE	1606	17-Dec-2018	17-Dec-2018	
10-5-7017002-0318	JANITORIAL - GLOBAL				101.70
37585384-00	PARKS BUILDINGS	62	10-Jan-2019	10-Jan-2019	
10-5-7017002-0317	PARKBL FACILITIES - BUILDING MAINTENANCE				99.36
37586964-00	HEALTH & SAFETY ITEM	135	06-Feb-2019	06-Feb-2019	
10-5-7017002-0317	PWD FACILITIES - BUILDING MAINTENANCE				791.00
37587872-00	PLUMBING REPAIRS TOWN HALL	204	06-Feb-2019	06-Feb-2019	
10-5-7017002-0317	TOWN FACILITIES - BUILDING MAINTENANCE				158.11
37588088-00	PLUMBING REPAIRS FIRE HALL	204	13-Feb-2019	13-Feb-2019	
10-5-7017002-0317	FIRE FACILITIES - BUILDING MAINTENANCE				308.76
37588889-00	PLUMBING REPAIRS	204	19-Feb-2019	19-Feb-2019	
10-5-7017002-0317	PARKBL FACILITIES - BUILDING MAINTENANCE				63.02
37589144-00	PLUMBING REPAIRS	204	22-Feb-2019	22-Feb-2019	
10-5-7017002-0317	PARKBL FACILITIES - BUILDING MAINTENANCE				117.47
37589151-00	PLUMBING REPAIRS	204	22-Feb-2019	22-Feb-2019	
10-5-7017002-0317	PARKBL FACILITIES - BUILDING MAINTENANCE				62.36
37589185-00	PLUMBING REPAIRS	204	22-Feb-2019	22-Feb-2019	
10-5-7017002-0317	PARKBL FACILITIES - BUILDING MAINTENANCE				38.11
37590285-00	MAINTENANCE MATERIAL	280	06-Mar-2019	06-Mar-2019	
10-5-7017002-0317	99THOM FACILITIES - BUILDING MAINTENANCE				90.08
37590380-00	MAINTENANCE MATERIALS	296	07-Mar-2019	07-Mar-2019	
10-5-7017002-0317	FIRE FACILITIES - BUILDING MAINTENANCE				50.99
37591301-00	MAINTENANCE	389	19-Mar-2019	19-Mar-2019	
10-5-7017002-0316	PARKBL FACILITIES - UTILITIES				29.71
37592045-00	PLUMBING MATERIALS	347	02-Apr-2019	02-Apr-2019	
10-5-7017002-0317	FIRE FACILITIES - BUILDING MAINTENANCE				406.74
37592280-00	MAINTENANCE	389	28-Mar-2019	28-Mar-2019	
10-5-7017002-0317	TOWN FACILITIES - BUILDING MAINTENANCE				370.08
37592561-00	MAINTENANCE	347	02-Apr-2019	02-Apr-2019	
10-5-7017002-0317	FIRE FACILITIES - BUILDING MAINTENANCE				1,437.70
37592595-00	MAINTENANCE	347	02-Apr-2019	02-Apr-2019	
10-5-7017002-0317	FIRE FACILITIES - BUILDING MAINTENANCE				496.67
37592598-00	MAINTENANCE	347	02-Apr-2019	02-Apr-2019	
10-5-7017002-0317	FIRE FACILITIES - BUILDING MAINTENANCE				33.04
37592608-00	MAINTENANCE	347	02-Apr-2019	02-Apr-2019	



Vendor : CAT038 To ZUL180

Batch : All

Department : All

Cheque Print Date : 01-Jan-2019 To 31-May-2019

Bank : 1 To 99

Class : All

Vendor Invoice	Vendor Name Description	Batch	Inv Date	Inv Due Date	Amount
G.L. Account	CC1 CC2 CC3 GL Account Name				
<b>DEPARTMENT 7017002 FACILITIES</b>					
10-5-7017002-0317	FIRE FACILITIES - BUILDING MAINTENANCE				53.45
37592610-00	MAINTENANCE	347	02-Apr-2019	02-Apr-2019	
10-5-7017002-0317	FIRE FACILITIES - BUILDING MAINTENANCE				82.87
37592643-00	MAINTENANCE	347	02-Apr-2019	02-Apr-2019	
10-5-7017002-0317	FIRE FACILITIES - BUILDING MAINTENANCE				71.12
37593103-00	MAINTENANCE	347	08-Apr-2019	08-Apr-2019	
10-5-7017002-0317	PARKBL FACILITIES - BUILDING MAINTENANCE				44.23
37593193-00	PLUMBING REPAIRS	436	08-Apr-2019	08-Apr-2019	
10-5-7017002-0317	FIRE FACILITIES - BUILDING MAINTENANCE				60.44
37596186-00	WATER FILL STATION PUBLIC WORKS	525	09-May-2019	09-May-2019	
10-5-7017002-0317	PWD FACILITIES - BUILDING MAINTENANCE				120.89
<b>EMP481 EMPIRE ROOFING CORPORATION</b>					
S19-019		62	15-Jan-2019	15-Jan-2019	
10-5-7017002-0317	FIRE FACILITIES - BUILDING MAINTENANCE				620.37
S19-111	ROOF REPAIRS	280	28-Feb-2019	28-Feb-2019	
10-5-7017002-0317	PWD FACILITIES - BUILDING MAINTENANCE				529.97
S19-229	ROOF REPAIRS	525	30-Apr-2019	30-Apr-2019	
10-5-7017002-0317	PWD FACILITIES - BUILDING MAINTENANCE				983.95
<b>ESS360 ESSEX WINDSOR SOLID WASTE AUTH</b>					
IN000010191	FLUORESCENT LIGHT DIPOSAL	62	18-Jan-2019	18-Jan-2019	
10-5-7017002-0318	JANITORIAL - GLOBAL				266.62
IN000010238	FLOURESCENT LIGHT DISPOSAL FEE	250	28-Feb-2019	28-Feb-2019	
10-5-7017002-0317	PARKBL FACILITIES - BUILDING MAINTENANCE				77.06
<b>ESS959 ESSEX LINEN SUPPLY LTD</b>					
00293	RENTAL MATS	347	07-Mar-2019	07-Mar-2019	
10-5-7017002-0317	GORDOI FACILITIES - BUILDING MAINTENANCE				22.49
01697	MATS AND RAGS	436	21-Mar-2019	21-Mar-2019	
10-5-7017002-0317	PWD FACILITIES - BUILDING MAINTENANCE				67.47
460786	MATS & RAGS	1606	30-Nov-2018	30-Nov-2018	
10-5-7017002-0317	GORDOI FACILITIES - BUILDING MAINTENANCE				22.49
463099	MATS & RAGS	1606	20-Nov-2018	20-Nov-2018	
10-5-7017002-0317	GORDOI FACILITIES - BUILDING MAINTENANCE				22.49
464764	RAGS & MATS	250	10-Jan-2019	10-Jan-2019	
10-5-7017002-0317	GORDOI FACILITIES - BUILDING MAINTENANCE				22.49
467399	MATS AND RAGS	296	07-Feb-2019	07-Feb-2019	
10-5-7017002-0317	GORDOI FACILITIES - BUILDING MAINTENANCE				22.49
<b>FOR160 FOREST CITY FIRE PROTECTION &amp; SECURITY</b>					
125276	SPRINKLER MAINT. 99 THOMAS ROAD	204	19-Feb-2019	19-Feb-2019	
10-5-7017002-0317	99THOM FACILITIES - BUILDING MAINTENANCE				2,440.80
125575	FIRE SPPRESSION INSPECTIONS	204	22-Feb-2019	22-Feb-2019	
10-5-7017002-0317	99THOM FACILITIES - BUILDING MAINTENANCE				743.54
<b>GUA929 GUARDIAN FIRE PROTECTION</b>					
767	ANNUAL INSPECTIONS OF VARIOUS DEPARTMENT OCT 12, 2018	104	31-Jan-2019	31-Jan-2019	
10-5-7017002-0317	PWD FACILITIES - BUILDING MAINTENANCE				1,107.97
10-5-7017002-0317	FIRE FACILITIES - BUILDING MAINTENANCE				39.55
10-5-7017002-0317	TOWN FACILITIES - BUILDING MAINTENANCE				23.73
10-5-7017002-0317	PARKBL FACILITIES - BUILDING MAINTENANCE				70.06
811	MAINTENANCE OF FIRE EXTINGUISHERS	105	22-Jan-2019	22-Jan-2019	
10-5-7017002-0317	TOWN FACILITIES - BUILDING MAINTENANCE				274.76
883	FIRE SUPPRESSION SERVICES FIRE HALL	319	11-Mar-2019	11-Mar-2019	
10-5-7017002-0317	FIRE FACILITIES - BUILDING MAINTENANCE				346.35
<b>HEA693 HEATON SANITATION</b>					
333342	PUBLIC WORKS - OIL INTERCEPTOR SHOP	347	25-Mar-2019	25-Mar-2019	





Vendor : CAT038 To ZUL180

Batch : All

Department : All

Cheque Print Date : 01-Jan-2019 To 31-May-2019

Bank : 1 To 99

Class : All

Vendor Invoice	Vendor Name Description	Batch	Inv Date	Inv Due Date	Amount
G.L. Account	CC1 CC2 CC3 GL Account Name				
<b>DEPARTMENT 7017002 FACILITIES</b>					
10-5-7017002-0317	PWD FACILITIES - BUILDING MAINTENANCE				678.00
<b>HOL459 HOLLAND CLEANING SOLUTIONS LTD</b>					
467848	JANITORIAL	1607	12-Dec-2018	12-Dec-2018	
10-5-7017002-0318	JANITORIAL - GLOBAL				841.90
468518	MATERIALS JANITORIAL	1607	19-Dec-2018	19-Dec-2018	
10-5-7017002-0318	JANITORIAL - GLOBAL				250.75
469631	JANITORIAL	62	08-Jan-2019	08-Jan-2019	
10-5-7017002-0318	JANITORIAL - GLOBAL				676.67
470287	JANITORIAL	62	15-Jan-2019	15-Jan-2019	
10-5-7017002-0318	JANITORIAL - GLOBAL				565.00
470288	JANITORIAL	62	15-Jan-2019	15-Jan-2019	
10-5-7017002-0318	JANITORIAL - GLOBAL				246.43
470987	JANITORIAL SUPPLIES	105	22-Jan-2019	22-Jan-2019	
10-5-7017002-0318	JANITORIAL - GLOBAL				734.32
471025	JANITORIAL MAINTENANCE	105	22-Jan-2019	22-Jan-2019	
10-5-7017002-0318	JANITORIAL - GLOBAL				547.26
471026	JANITORIAL MACHINE MAINTENANCE	62	22-Jan-2019	22-Jan-2019	
10-5-7017002-0318	JANITORIAL - GLOBAL				3,929.87
471084	JANITORIAL SUPPLIES	105	23-Jan-2019	23-Jan-2019	
10-5-7017002-0318	JANITORIAL - GLOBAL				548.20
471810	JANITORIAL EQUIPMENT REPAIRS	134	30-Jan-2019	30-Jan-2019	
10-5-7017002-0318	JANITORIAL - GLOBAL				417.38
473189	JANITORIAL SUPPLIES	204	13-Feb-2019	13-Feb-2019	
10-5-7017002-0318	JANITORIAL - GLOBAL				242.70
474883	MAINTENANCE MATERIAL - JANITORIAL	296	04-Mar-2019	04-Mar-2019	
10-5-7017002-0318	JANITORIAL - GLOBAL				5,480.50
475025	JANITORIAL SUPPLIES	319	05-Mar-2019	05-Mar-2019	
10-5-7017002-0318	JANITORIAL - GLOBAL				945.63
475317	JANITORIAL MATERIALS	296	07-Mar-2019	07-Mar-2019	
10-5-7017002-0318	JANITORIAL - GLOBAL				23.23
475628	DISINFECTATION FIFTH INCIDENT	296	12-Mar-2019	12-Mar-2019	
10-5-7017002-0318	JANITORIAL - GLOBAL				108.48
477691	JANITORIAL SUPPLIES	389	03-Apr-2019	03-Apr-2019	
10-5-7017002-0318	JANITORIAL - GLOBAL				720.97
479402	JANITORIAL SUPPLIES	436	23-Apr-2019	23-Apr-2019	
10-5-7017002-0318	JANITORIAL - GLOBAL				621.50
<b>IND181 INDOOR ENVIRONMENTAL SPECIALIST</b>					
C3469	MOULD INSPECTION, AIR SAMPLING, COURIER	1523	17-Dec-2018	17-Dec-2018	
10-5-7017002-0317	TOWN FACILITIES - BUILDING MAINTENANCE				1,351.76
<b>JAN268 JANI SAFE INC.</b>					
187480	JANITORIAL	1607	14-Dec-2018	14-Dec-2018	
10-5-7017002-0318	JANITORIAL - GLOBAL				1,067.73
187950	JANITORIAL	62	09-Jan-2019	09-Jan-2019	
10-5-7017002-0318	JANITORIAL - GLOBAL				1,169.30
188123	JANITORIAL SUPPLIES	105	25-Jan-2019	25-Jan-2019	
10-5-7017002-0318	JANITORIAL - GLOBAL				328.90
188283	JANITORIAL SUPPLIES	105	25-Jan-2019	25-Jan-2019	
10-5-7017002-0318	JANITORIAL - GLOBAL				123.71
188356	JANITORIAL SUPPLIES	105	25-Jan-2019	25-Jan-2019	
10-5-7017002-0318	JANITORIAL - GLOBAL				826.72
188834	JANITORIAL SUPPLIES	204	14-Feb-2019	14-Feb-2019	
10-5-7017002-0318	JANITORIAL - GLOBAL				1,626.73
188834-1	JANITORIAL SUPPLIES	296	07-Mar-2019	07-Mar-2019	



Vendor : CAT038 To ZUL180

Batch : All

Department : All

Cheque Print Date : 01-Jan-2019 To 31-May-2019

Bank : 1 To 99

Class : All

Vendor Invoice	Vendor Name Description	Batch	Inv Date	Inv Due Date	Amount
G.L. Account	CC1 CC2 CC3 GL Account Name				
<b>DEPARTMENT 7017002 FACILITIES</b>					
10-5-7017002-0318	JANITORIAL - GLOBAL				99.32
189283	JANITORIAL SUPPLIES	296	07-Mar-2019	07-Mar-2019	
10-5-7017002-0318	JANITORIAL - GLOBAL				1,952.21
189995	JANITORIAL SUPPLIES	389	04-Apr-2019	04-Apr-2019	
10-5-7017002-0318	JANITORIAL - GLOBAL				2,191.57
190097	MAINTENANCE MATERIAL	347	15-Apr-2019	15-Apr-2019	
10-5-7017002-0317	TOWN FACILITIES - BUILDING MAINTENANCE				53.72
190437	JANITORIAL SUPPLIES	436	26-Apr-2019	26-Apr-2019	
10-5-7017002-0318	JANITORIAL - GLOBAL				1,616.66
190437-1	JANITORIAL SUPPLIES	525	16-May-2019	16-May-2019	
10-5-7017002-0318	JANITORIAL - GLOBAL				263.46
190955	JANITORIAL SUPPLIES	525	16-May-2019	16-May-2019	
10-5-7017002-0318	JANITORIAL - GLOBAL				1,793.03
<b>LOB898 LOBLAW'S INC</b>					
2018 RECEIPT PURCHASES MADE IN 2018					
10-5-7017002-0318	JANITORIAL - GLOBAL	175	31-Jan-2019	31-Jan-2019	25.98
10-5-7017002-0318	JANITORIAL - GLOBAL				11.64
10-5-7017002-0318	JANITORIAL - GLOBAL				24.39
10-5-7017002-0318	JANITORIAL - GLOBAL				38.23
10-5-7017002-0318	JANITORIAL - GLOBAL				34.88
<b>MET052 METRO KING PEST CONTROL INC.</b>					
2145 MONTHLY SERVICE AT VARIOUS LOCATIONS					
10-5-7017002-0317	TOWN FACILITIES - BUILDING MAINTENANCE	1606	30-Nov-2018	30-Nov-2018	39.55
10-5-7017002-0317	PWD FACILITIES - BUILDING MAINTENANCE				39.55
10-5-7017002-0317	GORDOI FACILITIES - BUILDING MAINTENANCE				28.25
10-5-7017002-0317	ACS FACILITIES - BUILDING MAINTENANCE				33.90
10-5-7017002-0317	FIRE FACILITIES - BUILDING MAINTENANCE				33.90
10-5-7017002-0317	FIRE FACILITIES - BUILDING MAINTENANCE				28.25
10-5-7017002-0317	PARKBL FACILITIES - BUILDING MAINTENANCE				28.25
10-5-7017002-0317	PWD FACILITIES - BUILDING MAINTENANCE				28.25
10-5-7017002-0317	PWD FACILITIES - BUILDING MAINTENANCE				28.25
10-5-7017002-0317	MALCOM FACILITIES - BUILDING MAINTENANCE				33.90
10-5-7017002-0317	FIRE FACILITIES - BUILDING MAINTENANCE				28.25
2146 MONTHLY SERVICE AT VARIOUS LOCATIONS					
10-5-7017002-0317	PWD FACILITIES - BUILDING MAINTENANCE	1606	31-Dec-2018	31-Dec-2018	28.25
10-5-7017002-0317	PWD FACILITIES - BUILDING MAINTENANCE				28.25
10-5-7017002-0317	MALCOM FACILITIES - BUILDING MAINTENANCE				33.90
10-5-7017002-0317	FIRE FACILITIES - BUILDING MAINTENANCE				28.25
10-5-7017002-0317	PWD FACILITIES - BUILDING MAINTENANCE				39.55
10-5-7017002-0317	GORDOI FACILITIES - BUILDING MAINTENANCE				28.25
10-5-7017002-0317	FIRE FACILITIES - BUILDING MAINTENANCE				33.90
10-5-7017002-0317	PARKBL FACILITIES - BUILDING MAINTENANCE				28.25
2147 MONTHLY SERVICE AT VARIOUS LOCATIONS					
10-5-7017002-0317	TOWN FACILITIES - BUILDING MAINTENANCE	345	28-Feb-2019	28-Feb-2019	39.55
10-5-7017002-0317	PWD FACILITIES - BUILDING MAINTENANCE				39.55
10-5-7017002-0317	GORDOI FACILITIES - BUILDING MAINTENANCE				28.25
10-5-7017002-0317	ACS FACILITIES - BUILDING MAINTENANCE				33.90
10-5-7017002-0317	99THOM FACILITIES - BUILDING MAINTENANCE				28.25
10-5-7017002-0317	FIRE FACILITIES - BUILDING MAINTENANCE				33.90
10-5-7017002-0317	FIRE FACILITIES - BUILDING MAINTENANCE				28.25
10-5-7017002-0317	PARKBL FACILITIES - BUILDING MAINTENANCE				28.25
10-5-7017002-0317	PWD FACILITIES - BUILDING MAINTENANCE				28.25
10-5-7017002-0317	PWD FACILITIES - BUILDING MAINTENANCE				28.25
10-5-7017002-0317	MALCOM FACILITIES - BUILDING MAINTENANCE				33.90
10-5-7017002-0317	FIRE FACILITIES - BUILDING MAINTENANCE				28.25
2148 MONTHLY SERVICE AT VARIOUS LOCATIONS					
10-5-7017002-0317	TOWN FACILITIES - BUILDING MAINTENANCE	345	31-Mar-2019	31-Mar-2019	39.55





Vendor : CAT038 To ZUL180  
 Batch : All  
 Department : All

Cheque Print Date : 01-Jan-2019 To 31-May-2019  
 Bank : 1 To 99  
 Class : All

Vendor Invoice	Vendor Name Description				Batch Invc Date	Invc Due Date	Amount
G.L. Account	CC1	CC2	CC3	GL Account Name			
<b>DEPARTMENT 7017002 FACILITIES</b>							
10-5-7017002-0317	PWD			FACILITIES - BUILDING MAINTENANCE			39.55
10-5-7017002-0317	GORDOI			FACILITIES - BUILDING MAINTENANCE			28.25
10-5-7017002-0317	ACS			FACILITIES - BUILDING MAINTENANCE			33.90
10-5-7017002-0317	99THOM			FACILITIES - BUILDING MAINTENANCE			28.25
10-5-7017002-0317	FIRE			FACILITIES - BUILDING MAINTENANCE			33.90
10-5-7017002-0317	FIRE			FACILITIES - BUILDING MAINTENANCE			28.25
10-5-7017002-0317	PARKBL			FACILITIES - BUILDING MAINTENANCE			28.25
10-5-7017002-0317	PWD			FACILITIES - BUILDING MAINTENANCE			28.25
10-5-7017002-0317	PWD			FACILITIES - BUILDING MAINTENANCE			28.25
10-5-7017002-0317	MALCOM			FACILITIES - BUILDING MAINTENANCE			33.90
10-5-7017002-0317	FIRE			FACILITIES - BUILDING MAINTENANCE			28.25
<b>MIK315 MIKE'S COMPUTER SHOP</b>							
WIN-259119	NETWORK EQUIPMENT & PRINTER				250 10-Feb-2019	10-Feb-2019	
10-5-7017002-0317	PARKBL			FACILITIES - BUILDING MAINTENANCE			384.13
<b>MIN25 MINISTER OF FINANCE PAYMENT PROCESSING CENTRE</b>							
114127	MAINTENANCE				62 11-Jan-2019	11-Jan-2019	
10-5-7017002-0317	PARKBL			FACILITIES - BUILDING MAINTENANCE			339.29
<b>MON183 MONARCH OFFICE SUPPLY LTD</b>							
133006	JANUARY 2018 PURCHASES				176 30-Jan-2019	30-Jan-2019	
10-5-7017002-0317	PWD			FACILITIES - BUILDING MAINTENANCE			334.21
<b>NAN329 NANTAIS ATHLETIC INC (LIBRO)</b>							
522	CLOTHING				345 29-Mar-2019	29-Mar-2019	
10-5-7017002-0161				UNIFORMS			1,075.64
537	UNIFORMS				481 31-Mar-2019	31-Mar-2019	
10-5-7017002-0161				UNIFORMS			1,598.21
<b>PAR004 PARENT DELAYNEY</b>							
MAY 10, 2019	REFUND FOR CANCELLATION OF GAZEBO @ KNYP AUG 17, 2019				481 10-May-2019	10-May-2019	
10-4-7017002-1305				FACILITIES RENTALS			86.09
<b>PAR372 PARRLINE ELECTRICAL WHOLESALE</b>							
78020	ELECTRICAL SUPPLIES (14-SET-2018)				175 31-Jan-2019	31-Jan-2019	
10-5-7017002-0317	PARKBL			FACILITIES - BUILDING MAINTENANCE			11.68
78624	ELECTRICAL SUPPLIES (25-OCT-2018)				175 31-Jan-2019	31-Jan-2019	
10-5-7017002-0317	PARKBL			FACILITIES - BUILDING MAINTENANCE			88.19
78625	ELECTRICAL SUUPLIES (25-OCT-2018)				175 31-Jan-2019	31-Jan-2019	
10-5-7017002-0317	PARKBL			FACILITIES - BUILDING MAINTENANCE			249.82
79318	ELECTRICAL SUPPLIES				1606 12-Nov-2018	12-Nov-2018	
10-5-7017002-0317	PARKBL			FACILITIES - BUILDING MAINTENANCE			697.01
79572	ELECTRICAL SUPPLIES				1523 10-Dec-2018	10-Dec-2018	
10-5-7017002-0317	PWD			FACILITIES - BUILDING MAINTENANCE			1,093.95
79739	ELECTRICAL MAINTENANCE				1523 12-Dec-2018	12-Dec-2018	
10-5-7017002-0317	FIRE			FACILITIES - BUILDING MAINTENANCE			195.04
79829	ELECTRICAL SUPPLIES				62 04-Jan-2019	04-Jan-2019	
10-5-7017002-0317	PARKBL			FACILITIES - BUILDING MAINTENANCE			341.34
79830	ELECTRICAL SUPPLIES				62 04-Jan-2019	04-Jan-2019	
10-5-7017002-0317	FIRE			FACILITIES - BUILDING MAINTENANCE			582.74
80009	ELECTRICAL SUPPLIES				62 08-Jan-2019	08-Jan-2019	
10-5-7017002-0317	PWD			FACILITIES - BUILDING MAINTENANCE			558.03
80146	ELECTRICAL MAINTENANCE				134 14-Jan-2019	14-Jan-2019	
10-5-7017002-0317	PARKBL			FACILITIES - BUILDING MAINTENANCE			98.38
80147	ELECTRICAL SUPPLIES				134 14-Jan-2019	14-Jan-2019	
10-5-7017002-0317	FIRE			FACILITIES - BUILDING MAINTENANCE			77.69
80478	ELECTRICAL SUPPLIES				177 04-Feb-2019	04-Feb-2019	
10-5-7017002-0317	FIRE			FACILITIES - BUILDING MAINTENANCE			66.09
80499	ELECTRICAL SUPPLIES				177 05-Feb-2019	05-Feb-2019	



Vendor : CAT038 To ZUL180

Batch : All

Department : All

Cheque Print Date : 01-Jan-2019 To 31-May-2019

Bank : 1 To 99

Class : All

Vendor Invoice	Vendor Name Description	Batch	Inv Date	Inv Due Date	Amount
G.L. Account	CC1 CC2 CC3 GL Account Name				
<b>DEPARTMENT 7017002 FACILITIES</b>					
10-5-7017002-0317	FIRE FACILITIES - BUILDING MAINTENANCE				19.55
80506	PARKS	204	05-Feb-2019	05-Feb-2019	
10-5-7017002-0317	PARKBL FACILITIES - BUILDING MAINTENANCE				219.33
80574	FIRE HALL	204	12-Feb-2019	12-Feb-2019	
10-5-7017002-0317	FIRE FACILITIES - BUILDING MAINTENANCE				66.53
80700	PARKS	204	14-Feb-2019	14-Feb-2019	
10-5-7017002-0317	PARKBL FACILITIES - BUILDING MAINTENANCE				223.88
81203	ELECTRICAL SUPPLIES	296	07-Mar-2019	07-Mar-2019	
10-5-7017002-0317	PARKBL FACILITIES - BUILDING MAINTENANCE				127.66
81346	ELECTRICAL SUPPLIES	347	26-Mar-2019	26-Mar-2019	
10-5-7017002-0317	PARKBL FACILITIES - BUILDING MAINTENANCE				159.88
81464	ELECTRICAL SUPPLIES	347	22-Mar-2019	22-Mar-2019	
10-5-7017002-0317	PARKBL FACILITIES - BUILDING MAINTENANCE				457.09
81932	ELECTRICAL SUPPLIES	481	11-Apr-2019	11-Apr-2019	
10-5-7017002-0317	TOWN FACILITIES - BUILDING MAINTENANCE				304.76
81947	ELECTRICAL SUPPLIES	481	12-Apr-2019	12-Apr-2019	
10-5-7017002-0317	PARKBL FACILITIES - BUILDING MAINTENANCE				16.51
81970	ELECTRICAL SUPPLIES	481	16-Apr-2019	16-Apr-2019	
10-5-7017002-0317	TOWN FACILITIES - BUILDING MAINTENANCE				102.08
81971	ELECTRICAL SUPPLIES	481	16-Apr-2019	16-Apr-2019	
10-5-7017002-0317	FIRE FACILITIES - BUILDING MAINTENANCE				37.26
82039	ELECTRICAL SUPPLIES	481	29-Apr-2019	29-Apr-2019	
10-5-7017002-0317	GORDOI FACILITIES - BUILDING MAINTENANCE				144.87
<b>PRA389 PRACTICA LTD</b>					
39962	MAINTENANCE	99	17-Jan-2019	17-Jan-2019	
10-5-7017002-0317	PARKBL FACILITIES - BUILDING MAINTENANCE				177.17
<b>RCW01 R.C. WHITE LTD.</b>					
255581	CLEAN BASEMENT OF DEBRIS	177	31-Jan-2019	31-Jan-2019	
10-5-7017002-0317	MALCOM FACILITIES - BUILDING MAINTENANCE				1,827.05
<b>REC09 RECEIVER GENERAL - CANADA REVENUE AGENCY TECHNOLOG</b>					
14596	MAINTENANCE	1606	21-Dec-2018	21-Dec-2018	
10-5-7017002-0317	PWD FACILITIES - BUILDING MAINTENANCE				152.55
14721	HEATING REPAIRS	250	08-Feb-2019	08-Feb-2019	
10-5-7017002-0317	PWD FACILITIES - BUILDING MAINTENANCE				853.94
14784	HVAC SERVICE	389	20-Mar-2019	20-Mar-2019	
10-5-7017002-0317	TOWN FACILITIES - BUILDING MAINTENANCE				354.15
<b>REL010 RELIGHTING</b>					
DECEMBER 17 SUPPLIES		1606	17-Dec-2018	17-Dec-2018	
10-5-7017002-0317	PWD FACILITIES - BUILDING MAINTENANCE				226.00
DECEMBER 20 SUPPLIES		1606	20-Dec-2018	20-Dec-2018	
10-5-7017002-0317	PARKBL FACILITIES - BUILDING MAINTENANCE				13.56
JANUARY 24, 2019 MAINTENANCE MATERIALS		250	24-Jan-2019	24-Jan-2019	
10-5-7017002-0317	PWD FACILITIES - BUILDING MAINTENANCE				63.28
JANUARY 7, 2019 MAINTENANCE MATERIALS		250	07-Jan-2019	07-Jan-2019	
10-5-7017002-0317	PWD FACILITIES - BUILDING MAINTENANCE				31.64
JULY 01, 2018 SUPPLIES		1606	01-Jul-2018	01-Jul-2018	
10-5-7017002-0317	PWD FACILITIES - BUILDING MAINTENANCE				28.00
<b>RIV10 RIVERSIDE GLASS</b>					
2650	SUPPLY AND INSTALL WINDOW	1523	10-Nov-2018	10-Nov-2018	
10-5-7017002-0317	PWD FACILITIES - BUILDING MAINTENANCE				3,848.78
2651	WINDOW REPLACEMENT	1523	10-Dec-2018	10-Dec-2018	
10-5-7017002-0317	PWD FACILITIES - BUILDING MAINTENANCE				3,848.78
<b>SAV085 SAVARIA SIS</b>					



Vendor : CAT038 To ZUL180

Batch : All

Department : All

Cheque Print Date : 01-Jan-2019 To 31-May-2019

Bank : 1 To 99

Class : All

Vendor Invoice	Vendor Name Description				Batch Invc Date	Invc Due Date	Amount
G.L. Account	CC1	CC2	CC3	GL Account Name			
<b>DEPARTMENT 7017002</b>				<b>FACILITIES</b>			
IN0000000402	ELEVATOR MAINTENANCE				204 28-Sep-2018	28-Sep-2018	
10-5-7017002-0317	CARNEC			FACILITIES - BUILDING MAINTENANCE			36.73
IN0000000425	ANNUAL ELEVATOR MAINTENANCE				62 08-Jan-2019	08-Jan-2019	
10-5-7017002-0317	CARNEC			FACILITIES - BUILDING MAINTENANCE			1,963.94
<b>STA444</b>	<b>STAPLES ADVANTAGE (MIS C/O T04446C)</b>						
49660479	FLOOR MATS				204 06-Feb-2019	06-Feb-2019	
10-5-7017002-0317	PWD			FACILITIES - BUILDING MAINTENANCE			666.59
<b>TAR324</b>	<b>TARGET BUILDING MATERIALS LTD</b>						
33499	MAINTENANCE MATERIAL				280 01-Mar-2019	01-Mar-2019	
10-5-7017002-0317	TOWN			FACILITIES - BUILDING MAINTENANCE			153.34
<b>TOW033</b>	<b>TOWN OF ESSEX</b>						
SALES0000000	COST SHARE MCC - DEC 2018				345 31-Mar-2019	31-Mar-2019	
10-5-7017002-0317	MCGREI			FACILITIES - BUILDING MAINTENANCE			3,371.89
<b>TYC452</b>	<b>TYCO INTEGRATED FIRE &amp; SECURITY</b>						
85344489	FIRE ALARM PANEL				319 29-Mar-2019	29-Mar-2019	
10-5-7017002-0317	TOWN			FACILITIES - BUILDING MAINTENANCE			518.17
<b>VIL417</b>	<b>VILLA CONSTRUCTION</b>						
6833	AFTER HOURS CALL OUT TO CLEAN DUMPED GARBAGE AT 7860 COUNTY ROAD 20				1595 20-Dec-2018	20-Dec-2018	
10-5-7017002-0317	MALCOM			FACILITIES - BUILDING MAINTENANCE			971.80
6905	REWORK AWNING AT LIBRARY				296 20-Feb-2019	20-Feb-2019	
10-5-7017002-0317	CARNEC			FACILITIES - BUILDING MAINTENANCE			1,565.62
<b>WIG035</b>	<b>WIGLE HOME HARDWARE BUILDING CENTRE</b>						
116008	PLUMBING REPAIRS				204 23-Feb-2019	23-Feb-2019	
10-5-7017002-0317	PARKBL			FACILITIES - BUILDING MAINTENANCE			96.73
125563	SUPPLIES				1523 11-Dec-2018	11-Dec-2018	
10-5-7017002-0317	FIRE			FACILITIES - BUILDING MAINTENANCE			22.58
126265	MAINTENANCE SUPPLIES				62 10-Jan-2019	10-Jan-2019	
10-5-7017002-0318				JANITORIAL - GLOBAL			9.03
126314	MAINTENANCE SUPPLIES				62 11-Jan-2019	11-Jan-2019	
10-5-7017002-0317	GORDOI			FACILITIES - BUILDING MAINTENANCE			8.09
126366	MAINTENANCE SUPPLIES				62 14-Jan-2019	14-Jan-2019	
10-5-7017002-0317	PWD			FACILITIES - BUILDING MAINTENANCE			11.29
126418	MAINTENANCE				62 15-Jan-2019	15-Jan-2019	
10-5-7017002-0317	GORDOI			FACILITIES - BUILDING MAINTENANCE			47.64
126644	MAINTENANCE				106 23-Jan-2019	23-Jan-2019	
10-5-7017002-0317	FIRE			FACILITIES - BUILDING MAINTENANCE			10.16
126648	MAINTENANCE SUPPLIES RETURNED				106 23-Jan-2019	23-Jan-2019	
10-5-7017002-0317	FIRE			FACILITIES - BUILDING MAINTENANCE			-10.16
126814	MAINTENANCE SUPPLIES				177 29-Jan-2019	29-Jan-2019	
10-5-7017002-0317	PARKBL			FACILITIES - BUILDING MAINTENANCE			13.15
127054	MAINTENANCE SUPPLIES				177 05-Feb-2019	05-Feb-2019	
10-5-7017002-0317	PARKBL			FACILITIES - BUILDING MAINTENANCE			97.50
127071	MAINTENANCE SUPPLIES				177 05-Feb-2019	05-Feb-2019	
10-5-7017002-0317	PARKBL			FACILITIES - BUILDING MAINTENANCE			29.36
127075	MAINTENANCE SUPPLIES				177 05-Feb-2019	05-Feb-2019	
10-5-7017002-0317	FIRE			FACILITIES - BUILDING MAINTENANCE			12.42
127133	MAINTENANCE SUPPLIES				177 07-Feb-2019	07-Feb-2019	
10-5-7017002-0317	PWD			FACILITIES - BUILDING MAINTENANCE			28.28
127134	MAINTENANCE SUPPLIES				177 07-Feb-2019	07-Feb-2019	
10-5-7017002-0317	PWD			FACILITIES - BUILDING MAINTENANCE			99.43
127150	MAINTENANCE SUPPLIES				177 07-Feb-2019	07-Feb-2019	
10-5-7017002-0317	PWD			FACILITIES - BUILDING MAINTENANCE			12.41
127230	MAINTENANCE				177 11-Feb-2019	11-Feb-2019	

Council/Board Report By Dept-(Computer)



Vendor : CAT038 To ZUL180

Batch : All

Department : All

Cheque Print Date : 01-Jan-2019 To 31-May-2019

Bank : 1 To 99

Class : All

Vendor Invoice	Vendor Name Description	Batch	Inv Date	Inv Due Date	Amount
G.L. Account	CC1 CC2 CC3 GL Account Name				
<b>DEPARTMENT 7017002 FACILITIES</b>					
10-5-7017002-0317	99THOM FACILITIES - BUILDING MAINTENANCE				24.01
127236	MAINTENANCE	176	11-Feb-2019	11-Feb-2019	
10-5-7017002-0317	99THOM FACILITIES - BUILDING MAINTENANCE				47.95
127615	SUPPLIES	250	25-Feb-2019	25-Feb-2019	
10-5-7017002-0317	PARKBL FACILITIES - BUILDING MAINTENANCE				55.35
127750	SUPPLIES	252	01-Mar-2019	01-Mar-2019	
10-5-7017002-0317	PARKBL FACILITIES - BUILDING MAINTENANCE				41.56
127860	SUPPLIES	252	05-Mar-2019	05-Mar-2019	
10-5-7017002-0317	FIRE FACILITIES - BUILDING MAINTENANCE				11.29
127874	SUPPLIES	252	06-Mar-2019	06-Mar-2019	
10-5-7017002-0317	PARKBL FACILITIES - BUILDING MAINTENANCE				58.76
128232	MAINTENANCE	296	18-Mar-2019	18-Mar-2019	
10-5-7017002-0317	PARKBL FACILITIES - BUILDING MAINTENANCE				14.44
128464	MAINTENANCE SUPPLIES	345	25-Mar-2019	25-Mar-2019	
10-5-7017002-0317	TOWN FACILITIES - BUILDING MAINTENANCE				40.34
128570	MAINTENANCE SUPPLIES	345	28-Mar-2019	28-Mar-2019	
10-5-7017002-0317	TOWN FACILITIES - BUILDING MAINTENANCE				0.78
128850	SUPPLIES	347	05-Apr-2019	05-Apr-2019	
10-5-7017002-0317	PARKBL FACILITIES - BUILDING MAINTENANCE				22.59
128862	SUPPLIES	347	05-Apr-2019	05-Apr-2019	
10-5-7017002-0317	TOWN FACILITIES - BUILDING MAINTENANCE				8.24
129167	MAINTENANCE SUPPLIES	406	13-Apr-2019	13-Apr-2019	
10-5-7017002-0317	TOWN FACILITIES - BUILDING MAINTENANCE				24.85
129188	SUPPLIES	389	15-Apr-2019	15-Apr-2019	
10-5-7017002-0317	PARKBL FACILITIES - BUILDING MAINTENANCE				23.71
129272	MAINTENANCE SUPPLIES	406	16-Apr-2019	16-Apr-2019	
10-5-7017002-0317	TOWN FACILITIES - BUILDING MAINTENANCE				10.72
129502	MAINTENANCE SUPPLIES	436	24-Apr-2019	24-Apr-2019	
10-5-7017002-0317	TOWN FACILITIES - BUILDING MAINTENANCE				13.09
129621	MAINTENANCE SUPPLIES	436	26-Apr-2019	26-Apr-2019	
10-5-7017002-0317	TOWN FACILITIES - BUILDING MAINTENANCE				21.45
129796	SUPPLIES	481	02-May-2019	02-May-2019	
10-5-7017002-0317	FIRE FACILITIES - BUILDING MAINTENANCE				25.32
<b>WIN210 WINDSOR FACTORY SUPPLY LTD</b>					
5015043	PLUMBING REPAIRS TO GORDON HOUSE	525	02-May-2019	02-May-2019	
10-5-7017002-0317	GORDOI FACILITIES - BUILDING MAINTENANCE				12.28
<b>Department Totals :</b>					<b>89,223.03</b>

<b>DEPARTMENT 7017300 LIBRO</b>					
<b>ACT409 ACTIVE NETWORK LTD.</b>					
CL305212_12-	REFUNDS DONE THROUGH CLASS P.O.S	1523	27-Dec-2018	27-Dec-2018	
10-5-7017300-0505	CREDIT CARD CHARGES				58.30
CL307118_12-	CLASS P.O.S PAYMENT PROCESSING FEES	1523	27-Dec-2018	27-Dec-2018	
10-5-7017300-0505	CREDIT CARD CHARGES				0.45
CL310055_12-	REFUNDS DONE THROUGH CLASS P.O.S	1523	31-Dec-2018	31-Dec-2018	
10-5-7017300-0505	CREDIT CARD CHARGES				1,121.88
CL310837_12-	CLASS P.O.S PAYMENT PROCESSING FEES	1523	31-Dec-2018	31-Dec-2018	
10-5-7017300-0505	CREDIT CARD CHARGES				2.10
CL312881_01-	CLASS - REFUNDS DONE THROUGH CLASS P.O.S	1557	31-Dec-2018	31-Dec-2018	
10-5-7017300-0505	CREDIT CARD CHARGES				151.80
CL314195_01-	CLASS P.O.S. PAYMENT PROCESSING FEES	1557	31-Dec-2018	31-Dec-2018	
10-5-7017300-0505	CREDIT CARD CHARGES				0.40

AGO713 AGO INDUSTRIES INC



Vendor : CAT038 To ZUL180

Batch : All

Department : All

Cheque Print Date : 01-Jan-2019 To 31-May-2019

Bank : 1 To 99

Class : All

Vendor Invoice	Vendor Name Description	Batch	Inv Date	Inv Due Date	Amount
G.L. Account	CC1 CC2 CC3 GL Account Name				
<b>DEPARTMENT 7017300</b>	LIBRO				
825247	CLOTHING	1607	14-Dec-2018	14-Dec-2018	
10-5-7017300-0161	CLOTHING				353.87
838461	CLOTHING	389	25-Mar-2019	25-Mar-2019	
10-5-7017300-0161	CLOTHING				1,283.47
<b>ALI224</b>	<b>ALIFT MATERIAL HANDLING &amp; EQUIPMENT SPECIALISTS</b>				
14087509	EQUIPMENT REPAIRS	134	02-Jan-2019	02-Jan-2019	
10-5-7017300-0317	BUILDING MAINTENANCE				874.47
17004100	PROPANE HANDLING PROGRAM	250	27-Feb-2019	27-Feb-2019	
10-5-7017300-0351	CONVENTIONS & SEMINARS				1,101.75
<b>AMH68</b>	<b>AMHERSTBURG REC &amp; CULTURE PETTY CASH</b>				
APRIL 1, 2010	APRIL 2019 PETTY CASH REIMBURSEMENT	347	01-Apr-2019	01-Apr-2019	
10-5-7017300-0250	HEALTH AND SAFETY				30.00
<b>ATH554</b>	<b>ATHLETICA SPORT SYSTEMS</b>				
312979	ASO OUTBOUND FREIGHT	406	22-Apr-2019	22-Apr-2019	
10-5-7017300-0962	PREMIER BASEBALL FIELD				180.80
<b>BET358</b>	<b>BETTER LOCKSMITHS INC</b>				
24035A	LOCKSMITH SERVICE	525	06-May-2019	06-May-2019	
10-5-7017300-0317	BUILDING MAINTENANCE				90.40
<b>CAN380</b>	<b>CANADIAN TIRE STORE #281</b>				
DECEMBER 20	DECEMBER 2018 PURCHASES	104	31-Jan-2019	31-Jan-2019	
10-5-7017300-0402	VEHICLE & EQUIPMENT MTCE.				65.38
10-5-7017300-0317	BUILDING MAINTENANCE				5.64
10-5-7017300-0317	BUILDING MAINTENANCE				1,919.87
FEBRUARY 20	FEBRUARY 2019 PURCHASES	280	28-Feb-2019	28-Feb-2019	
10-5-7017300-0402	VEHICLE & EQUIPMENT MTCE.				209.59
10-5-7017300-0402	VEHICLE & EQUIPMENT MTCE.				21.23
10-5-7017300-0317	BUILDING MAINTENANCE				23.70
10-5-7017300-0317	BUILDING MAINTENANCE				82.46
JANUARY 201	JANUARY 2019 PURCHASES	389	31-Jan-2019	31-Jan-2019	
10-5-7017300-0318	JANITORIAL				31.70
10-5-7017300-0317	BUILDING MAINTENANCE				169.49
10-5-7017300-0317	BUILDING MAINTENANCE				32.96
10-5-7017300-0317	BUILDING MAINTENANCE				22.59
10-5-7017300-0317	BUILDING MAINTENANCE				153.67
10-5-7017300-0317	BUILDING MAINTENANCE				-259.89
10-5-7017300-0317	BUILDING MAINTENANCE				276.82
MARCH 2019	MARCH 2019 PURCHASES	345	31-Mar-2019	31-Mar-2019	
10-5-7017300-0317	BUILDING MAINTENANCE				93.09
10-5-7017300-0317	BUILDING MAINTENANCE				125.34
10-5-7017300-0317	BUILDING MAINTENANCE				126.27
10-5-7017300-0317	BUILDING MAINTENANCE				107.26
NOVEMBER 20	NOVEMBER 2018 PURCHASES	133	31-Jan-2019	31-Jan-2019	
10-5-7017300-0317	BUILDING MAINTENANCE				37.70
10-5-7017300-0317	BUILDING MAINTENANCE				82.96
10-5-7017300-0317	BUILDING MAINTENANCE				60.94
10-5-7017300-0250	HEALTH AND SAFETY				167.64
10-5-7017300-0317	BUILDING MAINTENANCE				4.51
10-5-7017300-0317	BUILDING MAINTENANCE				155.19
10-5-7017300-0317	BUILDING MAINTENANCE				149.47
OCTOBER 201	OCTOBER 2018 INVOICES	1554	31-Oct-2018	31-Oct-2018	
10-5-7017300-0317	BUILDING MAINTENANCE				27.03
10-5-7017300-0317	BUILDING MAINTENANCE				9.03
10-5-7017300-0317	BUILDING MAINTENANCE				33.88
10-5-7017300-0317	BUILDING MAINTENANCE				90.33
10-5-7017300-0250	HEALTH AND SAFETY				162.69
10-5-7017300-0402	VEHICLE & EQUIPMENT MTCE.				31.59



Council/Board Report By Dept-(Computer)



Vendor : CAT038 To ZUL180

Batch : All

Department : All

Cheque Print Date : 01-Jan-2019 To 31-May-2019

Bank : 1 To 99

Class : All

Vendor Invoice	Vendor Name Description	Batch	Inv Date	Inv Due Date	Amount
G.L. Account	CC1 CC2 CC3 GL Account Name				
<b>DEPARTMENT 7017300</b>	LIBRO				
<b>CEN859</b>	<b>CENTENNIAL LOCK &amp; SAFE LIMITED</b>				
25512	MAINTENANCE	1606	17-Dec-2018	17-Dec-2018	
10-5-7017300-0317	BUILDING MAINTENANCE				508.44
25531	SERVICE REPAIR	105	11-Jan-2019	11-Jan-2019	
10-5-7017300-0317	BUILDING MAINTENANCE				237.30
25577	SUPPLIES	250	25-Feb-2019	25-Feb-2019	
10-5-7017300-0317	BUILDING MAINTENANCE				666.70
25583	SUPPLIES	250	21-Feb-2019	21-Feb-2019	
10-5-7017300-0317	BUILDING MAINTENANCE				688.82
25588	MAINTENANCE	389	05-Mar-2019	05-Mar-2019	
10-5-7017300-0317	BUILDING MAINTENANCE				465.50
25604	MAINTENANCE	389	26-Mar-2019	26-Mar-2019	
10-5-7017300-0317	BUILDING MAINTENANCE				134.47
25608	MAINTENANCE	389	03-Apr-2019	03-Apr-2019	
10-5-7017300-0317	BUILDING MAINTENANCE				266.68
25612	MAINTENANCE	347	09-Apr-2019	09-Apr-2019	
10-5-7017300-0317	BUILDING MAINTENANCE				1,159.26
<b>CIN177</b>	<b>CINTAS</b>				
84379438	MAT EXCHANGE	252	01-Mar-2019	01-Mar-2019	
10-5-7017300-0336	CONTRACTED SERVICES				91.84
847358403	MAT EXCHANGE	347	31-Jan-2019	31-Jan-2019	
10-5-7017300-0336	CONTRACTED SERVICES				91.84
847367802	MAT EXCHANGE	1523	14-Dec-2018	14-Dec-2018	
10-5-7017300-0336	CONTRACTED SERVICES				91.84
847368868	MAT EXCHANGE	406	19-Apr-2019	19-Apr-2019	
10-5-7017300-0336	CONTRACTED SERVICES				91.84
847368870	MAT EXCHANGE	1523	21-Dec-2018	21-Dec-2018	
10-5-7017300-0336	CONTRACTED SERVICES				91.84
847369932	MAT EXCHANGE	1523	28-Dec-2018	28-Dec-2018	
10-5-7017300-0336	CONTRACTED SERVICES				91.84
847370976	MAT EXCHANGE	15	04-Jan-2019	04-Jan-2019	
10-5-7017300-0336	CONTRACTED SERVICES				91.84
847372022	MAT EXCHANGE	62	11-Jan-2019	11-Jan-2019	
10-5-7017300-0336	CONTRACTED SERVICES				91.84
847373072	MAT EXCHANGE	62	18-Jan-2019	18-Jan-2019	
10-5-7017300-0336	CONTRACTED SERVICES				91.84
847374140	MAT EXCHANGE	99	25-Jan-2019	25-Jan-2019	
10-5-7017300-0336	CONTRACTED SERVICES				91.84
847375195	MAT EXCHANGE	135	01-Feb-2019	01-Feb-2019	
10-5-7017300-0336	CONTRACTED SERVICES				91.84
847376248	MAT EXCHANGE	177	08-Feb-2019	08-Feb-2019	
10-5-7017300-0336	CONTRACTED SERVICES				91.84
847377298	MAT EXCHANGE	204	15-Feb-2019	15-Feb-2019	
10-5-7017300-0336	CONTRACTED SERVICES				91.84
847378373	MAT EXCHANGE	204	22-Feb-2019	22-Feb-2019	
10-5-7017300-0336	CONTRACTED SERVICES				91.84
847380502	MAT EXCHANGE	280	08-Mar-2019	08-Mar-2019	
10-5-7017300-0317	BUILDING MAINTENANCE				91.84
847381543	MAT EXCHANGE	296	15-Mar-2019	15-Mar-2019	
10-5-7017300-0336	CONTRACTED SERVICES				91.84
847382636	MAT EXCHANGE	319	22-Mar-2019	22-Mar-2019	
10-5-7017300-0336	CONTRACTED SERVICES				91.84
847382638	MAT EXCHANGE	347	22-Mar-2019	22-Mar-2019	



Vendor : CAT038 To ZUL180

Batch : All

Department : All

Cheque Print Date : 01-Jan-2019 To 31-May-2019

Bank : 1 To 99

Class : All

Vendor Invoice	Vendor Name Description	Batch	Inv Date	Inv Due Date	Amount
G.L. Account	CC1 CC2 CC3 GL Account Name				
<b>DEPARTMENT 7017300 LIBRO</b>					
10-5-7017300-0336	CONTRACTED SERVICES				91.84
847383701 MAT EXCHANGE		345	29-Mar-2019	29-Mar-2019	
10-5-7017300-0336	CONTRACTED SERVICES				91.84
847384764 MAT EXCHANGE		347	05-Apr-2019	05-Apr-2019	
10-5-7017300-0336	CONTRACTED SERVICES				91.84
847385813 MAT EXCHANGE		347	12-Apr-2019	12-Apr-2019	
10-5-7017300-0336	CONTRACTED SERVICES				91.84
847387905 MAT EXCHANGE		436	26-Apr-2019	26-Apr-2019	
10-5-7017300-0336	CONTRACTED SERVICES				91.84
847388919 MAT EXCHANGE		481	03-May-2019	03-May-2019	
10-5-7017300-0336	CONTRACTED SERVICES				100.06
847389913 MAT EXCHANGE		511	10-May-2019	10-May-2019	
10-5-7017300-0336	CONTRACTED SERVICES				100.06
847390923 MAT EXCHANGE		525	17-May-2019	17-May-2019	
10-5-7017300-0331	REFRIGERATION MAINTENANCE				100.06
847931333 RENTAL MATS		347	29-Mar-2019	29-Mar-2019	
10-5-7017300-0336	CONTRACTED SERVICES				32.42
<b>COL277 COLAUTTI FLOORS</b>					
00057867-000 MAINTENANCE		345	29-Mar-2019	29-Mar-2019	
10-5-7017300-0317	BUILDING MAINTENANCE				88.14
00078143 MATERIALS OFFICE RENOVATION		347	01-Apr-2019	01-Apr-2019	
10-5-7017300-0317	BUILDING MAINTENANCE				88.14
<b>COL286 COLBRO EQUIPMENT RENTAL</b>					
113181-0		62	17-Jan-2019	17-Jan-2019	
10-5-7017300-0402	VEHICLE & EQUIPMENT MTCE.				189.07
114865-0 LIFT SCISSOR SKY JACK		436	15-Apr-2019	15-Apr-2019	
10-5-7017300-0301	OFFICE SUPPLIES				957.68
<b>CUL391 CULLIGAN WATER</b>					
2522987 WATER COOLER RENTALS		1607	31-Dec-2018	31-Dec-2018	
10-5-7017300-0336	CONTRACTED SERVICES				81.24
2534000 RENTAL WATER COOLER		134	31-Jan-2019	31-Jan-2019	
10-5-7017300-0336	CONTRACTED SERVICES				81.24
2544855 WATER COOLER RENTAL		280	28-Feb-2019	28-Feb-2019	
10-5-7017300-0336	CONTRACTED SERVICES				81.24
255889 RENTAL WATER COOLERS		389	31-Mar-2019	31-Mar-2019	
10-5-7017300-0336	CONTRACTED SERVICES				81.24
2568329 RENTAL OF WATER COOLER		525	30-Apr-2019	30-Apr-2019	
10-5-7017300-0336	CONTRACTED SERVICES				81.24
<b>DIB141 DIBSI</b>					
107695 MAINTENANCE		389	18-Apr-2019	18-Apr-2019	
10-5-7017300-0331	REFRIGERATION MAINTENANCE				754.84
<b>DOW547 DOWLER KARN</b>					
109749 PROPANE		1607	18-Dec-2018	18-Dec-2018	
10-5-7017300-0401	GASOLINE / PROPANE				16.00
109760 PROPANE		1607	27-Dec-2018	27-Dec-2018	
10-5-7017300-0401	GASOLINE / PROPANE				298.32
111917 PROPANE		1607	27-Dec-2018	27-Dec-2018	
10-5-7017300-0401	GASOLINE / PROPANE				99.44
111928 PROPANE		134	25-Jan-2019	25-Jan-2019	
10-5-7017300-0401	GASOLINE / PROPANE				198.88
111978 PROPANE		134	31-Jan-2019	31-Jan-2019	
10-5-7017300-0401	GASOLINE / PROPANE				174.02
112278 PROPANE		347	03-Apr-2019	03-Apr-2019	





Vendor : CAT038 To ZUL180

Batch : All

Department : All

Cheque Print Date : 01-Jan-2019 To 31-May-2019

Bank : 1 To 99

Class : All

Vendor Invoice	Vendor Name Description	Batch	Inv Date	Inv Due Date	Amount
G.L. Account	CC1 CC2 CC3 GL Account Name				
<b>DEPARTMENT 7017300 LIBRO</b>					
10-5-7017300-0401					
	GASOLINE / PROPANE				103.51
113748	PROPANE	525	25-Apr-2019	25-Apr-2019	
10-5-7017300-0401					
	GASOLINE / PROPANE				51.75
34481633	PROPANE	1607	31-Dec-2018	31-Dec-2018	
10-5-7017300-0401					
	GASOLINE / PROPANE				28.25
34622525	PROPANE	296	28-Feb-2019	28-Feb-2019	
10-5-7017300-0401					
	GASOLINE / PROPANE				28.25
34684502	PROPANE	347	31-Mar-2019	31-Mar-2019	
10-5-7017300-0401					
	GASOLINE / PROPANE				28.25
725055	PROPANE	1607	28-Nov-2018	28-Nov-2018	
10-5-7017300-0401					
	GASOLINE / PROPANE				223.74
761829	PROPANE	1607	05-Dec-2018	05-Dec-2018	
10-5-7017300-0401					
	GASOLINE / PROPANE				198.88
820227	PROPANE	1607	12-Dec-2018	12-Dec-2018	
10-5-7017300-0401					
	GASOLINE / PROPANE				223.74
832936	PROPANE	62	02-Jan-2019	02-Jan-2019	
10-5-7017300-0401					
	GASOLINE / PROPANE				198.88
836624	PROPANE	62	09-Jan-2019	09-Jan-2019	
10-5-7017300-0401					
	GASOLINE / PROPANE				273.46
844441	PROPANE	134	23-Jan-2019	23-Jan-2019	
10-5-7017300-0401					
	GASOLINE / PROPANE				248.60
852712	PROPANE	250	05-Feb-2019	05-Feb-2019	
10-5-7017300-0401					
	GASOLINE / PROPANE				198.88
856473	PROPANE	204	12-Feb-2019	12-Feb-2019	
10-5-7017300-0401					
	GASOLINE / PROPANE				248.60
860653	PROPANE	280	20-Feb-2019	20-Feb-2019	
10-5-7017300-0401					
	GASOLINE / PROPANE				298.32
864216	PROPANE	280	27-Feb-2019	27-Feb-2019	
10-5-7017300-0401					
	GASOLINE / PROPANE				248.60
867997	PROPANE	296	06-Mar-2019	06-Mar-2019	
10-5-7017300-0401					
	GASOLINE / PROPANE				223.74
873987	PROPANE	319	13-Mar-2019	13-Mar-2019	
10-5-7017300-0401					
	GASOLINE / PROPANE				99.44
876985	PROPANE	389	21-Mar-2019	21-Mar-2019	
10-5-7017300-0401					
	GASOLINE / PROPANE				149.16
880117	PROPANE	389	29-Mar-2019	29-Mar-2019	
10-5-7017300-0401					
	GASOLINE / PROPANE				248.60
889294	PROPANE	436	17-Apr-2019	17-Apr-2019	
10-5-7017300-0401					
	GASOLINE / PROPANE				77.63
894108	PROPANE	525	01-May-2019	01-May-2019	
10-5-7017300-0401					
	GASOLINE / PROPANE				51.75
896767	PROPANE	525	08-May-2019	08-May-2019	
10-5-7017300-0401					
	GASOLINE / PROPANE				51.75
<b>DSS150 DSSERVICES</b>					
1021	BUILDING MAINTENANCE	1523	06-Dec-2018	06-Dec-2018	
10-5-7017300-0331					
	REFRIGERATION MAINTENANCE				1,782.11
1024	HEATING AND COOLING MAINTENANCE	15	04-Jan-2019	04-Jan-2019	
10-5-7017300-0331					
	REFRIGERATION MAINTENANCE				375.73
<b>ELE400 ELECTRICAL SAFETY AUTHORITY</b>					
97662958	SAFETY SERVICES PROGRAM	177	01-Feb-2019	01-Feb-2019	
10-5-7017300-0317					
	BUILDING MAINTENANCE				4,636.55
<b>EMC530 EMCO CORPORATION</b>					
37586302-01	MAINTENANCE MATERIALS	105	24-Jan-2019	24-Jan-2019	



Vendor : CAT038 To ZUL180

Batch : All

Department : All

Cheque Print Date : 01-Jan-2019 To 31-May-2019

Bank : 1 To 99

Class : All

Vendor Invoice	Vendor Name Description	Batch	Inv Date	Inv Due Date	Amount
G.L. Account	CC1 CC2 CC3 GL Account Name				
<b>DEPARTMENT 7017300 LIBRO</b>					
10-5-7017300-0317	BUILDING MAINTENANCE				6.52
37588320-00	CARTRIDGE FOR WATER FILTER	204	12-Feb-2019	12-Feb-2019	
10-5-7017300-0317	BUILDING MAINTENANCE				393.10
37590381-00	PLUMBING SUPPLIES	319	07-Mar-2019	07-Mar-2019	
10-5-7017300-0317	BUILDING MAINTENANCE				96.05
37590546-00	PLUMBING MAINTENANCE	296	11-Mar-2019	11-Mar-2019	
10-5-7017300-0317	BUILDING MAINTENANCE				342.13
37590827-00	MAINTENANCE MATERIALS	296	13-Mar-2019	13-Mar-2019	
10-5-7017300-0317	BUILDING MAINTENANCE				442.96
37590836-00	PLUMBING SUPPLIES	319	13-Mar-2019	13-Mar-2019	
10-5-7017300-0317	BUILDING MAINTENANCE				68.90
37591300-00	PLUMBING MAINTENANCE	319	19-Mar-2019	19-Mar-2019	
10-5-7017300-0317	BUILDING MAINTENANCE				14.88
37593104-00	PLUMBING SUPPLIES	436	08-Apr-2019	08-Apr-2019	
10-5-7017300-0317	BUILDING MAINTENANCE				27.84
37593293-00	BUILDING MAINTENANCE SUPPLIES	436	09-Apr-2019	09-Apr-2019	
10-5-7017300-0317	BUILDING MAINTENANCE				14.52
37594103-00	PLUMBING SUPPLIES	436	18-Apr-2019	18-Apr-2019	
10-5-7017300-0317	BUILDING MAINTENANCE				81.36
37595390-00	SUMP PUMP REFRIGERATION SYSTEM	525	13-May-2019	13-May-2019	
10-5-7017300-0331	REFRIGERATION MAINTENANCE				299.45
<b>FCF160 FCFP</b>					
INV126489	ANNUAL INSPECTION FIRE STATION # 2 HALL	296	11-Mar-2019	11-Mar-2019	
10-5-7017300-0317	BUILDING MAINTENANCE				463.30
INV127816	BI MONTHLY SPRINKLER SERVICE	389	04-Apr-2019	04-Apr-2019	
10-5-7017300-0336	CONTRACTED SERVICES				163.29
<b>FEE256 THE FEED STORE</b>					
1000202108	FIELD STRIPE (50LB)	481	06-May-2019	06-May-2019	
10-5-7017300-0962	PREMIER BASEBALL FIELD				123.74
<b>FOR160 FOREST CITY FIRE PROTECTION &amp; SECURITY</b>					
124951	ISPECTION SUPPRESSION SYSTEM	204	05-Feb-2019	05-Feb-2019	
10-5-7017300-0336	CONTRACTED SERVICES				484.21
INV122253	SERVICE FOR FIRE PROTECTION	1607	12-Dec-2018	12-Dec-2018	
10-5-7017300-0336	CONTRACTED SERVICES				273.91
<b>GRE330 GREAT LAKES SAFETY PRODUCTS</b>					
00313873	HEALTH & SAFETY ITEMS (NOV 2, 2018)	133	31-Jan-2019	31-Jan-2019	
10-5-7017300-0250	HEALTH AND SAFETY				172.21
00314361	HEALTH & SAFETY ITEMS	296	22-Mar-2019	22-Mar-2019	
10-5-7017300-0250	HEALTH AND SAFETY				52.36
<b>GRE679 GREG BAILEY LTD</b>					
0000051865	MAINTENANCE SUPPLIES	347	08-Apr-2019	08-Apr-2019	
10-5-7017300-0402	VEHICLE & EQUIPMENT MTCE.				564.88
0000051921	HOSE ASSEMBLY	406	16-Apr-2019	16-Apr-2019	
10-5-7017300-0402	VEHICLE & EQUIPMENT MTCE.				122.03
0000052037	MAINTENANCE SUPPLIES	481	29-Apr-2019	29-Apr-2019	
10-5-7017300-0960	OUTDOOR SOCCER (NAT TURF)				3,752.55
<b>GRY115 GRYPHON GLASS</b>					
12102	REPAIRS TO SLIDING DOORS	134	23-Jan-2019	23-Jan-2019	
10-5-7017300-0317	BUILDING MAINTENANCE				605.68
12154	REPAIRS TO ARENA LEXAN GLASS	135	01-Feb-2019	01-Feb-2019	
10-5-7017300-0317	BUILDING MAINTENANCE				3,300.73
12351	LEXAN FOR RINK A	389	19-Mar-2019	19-Mar-2019	
10-5-7017300-0317	BUILDING MAINTENANCE				4,036.36



Vendor : CAT038 To ZUL180

Batch : All

Department : All

Cheque Print Date : 01-Jan-2019 To 31-May-2019

Bank : 1 To 99

Class : All

Vendor Invoice	Vendor Name Description	Batch	Inv Date	Inv Due Date	Amount
G.L. Account	CC1 CC2 CC3 GL Account Name				
<b>DEPARTMENT 7017300</b>	LIBRO				
12375	GLASS FOR OFFICE RENOVATIONS	347	02-Apr-2019	02-Apr-2019	
10-5-7017300-0317	BUILDING MAINTENANCE				929.94
12542	LEXAN BACKUP GLASS FOR LIBRO RINKS	525	08-May-2019	08-May-2019	
10-5-7017300-0317	BUILDING MAINTENANCE				3,698.49
<b>HER247</b>	<b>HERITAGE TIRE SALES INC.</b>				
AIN0002329	MAINTENANCE	481	03-May-2019	03-May-2019	
10-5-7017300-0402	VEHICLE & EQUIPMENT MTCE.				424.21
<b>ICE203</b>	<b>ICECO ADVANCED ARENA PRODUCTS</b>				
218198	MAINTENANCE MATERIALS	347	12-Apr-2019	12-Apr-2019	
10-5-7017300-0317	BUILDING MAINTENANCE				517.54
<b>JAC351</b>	<b>JACK SMITH FUELS LTD</b>				
CN010345	GLYCOL DRUM RETURN CREDIT	1607	08-Nov-2018	08-Nov-2018	
10-5-7017300-0331	REFRIGERATION MAINTENANCE				-101.70
IN329344	GLYCOL	1607	21-Aug-2018	21-Aug-2018	
10-5-7017300-0331	REFRIGERATION MAINTENANCE				444.36
IN339794	EXTENDED LIFE ANTIFREEZE 50/50 & DRUM	105	28-Jan-2019	28-Jan-2019	
10-5-7017300-0331	REFRIGERATION MAINTENANCE				1,593.30
<b>LAI130</b>	<b>LAING'S LAWN CARE &amp; PEST CONTROL</b>				
3088	MAINTENANCE	1606	31-Dec-2018	31-Dec-2018	
10-5-7017300-0317	BUILDING MAINTENANCE				881.40
<b>LOB898</b>	<b>LOBLAW'S INC</b>				
2018 RECEIPT PURCHASES MADE IN 2018		175	31-Jan-2019	31-Jan-2019	
10-5-7017300-0317	BUILDING MAINTENANCE				51.02
<b>LUC170</b>	<b>LUCIER GLOVE &amp; SAFETY PRODUCTS</b>				
32381	CLOTHING	1607	14-Dec-2018	14-Dec-2018	
10-5-7017300-0161	CLOTHING				438.28
32725	CLOTHING	62	04-Jan-2019	04-Jan-2019	
10-5-7017300-0161	CLOTHING				13.00
33133	CLOTHING	134	29-Jan-2019	29-Jan-2019	
10-5-7017300-0161	CLOTHING				824.83
34449	SAFETY ITEMS	525	27-Apr-2019	27-Apr-2019	
10-5-7017300-0250	HEALTH AND SAFETY				508.50
34450	SAFETY BOOTS	525	27-Apr-2019	27-Apr-2019	
10-5-7017300-0161	CLOTHING				226.00
34767	UNIFORMS	525	12-May-2019	12-May-2019	
10-5-7017300-0161	CLOTHING				223.72
<b>MAL256</b>	<b>MALDEN AUTOMOTIVE</b>				
5294-187835	HOSE & CLAMPS FOR ZAMBONI	319	19-Mar-2019	19-Mar-2019	
10-5-7017300-0402	VEHICLE & EQUIPMENT MTCE.				8.45
<b>MAR003</b>	<b>MAR-CO CLAY PRODUCTS INC</b>				
79318	MOUND CLAY PREMIER FIELD	436	24-Apr-2019	24-Apr-2019	
10-5-7017300-0962	PREMIER BASEBALL FIELD				607.38
<b>MET052</b>	<b>METRO KING PEST CONTROL INC.</b>				
2145	MONTHLY SERVICE AT VARIOUS LOCATIONS	1606	30-Nov-2018	30-Nov-2018	
10-5-7017300-0317	BUILDING MAINTENANCE				45.20
10-5-7017300-0317	BUILDING MAINTENANCE				28.25
2146	MONTHLY SERVICE AT VARIOUS LOCATIONS	1606	31-Dec-2018	31-Dec-2018	
10-5-7017300-0317	BUILDING MAINTENANCE				45.20
10-5-7017300-0317	BUILDING MAINTENANCE				28.25
2147	MONTHLY SERVICE AT VARIOUS LOCATIONS	345	28-Feb-2019	28-Feb-2019	
10-5-7017300-0317	BUILDING MAINTENANCE				45.20
10-5-7017300-0317	BUILDING MAINTENANCE				28.25
2148	MONTHLY SERVICE AT VARIOUS LOCATIONS	345	31-Mar-2019	31-Mar-2019	



Vendor : CAT038 To ZUL180

Batch : All

Department : All

Cheque Print Date : 01-Jan-2019 To 31-May-2019

Bank : 1 To 99

Class : All

Vendor Invoice	Vendor Name Description	Batch	Inv Date	Inv Due Date	Amount
G.L. Account	CC1 CC2 CC3 GL Account Name				
<b>DEPARTMENT 7017300</b>	LIBRO				
10-5-7017300-0317	BUILDING MAINTENANCE				45.20
10-5-7017300-0317	BUILDING MAINTENANCE				28.25
<b>MIC097 MICHAEL CHARBONNEAU GRAPHICS &amp; DESIGN</b>					
2018-3168	PAINTED LOGOS/TEXT ON LIBRO CENTRE RINKS	1523	12-Dec-2018	12-Dec-2018	
10-5-7017300-0336	CONTRACTED SERVICES				1,186.50
<b>MON183 MONARCH OFFICE SUPPLY LTD</b>					
127289	DECEMBER 2018 PURCHASES	1607	31-Dec-2018	31-Dec-2018	
10-5-7017300-0250	HEALTH AND SAFETY				138.36
<b>MOR26 MORNEAU SHEPELL LTD.</b>					
APRIL 2019	953243, 953244, 953245, 953246 APRIL 2019	347	01-Apr-2019	01-Apr-2019	
10-5-7017300-0207	BENEFITS - LIFE & DISABIL				16.64
FEBRUARY 20	921007, 921008, 921009, 921010 FEBRUARY 2019	135	01-Feb-2019	01-Feb-2019	
10-5-7017300-0207	BENEFITS - LIFE & DISABIL				199.69
JANUARY 2019	902738, 902739, 902740, 902741 JANUARY 2019	62	02-Jan-2019	02-Jan-2019	
10-5-7017300-0207	BENEFITS - LIFE & DISABIL				183.05
MARCH 2019	936899, 936900, 936901, 936902 MARCH 2019	280	01-Mar-2019	01-Mar-2019	
10-5-7017300-0207	BENEFITS - LIFE & DISABIL				199.69
MAY 2019	970411, 970412, 970413, 970414 MAY 2019	511	01-May-2019	01-May-2019	
10-5-7017300-0207	BENEFITS - LIFE & DISABIL				199.69
<b>MUN200 MUNICIPAL EMPLOYER PENSION CENTRE OF ONTARIO</b>					
MC004654	MEPCO 2019 EMPLOYEE CONTRIBUTION	15	02-Jan-2019	02-Jan-2019	
10-5-7017300-0350	MEMBERSHIPS				54.31
<b>NAN202 NANTAIS ATHLETIC INC.</b>					
305	LOGO ON FACILITY STAFF JACKETS	1554	17-Dec-2018	17-Dec-2018	
10-5-7017300-0161	CLOTHING				254.24
<b>NED112 NEDCO</b>					
6100200	MAINTENANCE	204	10-Dec-2018	10-Dec-2018	
10-5-7017300-0725	PARKING LOT MAINTENANCE - UCCU (2011)				176.17
<b>NEL277 NELLA CUTLERY (HAMILTON) INC</b>					
2375888	ICE RESURFACING BLADE SHARPENING	204	07-Feb-2019	07-Feb-2019	
10-5-7017300-0402	VEHICLE & EQUIPMENT MTCE.				33.90
IN2372720	ICE RESURFACING BLADE SHARPENING	1523	13-Dec-2018	13-Dec-2018	
10-5-7017300-0402	VEHICLE & EQUIPMENT MTCE.				67.80
IN2373802	ICE RESURFACING BLADE SHARPENING	15	02-Jan-2019	02-Jan-2019	
10-5-7017300-0402	VEHICLE & EQUIPMENT MTCE.				67.80
IN2374322	ICE RESURFACING BLADE SHARPENING	62	10-Jan-2019	10-Jan-2019	
10-5-7017300-0402	VEHICLE & EQUIPMENT MTCE.				67.80
IN2375293	ICE RESURFACING BLADE SHARPENING	134	25-Jan-2019	25-Jan-2019	
10-5-7017300-0336	CONTRACTED SERVICES				67.80
IN2376640	ICE RESURFACING BLADE SHARPENING	252	22-Feb-2019	22-Feb-2019	
10-5-7017300-0402	VEHICLE & EQUIPMENT MTCE.				101.70
IN2377348	ICE RESURFACING BLADE SHARPENING	319	07-Mar-2019	07-Mar-2019	
10-5-7017300-0402	VEHICLE & EQUIPMENT MTCE.				101.70
IN2378148	ICE RESURFACING - BLADE SHARPENING	345	21-Mar-2019	21-Mar-2019	
10-5-7017300-0402	VEHICLE & EQUIPMENT MTCE.				33.90
IN2378973	ICE RESURFACING BLADE SHARPENING	406	04-Apr-2019	04-Apr-2019	
10-5-7017300-0402	VEHICLE & EQUIPMENT MTCE.				101.70
IN2379723	ICE RESURFACING BLADE SHARPENING	436	18-Apr-2019	18-Apr-2019	
10-5-7017300-0402	VEHICLE & EQUIPMENT MTCE.				33.90
<b>PAR372 PARRLINE ELECTRICAL WHOLESALE</b>					
78315	ELECTRICAL SUPPLIES (3-OCT-2018)	175	31-Jan-2019	31-Jan-2019	
10-5-7017300-0317	BUILDING MAINTENANCE				4.15
78623	ELECTRICAL SUPPLIES (25-OCT-2018)	175	31-Jan-2019	31-Jan-2019	

Council/Board Report By Dept-(Computer)



Vendor : CAT038 To ZUL180

Batch : All

Department : All

Cheque Print Date : 01-Jan-2019 To 31-May-2019

Bank : 1 To 99

Class : All

Vendor Invoice	Vendor Name Description	Batch	Inv Date	Inv Due Date	Amount
G.L. Account	CC1 CC2 CC3 GL Account Name				
<b>DEPARTMENT 7017300 LIBRO</b>					
10-5-7017300-0317	BUILDING MAINTENANCE				130.84
79018	ELECTRICAL SUPPLIES	1606	19-Nov-2018	19-Nov-2018	
10-5-7017300-0317	BUILDING MAINTENANCE				94.48
79332	ELECTRICAL SUPPLIES (NOV 26, 2018)	250	28-Feb-2019	28-Feb-2019	
10-5-7017300-0317	BUILDING MAINTENANCE				21.26
79571	ELECTRICAL SUPPLIES	1606	10-Dec-2018	10-Dec-2018	
10-5-7017300-0317	BUILDING MAINTENANCE				125.71
79574	ELECTRICAL SUPPLIES	1523	10-Dec-2018	10-Dec-2018	
10-5-7017300-0317	BUILDING MAINTENANCE				22.50
79598	ELECTRICAL SUPPLIES	1523	12-Dec-2018	12-Dec-2018	
10-5-7017300-0725	PARKING LOT MAINTENANCE - UCCU (2011)				107.63
79748	ELECTRICAL SUPPLIES	1523	13-Dec-2018	13-Dec-2018	
10-5-7017300-0725	PARKING LOT MAINTENANCE - UCCU (2011)				146.00
79831	ELECTRICAL SUPPLIES	62	04-Jan-2019	04-Jan-2019	
10-5-7017300-0317	BUILDING MAINTENANCE				48.99
79920	ELECTRICAL SUPPLIES	1523	19-Dec-2018	19-Dec-2018	
10-5-7017300-0725	PARKING LOT MAINTENANCE - UCCU (2011)				277.69
80246	LIBRO DOOR BUZZERS	134	22-Jan-2019	22-Jan-2019	
10-5-7017300-0317	BUILDING MAINTENANCE				128.82
80507	ELECTRICAL SUPPLIES	177	05-Feb-2019	05-Feb-2019	
10-5-7017300-0317	BUILDING MAINTENANCE				540.76
80575	LIBRO	204	12-Feb-2019	12-Feb-2019	
10-5-7017300-0317	BUILDING MAINTENANCE				18.40
80646	ELECTRICAL SUPPLIES	177	07-Feb-2019	07-Feb-2019	
10-5-7017300-0317	BUILDING MAINTENANCE				24.01
80782	ELECTRICAL SUPPLIES	296	21-Feb-2019	21-Feb-2019	
10-5-7017300-0317	BUILDING MAINTENANCE				580.75
80796	ELECTRICAL SUPPLIES	296	22-Feb-2019	22-Feb-2019	
10-5-7017300-0317	BUILDING MAINTENANCE				2.76
80832	ELECTRICAL SUPPLIES	296	25-Feb-2019	25-Feb-2019	
10-5-7017300-0317	BUILDING MAINTENANCE				158.86
81245	ELECTRICAL SUPPLIES	347	12-Mar-2019	12-Mar-2019	
10-5-7017300-0317	BUILDING MAINTENANCE				518.76
81345	ELECTRICAL SUPPLIES	347	26-Mar-2019	26-Mar-2019	
10-5-7017300-0725	PARKING LOT MAINTENANCE - UCCU (2011)				62.24
81437	ELECTRICAL SUPPLIES	347	21-Mar-2019	21-Mar-2019	
10-5-7017300-0317	BUILDING MAINTENANCE				141.32
81438	ELECTRICAL SUPPLIES	347	21-Mar-2019	21-Mar-2019	
10-5-7017300-0331	REFRIGERATION MAINTENANCE				175.31
81674	ELECTRICAL SUPPLIES	481	02-Apr-2019	02-Apr-2019	
10-5-7017300-0317	BUILDING MAINTENANCE				12.88
81871	ELECTRICAL SUPPLIES	436	24-Apr-2019	24-Apr-2019	
10-5-7017300-0317	BUILDING MAINTENANCE				37.79
82013	ELECTRICAL SUPPLIES	436	26-Apr-2019	26-Apr-2019	
10-5-7017300-0317	BUILDING MAINTENANCE				87.95
82294	ELECTRICAL SUPPLIES	525	08-May-2019	08-May-2019	
10-5-7017300-0317	BUILDING MAINTENANCE				57.74
82295	222.59	511	08-May-2019	08-May-2019	
10-5-7017300-0317	BUILDING MAINTENANCE				222.59
<b>POW372 POWER DISTRIBUTION SUPPLY</b>					
1801 CREDIT	CREDIT	1607	11-Dec-2018	11-Dec-2018	
10-5-7017300-0725	PARKING LOT MAINTENANCE - UCCU (2011)				-32.77
1810	MAINTENANCE	1523	04-Dec-2018	04-Dec-2018	



Vendor : CAT038 To ZUL180

Batch : All

Department : All

Cheque Print Date : 01-Jan-2019 To 31-May-2019

Bank : 1 To 99

Class : All

Vendor Invoice	Vendor Name Description	Batch	Inv Date	Inv Due Date	Amount
G.L. Account	CC1 CC2 CC3 GL Account Name				
<b>DEPARTMENT 7017300</b>	LIBRO				
10-5-7017300-0317	BUILDING MAINTENANCE				235.83
1811 MAINTENANCE		1523	05-Dec-2018	05-Dec-2018	
10-5-7017300-0317	BUILDING MAINTENANCE				158.20
1812 MAINTENANCE		1607	11-Dec-2018	11-Dec-2018	
10-5-7017300-0725	PARKING LOT MAINTENANCE - UCCU (2011)				163.22
1813 MAINTENANCE		1523	12-Dec-2018	12-Dec-2018	
10-5-7017300-0725	PARKING LOT MAINTENANCE - UCCU (2011)				159.40
<b>REL010 RELIGHTING</b>					
0683 SUPPLIES		345	22-Mar-2019	22-Mar-2019	
10-5-7017300-0317	BUILDING MAINTENANCE				28.25
DECEMBER 18 BUILDING MAINTENANCE		1523	18-Dec-2018	18-Dec-2018	
10-5-7017300-0317	BUILDING MAINTENANCE				99.44
<b>RUS02 RUSSCO TRAINING SERVICES</b>					
4233 TRAINING CONFINED SPACES		436	27-Mar-2019	27-Mar-2019	
10-5-7017300-0351	CONVENTIONS & SEMINARS				565.00
<b>SIM535 SIMPLISTIC LINES INC.</b>					
1732040219 MAINTENANCE		389	02-Apr-2019	02-Apr-2019	
10-5-7017300-0960	OUTDOOR SOCCER (NAT TURF)				1,993.32
1744110718 CREDIT		389	18-Apr-2019	18-Apr-2019	
10-5-7017300-0960	OUTDOOR SOCCER (NAT TURF)				-988.75
<b>STA698 STANDARD REFRIGERATION COMPANY LIMITED</b>					
1242 MAINTENANCE		1523	31-Dec-2018	31-Dec-2018	
10-5-7017300-0317	BUILDING MAINTENANCE				653.22
1306 MAINTENANCE		1523	31-Dec-2018	31-Dec-2018	
10-5-7017300-0317	BUILDING MAINTENANCE				610.65
<b>STE531 STERLING MOTOR TECHNOLOGY INC</b>					
12385 MAINTENANCE		436	30-Apr-2019	30-Apr-2019	
10-5-7017300-0331	REFRIGERATION MAINTENANCE				968.55
13636 SERVICE CALL		436	30-Apr-2019	30-Apr-2019	
10-5-7017300-0331	REFRIGERATION MAINTENANCE				459.50
15833 SERVICE CALL		204	26-Feb-2019	26-Feb-2019	
10-5-7017300-0331	REFRIGERATION MAINTENANCE				894.51
<b>SUN293 SUNSET ENTERPRIZE &amp; WELDING</b>					
318196 MAINTENANCE		62	14-Jan-2019	14-Jan-2019	
10-5-7017300-0317	BUILDING MAINTENANCE				168.94
<b>THY410 THYSSENKRUPP ELEVATOR (CANADA) LIMITED</b>					
1504967 ANNUAL SERVICE CONTRACT		62	02-Jan-2019	02-Jan-2019	
10-5-7017300-0336	CONTRACTED SERVICES				1,139.35
1553719 ELEVATOR SERVICE		319	01-Apr-2019	01-Apr-2019	
10-5-7017300-0336	CONTRACTED SERVICES				1,206.57
<b>TRE515 TREMBLAR BUILDING SUPPLIES LTD.</b>					
59006 MAINTENANCE MATERIALS		1607	07-Dec-2018	07-Dec-2018	
10-5-7017300-0317	BUILDING MAINTENANCE				908.52
59787 BUILDING MATERIALS TO CONSTRUCT OFFICES AT LIBRO		436	07-Mar-2019	07-Mar-2019	
10-5-7017300-0317	BUILDING MAINTENANCE				824.90
59904 DOORS FOR NEW OFFICES		389	19-Mar-2019	19-Mar-2019	
10-5-7017300-0317	BUILDING MAINTENANCE				887.05
<b>TRI249 TRI GRAPHICS</b>					
5365 BUSINESS CARDS		406	24-Apr-2019	24-Apr-2019	
10-5-7017300-0301	OFFICE SUPPLIES				58.76
<b>TSC401 TSC STORES LTD</b>					
APRIL 16, 2019 HEALTH AND SAFETY, CUSTOMER NUMBER 4904		525	16-Apr-2019	16-Apr-2019	



## Council/Board Report By Dept-(Computer)



Vendor : CAT038 To ZUL180

Batch : All

Department : All

Cheque Print Date : 01-Jan-2019 To 31-May-2019

Bank : 1 To 99

Class : All

Vendor Invoice	Vendor Name Description	Batch	Inv Date	Inv Due Date	Amount
G.L. Account	CC1 CC2 CC3 GL Account Name				
<b>DEPARTMENT 7017300</b>	LIBRO				
10-5-7017300-0250	HEALTH AND SAFETY				763.51
<b>TYC452</b>	<b>TYCO INTEGRATED FIRE &amp; SECURITY</b>				
20748081	FIRE ALARM INSPECTED AND TESTED	280	01-Feb-2019	01-Feb-2019	
10-5-7017300-0336	CONTRACTED SERVICES				485.93
<b>UNI677</b>	<b>UNIQUE COMMUNICATIONS INC</b>				
15558	SECURITY SERVICES	319	29-Mar-2019	29-Mar-2019	
10-5-7017300-0336	CONTRACTED SERVICES				271.20
16325	SECURITY SYSTEM MONITORING	525	08-May-2019	08-May-2019	
10-5-7017300-0336	CONTRACTED SERVICES				271.20
<b>VIL417</b>	<b>VILLA CONSTRUCTION</b>				
6871	MAINTENANCE	1554	11-Dec-2018	11-Dec-2018	
10-5-7017300-0250	HEALTH AND SAFETY				1,614.04
6879	MAINTENANCE	1554	19-Dec-2018	19-Dec-2018	
10-5-7017300-0725	PARKING LOT MAINTENANCE - UCCU (2011)				672.35
6906	MAINTENANCE	296	22-Feb-2019	22-Feb-2019	
10-5-7017300-0317	BUILDING MAINTENANCE				624.33
6907	MAINTENANCE	296	01-Mar-2019	01-Mar-2019	
10-5-7017300-0317	BUILDING MAINTENANCE				2,005.75
<b>VOL001</b>	<b>VOLLMER A MULTI TRADE CONTRACTOR</b>				
W25714	MAINTENANCE	1606	12-Sep-2018	12-Sep-2018	
10-5-7017300-0331	REFRIGERATION MAINTENANCE				14,244.62
W27708	MAINTENANCE	1607	30-Nov-2018	30-Nov-2018	
10-5-7017300-0331	REFRIGERATION MAINTENANCE				1,934.47
W27743	MAINTENANCE REPAIRS	1607	30-Nov-2018	30-Nov-2018	
10-5-7017300-0317	BUILDING MAINTENANCE				902.68
W27800	MAINTENANCE	1607	17-Dec-2018	17-Dec-2018	
10-5-7017300-0317	BUILDING MAINTENANCE				4,455.79
W27835	MAINTENANCE REPAIRS	1607	17-Dec-2018	17-Dec-2018	
10-5-7017300-0331	REFRIGERATION MAINTENANCE				1,729.28
W28010	MAINTENANCE	1607	21-Dec-2018	21-Dec-2018	
10-5-7017300-0317	BUILDING MAINTENANCE				589.86
W28382	REFRIGERATION REPAIRS	134	29-Jan-2019	29-Jan-2019	
10-5-7017300-0331	REFRIGERATION MAINTENANCE				2,654.37
<b>WIG035</b>	<b>WIGLE HOME HARDWARE BUILDING CENTRE</b>				
119770	MAINTENANCE MATERIALS	1607	20-Jun-2018	20-Jun-2018	
10-5-7017300-0317	BUILDING MAINTENANCE				16.89
120132	MAINTENANCE MATERIALS	1607	29-Jun-2018	29-Jun-2018	
10-5-7017300-0317	BUILDING MAINTENANCE				6.20
123391	MAINTENANCE MATERIALS	1607	12-Oct-2018	12-Oct-2018	
10-5-7017300-0317	BUILDING MAINTENANCE				20.29
123489	MAINTENANCE MATERIALS	1607	15-Oct-2018	15-Oct-2018	
10-5-7017300-0317	BUILDING MAINTENANCE				6.43
125651	SUPPLIES DEC 13, 2018	133	31-Jan-2019	31-Jan-2019	
10-5-7017300-0317	BUILDING MAINTENANCE				20.55
126048	SUPPLIES	15	02-Jan-2019	02-Jan-2019	
10-5-7017300-0317	BUILDING MAINTENANCE				10.16
126182	SUPPLIES	15	08-Jan-2019	08-Jan-2019	
10-5-7017300-0317	BUILDING MAINTENANCE				10.72
126258	MAINTENANCE SUPPLIES	62	10-Jan-2019	10-Jan-2019	
10-5-7017300-0402	VEHICLE & EQUIPMENT MTCE.				13.80
126484	MAINTENANCE SUPPLIES	62	17-Jan-2019	17-Jan-2019	
10-5-7017300-0317	BUILDING MAINTENANCE				89.52
126639	MAINTENANCE SUPPLIES	106	23-Jan-2019	23-Jan-2019	



## Council/Board Report By Dept-(Computer)



Vendor : CAT038 To ZUL180

Batch : All

Department : All

Cheque Print Date : 01-Jan-2019 To 31-May-2019

Bank : 1 To 99

Class : All

Vendor Invoice	Vendor Name Description	Batch	Inv Date	Inv Due Date	Amount
G.L. Account	CC1 CC2 CC3 GL Account Name				
<b>DEPARTMENT 7017300</b>	LIBRO				
10-5-7017300-0317	BUILDING MAINTENANCE				197.14
127073	SUPPLIES FOR SIGN INSTALLATION	135	05-Feb-2019	05-Feb-2019	
10-5-7017300-0317	BUILDING MAINTENANCE				33.95
127164	MAINTENANCE SUPPLIES	177	07-Feb-2019	07-Feb-2019	
10-5-7017300-0317	BUILDING MAINTENANCE				8.34
127173	MAINTENANCE SUPPLIES	177	08-Feb-2019	08-Feb-2019	
10-5-7017300-0317	BUILDING MAINTENANCE				19.19
127522	MATERIALS	204	21-Feb-2019	21-Feb-2019	
10-5-7017300-0317	BUILDING MAINTENANCE				17.49
127616	SUPPLIES	250	25-Feb-2019	25-Feb-2019	
10-5-7017300-0317	BUILDING MAINTENANCE				20.32
128068	MAINTENANCE	296	12-Mar-2019	12-Mar-2019	
10-5-7017300-0317	BUILDING MAINTENANCE				110.01
128138	MAINTENANCE SUPPLIES	345	14-Mar-2019	14-Mar-2019	
10-5-7017300-0317	BUILDING MAINTENANCE				31.37
128143	MAINTENANCE	296	14-Mar-2019	14-Mar-2019	
10-5-7017300-0317	BUILDING MAINTENANCE				3.75
128281	REPAIRS/WATER LINES AND BOARD BRUSH	319	19-Mar-2019	19-Mar-2019	
10-5-7017300-0402	VEHICLE & EQUIPMENT MTCE.				38.47
128467	MAINTENANCE SUPPLIES	345	25-Mar-2019	25-Mar-2019	
10-5-7017300-0317	BUILDING MAINTENANCE				90.38
128708	MAINTENANCE SUPPLIES	347	02-Apr-2019	02-Apr-2019	
10-5-7017300-0317	BUILDING MAINTENANCE				26.83
128755	MAINTENANCE SUPPLIES	347	02-Apr-2019	02-Apr-2019	
10-5-7017300-0317	BUILDING MAINTENANCE				53.71
128849	SUPPLIES	347	05-Apr-2019	05-Apr-2019	
10-5-7017300-0317	BUILDING MAINTENANCE				32.66
128999	SUPPLIES	389	09-Apr-2019	09-Apr-2019	
10-5-7017300-0317	BUILDING MAINTENANCE				11.85
129003	HARDWARE FOR AMHA BANNERS INSTALLATION	347	09-Apr-2019	09-Apr-2019	
10-5-7017300-0317	BUILDING MAINTENANCE				73.34
129052	SUPPLIES	389	10-Apr-2019	10-Apr-2019	
10-5-7017300-0317	BUILDING MAINTENANCE				22.14
129460	MAINTENANCE SUPPLIES	436	23-Apr-2019	23-Apr-2019	
10-5-7017300-0960	OUTDOOR SOCCER (NAT TURF)				194.30
129568	MAINTENANCE SUPPLIES	436	25-Apr-2019	25-Apr-2019	
10-5-7017300-0317	BUILDING MAINTENANCE				123.68
129569	MAINTENANCE SUPPLIES	436	25-Apr-2019	25-Apr-2019	
10-5-7017300-0960	OUTDOOR SOCCER (NAT TURF)				42.94
129939	SUPPLIES	481	06-May-2019	06-May-2019	
10-5-7017300-0317	BUILDING MAINTENANCE				9.01
130197	HARDWARE	525	13-May-2019	13-May-2019	
10-5-7017300-0317	BUILDING MAINTENANCE				40.71
<b>WIN1506 WINMECH LTD</b>					
INV-0001	MAINTENANCE	135	02-Feb-2019	02-Feb-2019	
10-5-7017300-0331	REFRIGERATION MAINTENANCE				1,073.50
INV-0004	MAINTENANCE	135	04-Feb-2019	04-Feb-2019	
10-5-7017300-0331	REFRIGERATION MAINTENANCE				1,281.02
INV-0007	EQUIPMENT MAINTENANCE	177	06-Feb-2019	06-Feb-2019	
10-5-7017300-0331	REFRIGERATION MAINTENANCE				4,576.80
INV-0009	EQUIPMENT MAINTENANCE	177	11-Feb-2019	11-Feb-2019	
10-5-7017300-0331	REFRIGERATION MAINTENANCE				1,300.94
INV-0012	REFRIGERATIONS REPAIRS	204	14-Feb-2019	14-Feb-2019	



Vendor : CAT038 To ZUL180

Batch : All

Department : All

Cheque Print Date : 01-Jan-2019 To 31-May-2019

Bank : 1 To 99

Class : All

Vendor Invoice	Vendor Name Description	Batch	Inv Date	Inv Due Date	Amount
G.L. Account	CC1 CC2 CC3 GL Account Name				
<b>DEPARTMENT 7017300 LIBRO</b>					
10-5-7017300-0331					
	REFRIGERATION MAINTENANCE				904.00
INV-0014	REFRIGERATIONS REPAIRS	204	20-Feb-2019	20-Feb-2019	
10-5-7017300-0331					
	REFRIGERATION MAINTENANCE				751.45
INV-0015	REFRIGERATION REPAIRS	204	25-Feb-2019	25-Feb-2019	
10-5-7017300-0331					
	REFRIGERATION MAINTENANCE				736.93
INV-0028	MAINTENANCE	347	10-Apr-2019	10-Apr-2019	
10-5-7017300-0331					
	REFRIGERATION MAINTENANCE				2,542.50
INV-0029	MAINTENANCE	347	10-Apr-2019	10-Apr-2019	
10-5-7017300-0331					
	REFRIGERATION MAINTENANCE				1,446.40
INV-0034	MAINTENANCE	406	18-Apr-2019	18-Apr-2019	
10-5-7017300-0317					
	BUILDING MAINTENANCE				4,648.26
INV-0037	MAINTENANCE	406	18-Apr-2019	18-Apr-2019	
10-5-7017300-0331					
	REFRIGERATION MAINTENANCE				576.30
<b>WIN210 WINDSOR FACTORY SUPPLY LTD</b>					
4911857	LADDER SERVICE	1554	27-Nov-2018	27-Nov-2018	
10-5-7017300-0317					
	BUILDING MAINTENANCE				260.86
4961260	MAINTENANCE MATERIALS	204	12-Feb-2019	12-Feb-2019	
10-5-7017300-0317					
	BUILDING MAINTENANCE				92.50
4980719	MAINTENANCE MATERIALS	296	13-Mar-2019	13-Mar-2019	
10-5-7017300-0317					
	BUILDING MAINTENANCE				16.88
5001203	MAINTENANCE MATERIALS	347	11-Apr-2019	11-Apr-2019	
10-5-7017300-0317					
	BUILDING MAINTENANCE				78.02
5005501	SUPPLIES TO REPAIR NETTING PREMIER FIELD	436	17-Apr-2019	17-Apr-2019	
10-5-7017300-0962					
	PREMIER BASEBALL FIELD				73.90
5005534	SUPPLIES TO REPAIR NETTING PREMIER FIELD	436	17-Apr-2019	17-Apr-2019	
10-5-7017300-0962					
	PREMIER BASEBALL FIELD				70.30
5006155	SUPPLIESTO REPAIR NETTING PERMIER FIELD	436	18-Apr-2019	18-Apr-2019	
10-5-7017300-0962					
	PREMIER BASEBALL FIELD				504.84
5009644	BASEBALL SUPPLIES FOR THE PREMIER DIAMOND	436	25-Apr-2019	25-Apr-2019	
10-5-7017300-0962					
	PREMIER BASEBALL FIELD				273.67
5014989	SOCCER NET MAINTENANCE	525	02-May-2019	02-May-2019	
10-5-7017300-0960					
	OUTDOOR SOCCER (NAT TURF)				192.21
5015040	LIBRO MAINTENANCE MATERIALS	525	02-May-2019	02-May-2019	
10-5-7017300-0317					
	BUILDING MAINTENANCE				114.35
5015595	BASEBALL DIAMOND MAINTENANCE	525	03-May-2019	03-May-2019	
10-5-7017300-0962					
	PREMIER BASEBALL FIELD				61.12
<b>WIN270 WINDSOR DISPOSAL SERVICES LTD</b>					
0000927929	CARDBOARD SERVICES	250	29-Jan-2019	29-Jan-2019	
10-5-7017300-0336					
	CONTRACTED SERVICES				68.87
0000936556	CARDBOARD SERVICE	252	01-Mar-2019	01-Mar-2019	
10-5-7017300-0336					
	CONTRACTED SERVICES				67.18
<b>WOR415 WORK AUTHORITY</b>					
503852	CLOTHING	62	06-Jan-2019	06-Jan-2019	
10-5-7017300-0161					
	CLOTHING				207.11
504975	CLOTHING	62	13-Jan-2019	13-Jan-2019	
10-5-7017300-0161					
	CLOTHING				169.49
511358	BOOTS	204	10-Feb-2019	10-Feb-2019	
10-5-7017300-0161					
	CLOTHING				172.88
512799	CLOTHING	250	17-Feb-2019	17-Feb-2019	
10-5-7017300-0161					
	CLOTHING				223.73
517311	CLOTHING CREDIT	319	10-Mar-2019	10-Mar-2019	
10-5-7017300-0161					
	CLOTHING				-203.39
517312	CLOTHING	319	10-Mar-2019	10-Mar-2019	



Vendor : CAT038 To ZUL180

Batch : All

Department : All

Cheque Print Date : 01-Jan-2019 To 31-May-2019

Bank : 1 To 99

Class : All

Vendor Invoice	Vendor Name Description	Batch	Inv Date	Inv Due Date	Amount
G.L. Account	CC1 CC2 CC3 GL Account Name				
<b>DEPARTMENT 7017300 LIBRO</b>					
10-5-7017300-0161	CLOTHING				372.88
<b>ZAM038 ZAMBONI COMPANY LTD</b>					
098897	ZAMBONI REPAIRS	1523	06-Dec-2018	06-Dec-2018	
10-5-7017300-0402	VEHICLE & EQUIPMENT MTCE.				989.45
099082	BATTERIES FOR EDGER	1607	13-Dec-2018	13-Dec-2018	
10-5-7017300-0402	VEHICLE & EQUIPMENT MTCE.				915.30
099132	REPAIRS TO BOTH ZAMBONI'S RS2 & RS3	436	29-Apr-2019	29-Apr-2019	
10-5-7017300-0402	VEHICLE & EQUIPMENT MTCE.				10,500.55
099187	BATTERIES FOR ICE EDGER	1607	21-Dec-2018	21-Dec-2018	
10-5-7017300-0402	VEHICLE & EQUIPMENT MTCE.				87.52
099930	ZAMBONI SERVICES	280	15-Feb-2019	15-Feb-2019	
10-5-7017300-0402	VEHICLE & EQUIPMENT MTCE.				1,677.60
099931	ZAMBONI PARTS	280	15-Feb-2019	15-Feb-2019	
10-5-7017300-0402	VEHICLE & EQUIPMENT MTCE.				2,849.18
100130	ZAMBONI PARTS	296	06-Mar-2019	06-Mar-2019	
10-5-7017300-0402	VEHICLE & EQUIPMENT MTCE.				1,323.39
100702	ZAMBONI PARTS	525	06-May-2019	06-May-2019	
10-5-7017300-0317	BUILDING MAINTENANCE				659.25
<b>Department Totals :</b>					<b>151,475.90</b>

<b>DEPARTMENT 8010000 PLANNING &amp; LEGISLATIVE SERVICES</b>					
<b>ADV329 ADVANCE BUSINESS SYSTEMS</b>					
657976	SUPPLIES	280	18-Jan-2019	18-Jan-2019	
10-5-8010000-0301	OFFICE SUPPLIES				221.48
<b>AMH035 AMHERSTBURG HARDWARE INC.</b>					
MARCH 18, 20	PARTIAL REFUND - PLANNING FEES (SITE PLAN CONTROL APPLICATION)	282	18-Mar-2019	18-Mar-2019	
10-4-8010000-1910	PLANNING - OTHER FEES				754.87
<b>AMH268 AMHERSTBURG CHAMBER COMMERCE</b>					
3655	BUISNESS EXCELLENCE AWARDS DINNER TICKETS	436	28-Feb-2019	28-Feb-2019	
10-5-8010000-0342	MEETINGS				60.00
<b>CAC190 CANADIAN ASSOCIATION OF CERTIFIED PLANNING</b>					
2019 INVOICE	MEMBERSHIP 06151242 2019 ANNUAL DUES	99	23-Jan-2019	23-Jan-2019	
10-5-8010000-0327	PROFESSIONAL FEES				215.00
<b>ESS53 ESSEX REGION CONSERVATION AUTHORITY</b>					
IN000014504	MUNICIPAL PLAN REVIEW FEES PROCESSED BY ERCA BETWEEN JULY 1 AND DECEMBER 31, 2018	1554	31-Dec-2018	31-Dec-2018	
10-5-8010000-0339	ERCA PLAN REVIEW				7,735.00
<b>FRE040 FRENCH MATTHEW</b>					
B-6-19	CONSENT APPLICATION REFUND - WITHDRAWN BY APPLICANT B-6-19	204	26-Feb-2019	26-Feb-2019	
10-4-8010000-1905	PLANNING - DEPOSIT FEES				700.00
<b>HAR484 HARRIS KEN</b>					
APRIL 26, 201	PLANNING DEPOSIT REFUND(WITHDRAWL OF ZBA APPLICATION)	406	26-Apr-2019	26-Apr-2019	
10-4-8010000-1910	PLANNING - OTHER FEES				2,300.00
<b>MCT455 MCTAGUE LAW FIRM</b>					
300056	LEGAL FEES	1608	07-Dec-2018	07-Dec-2018	
10-5-8010000-0367	GLOBAL LEGAL FEES				14,389.99
300057	LEGAL FEES	1557	07-Dec-2018	07-Dec-2018	
10-5-8010000-0367	GLOBAL LEGAL FEES				1,154.59
300319	LEGAL FEES	1554	19-Dec-2018	19-Dec-2018	
10-5-8010000-0367	GLOBAL LEGAL FEES				4,768.98
300649	LEGAL FEES	62	14-Jan-2019	14-Jan-2019	
10-5-8010000-0367	GLOBAL LEGAL FEES				118.65



Vendor : CAT038 To ZUL180

Batch : All

Department : All

Cheque Print Date : 01-Jan-2019 To 31-May-2019

Bank : 1 To 99

Class : All

Vendor Invoice	Vendor Name Description	Batch	Inv Date	Inv Due Date	Amount
G.L. Account	CC1 CC2 CC3 GL Account Name				
<b>DEPARTMENT 8010000 PLANNING &amp; LEGISLATIVE SERVICES</b>					
300705	LEGAL FEES	62	14-Jan-2019	14-Jan-2019	
10-5-8010000-0367	GLOBAL LEGAL FEES				4,381.58
301242	PROFESSIONAL SERVICES	280	27-Feb-2019	27-Feb-2019	
10-5-8010000-0367	GLOBAL LEGAL FEES				39.55
301548	LEGAL FEES	436	08-Mar-2019	08-Mar-2019	
10-5-8010000-0367	GLOBAL LEGAL FEES				39.55
301549	LEGAL FEES	525	08-Mar-2019	08-Mar-2019	
10-5-8010000-0325	LEGAL FEES				4,690.16
301818	PROFESSIONAL SERVICES	436	31-Mar-2019	31-Mar-2019	
10-5-8010000-0373	LPAT EXPENSES				3,812.90
301978	LEGAL FEES	525	10-Apr-2019	10-Apr-2019	
10-5-8010000-0325	LEGAL FEES				39.55
302283	PROFESSIONAL SERVICES	525	01-May-2019	01-May-2019	
10-5-8010000-0325	LEGAL FEES				5,174.50
302483	PROFESSIONAL SERVICES	525	10-May-2019	10-May-2019	
10-5-8010000-0325	LEGAL FEES				565.57
71438	LEGAL FEES	1554	20-Dec-2018	20-Dec-2018	
10-5-8010000-0367	GLOBAL LEGAL FEES				11,845.26
<b>MON183 MONARCH OFFICE SUPPLY LTD</b>					
122755	NOVEMBER 2018 PURCHASES	1606	29-Nov-2018	29-Nov-2018	
10-5-8010000-0301	OFFICE SUPPLIES				221.30
133006	JANUARY 2018 PURCHASES	176	30-Jan-2019	30-Jan-2019	
10-5-8010000-0301	OFFICE SUPPLIES				83.85
10-5-8010000-0301	OFFICE SUPPLIES				180.16
138007	FEBRUARY 2019 PURCHASE	319	27-Feb-2019	27-Feb-2019	
10-5-8010000-0301	OFFICE SUPPLIES				107.91
10-5-8010000-0301	OFFICE SUPPLIES				21.18
143523	MARCH 2019 PURCHASES	406	29-Mar-2019	29-Mar-2019	
10-5-8010000-0301	OFFICE SUPPLIES				103.34
<b>MON610 MONTEITH BROWN PLANNING CONSULTANTS</b>					
13933	PROFESSIONAL FEES	105	15-Jan-2019	15-Jan-2019	
10-5-8010000-0327	PROFESSIONAL FEES				593.25
<b>MOR26 MORNEAU SHEPELL LTD.</b>					
FEBRUARY 20	921007, 921008, 921009, 921010 FEBRUARY 2019	135	01-Feb-2019	01-Feb-2019	
10-5-8010000-0207	BENEFITS - LIFE & DISABIL				16.64
JANUARY 2019	902738, 902739, 902740, 902741 JANUARY 2019	62	02-Jan-2019	02-Jan-2019	
10-5-8010000-0207	BENEFITS - LIFE & DISABIL				16.64
MARCH 2019	936899, 936900, 936901, 936902 MARCH 2019	280	01-Mar-2019	01-Mar-2019	
10-5-8010000-0207	BENEFITS - LIFE & DISABIL				16.64
MAY 2019	970411, 970412, 970413, 970414 MAY 2019	511	01-May-2019	01-May-2019	
10-5-8010000-0207	BENEFITS - LIFE & DISABIL				16.64
<b>MOU001 MOUSSEAU DELUCA McPHERSON PRINCE</b>					
58497	LEGAL FEES	1554	30-Nov-2018	30-Nov-2018	
10-5-8010000-0367	GLOBAL LEGAL FEES				176.93
58498	LEGAL FEES	1554	30-Nov-2018	30-Nov-2018	
10-5-8010000-0367	GLOBAL LEGAL FEES				173.71
58520	LEGAL FEES	1554	30-Nov-2018	30-Nov-2018	
10-5-8010000-0325	LEGAL FEES				476.64
58559	LEGAL FEES	1554	30-Nov-2018	30-Nov-2018	
10-5-8010000-0367	GLOBAL LEGAL FEES				949.20
58560	LEGAL FEES - 209 VICTORIA SITE CONDITION	1557	30-Nov-2018	30-Nov-2018	
10-5-8010000-0325	LEGAL FEES				786.55
58595	LEGAL SERVICES	1554	30-Nov-2018	30-Nov-2018	



Vendor : CAT038 To ZUL180

Batch : All

Department : All

Cheque Print Date : 01-Jan-2019 To 31-May-2019

Bank : 1 To 99

Class : All

Vendor Invoice	Vendor Name Description	Batch	Inv Date	Inv Due Date	Amount
G.L. Account	CC1 CC2 CC3 GL Account Name				
<b>DEPARTMENT 8010000</b>	PLANNING & LEGISLATIVE SERVICES				
10-5-8010000-0367	GLOBAL LEGAL FEES				98.88
58596	LEGAL FEES	1554	30-Nov-2018	30-Nov-2018	
10-5-8010000-0367	GLOBAL LEGAL FEES				8,080.91
58698	LEGAL FEES	1606	31-Dec-2018	31-Dec-2018	
10-5-8010000-0325	LEGAL FEES				1,233.96
58759	LEGAL FEES	250	08-Jan-2019	08-Jan-2019	
10-5-8010000-0367	GLOBAL LEGAL FEES				237.30
58978 (1)	LEGAL FEES	347	31-Jan-2019	31-Jan-2019	
10-5-8010000-0367	GLOBAL LEGAL FEES				474.60
58978 (2)	LEGAL PLANNING FEES	347	31-Jan-2019	31-Jan-2019	
10-5-8010000-0367	GLOBAL LEGAL FEES				508.50
58978 (3)	LEGAL FEES	347	31-Jan-2019	31-Jan-2019	
10-5-8010000-0367	GLOBAL LEGAL FEES				322.27
58981	LEGAL FEES	250	31-Jan-2019	31-Jan-2019	
10-5-8010000-0367	GLOBAL LEGAL FEES				3,565.15
59004	LEGAL FEES	250	31-Jan-2019	31-Jan-2019	
10-5-8010000-0367	GLOBAL LEGAL FEES				169.50
59006	LEGAL FEES	250	31-Jan-2019	31-Jan-2019	
10-5-8010000-0367	GLOBAL LEGAL FEES				440.70
59125 A	LEGAL FEES	280	28-Feb-2019	28-Feb-2019	
10-5-8010000-0367	GLOBAL LEGAL FEES				1,389.90
59125 C	LEGAL FEES	280	28-Feb-2019	28-Feb-2019	
10-5-8010000-0367	GLOBAL LEGAL FEES				949.20
59130	LEGAL FEES	280	28-Feb-2019	28-Feb-2019	
10-5-8010000-0325	LEGAL FEES				63.80
59159	GLOBAL LEGAL FEES	296	28-Feb-2019	28-Feb-2019	
10-5-8010000-0367	GLOBAL LEGAL FEES				169.50
59321	PROFESSIONAL SERVICES	406	30-Apr-2019	30-Apr-2019	
10-5-8010000-0325	LEGAL FEES				628.13
<b>MUN200 MUNICIPAL EMPLOYER PENSION CENTRE OF ONTARIO</b>					
MC004654	MEPCO 2019 E MPLOYEE CONTRIBUTION	15	02-Jan-2019	02-Jan-2019	
10-5-8010000-0350	MEMBERSHIPS				54.30
<b>PIT565 PITTAO'S AUTO CARE INC</b>					
MARCH 29, 20	REIMBURSEMENT PLANNING FEES (SITE PLAN CONTROL APPLICATION)	345	29-Mar-2019	29-Mar-2019	
10-4-8010000-1910	PLANNING - OTHER FEES				2,000.00
<b>RTT067 RIVER TOWN TIMES</b>					
1233	ADVERTISING	176	13-Feb-2019	13-Feb-2019	
10-5-8010000-0327	PROFESSIONAL FEES				141.00
<b>THO199 THOMSON REUTERS CANADA</b>					
8776037	OFFICE SUPPLIES	1595	20-Dec-2018	20-Dec-2018	
10-5-8010000-0301	OFFICE SUPPLIES				317.57
<b>TRA040 TRACY PILLON-ABBS RRP</b>					
000151	CONSULTING	347	08-Apr-2019	08-Apr-2019	
10-5-8010000-0327	PROFESSIONAL FEES				9,503.03
<b>TRI249 TRI GRAPHICS</b>					
5365	BUSINESS CARDS	406	24-Apr-2019	24-Apr-2019	
10-5-8010000-0301	OFFICE SUPPLIES				58.76
<b>VAN302 VANDENBRINK FARMS</b>					
MAY 17, 2019	CONSENT APPLICATION REFUND -	511	17-May-2019	17-May-2019	
10-4-8010000-1905	PLANNING - DEPOSIT FEES				1,200.00
<b>WIL870 WILKINS SCOTT GLENDON CAMPBELL</b>					
JANUARY 2019	PARTIAL REFUND PLANNING FEES	15	02-Jan-2019	02-Jan-2019	
10-4-8010000-1910	PLANNING - OTHER FEES				979.36



Vendor : CAT038 To ZUL180  
 Batch : All  
 Department : All

Cheque Print Date : 01-Jan-2019 To 31-May-2019  
 Bank : 1 To 99  
 Class : All

Vendor Invoice	Vendor Name Description				Batch Invc Date	Invc Due Date	Amount
G.L. Account	CC1	CC2	CC3	GL Account Name			
<b>DEPARTMENT 8010000 PLANNING &amp; LEGISLATIVE SERVICES</b>					<b>Department Totals : 99,534.08</b>		
-----							
<b>DEPARTMENT 8020000 TOURISM VISITOR INFORMATION CENTRE</b>							
<b>ALL180</b>	<b>ALLEGRA MARKETING PRINT MAIL</b>						
112628	GENERAL				525	13-May-2019	13-May-2019
10-5-8020000-0307		GENER/		ADVERTISING			333.35
<b>AMH377</b>	<b>AMHERSTBURG MINOR BASEBALL</b>						
APRIL 27, 2019 REFUND OF EVENT SECURITY DEPOSIT					436	27-Apr-2019	27-Apr-2019
10-4-8020000-1306				EVENT REVENUE			250.00
<b>ASI142</b>	<b>A SIGN 4 SUCCESS</b>						
1721	AMHERSTBURG UNCOMMON				345	26-Mar-2019	26-Mar-2019
10-5-8020000-0355				PRINTED MATERIAL\PROMOTIONAL PRODUCTS			268.38
<b>CIN205</b>	<b>CINNAMON TOAST CREATIVE + STRATEGY</b>						
0003549	BRANDING				319	19-Mar-2019	19-Mar-2019
10-5-8020000-0355				PRINTED MATERIAL\PROMOTIONAL PRODUCTS			6,215.00
<b>CKL164</b>	<b>CKLW-AM BELL MEDIA INC.</b>						
1322727-1	AMHERSTBURG HOUSE TOUR				1554	25-Nov-2018	25-Nov-2018
10-5-8020000-0355				PRINTED MATERIAL\PROMOTIONAL PRODUCTS			1,175.20
1327134-1	RIVER LIGHTS				1554	25-Nov-2018	25-Nov-2018
10-5-8020000-0340		RIVERL		COMMUNITY EVENTS			1,175.20
<b>CTV001</b>	<b>CTV2 WINDSOR (CHWI-TV) DIVISION OF BELL MEDIA</b>						
0142002169	RIVER LIGHTS				1554	25-Nov-2018	25-Nov-2018
10-5-8020000-0307		RIVERL		ADVERTISING			542.40
<b>DEL091</b>	<b>DELISLE SIGNS</b>						
283	GENERAL				345	29-Mar-2019	29-Mar-2019
10-5-8020000-0355				PRINTED MATERIAL\PROMOTIONAL PRODUCTS			127.69
284	GENERAL				436	24-Apr-2019	24-Apr-2019
10-5-8020000-0307		GENER/		ADVERTISING			384.20
<b>HAL561</b>	<b>HALLMARK MEMORIAL &amp; SIGNS</b>						
20018	RIVER LIGHTS				319	16-Mar-2019	16-Mar-2019
10-5-8020000-0355				PRINTED MATERIAL\PROMOTIONAL PRODUCTS			819.25
<b>HEN865</b>	<b>HENDERSON JASON</b>						
001000	AMHERSTBURG UNCOMMON				345	01-Mar-2019	01-Mar-2019
10-5-8020000-0340		UNCOMI		COMMUNITY EVENTS			2,542.50
<b>HIC441</b>	<b>HICKS ELECTRIC</b>						
9685	RIVER LIGHTS				1554	13-Dec-2018	13-Dec-2018
10-5-8020000-0340		RIVERL		COMMUNITY EVENTS			339.00
<b>IMP683</b>	<b>4IMPRINT INC.</b>						
17720052	GENERAL				406	11-Apr-2019	11-Apr-2019
10-5-8020000-0307		GENER/		ADVERTISING			373.36
<b>IPR571</b>	<b>IPROMOTEU CANADA INC</b>						
120476ZAY	GENERAL				62	14-Jan-2019	14-Jan-2019
10-5-8020000-0355				PRINTED MATERIAL\PROMOTIONAL PRODUCTS			86.98
122109ZAY	AMHERSTBURG UNCOMMON				406	15-Apr-2019	15-Apr-2019
10-5-8020000-0307		UNCOMI		ADVERTISING			2,048.41
12229ZAY	GENERAL				481	25-Apr-2019	25-Apr-2019
10-5-8020000-0307		GENER/		ADVERTISING			1,548.89
<b>JAC142</b>	<b>JACOBSON HAT CO.INC</b>						
63272	AMHERSTBURG UNCOMMON				436	09-Apr-2019	09-Apr-2019
10-5-8020000-0355				PRINTED MATERIAL\PROMOTIONAL PRODUCTS			1,449.92
<b>JAN473</b>	<b>JANA CURLL ILLUSTRATION &amp; DESIGN</b>						





Vendor : CAT038 To ZUL180

Batch : All

Department : All

Cheque Print Date : 01-Jan-2019 To 31-May-2019

Bank : 1 To 99

Class : All

Vendor Invoice	Vendor Name Description	Batch	Inv Date	Inv Due Date	Amount
G.L. Account	CC1 CC2 CC3 GL Account Name				
<b>DEPARTMENT 8020000</b>	<b>TOURISM VISITOR INFORMATION CENTRE</b>				
19-003 GENERAL		389	30-Mar-2019	30-Mar-2019	
10-5-8020000-0355	PRINTED MATERIAL\PROMOTIONAL PRODUCTS				1,000.00
<b>KIN309 KINGSFORT ENVIRONMENTAL FALCONRY SERVICES INC.</b>					
2019-20 AMHERSTBURG UNCOMMON		204	11-Jan-2019	11-Jan-2019	
10-5-8020000-0340 UNCOMI	COMMUNITY EVENTS				2,480.35
<b>KNE725 KNELSEN AGATHA</b>					
291 GENERAL		436	23-Apr-2019	23-Apr-2019	
10-5-8020000-0307 GENERA/	ADVERTISING				1,000.00
<b>LAS111 LASALLE POST</b>					
00038930 HOLIDAY HOUSE TOURS		1554	02-Nov-2018	02-Nov-2018	
10-5-8020000-0307 HOUSTC	ADVERTISING				936.77
<b>LEC171 LECOURS MICHELLE</b>					
APRIL 2019 CAKE DECORATING AMHERSTBURG UNCOMMON		525	30-Apr-2019	30-Apr-2019	
10-5-8020000-0307 UNCOMI	ADVERTISING				175.00
<b>MAG148 MAGIC ENTERPRISES PRODUCTIONS</b>					
CANADA DAY : CANADA DAY DEPOSIT		62	22-Jan-2019	22-Jan-2019	
10-5-8020000-0340 CDADAY	COMMUNITY EVENTS				1,045.25
<b>MIC131 MICKLE RYAN</b>					
1 CANADA DAY		319	22-Mar-2019	22-Mar-2019	
10-5-8020000-0340 CDADAY	COMMUNITY EVENTS				250.00
<b>MON183 MONARCH OFFICE SUPPLY LTD</b>					
122755 NOVEMBER 2018 PURCHASES		1606	29-Nov-2018	29-Nov-2018	
10-5-8020000-0301	OFFICE SUPPLIES				97.05
<b>MOR26 MORNEAU SHEPELL LTD.</b>					
APRIL 2019 953243, 953244, 953245, 953246 APRIL 2019		347	01-Apr-2019	01-Apr-2019	
10-5-8020000-0207	BENEFITS - LIFE & DISABILITY				16.64
FEBRUARY 20 921007, 921008, 921009, 921010 FEBRUARY 2019		135	01-Feb-2019	01-Feb-2019	
10-5-8020000-0207	BENEFITS - LIFE & DISABILITY				16.65
JANUARY 2019 902738, 902739, 902740, 902741 JANUARY 2019		62	02-Jan-2019	02-Jan-2019	
10-5-8020000-0207	BENEFITS - LIFE & DISABILITY				16.64
MARCH 2019 936899, 936900, 936901, 936902 MARCH 2019		280	01-Mar-2019	01-Mar-2019	
10-5-8020000-0207	BENEFITS - LIFE & DISABILITY				16.64
MAY 2019 970411, 970412, 970413, 970414 MAY 2019		511	01-May-2019	01-May-2019	
10-5-8020000-0207	BENEFITS - LIFE & DISABILITY				16.64
<b>MUN200 MUNICIPAL EMPLOYER PENSION CENTRE OF ONTARIO</b>					
MC004654 MEPCO 2019 EMPLOYEE CONTRIBUTION		15	02-Jan-2019	02-Jan-2019	
10-5-8020000-0350	MEMBERSHIPS				54.30
<b>PAR372 PARRLINE ELECTRICAL WHOLESALE</b>					
79059 RIVER LIGHTS		1523	10-Nov-2018	10-Nov-2018	
10-5-8020000-0340 RIVERL	COMMUNITY EVENTS				238.10
79073 RIVER LIGHTS		1523	12-Nov-2018	12-Nov-2018	
10-5-8020000-0340 RIVERL	COMMUNITY EVENTS				808.15
79082 2018 EXPENSES RIVER LIGHTS		280	15-Mar-2019	15-Mar-2019	
10-5-8020000-0340 RIVERL	COMMUNITY EVENTS				899.93
79121 RIVER LIGHTS		1523	08-Nov-2018	08-Nov-2018	
10-5-8020000-0340 RIVERL	COMMUNITY EVENTS				152.99
79258 RIVER LIGHTS		1523	16-Nov-2018	16-Nov-2018	
10-5-8020000-0340 RIVERL	COMMUNITY EVENTS				243.61
<b>PUR700 PUROLATOR INC.</b>					
441045798 GENERAL		436	05-Apr-2019	05-Apr-2019	
10-5-8020000-0307 GENERA/	ADVERTISING				4.53
<b>RTT067 RIVER TOWN TIMES</b>					





Vendor : CAT038 To ZUL180

Batch : All

Department : All

Cheque Print Date : 01-Jan-2019 To 31-May-2019

Bank : 1 To 99

Class : All

Vendor Invoice	Vendor Name Description				Batch Invc Date	Invc Due Date	Amount
G.L. Account	CC1	CC2	CC3	GL Account Name			
<b>DEPARTMENT 8020000</b>				<b>TOURISM VISITOR INFORMATION CENTRE</b>			
1006	ADVERTISING				34	10-Jan-2019	10-Jan-2019
10-5-8020000-0307		GENER/		ADVERTISING			87.24
1097	ADVERTISING				134	30-Jan-2019	30-Jan-2019
10-5-8020000-2001				CAPITAL EXPENDITURES			141.00
1773	GENERAL				436	12-Apr-2019	12-Apr-2019
10-5-8020000-0307		GENER/		ADVERTISING			678.00
<b>SAR715 SARAH PARKS HORSEMANSHIP</b>							
JAN 21, 2019	CANADA DAY 2019 DEPOSIT				204	21-Jan-2019	21-Jan-2019
10-5-8020000-0340		CDADAY		COMMUNITY EVENTS			500.00
<b>SOU842 SWOTC SOUTH WEST ONTARIO TOURISM CORPORATION</b>							
2019	2019 OSW TOURISM CONFERENCE				15	02-Jan-2019	02-Jan-2019
10-5-8020000-0351				TRAINING & CONFERENCES			366.00
<b>SOU977 SOUNDS PLUS</b>							
S+43566-116	CANADA DAY				406	11-Apr-2019	11-Apr-2019
10-5-8020000-0340		CDADAY		COMMUNITY EVENTS			2,484.87
<b>STJ05 ST. JOHN THE BAPTIST CHURCH</b>							
APRIL 19, 2019	EVENT SECURITY DEPOSIT REFUND				436	19-Apr-2019	19-Apr-2019
10-4-8020000-1306				EVENT REVENUE			250.00
<b>SUN293 SUNSET ENTERPRIZE &amp; WELDING</b>							
318192	RIVER LIGHTS LIGHT DISPLAY REPAIRS 2018				204	10-Jan-2019	10-Jan-2019
10-5-8020000-0340		RIVERL		COMMUNITY EVENTS			7,487.99
318193	RIVER LIGHTS 2018 EXPENSE				204	14-Jan-2019	14-Jan-2019
10-5-8020000-0340		RIVERL		COMMUNITY EVENTS			1,731.25
<b>TOU333 TOURISM WINDSOR ESSEX PELEE ISLAND</b>							
4040	VISITOR GUIDE				204	06-Feb-2019	06-Feb-2019
10-5-8020000-0307		GENER/		ADVERTISING			1,921.00
4241	GENERAL				436	15-Apr-2019	15-Apr-2019
10-5-8020000-0307		GENER/		ADVERTISING			395.50
<b>TTO1 T-TOGS</b>							
19010	GENERAL				406	16-Apr-2019	16-Apr-2019
10-5-8020000-0307		GENER/		ADVERTISING			270.64
<b>USH021 USHER MARK</b>							
DECEMBER 27	RIVER LIGHTS				1554	27-Dec-2018	27-Dec-2018
10-5-8020000-0340		RIVERL		COMMUNITY EVENTS			16.95
OCTOBER 10,	RIVER LIGHTS				1554	10-Oct-2018	10-Oct-2018
10-5-8020000-0340		RIVERL		COMMUNITY EVENTS			81.86
<b>WIG035 WIGLE HOME HARDWARE BUILDING CENTRE</b>							
120265	AMHERSTBURG UNCOMMON				1595	05-Jul-2018	05-Jul-2018
10-5-8020000-0340		UNCOMI		COMMUNITY EVENTS			46.09
120303	AMHERSTBURG UNCOMMON				1595	06-Jul-2018	06-Jul-2018
10-5-8020000-0340		UNCOMI		COMMUNITY EVENTS			29.67
121132	AMHERSTBURG UNCOMMON				1595	30-Jul-2018	30-Jul-2018
10-5-8020000-0340		UNCOMI		COMMUNITY EVENTS			21.32
121304	AMHERSTBURG UNCOMMON				1608	04-Aug-2018	04-Aug-2018
10-5-8020000-0340		UNCOMI		COMMUNITY EVENTS			91.50
124061	RIVER LIGHTS				1595	30-Oct-2018	30-Oct-2018
10-5-8020000-0340		RIVERL		COMMUNITY EVENTS			498.47
124092	RIVER LIGHTS				1595	31-Oct-2018	31-Oct-2018
10-5-8020000-0340		RIVERL		COMMUNITY EVENTS			218.61
124142	RIVER LIGHTS				1595	01-Nov-2018	01-Nov-2018
10-5-8020000-0340		RIVERL		COMMUNITY EVENTS			31.64
126013	RIVER LIGHTS				1595	29-Dec-2018	29-Dec-2018

Council/Board Report By Dept-(Computer)



Vendor : CAT038 To ZUL180  
 Batch : All  
 Department : All

Cheque Print Date : 01-Jan-2019 To 31-May-2019  
 Bank : 1 To 99  
 Class : All

Vendor Invoice	Vendor Name Description	Batch	Inv Date	Inv Due Date	Amount
G.L. Account	CC1 CC2 CC3 GL Account Name				
<b>DEPARTMENT 8020000</b>	TOURISM VISITOR INFORMATION CENTRE				
10-5-8020000-0340	RIVERL COMMUNITY EVENTS				8.44
126165 RIVER LIGHTS		62	07-Jan-2019	07-Jan-2019	
10-5-8020000-0340	RIVERL COMMUNITY EVENTS				11.84
<b>Department Totals :</b>					<b>46,518.85</b>

<b>DEPARTMENT 8052018</b>	CAPITAL ASSETS				
<b>SLR626</b>	<b>SLR CONTRACTING GROUP INC.</b>				
M411C # 3 PPC # 3		1554	30-Nov-2018	30-Nov-2018	
80-7-8052018-0004	PICKERING WATERMAIN KING TO FRYER				105,372.35
<b>WOO4090</b>	<b>WOOD ENVIRONMENTAL &amp; INFRASTRUCTURE SOLUTIONS</b>				
GS6258 PICKERING W/M		1555	22-Nov-2018	22-Nov-2018	
80-7-8052018-0004	PICKERING WATERMAIN KING TO FRYER				2,297.05
<b>Department Totals :</b>					<b>107,669.40</b>

**Computer Paid Total : 10,266,836.22**

Council/Board Report By Dept-(EFT)



Vendor : CAT038 To ZUL180  
 Batch : All  
 Department : All

EFT Paid Date : 01-Jan-2019 To 31-May-2019  
 Bank : 1 To 99  
 Class : All

Vendor Code	Vendor Name Description	Batch	Inv Date	Inv Due Date	Amount
G.L. Account	CC1 CC2 CC3 GL Account Name				
<b>DEPARTMENT 0000000</b>	WATER DEPARTMENT EXPENDITURES				
<b>AME972</b>	<b>AMERICAN WATER WORKS ASSOCIATION</b>				
0001901404	ELORGSUB ORGANIZATIONAL SUBSCRIPTION FOR ELEARNING 01-APR - 2019 TO MAR 2020	533	15-May-2019	15-May-2019	
80-5-0000000-0350	MEMBERSHIPS				3,364.83
<b>AMH19</b>	<b>AMHERSTBURG PAYROLL-TOWN OF</b>				
PP#01-2019	PP#01-2019 PAYROLL TRANSFER	2	03-Jan-2019	03-Jan-2019	
10-1-0000000-0302	WFCU-PAYROLL 6429187				110,903.08
PP#02-2019	PP#02-2019 PAYROLL TRANSFER	27	10-Jan-2019	10-Jan-2019	
10-1-0000000-0302	WFCU-PAYROLL 6429187				98,781.19
PP#03-2019	PP#03-2019 PAYROLL TRANSFER	73	17-Jan-2019	17-Jan-2019	
10-1-0000000-0302	WFCU-PAYROLL 6429187				96,993.60
PP#04-2019	PP#04-2019 PAYROLL TRANSFER	71	24-Jan-2019	24-Jan-2019	
10-1-0000000-0302	WFCU-PAYROLL 6429187				473,925.08
PP#05-2019	PP#05-2019 PAYROLL TRANSFER	91	31-Jan-2019	31-Jan-2019	
10-1-0000000-0302	WFCU-PAYROLL 6429187				170,412.63
PP#06-2019	PP#06-2019 PAYROLL TRANSFER	156	07-Feb-2019	07-Feb-2019	
10-1-0000000-0302	WFCU-PAYROLL 6429187				99,583.66
PP#07-2019	PP#07-2019 PAYROLL TRANSFER	158	14-Feb-2019	14-Feb-2019	
10-1-0000000-0302	WFCU-PAYROLL 6429187				96,033.14
PP#08-2019	PP#08-2019 PAYROLL TAXES	195	21-Feb-2019	21-Feb-2019	
10-1-0000000-0302	WFCU-PAYROLL 6429187				102,590.12
PP#09-2019	PP#09-2019 PAYROLL TRANSFER	211	28-Feb-2019	28-Feb-2019	
10-1-0000000-0302	WFCU-PAYROLL 6429187				113,287.10
PP#10-2019	PP#10-2019 PAYROLL TRANSFER	256	07-Mar-2019	07-Mar-2019	
10-1-0000000-0302	WFCU-PAYROLL 6429187				99,079.62



Vendor : CAT038 To ZUL180

Batch : All

Department : All

EFT Paid Date : 01-Jan-2019 To 31-May-2019

Bank : 1 To 99

Class : All

Vendor Code	Vendor Name	Batch	Inv Date	Inv Due Date	Amount
Invoice No.	Description				
G.L. Account	CC1 CC2 CC3 GL Account Name				
<b>DEPARTMENT 0000000 WATER DEPARTMENT EXPENDITURES</b>					
PP#11-2019	PP#11-2019 PAYROLL TRANSFER	300	14-Mar-2019	14-Mar-2019	
10-1-0000000-0302	WFCU-PAYROLL 6429187				294,700.31
PP#12-2019	PP#12-2019 PAYROLL TRANSFER	302	21-Mar-2019	21-Mar-2019	
10-1-0000000-0302	WFCU-PAYROLL 6429187				109,771.37
PP#13-2019	PP#13-2019 PAYROLL TRANSFER	323	28-Mar-2019	28-Mar-2019	
10-1-0000000-0302	WFCU-PAYROLL 6429187				110,463.05
PP#14-2019	PP#14-2019 PAYROLL TRANSFER	348	04-Apr-2019	04-Apr-2019	
10-1-0000000-0302	WFCU-PAYROLL 6429187				107,877.78
PP#15-2019	PP#15-2019 PAYROLL TRANSFER	390	11-Apr-2019	11-Apr-2019	
10-1-0000000-0302	WFCU-PAYROLL 6429187				95,659.35
PP#16-2019	PP#16-2019 PAYROLL TRANSFER	392	18-Apr-2019	18-Apr-2019	
10-1-0000000-0302	WFCU-PAYROLL 6429187				99,949.68
PP#17-2019	PP#17-2019 PAYROLL TRANSFER	417	25-Apr-2019	25-Apr-2019	
10-1-0000000-0302	WFCU-PAYROLL 6429187				121,282.30
PP#18-2019	PP#18-2019 PAYROLL TRANSFER	444	02-May-2019	02-May-2019	
10-1-0000000-0302	WFCU-PAYROLL 6429187				104,245.74
PP#19-2019	PP#19-2019 PAYROLL TRANSFER	531	09-May-2019	09-May-2019	
10-1-0000000-0302	WFCU-PAYROLL 6429187				102,055.83
PP#20-2019	PP#20-2019 PAYROLL TRANSFER	507	16-May-2019	16-May-2019	
10-1-0000000-0302	WFCU-PAYROLL 6429187				108,154.56
PP#21-2019	PP#21-2019 PAYROLL TRANSFER	537	23-May-2019	23-May-2019	
10-1-0000000-0302	WFCU-PAYROLL 6429187				106,854.65
PP#22-2019	PP#2019-22 PAYROLL TRANSFER	566	30-May-2019	30-May-2019	
10-1-0000000-0302	WFCU-PAYROLL 6429187				128,868.43
<b>BEL03 BELL MOBILITY INC.</b>					
APR 2019	APRIL 2019 USAGE	403	06-Apr-2019	06-Apr-2019	
80-5-0000000-0345	CELL PHONE				45.20
FEB 2019	FEBRUARY 2019 USAGE	188	06-Feb-2019	06-Feb-2019	
80-5-0000000-0345	CELL PHONE				34.18
JAN 2019	JANUARY 2019 USAGE	58	06-Jan-2019	06-Jan-2019	
80-5-0000000-0345	CELL PHONE				34.36
MAR 2019	MARCH 2019 USAGE	326	06-Mar-2019	06-Mar-2019	
80-5-0000000-0345	CELL PHONE				41.95
MAY 2019	MAY 2019 USAGE	543	06-May-2019	06-May-2019	
80-5-0000000-0345	CELL PHONE				46.63
<b>DIR03 DIRECTOR OF FAMILY RESPONSIBLTY</b>					
APRIL 2019	FAMILY SUPPORT FOR THE MONTH OF APRIL 2019	443	30-Apr-2019	30-Apr-2019	
10-2-0000000-1155	A/P - PAYROLL DED. - FAM.				1,264.00
FEBRUARY 2019	FAMILY SUPPORT FOR THE MONTH OF FEBRUARY 2019	244	28-Feb-2019	28-Feb-2019	
10-2-0000000-1155	A/P - PAYROLL DED. - FAM.				1,264.00
JANUARY 2019	FAMILY SUPPORT FOR THE MONTH OF JANUARY 2019	111	31-Jan-2019	31-Jan-2019	
10-2-0000000-1155	A/P - PAYROLL DED. - FAM.				1,264.00
MARCH 2019	FAMILY SUPPORT FOR THE MONTH OF MARCH 2019	355	31-Mar-2019	31-Mar-2019	
10-2-0000000-1155	A/P - PAYROLL DED. - FAM.				1,264.00
MAY 2019	FAMILY SUPPORT FOR THE MONTH OF MAY 2019	575	30-May-2019	30-May-2019	
10-2-0000000-1155	A/P - PAYROLL DED. - FAM.				1,264.00
<b>ESS46 ESSEX POWERLINES CORPORATION</b>					
APR 2019	ELECTRICITY, WATER & SEWAGE APRIL 2019	517	30-Apr-2019	30-Apr-2019	
80-5-0000000-0316	UTILITIES				350.36
DEC 2018	ELECTRICITY, WATER & SEWAGE DECEMBER 2018	1585	31-Dec-2018	31-Dec-2018	
80-5-0000000-0316	UTILITIES				385.33
FEB 2019	ELECTRICITY, WATER & SEWAGE FEBRUARY 2019	309	28-Feb-2019	28-Feb-2019	
80-5-0000000-0316	UTILITIES				530.03
JAN 2019	ELECTRICITY, WATER & SEWAGE JANUARY 2019	193	31-Jan-2019	31-Jan-2019	



Vendor : CAT038 To ZUL180

Batch : All

Department : All

EFT Paid Date : 01-Jan-2019 To 31-May-2019

Bank : 1 To 99

Class : All

Vendor Code	Vendor Name	Batch	Inv Date	Inv Due Date	Amount
Invoice No.	Description				
G.L. Account	CC1 CC2 CC3 GL Account Name				
<b>DEPARTMENT 0000000 WATER DEPARTMENT EXPENDITURES</b>					
80-5-0000000-0316	UTILITIES				397.52
MAR 2019	ELECTRICITY, WATER & SEWAGE MARCH 2019	411	31-Mar-2019	31-Mar-2019	
80-5-0000000-0316	UTILITIES				415.70
<b>GRE03 GREEN SHIELD CANADA</b>					
APR 2019	APRIL 2019 BENEFITS	375	01-Apr-2019	01-Apr-2019	
10-1-0000000-2068	A/R - EMPLOYEE BENEFITS REGULAR				175.79
10-1-0000000-2064	A/R - EMPLOYEE BENEFITS				1,249.57
80-5-0000000-0206	BENEFITS - GREENSHIELD RE - WATER DEPART				1,757.99
80-5-0000000-0205	BENEFITS - GREENSHIELD				4,302.31
FEB 2019	FEBRUARY 2019 BENEFITS	98	01-Feb-2019	01-Feb-2019	
10-1-0000000-2066	A/R - CLEARING				10,477.42
10-1-0000000-2064	A/R - EMPLOYEE BENEFITS				1,249.57
10-1-0000000-2068	A/R - EMPLOYEE BENEFITS REGULAR				175.79
80-5-0000000-0205	BENEFITS - GREENSHIELD				4,302.31
80-5-0000000-0206	BENEFITS - GREENSHIELD RE - WATER DEPART				1,757.99
JAN 2019	JANUARY 2019 BENEFITS	5	02-Jan-2019	02-Jan-2019	
10-1-0000000-2064	A/R - EMPLOYEE BENEFITS				1,249.57
10-1-0000000-2068	A/R - EMPLOYEE BENEFITS REGULAR				175.79
80-5-0000000-0205	BENEFITS - GREENSHIELD				4,302.31
80-5-0000000-0206	BENEFITS - GREENSHIELD RE - WATER DEPART				1,757.99
MAR 2019	MARCH 2019 BENEFITS	228	01-Mar-2019	01-Mar-2019	
10-1-0000000-2068	A/R - EMPLOYEE BENEFITS REGULAR				175.79
10-1-0000000-2064	A/R - EMPLOYEE BENEFITS				1,249.57
80-5-0000000-0206	BENEFITS - GREENSHIELD RE - WATER DEPART				1,757.99
80-5-0000000-0205	BENEFITS - GREENSHIELD				4,302.31
MAY 2019	MAY 2019 BENEFITS	619	01-May-2019	01-May-2019	
10-1-0000000-2068	A/R - EMPLOYEE BENEFITS REGULAR				175.79
10-1-0000000-2064	A/R - EMPLOYEE BENEFITS				1,249.57
80-5-0000000-0206	BENEFITS - GREENSHIELD RE - WATER DEPART				1,757.99
80-5-0000000-0205	BENEFITS - GREENSHIELD				4,302.31
<b>HYD02 HYDRO ONE NETWORKS</b>					
APR 2019	MICS HYDRO ACCTS FOR APRIL 2019	490	30-Apr-2019	30-Apr-2019	
80-5-0000000-0316	UTILITIES				13,614.76
APR 2019	MAIN ACCOUNT APRIL 2019	500	30-Apr-2019	30-Apr-2019	
80-5-0000000-0316	UTILITIES				133.45
DEC 2018	MISC HYDRO ACCTS FOR DECEMBER 2018	1584	31-Dec-2018	31-Dec-2018	
80-5-0000000-0316	UTILITIES				16,609.63
DEC 2018	MAIN ACCOUNT	1583	31-Dec-2018	31-Dec-2018	
80-5-0000000-0316	UTILITIES				142.51
FEB 2019	MISC HYDRO ACCTS FOR FEBRUARY 2019	278	28-Feb-2019	28-Feb-2019	
80-5-0000000-0316	UTILITIES				14,658.37
FEB 2019	MAIN ACCOUNT FEBRUARY 2019	279	28-Feb-2019	28-Feb-2019	
80-5-0000000-0316	UTILITIES				133.35
JAN 2019	MISC HYDRO ACCTS FOR JANUARY 2019	182	31-Jan-2019	31-Jan-2019	
80-5-0000000-0316	UTILITIES				15,351.83
JAN 2019	MAIN ACCOUNT JANUARY 2019	192	31-Jan-2019	31-Jan-2019	
80-5-0000000-0316	UTILITIES				138.03
MAR 2019	MISC HYDRO ACCTS FOR MARCH 2019	373	31-Mar-2019	31-Mar-2019	
80-5-0000000-0316	UTILITIES				15,729.92
MAR 2019	MAIN ACCOUNT MARCH 2019	370	31-Mar-2019	31-Mar-2019	
80-5-0000000-0316	UTILITIES				191.39
<b>MIN24 MINISTRY OF FINANCE-PAYMENT</b>					
APRIL 2019	EHT FOR THE MONTH OF APRIL 2019	441	30-Apr-2019	30-Apr-2019	
10-2-0000000-1152	A/P - PAYROLL DED. - EHT				12,545.72
DECEMBER 20	EHT FOR THE MONTH OF DECEMBER 2018	1527	31-Dec-2018	31-Dec-2018	
10-2-0000000-1152	A/P - PAYROLL DED. - EHT				22,382.00



Vendor : CAT038 To ZUL180

Batch : All

Department : All

EFT Paid Date : 01-Jan-2019 To 31-May-2019

Bank : 1 To 99

Class : All

Vendor Code	Vendor Name	Batch	Inv Date	Inv Due Date	Amount
Invoice No.	Description				
G.L. Account	CC1 CC2 CC3 GL Account Name				
<b>DEPARTMENT 0000000 WATER DEPARTMENT EXPENDITURES</b>					
FEBRUARY 2019 EHT FOR THE MONTH OF FEBRUARY 2019					
10-2-0000000-1152	A/P - PAYROLL DED. - EHT	243	28-Feb-2019	28-Feb-2019	12,375.73
JANUARY 2019 EHT FOR THE MONTH OF JANUARY 2019					
10-2-0000000-1152	A/P - PAYROLL DED. - EHT	154	31-Jan-2019	31-Jan-2019	17,898.64
MARCH 2019 EHT FOR THE MONTH OF MARCH 2019					
10-2-0000000-1152	A/P - PAYROLL DED. - EHT	353	31-Mar-2019	31-Mar-2019	15,212.00
<b>OME001 OMERS</b>					
APRIL 2019 OMERS CONTRIBUTION FOR APRIL 2019					
10-2-0000000-1144	OMERS PAYABLE	440	30-Apr-2019	30-Apr-2019	105,446.40
DECEMBER 20 OMERS CONTRIBUTION FOR DECEMBER 2018					
10-2-0000000-1144	OMERS PAYABLE	1529	31-Dec-2018	31-Dec-2018	197,809.76
FEBRUARY 2019 OMERS CONTRIBUTION FOR FEBRUARY 2019					
10-2-0000000-1144	OMERS PAYABLE	241	28-Feb-2019	28-Feb-2019	113,350.24
JANUARY 2019 OMERS CONTRIBUTION FOR JANUARY 2019					
10-2-0000000-1144	OMERS PAYABLE	153	31-Jan-2019	31-Jan-2019	151,798.90
MARCH 2019 OMERS CONTRIBUTION FOR MARCH 2019					
10-2-0000000-1144	OMERS PAYABLE	421	31-Mar-2019	31-Mar-2019	116,086.78
MAY 2019 OMERS CONTRIBUTION FOR THE MONTH OF MAY 2019					
10-2-0000000-1144	OMERS PAYABLE	573	31-May-2019	31-May-2019	144,631.22
<b>REC04 RECEIVER GENERAL</b>					
PP#2019-01 FU PP#2019-01 FULL TIME PAYROLL TAXES					
10-2-0000000-1141	A/P - PAYROLL DED. - INC.	1	03-Jan-2019	03-Jan-2019	29,196.55
10-2-0000000-1142	A/P - PAYROLL DED. - CPP				13,685.68
10-2-0000000-1143	A/P - PAYROLL DED. - E.I.				4,999.99
PP#2019-01 PA PP#2019-01 PART TIME PAYROLL TAXES					
10-2-0000000-1143	A/P - PAYROLL DED. - E.I.	1	03-Jan-2019	03-Jan-2019	1,071.71
10-2-0000000-1142	A/P - PAYROLL DED. - CPP				2,197.42
10-2-0000000-1141	A/P - PAYROLL DED. - INC.				3,953.78
PP#2019-02 FU PP#2019-02 FULL TIME PAYROLL TAXES					
10-2-0000000-1141	A/P - PAYROLL DED. - INC.	28	10-Jan-2019	10-Jan-2019	26,837.14
10-2-0000000-1143	A/P - PAYROLL DED. - E.I.				4,491.07
10-2-0000000-1142	A/P - PAYROLL DED. - CPP				12,415.36
PP#2019-02 PA PP#2019-02 PART TIME PAYROLL TAXES					
10-2-0000000-1142	A/P - PAYROLL DED. - CPP	28	10-Jan-2019	10-Jan-2019	2,007.12
10-2-0000000-1143	A/P - PAYROLL DED. - E.I.				971.53
10-2-0000000-1141	A/P - PAYROLL DED. - INC.				3,495.82
PP#2019-03 FU PP#2019-03 FULL TIME PAYROLL TAXES					
10-2-0000000-1141	A/P - PAYROLL DED. - INC.	72	17-Jan-2019	17-Jan-2019	24,743.36
10-2-0000000-1143	A/P - PAYROLL DED. - E.I.				4,300.34
10-2-0000000-1142	A/P - PAYROLL DED. - CPP				11,862.24
PP#2019-03 PA PP#2019-03 PART TIME PAYROLL TAXES					
10-2-0000000-1142	A/P - PAYROLL DED. - CPP	72	17-Jan-2019	17-Jan-2019	2,032.38
10-2-0000000-1143	A/P - PAYROLL DED. - E.I.				969.49
10-2-0000000-1141	A/P - PAYROLL DED. - INC.				3,573.70
PP#2019-04 FU PP#2019-04 FULL TIME PAYROLL TAXES					
10-2-0000000-1141	A/P - PAYROLL DED. - INC.	70	24-Jan-2019	24-Jan-2019	25,255.46
10-2-0000000-1143	A/P - PAYROLL DED. - E.I.				4,361.93
10-2-0000000-1142	A/P - PAYROLL DED. - CPP				12,040.10
PP#2019-04 PA PP#2019-04 PART TIME PAYROLL TAXES					
10-2-0000000-1142	A/P - PAYROLL DED. - CPP	70	24-Jan-2019	24-Jan-2019	6,445.24
10-2-0000000-1143	A/P - PAYROLL DED. - E.I.				2,905.70
10-2-0000000-1141	A/P - PAYROLL DED. - INC.				152,332.78
PP#2019-05 FU PP#2019-05 FULL TIME PAYROLL TAXES REDUCED					
10-2-0000000-1141	A/P - PAYROLL DED. - INC.	90	29-Jan-2019	29-Jan-2019	26,030.80
10-2-0000000-1143	A/P - PAYROLL DED. - E.I.				4,442.42
10-2-0000000-1142	A/P - PAYROLL DED. - CPP				12,272.50





Vendor : CAT038 To ZUL180

Batch : All

Department : All

EFT Paid Date : 01-Jan-2019 To 31-May-2019

Bank : 1 To 99

Class : All

Vendor Code	Vendor Name					Batch	Inv Date	Inv Due Date	Amount	
Invoice No.	Description									
G.L. Account	CC1	CC2	CC3	GL Account Name						
<b>DEPARTMENT 0000000 WATER DEPARTMENT EXPENDITURES</b>										
PP#2019-05 PA	PP#2019-05	PART TIME REGULAR & EXEMPT EMPLOYESS PAYROLL TAXES				90	29-Jan-2019	29-Jan-2019		
10-2-0000000-1142				A/P - PAYROLL DED. - CPP					10,970.92	
10-2-0000000-1143				A/P - PAYROLL DED. - E.I.					4,057.61	
10-2-0000000-1141				A/P - PAYROLL DED. - INC.					18,548.81	
PP#2019-06 FU	PP#2019-06	FULL TIME PAYROLL TAXES				157	07-Feb-2019	07-Feb-2019		
10-2-0000000-1142				A/P - PAYROLL DED. - CPP					12,579.72	
10-2-0000000-1141				A/P - PAYROLL DED. - INC.					26,915.06	
10-2-0000000-1143				A/P - PAYROLL DED. - E.I.					4,548.43	
PP#2019-06 PA	PP#2019-06	PART TIME PAYROLL TAXES				157	07-Feb-2019	07-Feb-2019		
10-2-0000000-1143				A/P - PAYROLL DED. - E.I.					881.80	
10-2-0000000-1141				A/P - PAYROLL DED. - INC.					3,113.09	
10-2-0000000-1142				A/P - PAYROLL DED. - CPP					1,810.46	
PP#2019-07 FU	PP#2019-07	FULL TIME PAYROLL TAXES				159	14-Feb-2019	14-Feb-2019		
10-2-0000000-1143				A/P - PAYROLL DED. - E.I.					4,362.22	
10-2-0000000-1142				A/P - PAYROLL DED. - CPP					12,041.06	
10-2-0000000-1141				A/P - PAYROLL DED. - INC.					25,374.66	
PP#2019-07 PA	PP#2019-07	PART TIME PAYROLL TAXES				194	14-Feb-2019	14-Feb-2019		
10-2-0000000-1142				A/P - PAYROLL DED. - CPP					1,748.92	
10-2-0000000-1141				A/P - PAYROLL DED. - INC.					3,102.34	
10-2-0000000-1143				A/P - PAYROLL DED. - E.I.					865.11	
PP#2019-08 FU	PP#2019-08	FULL TIME PAYROLL TAXES				196	21-Feb-2019	21-Feb-2019		
10-2-0000000-1143				A/P - PAYROLL DED. - E.I.					4,311.37	
10-2-0000000-1141				A/P - PAYROLL DED. - INC.					25,002.10	
10-2-0000000-1142				A/P - PAYROLL DED. - CPP					11,900.32	
PP#2019-08 PA	PP#2019-08	PART TIME PAYROLL TAXES				196	21-Feb-2019	21-Feb-2019		
10-2-0000000-1142				A/P - PAYROLL DED. - CPP					2,028.52	
10-2-0000000-1141				A/P - PAYROLL DED. - INC.					3,426.26	
10-2-0000000-1143				A/P - PAYROLL DED. - E.I.					1,186.44	
PP#2019-09 PA	PP#2019-09	PART TIME PAYROLL TAXES				212	28-Feb-2019	28-Feb-2019		
10-2-0000000-1143				A/P - PAYROLL DED. - E.I.					1,038.81	
10-2-0000000-1141				A/P - PAYROLL DED. - INC.					8,172.70	
10-2-0000000-1142				A/P - PAYROLL DED. - CPP					3,298.64	
PP#2019-09 FU	PP#2019-09	FULL TIME PAYROLL TAXES				212	28-Feb-2019	28-Feb-2019		
10-2-0000000-1142				A/P - PAYROLL DED. - CPP					13,140.52	
10-2-0000000-1141				A/P - PAYROLL DED. - INC.					30,084.29	
10-2-0000000-1143				A/P - PAYROLL DED. - E.I.					4,740.32	
PP#2019-10 FU	PP#2019-10	FULL TIME PAYROLL TAXES				258	07-Mar-2019	07-Mar-2019		
10-2-0000000-1143				A/P - PAYROLL DED. - E.I.					4,198.43	
10-2-0000000-1141				A/P - PAYROLL DED. - INC.					24,209.71	
10-2-0000000-1142				A/P - PAYROLL DED. - CPP					11,582.18	
PP#2019-10 PA	PP#2019-10	PART TIME PAYROLL TAXES				258	07-Mar-2019	07-Mar-2019		
10-2-0000000-1141				A/P - PAYROLL DED. - INC.					4,833.74	
10-2-0000000-1143				A/P - PAYROLL DED. - E.I.					1,204.58	
10-2-0000000-1142				A/P - PAYROLL DED. - CPP					2,608.42	
PP#2019-11 FU	PP#2019-11	FULL TIME PAYROLL TAXES				301	14-Mar-2019	14-Mar-2019		
10-2-0000000-1143				A/P - PAYROLL DED. - E.I.					4,652.88	
10-2-0000000-1141				A/P - PAYROLL DED. - INC.					26,207.96	
10-2-0000000-1142				A/P - PAYROLL DED. - CPP					12,891.50	
PP#2019-11 PA	PP#2019-11	PART TIME				301	14-Mar-2019	14-Mar-2019		
10-2-0000000-1142				A/P - PAYROLL DED. - CPP					28,675.32	
10-2-0000000-1141				A/P - PAYROLL DED. - INC.					59,569.67	
10-2-0000000-1143				A/P - PAYROLL DED. - E.I.					11,209.28	
PP#2019-12 FU	PP#2019-12	FULL TIME PAYROLL TAXES				303	21-Mar-2019	21-Mar-2019		
10-2-0000000-1143				A/P - PAYROLL DED. - E.I.					5,002.63	
10-2-0000000-1141				A/P - PAYROLL DED. - INC.					28,984.56	
10-2-0000000-1142				A/P - PAYROLL DED. - CPP					13,894.28	
PP#2019-12 PA	PP#2019-12	PART TIME PAYROLL TAXES				303	21-Mar-2019	21-Mar-2019		
10-2-0000000-1142				A/P - PAYROLL DED. - CPP					1,927.60	

Council/Board Report By Dept-(EFT)



Vendor : CAT038 To ZUL180

Batch : All

Department : All

EFT Paid Date : 01-Jan-2019 To 31-May-2019

Bank : 1 To 99

Class : All

Vendor Code	Vendor Name	Batch	Inv Date	Inv Due Date	Amount
Invoice No.	Description				
G.L. Account	CC1 CC2 CC3 GL Account Name				
<b>DEPARTMENT 0000000 WATER DEPARTMENT EXPENDITURES</b>					
10-2-0000000-1141	A/P - PAYROLL DED. - INC.				3,912.73
10-2-0000000-1143	A/P - PAYROLL DED. - E.I.				996.96
PP#2019-13 FU PP#2019-13 FULL TIME PAYROLL TAXES		322	28-Mar-2019	28-Mar-2019	
10-2-0000000-1141	A/P - PAYROLL DED. - INC.				24,761.31
10-2-0000000-1142	A/P - PAYROLL DED. - CPP				11,784.12
10-2-0000000-1143	A/P - PAYROLL DED. - E.I.				4,266.81
PP#2019-13 PA PP#2019-13 PAYROLL TAXES		322	28-Mar-2019	28-Mar-2019	
10-2-0000000-1143	A/P - PAYROLL DED. - E.I.				1,193.21
10-2-0000000-1142	A/P - PAYROLL DED. - CPP				3,143.40
10-2-0000000-1141	A/P - PAYROLL DED. - INC.				7,664.11
PP#2019-14 FU PP#2019-14 FULL TIME PAYROLL TAXES		349	04-Apr-2019	04-Apr-2019	
10-2-0000000-1143	A/P - PAYROLL DED. - E.I.				3,940.50
10-2-0000000-1141	A/P - PAYROLL DED. - INC.				26,972.28
10-2-0000000-1142	A/P - PAYROLL DED. - CPP				11,422.80
PP#2019-14 PA PP#2019-14 PART TIME PAYROLL TAXES		349	04-Apr-2019	04-Apr-2019	
10-2-0000000-1142	A/P - PAYROLL DED. - CPP				3,308.20
10-2-0000000-1141	A/P - PAYROLL DED. - INC.				6,132.90
10-2-0000000-1143	A/P - PAYROLL DED. - E.I.				1,447.93
PP#2019-15 FU PP#2019-15 FULL TIME PAYROLL TAXES		391	11-Apr-2019	11-Apr-2019	
10-2-0000000-1143	A/P - PAYROLL DED. - E.I.				4,025.13
10-2-0000000-1141	A/P - PAYROLL DED. - INC.				23,757.16
10-2-0000000-1142	A/P - PAYROLL DED. - CPP				11,190.26
PP#2019-15 PA PP#2019-15 PART TIME PAYROLL TAXES		391	11-Apr-2019	11-Apr-2019	
10-2-0000000-1142	A/P - PAYROLL DED. - CPP				1,941.02
10-2-0000000-1141	A/P - PAYROLL DED. - INC.				3,454.13
10-2-0000000-1143	A/P - PAYROLL DED. - E.I.				940.19
PP#2019-16 FU PP#2019-16 FULL TIME PAYROLL TAXES		393	18-Apr-2019	18-Apr-2019	
10-2-0000000-1142	A/P - PAYROLL DED. - CPP				11,876.80
10-2-0000000-1143	A/P - PAYROLL DED. - E.I.				4,291.82
10-2-0000000-1141	A/P - PAYROLL DED. - INC.				27,030.11
PP#2019-16 PA PP#2019-16 PART TIME PAYROLL TAXES		393	18-Apr-2019	18-Apr-2019	
10-2-0000000-1141	A/P - PAYROLL DED. - INC.				3,355.88
10-2-0000000-1143	A/P - PAYROLL DED. - E.I.				904.13
10-2-0000000-1142	A/P - PAYROLL DED. - CPP				1,851.54
PP#2019-17 FU PP#2019-17 FULL TIME PAYROLL TAXES		418	25-Apr-2019	25-Apr-2019	
10-2-0000000-1141	A/P - PAYROLL DED. - INC.				26,578.90
10-2-0000000-1142	A/P - PAYROLL DED. - CPP				11,695.60
10-2-0000000-1143	A/P - PAYROLL DED. - E.I.				4,240.51
PP#2019-17 PA PP#2019-17 PART TIME PAYROLL TAXES		418	25-Apr-2019	25-Apr-2019	
10-2-0000000-1143	A/P - PAYROLL DED. - E.I.				1,239.58
10-2-0000000-1142	A/P - PAYROLL DED. - CPP				4,277.10
10-2-0000000-1141	A/P - PAYROLL DED. - INC.				10,498.04
PP#2019-18 FU PP#2019-18 FULL TIME PAYROLL TAXES		445	02-May-2019	02-May-2019	
10-2-0000000-1142	A/P - PAYROLL DED. - CPP				12,341.20
10-2-0000000-1141	A/P - PAYROLL DED. - INC.				28,292.49
10-2-0000000-1143	A/P - PAYROLL DED. - E.I.				4,461.50
PP#2019-18 PA PP#2019-18 PART TIME PAYROLL TAXES		445	02-May-2019	02-May-2019	
10-2-0000000-1143	A/P - PAYROLL DED. - E.I.				983.96
10-2-0000000-1141	A/P - PAYROLL DED. - INC.				3,669.28
10-2-0000000-1142	A/P - PAYROLL DED. - CPP				2,065.28
PP#2019-19 FU PP#2019-19 FULL TIME PAYROLL TAXES		491	09-May-2019	09-May-2019	
10-2-0000000-1141	A/P - PAYROLL DED. - INC.				24,758.50
10-2-0000000-1142	A/P - PAYROLL DED. - CPP				11,205.70
10-2-0000000-1143	A/P - PAYROLL DED. - E.I.				3,952.85
PP#2019-19 PA PP#2019-19 PART TIME PAYROLL TAXES		491	09-May-2019	09-May-2019	
10-2-0000000-1143	A/P - PAYROLL DED. - E.I.				1,171.28
10-2-0000000-1142	A/P - PAYROLL DED. - CPP				2,435.84
10-2-0000000-1141	A/P - PAYROLL DED. - INC.				4,659.24





Vendor : CAT038 To ZUL180  
 Batch : All  
 Department : All

EFT Paid Date : 01-Jan-2019 To 31-May-2019  
 Bank : 1 To 99  
 Class : All

Vendor Code	Vendor Name				Batch	Inv Date	Inv Due Date	Amount
Invoice No.	Description							
G.L. Account	CC1	CC2	CC3	GL Account Name				
<b>DEPARTMENT 0000000 WATER DEPARTMENT EXPENDITURES</b>								
PP#2019-20 FU	PP#2019-20	FULL TIME PAYROLL TAXES			508	16-May-2019	16-May-2019	
10-2-0000000-1142				A/P - PAYROLL DED. - CPP				11,056.70
10-2-0000000-1143				A/P - PAYROLL DED. - E.I.				4,017.87
10-2-0000000-1141				A/P - PAYROLL DED. - INC.				25,392.48
PP#2019-20 PA	PP#2019-20	PART TIME PAYROLL TAXES			508	16-May-2019	16-May-2019	
10-2-0000000-1141				A/P - PAYROLL DED. - INC.				5,183.62
10-2-0000000-1143				A/P - PAYROLL DED. - E.I.				1,345.58
10-2-0000000-1142				A/P - PAYROLL DED. - CPP				2,922.92
PP#2019-22 FU	PP#2019-22	FULL TIME PAYROLL TAXES			565	30-May-2019	30-May-2019	
10-2-0000000-1142				A/P - PAYROLL DED. - CPP				10,875.48
10-2-0000000-1141				A/P - PAYROLL DED. - INC.				27,931.93
10-2-0000000-1143				A/P - PAYROLL DED. - E.I.				3,811.09
PP#2019-22 PA	PP#2019-22	PART TIME PAYROLL TAXES			565	30-May-2019	30-May-2019	
10-2-0000000-1143				A/P - PAYROLL DED. - E.I.				1,666.61
10-2-0000000-1141				A/P - PAYROLL DED. - INC.				10,177.81
10-2-0000000-1142				A/P - PAYROLL DED. - CPP				4,337.94
<b>SUN11 SUN LIFE ASSURANCE CO. OF CANADA - BILLING</b>								
APR 2019	APRIL 2019 BENEFITS				404	01-Apr-2019	01-Apr-2019	
80-5-0000000-0207				BENEFITS - LIFE & DISABILITY				2,626.04
DEC 2018	DECEMBER 2018 BENEFITS				1468	01-Dec-2018	01-Dec-2018	
80-5-0000000-0207				BENEFITS - LIFE & DISABILITY				2,622.76
FEB 2019	FEBRUARY 2019 BENEFITS				124	01-Feb-2019	01-Feb-2019	
80-5-0000000-0207				BENEFITS - LIFE & DISABILITY				2,628.09
JAN 2019	JANUARY 2019 BENEFITS				123	02-Jan-2019	02-Jan-2019	
80-5-0000000-0207				BENEFITS - LIFE & DISABILITY				2,625.22
MAR 2019	MARCH 2019 BENEFITS				227	01-Mar-2019	01-Mar-2019	
80-5-0000000-0207				BENEFITS - LIFE & DISABILITY				2,626.04
MAY 2019	MAY 2019 BENEFITS				472	01-May-2019	01-May-2019	
80-5-0000000-0207				BENEFITS - LIFE & DISABILITY				2,737.74
<b>USB01 US BANK NATIONAL ASSOCIATION-VISA</b>								
APRIL 2019	APRIL 2019 PURCHASES				528	30-Apr-2019	30-Apr-2019	
80-5-0000000-0249				TRAINING				367.25
80-5-0000000-0249				TRAINING				145.00
FEBRUARY 2019	FEBRUARY 2019 PURCHASES				374	28-Feb-2019	28-Feb-2019	
10-1-0000000-2066				A/R - CLEARING				62.22
10-1-0000000-2066				A/R - CLEARING				-242.03
10-1-0000000-2066				A/R - CLEARING				-242.03
80-5-0000000-0249				TRAINING				-406.80
80-5-0000000-0249				TRAINING				145.00
80-5-0000000-0249				TRAINING				145.00
80-5-0000000-0920				DWQMS MAINTENANCE				99.45
80-5-0000000-0420				EQUIPMENT MAINTENANCE				740.15
JANUARY 2019	JANUARY 2019 PURCHASES				132	31-Jan-2019	31-Jan-2019	
80-5-0000000-0249				TRAINING				423.75
80-5-0000000-0249				TRAINING				145.00
80-5-0000000-0249				TRAINING				80.00
80-5-0000000-0249				TRAINING				80.00
MARCH 2019	MARCH 2019 PURCHASES				524	31-Mar-2019	31-Mar-2019	
10-1-0000000-2066				A/R - CLEARING				242.03
80-5-0000000-0249				TRAINING				310.13
80-5-0000000-0249				TRAINING				1,515.00
80-5-0000000-0249				TRAINING				1,515.00
80-5-0000000-0249				TRAINING				345.00
80-5-0000000-0249				TRAINING				-345.00
80-5-0000000-0810				WATER - MAIN MAINTENANCE				126.11
80-5-0000000-0350				MEMBERSHIPS				249.12
MAY 2019	MAY 2019 PURCHASES				746	31-May-2019	31-May-2019	



Vendor : CAT038 To ZUL180  
 Batch : All  
 Department : All

EFT Paid Date : 01-Jan-2019 To 31-May-2019  
 Bank : 1 To 99  
 Class : All

Vendor Code	Vendor Name	Batch	Inv Date	Inv Due Date	Amount
Invoice No.	Description				
G.L. Account	CC1 CC2 CC3 GL Account Name				
<b>DEPARTMENT 0000000</b>	<b>WATER DEPARTMENT EXPENDITURES</b>				
80-5-0000000-0350	MEMBERSHIPS				249.12
<b>WOR03</b>	<b>WORKPLACE SAFETY &amp; INSURANCE BOARD</b>				
APRIL 2019	APRIL 2019 WSIB PREMIUMS	442	30-Apr-2019	30-Apr-2019	
10-2-0000000-1153	A/P - PAYROLL DED. - WSIB				18,464.88
DECEMBER 20	DECEMBER 2018 WSIB PREMIUMS	1526	31-Dec-2018	31-Dec-2018	
10-2-0000000-1153	A/P - PAYROLL DED. - WSIB				13,808.33
FEBRUARY 201	FEBRUARY 2019 WSIB PREMIUMS	242	28-Feb-2019	28-Feb-2019	
10-2-0000000-1153	A/P - PAYROLL DED. - WSIB				17,503.87
10-2-0000000-1153	A/P - PAYROLL DED. - WSIB				764.82
JANUARY 2019	JANUARY 2019 WSIB PREMIUMS	155	31-Jan-2019	31-Jan-2019	
10-2-0000000-1153	A/P - PAYROLL DED. - WSIB				34,541.45
MARCH 2019	MARCH 2019 WSIB PREMIUMS	354	31-Mar-2019	31-Mar-2019	
10-2-0000000-1153	A/P - PAYROLL DED. - WSIB				27,176.20
MAY 2019	MAY 2019 WSIB PREMIUMS	574	31-May-2019	31-May-2019	
10-2-0000000-1153	A/P - PAYROLL DED. - WSIB				24,397.70
10-2-0000000-1153	A/P - PAYROLL DED. - WSIB				-4,479.70
<b>Department Totals :</b>					<b>5,503,983.78</b>

<b>DEPARTMENT 1001010</b>	<b>COUNCIL</b>				
<b>BEL03</b>	<b>BELL MOBILITY INC.</b>				
APR 2019	APRIL 2019 USAGE	403	06-Apr-2019	06-Apr-2019	
10-5-1001010-0345	COUNCIL - CELL PHONE EXPENSE				65.58
FEB 2019	FEBRUARY 2019 USAGE	188	06-Feb-2019	06-Feb-2019	
10-5-1001010-0345	COUNCIL - CELL PHONE EXPENSE				48.06
JAN 2019	JANUARY 2019 USAGE	58	06-Jan-2019	06-Jan-2019	
10-5-1001010-0345	COUNCIL - CELL PHONE EXPENSE				67.91
MAR 2019	MARCH 2019 USAGE	326	06-Mar-2019	06-Mar-2019	
10-5-1001010-0345	COUNCIL - CELL PHONE EXPENSE				48.90
MAY 2019	MAY 2019 USAGE	543	06-May-2019	06-May-2019	
10-5-1001010-0345	COUNCIL - CELL PHONE EXPENSE				46.35
<b>USB01</b>	<b>US BANK NATIONAL ASSOCIATION-VISA</b>				
APRIL 2019	APRIL 2019 PURCHASES	528	30-Apr-2019	30-Apr-2019	
10-5-1001010-0342	COUNCIL MEETINGS				909.65
10-5-1001010-0342	COUNCIL MEETINGS				144.40
FEBRUARY 201	FEBRUARY 2019 PURCHASES	374	28-Feb-2019	28-Feb-2019	
10-5-1001010-0342	COUNCIL MEETINGS				120.05
10-5-1001010-0342	COUNCIL MEETINGS				119.04
JANUARY 2019	JANUARY 2019 PURCHASES	132	31-Jan-2019	31-Jan-2019	
10-5-1001010-0342	COUNCIL MEETINGS				101.25
MARCH 2019	MARCH 2019 PURCHASES	524	31-Mar-2019	31-Mar-2019	
10-5-1001010-0342	COUNCIL MEETINGS				156.86
10-5-1001010-0342	COUNCIL MEETINGS				172.38
MAY 2019	MAY 2019 PURCHASES	746	31-May-2019	31-May-2019	
10-5-1001010-0342	COUNCIL MEETINGS				136.09
10-5-1001010-0342	COUNCIL MEETINGS				134.28
<b>Department Totals :</b>					<b>2,270.80</b>

<b>DEPARTMENT 1001011</b>	<b>COUNCIL - MAYOR</b>				
<b>USB01</b>	<b>US BANK NATIONAL ASSOCIATION-VISA</b>				
FEBRUARY 201	FEBRUARY 2019 PURCHASES	374	28-Feb-2019	28-Feb-2019	
10-5-1001011-0340	18MAYO MAYOR - PUBLIC RECEPTIONS, ETC.				3,500.00
10-5-1001011-0340	18MAYO MAYOR - PUBLIC RECEPTIONS, ETC.				300.00
MAY 2019	MAY 2019 PURCHASES	746	31-May-2019	31-May-2019	
10-5-1001011-0340	18MAYO MAYOR - PUBLIC RECEPTIONS, ETC.				125.00



Vendor : CAT038 To ZUL180  
 Batch : All  
 Department : All

EFT Paid Date : 01-Jan-2019 To 31-May-2019  
 Bank : 1 To 99  
 Class : All

Vendor Code	Vendor Name	Batch	Inv Date	Inv Due Date	Amount
Invoice No.	Description				
G.L. Account	CC1 CC2 CC3 GL Account Name				
<b>DEPARTMENT 1001011</b>	<b>COUNCIL - MAYOR</b>				
10-5-1001011-0340	18MAYO MAYOR - PUBLIC RECEPTIONS, ETC.				130.00
10-5-1001011-0340	18MAYO MAYOR - PUBLIC RECEPTIONS, ETC.				400.00
10-5-1001011-0340	18MAYO MAYOR - PUBLIC RECEPTIONS, ETC.				200.00
10-5-1001011-0340	18MAYO MAYOR - PUBLIC RECEPTIONS, ETC.				220.00
<b>Department Totals :</b>					<b>4,875.00</b>

<b>DEPARTMENT 1001012</b>	<b>COUNCIL - DEPUTY MAYOR</b>				
<b>USB01</b>	<b>US BANK NATIONAL ASSOCIATION-VISA</b>				
APRIL 2019	APRIL 2019 PURCHASES	528	30-Apr-2019	30-Apr-2019	
10-5-1001012-0351	DEPUTY MAYOR - TRAINING & CONFERENCES				1,004.88
10-5-1001012-0351	DEPUTY MAYOR - TRAINING & CONFERENCES				135.60
MAY 2019	MAY 2019 PURCHASES	746	31-May-2019	31-May-2019	
10-5-1001012-0351	DEPUTY MAYOR - TRAINING & CONFERENCES				665.42
10-5-1001012-0340	18DEPU DEP MAYOR - PUBLIC RECEPTIONS, ETC.				125.00
10-5-1001012-0340	18DEPU DEP MAYOR - PUBLIC RECEPTIONS, ETC.				130.00
<b>Department Totals :</b>					<b>2,060.90</b>

<b>DEPARTMENT 1001014</b>	<b>COUNCIL - COUNCILLOR 2</b>				
<b>USB01</b>	<b>US BANK NATIONAL ASSOCIATION-VISA</b>				
MAY 2019	MAY 2019 PURCHASES	746	31-May-2019	31-May-2019	
10-5-1001014-0340	18COU1 COUNCILLOR 2 - PUBLIC RECEPTIONS, ETC.				130.00
10-5-1001014-0340	18COU1 COUNCILLOR 2 - PUBLIC RECEPTIONS, ETC.				125.00
<b>Department Totals :</b>					<b>255.00</b>

<b>DEPARTMENT 1001018</b>	<b>COUNCIL - COUNCILLOR 5</b>				
<b>USB01</b>	<b>US BANK NATIONAL ASSOCIATION-VISA</b>				
APRIL 2019	APRIL 2019 PURCHASES	528	30-Apr-2019	30-Apr-2019	
10-5-1001018-0351	18COU4 COUNCILLOR 5 - TRAINING & CONFERENCES				909.65
MAY 2019	MAY 2019 PURCHASES	746	31-May-2019	31-May-2019	
10-5-1001018-0351	18COU4 COUNCILLOR 5 - TRAINING & CONFERENCES				654.56
<b>Department Totals :</b>					<b>1,564.21</b>

<b>DEPARTMENT 1001020</b>	<b>ADMINISTRATION</b>				
<b>GRE03</b>	<b>GREEN SHIELD CANADA</b>				
APR 2019	APRIL 2019 BENEFITS	375	01-Apr-2019	01-Apr-2019	
10-5-1001020-0206	BENEFITS - GREENSHIELD RE				5,227.66
FEB 2019	FEBRUARY 2019 BENEFITS	98	01-Feb-2019	01-Feb-2019	
10-5-1001020-0206	BENEFITS - GREENSHIELD RE				5,227.66
JAN 2019	JANUARY 2019 BENEFITS	5	02-Jan-2019	02-Jan-2019	
10-5-1001020-0206	BENEFITS - GREENSHIELD RE				5,227.66
MAR 2019	MARCH 2019 BENEFITS	228	01-Mar-2019	01-Mar-2019	
10-5-1001020-0206	BENEFITS - GREENSHIELD RE				5,227.66
MAY 2019	MAY 2019 BENEFITS	619	01-May-2019	01-May-2019	
10-5-1001020-0206	BENEFITS - GREENSHIELD RE				5,227.66
<b>USB01</b>	<b>US BANK NATIONAL ASSOCIATION-VISA</b>				
FEBRUARY 2019	FEBRUARY 2019 PURCHASES	374	28-Feb-2019	28-Feb-2019	
10-5-1001020-0307	ADVERTISING				904.00
10-5-1001020-0307	ADVERTISING				529.97
10-5-1001020-0307	ADVERTISING				282.50
JANUARY 2019	JANUARY 2019 PURCHASES	132	31-Jan-2019	31-Jan-2019	
10-5-1001020-0307	ADVERTISING				22.54
MAY 2019	MAY 2019 PURCHASES	746	31-May-2019	31-May-2019	
40-7-1001020-0003	PROPDI CAPITAL - ADMINISTRATION				105.27
40-7-1001020-0003	PROPDI CAPITAL - ADMINISTRATION				105.27



Vendor : CAT038 To ZUL180

Batch : All

Department : All

EFT Paid Date : 01-Jan-2019 To 31-May-2019

Bank : 1 To 99

Class : All

Vendor Code	Vendor Name		Description		Batch	Inv Date	Inv Due Date	Amount
Invoice No.	CC1	CC2	CC3	GL Account Name				
G.L. Account								

DEPARTMENT 1001020 ADMINISTRATION

Department Totals : **28,087.85**

DEPARTMENT 1001021 TREASURY

**BEL03 BELL MOBILITY INC.**

APR 2019	APRIL 2019 USAGE				403	06-Apr-2019	06-Apr-2019	
10-5-1001021-0345				CELL PHONE EXPENSE - TREASURY				67.99
FEB 2019	FEBRUARY 2019 USAGE				188	06-Feb-2019	06-Feb-2019	
10-5-1001021-0345				CELL PHONE EXPENSE - TREASURY				103.69
JAN 2019	JANUARY 2019 USAGE				58	06-Jan-2019	06-Jan-2019	
10-5-1001021-0345				CELL PHONE EXPENSE - TREASURY				85.03
MAR 2019	MARCH 2019 USAGE				326	06-Mar-2019	06-Mar-2019	
10-5-1001021-0345				CELL PHONE EXPENSE - TREASURY				65.28
MAY 2019	MAY 2019 USAGE				543	06-May-2019	06-May-2019	
10-5-1001021-0345				CELL PHONE EXPENSE - TREASURY				80.86

**BRI459 BRINKS CANADA**

3189410229	SERVICE CHARGES FOR THE MONTH OF DECEMBER 2018				1589	01-Dec-2018	01-Dec-2018	
10-5-1001021-0336				CONTRACTED SERVICES - BRINKS				2,272.37
3199050229	SERVICE CHARGES FOR THE MONTH OF JANUARY 2019				89	02-Jan-2019	02-Jan-2019	
10-5-1001021-0336				CONTRACTED SERVICES - BRINKS				1,534.48
3205990229	SERVICE CHARGES FOR THE MONTH OF FEBRUARY 2019				221	01-Feb-2019	01-Feb-2019	
10-5-1001021-0336				CONTRACTED SERVICES - BRINKS				1,534.48
3213090229	SERVICE CHARGES FOR THE MONTH OF MARCH 2019				336	01-Mar-2019	01-Mar-2019	
10-5-1001021-0336				CONTRACTED SERVICES - BRINKS				1,534.48
3222560229	SERVICE CHARGE FOR THE MONTH OF APRIL 2019				644	01-Apr-2019	01-Apr-2019	
10-5-1001021-0336				CONTRACTED SERVICES - BRINKS				1,657.24
3229730229	SERVICES CHARGES FOR THE MONTH OF MAY 2019				645	01-May-2019	01-May-2019	
10-5-1001021-0336				CONTRACTED SERVICES - BRINKS				1,657.24

**GRE03 GREEN SHIELD CANADA**

APR 2019	APRIL 2019 BENEFITS				375	01-Apr-2019	01-Apr-2019	
10-5-1001021-0205				BENEFITS - GREENSHIELD				3,801.78
FEB 2019	FEBRUARY 2019 BENEFITS				98	01-Feb-2019	01-Feb-2019	
10-5-1001021-0205				BENEFITS - GREENSHIELD				3,801.78
JAN 2019	JANUARY 2019 BENEFITS				5	02-Jan-2019	02-Jan-2019	
10-5-1001021-0205				BENEFITS - GREENSHIELD				3,801.78
MAR 2019	MARCH 2019 BENEFITS				228	01-Mar-2019	01-Mar-2019	
10-5-1001021-0205				BENEFITS - GREENSHIELD				3,801.78
MAY 2019	MAY 2019 BENEFITS				619	01-May-2019	01-May-2019	
10-5-1001021-0205				BENEFITS - GREENSHIELD				3,801.78

**SUN11 SUN LIFE ASSURANCE CO. OF CANADA - BILLING**

APR 2019	APRIL 2019 BENEFITS				404	01-Apr-2019	01-Apr-2019	
10-5-1001021-0207				BENEFITS - LIFE & DISABILITY				3,325.34
DEC 2018	DECEMBER 2018 BENEFITS				1468	01-Dec-2018	01-Dec-2018	
10-5-1001021-0207				BENEFITS - LIFE & DISABILITY				3,321.23
FEB 2019	FEBRUARY 2019 BENEFITS				124	01-Feb-2019	01-Feb-2019	
10-5-1001021-0207				BENEFITS - LIFE & DISABILITY				3,329.45
JAN 2019	JANUARY 2019 BENEFITS				123	02-Jan-2019	02-Jan-2019	
10-5-1001021-0207				BENEFITS - LIFE & DISABILITY				3,321.23
MAR 2019	MARCH 2019 BENEFITS				227	01-Mar-2019	01-Mar-2019	
10-5-1001021-0207				BENEFITS - LIFE & DISABILITY				3,325.34
MAY 2019	MAY 2019 BENEFITS				472	01-May-2019	01-May-2019	
10-5-1001021-0207				BENEFITS - LIFE & DISABILITY				3,437.59

**USB01 US BANK NATIONAL ASSOCIATION-VISA**

APRIL 2019	APRIL 2019 PURCHASES				528	30-Apr-2019	30-Apr-2019	
10-5-1001021-0327				PROFESSIONAL FEES				105.27



Vendor : CAT038 To ZUL180  
 Batch : All  
 Department : All

EFT Paid Date : 01-Jan-2019 To 31-May-2019  
 Bank : 1 To 99  
 Class : All

Vendor Code	Vendor Name	Batch	Inv Date	Inv Due Date	Amount
Invoice No.	Description				
G.L. Account	CC1 CC2 CC3 GL Account Name				
<b>DEPARTMENT 1001021</b>	<b>TREASURY</b>				
10-5-1001021-0351	TRAINING & CONFERENCES				10.75
MAY 2019	MAY 2019 PURCHASES	746	31-May-2019	31-May-2019	
10-5-1001021-0351	TRAINING & CONFERENCES				1,186.50
10-5-1001021-0351	TRAINING & CONFERENCES				33.01
10-5-1001021-0350	MEMBERSHIPS				238.43
<b>Department Totals :</b>					<b>51,236.18</b>

<b>DEPARTMENT 1001022</b>	<b>CLERKS</b>				
<b>BEL03</b>	<b>BELL MOBILITY INC.</b>				
APR 2019	APRIL 2019 USAGE	403	06-Apr-2019	06-Apr-2019	
10-5-1001022-0345	CELL PHONE EXPENSE - CLERKS				129.48
FEB 2019	FEBRUARY 2019 USAGE	188	06-Feb-2019	06-Feb-2019	
10-5-1001022-0345	CELL PHONE EXPENSE - CLERKS				706.55
JAN 2019	JANUARY 2019 USAGE	58	06-Jan-2019	06-Jan-2019	
10-5-1001022-0345	CELL PHONE EXPENSE - CLERKS				147.53
MAR 2019	MARCH 2019 USAGE	326	06-Mar-2019	06-Mar-2019	
10-5-1001022-0345	CELL PHONE EXPENSE - CLERKS				-350.03
MAY 2019	MAY 2019 USAGE	543	06-May-2019	06-May-2019	
10-5-1001022-0345	CELL PHONE EXPENSE - CLERKS				150.82
<b>GRE03</b>	<b>GREEN SHIELD CANADA</b>				
APR 2019	APRIL 2019 BENEFITS	375	01-Apr-2019	01-Apr-2019	
10-5-1001022-0205	BENEFITS - GREENSHIELD - CLERKS				833.00
10-5-1001022-0205	BENEFITS - GREENSHIELD - CLERKS				445.39
FEB 2019	FEBRUARY 2019 BENEFITS	98	01-Feb-2019	01-Feb-2019	
10-5-1001022-0205	BENEFITS - GREENSHIELD - CLERKS				833.00
10-5-1001022-0205	BENEFITS - GREENSHIELD - CLERKS				445.39
JAN 2019	JANUARY 2019 BENEFITS	5	02-Jan-2019	02-Jan-2019	
10-5-1001022-0205	BENEFITS - GREENSHIELD - CLERKS				445.39
10-5-1001022-0205	BENEFITS - GREENSHIELD - CLERKS				833.00
MAR 2019	MARCH 2019 BENEFITS	228	01-Mar-2019	01-Mar-2019	
10-5-1001022-0205	BENEFITS - GREENSHIELD - CLERKS				833.00
10-5-1001022-0205	BENEFITS - GREENSHIELD - CLERKS				445.39
MAY 2019	MAY 2019 BENEFITS	619	01-May-2019	01-May-2019	
10-5-1001022-0205	BENEFITS - GREENSHIELD - CLERKS				833.00
10-5-1001022-0205	BENEFITS - GREENSHIELD - CLERKS				445.39
<b>SUN11</b>	<b>SUN LIFE ASSURANCE CO. OF CANADA - BILLING</b>				
APR 2019	APRIL 2019 BENEFITS	404	01-Apr-2019	01-Apr-2019	
10-5-1001022-0207	BENEFITS - LIFE & DISABIL - CLERKS				981.05
DEC 2018	DECEMBER 2018 BENEFITS	1468	01-Dec-2018	01-Dec-2018	
10-5-1001022-0207	BENEFITS - LIFE & DISABIL - CLERKS				1,042.81
FEB 2019	FEBRUARY 2019 BENEFITS	124	01-Feb-2019	01-Feb-2019	
10-5-1001022-0207	BENEFITS - LIFE & DISABIL - CLERKS				981.05
JAN 2019	JANUARY 2019 BENEFITS	123	02-Jan-2019	02-Jan-2019	
10-5-1001022-0207	BENEFITS - LIFE & DISABIL - CLERKS				981.05
MAR 2019	MARCH 2019 BENEFITS	227	01-Mar-2019	01-Mar-2019	
10-5-1001022-0207	BENEFITS - LIFE & DISABIL - CLERKS				981.05
MAY 2019	MAY 2019 BENEFITS	472	01-May-2019	01-May-2019	
10-5-1001022-0207	BENEFITS - LIFE & DISABIL - CLERKS				1,045.25
<b>USB01</b>	<b>US BANK NATIONAL ASSOCIATION-VISA</b>				
FEBRUARY 2019	FEBRUARY 2019 PURCHASES	374	28-Feb-2019	28-Feb-2019	
10-5-1001022-0350	MEMBERSHIPS - CLERKS				447.48
10-5-1001022-0350	MEMBERSHIPS - CLERKS				447.48
10-5-1001022-0351	TRAINING & CONFERENCES - CLERKS				446.35
10-5-1001022-0251	MEMBERSHIPS AND SUB. - CLERKS				36.65
JANUARY 2019	JANUARY 2019 PURCHASES	132	31-Jan-2019	31-Jan-2019	



Vendor : CAT038 To ZUL180  
 Batch : All  
 Department : All

EFT Paid Date : 01-Jan-2019 To 31-May-2019  
 Bank : 1 To 99  
 Class : All

Vendor Code	Vendor Name				Batch	Inv Date	Inv Due Date	Amount
Invoice No.	Description							
G.L. Account	CC1	CC2	CC3	GL Account Name				
<b>DEPARTMENT 1001022</b>				CLERKS				
10-5-1001022-0342				MEETINGS				20.73
10-5-1001022-0352				TRAVEL & MILEAGE - CLERKS				30.00
10-5-1001022-0351				TRAINING & CONFERENCES - CLERKS				587.60
MAY 2019	MAY 2019 PURCHASES				746	31-May-2019	31-May-2019	
10-5-1001022-0351				TRAINING & CONFERENCES - CLERKS				44.27
10-5-1001022-0351				TRAINING & CONFERENCES - CLERKS				50.00
10-5-1001022-0351				TRAINING & CONFERENCES - CLERKS				513.34
10-5-1001022-0351				TRAINING & CONFERENCES - CLERKS				11.60
10-5-1001022-0351				TRAINING & CONFERENCES - CLERKS				11.73
10-5-1001022-0351				TRAINING & CONFERENCES - CLERKS				399.61
10-5-1001022-0351				TRAINING & CONFERENCES - CLERKS				5.64
<b>Department Totals :</b>								<b>16,241.04</b>

<b>DEPARTMENT 1001023</b>				C.A.O.				
<b>BEL03</b>				<b>BELL MOBILITY INC.</b>				
APR 2019	APRIL 2019 USAGE				403	06-Apr-2019	06-Apr-2019	
10-5-1001023-0345				CELL PHONE				236.46
FEB 2019	FEBRUARY 2019 USAGE				188	06-Feb-2019	06-Feb-2019	
10-5-1001023-0345				CELL PHONE				159.35
JAN 2019	JANUARY 2019 USAGE				58	06-Jan-2019	06-Jan-2019	
10-5-1001023-0345				CELL PHONE				168.88
MAR 2019	MARCH 2019 USAGE				326	06-Mar-2019	06-Mar-2019	
10-5-1001023-0345				CELL PHONE				139.16
MAY 2019	MAY 2019 USAGE				543	06-May-2019	06-May-2019	
10-5-1001023-0345				CELL PHONE				114.88
<b>GRE03</b>				<b>GREEN SHIELD CANADA</b>				
APR 2019	APRIL 2019 BENEFITS				375	01-Apr-2019	01-Apr-2019	
10-5-1001023-0205				BENEFITS - GREENSHIELD - C.A.O.				1,249.50
FEB 2019	FEBRUARY 2019 BENEFITS				98	01-Feb-2019	01-Feb-2019	
10-5-1001023-0205				BENEFITS - GREENSHIELD - C.A.O.				1,249.50
JAN 2019	JANUARY 2019 BENEFITS				5	02-Jan-2019	02-Jan-2019	
10-5-1001023-0205				BENEFITS - GREENSHIELD - C.A.O.				1,249.50
MAR 2019	MARCH 2019 BENEFITS				228	01-Mar-2019	01-Mar-2019	
10-5-1001023-0205				BENEFITS - GREENSHIELD - C.A.O.				1,249.50
MAY 2019	MAY 2019 BENEFITS				619	01-May-2019	01-May-2019	
10-5-1001023-0205				BENEFITS - GREENSHIELD - C.A.O.				1,249.50
<b>SUN11</b>				<b>SUN LIFE ASSURANCE CO. OF CANADA - BILLING</b>				
APR 2019	APRIL 2019 BENEFITS				404	01-Apr-2019	01-Apr-2019	
10-5-1001023-0207				BENEFITS - LIFE & DISABIL - C.A.O.				901.37
DEC 2018	DECEMBER 2018 BENEFITS				1468	01-Dec-2018	01-Dec-2018	
10-5-1001023-0207				BENEFITS - LIFE & DISABIL - C.A.O.				901.37
FEB 2019	FEBRUARY 2019 BENEFITS				124	01-Feb-2019	01-Feb-2019	
10-5-1001023-0207				BENEFITS - LIFE & DISABIL - C.A.O.				901.37
JAN 2019	JANUARY 2019 BENEFITS				123	02-Jan-2019	02-Jan-2019	
10-5-1001023-0207				BENEFITS - LIFE & DISABIL - C.A.O.				901.37
MAR 2019	MARCH 2019 BENEFITS				227	01-Mar-2019	01-Mar-2019	
10-5-1001023-0207				BENEFITS - LIFE & DISABIL - C.A.O.				901.37
MAY 2019	MAY 2019 BENEFITS				472	01-May-2019	01-May-2019	
10-5-1001023-0207				BENEFITS - LIFE & DISABIL - C.A.O.				942.42
<b>USB01</b>				<b>US BANK NATIONAL ASSOCIATION-VISA</b>				
APRIL 2019	APRIL 2019 PURCHASES				528	30-Apr-2019	30-Apr-2019	
10-5-1001023-0351				CONVENTIONS & SEMINARS - C.A.O.				-82.29
10-5-1001023-0351				CONVENTIONS & SEMINARS - C.A.O.				153.41
10-5-1001023-0351				CONVENTIONS & SEMINARS - C.A.O.				121.40
10-5-1001023-0342				MEETING EXPENSES - C.A.O.				84.63





Vendor : CAT038 To ZUL180  
 Batch : All  
 Department : All

EFT Paid Date : 01-Jan-2019 To 31-May-2019  
 Bank : 1 To 99  
 Class : All

Vendor Code	Vendor Name				Batch	Inv Date	Inv Due Date	Amount
Invoice No.	Description							
G.L. Account	CC1	CC2	CC3	GL Account Name				
<b>DEPARTMENT 1001023</b>				C.A.O.				
10-5-1001023-0342				MEETING EXPENSES - C.A.O.				38.70
10-5-1001023-0342				MEETING EXPENSES - C.A.O.				70.17
10-5-1001023-0342				MEETING EXPENSES - C.A.O.				5.54
10-5-1001023-0342				MEETING EXPENSES - C.A.O.				104.65
FEBRUARY 2019	FEBRUARY 2019 PURCHASES				374	28-Feb-2019	28-Feb-2019	
10-5-1001023-0342				MEETING EXPENSES - C.A.O.				50.68
10-5-1001023-0342				MEETING EXPENSES - C.A.O.				2.50
10-5-1001023-0342				MEETING EXPENSES - C.A.O.				8.25
10-5-1001023-0342				MEETING EXPENSES - C.A.O.				75.30
10-5-1001023-0342				MEETING EXPENSES - C.A.O.				24.01
10-5-1001023-0342				MEETING EXPENSES - C.A.O.				62.38
10-5-1001023-0351				CONVENTIONS & SEMINARS - C.A.O.				6.32
10-5-1001023-0342				MEETING EXPENSES - C.A.O.				50.00
10-5-1001023-0351				CONVENTIONS & SEMINARS - C.A.O.				219.22
10-5-1001023-0342				MEETING EXPENSES - C.A.O.				175.15
10-5-1001023-0351				CONVENTIONS & SEMINARS - C.A.O.				615.85
JANUARY 2019	JANUARY 2019 PURCHASES				132	31-Jan-2019	31-Jan-2019	
10-5-1001023-0342				MEETING EXPENSES - C.A.O.				2.50
10-5-1001023-0342				MEETING EXPENSES - C.A.O.				31.25
10-5-1001023-0342				MEETING EXPENSES - C.A.O.				8.90
10-5-1001023-0342				MEETING EXPENSES - C.A.O.				130.52
10-5-1001023-0351				CONVENTIONS & SEMINARS - C.A.O.				446.35
10-5-1001023-0342				MEETING EXPENSES - C.A.O.				40.80
MARCH 2019	MARCH 2019 PURCHASES				524	31-Mar-2019	31-Mar-2019	
10-5-1001023-0342				MEETING EXPENSES - C.A.O.				51.34
10-5-1001023-0342				MEETING EXPENSES - C.A.O.				5.00
10-5-1001023-0342				MEETING EXPENSES - C.A.O.				56.50
10-5-1001023-0351				CONVENTIONS & SEMINARS - C.A.O.				832.77
MAY 2019	MAY 2019 PURCHASES				746	31-May-2019	31-May-2019	
10-5-1001023-0351				CONVENTIONS & SEMINARS - C.A.O.				-540.85
10-5-1001023-0351				CONVENTIONS & SEMINARS - C.A.O.				125.00
10-5-1001023-0351				CONVENTIONS & SEMINARS - C.A.O.				20.68
10-5-1001023-0351				CONVENTIONS & SEMINARS - C.A.O.				203.82
10-5-1001023-0342				MEETING EXPENSES - C.A.O.				42.89
10-5-1001023-0342				MEETING EXPENSES - C.A.O.				41.91
10-5-1001023-0351				CONVENTIONS & SEMINARS - C.A.O.				5.56
10-5-1001023-0351				CONVENTIONS & SEMINARS - C.A.O.				-219.22
<b>Department Totals :</b>								<b>15,587.09</b>

<b>DEPARTMENT 1001024</b>		<b>HUMAN RESOURCES</b>						
<b>BEL03</b>	<b>BELL MOBILITY INC.</b>							
APR 2019	APRIL 2019 USAGE				403	06-Apr-2019	06-Apr-2019	
10-5-1001024-0345				CELL PHONE				85.32
FEB 2019	FEBRUARY 2019 USAGE				188	06-Feb-2019	06-Feb-2019	
10-5-1001024-0345				CELL PHONE				40.12
JAN 2019	JANUARY 2019 USAGE				58	06-Jan-2019	06-Jan-2019	
10-5-1001024-0345				CELL PHONE				68.08
MAR 2019	MARCH 2019 USAGE				326	06-Mar-2019	06-Mar-2019	
10-5-1001024-0345				CELL PHONE				86.50
MAY 2019	MAY 2019 USAGE				543	06-May-2019	06-May-2019	
10-5-1001024-0345				CELL PHONE				85.60
<b>GRE03</b>	<b>GREEN SHIELD CANADA</b>							
APR 2019	APRIL 2019 BENEFITS				375	01-Apr-2019	01-Apr-2019	
10-5-1001024-0205				BENEFITS - GREENSHIELD - HUMAN RESOURCES				833.00
FEB 2019	FEBRUARY 2019 BENEFITS				98	01-Feb-2019	01-Feb-2019	
10-5-1001024-0205				BENEFITS - GREENSHIELD - HUMAN RESOURCES				833.00
JAN 2019	JANUARY 2019 BENEFITS				5	02-Jan-2019	02-Jan-2019	





Vendor : CAT038 To ZUL180

Batch : All

Department : All

EFT Paid Date : 01-Jan-2019 To 31-May-2019

Bank : 1 To 99

Class : All

Vendor Code	Vendor Name				Batch	Inv Date	Inv Due Date	Amount
Invoice No.	Description							
G.L. Account	CC1	CC2	CC3	GL Account Name				
<b>DEPARTMENT 1001024</b>				<b>HUMAN RESOURCES</b>				
10-5-1001024-0205				BENEFITS - GREENSHIELD - HUMAN RESOURCES				833.00
MAR 2019	MARCH 2019 BENEFITS				228	01-Mar-2019	01-Mar-2019	
10-5-1001024-0205				BENEFITS - GREENSHIELD - HUMAN RESOURCES				833.00
MAY 2019	MAY 2019 BENEFITS				619	01-May-2019	01-May-2019	
10-5-1001024-0205				BENEFITS - GREENSHIELD - HUMAN RESOURCES				833.00
<b>SUN11</b>				<b>SUN LIFE ASSURANCE CO. OF CANADA - BILLING</b>				
APR 2019	APRIL 2019 BENEFITS				404	01-Apr-2019	01-Apr-2019	
10-5-1001024-0207				BENEFITS - LIFE & DISABIL - HUMAN RESOUR				808.36
DEC 2018	DECEMBER 2018 BENEFITS				1468	01-Dec-2018	01-Dec-2018	
10-5-1001024-0207				BENEFITS - LIFE & DISABIL - HUMAN RESOUR				799.77
FEB 2019	FEBRUARY 2019 BENEFITS				124	01-Feb-2019	01-Feb-2019	
10-5-1001024-0207				BENEFITS - LIFE & DISABIL - HUMAN RESOUR				799.77
JAN 2019	JANUARY 2019 BENEFITS				123	02-Jan-2019	02-Jan-2019	
10-5-1001024-0207				BENEFITS - LIFE & DISABIL - HUMAN RESOUR				799.77
MAR 2019	MARCH 2019 BENEFITS				227	01-Mar-2019	01-Mar-2019	
10-5-1001024-0207				BENEFITS - LIFE & DISABIL - HUMAN RESOUR				885.71
MAY 2019	MAY 2019 BENEFITS				472	01-May-2019	01-May-2019	
10-5-1001024-0207				BENEFITS - LIFE & DISABIL - HUMAN RESOUR				879.36
<b>USB01</b>				<b>US BANK NATIONAL ASSOCIATION-VISA</b>				
APRIL 2019	APRIL 2019 PURCHASES				528	30-Apr-2019	30-Apr-2019	
10-5-1001024-0372				RECRUITMENT EXPENSES				22.54
10-5-1001024-0250				HEALTH AND SAFETY - HUMAN RESOURCES				1,921.00
10-5-1001024-0250				HEALTH AND SAFETY - HUMAN RESOURCES				711.90
10-5-1001024-0250				HEALTH AND SAFETY - HUMAN RESOURCES				392.10
10-5-1001024-0342				MEETING EXPENSES				7.30
10-5-1001024-0342				MEETING EXPENSES				20.50
FEBRUARY 2019	FEBRUARY 2019 PURCHASES				374	28-Feb-2019	28-Feb-2019	
10-5-1001024-0342				MEETING EXPENSES				7.51
10-5-1001024-0250				HEALTH AND SAFETY - HUMAN RESOURCES				32.77
10-5-1001024-0240				EMPLOYEE RECOGNITION				67.79
JANUARY 2019	JANUARY 2019 PURCHASES				132	31-Jan-2019	31-Jan-2019	
10-5-1001024-0250				HEALTH AND SAFETY - HUMAN RESOURCES				13.55
10-5-1001024-0240				EMPLOYEE RECOGNITION				108.03
10-5-1001024-0240				EMPLOYEE RECOGNITION				50.00
10-5-1001024-0240				EMPLOYEE RECOGNITION				67.79
10-5-1001024-0240				EMPLOYEE RECOGNITION				75.00
10-5-1001024-0240				EMPLOYEE RECOGNITION				75.00
10-5-1001024-0240				EMPLOYEE RECOGNITION				74.57
10-5-1001024-0240				EMPLOYEE RECOGNITION				75.00
MARCH 2019	MARCH 2019 PURCHASES				524	31-Mar-2019	31-Mar-2019	
10-5-1001024-0372				RECRUITMENT EXPENSES				367.25
10-5-1001024-0372				RECRUITMENT EXPENSES				169.50
10-5-1001024-0372				RECRUITMENT EXPENSES				3.59
10-5-1001024-0372				RECRUITMENT EXPENSES				5.49
10-5-1001024-0372				RECRUITMENT EXPENSES				-169.50
10-5-1001024-0372				RECRUITMENT EXPENSES				163.85
10-5-1001024-0240				EMPLOYEE RECOGNITION				74.57
10-5-1001024-0240				EMPLOYEE RECOGNITION				74.57
10-5-1001024-0240				EMPLOYEE RECOGNITION				43.45
10-5-1001024-0240				EMPLOYEE RECOGNITION				46.45
10-5-1001024-0240				EMPLOYEE RECOGNITION				22.02
10-5-1001024-0240				EMPLOYEE RECOGNITION				74.57
MAY 2019	MAY 2019 PURCHASES				746	31-May-2019	31-May-2019	
10-5-1001024-0342				MEETING EXPENSES				5.80
10-5-1001024-0240				EMPLOYEE RECOGNITION				74.57
10-5-1001024-0351				TRAINING & CONFERENCE - HUMAN RESOURCES				281.37
10-5-1001024-0350				MEMBERSHIPS - HUMAN RESOURCES				458.78
10-5-1001024-0372				RECRUITMENT EXPENSES				24.74



Vendor : CAT038 To ZUL180  
 Batch : All  
 Department : All

EFT Paid Date : 01-Jan-2019 To 31-May-2019  
 Bank : 1 To 99  
 Class : All

Vendor Code	Vendor Name	Batch	Inv Date	Inv Due Date	Amount
Invoice No.	Description				
G.L. Account	CC1 CC2 CC3 GL Account Name				

DEPARTMENT 1001024 HUMAN RESOURCES

Department Totals : **14,946.78**

DEPARTMENT 1001025 INFORMATION TECHNOLOGY

**BEL01 BELL CANADA**

APR 2019	APRIL 2019 MONTHLY CHARGES	497	18-Apr-2019	18-Apr-2019	
10-5-1001025-0315	TELEPHONE				30.54
10-5-1001025-0315	TELEPHONE				56.90
APR 2019	APRIL 2019 MONTHLY CHARGES	365	18-Apr-2019	18-Apr-2019	
10-5-1001025-0315	TELEPHONE				1,097.67
DEC 2018	(201 DECEMBER 2018 MONTHLY CHARGES	1590	18-Dec-2018	18-Dec-2018	
10-5-1001025-0315	TELEPHONE				30.55
10-5-1001025-0315	TELEPHONE				57.31
FEB 2019	FEBRUARY 2019 MONTHLY CHARGES	368	18-Feb-2019	18-Feb-2019	
10-5-1001025-0315	TELEPHONE				30.54
10-5-1001025-0315	TELEPHONE				56.89
FEB 2019	FEBRUARY 2019 MONTHLY CHARGES	180	18-Feb-2019	18-Feb-2019	
10-5-1001025-0315	TELEPHONE				1,181.48
FEB 2019	FINAI FEBRUARY FINAL BILLS	1024	18-Feb-2019	18-Feb-2019	
10-5-1001025-0315	TELEPHONE				63.25
JAN 2019	JANUARY 2019 MONTHLY CHARGES	59	18-Jan-2019	18-Jan-2019	
10-5-1001025-0315	TELEPHONE				1,176.70
JAN 2019	JANUARY 2019 MONTHLY CHARGES	57	18-Jan-2019	18-Jan-2019	
10-5-1001025-0315	TELEPHONE				30.53
10-5-1001025-0315	TELEPHONE				56.62
MAR 2019	MARCH 2019 MONTHLY CHARGES	369	18-Mar-2019	18-Mar-2019	
10-5-1001025-0315	TELEPHONE				30.54
10-5-1001025-0315	TELEPHONE				57.12
MAR 2019	MARCH 2019 MONHTLY CHARGES	327	18-Mar-2019	18-Mar-2019	
10-5-1001025-0315	TELEPHONE				1,089.72
MAY 2019	MAY 2019 MONTHLY CHARGES	499	18-Feb-2019	18-Feb-2019	
10-5-1001025-0315	TELEPHONE				1,085.49

**BEL03 BELL MOBILITY INC.**

APR 2019	APRIL 2019 USAGE	403	06-Apr-2019	06-Apr-2019	
10-5-1001025-0332	INTERNET ACCESS				359.03
10-5-1001025-0345	CELL PHONE				247.82
FEB 2019	FEBRUARY 2019 USAGE	188	06-Feb-2019	06-Feb-2019	
10-5-1001025-0345	CELL PHONE				241.69
10-5-1001025-0332	INTERNET ACCESS				359.71
JAN 2019	JANUARY 2019 USAGE	58	06-Jan-2019	06-Jan-2019	
10-5-1001025-0332	INTERNET ACCESS				376.66
10-5-1001025-0345	CELL PHONE				200.73
MAR 2019	MARCH 2019 USAGE	326	06-Mar-2019	06-Mar-2019	
10-5-1001025-0345	CELL PHONE				227.39
10-5-1001025-0332	INTERNET ACCESS				354.40
MAY 2019	MAY 2019 USAGE	543	06-May-2019	06-May-2019	
10-5-1001025-0345	CELL PHONE				266.62
10-5-1001025-0332	INTERNET ACCESS				336.71

**BEL12 BELL CANADA**

APR 2019	APRIL 2019 SERVICES	367	01-Apr-2019	01-Apr-2019	
10-5-1001025-0315	TELEPHONE				158.20
FEB 2019	FEBRUARY 2019 SERVICES	226	01-Feb-2019	01-Feb-2019	
10-5-1001025-0315	TELEPHONE				158.20
JAN 2019	JANUARY 2019 SERVICES	79	02-Jan-2019	02-Jan-2019	
10-5-1001025-0315	TELEPHONE				239.11
MAR 2019	MARCH 2019 SERVICES	277	01-Mar-2019	01-Mar-2019	



Vendor : CAT038 To ZUL180

Batch : All

Department : All

EFT Paid Date : 01-Jan-2019 To 31-May-2019

Bank : 1 To 99

Class : All

Vendor Code	Vendor Name	Batch	Inv Date	Inv Due Date	Amount
Invoice No.	Description				
G.L. Account	CC1 CC2 CC3 GL Account Name				
<b>DEPARTMENT 1001025</b>	<b>INFORMATION TECHNOLOGY</b>				
10-5-1001025-0315	TELEPHONE				158.20
MAY 2019	MAY 2019 SERVICES	488	01-May-2019	01-May-2019	
10-5-1001025-0315	TELEPHONE				158.20
<b>COG02</b>	<b>COGECO PAYMENT CENTRE</b>				
APR 2019	APRIL 2019 INTERNET	456	01-Apr-2019	01-Apr-2019	
10-5-1001025-0332	INTERNET ACCESS				115.20
APR 2019 B	APRIL 2019 INTERNET	457	01-Apr-2019	01-Apr-2019	
10-5-1001025-0332	INTERNET ACCESS				180.74
10-5-1001025-0332	INTERNET ACCESS				3,167.39
DEC 2018	DECEMBER 2018 INTERNET	1533	01-Dec-2018	01-Dec-2018	
10-5-1001025-0332	INTERNET ACCESS				180.74
10-5-1001025-0332	INTERNET ACCESS				115.20
10-5-1001025-0332	INTERNET ACCESS				19,004.34
FEB 2019	FEBRUARY 2019 INTERNET	452	01-Feb-2019	01-Feb-2019	
10-5-1001025-0332	INTERNET ACCESS				115.20
FEB 2019 B	FEBRUARY 2019 INTERNET	453	01-Feb-2019	01-Feb-2019	
10-5-1001025-0332	INTERNET ACCESS				180.74
10-5-1001025-0332	INTERNET ACCESS				3,167.39
JAN 2019	JANUARY 2018 INTERNET	80	02-Jan-2019	02-Jan-2019	
10-5-1001025-0332	INTERNET ACCESS				180.74
10-5-1001025-0332	INTERNET ACCESS				267.69
JAN 2019 B	JANUARY 2019 INTERNET BILL	81	02-Jan-2019	02-Jan-2019	
10-5-1001025-0332	INTERNET ACCESS				3,167.39
MAR 2019	MARCH 2019 INTERNET	454	01-Mar-2019	01-Mar-2019	
10-5-1001025-0332	INTERNET ACCESS				115.20
MAR 2019 B	MARCH 2019 INTERNET	455	01-Mar-2019	01-Mar-2019	
10-5-1001025-0332	INTERNET ACCESS				180.74
10-5-1001025-0332	INTERNET ACCESS				3,167.39
MAY 2019	MAY 2019 INTERNET	653	01-May-2019	01-May-2019	
10-5-1001025-0332	INTERNET ACCESS				115.20
<b>GRE03</b>	<b>GREEN SHIELD CANADA</b>				
APR 2019	APRIL 2019 BENEFITS	375	01-Apr-2019	01-Apr-2019	
10-5-1001025-0205	BENEFITS - GREENSHIELD				1,427.93
FEB 2019	FEBRUARY 2019 BENEFITS	98	01-Feb-2019	01-Feb-2019	
10-5-1001025-0205	BENEFITS - GREENSHIELD				1,427.93
JAN 2019	JANUARY 2019 BENEFITS	5	02-Jan-2019	02-Jan-2019	
10-5-1001025-0205	BENEFITS - GREENSHIELD				1,427.93
MAR 2019	MARCH 2019 BENEFITS	228	01-Mar-2019	01-Mar-2019	
10-5-1001025-0205	BENEFITS - GREENSHIELD				1,427.93
MAY 2019	MAY 2019 BENEFITS	619	01-May-2019	01-May-2019	
10-5-1001025-0205	BENEFITS - GREENSHIELD				1,427.93
<b>SUN11</b>	<b>SUN LIFE ASSURANCE CO. OF CANADA - BILLING</b>				
APR 2019	APRIL 2019 BENEFITS	404	01-Apr-2019	01-Apr-2019	
10-5-1001025-0207	BENEFITS - LIFE & DISABILITY				1,025.23
DEC 2018	DECEMBER 2018 BENEFITS	1468	01-Dec-2018	01-Dec-2018	
10-5-1001025-0207	BENEFITS - LIFE & DISABILITY				1,025.23
FEB 2019	FEBRUARY 2019 BENEFITS	124	01-Feb-2019	01-Feb-2019	
10-5-1001025-0207	BENEFITS - LIFE & DISABILITY				1,025.23
JAN 2019	JANUARY 2019 BENEFITS	123	02-Jan-2019	02-Jan-2019	
10-5-1001025-0207	BENEFITS - LIFE & DISABILITY				1,025.23
MAR 2019	MARCH 2019 BENEFITS	227	01-Mar-2019	01-Mar-2019	
10-5-1001025-0207	BENEFITS - LIFE & DISABILITY				1,025.23
MAY 2019	MAY 2019 BENEFITS	472	01-May-2019	01-May-2019	
10-5-1001025-0207	BENEFITS - LIFE & DISABILITY				1,116.43
<b>USB01</b>	<b>US BANK NATIONAL ASSOCIATION-VISA</b>				



Vendor : CAT038 To ZUL180  
 Batch : All  
 Department : All

EFT Paid Date : 01-Jan-2019 To 31-May-2019  
 Bank : 1 To 99  
 Class : All

Vendor Code	Vendor Name	Batch	Inv Date	Inv Due Date	Amount
Invoice No.	Description				
G.L. Account	CC1 CC2 CC3 GL Account Name				
<b>DEPARTMENT 1001025 INFORMATION TECHNOLOGY</b>					
APRIL 2019	APRIL 2019 PURCHASES	528	30-Apr-2019	30-Apr-2019	
10-5-1001025-0310	COMPUTER MAINTENANCE				112.98
10-5-1001025-0308	PHOTOCOPIES				90.39
FEBRUARY 2019	FEBRUARY 2019 PURCHASES	374	28-Feb-2019	28-Feb-2019	
10-5-1001025-0310	COMPUTER MAINTENANCE				198.85
10-5-1001025-0310	COMPUTER MAINTENANCE				74.43
10-5-1001025-0310	COMPUTER MAINTENANCE				1,810.30
10-5-1001025-0350	MEMBERSHIPS				503.98
10-5-1001025-0311	WEBSITE DEVELOPMENT & SOFTWARE				779.96
10-5-1001025-0311	WEBSITE DEVELOPMENT & SOFTWARE				678.00
10-5-1001025-0301	OFFICE SUPPLIES				187.53
JANUARY 2019	JANUARY 2019 PURCHASES	132	31-Jan-2019	31-Jan-2019	
10-5-1001025-0310	COMPUTER MAINTENANCE				-55.36
10-5-1001025-0310	COMPUTER MAINTENANCE				512.49
10-5-1001025-0310	COMPUTER MAINTENANCE				80.12
10-5-1001025-0310	COMPUTER MAINTENANCE				192.79
10-5-1001025-0345	CELL PHONE				36.97
10-5-1001025-0345	CELL PHONE				47.46
MARCH 2019	MARCH 2019 PURCHASES	524	31-Mar-2019	31-Mar-2019	
10-5-1001025-0310	COMPUTER MAINTENANCE				1,970.81
10-5-1001025-0332	INTERNET ACCESS				406.12
10-5-1001025-0308	PHOTOCOPIES				22.44
MAY 2019	MAY 2019 PURCHASES	746	31-May-2019	31-May-2019	
10-5-1001025-0308	PHOTOCOPIES				124.85
10-5-1001025-0351	TRAINING				300.00
10-5-1001025-0351	TRAINING				171.49
10-5-1001025-0310	COMPUTER MAINTENANCE				185.97
<b>Department Totals :</b>					<b>65,210.61</b>

<b>DEPARTMENT 1001029 RECORDS RETENTION</b>					
<b>USB01</b>	<b>US BANK NATIONAL ASSOCIATION-VISA</b>				
MARCH 2019	MARCH 2019 PURCHASES	524	31-Mar-2019	31-Mar-2019	
10-5-1001029-0317	BUILDING MAINTENANCE - RECORDS RETENTION				19.95
<b>Department Totals :</b>					<b>19.95</b>

<b>DEPARTMENT 1008030 UNFINANCED DRAINS</b>					
<b>ESS46</b>	<b>ESSEX POWERLINES CORPORATION</b>				
DEC 2018	ELECTRICITY, WATER & SEWAGE DECEMBER 2018	1585	31-Dec-2018	31-Dec-2018	
10-1-1008030-8965	WILLOW BEACH PUMP				77.97
MAR 2019	ELECTRICITY, WATER & SEWAGE MARCH 2019	411	31-Mar-2019	31-Mar-2019	
10-1-1008030-8965	WILLOW BEACH PUMP				85.45
<b>GRE03</b>	<b>GREEN SHIELD CANADA</b>				
APR 2019	APRIL 2019 BENEFITS	375	01-Apr-2019	01-Apr-2019	
10-5-1008030-0205	BENEFITS GREENSHIELD				416.50
MAY 2019	MAY 2019 BENEFITS	619	01-May-2019	01-May-2019	
10-5-1008030-0205	BENEFITS GREENSHIELD				416.50
<b>HYD02</b>	<b>HYDRO ONE NETWORKS</b>				
APR 2019	MAIN ACCOUNT APRIL 2019	500	30-Apr-2019	30-Apr-2019	
10-1-1008030-8555	LEO BEAUDOIN PUMP				128.75
10-1-1008030-8510	LAKWOOD PUMP #1				76.16
10-1-1008030-8120	BAILEY'S BEACH DRAIN & PUMP				34.69
10-1-1008030-8965	WILLOW BEACH PUMP				815.67
DEC 2018	MAIN ACCOUNT	1583	31-Dec-2018	31-Dec-2018	
10-1-1008030-8120	BAILEY'S BEACH DRAIN & PUMP				34.79
10-1-1008030-8965	WILLOW BEACH PUMP				821.62
10-1-1008030-8515	LAKWOOD PUMP #2				46.66



Vendor : CAT038 To ZUL180  
 Batch : All  
 Department : All

EFT Paid Date : 01-Jan-2019 To 31-May-2019  
 Bank : 1 To 99  
 Class : All

Vendor Code	Vendor Name				Batch	Inv Date	Inv Due Date	Amount	
Invoice No.	Description								
G.L. Account	CC1	CC2	CC3	GL Account Name					
<b>DEPARTMENT 1008030</b>		<b>UNFINANCED DRAINS</b>							
10-1-1008030-8675				MICKLE PARK AVE PUMP				72.98	
10-1-1008030-8510				LAKWOOD PUMP #1				45.38	
10-1-1008030-8555				LEO BEAUDOIN PUMP				256.08	
FEB 2019	MAIN ACCOUNT FEBRUARY 2019				279	28-Feb-2019	28-Feb-2019		
10-1-1008030-8120				BAILEY'S BEACH DRAIN & PUMP				31.80	
10-1-1008030-8965				WILLOW BEACH PUMP				655.58	
10-1-1008030-8510				LAKWOOD PUMP #1				35.94	
10-1-1008030-8515				LAKWOOD PUMP #2				41.11	
10-1-1008030-8675				MICKLE PARK AVE PUMP				299.99	
10-1-1008030-8555				LEO BEAUDOIN PUMP				80.32	
JAN 2019	MAIN ACCOUNT JANUARY 2019				192	31-Jan-2019	31-Jan-2019		
10-1-1008030-8515				LAKWOOD PUMP #2				64.11	
10-1-1008030-8675				MICKLE PARK AVE PUMP				144.96	
10-1-1008030-8120				BAILEY'S BEACH DRAIN & PUMP				33.55	
10-1-1008030-8965				WILLOW BEACH PUMP				900.34	
10-1-1008030-8510				LAKWOOD PUMP #1				45.47	
10-1-1008030-8555				LEO BEAUDOIN PUMP				140.03	
MAR 2019	MAIN ACCOUNT MARCH 2019				370	31-Mar-2019	31-Mar-2019		
10-1-1008030-8555				LEO BEAUDOIN PUMP				219.10	
10-1-1008030-8510				LAKWOOD PUMP #1				59.39	
10-1-1008030-8120				BAILEY'S BEACH DRAIN & PUMP				34.26	
10-1-1008030-8965				WILLOW BEACH PUMP				936.94	
10-1-1008030-8515				LAKWOOD PUMP #2				45.78	
10-1-1008030-8675				MICKLE PARK AVE PUMP				201.56	
<b>SUN11</b>		<b>SUN LIFE ASSURANCE CO. OF CANADA - BILLING</b>							
APR 2019	APRIL 2019 BENEFITS				404	01-Apr-2019	01-Apr-2019		
10-5-1008030-0207				BENEFITS LIFE & DISABILITY				386.63	
MAY 2019	MAY 2019 BENEFITS				472	01-May-2019	01-May-2019		
10-5-1008030-0207				BENEFITS LIFE & DISABILITY				419.83	
<b>USB01</b>		<b>US BANK NATIONAL ASSOCIATION-VISA</b>							
APRIL 2019	APRIL 2019 PURCHASES				528	30-Apr-2019	30-Apr-2019		
10-5-1008030-0328				PROFESSIONAL & ENGINEERING FEES				248.60	
							<b>Department Totals :</b>	<b>8,354.49</b>	

<b>DEPARTMENT 2010000</b>		<b>FIRE DEPARTMENT</b>							
<b>BEL03</b>		<b>BELL MOBILITY INC.</b>							
APR 2019	APRIL 2019 USAGE				403	06-Apr-2019	06-Apr-2019		
10-5-2010000-0345				FIRE - CELL PHONE EXPENSE				332.73	
FEB 2019	FEBRUARY 2019 USAGE				188	06-Feb-2019	06-Feb-2019		
10-5-2010000-0345				FIRE - CELL PHONE EXPENSE				393.33	
JAN 2019	JANUARY 2019 USAGE				58	06-Jan-2019	06-Jan-2019		
10-5-2010000-0345				FIRE - CELL PHONE EXPENSE				336.10	
MAR 2019	MARCH 2019 USAGE				326	06-Mar-2019	06-Mar-2019		
10-5-2010000-0345				FIRE - CELL PHONE EXPENSE				374.47	
MAY 2019	MAY 2019 USAGE				543	06-May-2019	06-May-2019		
10-5-2010000-0345				FIRE - CELL PHONE EXPENSE				429.91	
<b>BEL900</b>		<b>BELL CANADA</b>							
APR 2019	APRIL 2019 EMERGENCY PREPARENESS				383	01-Apr-2019	01-Apr-2019		
10-5-2010000-0800				EMERGENCY OPERATIONS CENTRE EXPENSES				217.76	
FEB 2019	FEBRUARY 2019 EMERGENCY PREPARENESS				240	01-Feb-2019	01-Feb-2019		
10-5-2010000-0800				EMERGENCY OPERATIONS CENTRE EXPENSES				217.72	
JAN 2019	JANUARY 2019 EMERGENCY PREPARENESS				78	02-Jan-2019	02-Jan-2019		
10-5-2010000-0800				EMERGENCY OPERATIONS CENTRE EXPENSES				217.80	
MAR 2019	MARCH 2019 EMERGENCY PREPARENESS				308	01-Mar-2019	01-Mar-2019		
10-5-2010000-0800				EMERGENCY OPERATIONS CENTRE EXPENSES				217.76	
MAY 2019	MAY 2019 EMERGENCY PREPARENESS				487	01-May-2019	01-May-2019		



Vendor : CAT038 To ZUL180  
 Batch : All  
 Department : All

EFT Paid Date : 01-Jan-2019 To 31-May-2019  
 Bank : 1 To 99  
 Class : All

Vendor Code	Vendor Name	Batch	Inv Date	Inv Due Date	Amount
Invoice No.	Description				
G.L. Account	CC1 CC2 CC3 GL Account Name				
<b>DEPARTMENT 2010000</b>	<b>FIRE DEPARTMENT</b>				
10-5-2010000-0800	EMERGENCY OPERATIONS CENTRE EXPENSES				217.76
<b>COG02</b>	<b>COGECO PAYMENT CENTRE</b>				
APR 2019 B	APRIL 2019 INTERNET	457	01-Apr-2019	01-Apr-2019	
10-5-2010000-0251	FIRE PREVENTION & TRAININ				80.22
DEC 2018	DECEMBER 2018 INTERNET	1533	01-Dec-2018	01-Dec-2018	
10-5-2010000-0251	FIRE PREVENTION & TRAININ				80.22
FEB 2019 B	FEBRUARY 2019 INTERNET	453	01-Feb-2019	01-Feb-2019	
10-5-2010000-0251	FIRE PREVENTION & TRAININ				80.22
JAN 2019 B	JANUARY 2019 INTERNET BILL	81	02-Jan-2019	02-Jan-2019	
10-5-2010000-0251	FIRE PREVENTION & TRAININ				80.22
MAR 2019 B	MARCH 2019 INTERNET	455	01-Mar-2019	01-Mar-2019	
10-5-2010000-0251	FIRE PREVENTION & TRAININ				80.22
<b>EVE740</b>	<b>EVERBRIDGE INC.</b>				
M41942 AMENC MASS NOTIFICATION ANNUAL PAYMENT		433	28-Feb-2019	28-Feb-2019	
10-5-2010000-0800	EMERGENCY OPERATIONS CENTRE EXPENSES				3,604.61
<b>GRE03</b>	<b>GREEN SHIELD CANADA</b>				
APR 2019	APRIL 2019 BENEFITS	375	01-Apr-2019	01-Apr-2019	
10-5-2010000-0205	BENEFITS - GREENSHIELD - FIRE				3,645.30
10-5-2010000-0206	BENEFITS - GREENSHIELD RE				2,369.12
FEB 2019	FEBRUARY 2019 BENEFITS	98	01-Feb-2019	01-Feb-2019	
10-5-2010000-0206	BENEFITS - GREENSHIELD RE				2,369.12
10-5-2010000-0205	BENEFITS - GREENSHIELD - FIRE				3,645.30
JAN 2019	JANUARY 2019 BENEFITS	5	02-Jan-2019	02-Jan-2019	
10-5-2010000-0206	BENEFITS - GREENSHIELD RE				2,369.12
10-5-2010000-0205	BENEFITS - GREENSHIELD - FIRE				3,645.30
MAR 2019	MARCH 2019 BENEFITS	228	01-Mar-2019	01-Mar-2019	
10-5-2010000-0205	BENEFITS - GREENSHIELD - FIRE				3,645.30
10-5-2010000-0206	BENEFITS - GREENSHIELD RE				2,369.12
MAY 2019	MAY 2019 BENEFITS	619	01-May-2019	01-May-2019	
10-5-2010000-0205	BENEFITS - GREENSHIELD - FIRE				3,645.30
10-5-2010000-0206	BENEFITS - GREENSHIELD RE				2,369.12
<b>HYD02</b>	<b>HYDRO ONE NETWORKS</b>				
APR 2019	MAIN ACCOUNT APRIL 2019	500	30-Apr-2019	30-Apr-2019	
10-5-2010000-0800	EMERGENCY OPERATIONS CENTRE EXPENSES				39.47
APR 2019	EME I 2N CONC LOT 10, SIRENS	413	01-Apr-2019	01-Apr-2019	
10-5-2010000-0800	EMERGENCY OPERATIONS CENTRE EXPENSES				39.83
APR 2019	EME I 2S CONC LOT 20, SIRENS	384	01-Apr-2019	01-Apr-2019	
10-5-2010000-0800	EMERGENCY OPERATIONS CENTRE EXPENSES				39.83
DEC 2018	MAIN ACCOUNT	1583	31-Dec-2018	31-Dec-2018	
10-5-2010000-0800	EMERGENCY OPERATIONS CENTRE EXPENSES				39.63
DEC 2018	EME 2N CONC LOT 10, SIRENS	1508	18-Dec-2018	18-Dec-2018	
10-5-2010000-0800	EMERGENCY OPERATIONS CENTRE EXPENSES				39.84
FEB 2019	MAIN ACCOUNT FEBRUARY 2019	279	28-Feb-2019	28-Feb-2019	
10-5-2010000-0800	EMERGENCY OPERATIONS CENTRE EXPENSES				39.24
FEB 2019	EMEF 2N CONC LOT 10, SIRENS	200	18-Feb-2019	18-Feb-2019	
10-5-2010000-0800	EMERGENCY OPERATIONS CENTRE EXPENSES				39.83
FEB 2019	EMEF 2S CONC LOT 20, SIRENS	199	19-Feb-2019	19-Feb-2019	
10-5-2010000-0800	EMERGENCY OPERATIONS CENTRE EXPENSES				39.83
JAN 2019	MAIN ACCOUNT JANUARY 2019	192	31-Jan-2019	31-Jan-2019	
10-5-2010000-0800	EMERGENCY OPERATIONS CENTRE EXPENSES				39.95
JAN 2019	EMEF 2N CONC LOT 10, SIRENS	54	19-Jan-2019	19-Jan-2019	
10-5-2010000-0800	EMERGENCY OPERATIONS CENTRE EXPENSES				39.83
JAN 2019	EMEF 2S CON LOT 20, SIRENS	55	18-Jan-2019	18-Jan-2019	
10-5-2010000-0800	EMERGENCY OPERATIONS CENTRE EXPENSES				39.83
MAR 2019	MAIN ACCOUNT MARCH 2019	370	31-Mar-2019	31-Mar-2019	





Vendor : CAT038 To ZUL180

Batch : All

Department : All

EFT Paid Date : 01-Jan-2019 To 31-May-2019

Bank : 1 To 99

Class : All

Vendor Code	Vendor Name				Batch	Inv Date	Inv Due Date	Amount	
Invoice No.	Description								
G.L. Account	CC1	CC2	CC3	GL Account Name					
<b>DEPARTMENT 2010000</b>		<b>FIRE DEPARTMENT</b>							
10-5-2010000-0800				EMERGENCY OPERATIONS CENTRE EXPENSES				39.22	
MAR 2019	EME 2N CONC LOT 10, SIRENS				315	01-Mar-2019	01-Mar-2019		
10-5-2010000-0800				EMERGENCY OPERATIONS CENTRE EXPENSES				39.83	
MAR 2019	EME 2S CONC LOT 20, SIRENS				372	18-Mar-2019	18-Mar-2019		
10-5-2010000-0800				EMERGENCY OPERATIONS CENTRE EXPENSES				39.83	
<b>SHA253 SHAW DIRECT</b>									
APRIL 2019	APR 3- MAY 2, 2019 SATELLITE				376	04-Apr-2019	04-Apr-2019		
10-5-2010000-0800				EMERGENCY OPERATIONS CENTRE EXPENSES				83.62	
FEBRUARY 2019	FEB 3-MAR 2, 2019 SATELLITE				197	04-Feb-2019	04-Feb-2019		
10-5-2010000-0800				EMERGENCY OPERATIONS CENTRE EXPENSES				83.62	
JANUARY 2018	JAN 3-JAN 19, 2019 SATELLITE				9	04-Jan-2019	04-Jan-2019		
10-5-2010000-0800				EMERGENCY OPERATIONS CENTRE EXPENSES				89.26	
MARCH 2019	MAR 3 - APR 2, 2019 SATELLITE				198	04-Feb-2019	04-Feb-2019		
10-5-2010000-0800				EMERGENCY OPERATIONS CENTRE EXPENSES				83.62	
MAY 2019	MAY 3- JUN 2, 2019 SATELLITE				549	04-May-2019	04-May-2019		
10-5-2010000-0800				EMERGENCY OPERATIONS CENTRE EXPENSES				83.62	
<b>SUN11 SUN LIFE ASSURANCE CO. OF CANADA - BILLING</b>									
APR 2019	APRIL 2019 BENEFITS				404	01-Apr-2019	01-Apr-2019		
10-5-2010000-0207				BENEFITS - LIFE & DISABIL				2,541.14	
DEC 2018	DECEMBER 2018 BENEFITS				1468	01-Dec-2018	01-Dec-2018		
10-5-2010000-0207				BENEFITS - LIFE & DISABIL				2,521.59	
FEB 2019	FEBRUARY 2019 BENEFITS				124	01-Feb-2019	01-Feb-2019		
10-5-2010000-0207				BENEFITS - LIFE & DISABIL				2,560.69	
JAN 2019	JANUARY 2019 BENEFITS				123	02-Jan-2019	02-Jan-2019		
10-5-2010000-0207				BENEFITS - LIFE & DISABIL				2,521.59	
MAR 2019	MARCH 2019 BENEFITS				227	01-Mar-2019	01-Mar-2019		
10-5-2010000-0207				BENEFITS - LIFE & DISABIL				2,541.14	
MAY 2019	MAY 2019 BENEFITS				472	01-May-2019	01-May-2019		
10-5-2010000-0207				BENEFITS - LIFE & DISABIL				2,792.44	
<b>USB01 US BANK NATIONAL ASSOCIATION-VISA</b>									
APRIL 2019	APRIL 2019 PURCHASES				528	30-Apr-2019	30-Apr-2019		
10-5-2010000-0254				FIRE FIGHTER TRAINING				105.00	
10-5-2010000-0800				EMERGENCY OPERATIONS CENTRE EXPENSES				31.11	
10-5-2010000-0318				JANITORIAL				147.43	
10-5-2010000-0318				JANITORIAL				91.94	
10-5-2010000-0800				EMERGENCY OPERATIONS CENTRE EXPENSES				30.51	
10-5-2010000-0800				EMERGENCY OPERATIONS CENTRE EXPENSES				333.63	
10-5-2010000-0254				FIRE FIGHTER TRAINING				232.10	
10-5-2010000-0340				RECEPTIONS & AWARDS				67.75	
10-5-2010000-0324				DISPATCHING				186.42	
10-5-2010000-0420				FIREFIGHTING EQUIPMENT				239.56	
10-5-2010000-0402				VEHICLE & EQUIPMENT MTCE.				241.67	
10-5-2010000-0402				VEHICLE & EQUIPMENT MTCE.				28.86	
10-5-2010000-0251				FIRE PREVENTION & TRAININ				96.08	
10-5-2010000-0420				FIREFIGHTING EQUIPMENT				474.03	
10-5-2010000-0420				FIREFIGHTING EQUIPMENT				67.78	
10-5-2010000-0345				FIRE - CELL PHONE EXPENSE				24.85	
10-5-2010000-0345				FIRE - CELL PHONE EXPENSE				12.42	
10-5-2010000-0345				FIRE - CELL PHONE EXPENSE				8.99	
FEBRUARY 2019	FEBRUARY 2019 PURCHASES				374	28-Feb-2019	28-Feb-2019		
10-5-2010000-0307				ADVERTISING				5.65	
10-5-2010000-0307				ADVERTISING				263.24	
10-5-2010000-0251				FIRE PREVENTION & TRAININ				92.05	
10-5-2010000-0402				VEHICLE & EQUIPMENT MTCE.				746.16	
10-5-2010000-0350				MEMBERSHIPS				288.15	
10-5-2010000-0350				MEMBERSHIPS				288.15	
10-5-2010000-0350				MEMBERSHIPS				288.15	





Vendor : CAT038 To ZUL180

Batch : All

Department : All

EFT Paid Date : 01-Jan-2019 To 31-May-2019

Bank : 1 To 99

Class : All

Vendor Code	Vendor Name	Batch	Inv Date	Inv Due Date	Amount
Invoice No.	Description				
G.L. Account	CC1 CC2 CC3 GL Account Name				
<b>DEPARTMENT 2010000 FIRE DEPARTMENT</b>					
10-5-2010000-0800	EMERGENCY OPERATIONS CENTRE EXPENSES				370.64
10-5-2010000-0318	JANITORIAL				48.68
10-5-2010000-0254	FIRE FIGHTER TRAINING				43.99
10-5-2010000-0351	TRAINING & PROF.DEVELOPMENT				108.78
10-5-2010000-0351	TRAINING & PROF.DEVELOPMENT				263.28
10-5-2010000-0351	TRAINING & PROF.DEVELOPMENT				135.00
10-5-2010000-0352	TRAVEL & MILEAGE				94.26
10-5-2010000-0352	TRAVEL & MILEAGE				55.18
10-5-2010000-0352	TRAVEL & MILEAGE				51.00
JANUARY 2019	JANUARY 2019 PURCHASES	132	31-Jan-2019	31-Jan-2019	
10-5-2010000-0251	FIRE PREVENTION & TRAININ				21.17
10-5-2010000-0251	FIRE PREVENTION & TRAININ				192.10
10-5-2010000-0251	FIRE PREVENTION & TRAININ				712.97
MARCH 2019	MARCH 2019 PURCHASES	524	31-Mar-2019	31-Mar-2019	
10-5-2010000-0402	VEHICLE & EQUIPMENT MTCE.				62.13
10-5-2010000-0402	VEHICLE & EQUIPMENT MTCE.				72.30
10-5-2010000-0420	FIREFIGHTING EQUIPMENT				291.54
10-5-2010000-0324	DISPATCHING				639.00
10-5-2010000-0800	EMERGENCY OPERATIONS CENTRE EXPENSES				71.20
10-5-2010000-0800	EMERGENCY OPERATIONS CENTRE EXPENSES				102.93
10-5-2010000-0800	EMERGENCY OPERATIONS CENTRE EXPENSES				62.65
10-5-2010000-0800	EMERGENCY OPERATIONS CENTRE EXPENSES				46.46
10-5-2010000-0800	EMERGENCY OPERATIONS CENTRE EXPENSES				12.60
10-5-2010000-0800	EMERGENCY OPERATIONS CENTRE EXPENSES				43.13
10-5-2010000-0800	EMERGENCY OPERATIONS CENTRE EXPENSES				46.48
10-5-2010000-0800	EMERGENCY OPERATIONS CENTRE EXPENSES				56.95
10-5-2010000-0800	EMERGENCY OPERATIONS CENTRE EXPENSES				22.67
10-5-2010000-0800	EMERGENCY OPERATIONS CENTRE EXPENSES				775.64
10-5-2010000-0800	EMERGENCY OPERATIONS CENTRE EXPENSES				775.64
10-5-2010000-0800	EMERGENCY OPERATIONS CENTRE EXPENSES				48.00
MAY 2019	MAY 2019 PURCHASES	746	31-May-2019	31-May-2019	
10-5-2010000-0351	TRAINING & PROF.DEVELOPMENT				149.64
10-5-2010000-0352	TRAVEL & MILEAGE				64.01
10-5-2010000-0352	TRAVEL & MILEAGE				40.00
10-5-2010000-0254	FIRE FIGHTER TRAINING				315.95
10-5-2010000-0254	FIRE FIGHTER TRAINING				105.73
10-5-2010000-0800	EMERGENCY OPERATIONS CENTRE EXPENSES				23.00
10-5-2010000-0402	VEHICLE & EQUIPMENT MTCE.				269.00
10-5-2010000-0402	VEHICLE & EQUIPMENT MTCE.				88.59
10-5-2010000-0420	FIREFIGHTING EQUIPMENT				31.50
<b>WOR03 WORKPLACE SAFETY &amp; INSURANCE BOARD</b>					
APRIL 2019	APRIL 2019 WSIB PREMIUMS	442	30-Apr-2019	30-Apr-2019	
10-5-2010000-0208	BENEFITS - WORKER'S COMP.				1,540.74
DECEMBER 20	DECEMBER 2018 WSIB PREMIUMS	1526	31-Dec-2018	31-Dec-2018	
10-5-2010000-0208	BENEFITS - WORKER'S COMP.				1,565.20
FEBRUARY 2019	FEBRUARY 2019 WSIB PREMIUMS	242	28-Feb-2019	28-Feb-2019	
10-5-2010000-0208	BENEFITS - WORKER'S COMP.				1,565.20
JANUARY 2019	JANUARY 2019 WSIB PREMIUMS	155	31-Jan-2019	31-Jan-2019	
10-5-2010000-0208	BENEFITS - WORKER'S COMP.				1,565.20
MARCH 2019	MARCH 2019 WSIB PREMIUMS	354	31-Mar-2019	31-Mar-2019	
10-5-2010000-0208	BENEFITS - WORKER'S COMP.				1,540.74
MAY 2019	MAY 2019 WSIB PREMIUMS	574	31-May-2019	31-May-2019	
10-5-2010000-0208	BENEFITS - WORKER'S COMP.				1,540.74
<b>Department Totals :</b>					<b>73,514.76</b>



Vendor : CAT038 To ZUL180

Batch : All

Department : All

EFT Paid Date : 01-Jan-2019 To 31-May-2019

Bank : 1 To 99

Class : All

Vendor Code	Vendor Name	Batch	Inv Date	Inv Due Date	Amount
Invoice No.	Description				
G.L. Account	CC1 CC2 CC3 GL Account Name				
<b>DEPARTMENT 2020000 POLICE DEPARTMENT</b>					
10-5-2020000-0315	TELEPHONE				514.69
FEB 2019	FEBRUARY 2019 MONTHLY CHARGES	180	18-Feb-2019	18-Feb-2019	
10-5-2020000-0315	TELEPHONE				514.96
JAN 2019	JANUARY 2019 MONTHLY CHARGES	59	18-Jan-2019	18-Jan-2019	
10-5-2020000-0315	TELEPHONE				519.63
MAR 2019	MARCH 2019 MONTHLY CHARGES	327	18-Mar-2019	18-Mar-2019	
10-5-2020000-0315	TELEPHONE				515.18
MAY 2019	MAY 2019 MONTHLY CHARGES	499	18-Feb-2019	18-Feb-2019	
10-5-2020000-0315	TELEPHONE				515.82
<b>BEL03 BELL MOBILITY INC.</b>					
FEB 2019	FEBRUARY 2019 USAGE	188	06-Feb-2019	06-Feb-2019	
10-5-2020000-0332	INTERNET ACCESS				-2.83
10-5-2020000-0315	TELEPHONE				62.69
JAN 2019	JANUARY 2019 USAGE	58	06-Jan-2019	06-Jan-2019	
10-5-2020000-0315	TELEPHONE				558.50
10-5-2020000-0332	INTERNET ACCESS				4.40
<b>CIT350 CITY OF WINDSOR</b>					
APRIL 2019	WPS CONTRACT	493	01-Apr-2019	01-Apr-2019	
10-5-2020000-0605	SERVICE CONTRACT -WPS				384,020.41
FEBRUARY 2019	WPS CONTRACT	213	04-Feb-2019	04-Feb-2019	
10-5-2020000-0605	SERVICE CONTRACT -WPS				385,408.57
JANUARY 2019	WPS CONTRACT	26	02-Jan-2019	02-Jan-2019	
10-5-2020000-0605	SERVICE CONTRACT -WPS				358,486.08
MARCH 2019	WPS CONTRACT	214	01-Mar-2019	01-Mar-2019	
10-5-2020000-0605	SERVICE CONTRACT -WPS				389,542.16
MAY 2019	WPS CONTRACT	494	01-May-2019	01-May-2019	
10-5-2020000-0605	SERVICE CONTRACT -WPS				401,768.56
<b>ESS46 ESSEX POWERLINES CORPORATION</b>					
APR 2019	ELECTRICITY, WATER & SEWAGE APRIL 2019	517	30-Apr-2019	30-Apr-2019	
10-5-2020000-0316	UTILITIES - POLICE DEPT				1,185.61
DEC 2018	ELECTRICITY, WATER & SEWAGE DECEMBER 2018	1585	31-Dec-2018	31-Dec-2018	
10-5-2020000-0316	UTILITIES - POLICE DEPT				1,930.59
FEB 2019	ELECTRICITY, WATER & SEWAGE FEBRUARY 2019	309	28-Feb-2019	28-Feb-2019	
10-5-2020000-0316	UTILITIES - POLICE DEPT				1,550.96
JAN 2019	ELECTRICITY, WATER & SEWAGE JANUARY 2019	193	31-Jan-2019	31-Jan-2019	
10-5-2020000-0316	UTILITIES - POLICE DEPT				1,428.99
MAR 2019	ELECTRICITY, WATER & SEWAGE MARCH 2019	411	31-Mar-2019	31-Mar-2019	
10-5-2020000-0316	UTILITIES - POLICE DEPT				1,585.56
<b>GRE03 GREEN SHIELD CANADA</b>					
APR 2019	APRIL 2019 BENEFITS	375	01-Apr-2019	01-Apr-2019	
10-5-2020000-0205	BENEFITS - GREENSHIELD				2,338.88
10-5-2020000-0206	BENEFITS - GREENSHIELD RE				9,686.52
FEB 2019	FEBRUARY 2019 BENEFITS	98	01-Feb-2019	01-Feb-2019	
10-5-2020000-0206	BENEFITS - GREENSHIELD RE				9,686.52
10-5-2020000-0205	BENEFITS - GREENSHIELD				-10,477.42
JAN 2019	JANUARY 2019 BENEFITS	5	02-Jan-2019	02-Jan-2019	
10-5-2020000-0205	BENEFITS - GREENSHIELD				15,427.16
10-5-2020000-0206	BENEFITS - GREENSHIELD RE				8,664.00
MAR 2019	MARCH 2019 BENEFITS	228	01-Mar-2019	01-Mar-2019	
10-5-2020000-0206	BENEFITS - GREENSHIELD RE				9,686.52
10-5-2020000-0205	BENEFITS - GREENSHIELD				2,338.88
MAY 2019	MAY 2019 BENEFITS	619	01-May-2019	01-May-2019	
10-5-2020000-0206	BENEFITS - GREENSHIELD RE				9,686.52
10-5-2020000-0205	BENEFITS - GREENSHIELD				1,370.14
<b>SUN11 SUN LIFE ASSURANCE CO. OF CANADA - BILLING</b>					



Vendor : CAT038 To ZUL180  
 Batch : All  
 Department : All

EFT Paid Date : 01-Jan-2019 To 31-May-2019  
 Bank : 1 To 99  
 Class : All

Vendor Code	Vendor Name				Batch	Inv Date	Inv Due Date	Amount	
Invoice No.	Description	CC1	CC2	CC3	GL Account Name				
G.L. Account									
<b>DEPARTMENT 2020000</b>		<b>POLICE DEPARTMENT</b>							
APR 2019	APRIL 2019 BENEFITS					404	01-Apr-2019	01-Apr-2019	
10-5-2020000-0207					BENEFITS - LIFE & DISABIL			1,124.93	
DEC 2018	DECEMBER 2018 BENEFITS					1468	01-Dec-2018	01-Dec-2018	
10-5-2020000-0207					BENEFITS - LIFE & DISABIL			14,570.44	
FEB 2019	FEBRUARY 2019 BENEFITS					124	01-Feb-2019	01-Feb-2019	
10-5-2020000-0207					BENEFITS - LIFE & DISABIL			1,217.36	
JAN 2019	JANUARY 2019 BENEFITS					123	02-Jan-2019	02-Jan-2019	
10-5-2020000-0207					BENEFITS - LIFE & DISABIL			2,786.33	
MAR 2019	MARCH 2019 BENEFITS					227	01-Mar-2019	01-Mar-2019	
10-5-2020000-0207					BENEFITS - LIFE & DISABIL			-1,605.89	
MAY 2019	MAY 2019 BENEFITS					472	01-May-2019	01-May-2019	
10-5-2020000-0207					BENEFITS - LIFE & DISABIL			571.29	
<b>UNI01 UNION GAS LTD</b>									
APR 2019	APRIL 2019 MONTHLY CHARGES					518	30-Apr-2019	30-Apr-2019	
10-5-2020000-0316					UTILITIES - POLICE DEPT			216.72	
DEC 2018	DECEMBER 2018 MONTHLY CHARGES					1586	31-Dec-2018	31-Dec-2018	
10-5-2020000-0316					UTILITIES - POLICE DEPT			276.81	
FEB 2019	FEBRUARY 2019 MONTHLY CHARGES					295	28-Feb-2019	28-Feb-2019	
10-5-2020000-0316					UTILITIES - POLICE DEPT			531.86	
JAN 2019	JANUARY 2019 MONTHLY CHARGES					220	31-Jan-2019	31-Jan-2019	
10-5-2020000-0316					UTILITIES - POLICE DEPT			313.80	
MAR 2019	MARCH 2019 MONTHLY CHARGES					318	31-Mar-2019	31-Mar-2019	
10-5-2020000-0316					UTILITIES - POLICE DEPT			427.31	
<b>USB01 US BANK NATIONAL ASSOCIATION-VISA</b>									
JANUARY 2019	JANUARY 2019 PURCHASES					132	31-Jan-2019	31-Jan-2019	
10-5-2020000-0360					MISCELLANEOUS EXPENSES			154.97	
<b>WOR03 WORKPLACE SAFETY &amp; INSURANCE BOARD</b>									
DECEMBER 20	DECEMBER 2018 WSIB PREMIUMS					1526	31-Dec-2018	31-Dec-2018	
10-5-2020000-0208					BENEFITS - WORKER'S COMP.			240.80	
							<b>Department Totals :</b>	<b>2,009,344.98</b>	

<b>DEPARTMENT 2043010</b>		<b>BUILDING DEPARTMENT</b>						
<b>BEL03 BELL MOBILITY INC.</b>								
APR 2019	APRIL 2019 USAGE					403	06-Apr-2019	06-Apr-2019
10-5-2043010-0345					BLDG. - CELL PHONE EXPENSE			234.90
FEB 2019	FEBRUARY 2019 USAGE					188	06-Feb-2019	06-Feb-2019
10-5-2043010-0345					BLDG. - CELL PHONE EXPENSE			119.22
JAN 2019	JANUARY 2019 USAGE					58	06-Jan-2019	06-Jan-2019
10-5-2043010-0345					BLDG. - CELL PHONE EXPENSE			104.33
MAR 2019	MARCH 2019 USAGE					326	06-Mar-2019	06-Mar-2019
10-5-2043010-0345					BLDG. - CELL PHONE EXPENSE			134.95
MAY 2019	MAY 2019 USAGE					543	06-May-2019	06-May-2019
10-5-2043010-0345					BLDG. - CELL PHONE EXPENSE			99.20
<b>GRE03 GREEN SHIELD CANADA</b>								
APR 2019	APRIL 2019 BENEFITS					375	01-Apr-2019	01-Apr-2019
10-5-2043010-0205					BENEFITS - GREENSHIELD			1,067.75
10-5-2043010-0206					BENEFITS - GREENSHIELD RE			2,257.01
FEB 2019	FEBRUARY 2019 BENEFITS					98	01-Feb-2019	01-Feb-2019
10-5-2043010-0206					BENEFITS - GREENSHIELD RE			2,257.01
10-5-2043010-0205					BENEFITS - GREENSHIELD			1,067.75
JAN 2019	JANUARY 2019 BENEFITS					5	02-Jan-2019	02-Jan-2019
10-5-2043010-0206					BENEFITS - GREENSHIELD RE			2,257.01
10-5-2043010-0205					BENEFITS - GREENSHIELD			1,067.75
MAR 2019	MARCH 2019 BENEFITS					228	01-Mar-2019	01-Mar-2019



Vendor : CAT038 To ZUL180  
 Batch : All  
 Department : All

EFT Paid Date : 01-Jan-2019 To 31-May-2019  
 Bank : 1 To 99  
 Class : All

Vendor Code	Vendor Name	Batch	Inv Date	Inv Due Date	Amount
Invoice No.	Description				
G.L. Account	CC1 CC2 CC3 GL Account Name				
<b>DEPARTMENT 2043010 BUILDING DEPARTMENT</b>					
10-5-2043010-0206	BENEFITS - GREENSHIELD RE				2,257.01
10-5-2043010-0205	BENEFITS - GREENSHIELD				1,067.75
MAY 2019	MAY 2019 BENEFITS	619	01-May-2019	01-May-2019	
10-5-2043010-0205	BENEFITS - GREENSHIELD				1,067.75
10-5-2043010-0206	BENEFITS - GREENSHIELD RE				2,257.01
<b>SUN11 SUN LIFE ASSURANCE CO. OF CANADA - BILLING</b>					
APR 2019	APRIL 2019 BENEFITS	404	01-Apr-2019	01-Apr-2019	
10-5-2043010-0207	BENEFITS - LIFE & DISABIL				1,079.55
DEC 2018	DECEMBER 2018 BENEFITS	1468	01-Dec-2018	01-Dec-2018	
10-5-2043010-0207	BENEFITS - LIFE & DISABIL				1,079.55
FEB 2019	FEBRUARY 2019 BENEFITS	124	01-Feb-2019	01-Feb-2019	
10-5-2043010-0207	BENEFITS - LIFE & DISABIL				1,079.55
JAN 2019	JANUARY 2019 BENEFITS	123	02-Jan-2019	02-Jan-2019	
10-5-2043010-0207	BENEFITS - LIFE & DISABIL				1,079.55
MAR 2019	MARCH 2019 BENEFITS	227	01-Mar-2019	01-Mar-2019	
10-5-2043010-0207	BENEFITS - LIFE & DISABIL				1,079.55
MAY 2019	MAY 2019 BENEFITS	472	01-May-2019	01-May-2019	
10-5-2043010-0207	BENEFITS - LIFE & DISABIL				1,175.74
<b>USB01 US BANK NATIONAL ASSOCIATION-VISA</b>					
FEBRUARY 201	FEBRUARY 2019 PURCHASES	374	28-Feb-2019	28-Feb-2019	
10-5-2043010-0350	MEMBERSHIPS				714.16
<b>Department Totals :</b>					<b>24,604.05</b>

<b>DEPARTMENT 2043015 LICENSING AND ENFORCEMENT</b>					
<b>BEL03 BELL MOBILITY INC.</b>					
APR 2019	APRIL 2019 USAGE	403	06-Apr-2019	06-Apr-2019	
10-5-2043015-0345	BY-LAW ENF. - CELL PHONE EXPENSE				171.55
FEB 2019	FEBRUARY 2019 USAGE	188	06-Feb-2019	06-Feb-2019	
10-5-2043015-0345	BY-LAW ENF. - CELL PHONE EXPENSE				144.01
JAN 2019	JANUARY 2019 USAGE	58	06-Jan-2019	06-Jan-2019	
10-5-2043015-0345	BY-LAW ENF. - CELL PHONE EXPENSE				174.84
MAR 2019	MARCH 2019 USAGE	326	06-Mar-2019	06-Mar-2019	
10-5-2043015-0345	BY-LAW ENF. - CELL PHONE EXPENSE				164.41
MAY 2019	MAY 2019 USAGE	543	06-May-2019	06-May-2019	
10-5-2043015-0345	BY-LAW ENF. - CELL PHONE EXPENSE				132.52
<b>GRE03 GREEN SHIELD CANADA</b>					
APR 2019	APRIL 2019 BENEFITS	375	01-Apr-2019	01-Apr-2019	
10-5-2043015-0205	BENEFITS - GREENSHIELD				1,454.18
FEB 2019	FEBRUARY 2019 BENEFITS	98	01-Feb-2019	01-Feb-2019	
10-5-2043015-0205	BENEFITS - GREENSHIELD				1,454.18
JAN 2019	JANUARY 2019 BENEFITS	5	02-Jan-2019	02-Jan-2019	
10-5-2043015-0205	BENEFITS - GREENSHIELD				1,454.18
MAR 2019	MARCH 2019 BENEFITS	228	01-Mar-2019	01-Mar-2019	
10-5-2043015-0205	BENEFITS - GREENSHIELD				1,454.18
MAY 2019	MAY 2019 BENEFITS	619	01-May-2019	01-May-2019	
10-5-2043015-0205	BENEFITS - GREENSHIELD				1,454.18
<b>SUN11 SUN LIFE ASSURANCE CO. OF CANADA - BILLING</b>					
APR 2019	APRIL 2019 BENEFITS	404	01-Apr-2019	01-Apr-2019	
10-5-2043015-0207	BENEFITS - LIFE & DISABILITY				851.29
DEC 2018	DECEMBER 2018 BENEFITS	1468	01-Dec-2018	01-Dec-2018	
10-5-2043015-0207	BENEFITS - LIFE & DISABILITY				849.92
FEB 2019	FEBRUARY 2019 BENEFITS	124	01-Feb-2019	01-Feb-2019	
10-5-2043015-0207	BENEFITS - LIFE & DISABILITY				852.66
JAN 2019	JANUARY 2019 BENEFITS	123	02-Jan-2019	02-Jan-2019	



Vendor : CAT038 To ZUL180  
 Batch : All  
 Department : All

EFT Paid Date : 01-Jan-2019 To 31-May-2019  
 Bank : 1 To 99  
 Class : All

Vendor Code	Vendor Name	Batch	Inv Date	Inv Due Date	Amount
Invoice No.	Description				
G.L. Account	CC1 CC2 CC3 GL Account Name				
<b>DEPARTMENT 2043015 LICENSING AND ENFORCEMENT</b>					
10-5-2043015-0207	BENEFITS - LIFE & DISABILITY				849.92
MAR 2019	MARCH 2019 BENEFITS	227	01-Mar-2019	01-Mar-2019	
10-5-2043015-0207	BENEFITS - LIFE & DISABILITY				851.29
MAY 2019	MAY 2019 BENEFITS	472	01-May-2019	01-May-2019	
10-5-2043015-0207	BENEFITS - LIFE & DISABILITY				884.49
<b>USB01 US BANK NATIONAL ASSOCIATION-VISA</b>					
APRIL 2019	APRIL 2019 PURCHASES	528	30-Apr-2019	30-Apr-2019	
10-5-2043015-0351	TRAINING AND CONFERENCES				-355.95
10-5-2043015-0351	TRAINING AND CONFERENCES				247.75
JANUARY 2019	JANUARY 2019 PURCHASES	132	31-Jan-2019	31-Jan-2019	
10-5-2043015-0351	TRAINING AND CONFERENCES				-1,356.00
MARCH 2019	MARCH 2019 PURCHASES	524	31-Mar-2019	31-Mar-2019	
10-5-2043015-0351	TRAINING AND CONFERENCES				355.95
10-5-2043015-0351	TRAINING AND CONFERENCES				1,354.87
MAY 2019	MAY 2019 PURCHASES	746	31-May-2019	31-May-2019	
10-5-2043015-0351	TRAINING AND CONFERENCES				316.13
10-5-2043015-0351	TRAINING AND CONFERENCES				24.00
10-5-2043015-0351	TRAINING AND CONFERENCES				10.50
10-5-2043015-0351	TRAINING AND CONFERENCES				468.95
10-5-2043015-0351	TRAINING AND CONFERENCES				10.00
<b>Department Totals :</b>					<b>14,274.00</b>

<b>DEPARTMENT 3010000 PUBLIC WORKS</b>					
<b>BELO3 BELL MOBILITY INC.</b>					
APR 2019	APRIL 2019 USAGE	403	06-Apr-2019	06-Apr-2019	
10-5-3010000-0345	P.W. - CELL PHONE EXPENSE				508.59
FEB 2019	FEBRUARY 2019 USAGE	188	06-Feb-2019	06-Feb-2019	
10-5-3010000-0345	P.W. - CELL PHONE EXPENSE				564.84
JAN 2019	JANUARY 2019 USAGE	58	06-Jan-2019	06-Jan-2019	
10-5-3010000-0345	P.W. - CELL PHONE EXPENSE				548.01
MAR 2019	MARCH 2019 USAGE	326	06-Mar-2019	06-Mar-2019	
10-5-3010000-0345	P.W. - CELL PHONE EXPENSE				444.04
MAY 2019	MAY 2019 USAGE	543	06-May-2019	06-May-2019	
10-5-3010000-0345	P.W. - CELL PHONE EXPENSE				483.27
<b>GRE03 GREEN SHIELD CANADA</b>					
APR 2019	APRIL 2019 BENEFITS	375	01-Apr-2019	01-Apr-2019	
10-5-3010000-0205	BENEFITS - GREENSHIELD				5,645.62
10-5-3010000-0206	BENEFITS - GREENSHIELD RE				8,088.87
FEB 2019	FEBRUARY 2019 BENEFITS	98	01-Feb-2019	01-Feb-2019	
10-5-3010000-0205	BENEFITS - GREENSHIELD				6,062.12
10-5-3010000-0206	BENEFITS - GREENSHIELD RE				8,088.87
JAN 2019	JANUARY 2019 BENEFITS	5	02-Jan-2019	02-Jan-2019	
10-5-3010000-0205	BENEFITS - GREENSHIELD				6,062.12
10-5-3010000-0206	BENEFITS - GREENSHIELD RE				7,141.62
MAR 2019	MARCH 2019 BENEFITS	228	01-Mar-2019	01-Mar-2019	
10-5-3010000-0206	BENEFITS - GREENSHIELD RE				8,088.87
10-5-3010000-0205	BENEFITS - GREENSHIELD				6,062.12
MAY 2019	MAY 2019 BENEFITS	619	01-May-2019	01-May-2019	
10-5-3010000-0205	BENEFITS - GREENSHIELD				5,645.62
10-5-3010000-0206	BENEFITS - GREENSHIELD RE				8,088.87
<b>SUN11 SUN LIFE ASSURANCE CO. OF CANADA - BILLING</b>					
APR 2019	APRIL 2019 BENEFITS	404	01-Apr-2019	01-Apr-2019	
10-5-3010000-0207	BENEFITS - LIFE & DISABIL				3,575.04
DEC 2018	DECEMBER 2018 BENEFITS	1468	01-Dec-2018	01-Dec-2018	
10-5-3010000-0207	BENEFITS - LIFE & DISABIL				4,376.24



Vendor : CAT038 To ZUL180  
 Batch : All  
 Department : All

EFT Paid Date : 01-Jan-2019 To 31-May-2019  
 Bank : 1 To 99  
 Class : All

Vendor Code	Vendor Name	Batch	Inv Date	Inv Due Date	Amount
Invoice No.	Description				
G.L. Account	CC1 CC2 CC3 GL Account Name				
<b>DEPARTMENT 3010000 PUBLIC WORKS</b>					
FEB 2019	FEBRUARY 2019 BENEFITS	124	01-Feb-2019	01-Feb-2019	
10-5-3010000-0207	BENEFITS - LIFE & DISABIL				4,386.06
JAN 2019	JANUARY 2019 BENEFITS	123	02-Jan-2019	02-Jan-2019	
10-5-3010000-0207	BENEFITS - LIFE & DISABIL				4,376.24
MAR 2019	MARCH 2019 BENEFITS	227	01-Mar-2019	01-Mar-2019	
10-5-3010000-0207	BENEFITS - LIFE & DISABIL				4,381.15
MAY 2019	MAY 2019 BENEFITS	472	01-May-2019	01-May-2019	
10-5-3010000-0207	BENEFITS - LIFE & DISABIL				3,898.55
<b>USB01 US BANK NATIONAL ASSOCIATION-VISA</b>					
APRIL 2019	APRIL 2019 PURCHASES	528	30-Apr-2019	30-Apr-2019	
10-5-3010000-0425	VEHICLE LICENCES				120.00
10-5-3010000-0425	VEHICLE LICENCES				100.00
10-5-3010000-0425	VEHICLE LICENCES				120.00
FEBRUARY 2019	FEBRUARY 2019 PURCHASES	374	28-Feb-2019	28-Feb-2019	
10-5-3010000-0301	OFFICE SUPPLIES				219.22
10-5-3010000-0301	OFFICE SUPPLIES				219.22
10-5-3010000-0301	OFFICE SUPPLIES				16.35
10-5-3010000-0351	TRAINING & CONFERENCES				232.68
10-5-3010000-0351	TRAINING & CONFERENCES				232.68
10-5-3010000-0351	TRAINING & CONFERENCES				175.15
JANUARY 2019	JANUARY 2019 PURCHASES	132	31-Jan-2019	31-Jan-2019	
10-5-3010000-0301	OFFICE SUPPLIES				6.77
MAY 2019	MAY 2019 PURCHASES	746	31-May-2019	31-May-2019	
10-5-3010000-0425	VEHICLE LICENCES				72.00
<b>Department Totals :</b>					<b>98,030.80</b>

<b>DEPARTMENT 3020000 ROADS</b>					
<b>HYD02 HYDRO ONE NETWORKS</b>					
DEC 2018	MAIN ACCOUNT	1583	31-Dec-2018	31-Dec-2018	
10-5-3020000-0757	STORM SEWER CLEANING & FLUSHING				44.35
FEB 2019	MAIN ACCOUNT FEBRUARY 2019	279	28-Feb-2019	28-Feb-2019	
10-5-3020000-0757	STORM SEWER CLEANING & FLUSHING				41.37
JAN 2019	MAIN ACCOUNT JANUARY 2019	192	31-Jan-2019	31-Jan-2019	
10-5-3020000-0757	STORM SEWER CLEANING & FLUSHING				43.68
MAR 2019	MAIN ACCOUNT MARCH 2019	370	31-Mar-2019	31-Mar-2019	
10-5-3020000-0757	STORM SEWER CLEANING & FLUSHING				45.97
<b>Department Totals :</b>					<b>175.37</b>

<b>DEPARTMENT 3050000 STREET LIGHTING</b>					
<b>ESS46 ESSEX POWERLINES CORPORATION</b>					
APR 2019	ELECTRICITY, WATER & SEWAGE APRIL 2019	517	30-Apr-2019	30-Apr-2019	
10-5-3050000-0316	UTILITIES				13,466.73
DEC 2018	ELECTRICITY, WATER & SEWAGE DECEMBER 2018	1585	31-Dec-2018	31-Dec-2018	
10-5-3050000-0316	UTILITIES				17,612.49
FEB 2019	ELECTRICITY, WATER & SEWAGE FEBRUARY 2019	309	28-Feb-2019	28-Feb-2019	
10-5-3050000-0316	UTILITIES				14,601.59
JAN 2019	ELECTRICITY, WATER & SEWAGE JANUARY 2019	193	31-Jan-2019	31-Jan-2019	
10-5-3050000-0316	UTILITIES				16,593.28
MAR 2019	ELECTRICITY, WATER & SEWAGE MARCH 2019	411	31-Mar-2019	31-Mar-2019	
10-5-3050000-0316	UTILITIES				15,902.92
<b>HYD02 HYDRO ONE NETWORKS</b>					
APR 2019	MICS HYDRO ACCTS FOR APRIL 2019	490	30-Apr-2019	30-Apr-2019	
10-5-3050000-0316	UTILITIES				9,944.62
DEC 2018	MISC HYDRO ACCTS FOR DECEMBER 2018	1584	31-Dec-2018	31-Dec-2018	





Vendor : CAT038 To ZUL180

Batch : All

Department : All

EFT Paid Date : 01-Jan-2019 To 31-May-2019

Bank : 1 To 99

Class : All

Vendor Code	Vendor Name	Batch	Inv Date	Inv Due Date	Amount
Invoice No.	Description				
G.L. Account	CC1 CC2 CC3 GL Account Name				
<b>DEPARTMENT 3050000 STREET LIGHTING</b>					
10-5-3050000-0316	UTILITIES				11,260.10
FEB 2019	MISC HYDRO ACCTS FOR FEBRUARY 2019	278	28-Feb-2019	28-Feb-2019	
10-5-3050000-0316	UTILITIES				8,862.50
JAN 2019	MISC HYDRO ACCTS FOR JANUARY 2019	182	31-Jan-2019	31-Jan-2019	
10-5-3050000-0316	UTILITIES				10,607.02
MAR 2019	MISC HYDRO ACCTS FOR MARCH 2019	373	31-Mar-2019	31-Mar-2019	
10-5-3050000-0316	UTILITIES				10,372.29
<b>Department Totals :</b>					<b>129,223.54</b>

<b>DEPARTMENT 3250000 TRAFFIC CONTROL</b>					
<b>ESS46 ESSEX POWERLINES CORPORATION</b>					
APR 2019	ELECTRICITY, WATER & SEWAGE APRIL 2019	517	30-Apr-2019	30-Apr-2019	
10-5-3250000-0316	UTILITIES - TRAFFIC LIGHTS				849.96
DEC 2018	ELECTRICITY, WATER & SEWAGE DECEMBER 2018	1585	31-Dec-2018	31-Dec-2018	
10-5-3250000-0316	UTILITIES - TRAFFIC LIGHTS				1,135.49
FEB 2019	ELECTRICITY, WATER & SEWAGE FEBRUARY 2019	309	28-Feb-2019	28-Feb-2019	
10-5-3250000-0316	UTILITIES - TRAFFIC LIGHTS				800.60
JAN 2019	ELECTRICITY, WATER & SEWAGE JANUARY 2019	193	31-Jan-2019	31-Jan-2019	
10-5-3250000-0316	UTILITIES - TRAFFIC LIGHTS				920.22
MAR 2019	ELECTRICITY, WATER & SEWAGE MARCH 2019	411	31-Mar-2019	31-Mar-2019	
10-5-3250000-0316	UTILITIES - TRAFFIC LIGHTS				958.04
<b>Department Totals :</b>					<b>4,664.31</b>

<b>DEPARTMENT 4017720 MCGREGOR SEWERS</b>					
<b>HYD02 HYDRO ONE NETWORKS</b>					
APR 2019	MAIN ACCOUNT APRIL 2019	500	30-Apr-2019	30-Apr-2019	
10-5-4017720-0316	UTILITIES				679.10
DEC 2018	MAIN ACCOUNT	1583	31-Dec-2018	31-Dec-2018	
10-5-4017720-0316	UTILITIES				1,506.97
FEB 2019	MAIN ACCOUNT FEBRUARY 2019	279	28-Feb-2019	28-Feb-2019	
10-5-4017720-0316	UTILITIES				1,370.35
JAN 2019	MAIN ACCOUNT JANUARY 2019	192	31-Jan-2019	31-Jan-2019	
10-5-4017720-0316	UTILITIES				2,094.83
MAR 2019	MAIN ACCOUNT MARCH 2019	370	31-Mar-2019	31-Mar-2019	
10-5-4017720-0316	UTILITIES				1,808.04
<b>Department Totals :</b>					<b>7,459.29</b>

<b>DEPARTMENT 4017730 EDGEWATER SEWERS</b>					
<b>HYD02 HYDRO ONE NETWORKS</b>					
APR 2019	MAIN ACCOUNT APRIL 2019	500	30-Apr-2019	30-Apr-2019	
10-5-4017730-0316	UTILITIES				2,681.06
DEC 2018	MAIN ACCOUNT	1583	31-Dec-2018	31-Dec-2018	
10-5-4017730-0316	UTILITIES				2,599.89
FEB 2019	MAIN ACCOUNT FEBRUARY 2019	279	28-Feb-2019	28-Feb-2019	
10-5-4017730-0316	UTILITIES				2,431.38
JAN 2019	MAIN ACCOUNT JANUARY 2019	192	31-Jan-2019	31-Jan-2019	
10-5-4017730-0316	UTILITIES				2,742.62
MAR 2019	MAIN ACCOUNT MARCH 2019	370	31-Mar-2019	31-Mar-2019	
10-5-4017730-0316	UTILITIES				2,940.04
<b>Department Totals :</b>					<b>13,394.99</b>

DEPARTMENT 4017740 AMHERSTBURG SEWERS

ESS46 ESSEX POWERLINES CORPORATION





Vendor : CAT038 To ZUL180

Batch : All

Department : All

EFT Paid Date : 01-Jan-2019 To 31-May-2019

Bank : 1 To 99

Class : All

Vendor Code	Vendor Name					Batch	Invc Date	Invc Due Date	Amount
Invoice No.	Description								
G.L. Account	CC1	CC2	CC3	GL Account Name					
<b>DEPARTMENT 4017740 AMHERSTBURG SEWERS</b>									
APR 2019	ELECTRICITY, WATER & SEWAGE			APRIL 2019		517	30-Apr-2019	30-Apr-2019	
10-5-4017740-0316				UTILITIES - SEWERS					27,118.79
DEC 2018	ELECTRICITY, WATER & SEWAGE			DECEMBER 2018		1585	31-Dec-2018	31-Dec-2018	
10-5-4017740-0316				UTILITIES - SEWERS					23,593.16
FEB 2019	ELECTRICITY, WATER & SEWAGE			FEBRUARY 2019		309	28-Feb-2019	28-Feb-2019	
10-5-4017740-0316				UTILITIES - SEWERS					19,498.34
JAN 2019	ELECTRICITY, WATER & SEWAGE			JANUARY 2019		193	31-Jan-2019	31-Jan-2019	
10-5-4017740-0316				UTILITIES - SEWERS					21,410.91
MAR 2019	ELECTRICITY, WATER & SEWAGE			MARCH 2019		411	31-Mar-2019	31-Mar-2019	
10-5-4017740-0316				UTILITIES - SEWERS					25,560.25
<b>UNIO1 UNION GAS LTD</b>									
APR 2019	APRIL 2019 MONTHLY CHARGES					518	30-Apr-2019	30-Apr-2019	
10-5-4017740-0316				UTILITIES - SEWERS					1,675.77
DEC 2018	DECEMBER 2018 MONTHLY CHARGES					1586	31-Dec-2018	31-Dec-2018	
10-5-4017740-0316				UTILITIES - SEWERS					1,687.15
FEB 2019	FEBRUARY 2019 MONTHLY CHARGES					295	28-Feb-2019	28-Feb-2019	
10-5-4017740-0316				UTILITIES - SEWERS					3,381.08
JAN 2019	JANUARY 2019 MONTHLY CHARGES					220	31-Jan-2019	31-Jan-2019	
10-5-4017740-0316				UTILITIES - SEWERS					2,281.53
MAR 2019	MARCH 2019 MONTHLY CHARGES					318	31-Mar-2019	31-Mar-2019	
10-5-4017740-0316				UTILITIES - SEWERS					2,994.64
<b>Department Totals :</b>									<b>129,201.62</b>
<hr/>									
<b>DEPARTMENT 4017750 BIG CREEK RBC SEWER</b>									
<b>HYD02 HYDRO ONE NETWORKS</b>									
APR 2019	MAIN ACCOUNT			APRIL 2019		500	30-Apr-2019	30-Apr-2019	
10-5-4017750-0316				UTILITIES					2,804.41
DEC 2018	MAIN ACCOUNT					1583	31-Dec-2018	31-Dec-2018	
10-5-4017750-0316				UTILITIES					2,173.35
FEB 2019	MAIN ACCOUNT			FEBRUARY 2019		279	28-Feb-2019	28-Feb-2019	
10-5-4017750-0316				UTILITIES					2,426.90
JAN 2019	MAIN ACCOUNT			JANUARY 2019		192	31-Jan-2019	31-Jan-2019	
10-5-4017750-0316				UTILITIES					2,723.28
MAR 2019	MAIN ACCOUNT			MARCH 2019		370	31-Mar-2019	31-Mar-2019	
10-5-4017750-0316				UTILITIES					3,063.15
<b>Department Totals :</b>									<b>13,191.09</b>
<hr/>									
<b>DEPARTMENT 4017755 MCLEOD SBR SEWER</b>									
<b>ESS46 ESSEX POWERLINES CORPORATION</b>									
DEC 2018	ELECTRICITY, WATER & SEWAGE			DECEMBER 2018		1585	31-Dec-2018	31-Dec-2018	
10-5-4017755-0316				UTILITIES					444.54
MAR 2019	ELECTRICITY, WATER & SEWAGE			MARCH 2019		411	31-Mar-2019	31-Mar-2019	
10-5-4017755-0316				UTILITIES					349.45
<b>HYD02 HYDRO ONE NETWORKS</b>									
APR 2019	MAIN ACCOUNT			APRIL 2019		500	30-Apr-2019	30-Apr-2019	
10-5-4017755-0316				UTILITIES					8,572.31
DEC 2018	MAIN ACCOUNT					1583	31-Dec-2018	31-Dec-2018	
10-5-4017755-0316				UTILITIES					8,713.88
FEB 2019	MAIN ACCOUNT			FEBRUARY 2019		279	28-Feb-2019	28-Feb-2019	
10-5-4017755-0316				UTILITIES					7,106.41
JAN 2019	MAIN ACCOUNT			JANUARY 2019		192	31-Jan-2019	31-Jan-2019	
10-5-4017755-0316				UTILITIES					8,447.64
MAR 2019	MAIN ACCOUNT			MARCH 2019		370	31-Mar-2019	31-Mar-2019	



Vendor : CAT038 To ZUL180

Batch : All

Department : All

EFT Paid Date : 01-Jan-2019 To 31-May-2019

Bank : 1 To 99

Class : All

Vendor Code	Vendor Name					Batch	Inv Date	Inv Due Date	Amount
Invoice No.	Description								
G.L. Account	CC1	CC2	CC3	GL Account Name					
<b>DEPARTMENT 4017755</b>				MCLEOD SBR SEWER					
10-5-4017755-0316				UTILITIES					8,604.06
<b>UNIO1</b>	<b>UNION GAS LTD</b>								
APR 2019	APRIL 2019 MONTHLY CHARGES				518	30-Apr-2019	30-Apr-2019		
10-5-4017755-0316				UTILITIES					190.63
DEC 2018	DECEMBER 2018 MONTHLY CHARGES				1586	31-Dec-2018	31-Dec-2018		
10-5-4017755-0316				UTILITIES					228.18
FEB 2019	FEBRUARY 2019 MONTHLY CHARGES				295	28-Feb-2019	28-Feb-2019		
10-5-4017755-0316				UTILITIES					370.06
JAN 2019	JANUARY 2019 MONTHLY CHARGES				220	31-Jan-2019	31-Jan-2019		
10-5-4017755-0316				UTILITIES					268.96
MAR 2019	MARCH 2019 MONTHLY CHARGES				318	31-Mar-2019	31-Mar-2019		
10-5-4017755-0316				UTILITIES					302.23
<b>Department Totals :</b>									<b>43,598.35</b>

<b>DEPARTMENT 4017760</b>				BOBLO SEWER					
<b>ESS46</b>	<b>ESSEX POWERLINES CORPORATION</b>								
DEC 2018	ELECTRICITY, WATER & SEWAGE DECEMBER 2018				1585	31-Dec-2018	31-Dec-2018		
10-5-4017760-0316				UTILITIES					174.09
MAR 2019	ELECTRICITY, WATER & SEWAGE MARCH 2019				411	31-Mar-2019	31-Mar-2019		
10-5-4017760-0316				UTILITIES					165.43
<b>HYD02</b>	<b>HYDRO ONE NETWORKS</b>								
APR 2019	MAIN ACCOUNT APRIL 2019				500	30-Apr-2019	30-Apr-2019		
10-5-4017760-0316				UTILITIES					2,350.35
DEC 2018	MAIN ACCOUNT				1583	31-Dec-2018	31-Dec-2018		
10-5-4017760-0316				UTILITIES					3,823.33
FEB 2019	MAIN ACCOUNT FEBRUARY 2019				279	28-Feb-2019	28-Feb-2019		
10-5-4017760-0316				UTILITIES					2,488.67
JAN 2019	MAIN ACCOUNT JANUARY 2019				192	31-Jan-2019	31-Jan-2019		
10-5-4017760-0316				UTILITIES					4,180.66
MAR 2019	MAIN ACCOUNT MARCH 2019				370	31-Mar-2019	31-Mar-2019		
10-5-4017760-0316				UTILITIES					2,490.24
<b>Department Totals :</b>									<b>15,672.77</b>

<b>DEPARTMENT 4057710</b>				GARBAGE COLLECTION					
<b>USB01</b>	<b>US BANK NATIONAL ASSOCIATION-VISA</b>								
FEBRUARY 2019	FEBRUARY 2019 PURCHASES				374	28-Feb-2019	28-Feb-2019		
10-5-4057710-0602				GARBAGE COLLECTION					50.00
10-5-4057710-0602				GARBAGE COLLECTION					61.14
<b>Department Totals :</b>									<b>111.14</b>

<b>DEPARTMENT 4067715</b>				GARBAGE DISPOSAL					
<b>CAN066</b>	<b>CANADA POST CORPORATION</b>								
99676805368	WASTE CALENDAR DELIVERY COST				100	21-Jan-2019	21-Jan-2019		
10-5-4067715-0307				COLLECTION CALENDAR EXPENSES					1,412.50
<b>Department Totals :</b>									<b>1,412.50</b>

<b>DEPARTMENT 7010000</b>				PARKS AND RECREATION PROGRAMMING					
<b>BEL03</b>	<b>BELL MOBILITY INC.</b>								
APR 2019	APRIL 2019 USAGE				403	06-Apr-2019	06-Apr-2019		
10-5-7010000-0345				CELL PHONE EXPENSE					100.21
FEB 2019	FEBRUARY 2019 USAGE				188	06-Feb-2019	06-Feb-2019		
10-5-7010000-0345				CELL PHONE EXPENSE					62.90
JAN 2019	JANUARY 2019 USAGE				58	06-Jan-2019	06-Jan-2019		



Vendor : CAT038 To ZUL180

Batch : All

Department : All

EFT Paid Date : 01-Jan-2019 To 31-May-2019

Bank : 1 To 99

Class : All

Vendor Code	Vendor Name	Batch	Inv Date	Inv Due Date	Amount
Invoice No.	Description				
G.L. Account	CC1 CC2 CC3 GL Account Name				
<b>DEPARTMENT 7010000</b>	<b>PARKS AND RECREATION PROGRAMMING</b>				
10-5-7010000-0345	CELL PHONE EXPENSE				89.52
MAR 2019	MARCH 2019 USAGE	326	06-Mar-2019	06-Mar-2019	
10-5-7010000-0345	CELL PHONE EXPENSE				96.65
MAY 2019	MAY 2019 USAGE	543	06-May-2019	06-May-2019	
10-5-7010000-0345	CELL PHONE EXPENSE				61.42
<b>BEL34</b>	<b>BELL</b>				
APR 2019	APRIL 2019 SATELITTE SERVICES	473	10-Apr-2019	10-Apr-2019	
10-5-7010000-0349	MARKETING				76.78
FEB 2019	FEBRUARY 2019 SATELITTE SERVICES	225	10-Feb-2019	10-Feb-2019	
10-5-7010000-0349	MARKETING				76.78
JAN 2019	JANUARY 2019 SATELLITE SERVICES	56	10-Jan-2019	10-Jan-2019	
10-5-7010000-0349	MARKETING				76.78
MAR 2019	MARCH 2019 SATELITTE SERVICES	339	10-Mar-2019	10-Mar-2019	
10-5-7010000-0349	MARKETING				76.78
MAY 2019	MAY 2019 SATELITTE SERVICES	498	10-May-2019	10-May-2019	
10-5-7010000-0349	MARKETING				76.78
<b>GRE03</b>	<b>GREEN SHIELD CANADA</b>				
APR 2019	APRIL 2019 BENEFITS	375	01-Apr-2019	01-Apr-2019	
10-5-7010000-0205	BENEFITS - GREENSHIELD				1,037.68
FEB 2019	FEBRUARY 2019 BENEFITS	98	01-Feb-2019	01-Feb-2019	
10-5-7010000-0205	BENEFITS - GREENSHIELD				1,037.68
JAN 2019	JANUARY 2019 BENEFITS	5	02-Jan-2019	02-Jan-2019	
10-5-7010000-0205	BENEFITS - GREENSHIELD				1,037.68
MAR 2019	MARCH 2019 BENEFITS	228	01-Mar-2019	01-Mar-2019	
10-5-7010000-0205	BENEFITS - GREENSHIELD				1,037.68
MAY 2019	MAY 2019 BENEFITS	619	01-May-2019	01-May-2019	
10-5-7010000-0205	BENEFITS - GREENSHIELD				1,037.68
<b>PEP01</b>	<b>PEPSI BOTTLING GROUP (CANADA) CO</b>				
69440163	CONCESSION PURCHASE	1580	11-Dec-2018	11-Dec-2018	
10-5-7010000-0384	CONCESSION PRODUCT				702.47
69544056	CONCESSION PURCHASE	1581	18-Dec-2018	18-Dec-2018	
10-5-7010000-0384	CONCESSION PRODUCT				626.15
69953554	CONCESSION PURCHASE	69	15-Jan-2019	15-Jan-2019	
10-5-7010000-0384	CONCESSION PRODUCT				1,274.18
70294606	CONCESSION PURCHASE	249	12-Feb-2019	12-Feb-2019	
10-5-7010000-0384	CONCESSION PRODUCT				1,202.13
70941655	CONCESSION PURCHASE	366	19-Mar-2019	19-Mar-2019	
10-5-7010000-0384	CONCESSION PRODUCT				613.52
<b>SUN11</b>	<b>SUN LIFE ASSURANCE CO. OF CANADA - BILLING</b>				
APR 2019	APRIL 2019 BENEFITS	404	01-Apr-2019	01-Apr-2019	
10-5-7010000-0207	BENEFITS - LIFE & DISABILITY				621.95
DEC 2018	DECEMBER 2018 BENEFITS	1468	01-Dec-2018	01-Dec-2018	
10-5-7010000-0207	BENEFITS - LIFE & DISABILITY				621.95
FEB 2019	FEBRUARY 2019 BENEFITS	124	01-Feb-2019	01-Feb-2019	
10-5-7010000-0207	BENEFITS - LIFE & DISABILITY				621.95
JAN 2019	JANUARY 2019 BENEFITS	123	02-Jan-2019	02-Jan-2019	
10-5-7010000-0207	BENEFITS - LIFE & DISABILITY				621.95
MAR 2019	MARCH 2019 BENEFITS	227	01-Mar-2019	01-Mar-2019	
10-5-7010000-0207	BENEFITS - LIFE & DISABILITY				621.95
MAY 2019	MAY 2019 BENEFITS	472	01-May-2019	01-May-2019	
10-5-7010000-0207	BENEFITS - LIFE & DISABILITY				655.15
<b>USB01</b>	<b>US BANK NATIONAL ASSOCIATION-VISA</b>				
APRIL 2019	APRIL 2019 PURCHASES	528	30-Apr-2019	30-Apr-2019	
10-5-7010000-0349	MARKETING				79.00



Vendor : CAT038 To ZUL180

Batch : All

Department : All

EFT Paid Date : 01-Jan-2019 To 31-May-2019

Bank : 1 To 99

Class : All

Vendor Code	Vendor Name					Batch	Inv Date	Inv Due Date	Amount
Invoice No.	Description								
G.L. Account	CC1	CC2	CC3	GL Account Name					
<b>DEPARTMENT 7010000</b>									
<b>PARKS AND RECREATION PROGRAMMING</b>									
10-5-7010000-0420				RECREATION EXPENSES					82.92
10-5-7010000-0351				CONVENTIONS & SEMINARS					31.01
10-5-7010000-0351				CONVENTIONS & SEMINARS					45.48
10-5-7010000-0351				CONVENTIONS & SEMINARS					42.86
10-5-7010000-0351				CONVENTIONS & SEMINARS					39.00
10-5-7010000-0351				CONVENTIONS & SEMINARS					24.00
10-5-7010000-0351				CONVENTIONS & SEMINARS					63.39
10-5-7010000-0351				CONVENTIONS & SEMINARS					31.00
10-5-7010000-0351				CONVENTIONS & SEMINARS					13.74
10-5-7010000-0420				RECREATION EXPENSES					19.78
<b>FEBRUARY 2019 FEBRUARY 2019 PURCHASES</b>						374	28-Feb-2019	28-Feb-2019	
10-5-7010000-0420				RECREATION EXPENSES					49.21
10-5-7010000-0351				CONVENTIONS & SEMINARS					520.98
10-5-7010000-0351				CONVENTIONS & SEMINARS					25.01
10-5-7010000-0384				CONCESSION PRODUCT					169.15
10-5-7010000-0384				CONCESSION PRODUCT					218.75
10-5-7010000-0349				MARKETING					79.00
10-5-7010000-0350				MEMBERSHIPS					1,998.97
<b>JANUARY 2019 JANUARY 2019 PURCHASES</b>						132	31-Jan-2019	31-Jan-2019	
10-5-7010000-0420				RECREATION EXPENSES					43.84
10-5-7010000-0307				ADVERTISING					65.80
10-5-7010000-0301				OFFICE SUPPLIES					16.94
10-5-7010000-0420				RECREATION EXPENSES					22.60
10-5-7010000-0349				MARKETING					79.00
10-5-7010000-0349				MARKETING					119.78
10-5-7010000-0776				ESSEX POWER YOUTH IN COMM FD					461.72
10-5-7010000-0351				CONVENTIONS & SEMINARS					5.00
10-5-7010000-0351				CONVENTIONS & SEMINARS					39.49
10-5-7010000-0384				CONCESSION PRODUCT					121.21
10-5-7010000-0384				CONCESSION PRODUCT					258.10
10-5-7010000-0776				ESSEX POWER YOUTH IN COMM FD					186.91
<b>MARCH 2019 MARCH 2019 PURCHASES</b>						524	31-Mar-2019	31-Mar-2019	
10-5-7010000-0349				MARKETING					79.00
10-5-7010000-0420				RECREATION EXPENSES					20.34
10-5-7010000-0420				RECREATION EXPENSES					42.38
10-5-7010000-0420				RECREATION EXPENSES					8.03
10-5-7010000-0420				RECREATION EXPENSES					33.54
10-5-7010000-0349				MARKETING					384.00
10-5-7010000-0384				CONCESSION PRODUCT					300.75
10-5-7010000-0384				CONCESSION PRODUCT					21.40
10-5-7010000-0384				CONCESSION PRODUCT					439.55
10-5-7010000-0384				CONCESSION PRODUCT					97.63
10-5-7010000-0351				CONVENTIONS & SEMINARS					38.00
10-5-7010000-0351				CONVENTIONS & SEMINARS					37.00
10-5-7010000-0351				CONVENTIONS & SEMINARS					64.68
<b>MAY 2019 MAY 2019 PURCHASES</b>						746	31-May-2019	31-May-2019	
10-5-7010000-0771				SPECIAL EVENTS					1,740.20
10-5-7010000-0771				SPECIAL EVENTS					345.65
10-5-7010000-0771				SPECIAL EVENTS					707.60
10-5-7010000-0351				CONVENTIONS & SEMINARS					71.65
10-5-7010000-0421				CONCESSION EQUIPMENT					137.01
10-5-7010000-0384				CONCESSION PRODUCT					600.00
10-5-7010000-0384				CONCESSION PRODUCT					1,688.93
10-5-7010000-0384				CONCESSION PRODUCT					642.84
10-5-7010000-0384				CONCESSION PRODUCT					85.95
10-5-7010000-0384				CONCESSION PRODUCT					165.48
10-5-7010000-0384				CONCESSION PRODUCT					217.30
10-5-7010000-0384				CONCESSION PRODUCT					105.90
10-5-7010000-0349				MARKETING					79.00
10-5-7010000-0420				RECREATION EXPENSES					43.79



Vendor : CAT038 To ZUL180

Batch : All

Department : All

EFT Paid Date : 01-Jan-2019 To 31-May-2019

Bank : 1 To 99

Class : All

Vendor Code	Vendor Name	Batch	Inv Date	Inv Due Date	Amount
Invoice No.	Description				
G.L. Account	CC1 CC2 CC3 GL Account Name				
<b>DEPARTMENT 7010000</b> PARKS AND RECREATION PROGRAMMING					
10-5-7010000-0420	RECREATION EXPENSES				28.24
10-5-7010000-0420	RECREATION EXPENSES				123.86
10-5-7010000-0420	RECREATION EXPENSES				127.76
10-5-7010000-0420	RECREATION EXPENSES				37.19
10-5-7010000-0420	RECREATION EXPENSES				25.43
10-5-7010000-0420	RECREATION EXPENSES				55.24
10-5-7010000-0420	RECREATION EXPENSES				176.55
10-5-7010000-0301	OFFICE SUPPLIES				90.38
<b>Department Totals :</b>					<b>27,982.24</b>
<hr/>					
<b>DEPARTMENT 7010160</b> LION'S POOL PROGRAMMING					
<b>ESS46 ESSEX POWERLINES CORPORATION</b>					
APR 2019	ELECTRICITY, WATER & SEWAGE APRIL 2019	517	30-Apr-2019	30-Apr-2019	
10-5-7010160-0316	UTILITIES - LIONS POOL				46.96
DEC 2018	ELECTRICITY, WATER & SEWAGE DECEMBER 2018	1585	31-Dec-2018	31-Dec-2018	
10-5-7010160-0316	UTILITIES - LIONS POOL				52.39
FEB 2019	ELECTRICITY, WATER & SEWAGE FEBRUARY 2019	309	28-Feb-2019	28-Feb-2019	
10-5-7010160-0316	UTILITIES - LIONS POOL				51.82
JAN 2019	ELECTRICITY, WATER & SEWAGE JANUARY 2019	193	31-Jan-2019	31-Jan-2019	
10-5-7010160-0316	UTILITIES - LIONS POOL				54.13
MAR 2019	ELECTRICITY, WATER & SEWAGE MARCH 2019	411	31-Mar-2019	31-Mar-2019	
10-5-7010160-0316	UTILITIES - LIONS POOL				42.47
<b>Department Totals :</b>					<b>247.77</b>
<hr/>					
<b>DEPARTMENT 7017000</b> PARKS MAINTENANCE					
<b>BEL03 BELL MOBILITY INC.</b>					
APR 2019	APRIL 2019 USAGE	403	06-Apr-2019	06-Apr-2019	
10-5-7017000-0345	CELL PHONE EXPENSE - PARKS MAINTENANCE				32.84
FEB 2019	FEBRUARY 2019 USAGE	188	06-Feb-2019	06-Feb-2019	
10-5-7017000-0345	CELL PHONE EXPENSE - PARKS MAINTENANCE				33.23
JAN 2019	JANUARY 2019 USAGE	58	06-Jan-2019	06-Jan-2019	
10-5-7017000-0345	CELL PHONE EXPENSE - PARKS MAINTENANCE				28.53
MAR 2019	MARCH 2019 USAGE	326	06-Mar-2019	06-Mar-2019	
10-5-7017000-0345	CELL PHONE EXPENSE - PARKS MAINTENANCE				57.92
MAY 2019	MAY 2019 USAGE	543	06-May-2019	06-May-2019	
10-5-7017000-0345	CELL PHONE EXPENSE - PARKS MAINTENANCE				30.26
<b>GRE03 GREEN SHIELD CANADA</b>					
APR 2019	APRIL 2019 BENEFITS	375	01-Apr-2019	01-Apr-2019	
10-5-7017000-0205	BENEFITS - GREENSHIELD - PARKS & GROUNDS				2,487.36
FEB 2019	FEBRUARY 2019 BENEFITS	98	01-Feb-2019	01-Feb-2019	
10-5-7017000-0205	BENEFITS - GREENSHIELD - PARKS & GROUNDS				2,487.36
JAN 2019	JANUARY 2019 BENEFITS	5	02-Jan-2019	02-Jan-2019	
10-5-7017000-0205	BENEFITS - GREENSHIELD - PARKS & GROUNDS				1,773.15
MAR 2019	MARCH 2019 BENEFITS	228	01-Mar-2019	01-Mar-2019	
10-5-7017000-0205	BENEFITS - GREENSHIELD - PARKS & GROUNDS				2,487.36
MAY 2019	MAY 2019 BENEFITS	619	01-May-2019	01-May-2019	
10-5-7017000-0205	BENEFITS - GREENSHIELD - PARKS & GROUNDS				2,487.36
<b>SUN11 SUN LIFE ASSURANCE CO. OF CANADA - BILLING</b>					
APR 2019	APRIL 2019 BENEFITS	404	01-Apr-2019	01-Apr-2019	
10-5-7017000-0207	BENEFITS - LIFE & DISABIL - PARKS & GRDS				1,813.79
DEC 2018	DECEMBER 2018 BENEFITS	1468	01-Dec-2018	01-Dec-2018	
10-5-7017000-0207	BENEFITS - LIFE & DISABIL - PARKS & GRDS				1,811.45
FEB 2019	FEBRUARY 2019 BENEFITS	124	01-Feb-2019	01-Feb-2019	
10-5-7017000-0207	BENEFITS - LIFE & DISABIL - PARKS & GRDS				1,816.13



Vendor : CAT038 To ZUL180  
 Batch : All  
 Department : All

EFT Paid Date : 01-Jan-2019 To 31-May-2019  
 Bank : 1 To 99  
 Class : All

Vendor Code	Vendor Name	Batch	Inv Date	Inv Due Date	Amount
Invoice No.	Description				
G.L. Account	CC1 CC2 CC3 GL Account Name				
<b>DEPARTMENT 7017000 PARKS MAINTENANCE</b>					
JAN 2019	JANUARY 2019 BENEFITS	123	02-Jan-2019	02-Jan-2019	
10-5-7017000-0207	BENEFITS - LIFE & DISABIL - PARKS & GRDS				1,811.45
MAR 2019	MARCH 2019 BENEFITS	227	01-Mar-2019	01-Mar-2019	
10-5-7017000-0207	BENEFITS - LIFE & DISABIL - PARKS & GRDS				1,813.79
MAY 2019	MAY 2019 BENEFITS	472	01-May-2019	01-May-2019	
10-5-7017000-0207	BENEFITS - LIFE & DISABIL - PARKS & GRDS				2,849.73
<b>USB01 US BANK NATIONAL ASSOCIATION-VISA</b>					
APRIL 2019	APRIL 2019 PURCHASES	528	30-Apr-2019	30-Apr-2019	
10-5-7017000-0351	TRAINING & CONFERENCES				1,356.00
FEBRUARY 2019	FEBRUARY 2019 PURCHASES	374	28-Feb-2019	28-Feb-2019	
10-5-7017000-0402	VEHICLE & EQUIPMENT MAINTENANCE PARKS				1,424.64
MAY 2019	MAY 2019 PURCHASES	746	31-May-2019	31-May-2019	
10-5-7017000-0351	TRAINING & CONFERENCES				788.27
10-5-7017000-0322	GENERAL SUPPLIES - PARKS & REC				50.85
10-5-7017000-0322	GENERAL SUPPLIES - PARKS & REC				1,575.22
10-5-7017000-0301	OFFICE SUPPLIES				361.55
<b>Department Totals :</b>					<b>29,378.24</b>

<b>DEPARTMENT 7017002 FACILITIES</b>					
<b>BEL03 BELL MOBILITY INC.</b>					
APR 2019	APRIL 2019 USAGE	403	06-Apr-2019	06-Apr-2019	
10-5-7017002-0345	CELL PHONE				123.12
FEB 2019	FEBRUARY 2019 USAGE	188	06-Feb-2019	06-Feb-2019	
10-5-7017002-0345	CELL PHONE				209.21
JAN 2019	JANUARY 2019 USAGE	58	06-Jan-2019	06-Jan-2019	
10-5-7017002-0345	CELL PHONE				120.98
MAR 2019	MARCH 2019 USAGE	326	06-Mar-2019	06-Mar-2019	
10-5-7017002-0345	CELL PHONE				122.12
MAY 2019	MAY 2019 USAGE	543	06-May-2019	06-May-2019	
10-5-7017002-0345	CELL PHONE				116.56
<b>ESS46 ESSEX POWERLINES CORPORATION</b>					
APR 2019	ELECTRICITY, WATER & SEWAGE APRIL 2019	517	30-Apr-2019	30-Apr-2019	
10-5-7017002-0316	SCOUT FACILITIES - UTILITIES				176.38
10-5-7017002-0316	CENTW FACILITIES - UTILITIES				235.18
10-5-7017002-0316	ACS FACILITIES - UTILITIES				665.58
10-5-7017002-0316	PWD FACILITIES - UTILITIES				1,489.69
10-5-7017002-0316	FIRE FACILITIES - UTILITIES				475.76
10-5-7017002-0316	TODDY FACILITIES - UTILITIES				691.84
10-5-7017002-0316	CARNEC FACILITIES - UTILITIES				53.64
10-5-7017002-0316	99THOM FACILITIES - UTILITIES				628.70
10-5-7017002-0316	BELLEV FACILITIES - UTILITIES				53.64
10-5-7017002-0316	32ORIC FACILITIES - UTILITIES				684.06
10-5-7017002-0316	TOWN FACILITIES - UTILITIES				1,293.59
10-5-7017002-0316	KNYP FACILITIES - UTILITIES				679.19
10-5-7017002-0316	GORDOI FACILITIES - UTILITIES				189.09
10-5-7017002-0316	WIGLE FACILITIES - UTILITIES				165.89
10-5-7017002-0316	NORTHG FACILITIES - UTILITIES				290.58
APR 2019	AMEI ELECTRICITY, WATER & SEWAGE APRIL 2019	757	30-Apr-2019	30-Apr-2019	
10-5-7017002-0316	KNYP FACILITIES - UTILITIES				53.64
DEC 2018	ELECTRICITY, WATER & SEWAGE DECEMBER 2018	1585	31-Dec-2018	31-Dec-2018	
10-5-7017002-0316	TOWN FACILITIES - UTILITIES				1,724.91
10-5-7017002-0316	KNYP FACILITIES - UTILITIES				924.68
10-5-7017002-0316	GORDOI FACILITIES - UTILITIES				253.91
10-5-7017002-0316	WIGLE FACILITIES - UTILITIES				162.24
10-5-7017002-0316	NORTHG FACILITIES - UTILITIES				243.42
10-5-7017002-0316	SCOUT FACILITIES - UTILITIES				198.00



Council/Board Report By Dept-(EFT)



Vendor : CAT038 To ZUL180

Batch : All

Department : All

EFT Paid Date : 01-Jan-2019 To 31-May-2019

Bank : 1 To 99

Class : All

Vendor Code	Vendor Name				Batch	Inv Date	Inv Due Date	Amount
Invoice No.	Description							
G.L. Account	CC1	CC2	CC3	GL Account Name				
<b>DEPARTMENT 7017002 FACILITIES</b>								
10-5-7017002-0316	CENTW			FACILITIES - UTILITIES				240.95
10-5-7017002-0316	ACS			FACILITIES - UTILITIES				820.00
10-5-7017002-0316	PWD			FACILITIES - UTILITIES				21.47
10-5-7017002-0316	FIRE			FACILITIES - UTILITIES				181.23
10-5-7017002-0316	MALWAS			FACILITIES - UTILITIES				77.97
10-5-7017002-0316	MALCOM			FACILITIES - UTILITIES				171.66
10-5-7017002-0316	TODDY			FACILITIES - UTILITIES				1,753.08
10-5-7017002-0316	CARNEC			FACILITIES - UTILITIES				52.63
10-5-7017002-0316	99THOM			FACILITIES - UTILITIES				717.58
10-5-7017002-0316	BELLEV			FACILITIES - UTILITIES				52.63
10-5-7017002-0316	32ORIC			FACILITIES - UTILITIES				295.59
FEB 2019	ELECTRICITY, WATER & SEWAGE FEBRUARY 2019				309	28-Feb-2019	28-Feb-2019	
10-5-7017002-0316	TOWN			FACILITIES - UTILITIES				1,503.77
10-5-7017002-0316	KNYP			FACILITIES - UTILITIES				694.47
10-5-7017002-0316	GORDOI			FACILITIES - UTILITIES				204.47
10-5-7017002-0316	WIGLE			FACILITIES - UTILITIES				163.55
10-5-7017002-0316	NORTHG			FACILITIES - UTILITIES				295.72
10-5-7017002-0316	SCOUT			FACILITIES - UTILITIES				168.94
10-5-7017002-0316	CENTW			FACILITIES - UTILITIES				227.34
10-5-7017002-0316	ACS			FACILITIES - UTILITIES				781.91
10-5-7017002-0316	PWD			FACILITIES - UTILITIES				1,695.07
10-5-7017002-0316	TODDY			FACILITIES - UTILITIES				1,261.32
10-5-7017002-0316	CARNEC			FACILITIES - UTILITIES				52.63
10-5-7017002-0316	99THOM			FACILITIES - UTILITIES				911.75
10-5-7017002-0316	BELLEV			FACILITIES - UTILITIES				52.63
10-5-7017002-0316	32ORIC			FACILITIES - UTILITIES				750.68
FEB 2019 (AME	ELECTRICITY, WATER & SEWAGE FEBRUARY 2019				590	31-May-2019	31-May-2019	
10-5-7017002-0316	32ORIC			FACILITIES - UTILITIES				72.49
JAN 2019	ELECTRICITY, WATER & SEWAGE JANUARY 2019				193	31-Jan-2019	31-Jan-2019	
10-5-7017002-0316	TOWN			FACILITIES - UTILITIES				1,227.23
10-5-7017002-0316	KNYP			FACILITIES - UTILITIES				859.58
10-5-7017002-0316	GORDOI			FACILITIES - UTILITIES				185.79
10-5-7017002-0316	WIGLE			FACILITIES - UTILITIES				163.55
10-5-7017002-0316	NORTHG			FACILITIES - UTILITIES				313.58
10-5-7017002-0316	SCOUT			FACILITIES - UTILITIES				167.85
10-5-7017002-0316	CENTW			FACILITIES - UTILITIES				232.48
10-5-7017002-0316	ACS			FACILITIES - UTILITIES				603.96
10-5-7017002-0316	PWD			FACILITIES - UTILITIES				5,214.37
10-5-7017002-0316	FIRE			FACILITIES - UTILITIES				230.95
10-5-7017002-0316	MALCOM			FACILITIES - UTILITIES				55.31
10-5-7017002-0316	TODDY			FACILITIES - UTILITIES				1,284.34
10-5-7017002-0316	CARNEC			FACILITIES - UTILITIES				52.63
10-5-7017002-0316	99THOM			FACILITIES - UTILITIES				738.31
10-5-7017002-0316	BELLEV			FACILITIES - UTILITIES				52.63
10-5-7017002-0316	32ORIC			FACILITIES - UTILITIES				397.72
MAR 2019	ELECTRICITY, WATER & SEWAGE MARCH 2019				411	31-Mar-2019	31-Mar-2019	
10-5-7017002-0316	SCOUT			FACILITIES - UTILITIES				169.32
10-5-7017002-0316	CENTW			FACILITIES - UTILITIES				222.35
10-5-7017002-0316	BELLEV			FACILITIES - UTILITIES				53.64
10-5-7017002-0316	32ORIC			FACILITIES - UTILITIES				807.31
10-5-7017002-0316	TOWN			FACILITIES - UTILITIES				1,409.82
10-5-7017002-0316	KNYP			FACILITIES - UTILITIES				726.08
10-5-7017002-0316	GORDOI			FACILITIES - UTILITIES				186.10
10-5-7017002-0316	WIGLE			FACILITIES - UTILITIES				161.94
10-5-7017002-0316	NORTHG			FACILITIES - UTILITIES				299.10
10-5-7017002-0316	ACS			FACILITIES - UTILITIES				692.87
10-5-7017002-0316	PWD			FACILITIES - UTILITIES				1,616.30
10-5-7017002-0316	FIRE			FACILITIES - UTILITIES				175.90
10-5-7017002-0316	MALWAS			FACILITIES - UTILITIES				64.94
10-5-7017002-0316	TODDY			FACILITIES - UTILITIES				1,194.14





Vendor : CAT038 To ZUL180

Batch : All

Department : All

EFT Paid Date : 01-Jan-2019 To 31-May-2019

Bank : 1 To 99

Class : All

Vendor Code	Vendor Name				Batch	Inv Date	Inv Due Date	Amount
Invoice No.	Description							
G.L. Account	CC1	CC2	CC3	GL Account Name				
<b>DEPARTMENT 7017002</b>				FACILITIES				
10-5-7017002-0316	CARNEC			FACILITIES - UTILITIES				53.64
10-5-7017002-0316	99THOM			FACILITIES - UTILITIES				792.06
<b>GRE03 GREEN SHIELD CANADA</b>								
APR 2019	APRIL 2019 BENEFITS				375	01-Apr-2019	01-Apr-2019	
10-5-7017002-0205				BENEFITS - GREENSHIELD - FACILITIES				890.78
FEB 2019	FEBRUARY 2019 BENEFITS				98	01-Feb-2019	01-Feb-2019	
10-5-7017002-0205				BENEFITS - GREENSHIELD - FACILITIES				890.78
JAN 2019	JANUARY 2019 BENEFITS				5	02-Jan-2019	02-Jan-2019	
10-5-7017002-0205				BENEFITS - GREENSHIELD - FACILITIES				890.78
MAR 2019	MARCH 2019 BENEFITS				228	01-Mar-2019	01-Mar-2019	
10-5-7017002-0205				BENEFITS - GREENSHIELD - FACILITIES				890.78
MAY 2019	MAY 2019 BENEFITS				619	01-May-2019	01-May-2019	
10-5-7017002-0205				BENEFITS - GREENSHIELD - FACILITIES				890.78
<b>HYD02 HYDRO ONE NETWORKS</b>								
APR 2019	MISC HYDRO ACCTS FOR APRIL 2019				490	30-Apr-2019	30-Apr-2019	
10-5-7017002-0316	TENNIS			FACILITIES - UTILITIES				61.94
APR 2019	MAIN ACCOUNT APRIL 2019				500	30-Apr-2019	30-Apr-2019	
10-5-7017002-0316	TOWN			FACILITIES - UTILITIES				869.31
10-5-7017002-0316	FIRE			FACILITIES - UTILITIES				68.72
10-5-7017002-0316	PWD			FACILITIES - UTILITIES				1,030.34
10-5-7017002-0316	MALCOM			FACILITIES - UTILITIES				109.20
DEC 2018	MISC HYDRO ACCTS FOR DECEMBER 2018				1584	31-Dec-2018	31-Dec-2018	
10-5-7017002-0316	TENNIS			FACILITIES - UTILITIES				86.97
DEC 2018	MAIN ACCOUNT				1583	31-Dec-2018	31-Dec-2018	
10-5-7017002-0316	TOWN			FACILITIES - UTILITIES				959.35
10-5-7017002-0316	FIRE			FACILITIES - UTILITIES				74.68
10-5-7017002-0316	PWD			FACILITIES - UTILITIES				1,279.64
10-5-7017002-0316	MALCOM			FACILITIES - UTILITIES				123.67
FEB 2019	MISC HYDRO ACCTS FOR FEBRUARY 2019				278	28-Feb-2019	28-Feb-2019	
10-5-7017002-0316	TENNIS			FACILITIES - UTILITIES				30.12
FEB 2019	MAIN ACCOUNT FEBRUARY 2019				279	28-Feb-2019	28-Feb-2019	
10-5-7017002-0316	TOWN			FACILITIES - UTILITIES				856.35
10-5-7017002-0316	FIRE			FACILITIES - UTILITIES				67.89
10-5-7017002-0316	PWD			FACILITIES - UTILITIES				1,168.45
10-5-7017002-0316	MALCOM			FACILITIES - UTILITIES				106.07
JAN 2019	MISC HYDRO ACCTS FOR JANUARY 2019				182	31-Jan-2019	31-Jan-2019	
10-5-7017002-0316	TENNIS			FACILITIES - UTILITIES				40.03
JAN 2019	MAIN ACCOUNT JANUARY 2019				192	31-Jan-2019	31-Jan-2019	
10-5-7017002-0316	TOWN			FACILITIES - UTILITIES				984.25
10-5-7017002-0316	FIRE			FACILITIES - UTILITIES				69.55
10-5-7017002-0316	PWD			FACILITIES - UTILITIES				1,301.24
10-5-7017002-0316	MALCOM			FACILITIES - UTILITIES				112.35
MAR 2019	MISC HYDRO ACCTS FOR MARCH 2019				373	31-Mar-2019	31-Mar-2019	
10-5-7017002-0316	TENNIS			FACILITIES - UTILITIES				30.12
MAR 2019	MAIN ACCOUNT MARCH 2019				370	31-Mar-2019	31-Mar-2019	
10-5-7017002-0316	TOWN			FACILITIES - UTILITIES				1,085.74
10-5-7017002-0316	FIRE			FACILITIES - UTILITIES				70.99
10-5-7017002-0316	PWD			FACILITIES - UTILITIES				1,325.32
10-5-7017002-0316	MALCOM			FACILITIES - UTILITIES				112.86
<b>REL002 RELIANCE HOME COMFORT</b>								
APR 2019	APRIL 2019 RENTAL CHARGES				412	30-Apr-2019	30-Apr-2019	
10-5-7017002-0316	FIRE			FACILITIES - UTILITIES				27.12
10-5-7017002-0316	PARKST			FACILITIES - UTILITIES				76.35
DEC 2018	DECEMBER 2018				1532	31-Dec-2018	31-Dec-2018	
10-5-7017002-0316	FIRE			FACILITIES - UTILITIES				27.12
10-5-7017002-0316	PARKST			FACILITIES - UTILITIES				76.35



Vendor : CAT038 To ZUL180  
 Batch : All  
 Department : All

EFT Paid Date : 01-Jan-2019 To 31-May-2019  
 Bank : 1 To 99  
 Class : All

Vendor Code	Vendor Name				Batch	Inv Date	Inv Due Date	Amount
Invoice No.	Description							
G.L. Account	CC1	CC2	CC3	GL Account Name				
<b>DEPARTMENT 7017002 FACILITIES</b>								
FEB 2019	FEBRUARY 2019 RENTAL CHARGES				219	28-Feb-2019	28-Feb-2019	
10-5-7017002-0316	FIRE			FACILITIES - UTILITIES				27.12
10-5-7017002-0316	PARKST			FACILITIES - UTILITIES				76.35
JAN 2019	JANUARY 2019 RENTAL CHARGES				88	31-Jan-2019	31-Jan-2019	
10-5-7017002-0316	FIRE			FACILITIES - UTILITIES				27.12
10-5-7017002-0316	PARKST			FACILITIES - UTILITIES				76.35
MAR 2019	MARCH 2019 RENTAL CHARGES				321	31-Mar-2019	31-Mar-2019	
10-5-7017002-0316	FIRE			FACILITIES - UTILITIES				27.12
10-5-7017002-0316	PARKST			FACILITIES - UTILITIES				76.35
<b>SUN11 SUN LIFE ASSURANCE CO. OF CANADA - BILLING</b>								
APR 2019	APRIL 2019 BENEFITS				404	01-Apr-2019	01-Apr-2019	
10-5-7017002-0207				BENEFITS - LIFE & DISABIL - FACILITIES				475.72
DEC 2018	DECEMBER 2018 BENEFITS				1468	01-Dec-2018	01-Dec-2018	
10-5-7017002-0207				BENEFITS - LIFE & DISABIL - FACILITIES				475.33
FEB 2019	FEBRUARY 2019 BENEFITS				124	01-Feb-2019	01-Feb-2019	
10-5-7017002-0207				BENEFITS - LIFE & DISABIL - FACILITIES				476.11
JAN 2019	JANUARY 2019 BENEFITS				123	02-Jan-2019	02-Jan-2019	
10-5-7017002-0207				BENEFITS - LIFE & DISABIL - FACILITIES				475.33
MAR 2019	MARCH 2019 BENEFITS				227	01-Mar-2019	01-Mar-2019	
10-5-7017002-0207				BENEFITS - LIFE & DISABIL - FACILITIES				475.72
MAY 2019	MAY 2019 BENEFITS				472	01-May-2019	01-May-2019	
10-5-7017002-0207				BENEFITS - LIFE & DISABIL - FACILITIES				475.72
<b>UNI01 UNION GAS LTD</b>								
APR 2019	APRIL 2019 MONTHLY CHARGES				518	30-Apr-2019	30-Apr-2019	
10-5-7017002-0316	PWD			FACILITIES - UTILITIES				184.04
10-5-7017002-0316	TOWN			FACILITIES - UTILITIES				112.62
10-5-7017002-0316	KNYP			FACILITIES - UTILITIES				59.18
10-5-7017002-0316	PWD			FACILITIES - UTILITIES				973.44
10-5-7017002-0316	PWD			FACILITIES - UTILITIES				556.07
10-5-7017002-0316	FIRE			FACILITIES - UTILITIES				220.22
10-5-7017002-0316	CENTW			FACILITIES - UTILITIES				47.31
10-5-7017002-0316	GORDO			FACILITIES - UTILITIES				194.92
10-5-7017002-0316	SCOUT			FACILITIES - UTILITIES				113.85
10-5-7017002-0316	TOWN			FACILITIES - UTILITIES				579.42
10-5-7017002-0316	TOWN			FACILITIES - UTILITIES				279.49
10-5-7017002-0316	FIRE			FACILITIES - UTILITIES				279.48
10-5-7017002-0316	FIRE			FACILITIES - UTILITIES				112.61
10-5-7017002-0316	320RIC			FACILITIES - UTILITIES				995.20
10-5-7017002-0316	ACS			FACILITIES - UTILITIES				109.13
DEC 2018	DECEMBER 2018 MONTHLY CHARGES				1586	31-Dec-2018	31-Dec-2018	
10-5-7017002-0316	KNYP			FACILITIES - UTILITIES				114.96
10-5-7017002-0316	PWD			FACILITIES - UTILITIES				485.46
10-5-7017002-0316	FIRE			FACILITIES - UTILITIES				206.00
10-5-7017002-0316	CENTW			FACILITIES - UTILITIES				31.37
10-5-7017002-0316	ACS			FACILITIES - UTILITIES				151.35
10-5-7017002-0316	GORDO			FACILITIES - UTILITIES				243.90
10-5-7017002-0316	SCOUT			FACILITIES - UTILITIES				179.43
10-5-7017002-0316	TOWN			FACILITIES - UTILITIES				703.56
10-5-7017002-0316	TOWN			FACILITIES - UTILITIES				355.64
10-5-7017002-0316	FIRE			FACILITIES - UTILITIES				355.63
10-5-7017002-0316	PWD			FACILITIES - UTILITIES				193.84
10-5-7017002-0316	TOWN			FACILITIES - UTILITIES				144.35
10-5-7017002-0316	FIRE			FACILITIES - UTILITIES				144.34
10-5-7017002-0316	PWD			FACILITIES - UTILITIES				23.73
FEB 2019	FEBRUARY 2019 MONTHLY CHARGES				295	28-Feb-2019	28-Feb-2019	
10-5-7017002-0316	PWD			FACILITIES - UTILITIES				394.23
10-5-7017002-0316	TOWN			FACILITIES - UTILITIES				208.37
10-5-7017002-0316	FIRE			FACILITIES - UTILITIES				208.36



Vendor : CAT038 To ZUL180

Batch : All

Department : All

EFT Paid Date : 01-Jan-2019 To 31-May-2019

Bank : 1 To 99

Class : All

Vendor Code	Vendor Name				Batch	Inv Date	Inv Due Date	Amount
Invoice No.	Description							
G.L. Account	CC1	CC2	CC3	GL Account Name				
<b>DEPARTMENT 7017002 FACILITIES</b>								
10-5-7017002-0316	320LEA			FACILITIES - UTILITIES				1,913.95
10-5-7017002-0316	KNYP			FACILITIES - UTILITIES				160.71
10-5-7017002-0316	PWD			FACILITIES - UTILITIES				1,958.47
10-5-7017002-0316	PWD			FACILITIES - UTILITIES				871.73
10-5-7017002-0316	FIRE			FACILITIES - UTILITIES				392.73
10-5-7017002-0316	CENTW&			FACILITIES - UTILITIES				83.29
10-5-7017002-0316	ACS			FACILITIES - UTILITIES				239.71
10-5-7017002-0316	GORDO			FACILITIES - UTILITIES				392.67
10-5-7017002-0316	SCOUT			FACILITIES - UTILITIES				258.72
10-5-7017002-0316	TOWN			FACILITIES - UTILITIES				1,518.06
10-5-7017002-0316	TOWN			FACILITIES - UTILITIES				832.97
10-5-7017002-0316	FIRE			FACILITIES - UTILITIES				832.96
JAN 2019	JANUARY 2019 MONTHLY CHARGES				220	31-Jan-2019	31-Jan-2019	
10-5-7017002-0316	KNYP			FACILITIES - UTILITIES				124.03
10-5-7017002-0316	PWD			FACILITIES - UTILITIES				586.22
10-5-7017002-0316	PWD			FACILITIES - UTILITIES				557.33
10-5-7017002-0316	FIRE			FACILITIES - UTILITIES				243.87
10-5-7017002-0316	CENTW&			FACILITIES - UTILITIES				44.11
10-5-7017002-0316	ACS			FACILITIES - UTILITIES				208.15
10-5-7017002-0316	GORDO			FACILITIES - UTILITIES				301.01
10-5-7017002-0316	SCOUT			FACILITIES - UTILITIES				203.62
10-5-7017002-0316	TOWN			FACILITIES - UTILITIES				1,278.02
10-5-7017002-0316	TOWN			FACILITIES - UTILITIES				440.54
10-5-7017002-0316	FIRE			FACILITIES - UTILITIES				440.53
10-5-7017002-0316	PWD			FACILITIES - UTILITIES				265.54
10-5-7017002-0316	TOWN			FACILITIES - UTILITIES				178.94
10-5-7017002-0316	FIRE			FACILITIES - UTILITIES				178.93
10-5-7017002-0316	PWD			FACILITIES - UTILITIES				1,958.75
MAR 2019	MARCH 2019 MONTHLY CHARGES				318	31-Mar-2019	31-Mar-2019	
10-5-7017002-0316	320RIC			FACILITIES - UTILITIES				2,186.70
10-5-7017002-0316	SCOUT			FACILITIES - UTILITIES				204.97
10-5-7017002-0316	TOWN			FACILITIES - UTILITIES				1,125.22
10-5-7017002-0316	TOWN			FACILITIES - UTILITIES				386.75
10-5-7017002-0316	FIRE			FACILITIES - UTILITIES				386.75
10-5-7017002-0316	PWD			FACILITIES - UTILITIES				264.71
10-5-7017002-0316	TOWN			FACILITIES - UTILITIES				144.60
10-5-7017002-0316	FIRE			FACILITIES - UTILITIES				144.60
10-5-7017002-0316	KNYP			FACILITIES - UTILITIES				130.96
10-5-7017002-0316	PWD			FACILITIES - UTILITIES				1,696.31
10-5-7017002-0316	PWD			FACILITIES - UTILITIES				676.03
10-5-7017002-0316	FIRE			FACILITIES - UTILITIES				325.97
10-5-7017002-0316	CENTW&			FACILITIES - UTILITIES				66.30
10-5-7017002-0316	ACS			FACILITIES - UTILITIES				172.21
10-5-7017002-0316	GORDO			FACILITIES - UTILITIES				313.55
<b>USB01 US BANK NATIONAL ASSOCIATION-VISA</b>								
APRIL 2019	APRIL 2019 PURCHASES				528	30-Apr-2019	30-Apr-2019	
10-5-7017002-0317	IT			FACILITIES - BUILDING MAINTENANCE				153.54
10-5-7017002-0317	TOWN			FACILITIES - BUILDING MAINTENANCE				47.37
FEBRUARY 2019	FEBRUARY 2019 PURCHASES				374	28-Feb-2019	28-Feb-2019	
10-5-7017002-0317	PWD			FACILITIES - BUILDING MAINTENANCE				31.64
MARCH 2019	MARCH 2019 PURCHASES				524	31-Mar-2019	31-Mar-2019	
10-5-7017002-0317	PARKBL			FACILITIES - BUILDING MAINTENANCE				36.70
10-5-7017002-0317	99THOM			FACILITIES - BUILDING MAINTENANCE				141.24
<b>Department Totals :</b>								<b>99,566.43</b>

DEPARTMENT 7017300 LIBRO

BEL03 BELL MOBILITY INC.

APR 2019 APRIL 2019 USAGE

403 06-Apr-2019 06-Apr-2019

10-5-7017300-0345 CELL PHONE - ARENA

127.31



Vendor : CAT038 To ZUL180

Batch : All

Department : All

EFT Paid Date : 01-Jan-2019 To 31-May-2019

Bank : 1 To 99

Class : All

Vendor Code	Vendor Name				Batch	Inv Date	Inv Due Date	Amount
Invoice No.	Description							
G.L. Account	CC1	CC2	CC3	GL Account Name				
<b>DEPARTMENT 7017300</b>				LIBRO				
FEB 2019	FEBRUARY 2019 USAGE				188	06-Feb-2019	06-Feb-2019	
10-5-7017300-0345				CELL PHONE - ARENA				79.74
JAN 2019	JANUARY 2019 USAGE				58	06-Jan-2019	06-Jan-2019	
10-5-7017300-0345				CELL PHONE - ARENA				98.03
MAR 2019	MARCH 2019 USAGE				326	06-Mar-2019	06-Mar-2019	
10-5-7017300-0345				CELL PHONE - ARENA				62.79
MAY 2019	MAY 2019 USAGE				543	06-May-2019	06-May-2019	
10-5-7017300-0345				CELL PHONE - ARENA				121.89
<b>ESS46</b>				<b>ESSEX POWERLINES CORPORATION</b>				
APR 2019	ELECTRICITY, WATER & SEWAGE APRIL 2019				517	30-Apr-2019	30-Apr-2019	
10-5-7017300-0316				UTILITIES				2,099.62
DEC 2018	ELECTRICITY, WATER & SEWAGE DECEMBER 2018				1585	31-Dec-2018	31-Dec-2018	
10-5-7017300-0316				UTILITIES				2,806.50
FEB 2019	ELECTRICITY, WATER & SEWAGE FEBRUARY 2019				309	28-Feb-2019	28-Feb-2019	
10-5-7017300-0316				UTILITIES				2,605.62
JAN 2019	ELECTRICITY, WATER & SEWAGE JANUARY 2019				193	31-Jan-2019	31-Jan-2019	
10-5-7017300-0316				UTILITIES				2,307.54
MAR 2019	ELECTRICITY, WATER & SEWAGE MARCH 2019				411	31-Mar-2019	31-Mar-2019	
10-5-7017300-0316				UTILITIES				2,452.72
<b>GRE03</b>				<b>GREEN SHIELD CANADA</b>				
APR 2019	APRIL 2019 BENEFITS				375	01-Apr-2019	01-Apr-2019	
10-5-7017300-0206				BENEFITS - GREENSHIELD RE				2,017.78
10-5-7017300-0205				BENEFITS - GREENSHIELD				1,066.57
FEB 2019	FEBRUARY 2019 BENEFITS				98	01-Feb-2019	01-Feb-2019	
10-5-7017300-0206				BENEFITS - GREENSHIELD RE				2,017.78
10-5-7017300-0205				BENEFITS - GREENSHIELD				1,066.57
JAN 2019	JANUARY 2019 BENEFITS				5	02-Jan-2019	02-Jan-2019	
10-5-7017300-0206				BENEFITS - GREENSHIELD RE				2,017.78
10-5-7017300-0205				BENEFITS - GREENSHIELD				257.77
MAR 2019	MARCH 2019 BENEFITS				228	01-Mar-2019	01-Mar-2019	
10-5-7017300-0206				BENEFITS - GREENSHIELD RE				2,017.78
10-5-7017300-0205				BENEFITS - GREENSHIELD				1,066.57
MAY 2019	MAY 2019 BENEFITS				619	01-May-2019	01-May-2019	
10-5-7017300-0206				BENEFITS - GREENSHIELD RE				2,850.78
10-5-7017300-0205				BENEFITS - GREENSHIELD				1,066.57
<b>HYD02</b>				<b>HYDRO ONE NETWORKS</b>				
APR 2019	APRIL 2019 LIBRO USAGE				489	18-May-2019	18-May-2019	
10-5-7017300-0316				UTILITIES				226.62
10-5-7017300-0316				UTILITIES				44,664.05
10-5-7017300-0316				UTILITIES				83.27
DEC 2018	LIBRO USAGE				1582	18-Dec-2018	18-Dec-2018	
10-5-7017300-0316				UTILITIES				205.18
10-5-7017300-0316				UTILITIES				72,462.94
10-5-7017300-0316				UTILITIES				105.76
FEB 2019	FEBRUARY 2019 LIBRO USAGE				272	18-Feb-2019	18-Feb-2019	
10-5-7017300-0316				UTILITIES				226.04
10-5-7017300-0316				UTILITIES				41,421.63
10-5-7017300-0316				UTILITIES				85.05
JAN 2019	JANUARY 2019 LIBRO USAGE				181	18-Jan-2019	18-Jan-2019	
10-5-7017300-0316				UTILITIES				280.57
10-5-7017300-0316				UTILITIES				61,581.83
10-5-7017300-0316				UTILITIES				109.82
MAR 2019	MARCH 2019 LIBRO USAGE				371	18-Mar-2019	18-Mar-2019	
10-5-7017300-0316				UTILITIES				172.46
10-5-7017300-0316				UTILITIES				54,375.02
10-5-7017300-0316				UTILITIES				104.80



Vendor : CAT038 To ZUL180  
 Batch : All  
 Department : All

EFT Paid Date : 01-Jan-2019 To 31-May-2019  
 Bank : 1 To 99  
 Class : All

Vendor Code	Vendor Name	Batch	Inv Date	Inv Due Date	Amount
Invoice No.	Description				
G.L. Account	CC1 CC2 CC3 GL Account Name				
<b>DEPARTMENT 7017300</b>	<b>LIBRO</b>				
<b>SUN11</b>	<b>SUN LIFE ASSURANCE CO. OF CANADA - BILLING</b>				
APR 2019	APRIL 2019 BENEFITS	404	01-Apr-2019	01-Apr-2019	
10-5-7017300-0207	BENEFITS - LIFE & DISABIL				475.72
DEC 2018	DECEMBER 2018 BENEFITS	1468	01-Dec-2018	01-Dec-2018	
10-5-7017300-0207	BENEFITS - LIFE & DISABIL				472.37
FEB 2019	FEBRUARY 2019 BENEFITS	124	01-Feb-2019	01-Feb-2019	
10-5-7017300-0207	BENEFITS - LIFE & DISABIL				476.50
JAN 2019	JANUARY 2019 BENEFITS	123	02-Jan-2019	02-Jan-2019	
10-5-7017300-0207	BENEFITS - LIFE & DISABIL				487.79
MAR 2019	MARCH 2019 BENEFITS	227	01-Mar-2019	01-Mar-2019	
10-5-7017300-0207	BENEFITS - LIFE & DISABIL				475.72
MAY 2019	MAY 2019 BENEFITS	472	01-May-2019	01-May-2019	
10-5-7017300-0207	BENEFITS - LIFE & DISABIL				475.72
<b>UNI01</b>	<b>UNION GAS LTD</b>				
APR 2019	APRIL 2019 MONTHLY CHARGES	518	30-Apr-2019	30-Apr-2019	
10-5-7017300-0316	UTILITIES				6,425.81
DEC 2018	DECEMBER 2018 MONTHLY CHARGES	1586	31-Dec-2018	31-Dec-2018	
10-5-7017300-0316	UTILITIES				7,200.81
FEB 2019	FEBRUARY 2019 MONTHLY CHARGES	295	28-Feb-2019	28-Feb-2019	
10-5-7017300-0316	UTILITIES				10,157.82
JAN 2019	JANUARY 2019 MONTHLY CHARGES	220	31-Jan-2019	31-Jan-2019	
10-5-7017300-0316	UTILITIES				9,553.68
MAR 2019	MARCH 2019 MONTHLY CHARGES	318	31-Mar-2019	31-Mar-2019	
10-5-7017300-0316	UTILITIES				11,062.00
<b>USB01</b>	<b>US BANK NATIONAL ASSOCIATION-VISA</b>				
APRIL 2019	APRIL 2019 PURCHASES	528	30-Apr-2019	30-Apr-2019	
10-5-7017300-0350	MEMBERSHIPS				-6.78
10-5-7017300-0350	MEMBERSHIPS				135.60
10-5-7017300-0350	MEMBERSHIPS				300.79
10-5-7017300-0317	BUILDING MAINTENANCE				235.36
10-5-7017300-0317	BUILDING MAINTENANCE				535.83
10-5-7017300-0317	BUILDING MAINTENANCE				1,077.13
10-5-7017300-0250	HEALTH AND SAFETY				62.15
FEBRUARY 2019	FEBRUARY 2019 PURCHASES	374	28-Feb-2019	28-Feb-2019	
10-5-7017300-0317	BUILDING MAINTENANCE				177.98
10-5-7017300-0350	MEMBERSHIPS				50.00
10-5-7017300-0250	HEALTH AND SAFETY				150.89
JANUARY 2019	JANUARY 2019 PURCHASES	132	31-Jan-2019	31-Jan-2019	
10-5-7017300-0350	MEMBERSHIPS				830.55
10-5-7017300-0301	OFFICE SUPPLIES				152.55
10-5-7017300-0317	BUILDING MAINTENANCE				176.17
MARCH 2019	MARCH 2019 PURCHASES	524	31-Mar-2019	31-Mar-2019	
10-5-7017300-0250	HEALTH AND SAFETY				821.98
MAY 2019	MAY 2019 PURCHASES	746	31-May-2019	31-May-2019	
10-5-7017300-0962	PREMIER BASEBALL FIELD				183.59
10-5-7017300-0317	BUILDING MAINTENANCE				207.47
10-5-7017300-0317	BUILDING MAINTENANCE				173.05
<b>Department Totals :</b>					<b>356,841.00</b>

**DEPARTMENT 8010000** PLANNING & LEGISLATIVE SERVICES

<b>BEL03</b>	<b>BELL MOBILITY INC.</b>				
APR 2019	APRIL 2019 USAGE	403	06-Apr-2019	06-Apr-2019	
10-5-8010000-0345	CELL PHONE				85.03
FEB 2019	FEBRUARY 2019 USAGE	188	06-Feb-2019	06-Feb-2019	
10-5-8010000-0345	CELL PHONE				-147.54



Vendor : CAT038 To ZUL180

Batch : All

Department : All

EFT Paid Date : 01-Jan-2019 To 31-May-2019

Bank : 1 To 99

Class : All

Vendor Code	Vendor Name					Batch	Inv Date	Inv Due Date	Amount
Invoice No.	Description								
G.L. Account	CC1	CC2	CC3	GL Account Name					
<b>DEPARTMENT 8010000 PLANNING &amp; LEGISLATIVE SERVICES</b>									
JAN 2019	JANUARY 2019 USAGE					58	06-Jan-2019	06-Jan-2019	
10-5-8010000-0345				CELL PHONE					816.37
MAR 2019	MARCH 2019 USAGE					326	06-Mar-2019	06-Mar-2019	
10-5-8010000-0345				CELL PHONE					62.43
MAY 2019	MAY 2019 USAGE					543	06-May-2019	06-May-2019	
10-5-8010000-0345				CELL PHONE					101.98
<b>GRE03 GREEN SHIELD CANADA</b>									
APR 2019	APRIL 2019 BENEFITS					375	01-Apr-2019	01-Apr-2019	
10-5-8010000-0205				BENEFITS - GREENSHIELD					445.39
10-5-8010000-0206				BENEFITS - GREENSHIELD RETIREES					1,036.87
FEB 2019	FEBRUARY 2019 BENEFITS					98	01-Feb-2019	01-Feb-2019	
10-5-8010000-0206				BENEFITS - GREENSHIELD RETIREES					1,036.87
10-5-8010000-0205				BENEFITS - GREENSHIELD					1,278.39
JAN 2019	JANUARY 2019 BENEFITS					5	02-Jan-2019	02-Jan-2019	
10-5-8010000-0205				BENEFITS - GREENSHIELD					1,278.39
10-5-8010000-0206				BENEFITS - GREENSHIELD RETIREES					1,036.87
MAR 2019	MARCH 2019 BENEFITS					228	01-Mar-2019	01-Mar-2019	
10-5-8010000-0206				BENEFITS - GREENSHIELD RETIREES					1,036.87
10-5-8010000-0205				BENEFITS - GREENSHIELD					1,278.39
MAY 2019	MAY 2019 BENEFITS					619	01-May-2019	01-May-2019	
10-5-8010000-0205				BENEFITS - GREENSHIELD					1,218.75
10-5-8010000-0206				BENEFITS - GREENSHIELD RETIREES					1,036.87
<b>SUN11 SUN LIFE ASSURANCE CO. OF CANADA - BILLING</b>									
APR 2019	APRIL 2019 BENEFITS					404	01-Apr-2019	01-Apr-2019	
10-5-8010000-0207				BENEFITS - LIFE & DISABIL					772.20
DEC 2018	DECEMBER 2018 BENEFITS					1468	01-Dec-2018	01-Dec-2018	
10-5-8010000-0207				BENEFITS - LIFE & DISABIL					1,245.94
FEB 2019	FEBRUARY 2019 BENEFITS					124	01-Feb-2019	01-Feb-2019	
10-5-8010000-0207				BENEFITS - LIFE & DISABIL					1,245.94
JAN 2019	JANUARY 2019 BENEFITS					123	02-Jan-2019	02-Jan-2019	
10-5-8010000-0207				BENEFITS - LIFE & DISABIL					1,245.94
MAR 2019	MARCH 2019 BENEFITS					227	01-Mar-2019	01-Mar-2019	
10-5-8010000-0207				BENEFITS - LIFE & DISABIL					1,245.94
MAY 2019	MAY 2019 BENEFITS					472	01-May-2019	01-May-2019	
10-5-8010000-0207				BENEFITS - LIFE & DISABIL					1,166.23
<b>USB01 US BANK NATIONAL ASSOCIATION-VISA</b>									
APRIL 2019	APRIL 2019 PURCHASES					528	30-Apr-2019	30-Apr-2019	
10-5-8010000-0345				CELL PHONE					3.25
FEBRUARY 2019	FEBRUARY 2019 PURCHASES					374	28-Feb-2019	28-Feb-2019	
10-5-8010000-0350				MEMBERSHIPS					248.60
10-5-8010000-0352				TRAVEL & MILEAGE					11.00
JANUARY 2019	JANUARY 2019 PURCHASES					132	31-Jan-2019	31-Jan-2019	
10-5-8010000-0350				MEMBERSHIPS					2,487.13
10-5-8010000-0351				TRAINING, CONVENTIONS & SEMINARS					2.75
10-5-8010000-0351				TRAINING, CONVENTIONS & SEMINARS					1.25
10-5-8010000-0351				TRAINING, CONVENTIONS & SEMINARS					2.50
MARCH 2019	MARCH 2019 PURCHASES					524	31-Mar-2019	31-Mar-2019	
10-5-8010000-0342				MEETINGS					58.48
10-5-8010000-0352				TRAVEL & MILEAGE					4.75
MAY 2019	MAY 2019 PURCHASES					746	31-May-2019	31-May-2019	
10-5-8010000-0352				TRAVEL & MILEAGE					3.50
10-5-8010000-0351				TRAINING, CONVENTIONS & SEMINARS					237.30

Department Totals : 21,584.63





Vendor : CAT038 To ZUL180

Batch : All

Department : All

EFT Paid Date : 01-Jan-2019 To 31-May-2019

Bank : 1 To 99

Class : All

Vendor Code	Vendor Name	Batch	Inv Date	Inv Due Date	Amount
Invoice No.	Description				
G.L. Account	CC1 CC2 CC3 GL Account Name				
<b>DEPARTMENT 8020000</b>	<b>TOURISM VISITOR INFORMATION CENTRE</b>				
<b>BELO3</b>	<b>BELL MOBILITY INC.</b>				
APR 2019	APRIL 2019 USAGE	403	06-Apr-2019	06-Apr-2019	
10-5-8020000-0345	CELL PHONE				157.82
FEB 2019	FEBRUARY 2019 USAGE	188	06-Feb-2019	06-Feb-2019	
10-5-8020000-0345	CELL PHONE				203.11
JAN 2019	JANUARY 2019 USAGE	58	06-Jan-2019	06-Jan-2019	
10-5-8020000-0345	CELL PHONE				202.57
MAR 2019	MARCH 2019 USAGE	326	06-Mar-2019	06-Mar-2019	
10-5-8020000-0345	CELL PHONE				206.02
MAY 2019	MAY 2019 USAGE	543	06-May-2019	06-May-2019	
10-5-8020000-0345	CELL PHONE				184.93
<b>GRE03</b>	<b>GREEN SHIELD CANADA</b>				
APR 2019	APRIL 2019 BENEFITS	375	01-Apr-2019	01-Apr-2019	
10-5-8020000-0205	BENEFITS - GREENSHIELD - TOURISM				833.00
FEB 2019	FEBRUARY 2019 BENEFITS	98	01-Feb-2019	01-Feb-2019	
10-5-8020000-0205	BENEFITS - GREENSHIELD - TOURISM				833.00
JAN 2019	JANUARY 2019 BENEFITS	5	02-Jan-2019	02-Jan-2019	
10-5-8020000-0205	BENEFITS - GREENSHIELD - TOURISM				833.00
MAR 2019	MARCH 2019 BENEFITS	228	01-Mar-2019	01-Mar-2019	
10-5-8020000-0205	BENEFITS - GREENSHIELD - TOURISM				833.00
MAY 2019	MAY 2019 BENEFITS	619	01-May-2019	01-May-2019	
10-5-8020000-0205	BENEFITS - GREENSHIELD - TOURISM				1,666.00
<b>SUN11</b>	<b>SUN LIFE ASSURANCE CO. OF CANADA - BILLING</b>				
APR 2019	APRIL 2019 BENEFITS	404	01-Apr-2019	01-Apr-2019	
10-5-8020000-0207	BENEFITS - LIFE & DISABILITY				638.99
DEC 2018	DECEMBER 2018 BENEFITS	1468	01-Dec-2018	01-Dec-2018	
10-5-8020000-0207	BENEFITS - LIFE & DISABILITY				638.99
FEB 2019	FEBRUARY 2019 BENEFITS	124	01-Feb-2019	01-Feb-2019	
10-5-8020000-0207	BENEFITS - LIFE & DISABILITY				638.99
JAN 2019	JANUARY 2019 BENEFITS	123	02-Jan-2019	02-Jan-2019	
10-5-8020000-0207	BENEFITS - LIFE & DISABILITY				638.99
MAR 2019	MARCH 2019 BENEFITS	227	01-Mar-2019	01-Mar-2019	
10-5-8020000-0207	BENEFITS - LIFE & DISABILITY				638.99
MAY 2019	MAY 2019 BENEFITS	472	01-May-2019	01-May-2019	
10-5-8020000-0207	BENEFITS - LIFE & DISABILITY				913.57
<b>USB01</b>	<b>US BANK NATIONAL ASSOCIATION-VISA</b>				
APRIL 2019	APRIL 2019 PURCHASES	528	30-Apr-2019	30-Apr-2019	
10-5-8020000-0307	GENERAL ADVERTISING				162.50
10-5-8020000-0355	UNCOMI PRINTED MATERIAL\PROMOTIONAL PRODUCTS				734.50
10-5-8020000-0355	UNCOMI PRINTED MATERIAL\PROMOTIONAL PRODUCTS				32.26
10-5-8020000-0355	UNCOMI PRINTED MATERIAL\PROMOTIONAL PRODUCTS				51.55
10-5-8020000-0355	UNCOMI PRINTED MATERIAL\PROMOTIONAL PRODUCTS				32.26
10-5-8020000-0355	UNCOMI PRINTED MATERIAL\PROMOTIONAL PRODUCTS				230.46
10-5-8020000-0355	UNCOMI PRINTED MATERIAL\PROMOTIONAL PRODUCTS				21.55
10-5-8020000-0355	UNCOMI PRINTED MATERIAL\PROMOTIONAL PRODUCTS				34.35
FEBRUARY 2019	FEBRUARY 2019 PURCHASES	374	28-Feb-2019	28-Feb-2019	
10-5-8020000-0307	GENERAL ADVERTISING				26.39
10-5-8020000-0351	TRAINING & CONFERENCES				87.55
MARCH 2019	MARCH 2019 PURCHASES	524	31-Mar-2019	31-Mar-2019	
10-5-8020000-0307	GENERAL ADVERTISING				88.83
10-5-8020000-0355	PRINTED MATERIAL\PROMOTIONAL PRODUCTS				208.94
MAY 2019	MAY 2019 PURCHASES	746	31-May-2019	31-May-2019	
10-5-8020000-0355	UNCOMI PRINTED MATERIAL\PROMOTIONAL PRODUCTS				32.39
10-5-8020000-0355	UNCOMI PRINTED MATERIAL\PROMOTIONAL PRODUCTS				41.29
10-5-8020000-0355	UNCOMI PRINTED MATERIAL\PROMOTIONAL PRODUCTS				328.91



Council/Board Report By Dept-(EFT)



Vendor : CAT038 To ZUL180

Batch : All

Department : All

EFT Paid Date : 01-Jan-2019 To 31-May-2019

Bank : 1 To 99

Class : All

Vendor Code	Vendor Name				Batch	Inv Date	Inv Due Date	
Invoice No.	Description							Amount
G.L. Account	CC1	CC2	CC3	GL Account Name				
<b>DEPARTMENT 8020000</b>				TOURISM VISITOR INFORMATION CENTRE				
10-5-8020000-0307			GENERA	ADVERTISING				828.98
10-5-8020000-0307			UNCOMI	ADVERTISING				14.79
10-5-8020000-0307			UNCOMI	ADVERTISING				34.32
10-5-8020000-0307			GENERA	ADVERTISING				1,223.26
10-5-8020000-0307			GENERA	ADVERTISING				106.91
<b>Department Totals :</b>								<b>14,382.96</b>

EFT Paid Total : **8,842,550.51**

Total Unpaid for Approval : 0.00  
 Total Manually Paid for Approval : 0.00  
 Total Computer Paid for Approval : 10,266,836.22  
 Total EFT Paid for Approval : 8,842,550.51  
**Grand Total ITEMS for Approval : 19,109,386.73**



2021 Division Road North  
Kingsville, Ontario N9Y 2Y9  
Phone: (519) 733-2305  
www.kingsville.ca  
kingsvilleworks@kingsville.ca

**SENT VIA EMAIL**

October 25, 2019

The Honourable Doug Ford, Premier  
Legislative Building  
Queen's Park  
Toronto, ON M7A 1A1

Dear Premier Ford:

**RE: LOCAL HEALTH CARE SERVICES**

At its Regular Meeting held on October 15, 2019 Council of the Town of Kingsville passed the following Resolution:

**"533-2019**

**Moved By** Councillor Kimberly DeYong

**Seconded By** Councillor Larry Patterson

WHEREAS public health care consistently ranks as the top priority in public opinion polls, and;

WHEREAS Public Health provides vital health promotion and prevention services based on the unique demographic and economic, social, and cultural needs of our communities; and;

WHEREAS the evidence from hospital amalgamation in Ontario and across Canada is that they have cost billions of dollars and have not yielded the promised administrative savings but have taken money away from frontline care, and;

WHEREAS there is no evidence to support the proposed closure of 25 out of 35 local Public Health Units, the closure of 12 of 22 local ambulance dispatch centres, and the closure of 49 out of 59 local ambulance services, and;

WHEREAS there is a deep consensus among virtually all stakeholders that increasing acuity in our long-term care homes requires additional staff and resources, not

cancellation of the two special funds and real dollar cuts to per diem funding of our long-term care homes, and;

WHEREAS our local hospitals have been downsized for an entire generation and cannot meet population needs while sustaining real dollar cuts to hospital global budgets.

THEREFORE BE IT RESOLVED:

That The Corporation of the Town of Kingsville calls upon the Ontario government to halt the closures of, mergers of, and cuts to our local health care services including Public Health Units, land ambulance services, hospitals and long-term care homes and the Town of Kingsville forward this resolution to all municipalities in the Province of Ontario.”

Yours very truly,



Jennifer Astrologo, B.H.K. (Hons), LL.B.  
Director of Corporate Services/Clerk  
Corporate Services Department  
jastrologo@kingsville.ca

cc: Association of Municipalities of Ontario (AMO)  
cc: All Ontario Municipalities  
cc: Taras Natyshak, MPP  
cc: Windsor-Essex County Health Unit

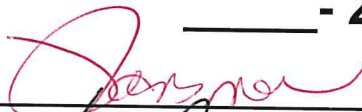
**PRESCOTT**  
EST 1784  
THE FORT TOWN

**Regular Council**

**October 28, 2019**

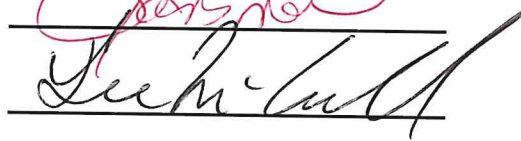
\_\_\_\_\_ - 2019

**Moved by:**



Item 11.2

**Seconded by:**



WHEREAS, the Province of Ontario has legislated in the *Building Code Act* that “the council of each municipality is responsible for the enforcement of this Act in the municipality” and “the council of each municipality shall appoint a chief building official and such inspectors as are necessary for the enforcement of this Act in the areas in which the municipality has jurisdiction”,

AND WHEREAS, “the council of a municipality may pass by-laws applicable to the matters for which and in the area in which the municipality has jurisdiction for the enforcement of this Act”,

AND WHEREAS, the Province has asked local governments to find efficient and cost effective ways to deliver municipal services is now asking municipalities to collect a tax on their behalf to create a new Delegated Administrative Authority to deliver services that have historically been the responsibility of the Ontario Government,

AND WHEREAS, Premier Ford stated in his keynote address at the Association of Ontario Municipalities 2019 Conference, that “we can’t continue throwing money at the problem (broken systems) as our predecessors did, into top-down, big government schemes. That is neither compassionate nor sustainable”,

AND WHEREAS, alternative methods of building administration and enforcement have been proposed in this consultation that remove municipal authority but not the associated liability,

THEREFORE LET IT BE RESOLVED that the The Municipality of Prescott requests that, the Province of Ontario work with the current building sector groups that, for the past fifteen years, have been working to support the Ministry of Municipal Affairs and Housing, and provide evidence based justification to municipalities that the creation of a

# PRESCOTT

EST 1784

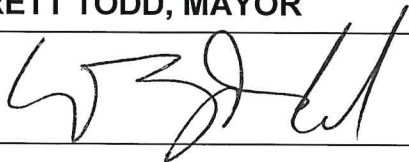
## THE FORT TOWN

new Delegated Administrative Authority is necessary prior to any legislative changes to the *Building Code Act*, with regard to building service delivery, are introduced in the Legislature.

Be it further resolved that a copy of this motion be sent to The Honourable Doug Ford, Premier of Ontario, The Honourable Steve Clark, Minister of Municipal Affairs and Housing, The Honourable Jim McDonnell, Parliamentary Assistant for Municipal Affairs and Housing.

Be it further resolved that a copy of this motion be sent to the Associations of Municipalities of Ontario (AMO) and all Ontario Municipalities for their consideration.

<b>REQUESTED BY:</b>			
<b>RECORDED VOTE</b>		<b>YES</b>	<b>NO</b>
	Councillor Leanne Burton		
	Councillor Teresa Jansman		
	Councillor Lee McConnell		
<b>CARRIED:</b>	Councillor Mike Ostrander		
<b>TABLED:</b>	Councillor Gauri Shankar		
<b>DEFEATED:</b>	Mayor Brett Todd		
<b>RECORDED VOTE:</b>	Councillor Ray Young		

<b>BRETT TODD, MAYOR</b>	<b>ACTING CLERK</b>
	



237897 Inglis Falls Road, R.R.#4, Owen Sound, ON N4K 5N6  
Telephone: 519.376.3076 Fax: 519.371.0437  
[www.greysauble.on.ca](http://www.greysauble.on.ca)

November 1<sup>st</sup>, 2019

The Honourable Jeff Yurek  
Minister of the Environment, Conservation and Parks  
5<sup>th</sup> Floor 777 Bay Street  
Toronto, ON M7A 2J3

sent via email: [jeff.yurek@pc.ola.org](mailto:jeff.yurek@pc.ola.org)

**RE: Grey Sauble Conservation Authority Board of Directors Resolution FA-19-116**

Please be advised that the following resolution was passed at the October 23, 2019 meeting of the Grey Sauble Conservation Authority Board of Directors.

**Motion No.: FA-19-116**

**Moved by: Scott Greig**

**Seconded By: Marion Koepke**

**Whereas** the Grey Sauble Conservation Authority (GSCA) Board of Directors is comprised of elected representatives from the Municipality of Arran-Elderslie, the Township of Chatsworth, the Township of Georgian Bluffs, the Municipality of Grey Highlands, the Town of Meaford, the City of Owen Sound, the Town of South Bruce Peninsula, and the Town of the Blue Mountains; and,

**Whereas** the Board of Directors determines the policies, priorities, projects, fees and budget of the GSCA; and,

**Whereas** the GSCA provides important and valued programs and services to the residents of its member municipalities that include recreation, education, water quality monitoring, forestry services, biodiversity preservation, stewardship, as well as protecting life and property through a variety of measures;

**Therefore**, be it resolved that the publicly elected and municipally appointed GSCA Board of Directors supports the continuation of the programs and services of the GSCA, both mandatory and non-mandatory, and that no programs or services of GSCA be "wound down" at this time; and,

**That** the Minister of the Environment, Conservation and Parks give clear direction as to what programs and services are considered mandatory and non-mandatory and how those programs will be funded in the future; and,

**That** the Minister of the Environment, Conservation and Parks utilize the Conservation Authorities Act regulations to ensure that all programs and projects of the Authority that are consistent with the Objects and Powers of an Authority be considered core programs.

1 of 2



**Watershed Municipalities**  
Arran-Elderslie, Chatsworth, Georgian Bluffs, Grey Highlands  
Meaford, Owen Sound, South Bruce Peninsula, Blue Mountains

The Honourable Jeff Yurek, MECP  
Re: Grey Sauble Conservation Authority Board Support of Authority Programs  
November 1st, 2019

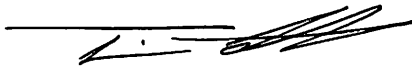
---

***That this resolution be forwarded to the Minister of the Environment, Conservation and Parks, Premier Doug Ford, MPP Bill Walker, the Association of Municipalities of Ontario, Conservation Ontario, and all Ontario municipalities.***

**CARRIED**

I look forward to hearing from you.

Regards,



Tim Lanthier  
Interim General Manager  
Grey Sauble Conservation Authority

cc: Premier Doug Ford  
MPP Bill Walker  
Association of Municipalities of Ontario  
Ontario Municipalities  
Conservation Ontario



Ms. Morencie,

Please view the attached cover page for 2020 Veterans Day Magazine.

For 2020, Will the Town of Amherstburg repeat the same ad and sponsorship as last year?  
Prices remain the same.

2020 Veterans Day Magazine

Quarter-page AD \$530.00

Sponsorship of Veterans / Students Table \$500.00

Thank you.



Dann Bouzide - President / Co-ordinator  
[519\) 564-7646](tel:5195647646) [519-944-1176](tel:5199441176)  
[dann@windsorhistoricalsociety.com](mailto:dann@windsorhistoricalsociety.com)

# VETERANS DAY MAGAZINE



2020

Lest We Forget



**WINDSOR HISTORICAL SOCIETY**  
[veteransmemoriesproject.com](http://veteransmemoriesproject.com)

Donation \$5.00



**TOWN OF AMHERSTBURG  
MAYOR'S YOUTH ADVISORY COMMITTEE MEETING**

**Monday, October 21, 2019  
5:00 PM**

**Libro Centre, Energy Zone  
3295 Meloche Road, Amherstburg, ON, N9V 2Y8**

**MINUTES**

**PRESENT**

Hannah Rusenstrom, Chair  
Adam Tronchin, Vice Chair  
Katie McEvoy  
Kyra Glendenning  
Alex Glendenning  
Bo O'Rourke-Caton  
Phoebe Trealout  
Jacqueline Pento  
Tayten Goddard

Mayor Aldo DiCarlo

Phil Roberts, Staff Representative  
Kevin Fox, Recording Secretary

**ABSENT**

Linden Crain (Regrets)  
Alessia Favrin (Regrets)  
Audrey Erickson  
Thomas Catherwood

**1.0 CALL TO ORDER**

The Chair called the meeting to order at 5:00 p.m.

**2.0 DISCLOSURE OF PECUNIARY INTEREST & GENERAL NATURE THEREOF**

There were no disclosures of pecuniary interest noted.

**3.0 ADOPTION OF PUBLISHED AGENDA**

**Moved By** B. O'Rourke-Caton

**Seconded By** P. Trealout

**That the agenda BE ADOPTED as presented.**

The Chair put the Motion.

**Motion Carried**

**4.0 ADOPTION OF MINUTES OF PREVIOUS MEETING**

**Moved By** A. Tronchin

**Seconded By** P. Trealout

**That the minutes of the Mayor's Youth Advisory Committee meeting of September 17, 2019 BE ADOPTED as presented.**

The Chair put the Motion.

**Motion Carried**

**5.0 ORDER OF BUSINESS**

**5.1 Emergency Services Staff Introductions**

*Emergency Services staff provided an overview of their organizations role and responsibilities and information on potential areas of interest for youth with regards to programming, co-op and vocational opportunities.*

**5.1.1 Chief Bruce Montone, Amherstburg Fire Service**

**5.1.2 Constable Fred Adair, Windsor Police Service**

**5.1.3 Deputy Chief Justin Lammers, Essex-Windsor EMS**

**5.2 Mayor's Youth Advisory Committee Conflict of Interest Training – Kevin Fox, Policy and Committee Coordinator**

**5.3 Discussion of Mayor's Youth Advisory Committee Issues, Goals and Objectives**

*The Mayor's Youth Advisory Committee discussed items of interest including the following items; recreational programming (athlete training regimens/clinics, life skills development, crafts/maker-space/robotics, and e-sports/animation opportunities), facilities and parks usage (Libro Centre, Health and Wellness Community Hub, Purdy Park, Skate Park, etc.), environmental concerns (litter abatement) and the need for a communication strategy.*

**Moved By** A. Tronchin  
**Seconded By** B. O'Rourke-Caton

**That the manager of Parks BE INVITED to provide an overview of the parks amenities in the Town and the Parks Master Plan.**

The Chair put the Motion.

**Motion Carried**

**6.0 UNFINISHED BUSINESS**

None noted.

**7.0 NEW BUSINESS**

None noted.

**8.0 NEXT MEETING**

The next meeting of the Mayor's Youth Advisory Committee is November 28, 2019 at 5:00 p.m.

**9.0 ADJOURNMENT**

**Moved By** B. O'Rourke-Caton  
**Seconded By** P. Trealout

**That the meeting adjourn at 6:44 p.m.**

The Chair put the Motion.

**Motion Carried**

---

**Committee Chair  
Hannah Rusenstrom**

---

**Committee Coordinator  
Kevin Fox**



**TOWN OF AMHERSTBURG  
AMHERSTBURG ACCESSIBILITY ADVISORY COMMITTEE  
MEETING**

**Tuesday, October 22, 2019  
5:00 PM**

Board Room, Town Hall 271 Sandwich Street South  
Amherstburg, ON, N9V 2A5

**MINUTES**

**PRESENT**

William Whittall, Chair  
Shirley Curson-Prue, Vice Chair  
Councillor Marc Renaud  
Angela Kelly  
Christine Easterbrook  
Chris Drew  
Tony Pietrangelo

Phil Roberts, Director of Parks, Facilities, Recreation and  
Culture  
Sabrina Bilyk, Human Resources/Health and Safety  
Coordinator  
Kevin Fox, Recording Secretary

**ABSENT**

Robert MacMillan (Regrets)

---

**1.0 CALL TO ORDER**

The Chair called the meeting to order at 5:05 p.m.



**2.0 DISCLOSURE OF PECUNIARY INTEREST & GENERAL NATURE THEREOF**

There were no disclosures of pecuniary interest noted.

**3.0 ADOPTION OF PUBLISHED AGENDA**

**Moved By** C. Drew

**Seconded By** T. Pietrangelo

**That the agenda BE ADOPTED as presented.**

The Chair put the Motion.

**Motion Carried**

**4.0 ADOPTION OF MINUTES OF PREVIOUS MEETING**

**Moved By** C. Drew

**Seconded By** A. Kelly

**That the minutes of the Amherstburg Accessibility Advisory Committee meeting of September 19, 2019 BE ADOPTED as presented.**

The Chair put the Motion.

**Motion Carried**

**5.0 PRESENTATION**

**5.1 Individual Accommodation Plan (IAP) Procedure – Sabrina Bilyk, Human Resources/Health and Safety Coordinator**

**Moved By** C. Drew

**Seconded By** Councillor Renaud

**That the presentation BE RECEIVED.**

The Chair put the Motion.

**Motion Carried**

**5.2 Health and Wellness Community Hub – Phil Roberts, Director of Parks, Facilities, Recreation and Culture**

*The Director of Parks, Facilities, Recreation and Culture provided an introduction to the Health and Wellness Community Hub location and what may be proposed at that location at a future date. A formal site review will be conducted by the committee at a later date.*

**6.0 ORDER OF BUSINESS**

**6.1 Co-An Park Accessible Picnic Table Funding Request**

**Moved By C. Drew**

**Seconded By C. Easterbrook**

**That the Town of Amherstburg MATCH the Accessibility Committee of the Town of Essex in providing an equal portion of \$5,445.47 for the purchase of 5 accessible picnic tables at Co-An Park.**

The Chair put the Motion.

**Motion Carried**

**6.2 Talking Accessibly – Kevin Fox, Policy and Committee Coordinator**

**Moved By A. Kelly**

**Seconded By C. Drew**

**That Person First Language (PFL) BE ADOPTED as a pilot project at the Accessibility Committee level with further consideration of use in the organization at a later date.**

The Chair put the Motion.

**Motion Carried**

**6.3 Assistive Listening Devices (ALD) for the Libro Centre – Kevin Fox, Policy and Committee Coordinator**

*The Policy and Committee Coordinator in his capacity as an Accessibility Coordinator for the Town of Amherstburg introduced equipment which administration recommends be purchased to address a noted accessibility concern at the Libro Centre. The Assistive Listening Device is the same technology as currently employed at Town Hall to address concerns, although it is designed to be portable and to function for a dozen participants with the ability to add more as needed.*

**Moved By** T. Pietrangelo  
**Seconded By** S. Curson-Prue

**That the discussion of purchasing a portable assistive listening device system BE POSTPONED to the next meeting of the Accessibility Advisory Committee.**

The Chair put the Motion.

**Motion Carried**

**7.0 UNFINISHED BUSINESS**

None noted.

**8.0 NEW BUSINESS**

None noted.

**9.0 NEXT MEETING**

The next meeting of the Amherstburg Accessibility Advisory Committee will be tentatively scheduled for November 22, 2019 at 5:00 p.m. in Community Room A of the Libro Centre.

**10.0 ADJOURNMENT**

**Moved By** C. Drew  
**Seconded By** S. Curson-Prue

**That the meeting adjourn at 6:39 p.m.**

The Chair put the Motion.

**Motion Carried**

---

**Committee Chair**  
**William Whittall**

---

**Committee Coordinator**  
**Kevin Fox**

# TALKING ACCESSIBLY

ACCESSIBLE LANGUAGE AND THE  
CREATION OF EQUALITY IN  
COMMUNICATION

# PERSON FIRST LANGUAGE (PFL)

- **What is it?**
  - Person first language is a linguistic prescription that recommends that people place the emphasis on the person before the diagnosis, describing what a person has, rather than what a person is.
- **Why is it important?**
  - By carefully constructing language to avoid marginalization or dehumanization, language becomes more egalitarian and treats everyone with the dignity and respect they deserve as a person.

# HOW TO USE IT

- **Avoid using labels or adjectives to define a person.**
  - Instead of saying a diabetic, use the term a person with diabetes. Instead of saying an alcoholic, say a person with alcoholism.
- **Intention**
  - The intention is that a person is seen foremost as a person and only secondly as a person with some trait.



# People First Language

Person with a disability

Person without a disability

Person with an intellectual, cognitive, developmental disability

Person with an emotional or behavioural disability, person with a mental health or psychiatric disability

Person who is blind/visually impaired

Person who has a communication disorder, is unable to speak, or uses a device to speak

Person who uses a wheelchair

Person with a physical disability

Person with epilepsy or seizure disorder

Person with multiple sclerosis

Person with cerebral palsy

Accessible parking or accessible bathroom

# COMPETING MODELS, ALTERNATIVE VIEWS

- **In deaf culture, a person-first language has long been rejected. Instead, deaf culture uses deaf-first language since being culturally deaf is a source of positive identity and pride.**

## Suggested Terms

- Deaf person
- Hard of hearing person

## Terms that are Not Acceptable

- Hearing impaired, as it focuses on the negative connotation of what a person cannot do.

# COMPETING MODELS, ALTERNATIVE VIEWS

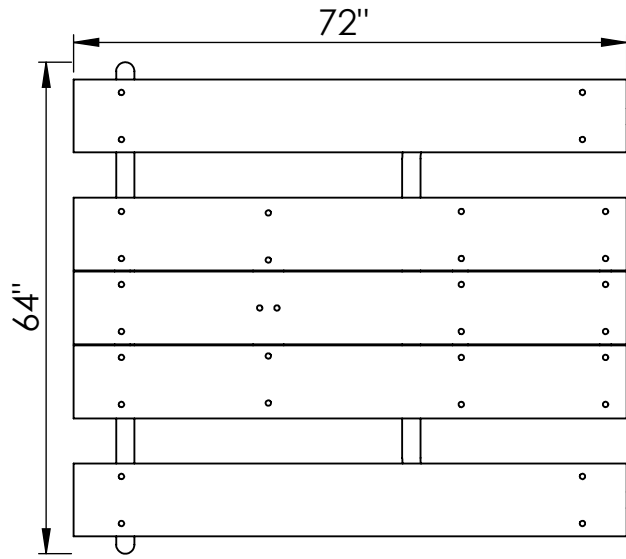
## **Identity-first language:**

- **Some individuals and groups prefer an approach which places the identifying condition before the personal term. For example; a person with autism would be an autistic person under the identity-first language model.**

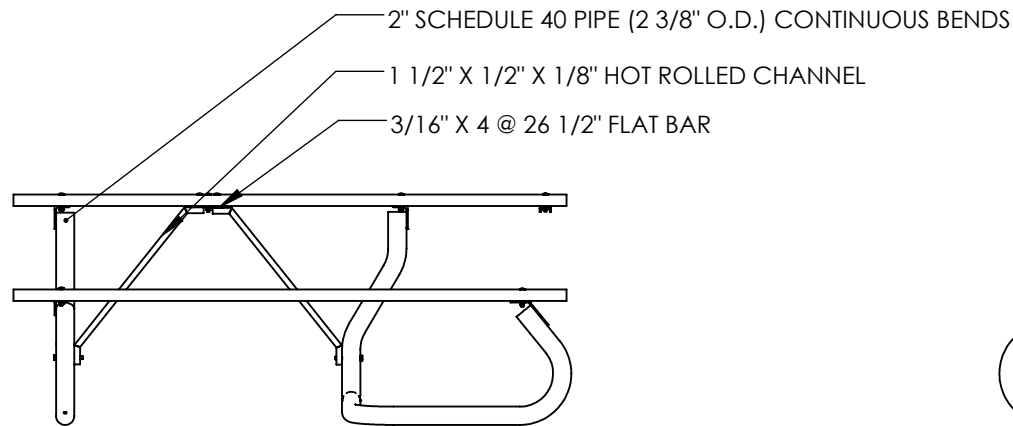
# AMHERSTBURG ACCESSIBILITY ADVISORY COMMITTEE

**It is difficult, if not impossible, to know what to say in every situation, and to anticipate personal preference. Should an individual or group indicate a preference, it is respectful to defer to that usage.**

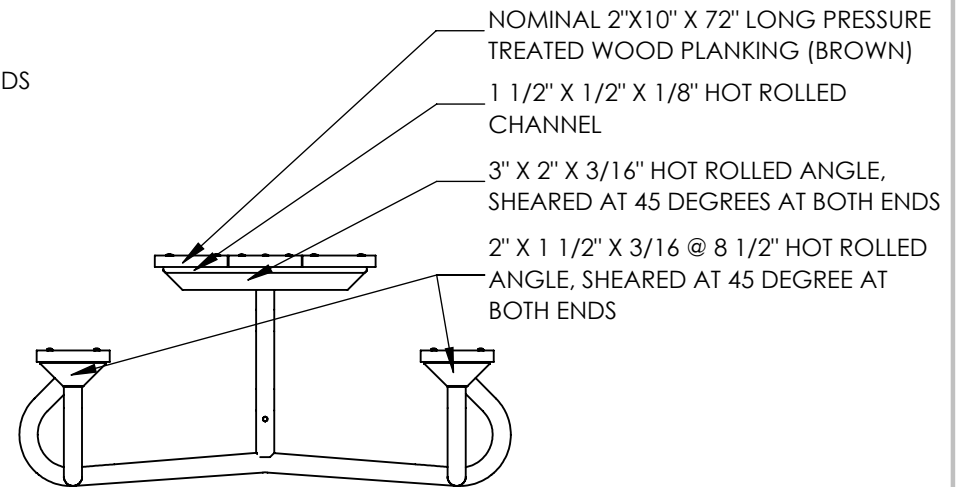
**For the purposes of the AAAC we will use the person-first language as a pilot project.**



TOP VIEW



SIDE VIEW



FRONT VIEW

**W.H. REYNOLDS**  
[www.bleacherguys.com](http://www.bleacherguys.com)  
**1-888-653-9721**

**PROPRIETARY AND CONFIDENTIAL**  
 THE INFORMATION CONTAINED IN THIS DRAWING IS THE SOLE  
 PROPERTY OF W.H. REYNOLDS (CAMBRIDGE) LTD. ANY  
 REPRODUCTION IN PART OR AS A WHOLE WITHOUT WRITTEN  
 PERMISSION OF W.H. REYNOLDS (CAMBRIDGE) LTD IS PROHIBITED.

MODEL: LT6-BF-PT		
	NAME	DATE
DRAWN	EL	10/06/2015
CHECKED		
ENG APPR.		

TITLE: 6FT ACCESSIBLE PICNIC TABLE WITH PRESSURE TREATED WOOD PLANKING		
LOCATION:		NO.
SCALE: N.T.S.	DO NOT SCALE DRAWING	SHEET 1 OF 1



**TOWN OF AMHERSTBURG  
DRAINAGE BOARD  
Tuesday, November 5, 2019  
6:00 PM**

Council Chambers, 271 Sandwich Street South, Amherstburg

---

**MINUTES**

---

**PRESENT**

Bob Bezaire, Chair  
Allan Major, Vice-Chair  
Brad Laramie  
Bob Pillon  
Anthony Campigotto  
Shane McVitty, Drainage Superintendent &  
Engineering Coordinator  
Gwen Greenaway, Recording Secretary  
Kevin Fox, Policy and Committee Coordinator

**ABSENT**

None

**CALL TO ORDER**

Bob Bezaire called the meeting to order at 6:00 p.m.

**DISCLOSURE OF PECUNIARY INTEREST & GENERAL NATURE THEREOF**

There were none.

### **3. MINUTES OF PREVIOUS MEETING**

Bob Pillon moved, Allan Major seconded;

**That the minutes of the previous meeting BE ADOPTED:**

#### **1. Drainage Board Meeting Minutes – September 3, 2019**

**Motion Carried**

### **4. ORDER OF BUSINESS**

#### **4.1 Consideration of Final Drainage Report – New Access Culvert on the Dupuis Drain for Bastien**

Josh Warner, P.Eng., of R. Dobbin Engineering, provided the Board members with an overview of the project. He indicated that his report has been completed under Section 78 of the Drainage Act in response to a request from a landowner for a new farm culvert in the Dupuis Drain. The landowner has indicated that he would like to have the drain enclosed across the entire length of his property. Additionally, the report extends the new drain enclosure culvert in order to replace the existing farm access bridge located immediately downstream of the proposed enclosure. This extension will provide access across the drain for the farm lands to the north. Mr. Warner indicated that the work has been assessed to both of the abutting landowners and to the lands upstream. Each landowner abutting the new culvert is assessed 50% of the cost to provide an access having a 6.0 metre wide top. The remaining 50% for the standard, 6.0m wide topwidth, is assessed to the upstream lands as an outlet assessment. All additional costs relating to the enclosure beyond the costs to provide the standard access is assessed to the Bastien lands as a benefit assessment. The total cost of the project, including construction, engineering, and allowances, is estimated at \$103,690.00.

The Chair invited the audience members to speak.

The Board heard from:



- **Ed Monforton**

Mr. Monforton indicated that his 25 acre farm does not drain into the Dupuis Drain. He added that the Dupuis Drain is shallow, and has tiled his farm to westerly. He provided the engineer with tile maps to support his assertion.

Mr. Monforton also questioned who is paying to enclose the drain through the Bastien farm.

Mr. Warner received the tile maps and indicated that he would review same and offer his findings at the Court of Revision. Any changes to assessments as a result of his review could be handled by the Court.

Mr. Warner clarified that all additional costs to enclose the drain, beyond the costs to provide a standard access bridge, is assessed to the Bastien lands.

- **Peter Kosyk**

Mr. Kosyk spoke on behalf of his parents who are assessed as upstream landowners. He indicated that he was not happy with the project costs and did not feel that the project provided any benefit to his parents lands. He indicated that there is a disproportion of costs and questioned how the assessments could be varied. He also questioned how the values were calculated and whether or not a land survey was completed to verify the lands in the watershed. He indicated that his parents lands drain into three different drains and wondered how these were assessed.

Mr. Warner indicated that assessment and watershed disputes are issues that are dealt with at the Court of Revision. He explained that there are two benefitting properties that are getting new accesses. The landowners of these properties are paying 50% of the costs to provide a standard bridge having a 6m-wide driveable top. The remaining 50% for both accesses is assessed to the upstream lands as outlet assessments based on their equivalent acreage. The remaining costs for the enclosure are assessed to the abutting Bastien farm as a benefit. He added that he believes that the assessments are fair.

Mr. Warner indicated that he did not survey the watershed lands. He used the existing drainage reports for the Dupuis, as well as those of the neighbouring drains (Hamel Drain, 3<sup>rd</sup> Concession Drain) to determine the

limits of the watershed. If additional land surveying is needed, he would require instruction to do so since the associated costs would be assessed to the drain. He added that there is a process through the Drainage Act for moving lands from one watershed to another. A request from the landowner to have a reassessment completed by an engineer is needed, and the associated costs are paid by that landowner.

Bob Bezaire indicated that the engineer can be directed to go back and complete additional surveys, but the survey costs would get re-assessed and distributed to the landowners. He added that removal of lands from the watershed will increase the costs to the other lands. He suggested that reviewing the available tile maps and reporting the findings back to the Court of Revision would be more economical.

- **Loris Colovino**

Mr. Colovino questioned the watershed that comes off of each property and wondered what the flows from his property would be should he want to redirect his water. He also questioned the process that would need to be followed should he want to enclose a section of a drain.

Mr. McVitty indicated that the redirection of water to a different watershed would require a separate engineering report. Engineering analysis would be required to verify that the receiving drains would be hydraulically capable of managing the additional flows. Enclosure of a drain would require an engineer's report as well.

- **John-Paul Bezaire**

Mr. Bezaire indicated that his access bridge is being replaced under the report. He wondered if the new bridge would be separated from the Bastien enclosure, or attached at the property line.

Mr. Warner indicated that the enclosure will be extended into the Bezaire property and his new access will be attached to the enclosure.

The Chair invited the members of the Board to speak.

Board Member Bob Pillon questioned whether the engineer walked the drain. Mr. Warner indicated that he walked the portion of the drain that is being proposed for enclosure. Mr. Pillon expressed that he was upset with this, and felt that Mr. Warner should have looked into Mr. Monforton's tiling further. He added

that engineers rely too heavily on old reports, but still charge high engineering fees. He added that if Mr. Monforton isn't draining into the Dupuis Drain, he shouldn't have to pay.

Board Member Brad Laramie asked if upstream lands are being charged for the added enclosure portion. Mr. Warner answered that they were not. Mr. Laramie questioned the upstream limit of the drain, and speculated that it extended further south. Mr. Warner reiterated that he used the previous reports to establish the limits of the drain and watershed.

Mr. McVitty indicated that the limits of the drain are established under by-law and the engineer was not instructed to review the upstream extent of the drain. Any sections that appear to extend beyond the bylaw limits are not part of the drain. It was not within Mr. Warner's scope of work to investigate or recommend changes to the upstream end of the drain.

Board Member Anthony Campigotto questioned whether there were any topographical surveys performed since 1961 when the last report was done.

Board Member Brad Laramie suggested that if there are additional lands upstream (Bastien lands) that are part of the watershed, the other assessments would be reduced. Mr. McVitty added that if these properties are added under this report, the other neighbouring drains would not be updated until such time that engineering reports are completed for said drains. In the meantime, notes would be added to their respective files to alert the engineer of the watershed changes in the future.

Bob Pillon moved, Brad Laramie seconded;

- 1. The engineer BE DIRECETED to review available tile maps to investigate the upstream watershed prior to the Court of Revision;**

**Motion Carried**

Bob Pillon moved, Brad Laramie seconded;

That:

1. **The engineer's report, prepared by R. Dobbin Engineering on September 24, 2019 for the New Access Culvert on the Dupuis Drain for Bastien BE RECEIVED;**
2. **The engineer's report for the New Access Culvert on the Dupuis Drain for Bastien BE CONSIDERED;**
3. **The PROVISIONAL ADOPTION of By-law 2019-093 of the engineer's report for the New Access Culvert on the Dupuis Drain for Bastien BE BROUGHT to the next Regular Council meeting for Council's consideration; and,**
4. **Administration BE DIRECTED to schedule the Court of Revision for the New Access Culvert on the Dupuis Drain for Bastien.**

**Motion Carried**

#### **4.2 Consideration of Final Drainage Report – John Parks No.1**

Mike Gerrits, P.Eng., of R. Dobbin Engineering, provided the Board members with an overview of the project. Mr. Gerrits indicated that his report has been completed under S.78 of the Drainage Act in response to concerns raised by the Town of Amherstburg relating to culvert failures at the downstream end of the drain. He added that the CSP drain culvert has collapsed, and additional sink holes have developed since he was originally instructed. Mr. Gerrits indicated that his report deals with the enclosure portion of the drain that outlets into the Detroit River. His report also incorporates a section of enclosure pipe that was previously installed without benefit of an engineering report or municipal bylaw. Mr. Gerrit's report addresses this section of the enclosure, and formally makes it part of the John Parks No.1 Drain.

Mr. Gerrits proceeded to describe the existing drain and enclosure arrangement. He provided an overview of the existing arch pipe that was installed privately, and the extensive correspondence between the landowners and the Town between 1997 and 2000. He reiterated that this pipe has never been a legal part of the drain, and emphasized that the landowners were made aware of this through the correspondence that was provided to them over the years.

Mr. Gerrits indicated that minor amendments to the report are required to satisfy concerns that were raised by the Essex Region Conservation Authority (ERCA). He also indicated that he has prepared a letter to address these concerns and report amendments. He recommended that this letter be brought forward to the Board for their consideration.

Mr. Gerrits presented his design recommendations. He indicated that the flow through the proposed drainage system is governed by the levels of the Detroit River and suggested that a pump would be the only way to eliminate the river effects. Mr. Gerrits added that pumped systems are expensive to install and operate, and have not been recommended under his report. Mr. Gerrits explained that his report also provides a new maintenance schedule that can be used in the future to assess the costs of maintenance work on the proposed new enclosure, the existing arch culvert, along with the upstream drain and existing access culverts.

Mr. Gerrits presented his assessment rationale according to his report. The assessment of each section of the proposed new enclosure was described by Mr. Gerrits. Mr. Gerrits also explained the allowances that his report recommends under Section 30 and 31 of the Drainage Act.

The Chair invited the audience members to speak.

- **Gina and Frank Storino**

Ms. Storino indicated that she is assessed for \$66,000.00 and that the proposed works run through her three properties. Ms. Storino strongly feels that she is being over-assessed. She added that the drain was covered when they purchased the property in 1978 from the Amherstburg Quarry. Ms. Storino indicated that they have tried their best to maintain the drain over the years, but feels that the Town has neglected it. She added that a neighbor has trenched a tile into the drain. Ms. Storino also questioned the condition of the culvert pipe and suggested that the culvert is not damaged beneath her driveway, but only in the areas that are clearly failing. Ms. Storino questioned whether or not the engineer looked inside the culvert pipe. Mr. Storino added that the road and salting has ruined the pipe.

Mr. Gerrits indicated that the Town normally maintains its drains reactively when landowners request maintenance. He added that, to his knowledge,

maintenance of the enclosure pipe has not been requested. Mr. Gerrits also spoke to the condition of the existing pipe. He indicated that the CSP culvert is over 43 years old and is visibly failing in numerous locations. Mr. Gerrits offered that the MTO suggests that 16 gauge CSP pipe only has a lifespan of 25-35 years, while most suppliers may give them 50 years under ideal conditions. Due to the high river levels, it was impossible for him to inspect the interior of the culvert pipe, though he did attempt to have it camera run through. Nonetheless, given the pipe age, failures, river effects, and roadway salting, Mr. Gerrits professional opinion is that the entire length of the culvert pipe should be replaced. Mike added that the Road Authority (County of Essex) is heavily assessed to account for the benefit that the roadway derives from the enclosure and to account for the effects that the roadway has on the culvert.

Mr. Gerrits indicated that the enclosure pipe was present when the Storino's purchased the property. He added that the purchase of the property carries with it a responsibility to the existing enclosure. He indicated that this is typical for properties that abut municipal drains that are enclosed.

Mr. Storino indicated that Lou Zarlenga and Bob Crawford (formerly working for the Township of Malden) approved and inspected the installation of the arch culvert. Ms. Storino added that Council approved the culvert installation.

Mr. Gerrits reiterated that this section of the enclosure, installed in 2000, is not part of the drain, but is private. An engineer report or bylaw was never completed to address this section of the enclosure. Mr. Gerrits added that he is obligated to work under the provisions of the Drainage Act, and he has made the necessary recommendations to adopt the enclosure as part of the drain under his report. He emphasized that there will be no construction work on this section of the enclosure.

- **David Goodchild**

Mr. Goodchild, (Parcel 55, Roll No. 600-02200 on the watershed map) indicated that he is assessed \$323.00, but questioned whether his water enters the drain. He added that he has installed private tiles around the perimeter of his property and has drilled an outlet tile across Front Road to the River. He also indicated that water stands in his back yard and never reaches the John Parks No.1 Drain.

- **Mark Pillon**

Mr. Pillon agreed with Mr. Goodchild, and indicated that the back of his lot also floods. He questioned what he can do to solve this problem.

Mr. Gerrits addressed Mr. Goodchild's and Mr. Pillon's concerns. He indicated that his firm surveyed the limits of the watershed and verified the catchment areas. He added that his survey confirms that both properties are within the catchment area of the drain and he is comfortable with these findings. He also indicated that he personally walked parts of the drain to confirm the catchment. Previous drainage reports were also used to confirm the catchment. Mr. Gerrits suggested to Mr. Pillon that he could petition the Town for a new municipal drain to be established to drain the back of his lot to the John Parks Drain No.1. He added that this would be costly, and there is a process involved.

The Chair invited the members of the Board to speak.

Board Member Allan Major questioned whether upstream flooding was being caused by blocked tiles downstream.

Mr. Gerrits indicated that he didn't believe so.

Board Member Brad Laramie questioned whether the drain can be opened where the enclosure presently exists.

Mr. Gerrits questioned whether an open drain would be desirable to the adjacent landowners. He also indicated that there is likely not enough space between existing structures to accommodate an open drain and maintenance corridor. Existing utilities would also pose a problem to an open drain.

Mr. Storino suggested that a pipe sleeve could be installed through the existing pipe rather than fully replacing it. Ms. Storino requested that more options be provided that would be less costly, and consider only fixing the sections that are broken.

Mr. Gerrits responded by saying that a sleeve is prohibitive due to the alignment and overall condition of the existing pipe. He added that his report offers a complete solution to the drainage problem and not a Band-Aid fix. Replacing sections of the 43 year old enclosure pipe would merely push the problem down the road, and would not even be practical during construction, suggesting that the



contractor would be chasing the deteriorated pipe. He added that his report provides recommendations for improvement but the decision will ultimately be up to Council.

Board Member Bob Pillon questioned the age of the pipe that was privately installed by the Storino's.

Mr. Gerrits indicated that the pipe was installed in 2000.

Prior to moving through the recommended motions, Mr. McVitty suggested that additional motions be considered by the Drainage Board to address the letter provided by the engineer relating to ERCA concerns.

Anthony Campigotto moved, Allan Major seconded;

- 1. The engineer's letter, prepared by R. Dobbin Engineering on October 29, 2019 for the Report Revisions Recommended for the November 5, 2019 Meeting to Consider the Report, BE RECEIVED;**
- 2. The amendments recommended under the engineer's letter, prepared by R. Dobbin Engineering on October 29, 2019 for the Report Revisions Recommended for the November 5, 2019 Meeting to Consider the Report, BE ACCEPTED as part of the engineer's report for the John Parks Drain No. 1;**
- 3. Administration BE DIRECTED to include the engineer's letter, prepared by R. Dobbin Engineering on October 29, 2019 for the Report Revisions Recommended for the November 5, 2019 Meeting to Consider the Report, in the notice of the Court of Revision to be sent to all affected landowners and all parties as required under the provisions of the Drainage Act.**

**Motion Carried**

Anthony Campigotto moved, Allan Major seconded;

That:

1. **The engineer's report, prepared by R. Dobbin Engineering on October 18, 2019 for the John Parks Drain No. 1 Improvements BE RECEIVED;**
2. **The engineer's report for the John Parks Drain No. 1 Improvements BE CONSIDERED;**
3. **The PROVISIONAL ADOPTION of By-law 2019-095 of the engineer's report for the John Parks Drain No. 1 Improvements BE BROUGHT to the next Regular Council meeting for Council's consideration; and,**
4. **Administration BE DIRECTED to schedule the Court of Revision for the John Parks Drain No. 1 Improvements.**

**Motion Carried**

Following additional questions from the audience relating to the John Parks Drain No. 1, the following motion was moved by Bob Pillon, seconded by Brad Laramie;

That:

1. **Discussions on the John Parks Drain No. 1 to review possible options for consideration by the engineer BE RE-OPENED to the Board and members of the audience and to RECONSIDER the previous motions.**

**Motion Carried**

Ms. Storino requested that additional options be explored that would be less expensive.

Board Member Bob Pillon indicated that, in his opinion, the Drainage Board does not have the right to make amendments to the engineer's report. He suggested to Ms. Storino that she could appeal to Council and appear as a delegate when the bylaw is scheduled to be passed. He added that the Board does not have the authority to offer cheaper solutions, though Council may.

Mr. McVitty indicated that the Drainage Board is in place to make recommendations to Council. Bringing the issue directly to Council may not be a good avenue to take since Council has not been a part of this meeting. The

Drainage Board does have the authority to send the report back to the engineer to review options and costs should they feel that it is necessary. If landowners are not satisfied with the decisions made by the Board, Council or the Court of Revision, they have the option to appeal to the Drainage Tribunal.

Mr. Gerrits acknowledged that the Storino's are being heavily assessed, but not unfairly assessed. He indicated that enclosure projects usually carry with them high assessments to lands abutting the enclosures. He added that the spot repair and open drain options are not practical for reasons previously stated. Mr. Gerrits indicated that cheaper options will be difficult to find and that he doesn't know of any cheaper options with which he would be satisfied.

Board Member Bob Pillon indicated that any time a drain is repaired it shouldn't be completed piece-meal or in small, isolated sections. He added that he felt that the Board has given the matter good consideration, but believes that the engineer has done his job under the Drainage Act.

Board Chair Bob Bezaire indicated that all sides have been heard, and re-opened the motions.

Bob Pillon moved, Anthony Campigotto seconded;

That:

1. **The engineer's report, prepared by R. Dobbin Engineering on October 18, 2019 for the John Parks Drain No. 1 Improvements BE RECEIVED;**
2. **The engineer's report for the John Parks Drain No. 1 Improvements BE CONSIDERED;**
3. **The PROVISIONAL ADOPTION of By-law 2019-095 of the engineer's report for the John Parks Drain No. 1 Improvements BE BROUGHT to the next Regular Council meeting for Council's consideration; and,**
4. **Administration BE DIRECTED to schedule the Court of Revision for the John Parks Drain No. 1 Improvements.**

**Motion Carried**

#### 4.3 Engineering Appointment – John Parks Drain No. 2

Shane McVitty, Drainage Superintendent and Engineering Coordinator, P.Eng., provided the Board members with a brief overview of the project. He indicated that a request for drainage improvement was received for the John Parks Drain No. 2. He added that the enclosure portion of the drain, located at the downstream end, is failing and is in need of replacement. Administration is recommending the appointment of R. Dobbin Engineering Inc. to complete the necessary work to complete a drainage report to address the repair of the failing drain enclosure.

Bob Pillon moved; Anthony Campigotto seconded;

That:

1. **The report from the Drainage Superintendent and Engineering Coordinator dated October 21, 2019, regarding the John Parks Drain No.2 – Engineering Appointment BE RECEIVED; and,**
2. **The Drainage Board recommend that Council ACCEPT the request from Peter Crump for the repair and improvement of the John Parks Drain No.2 per Section 78 of the Drainage Act; and,**
3. **The Drainage Board recommend that the appointment of the firm of R. Dobbin Engineering Inc. for the repair and improvement to the John Parks Drain No.2 BE APPROVED by Council.**

**Motion Carried**

#### 4.4 Subsequent Connection – Tremblay Drain (Lepera Section 65)

Mr. McVitty advised the Board members that the proposed development at 7751 Howard Avenue has requested that an engineer complete the required reapportionments to accommodate additional stormwater discharge into the Tremblay Drain. To that end, a subsequent connection report has been completed by Gerard Rood, P.Eng., according to Section 65(3) of the Drainage Act.

As part of his work, Mr. Rood has submitted the subject engineering report that addresses the subsequent connection and provides an assessment of costs to

the subject lands into the Tremblay Drain. Mr. Rood's report also considers the nature and extent of the land usage being proposed in his assessment rationale. In the future, when works of maintenance are performed on the Tremblay Drain, these adjusted assessment values will be applied to ensure that associated maintenance costs are fairly and accurately assessed.

The Chair asked if any of the Board members had any questions.

There were none.

Allan Major moved, Brad Laramie seconded;

That:

1. **The report from the Drainage Superintendent and Engineering Coordinator dated October 22, 2019, regarding the Subsequent Connection – Tremblay Drain (Lepera Section 65) BE RECEIVED;**
2. **The engineer's report, prepared by Rood Engineering Inc. on October 2, 2019, for the Tremblay Drain (Lepera Section 65) BE RECEIVED;**
3. **The assessment adjustments as listed in the engineering report prepared by Rood Engineering Inc. BE APPROVED, and;**
4. **Administration BRING FORWARD the Drainage Board's recommendation to approve the assessment adjustments at a future Regular Council Meeting.**

**Motion Carried**

**7. NEXT MEETING DATE**

Thursday, November 7, 2019 @ 6:00 p.m.

**8. ADJOURNMENT**

Anthony Campigotto moved, Allan Major seconded;

That:

**The meeting of the Drainage Board be ADJOURNED;**

**Motion Carried**

The meeting adjourned at 7:30 p.m.

\_\_\_\_\_  
Chair – Bob Bezaire

\_\_\_\_\_  
Staff Liaison – Shane McVitty

September 24, 2019

The Mayor and Council  
Town of Amherstburg  
271 Sandwich Street South  
Amherstburg, Ontario  
N9V 2A5

Gentlemen and Mesdames:

**Re: Access Culvert on the Dupuis Drain**

As instructed, I have undertaken an examination of the Dupuis Drain with regards to the replacement of two culverts with a single culvert. The proposed culvert addressed in this report will be located in Pt. of the S ½ and the Cntr. Pt. of Lot 14, Concession 3 (Roll No. 490-03800 and 490-03900) in the Town of Amherstburg (former Geographic Township of Anderdon).

Authorization under the Drainage Act

This Engineers Report has been prepared under Section 78 of the Drainage Act as per the request of an affected Landowner.

Section 78 of the Drainage Act states that, where, for the better use, maintenance or repair of any drainage works constructed under a bylaw passed under this Act, or of lands or roads, it is considered expedient to change the course of the drainage works, or to make a new outlet for the whole or any part of the drainage works, or to construct a tile drain under the bed of the whole or any part of the drainage works as ancillary thereto, or to construct, reconstruct or extend embankments, walls, dykes, dams, reservoirs, bridges, pumping stations, or other protective works as ancillary to the drainage works, or to otherwise improve, extend to an outlet or alter the drainage works or to cover the whole or any part of it, or to consolidate two or more drainage works, the Council whose duty it is to maintain and repair the drainage works or any part thereof may, without a petition required under Section 4 but on the report of an Engineer appointed by it, undertake and complete the drainage works as set forth in such report.

Existing Drainage

The existing drainage works consists of an approximately 1,510 metres of open channel that outlets into the River Canard Drain in Lot 6, Concession 1 Petite Cote in the Town of



Lasalle. The drain then heads southeasterly to the southeast corner of the intersection of North Townline Road and Concession Road 3 North. It then heads east for approximately 450m. It then extends southerly to the center of Lot 13, Concession 3 where it continues as a tile drain southerly for 650m.

The Dupuis Drain was last improved under an Engineer's Report dated February 15, 1995. Under this report, a farm access culvert was extended. Under an Engineer's Report dated October 14, 1980 the Dupuis Drain was deepened and two access culverts were lowered. Under an Engineer's Report dated August 29, 1968 the upper end of the Dupuis Drain was enclosed and the lower portion of the drain was cleaned. Under an Engineer's Report dated November 23, 1961 the Dupuis Drain was incorporated and allowances were paid for existing culverts.

#### Drain Classification

The Dupuis Drain is currently classified as a class "F" drain along its length according to the Ontario Ministry of Agriculture, Food and Rural Affairs Agricultural Information Atlas.

Class "F" drains are intermittent or ephemeral (dry for more than two consecutive months). Authorization is not required if work is done in the dry.

The proposed work will have very little effect on the drainage works if carried out during low flows in the channel. The work area is to be maintained in a dry condition during construction by the Contractor.

The Department of Fisheries and Oceans Canada (DFO) has reviewed the proposed work and has sent an email stating that an authorization under the Fisheries Act or a permit under the Species at Risk Act is not required.

The Essex Region Conservation Authority (ERCA) was contacted via an email dated December 11, 2018 to inform them of the project. Written confirmation from the ERCA was requested with respect to their intention to proceed or waive the right to an environmental appraisal. The ERCA has yet to confirm if an environmental appraisal is required on this project. Construction shall not commence without ERCA approval.

#### Onsite Meeting

An onsite meeting was held on March 7, 2019 to discuss the proposed enclosure of the Dupuis Drain on Pt. S ½ of Lot 14, Concession 3 (Roll Number 490-03800). The following were present:

- Josh Warner (Engineer, R. Dobbin Engineering)
- Mike Gerrits (Engineer, R. Dobbin Engineering)
- Shane McVitty (Drainage Superintendent, Town of Amherstburg)
- Mark Fishleigh (County of Essex)
- Loris Collavino (Landowner)
- Mike Collavino (Landowner)
- J.P. Bezaire (Landowner)
- Peter Kosyk (Landowner)
- Ed Monforton (Landowner)

It was discussed that the culvert immediately downstream of the proposed enclosure requires replacement. The enclosure will therefore need to be extended to provide access to the downstream property. It was mentioned that there are existing tiles from the east that are tied into the open channel. These tiles will therefore need to be extended downstream of the proposed enclosure. It was also discussed that preliminary discussions with the ERCA and DFO shall take place before proceeding further in order to minimize costs should the ERCA or DFO have major concerns. Discussion of possible maintenance work downstream of the proposed enclosure also occurred. The Landowners in attendance opted not to have such work take place.

### Discussion

The proposed enclosure was sent to the ERCA and DFO for comment on April 22, 2019.

On May 1, 2019 the ERCA responded in an email regarding the proposed enclosure. The ERCA stated they would consider a proposal that can demonstrate that the enclosure does not adversely impact the existing 1:100 year flood level, increase flooding outside of the drain channel, and that incorporates a conveyance swale for extreme storm events. On May 9, 2019 the ERCA responded regarding a preliminary report and hydraulic analysis stating that they found the report acceptable. Final approval will be required prior to construction.

On June 18, 2019 the DFO responded in an email stating that an authorization under the Fisheries Act or a permit under the Species at Risk Act is not required.

### Recommendations

It is therefore recommended that the following work be carried out:

1. The culverts on Pt. S ½ (Roll No. 490-03800) and the Cntr. Pt. (Roll No. 490-03900) of Lot 14, Concession 3 shall be removed and replaced with a single culvert. The

proposed culvert shall provide access through the entire length of Pt. S ½ (Roll No. 490-03800) and 6m of access into the Cntr. Pt. (Roll No. 490-03900) of Lot 14, Concession 3. The culvert shall be 104m of 1390x970mm dia. CSPA c/w rip rap end walls. As a result of the enclosure the existing tile outlets shall be connected to a header and tied into the open channel downstream of the culvert.

### Design

The proposed Dupuis Drain enclosure has been designed to not adversely impact the existing 1:100 year flood elevation. This has required the culvert be sized to accommodate a 1 in 10 year storm event.

### Estimate of Cost

It is recommended that the work be carried out in accordance with the accompanying Specification of Work and the Profile, which form part of this Report. There has been prepared an Estimate of Cost in the amount of \$103,690.00, including the cost of engineering. Appearances before appeal bodies have not been included in the cost estimate. A Plan has been prepared showing the location of the work and the approximate drainage area.

### Assessment

As per Section 21 of the Drainage Act, the Engineer in his report shall assess for benefit and outlet for each parcel of land and road liable for assessment.

Lands, roads, buildings, utilities, or other structures that are increased in value or are more easily maintained as a result of the construction, improvement, maintenance, or repair of a drainage works may be assessed for benefit. (Section 22)

Lands and roads that use a drainage works as an outlet, or for which, when the drainage works is constructed or improved, an improved outlet is provided either directly or indirectly through the medium of any other drainage works or of a swale, ravine, creek, or watercourse may be assessed for outlet. The assessment for outlet shall be based on the volume and rate of flow of the water artificially caused to flow into the drainage works from the lands and roads liable for such assessments. (Section 23)

The Engineer may assess for special benefit any lands for which special benefits have been provided by the drainage works. (Section 24)

A Schedule of Assessment for lands and roads affected by the work and therefore liable for the cost thereof has been prepared as per the Drainage Act. Any affected public utility or road authority shall be assessed, as per Section 26 of the Drainage Act, any increased costs for the removal or relocation of any of its facilities and plant that may be necessitated by construction or future maintenance and repair work. The cost of any fees for permits or approvals or any extra work required by any affected utility, road authority, conservation authority, ministry, government agency, etc., federal or provincial, shall be assessed to that organization requiring the permit, approval, or extra work.

1. The culvert in Pt. of the S ½ and Cntr. Pt. of Lot 14, Concession 3 has been assessed with 11 metres of the culvert assessed with 50% of the cost applied as benefit assessment to each of the Landowners of the property and the remainder of the cost assessed as an outlet assessment on upstream lands and roads based on equivalent hectares. An 11 metre culvert will provide the standard 6 metre top width. All costs beyond the 22 metres has been assessed as a benefit assessment to the S ½ of Lot 14, Concession 3 (Roll No. 490-03800). Based on the above, the 104m culvert has been assessed with 76% of the cost applied as benefit assessment to the owner of Pt. of the S ½ of Lot 14, Concession 3 (Roll No. 490-03800), 8% of the cost applied as benefit assessment to the owner of Cntr. Pt. of Lot 14, Concession 3 (Roll No. 490-03900) and the remainder of the cost assessed as an outlet assessment on upstream lands and roads based on equivalent hectares.
2. The cost of extending the private sub-surface drains has been assessed to Pt. of the S ½ of Lot 14, Concession 3 (Roll Number 490-03800) as a benefit assessment.

#### Allowances

Under Section 29 of the Drainage Act, the Engineer in their report shall estimate and allow in money to the Owner of any land that it is necessary to use for the construction or improvement of a drainage works or for the disposal of material removed from a drainage works. This shall be considered an allowance for right of way. Section 29 allowances will not be provided since the work includes improving an existing drain.

Under Section 30 of the Drainage Act, the Engineer shall determine the amount to be paid to persons entitled thereto to damage, if any, to ornamental trees, fences, land, and crops occasioned by the disposal of material removed from a drainage works. This shall be considered an allowance for damages. Section 30 allowances will be provided under this report.

Allowances for crop loss are based on \$1,500.00 per hectare for the first year and \$750.00 for the second year (\$2,250.00 per hectare total).

### Access and Working Area

The working area at the culvert shall extend 10 metres from the bank and for 10 metres along the channel on either side of the culvert.

Access for installation of the culvert and also for any future maintenance and repair shall be from Concession Road 4 North and through Pt. S ½ of Lot 14, Concession 14 (Roll No. 490-03800). Access shall generally be restricted to a width of 6 metres.

### Restrictions

No trees and shrubs shall be planted nor shall permanent structures be erected within 10 metres of either side of the proposed drain without prior written permission of Council. If trees are planted that interfere with access for future maintenance of the drainage works, they shall be removed at the expense of the Landowner.

Attention is also drawn to Sections 80 and 82 of the Drainage Act that refers to the obstruction of a drainage works.

### Agricultural Grant

It is recommended that application for subsidy be made for eligible agricultural properties. Any assessments against non agricultural properties are shown separately in the Schedule of Assessment. Eligibility for grant is at the discretion of OMAFRA according to their ADIP policies.

### Maintenance

The portion of the culvert in Pt. of the S ½ of Lot 14, Concession 3 (Roll No. 490-03800) shall generally be maintained and repaired with 90% of the cost assessed to the benefitting property and the remainder assessed to upstream properties based on equivalent hectares.

The portion of the culvert in the Cntr. of Lot 14, Concession 3 (Roll No. 490-03900) shall generally be maintained and repaired with 50% of the cost assessed to the benefitting property and the remainder assessed to upstream properties based on equivalent hectares.

When the culvert proposed under this report is replaced in its entirety it shall be replaced in the same relative proportions as contained in the Schedule of Assessment enclosed with this report unless otherwise altered under provisions of the Drainage Act.

If a Landowner requests an additional length of culvert beyond that specified in this report, the extra cost shall be borne by the Landowner making the request including the future maintenance and repair. Each property is allowed one access culvert for each municipal drain with any second culvert on the property maintained and repaired 100% by the Landowner.

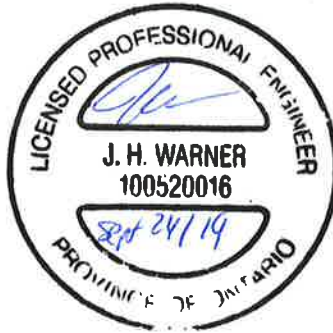
These above conditions will apply unless otherwise altered under the provisions of the Drainage Act.

All of the above is submitted for your consideration.

Yours truly,



Josh Warner, P. Eng.



Access Culvert on the Dupuis Drain  
 Town of Amherstburg  
 September 24, 2019

**ALLOWANCES**

Allowances have been made as per Sections 30 of the Drainage Act for damages to lands and crops.

Conc.	Lot or part	Roll No.	Owner	Section 29	Section 30	Total
3	Pt. S 1/2 Lot 14	490-03800	R. Bastien	-	1,510	1,510
	Cntr Pt. Lot 14	490-03900	J. & S. Bezaire	-	100	100
<b>TOTAL ALLOWANCES</b>				<b>\$0</b>	<b>\$1,610</b>	<b>\$1,610</b>



**Estimate of Cost**

Culvert Installation on the Dupuis Drain.

	<u>Quantity</u>	<u>Unit</u>	<u>Material</u>	<u>Labour</u>	
Clearing and Grubbing	1.0	LS	-	2,000	2,000
Remove Culvert (Roll Number 490-03900)	1.0	LS	-	320	320
Remove Culvert (Roll Number 490-03800)	1.0	LS	-	320	320
Culvert (Roll Number 490-03900 & 490-03800)					
Supply & install 1390x970mm dia. CSPA	104.0	m	43,680	2,560	
Supply & install bedding material	260.0	tonne	5,200	2,560	
Supply and install granular backfill	700.0	tonne	12,600	2,240	
Install Native Backfill	30.0	tonne	-	320	
Supply & install rip rap end protection	25.0	tonne	1,500	640	
			62,980	8,320	71,300
250mm dia. PE Tile c/w Connections	90.0	m	1,620	1,280	2,900
Silt Fence	1.0	LS	300	-	300
					77,140
					3,880
					1,610
					15,060
					540
					3,400
					300
					<b>101,930</b>
					1,760
					<b>\$103,690</b>

**SCHEDULE OF ASSESSMENT**

Conc.	Lot or Part	Affected Acres	Affected Hect.	Roll No.	Owner	Benefit	Outlet	Total
4. Privately Owned Non-Agricultural Lands								
3	SW Pt. Lot 14	4.50	1.82	490-03600	R. Blais	-	581	581
	SE Pt. Lot 14	0.99	0.40	490-04500	R. Blais	-	128	128
						-	709	709
					Total Benefit	-		
					Total Outlet	709		
					Total - Privately Owned Non-Agricultural Lands	709		

Conc.	Lot or Part	Affected Acres	Affected Hect.	Roll No.	Owner	Benefit	Outlet	Total	
5. Privately Owned Agricultural Lands (Eligible for Available Grants)									
3	N 1/2 S 1/2 & SW 1/4 N 1/2 Lot 12	32.12	13.00	490-02200	R. Bastien	-	4,152	4,152	
	SE 1/4 N 1/2 Lot 12	10.21	4.13	490-04800	E. Monforton	-	1,319	1,319	
	N 1/4 Lot 12	22.98	9.30	490-02700	D. & N. Kosyk	-	2,970	2,970	
	SW 1/4 Lot 13	26.76	10.83	490-02800	R. Bastien	-	3,459	3,459	
	SE Pt. Lot 13	3.71	1.50	490-04700	S. Gubica	-	479	479	
	SW Pt. N 1/2 Lot 13	2.00	0.81	490-03000	E., M. & P. Monforton	-	259	259	
	NW Pt. Lot 13	2.42	0.98	490-03010	E. & M. Monforton	-	313	313	
	NE Pt. Lot 13	8.30	3.36	490-04600	H. & S. Gubica	-	1,073	1,073	
	Pt. S 1/2 Lot 14			490-03800	R. Bastien	81,590	-	81,590	
	Cntr Pt. Lot 14			490-03900	J. & S. Bezaire	7,367	-	7,367	
						<u>88,957</u>	<u>14,024</u>	<u>102,981</u>	
					Total Benefit	88,957			
					Total Outlet	<u>14,024</u>			
	Total - Privately Owned Agricultural Lands (Eligible for Available Grants)						102,981		
	Total - Privately Owned Non-Agricultural Lands						<u>709</u>		
					Total Assessment	\$103,690			

Culvert on the Dupuis Drain  
Town of Amherstburg  
September 24, 2019

## SPECIFICATION OF WORK

### **1. Scope of Work**

The work to be included in this specification includes the installation of an access culvert on the Dupuis Drain in Pt. of the S ½ and the Cntr. Pt. of Lot 14, Concession 3 (Roll No. 490-03800 and 490-03900) in the Town of Amherstburg (former Geographic Township of Anderdon).

### **2. General**

Each tenderer must inspect the site prior to submitting their tender and satisfy themselves by personal examination as to the local conditions that may be encountered during this project. The Contractor shall make allowance in the tender for any difficulties which they may encounter. Quantities or any information supplied by the Engineer is not guaranteed and is for reference only.

All work and materials shall be to the satisfaction of the Drainage Superintendent who may vary these specifications as to minor details but in no way decrease the proposed capacity of the drain.

The Contractor shall be responsible for the notification of all utilities prior to the start of construction.

### **3. Plans and Specifications**

These specifications shall apply and be part of the contract along with the General Specifications for Open Drains. This specification of work shall take precedence over all plans and general conditions pertaining to the contract. The Contractor shall provide all labour, equipment, and supervision necessary to complete the work as shown in the plans and described in these specifications. Any work not described in these specifications shall be completed according to the Ontario Provincial Standard Specifications and Standard Drawings.

#### **4. Health and Safety**

The Contractor at all times shall be responsible for health and safety on the worksite including ensuring that all employees wear suitable personal protective equipment including safety boots and hard hats.

The Contractor shall be responsible for traffic control as per the Ontario Traffic Manual Book 7 – Temporary Conditions (latest revision) when working on public road allowances. A copy of a traffic control plan shall be kept on site at all times. The Contractor shall maintain suitable barricades, warning lights, and temporary traffic notices, at his expense, in their proper position to protect the public both day and night. Flagmen are the responsibility of the Contractor when working on the road allowance and when entering or exiting a worksite onto a roadway.

The Contractor shall be responsible to ensure that all procedures are followed under the Occupational Health and Safety Act to ensure that work sites are safe and that accidents are prevented. In the event of a serious or recurring problem, a notice of noncompliance will be issued. The Contractor will be responsible for reacting immediately to any deficiency and correcting any potential health and safety risk. Continuous disregard for any requirement of the Occupational Health and Safety Act could be cause for the issuance of a stop work order or even termination of the contract.

They shall also ensure that only competent workmen are employed onsite and that appropriate training and certification is supplied to all employees.

#### **5. Workplace Safety and Insurance Board**

Upon award of the contract and prior to commencement of work, the Contractor shall furnish the Town of Amherstburg with a satisfactory Certificate of Insurance (COI) containing the information below, for the period of the execution of the work:

- i. A Commercial General Liability (CGL) policy that shall be not less than 5 million dollars per occurrence.
- ii. The CGL policy shall include bodily injury including death, personal injury, property damage, tenants legal liability, non-owned automobile and contain a cross liability/severability of interest clause. The certificate must also include acknowledgement that coverage under the policy specifically extends to the works in question. The COI shall name the Town of Amherstburg and R. Dobbin Engineering Inc. as additional insured to the policy.

- iii. The CGL policy shall not contain any exclusion or limitation in respect to shoring, underpinning, raising or demolition of any building or structure, pile driving, caisson work, collapse of any structure or subsidence of any property, structure or land from any cause.
- iv. The Contractor shall note that where construction works are performed within lands owned by the County of Essex or Ministry of Transportation the CGL policy shall also name the County of Essex and/or the Ministry of Transportation as additional insured to the policy.
- v. The liability insurance shall be endorsed to provide that the policy shall not be altered, cancelled or allowed to lapse without 30 days prior written notice to the Town of Amherstburg.

## **6. MNRF Drain Registration**

The Contractor is advised that the Town of Amherstburg has conducted an "Endangered Species Act Review" and has registered it's drainage activities with the Ministry of Natural Resources and Forestry.

The Town of Amherstburg, in pursuant to the Endangered Species Act Municipal Agreement, has identified the potential presence of certain species within the project area. It is the responsibility of the Contractor to make certain that necessary provisions are undertaken to ensure the protection of all species at risk and their habitats throughout the course of construction. It is also the responsibility of the Contractor to make itself familiar with the following documents:

1. Town of Amherstburg – Complete Mitigation Documents
2. Town of Amherstburg - Additional Mitigation Measures for Snakes Species
3. Town of Amherstburg - Additional Mitigation Measures for Turtle Species
4. Snakes of Ontario Identifier Guide
5. Turtles of Ontario Identifier Guide

These documents will be provided to the successful bidder.

The Contractor will be responsible for providing the necessary equipment and materials required by the mitigation plans and shall contact the Town of Amherstburg Drainage Superintendent immediately if any endangered species are encountered during construction.

## **7. Brushing and Tree Removal**

All brush, trees, woody vegetation, etc. shall be removed from the working area. They shall be removed in their entirety including stumps.

It is recommended that a mechanical grinder attached to an excavator be used for the removal of brush and trees. Any brush and trees too large to grind shall be close cut. The Contractor shall be responsible for disposal of the trees and brush. The Contractor is responsible for obtaining all necessary permits for any disposal sites. Burning of the trees and brush is subject to local bylaws and guidelines of the Ministry of the Environment.

Certain trees may be left in place at the direction of the Drainage Superintendent. Any trees to be salvaged by individual Landowners shall be marked by the landowner prior to construction. These trees shall be close cut and piled in one pile for each landowner. The disposal of these trees is the responsibility of the Landowner.

For future maintenance it is recommended that, if necessary, appropriate spray be applied to the stumps, brush, and after-growth for two years following construction to maintain brush control.

## **8. Removals**

The existing access culverts shall be removed in its entirety from the open channel. The culvert and the concrete rubble shall be disposed offsite at the expense of the Contractor. Suitable backfill shall be stockpiled adjacent to the site for reuse during installation of the proposed culvert. Any broken concrete or rip rap (concrete bags) from the existing structures may be reused as erosion protection in the immediate vicinity (within 1 metre) of the proposed culvert replacement. The broken concrete or rip rap must be placed over filter fabric flush with the existing channel side slope. Large pieces of concrete, excavated material from the side slope to accommodate erosion protection and any material not suitable for use shall be disposed offsite by the Contractor.

## **9. Installation of Access Culvert**

The Contractor shall supply, install, and backfill aluminized corrugated steel pipe with a minimum wall thickness of 2.8mm in all cases. All corrugation profiles shall be of helical



lockseam manufacture using 68 x 13mm corrugations for 1600mm dia. pipe and smaller and 125 x 25mm corrugations for 1800mm dia. pipe and larger. Pipe with 125 x 25mm corrugations shall be used if 68 x 13mm corrugations are not available. Future culvert replacement shall be to the same specifications.

The culvert under this report shall be examined after any cleanout of the open channel as to its condition. If it is found to be in disrepair (i.e. there are holes corroded in the bottom or sides) it shall be replaced as per these specifications.

The culvert shall be installed with the invert 10% (minimum 150mm) below the hard bottom of the channel, as shown on the drawings. The location of the culvert may be moved a short distance upstream or downstream if approved by the Drainage Superintendent or Engineer.

If an owner requests a longer culvert than that specified above, please refer to the report. The culvert length is based on using rip rap ends. If concrete block ends are to be utilized in the future, the culvert shall be 100 metres in length.

The bottom of the excavation shall be excavated to the required depth with any over excavation backfilled with granular material or drainage stone. Native topsoil shall be placed adjacent the channel and re-used for backfill. When the pipe has been installed to the proper grade and depth, the excavation shall be backfilled with granular or drainage stone from the bottom of the excavation to the spring line of the pipe. Care shall be taken to ensure that the backfill on either side of the culvert does not differ by more than 300mm so that the pipe is not displaced. The access culverts shall then be backfilled from the spring line with granular "B1". The final 150mm (minimum) shall be backfilled with native topsoil from the channel excavation.

All backfill shall be free from deleterious material. All granular bedding material shall be mechanically compacted to 95% modified standard proctor density. All backfill material above the spring line shall be mechanically compacted to 95% modified proctor density using appropriate compaction equipment.

Rip rap ends are to be used with 1.5:1 side slopes. The rip rap shall consist of 100mm x 250mm quarry stone or approved equal. The area to receive the rip rap shall be graded to a depth of 400mm below finished grade. Filter fabric (Terrafix 270R or approved equal) shall then be placed with any joints overlapped a minimum 600mm. The quarry stone shall then be placed with the smaller pieces placed in the gaps and voids to give it a uniform appearance.

If concrete blocks are used the culvert shall be 100 metres in length. The concrete blocks shall have dimensions of approx. 600mm x 600mm x 1200mm, 600mm x 600mm x 2400mm or 300mm x 600mm x 1200mm as required. The top of the culvert shall govern block elevation. The correct block shall be set with the top of the block equal to the top of the culvert. The blocks shall be set at each end of the culvert so that each row of blocks will be offset approx. 100mm from the row below. The bottom row shall consist of one block placed parallel to the culvert. The blocks shall be imbedded a minimum of 300mm into each bank and shall extend into the drain bottom to match the pipe invert or below.

The blocks shall be placed over a layer of filter fabric (Terrafix 270R or approved equal). The culvert shall be backfilled in conjunction with the placement of the blocks. The gaps between the culvert and the blocks shall be filled with concrete cinder blocks/bricks and mortar to give the endwall a finished appearance.

#### **10. Tile Header**

There are approximately 12 tiles outletting into the open channel from the east. These tiles shall be extended downstream of the proposed culvert with connection to a header. The header shall be 250mm diameter non-perforated HDPE agricultural tubing with a manufactured coupling, elbow and rodent grate.

#### **11. Environmental Considerations**

The Contractor shall take care to adhere to the following considerations.

1. All excavated and stockpiled material shall be placed a minimum of 1.5 metres from the top of the bank. Material shall not be placed in surface water runs or open inlets that enter the channel.
2. All granular and erosion control materials shall be stockpiled a minimum of 1.5 metres from the top of the bank. Material shall not be placed in surface water runs or open inlets that enter the channel.
3. All activities, including maintenance procedures, shall be controlled to prevent the entry of petroleum products, debris, rubble, concrete, or other deleterious substances into the water. Vehicle and equipment refuelling and maintenance shall be conducted away from the channel, any surface water runs, or open inlets. All waste materials shall be stockpiled well back from the top of the bank and all surface water runs and open inlets that enter the drain.
4. All construction in the channel shall be carried out during periods of low flow.

The Contractor shall maintain a dry working area during construction. The Contractor shall install a silt fence downstream of the work area. The silt fence shall consist of filter fabric or manufactured silt fence supported with posts. A temporary dam consisting of excavated material shall be constructed upstream and downstream of the work area if working during low water flow. The temporary dams shall be covered with filter fabric or plastic that shall be anchored with rip rap material or broken concrete. Water shall be bailed and pumped from the work area to an area downstream of the temporary dam and upstream of the silt fence. Water will be controlled in the area between the two temporary dams for the duration of construction using pumps, if necessary.

After completion of the construction, the temporary dams and any collected sediment shall be removed. The final removal shall be the silt fence. By following the above procedure, the work should have little or no impact on the existing channel if carried out during low flows. Timing restrictions should not apply, in my opinion, if the above procedures are followed.

5. The Contractor shall take care to adhere to the following Best Management Practices prepared by the Department of Fisheries and Ocean.

a) Culvert Replacements in Municipal Drains (Appendix A)

6. The Contractor shall take care to familiarize them with the Town of Amherstburg's mitigation documents and species identification guidelines which will be provided to the successful bidder.

## **12. Benchmarks**

The benchmarks are based on geodetic elevations. Elevations are available at the culvert locations shown on the drawings. Where these elevations are on existing structures to be replaced, they shall be moved prior to the removal of the culverts.

## **13. Culvert Maintenance**

The Contractor shall be responsible for maintenance of the access culverts for a period of one year after their installation. This will include repairing any settlement areas on the travel surface with topsoil.

**14. Miscellaneous**

Any subsurface drains encountered upstream of the culvert that conflict with the proposed culvert shall be extended to an outlet to the open channel to the approval of the Drainage Superintendent.

Any fences that must be removed to allow construction or maintenance shall be reinstalled by the Contractor using the existing materials.

It will be the Landowner's responsibility to mark all tile and tile mains prior to maintenance being carried out.

# APPENDIX A

## Best Management Practices – Culvert Replacements in Municipal Drains

This document describes the conditions on which one may proceed with a culvert replacement in a municipal drain without DFO approval/notification. All municipal, provincial, or federal legislation that applies to the work being proposed must be respected. If the conditions/requirements below cannot be met, please complete the drain notification form and submit it to the Fisheries Protection Program form review at: [FisheriesProtection@dfo-mpo.gc.ca](mailto:FisheriesProtection@dfo-mpo.gc.ca).

### Potential Impacts to Fish Habitat

- Infilling fish habitat by encroachment of the water crossing footprint or channel realignment to accommodate culvert
- Harmful substrate alteration of fish habitat (e.g. blockage of groundwater upwellings, critical SAR habitat, spawning areas)
- Removal of riparian vegetation and cover along the banks of the municipal drain
- Removal of edge habitat (e.g. undercut bank, shallower areas with lower velocity, aquatic vegetation) creation of barriers to fish movement (e.g. perched crossings, velocity barriers, alteration of the natural stream gradient)
- Alteration of channel flow velocity and/or depth (e.g. oversized culvert resulting in insufficient depth for fish passage at low flow or undersized culvert resulting in a flow velocity barrier at high flow)
- Alteration of channel morphology and sediment transport processes caused by the physical structure of the crossing resulting in upstream and downstream sediment aggradation/erosion
- Re-entry of sediment that was removed/stockpiled into the watercourse
- Erosion downstream from sudden release of water due to the failure of site isolation
- Stranding of fish in isolated ponds following de-watering of the site
- Impingement or entrainment of fish when de-watering pumps are used
- Short term or chronic transport of deleterious substances, including sediment, into fish habitat from construction or road drainage

### Requirements

The following requirements must be met:

- There are no aquatic Species at Risk present in the work zone or impact zone. To confirm there are no aquatic Species at Risk present, refer to the document, [A Guide for Interpreting Fish and Mussel Species at Risk Maps in Ontario](http://www.dfo-mpo.gc.ca/Library/356763.pdf) which can be found at: <http://www.dfo-mpo.gc.ca/Library/356763.pdf>. Links for Ontario Conservation Area specific fish and mussel maps that include critical habitat extents and a list of aquatic Species at Risk found within the conversation authority boundary can be found on Page 5 of [A Guide for Interpreting Fish and Mussel Species at Risk Maps in Ontario](#).
- The culvert is embedded into the streambed and must allow for the free passage of fish.
- The work involves like-for-like replacements of existing road or private access culverts on all drain types without SAR.
- On C and F Drains only, this can also include replacements with extensions and end walls for the purposes of providing the property or road with safe access, but the project permanent footprint will not increase more than 250 m<sup>2</sup> below the high water mark.
- The project does not involve replacing a bridge or arch with one or more culverts installed in parallel or a larger-diameter culvert with more than one culvert installed in parallel.

- The project does not involve building more than one culvert installed in parallel on a single watercourse crossing site (e.g. twin culvert).
- The project does not involve temporarily narrowing the watercourse to an extent or for a duration that is likely to cause erosion, structural instability or fish passage problems.
- The municipal drain has no flow/low flow or is frozen to the bottom at the time of the replacement.
- In-water work is scheduled to respect timing windows (Tables 1 and 2) to protect fish, including their eggs, juveniles, spawning adults, and/or the organisms upon which they feed.
- The work can be conducted using the Culvert Removal Method described below and Standard Measures to Avoid Causing *Serious Harm to Fish* will be implemented when required.

Note: If your project must be conducted without delay in response to an emergency (e.g. the project is required to address an emergency that poses a risk to public health or safety or to the environment or property), you may apply for an Emergency Authorization (<http://www.dfo-mpo.gc.ca/asp/forceDownload.asp?FilePath=/pnw-ppe/reviews-revues/Emergency-Authorizations-Autorisations-Urgences-eng.pdf>).

### **Culvert Removal Methodology**

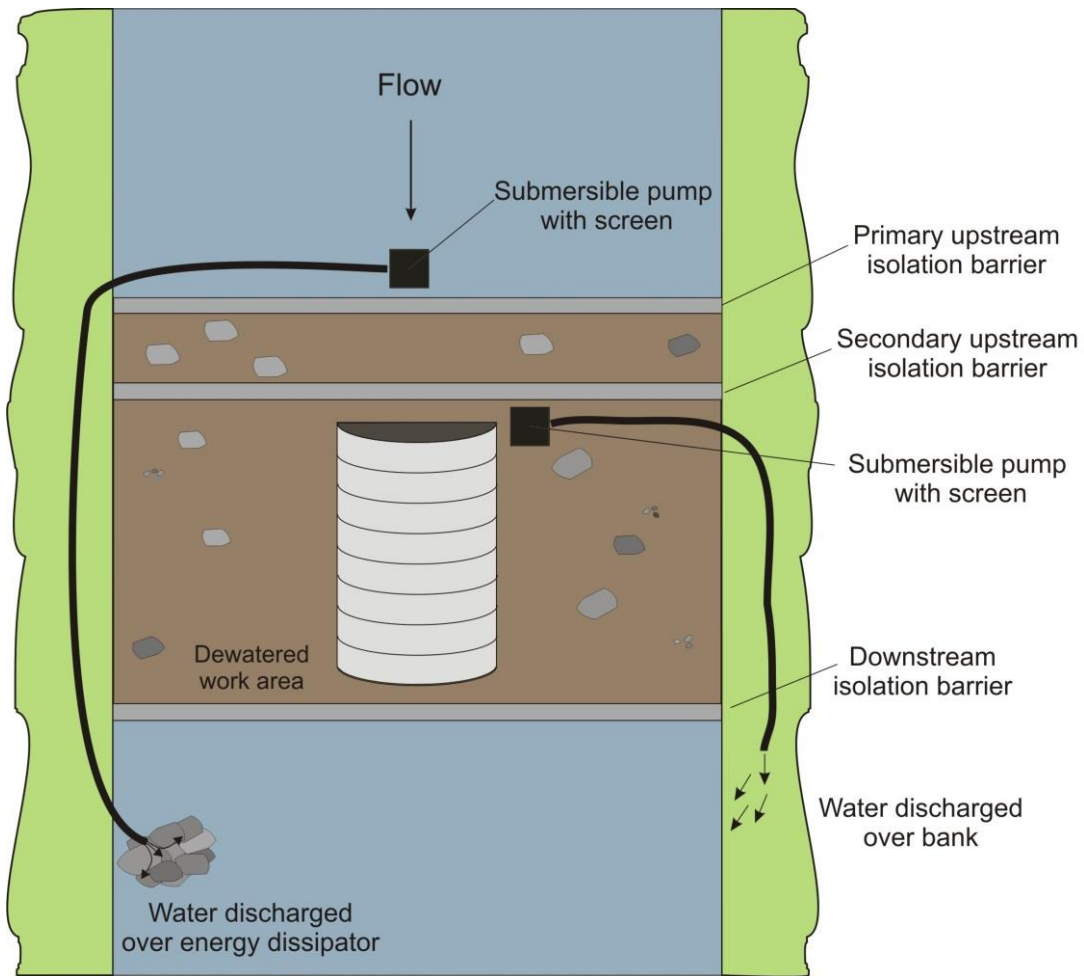
- Plan/manage the work site in a manner that prevents sediment from entering the municipal drain by installing sediment and erosion control materials where required. Ensure that a sediment and erosion control plan is developed and modified as necessary for the site.
- Where required, install effective erosion and sediment control measures before starting work to prevent sediment from entering the municipal drain.
- Implement site isolation measures when in-water work is required.
  - Install an impervious barrier upstream of the work area (Figure 1). If possible, install a secondary barrier upstream of the work area for added protection.
  - Attempt to drive out the fish from the work area and then install the impervious barrier downstream of the work area. This may reduce or eliminate the need for a fish salvage.
  - When the drain is flowing, maintain downstream flows (e.g. bypass water around the work site using pumps or flume pipes; Figure 2). Provide temporary energy dissipation measures (e.g. rip-rap) at discharge point of the hose or temporary outlet pipe when required. Routinely inspect bypass pump and hose or pipe to ensure proper operation. Inspect discharge point for erosion and reposition hose/pipe or install additional temporary energy dissipation material as needed.
  - Dewater the isolated work area. The hose for a pump may discharge along the top of the bank into existing vegetation; however, the area should be monitored for signs of erosion. Reposition the hose or install additional temporary energy dissipation material as needed.
  - A fish screen with openings no larger than 2.54 mm (0.10 inches) should be equipped on any pump used during the operation. Note: Additional information regarding fish screens can be found in the DFO Freshwater Intake End-of-Pipe Fish Screen Guideline document (<http://www.dfo-mpo.gc.ca/Library/223669.pdf>).
  - Collect any fish present in the isolated work area and relocate them downstream.
  - Fish salvage operations must be conducted under a license issued by the Ontario Ministry of Natural Resources and Forestry (MNRF). The MNRF should be contacted well in advance of any work to obtain the required fish collection license.
- Install the culvert so that it is embedded into the streambed; ensure the culvert remains passable (e.g. does not become perched) by fish and wildlife.



- Decommission the site isolation in a manner that minimizes the introduction of sediment. The downstream isolation barrier shall gradually be removed first, to equalize water levels inside and outside of the isolated area and to allow suspended sediments to settle.
- Stabilize and remove waste from the site.
- Where required, maintain effective erosion and sediment control measures until complete re-vegetation of disturbed areas is achieved.



**Figure 2. Isolation of Site**



**Figure 3. Isolation and Bypass Diversion when Working In-Water**

## Timing Windows

Figure 1 and Tables 1 and 2 can be used to determine the Restricted Activity period for the drain based on its classification. Note: Timing windows identified on [Conservation Authority](#) permits or [Ministry of Natural Resources](#) (Government of Ontario) work permits may differ and take precedence.



**Figure 1. Ontario's Northern and Southern Region boundaries for determining application of restricted activity timing windows.**

**Table 1. Restricted Activity timing windows for the protection of spawning fish and developing eggs and fry in the Northern Region. Dates represent when work should be avoided.**

DRAIN TYPE	RESTRICTED ACTIVITY PERIOD
A	SEPTEMBER 1 TO JULY 15
B	SEPTEMBER 1 TO JULY 15
C	APRIL 1 TO JULY 15
D	SEPTEMBER 1 TO JULY 15
E	APRIL 1 TO JULY 15

**Table 2. Restricted Activity timing windows for the protection of spawning fish and developing eggs and fry in the Southern Region. Dates represent when work should be avoided.**

DRAIN TYPE	RESTRICTED ACTIVITY PERIOD
A	SEPTEMBER 15 TO JULY 15
B	MARCH 15 TO JULY 15
C	MARCH 15 TO JULY 15
D	OCTOBER 1 TO JULY 15
E	MARCH 15 TO JULY 15

### Standard Measures to Avoid Causing *Serious Harm to Fish*

When implementing a culvert removal project in a municipal drain, the *Fisheries Act* still requires an individual/company to ensure they avoid causing *serious harm to fish* during any activities in or near water. The following advice will help one avoid causing harm and comply with the *Act* (for additional information see <http://www.dfo-mpo.gc.ca/pnw-ppe/measures-mesures/measures-mesures-eng.html>).

1. Schedule work to avoid wet, windy and rainy periods that may increase erosion and sedimentation.
2. Whenever possible, operate machinery on land above the high water mark or on ice and in a manner that minimizes disturbance to the banks and bed of the municipal drain.
  - Ensure that machinery arrives on site in a clean condition and is maintained free of fluid leaks.
  - Limit machinery fording of the municipal drain to a one-time event (i.e., over and back), and only if no alternative crossing method is available. If repeated crossings of the municipal drain are required, construct a temporary crossing structure.
  - Wash, refuel and service machinery and store fuel and other materials for the machinery in such a way as to prevent any deleterious substances from entering the water.
  - Keep an emergency spill kit on site in case of fluid leaks or spills from machinery.
3. Install effective sediment and erosion control measures before starting work to prevent sediment from entering the municipal drain. Inspect them regularly during the course of construction and make all necessary repairs if any damage occurs.
4. Erosion and sediment control measures should be maintained until all disturbed ground has been permanently stabilized, suspended sediment has resettled to the bed of the municipal drain and runoff water is clear.
5. Undertake all in-water activities in isolation of open or flowing water while maintaining the natural flow of water downstream and avoid introducing sediment into the municipal drain.
6. Ensure applicable permits for relocating fish are obtained and relocate any fish that become trapped in isolated pools or stranded in newly flooded areas to the main channel of the watercourse.
7. Ensure that the water that is being pumped/diverted from the site is filtered (sediment remove) prior to being released (e.g. pumping/diversion of water to a vegetated area).
8. Implement measures for containing and stabilizing waste material (e.g. dredging spoils, construction waste and materials, commercial logging waste, uprooted or cut aquatic plants, accumulated debris) above the high water mark of nearby waterbodies to prevent re-entry.
9. Stabilize shoreline or banks disturbed by any activity associated with the project to prevent erosion and/or sedimentation, preferably through re-vegetation with native species suitable for the site.
10. If replacement rock reinforcement/armouring is required to stabilize eroding or exposed areas, then ensure that appropriately-sized, clean rock is used; and that rock is installed at a similar slope to maintain a uniform bank/shoreline and natural stream/shoreline alignment.
11. Remove all construction materials from site upon project completion.

CONCESSION 1 PETTITE COTE

CONCESSION 2 PETTITE COTE

LOT 6

SHORT MALDEN RD

LOT 1 LOT 2

NORTH TOWNLINE ROAD

RIVER CANARD

LOT 14

LOT 13

LOT 12

LOT 11

CONCESSION ROAD 3 NORTH

CONCESSION ROAD 4 NORTH

DOLPHIS MELOCHE DRAIN

3RD CONCESSION DRAIN

DUPUIS DRAIN

BENATEAU DRAIN

HAMEL DRAIN

TILE OUTLET

EXISTING CULVERTS  
TO BE REMOVED

BM #2

490-03900  
J. & S. BEZAIRE

490-03800  
R. BASTIEN

490-04500  
R. BLAIS  
0.40 Ha

490-04600  
H. & S. GUBICA  
3.36 Ha

490-03010  
E. & M. MONFORTON  
0.98 Ha

490-03000  
E., M. & P. MONFORTON  
0.81 Ha

490-02800  
R. BASTIEN  
10.83 Ha

490-04700  
S. GUBICA  
1.50 Ha

490-02700  
D. & N. KOSYK  
9.30 Ha

490-02200  
R. BASTIEN  
13.00 Ha

490-04800  
E. MONFORTON  
4.13 Ha

490-02000  
R. BASTIEN  
0.00 Ha  
(AS PER DOLPHIS MELOCHE  
DRAIN REPORT 1997)

490-04900  
R. BASTIEN  
0.00 Ha  
(AS PER DOLPHIS MELOCHE  
DRAIN REPORT 1997)

CONCESSION 3

LEGEND

- DRAINAGE AREA
- DUPUIS DRAIN
- MUNICIPAL DRAIN
- EXISTING CULVERT
- PROPOSED CULVERT



DRAWING NAME: Dupuis Drain Plan  
PROJECT No. 2019-1016

4218 Oil Heritage Road  
Petrolia Ontario, N0N 1R0  
Phone: (519) 882-0032 Fax: (519) 882-2233

APPROVED	NO.	REVISIONS	DATE	BY
J. WARNER	2	FINAL REPORT	SEPT. 24, 2019	JW
CHECKED	1	TO ERCA	JULY 18, 2019	JW
B. VAN RUITTENBURG				
DRAWN				
J. WARNER				

SCALE: 1:7500  
0 100 200 300m

# TOWN of AMHERSTBURG

## ACCESS CULVERT ON THE DUPUIS DRAIN

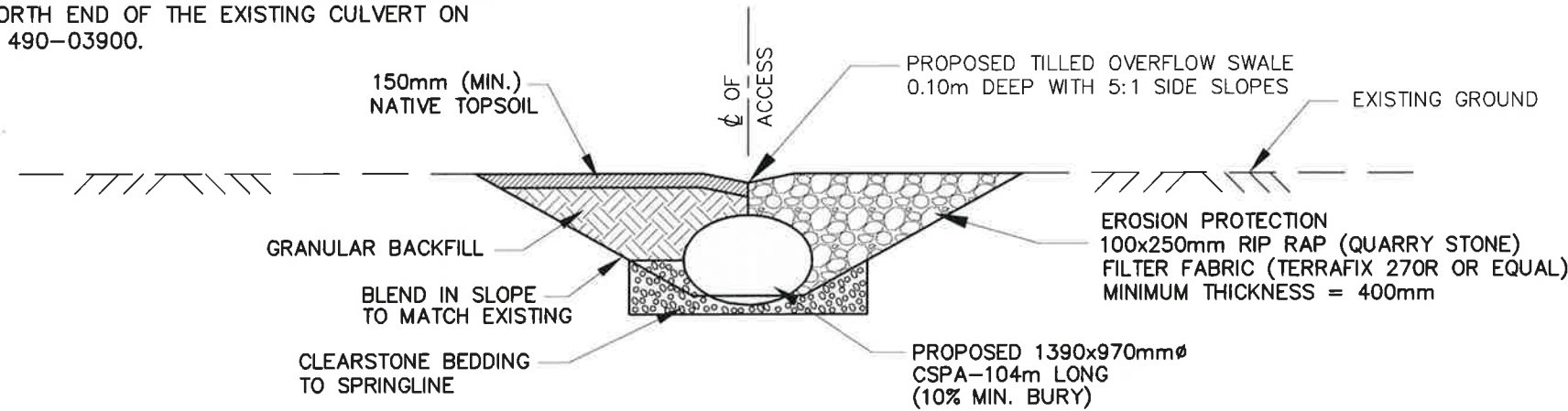
### PLAN

1 OF 2



**NOTES:**

1. THE EXISTING SOUTH PROPERTY LINE OF ROLL NUMBER 490-03800 IS APPROXIMATELY 2m SOUTH OF THE SOUTH END OF THE EXISTING ACCESS CULVERT ON THE PROPERTY.
2. THE PROPOSED CULVERT'S NORTH END SHALL GENERALLY MATCH THE NORTH END OF THE EXISTING CULVERT ON ROLL NUMBER 490-03900.

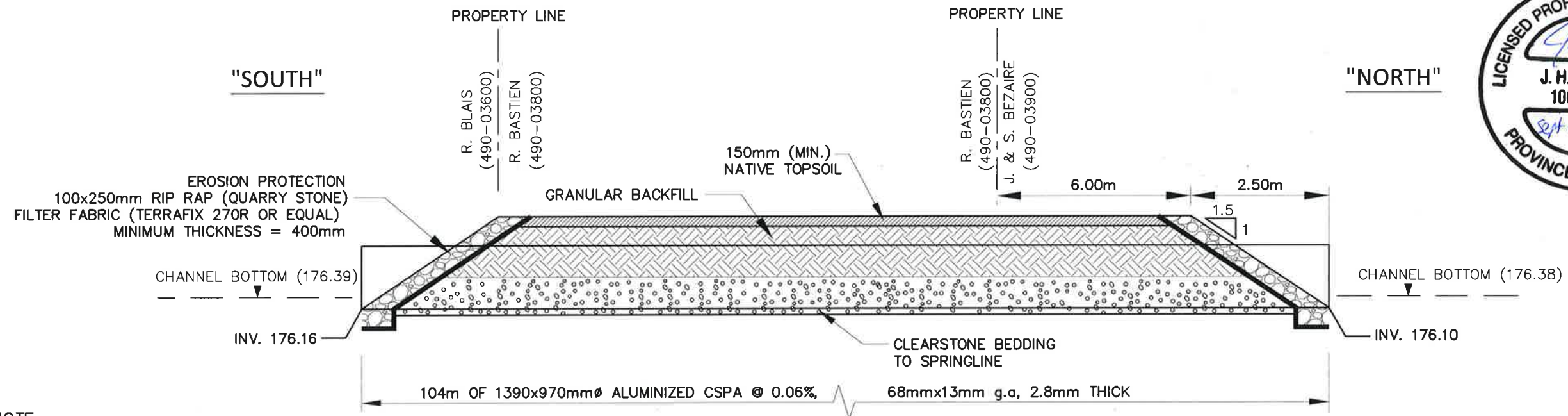


**PROPOSED PIPE END SECTION**

**BENCHMARK No.1 ELEV. 177.70**  
TOP OF NAIL ON HYDRO POLE,  
JUST SOUTH OF THE INTERSECTION  
OF NORTH TOWNLINE ROAD AND  
SHORT MALDEN ROAD

**BENCHMARK No.2 ELEV. 177.05**  
TOP OF SOUTH END OF EXISTING  
900mmØ CSP ON THE SOUTH  
LIMIT OF THE CENTER PT. LOT 14  
(ROLL NUMBER 490-03900)

**CULVERT IS TO BE REMOVED. THE BENCHMARK SHALL BE TRANSFERED PRIOR TO REMOVAL.**



**PROPOSED CROSS-SECTION**

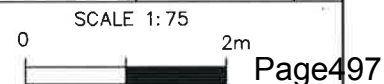


4218 Oil Heritage Road  
Petrolia Ontario, N0N 1R0  
Phone: (519) 882-0032 Fax: (519) 882-2233

DRAWING NAME:  
Dupuis Drain Culvert Detail

PROJECT No.  
2019-1016

APPROVED	J. WARNER	NO.	REVISIONS	DATE	BY
CHECKED	B. VAN RUITENBURG	2	FINAL REPORT	SEPT. 24, 2019	JW
DRAWN	J. WARNER	1	TO ERCA	JULY 18, 2019	JW



**TOWN of AMHERSTBURG**

ACCESS CULVERT ON THE DUPUIS DRAIN  
CULVERT DETAIL

2  
OF 2

**THE CORPORATION OF THE TOWN OF AMHERSTBURG**

**BY-LAW NO. 2019 – 093**

**By-law to provide for the New Access Culvert on the Dupuis Drain for Bastien based on the Drainage Report by R. Dobbin Engineering Inc.**

---

**WHEREAS** a request for repair and improvement of the on the Dupuis Drain was received under section 78 of the Drainage Act;

**WHEREAS** Council of the Corporation of the Town of Amherstburg felt it necessary to appoint an engineer for the purpose of preparation of an engineer's report for the New Access Culvert on the Dupuis Drain for Bastien under section 78 of the Drainage Act;

**WHEREAS** Council of the Corporation of the Town of Amherstburg has authorized Josh Warner, P. Eng., to prepare a report and said engineer's report dated September 24, 2019, can be referenced as Schedule A, as attached hereto;

**WHEREAS** \$103,690.00 is the amount to be contributed by the Town of Amherstburg for the drainage works;

**AND WHEREAS** the report was considered by the Amherstburg Drainage Board at the meeting held on Tuesday, November 5<sup>th</sup>, 2019.

**NOW THEREFORE** the Council of the Corporation of the Town of Amherstburg hereby enacts as follows:

**1. AUTHORIZATION**

The attached report is adopted and the drainage works is authorized and shall be completed as specified in the report

**2. BORROWING**

The Corporation of the Town of Amherstburg may borrow on the credit of the Corporation the amount of \$103,690.00 being the amount necessary for the improvements of the drainage works.

This project being the New Access Culvert on the Dupuis Drain for Bastien.

**3. DEBENTURE(S)**

The Corporation may issue debenture(s) for the amount borrowed less the total amount of:

- (a) Grants received under section 85 of the Drainage Act;
- (b) Monies paid as allowances;
- (c) Commuted payments made in respect of lands and roads assessed with the municipality;
- (d) Money paid under subsection 61(3) of the Drainage Act; and
- (e) Money assessed in and payable by another municipality.

**4. PAYMENT**

Such debenture(s) shall be made payable within 5 years from the date of the debenture(s) shall bear interest at a rate not higher than 1% more than the municipal lending rates as posted by The Town of Amherstburg's Bank's Prime Lending Rate on the date of sale of such debenture(s).

- (1) A special equal annual rate sufficient to redeem the principal and interest on the debenture(s) shall be levied upon the lands and roads as shown in the schedule and shall be collected in the same manner and at the same as



other taxes are collected in each year for 5 years after the passing of this by-law.

(2) For paying the amount \$0.00 being the amount assessed upon the lands and roads belonging to or controlled by the municipality a special rate sufficient to pay the amount assessed plus interest thereon shall be levied upon the whole rateable property in the Town of Amherstburg in each year for 5 years after the passing of this by-law to be collected in the same manner and at the same time as other taxes collected.

(3) All assessments of \$1000.00 or less are payable in the first year in which the assessments are imposed.

**5. SCHEDULE OF ASSESSMENTS OF LANDS AND ROADS**

Property Description				Estimated Assessment as per Report	Estimated Grants 33 1/3%	Annual Debenture Payment Amount
Lot or Part Lot No.	Concession	Geographic Township	Parcel Roll No.			
N 1/2 S 1/2 & SW 1/4 N 1/2 Lot 12	3	Anderdon	490-02200	\$4,152.00	\$1,384.00	623.08
N 1/4 Lot 12	3	Anderdon	490-02700	\$2,970.00	\$990.00	445.70
SW 1/4 Lot 13	3	Anderdon	490-02800	\$3,459.00	\$1,153.00	519.08
S 1/2 Lot 14	3	Anderdon	490-03800	\$80,080.00	\$27,196.67	11,904.07
Cntr Pt. Lot 14	3	Anderdon	490-03900	\$7,267.00	2,455.67	1,083.03
<b>Total</b>				<b>\$97,928.00</b>	<b>\$33,179.34</b>	<b>\$14,574.96</b>

Read a first and second time and provisionally adopted this 12<sup>th</sup> day of November, 2019.

\_\_\_\_\_  
MAYOR – ALDO DICARLO

\_\_\_\_\_  
CLERK – PAULA PARKER

Read a third time and finally passed this \_\_\_ day of \_\_\_\_\_, 2019.

\_\_\_\_\_  
MAYOR – ALDO DICARLO

\_\_\_\_\_  
CLERK – PAULA PARKER

October 18, 2019

The Mayor and Council  
Town of Amherstburg  
271 Sandwich Street South  
Amherstburg, Ontario  
N9V 2A5

Gentlemen and Mesdames:

**Re: John Parks No. 1 Drain Improvements**

As instructed, we have undertaken an examination of the John Parks No. 1 Drain on part of Lot 11, Concession 1 with regards to extending the drain to the Detroit River, replacing an existing lawn enclosure across two properties and incorporating a lawn enclosure across a third property which was completed outside of the Drainage Act. The lawn enclosures are located on the properties with the Area Roll Numbers (ARN) ending in 600-07100, 600-07200 and 600-07201 in the Town of Amherstburg (former geographic Township of Malden).

Authorization under the Drainage Act

The Town of Amherstburg received concerns relating to the deterioration and safety of a failing section of the John Parks No. 1 Drain. The Town of Amherstburg appointed an Engineer under Section 78 of the Drainage Act to prepare a report to address the failure.

Section 78 of the Drainage Act states that, where, for the better use, maintenance or repair of any drainage works constructed under a bylaw passed under this Act, or of lands or roads, it is considered expedient to change the course of the drainage works, or to make a new outlet for the whole or any part of the drainage works, or to construct a tile drain under the bed of the whole or any part of the drainage works as ancillary thereto, or to construct, reconstruct or extend embankments, walls, dykes, dams, reservoirs, bridges, pumping stations, or other protective works as ancillary to the drainage works, or to otherwise improve, extend to an outlet or alter the drainage works or to cover the whole or any part of it, or to consolidate two or more drainage works, the Council whose duty it is to maintain and repair the drainage works or any part thereof may, without a petition required under Section 4 but on the report of an Engineer appointed by it, undertake and complete the drainage works as set forth in such report.

### Existing Drainage

The drain outlets to the Detroit River via the Country Road 20 (Front Road South) centreline culvert. The drain extends 20m to the east and then 8m in a northerly direction to the north property limit of the 2627884 Ontario Inc. property (ARN 600-07201) as a 900mm dia. corrugated steel pipe drain. The drain extends 20m in a northerly direction to the north property limit of the F. & G. Storino property (ARN 600-07200) as a 900mm dia. corrugated steel pipe drain. The drain then extends 40m in an easterly direction along the north property limit of the F. & G. Storino property (ARN 600-07200) as a 900mm dia. corrugated steel pipe drain. The drain then extends 44m in a north easterly direction across the F. & G. Storino property (ARN 600-07100) as a 1,030mmX740mm corrugated steel pipe arch (CSPA). The drain then extends in a northerly direction for 1,187m as an open channel where it terminates in the centre of Lot 7, Concession 1.

In 1999, L. Zarlenga of Bruce D. Crozier Engineering Inc. prepared a report that included maintenance recommendations for the existing drain. The report also commented on extending the existing enclosure across the F. & G. Storino property (ARN 600-07100) between Station 0+088 and Station 0+132. The report stated that extending the enclosure across the F. & G. Storino property (ARN 600-07100) between Station 0+088 and Station 0+132 would need to be completed under a new Engineers Report under the Drainage Act. It appears the drain enclosure was extended across the F. & G. Storino property (ARN 600-07100) privately and was not completed under the Drainage Act. A by-law was not adopted by Council for the private enclosure of an existing municipal drain.

### Drain Classification

The open portion of the John Parks Drain No. 1 is currently classified as a class “E” drain from the drain outlet to the northerly limit of Lot 11, Concession 1. The remainder of the drain is classified as a class “F” drain. These classifications are according to the Ontario Ministry of Agriculture, Food and Rural Affairs Agricultural Information Atlas.

The report and the DFO’s Request for Review Form were submitted on July 9, 2019 to ensure compliance. A letter of advice was issued from the DFO on October 7, 2019. All DFO requirements have been included in this report.

The Essex Region Conservation Authority (ERCA) was contacted via an email dated June 6, 2018 to inform them of the project. A report was mailed to the ERCA on July 9, 2019. Correspondence from ERCA was received on September 4, 2019. All ERCA requirements have been included in this report.

### Onsite Meeting

An onsite meeting was held on June 14, 2018 to discuss the project. The following were in attendance.

Shane McVitty, Town of Amherstburg Drainage Superintendent  
 Michael Gerrits, R. Dobbin Engineering Inc.  
 Josh Warner, R. Dobbin Engineering Inc.

Bob Sutts, Landowner	Del Oxford, Landowner
Frank Storino, Landowner	Gina Storino, Landowner
John Gibb, Landowner	Gene Reaume, Landowner
Garry Balogh, Landowner	Pierretta Puzzango, Landowner
Ross Scott, Landowner	Charlene Scott, Landowner
Steve Bernyk, Landowner	Dave McWhinnie, Landowner
James Hodges, Landowner	Julie Kotsis-Wilder, Landowner
Bill Wilder, Landowner	

The following was discussed at the site meeting:

- General discussion of the Drainage Act and Landowners rights under the Drainage Act.
- General discussion of the request for a Section 78 report under the Drainage Act.
- Landowners were informed that the portion of the drain that was installed under the 1976 report is 43 years old and may be coming close to the end of its service life. Without exposing the pipe and completing an inspection it is unclear whether the project will be an isolated repair or a full replacement of the closed drain.
- Landowners were informed that the enclosed portion of the drain which was completed outside of the Drainage Act needs to be incorporated into the John Parks Drain No. 1. The Landowner who paid for the enclosure that was completed outside of the Drainage Act clarified that the enclosure was engineered.
- Landowners were informed that the drains capacity to convey water to the Detroit River is governed by the existing outlet and water levels of the Detroit River. The water levels on the Detroit River are high and causes water to back up in the drain.
- The current drain report plan does not include a watershed plan, the new report will include one. A number of Landowners requested the watershed boundary be verified on their lands. The Landowners were informed that R. Dobbin Engineering Inc. will complete a topographic survey and will address any Landowners request for boundary verification.

## Discussion

The water level in the drain is governed by the Detroit River water levels. R. Dobbin Engineering Inc. was unable to video the drain due to the high water level. Without a video it is difficult to determine the condition of the drain particularly the bottom 1/3 of the corrugated steel pipe. Culverts that have fluctuating water levels have increased dissolved gases which accelerate corrosion within the structure.

The existing enclosed drain is 43 years old. R Dobbin Engineering Inc. noted one failed section at the June 14, 2018 site meeting. R. Dobbin Engineering Inc. noted a second failure section immediately up gradient of the initial failure on July 10, 2019.

The Ministry of Transportation of Ontario's gravity pipe manual estimates the service life of a 16 gauge corrugated steel galvanized culvert in this area to be between 25 and 35 years. Armtec estimates the service life of galvanized culverts to be 50 years under ideal conditions. The Steel Drainage and Highway Construction Products handbook states a galvanized culvert should last a minimum of 50 years depending on the soils and water.

Under this report R. Dobbin Engineering Inc. recommends the culvert be replaced based on the age of the culvert, the estimated life spans of galvanized culverts, the amount of standing water within the culvert and that the existing pipe has failed in two locations and is expected to fail in other locations on a regular basis. Maintaining the failing sections of the enclosure will be difficult since it is expected that the remainder of the enclosure is in similar condition and there will be no end to the repairs.

There has been significant correspondence relating to lawn enclosures on this drain, specifically who is responsible for the cost of a lawn enclosure. Brief excerpts from the correspondence are listed below:

### *Existing Reports*

- C. Armstrong prepared a report in 1948, the report included incorporating an existing ditch complete with improvements into a drain report.
- W. Settrington prepared a report in 1976 which included improvements to both an open and closed channel. It appears W. Settrington assessed all costs associated with the existing enclosure between Station 0+020 and Station 0+088 to the landowner benefitting from the enclosure.
- N. Peralta prepared a report in 1985 to update maintenance schedules. The report appears to be based on maintaining the drain without consideration for any bridge, culvert or enclosure replacements.

*Correspondence with the Storino's (ARN ending in 600-07100)*

- June 19, 1997 – F. Storino wrote a letter to the Township of Malden expressing concern over the condition of the existing open drain on the Storino property between Station 0+088 and Station 0+122.
- June 26, 1997 – the Township of Malden retained L. Zarlenga to investigate the complaint.
- August 27, 1997 – L. Zarlenga prepared a report addressing his investigation. The report concluded that enclosing the drain on the Storino Property between Station 0+088 and 0+122 (immediately upstream of the existing enclosure) would be difficult due to the amount of cover. The report also stated that the outlet is governed by the Detroit River and in order to prevent standing water a pump system would be required. The report recommended the open channel portion of the drain between Station 0+088 and 0+335 be maintained as per the current Drain Report.
- May 20, 1999 – G. Storino wrote a letter to the Town of Amherstburg reiterating the complaints addressed in the June 19, 1997 letter prepared by F. Storino.
- June 1, 1999 – G. Storino requested maintenance be completed on the drain between Station 0+088 and 0+122.
- June 29, 1999 – The Town of Amherstburg retained L. Zarlenga to investigate the request for maintenance between Station 0+088 and 0+122.
- November 9, 1999 – L. Zarlenga prepared a report which stated the existing pipe between Station 0+020 and Station 0+088 was installed in 1976 at the expense of the landowner at that time. The report identified that water was ponding within the pipe up to approximately 6” in depth. The report identified that the channel upstream of the closed drain was vegetated. The report recommended drain maintenance be completed on the open channel and the closed pipe be flushed. L. Zarlenga informed the Storino’s if they wished to proceed with an enclosure a report would be required under the Drainage Act. L. Zarlenga did not prepare a report under the provisions of the Drainage Act to address the proposed drain enclosure.
- November 10, 1999– L. Zarlenga prepared a report to address the Storino’s request for an enclosure across their property between Station 0+088 and Station 0+122. The report stated that the first time a bridge or enclosure occurs on a Municipal Drain it is at the entire expense of the Landowner requesting the improvement and that a new report would be required under the Drainage Act. The Storino’s were given an estimate that included a cost for a new drainage report. L. Zarlenga did not prepare a report under the provisions of the Drainage Act to address the drain enclosure.
- January 18, 2000 – The Town of Amherstburg sent the Storino’s a letter requesting confirmation on whether they want to proceed with the maintenance or with an enclosure.

- January 25, 2000 – The Town of Amherstburg received a letter from the Storino's requesting maintenance be completed on the drain. The Storino's did not feel paying for the entire cost of a lawn enclosure was fair and therefore only requested maintenance be completed on the drain.
- April 6, 2000 – The Town of Amherstburg's Drainage Superintendent, B. Crawford, contacted L. Zarlenga to inform him the Storino's intended to enclose the drain between Station 0+088 and Station 0+120 privately without the benefit of a drainage report.
- April 7, 2000 – L. Zarlenga prepared a letter to the Town of Amherstburg informing the Town that the pipe enclosure between Station 0+088 and Station 0+120 would be considered a first time installation and would be performed totally at the owners costs. Maintenance and liabilities and costs associated with a private structure within the Municipal Drain are the responsibility of the structure owner. The Town was informed that future maintenance of the enclosure would be at the cost of the Storino's even if it was installed as part of a Drainage Report. L. Zarlenga informed the Town of Amherstburg that the drainage enclosure would require approval of Town Council.
- May 5, 2000 – The Town of Amherstburg sent a memo to B. Crawford advising that the construction of the enclosure across the Storino property was approved by Council.

This above correspondence demonstrates the Landowners were aware of the consequences of enclosing a drain. The enclosure between Station 0+088 and Station 0+122 is currently not part of the drain and will be incorporated into the drain under this report. The correspondence also demonstrates that the Landowners have been informed that the majority of the costs associated with the existing enclosure on their property is considered a special benefit under the Drainage Act.

### Recommendations

It is therefore recommended that the following work be carried out:

1. Remove and replace the existing headwall at the drain outlet at Station 0+000;
2. Remove and replace the closed drain between Station 0+020 and Station +088 that was installed in 1976 under the W. Settrington report complete with reconnecting the existing catch basin, restoration and the installation of new catch basins;
3. Update Maintenance Schedule; and
4. It is proposed to incorporate the 1,030mm x 740mm corrugated steel pipe arch on the F. & G. Storino property (ARN 600-07100) between Station 0+088 and Station 0+132 under this report. Once incorporated the existing enclosure will then become part of the drain.



### Design

The proposed replacement between the outlet to the Detroit River (Station 0+000) and Station 0+132 shall be designed to accommodate a minimum 1 in 2 year storm event complete with maintenance provisions. The proposed drain will provide a better level of service for Landowners within the watershed, however it will not be designed to road standards. Due to the minimal grades, the cover on the drain will be minimal when it crosses under the road side ditches. Ditch grading will be required to increase the cover to a minimum of 0.3 m in these areas. Hydraulically, the drain is governed by the Detroit River water levels. In order to utilize the capacity of the drain during elevated water levels, a pump system would be required.

### Estimate of Cost

It is recommended that the work be carried out in accordance with the accompanying Specification of Work and the Profile, which form part of this Report. There has been prepared an Estimate of Cost in the amount of \$145,260 including the following:

Construction	\$ 80,073
Construction Contingency Allowance	\$ 15,000
Allowances	\$ 1,340
Engineering	\$ 34,412
Updated Maintenance Schedule	\$ 2,000
Locates	\$ 3,350
Conservation Fees	\$ 800
Tendering (Provisional)	\$ 810
Inspection (Provisional)	<u>\$ 5,000</u>
Total	\$145,260

### Assessment

As per Section 21 of the Drainage Act, the Engineer in his report shall assess for benefit and outlet for each parcel of land and road liable for assessment. Outlet assessments shall be based on equivalent hectares which represents the amount of water generated on properties. The equivalent hectare area considers the properties impervious surfaces such as buildings, paved areas etc.

The following are the equivalent hectare conversions rates utilized in this report.

<b>Description</b>	<b>Area (ha)</b>	<b>Factor</b>	<b>Equivalent Area (ha)</b>
Agricultural	1.0	1.0	1.0
Roads	1.0	4.0	4.0
Residential Lots	1.0	1.5-2.0	1.5-2.0

Lands, roads, buildings, utilities, or other structures that are increased in value or are more easily maintained as a result of the construction, improvement, maintenance, or repair of a drainage works may be assessed for benefit. (Section 22)

Lands and roads that use a drainage works as an outlet, or for which, when the drainage works is constructed or improved, an improved outlet is provided either directly or indirectly through the medium of any other drainage works or of a swale, ravine, creek, or watercourse may be assessed for outlet. The assessment for outlet shall be based on the volume and rate of flow of the water artificially caused to flow into the drainage works from the lands and roads liable for such assessments. (Section 23)

The Engineer may assess for special benefit any lands for which special benefits have been provided by the drainage works. (Section 24) The Storino's own the properties with the ARN ending in 600-07100 and 600-07200 and 600-07201. There has been significant correspondence with the Storino's over the cost associated with a lawn enclosure across their properties. It is R. Dobbin Engineering Inc.'s opinion that all costs, less maintenance and access credits, related to the maintenance, repair and replacement of the lawn enclosure are borne by the Landowners benefiting from the enclosure.

A Schedule of Assessment for lands and roads affected by the work and therefore liable for the cost thereof has been prepared as per the Drainage Act. Any affected public utility or road authority shall be assessed, as per Section 26 of the Drainage Act, any increased costs for the removal or relocation of any of its facilities and plant that may be necessitated by construction or future maintenance and repair work. The cost of any fees for permits or approvals or any extra work required by any affected utility, road authority, conservation authority, ministry, government agency, etc., federal or provincial, shall be assessed to that organization requiring the permit, approval, or extra work.

The estimated cost of the drainage works has been assessed in the following manner:

1. The headwall has been assessed with 66% of the costs as benefit assessment to the road authority and 34% of the costs assessed as an outlet assessment to upstream lands and roads based on equivalent hectares.

2. The catch basin fronting on Front Road South, Catch Basin #1, has been assessed with 33% of the cost applied as benefit assessment to the adjacent Landowner (ARN 600-07201), 33% of the costs as benefit assessment to the road authority and 33% of the costs assessed as an outlet assessment to upstream lands and roads based on equivalent hectares.
3. Catch Basin #3 has been assessed equally to the properties with the ARN's ending in 600-07100 and 600-07200.
4. Junction Box #2 has been assessed with 50% of the cost applied as benefit assessment to the adjacent Landowner (ARN 600-07100) and the remainder of the cost assessed as an outlet assessment on upstream lands and roads based on equivalent hectares.
5. Lawn enclosures which serve as an access have been assessed with 10 metres of the enclosure assessed with 50% of the cost applied as benefit assessment and the remainder of the cost assessed as an outlet assessment on upstream lands and roads based on equivalent hectares. The 10 meter enclosure equates to a standard access with a 6 metre top width and as such, costs beyond that have been assessed as a benefit assessment to the Landowner of the property. Based on the above, the lawn enclosures have been assessed as follows:
  - Station 0+020 to Station 0+028 – 25% of the cost applied as benefit assessment to the property (600-07201), 25% to the Road Authority and the remainder of the cost assessed as an outlet assessment on upstream lands and roads based on equivalent hectares.
  - Station 0+038 to Station 0+048 – 25% of the cost applied as benefit assessment to the property (600-07200), 25% to the Road Authority and the remainder of the cost assessed as an outlet assessment on upstream lands and roads based on equivalent hectares.
6. The lawn enclosures which do not serve as an access have been assessed as follows:
  - Station 0+028 to Station 0+038 – 43% of the cost applied as benefit assessment to the property (600-07200), 53% of the costs applied as a benefit to the road authority and the remainder of the cost assessed as an outlet assessment on upstream lands and roads based on equivalent hectares.
  - Station 0+048 to Station 0+088 – 67% of the cost applied as benefit assessment to the property (600-07200), 29% of the cost applied as benefit assessment to the property (600-07100) and the remainder of the cost assessed as an outlet assessment on upstream lands and roads based on equivalent hectares.

- Under this report it is proposed to incorporate the existing private drain enclosure into the drain under Section 31 of the Drainage Act. The incorporated drain has been assessed with 10 metres of the drain enclosure between Station 0+122 and Station 0+132 assessed with 50% of the cost applied as benefit assessment to the Landowner of the property and the remainder of the cost assessed as an outlet assessment on upstream lands and roads based on equivalent hectares. The 10 meter enclosure equates to a standard access with a 6 metre top width.

### Allowances

Under Section 29 of the Drainage Act, the Engineer in his report shall estimate and allow in money to the Landowner of any land that it is necessary to use for the construction or improvement of a drainage works or for the disposal of material removed from drainage works. This shall be considered an allowance for right-of-way. Section 29 allowances will not be provided on private lands since the work includes improving an existing drain.

Under Section 30 of the Drainage Act, the Engineer shall determine the amount to be paid to persons entitled thereto for damage, if any, to ornamental trees, lawns, fences, land and crops occasioned by the disposal of material removed from a drainage works. This shall be considered an allowance for damages.

Under Section 31 of the Drainage Act, where an existing drain that was not constructed on requisition or petition under this Drainage Act or any predecessor of this Drainage Act is incorporated in whole or in part in a drainage works, the engineer in the report shall estimate and allow in money to the Landowner of such drain or part the value to the drainage works of such drain or part and shall include such sum in the estimates of the cost of the construction, improvement, repair or maintenance of the drainage works.

Allowances have been made, where appropriate, as per Section 30 of the Drainage Act for damages to lands and crops and as per Section 31 of the Drainage Act for an existing CSPA. Section 31 costs for the existing CSPA are \$108.18/m and are based on the 50% of the actual costs (1999) of the CSPA. The allowance of \$541 reflects 50% of a 10 m access culvert.

Conc.	Lot or Part	Roll No.	Owner	Section 30	Section 31	Total
1	Pt. Lot 11	600-07100	F. & G. Storino	200	540	740
	Pt. Lot 11	600-07200	F. & G. Storino	400		400
	Pt. Lot 11	600-07201	2627884 Ontario Inc.	100		100
	Pt. Lot 11	600-07250	2627884 Ontario Inc.	100		100
Total Allowances				\$800	\$540	\$1,340

### Access and Working Area

The working area for the closed drain where buildings are not located within 10 m of the drain shall be 20 meters centred on the drain. The working area for the closed drain where buildings are located within 10 m of the drain shall be reduced to account for the existing buildings.

Access to the work site shall be gained from road allowances when possible, along existing private lanes and along the fence lines. Access to the working area along the private lanes and fence lines shall be restricted to a width of 6 metres.

### Restrictions

No trees and shrubs shall be planted nor shall permanent structures be erected within 10 metres of either side of the proposed drain without prior written permission of Council. If trees are planted that interfere with access for future maintenance of the drainage works, they shall be removed at the expense of the Landowner.

Attention is also drawn to Sections 80 and 82 of the Drainage Act that refers to the obstruction of a drainage works.

### Agricultural Grant

It is recommended that application for subsidy be made for eligible agricultural properties. Any assessments against non agricultural properties are shown separately in the Schedule of Assessment.

## Maintenance

Upon completion of the work, the drainage works shall be maintained as per the applicable Schedules of Maintenance enclosed with this report unless otherwise altered under provisions of the Drainage Act or as outlined below. The maintenance schedules are used to prorate the actual maintenance costs when maintenance occurs. The costs illustrated on the Schedules of Maintenance are not part of the proposed improvements.

The cost to maintain the headwall at the outlet to the Detroit River shall be assessed to upstream properties based on equivalent hectares.

The Front Road South road crossing (Station 0+000 to Station 0+020) shall be maintained using the following cost distribution: 95% of the costs assessed to the road authority and 5% of the costs assessed to upstream properties based on equivalent hectares.

The cost to maintain Catch Basin #1 (CB #1) shall be assessed with 1/3 of the costs to the adjacent landowner (ARN 600-07201), 1/3 of the costs to the road authority and the remainder of costs to upstream properties based on equivalent hectares.

The cost to maintain Catch Basin #3 (CB #3) shall be assessed with 1/2 of the costs to the adjacent landowner (ARN 600-07100) and 1/2 of the costs to the adjacent landowner (ARN 600-07201).

The Cost to maintain the catchbasins with the paved portion the Front Street South shall be at the cost of the Road Authority.

The cost to maintain Junction Box 2 (JB #2) shall be assessed with 1/2 of the cost applied as benefit assessment to the adjacent Landowner (ARN 600-07100) and the remainder of the cost assessed as an outlet assessment on upstream lands and roads based on equivalent hectares.

The drain enclosure between Station 0+020 and 0+088 shall be maintained using the following cost distribution: 5% of the costs assessed to the Landowner (ARN 600-07100), 55% of the costs assessed to the Landowner (ARN 600-07200), 3% of the costs assessed to the Landowner (ARN 600-07201), 25% of the costs assessed to the Road Authority and the remainder of the cost assessed as an outlet assessment to upstream lands and roads based on equivalent hectares. In the future this section for drain may be utilized for an access to the property. Costs assessed upstream are based on a Granular 'A' driving surface. Any other surface shall be assessed as an additional special benefit to the Landowner.

The drain enclosure between Station 0+088 and 0+132 shall be maintained using the following cost distribution: 70% of the costs assessed to the Landowner (ARN 600-07100) and the remainder of the cost assessed as an outlet assessment to upstream lands and roads based on equivalent hectares. In the future this section for drain may be utilized for an access to the property. Costs assessed upstream are based on a Granular 'A' driving surface. Any other surface shall be assessed as an additional special benefit to the Landowner.

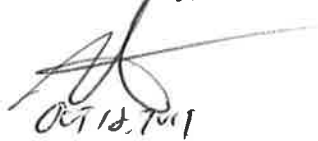
Maintenance of the open portions of the drain shall be assessed in accordance with the attached maintenance schedule (1).

The existing bridges between Station 0+132 and Station 1+317 shall be maintained or removed using the following cost distribution: 50% of the costs assessed to the benefiting Landowner and the remainder of the cost assessed as an outlet assessment to upstream lands and roads based on equivalent hectares.

These above conditions will apply unless otherwise altered under the provisions of the Drainage Act.

All of the above is submitted for your consideration.

Yours truly,



OCT 12, 2019

Mike Gerrits, P. Eng.





John Parks Drain No. 1  
 Town of Amherstburg  
 October 18, 2019

### ALLOWANCES

Allowances have been made as per Section 30 and Section 31 of the Drainage Act.

Conc.	Lot or Part	Roll No.	Owner	Section 30	Section 31	Total
1	Pt. Lot 11	600-07100	F. & G. Storino	200	540	740
	Pt. Lot 11	600-07200	F. & G. Storino	400		400
	Pt. Lot 11	600-07201	2627884 Ontario Inc.	100		100
	Pt. Lot 11	600-07250	2627884 Ontario Inc.	100		100
Total Allowances				\$ 800	\$ 540	\$ 1,340

John Parks Drain No. 1  
Town of Amherstburg  
October 18, 2019

## ESTIMATE OF COST

	Quantity	Unit	Material	Labour	Total
1 Traffic Control	1	l.s.	750	1,500	2,250
2 Locate Existing Corrugated Steel Pipe Culvert at Front Road South (Station 0+020)	1	l.s.	-	150	150
3 Locate Existing Corrugated Steel Pipe Culvert at Station 0+048	1	l.s.	-	150	150
4 Test Pit at Station 0+035	2	l.s.	-	150	150
5 Confirm Invert Elevation at Station 0+020 and Station 0+088	2	l.s.	-	300	300
6 Remove and Dispose of 900mm dia. Corrugated Steel Pipe Culvert	68	m	-	3,400	3,400
7 Remove and Dispose of 900mm dia. Corrugated Steel Pipe 90 Degree Bend	3	ea	-	75	75
8 Remove and Dispose of Existing Catch Basin	2	ea	-	300	300
9 Remove and Dispose of Existing Headwall (Station 0+000)	1	l.s.	-	500	500
10 Remove, Stockpile and Reinstall Paving Stones at 1217 Frot Road South	60	sq.m.	-	900	900
11 Remove, Dispose and Repair Existing Concrete Curb at 1217 Frot Road South	12	m	600	600	1,200
12 1050mm HDPE Drain c/w Bedding and Backfill	68	m	36,516	8,160	44,676
13 300mm HDPE CB Lead c/w connection to existing Road Catch Basin	5	m	230	225	455
14 1800mm X 1800mm Catchbasin (CB1) c/w Connection to Existing 900mm CSP	1	ea	2,200	680	2,880
15 1800mm X 1800mm Junction Box (JB2)	1	ea	2,200	680	2,880
16 1800mm dia. (CB3) c/w Connection to Existing CSPA	1	ea	2,200	680	2,880
17 Ditch Grading Around CBI	10	m	0	250	250
18 Yard Restoration c/w 100mm Topsoil and Hydroseed	368	sq.m.	1,840	1,472	3,312
19 Concrete Block Outlet Headwall c/w Clear Stone Base (Station 0+000)	17	blocks	3,825	2,040	5,865
20 Triton Type 1 DOT Turbidity Barrier	1	l.s.	1,500	125	1,625
21 Rip Rap (Station 0+000)	10	l.s.	250	500	750
22 Work Around Existing Entrance Walls (Station 0+040)	1	l.s.	-	750	750
23 Work Around Gas Utility	1	l.s.	-	750	750
24 Work Around Waterline	1	l.s.	-	750	750
25 Work Around Hydro	1	l.s.	-	750	750
26 Work Around Fibre Optic Cable	1	l.s.	-	750	750
27 Work Around Telephone	1	l.s.	-	750	750
28 Granular B Backfill (Provisional)	25	t	375	250	625
Miscellaneous					15,000
Sub Total					95,073
Allowances					1,340
Survey, Design, Report and Meetings					34,412
Updated Maintenance Schedule					2,000
Utility Locates and Survey					3,350
Tendering (Provisional)					810
Inspection (Provisional)					5,000
ERCA Fee					800
<b>Total Estimate excluding HST</b>					<b>142,785</b>
Non-Recoverable HST (1.76%)					2,475
<b>Total Estimate</b>					<b>145,260</b>

John Parks Drain No. 1  
Town of Amherstburg  
October 18, 2019

**SCHEDULE OF ASSESSMENT**

Conc.	Lot or Part	Affected Hect.	Roll No.	Owner	Special Benefit	Benefit	Outlet	Total
<b>3. Municipal Lands</b>								
	County Road 20 (Front Street)	0.14		County of Essex	5,827	15,413	246	21,486
	Watermian			Town of Amherstburg	1,668	-	-	1,668
					<u>7,495</u>	<u>15,413</u>	<u>246</u>	<u>23,154</u>
				Total Special Benefit	7,495			
				Total Benefit	15,413			
				Total Outlet			246	
				Total - Municipal Lands	<u>7,495</u>			<u>23,154</u>
<b>4. Privately-Owned Non-Agricultural Lands</b>								
1	Pt. Lot 12	0.01	600-07500	E. & P. Reaume	-	-	7	7
	Pt. Lot 12	0.02	600-07400	2627884 Ontario Inc.	-	-	15	15
	Pt. Lots 11 & 12	0.18	600-07300	2627884 Ontario Inc.	-	-	134	134
	Pt. Lot 11	-	600-07250	2627884 Ontario Inc.	-	-	-	-
	Pt. Lot 11	0.14	600-07201	2627884 Ontario Inc.	-	3,590	104	3,694
	Pt. Lot 11	0.14	600-07200	F. & G. Storino	41,818	8,197	140	50,155
	Pt. Lot 11	0.73	600-07100	F. & G. Storino	15,312	-	735	16,047
	Pt. Lot 11	0.62	600-07000	T. & G. Gillen	-	-	652	652
	Pt. Lot 11	0.16	600-06900	R. & C. Scott	-	-	229	229
	Pt. Lot 11	0.24	600-06800	M. Soullier	-	-	344	344
	Pt. Lot 11	0.12	600-06700	E. & E. Mooney	-	-	172	172
	Pt. Lot 11	0.14	600-06600	J. Neufeld	-	-	200	200
	Pt. Lot 11	0.05	600-06501	G. Michael & J. McLam	-	-	72	72
	Pt. Lot 11	0.03	600-06500	R. Leblanc	-	-	43	43
	Pt. Lot 11	1.19	600-06400	B. & S. Sutts	-	-	1,269	1,269
	Pt. Lot 10	0.11	600-06100	B. Wilder & J. Kotsis-Wilder	-	-	163	163

Conc.	Lot or Part	Affected Hect.	Roll No.	Owner	Special Benefit	Benefit	Outlet	Total
	Pt. Lot 10	0.15	600-06000	G. & A. Esposito	-	-	223	223
	Pt. Lot 10	0.10	600-05900	R. & S. Metcalfe	-	-	148	148
	Pt. Lot 10	0.16	600-05800	W. & S. Gibb	-	-	238	238
	Pt. Lot 10	0.36	600-05700	S. Bernyk	-	-	516	516
	Pt. Lot 10	0.20	600-05500	J. Brown	-	-	286	286
	Pt. Lot 10	0.15	600-05400	R. & C. Pouget	-	-	223	223
	Pt. Lot 10	0.05	600-05300	W. Pare	-	-	74	74
	Pt. Lot 10	0.04	600-05200	J. & M. Crump	-	-	59	59
	Pt. Lot 10	0.13	600-05100	N. Gyorgy	-	-	193	193
	Pt. Lot 10	0.22	600-05000	R. Giegerich	-	-	327	327
	Pt. Lot 10	0.23	600-04900	D. & R. Delbert	-	-	341	341
	Pt. Lot 10	0.54	600-04800	H. & R. Brough	-	-	773	773
	Pt. Lot 10	0.47	600-04620	M. & D. Gobbato & T. Berlasty	-	-	673	673
	Pt. Lot 10	0.80	600-04400	R. Levack & L. Bastien	-	-	1,146	1,146
	Pt. Lot 9	0.18	600-04300	Coulson Design-Build Inc.	-	-	273	273
	Pt. Lot 9	0.76	600-04200	J. & L Neufeld	-	-	1,275	1,275
	Pt. Lot 9	0.13	600-04100	J. & L Neufeld	-	-	197	197
	Pt. Lot 9	0.15	600-03900	C. Billingsley	-	-	227	227
	Pt. Lot 9	0.10	600-03800	S. & T. Waters	-	-	152	152
	Pt. Lot 9	0.12	600-03700	L. Dipierdomenico	-	-	182	182
	Pt. Lot 9	0.13	600-03600	R. Pare	-	-	197	197
	Pt. Lot 9	0.10	600-03500	J. Rice and C. Armstrong-Rice	-	-	152	152
	Pt. Lot 9	0.21	600-03400	S. & A. Colasanti	-	-	318	318
	Pt. Lot 8	0.11	600-03300	R. & D. Rivard	-	-	177	177
	Pt. Lot 8	0.16	600-03200	G. & A Balogh	-	-	258	258
	Pt. Lot 8	0.25	600-03100	J. Lovell	-	-	403	403
	Pt. Lot 8	0.12	600-03000	H. & M. Walschots	-	-	194	194
	Pt. Lot 8	0.24	600-02965	L. & N. Bieszk	-	-	387	387
	Pt. Lot 8	0.23	600-02955	A. & G. Pizzuto	-	-	371	371
	Pt. Lot 8	0.21	600-02945	R. & K. Spry	-	-	339	339
	Pt. Lot 8	0.17	600-02935	S. & A. Bazinski	-	-	274	274
	Pt. Lot 8	0.17	600-02925	M. Gobbato	-	-	274	274
	Pt. Lot 8	0.19	600-02916	J. Hodges & L. Lawrence	-	-	306	306
	Pt. Lot 8	0.19	600-02912	R. & C. Ball	-	-	306	306

Conc.	Lot or Part	Affected Hect.	Roll No.	Owner	Special Benefit	Benefit	Outlet	Total
	Pt. Lot 7	0.10	600-02800	D. & D. McWhinnie	-	-	161	161
	Pt. Lot 7	0.07	600-02700	G. & M. Mailloux	-	-	105	105
	Pt. Lot 7	0.14	600-02500	M. Mailloux	-	-	226	226
	Pt. Lot 7	0.12	600-02400	J. Hunt	-	-	194	194
	Pt. Lot 7	0.14	600-02301	J. & R. Thrasher	-	-	226	226
	Pt. Lot 7	0.20	600-02200	J. & L. Goodchild	-	-	323	323
	Pt. Lot 7	0.18	600-02100	M. & M. Pillon	-	-	290	290
					<u>57,129</u>	<u>11,787</u>	<u>17,286</u>	<u>86,203</u>
Total Special Benefit					57,129			
Total Benefit					11,787			
Total Outlet					17,286			
Total - Privately-Owned Non-Agricultural Lands					<u>86,203</u>			
 <b>5. Privately-Owned Agricultural Lands</b>								
1	Pt. Lot 11	3.8	600-06300	G. & R. Vandenbrink	-	750	2,663	3,413
	Pt. Lots 10 & 11	3.3	600-05600	S. & R. Gyori	-	750	2,363	3,113
	Pt. Lot 10	2.8	600-04610	S. Gyori & T. Rex	-	750	2,078	2,828
	Pt. Lot 9	6.4	600-04000	S. Gyori & T. Rex	-	750	4,750	5,500
	Pt. Lot 8	7.4	600-02900	S. Gyori & T. Rex	-	750	5,801	6,551
	Pt. Lot 7	9.4	600-02300	T.(Jr.) & T.(Sr.) Grace/M. Buchanan	-	-	7,827	7,827
					-	<u>3,750</u>	<u>25,482</u>	<u>29,232</u>
Total Special Benefit					-			
Total Benefit					3,750			
Total Outlet					<u>25,482</u>			
Total - Privately-Owned Agricultural Lands					<u>29,232</u>			

Conc.	Lot or Part	Affected Hect.	Roll No.	Owner	Special Benefit	Benefit	Outlet	Total
<b>6. Special Non-Prorateable Assesments</b>								
	Gas			Union Gas	1,668	-	-	1,668
	Telephone			Bell Telephone	1,668	-	-	1,668
	Fiber Optic Cable			Cogeco	1,668	-	-	1,668
	Hydro			Hydro One	1,668	-	-	1,668
					<u>6,672</u>	-	-	<u>6,672</u>
				Total Special Benefit	6,672			
				Total Benefit	-			
				Total Outlet	-			
				Total - Special Non-Prorateable Assesments	<u>6,672</u>			
				Total - Municipal Lands	23,154			
				Total - Privately-Owned Non-Agricultural Lands	86,203			
				Total - Privately-Owned Agricultural Lands	29,232			
				Total - Special Non-Prorateable Assesments	<u>6,672</u>			
				Total Assessment	<u>\$145,260</u>			

John Parks Drain No. 1  
Town of Amherstburg  
October 18, 2019

### SCHEDULE OF MAINTENANCE NO. 1

For maintaining the open section of the John Parks Drain between Station 0+132 and Station 1+317

Conc.	Lot or Part	Affected Hect.	Roll No.	Owner	Benefit	Outlet	Total	Equivalent Ha.
<b>4. Privately-Owned Non-Agricultural Lands</b>								
	Pt. Lot 11	0.62	600-07000	T. & G. Gillen	558	-	558	0.9
	Pt. Lot 11	0.16	600-06900	R. & C. Scott	-	8	8	0.3
	Pt. Lot 11	0.24	600-06800	M. Soullier	-	12	12	0.5
	Pt. Lot 11	0.12	600-06700	E. & E. Mooney	-	6	6	0.2
	Pt. Lot 11	0.14	600-06600	J. Neufeld	-	7	7	0.3
	Pt. Lot 11	0.05	600-06501	G. Michael & J. McLam	-	2	2	0.1
	Pt. Lot 11	0.03	600-06500	R. Leblanc	-	1	1	0.1
	Pt. Lot 11	1.19	600-06400	B. & S. Sutts	612	13	625	1.8
	Pt. Lot 10	0.11	600-06100	B. Wilder & J. Kotsis-Wilder	-	18	18	0.2
	Pt. Lot 10	0.15	600-06000	G. & A. Esposito	-	25	25	0.3
	Pt. Lot 10	0.10	600-05900	R. & S. Metcalfe	-	17	17	0.2
	Pt. Lot 10	0.16	600-05800	W. & S. Gibb	-	27	27	0.3
	Pt. Lot 10	0.36	600-05700	S. Bernyk	229	17	246	0.7
	Pt. Lot 10	0.20	600-05500	J. Brown	229	10	238	0.4
	Pt. Lot 10	0.15	600-05400	R. & C. Pouget	-	25	25	0.3
	Pt. Lot 10	0.05	600-05300	W. Pare	-	8	8	0.1
	Pt. Lot 10	0.04	600-05200	J. & M. Crump	-	7	7	0.1
	Pt. Lot 10	0.13	600-05100	N. Gyorgy	-	22	22	0.3
	Pt. Lot 10	0.22	600-05000	R. Giegerich	-	37	37	0.4
	Pt. Lot 10	0.23	600-04900	D. & R. Delbert	-	38	38	0.5
	Pt. Lot 10	0.54	600-04800	H. & R. Brough	229	26	255	1.1
	Pt. Lot 10	0.47	600-04620	M. & D. Gobbato & T. Berlasty	229	23	251	0.9



Conc.	Lot or Part	Affected Hect.	Roll No.	Owner	Benefit	Outlet	Total	Equivalent Ha.
	Pt. Lot 10	0.80	600-04400	R. Levack & L. Bastien	229	39	267	1.6
	Pt. Lot 9	0.18	600-04300	Coulson Design-Build Inc.	-	32	32	0.4
	Pt. Lot 9	0.76	600-04200	J. & L Neufeld	594	28	622	1.1
	Pt. Lot 9	0.13	600-04100	J. & L Neufeld	-	23	23	0.3
	Pt. Lot 9	0.15	600-03900	C. Billingsley	-	26	26	0.3
	Pt. Lot 9	0.10	600-03800	S. & T. Waters	-	18	18	0.2
	Pt. Lot 9	0.12	600-03700	L. Dipierdomenico	-	21	21	0.2
	Pt. Lot 9	0.13	600-03600	R. Pare	-	23	23	0.3
	Pt. Lot 9	0.10	600-03500	J. Rice and C. Armstrong-Rice	-	18	18	0.2
	Pt. Lot 9	0.21	600-03400	S. & A. Colasanti	-	37	37	0.4
	Pt. Lot 8	0.11	600-03300	R. & D. Rivard	-	45	45	0.2
	Pt. Lot 8	0.16	600-03200	G. & A Balogh	-	66	66	0.3
	Pt. Lot 8	0.25	600-03100	J. Lovell	-	102	102	0.5
	Pt. Lot 8	0.12	600-03000	H. & M. Walschots	-	49	49	0.2
	Pt. Lot 8	0.24	600-02965	L. & N. Bieszk	-	98	98	0.5
	Pt. Lot 8	0.23	600-02955	A. & G. Pizzuto	-	94	94	0.5
	Pt. Lot 8	0.21	600-02945	R. & K. Spry	-	86	86	0.4
	Pt. Lot 8	0.17	600-02935	S. & A. Bazinski	-	70	70	0.3
	Pt. Lot 8	0.17	600-02925	M. Gobbato	-	70	70	0.3
	Pt. Lot 8	0.19	600-02916	J. Hodges & L. Lawrence	-	78	78	0.4
	Pt. Lot 8	0.19	600-02912	R. & C. Ball	-	78	78	0.4
	Pt. Lot 7	0.10	600-02800	D. & D. McWhinnie	-	146	146	0.2
	Pt. Lot 7	0.07	600-02700	G. & M. Mailloux	-	95	95	0.1
	Pt. Lot 7	0.14	600-02500	M. Mailloux	-	204	204	0.3
	Pt. Lot 7	0.12	600-02400	J. Hunt	-	175	175	0.2
	Pt. Lot 7	0.14	600-02301	J. & R. Thrasher	-	204	204	0.3
	Pt. Lot 7	0.20	600-02200	J. & L. Goodchild	-	291	291	0.4
	Pt. Lot 7	0.18	600-02100	M. & M. Pillon	-	262	262	0.4
					2,907	2,822	5,729	
				Total Benefit	2,907			
				Total Outlet	2,822			
				Total - Privately-Owned Non-Agricultural Lands	5,729			

Conc.	Lot or Part	Affected Hect.	Roll No.	Owner	Benefit	Outlet	Total	Equivalent Ha.
<b>5. Privately-Owned Agricultural Lands</b>								
1	Pt. Lot 11	3.8	600-06300	G. & R. Vandenbrink	612	22	634	3.8
	Pt. Lots 10 & 11	3.3	600-05600	S. & R. Gyori	572	80	652	3.3
	Pt. Lot 10	2.8	600-04610	S. Gyori & T. Rex	572	68	639	2.8
	Pt. Lot 9	6.4	600-04000	S. Gyori & T. Rex	1,782	532	2,314	6.4
	Pt. Lot 8	7.4	600-02900	S. Gyori & T. Rex	2,700	1,084	3,784	7.4
	Pt. Lot 7	9.4	600-02300	T.(Jr.) & T.(Sr.) Grace/M. Buchanan	1,485	2,478	3,963	9.4
					<u>7,722</u>	<u>4,264</u>	<u>11,986</u>	
				Total Benefit	7,722			
				Total Outlet		4,264		
				Total - Privately-Owned Agricultural Lands			<u>11,986</u>	
				Total - Privately-Owned Non-Agricultural Lands	5,729			
				Total - Privately-Owned Agricultural Lands			<u>11,986</u>	
				Total Assessment	\$ 17,715			

John Parks Drain No.1  
Town of Amherstburg  
October 18, 2019

## SPECIFICATION OF WORK

### **1. Scope of Work**

The work to be included in this specification includes the replacement of an existing culvert, replacement of an existing headwall and future replacement of a culvert in the South Part of Lot 11, Concession 1 in the Town of Amherstburg. Specifications for the maintenance and repair of the open channel works are to be in accordance with William J. Settingington's Engineers Report dated February 6, 1976.

### **2. General**

Each tenderer must inspect the site prior to submitting their tender and satisfy themselves by personal examination as to the local conditions that may be encountered during this project including, but not limited to construction under water due to the high water level conditions in the Detroit River. The Contractor shall make allowance in the tender for any difficulties which they may encounter. Quantities or any information supplied by the Engineer is not guaranteed and is for reference only.

All work and materials shall be to the satisfaction of the Drainage Superintendent who may vary these specifications as to minor details but in no way decrease the proposed capacity of the drain.

The Contractor shall be responsible for the notification of all utilities prior to the start of construction.

All work must be completed in accordance with the attached Fisheries and Oceans Canada letter (19-HCAA-00837) dated October 7, 2019.

### **3. Plans and Specifications**

These specifications shall apply and be part of the Contract along with the General Specifications for Closed Drains and the General Specifications for Open Drains. This Specification of Work shall take precedence over all plans and general conditions pertaining to the Contract. The Contractor shall provide all labour, equipment, materials, and supervision necessary to complete the work as shown in the Plans and described in

these specifications. Any work not described in these specifications shall be completed according to the Ontario Provincial Standard Specifications and Standard Drawings.

Any reference to the Owner contained in these Contract Documents shall refer to the Town of Amherstburg or the Engineer authorized by the Town of Amherstburg to act on its behalf.

#### **4. Health and Safety**

The Contractor at all times shall be responsible for health and safety on the worksite including ensuring that all employees wear suitable personal protective equipment including safety boots and hard hats.

The Contractor shall be responsible for traffic control as per the Ontario Traffic Manual Book 7 – Temporary Conditions (latest revision) when working on public road allowances. A copy of a traffic control plan shall be kept on site at all times. The Contractor shall maintain suitable barricades, warning lights, and temporary traffic notices, at his expense, in their proper position to protect the public both day and night. Flagmen are the responsibility of the Contractor when working on the road allowance and when entering or exiting a worksite onto a roadway.

The Contractor shall be responsible to ensure that all procedures are followed under the Occupational Health and Safety Act to ensure that work sites are safe and that accidents are prevented. In the event of a serious or recurring problem, a notice of noncompliance will be issued. The Contractor will be responsible for reacting immediately to any deficiency and correcting any potential health and safety risk. Continuous disregard for any requirement of the Occupational Health and Safety Act could be cause for the issuance of a stop work order or even termination of the contract.

He shall also ensure that only competent workmen are employed onsite and that appropriate training and certification is supplied to all employees.

#### **5. Workplace Safety and Insurance Board**

Upon award of the contract and prior to commencement of work, the Contractor shall furnish the Town of Amherstburg with a satisfactory Certificate of Insurance (COI) containing the information below, for the period of the execution of the work:

- i. A Commercial General Liability (CGL) policy that shall be not less than 5 million dollars per occurrence.

- ii. The CGL policy shall include bodily injury including death, personal injury, property damage, tenants legal liability, non-owned automobile and contain a cross liability/severability of interest clause. The certificate must also include acknowledgement that coverage under the policy specifically extends to the works in question. The COI shall name the Town of Amherstburg as additional insured to the policy.
- iii. The CGL policy shall not contain any exclusion or limitation in respect to shoring, underpinning, raising or demolition of any building or structure, pile driving, caisson work, collapse of any structure or subsidence of any property, structure or land from any cause.
- iv. The Contractor shall note that where construction works are performed within lands owned by the County of Essex or Ministry of Transportation the CGL policy shall also name the County of Essex and/or the Ministry of Transportation as additional insured to the policy.
- v. The liability insurance shall be endorsed to provide that the policy shall not be altered, cancelled or allowed to lapse without 30 days prior written notice to the Town of Amherstburg.

## **6. MNRF Drain Registration**

The Contractor is advised that the Town of Amherstburg has conducted an "Endangered Species Act Review" and has registered it's drainage activities with the Ministry of Natural Resources and Forestry.

The Town of Amherstburg, in pursuant to the Endangered Species Act Municipal Agreement, has identified the potential presence of certain species within the project area. It is the responsibility of the Contractor to make certain that necessary provisions are undertaken to ensure the protection of all species at risk and their habitats throughout the course of construction. It is also the responsibility of the Contractor to make itself familiar with the following documents:

1. Town of Amherstburg – Complete Mitigation Documents
2. Town of Amherstburg - Additional Mitigation Measures for Snakes Species
3. Town of Amherstburg - Additional Mitigation Measures for Turtle Species
4. Snakes of Ontario Identifier Guide

## 5. Turtles of Ontario Identifier Guide

These documents will be provided to the successful bidder.

The Contractor will be responsible for providing the necessary equipment and materials required by the mitigation plans and shall contact the Town of Amherstburg Drainage Superintendent immediately if any endangered species are encountered during construction.

## 7. Benchmarks

The benchmark is based on geodetic elevations. Elevations are available at the hydrant at the front of #1205 Front Road South.

## 8. Access and Working Area

The working area for the closed drain where buildings are not located within 10 m of the drain shall be 20 meters centred on the drain. The working area for the closed drain where buildings are located within 10 m of the drain shall be reduced to account for the existing buildings.

Access to the work site shall be gained from road allowances when possible, along existing private lanes and along the fence lines. Access to the working area along the private lanes and fence lines shall be restricted to a width of 6 metres.

## 9. Removals

All required corrugated steel pipe material, headwalls and catch basins shall be removed in its entirety and disposed of offsite by the Contractor.

During future maintenance operations the access culvert at Station 0+211 shall be and disposed of offsite.

## 10. Locate Existing Drain, Verify Invert Elevations and Grade Changes

The Contractor shall locate the existing corrugated steel pipe drain at Station 0+020, Station 0+048 and Station 0+088. The Contractor shall also complete a test pipe at Station 0+035 to confirm that the alignment is not located within an existing septic weeping bed. The Contractor shall notify the Engineer of all invert elevations prior to completing any drainage works. If necessary, the Engineer will confirm a revised gradeline between CB#1 and CB#3 prior to installing the drain.

## 11. Installation of High Density Polyethylene Pipe Drain

The Contractor shall supply, install and backfill the drain. The pipe shall be high density polyethylene (HDPE) smooth wall pipe (320 kPa) shall be with bell and spigot joints. The drain between Station 0+020 and Station 0+088 shall be replaced with a 1050mm HDPE pipe. The drain between Station 0+088 and Station 0+132 shall be replaced with a 1050mm HDPE pipe in the future or equivalent arch pipe.

The proposed HDPE pipe drain may be installed along a different alignment and will require the Contractor to work around an existing septic bed, masonry entrance feature and adjacent to existing buildings.

The bottom of the excavation shall be excavated to the required depth with any over excavation backfilled with granular material or 3/4 inch clear stone. When the pipe has been installed to the proper grade and depth, the excavation shall be backfilled with granular or clear stone from the bottom of the excavation to the springline of the pipe. Care shall be taken to ensure that the backfill on either side of the culvert does not differ by more than 300mm so that the pipe is not displaced. The drain shall be backfilled from the springline to within 100mm of finished grade with excavated material. The top 100mm shall be backfilled with topsoil. In areas where there are residential driveways the drain shall be backfilled from the springline to finished grade with granular "B 1" to within 300mm of finished grade. The top 300mm shall be backfilled with compacted granular "A" material to finished grade.

Note that if excavated material is found unsuitable for backfill purposes, then granular material will be required as backfill. Unit prices shall be established in any tender for the disposal of the excavated material and the import of approved granular material at the expense of the drainage works.

All backfill shall be free from deleterious material. All granular bedding material shall be mechanically compacted to 95% modified standard proctor density. All backfill material



above the springline shall be mechanically compacted to 95% modified proctor density using appropriate compaction equipment.

These specifications apply to proposed and future works on the drain.

## 12. Installation of Culverts (Future)

The Contractor shall supply, install, and backfill pipe culverts. Pipe materials can be either HDPE Pipe Culverts or Corrugated Steel Pipe (CSP) culverts as specified below. High density polyethylene (HDPE) smooth wall pipe (320 kPa) with coupler joints. Corrugated Steel Pipe (CSP) culverts shall be aluminized corrugated steel pipe with a minimum wall thickness of 2.8mm in all cases. All corrugation profiles shall be of helical lockseam manufacture using 68mm x 13mm corrugations for 1600mm diameter pipe and smaller. Pipe with 125mm x 25mm corrugations shall be used if 68mm x 13mm corrugations are not available. Culvert material shall meet all ASTM and CSA requirements.

Access Culvert	Station	HDPE (mm)	CSP (mm)
2	0+334	900	1000
3	0+390	900	900
4	0+594	900	900
5	0+739	900	900
6	1+030	760	900

All granular bedding and backfill material shall be mechanically compacted to 95% modified standard proctor density. The top 300mm of Granular "B" material shall be mechanically compacted to 98% modified standard proctor density and the top 150mm of Granular "A" material shall be mechanically compacted to 100% modified standard proctor density. The Contractor shall supply any extra backfill material required above the springline. Payment for additional material shall be specified in the Contract documents.

Pipe culverts shall be constructed 150mm below the original grade line identified in the W. Settrington report prepared in 1976. The bottom of the excavation shall be excavated to the required depth with any over excavation backfilled with granular material or clear stone. When the pipe has been installed to the proper grade and depth, the excavation shall be backfilled with Granular "A" or clear stone from the bottom of the excavation to the springline of the pipe. Care shall be taken to ensure

that the backfill on either side of the culvert does not differ by more than 300mm so that the pipe is not displaced.

The Contractor shall maintain a dry working area during construction. The Contractor shall install a silt fence downstream of the work area (at bottom end of channel improvement if all work is completed at the same time). The silt fence shall consist of filter fabric or manufactured silt fence supported with posts (OPSD 219.190). For access culverts that are to be constructed, a temporary dam may be necessary.

### 13. Catchbasins

The catch basins shall be installed to the elevations and in the locations shown on the drawings as follows:

Structure	Station	Type Elev. (mm)	Inlet (Top) (m)	Outlet Pipe Elev. (m)	Inlet Pipe Elev. (m)
CB #1	0+020	1800X1800	175.69	174.39 (914mm)	174.39 (1050mm)
CB #3	0+088	1800X1800	175.90	174.41 (1050mm)	174.33 (1030mmX740mm)

Note – CB#3 Inlet Invert lower than outlet invert

The structures shall be precast concrete structures as noted above. The structures shall have a flat top with herringbone grates in accordance with OPSD 400.0100.

The structures shall be made with the top sections separate from the base sections in order to allow riser sections to be installed or removed as necessary (i.e. the base section shall not extend for more than 150mm above the top of the highest opening in the base section). The wall thickness of all structures shall be 115mm and each shall have a 600mm sump.

The structures shall be set at the final elevations as directed by the Drainage Superintendent. The catch basins shall be set on a layer of clear stone. The clear stone shall be extended up to the springline of the inlet and outlet pipe connections.

The tile at the connection to the structures shall be concreted on both the inside and outside prior to backfilling. Any pipe or tile shall not protrude more than 50mm inside the wall.

The existing catch basin is to be removed and replaced in a new location. Minor grading within the road allowance will be required to ensure water is directed to the proposed catch basin. The 300mm dia. lead connecting the existing Front Road South catch basin to the new main shall be replaced with an HDPE tile. The HDPE tile shall be smooth wall pipe shall be coupler joint (320 kPa).

Restoration in accordance with specification 15.

#### 14. Junction Box

The junction box shall be installed to the elevations and in the locations shown on the drawings as follows:

Structure	Station	Type (mm)	Base Elev. (m)	Outlet Pipe Elev. (m)	Inlet Pipe Elev. (m)
JB #2	0+048	1800X1800	173.80	174.40 (1050mm)	174.40 (1050mm)

The junction box shall be 1800 mm x 1800 mm square precast concrete structures as noted above.

The junction boxes shall be made with the top sections separate from the base sections in order to allow riser sections to be installed or removed as necessary (i.e. the base section shall not extend for more than 150mm above the top of the highest opening in the base section). The wall thickness of all structures shall be 115mm and each shall have a 600mm sump.

The junction boxes shall be set on a layer of clear stone. The clear stone shall be extended up to the top of the inlet and outlet pipe connections

The tile at the connection to the ditch inlet shall be concreted on both the inside and outside prior to backfilling. Any pipe or tile shall not protrude more than 50mm inside the wall.

## 15. Installation of Headwall

End protection shall consist of concrete blocks with dimensions of approx. 600mm x 600mm x 1200mm, 600mm x 600mm x 2400mm or 300mm x 600mm x 1200mm as required. The top of the culvert shall govern block elevation. The correct block shall be set with the top of the block equal to the top of the culvert. The blocks shall be set at each end of the culvert so that each row of blocks will be offset approx. 100mm from the row below. The bottom row shall consist of one block placed parallel to the culvert. The blocks shall be imbedded a minimum of 300mm into each bank and shall extend into the drain bottom to match the pipe invert or below.

The blocks shall be placed over a layer of filter fabric (Terrafix 270R or approved equal). The culvert shall be backfilled in conjunction with the placement of the blocks. The gaps between the culvert and the blocks shall be filled with concrete cinder blocks/bricks and mortar to give the endwall a finished appearance. Any voids in the backfill shall be filled with clear stone.

The Contractor shall maintain a dry working area during construction. The Contractor shall install a silt fence downstream of the work area (at bottom end of channel improvement if all work is completed at the same time). The silt fence shall consist of filter fabric or manufactured silt fence supported with posts (OPSD 219.190).

The concrete blocks shall be Easy Block by Underground Specialties or an approved equivalent. Approved equivalents must be approved in writing by the engineer or drainage superintendent prior to purchasing the blocks. A water control plan shall be submitted by the Contractor prior to removing the existing headwall.

## 16. Restoration

Restoration of the boulevards shall be in accordance with the following:

- Disturbed areas shall be restored in accordance with the Contract drawings and include a minimum of 100mm of native topsoil and hydroseed. Native topsoil is to match existing depths. Topsoil is to be placed in accordance with OPSS 802. Seed is to be supplied and placed in accordance with OPSS 804.

Restoration of the drive ways shall be in accordance with the following:

- Paving stones shall be removed and stockpiled for reuse.
- Contractor shall restore disturbed areas with the salvaged stones, 300mm of granular B compacted to 98% modified standard proctor density and 150mm of

screenings. Screenings shall be compacted to 100% modified standard proctor density.

Restoration (Future) of the Front Road South culvert shall be in accordance with the following:

- Excavation in accordance with OPSS 206
- Compaction in accordance with OPSS 501 (Prov.)
- HL4 asphalt to match the existing depths. Asphalt in accordance with OPSS 310.
- 150mm (minimum) of Granular 'A' and 300mm (minimum) of Granular '13'. Granular in accordance with OPSS 1010. Granular depths can be increased to match existing granular depths.
- Disturbed areas within the road right of way shall be restored in accordance with the contract drawings and include roadside ditching, 100mm of native topsoil, seed and mulch. Topsoil in accordance with OPSS 802. Seed and mulch in accordance with OPSS 804.

### **17. Turbidity Barrier**

A turbidity barrier shall be installed in the Detroit River at the John Parks Drain No. 1 outlet. The turbidity curtain shall be installed by dragging it away from the headwall to scare any fish away from the headwall. The turbidity barrier shall be Triton Type 1 DOT by GEI Works or an approved equivalent. Approved equivalents must be approved in writing by the engineer or drainage superintendent prior to purchasing the turbidity barrier. The Contractor shall inspect the turbidity curtain on a daily basis to ensure it is functioning properly.

### **18. Environmental Considerations**

The Contractor shall take care to adhere to the following considerations.

1. All excavated and stockpiled material shall be placed a minimum of 1.5 metres from the top of the bank. Material shall not be placed in surface water runs or open inlets that enter the channel.
2. All granular and erosion control materials shall be stockpiled a minimum of 1.5 metres from the top of the bank. Material shall not be placed in surface water runs or open inlets that enter the channel.

3. All activities, including maintenance procedures, shall be controlled to prevent the entry of petroleum products, debris, rubble, concrete, or other deleterious substances into the water. Vehicle and equipment refuelling and maintenance shall be conducted away from the channel, any surface water runs, or open inlets. All waste materials shall be stockpiled well back from the top of the bank and all surface water runs and open inlets that enter the drain.

4. All construction in the channel shall be carried out during periods of low flow. When possible the Contractor shall schedule work to avoid periods of high winds and rain. The Contractor shall maintain a dry working area during construction. The Contractor shall install a silt fence downstream of the work area. The silt fence shall consist of filter fabric or manufactured silt fence supported with posts. A temporary dam consisting of excavated material shall be constructed upstream and downstream of the work area if working during low water flow. The temporary dams shall be covered with filter fabric or plastic that shall be anchored with rip rap material or broken concrete. Water shall be bailed and pumped from the work area to an area downstream of the temporary dam and upstream of the silt fence. Water will be controlled in the area between the two temporary dams for the duration of construction using pumps, if necessary.

After completion of the construction, the temporary dams and any collected sediment shall be removed. The final removal shall be the silt fence. By following the above procedure, the work should have little or no impact on the existing channel if carried out during low flows. Timing restrictions should not apply, in my opinion, if the above procedures are followed.

5. The Contractor shall take care to adhere to the following Best Management Practices prepared by the Department of Fisheries and Ocean.

a) Culvert Replacements in Municipal Drains (Appendix A)

6. The Contractor shall take care to familiarize them with the Town of Amherstburg's mitigation documents and species identification guidelines which will be provided to the successful bidder.

7. The timing window for this project is July 15 to October 1 of any calendar year.

## **19. MNRF Drain Registration**

The Contractor is advised that the Town of Amherstburg has conducted an "Endangered Species Act Review" and has registered it's drainage activities with the Ministry of Natural Resources and Forestry.

The Town of Amherstburg, in pursuant to the Endangered Species Act Municipal Agreement, has identified the potential presence of certain species within the project area. It is the responsibility of the Contractor to make certain that necessary provisions are undertaken to ensure the protection of all species at risk and their habitats throughout the course of construction. It is also the responsibility of the Contractor to make itself familiar with the following documents:

6. Town of Amherstburg – Complete Mitigation Documents
7. Town of Amherstburg - Additional Mitigation Measures for Snakes Species
8. Town of Amherstburg - Additional Mitigation Measures for Turtle Species
9. Snakes of Ontario Identifier Guide
10. Turtles of Ontario Identifier Guide

These documents will be provided to the successful bidder.

The Contractor will be responsible for providing the necessary equipment and materials required by the mitigation plans and shall contact the Town of Amherstburg Drainage Superintendent immediately if any endangered species are encountered during construction.

## **20. Miscellaneous**

Any subsurface drains encountered upstream of the culvert that conflict with the proposed culvert shall be extended to an outlet to the open channel to the approval of the Drainage Superintendent.

Any fences that must be removed to allow construction or maintenance shall be reinstalled by the Contractor using the existing materials.

It will be the Landowner's responsibility to mark all tile and tile mains prior to maintenance being carried out.





Central and Arctic Region  
Fish and Fish Habitat Protection Program  
867 Lakeshore Road  
Burlington, Ontario  
L7S 1A1

Région centrale et de l'Arctique  
Programme de protection du poisson et de son  
habitat  
867 chemin Lakeshore  
Burlington, Ontario  
L7S 1A1

*Your file            Votre référence*

October 7, 2019

*Our file    Notre référence*  
19-HCAA-00837

Michael Gerrits  
R. Dobbin Engineering Inc.  
4218 Oil Heritage Road  
Petrolia, ON  
N0N 1R0

**Subject: Headwall and Enclosure Replacement, John Parks Drain No.1, C,  
Amhurstberg (19-HCAA-00837) - Implementation of Measures to Avoid  
and Mitigate the Potential for Prohibited Effects to Fish and Fish Habitat**

Dear Mr. Gerrits:

The Fish and Fish Habitat Protection Program (the Program) of Fisheries and Oceans Canada (DFO) received your proposal on July 9, 2019. We understand that you propose to:

- Replace an existing enclosed drain with a new HPDE pipe; and
- Replace an existing headwall structure.

Our review considered the following information:

- Request for Review and supporting documents submitted by Ryan Smith on July 9<sup>th</sup>, 2019;
- Email correspondence on August 16<sup>th</sup> with Mike Gerrits confirming that the area would be isolated from fish using a turbidity curtain; and
- Email correspondence with Mike Gerrits on August 22<sup>nd</sup> confirming that the enclosure will be replaced with an HPDE pipe.

Your proposal has been reviewed to determine whether it is likely to result in:

- the death of fish by means other than fishing and the harmful alteration, disruption or destruction of fish habitat which are prohibited under subsections 34.4(1) and 35(1) of the *Fisheries Act*; and
- effects to listed aquatic species at risk, any part of their critical habitat or the residences of their individuals in a manner which is prohibited under sections 32, 33 and subsection 58(1) of the *Species at Risk Act*.

The aforementioned impacts are prohibited unless authorized under their respective legislation and regulations.

To avoid and mitigate the potential for prohibited effects to fish and fish habitat (as listed above), we recommend implementing the measures listed below:

- Plan in-water works, undertakings and activities to respect timing windows to protect fish, including their eggs, juveniles, spawning adults and/or the organisms upon which they feed and migrate (<http://www.dfo-mpo.gc.ca/pnw-ppe/timing-periodes/index-eng.html>)
- No temporary or permanent increase in existing footprint below the high water mark
- Conduct in-water undertakings and activities during periods of low flow
- Limit the duration of in-water works, undertakings and activities so that it does not diminish the ability of fish to carry out one or more of their life processes (spawning, rearing, feeding, migrating)
- Develop and implement a Sediment Control Plan to minimize sedimentation of the waterbody during all phases of the work, undertaking or activity
  - Conduct all in-water works, undertakings or activities in isolation of open or flowing water to reduce the introduction of sediment into the watercourse
  - Schedule work to avoid wet, windy and rainy periods (and heed weather advisories)
  - Inspect and maintain regularly the erosion and sediment control measures and structures during all phases of the project
  - Remove all exposed non-biodegradable sediment control materials once site has been stabilized
  - Monitor the watercourse to observe signs of sedimentation during all phases of the work, undertaking or activity and take corrective action
  - Dispose and stabilize all dredged material above the high water mark of nearby waterbodies to prevent entry in the water
- Do not deposit any deleterious substances in the water course
- Develop and implement a response plan to avoid a spill of deleterious substances
  - Stop work, contain sediment-laden water and other deleterious substances and prevent their further migration into the watercourse
  - Keep an emergency spill kit on site during the work, undertaking or activity
  - Report any spills of sewage, oil, fuel or other deleterious material, whether near or directly into a water body
  - Ensure clean-up measures are suitably applied so as not to result in further alteration of the bed and/or banks of the watercourse

.../3

- Clean-up and appropriately dispose of the sediment-laden water and deleterious substances
- Maintain all machinery on site in a clean condition and free of fluid leaks
- Wash, refuel and service machinery and store fuel and other materials for the machinery in such a way as to prevent any deleterious substances from entering the water

Provided that you incorporate these measures into your plans, the Program is of the view that your proposal will not require an authorization under the *Fisheries Act* or the *Species at Risk Act*.

Should your plans change or if you have omitted some information in your proposal, further review by the Program may be required. Consult our website (<http://www.dfo-mpo.gc.ca/pnw-ppe/index-eng.html>) or consult with a qualified environmental consultant to determine if further review may be necessary. It remains your responsibility to remain in compliance with the *Fisheries Act*, avoid prohibited effects on listed aquatic species at risk, any part of their critical habitat or the residences of their individuals.

It is also your *Duty to Notify* DFO if you have caused, or are about to cause, the death of fish by means other than fishing and/or the harmful alteration, disruption or destruction of fish habitat. Such notifications should be directed to (<http://www.dfo-mpo.gc.ca/pnw-ppe/CONTACT-eng.html>)

Please notify this office at least 10 days before starting your project. A copy of this letter should be kept on site while the work is in progress. It remains your responsibility to meet all other federal, territorial, provincial and municipal requirements that apply to your proposal.

If you have any questions with the content of this letter, please contact Jessica Cotton at our Burlington office by email at [jessica.cotton@dfo-mpo.gc.ca](mailto:jessica.cotton@dfo-mpo.gc.ca). Please refer to the file number referenced above when corresponding with the Program.

Yours sincerely,



Sara Eddy  
Team Leader, Triage and Planning

# APPENDIX A

## Best Management Practices – Culvert Replacements in Municipal Drains

This document describes the conditions on which one may proceed with a culvert replacement in a municipal drain without DFO approval/notification. All municipal, provincial, or federal legislation that applies to the work being proposed must be respected. If the conditions/requirements below cannot be met, please complete the drain notification form and submit it to the Fisheries Protection Program form review at: [FisheriesProtection@dfo-mpo.gc.ca](mailto:FisheriesProtection@dfo-mpo.gc.ca).

### Potential Impacts to Fish Habitat

- Infilling fish habitat by encroachment of the water crossing footprint or channel realignment to accommodate culvert
- Harmful substrate alteration of fish habitat (e.g. blockage of groundwater upwellings, critical SAR habitat, spawning areas)
- Removal of riparian vegetation and cover along the banks of the municipal drain
- Removal of edge habitat (e.g. undercut bank, shallower areas with lower velocity, aquatic vegetation) creation of barriers to fish movement (e.g. perched crossings, velocity barriers, alteration of the natural stream gradient)
- Alteration of channel flow velocity and/or depth (e.g. oversized culvert resulting in insufficient depth for fish passage at low flow or undersized culvert resulting in a flow velocity barrier at high flow)
- Alteration of channel morphology and sediment transport processes caused by the physical structure of the crossing resulting in upstream and downstream sediment aggradation/erosion
- Re-entry of sediment that was removed/stockpiled into the watercourse
- Erosion downstream from sudden release of water due to the failure of site isolation
- Stranding of fish in isolated ponds following de-watering of the site
- Impingement or entrainment of fish when de-watering pumps are used
- Short term or chronic transport of deleterious substances, including sediment, into fish habitat from construction or road drainage

### Requirements

The following requirements must be met:

- There are no aquatic Species at Risk present in the work zone or impact zone. To confirm there are no aquatic Species at Risk present, refer to the document, [A Guide for Interpreting Fish and Mussel Species at Risk Maps in Ontario](http://www.dfo-mpo.gc.ca/Library/356763.pdf) which can be found at: <http://www.dfo-mpo.gc.ca/Library/356763.pdf>. Links for Ontario Conservation Area specific fish and mussel maps that include critical habitat extents and a list of aquatic Species at Risk found within the conversation authority boundary can be found on Page 5 of [A Guide for Interpreting Fish and Mussel Species at Risk Maps in Ontario](http://www.dfo-mpo.gc.ca/Library/356763.pdf).
- The culvert is embedded into the streambed and must allow for the free passage of fish.
- The work involves like-for-like replacements of existing road or private access culverts on all drain types without SAR.
- On C and F Drains only, this can also include replacements with extensions and end walls for the purposes of providing the property or road with safe access, but the project permanent footprint will not increase more than 250 m<sup>2</sup> below the high water mark.
- The project **does not** involve replacing a bridge or arch with one or more culverts installed in parallel or a larger-diameter culvert with more than one culvert installed in parallel.

- The project does not involve building more than one culvert installed in parallel on a single watercourse crossing site (e.g. twin culvert).
- The project does not involve temporarily narrowing the watercourse to an extent or for a duration that is likely to cause erosion, structural instability or fish passage problems.
- The municipal drain has no flow/low flow or is frozen to the bottom at the time of the replacement.
- In-water work is scheduled to respect timing windows (Tables 1 and 2) to protect fish, including their eggs, juveniles, spawning adults, and/or the organisms upon which they feed.
- The work can be conducted using the Culvert Removal Method described below and Standard Measures to Avoid Causing Serious Harm to Fish will be implemented when required.

Note: If your project must be conducted without delay in response to an emergency (e.g. the project is required to address an emergency that poses a risk to public health or safety or to the environment or property), you may apply for an Emergency Authorization (<http://www.dfo-mpo.gc.ca/asp/forceDownload.asp?FilePath=/pnw-ppe/reviews-revues/Emergency-Authorizations-Autorisations-Urgences-eng.pdf>).

### **Culvert Removal Methodology**

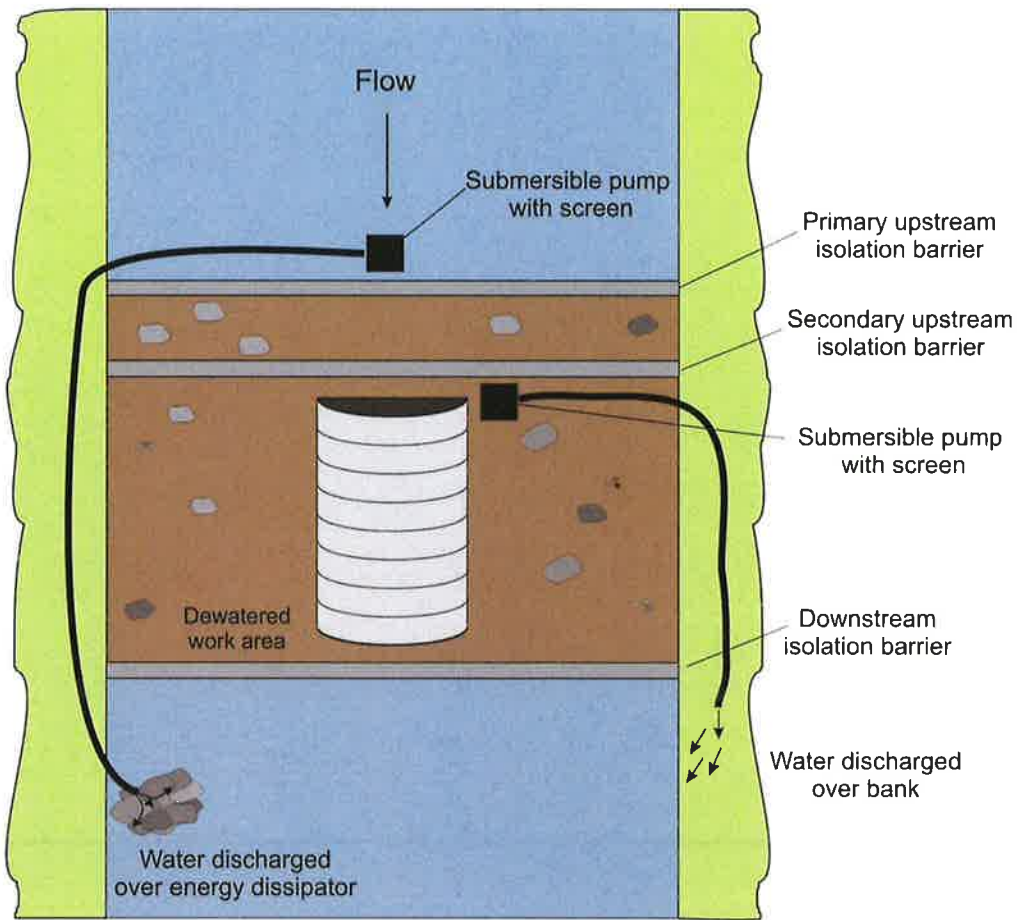
- Plan/manage the work site in a manner that prevents sediment from entering the municipal drain by installing sediment and erosion control materials where required. Ensure that a sediment and erosion control plan is developed and modified as necessary for the site.
- Where required, install effective erosion and sediment control measures before starting work to prevent sediment from entering the municipal drain.
- Implement site isolation measures when in-water work is required.
  - Install an impervious barrier upstream of the work area (Figure 1). If possible, install a secondary barrier upstream of the work area for added protection.
  - Attempt to drive out the fish from the work area and then install the impervious barrier downstream of the work area. This may reduce or eliminate the need for a fish salvage.
  - When the drain is flowing, maintain downstream flows (e.g. bypass water around the work site using pumps or flume pipes; Figure 2). Provide temporary energy dissipation measures (e.g. rip-rap) at discharge point of the hose or temporary outlet pipe when required. Routinely inspect bypass pump and hose or pipe to ensure proper operation. Inspect discharge point for erosion and reposition hose/pipe or install additional temporary energy dissipation material as needed.
  - Dewater the isolated work area. The hose for a pump may discharge along the top of the bank into existing vegetation; however, the area should be monitored for signs of erosion. Reposition the hose or install additional temporary energy dissipation material as needed.
  - A fish screen with openings no larger than 2.54 mm (0.10 inches) should be equipped on any pump used during the operation. Note: Additional information regarding fish screens can be found in the DFO Freshwater Intake End-of-Pipe Fish Screen Guideline document (<http://www.dfo-mpo.gc.ca/Library/223669.pdf>).
  - Collect any fish present in the isolated work area and relocate them downstream.
  - Fish salvage operations must be conducted under a license issued by the Ontario Ministry of Natural Resources and Forestry (MNRF). The MNRF should be contacted well in advance of any work to obtain the required fish collection license.
- Install the culvert so that it is embedded into the streambed; ensure the culvert remains passable (e.g. does not become perched) by fish and wildlife.

- Decommission the site isolation in a manner that minimizes the introduction of sediment. The downstream isolation barrier shall gradually be removed first, to equalize water levels inside and outside of the isolated area and to allow suspended sediments to settle.
- Stabilize and remove waste from the site.
- Where required, maintain effective erosion and sediment control measures until complete re-vegetation of disturbed areas is achieved.



**Figure 2. Isolation of Site**

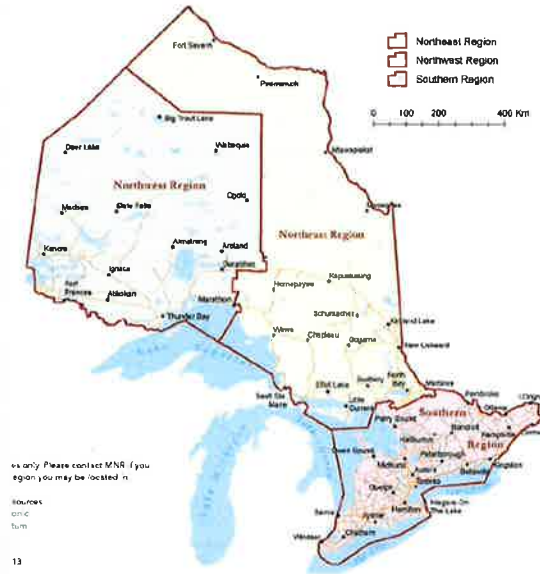




**Figure 3. Isolation and Bypass Diversion when Working In-Water**

## Timing Windows

Figure 1 and Tables 1 and 2 can be used to determine the Restricted Activity period for the drain based on its classification. Note: Timing windows identified on [Conservation Authority](#) permits or [Ministry of Natural Resources](#) (Government of Ontario) work permits may differ and take precedence.



**Figure 1. Ontario's Northern and Southern Region boundaries for determining application of restricted activity timing windows.**

**Table 1. Restricted Activity timing windows for the protection of spawning fish and developing eggs and fry in the Northern Region. Dates represent when work should be avoided.**

DRAIN TYPE	RESTRICTED ACTIVITY PERIOD
A	SEPTEMBER 1 TO JULY 15
B	SEPTEMBER 1 TO JULY 15
C	APRIL 1 TO JULY 15
D	SEPTEMBER 1 TO JULY 15
E	APRIL 1 TO JULY 15

**Table 2. Restricted Activity timing windows for the protection of spawning fish and developing eggs and fry in the Southern Region. Dates represent when work should be avoided.**

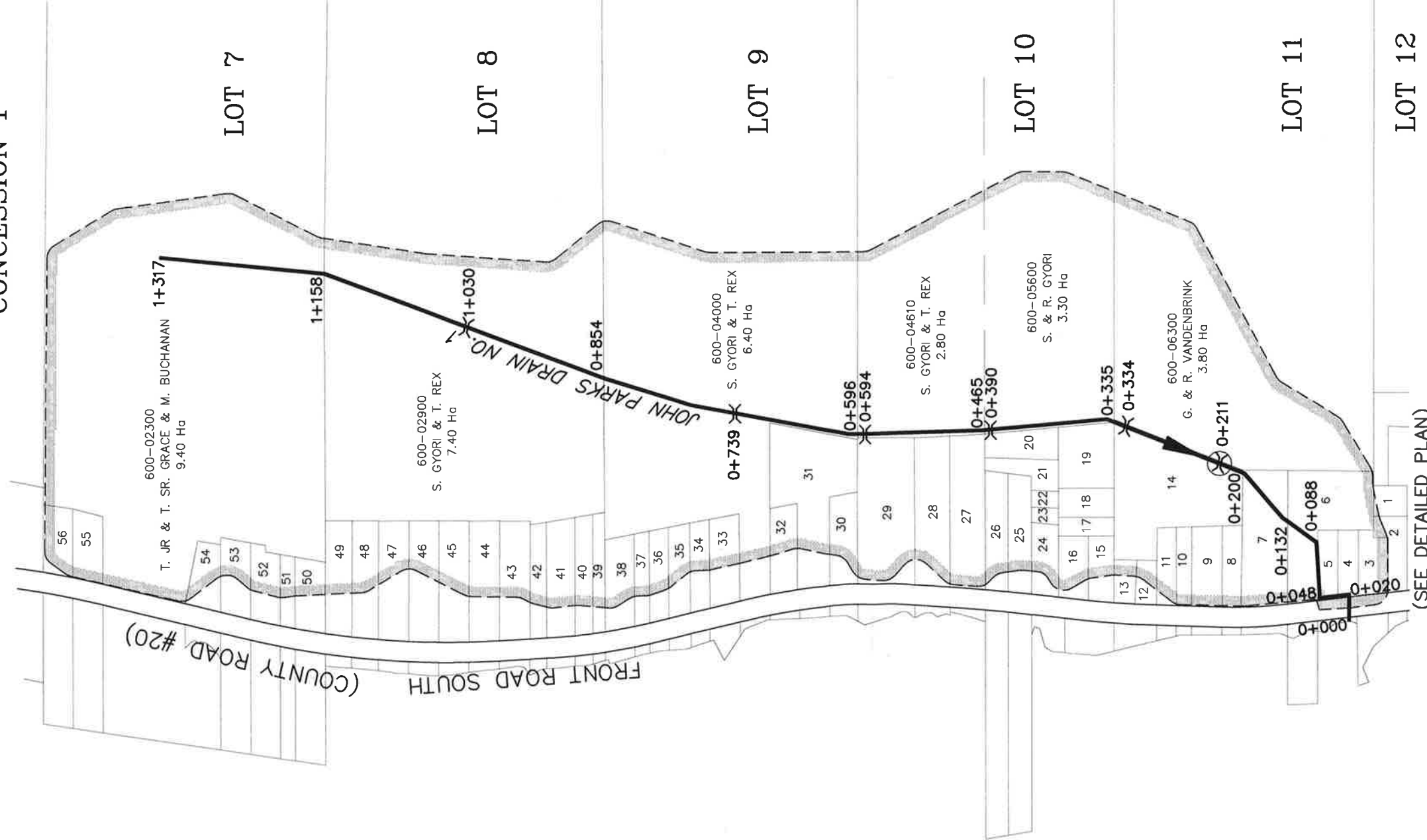
DRAIN TYPE	RESTRICTED ACTIVITY PERIOD
A	SEPTEMBER 15 TO JULY 15
B	MARCH 15 TO JULY 15
C	MARCH 15 TO JULY 15
D	OCTOBER 1 TO JULY 15
E	MARCH 15 TO JULY 15

### Standard Measures to Avoid Causing *Serious Harm to Fish*

When implementing a culvert removal project in a municipal drain, the *Fisheries Act* still requires an individual/company to ensure they avoid causing *serious harm to fish* during any activities in or near water. The following advice will help one avoid causing harm and comply with the *Act* (for additional information see <http://www.dfo-mpo.gc.ca/pnw-ppe/measures-mesures/measures-mesures-eng.html>).

1. Schedule work to avoid wet, windy and rainy periods that may increase erosion and sedimentation.
2. Whenever possible, operate machinery on land above the high water mark or on ice and in a manner that minimizes disturbance to the banks and bed of the municipal drain.
  - Ensure that machinery arrives on site in a clean condition and is maintained free of fluid leaks.
  - Limit machinery fording of the municipal drain to a one-time event (i.e., over and back), and only if no alternative crossing method is available. If repeated crossings of the municipal drain are required, construct a temporary crossing structure.
  - Wash, refuel and service machinery and store fuel and other materials for the machinery in such a way as to prevent any deleterious substances from entering the water.
  - Keep an emergency spill kit on site in case of fluid leaks or spills from machinery.
3. Install effective sediment and erosion control measures before starting work to prevent sediment from entering the municipal drain. Inspect them regularly during the course of construction and make all necessary repairs if any damage occurs.
4. Erosion and sediment control measures should be maintained until all disturbed ground has been permanently stabilized, suspended sediment has resettled to the bed of the municipal drain and runoff water is clear.
5. Undertake all in-water activities in isolation of open or flowing water while maintaining the natural flow of water downstream and avoid introducing sediment into the municipal drain.
6. Ensure applicable permits for relocating fish are obtained and relocate any fish that become trapped in isolated pools or stranded in newly flooded areas to the main channel of the watercourse.
7. Ensure that the water that is being pumped/diverted from the site is filtered (sediment remove) prior to being released (e.g. pumping/diversion of water to a vegetated area).
8. Implement measures for containing and stabilizing waste material (e.g. dredging spoils, construction waste and materials, commercial logging waste, uprooted or cut aquatic plants, accumulated debris) above the high water mark of nearby waterbodies to prevent re-entry.
9. Stabilize shoreline or banks disturbed by any activity associated with the project to prevent erosion and/or sedimentation, preferably through re-vegetation with native species suitable for the site.
10. If replacement rock reinforcement/armouring is required to stabilize eroding or exposed areas, then ensure that appropriately-sized, clean rock is used; and that rock is installed at a similar slope to maintain a uniform bank/shoreline and natural stream/shoreline alignment.
11. Remove all construction materials from site upon project completion.

CONCESSION 1



(SEE DETAILED PLAN)

LEGEND

- ▶ JOHN PARKS DRAIN NO. 1
- ▬ DRAINAGE AREA
- ( ) EXISTING CULVERT
- (⊗) EXISTING CULVERT TO BE REMOVED



4218 Oil Heritage Road  
Petrolia Ontario, N0N 1R0  
Phone: (519) 882-0032 Fax: (519) 882-2333



DRAWING NAME:  
John Parks Drain No. 1 Plan

PROJECT No.  
2018-933

TOWN of AMHERSTBURG

JOHN PARKS DRAIN NO.1  
PLAN

1  
OF 5

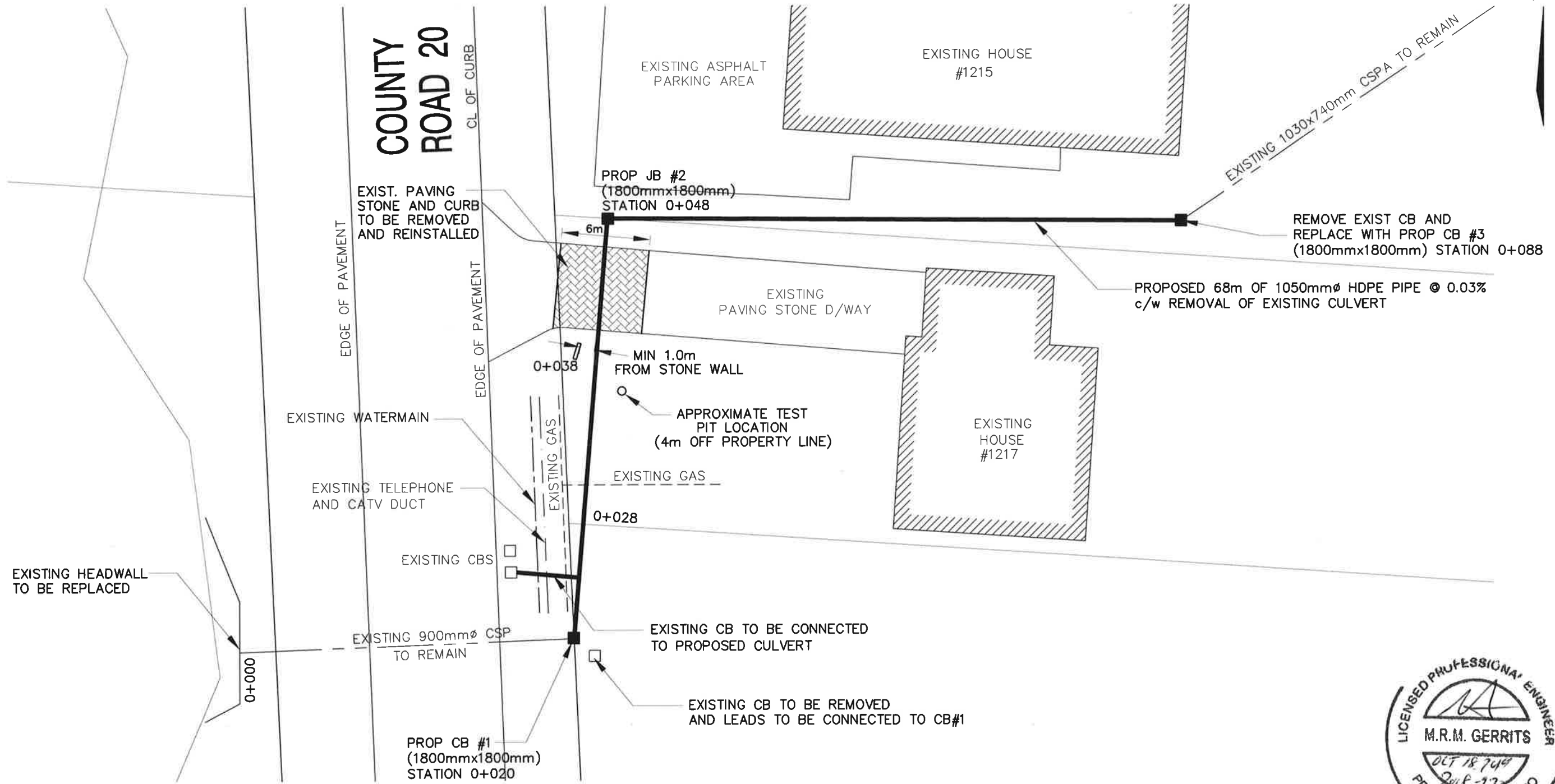
APPROVED	NO.	REVISIONS	DATE	BY
M. GERRITS				
CHECKED	1	FINAL REPORT	OCT. 18, 2019	JW
B. VAN RUITENBURG	SCALE: 1:5000			
DRAWN	0 50 100 150m			
J. WARNER				

OWNER INDEX NUMBER

1. 600-07500 E. & P. REAUME 0.01 Ha
2. 600-07400 2627884 ONTARIO INC. 0.02 Ha
3. 600-07300 2627884 ONTARIO INC. 0.18 Ha
4. 600-07201 2627884 ONTARIO INC. 0.14 Ha
5. 600-07200 F. & G. STORINO 0.14 Ha
6. 600-07100 F. & G. STORINO 0.73 Ha
7. 600-07000 T. & C. GILLEN 0.62 Ha
8. 600-06900 R. & C. SCOTT 0.16 Ha
9. 600-06800 M. SOULLIER 0.24 Ha
10. 600-06700 E. & E. MOONEY 0.12 Ha
11. 600-06600 J. NEUFELD 0.14 Ha
12. 600-06501 G. MICHAEL & J. McLAM 0.05 Ha
13. 600-06500 B. & S. SUITTS 1.19 Ha
14. 600-06400 B. & S. SUITTS 1.19 Ha
15. 600-06100 B. WILDER & J. KOTSIS-WILDER 0.11 Ha
16. 600-06000 G. & A. ESPOSITO 0.15 Ha
17. 600-05900 R. & S. GIBB 0.16 Ha
18. 600-05800 W. & S. GIBB 0.16 Ha
19. 600-05700 S. BERNYK 0.36 Ha
20. 600-05500 J. BROWN 0.20 Ha
21. 600-05400 R. & C. POUGET 0.15 Ha
22. 600-05300 W. PARE 0.05 Ha
23. 600-05200 J. & M. CRUMP 0.04 Ha
24. 600-05100 N. GYORGY 0.13 Ha
25. 600-05000 R. GIEGERICH 0.22 Ha
26. 600-04900 D. & R. DELBERT 0.23 Ha
27. 600-04800 H. & R. BROUGH 0.54 Ha
28. 600-04620 M. & D. GOBBATO & T. BERLASTY 0.47 Ha
29. 600-04400 R. LEVACK & L. BASTIEN 0.80 Ha
30. 600-04300 COULSON DESIGN-BUILD INC. 0.18 Ha
31. 600-04200 J. & L. NEUFELD 0.76 Ha
32. 600-04100 J. & L. NEUFELD 0.13 Ha
33. 600-03900 C. BILLINGSLEY 0.15 Ha
34. 600-03800 S. & T. WATERS 0.10 Ha
35. 600-03700 L. DIPIERDOMENICO 0.12 Ha
36. 600-03600 R. PARE 0.13 Ha
37. 600-03500 J. RICE & C. ARMSTRONG-RICE 0.10 Ha
38. 600-03400 S. & A. COLASANTI 0.21 Ha
39. 600-03300 R. & D. RIVARD 0.11 Ha
40. 600-03200 G. & A. BALOGH 0.16 Ha
41. 600-03100 J. LOVELL 0.25 Ha
42. 600-03000 H. & M. WALSCHOTS 0.12 Ha
43. 600-02965 L. & N. BIESZK 0.24 Ha
44. 600-02955 A. & G. PIZZUTO 0.23 Ha
45. 600-02945 R. & K. SPRY 0.21 Ha
46. 600-02935 S. & A. BAZINSKI 0.17 Ha
47. 600-02925 M. GOBBATO 0.17 Ha
48. 600-02916 J. HODGES & L. LAWRENCE 0.19 Ha
49. 600-02912 R. & C. BALL 0.19 Ha
50. 600-02800 D. & D. McWHINIE 0.10 Ha
51. 600-02700 G. & M. MAILLOUX 0.07 Ha
52. 600-02500 M. MAILLOUX 0.14 Ha
53. 600-02400 J. HUNT 0.12 Ha
54. 600-02301 J. & R. THRASHER 0.14 Ha
55. 600-02200 J. & L. GOODCHILD 0.20 Ha
56. 600-02100 M. & M. PILLON 0.18 Ha

**GENERAL NOTES**

1. ALIGNMENT MAY CHANGE TO ACCOMMODATE CONFLICTS WITH UTILITIES, SEPTIC, ETC.



4218 Oil Heritage Road  
 Petrolia Ontario, N0N 1R0  
 Phone: (519) 882-0032 Fax: (519) 882-2233

DRAWING NAME:  
 John Parks Drain No. 1 Detailed Plan

PROJECT No.  
 2018-933

APPROVED	NO.	REVISIONS	DATE	BY
M. GERRITS				
CHECKED	1	FINAL REPORT	OCT. 18, 2019	JW
B. VAN RUITENBURG				
DRAWN	SCALE 1:300			
J. WARNER	0 2 4 6m			

**TOWN of AMHERSTBURG**  
**JOHN PARKS DRAIN NO. 1**  
**DETAILED PLAN**

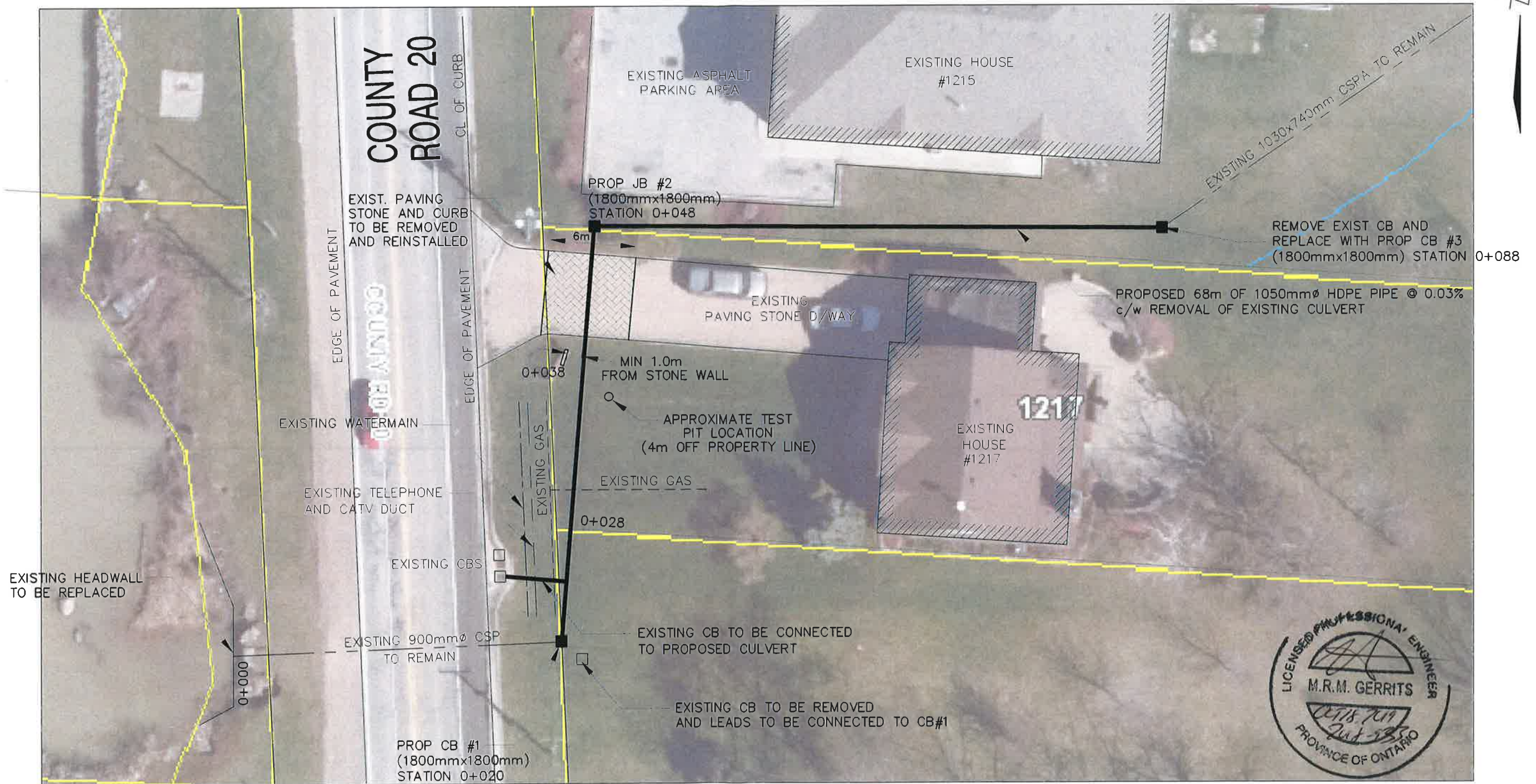
**2**  
**OF 5**

Last Updated: October 11, 2019



**GENERAL NOTES**

- ALIGNMENT MAY CHANGE TO ACCOMMODATE CONFLICTS WITH UTILITIES, SEPTIC, ETC.



4218 Oil Heritage Road  
 Petrolia Ontario, N0N 1R0  
 Phone: (519) 882-0032 Fax: (519) 882-2233

DRAWING NAME:  
 John Parks Drain No. 1 Detailed Plan

PROJECT No.  
 2018-933

APPROVED	NO.	REVISIONS	DATE	BY
M. GERRITS				
CHECKED	1	FINAL REPORT	OCT. 18, 2019	JW
B. VAN RUITENBURG				
DRAWN	SCALE 1:300			
J. WARNER	0 2 4 6m			

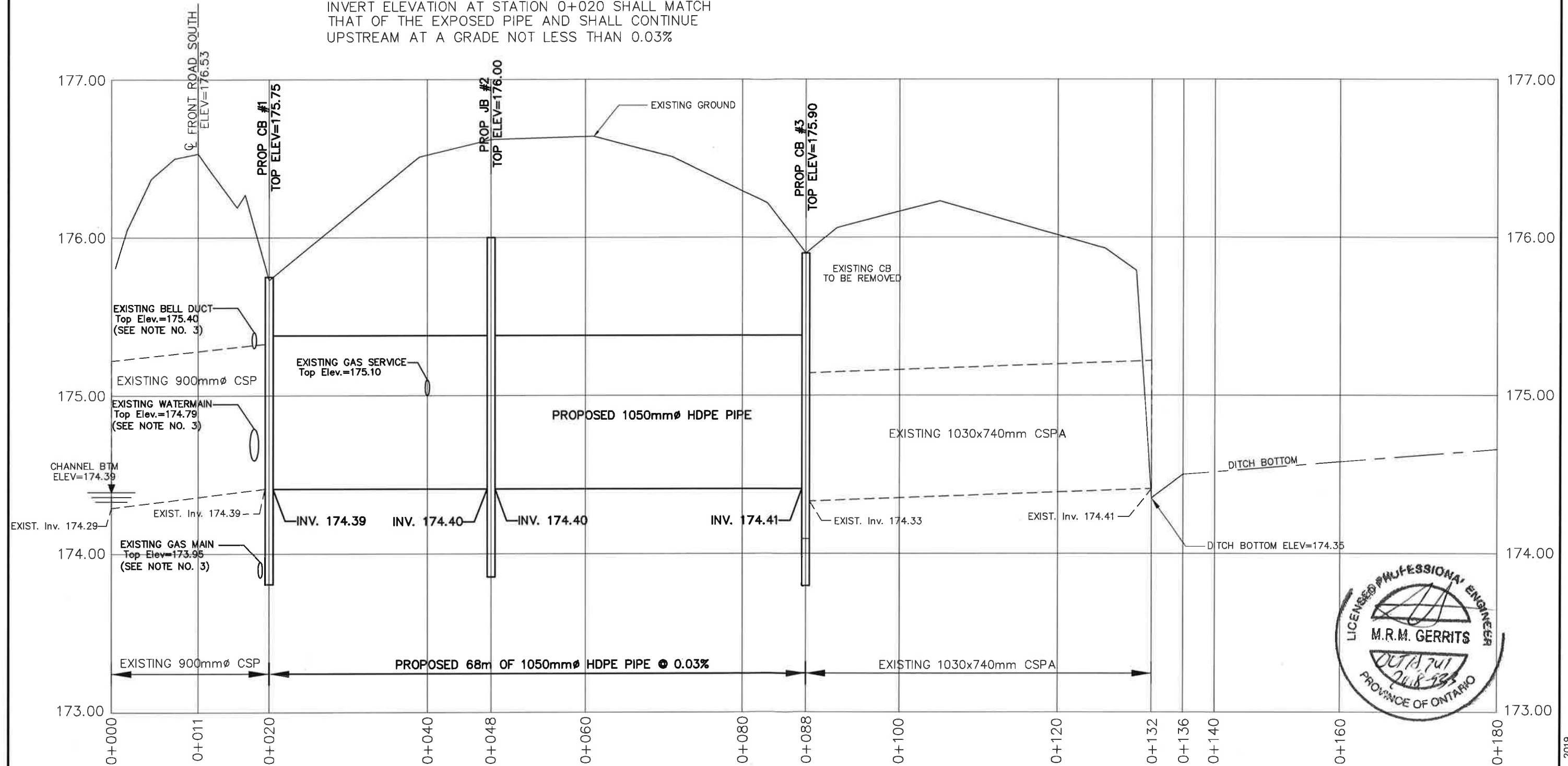
**TOWN of AMHERSTBURG**  
 JOHN PARKS DRAIN NO. 1  
 DETAILED PLAN

**3**  
**OF 5**

Last Updated: October 11, 2019

**GENERAL NOTES**

1. BENCHMARK No.1 ELEV. 177.35  
TOP SPINDLE OF FIRE HYDRANT  
AT #1205 FRONT ROAD SOUTH
2. EXISTING INVERT ELEVATIONS ARE AN APPROXIMATE  
AND SHALL BE CONFIRMED PRIOR TO CONSTRUCTION.  
IF THE INVERTS VARY COMPARED THOSE SHOWN, THE  
DRAINAGE SUPERINTENDENT OR ENGINEER SHALL BE  
CONSULTED BEFORE CONSTRUCTION. THE PROPOSED  
INVERT ELEVATION AT STATION 0+020 SHALL MATCH  
THAT OF THE EXPOSED PIPE AND SHALL CONTINUE  
UPSTREAM AT A GRADE NOT LESS THAN 0.03%
3. UTILITY LOCATES IDENTIFIED ON THE PROFILE  
WERE SHOT 10m NORTH OF THE ROAD CROSSING.  
THEIR ELEVATION MAY DIFFER AT THE ACTUAL  
LOCATION OF THE ROAD CROSSING.



**R Dobbin Engineering Inc.**  
 4218 Oil Heritage Road  
 Petrolia Ontario, N0N 1R0  
 Phone: (519) 882-0032 Fax: (519) 882-2233

DRAWING NAME:  
John Parks Drain No. 1 Profile

PROJECT No.  
2018-933

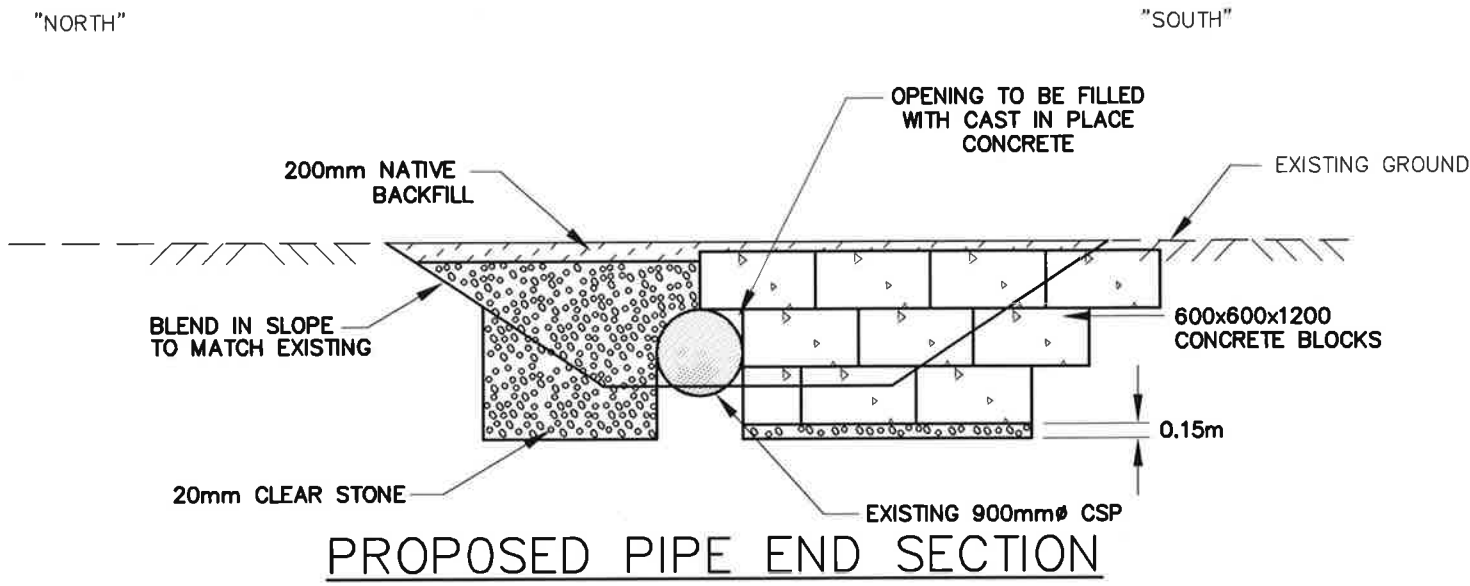
APPROVED	NO.	REVISIONS	DATE	BY
M. GERRITS				
CHECKED	1	FINAL REPORT	OCT. 18, 2019	JW
B. VAN RUITENBURG				
DRAWN	SCALE: 1:500			
J. WARNER	0 5 10 15m			

**TOWN of AMHERSTBURG**  
**JOHN PARKS DRAIN NO.1**  
**PROFILE**

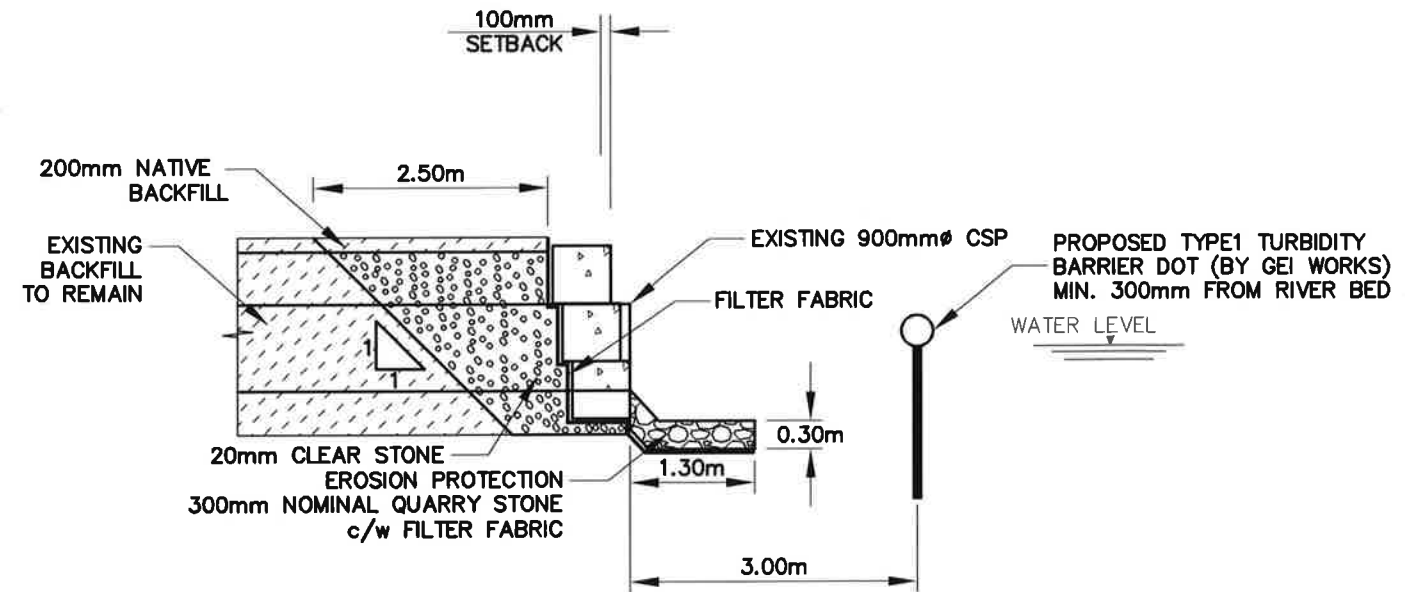
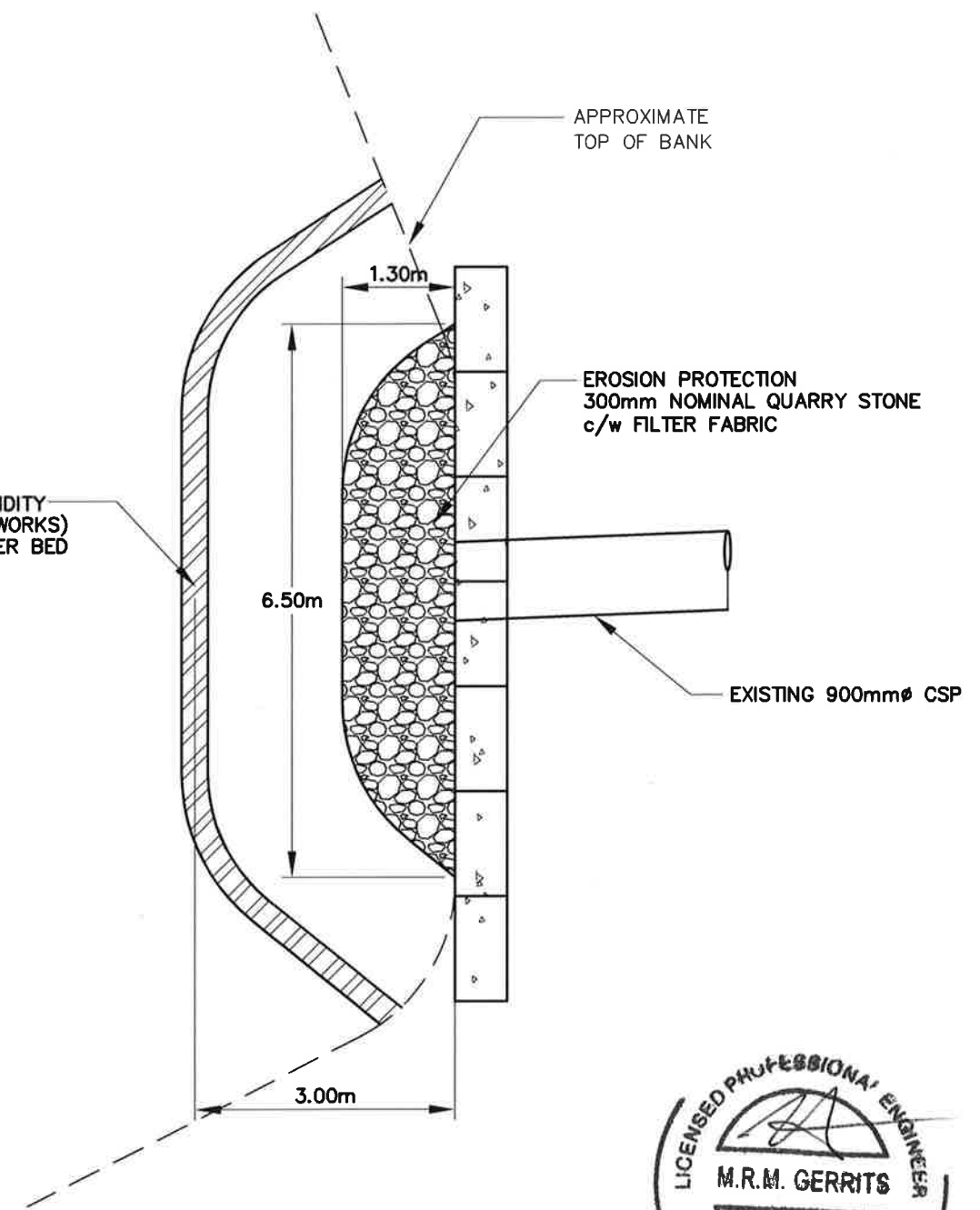
**4**  
**OF 5**

Last Updated: October 11, 2019





**PROPOSED PIPE END SECTION**



**PROPOSED CROSS-SECTION**



4218 Oil Heritage Road  
 Petrolia Ontario, N0N 1R0  
 Phone: (519) 882-0032 Fax: (519) 882-2233

DRAWING NAME:  
 John Parks Drain No. 1 Outlet Detail

PROJECT No.  
 2018-933

APPROVED	NO.	REVISIONS	DATE	BY
M. GERRITS				
CHECKED	1	FINAL REPORT	OCT. 18, 2019	JW
B. VAN RUITENBURG				
DRAWN				
J. WARNER				

SCALE 1:75

**TOWN of AMHERSTBURG**  
 JOHN PARKS DRAIN NO. 1  
 OUTLET DETAIL

5  
 OF 5

Last Updated: October 18, 2019

The Mayor and Council

October 29, 2019

Town of Amherstburg  
271 Sandwich Street South  
Amherstburg, Ontario  
N9V 2A5

Gentlemen and Mesdames:

**Re: John Parks Drain No. 1 – Report Revisions Recommended for the  
November 5, 2019 Meeting to Consider the Report**

The Drain report for the John Parks Drain No. 1 identifies that the outlet of the drain is governed by the Detroit River water levels. In correspondence with Essex Region Conservation Authority it was agreed to raise a catch basin inlet elevation 0.06 m and add a line to the report highlighting that water may surcharge the Front Road South roadside ditch under high water levels. The following changes have been made to the report.

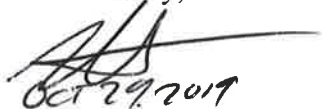
- 1 – The Design section on page 7 of the Engineers Report has been revised and is appended to this letter. The revisions include the bolded text.
- 2 – Specification 13 on page 7 of the Specifications has been revised and is appended to this letter. The revisions include a revised CB#1 inlet elevation. The elevation was revised from 175.69 m to 175.75 m.

The remainder of the report remains unchanged.

R. Dobbin Engineering Inc. is requesting that Council to review and consider the proposed changes at the November 5, 2019 Meeting to Consider the Report. If the revisions are accepted, the revised pages can be sent to the Landowners with the Notice of the Court of Revision. As part of my Meeting to Consider the Report presentation I will address the revisions and answer any questions for the adjacent landowner.

All of the above is submitted for your consideration.

Yours truly,



Mike Gerrits, P. Eng.

### Design

The proposed replacement between the outlet to the Detroit River (Station 0+000) and Station 0+132 shall be designed to accommodate a minimum 1 in 2 year storm event complete with maintenance provisions. The proposed drain will provide a better level of service for Landowners within the watershed, however it will not be designed to road standards. Due to the minimal grades, the cover on the drain will be minimal when it crosses under the road side ditches. Ditch grading will be required to increase the cover to a minimum of 0.3 m in these areas. Hydraulically, the drain is governed by the Detroit River water levels. **Under high water levels, water may surcharge into the Front Road South ditch at CB#1.** In order to utilize the capacity of the drain during elevated water levels, a pump system would be required.

### Estimate of Cost

It is recommended that the work be carried out in accordance with the accompanying Specification of Work and the Profile, which form part of this Report. There has been prepared an Estimate of Cost in the amount of \$145,260 including the following:

Construction	\$ 80,073
Construction Contingency Allowance	\$ 15,000
Allowances	\$ 1,340
Engineering	\$ 34,412
Updated Maintenance Schedule	\$ 2,000
Locates	\$ 3,350
Conservation Fees	\$ 800
Tendering (Provisional)	\$ 810
Inspection (Provisional)	<u>\$ 5,000</u>
Total	\$145,260

### Assessment

As per Section 21 of the Drainage Act, the Engineer in his report shall assess for benefit and outlet for each parcel of land and road liable for assessment. Outlet assessments shall be based on equivalent hectares which represents the amount of water generated on properties. The equivalent hectare area considers the properties impervious surfaces such as buildings, paved areas etc.

that the backfill on either side of the culvert does not differ by more than 300mm so that the pipe is not displaced.

The Contractor shall maintain a dry working area during construction. The Contractor shall install a silt fence downstream of the work area (at bottom end of channel improvement if all work is completed at the same time). The silt fence shall consist of filter fabric or manufactured silt fence supported with posts (OPSD 219.190). For access culverts that are to be constructed, a temporary dam may be necessary.

### 13. Catchbasins

The catch basins shall be installed to the elevations and in the locations shown on the drawings as follows:

Structure	Station	Type Elev. (mm)	Inlet (Top) (m)	Outlet Pipe Elev. (m)	Inlet Pipe Elev. (m)
CB #1	0+020	1800X1800	175.75	174.39 (914mm)	174.39 (1050mm)
CB #3	0+088	1800X1800	175.90	174.41 (1050mm)	174.33 (1030mmX740mm)

Note – CB#3 Inlet Invert lower than outlet invert

The structures shall be precast concrete structures as noted above. The structures shall have a flat top with herringbone grates in accordance with OPSD 400.0100.

The structures shall be made with the top sections separate from the base sections in order to allow riser sections to be installed or removed as necessary (i.e. the base section shall not extend for more than 150mm above the top of the highest opening in the base section). The wall thickness of all structures shall be 115mm and each shall have a 600mm sump.

The structures shall be set at the final elevations as directed by the Drainage Superintendent. The catch basins shall be set on a layer of clear stone. The clear stone shall be extended up to the springline of the inlet and outlet pipe connections.

The tile at the connection to the structures shall be concreted on both the inside and outside prior to backfilling. Any pipe or tile shall not protrude more than 50mm inside the wall.

**THE CORPORATION OF THE TOWN OF AMHERSTBURG**

**BY-LAW NO. 2019 – 095**

**By-law to provide for the John Parks No. 1 Drain Improvements based on the  
Drainage Report by R. Dobbin Engineering Inc.**

---

**WHEREAS** a request for repair and improvement of the on the John Parks No. 1 Drain was received under section 78 of the Drainage Act;

**WHEREAS** Council of the Corporation of the Town of Amherstburg felt it necessary to appoint an engineer for the purpose of preparation of an engineer's report for the John Parks No.1 Drain Improvements under section 78 of the Drainage Act;

**WHEREAS** Council of the Corporation of the Town of Amherstburg has authorized Mike Gerrits, P. Eng., to prepare a report and said engineer's report dated October 18, 2019, can be referenced as Schedule A, as attached hereto;

**WHEREAS** \$145,260.00 is the amount to be contributed by the Town of Amherstburg for the drainage works;

**AND WHEREAS** the report was considered by the Amherstburg Drainage Board at the meeting held on Tuesday, November 5<sup>th</sup>, 2019.

**NOW THEREFORE** the Council of the Corporation of the Town of Amherstburg hereby enacts as follows:

**1. AUTHORIZATION**

The attached report is adopted and the drainage works is authorized and shall be completed as specified in the report

**2. BORROWING**

The Corporation of the Town of Amherstburg may borrow on the credit of the Corporation the amount of \$145,260.00 being the amount necessary for the improvements of the drainage works.

This project being the John Parks No.1 Drain Improvements.

**3. DEBENTURE(S)**

The Corporation may issue debenture(s) for the amount borrowed less the total amount of:

- (a) Grants received under section 85 of the Drainage Act;
- (b) Monies paid as allowances;
- (c) Commuted payments made in respect of lands and roads assessed with the municipality;
- (d) Money paid under subsection 61(3) of the Drainage Act; and
- (e) Money assessed in and payable by another municipality.

**4. PAYMENT**

Such debenture(s) shall be made payable within 5 years from the date of the debenture(s) shall bear interest at a rate not higher than 1% more than the municipal lending rates as posted by The Town of Amherstburg's Bank's Prime Lending Rate on the date of sale of such debenture(s).

- (1) A special equal annual rate sufficient to redeem the principal and interest on the debenture(s) shall be levied upon the lands and roads as shown in the schedule and shall be collected in the same manner and at the same as

other taxes are collected in each year for 5 years after the passing of this by-law.

(2) For paying the amount \$1,668.00 being the amount assessed upon the lands and roads belonging to or controlled by the municipality a special rate sufficient to pay the amount assessed plus interest thereon shall be levied upon the whole rateable property in the Town of Amherstburg in each year for 5 years after the passing of this by-law to be collected in the same manner and at the same time as other taxes collected.

(3) All assessments of \$1000.00 or less are payable in the first year in which the assessments are imposed.

**5. SCHEDULE OF ASSESSMENTS OF LANDS AND ROADS**

Property Description				Estimated Assessment as per Report	Estimated Grants 33 1/3%	Annual Debenture Payment Amount
Lot or Part Lot No.	Concession	Geographic Township	Parcel Roll No.			
Pt. Lot 11	1	Malden	600-07201	\$3,590.00	\$0.00	808.11
Pt. Lot 11	1	Malden	600-07200	\$50,155.00	\$0.00	11,289.92
Pt. Lot 11	1	Malden	600-07100	\$16,047.00	\$0.00	3,612.19
Pt. Lot 11	1	Malden	600-06400	\$1,269.00	\$0.00	285.65
Pt. Lot 9	1	Malden	600-04200	\$1,275.00	\$0.00	287.00
Pt. Lot 11	1	Malden	600-06300	\$3,413.00	\$1,137.67	512.18
Pt. Lot 10&11	1	Malden	600-05600	\$3,113.00	\$1,037.00	467.31
Pt. Lot 10	1	Malden	600-04610	\$2,828.00	\$942.67	424.39
Pt. Lot 9	1	Malden	600-04000	\$5,500.00	\$1,833.33	825.37
Pt. Lot 8	1	Malden	600-02900	\$6,551.00	\$2,183.67	983.09
Pt. Lot 7	1	Malden	600-02300	\$7,827.00	\$2,609.00	1174.57
<b>Total</b>				<b>\$101,568.00</b>	<b>\$9,743.34</b>	<b>\$20,669.78</b>

Read a first and second time and provisionally adopted this 12<sup>th</sup> day of November, 2019.

\_\_\_\_\_  
MAYOR – ALDO DICARLO

---

CLERK – PAULA PARKER

Read a third time and finally passed this \_\_\_ day of \_\_\_\_\_, 2019.

---

MAYOR – ALDO DICARLO

---

CLERK – PAULA PARKER





THE CORPORATION OF THE TOWN OF AMHERSTBURG

OFFICE OF ENGINEERING AND PUBLIC WORKS

*MISSION STATEMENT: Committed to delivering cost-effective and efficient services for the residents of the Town of Amherstburg with a view to improve and enhance their quality of life.*

Author's Name: Shane McVitty	Report Date: October 21, 2019
Author's Phone: 519 736-3664 ext. 2318	Date to Drainage Board: November 5, 2019
Author's E-mail: <a href="mailto:smcvitty@amherstburg.ca">smcvitty@amherstburg.ca</a>	Resolution #: N/A

To: Members of the Drainage Board

Subject: John Parks Drain No.2 – Engineering Appointment

1. **RECOMMENDATION:**

It is recommended that:

1. The report from the Drainage Superintendent and Engineering Coordinator dated October 21, 2019, regarding the John Parks Drain No.2 – Engineering Appointment **BE RECEIVED**; and,
2. The Drainage Board recommend that Council **ACCEPT** the request from Peter Crump for the repair and improvement of the John Parks Drain No.2 per Section 78 of the Drainage Act; and,
3. The Drainage Board recommend that the appointment of the firm of R. Dobbin Engineering Inc. for the repair and improvement to the John Parks Drain No.1 **BE APPROVED** by Council.

2. **BACKGROUND:**

On April 12, 2019, Amherstburg resident Peter Crump submitted a request for the repair and improvement of the John Parks Drain No. 2. Mr. Crump has raised concerns regarding the condition of an existing drain enclosure pipe where it extends from Front Road (County Road 20) and through his residential property. Upon examination from Administration and follow-up discussions with landowners, it was determined that the existing corrugated steel pipe at 1369 County Road 20 was failing and has caused

sinkhole collapses within portions of the adjacent yard and lawn areas. The condition of the culvert to west of the roadway through 1370 County Road 20 is also questionable, and is starting to exhibit signs of deterioration. The subject enclosure pipes form part of the John Parks Drain No.2, which is a municipal drain in the Town of Amherstburg. Based on a review of the drain history and previous engineering reports, Administration is recommending that an engineer be appointed to complete an engineering report under the provisions of the Drainage Act in order to properly complete the required repairs.

### **3. DISCUSSION:**

The John Parks Drain No.2 Municipal Drain was last improved under a report authored by Nick Peralta, P. Eng. dated September 9, 1991. This report provided for the improvement of the entire length of the drain and included provisions for the installation of the subject enclosure pipe that is presently failing and located to the east of County Road 20. Other than the installation of a new, steel flap gate at the outlet culvert at the Detroit River, no other works were completed westerly of County Road 20. Through our review of previous drainage reports relating to the John Parks Drain No. 2, the details of the installation of the pipe-work west of County Road 20 are unclear. The following provides a brief historical overview of additional reports for the John Parks Drain No.2:

- Report dated August 11, 1913, by A. Baird, established the drain under the provisions of the Ditches and Watercourse Act.
- Report dated April 30, 1948, by C.G.R. Armstrong, P.Eng., constructed the upper 2,806 feet (855m) as a tile drain, with the balance of the drain constructed as an open drain, with the exception of the culvert crossing County Road 20.
- Report dated October 27, 1951, by C.G.R. Armstrong, P.Eng., extended the enclosure pipe at the outlet. This report notes that the culvert beneath County Road 20 is a concrete box structure, joining to an existing 36" (900mm) diameter, corrugated steel pipe (CSP) to the west of the roadway. The CSP was further extended by a distance of 46 feet to the River under this report.
- Report dated November 14, 1957, by C.G.R. Armstrong, P.Eng., provided for cleaning of the open drain upstream of County Road 20.
- Report dated September 15, 1969 by W.J. Settingington, P.Eng., provided for the installation of drainage tiles at the upstream end of the drain, along with clean-out of the open portion of the drain. There was no work completed on any of the drain enclosures under this report.

Through our review of the drainage history and following our site investigations, Administration has determined that there are issues relating to the bottom portion of the John Parks Drain No.2. Firstly, the existing reports that have been completed for the drain do not provide Administration with the necessary tools that it needs to complete the repair work to the failing culvert and assess the associated cost in a manner that is fair and equitable to affected landowners. Secondly, the enclosure to the west of County Road 20 was never formalized under the procedures of the Drainage Act and

was never adopted as part of the drain under municipal by-law. In the future, should the Town be required to perform any works of maintenance on this section of the drain, it would not have the technical specifications to do so, nor would it have any legal basis of assessment of cost. In order to rectify these shortcomings, an engineering report, adopted under by-law, is required.

A motion was passed at the January 15, 2018 Council Meeting to authorize administration to utilize a roster for drainage services under the Drainage Act. Among others, R. Dobbin Engineering Inc. was selected to be included as part of this roster and is thereby eligible to prepare a drainage report pursuant to Section 78 of the Drainage Act for repair and improvement to the John Parks Drain No.2.

**4. RISK ANALYSIS:**

The lower pipe enclosure within the John Parks Drain No.2 has been identified by Administration as needing replacement and is in poor condition. This culvert is over 28 years old and has collapsed in some areas. In addition, the enclosure to the west of County Road 20 has no legal status within the drain and the Municipality has no legal method for conducting future repairs or levying the associated assessments that would accompany these repairs. Failing to appoint an engineer to evaluate the lower portion of this drain and subsequently complete a report under the provisions of the Drainage Act in an expedient manner could place landowners in jeopardy should any of these concerns worsen. Also, the deterioration of culvert piping may permit gravel and earthen backfill to migrate into the drain. This can cause flow blockages, thereby decreasing the ability of the drain to efficiently convey water, resulting in an increased risk of water overtopping driveways and upstream flooding.

Under the Drainage Act, the municipality can be held responsible for damages due to flooding and bridge failures if the improvements are not completed.

**5. FINANCIAL MATTERS:**

The financial implications will be determined by the appointed engineer and will be provided in the schedule of assessment within the engineer's drainage report for the improvements to the John Parks Drain No.2.

**6. CONSULTATIONS:**

N/A

7. **CONCLUSION:**

Administration is recommending that the appointment of the firm of R. Dobbin Engineering Inc. for the repair and improvement to the John Parks Drain No.2 be brought to the next Regular Council meeting for Council's consideration pursuant to the provisions of the Drainage Act.



---

Shane McVitty  
**Drainage Superintendent and  
Engineering Coordinator**

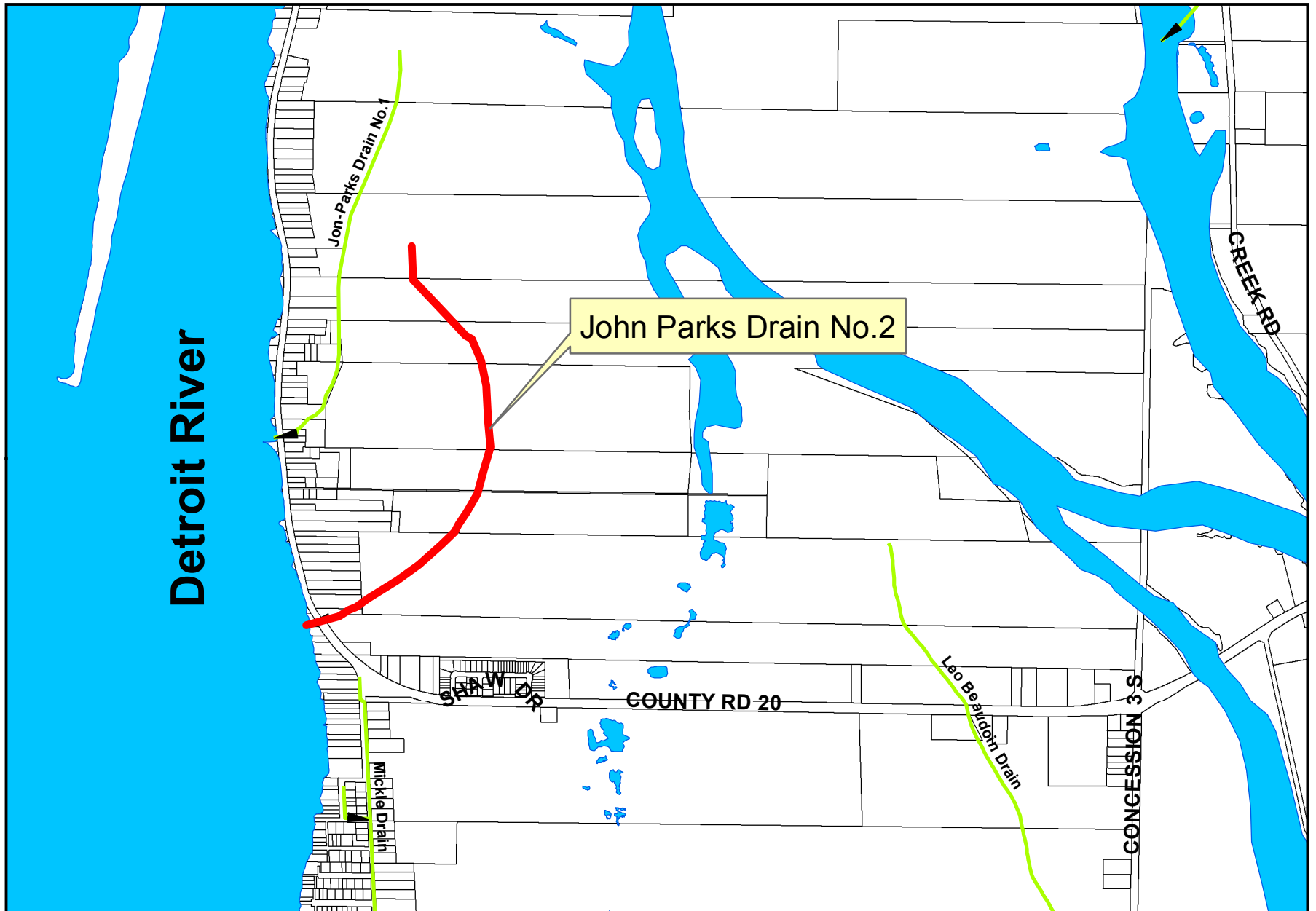
sm

**Attachment(s):**

- Request for Improvement submitted by Mr. Crump
- Maps of John Parks Drain No.2

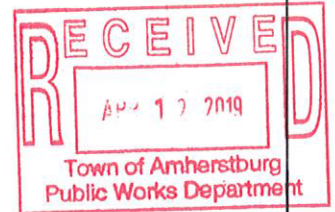


# John Parks Drain No. 2





# The Corporation of The Town of Amherstburg



## REPAIR/IMPROVEMENT of a MUNICIPAL DRAIN (Section 66, 76 and 78 Drainage Act)

FROM: Peter Crump

DRAIN: Jon Parks Drain No. 2

I/We are the owner of the following land(s): \_\_\_\_\_

Roll Number(s): [REDACTED]

And I/We request the following work on the above drain:

- a)  Subsequent Connections (Section 66(1))
- b)  New Schedule of Assessment (Section 76)
- c)  Improvements upon Examination and Report of Engineer (Section 78)
- d)  New Access Bridge (Section 78)

Residential Bridge

Agricultural Bridge

Culvert needs to be examined, there is a hole full of water beside culvert

I request that if necessary, an Engineer be appointed and that he will determine a time and place at which he will attend an on-site meeting and examine the drainage area with all assessed ratepayers to be invited.

In signing this form, the owner is advised that they may be charged for work performed by the appointed Engineer should the works not proceed as requested.

Dated this 12<sup>th</sup> day of April, 2019.

Peter Crump  
Signature of Owner

\_\_\_\_\_  
Signature of Owner

[REDACTED]

Telephone Number

\_\_\_\_\_  
Telephone Number



## THE CORPORATION OF THE TOWN OF AMHERSTBURG

### OFFICE OF ENGINEERING AND PUBLIC WORKS

*MISSION STATEMENT: Committed to delivering cost-effective and efficient services for the residents of the Town of Amherstburg with a view to improve and enhance their quality of life.*

<b>Author's Name: Shane McVitty</b>	<b>Report Date: October 22, 2019</b>
<b>Author's Phone: 519 736-3664 ext. 2318</b>	<b>Date to Drainage Board: November 5, 2019</b>
<b>Author's E-mail: <a href="mailto:smcvitty@amherstburg.ca">smcvitty@amherstburg.ca</a></b>	<b>Resolution #: N/A</b>

**To: Members of the Drainage Board**

**Subject: Subsequent Connection – Tremblay Drain (Lepera Section 65)**

---

#### 1. **RECOMMENDATION:**

It is recommended that:

1. The report from the Drainage Superintendent and Engineering Coordinator dated October 22, 2019, regarding the Subsequent Connection – Tremblay Drain (Lepera Section 65) **BE RECEIVED**;
2. The engineer's report, prepared by Rood Engineering Inc. on October 2, 2019, for the Tremblay Drain (Lepera Section 65) **BE RECEIVED**;
3. The assessment adjustments as listed in the engineering report prepared by Rood Engineering Inc. **BE APPROVED**, and;
4. Administration **BRING FORWARD** the Drainage Board's recommendation to approve the assessment adjustments at a future Regular Council Meeting.

#### 2. **BACKGROUND:**

Under the provisions of the Drainage Act, when lands that are not assessed for drainage wish to subsequently connect those lands to a drain for the purpose of drainage, or if the nature of the use of the lands are subsequently altered, the Municipality must take steps to examine such changes and assess the lands for a just proportion of the drainage works. Under these circumstances, the Municipality is required to instruct an engineer to inspect the lands and drainage works in question and complete the necessary reapportionment of assessments relating to the affected drain(s). In this case, the proposed development at 7751 Howard Avenue has



requested that an engineer perform the necessary examinations and complete the required reapportionments to accommodate additional discharge into the Tremblay Drain.

### 3. **DISCUSSION:**

Section 65 of the Drainage Act discusses the obligation of a Municipality to manage changes in assessments due to sub-divisions of land, subsequent connections and disconnections of lands from drainage works, and the altering of the nature or extent of land usage for the purpose of drainage. Section 65(3) requires the Municipality to instruct an engineer to complete the necessary examinations and make the assessment adjustments to lands that subsequently connect to a drainage work. Specifically, the procedures by which subsequent connections are to be administered are outlined under Section 65(3) of the Act, which stipulates that:

#### **Subsequent connection to drainage works, etc.**

*65. (3) If an owner of land that is not assessed for a drainage works subsequently connects the land with the drainage works for the purpose of drainage, or if the nature or extent of the use of a drainage works by land assessed for the drainage works is subsequently altered, the clerk of the local municipality in which the land is situate shall instruct an engineer in writing to inspect the land and assess it for a just proportion of the drainage works, taking into account any compensation paid to the owner of the land in respect of the drainage works. 2010, c. 16, Sched. 1, s. 2 (26).*

In this case, the owners of the lands at 7751 Howard Avenue [REDACTED] intend to increase their usage of the Tremblay Drain to better suit their proposed industrial development and associated private Storm Water Management (SWM) facilities. Presently, only 9.17 hectares (22.66 acres) of the total 10.241 hectares (25.31 acres) are assessed to the Tremblay Drain. The owners of the property wish to direct the remaining 1.071 hectares (2.65 acres) to the Tremblay Drain. Pursuant to the provisions of the Drainage Act, the Town instructed Gerard Rood, P.Eng., to complete an examination of the Tremblay Drain and subsequent connection of the remaining lands into said drain.

As part of his work, Mr. Rood has submitted the attached report that addresses the subsequent connection and provides an assessment of costs to the subject lands into the Tremblay Drain. Mr. Rood's report also considers the nature and extent of the land usage being proposed in his assessment rationale. In the future, when works of maintenance are performed on the Tremblay Drain, these adjusted assessment values will be applied to ensure that associated maintenance costs are fairly and accurately assessed.

Subsequent connections, once accepted by the Drainage Board and approved by Council through resolution, will be reflected in the assessments of all future works of maintenance on the Tremblay Drain.

**4. RISK ANALYSIS:**

Under the Drainage Act, when lands that are not assessed for drainage wish to subsequently connect to a drain for the purposes of drainage, or if the nature or usage of lands is subsequently altered, it is the Municipality's obligation to take the proper steps to examine and complete the necessary assessments to reflect the changes. Failing to do so could lead to unfair assessments of drain maintenance costs that do not accurately reflect the prevalent drainage conditions within the watershed. This could lead to conflicts between the Municipality and landowners over drainage assessments and the possible denial of agricultural grants from the Ontario Ministry of Agriculture, Food and Rural Affairs (OMAFRA).

**5. FINANCIAL MATTERS:**

Section 65(10) of the Drainage Act stipulates the following:

**Costs**

*65 (10) The costs of the assessment, including the fees of the engineer, shall be paid by the owners of the lands in the proportion fixed by the engineer or, on appeal, by the Tribunal, and subsection 61 (4) applies to these costs. 2010, c. 16, Sched. 1, s. 2 (26).*

Accordingly, all costs associated with the preparation of the engineering report will be paid for by the owner of the lands at 7751 Howard Avenuem [REDACTED]

**6. CONSULTATIONS:**

N/A

7. **CONCLUSION:**

Administration is recommending that the assessment adjustments provided in the report prepared by Rood Engineering Inc. on October 2, 2019, for the Tremblay Drain (Lepera Section 65) be approved and that said assessment adjustments be approved by Council resolution.



---

Shane McVitty  
**Drainage Superintendent and  
Engineering Coordinator**

sm

**Attachment(s):**

- Tremblay Drain (Lepera Section 65) – report prepared by Gerard Rood, P.Eng., dated October 2, 2019.
- Landowner submission for Request for Subsequent Connection

October 2nd, 2019

Corporation of the Town of Amherstburg  
512 Sandwich Street South  
Amherstburg, Ontario  
N9V 3R2

Attention: Shane McVitty, P.Eng.  
Drainage Superintendent

Dear Shane:

**TREMBLAY DRAIN (Lepera Section 65) E09-2017-007  
(Geographic Twp. of Anderdon)  
Project REI2017D008  
Town of Amherstburg, County of Essex**

## **1.0 Authorization**

In accordance with instructions received from the Municipality on March 2nd, 2017, we have made all of the necessary investigations and determinations for the preparation of a report, in accordance with Section 65 of the "Drainage Act, R.S.O. 1990, Chapter D.17, as amended 2010". This report deals with adjustments to the Value of Outlet Liability within Parcel 470-00400 owned by 2402592 Ontario Inc. and being utilized by J.&J. Lepera Infrastructures Inc., to reflect its utilization of the "Tremblay Drain" for an increase in total flow volumes from the parcel due to the proposed industrial development on the site, along with diversion of flows from the central portion of the site out of the Drouillard D&W Drain to the Tremblay Drain. The affected parcel is located at 7751 Howard Avenue and is shown on the plans in **Appendix "REI-B"**.

Our appointment to deal with this request, where "the nature or extent of the use of a drainage works by land assessed for the drainage works is subsequently altered", is in accordance with and pursuant to Section 65.(3) of the "Drainage Act, R.S.O. 1990, Chapter D.17, as amended 2010". We have inserted herein a copy of Section 65 for reference purposes, labeled **Appendix "REI-A"**. We have therefore performed all of the necessary research, investigations, and review of all pertinent documentation, etcetera for the carrying out of our study and we report thereon as follows.

## **2.0 Background**

From plans and information provided by the Owner's engineer, Dillon Consulting Limited (Dillon), and the Town, we have established those areas that are to be developed and diverted that will result in increased total flow volumes to the "Tremblay Drain". Work on the parcel will include preparation and approval of storm water management reports and plans by Dillon and these reports and plans must be submitted to the Town for review and approval of new industrial development on the site.

We have also obtained reference information from the Town Drainage Department for the affected portion of the drain, including the current governing by-law, being the March 14th, 1984 report, and the assessment schedule within same that are for the "Tremblay Drain", which was prepared by Mike Horan, P.Eng. We find that the lands affected by the proposed industrial

development are the parcel shown in the Horan report that was owned by Orville Bondy, and described as Part Lot 11, Concession 7, Geographic Township of Anderdon.

### **3.0 Existing Drainage Conditions**

From our review of the plans dated April 1st, 2014 as carried out on behalf of J.&J. Lepera Infrastructures Inc. (parcel currently owned by 2402592 Ontario Inc.) by Dillon, we were able to establish the overall parcel areas affected by this study.

We reviewed the latest engineer's report on the "Tremblay Drain", which is the March 14th, 1984 report by Mike Horan, P.Eng. From same we were able to determine which areas within the affected parcel are currently assessed to and utilize the "Tremblay Drain" as an outlet.

Based on the above research and investigations, we have plans prepared by Dillon included herein as **Appendix "REI-B"** which show:

1. the boundaries of the affected Parcel 470-00400 owned by 2402592 Ontario Inc. (J.&J. Lepera Infrastructures Inc.)
2. the proposed development for the industrial site
3. the proposed S.W.M. design

Parcel 470-00400 currently comprises approximately 10.241 hectares (25.31 acres) and encompasses the entire portion of the original parcel. The parcel is presently assessed the following affected area to the "Tremblay Drain" in the current report:

- a) Parcel 470-00400      9.17 hectares (22.66 acres)

This is confirmed by the March 14th, 1984 report and assessment schedule for the "Tremblay Drain" prepared by Mike Horan, P.Eng.

### **4.0 Allowable Release Rates and Storm Water Management**

The S.W.M. report documentation provided by the Owners' consultant Dillon to the Town will show that storm water management (S.W.M.) practices are being or are intended to be utilized for the proposed industrial development on the parcel. Under no circumstance would the additional runoff volumes be permitted to drain into the "Tremblay Drain" unless storm water management is provided. The storm water management systems must ensure that the allowable release rate into the "Tremblay Drain" for the parcel does not exceed the 1:2 year storm pre-development runoff rate for the entire area to be connected based on utilizing a maximum outflow rate of 110 litres/second up to and including for a 1:100 year storm as per the Dillon analysis. Under no circumstance should the Town consider allowing the increased total flow volumes into the "Tremblay Drain" unless this condition is met. Proper storm water management facilities restricting the flows to the allowable release rate will ensure that the subsequent flows will have no adverse effect on the capacity of the "Tremblay Drain".

Storm water management reports must be prepared for any proposed development taking the allowable release rate into consideration, and these should be submitted to the Town for review

by the staff and approved by them and the Essex Region Conservation Authority (E.R.C.A.) before any work proceeds.

The flows from the parcel will generally outlet at the west side of the original Parcel 470-00400 and discharge directly to the “Tremblay Drain” along the east side of Howard Avenue (County Road 9). We also find that the use of S.W.M. controls will reduce the peak flows in the drain and therefore the industrial development will not adversely impact on the downstream drain sections and the receiving Shuell Creek Drain watercourse. Based on our findings, we believe that it is reasonable to allow for the increased total flow volumes from the proposed industrial lands into the Tremblay Drain, provided that the necessary storm water management provisions are made and maintained for the proposed industrial use and any future expansions.

## **5.0 Subsequent Connection Charges**

We find that the area being drained to the “Tremblay Drain” from the affected parcel will be increased as a result of the industrial development. Normally an increase in parcel area would result in buy-in charges to the affected parcel for the additional area being brought into the drain based on the remaining life of any recent work carried out on the Municipal drain. For this project we find from our investigations with the Town that the total area from the affected parcel now draining to the “Tremblay Drain” will become 10.241 hectares (25.31 acres), which is an increase from the 9.17 hectares (22.66 acres) of affected area that was originally assessed for the parcel. Accordingly, there is an area of approximately 1.071 hectares (2.65 acres) that requires a subsequent connection to the drain and consequently charges are required to the affected parcel for the area being brought into the drain; however, the Town has checked their records and there are no maintenance works with a remaining life at this time and therefore there is no current buy-in cost. As noted above, the S.W.M. controls must restrict the outflow rate to the 1:2 year predevelopment rates from the original affected area of the parcel up to and including for the 1:100 year storm and therefore no adverse impact on flow rates in the drain will occur.

## **6.0 Assessment for Increased Flow Volumes**

With implementation of a storm water management system limiting the outflows into the “Tremblay Drain” to the pre-development flow rate, as outlined above, the increased total flow volumes from the affected parcel would have no adverse effect on the capacity of the “Tremblay Drain”. Therefore, based on the above conditions, we find that the “Tremblay Drain” has the ability to accept the additional total flow volumes from within the affected parcel, and we are therefore prepared to recommend the approval of this industrial development with respect to storm drainage.

If the Town of Amherstburg is prepared to approve the increased total flow volumes from the lands of 2402592 Ontario Inc. (J.&J. Lepera Infrastructures Inc.) into the “Tremblay Drain”, an update to the assessments is to be established by the engineer and the cost for same shall be charged entirely to the owners of the affected lands. Section 65.(3) of the “Drainage Act, R.S.O. 1990, Chapter D.17, as amended 2010” requires that “*where the nature or extent of the use of a drainage works by land assessed for the drainage works is subsequently altered, an engineer appointed by the Municipality for the purpose shall make an inspection and assess the land for a just proportion of the drainage works*”.

From our investigations of the Town’s drainage files, we have determined that the drainage works for which the affected parcel must be assessed for a just proportion is the “Tremblay Drain”.

The increased Outlet Liability charge to the owners of the affected parcel should be based on the increased total flow volumes from the already assessed area and from the portions to be subsequently connected to the “Tremblay Drain”.

**7.0 Assessment Adjustments for Increased Total Flow Volume**

We find that the Parcel affected in the March 14th, 1984 report and assessment schedule owned at the time by Orville Bondy, should have its “Value of Outlet Liability” and “Total Value of Improvement” amounts adjusted to reflect the increased total flow volume that will result from the proposed industrial development on the parcel. The “Value of Benefit” for this parcel will remain unchanged from the value shown in the original 1984 report.

**8.0 Future Maintenance Charges**

Based on our review of the existing and proposed areas of building construction and hard surface areas that are there now and that are to be created by the development of the site, we find that the following adjustments should be made to the March 14th, 1984 assessment schedule for the Outlet and Total Values:

<u>Description</u>	<u>Ha. Afft’d</u>	<u>Original Value of Outlet</u>	<u>Original Total Value</u>	<u>Updated Value of Outlet</u>	<u>Updated Total Value</u>
<b><u>2402592 Ontario Inc. (J.&amp;J. Lepera Infrastructures Inc.) (470-00400)</u></b>					
former Orville Bondy	10.241	\$645.00	\$1,310.00	\$1,078.00	\$1,743.00
<b>UPDATED TOTAL ON LANDS</b>				<b>\$4,478.00</b>	<b>\$8,878.00</b>
<b>UPDATED TOTAL ASSESSMENT</b>				<b>\$5,483.00</b>	<b>\$15,948.00</b>

In accordance with Section 65.(3) of the “Drainage Act, R.S.O. 1990, Chapter D.17, as amended 2010”, we recommend that the values in the March 14th, 1984 Schedule of Assessment which is included within the current governing by-law be amended for the current affected parcel to show the updated values as noted above, being an increase of \$433.00.

Therefore, in accordance with Section 65.(3) of the “Drainage Act, R.S.O. 1990, Chapter D.17, as amended 2010”, we recommend that the above noted updated values be collected from the affected parcel by the Town of Amherstburg on a pro-rata basis only when there is future maintenance or repairs of the “Tremblay Drain”, pursuant to the “Drainage Act, R.S.O. 1990, Chapter D.17, as amended 2010”.



## 9.0 Summary and Recommendations

As already established herein, we have conducted a drainage study of the “Tremblay Drain” and have determined that the increased total flow volumes for Parcel 470-00400 from development as an industrial site and diversion of flows, as shown on the plans within **Appendix “REI-B”**, shall not adversely affect the performance of said Municipal Drain as long as the Storm Water Management (S.W.M.) facilities limit the total release rate allowed into said drain to the 1:2 year pre-development runoff of 110 litres/second from the originally assessed area.

The pre-development runoff to be utilized shall be 110 l/s for these lands and shall be established in the current and any future Storm Water Management Reports to be submitted to the Town of Amherstburg and E.R.C.A. for their approval.

We have also established herein updated Value of Outlet charges to be paid by the affected Parcel 470-00400, which is a reflection of the increased total flow volumes from the developed site.

Based on all of the above, we would therefore recommend that the Town of Amherstburg approve the proposed industrial development and flow diversion and increased volume for Parcel 470-00400 into the “Tremblay Drain”, as long as all of the above requirements and conditions are complied with. We further recommend that the costs for preparation of this report be assessed 100% to the affected Parcel 470-00400 that is being developed.

If you, or Council, have any questions regarding this “Changes in Assessment Report”, please do not hesitate to contact us. It is our understanding that this report is to be approved at the earliest to allow for construction works to be carried out on the proposed industrial development.

We respectfully remain,

Yours truly,

**Rood Engineering Inc.**



Gerard Rood, P.Eng.



GR

Att.

## APPENDIX "REI-A"

## SPECIAL PROVISIONS

### **Changes in assessment**

#### **Subsequent subdivision of land**

**65.** (1) If, after the final revision of an engineer's assessment of land for a drainage works, the land is divided by a change in ownership of any part, the clerk of the local municipality in which the land is situate shall instruct an engineer in writing to apportion the assessment among the parts into which the land was divided, taking into account the part of the land affected by the drainage works. 2010, c. 16, Sched. 1, s. 2 (26).

#### **Agreement on share of assessment**

(2) If the owners of the subdivided land mutually agree on the share of the drainage assessment that each should pay, they may enter into a written agreement and file it with the clerk of the local municipality and, if the agreement is approved by the council by resolution, no engineer need be instructed under subsection (1). 2010, c. 16, Sched. 1, s. 2 (26).

#### **Subsequent connection to drainage works, etc.**

(3) If an owner of land that is not assessed for a drainage works subsequently connects the land with the drainage works for the purpose of drainage, or if the nature or extent of the use of a drainage works by land assessed for the drainage works is subsequently altered, the clerk of the local municipality in which the land is situate shall instruct an engineer in writing to inspect the land and assess it for a just proportion of the drainage works, taking into account any compensation paid to the owner of the land in respect of the drainage works. 2010, c. 16, Sched. 1, s. 2 (26).

#### **Subsequent disconnection from drainage works**

(4) If an owner of land that is assessed for a drainage works subsequently disconnects the land from the drainage works, the clerk of the local municipality in which the land is situate shall instruct an engineer in writing to inspect the land and determine the amount by which the assessment of the land should change. 2010, c. 16, Sched. 1, s. 2 (26).

#### **Restriction on connection or disconnection**

(5) No person shall connect to or disconnect from drainage works without the approval of the council of the municipality. 2010, c. 16, Sched. 1, s. 2 (26).

#### **Notice of instructions**

(6) The clerk of the local municipality shall send a copy of the instructions mentioned in subsection (1), (3) or (4) to the owners of the affected lands as soon as reasonably possible. 2010, c. 16, Sched. 1, s. 2 (26).

#### **Engineer's assessment**

(7) An engineer who prepares an assessment pursuant to instructions received under subsection (1), (3) or (4) shall file the assessment with the clerk of the local municipality. 2010, c. 16, Sched. 1, s. 2 (26).

#### **Notice of assessment**

(8) The clerk of the local municipality shall attach the engineer's assessment to the original assessment and send a copy of both to the owners of the affected lands. 2010, c. 16, Sched. 1, s. 2 (26).

#### **Assessment binding**



(9) Subject to subsection (11), the engineer's assessment is binding on the assessed land. 2010, c. 16, Sched. 1, s. 2 (26).

### **Costs**

(10) The costs of the assessment, including the fees of the engineer, shall be paid by the owners of the lands in the proportion fixed by the engineer or, on appeal, by the Tribunal, and subsection 61 (4) applies to these costs. 2010, c. 16, Sched. 1, s. 2 (26).

### **Appeal of assessment**

(11) If the engineer's assessment is for an amount greater than \$500, the owner of the land may appeal to the Tribunal within 40 days after the date the clerk sends a copy of the assessment to the owner. 2010, c. 16, Sched. 1, s. 2 (26).

### **Use of amount collected**

(12) Any amount collected under subsection (3) shall be credited to the account of the drainage works and shall be used only for the improvement, maintenance or repair of the whole or any part of the drainage works. 2010, c. 16, Sched. 1, s. 2 (26).

66. Repealed: 2010, c. 16, Sched. 1, s. 2 (26).

Unfinished Business List - eScribe as at November 12, 2019

Agenda Item	Assigned To	Comment	Description	Date
NEW BUSINESS	Nicole Rubli, Mark Galvin	20190227 - awaiting LPAT decision. RTC will cover full animal control by-law. Public Consultation Meeting being held May 14th, 2019 for Animal control By-law including kennels. Anticipate report to Council end of 4th quarter 2019.	Resolution # 20180910-301 Lavigne/Meloche That Administration BE DIRECTED to look at surrounding municipalities and their by-law regarding dogs and kennels and bring a report back for Council's consideration.	10-Sep-18
NEW BUSINESS	Mark Galvin, Angelo Avolio	Reviewing best practices and comparator municipalities. Anticipate Council report for 1st quarter 2020.	Resolution # 20180910-302 Lavigne/Meloche That Administration BE DIRECTED to look at surrounding municipalities regarding fill by-laws and bring back a report for Council's consideration.	10-Sep-18
Feasibility of Developing a Fee for Planting Trees on Public Land	Mark Galvin, Rebecca Belanger	Report to Council with background and Administrative recommendation. Anticipated for Winter 2020. Examining impact of Bill 108 on fees related to parkland.	Resolution # 20181023- 348 Pouget/Courtney That Administration BE DIRECTED to bring a back a report amending the User Fee By-law to contain a fee for the planting of a tree on the right-of-way; and, That the information be sent to the Parks and Recreation Advisory Committee.	23-Oct-18
UNFINISHED BUSINESS	Rebecca Belanger, Mark Galvin	First public consultation scheduled for May 14th. Anticipate report to Council at the end of the 4th quarter 2019	Resolution # 20181023-356 Fryer/Courtney That Administration BE DIRECTED to bring the report regarding urban chickens along with permit fees for Council's consideration.	23-Oct-18
Off-Road Vehicle Use on Municipal Roadways - Kevin Schmidt and Shawn Ellenberger, Essex County ATV Club	Nicole Rubli, Mark Galvin	Meeting held with County and ERCA Administration. Anticipate report to Council in Fall 2019	Resolution # 20190325-202 Prue/Renaud That Administration continue to work with the Essex County ATV Club, the County of Essex, ERCA, and the Police to find a possible trial area for off-road vehicle use.	25-Mar-19
NEW BUSINESS	Eric Chamberlain, Antonietta Giofu	This will be a long term plan for the downtown core/future developments. Pending outcome of EA process (former Duffy's property) and progress of new developments (i.e. hotel), could affect timing of this report and recommendations presented to Council. Council Resolution #20180212-38 notes: "A downtown core parking study, with funding to be allocated in a future year budget, after the completion of the development of the former Duffy lands BE SUPPORTED." Estimated timing per Development Charge Study is 2020-2021.	Resolution # 20190408-238 Prue/McArthur That Administration BE DIRECTED to prepare a report regarding angled parking on the west side of Dalhousie Street from Richmond Street to Gore Street with the possibility of one-way traffic going south bound.	08-Apr-19
NEW BUSINESS	Mark Galvin, Frank Garardo	Administration compiling information and anticipate report to Council Summer 2019. Final report to council scheduled for November 25, 2019	Resolution # 20190408-239 Prue/Simone That Administration BE DIRECTED to prepare a report regarding in-law suites, granny flats, and laneway units.	08-Apr-19
Request to Operate a Refreshment Cart on Town Property - Camille Jabbour	Nicole Rubli, Mark Galvin	Public consultation held on August 22nd 2019, 4 businesses in attendance. Report and By-law will be brought back Fall 2019.	Resolution # 20190408-216 Prue/Simone That Administration BE DIRECTED to provide a report to Council outlining discussions with local restaurants and/or interested food purveyors, and to establish suitable locations within the Town to accommodate qualified food purveyors.	08-Apr-19
Request for Noise By-law Exemption on Outdoor Patio - Laurie Fryer Cavanaugh, Branch President, Royal Canadian Legion Fort Malden Branch 157	Mark Galvin	Administration spoke to Colin Novack of Akoustik Engineering on September 10th, noise measurements will be taken until the end of September. The Legion has indicated that bands are scheduled until the end of October however they only play weather dependent. A report and recommendations From Dr. Novack will come to Council at the November 12th Council meeting.	Resolution # 20190527-292 Prue/McArthur That: 1. An exemption from table number 3-1-2 of Noise By-law #2001-43 with respect to the operation of any electronic device or group of connected electronic devices incorporating one or more loudspeakers to allow for music BE GRANTED to the Royal Canadian Legion located at 281 Dalhousie for 6 months from May to October, (weather dependent), with regular dates & times as follows: Fridays & Saturdays no later than 11:00pm and Sundays until 8:00pm; 2. The Town FACILITATE meetings between the Legion, the affected residents, and the Town; 3. The noise level BE MONITORED throughout the 6 months with a sound engineer to determine noise level; and, 4. A report BE BROUGHT back to Council on the successes and failures.	27-May-19
NEW BUSINESS	Antonietta Giofu	Administration is coordinating options with the County of Essex. Report to Council - March 2020.	Resolution # 20190624-TBD Courtney/McArthur That Administration BE DIRECTED to provide a report to Council regarding the feasibility of safe pedestrian travel along County Road 10.	24-Jun-19
Request for Exemption to Open Air Fire By-law - Peter Thyrring, Headmaster, St. Peter's ACHS College School	Bruce Montone	Anticipate report to Council November 25, 2019	Resolution # 20191015-TBD Prue/Renaud That Administration BE DIRECTED to bring back a report outlining the impact to all types of sensitive receptors listed within the Open Air Fire By-law if exemptions were to be granted.	15-Oct-19

Unfinished Business List - eScribe as at November 12, 2019

Agenda Item	Assigned To	Comment	Description	Date
NEW BUSINESS	Phil Roberts	Port-a-Potties in Toddy Jones Park are in place when the washrooms are closed. Administration is consistently seeking long term solutions to vandalism throughout the Town.	Resolution # 20191015-TBD McArthur/Meloche That a porta-potty BE PLACED at Toddy Jones Park for the remainder of the season; and further, that Administration BE DIRECTED to seek long term solutions to deter vandalism in Town park washrooms.	15-Oct-19
NEW BUSINESS	Antonietta Giofu, Mark Galvin, Frank Garardo	Administration compiling information. Anticipate report to Council in 1st quarter 2020.	Resolution # 20191015-TBD Prue/Simone That Administration BE DIRECTED to bring back a report regarding the finalization of the development of the north end of Boblo Island with the intent to enforce the by-law and development agreement relating to roads, sidewalks, curbs, and lighting, and to outline all municipal costs, if any.	15-Oct-19
Request for the Town of Amherstburg to Take Part in 'Green' Initiatives - Paul Hertel	Eric Chamberlain, Antonietta Giofu, Anne Rota, Phil Roberts, Frank Garardo, Mark Galvin, Kevin Fox, Paula Parker	Multiple cross departmental coordination underway. Updates will be provided as the process continues.	Resolution # 20191028-TBD Prue/Courtney That: The delegation BE RECEIVED and Mr. Hertel's report BE SENT to the Manager of Planning Services for inclusion at the November 12, 2019 Official Plan meeting; A green review BE DEVELOPED on Town fleet; Green festivals BE INVESTIGATED; Green builds BE INVESTIGATED on all new housing and building developments, and existing commercial, industrial and residential assessed property; and, Administration BE DIRECTED to bring back a report on the feasibility of a Committee on the Environment inclusive of Terms of Reference.	28-Oct-19
Parking on Windermere Place - Mark & Heidi Olivito and Lisa Carnelos, Windermere Place Residents	Antonietta Giofu	Administration is gathering information and working with residents to determine feasibility. Estimated completion summer 2020.	Resolution # 20191028-TBD Prue/Simone That: The delegation BE RECEIVED; The neighbours be encouraged to work with Administration on a Local Improvement Plan; and, A report BE BROUGHT back if the issue cannot be resolved.	28-Oct-19



## NOTICE OF MOTION

**Re: Declaration of Climate Emergency in the Town of Amherstburg**

---

I, Councillor McArthur, hereby provide Notice of Motion to Town of Amherstburg Council:

That Amherstburg Council join the more than 400 other Canadian municipalities who have declared a Climate Emergency and work to reduce emissions as recommended by the Windsor-Essex County Environment Committee.

*“**WHEREAS** the Windsor-Essex County Environment Committee is sounding the alarm and urging the City of Windsor and the County of Essex to declare Climate Emergencies and work together to reduce emissions; and*

***WHEREAS** more than 444 Canadian municipalities (including Chatham-Kent, London, Sarnia, Hamilton, St. Catharines, Guelph, Kingston, Kitchener and the Waterloo Region) have declared Climate Emergencies, some of which are also implementing strategic plans in order to help reduce global carbon emissions and mitigate the impacts of climate change; and*

***WHEREAS** Amherstburg distributed sandbags to residents this summer in the face of historic water levels and has 43.7 km of shoreline along the Detroit River and Lake Erie, along with 12.4 km of shoreline on inland waterways, and is thus greatly affected by water levels in the Great Lakes basin; and*



**WHEREAS** the most recent report by the UN Intergovernmental Panel on Climate Change (IPCC) has indicated that within 12 years, in order to keep the global average temperature increase to 1.5 degree C and maintain a climate compatible with human civilization, there must be a reduction in carbon emissions of about 45% from 2010 levels, reaching net zero carbon emissions by 2050; and

**WHEREAS** based on current projections of the future impacts of human-caused climate change, climate change will adversely the local economy, local infrastructure and property, put a strain on municipal budgets and result in significant economic and health burdens for local residents, particularly our vulnerable populations; and

**WHEREAS** climate change will jeopardize the health and survival of many local plant and animal species as well as their natural environments and ecosystems; and

**WHEREAS** Amherstburg and the surrounding region is already experiencing climate change impacts including, but not limited to, overland flooding, heavy rain event flooding, emergence of invasive species, an increased number of high heat days, the rise of vector borne diseases, the re-emergence of blue-green algae and harmful algal blooms in our lakes and rivers; and

**WHEREAS** municipalities are understood to produce and/or have regulatory jurisdiction over approximately 50% of carbon emissions in Canada; and

**WHEREAS** Amherstburg is embarking on a review of the Town's Official Plan; and

**WHEREAS** implementing climate action and making a transition to a low-carbon economy also represents a significant opportunity to stimulate economic growth, increase job opportunities and develop new technologies;

**THEREFORE BE IT RESOLVED** that Amherstburg declare a Climate Emergency and direct administration to prepare a report containing recommendations for priority actions items, implementation measures and cost requirements to accelerate and urgently work towards the reduction of emissions and preparing for our climate future.”

**THE CORPORATION OF THE TOWN OF AMHERSTBURG**

**BY-LAW NO. 2019-103**

**By-law to Confirm the Proceedings of the Council  
of the Corporation of the Town of Amherstburg**

---

**WHEREAS** pursuant to Section 5(1) of the Municipal Act, 2001, S.O. 2001, c. 25 as amended, the powers of a municipality shall be exercised by its Council;

**WHEREAS** pursuant to Section 5(3) of the Municipal Act, 2001, S.O. 2001, c.25 as amended, a municipal power, including a municipality's capacity rights, powers and privileges under Section 8 of the Municipal Act, 2001, S.O. 2001, c.25 as amended, shall be exercised by By-law unless the municipality is specifically authorized to do otherwise;

**WHEREAS** it is deemed expedient that a By-law be passed to authorize the execution of agreements and other documents and that the Proceedings of the Council of the Corporation of the Town of Amherstburg at its meeting be confirmed and adopted by By-law; and,

**NOW THEREFORE** the Council of the Corporation of the Town of Amherstburg hereby enacts as follows:

1. THAT the action(s) of the Council of the Corporation of the Town of Amherstburg in respect of all recommendations in reports and minutes of committees, all motions and resolutions and all actions passed and taken by the Council of the Corporation of the Town of Amherstburg, documents and transactions entered into during the November 4<sup>th</sup> and 12<sup>th</sup> 2019, meetings of Council, are hereby adopted and confirmed, as if the same were expressly contained in this By-law;
2. THAT the Mayor and proper officials of the Corporation of the Town of Amherstburg are hereby authorized and directed to do all things necessary to give effect to the action(s) of the Council of the Corporation of the Town of Amherstburg during the said meetings referred to in paragraph 1 of this By-law;
3. THAT the Mayor and Clerk are hereby authorized and directed to execute all documents necessary to the action taken by this Council as described in Section 1 of this By-law and to affix the Corporate Seal of the Corporation of the Town of Amherstburg to all documents referred to in said paragraph 1.

Read a first, second and third time and finally passed this 12<sup>th</sup> day of November, 2019.

---

MAYOR – Aldo DiCarlo

---

CLERK – Paula Parker