



TÜRK SERAMİK DERNEĞİ
Bilim-Teknoloji Webinerleri



Seramik Tozlarının Kimyasal Yöntemlerle Sentezi

Prof. Sedat ALKOY

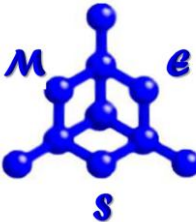

Definitions

Ceramics : *Keramos* in Greek for potter's clay or ware made from clay and fired.

Chemically, with the exception of carbon, **ceramics are nonmetallic, inorganic compounds**. Such as;

- Silicates - Kaolinite $[Al_2Si_2O_5(OH)_4]$,
- Simple oxides - Alumina (Al_2O_3) ,
- Complex oxides - $YBa_2Cu_3O_{6-x}$ ($0 \leq x \leq 1$).
- Non-oxides - Silicon carbide (SiC), Silicon nitride (Si_3N_4) ,

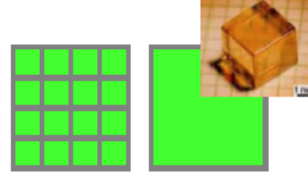
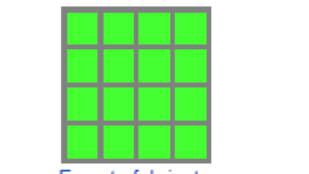
<p>Ceramics (Old concept) : Pottery</p>	<p>Ceramics (Current, wide concept) : all inorganic nonmetallic materials (single crystal + polycrystalline materials + amorphous materials)</p>	<p>Ceramics (Current, narrow concept) : polycrystalline nonmetallic materials that acquire their mechanical strength through a firing or sintering process.</p>
		
	<p>Difficult to fabricate Expensive</p>	<p>Easy to fabricate Economic</p>

Structurally, all materials are either **crystalline** or **amorphous** (also referred to as *glassy*). The difficulty and expense of growing single crystals means that, **normally, crystalline ceramics are actually polycrystalline—they are made up of a large number of small crystals, or grains, separated from one another by grain boundaries**.

In ceramics, we are concerned with **two types of structure**, both of which have a profound effect on properties.

- 1) At the atomic scale: **the type of bonding and the crystal structure** (for a crystalline ceramic) or the amorphous structure (if it is glassy).
- 2) At a larger scale: **the microstructure**, which refers to the nature, quantity, and distribution of the structural elements or phases in the ceramic (e.g., crystals, glass, and porosity).

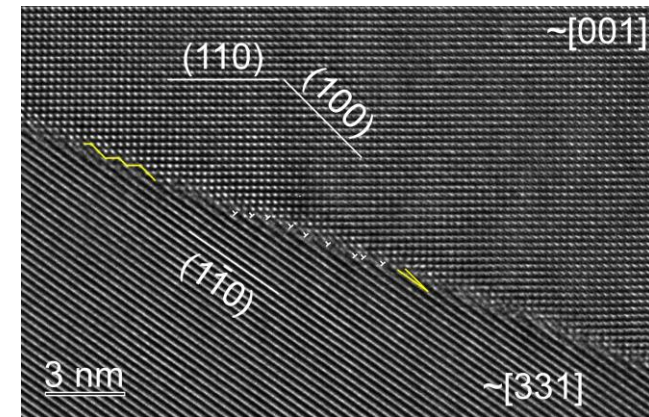

STEPS AT INTERFACES IN $SrTiO_3$

Refs: *Ceramic Processing and Sintering*, (2009)
S.D. Hutagalung, Introduction to Electroceramics (2013).
<https://program.eventact.com/viewabstract?Abst=122449&Code=2029348>

Historical Development of Ceramics

Outline of Prehistory of Ceramics & Main Lines of Technological Development

- ~ 22,000 B.C. Earliest known fired clay figures
- ~ 8,000 B.C. Fired earthenware vessels in Near East
- ~ 6,000 B.C. Slip coatings and clays prepared by decanting suspensions. decoration. control of oxidation, reduction during firing. joining paddle and anvil shaping, carving, and trimming
- ~ 4,000 B.C. Egyptian faience
- 4,000-3,500 B.C. Wheel throwing, earthenware molds, craft shops
- ~ 1600 B.C. Vapor glazing, prefritted glazes. lead glazes
- ~ 1500 B.C. Glass making, alkaline glazes in Egypt.
- ~ 1000 B.C. Glazed stoneware in China
- ~ 900 B.C. Tin glaze in Baghdad
- ~ 700 B.C. Greek black and red wares
- ~ 800 A.D. Crude porcelain in China during the T'ang dynasty
- ~ 1100 A.D. Porcelain production in Korea
- ~ 1600 A.D. Porcelain production in Japan
- ~ 1700 A.D. Porcelain production in Europe
- ~ 1950s Advanced Ceramics



Terracotta Warriors

Tomb of Emperor Qin Shi Huang in China from 208 BC

Classification of Ceramics

➤ The subject of ceramics covers a wide range of materials, but can generally be divided into two parts:

Traditional & Advanced (technical, special, fine, and engineering) Ceramics.

Traditional ceramics bear a close relationship to those materials that have been developed since the earliest civilizations. They are pottery, structural clay products, and clay-based refractories, with which we may also group cements and concretes and glasses. Whereas traditional ceramics still represent a major part of the ceramics industry, the interest in recent years has focused on advanced ceramics, ceramics that with minor exceptions have been developed within the last 50 years or so.

Advanced ceramics include ceramics for electrical, magnetic, electronic, and optical applications (sometimes referred to as functional ceramics) and ceramics for structural applications at ambient as well as at elevated temperatures (structural ceramics).

➤ The main differences between the two classes are the purity and particle size of the powders that are used in their fabrication, and the applications and the added value of the resultant products.

Our webinar mainly deals with synthesis of ceramic powders that are used in the fabrication of advanced ceramic parts.

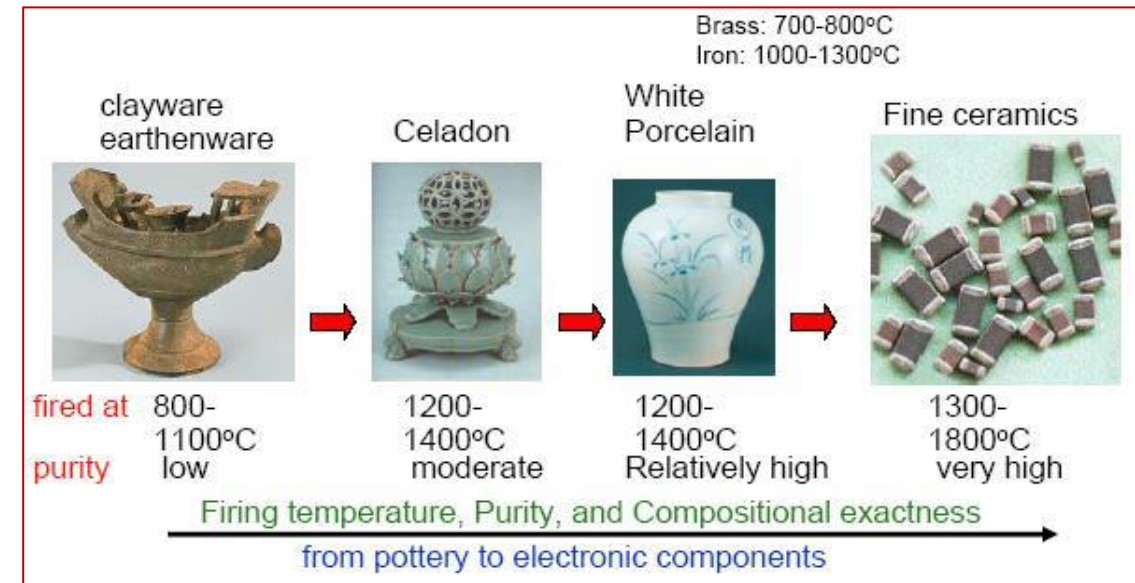

Applications of Advanced Ceramics by Function

Function	Ceramic	Application
Electric	Insulation materials (Al_2O_3 , BeO, MgO)	Integrated circuit substrate, package, wiring substrate, resistor substrate, electronics interconnection substrate
	Ferroelectric materials (BaTiO_3 , SrTiO_3) Piezoelectric materials (PZT)	Ceramic capacitor Vibrator, oscillator, filter, etc. Transducer, ultrasonic humidifier, piezoelectric spark generator, etc.
	Semiconductor materials (BaTiO_3 , SiC, ZnO- Bi_2O_3 , V_2O_5 and other transition metal oxides)	NTC thermistor: temperature sensor, temperature compensation, etc. PTC thermistor: heater element, switch, temperature compensation, etc. CTR thermistor: heat sensor element Thick-film sensor: infrared sensor Varistor: noise elimination, surge current absorber, lightning arrestor, etc.
	Ion-conducting materials ($\beta\text{-Al}_2\text{O}_3$, ZrO_2)	Sintered CdS material: solar cell SiC heater: electric furnace heater, miniature heater, etc. Solid electrolyte for sodium battery ZrO_2 ceramics: oxygen sensor, pH meter, fuel cells

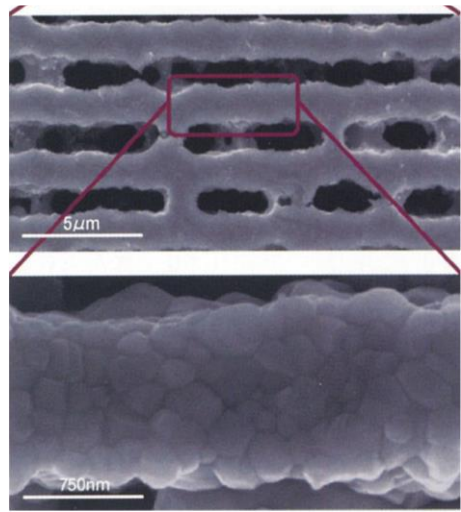

Fig. 6.40 Cross-sectional view of a capacitor incorporating 1 µm dielectric layers. Cross-sectional view of a 1608 (1.6 mm×0.8 mm) B characteristic (Note 6.21) 10 µF chip capacitor. Electrodes and dielectric layers are layered in an orderly manner and cannot be identified by the naked eye. As seen in the SEM picture at the bottom, about five small ceramic grains, sized 100–200 nm, are formed between the electrodes

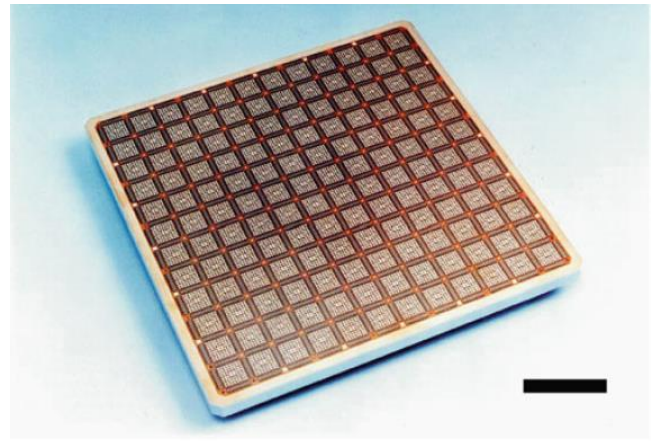

Fig. 7.1 Image of a multilayer ceramic circuit substrate (Bar=50 mm). Slurry, a mixture of ceramic powder, organic binder and solvent, is tape-cast to create a green sheet, on which via holes and wiring patterns are screen-printed to create a thick film conductor. Following this, thermal compression stacked layers are sintered at high temperature to produce the substrate

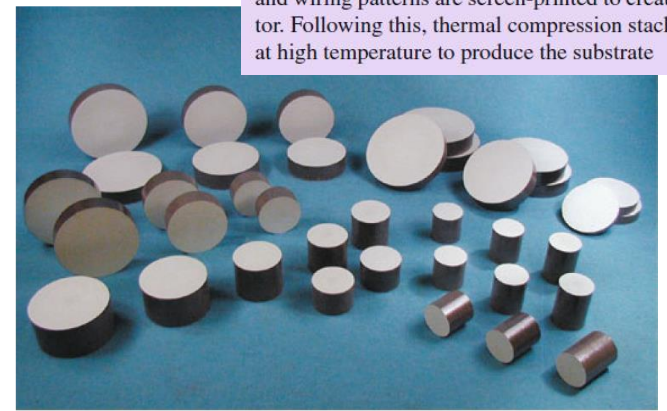

Fig. 14.5 ZnO varistors for power system. Disk-shaped nonlinear resistance ceramics, Φ 30–100 mm, are applied with an insulating coating on the circumference and have electrodes formed on both faces. They are used in arrestors of various voltage classes

Text Ref: Ceramic Processing and Sintering, (2009)
Figures Ref: Advanced Ceramic Technologies and Products (2012)

Applications of Advanced Ceramics by Function

Function	Ceramic	Application
Magnetic	Soft ferrite	Magnetic recording head, temperature sensor, etc.
	Hard ferrite	Ferrite magnet, fractional horse power motors, etc.
Optical	Translucent alumina	High-pressure sodium vapor lamp
	Translucent Mg-Al spinel, mullite, etc.	Lighting tube, special-purpose lamp, infrared transmission window materials
	Translucent $Y_2O_3-ThO_2$ ceramics	Laser materials
	PLZT ceramics	Light memory element, video display and storage system, light modulation element, light shutter, light valve

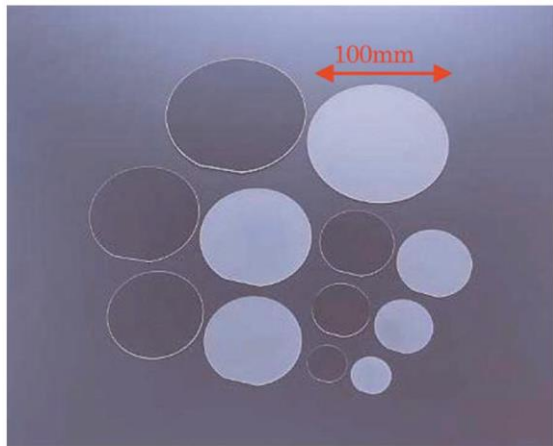

Fig. 7.22 Sapphire substrate for thin films

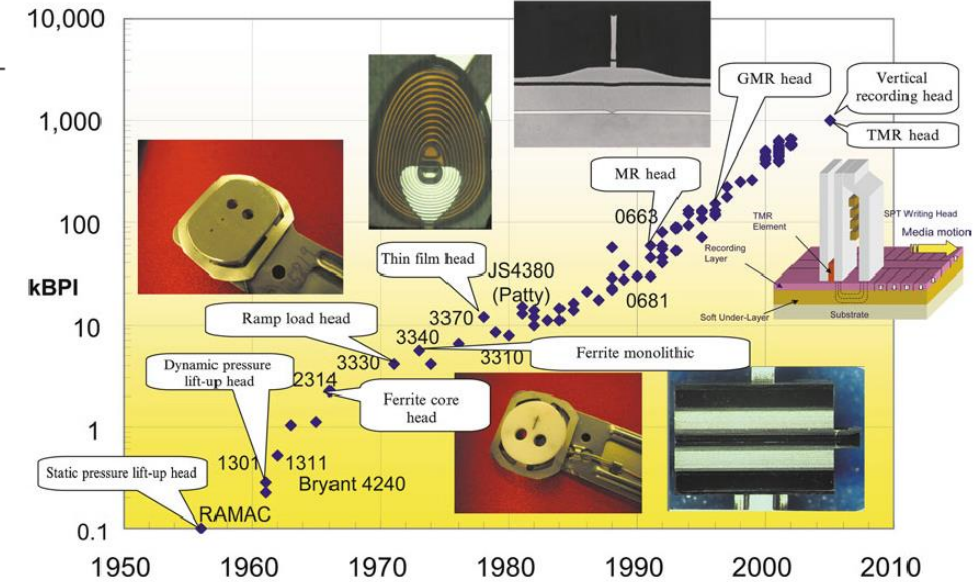

Fig. 10.19 Advancement of HDD magnetic head technologies and evolution of surface recording density. The relationship between advancement of HDD magnetic head technologies and surface recording density (vertical axis) versus year is shown. The ALTIC material was first used in the 3370 type thin film magnetic head released in 1978 by IBM [reference: IDEMA JAPAN, Exhibition Commemorating the 50th Anniversary of Magnetic Disk, June 2006 (approved by IDEMA JAPAN)]



Fig. 9.26 The world's first ferrite core. The world's first ferrite core was invented in 1930 by Dr. Y. Kato and Dr. T. Takei

Applications of Advanced Ceramics by Function

Function	Ceramic	Application
Chemical	Gas sensor (ZnO , Fe_2O_3 , SnO_2)	Gas leakage alarm, automatic ventilation alarm; hydrocarbon, fluorocarbon detectors, etc.
	Humidity sensor ($MgCr_2O_4-TiO_2$)	Cooking control element in microwave oven, etc.
	Catalyst carrier (cordierite)	Catalyst carrier for emission control
	Organic catalysts Electrodes (titanates, sulfides, borides)	Enzyme carrier, zeolites Electrowinning aluminum, photochemical processes, chlorine production
Thermal	ZrO_2 , TiO_2	Infrared radiator
Mechanical	Cutting tools (Al_2O_3 , TiC , TiN , others)	Ceramic tool, sintered CBN; cermet tool, artificial diamond; nitride tool
	Wear-resistant materials (Al_2O_3 , ZrO_2)	Mechanical seal, ceramic liner, bearings, thread guide, pressure sensors
	Heat-resistant materials (SiC , Al_2O_3 , Si_3N_4 , others)	Ceramic engine, turbine blade, heat exchangers, welding burner nozzle, high frequency combustion crucibles)
Biological	Alumina ceramics implantation, hydroxyapatite, bioglass	Artificial tooth root, bone and joint.
Nuclear	UO_2 , UO_2-PuO_2	Nuclear fuels
	C , SiC , B_4C	Cladding materials
	SiC , Al_2O_3 , C , B_4C	Shielding materials

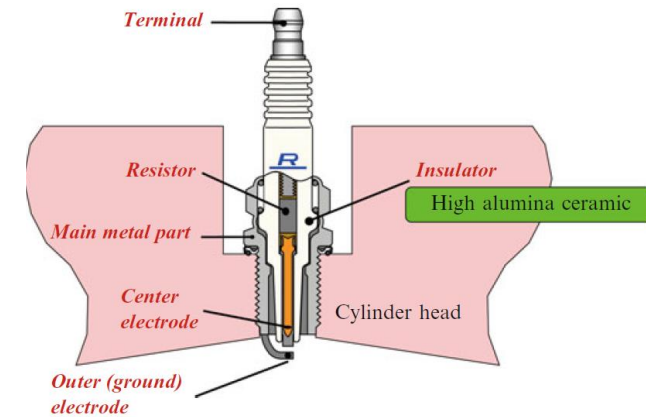

Fig. 12.6 Structure of the spark plug. Spark plugs are affixed to engine cylinder heads via the threads formed on the main metal part. The spark gap on the tip is projected into the combustion chamber and ignites the gas mixture



BWR fuel pellet

Diameter: approx. 9.6 mm
Height: approx. 10 mm
Chamfered



PWR fuel pellet

Diameter: approx. 8mm
Height: approx. 10 mm
With dish and chamfer

Fig. 14.12 Uranium dioxide (UO_2) pellet. Uranium oxide powder is formed, sintered and ground to create cylindrical pellets. BWR pellets are chamfered, while PWR pellets have a dish (dent) on the face and are chamfered

Synthesis of Powders

- The characteristics of the powder is very important on subsequent processing, such as consolidation into a green body and firing to produce the desired microstructure.
- In practice, the choice of a powder preparation method will depend on the production cost and the capability of the method for achieving a certain set of desired characteristics.
- For convenience, the powder synthesis methods can be divided into two categories: ***mechanical methods*** and ***chemical methods***.
- Powder synthesis by chemical methods is an area of ceramic processing that has received a high degree of interest and has undergone considerable changes in the last 25 years. Further new developments in this area are expected in the future.
- ***Our talk mainly deals with synthesis of ceramic powders through chemical methods.***

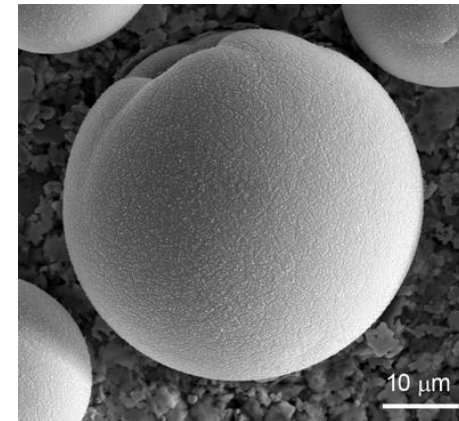
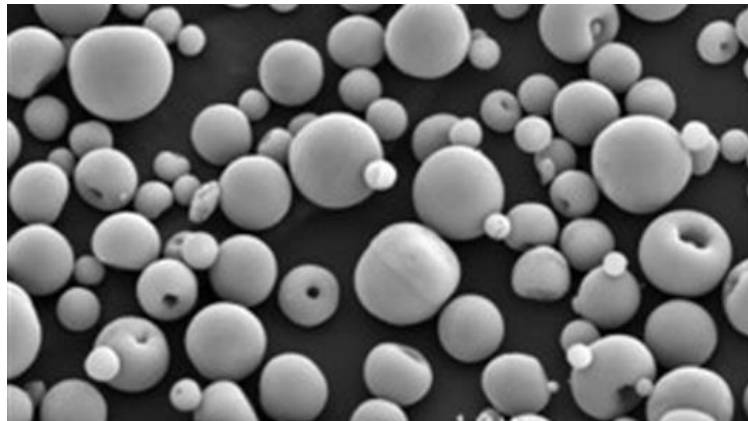

Desirable Powder Characteristics

Traditional ceramics

- Generally, less specific property requirements than advanced ceramics.
- They can be **chemically inhomogeneous**
- They can have **complex microstructures**.
- Unlike the case of advanced ceramics, **chemical reaction during firing** is often a requirement. The starting materials for traditional ceramics therefore consist of mixtures of powders with a chosen reactivity.
- **Fine particle size is desirable for good chemical reactivity.**
- The powders must also be chosen to give a reasonably **high packing density** that serves to limit the shrinkage and distortion of the body during firing.
- Generally, **low cost powder preparation methods** are used for traditional ceramics.

Advanced ceramics

- ❖ Must meet very specific property requirements.
- ❖ **Chemical composition and microstructure must be well controlled.**
- ❖ Careful attention must be paid to the **quality of the starting powders.**
- ❖ The important powder characteristics are the **size, size distribution, shape, state of agglomeration, chemical composition, and phase composition.**
- ❖ The **structure and chemistry of the surface** are also important.

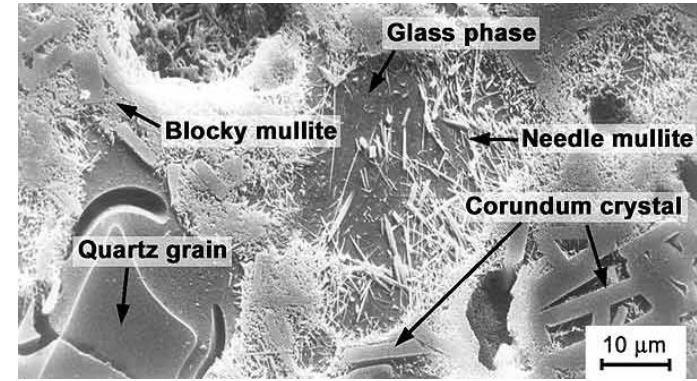

SEM microstructure of an alumina porcelain

http://www.keramverband.de/brevier_engl/3/4/1/3_4_1.htm

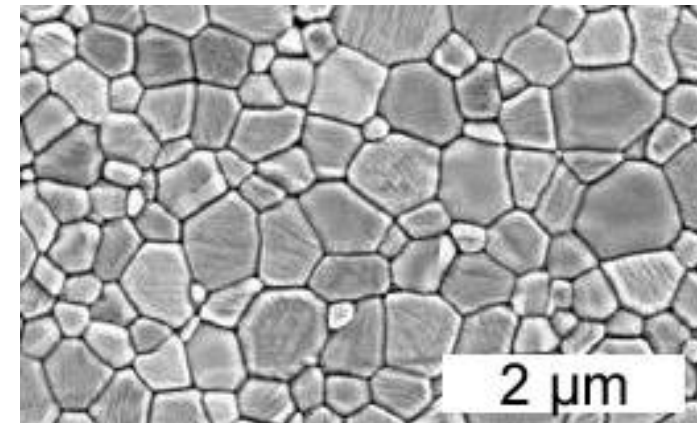

Microstructure of MgO doped alumina bioceramic

https://www.ikts.fraunhofer.de/en/departments/structural_ceramics

Desirable Powder Characteristics

- The **size**, **size distribution**, **shape**, and **state of agglomeration** have an important influence on both the powder consolidation step and the microstructure of the fired body.
- A **particle size** greater than $\sim 1 \mu\text{m}$ generally precludes the use of colloidal consolidation methods because the settling time of the particles is fairly short.
- The most profound effect of the particle size, however, is on the sintering. The rate at which the body densifies increases strongly with a decrease in particle size. Normally, if other factors do not cause severe difficulties during firing, **a particle size of less than $\sim 1 \mu\text{m}$** allows the achievement of high density within a reasonable time (e.g., a few hours).
- A powder with a wide **distribution of particle sizes** (sometimes referred to as a polydisperse powder) may lead to higher packing density in the green body, this benefit is usually vastly outweighed by difficulties in microstructural control during sintering. A common problem is that the large grains coarsen rapidly at the expense of the smaller grains, making the attainment of high density with controlled grain size impossible.
- Homogeneous packing of **a narrow size distribution powder** (i.e., a nearly monodisperse powder) generally allows greater control of the microstructure.
- A **spherical or equiaxial shape** is beneficial for controlling the uniformity of the packing.

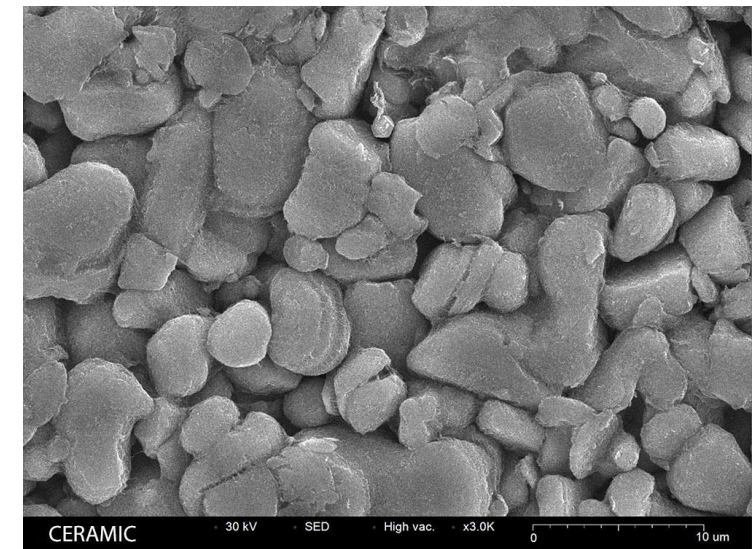
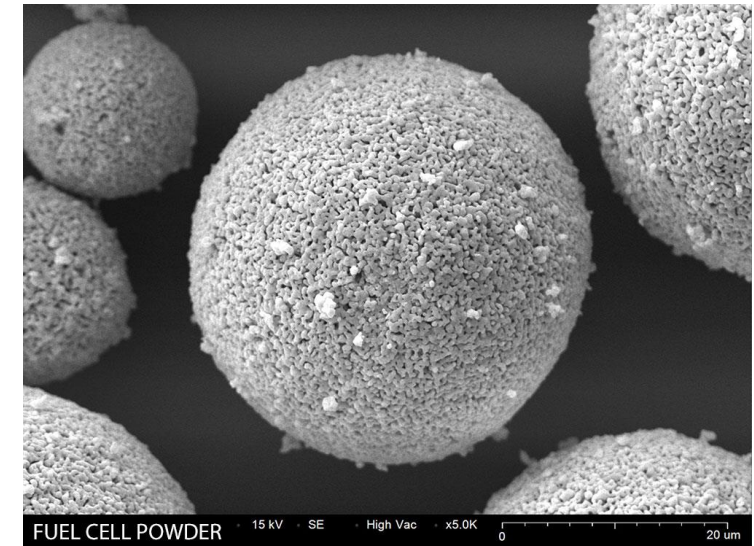

<https://www.nanoimages.com/sem-applications/energy/>

Desirable Powder Characteristics

- **Agglomerates** lead to heterogeneous packing in the green body which, in turn, leads to differential sintering during the firing stage. Differential sintering occurs when different regions of the body shrink at different rates. This can lead to serious problems such as the development of large pores and crack-like voids in the fired body.
- Furthermore, the rate at which the body densifies is roughly similar to that for a coarse-grained body with a particle size equivalent to that of the agglomerates. An agglomerated powder therefore has serious limitations for the fabrication of ceramics when high density coupled with a fine grained microstructure is desired.

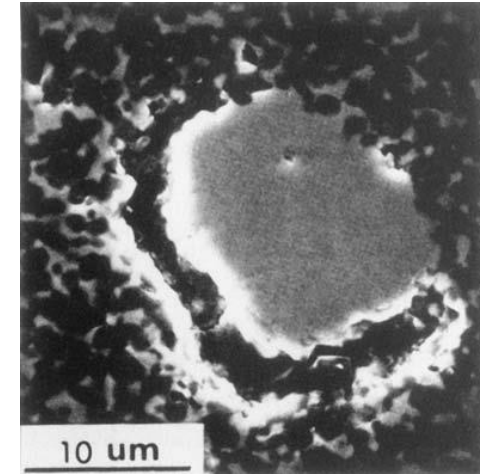

Cracklike void produced by a ZrO_2 agglomerate shrinking away from the surrounding Al_2O_3/ZrO_2 matrix during firing

➤ Agglomerates are classified into two types: **soft agglomerates** in which the particles are held together by weak van der Waals forces and **hard agglomerates** in which the particles are chemically bonded together by strong bridges.

➤ The ideal situation is the **avoidance of agglomeration** in the powder. However, in most cases this is not possible. In such cases, we would then prefer to have **soft agglomerates** rather than hard agglomerates. Soft agglomerates can be broken down relatively easily by mechanical methods or by dispersion in a liquid. Hard agglomerates cannot be easily broken down and must be avoided or removed.

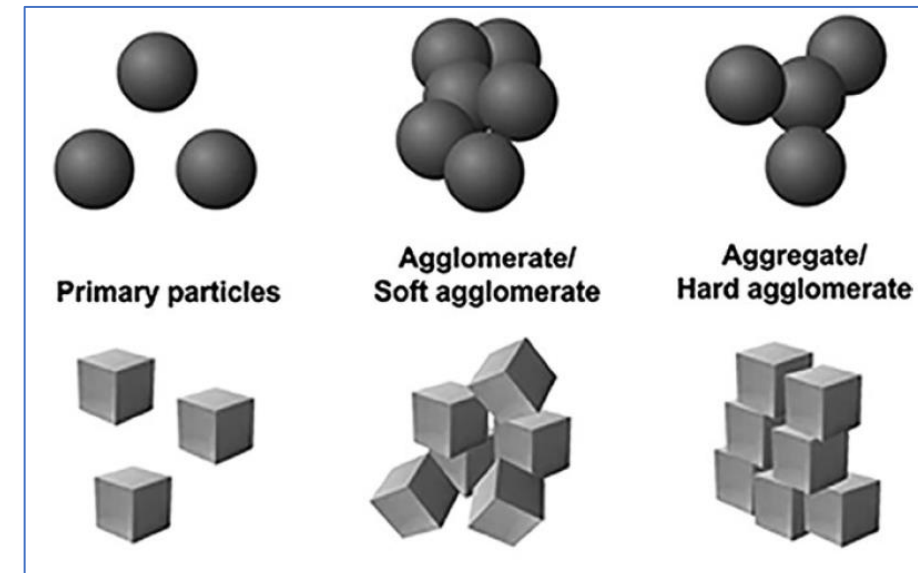

Characteristics of pigments, modification, and their functionalities, <https://doi.org/10.1002/col.22359>

Desirable Powder Characteristics

- **Surface impurities** may have a significant influence on the dispersion of the powder in a liquid, but the most serious effects of variations in chemical composition are encountered in the firing stage.
- Impurities may lead to the formation of a small amount of liquid phase at the sintering temperature, which causes selected growth of large individual grains. In such a case, the achievement of a fine uniform grain size would be impossible.
- Thus, it is preferable to **avoid surface impurities**.

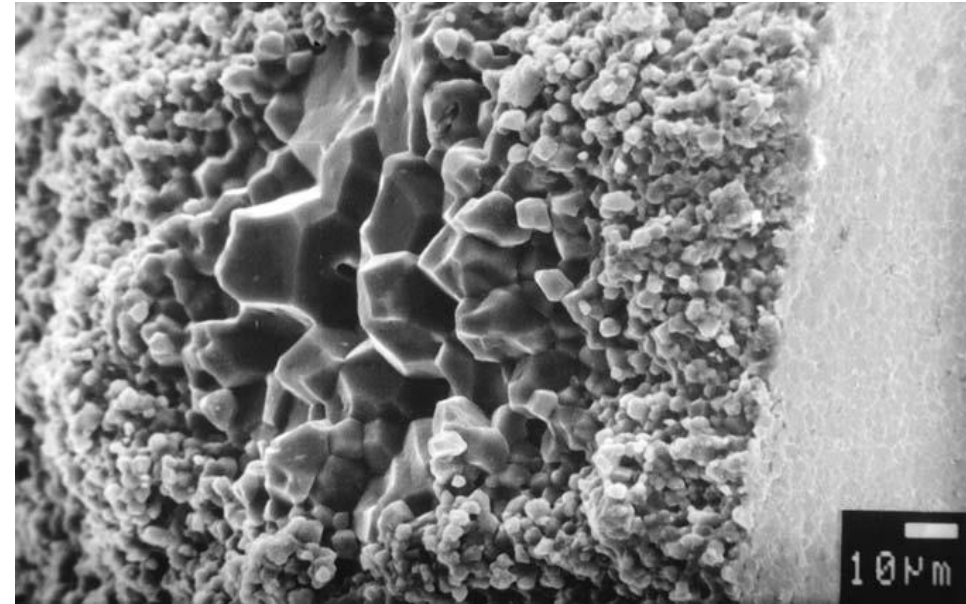

Large grained region of microstructural heterogeneity resulting from an impurity in hot pressed Al_2O_3 .

- **Chemical reactions** between incompletely reacted phases can also be a source of problems. We would therefore like to have **no chemical change in the powder during firing**.
- For some materials, **polymorphic transformation** between different crystalline structures can also be a source of severe difficulties for microstructure control. Common examples are ZrO_2 , for which cracking is a severe problem on cooling, and $\gamma\text{-Al}_2\text{O}_3$, where the transformation to the α -phase results in rapid grain growth and a severe retardation in the densification rate. Thus, if possible, **polymorphic transformations should be avoided**.

Desirable Powder Characteristics for Advanced Ceramics

Powder characteristic	Desired property
Particle size	Fine ($< \sim 1 \mu\text{m}$)
Particle size distribution	Narrow or monodisperse
Particle shape	Spherical or equiaxial
State of agglomeration	No agglomeration or soft agglomerates
Chemical composition	High purity
Phase composition	Single phase

Powder Synthesis Methods

- A variety of methods exist for the synthesis of ceramic powders. They can be divided into two categories: ***mechanical methods*** and ***chemical methods***.
- ***Mechanical methods*** are generally used to prepare powders of traditional ceramics from naturally occurring raw materials. Powder preparation by mechanical methods is a fairly mature area of ceramic processing in which the scope for new developments is rather small.
- However, in recent years, the preparation of fine powders of some advanced ceramics by mechanical methods involving milling at high speeds, or mechanochemical processes have received a fair amount of interest.
- ***Chemical methods*** are generally used to prepare powders of advanced ceramics from synthetic materials or from naturally occurring raw materials that have undergone a considerable degree of chemical refinement.
- Some of the methods categorized as chemical involve a mechanical milling step as part of the process. The milling step is usually necessary for the breakdown of agglomerates and for the production of the desired physical characteristics of the powder such as average particle size and particle size distribution.
- Powder preparation by chemical methods is an area of ceramic processing that has seen several new developments in the past 25 years and further new developments are expected in the future.

Powder Preparation Methods for Ceramics

Powder preparation method

Advantages

Disadvantages

Mechanical

Comminution

Inexpensive, wide applicability

Limited purity, limited homogeneity, large particle size

Mechanochemical synthesis

Fine particle size, good for nonoxides, low temperature route

Limited purity, limited homogeneity

Chemical

Solid-state reaction

Decomposition, reaction between solids

Simple apparatus, inexpensive

Agglomerated powder, limited homogeneity for multicomponent powders

Powder Preparation Methods for Ceramics

Powder preparation method	Advantages	Disadvantages
<p>Liquid solutions</p> <p>Precipitation or coprecipitation; solvent vaporization (spray drying, spray pyrolysis, freeze drying); gel routes (sol–gel, Pechini, citrate gel, glycine nitrate)</p>	<p>High purity, small particle size, composition control, chemical homogeneity</p>	<p>Expensive, poor for nonoxides, powder agglomeration commonly a problem</p>
<p>Nonaqueous liquid reaction</p>	<p>High purity, small particle size</p>	<p>Limited to nonoxides</p>

Powder Preparation Methods for Ceramics

Powder preparation method

Advantages

Disadvantages

Vapor-phase reaction

Gas–solid reaction

Commonly inexpensive for large particle size

Commonly low purity, expensive for fine powders

Gas–liquid reaction

High purity, small particle size

Expensive, limited applicability

Reaction between gases

High purity, small particle size, inexpensive for oxides

Expensive for nonoxides, agglomeration commonly a problem

Economy of Advanced Ceramics

- Processing of advanced ceramics are very similar with the traditional ceramics, namely ; mixing raw materials, reacting to obtain the final composition, shaping and sintering.
- However, the purity of the raw materials, the sintering temperature and field of final applications differentiate the advanced ceramics from the traditional ones and lend them a very high added value.
- For Ex ;

Ceramic Tiles	0.2 \$/kg
Ceramic cutting tips	2,000.0 \$/kg
Multilayer piezoelectric actuators	20,000.0 \$/kg

Table 1. Advanced ceramics demand by market (million dollars).

	1997	2002	2007	2012	2017
Electronic components	2763	2394	2620	3020	3385
Electrical equipment	1217	1349	1880	2395	2940
Industrial machinery	914	965	1410	1780	2280
Transportation equipment	840	992	1325	1735	2255
Chemical and plastic	606	713	1130	1380	1665
Body armor	3	30	650	350	350
Environmental	319	420	575	755	980
Medical products	60	96	155	240	360
Other markets	378	506	715	975	1285
Total market	7100	7465	10,460	12,630	15,500

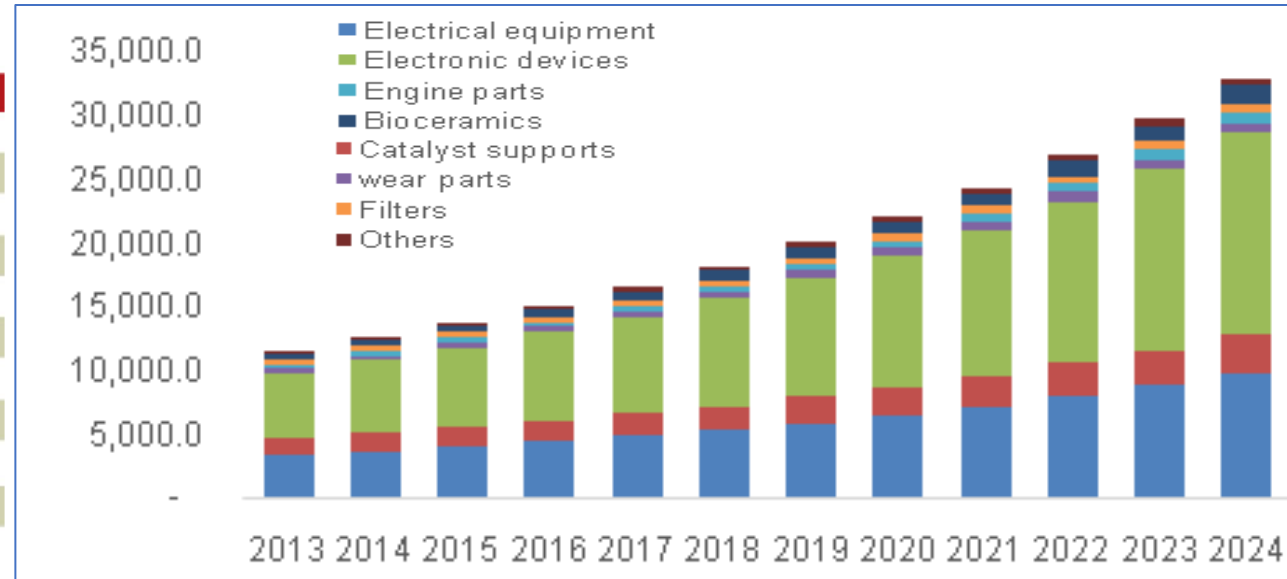

USA Advanced Ceramics Market Trend (2013 – 2024) (Million US\$)

Ref: H. Mandal et al. "Yeni geliştirilen SiAlON seramiklerin kesici takım ucu olarak kullanımı", 5. Uluslararası Katılımlı Seramik Kongresi'nde sözlü sunuş, 3-5 Ekim 2001, İstanbul.
 "U.S. Advanced Ceramics Growth Continues", <http://www.ceramicindustry.com/articles/u-s-advanced-ceramics-growth-continues>
 "Global Advanced Ceramics Market Size Growth, Industry Report, 2024"
<http://www.grandviewresearch.com/industry-analysis/advanced-ceramics-market>, June 2016.

USA Advanced Ceramics Market (2004)

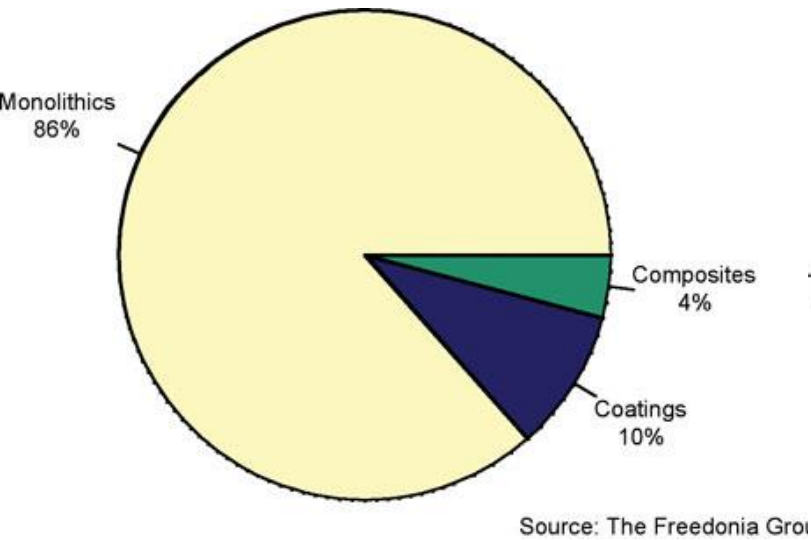

by Form

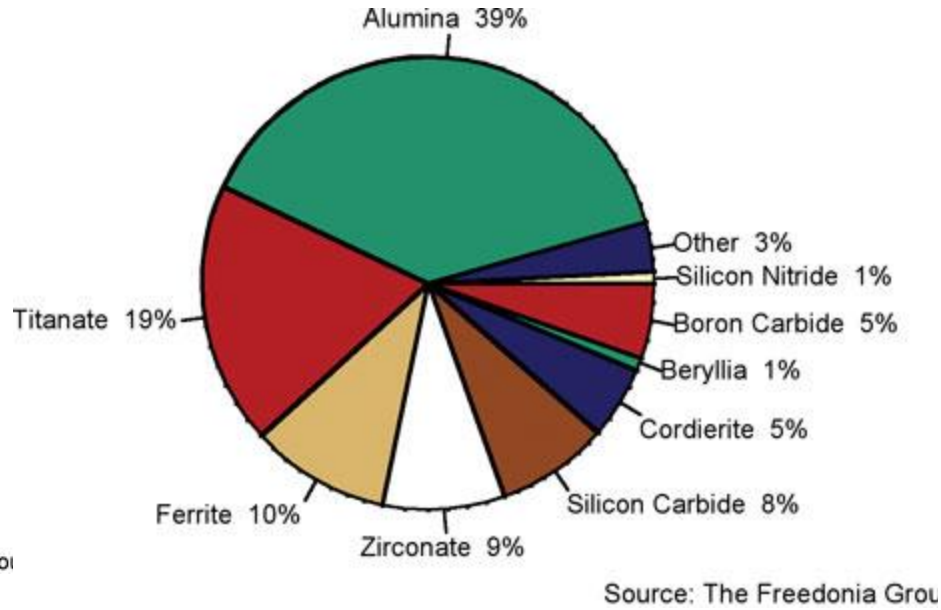

by Composition

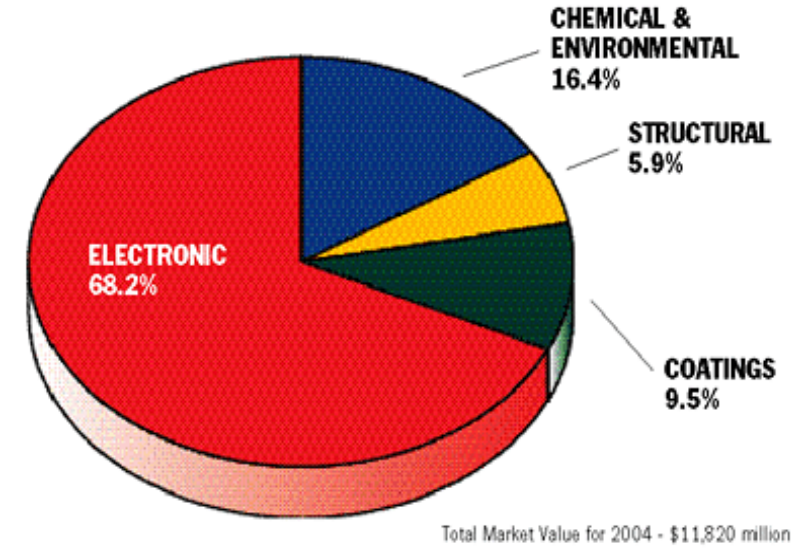

by Market Share

TURKEY's Advanced Ceramics Market

İleri seramikler 1994/95 yıllık ulusal pazar potansiyeli

Uygulama	milyon US\$
Aşınma plakaları	0.7 - 0.9
Sızdırmazlık elemanları	3.5 - 4.0
Aşınma ve öğütme topları	0.5 - 0.7
Pota, kruze, termokupl kılıfları	0.3 - 0.4
Tekstil kılavuzları ve diğerleri	2.0 - 2.2
Nozüller (kaynak, püskürtme, alev)	0.3 - 0.5
Özel döküm filtreleri	3.0 - 4.0
Partikül tutucular	2.0 - 3.0
Ateşleme bujileri	2.0 - 3.0
Isı dağıtıcılar	2.0 - 3.0
Kesici takımlar	1.0 - 1.2
Plazma püskürtme kaplama	3.5 - 4.0
Elektrik - elektronik seramikler	45.0 - 55.0
Diğer yapısal amaçlı uygulamalar	2.0 - 3.0
TOPLAM*	67.8 - 74.9

Elektroseramikler 1994/95 yıllık ulusal pazar potansiyeli

Adı	milyon US\$
Ferritler	5.0 - 6.0
Ferritler	1.2 - 1.5
Seramik dielektrik	5.0 - 6.0
Parafudr	0.4 - 0.8
Piezoelektrik seramik	9.5 - 11.0
Seramik izolatör	1.0 - 1.2
Fiberoptik, yarı iletken devre, çok kristal yarı iletken ve diğer	19.0 - 23.0
TOPLAM	45.0 - 55.0

- 1994/1995 ithalat verilerine göre Türkiye gelişmiş ülkelere oranla oldukça kısıtlı bir ileri seramik pazarına sahiptir.
- Bununla birlikte yerli üretimin olmaması, olası girişimciler açısından bu pazarı cazip kılmaktadır.
- Dünyadaki eğilime benzer bir şekilde yerli pazarın önemli bir kısmını elektrik-elektronik seramikler oluşturmaktadır.

TURKEY'S Advanced Ceramics Market

Grafik 26: Türkiye Teknik Seramik Ürün İthalatı ve İhracatı

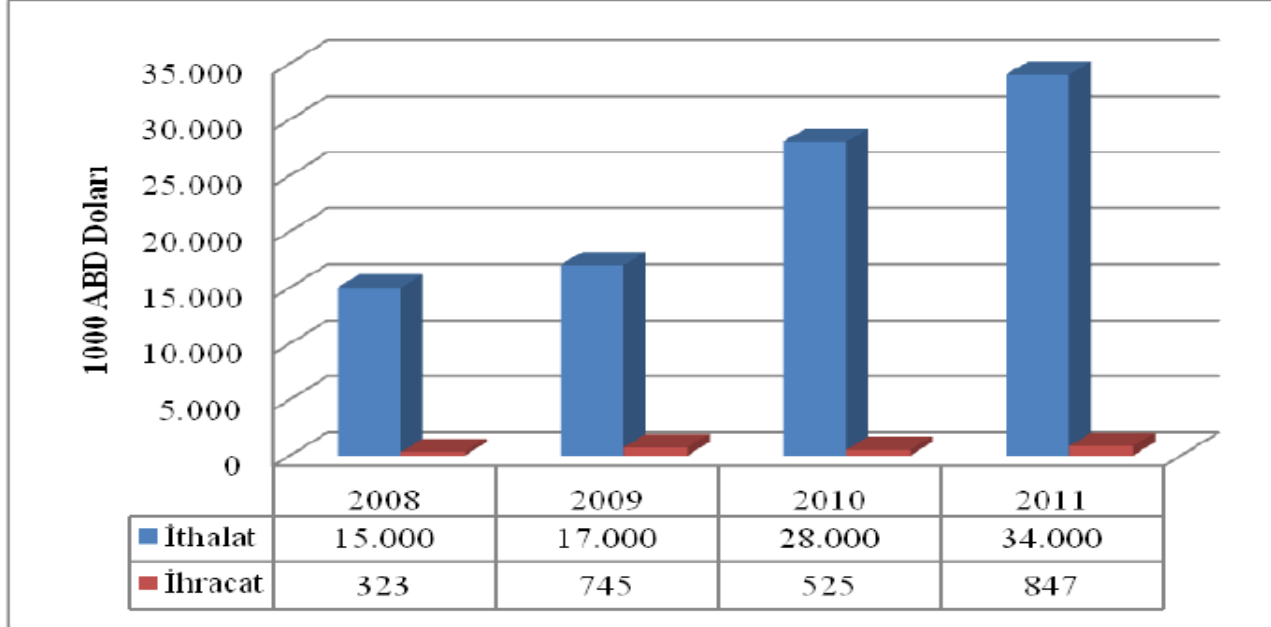

Kaynak: TÜİK (GTİP 6909 kodlu ürünler)

- Türk Seramik Sektörü, 2009 yılında 273 milyon US\$ ithalat gerçekleştirmiştir.
- Bu ithalatın 17 milyon US\$ kısmını teknik seramik sektörü oluştururken, 668 tonluk teknik seramik ithalatı yapılmıştır.
- 2010 yılında ise gerçekleşen 28 milyon US\$ ithalat,
- 2011 yılında 34 milyon US\$ seviyesine yükselmiştir.

- Günümüzde Türkiye'de üretilen teknik seramiklerin, yaklaşık % 80'i porselen izolatör ve % 15'i elektroporselen ürünlerdir
- 1999 yılında Türkiye pazarında yerli üretimin payı % 17 seviyesindeyken, 2005 yılında % 7 olarak gerçekleşmiştir.
- Porselen izolatörler, elektroporselen malzemeler ve ileri seramik malzemelerin üretimini içeren teknik seramik sektöründe, üretim yapan 10 firma bulunmaktadır.
- Türkiye'nin teknik seramik ürünleri ihracat seviyesi oldukça düşük seyretmekle birlikte; 2010 yılında 525 bin US\$, 2011 yılında 847 bin US\$ seviyelerine ulaşmıştır.

Advanced Ceramics Producers in TURKEY

Nanomaterials and Nanopowders

Entekno Endüstriyel Teknolojik ve Nano Malzemeler Ltd (Eskişehir)
BORTEK Bor Teknolojileri ve Mekatronik AŞ (İstanbul)



<https://www.enteknomaterials.com/>

Structural Ceramics and Ceramic Cutting Tools

MDA İleri Seramikler Ltd (Eskişehir)



<https://www.borteknolojileri.com/>

Electroceramics and Bioceramics

Ankara Seramik A.Ş. (Ankara)
Nanotech İleri Teknolojik Malzemeler Ltd (Eskişehir)
ENS Piezoaygıtlar Ltd (Gebze)



<https://mdaceramic.com/>



<https://www.ankaraseramik.com/>



<http://piezodevices.com/>



<http://www.nanotech.com.tr/>

Solid State Methods I

DECOMPOSITION

Solid-State Decomposition Reactions

➤ Chemical decomposition reactions, in which *a solid reactant is heated to produce a new solid + a gas*, are commonly used for the production of powders of simple oxides from carbonates, hydroxides, nitrates, sulfates, acetates, oxalates, alkoxides, and other metal salts.

➤ In general, the reactions produce an oxide and a volatile gaseous reaction product, such as CO₂, SO₂, or H₂O.

➤ An example is the decomposition of calcium carbonate (calcite) to produce calcium oxide and carbon dioxide gas:

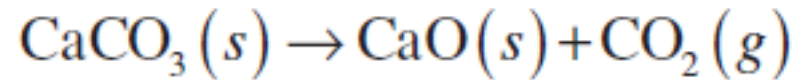

➤ Depending on the particular conditions of time, temperature, ambient pressure of CO₂, relative humidity, particle size, and so on, the process may be controlled by :

* *Reaction rate at the reaction surface*

* *Gas diffusion or permeation through oxide product layer*

* *Heat transfer*

Thermodynamics of Decomposition

➤ Ex: Decomposition of calcite (CaCO₃).

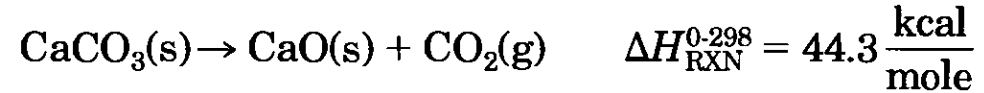

➤ **Reaction is strongly endothermic**, which is typical of most salt decompositions. This means that heat must be supplied to the reaction for it to continue.

➤ From the Gibbs free energy change : $\Delta G_{\text{RXN}} = \Delta G^0 + R_g T \ln K$

The equilibrium constant (**K**) for the decomposition reaction of calcium carbonate:

$$K = \frac{f_{\text{CO}_2} a_{\text{CaO}}}{a_{\text{CaCO}_3}} \cong \frac{P_{\text{CO}_2}}{P_{\text{TOT}}}$$

The partial pressure of the CO₂ gas becomes critical.

Thermodynamics of Decomposition

- For example, CaCO_3 becomes unstable above 810K, MgCO_3 above 480K, and depending on the relative humidity, $\text{Mg}(\text{OH})_2$ becomes unstable above 445–465K.
- Furthermore, acetates, sulfates, oxalates, and nitrates have essentially zero partial pressure of the product gas in the ambient atmosphere so they are predicted to be unstable at room temperature.
- The fact that these compounds are observed to be stable at much higher temperatures indicates that their decomposition is controlled by kinetic factors and not by thermodynamics.

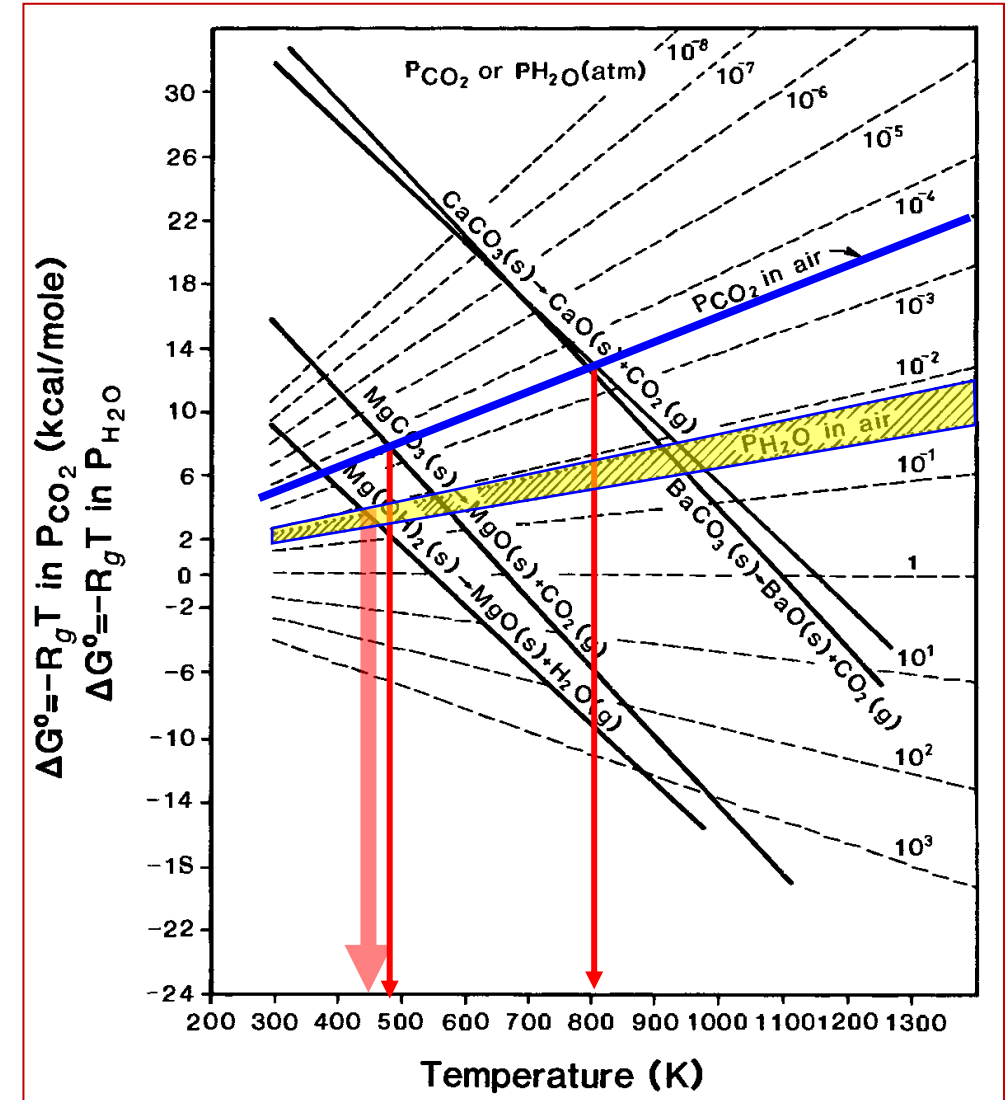

Standard free energy of reaction as a function of temperature. The dashed lines are the equilibrium gas pressure above the oxide/carbonate and oxide/hydroxide.

Kinetics of Decomposition

The kinetics may be limited by:

- *The reaction at the surface*
- *The flow of heat from the furnace to the reaction surface*
- *The diffusion (permeation) of the product gas from the reaction surface to the ambient furnace atmosphere.*

➤ The molar volume of the solid product is commonly smaller than that for the reactant, so that very often, the product forms a porous layer around the nonporous core of reactant as shown in Figure.

➤ Like most solid-state reactions, the reaction is heterogeneous in that it occurs at a sharply defined interface.

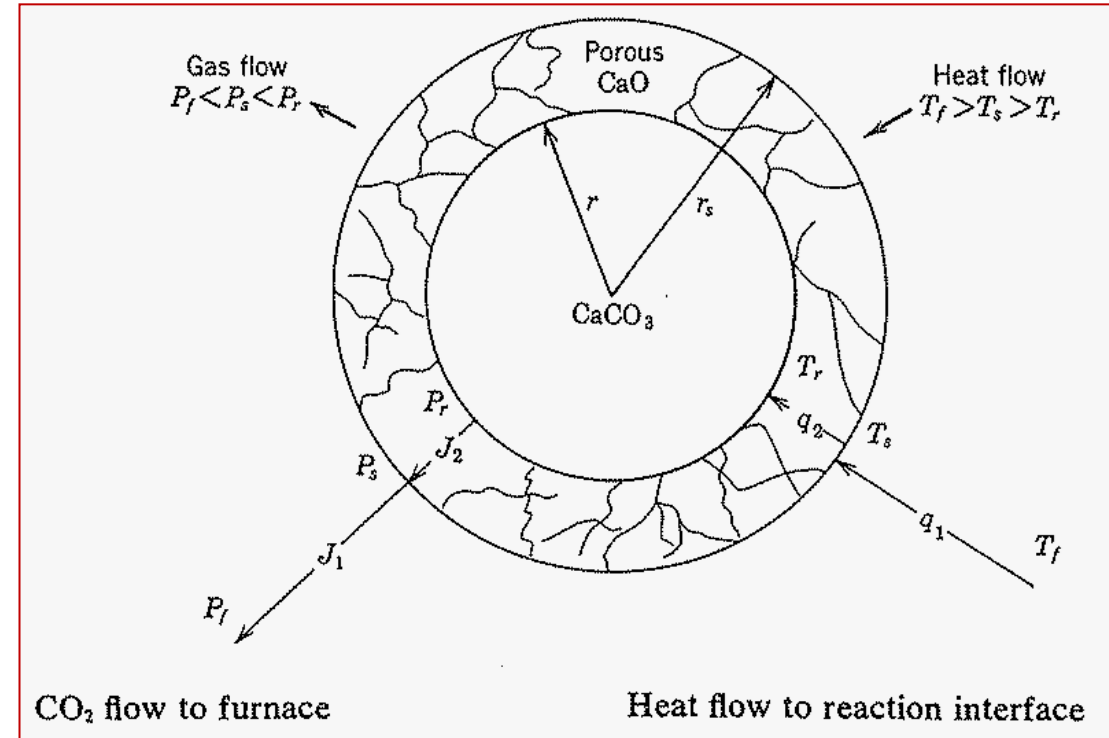

Schematic representation of decomposition of a spherical particle (e.g. CaCO₃) of a salt which yields a porous oxide product (e.g. CaO) and a gas (CO₂). The reaction is endothermic, requiring heat transfer. The driving forces for heat and mass transport for steady-state decomposition are expressed as temperatures and pressures in the furnace (T_f , P_f), at the particle surface (T_s , P_s), and at the reaction interface (T_r , P_r)

Kinetics of Decomposition

- The kinetic investigations of decomposition rxns are conducted isothermally or at a fixed heating rate.
- In isothermal studies, the maintenance of a constant temperature represents an ideal that cannot be achieved in practice, since a finite time is required to heat the sample to the required temperature. However, isothermal decomposition kinetics are easier to analyze.

- The progress of the reaction is commonly measured by the weight loss and the data are plotted as the fraction of the reactant decomposed α versus time t with α defined as:

$$\alpha = \frac{\Delta W}{\Delta W_{\max}}$$

where ΔW and ΔW_{\max} are the weight loss at time t and the maximum weight loss according to the decomposition reaction, respectively.

- There is no general theory of decomposition reactions. However, a generalized α versus time t curve similar to that shown in Figure is often observed.

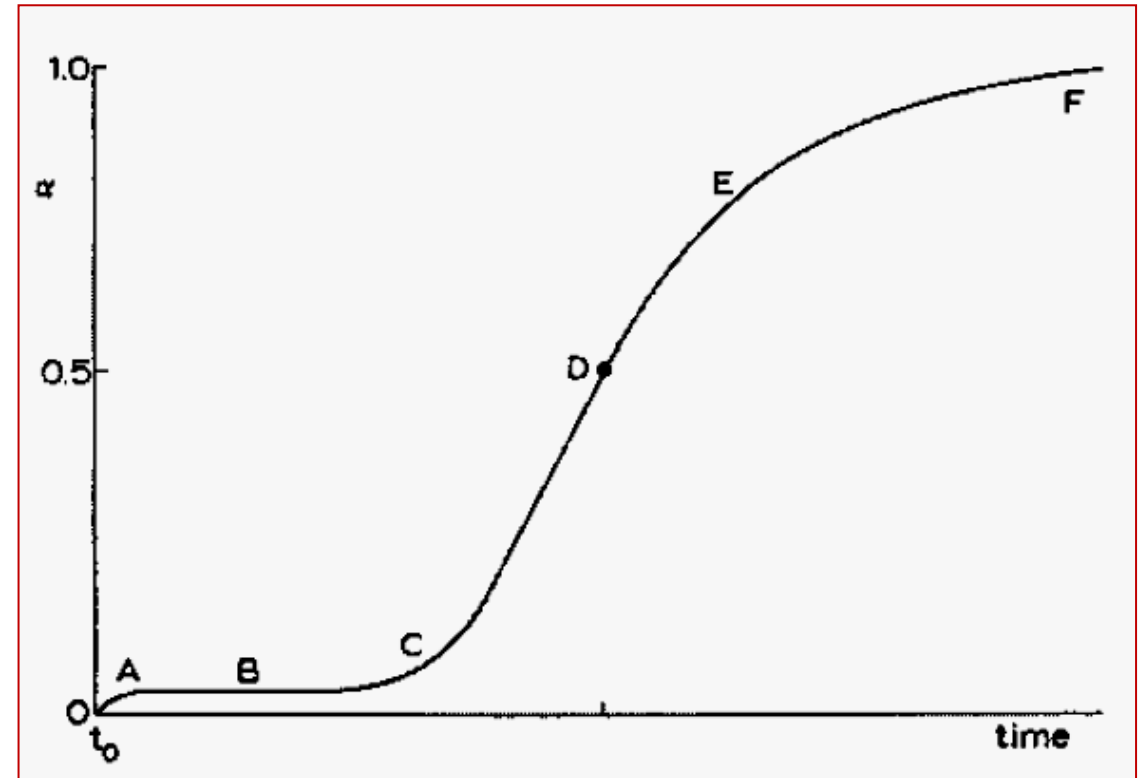

Generalized versus time plot summarizing characteristic kinetic behavior observed for isothermal decomposition of solids. α represents the weight loss divided by the maximum weight loss.

Kinetics of Decomposition

➤ The stage **A** is an initial reaction, sometimes associated with the decomposition of impurities or unstable superficial material. **B** is an induction period that is usually regarded as terminated by the development of stable nuclei, while **C** is the acceleratory period of growth of such nuclei, perhaps accompanied by further nucleation, which extends to the maximum rate of reaction at **D**.

➤ Thereafter, the continued expansion of nuclei is no longer possible due to impingement and the consumption of the reactant, and this leads to a decay period, **E**, that continues until the completion of the reaction **F**. In practice, one or more of these features (except D) may be absent or negligible.

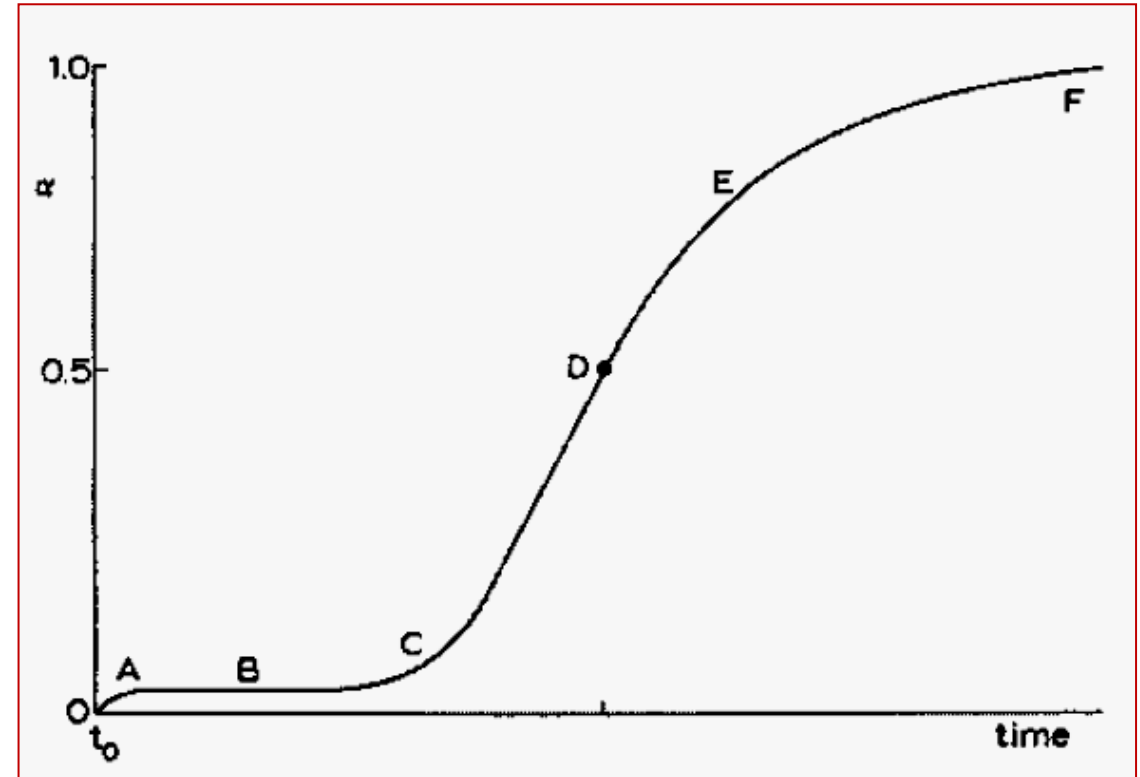

Generalized versus time plot summarizing characteristic kinetic behavior observed for isothermal decomposition of solids. α represents the weight loss divided by the maximum weight loss.

Solid State Methods II

REACTIONS BETWEEN SOLIDS

(Mixing & Calcination)

Chemical Reactions Between Solids

- The simplest system involves **reaction between two solid phases, A and B, to produce a solid solution C.**
- A and B are commonly elements for metallic systems, while for ceramics they are commonly crystalline compounds.
- Solid state reactions can be divided into **two stages**: **nucleation of the reaction product** and its **subsequent growth.**
- They are **heterogenous type of reactions** where there is reaction interface between the reacting phases, such as nucleus and matrix, or phase A and phase B.
- After the initiation of the reaction, A and B are separated by the solid reaction product C (see Figure).

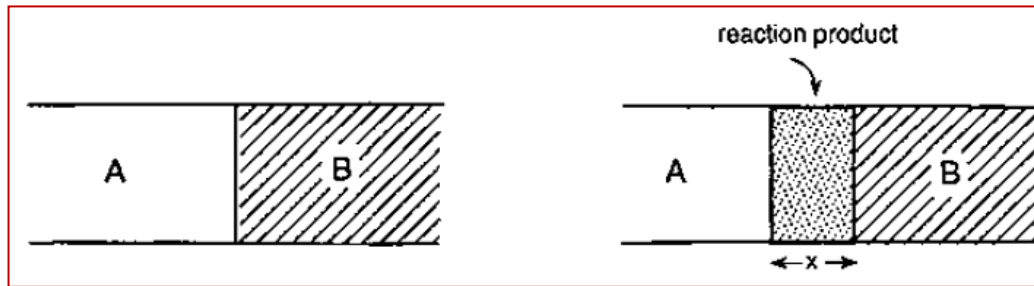

- In order for the reaction to proceed, **three steps** must take place in series:
 - I- **Material transport** (the transport of atoms, ions, or molecules by several possible mechanisms) through the phase boundaries and the reaction product to the interface .
 - II- **Reaction at the phase boundary**
 - III- **Sometimes transport of reaction products from the interface.**

Chemical Reactions Between Solids

- Reactions at the phase boundary liberate or absorb heat, changing the boundary temperature and limiting the rate of the process. The slowest of any of these steps may determine the overall rate.
- *Reactions between mixed powders are technologically important for powder synthesis.*
- The reaction between two (or more) types of solid is frequently practiced to produce multicomponent ceramic powders.
- Several examples include:
 - $\text{NiO(s)} + \text{Al}_2\text{O}_3\text{(s)} \rightarrow \text{NiAl}_2\text{O}_4\text{(s)}$
 - $\text{MgO(s)} + \text{Al}_2\text{O}_3\text{(s)} \rightarrow \text{MgAl}_2\text{O}_4\text{(s)}$
 - $\text{ZnO(s)} + \text{Fe}_2\text{O}_3\text{(s)} \rightarrow \text{ZnFe}_2\text{O}_4\text{(s)}$
 - $\text{ZnO(s)} + \text{Al}_2\text{O}_3\text{(s)} \rightarrow \text{ZnAl}_2\text{O}_4\text{(s)}$
 - $\text{BaCO}_3\text{(s)} + \text{SiO}_2\text{(s)} \rightarrow \text{BaSiO}_3\text{(s)} + \text{CO}_2\text{(g)}$
 - $\frac{1}{2}\text{Y}_2\text{O}_3\text{(s)} + 2\text{BaCO}_3\text{(s)} + 3\text{CuO(s)} \rightarrow \text{YBa}_2\text{Cu}_3\text{O}_{6.5}\text{(s)} + \text{CO}_2\text{(g)}$
- The spinel formation reaction is one of the most widely studied reactions among these where where a divalent oxide (AO) and a trivalent oxide (B_2O_3) in a 1:1 molar ratio react to form a product having the spinel structure (AB_2O_4).

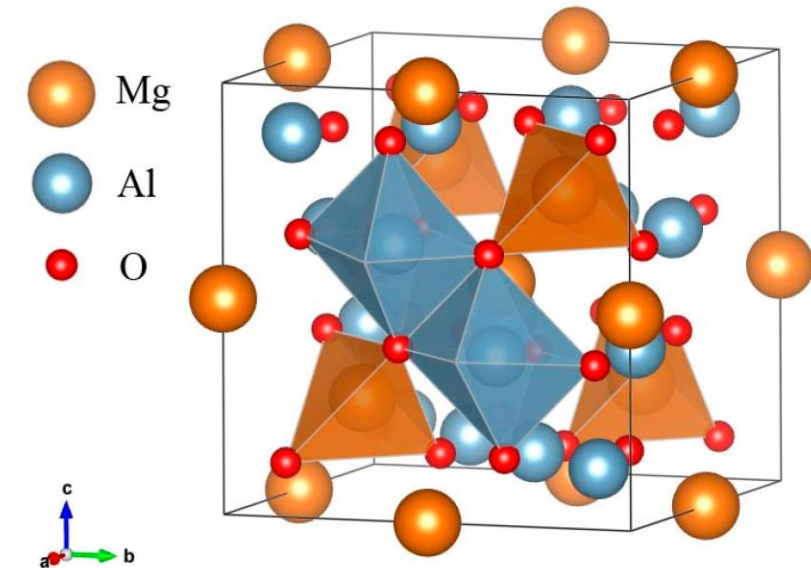

Crystallographic illustration of the MgAl_2O_4 -spinel (normal spinel structure).

Spinel Formation by Solid State Reactions

Nickel aluminate spinel (NiAl_2O_4) is formed as a reaction layer between the NiO and Al_2O_3 reactants.

➤ There are many possible reaction paths. Although five are shown schematically, not all of them are possible because diffusion coefficients of the ions differ widely.

Mechanisms in which O_2 molecules are transported through the gaseous phase and electroneutrality is maintained by electron transport through the product layer,

(1) Reaction occurs at AB_2O_4 - B_2O_3 interface: oxygen gas phase transport with A^{2+} ion and electron transport through AB_2O_4 :

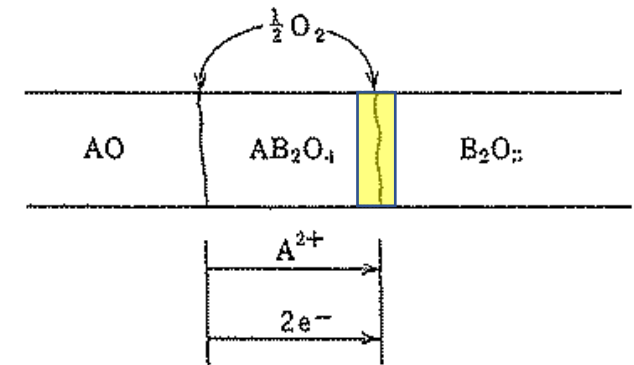
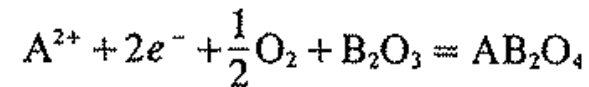

If ideal contact occurs at the phase boundaries so that transport of O_2 molecules is slow, then the *mechanisms in which O_2 molecules are transported through the gaseous phase and electroneutrality is maintained by electron transport through the product layer* are unimportant.

(2) Reaction occurs at AO - AB_2O_4 interface: oxygen gas phase transport with B^{3+} ion and electron transport through AB_2O_4 :

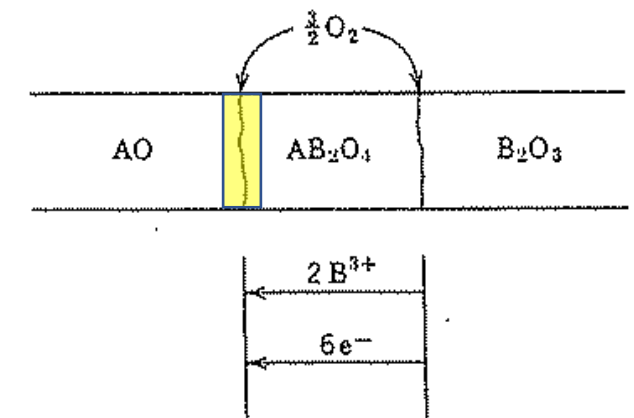
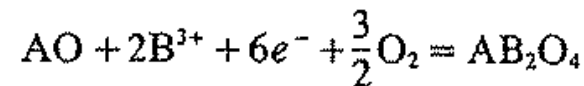

Spinel Formation by Solid State Reactions

Mechanisms in which O_2 ions diffuse through the product layer

(3) A^{2+} and O^{2-} diffuse. AB_2O_4 - B_2O_3 interface
 Reaction at $A^{2+} + O^{2-} + B_2O_3 = AB_2O_4$

(4) B^{3+} and O^{2-} diffuse. AO - AB_2O_4 interface
 Reaction at $AO + 2B^{3+} + 3O^{2-} = AB_2O_4$

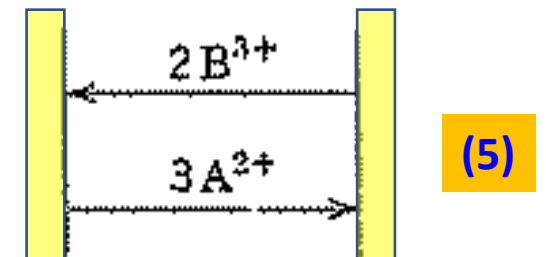
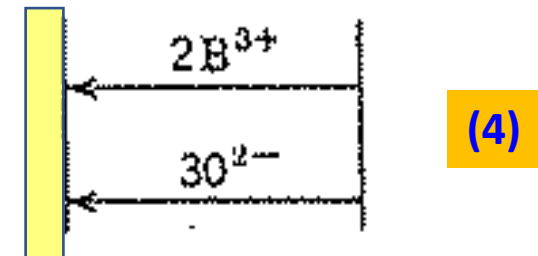
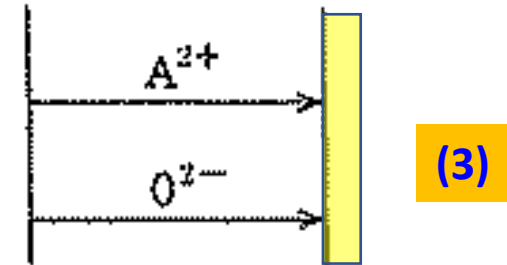
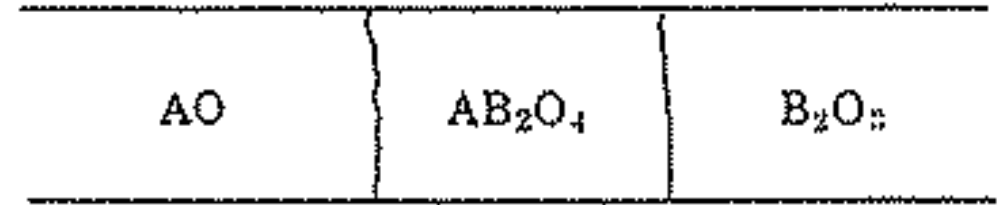

In spinels, diffusion of the large O_2 ions is rather slow when compared to cationic diffusion so that the *mechanisms in which O_2 ions diffuse through the product layer* can be eliminated.

Mechanism involving counter diffusion of the cations with the oxygen ions remaining essentially stationary

The most likely mechanism is the *mechanism involving counter diffusion of the cations with the oxygen ions remaining essentially stationary*, where the flux of the cations is coupled to maintain electroneutrality.

Oxygen and cation transport through AB_2O_4 :

(5) Both cations diffuse $(J_{B^{3+}} = \frac{2}{3}J_{A^{2+}})$.

Reactions occur at

AO - AB_2O_4 interface

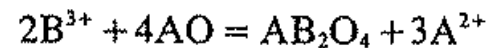

and at

AB_2O_4 - B_2O_3 interface



Spinel Formation by Solid State Reactions

➤ When the rate of reaction-product formation is controlled by diffusion through the planar product layer, the parabolic rate law is observed

$$x^2 = Kt$$

where K is a rate constant that obeys the Arrhenius relation and the wall thickness of the planar product layer increases with the square root of time.

- Figure shows the parabolic time dependence for NiAl_2O_4 formation.
- A parabolic growth rate for the reaction layer is usually taken to mean that the reaction is diffusion controlled .

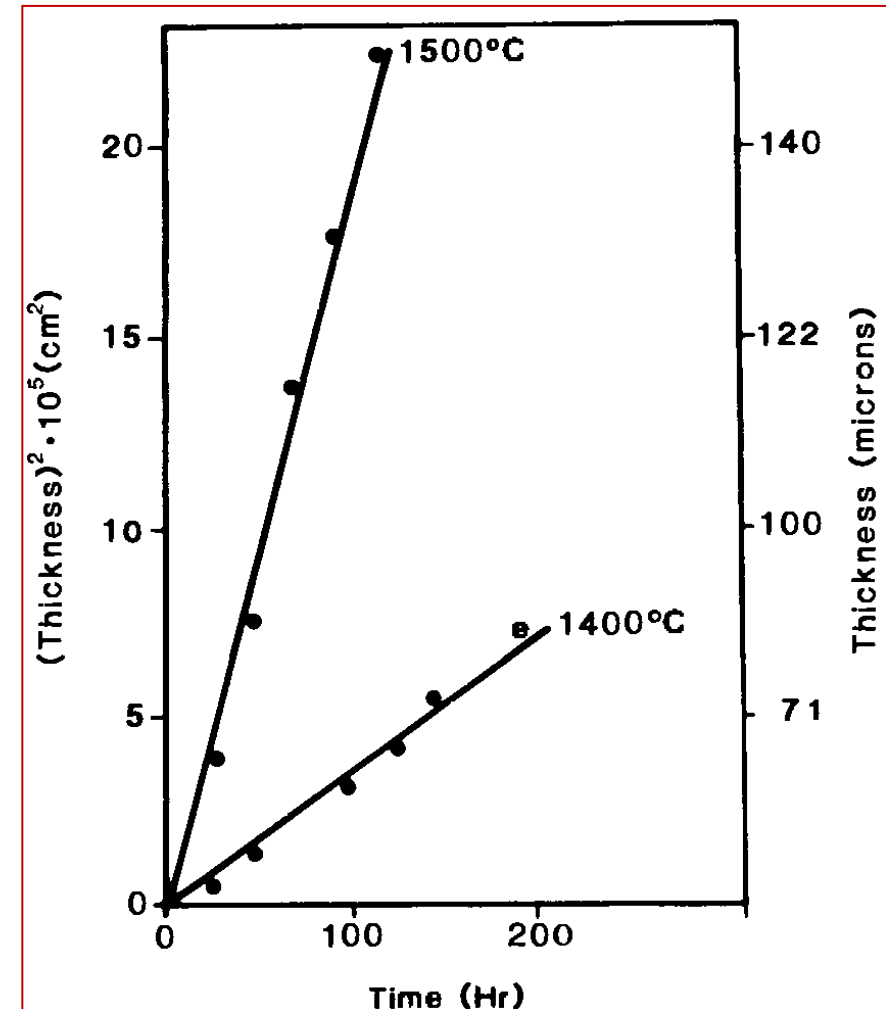

Thickness of NiAl_2O_4 formed in $\text{NiO-Al}_2\text{O}_3$ couples as a function of time heated in argon at 1400 and 1500°C.

Ref: W.D. Kingery, Introduction to Ceramics, John Wiley and Sons, Inc. (1976)

Ref: M.N. Rahaman, Ceramic Processing and Sintering, Marcel and Dekker (2009)

Powder Solid State Reactions

- For powder reactions (see figure), a complete description of the reaction kinetics must take into account several parameters, thereby making the analysis very complicated.
- Simplified assumptions are commonly made in the derivation of kinetic equations. For isothermal reaction conditions, a frequently used equation has been derived. In the derivation, it is assumed that equalized spheres of reactant A are embedded in a quasi-continuous medium of reactant B and that the reaction product forms coherently and uniformly on the A particles.
- The volume of unreacted material at time **t** is

$$V = \frac{4}{3} \pi (r - y)^3$$

where **r** is the initial radius of the spherical particles of reactant A and **y** is the thickness of the reaction layer.

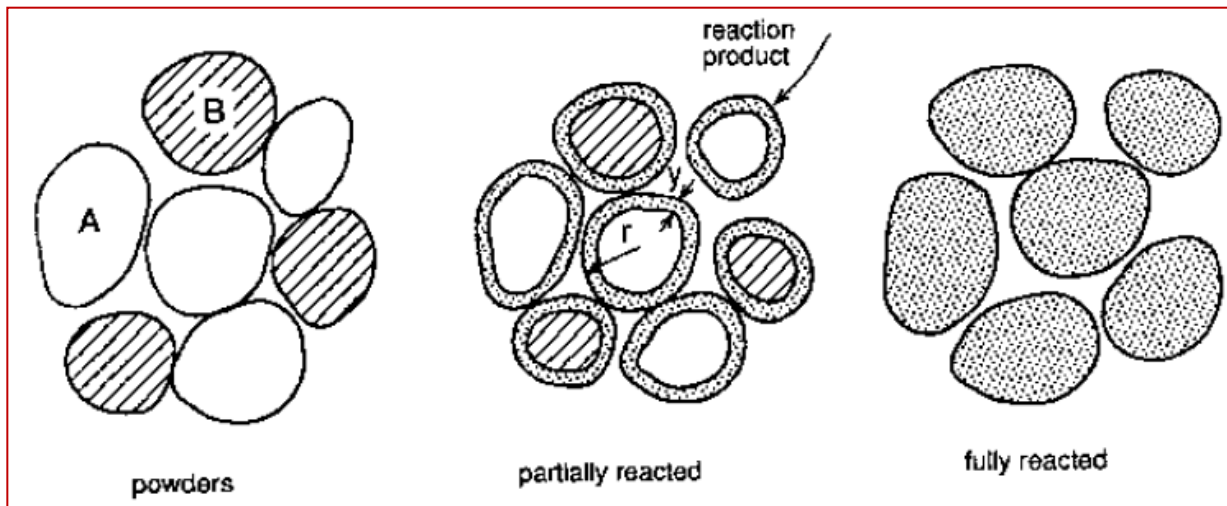

Schematic of solid-state reaction in mixed powders

Powder Solid State Reactions

➤ The volume of unreacted material is also given by $V = \frac{4}{3}\pi r^3(1-\alpha)$

where α is the fraction of the volume that has already reacted.

➤ Combining these equations $y = r \left[1 - (1 - \alpha) \right]^{1/3}$

➤ Assuming that y grows according to the parabolic relationship given by

then the reaction rate is; $\left[1 - (1 - \alpha) \right]^{1/3} = \frac{Kt}{r^2}$

➤ Figure illustrates the applicability of this equation to the solid state powder reaction



➤ In Figure linear time dependence of $\left[1 - (1 - \alpha) \right]^{1/3}$ is plotted for several temperatures.

➤ Figure (c) shows the Arrhenius expression, $K = K^0 \exp\left(\frac{-Q}{R_g T}\right)$

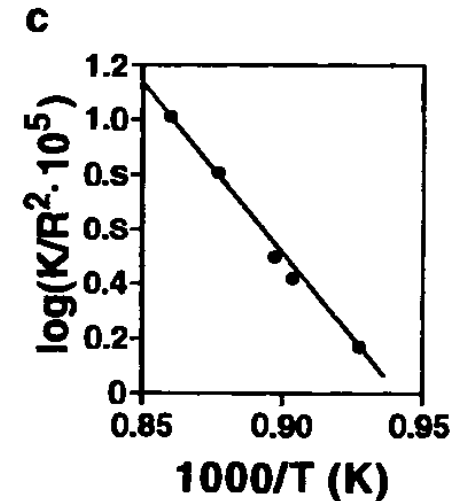
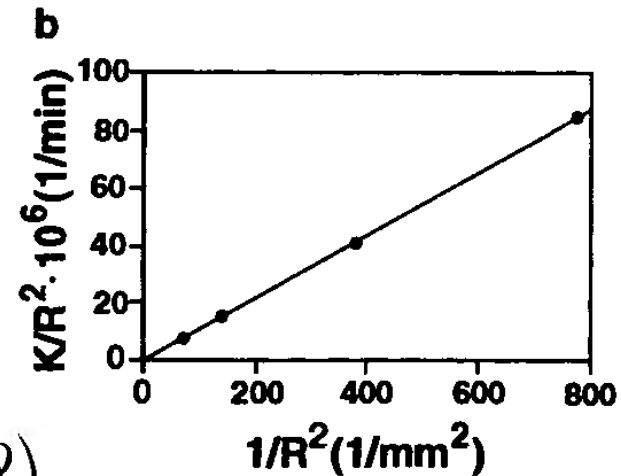
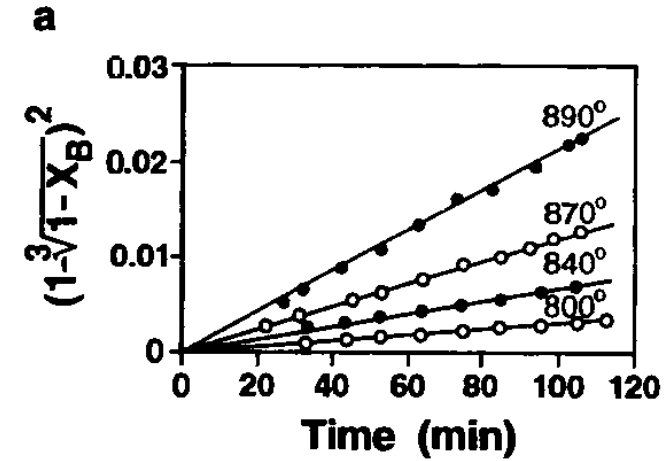

Powder Solid State Reactions

➤ This equation, referred to as the **Jander equation**, suffers from two oversimplifications that limit its applicability and the range over which it adequately predicts reaction rates.

(1) It is valid for small reaction thicknesses;

(2) It assumes product and reactants have the same molar volume.

➤ These two oversimplifications have been taken into account by Carter, who derived the following equation:

$$\left[1 + (Z - 1)\alpha\right]^{2/3} + (Z - 1)(1 - \alpha)^{2/3} = Z + (1 - Z)\frac{Kt}{r^2}$$

where **Z** is the volume of the reaction product formed from unit volume of the reactant A.

➤ This equation, referred to as the **Carter equation**, is applicable to the formation of $ZnAl_2O_4$ by the reaction between ZnO and Al_2O_3 even up to 100% of reaction (see Figure).

➤ This equation is also valid for the oxidation of metal powders.

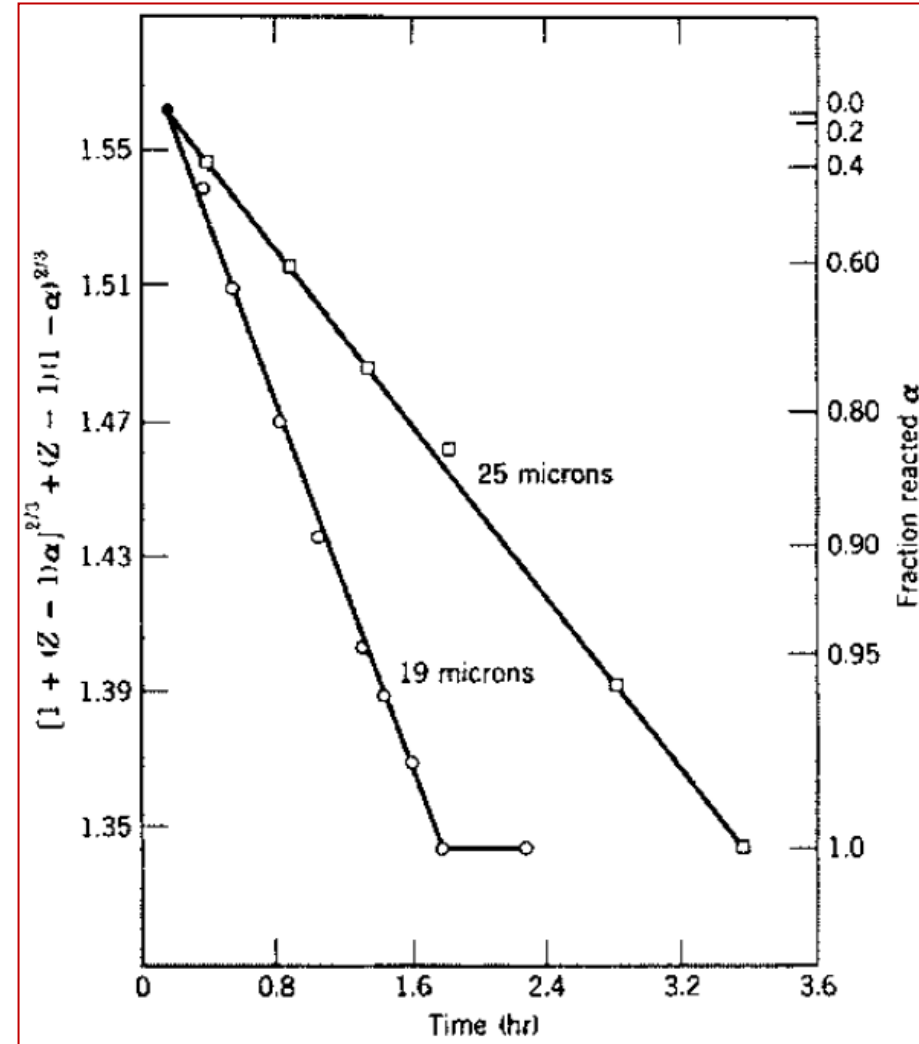

Kinetics of reaction between spherical particles of ZnO and Al_2O_3 to form $ZnAl_2O_4$ at 1400C in air, showing the validity of the Carter equation.

Powder Solid State Reactions

- For a solid-state diffusion mechanism, the growth of the reaction product in powder systems occurs at the contact points and for nearly equal-sized spheres, the number of contact points is small as in the figure.
- Nevertheless, for many systems, the Jander equation and the Carter equation give a good description of the reaction kinetics for at least the initial stages of the reaction.
- It appears that rapid surface diffusion provides a uniform supply of one of the reactants over the other.
- Alternatively, if the vapor pressure of one of the reactants is high enough as in the example rxn below

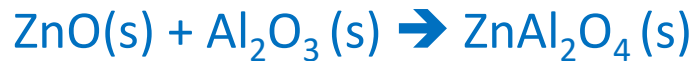

Then condensation on the surface of the other reactant can also provide a uniform supply of the other reactant.

- In this case, the powder reaction can be better described as a gas–solid reaction rather than a solid-state reaction.

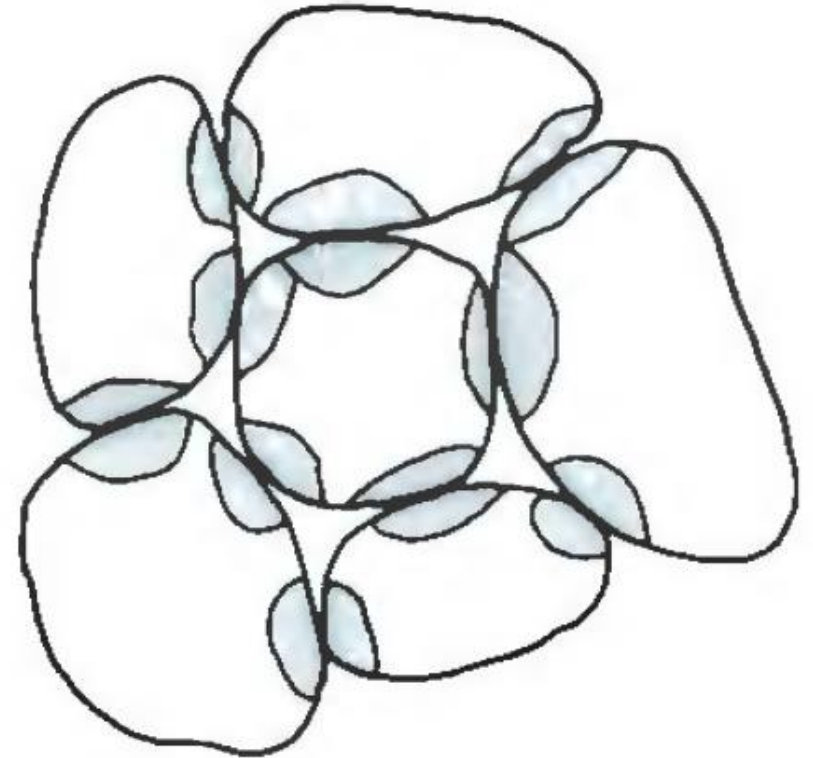

Powder Solid State Reactions

Solid state reaction in powder systems depends on several parameters:

- The chemical nature of the reactants and the product;
 - The size, size distribution, and shape of the particles;
 - The relative sizes of the reactant particles in the mixture;
 - The uniformity of the mixing, the reaction atmosphere; the temperature; and the time.
- The reaction rate will decrease with an increase in particle size of the reactants.
 - For coherent reaction layers and nearly spherical particles, the dependence of the reaction kinetics on particle size is given by Jander or Carter equations.
 - The reaction rate will increase with temperature according to the Arrhenius relation.
 - *The homogeneity of mixing is one of the most important parameters. It influences the diffusion distance between the reactants and the relative number of contacts between the reactant particles, and thus the ability to produce homogeneous, single-phase powders.*
 - *Powder preparation by solid-state reactions generally has an advantage in terms of production cost, but the powder quality is also an important consideration for advanced ceramics.*
 - The powders are normally agglomerated and a grinding step is almost always required to produce powders with better characteristics.
 - Grinding in ball mills leads to the contamination of the powder with impurities.
 - Incomplete reactions, especially in poorly mixed powders, may produce undesirable phases.
 - The particle shape of ground powders is usually difficult to control.



ELSEVIER

BOLETIN DE LA SOCIEDAD ESPAÑOLA DE
Cerámica y Vidrio

www.elsevier.es/bsecv

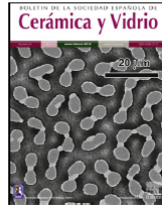

Effect of powder processing conditions on the electromechanical properties of lithium doped potassium sodium niobate

Ebru Mensur-Alkoy^{a,*}, Ayse Berksoy-Yavuz^b

Two different calcination routes were used to prepare the ceramic powders. In the first calcination method that is named as the ‘loose-calcination’ and referred to in the text as R1, the mixing step by ball-milling was followed by drying the green powder mixture on a hot plate while continuously stirring using a magnetic stirrer. Then the dried green powders were put into an alumina crucible as a loose powder and calcined. This was the procedure that we have followed in our previous studies on KNN [7,9–11]. Calcined powders were again ball-milled for 24 h. The Li content was $x=0.04$ and 0.07 with the samples produced with R1 and they were named as KL4 and KL7, respectively. This naming convention is the same with our previous studies [9,11].

Route 1 (R1) Loose Calcination → KL Samples

Ref: Ebru Mensur-Alkoy, Ayse Berksoy-Yavuz, ‘Effect of powder processing conditions on the electromechanical properties of lithium doped potassium sodium niobate’ Boletín de la Sociedad Española de Cerámica y Vidrio, Volume 55, Issue 6, Pages 246-252 (2016)

Route 2 (R2) Compact Calcination → L Samples

On the other hand, in the new calcination method that is named as the ‘compact-calcination’ and referred to in the text as R2, disc-shaped samples were prepared from the dried powder mixture by dry pressing under a uniaxial pressure of 55 MPa. These disc samples were then calcined instead of calcining loose powders. After calcination, samples were crashed using mortar and pestle. The crashed powders were again ball-milled for 24 h. The Li content was $x=0.04$ and 0.07 with the samples produced by R2 and named as L4 and L7, respectively.

Calcination of the all the samples in both of the calcination routes was done at 900°C for 1 h. After the calcination process, disc-shaped samples with ~ 10.5 mm diameter and ~ 1 mm thickness were prepared by pressing under a uniaxial pressure of 100 MPa and then sintered at 1090°C for 1 h. Finally, silver-palladium electrode was applied to the parallel surfaces of the discs for electrical measurements, and annealed at 850°C for 30 min.

CASE STUDY

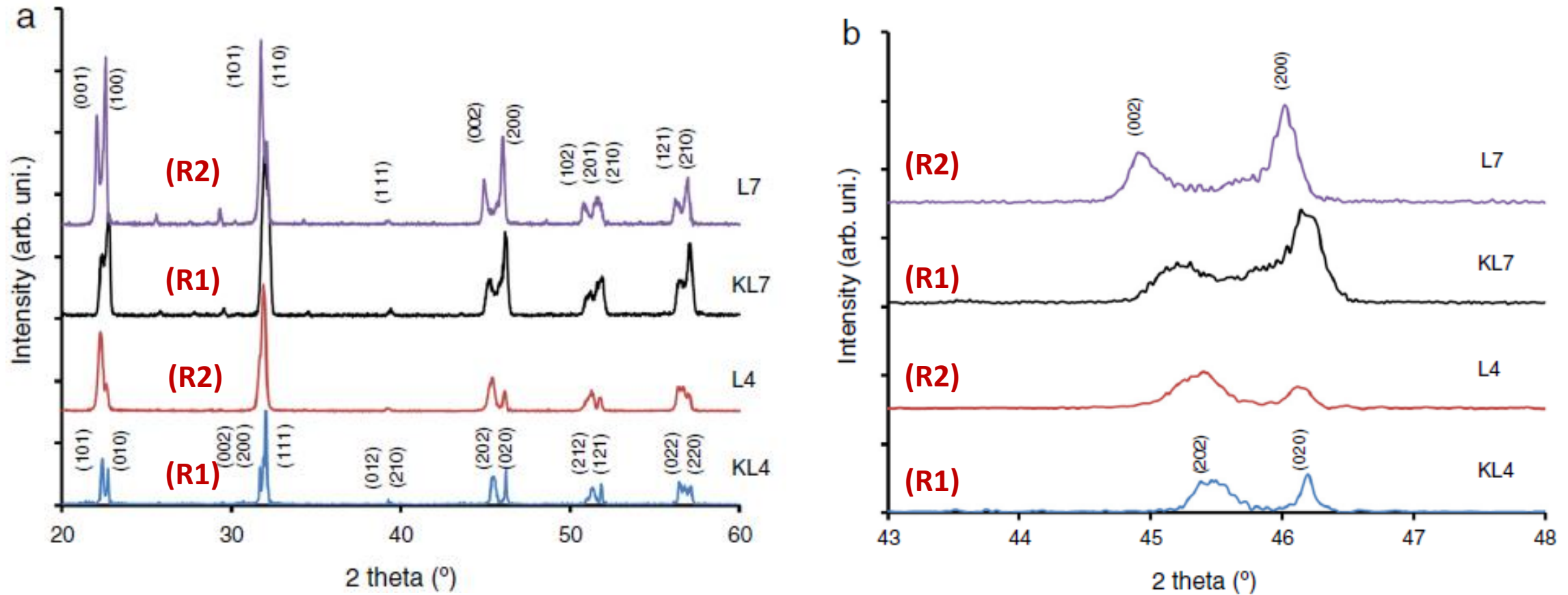
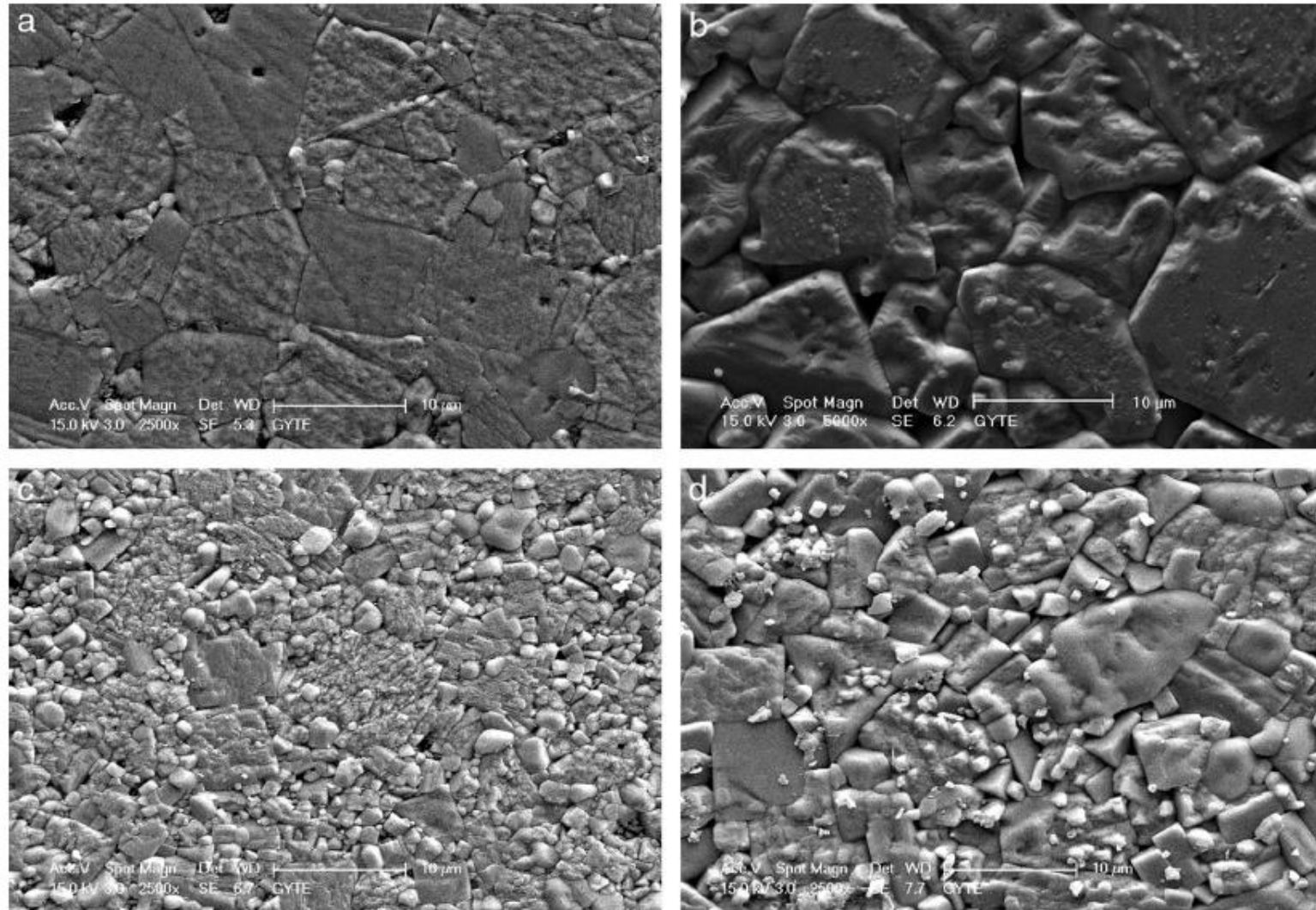

Fig. 1 – XRD patterns of (a) KL4, L4, KL7 and L7 samples, and (b) XRD patterns of selected region of the same samples. The peaks of KL4 and L4 were indexed based on the perovskite structure with orthorhombic symmetry and the peaks of KL7 and L7 were indexed based on the tetragonal symmetry.



R1 - Loose Calcination

R2 - Compact Calcination

Fig. 2 – The SEM micrographs of (a) KL4, (b) KL7, (c) L4 and (d) L7 samples.

CASE STUDY

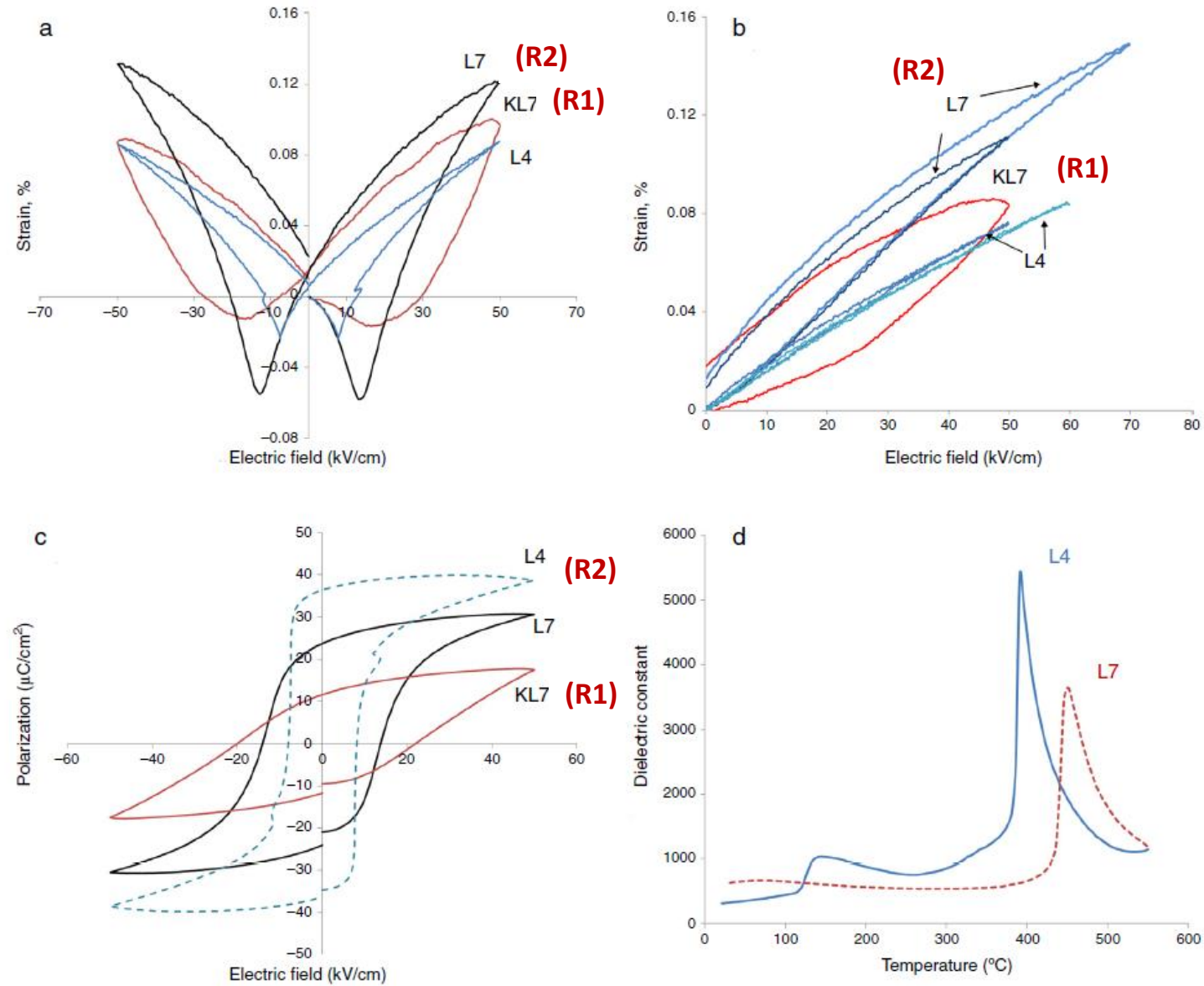

Fig. 3 – Comparison of (a) bipolar strain, (b) monopolar strain and (c) polarization vs. hysteresis of 4 and 7 mol% Li modified L4, KL7 and L7 samples. (d) Comparison of the temperature dependent dielectric constant of L7 and L4 samples.

Solid State Methods III

OXIDATION, REDUCTION & NITRIDATION

Oxidation of Sulphides

- Two types of oxidation reactions are of interest in ceramics: *oxidation of metals* and *oxidation of sulphides*.
- The **oxidation of sulphides** is a common extractive metallurgical process, generating an oxide ceramic powder. The oxide product is usually an intermediate product on the way to metal production but if sufficiently pure it can be used directly as a ceramic powder.
- A common example is the roasting of zinc sulphide to form zinc oxide;

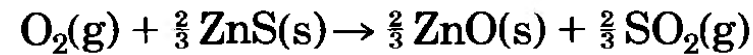

$$\Delta H_{\text{RXN}}^{0-298} = -166.9 \frac{\text{kcal}}{\text{mole}}$$

or the roasting of iron pyrite, FeS₂ by the reaction;

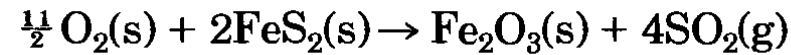

$$\Delta H_{\text{RXN}}^{0-298} = -592 \frac{\text{kcal}}{\text{mole}}$$

- These reactions are **strongly exothermic**, which is typical of these types of oxidation reactions. This means that the heat produced by the reaction will heat up the particle and further increase the reaction rate.
- The equilibrium constant, K_e , for the oxidation of zinc sulphide is given by;

$$K_e = \frac{P_{\text{SO}_2}^{\frac{2}{3}} P_{\text{TOT}}^{\frac{1}{3}}}{P_{\text{O}_2}}$$

assuming all gasses are ideal and the fugacities are equal to the partial pressures.

- The equilibrium constant is related to the standard free energy, ΔG^0 , as shown in equation; $\Delta G^0 = -R_g T \ln K_e$
- When the ratio of partial pressures, $P_{\text{SO}_2}^{\frac{2}{3}}/P_{\text{O}_2}$, is less than that at equilibrium, the reactant, ZnS, is unstable at that temperature.

Oxidation of Metals

➤ The **oxidation of metal** powders is a method to produce relatively pure oxides. A common metal oxidation is;

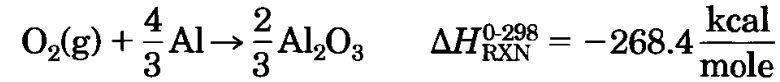

➤ This reaction, like all metal oxidation reactions, is strongly exothermic. The standard free energy of this and many other oxidation reactions are given in Figure.

➤ The distribution coefficient for all metal oxidation reactions is given by;

$$K = P_{\text{O}_2}^{-1} P_{\text{TOT}} \quad \text{assuming ideal gas.}$$

➤ The distribution coefficient and the standard free energy make up the total free energy of reaction according to equation;

$$\Delta G_{\text{RXN}} = \Delta G^0 + R_g T \ln K$$

➤ Term $-R_g T \ln P_{\text{O}_2}$ is also given in Figure on the outside scale of the graph.

➤ When the standard free energy, ΔG^0 is less than $-R_g T \ln P_{\text{O}_2}/P_{\text{TOT}}$ then the oxide is stable.

➤ In gas fired metal oxidations, the fuel gives a combustion gas of a particular CO₂ and H₂O composition. At these high temperatures, the decomposition of CO₂;

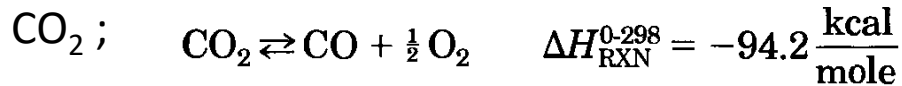

creates an equilibrium partial pressure of oxygen that influences the metal oxide stability at temperature, as does the decomposition of water;

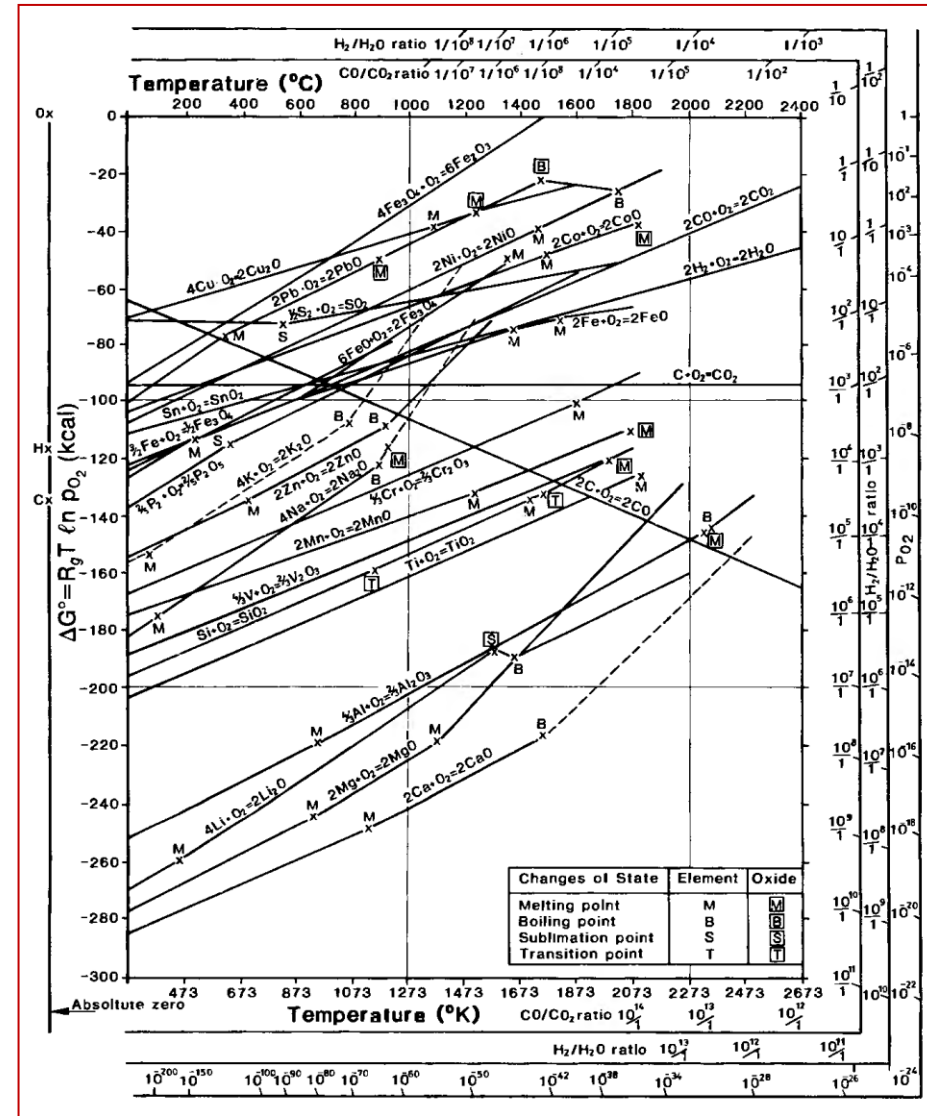

Standard free energy of formation of oxides as a function of temperature.

Reduction Reactions

- The **reduction of oxides** in reducing atmospheres is also an important industrial reaction that produces a powder. However, these reduction reactions are frequently used to produce metal powders and are not often used to produce ceramic powders.
- These reduction reaction can, however, be the first step in a sequence of steps to produce carbide and nitride powders. Several examples of reduction reactions are;

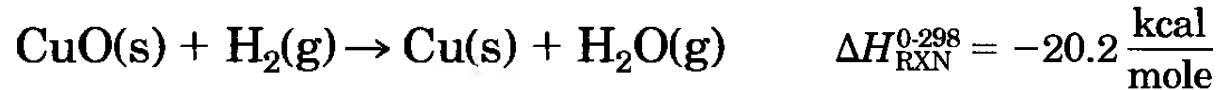
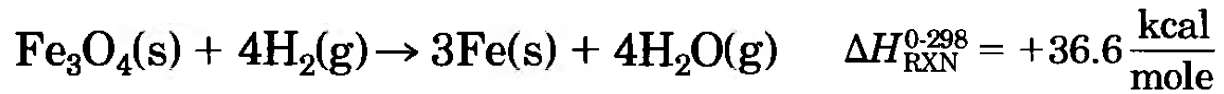

- However, there is a much more broadly applicable and used method of traditional reaction processing of mainly binary nonoxide ceramic powders, namely **carbothermal reduction**.
- This simply entails intimate mixing of oxide powders of the desired metals, metalloids, and carbon (or a source of it) to reduce the oxides, and if producing a carbide, to react with the reduced metal to form its desired carbide.
- Fine, uniformly, and intimately mixed reactive ingredients are important to react to the desired products with little or no residual oxide or excess carbon, at temperatures and times to limit excessive particle growth and sintering.
- Removal of residual undesired phases can sometimes be done with limited negative effects, but are an added cost and pose their own contamination problems.
- Fine carbon powders or liquid precursors such as sugar (dissolved in water) or furfuryl alcohol can be useful and are of modest cost, especially sugar, which has been used in a number of cases.

Carbothermal Reduction

➤ The reduction of silica by carbon is used industrially to produce silicon carbide powders:



➤ This reaction should occur somewhat above 1500°C but is usually carried out at much higher temperatures so that the SiO₂ is actually a liquid. The process is carried out on a large scale industrially and is referred to as the *Acheson Process*.

➤ The mixture is self-conducting and is heated electrically to temperatures of 2500°C. Side reactions occur so that the reaction is more complex than given above.

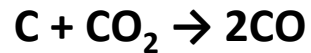

➤ The product obtained after several days of reaction consist of an aggregate

of black or green crystals. It is crushed, washed, ground, and classified to produce the desired powder sizes.

➤ One disadvantage of the Acheson process is that powder quality is often too poor for demanding applications such as high-temperature structural ceramics. Because the reactants exist as mixed particles, the extent of the reaction is limited by the contact area and inhomogeneous mixing between reactant particles with the result that the SiC product contains unacceptably high quantities of unreacted SiO₂ and C.

➤ These limitations have been surmounted by a process in which the SiO₂ particles are coated with the C prior to reduction. Relatively pure SiC powders with fine particle sizes (<0.2 μm) can be produced

➤ Laboratory scale methods employing gas-phase reactions can also produce fine and pure SiC powders, but the methods are expensive.

Cross-section of an Acheson furnace

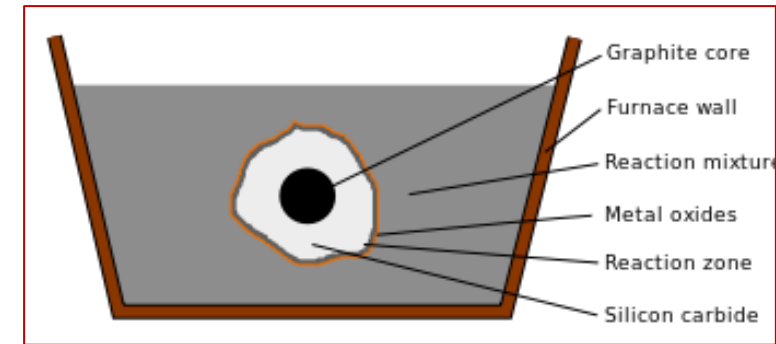

Carbothermal Reduction

➤ Another example of these reduction reactions is the preparation of Si_3N_4 by carbothermal reduction of SiO_2 (which basically avoids the issue of Si melting) in a N_2 or NH_3 atmosphere, the latter being somewhat more reactive, generally producing mostly α - Si_3N_4 ($\sim 2 \mu\text{m}$) at $\sim 1400^\circ\text{C}$.

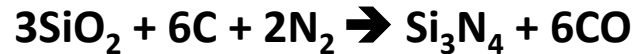

➤ Either fluidized-bed reactors or rotary calciners can be useful whether one of the reactants is a gas or all are solid (e.g., as for SiC) and may reduce agglomeration common in static bed reactors.

➤ The phase of the oxides can aid in some cases; for example, γ - Al_2O_3 is beneficial for making AlN at $\sim 1500^\circ\text{C}$ because of its finer character, but with effects of the starting skeletal structure of different Al_2O_3 phases.

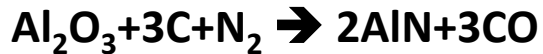

➤ On the other hand, anatase or rutile precursors for TiN have limited differences other than via some benefit of finer TiO_2 particle size and negative effects of purposely added particle TiO_2 coatings for pigment-grade material in making TiN at $\sim 1150^\circ\text{C}$.

➤ Reactions can be affected, often significantly, by various parameters, particularly temperature — e.g., SiC formation is via a solid-state carbon - SiO_2 reaction below 1400°C , while above this temperature gaseous reaction of SiO and C becomes dominant.

➤ Vacuum processing or other control of CO pressure and continuous mixing (e.g., via a fluidized bed or rotary calciner) can also be important.

➤ More complex compositions can be made, such as SiAlONs, sometimes using natural clays as lower cost raw materials

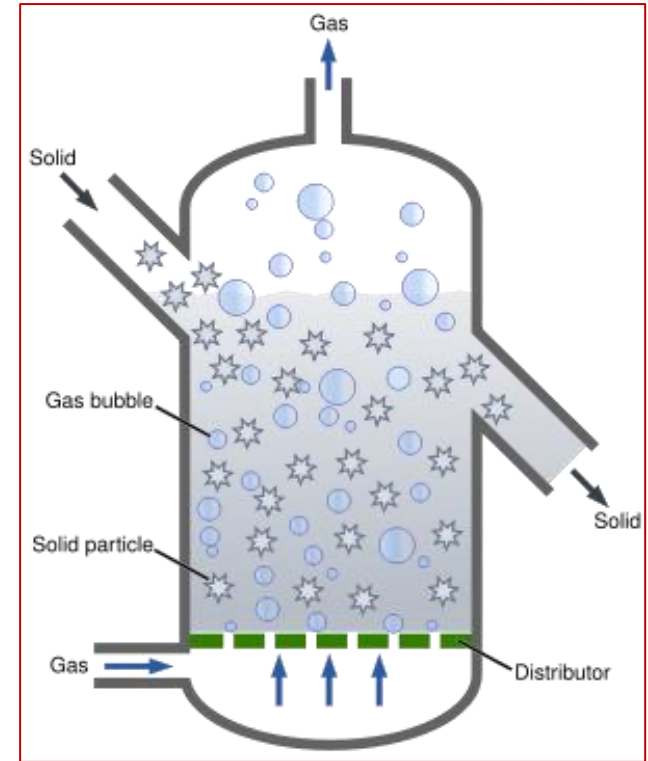

A fluidized-bed reactor.

Carbothermal Reduction

- There are three extensions of carbothermal processing that should be noted.
- **First extension**, while such processing reduces or precludes melting of elemental precursors such as Al and especially Si, there are important cases where a low melting precursor is used, with the use of B₂O₃ for boron containing compounds being particularly important.
- Thus, for example, in the preparation of BN, B₂O₃ (or boric acid – H₃BO₃) is the typical source of B in a variety of reactions involving carbothermal or other reductions.



- Complications that may result from forming liquid phases during reaction are limited by actual or effective encapsulation of the initial solid particles that will melt so melted particles cannot coalesce. Such encapsulation may be via other solid constituents of the reaction, fillers (such as tricalcium orthophosphate) that are inert to the reaction, or an initial liquid phase, e.g., sugar solution or furfuryl alcohol precursor for carbon where this is a constituent of the reaction.
- The **second extension** of carbothermal processing is to more complex compounds than just binary compounds, e.g., of ternary compounds TiZrC and TiZrB₂, where such processing of the end members at ~ 2000°C resulted in particle sizes of ~ 2-13 μm and various stoichiometries of ternary solid solution compounds with intermediate particle sizes.
- The **third extension** of reduction processing noted above is often used to directly produce ceramic composites without specifically producing a powder that is subsequently densified, but the latter route has also been pursued. Thus, for example, powders produced by the following reactions gave composite powders that could yield composite character and properties comparable to those obtained by making the composites from constituents oxide and nonoxide powders:



Direct Nitridation Reactions

➤ The direct nitridation of metal powders is commonly used to produce Si_3N_4 , BN, AlN, and other nitrides:

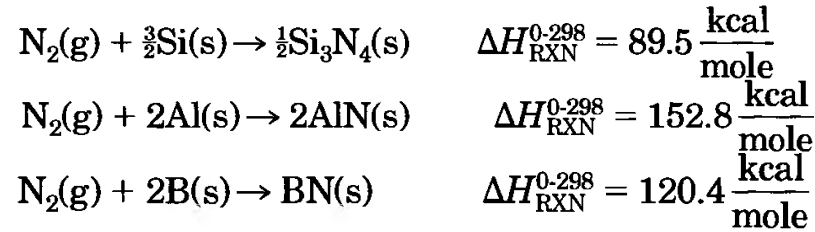

➤ These and other nitrogen reactions are strongly endothermic, requiring energy to continue.

➤ The standard free energy of several nitridation reactions are given in Figure.

➤ The distribution coefficient is defined by; $K = P_{\text{N}_2}^{-1} P_{\text{TOT}}$

➤ This and the standard free energy make up the total free energy of reaction as shown in equation

➤ In a gas mixture where $P_{\text{N}_2} = 0.79$ atm and the rest is an inert gas, all the metal nitrides are stable with respect to their metals, except Fe above 250 K and Cr above 1325 K.

➤ In air where $P_{\text{N}_2} = 0.79$ atm, this result is not true because the metals may also oxidize. Due to the presence of O_2 in air, oxidation reactions occur at the same time.

➤ In addition to metal nitridation, metal carbides may be reacted as follows to produce nitrides or carbonitride powders.

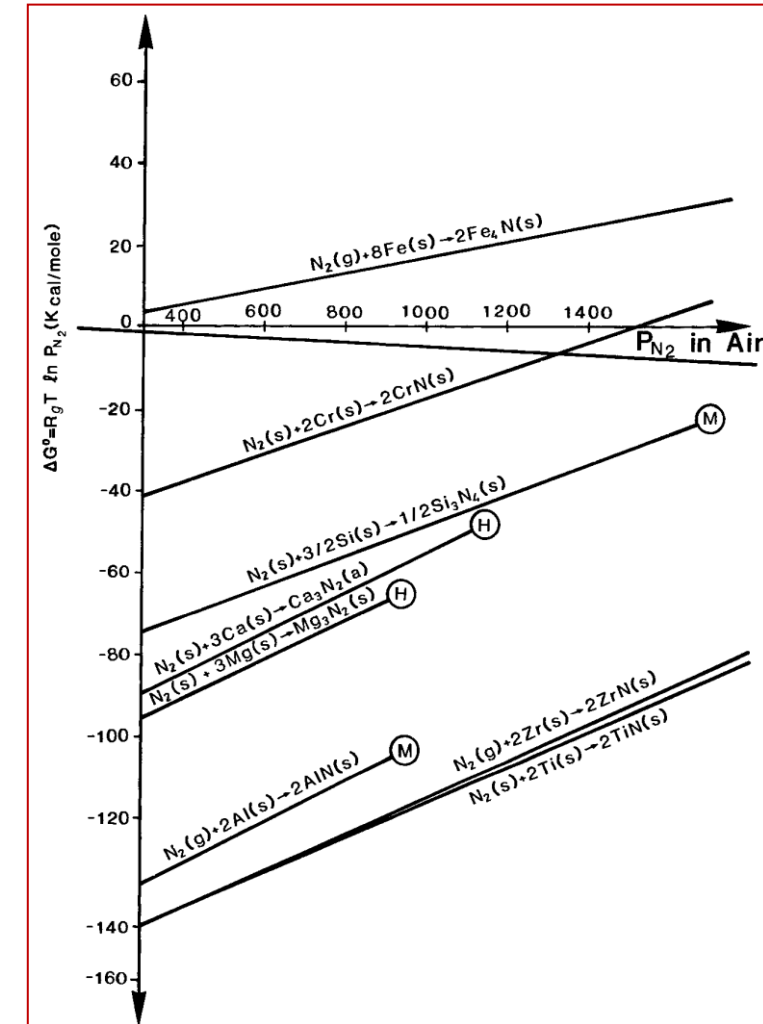
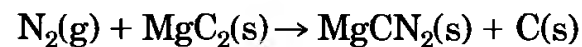
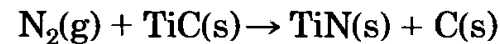

Standard free energy of formation of nitrides as a function of temperature.

Crystallization Behavior and Characterization of Turbostratic Boron Nitride

Sedat Alkoy, Cetin Toy,* Turgay Gönül & Adnan Tekin

Faculty of Chemical and Metallurgical Engineering, Istanbul Technical University, 80626 Maslak-Istanbul, Turkey

(Received 1 February 1996; revised version received 20 January 1997; accepted 24 January 1997)

Abstract

X-ray diffraction studies of boron nitride powders synthesized from boric oxide and ammonia at 900°C indicates a turbostratic structure which is characterized by the absence of ordering in the third dimension. Turbostratic boron nitride (t-BN) powders are found to be unstable and decompose into ammonium borate compound ($\text{NH}_4\text{B}_5\text{O}_8 \cdot 4\text{H}_2\text{O}$) after long storing periods. Thermal transformation of t-BN into the stable, hexagonal ordered layer lattice structure was promoted with heat treatments at 1500–1800°C for 15 min–5 h. The transformation and degree of crystallization was observed with X-ray diffraction analysis. The effect of crystallization period and temperature on the particle sizes and shapes of the powders was examined with transmission electron microscope. BET surface area measurements of the powders were also performed for the characterization of powder properties. © 1997 Elsevier Science Limited.

a compound, boron nitride, isoelectronic with the structure of C–C bonds, and display crystallographic transformations analogous to carbon. Under normal conditions, the graphite-like hexagonal form (h–BN) is stable but the other two main forms zinc blende cubic structure (c–BN) and wurtzite-like close packed hexagonal structure (w–BN), with a tetrahedral distribution of atoms, are stable at high pressures and temperatures. However, they can also be found in a metastable state under normal conditions.³ In addition to these main polymorphs, stacking faults in (001) plane of h–BN cause them to form a structure analogous to a ‘rhombohedral’ lattice, which is also presented as a structural modification of h–BN and can be present in small quantities in the h–BN powder.³

The hexagonal structure of boron nitride, first proposed by Pease,^{4,5} is constructed from layers consisting of a flat or nearly flat network of B_3N_3 hexagons with a bond length of 1.446 Å and strong

2 Experimental Studies

Turbostratic boron nitride powders were obtained by nitridation of boric oxide (B_2O_3) under the flow of ammonia (NH_3) gas at $900^\circ C$ in 2 h. The synthesis experiments were carried out under the dynamic conditions of a stainless steel rotary tube furnace that contained an intimate mixture of boric oxide and an inert filler material. Two different sizes of rotary furnaces were used for small and large quantities (less than 10 g and more than 500 g, respectively) of turbostratic boron nitride production to evaluate potential problems with the scale-up process. Tri-calcium phosphate [$Ca_3(PO_4)_2$], with a specific surface area of $60\text{ m}^2\text{ g}^{-1}$ was used as an inert filler material to provide sufficient reaction surface to the boric oxide, which is a viscous fluid at the reaction temperatures. Unreacted boric oxide and inert filler material were removed from the reaction products with an HCl acidic leaching process at $pH=0.5$, $T=20^\circ C$ with a pulp density of 10%.

Crystallization heat treatments of the turbostratic BN powders were carried out in graphite boats and crucibles under argon gas atmosphere. The turbostratic BN powders that were obtained by utilizing the small reactor were heat-treated only at a temperature of $1500^\circ C$. On the other hand, all of the powders heat-treated above $1500^\circ C$ were obtained from the same batch of the large-scale production operation. Duration of heat treatments varied between 15 min and 5 h, depending on the crystallization temperature employed.

The three-dimensional ordering of the structure with increasing heat-treatment times and temperatures was investigated with utilization of X-ray diffraction (XRD) analysis. All the XRD analyses were carried out by using a Rigaku Rint X-ray diffractometer, with a horizontal goniometer and a Cu- $K\alpha$ radiation tube. Effect of crystallization on the shapes and sizes of the powder particles was examined with a JEM-2000 EX-type transmission electron microscope (TEM). Specific surface area of the heat-treated samples were also measured by a 3-point BET method with a Quantachrome Autosorb1 instrument.

CASE STUDY

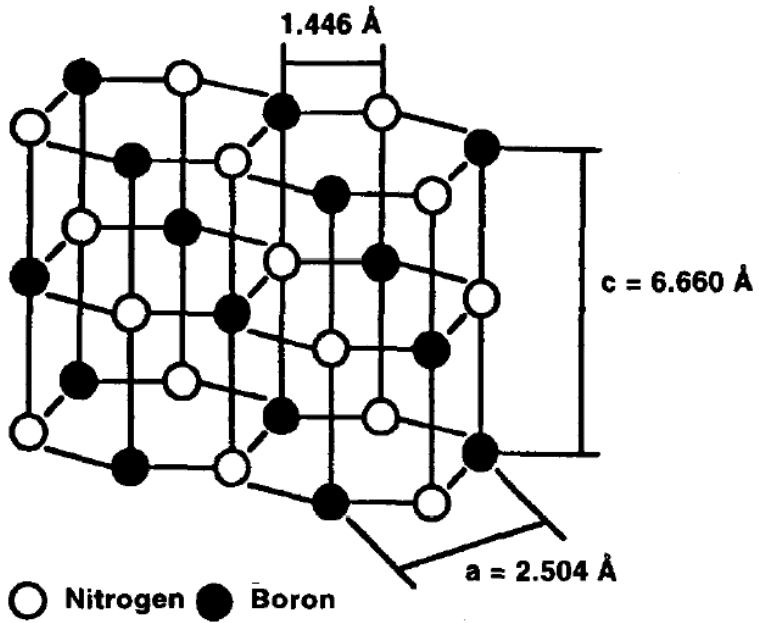

Fig. 1. Schematic crystal structure of hexagonal boron nitride.

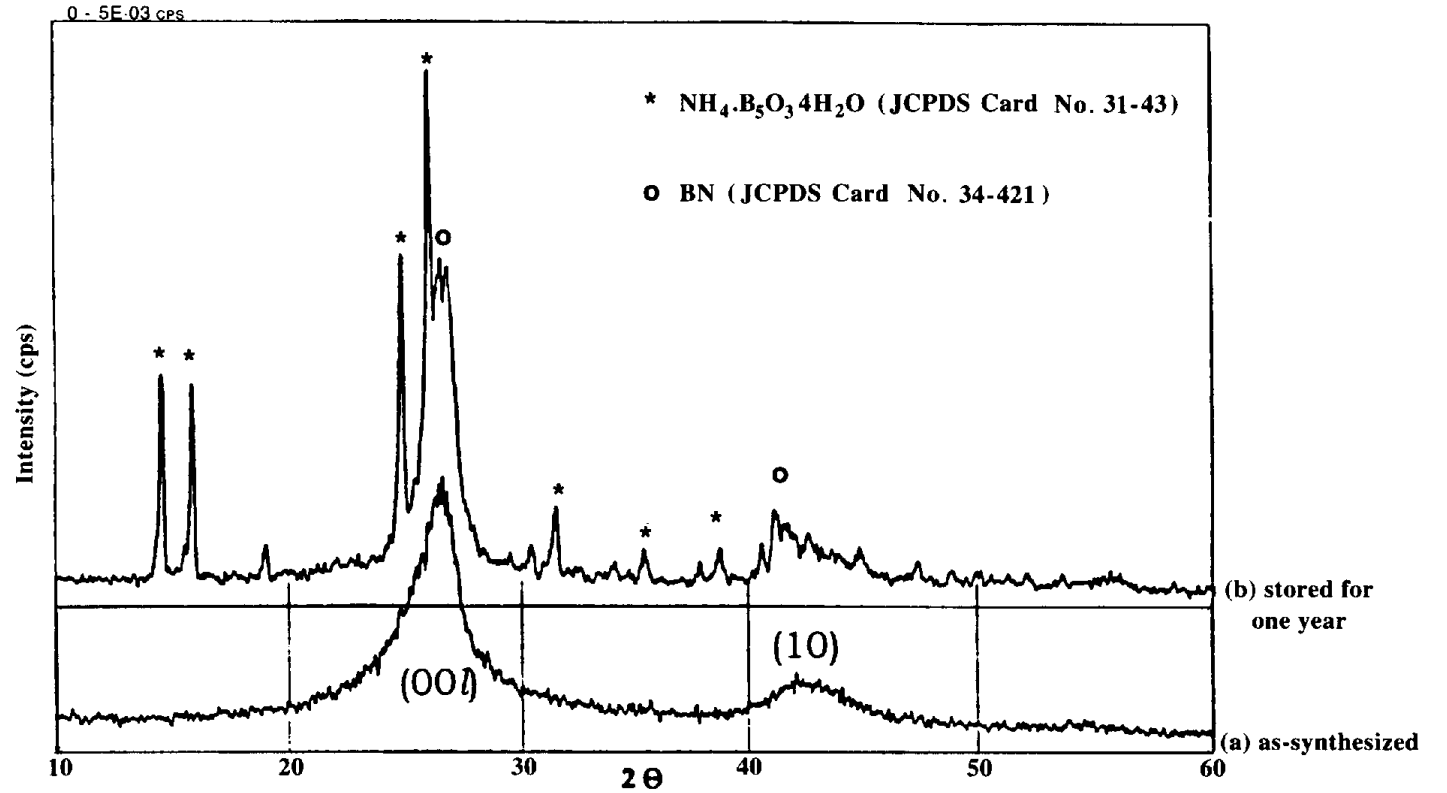

Fig. 2. XRD patterns of the samples (a) as-synthesized, and (b) stored for one year under atmospheric conditions.

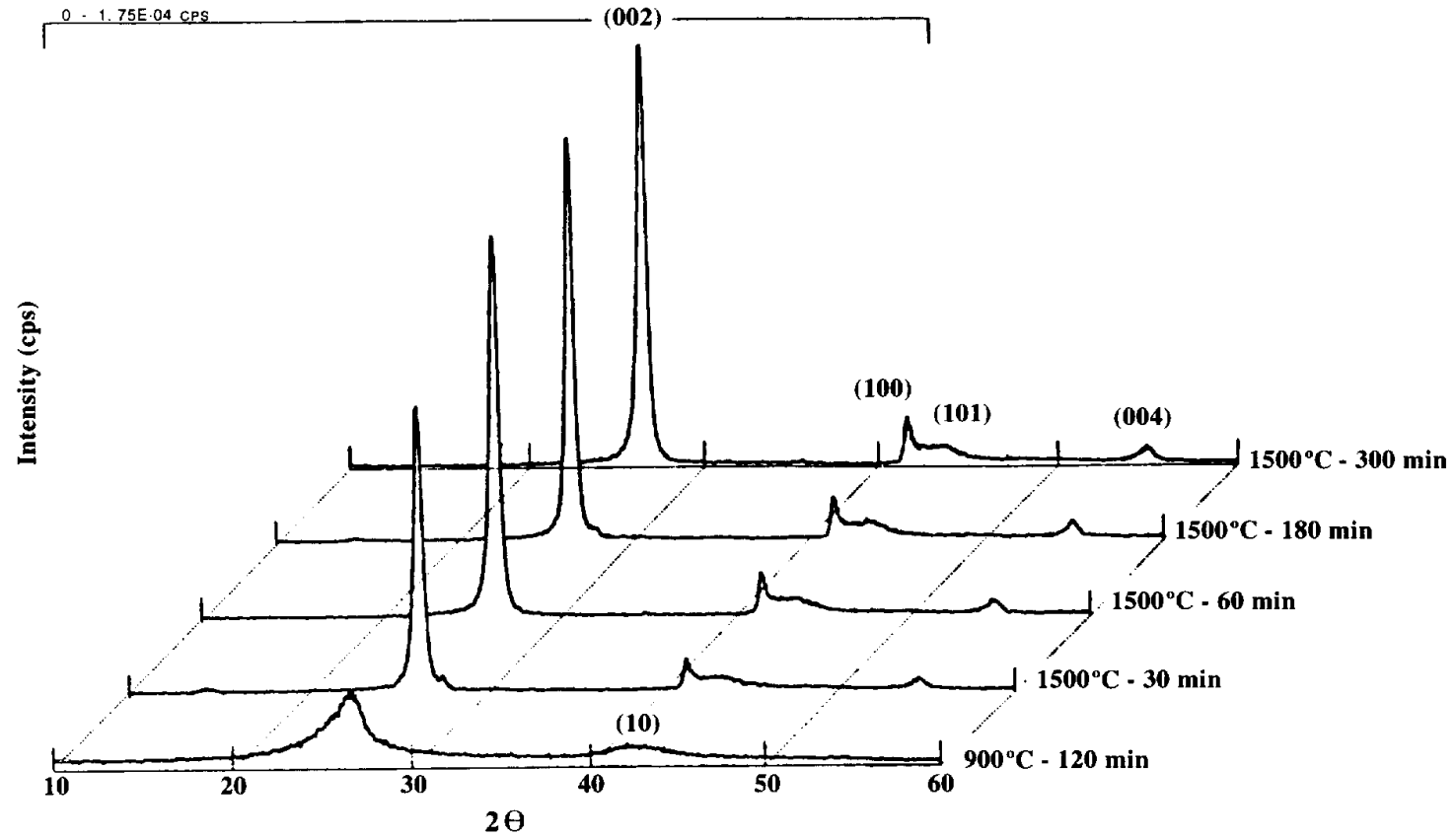

Fig. 3. X-ray diffraction patterns of samples before and after heat treatment at 1500°C for various times (small batch operation).

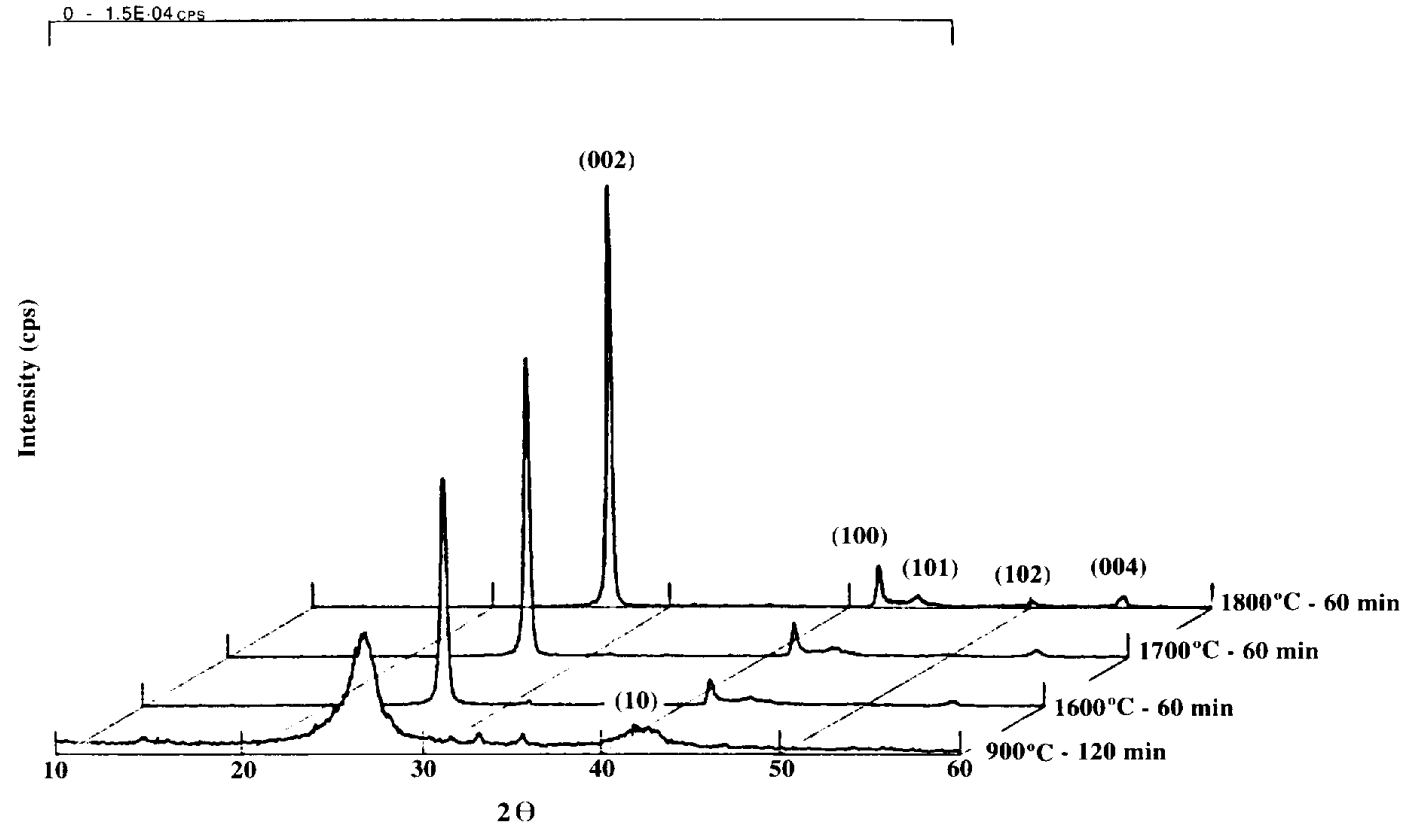

Fig. 5. X-ray diffraction patterns of the samples before crystallization and after heat treatment for 1 h at various temperatures (large batch operation).

Liquid Phase Methods I

PRECIPITATION FROM SOLUTIONS

Precipitation from Solutions

- Ceramic powders can be produced by precipitation using liquid phase reactants.
- In most cases, ceramic powder precursors (i.e., sulfates, carbonates, oxalates, hydroxides, etc.) are produced by precipitation. These powders must be thermally decomposed to their oxides in a separate step that frequently maintains their precipitated particle morphology although some degree of particle sticking often occurs.

Examples:

- **$\text{Al}_2\text{O}_3 \cdot 3\text{H}_2\text{O}$ (gibbsite)** precipitated from a sodium aluminate solution that is thermally decomposed to give alumina.
- **$\text{Mg}(\text{OH})_2$ (brucite)** precipitated from a brine solution, which is again calcined to give "dead burnt" magnesia.

Advantages:

- Precipitation gives a pure solid product, rejecting to the supernatant most of the impurities.
- Particle morphology and particle size distribution can be controlled to some degree.

Disadvantages:

- Powders must be separated from their supernatants and dried, as well as, frequently thermally decomposed to the desired ceramic material.
- Drying and calcination often leads to aggregates that are cemented together. Special precautions must be used to prevent aggregate formation during drying and calcination (e.g. calcination in very dry atmospheres).

Precipitation from Solutions

The precipitation of powders involves nucleation and growth from a supersaturated solution. There are **several ways to cause a solution to become supersaturated** to induce nucleation and growth, as illustrated in Figure.

Curve A : For systems in which the solubility is NOT a strong function of temperature, **evaporation** is used to cause supersaturation.

Curve S / Curve C : For those in which solubility drastically changes with temperature, **cooling / heating** is used to supersaturate the solution.

High pressures are also used to precipitate a particular crystal phase that may not be stable at ambient pressure (e.g., rutile TiO_2 instead of $\text{Ti}(\text{OH})_4$). The use of high pressure precipitation is referred to as **hydrothermal synthesis**.

- Supersaturation can also be produced by **adding another component** in which the solute is insoluble.
- The most common method, **reactive precipitation**, occurs when a chemical reaction produces an insoluble species. Reaction-induced supersaturation is often very high, giving high nucleation rates. With the high number densities of nuclei produced, agglomeration is an important growth mechanism leading to spherical particles that are either polycrystalline or amorphous.

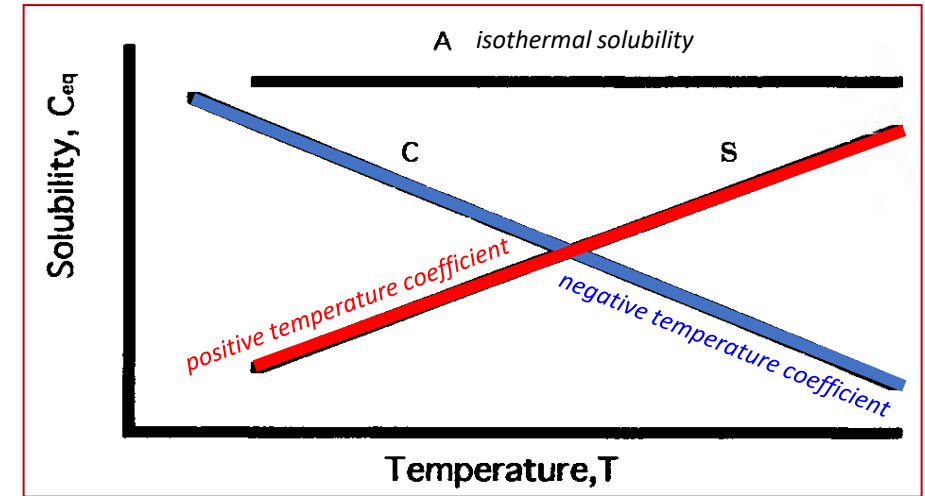

Solubility curves for various types of crystallization systems:

Nucleation in the Precipitation from Solutions

- Precipitation from solution consists of **two basic steps**:
 - i. Nucleation of fine particles and*
 - ii. Their growth by addition of more material to the surfaces.*
- In practice, control of the powder characteristics is achieved by controlling the reaction conditions for nucleation and growth and the extent of coupling between these two processes.
- Control of the kinetics of each of these fundamental steps controls the particle morphology and size distribution during precipitation.
- The nucleation rate generally has a dominating influence on the particle size distribution. Nucleation is also the least understood of the various rate processes in precipitation.
- There are **three main categories of nucleation**:
 - i. Primary homogeneous,*
 - ii. Primary heterogeneous,*
 - iii. Secondary.*

Homogeneous nucleation occurs in the absence of a solid interface

Heterogeneous nucleation occurs in the presence of a solid interface of a foreign seed

Secondary nucleation occurs in the presence of a solute particle interface.

Homogeneous Nucleation

- In very small quantities of matter such as clusters of solute molecules, a large fraction of the molecules are at the surface in a state of higher potential energy than the interior molecules (i.e., fewer and weaker bonds).
- This excess energy is not compensated by an excess of entropy and consequently the free energy for the surface molecules is greater than the free energy for the interior molecules.
- The overall free energy per cluster, ΔG , of the aggregates is a result of two terms, the free energy due to the new surface and the free energy due to the formation of new solid:

$$\Delta G = -(v/\hat{V})R_gT \ln(S) + \gamma a$$

where $v(=\beta_v r^3)$ is the volume and $a(=\beta_a r^2)$ is the area of the aggregate, V is the molar volume of the precipitate, and γ is the surface free energy per unit area. Thus, the total free energy:

$$\Delta G(r) = -(\beta_v r^3/\hat{V})R_gT \ln(S) + \gamma\beta_a r^2$$

where β_v is the volume conversion factor and β_a is the surface area conversion factor. For a sphere, $\beta_v=4\pi/3$ and $\beta_a=4\pi$.

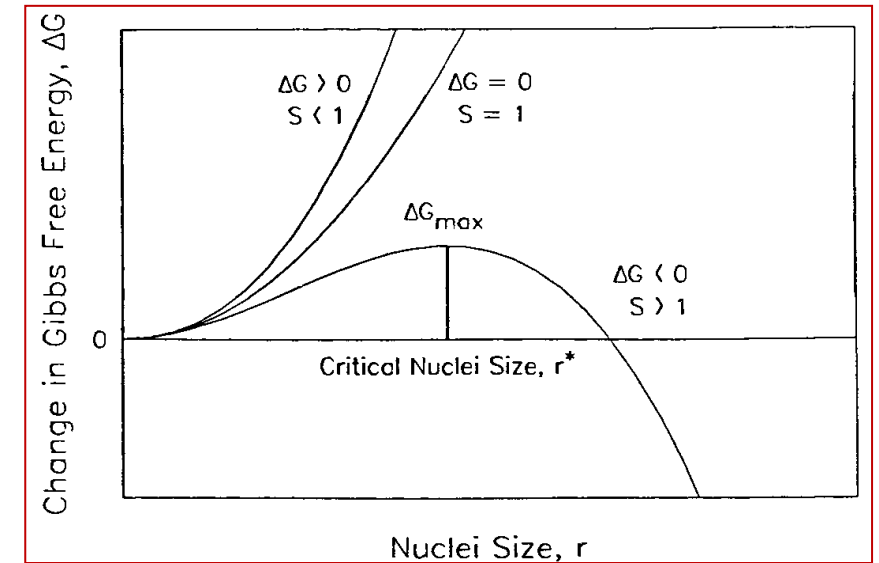

Classical nucleation theory dependence of nuclei size on Gibbs free energy at a function of saturation ratio, S.

*$S < 1.0$ & $\Delta G > 0 \rightarrow$ nonspontaneous formation,
 $S = 1.0$ & $\Delta G = 0 \rightarrow$ transient equilibrium,
 $S > 1.0$ & $\Delta G < 0 \rightarrow \Delta G(r)$ has a positive maximum at the critical size, r^* , spontaneous formation of a solids phase.*

Heterogeneous Nucleation

- Most nucleation is in practice likely to be heterogeneous nucleation induced by solid impurity surfaces other than the solute.
- Nucleation on a foreign surface has a lower surface energy, which leads to a lower critical supersaturation.
- The rate of heterogeneous nucleation is the same form as that describing homogeneous nucleation, except that the surface energy, γ , of the solid-liquid interface is replaced by the surface energy of the solid-seed interface.
- The only difference between the homogeneous and heterogeneous nucleation is that, once the heteronuclei are used up, there are no more of them, limiting the maximum heterogeneous nucleation rate.
- Thus the total nucleation rate J_T is the sum of the homogeneous and the heterogeneous nucleation rates:

$$J_T = J_{\text{homo}} + J_{\text{hetero}}$$

- A plot of these two nucleation rates and the total is given in Figure.
- Here we see the heterogeneous nucleation taking place at a lower saturation ratio, giving a maximum nucleation rate of 10^{-6} , which corresponds to all the foreign nuclei.
- At higher supersaturation, homogeneous nucleation takes place.

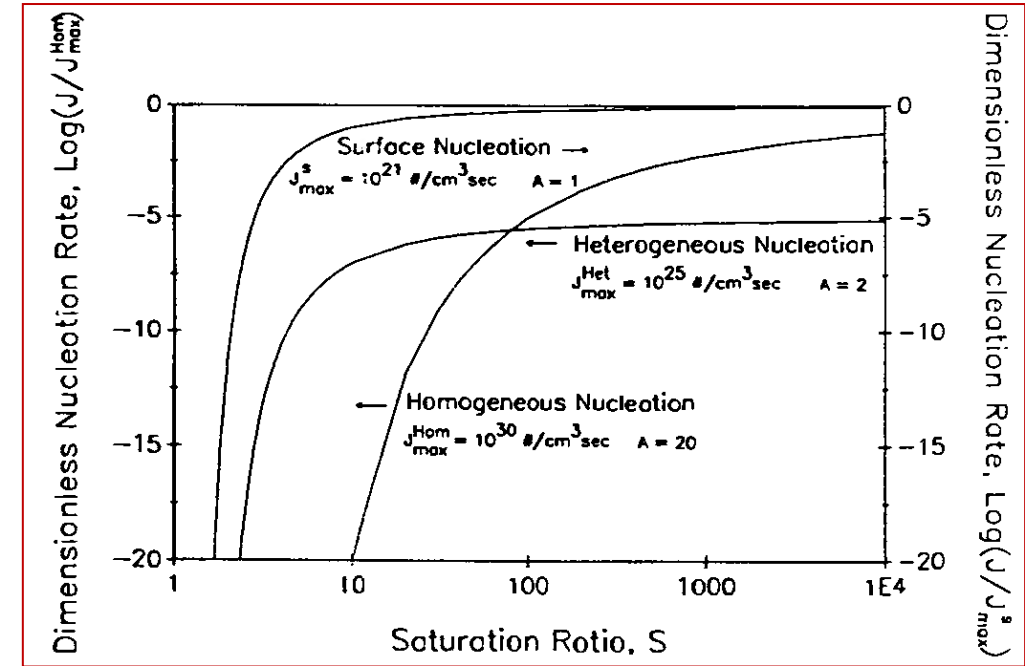

Generalized nucleation rate diagram describing the characteristic differences between homogeneous, heterogeneous, and surface nucleation

Secondary Nucleation

Secondary nucleation results from the presence of solute particles in solution.

- This can be classified into three categories: *apparent*, *true*, and *contact*.
- *Apparent secondary nucleation* refers to the small fragments washed from the surface of seeds when they are introduced into the crystallizer.
- *True secondary nucleation* occurs due simply to the presence of solute particles in solution.
- *Contact secondary nucleation* occurs when a growing particle contacts the walls of the container, the stirrer, the pump impeller, or other particles, producing new nuclei.
- After a particle is nucleated, it can grow by various mechanisms.
- The kinetics of these growth mechanisms are important in determining the resultant particle structure and size distribution. In the next section, we will discuss the more common growth mechanisms.

Growth Kinetics

The nature of the crystal-solution interface

- Both atomically smooth and rough surfaces are shown in Figure where atoms are represented by cubes.
- Inside a crystal, an atom will have six neighbors with a binding energy of three times the bond energy ($3E_{a-a}$) because each bond is shared by two atoms. For simplicity, only nearest neighbor interactions are considered.
- If a single new atom is added to the smooth surface, it can form a bond with only one nearest neighbor, so that its binding energy is only one-half the bond energy ($\frac{1}{2}E_{a-a}$).
- Other atoms with extra bonds may add to this atom and stabilize a cluster; however, the small binding energy of the first atom is clearly a major barrier to the growth of the crystal.
- Any atom incident on a rough surface has a greater sticking probability than one incident on a smooth surface.
- From this simple argument, it can be concluded that the growth rate on a rough surface will be larger than on a smooth surface.

The sketch below illustrates some of the features on a growing or dissolving crystal. The key point is that not all atoms at the crystal's surface are equally bonded to that surface (see table at right), and not all exposed surface provides equal bonding opportunities for ions that might precipitate onto the crystal. Terraces are comparatively inert and kinks are likely sites of dissolution or precipitation.

Location	Bonding counterion neighbors
Atom in terrace	5
Atom in step	4
Atom at exterior kink	3
Lone atom at step	2
Lone atom on terrace	1

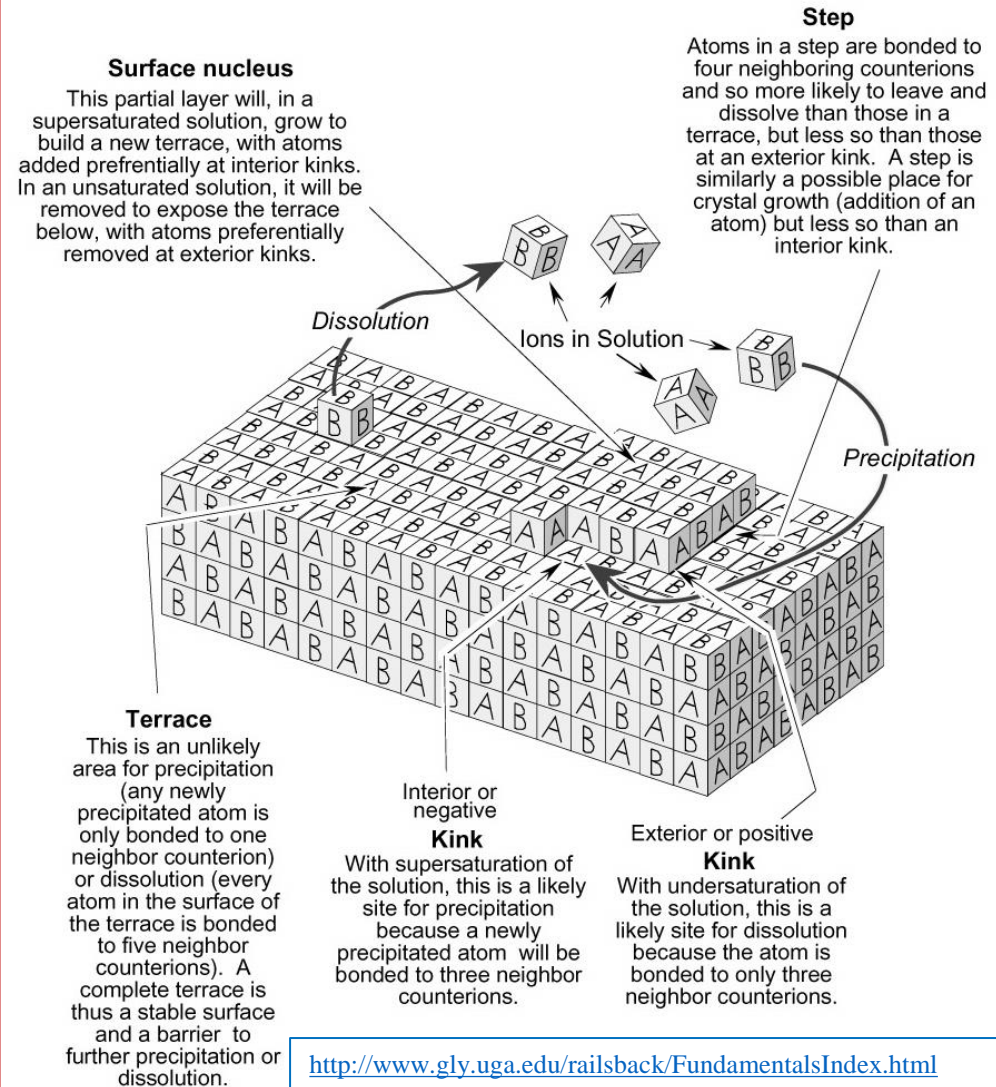

Growth Kinetics

Particle Growth by Aggregation

- High-resolution electron micrographs of particles synthesized by several routes involving precipitation from solution show that the particles consist of aggregates of much finer primary particles.
- Particle growth occurs by aggregation of fine particles rather than by diffusion of solute to existing particles.
- During a precipitation reaction, the first nuclei grow rapidly by aggregation to a colloidally stable size. These particles then sweep through the suspension, picking up freshly formed nuclei and smaller aggregates. The formation of particles with uniform size is thus achieved through size-dependent aggregation rates.

Particle Growth by Ostwald Ripening

- Particles in a liquid can also grow by a process in which the smaller particles dissolve and the solute precipitates on the larger particles.
- This type of growth, better described as *coarsening*, is referred to as *Ostwald ripening*.
- The coarsening of precipitates in a solid medium can also occur by a similar process.

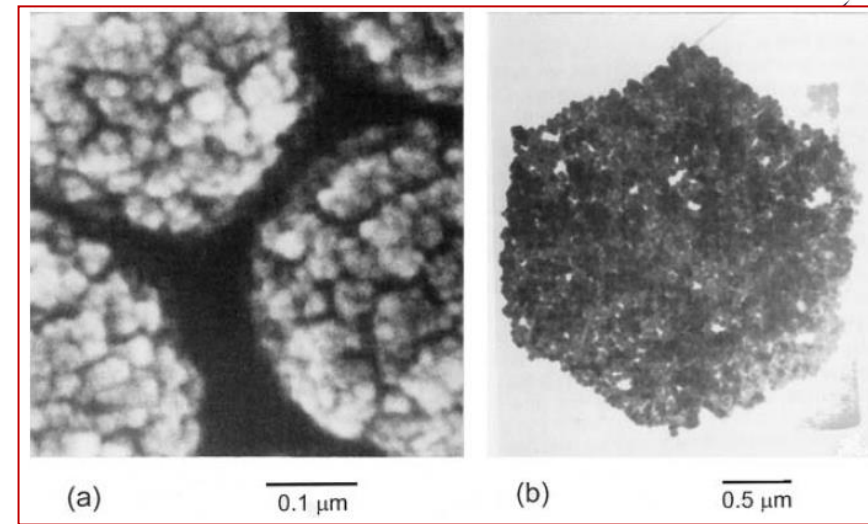
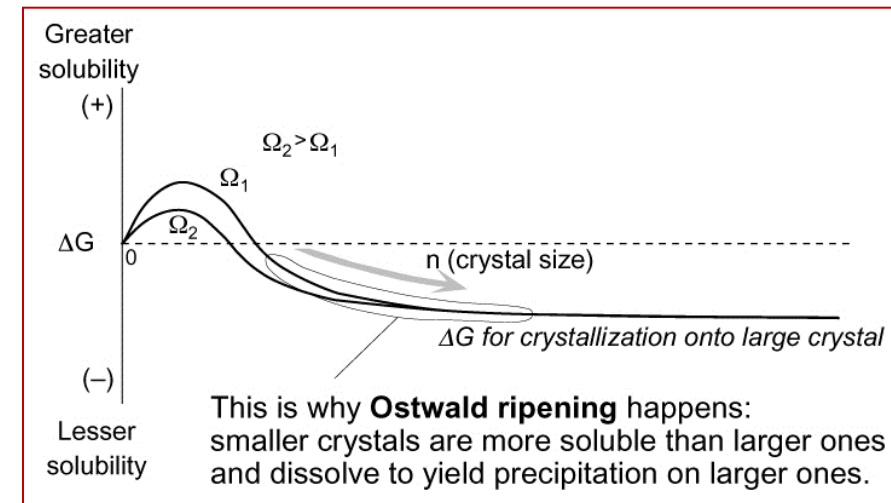

Figure (a). Titania particles prepared by the Stober process show primary particle features that are smaller than 10 nm
Figure (b). CeO₂ particles synthesized by hydrolysis of cerium nitrate salts in the presence of sulfate ions show that the hexagonal particles consist of smaller primary particles with a spherical shape.



Crystal Shape

➤ The shape of a crystal (i.e., crystal habit) can be controlled by either thermodynamics or kinetics. Only for crystals grown under very, very low supersaturation ratios is a crystal habit established by thermodynamic considerations. These crystals tend to be of mineralogical origin. For most other crystal growth conditions, the kinetics of the slowest growing crystal faces give rise to a crystal shape.

Equilibrium Shape

- In Figure, the flat F faces, stepped S faces, and kinked K faces are shown for a cubic crystal system. The rougher S and K faces grow very quickly and are rarely, if ever, observed.
- The crystal habit is dominated by the slow growing F faces. From a knowledge of the crystal structure, it is possible to predict the slow growing F faces and therefore the final crystal morphology.

Kinetic Shape

- The rate determining step for crystal growth of the F faces of a crystal determines its kinetic shape. The S and K faces will almost always grow faster than the F faces.
- The only exception to this rule is when an impurity is adsorbed on a S or K face, drastically reducing its growth rate to that below an F face.
- Growth rates of different F faces often exhibit different dependences on the supersaturation ratio.
- If, for example, these growth rates have the form shown in Figure, face 2 will be the slowest growing and dominate the crystal structure at low supersaturation and face 1 will dominate the crystal structure at high supersaturations.

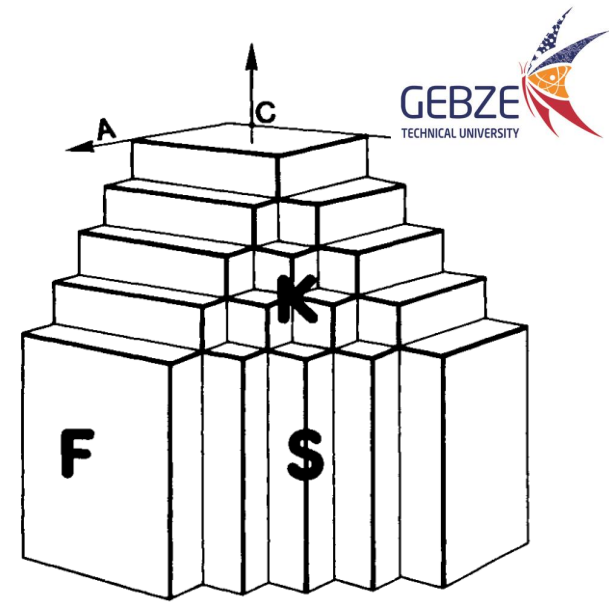

Hypothetical three-dimensional crystal presenting the three main types of possible faces: flat (F), step (S), kink (K) faces.

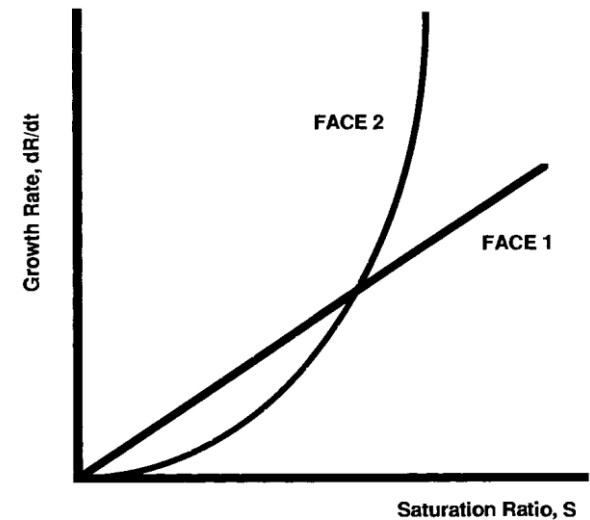

Comparison of hypothetical growth rates, for two faces as a function of saturation ratio, S.

Crystal Shape

Crystal Habit Modification by Impurities

➤ All of these changes in crystal habit caused by kinetic factors are drastically effected by the presence of impurities that adsorb specifically to one or another face of a growing crystal. With some surface active impurities, small traces, about 0.01%, are all that is required to change crystal habit during crystallization.

➤ These impurities can:

1. Reduce the supply of material to the crystal face,
2. Reduce the specific surface energy,
3. Block surface sites and pin the steps of the growing crystal.

➤ The impurities that modify crystal habit fall into four categories:

1. Ions, either anions or cations;
2. Ionic surfactants, either anionic or cationic;
3. Nonionic surfactants like polymers;
4. Chemical binding complexes (e.g., organic dye compounds or enzymes).

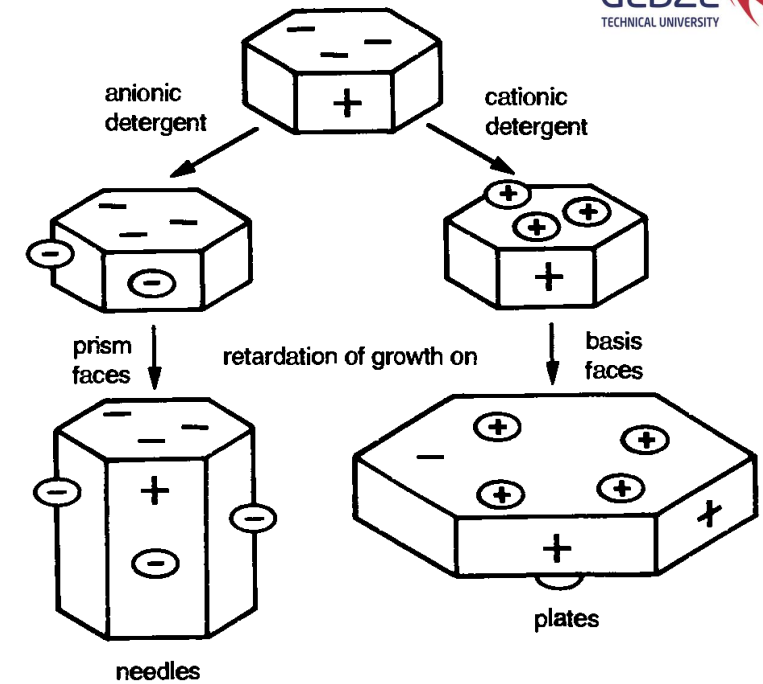

Influence of impurity adsorption on the crystal habit, for the case of adipic acid.

Example : The use of anionic and cationic surfactants to change the habit of adipic acid ($C_6H_{10}O_4$) crystals.

➤ The addition of **cationic surfactant** will specifically adsorb on the negatively charged surfaces of adipic acid and limit their growth, yielding platelike particles, as shown in Figure.

➤ **Anionic surfactants** will adsorb on the positively charged surfaces of the adipic acid crystals and limit their growth rate, yielding needle-like particles. The preferential and strong adsorption of ionic surfactants is frequently used industrially to control crystal habit.

EXAMPLES of Particles Precipitated from Solutions

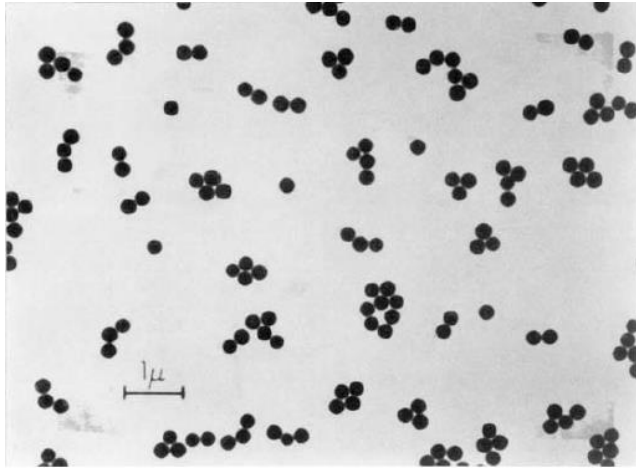

Silica spheres produced by the hydrolysis of a solution of silicon tetraethoxide in ethanol.

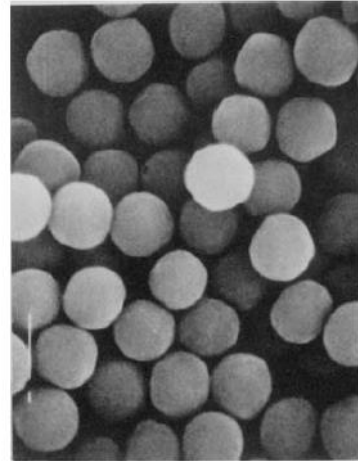

(a)

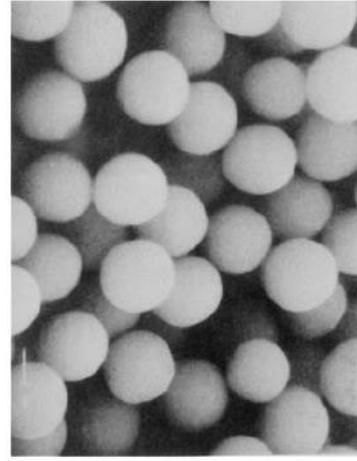

(b)

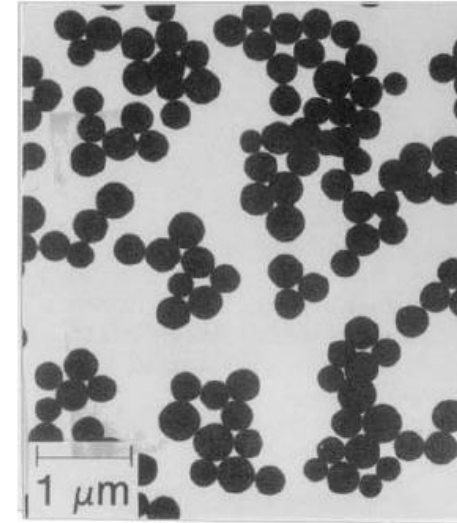

(a)

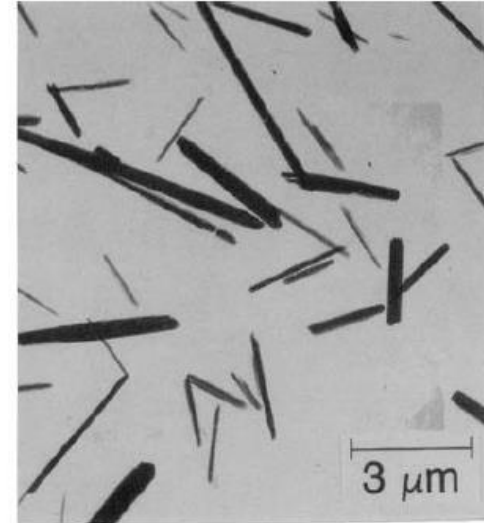

(b)

Yttrium basic carbonate particles obtained :

- (a) by aging for 2.5 h at 90°C a solution of 1.5×10^{-2} mol/dm³ YCl₃ and 0.5 mol/dm³ urea and
- (b) by aging for 18 h at 115°C a solution of 3.0×10^{-2} mol/dm³ YCl₃ and 3.3 mol/dm³ urea.

Examples of the sizes, shapes and chemical compositions for powders prepared by precipitation from metal salt solutions, showing particles of

- (a) hematite ($\alpha\text{Fe}_2\text{O}_3$),
- (b) cadmium sulfide,
- (c) iron (III) oxide,
- (d) calcium carbonate.



(c)

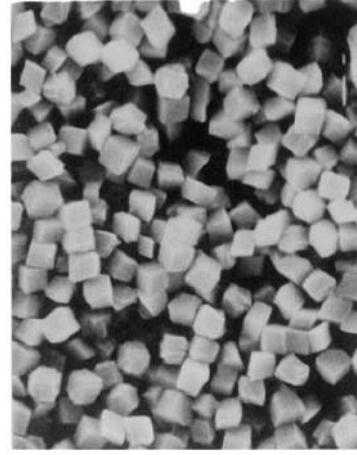

(d)

Liquid Phase Methods II

HYDROTHERMAL SYNTHESIS

Precipitation under Hydrothermal Conditions

- Precipitation and growth from solution is a widely used method to produce powders, however, very often, the *solubility of a material in a solvent, e.g. water, is insufficient under normal conditions* (atmospheric pressure and temperatures of less than 100°C for water) to allow solution phase synthesis and/or crystallization to be carried out.
- In such cases, *solvents may be more effective in the supercritical state, i.e. at temperatures and pressures above the critical point (T_{cr} , p_{cr}) in the liquid-vapor phase diagram* given in the Figure, where the liquid and gaseous state become indistinguishable and form a common fluid phase.
- *Supercritical water ($T_{cr}= 647,3\text{ K}$, $p_{cr}= 22,12\text{ Mpa}$)* is an effective solvent for many inorganic materials, particularly in the presence of a mineralizer, a soluble compound producing ions that otherwise would not be present and which increase the solubility of the solute.
- *Synthesis involving supercritical water is also known as the hydrothermal growth method.*
- *Supercritical CO_2 ($T_{cr}= 304,2\text{ K}$, $p_{cr}= 7,38\text{ Mpa}$)* is also increasingly being used as a solvent for organic molecules and polymers.

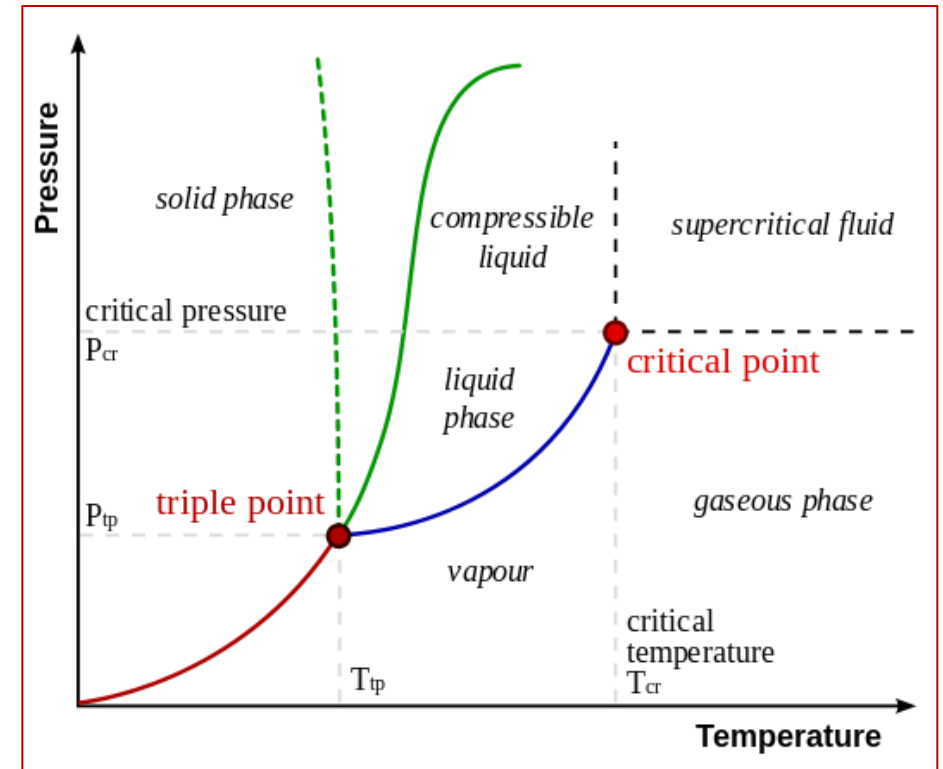

Pressure–temperature diagram of water.

Precipitation under Hydrothermal Conditions

- Hydrothermal synthesis has been known for decades as a method for synthesizing fine, crystalline oxide particles.
- Interest in the method has increased in recent years because of the need for fine, pure powders in the production of ceramics for electronic applications.
- The process involves heating reactants, often metal salts, oxide, hydroxide, or metal powder, as a solution or a suspension, usually in water, at temperatures between the boiling and critical points of water (100–374°C) and pressures up to 22.1 MPa.
- The term *hydrothermal* comes from the earth sciences, where it implies *a regime of high temperatures and water pressures*.

Geological gypsum crystals formed by natural processes. (Annu. Rev. Mater. Res. 2013. 43:359–86)

Major differences of hydrothermal processing with other methods :

1. Powders are formed directly from solution.
2. Powders are anhydrous, crystalline, or amorphous depending on the hydrothermal temperature.
 1. Particle size controlled by hydrothermal temperature.
 2. Particle shape controlled by starting materials.
3. Ability to control chemical composition, stoichiometry
4. Powders are highly reactive in sintering.
5. In many cases, powders do not need calcination.
6. In many cases, powders do not need a milling process.



Hydrothermal Reactors

- For typical hydrothermal research one needs a high-temperature, high-pressure apparatus called an autoclave or bomb. It is commonly carried out in a hardened steel autoclave, the inner surfaces of which are lined with a plastic (e.g., Teflon) to limit corrosion of the vessel.
- A great deal of early experimental work was done using the Morey bomb and Tuttle-Roy test tube bomb (made by Tem-Press).

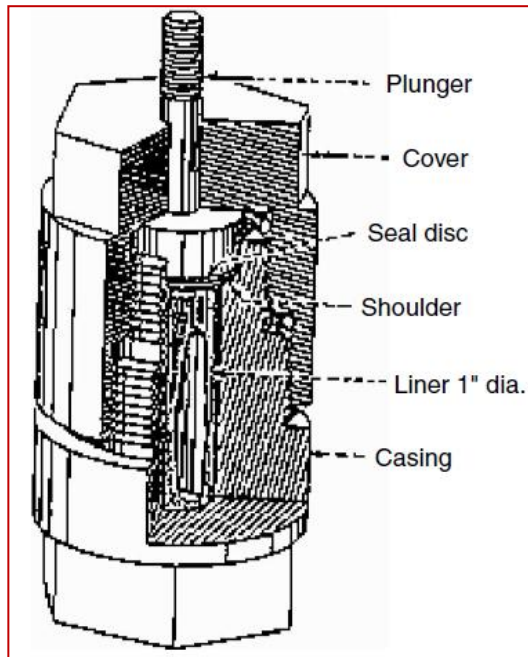

Autoclave with flat plate closure (Morey).

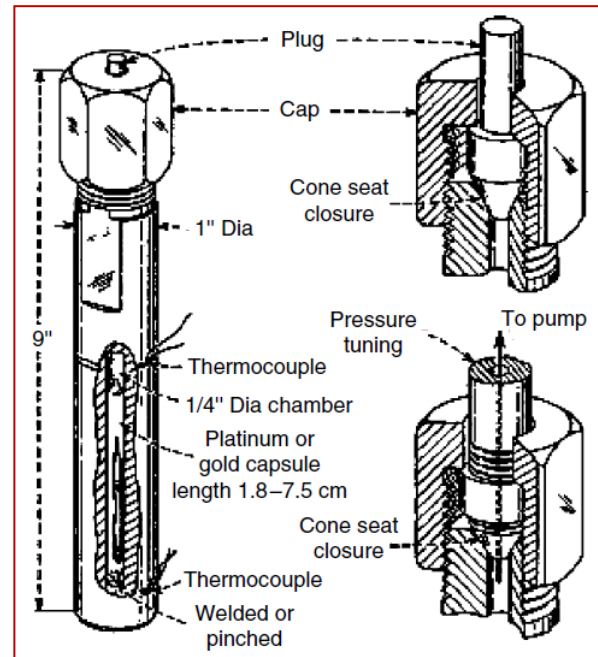

Reaction vessel with a cold-cone seat closure (Tem-Press).

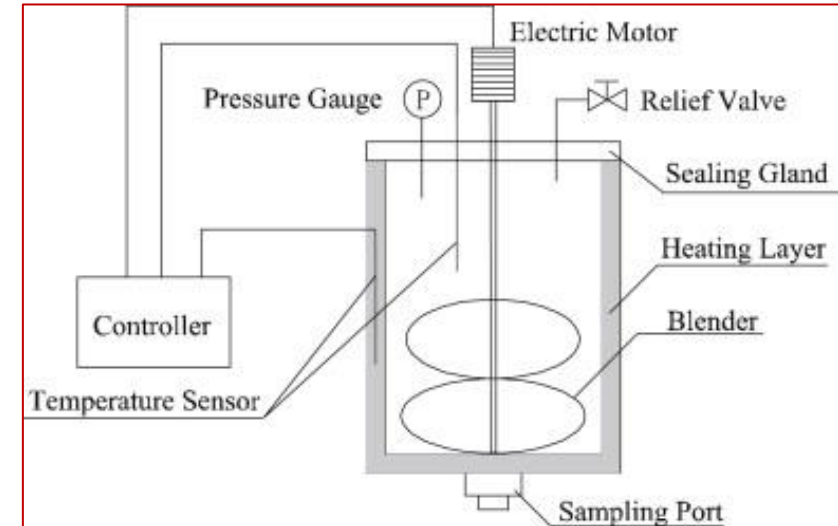

Schematic diagram of a hydrothermal reactor



Hydrothermal reactor and the parts of the chamber

Hydrothermal Crystal Growth

- Crystal growth under hydrothermal conditions takes place in the reactor shown schematically in the Figure, where the material to be dissolved and subsequently crystallized is placed at the bottom, with seed crystals suspended at the top, and the reactor is part filled with water.
- The reactor is put in a temperature gradient so that the temperature, T_2 , at the bottom is higher than at the top, T_1 . Material at the bottom is therefore dissolved and the resulting solution is conveyed by convection to the top where, because the temperature is lower, the solution becomes supersaturated and crystallization on to the seeds occurs.

➤ Hydrothermal growth is commonly used to prepare large single crystals of the α -Quartz crystalline modification of silica under conditions of 400°C and 170 Mpa using NaOH as the mineralizer.

➤ The method can also be used to grow single crystals of corundum (or synthetic sapphire, $\alpha\text{-Al}_2\text{O}_3$).



Hydrothermal grown synthetic quartz crystals. (<http://www.watchesbysjx.com/>)

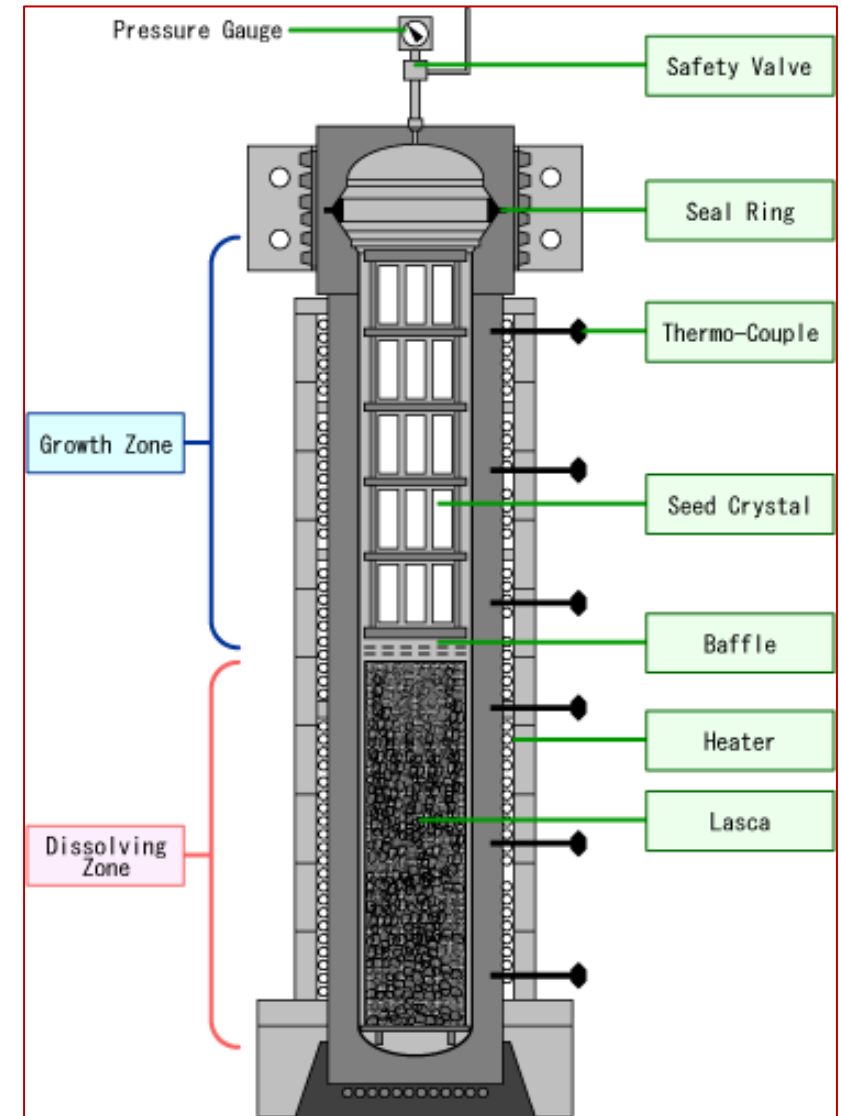

Schematic diagram of a hydrothermal reactor used for hydrothermal crystal growth. ([http:// www.global.kyocera.com](http://www.global.kyocera.com))

Hydrothermal Precipitation or Hydrolysis

Alumina: One of the industrial applications of hydrothermal precipitation is ordinary alumina production, the Bayer process.

Zirconia: Hydrothermal homogeneous precipitation is one of the best ways to produce zirconia powders.

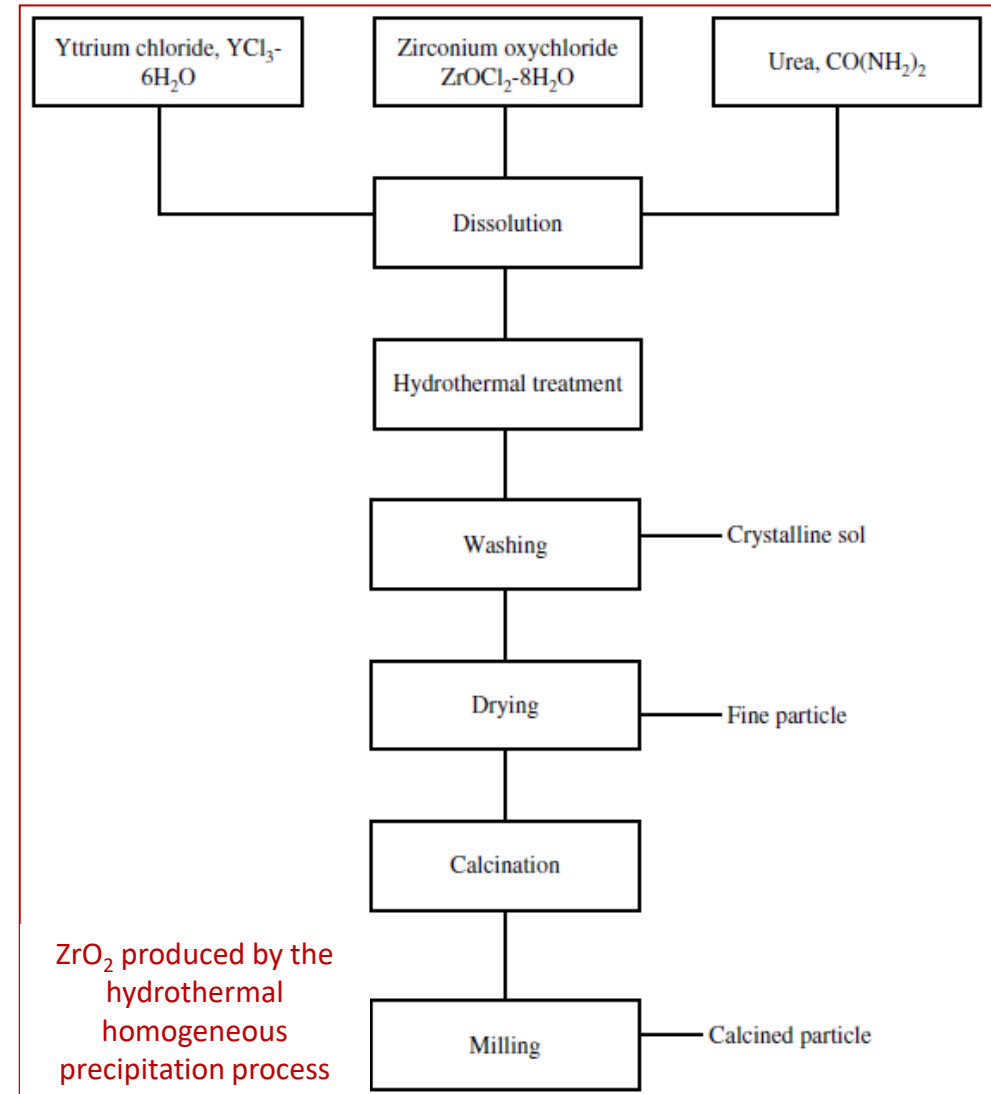
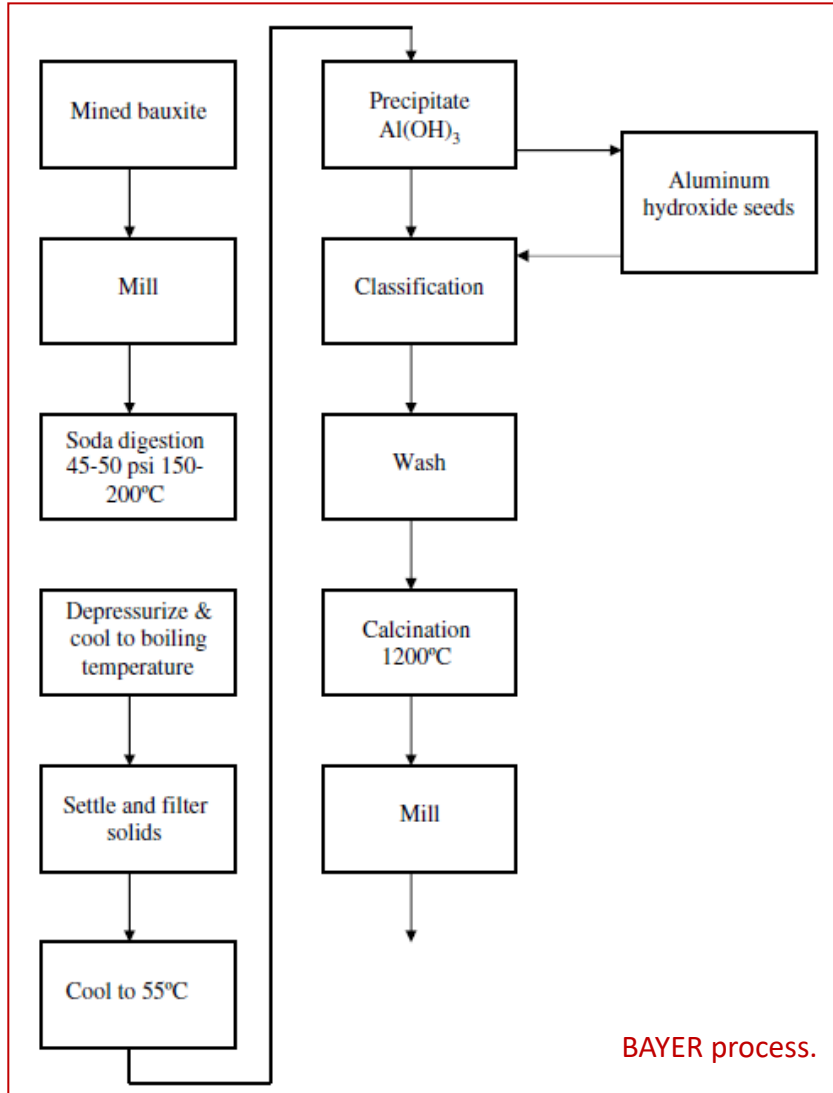

CASE STUDY - Synthesis of Needle-like NaNbO_3 Particles

- In this study, sodium niobate powders were prepared by hydrothermal process for further use as template particles in the texturing of piezoelectric potassium sodium niobate fibers.
- Sodium hydroxide pellets (Merck KGaA, Germany) were dissolved in distilled water in this hydrothermal process, and niobium oxide (Merck KGaA, Germany) was added to this solution and stirred for 30 minutes. The dissolved mixture was put into the Teflon reaction vessel of the hydrothermal chamber (Parr Instruments).
- Various experimental parameters such as the concentration of the reactants, as well as the hydrothermal synthesis temperature and time were investigated. The hydrothermally synthesized powders in the solution were then washed repeatedly with distilled water to remove the NaOH and then filtered two times. Finally, the filtered precursor powders were dried at 75°C for 24 hours. The precursor powders were then annealed at 400°C and sintered 1135°C for 1 hour.

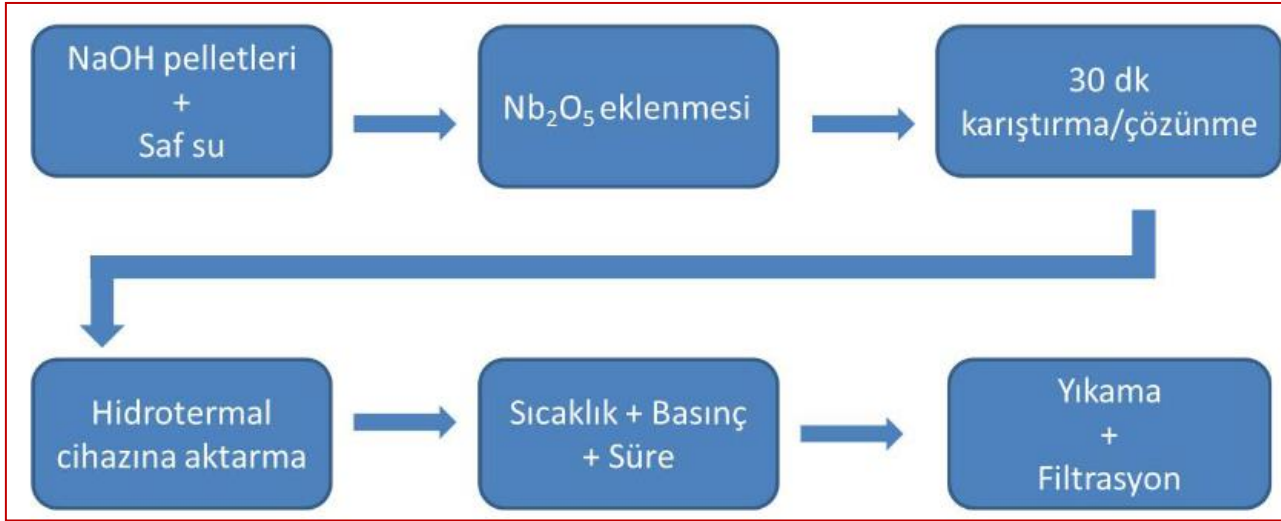

Process Flow Chart

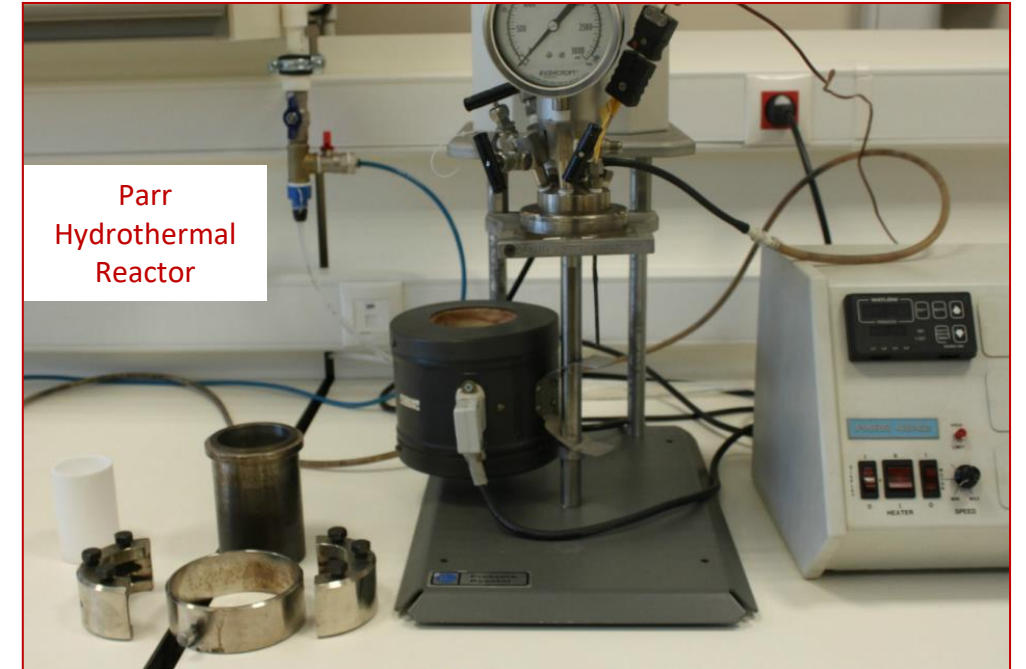

CASE STUDY

Effect of filtering on the phase composition and morphology of the powders.

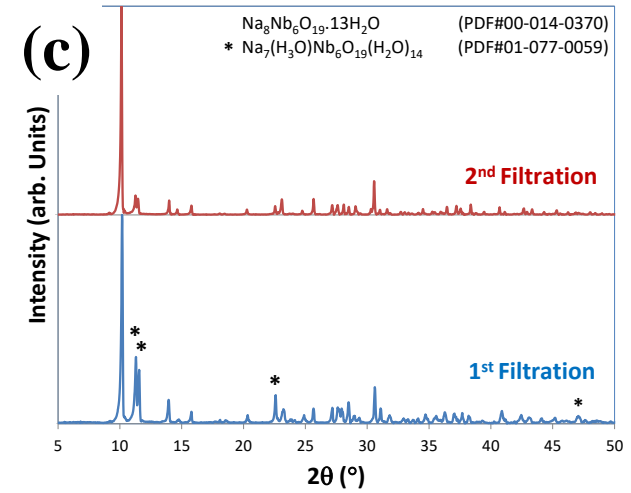
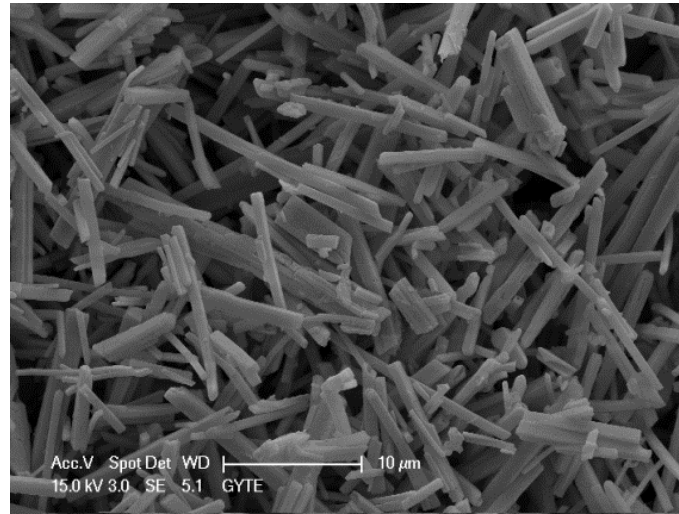
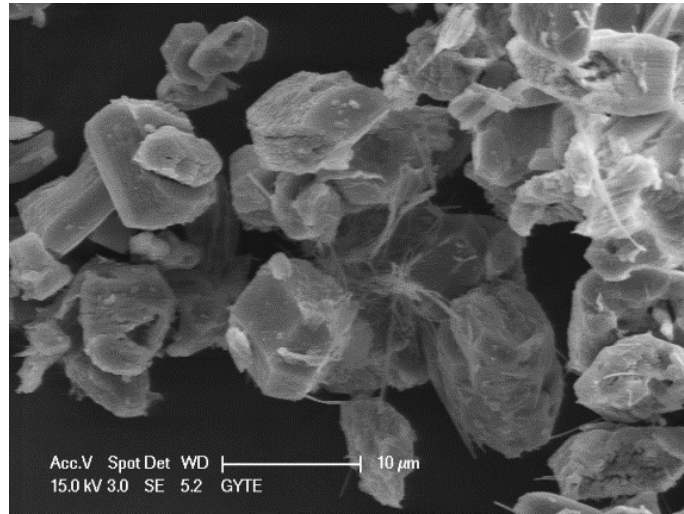

SEM micrographs @120°C (a) first and (b) second filtrations & (c) XRD patterns of samples.

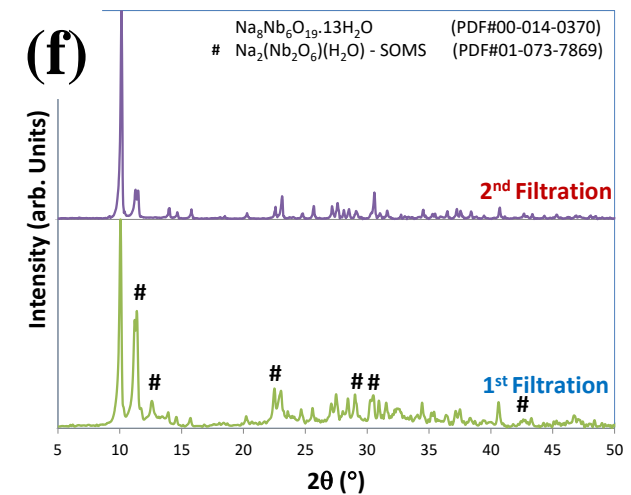
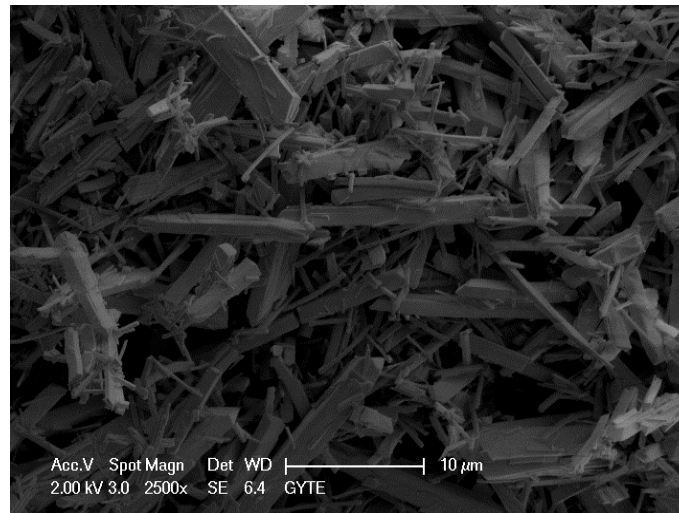
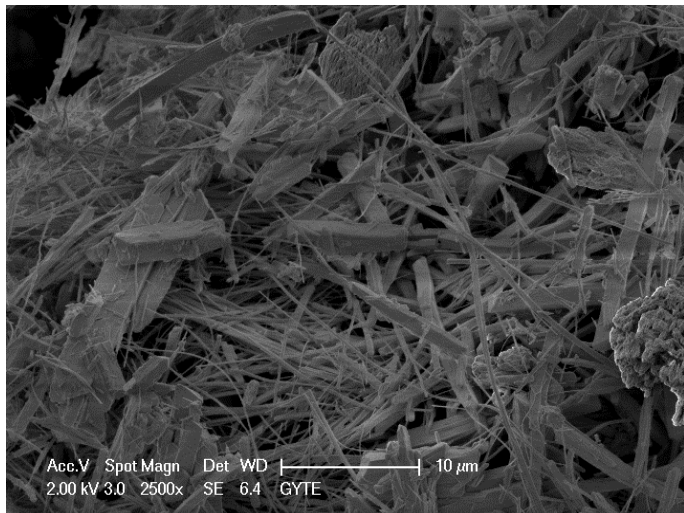

SEM micrographs @140°C (d) first and (e) second filtrations & (f) XRD patterns of samples.

CASE STUDY

Effect of hydrothermal treatment temperature on the phase composition and morphology of the powders.

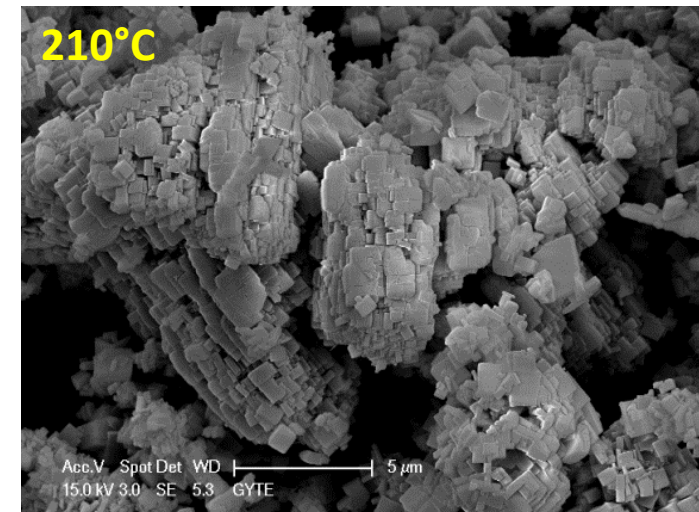
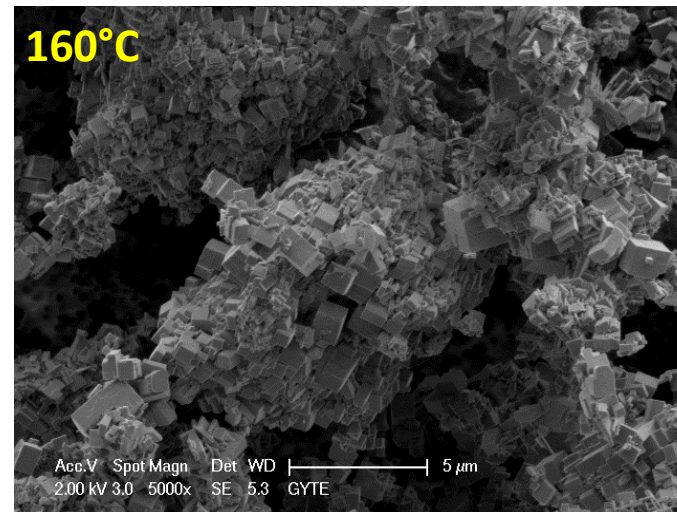
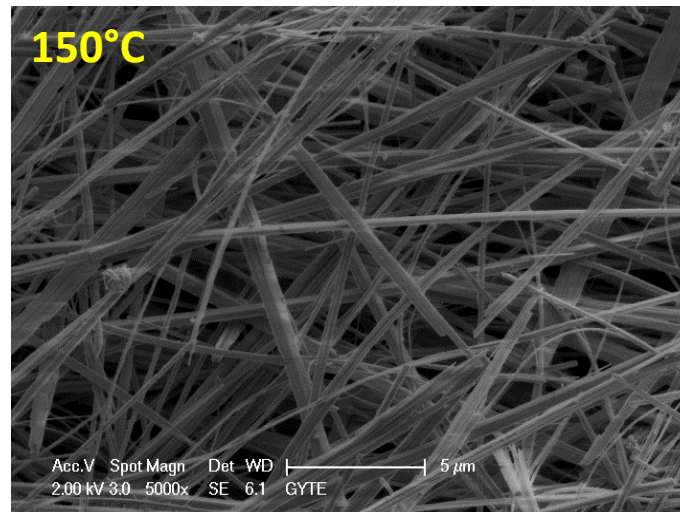
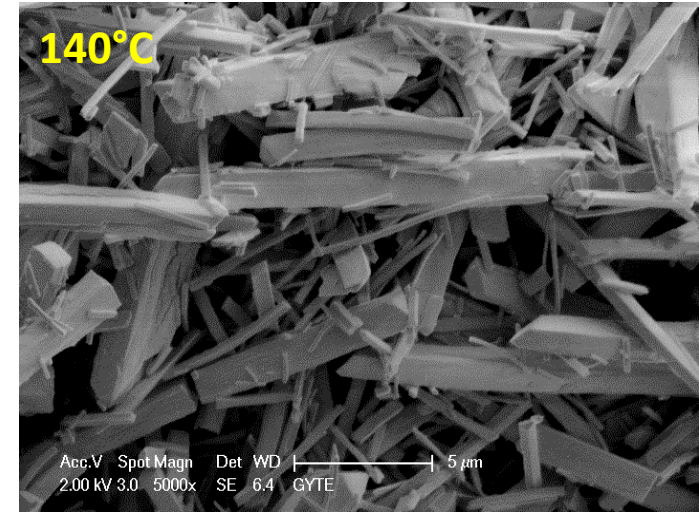
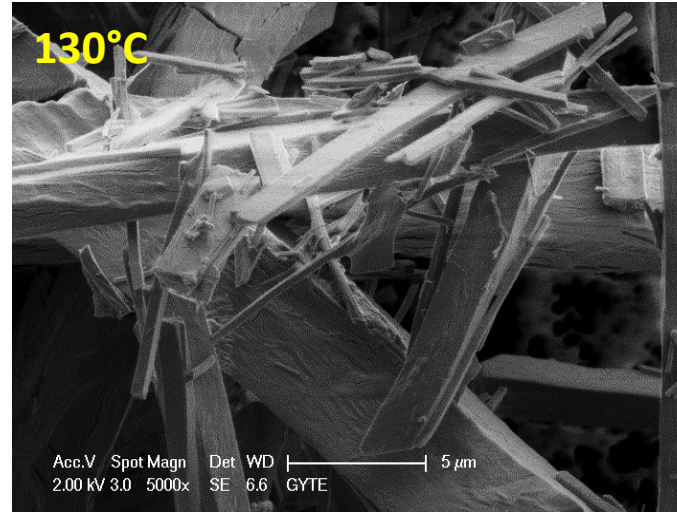
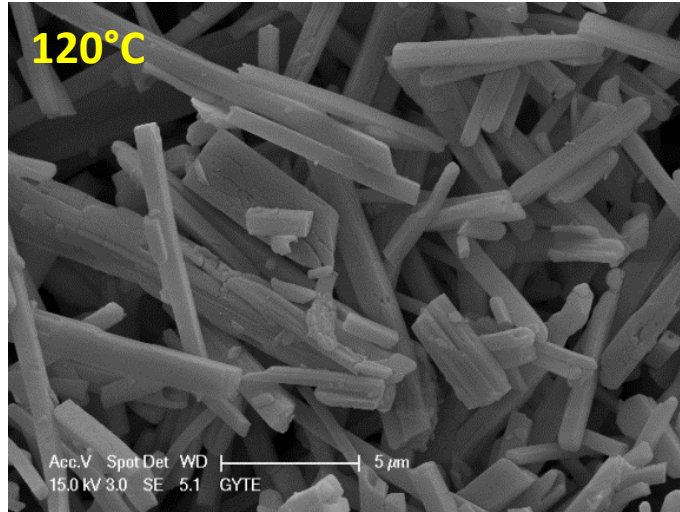

CASE STUDY

Effect of hydrothermal treatment temperature on the phase composition and morphology of the powders.

- When the hydrothermal synthesis temperature was increased to above 140°C the morphology changed drastically. Above 140°C, the synthesis products almost fully remained in the first filtration cake.
- The XRD diffraction patterns of the as-synthesized particles indicates that hydrothermal synthesis at 140°C yields almost fully the sodium hexaniobate phase with a limited presence of SOMS phase.
- Hydrothermal synthesis at 150°C yields almost fully the SOMS phase with a limited presence of the orthorhombic perovskite NN phase. The fully needle-like morphology of the particles was observed at 150°C .
- Hydrothermal synthesis at 160°C yields fully the orthorhombic perovskite NaNbO_3 phase with a cubic morphology of the particles.

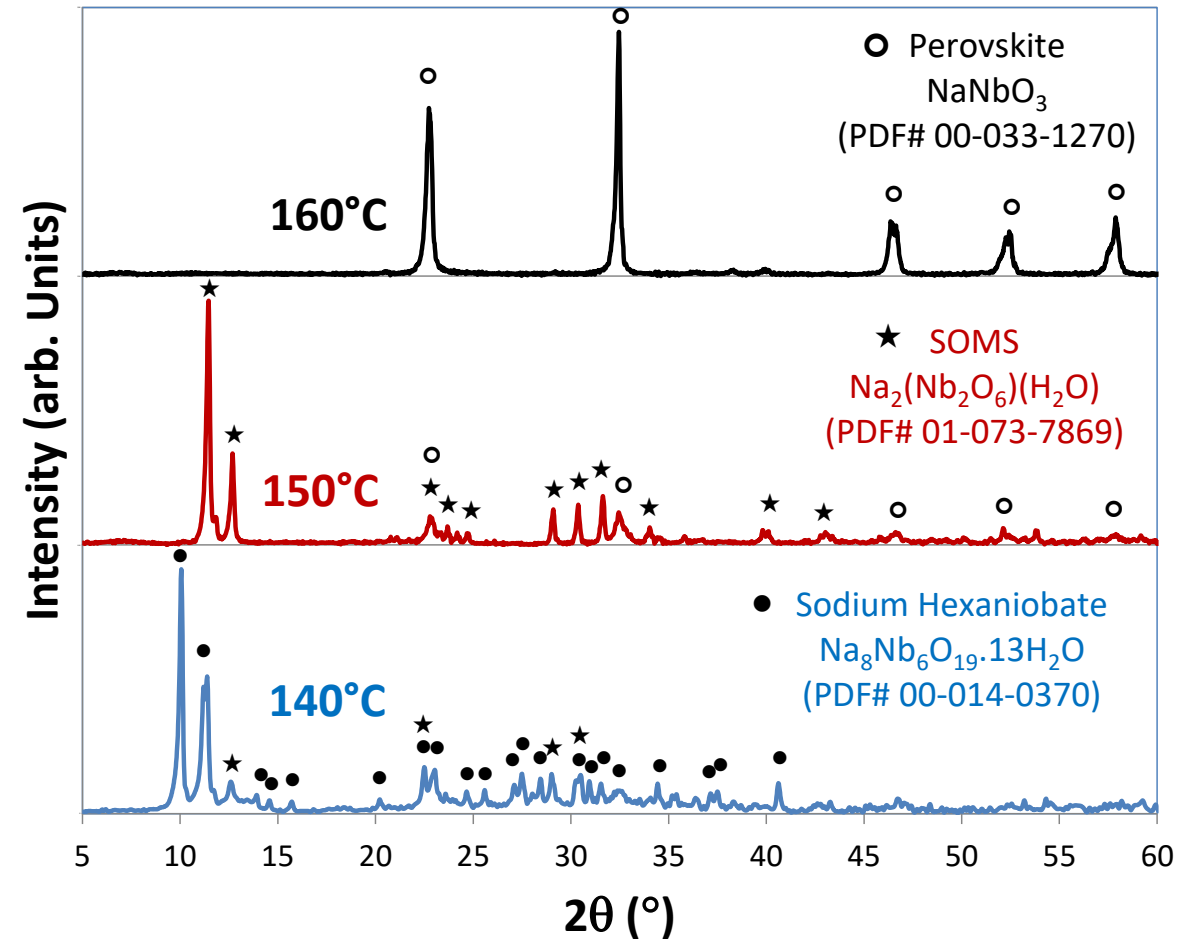

CASE STUDY

Effect of NaOH concentration on the phase composition and morphology of the powders.

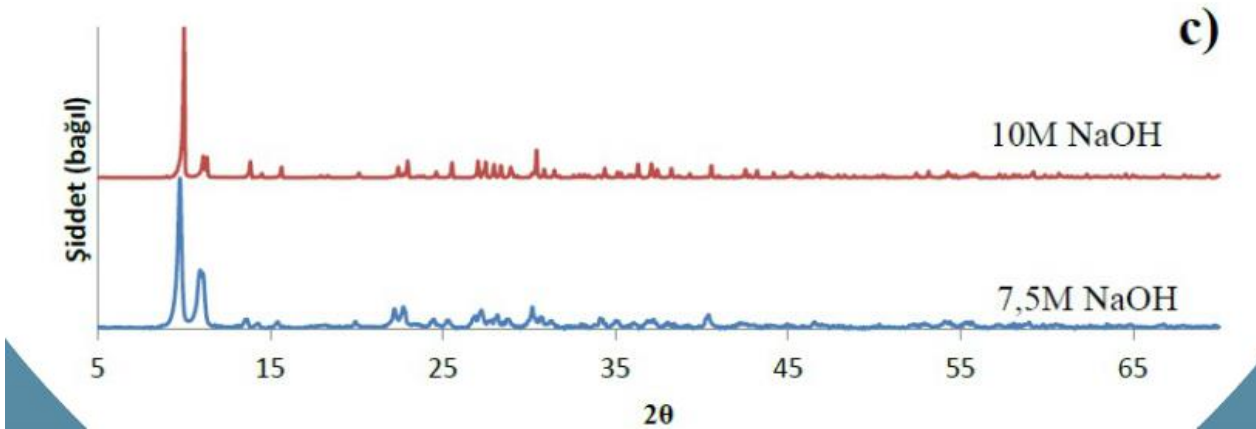
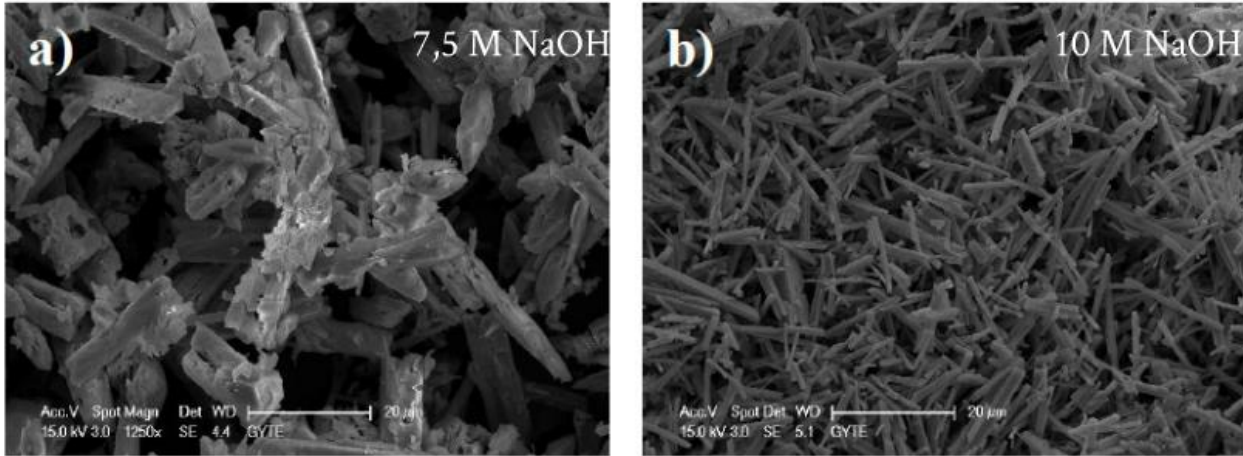

Effect of Nb_2O_5 concentration on the phase composition and morphology of the powders.

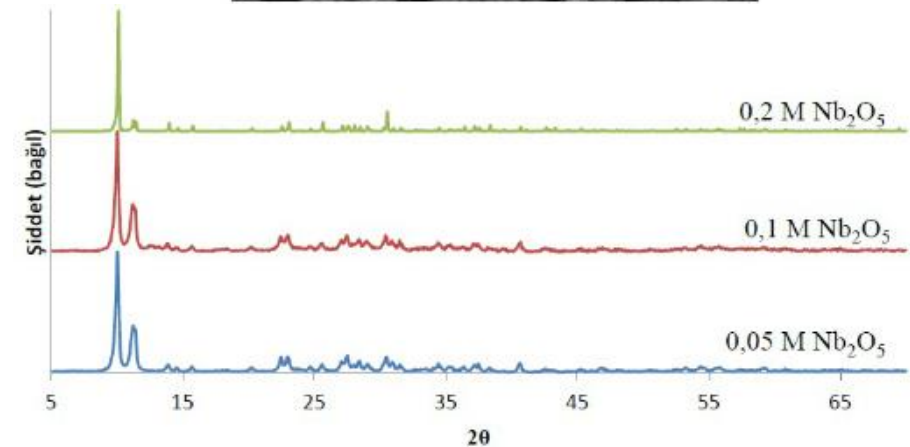
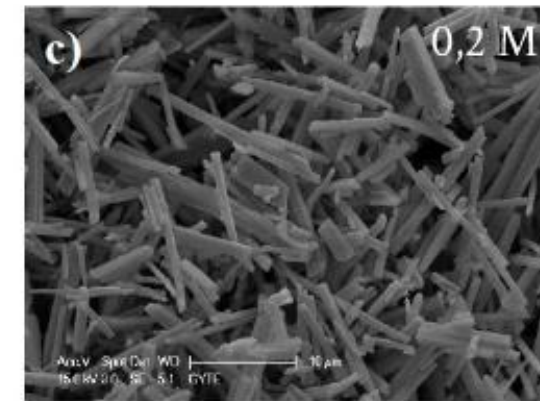
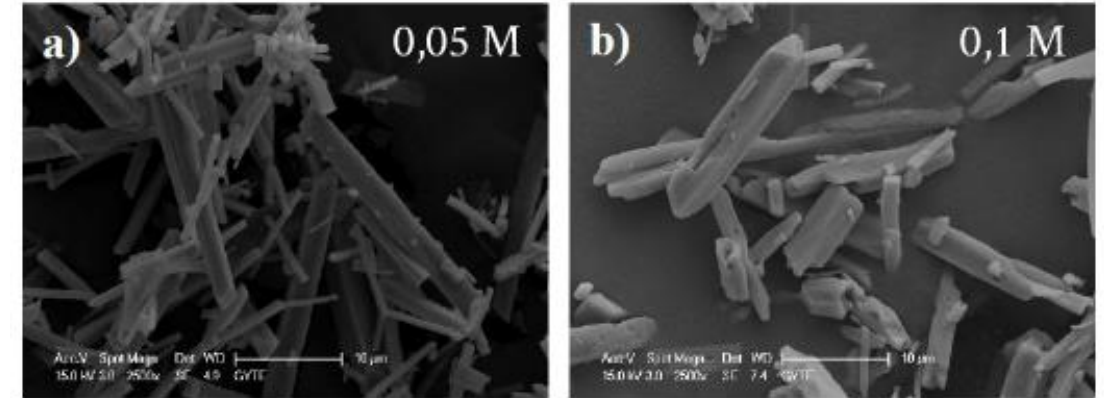

CASE STUDY

Effect of post-synthesis annealing at 400°C on the phase composition and morphology of the powders.

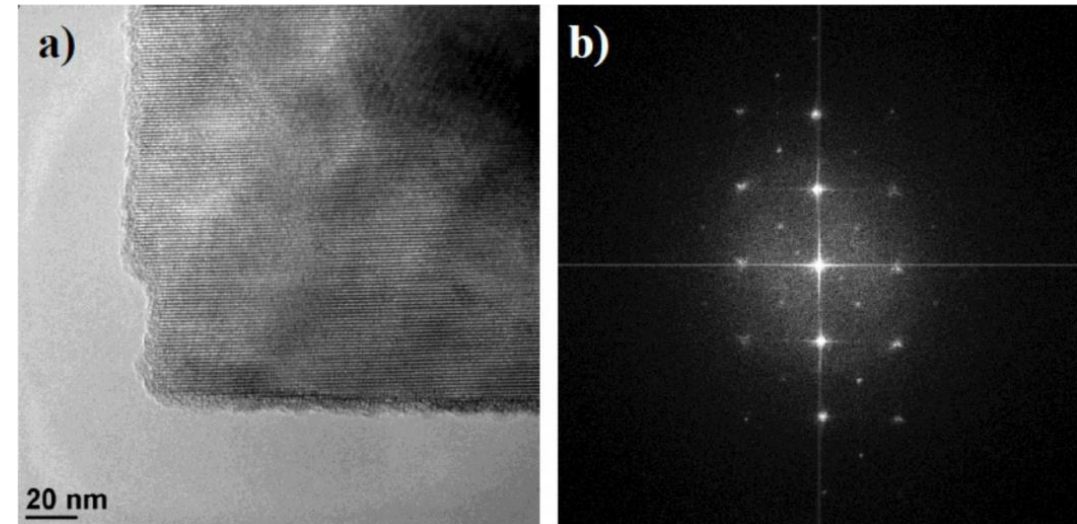
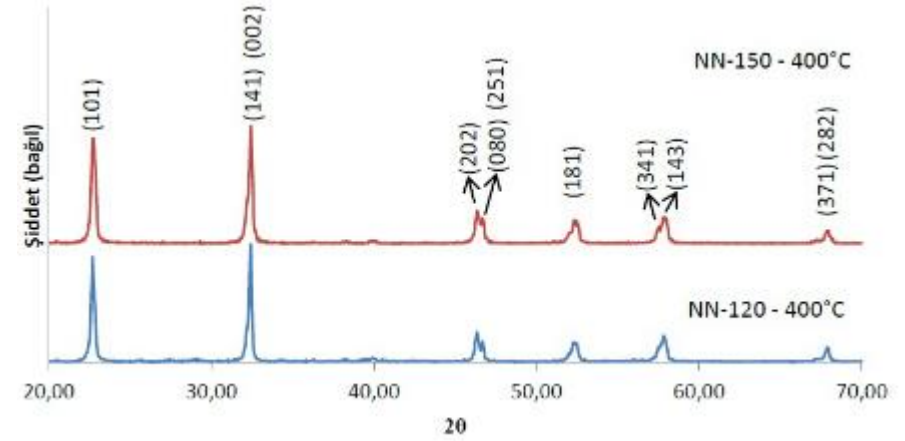
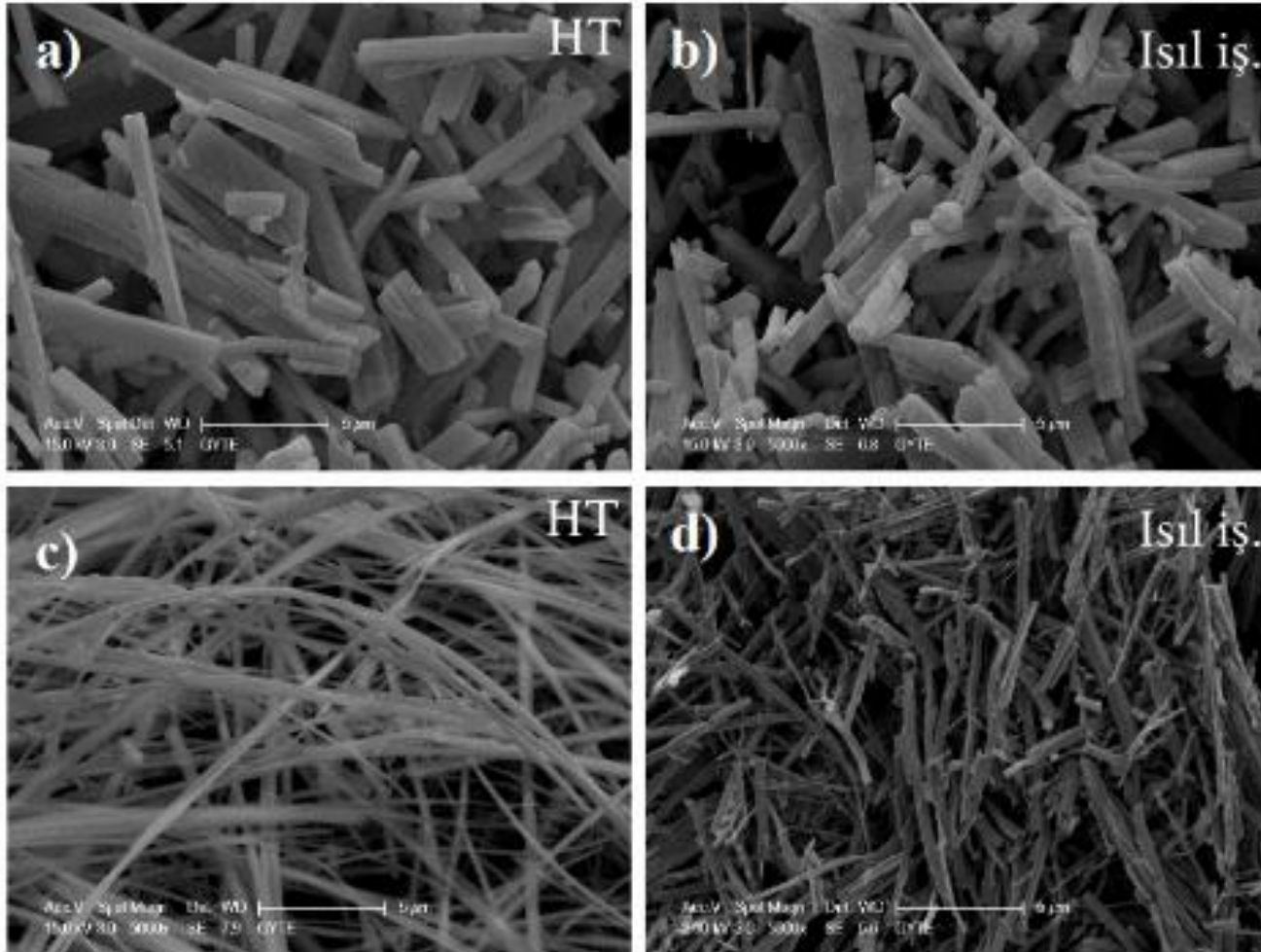

Liquid Phase Methods III

MOLTEN SALT SYNTHESIS

Molten Salt Synthesis

- **Molten salt synthesis** involves the use of a molten salt as the medium for preparing complex oxides powders from their constituent materials (oxides and carbonates).
- Molten salt synthesis is a modification of the powder metallurgical method. Salt with a low melting point is added to the reactants and heated above the melting point of the salt. The *molten salt acts as the solvent*.
- *Molten salts* have been used *as additives to enhance the rates of solid state reactions* for a long time. The amount of salt is small, typically a few percent of the total weight.
- In contrast, *in molten salt synthesis, a large amount of salt is used as the solvent to control powder characteristics (size, shape, etc.)*. In this sense, molten salt synthesis is different from the flux method, which uses the salt as an additive to enhance the reaction rate.
- Typical examples of salts used in molten salt synthesis are chlorides and sulfates. In many cases, eutectic mixtures of salts are used to lower the liquid formation temperature. The melting points of NaCl and KCl are 801°C and 770°C, respectively, and that of 0.5NaCl–0.5KCl (eutectic composition) is 650°C. For example, 0.635Li₂SO₄–0.365Na₂SO₄ is the most commonly used salt among sulfates because of its low melting temperature, which is 594°C, whereas that of Na₂SO₄–K₂SO₄ is 823°C.
- The solubilities of oxides in molten salts vary greatly from less than 1×10^{-10} mole fraction to more than 0.5 mole fraction, typically 1×10^{-3} - 1×10^{-7} mole fraction.
- In many cases, *the formation reaction occurs in the presence of solid reactant particles*. In this sense, molten salt is somewhat *different from ordinary solvents, which dissolve all reactant* particles and the product particles precipitate from a homogeneous liquid phase.

Molten Salt Synthesis

The requirements on the salt:

- They should be *stable*, *readily available*, *inexpensive*, and *easily washed away with water*.
- A *low melting temperature* is desirable, and the eutectic composition or the composition at the minimum liquidus temperature is often used.
- They should have a *low vapor pressure* at the heating temperature and
- Do *not cause undesirable reactions* with either the reactants or the product.

Procedure :

1. A mixture of the reactants and salt is heated above the melting temperature of the salt.
2. At the heating temperature, the salt melts and the product particles form. The characteristics of the product powder are controlled by selecting the temperature and duration of the heating.
3. Then, the reacted mass is cooled to room temperature and washed with an appropriate solvent (typically, water) to remove the salt.
4. The complex oxide powder is obtained after drying. The procedure is the same as that of a conventional powder metallurgical method and is easily scaled up for the fabrication of large quantities of materials.

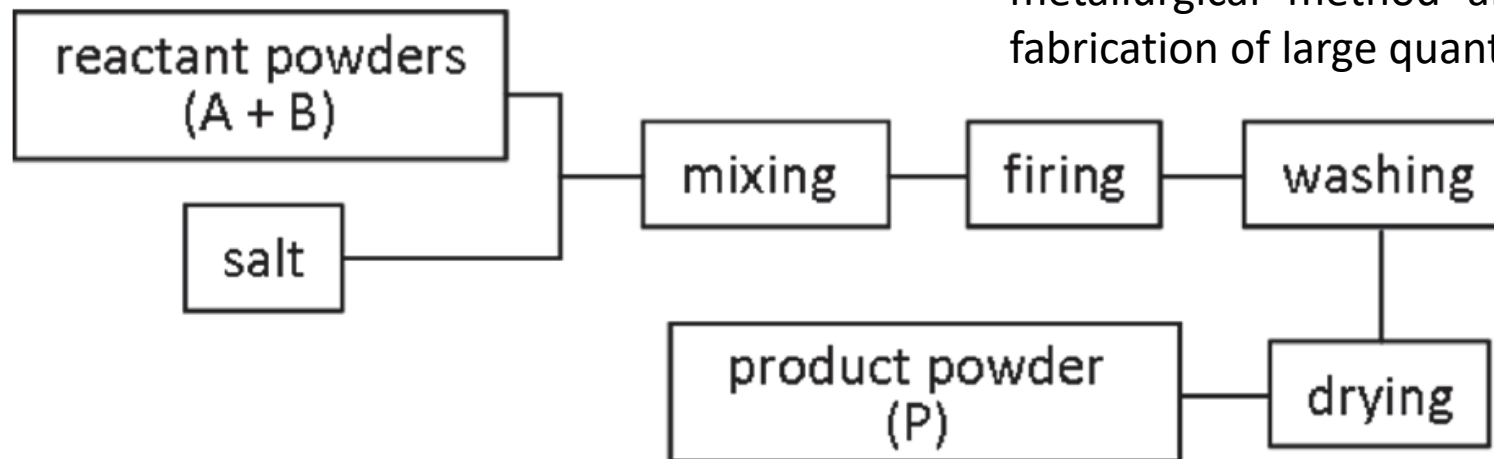

Fundamentals of Molten Salt Synthesis

Reaction rate

Molten salts increase the reaction rate, and the product formation is completed at lower temperatures than that in solid state reaction.

➤ Figure shows the fractional completion of the ferrite formation from the constituent oxides heated at various temperatures for 1 h in the solid state reaction and molten salt synthesis using $\text{Li}_2\text{SO}_4\text{-Na}_2\text{SO}_4$.

The increase in the formation rate is a consequence of:

- 1. An increase in the contact area of the reactant particles and*
- 2. An increase in the mobility of the reactant species in the molten salt.*

The position of the product formation is limited to the contact points of the dissimilar reactants in the *solid state reaction*, and further increase in the product volume is caused by material transport through the product phase. The mobility of material through this route is in the order of $10^{-18} \text{ cm}^2 \text{ sec}^{-1}$.

➤ Conversely, in *molten salt synthesis*, the surfaces of the reactant particles are covered with melt and they become available to the reaction. In the molten salt, the mobility of the species ranges from 10^{-5} to $10^{-8} \text{ cm}^2 \text{ sec}^{-1}$. This is fairly larger than the mobility in the solid state reaction.

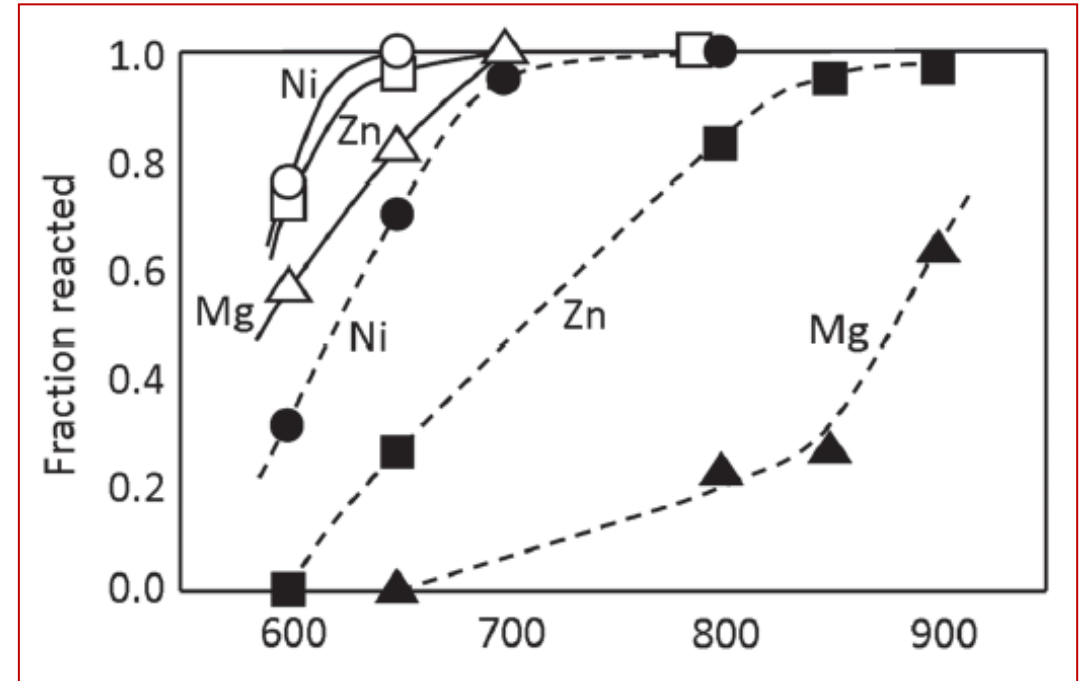

Formation of MFe_2O_4 ($\text{M}=\text{Ni}, \text{Zn}, \text{Mg}$) with (solid lines) and without (dashed lines) molten $\text{Li}_2\text{SO}_4\text{-K}_2\text{SO}_4$ salt, heated for 1 h.

Fundamentals of Molten Salt Synthesis

Powder characteristics - Homogeneity of composition

Molten salt enhances the material transport, and it is expected that the product powders are more homogeneous than those prepared by the solid state reaction.

- To examine the compositional homogeneity in $(\text{Ni,Zn})\text{Fe}_2\text{O}_4$ powders, NiFe_2O_4 and ZnFe_2O_4 powders are reacted at 900°C for 4 h by molten salt synthesis using $\text{Li}_2\text{SO}_4\text{-Na}_2\text{SO}_4$ and by the solid state reaction.
- The compositional fluctuation in the obtained powders is analyzed by measuring the Curie temperature because it is a function of composition.
- Figure shows the distribution of the Curie temperature for $(\text{Ni,Zn})\text{Fe}_2\text{O}_4$ powders obtained by molten salt synthesis and solid state reaction.
- In the absence of molten salt, the distribution curve is broad, indicating a large compositional fluctuation. The molten salt narrows the distribution of the composition.

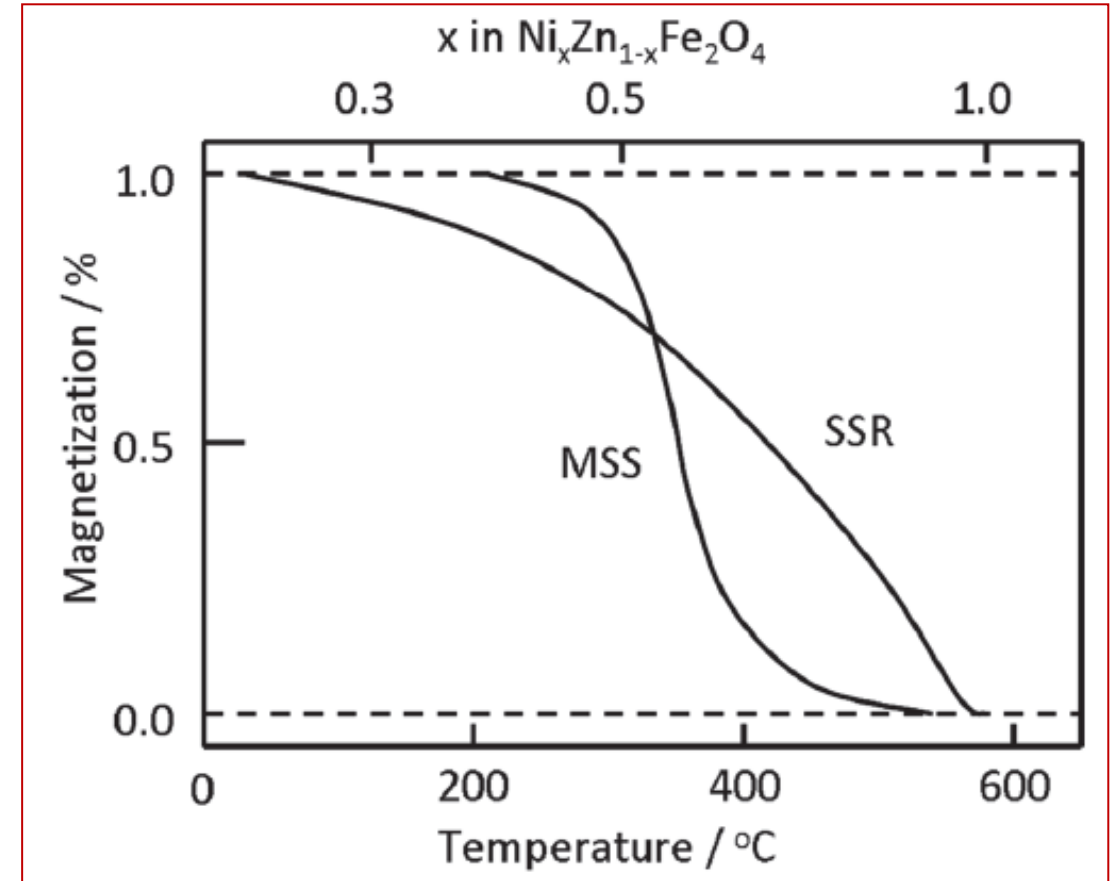

Distribution of the Curie temperature in $(\text{Ni,Zn})\text{Fe}_2\text{O}_4$ powders prepared by the molten salt synthesis (MSS) and solid state reaction (SSR), heated at 900°C for 4 h.

Fundamentals of Molten Salt Synthesis

Powder characteristics – Agglomeration

➤ During the solid state reaction, sintering (neck growth) of the product particles proceeds concurrently with their formation, which results in the formation of aggregates.

➤ In contrast, *in molten salt synthesis, molten salt covers the surfaces of all particles present and prevents the formation of necks between the product particles. Therefore, it is expected that powders with a low degree of aggregation are obtained.*

➤ Figure shows the particle size distribution of rod-shaped BaTiO_3 particles obtained by the reaction between rod-shaped $\text{TiO}_2 \cdot \text{H}_2\text{O}$ and BaCO_3 .

➤ Heating temperatures are 700°C for the molten salt synthesis using NaCl-KCl and 1000°C for the solid state reaction; these are minimum heating temperatures needed to complete the reaction within 1 h.

➤ The grain size of powder obtained by the molten salt synthesis is smaller than that obtained by the solid state reaction. Because the size of the primary particles is almost the same for both powders as observed with a scanning electron microscope, this size distribution reflects the size of the aggregates in the product powders.

➤ Thus, molten salt synthesis produces powders with a low degree of aggregation.

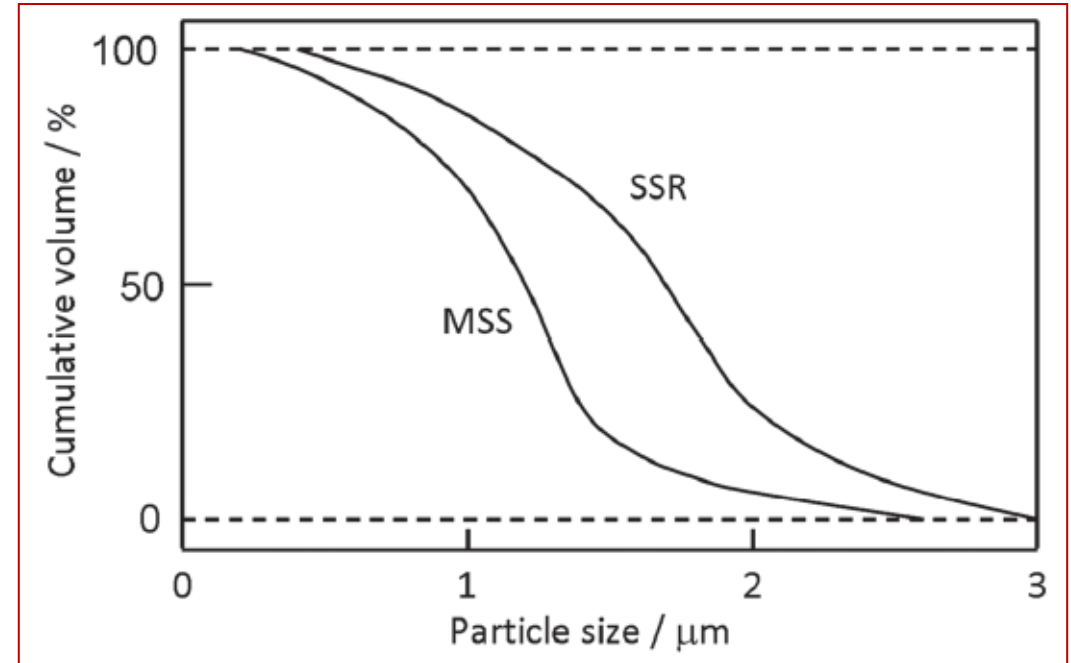

Particle size distribution of BaTiO_3 powders obtained by the molten salt synthesis (MSS) and solid state reaction (SSR), measured by the sedimentation method.

CASE STUDY - Synthesis of Plate-like NaNbO_3 Particles

- The plate-like single crystal NaNbO_3 - NN template particles for the Templated Grain Growth (TGG) process were prepared by a two-stage molten salt synthesis (MSS) method.
- In the **first stage**, NaCl salt was mixed with Na_2CO_3 , Bi_2O_3 and Nb_2O_5 powders and then reacted at various temperatures ranging from 1100°C to 1150°C for 6 h. The reaction products contained plate-like $\text{Bi}_{2.5}\text{Na}_{3.5}\text{Nb}_5\text{O}_{18}$ (BNN) particles.
- In the **second stage** of **topochemical microcrystal transformation**, these BNN particles were mixed with Na_2CO_3 and reacted at 975°C for 6 h in NaCl molten salt bath to obtain plate-like particles by chemically converting the BNN particles to NN while retaining their plate-like morphology.

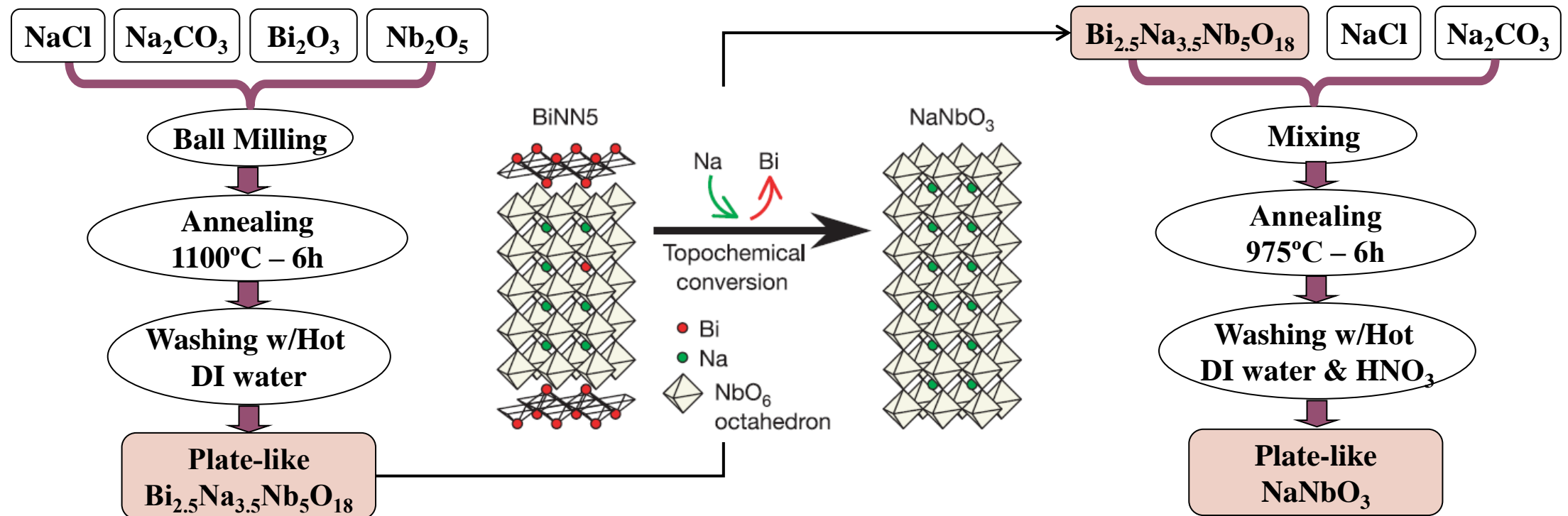

CASE STUDY - Synthesis of Plate-like NaNbO_3 Particles

- The first stage synthesis yielded phase-pure BNN particles with a plate-like morphology as shown in Figure.
- The XRD pattern shown in Figure indicates that the particles are in the layered perovskite $\text{Bi}_{2.5}\text{Na}_{3.5}\text{Nb}_5\text{O}_{18}$ (BNN) phase.
- The particles that were obtained through topochemical microcrystal conversion of BNN in the second stage synthesis transform fully into the cubic perovskite NaNbO_3 (NN) phase as shown in Figure, they retain their plate-like morphology as clearly seen in Figure, as required.

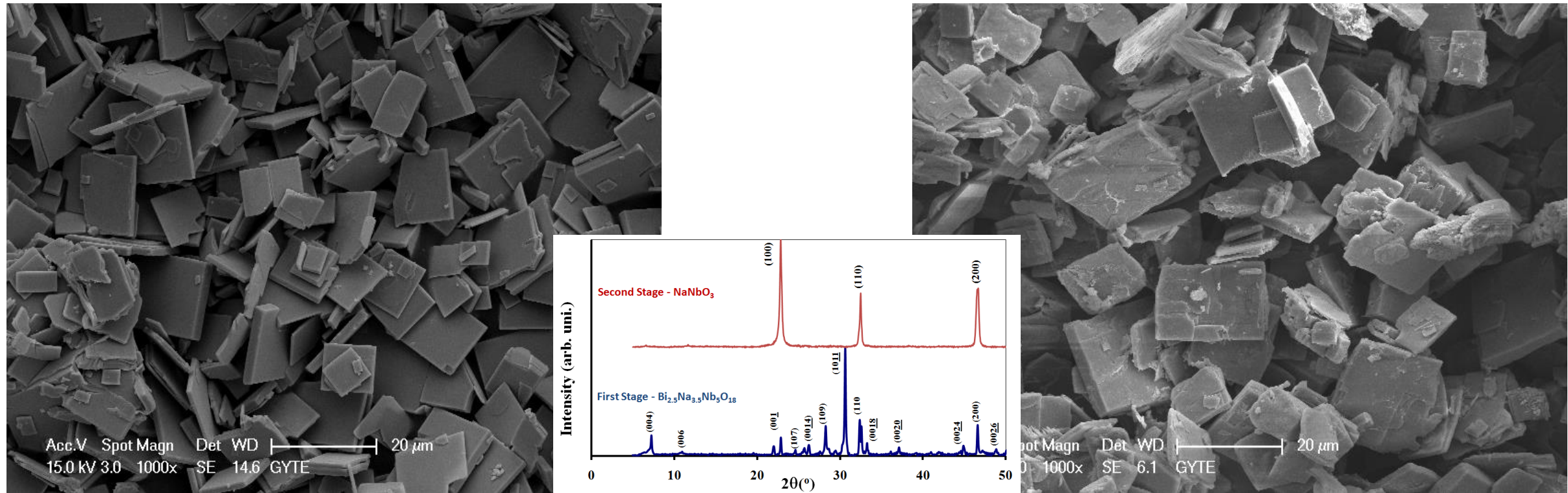

CASE STUDY - Synthesis of Plate-like NaNbO_3 Particles

- In the next step of our study, 10 wt% template particles were added into the KNN slurries, ribbons were drawn and identical sintering conditions were applied.
- The preferred alignment of template particles (some of which are identified in the figure with white arrows) along the ribbon drawing direction (which is the horizontal direction in this figure) is clearly seen in this micrograph.
- A fully dense microstructure was obtained. The growth of template particles through thickening is clearly visible in the particles marked by white arrows, however, it was also observed that the fine matrix grains are still present in this structure.
- Development of texture i.e. degree of orientation was clearly observable.

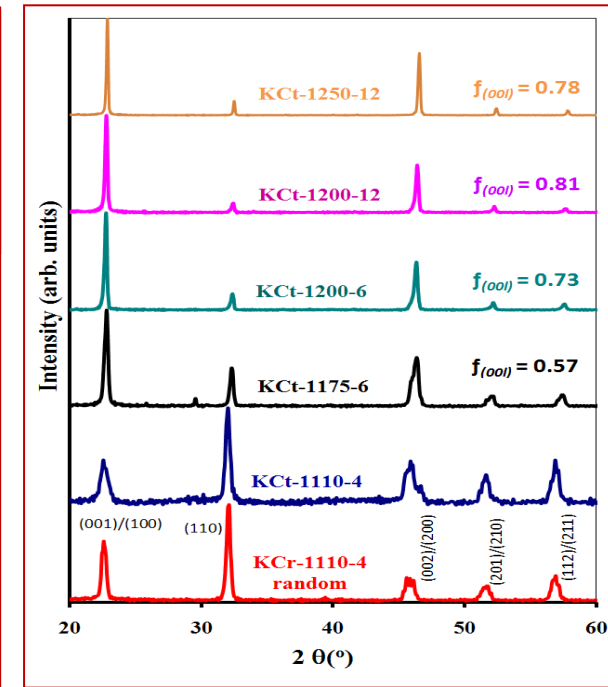
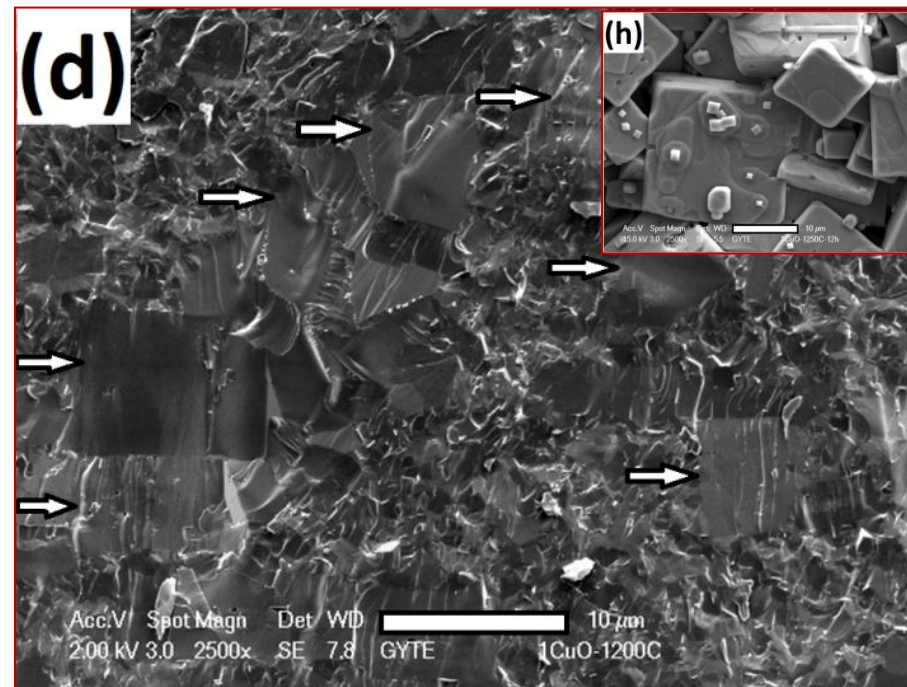
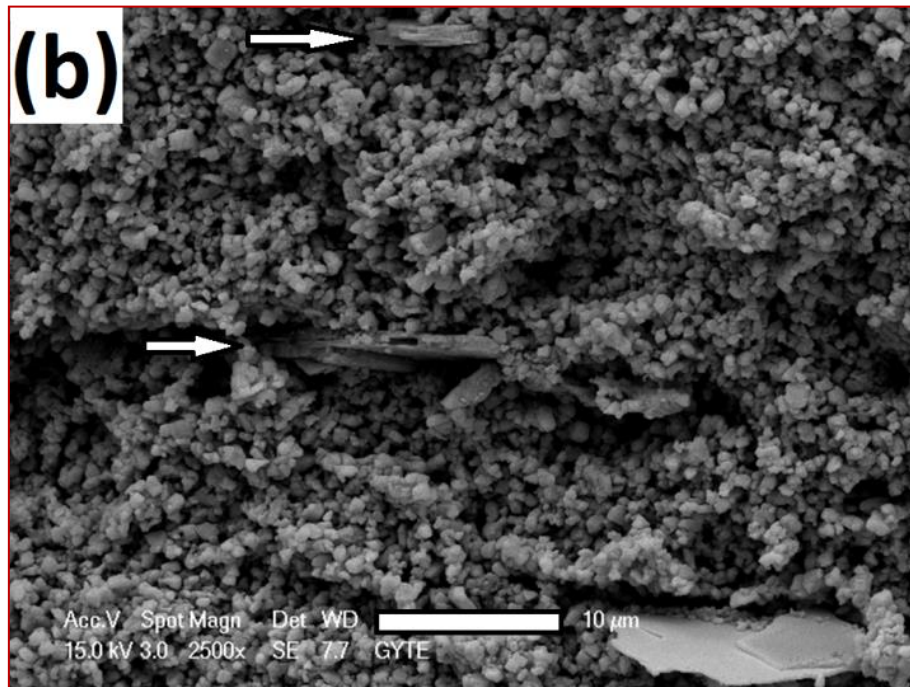

CASE STUDY - Synthesis of Plate-like $\text{Bi}_4\text{Ti}_3\text{O}_{12}$ Particles

- The objective was to investigate the effect of a strong magnetic field during the gel casting process on the texture formation and grain orientation in anisometric $\text{Bi}_4\text{Ti}_3\text{O}_{12}$ - BiT piezoelectric powders with plate-like morphology.
- Due to the persistence of magnetocrystalline anisotropy at high temperature, the crystal orientation in materials (including paramagnetic and even diamagnetic materials) can be controlled by applying a high magnetic field.
- This principle can be applied not only to magnetic materials but also to nonmagnetic materials with an asymmetric unit cell.

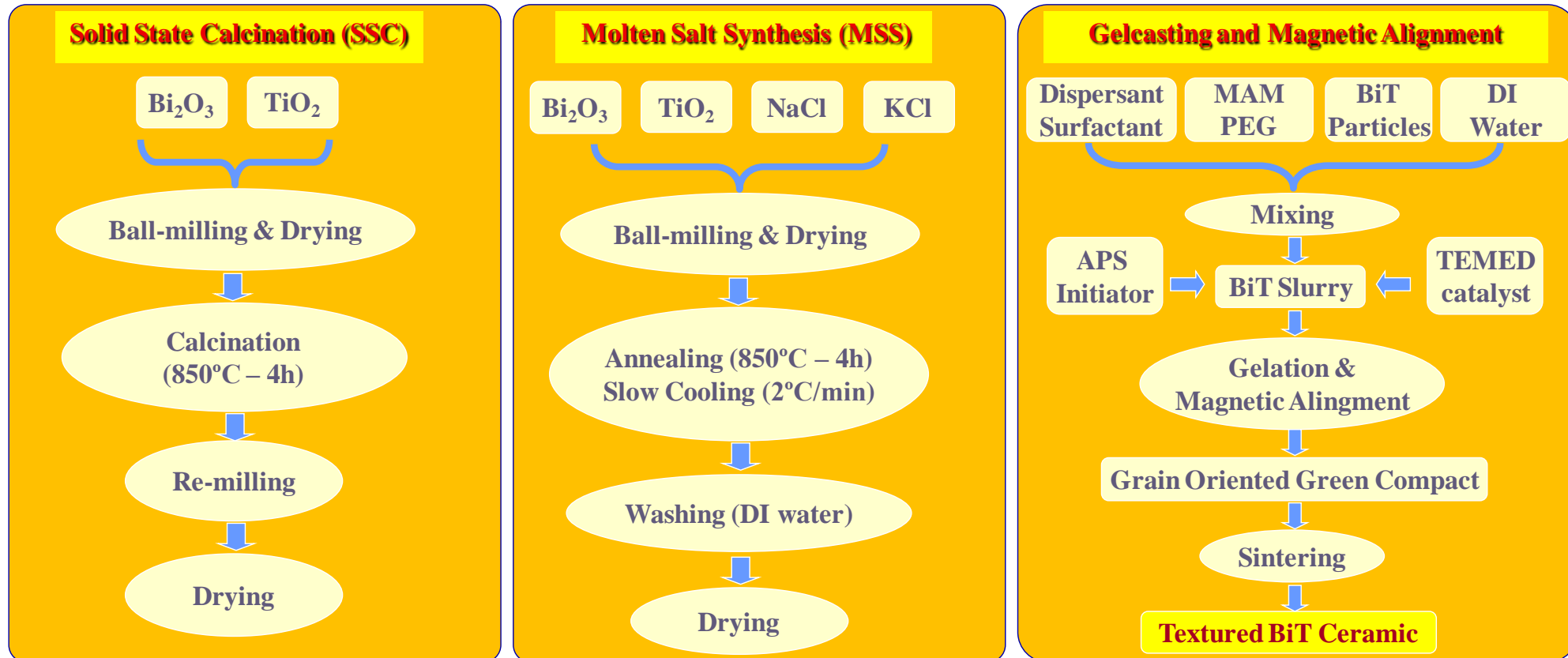

CASE STUDY - Synthesis of Plate-like $\text{Bi}_4\text{Ti}_3\text{O}_{12}$ Particles

Structural Features of the BiT Particles Synthesized with Two Different Methods

- XRD patterns show that both of the processes yielded pure $\text{Bi}_4\text{Ti}_3\text{O}_{12}$ powders.
- Molten salt synthesized powders had higher crystallinity and a c-axis orientation due to the plate-like morphology of the particles.

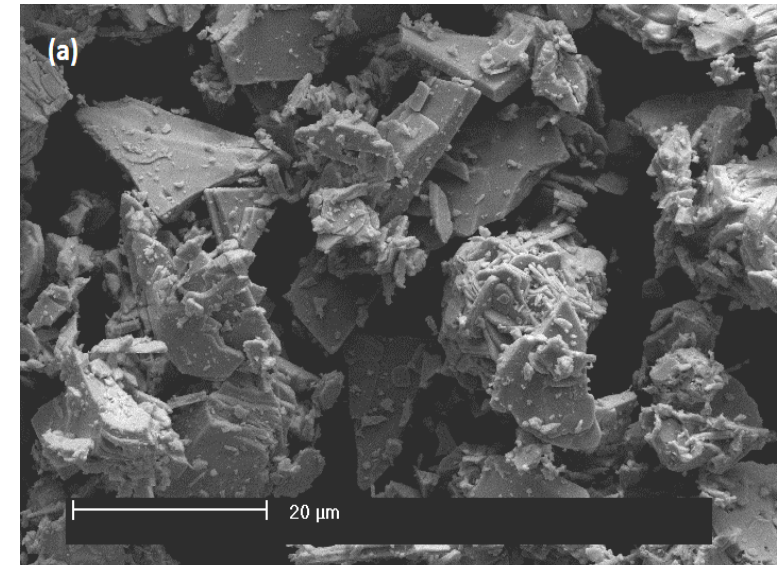
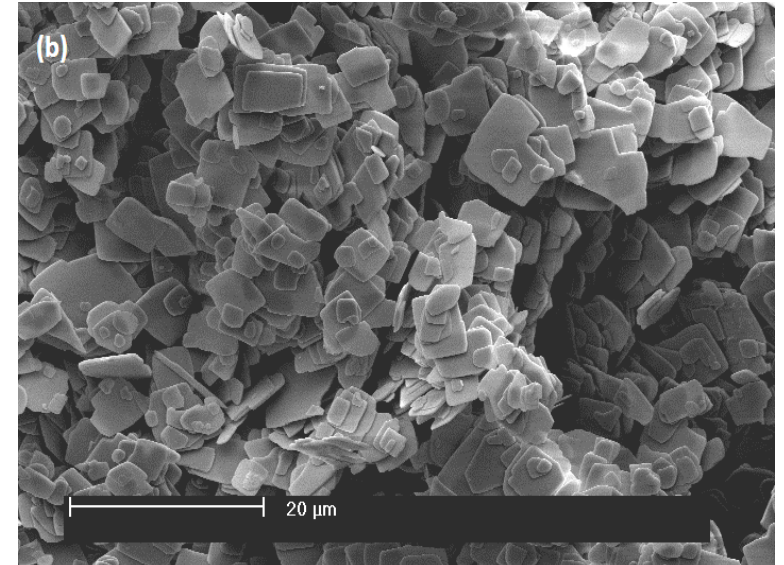
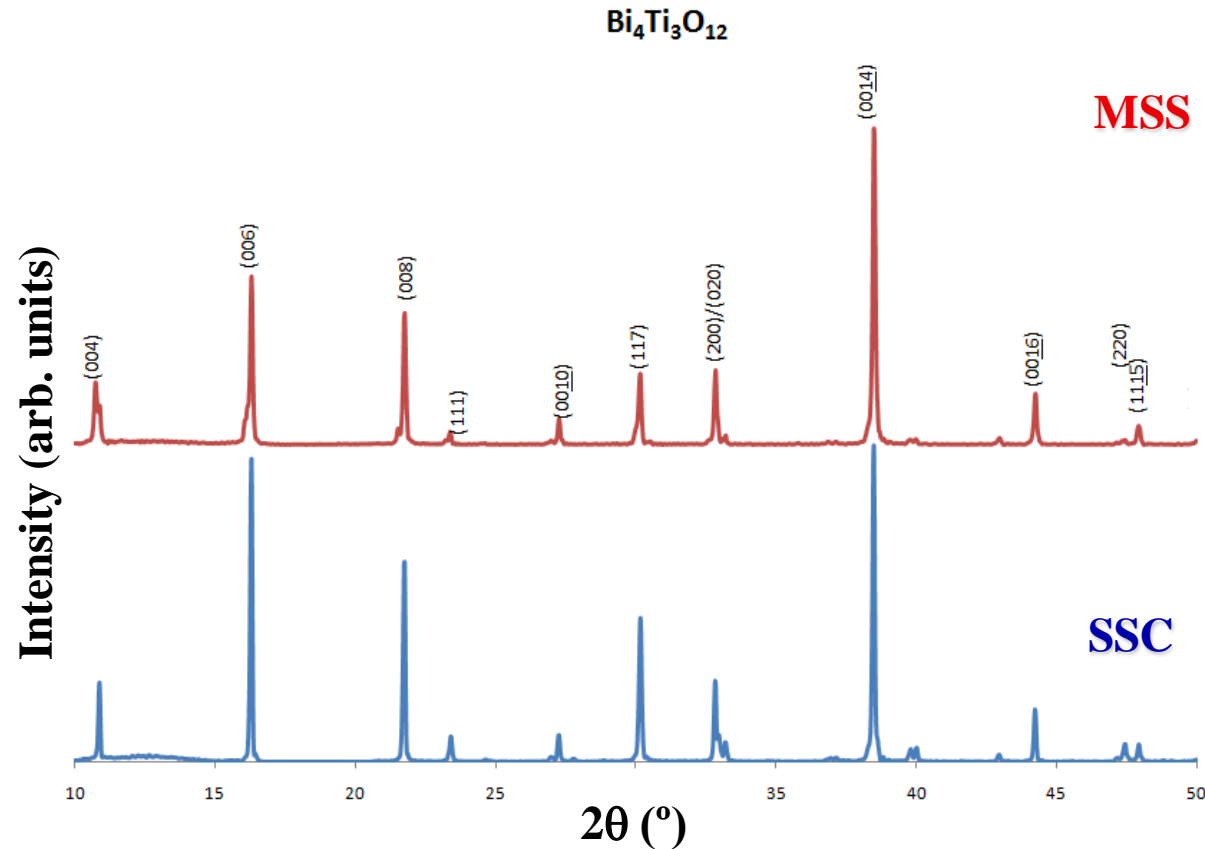

CASE STUDY – Textured $\text{Bi}_4\text{Ti}_3\text{O}_{12}$ Piezoceramics

Texture Development in BiT ceramics

- A notable change was observed in the peak intensities of the (111), (200), (020) and (220) planes of the samples that are cut parallel and perpendicular to the magnetic field direction.
- A drastic change was also observed in the microstructure where the plate-like BiT particles were found to align parallel to the magnetic field direction.
- The preferred orientation of grains and development of texture increased with increasing magnetic field strength.
- The ceramics contained porosity due to the plate-like morphology of the particles which prevents perfect packing.

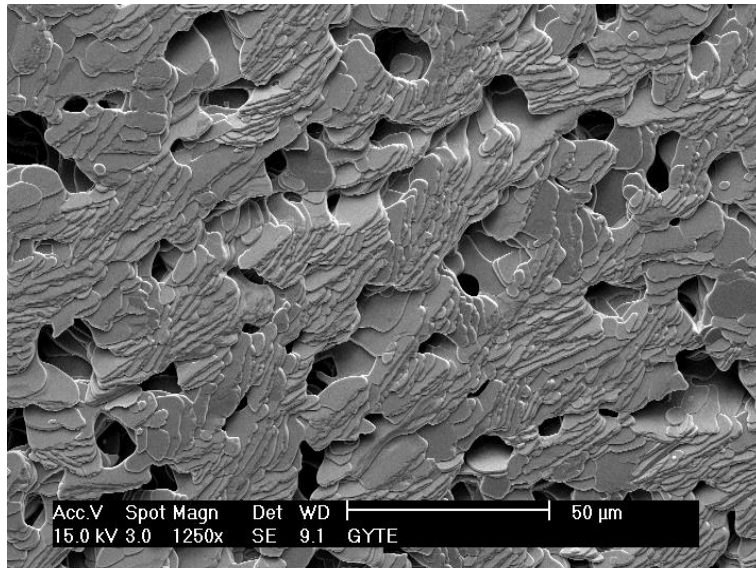

0 Tesla

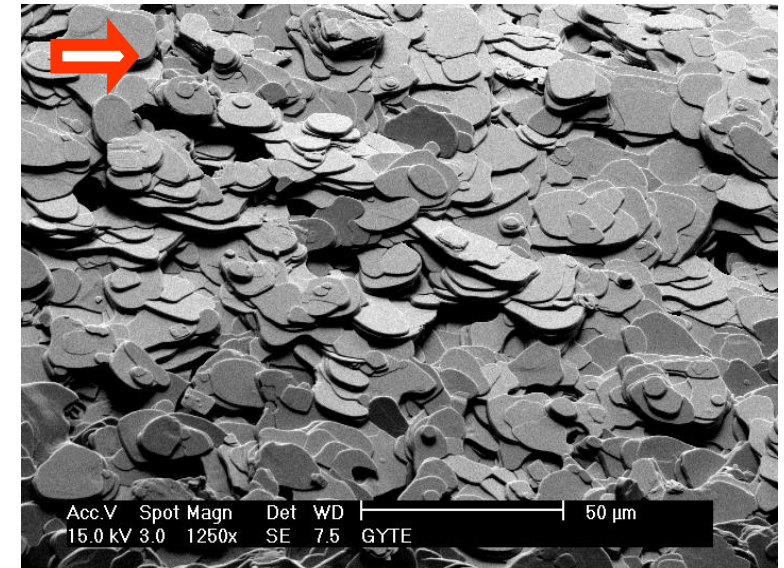
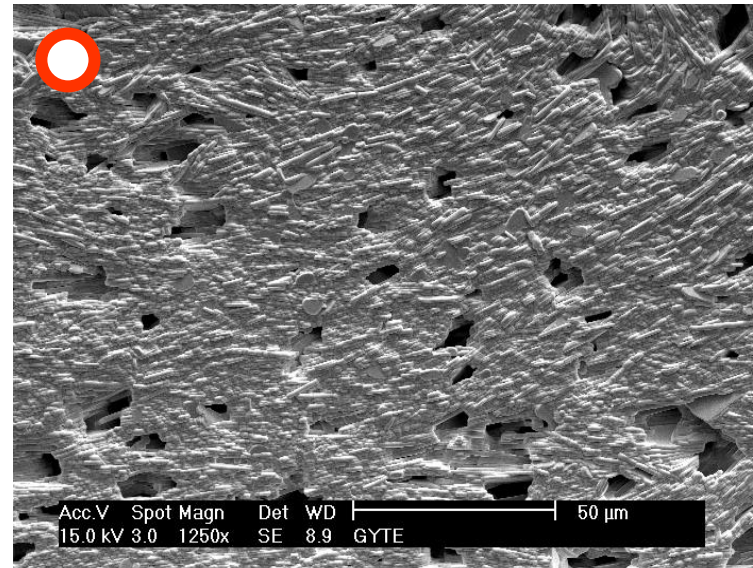

9 Tesla

CASE STUDY - Synthesis of Needle-like $\text{KSr}_2\text{Nb}_5\text{O}_{15}$

- Needle like $\text{KSr}_2\text{Nb}_5\text{O}_{15}$ (KSN) single crystal template particles were successfully synthesized by molten salt synthesis method from the $\text{KCl-SrNb}_2\text{O}_6$ system.
- Effect of salt/powder ratio in the case of KSN, on the morphology and size of KSN particles were investigated.
- KSN particles exhibited a stepwise morphology.

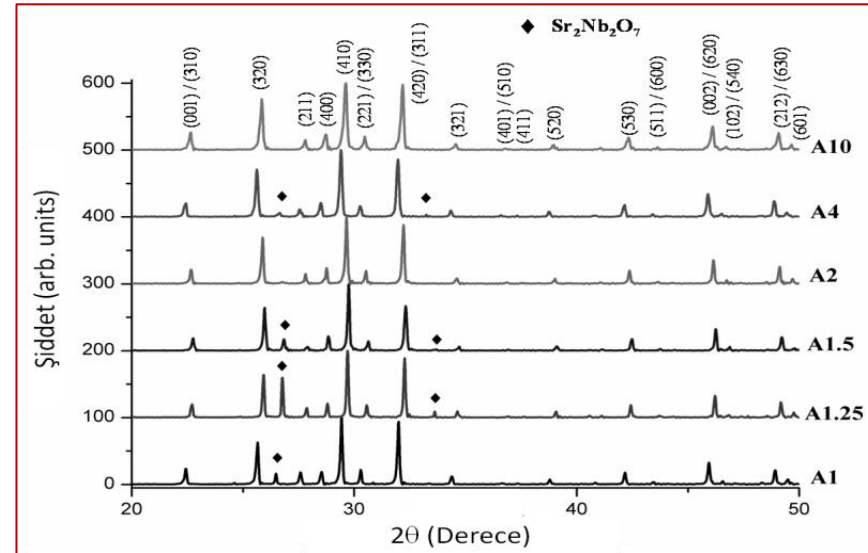
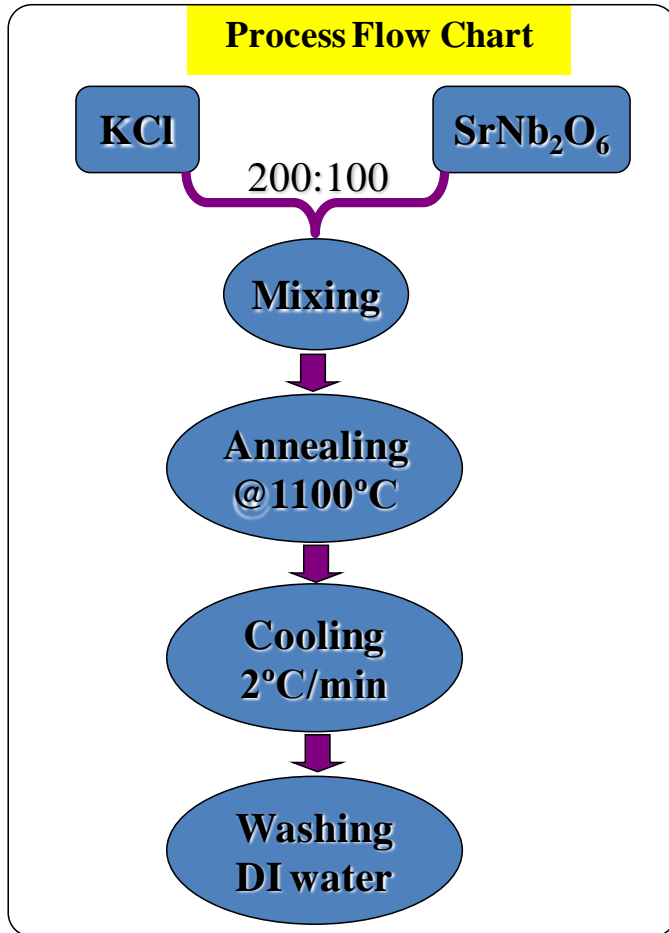

Şablon ismi	Ağırlıkça Tuz/Toz Oranı	Ortalama Çap (µm)	Ortalama Boy (µm)	Ortalama Boy/Çap	FWHM (°)
A1	1:1	1,7	12	7,05	0,112
A1.25	1,25:1	1,6	17	10,62	0,106
A1.5	1,5:1	2,5	20	8	0,109
A2	2:1	2,8	27	9,6	0,118
A4	4:1	2,2	21	9,54	0,14
A10	10:1	2,4	19	7,91	0,17

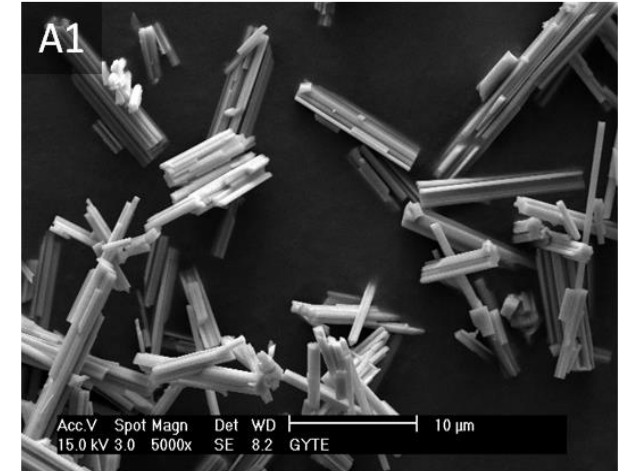
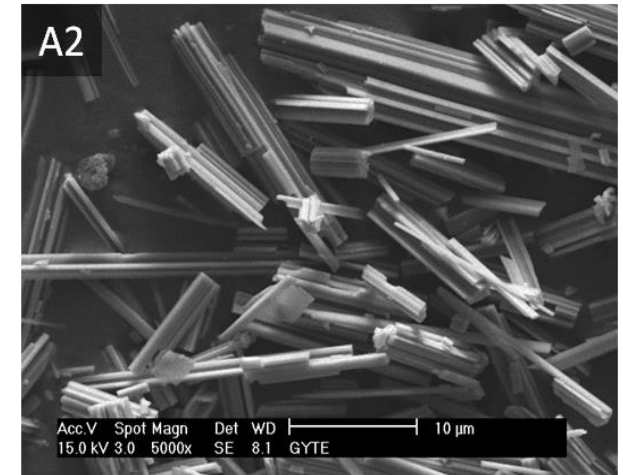

CASE STUDY - Textured $\text{KSr}_2\text{Nb}_5\text{O}_{15}$ Piezoceramics

- Textured ceramic fibers were fabricated from the tungsten-bronze-type piezoelectric $\text{KSr}_2\text{Nb}_5\text{O}_{15}$.
- Development of crystallographic texture was evaluated through rocking curve analysis and a texture with Lotgering factor of 0.97 was achieved.
- 1–3 piezocomposites were prepared from the textured fibers and their electrical properties were evaluated. Highly enhanced properties that are 2 to 3 times higher than the random case were observed with increasing texture fraction.

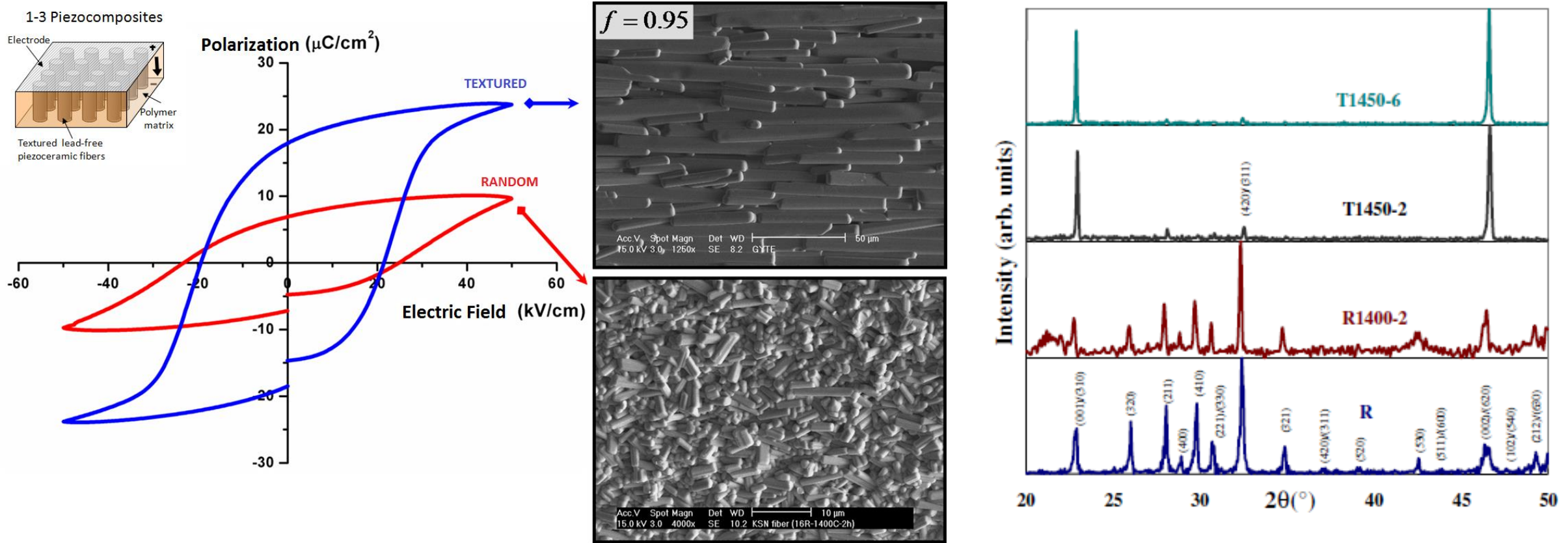

Thanks for listening!

Q & A

<https://www.seres2021.org/>

SERES'21 V. Uluslararası Seramik, Cam, Emaye, Sır ve Boya Kongresi 13-15 Ekim 2021'de Yine Eskişehir'de

WEBCASTER 14 MART 2021 GENEL



seres'21

<https://seramikdergisi.org/>

Mangan Katkısının $94(\text{Na}_{0.5}\text{Bi}_{0.5})\text{TiO}_3\text{-}6\text{BaTiO}_3$ Çok Katmanlı Piezoelektrik Seramiklerin Elektriksel Yorulma Davranışına Etkisi

Mert GÜL^{1,2}, A.Baturay GÖKÇEYREK³, Mevlüt GÜRBÜZ⁴, Ayşe Gül TOKTAŞ^{2,3}, Taner KAVAS¹, Aydın DOĞAN^{2,3}

¹Afyon Kocatepe Üniversitesi, Malzeme Bil. Ve Müh. Bölümü, 03200 Afyonkarahisar.

²Nanotech İleri Tek. Malz. Elk-Elkt. Sis. San. Tic. Ltd. Şti., Eskişehir

³Eskişehir Teknik Üniversitesi, Malzeme Bil. Ve Müh. Bölümü, Tepebaşı, Eskişehir

⁴Samsun Ondokuz Mayıs Üniversitesi, Makine Müh. Bölümü, Samsun

Sorumlu Yazar / Corresponding Author
Mert GÜL
mertgg@gmail.com

Makale Bilgisi / Article Info
Sunulma / Received : 15/01/2020
Düzeltilme / Revised : 12/02/2020
Kabul / Accepted : 01/03/2020

Destekleyen Kuruluş / Funding Agency
Afyon Kocatepe Üniv. BAP Birimi
Proje No: 17.FEN.BİL.71 ve
Eskişehir Teknik Üniv. BAP Birimi
Proje No: 1705F199 ve 1605F333

Anahtar Kelimeler
Kurşunsuz
piezoelektrik
çok katmanlı
elektriksel yorulma
mangan

Keywords
Lead-free
piezoelectric
multilayer
electrical fatigue
manganese

Özet

Piezoelektrik çok katmanlı seramikler eyleyici uygulamalarında yüksek mekanik dayanım ve deplasman özellikleri nedeniyle kullanılmaktadırlar. Bu uygulamalarda çok fazla elektriksel çevrime maruz kalan malzemelerin elektriksel tepkileri, çevrim sayısına bağlı olarak düşmektedir. Buna elektriksel yorulma denmektedir. Eyleyici olarak kullanılacak olan malzemelerin yorulma davranışının belirlenmesi ve minimum dayanımın artırılması gerekmektedir. Eyleyici uygulamalarında genellikle kurşun içerikli PZT tabanlı malzemeler kullanılmaktadır. Kurşunsuz piezoelektrik malzemeler ise kapasitör uygulamalarında sıklıkla kullanılmaktadır. Toksik etkileri sebebiyle RoHs standartları gereği kurşun içerikli malzemelerin tüm endüstriyel türlerde sınırlandırılması istenmektedir. Bu sebeple tüm dünyada kurşunsuz piezoelektrik malzemeler geliştirilmektedir. Eyleyici uygulamalarında kullanılmak üzere geliştirilen kompozisyonlardan bir tanesi de $94(\text{Na}_{0.5}\text{Bi}_{0.5})\text{TiO}_3\text{-}6\text{BaTiO}_3$ kısaca NBT-6BT kompozisyonudur. Bu çalışmada kurşunsuz NBT-6BT kompozisyonuna Mangan ilavesi yapılmış, çok katmanlı seramik üretilmiş ve katkısız NBT-6BT kompozisyonu ile karşılaştırılmıştır. Bu sayede Mangan katkısının NBT-6BT çok katmanlı seramiklerin elektriksel yorulma davranışlarına etkisi araştırılmıştır. Kurşunsuz çok katmanlı seramikler su çözelti sistemiyle ve gümüş-paladyum (Ag-Pd) elektrot kullanılarak $1115\text{-}1120^\circ\text{C}$ sinterleme sıcaklığı ve 2-4-6 saat olmak üzere farklı sinterleme sürelerinde sintirlenerek üretilmiştir. Mangan katkısının kalıcı polarizasyon değerini artırdığı, histeris eğrisinin kareselliğindeki bozulma oranını düşürdüğü belirlenmiştir.

Effect of Manganese Additive on Electrical Fatigue Behavior of $94(\text{Na}_{0.5}\text{Bi}_{0.5})\text{TiO}_3\text{-}6\text{BaTiO}_3$ Multilayer Piezoelectric Ceramics

Abstract

Piezoelectric multilayer ceramics are used in actuator applications related to high mechanical strength and actuating performances. In these applications, the electrical response of materials decreases depending on the number of applied cycles. This is called electrical fatigue. Fatigue behavior of the materials must be determined if possible fatigue strength increased to be used as actuators. PZT based materials with lead content are generally used in actuator applications. Lead-free piezoelectric materials are frequently used in capacitor applications. Due to its toxic effects, it is desirable to limit lead containing materials in all industrial products as required by RoHs standards. Therefore, lead-free piezoelectric materials are being developed all over the world. One of the compositions developed for use in actuator applications is $94(\text{Na}_{0.5}\text{Bi}_{0.5})\text{TiO}_3\text{-}6\text{BaTiO}_3$, in short NBT-6BT. In this study, manganese was added to lead free NBT-6BT composition, multilayer ceramics were produced and compared with NBT-6BT multilayer ceramics. Thus, the effect of manganese additive on the electrical fatigue behaviour of NBT-6BT multilayer ceramics was investigated. Lead-free multilayer ceramics were produced with water-based tape casting slurry system and Ag-Pd electrode by sintering at $1115\text{-}1120^\circ\text{C}$ sintering temperature and 2-4-6 hours at different sintering times. It has been observed that manganese additive increases the permanent polarization value, decreases the deformation ratio of squareness of hysteresis.



Prof. Dr. Hüseyin YILMAZ



Gebze Teknik Üniversitesi
Malzeme Bilimi ve Mühendisliği

Seramiklerin Sinterlenmesi

Konvansiyonel sinterleme, basit olarak, parçacıkların katı bir obje olacak şekilde birbirine termal bir prosesle bağlanması olarak tanımlanmaktadır. Bu termal proses(ler) sonunda önceden şekillendirilmiş fakat zayıf olan obje (yaş numune olarak adlandırılır) mekanik mukavemet (veya başka bir fonksiyon) kazanmaktadır. Sinterleme, “pişirme” olarak adlandırılır ve bu kullanım şekli ile binlerce yıldır hayatımızın vazgeçilmez bir parçasıdır. Hemen her hanede sinterlenerek üretilmiş çok sayıda ürün bulunmaktadır. Hatta arkeologlar insanoğlunun sinterlemeyi 26000 yıl önce keşfettiğini öne sürmektedirler. Sinterlemenin teorisi geçen yüzyılın ikinci yarında önemli ilerlemeler katetmesine rağmen, proses sırasında gerçekleşen olaylar basit değildir ve bilgi birikimi iyi bir sinterleme yapabilmek için önemlidir.

Günümüzde sinterlemenin konvansiyonel, sıcak pressleme, sıcak izostatik presleme, mikrodalga sinterleme, plazma sinterleme, lazer sinterleme gibi pek çok şekli mevcuttur. Her birinin kendine göre avantaj ve dezavantajları vardır. Bu proseslerden hangisinin üretimde tercih edileceğini ağırlıklı olarak maliyet ve üretim kapasitesi belirlemektedir. Bir diğer önemli nokta ise bu sinterleme yöntemleri yüksek enerji dolayısıyla da yüksek sıcaklık prosesleri olup uygun fırın tasarımı ve pahalı malzeme seçimi gerektirmektedir. Bir malzemenin sinterlenme sıcaklığını yüzey alanı (birim miktar malzeme), sinterleme katkı çeşidi ve oranı, sıvı fazın



varlığı, basınç gibi pek çok parametre belirlemektedir. Konvansiyonel sinterlemede malzemeler genel olarak ergime sıcaklıklarının ~2/3 oranında bir sıcaklıkta sinterlendikleri bilinmektedir. Seramiklerin ergime sıcaklıkları dolayısıyla sinterlenme sıcaklıkları yüksektir ve bu durum sinterlemeyi enerji yoğun bir proses kılmaktadır. Bu sunumda en yeni sinterleme tekniklerinden birisi olan soğuk sinterleme tekniğinden de bahsedilecektir.

