

**COOP'S  
SATELLITE  
DIGEST**



AUGUST 01, 1985

INTERNATIONAL EDITION

4:52:18

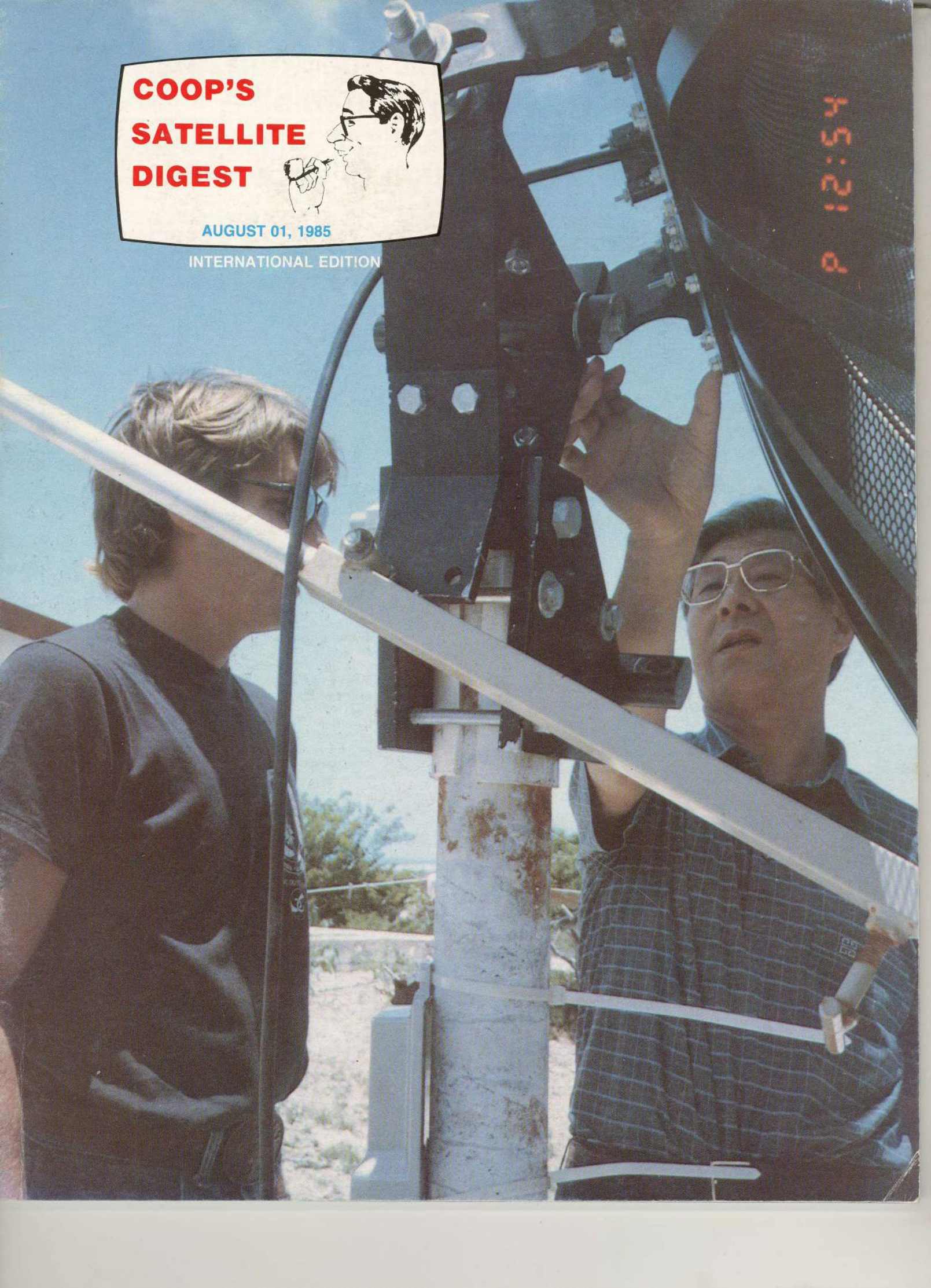

# AVCOM's PSA-35 Portable Spectrum Analyzer

## Designed with you in mind— Basic enough to begin with— Sophisticated enough to grow with!

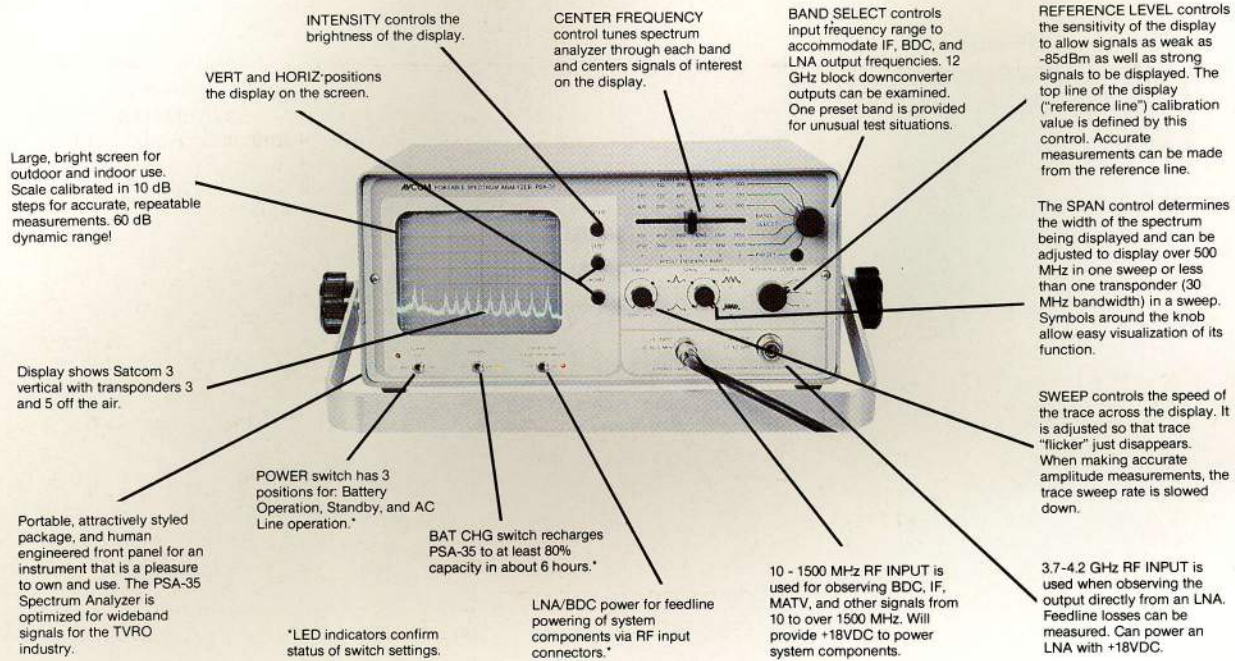

### KEYWORD EXPLANATIONS

**SPECTRUM ANALYZER** — an instrument used to display signal amplitude vs. frequency over a selected range of frequencies (bandwidth). Amplitude is shown by the height of the trace on the screen.

**REFERENCE LEVEL** — in our context, a line at the top of the display that defines signal level at that point. Equally spaced lines below it at 10 dB intervals enable easy readout of various signal levels.

**dBm** — the most useful unit of measurement of signal strength (power) for our industry. It means decibel referenced to 1/1,000 of a watt of power. The following list will help you put dBm values into perspective:

- +20dBm — 100 mw (1/10 watt)
- +10dBm — 10 mw (1/100 watt)
- 0 dBm — 1 mw (1/1,000 watt)
- 10dBm — .1 mw
- 40 dBm — .0001 mw (typical BDC output)
- 70 dBm — typical 4 GHz feedline signal

### FOR DEMANDING BENCH-TEST SITUATIONS, AVCOM'S MSA-85 SPECTRUM ANALYZER

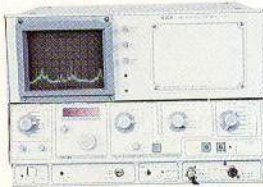

- Digital Frequency Readout
- Accurate Enough for Production and Lab Use
- Built-in DC Block and Power for LNA
- Sophisticated Styling
- Reliable Design

### SOME APPLICATIONS

Measure and document TVRO system performance after installation or service. Customer should be given copy of results per AVCOM's SASAR (Spectrum Analyzer System Analysis Report) to insure customer confidence and satisfaction.

Troubleshoot system problems by observing output signals from LNA's, BDC's, Line Amps and Splitters, and other RF signal components. Measure block system signal balance.

Identify and resolve terrestrial interference problems quickly and precisely by displaying offending signals on the PSA-35. Customers can be shown the nature of TI problems for clearer understanding.

(More applications in our next series of ads — send us yours for publication.)

AVCOM's high performance spectrum analyzers become even more attractive when price is considered. The PSA-35 is \$1965 and the MSA-85 is priced at \$5345. Nothing on the market offers their performance at a comparable price.

Progressive TVRO Dealers, Repair Centers, and Manufacturers will find AVCOM's Spectrum Analyzers to be indispensable instruments for rapid testing and alignment of satellite equipment. Problems that might otherwise take hours, even days to resolve, can be identified and corrected in minutes, saving money and time, and reinforcing customers' confidence and trust. It is difficult to express in writing the diagnostic power a technician has with an AVCOM Spectrum Analyzer. In terms of time saved and customer good will, an AVCOM Spectrum Analyzer will pay for itself quickly.

For more information write: AVCOM, 500 Southlake Blvd., Richmond, VA 23236 or call (804) 794-2500. To order, call 1-800-446-2500.

### AVCOM's PSA-35

**THE MOST VALUABLE TEST INSTRUMENT  
YOU CAN BUY FOR INSTALLING  
AND SERVICING TVRO SYSTEMS!!**

TOP OF THE MONTH

**BEST** of Japan? With plenty of 'original' and new product rolling out of Japan these days, CSD begins a look at 'the technology to beat' from DX, Panasonic, Uniden and USS/Maspro in this issue. There is plenty of 'newness' buried in the latest Japanese TVRO circuit boards and performance has become the new watchword.

**BDC** installations, using the 400 (430) to 900 (930) MHz band remains a challenge. With Janeil and Sat-Tec/Ramsey introducing new 400-900 MHz receivers, the pendulum may be starting to swing away from the defacto 950-1450 'standard.' System engineer **David Lantz** is back with 'Part Two' describing the world of UHF band signal distribution; must reading for any serious system planner.

**TVRO test** equipment? There has been a rapid increase in the amount of available test equipment for dealers to put to work and we look at a pair of new units from Focii and Northwest Satlabs. The 'bottom line' is that system installation is getting more foolproof all the time if the dealer avails himself of the equipment now available.

**IN COMMENTS** this month Coop looks at a well thought out marketing plan originating at DX, Ted Turner's Announcement that he wants \$25 from all home TVRO viewers using CNN and CNN/2, and the 'battle of consumer publications' to educate the public about TVRO.

AUGUST 01 1985

COOP'S COMMENTS ..... page 6  
**BEST OF JAPAN/ Part One** ..... page 8



**BDC DISTRIBUTION/ David Lantz (Part Two)**..... page 13  
**ROOTS OF TVRO (Part 16)** ..... page 38  
**TECHNICAL TOPICS/Surge Protection** ..... page 42  
**PRODUCT REVIEWS:**  
 1) Squawker and Tweaker II Test Sets ..... page 42  
 2) Superwinch 2010 Drive/Controller ..... page 57  
**CORRESPONDENCE** ..... page 64  
**TRANSPONDER WATCH** ..... page 65



**OUR COVER/** A trip to CSD's lab test site in the Turks and Caicos Islands, by **Doctor Yoshihiro Konishi**, President of Uniden Satellite Technology resulted in significant structural and operational improvement suggestions for the Uniden 10.7 antenna. Here, Marshall Foiles and Dr. Konishi discuss a change in the declination adjust mechanics.

COOP'S  
 SATELLITE  
 DIGEST



INTERNATIONAL EDITION

COOP'S SATELLITE DIGEST published twice per month by West Indies Video, Ltd., a Turks and Caicos Corporation with corporate offices located at WIV-TV, Grace Bay, Providenciales, Turks and Caicos Islands, BVI. US offices for the processing of subscriptions, advertising, and editorial material maintained in Ft. Lauderdale, FL (P.O. Box 100858, Fort Lauderdale, FL 33310; telephone 305/771-0505 weekdays between 9 AM and 4 PM eastern). CSD is issued on the 1st of each month as it has been since October 01, 1979; the 'birth' of the TVRO industry. CSD/2 is issued on the 15th of each month. CSD + CSD/2 are inseparable for domestic US subscriptions although CSD is available alone for subscribers outside of the USA. Subscription rates are \$75 per year for US zip-coded addresses, \$85 per year (US funds) for Canada and Mexico addresses and \$100 per year (in US funds) elsewhere. All copies are sent worldwide via AIRmail. West Indies Video is a 'Pioneer/Dealer Class Member' of SPACE, the international trade association of the TVRO industry. CSD is copyright 1985 © by Robert B., Susan T., Kevin P. and Tasha A. Cooper.

**Introducing  
the six-foot dish  
that's getting  
great reception.  
Even from skeptics.**



SpaceMate™ is changing a lot of people's minds about the practicality of a six-foot satellite dish.

Over \$1-million have been invested in the technology behind SpaceMate—and the result is a dish that, with the proper electronics, provides exceptional video reception from any C-band satellite.

SpaceMate has been engineered for convenience. Its seven-piece dish and unique polar mount fit into two compact boxes that simplify storage and are UPS-shippable. Plus SpaceMate's size makes it easier to handle, reducing the man-hours required for installation.

In addition, SpaceMate has been designed for maximum consumer acceptance, with a "see-through" construction and ebony color that reduces its visual impact regardless of the surrounding terrain.

And SpaceMate is available for immediate delivery.

If you're one of those skeptics who thought you'd never be satisfied with the performance of a six-foot dish, why not get more details, or even a free demonstration? Distributors contact THE STOLLE CORPORATION, a subsidiary of Aluminum Company of America, 1501 Michigan Street, P.O. Box 221, Sidney, OH 45365. Phone: 1-800-556-3203



Feedhorn not included.

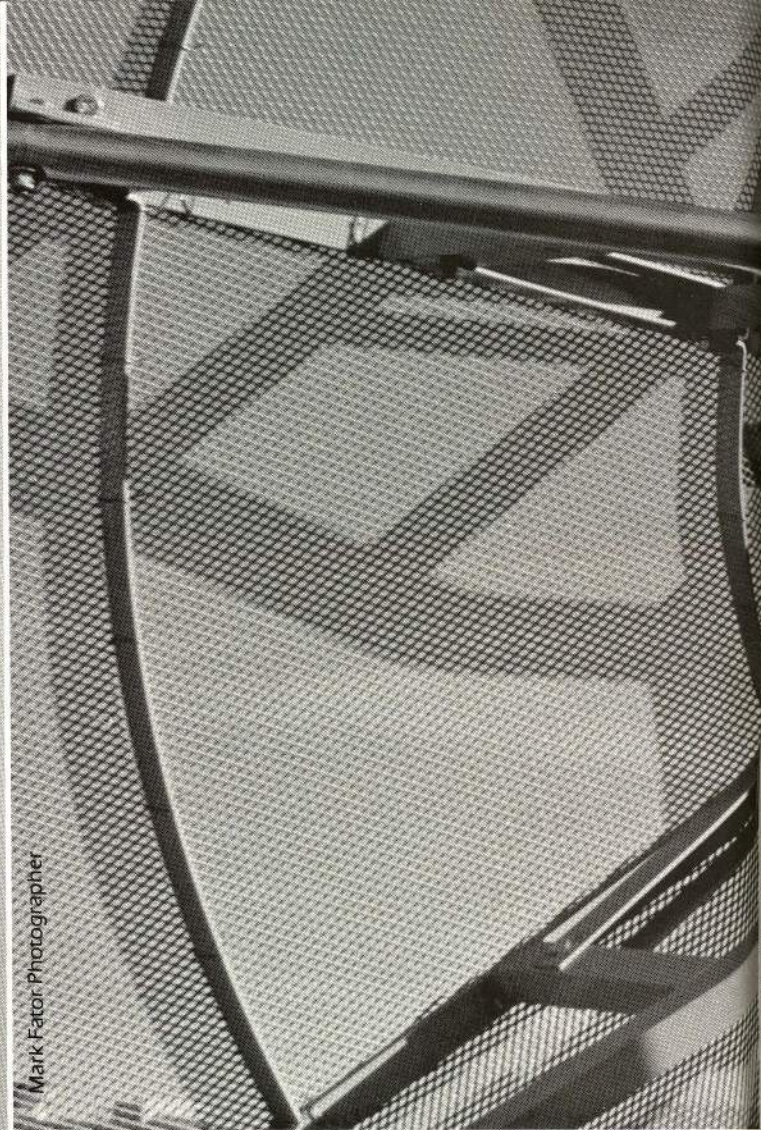
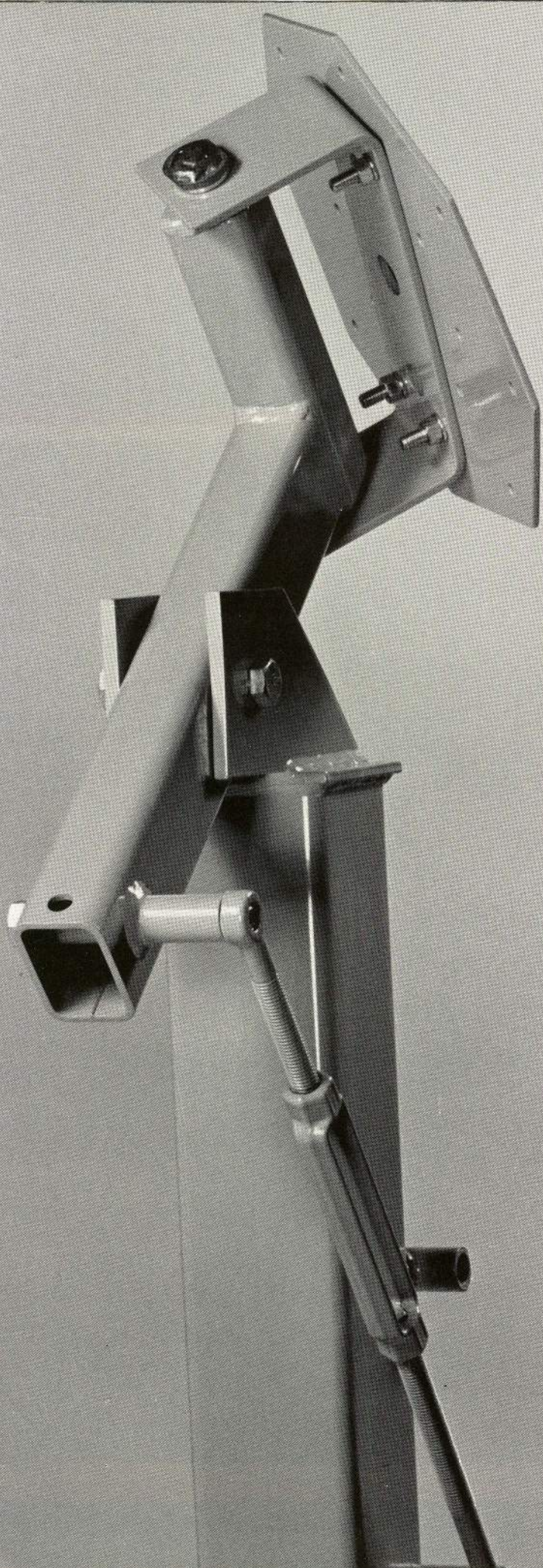

Mark Fator: Photographer

## PRECISION TO A T

Introducing the Latest Reason  
to Choose Paracclipse:  
**Our New Single Post Polar T Mount.**

Our new polar T mount has been precision engineered to yield greater strength and stability. We've eliminated the "slop" so your customers can enjoy smooth, easy operation and improved accuracy. And like its predecessor, the polar L mount, it is made of powder-coated steel so it is protected from the elements.

Improved accuracy, greater stability, and longer life. Three more high performance promises from Paracclipse.

# Paracclipse

HIGH PERFORMANCE  
SATELLITE TELEVISION SYSTEMS

Paracclipse Inc. 3711 Meadowview Drive  
Redding, California 96002 (916) 365-9131

Copyright 1985 Paracclipse Inc.

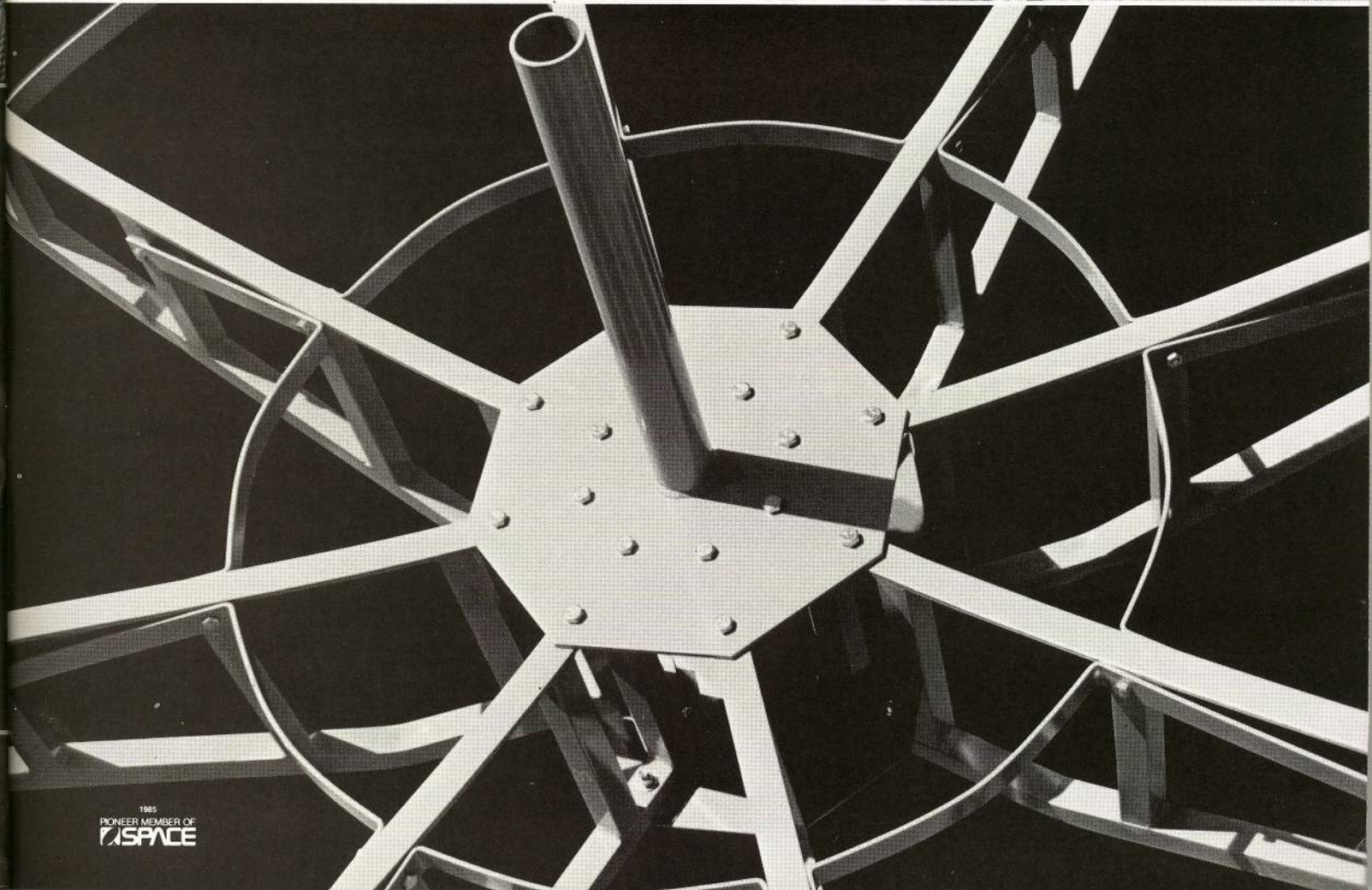
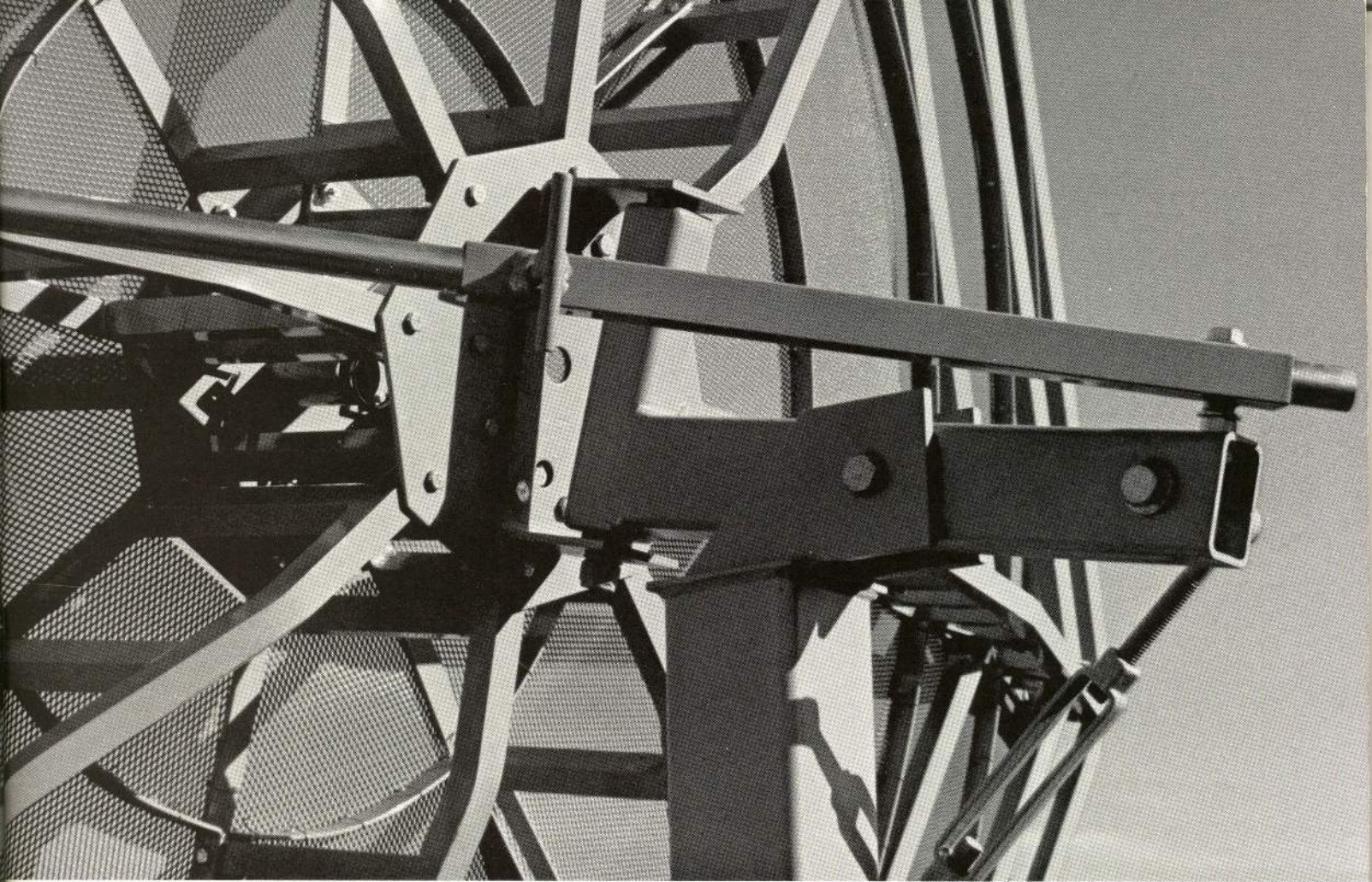



**COOP'S  
SATELLITE  
COMMENT**

- SENDING Turner \$25
- CONSUMER Magazine 'Battle'
- DX Advantage Plan

#### TURNER Wants Bucks

Under the master plan outlined in the 'Satellite Viewing Rights Act' adopted last fall by Congress, (cable) programmers can collect money by doing **either** of two things:

- 1) **Scrambling** their transmissions, and then entering into a marketing plan for descramblers (and the programming 'software'), or,
- 2) By announcing a **'marketing plan'** for unscrambled services and creating some marketing framework to accept money for the unscrambled service(s).

The concept of the latter segment of the law was that scrambling might not be mandatory to achieve payment for cable programming if the users, the home TVRO viewers, would respond with reasonable honesty and 'turn themselves in' by paying on a sort of voluntary basis. Both plans, scrambled or not scrambled, are subject to possible court or even FCC review of the per-service charges and if the rates set for scrambled or unscrambled 'service marketing' are found to be out of line, there is at least the probability that some adjustments (perhaps court mandated) could be achieved.

The 'voluntary payment' aspect of the 1984 law has received little attention to date. It is rather nebulously stated in the law and its actual implementation depends to a large extent on the fine tuning administered by any programmer electing this course. Here is how Ted Turner wants you to pay him for CNN and CNN/2.

- 1) The fee is **\$25 per year**. For both services.
- 2) The money, in check or money order form, should be sent to Turner Broadcasting Service (1). That gives you the legal right to tune in and use these services. This does **not cover** WTBS since Turner does not actually 'own' the WTBS satellite rights; they belong to a common carrier company disassociated from Turner. The common carrier has not yet made an announcement concerning WTBS.
- 3) If Turner's announced plans are followed, he will be springing with significant advertisements in our industry's **programming trade press** shortly, telling home TVRO viewers that they are required (by law), after reading the advertisement/notice to send \$25 to TBS (Turner Broadcasting Service).

#### And if you don't?

A marketing representative from TBS has been quoted as warning TVRO dealers and others that if they walk into a store and find you tuning in either CNN or CNN/2 without some evidence that you have paid for the services, they will instigate legal proceedings against you. Since anyone walking in the door could be a representative from TBS, certainly the prudent thing to do would be to pay as requested, **when you actually see** the formal announcements in the guide publications. Yes, being 'sued' for non-payment could be nasty and expensive. Certainly TBS will be looking for several people who have not paid, to make 'examples' of them, perhaps 30 to 60 days after they

announce formally their request for payment. I'd not want to be one of those used as an example.

From a practical standpoint, let's review where this places us.

**First, \$25 a year.** That's slightly more than a dollar a month for each service. I haven't heard them offer to split the services so you pay \$12.50 for only one yet and I doubt they will because of the logistics of keeping track of who has paid for which one. And that works out to around 3.3 cents per day for CNN and the same for CNN/2. Cable operators pay less, typically around 18 cents per month rather than a dollar per month. We might build a case for excessive charging here and undoubtedly someone will try to do that; not because Turner doesn't deserve \$1 a home a month, but more because this establishes a 'pricing precedent' which other services are bound to follow. If we had 20 services such as CNN charging us \$1 a month, we'd end up with our TVRO customers paying \$20 a month **before** they elected a few of the premium channels. At the HBO quoted \$12.95 a month, a home would get to over \$50 a month before it got to its third premium channel. I'm not sure these are market-viable numbers.

The industry, through SPACE, has been telling the world since 1979 that **"We are willing to pay for programming services"**. We have told this message to Congress so many times that they believe it. Now that we have our foot firmly implanted in our mouth, the time has come for us to 'prove' that we meant this. Which brings us back to the 'how-much-do-we-pay' argument.

While Turner managed to get plenty of free press coverage for his TBS announcement, at least one other service has also announced in a quiet way that they also want money. **ESPN** has been running an announcement slide which says that we are to pay **\$19.95 per year** for their single channel of service. The announcement slide and audio with it tells us that by paying up front, now, we will gain some unexplained 'position' in the list to obtain real-world descramblers when they are available. I doubt anyone in ESPN's legal department saw this copy before it was aired on the network (first seen at midnight on June 26). **ESPN is in no position to guarantee nor promise** anyone that by sending them \$19.95 'now', the person sending in the money will be gaining any type of preferential treatment for descrambler delivery. Not unless ESPN intends to manufacture and market its own proprietary descrambler unit. And that is highly unlikely, possibly even illegal.

So into the ongoing confusion over scrambling we have **three channels** now asking a total of **\$44.95 per year** or \$14.98 each per year or \$1.25 each per month. And if ESPN follows the lead taken by TBS, they will also be showing up in programming guides with an announcement and warning that failure to pay will be cause for legal action.

#### What should you, the dealer, do?

First of all, protect your own shop as soon as you see the programming guide announcements. You don't want to be singled out for failure to pay when you could be nabbed so easily by someone posing as an interested consumer walking in your door. However, on my check(s) I am writing in the lower left corner the following phrase:

**"Paid with protest of excessive rates"**.

\*1/ TBS will provide a correct mailing address **when** they announce their program in consumer guides. Any address we might pass along to you, in advance of their announcement, could be the wrong 'mail slot' for TBS and cause the checks to be mis-directed. Just wait until you see the formal announcement.



# SKYBEAM™

“THE STANDARD”

5 Year Warranty

## JUST COMPARE

It's as simple as that. When you do, you'll see why the Skybeam™ ten foot steel mesh antenna is, without a doubt, the standard in the industry by which low cost, high efficient dishes of this type are judged.

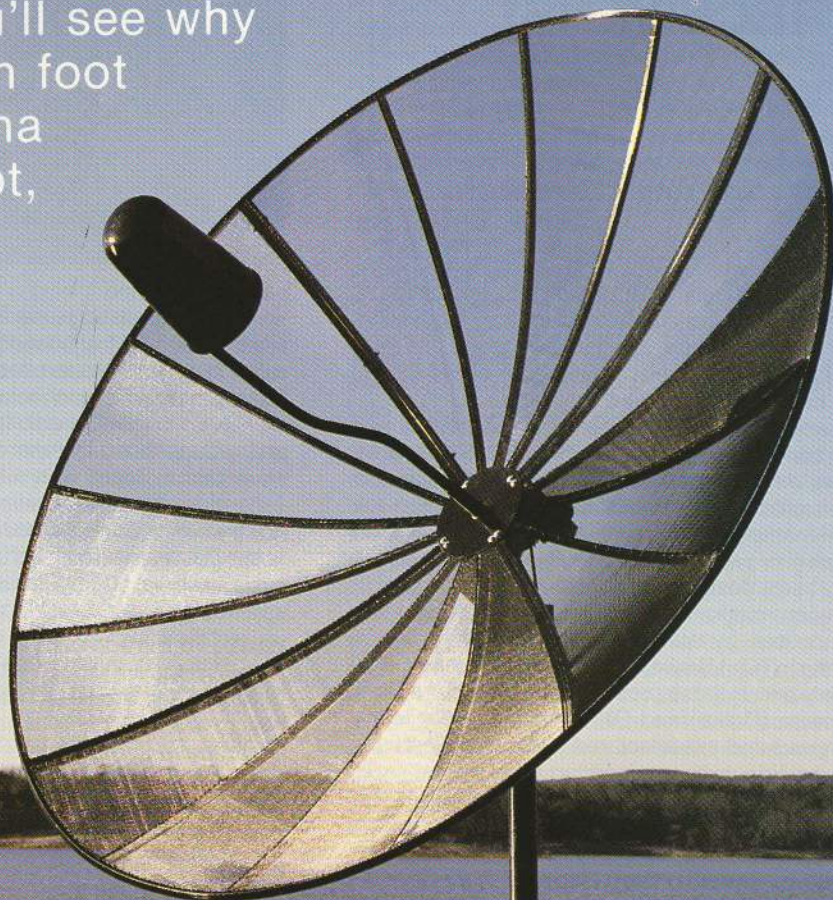

**INSIST ON  
THE ORIGINAL SKYBEAM™  
ANTENNA, THERE IS A  
DIFFERENCE!**

- 10 Foot Diameter
- .4 F/D Ratio
- 4 Piece
- 40.2 DB Gain  
(DOCUMENTED)

## MOUNT OPTIONS

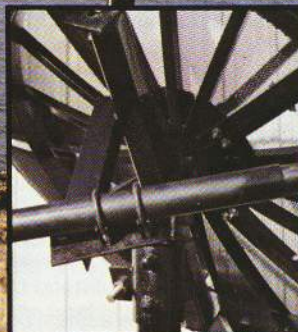

RING STYLE MOUNT



WORM GEAR DRIVEN  
HORIZON TO HORIZON MOUNT

R & W Antenna Technology, Inc.  
P.O. Box 171 • Quitman, Arkansas 72131  
1-501-589-2214 or 1-501-589-3515

## BEST OF JAPAN (RECEIVERS)

### THE BEST Of The Best

Four recently introduced TVRO receivers, originating in Japan, have attracted uncommon interest for their innovation, styling, and performance. From 'me-too' designs of one year ago, the 'best of Japan' has taken on a new look of 'we are the innovators . . . catch us if you can'.

The TVRO world has become extremely competitive and no place is that competition more evident than in the receiver portion of the system. The 'best of Japan' highlights a diverse set of hardware created to establish the domination in the North American marketplace of products not only assembled and manufactured in Japan, but with one exception (in the examples cited here) designed also exclusively in Japan.

The most recent marketing studies suggest that the four top receiver suppliers, by volume, in North America are (in alphabetical order): (R.L.) Drake, DX Antenna Company, STS and Uniden. Only one of those products is manufactured with a primary US base (Drake) and DX and Uniden are totally Japanese designed and manufactured. STS represents the US firm which has done its engineering here but taken its products off-shore for production.

The four receivers we will look at in this series represent four separate approaches to Japanese design and technology. In many cases, the end result comes out about equal although as we shall see, not always. We have chosen the top-end or top-of-the-line products from (again, in alphabetical order): **DX Antenna Company** (the DSB 700 receiver), **Panasonic** (C-2000), **Uniden** (7000) and the **USS/Maspro SR-3**. These four products will be studied for features and marketing philosophy and their overall contribution to both the 'excitement level of the industry' as well as their niche they have created or are expected to create in the ultimate marketplace of this fall selling season.

### REMOTES Are In

All four receivers have remote control; three use infrared, one UHF radio. Two of the products have full antenna positioner interfacing control built in and one of these units incorporates the antenna positioner control system totally within the receiver proper. The two, that 'do not' include the antenna positioner control **within the receiver, interface to companion units** (also available) which 'talk to' the receiver proper as if they were one.

Each of the four designs believes it is the easiest consumer package to operate in the field today. Each believes that the consumer wants full remote control over every receiver function without having to get up and touch the receiver proper. Each believes the consumer is willing to pay top dollar for that

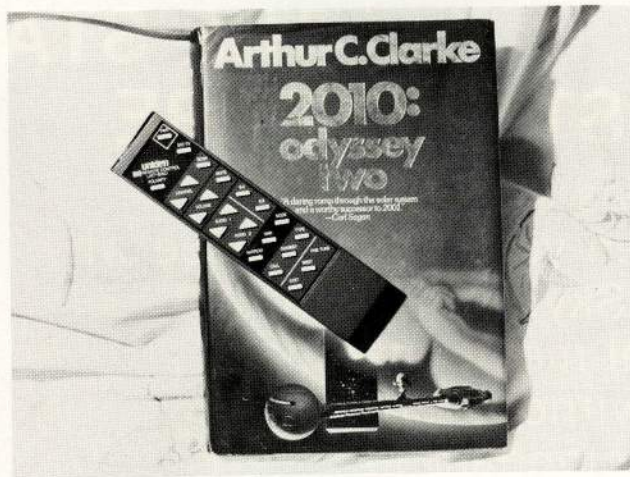

ease of operation.

On screen displays are also 'in'; from simplistic messages that translate the transponder chosen with an on-screen bright color, to a full on-screen 'report' to the user of the condition of his system down to and including the position of the antenna.

"Mute on tune" is also in; gone are those annoying 'hiss' and 'groans' when the user is switching channels or re-tuning the audio; replaced with the -60 dBm sound of silence.

And in at least one model included in this report, the nightmares associated with installation of the receiver/controller/actuator portions of the system have been carefully considered; an attempt, as it were, to make the more complex systems not only 'user friendly' but 'installer friendly' as well.

### WHEN To Introduce?

Most industry groups within the consumer electronics field have adopted a dual technique for the release of innovative, new products. Most of these new product introductions are built around the two major shows in consumer electronics; CES each January and CES (2) each June. Manufacturers such as Sony have learned that they can 'tease' in January and 'display' in June; with their new-product production schedules timed to coincide with the traditional fall/holiday selling seasons.

TVRO is different. Slightly.

**TVRO has two major shows per year;** in February/March and in early September. The dates were chosen by the show creators, not by the industry's suppliers and perhaps if it could be re-done the whole process would be re-structured. Here's why.

Major consumer electronic pieces have relatively long lead times. TVRO receiver electronics face the same sort of problems; working, hand-crafted proto-types shown in January can be in early production runs (involving small quantities) by June. But full scale production will usually be in August. And that happens to work out for the large sales hump that comes on line starting around September 1st. Ideally, that would involve a pair of shows timed more or less with the same dates chosen for CES: January for show-and-tell, June for hard-order writing.

With hard orders in hand, this allows the manufacturers to properly schedule production quantities to coincide then with the significant sales bubble that occurs in the fall. **A manufacturer needs that 90 days** from early June to early September (when big deliveries should begin) to crank into his production schedule the order input gathered at a show scheduled in late May or early June.

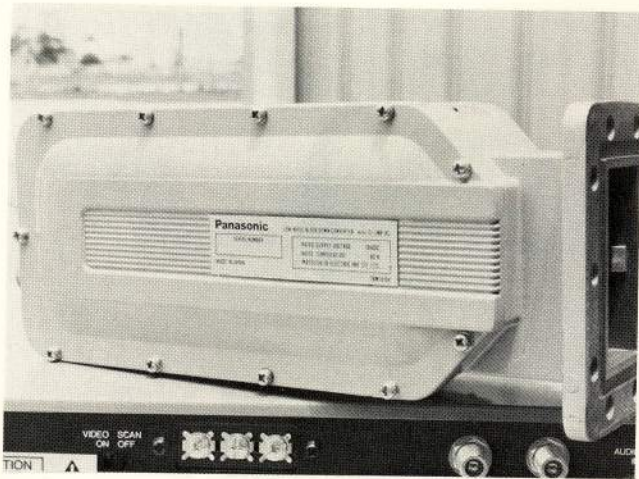

With an annual February/March show, and another annual early September show, the TVRO world is 'tilted' away from both the major selling season **and** the reasonable lead times the large scale producers of hardware need to be ready for the fall selling season. New products introduced in February/March can certainly be shown in early production form by September 1st, but that allows no time for the products to turn from small scale production to volume production to meet **that fall's** order rush. And this has caused a considerable amount of confusion, and produced a less than organized 'year' for the producers who would like to make their new product announcements and order taking phases coincide with the needs of the marketplace. It leads to the premature introduction of products at the September show; products not backed up by adequate production resources, as we have seen in years' past.

All of this also interplays on the poor distributor who is caught in the middle. With no 'organized', universal 'new production introduction window', distributors are often caught with inventories of established products which do not match the sales curves of the industry. A distributor caught with a warehouse of 1985 model receivers in September, 'semi-surprised' by the showing of 1986 models at the September trade show, must wrestle with dealers who are holding out for the 1986 models even though the '86s may not be available (or in quantity) until the fall selling season is virtually over. For these reasons and more, the industry has never been able to focus on and adopt anything approaching a universal 'product introduction' and 'product availability' window. And the four products to be studied here are no exception.

The **DX DSB-700**, the oldest design in the quartet, first appeared in quantity at our Nashville show in September of 1984. The unit proved more popular than DX had anticipated and the firm ran in a significant backorder status through the fall of 1984 selling season. The **Uniden 7000** and the **Panasonic C-2000** were first shown to TVRO dealers at the March/April Las Vegas show. Both were close to volume delivery by the show although Uniden would be into May before they could reach the shipping levels required by their distributors (and even today, the unit is running on a backorder status). The **USS/Maspro SR-3** was first shown to dealers at the June Tulsa show and it will be hard pressed to be available in the volumes required by the September show in Nashville.

All of this points up some of the major problems faced by equipment OEMs who are faced with not only the design problems but **the marketing and timing problems** that go

with the introduction of any significant new products in our field. And your own 'better understanding' of these problems, from the discussion here, will perhaps make you more tolerant (if not more agreeable) with the problems you face getting delivery on a 'hot, new' item in the industry.

#### EACH Tested

Although we are not approaching this three-part series as an equipment evaluation or review, some discussion of the actual operating performance of the four units cited here will appear. In our concluding part, we'll do side-by-side comparisons for the four units looking at overall video and audio performance. To do this, we have gone into the marketplace (with one exception; the SR-3 which is too new to be in the marketplace and was therefore only available directly from the manufacturer/designer) to openly acquire the units for test.

#### UNIDEN UST-7000

The UST-7000, like all four of the units to be considered, is a 950-1450 MHz block downconversion unit. This simply means that with the appropriate frequency range signal splitters, amplifiers and tap-off units, two or more receivers can share a single satellite antenna equipped with either a switchable polarization system, or, dual polarization and a pair of LNB (or LNA plus downconverter) units.

The UST-700 is designed to interface with a companion motor drive, the **UST 705 actuator** which is available with its own 'power supply'; the **UST 750**. Uniden has chosen to create a totally separate power supply for the motor drive system; a consideration that involves moving the considerable 'heat generation' associated with a 36 VDC, 4 to 8 amp power supply out of the receiver housing largely to protect the receiver components from unwanted heat buildup. And there is one other reason why the drive power supply might be separated from the receiver; not every dish sold has a drive and to 'burden' the price of the receiver with a receiver power supply capable of handling the drive would make non-drive systems cost more, for no benefits. In the real world, most systems now have drives and certainly those that sell in the 'high end' (as do all four receivers described here) have drives as part of the package.

Interfacing, between the 750 power supply and the 7000 receiver is through a factory supplied cable (16' in length for hiding the power supply out of the way). The cable provides a 'talking line' between the commands received from the IR handheld unit and the antenna through the 750 power supply and its five wire cabling that connects the power supply to the 705 actuator. For short runs, relatively lightweight wire (#18) is suggested (up to 125 feet, which covers the majority of installations) but larger diameter power cable (two leads out of five between actuator and supply) can extend the permissible distances to more than 200 feet.

The 7000 receiver allows the user to control all receiver and dish movement functions from the infrared (IR) handheld, or from the front panel of the receiver. The dish is 'walked through the arc' from furthest west to furthest east a bird at a time and as each satellite location is fine tuned for best picture (or better yet, signal level using a device such as the Squawker or Tweaker II) the position is 'locked' into memory in a two-step operation.

On the front of the 7000 is an LED display which combines a number of display features; including the name or designator for the satellites. In permanent memory are the various satellite designators and a range of numbers so the individual satellites can be identified in the programming process by their proper name and number (**W3** for **Westar 3**, for example). This

is an important installation process since the customer will 'recall' the satellites by name with the IR handheld or with the receiver front panel buttons. The 7000 has a 'fast scan' button on the front of the receiver proper, and a 'slow scan' button on the IR unit. The theory is that the user will use the fast scan button when searching for new satellites or aligning the antenna (not an everyday occurrence) while the slow scan button allows each program to be 'sampled' in normal use; a sort of "Let's see what's on (name of bird)" exercise.

Programming the 7000 is rapid and in about five minutes time each of the various satellites are stored in memory (assuming the dish tracking has been completed previously). To recall a satellite, from memory, there are two buttons on the IR unit; one to select the desired satellite family (i.e. W for Westar) and another to select the desired satellite (by number, such as W4). With the selection selected, and the front panel LED indicator telling you which bird has been selected, you push a third button marked 'call' and that starts the dish moving to the memorized position of that satellite.

Transponder number and audio is set in much the same way. LED displays tell you that you have selected transponder 12 (for example) and which audio frequency (6.20 for example). A vertical/horizontal (or in a sense, format, button) selects the appropriate feed polarization.

The 7000 offers mono audio, matrix stereo audio and discrete stereo audio. Both 6.2 and 6.8 (mono) audio have IR pre-set buttons so the user can select either of these two common audio sub-carrier channels with a stroke on a marked button. Tuning in discrete or matrix audio requires programming the sub-carrier tuning by using 'toggle buttons' on the IR unit; there are separate buttons for moving the audio sub-carrier frequency up or down for each of the two audio channels. The LED display reads out the frequency as you 'toggle' through the spectrum so the user can quickly see and know when he or she has arrived at a desired sub-carrier frequency.

The front of the 7000 is a virtual Christmas Tree display of LEDs, lights and indicators of the receiver's actual settings. All of these user aids are grouped on the left hand side of the unit's front panel while behind the right hand side of the panel, through a hinged door, are various setup buttons such as initially naming the satellites. There is one well thought out routine involved here; while we all wish and hope that actuators always return to precisely the right location at all times, in truth there is the need to touch up antenna positioning from time to time. Once a satellite is in memory and 'locked' in memory, the 7000 provides a  $\pm 10$  (LED numerical count) fine tuning range. On the receiver proper, and on the IR handheld are 'east' and 'west' buttons which the user can initiate to cause the dish to look slightly away from the memorized/locked position by approximately 3/10ths of an inch (in actuator arm travel).

The receiver and the IR handheld give the user just about every possible control option available in home systems today. Because the receiver is a 950-1450 MHz block system, two other considerations require attention:

- 1) **Terrestrial interference**, not easily cured with many receivers in the block configuration, is handled through an external 70 MHz loop which appears on the back of the receiver. In effect, the 950-1450 MHz block IF is further reduced to 70 MHz within the 7000 receiver and this 70 MHz signal is brought out to an 'F' fitting. This allows the receiver installer to insert external TI traps or filters then loop back into a second 70 MHz fitting on the same rear apron. When no filter or trap is in use, a jumper connects the two fittings together.

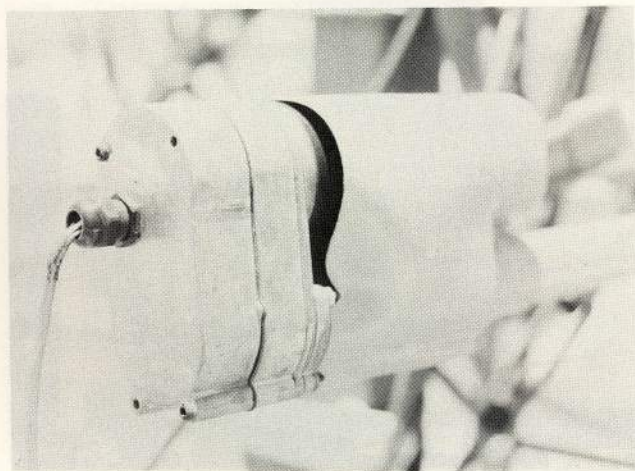

UNIDEN UST 705 actuator is powered by its own 36 VDC power supply which can be up to 16 feet from the receiver proper. Connection to the receiver also interfaces the actuator controls to the IR handheld unit.

- 2) One of the advantages to any block system is **the ability to share** two or more separate TV receiver locations with the same antenna and outdoor electronics. The 7000 provides connections for powering line amplifier electronics as well as operating with an antenna equipped with either two separate LNAs (through an ortho-mode or dual pole feed) or a single LNA and polarization selection probe. Uniden clearly suggests that in such multiple receiver applications, the installer select the two-LNA (one per polarity) approach, using Uniden accessories (signal splitters and model **UST 502** vertical and horizontal switches, driven by the individual receiver vertical and horizontal selection buttons).

#### UNIQUE Design

The Uniden 5000/6000/7000 receivers have one other 'feature' going for them which no other TVRO receiver can claim; now or ever. **Doctor Yoshihiro Konishi**, President of Uniden Satellite Technology (see front cover, this issue of **CSD**). Doctor Konishi made his mark in the microwave world

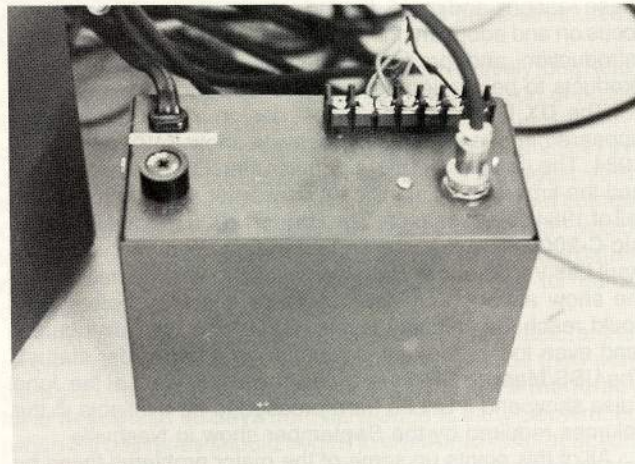

UNIDEN UST 750 power supply is the companion piece to the 705 actuator.

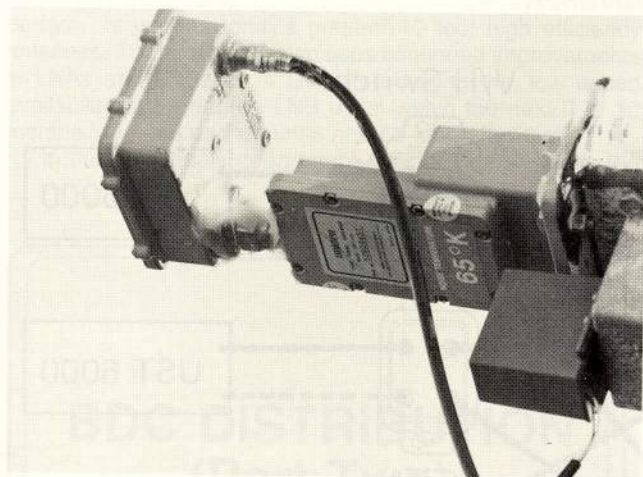

UST 550 block downconverter plus Uniden low noise amplifier (LNA) is typical configuration for outdoor electronics with the UST 7000 receiver. Doctor Konishi forecasts 45 degree LNB units within foreseeable future.

as 'Mr. 12 Gig-A-Hertz' a decade ago. At the time he was Chief Scientist for the prestigious Japanese national network, NHK. His assignment was to create a 12 GHz or Ku band satellite microwave receiver. NHK, farsighted as usual, saw a day coming (although it would turn out not to be soon) where direct broadcasts, from satellites, would be commonplace worldwide; NHK wanted to solve the 'receiver cost problem'. At the time, as Doctor Konishi recalls, you could buy 12 GHz microwave (video) receivers but the price was high; upwards of \$10,000 (US) each. He, and NHK, saw little hope that receivers such as this would help an international DBS service get off the ground.

There was another factor as well. The \$10,000 (+) receivers were not sensitive enough for the planned DBS power (satellite EIRP) levels. In fact, their 18 dB noise figures (many thousands degrees Kelvin!) were far out of line with early DBS planning.

Doctor Konishi created something called the 'Planar Waveguide Receiver'. The electronic world promptly 'rewarded' him by re-naming it 'The Konishi Receiver' and an even larger world rewarded him by using his receiver design as a 'basis' for an international DBS service.

The Konishi (12 GHz) receiver was a significant breakthrough. Low cost (\$100 each in quantity OEM cost), very mass produceable, and best of all, far more sensitive than other existing receivers (4 dB noise figure).

It was the Doctor's receiver system which the nations of the world used to formulate, on paper, the DBS service at the 1979 World Administrative Radio Conference (WARC). By combining this receiver system with 2 foot dishes at Ku band, the planners backed into a worldwide adoption of 200 to 250 watt DBS power transmitters in the sky. Everything done with DBS, on paper or in labs since 1979, has followed this plan.

Well, as any 4 GHz installer knows, in the interim ten years the 'DBS world' has turned over several times. First of all, we have a 4 GHz 'DBS' which nobody but a handful of crazy Americans envisioned back in 1979. We also have GaAs-FETs that work well, have low noise figures, and sell cheap at 12 GHz. The Konishi Receiver used **no pre-amplification** at 12 GHz at all; that 4 dB noise figure was achieved with just a highly tuned, low-loss mixer stage at the waveguide entrance

from the feed!

So with the creation of low noise GaAs-FET pre-amplifiers, now married to the 1975 era Konishi receiver circuit, the 1985-version DBS planners have been able to scale down planned DBS power levels from 200 watts (+) to the 50 to 100 watt level. 12 GHz DBS still looks years away to most, but at least now it is headed in a more common sense direction.

When Doctor Konishi became the President of Uniden Satellite Technology in the fall of 1983, he brought with him a reputation and a set of talents which could not be matched by the Uniden competition. The Uniden 5000/6000/7000 receivers are the first created under Doctor Konishi.

Appearing on BORESIGHT August 8th and 15th (1), Doctor Konishi explains two of his 'immediate attentions' given to his design work for the latest series of Uniden receivers.

Limiter circuits are of special concern to him.

"**Most TVRO receivers create limiters** which are measured and designed around the assumption that there is 30% amplitude modulation (mixed with the normal satellite frequency modulation). I believe this is a mistake. I prefer to use hard limiting, and to test and design using 90 to 100% amplitude modulation; for this reason. The presence of amplitude variations is most concerning when the (FM) signal is at or below threshold. Above threshold, the signal to noise ratio is so good that the amplitude variations present do not cause picture degradation, usually. But at threshold and below, **the noise** is pure amplitude varied. This is where the receiver must have limiting which is designed around 90 to 100% amplitude variation.

"**The hard limiting** should work hardest and best at and below threshold, and the designer must assume 90 to 100% amplitude modulation equivalent because the random noise is amplitude varied and it is that low signal to noise ratio which causes the noise portion to modulate or vary the picture stability."

Another important consideration for Doctor Konishi has been **the clamping circuits** in the Uniden receivers. As he points out on BORESIGHT, most receivers employ a clamp which consists of either a single diode or a pair of diodes. He suggests that a lack of 'hard clamping' causes the vertical synchronization signal(s) to fold back over with the energy dispersal waveform (the clamp is designed to remove the energy dispersal waveform).

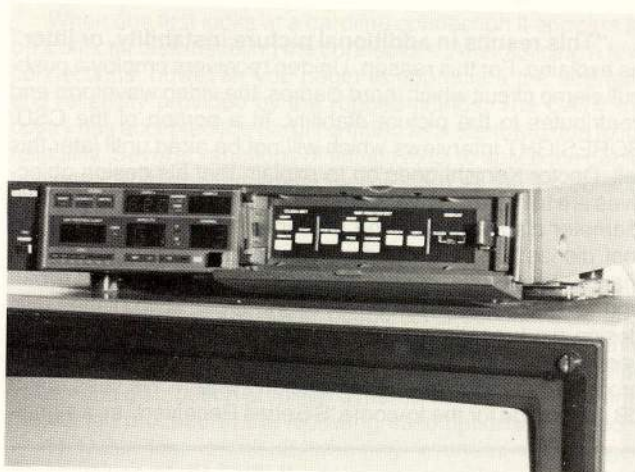

UNIDEN UST 7000 receiver has operational readouts grouped on left, front of panel and setup controls hidden behind recessed and hinged door on right.

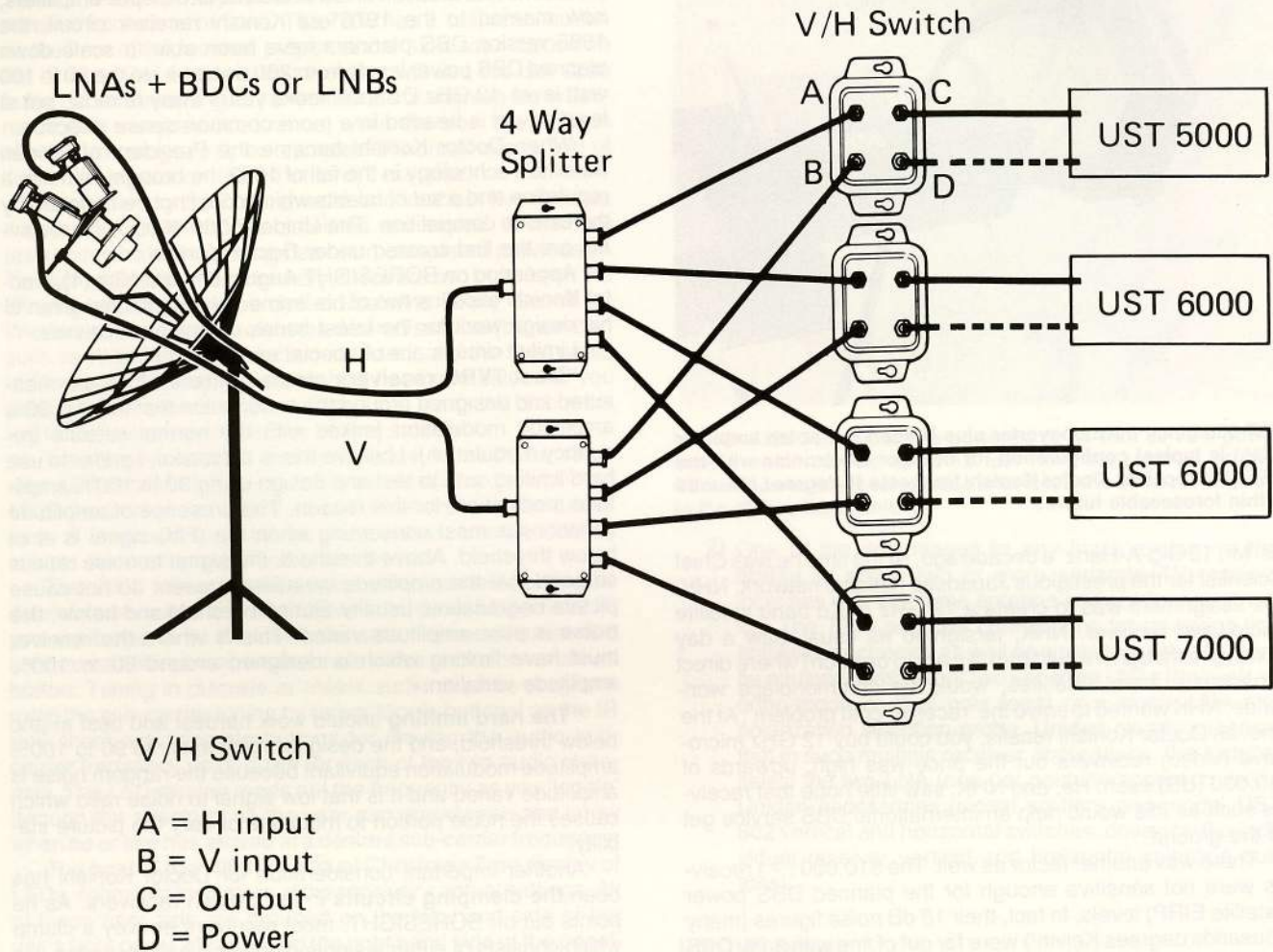

**SHARED RECEIVER SYSTEM/** Uniden UST series family package depicted here has four separate receivers each with independent selection of either vertical or horizontal polarized signals through cross-strapped splitters and model 502 horizontal/vertical switches fed by dual LNAs and ortho-mode dual pole feed. (Drawing courtesy of Uniden Corporation of America).

"This results in additional picture instability, or jitter" he explains. For this reason, Uniden receivers employ a push-pull clamp circuit which 'hard clamps' the video waveform and contributes to the picture stability. In a portion of the CSD/BORESIGHT interviews which will not be aired until later this fall, Doctor Konishi goes on to explain that his design objectives are to have receivers which will perform with 5 and 6 foot diameter dishes just as the present perform with 10 and 11 foot dishes. He, and Uniden, believe strongly in the urban marketplace for TVRO but recognize the limitations of urban and suburban backyards to absorb larger style dishes. His design work continues in this area and he hints that an 'S version' receiver will be announced which incorporates a proprietary '2 dB threshold extension system'. He sees that 2 dB advantage for the to-come 'S Series Receivers' as a signifi-

1/ BORESIGHT TVRO Magazine is telecast each Thursday evening at 9PM eastern time on Satcom F4, transponder 20 as a service to the TVRO dealers, distributors and OEMs.

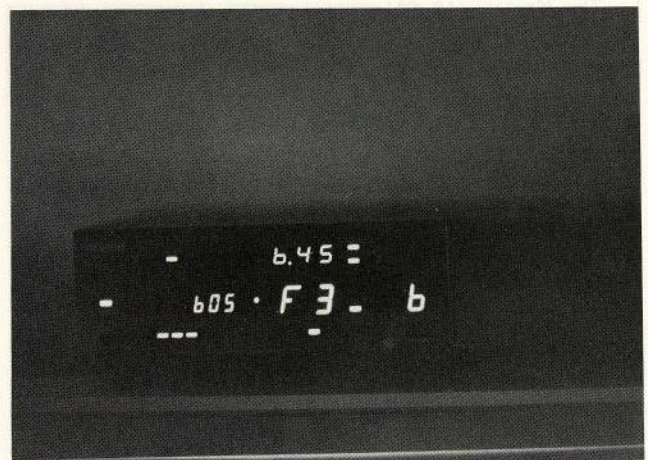

**LED DISPLAY** tells user where he is, what he is tuned to, and what the receiver's internal circuits are doing.

cant ingredient leading towards 5 and 6 foot dish systems that perform as well as today's present 10 foot high efficiency antennas. Doctor Konishi also sees continued improvements in LNAs and LNBs for 4 GHz, forecasting the 'low priced availability of 55 degree LNB units' within the next 9 to 12 months, and, '45 degree units not too long after that'.

In the credentials department, Doctor Konishi leads the

pack and while many other firms may have innovative engineers with good concepts and circuits, Uniden would appear to have at least a 'psychological edge' on most of the competition with Doctor Konishi in charge.

We'll continue this series in **CSD/2** for **August 15th** with a look at the Panasonic C-2000 receiver package.

## BDC DISTRIBUTION (Part Two)

### SYSTEM Design

The "block" receiver popularity has grown and now most block receivers either operate in the 450 MHz to 950 MHz band or the 950 MHz to 1450 MHz band. Multiple block receivers may be "networked" to a single antenna by providing each with the block downconverted satellite signals.

In part one (\*), the factors controlling the headend signal quality were discussed. It was shown that a quality **BDC Headend** will produce a 'flat,' clean, output of 50 dBmV per transponder. The distribution network for the high frequency signals must be designed to deliver each receiver in the network the same quality of signal as received at the antenna.

In part II of **BDC DISTRIBUTION NETWORKS**, multiple receiver cable "network" design will be discussed for the 450 MHz to 950 MHz band.

### HEADEND Selection

Placement of the antenna and the associated headend

\*/ Part one appeared in CSD for May 1st.

**Engineer David Lantz** writes about the distribution segment of the 439/930 MHz block downconversion system in an 'SMATV environment' where individual system viewing locations are equipped with BDC receivers over a relatively wide area. Lantz first wrote about the headend design in **CSD** for May 1st. His firm plans complex BDC distribution systems for installers and OEMs from coast to coast and he has been a pioneer in the field of marrying cable television technology, usually practiced at frequencies below 400 MHz, and satellite master distribution systems.

by  
**David L. Lantz**  
Network Communication Services  
16134 128th Ave. S.E.  
Renton, Wa. 98055  
(206/271-5636)

electronics is frequently beyond the control of the system designer. If there is some flexibility the dealer should try to locate the antenna near **the center** of the distribution system and nearby a building that can be used to house the headend electronics. The headend electronics for BDC Distribution Networks easily fits in standard CATV apartment boxes (see part 1). When a convenient indoor location is unavailable, the 'apartment box' may be mounted directly to the back of the antenna provided AC power is made available.

Microwave interference should also be considered when placing the antenna. The dealer should take advantage of existing structures to shield the antenna from possible interfering signals. A site survey using a portable dish will identify possible interference.

### TRUNK Cable Routing

Practical limitations such as sidewalks and driveways should be considered before planning the cable routing. When working with new housing construction projects it is often convenient to place the TV trunk cable or conduit in the utility easement trenches.

An efficient cable design would provide for as many **equal length** "feeder" trunks as possible. More distance can be covered by splitting the signal into multiple "**feeder trunks**" than running long, snaking trunk lines. The CATV industry rates system efficiency by the Feeder-to-Trunk ratio. A system that has 500 feet of main trunk and 500 feet of feeder trunk would have an F/T ratio of one. A system that has 100 feet of main trunk and 500 feet of feeder trunk would have an F/T ratio of five and would be more efficient.

The reliability and low loss characteristics of aluminum hardline cable make it the practical trunk cable. The commonly available 0.500 inch diameter flooded direct burial P-3 cable will be used in each of the examples. This cable has a loss of 2.6 dB per 100 feet at 950 MHz.

When one first looks at a hardline connection it appears to be a difficult task installing the connectors. After splicing a few connections, however, you begin to appreciate the strength and reliability provided by the rugged fittings. The CATV industry has accepted the hardline fitting as a standard due to its reliability. Several variations of fittings exist to splice the cable to cable, cable to a threaded chassis such as the TX 50-950 tap, or cable to "F" fitting (**figure 1**).

### TRUNK Cable Plant Design

The design method recommended quickly calculates trunk cable requirements, value and location of directional taps, and the location of trunk amplifiers. The design can be greatly simplified if one defines the available directional coupler values and distribution amplifier dynamic range. In simplifying the design procedure, the following assumptions are used:

- 1) Cable loss is calculated using "rounded up" integer values of dB / 100 ft.

BDC DISTRIBUTION/ continues page 16



MASTER DISTRIBUTOR FOR:

# The First Name In HOME SATELLITE TV...

- ANDERSON
- ATV RESEARCH
- BOMAN
- CALIFORNIA AMPLIFIER
- CHAPARRAL
- DEXCEL
- DRACO
- DRAKE
- DX ANTENNA
- GENERAL SATELLITE
- TRACKER
- JANIEL
- NEWTON
- PROSAT
- SAT-PAK
- STARDUSTER
- STS
- TWEAKER
- UNIDEN

To become a Delta Satellite dealer call today.

ONE ECHO PLAZA • CEDARBURG, WISCONSIN • 53012

TOLL FREE NATIONAL: 800-558-5582 • TOLL FREE WISCONSIN: 800-242-2290 • LOCAL: 414-375-1000

TELEX: 25886 / ANS BK 26886 CEDA • CABLE: DELTA SAT



# COMPLETE SYSTEMS FROM DELTA

## STS

The MBS-SR BLOCK stereo receiver and matching MBS-AA programmable actuator system are all you need to totally enjoy satellite programming.

## STARDUSTER

The XL-Series spun-aluminum dishes are proven performers available in 6', 8' and 8' 6" sizes.

## STS/ STARDUSTER

System is just one of the hundreds of satellite systems available from Delta.

For more information on Delta Satellite Systems, call today!



ONE ECHO PLAZA • CEDARBURG, WISCONSIN • 53012  
TOLL FREE NATIONAL: 800-558-5582 • TOLL FREE WISCONSIN: 800-242-2290 • LOCAL: 414-375-1000  
TELEX: 25886 / ANS BK 26886 CEDA • CABLE: DELTA SAT

BDC/ continued from page 13

- 2) Directional tap insertion loss is the average of the insertion losses of each tap value, "rounded up."
- 3) CATV 50-950 MHz **four port** directional taps are available from TX Engineering in the following drop values: 8, 11, 14, 17, 20, 23, 26, 29, 32, 35 dB (the 8 dB directional tap is self-terminating).
- 4) **Single port** directional couplers are available in the following drop values 6, 9, 12, 16, 20, 24, 27, 30 dB.
- 5) Amplifiers are placed at regularly spaced **increments of passive loss** equaling the gain setting of the amplifier. The maximum output level must not be exceeded. The TX LX-50 amplifiers used in the example designs are set for **30 dB of gain** and have maximum output capability of 52 dBmV.
- 6) The worst case drop cable length is 200 feet. Drop cables are RG-6 flooded foam having a loss of 7 dB per 100 feet at transponder 24.

#### THE BDC Receiver

A good place to start annotating the signal map in the design of a blockconverted satellite distribution system is at the satellite receiver. Knowing the **input requirements** of the receiver allows the designer to **work backwards** through the

distribution system calculating minimum system requirements.

Most low cost 450 MHz to 950 MHz block receivers specify a minimum signal level input on each transponder to be greater than  $-6$  dBmV ( $-55$  dBm). A **signal margin** should be planned to compensate for transponder level variations and receiver performance variations.

Knowing the **minimum signal level required at each receiver**, we may now determine the minimum directional tap **output** level. The minimum output level from each directional tap port is the drop cable **loss**, plus the minimum receiver **input level**, plus the desired signal **margin**. The drop cable from the directional tap should be RG-6 flooded (aluminum shielding acceptable). Using 200 feet as the worst case drop length, a signal loss of 14 dB can be expected at the upper channel. Using a 6 dB as the safety margin, each directional tap must have a minimum tap port output level of:

$$\frac{(\text{drop loss})}{(14 \text{ dB})} + \frac{(\text{Rcvr. Input})}{(-6 \text{ dBmV})} + \frac{(\text{Margin})}{(6 \text{ dB})} = \frac{\text{Tap Signal}}{14 \text{ dBmV}}$$

#### FEEDER Trunk Directional Tap Value Selection

Multi-port directional couplers "tap" the signal from the trunk cable input, "directs" some of the trunk signal to the drop cable, while passing the trunk signals thru with minimum insertion loss. In single home applications it is more efficient and

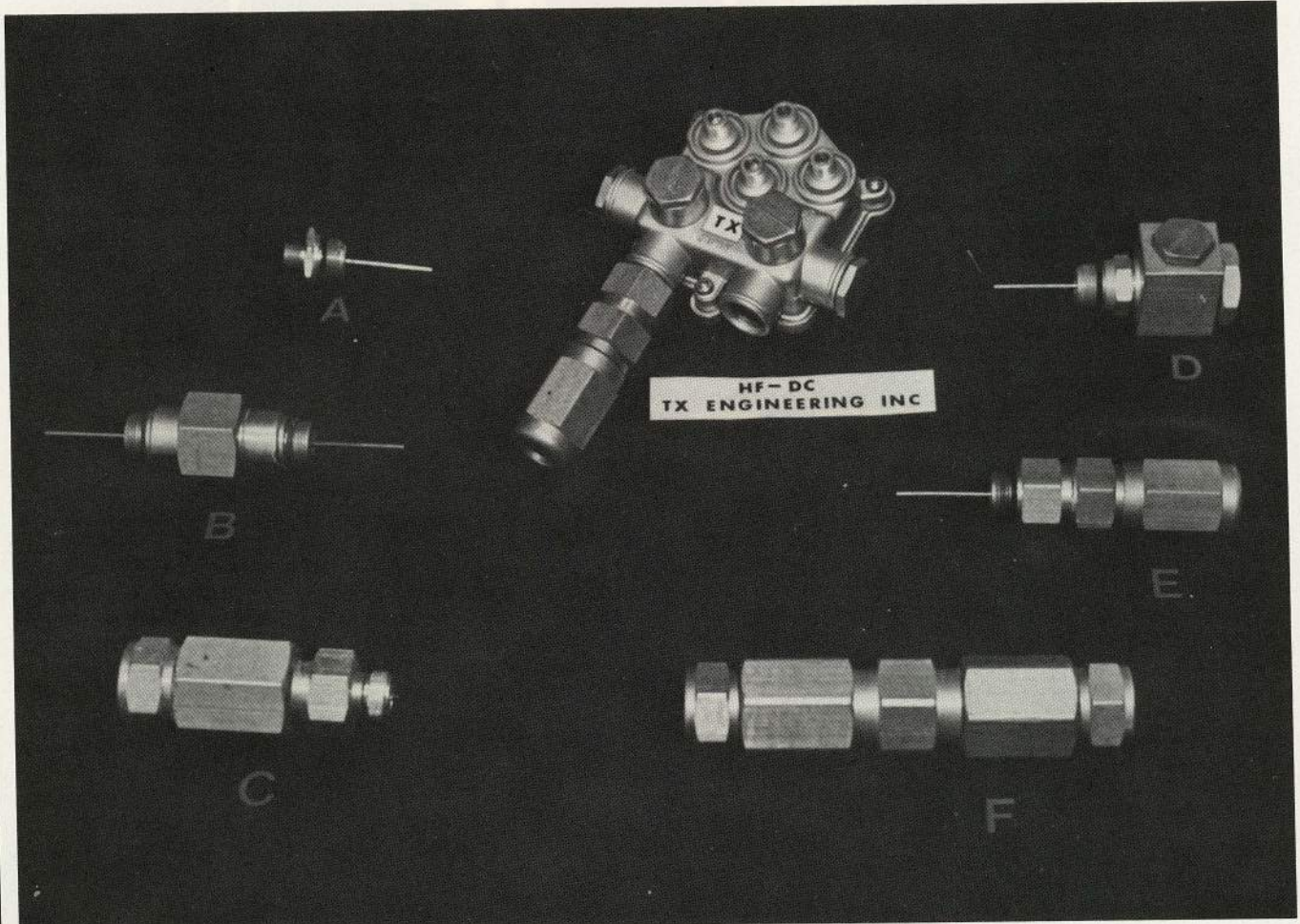

FIGURE 1/ 0.500 inch hardline cable connectors. (A) is a 'chassis stinger' to 'F'; (B) is a chassis to chassis connector; (C) is a hardline to 'F' male; (D) is a chassis right angle adapter; (E) is a hardline to chassis and (F) is a hardline to hardline 'splice.' In the 450-950 MHz band, improper connectors, or improper installation of connectors is a major factor in system maintenance.

less time-consuming to splice in **multi-port** directional taps than several single port taps.

The selection of tap values begins at the **end** of each feeder trunk. Previously the minimum tap output signal was computed to be 14 dBmV when feeding up to 200 feet of drop cable. If a feeder trunk was terminated with an **8 dB multi-port tap** the minimum trunk level required would be equal to the tap value **plus** the minimum tap port output level.

$$\frac{(\text{tap value}) + (\text{Tap output})}{(8 \text{ dB}) + (14 \text{ dBmV})} = \text{Trunk level} = 22 \text{ dBmV}$$

Moving backwards along the feeder trunk towards the headend to the next set of four homes, we can calculate the trunk signal level at the input to the next 4 port directional tap.

The trunk input level to the second tap is the **input level** to the previous tap **plus** the trunk cable **loss**, plus the tap **insertion loss**. If 3 dB of cable loss was expected between taps, the next tap trunk level would be:

$$\frac{(\text{Previous Tap Input}) + (\text{Trunk loss}) + (\text{Tap loss})}{(22 \text{ dBmV}) + (3 \text{ dB}) + (2 \text{ dB})} = \text{Trunk Level} = 27 \text{ dBmV}$$

As with the first tap we want a tap port **output of 14 dBmV**. The tap value is then the trunk input minus the tap output.

$$\frac{(\text{Trunk level}) - (\text{Tap level})}{(27 \text{ dBmV}) - (14 \text{ dBmV})} = \text{Tap value} = 13 \text{ dB}$$

Since no 13 dB tap is available, one must select either a 14 dB or an 11 dB tap. The 11 dB tap is preferred since it will provide greater than the minimum tap port output.

The process of selecting tap values and annotating trunk levels in each feeder trunk continues until one reaches the main trunk **or** the feeder trunk level approaches the level of the maximum amplifier output.

TX LX-50 DISTRIBUTION AMPLIFIER

Bandwidth 3dB	: 430 MHz to 950 MHz
Gain	: (22 dB to 36 dB) adjustable
1 dB compression	: 71 dBmV, 22 dBm, 200 milliwatt
Max Output (12 Channel)	: 53 dBmV (at cross modulation level down greater than 40 dB)
AGC Control	: 52 dBmV output for input levels from 17 dBmV to 30 dBmV

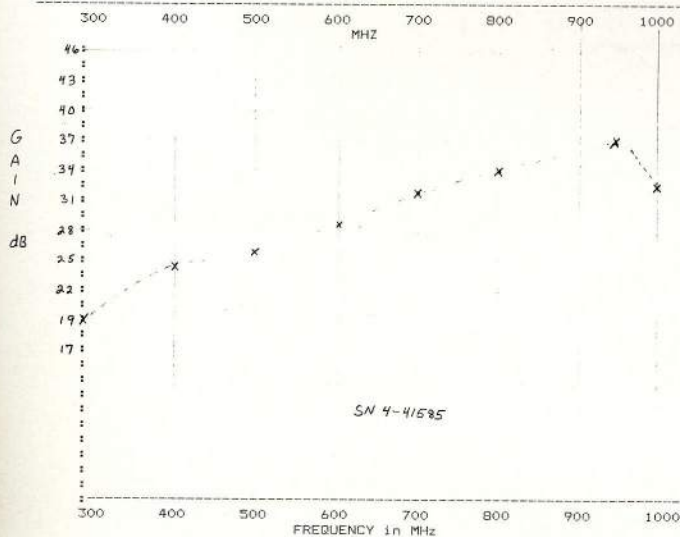

INPUT dBmV	OUTPUT dBmV	AGC Voltage V dc
0	27	2.76
10	27	3.44
20	52	4.96
30	52	5.64
36	53	6.37

**FIGURE 2/ TX Engineering LX-50 amplifier data sheet. Knowing the pre-installation operational condition for each solid-state amplifier is an important part of creating a trouble-free system.**

GRAPHIC SYMBOLS (UNDERGROUND DESIGNATIONS)	
UNDERGROUND ROUTING— DIRECT BURIED	-----
PEDESTAL	
BURIAL OF CABLE IN CONDUIT	
MULTIPLE DWELLING UNITS NUMERAL INDICATES NUMBER OF DWELLING UNITS	
AMPLIFIERS (IEC)	
2-WAY SPLITTER (IEC)	
3-WAY SPLITTER (IEC) DOT SHOWS HIGH OUTPUT	
4-WAY SPLITTER (IEC)	
DIRECTIONAL COUPLER (IEC), VALUE DESIGNATOR IS SHOWN ADJACENT TO SYMBOLS. HIGH LOSS LEG OFF THE ANGULAR #	
AC/DC POWER BLOCKS (IEC)	
4 OUTPUT DIRECTIONAL TAP	
LINE TERMINATIONS	
COAXIAL CABLES	
0.750 INCH (19.05mm) COAXIAL CABLE	
0.500 INCH (12.70mm) COAXIAL CABLE	
<b>NOTE: SPECIFIC COAXIAL CABLE FUNCTION, OTHER SIZES, OR TYPE, SHOULD BE DESIGNATED BY MODIFICATION OF THESE SYMBOLS OR THE LISTINGS OF NEW SYMBOLS ON THE LEGEND SHEET FOR EACH DESIGN.</b>	

### AMPLIFIER Placement

The distribution system operating level is described by the maximum signal level of the trunk. One must know the maximum output, minimum gain, and Automatic Gain Control capabilities of the amplifiers considered for use in the distribution system (see part one for amplifier rating). The TX headend shown in part one amplified the incoming block converted signals to a level of **52 dBmV**. The amplifier required to produce a clean 52 dBmV output must have a 1 dB compression point of greater than +70 dBmV (i.e. +21 dBm). The TX

# See Everything More Clearly

See for yourself how beautifully this Raydx™ antenna blends with the environment. Imagine how complimentary it is to the home setting.

Other splendid features of the Raydish™ include precision-formed aluminum extrusions and stainless steel hardware. The outstanding construction of this unique design assures you excellent performance and years of trouble-free satellite television entertainment. Quality and performance is what makes Raydx™ number one in satellite antennas.

Experience the Raydish.™  
It's clearly unique.

Available in 10½', 8½' and Expandable 6'

*"We pay attention to Quality"*

# RAYDX™

**SATELLITE SYSTEMS, LTD.**

9 Oak Drive • Silver Springs Shores Industrial Park  
P.O. Box 4078 • Ocala, Florida 32678-4078 • (904) 687-2003

PATENT PENDING  
© 1984, RAYDX SATELLITE SYSTEMS, LTD

# Raydx<sup>TM</sup> Proudly Showcases its Distributors

**ALABAMA:** CARMICHAEL ELECTRONICS, 140 So. Foster St., Dothan, AL 36301, (205) 793-7066, (800) 633-0911, ARCHIE CARMICHAEL IV. **STAR PATH**, 232 Roebuck Industrial Park, Birmingham, AL 35235, (205) 655-3235, JERRY WILLIAMS. **ALASKA:** MICRO-COM, 201 E. 56th Ave., Anchorage, AK 99502, (907) 563-8831, CHUCK SCHUMAN. **ARIZONA:** ECHOSPHERE, 2510 W. Geneva Drive, Tempe, AZ 85282, (602) 431-0900, LORAN BOURDO. **THE SATELLITE MAN**, 7878 E. Tanque Verde, Tucson, AZ 85715, (602) 721-2485, AZ Watts: (800) 824-3146, JACK JAMACK. **ARKANSAS:** IVC, 4005 Landski Dr., N. Little Rock, AR 72118, (501) 771-2800, Nat'l Watts: (800) 643-5427, DAVE MULLENAX or LARRY JAMES. **CALIFORNIA:** ECHOSPHERE WEST, 5671 Warehouse Way, Sacramento, CA 95826, (916) 381-5084, CA Watts: (800) 338-5478, CHRIS. **SATELLITE RELAY**, 11211 Sorento Valley Rd., San Diego, CA 92121, (619) 458-1000, JIM KUNISCH or SAM. **HOOSIER ELECTRONICS**, 1630 Cebriam, W. Sacramento, CA 95826, Nat'l Watts: (800) 457-3330, RICH McLAUGHLIN. **RECREATIONAL SPORTS (RSI)**, 1891 Wardrobe, Merced, CA, (209) 383-2700, BRIAN DERUSCHA. **SOLIR CORP.**, 15219 Stagg St., Van Nuys, CA 91405, (818) 989-4716, GOODY. **ACRO-ENERGY**, 2206 So. Baker, Van Nuys, CA 91761, (916) 685-8943, BOB BIER or LARRY NEWTON. **COLORADO:** ECHOSPHERE CORP., 1925 W. Dartmouth Ave., Englewood, CA 80110, (303) 761-4782, CO Watts: (800) 521-9282, Central Zone Watts: (800) 529-9282, CHARLIE ERGEN. **NATIONAL MICROTCH WEST**, 510 29-1/2 Road, Grand Junction, CO 81504, (303) 245-4433, CO: (800) 233-8967, (800) 321-2417, JERRY JOHNSON. **FLORIDA:** STAR COM SOUTH, 3402 Apalachee Pkwy., Tallahassee, FL 32301, (904) 878-0816, RICHARD MILLER or WAYNE. **FLORIDA SATELLITE**, 3888 No. Lake Blvd., Lake Park, FL 33403, (305) 626-6376, DAN WYNNE. **PRECISION SATELLITE**, 715 Grove St., Clearwater, FL 33515, (813) 441-9438, Watts: (800) HOT DISH, DARRYL VANKIRK. **SOUTHEAST SATELLITE**, U.S. 1, Tall Pines Industrial Park, St. Augustine, FL 32084, (904) 824-1915, FL Watts: (800) 824-3300, Nat'l Watts: (800) 824-3474, ROBERT DAVIS-RON ADAMS. **SOUTHEAST SATELLITE**, 1291 S.W. 27th Ave., Pompano Beach, FL 33060, FL Watts: (800) 548-3500, (305) 975-5300. **SKY ROCKER**, 1603 N.E. 32nd Ave., Ocala, FL 32670, (904) 629-9717, CHARLIE. **SERVI-SAT**, 801 So. Main St., Gainesville, FL 32601, (904) 376-6091, DON McBRIDE or STEVE REISE. **UNITED DISTRIBUTORS**, Rt. 13, Box 45, Lake City, FL 32085, (904) 755-0929, ROBY WARD. **UNITED COMM. SUPPLY**, 13748 Nebraska Ave., Tampa, FL 33612, (813) 971-1648 BOB McGEE. **GEORGIA:** SATELLITE EARTH STATIONS, 2039 Oglesby Place, Macon, GA 31206, (912) 743-9099, Nat'l Watts: (800) 334-9819, GA Watts: (800) 553-1976, LARRY WITHERALL. **QUARLES OF ALMA**, 130 West 12th St., Alma, GA 31510, (912) 632-8723, EARL DOWDY. **NAT'L MICRODYNAMICS**, 1600 Slappy Blvd., Albany, GA 31706, (912) 436-1211, Nat'l Watts: (800) 845-0813, RICH TUCKER. **SOUTHERN ELEC. DIST.**, 4916 No. Royal Drive, Tucker, GA 30084, (404) 491-8962, JERRY DIAMOND. **IDAHO:** REC. SPORTS & IMPORTS, 2436 No. Woodruff Ave., Idaho Falls, ID 83401, (208) 523-5721, LEE TAYLOR. **ILLINOIS:** COMMUNICATIONS UNLIMITED, Courthouse Square, P.O. Box 323, Toledo, OH 62468, (217) 849-2011, JOHN SCOTT. **DYNASAT**, 800 Touhy, Elk Grove Village, IL 60007, (312) 981-8686, JOHN BERGQUIST. **ATECH INDUSTRIES**, 110 Beltline Hwy., Alton, IL 62002. **SAT. RECEIVERS LTD.**, 604 W. Seminary, Charlotte, MI 48813, (517) 543-5656, RICK McCLURE. **MINNESOTA:** EARTH STAR COMM., 7401 Old Central Ave., Minneapolis, MN 55432, (612) 786-5127, DAN FISH. **MISSOURI:** SKY WALKER COMM., 1369 Josephsville Rd., Wentzville, MO 63385, (314) 327-7011, ROGER CRIEBAUM. **STAR COM**, 2717 Merchants Dr., Jefferson City, MO 65101, (314) 893-6666, Nat'l Watts: (800) 421-7242, MO Watts: (800) 892-6080, WILLIAM FOX. **DISCO DISTRIBUTING (YEOMAN)**, 3937 Park Ave., St. Louis, MO 63110, (314) 664-2000, MACK. **NEW YORK:** NAT. SATELLITE COMM., 21 Century Park, Clifton Park, NY 12065, (518) 383-2211, Nat'l Watts: (800) 833-4485, NY Watts: (800) 522-3538, RON BRUCE. **MOOG ELECTRONICS**, 2500 Walden, Buffalo, NY 14225, (716) 681-7200, BOB HACKETT. **STARVISION**, 679 Remsen Ave., Brooklyn, NY 11236, (718) 345-8000, JOE FIERO. **NORTH CAROLINA:** MICRO-DISH, Rt. 2, Box 53B, Youngsville, NC 27596, (800) 683-1864, JOHN CARROLL. **QUARLES OF CHARLOTTE**, 801 F Atlando Avenue, Charlotte, NC 28206, (704) 374-0153, MIKE BAIN. **STARTECH, INC.**, 14053 Mechanical Blvd., Garney, NC 27529, (919) 779-0274, Nat'l Watts: (800) 362-6154, SHIRLEY BAIN. **STARTECH, INC.**, 1620 Hwy. 6470 S.W., Hickory, NC 28601, (704) 322-6285, SPINNER JOHNSON. **STAR PATH**, 23 Daniel Boone Complex, Hillsborough, NC 27278, (919) 732-9367, DOLF JAMES. **NORTH DAKOTA:** JOHNSON ENTERPRISES, Highway 281 South, Jamestown, ND 58401, (701) 252-1431, WALT JOHNSON. **OHIO:** MICRODISH, 225 E. Main St., Logan, OH 43138, (614) 385-3200, Nat'l Watts: (800) 638-1864, JOHN RICKETTS. **ENERGY CONNECTION**, 122 Front Street, Marietta, OH 45750, (618) 466-6032, JOHN WOODEN or JACK. **INDIANA:** HOOSIER ELECTRONICS, 925 N. Fruitridge Ave., Terre Haute, IN 47805, (812) 238-1456, Nat'l Watts: (800) 457-3330, IN Watts: (800) 321-7291, JEFF VICARS. **IOWA:** YEOMAN'S DISTRIBUTING, 3629 Mississippi Ave., Davenport, IA 52807, (319) 386-2910, BILL YEOMAN. **KANSAS:** MID-AMER. TEL., 420 No. Lancaster, Heston, KS 67062, (316) 327-4243, CARL WEAVER or ROBERT SHORT. **NAT'L SAT. COMM.**, 9200 Cody, Overland Park, KS 66214, (913) 888-6333, Watts: (800) 833-4485, BRUCE BACHELDER. **HOOSIER ELECTRONICS**, 8920 Bond Ave., Overland Park, KS 66214, (913) 888-9444, Watts: (800) 321-7291, TERRY JONES. **KENTUCKY:** QUARLES NORTH, 515 29th St., Ashland, KY 41105, Nat'l Watts: (800) 228-5761, KY Watts: (800) 562-8862, BOB HOSRI. **STAR PATH**, 2532 Regency Rd., Lexington, KY 40503, (606) 276-4435, GERALD BELCHER. **STAR PATH**, Highway 127 So., Jamestown, KY 42629, (502) 343-2541, ROY HELMS. **LOUISIANA:** INTERSTATE ELECTRIC, 1419 Culpepper St., Shreveport, LA 71130, (318) 459-3641, BUDDY PARKER or RANDY OLSON. **SAT. EARTH STATIONS**, Route 6, Industry Lane, Box 17 JM, Covington, LA 70433, (504) 893-4514, National Watts: (800) 654-9144, LA Watts: (800) 558-0019, DEBBIE LESTELLE. **SAT. EARTH STATIONS**, Hwy 13 & Pine, Mamou, LA 70554, (318) 468-2203, Nat'l Watts: (800) 762-2110, LA Watts: (800) 252-3307, JOE FONTENOTE. **SATELLITE SPECIALISTS**, 240 Columbia St., Bogalusa, LA 70427, (504) 735-9915, TOMMY RICHARDSON. **MARYLAND:** PRO COMM (LEISURE TECH), 914 C. Bestgate, Annapolis, MD 21401, (301) 266-6080, DAVE SHINEMAN or LEE ROBINSON. **MICHIGAN:** ECLIPSE ELECTRONICS, 9818 Cherry Valley S.E., Caledonia, MI 49316, (616) 891-1398, (800) 762-8626, DAN SWITZER or DENNY. **OKLAHOMA:** STAR COM, 2101 S.E. 69th St., (I-240 & Eastern), Oklahoma City, OK 73149, (405) 672-9617, Nat'l Watts: (800) 348-0008, OK Watts: (800) 522-7052, BOB GREEN or BOB WOOD. **OREGON:** MICRODISH WEST, 1375 N.E. Forbes Road, Bend, OR 97701, (503) 388-5193, Nat'l Watts: (800) 638-1864, JEFF SMITH. **PENNSYLVANIA:** HOME SATELLITE, Rtd 2, Box 538, Muncy, PA 17756, (717) 323-7870, GARY BURKHART. **KRUPA ENTERPRISES**, Rt. 150, P.O. Box 516, Avis, PA 17721, (717) 753-3732, JOHN KRUPA. **SOUTH CAROLINA:** QUARLES SAT. SYSTEMS, 1616 Calhoun Rd., Greenwood, SC 29646, (803) 229-7990, Nat'l Watts: (800) 845-6952, SC Watts: (800) 922-9704, BILL QUARLES. **QUARLES OF FLORENCE**, 1337 Interstate Blvd., Florence, SC 29501, (803) 667-4119, MIKE RHODES. **IVS**, Rt. 6, Box 768H, Greer, SC 29651, (803) 877-2463, RICHARD BEVERLY. **SOUTH DAKOTA:** WARREN SUPPLY CO., 300 E. 50th N., Sioux Falls, SD 57104, (605) 336-1830, Nat'l Watts: (800) 492-7736, SD Watts: (800) 952-3046, RALPH WARREN. **TENNESSEE:** AMERICAN VIDEO, 5300 Memorial Blvd., Kingsport, TN 37664, Nat'l Watts: (800) 344-0065, TN Watts: (800) 451-2553, GARRY ALEXANDER. **BEST RECEPTION**, 141 So. Front Ave., Rockwood, TN 37854, (615) 354-2999, JEFF & BOB CRABTREE. **ECHOSPHERE**, 10536 Lexington Dr., Knoxville, TN 37922, (615) 966-4114, Nat'l Watts: (800) 223-1507, TN Watts: (800) 421-9935, DAVE THOMAS. **IVS**, 1742 F. Edgemont Ave., Bristol, TN 37620, (615) 968-2334, Nat'l Watts: (800) 824-8830, TN Watts: (800) 551-8104, JIM ROBINETTE. **LEWIS ELECTRONICS**, West Elm St., Humboldt, TN 38343, (901) 784-2191, AUSTIN LEWIS. **NAT. MICRODYNAMICS**, 6153 Airways Blvd., Chattanooga, TN 37421, (615) 892-3901, Nat'l Watts: (800) 854-0813, TN Watts: (800) 228-5649, HAL, WALTER, EDDIE. **SAT EARTH STATIONS**, 1865 Airline Dr., Suite 4, Nashville, TN 37210, (615) 889-3345, Nat'l Watts: (800) 522-8876, TN Watts: (800) 621-8876, OLIVIA ANTHONY. **TEXAS:** DEL STAR SYSTEMS, 7800 Bissonnet, Suite 200, Houston, TX 77074, (713) 776-0543, Watts: (800) 358-6938, RAYMOND KRAEMER. **DEL STAR SYSTEMS**, 4418 Centergate, San Antonio, TX 78217, (512) 650-9575, LANCE BILLMAN. **ECHOSPHERE**, 3901 LaReunion Pkwy., Bldg. 15, Dallas, TX 75212, (214) 630-8625, Nat'l Watts: (800) 521-9282, TX Watts: (800) 252-9282, STEVE SHAVER. **SAT. EARTH STATIONS**, 1106 Smith Rd., Suite 101, Austin, TX 78721, (512) 385-0738, Nat'l Watts: (800) 325-5043, TX Watts: (800) 252-3457, CRAIG LEDOUX. **THE SAT SHOP**, 2423 So. Henderson Blvd., Kilgore, TX 75662, (214) 983-3524, WAYNE SCOTT or BOB RAGAN. **STAR COM**, 511 Gregg St., Big Springs, TX 79720, (915) 263-1281, CLEO CARLISLE. **STAR COM**, 4732 Whirlwind, San Antonio, TX 78217, (512) 650-3291, JOHN SHERIDAN. **STAR COM**, 1014 Oak Mead Dr., Arlington, TX 76011, (817) 640-1121, JEFF GIBSON. **STAR COM**, 1321 E. Expressway 83, Mission, TX 78572, (512) 581-2785, GENE BALL. **STAR COM**, 9009 No. Loop East (Suite 130), Houston, TX 77029, (713) 675-7003, Nat'l Watts: (800) 222-1384, TX Watts: (800) 833-5364, CHUCK McDONALD. **VIRGINIA:** IVS, 1305 Barberbrook Sq., Staunton, VA 24401, (703) 885-0419, CARL SCHANAGEL. **IVS**, 101 Front St., Coeburn, VA 24230, (703) 395-6819, Watts: (800) 824-8830, GARY LAWSON. **STARTECH**, 29 Hammit Lane, Salem, VA 24153, (703) 387-0062, Nat'l Watts: (800) 221-4656, DICK GOODWIN. **WISCONSIN:** SAT. RECEIVERS LTD., 1740 Cofrin Dr., Green Bay, WI 54302, (414) 432-5777, Watts: (800) 556-8876, DAVE CHARLES. **WYOMING:** SKY SUPPLY, 1714 Rollins, Cheyenne, WY 82001, (307) 634-9505, FRANK BEHLIN.

BDC/ continued from page 17

LX-50 amplifier will be used in the simplified design procedure. If you plan to use other amplifiers in your distribution design substitute the desired amplifier's specifications in place of the LX-50 (1).

Let us return to the tap selection and trunk annotation procedure previously described. Assume the last tap value selected was a 35 dB multiport tap and the corresponding trunk level was 49 dBmV.

Since the trunk level is approaching the maximum, the combination of the trunk loss and tap insertion loss may require the next tap input to be greater than the maximum system level. If the new tap requires an input level that **equals or exceeds the maximum system level**, one must return to the **previous tap and add an amplifier**.

For example, assume the trunk loss from the previous tap is 3 dB and the tap insertion loss is 2 dB.

$$\text{(Previous Tap Input)} + \text{(Trunk loss)} + \text{(Tap loss)} = \text{Trunk Level}$$

$$(49 \text{ dBmV}) + (3 \text{ dB}) + (2 \text{ dB}) = 54 \text{ dBmV}$$

The amplifier must be placed at the **input** of the previous tap since the system operation **limit is 52 dBmV**.

Those that have followed the math will notice that we now have an **amplifier placement margin** of 3 dB.

$$(52 \text{ dBmV}) - (49 \text{ dBmV}) = 3 \text{ dB}$$

The total **system margin** is therefore the drop margin **plus** the amplifier placement margin (6 dB + 3 dB) = 9 dB.

Remember that a 20% error in trunk distance between amplifiers will cause a 6 dB error to the input of the next amplifier. I recommend using a **6 dB error budget** in amplifier spacing especially when direct supervision is not provided during cable installation.

**Amplifier spacing was defined as the distance in dB between amplifiers.** The spacing should not exceed the preset gain of the amplifiers. The preset gain is set **below** the

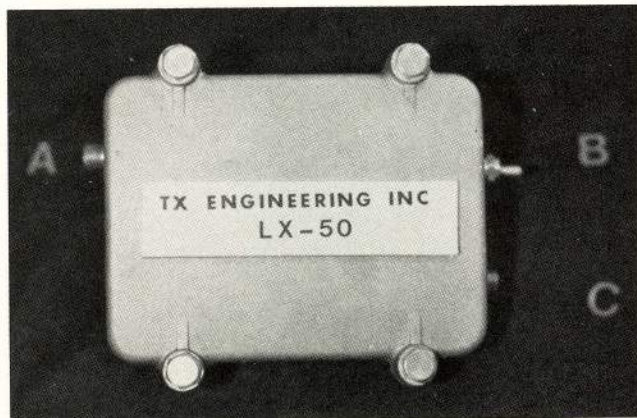

FIGURE 3/ TX Engineering LX-50 distribution amplifier; (A) is input, (B) is output and (C) is powering connection.

**1/ Note:** If complete specifications of the amplifiers you wish to use are not available, 'Network Communication Services' provides complete swept-tested-reports for the amplifier you are considering or have chosen. The tested BDC parameters include: 3 dB bandwidth, minimum gain, maximum gain, 1 dB compression point, AGC control range and power requirements. Contact **David Lantz**, Network Communication Services, 16134 128th Avenue S.E., Renton, Wa. 98055; 206/271-5636).

amplifier maximum gain. The additional margin allows the installer to increase the gain if trunk losses exceed the design values. The TX LX-50 amplifiers have a maximum available gain of 36 dB.

In the above example the amplifier was spaced 27 dB from the input to the 8 dB tap; (49 dBmV – 22 dBmV) = 27 dB. When additional safety margin is desired the spacing would **decrease** further. It is critical that the amplifiers used have sufficient AGC control to handle the increased signal input.

**MAIN Trunk Directional Coupler Selection**

At this point all **feeder trunk tap value** selections and signal levels have been calculated. The **main trunk signal levels** are now specified to provide **each feeder trunk** with its required signal amplitude. The trunk level calculations begin **at the headend** and the signal level is annotated at each feeder junction. Single port directional coupler values are selected to provide the minimum feeder amplitudes.

For example, suppose main trunk "A" leaves the headend at a peak signal level of 46 dBmV. The cable loss in reaching feeder trunk "A1" is 6 dB. The signal level available for coupling to "A1" is 40 dBmV. Since the feeder requires 30 dBmV, a 9 dB directional coupler is used to direct the necessary signal in the feeder. The thru port of the directional coupler is then 44 dBmV.

**SYSTEM Math**

The mathematics involved in measuring system performance is centered around one term; **the dB**. The dB system is used constantly in the communications field because of the extreme range of signal levels. The dB system is a relative power measuring system; dB = 10 log (power/reference power).

The CATV standard quantity of reference is the **dBmV**. This is a reference power level of **1 millivolt across a 75 ohm load**. A reading of 0 dBmV is equal to a **voltage of 1 millivolt** across 75 ohms.

Another standard quantity of reference used when dealing

dBmV	millivolts	dBm	milliwatts	dBw
-10	0.3	-58.8	1.2E-6	-89.8
-6	0.5	-54.8	3.3E-6	-84.8
-3	0.7	-51.8	6.5E-6	-81.8
0	1.0	-48.8	1.3E-5	-78.8
3	1.4	-45.8	2.6E-5	-75.8
6	2.0	-42.8	5.3E-5	-72.8
10	3.2	-38.8	1.4E-4	-68.8
15	5.6	-33.8	4.2E-4	-63.8
18	8.0	-30.8	8.5E-4	-60.8
20	10.0	-28.8	1.3E-3	-58.8
26	20	-22.8	5.3E-3	-52.8
32	40	-16.8	2.1E-2	-46.8
38	80	-10.8	8.5E-2	-40.8
40	100	-8.8	1.3E-1	-38.8
43	137	-6	0.25	-36
46	194	-3	0.5	-33
49	274	0	1.0	-30
52	387	3	2.0	-27
55	546	6	4.0	-24
59	866	10	10.0	-20
69	2.8E3	20	1 E-2	-10
78	8.7E3	30	1 E-3	0
85	19.4E3	37	5 E-3	7
			8.5E-3	9.2

FIGURE 6  
Table of Log Reference Standards

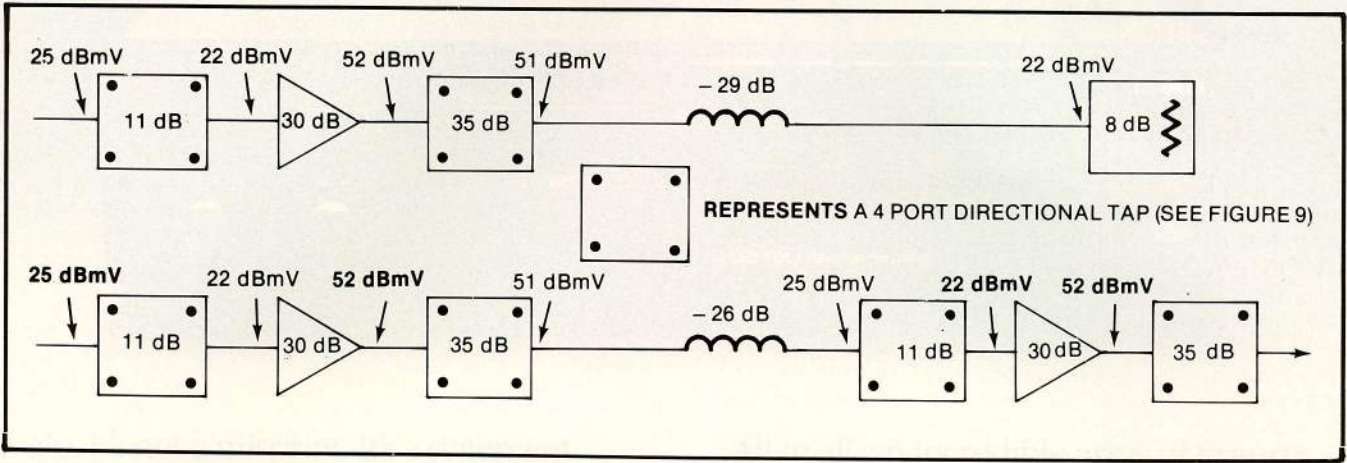

FIGURE 4/ 30 dB AMPLIFIER SPACING: The highest value tap (i.e. 35 in example) follows each amplifier while the trunk may be extended by replacing the lowest value tap with an amplifier, and the highest value tap. Note lower or lowest value tap(s) precede an amplifier.

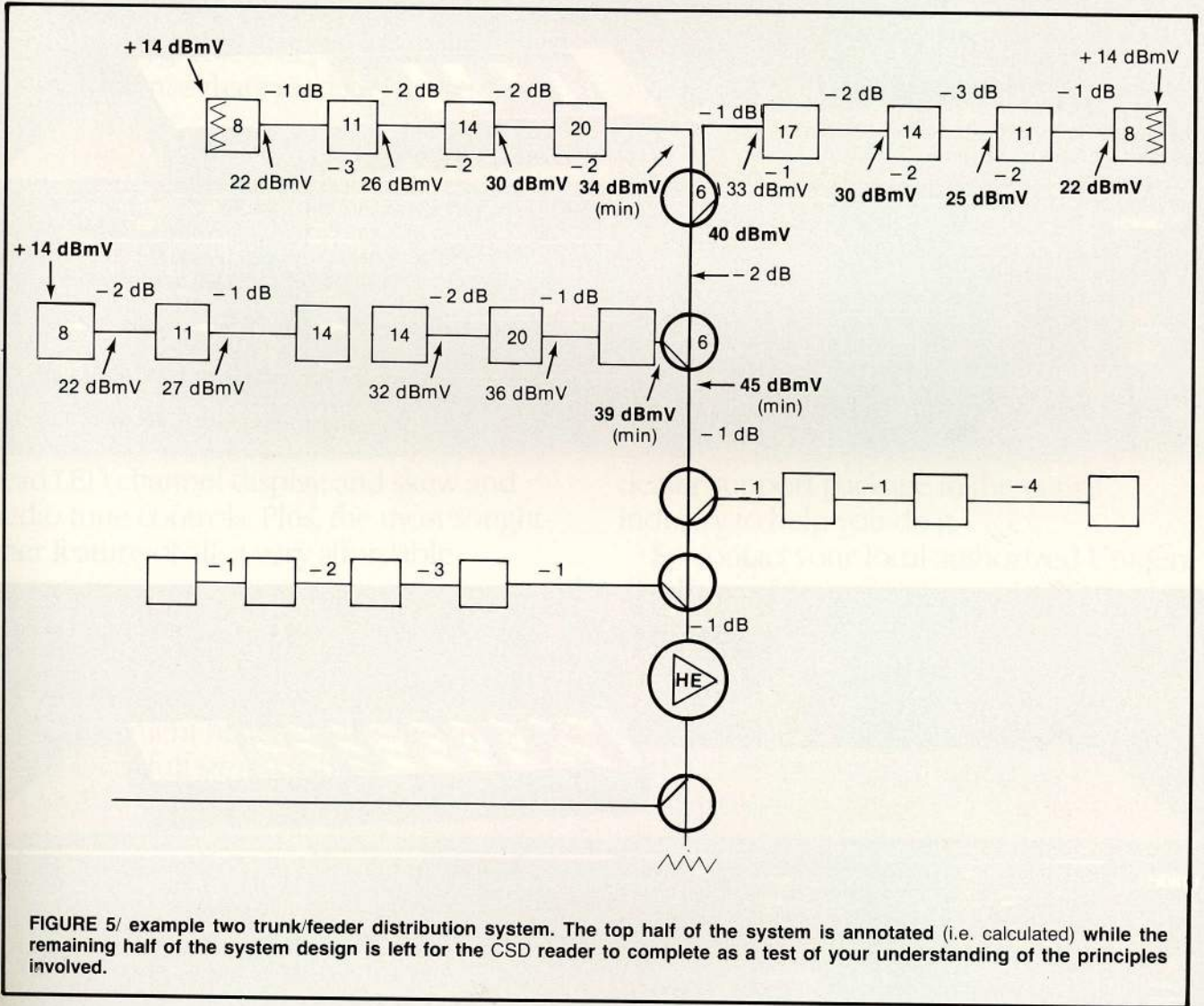

FIGURE 5/ example two trunk/feeder distribution system. The top half of the system is annotated (i.e. calculated) while the remaining half of the system design is left for the CSD reader to complete as a test of your understanding of the principles involved.

with the received power of transmitted signals is the dBm. This is a measure of power relative to 1 milliwatt. A reading of 0





# Introducing the top-of-the-line line.

No, it's not a misprint. It's a statement of fact.

Because every new receiver in the 1985 Uniden line delivers top-of-the-line performance, regardless of price. It's the kind of performance that's made us the leader in the industry.

Like our UST-5000 for instance. It's the simplest block downconversion unit in our top-of-the-line line, yet it offers your customers all the sophistication of Uniden technology and styling along with features usually found on more expensive receivers.

Like soft-touch controls for easy channel selection, slow/fast channel scan, easy-to-read LED channel display, and skew and audio tune controls. Plus, the most sought-after feature of all: a very affordable price tag.

There's also our UST-6000. An incredibly reliable mid-priced blockdown receiver that offers all the features of the UST-5000 plus convenient handheld wireless remote control and full stereo sound.

Our UST-7000 combines the most sophisticated engineering in the industry with the most advanced convenience features. Like a built-in programmable antenna controller. Easy-to-read LED displays that provide a full range of information at a glance. And a full-function remote control for total 'armchair' operation.

All in all, an incredible array of features, functions and models. All with block downconversion and at competitive prices, making it easy to multiply your profits by selling multi-receiver systems to families with more than one TV.



And we'll be backing our entire top-of-the-line line with the most impressive dealer support package in the entire industry to help you do it.

So contact your local authorized Uniden distributor for more information on our complete line of satellite television systems. Or call toll-free 1-800-582-5360. In Canada call 1-800-663-0296. And start stocking Uniden's top-of-the-line line.

It will do amazing things for your bottom line.

## uniden®

Win with Uniden in '85.

PIONEER MEMBER OF  
**ISPACE**  
© Uniden Corporation of America 1985

BDC/ continued from page 21

dBm is equal to a **power level of 1 milliwatt**.

The final standard quantity of reference is the dBw. A reading of 0 dBw is equal to a **power level of 1 watt**. Satellite transponders are rated in watts, although the signal hitting your antenna is rated in dBw. To understand the loss/gain relationships it is necessary to bring all values to a common reference. **Figure 6** is a cross-reference of the above standards. The table is based on voltages across a (75) ohm coaxial cable.

**Power** = voltage squared divided by 75

**dBw** = 10 log (watts/1 watt)

**dBm** = 10 log (milliwatts/1 milliwatt)

**dBmV** = 20 log (millivolt/1 millivolt)

**Question:** The **voltage** out of the amplifier increased from 0.137 volts to 0.274 volts. What is the **voltage gain**? What is the **power gain**?

**Answer:** 0.137 volts = -6 dBm = 43 dBmV = -36 dBw  
 0.274 volts = 0 dBm = 49 dBmV = -30 dBw  
 The **doubling of the voltage** (into a 75 ohm load) results in a **gain of 6 dB** in all three reference systems.

**Question:** The amplifier **power** is increased from 1 milliwatt to 2 milliwatts. What is the **power** and **voltage gain**?

**Answer:** 1 milliwatt = 0 dBm = 49 dBmV = -30 dBw  
 2 milliwatt = 3 dBm = 52 dBmV = -27 dBw  
 The **doubling of the power** results in a **gain of 3 dB** in all three reference systems.

**Question:** What is the dB difference between a 5 watt transponder and a 8.5 watt transponder?

**Answer:** 5 watts = 7 dBw  
 8.5 watts = 9.2 dBw  
 The difference is **2.2 dB**.

**COAXIAL Cable**

Coaxial cable is the distribution medium for any signal source. System designers must understand the basic properties of cable; **resistance, reactance, and impedance**. Installers must be made aware of the havoc that can result from poor handling of the cable during the installation.

It is very important to maintain the integrity of the cable during the installation. Kinks, nicks, or the flattening of the

TRANSPONDER	TRANSMIT FREQUENCY	TX DOWNCONVERTED FREQUENCY
1	3720	450
2	3740	470
3	3760	490
4	3780	510
5	3800	530
6	3820	550
7	3840	570
8	3860	590
9	3880	610
10	3900	630
11	3920	650
12	3940	670
13	3960	690
14	3980	710
15	4000	730
16	4020	750
17	4040	770
18	4060	790
19	4080	810
20	4100	830
21	4120	850
22	4140	870
23	4160	890
24	4180	910

FIGURE 7

coax during the installation will cause an impedance change at the point of the discontinuity. The result is that some of the signal will be reflected.

The presence of moisture in the coax has the effect of changing the dielectric properties of the cable. Again, this causes a change in the impedance.

It is beyond the scope of this article to include a complete cable practices chapter. A good source for information on cable installation is located in most cable catalogs. Both Times Fiber and ComScope provide such information.

**TEMPERATURE Effects**

To visualize the effects of temperature on a system, we shall select a trunk with one mile of 0.500 inch P-3 cable. The attenuation **change** of coaxial cable is **0.125% per degree F**.  
 TOTAL ATTENUATION: 1 mile x 5280 ft/mi x 2.6dB/100ft = 138 dB  
**at 440 MHz:** 1 mile x 5280 ft/mi x 1.7dB/100ft = 90 dB

**Q:** If the mean temperature should rise to **100 degrees**,

CABLE SIZE DIELECTRIC	NOMINAL CABLE ATTENUATION (dB) PER 100 FEET @ 68 DEGREES F					
	DC Resistance Ohms/1000 ft.	FREQUENCY (MHz)				
		25	55	211	440	940
<b>ComScope P3</b>						
1.000 Foam Poly	0.58	0.24	0.33	0.70	1.01	1.46
0.750 Foam Poly	0.76	0.29	0.41	0.84	1.52	1.75
0.500 Foam Poly	1.94	0.42	0.59	1.21	1.70	2.60
	DC	25	55	211	440	940
<b>RG-11</b> Foam Poly	3.0*	0.76	1.0	2.2	3.6	5.2
<b>RG-6</b> Foam Poly	5.2*	1.07	1.5	3.1	4.9	7.0
<b>RG-59</b> Foam Poly	6.8*	1.3	1.8	3.8	6.1	8.5
<b>RG-59</b> Solid Poly	22.5#	1.8	2.4	5.3	7.6	11.0
	DC	25	55	211	440	940

**Notes:**

ComScope **P1** has slightly higher losses due to a decrease in the velocity of propagation, from 87% to 82%

\* Copper Braid

# Aluminum Braid

FIGURE 8



## Uniden receivers have met their match.

For years, no one was quite good enough.

No one satellite dish antenna quite possessed the exceptional standards of performance that Uniden receivers do.

So we had to create one.

Introducing the Uniden UST-110. An incredibly durable, lightweight satellite dish antenna. The perfect match for the Uniden line of receivers and system components.

The UST-110 features an exclusive Uniden all-extruded-aluminum design with expanded mesh panels, a 5-step baked-on painted weather coating, plus an extra-rigid, heat-treated rib design that

maintains high parabolic accuracy.

And to aim the UST-110 there's our advanced line of precision antenna positioners.

Like our economical UST-710 and our fully programmable UST-730.



So contact your local authorized Uniden distributor. Or call toll free 1-800-582-5360. In Canada call 1-800-663-0296. And find out how you can start stocking the entire line of Uniden Satellite Television Systems. Including our exceptional receivers and our UST-110 satellite antenna.

It might not be a match made in heaven. But it's close.

# uniden®

Win with Uniden in '85.

PIONEER MEMBER OF  
SPACE

what will be the total attenuation?

**A:** On the **highest** satellite channel  
 Attenuation change:  $(100 - 68) \text{ degrees} \times 0.125\% = 4\%$   
 The net increase is:  $4\% \text{ of } 138 \text{ dB} = 5.5 \text{ dB more attenuation}$

**A:** On the **lowest** satellite channel  
 A 4% increase on the low channel is therefore:  
 $4\% \text{ of } 90 \text{ dB} = 3.6 \text{ dB}$

When the temperature **decreases** the attenuation decreases by the same  $(0.125\% / \text{degree})$ . In the above example we shall let the temperature drop to zero degrees fahrenheit.

TEMPERATURE CHANGE:  $68 - 0 = 68$

ATTENUATION CHANGE:  $68 \times .125\% = 8.5\%$

The signals at the end of the trunk shall be **higher by:**

**Low channel** =  $8.5\% \times 90 \text{ dB} = 7.6 \text{ dB}$

**Hi channel** =  $8.5\% \times 138 \text{ dB} = 11.7 \text{ dB}$

This means that in **hot weather**, amplifier input levels will be **lower than normal**, and in **cold weather** amplifier levels will be **higher than normal**.

In the above example, the **maximum attenuation variation** on the upper channel from (0 to 100) degrees F was: **17.2 dB**.

Dividing the total attenuation of 138 dB by the 30 dB amplifier spacing requirement, yields the number of amplifiers required in the 1 mile trunk example.

$138 / 30 = 4.6 = 5 \text{ amplifiers.}$

In order for the trunk level not to vary, each amp would require approximately **4 dB** of automatic level control.

**ISOLATED Four-Way Taps**

It is critical that all devices that feed the drop cables have high isolation **from** the trunk cable. What **the customer does** to the drop cable is **not under the control** of the system technician. Studies indicate that a minimum of 18 dB of isolation will prevent customer drop cable misuse from showing up on the trunk cable.

**Multi-tap desirable features**

- 1) The same device can be used for **either** overhead or underground installation.
- 2) Die cast housing with RF and Environmental **seals** and corrosion proof finish.
- 3) Tapered **counter-bored** entry ports for gasket seating and 100% metal to metal contact.
- 4) **Seized** center conductor screws that may be tightened by either a hex wrench or a flat blade screwdriver.
- 5) All electrical contacts are either nickel or silver **plated** to increase the high frequency response and to prevent corrosion.
- 6) Power Passing: 3 Amp maximum
- 7) All port Return Loss of greater than 20 dB
- 8) **Isolation** of tap to tap, and, tap to trunk of greater than 20 dB
- 9) Tap housing will fit into a 4" pedestal enclosure for low cost underground construction.

**DESIGN/Drafting Specifications**

The following criteria are intended to maximize efficiency,



**FIGURE 9/** installation of TX 'high frequency' multi-tap device on 0.500" cable 'risers' in buried cable plant.

accuracy and accountability. Symbols used are considered to be standard in the cable industry. It is strongly suggested that all involved in CTN design follow the same set of symbols. If variations exist, please note those variations on any layout sent to NETWORK COMMUNICATION SERVICES for evaluation. (See symbols chart, page 17.)

In all stages of mapping, from field walk-outs to final drafting, all information is to be placed **on the maps** in such a manner as to be read from the bottom or the right of the print.

**BASE-MAP Walk-Outs**

Walk-outs are to be performed using blue or black-line paper prints, preferably 1"=100' scale, but no less than 1"=200' scale. These maps are to include streets, property lines, right-of-ways and lot dimensions. Information to be placed on walk-out maps shall consist of the following.

- 1) Dimensions of all affected streets are to be indicated, including:
  - a) Pavement width
  - b) Gutter width (if any)
  - c) Curb width (if any)
  - d) Parkway width (if any)
  - e) Sidewalk width (if any)
- 2) Linear lot dimensions are to be indicated, including:
  - a) Driveway widths
  - b) Residential sidewalk widths
  - c) Remaining lot dimensions adjacent to right-of-way
- 3) Proposed pedestal locations are to be indicated, preferably **every other** property line.

**SYSTEM Map**

All headends are alike in that all of their components are located at one place. If there is a question, the technician can simply look at the headend and trace out the various signal

Tap Value in dB	:	8	11	14	17	20	23	26	29	32	35
Maximum Insertion Loss at 440 MHz	:	*	2.3	1.4	1.0	1.0	1.0	1.0	0.5	0.5	0.5
Maximum Insertion Loss at 940 MHz	:	*	3.0	2.0	1.6	1.4	1.4	1.4	0.9	0.9	0.9

\* This value tap has the thru port terminated for **end-of-trunk** use.

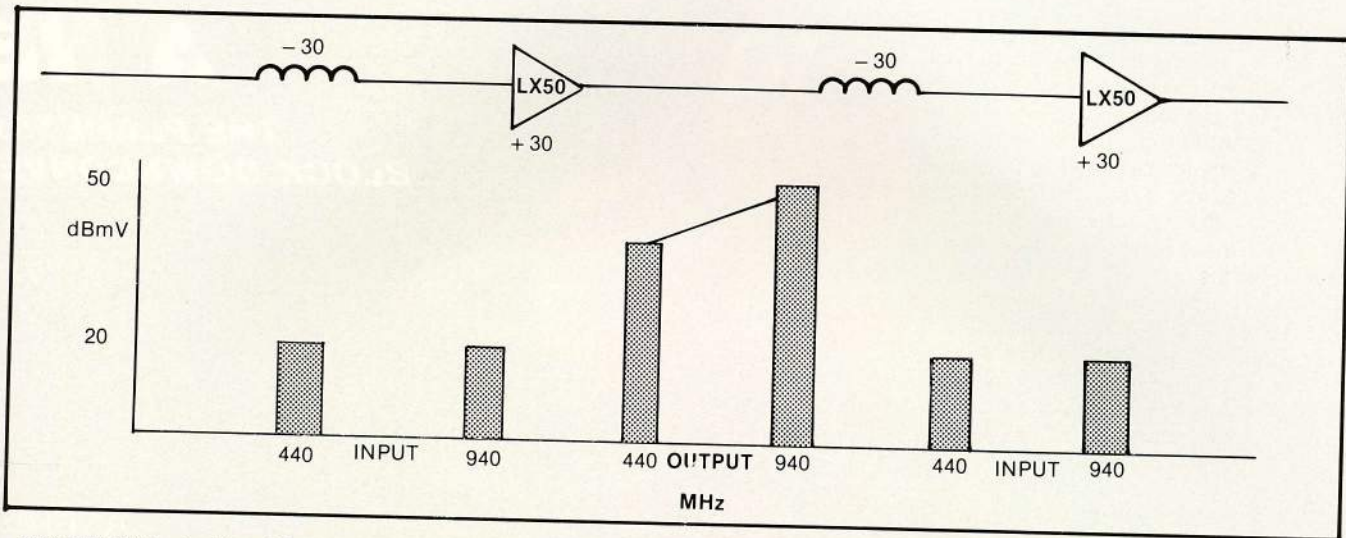

FIGURE 10/ Illustration of 'full tilt' system; note input to LX-50 amplifiers is flat (i.e. +20 dBmV at both 440 and 940 MHz) while the output is tilted by 6 dB (in favor of the 940 MHz end of the spectrum). Cable and device-loss between amplifier stations is shown as 30 dB.

paths. As far as the rest of the distribution system is concerned, there are major differences between one system and another. Here, the components are not located all in one place but are spread throughout the system. For this reason, probably the most important tool that a technician can have in maintaining a (cable TV) system is a complete, accurate, and detailed map of the system.

Usually, this map is prepared at the time the system is originally designed, but quite frequently the map is not kept up to date when changes are made to the system. Attempting to troubleshoot or maintain a system without a detailed blueprint is something like trying to find a house in a subdivision with a map that does not show some of the streets.

A system map should show everything. The location of each pedestal, amplifier, and power supply should be clearly annotated. **Signal levels** of the tap outputs should be noted.

The chief limitation of most CTN maps is inaccuracies in distance. A map error of 20% in a system with a 30-dB spacing between amplifiers amounts to a 6.0 dB error in signal level. This could easily place the operating point of an amplifier near one end of its dynamic range.

The location of the amplifiers should be carefully noted. Of course, it is impossible to put all of this information on a single sheet of paper. The usual approach is to make an overall system map showing general information, such as a pedestal number and location, and make individual sheets showing details of the various trunk and feeder lines.

In most systems, two different types of coaxial cable are used. For reasons of economy, the cable in each part of the system is made no larger than necessary. Trunk lines, which carry the signal throughout the system, are usually made of larger cable because the larger cable has lower losses. CTNs usually are designed with 0.750 inch or 0.500 inch hardline cable for the main trunks. CTNs commonly use 0.500 inch hardline cable for the feeders.

### CONNECTORS

The connector is a frequently ignored but critical part of the distribution system. Failures in the distribution system are commonly traced to improperly installed connectors.

Each connection must be inspected for proper seating and weatherproofing. Special tools are required to core the hard-

line cable and strip away the 'invisible' center conductor coating. Tests are performed to verify the integrity of the connection prior to sealing each connector.

Connector installation procedures are provided in most hardline connector catalogs. I strongly suggest, however, the use of experienced cable sub-contractors for those with little experience with hardline cable. **A shorted connector** can damage the high power amplifiers used in the distribution system.

### PASSIVE Devices

In addition to the cable, connectors, and amplifiers, there are many passive devices such as signal splitters, directional couplers, and drop taps located at various points along the system. Each passive device inserted in the distribution system has an insertion loss. Information including insertion loss, spacing, type of component, and location of each component, should be carefully marked on the system map. Above all, **any change** that is made on the system should be shown on the map.

Finally, drop cables, which carry the signals into the participant homes, are made of the smallest cable, usually dielectric-filled RG-type cable. Although the propagation characteristics of RG-type cable are far inferior to those of larger-type cable, the runs are usually so short that the problems involved are not too serious.

### TILT Compensation

The attenuation of the cable is not the same at all frequencies but varies approximately as the square root of the frequency. This means that the amplifier must provide more gain at channel 24 than at channel 1.

Distribution systems may be operated in one of three tilt compensated modes; flat, full tilt, and half tilt. Obviously, if all signals are at the same level when they leave the headend, they will not be at the same level when they arrive at the input of the first amplifier. Sending the signals out of the amplifiers at **equal levels** is known as **FLAT** operation.

At the other extreme, the signal levels at the output of the headend and at each amplifier may be set so that the **higher-**

# A NEW

## THE PLANET'S ONLY BLOCK DOWNCONVERSION

### ANDERSON SCIENTIFIC



#### Anderson ST2010 Master Receiver

The ST2010 is a deluxe, full-featured, block downconversion satellite receiver intended for use in the main viewing area of a home or business. The ST2010 has a unique, infinitely adjustable bandwidth control permitting optimization of picture quality on any transponder, on any system, anywhere in the world. Anderson's proven block downconversion permits easy hookup of additional Master or Slave receivers for multiple television systems.

#### FEATURES INCLUDE:

- Fixed and Tuneable Bandwidth
- Polarotor I and PolarAmp Control
- Fixed and Tuneable Self-Seeking Audio
- Audio Deviation Control
- Video Fine Tune Control
- Channel Scan
- Wide Range AGC
- Improved AFC with AFC Defeat
- Video, Audio, TV, and Subcarrier Outputs
- IR Remote Option



#### The Anderson ST910 Slave

The ST910 is a basic, low-cost, block downconversion satellite receiver intended for use in auxiliary viewing areas of a home or business. The ST2010 (or ST1010) serves as a Master Control receiver, while the ST910 Slave provides independent channel selection to other rooms and televisions. The ST910 is the ideal receiver for multiple home and other multiple unit systems, with an ST910 provided for each dwelling.

#### FEATURES INCLUDE:

- Tuneable, Independent Channel Selection
- Tuneable, Self-Seeking Audio
- Wide Range AGC
- Improved AFC
- Switchable LNA Power
- Video, Audio, TV, and Subcarrier Outputs
- IR Remote Option

### I.R. REMOTE!



# ERA HAS DAWNED!

**COMPLETE LINE OF MATCHING COMPONENT RECEIVERS AND ACCESSORIES HAS ARRIVED!**

- UNEXCELLED SMALL DISH PERFORMANCE
- INCREDIBLY LOW THRESHOLD FIGURE
- MANUFACTURED IN THE U.S.A.
- COMPLETE DISTRIBUTOR AND DEALER SUPPORT

ANDERSON SCIENTIFIC, INC. • 2693 COMMERCE ROAD • RAPID CITY, SD 57702 • 605-341-3781



## Anderson ST1010 Receiver

The ST1010 is a simple-to-operate, yet complete, block conversion satellite receiver. The ST1010 is intended for use in affordable single television systems, or as an economical Master receiver in multiple television systems. The ST1010 is also ideal in multiple home or multiple unit hookups where signal strength metering at each location is desired.

### FEATURES INCLUDE:

- Polarotor I and PolarAmp Control
- Tuneable, Self-Seeking Audio
- Wide Range AGC
- Improved AFC
- Switchable LNA Power
- Signal Strength Metering
- Video, Audio, TV, and Subcarrier Outputs
- IR Remote Option

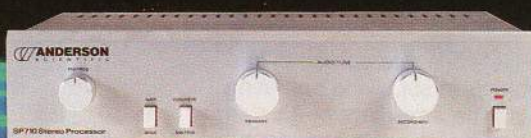

## SP710 Stereo Processor

The SP710 is designed to provide high quality stereo from any of Anderson Scientific's block conversion satellite receivers, in a housing that matches the models ST910, ST1010, and ST2010. In addition to the matrix and discrete stereo handled by many other processors, the SP710 provides the ability to process multiplexed stereo. Further, the SP710 has a tuneable FM output which can be input to any FM radio or receiver.

### FEATURES INCLUDE:

- Matrix and Discrete Stereo Processing
- Multiplexed Signal Stereo Processing
- Tuneable FM Frequency Output
- Left and Right Audio Baseband Outputs
- Wide/Narrow Audio Deviation Control

## CHOICE OF FINISH!



BDC/ continued from page 27

frequency signals have a **higher level** than the lower-frequency signals. This is done so that when the signals reach the **input** of the next amplifier, they will all have the **same level**. This mode of operation is called FULL TILT. Half Tilt systems operate between the two extremes. I design CTNs to operate at FULL TILT because it allows the amplifiers to operate with lower intermodulation for a given power level.

**FULL Tilt Amplifier Spacing**

Although the spacing between amplifiers is based on amplifier characteristics, **cable characteristics must be considered**. Since larger-diameter cables have lower losses than smaller-diameter cables, a given length **expressed in decibels** will represent a greater physical length of the larger cable.

**Trunk cables using lower-loss cable will permit a longer system for the same number of amplifiers.**

Feeder cables, which will not be as long, can use smaller cable with higher losses. The actual selection of the type of cable to be used in each part of a system is a **compromise** between the **cost of the cable** and the **cost of the amplifiers**. It is also desirable in small systems to eliminate the need for non-headend trunk amplifiers by using larger diameter, lower loss cable.

**POWERING The CTN**

Because Custom Television Networks are spread over a wide area, there are unique problems in supplying operating power to its various components. The amplifiers of a cable system are spaced several hundred feet from each other and often cover an entire community. **Each amplifier** must be supplied with an **operating power**.

Because transistor amplifiers operate on low dc voltage, it would seem ideal to transmit a low **dc voltage** along the cable with the TV signal. This is impractical because of the corrosion resulting from electrolysis.

A CTN uses several different types of metals, such as copper and aluminum. Whenever two dissimilar metals are connected together in the presence of moisture and the normal impurities that are found in the atmosphere, the 'junction' tends to act like a small **battery**, and **electrolysis will result**. When a direct current flows through a **series** of such junctions, it will aid some of the small "batteries" and oppose others. As a result, the electrolysis, and hence the corrosion, will be increased considerably at some of the junctions. This is why connection at the **positive pole** of an automobile battery will corrode more than the negative terminal. To avoid this effect, Custom Television Networks use a **separate** two conductor **power cable** for each amplifier in the trunk system.

PEDESTAL DATA SHEET  
Installation: SAMPLE Date: 7-1-1985

FLAT INPUT SWEEP TEST

FREQUENCY	: 440 MHz	: 940 MHz	:
Trunk Input / Output	: 40 / 39	: 40 / 39	:
Expected Tap Signal Level	: 20	: 20	:
Measured Tap signal	:	:	:
Replaced Tap signal level	:	:	:

TILTED INPUT SATELLITE SIGNAL TEST

CHANNEL NUMBER	: 1	: 12	: 24	:
Trunk Input / Output Peak	: 40 / 39	: 45 / 44	: 50 / 49	:
Expected Tap Signal Level	: 20	: 25	: 30	:
Measured Tap Signal Level	:	:	:	:
Peak Signal / Avg Noise Expected at tap	: 29	: 29	: 29	:
Measured FM Peak Signal / Avg Noise	:	:	:	:
Replaced Tap signal level	:	:	:	:
Tap Value	:	:	:	:

PEDESTAL DRAWING (Indicate any changes with value, initials and date)

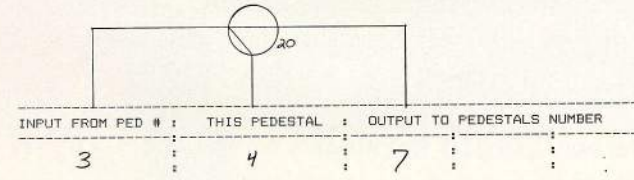

**PEDESTAL DATA SHEET/ suggested format for individual pedestal mounted equipment units. Precise records, stored at each pedestal location, simplify service work during and after system construction.**

**PEDESTAL Data Sheets**

In addition to distribution system maps, data sheets on each pedestal in the system provide the installer and technician detailed information on construction and expected signal levels. The **expected** signal levels are annotated by the system designer. The field technician uses the pedestal data sheets to note **measured** signal levels. They serve as "note pads" between the installer and the designer. Once the system is up and operating the **final signal information** is entered on the system map.

Trunk Amps (non-headend)	Max Level dBmV	System Size dB	0.500" feet*	0.750" feet*	1.00" feet*
0	53	30	900	1400	1800
1	53	60	1800	2800	3600
2	50	90	2700	4200	5400
3	48	120	3500	5500	7100
4	47	150	4400	6900	8900
5	46	180	5200	8200	10600

**FIGURE 11 TRUNK SIGNAL LEVEL VS CASCADED TRUNK AMPLIFIERS**

\* The system size distances are only estimates. The actual distances will be determined by the ratio of taps per amplifier.



# SATELLITE AGILE



## The DSA-654 Ku/C Dual-Band Receiver from DX. The Only Receiver That Offers Ku-Band Reception with Synthesized 1 MHz Step Tuning.

There's a Ku-band receiver that's in a league by itself. The new DSA-654 dual-band receiver from DX. It's specifically designed to give your applications the most precise Ku-band and C-band reception available.

The DSA-654 features frequency-synthesized tuning in 1 MHz steps between 11.7 and 12.2 GHz. Exact transponder and downlink frequencies for SBS, GSTAR, RCA, ANIK, and SPACENET, or any other format can be selected directly from the front panel. It provides a simple solution for total flexibility required for broadcast, video conferencing, and private satellite network applications. It also features clamped/unclamped video and composite baseband outputs for descrambler connection and frequency-

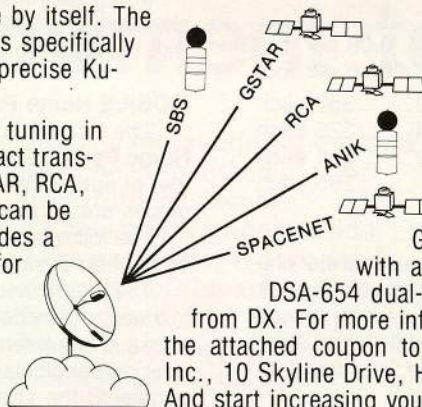

synthesized 10 kHz step tunable audio. Optional field-installable 24 MHz and 17 MHz IF filters are available. The DSA-654 provides the same excellent performance and reliability as the DSA-643A receiver. Performance-proven Ku-band LNBS to complement the DSA-654 are also available from DX Communications, Inc.

Get the Ku-band receiver with all the right steps. The DSA-654 dual-band satellite receiver from DX. For more information, just send in the attached coupon to DX Communications, Inc., 10 Skyline Drive, Hawthorne, NY 10532. And start increasing your receptions.



**DX COMMUNICATIONS, INC.**  
A Subsidiary of C. Itoh & Co. (America) Inc.  
10 Skyline Drive, Hawthorne, NY 10532  
(914) 347-4040



Please send me information on the DSA-654 DX receiver.

Company Name \_\_\_\_\_

Name \_\_\_\_\_

Street \_\_\_\_\_

City \_\_\_\_\_ State \_\_\_\_\_ Zip \_\_\_\_\_

K-8

**CTN COST Estimation**

Equipment and services listed are based upon local contracting of many of items. The prices below should be used for estimating purposes.

**System Design**

Rough Estimated Pricing .....	No charge
Complete Design Package .....	\$10 per Drop
Includes: Equipment List	
Cable/Pedestal System Map	
Pedestal by Pedestal Data Sheets	

**Pre-Assembled, Pre-Tested Headend Electronics**

TX 110 degree LNB .....	295
LNB DC Power Supply with DC inserter .....	60
Distribution Amplifier LX-50 HE .....	420
Headend Amplifier Power Supply .....	60
Headend Enclosure .....	60
Multiple Outlet AC Power Strip .....	12
Headend Assembly and Test by Network Services .....	200
	<b>\$1,107</b>

**Locally Procured Headend Equipment**

4 Meter Receive Antenna with Feed .....	1500
Installation .....	500
	<b>\$2,000</b>

**Distribution**

0.500 inch P-3 or 4500 Flooded Cable .....	0.25 per foot
0.750 inch P-3 or 4750 Flooded Cable .....	0.50 per foot
1.000 inch P-3 or 41000 Flooded Cable .....	0.95 per foot
<b>Installation</b> .....	1.50 per foot
18 gauge 2 conductor stranded jacketed cable .....	0.10 per foot
Street Crossings .....	6.95 per foot
LX-50 0.2 Watt Distribution Amplifiers .....	410 each
<b>TX High Frequency CATV Taps</b> (1 per 4 homes) .....	19 each
<b>Pedestals</b>	
Drop (4" x 4" x 4") .....	10 each
Amplifier .....	39 each
Hardline Connectors (average 2 per pedestal)	5 each
Installation .....	5 each

**Proof of Performance Testing**

Rough alignment sweep test .....	0.08 per foot
Final alignment .....	0.10 per foot

<b>TX 200 Set-Top Converters</b> .....	1 to 9 .....	350 each
	10 to 24 .....	325 each
	25 to 49 .....	315 each
	50+ .....	295 each

**CTN Example Design**

The example installation is based on previous test installations performed by TX Engineering in the Pacific Northwest. Three major types of communities fit the cooperatively owned Community Television Network profile; the mobile home park, the individual family residential neighborhood, and the condominium complex.

**CONDOMINIUM Complex**

Of the three basic community types, the condominium has the highest density. Condominiums are frequently pre-wired for cable TV. When approaching a pre-wired condominium complex, it is critical that a cable map be provided. If one is not available, one should be drawn by tracing cable routing. Details on the cable **type**, the location and values of the passive

devices, and cable distances are essential. If an accurate cable map is provided, the CTN designer can provide the installers a turn-key system where they simply replace the existing passive hardware with TX **High Frequency** devices.

When the condominium complex is not pre-wired, the following design **recommendations** should be considered.

**Eight to Sixteen Units per Building**

Use a single port directional coupler off the trunk to feed multi-port TX High Frequency Taps. Each condominium unit would receive their signal directly from a centrally located mini-headend.

**Sixteen to Forty Units per Building**

Provide a +22 dBmV signal level from the trunk cable to an amplified mini-headend. A TX LX-50 amplifier with a signal level of +22 dBmV (channel 24) at its input will provide an Automatic Level Controlled signal of +50 dBmV for distribution. The four-way drop taps may be placed either in the centrally located mini-headend or distributed along a trunk line.

**Greater than Forty Units per Building**

A low loss distribution system should be designed for the building. When the building has many floors, one should plan a vertical main trunk with horizontal feeder trunks on each floor. Amplifiers are required after every 30 dB of signal loss. Due to the **density** of condominiums, **less tilt is required** in the amplifiers. As a rule of thumb, approximately **50 drops** may be serviced by a **single amplifier**.

Where more than 50 drops exist in a building, several mini-headend locations should be planned to minimize the length of drop cable to each unit. Each mini-headend should be provided with +22 dBmV of signal from the trunk. An amplifier will be located in each mini-headend to provide an Automatic Level Controlled signal of +50 dBmV for distribution.

**General Comments**

Whenever possible each unit in a multi-unit building should have an individual cable connection from a central location in the building. The individual cable configuration allows for maximum flexibility should additional service be added at a future date.

If VHF signals are required, each mini-headend should also include a VHF headend. The VHF signals are combined with the CTN signals AFTER the BDC amplifier.

**MOBILE Home Parks**

The second highest density population area is the **Mobile Home Park**. Units in mobile home parks are usually within 50 feet of each other and are located such that drop cable distances are no more than 150 feet.

The following design recommendations should be considered when designing a CTN for a mobile home park:

The main trunk should be routed through the development in a way to provide a maximum number of equal length feeder trunks. It has been my experience that the main trunk usually runs perpendicular to the streets while the feeder trunks run parallel to the streets. The actual routing will be dependent upon the best location for street crossings.

The optimum location for the antenna and the headend is in a community area near a utility closet or community laundry building. Frequently, the headend can be located near the park manager. When options are available for the headend location, select one that is **centrally located** and has a convenient **indoor** headend electronics area.

Once the trunk routing has been determined, the total



**MOVE**  
 more  
 merchandise  
 with  
**GECC**  
 Floor  
 Planning  
 and  
 Echosphere  
 Corp.

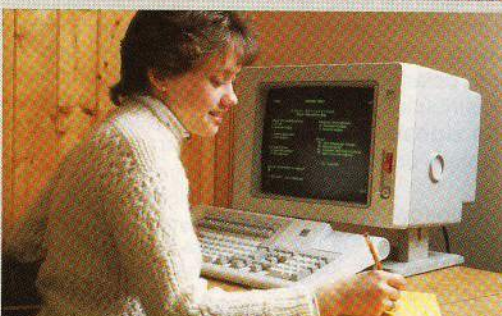
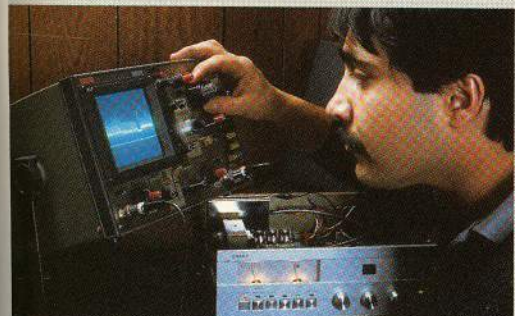

# Our commitment to the satellite TV industry goes beyond low prices. We deliver a commitment to YOU.

Echosphere is committed to bringing you the finest products and the best service in the industry. That's important. With the rapid-fire changes characteristic of high technology, it's essential that you have the means to solve inventory problems, keep up

with the latest equipment and stay one step ahead of your discerning customers.

Echosphere understands these problems. We respond with state-of-the-art equipment, dealer financing, ongoing dealer training programs and a superb technical staff to

assist you. We also provide 48-hour delivery anywhere in the nation and toll free hotlines, for instant access to the information you need. Call us. We look forward to answering your questions. Let us give you a taste of our commitment today.

**\*Call Toll Free Nationwide 1-800-521-9282**

**ECHOSPHERE WEST**  
 5671 Warehouse Way  
 Sacramento, CA 95826  
 916-381-5084

**ECHOSPHERE CORP.**  
 1925 W. Dartmouth Ave.  
 Englewood, CO 80110  
 303-761-4782

**ECHOSPHERE S.W.**  
 3901 La Reunion Parkway  
 Dallas, TX 75212  
 214-630-8625

**ECHOSPHERE EAST**  
 10536 Lexington Drive  
 Knoxville, TN 37922  
 615-966-4114



\*Dealers Only

The Distributor That Makes A Difference. <sup>TM</sup>

distances should be measured. The cable size will be selected based upon minimizing the number of trunk amplifiers. The first iteration will be calculated using 0.500" hardline cable. If at the end of the last feeder there is too little signal, a decision will be made to **either increase** the trunk cable diameter **or add** an amplifier. The decision is based both on cost and system reliability. Ideally it is better to have a larger diameter trunk cable than an additional amplifier.

**EXAMPLE Installation: "Pleasant Valley"**

The "Pleasant Valley" park is located well away from areas serviced by municipal cable companies. They can receive fair VHF local programming at only a few of the mobile home sites. The owner has expressed an interest in having cable television available to the residents.

Two tiers of service will be offered to the residents of "Pleasant Valley." A **VHF headend** will be installed to provide better **local** programming. Residents who wish better local TV signals may select this 'basic' service. Both polarities of the Galaxy 1 satellite will also be placed in the distribution system. Residents who wish to receive the **satellite signals** will purchase a **TX 200 satellite receiver** to personally demodulate any of the possible 24 satellite channels.

Salesmen canvassed the individual homeowners and found that thirty of the 63 residents were interested in the full service option. Twenty residents desired only the VHF local service. A rough design is performed to determine the per resident cost of the CTN based on the expected levels of participation. With firm cost figures the salesmen can return to the park and obtain deposits from the individual homeowners.

**CTN COST Estimate for "Pleasant Valley"**

The installation site is inspected by the CTN representative and the owner of "Pleasant Valley." The headend site is selected to be on lot 34 based upon reception of VHF and satellite signals and owner preference (see figure 12).

The owner does not have a plat map of the development so one is drawn by the CTN representative (figure 12). In drawing the map, the CTN rep notes the convenient path for the trunk cable, and drop pedestals. Road crossings are also selected for ease of installation.

**Distances are measured** between each pedestal as annotated on the map. The map is returned to NETWORK COMMUNICATION SERVICES for a rough design. From the headend on lot 34, two main trunks are anticipated. Trunk "A" would extend from the headend to lot 14. Trunk "B" would extend from the headend to lot 12. **The ends of each trunk** are selected to give each the **same approximate length**.

Trunk "A" has a total length of 1400 feet. Trunk "B" has a total length of 1300 feet. One feeder trunk branches off trunk "B."

**Figure 11** may be used to **estimate** the number of LX50 line amplifiers required for each trunk. Each trunk is greater than 900 feet and less than 1800 feet. One amplifier would be required in each trunk if 0.500" hardline cable is selected. If 0.750" cable was used for each trunk, the 1300 foot trunk length would be less than the 1400 foot maximum listed in the table. Assume the actual cable placement may differ by 10% from those measured by the CTN representative.

1300 + 10% of 1300 = 1430 feet.

As one can see, an error of 10% could cause the last drop to be low on signal. Selection of the 0.500" cable with **two external LX 50 amplifiers** provides a safety margin for installation variations.

A 4 meter antenna with an 80 degree LNB is selected to

provide a signal quality margin. The additional cost of the commercial grade antenna results in only a marginal cost increase to each participant but provides significant picture quality improvement.

The VHF headend consists of a 25 foot tower, a broadband antenna, a low noise pre-amp, individual channel processors, and a high power VHF broadband amplifier. The cable loss of the highest VHF channel (211 MHz) is 1.21 dB per 100 feet of 0.500" hardline. The maximum VHF loss is therefore;

(1400 feet) (1.21dB/100 ft) = **17 dB.**

System Design	Dealer Cost
Rough Estimate Pricing .....	No Charge
Complete Design Package .....	\$10 per drop 630
<b>Pre-Assembled, Pre-Tested TX Electronics Headend</b>	
TX 80 degree LNB .....	495
LNB Power Supply with DC inserter .....	60
Distribution Amplifier LX-50 HE .....	420
Headend Amplifier Power Supply .....	60
Headend Enclosure .....	60
Multiple Outlet Power Strip .....	12
VHF Diplexer .....	20
Directional Couplers .....	20
Headend Assembly and Test by Network Services .....	200
<b>Locally Procured Headend Equipment</b>	
4 Meter Receive Antenna with feed .....	1500
Installation .....	400
VHF Headend Equipment .....	1000
<b>Distribution</b>	
0.500" P-3 or 4500 Flooded Cable (0.24 per ft.)	
(3450 feet) (0.25) .....	862
Installation (3450 feet) (\$1.50 per foot) .....	5175
18 gauge 2 conductor stranded jacketed cable	
(1000 ft.) (0.10) .....	100
Street Crossings .....	\$6.95 per foot
(200 feet) (\$6.95 per foot) .....	1390
LX 50 Distribution Amplifiers — \$410 each .....	820
TX High Frequency 4-Way Taps — \$19 each .....	
(26 pedestals) (\$19) .....	494
<b>Pedestals</b>	
Drop (24 peds) (\$14 each) .....	336
Amplifier (2 peds) (\$39 each) .....	78
Hardline connectors (26 peds) (\$10 each) .....	260
Installation (26 peds) (\$10 each) .....	260
<b>Proof of Performance Testing</b>	
Rough Alignment sweep test	
(3450 feet) (\$0.07 per foot) .....	242
<b>Final Alignment</b>	
(3450 feet) (\$0.08 per foot) .....	276
Distribution TOTAL \$15,768	
<b>Customer Hardware (Both tiers of service)</b>	
Drop Cable (RG-6 Flooded) .....	\$0.08 per foot
(50 drops) (150 ft. per drop) (\$0.08 per ft.) .....	600
Installation — \$0.25 per foot	
(50 drops) (150 ft.) (\$0.25) .....	1875
Drop Hardware (\$9 per drop) (50 drops) .....	450
VHF ONLY Customer Payment (20 drops) (\$200) .....	4000
TX 200 Receivers (\$325 per drop) (20 drops) .....	6500
FULL SERVICE SYSTEM TOTAL \$24,423	
<b>Dealer Cost Per Full Service Subscriber .....</b>	
(\$24,423) / 30 = .....	<b>\$814</b>

The final type of population center that fits the CTN requirements is the **INDIVIDUAL RESIDENCE NEIGHBORHOOD**. Lot sizes and unit spacings vary considerably. Each installation must be considered on a case by case basis. The lower density of units forces the **per unit cost of the CTN** to increase. Our experience indicates the type of neighborhood

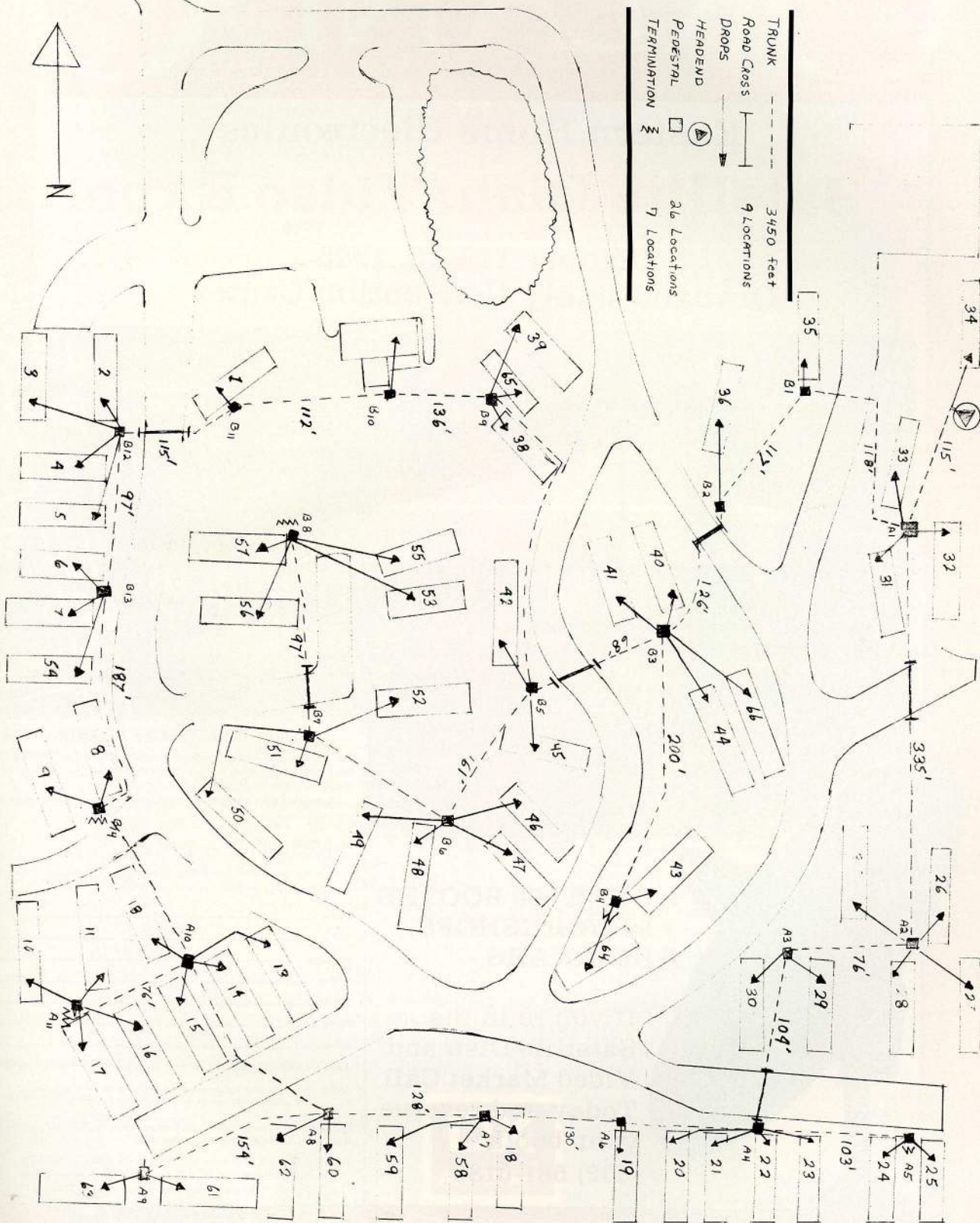

FIGURE 12/ Pleasant Valley BDC SMATV system layout involves precise measurement of the development and then 'laying in,' on paper, the equipment (wiring and electronics) required.

# ORLANDO

## Eastern Home Electronics Satellite Dish/Video Expo

October 11 - 13, 1985  
Orange County Convention Center



- OVER 500 BOOTHS
- 30 WORKSHOPS
- SEMINARS

If you're in the  
Satellite Dish and  
Video Market Call  
Today and reserve  
your booth  
**(602) 581-0188**

### ADVANCE ATTENDEE REGISTRATION

YES - I wish to register for attending the EASTERN HOME ELECTRONICS SATELLITE DISH/VIDEO EXPO at the Orange County Convention/Civic Center to be held in Orlando, FL, Oct. 11-13, 1985.

I understand that each registration fee includes FREE seminars and workshops for each day I have registered.

I wish to register for:

- One day (\$15.00) -  Friday  Saturday  Sunday
- Two days (\$20.00) -  Friday & Saturday  Saturday & Sunday
- Three Days (25.00)

Name \_\_\_\_\_

Title \_\_\_\_\_

Company \_\_\_\_\_

Address \_\_\_\_\_

City/State/Zip \_\_\_\_\_

Phone \_\_\_\_\_

Spouse \_\_\_\_\_

(Spouse - additional \$5.00 for all three days & children under 18 admitted free).

\*NOTE - No registration will be processed without payment in advance.  
All exhibitors will receive three free passes per booth.

Check here if you would like your badges mailed to you, otherwise you may pick them up in the registration area at the show.

PLEASE COMPLETE AND MAIL WITH CHECK OR MONEY ORDER TO:  
SATELLITE TODAY, P.O. Box 41591, Phoenix, AZ 85080  
For more information phone (602) 581-0188

Sponsored by **SATELLITE TODAY**  
P.O. Box 41591, Phoenix, AZ 85080

Descrambler  
Compatible

12 GHz and 4 GHz

Block  
Downconversion



## READY YESTERDAY

Both DX DSB-600 and DSB-700 receivers have all the advanced high-quality features you need for great reception and successful installations...now and in the future.

Both are capable of receiving 12 GHz and 4 GHz signals automatically. Both come with video clamp/unclamp switch and composite baseband output for descrambler compatibility. And DX led the industry with quality block downconversion for multiple-

receiver hookup. State-of-the-art features that deliver unsurpassed performance at a low price. From DX, world leader in satellite reception systems... yesterday, today, tomorrow.

### DX COMMUNICATIONS, INC.

A Subsidiary of C. Itoh & Co. (America) Inc.  
10 Skyline Drive, Hawthorne, NY 10532  
(914) 347-4040



interested in CTNs are typically located well away from major population centers. These areas are usually more exclusive and many have association rules restricting the installation of unsightly large satellite dishes. **A single antenna** set off to one side of the development is preferred to having many antennas scattered throughout the neighborhood. The following design recommendations should be considered when designing a CTN for a neighborhood:

The main trunk should be routed through the development in a way to provide a maximum number of equal-length feeder trunks. It has been our experience that the main trunk in a single family neighborhood will be long compared to the feeder trunk length. As a result, the **main trunk** is usually **0.750" hardline** cable. The feeder trunks may be the smaller 0.500" hardline. The actual routing will be dependent upon the best location for street crossings.

The optimum location for the antenna and the headend is frequently **not** up to the designer. The community will prefer a particular location. Try to bias them towards a **central location**. The headend should be located inside a fabricated shelter or in one of the homes. Frequently, free service is provided to the resident of that home in exchange for the power required for the headend.

If external amplifiers are required, a location must be selected for their power supplies.

Once the trunk routing has been determined, the total distances should be measured. The cable size will be selected based upon minimizing the number of trunk amplifiers. The first iteration will be calculated using 0.750" hardline cable. If at the end of the last feeder there is excess signal, a decision will be made to either decrease the diameter of a section of main

trunk cable or eliminate an amplifier. The decision is based both on cost and system reliability. It is usually better to have a larger diameter trunk cable than an additional amplifier.

#### CONCLUSION

The distribution of the UHF block of satellite signals to multiple receivers has one very distinct advantage over distribution methods which utilize the 950 to 1450 MHz band. That being, by using 450-950 MHz, you are following time-proven techniques developed in tens of thousands of cable television system installations. Community Television Networks (CTNs) also offer VHF signals to the participating home units through the same cable. CTNs are quite comparable in scope and complexity to modern SMATV systems except that the need for individual **headend** satellite receivers and individual (VHF) channel modulators is eliminated with CTNs since each home unit participating in the system makes his (or her) own individual program-channel selection by having their own satellite video demodulator inside of their home.

Additionally, the ready availability of distribution design services, fully tested distribution equipment, and cable contractors familiar with cable plant construction techniques reduces the financial risk for the satellite dealer who is interested in selling such 'CTN' systems.

**In part three** of this series (in our October 01 CSD) we will look at the increasingly popular 'cable-less' technique of re-broadcasting the same 450-950 MHz block of signals through the air to individual satellite-demodulator-equipped homes. Finally, in **part four** of this series, we will look at the electronic balancing of the CTN system and the proper use of test equipment in this specialized field of satellite video service.

## ROOTS OF TVRO (Part 16)

By early fall in 1956, Colorado's new Governor, former United States Senator Ed Johnson (recall that Johnson served as Chairman of the Senate Interstate and Foreign Commerce Committee), issued a *state proclamation* that put Washington on notice, by releasing a trio of executive orders:

"...**This office** (the office of Governor) **hereby proclaims that the continued televi-**

#### ABOUT This Series

History repeats. While many of those involved in the latest 'American television revolution' are either too young, or were not involved in the broadcast industry during the first 'television revolution', the unfolding of 'current' events now closely parallels the events of the early 50's in our field. Television began as a technical curiosity of the 30's and was first introduced to America by RCA at a Long Island World's Fair just prior to World War Two. Immediately after the war, commercial broadcasting renewed in the larger cities. There was mushrooming growth in the late 40's and early 50's and bureaucratic stumbling threatened to stop that growth. Rural people were anxious to have television and put American ingenuity to work to find ways to obtain TV. This report traces those days and shows how television's last frontier, **rural America**, was never really fulfilled until there would one day be something called satellite television. This series originally appeared in two blockbuster back to back issues of **CATJ** in the mid 70s.

**sion service made possible throughout the State of Colorado by devices variously known as boosters, repeaters and translators, shall, by executive order, be allowed to continue in operation; not withstanding the existence of federal orders issued by the Federal Communications Commission to shut these units off and to dismantle them."**

The FCC Legal Department backed *way off, in a hurry*. For the time being,



they were content to let the courts look at the matter, because as one FCC attorney said, "We have no desire to tangle with Governor Johnson." The Governor said things like "Colorado is going to test the arbitrary and incomprehensible action of the FCC to deny entertainment and education to the people of isolated areas"; and the voters loved him for it.

Meanwhile the Commission *rushed* out its program for an all-UHF translator program, for areas like Colorado, they said. Former Senator Johnson was still close to Washington when the first UHF licensees started trooping back to Washington with licenses in hand, to turn their licenses in while they were on their way to the unemployment line and to file for bankruptcy. Governor Johnson knew well *what a fiasco* UHF was turning out to be, and he wanted no part of it for the Coaldales of his state. So he told the Commission:

**"Your approved (UHF) translator plan may be splendid for the Atlantic Seaboard, but it will not work in the Rocky Mountains. What is wrong with two different systems in this country? Just because you have found something that you believe may fit the areas with which you are familiar, please don't force it down our throats arbitrarily. Why are you picking on us mountain folks? We are people too!"**

By the *fall of 1957*, the problem was *still not solved*. The FCC was still intent on making a UHF translator service work, just as it was intent on making a UHF broadcasting service work; even if it bankrupted hundreds of television broadcasters (who were foolish enough to try UHF) in the process. So in the fall of 1957, a new Governor of Colorado, Steve McNichols, took up

where former Governor and ex-Senator Johnson had left off. Again a Colorado Governor appealed to the FCC bureaucrats, with:

**"...VHF boosters are preferable to and better adapted to the western geographical conditions than UHF translators. VHF boosters are less expensive, which means they can serve smaller pockets of people—pockets too small to afford UHF translators. I urge that both VHF boosters and UHF translators be legalized jointly, with each being used where each can best be used to provide service."**

And that was 1957, some three years after the existence of illegal VHF boosters became known to the FCC. What did the Commission finally do with VHF boosters? In 1961, they authorized their operation, under federal control. *But it took seven long, hard years for the Commission to wrestle out a solution to this very simple, uncomplex, technical problem.* Considering it took them three and a half years to wrestle out a lousy solution to the color-and-allocation problems, Commission handling of boosters in perspective was about par for the agency.

Today there are approximately 2,900 FCC-licensed VHF booster/ translators and UHF translators in operation, slightly more than 2,000 VHF, and the balance (900) UHF. Not surprisingly, 542 (19%) of the existing operating translators (VHF and UHF) *are owned and operated by television broadcast stations.* Station-owned-and-operated translators are confined to operation *within* the station's predicted Grade B (regular service) contours, but they often become a new kind of weapon or tool for the broadcaster.

**THIS SERIES** will continue in **CSD** as we trace the amazing parallel between TVRO and fringe area terrestrial TV growth over 20 years ago.

# At Last...

## INTRODUCING...

The all new - -  
All in One Super  
Satellite Stereo  
Receiver from  
Boman Industries.

Convenience and style  
combined with the latest in  
TVRO technology makes the  
Boman Model SR2500 the receiver  
to which others will be compared.

### Audio Group

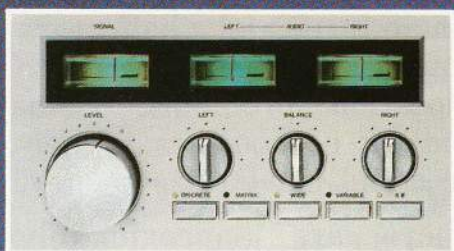

Separate meters showing Signal Strength and Left - Right audio levels are provided with soft green illumination. Left-Right audio channel tuning is adjusted by separate controls. A balance control is provided for attaining that perfect stereo effect.

The pushbutton group consists of the "Discrete" and "Matrix" stereo buttons. Bandwidth is expanded by use of the "Wide" button. These three controls enhance the reception of all available audio transmissions.

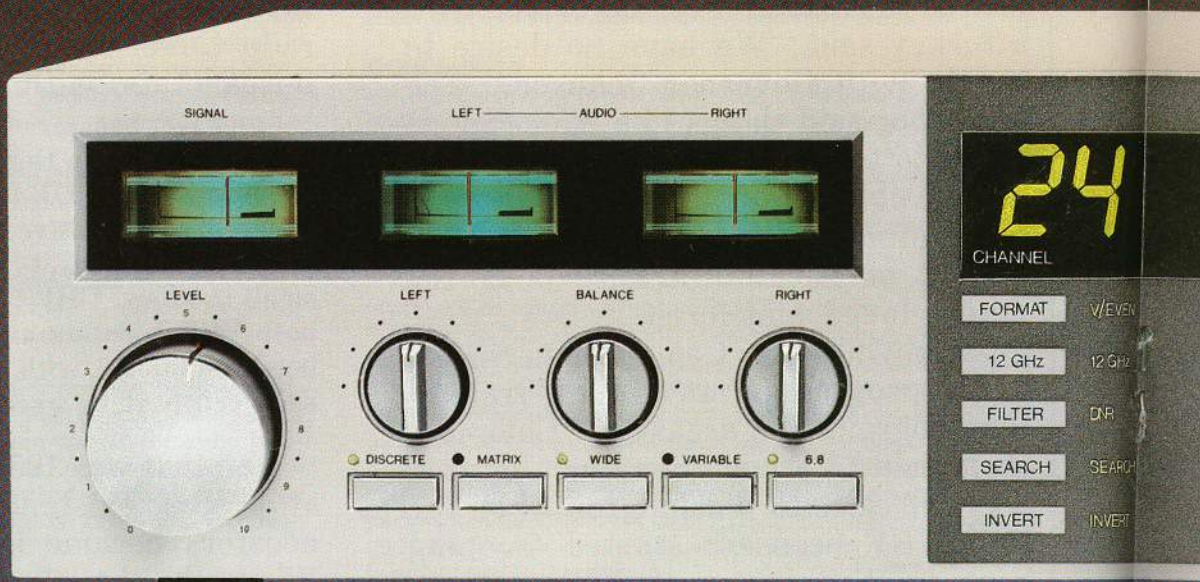

The audio pushbuttons offer a choice of preset 6.8 tuning frequency for most video channels and variable audio for stereo or sub-carrier reception.

The Detent Volume control adjusts the volume and adds to the attractive design of the stereo section.

### Function Group

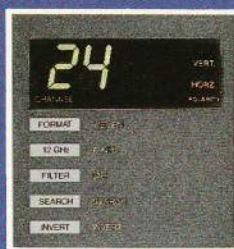

The attractive display panel shows channel number and polarity position in a soft green color.

The Format button transposes the polarity mode when receiving signals from the few satellites with reversed polarity signals.

The 12 GHz button changes the operation of the SR-2500 from

4 to 12 GHz when used with appropriate 12 GHz hardware.

DNR function provides a filtering of background noise from the audio thus providing very high quality audio performance especially on weaker signals.

A Search button gives a fast scan of all channels and is of assistance during the initial alignment and orientation of the programmable moving control.

The Invert button is provided for reception of inverted video signals.

### Satellite Selection Group

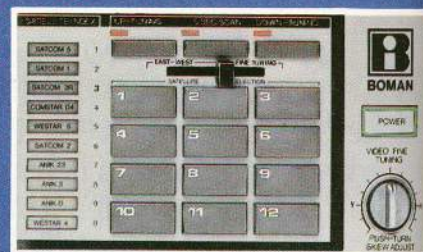

Satellite selection is accomplished with the 12 pushbutton pad.

# All In One.

## \$389.50

*Down Converter  
And  
Automatic Actuator  
Control  
Included*

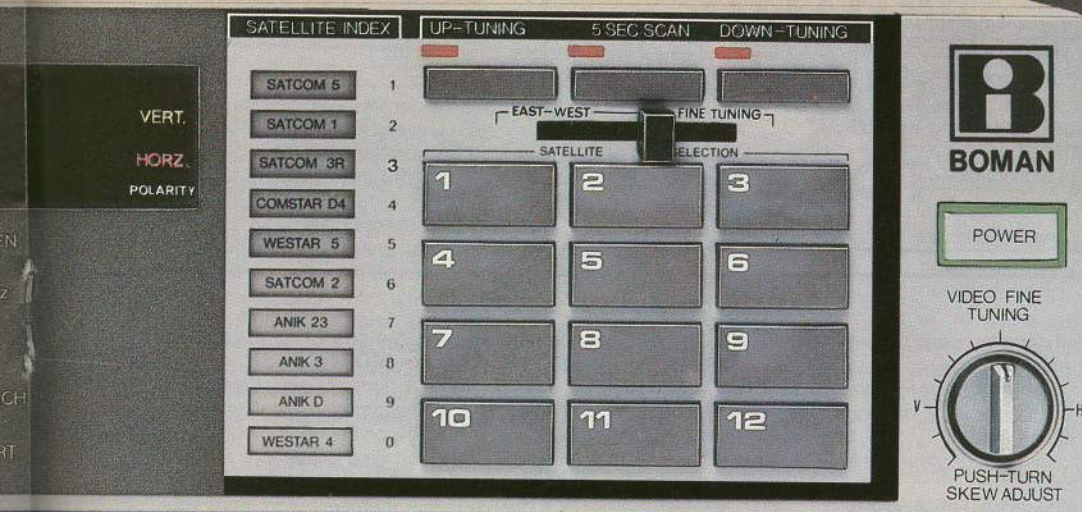

The interfaced control then automatically moves the antenna to the pre-programed position.

A removable Satellite Index is provided which indicates the selected satellite. Up to 12 different choices of satellites may be illuminated individually. Additional satellite decals are furnished to provide a maximum of 24 satellite variations.

The East/West fine tuning control is used for that extra special antenna peaking which is sometimes required.

The "UP" and "DOWN" tuning buttons provide manual selection or scan of channels in 1 step or 2 step and continuous operation. The 5 second Scan button allows the user to view each channel for 5 seconds during the 24 channel scan.

Video Fine Tuning and Skew adjustment is made quick and easy using the dual function fine tuning control.

Other features found either inside or on the rear panel of the SR-2500 are:

- Automatic Polarity Switching.
- Command Tone Response: A "Beep" audio tone is heard when any of the Feather-Touch push-buttons is used.
- LNA/Down Converter power remains on when the unit power is switched off: No more LNA/DC warm-up drift.
- Integrated Channel 3 - 4 Modulator.
- 1 - 2 Step Channel Advance Switch.
- Separate Sub-carrier Outlet.
- IF Gain Control.
- Cable Length Compensation Control.
- Parental Guidance Switch.
- Remote Control Switch.

*MODEL SR-2500  
The ultimate combination of product innovation, user convenience and value... ALL IN ONE product.*

*Use our toll free numbers shown below to order yours today.*

*Boman Industries*



*Anniversary*

**B** **BOMAN INDUSTRIES**  
SATELLITE PRODUCTS DIVISION  
9300 Hall Road Downey, CA 90241

**Toll Free Number :** INSIDE CA. (800) 352-2553  
OUTSIDE CA. (800) 421-2533

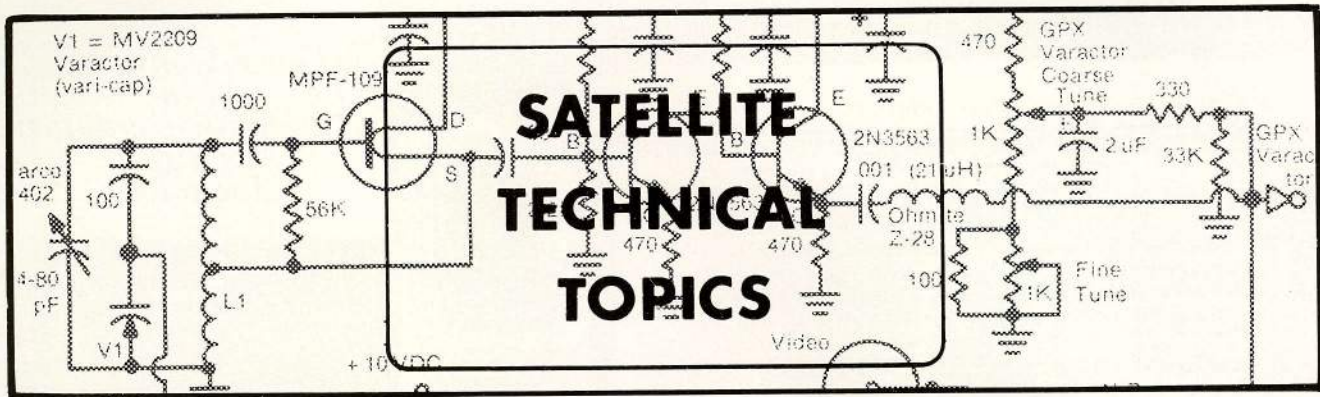

A frequent cause of service calls is damage done by power surges on our commercial AC power mains. They are most likely to occur during lightning strikes on the power lines or when a power failure occurs or ends. Inductive loads on the line (air conditioners, motors, etc.) are frequent causes of power failure-related surges.

There are a few things dealers can do to minimize damage to the solid state equipment used in satellite systems:

A first line of defense is to plug the equipment into a **surge suppressor** which may have 1 to 6 AC outlets. These surge suppressors contain **metal oxide varistors**, or MOV's placed across the AC power line. When the line voltage exceeds a certain value, for example 130 Volts, the MOV's conduct heavily, clamping the surge voltage, which may be as high as 1500 Volts.

A second thing that we can do is to go **into the equipment** and install surge suppression **diodes** across the **DC power supply lines** inside the equipment. The **SSD**, or surge clamping diode is a solid state device, similar to a Zener diode, and must be installed with the cathode (banded end) **towards** the most positive side of the power

supply. Surge clamping diodes are available thru ECG distributors; part numbers ECG4900-ECG4986. **Like MOV's**, these must be selected to **match** the maximum voltage normally expected to be present. MOV's, as components, can be directly installed inside equipment **across** the power line, preferably on the equipment side of the fuse. Bare MOV's resemble oversized disc capacitors and are available through Radio Shack, as well as ECG distributors.

Be advised that MOV's may sacrifice themselves to save your equipment by shorting and popping the fuse or circuit breaker on the line. In this case, the MOV must be replaced before the equipment is usable again.

Small, inexpensive AC outlet testers with 3 neon lamps should be used to insure that the outlet is properly wired and has a good third-wire ground (earth ground). A good earth ground is **imperative** for plug-in-the-wall surge suppressors to function properly. The use of shielded cables from the indoor electronics to the dish is also beneficial, particularly actuator position sense and polarization control lines. In short, an ounce of prevention is worth a pound of cure.

## FOCII AND TWEAKER II REVIEWS

### GREATER Sophistication

The first installer test equipment available to TVRO dealers consisted of a metering system which allowed the installer to monitor the relative (satellite) signal strength at the dish. **Northwest Satlabs**, and others, developed 70 MHz 'IF line' metering systems which sensed the amount of RF signal present in the line leading out of the downconverter and displayed that level for you on some sort of indicator meter (see **CSD** for May, 1984).

Ultra sophisticated testing equipment, such as a spectrum analyzer, has been available but only if 'imported' from other fields of endeavor; such as CATV or broadcast. And the price

has also been 'ultra high' since the high precision measurements required in many fields far exceeds our rather modest 'go' and 'no-go' situations. Recently, a significant amount of tailored-for-TVRO test equipment has appeared including at least two made-for-TVRO spectrum analyzer lines (AVCOM and Luly) and a considerable variety of more sophisticated signal level metering or measurement devices. As the sophistication has increased with each new piece of equipment, the price has also increased. And while \$50 range simple signal level meters are still available (**CSD** published a do-it-yourself circuit for such a meter in our February 1, 1984 issue), the trend is clearly to more versatile equipment created by people who recognize that the 1985 world of TVRO is more demanding than the early days of five years ago.

### BDC Element

When virtually all receiver IFs were at 70 MHz, building a metering device to insert into the line between the down-converter output and the line running indoors to the receiver proper was a simple task. The metering circuit had to detect (and perhaps amplify) an FM wideband video signal centered on 70 MHz. This allowed a 'tuned detector' circuit, centered on 70 MHz, to capture and monitor the signal level in a single frequency range. And that was before the sudden increase in BDC type receivers.

**BDC** receivers present new and unique problems to the metering circuit designer. Without a common 70 MHz IF, the 'tuned detector' must be relatively broadband in nature. With block IFs operating in the 270-770 region (AVCOM), 430-930 MHz region (Anderson, Janeil, Sat-Tec and many others),

and, in the 900-1450 MHz region a signal detector capable of providing meaningful signal level indication has quite a wide-band task before it.

There are several approaches to resolving this problem. A detector can be 'broadbanded' over a frequency range such

#### 'TWEEK' With An 'E'

For many years in the audio field, there have been various solvents and fluids which have been designed to **clean** corrosion from jacks, plugs and switches which must make metal to metal contact for the proper transfer of (signal) energy. Here is a relatively new product we recently discovered which may help the TVRO installer clear up some troublesome 'intermittent' connections problems. Appropriately, it is called '**Tweek**' and we recommend it with one caution.

Tweek works on the theory that most metal to metal contacts are actually metal to air contacts; that all jacks and plugs and switch contacts mate to pieces of (similar) metal to allow a circuit to exist. They claim that in virtually every such product, the metal to metal contact, **because of surface irregularities in the metal**, ends up being more **metal-to-air** than metal to metal. They provide microscopic data that shows two mating contacts only touching one another at irregular spots.

The fluid in Tweek (they don't say what it is but there are no cautions on the container so apparently it will not harm you) is a 'long chain organic molecule' which (like most fluids) will not conduct (electrically). However, when the fluid is compressed between two closely spaced metal surfaces, the fluid's molecules reshape and they claim it conducts 'across' the polymer molecules.

You don't really care about theory, if it works and won't hurt you. **It does work**, and while we haven't tried to inhale the stuff, chances are it is harmless. We tried it on video and audio fittings, troublesome switches, and even 70 MHz IF (F fitting) contacts. It didn't hurt anything in the worst case and in the best case it 'cleaned up' dirty or intermittent contacts ending problems we had been having with numerous switches and connectors.

It's not cheap but then if it fixes a connection (apparently permanently) it could be worth its weight in gold (which is sort of how it is priced). The smallest size available is 60 cc (a cc is 0.338 fluid ounces) and the price is \$42. Source is **Sumiko**, P.O. Box 5046, Berkeley, California 94705; 415/843-4500.

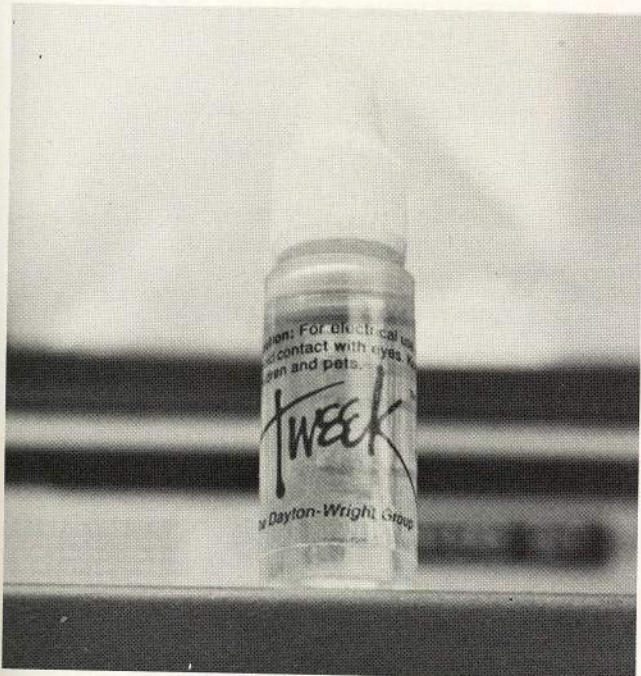

'TWEEK' (™, and patent pending) CURES NOISE

as 50 to 1500 MHz but there is no inexpensive way to 'compensate' for the fact that the detector's efficiency is going to change over the frequency spectrum. Typically, the detector will be **most efficient** (i.e. produce the **highest** reading signal level) at the lower end of the 'bandwidth' (such as close to 50 MHz in our example) and **least efficient** at the higher end of the desired bandwidth (such as 1500 MHz in our example). This becomes a 'difference-in-sensitivity' factor for both meter design and meter use. Let's illustrate what might happen:

- 1) You are tuned to a satellite with a well-rounded transponder loading condition; i.e. such as Galaxy 1. The transponders located at the low end of the satellite band also show up at the low end of the BDC band. Each transponder coming off the dish and through the downconverter provides some amount of 'signal power' to the signal level detector. But when the meter detector circuit has more gain or greater efficiency at the 'low end' of the band than at the high end, the low-end transponders carry an unusually high percentage of the total detected signal display(ed).
- 2) You are tuned to a satellite such as Westar 3 and the only transponder active at the time is TR21. Now the signal level displayed is the sum of only a single transponder and that transponder, being quite 'high' in the band, is detected at a relatively low efficiency. The display, then, is reduced greatly in amplitude because of these two factors.

So the primary and most important difference between a simple field strength metering system which monitors the 70 MHz IF line, where only a single transponder is present, and the newer generation 'broadbanded' metering systems is that the later models 'sum' all carriers present in a broadbanded circuit and the display you hear or see is a function of **all of the activity**, as detected, on that bird.

#### PRACTICAL User Problems

As nice as having a well-defined meter display at the dish is for the professional installer, there has always been the 'one-man-syndrome' problem; how does one person, all by him (or her) self adjust a feed, for example, for maximum signal strength or best polarization orientation AND watch a meter at the same time? The answer is that you don't unless you have a third arm handy to balance the meter while using the normal two hands to adjust the feed. A third eye is also useful to keep an eye on the meter.

The solution to this problem is to provide **two separate displays**; one visual and one 'audible'. **The Squawker™** did pioneering work in this field by providing an installer meter which emits an audible 'tone' and the tone is 'modulated' by the changes in the field strength level within the detector circuit. As the signal level rises, so does the tone and all an installer needs to do is to 'listen' to the tone. If its frequency is going up (i.e. higher tone), the signal level is also increasing at the same time. And conversely, a lower tone is a reduction in signal level. Now the installer can handle his installation with the normal two hands and two eyes.

Another practical problem faced by early installers was meter definition; an analog meter, using a pointer that changes on the scale as a function of signal strength, is difficult to read for small changes in relative signal level. Additionally, 'absolute readings' require that the user place himself squarely in front of the meter face to avoid any parallax problems; 'optical illusions' created by being off to 'the side' of the meter face.

One solution cured both problems; a digital display using

real numbers. The Squawker as well as the Tweaker II adopted the numerical display technique and now you can read it from an angle and anyone who can count will have foolproof 'readouts'.

Yet another practical problem involves human forgetfulness; leaving the meter switch 'on' after you are done with a job. The solution was to build the instrument into a case with a lid that closes down over the display portion as protection from damage. Then incorporate a shut-off switch into the lid-closing function so that as the lid closes, the instrument shuts down. No more forgetfulness and again both the Squawker and the Tweaker II adopted variations of this proven technique.

#### THE Squawker

The Squawker™ unit beat the Tweaker II to the marketplace by nearly six months. Tweaker (I) had been in the marketplace for several years, as we reviewed in CSD in 1984. But the Squawker was the first generally available test instrument to allow a dealer to install either 70 MHz receivers or BDC range receivers (and their attached antennas) with equal ease. Most of all, the Squawker was a relatively inexpensive unit.

The attraction of the Squawker is simply this; anyone who has attempted to do dish alignment, dish peaking, feed peaking or even LNA comparison with a TV set stashed in a cardboard box sitting at the foot of the antenna knows the frustrations attached to such an exercise. Very few (if indeed, any) TV sets have a screen display that is adequate for outdoor use. Small screen TV sets, the kind you are likely to lug to



**SQUAWKER** by Focil arrives in dealer hands ready to go to work.

## WESTERN ENTERTAINMENT SATELLITE TELEVISION INC.

### DISTRIBUTORS

#### CAYSON ELECTRONICS

FULTON, MS 800 892-4916  
In State 601 862-2132

DECATUR, IL 800 382-1811  
In State 217 877-7954

#### CARMICHAEL ELECTRONICS

DOTHAN, AL 205 793-7066

#### D.H. SATELLITE T.V. INC.

PRAIRIE DU CHIEN, WI  
608 326-6705

WASECA, MN 507 835-4454

TIFTON, GA 912 382-3867

BUCKEYE, AZ 602 386-7131

MT. PLEASANT, PA  
412 547-6160

#### DULANEY'S

OKLAHOMA CITY, OK  
405 528-0511

#### FOCII ANTENNA SYSTEMS, INC.

TOPEKA, KS 800 358-3079 ext

#### HOOSIER ELECTRONICS, IN

TERRE HAUTE, IN 800 457-3330

OVERLAND PARK, KS  
800 457-3330

WEST SACRAMENTO, CA  
800 458-3330

ORLANDO, FL 305 423-4596

#### INTERNATIONAL SATELLITE DIST.

BEAUMONT, TX 409 842-0497

#### KEITH ELECTRONICS

LAUREL, MS 601 649-2960

#### LEWIS ELECTRONICS

HUMBOLT, TN 901 784-2191

#### OZARK MARKETING, INC

KIMBERLING CITY, MS  
417 739-4132

#### POWER COMM INTERNATIONAL

MINNEAPOLIS, MN 913 582-4508

#### SKY SPAN TECHNOLOGY, INC

PHENIX CITY, AL 205 297-7119

#### S.R.C. INDUSTRIES

ONTARIO, OR 503 889-7261

WILSONVILLE, OR 503 682-2467

KERRVILLE, TX 512 895-5501

#### U.S. COMMUNICATIONS, INC.

WILLIAMSPORT, PA 800 233-2303

In State 717 326-7133

(916) 337-6202

P.O. Box 70 • Round Mountain • California 96084

# MAXUM™

RC-011S

a good deal  
more  
for a good deal  
less



SINGLE AND BLOCK  
CONVERSION

QUARTZ TUNED

MANUFACTURED BY WESTERN SATELLITE

a job site, tend to 'mask' or 'hide' picture imperfections, especially when in a bright light. You are often fooled by the outdoor display and equally often disappointed when you get inside with the electronics and discover what the pictures really look like on a living room screen.

The Squawker installs into the line **between** the down-converter **and** the inside electronics. It may be installed outside, after the downconverter, but adjacent to the antenna so you can use it as you align the antenna; or, it can go inside with the receiver but just ahead of the IF input to the receiver itself.

The Squawker is **not** a loop-through device; i.e. you are supplied with a power-passing two-way splitter, by the manufacturer (Focii Antenna Systems, Inc.; 1) and instructions for its use. The IF line, whether at 70 MHz or someplace in the block range of 30 to 1400 MHz goes into the input on the splitter; there are two outputs. **One of the outputs** attaches to the Squawker and **the other** goes on to the satellite receiver's IF input. In effect, the two-way splitter is simply placed in series with the IF line.

There are **two separate inputs** on the Squawker. One is marked 70 MHz while the other is marked BDC. Actually the two inputs are the same except that the 70 MHz jack has a bandpass filter, for 70 MHz, between it and the input to the Squawker signal voltage amplifier. The BDC input goes direct-

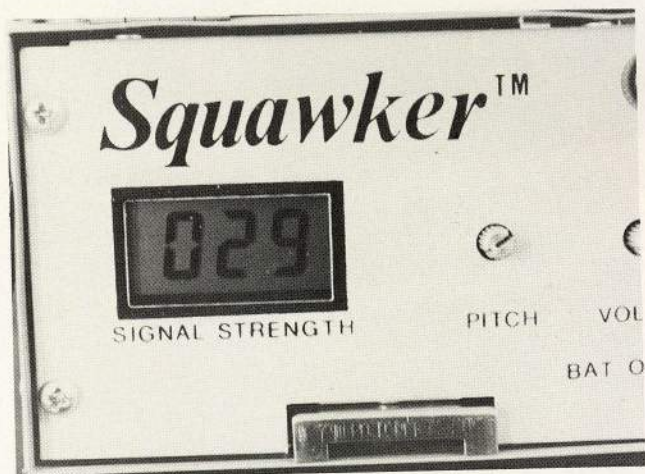

LOW END RESOLUTION TEST/ 'Weak' (picture corresponds to meter reading, using strongest transponder from test dish)

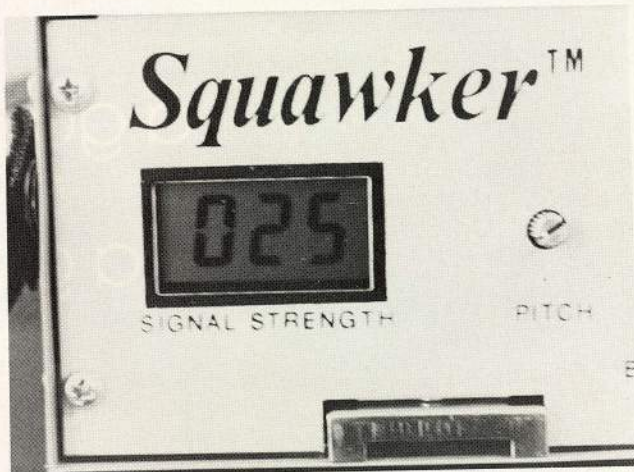

LOW END RESOLUTION TEST/ 'Weaker' (picture corresponds to meter reading, using strongest transponder from test dish)

ly to the 30-1400 MHz signal amplifier (as does the 70 MHz input, **after** signal filtering). Following the amplifier is a 'level detector'; a device or circuit to detect the signal voltages present from the input line. Once detected, these signal voltages (one or more transponders) then are amplified in their detected (DC) form and fed to a pair of 'displays'; one is the three-digit 'voltmeter' display; the counting display on the front panel. The second is an audio signal generator which is frequency-tuned by the amount of DC voltage present. In effect, as the detected voltage changes, the tone or pitch of the tone generator changes. More signal, higher pitch; less signal, lower pitch.

So you have a 'dual sense' or 'sensor' system operating. Between what your eyes tell you (from the digital voltmeter number display) and what your ears tell you (from the 'tone' or 'pitch' of the emitted squeal), there is little opportunity for an antenna installer to leave a job not knowing that his antenna has been 'peaked to perfection'.

The acceptable input signal level range with the Squawker is  $-40$  dBm to  $-10$  dBm. That corresponds to the type of signal levels you are likely to encounter from **most** down-converters. Internal to the unit, there is an adjustment (and

METERS/ continues on page 50



# The Best TVRO Filter Just Got Better!



Our PFG-series filters have solved thousands of terrestrial interference problems for dealers. That isn't enough for ESP. We made improvements for even better results.

**New!**  
**Three important advances make them even better.**

Now, there's a bypass switch for channels that are unaffected. So you only use the filter on transponders affected by terrestrial interference in the 4GHz band. We've also added an adjustable gain control (-2dB to +4dB) for optimum performance.

And now, there's a filter for block down conversion receivers with a second IF of 134MHz.

**The PFG-series filter...  
a proven performer that's  
easy to install.**

Using advanced delay line technology, superior interference rejection is achieved over that of conventional notch designs. Installation is easy. Simply make an in-line connection between the down converter and receiver.

## **Unconditional Moneyback Guarantee**

We're still the only filter in the industry being advertised with an unconditional moneyback guarantee. And after selling thousands of TVRO filters to satisfied dealers throughout the country, our return rate is less than 2%.

To solve your TI problems, call today. We have a stocking distributor near you. Dial 606-278-1209 and ask for Gary Friesz.

Once you try this filter, you'll wonder where it's been all along!

**ESP INC.**

2532 Regency Rd. Lexington, KY 40503

ORDER CSD HERE!



ORDER CSD HERE!

# NUMBER ONE FOR SIX YEARS

# 1

and  
STILL  
number  
ONE!

**CSD/COOP'S SATELLITE DIGEST.** The ONLY industry publication that was 'there' when this industry began, helping lay the foundation for what has today become a billion-dollar consumer business functioning worldwide! **CSD/** two complete issues per month (CSD/2 issued on the 15th of each month) covering EVERY important aspect of TVRO from hands-on equipment reports to detailed learning courses designed to help you own and operate a more profitable TVRO business. **CSD/** strong opinions in an often confusing mamby-pamby glut of meaningless press releases, claims and counterclaims, and, 'softshoe routine' editorials which say nothing and do nothing. **CSD/** a virtual 'correspondence course' in TVRO communications designed issue after issue to make you smarter and better equipped to deal with a run-away technology base. **CSD/** not a 'give away' publication paid for by advertiser support and 'advertiser favorable' editorials; supported BY dealers and distributors because it is the ONLY publication willing to stand behind and support dealers and distributors. CSD/ "Coop's" Satellite Digest from **the man** who started it all; and **THAT** says it all!

**SIGN ME UP!**

- \_\_\_ **ENTER MY U.S.** subscription (where US zip codes apply) for **24 issues** of CSD via AIRmail; **\$75** (US funds) enclosed.
- \_\_\_ **CANADA/MEXICO** — Enter my **24** issue subscription to CSD, via AIRmail; **\$85** (US funds) enclosed.
- \_\_\_ **ELSEWHERE** — Enter my **24** issue subscription to CSD, via AIRmail; **\$100** (US funds) enclosed.

NAME \_\_\_\_\_

Company (if applicable) \_\_\_\_\_

Address \_\_\_\_\_

Town/City \_\_\_\_\_ State \_\_\_\_\_ Zip \_\_\_\_\_ Country \_\_\_\_\_

**MAIL** order with payment ENCLOSED, or, use VISA/ Mastercharge by calling 305-771-0505 weekdays between 9 AM and 4 PM eastern.

CSD Magazine  
P.O. Box 100858  
Ft. Lauderdale, Fl. 33310

ORDER CSD HERE!

**We still believe  
promises are golden.**

# NSC

COMMUNICATIONS  
NATIONAL SATELLITE

**While many reflect  
their good intentions,  
strong principles  
create our image.**

Basic truths form the foundation of our Nationwide Service Commitment. Time and effort have made NSC a national distributor for all major brands of satellite receiving equipment. Quality support to our vast network while keeping the best interests of the consumer at heart, have meant something. Years of uncompromising professionalism helped shape our mutual goals. We constantly strive to be the best and encourage and train our dealer network to do the same.

Call (Toll Free) today for the location of the nearest "Authorized NSC Dealer". Through NSC, his promises to you are golden.

For More Information:

In New York: 1-518-383-2211

In Florida: 1-305-851-4738

To Place Orders Call:

New York Office:

1-800-833-4485 (National)

1-800-522-3538 (In State)

Florida Office:

1-800-322-4044 (Regional)

1-800-832-8659 (In State)

TELEX: 324701 SATELLITE



**NATIONAL SATELLITE  
COMMUNICATIONS™**

CORPORATE OFFICE:

21<sup>st</sup> Century Park  
Clifton Park, NY 12065

FLORIDA OFFICE:

10779 Satellite Blvd.  
Orlando, FL 32821

PIONEER MEMBER OF  
**SPACE®**

KANSAS CITY OFFICE: (LOCAL) 913-888-6333 (STATE) 800-432-0141 (NATIONAL) 800-633-5027

## METERS/ continued from page 46

instructions in the manual) telling you how to increase or decrease the sensitivity of the digital readout voltmeter display.

The Squawker claims a 'resolution' (the ability to detect changes) 'better than 0.1 dB'. In theory, it would be virtually infinite but as a practical matter a change of 0.1 dB is beyond your capability to visually resolve on the TV screen anyhow; so the unit's ability to detect signal level changes exceeds your ability, or your customer's ability to 'see change' in the received signal(s).

Squawker is mounted in a metal box and as previously noted, includes an automatic 'shut-off switch' built into the lid. The metal box has a familiar ring to it, being similar to the Recipe Box your wife probably has on her kitchen counter someplace. Powering is from a set of 10 AA cells and the manufacturer claims 10 hour operational life with fresh batteries. The unit is supplied with a nylon neck strap which snaps onto brads at either end; somebody placed the snaps in the right position because when you hang it around your neck, it hangs in the right direction so you can see it! The size is small (6" wide by 4" deep by 3" high) and the weight insignificant (2 pounds with batteries).

**Squawker Performance**

We tested the operation using both weak and strong signals; an easy trick for us at the **CSD Lab** on Provo since we have such a variety of antennas from just over 7 feet to more than 25 feet. We were primarily concerned with the resolution at opposite ends of the scale; **using very strong signals**, would the Squawker still 'resolve' small differences in antenna aiming? And, **using very weak signals**, would the Squawker be capable of separating the weak signals from the noise?

On a big antenna, producing exceptionally strong signals, we found that the voltmeter sensitivity should be increased from the factory setting. With a plurality of strong signals rocking through the instrument, there seemed to be some amount of 'signal limiting' occurring. In other words, the meter was having some difficulty deciding whether the 'sum' of all of those BDC signals was actually decreasing or not. However, by increasing the sensitivity as described in manual, we were able to compensate for that.

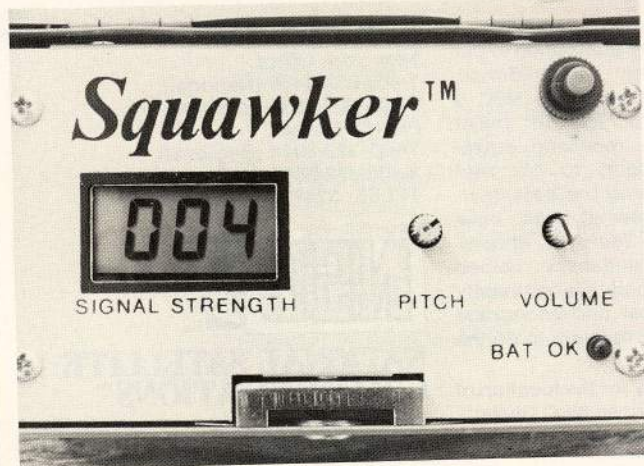

1/ The Squawker, available from **Focii Antenna Systems, Inc.**, 2730 SW 57th Street, Topeka, Kansas 66609; 913/862-2703.

**F0CII SQUAWKER Specifications:**

**Input Frequency Range:** Dual inputs (70 MHz,  $\pm$  10 MHz; 30-1,400 MHz)

**Input Signal Levels:** -40 dBm up to -10 dBm recommended

**Input Impedance:** 75 ohms (match not specified)

**Resolution:** 0.1 dB or better claimed

**Powering:** Ten (10) AA type batteries; 10 hour operation specified

**Display:** Dual (three digit LCD display, tone emitting audio)

**Weight:** 2 pounds

**Size:** 6" (w) by 4" (d) by 3" (h)

**Accessories:** Supplied with 5-900 MHz splitter (note possible problem with 900-1450 MHz band signals and also note 1400 MHz limit of internal amplifier, leaving top 50 MHz of 950-1450 MHz band not amplified), pair of jumper cables (59) with push-on connectors on one end, neck strap. Optional accessories are BNC connectors (Bird-view, Earth Terminals, et al) and UHF/PL-259 (Automation Techniques 800 series receivers).

**Dealer Protection:** One year on all parts, 90 days on labor

**Price:** \$169

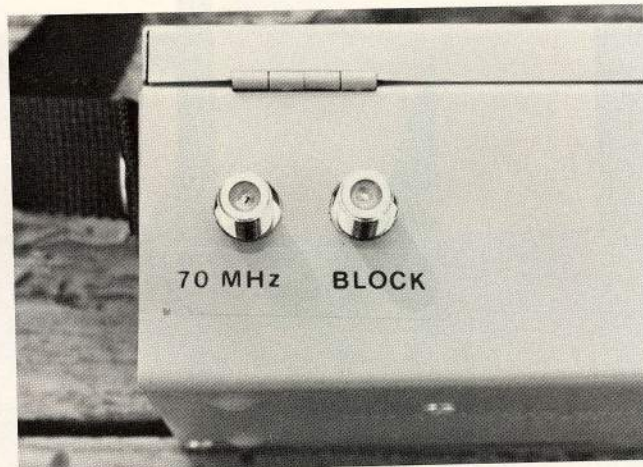

**REAR PANEL has 70 MHz and BDC inputs; inputs are isolated from line powering.**

On a small antenna, the increased sensitivity didn't seem to hurt although we were satisfied with the 'resolution' before we took the four screws out of the front panel to play with the sensitivity adjustment. Some examples of the resolution at the small antenna test are shown here.

The front panel volume and pitch controls are handy but the pitch control is exceptionally responsive to small adjustments. The purpose of the pitch control is to adjust the audio range so your own ears can respond to what they are hearing. You can vary the pitch present at any input signal level from a rumbling low pitch to an almost-out-of-hearing range squeal. Someplace in between is usually best. We'd like to see the pitch control require more adjustment range for smaller changes in frequency since the user may not always be in a position (balancing on a ladder at a feed) to 'fine tune' the control delicately.

**The metal box**, as we are sure they have been told repeatedly, may be a long term problem. You can 'close' the lid quickly and not snap it shut. Half the time the lid is sufficiently 'down' to operate the on/off switch and thus the battery life is preserved. The other half of the time, if the Squawker is bouncing on the front seat of your pickup truck, the lid can work up and the Squawker can bounce back to life. This is not

METERS/ continues on page 54

# THE ROAD TO SUCCESS IS MEASURED BY SUPERIOR QUALITY

For any business the road to success is long and difficult. But measured by the quality of Superior™ aluminum mesh antennas, the road is shortened considerably.

Superior™ high performance antennas are scientifically designed for low wind resistance, light weight and stability in the field. And because we want our Superior™ quality to shorten your road to success, the manufacturing process of our five and one-half, eight, ten, twelve, sixteen and twenty-five foot antennas are monitored by a strict quality control program.

U.P. Superior Satellite Dish Manufacturing. Our Superior™ quality shortens your road to success.

**U.P. SUPERIOR  
SATELLITE  
DISH MFG.**

1651 17.4 Rd., Escanaba, MI 49829 906-789-1027



#### **Micro Dish**

Logan, OH  
1-614-385-3200  
Outside Ohio  
1-800-638-1864

#### **John-Co Electronics**

Auburndale, WI  
715-652-3175

#### **Satellite TV Systems**

Marquette, MI  
906-228-2324  
1-800-551-0551 U.P. Watts

#### **Buddy's Electronics**

Live Oak, FL  
904-362-4505

#### **Herman Electronics**

Miami, FL  
305-634-6591

#### **National Micro Dynamics**

Chattanooga, TN  
800-845-0813

#### **Stellarview Satellite**

Surfside Beach, SC  
803-238-1098

#### **Vidcom Satellite**

Rochester, NY  
716-225-6130

#### **Lycon Farm Implement**

Palestine, IL  
618-586-5246

#### **T & T Satellite**

Glenns Falls, NY  
518-792-4913

#### **Satellite Antenna Systems**

Houghton Lake, MI  
517-366-9419

#### **C-Z Labs**

Garnerville, NY  
800-423-2322

#### **Ultra Satellite Systems**

Jarrettsville, MD  
301-557-8381

#### **Telsat East**

Front Royal, VA  
703-636-1777

#### **Bell Services, Ltd.**

Paget, Bermuda  
809-292-4500

DISTRIBUTORS CAN

**“SEE — THRU”**

OUR NEW SUPER  
EXPANDED/PERFORATED  
ANTENNA PRICING  
SCHEDULE

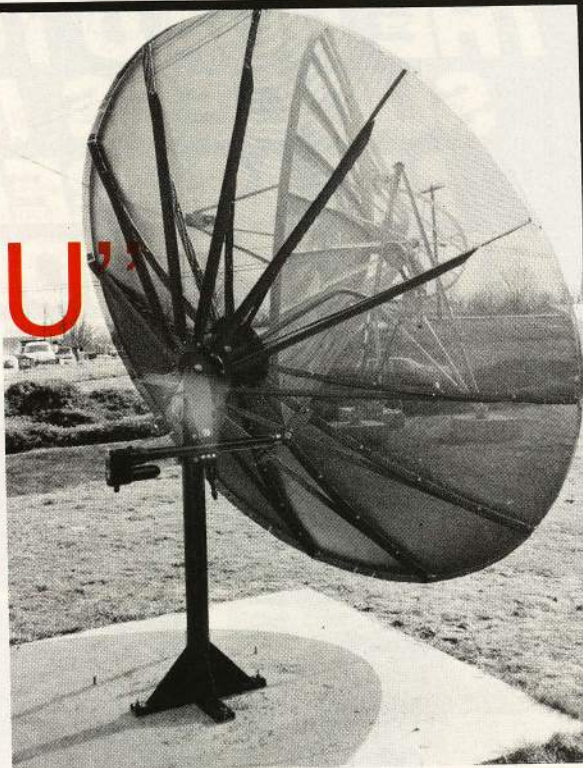

**WE ARE CHEAPER BY THE TRAILER LOAD!**

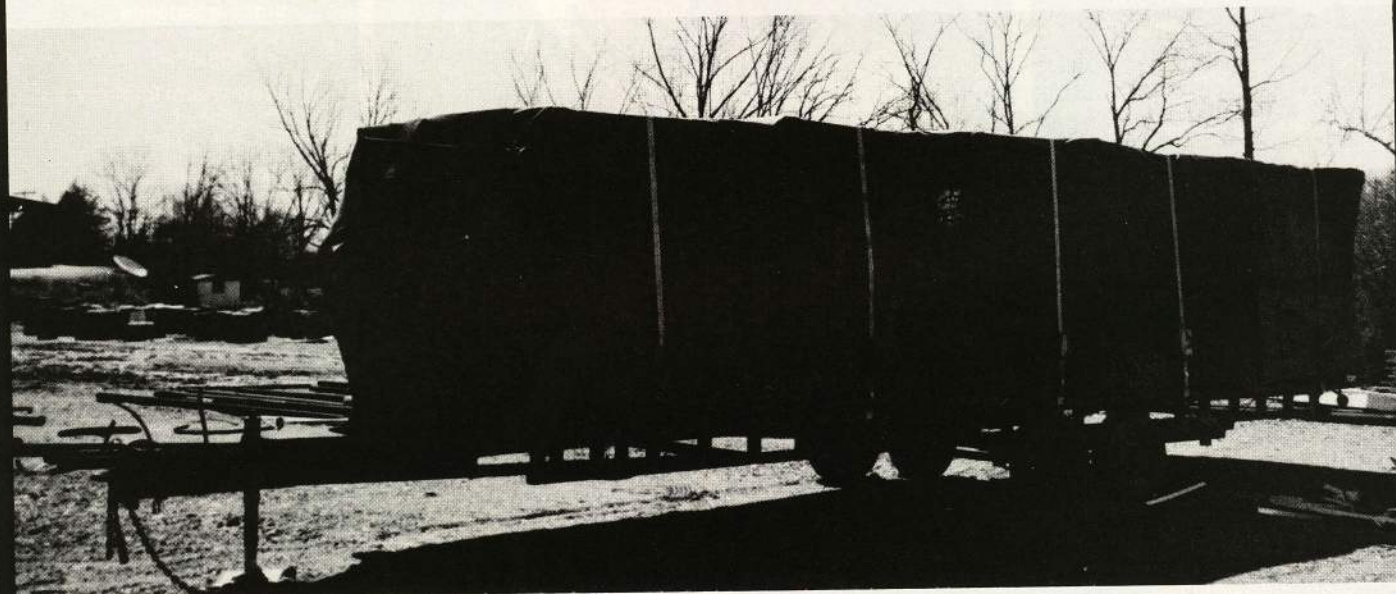

**ONE TRAILER/** Our new super-light-weight, highly refined 9, 10 or 11 foot **'Super-Expanded-Perforated'** TVRO antennas are real Dealer-Pleasing, Customer-Pleasing innovations. Lighter, stronger, quicker to install and believe it or not . . . **12 GHz performance certified!** NOW that is one super-accurate common sense answer to making everyone happier with a TVRO antenna product. Stay a step ahead of the competition with the latest in 'Super-Perforated' **Dual-Band antennas** from the firm that built THE FIRST home TVRO antennas. **Oh yes/** we ship from our door to your door by the trailer load. And that makes you more money than ever before!

ANTENNA  
DEVELOPMENT &  
MANUFACTURING, INC.

**ADM**

P.O. Box 1178  
Poplar Bluff, Missouri 63901  
314/785-5988



# **SATELLITE TELEVISION SYSTEMS**

**WE WILL NOT BE UNDERSOLD!!**

**Complete Systems, Antennas,  
Receivers, LNA's & Accessories**

**CALL US TODAY!**

**800-457-3330**

**hoosier  
electronics**

**Kansas City  
8920 Bond Avenue  
Overland Park, Kansas 66214**

**Sacramento  
1630 Cebrian  
West Sacramento, California 95691**

**Terre Haute  
925 N. Fruitridge  
Terre Haute, Indiana 47803**

**Orlando  
3843 St. Valentine Way  
Orlando, Florida 32811**

**Call Toll-Free: 800-457-3330**

**METERS/ continued from page 50**

necessarily a design fault, but more of a user training problem. The lid snaps shut with some authority and anyone who wants to take the extra 1/2 second required will close it properly after use. Remember, shutting the lid shuts it down.

**Changing batteries**, those 10 AA cells, requires removal of four phillips-head screws on the front panel. With ten hours of operational life forecast, a user will be changing batteries often enough that he will in short order be intimately acquainted with each of those four screws. An alternate design, allowing direct access through a snap-shut cover to the battery compartment would be useful for the heavy user. Removing the four screws then allows you to remove the front cover, and with the front cover comes the 'guts' of the unit mounted to the rear of the front panel. The batteries are held in place with a Velcro fastener system. Having the unit apart, and then discovering you are short of batteries for a reload, would probably result in the user laying the whole system on a bench while he scouted for additional batteries. Sooner or later, with a disassembled unit laying open like that, somebody is bound to spill a Coke or a cup of coffee or drop a wrench into the innards. All of this could be avoided by making access to the batteries a less direct route, 'detouring' around the electronics.

**The Focii Antenna Systems Squawker** meter, in spite of our nit-picking, **is an exceptional value to the TVRO antenna installer.** As the literature plainly says, and as CSD has written for many years now, any installer who has somehow stumbled through life doing antenna alignment and fine tweaking adjustment using a TV set stuck in a cardboard box at the base of the antenna will instantly think he has died and gone to 'satellite heaven' when he gets his hand on an instrument such as the Squawker. This instrument sells to the dealer for a pittance, performs very well, and if the user will take some precautions on his own to protect the instrument from careless use and treats it like the important trade tool that it is, he will have years of trouble-free use.

In short, we recommend the Squawker as a dealer system install aid and hope that enough people use it that the creators are moved to bring out a second version which corrects those small things that bother us about the first generation unit.

**TWEAKER II**

In a review such as this, it is always difficult for the second product in the series to **not play** a 'me-too!' catch-up game. The comparisons between the Squawker and Tweaker II (2) are unavoidable.

Both produce visible displays and both displays are three digits. Both produce an audible tone which tracks the relative signal level present. Both are battery operated and both are very lightweight. And both are block or wideband instruments. The price is not the same; Tweaker II is considerably more money.

A side by side comparison of the two units, a visual inspection as it were, gives a clue to the difference in pricing. Although both are of about the same height and width, the Tweaker is considerably deeper than Squawker. There are reasons; the electronics inside of Tweaker II is considerably more complex than the Squawker. And it offers some additional features which Squawker does not offer. For example:

- 1) Tweaker operates from a single **9 volt** battery and it builds in a reserve, second battery holder supported by a front panel switch. This means that the user can run on one battery, and if he exhausts it in service, merely flip to the reserve. One 9 volt battery costs less than 10

1.5 volt (AA) cells as well. The operational time claimed between the two for battery life is comparable.

- 2) Tweaker beeps once each two minutes **to remind you**



TWEAKER II front panel has row of buttons along bottom of case front to select metering functions.

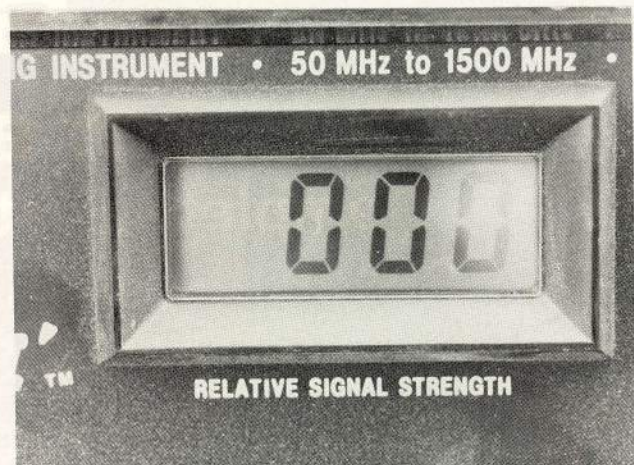

2) TWEAKER II is available at a dealer net price of \$395 from Northwest Satlabs, 806 N.W. 4th Street, Corvallis, Oregon 97330; 503/754-1136.



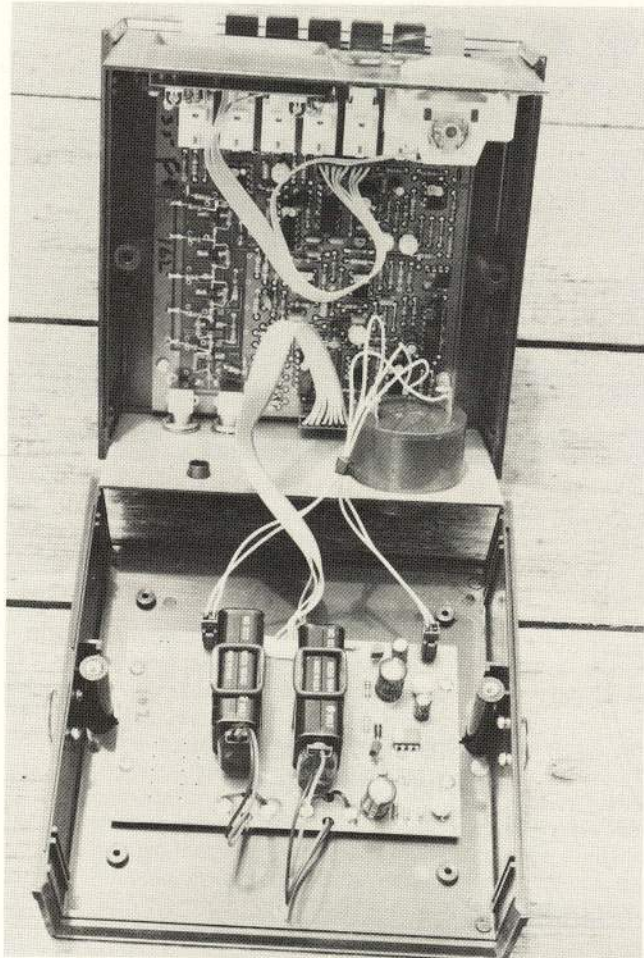

**TWEAKER II with case open shows double/hinged construction. Twin batteries are 'one and a spare' designed so you should never run out in the field.**

that it is turned on. Lacking a shut-down lid that turns the unit off automatically (i.e. Squawker), Tweaker II announces it-is-on so you are less likely to forget and run the batteries down.

- 3) Tweaker has both a digital signal level meter **and** an analog meter; you can count or you can watch a meter needle move on the dial.
- 4) Tweaker has a **pair** of gain control settings; for 'high gain' and 'low gain' applications; that allows it to work in a wider range of downconverter or transponder loading situations.
- 5) Tweaker has a **tone-off** and on switch so you can eliminate the tone if you wish (remember that Squawker has a knobless volume control pot).
- 6) Tweaker has a reset button for the **tone** to change the pitch if the signal level (and pitch) become too high; remember that Squawker has a knobless shaft to change the pitch.
- 7) Tweaker can be used in the dark (the LCD is **illuminated** with a switch).
- 8) Tweaker has an optional battery charge system available and an additional optional 'power pack' so that the user can operate all of the outdoor components without dragging power along (i.e. LNA, downconverter). Inside the case however there are other differences. Re-

call that the Squawker has a claimed bandwidth of 30 to 1400 MHz and they have a separate input spigot for 70 MHz signals. Also recall that to link into the Squawker unit, you use a (provided) two-way hybrid splitter which allows both the Squawker and down-range receiver to 'see' the IF signal(s) at the same time.

Tweaker has a **loop-through approach**; a pair of rear panel 'F' fittings accept the IF line and then after extracting the required 'sample' of the IF signal, it passes out through the second fitting. Tweaker also is a slightly wider-band instrument, covering 50 to 1500 MHz.

Our concern was whether or not the amplifier system employed by the Tweaker, for the 50 to 1500 MHz region, was really providing more, flatter gain all the way to the top end of the BDC band (1400 to 1450 MHz) and what, if anything, you were 'missing' with the Squawker. Our analysis is as follows:

- 1) There are **no meaningful differences** in signal level sensitivity between the two instruments with 70 MHz IF range signals.
- 2) There is a **slight edge in sensitivity** to a satellite filled with signals (such as Galaxy 1) **in favor of Tweaker II**, but it is not a dramatic difference. The 'bandwidth' of the amplifier in the Tweaker is better, and flatter, than Squawker but for most field applications, we doubt the user would notice this difference.

#### Operational Differences

Because the Tweaker II does not require an external two-way splitter, you will probably, as we did, find the Tweaker II somewhat easier to lug around and use. We found it easier to push a button to change the level or frequency of the tone than reaching in with gritty fingers to twist on a pair of knobless shafts.

On the other hand, while the metal case of the Squawker is probably not the best long-term choice for heavy field use, the two-piece plastic case of the Tweaker II with its **unprotected** front display panel may be an even poorer choice. (Northwest Satlabs **does offer** an optional nylon case for Tweaker II and we encourage anyone ordering this unit to obtain one since the unprotected instrument invites careless handling and disaster.) The push-button knobs 'protrude' like buck teeth and probably would be susceptible to physical damage if the meter



**REAR PANEL of TWEAKER II includes a pair of 'F' style fittings; you loop-through the instrument and can power your LNA and downconverter with accessory 'power pack' unit (optional) for total wireless testing on a roof.**

# Where Custom Satellite Systems Originate ●●●●●●●●●●●●●●●●●●●●

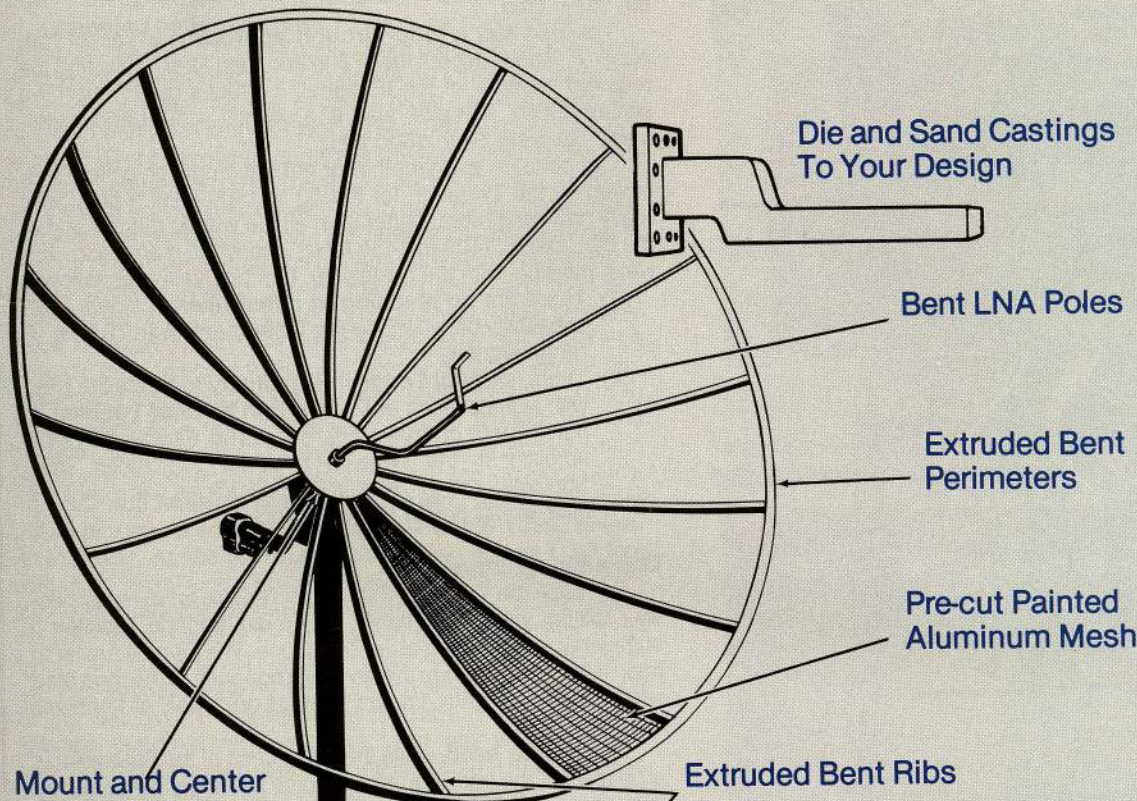

NSM currently provides custom aluminum extruding and fabricating services to many leading TVRO companies. NSM can handle aluminum extrusion of various electronic components such as front panels and housings, aluminum fabrication of antennas and aluminum die-casting such as LNA castings.

In fabrication NSM can punch, machine, bend, drill, tap, cut and miter.

In finishes NSM can anodize, hard coat, paint, polish, buff and powder coat. NSM is one source that solves handling, quality and cash flow problems.

Call or write today for more information.

**1 (203)-236-1613**

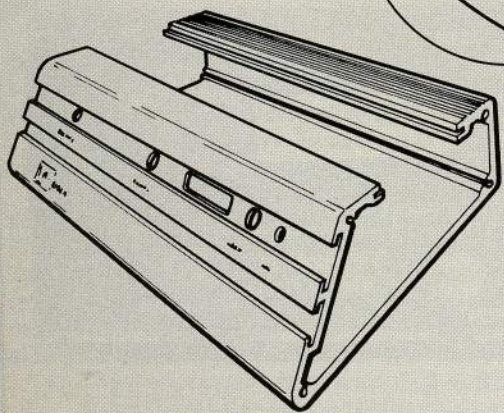
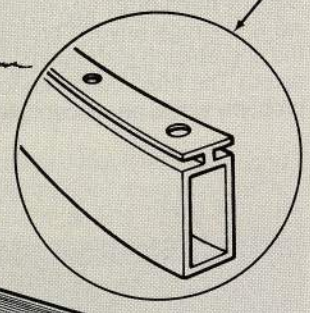

Fabricated and Extruded Housings

EXTRUDED ALUMINUM, FABRICATION, FINISHING

**NSM CORPORATION**

BOX 666, W. HARTFORD, CT. 06107 (203) 236-1613

AFFILIATE OF NORTHERN STATES METALS CORP.





is used in a normal fashion.

In side by side comparisons, both instruments tracked at about the same 'sensitivity rate' (of change) as a test dish was run into and out of a satellite's heading. There is no clear 'best choice' here.

#### APPLICATIONS

Both instruments may be more valuable than their instruction manuals relate (the Tweaker II manual is easily the best of the two). For example:

- 1) Because both instruments 'sum' all of the signal voltages present on a satellite, you can do satellite to satellite 'comparisons' at a site. Measuring individual transponders, a channel at a time, and 'adding up' their relative footprint numbers is messy; in just a matter of minutes, as fast as you can move the dish, peak it, and read the meter, you can do a 'sky scan-number-search' at an installation.

If you wrote down these numbers and provided your installation crew with a table of these numbers, any installation where Westar 4, for example, was **not** 10% lower than Westar 5 would immediately be suspect.

- 2) Anything which might affect the performance of the system can be 'graded' with either instrument. For ex-

ample, while the meters are intended for the purpose of peaking antennas, you can also:

- A) Compare LNAs for real gain. Lower gain LNAs will create lower readings on the meter; and since the meters are broadband, you are comparing the overall gain performance of the LNAs. This won't help you sort out an LNA that is down in a **segment** of the band, but you could quickly find the 'best' LNAs in stock this way.
- B) If you rotate the antenna off of any satellites, and far enough away from any satellites so you are not getting sidelobe energy, the antenna pointing at the 'cold sky' allows you to rate the LNAs for noise performance. How?

**The sky has noise;** but not much (around 4 degrees Kelvin if you can focus deeply enough in space). The LNA, on the other hand, has far more noise. And when the noise from the feed, including the antenna surface, is added, the **'system noise temperature'** can be quite significant; perhaps over 100 degrees Kelvin. By pointing the dish towards no satellites, but into the sky, **your system noise temperature shows up.** You can 'read this noise' on the meters discussed here. Now, using that information.

The no-satellite signal 'noise' you will read is a function of LNA gain, and, LNA noise temperature (plus system noise temperature). You can get relative readings if you are checking LNAs of the same gain by simply comparing the relative amount of 'amplified noise' indicated on the Tweaker or Squawker LCD readout. If the gain of the LNAs being compared is constant within a dB or two, the number you read on the screen will be a relative indication of **LNA noise contribution;** less noise means a lower noise factor for the LNA.

So the instruments here have many, quite valuable functions in not only day to day installations and service but equipment evaluation as well. Having a broadband (all satellite-band) amplifier and detector, combined with a 'detected signal output' indicator such as the LCD read out can be perhaps the most important dollars you invest as a dealer in early test equipment. **Both instruments are excellent devices** and your choice will depend upon your own use of the instrument and your commitment to taking care of the instruments after you have laid out the cold, hard cash.

## SUPERWINCH 2010 PAYS YOU FOR OEM MISTAKES

"AN OFFER You Can't Refuse . . ."

When the SPACE Dealer Board held a public forum allowing TVRO dealers to 'grill' OEMs and distributors, during the

Tulsa show in June, many dealers found the opportunity to ask questions that have been bothering them for many months or years (1). Up in the front row, flanked by two lieutenants, sat a normally quiet man from New England; **Frank Tolsdorf**. His company, **Superwinch**, has been in the TVRO actuator business for more than two years. The firm seemed like a natural to be in TVRO making actuators; a good reputation, many years of experience building motor driven power arm devices. Only their first products, sparked by Tolsdorf's own purchase of a dish and his observation that dish movers were not exactly 'state of the art,' turned out to have as many problems (although perhaps not the 'same' problems) as those products already in the marketplace.

In response to an angry dealer question from the rear of the room, Tolsdorf raised his hand to speak. The dealer wanted to know **why he should be responsible** for the grief, aggravation and expense that went with opening up a new

SUPERWINCH/ continues on page 60

**WANT  
TO KNOW  
WHAT'S HAPPENING  
IN YOUR INDUSTRY**

**THIS WEEK?**

**BORESIGHT/9 PM  
THURSDAYS  
SATCOM F4, TRANSPONDER 20**

**Sponsored by Progressive Manufacturers and Distributors as the TVRO Industry's Only Independent Weekly  
Television News Magazine!**

Dear Dealer,  
Welcome to the  
Nashville Show.  
Our space  
numbers are  
1321 and 1319.

SATELLITE EARTH STATIONS EAST, INC.  
Hwy 13 and Pine - P.O. Box 160  
MAMOU, LOUISIANA 70554  
Phone 318-468-2203  
La. Watts: 800-252-3307  
Nat'l Watts: 800-762-2110  
Service: 318-468-2201  
"NOUS PARLER FRANCAIS"

TVRO WEST, INC.  
dba SATELLITE EARTH STATIONS  
1106 Smith Rd. - Suite 101  
AUSTIN, TEXAS 78721  
Phone 512-385-0738  
Tx. Watts: 800-252-3457  
Nat'l Watts: 800-325-5043  
"SE HABLA ESPANOL"

JO'MIL ELECTRONICS, INC.  
Rt. 6, Box 17 JM  
P.O. Box 2778  
COVINGTON, LA. 70433  
Phone: 504-893-4514  
La. Watts: 800-558-0019  
Nat'l Watts: 800-654-9144

SATELLITE EARTH STATIONS  
of GEORGIA, INC.  
2039 Oglesby Place  
MACON, GEORGIA 31206  
Phone: 912-743-9099  
Ga. Watts: 800-553-1976  
Nat'l Watts: 800 334-9819

SATELLITE EARTH STATIONS  
OF TENNESSEE, INC.  
1865 Airline Dr.-Suite #4  
NASHVILLE, TENNESSEE 37210  
Phone: 615-889-3345  
Tenn. Watts: 800-621-8876  
Nat'l Watts: 800-522-8876

SATELLITE EARTH STATIONS  
OF FLORIDA INC.  
4360 S.W. 36th Street  
ORLANDO, FLORIDA 32805  
Local Lines: 305-843-0272  
305-843-0273  
Fla. Watts: 800-826-1945

AFFILIATE JACK & MARTY BRANSCUM  
GULF COAST SATELLITE SYSTEMS  
1209 N. Moody  
VICTORIA, TEXAS 77901  
Phone: 512-576-4179



**2010 CONTROLLER** has 16 user-settable memory positions. Stick-on labeling allowing the user to create his own 'loading sequence' might be a better idea than the silk screened designations since the satellite world remains unstable regarding new satellites.

product box, unpacking the unit, finding out it did not work (i.e. DOA/ dead on arrival); and then, having to pay the cost of returning the unit to the supplier as well perhaps as the additional freight cost to have a replacement unit returned to him.

"My firm will do you one better than that" said Tolsdorf. "We will not only pay the shipping charges both ways, BUT, we will also send you a \$50 check from our firm to your firm to compensate you for your lost time and effort in going to a customer's home, taking out the bad unit, and having to replace that unit!" The dealer, perhaps stunned by the response, sat back down. But from another corner of the room came another dealer's request. "What did you say the NAME of your firm is???"

SUPERWINCH (2) believes they have the problems which plagued their first-run TVRO actuators and controllers solved. They believe it so strongly that they are willing to 'bet \$50 of their money' against the dealer's time to back up their product in the field. Let's see what the Superwinch actuator and controller system is all about.

Superwinch supplies a pair of controllers and a single actuator. The two 'systems' are aptly named **2001** and **2010** (with apologies to Arthur C. Clarke). System 2001 has a manual control with an east and a west button. And, on the front panel, a three digit LED indicator that 'counts' relative to antenna position as an aid to the user in returning the dish to a satellite location. Model 2010 is a programmable control system with 16 possible bird locations. The user selects which of the 16 locations he wishes with a front panel select button and then commands the controller to move the dish to that location. A manual east and west position pair of buttons also allows the user to search between satellites, fine tune the dish, or simply 'verify' that the memorized 16 positions are in fact 'holding.'

Superwinch supplies a mechanical installation manual

1/ Dealers will have the opportunity to 'grill' OEMs and distributors again during the forthcoming Nashville STTI/SPACE show September 2-4. The SPACE Dealer Board will sponsor another 'Ask The (OEM) (Distributor)' session during this upcoming trade show.

2/ SUPERWINCH, Winch Drive, Putnam, Connecticut 06260; 203/928-7787.

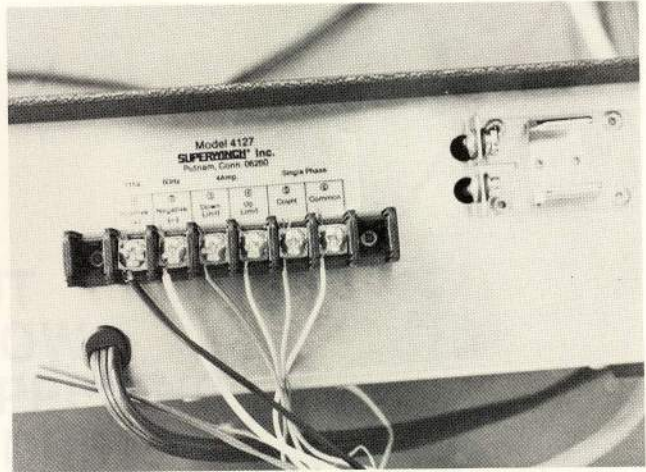

**REAR** of 2010 controller has plainly marked connection points for hook-up of the six wires required between controller and motor drive. Runs to 400 feet are possible with appropriate wire selection.

which has few equals. The manual begins by telling the installer what his parts consist of, lists the materials (such as inter-connecting cable) **not supplied** with the package, and also lists the tools required for the installation.

The actual step by step instructions go further than many, explaining in comprehensible terms the various forces and weight loads involved with ANY actuator system. Pages 6-9 are a mini-textbook in actuator installation procedures and dealers who read and understand this text (and the liberal dose of line drawings) will save themselves countless grief in drive installations.

An interesting recurring 'theme' in the instructions is the well planted fear that an **ungrounded** 'system' is an invitation to disaster. Superwinch as a corporation has been exceedingly involved in consumer safety standard committees in many fields and apparently one of the corporate mandates is to build products which are not only reliable but also safe to operate.

For example, there has been a growing concern that municipal electrical safety codes not be violated by actuator power supplies. Different codes apply in different areas, but some cities will not allow outdoor wiring which exceeds 36 volts DC unless there are special engineering considerations met by the installer. Other communities have a 60 volt DC standard.

All DC supplies powering actuators have an instantaneous 'surge voltage' which is typically 1.8 to 1.9 times the actual operating voltage. A 36 volt DC supply, as an illustration, will produce **a measured 65 volts** at the instant of start-up although a typical digital voltmeter will not 'catch' that start-up 'spike' and someone checking the voltage with a typical DC instrument will never notice the start-up spike. **Superwinch noticed it.**

And they did something about it by redesigning their motors and the power supplies so that if the start-up spike could not be avoided (there are ways to avoid it, but they are quite expensive), the spike would not exceed the 60 volt codes found in most reasonable cities and states. **We measured 29.2 volts DC** as the average operating voltage from the rear terminal of the combination power supply and programmable control console; and that would bring the peak spike in at under 53 volts.

In fact, the entire Superwinch actuator/controller system has been designed, from the ground up, to function in the

precise field of endeavor which we are engaged in. Every part, from the actuator at the dish to the controller inside are intended for our application only. That may be something of a first in the motor drive and controller end of our business since many of the units offered to date have been created by taking off-the-shelf parts from other industries and trying to 'force' them to do the specialized job we need done.

In spite of the passion for safety and performance, the Superwinch packages are not 'luxury end' units. Their pricing is fair but not super cheap and the performance features, on the present top-of-the-line 2010 unit, are by some standards 'behind the times' (even though the units have only recently been introduced to the marketplace). Some examples.

- 1) There are sixteen satellite memory positions. The memory is set by the user/installer by simply starting at the low end (F1R, G1) end of the belt and moving upward a satellite at a time. Each satellite is peaked for best picture with the manual east/west buttons and then the 'load' button is pressed. This commits that location to memory, with the appropriate memory position selected with the LED indicator system on the front panel.

The count is performed magnetically with a reed switch.

- 2) To operate the system, the user switches a front panel



2010 DRIVE is exceptionally weathertight and finished to withstand a wide range of temperatures as well as climates. An 'A' for good outdoor engineering.

#### SUPERWINCH 2010 PRODUCT Specifications:

Product Model Number: 2010 (actuator no. 4103 and controller no. 4127)

Actuator Arm Length: 18 inches

Wiring Required: Six wires total, 2 for powering, four control

#### Operating Voltage:

- 1) Primary 117 VAC ( $\pm$  limits not specified)
- 2) Secondary (motor drive) 29 volts nominal, DC

Memory Positions: 16 (user programmable in any sequence)

Controls: Local control, 'manual' or 'automatic'

Limit Sets: Inner limit factory set, outer limit set by installer

#### Back Up:

- 1) 9 volt battery for memory retention (period of time not specified)
- 2) 'Benchmark' system for returning dish to 000 indication and restoring all locations in proper locations in the event of drive 'drift'

Price: \$380

Source: Superwinch, Winch Drive, Putnam, Connecticut 06260; 203/928-7787.

button from 'manual' to 'auto(matic)'. The dish will move automatically to the position which the user has selected with the 16 push buttons on the front panel.

On the 2010 unit, there is no easy interfacing of the drive/controller to the receiver itself nor to a remote control system. The unit is basic, and not filled with potentially troublesome frills. The closest the system comes to having a 'frill' is a mechanical lock-out system with a key; the user can simply 'lock-up' the system thereby preventing tampering with the dish drive control when they are not present.

The unit also has an outboard (rear panel) 9 volt battery holder which supports a memory back up system should the AC power service fail (length of retention not specified in the manual) as well as a set of limit switches, which the installer sets for the outer-end only (inner end is factory set), that are accessible through a well sealed housing.

#### PERFORMANCE

We found the 2010 system incredibly simple to install and flawless in performance. We won't be asking Frank Tolsdorf to send us \$50 for our time and trouble because we had no trouble.

The magnetic counting system married to the reed switch works well, and as a proven technology employed by many other actuator companies it is one of those 'design approaches' which should create a product with few in-field problems. The dish we tested the system with is a relatively lightweight fiberglass antenna which by itself had some difficulty staying 'on the bird' in our gusty winds. With the 2010 unit driving the dish, we found the signal flutter went away simply because the braking power of the 2010 was more than enough to steady up the dish in the winds.

The system is easy to use and adapt to and we doubt very many consumers would find the controls or even the satellite setting exercise 'frightening.' It might be tempting to 'fault' the system for its basic 'simplicity,' but Superwinch set out to build a product which they could be so sure of that they would be able to back it up with a dealer replacement/warranty/compensation program which nobody else had dared to do previously. **They did this** and there is still a significant market out there for controller and actuator systems which move dishes, **where** they are supposed to move **when** they are supposed to move, even if the user has to push separate buttons for moving the dish, and, tuning the satellite receiver.

In the 'fault department,' as complete as the manual is (in

SUPERWINCH/ continues on page 64

# California Amplifier's TVRO Products Now Have 2-Year Warranties!

## One Word Explains How We Do It: QUALITY.

Yes. The first company to break the noise barrier in the Home Satellite TV industry with strong, silent LNA's, now gives you two-year warranties on all TVRO products.\*

How can we move ahead of the industry with extended warranties on our proven line of LNA's and TVRO accessories?

Quality. Plus strong engineering, and the best made-in-America technology.

California Amplifier products incorporate computer-controlled automated assembly. Every LNA is burned in and electronically tested five different times



in the production cycle. Assembly processes are inspected under a microscope to meet rigid quality standards.

Our products are subjected to a series of grueling random-sample tests. Water immersion. Shock. Temperature cycling. Everything in the book! The result? Long-term reliability is built in.



We give them two-year warranties because we're absolutely sure they're going to last!

If any problem ever occurs, we also give you the fastest service response in the business. Including 24-hour turn-around on all warranty returns, and full-time technical assistance.

Strong engineering. Consistently reliable automated assembly. Quality control second to none, LNA's with the widest range of noise temperatures available, lightning protection, built-in band-pass filters, internal voltage regulation,

weatherproof construction, and more. That's what you want.

That's what we give you! Our people started out as

pioneers in the TVRO business. Now, as a successful public company, we're proud to be the leader in new product innovation and service.



 **California Amplifier Inc.**

460 Calle San Pablo, Camarillo, CA 93030 (805) 987-9000 TLX 469193 Outside California: (800) 621-4080

\*Applies to all products purchased after November 1, 1984.



uniden®



**UST 5000** Block receiver offers LED channel display, automatic polarity control, slow and fast scan.



**UST 730** Antenna Positioner features built-in programmable antenna control and Opto-Interrupt circuitry.

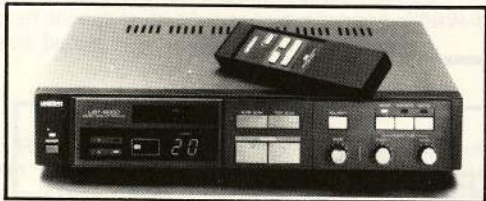

**UST 6000** Block receiver features expanded audio format and fine tuning skew adjustments.



**UST 710** Antenna positioner offers compact styling, manual east west control and 3 digit LED readout.



**UST 7000** Block receiver features IR remote built-in programmable antenna control accommodating up to 81 satellite positions in memory.

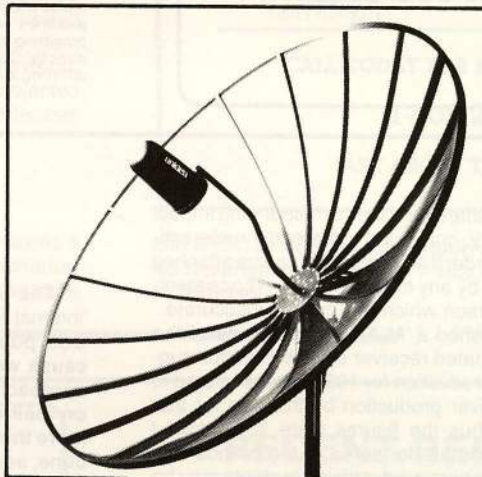

**UST 110** Aluminum Mesh Antenna is designed for maximum flexibility and maintenance, easy to install and weather resistant.



## The Northeast's Leading Distributor

Sales and Marketing Assistance  
Factory Authorized Service  
Professional Training Seminars  
Co-op Advertising Support

### Satellite Video Services, Inc.

RR #1, Box 85-S, Catskill, NY 12414  
518-678-9581 • 800-528-DISH - National  
800-831-DISH - NY Only

### Satellite Video Services PA, Inc.

317 E. Pleasant Valley Blvd., Altoona, PA 16602  
814-942-5003 • 800-242-3860 - PA Only  
800-367-8899 - National

### Satellite Video Services NH, Inc.

RR #2, Harriman Hill Rd., Raymond, NH 03077  
603-895-3182 • 800-448-0012 - National

### Satellite Video Services WNY, Inc.

East Avenue Extension, Hornell, NY 14843  
607-324-3435 • 800-642-0018 - NY Only  
800-831-1134 - National

Luxor M/A Com Norsat Gensat Houston Tracker Winegard Conifer Laux Orbitron Kaul-Tronics

in  
stock  
now

## SUPERWINCH/ continued from page 61

particular, in the mechanical installation of the unit), there are shortcomings which dealers will notice. No place in the manual does it tell you what the proper motor operating voltage is nor does it **adequately explain** the purpose and function of the six wires required between the controller and the motorized drive. An experienced dealer would have no difficulty tracing them out in the event of a field problem, but the newer dealer might be bewildered by the four wires associated with the control circuits. There is no way to screw them up, during

installation, if the instructions are followed (terminal connection points are well and properly marked) but if you have done everything 'according to the book' and it still does not work, what then?

A page on electrical theory, as well as an expanded 'troubleshooting' section which hands to the installer some voltage and continuity circuit guidelines would be very helpful. It might even save Superwinch a needless \$50 check if they gave the competent dealer a little more to work with in the field before he boxed a seemingly defective unit up and shipped it back to Connecticut for repair.

## INDUSTRY AT LARGE

## CORRESPONDENCE, NOTES, REBUTTALS AND CHARGES . . .

CSD provides this industry 'forum' for the purpose of allowing members of the industry to comment on industry activities. CSD assumes no legal responsibility for statements made here and those providing such communications are held liable for their statements directly. CSD/2, issued on the 15th of each month, provides a forum for differing views on industry trends.

### M/A-Com 'Numbers'

Anderson Scientific's market share, and the corresponding impact by our firm on the TVRO industry, continues to be badly underestimated by TVRO magazines. I wonder if any credibility can be attached to market share figures published by any magazine when I consistently read figures concerning Anderson which are grossly inaccurate.

The June issue of CSD published a 'M/A-Com Estimate of the TVRO Universe' where the estimated receiver sales by various suppliers was listed. The Anderson production for 1984 was estimated to be 3,000 units. The actual receiver production by this firm for that 12-month period was 21,151; thus the figures were 700% low! I suspect that the errors in the estimate for some of the brands with more effective press and more elaborate advertising budgets may be just as far off, on the high side. Our projected receiver production for 1985, by the way, is 35,000 units and we are 'dead on target' at this writing.

I recognize the difficulty attached to trying to gather figures for the industry as a whole and the desire of all of us to have such information. However, published information which is grossly in error can be unfortunately damaging. Thanks for the opportunity to set the record straight!

Mark Anderson, President  
ANDERSON SCIENTIFIC, INC.  
2693 Commerce Road  
Rapid City, SD 57702

The table published in CSD for June 1st (page 34) was an 'internal figure' obtained from a memorandum within M/A-Com. CSD published the table and noted that it was not accurate because we felt the industry should be aware that the M/A-Com approach to the descrambling situation was based at least in part on their own faulty assumptions. Yes, Anderson did produce far more than 3,000 TVRO receivers during 1984. And as we noted in June, some of the listings for receiver suppliers was inaccurate to the extent that firms such as Hero Communications, which never produced receivers of its own, was listed with a 1% market share. We asked the industry to communicate directly with James F. Bunker at M/A-Com to straighten out the M/A-Com numbers, aware that as long as M/A-Com believed these numbers to be accurate, their on-going plans in the scrambling area would continue to be fouled up. CSD/2 for August 15th will release 'bit error rate' testing results for a dozen TVRO receivers using M/A-Com approved testing procedures.

### OLD Problem

In the June 1984 issue of CSD, Marshall Foiles describes an inexpensive method for reception of SCPC signals using receivers where the tuning voltage or operating voltage is duplexed on the same 59 cable as the incoming 70 MHz IF signals. I cannot make this work.

I have an Earth Terminals receiver with a Sony FM receiver and all I receive is a loud buzzing sound from the Sony receiver; no SCPC signals. Do you have any solutions?

Robert H. Codey  
15 Maple Avenue  
West Orange, N.J. 07052

Your system lash-up is not well explained; the 70 MHz IF signal, available on the IF line of RG-59/U, must feed into a FM demodulator or receiver capable of tuning the 60-80 MHz region. The receiver must be capable of normal FM bandwidth (200 kHz) signals. Preferably, it would be a receiver that tunes this range with a far narrower IF bandwidth; such as 30-50 kHz. The satellite

## SATELLITE MAGIC ©

A VIDEO TAPE WHICH CATALOGS  
SATELLITE PROGRAMING

This video tape sells your  
customers on satellite TV  
by presenting the logos &  
program clips from all  
75 networks in just  
12 minutes.

BETA, VHS or 3/4"  
614-378-6297

Shelburne Films 54545 S.R. 681  
Reedsville, Ohio 45772



receiver must be set to a transponder which carries only FM SCPC signals; a loud buzzing tells us that you are trying to find FM SCPC signals on a transponder that has TV on it. TV and FM SCPC are seldom found on the same transponder (TR3, G1 is one exception).

**THAILAND Systems?**

I am a retired US Navy Radioman and I live in Bangkok, Thailand. As far as I can determine, there is only one satellite available to us here. I know that given the price range of US satellite systems, I could sell at least 1,000 systems here in the first year if there is some English language television programming available. Can anyone help me get smart enough to do a better evaluation of the hardware selling prospects here?

R.A. Glendenning  
Jusmagthai Box R3009  
APO, S.F., Ca. 96346

Reception from Palapa (Indonesian satellite) would be feasible with 14 to 16 foot quality antenna systems. Plenty of English language programming there, and with 20 foot size antennas, CNN on Intelsat as well as other (US) network feeds. Those involved in marketing overseas might drop the man a line and offer to help.

**WANTS Russian TV**

I read with great relish Coop's article describing Russian TV reception in the first issue of Home Satellite TV. My wife is a Russian refugee and I am very interested in purchasing a satellite system which would be capable of enabling her to watch Russian television. Can someone supply me with a system description and projected price for a complete system which would receive Russian teletcasts from my suburban location near Boston?

Marc S. Alpert, Esq.  
Fifteen Court Square  
Boston, Mass. 02108

We trust that those handful of dealers equipped to handle a high quality 16 foot (ECI or Paraclipse) or 20 foot installation (ADM) with the appropriate right hand circular polarization system

# ECI-11

■ OUTSTANDING PERFORMANCE

■ CONSISTANT QUALITY

■ AFFORDABLE PRICING



CALL TODAY FOR MORE INFORMATION

1-800-272-7788

ASK ABOUT THE NEW ECI-16

**ECI** ENGINEERED COMMUNICATIONS, INCORPORATED  
18-A Home News Row  
New Brunswick, N.J. 08901  
(201) 828-5009

and NTSC to SECAM conversion will contact Mr. Alpert directly; his telephone number is 617/482-7155 and just to warn you, he is an attorney.

## TRANSPONDER WATCH

## RECENT REPORTS OF ACTIVITY ON DOMESTIC / INTERNATIONAL SATELLITES

Send your reports to CSD Transponder Watch, P.O. Box 100858, Ft. Lauderdale, FL 33310. For late news, call (305) 771-0505.

SPACE has 'gone on record' as 'vigorously opposing' the most recent attempts by cable programmers to corner the program distribution market. Tulsa SPACE/STTI show provided forum for SPACE members to coagulate views concerning payment for services and who should be in charge of collecting payments.

SPACE 'downlinking seminars,' held late in July, drew lower response than hoped from downlink operators and fewer 'course sites' were established than had been predicted. SPACE paid downlinkers \$7 for each student attending.

FCC plans to deal with 'zoning matter' for TVRO (and other dishes) this fall. After soliciting official comments on Notice of Proposed Rulemaking last spring, Commission had to take time to 'digest' the more than 150 comments received before coming to a final decision.

All indications are that FCC will intervene in this area and direct communities to follow 'standards' when establishing local zoning ordinances.

SBS, the giant telephone company in the sky using SBS-series 12 GHz satellites, has sold. MCI, the giant number two long distance company on the ground has purchased the assets. Purchase included first three SBS birds but not last three which must now be sold in marketplace.

NASA will attempt to repair, in orbit, U.S. Navy Leasat bird during Space Shuttle mission late this month. Hughes still 'owns' bird because it failed to go into Clarke Orbit and insurance carriers finally decided it would be less expensive to repair it in orbit (if that works)

## IMMEDIATE DELIVERY FROM STOCK ON OVER 900 CABLE, CONNECTOR & SMATV PRODUCTS!



### WIRE & CABLE

- Coaxial/RG
- Cable Assemblies
- Multiconductor
- Plenum/Teflon  
(NEC 725, 760, 800)
- Alarm
- Computer/Low-Cap
- Telephone
- Hardline
- Satellite Control

### CONNECTORS

- Type N
- Type C, LC
- BNC
- TNC
- SMA
- Type F
- UHF
- Twinaxial
- D subminiature
- Crimp/Solder

### SMATV

- Modulators
- Distribution Amps
- Taps
- Splitters
- Switches
- Transformers
- Trunkline
- Traps
- Jumper Cables

### ACCESSORIES

- Crimping Tools • Test Equipment • Coax Seal
- Power Filters • Cable Ties • Shrink Tubing

### COMPLETE LINES

Amphenol, Kings, Columbia, Cablewave  
B&K, Tyton, Blonder-Tongue, Coleflex

### ORDER TOLL-FREE

Nationwide: 1-800-327-5999

Florida: 1-800-52-CABLE / Telex: 532362

# NEMAL

ELECTRONICS INTERNATIONAL  
12240 N.E. 14th Avenue  
N. Miami, FL 33161 (305) 893-3924



than attempt retrieval and return to earth.

**NASA** is battling for funds to continue research work on so-called 'ACTS satellite system,' an experimental 30 GHz 'up' and 20 GHz 'down' bird. NASA has been working on system planning for several years, hoped to get such a test satellite flying before end of the 80s. Hughes has proposed a similar satellite, at company expense.

**MORELOS A**, Arabsat 2 and Telstar satellites launched by Shuttle in June should be operational as you read this. Morelos is first Mexican domestic bird and will be new occupant of sky between western end of Canadian sub-belt and Southern Pacific bird at 119. AT&T's Telstar will occupy spot at 125 west and when it is operational D4 at 128.5 will scoot east to the far end of the belt as a reserve.

**INTELSAT** has decided to compete harder for domestic satellite business, reducing transponder rates to as low as \$500,000 per year for full 36 MHz transponder in C band with spot beam configuration. Half transponder (18 MHz wide) will go for \$375,000 per year; on 5 year leases.

**JAPAN** has moved step closer to domestic satellites by authorizing use of a pair of Hughes satellites for Ku band business/data/video services. The satellites will have 32 transponders each, be 20 watts of power per transponder and use 27 MHz of bandwidth per transponder. One of the major partners in the ventures is C. Itoh and Co. Ltd. (40%) which manufactures DX line of TVRO receiver systems. Mitsui Co. Ltd. owns 20% and it manufactures TV tuners and other parts which are used in TVRO receivers. Planned launch date for bird-one is February 1988.

**UK** is now 'routinely processing' TVRO receiving licenses for private individuals with an annual fee of 10 pounds per-license per-year (presently, terrestrial 'TV licenses' amounting to more than 50 pounds per year apply to ALL TV watching homes). SMATV systems require this license plus second license issued under 1984 Cable Broadcasting Act.

The floundering Direct Broadcast Satellite Association, an attempt to put together a trade organization for 12 GHz DBS before there is 12 GHz DBS, is focusing on four separate 'encryption transmission systems' for comparative testing. M/A-Com, Scientific-Atlanta, General Instrument and Telease each have systems which the creators would like adopted as the 'standard' for DBS transmissions.

**US** position at WARC '85 (see **Coop's Comments** this month) changing slightly in final days; US may accept some form of limited assignment of orbit spots to developing nations for set period of time such as ten years. If assignments were not in use at end of period, they would be reassignable to others with demonstrated need.

**PanAmSat**, firm proposing domestic C band satellites to service Central and South America, claims recent Intelsat decision to reduce transponder charges for half and full transponder spot beam service is 'predatory'; and can only be justified if Intelsat raises rates for other services to subsidize the low rates. US FCC is against such practices.

**NEXT** Arianespace flights with domestic satellites on board include September 11th scheduled flight with SpaceNet 3 (GT&E) and

## Use Your Wireless Control FROM ANY ROOM!

Works with most infrared  
remote control receivers or VCR's.

# XTRA-LINK™



## SWITCH COMPONENTS REMOTELY

FOR YOUR  
**MULTI-ROOM TELEVISION SYSTEM**



Wholesale and Retail Sales

# 800-545-3522

In Wisconsin 800-362-7212  
(Authorized Video Link™ Distributor)

# MERRIMAC SATELLITE

327 Palisade St. Merrimac WI 53561

SPACE

VISA

AMERICAN EXPRESS

MasterCard

# AVCOM

## SATELLITE RECEIVERS • SPECTRUM ANALYZERS MICROWAVE INSTRUMENTS AND COMPONENTS

Quality, Reliability & Ease of Operation  
For Your Specific Needs

AVCOM is known for its high standard of performance, reliability and value in a full range of communications equipment to meet your every need. The quality and workmanship that has gone into the design and production of AVCOM's full line of Satellite Receivers is also a "standard feature" of AVCOM's new line of Spectrum Analyzers, featuring the Portable PSA-35.

### NEW! ANOTHER INDUSTRY FIRST FROM AVCOM!



### PSA-35 SPECTRUM ANALYZER

AVCOM's PSA-35 Portable Spectrum Analyzer offers frequency coverages of 10 to 1500 MHz and 3.7 to 4.2 GHz for checking signal strength, inband attenuations, terrestrial interference and filter alignment, faulty connectors and LNA's, feedhorn isolation, and cable loss at all frequencies used in the TVRO industry, including 12 GHz downconverters.



### COM-3R

AVCOM's COM-3(R) Series of reliable Satellite Receivers features 24-channel detented tuning, APS-24 (automatic polarity switching), crystal controlled modulator, unclamped video output for decoders, tunable audio (4 to 8 MHz) with wide and narrow IF bandwidth, sensitive signal strength meter, excellent threshold sensitivity, scan-tune circuitry, and internal DC power block. The COM-3 features a convenient remote control unit for ease of operation. The COM-3(R) Series is among the best performing Satellite Receivers available for weak signals and excellent video reception.

### SPECIAL HALF-TRANSPONDER RECEIVERS FOR INTERNATIONAL- TYPE TRANSMISSIONS

AVCOM's COM-3, COM-3R and COM-60 Series Receivers can be ordered with options to receive half-transponder international-type signals. The THRESHOLD PEAKING option greatly enhances threshold performance on weak half-transponder signals. The DUAL IF electronically-switched full and half-transponder filter option allows reception of international-type signals as well as standard domestic satellites.

### BLOCK DOWNCONVERTER SYSTEM

For Cost-Effective  
Multi-Channel Installations



### COM-66T

AVCOM's COM-60 Series of Satellite Receivers features commercial quality, double conversion, high stability, compatibility with SA's 6650 receivers, rack mounting, flexible downconverter for use with any degree or brand of LNA, scan tune, signal strength meter, tunable audio, and horizontal/vertical control output. No isolators are needed for these block downconversion systems, and numerous options are available. The COM-65T is equipped with a unique group card channel selector.

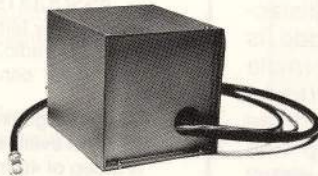

AVCOM's BDC-60 BLOCK DOWNCONVERTER is used with the COM-65T and COM-66T Satellite Receivers to convert the 3.7 to 4.2 GHz signal from any low noise amplifier to a 270 to 770 MHz block of frequencies. The BDC-60 has a built-in DC power block and can be used to replace more expensive LNC's.



### COM-2A

AVCOM's COM-2A and COM-2B Satellite Receivers offer attractive styling and convenience with the quality AVCOM is known for. Tunable Audio with wide and narrow IF, scan tune, signal strength meter, and provision for internal crystal controlled modulator are standard features. The COM-2A receiver features a comprehensive remote control unit. Numerous options are available for both receivers.



### SCPC-100

AVCOM's SCPC-100 offers a versatile approach for receiving specific frequencies of SINGLE CHANNEL PER CARRIER transmissions. The SCPC-100 solves the problem of receiving audio transmitted separately from video. Radio stations can use the SCPC-100 to receive program feeds. Down-converter may be remoted at antenna or installed in the receiver mainframe. The SCPC-100 is used with an FM tuner.

Check with us. Different needs require different receivers. So let us know what you need, then we can recommend the AVCOM Receiver that's best for you. AVCOM will make custom modifications on equipment you order to give you maximum performance and to allow for special applications. AVCOM also carries a complete line of TVRO accessories and satellite receiving components. To simplify satellite installations and other TVRO test situations, AVCOM manufactures a line of Spectrum Analyzers, featuring the PSA-35. For more information on any of AVCOM's reliable TVRO equipment, write: AVCOM, 500 Southlake Blvd., Richmond, VA 23236. Or call (804) 794-2500. To place an order, call toll-free: 1-800-446-2500.

## What Have You Got To Gain?

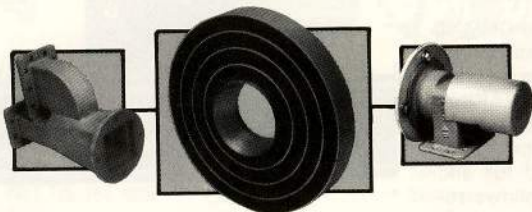

**S**tronger and clearer TV pictures are what you have to gain using patented Seavey Feeds manufactured by Pico. Whatever antenna system you sell, Seavey Feeds will deliver that system's maximum performance capability. Best of all, customized Seavey Feeds are now available for about \$60.00 from Pico. Seavey Feeds, the best you can buy.



**PICO PRODUCTS, INC.**  
HOME SATELLITE DIVISION  
103 Commerce Blvd.  
Liverpool, NY 13088

CALL TOLL FREE: 1-800-336-3363

## The Cure For Curing Sat-Base Cement

Imagine being able to complete an installation the same day you set the pole for the antenna. Sat-Base Cement sets in 15 minutes and is completely dry in about an hour. After 15 minutes you can proceed with your installation and achieve customer satisfaction in one trip. All you add is water, and the easy-mix formula performs well in temperatures as low as 20°F. What could be easier except picking up the phone to order your supply?

To Order Call Toll Free  
**1-800-228-5965 or 601-454-7505**  
Attention Distributors.

Be the first in your area to offer this product.

**Stockmont, Inc.**  
P.O. Box 542, Belmont, MS 38827

ECS-3 (European TV and data bird) as well as December 11th Gstar2 (GTE Corporation) and Brazilsat 2 (SBTS).

**INTELSAT** has also decided to revise the transponder bandwidth for TV transmissions, from 17.5 MHz to 20 MHz. Several half-transponder users, such as Chile in western hemisphere, have been unable to get acceptable video performance from 17.5 MHz wide half transponder.

**BRITISH** Unisat project, designed to create British national domestic DBS program with shared users, is dead. Some \$38M (US) was spent on planning of project which would have consisted of 3 transponder birds, a pair, to provide six channels of service. Observers in UK predict final death of Unisat will ultimately have positive effect on development of SMATV in UK and that British telecasters will seek other satellite outlets for their program products.

**US** Better Business Bureau got 'word' from SPACE; TVRO systems are 'not illegal.' Some BBB offices had been responding to requests for information by advising people TVROs were considered illegal; thought to be a policy originating in cable TV quarters.

**SENATOR** Goldwater has gone to bat for TVRO industry with Department of Commerce concerning export of TVRO hardware. DOC has maintained policy that restricts overseas shipment of TVRO system parts or complete systems since 1970's. If policy can be changed or restrictions lifted, time spent preparing elaborate paperwork to ship TVRO system overseas would be avoided and US shipments to overseas points would increase.

**SPACE** Certification will be available in courses to be conducted August 2 and 3 during fifth annual Northwest Satellite Conference. 'Antennas for Satellite Reception' and 'Satellite Antenna Installation' courses will be offered at \$75 for SPACE members, \$125 for non-members. Details from Kim Young at 703/549-6990.

**HR1769**, the 'scrambling moratorium' bill proposed last March by Congressman Judd of New Hampshire, has 20 'co-sponsors' and the list is growing. SPACE maintains that there should be a two-year 'treading water' period for scrambling while the marketplace adjusts to the many proposed scrambling marketing schemes. Cable and hardware suppliers oppose any such legislation.

**The Bahamas** has become the 110th member nation to Intelsat. The island nation, to date, has relied on its extensive interconnection with the USA for international communication needs.

**AMERICAN** Stock Exchange customers will be able to acquire 2 foot terminals created by Equatorial Communications for real-time stock market reports.

**WIMBLEDON** Tennis play-offs transported to US by UK's Brightstar Communications through Intelsat link-up with NBC as receiving customer. Live service for US and North America came through on transponder 11 of F1R.

**WITH** approval in Japan of Hughes satellite system, RCA and Sony are now pressing for a second system to include an RCA-pair of birds. The first (Hughes built) system was 'sold out' in a matter of weeks from announcement (64 transponders) and additional transponder capacity seems needed.

**CBS** wants a major uplink to be located in suburbs of Washington, at Silver Spring, Maryland; and has asked FCC for permission to build.

**ASSOCIATED** Press will convert nearly 1,000 C band, ten foot receive-only terminals to two-way data terminals. The plan is to allow individual radio, television station customers to uplink local stories back to AP 'central' for refining and then inclusion in outward bound path.

**NASA** getting heat for launching Arabsat bird in June because of timing of event against kidnapping in middle east of TWA passengers. A group of 40 members of the U.S. House wrote NASA complaining about using US funds and assistance to expand the communications ability of the Arabic world.

**TED TURNER**, meanwhile, is talking with the operators of Arabsat about obtaining a transponder on the Arabsat system to beam CNN into the middle east. If program flies, dual audio channels with English on one and Arabic on second is possibility.

**NCTA** President James Mooney is quoted as saying about C band TVRO "These people have contributed nothing to the creation of the satellite distribution systems; they've contributed nothing to the creation of the satellite-delivered cable programming services. And, they don't seem to be interested in contributing anything to the crea-

# YOU HOLD THE CARDS

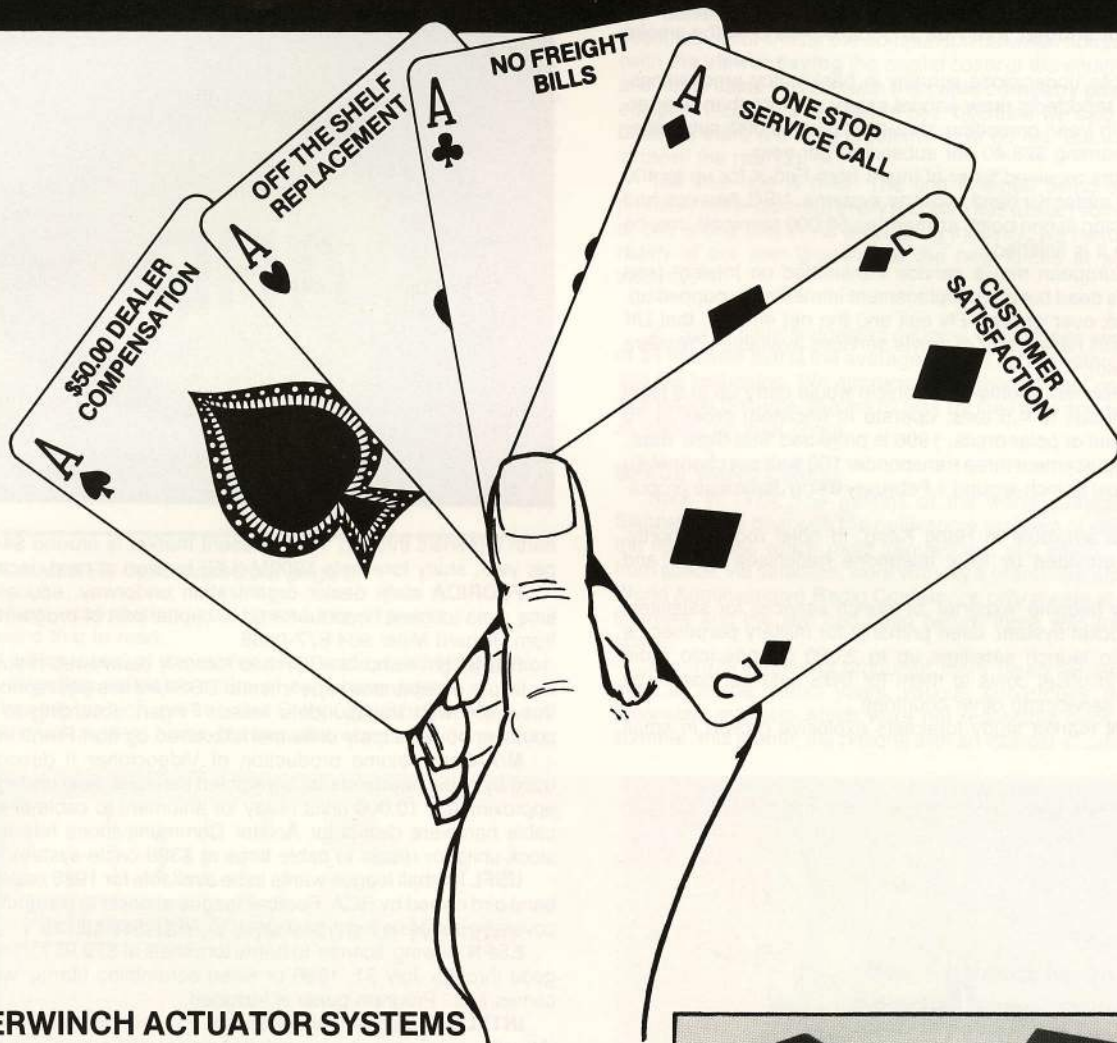

## WITH SUPERWINCH ACTUATOR SYSTEMS

**PAY THE DEALER \$50.00.** Superwinch will pay you, our dealer, \$50.00 cash for replacing a Superwinch 2001 or 2010 actuator drive system that is not operating as advertised.

**OFF-THE-SHELF REPLACEMENT.** No waiting for repaired units to be returned. Superwinch permits replacement of defective drive systems with brand new product.

**NO FREIGHT BILLS ON WARRANTY.** Defective drive systems can be returned to our factory freight collect. New product replacement units are shipped to you freight pre-paid.

**ONE-STOP SERVICE CALL.** Under the unprecedented Superwinch Warranty Program, you make only one service call and you're paid \$50.00 for your time and effort.

**CUSTOMER SATISFACTION** is guaranteed with down time limited to the time it takes you to visit your customer.

**NOTE:** If you're a typical dealer, you've experienced problems with drive systems. Superwinch has The Solution - and our Warranty Program proves it. How can you lose?

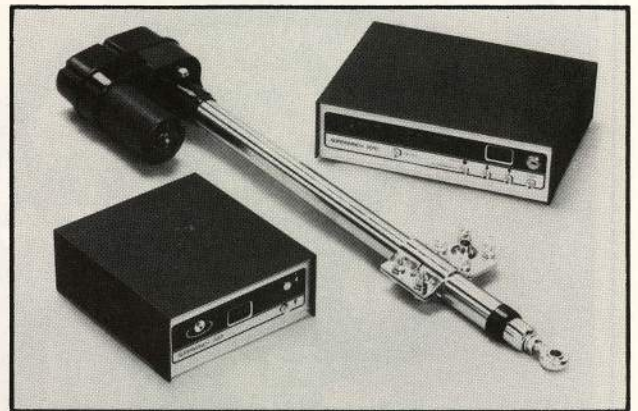

# SUPERWINCH<sup>®</sup>

Actuator Systems Division

WINCH ROAD  
PUTNAM, CT 06260

(203) 928-7787 • TELEX 643981

OR CALL SPECTRUM CONSULTING SERVICES  
(203) 928-0491

PIONEER MEMBER OF  
**SPACE**

Superwinch products are made in North America

tion of programming marketing mechanisms to serve the home dish user. **They want another free ride** and that's behind all the smoke and bombast."

**USCI** finances under close scrutiny in bankruptcy proceedings. Firm President reportedly drew annual salary of more than quarter-million dollars in year preceding shut-down; at 10,000 subscriber base, he was earning \$28.40 per subscriber per year.

**M/A-Com** has received letter of intent from Fed-X for up to 400 on-premise 1.8 meter Ku band two-way systems. NEC America had been in the running at one point; as many as 50,000 terminals may be involved before it is finished.

**TEN**, the European movie service transmitted on Intelsat (see **CSD**, July 1st) is dead but a live replacement immediately popped up. Mirrorvision took over where TEN quit and the net effect is that UK TVRO owners still have a pair of movie services available (Premiere being the second).

**FRENCH** 'Hermes' shuttle-type vehicle would carry up to 6 flight personnel, payloads to 4.5 tons, operate in (inclined) orbits to 70 degrees in normal or polar orbits. 1996 is projected 'first-flight' date.

**JAPAN's** replacement three transponder 100 watt per channel Ku band bird will now launch around 1 February using Japanese propulsion system.

**CNN** will be available in Hong Kong, in hotel rooms, shortly. Service to be provided by local telephone franchisee Cable and Wireless.

**CHINA** may become 'exporter' of launch services for satellites; 'Long March' rocket system, used primarily for military purposes, is being offered to launch satellites up to 2,000 pounds into orbit. Chinese hope to offset costs to them for DBS satellite system by 'selling' launch services to other countries.

**EUROPEAN** market study forecasts explosive growth in small

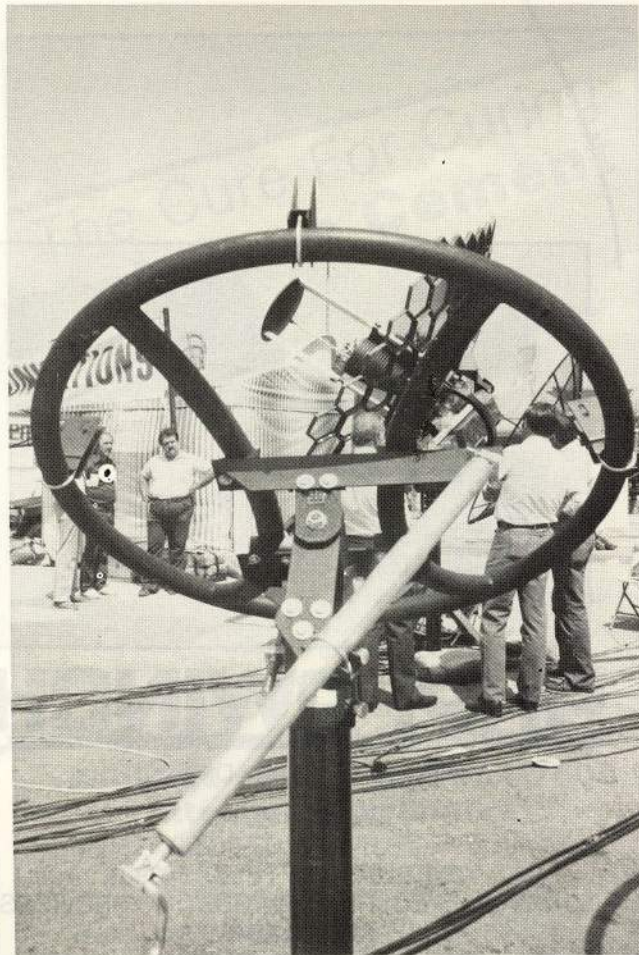

earth terminals through 1990; present market is around \$44M (US) per year, study forecasts \$900M (US) by start of next decade.

**FLORIDA** state dealer organization underway; education, full-time state lobbyist headquartered in capital part of program. Details from Richard Miller 904/877-0888.

**FRENCH** Thompson-CSF had formally disavowed responsibility for failure of Japanese experimental DBS bird this past spring; two of three 100 watt transponders failed. Finger, according to French, points at power supply units manufactured by non-French firm.

**M/A-Com** volume production of Videocipher II descramblers, used by cable headends for scrambled services, now underway with approximately 10,000 units ready for shipment to cable firms. Mass cable hardware distributor Anixter Communications has agreed to stock units for resale to cable firms at \$399 cable-system price.

**USFL** football league wants to be available for 1986 season on Ku band bird owned by RCA. Football league expects to distribute its own coverage separate from past year(s) ABC distribution.

**ESPN** viewing 'license' to home terminals at \$19.95 for first year is good through July 31, 1986 or when scrambling starts, 'whichever comes first.' Program guide is included.

**INTELSAT** launch of V series bird F11 will locate at 27.5 west in 'Atlantic spare' capacity. Launch handled by US Atlas/Centaur rocket system.

**PALAPA B2** satellite, rescued from space and refurbished, likely to become first domestic satellite for Thailand. Bird's name will change and re-launch date will be announced.

**EUROPEAN** space sources predicting that if 'third world' nations do win their plan to reserve orbital spaces for all nations on equal basis, USA will 'pull out' of ITU organization which presently coordinates orbital locations (see **Coop's Comments** this issue).

**TELECONFERENCE** directory of equipment, facilities and services available from University of Wisconsin-Extension, 610 Langdon Street/Lowell Hall, Madison, Wisconsin 53703.

**EUROPEAN** Halley Comet probe 'Giotto' launched from Ariane and beginning 8 month voyage to Halley encounter next March 13th. Vehicle under flight control from West German tracking and command station, will provide TV and measurement 'close-ups' of comet.

**SOUTH** Africa plans to lease Intelsat transponder space to transmit television and radio (national) services into rural areas for direct reception or terrestrial re-broadcast.

**DBS** standards concerning AT&T which claims that 12 GHz receivers could be 'hazard' to terrestrial microwave systems unless FCC or industry adopts receiver local oscillator standards. Telco worries that millions of LOs will 'leak' signals into air causing potential interference with point-to-point microwave communications systems.

**CONTROL** of accidental interference to satellite services, caused by uplinking errors, might be resolved if all uplinkers were required to transmit 'source identification' within vertical blanking interval of video signal. Unexplained is how the source ID would be recovered if two interfering carriers through satellite are so completely degraded that



no video information from either can be recovered.

**FUJITSU** claims breakthrough in low noise amplifiers; a challenge to GaAs-FETs (Gallium Arsenide transistors). New process claims noise figure 50% lower than GaAs-FETs at 18 GHz but gain-per-stage remains marginal for commercial production.

**INSURANCE** payment of \$85M for defunct Leasat bird, scheduled for attempted repair in space during Shuttle late this month, paid. Chances for successful repair considered low and replacement bird now being built.

**ROUTINE** operation of French twin satellite system Telecom (1A and 1B) expected by September 1st. 1A bird at 8 west has been in test phase for several months; 1B recently launched.

**TELESAT** Canada, already receiving highest transponder rates for equivalent space in world, had rate increases approved by regulators; 5% rate increase this year followed by 5.5% rate increases per year for next five years.

**WESTERN UNION** testing new technique to combine video with data channels on TR12 (receive 23) on Westar 3. Technique places data carriers at very 'edges' of transponder, carrying video in center. Similar technique in operation by United Video, TR3, G1 for more than a year transmitting 'Rock America' audio service(s).

#### COOP COMMENTS/ continued from page 6

If you have more room on your checks than I have on mine, you might expand that to read:

**"Paid with protest of excessive rates and retaining rights for refund if litigation validates claim of excessive rates".**

The rates are too high, not because CNN, CNN/2 or ESPN are not 'worth' that much money, alone, but because when all of these rates

are 'bundled' and added together, the sum of the individual rates becomes out of line for the comparison between home TVRO service (with **the viewer paying** the capital costs of the equipment required) and home cable service (with **the cable company paying** the capital equipment costs). We need to pay, because we said we would and because there are legal problems if we do not. But we also need to 'protest' the rate (2).

The free ride is over. The first charges being announced will probably not endure but every program has to start someplace; even if at 'the wrong place'. As a maturing industry, we need to accept the reality of our own growth and the new forces at work within our industry.

2/ Some have suggested sending TBS \$2 per service per year or \$4 because that is the average rate for cable systems, in lieu of the \$25 fee requested. We appreciate the thought that goes behind this suggestion but urge dealers to play by the rules and simply 'protest', as stated, on your check.

#### SPACE WARC Coming

Back in 1979, 154 nations of the world gathered in Geneva, Switzerland to deal with the nettlesome problem of which nation had the right to use which radio frequencies, and when. Transmissions from space, via satellites, were virtually a brand new subject since the World Administrative Radio Conference only meets at about 20 year intervals and the last had been before there was much activity in space.

The 1979 gathering produced more disagreement than agreement so in the interim years, various 'sub-groups' have re-met to reconsider subjects which were not resolvable back in 1979. This summer, this month, the nations with an interest in satellite transmis-

# ADM-20'

Performance . . . Horizon to Horizon

The ADM-20' satellite antenna system is known throughout the world as the leader in state-of-the-art precision and performance. Twenty-four hours a day, in extreme climates and adverse environmental conditions, the ADM-20' aluminum hub, petal and truss construction insures pinpoint accuracy for years to come.

ADM-20'—the competitive edge around the world.

New horizon-to-horizon motorized polar mount available. Rugged reliability with fail-safe chain-driven performance.

ANTENNA  
DEVELOPMENT &  
MANUFACTURING, INC.

(314) 785-5988

POPLAR BLUFF, MO 63901

P. O. BOX 1178

sion allocations are holding their 'post-WARC' gathering. It is subtitled 'SPACE WARC.'

Basically, there is one overriding issue which followed us from 1979. Time has not mellowed that issue; it is probably going to be a bigger problem this meeting than last and they were not able to resolve it in 1979. The issue? A battle between the 'haves' and the 'have nots.' Here's the scene.

There are at least two different ways to approach the subject of Clarke Orbit Belt assignments. In the first situation, the guys who need the space assignments, and who can launch their satellites **first**, have the **first call** on the available orbital locations. Just like parking your car downtown on a busy weekday.

In the next situation, those nations who would like to have a space-spot, but who are not economically or technically prepared today to use it, want some spaces reserved for them. This is akin to the 'Disabled Person Parking spots' you see downtown.

The US, the UK, and most of the other developed nations, are totally in favor of 'first-call parking zones.' Countries you never heard of, couldn't pronounce if asked and too poor to even afford a working telephone system are in favor of orbital allocations being reserved, permanently, to protect their 'long-term interests.' Each nation has a single vote in the sessions so Chad and other poorer nations count just like the US. I don't need to point out that there are more poorer nations than richer nations so the odds are 'agin us' walking in.

So what should be a technical meeting of system technical managers turns into a super-charged political meeting where delegates are selected for their political savvy and their persuasive powers rather than their technical savvy or understanding of the details of the matter at hand.

The conference has been called for the stated purpose of "Providing all countries with a guarantee of equitable access to the Clarke Orbit Belt." That may suggest to you which 'side' wrote the agenda.

For the very first time, the fact that 'we' (home TVRO owners) exist will be acknowledged. The US delegation has completed a study of our industry and they came to the reasoned conclusion that there are more than 1,000,000 of us spending around \$2,600 each for our terminals. We may find small dispute with their exact numbers but at least they are walking on the same side of the street as us. Their recognition that we exist was not by chance; the US delegates believe there is a 'political' message concerning our numbers and the cost of our terminals; they intend to drive home the point that 'low cost' TVROs are here and that any nation that wishes to avail itself of this technology can do so, today. Of course we also recognize that many (read most) nations of the world would be frightened to death by our North American 'free access' to satellite television technology and the possibility that any citizen could tune in non-censored news and other events which are not available on a local basis.

Those underlying concerns set aside, the US makes strong arguments for 'freezing technology' if the long-term plan to reserve orbit spots is adopted. The US fears (with some agreement from other nations) that by assigning reserved spots, new technology breakthroughs might never occur since there could be no place in space to put those breakthroughs to work. The US says 'technology cannot be allowed to go stagnant.'

The five-week session, beginning the 8th of this month, is designed to settle how and what will be ultimately decided; 'ultimate' is a long-term plan since the actual assignment of orbital locations will not be in place until at least 1988, when the group again meets.

Interestingly, one of the primary reasons there is such a conference at all (i.e., why this was not all settled back in 1979) is a battle the Indians had with the folks at Intelsat. India, in launching its own domestic satellite system, ran into severe problems trying to negotiate an orbit spot with Intelsat. Intelsat had a number of 4 GHz birds in place or planned over the Indian Ocean region and each time the Indians studied the problem and found a solution, the bureaucracy at Intelsat responded by moving one of their planned birds. It was a hopeless game of space-Chess and in the end the Indians had to accept a less than desirable assignment. At about the same time, Indonesia was trying to plan its own 4 GHz domestic system and they kept running into similar problems with the Russian 4 GHz birds over the Pacific. Both countries, considered to be 'bridges' between the developed nations and the small, poorer nations, gathered consider-

able support for their problems at the 1979 WARC. In effect, if Intelsat could push India around and if Russia could push Indonesia all over the skies, what possible future would there be for Chad?

There are other nagging issues and concerns. Several of the nations who exist on the equator still maintain that the Clarke Orbit space **over their countries belongs to them**; international aviation agreements aside. They want a special class of 'ownership' for any spots overhead and to them, this is an economic issue. The US fears a second economic issue. If the majority of the countries adopt the 'planned, reserved assignment' approach, there is the concern that nations such as Chad will never have a bird to place in their spot. Never. But they will 'own' a spot nonetheless. What would a country such as Chad do if they had a spot and were not using it? Rent it out of course.

And that could establish an economic precedent which the US and other nations fear; a new form of international 'subsidy' between the wealthier nations and the poorer nations. Space-spots would become a commodity; just like people with disabled parking permits renting out those parking spots to others without permits, rather than allowing them to go follow.

The domestic belt places occupied now by the US are **not** in any direct contention. Most of the 'heat' is coming from nations in South America (which can use virtually the same spots we do since their birds 'point south'), Africa and Asia. But the international nature and long-range planning of US communication consortiums does carry concern for the direction which WARC '85 points the nations of the world.

#### 15.92 vs. 38.82

If you like numbers, and are fascinated by projections, you may have been amused (or downright frightened) by our report appearing in CSD/2 for July 15th. We took the now (in)famous **Malarkey-Taylor Associates** report prepared for the cable trade association (NCTA) and dissected their math to find out just what size TVRO market these big time cable guys were projecting for TVRO between now and 1990.

MTA didn't come right out and reveal their number so you had to back into it by reading the 'footnotes' and 'appendix' and then writing a computer program to 'test' their 'revealed' numbers. Here is what we found.

- 1) Malarkey-Taylor believes there could be **8,154,000 TVROs** in the US by 1990. If you back out the 1,750,000 likely by the end of 1985, that leaves us with an MTA projected 6,404,000 to be sold in the 60-month period beginning January 1, 1986.
- 2) MTA also tells us that overall, **they anticipate** cable TV operators 'capturing' **59%** of the total market (that's market inside of their franchise areas **and** market outside of their franchised and wired areas).
- 3) So if MTA believes cable will capture 59% of a market that will total 8,154,000 TVROs by December 31, 1990, what does that tell us about the chances that an 'independent,' non-cable-operator retailer of TVRO programming (and hardware; i.e. systems) can survive?
  - A) We took the 3,500 dealer base we now have (i.e. full-time, retail, store-front dealers) and did some simple math. We found that if cable captures 59% of the projected market, 'independent TVRO' sellers (that's you, and you and you!) will have to limp along averaging **15.92 terminals sold per month** between January 1986 and December 1990.
  - B) On the other hand, if cable got **0%** of the total TVRO marketplace for the same period of time, and the MTA projections are correct, the 'indie' TVRO dealer would realize **38.82 terminals sold per month**.

So there you are. If we let cable get their 'nose under our tent,' they plan to take 59% of what we do and for the average, typical dealer, that means your growth will be severely limited by cable's presence in your marketplace. If you can run a profitable business between January 1986 and December 1990 by selling 15.92 terminals each month, you can relax. **On the other hand**, if you would rather be selling 38.82 terminals each month for each month for those 60 months, now you can understand why the 'cable threat' will hurt you, and you, **and you**.

Cable wants to get into your pocketbook. It is just as simple as that. Because they control, directly or indirectly, the programming that we need to survive, they figure we are short-timers who will eventually all

but disappear. If you figure they are wrong, it is time for you to speak up and get active. Or, resign yourself to a five-year 0-growth pattern controlled by your friendly cable operator.

#### REACHING Consumers

During the June STTI/SPACE gathering in Tulsa, someone with time on their hands studied the 'take-a-publication' bins and counted 28 separate publications in the TVRO field. I think they missed a few but the message is abundantly clear nonetheless; we have a considerable overabundance of magazines. And since I started the first one, the 27 plus that followed me into TVRO are of some interest to me. I think **some** of them should be of interest **to you as well**.

We are now witnessing, on the newsstands, the first wave of consumer-directed TVRO publications. Most of the best names were already spoken for so we end up with publication titles such as 'TV Satellite Videoworld' and 'Home Satellite TV/ The Magazine Of Total Television'. A person could spend the first 50 cents of his long distance call listening to them answer the telephone and telling you who they are.

Both of these two publications (unfortunately, more are promised) have gotten past their first issues now and the first out ('Home Satellite TV'; HSTV from here on) is now reaching the newsstands with number two. In a year when we have been concerned as dealers, distributors and OEMs about getting 'our message' into consumer or would-be consumer hands, **both publications** are important potential tools of the industry.

As we have reported here and in CSD/2 over the past few months, while TVRO has a much improved visibility in the consumer world today, there are still many more confused people to straighten out. A well done, consumer magazine, available at the super market or drug store or airline newsstand is a powerful propaganda instrument provided it is devoted to our best long-range interests. **And that raises the first concern**; who are these people who are creating these magazines and what are their qualifications to be self-appointed to speak for us to the consumers at large?

TV Satellite Videoworld (hereinafter TVSV) is one of seventy-one different magazines published by a group calling itself Harris Publications, Inc. (1). Harris is a magazine 'factory' cranking out a couple of new consumer magazines each day of the month. They started out by finding a TVRO dealer on Long Island (Charles Saracino) who knew nothing about magazines but probably knows something about TVRO. Saracino was their point man and by getting on the telephone he lined up a number of writers and others from our industry to create material for their first issue. Dated September, it hit the newsstands the latter part of June. A number of TVRO folks, myself included, agreed to help out with the first issue. Anthony (Terry) Easton, who has authored a couple of well-selling consumer books in our field, and his blond-headed wife Susan are a major part of the TVSV regular team. Susan writes a column for Channel Guide as well. TVSV says they printed 150,000 copies of their first issue and placed them on newsstands. By the 1st of September or so, they'll know how well they sold. **Until** a magazine has been out a month plus, there is **no good way** to tell how it sells.

HSTV is from a much smaller publication house; Miller Magazines, Inc. (2) cranks out several different magazines each month but nothing to compare with Harris. HSTV also went to our industry to find people who understood our field as contributing writers. I agreed to write for HSTV as well since there was a sixteen minute opening on the third Thursday of each month when my typewriter was not otherwise booked. HSTV put out 90,000 copies of their first issue and like TVSV some time had to lapse before the sales results were in.

HSTV is issued at the present time every **other** month. A full year's subscription will result in six issues and the consumer's cost is \$10 for a mail subscription. The newsstand price is **\$2.50** and it will be some time before the mail subscriptions (on this or any other new magazine) reach even 25% of the total circulation.

TVSV sells for **\$2.95** on the newsstand (although most super markets now routinely discount magazines and milk by raising the

COOP/ continues on page 76

## THE HIDDEN SIGNALS ON SATELLITE TV

### "THE SECRET SIGNALS ON THE BIRDS"

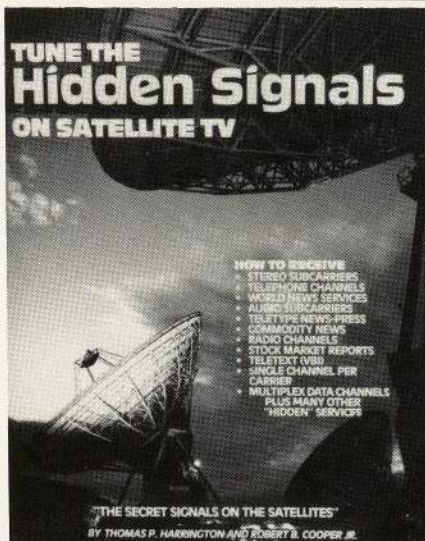

#### A Technical Book Covering the Reception of:

- Stereo Subcarriers
- Telephone Channels
- World News Services
- Audio Subcarriers
- Teleprinter News — Press
- Commodity News Services
- Radio Channels — Networks
- Stock Market Reports
- Teletext (VBI)
- All Single Channel Per Carrier Services (SCPC)
- Multiplex Data Channels Plus Many Other "Hidden Services"

#### NEW "SECRET SIGNALS" BOOK

A complete work covering the Hidden Services, the systems, the equipment, how these services are used, how these services can be utilized, what they mean to our field. This book for information use only. Not to be used for the reception of unauthorized signals or pay services.

Visa and MasterCard Welcome **\$14.95** plus \$1.75 for shipping & handling.

CSD READER SERVICE, P.O. Box 100858  
 Fort Lauderdale, FL 33310; 305/771-0505  
 Dealer Inquiries Invited

Dealer Member  
**SPACE**

# A LEGACY OF EXCELLENCE CONTINUES.

## **Viewstar, Inc.:**

- Developed the first infrared remote, fully programmable digital converter.
- Developed 300 MHz crystal controlled UHF block up-converter.
- Patented CCD scrambling technology.
- Developed first remote volume control stand alone digital converter.
- Developed non-volatile parental control in CATV converters.
- Developed addressable baseband scrambling system for pay TV.

**And now, 1,000,000 units of CATV converters later, a new star is born to the home satellite TV market, the latest in state-of-the-art receiver technology . . . We call it simple yet sophisticated.**



## **Viewstar**

Viewstar, Inc. 55 Milner Ave.,  
Scarborough, Ontario,  
Canada M1S 3P6  
(416) 298-9919. In USA call  
Spectrum Consulting Services  
(203) 928-0491.

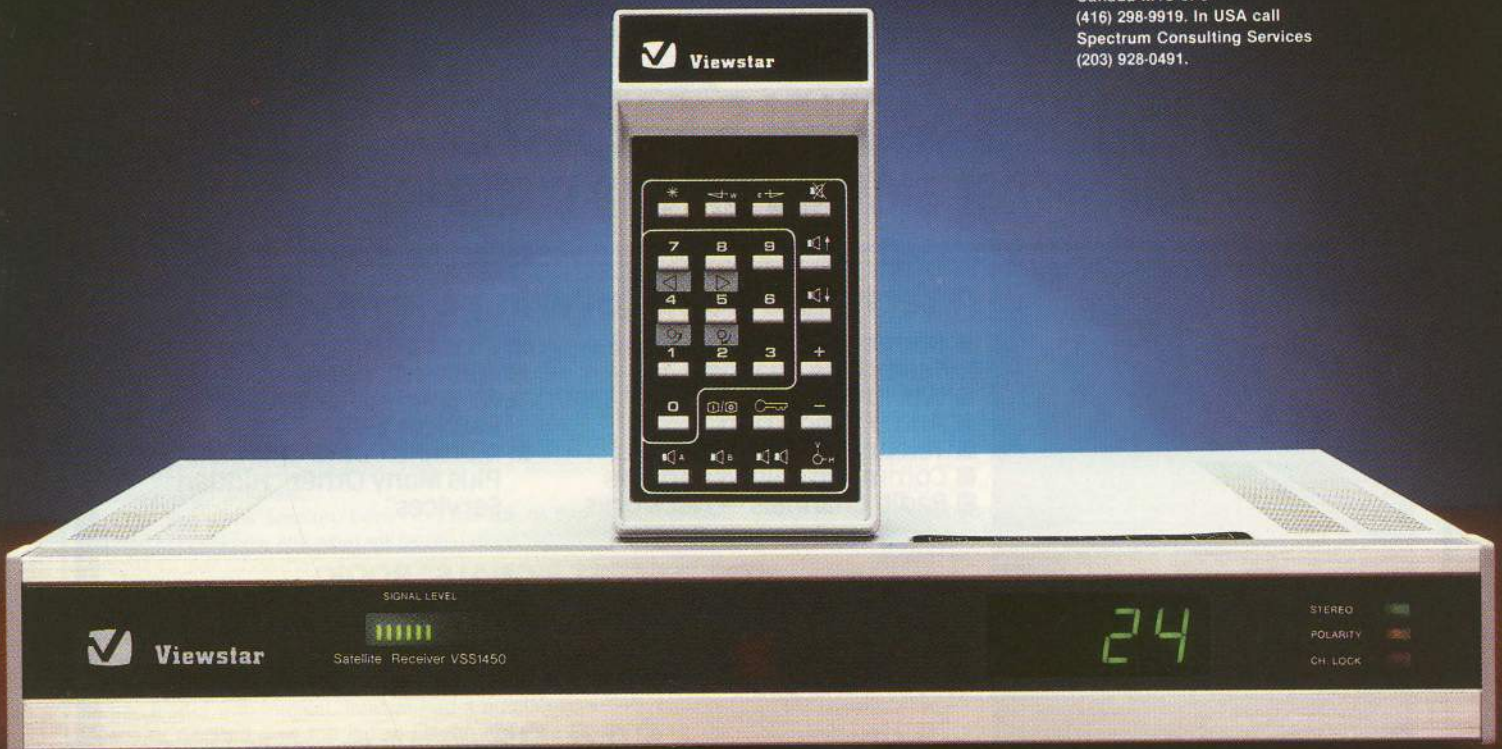

Check **HiTec** **9000**<sup>®</sup>  
Saginaw gear  
steering gear

# ANTENNA POSITIONER

YOU said YOU wanted!  
for the features



## NEW FEATURES

- Integral Ball Clevis
- Water-Tight Wiring Connector
- Protective Boot with Heavy-Duty Stainless Steel Clamps
- Internal Motor Leads
- Enhanced Corrosion Protection
- Fully-Vented Design

## OPTIONAL POSITION SENSING FEATURES

- Static/Surge-Protected Hall Effect
- Static/Surge-Protected Hall Effect with Stroke Limits
- Spur-Gear Driven Sealed Potentiometer

## CONSTRUCTION, DESIGN AND MANUFACTURING FEATURES

- Machine-Welded Heavy-Wall Inner Tube
- Durable HiTec Engineered Gearing
- Corrosion Resistant, Precision Die-Cast Zinc Gear Box
- Drive-Train Protecting Slip Clutch
- All-Steel Load Path
- Threaded and Swaged Drive and End Load Connection
- Extensive Laboratory Testing
- Continuous Engineering Re-evaluation
- Quiet Operation
- Low Maintenance
- In Production since 1970
- Manufactured and Backed by a General Motors Division.



Manufactured by

**Saginaw Steering Gear Division**

GENERAL MOTORS CORPORATION • SAGINAW, MICHIGAN 48605 • (517) 776-4123

Sold and Distributed Outside United States by Saginaw Steering Gear Division, General Motors Overseas Distribution Corporation

COOP COMMENTS/ continued from page 73

price of dog food!). If you can subscribe to TVSV easily, they forget to tell you how, how much money to send, or where to send it on their title page.

Both publications had staff on hand in Las Vegas and both were looking for enough background material to make their first issues seem 'up-to-date' and 'timely'. HSTV beat TVSV onto the newsstands by about three weeks to a month and both join Triple D's 'STV Magazine' on the newsstands.

STV, unlike the two latecomers, was 'home grown'. It sprung from the same desks which today bring you **On-Sat** and **Satellite Retailer**. STV was the first from Triple D and the co-owners, **Christ Schultheiss** and **Doug Brown**, have deep roots in TVRO. STV is something of a sleeper in TVRO because it started out first as a quasi-dealer publication. More recently, it has moved more and more into the consumer realm and when Triple D brought out their **Satellite Retailer** (for dealers) this year, the die for STV was firmly cast in favor of consumers. STV may well be the most underrated publication in TVRO since they routinely print and ship more than 118,000 copies these days. More important than the number of copies is the response one (such as an advertiser) can measure from a publication. I won't betray a confidence here but one knowledgeable marketer in TVRO tried **Orbit**, **STV**, **Satellite TV Week** and some others with a new product and found STV out-pulled the balance by a 4 or 5 to 1 margin. I'll give you some numbers on Orbit and the others shortly.

So how did the first issues from TVSV and HSTV 'read'? What kind of 'first-time' impression did each publication make on the neophyte reader who sprung for the newsstand price while waiting in line to pay for his six pack and loaf of bread?

TVSV/ TV Satellite Videoworld. The overwhelming message in the issue dated September is (1) TVRO is 'here', now, (2) TVRO is not complicated to understand, (3) Sports are everywhere on satellite, and (4) 'Stars' such as Ed McMahon are buying TVROs.

The articles are basically short, usually quite general in text, and usually end on an upbeat note. With 19 article-titles in the first issue, there is plenty of reading material. And there are mistakes. TVSV decided to tackle the scrambling issue and the report was filled with factual errors that would bother a purist like me ("Many cable networks and regular channels have scramblers which work for about 75 miles but not after that and the dish gets right through the scramblers . . ."). I hope nobody bought a new house 75.1 miles away from the dreaded scrambler cited here in hopes that they would get a much



HOME SATELLITE TV/ HSTV is now two-issues old and it is issued at two-month intervals.

sought after event.

HSTV/ Home Satellite TV. With two issues now out, there is the opportunity to look for 'consistency' from Miller Publications. Both issues recite a now familiar theme: (1) Scrambling is not a threat, (2) Families can share up to 117 channels with one antenna, (3) Satellite TV is worldwide and very exciting, (4) You could install it yourself if you wanted to, but buying from a dealer is probably more intelligent.

The articles are generally slightly longer in HSTV (18 feature titles per issue average in the first two issues), usually more specific in text (than TVSV) and always end on an upbeat note. The mistakes we found were printer/publisher errors rather than factual; typographical, for example.

If I had to rate the two as competition, I'd place HSTV in front and TVSV behind but the differences are slight and if you closed your eyes and took a copy of each (both have the same number of pages) to an unmarked page and starting reading text, you'd be hard pressed to know which one was in front of you.

There is something of concern in both, to me, and I cite it in my concern for dealers who are paranoid about keeping TVRO a 'closed shop'. The advertising one finds in the two publications.

At the Tulsa meeting of the SPACE Dealer Board, I heard several dealers speak out against (1) how much advertising money OEMs are pouring into the myriad of 'trade books', and, (2) the shortage of 'public awareness campaigns' by OEMs. What the dealers are saying is that they would rather see manufacturers spend bucks in TV Guide or Sports Illustrated to attract consumers into TVRO stores. Drake is presently doing this; Winegard and Uniden and Curtis-Mathis have done this in the past. DX will be doing it later this fall, as I also comment on in these pages this month.

Unfortunately, an advertisement created to attract a dealer to handle Uniden (for example) is not the same advertisement that should appear in TVSV. More unfortunately, that is exactly what happened in the September issue of TVSV; a two-page spread titled 'Introducing the top-of-the-line line' said wonderful things about the UST-5000, 6000 and 7000 receivers. Sadly, as many dealers noticed, the advertisement listed 'suggested dealer pricing' for each model (\$249/5000; \$389/6000 and \$799/7000) and 150,000 potential consumers now know what Uniden dealers are expected to pay for these pieces. I couldn't believe Uniden made this type of error; they did not. The fault was traced to the publication where instructions to 'pull' the wholesale pricing somehow slipped by.

I'm glad this happened because while Uniden dealers will have to talk their way out of the error, it draws attention to the obvious solution; these new consumer publications should have totally different artwork and copy. An advertisement created for 'trade publications' should never even get close to a consumer publication. The Uniden wholesale pricing error aside, flipping through either TVSV or

Your Comprehensive Guide to Home Satellite Television.

# TV SATELLITE

THE COMPLETE GUIDE TO CHOOSING & USING A HOME SATELLITE DISH

**FREE**  
Over 100 CHANNELS  
Plus ALL CABLE  
TV PROGRAMS!

Special Report:  
COMPLETE SYSTEMS  
FOR UNDER \$1,500

Experts Tell You How To:  
BUY A DISH FOR ANY BUDGET  
CHOOSE THE RIGHT SITE FOR YOUR DISH  
PICK THE ACCESSORIES YOU REALLY NEED

Linking Up Your

"Tonight" Show's  
Ed McMahon Tells Why  
Celebrities Are Pushing to  
Buy Satellite Dishes

TV SATELLITE VIDEO WORLD/ TVSV is monthly and the second issue is reaching newsstands as you read this.

HSTV points out advertisement after advertisement that at best will confuse the consumer ('One Step Closer' by Chaparral), or, at least befuddle the consumer ('Call 1-800-228-1926 for the name and location of your regional distributor'; KLM), or tick-off the dealer ('Buy Direct and Save'; National Satellite Sales). Birdview's advertisement suggested that readers call an 800 number for the name of the dealer nearest them. Drake sent readers to the yellow pages for their local dealer.

Now, getting into TV Guide can cost upwards of \$40,000 for one shot. One-shot would be quite useless as a rule so if you are going to play in those leagues, you'd better be prepared with a hefty six figure budget. On the other hand, getting into either HSTV or TVSV will cost you something closer to \$2,000; about what it costs to advertise in a couple of the 'trade' publications.

Putting \$2,000 into ORBIT gets you out to 160,000 recipients (actual June 1985 issue mailing records; 158,863 copies). Unfortunately, virtually all of those 160,000 already own a dish. Putting \$2,000 into HSTV or TVSV reaches someplace around 100,000 readers but the difference is that most of these people have yet to make a dish decision. Even if you, as an OEM, cannot or will not figure out a way to place these people in direct contact with their nearest dealer, just being in front of the would-be dish buyer is going to have a considerable 'recall' influence on what the consumer elects to purchase when he does finally step into a TVRO store.

**Note:** Just in case you have some interest in how the various 'consumer satellite guides' are distributed, here are some recent circulation numbers derived under the Freedom Of Information Act through U.S. Post Office records. (1) Satellite TV Week, 296,039 copies (June 02-08, 1985); (2) Satellite Orbit, 158,863 copies (June 1985); (3) ON-SAT, 128,152 copies (June 02-08, 1985); (4) Channel Guide, 43,031 copies (April 29, 1985); (5) Satellite Dish Magazine, 28,303 copies (May 30, 1985 issue).

There is a significant advantage to 'testing' the consumer waters with magazines such as STV, HSTV and TVSV; the people who are buying these publications are 'pre-culled'; they are voicing their vote in favor of TVRO by simply plunking down money for the publications. That means they are at least inquisitive about TVRO and that makes them receptive to a sales pitch. A full page ad in TV Guide has to fight for attention, and most people don't read TV Guide from cover to cover so back page ads are usually buried where they are not seen by a high percentage of the readers. An advertisement in TV Guide has to 'stop' the page flipper and grab his or her attention to TVRO. A full page ad in the three consumer books is in a totally friendly, totally TVRO environment. That's good and when you weigh the difference between \$40,000 and \$2,000, the new consumer TVRO books are inexpensive enough that virtually any OEM can and should be in their pages.

Some final words of advice. The whole purpose of advertising is to attract attention and create sales. Sending people to their yellow pages is not nearly as effective as sending them to their telephone. (The first problem with yellow pages is that the reader has to decide what classification to look under; a not insignificant problem). AT&T will lease you an 800 number starting at \$36.50 per month (call 1-800-222-0400 and ask about it) plus of course a charge per call. If you hire a gal to answer that telephone and take down the caller's name and address at the same time you give out the name and telephone number of your nearest dealer to the caller, you can recycle the interested party's name and address directly to your dealers. This will usually cost you \$1.50 to \$2.50 per name processed if you watch your overhead. The OEMs that do this well, tying together the would-be consumers, and the dealers in a nice, neat package will build the best dealer network(s) this industry has ever seen. In six months time, you will have the most loyal group of dealers of any OEM in the industry. Remember that the average or typical dealer sells fewer than 12 terminals per month. You only have to add a few, through consumer sales leads, to that number to have a profound

**BALDWIN Odom ENTERPRISES**  
*presents:*  
**ACCL-WAVE 10**

**"AS GOOD AS THE BEST,  
 BETTER THAN THE REST."**

"Distributors in the Satellite Industry need the stabilizing support of an honest, reliable manufacturer. Baldwin-Odom Enterprises is that manufacturer. We are strong because our business principles and practices are strong: excellent product, with immediate service, at a competitive price. We believe in the integrity of our people and the quality of our product."  
 Randall V. Odom / Jerry C. Baldwin

*For the wave of the  
 future insist on the  
 quality and consistency  
 of* **ACCL-WAVE 10**

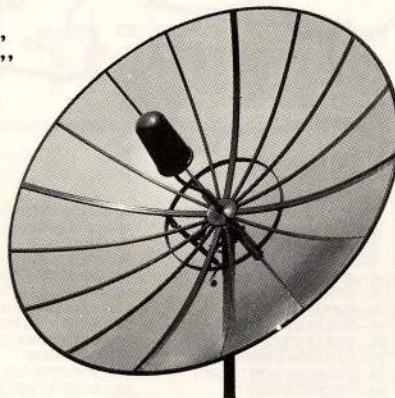

**ANTENNA  
 SPECIFICATIONS:**

CONSTRUCTION 4pc. STEEL  
 DIAMETER ..... 10 ft  
 DPTH ..... 22½  
 F.D. RATIO ..... .33  
 FOCAL LENGTH ..... 40"  
 GAIN ..... 40.1 D.B.  
 FINISH ..... BLACK

CONTACT  
**BRIAN FAUGHT**  
 Marketing Director  
 IN ARKANSAS 1-843-8227 or  
 TOLL FREE  
 1-800-847-0061

**DISTRIBUTORS**  
 • MARKET PROTECTION  
 • CONSISTENT QUALITY  
 • COMPETITIVE PRICING

**BALDWIN Odom ENTERPRISES**  
 PO BOX 1537 • CABOT, AR 72023

impact on both your dealer's volume and your own volume.

1/ Harris Publications, Inc. (TV Satellite Videoworld), 1115 Broadway, New York, New York 10010; 212/807-7100, Matt Stander, for advertising information.

2/ Miller Magazines, Inc. (Home Satellite TV), 2660 E. Main Street, Ventura, California 93003; 601/226-6807, Martha Ray Fedric for advertising information.

**DX ADvantage**

One year ago I had the opportunity to try out a new TVRO receiver from DX; their first shipment of DSB-600 units. I was in the backyard of industry pundit Peter Sutro and a DX unit brought out from their nearby corporate headquarters was run through the paces on a 5 foot antenna. Peter lives in New Jersey so we didn't have much signal or clearance to work with. I was impressed and said so shortly thereafter. I also did one of my end-of-limb acts and forecast that DX would change from an SMATV supplier to an influential and impressive supplier to consumer (home) TVRO over the next 12 months.

Now comes J. Richard Gonzalez who has taken control of the DX marketing program and he is making big points with DX dealers nationwide by giving them the opportunity to appear in TV GUIDE magazine. It will be interesting to see how it all turns out, for the dealer.

**Here's the program.** DX is taking a full page advertisement in TV Guide for September 7th. That's a good issue to be in since the new TV season for the fall is just starting up and people are changing their

priorities away from outdoor activities after the Labor Day weekend. Right there on the full page is an offer which should help grab the page-flippers long enough to make them curious about home satellite TV. We show it here.

Now, if you are a DX dealer (you had to buy a minimum of 4 DX receivers and 2 DX antenna positioners between June 1st and July 15th), you could be listed right there in TV Guide. As a place to go for a **free introduction to satellite TV.**

As a DX dealer, you will receive not only the 'free listing' in TV Guide, but you will also receive: (1) 50 copies of a special edition of 'Orbit' magazine, (2) 50 copies of the handbook 'Tuning In', an introductory publication from CommTek. **Free to the dealer.** And there is more: (3) With each DX receiver or antenna positioner you purchase during the promotional program, you receive a three month (free) subscription to Orbit. This of course becomes a 'gift' from you, the dealer, to the customer who buys a system.

**Pretty neat.**

For the handling of four receivers and two positioners, the dealer becomes a part of a national promotional campaign which will appear in the 'regional editions' of TV Guide on September 7th (see map).

One of the common sense answers to the high cost of national advertising is to **not do it nationally**, but rather use the **regional editions** of publications such as TV Guide. Regional editions offer two advantages to the national advertiser; (1) He can 'target' his market, try out something on a smaller, less expensive scale without springing for national coverage all at once; (2) He can re-make the ad slightly to feature different dealers in different editions. The Southeast Texas

**The DX TV Guide full-page ad will appear on Sept. 7 in your area.**



Select the regional edition in which you want to be listed and write the corresponding number in the space provided on the five-part participation form.

- 1—ALABAMA (NORTHERN)
- 2—ALABAMA (SOUTHERN)
- 4—ARKANSAS
- 5—ATLANTA
- 7—BRISTOL-KINGSPORT-JOHNSON CITY
- 10—CHARLOTTE
- 17—DALLAS-FT. WORTH
- 21—EVANSVILLE-PADUCAH
- 23—FLORIDA (NORTHERN)
- 24—FLORIDA (SOUTHERN)
- 26—GEORGIA (SOUTH)
- 28—GREENVILLE-SPARTANBURG-ASHEVILLE
- 29—GULF COAST
- 32—HOUSTON
- 43—KENTUCKY
- 44—KNOXVILLE-CHATTANOOGA
- 46—LOUISIANA
- 48—MEMPHIS
- 52—MISSISSIPPI (CENTRAL)
- 53—MISSISSIPPI (SOUTH)
- 56—NASHVILLE
- 61—NEW ORLEANS
- 64—NORTH CAROLINA (EASTERN)
- 67—OKLAHOMA CITY
- 69—ORLANDO
- 84—SHREVEPORT-TEXARKANA
- 85—SOUTH CAROLINA
- 89—TAMPA-SARASOTA
- 90—TEXAS (NORTH)
- 91—TEXAS (SOUTH)
- 92—TEXAS (SOUTHEAST)
- 93—TEXAS (WEST)
- 96—TULSA
- 98—VIRGINIA (CENTRAL)
- 99—VIRGINIA (EASTERN)
- 103—WEST VIRGINIA

**TV GUIDE SEGMENT/ part of the USA broken up in TV Guide 'regions' so the dealer can select which regional edition he wishes to be listed in.**



# Introducing... The Only Cable Routinely "Sweep Tested" for 950-1450 MHz Accuracy

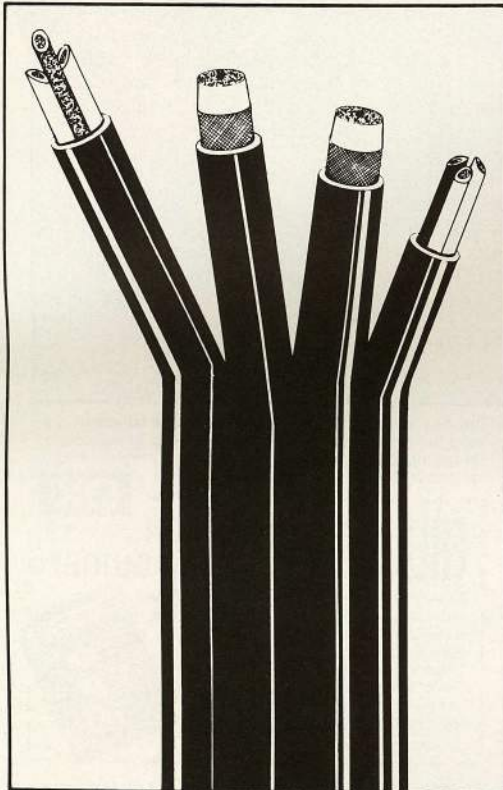

**M/A COM**

## Multi-Pak

**Ribbon Cable**

Your cable worries are over. Satellite Video Services now offers you Direct Burial cable that is guaranteed by M/A Com to accurately carry a 950 - 1450 MHz signal. M/A Com's RG 59, RG 6 and Dual 6 Ribbon Cable is routinely "Sweep Tested" to ensure you the perfect performance standards demanded in all your block conversion installations. M/A Com Multi-Pak Ribbon Cable is available in custom cut lengths or 1000' spools.

Volume discounts are available.

**IN STOCK NOW AT**

**Satellite Video Services, Inc.**

Master Stocking Distributors of M/A Com LNAs, receivers, drives, antennas & cable.

## The Northeast's Leading Distributor Factory Authorized Service Dealer Training Seminars



**Uniden    Norsat    M/A Com**  
**Luxor     Conifer    Gensat**  
**Houston Tracker    Winegard**

**Satellite Video Services, Inc.**

RR #1, Box 85-S  
Catskill, NY 12414  
**518-678-9581**

**800-528-DISH**  
**800-831-DISH-NY Only**

**Satellite Video Services PA, Inc.**

317 E. Pleasant Valley Rd.  
Altoona, PA 16602  
**814-942-5003**

**800-242-3860-PA Only**  
**800-367-8899-National**

**Satellite Video**

**Services WNY, Inc.**

East Avenue Extension  
Hornell, NY 14843  
**607-324-3435**

**800-831-1121-National**  
**800-641-0018-NY Only**

**Satellite Video Services NH, Inc.**

RFD #2, Harriman Hill Rd.  
Raymond, NH 03077  
**603-895-3182**

**800-448-0012-National**

## IN STOCK IN TAMPA

DX COMMUNICATIONS  
Receivers & Accessories

## ARISTOCOM ANTENNAS

*Paraclipse*

- 16 Foot Antenna
- 12 Foot Antenna
- 12 Foot Powder Coated Antenna
- 9 Foot Antenna
- Actuator Rib Mounting Bracket

**CHAPARRAL**

Polarotor I and Polarotor II  
Tune Feed Polarotor I for Paraclipse

HOUSTON TRACKER SYSTEMS  
All Models

 **California Amplifier Inc**  
52 dB Gain LNAs

SPACE VISION LNAs  
STS/MBS & LSR SYSTEMS

**CALL TOLL FREE  
FOR PRICES**

813/876-7677  
TELEX: 52-825  
1-800-237-2903  
1-800-282-7713

PROMAR, INC.  
4912 W. LaSalle St.  
Tampa, Fl. 33607

## Authorized



## Dealers

State  
City  
Co. Name  
Street Address  
Phone No.

State  
City  
Co. Name  
Street Address  
Phone No.

State  
City  
Co. Name  
Street Address  
Phone No.

State  
City  
Co. Name  
Street Address  
Phone No.

State  
City  
Co. Name  
Street Address  
Phone No.

State  
City  
Co. Name  
Street Address  
Phone No.



Discover a new dimension in home entertainment! DX Satellite TV brings you over 200 channels of education, sports, news, movies, and entertainment programming... for less than what you could pay for cable.



**FREE DEMONSTRATION.**  
**\$4.00 PROGRAM GUIDE.\***

To learn more about satellite TV, bring this coupon to any DX dealer listed and receive a free demonstration plus a free copy of Satellite ORBIT, world's leading satellite TV program guide (a \$4.00 value). Your dealer will be glad to answer any questions you have about satellite TV.

**NO COST OR OBLIGATION.**  
\*Limited time offer while supply lasts.



DX Communications, Inc., A subsidiary of C. Itoh & Co. (America) Inc.

DX ADvantage will include this full page advertisement in September 7th edition of TV Guide; second page as required to list dealers in region.

edition, for example, will only list DX dealers participating in the program in an area east of Houston, west of Lake Charles, and south of Tyler. DX says they may use up to two pages to list all of the dealers in a 'region'; one for the master ad (as shown here) and another just listing dealers.

**DX and Gonzalez are smart to do this.** The conventional wisdom is that with TVRO sales taking off again around the 1st of September, that's the time to 'hit' the consumers. More important to DX competition, Gonzalez will be giving reasons to 'think DX' (like 'Think Snow!') early in the fall selling season, making it more difficult for dealers to 'Think STS' or 'Think Uniden' once business picks up for the fall rush. Very bright indeed.

We have lamented in past months that until this point in time, the industry has largely been dominated by order takers posing as salesmen. **Creative marketing** starts with establishing goals and then setting out a common sense way to achieve those goals at a realistic price. This one looks good and DX and DX dealers should do well with the program.

(As an aside, in the fine print of the TV Guide advertisement, you will notice just right of the antenna it says 'Paraclipse'. Look closely at that dish. Does that look like a Paraclipse dish to you? 'Yes and No?'. Would DX make a deal with Paraclipse to show a Paraclipse dish in the advertisement, and label it as a Paraclipse dish AND THEN show a drawing of a **non-Paraclipse** dish? Would they? Hold your breath 30 days . . . **the answer on September 1st in CSD!**)

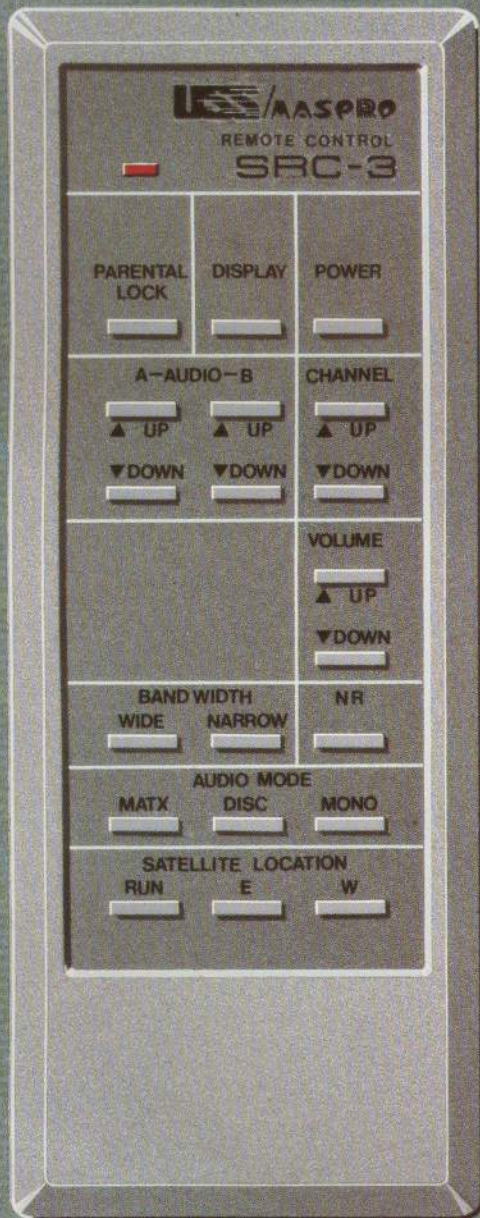

## INTRODUCING ANOTHER FIRST FROM USS THE NEW SR-3 USS/MASPRO

*We've set the pace for industry standards by being there first.*

### First with:

- Quartz Synthesized Tuning
- Automatic Audio Tuning
- Audio Deviation Compression
- Saw Filtered I.F.
- Full Function P.L.C. Remote Control
- Saw Resonator Stabilized Modulators
- 400 Mhz Linear Phase Locked Loop Video Demodulator
- Built-in Polarity Control
- Outdoor Multiplexed Single Coaxial Cable Control
- First With Antenna Peaking Test Point
- Soft Touch Controls
- UHF Full Function Remote Control

### The NEW SR-3

*All the firsts and so much more.*

**Block Down Conversion** Allows simultaneous viewing of different transponders with master receiver and two or more televisions with slave receivers.

**Screen Display of Operating Functions** Displays selected satellite, transponder, volume level, and audio mode momentarily and automatically.

#### Total Programming Capabilities

Allows user to program in satellite locations, frequently watched transponders along with audio levels and stereo audio modes for automatic retrieval.

**Selective Parental Lock-Out** Allows a specific transponder to be locked out for parental discretion without affecting other transponders on the designated satellite.

#### UHF Full Function Remote Control

Allows every room operation of all receiver and antenna functions.

**Prima Picture Quality** 400 Mhz Linear Phase Locked Loop Demodulator is the lowest threshold in the industry affording the finest reception available.

#### Complete Descrambler Compatability

No modification required. VideoCiper II and Oak Orion, tested for true compatibility with all signal descrambling systems.

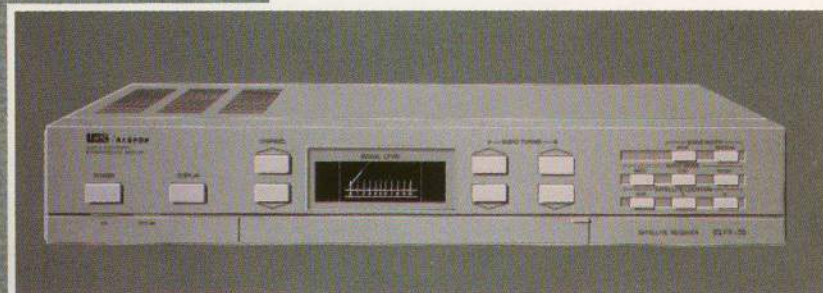

(800) 328-7733 in Minnesota

(218) 681-5616

UNITED  
SATELLITE  
SYSTEMS 

St. Hilaire, Minnesota 56754

# SAT-TEC ANNOUNCES THE END OF THE CHANNEL WARS



## INTRODUCING THE R-5100 BLOCK RECEIVER

Now SAT-TEC offers you a new dimension in satellite TV entertainment—freedom of choice.

At last—here's the end to the "Which channel should we watch?" debates. You can enjoy your favorite satellite TV program while the rest of the family watches their favorite satellite channel on another TV set. SAT-TEC's new R-5100 block receiver makes it easier than ever before.

### R-5100—THE FIRST AFFORDABLE BLOCK RECEIVER THAT'S WORTH MORE

SAT-TEC introduces the first affordable block receiver that's reliable, too. The R-5100's new-generation circuitry delivers unsurpassed performance and picture quality. And it has features you won't find on many other units, such as the convenient A/B switch that automatically switches your TV from the VHF to the dish antenna. The R-5100 interfaces with the Polarotor I™, doubling your viewing capability, and a skew control easily adjusts the polarotor for optimum performance. AGC (automatic gain control) and AFC (automatic fine tune) are standard features.

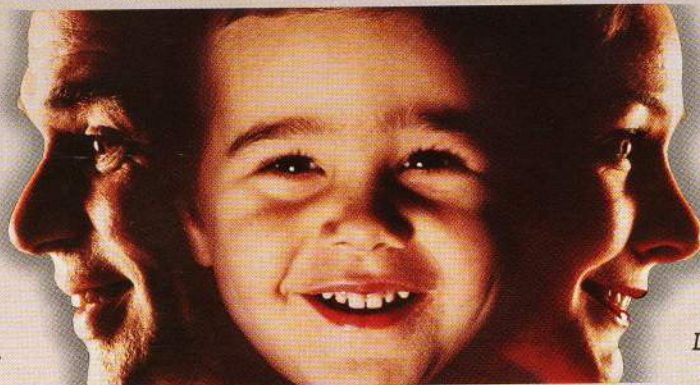

**you watch your favorite program  
she watches her favorite program  
he watches his favorite program  
it's easy with SAT-TEC'S R-5100**

If you're serious about your TV system, you need a receiver that can handle the channel wars.

in features that insure consistently sharp and clear pictures. Circuit boards are plated through, not just on the surface, for good, strong solder joints. A built-in crystal-controlled modulator gives you additional insurance of reliable performance. The downconverter is a commercial-grade unit with a DRO (Dielectric resonator oscillator) circuit that guards against signal fluctuations due to outside temperature variations. The result is super-stable signals for a beautiful picture.

MENT  
1987

of  
nt.  
new  
ment.  
e block  
d easy to  
00.