

SERVICE MANUAL

W547CZ/W548CZ/W549CZ

notebook



Notebook Computer

W547CZ/W548CZ/W549CZ

Service Manual

Notice

The company reserves the right to revise this publication or to change its contents without notice. Information contained herein is for reference only and does not constitute a commitment on the part of the manufacturer or any subsequent vendor. They assume no responsibility or liability for any errors or inaccuracies that may appear in this publication nor are they in anyway responsible for any loss or damage resulting from the use (or misuse) of this publication.

This publication and any accompanying software may not, in whole or in part, be reproduced, translated, transmitted or reduced to any machine readable form without prior consent from the vendor, manufacturer or creators of this publication, except for copies kept by the user for backup purposes.

Brand and product names mentioned in this publication may or may not be copyrights and/or registered trademarks of their respective companies. They are mentioned for identification purposes only and are not intended as an endorsement of that product or its manufacturer.

Version 1.0
January 2013

Trademarks

Intel, Pentium and Intel Core are trademarks of Intel Corporation.

Windows[®] is a registered trademark of Microsoft Corporation.

Other brand and product names are trademarks and /or registered trademarks of their respective companies.

About this Manual

This manual is intended for service personnel who have completed sufficient training to undertake the maintenance and inspection of personal computers.

It is organized to allow you to look up basic information for servicing and/or upgrading components of the *W547CZ/W548CZ/W549CZ* series notebook PC.

The following information is included:

Chapter 1, Introduction, provides general information about the location of system elements and their specifications.

Chapter 2, Disassembly, provides step-by-step instructions for disassembling parts and subsystems and how to upgrade elements of the system.

Appendix A, Part Lists

Appendix B, Schematic Diagrams

Appendix C, Updating the FLASH ROM BIOS

IMPORTANT SAFETY INSTRUCTIONS

Follow basic safety precautions, including those listed below, to reduce the risk of fire, electric shock and injury to persons when using any electrical equipment:

1. Do not use this product near water, for example near a bath tub, wash bowl, kitchen sink or laundry tub, in a wet basement or near a swimming pool.
2. Avoid using a telephone (other than a cordless type) during an electrical storm. There may be a remote risk of electrical shock from lightning.
3. Do not use the telephone to report a gas leak in the vicinity of the leak.
4. Use only the power cord and batteries indicated in this manual. Do not dispose of batteries in a fire. They may explode. Check with local codes for possible special disposal instructions.
5. This product is intended to be supplied by a Listed Power Unit:
AC Input of 100 - 240V, 50 - 60Hz, DC Output of 19V, 2.1A (40 Watts) minimum AC/DC Adapter.

CAUTION

This Computer's Optical Device is a Laser Class 1 Product

FCC Statement

This device complies with Part 15 of the FCC Rules. Operation is subject to the following two conditions:

This device may not cause harmful interference.

This device must accept any interference received, including interference that may cause undesired operation.

Instructions for Care and Operation

The notebook computer is quite rugged, but it can be damaged. To prevent this, follow these suggestions:

1. **Don't drop it, or expose it to shock.** If the computer falls, the case and the components could be damaged.



2. **Keep it dry, and don't overheat it.** Keep the computer and power supply away from any kind of heating element. This is an electrical appliance. If water or any other liquid gets into it, the computer could be badly damaged.

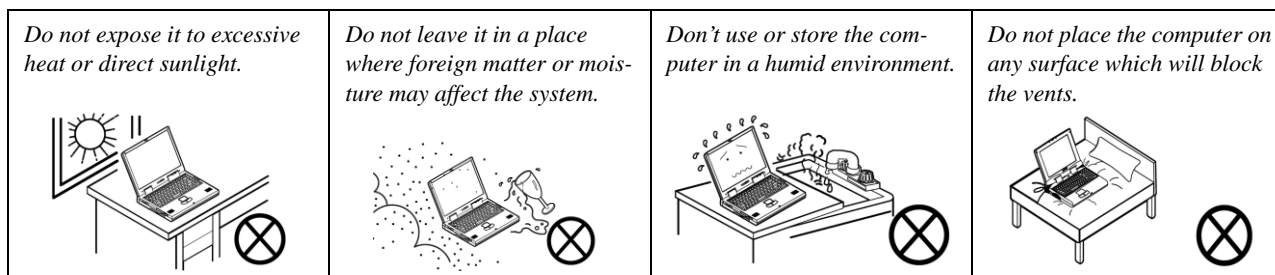

3. **Follow the proper working procedures for the computer.** Shut the computer down properly and don't forget to save your work. Remember to periodically save your data as data may be lost if the battery is depleted.

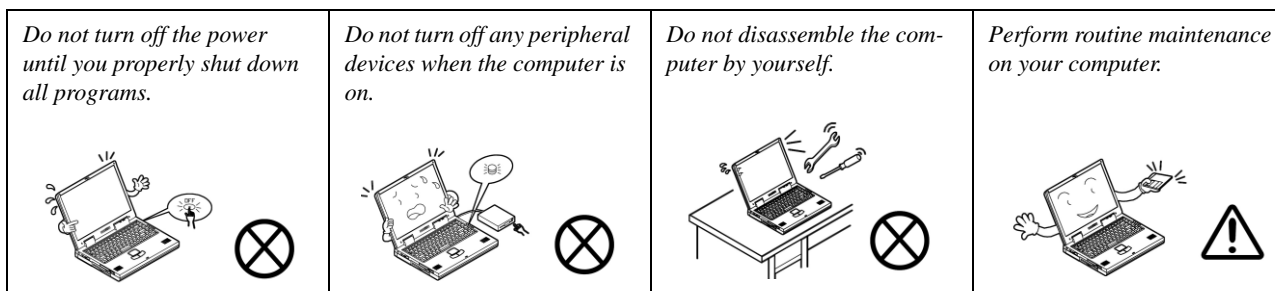

4. **Avoid interference.** Keep the computer away from high capacity transformers, electric motors, and other strong magnetic fields. These can hinder proper performance and damage your data.
5. **Take care when using peripheral devices.**

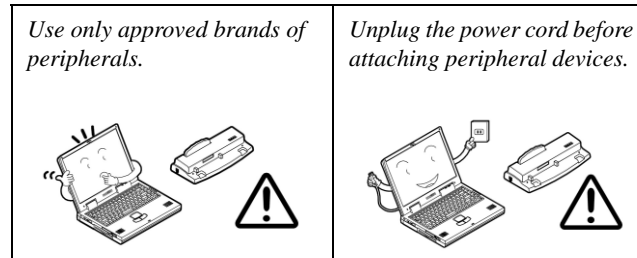

Power Safety

The computer has specific power requirements:

- Only use a power adapter approved for use with this computer.
- Your AC adapter may be designed for international travel but it still requires a steady, uninterrupted power supply. If you are unsure of your local power specifications, consult your service representative or local power company.
- The power adapter may have either a 2-prong or a 3-prong grounded plug. The third prong is an important safety feature; do not defeat its purpose. If you do not have access to a compatible outlet, have a qualified electrician install one.
- When you want to unplug the power cord, be sure to disconnect it by the plug head, not by its wire.
- Make sure the socket and any extension cord(s) you use can support the total current load of all the connected devices.
- Before cleaning the computer, make sure it is disconnected from any external power supplies.

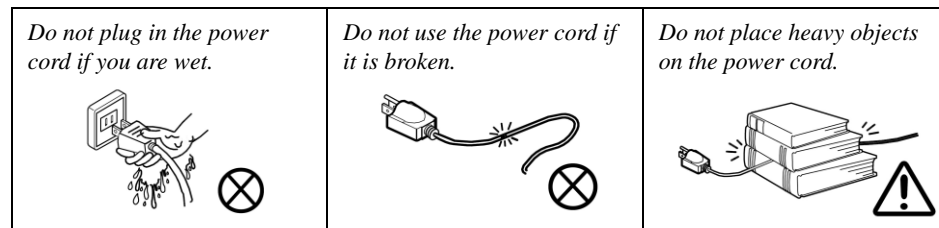

Power Safety Warning

Before you undertake any upgrade procedures, make sure that you have turned off the power, and disconnected all peripherals and cables (including telephone lines and power cord). It is advisable to also remove your battery in order to prevent accidentally turning the machine on.

Battery Precautions

- Only use batteries designed for this computer. The wrong battery type may explode, leak or damage the computer.
- Do not continue to use a battery that has been dropped, or that appears damaged (e.g. bent or twisted) in any way. Even if the computer continues to work with a damaged battery in place, it may cause circuit damage, which may possibly result in fire.
- Recharge the batteries using the notebook's system. Incorrect recharging may make the battery explode.
- Do not try to repair a battery pack. Refer any battery pack repair or replacement to your service representative or qualified service personnel.
- Keep children away from, and promptly dispose of a damaged battery. Always dispose of batteries carefully. Batteries may explode or leak if exposed to fire, or improperly handled or discarded.
- Keep the battery away from metal appliances.
- Affix tape to the battery contacts before disposing of the battery.
- Do not touch the battery contacts with your hands or metal objects.

Battery Guidelines

The following can also apply to any backup batteries you may have.

- If you do not use the battery for an extended period, then remove the battery from the computer for storage.
- Before removing the battery for storage charge it to 60% - 70%.
- Check stored batteries at least every 3 months and charge them to 60% - 70%.



Battery Disposal

The product that you have purchased contains a rechargeable battery. The battery is recyclable. At the end of its useful life, under various state and local laws, it may be illegal to dispose of this battery into the municipal waste stream. Check with your local solid waste officials for details in your area for recycling options or proper disposal.

Caution

Danger of explosion if battery is incorrectly replaced. Replace only with the same or equivalent type recommended by the manufacturer. Discard used battery according to the manufacturer's instructions.

Battery Level

Click the battery icon  in the taskbar to see the current battery level and charge status. A battery that drops below a level of 10% will not allow the computer to boot up. Make sure that any battery that drops below 10% is recharged within one week.

Related Documents

You may also need to consult the following manual for additional information:

User's Manual on CD/DVD

This describes the notebook PC's features and the procedures for operating the computer and its ROM-based setup program. It also describes the installation and operation of the utility programs provided with the notebook PC.

System Startup

1. Remove all packing materials.
2. Place the computer on a stable surface.
3. Insert the battery and make sure it is locked in position.
4. Securely attach any peripherals you want to use with the computer (e.g. keyboard and mouse) to their ports.
5. Attach the AC/DC adapter to the DC-In jack on the left of the computer, then plug the AC power cord into an outlet, and connect the AC power cord to the AC/DC adapter.
6. Use one hand to raise the lid/LCD to a comfortable viewing angle (**do not exceed 130 degrees**); use the other hand (as illustrated in Figure 1) to support the base of the computer (**Note: Never** lift the computer by the lid/LCD).
7. Press the power button to turn the computer "on".

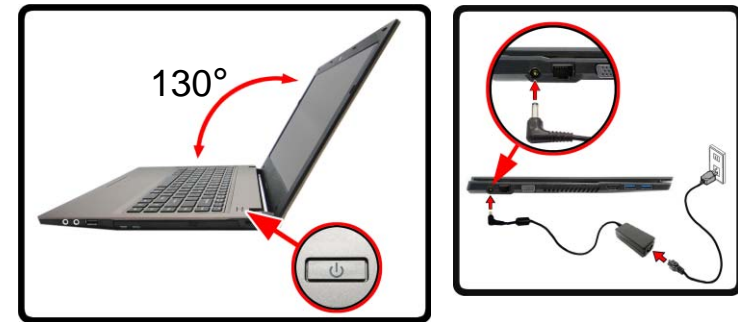

Figure 1
**Opening the Lid/LCD/
Computer with AC/DC
Adapter Plugged-In**

Shutdown

Note that you should always shut your computer down by choosing the **Shut Down** command from the **Power** item in **Settings** in the **Charms Bar** (use the **Windows Logo Key + C** key combination to access the **Charms Bar**) in **Windows 8**. This will help prevent hard disk or system problems.

Contents

Introduction1-1

Overview	1-1
Specifications	1-2
External Locator - Top View with LCD Panel Open	1-4
External Locator - Front & Right Side Views	1-5
External Locator - Left Side & Rear View	1-6
External Locator - Bottom View	1-7
Mainboard Overview - Top (Key Parts)	1-8
Mainboard Overview - Bottom (Key Parts)	1-9
Mainboard Overview - Top (Connectors)	1-10
Mainboard Overview - Bottom (Connectors)	1-11

Disassembly2-1

Overview	2-1
Maintenance Tools	2-2
Connections	2-2
Maintenance Precautions	2-3
Disassembly Steps	2-4
Removing the Optical (CD/DVD) Device	2-5
Removing the Battery	2-7
Removing the Hard Disk Drive	2-9
Removing the System Memory (RAM)	2-11
Removing the Keyboard	2-13
Removing the Wireless LAN Module	2-15
Removing the CCD	2-16

Part ListsA-1

Part List Illustration Location	A-2
Top (W547CZ)	A-3
Top (W548CZ)	A-4
Top (W549CZ)	A-5

LCD (W547CZ)	A-6
LCD (W548CZ)	A-7
LCD (W549CZ)	A-8
Bottom	A-9
DVD Dual	A-10

Schematic Diagrams.....B-1

System Block Diagram	B-2
Processor 1/7-DMI, FDI, PEG	B-3
Processor 2/7- CLK, MISC	B-4
Processor 3/7- (DDR3)	B-5
Processor 4/7- Power	B-6
Processor 5/7- GFX PWR	B-7
Processor 6/7- GND	B-8
Processor 7/7- RSVD	B-9
DDR3 SO-DIMM_0	B-10
DDR3 SO-DIMM_1	B-11
PANEL, INVERTER, CRT	B-12
PCH 1/9- RTC, HDA, SATA	B-13
PCH 2/9- PCIE, SMBUS, CLK	B-14
PCH 3/9- DMI, FDI, PWRGD	B-15
PCH 4/9- LVDS, DDI, CRT	B-16
PCH 5/9- PCI, USB, RSVD	B-17
PCH 6/9- GPIO, CPU	B-18
PCH 7/9- PWR	B-19
PCH 8/9 POWER	B-20
PCH 9/9- GND	B-21
Mini-PCIE (WLAN)	B-22
CCD, FAN, CLICK, P/W	B-23
USB, LID SWITCH	B-24
LAN RTL8402, Card Reader	B-25

Preface

SATA ODD, LED	B-26
HDMI, RJ45	B-27
AUDIO CODEC VT1802S	B-28
KBC-ITE IT8518E	B-29
5VS, 3VS, 1.5VS CPU	B-30
VDD3, VDD5	B-31
Power 0.85VS, 1.8VS	B-32
POWER 1.5V/1.05VS	B-33
POWER VCORE1	B-34
POWER VCORE2	B-35
AC IN, CHARGER	B-36
AUDIO BOARD	B-37
POWER SW BOARD	B-38
Power On SEQ	B-39
Updating the FLASH ROM BIOS.....	C-1
Download the BIOS	C-1
Unzip the downloaded files to a bootable CD/DVD/ or	
USB Flash drive	C-1
Set the computer to boot from the external drive	C-1
Use the flash tools to update the BIOS	C-2
Restart the computer (booting from the HDD)	C-2

Chapter 1: Introduction

Overview

This manual covers the information you need to service or upgrade the **W547CZ/W548CZ/W549CZ** series notebook computer. Information about operating the computer (e.g. getting started, and the *Setup* utility) is in the *User's Manual*. Information about drivers (e.g. VGA & audio) is also found in the *User's Manual*. The manual is shipped with the computer.

Operating systems (e.g. *Windows 8*, etc.) have their own manuals as do application softwares (e.g. word processing and database programs). If you have questions about those programs, you should consult those manuals.

The **W547CZ/W548CZ/W549CZ** series notebook is designed to be upgradeable. See *Disassembly on page 2 - 1* for a detailed description of the upgrade procedures for each specific component. Please take note of the warning and safety information indicated by the “” symbol.

The balance of this chapter reviews the computer's technical specifications and features.

Introduction

Specifications



Latest Specification Information

The specifications listed here are correct at the time of sending them to the press. Certain items (particularly processor types/speeds) may be changed, delayed or updated due to the manufacturer's release schedule. Check with your service center for more details.



CPU

The CPU is not a user serviceable part. Accessing the CPU in any way may violate your warranty.

Processor Options

Intel® Celeron™ Processor
847 (1.10GHz), 877 (1.40GHz)
 2MB L3 Cache, **32nm**, DDR3-1333MHz, TDP 17W

Core Logic

Intel® NM70 Chipset

BIOS

48Mb SPI Flash ROM
 AMI BIOS

Memory

Two 204 Pin SO-DIMM Sockets Supporting **DDR3 1333/1600MHz** Memory
 Memory Expandable up to 16GB

(The real memory operating frequency depends on the FSB of the processor.)

LCD

14" (35.56cm) HD LCD

Storage

One Changeable 12.7mm(h) Super Multi Optical Device Drive
 One Changeable 2.5" 9.5mm (h) SATA HDD

Audio

High Definition Audio Compliant Interface
 2 * Built-In Speakers
 Built-In Microphone

Security

Security (Kensington® Type) Lock Slot
 BIOS Password

Keyboard

"WinKey" keyboard (with embedded numeric keypad)

Pointing Device

Built-in Touchpad

Interface

Three USB 2.0 Ports
 One HDMI-Out Port
 One External Monitor Port
 One Headphone-Out Jack
 One Microphone-In Jack
 One RJ-45 LAN Jack
 One DC-in Jack

Mini Card Slot

One Slot for **WLAN** Module or **WLAN and Bluetooth** Combo Module

Video Adapter

Intel HD Graphics

Dynamic Frequency (Intel Dynamic Video Memory Technology for up to **1.7GB**)
 Microsoft DirectX®10.1Compatible

Card Reader

Embedded Multi-In-1 Card Reader
 MMC (MultiMedia Card) / RS MMC
 SD (Secure Digital) / Mini SD / SDHC/ SDXC
 MS (Memory Stick) / MS Pro / MS Duo

Communication

Built-In 10/100Mb Ethernet LAN
 1M HD PC Camera Module

WLAN/ Bluetooth Half Mini-Card Modules:

(**Factory Option**) Intel® Centrino® Wireless-N 105 Wireless LAN (**802.11b/g/n**)

(**Factory Option**) Intel® Centrino® Wireless-N 135 Wireless LAN (**802.11b/g/n**) + Bluetooth 4.0

(**Factory Option**) Third-Party Wireless LAN (**802.11b/g/n**)

(**Factory Option**) Third-Party Wireless LAN (**802.11b/g/n**) + Bluetooth 4.0

Environmental Spec

Temperature

Operating: 5°C - 35°C

Non-Operating: -20°C - 60°C

Relative Humidity

Operating: 20% - 80%

Non-Operating: 10% - 90%

Power

Full Range AC/DC Adapter

AC Input: 100 - 240V, 50 - 60Hz

DC Output: 19V, 2.1A (**40W**)

(**Factory Option**) 4 Cell Smart Lithium-Ion Battery Pack,
32.56WH

(**Factory Option**) 6 Cell Smart Lithium-Ion Battery Pack,
48.84WH

Dimensions & Weight

340mm (w) * 241mm (d) * 11 - 25.4mm (h)

2.15kg (with ODD and 48.84WH Battery)

Introduction

Figure 1
Top View

External Locator - Top View with LCD Panel Open

1. PC Camera
(Optional)
2. Built-In
Microphone
3. *PC Camera LED
**When the PC
camera is in use,
the LED will be
illuminated in red.*
4. LCD
5. Power Button
6. Keyboard
7. Touchpad &
Buttons

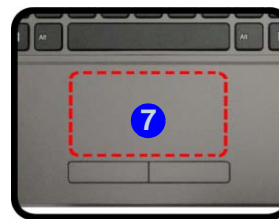
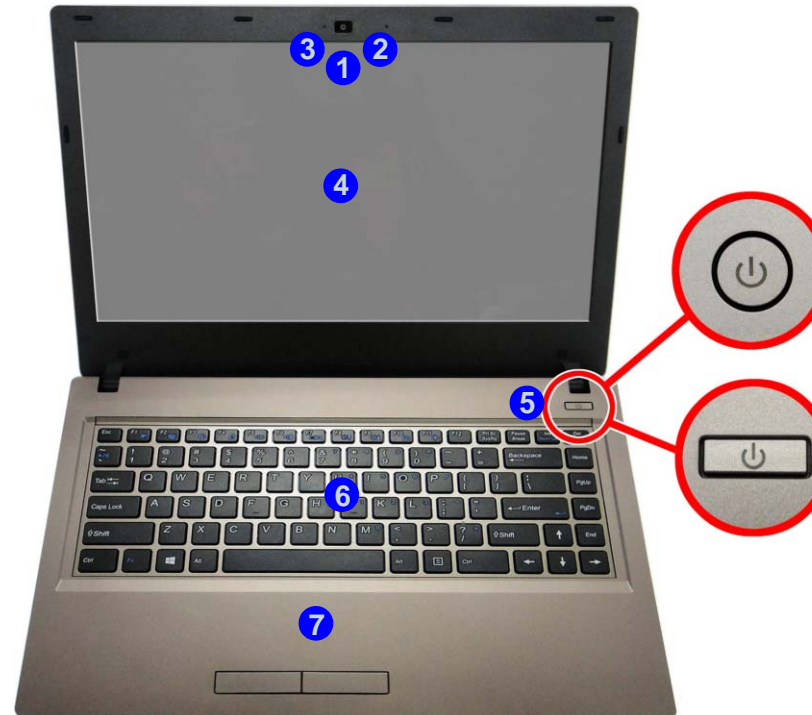

Note that the Touchpad and Buttons valid operational area is that indicated within the red dotted lines above.

External Locator - Front & Right Side Views

FRONT VIEW



Figure 2
Front View

1. LED Indicator
2. Multi-in-1 Card Reader

RIGHT SIDE VIEW



Figure 3
Right Side View

1. Microphone-In Jack
2. Headphone-Out Jack
3. USB 2.0 Port
4. Optical Device Drive Bay
5. Emergency Eject Hole
6. Security Lock Slot

Introduction

External Locator - Left Side & Rear View

Figure 4
Left Side View

- 1. DC-In Jack
- 2. RJ-45 LAN Jack
- 3. External Monitor Port
- 4. Vent
- 5. HDMI-Out Port
- 6. USB 2.0 Ports

LEFT SIDE VIEW



Figure 5
Rear View

- 1. Battery location

REAR VIEW



External Locator - Bottom View

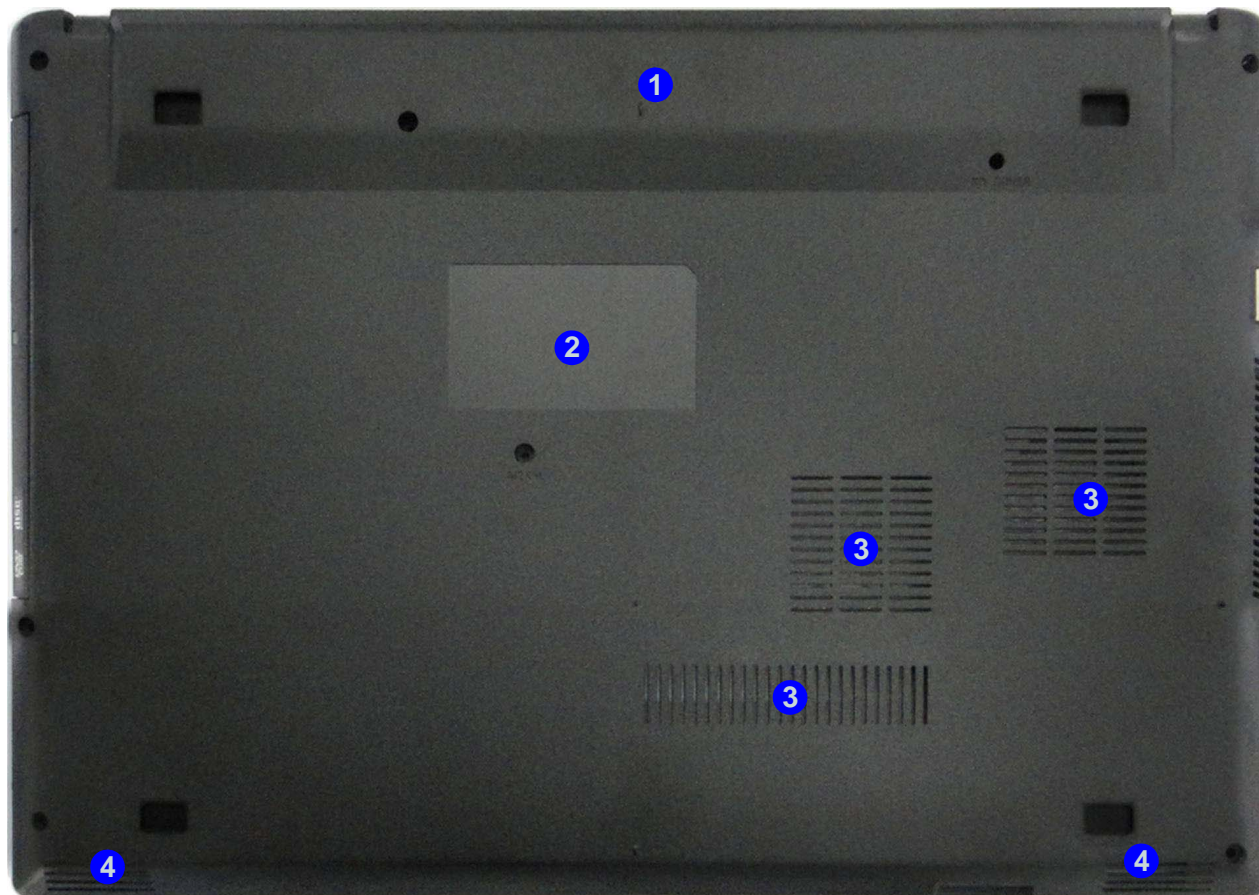

Figure 6
Bottom View

1. Battery Location
2. Bay Cover
3. Vent
4. Speakers



Overheating

To prevent your computer from overheating, make sure nothing blocks any vent while the computer is in use.

Introduction

Figure 7
Mainboard Top
Key Parts

1. KBC-ITE IT8518

Mainboard Overview - Top (Key Parts)

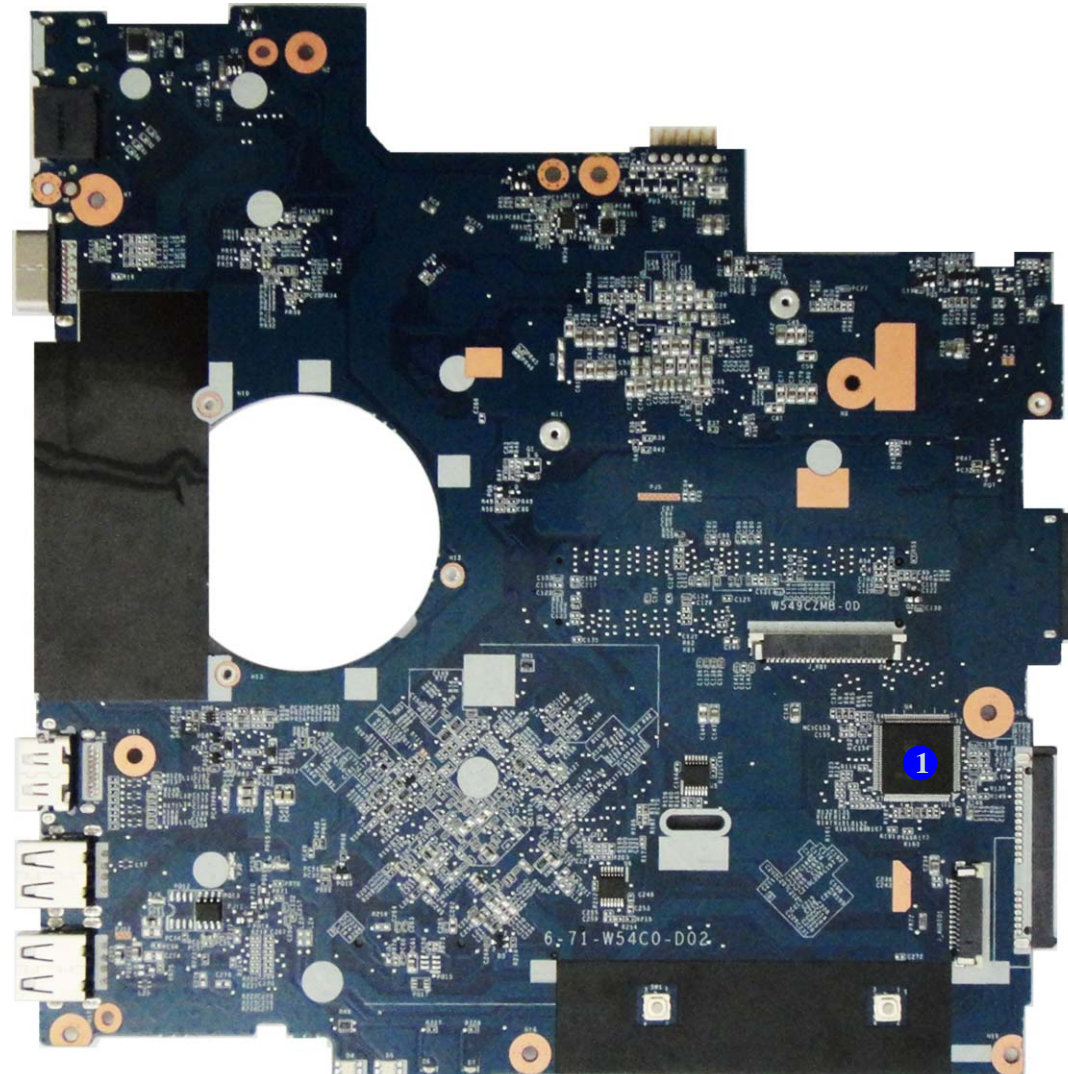

Mainboard Overview - Bottom (Key Parts)

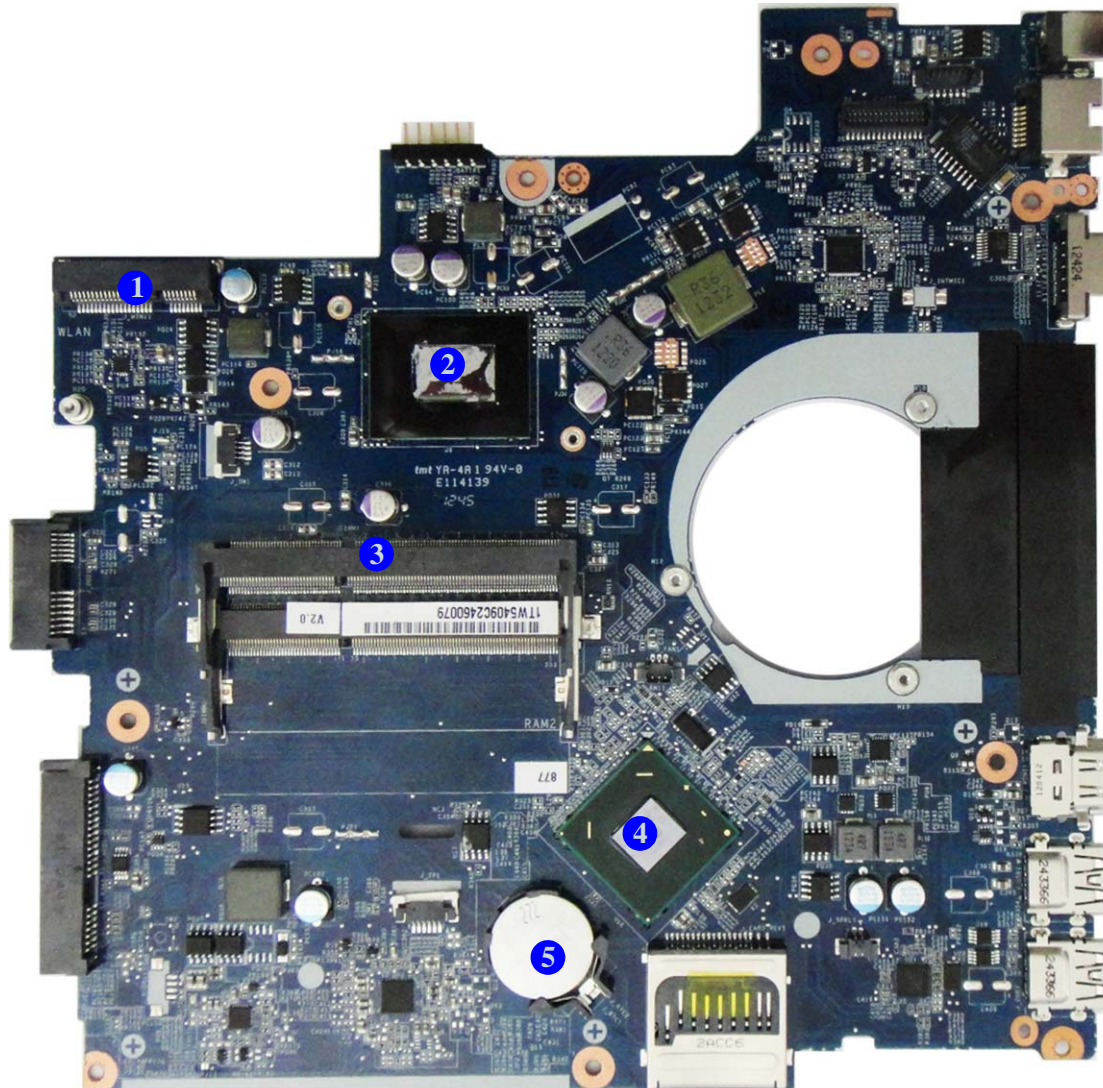

Figure 8
**Mainboard Bottom
Key Parts**

1. Mini-Card Connector
2. CPU
3. Memory Slots
DDR3 SO-DIMM
4. Platform Controller Hub
5. CMOS Battery

Mainboard Overview - Top (Connectors)

Figure 9
**Mainboard Top
Connectors**

1. HDMI-Out Port
2. USB Port 3.0
3. Keyboard Cable Connector
4. Audio Board Cable Connector

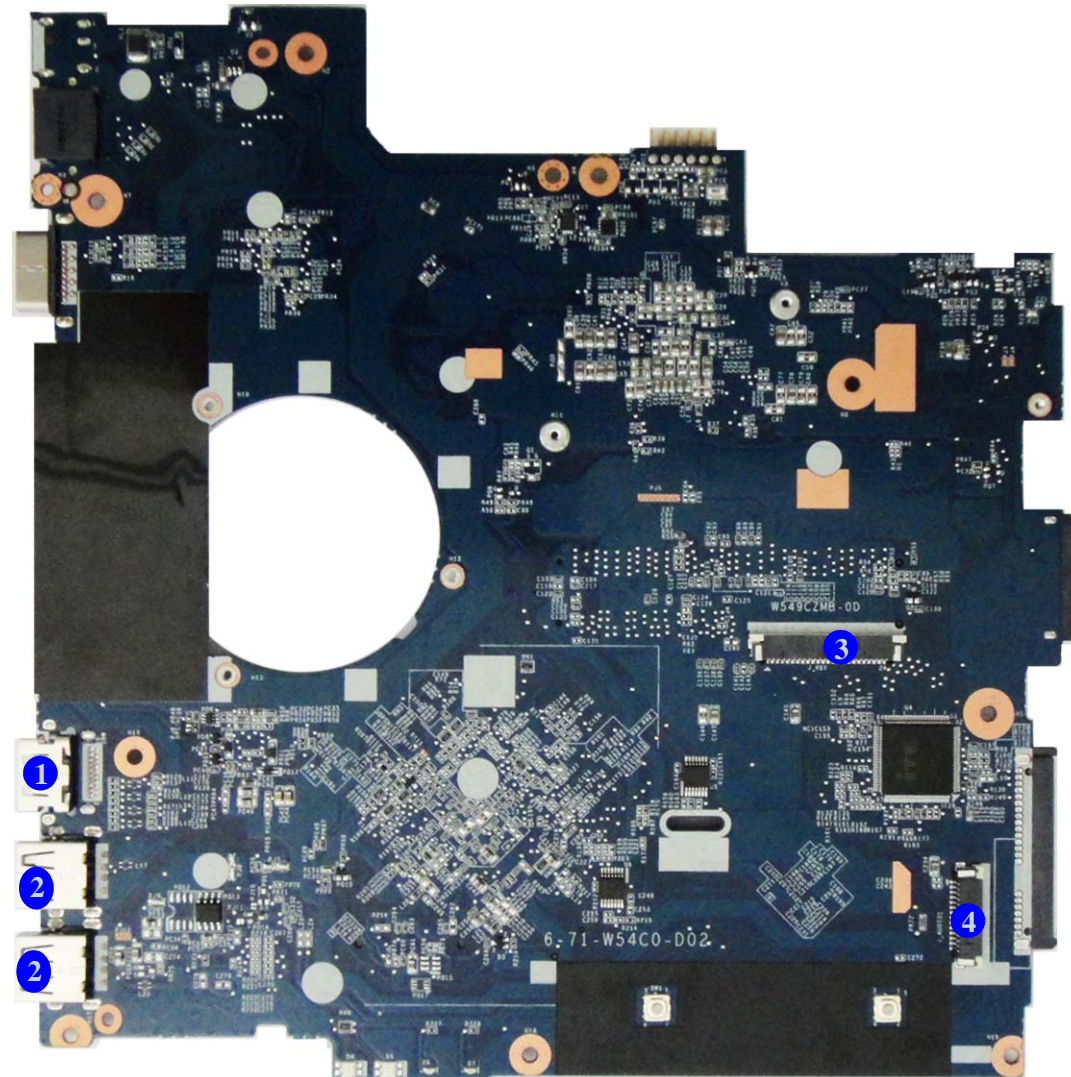

Mainboard Overview - Bottom (Connectors)

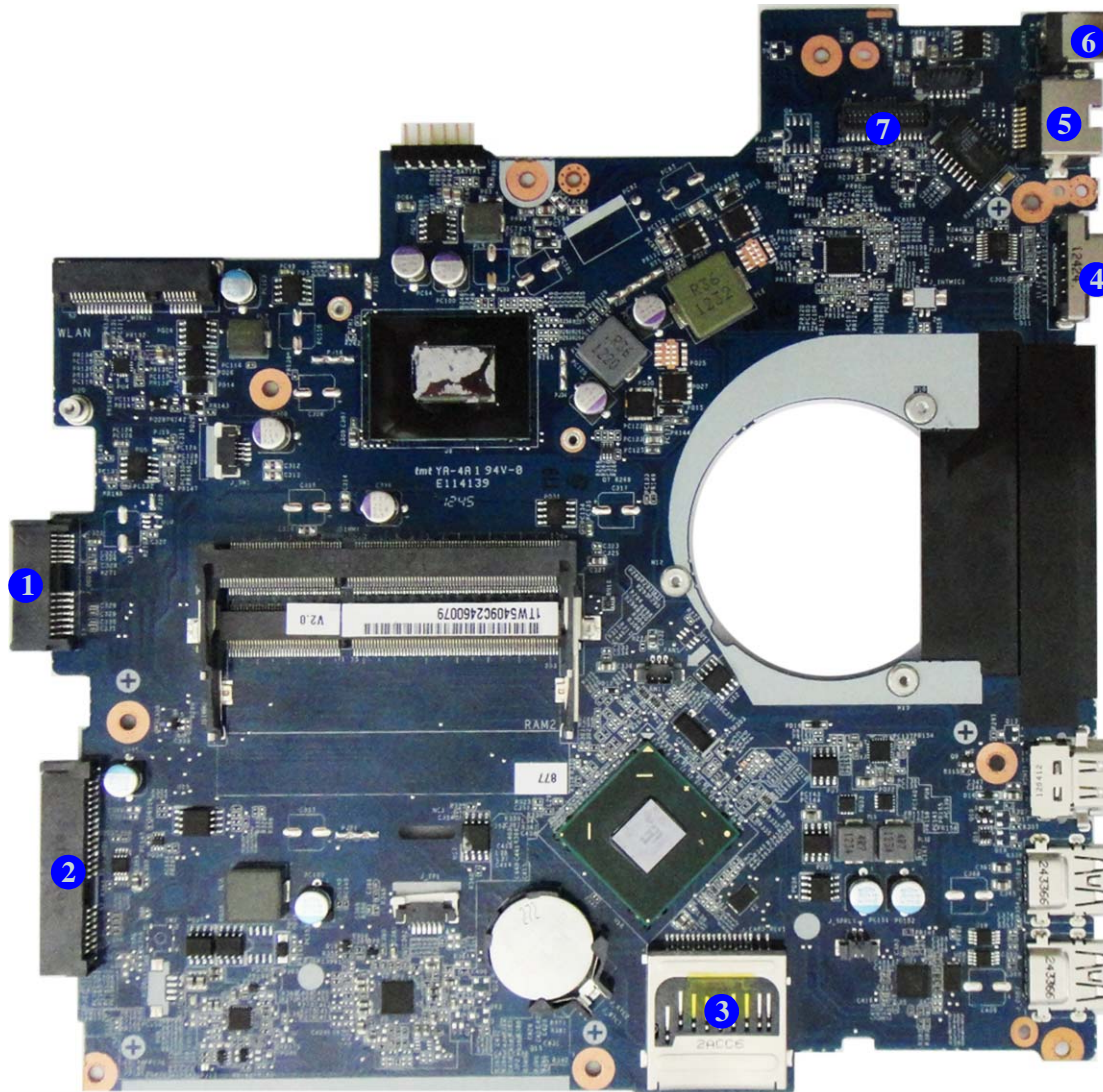

Figure 10
**Mainboard Bottom
Connectors**

1. ODD Connector
2. HDD Connector
3. Multi-in-1 Card Reader
4. External Monitor Port
5. RJ-45 LAN Jack
6. DC-In Jack
7. LCD Cable Connector

Chapter 2: Disassembly

Overview

This chapter provides step-by-step instructions for disassembling the *W547CZ/W548CZ/W549CZ* series notebook's parts and subsystems. When it comes to reassembly, reverse the procedures (unless otherwise indicated).

We suggest you completely review any procedure before you take the computer apart.

Procedures such as upgrading/replacing the RAM, optical device and hard disk are included in the User's Manual but are repeated here for your convenience.

To make the disassembly process easier each section may have a box in the page margin. Information contained under the figure # will give a synopsis of the sequence of procedures involved in the disassembly procedure. A box with a  lists the relevant parts you will have after the disassembly process is complete. **Note:** The parts listed will be for the disassembly procedure listed ONLY, and not any previous disassembly step(s) required. Refer to the part list for the previous disassembly procedure. The amount of screws you should be left with will be listed here also.

A box with a  will also provide any possible helpful information. A box with a  contains warnings.

An example of these types of boxes are shown in the sidebar.

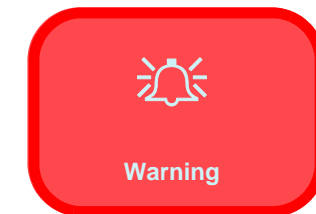
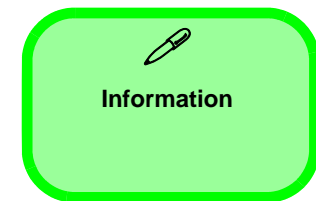

Disassembly

NOTE: All disassembly procedures assume that the system is turned **OFF**, and disconnected from any power supply (the battery is removed too).

Maintenance Tools

The following tools are recommended when working on the notebook PC:

- M3 Philips-head screwdriver
- M2.5 Philips-head screwdriver (magnetized)
- M2 Philips-head screwdriver
- Small flat-head screwdriver
- Pair of needle-nose pliers
- Anti-static wrist-strap

Connections

Connections within the computer are one of four types:

Locking collar sockets for ribbon connectors	To release these connectors, use a small flat-head screwdriver to gently pry the locking collar away from its base. When replacing the connection, make sure the connector is oriented in the same way. The pin1 side is usually not indicated.
Pressure sockets for multi-wire connectors	To release this connector type, grasp it at its head and gently rock it from side to side as you pull it out. Do not pull on the wires themselves. When replacing the connection, do not try to force it. The socket only fits one way.
Pressure sockets for ribbon connectors	To release these connectors, use a small pair of needle-nose pliers to gently lift the connector away from its socket. When replacing the connection, make sure the connector is oriented in the same way. The pin1 side is usually not indicated.
Board-to-board or multi-pin sockets	To separate the boards, gently rock them from side to side as you pull them apart. If the connection is very tight, use a small flat-head screwdriver - use just enough force to start.

Maintenance Precautions

The following precautions are a reminder. To avoid personal injury or damage to the computer while performing a removal and/or replacement job, take the following precautions:

1. **Don't drop it.** Perform your repairs and/or upgrades on a stable surface. If the computer falls, the case and other components could be damaged.
2. **Don't overheat it.** Note the proximity of any heating elements. Keep the computer out of direct sunlight.
3. **Avoid interference.** Note the proximity of any high capacity transformers, electric motors, and other strong magnetic fields. These can hinder proper performance and damage components and/or data. You should also monitor the position of magnetized tools (i.e. screwdrivers).
4. **Keep it dry.** This is an electrical appliance. If water or any other liquid gets into it, the computer could be badly damaged.
5. **Be careful with power.** Avoid accidental shocks, discharges or explosions.
 - Before removing or servicing any part from the computer, turn the computer off and detach any power supplies.
 - When you want to unplug the power cord or any cable/wire, be sure to disconnect it by the plug head. Do not pull on the wire.
6. **Peripherals** – Turn off and detach any peripherals.
7. **Beware of static discharge.** ICs, such as the CPU and main support chips, are vulnerable to static electricity. Before handling any part in the computer, discharge any static electricity inside the computer. When handling a printed circuit board, do not use gloves or other materials which allow static electricity buildup. We suggest that you use an anti-static wrist strap instead.
8. **Beware of corrosion.** As you perform your job, avoid touching any connector leads. Even the cleanest hands produce oils which can attract corrosive elements.
9. **Keep your work environment clean.** Tobacco smoke, dust or other air-borne particulate matter is often attracted to charged surfaces, reducing performance.
10. **Keep track of the components.** When removing or replacing any part, be careful not to leave small parts, such as screws, loose inside the computer.

Cleaning

Do not apply cleaner directly to the computer, use a soft clean cloth.

Do not use volatile (petroleum distillates) or abrasive cleaners on any part of the computer.



Power Safety Warning

Before you undertake any upgrade procedures, make sure that you have turned off the power, and disconnected all peripherals and cables (including telephone lines and power cord). It is advisable to also remove your battery in order to prevent accidentally turning the machine on.

Disassembly Steps

The following table lists the disassembly steps, and on which page to find the related information. **PLEASE PERFORM THE DISASSEMBLY STEPS IN THE ORDER INDICATED.**

To remove the Optical Device:

1. Remove the Optical device *page 2 - 5*

To remove the Battery:

1. Remove the Optical device *page 2 - 5*
2. Remove the battery *page 2 - 7*

To remove the HDD:

1. Remove the Optical device *page 2 - 5*
2. Remove the battery *page 2 - 7*
3. Remove the HDD *page 2 - 9*

To remove the System Memory:

1. Remove the Optical device *page 2 - 5*
2. Remove the battery *page 2 - 7*
3. Remove the system memory *page 2 - 11*

To remove the Keyboard:

1. Remove the Optical device *page 2 - 5*
2. Remove the battery *page 2 - 7*
3. Remove the keyboard *page 2 - 15*

To remove the Wireless LAN Module :

1. Remove the Optical device *page 2 - 5*
2. Remove the battery *page 2 - 7*
3. Remove the WLAN *page 2 - 15*

To remove the CCD Module:

1. Remove the Optical device *page 2 - 5*
2. Remove the battery *page 2 - 7*
3. Remove the CCD module *page 2 - 16*

Removing the Optical (CD/DVD) Device

1. Turn the computer **off**, and turn it over.
2. Remove the screw **1** (*Figure 1a*).
3. Carefully pull out the optical device **3** out of the bay at point **2** (*Figure 1b*).
4. Carefully pry the bezel **5** off the optical device at point **4**.
5. Separate the bezel **5** and the optical device.

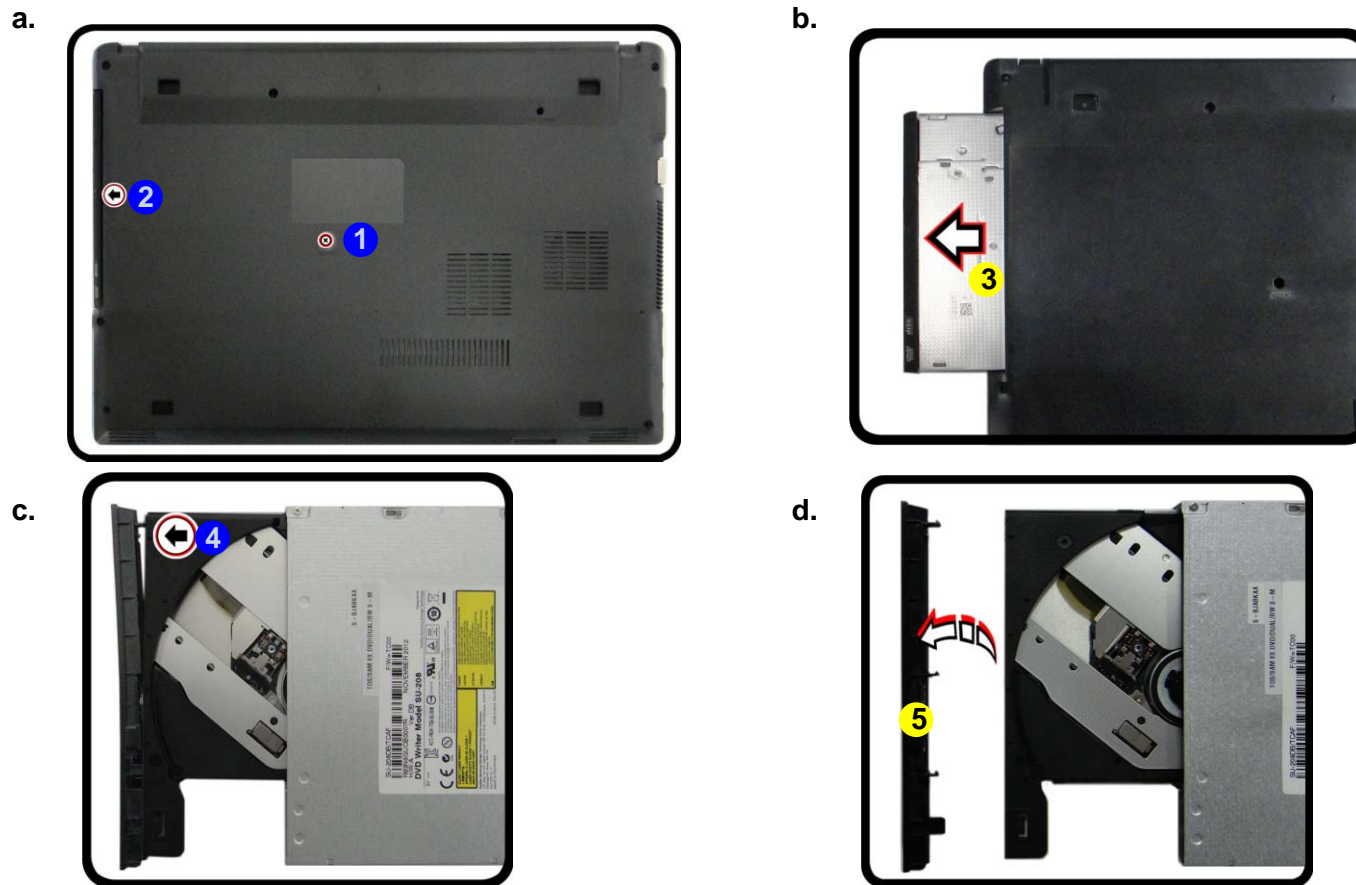



Figure 1
**Optical Device Re-
moval**

- a. Remove the screw.
- b. Pull out the optical device.
- c. Pry the bezel off the optical device.
- d. Separate the bezel and optical device



3. Optical Device
5. Bezel

- 1 Screw

Disassembly

Figure 2
Optical Device Assembly

- e. Install the front bezel.
f. Insert the optical device.
g. Tighten the screw.

6. Reverse the process to attach the front bezel **5** with the new optical device at point **6** (*Figure 2e*).
7. Insert the new optical device **3** and carefully slide it into the computer (the device only fits one way. DO NOT FORCE IT; The screw holes should line up).
8. Replace and tighten the screw **7** (*Figure 2g*).
9. Restart the computer to allow it to automatically detect the new device.

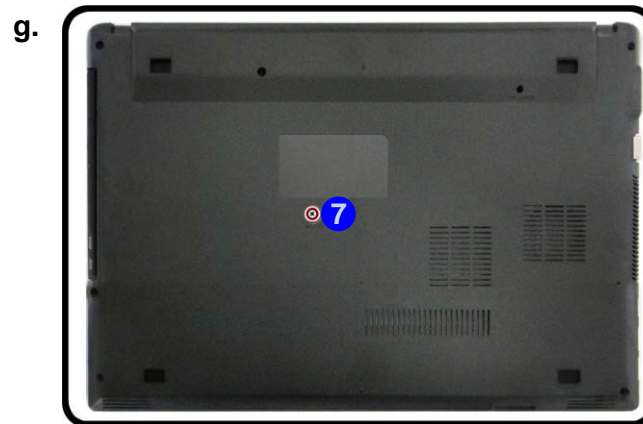
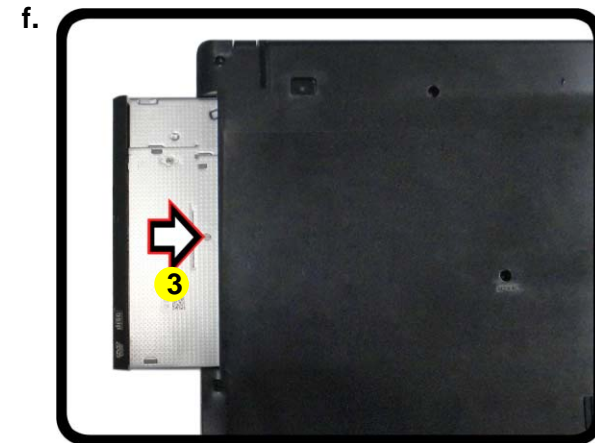

- 3. Optical Device
- 5. Bezel

- 1 Screw

Removing the Battery

1. Turn **off** the computer, turn it over to first remove the optical device ([page 2 - 5](#)).
2. Remove screws **1** - **6** from the bottom case ([Figure 3a](#)).
3. Carefully separate the bottom case **8** from the top case in the direction of the arrow at point **7** ([Figure 3b](#)).
4. The battery will be visible at point **9** ([Figure 3c](#)).

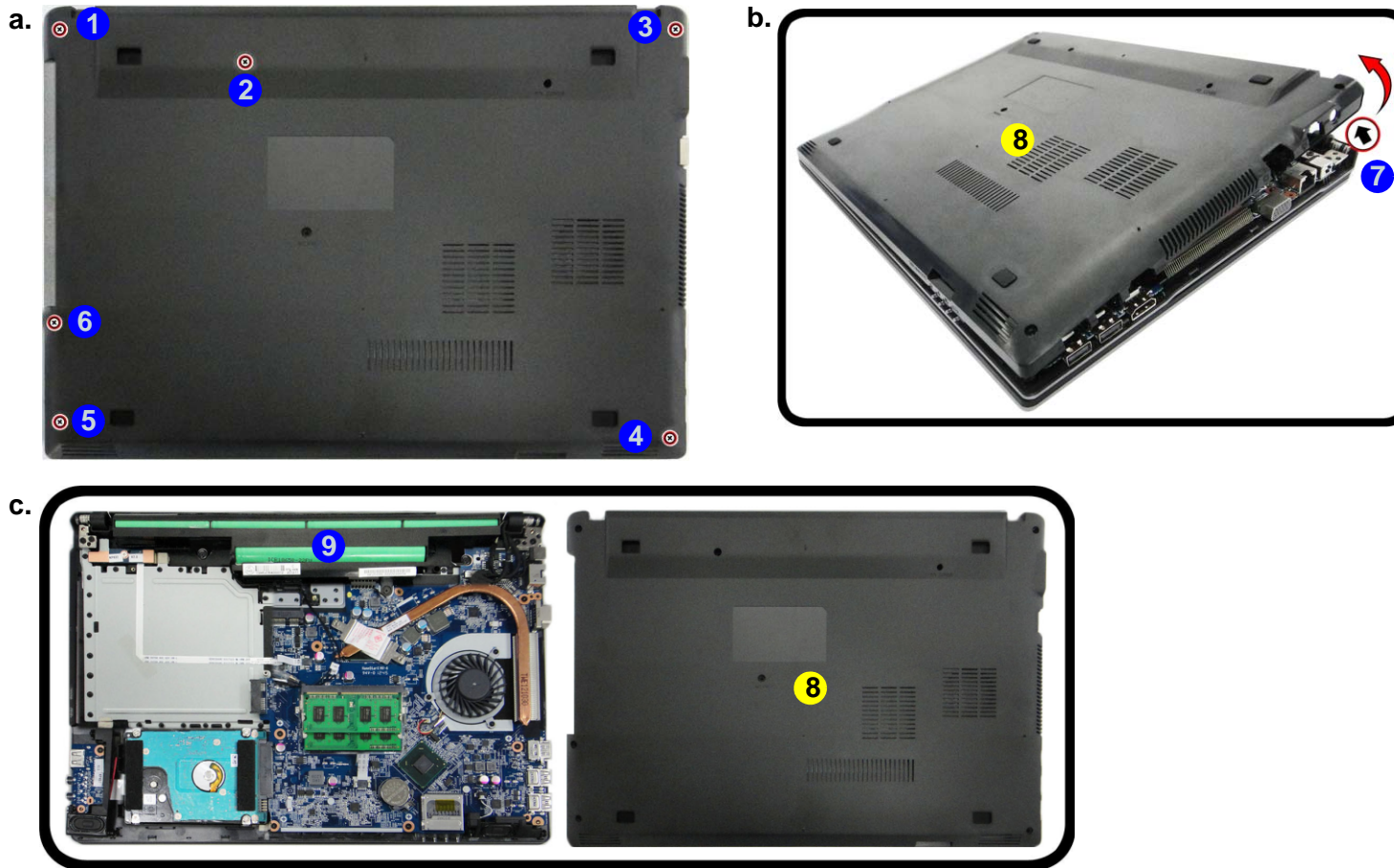
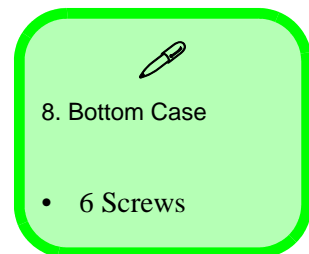

Figure 3
Battery Removal

- a. Remove screws from the bottom case.
- b. Separate the top and bottom case.
- c. The battery will be visible.



Disassembly

Figure 4 Battery Removal & Assembly (cont'd.)

- d. Remove the screws.
- e. Turn the battery in the direction of the arrow and lift it out.
- f. Install a new battery and turn the battery to align the connector.
- g. Tighten the screws.
- h. Reattach the bottom cover and top case.
- i. Snap the sides to close and replace the screws.

5. Remove screws 10 - 12 from the battery (Figure 4d).
6. Turn the battery 13 in the direction of the arrow 14 and lift it out 15 (Figure 4e).
7. Insert a new battery 13 at point 16 in the direction of the arrow 17. Turn the battery 18 to align the connectors.
8. Tighten screws 19 - 21 (Figure 4g).
9. Reattach the bottom cover with the top case at point 22 in the direction of the arrow 23 (Figure 4h).
10. Snap together the sides 24 - 26 of the bottom cover and top case (Figure 4i) and replace the corresponding screws.

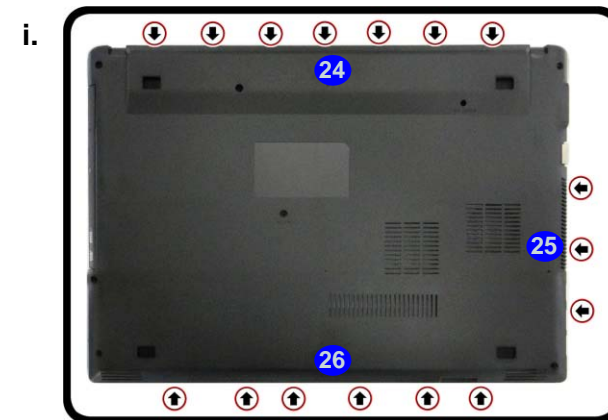
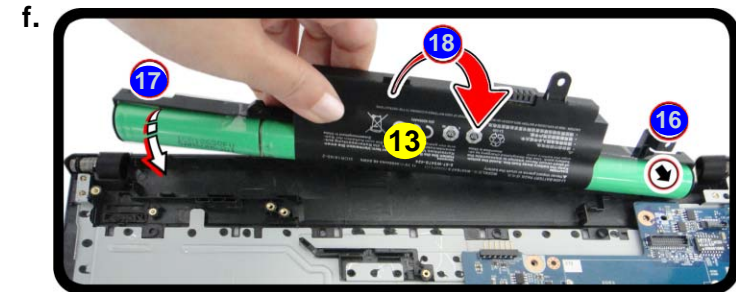
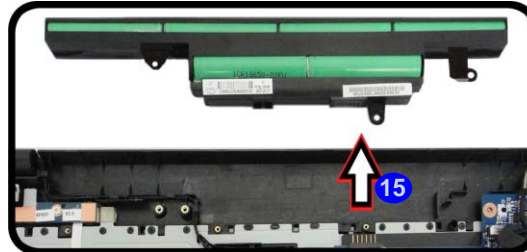

13. Battery

- 3 Screws

Removing the Hard Disk Drive

The hard disk drive can be taken out to accommodate other 2.5" serial (SATA) hard disk drives with a height of 9.5mm (h). Follow your operating system's installation instructions, and install all necessary drivers and utilities (as outlined in **Chapter 4 of the User's Manual**) when setting up a new hard disk.

Hard Disk Upgrade Process

1. Turn **off** the computer, turn it over to remove the optical device ([page 2 - 5](#)) and battery ([page 2 - 7](#)).
2. The hard disk drive will be visible at point **1** ([Figure 5a](#)).

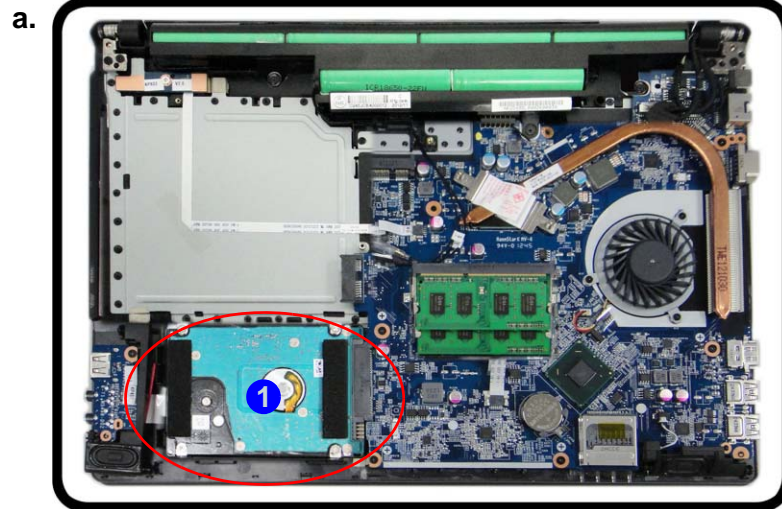

HDD System Warning

New HDD's are blank. Before you begin make sure:

You have backed up any data you want to keep from your old HDD.

You have all the CD-ROMs and FDDs required to install your operating system and programs.

If you have access to the internet, download the latest application and hardware driver updates for the operating system you plan to install. Copy these to a removable medium.

Figure 5
**HDD Assembly
Removal**

- a. Locate the HDD assembly.

Disassembly

Figure 6 HDD Assembly Removal (cont'd.)

- b. Slightly lift and pull the HDD assembly in the direction of the arrow.
- c. Lift the HDD assembly out of the bay.
- d. Remove the screws and adhesive cover.

3. Slightly lift and pull the hard disk assembly in the direction of arrow ② (Figure 6b).
4. Lift the hard disk assembly ③ out of the bay ④ (Figure 6c).
5. Remove the screws ⑤ - ⑧ and the adhesive cover ⑨ from the hard disk ⑩ (Figure 6d).
6. Reverse the process to install a new hard disk (do not forget to replace all the screws and bay cover).

b.



c.

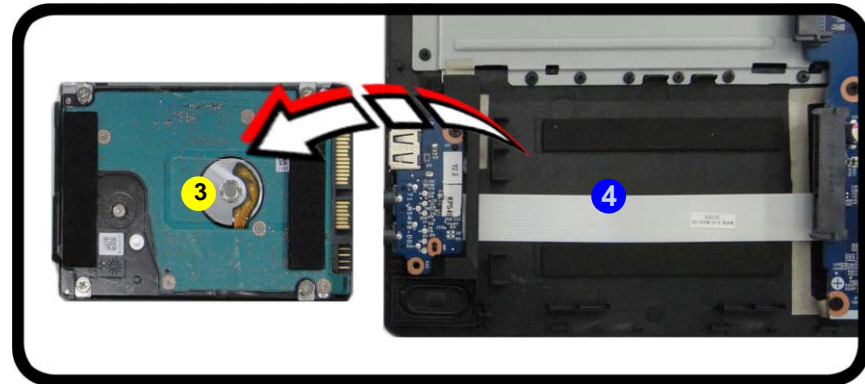

d.

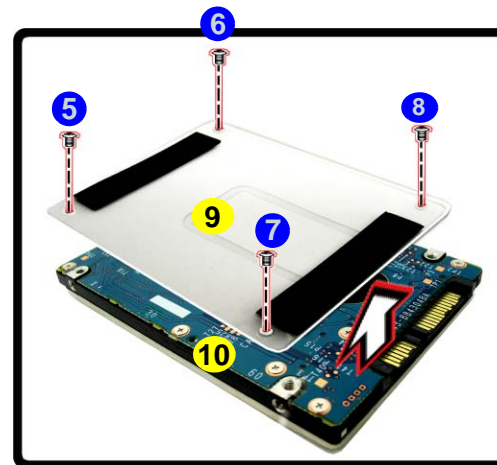

3. HDD Assembly
9. Adhesive Cover
10. HDD

- 4 Screws

Removing the System Memory (RAM)

The computer has two memory sockets for 204 pin Small Outline Dual In-line Memory Modules (SO-DIMM) supporting DDRIII (DDR3) Up to 1333/1600 MHz. The main memory can be expanded up to 16GB. The SO-DIMM modules supported are 1024MB and 2048MB **DDRIII** Modules. The total memory size is automatically detected by the POST routine once you turn on your computer.

Memory Upgrade Process

1. Turn **off** the computer, turn it over to remove the optical device ([page 2 - 5](#)) and battery ([page 2 - 7](#)).
2. The RAM modules will be visible at point **1** on the mainboard ([Figure 7b](#)).
3. Gently pull the two release latches (**2** & **3**) on the sides of the memory socket in the direction indicated by the arrows ([Figure 7b](#)). The RAM module **4** will pop-up ([Figure 7c](#)), and you can then remove it.

Figure 7
RAM Module Removal

- a. The RAM modules will be visible at point **1** on the mainboard.
- b. Pull the release latches.
- c. Remove the module.

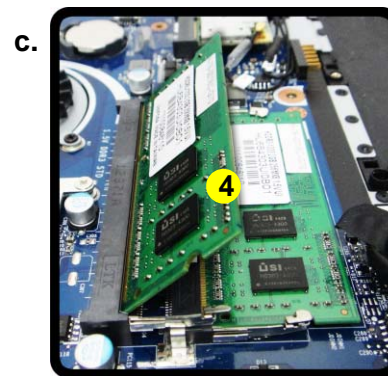
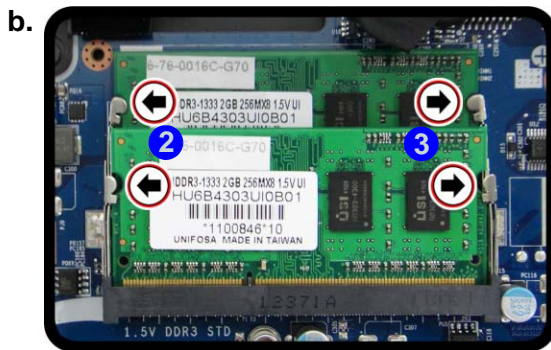
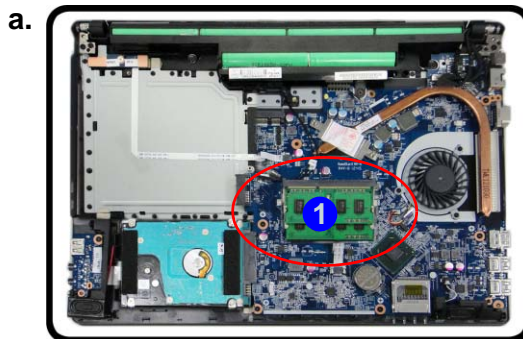



Single Memory Module Installation

If your computer has a single memory module, then insert the module into the **Channel 0 (JDIMM1)** socket. In this case this is the **lower memory socket** (the socket closest to the mainboard).



Contact Warning

Be careful not to touch the metal pins on the module's connecting edge. Even the cleanest hands have oils which can attract particles, and degrade the module's performance.



4. RAM Module

Disassembly

4. Pull the latches to release the second module if necessary.
5. Insert a new module holding it at about a 30° angle and fit the connectors firmly into the memory slot.
6. The module will only fit one way as defined by its pin alignment. Make sure the module is seated as far into the slot as it will go. DO NOT FORCE IT; it should fit without much pressure.
7. Press the module in and down towards the mainboard until the slot levers click into place to secure the module.
8. Replace the bottom cover and the screws (see [page 2 - 7](#)).
9. Restart the computer to allow the BIOS to register the new memory configuration as it starts up.

Removing the Keyboard

1. Turn **off** the computer, turn it over to remove the optical device ([page 2 - 5](#)) and battery ([page 2 - 7](#)).
2. Press at point **1** to release the cover module ([Figure 8a](#)).
3. Turn the computer over, unsnap up the cover module **2** in the direction of the arrow **3** ([Figure 8b](#)).
4. Remove screws **4** - **7** from the keyboard ([Figure 8c](#)).
5. Carefully lift the keyboard up, being careful not to bend the keyboard ribbon cable **8**. Disconnect the keyboard ribbon cable from the locking collar socket **9** ([Figure 8d](#)).
6. Carefully lift up the keyboard **10** off the computer ([Figure 8e](#)).

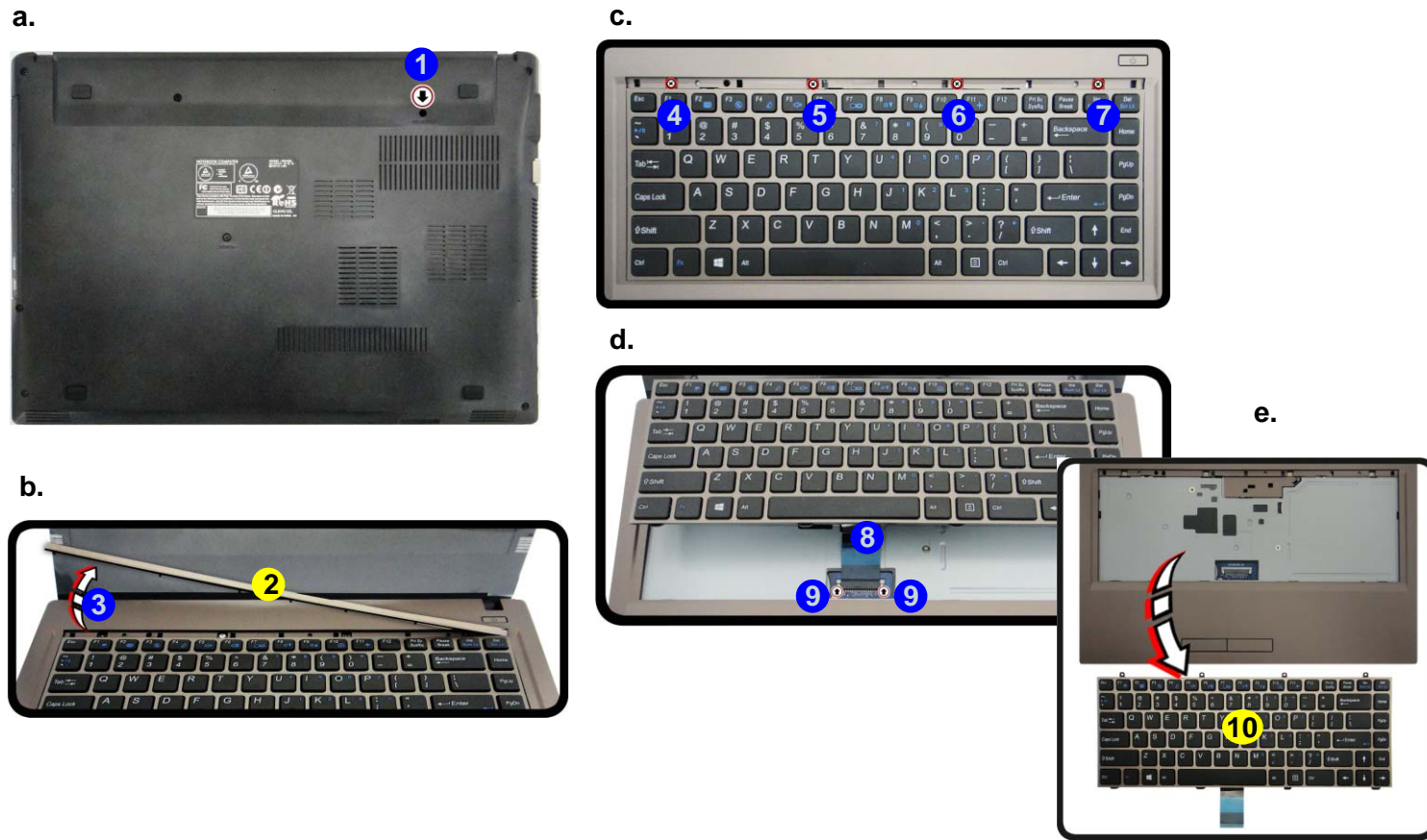

Figure 8
Keyboard Removal

- a. Release the cover module by pressing at point **1**.
- b. Unsnap the cover module.
- c. Remove the screws.
- d. Disconnect the keyboard ribbon cable from the locking collar socket.
- e. Remove the keyboard.

2. Cover Module
10. Keyboard

- 4 Screws

Disassembly

Figure 9
Keyboard Assembly

- f. Connect the keyboard ribbon cable to the locking collar socket.
- g. Tighten the screws.
- h. Replace the cover module.

7. Connect the keyboard ribbon cable from the locking collar socket **12**, and be careful not to bend the keyboard ribbon cable **11** (*Figure 9f*).
8. Tighten the screws **13** - **16** (*Figure 9g*).
9. Replace the cover module as shown (*Figure 9h*).

f.

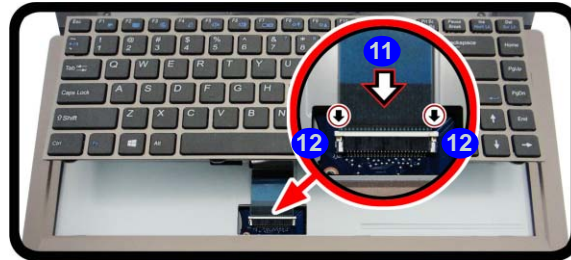

g.



h.

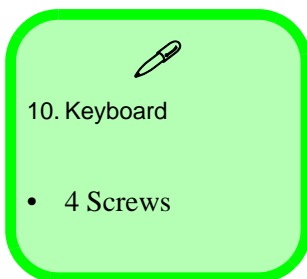

Removing the Wireless LAN Module

1. Turn **off** the computer, turn it over to remove the optical device ([page 2 - 5](#)) and battery ([page 2 - 7](#)).
2. The Wireless LAN module will be visible at point **1** on the mainboard ([Figure 10a](#)).
3. Carefully disconnect the cables **2** & **3**, and then remove the screw **4** ([Figure 10b](#))
4. The Wireless LAN module **5** ([Figure 10c](#)) will pop-up, and you can remove it from the computer.

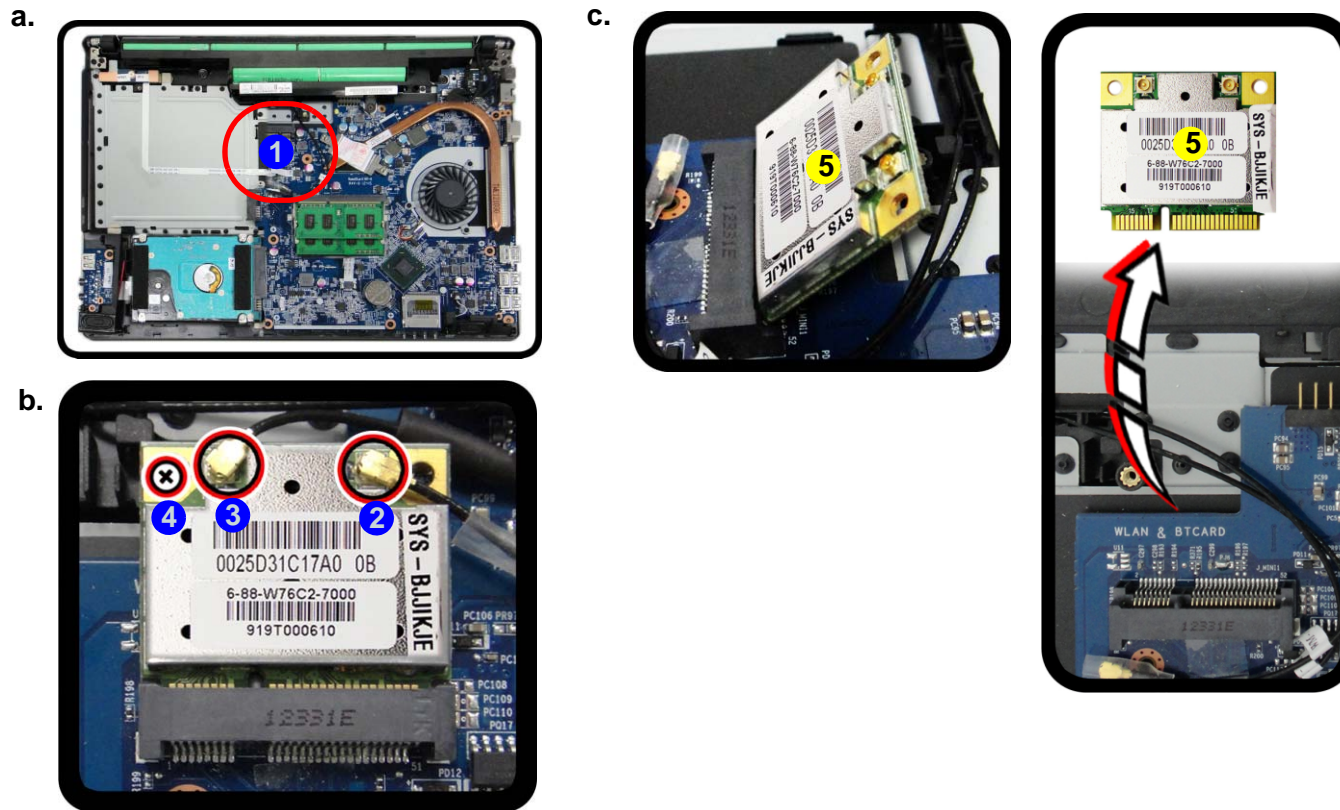



Figure 10
**Wireless LAN
Module Removal**

- a. Locate the WLAN.
- b. Disconnect the cable and remove the screw.
- c. The WLAN module will pop up and lift it out of the computer.

Note: Make sure you reconnect the antenna cable to the “1 + 2” socket ([Figure 10b](#)).



5. Wireless LAN Module

- 1 Screw

Disassembly

Figure 11
CCD Removal

- a. Carefully remove the rubber screw covers and screws from the front cover.
 - k. Run your fingers around the inner frame of the LCD panel at the points indicated by the arrows.
 - l. Lay the computer down on a flat surface with the top case up forming a 90 degree angle. Push the LCD front panel upwards before carefully lifting it up.
 - d. Remove the LCD front cover.
1. Turn **off** the computer, turn it over to remove the optical device ([page 2 - 5](#)) and battery ([page 2 - 7](#)).
 2. Carefully remove the rubber screw covers **1** - **2** and screws **3** - **4** from the front cover ([Figure 11a](#)).
 3. Run your fingers around the inner frame of the LCD panel at the points as indicated by the arrows **5** - **8**.
 4. Lay the computer down on a flat surface with the top case up forming a 90 degree angle. Push the LCD front cover **9** upwards before carefully lifting it up.
 5. Remove the LCD front cover **9** ([Figure 11c](#)).

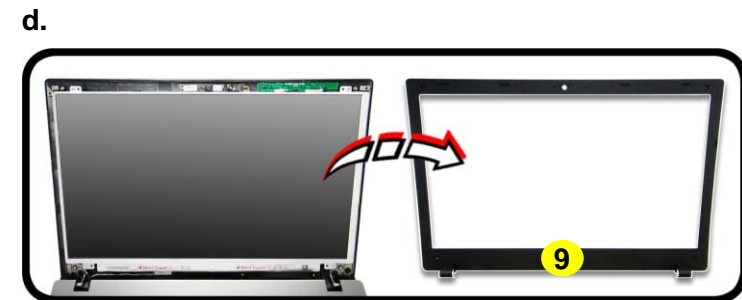
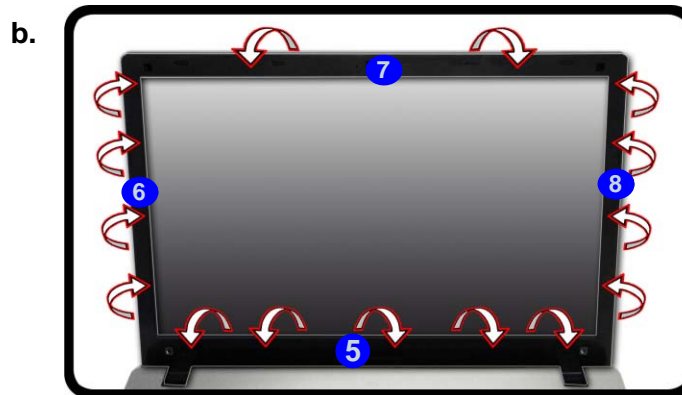
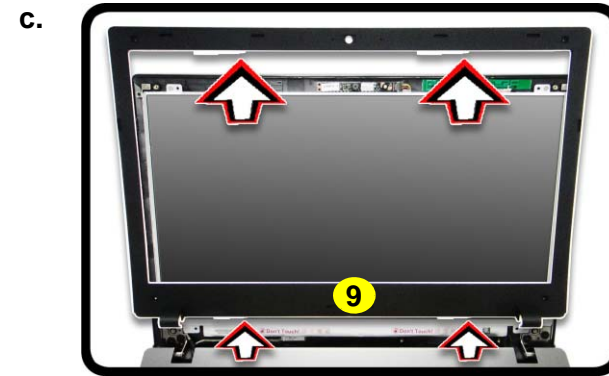

9. LCD Front Cover

- 2 Screws

6. Disconnect the cable **14**.
7. Remove the CCD module **15** (*Figure 12f*).
8. Reverse the process to install a new CCD module.

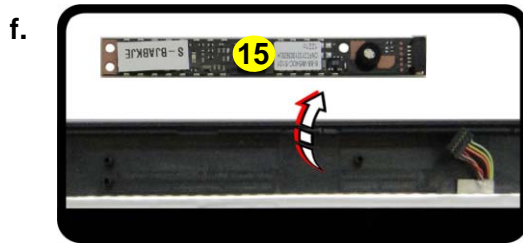
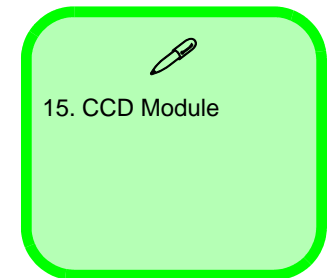

Figure 12
CCD Removal
(cont'd)

- e. Disconnect the cable.
- f. Remove the CCD module.



Appendix A:Part Lists

This appendix breaks down the *W547CZ/W548CZ/W549CZ* series notebook's construction into a series of illustrations. The component part numbers are indicated in the tables opposite the drawings.

Note: This section indicates the *manufacturer's* part numbers. Your organization may use a different system, so be sure to cross-check any relevant documentation.

Note: Some assemblies may have parts in common (especially screws). However, the part lists DO NOT indicate the total number of duplicated parts used.

Note: Be sure to check any update notices. The parts shown in these illustrations are appropriate for the system at the time of publication. Over the product life, some parts may be improved or re-configured, resulting in *new* part numbers.

Part List Illustration Location

The following table indicates where to find the appropriate part list illustration.

Table A - 1
Part List Illustration
Location

Part	W547CZ	W548CZ	W549CZ
Top	<i>page A - 3</i>	<i>page A - 4</i>	<i>page A - 5</i>
LCD	<i>page A - 6</i>	<i>page A - 7</i>	<i>page A - 8</i>
Bottom	<i>page A - 9</i>		
DVD Dual Drive	<i>page A - 10</i>		

Top (W549CZ)

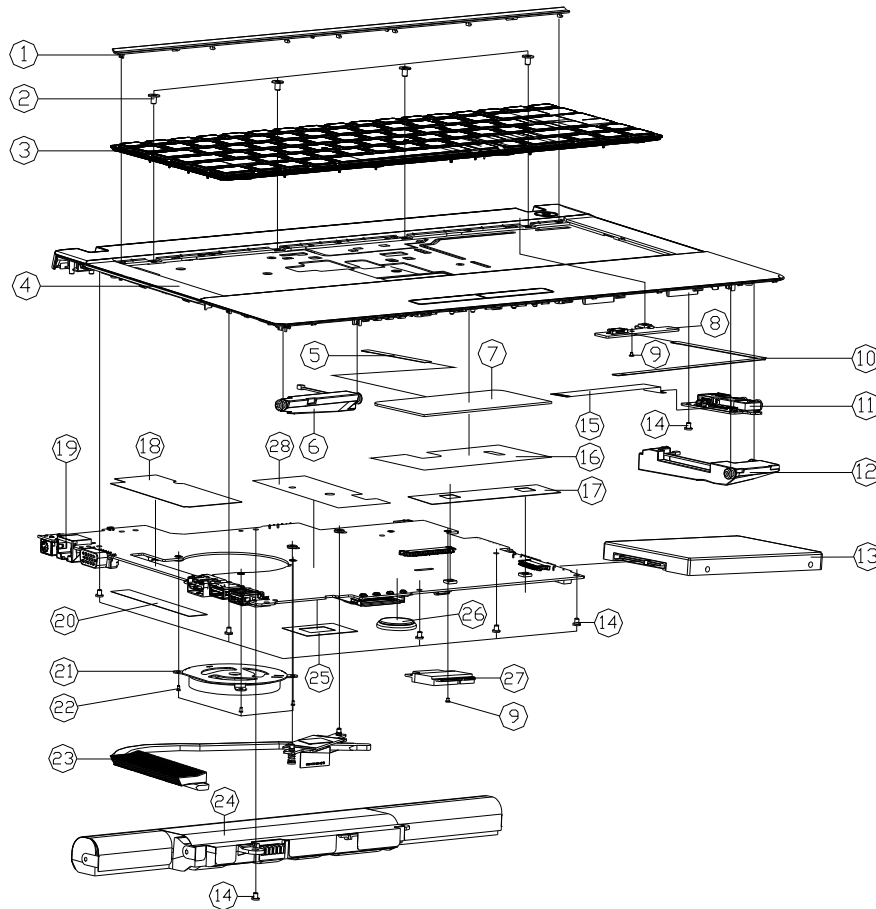

ITEM	PART NAME	PART NO	REMARK
1	K/B COVER (ABS+PC) W549CZ	6-42-W54C2-011	
2	SCREW M2x2.5L KI BK/2 ICT NY#35 1+03	6-35-B6120-2RB	
3	W/B K/B US&R/ACKN FRAME(US) MODULE W549CZ	6-79-W549CZK-010-W	
4	TDP CASE MODULE W549CZ	6-39-W54C2-011	
4	TDP CASE MODULE W549CZ-C	6-39-W54C2-011-C	
5	FFC CABLE FOR TOUCH PAD 6PIN (SHENGSHANG)	6-43-C4502-010-2	
6	SPK/CABLE L (27) 10V B? W540EU (WITH SPONGE/XYTECH)	6-23-5W540-0L1-1	
7	TOUCH PAD SYNAPTICS TM-0146-003 MULTI-GE5	6-49-C4802-010	
8	POWER SWITCH BOARD V2.0 W549BL	6-77-W549S-D02	
9	SCREW M2x3L KI NI ICT NY (000-045)DT-041	6-35-B1120-3RE	
10	FFC CABLE FOR POWER BOARD TO M/B 4P 05D W547B	6-43-W5470-011	
11	AUDIO BOARD V2.0 W549BL	6-77-W549B-D02	
12	SPK/CABLE R(SD) 10V B? W540EU (CIVITECH)	6-23-5W540-0R1-1	
13	W/D HDD ASS'Y C4800	6-79-C48000J-010	
13	W/HDD ASS'Y E5120Q	6-79-E51200J-020	
14	SCREW M2.5x4L KIKT-05 D=4.5) BK/2 ICT	6-35-B6125-4R0	
15	FFC CABLE FOR AUDIO BOARD TO M/B 4P 05S	6-43-W5470-020	
16	TP TAPE MYLAR PET W540EU	6-40-W5401-010	
17	MB MYLAR PET W548CZ	6-40-W54ZS-010	
18	MB FAN MYLAR PET W547CZ	6-40-W54CS-010	
19	MAIN BOARD V2.0 W549CZ	6-77-W549CZ00-D02	
20	MYLAR FOR MB FAN (C40110A151) (PET)3M 467) W540EU	6-40-W540S-010	
21	FAN MODULE (A-POWER) W547BL	6-31-W547S-101-1	
22	SCREW M1.6x3.5L KIKT-12 D=4.5) BZ ICT NY	6-35-82116-3R5	
23	CPU HEATSINK MODULE W547CZ	6-31-W54CN-100	
24	MB P/S U11 10V/400MA/2500RZP COP COPPER 200W W? B?500A C/MS/PL	6-87-W547S-4241	
24	MB P/S U11 10V/400MA/2500RZP COP COPPER 200W W? B?500A C/MS/PL	6-87-W547S-4U41	
24	MB P/S U11 10V/400MA/2500RZP COP COPPER 200W W? B?500A C/MS/PL	6-87-W547S-42F1	
24	MB P/S U11 10V/400MA/2500RZP COP COPPER 200W W? B?500A C/MS/PL	6-87-W547S-4UF1	
25	MB CPU MYLAR PET W547CZ	6-40-W54CS-020	
26	BATTERY 3V 220MA BBBCR2032B (KTS)	6-23-6A2B2-030	
27	W/B KEYPAD AN VECTA (ALUMINUM) 2 1/2 HOLE (SHEET) 16 1/2" WIDE (COP) PET 7000	6-88-W25H2-7000	
27	W/B KEYPAD AN VECTA (ALUMINUM) 2 1/2 HOLE (SHEET) 16 1/2" WIDE (COP) PET 9400	6-88-W25H2-9400	
27	W/B KEYPAD AN VECTA (ALUMINUM) 2 1/2 HOLE (SHEET) 16 1/2" WIDE (COP) PET 7000	6-88-W345F-7000	
27	W/B KEYPAD AN VECTA (ALUMINUM) 2 1/2 HOLE (SHEET) 16 1/2" WIDE (COP) PET 9400	6-88-W345F-9400	
27	W/B KEYPAD AN VECTA (ALUMINUM) 2 1/2 HOLE (SHEET) 16 1/2" WIDE (COP) PET 7000	6-88-W1102-4200	
27	W/B KEYPAD AN VECTA (ALUMINUM) 2 1/2 HOLE (SHEET) 16 1/2" WIDE (COP) PET 9400	6-88-W110F-4200	
27	W/B KEYPAD AN VECTA (ALUMINUM) 2 1/2 HOLE (SHEET) 16 1/2" WIDE (COP) PET 7000	6-88-P3702-9400	
27	W/B KEYPAD AN VECTA (ALUMINUM) 2 1/2 HOLE (SHEET) 16 1/2" WIDE (COP) PET 9400	6-88-P3702-7000	
28	M/B AL_MYLAR PET W547CZ	6-40-W54CS-030	

Figure A - 3
Top (W549CZ)

LCD (W547CZ)

Figure A - 4
LCD (W547CZ)

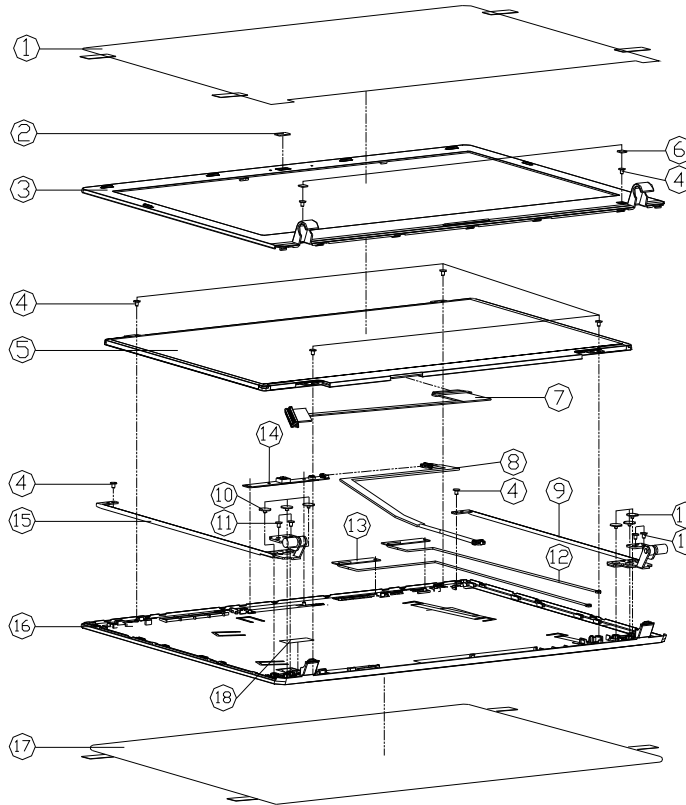

ITEM	PART NAME	PART NO	REMARK
1	LCD FRONT COVER PROTECTION MYLAR PET (300MM X 300MM X 0.05MM)	6-40-C4501-011	
2	CCD LENS PMMA W540EU	6-42-W5401-010	OPTION
3	LCD FRONT COVER MODULE (AOD TYPE) W540EU	6-39-W5401-012	
4	SCREW M2x3L KI NI ICT NY (D0=04.5,D1=0.4)	6-35-B1120-3RE	
5	LCD TAP HD LG (P404) 11.2 CLARE TYPE QLED 330NM	6-50-J8136-L06	OPTION
5	LCD TAP HD MIDDLE (P404) 11.2 CLARE TYPE QLED 330NM	6-50-J8136-N01	OPTION
5	LCD TAP HD COVER (P404) 11.2 CLARE TYPE QLED 330NM	6-50-J8136-D04	OPTION
5	LCD TAP HD SIDE (P404) 11.2 CLARE TYPE QLED 330NM	6-50-J8136-H00	OPTION
6	FRONT COVER SCREW RUBBER W540EU	6-47-W5401-011	
7	WIRE CABLE FOR LVDS FROM OLEY (300X300-28-40) W547C	6-43-W5471-010-N	
8	WIRE CABLE FOR CCD (P 370MM (D1) W540EU)	6-43-W5471-011-I	
9	LCD HINGE R (SUS301+S50C) W547BL	6-33-W5471-0R0	
10	SCREW M2x2L KI BK/Z ICT NY(0.8,1+0.6)	6-35-B6120-2RE	
11	SCREW M2.5x4L KI CT-0.5 D=4.5 BK/Z ICT	6-35-B6125-4R0	
12	ANTENNA MYLAR PET PFC 24623502/25 WPC 500M W547C	6-23-7W549-020	
13	ANTENNA MYLAR PET PFC 24623502/25 WPC 500M W547C	6-23-7W549-010	
14	LCD COVER (P404) 11.2 CLARE TYPE QLED 330NM	6-88-W540C-4901	OPTION
14	LCD COVER (P404) 11.2 CLARE TYPE QLED 330NM	6-88-W540C-5101	OPTION
14	LCD COVER (P404) 11.2 CLARE TYPE QLED 330NM	6-88-W540C-4900	OPTION
15	LCD HINGE L (SUS301+S50C) W547BL	6-33-W5471-0L1	
16	LCD BACK COVER MODULE W540EU	6-39-W5401-022	
17	LCD BACK COVER MODULE W540EU-C	6-39-W5401-022-C	
17	LCD BACK COVER PROTECT MYLAR PET W345CU	6-40-W3458-020	
18	TAPE MYLAR (CB) MYLAR M550J	6-40-M55J2-020	

LCD (W548CZ)

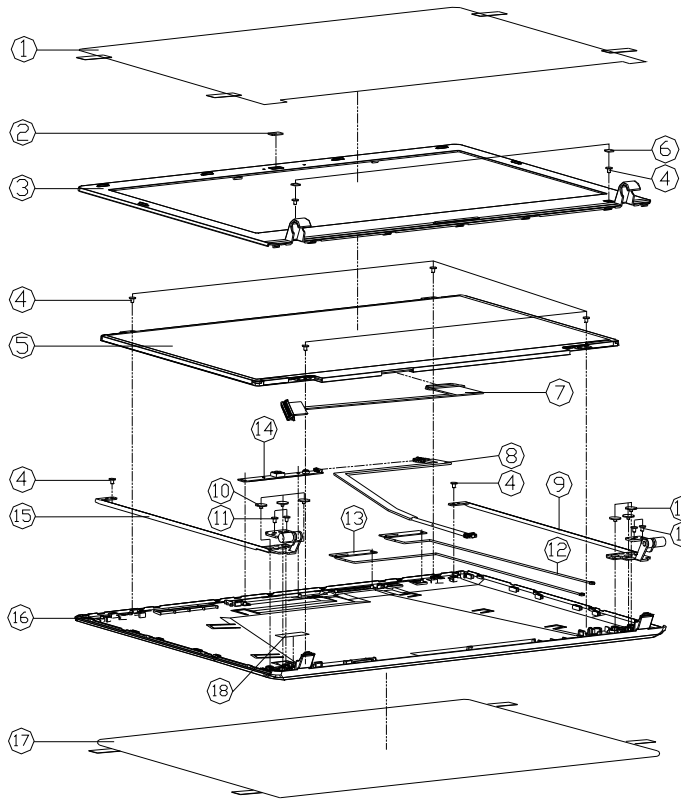

Figure A - 5
LCD (W548CZ)

ITEM	PART NAME	PART NO	REMARK
1	LCD FRONT COVER PROTECT MYLAR PET (300X3) (0.3MM) (0.5M)	6-40-C4501-011	
2	CCD LENS PMMA W540EU	6-42-W5401-010	OPTION
3	LCD FRONT COVER MODULE (A00 TYPE) W540EU	6-39-W5401-012	
4	SCREW M4x3L K1 NI ICT NY (00=04.5,01=04)	6-35-B1120-3RE	
5	LCD TAP HD LG (P/PA/PC-112) GLARE TYPE (LED) 30MM	6-50-J8136-L06	OPTION
5	LCD TAP HD (M/CM/PC-112) GLARE TYPE (LED) 30MM	6-50-J8136-N01	OPTION
5	LCD TAP HD (M/CM/PC-112) GLARE TYPE (LED) 30MM	6-50-J8136-D04	OPTION
5	LCD TAP HD (M/CM/PC-112) GLARE TYPE (LED) 30MM	6-50-J8136-H00	OPTION
6	FRONT COVER SCREW RUBBER W540EU	6-47-W5401-011	
7	WIRE CABLE FOR LVDS FROM BLAY (CON VESPA-22-H) W540E	6-43-W5471-010-N	
8	WIRE CABLE FOR CCD 6P 370MM (07) W540EU	6-43-W5401-011-I	
9	LCD HINGE R (SUS301+S50C) W547BL	6-33-W5471-0R0	
10	SCREW M4x2L K1 BK/Z ICT NY(00,1=0.6)	6-35-B6120-2RE	
11	SCREW M2.5x4L K1CT(0.5 D=4.5) BK/Z ICT	6-35-B6125-4R0	
12	ANTENNA W/VAI VAI W/VAI P/2.6/2500/25 W/VAI 0.5MM W540E	6-23-7W549-020	
13	ANTENNA W/VAI VAI W/VAI P/2.6/2500/25 W/VAI 0.5MM W540E	6-23-7W549-010	
14	THE COVER COVER FOR DISPLAY ON THE DISPLAY PANEL (TYPE) W540E	6-88-W540C-4901	OPTION
14	THE COVER COVER FOR DISPLAY ON THE DISPLAY PANEL (TYPE) W540E	6-88-W540C-5101	OPTION
14	THE COVER COVER FOR DISPLAY ON THE DISPLAY PANEL (TYPE) W540E	6-88-W540C-4900	OPTION
15	LCD HINGE L (SUS301+S50C) W547BL	6-33-W5471-0L1	
16	LCD BACK COVER MODULE W548CZ	6-39-W5421-021	
17	LCD BACK COVER MODULE W548CZ-C	6-39-W5421-021-C	
17	LCD BACK COVER PROTECT MYLAR PET V345EU	6-40-W3458-020	
18	TAPE MYLAR (B) MYLAR M550J	6-40-M55J2-020	

A.Part Lists

LCD (W549CZ)

Figure A - 6
LCD (W549CZ)

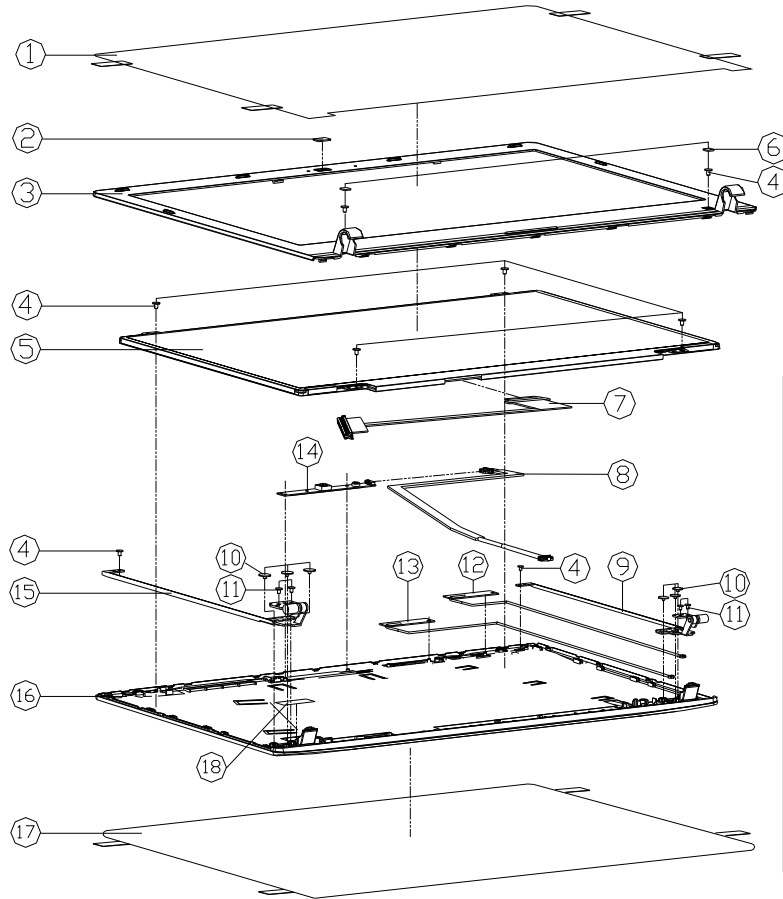

ITEM	PART NAME	PART NO	REMARK
1	LCD FRONT COVER PROTECT MYLAR PET (M550) (88.888) (CB)	6-40-C4501-011	
2	CCD LENS PMMA W540EU	6-42-W5401-010	OPTION
2	W/D CCD LENS PMMA W540EU	6-42-W5401-020	OPTION
3	LCD FRONT COVER MODULE (ADD TYPE) W540EU	6-39-W5401-012	
4	SCREW M2x2L KI NI ICT NY (D0)M45.01-040	6-35-B1120-3RE	
5	LCD TAP HD LG LPM40W2-1122 GLARE TYPE OLED 38MM	6-50-J8136-L06	OPTION
5	LCD TAP HD HANGAR H5040W2-1122 GLARE TYPE OPEN AND OLED 38MM	6-50-J8136-N01	OPTION
5	LCD TAP HD CHUCK M400W2-1122 GLARE TYPE OLED 38MM	6-50-J8136-D04	OPTION
5	LCD TAP HD ICE H5040W2-300 GLARE TYPE OLED 38MM	6-50-J8136-H00	OPTION
6	FRONT COVER SCREW RUBBER W540EU	6-47-W5401-011	
7	WIRE CABLE FOR LVIS FROM ONLY CON.V30M-2E-H) W57BL	6-43-W5471-010-N	
8	WIRE CABLE FOR CCD 6P 370MM (D1) W540EU	6-43-W5401-011-1	
9	LCD HINGE R (SUS301+S50C) W547BL	6-33-W5471-0R0	
10	SCREW M2x2L KI BK/Z ICT NY(88.1=06)	6-35-B6120-2RE	
11	SCREW M2.5x4L K1K1-05 D=4.5 BK/Z ICT	6-35-B6125-4R0	
12	ANTENNA MYLAR VEST WIRE PCB 2.6/2550/25 WIRE 50MM W549L	6-23-7W549-010	
13	ANTENNA MYLAR VEST WIRE PCB 2.6/2550/25 WIRE 60MM W549L	6-23-7W549-020	
14	THE COVER ORIGIN TO PROTECT HD IN HD (D0)S50 WIRE W540C (M550)	6-88-W540C-4901	OPTION
14	THE COVER ORIGIN TO PROTECT HD IN HD (D0)S50 WIRE W540C (M550)	6-88-W540C-5101	OPTION
14	THE COVER ORIGIN TO PROTECT HD IN HD (D0)S50 WIRE W540C (M550)	6-88-W540C-4900	OPTION
15	LCD HINGE L (SUS301+S50C) W547BL	6-33-W5471-0L1	
16	LCD BACK COVER MODULE W545EU	6-39-W5451-021	
17	LCD BACK COVER MODULE W545EU-C	6-39-W5451-021-C	
17	LCD BACK COVER PROTECT MYLAR PET W345EU	6-40-W3458-020	
18	TAPE MYLAR (CB)MYLAR M550J	6-40-M55J2-020	

Bottom

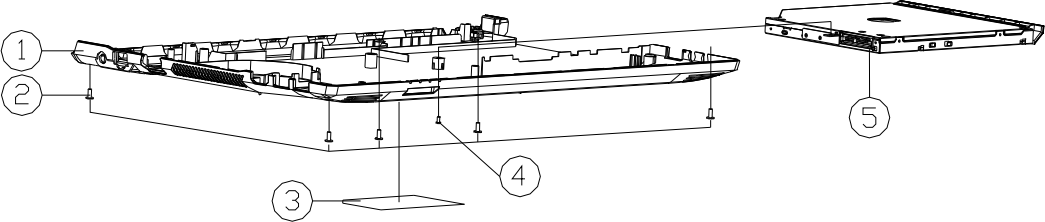
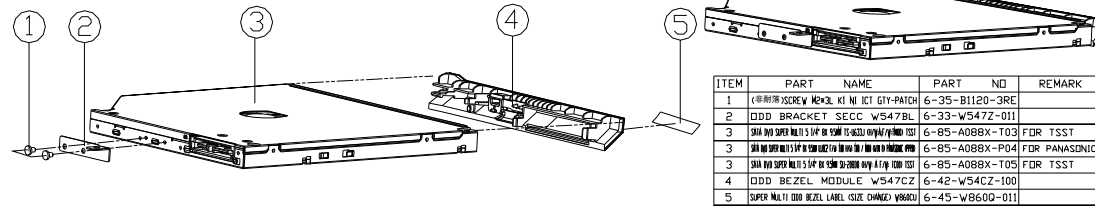

Figure A - 7
Bottom

ITEM	PART NAME	PART NO	REMARK
1	BOTTOM CASE MODULE W547CZ	6-39-W54C3-011	
1	BOTTOM CASE MODULE W547CZ-C	6-39-W54C3-011-C	
2	SCREW M2.5x8L KI BK/Z NY ICT	6-35-B6125-BR0	
3	PRODUCT LABEL FDR W547CZ	6-45-W547CZ03-010	
3	PRODUCT LABEL FDR W548CZ	6-45-W548CZ03-010	
3	PRODUCT LABEL FDR W549CZ	6-45-W549CZ03-010	
4	SCREW M2x4L KI BZ ICT NY	6-35-B6120-4RA	
5	SATA DVD SUPER MULTI ASS'Y (OPTIO)	6-79-W547BL00-000	(OPTIO)
5	SATA DVD SUPER MULTI ASS'Y (OPTIO)	6-79-W547CZ00-010	(OPTIO)
5	W/O DVD ASS'Y W547BL	6-79-W547BL0Z-000	(OPTIO)

DVD Dual

Figure A - 8
DVD Dual



ITEM	PART NAME	PART NO	REMARK
1	SCREW M2X2.5 KI NI ICT GY-PATCH	6-35-B1120-3RE	
2	ODD BRACKET SECC W547BL	6-33-W547Z-011	
3	ODD BEZEL MODULE FOR 85MM DIA DVD RW DRIVE (P03)	6-85-A08BX-T03	FDR TSST
3	ODD BEZEL MODULE FOR 85MM DIA DVD RW DRIVE (P04)	6-85-A08BX-P04	FDR PANASONIC
3	ODD BEZEL MODULE FOR 85MM DIA DVD RW DRIVE (P05)	6-85-A08BX-T05	FDR TSST
4	ODD BEZEL MODULE W547CZ	6-42-W54CZ-100	
5	SUPER MULTI DVD BEZEL LABEL SIZE CHANGED V0600	6-45-W8600-011	

Appendix B: Schematic Diagrams

This appendix has circuit diagrams of the *W547CZ/W548CZ/W549CZ* notebook's PCB's. The following table indicates where to find the appropriate schematic diagram.

Diagram - Page	Diagram - Page	Diagram - Page
<i>System Block Diagram - Page B - 2</i>	<i>PCH 4/9- LVDS, DDI, CRT - Page B - 16</i>	<i>5VS, 3VS, 1.5VS CPU - Page B - 30</i>
<i>Processor 1/7-DMI, FDI, PEG - Page B - 3</i>	<i>PCH 5/9- PCI, USB, RSVD - Page B - 17</i>	<i>VDD3, VDD5 - Page B - 31</i>
<i>Processor 2/7- CLK, MISC - Page B - 4</i>	<i>PCH 6/9- GPIO, CPU - Page B - 18</i>	<i>Power 0.85VS, 1.8VS - Page B - 32</i>
<i>Processor 3/7- (DDR3) - Page B - 5</i>	<i>PCH 7/9- PWR - Page B - 19</i>	<i>POWER 1.5V/1.05VS - Page B - 33</i>
<i>Processor 4/7- Power - Page B - 6</i>	<i>PCH 8/9 POWER - Page B - 20</i>	<i>POWER VCORE1 - Page B - 34</i>
<i>Processor 5/7- GFX PWR - Page B - 7</i>	<i>PCH 9/9- GND - Page B - 21</i>	<i>POWER VCORE2 - Page B - 35</i>
<i>Processor 6/7- GND - Page B - 8</i>	<i>Mini-PCIE (WLAN) - Page B - 22</i>	<i>AC IN, CHARGER - Page B - 36</i>
<i>Processor 7/7- RSVD - Page B - 9</i>	<i>CCD, FAN, CLICK, P/W - Page B - 23</i>	<i>AUDIO BOARD - Page B - 37</i>
<i>DDR3 SO-DIMM_0 - Page B - 10</i>	<i>USB, LID SWITCH - Page B - 24</i>	<i>POWER SW BOARD - Page B - 38</i>
<i>DDR3 SO-DIMM_1 - Page B - 11</i>	<i>LAN RTL8402, Card Reader - Page B - 25</i>	<i>Power On SEQ - Page B - 39</i>
<i>PANEL, INVERTER, CRT - Page B - 12</i>	<i>SATA ODD, LED - Page B - 26</i>	
<i>PCH 1/9- RTC, HDA, SATA - Page B - 13</i>	<i>HDMI, RJ45 - Page B - 27</i>	
<i>PCH 2/9- PCIE, SMBUS, CLK - Page B - 14</i>	<i>AUDIO CODEC VT1802S - Page B - 28</i>	
<i>PCH 3/9- DMI, FDI, PWRGD - Page B - 15</i>	<i>KBC-ITE IT8518E - Page B - 29</i>	

Table B - 1
**SCHEMATIC
DIAGRAMS**



Version Note

The schematic diagrams in this chapter are based upon version 6-7P-W5406-001. If your mainboard (or other boards) are a later version, please check with the Service Center for updated diagrams (if required).

System Block Diagram

Sheet 1 of 38
System Block
Diagram

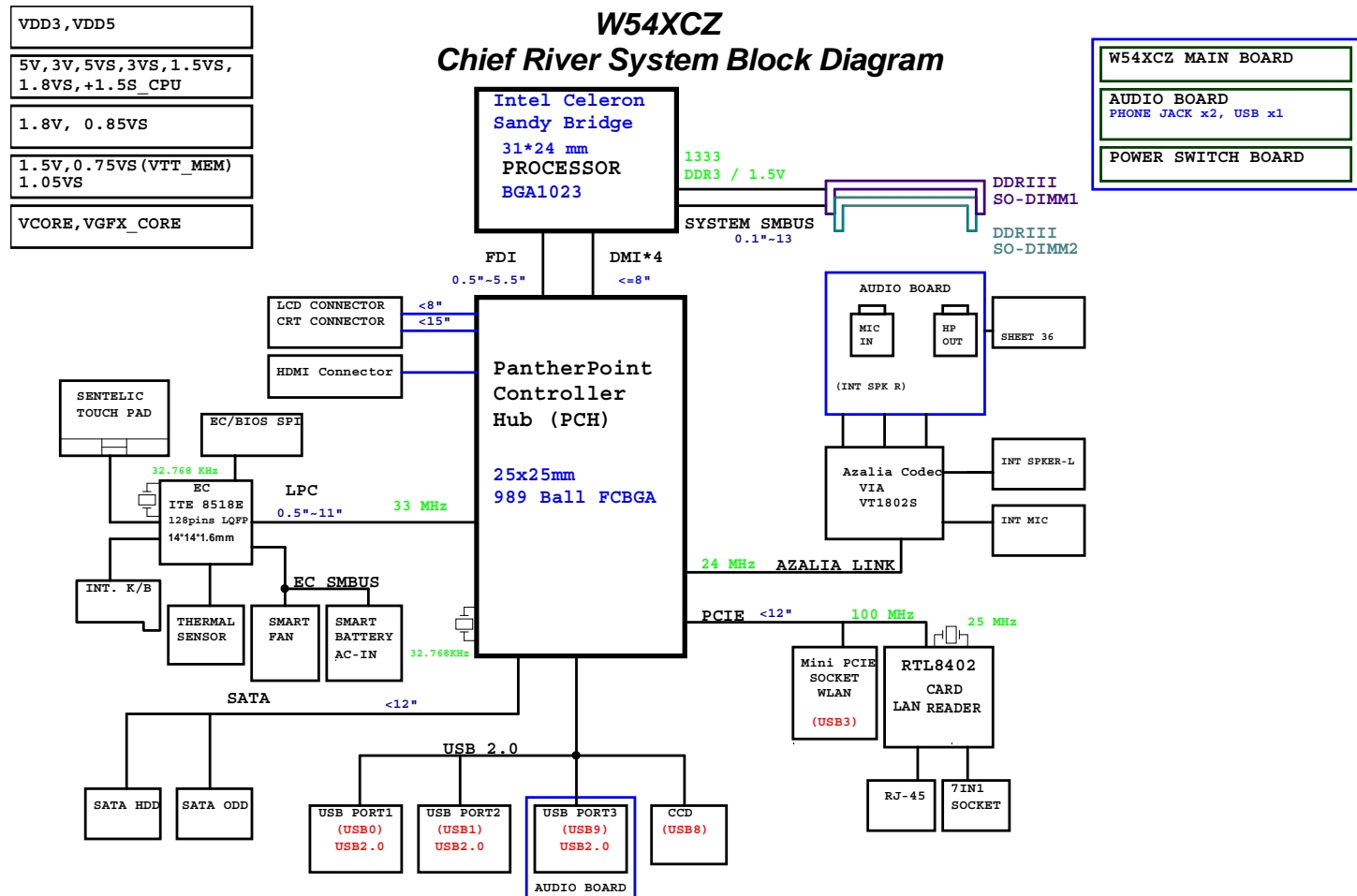

Processor 1/7-DMI, FDI, PEG

Ivy Bridge Processor 1/7 (DMI, PEG, FDI)

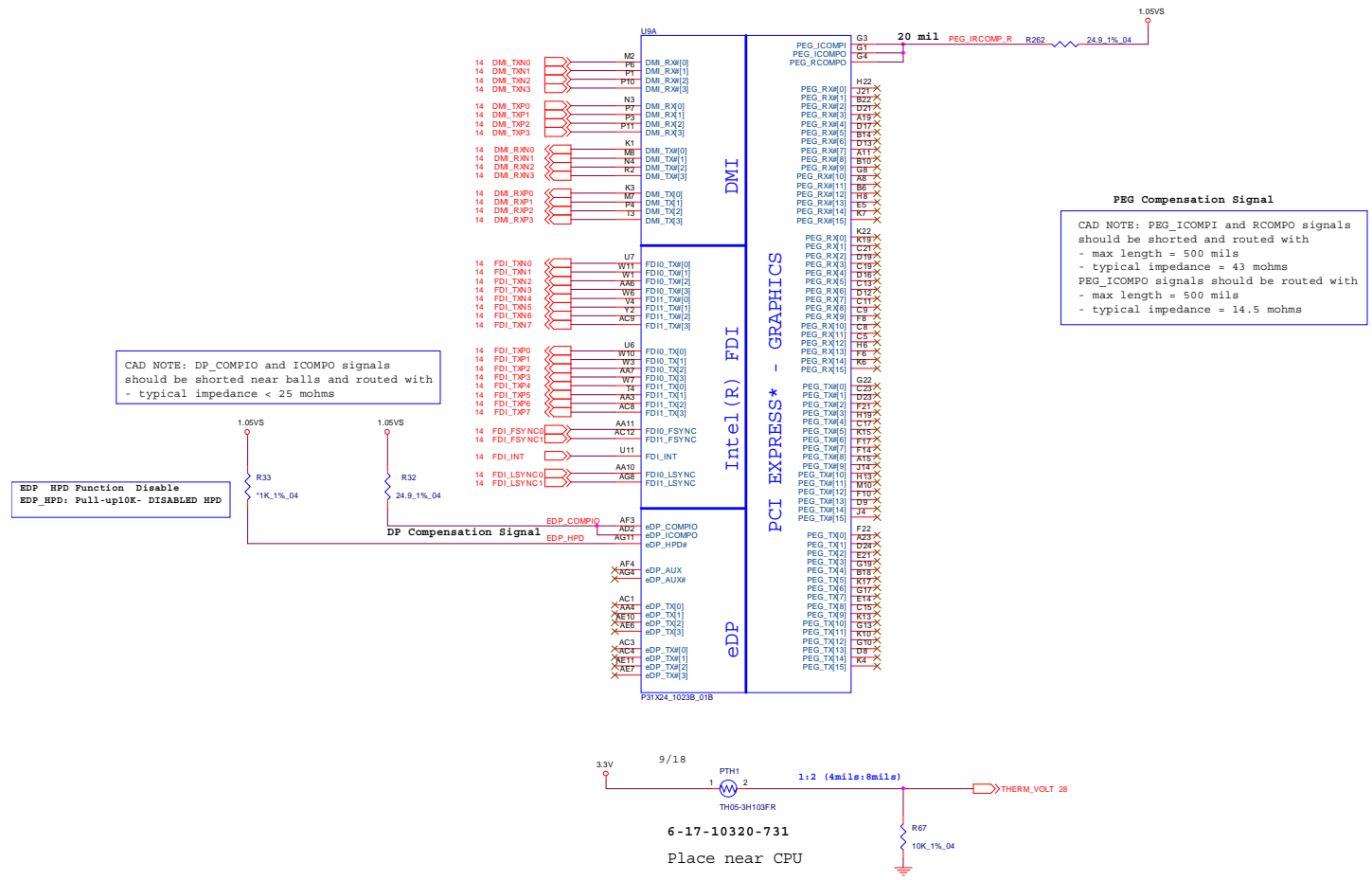

B.Schematic Diagrams

Sheet 2 of 38
Processor 1/7-DMI,
FDI, PEG

Processor 4/7- Power

Ivy Bridge Processor 4/7 (POWER)

Sheet 5 of 38
Processor 4/7-
Power

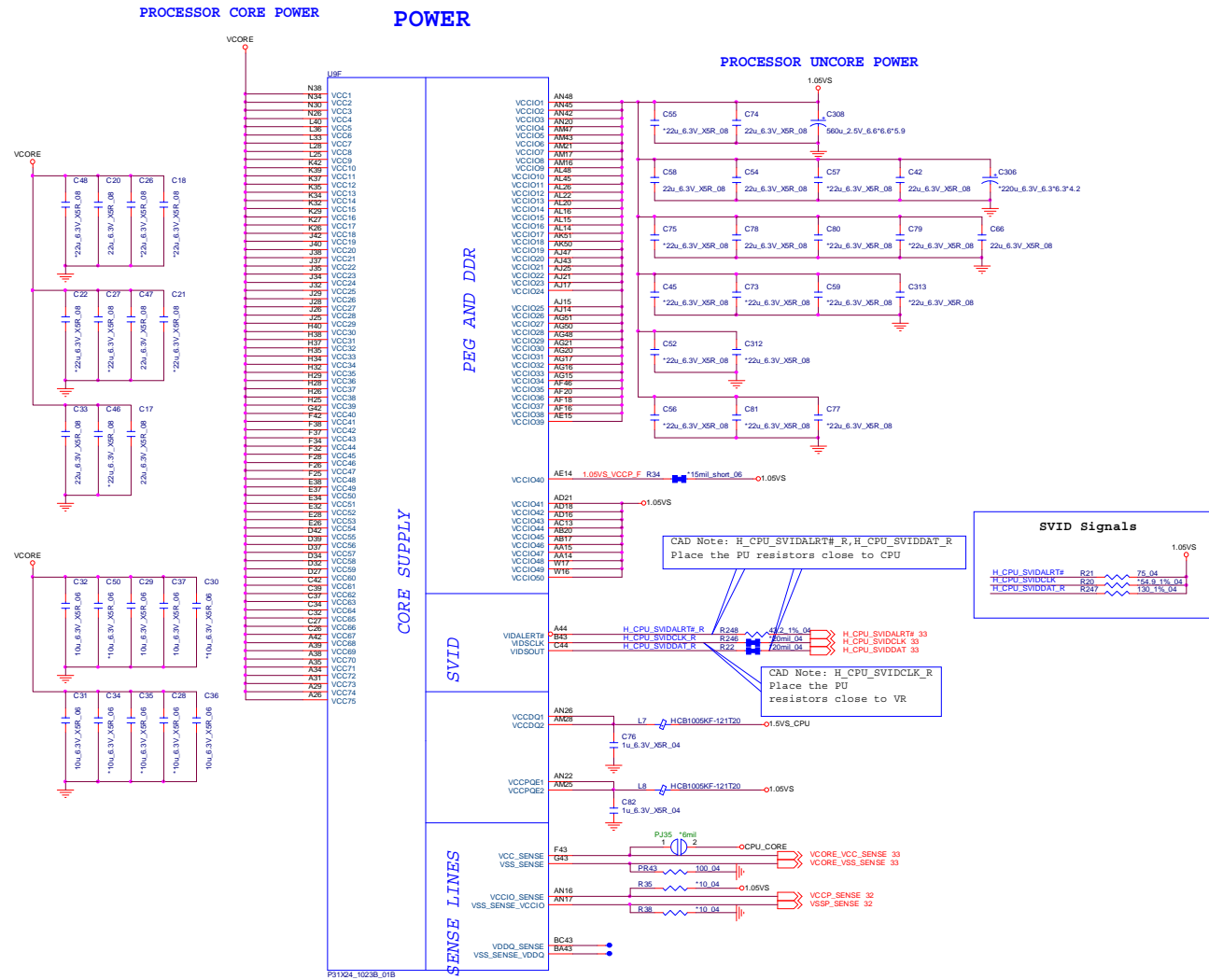

Processor 5/7- GFX PWR

Ivy Bridge Processor 5/7 (GRAPHICS POWER)

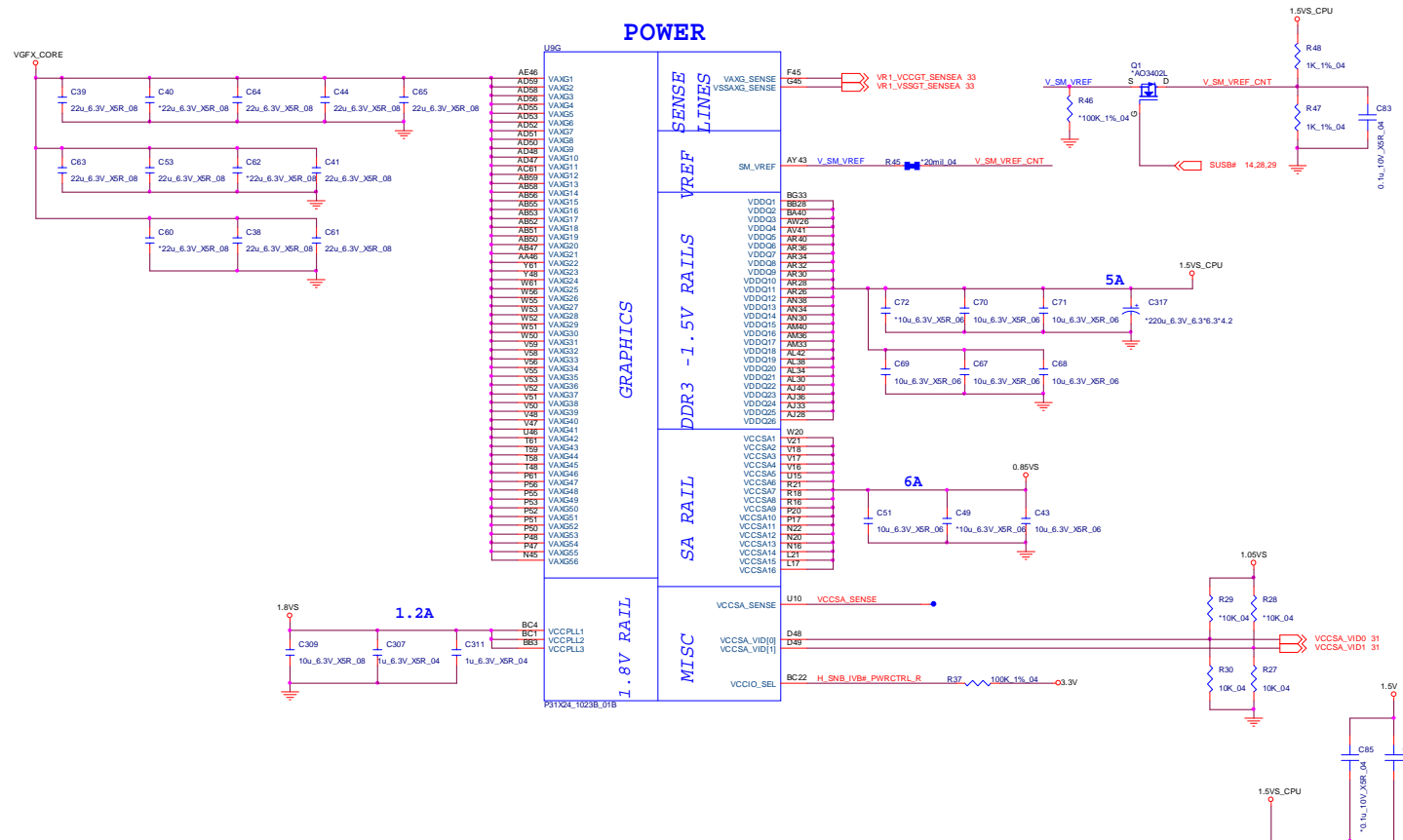

Sheet 6 of 38
Processor 5/7- GFX
PWR

B.Schematic Diagrams

Processor 6/7- GND

Ivy Bridge Processor 6/7 (GND)

Sheet 7 of 38
Processor 6/7- GND

CAD Note: 0 ohm resistor should be placed close to CPU

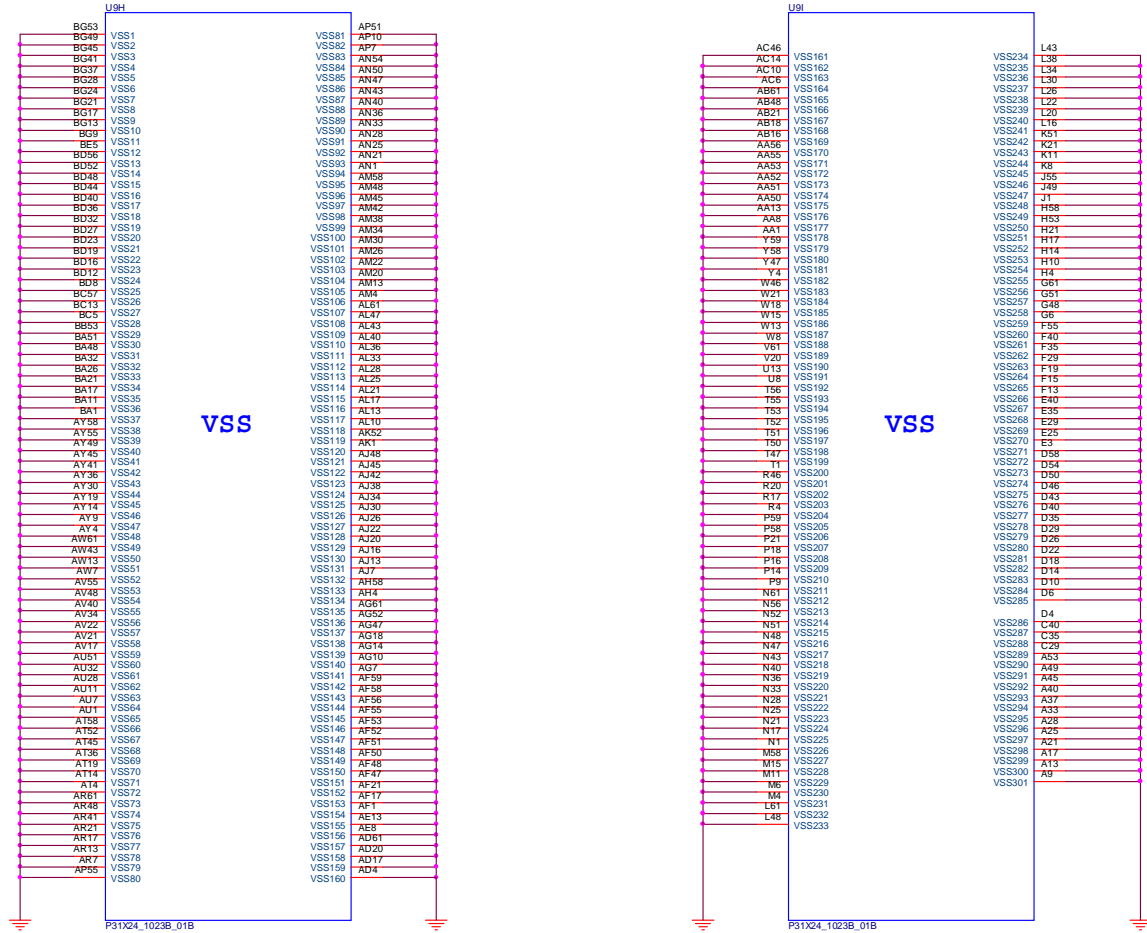

DDR3 SO-DIMM_0

SO-DIMM A

Sheet 9 of 38
DDR3 SO-DIMM_0

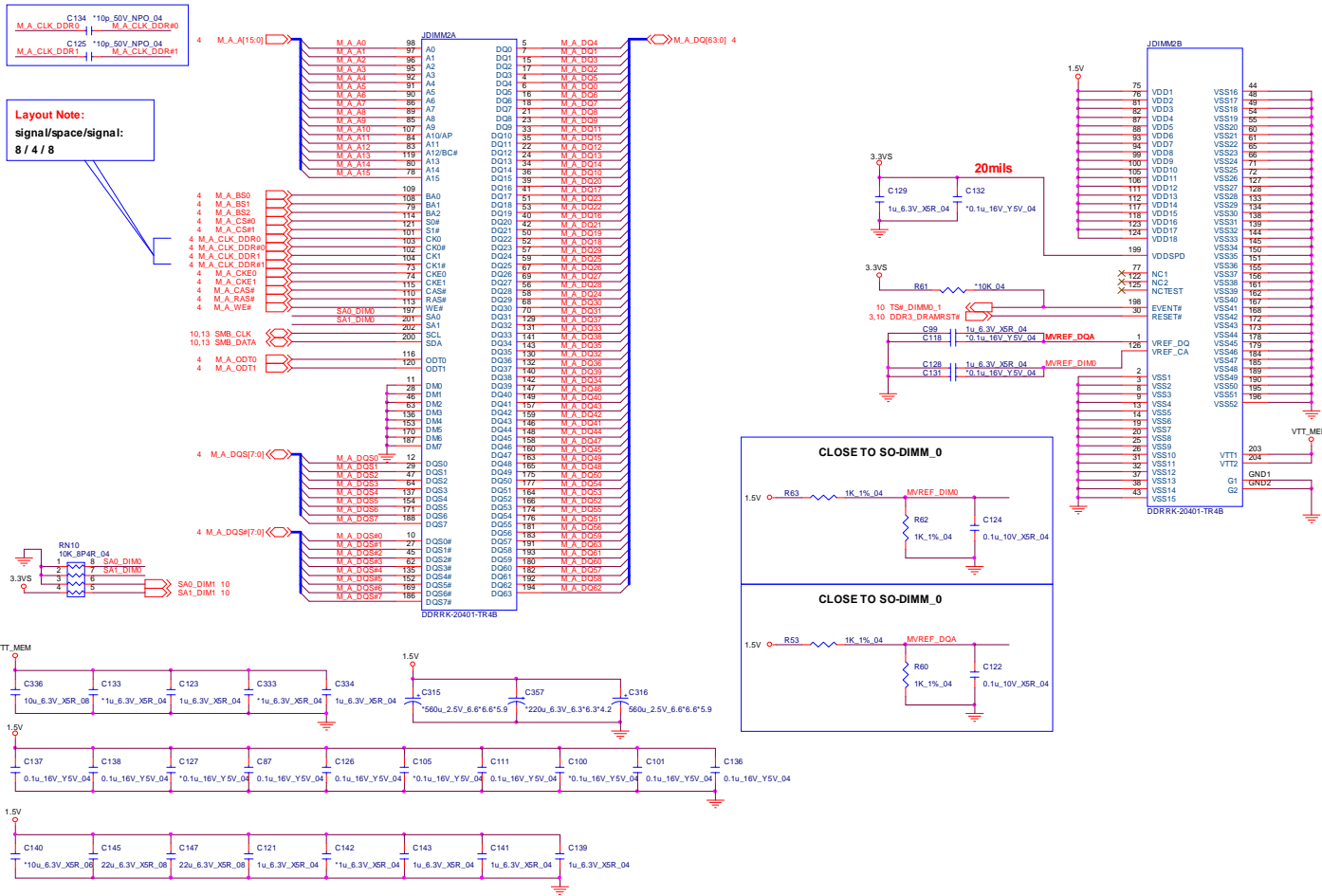

PCH 1/9- RTC, HDA, SATA

PantherPoint - M (HDA, JTAG, SATA)

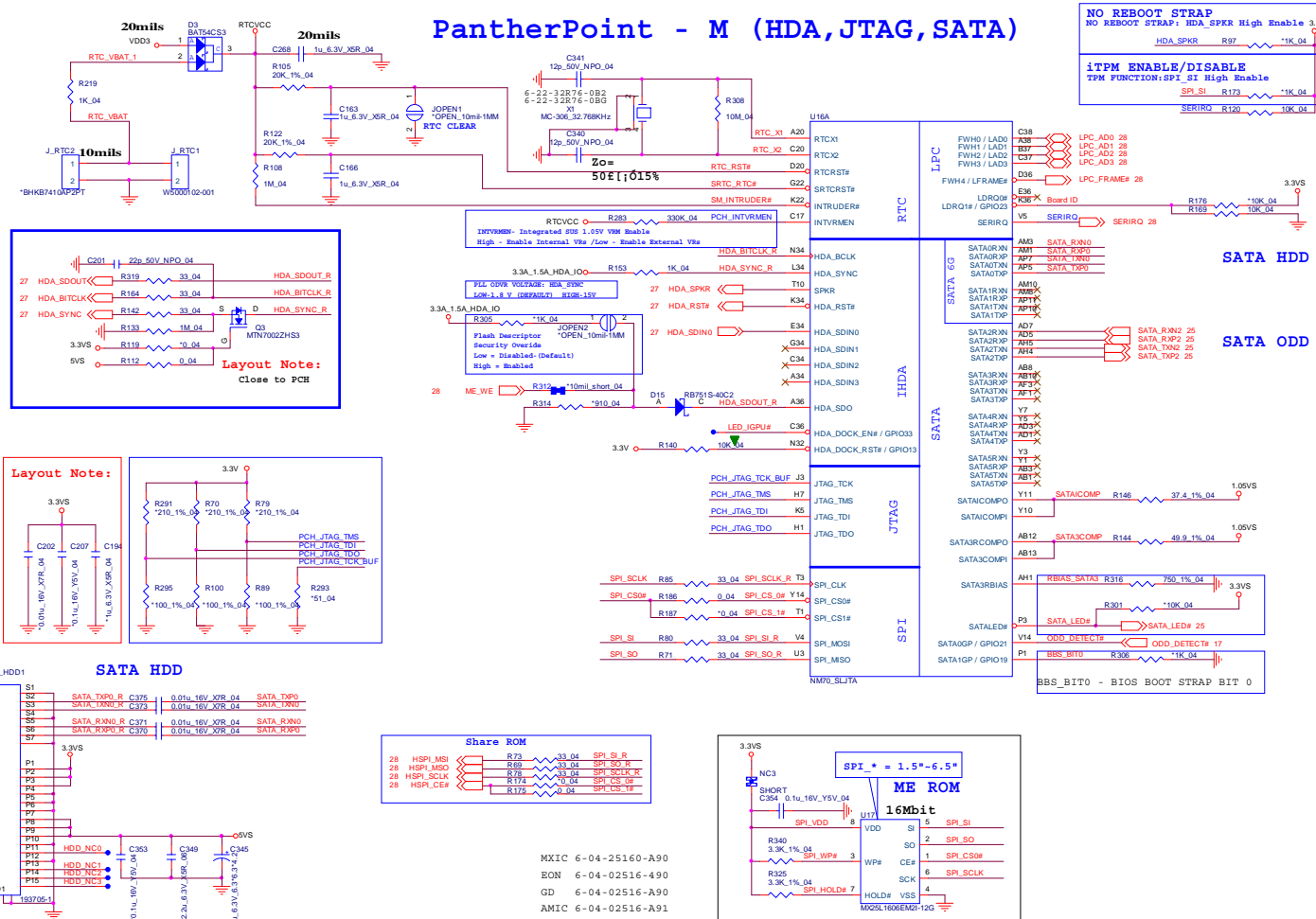

Sheet 12 of 38
PCH 1/9- RTC, HDA,
SATA

PCH 3/9- DMI, FDI, PWRGD

PantherPoint -M (DMI, FDI, GPIO)

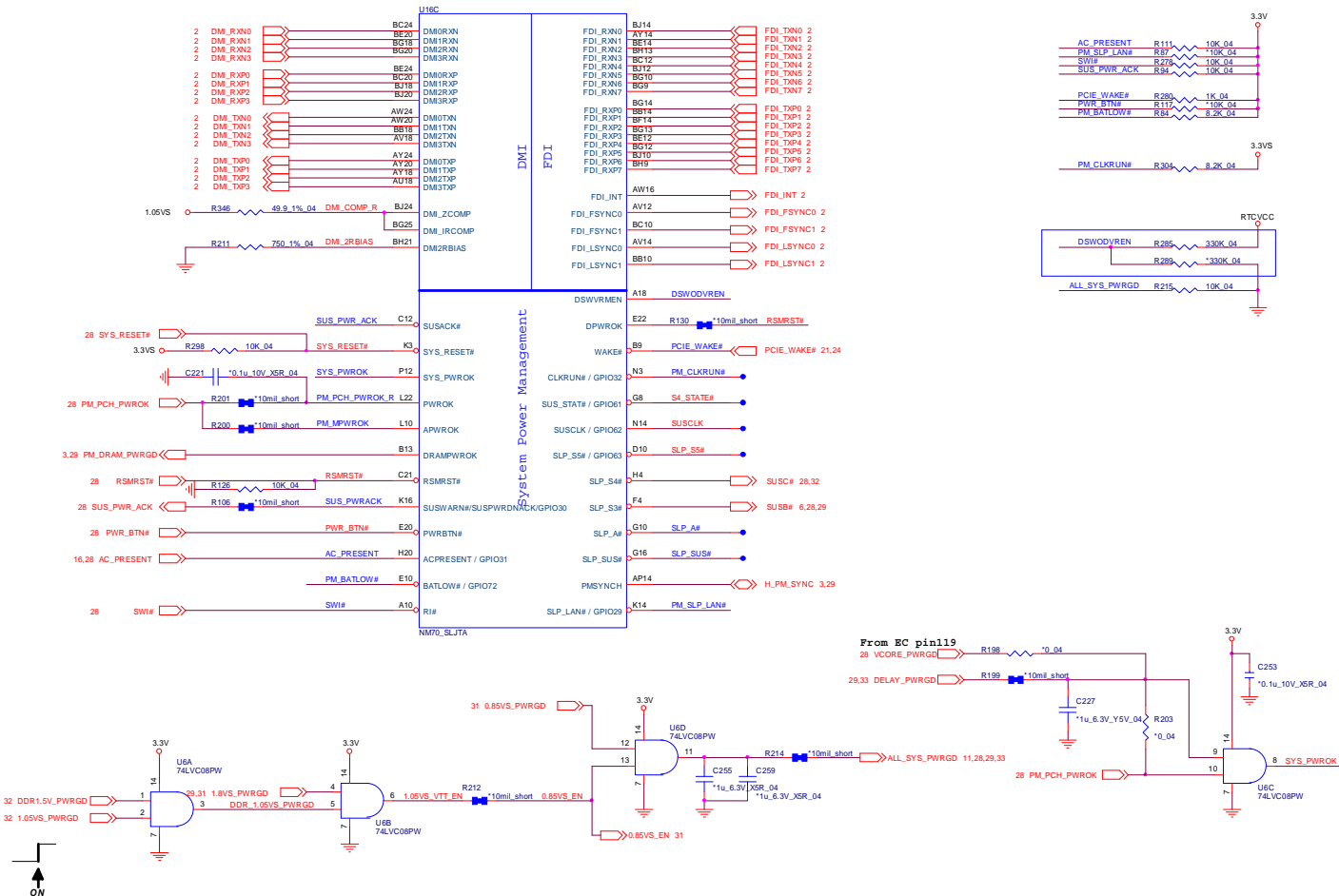

Sheet 14 of 38
PCH 3/9- DMI, FDI,
PWRGD

B.Schematic Diagrams

PCH 4/9- LVDS, DDI, CRT

Sheet 15 of 38
PCH 4/9- LVDS,
DDI, CRT

PantherPoint -M (LVDS,DDI)

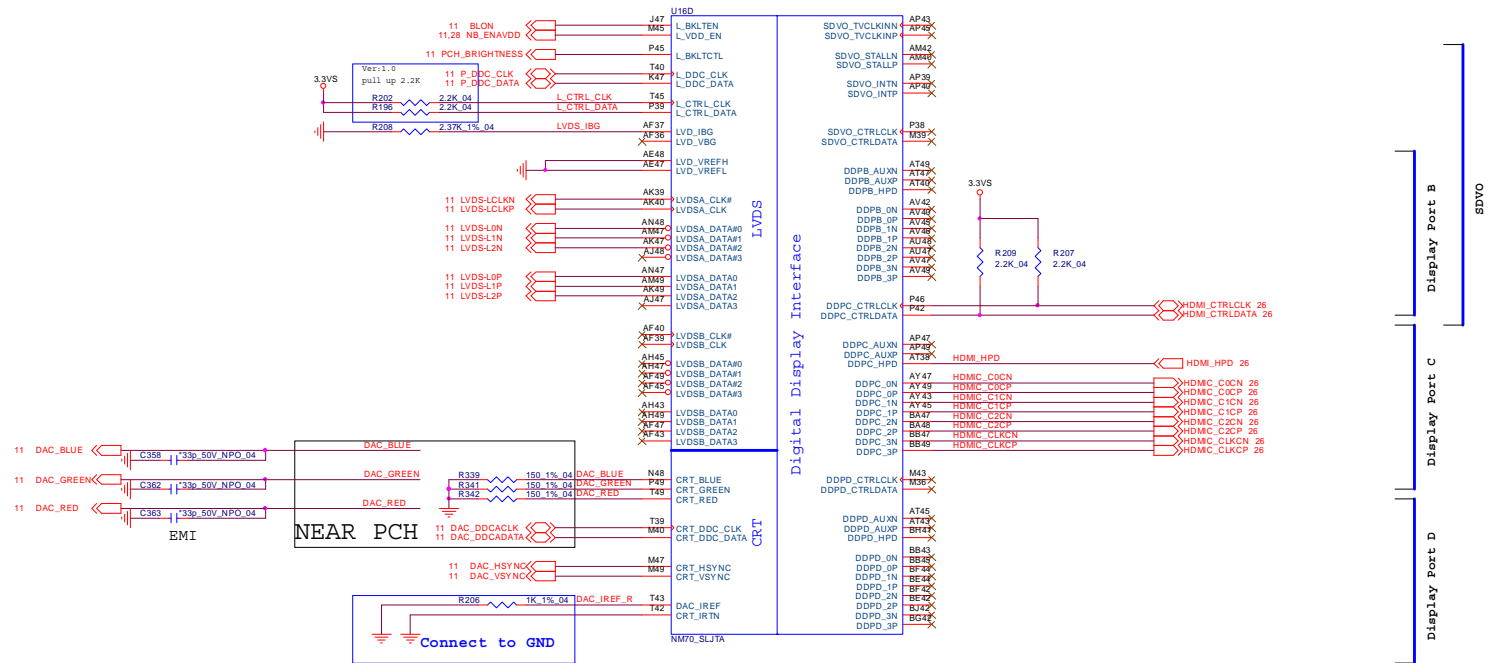

PCH 7/9- PWR

PantherPoint -M (POWER)

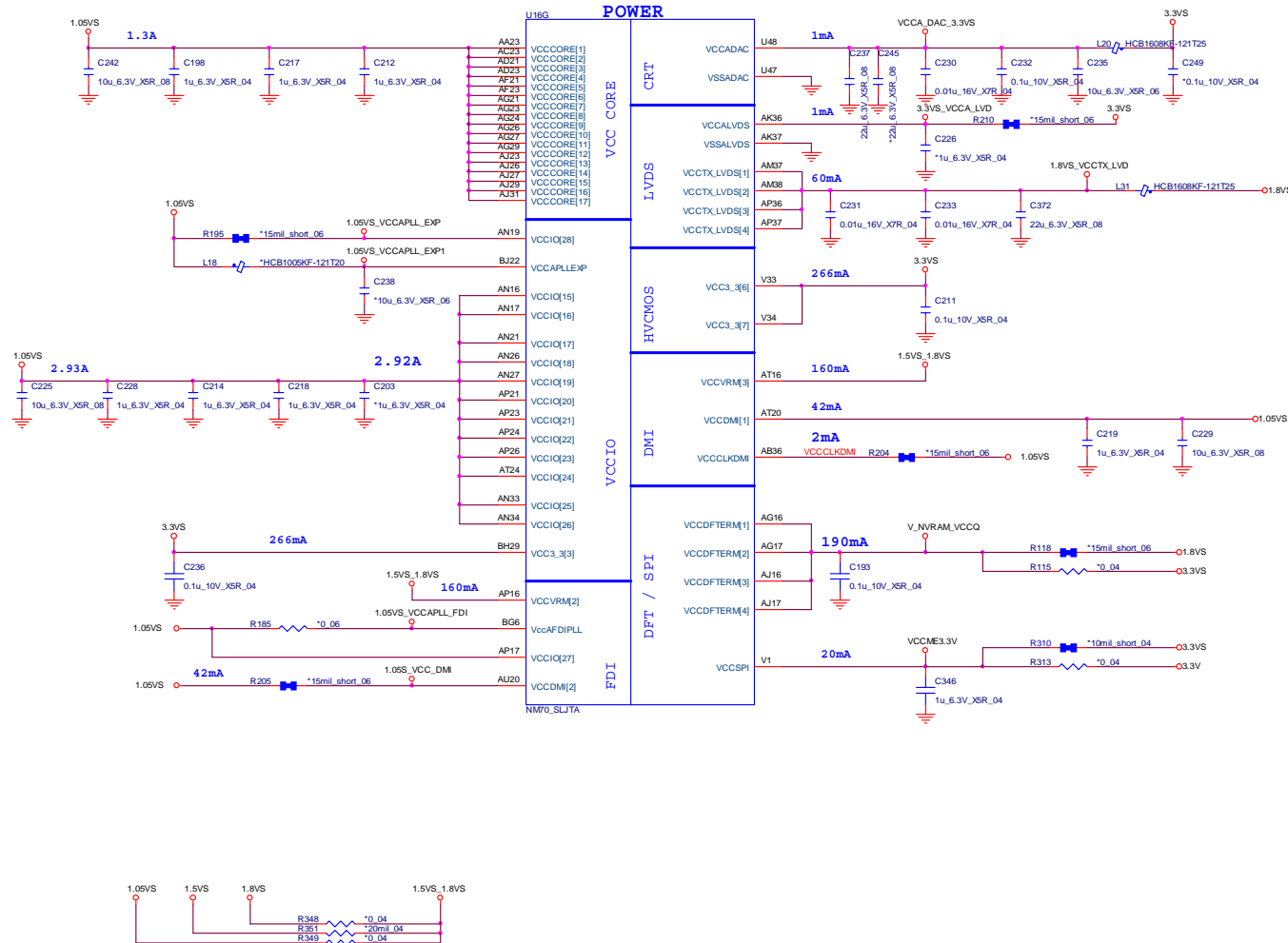

Sheet 18 of 38
PCH 7/9- PWR

B.Schematic Diagrams

PCH 8/9 POWER

Sheet 19 of 38
PCH 8/9 POWER

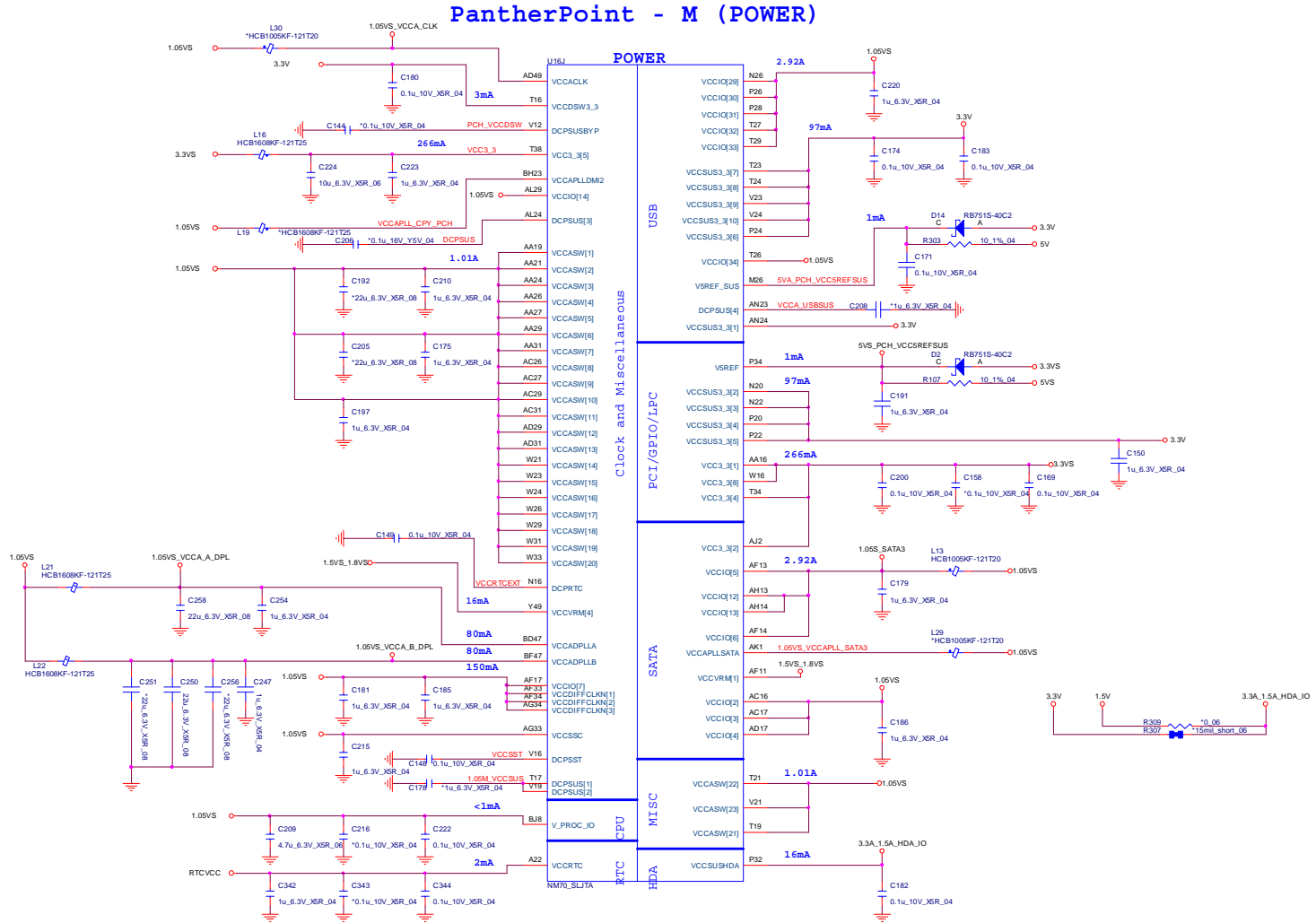

Mini-PCIE (WLAN)

WLAN MINI CARD

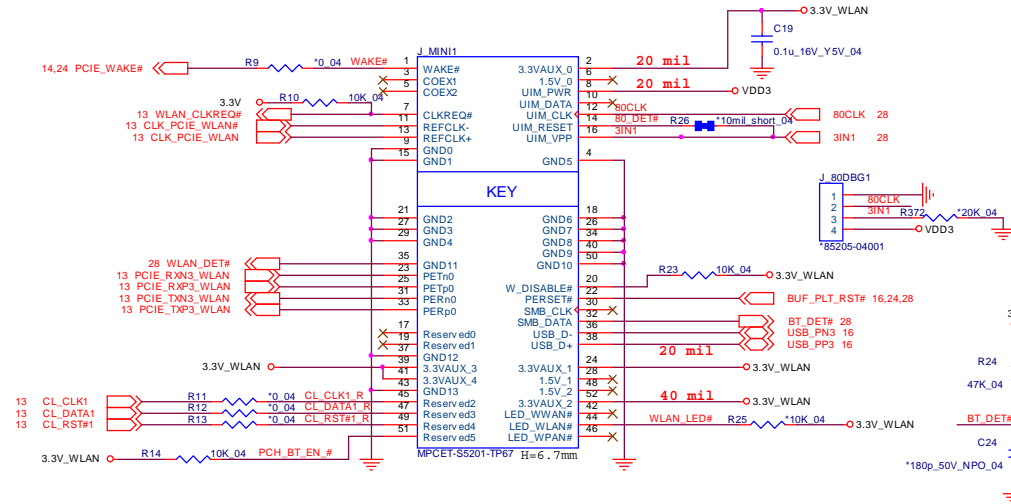

WLAN POWER

WLAN Power" PJ2 Short " for windows 7 and Windows 8 Intel Smart Connect.
 #WY6 U7 " for windows 8 Shark Bay Support WoWLAN function & Rapid Start Technology
 (s0>t{]x+), YN°6win8 08"awake up on WLAN"-n"D1A2N#u·|mä°s3 and S4|A"ÄdE·|mä°s51c

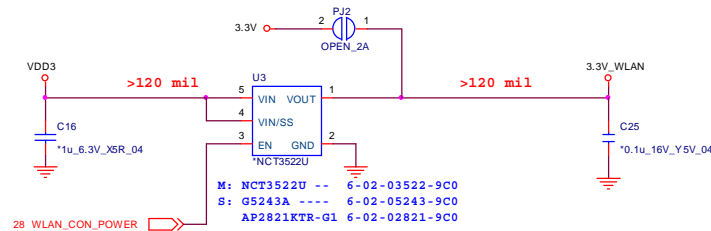

CCD, FAN, CLICK, P/W

FOR POWER SW BOARD

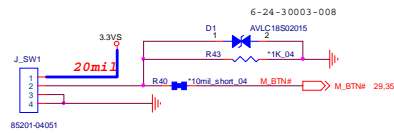

CPU FAN CONTROL

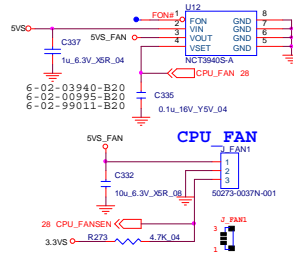
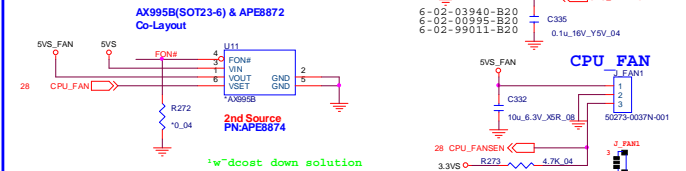

CLICK CONN

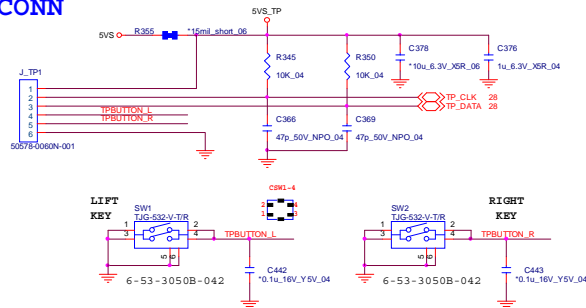

CCD + Internal MIC

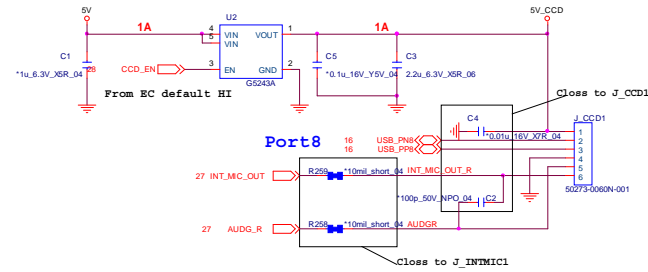

Sheet 22 of 38
CCD, FAN, CLICK,
P/W

USB, LID SWITCH

USB 2.0

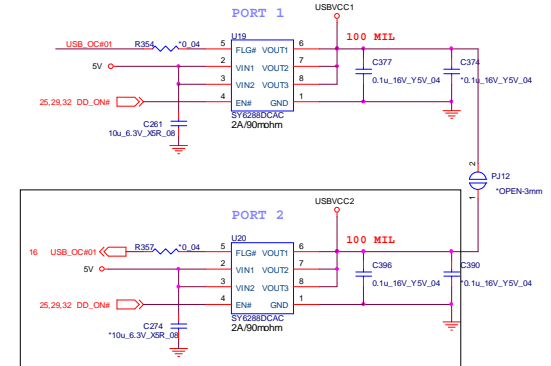
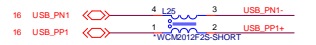
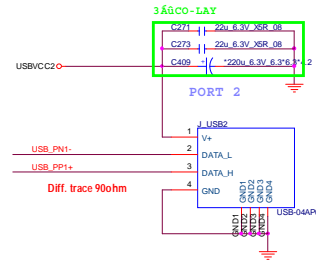
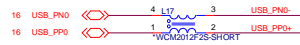
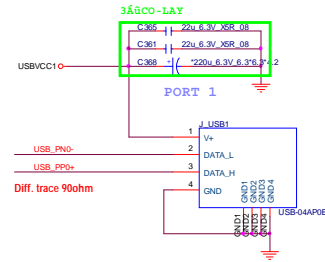

Sheet 23 of 38
USB, LID SWITCH

LID SWITCH IC

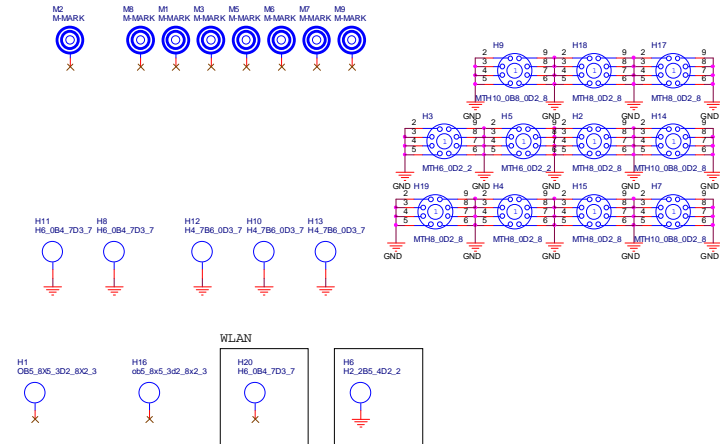
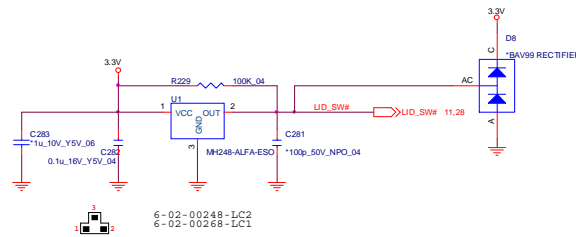

LAN RTL8402, Card Reader

RTL8402

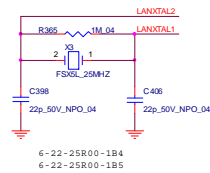

LAN_VDD33 Rising Time;G
1ms ~ 100ms

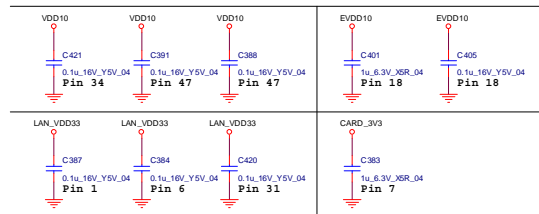
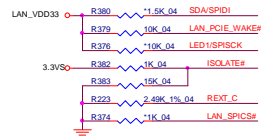

SD UHS Mode Power Supply

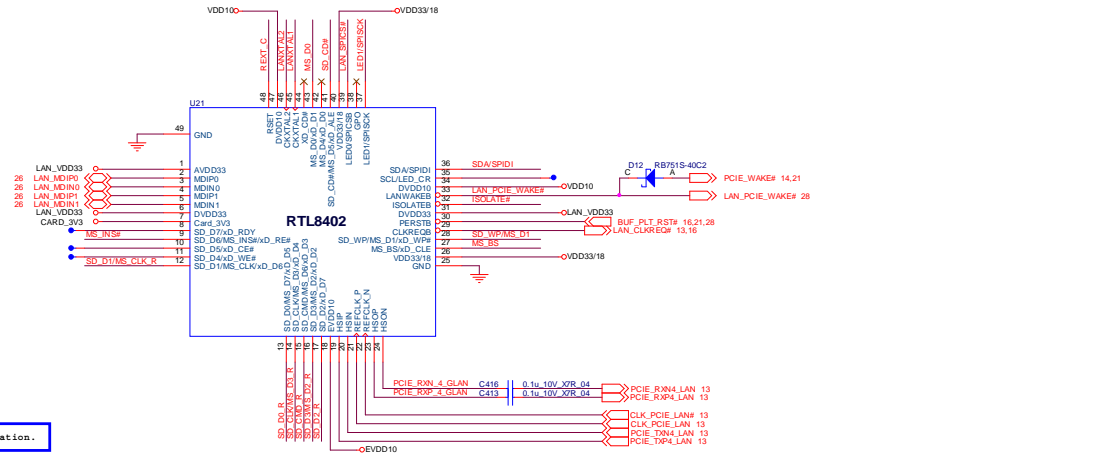

Close to RTL8402 for SDXC EMI

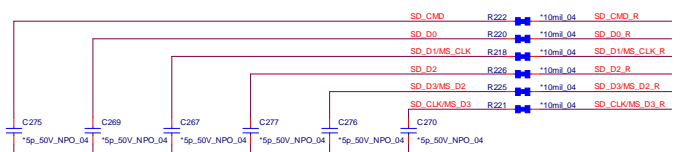

4 IN 1 SOCKET SD/MMC/MS/MS Pro

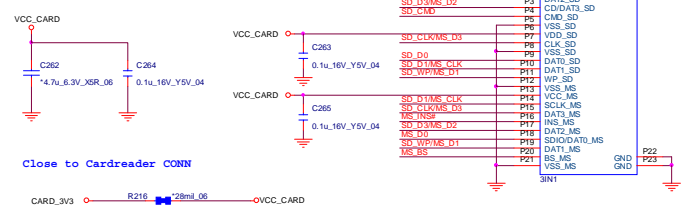

Sheet 24 of 38
LAN RTL8402,
Card Reader

B.Schematic Diagrams

SATA ODD, LED

Sheet 25 of 38
SATA ODD, LED

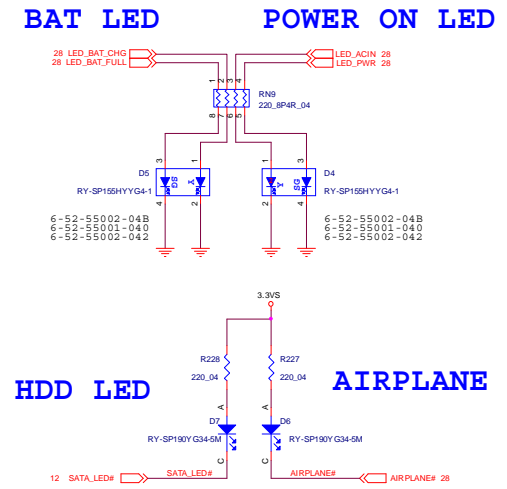
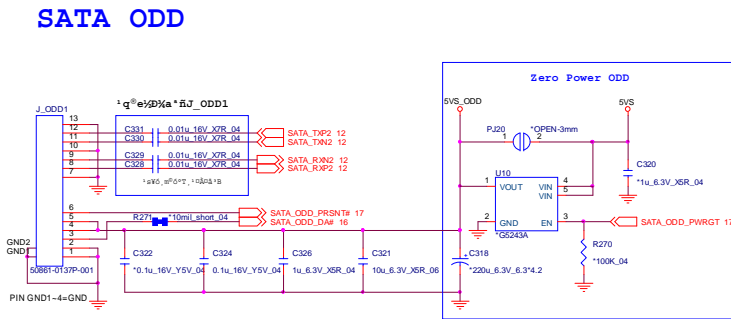

FOR AUDIO BOARD

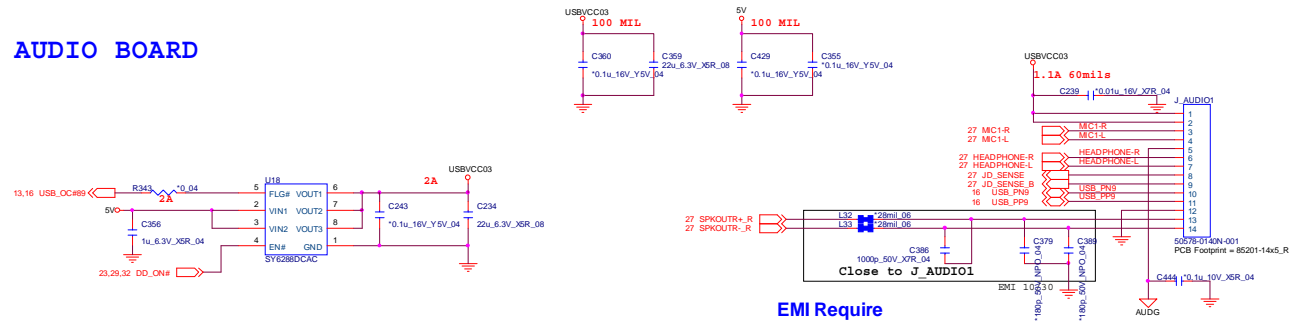

HDMI, RJ45

LAN PORT

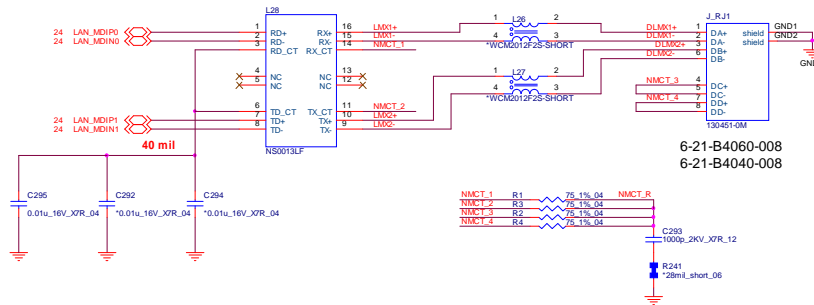

Sheet 26 of 38
HDMI, RJ45

B.Schematic Diagrams

FOR INTEL GRAPHIC

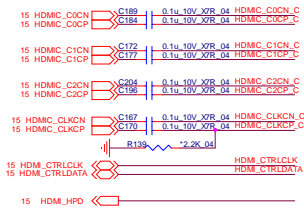

HDMI CONNECTOR

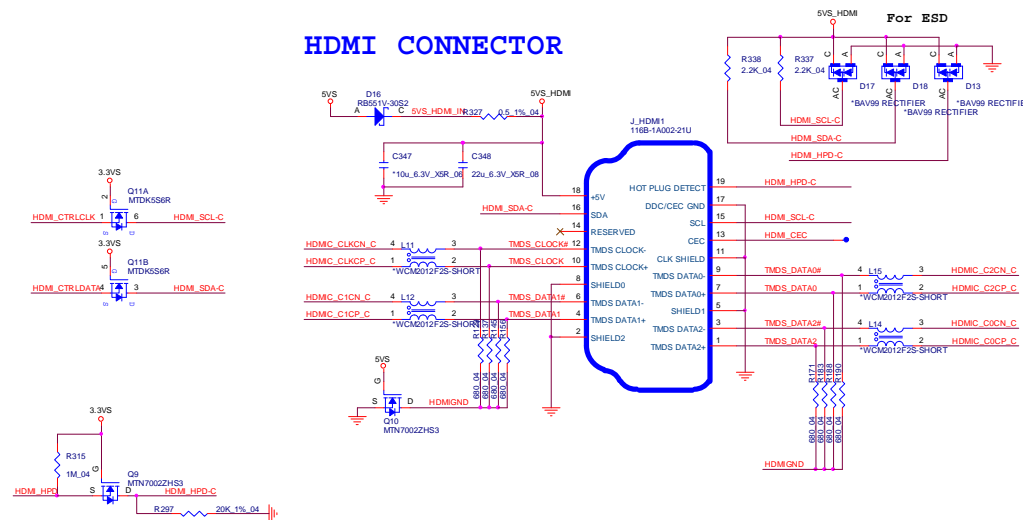

AUDIO CODEC VT1802S

CODEC VT1802S

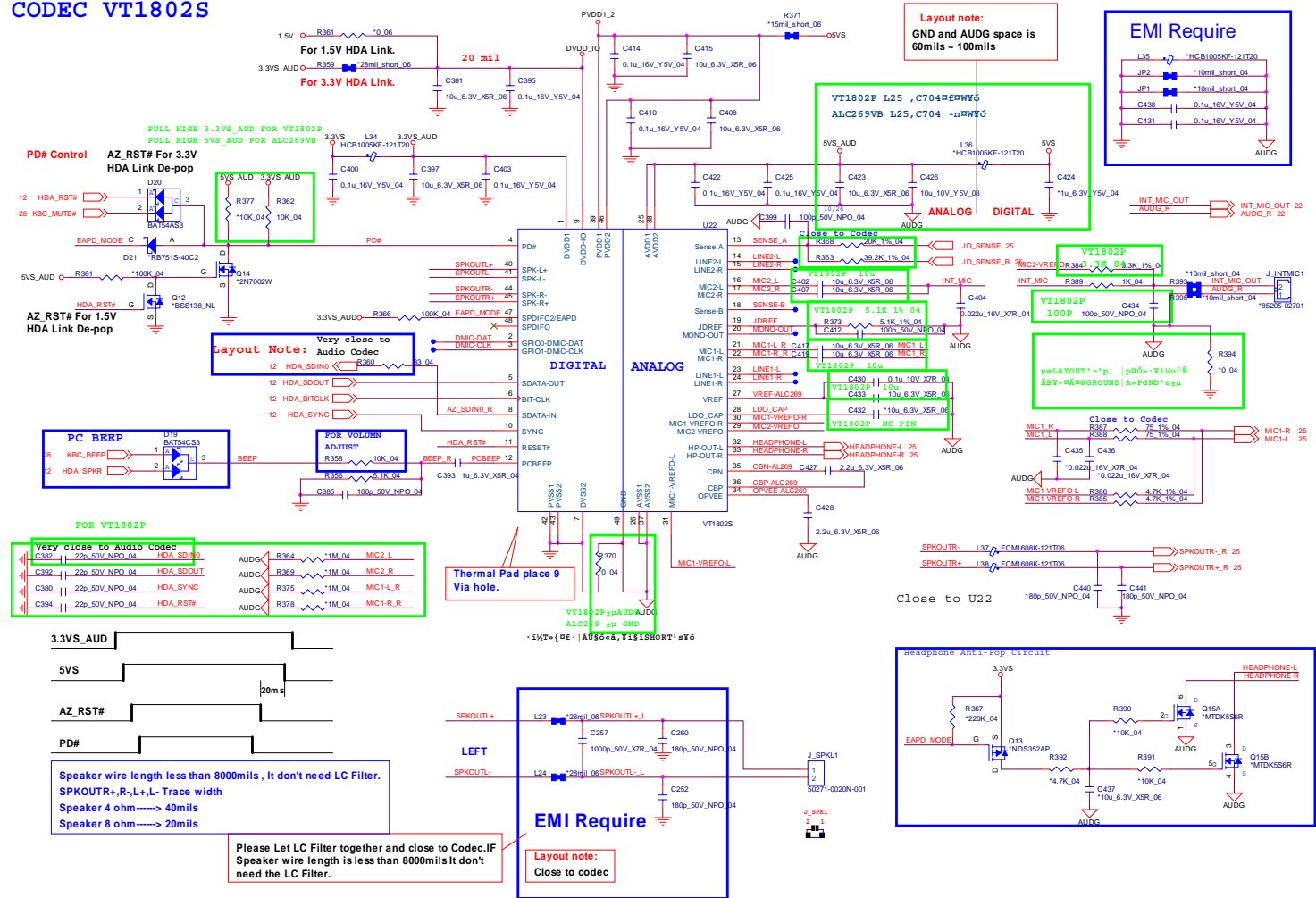

Sheet 27 of 38
AUDIO CODEC
VT1802S

B.Schematic Diagrams

Schematic Diagrams

5VS, 3VS, 1.5VS CPU

Sheet 29 of 38
5VS, 3VS, 1.5VS
CPU

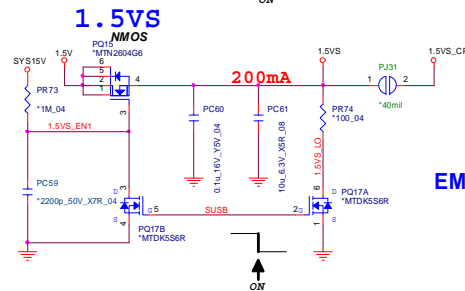
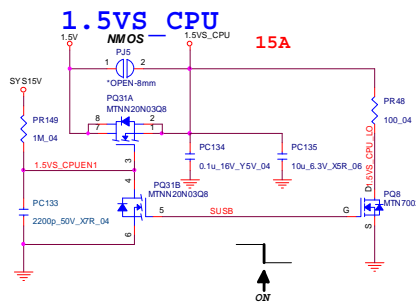
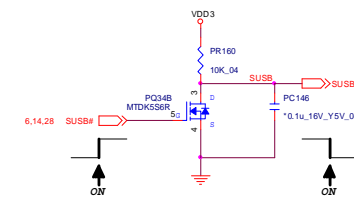
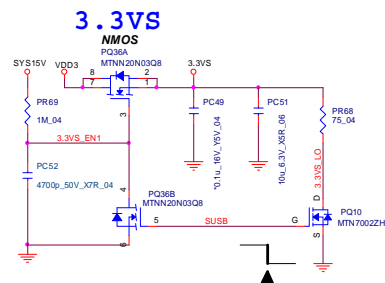
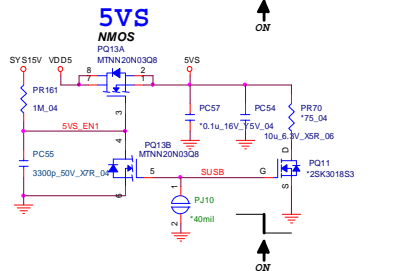
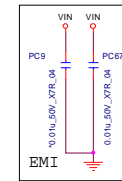
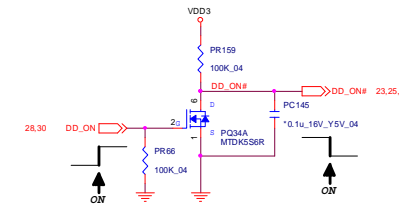
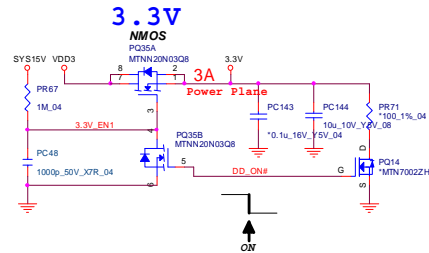
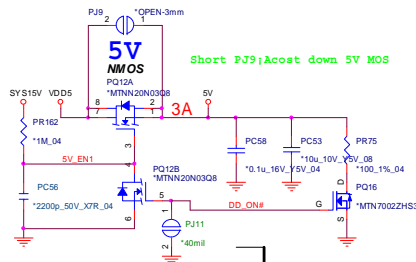
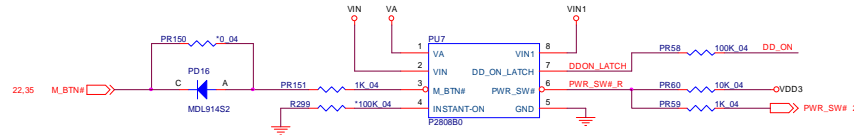

EMI Require

3.14 H_PM_SYNC#	C199	*0.01u_16V_XTR_04
3.17.28 H_PECI	C173	*0.01u_16V_XTR_04
6.14.28 SUSB#	C156	*0.01u_16V_XTR_04
3.17 H_SNB_IVB#	C351	*0.01u_16V_XTR_04
1.14.28.33 ALL_SYS_PWRGD	C164	*0.01u_16V_XTR_04
14.33 DELAY_PWRGD	C213	*0.01u_16V_XTR_04
VIN	C272	*0.01u_50V_XTR_04
	C266	*0.01u_50V_XTR_04
	C280	*0.01u_50V_XTR_04
3.3VS	C135	*0.01u_16V_XTR_04
3.17 H_CRUPWRGD	C176	*0.01u_16V_XTR_04
	C195	*0.01u_16V_XTR_04
	C23	*0.01u_16V_XTR_04
14.31 1.8VS_PWRGD	C248	*0.01u_16V_XTR_04
3.14 PM_DRAM_PWRGD	C86	*0.01u_16V_XTR_04

Schematic Diagrams

Power 0.85VS, 1.8VS

Sheet 31 of 38
Power 0.85VS,
1.8VS

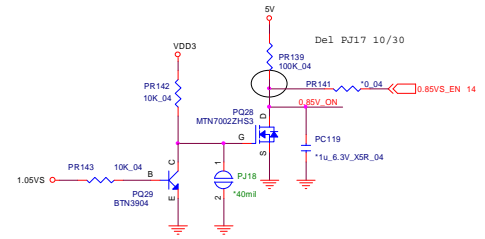
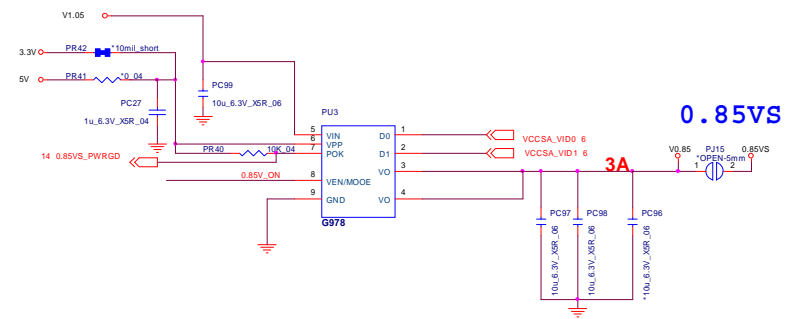
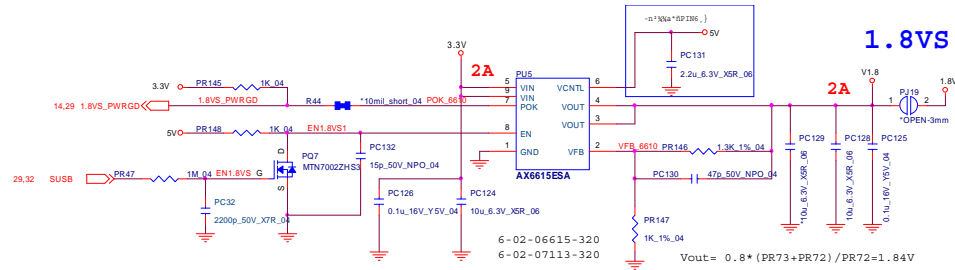

	0.9V	0.8V	0.725V	0.675V
VCCSA_VID0	0	0	1	1
VCCSA_VID1	0	1	0	1
	SET0	SET2	SET1	SET3

POWER 1.5V/1.05VS

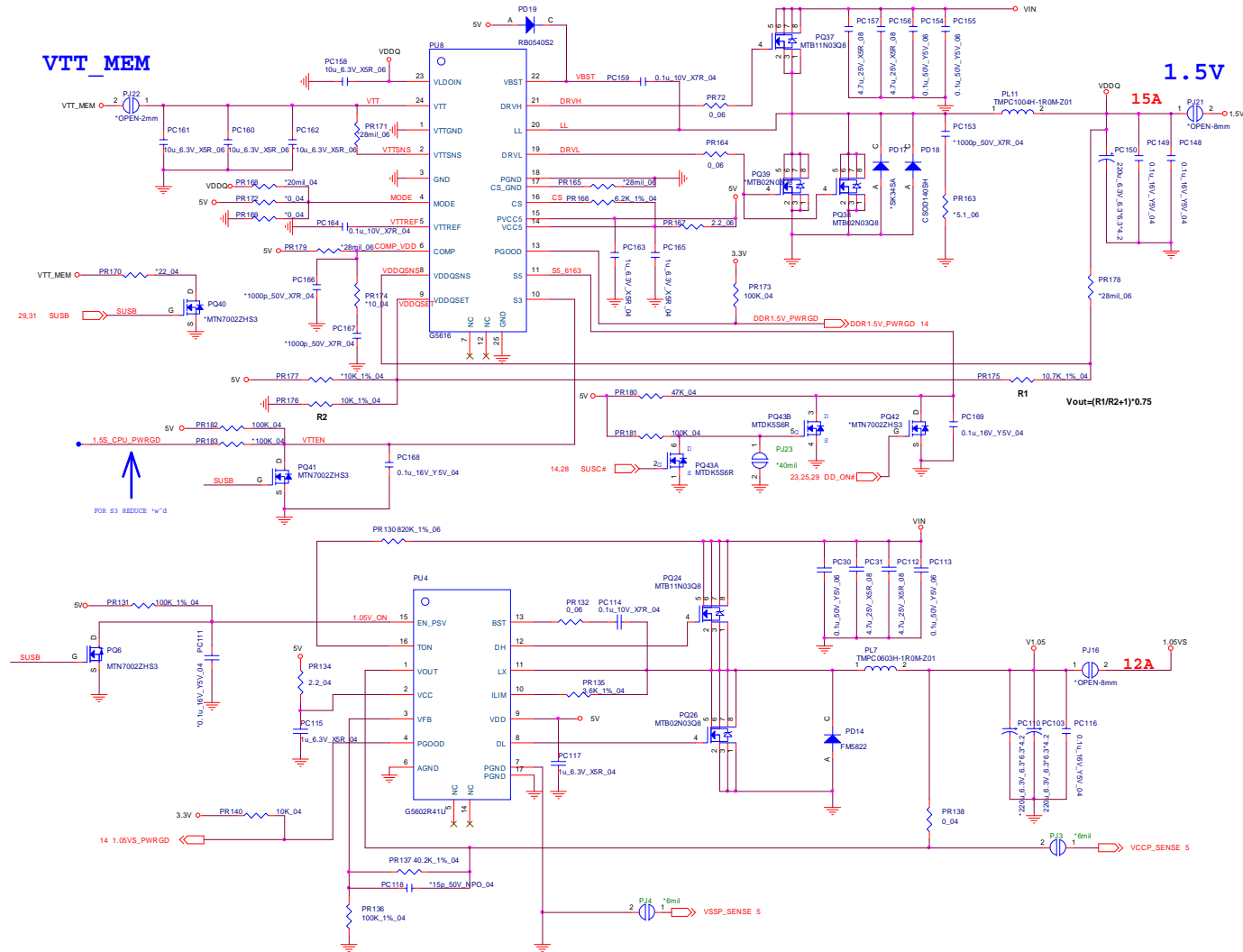

Sheet 32 of 38
POWER 1.5V/
1.05VS

B.Schematic Diagrams

POWER VCORE2

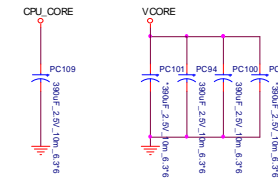
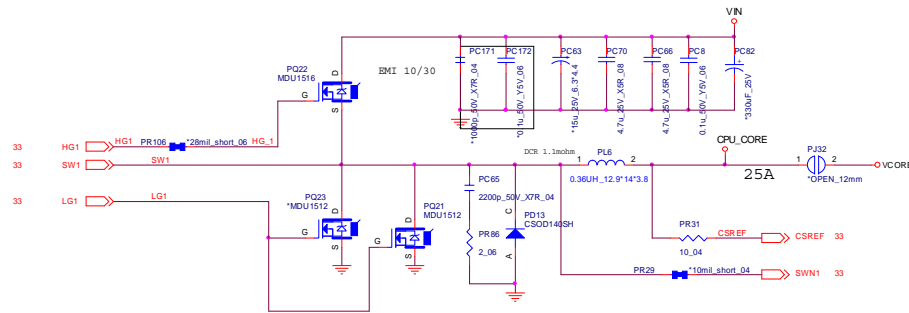

Sheet 34 of 38
POWER VCORE2

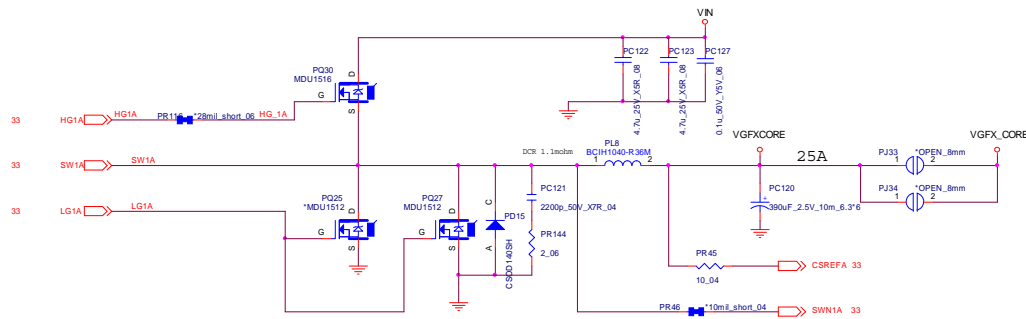

AC IN, CHARGER

Sheet 35 of 38
AC IN, CHARGER

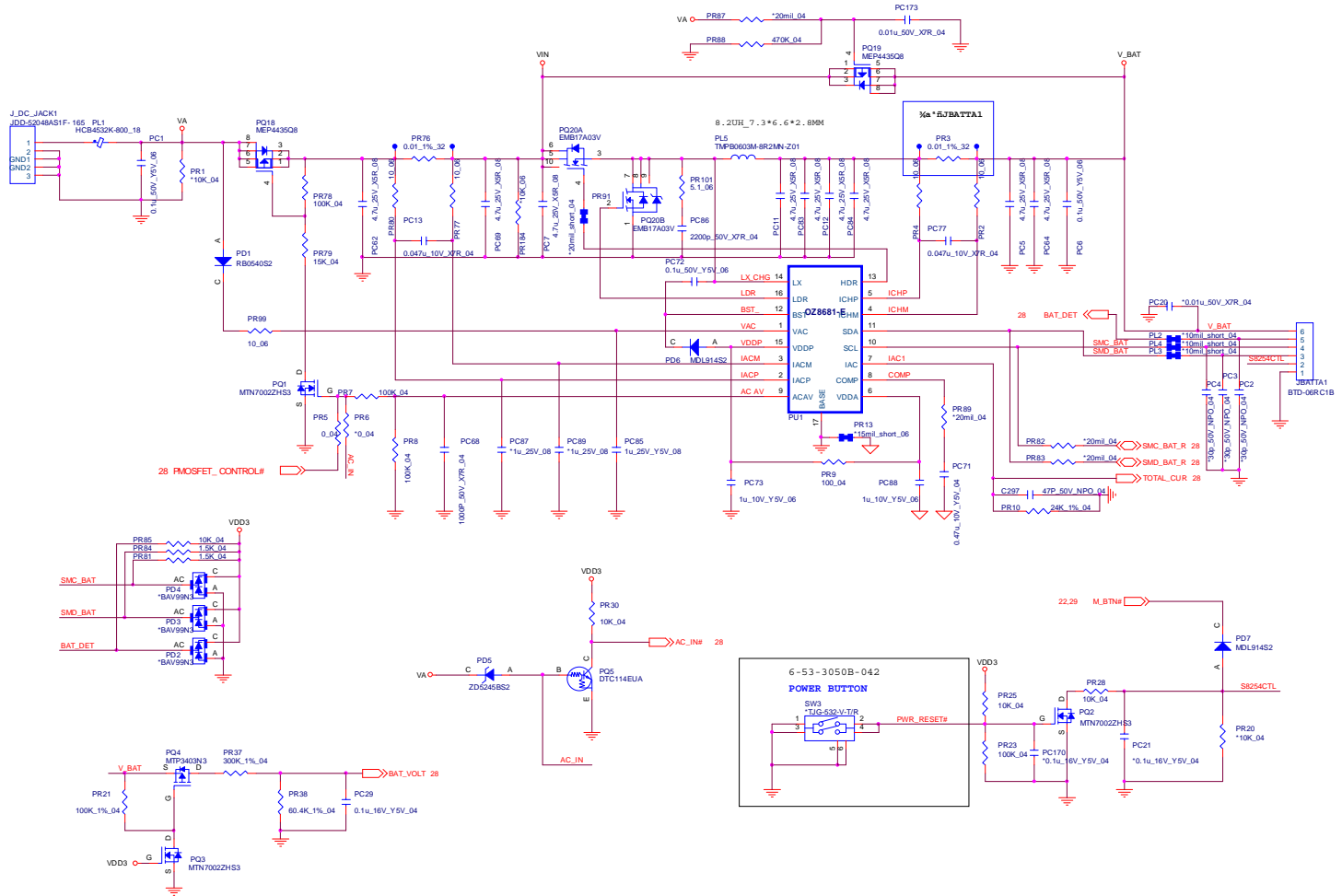

AUDIO BOARD

USB PORT

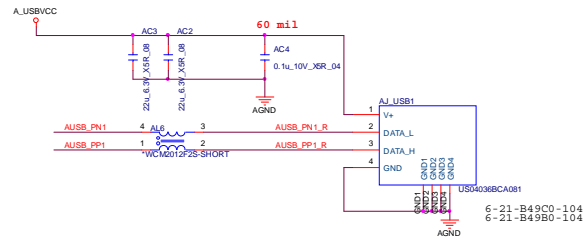

TO M/B

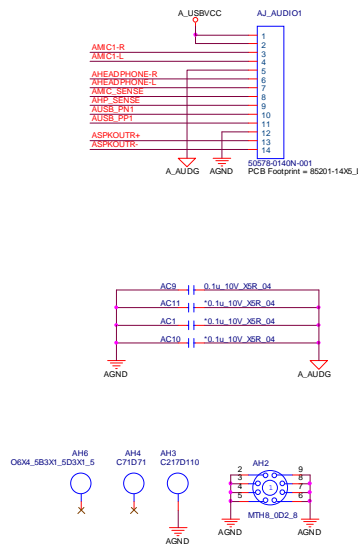

AUDIO JACK

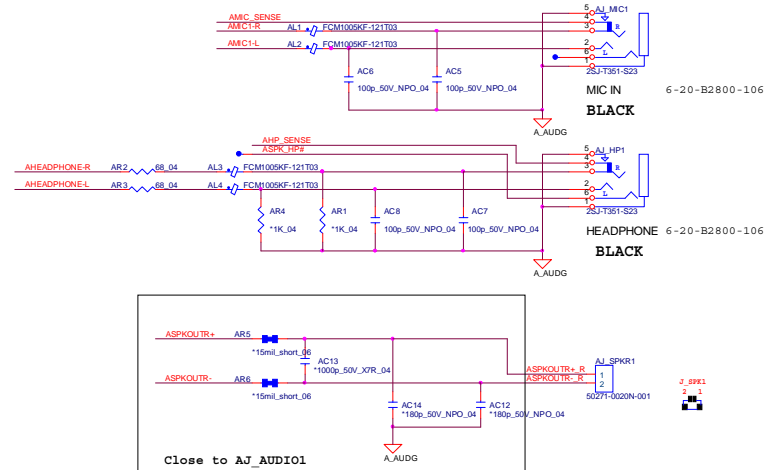

Sheet 36 of 38
AUDIO BOARD

POWER SW BOARD

POWER SW & LED

Sheet 37 of 38
POWER SW
BOARD

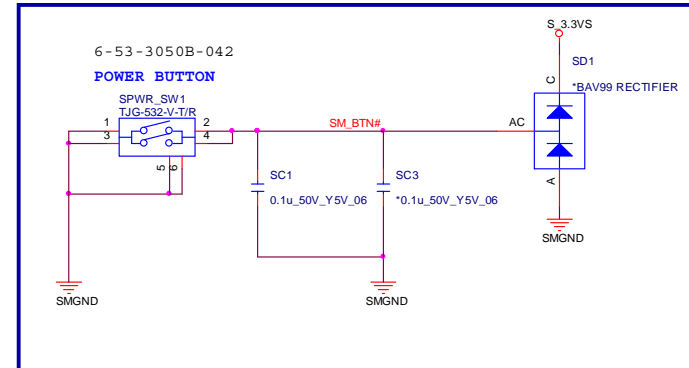
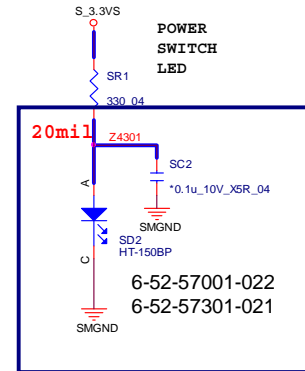
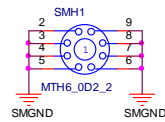
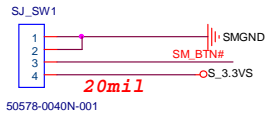

Power On SEQ

POWER ON SEQUENCE

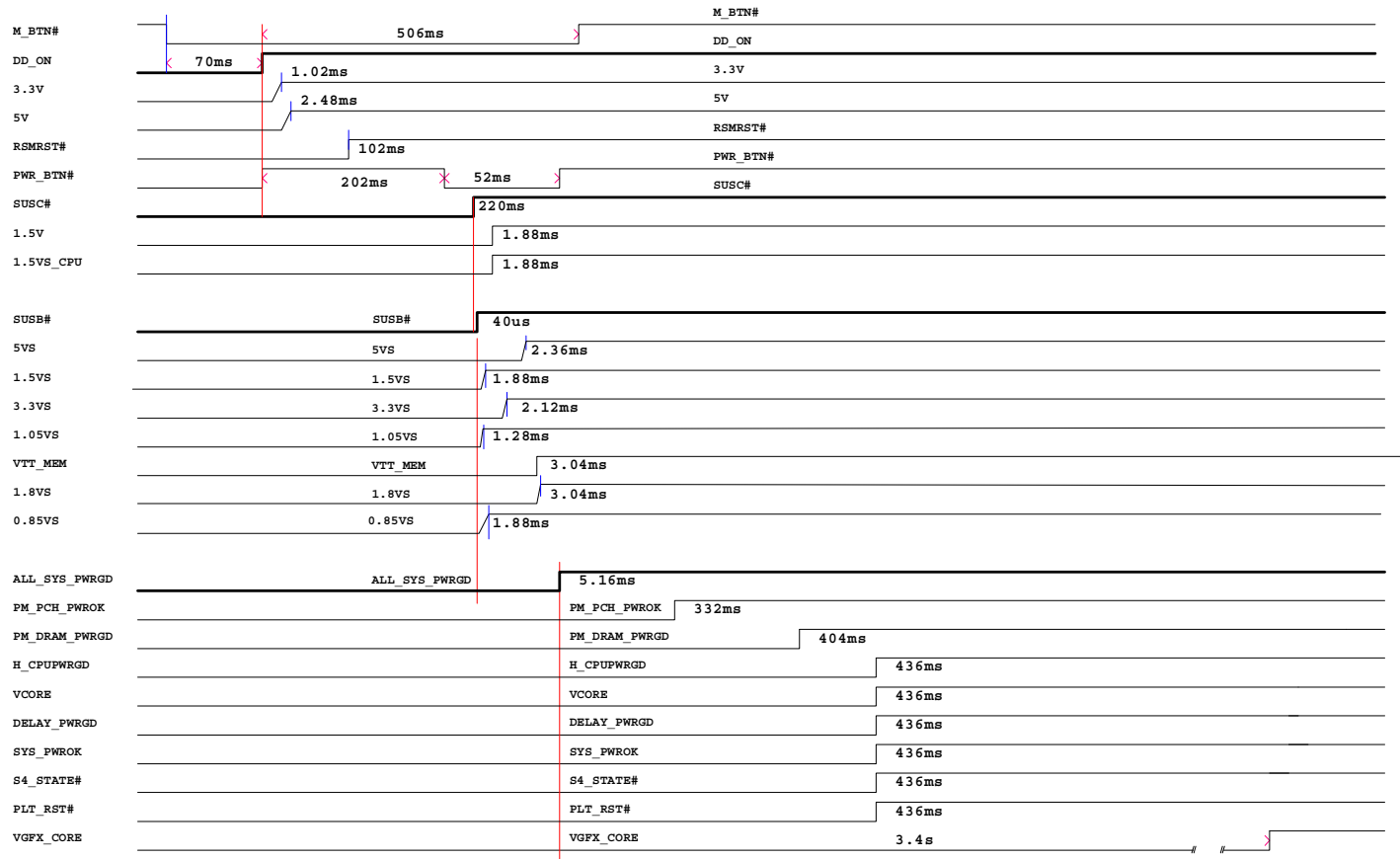

Sheet 38 of 38
Power On SEQ

Schematic Diagrams

Appendix C: Updating the FLASH ROM BIOS

To update the FLASH ROM BIOS, you must:

- Download the BIOS update from the web site.
- Unzip the files onto a bootable CD/DVD/USB Flash Drive.
- Reboot your computer from an external CD/DVD/USB Flash Drive.
- Use the flash tools to update the flash BIOS using the commands indicated below.
- Restart the computer booting from the HDD and press **F2** at startup enter the BIOS.
- Load setup defaults from the BIOS and save the default settings and exit the BIOS to restart the computer.
- After rebooting the computer you may restart the computer again and make any required changes to the default BIOS settings.

Download the BIOS

1. Go to www.clevo.com.tw and point to **E-Services** and click **E-Channel**.
2. Use your user ID and password to access the appropriate download area (BIOS), and download the latest BIOS files (the BIOS file will be contained in a batch file that may be run directly once unzipped) for your computer model (see sidebar for important information on BIOS versions).

Unzip the downloaded files to a bootable CD/DVD/ or USB Flash drive

1. Insert a bootable CD/DVD/USB flash drive into the CD/DVD drive/USB port of the computer containing the downloaded files.
2. Use a tool such as Winzip or Winrar to unzip all the BIOS files and refresh tools to your bootable CD/DVD/USB flash drive (you may need to create a bootable CD/DVD with the files using a 3rd party software).

Set the computer to boot from the external drive

1. With the bootable CD/DVD/USB flash drive containing the BIOS files in your CD/DVD drive/USB port, restart the computer and press **F2** (in most cases) to enter the BIOS.
2. Use the arrow keys to highlight the **Boot** menu.
3. Use the “+” and “-” keys to move boot devices up and down the priority order.
4. Make sure that the CD/DVD drive/USB flash drive is set first in the boot priority of the BIOS.
5. Press **F4** to save any changes you have made and exit the BIOS to restart the computer.



BIOS Version

Make sure you download the latest correct version of the BIOS appropriate for the computer model you are working on.

You should only download BIOS versions that are **V1.01.XX or higher** as appropriate for your computer model.

Note that BIOS versions are not backward compatible and therefore **you may not downgrade your BIOS to an older version** after upgrading to a later version (e.g if you upgrade a BIOS to ver 1.01.05, you **MAY NOT** then go back and flash the BIOS to ver 1.01.04).

BIOS Update

Use the flash tools to update the BIOS

1. Make sure you are not loading any memory management programs such as HIMEM by holding the **F8** key as you see the message “**Starting MS-DOS**”. You will then be prompted to give “**Y**” or “**N**” responses to the programs being loaded by DOS. Choose “**N**” for any memory management programs.
2. You should now be at the DOS prompt e.g: DISK C:\> (C is the designated drive letter for the CD/DVD drive/USB flash drive).
3. **Type the following command** at the DOS prompt:

C:\> Flash.bat

4. The utility will then proceed to flash the BIOS.
5. You should then be prompted to press any key to restart the system or turn the power off, and then on again but make sure you remove the CD/DVD/USB flash drive from the CD/DVD drive/USB port before the computer restarts.

Restart the computer (booting from the HDD)

1. With the CD/DVD/USB flash drive removed from the CD/DVD drive/USB port the computer should restart from the HDD.
2. Press **F2** as the computer restarts to enter the BIOS.
3. Use the arrow keys to highlight the **Exit** menu.
4. Select **Load Setup Defaults** (or press **F3**) and select “**Yes**” to confirm the selection.
5. Press **F4** to save any changes you have made and exit the BIOS to restart the computer.

Your computer is now running normally with the updated BIOS

You may now enter the BIOS and make any changes you require to the default settings.