



# Product Catalog

## Packaged Rooftop Air Conditioners Precedent™ — Cooling and Gas/Electric 3 – 10 Tons — 60 Hz





# Introduction

## Packaged Rooftop Air Conditioners

Figure 1. Packaged Cooling



Figure 2. Packaged Gas/Electric



Trane customers demand products that provide exceptional reliability, meet stringent performance requirements, and are competitively priced. Trane delivers with Precedent™.

Precedent features cutting edge technologies: reliable compressors, Trane engineered ReliaTel controls, computer-aided run testing, and Integrated Comfort™ Systems. So, whether you're the contractor, the engineer, or the owner you can be certain Precedent products are built to meet your needs.

Through the years, Trane has designed and developed the most complete line of Packaged Rooftop products available in the market today. Trane was the first to introduce the Micro—microelectronic unit controls—and has continued to improve and revolutionize this design concept.

Electromechanical controls are available for simpler applications, and for the more sophisticated, ReliaTel™ microprocessor controls.

The ReliaTel control platform offers the same great features and functionality as the original Micro, with additional benefits for greater application flexibility.

With its sleek, compact cabinet, Precedent continues to provide the highest standards in quality and reliability, comfort, ease of service, and the performance of Trane light commercial products.

### Trademarks

CompleteCoat, Froststat, Integrated Comfort Systems, Precedent, ReliaTel, Tracer, Tracker, Trane and the Trane logo are trademarks of Trane in the United States and other countries. BACnet is a registered trademark. All trademarks referenced in this document are the trademarks of their respective owners.





# Table of Contents

Introduction .....	2
Packaged Rooftop Air Conditioners .....	2
Features and Benefits .....	4
Standard Features .....	4
Options .....	5
Other Benefits .....	6
Standard Features .....	6
Variety of Options .....	9
Factory Installed Options .....	9
Factory or Field Installed Options .....	12
Field Installed Options .....	13
Other Benefits .....	14
Application Considerations .....	17
Selection Procedure .....	19
Cooling Capacity .....	19
Heating Capacity .....	20
Air Delivery Selection .....	20
Dehumidification Selection .....	21
Model Number Description - 3-10 Ton .....	23
Model Number Notes .....	24
General Data .....	25
Performance Data .....	41
Direct Drive - Evaporator Fan Performance .....	78
Evaporator Fan Performance .....	84
Fan Performance .....	182
Controls .....	193
ReliaTel™ Controlled Units .....	193
Electrical Data .....	196
Jobsite Connections .....	208
Dimensional Data .....	209
Weights .....	225
Mechanical Specifications .....	227
Factory Installed Options .....	229
Factory or Field Installed Options .....	231
Field Installed Options .....	232



# Features and Benefits

## Standard Features

- 5-year Limited Compressor Warranty
- 5-year Limited Heat Exchanger Warranty
- 1-year Limited Parts Warranty
- Anti-Short Cycle Timer (Standard with ReliaTel™)
- Colored and Numbered Wiring
- Convertible Airflow
- Crankcase Heaters<sup>1</sup>
- Direct Drive Plenum Fan<sup>2</sup>
- Easy Access Low Voltage Terminal Board (LTB)
- Electromechanical or ReliaTel Microprocessor Controls
- Filters are Standard on all Units
- Foil-Faced and Edge Captured Insulation
- High Pressure Control
- IAQ Dual Sloped and Removable Drain Pans
- Liquid Line Refrigerant Drier
- Low Ambient Cooling to 0°F on Microprocessor Models
- Low Ambient Cooling to 40°F on Electromechanical Models
- Low Pressure Control
- Microchannel Coils<sup>3</sup>
- Multispeed Direct Drive Motors
- Operating Charge of R-410A
- Patent-Pending Hybrid Condenser Coil for easy cleaning
- Phase Loss Protection
- Phase Monitor
- Phase Reversal Protection
- Phase Balance Protection
- Progressive Tubular Aluminized Steel Heat Exchanger
- Provisions for Through-the-Base Gas and Condensate Drain Connections
- Quick Access Panels
- Quick Adjust Fan Motor Mounting Plate
- Single Point Power
- Single Side Service
- Standardized Components
- Thermal Expansion Valve
- Trane built Scroll Compressors

<sup>1</sup> Crankcase heaters are optional on: (T,Y)SC(036,048,060)E, (T,Y)SC(072,090,092,102,120)F

<sup>2</sup> Standard on: (T,Y)SC120F, (T,Y)HC092E,F, (T,Y)HC102,120E

<sup>3</sup> The microchannel type condenser coil is standard for T/YSC(072,090,092,102,120)F and T/YHC (048,060,072,092)F models. The micro-channel type condenser coil is not offered on the T/YHC(048,060,092)F dehumidification model.

## Options<sup>1</sup>

### ***Factory Installed Options***

- Belt Drive Motors<sup>2</sup> (Three-phase)
- Black Epoxy Pre-Coated Coils<sup>3</sup>
- CompleteCoat™ Condenser Coil
- Crankcase Heaters
- Dehumidification Option
- Hinged Access Doors
- Novar Return Air Sensor
- Novar Unit Controls
- Powered or Unpowered Convenience Outlet
- Single Zone Variable Air Volume (SZVAV)
- Stainless Steel Heat Exchanger with 10-year warranty
- Supply and/or Return Air Smoke Detector
- Through the Base Electrical Access
- Multi-Speed Indoor Fan System
- Through the Base Electrical with Circuit Breaker
- Through the Base Electrical with Disconnect Switch
- 2" MERV 7 Filters or 2" MERV 13 Filters

### ***Factory or Field Installed Options***

- Barometric Relief
- Clogged Filter/Fan Failure Switch
- Discharge Air Sensing Kit
- Economizer
- Electric Heaters
- Froststat™
- LonTalk® Communications Interface (LCI)
- BACnet™ Communications Interface (BCI)
- Reference or Comparative Enthalpy
- Tool-less Hail Guards
- Trane Communications Interface (TCI)

### ***Field Installed Options***

- CO<sub>2</sub> Sensor
- Dual Thermistor Remote Zone Sensor
- High Altitude Kit
- High Static Drive

---

<sup>1</sup> Refer to Model Number Description for option availability.

<sup>2</sup> Option on 3-5 Ton High Efficiency Units

<sup>3</sup> Not available on Microchannel coils.



## Features and Benefits

---

- Humidity Sensor/Humidistat
- LP Conversion Kit
- Manual Outside Air Damper
- Motorized Outside Air Dampers
- Powered Exhaust
- Quick Adapt Curbs
- Quick Start Kit
- Remote Potentiometer
- Roof Curb
- Thermostat
- Ventilation Override Accessory
- Wireless Zone Sensor
- Zone Sensor

## Other Benefits

- Cabinet design ensures water integrity
- Ease of Service, Installation and Maintenance
- Mixed model build enables “fastest in the industry” ship cycle times
- Outstanding Airflow Distribution
- ReliaTel Controls
- Unmatched Product Support is one of our finest assets. Trane Sales Representatives are a Support Group that can assist you with:
  - Product
  - Application
  - Service
  - Training
  - Special Applications
  - Specifications
  - Computer Programs and much more

## Standard Features

### **Anti-Short Cycle Timer (Standard with ReliaTel)**

Provides a 3 minute minimum “ON” time and 3 minute “OFF” time for compressors to enhance compressor reliability by assuring proper oil return.

### **Direct Drive Motors**

For additional static requirements, single-phase units offer multi-speed, direct drive motors. All 10 ton units and 7½-8½ high efficiency units offer variable speed direct drive motors.

### **Colored And Numbered Wiring**

Save time and money tracing wires and diagnosing the unit.

### Compressors



Precedent contains the best compressor technology available to achieve the highest possible performance. Dual compressors are outstanding for humidity control, light load cooling conditions and system back-up applications.

Dual compressors are available on 7½ to 10 ton models and allow for efficient cooling utilizing 3-stages of compressor operation (high efficiency models only).

### Condenser Coil



Precedent boasts a patent-pending 1+1+1 condenser coil, permanently gapped for easy cleaning.

### Microchannel Condenser Coils

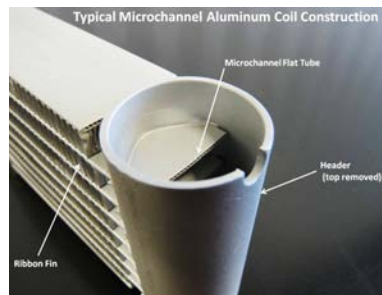

Due to flat streamlined tubes with small ports, and metallurgical tube-to-fin bond, microchannel coil has better heat transfer performance. Microchannel condenser coil can reduce system refrigerant charge by up to 50% because of smaller internal volume, which leads to better compressor reliability. Compact all-aluminum microchannel coils also help to reduce the unit weight. These all aluminum coils are recyclable. Galvanic corrosion is also minimized due to all aluminum construction. Strong aluminum brazed structure provides better fin protection. In addition, flat streamlined tubes also make microchannel coils more dust resistant and easier to clean.

### Controls – ReliaTel or Electromechanical

ReliaTel microprocessor controls provide unit control for heating, cooling and ventilating utilizing input from sensors that measure indoor and outdoor temperature and other zone sensors. ReliaTel also provides outputs for building automation systems and expanded diagnostics. For a complete list of ReliaTel offerings, refer to the “Other Benefits” section within the Features and Benefits section of this catalog.

For the simpler job that does not require a building automation system, or expanded diagnostics capabilities, Precedent offers electromechanical controls. This 24-volt control includes the control transformer and contactor pressure lugs for power wiring.

### Convertible Units



The units ship in a downflow configuration. They can be easily converted to horizontal by simply moving two panels.

Units come complete with horizontal duct flanges so the contractor doesn’t have to field fabricate them. These duct flanges are a time and cost saver.

### Cooling

Standard or High Efficiency cooling available.

## Features and Benefits

---

### Crankcase Heaters<sup>1</sup>

These band heaters provide improved compressor reliability by warming the oil to prevent migration during off-cycles or low ambient conditions.

### Dual Sloped Drain Pans



Every Precedent unit has a non-corrosive, removable, double-sloped drain pan that's easy to clean and reversible to allow installation of drain trap on either side of the unit.

### Easy Access Low Voltage Terminal Board

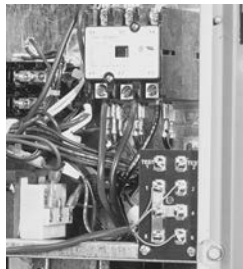

Precedent's Low Voltage Terminal Board is external to the electrical control cabinet. It is extremely easy to locate and attach the thermostat wire and test operation of all unit functions. This is another cost and time saving installation feature.

### Foil Faced Insulation



All panels in the evaporator section of the unit have cleanable foil-faced insulation. All edges are either captured or sealed to ensure no insulation fibers get into the airstream.

### Heat Exchanger

The compact cabinet features a progressive tubular heat exchanger in low, medium and high heat capacities.

The heat exchanger is fabricated using stainless steel burners and corrosion-resistant aluminized steel tubes as standard on all models. It has an induced draft blower to pull the gas mixture through the burner tubes. The heater has a direct spark ignition system which doubles as a safety device to prove the flame.

Gas/Electric Precedent models exceed all California seasonal efficiency requirements. They also perform better than required to meet the California NOx emission requirements.

### High Pressure Control

All units include High Pressure Control as standard.

### Low Ambient Cooling

All Precedent microprocessor units have cooling capabilities down to 0°F as standard.

Electromechanical models have cooling capabilities to 40°F as built, or to 0°F by adding the optional low ambient control (frostat).

### Low Voltage Connections

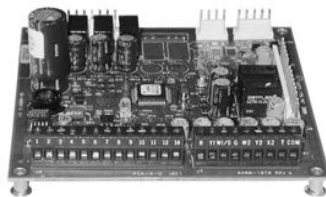

The wiring of the low voltage connections to the unit and the zone sensors is as simple as 1-1, 2-2, and 3-3. This simplified system makes it easy for the installer to wire.

<sup>1</sup> Crankcase heaters are optional on: (T,Y)SC(036,048,060)E



### **Phase Monitoring Protection**

Precedent™ units with 3-phase power are equipped with phase monitoring protection as standard. These devices protect motors and compressors against problems caused by phase loss, phase imbalance and phase reversal indication.

### **Plenum Fan<sup>1</sup>**

The following units are equipped with a direct drive plenum fan design (all 10 ton units and 7½-8½ ton high efficiency units). Plenum fan design includes a backward-curved fan wheel along with an external rotor direct drive variable speed indoor motor. All plenum fan designs have a variable speed adjustment potentiometer located in the control box.

### **Quick-Access Panels**

Remove two screws for access to the standardized internal components and wiring.

### **Single Point Power**

A single electrical connection powers the unit.

### **Single Side Service**

Single side service is standard on all units.

### **Standardized Components**

Components are placed in the same location on all Precedent units.

Due to standardized components throughout the Precedent line, contractors/owners can stock fewer parts.

### **Thermal Expansion Valve**

This feature is standard on all units.

### **Through the Base Condensate**

Every unit includes provisions for through the base condensate drain connections. This allows the drain to be connected through the roof curb instead of a roof penetration.

## **Variety of Options**

### **Factory Installed Options<sup>2</sup>**

#### **Black Epoxy Pre-Coated Coils<sup>3</sup>**

The pre-coated coils are an economical option for protection in mildly corrosive environments.

#### **CompleteCoat™ Condenser Coil**

These coils provide excellent corrosion resistance as well as uniformity of coverage and coating thickness. This option is available for both fin-tube and microchannel condenser coils.

#### **Novar Unit Controls**

Novar 3051 and 2024 are available for Precedent Gas and Electric Heat models.

---

<sup>1</sup> Standard on: (T,Y)SC120F, (T,Y)HC092E,F, (T,Y)HC102,120E

<sup>2</sup> Refer to Model Number Description for option availability.

<sup>3</sup> Not available on Microchannel condenser coils.

## Features and Benefits

---

### Belt Drive Motors (Three-phase)



For additional static requirements, Precedent 3-5 ton units offer an optional belt drive motor to meet a wide range of airflow needs.

### Dehumidification (Hot Gas Reheat) Option



This option allows for increased outdoor air ventilation. It reduces humidity levels while increasing comfort level in the air space. Cooling can operate without a demand for dehumidification. The hot gas reheat coil is designed to deliver maximum reheat temperatures and pivot to allow for easy access cleaning.

### Disconnect Switch (Available on units equipped with Through-the-Base Electrical)

Factory installed 3-pole, molded case, disconnect switch for through-the-base electrical connections.

Codes require a method of assured unit shutdown for servicing. Field-installed disconnects sometimes interfere with service access. Factory installation of unit disconnects reduces costs, assures proper mounting and provides the opportunity to upgrade to unit circuit breaker protection.

### Circuit Breaker (Available on units equipped with Through-the-Base Electrical)



This option is a factory installed thermal magnetic, molded case, HACR Circuit Breaker with provisions for through the base electrical connections.

### Hinged Access Doors



These doors permit easy access to the filter, fan/heat and compressor/control sections. They reduce the potential roof damage from screws or sharp access door corners.

### Single Zone VAV – One Zone Variable Air Volume Mode

Single zone VAV is designed for use in single zone applications like gymnasiums, auditoriums, manufacturing facilities, retail box stores, and any large open spaces, where there is a lot of diversity in the load profile. Single Zone VAV (SZ VAV) is an ideal replacement to “yesterday’s” constant volume (CV) systems, by reducing operating costs while improving occupant comfort. SZ VAV systems combine Trane application, control and system integration knowledge to exactly match fan speed with cooling and heating loads, regardless of the operating condition. Trane algorithms meet/exceed ASHRAE 90.1- 2010 SZ VAV energy-saving recommendations, and those of CA Title 24. The result is an optimized balance between zone temperature control and system energy savings. Depending on your specific application, energy savings can be as much as 20+%.

**Note:** Building system modeling in energy simulation software like TRACE is recommended to evaluate performance improvements for your application.

SZVAV is fully integrated into the ReliaTel™ control system and is available today. It provides the simplest and fastest commissioning in the industry through proven factory-installed, wired, and tested system controllers. All control modules, logic and sensors are factory installed, and tested to assure the highest quality and most reliable system available. This means no special programming of algorithms, or hunting at the jobsite for sensors, boards, etc. that need to be installed in the field. Single zone VAV is a quick and simple solution for many applications and is available from your most trusted rooftop VAV system solution provider - Trane.

### Multi-Speed Indoor Fan System

Multi-speed indoor fan system is designed for use in applications for meeting the minimum requirement of CA Title 24.

This system incorporates a multi-speed fan control to change the speed of the fan to 67% of full airflow based off of compressor stages.

### Supply and/or Return Air Smoke Detector Through-the-Base Electrical Utility Access



With this option installed, if smoke is detected, all unit operation will be shut down. Reset will be manual at the unit. Return Air Smoke Detectors require minimum allowable airflow when used with certain models.



An electrical service entrance shall be provided allowing electrical access for both control and main power connections inside the curb and through the base of the unit. Option will allow for field installation of liquid-tight conduit and an external field installed disconnect switch.



Factory provided through the base openings simplify wiring and piping. Because these utility openings frequently minimize the number of roof penetrations, the integrity of roofing materials is enhanced.

### Stainless Steel Heat Exchanger

The optional stainless steel heat exchanger is constructed of 409 stainless steel. It is resistant to corrosion and oxidation and easy to clean. The high strength to weight ratio allows for high ventilation rates with gas units. It is an excellent option to compliment the dehumidification option as a high outside air ventilation unit. With this option, a 10-year stainless steel heat exchanger warranty is standard.

### Powered or Unpowered Convenience Outlet



This option is a GFCI, 120V/15amp, 2 plug, convenience outlet, either powered or unpowered. This option can only be ordered when Through the Base Electrical with either the Disconnect Switch or Circuit Breaker option is ordered.

**Note:** Not available on 10 Ton 575V units.

**Note:** Not available on 3-5 Ton High Efficiency units with Direct Drive Indoor Motor.



## Features and Benefits

---

### Factory or Field Installed Options<sup>1</sup>

#### **Barometric Relief**

Designed to be used on downflow units, barometric relief is an unpowered means of relieving excess building pressure.

#### **Clogged Filter/Fan Failure Switch**

A dedicated differential pressure switch is available to achieve active fan failure indication and/or clogged filter indication.

These sensors allow a zone sensor service light or Integrated Comfort System to indicate a dirty filter or a fan that's not working. The field installation charges for these valuable feedback devices often eliminate them from consideration. Factory installation can make such features a good investment.

#### **Discharge Air Sensing Kit**

Provides true discharge air sensing in heating models. The kit is functional only with the ReliaTel Options Module.

#### **Electric Heaters**

Electric heat modules are available within the basic unit. If ordering the Through the Base Electrical option with an Electrical Heater, the heater must be factory installed.

#### **Fresh Air Options – Dampers and Economizer**

0 - 25% manual or 0 - 50% motorized outside air hoods are available.

Economizers are equipped with either dry bulb or reference or comparative enthalpy sensing. These economizers provide free cooling as the outdoor temperature and/or humidity decreases. Correctly installed, they offer a valuable energy savings. Factory-installed economizers save time and ensure proper installation.

The economizers come with three control options — dry bulb is standard, enthalpy and differential enthalpy are optional.

#### **Frostat**

This capillary bulb embedded in the face of the evaporator coil monitors coil temperature to prevent evaporator icing and protect the compressor. Recommended for applications with low leaving air temperatures, low airflow and or high latent load applications.

#### **LonTalk® Communications Interface**

The LonTalk communications interface allows the unit to communicate as a Tracer™ LCI-V device or directly with the generic LonTalk Network Building Automation System Controls.

#### **BACnet™ Communications Interface**

The BACnet communications interface allows the unit to communicate directly with a generic open protocol BACnet MS/TP Network Building Automation System Controls.

#### **Reference or Comparative Enthalpy**

Measures and communicates humidity while maximizing comfort control.

#### **Trane Communication Interface (TCI)**

Available factory or field installed. This module when applied with the ReliaTel™ easily interfaces with Trane's Integrated Comfort™ System.

---

<sup>1</sup> Refer to Model Number Description for option availability.

### **Tool-less Hail Guards**



Tool-less, hail protection quality coil guards shall be either factory or field-installed for condenser coil protection. This option protects the condenser coil from vandalism and/or hail damage.

## **Field Installed Options<sup>1</sup>**

### **CO<sub>2</sub> Sensor - Demand Control Ventilation (DCV)**

Demand-controlled ventilation (DCV) is a control strategy that responds to the actual demand (need) for ventilation by regulating the rate at which the HVAC system brings outdoor air into the building. A CO<sub>2</sub> sensor measures the concentration (parts per million, ppm) of CO<sub>2</sub> (Carbon Dioxide) in the air. As the CO<sub>2</sub> concentration changes, the outside air damper modulates to meet the current ventilation needs of the zone. The CO<sub>2</sub> sensor kit is available as a field installed accessory.

### **High Altitude Kit**

Previously a Canadian Agency requirement for units applied above 2000 feet, it is not required by the U.S. Domestic contractors should consult with local authority on best practice. Derates gas orifices by 10%.

### **High Static Drive**

Available on many models, this high static drive accessory extends the capability of the standard motor. Avoid expensive motors and operating costs by installing this optimized sheave accessory.

### **Humidity Sensor/Humidistat**

The humidity sensor/humidistat, when used in conjunction with our Dehumidification (Hot Gas Reheat) units will provide outstanding humidity control and comfort. Humidity sensors can be wall or duct mounted. The humidity deadband can be set between 40% and 60% relative humidity.

### **LP Conversion Kit**

Provided for field conversion of gas/electric units from Natural gas to Propane.

### **Quick Adapt Curbs**

Enables easy conversion of existing Voyager 3-10 ton units to Precedent units on replacement jobs.

### **Quick Start Kits**

Single phase equipment to enable startup and prevent building lighting dimming during low voltage.

### **Roof Curbs**

Available for downflow units. Only three roof curbs for the entire line simplifies curb selection.

### **Remote Potentiometer**

When properly installed in the economizer control circuitry, this accessory provides a remote variable resistance to enable the operator to adjust the minimum damper position.

---

<sup>1</sup> Refer to Model Number Description for option availability.

## Features and Benefits

---

### Ventilation Override Accessory

With the Ventilation Override Accessory installed, the unit can be set to transition to up to 3 different pre-programmed sequences for Smoke Purge, Pressurization, and Exhaust. The transition occurs when a binary input on the RTOM is closed (shorted). This would typically be a hard wired relay output from a smoke detector or fire control panel. The ventilation override kit is available as a field installed accessory.

### Zone Sensors/Thermostats

Available in programmable, automatic and manual styles.

## Other Benefits

### Easy to Install, Service and Maintain

Because today's owners are very cost-conscious when it comes to service and maintenance, the Precedent was designed with direct input from service contractors. This valuable information helped to design a product that would get the service person off the job quicker and save the owner money. Precedent offers outstanding standard features enhanced by a variety of factory and field installed options, multiple control options, rigorously tested proven designs and superior product and technical support.

### Airflow Distribution

Airflow is outstanding. Precedent can replace an older machine with old ductwork and, in many cases, improve the comfort through better air distribution.

### Cabinet Integrity



For added water integrity, Precedent has a raised 1 1/8" lip around the supply and return of the downflow units to prevent water from blowing into the ductwork.

### Flexibility

Precedent offers ultimate flexibility. Units are built to order in our standard "shortest in the industry" ship cycle time.

### ReliaTel™ Controls

ReliaTel controls provide unit control for heating, cooling and ventilating utilizing input from sensors that measure outdoor and indoor temperature.

ReliaTel Control Logic Enhances Quality and Reliability

- prevents the unit from short cycling, considerably improving compressor life.
- ensures that the compressor will run for a specific amount of time which allows oil to return for better lubrication, enhancing the reliability of the compressor.

Precedent units with ReliaTel reduces the number of components required to operate the unit, thereby reducing possibilities for component failure.

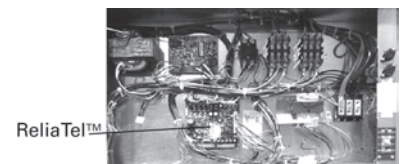
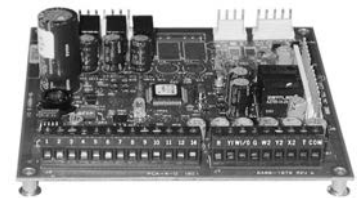

### ***ReliaTel Makes Installing and Servicing Easy***

ReliaTel eliminates the need for field installed anti-shortcycle timer and time delay relays. ReliaTel controls provide these functions as an integral part of the unit. The contractor no longer has to purchase these controls as options and pay to install them.

The wiring of the low voltage connections to the unit and the zone sensors is as easy as 1-1, 2-2, and 3-3. This simplified system makes wiring easier for the installer.

### ***ReliaTel Makes Testing Easy***

ReliaTel requires no special tools to run the Precedent unit through its paces. Simply place a jumper between Test 1 and Test 2 terminals on the Low Voltage Terminal Board and the unit will walk through its operational steps automatically.

The unit automatically returns control to the zone sensor after stepping through the test mode a single time, even if the jumper is left on the unit.

As long as the unit has power and the “system on” LED is lit, ReliaTel is operational. The light indicates that the controls are functioning properly.

ReliaTel features expanded diagnostic capabilities when utilized with Trane Integrated Comfort™ Systems.

Some zone sensor options have central control panel lights which indicate the mode the unit is in and possible diagnostic information (dirty filters for example).

### ***Other ReliaTel Benefits***

The ReliaTel built-in anti-shortcycle timer, time delay relay and minimum “on” time control functions are factory tested to assure proper operation.

ReliaTel softens electrical “spikes” by staging on fans, compressors and heaters.

Intelligent Fallback is a benefit to the building occupant. If a component fails, the unit will continue to operate at predetermined temperature setpoint.

Intelligent Anticipation is a standard ReliaTel feature. It functions continuously as ReliaTel and zone sensor(s) work together in harmony to provide much tighter comfort control than conventional electro-mechanical thermostats.

The same ReliaTel Board fits all Packaged Gas/Electric and Cooling with Electric Heat models. This provides standardization of parts for contractors. Less money is tied up in inventory with ReliaTel.

### **Unit Cabinet**

The compact cabinet with rounded corners takes up less room. The beveled and ribbed top aesthetically pleasing and designed to prevent water from pooling.

### **VariTrac® – Building Automation System**

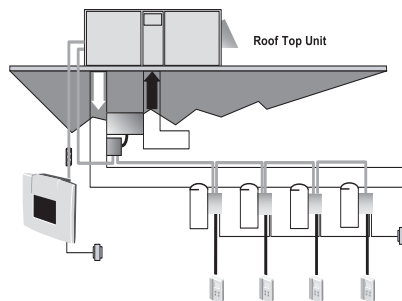

When Trane’s changeover VAV System for light commercial applications is coupled with Precedent, it provides the latest in technological advances for comfort management systems and can allow thermostat control in every zone served by VariTrac®.

**Note:** VariTrac® is not recommended for SZVAV and Multi-Speed Indoor Fan Applications.

### **Rigorous Testing**

All of Precedent’s designs were rigorously rain tested at the factory to ensure water integrity.



## Features and Benefits

---

Actual shipping tests were performed to determine packaging requirements. Units were test shipped around the country to determine the best packaging design. Factory shake and drop tests were used as part of the package design process to help assure that the unit arrives at the job site in top condition.

Rigging tests include lifting a unit into the air and letting it drop one foot, assuring that the lifting lugs and rails hold up under stress.

We perform a 100% coil leak test at the factory. The evaporator and condenser coils are leak tested at 600 psig. The assembled unit is leak tested to 465 psig.

All parts are inspected at the point of final assembly. Sub-standard parts are identified and rejected immediately.

Every unit receives a 100% unit run test before leaving the production line to make sure it meets rigorous Trane requirements.



# Application Considerations

Application of this product should be within the cataloged airflow and cooling considerations.

## Barometric Relief

This product line offers an optional barometric relief damper for use in conjunction with economizer option. This accessory consists of gravity dampers which open with increased pressure. As the building air pressure increases, the pressure in the unit return air section also increases, opening the dampers and relieving the conditioned space.

**Note:** *The effectiveness of barometric relief damper during economizing operation is system related. Pressure drop of the return air system should be considered to control building pressurization.*

## Black Epoxy Coil

The coils are manufactured with a thermoset, vinyl coating that is bonded to the aluminum fin stock prior to the fin stamping process. These coils are an economical option for protection in mildly corrosive environments.

**Note:** *Not to be used where seacoast applications exist.*

**Note:** *Not available on Microchannel condenser coils.*

## Clearance Requirements

The recommended clearances identified with unit dimensions should be maintained to assure adequate service maximum capacity and peak operating efficiency. Actual clearances which appear inadequate should be reviewed with the local Trane sales personnel.

Model Number	Clearance required from duct to combustible surfaces (inches)
T(S/H)C036E	0
T(S/H)C048E	0
THC048F	0
T(S/H)C060E	0
THC060F	0
TSC072F	0
THC072F	1
TSC090F	1
TSC092F	0
THC092E	1
THC092F	1
TSC102F	0
THC102E	1
TSC120F	1
THC120E	1

## CompleteCoat™ Condenser Coil

The coils provide protection from corrosive environments and are ideal for seacoast applications.

## Condensate Trap

The evaporator is a draw-thru configuration. A trap must be field provided prior to start-up on the cooling cycle.



## Application Considerations

---

### Heating Operation

The heat exchanger is manufactured with aluminized steel. To prevent condensation within the heat exchanger, do not exceed 50% outside air or a minimum mixed air temperature of 40°F.

### Low Ambient Cooling

The Precedent™ line features, with ReliaTel™ microprocessor controls, low ambient cooling down to 0°F. With electromechanical controls, Precedent features low ambient cooling to 40°F. The following features or options need to be included/considered when low ambient applications are required: continuous fan operation, crankcase heaters, thermal expansion valves, froststat.

Contact a local Trane Representative for more assistance with low ambient cooling applications.

### Optional Stainless Steel Heat Exchanger

The optional stainless steel heat exchanger is manufactured with 409 stainless steel. To prevent corrosion and prolong heat exchanger reliability, the minimum mixed air temperature allowed across the heat exchanger is 20°F.

The stainless steel heat exchanger option is an excellent option that compliments the dehumidification package. Whenever high outside air or outside applications exist, these options should be utilized.

### Single Zone Variable Air Volume (SZVAV)

Not to be utilized with change-over bypass VAV system. Not to be utilized with VariTrac® systems.

### Unit Pitch

These units have reversible sloped condensate drain pans. Units must be installed level. Any unit slope must be toward the side of unit where condensate drain is connected.

# Selection Procedure

## Cooling Capacity

**Note:** Cooling Capacity Procedure is the same for electric heat (T\*C) and gas heat (Y\*C).

### Step 1.

Calculate the building's total and sensible cooling loads at design conditions. Use the Trane calculation methods or any other standard accepted method.

Factors used in unit selection:

- Packaged Cooling with Optional Electric Heat
- Total Cooling Load: 59 MBh
- Sensible Cooling Load: 40 MBh
- Airflow: 2000 cfm
- Electrical Characteristics: 460/60/3
- Summer Design Conditions: Entering Evaporator Coil: 80 DB
- 67WB Outdoor Ambient: 95
- External Static Pressure: 0.36 in. wg
- Downflow Configuration
- Efficiency: 13 SEER
- Economizer

### Step 2.

As a starting point, a rough determination must be made of the size of the unit. The final selection will be made after examining the performance at the given conditions. Divide the total cooling load by nominal Btuh per ton (12 MBh per ton); then round up to the nearest unit size.

59 MBh / 12 MBh = approx. 5 tons

### Step 3.

Table 13, p. 45 shows that a TSC060E4 has a **gross** cooling capacity of 62.3 MBh and 48.1 MBh sensible capacity at 2000 cfm and 95 DB outdoor ambient with 80 DB, 67 WB air entering the evaporator.

### To Find Capacity at Intermediate Conditions not in the table.

When the design conditions are between two numbers that are in the capacity table, interpolation is required to approximate the capacity.

**Note:** Extrapolation outside of the table conditions is not recommended.

### Step 4.

In order to select the correct unit which meets the building's requirements, the fan motor heat must be deducted from the gross cooling capacity. The amount of heat that the fan motor generates is dependent on the effort by the motor - cfm and static pressure. To determine the total unit static pressure:

External Static Duct System	0.36 wg
Standard Filter 2 in. from Table 145, p. 186	0.049 wg
Economizer from Table 145, p. 186 (100% Outside Air) *worst case	0.105 wg
Electric Heater Size 6 kW from Table 145, p. 186 (reference "Heating Capacity" section on this page for determination of heater size)	0.021 wg
Total Static Pressure	0.535 wg

**Note:** The Evaporator Fan Performance Table 36, p. 81 has deducted the pressure drop for a filter already in the unit (see note below Table 36, p. 81). Therefore, the actual total static pressure is 0.535 - 0.049 (from Table 145, p. 186) = 0.486 wg.

## Selection Procedure

---

With 2000 cfm and 0.5 wg.

[Table 36, p. 81](#) shows 0.575 bhp for this unit.

**Note:** Below the table is the formula to calculate Fan Motor Heat

$$2.87 \times \text{bhp} + 0.75 = \text{MBh.}$$

$$2.87 \times 0.575 + 0.15 = 1.8 \text{ MBh.}$$

Now subtract the fan motor heat from the gross cooling capacity of the unit:

**Net** Total Cooling Capacity  
= 62.3 MBh - 1.8 = 60.5 MBh.

**Net** Sensible Cooling Capacity  
= 48.1 MBh - 1.8 = 46.3 MBh.

Subtracting Sensible from Total Capacity to find Latent Capacity

**Net** Latent Capacity  
= 60.5 - 46.3 = 14.2 MBh.

### Step 5.

Compare your resulting capacities to the building load. If the performance will not meet the required load of the building's total or sensible cooling load, try a selection at the next higher size unit.

## Heating Capacity

**Note:** Heating capacity procedure DIFFERS for electric heat (T°C) and gas heat (Y°C) units

### Step 1.

Calculate the building heating load using the Trane calculation form or other standard accepted method.

### Step 2.

Size the system heating capacity to match the calculated building heating load. The following are building heating requirements:

Total heating load of 15 MBh  
2000 cfm

T°C units with optional electric heat: 460V/3 phase Power Supply

The electric heat accessory capacities are listed in [Table 148, p. 189](#). From the table, a 6 kW heater will deliver 20.48 MBh at 480 volts. In order to determine capacity at 460 volts, the heater voltage correction factor from [Table 150, p. 191](#) must be used. Therefore, 20.48 MBh x 0.918 (voltage correction factor) = 18.8 MBh.

Y°C units with gas heat: Fuel- natural gas.

60 MBh, 80 MBh and 130 MBh input models shown in [Table 146, p. 187](#). The output capacities of these furnaces are 48 MBh, 64 MBh and 104 MBh respectively. The low heat model with 48 MBh best matches the building requirements.

## Air Delivery Selection

**Note:** Air Delivery procedure is the same for electric heat and gas heat units.)

External static pressure drop through the air distribution system has been calculated to be 0.5 inches of water. Enter [Table 52, p. 97](#) for a TSC060E4 at 2000 cfm and 0.5 static pressure. The standard direct drive motor will give the desired airflow at a rated bhp of 0.73 and 951 rpm.

## Dehumidification Selection

**Note:** Dehumidification selection procedure is the same for both electric heat (THC) and gas heat (YHC) models).

Typical 5 ton THC060E  
 2000 cfm Total Supply airflow  
 400 cfm Outside Air (40%)  
 600 cfm Return Air  
 0.34" External Static Pressure  
 OA Conditions  
 Part load day and raining  
 68°F db  
 67°F wb  
 95% RH  
 RA conditions  
 75°F db  
 63°F wb

### Step 1:

Determine the mixed/entering air condition (MA)

MA = (% outside air\*outside air dry-bulb temperature) + (% return air\*return air dry-bulb temperature)

$$MA = (0.40*68°F) + (0.60*75°F)$$

$$MA = 72.20°F \text{ db}$$

Repeat for wet-bulb temperature (wb).

MA

$$72.2°F \text{ db}$$

$$64.6°F \text{ wb}$$

### Step 2:

Determine the additional static pressure drop for a reheat unit

Table 145, p. 186 shows a static pressure drop of 0.13" for the reheat coil and an additional 0.08 for the mandatory 2" pleated filters required when ordering the dehumidification option. Total static pressure =

$$.34 + 0.08 + 0.13 = 0.55$$

Do not forget to also add any additional static from other accessories. This selection does not include additional accessories.

Table 101, p. 146 (airflow table for 5 ton downflow unit) indicates that a standard motor and drive is needed for this airflow and static pressure range.

### Step 3a:

Determine leaving evaporator temperature (SA')

Leaving Evaporator Temperature = SA'

Utilizing the manual **Cooling Capacity** selection method as previously described, find the leaving evaporator temperatures with the formula:

$$\Delta \text{ Temp} = \frac{\text{gross sensible or gross latent cooling capacity in Btuh}}{(\text{cfm}) (1.085)}$$



## Selection Procedure

---

Subtract your sensible  $\Delta$  temp from the entering db and latent  $\Delta$  temp from the entering wb to determine the leaving evaporator db & wb (temperatures without the addition of fan heat).

52.7°F db  
52.7°F wb  
52.7°F dp

### Step 3b:

Determine leaving unit temperature in standard cooling mode

Repeat Step 3a substituting **net** sensible or latent capacity for **gross** sensible or latent capacity to find the leaving unit temperature including fan heat.

53.7°F db  
53.1°F wb

### Step 4:

Determine reheat temperature rise

Using the leaving evaporator temp (SA'), go to [Table 150, p. 191](#) and determine the reheat temperature rise for that particular cfm:  $\cong 19.0^\circ\text{F db}$

**Note:** Reheat temperature rise is based on **supply airflow** and leaving **evaporator coil** temperature.

### Step 5:

Determine leaving unit sensible temperature with reheat active (SA)

Reheat temperature (obtained in step 4) + (SA' + fan heat) = SA

(SA' + fan heat) = leaving unit temperature in standard cooling mode from step 3b.

$19.0^\circ\text{F db} + 53.7^\circ\text{F} = 72.7^\circ\text{F db}$

SA=72.7°F

Since reheat adds only sensible heat, the dewpoint temperature will remain constant so follow the dewpoint temperature line across the psychrometric chart to find the new wb temperature.

$\cong 60.5^\circ\text{F wb}$   
52.7 dp  
49.9% RH

If the space relative humidity is equal to or above the space relative humidity setpoint, the Dehumidification option will:

- Energize compressor or both compressors (2 stage compressor units).
- Hot gas reheat valve is energized and hot gas is diverted to the reheat coil.
- Dehumidification/reheat is terminated when space humidity is reduced to 5% below relative humidity setpoint.

At MA air enters the RTU. The RTU filters, cools, and dehumidifies the air as it moves through the evaporator coil. Air leaves the evaporator coil saturated at the preset dew point condition (SA') and is reheated by the hot gas reheat coil to deliver 72.7°F (SA) supply air to the space.



# Model Number Description - 3-10 Ton

Y	S	C	O	3	6	E	3	R	Z	B	*	*
1	2	3	4	5	6	7	8	9	10	11	12	13
<b>Digit 1 - Unit Type</b>			<b>Digit 14 - Fresh Air Selection</b>						<b>Digit 19 - Disconnect/Circuit Breaker (three- phase only)</b>			
T	DX Cooling		0 No Fresh Air						0 No Disconnect/No Circuit Breaker			
Y	DX Cooling, Gas Heat		A Manual Outside Air Damper 0-50% <sup>4</sup>						1 Unit Mounted Non-Fused Disconnect <sup>8</sup>			
<b>Digit 2 - Efficiency</b>			B Motorized Outside Air Damper 0-50% <sup>28</sup>						2 Unit Mounted Circuit Breaker <sup>8</sup>			
S	Standard Efficiency		C Economizer, Dry Bulb 0-100% without Barometric Relief <sup>7</sup>						<b>Digit 20 - Convenience Outlet</b>			
H	High Efficiency		D Economizer, Dry Bulb 0-100% with Barometric Relief <sup>7</sup>						0 No Convenience Outlet			
<b>Digit 3 - Airflow</b>			E Economizer, Reference Enthalpy 0-100% without Barometric Relief <sup>3,7</sup>						A Unpowered Convenience Outlet			
C	Convertible		F Economizer, Reference Enthalpy 0-100% with Barometric Relief <sup>3,7</sup>						B Powered Convenience Outlet (three-phase only) <sup>9</sup>			
<b>Digit 4,5,6 - Nominal Gross Cooling Capacity (MBh)</b>			G Economizer, Comparative Enthalpy 0-100% without Barometric Relief <sup>3,7</sup>						<b>Digit 21 - Communications Options<sup>3</sup></b>			
036	3Ton		H Economizer, Comparative Enthalpy 0-100% with Barometric Relief <sup>3,7</sup>						0 No Communications Interface			
048	4Ton		<b>Digit 15 - Supply Fan/Drive Type/ Motor</b>						1 Trane Communications Interface			
060	5Ton		0 Standard Drive <sup>6</sup>						2 LonTalk® Communications Interface			
072	6Ton		1 Oversized Motor						3 Novar 2024 Controls <sup>30</sup>			
090	7½Ton, Single Compressor		2 Optional Belt Drive Motor <sup>18</sup>						4 Novar 3051 Controls without Zone Sensor <sup>30</sup>			
092	7½Ton, Dual Compressor		6 Single Zone VAV <sup>26</sup>						5 Novar 3051 Controls Interface with DCV <sup>30</sup>			
102	8½Ton		7 Multi-Speed Indoor Fan <sup>27</sup>						6 BACnet™ Communications Interface			
120	10Ton		<b>Digit 16 - Hinged Service Access/ Filters</b>						<b>Digit 22 - Refrigeration System Option</b>			
<b>Digit 7 - Major Design Sequence</b>			0 Standard Panels/Standard Filters						0 Standard Refrigeration System <sup>10</sup>			
E	R-410A Refrigerant		A Hinged Access Panels/Standard Filters						B Dehumidification Option <sup>22,23</sup>			
F	Microchannel Type Condenser Coils <sup>24</sup>		B Standard Panels/2" MERV 7 Filters						<b>Digit 23 - Refrigeration Controls</b>			
<b>Digit 8 - Voltage Selection</b>			C Hinged Access Panels/2" MERV 7 Filters						<i>Note: Applicable to Digit 7 = E, F</i>			
1	208/230/60/1		D Standard Panels/2" MERV 13 Filters						0 No Refrigeration Control <sup>5</sup>			
3	208-230/60/3		E Hinged Access Panels/2" MERV 13 Filters						1 Frostat <sup>11,29</sup>			
4	460/60/3		<b>Digit 17 - Condenser Coil Protection</b>						2 Crankcase Heater <sup>2</sup>			
W	575/60/3		0 Standard Coil						3 Frostat <sup>11,29</sup> and Crankcase Heater <sup>2</sup>			
<b>Digit 9 - Unit Controls</b>			1 Standard Coil with Hail Guard						<b>Digit 24 - Smoke Detector<sup>17</sup></b>			
E	Electromechanical		2 Black Epoxy Pre-Coated Condenser Coil <sup>25</sup>						0 No Smoke Detector			
R	ReliaTel™ Microprocessor		3 Black Epoxy Pre-Coated Condenser Coil with Hail Guard <sup>25</sup>						A Return Air Smoke Detector <sup>12,13</sup>			
<b>Digit 10 - Heating Capacity</b>			4 CompleteCoat™ Condenser Coil						B Supply Air Smoke Detector			
0	No Electric Heat		5 CompleteCoat™ Condenser Coil with Hail Guard						C Supply and Return Air Smoke Detectors <sup>12,13</sup>			
A	5 kW (1 phase) <sup>1</sup>		<b>Digit 18 - Through the Base Provisions</b>						<b>Digit 25 - Monitoring Controls</b>			
B	6 kW (3 phase)		0 No Through the Base Provisions						0 No Monitoring Control <sup>14</sup>			
C	9 kW (3 phase)		A Through the Base Electric <sup>8</sup>						1 Clogged Filter Switch <sup>14</sup>			
D	10 kW (1 phase) <sup>1</sup>		<i>Note: Applicable to Digit 1, Y models only</i>						2 Fan Failure Switch <sup>14</sup>			
E	12 kW (3 phase)		B Through the Base Gas Piping <sup>16</sup>						3 Discharge Air Sensing Tube <sup>14</sup>			
L	Low Heat		C Through the Base Electric and Gas Piping <sup>16</sup>						4 Clogged Filter Switch and Fan Fail Switch <sup>14</sup>			
M	Medium Heat								5 Clogged Filter Switch and Discharge Air Sensing Tube <sup>14</sup>			
H	High Heat								6 Fan Fail Switch and Discharge Air Sensing Tube <sup>14</sup>			
X	Low Heat, Stainless Steel Heat Exchanger								7 Clogged Filter and Fan Fail Switches and Discharge Air Sensing Tube <sup>14</sup>			
Y	Medium Heat, Stainless Steel Heat Exchanger								8 Novar Return Air Sensor <sup>15,30</sup>			
Z	High Heat, Stainless Steel Heat Exchanger								9 Novar 3051 Zone Sensor <sup>19,30</sup>			
<b>Digit 11 - Minor Design Sequence</b>												
A	First Sequence <sup>21</sup>											
B	Second Sequence <sup>20</sup>											
<b>Digit 12,13 - Service Sequence</b>												
**	Factory Assigned											



## Model Number Description - 3-10 Ton

### Model Number Notes

1. Available on 3-5 ton models.
2. Standard on 4-5Ton E3,4,W and 6-10Ton Heat Pumps and all High Efficiency models.
3. Not available with electromechanical controls.
4. Manual outside air damper will ship factory supplied within the unit, but must be field installed.
5. High pressure control is standard on all units.
6. On 3-5 ton, multispeed direct drive is standard on single phase and 15 SEER. On 6-10 ton, multispeed direct drive is standard on all 10 ton and 7.5-8.5 ton high efficiency. Belt drive is standard on all other units.

#### Digit 15 = 0

Standard Efficiency  
 1 Phase = High Efficiency Multispeed Direct Drive Motor  
 3 Phase (3-8½ Ton) = Belt Drive  
 3 Phase (10 Ton) = Ultra High Efficiency Direct Drive Plenum Fan  
 High Efficiency  
 1 Phase = High Efficiency Multispeed Direct Drive Motor  
 3 Phase (3-5 ton) = High Efficiency Multispeed Direct Drive Motor  
 3 Phase (3-5 ton w/Dehumidification) = Belt Drive Motor  
 3 Phase (7½-10 ton) = Ultra High Efficiency Direct Drive Plenum Fan

7. Economizer with Barometric Relief is for downflow configured units only. Order Economizer without Barometric Relief for horizontal configuration. Barometric Relief for horizontal configured units must be ordered as field installed accessory.
8. Through the base electric required when ordering disconnect/circuit breaker options.
9. Requires use of Disconnect or Circuit Breaker.

#### Not Available

Standard Efficiency  
 10 Ton w/575V  
 High Efficiency  
 3-5 ton w/Standard Indoor Motor w/460V

10. Standard metering devices are TXVs.
11. Froststat cannot be field installed in electro-mechanical units.
12. The return air smoke detector may not fit up or work properly on the Precedent units when used in conjunction with 3rd party accessories such as bolt on heat wheels, economizers and power exhaust. Do not order the return air smoke detectors when using this type of accessory.
13. Return Air Smoke Detector cannot be ordered with Novar Controls.
14. These options are standard when ordering Novar Controls.
15. This option is used when ordering Novar Controls.
16. Includes gas piping and shutoff (field assembly required).
17. Not available with high temperature duct sensor accessory.

#### 18. Digit 15 = 2

Standard Efficiency  
 1 Phase = Not Available  
 3 Phase = Not Available  
 High Efficiency  
 1 Phase = Not Available  
 3 Phase (3-5 ton) = **May be Ordered**  
 3 Phase (3-5 ton w/Dehumidification) = Not Available  
 3 Phase (6-10 ton) = Not Available

19. Novar Sensor utilized with Digit 21 = (4) Novar 3051 Controls without Zone Sensor.
20. Available for T/Y 10 ton standard efficiency models only.
21. Available for T/Y 3, 4, 5, 6, 7½, 8½ ton standard/high efficiency models only.
22. Requires selection of 2" Pleated Filters (option B or C) for Digit 16.
23. Not available on 6 ton units and all single phase or standard efficiency.
24. Standard on T/YSC 6, 7½ (single and dual systems), 8½, 10 ton standard efficiency models and T/YHC 4, 5, 6, 7½ ton high efficiency

- models (except for dehumidification models).
25. Epoxy coil and epoxy with hailguard options are not available for units with microchannel condenser coil.
26. Single Zone VAV is only available on 7.5-10 ton high efficiency and 10 ton standard efficiency products with ReliaTel™ controls.
27. Multi-speed indoor fan available only on 7.5 & 8.5 ton high efficiency, and 10 ton products with ReliaTel™ controls.
28. Motorized Outside Air Damper is not available on Multi-Speed or SZVAV (Single Zone Variable Air Volume) products.
29. Froststat standard on Multi-Speed and SZVAV (Single Zone Variable Air Volume) products.
30. Novar is not available with SZVAV products.





# General Data

**Table 1. General data - 3-4 tons - standard efficiency**

	3 Tons		4 Tons	
	T/YSC036E1	T/YSC036E3,4,W	T/YSC048E1	T/YSC048E3,4,W
<b>Cooling Performance<sup>(a)</sup></b>				
Gross Cooling Capacity	35,620	37,150	49,210	49,450
EER/SEER <sup>(b)</sup>	11.5/13.0	11.2/13.0	11.1/13.0	10.9/13.0
Nominal cfm/ARI Rated cfm	1,200/1,200	1,200/1,200	1,600/1,600	1,600/1,600
ARI Net Cooling Capacity	35,000	35,800	48,000	48,000
System Power (kW)	3.04	3.20	4.32	4.39
<b>Compressor</b>				
Number/Type	1/Scroll	1/Scroll	1/Scroll	1/Scroll
<b>Sound</b>				
Outdoor Sound Rating (dB) <sup>(c)</sup>	81	81	82	82
<b>Outdoor Coil - Type</b>				
Configuration	Lanced	Lanced	Lanced	Lanced
Tube Size (in.)	0.3125	0.3125	0.3125	0.3125
Face Area (sq. ft.)	10.96	9.59	10.96	10.96
Rows/FPI	2/16	2/16	2/16	2/16
<b>Indoor Coil - Type</b>				
Configuration	Lanced	Lanced	Lanced	Lanced
Tube Size (in.)	0.3125	0.3125	0.3125	0.3125
Face Area (sq. ft.)	7.71	7.71	7.71	7.71
Rows/FPI	3/16	3/16	4/16	4/16
Refrigerant Control	Thermal Expansion Valve	Thermal Expansion Valve	Thermal Expansion Valve	Thermal Expansion Valve
Drain Connection Number/Size (in.)	1¼ NPT	1¼ NPT	1¼ NPT	1¼ NPT
<b>Outdoor Fan - Type</b>				
Number Used/Diameter (in.)	Propeller	Propeller	Propeller	Propeller
Drive Type/No. Speeds	1/22	1/22	1/22	1/22
cfm	Direct/1	Direct/1	Direct/1	Direct/1
Motor hp	3,466	3,375	3,411	3,403
Motor rpm	0.33	0.33	0.33	0.33
	1,075	1,075	1,075	1,075
<b>Indoor Fan - Type (Standard)</b>				
Number Used/Diameter (in.)/Width (in.)	FC Centrifugal	FC Centrifugal	FC Centrifugal	FC Centrifugal
Drive Type/No. Speeds/RPM	1/11x11	1/11x11	1/11x11	1/11x11
Number Motors	Direct/5 <sup>(d)</sup>	Belt/Variable/1,750	Direct/5 <sup>(d)</sup>	Belt/Variable/1,750
Motor hp	1	1	1	1
Motor Frame Size	0.75	1.0	1.0	1.0
	48	56	48	56
<b>Filters<sup>(e)</sup></b>				
Type Furnished	Throwaway	Throwaway	Throwaway	Throwaway
Number Size Recommended	(2) 20x30x2	(2) 20x30x2	(2) 20x30x2	(2) 20x30x2
<b>Refrigerant Charge<sup>(f)</sup></b>				
Pounds of R-410A	6.3	6.0	7.0	7.0

continued on next page



## General Data

**Table 1. General data - 3-4 tons - standard efficiency (continued)**

	3 Tons		4 Tons	
	T/YSC036E1	T/YSC036E3,4,W	T/YSC048E1	T/YSC048E3,4,W
<b>Heating Performance<sup>(g)</sup></b>				
<b>(Gas/Electric Only)</b>				
<b>Heating Input</b>				
Low Heat Input (Btu)	60,000	60,000	60,000	60,000
Mid Heat Input (Btu)	80,000	80,000	80,000	80,000
High Heat Input (Btu)	120,000	120,000	120,000	120,000
<b>Heating Output</b>				
Low Heat Input (Btu)	48,000	48,000	49,000	48,000
Mid Heat Input (Btu)	65,000	64,000	65,000	64,000
High Heat Input (Btu)	96,000	96,000	96,000	96,000
<b>AFUE%<sup>(h)</sup></b>				
Low Heat Input (Btu)	78	80	79	80
Mid Heat Input (Btu)	78	80	79	80
High Heat Input (Btu)	78	80	79	80
<b>Steady State Efficiency%</b>				
Low Heat Input (Btu)	80	80	81	80
Mid Heat Input (Btu)	81	80	81	80
High Heat Input (Btu)	80	80	80	80
<b>No. Burners</b>				
Low Heat Input (Btu)	2	2	2	2
Mid Heat Input (Btu)	2	2	2	2
High Heat Input (Btu)	3	3	3	3
<b>No. Stages</b>				
Low Heat Input (Btu)	1	1	1	1
Mid Heat Input (Btu)	1	1	1	1
High Heat Input (Btu)	1	1	1	1
<b>Gas Supply Line Pressure</b>				
Natural (minimum/maximum)	4.5/14.0	4.5/14.0	4.5/14.0	4.5/14.0
LP (minimum/maximum)	11.0/14.0	11.0/14.0	11.0/14.0	11.0/14.0
<b>Gas Connection Pipe Size (in)</b>				
Low Heat	1/2	1/2	1/2	1/2
Mid Heat	1/2	1/2	1/2	1/2
High Heat	1/2	1/2	1/2	1/2

- (a) Cooling performance is rated at 95°F ambient, 80°F entering dry bulb, 67°F entering wet bulb. Gross capacity does not include the effect of fan motor heat. ARI capacity is net and includes the effect of fan motor heat. Units are suitable for operation to ±20% of nominal cfm. Units are certified in accordance with the Unitary Air-Conditioner Equipment certification program, which is based on ARI Standard 210/240.
- (b) EER and/or SEER are rated at ARI conditions and in accordance with DOE test procedures.
- (c) Outdoor Sound Rating shown is tested in accordance with ARI Standard 270. For additional information refer to [Table 143, p. 184](#).
- (d) For multispeed direct drive rpm TSC values, reference [Table 33, p. 78](#). For multispeed direct drive rpm YSC (low & medium gas heat) values reference [Table 34, p. 79](#). For multispeed direct drive rpm YSC (high gas heat) values reference [Table 35, p. 80](#).
- (e) Optional 2" MERV 7 and MERV 13 filters also available.
- (f) Refrigerant charge is an approximate value. For a more precise value, see unit nameplate and service instructions.
- (g) Heating performance limit settings and rating data were established and approved under laboratory test conditions using American National Standards Institute standards. Ratings shown are for elevations up to 2000 feet. For elevations above 2000 feet, ratings should be reduced at the rate of 4% for each 1000 feet above sea level. Applicable to Gas/Electric units only.
- (h) AFUE is rated in accordance with DOE test procedures.

**Table 2. General data - 5 tons - standard efficiency**

	5 Tons	
	T/YSC060E1	T/YSC060E3,4,W
<b>Cooling Performance<sup>(a)</sup></b>		
Gross Cooling Capacity	59,900	62,270
EER/SEER <sup>(b)</sup>	11.0/13.0	11.0/13.0
Nominal cfm/ARI Rated cfm	2,000/2,000	2,000/2,000
ARI Net Cooling Capacity	58,000	60,000
System Power (kW)	5.25	5.46
<b>Compressor</b>		
Number/Type	1/Scroll	1/Scroll
<b>Sound</b>		
Outdoor Sound Rating (dB) <sup>(c)</sup>	82	82
<b>Outdoor Coil - Type</b>	Lanced	Lanced
Configuration	Full Face	Full Face
Tube Size (in.)	0.3125	0.3125
Face Area (sq. ft.)	10.96	10.96
Rows/FPI	3/16	3/16
<b>Indoor Coil - Type</b>	Lanced	Lanced
Configuration	Full Face	Full Face
Tube Size (in.)	0.3125	0.3125
Face Area (sq. ft.)	7.71	7.71
Rows/FPI	4/16	4/16
Refrigerant Control	Thermal Expansion Valve	Thermal Expansion Valve
Drain Connection Number/Size (in.)	1¾ NPT	1¾ NPT
<b>Outdoor Fan - Type</b>	Propeller	Propeller
Number Used/Diameter (in.)	1/22	1/22
Drive Type/No. Speeds	Direct/1	Direct/1
cfm	3,271	3,245
Number Motors/hp	0.40	0.40
Motor rpm	1,075	1,075
<b>Indoor Fan - Type (Standard)</b>	FC Centrifugal	FC Centrifugal
Number Used/Diameter (in.)/Width (in.)	1/11x11	1/11x11
Drive Type/No. Speeds/rpm	Direct/5 <sup>(d)</sup>	Belt/Variable/1,750
Motor hp	1.0	1.0
Motor Frame Size	48	56
<b>Filters<sup>(e)</sup></b>		
Type Furnished	Throwaway	Throwaway
Number Size Recommended	(2) 20x30x2	(2)20x30x2
<b>Refrigerant Charge <sup>(f)</sup></b>		
Pounds of R-410A	9.5	9.4

continued on next page



## General Data

**Table 2. General data - 5 tons - standard efficiency (continued)**

	5 Tons	
	T/YSC060E1	T/YSC060E3,4,W
<b>Heating Performance<sup>(g)</sup></b>		
<b>(Gas/Electric Only)</b>		
<b>Heating Input</b>		
Low Heat Input (Btu)	60,000	60,000
Mid Heat Input (Btu)	80,000	80,000
High Heat Input (Btu)	130,000	130,000
<b>Heating Output</b>		
Low Heat Input (Btu)	48,000	48,000
Mid Heat Input (Btu)	65,000	64,000
High Heat Input (Btu)	104,000	104,000
<b>AFUE%<sup>(h)</sup></b>		
Low Heat Input (Btu)	78	80
Mid Heat Input (Btu)	79	80
High Heat Input (Btu)	78	80
<b>Steady State Efficiency%</b>		
Low Heat Input (Btu)	80	80
Mid Heat Input (Btu)	81	80
High Heat Input (Btu)	80	80
<b>No. Burners</b>		
Low Heat Input (Btu)	2	2
Mid Heat Input (Btu)	2	2
High Heat Input (Btu)	3	3
<b>No. Stages</b>		
Low Heat Input (Btu)	1	1
Mid Heat Input (Btu)	1	1
High Heat Input (Btu)	1	1
<b>Gas Supply Line Pressure</b>		
Natural (minimum/maximum)	4.5/14.0	4.5/14.0
LP (minimum/maximum)	11.0/14.0	11.0/14.0
<b>Gas Connection Pipe Size (in)</b>		
Low Heat	1/2	1/2
Mid Heat	1/2	1/2
High Heat	1/2	1/2

(a) Cooling performance is rated at 95°F ambient, 80°F entering dry bulb, 67°F entering wet bulb. Gross capacity does not include the effect of fan motor heat. ARI capacity is net and includes the effect of fan motor heat. Units are suitable for operation to ±20% of nominal cfm. Units are certified in accordance with the Unitary Air-Conditioner Equipment certification program, which is based on ARI Standard 210/240.

(b) EER and/or SEER are rated at ARI conditions and in accordance with DOE test procedures.

(c) Outdoor Sound Rating shown is tested in accordance with ARI Standard 270. For additional information refer to [Table 143, p. 184](#).

(d) For multispeed direct drive rpm TSC values, reference [Table 33, p. 78](#). For multispeed direct drive rpm YSC (low & medium gas heat) values reference [Table 34, p. 79](#). For multispeed direct drive rpm YSC (high gas heat) values reference [Table 35, p. 80](#).

(e) Optional 2" MERV 7 and MERV 13 filters also available.

(f) Refrigerant charge is an approximate value. For a more precise value, see unit nameplate and service instructions.

(g) Heating performance limit settings and rating data were established and approved under laboratory test conditions using American National Standards Institute standards. Ratings shown are for elevations up to 2000 feet. For elevations above 2000 feet, ratings should be reduced at the rate of 4% for each 1000 feet above sea level. Applicable to Gas/Electric units only.

(h) AFUE is rated in accordance with DOE test procedures.

**Table 3. General data - 6-7½ tons - standard efficiency**

	6 Tons	7½ Tons	7½ Tons
	T/YSC072F3,4,W	T/YSC090F3,4,W	T/YSC092F3,4,W
<b>Cooling Performance<sup>(a)</sup></b>			
Gross Cooling Capacity	75,000	89,000	94,000
EER <sup>(b)</sup>	11.2	11.2	11.2
Nominal cfm/ARI Rated cfm	2,400/2,100	3,000/2,400	3,000/2,625
ARI Net Cooling Capacity	71,200	83,000	89,000
IEER <sup>(c)</sup>	13.0	12.2	13.0
System Power (kW)	6.36	7.48	7.97
<b>Compressor</b>			
Number/Type	1/Scroll	1/Scroll	2/Scroll
<b>Sound</b>			
Outdoor Sound Rating (dB) <sup>(d)</sup>	89	89	91
<b>Outdoor Coil - Type</b>			
Configuration	Microchannel	Microchannel	Microchannel
Tube Size (in.)	Full Face	Full Face	Face-Split
Face Area (sq. ft.)	0.71	0.71	0.71
Rows/FPI	16.91	16.91	17.31
	1/23	1/23	1/23
<b>Indoor Coil - Type</b>			
Configuration	Lanced	Lanced	Lanced
Tube Size (in.)	Full Face	Full Face	Face-Split
Face Area (sq. ft.)	0.3125	0.3125	0.3125
Rows/FPI	9.89	9.89	12.36
Refrigerant Control	3/16	4/16	3/16
Drain Connection Number/Size (in.)	Thermal Expansion Valve	Thermal Expansion Valve	Thermal Expansion Valve
	1¼ NPT	1¼ NPT	1¼ NPT
<b>Outdoor Fan - Type</b>			
Number Used/Diameter (in.)	Propeller	Propeller	Propeller
Drive Type/No. Speeds	1/26	1/26	1/26
cfm	Direct/1	Direct/1	Direct/1
Motor hp	6,037	6,037	6,610
Motor rpm	0.7	0.7	0.75
	1,100	1,100	1,100
<b>Indoor Fan - Type</b>			
Number Used/Diameter (in.)/Width (in.)	FC Centrifugal	FC Centrifugal	FC Centrifugal
Drive Type/No. Speeds/rpm	1/12x12	1/12x12	1/15x15
Motor hp (Standard/Oversized)	Belt/Variable/1,750	Belt/Variable/1,750	Belt/Variable/1,750
Motor Frame Size (Standard/Oversized)	1.0/2.0	1.0/3.0	1.0/3.0
	56/56	56/56	56/56
<b>Filters<sup>(e)</sup></b>			
Type Furnished	Throwaway	Throwaway	Throwaway
Number Size Recommended	(4) 16x25x2	(4) 16x25x2	(4) 20x25x2
<b>Refrigerant Charge <sup>(f)</sup></b>			
Pounds of R-410A	5.5	5.9	3.9/3.6

continued on next page



## General Data

**Table 3. General data - 6-7½ tons - standard efficiency (continued)**

	6 Tons	7½ Tons	7½ Tons
	T/YSC072F3,4,W	T/YSC090F3,4,W	T/YSC092F3,4,W
<b>Heating Performance<sup>(g)</sup></b>			
<b>(Gas/Electric Only)</b>			
<b>Heating Input</b>			
Low Heat Input (Btu)	80,000	120,000	120,000
Mid Heat Input (Btu)	120,000	150,000/105,000	150,000/105,000
High Heat Input (Btu)	150,000/105,000	200,000/140,000	200,000/140,000
<b>Heating Output</b>			
Low Heat Input (Btu)	64,000	96,000	96,200
Mid Heat Input (Btu)	96,000	120,000/84,000	120,000/84,000
High Heat Input (Btu)	120,000/84,000	160,000/112,000	160,000/112,000
<b>AFUE%<sup>(h)</sup></b>			
Low Heat Input (Btu)	80	80	80
Mid Heat Input (Btu)	80	80	80
High Heat Input (Btu)	80	80	80
<b>Steady State Efficiency%</b>			
Low Heat Input (Btu)	80	80	80
Mid Heat Input (Btu)	80	80	80
High Heat Input (Btu)	80	80	80
<b>No. Burners</b>			
Low Heat Input (Btu)	2	3	3
Mid Heat Input (Btu)	3	3	3
High Heat Input (Btu)	3	4	4
<b>No. Stages</b>			
Low Heat Input (Btu)	1	1	1
Mid Heat Input (Btu)	1	2	2
High Heat Input (Btu)	2	2	2
<b>Gas Supply Line Pressure</b>			
Natural (minimum/maximum)	4.5/14.0	4.5/14.0	4.5/14.0
LP (minimum/maximum)	11.0/14.0	11.0/14.0	11.0/14.0
<b>Gas Connection Pipe Size (in)</b>			
Low Heat	1/2	1/2	1/2
Mid Heat	1/2	3/4	3/4
High Heat	3/4	3/4	3/4

(a) Cooling performance is rated at 95°F ambient, 80°F entering dry bulb, 67°F entering wet bulb. Gross capacity does not include the effect of fan motor heat. ARI capacity is net and includes the effect of fan motor heat. Units are suitable for operation to ±20% of nominal cfm. Units are certified in accordance with the Unitary Air-Conditioner Equipment certification program, which is based on ARI Standard 340/360.

(b) EER is rated at ARI conditions and in accordance with DOE test procedures.

(c) Integrated Efficiency Ratio (IEER) is rated in accordance with ARI Standard 340/360. The IEER rating requires that the unit efficiency be determined at 100%, 75%, 50% and 25% load (net capacity) at the specified in ARI Standard.

(d) Outdoor Sound Rating shown is tested in accordance with ARI Standard 270. For additional information refer to [Table 143, p. 184](#).

(e) Optional 2" MERV 7 and MERV 13 filters also available.

(f) Refrigerant charge is an approximate value. For a more precise value, see unit nameplate and service instructions.

(g) Heating performance limit settings and rating data were established and approved under laboratory test conditions using American National Standards Institute standards. Ratings shown are for elevations up to 2000 feet. For elevations above 2000 feet, ratings should be reduced at the rate of 4% for each 1000 feet above sea level. Applicable to Gas/Electric units only.

(h) AFUE is rated in accordance with DOE test procedures.

**Table 4. General data - 8½-10 tons - standard efficiency**

	<b>8½ Tons</b>	<b>10 Tons</b>
	<b>T/YSC102F3,4,W</b>	<b>T/YSC120F3,4,W</b>
<b>Cooling Performance<sup>(a)</sup></b>		
Gross Cooling Capacity	102,000	119,000
EER <sup>(b)</sup>	11.2	11.3
Nominal cfm/ARI Rated cfm	3,400/2,720	4,000/3,500
ARI Net Cooling Capacity	96,600	113,000
IEER <sup>(c)</sup>	13.0	12.5
System Power (kW)	8.62	10.0
<b>Compressor</b>		
Number/Type	2/Scroll	2/Scroll
<b>Sound</b>		
Outdoor Sound Rating (dB) <sup>(d)</sup>	89	88
<b>Outdoor Coil - Type</b>		
Configuration	Microchannel	Microchannel
Tube Size (in.)	Face-Split	Face Split
Face Area (sq. ft.)	1	1
Face Area (sq. ft.)	20.77	20.77
Rows/FPI	1/20	1/20
<b>Indoor Coil - Type</b>		
Configuration	Lanced	Lanced
Tube Size (in.)	Face-Split	Intertwined
Face Area (sq. ft.)	0.3125	0.3125
Face Area (sq. ft.)	12.36	12.36
Rows/FPI	3/16	4/16
Refrigerant Control	Thermal Expansion Valve	Thermal Expansion Valve
Drain Connection Number/Size (in.)	1¼ NPT	1¼ NPT
<b>Outdoor Fan - Type</b>		
Number Used/Diameter (in.)	Propeller	Propeller
Drive Type/No. Speeds	1/26	1/26
cfm	Direct/1	Direct/1
Motor hp	6,610	6,800
Motor rpm	0.75	0.75
	1,100	1,100
<b>Indoor Fan - Type</b>		
Number Used/Diameter (in.)/Width (in.)	FC Centrifugal	BC Plenum
Drive Type/No. Speeds/rpm	1/15x15	1/19.7x15
Motor hp (Standard/Oversized)	Belt/Variable/1,750	Direct/Variable <sup>(e)</sup>
Motor Frame Size (Standard/Oversized)	2.0/3.0	3.75/—
	56/56	—/—
<b>Filters<sup>(f)</sup></b>		
Type Furnished	Throwaway	Throwaway
Number Size Recommended	(4) 20x25x2	(4) 20x25x2
<b>Refrigerant Charge <sup>(g)</sup></b>		
Pounds of R-410A	4.7/3.9	5.5/4.2

**continued on next page**



## General Data

**Table 4. General data - 8½-10 tons - standard efficiency (continued)**

	8½ Tons	10 Tons
	T/YSC102F3,4,W	T/YSC120F3,4,W
<b>Heating Performance<sup>(h)</sup></b>		
<b>(Gas/Electric Only)</b>		
<b>Heating Input</b>		
Low Heat Input (Btu)	120,000	150,000/105,000
Mid Heat Input (Btu)	150,000/105,000	200,000/140,000
High Heat Input (Btu)	200,000/140,000	250,000/175,000
<b>Heating Output</b>		
Low Heat Input (Btu)	96,000	120,000/84,000
Mid Heat Input (Btu)	120,000/84,000	160,000/112,000
High Heat Input (Btu)	160,000/112,000	200,000/140,000
<b>AFUE%<sup>(i)</sup></b>		
Low Heat Input (Btu)	80	80
Mid Heat Input (Btu)	80	80
High Heat Input (Btu)	80	80
<b>Steady State Efficiency%</b>		
Low Heat Input (Btu)	80	80
Mid Heat Input (Btu)	80	80
High Heat Input (Btu)	80	80
<b>No. Burners</b>		
Low Heat Input (Btu)	3	3
Mid Heat Input (Btu)	3	4
High Heat Input (Btu)	4	5
<b>No. Stages</b>		
Low Heat Input (Btu)	1	2
Mid Heat Input (Btu)	2	2
High Heat Input (Btu)	2	2
<b>Gas Supply Line Pressure</b>		
Natural (minimum/maximum)	4.5/14.0	4.5/14.0
LP (minimum/maximum)	11.0/14.0	11.0/14.0
<b>Gas Connection Pipe Size (in)</b>		
Low Heat	1/2	3/4
Mid Heat	3/4	3/4
High Heat	3/4	3/4

(a) Cooling performance is rated at 95°F ambient, 80°F entering dry bulb, 67°F entering wet bulb. Gross capacity does not include the effect of fan motor heat. ARI capacity is net and includes the effect of fan motor heat. Units are suitable for operation to ±20% of nominal cfm. Units are certified in accordance with the Unitary Air-Conditioner Equipment certification program, which is based on ARI Standard 340/360.

(b) EER is rated at ARI conditions and in accordance with DOE test procedures.

(c) Integrated Efficiency Ratio (IEER) is rated in accordance with ARI Standard 340/360. The IEER rating requires that the unit efficiency be determined at 100%, 75%, 50% and 25% load (net capacity) at the specified in ARI Standard.

(d) Outdoor Sound Rating shown is tested in accordance with ARI Standard 270. For additional information refer to [Table 143, p. 184](#).

(e) For multispeed direct drive rpm T/YSC values, reference [Table 142, p. 183](#).

(f) Optional 2" MERV 7 and MERV 13 filters also available.

(g) Refrigerant charge is an approximate value. For a more precise value, see unit nameplate and service instructions.

(h) Heating performance limit settings and rating data were established and approved under laboratory test conditions using American National Standards Institute standards. Ratings shown are for elevations up to 2000 feet. For elevations above 2000 feet, ratings should be reduced at the rate of 4% for each 1000 feet above sea level. Applicable to Gas/Electric units only.

(i) AFUE is rated in accordance with DOE test procedures.



**Table 5. General data - 3-4 tons - high efficiency**

	3 Tons		4 Tons		
	T/YHC036E1	T/YHC036E3,4	T/YHC048F1	T/YHC048E3,4	T/YHC048F3,4
<b>Cooling Performance<sup>(a)</sup></b>					
Gross Cooling Capacity	38,490	37,600	48,930	49,930	49,930
EER/SEER <sup>(b)</sup>	13.0/15.2	12.7/15.0	12.55/15.0	15.0	13.35/15.0
Nominal cfm/ARI Rated cfm	1,200/1,200	1,200/1,200	1,600/1,600	1,600/1,600	1,600/1,600
ARI Net Cooling Capacity	37,000	37,000	48,000	49,000	49,000
System Power (kW)	2.93	2.99	3.83	3.67	3.67
<b>Compressor</b>					
Number/Type	1/Scroll	1/Scroll	1/Scroll	1/Scroll	1/Scroll
<b>Sound</b>					
Outdoor Sound Rating (dB) <sup>(c)</sup>	81	81	87	87	87
<b>Outdoor Coil - Type</b>					
Configuration	Lanced	Lanced	Microchannel	Lanced	Microchannel
Tube Size (in.)	Full Face	Full Face	Full Face	Full Face	Full Face
Face Area (sq. ft.)	0.3125	0.3125	0.71	0.3125	0.71
Rows/FPI	10.96	10.96	16.91	17.00	16.91
	2/16	2/16	1/23	3/16	1/23
<b>Indoor Coil - Type</b>					
Configuration	Lanced	Lanced	Lanced	Lanced	Lanced
Tube Size (in.)	Full Face	Full Face	Full Face	Full Face	Full Face
Face Area (sq. ft.)	0.3125	0.3125	0.3125	0.3125	0.3125
Rows/FPI	7.71	7.71	9.27	9.27	9.27
Refrigerant Control	3/16	3/16	3/16	3/16	3/16
Drain Connection Number/Size (in.)	Thermal Expansion Valve	Thermal Expansion Valve	Thermal Expansion Valve	Thermal Expansion Valve	Thermal Expansion Valve
	1¾ NPT	1¾ NPT	1¾ NPT	1¾ NPT	1¾ NPT
<b>Outdoor Fan - Type</b>					
Number Used/Diameter (in.)	Propeller	Propeller	Propeller	Propeller	Propeller
Drive Type/No. Speeds	1/22	1/22	1/26	1/26	1/26
cfm	Direct/1	Direct/1	Direct/1	Direct/1	Direct/1
Motor hp	3,064	3,064	3,986	3,982	3,982
Motor rpm	0.2	0.2	0.4	0.4	0.4
	1,075	1,075	1,075	1,075	1,075
<b>Indoor Fan - Type (Standard)<sup>(d)</sup></b>					
Number Used/Diameter (in.)/Width (in.)	FC Centrifugal	FC Centrifugal	FC Centrifugal	FC Centrifugal	FC Centrifugal
Drive Type/No. Speeds/rpm	1/11x11	1/11x11	1/11x11	1/11x11	1/11x11
Number Motors	Direct/5 <sup>(e)</sup>	Direct/5 <sup>(e)</sup>	Direct/5 <sup>(e)</sup>	Direct/5 <sup>(e)</sup>	Direct/5 <sup>(e)</sup>
Motor hp (Standard/Oversized)	1	1	1	1	1
Motor Frame Size (Standard/Oversized)	0.75	.75	1.0	1.0	1.0
	48	48	48	48	48
<b>Indoor Fan - Type (Optional)</b>					
Number Used/Diameter (in.)/Width (in.)	—	FC Centrifugal	—	FC Centrifugal	FC Centrifugal
Drive Type/No. Speeds	—	1/11x11	—	1/11x11	1/11x11
Number Motors	—	Belt/Variable	—	Belt/Variable	Belt/Variable
Motor hp (Standard/Oversized)	—	1	—	1	1
Motor Frame Size (Standard/Oversized)	—	1.0	—	1.0	1.0
	—	56	—	56	56
<b>Filters<sup>(f)</sup></b>					
Type Furnished	Throwaway	Throwaway	Throwaway	Throwaway	Throwaway
Number Size Recommended	(2) 20x30x2	(2) 20x30x2	(4) 16x25x2	(4) 16x25x2	(4) 16x25x2
<b>Optional Hot Gas Reheat Coil (Type)</b>					
Tube Size (in.) OD	—	0.375	—	0.375	—
Face Area (sq. ft.)	—	4.72	—	6.83	—
Rows/FPI	—	2/18	—	2/18	—
<b>Refrigerant Charge (Lbs. of R-410A)<sup>(g)</sup></b>					
Standard	6.2	6.2	5.2	—	5.2
Optional Hot Gas Reheat Coil	—	6.6	—	12.0	—



## General Data

**Table 5. General data - 3-4 tons - high efficiency (continued)**

	3 Tons		4 Tons		
	T/YHC036E1	T/YHC036E3,4	T/YHC048F1	T/YHC048E3,4	T/YHC048F3,4
<b>Heating Performance<sup>(h)</sup></b>					
<b>(Gas/Electric Only)</b>					
<b>Heating Input</b>					
Low Heat Input (Btu)	60,000	60,000	60,000	60,000	60,000
Mid Heat Input (Btu)	80,000	80,000	80,000	80,000	80,000
High Heat Input (Btu)	120,000	120,000	120,000	120,000	120,000
<b>Heating Output</b>					
Low Heat Input (Btu)	48,000	48,000	49,000	49,000	49,000
Mid Heat Input (Btu)	65,000	64,000	64,000	64,000	64,000
High Heat Input (Btu)	96,000	96,000	96,000	96,000	96,000
<b>AFUE%<sup>(i)</sup></b>					
Low Heat Input (Btu)	78	78	80	80	80
Mid Heat Input (Btu)	78	78	79	79	79
High Heat Input (Btu)	78	78	79	79	79
<b>Steady State Efficiency%</b>					
Low Heat Input (Btu)	80	80	81	81	81
Mid Heat Input (Btu)	81	80	80	80	80
High Heat Input (Btu)	80	80	80	81	81
<b>No. Burners</b>					
Low Heat Input (Btu)	2	2	2	2	2
Mid Heat Input (Btu)	2	2	2	2	2
High Heat Input (Btu)	3	3	3	3	3
<b>No. Stages</b>					
Low Heat Input (Btu)	1	1	1	1	1
Mid Heat Input (Btu)	1	1	1	1	1
High Heat Input (Btu)	1	1	1	1	1
<b>Gas Supply Line Pressure</b>					
Natural (minimum/maximum)	4.5/14.0	4.5/14.0	4.5/14.0	4.5/14.0	4.5/14.0
LP (minimum/maximum)	11.0/14.0	11.0/14.0	11.0/14.0	11.0/14.0	11.0/14.0
<b>Gas Connection Pipe Size (in)</b>					
Low Heat	1/2	1/2	1/2	1/2	1/2
Mid Heat	1/2	1/2	1/2	1/2	1/2
High Heat	1/2	1/2	1/2	1/2	1/2

- (a) Cooling performance is rated at 95°F ambient, 80°F entering dry bulb, 67°F entering wet bulb. Gross capacity does not include the effect of fan motor heat. ARI capacity is net and includes the effect of fan motor heat. Units are suitable for operation to ±20% of nominal cfm. Units are certified in accordance with the Unitary Air-Conditioner Equipment certification program, which is based on ARI Standard 210/240.
- (b) EER and/or SEER are rated at ARI conditions and in accordance with DOE test procedures.
- (c) Outdoor Sound Rating shown is tested in accordance with ARI Standard 270. For additional information refer to [Table 143, p. 184](#).
- (d) Belt drive fan is standard on units with reheat option.
- (e) For multispeed direct drive rpm THC values, reference [Table 36, p. 81](#). For multispeed direct drive rpm YHC (low & medium gas heat) values reference [Table 37, p. 82](#). For multispeed direct drive rpm YHC (high gas heat) values reference [Table 38, p. 83](#).
- (f) Optional 2" MERV 7 and MERV 13 filters also available.
- (g) Refrigerant charge is an approximate value. For a more precise value, see unit nameplate and service instructions.
- (h) Heating performance limit settings and rating data were established and approved under laboratory test conditions using American National Standards Institute standards. Ratings shown are for elevations up to 2000 feet. For elevations above 2000 feet, ratings should be reduced at the rate of 4% for each 1000 feet above sea level. Applicable to Gas/Electric units only.
- (i) AFUE is rated in accordance with DOE test procedures.

**Table 6. General data - 5 tons - high efficiency**

	5 Tons		
	T/YH060F1	T/YHC060E3,4	T/YHC060F3,4
<b>Cooling Performance<sup>(a)</sup></b>			
Gross Cooling Capacity	61,000	61,000	61,000
EER/SEER <sup>(b)</sup>	12.85/15.0	15.0	12.85/15.0
Nominal cfm/ARI Rated cfm	2,000/2,000	2,000/2,000	2,000/2,000
ARI Net Cooling Capacity	59,500	6,000	60,000
System Power (kW)	4.63	4.67	4.67
<b>Compressor</b>			
Number/Type	1/Scroll	1/Scroll	1/Scroll
<b>Sound</b>			
Outdoor Sound Rating (dB) <sup>(c)</sup>	87	87	87
<b>Outdoor Coil - Type</b>			
Configuration	Microchannel	Lanced	Microchannel
Tube Size (in.)	Full Face	Full Face	Full Face
Face Area (sq. ft.)	0.71	0.3125	0.71
Rows/FPI	16.91	17	16.91
	1/23	3/16	1/23
<b>Indoor Coil - Type</b>			
Configuration	Lanced	Lanced	Lanced
Tube Size (in.)	Full Face	Full Face	Full Face
Face Area (sq. ft.)	0.3125	0.3125	0.3125
Rows/FPI	9.89	9.89	9.89
Refrigerant Control	4/16	4/16	4/16
Drain Connection Number/Size (in.)	Thermal Expansion Valve	Thermal Expansion Valve	Thermal Expansion Valve
	1¼ NPT	1¼ NPT	1¼ NPT
<b>Outdoor Fan - Type</b>			
Number Used/Diameter (in.)	Propeller	Propeller	Propeller
Drive Type/No. Speeds	1/26	1/26	1/26
cfm	Direct/1	Direct/1	Direct/1
Number Motors/hp	3,953	3,953	3,953
Motor rpm	0.40	0.40	0.40
	1,075	1,075	1,075
<b>Indoor Fan - Type (Standard)<sup>(d)</sup></b>			
Number Used/Diameter (in.)/Width (in.)	FC Centrifugal	FC Centrifugal	FC Centrifugal
Drive Type/No. Speeds/rpm	1/11x11	1/11x11	1/11x11
Motor hp	Direct/5 <sup>(e)</sup>	Direct/5 <sup>(d)</sup>	Direct/5 <sup>(d)</sup>
Motor Frame Size	1.0	1.0	1.0
	48	48	48
<b>Indoor Fan - Type (Optional)</b>			
Number Used/Diameter (in.)/Width (in.)	—	FC Centrifugal	FC Centrifugal
Drive Type/No. Speeds	—	1/11x11	1/11x11
Motor hp	—	Belt/Variable	Belt/Variable
Motor Frame Size	—	1.0	1.0
	—	56	56
<b>Filters<sup>(f)</sup></b>			
Type Furnished	Throwaway	Throwaway	Throwaway
Number Size Recommended	(4) 16x25x2	(4) 16x25x2	(4) 16x25x2
<b>Optional Hot Gas Reheat Coil - Type</b>			
Tube Size (in.) OD	—	0.375	—
Face Area (sq. ft.)	—	6.83	—
Rows/FPI	—	2/18	—
<b>Refrigerant Charge (Lbs. of R-410A) <sup>(g)</sup></b>			
Standard	6.1	—	6.1
Optional Hot Gas Reheat Coil	—	13.9	—

continued on next page



## General Data

**Table 6. General data - 5 tons - high efficiency (continued)**

	5 Tons		
	T/YH060F1	T/YHC060E3,4	T/YHC060F3,4
<b>Heating Performance<sup>(h)</sup></b>			
<b>(Gas/Electric Only)</b>			
<b>Heating Input</b>			
Low Heat Input (Btu)	60,000	60,000	60,000
Mid Heat Input (Btu)	80,000	80,000	80,000
High Heat Input (Btu)	130,000	130,000	130,000
<b>Heating Output</b>			
Low Heat Input (Btu)	49,000	49,000	49,000
Mid Heat Input (Btu)	64,000	64,000	64,000
High Heat Input (Btu)	104,000	104,000	104,000
<b>AFUE%<sup>(i)</sup></b>			
Low Heat Input (Btu)	80	80	80
Mid Heat Input (Btu)	79	79	79
High Heat Input (Btu)	80	80	80
<b>Steady State Efficiency%</b>			
Low Heat Input (Btu)	81	81	81
Mid Heat Input (Btu)	80	80	80
High Heat Input (Btu)	80	80	80
<b>No. Burners</b>			
Low Heat Input (Btu)	2	2	2
Mid Heat Input (Btu)	2	2	2
High Heat Input (Btu)	3	3	3
<b>No. Stages</b>			
Low Heat Input (Btu)	1	1	1
Mid Heat Input (Btu)	1	1	1
High Heat Input (Btu)	1	1	1
<b>Gas Supply Line Pressure</b>			
Natural (minimum/maximum)	4.5/14.0	4.5/14.0	4.5/14.0
LP (minimum/maximum)	11.0/14.0	11.0/14.0	11.0/14.0
<b>Gas Connection Pipe Size (in)</b>			
Low Heat	1/2	1/2	1/2
Mid Heat	1/2	1/2	1/2
High Heat	1/2	1/2	1/2

- (a) Cooling performance is rated at 95°F ambient, 80°F entering dry bulb, 67°F entering wet bulb. Gross capacity does not include the effect of fan motor heat. ARI capacity is net and includes the effect of fan motor heat. Units are suitable for operation to ±20% of nominal cfm. Units are certified in accordance with the Unitary Air-Conditioner Equipment certification program, which is based on ARI Standard 210/240.
- (b) EER and/or SEER are rated at ARI conditions and in accordance with DOE test procedures.
- (c) Outdoor Sound Rating shown is tested in accordance with ARI Standard 270. For additional information refer to [Table 143, p. 184](#).
- (d) Belt drive is standard on units with reheat option.
- (e) For multispeed direct drive rpm THC values, reference [Table 36, p. 81](#). For multispeed direct drive rpm YHC (low & medium gas heat) values reference [Table 37, p. 82](#). For multispeed direct drive rpm YHC (high gas heat) values reference [Table 38, p. 83](#).
- (f) Optional 2" MERV 7 and MERV 13 filters also available.
- (g) Refrigerant charge is an approximate value. For a more precise value, see unit nameplate and service instructions.
- (h) Heating performance limit settings and rating data were established and approved under laboratory test conditions using American National Standards Institute standards. Ratings shown are for elevations up to 2000 feet. For elevations above 2000 feet, ratings should be reduced at the rate of 4% for each 1000 feet above sea level. Applicable to Gas/Electric units only.
- (i) AFUE is rated in accordance with DOE test procedures.

**Table 7. General data - 6-7½ tons - high efficiency**

	6 Tons	7½ Tons	7½ Tons
	T/YHC072F3,4	T/YHC092E3,4	T/YHC092F3,4
<b>Cooling Performance<sup>(a)</sup></b>			
Gross Cooling Capacity	72,000	92,000	92,000
EER <sup>(b)</sup>	12.6	13.0	12.6
Nominal cfm/ARI Rated cfm	2,400/2,100	3,000/2,625	3,000/2,625
ARI Net Cooling Capacity	68,000	89,000	89,000
IEER <sup>(c),(d)</sup>	14.5	15.0	14.5
System Power (kW)	5.37	6.85	7.06
<b>Compressor</b>			
Number/Type	1/Scroll	2/Scroll	2/Scroll
<b>Sound</b>			
Outdoor Sound Rating (dB) <sup>(e)</sup>	89	87	88
<b>Outdoor Coil - Type</b>			
Configuration	Microchannel	Lanced	Microchannel
Tube Size (in.)	Full Face	Full Face	Face-Split
Face Area (sq. ft.)	0.71	0.3125	1
Face Area (sq. ft.)	20.77	36.1	20.77
Rows/FPI	1/23	3/16	1/20
<b>Indoor Coil - Type</b>			
Configuration	Lanced	Lanced	Lanced
Tube Size (in.)	Full Face	Intertwined	Intertwined
Face Area (sq. ft.)	0.3125	0.3125	0.3125
Face Area (sq. ft.)	12.36	16.65	12.36
Rows/FPI	4/16	4/16	4/16
Refrigerant Control	Thermal Expansion Valve	Thermal Expansion Valve	Thermal Expansion Valve
Drain Connection Number/Size (in.)	1¾ NPT	1¾ NPT	1¾ NPT
<b>Outdoor Fan - Type</b>			
Number Used/Diameter (in.)	Propeller	Propeller	Propeller
Drive Type/No. Speeds	1/26	1/30	1/26
cfm	Direct/1	Direct/1	Direct/1
Motor hp	5,900	7,540	6,800
Motor rpm	0.7	0.75	0.75
	1,100	1,100	1,100
<b>Indoor Fan - Type</b>			
Number Used/Diameter (in.)/Width (in.)	FC Centrifugal	BC Plenum	BC Plenum
Drive Type/No. Speeds/rpm	1/15x15	1/19.7x15	1/19.7x15
Motor hp (Standard/Oversized)	Belt/Variable/1,750	Direct/Variable <sup>(f)</sup>	Direct/Variable <sup>(g)</sup>
Motor Frame Size (Standard/Oversized)	1.0/2.0	3.75/—	3.75/—
	56/56	—/—	—/—
<b>Filters<sup>(h)</sup></b>			
Type Furnished	Throwaway	Throwaway	Throwaway
Number Size Recommended	(4) 20x25x2	(3) 20x25x2 (2) 20x30x2	(4) 20x25x2
<b>Optional Hot Gas Reheat Coil - Type</b>			
Tube Size (in.) OD	—	0.375	—
Face Area (sq. ft.)	—	13.89	—
Rows/FPI	—	2/16	—
<b>Refrigerant Charge (Lbs. of R-410A)<sup>(i)</sup></b>			
Standard	7.7	—	5.5/4.2
Optional Hot Gas Reheat Coil	—	14/11.75	—

continued on next page



## General Data

**Table 7. General data - 6-7½ tons - high efficiency (continued)**

	6 Tons	7½ Tons	7½ Tons
	T/YHC072F3,4	T/YHC092E3,4	T/YHC092F3,4
<b>Heating Performance<sup>(j)</sup></b>			
<b>(Gas/Electric Only)</b>			
<b>Heating Input</b>			
Low Heat Input (Btu)	80,000	120,000	120,000
Mid Heat Input (Btu)	120,000	150,000/105,000	150,000/105,000
High Heat Input (Btu)	150,000/105,000	200,000/140,000	200,000/140,000
<b>Heating Output</b>			
Low Heat Input (Btu)	64,000	96,000	96,000
Mid Heat Input (Btu)	96,000	120,000/84,000	120,000/84,000
High Heat Input (Btu)	120,000/84,000	160,000/112,000	160,000/112,000
<b>AFUE%<sup>(k)</sup></b>			
Low Heat Input (Btu)	80	80	80
Mid Heat Input (Btu)	80	80	80
High Heat Input (Btu)	80	80	80
<b>Steady State Efficiency%</b>			
Low Heat Input (Btu)	80	80	80
Mid Heat Input (Btu)	80	80	80
High Heat Input (Btu)	80	80	80
<b>No. Burners</b>			
Low Heat Input (Btu)	3	3	3
Mid Heat Input (Btu)	3	3	3
High Heat Input (Btu)	4	4	4
<b>No. Stages</b>			
Low Heat Input (Btu)	1	1	1
Mid Heat Input (Btu)	1	2	2
High Heat Input (Btu)	2	2	2
<b>Gas Supply Line Pressure</b>			
Natural (minimum/maximum)	4.5/14.0	4.5/14.0	4.5/14.0
LP (minimum/maximum)	11.0/14.0	11.0/14.0	11.0/14.0
<b>Gas Connection Pipe Size (in)</b>			
Low Heat	1/2	1/2	1/2
Mid Heat	1/2	3/4	3/4
High Heat	3/4	3/4	3/4

(a) Cooling performance is rated at 95°F ambient, 80°F entering dry bulb, 67°F entering wet bulb. Gross capacity does not include the effect of fan motor heat. ARI capacity is net and includes the effect of fan motor heat. Units are suitable for operation to ±20% of nominal cfm. Units are certified in accordance with the Unitary Air-Conditioner Equipment certification program, which is based on ARI Standard 340/360.

(b) EER is rated at ARI conditions and in accordance with DOE test procedures.

(c) Integrated Efficiency Ratio (IEER) is rated in accordance with ARI Standard 340/360. The IEER rating requires that the unit efficiency be determined at 100%, 75%, 50% and 25% load (net capacity) at the specified in ARI Standard.

(d) 15.0 IEER for SZVAV.

(e) Outdoor Sound Rating shown is tested in accordance with ARI Standard 270. For additional information refer to [Table 143, p. 184](#).

(f) For multispeed direct drive rpm THC/YHC values, reference [Table 142, p. 183](#).

(g) For multispeed direct drive rpm THC/YHC values, reference [Table 142, p. 183](#).

(h) Optional 2" MERV 7 and MERV 13 filters also available.

(i) Refrigerant charge is an approximate value. For a more precise value, see unit nameplate and service instructions.

(j) Heating performance limit settings and rating data were established and approved under laboratory test conditions using American National Standards Institute standards. Ratings shown are for elevations up to 2000 feet. For elevations above 2000 feet, ratings should be reduced at the rate of 4% for each 1000 feet above sea level. Applicable to Gas/Electric units only.

(k) AFUE is rated in accordance with DOE test procedures.

**Table 8. General data - 6-10 tons - high efficiency**

	<b>8½ Tons</b>	<b>10 Tons</b>
	<b>T/YHC102E3,4</b>	<b>T/YHC120E3,4</b>
<b>Cooling Performance<sup>(a)</sup></b>		
Gross Cooling Capacity	103,000	119,000
EER <sup>(b)</sup>	13.0	12.5
Nominal cfm/ARI Rated cfm	3,400/2,975	4,000/3,500
ARI Net Cooling Capacity	98,200	113,000
IEER <sup>(c),(d)</sup>	15.0	14.0 <sup>(e)</sup>
System Power (kW)	7.55	9.04
<b>Compressor</b>		
Number/Type	2/Scroll	2/Scroll
<b>Sound</b>		
Outdoor Sound Rating (dB) <sup>(f)</sup>	87	87
<b>Outdoor Coil - Type</b>		
Configuration	Lanced	Full Face
Tube Size (in.)	0.3125	0.3125
Face Area (sq. ft.)	36.1	36.1
Rows/FPI	3/16	3/16
<b>Indoor Coil - Type</b>		
Configuration	Lanced	Lanced
Tube Size (in.)	Intertwined	Intertwined
Face Area (sq. ft.)	0.3125	0.3125
Rows/FPI	16.65	16.65
Refrigerant Control	4/16	4/16
Drain Connection Number/Size (in.)	Thermal Expansion Valve	Thermal Expansion Valve
	1¼ NPT	1¼ NPT
<b>Outdoor Fan - Type</b>		
Number Used/Diameter (in.)	Propeller	Propeller
Drive Type/No. Speeds	1/30	1/30
cfm	Direct/1	Direct/1
Motor hp	7,540	7,540
Motor rpm	0.75	0.75
	1,100	1,100
<b>Indoor Fan - Type</b>		
Number Used/Diameter (in.)/Width (in.)	BC Plenum	BC Plenum
Drive Type/No. Speeds/rpm	1/19.7x15	1/19.7x15
Motor hp (Standard/Oversized)	Direct/Variable <sup>(f)</sup>	Direct/Variable <sup>(f)</sup>
Motor Frame Size (Standard/Oversized)	3.75/—	3.75/—
	—/—	—/—
<b>Filters<sup>(g)</sup></b>		
Type Furnished	Throwaway	Throwaway
Number Size Recommended	(3) 20x25x2	(3) 20x25x2
	(2) 20x30x2	(2) 20x30x2
<b>Optional Hot Gas Reheat Coil - Type</b>		
Tube Size (in.) OD	0.375	0.375
Face Area (sq. ft.)	13.89	13.89
Rows/FPI	2/16	2/16
<b>Refrigerant Charge (Lbs. of R-410A)<sup>(h)</sup></b>		
Standard	12.75/11.75	12.75/11.75
Optional Hot Gas Reheat Coil	14/11.75	14/11.75

**continued on next page**



## General Data

**Table 8. General data - 6-10 tons - high efficiency (continued)**

	8½ Tons	10 Tons
	T/YHC102E3,4	T/YHC120E3,4
<b>Heating Performance<sup>(i)</sup></b>		
<b>(Gas/Electric Only)</b>		
<b>Heating Input</b>		
Low Heat Input (Btu)	120,000	150,000/105,000
Mid Heat Input (Btu)	150,000/105,000	200,000/140,000
High Heat Input (Btu)	200,000/140,000	250,000/175,000
<b>Heating Output</b>		
Low Heat Input (Btu)	96,000	120,000/84,000
Mid Heat Input (Btu)	120,000/84,000	160,000/112,000
High Heat Input (Btu)	160,000/112,000	200,000/140,000
<b>AFUE%<sup>(j)</sup></b>		
Low Heat Input (Btu)	80	80
Mid Heat Input (Btu)	80	80
High Heat Input (Btu)	80	80
<b>Steady State Efficiency%</b>		
Low Heat Input (Btu)	80	80
Mid Heat Input (Btu)	80	80
High Heat Input (Btu)	80	80
<b>No. Burners</b>		
Low Heat Input (Btu)	3	3
Mid Heat Input (Btu)	3	4
High Heat Input (Btu)	4	5
<b>No. Stages</b>		
Low Heat Input (Btu)	1	2
Mid Heat Input (Btu)	2	2
High Heat Input (Btu)	2	2
<b>Gas Supply Line Pressure</b>		
Natural (minimum/maximum)	4.5/14.0	4.5/14.0
LP (minimum/maximum)	11.0/14.0	11.0/14.0
<b>Gas Connection Pipe Size (in)</b>		
Low Heat	1/2	3/4
Mid Heat	3/4	3/4
High Heat	3/4	3/4

(a) Cooling performance is rated at 95°F ambient, 80°F entering dry bulb, 67°F entering wet bulb. Gross capacity does not include the effect of fan motor heat. ARI capacity is net and includes the effect of fan motor heat. Units are suitable for operation to ±20% of nominal cfm. Units are certified in accordance with the Unitary Air-Conditioner Equipment certification program, which is based on ARI Standard 340/360.

(b) EER is rated at ARI conditions and in accordance with DOE test procedures.

(c) Integrated Efficiency Ratio (IEER) is rated in accordance with ARI Standard 340/360. The IEER rating requires that the unit efficiency be determined at 100%, 75%, 50% and 25% load (net capacity) at the specified in ARI Standard.

(d) 15.5 IEER for SZVAV.

(e) 14.5 IEER for SZVAV.

(f) Outdoor Sound Rating shown is tested in accordance with ARI Standard 270. For additional information refer to [Table 143, p. 184](#).

(g) Optional 2" MERV 7 and MERV 13 filters also available.

(h) Refrigerant charge is an approximate value. For a more precise value, see unit nameplate and service instructions.

(i) Heating performance limit settings and rating data were established and approved under laboratory test conditions using American National Standards Institute standards. Ratings shown are for elevations up to 2000 feet. For elevations above 2000 feet, ratings should be reduced at the rate of 4% for each 1000 feet above sea level. Applicable to Gas/Electric units only.

(j) AFUE is rated in accordance with DOE test procedures.





# Performance Data

**Table 9. Gross cooling capacities 3 tons standard efficiency - single phase T/YSC036E1**

		Ambient Temperature																	
		85						95						105					
Air Flow cfm	Ent DB (F)	Entering Wet Bulb																	
		61		67		73		61		67		73		61		67		73	
		MBh	SHC	MBh	SHC	MBh	SHC	MBh	SHC	MBh	SHC	MBh	SHC	MBh	SHC	MBh	SHC	MBh	SHC
960	75	32.7	26.3	36.4	19.7	40.1	12.2	30.2	24.8	33.6	18.1	37.2	10.7	27.4	23.0	30.7	16.7	34.1	9.2
960	80	33.4	32.2	36.8	25.1	40.8	18.7	30.9	30.6	34.1	23.3	37.9	17.2	28.5	28.5	31.2	21.9	34.9	15.8
960	85	35.2	35.2	37.2	30.4	41.2	23.7	33.0	33.0	34.5	28.8	38.3	22.3	30.6	30.6	31.7	27.2	35.2	20.5
960	90	37.4	37.4	37.8	36.3	41.5	28.9	35.2	35.2	35.2	34.8	38.6	27.4	32.8	32.8	32.7	32.7	35.6	25.9
1080	75	33.6	28.2	37.2	20.6	41.0	12.4	31.0	26.6	34.4	19.3	38.0	10.9	28.2	25.2	31.4	17.4	34.9	9.2
1080	80	34.6	34.5	37.7	26.6	41.7	19.7	32.2	32.2	34.9	25.2	38.8	17.6	29.8	29.8	31.9	23.5	35.6	16.2
1080	85	36.8	36.8	38.2	32.8	42.1	25.2	34.4	34.4	35.4	31.3	39.1	23.5	32.0	32.0	32.5	30.0	36.0	22.0
1080	90	39.1	39.1	39.2	39.1	42.4	30.9	36.8	36.8	36.7	36.7	39.5	29.4	34.3	34.3	34.2	34.2	36.4	27.9
1200	75	34.4	30.2	38.0	21.7	41.8	12.5	31.7	28.7	35.1	20.2	38.7	11.6	28.9	27.3	32.0	18.4	35.5	9.5
1200	80	35.8	35.8	38.5	28.2	42.6	20.0	33.4	33.4	35.6	26.9	39.5	18.6	30.9	30.9	32.6	25.1	36.2	16.9
1200	85	38.2	38.2	39.0	35.3	42.8	26.4	35.8	35.8	36.2	34.0	39.8	24.9	33.2	33.2	33.4	32.5	36.6	23.5
1200	90	40.6	40.6	40.6	40.6	43.2	33.1	38.2	38.2	38.1	38.1	40.2	31.5	35.6	35.6	35.5	35.5	37.1	29.9
1320	75	35.0	32.3	38.6	22.6	42.4	12.7	32.4	30.7	35.6	20.9	39.3	11.1	29.6	29.0	32.5	19.4	36.0	10.3
1320	80	37.0	37.0	39.1	30.3	43.2	20.9	34.5	34.5	36.2	28.5	40.0	19.3	31.8	31.8	33.2	26.8	36.7	17.7
1320	85	39.4	39.4	39.8	37.9	43.5	27.9	36.9	36.9	37.1	36.3	40.4	26.4	34.3	34.3	34.3	34.2	37.1	24.7
1320	90	41.9	41.9	41.9	41.9	43.9	35.0	39.4	39.4	39.4	39.4	40.8	33.6	36.7	36.7	36.6	36.6	37.6	32.2
1440	75	35.7	34.2	39.1	23.7	43.0	13.6	33.0	32.4	36.1	22.2	39.8	11.4	30.2	30.2	33.0	20.4	36.5	10.6
1440	80	38.0	38.0	39.7	31.6	43.7	21.7	35.4	35.4	36.7	30.1	40.5	20.4	32.7	32.7	33.7	28.8	37.1	18.4
1440	85	40.5	40.5	40.6	40.0	44.0	29.3	37.9	37.9	37.9	37.9	40.9	27.8	35.2	35.2	35.2	35.2	37.6	26.2
1440	90	43.1	43.1	43.1	43.1	44.5	37.2	40.5	40.5	40.4	40.4	41.5	36.1	37.7	37.7	37.7	37.7	38.3	34.8

		Ambient Temperature											
		115						125					
Air Flow cfm	Ent DB (F)	Entering Wet Bulb											
		61		67		73		61		67		73	
		MBh	SHC	MBh	SHC	MBh	SHC	MBh	SHC	MBh	SHC	MBh	SHC
960	75	24.6	21.5	27.7	14.7	31.0	8.1	21.7	19.3	24.2	14.1	27.9	5.9
960	80	26.0	26.0	28.1	20.2	31.6	14.2	23.1	23.1	24.8	19.5	27.9	12.9
960	85	28.1	28.1	28.7	25.9	32.0	19.0	25.6	25.6	25.9	24.0	28.3	19.0
960	90	30.2	30.2	30.2	30.2	32.4	24.2	27.3	27.3	27.3	27.3	29.1	24.3
1080	75	25.3	23.7	28.3	15.8	31.6	8.3	22.6	20.3	24.8	14.9	28.4	6.6
1080	80	27.1	27.1	28.8	21.8	32.3	14.6	24.0	24.0	25.7	20.4	28.6	13.7
1080	85	29.4	29.4	29.6	28.6	32.7	20.4	26.6	26.6	26.8	25.1	29.1	20.0
1080	90	31.6	31.6	31.6	31.6	33.1	26.3	28.4	28.4	28.4	28.4	30.0	25.4
1200	75	26.0	25.5	28.8	16.7	32.1	8.5	23.3	21.2	25.4	15.6	28.9	7.1
1200	80	28.2	28.2	29.4	23.5	32.8	15.6	24.9	24.9	26.4	21.3	29.2	14.4
1200	85	30.5	30.5	30.5	30.4	33.2	21.8	27.4	27.4	27.7	26.1	29.8	20.8
1200	90	32.8	32.8	32.8	32.8	33.8	28.5	29.4	29.4	29.4	29.4	30.9	26.3
1320	75	26.7	26.7	29.3	17.8	32.6	8.7	23.9	21.9	25.9	16.2	29.2	7.5
1320	80	29.1	29.1	29.9	25.4	33.2	16.4	25.6	25.6	26.9	22.0	29.6	14.9
1320	85	31.4	31.4	31.4	31.4	33.8	23.1	28.1	28.1	28.4	27.0	30.4	21.5
1320	90	33.8	33.8	33.8	33.8	34.3	31.1	30.2	30.2	30.2	30.2	31.6	27.2
1440	75	27.4	27.4	29.7	18.6	32.9	8.9	24.3	22.6	26.2	16.6	29.4	7.7
1440	80	29.9	29.9	30.4	27.3	33.6	16.7	26.2	26.2	27.4	22.6	29.9	15.3
1440	85	32.3	32.3	32.3	32.3	34.2	24.7	28.7	28.7	29.0	27.7	30.9	22.1
1440	90	34.7	34.7	34.7	34.7	35.0	33.5	31.0	31.0	31.0	31.0	32.2	27.9

**Notes:**

1. All capacities shown are gross and have not considered indoor fan heat. To obtain **NET** cooling capacity subtract indoor fan heat. For indoor fan heat formula, refer to appropriate airflow table notes.
2. MBh = Total Gross Capacity
3. SHC = Sensible Heat Capacity



## Performance Data

**Table 10. Gross cooling capacities 3 tons standard efficiency - three phase T/YSC036E3,4,W**

		Ambient Temperature																	
		85						95						105					
Air Flow cfm	Ent DB (F)	Entering Wet Bulb																	
		61		67		73		61		67		73		61		67		73	
		MBh	SHC	MBh	SHC	MBh	SHC	MBh	SHC	MBh	SHC	MBh	SHC	MBh	SHC	MBh	SHC	MBh	SHC
960	75	33.9	27.2	37.7	20.1	41.6	12.2	31.5	25.7	35.2	18.9	38.9	11.1	29.0	24.3	32.5	17.5	36.1	9.8
960	80	34.4	33.0	38.1	25.9	42.2	18.5	32.1	31.8	35.5	24.4	39.5	16.9	29.8	29.8	32.9	23.1	36.6	15.7
960	85	36.2	36.2	38.4	31.3	42.5	24.2	34.2	34.2	35.9	29.9	39.8	22.9	32.0	32.0	33.2	28.4	37.0	21.5
960	90	38.3	38.3	38.8	36.8	42.8	29.8	36.3	36.3	36.5	35.9	40.1	28.3	34.1	34.1	34.0	34.0	37.3	27.0
1080	75	34.9	29.1	38.7	21.5	42.6	12.9	32.4	27.7	36.0	19.8	39.8	11.8	29.8	26.2	33.3	18.4	36.9	9.9
1080	80	35.6	35.6	39.0	27.6	43.2	19.3	33.5	33.5	36.4	26.1	40.3	18.2	31.2	31.2	33.6	24.7	37.4	16.7
1080	85	37.9	37.9	39.4	33.5	43.5	25.8	35.7	35.7	36.8	32.2	40.7	24.5	33.5	33.5	34.1	30.9	37.8	23.3
1080	90	40.1	40.1	40.1	40.1	43.7	31.8	38.0	38.0	37.9	37.9	41.0	30.5	35.7	35.7	35.6	35.6	38.1	29.1
1200	75	35.6	31.1	39.4	22.3	43.4	13.3	33.2	29.7	36.7	21.0	40.5	11.2	30.5	28.3	33.9	19.3	37.5	10.1
1200	80	36.9	36.9	39.8	29.2	43.9	19.6	34.7	34.7	37.2	27.8	41.1	18.7	32.4	32.4	34.4	26.3	38.1	17.9
1200	85	39.3	39.3	40.2	36.1	44.3	27.3	37.1	37.1	37.6	34.8	41.5	26.0	34.7	34.7	35.0	33.8	38.5	24.6
1200	90	41.7	41.7	41.6	41.6	44.5	33.9	39.4	39.4	39.4	39.4	41.7	32.6	37.0	37.0	37.0	37.0	38.8	31.2
1320	75	36.3	33.1	40.1	23.3	44.0	13.2	33.8	31.7	37.3	22.0	41.1	11.4	31.2	30.4	34.4	20.1	38.0	10.0
1320	80	38.1	38.1	40.5	30.9	44.6	21.0	35.8	35.8	37.8	29.4	41.7	20.1	33.4	33.4	34.9	28.1	38.6	17.9
1320	85	40.6	40.6	41.0	38.8	45.0	28.7	38.3	38.3	38.5	37.6	42.0	27.0	35.8	35.8	35.9	35.8	39.0	25.9
1320	90	43.0	43.0	43.0	43.0	45.2	36.0	40.7	40.7	40.6	40.6	42.4	34.8	38.2	38.2	38.1	38.1	39.4	33.3
1440	75	37.0	35.1	40.6	24.3	44.6	13.4	34.5	33.8	37.8	22.8	41.6	12.0	31.8	31.8	34.9	21.5	38.5	10.7
1440	80	39.1	39.1	41.1	32.6	45.2	22.3	36.8	36.8	38.3	31.1	42.2	21.2	34.3	34.3	35.4	29.8	39.1	19.6
1440	85	41.7	41.7	41.8	41.3	45.5	30.2	39.3	39.3	39.3	39.3	42.5	28.7	36.8	36.8	36.8	36.8	39.5	27.1
1440	90	44.2	44.2	44.2	44.2	45.8	38.1	41.8	41.8	41.7	41.7	43.0	36.7	39.2	39.2	39.2	39.2	39.9	35.6

		Ambient Temperature											
		115						125					
Air Flow cfm	Ent DB (F)	Entering Wet Bulb											
		61		67		73		61		67		73	
		MBh	SHC	MBh	SHC	MBh	SHC	MBh	SHC	MBh	SHC	MBh	SHC
960	75	26.3	22.8	29.6	16.2	33.0	8.4	23.5	20.8	26.1	15.4	30.1	7.0
960	80	27.5	27.5	30.0	21.7	33.5	14.8	24.8	24.7	26.7	20.9	30.0	14.0
960	85	29.6	29.6	30.4	27.0	33.9	20.3	26.5	26.5	27.7	25.5	30.3	20.2
960	90	31.7	31.7	31.6	31.6	34.2	25.5	29.0	29.0	29.0	29.0	31.0	25.6
1080	75	27.0	24.8	30.3	16.9	33.7	8.6	24.4	21.9	26.9	16.3	30.7	7.7
1080	80	28.7	28.7	30.7	23.2	34.2	15.4	25.8	25.8	27.6	21.9	30.8	14.9
1080	85	30.9	30.9	31.2	29.8	34.6	21.6	27.6	27.6	28.7	26.7	31.2	21.3
1080	90	33.1	33.1	33.1	33.1	34.9	27.5	30.2	30.2	30.2	30.2	32.0	26.8
1200	75	27.7	27.0	30.8	18.0	34.3	8.7	25.2	22.8	27.5	17.0	31.2	8.3
1200	80	29.8	29.8	31.3	24.8	34.8	15.9	26.8	26.8	28.4	22.8	31.4	15.7
1200	85	32.1	32.1	32.1	32.1	35.2	23.0	29.4	29.4	29.7	27.7	32.0	22.2
1200	90	34.4	34.4	34.3	34.3	35.6	29.8	31.3	31.3	31.3	31.3	32.9	27.8
1320	75	28.4	28.4	31.3	18.7	34.7	8.6	25.8	23.6	28.0	17.7	31.5	8.7
1320	80	30.7	30.7	31.8	26.5	35.3	17.4	27.5	27.5	29.0	23.6	31.9	16.3
1320	85	33.1	33.1	33.1	33.1	35.7	24.4	30.1	30.1	30.4	28.7	32.6	22.9
1320	90	35.5	35.5	35.5	35.5	36.1	32.0	32.2	32.2	32.2	32.2	33.7	28.7
1440	75	29.1	29.1	31.7	19.8	35.1	9.2	26.3	24.2	28.3	18.1	31.7	9.0
1440	80	31.6	31.6	32.3	28.4	35.7	18.3	28.2	28.2	29.5	24.2	32.2	16.7
1440	85	34.0	34.0	34.0	34.0	36.2	25.9	30.7	30.7	31.1	29.4	33.1	23.6
1440	90	36.4	36.4	36.4	36.4	36.7	34.6	33.0	33.0	33.0	33.0	34.3	29.5

**Notes:**

1. All capacities shown are gross and have not considered indoor fan heat. To obtain **NET** cooling capacity subtract indoor fan heat. For indoor fan heat formula, refer to appropriate airflow table notes.
2. MBh = Total Gross Capacity
3. SHC = Sensible Heat Capacity

**Table 11. Gross cooling capacities 4 tons standard efficiency - single phase T/YSC048E1**

Air Flow cfm		Ent DB (F)		Ambient Temperature															
				85						95						105			
				Entering Wet Bulb															
		61		67		73		61		67		73		61		67		73	
		MBh	SHC	MBh	SHC	MBh	SHC	MBh	SHC	MBh	SHC	MBh	SHC	MBh	SHC	MBh	SHC	MBh	SHC
1280	75	45.0	35.9	50.4	26.8	56.0	16.7	41.7	34.0	46.8	24.9	52.3	15.7	38.1	31.9	43.1	22.9	48.3	13.8
1280	80	45.4	43.6	50.7	34.1	56.4	24.8	42.2	41.6	47.1	32.2	52.7	23.1	39.0	39.0	43.4	30.2	48.7	21.4
1280	85	47.7	47.7	50.9	41.5	56.7	32.1	44.9	44.9	47.5	39.6	53.0	30.3	41.8	41.8	43.8	37.7	49.1	28.4
1280	90	50.6	50.6	51.3	49.0	56.9	39.3	47.8	47.8	47.9	47.2	53.2	37.4	44.7	44.7	44.6	44.6	49.4	35.7
1440	75	46.2	38.6	51.6	28.3	57.2	17.8	42.8	36.7	48.0	26.4	53.4	15.6	39.1	34.6	44.1	24.4	49.3	15.6
1440	80	46.9	46.9	51.9	36.5	57.6	26.2	44.0	44.0	48.3	34.6	53.9	24.3	40.8	40.8	44.4	32.6	49.7	22.0
1440	85	49.9	49.9	52.2	44.8	57.9	34.2	47.0	47.0	48.6	42.9	54.1	32.3	43.8	43.8	44.9	41.1	50.1	30.4
1440	90	53.0	53.0	52.9	52.9	58.2	42.3	50.0	50.0	49.9	49.9	54.4	40.5	46.8	46.8	46.7	46.7	50.3	38.7
1600	75	47.2	41.3	52.6	29.7	58.3	18.0	43.8	39.3	48.9	27.8	54.3	18.1	40.0	37.4	44.9	25.8	50.2	14.1
1600	80	48.7	48.7	52.9	38.8	58.8	27.2	45.7	45.7	49.2	36.9	54.8	25.4	42.4	42.4	45.3	35.0	50.6	23.5
1600	85	51.9	51.9	53.3	48.2	59.0	36.2	48.8	48.8	49.7	46.4	55.1	34.4	45.5	45.5	45.9	44.4	51.0	32.5
1600	90	55.0	55.0	55.0	55.0	59.2	45.3	51.9	51.9	51.9	51.9	55.4	43.5	48.6	48.6	48.6	48.6	51.4	41.8
1760	75	48.2	44.0	53.5	31.1	59.1	18.2	44.6	42.0	49.7	29.2	55.1	16.2	40.8	40.0	45.6	27.1	50.8	14.8
1760	80	50.3	50.3	53.8	41.2	59.6	28.3	47.1	47.1	50.1	39.3	55.6	26.5	43.8	43.8	46.0	37.3	51.4	24.6
1760	85	53.6	53.6	54.2	51.5	59.9	38.3	50.4	50.4	50.7	49.7	56.0	36.4	47.0	47.0	46.9	46.9	51.7	34.6
1760	90	56.8	56.8	56.8	56.8	60.1	48.3	53.7	53.7	53.6	53.6	56.3	46.5	50.2	50.2	50.2	50.2	52.1	44.7
1920	75	48.9	46.6	54.2	32.5	59.9	20.1	45.3	44.7	50.3	30.6	55.7	17.1	41.7	41.7	46.2	28.7	51.4	14.4
1920	80	51.7	51.7	54.5	43.5	60.4	29.4	48.5	48.5	50.8	41.7	56.3	27.7	45.0	45.0	46.7	39.7	52.0	25.8
1920	85	55.0	55.0	55.3	54.9	60.6	40.3	51.8	51.8	51.8	51.8	56.6	38.5	48.3	48.3	48.3	48.3	52.4	36.6
1920	90	58.4	58.4	58.3	58.3	60.9	51.3	55.2	55.2	55.1	55.1	57.0	49.6	51.7	51.7	51.6	51.6	52.9	47.8

Air Flow cfm		Ent DB (F)		Ambient Temperature											
				115						125					
				Entering Wet Bulb											
		61		67		73		61		67		73			
		MBh	SHC	MBh	SHC	MBh	SHC	MBh	SHC	MBh	SHC	MBh	SHC		
1280	75	34.4	29.9	39.1	20.9	44.0	12.7	30.5	27.0	34.2	19.9	39.9	8.9		
1280	80	35.7	35.7	39.4	28.2	44.5	19.2	32.2	32.0	34.9	27.0	39.6	18.1		
1280	85	38.5	38.5	39.8	35.7	44.8	26.4	34.3	34.3	36.1	33.0	39.9	26.2		
1280	90	41.4	41.4	41.3	41.3	45.2	33.7	37.5	37.5	37.9	37.8	40.7	33.1		
1440	75	35.3	32.6	40.0	22.3	44.9	11.9	31.7	28.3	35.2	21.0	40.7	9.8		
1440	80	37.4	37.4	40.3	30.6	45.5	20.3	33.5	33.5	36.1	28.3	40.6	19.2		
1440	85	40.4	40.4	40.9	39.1	45.8	28.5	35.9	35.9	37.5	34.5	41.1	27.5		
1440	90	43.3	43.3	43.3	43.3	46.2	36.7	39.5	39.5	39.5	39.5	42.1	34.7		
1600	75	36.1	35.2	40.7	23.7	45.6	12.5	32.8	29.5	36.1	22.0	41.3	10.6		
1600	80	38.9	38.9	41.2	33.0	46.3	21.4	34.8	34.8	37.1	29.6	41.4	20.3		
1600	85	41.9	41.9	42.0	42.0	46.6	30.6	37.3	37.3	38.7	36.0	42.1	28.8		
1600	90	45.0	45.0	45.0	45.0	47.0	39.8	40.9	40.9	40.9	40.9	43.3	36.1		
1760	75	37.0	37.0	41.3	25.2	46.3	12.6	33.6	30.6	36.8	22.9	41.8	11.4		
1760	80	40.2	40.2	41.8	35.3	46.8	22.6	35.8	35.8	38.0	30.7	42.1	21.2		
1760	85	43.4	43.4	43.3	43.3	47.2	32.6	38.6	38.6	39.8	37.3	42.9	29.9		
1760	90	46.5	46.5	46.4	46.4	47.7	42.8	42.1	42.1	42.1	42.1	44.3	37.5		
1920	75	38.1	38.1	41.8	26.5	46.8	12.4	34.4	31.7	37.3	23.8	42.1	12.0		
1920	80	41.3	41.3	42.4	37.7	47.4	23.7	36.7	36.7	38.7	31.8	42.6	22.1		
1920	85	44.6	44.6	44.6	44.6	47.9	34.7	39.7	39.7	40.7	38.6	43.6	31.0		
1920	90	47.8	47.8	47.8	47.8	48.3	45.8	43.2	43.2	43.2	43.2	45.2	38.8		

**Notes:**

1. All capacities shown are gross and have not considered indoor fan heat. To obtain **NET** cooling capacity subtract indoor fan heat. For indoor fan heat formula, refer to appropriate airflow table notes.
2. MBh = Total Gross Capacity
3. SHC = Sensible Heat Capacity



## Performance Data

**Table 12. Gross cooling capacities 4 tons standard efficiency - three phase T/YSC048E3,4,W**

		Ambient Temperature																	
		85						95						105					
Air Flow cfm	Ent DB (F)	Entering Wet Bulb																	
		61		67		73		61		67		73		61		67		73	
		MBh	SHC	MBh	SHC	MBh	SHC	MBh	SHC	MBh	SHC	MBh	SHC	MBh	SHC	MBh	SHC	MBh	SHC
1280	75	45.0	36.2	50.4	27.1	56.1	17.9	41.6	34.3	47.0	25.4	52.3	15.7	38.1	32.3	43.1	23.0	48.3	13.8
1280	80	45.5	43.8	50.8	34.4	56.6	25.0	42.3	42.0	47.3	32.6	52.8	24.0	39.2	39.2	43.5	30.6	48.7	20.6
1280	85	48.1	48.1	51.2	42.0	56.9	32.4	45.2	45.2	47.7	40.1	53.2	30.5	42.2	42.2	44.0	38.1	49.3	29.3
1280	90	51.1	51.1	51.7	49.4	57.3	39.8	48.2	48.2	48.3	47.7	53.6	38.0	45.1	45.1	45.1	45.1	49.6	36.3
1440	75	46.2	38.9	51.7	28.6	57.3	17.6	42.8	37.0	48.0	26.6	53.5	16.0	39.2	35.0	44.1	24.5	49.3	14.0
1440	80	47.2	47.2	52.0	36.8	57.9	25.5	44.2	44.2	48.4	34.9	54.0	24.4	41.1	41.1	44.6	33.1	49.9	22.8
1440	85	50.4	50.4	52.5	45.3	58.3	34.5	47.4	47.4	48.9	43.4	54.4	32.7	44.2	44.2	45.2	41.5	50.3	31.0
1440	90	53.5	53.5	53.5	53.5	58.7	42.8	50.5	50.5	50.4	50.4	54.8	40.9	47.3	47.3	47.2	47.2	50.8	39.2
1600	75	47.3	41.6	52.7	29.9	58.3	17.6	43.8	39.7	48.9	27.9	54.4	16.2	40.1	37.6	44.9	25.9	50.1	14.1
1600	80	49.1	49.1	53.1	39.2	59.0	27.8	46.0	46.0	49.4	37.3	55.0	25.6	42.7	42.7	45.5	35.5	50.8	23.8
1600	85	52.3	52.3	53.7	48.6	59.4	36.5	49.3	49.3	50.0	46.6	55.4	35.0	46.0	46.0	46.2	44.9	51.2	32.9
1600	90	55.6	55.6	55.6	55.6	59.8	45.8	52.5	52.5	52.4	52.4	55.9	44.1	49.2	49.2	49.1	49.1	51.8	42.3
1760	75	48.3	44.3	53.5	31.3	59.3	18.4	44.7	42.3	49.7	29.3	55.2	16.2	41.0	40.5	45.6	27.7	50.8	14.5
1760	80	50.7	50.7	54.1	41.6	59.9	28.9	47.6	47.6	50.3	39.7	55.9	27.0	44.1	44.1	46.3	37.8	51.5	24.7
1760	85	54.1	54.1	54.7	51.9	60.3	38.6	50.9	50.9	51.1	50.2	56.3	36.8	47.5	47.5	47.4	47.4	52.0	34.8
1760	90	57.5	57.5	57.5	57.5	60.8	48.9	54.3	54.3	54.3	54.3	56.9	47.2	50.8	50.8	50.7	50.7	52.6	45.2
1920	75	49.1	46.9	54.3	32.9	59.9	18.3	45.5	45.0	50.4	30.8	55.8	16.6	42.0	42.0	46.2	29.0	51.3	15.3
1920	80	52.1	52.1	54.8	44.1	60.7	30.0	48.9	48.9	51.1	42.1	56.5	27.3	45.4	45.4	46.9	40.1	52.1	26.2
1920	85	55.6	55.6	55.7	55.3	61.1	40.8	52.3	52.3	52.3	52.3	57.0	38.9	48.8	48.8	48.8	48.8	52.7	37.1
1920	90	59.2	59.2	59.2	59.2	61.6	52.0	55.8	55.8	55.8	55.8	57.6	50.1	52.3	52.3	52.2	52.2	53.4	48.1
		Ambient Temperature																	
		115									125								
Air Flow cfm	Ent DB (F)	Entering Wet Bulb																	
		61		67		73		61		67		73		61		67		73	
		MBh	SHC	MBh	SHC	MBh	SHC	MBh	SHC	MBh	SHC	MBh	SHC	MBh	SHC	MBh	SHC	MBh	SHC
1280	75	34.3	30.2	39.0	21.0	44.0	11.9	30.7	27.2	34.3	20.3	39.9	9.6						
1280	80	36.0	36.0	39.5	28.6	44.5	19.5	32.4	32.2	35.1	27.4	39.7	18.8						
1280	85	38.9	38.9	40.0	36.2	45.0	26.7	34.7	34.7	36.4	33.4	40.1	26.8						
1280	90	41.8	41.8	41.7	41.7	45.4	34.2	37.9	37.9	38.3	38.2	41.0	33.7						
1440	75	35.3	32.9	39.9	22.7	44.8	11.5	31.8	28.6	35.3	21.5	40.6	10.6						
1440	80	37.7	37.7	40.5	31.1	45.5	20.6	33.8	33.8	36.3	28.9	40.7	20.0						
1440	85	40.8	40.8	41.0	39.5	46.0	28.8	36.3	36.3	37.8	35.0	41.3	28.2						
1440	90	43.8	43.8	43.7	43.7	46.4	37.2	39.9	39.9	39.9	39.9	42.4	35.3						
1600	75	36.2	35.7	40.7	23.7	45.5	11.5	32.9	29.9	36.1	22.6	41.2	11.4						
1600	80	39.2	39.2	41.3	33.4	46.3	21.7	35.0	35.0	37.3	30.1	41.5	21.0						
1600	85	42.4	42.4	42.3	42.3	46.8	30.9	37.7	37.7	39.0	36.5	42.3	29.5						
1600	90	45.5	45.5	45.5	45.5	47.4	40.5	41.3	41.3	41.3	41.3	43.6	36.8						
1760	75	37.2	37.2	41.3	25.7	46.2	12.5	33.7	31.0	36.7	23.5	41.7	12.1						
1760	80	40.5	40.5	42.0	35.8	46.9	23.0	36.1	36.1	38.1	31.3	42.1	21.9						
1760	85	43.8	43.8	43.8	43.8	47.5	32.9	38.9	38.9	40.1	37.9	43.1	30.6						
1760	90	47.0	47.0	46.9	46.9	48.1	43.4	42.6	42.6	42.6	42.6	44.7	38.2						
1920	75	38.3	38.3	41.8	26.9	46.8	13.0	34.4	32.0	37.2	24.2	42.0	12.6						
1920	80	41.7	41.7	42.6	38.1	47.5	24.1	37.0	37.0	38.8	32.2	42.6	22.7						
1920	85	45.0	45.0	44.9	44.9	48.0	35.0	40.6	40.6	41.0	39.1	43.8	31.6						
1920	90	48.4	48.4	48.4	48.4	48.8	46.4	43.7	43.7	43.7	43.7	45.6	39.4						

**Notes:**

1. All capacities shown are gross and have not considered indoor fan heat. To obtain **NET** cooling capacity subtract indoor fan heat. For indoor fan heat formula, refer to appropriate airflow table notes.
2. MBh = Total Gross Capacity
3. SHC = Sensible Heat Capacity

**Table 13. Gross cooling capacities 5 tons standard efficiency - single phase T/YSC060E1**

		Ambient Temperature																	
		85						95						105					
Air Flow cfm	Ent DB (F)	Entering Wet Bulb																	
		61		67		73		61		67		73		61		67		73	
		MBh	SHC	MBh	SHC	MBh	SHC	MBh	SHC	MBh	SHC	MBh	SHC	MBh	SHC	MBh	SHC	MBh	SHC
1600	75	55.1	45.0	61.1	33.1	67.6	20.1	51.4	43.0	57.2	30.8	63.4	18.3	47.4	40.9	53.0	29.1	58.9	16.5
1600	80	55.7	54.7	61.5	42.2	68.0	29.8	52.2	52.2	57.6	40.3	63.9	28.0	48.7	48.7	53.4	38.3	59.4	26.1
1600	85	58.6	58.6	61.9	51.6	68.4	39.3	55.5	55.5	58.0	49.7	64.2	37.4	52.0	52.0	53.8	47.8	59.7	35.5
1600	90	62.1	62.1	62.5	61.3	68.7	48.5	58.8	58.8	58.9	58.8	64.5	46.6	55.3	55.3	55.2	55.2	60.1	44.8
1800	75	56.4	48.2	62.4	34.4	69.0	21.3	52.6	46.3	58.4	32.8	64.7	18.5	48.5	44.2	54.1	30.8	60.1	17.6
1800	80	57.5	57.5	62.8	45.1	69.4	31.1	54.3	54.3	58.9	43.2	65.2	29.5	50.7	50.7	54.5	41.2	60.5	27.6
1800	85	61.1	61.1	63.3	55.7	69.8	41.7	57.8	57.8	59.3	53.8	65.5	39.9	54.2	54.2	55.1	51.9	60.9	38.0
1800	90	64.7	64.7	64.6	64.6	70.1	52.1	61.3	61.3	61.2	61.2	65.9	50.3	57.6	57.6	57.6	57.6	61.3	48.4
2000	75	57.5	51.4	63.6	36.1	70.1	21.4	53.7	49.5	59.5	34.1	65.8	19.9	49.6	47.6	55.0	32.2	61.1	17.4
2000	80	59.5	59.5	64.0	47.9	70.6	32.6	56.1	56.1	59.9	46.0	66.3	30.7	52.5	52.5	55.5	44.1	61.6	28.8
2000	85	63.2	63.2	64.6	59.7	71.0	44.1	59.8	59.8	60.5	58.0	66.6	42.5	56.1	56.1	56.4	56.0	61.9	40.4
2000	90	67.0	67.0	66.9	66.9	71.4	55.8	63.5	63.5	63.5	63.5	67.0	53.9	59.7	59.7	59.6	59.6	62.3	52.1
2200	75	58.6	54.7	64.6	37.8	71.2	22.1	54.7	52.8	60.3	35.9	66.7	18.5	50.6	50.3	55.8	34.0	61.9	17.6
2200	80	61.3	61.3	65.0	50.7	71.6	33.9	57.8	57.8	60.8	48.9	67.2	32.1	54.0	54.0	56.3	47.0	62.3	30.2
2200	85	65.1	65.1	65.8	63.9	72.0	46.6	61.6	61.6	61.8	61.6	67.5	44.8	57.8	57.8	57.7	57.7	62.7	42.9
2200	90	69.0	69.0	68.9	68.9	72.4	59.3	65.4	65.4	65.4	65.4	68.0	57.7	61.4	61.4	61.4	61.4	63.2	55.8
2400	75	59.5	57.9	65.4	39.5	72.1	20.4	55.6	55.4	61.1	37.6	67.4	19.7	51.6	51.6	56.5	35.6	62.5	17.6
2400	80	62.8	62.8	65.9	53.6	72.5	34.9	59.2	59.2	61.6	51.8	68.0	33.5	55.3	55.3	57.0	49.8	63.1	31.5
2400	85	66.8	66.8	66.9	66.8	72.9	49.2	63.2	63.2	63.2	63.2	68.3	47.3	59.2	59.2	59.1	59.1	63.4	45.4
2400	90	70.9	70.9	70.7	70.7	73.3	63.1	67.0	67.0	67.0	67.0	68.8	61.4	63.0	63.0	62.9	62.9	64.0	59.7

		Ambient Temperature																
		115						125										
Air Flow cfm	Ent DB (F)	Entering Wet Bulb																
		61		67		73		61		67		73		61		67		73
		MBh	SHC	MBh	SHC	MBh	SHC	MBh	SHC	MBh	SHC	MBh	SHC	MBh	SHC	MBh	SHC	MBh
1600	75	43.1	38.8	48.4	26.7	54.1	14.9	38.8	35.1	43.0	26.2	49.3	12.2					
1600	80	45.0	45.0	48.8	36.3	54.5	24.2	40.7	40.7	43.7	35.0	48.9	23.7					
1600	85	48.2	48.2	49.3	45.8	54.8	33.5	43.2	43.2	45.1	42.3	49.2	33.8					
1600	90	51.4	51.4	51.4	51.4	55.1	42.8	47.1	47.1	47.1	47.1	50.1	42.4					
1800	75	44.2	42.1	49.4	28.4	55.1	15.2	40.2	36.6	44.1	27.4	50.2	13.2					
1800	80	46.9	46.9	49.8	39.1	55.5	25.5	42.2	42.2	45.0	36.5	50.1	25.0					
1800	85	50.2	50.2	50.5	49.9	55.8	35.9	44.9	44.9	46.6	44.1	50.5	35.3					
1800	90	53.5	53.5	53.5	53.5	56.2	46.5	48.8	48.8	48.8	48.8	51.6	44.1					
2000	75	45.2	45.0	50.2	30.2	55.9	15.2	41.3	38.0	45.0	28.6	50.9	14.0					
2000	80	48.5	48.5	50.7	42.0	56.3	26.9	43.6	43.6	46.2	37.8	51.0	26.1					
2000	85	51.9	51.9	51.9	51.9	56.7	38.5	46.5	46.5	48.0	45.6	51.7	36.6					
2000	90	55.4	55.4	55.4	55.4	57.2	50.2	50.4	50.4	50.4	50.4	53.0	45.7					
2200	75	46.3	46.3	50.9	31.9	56.6	15.6	42.3	39.2	45.7	29.5	51.4	14.7					
2200	80	49.8	49.8	51.4	44.9	57.0	28.2	44.8	44.8	47.1	39.0	51.7	27.0					
2200	85	53.4	53.4	53.4	53.4	57.4	41.0	47.9	47.9	49.1	47.0	52.6	37.8					
2200	90	57.0	57.0	57.0	57.0	58.0	54.0	51.8	51.8	51.8	51.8	54.2	47.1					
2400	75	47.5	47.5	51.5	33.6	57.2	15.7	43.1	40.2	46.3	30.3	51.8	15.3					
2400	80	51.0	51.0	52.1	47.9	57.6	29.6	45.8	45.8	47.9	40.0	52.3	27.8					
2400	85	54.7	54.7	54.7	54.7	58.0	43.6	49.6	49.6	50.1	48.3	53.4	38.8					
2400	90	58.4	58.4	58.4	58.4	58.8	57.7	53.0	53.0	53.0	53.0	55.2	48.3					

**Notes:**

1. All capacities shown are gross and have not considered indoor fan heat. To obtain **NET** cooling capacity subtract indoor fan heat. For indoor fan heat formula, refer to appropriate airflow table notes.
2. MBh = Total Gross Capacity
3. SHC = Sensible Heat Capacity



## Performance Data

**Table 14. Gross cooling capacities 5 tons standard efficiency - three phase T/YSC060E3,4,W**

		Ambient Temperature																	
		85						95						105					
Air Flow cfm	Ent DB (F)	Entering Wet Bulb																	
		61		67		73		61		67		73		61		67		73	
		MBh	SHC	MBh	SHC	MBh	SHC	MBh	SHC	MBh	SHC	MBh	SHC	MBh	SHC	MBh	SHC	MBh	SHC
1600	75	57.3	46.6	63.6	34.8	70.2	23.4	53.3	44.5	59.4	32.7	65.8	21.3	49.2	42.2	55.0	30.7	61.1	18.4
1600	80	57.8	56.1	63.9	44.0	70.7	32.1	54.0	53.9	59.7	41.9	66.2	30.2	50.4	50.4	55.3	39.9	61.5	28.5
1600	85	60.9	60.9	64.4	53.5	71.0	41.1	57.5	57.5	60.2	51.5	66.5	39.1	53.8	53.8	55.7	49.2	61.8	36.9
1600	90	64.4	64.4	64.9	62.9	71.3	50.3	60.9	60.9	60.8	60.7	66.9	48.7	57.2	57.2	57.1	57.1	62.1	46.2
1800	75	58.8	50.1	65.0	36.7	71.7	22.6	54.7	47.9	60.6	35.4	67.1	20.8	50.3	45.5	56.1	32.4	62.3	19.5
1800	80	59.9	59.9	65.4	47.0	72.1	33.4	56.3	56.3	61.1	44.9	67.5	31.4	52.6	52.6	56.6	42.9	62.7	29.6
1800	85	63.5	63.5	65.9	57.7	72.5	43.9	59.9	59.9	61.6	55.6	67.9	41.6	56.1	56.1	57.0	53.3	63.0	39.8
1800	90	67.1	67.1	67.1	67.1	72.9	54.1	63.5	63.5	63.5	63.5	68.2	52.3	59.6	59.6	59.5	59.5	63.4	50.3
2000	75	60.0	53.4	66.2	38.7	72.9	24.5	55.8	51.1	61.8	35.8	68.2	22.4	51.5	49.0	57.1	34.3	63.3	20.3
2000	80	62.0	62.0	66.7	50.2	73.4	35.3	58.4	58.4	62.3	48.1	68.6	33.6	54.5	54.5	57.6	46.0	63.6	30.5
2000	85	65.8	65.8	67.2	61.8	73.8	46.5	62.1	62.1	62.8	59.8	69.1	44.7	58.1	58.1	58.1	57.5	64.1	42.6
2000	90	69.6	69.6	69.6	69.6	74.1	58.0	65.8	65.8	65.8	65.8	69.3	56.1	61.7	61.7	61.7	61.7	64.5	54.2
2200	75	61.0	56.8	67.3	41.3	74.0	24.2	56.8	54.4	62.7	38.2	69.2	22.2	52.4	52.1	58.0	36.2	64.1	21.3
2200	80	63.9	63.9	67.7	53.1	74.5	38.1	60.1	60.1	63.2	51.0	69.6	35.1	56.1	56.1	58.5	49.0	64.6	32.2
2200	85	67.8	67.8	68.4	66.0	74.8	49.4	64.0	64.0	64.0	63.7	70.0	47.3	59.9	59.9	59.7	59.7	64.9	45.4
2200	90	71.7	71.7	71.8	71.8	75.2	62.0	67.8	67.8	67.8	67.8	70.4	60.1	63.6	63.6	63.5	63.5	65.2	57.8
2400	75	62.0	60.1	68.1	42.2	74.9	24.2	57.8	57.6	63.5	40.0	70.0	22.2	53.7	53.7	58.7	38.0	64.9	20.6
2400	80	65.6	65.6	68.6	56.1	75.2	39.4	61.7	61.7	64.0	54.1	70.5	36.4	57.6	57.6	59.2	51.9	65.3	34.4
2400	85	69.6	69.6	69.6	69.5	75.7	51.8	65.7	65.7	65.6	65.6	70.9	50.1	61.4	61.4	61.4	61.4	65.7	47.9
2400	90	73.6	73.6	73.5	73.5	76.2	65.7	69.6	69.6	69.5	69.5	71.2	63.6	65.2	65.2	65.2	65.2	66.1	61.5

		Ambient Temperature											
		115						125					
Air Flow cfm	Ent DB (F)	Entering Wet Bulb											
		61		67		73		61		67		73	
		MBh	SHC	MBh	SHC	MBh	SHC	MBh	SHC	MBh	SHC	MBh	SHC
1600	75	44.8	40.0	50.2	28.5	56.0	17.0	40.6	36.3	44.9	27.9	51.4	15.0
1600	80	46.6	46.6	50.6	37.7	56.4	26.1	42.5	42.2	45.7	36.3	51.0	25.9
1600	85	49.9	49.9	51.0	47.0	56.7	35.0	45.1	45.1	47.0	43.3	51.3	35.3
1600	90	53.1	53.1	53.1	53.1	57.1	44.4	48.6	48.6	49.1	48.8	52.2	43.4
1800	75	45.8	43.3	51.2	30.4	57.1	18.0	42.0	38.0	46.0	29.4	52.3	16.2
1800	80	48.6	48.6	51.7	40.7	57.4	27.8	44.1	44.1	47.0	38.1	52.1	27.4
1800	85	52.0	52.0	52.2	51.2	57.8	37.7	46.9	46.9	48.6	45.3	52.6	37.1
1800	90	55.4	55.4	55.3	55.3	58.2	48.2	50.9	50.9	50.9	50.9	53.7	45.4
2000	75	46.9	46.7	52.1	32.2	58.0	16.9	43.2	39.6	47.0	30.7	53.0	17.3
2000	80	50.3	50.3	52.6	43.7	58.3	29.6	45.6	45.6	48.2	39.6	53.0	28.7
2000	85	53.8	53.8	53.8	53.8	58.7	40.5	48.5	48.5	50.0	47.1	53.8	38.7
2000	90	57.3	57.3	57.3	57.3	59.1	52.0	52.5	52.5	52.5	52.5	55.1	47.3
2200	75	48.2	48.2	52.9	34.0	58.7	17.6	44.2	40.9	47.7	31.8	53.5	18.2
2200	80	51.8	51.8	53.4	46.7	59.0	30.4	46.8	46.8	49.2	41.0	53.8	29.9
2200	85	55.4	55.4	55.4	55.4	59.4	43.1	50.0	50.0	51.2	48.8	54.7	40.2
2200	90	59.0	59.0	59.0	59.0	59.9	55.7	53.9	53.9	53.9	53.9	56.3	49.0
2400	75	49.3	49.3	53.5	35.7	59.3	17.7	45.0	42.1	48.3	32.8	53.8	18.9
2400	80	53.1	53.1	54.0	49.5	59.7	32.2	47.8	47.8	49.9	42.2	54.3	30.9
2400	85	56.8	56.8	56.8	56.8	60.1	45.8	51.7	51.7	52.2	50.3	55.5	41.4
2400	90	60.5	60.5	60.5	60.5	60.7	59.5	55.2	55.2	55.2	55.2	57.3	50.5

**Notes:**

1. All capacities shown are gross and have not considered indoor fan heat. To obtain **NET** cooling capacity subtract indoor fan heat. For indoor fan heat formula, refer to appropriate airflow table notes.
2. MBh = Total Gross Capacity
3. SHC = Sensible Heat Capacity

**Table 15. Gross cooling capacities 6 tons standard efficiency - three phase T/YSC072F3,4,W**

		Ambient Temperature																	
		85						95						105					
Air Flow cfm	Ent DB (F)	Entering Wet Bulb																	
		61		67		73		61		67		73		61		67		73	
		MBh	SHC	MBh	SHC	MBh	SHC	MBh	SHC	MBh	SHC	MBh	SHC	MBh	SHC	MBh	SHC	MBh	SHC
1920	75	69.0	55.1	75.2	40.7	83.7	19.8	65.0	52.5	70.8	38.6	79.0	18.1	60.7	49.8	66.2	36.3	74.0	16.3
1920	80	70.7	64.2	75.8	53.2	83.1	35.7	66.8	61.4	71.5	50.9	78.5	33.8	62.6	58.5	66.9	48.3	73.6	31.7
1920	85	73.0	71.4	76.9	63.8	83.1	49.8	69.2	68.4	72.7	61.3	78.5	47.6	65.1	65.1	68.2	58.5	73.7	45.3
1920	90	75.9	75.9	78.6	72.6	83.6	62.0	72.1	72.1	74.5	69.8	79.1	59.6	68.1	68.1	70.1	66.8	74.3	57.0
2160	75	71.0	57.3	77.0	42.5	85.3	21.2	66.9	54.7	72.5	40.3	80.4	19.4	62.5	51.8	67.8	37.9	75.3	17.5
2160	80	73.0	66.6	77.8	55.2	84.9	37.4	68.9	63.8	73.4	52.8	80.1	35.4	64.6	60.7	68.7	50.2	75.1	33.2
2160	85	75.5	74.1	79.1	66.1	85.0	51.7	71.5	71.0	74.8	63.4	80.3	49.4	67.3	67.3	70.2	60.5	75.4	46.9
2160	90	78.5	78.5	81.0	75.1	85.7	64.1	74.6	74.6	76.7	72.2	81.1	61.6	70.5	70.5	72.2	69.1	76.3	58.9
2400	75	72.8	59.3	78.5	44.1	86.5	22.5	68.6	56.6	73.9	41.8	81.6	20.6	64.1	53.6	69.1	39.3	76.4	18.5
2400	80	74.9	68.9	79.5	57.1	86.3	38.8	70.8	65.9	75.0	54.5	81.5	36.7	66.4	62.7	70.2	51.8	76.4	34.4
2400	85	77.6	76.6	81.0	68.2	86.7	53.4	73.6	73.4	76.6	65.4	81.9	51.0	69.2	69.2	71.9	62.4	76.9	48.4
2400	90	80.9	80.9	83.1	77.5	87.6	66.0	76.9	76.9	78.8	74.4	82.9	63.4	72.7	72.7	74.2	71.2	77.9	60.6
2640	75	74.3	61.2	79.8	45.6	87.6	23.5	70.0	58.3	75.1	43.2	82.5	21.5	65.4	55.3	70.2	40.6	77.2	19.3
2640	80	76.7	71.0	81.0	58.8	87.6	40.1	72.4	67.9	76.4	56.1	82.6	37.9	67.9	64.6	71.5	53.3	77.4	35.5
2640	85	79.6	78.9	82.7	70.1	88.1	54.9	75.4	75.4	78.2	67.2	83.2	52.4	71.0	71.0	73.4	64.1	78.1	49.7
2640	90	83.0	83.0	85.0	79.6	89.2	67.7	78.9	78.9	80.5	76.5	84.4	65.0	74.6	74.6	75.8	73.1	79.4	62.1
2880	75	75.6	62.9	80.8	46.9	88.4	24.4	71.1	59.9	76.0	44.4	83.2	22.3	66.5	56.8	71.0	41.6	77.8	20.0
2880	80	78.1	72.9	82.2	60.3	88.6	41.3	73.8	69.7	77.5	57.5	83.5	38.9	69.2	66.3	72.5	54.6	78.2	36.4
2880	85	81.2	81.1	84.1	71.9	89.3	56.2	76.9	76.9	79.5	68.9	84.3	53.6	72.4	72.4	74.6	65.7	79.1	50.9
2880	90	84.9	84.9	86.6	81.6	90.6	69.3	80.7	80.7	82.0	78.3	85.7	66.5	76.2	76.2	77.2	74.9	80.5	63.5
		Ambient Temperature																	
		115						125											
Air Flow cfm	Ent DB (F)	Entering Wet Bulb																	
		61		67		73		61		67		73							
		MBh	SHC	MBh	SHC	MBh	SHC	MBh	SHC	MBh	SHC	MBh	SHC	MBh	SHC	MBh	SHC	MBh	SHC
1920	75	56.2	46.9	61.3	33.8	68.8	14.3	51.4	43.8	56.2	31.2	63.3	12.0						
1920	80	58.2	55.3	62.2	45.6	68.4	29.4	53.5	52.0	57.1	42.7	63.0	27.0						
1920	85	60.7	60.7	63.5	55.5	68.6	42.8	56.1	56.1	58.6	52.4	63.3	40.1						
1920	90	64.8	64.8	65.4	63.6	69.4	54.2	60.0	60.0	60.6	60.2	64.1	51.3						
2160	75	57.9	48.8	62.8	35.3	70.0	15.3	53.0	45.6	57.6	32.5	64.4	13.0						
2160	80	60.1	57.4	63.8	47.3	69.9	30.8	55.3	54.0	58.7	44.3	64.4	28.2						
2160	85	62.8	62.8	65.4	57.5	70.2	44.3	58.1	58.1	60.3	54.2	64.8	41.5						
2160	90	66.8	66.8	67.5	65.8	71.2	56.0	61.9	61.9	62.5	62.3	65.9	52.9						
2400	75	59.4	50.5	64.0	36.6	71.0	16.2	54.4	47.2	58.7	33.7	65.3	13.8						
2400	80	61.7	59.4	65.2	48.9	71.0	31.9	56.9	55.8	60.0	45.7	65.4	29.2						
2400	85	64.7	64.7	67.0	59.2	71.6	45.7	59.9	59.9	61.8	55.9	66.1	42.7						
2400	90	68.6	68.6	69.3	67.7	72.8	57.6	63.6	63.6	64.2	64.1	67.3	54.4						
2640	75	60.6	52.1	65.0	37.7	71.7	17.0	55.5	48.6	59.6	34.8	65.9	14.4						
2640	80	63.2	61.1	66.4	50.2	71.9	32.9	58.2	57.5	61.1	47.0	66.2	30.1						
2640	85	66.3	66.3	68.4	60.8	72.7	46.9	61.4	61.4	63.1	57.4	67.1	43.8						
2640	90	70.2	70.2	70.9	69.6	74.1	59.0	65.7	65.7	65.7	65.7	68.5	55.7						
2880	75	61.5	53.4	65.7	38.7	72.2	17.5	56.3	49.9	60.2	35.6	66.3	14.9						
2880	80	64.3	62.7	67.3	51.4	72.6	33.6	59.2	59.0	61.9	48.1	66.8	30.7						
2880	85	67.6	67.6	69.5	62.3	73.6	47.9	62.6	62.6	64.1	58.7	67.9	44.7						
2880	90	71.5	71.5	72.2	71.2	75.1	60.3	66.9	66.9	66.9	66.9	69.5	56.9						

**Notes:**

1. All capacities shown are gross and have not considered indoor fan heat. To obtain **NET** cooling capacity subtract indoor fan heat. For indoor fan heat formula, refer to appropriate airflow table notes.
2. MBh = Total Gross Capacity
3. SHC = Sensible Heat Capacity



## Performance Data

**Table 16. Gross cooling capacities 7½ tons standard efficiency - three phase T/YSC090F3,4,W**

Air Flow cfm		Ent DB (F)		Ambient Temperature															
				85				95				105							
				Entering Wet Bulb															
		61		67		73		61		67		73		61		67		73	
		MBh	SHC	MBh	SHC	MBh	SHC	MBh	SHC	MBh	SHC	MBh	SHC	MBh	SHC	MBh	SHC	MBh	SHC
2400	75	82.8	67.2	88.9	49.1	97.0	22.6	78.5	64.5	84.3	46.9	92.1	21.0	73.7	61.4	79.2	44.4	86.8	19.0
2400	80	85.3	78.3	90.1	64.6	97.0	42.5	81.0	75.4	85.5	62.1	92.1	40.6	76.3	72.0	80.5	59.3	86.8	38.3
2400	85	88.4	87.2	91.9	77.8	97.5	60.0	84.2	83.9	100.8	10.6	83.3	83.3	79.4	79.4	82.3	72.0	87.4	55.3
2400	90	92.1	92.1	94.3	88.7	98.6	75.3	87.0	87.0	87.9	87.7	93.8	72.8	83.2	83.2	84.8	82.3	88.6	69.9
2700	75	84.9	69.8	90.6	51.4	98.4	24.6	80.5	67.0	85.9	49.1	93.4	22.8	75.6	63.8	80.7	46.5	88.0	20.7
2700	80	87.6	81.2	92.1	67.1	98.6	44.7	83.2	78.1	87.4	64.5	93.7	42.6	78.4	74.6	82.2	61.6	88.2	40.2
2700	85	90.9	90.3	94.1	80.5	99.4	62.4	86.6	86.6	102.0	12.4	86.6	86.6	81.7	81.7	84.3	74.4	89.0	57.4
2700	90	94.8	94.8	96.7	91.7	100.7	77.9	90.5	90.5	92.1	88.5	95.8	75.3	85.7	85.7	87.0	85.0	90.5	72.3
3000	75	86.7	72.2	92.1	53.4	99.6	26.3	82.2	69.2	87.3	51.0	94.5	24.4	77.2	65.9	82.0	48.2	88.9	22.1
3000	80	89.7	83.8	93.8	69.3	100.0	46.5	85.2	80.5	89.0	66.6	94.9	44.4	80.2	76.9	83.7	63.5	89.4	41.8
3000	85	93.2	93.1	96.0	83.0	101.0	64.5	94.9	44.4	103.0	13.8	96.0	62.0	83.8	83.8	86.1	76.6	90.5	59.2
3000	90	97.3	97.3	98.9	94.3	102.5	80.2	92.9	92.9	94.2	91.0	97.6	77.4	88.1	88.1	89.0	87.3	92.1	74.3
3300	75	88.2	74.2	93.3	55.1	100.5	27.6	83.6	71.1	88.4	52.5	95.3	25.6	78.5	67.6	83.0	49.6	89.6	23.2
3300	80	91.4	86.0	95.2	71.2	101.1	48.1	86.8	82.6	90.3	68.4	95.9	45.8	81.7	78.9	85.0	65.2	90.3	43.1
3300	85	95.2	95.2	97.7	85.1	102.3	66.3	95.9	45.8	103.6	14.8	97.2	63.7	85.6	85.6	87.5	78.4	91.6	60.7
3300	90	99.5	99.5	100.8	96.6	104.1	82.2	95.0	95.0	96.0	93.2	99.0	79.3	89.8	89.8	90.7	89.4	93.5	76.0
3600	75	89.5	75.9	94.2	56.4	101.1	28.6	84.8	72.7	89.2	53.7	95.8	26.5	79.5	69.1	83.7	50.7	90.0	24.0
3600	80	92.9	87.9	96.4	72.8	101.9	49.3	85.2	80.5	91.4	69.8	96.7	46.9	83.0	80.5	85.9	66.5	90.9	44.1
3600	85	96.9	96.9	99.1	86.9	103.4	67.7	96.7	46.9	104.1	15.6	98.2	65.0	87.1	87.1	88.7	79.9	90.5	59.2
3600	90	101.5	101.5	102.4	98.6	105.4	83.8	96.9	96.9	97.5	95.0	100.2	80.8	91.2	91.2	92.1	91.1	94.5	77.4
Air Flow cfm		Ent DB (F)		Ambient Temperature															
				115				125											
				Entering Wet Bulb															
		61		67		73		61		67		73							
		MBh	SHC	MBh	SHC	MBh	SHC	MBh	SHC	MBh	SHC	MBh	SHC						
2400	75	68.4	58.0	73.6	41.5	80.9	16.7	62.7	54.2	67.6	38.3	74.6	14.0						
2400	80	71.0	68.3	75.0	56.2	81.0	35.7	65.3	64.2	69.0	52.6	74.7	32.7						
2400	85	74.2	74.2	76.9	68.5	81.6	52.3	68.5	68.5	70.9	64.7	75.4	49.1						
2400	90	78.6	78.6	79.4	78.5	82.8	66.7	73.4	73.4	73.4	73.4	76.6	63.1						
2700	75	70.2	60.3	75.1	43.4	82.0	18.3	64.3	56.4	68.9	40.1	75.6	15.5						
2700	80	73.0	70.8	76.6	58.3	82.3	37.5	67.2	66.6	70.5	54.6	76.0	34.3						
2700	85	76.4	76.4	78.8	70.8	83.2	54.3	70.7	70.7	72.7	66.9	76.8	50.9						
2700	90	80.7	80.7	81.5	81.1	84.6	68.9	75.5	75.5	75.5	75.5	78.3	65.2						
3000	75	71.7	62.2	76.2	45.0	82.9	19.5	65.7	58.2	70.0	41.6	76.4	16.6						
3000	80	74.7	72.9	78.0	60.1	83.4	38.9	68.8	68.6	71.8	56.3	76.9	35.7						
3000	85	78.4	78.4	80.4	72.9	84.5	56.0	72.5	72.5	74.2	68.8	78.1	52.5						
3000	90	82.5	82.5	83.3	83.3	86.2	70.8	77.2	77.2	77.2	77.2	79.8	67.0						
3300	75	72.9	63.8	77.1	46.3	83.5	20.5	66.9	59.6	70.8	42.7	76.9	17.4						
3300	80	76.2	74.7	79.2	61.6	84.2	40.1	70.2	70.2	72.9	57.7	77.6	36.7						
3300	85	80.1	80.1	81.7	74.6	85.5	57.4	74.1	74.1	75.5	70.3	79.0	53.7						
3300	90	84.9	84.9	84.9	84.9	87.4	72.4	78.7	78.7	78.7	78.7	80.9	68.4						
3600	75	73.9	65.1	76.2	45.0	73.9	65.1	67.7	60.8	71.3	43.5	77.1	17.9						
3600	80	77.4	76.2	80.0	62.8	84.7	40.9	71.3	71.3	73.6	58.7	78.1	37.4						
3600	85	81.5	81.5	82.8	75.9	86.3	58.4	75.4	75.4	76.5	71.6	79.6	54.6						
3600	90	86.2	86.2	86.2	86.2	88.4	73.6	79.9	79.9	79.9	79.9	81.8	69.5						

**Notes:**

1. All capacities shown are gross and have not considered indoor fan heat. To obtain **NET** cooling capacity subtract indoor fan heat. For indoor fan heat formula, refer to appropriate airflow table notes.
2. MBh = Total Gross Capacity
3. SHC = Sensible Heat Capacity



**Table 17. Gross cooling capacities 7½ tons standard efficiency - three phase T/YSC092F3,4,W**

		Ambient Temperature																	
		85						95						105					
Air Flow cfm	Ent DB (F)	Entering Wet Bulb																	
		61		67		73		61		67		73		61		67		73	
		MBh	SHC	MBh	SHC	MBh	SHC	MBh	SHC	MBh	SHC	MBh	SHC	MBh	SHC	MBh	SHC	MBh	SHC
2400	75	87.1	70.9	94.8	53.8	105.4	29.1	82.4	67.9	89.7	51.4	99.9	27.2	77.5	64.7	84.3	48.6	94.1	24.9
2400	80	88.8	81.7	95.0	68.8	104.0	48.3	84.2	78.4	90.0	66.1	98.6	46.1	79.3	74.9	84.6	63.0	92.8	43.5
2400	85	91.2	90.1	95.8	81.5	103.3	65.2	86.7	86.6	90.8	78.4	97.9	62.6	81.8	81.8	85.6	75.1	92.2	59.7
2400	90	94.2	94.2	97.3	91.8	103.2	79.7	89.8	89.8	92.4	88.4	97.9	76.8	85.0	85.0	87.1	84.8	92.2	73.6
2700	75	89.5	73.7	96.8	56.3	107.1	31.2	84.7	70.7	91.6	53.7	101.5	29.1	79.6	67.3	86.1	50.9	95.5	26.7
2700	80	91.4	84.7	97.3	71.5	106.0	50.6	86.7	81.4	92.1	68.6	100.4	48.2	81.7	77.7	86.6	65.4	94.5	45.5
2700	85	94.1	93.4	98.3	84.4	105.5	67.7	89.4	89.4	93.2	81.2	100.0	65.0	84.4	84.4	87.8	77.7	94.1	62.0
2700	90	97.3	97.3	100.0	94.9	105.7	82.4	92.7	92.7	95.0	91.4	100.2	79.4	87.8	87.8	89.6	87.6	94.4	76.0
3000	75	91.6	76.4	98.6	58.6	108.6	33.1	86.7	73.2	93.3	55.8	102.8	30.8	81.4	69.7	87.6	52.8	96.7	28.3
3000	80	93.8	87.6	99.3	73.9	107.7	52.7	88.9	84.1	94.0	70.9	102.0	50.1	83.7	80.3	88.4	67.6	95.9	47.3
3000	85	96.7	96.4	100.6	87.0	107.5	69.9	91.8	91.8	95.4	83.7	101.8	67.1	86.7	86.7	89.8	80.0	95.8	63.9
3000	90	100.1	100.1	102.5	97.7	107.8	84.8	95.4	95.4	97.4	94.1	102.2	81.7	90.9	90.9	91.8	90.1	96.3	78.2
3300	75	93.4	78.7	100.2	60.5	109.8	34.7	88.4	75.4	94.7	57.7	103.9	32.3	83.0	71.8	88.8	54.5	97.6	29.6
3300	80	95.9	90.1	101.1	76.1	109.2	54.5	90.9	86.5	95.6	73.0	103.3	51.8	85.5	82.6	89.8	69.5	97.1	48.8
3300	85	99.0	99.0	102.6	89.4	109.1	71.9	94.0	94.0	97.2	85.9	103.3	68.9	88.7	88.7	91.5	82.1	97.2	65.6
3300	90	102.7	102.7	104.8	100.3	109.8	87.0	97.8	97.8	99.4	96.5	104.0	83.7	92.8	92.8	93.8	92.4	97.9	80.1
3600	75	95.0	80.8	101.4	62.2	110.7	36.0	89.8	77.3	95.8	59.2	104.7	33.5	84.2	73.6	89.8	55.9	98.3	30.6
3600	80	97.7	92.4	102.6	78.0	110.3	56.0	92.5	88.7	97.0	74.7	104.3	53.1	87.0	84.6	91.0	71.1	98.0	50.0
3600	85	101.0	101.0	104.3	91.5	110.5	73.6	95.9	95.9	98.8	87.9	104.6	70.5	90.5	90.5	92.9	84.0	98.3	67.1
3600	90	105.0	105.0	106.7	102.6	111.4	88.9	99.9	99.9	101.3	98.7	105.5	85.5	94.5	94.5	95.5	94.5	99.3	81.8
		Ambient Temperature																	
		115						125											
Air Flow cfm	Ent DB (F)	Entering Wet Bulb																	
		61		67		73		61		67		73							
		MBh	SHC	MBh	SHC	MBh	SHC	MBh	SHC	MBh	SHC	MBh	SHC						
2400	75	72.2	61.2	78.6	45.6	87.9	22.3	66.5	57.4	72.5	42.2	81.4	19.5						
2400	80	74.1	71.1	78.9	59.7	86.7	40.6	68.5	66.9	72.9	56.0	80.3	37.4						
2400	85	76.6	76.6	79.9	71.4	86.2	56.5	71.1	71.1	74.0	67.5	79.8	53.1						
2400	90	80.8	80.8	81.6	80.8	86.3	70.1	75.7	75.7	75.7	75.7	79.9	66.3						
2700	75	74.1	63.7	80.2	47.7	89.2	24.0	68.3	59.7	74.0	44.2	82.6	21.0						
2700	80	76.3	73.7	80.8	62.0	88.3	42.5	70.6	69.5	74.7	58.2	81.7	39.2						
2700	85	79.1	79.1	82.1	73.9	87.9	58.6	73.4	73.4	76.0	69.8	81.4	55.0						
2700	90	83.1	83.1	83.9	83.5	88.3	72.4	77.9	77.9	77.9	77.9	81.8	68.5						
3000	75	75.8	65.9	81.6	49.5	90.3	25.4	69.9	61.8	75.2	45.9	83.5	22.3						
3000	80	78.2	76.2	82.4	64.0	89.5	44.1	72.3	71.8	76.1	60.1	82.8	40.7						
3000	85	81.2	81.2	83.9	76.1	89.5	60.5	75.4	75.4	77.6	71.9	82.8	56.7						
3000	90	85.1	85.1	86.0	85.9	90.0	74.5	79.8	79.8	79.8	79.8	83.4	70.4						
3300	75	77.2	67.8	82.7	51.0	91.0	26.6	71.1	63.6	76.2	47.3	84.1	23.3						
3300	80	79.8	78.3	83.7	65.7	90.5	45.5	73.8	73.8	77.3	61.7	83.7	41.9						
3300	85	83.1	83.1	85.4	78.1	90.7	62.0	77.1	77.1	79.1	73.7	83.9	58.1						
3300	90	87.8	87.8	87.8	87.8	91.5	76.2	81.5	81.5	81.5	81.5	84.7	72.0						
3600	75	78.4	69.5	83.5	52.3	91.5	27.5	72.1	65.1	76.8	48.4	84.4	24.1						
3600	80	81.2	80.2	84.8	67.2	91.3	46.6	75.1	75.1	78.2	63.0	84.3	42.9						
3600	85	84.7	84.7	86.7	79.8	91.7	63.3	78.6	78.6	80.2	75.3	84.7	59.3						
3600	90	89.3	89.3	89.3	89.3	92.7	77.7	82.9	82.9	82.9	82.9	85.8	73.4						

**Notes:**

1. All capacities shown are gross and have not considered indoor fan heat. To obtain **NET** cooling capacity subtract indoor fan heat. For indoor fan heat formula, refer to appropriate airflow table notes.
2. MBh = Total Gross Capacity
3. SHC = Sensible Heat Capacity



## Performance Data

**Table 18. Gross cooling capacities 8½ tons standard efficiency - three phase T/YSC102F3,4,W**

		Ambient Temperature																	
		85						95						105					
Air Flow cfm	Ent DB (F)	Entering Wet Bulb																	
		61		67		73		61		67		73		61		67		73	
		MBh	SHC	MBh	SHC	MBh	SHC	MBh	SHC	MBh	SHC	MBh	SHC	MBh	SHC	MBh	SHC	MBh	SHC
2720	75	94.9	77.8	102.8	57.5	113.7	27.9	89.1	74.3	96.5	54.7	107.0	25.8	83.1	70.5	90.0	51.6	100.0	23.4
2720	80	97.3	90.2	103.6	74.9	113.0	50.3	91.6	86.3	97.4	71.7	106.3	47.8	85.6	82.0	90.9	68.2	99.4	44.9
2720	85	100.6	100.0	105.3	89.7	113.1	70.0	94.9	94.9	99.1	86.0	106.5	67.1	88.8	88.8	92.6	82.1	99.5	63.8
2720	90	104.6	104.6	107.8	101.8	114.0	87.1	98.9	98.9	101.6	97.7	107.4	83.7	94.2	94.2	95.1	93.3	100.4	80.0
3060	75	97.5	80.8	105.1	60.2	115.7	30.2	91.6	77.1	98.7	57.2	108.8	27.9	85.4	73.1	92.0	53.9	101.7	25.3
3060	80	100.3	93.5	106.3	77.9	115.3	52.9	94.4	89.4	99.9	74.5	108.4	50.2	88.2	85.0	93.2	70.7	101.3	47.1
3060	85	103.8	103.6	108.2	93.0	115.7	72.9	97.9	97.9	101.9	89.1	108.8	69.8	91.7	91.7	95.2	84.9	101.7	66.3
3060	90	108.1	108.1	111.0	105.4	116.8	90.3	102.3	102.3	104.6	101.1	110.0	86.7	97.0	97.0	98.0	96.5	102.9	82.8
3400	75	99.9	83.5	107.1	62.6	117.4	32.2	93.8	79.6	100.5	59.4	110.3	29.7	87.4	75.5	93.7	55.9	103.0	26.9
3400	80	102.9	96.6	108.5	80.6	117.2	55.2	96.8	92.3	102.0	77.0	110.2	52.3	90.4	87.7	95.1	73.0	102.9	49.1
3400	85	106.7	106.7	110.8	96.0	117.9	75.6	100.6	100.6	104.3	91.9	110.9	72.2	94.3	94.3	97.4	87.6	103.6	68.5
3400	90	111.3	111.3	113.8	108.7	119.4	93.3	105.3	105.3	107.3	104.2	112.4	89.5	99.5	99.5	100.5	99.4	105.1	85.4
3740	75	101.9	86.0	108.8	64.7	118.7	33.9	95.6	81.9	102.0	61.3	111.5	31.2	89.0	77.5	95.0	57.6	104.0	28.2
3740	80	105.2	99.4	110.5	83.0	118.8	57.3	98.9	94.9	103.8	79.2	111.7	54.1	92.3	90.0	96.7	75.1	104.2	50.7
3740	85	109.3	109.3	113.0	98.7	119.8	77.9	103.0	103.0	106.3	94.4	112.6	74.4	96.5	96.5	99.3	89.9	105.1	70.5
3740	90	114.2	114.2	116.3	111.7	121.5	95.9	107.9	107.9	109.6	107.0	114.4	91.9	101.6	101.6	102.6	102.1	106.9	87.7
4080	75	103.5	88.2	110.1	66.5	119.7	35.4	97.1	83.9	103.2	62.9	112.3	32.5	90.3	79.3	96.0	59.0	104.6	29.3
4080	80	107.1	101.9	112.1	85.1	120.1	59.0	100.7	97.2	105.2	81.1	112.8	55.7	93.9	92.2	98.0	76.8	105.1	52.1
4080	85	111.5	111.5	114.9	101.1	121.4	80.0	105.1	105.1	108.0	96.7	114.0	76.2	98.4	98.4	100.8	91.9	106.4	72.2
4080	90	116.7	116.7	118.5	114.5	123.4	98.3	110.3	110.3	111.7	109.6	116.1	94.1	103.4	103.4	104.5	104.4	108.4	89.6
		Ambient Temperature																	
		115						125											
Air Flow cfm	Ent DB (F)	Entering Wet Bulb																	
		61		67		73		61		67		73							
		MBh	SHC	MBh	SHC	MBh	SHC	MBh	SHC	MBh	SHC	MBh	SHC						
2720	75	76.7	66.4	83.2	48.3	92.7	20.7	70.0	62.0	76.0	44.6	85.1	17.8						
2720	80	79.2	77.5	84.1	64.4	92.1	41.8	72.5	72.5	77.0	60.3	84.5	38.4						
2720	85	82.5	82.5	85.8	77.8	92.2	60.3	75.8	75.8	78.7	73.3	84.6	56.4						
2720	90	88.4	88.4	88.4	88.4	93.2	76.0	81.2	81.2	81.2	81.2	85.6	71.8						
3060	75	78.8	68.8	85.0	50.3	94.2	22.4	71.9	64.3	77.6	46.5	86.4	19.3						
3060	80	81.6	80.3	86.2	66.7	93.8	43.8	74.8	74.8	78.9	62.5	86.0	40.2						
3060	85	85.2	85.2	88.2	80.5	94.3	62.6	78.4	78.4	80.9	75.8	86.5	58.6						
3060	90	91.0	91.0	91.0	91.0	95.5	78.7	83.7	83.7	83.7	83.7	87.7	74.2						
3400	75	80.6	71.0	86.5	52.1	95.3	23.8	73.6	66.2	78.9	48.0	87.3	20.5						
3400	80	83.7	82.8	88.0	68.8	95.2	45.6	76.7	76.7	80.5	64.4	87.3	41.8						
3400	85	87.6	87.6	90.2	82.9	96.0	64.6	80.5	80.5	82.8	78.0	88.0	60.4						
3400	90	93.3	93.3	93.3	93.3	97.5	81.0	85.9	85.9	85.9	85.9	89.5	76.4						
3740	75	82.1	72.9	87.6	53.6	96.1	25.0	74.9	67.9	79.9	49.3	88.0	21.4						
3740	80	85.5	85.0	89.4	70.7	96.3	47.0	78.2	78.2	81.7	66.0	88.2	43.0						
3740	85	89.6	89.6	92.0	85.1	97.3	66.4	82.4	82.4	84.3	79.9	89.2	61.9						
3740	90	95.3	95.3	95.3	95.3	99.1	83.1	87.7	87.7	87.7	87.7	91.0	78.2						
4080	75	83.2	74.5	88.4	54.8	96.6	25.8	75.8	69.3	80.5	50.4	88.3	22.1						
4080	80	86.9	86.9	90.5	72.2	97.1	48.2	79.5	79.5	82.6	67.3	88.8	44.0						
4080	85	91.3	91.3	93.3	86.9	98.4	67.8	83.9	83.9	85.5	81.6	90.1	63.2						
4080	90	97.0	97.0	97.0	97.0	100.4	84.9	89.1	89.1	89.1	89.1	92.2	79.8						

**Notes:**

1. All capacities shown are gross and have not considered indoor fan heat. To obtain **NET** cooling capacity subtract indoor fan heat. For indoor fan heat formula, refer to appropriate airflow table notes.
2. MBh = Total Gross Capacity
3. SHC = Sensible Heat Capacity

## Performance Data

**Table 19. Gross cooling capacities 10 tons standard efficiency - three phase T/YSC120F3,4,W**

Air Flow cfm		Ent DB (F)		Ambient Temperature															
				85				95				105							
				Entering Wet Bulb															
		61		67		73		61		67		73		61		67		73	
		MBh	SHC	MBh	SHC	MBh	SHC	MBh	SHC	MBh	SHC	MBh	SHC	MBh	SHC	MBh	SHC	MBh	SHC
3200	75	110.9	92.2	120.3	70.0	133.3	37.5	104.8	88.5	113.7	67.0	126.2	35.2	98.3	84.3	106.6	63.6	118.6	32.5
3200	80	113.5	106.1	120.8	89.5	131.8	62.6	107.4	102.0	114.2	86.1	124.7	59.9	100.9	97.4	107.2	82.2	117.1	56.7
3200	85	116.9	116.9	122.2	105.8	131.1	84.5	110.8	110.8	115.6	102.0	124.0	81.3	104.4	104.4	108.6	97.7	116.5	77.8
3200	90	121.1	121.1	124.4	119.0	131.3	103.2	115.1	115.1	117.9	114.8	124.3	99.7	109.8	109.8	110.9	110.1	116.8	95.7
3600	75	113.8	96.0	122.8	73.5	135.3	40.7	107.6	92.1	116.0	70.3	128.0	38.1	100.9	87.6	108.7	66.5	120.3	35.1
3600	80	116.7	110.2	123.5	93.3	134.1	66.0	110.4	105.8	116.8	89.6	126.8	63.0	103.8	101.0	109.6	85.5	119.1	59.6
3600	85	120.3	120.3	125.2	109.9	133.7	88.2	114.2	114.2	118.5	105.8	126.5	84.8	107.5	107.5	111.3	101.2	118.8	80.9
3600	90	124.9	124.9	127.7	123.4	134.2	107.2	118.7	118.7	121.0	118.8	127.0	103.4	112.8	112.8	113.9	113.8	119.3	99.1
4000	75	116.3	99.4	124.8	76.6	137.0	43.5	109.9	95.2	117.9	73.0	129.5	40.6	103.0	90.5	110.5	69.0	121.6	37.3
4000	80	119.5	113.9	125.9	96.6	136.0	69.0	113.1	109.2	119.0	92.7	128.6	65.8	106.2	104.1	111.6	88.2	120.7	62.0
4000	85	123.4	123.4	127.9	113.5	136.0	91.5	117.1	117.1	121.0	109.1	128.5	87.8	110.3	110.3	113.7	104.3	120.7	83.7
4000	90	128.3	128.3	130.7	127.2	136.7	110.8	122.6	122.6	123.8	122.4	129.4	106.7	116.6	116.6	116.6	116.6	121.5	102.1
4400	75	118.5	102.4	126.5	79.2	138.3	45.8	111.9	97.9	119.4	75.4	130.6	42.6	104.9	92.9	111.9	71.1	122.5	39.0
4400	80	121.9	117.1	127.9	99.5	137.6	71.6	115.3	112.2	120.8	95.3	130.0	68.0	108.3	106.8	113.3	90.6	121.9	64.1
4400	85	126.2	126.2	130.2	116.7	137.8	94.3	119.7	119.7	123.1	112.0	130.2	90.3	112.7	112.7	115.6	106.9	122.2	85.9
4400	90	131.3	131.3	133.3	130.6	138.9	113.9	125.0	125.0	126.3	125.6	131.4	109.5	118.8	118.8	118.8	118.8	123.4	104.6
4800	75	120.3	104.9	127.9	81.4	139.2	47.6	113.5	100.1	120.6	77.3	131.3	44.2	106.3	94.8	112.9	72.7	123.1	40.3
4800	80	124.0	119.9	129.6	102.0	138.8	73.7	117.2	114.7	122.3	97.4	131.0	69.9	110.1	109.0	114.6	92.4	122.8	65.6
4800	85	128.5	128.5	132.1	119.4	139.3	96.7	121.9	121.9	124.9	114.4	131.6	92.4	114.7	114.7	117.2	109.0	123.4	87.7
4800	90	134.2	134.2	135.5	133.6	140.7	116.5	127.0	127.0	128.3	128.2	133.0	111.8	120.7	120.7	120.7	120.7	124.8	106.7

Air Flow cfm		Ent DB (F)		Ambient Temperature											
				115				125							
				Entering Wet Bulb											
		61		67		73		61		67		73			
		MBh	SHC	MBh	SHC	MBh	SHC	MBh	SHC	MBh	SHC	MBh	SHC		
3200	75	91.3	79.7	99.1	59.7	110.5	29.3	83.9	74.7	91.1	55.3	102.0	25.7		
3200	80	94.0	92.4	99.7	77.9	109.1	53.1	86.6	86.6	91.8	73.2	100.7	49.0		
3200	85	97.5	97.5	101.2	93.0	108.5	73.7	90.1	90.1	93.3	87.8	100.1	69.3		
3200	90	103.5	103.5	103.5	103.5	108.9	91.2	95.7	95.7	95.7	95.7	100.5	86.4		
3600	75	93.7	82.8	101.1	62.4	112.0	31.6	86.1	77.5	92.9	57.7	103.4	27.7		
3600	80	96.6	95.7	102.0	80.9	110.9	55.7	89.1	89.1	93.9	75.8	102.3	51.4		
3600	85	100.4	100.4	103.7	96.2	110.7	76.6	92.9	92.9	95.7	90.8	102.1	71.9		
3600	90	106.4	106.4	106.4	106.4	111.3	94.4	98.3	98.3	98.3	98.3	102.7	89.2		
4000	75	95.7	85.3	102.6	64.6	113.2	33.6	88.0	79.7	94.3	59.7	104.4	29.4		
4000	80	99.0	98.5	103.8	83.4	112.4	57.9	91.2	91.2	95.6	78.1	103.6	53.3		
4000	85	103.0	103.0	105.9	99.0	112.4	79.1	95.4	95.4	97.7	93.3	103.6	74.1		
4000	90	108.8	108.8	108.8	108.8	113.3	97.1	100.6	100.6	100.6	100.6	104.6	91.7		
4400	75	97.4	87.5	103.8	66.4	114.0	35.0	89.4	81.6	95.4	61.2	105.0	30.5		
4400	80	100.9	100.9	105.3	85.4	113.4	59.6	93.0	93.0	96.9	79.8	104.5	54.7		
4400	85	105.3	105.3	107.7	101.3	113.8	81.1	97.4	97.4	99.3	95.3	104.8	75.8		
4400	90	110.9	110.9	110.9	110.9	114.9	99.4	102.6	102.6	102.6	102.6	106.1	93.7		
4800	75	98.6	89.1	104.7	67.7	114.4	36.0	90.6	83.0	96.1	62.3	105.2	31.3		
4800	80	102.5	102.5	106.5	87.0	114.1	60.9	94.4	94.4	97.9	81.2	105.0	55.7		
4800	85	107.1	107.1	109.1	103.2	114.7	82.6	99.1	99.1	100.6	96.9	105.7	77.0		
4800	90	112.6	112.6	112.6	112.6	116.2	101.2	104.1	104.1	104.1	104.1	107.2	95.2		

**Notes:**

1. All capacities shown are gross and have not considered indoor fan heat. To obtain **NET** cooling capacity subtract indoor fan heat. For indoor fan heat formula, refer to appropriate airflow table notes.
2. MBh = Total Gross Capacity
3. SHC = Sensible Heat Capacity



## Performance Data

**Table 20. Gross cooling capacities 3 tons high efficiency - single phase T/YHC036E1**

Air Flow cfm		Ent DB (F)		Ambient Temperature																	
				85						95						105					
				Entering Wet Bulb																	
		61		67		73		61		67		73		61		67		73			
		MBh	SHC	MBh	SHC	MBh	SHC	MBh	SHC	MBh	SHC	MBh	SHC	MBh	SHC	MBh	SHC	MBh	SHC		
600	75	30.5	23.4	34.4	17.3	39.7	8.3	28.5	22.1	32.2	16.3	37.2	7.5	26.4	20.8	29.8	15.2	34.7	6.5		
600	80	31.2	27.5	34.4	23.1	39.0	15.7	29.2	26.1	32.2	21.9	36.6	14.7	27.0	24.6	29.9	20.6	34.0	13.6		
600	85	32.2	30.7	34.8	27.9	38.8	22.2	30.2	29.1	32.6	26.6	36.3	21.0	28.1	27.5	30.3	25.1	33.8	19.8		
600	90	33.7	33.0	35.6	31.9	38.9	27.8	31.7	31.3	33.4	30.4	36.5	26.4	29.6	29.5	31.1	28.8	34.0	25.1		
720	75	32.1	25.1	35.8	18.8	40.9	9.6	30.0	23.7	33.5	17.7	38.4	8.7	27.8	22.3	31.1	16.5	35.8	7.7		
720	80	32.9	29.3	36.0	24.7	40.4	17.1	30.8	27.8	33.7	23.5	37.9	16.0	28.6	26.3	31.3	22.1	35.3	14.9		
720	85	34.1	32.7	36.5	29.7	40.3	23.8	32.0	31.1	34.2	28.3	37.8	22.5	29.8	29.3	31.9	26.8	35.2	21.2		
720	90	35.7	35.2	37.5	33.9	40.6	29.5	33.6	33.4	35.2	32.3	38.1	28.2	31.5	31.5	32.8	30.6	35.5	26.7		
840	75	33.5	26.6	37.1	20.2	42.0	10.8	31.3	25.2	34.7	19.0	39.5	9.8	29.0	23.8	32.2	17.7	36.8	8.7		
840	80	34.4	31.1	37.4	26.3	41.7	18.5	32.3	29.5	35.0	24.9	39.1	17.3	30.0	27.9	32.6	23.5	36.4	16.1		
840	85	35.8	34.6	38.1	31.4	41.7	25.3	33.7	32.9	35.7	29.9	39.2	24.0	31.4	31.1	33.3	28.4	36.5	22.6		
840	90	37.5	37.2	39.2	35.7	42.1	31.2	35.4	35.4	36.8	34.1	39.6	29.8	33.2	33.2	34.4	32.3	37.0	28.2		
960	75	35.0	27.4	38.8	20.7	42.8	13.0	32.8	26.0	36.4	19.2	40.2	12.0	30.4	24.6	33.9	17.7	37.5	10.3		
960	80	35.6	33.5	39.2	26.2	43.3	19.2	33.4	32.2	36.8	24.7	40.7	17.7	31.1	30.8	34.3	23.3	38.0	17.1		
960	85	37.3	37.3	39.6	31.5	43.7	24.3	35.3	35.3	37.2	30.1	41.2	23.6	33.2	33.2	34.7	28.7	38.4	22.1		
960	90	39.5	39.5	40.2	37.4	44.1	30.0	37.5	37.5	37.9	36.3	41.5	28.7	35.3	35.3	35.4	35.0	38.7	27.2		
1080	75	36.0	29.3	39.8	21.8	43.8	13.2	33.7	28.0	37.3	20.4	41.1	11.6	31.2	26.7	34.7	19.0	38.3	10.5		
1080	80	36.7	36.1	40.2	27.8	44.3	18.7	34.6	34.6	37.7	26.3	41.7	19.2	32.4	32.4	35.1	24.9	38.9	17.4		
1080	85	39.0	39.0	40.7	34.0	44.8	26.2	36.9	36.9	38.2	32.6	42.1	24.9	34.7	34.7	35.6	31.4	39.2	23.3		
1080	90	41.4	41.4	41.5	40.9	45.1	32.0	39.2	39.2	39.2	39.2	42.5	30.7	36.9	36.9	36.9	36.9	39.6	29.2		
1200	75	36.8	31.3	40.6	22.7	44.6	13.1	34.5	30.2	38.0	21.4	41.8	12.1	31.9	28.8	35.3	19.9	38.9	10.7		
1200	80	38.0	38.0	41.0	29.4	45.2	19.9	35.9	35.9	37.6	28.0	42.5	19.4	33.6	33.6	35.8	26.5	39.5	18.4		
1200	85	40.4	40.4	41.6	36.5	45.6	27.7	38.3	38.3	39.1	35.3	42.8	26.2	36.0	36.0	36.4	34.2	39.9	24.6		
1200	90	42.9	42.9	42.9	42.9	46.0	34.1	40.7	40.7	40.7	40.7	43.2	32.7	38.3	38.3	38.3	38.3	40.3	31.3		
1320	75	37.6	33.6	41.2	23.7	45.2	13.3	35.1	32.2	38.7	21.9	42.4	12.2	32.6	30.9	35.9	20.8	39.5	10.6		
1320	80	39.2	39.2	41.7	31.0	46.0	22.5	37.0	37.0	39.1	29.5	43.1	20.3	34.7	34.7	36.4	28.2	40.1	19.1		
1320	85	41.8	41.8	42.4	39.2	46.3	29.0	39.5	39.5	39.9	38.0	43.5	27.4	37.1	37.1	37.2	36.5	40.5	25.7		
1320	90	44.3	44.3	44.3	44.3	46.8	36.0	42.0	42.0	42.0	42.0	43.9	34.8	39.6	39.6	39.5	39.5	41.0	33.5		
1440	75	38.2	35.6	41.8	24.5	45.9	13.7	35.8	34.2	39.2	23.6	42.9	12.1	33.2	32.5	36.4	21.7	39.9	10.8		
1440	80	40.3	40.3	42.4	32.7	46.5	22.1	38.0	38.0	39.7	31.4	43.6	21.0	35.6	35.6	36.9	30.1	40.6	19.9		
1440	85	42.9	42.9	43.3	41.8	46.9	30.2	40.6	40.6	40.7	40.1	44.0	28.9	38.1	38.1	38.1	38.1	41.0	27.4		
1440	90	45.6	45.6	45.5	45.5	47.4	38.2	43.1	43.1	43.1	43.1	44.6	37.1	40.6	40.6	40.6	40.6	41.6	36.0		

continued on next page

**Table 20. Gross cooling capacities 3 tons high efficiency - single phase T/YHC036E1 (continued)**

Air Flow cfm		Ent DB (F)		Ambient Temperature											
				115						125					
				Entering Wet Bulb											
		61		67		73		61		67		73			
		MBh	SHC	MBh	SHC	MBh	SHC	MBh	SHC	MBh	SHC	MBh	SHC		
600	75	24.1	19.4	27.4	14.0	32.0	5.5	21.7	17.9	24.8	12.6	29.2	4.4		
600	80	24.8	23.0	27.4	19.2	31.4	12.4	22.4	21.4	24.8	17.8	28.6	11.2		
600	85	25.9	25.8	27.9	23.6	31.2	18.4	23.6	23.6	25.3	22.0	28.4	17.0		
600	90	28.4	28.4	28.7	27.1	31.3	23.6	25.9	25.9	26.2	25.3	28.6	22.0		
720	75	25.4	20.8	28.6	15.2	33.0	6.6	23.0	19.3	25.9	13.8	30.2	5.4		
720	80	26.3	24.6	28.8	20.6	32.6	13.6	23.9	22.9	26.1	19.1	29.7	12.3		
720	85	27.5	27.5	29.4	25.2	32.5	19.8	25.1	25.1	26.7	23.5	29.7	18.4		
720	90	30.0	30.0	30.3	28.9	32.8	25.1	27.5	27.5	27.7	27.0	30.0	23.5		
840	75	26.7	22.2	29.6	16.4	34.0	7.5	24.1	20.5	26.9	14.9	31.0	6.3		
840	80	27.7	26.2	30.0	22.0	33.7	14.8	25.2	24.3	27.3	20.4	30.7	13.4		
840	85	29.1	29.1	30.7	26.7	33.7	21.1	26.6	26.6	28.0	24.9	30.8	19.6		
840	90	31.5	31.5	31.9	30.5	34.2	26.6	28.9	28.9	29.2	28.6	31.3	24.9		
960	75	28.0	23.3	31.2	16.5	34.6	8.9	25.2	21.7	27.8	15.9	31.8	7.0		
960	80	28.9	28.9	31.6	21.8	35.1	15.1	26.4	25.7	28.3	21.5	31.6	14.3		
960	85	30.9	30.9	32.0	27.3	35.5	20.4	27.9	27.9	29.2	26.2	31.9	20.7		
960	90	33.0	33.0	33.0	33.0	35.8	25.6	30.2	30.2	30.5	30.1	32.5	26.1		
1080	75	28.7	25.5	31.9	17.5	35.3	9.2	26.1	22.8	28.6	16.7	32.4	7.7		
1080	80	30.1	30.1	32.3	23.4	35.9	16.2	27.4	26.9	29.2	22.5	32.4	15.1		
1080	85	32.3	32.3	32.8	30.1	36.2	21.8	29.1	29.1	30.3	27.4	32.8	21.6		
1080	90	34.5	34.5	34.5	34.5	36.6	27.7	31.4	31.4	31.7	31.4	33.6	27.3		
1200	75	29.4	27.5	32.5	18.4	35.9	9.0	26.8	23.7	29.2	17.5	32.9	8.2		
1200	80	31.2	31.2	33.0	25.1	36.5	16.5	28.3	28.0	30.0	23.4	33.0	15.8		
1200	85	33.5	33.5	33.7	32.9	36.8	23.2	30.2	30.2	31.2	28.5	33.6	22.5		
1200	90	35.8	35.8	35.8	35.8	37.3	29.8	32.5	32.5	32.8	32.6	34.5	28.3		
1320	75	30.0	29.3	33.0	19.0	36.4	9.3	27.5	24.5	29.7	18.1	33.2	8.7		
1320	80	32.2	32.2	33.5	27.0	37.0	17.3	29.1	29.0	30.6	24.2	33.5	16.4		
1320	85	34.5	34.5	34.5	34.5	37.4	24.6	31.1	31.1	32.0	29.4	34.2	23.3		
1320	90	36.9	36.9	36.9	36.9	37.9	32.4	33.7	33.7	33.7	33.7	35.3	29.3		
1440	75	30.7	30.6	33.4	20.3	36.8	9.4	28.0	25.2	30.0	18.6	33.4	9.0		
1440	80	33.0	33.0	34.0	28.9	37.4	18.3	29.8	29.8	31.2	24.9	33.9	16.9		
1440	85	35.5	35.5	35.4	35.4	37.9	26.0	31.9	31.9	32.7	30.3	34.7	23.9		
1440	90	37.9	37.9	37.9	37.9	38.5	34.9	34.6	34.6	34.6	34.6	36.0	30.1		

**Notes:**

1. All capacities shown are gross and have not considered indoor fan heat. To obtain **NET** cooling capacity subtract indoor fan heat. For indoor fan heat formula, refer to appropriate airflow table notes.
  2. MBh = Total Gross Capacity
  3. SHC = Sensible Heat Capacity
- \* Unit applications below 320 CFM/Ton are only applicable on THC models without electric heat. Electric and Gas heat applications are restricted to applications 320 CFM/Ton and above.



## Performance Data

**Table 21. Gross cooling capacities 3 tons high efficiency - three phase T/YHC036E3,4**

Air Flow cfm		Ent DB (F)		Ambient Temperature																	
				85						95						105					
				Entering Wet Bulb																	
		61		67		73		61		67		73		61		67		73			
		MBh	SHC	MBh	SHC	MBh	SHC	MBh	SHC	MBh	SHC	MBh	SHC	MBh	SHC	MBh	SHC	MBh	SHC		
600	75	30.5	23.1	34.4	16.9	39.8	7.7	28.2	21.7	32.0	15.8	37.1	6.9	25.9	20.3	29.4	14.6	34.3	5.9		
600	80	31.1	27.1	34.4	22.6	39.1	15.1	28.9	25.6	32.0	21.4	36.4	14.0	26.6	24.0	29.5	20.0	33.7	13.0		
600	85	32.2	30.3	34.8	27.5	38.8	21.5	30.0	28.7	32.4	26.0	36.2	20.4	27.7	26.9	29.9	24.6	33.4	19.1		
600	90	33.6	32.6	35.6	31.4	38.9	27.1	31.5	30.8	33.2	29.9	36.3	25.8	29.2	28.9	30.7	28.2	33.6	24.4		
720	75	32.0	24.9	35.9	18.6	41.0	9.2	29.7	23.5	33.3	17.4	38.3	8.2	27.3	22.0	30.7	16.1	35.4	7.2		
720	80	32.8	29.1	36.0	24.4	40.5	16.7	30.6	27.5	33.5	23.1	37.8	15.6	28.2	25.9	30.9	21.7	35.0	14.4		
720	85	34.1	32.5	36.5	29.4	40.4	23.3	31.8	30.8	34.0	27.9	37.7	22.1	29.4	28.9	31.5	26.4	34.9	20.7		
720	90	35.6	35.0	37.4	33.6	40.6	29.1	33.4	33.1	35.0	31.9	37.9	27.7	31.1	31.1	32.5	30.2	35.2	26.2		
840	75	33.5	26.6	37.1	20.1	42.2	10.5	31.1	25.1	34.5	18.8	39.3	9.4	28.6	23.5	31.8	17.4	36.4	8.3		
840	80	34.4	31.0	37.4	26.1	41.8	18.1	32.1	29.3	34.9	24.7	39.0	17.0	29.6	27.6	32.2	23.2	36.1	15.7		
840	85	35.8	34.5	38.1	31.3	41.8	25.0	33.5	32.7	35.6	29.7	39.0	23.6	31.0	30.8	32.9	28.0	36.2	22.2		
840	90	37.5	37.2	39.2	35.6	42.2	30.9	35.2	35.2	36.7	33.9	39.5	29.4	33.7	33.7	34.1	32.0	36.6	27.9		
960	75	35.0	27.4	39.0	20.8	43.0	13.1	32.6	25.9	36.4	18.7	40.3	11.7	30.1	24.4	33.6	17.6	37.3	10.3		
960	80	35.6	33.5	39.4	26.2	43.5	19.2	33.3	32.2	36.8	24.7	40.7	17.8	30.8	30.6	34.0	23.1	37.8	16.2		
960	85	37.3	37.3	39.8	31.6	43.9	25.2	35.2	35.2	37.2	30.1	41.2	23.5	33.0	33.0	34.4	28.7	38.2	21.8		
960	90	39.6	39.6	40.3	37.5	44.4	30.1	37.5	37.5	37.9	36.3	41.5	28.7	35.1	35.1	35.2	34.9	38.6	27.2		
1080	75	36.0	29.2	39.9	21.9	44.0	13.3	33.6	28.0	37.2	19.7	41.1	12.0	31.0	26.6	34.4	18.6	38.1	10.4		
1080	80	36.8	36.2	40.4	27.8	44.6	18.9	34.5	34.5	37.7	26.3	41.7	19.2	32.2	32.2	34.9	24.8	38.7	17.2		
1080	85	39.1	39.1	40.9	34.0	45.0	26.3	36.9	36.9	38.2	32.6	42.1	24.9	34.5	34.5	35.4	31.3	39.0	23.3		
1080	90	41.5	41.5	41.7	40.9	45.4	32.2	39.2	39.2	39.2	39.2	42.5	30.8	36.8	36.8	36.7	36.7	39.4	29.1		
1200	75	36.9	31.4	40.8	22.8	44.8	13.2	34.4	30.1	38.0	21.3	41.9	12.1	31.6	28.7	35.1	19.7	38.7	10.5		
1200	80	38.1	38.1	41.2	29.4	45.4	21.7	35.8	35.8	37.0	27.9	42.5	19.4	33.4	33.4	35.6	26.4	39.4	18.3		
1200	85	40.6	40.6	41.8	36.5	45.9	27.8	38.3	38.3	39.0	35.2	42.9	26.3	35.8	35.8	36.2	34.0	39.7	24.6		
1200	90	43.1	43.1	43.1	43.1	46.3	34.2	40.7	40.7	40.7	40.7	43.3	32.6	38.2	38.2	38.1	38.1	40.2	31.1		
1320	75	37.7	33.7	41.4	23.6	45.5	13.2	35.0	32.2	38.6	21.9	42.5	12.3	32.4	30.9	35.7	20.8	39.3	10.6		
1320	80	39.3	39.3	41.9	31.1	46.3	22.5	37.0	37.0	39.2	29.6	43.1	20.5	34.4	34.4	36.2	28.2	39.9	19.0		
1320	85	41.9	41.9	42.6	39.2	46.6	29.2	39.5	39.5	39.9	38.0	43.5	27.5	36.9	36.9	37.1	36.4	40.4	26.0		
1320	90	44.5	44.5	44.5	44.5	47.1	36.1	42.1	42.1	42.0	42.0	44.0	34.8	39.4	39.4	39.4	39.4	40.9	33.5		
1440	75	38.3	35.6	42.0	24.6	46.1	13.8	35.7	34.2	39.2	23.6	43.0	12.2	33.0	32.4	36.1	21.7	39.7	10.8		
1440	80	40.4	40.4	42.6	32.7	46.8	21.5	38.0	38.0	39.8	31.4	43.7	21.0	35.4	35.4	36.7	30.0	40.4	19.5		
1440	85	43.1	43.1	43.5	41.9	47.3	30.6	40.6	40.6	40.8	40.2	44.1	28.9	37.9	37.9	38.0	37.9	40.9	27.3		
1440	90	45.8	45.8	45.8	45.8	47.7	38.3	43.3	43.3	43.2	43.2	44.7	37.2	40.5	40.5	40.5	40.5	41.5	36.0		

continued on next page

**Table 21. Gross cooling capacities 3 tons high efficiency - three phase T/YHC036E3,4 (continued)**

Air Flow cfm		Ent DB (F)		Ambient Temperature											
				115						125					
				Entering Wet Bulb											
		61		67		73		61		67		73			
		MBh	SHC	MBh	SHC	MBh	SHC	MBh	SHC	MBh	SHC	MBh	SHC		
600	75	23.4	18.8	26.8	13.4	31.4	4.9	20.9	17.2	24.0	12.0	28.5	3.8		
600	80	24.2	22.4	26.8	18.6	30.8	11.8	21.7	20.6	24.2	17.1	27.9	10.5		
600	85	25.3	25.1	27.3	23.0	30.6	17.8	22.9	22.9	24.7	21.3	27.8	16.4		
600	90	27.9	27.9	28.2	26.5	30.8	22.9	25.3	25.3	25.5	24.7	28.0	21.3		
720	75	24.8	20.3	28.0	14.8	32.5	6.1	22.2	18.7	25.2	13.3	29.5	4.9		
720	80	25.7	24.1	28.2	20.2	32.1	13.1	23.2	22.3	25.4	18.6	29.1	11.8		
720	85	27.0	27.0	28.8	24.7	32.0	19.3	24.5	24.5	26.1	23.0	29.0	17.8		
720	90	29.5	29.5	29.8	28.4	32.3	24.6	26.9	26.9	27.1	26.5	29.4	23.0		
840	75	26.0	21.8	29.0	16.0	33.4	7.1	23.4	20.0	26.2	14.5	30.3	5.9		
840	80	27.1	25.7	29.4	21.6	33.1	14.4	24.5	23.8	26.6	19.9	30.1	12.9		
840	85	28.5	28.5	30.2	26.3	33.2	20.7	25.9	25.9	27.4	24.5	30.2	19.1		
840	90	31.0	31.0	31.4	30.1	33.7	26.2	28.3	28.3	28.6	28.2	30.7	24.5		
960	75	27.3	23.0	30.7	16.4	34.1	8.8	24.4	21.2	27.0	15.5	31.0	6.7		
960	80	28.4	28.4	31.1	21.6	34.5	13.9	25.6	25.2	27.6	21.1	30.9	13.9		
960	85	30.5	30.5	31.5	27.2	35.1	20.2	27.3	27.3	28.6	25.8	31.2	20.3		
960	90	32.7	32.7	32.6	32.6	35.4	25.5	29.6	29.6	29.9	29.7	31.9	25.8		
1080	75	28.1	25.2	31.4	17.4	34.8	9.0	25.3	22.3	27.8	16.4	31.6	7.4		
1080	80	29.7	29.7	31.8	23.2	35.4	16.0	26.7	26.4	28.5	22.1	31.7	14.8		
1080	85	31.9	31.9	32.4	30.0	35.8	21.7	28.5	28.5	29.6	27.1	32.1	21.3		
1080	90	34.1	34.1	34.1	34.1	36.2	27.5	30.8	30.8	31.1	31.1	32.9	27.0		
1200	75	28.8	27.3	32.0	18.2	35.4	8.8	26.1	23.2	28.4	17.1	32.1	7.9		
1200	80	30.8	30.8	32.5	25.0	36.0	16.4	27.6	27.5	29.3	23.0	32.3	15.5		
1200	85	33.1	33.1	33.3	32.6	36.4	23.0	29.5	29.5	30.5	28.1	32.9	22.2		
1200	90	35.4	35.4	35.4	35.4	36.9	29.8	32.2	32.2	32.2	32.2	33.8	28.1		
1320	75	29.5	29.0	32.5	18.7	35.9	9.5	26.7	24.0	28.9	17.7	32.4	8.3		
1320	80	31.8	31.8	33.0	26.8	36.5	17.2	28.4	28.4	29.9	23.8	32.8	16.1		
1320	85	34.2	34.2	34.2	34.2	37.0	24.2	30.5	30.5	31.3	29.1	33.5	23.0		
1320	90	36.6	36.6	36.5	36.5	37.5	32.2	33.1	33.1	33.1	33.1	34.6	29.0		
1440	75	30.2	30.1	32.9	20.1	36.3	9.3	27.2	24.6	29.2	18.1	32.6	8.6		
1440	80	32.6	32.6	33.5	28.8	36.9	17.9	29.0	29.0	30.4	24.4	33.1	16.5		
1440	85	35.1	35.1	35.1	35.1	37.5	25.8	31.3	31.3	32.0	29.9	34.0	23.6		
1440	90	37.5	37.5	37.5	37.5	38.1	34.8	33.9	33.9	33.9	33.9	35.3	29.8		

**Notes:**

1. All capacities shown are gross and have not considered indoor fan heat. To obtain **NET** cooling capacity subtract indoor fan heat. For indoor fan heat formula, refer to appropriate airflow table notes.
  2. MBh = Total Gross Capacity
  3. SHC = Sensible Heat Capacity
- \* Unit applications below 320 CFM/Ton are only applicable on THC models without electric heat. Electric and Gas heat applications are restricted to applications 320 CFM/Ton and above.



## Performance Data

**Table 22. Gross cooling capacities 4 tons high efficiency - single phase T/YHC048F1**

Air Flow cfm		Ent DB (F)		Ambient Temperature																	
				85						95						105					
				Entering Wet Bulb																	
		61		67		73		61		67		73		61		67		73			
		MBh	SHC	MBh	SHC	MBh	SHC	MBh	SHC	MBh	SHC	MBh	SHC	MBh	SHC	MBh	SHC	MBh	SHC		
800	75	38.1	28.9	42.8	21.8	49.1	11.3	35.7	27.5	40.2	20.6	46.2	10.3	33.1	25.9	37.3	19.2	43.1	9.2		
800	80	38.8	33.7	42.8	28.3	48.4	19.5	36.4	32.1	40.2	26.9	45.6	18.4	33.9	30.4	37.5	25.5	42.5	17.2		
800	85	39.9	37.5	43.3	33.8	48.1	26.8	37.6	35.8	40.7	32.3	45.3	25.6	35.1	33.9	38.0	30.7	42.4	24.2		
800	90	41.5	40.3	44.1	38.4	48.2	33.1	39.2	38.5	41.6	36.8	45.5	31.7	36.8	36.5	38.9	35.0	42.6	30.2		
960	75	40.4	31.2	45.0	23.7	51.1	12.9	37.9	29.6	42.2	22.4	48.1	11.8	35.2	28.0	39.3	21.0	44.9	10.6		
960	80	41.4	36.2	45.2	30.5	50.6	21.4	38.9	34.5	42.5	29.0	47.6	20.2	36.2	32.7	39.6	27.4	44.5	18.8		
960	85	42.7	40.3	45.8	36.3	50.5	28.9	40.3	38.5	43.2	34.7	47.6	27.6	37.7	36.5	40.4	33.0	44.5	26.1		
960	90	44.4	43.4	46.9	41.1	50.8	35.5	42.1	41.4	44.3	39.4	48.0	34.0	39.5	39.3	41.5	37.6	45.0	32.4		
1120	75	42.5	33.2	46.9	25.4	52.8	14.2	39.9	31.6	44.0	24.0	49.7	13.1	37.1	29.8	41.0	22.5	46.4	11.8		
1120	80	43.6	38.5	47.3	32.4	52.5	23.0	41.1	36.8	44.5	30.9	49.5	21.7	38.3	34.8	41.5	29.2	46.2	20.3		
1120	85	45.2	42.9	48.1	38.5	52.6	30.8	42.7	41.0	45.4	36.8	49.6	29.4	40.0	38.9	42.5	35.0	46.5	27.8		
1120	90	47.1	46.3	49.4	43.6	53.2	37.7	44.7	44.2	46.7	41.8	50.2	36.1	42.0	42.0	43.8	39.9	47.1	34.4		
1280	75	44.3	35.1	48.5	26.9	54.2	15.4	41.6	33.4	45.6	25.4	51.0	14.1	38.7	31.5	42.4	23.8	47.7	12.7		
1280	80	45.7	40.7	49.2	34.2	54.2	24.4	43.0	38.8	46.3	32.6	51.0	23.0	40.1	36.8	43.2	30.8	47.7	21.5		
1280	85	47.4	45.3	50.2	40.6	54.5	32.5	44.8	43.3	47.3	38.8	51.4	31.0	42.0	41.1	44.3	36.9	48.1	29.3		
1280	90	49.5	48.9	51.6	46.0	55.2	39.6	47.0	46.8	48.8	44.1	52.2	38.0	44.2	44.2	45.8	42.0	49.0	36.1		
1440	75	45.9	36.8	49.9	28.2	55.4	16.4	43.1	34.9	46.8	26.6	52.1	15.0	40.0	32.9	43.6	24.9	48.6	13.5		
1440	80	47.4	42.6	50.7	35.8	55.6	25.6	44.6	40.6	47.7	34.1	52.3	24.2	41.7	38.5	44.5	32.2	48.9	22.5		
1440	85	49.4	47.5	52.0	42.4	56.1	34.0	46.6	45.3	49.0	40.5	52.9	32.4	43.7	43.1	45.9	38.5	49.5	30.6		
1440	90	51.7	51.4	53.6	48.1	57.0	41.4	49.0	49.0	50.7	46.1	53.9	39.6	46.2	46.2	47.6	43.9	50.5	37.7		
1600	75	47.2	38.2	51.0	29.3	56.4	17.1	44.2	36.3	47.8	27.6	53.0	15.6	41.1	34.2	44.5	25.8	49.4	14.0		
1600	80	48.9	44.3	52.0	37.2	56.7	26.7	46.0	42.2	48.9	35.3	53.3	25.1	43.0	40.0	45.6	33.4	49.8	23.3		
1600	85	51.1	49.4	53.5	44.0	57.4	35.3	48.2	47.2	50.4	42.1	54.1	33.6	45.2	44.9	47.2	40.0	50.6	31.7		
1600	90	53.6	53.6	55.3	50.0	58.6	42.9	50.8	50.8	52.3	47.9	55.3	41.1	47.9	47.9	49.1	45.6	51.9	39.1		
1760	75	48.2	39.4	51.9	30.2	57.0	17.7	45.2	37.4	48.6	28.4	53.5	16.1	41.9	35.2	45.1	26.5	49.8	14.4		
1760	80	50.1	45.8	53.1	38.3	57.6	27.5	47.2	43.6	49.9	36.4	54.1	25.8	44.0	41.3	46.5	34.3	50.5	24.0		
1760	85	52.5	51.2	54.7	45.5	58.5	36.4	49.6	48.9	51.6	43.4	55.1	34.5	46.4	46.4	48.2	41.2	51.5	32.6		
1760	90	55.2	55.2	56.8	51.7	59.8	44.3	52.4	52.4	53.7	49.5	56.5	42.3	49.3	49.3	50.4	47.1	52.9	40.2		
1920	75	49.0	40.5	52.4	30.9	57.4	18.0	45.8	38.3	49.1	29.0	53.8	16.3	42.5	36.1	45.5	27.0	50.0	14.5		
1920	80	51.1	47.1	53.9	39.3	58.2	28.1	48.0	44.8	50.5	37.3	54.6	26.3	44.7	42.4	47.0	35.1	50.8	24.4		
1920	85	53.6	52.8	55.7	46.7	59.3	37.2	50.6	50.4	52.4	44.5	55.8	35.3	47.4	47.4	49.0	42.2	52.1	33.2		
1920	90	56.6	56.6	58.0	53.2	60.8	45.4	53.6	53.6	54.7	50.9	57.4	43.4	50.5	50.5	51.3	48.4	53.7	41.2		

continued on next page



**Table 22. Gross cooling capacities 4 tons high efficiency - single phase T/YHC048F1 (continued)**

Air Flow cfm		Ent DB (F)		Ambient Temperature											
				115						125					
				Entering Wet Bulb											
		61		67		73		61		67		73			
		MBh	SHC	MBh	SHC	MBh	SHC	MBh	SHC	MBh	SHC	MBh	SHC		
800	75	30.3	24.2	34.3	17.8	39.9	8.0	27.3	22.3	31.1	16.1	36.4	6.6		
800	80	31.2	28.5	34.5	23.8	39.3	15.8	28.2	26.5	31.3	22.1	35.9	14.3		
800	85	32.5	31.9	35.1	29.0	39.2	22.7	29.6	29.6	32.0	27.1	35.9	21.0		
800	90	34.2	34.2	36.1	33.1	39.5	28.6	32.7	32.7	33.0	31.1	36.2	26.8		
960	75	32.3	26.1	36.2	19.4	41.5	9.3	29.2	24.2	32.9	17.6	38.0	7.8		
960	80	33.4	30.7	36.6	25.7	41.2	17.3	30.4	28.6	33.3	23.9	37.7	15.7		
960	85	34.9	34.4	37.3	31.1	41.3	24.5	31.9	31.9	34.1	29.1	37.8	22.7		
960	90	36.8	36.8	38.5	35.6	41.8	30.7	35.0	35.0	35.4	33.4	38.4	28.8		
1120	75	34.1	27.9	37.8	20.8	42.9	10.3	30.9	25.8	34.3	19.0	39.3	8.7		
1120	80	35.4	32.8	38.3	27.4	42.8	18.7	32.3	30.6	35.0	25.4	39.2	16.9		
1120	85	37.1	36.7	39.3	33.1	43.1	26.1	34.0	34.0	36.0	31.0	39.5	24.2		
1120	90	39.2	39.2	40.7	37.8	43.8	32.5	37.1	37.1	37.5	35.5	40.3	30.5		
1280	75	35.6	29.5	39.1	22.0	44.1	11.2	32.3	27.3	35.6	20.1	40.3	9.5		
1280	80	37.1	34.6	39.9	28.9	44.2	19.8	33.9	32.3	36.4	26.8	40.5	18.0		
1280	85	39.0	38.8	41.1	34.8	44.6	27.5	35.8	35.8	37.6	32.6	41.0	25.5		
1280	90	41.3	41.3	42.7	39.8	45.5	34.2	38.9	38.9	39.3	37.5	41.9	32.1		
1440	75	36.8	30.8	40.2	23.0	45.0	11.8	33.5	28.5	36.5	21.0	41.1	10.1		
1440	80	38.5	36.2	41.1	30.2	45.2	20.7	35.2	33.8	37.6	28.0	41.4	18.8		
1440	85	40.6	40.6	42.5	36.4	45.9	28.7	37.3	37.3	39.0	34.1	42.2	26.6		
1440	90	43.1	43.1	44.3	41.6	47.0	35.7	40.4	40.4	40.9	39.2	43.3	33.5		
1600	75	37.8	32.0	40.9	23.8	45.6	12.3	34.3	29.6	37.2	21.7	41.6	10.4		
1600	80	39.7	37.6	42.1	31.2	46.1	21.5	36.3	35.1	38.5	29.0	42.1	19.4		
1600	85	42.0	42.0	43.7	37.7	47.0	29.7	38.6	38.6	40.1	35.3	43.1	27.5		
1600	90	44.7	44.7	45.7	43.2	48.2	36.9	41.7	41.7	42.2	40.7	44.4	34.6		
1760	75	38.5	32.9	41.5	24.4	45.9	12.6	34.9	30.4	37.6	22.2	41.9	10.6		
1760	80	40.6	38.8	42.9	32.1	46.6	22.0	37.1	36.2	39.1	29.7	42.6	19.8		
1760	85	43.1	43.1	44.7	38.8	47.7	30.4	39.6	39.6	40.9	36.3	43.7	28.2		
1760	90	46.0	46.0	46.9	44.6	49.2	38.0	42.8	42.8	43.2	42.0	45.3	35.6		
1920	75	39.0	33.6	41.7	24.8	46.0	12.6	35.3	31.1	37.8	22.5	41.8	10.5		
1920	80	41.3	39.9	43.3	32.8	46.9	22.3	37.6	37.2	39.4	30.3	42.8	20.1		
1920	85	44.0	44.0	45.3	39.8	48.2	31.0	40.4	40.4	41.5	37.2	44.1	28.7		
1920	90	47.3	47.3	47.7	45.8	49.9	38.8	43.5	43.5	44.0	43.1	45.9	36.3		

**Notes:**

1. All capacities shown are gross and have not considered indoor fan heat. To obtain **NET** cooling capacity subtract indoor fan heat. For indoor fan heat formula, refer to appropriate airflow table notes.
  2. MBh = Total Gross Capacity
  3. SHC = Sensible Heat Capacity
- \* Unit applications below 320 CFM/Ton are only applicable on THC models without electric heat. Electric and Gas heat applications are restricted to applications 320 CFM/Ton and above.



## Performance Data

**Table 23. Gross cooling capacities 4 tons high efficiency - three phase T/YHC048E3,4**

Air Flow cfm		Ent DB (F)		Ambient Temperature																	
				85						95						105					
				Entering Wet Bulb																	
		61		67		73		61		67		73		61		67		73			
		MBh	SHC	MBh	SHC	MBh	SHC	MBh	SHC	MBh	SHC	MBh	SHC	MBh	SHC	MBh	SHC	MBh	SHC		
800	75	39.5	31.1	44.6	23.3	51.6	11.5	36.8	29.6	41.6	22.2	48.3	10.8	33.9	28.0	38.5	20.9	44.9	9.9		
800	80	40.3	36.2	44.5	30.6	50.6	21.0	37.6	34.5	41.6	29.3	47.4	20.0	34.8	32.7	38.5	27.8	44.0	18.9		
800	85	41.6	40.1	45.0	36.7	50.2	29.2	39.0	38.2	42.1	35.1	47.0	28.0	36.2	36.2	39.0	33.4	43.6	26.7		
800	90	43.5	42.9	45.9	41.6	50.2	36.3	40.9	40.8	43.0	39.8	47.0	34.9	38.1	38.1	39.9	37.9	43.7	33.3		
960	75	41.5	33.1	46.4	25.1	53.2	13.0	38.7	31.5	43.4	23.8	49.9	12.1	35.7	29.8	40.1	22.5	46.3	11.1		
960	80	42.5	38.5	46.6	32.6	52.5	22.6	39.7	36.7	43.5	31.1	49.1	21.6	36.8	34.7	40.3	29.5	45.6	20.3		
960	85	44.0	42.6	47.2	38.9	52.2	31.1	41.3	40.6	44.2	37.2	48.9	29.8	38.4	38.4	41.0	35.4	45.4	28.4		
960	90	46.1	45.6	48.3	44.0	52.5	38.4	43.4	43.4	45.3	42.2	49.2	36.9	40.5	40.5	42.2	40.1	45.7	35.3		
1120	75	43.3	35.0	48.1	26.7	54.7	14.3	40.4	33.3	44.9	25.3	51.3	13.3	37.4	31.5	41.6	23.8	47.6	12.2		
1120	80	44.5	40.6	48.4	34.4	54.2	24.2	41.7	38.7	45.3	32.9	50.7	23.0	38.7	36.6	42.0	31.1	47.1	21.7		
1120	85	46.3	45.0	49.2	41.0	54.1	32.9	43.4	42.9	46.1	39.2	50.7	31.5	40.4	40.4	42.8	37.3	47.1	29.9		
1120	90	48.5	48.2	50.6	46.3	54.5	40.4	45.7	45.7	47.5	44.4	51.1	38.8	43.8	43.8	44.2	42.2	47.6	37.1		
1280	75	45.4	36.1	50.5	26.4	55.8	16.0	42.5	34.5	47.2	24.7	52.3	15.2	39.3	32.9	43.8	22.9	48.7	13.1		
1280	80	46.2	44.2	51.0	34.1	56.4	24.0	43.2	42.5	47.7	32.3	53.0	22.7	40.1	40.1	44.3	30.8	49.2	20.7		
1280	85	48.3	48.3	51.5	41.7	56.9	31.7	45.7	45.7	48.2	40.0	53.4	30.0	42.8	42.8	44.8	38.4	49.7	28.3		
1280	90	51.2	51.2	52.2	49.6	57.3	39.1	48.5	48.5	49.0	48.0	53.8	37.5	45.7	45.7	45.7	45.7	50.1	35.8		
1440	75	46.7	38.9	51.7	27.7	57.1	16.8	43.6	37.3	48.4	26.5	53.5	15.0	40.4	35.7	44.9	24.2	49.7	13.3		
1440	80	47.6	47.3	52.3	36.3	57.8	25.6	44.7	44.7	48.9	34.6	54.1	23.3	41.8	41.8	45.4	33.0	50.3	21.3		
1440	85	50.5	50.5	52.9	45.0	58.3	33.4	47.7	47.7	49.5	43.3	54.6	31.9	44.8	44.8	46.0	41.8	50.8	30.3		
1440	90	53.6	53.6	53.8	53.5	58.7	42.0	50.8	50.8	50.7	50.7	55.0	40.2	47.7	47.7	47.7	47.7	51.2	38.7		
1600	75	47.8	41.6	52.8	29.5	58.2	16.6	44.6	40.0	49.4	27.3	54.5	15.0	41.3	38.3	45.8	25.9	50.6	13.4		
1600	80	49.2	49.2	53.3	38.6	58.8	25.3	46.4	46.4	49.9	37.0	55.2	24.3	43.4	43.4	46.3	35.5	51.2	23.6		
1600	85	52.4	52.4	54.0	48.2	59.4	35.5	49.5	49.5	50.6	46.7	55.7	33.8	46.4	46.4	47.1	45.3	51.7	32.3		
1600	90	55.7	55.7	55.6	55.6	59.9	44.8	52.7	52.7	52.6	52.6	56.1	43.2	49.5	49.5	49.4	49.4	52.2	41.7		
1760	75	48.8	44.2	53.7	30.6	59.2	16.8	45.5	42.6	50.2	28.8	55.4	15.2	42.1	40.8	46.5	27.3	51.4	13.6		
1760	80	50.8	50.8	54.3	41.0	59.8	27.3	47.9	47.9	50.8	39.3	56.0	25.6	44.7	44.7	47.0	37.7	52.0	24.8		
1760	85	54.1	54.1	55.1	51.6	60.3	37.5	51.1	51.1	51.7	50.1	56.5	35.9	47.9	47.9	48.0	47.8	52.5	34.3		
1760	90	57.5	57.5	57.4	57.4	60.9	47.9	54.3	54.3	54.2	54.2	57.1	46.3	51.1	51.1	51.1	51.1	53.0	44.7		
1920	75	49.6	46.9	54.5	31.8	60.0	16.9	46.3	45.0	50.9	30.2	56.1	15.5	42.9	42.6	47.1	28.6	52.0	13.7		
1920	80	52.2	52.2	55.1	43.2	60.6	27.5	49.2	49.2	51.5	41.6	56.8	26.8	46.0	46.0	47.7	40.1	52.6	25.4		
1920	85	55.6	55.6	56.1	54.7	61.2	39.5	52.5	52.5	52.7	52.5	57.2	37.9	49.2	49.2	49.2	49.2	53.1	36.3		
1920	90	59.1	59.1	59.0	59.0	61.8	50.7	55.9	55.9	55.8	55.8	57.9	49.3	52.5	52.5	52.4	52.4	53.8	47.8		

continued on next page

**Table 23. Gross cooling capacities 4 tons high efficiency - three phase T/YHC048E3,4 (continued)**

Air Flow cfm		Ent DB (F)		Ambient Temperature											
				115						125					
				Entering Wet Bulb											
		61		67		73		61		67		73			
		MBh	SHC	MBh	SHC	MBh	SHC	MBh	SHC	MBh	SHC	MBh	SHC		
800	75	30.9	26.2	35.2	19.5	41.3	8.8	27.7	24.3	31.6	17.9	37.5	7.6		
800	80	31.8	30.7	35.2	26.1	40.4	17.6	28.6	28.5	31.7	24.3	36.6	16.2		
800	85	33.2	33.2	35.7	31.6	40.0	25.2	30.0	30.0	32.2	29.6	36.3	23.6		
800	90	36.3	36.3	36.7	35.8	40.1	31.6	33.3	33.3	33.3	33.3	36.4	29.8		
960	75	32.6	27.9	36.7	20.9	42.6	10.0	29.3	25.8	33.1	19.2	38.7	8.6		
960	80	33.7	32.6	36.9	27.8	41.9	19.0	30.4	30.3	33.3	25.9	38.1	17.4		
960	85	35.3	35.3	37.6	33.5	41.7	26.8	32.0	32.0	34.0	31.3	37.9	25.0		
960	90	38.4	38.4	38.8	38.0	42.1	33.4	35.3	35.3	35.3	35.3	38.2	31.5		
1120	75	34.2	29.5	38.1	22.2	43.8	10.9	30.8	27.3	34.4	20.4	39.9	9.5		
1120	80	35.5	34.4	38.5	29.3	43.3	20.2	32.1	32.0	34.8	27.3	39.4	18.5		
1120	85	37.2	37.2	39.4	35.2	43.3	28.2	33.9	33.9	35.7	33.0	39.4	26.4		
1120	90	40.3	40.3	40.8	39.9	43.8	35.1	37.1	37.1	37.1	37.1	39.9	33.0		
1280	75	35.9	31.2	40.1	21.3	44.7	11.5	32.1	28.6	35.5	21.4	40.8	10.2		
1280	80	37.2	37.2	40.6	29.0	45.3	19.2	33.6	33.6	36.1	28.5	40.5	19.5		
1280	85	39.8	39.8	41.1	36.7	45.7	26.7	35.6	35.6	37.2	34.5	40.7	27.6		
1280	90	42.5	42.5	42.5	42.5	46.0	34.1	38.8	38.8	38.8	38.8	41.4	34.5		
1440	75	36.9	34.0	41.1	22.7	45.7	11.6	33.2	29.8	36.5	22.3	41.6	10.8		
1440	80	38.7	38.7	41.6	31.3	46.2	19.7	34.9	34.9	37.3	29.7	41.5	20.3		
1440	85	41.6	41.6	42.2	40.2	46.7	28.7	37.1	37.1	38.5	35.8	41.9	28.7		
1440	90	44.4	44.4	44.3	44.3	47.0	37.1	40.3	40.3	40.3	40.3	42.8	35.8		
1600	75	37.7	36.6	41.8	24.1	46.4	11.8	34.2	30.9	37.2	23.1	42.2	11.3		
1600	80	40.2	40.2	42.4	33.7	47.0	21.8	36.0	36.0	38.2	30.7	42.3	21.0		
1600	85	43.1	43.1	43.3	43.0	47.5	30.7	38.4	38.4	39.7	37.1	42.9	29.6		
1600	90	46.0	46.0	46.0	46.0	47.9	40.0	41.7	41.7	41.7	41.7	44.0	37.0		
1760	75	38.5	38.4	42.5	25.6	47.1	12.0	35.0	31.8	37.9	23.7	42.6	11.6		
1760	80	41.4	41.4	43.1	36.1	47.7	22.2	37.0	37.0	39.0	31.5	42.9	21.6		
1760	85	44.4	44.4	44.4	44.4	48.1	32.7	39.6	39.6	40.7	38.2	43.7	30.4		
1760	90	47.4	47.4	47.4	47.4	48.6	43.2	42.9	42.9	42.9	42.9	45.0	38.0		
1920	75	39.3	39.3	43.0	26.9	47.7	12.5	35.6	32.6	38.3	24.2	42.9	11.8		
1920	80	42.5	42.5	43.7	38.4	48.2	23.5	37.9	37.9	39.7	32.3	43.4	22.0		
1920	85	45.6	45.6	45.5	45.5	48.7	34.7	40.6	40.6	41.6	39.1	44.4	31.1		
1920	90	48.7	48.7	48.6	48.6	49.4	46.5	43.9	43.9	43.9	43.9	45.8	38.9		

**Notes:**

1. All capacities shown are gross and have not considered indoor fan heat. To obtain **NET** cooling capacity subtract indoor fan heat. For indoor fan heat formula, refer to appropriate airflow table notes.
  2. MBh = Total Gross Capacity
  3. SHC = Sensible Heat Capacity
- \* Unit applications below 320 CFM/Ton are only applicable on THC models without electric heat. Electric and Gas heat applications are restricted to applications 320 CFM/Ton and above.



## Performance Data

**Table 24. Gross cooling capacities 4 tons high efficiency - three phase T/YHC048F3,4**

Air Flow cfm		Ent DB (F)		Ambient Temperature																	
				85						95						105					
				Entering Wet Bulb																	
		61		67		73		61		67		73		61		67		73			
		MBh	SHC	MBh	SHC	MBh	SHC	MBh	SHC	MBh	SHC	MBh	SHC	MBh	SHC	MBh	SHC	MBh	SHC		
800	75	38.6	28.5	43.5	21.3	50.0	10.6	36.1	27.0	40.8	20.0	47.1	9.7	33.5	25.3	37.9	18.6	43.9	8.5		
800	80	39.3	33.3	43.5	27.9	49.3	19.0	36.9	31.6	40.9	26.5	46.4	17.9	34.3	29.9	38.0	24.9	43.3	16.6		
800	85	40.5	37.2	44.0	33.5	49.0	26.4	38.2	35.4	41.4	32.0	46.1	25.1	35.6	33.5	38.6	30.3	43.1	23.7		
800	90	42.1	40.1	44.8	38.2	49.1	32.8	39.8	38.2	42.3	36.5	46.3	31.4	37.3	36.1	39.6	34.7	43.4	29.8		
960	75	41.0	30.8	45.8	23.3	52.1	12.2	38.4	29.2	42.9	21.9	49.0	11.2	35.7	27.5	39.9	20.4	45.8	10.0		
960	80	42.0	35.9	46.0	30.1	51.6	20.9	39.5	34.2	43.2	28.6	48.6	19.7	36.8	32.3	40.3	27.0	45.4	18.3		
960	85	43.4	40.1	46.6	36.0	51.5	28.5	40.9	38.2	43.9	34.4	48.5	27.2	38.3	36.2	41.0	32.7	45.4	25.7		
960	90	45.2	43.3	47.7	41.0	51.8	35.2	42.8	41.3	45.0	39.2	48.9	33.7	40.2	39.1	42.2	37.3	45.8	32.1		
1120	75	43.2	32.9	47.7	25.0	53.9	13.6	40.5	31.3	44.8	23.6	50.7	12.5	37.6	29.4	41.7	22.0	47.4	11.2		
1120	80	44.4	38.3	48.2	32.1	53.6	22.5	41.7	36.5	45.3	30.6	50.5	21.2	38.9	34.5	42.3	28.9	47.2	19.8		
1120	85	46.0	42.8	49.0	38.3	53.7	30.5	43.4	40.8	46.2	36.6	50.6	29.0	40.6	38.7	43.2	34.8	47.4	27.4		
1120	90	48.0	46.2	50.3	43.6	54.2	37.5	45.5	44.1	47.6	41.7	51.2	35.9	42.8	41.9	44.6	39.8	48.0	34.2		
1280	75	45.1	34.8	49.5	26.5	55.4	14.8	42.3	33.1	46.4	25.0	52.1	13.5	39.3	31.1	43.2	23.4	48.7	12.1		
1280	80	46.5	40.5	50.1	34.0	55.3	24.0	43.7	38.6	47.1	32.3	52.1	22.6	40.8	36.5	44.0	30.5	48.7	21.0		
1280	85	48.3	45.2	51.2	40.4	55.6	32.2	45.6	43.2	48.2	38.6	52.5	30.7	42.7	41.0	45.1	36.7	49.1	29.0		
1280	90	50.5	49.0	52.6	45.9	56.4	39.5	47.9	46.8	49.8	44.0	53.3	37.8	45.1	44.5	46.7	41.9	50.0	36.0		
1440	75	46.7	36.5	50.9	27.9	56.7	15.7	43.8	34.7	47.8	26.2	53.3	14.4	40.7	32.6	44.4	24.5	49.7	12.9		
1440	80	48.3	42.5	51.7	35.5	56.8	25.2	45.5	40.5	48.7	33.8	53.5	23.7	42.4	38.3	45.4	31.9	49.9	22.1		
1440	85	50.3	47.5	53.0	42.3	57.3	33.7	47.5	45.3	50.0	40.4	54.0	32.1	44.6	43.0	46.8	38.4	50.6	30.3		
1440	90	52.7	51.5	54.7	48.1	58.3	41.2	50.0	49.2	51.7	46.1	55.1	39.5	47.1	46.8	48.6	43.9	51.7	37.6		
1600	75	48.1	38.0	52.1	28.9	57.7	16.4	45.0	36.0	48.8	27.2	54.2	15.0	41.9	33.9	45.4	25.4	50.5	13.4		
1600	80	49.9	44.2	53.1	36.9	58.0	26.2	46.9	42.1	49.9	35.1	54.5	24.6	43.8	39.9	46.6	33.1	50.9	22.9		
1600	85	52.1	49.5	54.6	43.9	58.7	34.9	49.2	47.2	51.5	42.0	55.3	33.2	46.1	44.9	48.2	39.8	51.8	31.4		
1600	90	54.7	53.8	56.5	50.0	59.9	42.8	51.9	51.4	53.4	47.9	56.6	40.9	48.9	48.9	50.2	45.6	53.1	38.9		
1760	75	49.1	39.2	53.0	29.8	58.4	16.9	46.0	37.1	49.6	28.0	54.8	15.4	42.7	35.0	46.1	26.1	51.0	13.7		
1760	80	51.1	45.7	54.2	38.0	58.9	26.9	48.1	43.5	50.9	36.1	55.4	25.3	44.8	41.2	47.4	34.0	51.6	23.5		
1760	85	53.6	51.2	55.9	45.3	59.8	36.0	50.6	48.9	52.7	43.3	56.4	34.2	47.4	46.5	49.2	41.1	52.7	32.2		
1760	90	56.4	55.8	58.0	51.7	61.2	44.1	53.5	53.4	54.8	49.5	57.8	42.2	50.4	50.4	51.5	47.1	54.2	40.1		
1920	75	49.9	40.2	53.6	30.4	58.8	17.2	46.7	38.1	50.1	28.5	55.1	15.6	43.3	35.8	46.5	26.5	51.2	13.8		
1920	80	52.2	47.0	55.1	39.0	59.5	27.5	49.0	44.7	51.6	36.9	55.9	25.7	45.6	42.3	48.1	34.8	52.1	23.8		
1920	85	54.8	52.8	57.0	46.5	60.7	36.8	51.7	50.4	53.6	44.4	57.1	34.9	48.4	47.8	50.1	42.1	53.3	32.9		
1920	90	57.9	57.7	59.3	53.2	62.3	45.2	54.8	54.8	56.0	50.9	58.7	43.2	51.6	51.6	52.5	48.4	55.0	41.0		

continued on next page

**Table 24. Gross cooling capacities 4 tons high efficiency - three phase T/YHC048F3,4 (continued)**

Air Flow cfm		Ent DB (F)		Ambient Temperature											
				115						125					
				Entering Wet Bulb											
		61		67		73		61		67		73			
		MBh	SHC	MBh	SHC	MBh	SHC	MBh	SHC	MBh	SHC	MBh	SHC		
800	75	30.6	23.5	34.8	17.1	40.6	7.2	27.6	21.6	31.6	15.4	37.1	5.8		
800	80	31.6	27.9	35.0	23.3	40.1	15.2	28.6	25.9	31.8	21.5	36.6	13.6		
800	85	32.9	31.4	35.6	28.5	39.9	22.1	30.0	29.2	32.5	26.5	36.5	20.4		
800	90	34.7	33.9	36.7	32.8	40.2	28.2	31.8	31.6	33.6	30.7	36.9	26.3		
960	75	32.8	25.6	36.8	18.8	42.4	8.6	29.6	23.6	33.4	17.0	38.8	7.1		
960	80	33.9	30.3	37.2	25.3	42.0	16.8	30.8	28.1	33.9	23.4	38.5	15.1		
960	85	35.4	34.0	38.0	30.8	42.1	24.0	32.4	31.7	34.7	28.7	38.6	22.3		
960	90	37.4	36.8	39.2	35.3	42.6	30.3	34.5	34.4	36.0	33.1	39.2	28.4		
1120	75	34.6	27.4	38.4	20.3	43.8	9.7	31.4	25.3	35.0	18.4	40.1	8.1		
1120	80	35.9	32.4	39.0	27.0	43.7	18.2	32.8	30.2	35.6	25.0	40.0	16.4		
1120	85	37.7	36.4	40.1	32.8	44.0	25.7	34.6	34.1	36.7	30.7	40.4	23.8		
1120	90	39.9	39.5	41.5	37.6	44.7	32.3	36.8	36.8	38.2	35.4	41.2	30.3		
1280	75	36.2	29.1	39.8	21.6	45.0	10.6	32.8	26.9	36.2	19.6	41.2	8.9		
1280	80	37.7	34.3	40.6	28.6	45.1	19.4	34.4	32.0	37.1	26.5	41.4	17.5		
1280	85	39.7	38.6	41.9	34.6	45.6	27.2	36.5	36.1	38.4	32.4	41.9	25.2		
1280	90	42.1	42.0	43.5	39.7	46.5	34.0	38.9	38.9	40.1	37.4	42.9	31.9		
1440	75	37.5	30.5	40.9	22.6	46.0	11.3	34.0	28.2	37.2	20.5	42.0	9.5		
1440	80	39.2	36.0	41.9	29.9	46.3	20.3	35.8	33.6	38.3	27.7	42.4	18.4		
1440	85	41.4	40.6	43.4	36.2	47.0	28.4	38.1	38.0	39.8	33.9	43.1	26.3		
1440	90	44.0	44.0	45.3	41.6	48.1	35.5	40.7	40.7	41.7	39.1	44.3	33.3		
1600	75	38.5	31.7	41.8	23.4	46.6	11.7	34.9	29.3	38.0	21.3	42.6	9.8		
1600	80	40.5	37.5	43.0	31.0	47.1	21.0	37.0	34.9	39.3	28.7	43.1	19.0		
1600	85	42.9	42.3	44.7	37.6	48.0	29.4	39.4	39.4	41.0	35.2	44.1	27.2		
1600	90	45.7	45.7	46.7	43.2	49.4	36.8	42.3	42.3	43.1	40.7	45.5	34.5		
1760	75	39.2	32.6	42.3	24.0	47.0	11.9	35.6	30.1	38.4	21.8	42.9	9.9		
1760	80	41.4	38.7	43.8	31.8	47.7	21.5	37.8	36.1	39.9	29.5	43.6	19.4		
1760	85	44.0	43.8	45.6	38.7	48.8	30.1	40.5	40.5	41.9	36.2	44.8	27.9		
1760	90	47.0	47.0	47.9	44.7	50.4	37.8	43.6	43.6	44.2	42.0	46.4	35.5		
1920	75	39.7	33.3	42.6	24.3	47.1	11.9	36.0	30.8	38.6	22.0	42.9	9.8		
1920	80	42.1	39.7	44.3	32.5	48.0	21.8	38.4	37.0	40.3	30.0	43.8	19.6		
1920	85	44.9	44.9	46.4	39.6	49.4	30.7	41.3	41.3	42.5	37.0	45.2	28.4		
1920	90	48.2	48.2	48.9	45.8	51.1	38.7	44.6	44.6	45.0	43.1	47.0	36.2		

**Notes:**

1. All capacities shown are gross and have not considered indoor fan heat. To obtain **NET** cooling capacity subtract indoor fan heat. For indoor fan heat formula, refer to appropriate airflow table notes.
  2. MBh = Total Gross Capacity
  3. SHC = Sensible Heat Capacity
- \* Unit applications below 320 CFM/Ton are only applicable on THC models without electric heat. Electric and Gas heat applications are restricted to applications 320 CFM/Ton and above.



## Performance Data

**Table 25. Gross cooling capacities 5 tons high efficiency - single phase T/YHC060F1**

Air Flow cfm		Ent DB (F)		Ambient Temperature																	
				85						95						105					
				Entering Wet Bulb																	
		61		67		73		61		67		73		61		67		73			
		MBh	SHC	MBh	SHC	MBh	SHC	MBh	SHC	MBh	SHC	MBh	SHC	MBh	SHC	MBh	SHC	MBh	SHC		
1000	75	48.6	37.7	54.4	28.8	62.3	15.7	45.8	36.1	51.3	27.5	58.9	14.7	42.7	34.3	47.9	26.1	55.2	13.6		
1000	80	49.3	43.5	54.2	36.8	61.2	25.9	46.6	41.7	51.3	35.4	58.0	24.8	43.7	39.8	48.0	33.9	54.4	23.6		
1000	85	50.5	48.0	54.5	43.6	60.6	34.9	48.0	46.1	51.7	42.1	57.5	33.7	45.1	44.1	48.6	40.4	54.1	32.3		
1000	90	52.1	51.2	55.2	49.1	60.4	42.6	49.7	49.3	52.5	47.4	57.4	41.3	47.0	47.0	49.6	45.6	54.1	39.8		
1200	75	51.2	40.5	56.8	31.3	64.4	17.8	48.3	38.8	53.6	29.9	61.0	16.7	45.1	36.9	50.1	28.3	57.2	15.4		
1200	80	52.2	46.6	56.9	39.6	63.6	28.3	49.4	44.7	53.8	38.1	60.3	27.1	46.4	42.7	50.5	36.4	56.6	25.7		
1200	85	53.6	51.4	57.4	46.6	63.2	37.6	51.0	49.4	54.5	45.0	60.0	36.3	48.1	47.3	51.3	43.2	56.5	34.8		
1200	90	55.4	55.0	58.3	52.4	63.2	45.6	53.0	52.9	55.5	50.6	60.2	44.1	50.2	50.2	52.5	48.7	56.8	42.5		
1400	75	53.5	43.0	58.9	33.4	66.3	19.6	50.5	41.2	55.6	31.9	62.7	18.4	47.3	39.2	52.0	30.2	58.9	17.0		
1400	80	54.7	49.4	59.2	42.1	65.7	30.4	51.9	47.5	56.1	40.4	62.3	29.1	48.7	45.3	52.6	38.6	58.5	27.6		
1400	85	56.4	54.6	60.0	49.4	65.5	40.0	53.7	52.5	56.9	47.6	62.2	38.5	50.7	50.2	53.7	45.7	58.7	36.9		
1400	90	58.5	58.4	61.1	55.5	65.8	48.3	55.9	55.9	58.3	53.6	62.7	46.7	53.1	53.1	55.1	51.5	59.2	45.0		
1600	75	55.6	45.3	60.7	35.3	67.9	21.1	52.5	43.4	57.3	33.7	64.2	19.8	49.1	41.2	53.6	31.9	60.2	18.3		
1600	80	57.0	52.0	61.2	44.3	67.5	32.2	54.1	49.9	58.0	42.5	64.0	30.8	50.8	47.7	54.5	40.6	60.2	29.2		
1600	85	58.9	57.4	62.2	51.9	67.6	42.1	56.1	55.2	59.1	50.0	64.2	40.5	53.0	52.8	55.7	48.0	60.5	38.8		
1600	90	61.2	61.2	63.7	58.3	68.1	50.7	58.6	58.6	60.7	56.3	64.8	49.0	55.6	55.6	57.4	54.1	61.3	47.2		
1800	75	57.3	47.3	62.2	37.0	69.1	22.3	54.1	45.2	58.7	35.2	65.4	20.9	50.6	43.0	55.0	33.3	61.3	19.3		
1800	80	59.0	54.3	63.0	46.2	69.0	33.8	55.9	52.1	59.6	44.3	65.4	32.2	52.6	49.7	56.0	42.2	61.5	30.5		
1800	85	61.1	60.0	64.2	54.1	69.3	44.0	58.2	57.7	61.0	52.1	65.8	42.3	55.0	55.0	57.5	50.0	62.1	40.4		
1800	90	63.7	63.7	65.9	60.8	70.1	52.9	60.9	60.9	62.8	58.7	66.7	51.1	57.9	57.9	59.5	56.4	63.1	49.1		
2000	75	58.7	49.0	63.4	38.3	70.1	23.3	55.5	46.8	59.8	36.4	66.2	21.8	51.9	44.5	56.0	34.4	62.1	20.0		
2000	80	60.7	56.3	64.4	47.8	70.2	35.1	57.5	54.0	61.0	45.8	66.5	33.4	54.1	51.5	57.3	43.7	62.5	31.5		
2000	85	63.1	62.4	65.9	56.1	70.8	45.5	60.0	59.9	62.6	54.0	67.2	43.7	56.8	56.8	59.0	51.7	63.3	41.8		
2000	90	65.9	65.9	67.8	63.1	71.8	54.8	63.0	63.0	64.7	60.8	68.3	52.8	59.9	59.9	61.2	58.4	64.6	50.7		
2200	75	59.9	50.5	64.3	39.4	70.8	24.0	56.5	48.2	60.6	37.4	66.8	22.3	52.9	45.7	56.7	35.2	62.6	20.5		
2200	80	62.1	58.1	65.6	49.2	71.2	36.1	58.8	55.6	62.1	47.1	67.3	34.3	55.3	53.0	58.3	44.8	63.2	32.3		
2200	85	64.7	64.4	67.3	57.8	72.0	46.8	61.6	61.6	63.9	55.5	68.3	44.9	58.2	58.2	60.2	53.1	64.3	42.8		
2200	90	67.7	67.7	69.4	65.1	73.2	56.4	64.8	64.8	66.2	62.7	69.7	54.3	61.5	61.5	62.7	60.1	65.8	52.1		
2400	75	60.7	51.7	64.9	40.2	71.2	24.4	57.3	49.2	61.2	38.1	67.1	22.6	53.5	46.6	57.1	35.8	62.8	20.7		
2400	80	63.2	59.5	66.4	50.3	71.8	36.8	59.8	57.0	62.8	48.1	67.9	34.9	56.2	54.3	58.9	45.7	63.7	32.8		
2400	85	66.0	66.0	68.4	59.2	72.8	47.9	62.8	62.8	64.9	56.8	69.0	45.8	59.4	59.4	61.2	54.3	65.0	43.6		
2400	90	69.3	69.3	70.8	66.8	74.3	57.7	66.3	66.3	67.4	64.3	70.7	55.5	62.9	62.9	63.8	61.6	66.8	53.2		

continued on next page

**Table 25. Gross cooling capacities 5 tons high efficiency - single phase T/YHC060F1 (continued)**

Air Flow cfm		Ent DB (F)		Ambient Temperature											
				115						125					
				Entering Wet Bulb											
		61		67		73		61		67		73			
		MBh	SHC	MBh	SHC	MBh	SHC	MBh	SHC	MBh	SHC	MBh	SHC		
1000	75	39.3	32.4	44.3	24.5	51.3	12.3	35.7	30.3	40.3	22.7	47.0	10.8		
1000	80	40.5	37.8	44.5	32.1	50.6	22.2	37.0	35.6	40.7	30.2	46.5	20.6		
1000	85	42.1	41.9	45.2	38.5	50.4	30.8	38.7	38.7	41.6	36.4	46.4	29.0		
1000	90	44.1	44.1	46.3	43.6	50.6	38.1	42.4	42.4	42.8	41.4	46.8	36.3		
1200	75	41.7	34.8	46.4	26.6	53.1	14.0	37.9	32.6	42.3	24.7	48.8	12.4		
1200	80	43.1	40.5	46.9	34.5	52.7	24.2	39.5	38.2	43.0	32.5	48.5	22.5		
1200	85	44.9	44.9	47.8	41.2	52.7	33.1	41.4	41.4	44.0	39.0	48.7	31.2		
1200	90	47.2	47.2	49.2	46.6	53.2	40.7	45.1	45.1	45.5	44.3	49.3	38.8		
1400	75	43.7	37.0	48.2	28.4	54.7	15.5	39.9	34.7	44.1	26.4	50.3	13.8		
1400	80	45.3	43.0	48.9	36.6	54.5	25.9	41.6	40.6	44.9	34.5	50.3	24.1		
1400	85	47.4	47.4	50.1	43.6	54.8	35.1	43.9	43.9	46.2	41.3	50.7	33.2		
1400	90	49.9	49.9	51.7	49.3	55.5	43.1	47.5	47.5	48.0	46.9	51.5	41.0		
1600	75	45.4	38.9	49.7	29.9	56.0	16.6	41.5	36.5	45.5	27.8	51.5	14.8		
1600	80	47.3	45.3	50.7	38.5	56.1	27.4	43.5	42.7	46.6	36.2	51.7	25.4		
1600	85	49.6	49.6	52.1	45.7	56.6	36.9	46.0	46.0	48.1	43.3	52.3	34.8		
1600	90	52.4	52.4	53.9	51.7	57.5	45.1	49.6	49.6	50.1	49.2	53.4	42.9		
1800	75	46.9	40.6	50.9	31.2	57.0	17.5	42.9	38.0	46.6	28.9	52.4	15.6		
1800	80	49.0	47.2	52.1	40.0	57.3	28.6	45.1	44.5	48.0	37.6	52.8	26.5		
1800	85	51.6	51.6	53.8	47.6	58.0	38.4	47.8	47.8	49.8	45.1	53.7	36.2		
1800	90	55.3	55.3	55.9	53.9	59.2	46.9	51.5	51.5	52.0	51.3	55.0	44.6		
2000	75	48.1	42.0	51.8	32.2	57.7	18.1	43.9	39.3	47.4	29.8	53.0	16.1		
2000	80	50.4	48.9	53.3	41.3	58.2	29.5	46.4	46.0	49.0	38.8	53.7	27.3		
2000	85	53.2	53.2	55.2	49.2	59.2	39.6	49.4	49.4	51.1	46.6	54.8	37.3		
2000	90	56.9	56.9	57.5	55.8	60.6	48.4	53.0	53.0	53.5	53.1	56.3	46.0		
2200	75	48.9	43.0	52.5	32.9	58.1	18.5	44.7	40.2	48.0	30.4	53.3	16.3		
2200	80	51.5	50.3	54.2	42.3	58.9	30.1	47.5	47.3	49.8	39.7	54.2	27.8		
2200	85	54.6	54.6	56.3	50.5	60.1	40.6	50.6	50.6	52.1	47.8	55.6	38.1		
2200	90	58.3	58.3	58.9	57.4	61.7	49.7	54.2	54.2	54.8	54.6	57.4	47.1		
2400	75	49.5	43.9	52.8	33.3	58.2	18.5	45.2	40.9	48.2	30.7	53.3	16.2		
2400	80	52.3	51.4	54.7	43.1	59.2	30.5	48.2	48.2	50.3	40.3	54.5	28.1		
2400	85	55.6	55.6	57.1	51.6	60.7	41.2	51.6	51.6	52.8	48.7	56.1	38.7		
2400	90	59.3	59.3	59.9	58.8	62.6	50.7	55.8	55.8	55.8	55.8	58.1	48.0		

**Notes:**

1. All capacities shown are gross and have not considered indoor fan heat. To obtain **NET** cooling capacity subtract indoor fan heat. For indoor fan heat formula, refer to appropriate airflow table notes.
  2. MBh = Total Gross Capacity
  3. SHC = Sensible Heat Capacity
- \* Unit applications below 320 CFM/Ton are only applicable on THC models without electric heat. Electric and Gas heat applications are restricted to applications 320 CFM/Ton and above.



## Performance Data

**Table 26. Gross cooling capacities 5 tons high efficiency - three phase T/YHC060E3,4**

Air Flow cfm		Ent DB (F)		Ambient Temperature																	
				85						95						105					
				Entering Wet Bulb																	
		61		67		73		61		67		73		61		67		73			
		MBh	SHC	MBh	SHC	MBh	SHC	MBh	SHC	MBh	SHC	MBh	SHC	MBh	SHC	MBh	SHC	MBh	SHC		
1000	75	50.6	39.4	57.2	29.5	66.2	14.8	47.3	37.5	53.5	28.1	62.2	13.9	43.8	35.5	49.7	26.6	58.0	12.7		
1000	80	51.5	45.7	57.0	38.5	64.8	26.5	48.2	43.6	53.3	36.9	60.8	25.2	44.8	41.4	49.5	35.1	56.6	23.8		
1000	85	53.1	50.7	57.4	46.1	64.0	36.6	49.8	48.3	53.8	44.2	60.1	35.1	46.4	45.8	50.0	42.1	55.9	33.5		
1000	90	55.3	54.1	58.5	52.1	64.0	45.3	52.1	51.5	54.9	50.0	60.0	43.6	48.7	48.7	51.1	47.6	55.9	41.7		
1200	75	53.1	42.1	59.5	31.9	68.2	17.0	49.7	40.1	55.7	30.4	64.1	15.8	46.1	38.0	51.7	28.7	59.8	14.6		
1200	80	54.3	48.7	59.5	41.2	67.0	28.9	50.8	46.5	55.7	39.4	62.9	27.5	47.3	44.1	51.8	37.5	58.7	26.0		
1200	85	56.1	53.9	60.1	49.0	66.5	39.3	52.7	51.4	56.4	47.0	62.5	37.7	49.2	48.8	52.5	44.8	58.2	35.9		
1200	90	58.5	57.6	61.4	55.4	66.7	48.3	55.2	54.9	57.7	53.1	62.6	46.4	51.7	51.7	53.9	50.6	58.5	44.3		
1400	75	55.4	44.6	61.5	34.2	70.0	18.9	51.8	42.5	57.6	32.5	65.8	17.6	48.1	40.3	53.6	30.7	61.4	16.2		
1400	80	56.8	51.5	61.7	43.7	69.1	31.1	53.3	49.2	57.9	41.8	64.9	29.6	49.6	46.7	53.9	39.7	60.5	27.9		
1400	85	58.8	57.0	62.6	51.8	68.8	41.8	55.3	54.4	58.8	49.6	64.6	40.0	51.7	51.6	54.8	47.3	60.3	38.1		
1400	90	61.5	61.0	64.2	58.4	69.2	51.0	58.1	58.1	60.4	56.0	65.1	49.0	54.5	54.5	56.4	53.4	60.8	46.8		
1600	75	58.0	46.3	64.5	34.2	71.3	22.4	54.3	44.3	60.5	32.5	67.1	21.0	50.4	42.2	56.3	30.5	62.5	18.4		
1600	80	58.7	55.9	64.8	43.5	71.8	31.7	55.0	53.9	60.9	41.7	67.6	29.9	51.3	51.3	56.7	39.7	63.1	27.9		
1600	85	61.3	61.3	65.3	53.0	72.2	41.1	58.1	58.1	61.3	51.0	67.9	39.0	54.7	54.7	57.1	49.0	63.4	37.0		
1600	90	64.9	64.9	65.8	62.4	72.6	50.2	61.6	61.6	61.9	60.6	68.3	47.9	58.1	58.1	58.0	58.0	63.7	46.0		
1800	75	59.6	49.6	66.0	35.9	72.9	22.5	55.7	47.5	61.9	34.5	68.5	20.7	51.7	45.4	57.5	32.4	63.8	18.6		
1800	80	60.5	60.3	66.4	46.6	73.5	33.3	57.1	57.1	62.3	44.5	69.0	31.2	53.5	53.5	58.0	42.6	64.3	29.3		
1800	85	64.1	64.1	66.9	57.0	73.9	43.4	60.7	60.7	62.8	55.1	69.4	41.5	57.1	57.1	58.5	53.1	64.7	39.4		
1800	90	67.8	67.8	67.9	67.7	74.2	53.6	64.3	64.3	64.3	64.3	69.8	51.4	60.6	60.6	60.6	60.6	65.1	49.6		
2000	75	60.8	52.8	67.3	37.9	74.2	22.9	56.9	50.8	63.0	35.7	69.6	21.2	52.8	48.7	58.6	33.8	64.9	19.0		
2000	80	62.6	62.6	67.7	49.4	74.8	34.6	59.1	59.1	63.5	47.3	70.2	32.6	55.4	55.4	59.0	45.4	65.4	30.5		
2000	85	66.5	66.5	68.4	61.1	75.2	45.8	62.9	62.9	64.2	59.2	70.6	43.8	59.2	59.2	59.7	57.2	65.8	41.8		
2000	90	70.4	70.4	70.3	70.3	75.5	57.1	66.8	66.8	66.7	66.7	71.0	55.2	62.9	62.9	62.8	62.8	66.2	53.2		
2200	75	61.9	56.0	68.3	39.5	75.3	23.3	58.0	54.1	64.0	37.9	70.6	21.0	53.8	52.0	59.4	35.3	65.8	19.1		
2200	80	64.5	64.5	68.8	52.2	75.9	35.9	60.9	60.9	64.6	50.2	71.2	33.9	57.2	57.2	60.0	48.2	66.3	31.9		
2200	85	68.5	68.5	69.5	65.2	76.3	48.4	64.9	64.9	65.3	63.4	71.7	46.3	61.0	61.0	61.0	60.9	66.7	44.3		
2200	90	72.6	72.6	72.6	72.6	76.8	60.8	68.9	68.9	68.8	68.8	72.1	58.8	64.8	64.8	64.8	64.8	67.2	56.9		
2400	75	62.9	59.3	69.2	41.2	76.1	22.9	58.9	57.3	64.8	39.1	71.4	21.7	54.8	54.7	60.2	37.0	66.5	19.5		
2400	80	66.2	66.2	69.8	55.0	76.9	37.1	62.5	62.5	65.4	53.0	72.1	35.1	58.6	58.6	60.8	51.0	67.1	33.0		
2400	85	70.4	70.4	70.8	69.3	77.3	51.0	66.6	66.6	66.7	66.6	72.5	48.5	62.6	62.6	62.5	62.5	67.6	46.8		
2400	90	74.6	74.6	74.5	74.5	77.8	64.3	70.7	70.7	70.7	70.7	72.9	62.5	66.6	66.6	66.5	66.5	68.2	60.7		

continued on next page



**Table 26. Gross cooling capacities 5 tons high efficiency - three phase T/YHC060E3,4 (continued)**

Air Flow cfm		Ent DB (F)		Ambient Temperature											
				115						125					
				Entering Wet Bulb											
		61		67		73		61		67		73			
		MBh	SHC	MBh	SHC	MBh	SHC	MBh	SHC	MBh	SHC	MBh	SHC		
1000	75	40.1	33.4	45.7	24.9	53.6	11.4	36.3	31.1	41.5	23.0	49.0	10.0		
1000	80	41.1	39.0	45.5	33.1	52.3	22.3	37.3	36.5	41.4	31.0	47.8	20.6		
1000	85	42.8	42.8	46.0	39.8	51.6	31.7	39.0	39.0	41.9	37.5	47.2	29.7		
1000	90	46.8	46.8	47.2	45.1	51.7	39.6	42.7	42.7	43.1	42.5	47.3	37.4		
1200	75	42.3	35.7	47.6	26.9	55.3	13.2	38.3	33.3	43.3	24.9	50.7	11.6		
1200	80	43.5	41.6	47.7	35.4	54.2	24.3	39.6	38.9	43.4	33.1	49.6	22.5		
1200	85	45.5	45.5	48.4	42.4	53.8	33.9	41.6	41.6	44.2	39.9	49.3	31.9		
1200	90	49.4	49.4	49.9	48.0	54.1	42.1	45.2	45.2	45.7	45.2	49.6	39.8		
1400	75	44.2	37.9	49.3	28.7	56.8	14.7	40.2	35.3	44.9	26.6	52.0	13.0		
1400	80	45.7	44.0	49.7	37.5	56.0	26.1	41.7	41.2	45.3	35.1	51.3	24.1		
1400	85	47.9	47.9	50.7	44.8	55.8	36.0	43.9	43.9	46.3	42.1	51.1	33.8		
1400	90	51.8	51.8	52.3	50.6	56.3	44.5	47.6	47.6	48.0	47.7	51.7	42.0		
1600	75	46.3	40.0	51.8	28.3	57.7	16.5	41.9	37.1	46.4	28.1	53.2	14.2		
1600	80	47.8	47.8	52.2	37.5	58.2	25.8	43.6	43.3	47.0	36.9	52.7	25.6		
1600	85	51.0	51.0	52.6	46.9	58.5	35.0	46.1	46.1	48.2	44.2	52.8	35.6		
1600	90	54.3	54.3	54.3	54.3	58.9	44.0	49.7	49.7	50.2	50.1	53.6	44.1		
1800	75	47.4	43.3	52.9	30.0	58.9	16.7	43.3	38.7	47.6	29.4	54.2	15.2		
1800	80	49.8	49.8	53.4	40.3	59.4	27.1	45.3	45.2	48.4	38.5	53.9	26.9		
1800	85	53.3	53.3	54.0	51.0	59.8	37.2	48.0	48.0	49.9	46.1	54.3	37.2		
1800	90	56.7	56.7	56.7	56.7	60.1	47.7	52.1	52.1	52.1	52.1	55.3	45.9		
2000	75	48.5	46.5	53.8	31.6	59.8	17.0	44.6	40.2	48.6	30.6	55.0	16.1		
2000	80	51.6	51.6	54.4	43.2	60.4	28.5	46.8	46.8	49.7	39.9	54.9	28.1		
2000	85	55.2	55.2	55.3	55.1	60.7	40.2	49.7	49.7	51.4	47.8	55.5	38.6		
2000	90	58.7	58.7	58.7	58.7	61.2	51.3	53.8	53.8	53.8	53.8	56.8	47.6		
2200	75	49.4	49.3	54.6	33.2	60.6	17.3	45.6	41.5	49.4	31.6	55.6	16.8		
2200	80	53.1	53.1	55.2	46.0	61.1	29.8	48.1	48.1	50.7	41.2	55.7	29.0		
2200	85	56.8	56.8	56.8	56.8	61.6	42.5	51.2	51.2	52.7	49.3	56.5	39.8		
2200	90	60.6	60.6	60.5	60.5	62.1	55.1	55.3	55.3	55.3	55.3	58.0	49.1		
2400	75	50.7	50.7	55.3	35.0	61.3	17.5	46.4	42.6	50.0	32.4	55.9	17.3		
2400	80	54.5	54.5	55.9	49.0	61.8	31.1	49.1	49.1	51.5	42.2	56.3	29.8		
2400	85	58.3	58.3	58.2	58.2	62.3	44.9	52.5	52.5	53.7	50.7	57.4	40.8		
2400	90	62.2	62.2	62.1	62.1	62.9	58.8	56.6	56.6	56.6	56.6	59.1	50.4		

**Notes:**

1. All capacities shown are gross and have not considered indoor fan heat. To obtain **NET** cooling capacity subtract indoor fan heat. For indoor fan heat formula, refer to appropriate airflow table notes.
  2. MBh = Total Gross Capacity
  3. SHC = Sensible Heat Capacity
- \* Unit applications below 320 CFM/Ton are only applicable on THC models without electric heat. Electric and Gas heat applications are restricted to applications 320 CFM/Ton and above.



## Performance Data

**Table 27. Gross cooling capacities 5 tons high efficiency - three phase T/YHC060F3,4**

Air Flow cfm		Ent DB (F)		Ambient Temperature																	
				85						95						105					
				Entering Wet Bulb																	
		61		67		73		61		67		73		61		67		73			
		MBh	SHC	MBh	SHC	MBh	SHC	MBh	SHC	MBh	SHC	MBh	SHC	MBh	SHC	MBh	SHC	MBh	SHC		
1000	75	48.4	37.7	54.4	28.8	62.5	15.5	45.5	35.9	51.2	27.3	59.1	14.3	42.3	34.0	47.8	25.7	55.4	13.0		
1000	80	49.1	43.6	54.1	36.9	61.3	25.8	46.3	41.7	51.1	35.3	58.0	24.6	43.3	39.6	47.8	33.6	54.5	23.2		
1000	85	50.3	48.3	54.3	43.8	60.5	34.9	47.6	46.2	51.4	42.0	57.4	33.5	44.8	44.1	48.4	40.2	54.1	32.0		
1000	90	51.9	51.7	55.0	49.4	60.2	42.8	49.4	49.4	52.3	47.6	57.3	41.3	46.8	46.8	49.4	45.6	54.1	39.7		
1200	75	51.1	40.5	56.8	31.2	64.7	17.6	48.0	38.6	53.5	29.6	61.2	16.3	44.8	36.6	50.0	27.9	57.4	15.0		
1200	80	52.0	46.7	56.8	39.6	63.7	28.2	49.1	44.7	53.6	37.9	60.3	26.9	46.0	42.5	50.3	36.1	56.8	25.4		
1200	85	53.4	51.7	57.2	46.8	63.2	37.6	50.7	49.5	54.3	45.0	60.0	36.1	47.8	47.2	51.1	43.0	56.6	34.5		
1200	90	55.3	55.3	58.2	52.7	63.2	45.8	52.7	52.7	55.3	50.8	60.1	44.2	50.0	50.0	52.4	48.7	56.9	42.4		
1400	75	53.4	43.1	58.9	33.4	66.6	19.4	50.3	41.1	55.6	31.7	63.0	18.1	47.0	39.0	52.0	29.9	59.2	16.6		
1400	80	54.6	49.6	59.2	42.1	65.9	30.3	51.6	47.4	55.9	40.3	62.4	28.9	48.5	45.2	52.5	38.4	58.7	27.3		
1400	85	56.3	54.8	59.9	49.6	65.6	40.0	53.4	52.5	56.8	47.7	62.3	38.5	50.4	50.2	53.5	45.6	58.8	36.7		
1400	90	58.4	58.4	61.0	55.8	65.8	48.5	55.7	55.7	58.1	53.8	62.7	46.8	52.9	52.9	55.0	51.6	59.3	45.0		
1600	75	55.5	45.3	60.8	35.3	68.2	21.0	52.3	43.3	57.3	33.6	64.5	19.5	48.8	41.0	53.6	31.7	60.6	18.0		
1600	80	56.9	52.1	61.2	44.3	67.7	32.2	53.8	49.9	57.9	42.4	64.1	30.6	50.6	47.6	54.4	40.4	60.4	29.0		
1600	85	58.8	57.6	62.2	52.1	67.7	42.2	55.9	55.3	59.0	50.1	64.3	40.5	52.8	52.8	55.7	47.9	60.7	38.7		
1600	90	61.2	61.2	63.6	58.6	68.1	50.9	58.5	58.5	60.6	56.5	64.9	49.1	55.6	55.6	57.4	54.2	61.5	47.2		
1800	75	57.3	47.3	62.3	37.0	69.5	22.3	53.9	45.2	58.7	35.1	65.7	20.7	50.4	42.8	55.0	33.1	61.7	19.1		
1800	80	58.9	54.4	63.0	46.2	69.2	33.8	55.8	52.1	59.6	44.3	65.6	32.1	52.4	49.6	56.0	42.2	61.8	30.3		
1800	85	61.1	60.2	64.2	54.3	69.5	44.0	58.1	57.8	61.0	52.2	66.0	42.3	54.9	54.9	57.5	50.0	62.3	40.4		
1800	90	63.7	63.7	65.9	61.1	70.2	53.1	60.9	60.9	62.8	58.9	66.9	51.2	57.9	57.9	59.6	56.5	63.4	49.2		
2000	75	58.7	49.1	63.5	38.3	70.5	23.3	55.3	46.8	59.9	36.4	66.6	21.7	51.7	44.4	56.0	34.3	62.5	19.9		
2000	80	60.6	56.4	64.5	47.9	70.5	35.1	57.4	54.0	61.0	45.8	66.8	33.3	54.0	51.5	57.3	43.6	62.9	31.5		
2000	85	63.0	62.5	65.9	56.2	71.0	45.7	60.0	60.0	62.6	54.0	67.4	43.8	56.7	56.7	59.1	51.7	63.7	41.8		
2000	90	65.9	65.9	67.9	63.3	71.9	55.0	63.0	63.0	64.7	61.0	68.5	53.0	59.9	59.9	61.4	58.6	65.0	50.9		
2200	75	59.9	50.5	64.5	39.4	71.2	24.0	56.4	48.1	60.7	37.4	67.2	22.3	52.7	45.6	56.8	35.2	63.1	20.5		
2200	80	62.1	58.1	65.7	49.3	71.4	36.1	58.7	55.7	62.1	47.1	67.6	34.3	55.2	53.0	58.4	44.8	63.6	32.3		
2200	85	64.7	64.5	67.4	57.9	72.2	47.0	61.6	61.6	64.0	55.6	68.5	45.0	58.2	58.2	60.4	53.2	64.7	42.9		
2200	90	67.9	67.9	69.5	65.3	73.4	56.6	64.9	64.9	66.3	62.9	69.9	54.5	61.7	61.7	62.9	60.4	66.2	52.3		
2400	75	60.8	51.7	65.1	40.3	71.6	24.5	57.2	49.2	61.3	38.1	67.5	22.7	53.4	46.6	57.3	35.8	63.3	20.7		
2400	80	63.2	59.6	66.6	50.4	72.1	36.9	59.8	57.0	62.9	48.2	68.2	35.0	56.2	54.3	59.1	45.8	64.1	32.9		
2400	85	66.1	66.1	68.5	59.3	73.1	48.0	62.8	62.8	65.0	57.0	69.4	46.0	59.4	59.4	61.3	54.4	65.4	43.8		
2400	90	69.5	69.5	70.9	67.0	74.6	57.9	66.4	66.4	67.6	64.5	71.0	55.8	63.1	63.1	64.1	61.9	67.2	53.5		

continued on next page

**Table 27. Gross cooling capacities 5 tons high efficiency - three phase T/YHC060F3,4 (continued)**

Air Flow cfm		Ent DB (F)		Ambient Temperature											
				115						125					
				Entering Wet Bulb											
		61		67		73		61		67		73			
		MBh	SHC	MBh	SHC	MBh	SHC	MBh	SHC	MBh	SHC	MBh	SHC		
1000	75	39.0	31.9	44.2	23.9	51.6	11.6	35.5	29.7	40.5	22.0	47.6	10.1		
1000	80	40.1	37.4	44.4	31.7	50.9	21.6	36.8	35.1	40.8	29.7	47.0	20.0		
1000	85	41.8	41.7	45.1	38.2	50.6	30.4	38.6	38.6	41.7	36.1	46.9	28.6		
1000	90	43.9	43.9	46.3	43.5	50.8	37.9	42.6	42.6	43.0	41.2	47.3	36.0		
1200	75	41.4	34.4	46.4	26.1	53.5	13.4	37.8	32.1	42.5	24.1	49.4	11.8		
1200	80	42.8	40.3	46.8	34.2	53.0	23.7	39.4	37.8	43.2	32.1	49.1	22.0		
1200	85	44.7	44.7	47.8	41.0	53.0	32.8	41.4	41.4	44.3	38.7	49.2	30.9		
1200	90	47.1	47.1	49.2	46.5	53.5	40.6	45.4	45.4	45.8	44.2	49.9	38.6		
1400	75	43.5	36.7	48.2	28.0	55.2	15.0	39.8	34.3	44.3	25.9	51.0	13.3		
1400	80	45.1	42.8	48.9	36.3	54.9	25.6	41.6	40.3	45.2	34.1	50.9	23.7		
1400	85	47.3	47.3	50.1	43.4	55.1	34.9	43.9	43.9	46.5	41.1	51.3	32.9		
1400	90	49.9	49.9	51.8	49.3	55.8	43.0	47.9	47.9	48.4	46.9	52.2	40.9		
1600	75	45.3	38.7	49.8	29.6	56.5	16.3	41.5	36.2	45.8	27.5	52.2	14.4		
1600	80	47.2	45.1	50.8	38.3	56.5	27.1	43.6	42.4	46.9	36.0	52.4	25.2		
1600	85	49.6	49.6	52.2	45.7	57.0	36.8	46.1	46.1	48.5	43.2	53.0	34.7		
1600	90	52.5	52.5	54.1	51.8	57.9	45.1	50.1	50.1	50.6	49.3	54.2	42.9		
1800	75	46.8	40.4	51.1	31.0	57.5	17.3	42.9	37.8	47.0	28.7	53.2	15.3		
1800	80	48.9	47.1	52.3	39.9	57.8	28.4	45.2	44.4	48.3	37.5	53.6	26.4		
1800	85	51.6	51.6	54.0	47.6	58.5	38.3	48.1	48.1	50.2	45.1	54.5	36.2		
1800	90	54.7	54.7	56.1	54.0	59.7	47.0	52.0	52.0	52.5	51.4	55.9	44.7		
2000	75	48.0	41.8	52.0	32.1	58.3	18.0	44.0	39.1	47.9	29.7	53.9	16.0		
2000	80	50.4	48.8	53.5	41.3	58.8	29.5	46.6	46.0	49.5	38.8	54.5	27.3		
2000	85	53.3	53.3	55.4	49.3	59.7	39.7	49.7	49.7	51.6	46.7	55.6	37.4		
2000	90	57.3	57.3	57.9	56.0	61.2	48.6	53.6	53.6	54.2	53.3	57.3	46.2		
2200	75	48.9	43.0	52.7	32.9	58.7	18.5	44.9	40.2	48.5	30.4	54.2	16.4		
2200	80	51.6	50.3	54.4	42.4	59.5	30.2	47.7	47.3	50.3	39.8	55.1	28.0		
2200	85	54.7	54.7	56.6	50.7	60.7	40.7	51.0	51.0	52.7	48.0	56.5	38.3		
2200	90	58.7	58.7	59.3	57.7	62.4	50.0	55.0	55.0	55.5	54.9	58.4	47.5		
2400	75	49.5	43.9	53.1	33.4	58.9	18.7	45.4	41.0	48.8	30.9	54.3	16.4		
2400	80	52.4	51.4	55.1	43.2	59.9	30.7	48.5	48.4	50.9	40.6	55.4	28.4		
2400	85	55.8	55.8	57.5	51.8	61.3	41.5	52.0	52.0	53.5	49.0	57.1	39.0		
2400	90	59.8	59.8	60.4	59.1	63.3	51.0	56.0	56.0	56.6	56.2	59.2	48.5		

**Notes:**

1. All capacities shown are gross and have not considered indoor fan heat. To obtain **NET** cooling capacity subtract indoor fan heat. For indoor fan heat formula, refer to appropriate airflow table notes.
  2. MBh = Total Gross Capacity
  3. SHC = Sensible Heat Capacity
- \* Unit applications below 320 CFM/Ton are only applicable on THC models without electric heat. Electric and Gas heat applications are restricted to applications 320 CFM/Ton and above.



## Performance Data

**Table 28. Gross cooling capacities 6 tons high efficiency - three phase T/YHC072F3,4**

Air Flow cfm		Ent DB (F)		Ambient Temperature															
				85				95				105							
				Entering Wet Bulb															
		61		67		73		61		67		73		61		67		73	
		MBh	SHC	MBh	SHC	MBh	SHC	MBh	SHC	MBh	SHC	MBh	SHC	MBh	SHC	MBh	SHC	MBh	SHC
1200	75	57.38	45.11	64.42	34.56	73.89	18.95	54.03	43.15	60.77	33.00	69.96	17.80	50.35	40.96	56.80	31.22	65.70	16.42
1200	80	58.22	52.14	64.05	44.19	72.33	31.17	55.02	50.02	60.56	42.47	68.55	29.87	51.50	47.68	56.75	40.54	64.44	28.34
1200	85	59.60	57.69	64.23	52.33	71.31	41.91	56.56	55.42	60.90	50.46	67.68	40.46	53.19	52.92	57.24	48.38	63.73	38.78
1200	90	61.53	61.53	64.96	59.00	70.84	51.18	58.64	58.64	61.78	56.98	67.36	49.56	55.43	55.43	58.28	54.74	63.56	47.73
1440	75	60.55	48.45	67.30	37.48	76.48	21.46	57.11	46.38	63.56	35.82	72.45	20.20	53.35	44.08	59.51	33.93	68.10	18.73
1440	80	61.64	55.77	67.18	47.41	75.16	33.98	58.36	53.55	63.60	45.59	71.29	32.57	54.75	51.10	59.70	43.55	67.10	30.94
1440	85	63.28	61.62	67.62	55.85	74.40	45.02	60.15	59.24	64.19	53.88	70.68	43.46	56.69	56.64	60.44	51.68	66.63	41.67
1440	90	65.46	65.46	68.60	62.81	74.17	54.58	62.48	62.48	65.33	60.68	70.61	52.86	59.18	59.18	61.73	58.34	66.72	50.92
1680	75	63.35	51.47	69.80	40.09	78.69	23.66	59.82	49.29	65.98	38.32	74.57	22.30	55.97	46.89	61.83	36.33	70.13	20.71
1680	80	64.69	59.09	69.94	50.31	77.62	36.48	61.32	56.76	66.27	48.39	73.66	34.96	57.62	54.20	62.28	46.24	69.37	33.22
1680	85	66.58	65.23	70.62	59.05	77.10	47.81	63.36	62.74	67.11	56.97	73.30	46.14	59.82	59.82	63.27	54.67	69.16	44.25
1680	90	69.01	69.01	71.85	66.30	77.13	57.66	65.95	65.95	68.49	64.07	73.48	55.84	62.56	62.56	64.81	61.62	69.50	53.80
1920	75	65.78	54.17	71.93	42.38	80.52	25.54	62.16	51.88	68.01	40.51	76.31	24.07	58.22	49.38	63.78	38.41	71.78	22.38
1920	80	67.37	62.08	72.32	52.90	79.70	38.65	63.90	59.65	68.56	50.87	75.65	37.03	60.12	56.99	64.48	48.62	71.28	35.18
1920	85	69.51	68.52	73.25	61.93	79.44	50.28	66.19	65.93	69.65	59.75	75.54	48.51	62.56	62.56	65.72	57.34	71.32	46.51
1920	90	72.19	72.19	74.73	69.48	79.71	60.43	69.03	69.03	71.28	67.15	75.97	58.50	65.55	65.55	67.51	64.59	71.90	56.35
2160	75	67.82	56.56	73.67	44.36	81.97	27.11	64.11	54.16	69.67	42.38	77.67	25.53	60.08	51.55	65.35	40.17	73.05	23.73
2160	80	69.66	64.77	74.31	55.17	81.41	40.51	66.11	62.22	70.47	53.03	77.26	38.78	62.23	59.46	66.30	50.68	72.80	36.83
2160	85	72.05	71.50	75.50	64.50	81.39	52.44	68.65	68.65	71.81	62.21	77.40	50.56	64.93	64.93	67.79	59.70	73.09	48.45
2160	90	74.99	74.99	77.23	72.35	81.92	62.89	71.74	71.74	73.69	69.90	78.09	60.85	68.17	68.17	69.83	67.24	73.93	58.59
2400	75	69.49	58.62	75.05	46.02	83.04	28.36	65.69	56.13	70.95	43.93	78.66	26.67	61.57	53.41	66.54	41.62	73.95	24.77
2400	80	71.58	67.13	75.94	57.12	82.73	42.06	67.94	64.48	72.00	54.88	78.50	40.22	63.97	61.61	67.74	52.42	73.95	38.16
2400	85	74.22	74.16	77.37	66.75	82.97	54.28	70.73	70.73	73.59	64.35	78.89	52.29	66.92	66.92	69.48	61.74	74.49	50.08
2400	90	77.41	77.41	79.36	74.89	83.75	65.02	74.07	74.07	75.73	72.34	79.82	62.88	70.41	70.41	71.78	69.58	75.58	60.52
2640	75	70.78	60.38	76.04	47.36	83.74	29.29	66.89	57.78	71.86	45.17	79.26	27.50	62.68	54.95	67.36	42.75	74.47	25.49
2640	80	73.13	69.18	77.18	58.76	83.68	43.29	69.39	66.43	73.16	56.41	79.36	41.34	65.34	63.45	68.81	53.84	74.72	39.18
2640	85	76.02	76.02	78.87	68.68	84.17	55.80	72.44	72.44	75.00	66.18	80.00	53.71	68.53	68.53	70.80	63.46	75.51	51.39
2640	90	79.45	79.45	81.10	77.12	85.20	66.84	76.03	76.03	77.39	74.47	81.19	64.59	72.61	72.61	73.34	71.59	76.85	62.13
2880	75	71.69	61.82	76.66	48.39	84.06	29.90	67.72	59.11	72.39	46.09	79.50	28.01	63.42	56.18	67.79	43.56	74.61	25.89
2880	80	74.29	70.92	78.05	60.09	84.25	44.20	70.47	68.05	73.93	57.63	79.84	42.15	66.32	64.97	69.49	54.96	75.11	39.88
2880	85	77.43	77.43	79.99	70.30	84.99	57.01	73.76	73.76	76.03	67.69	80.73	54.81	69.77	69.77	71.74	64.87	76.15	52.39
2880	90	81.12	81.12	82.47	79.04	86.27	68.35	77.60	77.60	78.67	76.28	82.17	65.99	73.79	73.79	74.53	73.30	77.74	63.42

continued on next page

**Table 28. Gross cooling capacities 6 tons high efficiency - three phase T/YHC072F3,4 (continued)**

		Ambient Temperature											
		115						125					
Air Flow cfm	Ent DB (F)	Entering Wet Bulb											
		61		67		73		61		67		73	
		MBh	SHC	MBh	SHC	MBh	SHC	MBh	SHC	MBh	SHC	MBh	SHC
1200	75	46.36	38.55	52.51	29.22	61.11	14.83	42.04	35.93	47.90	27.00	56.20	13.02
1200	80	47.66	45.12	52.61	38.39	60.01	26.59	43.49	42.34	48.15	36.02	55.26	24.63
1200	85	49.50	49.50	53.26	46.07	59.45	36.88	45.49	45.49	48.95	43.55	54.85	34.76
1200	90	51.90	51.90	54.45	52.28	59.44	45.68	49.79	49.79	50.30	49.60	54.99	43.41
1440	75	49.26	41.57	55.13	31.83	63.43	17.03	44.85	38.84	50.42	29.50	58.43	15.11
1440	80	50.82	48.44	55.48	41.29	62.58	29.09	46.56	45.55	50.93	38.81	57.73	27.01
1440	85	52.91	52.91	56.37	49.27	62.27	39.67	48.81	48.81	51.98	46.64	57.58	37.44
1440	90	57.23	57.23	57.81	55.77	62.51	48.76	53.04	53.04	53.57	52.99	57.97	46.39
1680	75	51.80	44.27	57.36	34.12	65.37	18.91	47.30	41.43	52.57	31.69	60.28	16.88
1680	80	53.60	51.43	57.96	43.88	64.76	31.26	49.25	48.44	53.32	41.29	59.83	29.08
1680	85	55.95	55.95	59.11	52.15	64.71	42.14	51.76	51.76	54.62	49.42	59.93	39.81
1680	90	60.19	60.19	60.80	58.95	65.20	51.53	55.90	55.90	56.47	56.06	60.57	49.05
1920	75	53.95	46.66	59.22	36.09	66.93	20.47	49.36	43.71	54.34	33.55	61.75	18.34
1920	80	56.00	54.11	60.07	46.15	66.58	33.12	51.57	51.02	55.34	43.45	61.55	30.84
1920	85	58.60	58.60	61.47	54.72	66.77	44.29	54.32	54.32	56.89	51.88	61.90	41.85
1920	90	62.78	62.78	63.41	61.81	67.51	53.98	58.40	58.40	58.99	58.82	62.80	51.39
2160	75	55.73	48.72	60.70	37.75	68.11	21.71	51.05	45.67	55.73	35.10	62.85	19.48
2160	80	58.03	56.48	61.80	48.10	68.01	34.66	53.51	53.27	56.98	45.30	62.90	32.27
2160	85	60.88	60.88	63.45	56.97	68.46	46.13	56.51	56.51	58.79	54.02	63.50	43.59
2160	90	64.99	64.99	65.64	64.36	69.45	56.12	61.13	61.13	61.13	61.13	64.65	53.42
2400	75	57.13	50.48	61.80	39.09	68.92	22.65	52.36	47.32	56.74	36.34	63.56	20.30
2400	80	59.68	58.52	63.16	49.74	69.07	35.89	55.07	55.07	58.25	46.83	63.87	33.39
2400	85	62.78	62.78	65.05	58.90	69.77	47.65	58.32	58.32	60.30	55.85	64.72	45.00
2400	90	66.82	66.82	67.50	66.59	71.01	57.94	62.90	62.90	62.90	62.90	66.12	55.13
2640	75	58.15	51.91	62.53	40.11	69.35	23.26	53.29	48.65	57.38	37.26	63.90	20.81
2640	80	60.96	60.26	64.13	51.06	69.75	36.80	56.25	56.25	59.13	48.05	64.46	34.20
2640	85	64.31	64.31	66.28	60.52	70.70	48.86	59.76	59.76	61.44	57.36	65.56	46.10
2640	90	68.29	68.29	68.98	68.50	72.19	59.44	64.29	64.29	64.29	64.29	67.21	56.53
2880	75	58.79	53.03	62.88	40.82	69.40	23.56	53.85	49.66	57.64	37.86	63.86	21.00
2880	80	61.85	61.67	64.73	52.06	70.05	37.39	57.06	57.06	59.64	48.95	64.67	34.68
2880	85	65.45	65.45	67.13	61.82	71.25	49.75	60.82	60.82	62.20	58.55	66.02	46.89
2880	90	70.08	70.08	70.08	70.08	72.99	60.62	65.30	65.30	65.30	65.30	67.92	57.61

**Notes:**

1. All capacities shown are gross and have not considered indoor fan heat. To obtain **NET** cooling capacity subtract indoor fan heat. For indoor fan heat formula, refer to appropriate airflow table notes.
  2. MBh = Total Gross Capacity
  3. SHC = Sensible Heat Capacity
- \* Unit applications below 320 CFM/Ton are only applicable on THC models without electric heat. Electric and Gas heat applications are restricted to applications 320 CFM/Ton and above.



## Performance Data

**Table 29. Gross cooling capacities 7½ tons high efficiency - three phase T/YHC092E3.4**

Air Flow cfm		Ent DB (F)		Ambient Temperature																	
				85						95						105					
				Entering Wet Bulb																	
		61		67		73		61		67		73		61		67		73			
		MBh	SHC	MBh	SHC	MBh	SHC	MBh	SHC	MBh	SHC	MBh	SHC	MBh	SHC	MBh	SHC	MBh	SHC		
1500	75	73.5	54.9	82.9	43.9	95.3	28.5	68.8	52.1	77.6	41.5	89.5	26.5	63.9	49.2	72.2	38.9	83.5	24.3		
1500	80	74.4	62.6	82.4	53.8	93.4	40.6	69.8	59.6	77.3	51.2	87.8	38.4	65.0	56.4	71.9	48.3	81.8	35.9		
1500	85	76.1	69.0	82.8	62.4	92.4	51.4	71.7	65.7	77.8	59.5	86.8	48.9	67.0	62.2	72.5	56.4	81.0	46.2		
1500	90	78.7	74.0	84.0	69.6	92.2	60.8	74.4	70.5	79.1	66.4	86.8	58.0	69.8	66.7	73.9	63.1	81.0	55.0		
1800	75	78.1	59.7	87.1	47.8	99.1	31.6	73.2	56.7	81.6	45.2	93.1	29.3	68.0	53.5	75.9	42.4	86.7	26.9		
1800	80	79.5	68.2	87.1	58.5	97.7	44.4	74.6	64.9	81.7	55.6	91.7	41.9	69.5	61.4	76.0	52.5	85.5	39.2		
1800	85	81.6	75.2	87.9	67.7	97.1	55.9	76.9	71.7	82.6	64.6	91.2	53.1	71.9	68.0	77.0	61.2	85.1	50.1		
1800	90	84.6	80.9	89.5	75.6	97.3	66.0	80.0	77.2	84.3	72.2	91.6	62.9	75.1	73.2	78.8	68.6	85.6	59.7		
2100	75	82.0	63.9	90.6	51.1	102.2	34.0	76.8	60.6	84.8	48.3	95.9	31.5	71.3	57.2	78.8	45.2	89.3	28.8		
2100	80	83.8	73.0	91.0	62.5	101.2	47.6	78.7	69.5	85.3	59.3	95.0	44.8	73.3	65.8	79.4	56.0	88.4	41.8		
2100	85	86.4	80.8	92.2	72.4	101.0	59.7	81.3	77.0	86.6	69.0	94.9	56.7	76.0	73.1	80.7	65.5	88.5	53.5		
2100	90	89.8	87.2	94.2	81.0	101.6	70.5	84.8	83.2	88.7	77.4	95.6	67.2	79.7	79.0	83.0	73.5	89.3	63.8		
2400	75	85.2	70.4	93.8	55.1	105.6	32.8	79.7	66.9	87.6	52.2	99.0	30.5	73.9	63.2	81.3	49.1	92.0	27.9		
2400	80	87.3	80.7	94.2	69.3	104.3	51.0	81.8	76.8	88.1	66.1	97.7	48.3	76.1	72.7	81.8	62.6	90.8	45.4		
2400	85	90.3	88.7	95.5	81.4	104.0	67.0	84.9	84.5	89.5	77.7	97.4	63.9	79.2	79.2	83.2	73.8	90.5	60.6		
2400	90	94.3	94.3	97.7	91.1	104.5	80.7	88.9	88.9	91.8	87.1	98.0	77.2	83.2	83.2	85.5	82.8	91.2	73.5		
2700	75	87.8	73.7	96.0	57.9	107.5	35.2	82.1	70.0	89.7	54.9	100.6	32.7	76.1	66.1	83.2	51.5	93.5	29.9		
2700	80	90.3	84.3	96.7	72.5	106.5	53.7	84.6	80.3	90.5	69.1	99.7	50.9	78.7	76.0	84.0	65.3	92.7	47.7		
2700	85	93.7	92.7	98.4	84.9	106.5	70.1	88.0	88.0	92.2	81.1	99.7	66.8	82.2	82.2	85.8	76.9	92.7	63.3		
2700	90	98.0	98.0	101.0	95.0	107.4	84.1	92.4	92.4	94.9	90.8	100.7	80.5	86.6	86.6	88.5	86.3	93.7	76.5		
3000	75	90.2	76.6	97.9	60.4	109.0	37.2	84.3	72.7	91.5	57.1	102.0	34.5	78.1	68.6	84.7	53.5	94.7	31.5		
3000	80	93.0	87.6	99.0	75.4	108.4	56.1	87.1	83.4	92.6	71.7	101.4	53.0	81.0	78.8	85.9	67.7	94.2	49.6		
3000	85	96.7	96.4	101.0	88.1	108.7	72.8	90.9	90.9	94.7	84.0	101.8	69.3	84.8	84.8	88.1	79.7	94.6	65.5		
3000	90	101.3	101.3	104.0	98.6	110.0	87.2	95.6	95.6	97.7	94.1	103.1	83.3	90.2	90.2	91.1	89.4	96.0	79.2		
3300	75	92.2	79.1	99.6	62.5	110.3	38.8	86.2	75.1	92.9	59.0	103.1	35.9	79.8	70.7	86.1	55.2	95.6	32.7		
3300	80	95.4	90.5	101.0	77.8	110.0	58.1	89.3	86.1	94.4	73.9	102.9	54.8	83.1	81.3	87.6	69.8	95.5	51.2		
3300	85	99.4	99.4	103.4	90.9	110.7	75.1	93.5	93.5	96.8	86.6	103.6	71.4	87.2	87.2	90.1	82.1	96.2	67.5		
3300	90	104.4	104.4	106.7	101.7	112.3	89.9	98.5	98.5	100.2	97.1	105.2	85.8	92.5	92.5	93.5	92.1	97.9	81.5		
3600	75	94.0	81.3	100.9	64.1	111.2	40.0	87.7	77.0	94.1	60.5	103.9	36.9	81.3	72.5	87.1	56.5	96.2	33.5		
3600	80	97.5	93.0	102.7	79.8	111.3	59.6	91.3	88.4	96.0	75.8	104.0	56.1	84.8	83.4	89.0	71.4	96.4	52.4		
3600	85	101.9	101.9	105.4	93.3	112.3	77.0	95.7	95.7	98.7	88.8	105.1	73.2	89.3	89.3	91.8	84.1	97.5	69.0		
3600	90	107.2	107.2	109.1	104.5	114.3	92.2	101.1	101.1	102.4	99.6	107.1	87.9	94.6	94.6	95.5	94.5	99.6	83.4		

continued on next page

**Table 29. Gross cooling capacities 7½ tons high efficiency - three phase T/YHC092E3,4 (continued)**

		Ambient Temperature											
		115						125					
Air Flow cfm	Ent DB (F)	Entering Wet Bulb											
		61		67		73		61		67		73	
		MBh	SHC	MBh	SHC	MBh	SHC	MBh	SHC	MBh	SHC	MBh	SHC
1500	75	58.7	46.0	66.4	36.2	77.2	21.9	53.3	42.7	60.5	33.2	70.6	19.4
1500	80	59.9	53.0	66.3	45.3	75.6	33.3	54.6	49.4	60.4	42.1	69.2	30.5
1500	85	62.0	58.6	67.0	53.1	74.9	43.3	56.8	54.8	61.2	49.7	68.6	40.2
1500	90	64.9	62.8	68.5	59.5	75.1	51.9	59.8	58.7	62.8	55.8	68.8	48.5
1800	75	62.5	50.1	69.8	39.4	80.2	24.3	56.8	46.6	63.6	36.2	73.4	21.5
1800	80	64.2	57.8	70.1	49.2	79.1	36.3	58.6	54.0	64.0	45.8	72.3	33.3
1800	85	66.6	64.1	71.2	57.7	78.8	47.0	61.2	60.0	65.1	54.0	72.1	43.7
1800	90	70.0	69.0	73.1	64.9	79.3	56.3	64.6	64.6	67.2	60.9	72.8	52.8
2100	75	65.6	53.6	72.5	41.9	82.4	26.0	59.6	49.7	65.9	38.5	75.3	22.9
2100	80	67.6	61.9	73.2	52.5	81.7	38.7	61.8	57.8	66.7	48.8	74.7	35.4
2100	85	70.5	68.9	74.7	61.7	81.8	50.1	64.7	64.6	68.3	57.7	74.9	46.5
2100	90	74.2	74.2	77.0	69.5	82.8	60.1	68.6	68.6	70.8	65.3	76.0	56.3
2400	75	67.8	59.1	74.6	45.6	84.8	25.1	61.5	54.8	67.8	41.9	77.4	22.0
2400	80	70.1	68.3	75.2	58.7	83.7	42.1	63.8	63.6	68.4	54.6	76.3	38.6
2400	85	73.2	73.2	76.7	69.6	83.5	56.9	67.0	67.0	69.9	65.1	76.1	53.0
2400	90	78.3	78.3	79.1	78.2	84.2	69.5	72.4	72.4	72.4	72.4	76.9	65.2
2700	75	69.9	61.8	76.4	47.9	86.1	26.8	63.5	57.3	69.3	43.9	78.5	23.5
2700	80	72.5	71.3	77.3	61.3	85.3	44.3	66.1	66.1	70.3	57.0	77.8	40.5
2700	85	76.0	76.0	79.1	72.5	85.5	59.4	69.7	69.7	72.1	67.8	78.0	55.3
2700	90	81.0	81.0	81.8	81.5	86.5	72.3	74.9	74.9	74.9	74.9	79.1	67.8
3000	75	71.7	64.1	77.8	49.7	87.2	28.2	65.1	59.4	70.6	45.5	79.4	24.7
3000	80	74.7	74.0	79.0	63.5	86.7	46.0	68.1	68.1	71.9	59.0	79.0	42.0
3000	85	78.6	78.6	81.2	75.1	87.2	61.5	72.0	72.0	74.1	70.1	79.5	57.2
3000	90	84.3	84.3	84.3	84.3	88.6	74.8	77.2	77.2	77.2	77.2	81.0	70.0
3300	75	73.3	66.1	78.9	51.1	87.9	29.2	66.5	61.1	71.5	46.8	80.0	25.4
3300	80	76.6	76.3	80.5	65.3	87.8	47.3	69.8	69.8	73.2	60.6	79.9	43.2
3300	85	80.8	80.8	83.0	77.2	88.6	63.2	74.1	74.1	75.7	72.1	80.8	58.7
3300	90	86.5	86.5	86.5	86.5	90.4	76.8	79.2	79.2	79.2	79.2	82.6	71.9
3600	75	74.5	67.6	79.8	52.2	88.4	29.8	67.5	62.5	72.2	47.7	80.2	25.8
3600	80	78.2	78.2	81.7	66.7	88.6	48.3	71.2	71.2	74.2	61.8	80.5	43.9
3600	85	82.7	82.7	84.6	79.0	89.8	64.5	75.8	75.8	77.1	73.7	81.7	59.8
3600	90	88.4	88.4	88.4	88.4	91.9	78.5	81.0	81.0	81.0	81.0	83.9	73.4

**Notes:**

1. All capacities shown are gross and have not considered indoor fan heat. To obtain **NET** cooling capacity subtract indoor fan heat. For indoor fan heat formula, refer to appropriate airflow table notes.
  2. MBh = Total Gross Capacity
  3. SHC = Sensible Heat Capacity
- \* Unit applications below 320 CFM/Ton are only applicable on THC models without electric heat. Electric and Gas heat applications are restricted to applications 320 CFM/Ton and above.



## Performance Data

**Table 30. Gross cooling capacities 7½ tons high efficiency - three phase T/YHC092F3.4**

Air Flow cfm		Ent DB (F)		Ambient Temperature																	
				85						95						105					
				Entering Wet Bulb																	
		61		67		73		61		67		73		61		67		73			
		MBh	SHC	MBh	SHC	MBh	SHC	MBh	SHC	MBh	SHC	MBh	SHC	MBh	SHC	MBh	SHC	MBh	SHC		
1500	75	73.3	55.9	82.4	43.1	94.8	24.4	69.0	53.3	77.7	40.9	89.7	22.7	64.4	50.6	72.8	38.6	84.4	20.9		
1500	80	74.0	64.4	81.6	54.6	92.4	39.1	69.8	61.6	77.1	52.3	87.5	37.1	65.4	58.6	72.3	49.7	82.3	35.0		
1500	85	75.5	71.1	81.6	64.4	90.9	52.0	71.5	68.0	77.2	61.8	86.1	49.8	67.2	64.8	72.5	59.0	81.0	47.4		
1500	90	77.7	76.0	82.3	72.4	90.1	63.1	73.8	72.6	78.0	69.5	85.4	60.6	69.7	69.2	73.5	66.5	80.5	58.0		
1800	75	77.3	60.2	86.1	46.9	98.1	27.8	72.8	57.5	81.3	44.6	92.9	25.9	68.1	54.7	76.2	42.2	87.4	23.9		
1800	80	78.3	69.1	85.6	58.9	96.1	42.9	74.0	66.1	80.9	56.3	91.0	40.7	69.5	63.0	76.0	53.6	85.7	38.4		
1800	85	80.1	76.2	85.9	69.1	94.9	56.1	76.0	73.0	81.3	66.3	89.9	53.8	71.5	69.6	76.5	63.3	84.7	51.2		
1800	90	82.7	81.5	86.9	77.5	94.4	67.6	78.7	78.0	82.5	74.4	89.6	65.0	74.4	74.4	77.9	71.2	84.5	62.2		
2100	75	80.8	64.2	89.3	50.4	101.0	30.7	76.3	61.3	84.4	47.9	95.7	28.7	71.4	58.3	79.1	45.3	90.1	26.5		
2100	80	82.2	73.5	89.2	62.7	99.3	46.2	77.8	70.3	84.4	60.0	94.1	43.9	73.1	67.1	79.3	57.2	88.6	41.5		
2100	85	84.4	80.9	89.8	73.3	98.4	59.9	80.0	77.6	85.1	70.4	93.3	57.3	75.5	74.0	80.1	67.3	88.0	54.6		
2100	90	87.2	86.6	91.1	82.1	98.3	71.8	83.1	83.0	86.6	78.9	93.3	69.0	78.6	78.6	81.8	75.5	88.1	66.0		
2400	75	84.0	67.7	92.2	53.4	103.5	33.3	79.3	64.7	87.0	50.8	98.0	31.1	74.3	61.5	81.7	48.0	92.2	28.7		
2400	80	85.7	77.4	92.3	66.2	102.1	49.1	81.1	74.1	87.3	63.3	96.8	46.7	76.2	70.7	82.1	60.3	91.1	44.1		
2400	85	88.1	85.3	93.2	77.1	101.5	63.2	83.7	81.7	88.4	74.0	96.3	60.5	79.0	78.1	83.3	70.8	90.8	57.7		
2400	90	91.4	91.4	94.9	86.3	101.7	75.5	87.0	87.0	90.2	83.0	96.6	72.5	82.5	82.5	85.3	79.4	91.3	69.4		
2700	75	86.7	70.8	94.5	56.0	105.5	35.4	81.8	67.7	89.3	53.3	99.9	33.0	76.7	64.3	83.7	50.4	94.0	30.6		
2700	80	88.7	80.9	95.0	69.2	104.5	51.6	84.0	77.5	89.9	66.2	99.0	49.0	79.0	73.9	84.5	63.0	93.2	46.3		
2700	85	91.5	89.2	96.3	80.6	104.2	66.1	86.9	85.5	91.3	77.3	98.9	63.3	82.0	81.7	86.0	73.9	93.2	60.3		
2700	90	95.0	95.0	98.3	90.1	104.7	78.8	90.6	90.6	93.4	86.6	99.5	75.7	85.8	85.8	88.3	83.0	94.0	72.4		
3000	75	89.0	73.6	96.5	58.2	107.2	37.1	83.9	70.2	91.1	55.3	101.4	34.6	78.7	66.7	85.4	52.3	95.3	32.0		
3000	80	91.3	84.0	97.3	71.8	106.4	53.7	86.4	80.4	92.0	68.6	100.8	51.0	81.3	76.7	86.5	65.3	94.9	48.1		
3000	85	94.4	92.7	98.8	83.6	106.5	68.6	89.7	88.9	93.7	80.1	101.0	65.6	84.7	84.7	88.3	76.6	95.2	62.5		
3000	90	98.3	98.3	101.2	93.6	107.3	81.7	93.7	93.7	96.2	89.9	101.9	78.4	88.8	88.8	90.9	86.0	96.2	75.0		
3300	75	90.8	75.9	98.0	60.0	108.3	38.4	85.6	72.4	92.4	57.0	102.4	35.7	80.2	68.7	86.6	53.8	96.2	33.0		
3300	80	93.5	86.7	99.1	74.0	107.9	55.4	88.4	83.0	93.7	70.7	102.1	52.5	83.1	79.1	88.0	67.2	96.1	49.5		
3300	85	96.9	95.8	101.0	86.2	108.3	70.7	92.0	91.8	95.7	82.6	102.6	67.6	86.8	86.8	90.2	78.9	96.7	64.2		
3300	90	101.1	101.1	103.6	96.5	109.4	84.2	96.3	96.3	98.5	92.7	103.9	80.8	91.3	91.3	93.1	88.7	98.1	77.2		
3600	75	92.2	77.8	99.0	61.4	109.1	39.3	86.9	74.1	93.3	58.2	103.0	36.5	81.3	70.3	87.4	54.8	96.6	33.5		
3600	80	95.2	89.0	100.5	75.8	109.0	56.7	90.0	85.1	94.9	72.3	103.0	53.7	84.6	81.1	89.1	68.7	96.8	50.5		
3600	85	98.9	98.5	102.7	88.4	109.7	72.4	93.9	93.9	97.3	84.6	103.9	69.1	88.6	88.6	91.6	80.7	97.8	65.6		
3600	90	103.4	103.4	105.7	99.1	111.1	86.3	98.5	98.5	100.4	95.1	105.4	82.7	93.4	93.4	94.8	91.0	99.5	79.0		

continued on next page



**Table 30. Gross cooling capacities 7½ tons high efficiency - three phase T/YHC092F3,4 (continued)**

Air Flow cfm		Ent DB (F)		Ambient Temperature											
				115						125					
				Entering Wet Bulb											
		61		67		73		61		67		73			
		MBh	SHC	MBh	SHC	MBh	SHC	MBh	SHC	MBh	SHC	MBh	SHC		
1500	75	59.6	47.7	67.6	36.2	78.8	18.8	54.5	44.7	62.1	33.6	72.9	16.7		
1500	80	60.7	55.5	67.2	47.0	76.9	32.7	55.8	52.2	61.9	44.2	71.1	30.3		
1500	85	62.6	61.4	67.6	56.0	75.7	44.9	57.8	57.8	62.4	52.9	70.1	42.2		
1500	90	65.3	65.3	68.7	63.3	75.3	55.2	60.6	60.6	63.7	59.9	69.9	52.2		
1800	75	63.2	51.6	70.8	39.6	81.7	21.7	57.9	48.5	65.2	36.8	75.7	19.4		
1800	80	64.6	59.8	70.8	50.8	80.1	36.0	59.5	56.3	65.3	47.8	74.2	33.4		
1800	85	66.9	66.1	71.5	60.2	79.3	48.5	61.9	61.9	66.1	57.0	73.5	45.7		
1800	90	69.8	69.8	72.9	67.8	79.2	59.3	65.0	65.0	67.7	64.3	73.6	56.2		
2100	75	66.3	55.1	73.6	42.6	84.2	24.2	60.9	51.8	67.9	39.7	78.0	21.7		
2100	80	68.1	63.6	73.9	54.2	82.9	38.9	62.9	60.0	68.3	51.0	76.9	36.1		
2100	85	70.6	70.3	74.9	64.0	82.4	51.8	65.6	65.6	69.4	60.6	76.5	48.8		
2100	90	74.0	74.0	76.7	72.0	82.6	62.9	69.0	69.0	71.4	68.3	76.9	59.7		
2400	75	69.0	58.2	76.0	45.1	86.2	26.3	63.5	54.7	70.1	42.1	79.9	23.6		
2400	80	71.1	67.1	76.6	57.1	85.3	41.4	65.7	63.4	70.8	53.8	79.1	38.5		
2400	85	74.0	74.0	77.9	67.3	85.1	54.7	68.8	68.8	72.3	63.8	79.0	51.5		
2400	90	77.6	77.6	80.0	75.8	85.6	66.2	72.5	72.5	74.5	71.9	79.8	62.8		
2700	75	71.3	60.9	77.9	47.3	87.8	27.9	65.6	57.2	71.9	44.1	81.4	25.1		
2700	80	73.7	70.2	78.9	59.7	87.2	43.4	68.2	66.3	72.9	56.2	80.9	40.4		
2700	85	76.9	76.9	80.5	70.3	87.3	57.1	71.5	71.5	74.7	66.6	81.2	53.8		
2700	90	80.9	80.9	82.9	79.1	88.2	69.0	75.6	75.6	77.3	75.1	82.2	65.5		
3000	75	73.1	63.1	79.4	49.0	89.0	29.2	67.3	59.3	73.3	45.7	82.4	26.2		
3000	80	75.9	72.8	80.7	61.8	88.7	45.1	70.2	68.8	74.6	58.2	82.2	41.8		
3000	85	79.4	79.4	82.7	72.8	89.1	59.2	73.9	73.9	76.7	69.0	82.8	55.7		
3000	90	83.7	83.7	85.4	82.1	90.3	71.5	78.8	78.8	79.6	77.9	84.2	67.7		
3300	75	74.5	64.9	80.5	50.4	89.7	30.0	68.6	61.0	74.2	46.9	83.0	26.9		
3300	80	77.6	75.0	82.1	63.6	89.7	46.3	71.8	70.8	75.9	59.8	83.1	42.9		
3300	85	81.4	81.4	84.4	75.0	90.5	60.8	75.8	75.8	78.3	70.9	84.1	57.2		
3300	90	86.0	86.0	87.4	84.6	92.0	73.5	80.7	80.7	81.5	80.3	85.7	69.6		
3600	75	75.5	66.4	81.1	51.3	90.0	30.4	69.4	62.3	74.7	47.6	83.1	27.2		
3600	80	78.9	76.9	83.0	64.9	90.3	47.1	72.9	72.5	76.7	61.0	83.6	43.6		
3600	85	83.0	83.0	85.6	76.7	91.4	62.0	77.2	77.2	79.4	72.5	84.8	58.2		
3600	90	88.0	88.0	89.0	86.7	93.3	75.1	82.1	82.1	83.0	82.3	86.8	71.1		

**Notes:**

1. All capacities shown are gross and have not considered indoor fan heat. To obtain **NET** cooling capacity subtract indoor fan heat. For indoor fan heat formula, refer to appropriate airflow table notes.
  2. MBh = Total Gross Capacity
  3. SHC = Sensible Heat Capacity
- \* Unit applications below 320 CFM/Ton are only applicable on THC models without electric heat. Electric and Gas heat applications are restricted to applications 320 CFM/Ton and above.



## Performance Data

**Table 31. Gross cooling capacities 8½ tons high efficiency - three phase T/YHC102E3,4**

Air Flow cfm		Ent DB (F)		Ambient Temperature																	
				85						95						105					
				Entering Wet Bulb																	
		61		67		73		61		67		73		61		67		73			
		MBh	SHC	MBh	SHC	MBh	SHC	MBh	SHC	MBh	SHC	MBh	SHC	MBh	SHC	MBh	SHC	MBh	SHC		
1700	75	81.8	61.8	92.0	49.2	105.6	31.4	76.8	58.9	86.4	46.7	99.4	29.4	71.6	55.8	80.6	44.0	93.0	27.2		
1700	80	83.1	70.6	91.7	60.6	103.7	45.4	78.2	67.4	86.3	57.8	97.7	43.1	73.1	64.0	80.6	54.8	91.4	40.6		
1700	85	85.3	77.9	92.4	70.4	102.8	57.8	80.5	74.4	87.0	67.3	96.9	55.2	75.5	70.7	81.4	64.1	90.7	52.4		
1700	90	88.4	83.6	94.0	78.7	102.9	68.7	83.7	79.8	88.7	75.3	97.0	65.8	78.8	75.8	83.2	71.8	91.0	62.7		
2040	75	87.0	67.1	96.7	53.5	109.8	34.8	81.7	63.9	90.8	50.7	103.3	32.5	76.1	60.5	84.7	47.8	96.6	30.0		
2040	80	88.7	76.7	96.9	65.7	108.4	49.6	83.5	73.2	91.1	62.7	102.0	47.0	78.1	69.6	85.1	59.4	95.5	44.2		
2040	85	91.4	84.8	98.0	76.4	108.0	62.8	86.3	81.0	92.4	73.0	101.7	59.9	81.0	77.1	86.5	69.5	95.3	56.8		
2040	90	95.0	91.3	100.1	85.4	108.5	74.5	90.0	87.3	94.5	81.8	102.4	71.3	84.8	83.0	88.8	78.0	96.0	67.9		
2380	75	91.2	71.7	100.5	57.1	113.1	37.5	85.6	68.2	94.3	54.1	106.3	34.9	79.8	64.6	87.9	50.9	99.3	32.1		
2380	80	93.5	82.1	101.2	70.1	112.2	53.0	88.0	78.4	95.1	66.8	105.5	50.2	82.3	74.4	88.8	63.3	98.7	47.1		
2380	85	96.6	91.0	102.8	81.6	112.3	67.1	91.3	87.0	96.8	78.0	105.7	63.9	85.7	82.7	90.6	74.2	99.0	60.6		
2380	90	100.7	98.3	105.3	91.5	113.3	79.6	95.5	94.0	99.5	87.6	106.9	76.1	90.0	89.5	93.4	83.5	100.2	72.5		
2720	75	94.8	78.4	104.0	60.6	116.9	34.6	88.8	74.8	97.4	57.8	109.8	32.6	82.7	71.1	90.7	54.8	102.4	30.3		
2720	80	97.4	90.3	104.8	77.0	115.8	55.6	91.5	86.2	98.3	73.7	108.7	53.0	85.4	82.0	91.6	70.2	101.4	50.3		
2720	85	101.1	99.6	106.6	90.9	115.8	74.0	95.3	95.1	100.2	87.1	108.7	71.0	89.2	89.2	93.5	83.2	101.5	67.8		
2720	90	105.9	105.9	109.5	102.2	116.8	89.9	100.1	100.1	103.1	98.0	109.8	86.4	94.1	94.1	96.5	93.6	102.6	82.7		
3060	75	97.6	81.9	106.4	63.7	118.9	37.4	91.5	78.1	99.7	60.7	111.6	35.1	85.2	74.1	92.8	57.5	104.0	32.6		
3060	80	100.7	94.1	107.6	80.5	118.2	58.7	94.6	89.9	100.9	77.0	110.9	55.9	88.3	85.4	94.0	73.3	103.4	53.0		
3060	85	104.7	103.9	109.8	94.7	118.5	77.4	98.7	98.7	103.2	90.8	111.3	74.2	92.5	92.5	96.4	86.6	103.9	70.8		
3060	90	109.9	109.9	113.0	106.5	119.9	93.7	103.9	103.9	106.5	102.0	112.8	90.0	97.8	97.8	99.7	97.4	105.4	86.1		
3400	75	100.2	85.2	108.5	66.6	120.6	39.9	93.9	81.2	101.6	63.4	113.1	37.4	87.4	77.0	94.5	59.9	105.4	34.7		
3400	80	103.6	97.7	110.1	83.7	120.2	61.5	97.4	93.3	103.2	80.0	112.8	58.6	90.9	88.6	96.2	76.1	105.2	55.4		
3400	85	108.1	107.8	112.7	98.3	121.0	80.6	101.9	101.9	105.9	94.1	113.6	77.2	95.5	95.5	98.9	89.8	106.0	73.6		
3400	90	113.6	113.6	116.3	110.4	122.7	97.3	107.5	107.5	109.6	105.8	115.4	93.4	101.6	101.6	102.6	100.9	107.9	89.3		
3740	75	102.4	88.2	110.3	69.2	121.9	42.1	95.9	83.9	103.3	65.8	114.3	39.4	89.3	79.5	96.0	62.1	106.4	36.5		
3740	80	106.2	101.1	112.2	86.7	122.0	64.1	99.8	96.4	105.2	82.8	114.4	60.9	93.2	91.6	98.0	78.6	106.6	57.6		
3740	85	111.0	111.0	115.2	101.7	123.1	83.6	104.7	104.7	108.3	97.3	115.5	80.0	98.1	98.1	101.1	92.7	107.8	76.1		
3740	90	116.9	116.9	119.2	114.1	125.2	100.6	110.7	110.7	112.3	109.3	117.7	96.5	104.2	104.2	105.2	104.2	110.0	92.2		
4080	75	104.3	90.9	111.8	71.6	123.0	44.1	97.7	86.5	104.6	67.9	115.1	41.2	90.8	81.9	97.1	64.0	107.1	38.1		
4080	80	108.5	104.2	114.1	89.4	123.4	66.4	101.9	99.3	106.9	85.3	115.6	63.1	95.1	94.2	99.5	81.0	107.6	59.5		
4080	85	113.7	113.7	117.4	104.8	124.9	86.3	107.2	107.2	110.3	100.1	117.2	82.5	100.5	100.5	103.0	95.3	109.2	78.4		
4080	90	120.0	120.0	121.8	117.6	127.4	103.7	113.5	113.5	114.8	112.5	119.8	99.3	106.4	106.4	107.5	107.2	111.9	94.8		

continued on next page

**Table 31. Gross cooling capacities 8½ tons high efficiency - three phase T/YHC102E3,4 (continued)**

Air Flow cfm		Ent DB (F)		Ambient Temperature											
				115						125					
				Entering Wet Bulb											
		61		67		73		61		67		73			
		MBh	SHC	MBh	SHC	MBh	SHC	MBh	SHC	MBh	SHC	MBh	SHC		
1700	75	66.1	52.5	74.6	41.2	86.4	24.8	60.4	49.1	68.3	38.2	79.5	22.2		
1700	80	67.7	60.5	74.6	51.7	84.9	37.9	62.1	56.7	68.4	48.4	78.1	35.0		
1700	85	70.2	66.9	75.6	60.7	84.3	49.4	64.8	62.8	69.5	57.1	77.7	46.3		
1700	90	73.7	71.7	77.5	68.1	84.7	59.4	68.3	67.4	71.6	64.2	78.1	56.0		
2040	75	70.4	57.0	78.3	44.7	89.6	27.3	64.4	53.3	71.8	41.4	82.5	24.5		
2040	80	72.4	65.7	78.9	56.0	88.6	41.2	66.6	61.7	72.4	52.5	81.6	38.1		
2040	85	75.5	73.0	80.3	65.8	88.6	53.6	69.7	68.7	74.0	62.0	81.6	50.2		
2040	90	79.4	78.6	82.7	74.0	89.4	64.4	73.7	73.7	76.5	69.9	82.6	60.7		
2380	75	73.8	60.8	81.2	47.5	92.1	29.1	67.5	56.8	74.4	43.9	84.6	26.0		
2380	80	76.3	70.3	82.3	59.6	91.5	43.9	70.1	66.1	75.5	55.8	84.2	40.5		
2380	85	79.8	78.3	84.2	70.2	92.0	57.0	73.7	73.7	77.6	66.1	84.7	53.3		
2380	90	84.3	84.3	87.1	79.3	93.3	68.7	78.3	78.3	80.6	74.9	86.2	64.7		
2720	75	76.2	67.1	83.7	51.6	94.8	27.9	69.6	62.9	76.4	48.2	86.9	25.2		
2720	80	79.1	77.5	84.6	66.5	93.9	47.4	72.5	72.5	77.4	62.6	86.1	44.2		
2720	85	82.9	82.9	86.6	79.0	94.0	64.4	76.4	76.4	79.5	74.6	86.2	60.7		
2720	90	88.7	88.7	89.6	88.9	95.1	78.8	82.6	82.6	82.6	82.6	87.5	74.7		
3060	75	78.6	70.0	85.6	54.1	96.3	30.0	71.8	65.6	78.2	50.4	88.3	27.1		
3060	80	81.8	80.8	86.9	69.4	95.7	49.8	75.0	75.0	79.6	65.3	87.8	46.5		
3060	85	86.1	86.1	89.3	82.2	96.2	67.2	79.4	79.4	82.0	77.6	88.3	63.4		
3060	90	91.8	91.8	92.7	92.5	97.8	82.0	85.5	85.5	85.5	85.5	89.9	77.7		
3400	75	80.6	72.6	87.2	56.3	97.4	31.8	73.6	68.0	79.6	52.4	89.2	28.7		
3400	80	84.2	83.7	88.9	72.0	97.3	52.0	77.3	77.3	81.4	67.7	89.1	48.5		
3400	85	88.8	88.8	91.6	85.2	98.1	69.8	82.0	82.0	84.2	80.4	90.1	65.7		
3400	90	95.5	95.5	95.5	95.5	100.1	85.0	88.0	88.0	88.0	88.0	92.1	80.4		
3740	75	82.3	74.9	88.5	58.3	98.3	33.4	75.2	70.1	80.7	54.2	89.9	30.1		
3740	80	86.3	86.3	90.5	74.3	98.5	54.0	79.2	79.2	82.9	69.8	90.2	50.2		
3740	85	91.3	91.3	93.7	87.9	99.8	72.1	84.3	84.3	86.1	82.9	91.5	67.8		
3740	90	97.9	97.9	97.9	97.9	102.1	87.6	90.3	90.3	90.3	90.3	93.9	82.9		
4080	75	83.7	77.0	89.4	60.0	98.8	34.8	76.4	72.0	81.5	55.7	90.3	31.2		
4080	80	88.1	88.1	91.9	76.4	99.4	55.7	80.8	80.8	84.0	71.7	90.9	51.7		
4080	85	93.5	93.5	95.4	90.3	101.0	74.2	86.3	86.3	87.6	85.1	92.6	69.7		
4080	90	100.0	100.0	100.0	100.0	103.7	90.1	92.2	92.2	92.2	92.2	95.4	85.2		

**Notes:**

1. All capacities shown are gross and have not considered indoor fan heat. To obtain **NET** cooling capacity subtract indoor fan heat. For indoor fan heat formula, refer to appropriate airflow table notes.
  2. MBh = Total Gross Capacity
  3. SHC = Sensible Heat Capacity
- \* Unit applications below 320 CFM/Ton are only applicable on THC models without electric heat. Electric and Gas heat applications are restricted to applications 320 CFM/Ton and above.



## Performance Data

**Table 32. Gross cooling capacities 10 tons high efficiency - three phase T/YHC120E3,4**

Air Flow cfm		Ent DB (F)		Ambient Temperature															
				85				95				105							
				Entering Wet Bulb															
		61		67		73		61		67		73		61		67		73	
		MBh	SHC	MBh	SHC	MBh	SHC	MBh	SHC	MBh	SHC	MBh	SHC	MBh	SHC	MBh	SHC	MBh	SHC
2000	75	94.9	71.7	106.3	57.0	121.5	36.7	89.4	68.4	100.1	54.2	114.7	34.3	83.5	64.9	93.6	51.1	107.5	31.7
2000	80	96.4	81.9	106.1	70.1	119.6	52.7	91.0	78.3	100.0	67.0	112.8	50.1	85.2	74.5	93.6	63.6	105.7	47.2
2000	85	99.0	90.3	107.0	81.5	118.8	67.0	93.7	86.4	101.0	78.1	112.1	64.1	88.0	82.3	94.7	74.4	105.1	60.8
2000	90	102.7	97.0	108.9	91.1	119.0	79.5	97.4	92.7	103.0	87.3	112.4	76.2	91.9	88.3	96.8	83.3	105.5	72.7
2400	75	100.6	77.9	111.5	62.3	126.1	40.9	94.8	74.4	104.9	59.2	118.9	38.3	88.6	70.5	98.1	55.8	111.3	35.4
2400	80	102.8	89.1	111.9	76.3	124.8	57.9	97.0	85.2	105.4	72.9	117.7	54.9	90.9	81.0	98.7	69.2	110.2	51.7
2400	85	106.0	98.4	113.4	88.5	124.6	73.1	100.3	94.2	107.0	84.8	117.5	69.8	94.3	89.7	100.3	80.8	110.2	66.2
2400	90	110.3	105.9	115.9	99.0	125.4	86.4	104.7	101.3	109.7	94.9	118.5	82.8	98.8	96.6	103.1	90.6	111.2	78.9
2800	75	105.4	83.3	115.7	66.6	129.7	44.3	99.2	79.4	108.8	63.2	122.1	41.3	92.6	75.3	101.5	59.5	114.2	38.1
2800	80	108.2	95.3	116.7	81.5	129.0	62.1	102.1	91.1	109.9	77.8	121.5	58.8	95.6	86.6	102.8	73.8	113.7	55.3
2800	85	112.0	105.5	118.8	94.6	129.4	78.2	106.0	101.0	112.1	90.6	122.0	74.6	99.6	96.2	105.0	86.3	114.3	70.7
2800	90	116.9	113.8	122.0	105.9	130.8	92.4	111.0	109.0	115.4	101.6	123.6	88.5	104.7	103.9	108.4	96.9	115.9	84.3
3200	75	109.5	91.5	119.4	70.5	133.0	39.4	103.0	87.4	112.1	67.2	125.1	37.0	96.1	83.0	104.6	63.6	116.9	34.1
3200	80	112.8	105.3	120.8	90.0	132.5	64.6	106.3	100.7	113.6	86.2	124.7	61.6	99.5	95.7	106.1	82.0	116.5	58.2
3200	85	117.3	116.1	123.3	106.5	133.2	86.7	110.8	110.8	116.2	102.2	125.4	83.2	104.0	104.0	108.7	97.5	117.2	79.4
3200	90	122.8	122.8	127.0	120.0	134.9	105.9	116.4	116.4	119.9	115.2	127.2	101.9	109.7	109.7	112.5	110.0	119.1	97.5
3600	75	112.7	95.8	122.1	74.0	135.2	42.2	106.0	91.5	114.6	70.5	127.1	39.5	98.9	86.8	106.8	66.6	118.6	36.4
3600	80	116.5	110.1	123.9	94.1	135.2	67.9	109.8	105.3	116.5	90.0	127.1	64.7	102.7	100.1	108.8	85.6	118.7	61.1
3600	85	121.4	121.4	126.9	111.1	136.3	90.6	114.8	114.8	119.6	106.6	128.2	86.9	107.7	107.7	111.9	101.7	119.9	82.8
3600	90	127.4	127.4	131.1	125.2	138.5	110.4	120.8	120.8	123.8	120.2	130.5	106.1	115.0	115.0	116.1	114.7	122.2	101.5
4000	75	115.6	99.2	124.4	76.7	137.0	44.1	108.6	94.7	116.7	73.0	128.6	41.2	101.2	89.8	108.7	68.9	119.9	37.9
4000	80	119.8	114.2	126.7	97.4	137.4	70.4	112.9	109.2	119.1	93.1	129.1	67.0	105.6	103.7	111.1	88.5	120.5	63.1
4000	85	125.2	125.2	130.2	115.0	139.0	93.7	118.3	118.3	122.6	110.2	130.7	89.8	111.1	111.1	114.7	105.1	122.1	85.4
4000	90	131.7	131.7	134.8	129.7	141.7	114.1	124.8	124.8	127.2	124.4	133.5	109.6	118.2	118.2	119.4	118.7	124.9	104.7
4400	75	118.0	101.9	126.3	78.6	138.3	45.2	110.8	97.1	118.4	74.7	129.8	42.1	103.2	92.0	110.2	70.3	120.9	38.5
4400	80	122.7	117.5	129.1	99.8	139.3	72.1	115.6	112.2	121.3	95.3	130.7	68.4	108.1	106.5	113.1	90.5	121.9	64.4
4400	85	128.6	128.6	133.0	118.1	141.3	96.0	121.5	121.5	125.2	113.1	132.8	91.8	114.0	114.0	117.1	107.7	124.0	87.2
4400	90	135.5	135.5	138.1	133.3	144.4	116.9	128.5	128.5	130.3	127.8	136.0	112.2	121.0	121.0	122.3	121.9	127.3	107.1
4800	75	120.1	103.8	127.8	79.7	139.3	45.6	112.6	98.8	119.7	75.5	130.6	42.2	104.9	93.4	111.2	70.9	121.4	38.4
4800	80	125.2	119.9	131.1	101.5	140.7	73.0	117.9	114.4	123.0	96.8	132.0	69.1	110.2	108.5	114.6	91.7	122.9	64.8
4800	85	131.6	131.6	135.5	120.3	143.2	97.5	124.2	124.2	127.5	115.1	134.5	93.0	116.6	116.6	119.1	109.4	125.5	88.2
4800	90	139.0	139.0	141.0	136.1	146.9	119.0	131.7	131.7	133.1	130.4	138.2	114.0	123.5	123.5	124.8	124.2	129.2	108.7

continued on next page

**Table 32. Gross cooling capacities 10 tons high efficiency - three phase T/YHC120E3,4 (continued)**

		Ambient Temperature											
		115						125					
Air Flow cfm	Ent DB (F)	Entering Wet Bulb											
		61		67		73		61		67		73	
		MBh	SHC	MBh	SHC	MBh	SHC	MBh	SHC	MBh	SHC	MBh	SHC
2000	75	77.3	61.1	86.7	47.8	99.9	28.9	70.7	57.1	79.5	44.2	92.0	25.7
2000	80	79.1	70.4	86.8	60.0	98.3	44.0	72.7	66.0	79.7	56.1	90.5	40.6
2000	85	82.0	77.9	88.0	70.4	97.7	57.3	75.6	73.2	80.9	66.2	90.0	53.6
2000	90	85.9	83.5	90.2	79.0	98.2	68.8	79.7	78.5	83.3	74.5	90.6	64.8
2400	75	82.0	66.5	90.8	52.2	103.4	32.2	75.1	62.1	83.3	48.3	95.2	28.8
2400	80	84.4	76.6	91.5	65.3	102.4	48.2	77.6	72.0	84.0	61.1	94.3	44.5
2400	85	87.9	85.0	93.3	76.5	102.5	62.4	81.2	80.0	85.9	72.0	94.4	58.4
2400	90	92.5	91.5	96.1	86.0	103.6	74.8	85.9	85.9	88.8	81.2	95.6	70.5
2800	75	85.7	70.9	94.0	55.6	106.0	34.6	78.5	66.2	86.0	51.4	97.4	30.9
2800	80	88.8	81.9	95.3	69.5	105.6	51.5	81.6	76.9	87.4	65.0	97.1	47.5
2800	85	92.9	91.1	97.7	81.7	106.2	66.6	85.8	85.8	89.9	76.9	97.8	62.2
2800	90	98.1	98.1	101.1	92.1	108.0	79.9	91.1	91.1	93.5	86.9	99.6	75.2
3200	75	88.8	78.1	96.6	59.6	108.3	30.9	81.2	72.9	88.4	55.1	99.3	27.3
3200	80	92.3	90.4	98.2	77.5	107.9	54.5	84.8	84.7	90.0	72.5	99.0	50.4
3200	85	96.9	96.9	100.9	92.4	108.7	75.1	89.4	89.4	92.7	87.0	99.8	70.4
3200	90	103.6	103.6	104.7	104.4	110.6	92.7	96.6	96.6	96.6	96.6	101.8	87.6
3600	75	91.4	81.7	98.7	62.4	109.8	32.9	83.6	76.3	90.2	57.7	100.6	29.1
3600	80	95.3	94.5	100.7	80.9	109.9	57.1	87.6	87.6	92.3	75.7	100.8	52.7
3600	85	100.4	100.4	103.9	96.4	111.1	78.3	92.7	92.7	95.5	90.7	102.1	73.4
3600	90	108.1	108.1	108.1	108.1	113.5	96.5	99.8	99.8	99.8	99.8	104.5	91.1
4000	75	93.6	84.5	100.3	64.4	110.9	34.2	85.5	78.8	91.6	59.5	101.5	30.1
4000	80	98.0	97.9	102.8	83.4	111.5	58.9	90.0	90.0	94.2	78.0	102.1	54.3
4000	85	103.5	103.5	106.4	99.5	113.2	80.7	95.6	95.6	97.8	93.6	103.9	75.6
4000	90	111.2	111.2	111.2	111.2	116.0	99.5	102.6	102.6	102.6	102.6	106.8	93.8
4400	75	95.3	86.5	101.6	65.6	111.6	34.6	87.1	80.5	92.6	60.4	102.0	30.3
4400	80	100.2	100.2	104.5	85.2	112.7	59.9	92.0	92.0	95.7	79.6	103.1	55.1
4400	85	106.2	106.2	108.6	101.9	114.9	82.2	98.1	98.1	99.8	95.7	105.3	76.9
4400	90	113.8	113.8	113.8	113.8	118.2	101.6	105.1	105.1	105.1	105.1	108.7	95.7
4800	75	96.7	87.6	102.4	65.9	111.9	34.2	88.3	81.5	93.3	60.6	102.1	29.6
4800	80	102.1	102.1	105.9	86.2	113.5	60.1	93.7	93.7	96.8	80.3	103.7	55.0
4800	85	108.5	108.5	110.4	103.4	116.1	83.0	100.2	100.2	101.4	97.0	106.4	77.4
4800	90	116.1	116.1	116.1	116.1	119.9	102.9	107.1	107.1	107.1	107.1	110.2	96.8

**Notes:**

1. All capacities shown are gross and have not considered indoor fan heat. To obtain **NET** cooling capacity subtract indoor fan heat. For indoor fan heat formula, refer to appropriate airflow table notes.
  2. MBh = Total Gross Capacity
  3. SHC = Sensible Heat Capacity
- \* Unit applications below 320 CFM/Ton are only applicable on THC models without electric heat. Electric and Gas heat applications are restricted to applications 320 CFM/Ton and above.









## Direct Drive - Evaporator Fan Performance

**Table 36. Multispeed direct drive evaporator fan performance 3 - 5 tons - high efficiency - no electric heat  
THC036E1,3,4 / THC048 and 060E3,4 / THC048F and 060F1,3,4**

Unit Model		External Static Pressure (Inches of Water) & Motor Power (bhp) <sup>(a)</sup>															
		Tons	Number	cfm	Standard Low			Mid Speed			Standard High			High Speed			
					Rated Speed Set 1			Speed Set 2			Speed Set 3			Speed Set 4			Speed Set 5
ESP	rpm	bhp	ESP	rpm	bhp	ESP	rpm	bhp	ESP	rpm	bhp	ESP	rpm	bhp	ESP	rpm	bhp
3	THC036E1,3,4 Downflow	960	0.45	715	0.21	0.74	851	0.31	0.92	929	0.38	1.07	993	0.44	1.25	1053	0.52
		1020	0.39	695	0.20	0.66	826	0.30	0.84	905	0.37	0.99	969	0.43	1.17	1030	0.50
		1080	0.33	675	0.20	0.59	800	0.29	0.77	880	0.36	0.91	945	0.42	1.08	1007	0.49
		1140	0.27	654	0.19	0.51	774	0.28	0.69	855	0.35	0.83	921	0.41	1.00	985	0.48
		1200	0.21	634	0.18	0.43	749	0.27	0.61	831	0.34	0.75	898	0.40	0.91	962	0.47
		1260	0.15	614	0.18	0.35	723	0.26	0.53	806	0.33	0.67	874	0.39	0.83	939	0.46
		1320	0.09	593	0.17	0.28	697	0.25	0.45	782	0.32	0.59	850	0.38	0.74	916	0.45
	1380	0.03	573	0.17	0.20	671	0.24	0.37	757	0.31	0.51	826	0.37	0.66	893	0.44	
	1440	—	—	—	0.12	646	0.23	0.29	732	0.30	0.43	802	0.36	0.57	871	0.43	
	THC036E1,3,4 Horizontal Airflow	960	0.45	711	0.21	0.70	835	0.30	0.89	913	0.37	1.04	978	0.44	1.21	1037	0.51
		1020	0.39	689	0.20	0.63	811	0.29	0.81	890	0.36	0.96	957	0.43	1.13	1016	0.50
		1080	0.32	667	0.19	0.56	787	0.28	0.73	868	0.35	0.88	935	0.42	1.04	996	0.49
		1140	0.26	644	0.19	0.48	763	0.28	0.65	845	0.34	0.80	913	0.41	0.95	975	0.48
		1200	0.20	622	0.18	0.41	739	0.27	0.57	823	0.33	0.72	892	0.40	0.87	955	0.47
1260		0.13	599	0.17	0.33	715	0.26	0.50	800	0.32	0.64	870	0.39	0.78	934	0.46	
1320		0.07	577	0.17	0.26	691	0.25	0.42	777	0.32	0.56	848	0.38	0.69	913	0.45	
1380	0.01	555	0.16	0.18	667	0.24	0.34	755	0.31	0.48	826	0.37	0.61	893	0.44		
1440	—	—	—	0.11	642	0.23	0.26	732	0.30	0.40	805	0.36	0.52	872	0.43		
4	THC048E3,4/ THC048F1,3,4 Downflow Airflow	1280	0.65	805	0.31	0.86	902	0.40	1.04	966	0.48	1.27	1042	0.58	—	—	—
		1360	0.55	769	0.30	0.76	866	0.38	0.94	934	0.46	1.17	1010	0.56	1.43	1113	0.68
		1440	0.46	733	0.28	0.66	830	0.37	0.84	902	0.44	1.06	977	0.54	1.31	1078	0.66
		1520	0.36	696	0.27	0.56	794	0.35	0.74	869	0.43	0.95	944	0.52	1.20	1043	0.64
		1600	0.27	660	0.25	0.46	758	0.33	0.63	837	0.41	0.85	912	0.50	1.08	1009	0.62
	1680	0.17	624	0.24	0.36	722	0.32	0.53	805	0.40	0.74	879	0.49	0.97	974	0.60	
	1760	—	—	—	0.26	686	0.30	0.43	772	0.38	0.63	847	0.47	0.85	939	0.58	
	1840	—	—	—	0.16	650	0.29	0.33	740	0.36	0.53	814	0.45	0.74	905	0.55	
	1920	—	—	—	0.06	614	0.27	0.23	707	0.35	0.42	782	0.43	0.62	870	0.53	
	THC048E3,4/ THC048F1,3,4 Horizontal Airflow	1280	0.56	795	0.31	0.77	880	0.39	0.95	967	0.48	1.16	1040	0.57	—	—	—
1360		0.48	760	0.29	0.67	847	0.37	0.86	935	0.46	1.06	1010	0.56	1.26	1105	0.68	
1440		0.39	725	0.28	0.58	814	0.36	0.76	903	0.44	0.96	980	0.54	1.16	1075	0.66	
1520		0.30	690	0.27	0.48	780	0.34	0.66	871	0.43	0.86	951	0.53	1.06	1045	0.64	
1600		0.22	655	0.25	0.39	747	0.33	0.57	838	0.41	0.76	921	0.51	0.96	1016	0.62	
1680	0.13	619	0.24	0.30	714	0.31	0.47	806	0.40	0.66	891	0.49	0.86	986	0.60		
1760	—	—	—	0.20	681	0.30	0.37	774	0.38	0.56	861	0.48	0.76	956	0.59		
1840	—	—	—	0.11	647	0.29	0.28	742	0.37	0.46	831	0.46	0.66	926	0.57		
1920	—	—	—	0.01	614	0.27	0.18	710	0.35	0.36	802	0.44	0.56	896	0.55		
5	THC060E3,4/ THC060F1,3,4 Downflow Airflow	1600	0.82	918	0.50	1.04	1002	0.60	1.26	1087	0.72	—	—	—	—	—	—
		1700	0.67	873	0.47	0.89	957	0.58	1.11	1043	0.69	—	—	—	—	—	—
		1800	0.53	828	0.45	0.74	913	0.55	0.96	1000	0.66	1.16	1083	0.78	—	—	—
		1900	0.39	782	0.42	0.59	869	0.52	0.82	957	0.63	1.02	1041	0.75	1.17	1099	0.85
		2000	0.25	737	0.40	0.45	824	0.50	0.67	914	0.60	0.87	999	0.72	1.02	1056	0.82
	2100	0.11	692	0.37	0.30	780	0.47	0.52	870	0.58	0.72	957	0.69	0.87	1014	0.78	
	2200	—	—	—	0.15	735	0.44	0.37	827	0.55	0.57	914	0.66	0.71	971	0.75	
	2300	—	—	—	0.00	691	0.42	0.22	784	0.52	0.42	872	0.63	0.56	929	0.72	
	2400	—	—	—	—	—	—	0.07	741	0.49	0.27	830	0.60	0.41	886	0.68	
THC060E3,4/ THC060F1,3,4 Horizontal Airflow	1600	0.71	918	0.50	0.91	1001	0.60	1.09	1070	0.71	—	—	—	—	—	—	
	1700	0.59	875	0.47	0.78	959	0.58	0.96	1029	0.68	1.11	1102	0.79	—	—	—	
	1800	0.46	832	0.45	0.65	916	0.55	0.82	987	0.65	0.97	1063	0.77	—	—	—	
	1900	0.33	788	0.43	0.51	874	0.53	0.68	945	0.62	0.84	1023	0.74	1.01	1093	0.85	
2000	0.21	745	0.40	0.38	831	0.50	0.54	903	0.60	0.71	984	0.71	0.87	1052	0.81		
2100	0.08	701	0.38	0.25	788	0.47	0.41	861	0.57	0.57	944	0.68	0.73	1010	0.78		
2200	—	—	—	0.12	746	0.45	0.27	819	0.54	0.44	904	0.65	0.59	968	0.75		
2300	—	—	—	—	—	—	0.13	778	0.51	0.31	865	0.62	0.45	926	0.72		
2400	—	—	—	—	—	—	—	—	—	0.17	825	0.59	0.31	884	0.68		

For 036 Models, fan motor heat (MBh) = 2.72 x Fan Bhp + 0.16.

For 048 & 060 Models, fan motor heat (MBh) = 2.87 x Fan Bhp + 0.15.

Factory supplied motors, in commercial equipment, are definite purpose motors, specifically designed and tested to operate reliably and continuously at all cataloged conditions. Using the full horsepower range of our fan motors as shown in our tabular data will not result in nuisance tripping or premature motor failure. Our product's warranty will not be affected.

(a) Data includes pressure drop due to wet coil and filters.



## Direct Drive - Evaporator Fan Performance

**Table 37. Multispeed direct drive evaporator fan performance 3 - 5 tons - high efficiency - low & medium gas heat  
YHC036E1,3,4 / YHC048 and 060E3,4 / YHC048F and 060F1,3,4**

		External Static Pressure (Inches of Water) & Motor Power (bhp) <sup>(a)</sup>															
		Standard Low									Standard High						
		Rated Speed Set 1			Speed Set 2			Mid Speed Set 3			Speed Set 4			High Speed Set 5			
Tons	Unit Model Number	cfm	ESP	rpm	bhp	ESP	rpm	bhp	ESP	rpm	bhp	ESP	rpm	bhp	ESP	rpm	bhp
3	YHC036E1,3,4*L,M Downflow	960	0.43	718	0.19	0.64	825	0.27	0.88	923	0.35	1.12	1017	0.46	1.28	1074	0.52
		1020	0.37	696	0.18	0.57	800	0.26	0.80	900	0.35	1.04	997	0.45	1.20	1053	0.51
		1080	0.30	675	0.18	0.49	775	0.26	0.72	877	0.34	0.96	977	0.44	1.11	1033	0.50
		1140	0.24	654	0.17	0.42	749	0.25	0.64	854	0.33	0.87	957	0.43	1.03	1013	0.49
		1200	0.18	633	0.17	0.34	724	0.24	0.56	832	0.32	0.79	938	0.42	0.94	992	0.48
		1260	0.11	612	0.16	0.26	698	0.23	0.48	809	0.31	0.71	918	0.41	0.86	972	0.47
		1320	0.05	590	0.16	0.19	673	0.22	0.39	786	0.30	0.63	898	0.40	0.77	951	0.46
		1380	—	—	—	0.11	647	0.21	0.31	763	0.29	0.55	878	0.39	0.68	931	0.45
		1440	—	—	—	0.03	622	0.21	0.23	740	0.28	0.47	859	0.38	0.60	910	0.44
		3	YHC036E1,3,4*L,M Horizontal Airflow	960	0.42	715	0.19	0.67	842	0.28	0.90	937	0.36	1.15	1037	0.46	1.25
1020	0.37			695	0.18	0.61	819	0.27	0.83	916	0.35	1.07	1014	0.45	1.18	1047	0.50
1080	0.31			675	0.18	0.54	796	0.26	0.75	895	0.34	0.99	992	0.44	1.11	1032	0.50
1140	0.26			654	0.17	0.47	772	0.26	0.68	874	0.34	0.91	970	0.43	1.04	1017	0.49
1200	0.20			634	0.17	0.41	749	0.25	0.61	853	0.33	0.83	948	0.42	0.97	1002	0.48
1260	0.14			614	0.16	0.34	725	0.24	0.54	832	0.32	0.75	926	0.41	0.90	987	0.48
1320	0.09			594	0.16	0.27	702	0.23	0.47	811	0.31	0.67	903	0.40	0.83	972	0.47
1380	0.03			574	0.15	0.20	678	0.22	0.40	789	0.30	0.59	881	0.39	0.76	957	0.46
1440	—			—	—	0.14	654	0.22	0.33	768	0.29	0.51	859	0.38	0.69	942	0.45
4	YHC048***L,M Downflow Airflow			1280	0.69	820	0.33	0.88	903	0.41	1.07	969	0.49	1.07	969	0.49	1.27
		1360	0.59	785	0.32	0.78	869	0.40	0.96	936	0.48	0.96	936	0.48	1.16	1007	0.56
		1440	0.49	750	0.30	0.68	835	0.38	0.86	903	0.46	0.86	903	0.46	1.05	976	0.55
		1520	0.40	714	0.29	0.58	801	0.37	0.75	870	0.44	0.75	870	0.44	0.94	944	0.53
		1600	0.30	679	0.27	0.48	767	0.35	0.65	837	0.42	0.65	837	0.42	0.84	912	0.51
		1680	0.20	643	0.26	0.38	733	0.34	0.54	804	0.41	0.54	804	0.41	0.73	881	0.49
		1760	0.10	608	0.25	0.28	699	0.32	0.44	771	0.39	0.44	771	0.39	0.62	849	0.48
		1840	0.01	572	0.23	0.18	666	0.31	0.33	738	0.37	0.33	738	0.37	0.51	817	0.46
		1920	—	—	—	0.08	632	0.29	0.23	705	0.36	0.23	705	0.36	0.41	786	0.44
		4	YHC048***L,M Horizontal Airflow	1280	0.61	813	0.33	0.81	896	0.41	1.00	977	0.50	1.00	977	0.50	1.17
1360	0.51			777	0.31	0.70	862	0.40	0.89	944	0.48	0.89	944	0.48	1.06	1011	0.57
1440	0.42			742	0.30	0.60	828	0.38	0.79	911	0.46	0.79	911	0.46	0.95	979	0.55
1520	0.32			707	0.28	0.50	794	0.36	0.68	878	0.45	0.68	878	0.45	0.84	946	0.53
1600	0.22			671	0.27	0.40	760	0.35	0.57	845	0.43	0.57	845	0.43	0.73	913	0.51
1680	0.13			636	0.26	0.29	725	0.33	0.46	812	0.41	0.46	812	0.41	0.62	881	0.49
1760	0.03			600	0.24	0.19	691	0.32	0.36	779	0.40	0.36	779	0.40	0.51	848	0.47
1840	—			—	—	0.09	657	0.30	0.25	746	0.38	0.25	746	0.38	0.40	815	0.46
1920	—			—	—	—	—	—	0.14	713	0.36	0.14	713	0.36	0.29	783	0.44
5	YHC060***L,M Downflow Airflow			1600	0.90	962	0.55	1.07	1027	0.64	1.28	1099	0.75	—	—	—	—
		1700	0.76	919	0.53	0.93	985	0.61	1.14	1060	0.72	—	—	—	—	—	—
		1800	0.62	875	0.50	0.78	943	0.59	0.99	1022	0.70	1.15	1092	0.81	—	—	—
		1900	0.48	832	0.48	0.64	900	0.56	0.84	984	0.67	1.00	1051	0.78	1.18	1116	0.89
		2000	0.34	788	0.45	0.49	858	0.53	0.70	945	0.65	0.86	1010	0.75	1.03	1076	0.86
		2100	0.20	745	0.43	0.35	815	0.51	0.55	907	0.62	0.71	969	0.72	0.88	1037	0.83
		2200	0.06	701	0.40	0.20	773	0.48	0.41	868	0.59	0.56	928	0.69	0.73	997	0.80
		2300	—	—	—	0.06	730	0.46	0.26	830	0.57	0.41	887	0.66	0.58	958	0.77
		2400	—	—	—	—	—	—	0.12	792	0.54	0.26	846	0.63	0.43	918	0.73
		5	YHC060***L,M Horizontal Airflow	1600	0.75	944	0.54	0.91	1010	0.63	1.10	1094	0.75	—	—	—	—
1700	0.61			899	0.52	0.77	969	0.60	0.96	1052	0.72	1.12	1114	0.82	—	—	—
1800	0.48			855	0.49	0.63	927	0.58	0.82	1011	0.69	0.97	1074	0.79	—	—	—
1900	0.34			811	0.47	0.49	885	0.55	0.67	969	0.66	0.83	1035	0.76	1.01	1111	0.89
2000	0.20			766	0.44	0.35	843	0.53	0.53	928	0.63	0.68	995	0.74	0.87	1070	0.85
2100	0.07			722	0.42	0.21	801	0.50	0.39	887	0.61	0.54	956	0.71	0.72	1028	0.82
2200	—			—	—	0.07	759	0.47	0.25	845	0.58	0.39	916	0.68	0.57	987	0.79
2300	—			—	—	—	—	—	0.10	804	0.55	0.25	877	0.65	0.42	945	0.76
2400	—			—	—	—	—	—	—	—	—	0.10	837	0.62	0.27	904	0.72

For 036 Models, fan motor heat (MBh) = 2.72 x Fan Bhp + 0.16.

For 048 & 060 Models, fan motor heat (MBh) = 2.87 x Fan Bhp + 0.15.

Factory supplied motors, in commercial equipment, are definite purpose motors, specifically designed and tested to operate reliably and continuously at all cataloged conditions. Using the full horsepower range of our fan motors as shown in our tabular data will not result in nuisance tripping or premature motor failure. Our product's warranty will not be affected.

(a) Data includes pressure drop due to wet coil and filters.

## Direct Drive - Evaporator Fan Performance

**Table 38. Multispeed direct drive evaporator fan performance 3 - 5 tons - high efficiency - high heat YHC036E1,3,4 / YHC048 and 060E3,4 / YHC048F and 060F1,3,4**

		External Static Pressure (Inches of Water) & Motor Power (bhp) <sup>(a)</sup>															
		Standard Low									Standard High						
Tons	Unit Model Number	cfm	Rated Speed Set 1			Speed Speed Set 2			Mid Speed Speed Set 3			Speed Speed Set 4			High Speed Speed Set 5		
			ESP	rpm	bhp	ESP	rpm	bhp	ESP	rpm	bhp	ESP	rpm	bhp	ESP	rpm	bhp
3	YHC036E1,3,4*H Downflow Airflow	960	0.43	718	0.19	0.64	825	0.26	0.88	923	0.34	1.12	1017	0.44	1.28	1074	0.51
		1020	0.37	696	0.19	0.57	800	0.26	0.80	900	0.34	1.04	997	0.43	1.20	1053	0.50
		1080	0.30	675	0.18	0.49	775	0.25	0.72	877	0.33	0.96	977	0.42	1.11	1033	0.49
		1140	0.24	654	0.18	0.42	749	0.24	0.64	854	0.32	0.87	957	0.42	1.03	1013	0.48
		1200	0.18	633	0.17	0.34	724	0.23	0.56	832	0.31	0.79	938	0.41	0.94	992	0.47
		1260	0.11	612	0.16	0.26	698	0.22	0.48	809	0.30	0.71	918	0.40	0.86	972	0.46
		1320	0.05	590	0.16	0.19	673	0.21	0.39	786	0.29	0.63	898	0.39	0.77	951	0.45
		1380	—	—	—	0.11	647	0.21	0.31	763	0.28	0.55	878	0.38	0.68	931	0.44
		1440	—	—	—	0.03	622	0.20	0.23	740	0.28	0.47	859	0.37	0.60	910	0.43
		3	YHC036E1,3,4*H Horizontal Airflow	960	0.44	732	0.20	0.65	836	0.27	0.87	935	0.35	1.12	1033	0.45	1.25
1020	0.37			708	0.19	0.58	811	0.26	0.80	911	0.34	1.03	1010	0.44	1.17	1059	0.50
1080	0.31			684	0.18	0.51	787	0.25	0.72	886	0.33	0.95	987	0.43	1.09	1040	0.49
1140	0.24			660	0.18	0.43	762	0.24	0.64	862	0.32	0.87	964	0.42	1.01	1021	0.48
1200	0.18			636	0.17	0.36	737	0.24	0.56	838	0.31	0.79	941	0.41	0.93	1002	0.47
1260	0.11			612	0.16	0.29	712	0.23	0.48	814	0.30	0.70	918	0.40	0.85	983	0.47
1320	0.05			588	0.16	0.21	688	0.22	0.40	789	0.29	0.62	895	0.39	0.77	964	0.46
1380	—			—	—	0.14	663	0.21	0.32	765	0.28	0.54	872	0.38	0.69	945	0.45
1440	—			—	—	0.07	638	0.20	0.24	741	0.28	0.45	849	0.37	0.61	926	0.44
4	YHC048***H Downflow Airflow			1280	0.69	833	0.35	0.90	924	0.43	1.07	989	0.51	1.07	989	0.51	1.27
		1360	0.60	796	0.33	0.80	889	0.42	0.97	956	0.50	0.97	956	0.50	1.17	1033	0.59
		1440	0.50	759	0.32	0.71	855	0.40	0.87	922	0.48	0.87	922	0.48	1.06	1000	0.57
		1520	0.40	722	0.30	0.61	820	0.39	0.77	889	0.46	0.77	889	0.46	0.96	966	0.56
		1600	0.31	684	0.29	0.51	785	0.37	0.67	855	0.44	0.67	855	0.44	0.85	933	0.54
		1680	0.21	647	0.27	0.41	751	0.35	0.57	822	0.43	0.57	822	0.43	0.75	900	0.52
		1760	0.12	610	0.26	0.31	716	0.34	0.47	788	0.41	0.47	788	0.41	0.64	867	0.50
		1840	—	—	—	0.22	681	0.32	0.37	755	0.39	0.37	755	0.39	0.54	834	0.48
		1920	—	—	—	0.12	647	0.30	0.27	721	0.37	0.27	721	0.37	0.43	801	0.46
		4	YHC048***H Horizontal Airflow	1280	0.60	822	0.34	0.81	912	0.43	0.97	986	0.51	0.97	986	0.51	1.18
1360	0.51			787	0.33	0.70	876	0.41	0.87	952	0.49	0.87	952	0.49	1.07	1031	0.59
1440	0.41			752	0.31	0.60	840	0.40	0.76	918	0.48	0.76	918	0.48	0.96	998	0.57
1520	0.31			718	0.30	0.49	805	0.38	0.66	885	0.46	0.66	885	0.46	0.84	966	0.56
1600	0.22			683	0.29	0.38	769	0.36	0.55	851	0.44	0.55	851	0.44	0.73	933	0.54
1680	0.12			648	0.27	0.28	733	0.34	0.45	818	0.42	0.45	818	0.42	0.62	901	0.52
1760	0.03			613	0.26	0.17	697	0.33	0.34	784	0.41	0.34	784	0.41	0.51	868	0.50
1840	—			—	—	0.07	661	0.31	0.23	750	0.39	0.23	750	0.39	0.40	836	0.48
1920	—			—	—	—	—	—	0.13	717	0.37	0.13	717	0.37	0.29	803	0.46
5	YHC060***H Downflow Airflow			1600	0.90	955	0.57	1.06	1022	0.66	1.25	1095	0.77	—	—	—	—
		1700	0.76	910	0.54	0.92	977	0.63	1.11	1052	0.74	1.28	1113	0.85	—	—	—
		1800	0.62	865	0.52	0.77	932	0.60	0.96	1009	0.71	1.13	1072	0.82	—	—	—
		1900	0.47	819	0.49	0.63	888	0.57	0.82	966	0.68	0.98	1031	0.79	1.18	1105	0.91
		2000	0.33	774	0.46	0.49	843	0.54	0.67	922	0.65	0.83	990	0.75	1.02	1062	0.87
		2100	0.19	729	0.44	0.34	798	0.52	0.52	879	0.62	0.68	949	0.72	0.87	1019	0.84
		2200	0.04	683	0.41	0.20	754	0.49	0.38	836	0.59	0.54	908	0.69	0.71	976	0.80
		2300	—	—	—	0.05	709	0.46	0.23	793	0.56	0.39	867	0.66	0.55	933	0.77
		2400	—	—	—	—	—	—	0.09	750	0.53	0.24	826	0.63	0.40	890	0.73
		5	YHC060***H Horizontal Airflow	1600	0.77	948	0.57	0.95	1016	0.66	1.10	1093	0.77	—	—	—	—
1700	0.63			903	0.54	0.80	973	0.63	0.96	1052	0.74	—	—	—	—	—	
1800	0.48			859	0.51	0.66	930	0.60	0.81	1012	0.71	1.00	1084	0.83	—	—	—
1900	0.34			814	0.49	0.51	888	0.57	0.67	971	0.68	0.85	1042	0.79	1.01	1106	0.91
2000	0.20			770	0.46	0.36	845	0.55	0.52	931	0.65	0.70	1000	0.76	0.86	1063	0.87
2100	0.06			725	0.43	0.22	803	0.52	0.38	890	0.62	0.55	959	0.73	0.70	1021	0.84
2200	—			—	—	0.07	760	0.49	0.23	850	0.60	0.39	917	0.70	0.54	979	0.80
2300	—			—	—	—	—	—	0.09	809	0.57	0.24	875	0.67	0.39	937	0.77
2400	—			—	—	—	—	—	—	—	0.00	0.09	833	0.63	0.23	894	0.73

For 036 Models, fan motor heat (MBh) = 2.72 x Fan Bhp + 0.16. For 048 & 060 Models, fan motor heat (MBh) = 2.87 x Fan Bhp + 0.15. Factory supplied motors, in commercial equipment, are definite purpose motors, specifically designed and tested to operate reliably and continuously at all cataloged conditions. Using the full horsepower range of our fan motors as shown in our tabular data will not result in nuisance tripping or premature motor failure. Our product's warranty will not be affected.

(a) Data includes pressure drop due to wet coil and filters.



# Evaporator Fan Performance

**Table 39. Belt drive evaporator fan performance - 3 tons standard efficiency - TSC036E3,E4,EW downflow airflow**

External Static Pressure (Inches of Water)																					
		0.10		0.20		0.30		0.40		0.50		0.60		0.70		0.80		0.90		1.00	
cfm	rpm	bhp	rpm	bhp	rpm	bhp	rpm	bhp	rpm	bhp	rpm	bhp	rpm	bhp	rpm	bhp	rpm	bhp	rpm	bhp	
1-hp Standard Motor & Field Supplied Low Static Drive <sup>(a)</sup>											1-hp Standard Motor & Drive										
960	—	—	—	—	614	0.17	683	0.22	742	0.27	795	0.32	845	0.37	891	0.42	935	0.47	977	0.53	
1080	—	—	561	0.15	635	0.20	704	0.25	765	0.30	818	0.36	868	0.42	913	0.47	957	0.53	998	0.59	
1200	—	—	592	0.18	658	0.23	725	0.29	786	0.35	842	0.41	891	0.47	936	0.53	979	0.59	1019	0.66	
1320	555	0.17	625	0.22	686	0.27	747	0.33	807	0.39	862	0.46	914	0.53	959	0.59	1002	0.66	1043	0.73	
1440	592	0.21	658	0.27	717	0.32	772	0.38	828	0.44	882	0.51	933	0.58	980	0.66	1025	0.73	1065	0.80	

Continued

External Static Pressure (Inches of Water)											
		1.10		1.20		1.30		1.40		1.50	
cfm	rpm	bhp	rpm	bhp	rpm	bhp	rpm	bhp	rpm	bhp	
1-hp Standard Motor & Drive											
960	1016	0.59	1054	0.65	1089	0.70	1124	0.76	1155	0.82	
1080	1036	0.65	1075	0.72	1111	0.78	1146	0.84	1180	0.91	
1200	1058	0.72	1095	0.78	1131	0.85	1167	0.92	1201	0.99	
1320	1082	0.80	1119	0.87	1153	0.94	1188	1.01	1221	1.08	
1440	1104	0.88	1141	0.95	1176	1.03	1211	1.10	—	—	
1-hp Standard Motor & Field Supplied High Static Drive <sup>(b)</sup>											

**Notes:**

1. For Standard Evaporator Fan Speed (rpm), reference [Table 137, p. 182](#).
2. Data includes pressure drop due to standard filters and wet coils. No accessories or options are included in pressure drop data.
3. Data does not include pressure drop due to reheat coil.
4. Refer to [Table 144, p. 185](#) to determine additional static pressure drop due to other options/accessories.
5. 1-hp Fan Motor Heat (MBh) = 2.7672 x Fan bhp + 0.4705.
6. Factory supplied motors, in equipment, are definite purpose motors, specifically designed and tested to operate at all cataloged conditions. Using the full horsepower range of our fan motors as shown in our tabular data will not result in nuisance tripping or premature motor failure. Our product's warranty will not be affected.

(a) Field Supplied Fan Sheave AK71x3/4" required. Field Supplied Belt may be necessary.  
 (b) Field Supplied Fan Sheave AK41x3/4" required. Field Supplied Belt may be necessary.

## Evaporator Fan Performance

**Table 40. Belt drive evaporator fan performance - 3 tons standard efficiency - TSC036E3,E4,EW horizontal airflow**

External Static Pressure (Inches of Water)																					
		0.10		0.20		0.30		0.40		0.50		0.60		0.70		0.80		0.90		1.00	
cfm	rpm	bhp	rpm	bhp	rpm	bhp	rpm	bhp	rpm	bhp	rpm	bhp	rpm	bhp	rpm	bhp	rpm	bhp	rpm	bhp	
1-hp Standard Motor & Field Supplied Low Static Drive <sup>(a)</sup>											1-hp Standard Motor & Drive										
960	—	—	552	0.12	626	0.16	689	0.20	748	0.25	802	0.30	852	0.35	898	0.39	942	0.44	982	0.49	
1080	—	—	576	0.14	654	0.19	716	0.24	772	0.29	825	0.34	874	0.39	921	0.45	964	0.50	1005	0.55	
1200	—	—	600	0.17	681	0.23	744	0.28	799	0.33	850	0.39	898	0.44	943	0.50	987	0.56	1028	0.62	
1320	554	0.16	627	0.20	705	0.27	773	0.33	828	0.38	877	0.44	923	0.50	967	0.56	1010	0.62	1052	0.69	
1440	590	0.20	657	0.24	728	0.30	797	0.37	855	0.44	904	0.50	950	0.56	993	0.63	1034	0.69	1074	0.76	

Continued

External Static Pressure (Inches of Water)											
		1.10		1.20		1.30		1.40		1.50	
cfm	rpm	bhp	rpm	bhp	rpm	bhp	rpm	bhp	rpm	bhp	
1-hp Standard Motor & Drive											
960	1020	0.54	1057	0.59	1092	0.64	1126	0.69	1158	0.74	
1080	1045	0.61	1082	0.67	1116	0.72	1151	0.77	1183	0.83	
1200	1067	0.68	1104	0.74	1141	0.80	1174	0.86	1207	0.92	
1320	1091	0.75	1127	0.82	1163	0.88	1198	0.95	1230	1.02	
1440	1112	0.83	1150	0.90	1186	0.97	1221	1.04	1254	1.11	
1-hp Standard Motor & Field Supplied High Static Drive <sup>(b)</sup>											

**Notes:**

1. For Standard Evaporator Fan Speed (rpm), reference [Table 137, p. 182](#).
2. Data includes pressure drop due to standard filters and wet coils. No accessories or options are included in pressure drop data.
3. Data does not include pressure drop due to reheat coil.
4. Refer to [Table 144, p. 185](#) to determine additional static pressure drop due to other options/accessories.
5. 1-hp Fan Motor Heat (MBh) = 2.7672 x Fan bhp + 0.4705.
6. Factory supplied motors, in equipment, are definite purpose motors, specifically designed and tested to operate at all cataloged conditions. Using the full horsepower range of our fan motors as shown in our tabular data will not result in nuisance tripping or premature motor failure. Our product's warranty will not be affected.

(a) Field Supplied Fan Sheave AK71x3/4" required. Field Supplied Belt may be necessary.

(b) Field Supplied Fan Sheave AK41x3/4" required. Field Supplied Belt may be necessary.



## Evaporator Fan Performance

**Table 41. Belt drive evaporator fan performance - 3 tons standard efficiency - YSC036E3,E4,EW\*L,M low & medium gas heat downflow airflow**

External Static Pressure (Inches of Water)																					
		0.10		0.20		0.30		0.40		0.50		0.60		0.70		0.80		0.90		1.00	
cfm	rpm	bhp	rpm	bhp	rpm	bhp	rpm	bhp	rpm	bhp	rpm	bhp	rpm	bhp	rpm	bhp	rpm	bhp	rpm	bhp	
1-hp Standard Motor & Field Supplied Low Static Drive <sup>(a)</sup>											1-hp Standard Motor & Drive										
960	—	—	—	—	605	0.15	671	0.19	730	0.23	784	0.27	835	0.31	881	0.36	924	0.41	965	0.45	
1080	—	—	563	0.14	630	0.17	693	0.22	751	0.26	804	0.31	854	0.35	901	0.40	946	0.46	986	0.50	
1200	—	—	596	0.17	659	0.21	718	0.25	773	0.30	825	0.35	875	0.40	921	0.45	964	0.51	1005	0.56	
1320	555	0.16	629	0.20	689	0.25	745	0.29	797	0.34	848	0.40	897	0.45	941	0.51	984	0.56	1026	0.62	
1440	593	0.20	663	0.25	721	0.29	775	0.34	824	0.39	873	0.45	919	0.51	963	0.57	1006	0.63	1046	0.69	

Continued

External Static Pressure (Inches of Water)											
		1.10		1.20		1.30		1.40		1.50	
cfm	rpm	bhp	rpm	bhp	rpm	bhp	rpm	bhp	rpm	bhp	
1-hp Standard Motor & Drive											
960	1004	0.50	1039	0.55	1073	0.59	1105	0.64	1137	0.69	
1080	1025	0.56	1063	0.61	1098	0.66	1132	0.72	1163	0.77	
1200	1046	0.62	1082	0.67	1119	0.73	1153	0.79	1187	0.85	
1320	1064	0.68	1103	0.74	1139	0.80	1174	0.86	1207	0.93	
1440	1085	0.75	1123	0.81	1159	0.88	1193	0.94	—	—	
1-hp Standard Motor & Field Supplied High Static Drive <sup>(b)</sup>											

**Notes:**

1. For Standard Evaporator Fan Speed (rpm), reference [Table 137, p. 182](#).
2. Data includes pressure drop due to standard filters and wet coils. No accessories or options are included in pressure drop data.
3. Data does not include pressure drop due to reheat coil.
4. Refer to [Table 144, p. 185](#) to determine additional static pressure drop due to other options/accessories.
5. 1-hp Fan Motor Heat (MBh) = 2.7672 x Fan bhp + 0.4705.
6. Factory supplied motors, in equipment, are definite purpose motors, specifically designed and tested to operate at all cataloged conditions. Using the full horsepower range of our fan motors as shown in our tabular data will not result in nuisance tripping or premature motor failure. Our product's warranty will not be affected.

(a) Field Supplied Fan Sheave AK71x3/4" required. Field Supplied Belt may be necessary.  
 (b) Field Supplied Fan Sheave AK41x3/4" required. Field Supplied Belt may be necessary.

## Evaporator Fan Performance

**Table 42. Belt drive evaporator fan performance - 3 tons standard efficiency - YSC036E3,E4,EW\*L,M low & medium gas heat horizontal airflow**

External Static Pressure (Inches of Water)																					
		0.10		0.20		0.30		0.40		0.50		0.60		0.70		0.80		0.90		1.00	
cfm	rpm	bhp	rpm	bhp	rpm	bhp	rpm	bhp	rpm	bhp	rpm	bhp	rpm	bhp	rpm	bhp	rpm	bhp	rpm	bhp	
1-hp Standard Motor & Field Supplied Low Static Drive <sup>(a)</sup>											1-hp Standard Motor & Drive										
960	—	—	—	—	613	0.15	679	0.20	736	0.24	788	0.28	837	0.32	886	0.37	930	0.42	973	0.47	
1080	—	—	561	0.14	636	0.18	702	0.23	761	0.28	812	0.32	860	0.37	904	0.42	947	0.47	991	0.52	
1200	—	—	589	0.16	661	0.21	726	0.26	784	0.31	836	0.37	884	0.42	929	0.47	970	0.52	1011	0.58	
1320	—	—	619	0.20	687	0.25	750	0.30	807	0.36	859	0.41	909	0.47	953	0.53	995	0.59	1034	0.65	
1440	585	0.19	651	0.24	715	0.29	775	0.35	831	0.40	883	0.47	931	0.53	976	0.59	1019	0.66	1058	0.72	

Continued

External Static Pressure (Inches of Water)											
		1.10		1.20		1.30		1.40		1.50	
cfm	rpm	bhp	rpm	bhp	rpm	bhp	rpm	bhp	rpm	bhp	
1-hp Standard Motor & Drive											
960	1014	0.53	1051	0.58	1087	0.63	1121	0.68	1155	0.74	
1080	1031	0.58	1071	0.64	1108	0.69	1142	0.75	1177	0.81	
1200	1049	0.63	1087	0.69	1124	0.75	1161	0.82	1195	0.88	
1320	1071	0.70	1107	0.76	1143	0.82	1178	0.89	1213	0.96	
1440	1095	0.78	1130	0.84	1166	0.91	1199	0.97	—	—	
1-hp Standard Motor & Field Supplied High Static Drive <sup>(b)</sup>											

**Notes:**

1. For Standard Evaporator Fan Speed (rpm), reference [Table 137, p. 182](#).
2. Data includes pressure drop due to standard filters and wet coils. No accessories or options are included in pressure drop data.
3. Data does not include pressure drop due to reheat coil.
4. Refer to [Table 144, p. 185](#) to determine additional static pressure drop due to other options/accessories.
5. 1-hp Fan Motor Heat (MBh) = 2.7672 x Fan bhp + 0.4705.
6. Factory supplied motors, in equipment, are definite purpose motors, specifically designed and tested to operate reliably and continuously at all cataloged conditions. Using the full horsepower range of our fan motors as shown in our tabular data will not result in nuisance tripping or premature motor failure. Our product's warranty will not be affected.

(a) Field Supplied Fan Sheave AK71x3/4" required. Field Supplied Belt may be necessary.

(b) Field Supplied Fan Sheave AK41x3/4" required. Field Supplied Belt may be necessary.



## Evaporator Fan Performance

**Table 43. Belt drive evaporator fan performance - 3 tons standard efficiency - YSC036E3,E4,EW\*H high gas heat downflow airflow**

External Static Pressure (Inches of Water)																					
		0.10		0.20		0.30		0.40		0.50		0.60		0.70		0.80		0.90		1.00	
cfm	rpm	bhp	rpm	bhp	rpm	bhp	rpm	bhp	rpm	bhp	rpm	bhp	rpm	bhp	rpm	bhp	rpm	bhp	rpm	bhp	
1-hp Standard Motor & Field Supplied Low Static Drive <sup>(a)</sup>											1-hp Standard Motor & Drive										
960	—	—	—	—	609	0.15	671	0.19	730	0.24	785	0.28	835	0.33	881	0.37	924	0.42	966	0.47	
1080	—	—	572	0.14	638	0.18	697	0.23	752	0.27	805	0.32	855	0.37	900	0.42	945	0.47	986	0.53	
1200	—	—	606	0.18	668	0.22	725	0.26	778	0.31	827	0.36	876	0.42	922	0.47	964	0.52	1007	0.58	
1320	573	0.17	641	0.22	700	0.26	754	0.31	805	0.36	853	0.41	898	0.47	942	0.53	985	0.59	1026	0.65	
1440	613	0.21	677	0.27	733	0.31	786	0.36	835	0.42	881	0.47	925	0.53	966	0.59	1007	0.65	1047	0.71	

Continued

External Static Pressure (Inches of Water)											
		1.10		1.20		1.30		1.40		1.50	
cfm	rpm	bhp	rpm	bhp	rpm	bhp	rpm	bhp	rpm	bhp	
1-hp Standard Motor & Drive											
960	1004	0.52	1041	0.58	1076	0.63	1109	0.68	1142	0.73	
1080	1026	0.58	1063	0.64	1098	0.69	1133	0.75	1165	0.81	
1200	1046	0.64	1083	0.70	1120	0.76	1154	0.82	1187	0.88	
1320	1065	0.71	1103	0.77	1139	0.83	1175	0.90	1207	0.96	
1440	1086	0.78	1123	0.84	1160	0.91	1194	0.98	1227	1.05	
1-hp Standard Motor & Field Supplied High Static Drive <sup>(b)</sup>											

**Notes:**

1. For Standard Evaporator Fan Speed (rpm), reference [Table 137, p. 182](#).
2. Data includes pressure drop due to standard filters and wet coils. No accessories or options are included in pressure drop data.
3. Data does not include pressure drop due to reheat coil.
4. Refer to [Table 144, p. 185](#) to determine additional static pressure drop due to other options/accessories.
5. 1-hp Fan Motor Heat (MBh) = 2.7672 x Fan bhp + 0.4705.
6. Factory supplied motors, in equipment, are definite purpose motors, specifically designed and tested to operate at all cataloged conditions. Using the full horsepower range of our fan motors as shown in our tabular data will not result in nuisance tripping or premature motor failure. Our product's warranty will not be affected.

(a) Field Supplied Fan Sheave AK71x3/4" required. Field Supplied Belt may be necessary.  
 (b) Field Supplied Fan Sheave AK41x3/4" required. Field Supplied Belt may be necessary.



## Evaporator Fan Performance

**Table 44. Belt drive evaporator fan performance - 3 tons standard efficiency -YSC036E3,E4,EW\*H high gas heat horizontal airflow**

External Static Pressure (Inches of Water)																					
		0.10		0.20		0.30		0.40		0.50		0.60		0.70		0.80		0.90		1.00	
cfm	rpm	bhp	rpm	bhp	rpm	bhp	rpm	bhp	rpm	bhp	rpm	bhp	rpm	bhp	rpm	bhp	rpm	bhp	rpm	bhp	
1-hp Standard Motor & Field Supplied Low Static Drive <sup>(a)</sup>											1-hp Standard Motor & Drive										
960	—	—	—	—	621	0.15	685	0.20	745	0.24	799	0.29	849	0.33	894	0.38	936	0.42	975	0.47	
1080	—	—	580	0.14	649	0.19	711	0.23	768	0.28	821	0.32	871	0.38	917	0.43	960	0.48	1000	0.53	
1200	—	—	613	0.18	679	0.22	738	0.27	793	0.32	845	0.37	892	0.42	939	0.48	982	0.53	1024	0.59	
1320	574	0.17	647	0.22	710	0.26	767	0.31	820	0.37	870	0.42	917	0.48	962	0.53	1004	0.59	1046	0.66	
1440	612	0.21	682	0.26	742	0.31	797	0.37	849	0.42	897	0.48	943	0.54	986	0.60	1028	0.66	1068	0.72	

Continued

External Static Pressure (Inches of Water)											
		1.10		1.20		1.30		1.40		1.50	
cfm	rpm	bhp	rpm	bhp	rpm	bhp	rpm	bhp	rpm	bhp	
1-hp Standard Motor & Drive											
960	1012	0.52	1048	0.57	1082	0.62	1116	0.67	1148	0.72	
1080	1039	0.59	1075	0.64	1109	0.69	1142	0.74	1173	0.80	
1200	1063	0.65	1100	0.71	1134	0.77	1168	0.83	1199	0.88	
1320	1085	0.72	1122	0.78	1159	0.85	1193	0.91	1226	0.98	
1440	1107	0.79	1145	0.86	1181	0.93	1216	1.00	1248	1.07	
1-hp Standard Motor & Field Supplied High Static Drive <sup>(b)</sup>											

**Notes:**

1. For Standard Evaporator Fan Speed (rpm), reference [Table 137, p. 182](#).
2. Data includes pressure drop due to standard filters and wet coils. No accessories or options are included in pressure drop data.
3. Data does not include pressure drop due to reheat coil.
4. Refer to [Table 144, p. 185](#) to determine additional static pressure drop due to other options/accessories.
5. 1-hp Fan Motor Heat (MBh) = 2.7672 x Fan bhp + 0.4705.
6. Factory supplied motors, in equipment, are definite purpose motors, specifically designed and tested to operate at all cataloged conditions. Using the full horsepower range of our fan motors as shown in our tabular data will not result in nuisance tripping or premature motor failure. Our product's warranty will not be affected.

(a) Field Supplied Fan Sheave AK71x3/4" required. Field Supplied Belt may be necessary.

(b) Field Supplied Fan Sheave AK41x3/4" required. Field Supplied Belt may be necessary.



## Evaporator Fan Performance

**Table 45. Belt drive evaporator fan performance - 4 tons standard efficiency - TSC048E3,E4,EW downflow airflow**

External Static Pressure (Inches of Water)																					
		0.10		0.20		0.30		0.40		0.50		0.60		0.70		0.80		0.90		1.00	
cfm	rpm	bhp	rpm	bhp	rpm	bhp	rpm	bhp	rpm	bhp	rpm	bhp	rpm	bhp	rpm	bhp	rpm	bhp	rpm	bhp	
1-hp Standard Motor & Field Supplied Low Static Drive <sup>(a)</sup>											1-hp Standard Motor & Drive										
1280	—	—	619	0.20	680	0.24	735	0.29	789	0.34	843	0.39	894	0.45	940	0.51	983	0.56	1025	0.63	
1440	597	0.20	664	0.25	724	0.30	775	0.35	823	0.40	872	0.46	921	0.52	968	0.58	1012	0.65	1052	0.71	
1600	648	0.26	710	0.32	768	0.37	818	0.43	864	0.49	908	0.54	950	0.60	995	0.67	1039	0.74	1081	0.81	
1760	700	0.34	758	0.39	812	0.46	862	0.52	907	0.58	948	0.64	988	0.71	1027	0.77	1068	0.84	1108	0.91	
1920	753	0.43	807	0.49	858	0.55	906	0.62	952	0.70	992	0.76	1029	0.83	1066	0.89	1102	0.96	1138	1.03	

Continued

External Static Pressure (Inches of Water)											
		1.10		1.20		1.30		1.40		1.50	
cfm	rpm	bhp	rpm	bhp	rpm	bhp	rpm	bhp	rpm	bhp	
1-hp Standard Motor & Drive											
1280	1063	0.69	1101	0.75	1138	0.81	1175	0.88	1208	0.94	
1440	1091	0.78	1128	0.85	1164	0.91	1198	0.98	1233	1.05	
1600	1120	0.88	1157	0.95	1193	1.02	1227	1.10	1259	1.17	
1760	1147	0.99	1185	1.07	1220	1.14	1256	1.23	—	—	
1920	1174	1.11	1212	1.19	1247	1.27	—	—	—	—	
1-hp Standard Motor & Field Supplied High Static Drive <sup>(b)</sup>											

**Note:**

1. For Standard Evaporator Fan Speed (rpm), reference [Table 137, p. 182](#).
2. Data includes pressure drop due to standard filters and wet coils. No accessories or options are included in pressure drop data.
3. Data does not include pressure drop due to reheat coil.
4. Refer to [Table 144, p. 185](#) to determine additional static pressure drop due to other options/accessories.
5. 1-hp Fan Motor Heat (MBh) = 2.7672 x Fan bhp + 0.4705.
6. Factory supplied motors, in equipment, are definite purpose motors, specifically designed and tested to operate at all cataloged conditions. Using the full horsepower range of our fan motors as shown in our tabular data will not result in nuisance tripping or premature motor failure. Our product's warranty will not be affected.

(a) Field Supplied Fan Sheave AK69x3/4" required. Field Supplied Belt may be necessary.  
 (b) Field Supplied Fan Sheave AK41x3/4" required. Field Supplied Belt may be necessary.

## Evaporator Fan Performance

**Table 46. Belt drive evaporator fan performance - 4 tons standard efficiency - TSC048E3,E4,EW horizontal airflow**

External Static Pressure (Inches of Water)																					
		0.10		0.20		0.30		0.40		0.50		0.60		0.70		0.80		0.90		1.00	
cfm	rpm	bhp	rpm	bhp	rpm	bhp	rpm	bhp	rpm	bhp	rpm	bhp	rpm	bhp	rpm	bhp	rpm	bhp	rpm	bhp	
1-hp Standard Motor & Field Supplied Low Static Drive <sup>(a)</sup>											1-hp Standard Motor & Drive										
1280	—	—	633	0.20	704	0.26	767	0.31	822	0.37	871	0.42	915	0.48	957	0.54	997	0.60	1035	0.66	
1440	604	0.20	676	0.26	744	0.32	805	0.38	859	0.44	909	0.50	954	0.57	996	0.63	1035	0.69	1073	0.76	
1600	656	0.27	721	0.32	785	0.39	843	0.45	897	0.52	946	0.59	991	0.66	1034	0.73	1075	0.80	1110	0.87	
1760	709	0.34	768	0.40	827	0.47	883	0.54	936	0.61	984	0.69	1030	0.77	1072	0.84	1113	0.92	1149	1.00	
1920	762	0.43	817	0.50	872	0.57	925	0.64	975	0.72	1023	0.80	1067	0.88	1109	0.97	1150	1.05	1188	1.14	
											1-hp Standard Motor & Field Supplied High Static Drive <sup>(b)</sup>										

Continued

External Static Pressure (Inches of Water)											
		1.10		1.20		1.30		1.40		1.50	
cfm	rpm	bhp	rpm	bhp	rpm	bhp	rpm	bhp	rpm	bhp	
1-hp Standard Motor & Drive											
1280	1072	0.71	1107	0.77	1142	0.84	1176	0.90	1210	0.97	
1440	1108	0.83	1143	0.89	1176	0.96	1209	1.02	1239	1.09	
1600	1146	0.95	1180	1.02	1212	1.09	1243	1.16	—	—	
1760	1185	1.08	1219	1.16	1251	1.24	—	—	—	—	
1920	1223	1.22	1258	1.31	—	—	—	—	—	—	
1-hp Standard Motor & Field Supplied High Static Drive <sup>(b)</sup>											

**Notes:**

1. For Standard Evaporator Fan Speed (rpm), reference [Table 137, p. 182](#).
2. Data includes pressure drop due to standard filters and wet coils. No accessories or options are included in pressure drop data.
3. Data does not include pressure drop due to reheat coil.
4. Refer to [Table 144, p. 185](#) to determine additional static pressure drop due to other options/accessories.
5. 1-hp Fan Motor Heat (MBh) = 2.7672 x Fan bhp + 0.4705.
6. Factory supplied motors, in equipment, are definite purpose motors, specifically designed and tested to operate at all cataloged conditions. Using the full horsepower range of our fan motors as shown in our tabular data will not result in nuisance tripping or premature motor failure. Our product's warranty will not be affected.

(a) Field Supplied Fan Sheave AK69x3/4" required. Field Supplied Belt may be necessary.

(b) Field Supplied Fan Sheave AK41x3/4" required. Field Supplied Belt may be necessary.



## Evaporator Fan Performance

**Table 47. Belt drive evaporator fan performance - 4 tons standard efficiency - YSC048E3,E4,EW\*L,M low & medium gas heat downflow airflow**

External Static Pressure (Inches of Water)																					
		0.10		0.20		0.30		0.40		0.50		0.60		0.70		0.80		0.90		1.00	
cfm	rpm	bhp	rpm	bhp	rpm	bhp	rpm	bhp	rpm	bhp	rpm	bhp	rpm	bhp	rpm	bhp	rpm	bhp	rpm	bhp	
1-hp Standard Motor & Field Supplied Low Static Drive <sup>(a)</sup>											1-hp Standard Motor & Drive										
1280	571	0.17	641	0.22	701	0.26	755	0.31	807	0.36	858	0.42	907	0.49	953	0.55	996	0.61	1037	0.67	
1440	624	0.23	689	0.28	747	0.33	799	0.39	847	0.44	892	0.50	938	0.56	983	0.63	1027	0.71	1067	0.78	
1600	679	0.30	740	0.35	794	0.41	844	0.47	890	0.53	933	0.59	975	0.66	1016	0.72	1057	0.80	1097	0.88	
1760	735	0.38	791	0.44	843	0.51	891	0.58	936	0.64	977	0.71	1017	0.77	1056	0.84	1092	0.91	1130	0.99	
1920	791	0.48	844	0.55	893	0.62	939	0.69	982	0.76	1023	0.84	1061	0.91	1097	0.98	1133	1.05	1168	1.13	
											1-hp Standard Motor & Field Supplied High Static Drive <sup>(b)</sup>										

Continued

External Static Pressure (Inches of Water)											
		1.10		1.20		1.30		1.40		1.50	
cfm	rpm	bhp	rpm	bhp	rpm	bhp	rpm	bhp	rpm	bhp	
1-hp Standard Motor & Drive											
1280	1075	0.73	1113	0.79	1147	0.85	1181	0.92	1215	0.98	
1440	1106	0.85	1143	0.91	1179	0.98	1211	1.05	1245	1.11	
1600	1137	0.96	1173	1.04	1209	1.12	1242	1.19	—	—	
1760	1166	1.07	1203	1.16	1239	1.25	—	—	—	—	
1920	1201	1.21	1236	1.29	—	—	—	—	—	—	
1-hp Standard Motor & Field Supplied High Static Drive <sup>(b)</sup>											

**Notes:**

1. For Standard Evaporator Fan Speed (rpm), reference [Table 137, p. 182](#).
2. Data includes pressure drop due to standard filters and wet coils. No accessories or options are included in pressure drop data.
3. Data does not include pressure drop due to reheat coil.
4. Refer to [Table 144, p. 185](#) to determine additional static pressure drop due to other options/accessories.
5. 1-hp Fan Motor Heat (MBh) = 2.7672 x Fan bhp + 0.4705.
6. Factory supplied motors, in equipment, are definite purpose motors, specifically designed and tested to operate at all cataloged conditions. Using the full horsepower range of our fan motors as shown in our tabular data will not result in nuisance tripping or premature motor failure. Our product's warranty will not be affected.

(a) Field Supplied Fan Sheave AK69x3/4" required. Field Supplied Belt may be necessary.  
 (b) Field Supplied Fan Sheave AK41x3/4" required. Field Supplied Belt may be necessary.

## Evaporator Fan Performance

**Table 48. Belt drive evaporator fan performance - 4 tons standard efficiency - YSC048E3,E4,EW\*L,M low & medium gas heat horizontal airflow**

External Static Pressure (Inches of Water)																					
		0.10		0.20		0.30		0.40		0.50		0.60		0.70		0.80		0.90		1.00	
cfm	rpm	bhp	rpm	bhp	rpm	bhp	rpm	bhp	rpm	bhp	rpm	bhp	rpm	bhp	rpm	bhp	rpm	bhp	rpm	bhp	
1-hp Standard Motor & Field Supplied Low Static Drive <sup>(a)</sup>											1-hp Standard Motor & Drive										
1280	—	—	638	0.21	704	0.26	766	0.31	822	0.37	875	0.42	922	0.48	968	0.54	1010	0.60	1052	0.66	
1440	621	0.22	685	0.26	746	0.32	804	0.38	858	0.44	909	0.50	957	0.56	1002	0.63	1043	0.70	1084	0.76	
1600	676	0.29	734	0.34	790	0.39	844	0.45	896	0.52	946	0.59	992	0.66	1036	0.73	1078	0.80	1118	0.87	
1760	732	0.37	786	0.42	838	0.48	888	0.55	936	0.62	984	0.69	1029	0.76	1071	0.84	1112	0.91	1152	0.99	
1920	789	0.47	839	0.53	887	0.59	934	0.66	979	0.73	1023	0.80	1067	0.88	1108	0.96	1149	1.04	1187	1.13	
											1-hp Standard Motor & Field Supplied High Static Drive <sup>(b)</sup>										

Continued

External Static Pressure (Inches of Water)											
		1.10		1.20		1.30		1.40		1.50	
cfm	rpm	bhp	rpm	bhp	rpm	bhp	rpm	bhp	rpm	bhp	
1-hp Standard Motor & Drive											
1280	1091	0.73	1129	0.79	1166	0.85	1201	0.92	1234	0.98	
1440	1122	0.83	1159	0.90	1196	0.97	1230	1.04	—	—	
1600	1155	0.95	1192	1.02	1228	1.10	1261	1.17	—	—	
1760	1189	1.07	1225	1.15	1261	1.24	—	—	—	—	
1920	1225	1.21	1260	1.30	—	—	—	—	—	—	
1-hp Standard Motor & Field Supplied High Static Drive <sup>(b)</sup>											

**Notes:**

1. For Standard Evaporator Fan Speed (rpm), reference [Table 137, p. 182](#).
2. Data includes pressure drop due to standard filters and wet coils. No accessories or options are included in pressure drop data.
3. Data does not include pressure drop due to reheat coil.
4. Refer to [Table 144, p. 185](#) to determine additional static pressure drop due to other options/accessories.
5. 1-hp Fan Motor Heat (MBh) = 2.7672 x Fan bhp + 0.4705.
6. Factory supplied motors, in equipment, are definite purpose motors, specifically designed and tested to operate at all cataloged conditions. Using the full horsepower range of our fan motors as shown in our tabular data will not result in nuisance tripping or premature motor failure. Our product's warranty will not be affected.

(a) Field Supplied Fan Sheave AK69x3/4" required. Field Supplied Belt may be necessary.  
 (b) Field Supplied Fan Sheave AK41x3/4" required. Field Supplied Belt may be necessary.



## Evaporator Fan Performance

**Table 49. Belt drive evaporator fan performance - 4 tons standard efficiency - YSC048E3,E4,EW\*H high gas heat downflow airflow**

External Static Pressure (Inches of Water)																					
		0.10		0.20		0.30		0.40		0.50		0.60		0.70		0.80		0.90		1.00	
cfm	rpm	bhp	rpm	bhp	rpm	bhp	rpm	bhp	rpm	bhp	rpm	bhp	rpm	bhp	rpm	bhp	rpm	bhp	rpm	bhp	
1-hp Standard Motor & Field Supplied Low Static Drive <sup>(a)</sup>											1-hp Standard Motor & Drive										
1280	586	0.17	652	0.21	711	0.26	766	0.31	818	0.36	870	0.41	919	0.47	965	0.53	1008	0.59	1049	0.65	
1440	642	0.23	704	0.28	759	0.33	810	0.38	859	0.43	906	0.49	951	0.55	996	0.61	1039	0.68	1080	0.74	
1600	699	0.30	757	0.36	809	0.41	857	0.47	903	0.53	947	0.59	990	0.65	1030	0.71	1071	0.78	1111	0.85	
1760	757	0.39	811	0.45	861	0.51	906	0.57	950	0.63	991	0.70	1031	0.76	1071	0.83	1109	0.90	1146	0.97	
1920	816	0.49	867	0.56	914	0.63	957	0.69	998	0.76	1037	0.82	1076	0.89	1113	0.96	1149	1.04	1184	1.11	
											1-hp Standard Motor & Field Supplied High Static Drive <sup>(b)</sup>										

Continued

External Static Pressure (Inches of Water)											
		1.10		1.20		1.30		1.40		1.50	
cfm	rpm	bhp	rpm	bhp	rpm	bhp	rpm	bhp	rpm	bhp	
1-hp Standard Motor & Drive											
1280	1086	0.71	1122	0.77	1157	0.83	1190	0.89	1221	0.94	
1440	1119	0.81	1156	0.88	1191	0.94	1224	1.01	1257	1.08	
1600	1151	0.92	1187	0.99	1223	1.07	1258	1.14	—	—	
1760	1182	1.04	1218	1.12	1255	1.20	—	—	—	—	
1920	1219	1.19	1252	1.27	—	—	—	—	—	—	
1-hp Standard Motor & Field Supplied High Static Drive <sup>(b)</sup>											

**Notes:**

1. For Standard Evaporator Fan Speed (rpm), reference [Table 137, p. 182](#).
2. Data includes pressure drop due to standard filters and wet coils. No accessories or options are included in pressure drop data.
3. Data does not include pressure drop due to reheat coil.
4. Refer to [Table 144, p. 185](#) to determine additional static pressure drop due to other options/accessories.
5. 1-hp Fan Motor Heat (MBh) = 2.7672 x Fan bhp + 0.4705.
6. Factory supplied motors, in commercial equipment, are definite purpose motors, specifically designed and tested to operate reliably and continuously at all cataloged conditions. Using the full horsepower range of our fan motors as shown in our tabular data will not result in nuisance tripping or premature motor failure. Our product's warranty will not be affected.

(a) Field Supplied Fan Sheave AK69x3/4" required. Field Supplied Belt may be necessary.  
 (b) Field Supplied Fan Sheave AK41x3/4" required. Field Supplied Belt may be necessary.

## Evaporator Fan Performance

**Table 50. Belt drive evaporator fan performance - 4 tons standard efficiency - YSC048E3,E4,EW\*H high gas heat horizontal airflow**

External Static Pressure (Inches of Water)																					
		0.10		0.20		0.30		0.40		0.50		0.60		0.70		0.80		0.90		1.00	
cfm	rpm	bhp	rpm	bhp	rpm	bhp	rpm	bhp	rpm	bhp	rpm	bhp	rpm	bhp	rpm	bhp	rpm	bhp	rpm	bhp	
1-hp Standard Motor & Field Supplied Low Static Drive <sup>(a)</sup>											1-hp Standard Motor & Drive										
1280	587	0.18	659	0.23	722	0.28	782	0.33	835	0.39	886	0.45	931	0.51	975	0.57	1016	0.64	1056	0.70	
1440	641	0.24	709	0.29	769	0.35	824	0.41	876	0.47	924	0.53	970	0.60	1013	0.67	1053	0.74	1092	0.81	
1600	696	0.31	761	0.37	817	0.44	869	0.50	918	0.56	965	0.63	1009	0.70	1053	0.78	1092	0.85	1131	0.93	
1760	753	0.40	813	0.47	867	0.54	917	0.61	963	0.68	1008	0.75	1051	0.82	1092	0.90	1132	0.98	1169	1.06	
1920	810	0.50	867	0.58	919	0.66	966	0.73	1011	0.81	1053	0.88	1094	0.96	1134	1.04	1172	1.12	1209	1.21	
											1-hp Standard Motor & Field Supplied High Static Drive <sup>(b)</sup>										

Continued

External Static Pressure (Inches of Water)											
		1.10		1.20		1.30		1.40		1.50	
cfm	rpm	bhp	rpm	bhp	rpm	bhp	rpm	bhp	rpm	bhp	
1-hp Standard Motor & Drive											
1280	1095	0.76	1131	0.83	1167	0.89	1200	0.95	1233	1.02	
1440	1130	0.88	1164	0.95	1199	1.02	1234	1.09	—	—	
1600	1167	1.00	1201	1.08	1236	1.16	—	—	—	—	
1760	1206	1.14	1240	1.22	—	—	—	—	—	—	
1920	1245	1.30	—	—	—	—	—	—	—	—	
1-hp Standard Motor & Field Supplied High Static Drive <sup>(b)</sup>											

**Notes:**

1. For Standard Evaporator Fan Speed (rpm), reference [Table 137, p. 182](#).
2. Data includes pressure drop due to standard filters and wet coils. No accessories or options are included in pressure drop data.
3. Data does not include pressure drop due to reheat coil.
4. Refer to [Table 144, p. 185](#) to determine additional static pressure drop due to other options/accessories.
5. 1-hp Fan Motor Heat (MBh) = 2.7672 x Fan bhp + 0.4705.
6. Factory supplied motors, in commercial equipment, are definite purpose motors, specifically designed and tested to operate reliably and continuously at all cataloged conditions. Using the full horsepower range of our fan motors as shown in our tabular data will not result in nuisance tripping or premature motor failure. Our product's warranty will not be affected.

(a) Field Supplied Fan Sheave AK69x3/4" required. Field Supplied Belt may be necessary.  
 (b) Field Supplied Fan Sheave AK41x3/4" required. Field Supplied Belt may be necessary.



## Evaporator Fan Performance

**Table 51. Belt drive evaporator fan performance - 5 tons standard efficiency - TSC060E3,E4,EW downflow airflow**

External Static Pressure (Inches of Water)																					
		0.10		0.20		0.30		0.40		0.50		0.60		0.70		0.80		0.90		1.00	
cfm	rpm	bhp	rpm	bhp	rpm	bhp	rpm	bhp	rpm	bhp	rpm	bhp	rpm	bhp	rpm	bhp	rpm	bhp	rpm	bhp	
1-hp Standard Motor & Field Supplied Low Static Drive <sup>(a)</sup>											1-hp Standard Motor & Drive										
1600	—	—	706	0.31	763	0.37	814	0.42	862	0.47	908	0.53	951	0.59	992	0.65	1031	0.71	1069	0.77	
1800	710	0.35	767	0.41	819	0.47	868	0.53	913	0.59	957	0.66	998	0.72	1038	0.78	1075	0.85	1112	0.91	
2000	777	0.46	828	0.53	877	0.60	924	0.67	967	0.74	1008	0.80	1047	0.87	1086	0.94	1122	1.01	1157	1.08	
2200	844	0.60	892	0.68	938	0.75	981	0.83	1022	0.90	1061	0.97	1099	1.05	1136	1.13	1170	1.20	1205	1.28	
2400	912	0.77	957	0.85	999	0.93	1040	1.01	1079	1.09	1117	1.17	1153	1.25	1187	1.33	1222	1.42	1254	1.50	

Continued

External Static Pressure (Inches of Water)											
		1.10		1.20		1.30		1.40		1.50	
cfm	rpm	bhp	rpm	bhp	rpm	bhp	rpm	bhp	rpm	bhp	
1-hp Standard Motor & Drive											
1600	1105	0.83	1140	0.89	1174	0.96	1209	1.03	1242	1.10	
1800	1146	0.98	1181	1.05	1213	1.12	1245	1.19	1276	1.26	
2000	1191	1.15	1225	1.23	1256	1.30	1287	1.37	—	—	
2200	1238	1.35	1269	1.43	—	—	—	—	—	—	
2400	1286	1.58	—	—	—	—	—	—	—	—	

**Notes:**

1. For Standard Evaporator Fan Speed (rpm), reference [Table 137, p. 182](#).
2. Data includes pressure drop due to standard filters and wet coils. No accessories or options are included in pressure drop data.
3. Data does not include pressure drop due to reheat coil.
4. Refer to [Table 144, p. 185](#) to determine additional static pressure
5. drop due to other options/accessories.
6. 1-hp Fan Motor Heat (MBh) = 2.7672 x Fan bhp + 0.4705.
7. Factory supplied motors, in equipment, are definite purpose motors, specifically designed and tested to operate at all cataloged conditions. Using the full horsepower range of our fan motors as shown in our tabular data will not result in nuisance tripping or premature motor failure. Our product's warranty will not be affected.

(a) Field Supplied Fan Sheave AK61x3/4" required. Field Supplied Belt may be necessary.



## Evaporator Fan Performance

**Table 52. Belt drive evaporator fan performance - 5 tons standard efficiency - TSC060E3,E4,EW horizontal airflow**

cfm	External Static Pressure (Inches of Water)																			
	0.10		0.20		0.30		0.40		0.50		0.60		0.70		0.80		0.90		1.00	
	rpm	bhp	rpm	bhp	rpm	bhp	rpm	bhp	rpm	bhp	rpm	bhp	rpm	bhp	rpm	bhp	rpm	bhp	rpm	bhp
	1-hp Standard Motor & Field Supplied Low Static Drive <sup>(a)</sup>										1-hp Standard Motor & Drive									
1600	653	0.26	714	0.31	774	0.37	829	0.43	879	0.48	924	0.54	967	0.60	1007	0.66	1045	0.71	1082	0.78
1800	720	0.36	775	0.41	829	0.47	881	0.54	930	0.60	975	0.67	1016	0.73	1055	0.79	1093	0.86	1128	0.92
2000	787	0.47	837	0.54	887	0.60	935	0.67	982	0.74	1026	0.81	1068	0.88	1106	0.96	1142	1.03	1176	1.10
2200	856	0.61	902	0.68	947	0.75	992	0.83	1036	0.90	1078	0.98	1119	1.06	1157	1.14	1193	1.22	1227	1.30
2400	926	0.78	969	0.86	1010	0.94	1051	1.01	1092	1.09	1131	1.17	1170	1.26	1208	1.35	1244	1.43	1278	1.52

Continued

cfm	External Static Pressure (Inches of Water)									
	1.10		1.20		1.30		1.40		1.50	
	rpm	bhp	rpm	bhp	rpm	bhp	rpm	bhp	rpm	bhp
	1-hp Standard Motor & Drive									
1600	1118	0.84	1152	0.90	1187	0.97	1219	1.04	1253	1.11
1800	1163	0.99	1195	1.06	1228	1.13	1260	1.20	1291	1.28
2000	1210	1.17	1243	1.24	1274	1.32	—	—	—	—
2200	1260	1.38	1292	1.45	—	—	—	—	—	—
2400	—	—	—	—	—	—	—	—	—	—

**Notes:**

1. For Standard Evaporator Fan Speed (rpm), reference [Table 137, p. 182](#).
2. Data includes pressure drop due to standard filters and wet coils. No accessories or options are included in pressure drop data.
3. Data does not include pressure drop due to reheat coil.
4. Refer to [Table 144, p. 185](#) to determine additional static pressure drop due to other options/accessories.
5. 1-hp Fan Motor Heat (MBh) = 2.7672 x Fan bhp + 0.4705.
6. Factory supplied motors, in equipment, are definite purpose motors, specifically designed and tested to operate at all cataloged conditions. Using the full horsepower range of our fan motors as shown in our tabular data will not result in nuisance tripping or premature motor failure. Our product's warranty will not be affected.

(a) Field Supplied Fan Sheave AK61x3/4" required. Field Supplied Belt may be necessary.



## Evaporator Fan Performance

**Table 53. Belt drive evaporator fan performance - 5 tons standard efficiency - YSC060E3,E4,EW\*L,M low & medium gas heat downflow airflow**

cfm	External Static Pressure (Inches of Water)																			
	0.10		0.20		0.30		0.40		0.50		0.60		0.70		0.80		0.90		1.00	
	rpm	bhp	rpm	bhp	rpm	bhp	rpm	bhp	rpm	bhp	rpm	bhp	rpm	bhp	rpm	bhp	rpm	bhp	rpm	bhp
1-hp Standard Motor & Field Supplied Low Static Drive <sup>(a)</sup>										1-hp Standard Motor & Drive										
1600	704	0.31	762	0.36	815	0.42	861	0.47	904	0.53	947	0.58	987	0.64	1028	0.70	1064	0.75	1101	0.82
1800	777	0.42	831	0.48	880	0.54	925	0.60	966	0.67	1005	0.73	1043	0.79	1080	0.86	1116	0.92	1151	0.98
2000	851	0.56	901	0.63	947	0.70	990	0.77	1031	0.83	1068	0.90	1102	0.97	1137	1.04	1171	1.11	1205	1.18
2200	926	0.73	973	0.81	1016	0.88	1057	0.96	1096	1.03	1131	1.10	1165	1.18	1198	1.26	1229	1.33	1260	1.41
2400	1002	0.93	1045	1.01	1086	1.10	1124	1.18	1162	1.26	1197	1.34	1230	1.42	1261	1.51	1291	1.59	—	—

Continued

cfm	External Static Pressure (Inches of Water)									
	1.10		1.20		1.30		1.40		1.50	
	rpm	bhp	rpm	bhp	rpm	bhp	rpm	bhp	rpm	bhp
1-hp Standard Motor & Drive										
1600	1137	0.88	1172	0.95	1205	1.01	1238	1.08	1270	1.15
1800	1186	1.05	1217	1.12	1251	1.19	1281	1.26	—	—
2000	1237	1.25	1269	1.32	—	—	—	—	—	—
2200	1291	1.49	—	—	—	—	—	—	—	—
2400	—	—	—	—	—	—	—	—	—	—

**Notes:**

1. For Standard Evaporator Fan Speed (rpm), reference [Table 137, p. 182](#).
2. Data includes pressure drop due to standard filters and wet coils. No accessories or options are included in pressure drop data.
3. Data does not include pressure drop due to reheat coil.
4. Refer to [Table 144, p. 185](#) to determine additional static pressure drop due to other options/accessories.
5. 1-hp Fan Motor Heat (MBh) = 2.7672 x Fan bhp + 0.4705.
6. Factory supplied motors, in equipment, are definite purpose motors, specifically designed and tested to operate at all cataloged conditions. Using the full horsepower range of our fan motors as shown in our tabular data will not result in nuisance tripping or premature motor failure. Our product's warranty will not be affected.

(a) Field Supplied Fan Sheave AK61x3/4" required. Field Supplied Belt may be necessary.

## Evaporator Fan Performance

**Table 54. Belt drive evaporator fan performance - 5 tons standard efficiency - YSC060E3,E4,EW\*L,M low & medium gas heat horizontal airflow**

																						External Static Pressure (Inches of Water)									
		0.10		0.20		0.30		0.40		0.50		0.60		0.70		0.80		0.90		1.00											
cfm	rpm	bhp	rpm	bhp	rpm	bhp	rpm	bhp	rpm	bhp	rpm	bhp	rpm	bhp	rpm	bhp	rpm	bhp	rpm	bhp											
1-hp Standard Motor & Field Supplied Low Static Drive <sup>(a)</sup>											1-hp Standard Motor & Drive																				
1600	—	—	732	0.33	789	0.38	843	0.43	894	0.49	941	0.55	986	0.61	1028	0.68	1069	0.74	1107	0.80											
1800	741	0.38	795	0.43	848	0.49	898	0.55	946	0.61	991	0.68	1034	0.74	1075	0.81	1114	0.88	1151	0.95											
2000	811	0.50	861	0.57	909	0.63	956	0.69	1000	0.76	1044	0.83	1084	0.90	1124	0.97	1162	1.05	1198	1.12											
2200	883	0.65	929	0.72	973	0.79	1016	0.86	1058	0.94	1098	1.01	1138	1.09	1176	1.16	1213	1.24	1249	1.32											
2400	955	0.83	997	0.91	1038	0.99	1078	1.06	1118	1.14	1156	1.22	1193	1.30	1229	1.38	1264	1.46	—	—											

Continued

												External Static Pressure (Inches of Water)				
		1.10		1.20		1.30		1.40		1.50						
cfm	rpm	bhp	rpm	bhp	rpm	bhp	rpm	bhp	rpm	bhp						
1-hp Standard Motor & Drive																
1600	1144	0.87	1180	0.94	1213	1.00	1247	1.07	1279	1.14						
1800	1188	1.02	1224	1.10	1257	1.17	1289	1.24	—	—						
2000	1234	1.20	1269	1.28	—	—	—	—	—	—						
2200	1282	1.40	—	—	—	—	—	—	—	—						
2400	—	—	—	—	—	—	—	—	—	—						

**Notes:**

1. For Standard Evaporator Fan Speed (rpm), reference [Table 137, p. 182](#).
2. Data includes pressure drop due to standard filters and wet coils. No accessories or options are included in pressure drop data.
3. Data does not include pressure drop due to reheat coil.
4. Refer to [Table 144, p. 185](#) to determine additional static pressure drop due to other options/accessories.
5. 1-hp Fan Motor Heat (MBh) = 2.7672 x Fan bhp + 0.4705.
6. Factory supplied motors, in equipment, are definite purpose motors, specifically designed and tested to operate at all cataloged conditions. Using the full horsepower range of our fan motors as shown in our tabular data will not result in nuisance tripping or premature motor failure. Our product's warranty will not be affected.

(a) Field Supplied Fan Sheave AK61x3/4" required. Field Supplied Belt may be necessary.



## Evaporator Fan Performance

**Table 55. Belt drive evaporator fan performance - 5 tons standard efficiency -YSC060E3,E4,EW\*H high gas heat downflow airflow**

cfm	External Static Pressure (Inches of Water)																			
	0.10		0.20		0.30		0.40		0.50		0.60		0.70		0.80		0.90		1.00	
	rpm	bhp	rpm	bhp	rpm	bhp	rpm	bhp	rpm	bhp	rpm	bhp	rpm	bhp	rpm	bhp	rpm	bhp	rpm	bhp
	1-hp Standard Motor & Field Supplied Low Static Drive <sup>(a)</sup>										1-hp Standard Motor & Drive									
1600	714	0.32	773	0.37	827	0.43	873	0.48	916	0.54	959	0.60	1003	0.66	1044	0.73	1083	0.79	1122	0.86
1800	788	0.44	842	0.50	893	0.56	939	0.62	980	0.68	1019	0.75	1056	0.81	1095	0.88	1133	0.95	1170	1.02
2000	863	0.58	914	0.65	961	0.72	1005	0.79	1045	0.86	1082	0.93	1117	0.99	1152	1.07	1187	1.14	1221	1.22
2200	939	0.76	986	0.84	1030	0.92	1073	0.99	1112	1.07	1148	1.14	1182	1.21	1214	1.29	1246	1.37	1277	1.44
2400	1016	0.97	1060	1.05	1101	1.14	1141	1.22	1179	1.31	1215	1.39	1248	1.47	1280	1.55	—	—	—	—

Continued

cfm	External Static Pressure (Inches of Water)									
	1.10		1.20		1.30		1.40		1.50	
	rpm	bhp	rpm	bhp	rpm	bhp	rpm	bhp	rpm	bhp
	1-hp Standard Motor & Drive									
1600	1157	0.92	1193	0.99	1226	1.06	1258	1.12	1290	1.19
1800	1205	1.10	1240	1.17	1273	1.24	—	—	—	—
2000	1256	1.30	1289	1.38	—	—	—	—	—	—
2200	—	—	—	—	—	—	—	—	—	—
2400	—	—	—	—	—	—	—	—	—	—

**Notes:**

1. For Standard Evaporator Fan Speed (rpm), reference [Table 137, p. 182](#).
2. Data includes pressure drop due to standard filters and wet coils. No accessories or options are included in pressure drop data.
3. Data does not include pressure drop due to reheat coil.
4. Refer to [Table 144, p. 185](#) to determine additional static pressure drop due to other options/accessories.
5. 1-hp Fan Motor Heat (MBh) = 2.7672 x Fan bhp + 0.4705.
6. Factory supplied motors, in equipment, are definite purpose motors, specifically designed and tested to operate at all cataloged conditions. Using the full horsepower range of our fan motors as shown in our tabular data will not result in nuisance tripping or premature motor failure. Our product's warranty will not be affected.

(a) Field Supplied Fan Sheave AK61x3/4" required. Field Supplied Belt may be necessary.

## Evaporator Fan Performance

**Table 56. Belt drive evaporator fan performance - 5 tons standard efficiency - YSC060E3,E4,EW\*H high gas heat horizontal airflow**

cfm	External Static Pressure (Inches of Water)																			
	0.10		0.20		0.30		0.40		0.50		0.60		0.70		0.80		0.90		1.00	
	rpm	bhp	rpm	bhp	rpm	bhp	rpm	bhp	rpm	bhp	rpm	bhp	rpm	bhp	rpm	bhp	rpm	bhp	rpm	bhp
	1-hp Standard Motor & Field Supplied Low Static Drive <sup>(a)</sup>										1-hp Standard Motor & Drive									
1600	711	0.30	769	0.36	823	0.41	874	0.47	923	0.53	969	0.59	1010	0.65	1050	0.71	1088	0.78	1126	0.84
1800	784	0.42	839	0.48	889	0.54	935	0.60	981	0.67	1024	0.73	1066	0.80	1104	0.87	1142	0.94	1177	1.00
2000	859	0.56	910	0.63	956	0.69	999	0.76	1041	0.83	1083	0.90	1123	0.98	1161	1.05	1197	1.12	1232	1.20
2200	934	0.72	982	0.80	1026	0.88	1067	0.95	1106	1.03	1144	1.10	1181	1.18	1218	1.26	1254	1.34	1288	1.42
2400	1010	0.92	1055	1.01	1097	1.09	1135	1.17	1173	1.25	1208	1.34	1242	1.42	1277	1.50	—	—	—	—

Continued

cfm	External Static Pressure (Inches of Water)									
	1.10		1.20		1.30		1.40		1.50	
	rpm	bhp	rpm	bhp	rpm	bhp	rpm	bhp	rpm	bhp
	1-hp Standard Motor & Drive									
1600	1163	0.91	1197	0.98	1232	1.05	1265	1.12	1296	1.19
1800	1211	1.08	1244	1.15	1278	1.22	—	—	—	—
2000	1265	1.28	—	—	—	—	—	—	—	—
2200	—	—	—	—	—	—	—	—	—	—
2400	—	—	—	—	—	—	—	—	—	—

**Notes:**

1. For Standard Evaporator Fan Speed (rpm), reference [Table 137, p. 182](#).
2. Data includes pressure drop due to standard filters and wet coils. No accessories or options are included in pressure drop data.
3. Data does not include pressure drop due to reheat coil.
4. Refer to [Table 144, p. 185](#) to determine additional static pressure drop due to other options/accessories.
5. 1-hp Fan Motor Heat (MBh) = 2.7672 x Fan bhp + 0.4705.
6. Factory supplied motors, in equipment, are definite purpose motors, specifically designed and tested to operate at all cataloged conditions. Using the full horsepower range of our fan motors as shown in our tabular data will not result in nuisance tripping or premature motor failure. Our product's warranty will not be affected.

(a) Field Supplied Fan Sheave AK61x3/4" required. Field Supplied Belt may be necessary.



## Evaporator Fan Performance

**Table 57. Belt drive evaporator fan performance - 6 tons standard efficiency - TSC072F3,4,W downflow airflow**

External Static Pressure (Inches of Water)																						
		0.10		0.20		0.30		0.40		0.50		0.60		0.70		0.80		0.90		1.00		
cfm	rpm	bhp	rpm	bhp	rpm	bhp	rpm	bhp	rpm	bhp	rpm	bhp	rpm	bhp	rpm	bhp	rpm	bhp	rpm	bhp	rpm	bhp
1-hp Standard Motor & Field Supplied Low Static Drive <sup>(a)</sup>											1-hp Standard Motor & Drive											
1920	—	—	—	—	588	0.35	643	0.43	693	0.50	738	0.57	782	0.65	823	0.73	862	0.81	900	0.89		
2160	—	—	564	0.37	618	0.44	672	0.52	721	0.60	765	0.68	806	0.76	847	0.85	885	0.93	922	1.02		
2400	—	—	602	0.47	652	0.54	701	0.63	750	0.72	794	0.81	834	0.90	873	0.98	909	1.08	945	1.17		
2640	589	0.50	642	0.59	690	0.67	734	0.76	779	0.85	822	0.95	864	1.05	901	1.15	936	1.24	971	1.34		
2880	634	0.63	682	0.74	728	0.82	770	0.91	810	1.01	851	1.11	892	1.22	930	1.33	965	1.44	999	1.54		

Continued

External Static Pressure (Inches of Water)																						
		1.10		1.20		1.30		1.40		1.50		1.60		1.70		1.80		1.90		2.00		
cfm	rpm	bhp	rpm	bhp	rpm	bhp	rpm	bhp	rpm	bhp	rpm	bhp	rpm	bhp	rpm	bhp	rpm	bhp	rpm	bhp	rpm	bhp
1-hp Standard Motor & Drive											1-hp Standard Motor & High Static Drive Kit (or 2-hp Oversized Motor & Drive)											
1920	937	0.98	971	1.06	1004	1.14	1037	1.22	1068	1.30	1097	1.38	1127	1.47	1154	1.55	1182	1.64	1210	1.74		
2160	957	1.12	991	1.21	1024	1.30	1057	1.40	1087	1.49	1117	1.58	1146	1.67	1174	1.76	1201	1.85	1227	1.95		
2400	980	1.27	1013	1.37	1046	1.47	1076	1.57	1106	1.68	1137	1.78	1166	1.89	1194	1.99	1220	2.08	1248	2.19		
2640	1004	1.44 <sup>(b)</sup>	1036	1.55	1067	1.65	1098	1.77	1129	1.88	1158	1.99	1185	2.10	1214	2.22	—	—	—	—		
2880	1030	1.64	1061	1.75	1092	1.86	1123	1.98	1151	2.09	1181	2.22	—	—	—	—	—	—	—	—		
<b>2-hp Oversized Motor &amp; Drive</b>																						

**Notes:**

1. For Standard Evaporator Fan Speed (rpm), reference [Table 137, p. 182](#).
2. Data includes pressure drop due to standard filters and wet coils. No accessories or options are included in pressure drop data.
3. Refer to [Table 144, p. 185](#) to determine additional static pressure drop due to other options/accessories.
4. 1-hp Fan Motor Heat (MBh) = 2.829 x Fan bhp + .4024. 2-hp Fan Motor Heat (MBh) = 3.000 x Fan bhp + .5000.
5. Factory supplied motors, in commercial equipment, are definite purpose motors, specifically designed and tested to operate reliably and continuously at all cataloged conditions. Using the full horse power range of our fan motors as shown in our tabular data will not result in nuisance tripping or premature motor failure. Our product's warranty will not be affected.

(a) Field Supplied Fan Sheave AK84 and Belt AX36 required.  
 (b) 1-hp Standard Motor & High Static Drive Kit (or 2-hp Oversized Motor & Drive)

## Evaporator Fan Performance

**Table 58. Belt drive evaporator fan performance - 6 tons standard efficiency - TSC072F3,4,W horizontal airflow**

External Static Pressure (Inches of Water)																					
		0.10		0.20		0.30		0.40		0.50		0.60		0.70		0.80		0.90		1.00	
cfm	rpm	bhp	rpm	bhp	rpm	bhp	rpm	bhp	rpm	bhp	rpm	bhp	rpm	bhp	rpm	bhp	rpm	bhp	rpm	bhp	
1-hp Standard Motor & Field Supplied Low Static Drive <sup>(a)</sup>											1-hp Standard Motor & Drive										
1920	—	—	580	0.33	641	0.41	692	0.47	738	0.54	783	0.63	827	0.71	870	0.79	912	0.88	951	0.96	
2160	578	0.37	623	0.43	679	0.51	731	0.59	775	0.67	817	0.74	857	0.83	896	0.93	935	1.02	974	1.12	
2400	633	0.49	673	0.56	718	0.63	769	0.72	814	0.82	855	0.90	893	0.98	929	1.08	965	1.18	999	1.29	
2640	688	0.64	725	0.71	762	0.79	808	0.87	853	0.98	894	1.09	931	1.17	966	1.26	1000	1.36	1032	1.47 <sup>(b)</sup>	
2880	743	0.81	778	0.90	811	0.98	848	1.06	891	1.16	932	1.28	970	1.40	1004	1.49	1037	1.59	1068	1.69	
											1-hp Standard Motor & High Static Drive Kit (or 2-hp Oversized Motor)										

Continued

External Static Pressure (Inches of Water)																					
		1.10		1.20		1.30		1.40		1.50		1.60		1.70		1.80		1.90		2.00	
cfm	rpm	bhp	rpm	bhp	rpm	bhp	rpm	bhp	rpm	bhp	rpm	bhp	rpm	bhp	rpm	bhp	rpm	bhp	rpm	bhp	
1-hp Standard Motor & Drive											1-hp Standard Motor & High Static Drive Kit (or 2-hp Oversized Motor & Drive)										
1920	990	1.05	1026	1.14	1062	1.24	1096	1.33	1130	1.43	1160	1.52	1190	1.61	1218	1.71	1247	1.80	1273	1.90	
2160	1010	1.21	1047	1.31	1082	1.40	1116	1.50	1150	1.61	1182	1.71	1211	1.81	1242	1.92	1271	2.03	1298	2.14	
2400	1035	1.39	1070	1.50	1104	1.60	1137	1.70	1168	1.81	1201	1.92	1232	2.03	1261	2.14	1291	2.26	—	—	
2640	1065	1.59	1097	1.71	1129	1.82	1161	1.93	1192	2.05	1223	2.16	1252	2.27	—	—	—	—	—	—	
2880	1099	1.80	1130	1.93	1159	2.05	1188	2.18	1217	2.30	—	—	—	—	—	—	—	—	—	—	
2-hp Oversized Motor & Drive											2-hp Oversized Motor & Field Supplied Drive <sup>(c)</sup>										

**Notes:**

1. For Standard Evaporator Fan Speed (rpm), reference [Table 137, p. 182](#).
2. Data includes pressure drop due to standard filters and wet coils. No accessories or options are included in pressure drop data.
3. Refer to [Table 144, p. 185](#) to determine additional static pressure drop due to other options accessories.
4. 1-hp Fan Motor Heat (MBh) = 2.829 x Fan bhp + .4024. 2-hp Fan Motor Heat (MBh) = 3.000 x Fan bhp + .5000.
5. Factory supplied motors, in commercial equipment, are definite purpose motors, specifically designed and tested to operate reliably and continuously at all cataloged conditions. Using the full horsepower range of our fan motors as shown in our tabular data will not result in nuisance tripping or premature motor failure. Our product's warranty will not be affected.

(a) Field Supplied Fan Sheave AK84 and Belt AX36 required.  
 (b) 2-hp Oversized Motor & Field Supplied Drive  
 (c) Field Supplied Fan Sheave AK56 and Belt AX30.



## Evaporator Fan Performance

**Table 59. Belt drive evaporator fan performance - 6 tons standard efficiency with gas heat - YSC072F3,4,W\*L,M low & medium heat downflow airflow**

External Static Pressure (Inches of Water)																					
0.10		0.20		0.30		0.40		0.50		0.60		0.70		0.80		0.90		1.00			
cfm	rpm	bhp	rpm	bhp	rpm	bhp	rpm	bhp	rpm	bhp	rpm	bhp	rpm	bhp	rpm	bhp	rpm	bhp	rpm	bhp	
1-hp Standard Motor & Field Supplied Low Static Drive <sup>(a)</sup>										1-hp Standard Motor & Drive											
1920	—	—	—	—	597	0.37	652	0.44	700	0.51	745	0.58	788	0.66	829	0.74	869	0.82	906	0.91	
2160	—	—	575	0.38	629	0.46	683	0.54	730	0.62	774	0.70	815	0.78	854	0.86	893	0.95	929	1.04	
2400	561	0.41	615	0.49	664	0.57	714	0.65	762	0.74	805	0.83	844	0.92	882	1.01	918	1.10	954	1.20	
2640	606	0.53	657	0.62	703	0.70	747	0.79	792	0.88	835	0.98	875	1.08	912	1.18	947	1.27	980	1.37	
2880	651	0.67	699	0.77	743	0.85	785	0.94	825	1.05	867	1.15	906	1.26	943	1.37	978	1.47	1010	1.58	
																		2-hp Oversized Motor & Drive			

Continued

External Static Pressure (Inches of Water)																					
1.10		1.20		1.30		1.40		1.50		1.60		1.70		1.80		1.90		2.00			
cfm	rpm	bhp	rpm	bhp	rpm	bhp	rpm	bhp	rpm	bhp	rpm	bhp	rpm	bhp	rpm	bhp	rpm	bhp	rpm	bhp	
1-hp Standard Motor & Drive										1-hp Standard Motor & High Static Drive Kit (or 2-hp Oversized Motor & Drive)											
1920	941	0.99	977	1.07	1009	1.15	1041	1.23	1073	1.32	1103	1.40	1132	1.49	1159	1.57	1187	1.66	1213	1.75	
2160	964	1.13	997	1.23	1031	1.32	1061	1.41	1093	1.50	1123	1.60	1151	1.69	1179	1.78	1207	1.87	1234	1.97	
2400	988	1.29	1020	1.39	1054	1.50	1085	1.60	1114	1.70	1143	1.80	1171	1.90	1200	2.01	1227	2.11	1254	2.21	
2640	1014	1.47 <sup>(b)</sup>	1046	1.58	1077	1.69	1107	1.80	1138	1.91	1166	2.02	1193	2.13	1222	2.25	—	—	—	—	
2880	1042	1.68	1073	1.79	1103	1.90	1132	2.02	1162	2.14	1190	2.26	—	—	—	—	—	—	—	—	
																		2-hp Oversized Motor & Drive			

**Notes:**

1. For Standard Evaporator Fan Speed (rpm), reference [Table 137, p. 182](#).
2. Data includes pressure drop due to standard filters and wet coils. No accessories or options are included in pressure drop data.
3. Refer to [Table 144, p. 185](#) to determine additional static pressure drop due to other options/accessories.
4. 1-hp Fan Motor Heat (MBh) = 2.829 x Fan bhp + .4024. 2-hp Fan Motor Heat (MBh) = 3.000 x Fan bhp + .5000
5. Factory supplied motors, in commercial equipment, are definite purpose motors, specifically designed and tested to operate reliably and continuously at all cataloged conditions. Using the full horsepower range of our fan motors as shown in our tabular data will not result in nuisance tripping or premature motor failure. Our product's warranty will not be affected.

(a) Field Supplied Fan Sheave AK84 and Belt AX36 required.  
 (b) 1-hp Standard Motor & High Static Drive Kit (or 2-hp Oversized Motor & Drive)



## Evaporator Fan Performance

**Table 60. Belt drive evaporator fan performance - 6 tons standard efficiency with gas heat - YSC072F3,4,W\*L,M low & medium heat horizontal airflow**

External Static Pressure (Inches of Water)																					
		0.10		0.20		0.30		0.40		0.50		0.60		0.70		0.80		0.90		1.00	
cfm	rpm	bhp	rpm	bhp	rpm	bhp	rpm	bhp	rpm	bhp	rpm	bhp	rpm	bhp	rpm	bhp	rpm	bhp	rpm	bhp	
1-hp Standard Motor & Field Supplied Low Static Drive <sup>(a)</sup>										1-hp Standard Motor & Drive											
1920	—	—	591	0.34	649	0.42	699	0.48	745	0.56	789	0.64	834	0.72	877	0.81	918	0.89	957	0.97	
2160	587	0.38	633	0.44	690	0.52	740	0.61	784	0.68	825	0.76	865	0.85	904	0.95	943	1.04	981	1.13	
2400	643	0.51	682	0.58	732	0.65	781	0.75	825	0.84	864	0.92	902	1.01	938	1.11	974	1.21	1010	1.32 <sup>(b)</sup>	
2640	700	0.66	736	0.74	775	0.81	822	0.90	866	1.01	906	1.11	942	1.20	976	1.29	1009	1.40	1042	1.51	
2880	756	0.84	790	0.93	823	1.01	864	1.09	907	1.20	947	1.32	983	1.43	1017	1.53	1048	1.62	1080	1.73	
										<b>2-hp Oversized Motor &amp; Drive</b>											

Continued

External Static Pressure (Inches of Water)																					
		1.10		1.20		1.30		1.40		1.50		1.60		1.70		1.80		1.90		2.00	
cfm	rpm	bhp	rpm	bhp	rpm	bhp	rpm	bhp	rpm	bhp	rpm	bhp	rpm	bhp	rpm	bhp	rpm	bhp	rpm	bhp	
1-hp Standard Motor & Drive										1-hp Standard Motor & High Static Drive Kit (or 2-hp Oversized Motor & Drive)											
1920	996	1.06	1033	1.16	1067	1.25	1102	1.35	1134	1.44	1165	1.53	1195	1.63	1223	1.72	1251	1.82	1277	1.91	
2160	1018	1.23	1054	1.32	1090	1.42	1123	1.52	1156	1.63	1188	1.73	1218	1.84	1247	1.94	1276	2.05	1304	2.16	
2400	1044	1.42	1079	1.52	1112	1.62	1145	1.73	1177	1.83	1208	1.94	1240	2.06	1268	2.17	1298	2.29	—	—	
2640	1075	1.62	1107	1.74	1139	1.85	1170	1.96	1201	2.08	1232	2.19	—	—	—	—	—	—	—	—	
2880	1111	1.85	1140	1.97	1169	2.09	1200	2.22	—	—	—	—	—	—	—	—	—	—	—	—	
<b>2-hp Oversized Motor &amp; Drive</b>										<b>2-hp Oversized Motor &amp; Field Supplied High Static Drive<sup>(c)</sup></b>											

**Notes:**

1. For Standard Evaporator Fan Speed (rpm), reference [Table 137, p. 182](#).
2. Data includes pressure drop due to standard filters and wet coils. No accessories or options are included in pressure drop data.
3. Refer to [Table 144, p. 185](#) to determine additional static pressure drop due to other options/accessories.
4. 1-hp Fan Motor Heat (MBh) = 2.829 x Fan bhp + .4024. 2-hp Fan Motor Heat (MBh) = 3.000 x Fan bhp + .5000.
5. Factory supplied motors, in commercial equipment, are definite purpose motors, specifically designed and tested to operate reliably and continuously at all cataloged conditions. Using the full horsepower range of our fan motors as shown in our tabular data will not result in nuisance tripping or premature motor failure. Our product's warranty will not be affected.

(a) Field Supplied Fan Sheave AK84 and Belt AX36 required.  
 (b) 1-hp Standard Motor & High Static Drive (or 2-hp Oversized Motor)  
 (c) Field Supplied Fan Sheave AK56 and Belt AX30 required.



## Evaporator Fan Performance

**Table 61. Belt drive evaporator fan performance - 6 tons standard efficiency with gas heat - YSC072F3,4,W\*H high heat downflow airflow**

External Static Pressure (Inches of Water)																					
		0.10		0.20		0.30		0.40		0.50		0.60		0.70		0.80		0.90		1.00	
cfm	rpm	bhp	rpm	bhp	rpm	bhp	rpm	bhp	rpm	bhp	rpm	bhp	rpm	bhp	rpm	bhp	rpm	bhp	rpm	bhp	
1-hp Standard Motor & Field Supplied Low Static Drive <sup>(a)</sup>											1-hp Standard Motor & Drive										
1920	—	—	574	0.34	631	0.41	681	0.48	727	0.55	771	0.63	814	0.71	853	0.79	892	0.87	928	0.95	
2160	562	0.36	616	0.44	671	0.52	719	0.60	763	0.68	805	0.76	845	0.84	884	0.93	921	1.02	957	1.11	
2400	612	0.48	662	0.56	711	0.65	759	0.74	802	0.83	842	0.91	879	1.00	916	1.09	951	1.19	986	1.29	
2640	663	0.63	709	0.71	754	0.80	798	0.90	842	1.00	881	1.10	917	1.19	951	1.29	986	1.39	1018	1.49 <sup>(b)</sup>	
2880	715	0.80	758	0.88	799	0.98	840	1.08	880	1.19	920	1.30	955	1.41	990	1.51	1022	1.62	1053	1.72	
											2-hp Oversized Motor & Drive										

Continued

External Static Pressure (Inches of Water)																					
		1.10		1.20		1.30		1.40		1.50		1.60		1.70		1.80		1.90		2.00	
cfm	rpm	bhp	rpm	bhp	rpm	bhp	rpm	bhp	rpm	bhp	rpm	bhp	rpm	bhp	rpm	bhp	rpm	bhp	rpm	bhp	
1-hp Standard Motor & Drive											1-hp Standard Motor & High Static Drive Kit (or 2-hp Oversized Motor & Drive)										
1920	963	1.04	997	1.12	1028	1.20	1061	1.28	1090	1.36	1119	1.45	1149	1.54	1177	1.63	1203	1.71	1229	1.80	
2160	990	1.21	1023	1.30	1055	1.39	1086	1.48	1115	1.57	1144	1.66	1173	1.76	1200	1.85	1227	1.95	1253	2.04	
2400	1019	1.39	1051	1.49	1083	1.60	1113	1.70	1141	1.80	1171	1.90	1199	2.01	1225	2.10	1252	2.20	—	—	
2640	1050	1.59	1081	1.70	1111	1.81	1141	1.93	1170	2.04	1198	2.15	1226	2.27	—	—	—	—	—	—	
2880	1084	1.83	1114	1.94	1143	2.06	1172	2.18	1199	2.30	—	—	—	—	—	—	—	—	—	—	
											2-hp Oversized Motor & Drive										

**Notes:**

1. For Standard Evaporator Fan Speed (rpm), reference [Table 137, p. 182](#).
2. Data includes pressure drop due to standard filters and wet coils. No accessories or options are included in pressure drop data.
3. Refer to [Table 144, p. 185](#) to determine additional static pressure drop due to other options/accessories.
4. 1-hp Fan Motor Heat (MBh) = 2.829 x Fan bhp + .4024. 2-hp Fan Motor Heat (MBh) = 3.000 x Fan bhp + .5000
5. Factory supplied motors, in commercial equipment, are definite purpose motors, specifically designed and tested to operate reliably and continuously at all cataloged conditions. Using the full horsepower range of our fan motors as shown in our tabular data will not result in nuisance tripping or premature motor failure. Our product's warranty will not be affected.

(a) Field Supplied Fan Sheave AK84 and Belt AX36 required.  
 (b) 1-hp Standard Motor & High Static Drive Kit (or 2-hp Oversized Motor)

## Evaporator Fan Performance

**Table 62. Belt drive evaporator fan performance - 6 tons standard efficiency with gas heat - YSC072F3,4,W\*H high heat horizontal airflow**

External Static Pressure (Inches of Water)																					
		0.10		0.20		0.30		0.40		0.50		0.60		0.70		0.80		0.90		1.00	
cfm	rpm	bhp	rpm	bhp	rpm	bhp	rpm	bhp	rpm	bhp	rpm	bhp	rpm	bhp	rpm	bhp	rpm	bhp	rpm	bhp	
1-hp Standard Motor & Field Supplied Low Static Drive <sup>(a)</sup>											1-hp Standard Motor & Drive										
1920	565	0.31	627	0.39	680	0.46	727	0.52	772	0.61	816	0.69	859	0.77	902	0.86	942	0.94	981	1.03	
2160	621	0.43	677	0.50	729	0.59	774	0.66	816	0.74	856	0.83	895	0.93	934	1.02	973	1.11	1009	1.21 <sup>(b)</sup>	
2400	680	0.57	729	0.65	778	0.74	823	0.84	862	0.92	900	1.00	936	1.10	972	1.20	1006	1.31	1041	1.41	
2640	741	0.75	782	0.82	828	0.92	872	1.03	911	1.13	947	1.21	981	1.31	1014	1.41	1048	1.53	1079	1.64	
2880	802	0.95	837	1.04	880	1.13	921	1.24	960	1.36	995	1.47	1028	1.56	1060	1.66	1091	1.77	1122	1.89	
											2-hp Oversized Motor & Drive										

Continued

External Static Pressure (Inches of Water)																					
		1.10		1.20		1.30		1.40		1.50		1.60		1.70		1.80		1.90		2.00	
cfm	rpm	bhp	rpm	bhp	rpm	bhp	rpm	bhp	rpm	bhp	rpm	bhp	rpm	bhp	rpm	bhp	rpm	bhp	rpm	bhp	
1-hp Standard Motor & High Static Drive Kit (or 2-hp Oversized Motor & Drive)																					
1920	1018	1.12	1054	1.21	1089	1.31	1122	1.40	1154	1.50	1184	1.59	1212	1.69	1241	1.78	1268	1.88	1293	1.97	
2160	1045	1.30	1081	1.40	1114	1.50	1149	1.61	1181	1.71	1211	1.81	1241	1.92	1270	2.03	1298	2.13	1324	2.24	
2400	1076	1.51	1110	1.62	1143	1.72	1176	1.83	1206	1.94	1238	2.05	1267	2.16	1297	2.28	—	—	—	—	
2640	1111	1.75	1144	1.87	1174	1.98	1205	2.09	1236	2.21	—	—	—	—	—	—	—	—	—	—	
2880	1151	2.02	1180	2.14	1209	2.27	—	—	—	—	—	—	—	—	—	—	—	—	—	—	
2-hp Oversized Motor & Drive											2-hp Oversized Motor & Field Supplied High Static Drive <sup>(c)</sup>										

**Notes:**

1. For Standard Evaporator Fan Speed (rpm), reference [Table 137, p. 182](#).
2. Data includes pressure drop due to standard filters and wet coils. No accessories or options are included in pressure drop data.
3. Refer to [Table 144, p. 185](#) to determine additional static pressure drop due to other options/accessories.
4. 1-hp Fan Motor Heat (MBh) = 2.829 x Fan bhp + .4024. 2-hp Fan Motor Heat (MBh) = 3.000 x Fan bhp + .5000.
5. Factory supplied motors, in commercial equipment, are definite purpose motors, specifically designed and tested to operate reliably and continuously at all cataloged conditions. Using the full horsepower range of our fan motors as shown in our tabular data will not result in nuisance tripping or premature motor failure. Our product's warranty will not be affected.

(a) Field Supplied Fan Sheave AK84 and Belt AX36 required.  
 (b) 1-hp Standard Motor & High Static Drive Kit (or 2-hp Oversized Motor).  
 (c) Field Supplied Fan Sheave AK56 and Belt AX30 required.



## Evaporator Fan Performance

**Table 63. Belt drive evaporator fan performance - 7½ tons standard efficiency - TSC090F3,4,W downflow airflow**

External Static Pressure (Inches of Water)																					
		0.10		0.20		0.30		0.40		0.50		0.60		0.70		0.80		0.90		1.00	
cfm	rpm	bhp	rpm	bhp	rpm	bhp	rpm	bhp	rpm	bhp	rpm	bhp	rpm	bhp	rpm	bhp	rpm	bhp	rpm	bhp	
1-hp Standard Motor & Field Supplied Low Static Drive <sup>(a)</sup>											1-hp Standard Motor & Drive										
2400	613	0.42	668	0.50	711	0.57	756	0.65	798	0.72	838	0.80	875	0.88	911	0.96	945	1.04	978	1.12	
2700	676	0.56	733	0.69	767	0.74	808	0.83	848	0.91	886	1.00	922	1.09	956	1.18	989	1.27	1021	1.36	
3000	741	0.75	793	0.89	832	0.98	863	1.04	901	1.14	936	1.24	971	1.33	1003	1.43	1036	1.53	1067	1.63	
3300	807	0.98	849	1.10	897	1.26	925	1.32	954	1.40	989	1.51	1022	1.62	1053	1.73	1084	1.83	1113	1.94	
3600	874	1.25	909	1.36	957	1.55	990	1.67	1015	1.73	1042	1.82	1074	1.95	1104	2.07	1134	2.18	1163	2.30	
3-hp Oversized Motor & Drive																					

Continued

External Static Pressure (Inches of Water)																					
		1.10		1.20		1.30		1.40		1.50		1.60		1.70		1.80		1.90		2.00	
cfm	rpm	bhp	rpm	bhp	rpm	bhp	rpm	bhp	rpm	bhp	rpm	bhp	rpm	bhp	rpm	bhp	rpm	bhp	rpm	bhp	
1-hp Standard Motor & Drive											3-hp Oversized Motor & Drive										
2400	1011	1.20	1041	1.28	1070	1.36	1099	1.44	1127	1.52	1153	1.60	1178	1.68	1203	1.76	1229	1.84	1252	1.92	
2700	1051	1.45	1082	1.54	1111	1.63	1139	1.72	1166	1.81	1192	1.90	1217	1.98	1243	2.08	1268	2.17	1291	2.25	
3000	1096	1.73	1124	1.83	1153	1.93	1180	2.03	1207	2.13	1233	2.23	1258	2.33	1283	2.43	1308	2.53	1331	2.63	
3300	1142	2.05	1170	2.16	1197	2.27	1223	2.37	1249	2.48	1275	2.59	1300	2.71	1324	2.82	1347	2.92	1371	3.03	
3600	1191	2.41	1218	2.53	1244	2.65	1269	2.77	1294	2.89	1319	3.01	1342	3.12	1366	3.24	1389	3.36	—	—	
3-hp Oversized Motor & Field Supplied High Static Drive <sup>(b)</sup>																					

**Notes:**

1. For Standard Evaporator Fan Speed (rpm), reference [Table 137, p. 182](#).
2. Data includes pressure drop due to standard filters and wet coils. No accessories or options are included in pressure drop data.
3. Refer to [Table 144, p. 185](#) to determine additional static pressure drop due to other options/accessories.
4. 1-hp Fan Motor Heat (MBh) = 2.829 x Fan bhp + .4024. 3-hp Fan Motor Heat (MBh) = 2.900 x Fan bhp + .4750
5. Factory supplied motors, in commercial equipment, are definite purpose motors, specifically designed and tested to operate reliably and continuously at all cataloged conditions. Using the full horsepower range of our fan motors as shown in our tabular data will not result in nuisance tripping or premature motor failure. Our product's warranty will not be affected.

(a) Field Supplied Fan Sheave AK74 and Belt AX35  
 (b) Field Supplied Fan Sheave BK52 and Belt BX30

## Evaporator Fan Performance

**Table 64. Belt drive evaporator fan performance - 7½ tons standard efficiency - TSC090F3,4,W horizontal airflow**

External Static Pressure (Inches of Water)																					
		0.10		0.20		0.30		0.40		0.50		0.60		0.70		0.80		0.90		1.00	
cfm	rpm	bhp	rpm	bhp	rpm	bhp	rpm	bhp	rpm	bhp	rpm	bhp	rpm	bhp	rpm	bhp	rpm	bhp	rpm	bhp	
1-hp Standard Motor & Field Supplied Low Static Drive <sup>(a)</sup>											1-hp Standard Motor & Drive										
2400	681	0.52	726	0.60	770	0.69	811	0.77	852	0.85	892	0.94	931	1.02	969	1.11	1007	1.20	1046	1.31	
2700	754	0.72	796	0.81	835	0.90	874	0.99	910	1.08	947	1.18	983	1.27	1018	1.37	1052	1.47	1087	1.57	
3000	828	0.97	868	1.07	903	1.17	938	1.27	973	1.37	1005	1.47	1039	1.57	1072	1.68	1103	1.78	1135	1.90	
3300	904	1.26	940	1.37	974	1.48	1004	1.59	1037	1.71	1069	1.82	1098	1.93	1129	2.04	1159	2.15	1188	2.27	
3600	979	1.62	1013	1.74	1045	1.86	1074	1.98	1103	2.10	1133	2.22	1162	2.35	1189	2.46	1217	2.58	1245	2.71	
3-hp Oversized Motor & Drive																					

Continued

External Static Pressure (Inches of Water)																					
		1.10		1.20		1.30		1.40		1.50		1.60		1.70		1.80		1.90		2.00	
cfm	rpm	bhp	rpm	bhp	rpm	bhp	rpm	bhp	rpm	bhp	rpm	bhp	rpm	bhp	rpm	bhp	rpm	bhp	rpm	bhp	
1-hp Standard Motor & Drive											3-hp Oversized Motor & Drive										
2400	1083	1.42	1119	1.52	1153	1.63	1185	1.73	1218	1.84	1249	1.95	1278	2.06	1307	2.16	1337	2.28	1364	2.38	
2700	1120	1.67	1154	1.79	1188	1.91	1220	2.02	1252	2.14	1283	2.26	1313	2.39	1342	2.51	1370	2.63	1397	2.74	
3000	1166	2.00	1197	2.12	1227	2.23	1256	2.34	1288	2.47	1318	2.61	1347	2.73	1377	2.87	1406	3.01	1433	3.14	
3300	1217	2.39	1246	2.51	1274	2.63	1302	2.75	1330	2.88	1357	3.00	1384	3.13	1413	3.27	1441	3.42	—	—	
3600	1272	2.83	1299	2.96	1326	3.09	1352	3.22	1378	3.35	—	—	—	—	—	—	—	—	—	—	
3-hp Oversized Motor & Field Supplied High Static Drive <sup>(b)</sup>																					

**Notes:**

1. For Standard Evaporator Fan Speed (rpm), reference [Table 137, p. 182](#).
2. Data includes pressure drop due to standard filters and wet coils. No accessories or options are included in pressure drop data.
3. Refer to [Table 144, p. 185](#) to determine additional static pressure drop due to other options/accessories.
4. 1-hp Fan Motor Heat (MBh) = 2.829 x Fan bhp + .4024. 3-hp Fan Motor Heat (MBh) = 2.900 x Fan bhp + .4750
5. Factory supplied motors, in commercial equipment, are definite purpose motors, specifically designed and tested to operate reliably and continuously at all cataloged conditions. Using the full horsepower range of our fan motors as shown in our tabular data will not result in nuisance tripping or premature motor failure. Our product's warranty will not be affected.

(a) Field Supplied Fan Sheave AK74 and Belt AX35  
 (b) Field Supplied Fan Sheave BK52 and Belt BX30



## Evaporator Fan Performance

**Table 65. Belt drive evaporator fan performance - 7½ tons standard efficiency with gas heat - YSC090F3,4,W low & medium gas heat downflow airflow**

External Static Pressure (Inches of Water)																					
		0.10		0.20		0.30		0.40		0.50		0.60		0.70		0.80		0.90		1.00	
cfm	rpm	bhp	rpm	bhp	rpm	bhp	rpm	bhp	rpm	bhp	rpm	bhp	rpm	bhp	rpm	bhp	rpm	bhp	rpm	bhp	
1-hp Standard Motor & Field Supplied Low Static Drive <sup>(a)</sup>											1-hp Standard Motor & Drive										
2400	655	0.47	707	0.55	758	0.64	802	0.72	845	0.80	886	0.88	925	0.97	961	1.05	997	1.14	1028	1.22	
2700	724	0.64	770	0.73	817	0.83	861	0.92	900	1.02	939	1.11	976	1.20	1011	1.30	1045	1.39	1077	1.49	
3000	794	0.86	837	0.96	878	1.06	920	1.17	958	1.27	994	1.38	1029	1.48	1063	1.58	1096	1.69	1128	1.79	
3300	865	1.12	905	1.23	942	1.34	980	1.45	1018	1.57	1053	1.69	1085	1.80	1117	1.92	1148	2.03	1179	2.14	
3600	937	1.43	973	1.55	1008	1.67	1042	1.79	1077	1.91	1112	2.05	1144	2.18	1174	2.30	1203	2.42	1232	2.55	
<b>3-hp Oversized Motor &amp; Drive</b>																					

Continued

External Static Pressure (Inches of Water)																					
		1.10		1.20		1.30		1.40		1.50		1.60		1.70		1.80		1.90		2.00	
cfm	rpm	bhp	rpm	bhp	rpm	bhp	rpm	bhp	rpm	bhp	rpm	bhp	rpm	bhp	rpm	bhp	rpm	bhp	rpm	bhp	
1-hp Standard Motor & Drive											3-hp Oversized Motor & Drive										
2400	1060	1.30	1091	1.39	1120	1.48	1150	1.57	1178	1.65	1204	1.74	1231	1.83	1256	1.91	1281	2.00	1304	2.09	
2700	1109	1.58	1139	1.68	1167	1.77	1195	1.86	1223	1.96	1249	2.06	1275	2.16	1301	2.26	1325	2.35	1349	2.45	
3000	1158	1.90	1188	2.00	1216	2.11	1244	2.21	1271	2.32	1296	2.42	1321	2.53	1346	2.64	1371	2.75	1393	2.85	
3300	1209	2.26	1238	2.37	1265	2.49	1293	2.61	1319	2.72	1344	2.84	1369	2.95	1393	3.07	1416	3.18	1441	3.30	
3600	1261	2.67	1289	2.80	1316	2.92	1342	3.04	1368	3.17	1393	3.30	1419	3.43	—	—	—	—	—	—	
<b>3-hp Oversized Motor &amp; Field Supplied High Static Drive<sup>(b)</sup></b>																					

**Notes:**

1. For Standard Evaporator Fan Speed (rpm), reference [Table 137, p. 182](#).
2. Data includes pressure drop due to standard filters and wet coils. No accessories or options are included in pressure drop data.
3. Refer to [Table 144, p. 185](#) to determine additional static pressure drop due to other options/accessories.
4. 1-hp Fan Motor Heat (MBh) = 2.829 x Fan bhp + .4024. 3-hp Fan Motor Heat (MBh) = 2.900 x Fan bhp + .4750
5. Factory supplied motors, in commercial equipment, are definite purpose motors, specifically designed and tested to operate reliably and continuously at all cataloged conditions. Using the full horsepower range of our fan motors as shown in our tabular data will not result in nuisance tripping or premature motor failure. Our product's warranty will not be affected.

(a) Field Supplied Fan Sheave AK74 and Belt AX35  
 (b) Field Supplied Fan Sheave BK52 and Belt BX30

## Evaporator Fan Performance

**Table 66. Belt drive evaporator fan performance - 7½ tons standard efficiency with gas heat - YSC090F3,4,W low & medium gas heat - horizontal airflow**

External Static Pressure (Inches of Water)																					
		0.10		0.20		0.30		0.40		0.50		0.60		0.70		0.80		0.90		1.00	
cfm	rpm	bhp	rpm	bhp	rpm	bhp	rpm	bhp	rpm	bhp	rpm	bhp	rpm	bhp	rpm	bhp	rpm	bhp	rpm	bhp	
<b>1-hp Standard Motor &amp; Field Supplied Low Static Drive<sup>(a)</sup></b>											<b>1-hp Standard Motor &amp; Drive</b>										
2400	739	0.61	783	0.69	825	0.77	866	0.85	903	0.93	941	1.02	978	1.11	1013	1.20	1046	1.28	1078	1.37	
2700	821	0.85	861	0.94	898	1.03	935	1.12	972	1.21	1005	1.30	1038	1.39	1072	1.49	1104	1.59	1135	1.69	
3000	904	1.14	940	1.24	974	1.34	1008	1.44	1042	1.54	1075	1.65	1105	1.74	1135	1.85	1164	1.95	1195	2.06	
3300	987	1.49	1020	1.60	1052	1.71	1083	1.82	1113	1.93	1144	2.04	1174	2.16	1203	2.27	1230	2.38	1257	2.49	
3600	1071	1.92	1101	2.04	1131	2.15	1160	2.27	1188	2.39	1216	2.51	1244	2.64	1272	2.76	1298	2.88	1323	3.00	
<b>3-hp Oversized Motor &amp; Drive</b>											<b>3-hp Oversized Motor &amp; Field Supplied Drive<sup>(b)</sup></b>										

Continued

External Static Pressure (Inches of Water)																					
		1.10		1.20		1.30		1.40		1.50		1.60		1.70		1.80		1.90		2.00	
cfm	rpm	bhp	rpm	bhp	rpm	bhp	rpm	bhp	rpm	bhp	rpm	bhp	rpm	bhp	rpm	bhp	rpm	bhp	rpm	bhp	
<b>3-hp Oversized Motor &amp; Drive</b>																					
2400	1110	1.46	1140	1.55	1169	1.64	1198	1.73	1225	1.82	1251	1.91	1277	2.01	1301	2.10	1326	2.19	1350	2.28	
2700	1165	1.78	1195	1.88	1223	1.98	1251	2.08	1277	2.18	1304	2.29	1330	2.39	1355	2.49	1378	2.59	1402	2.70	
3000	1224	2.17	1252	2.28	1279	2.39	1306	2.49	1332	2.60	1358	2.71	1383	2.83	1407	2.94	1430	3.05	1454	3.16	
3300	1283	2.61	1311	2.73	1338	2.85	1364	2.97	1389	3.09	1413	3.21	1439	3.33	—	—	—	—	—	—	
3600	1349	3.13	1373	3.25	1398	3.38	—	—	—	—	—	—	—	—	—	—	—	—	—	—	
<b>3-hp Oversized Motor &amp; Field Supplied High Static Drive<sup>(b)</sup></b>																					

**Notes:**

1. For Standard Evaporator Fan Speed (rpm), reference [Table 137, p. 182](#).
2. Data includes pressure drop due to standard filters and wet coils. No accessories or options are included in pressure drop data.
3. Refer to [Table 144, p. 185](#) to determine additional static pressure drop due to other options/accessories.
4. 1-hp Fan Motor Heat (MBh) = 2.829 x Fan bhp + .4024. 3-hp Fan Motor Heat (MBh) = 2.900 x Fan bhp + .4750
5. Factory supplied motors, in commercial equipment, are definite purpose motors, specifically designed and tested to operate reliably and continuously at all cataloged conditions. Using the full horsepower range of our fan motors as shown in our tabular data will not result in nuisance tripping or premature motor failure. Our product's warranty will not be affected.

(a) Field Supplied Fan Sheave AK74 and Belt AX35  
 (b) Field Supplied Fan Sheave BK52 and Belt BX30



## Evaporator Fan Performance

**Table 67. Belt drive evaporator fan performance - 7½ tons standard efficiency with gas heat -YSC090F3,4,W high gas heat downflow airflow**

cfm	External Static Pressure (Inches of Water)																				
	0.10		0.20		0.30		0.40		0.50		0.60		0.70		0.80		0.90		1.00		
	rpm	bhp	rpm	bhp	rpm	bhp	rpm	bhp	rpm	bhp	rpm	bhp	rpm	bhp	rpm	bhp	rpm	bhp	rpm	bhp	
<b>1-hp Standard Motor &amp; Field Supplied Low Static Drive<sup>(a)</sup></b>										<b>1-hp Standard Motor &amp; Drive</b>											
2400	675	0.51	727	0.60	772	0.68	815	0.76	857	0.85	896	0.93	935	1.02	971	1.11	1006	1.19	1041	1.29	
2700	748	0.70	793	0.80	837	0.89	877	0.98	915	1.08	952	1.17	988	1.27	1022	1.37	1056	1.47	1089	1.57	
3000	821	0.94	862	1.04	903	1.15	941	1.25	976	1.35	1011	1.46	1045	1.57	1077	1.67	1109	1.78	1140	1.89	
3300	895	1.23	932	1.34	970	1.46	1007	1.58	1040	1.69	1072	1.79	1104	1.91	1134	2.03	1164	2.15	1194	2.27	
3600	969	1.57	1004	1.70	1038	1.82	1073	1.95	1106	2.07	1136	2.19	1166	2.32	1195	2.44	1223	2.57	1251	2.70	
<b>3-hp Oversized Motor &amp; Drive</b>																					

Continued

cfm	External Static Pressure (Inches of Water)																				
	1.10		1.20		1.30		1.40		1.50		1.60		1.70		1.80		1.90		2.00		
	rpm	bhp	rpm	bhp	rpm	bhp	rpm	bhp	rpm	bhp	rpm	bhp	rpm	bhp	rpm	bhp	rpm	bhp	rpm	bhp	
<b>3-hp Oversized Motor &amp; Drive</b>										<b>3-hp Oversized Motor &amp; Drive</b>											
2400	1074	1.37	1105	1.46	1136	1.55	1165	1.64	1194	1.73	1222	1.83	1250	1.92	1275	2.00	1301	2.10	1326	2.18	
2700	1121	1.66	1151	1.76	1181	1.86	1211	1.97	1238	2.06	1266	2.17	1292	2.27	1318	2.37	1344	2.47	1369	2.57	
3000	1170	2.00	1199	2.11	1229	2.22	1256	2.33	1285	2.44	1311	2.55	1336	2.66	1363	2.77	1388	2.89	1413	3.00	
3300	1223	2.39	1251	2.50	1279	2.62	1305	2.74	1333	2.87	1358	2.98	1384	3.11	1408	3.23	1434	3.35	—	—	
3600	1279	2.83	1305	2.95	1331	3.08	1357	3.21	1383	3.34	—	—	—	—	—	—	—	—	—	—	
<b>3-hp Oversized Motor &amp; Field Supplied High Static Drive<sup>(b)</sup></b>																					

**Notes:**

1. For Standard Evaporator Fan Speed (rpm), reference [Table 137, p. 182](#).
2. Data includes pressure drop due to standard filters and wet coils. No accessories or options are included in pressure drop data.
3. Refer to [Table 144, p. 185](#) to determine additional static pressure drop due to other options/accessories.
4. 1-hp Fan Motor Heat (MBh) = 2.829 x Fan bhp + .4024. 3-hp Fan Motor Heat (MBh) = 2.900 x Fan bhp + .4750
5. Factory supplied motors, in commercial equipment, are definite purpose motors, specifically designed and tested to operate reliably and continuously at all cataloged conditions. Using the full horsepower range of our fan motors as shown in our tabular data will not result in nuisance tripping or premature motor failure. Our product's warranty will not be affected.

(a) Field Supplied Fan Sheave AK74 and Belt AX35  
 (b) Field Supplied Fan Sheave BK52 and Belt BX30



## Evaporator Fan Performance

**Table 68. Belt drive evaporator fan performance - 7½ tons standard efficiency with gas heat -YSC090F3,4,W high gas heat horizontal airflow**

External Static Pressure (Inches of Water)																					
		0.10		0.20		0.30		0.40		0.50		0.60		0.70		0.80		0.90		1.00	
cfm	rpm	bhp	rpm	bhp	rpm	bhp	rpm	bhp	rpm	bhp	rpm	bhp	rpm	bhp	rpm	bhp	rpm	bhp	rpm	bhp	
1-hp Standard Motor & Field Supplied Low Static Drive <sup>(a)</sup>											1-hp Standard Motor & Drive										
2400	776	0.70	819	0.79	859	0.87	898	0.96	936	1.05	972	1.13	1007	1.22	1039	1.31	1071	1.40	1102	1.49	
2700	863	0.97	901	1.07	938	1.16	974	1.26	1009	1.36	1043	1.46	1075	1.55	1106	1.65	1136	1.75	1165	1.85	
3000	951	1.31	985	1.42	1019	1.52	1052	1.63	1084	1.73	1116	1.84	1146	1.95	1176	2.06	1205	2.17	1232	2.28	
3300	1039	1.72	1071	1.84	1102	1.95	1132	2.07	1162	2.18	1191	2.30	1220	2.42	1248	2.54	1275	2.66	1302	2.78	
3600	1128	2.21	1157	2.34	1186	2.46	1214	2.59	1242	2.71	1269	2.84	1296	2.97	1322	3.10	1348	3.23	1373	3.36	
3-hp Oversized Motor & Drive											3-hp Oversized Motor & Field Supplied High Static Drive <sup>(b)</sup>										

Continued

External Static Pressure (Inches of Water)																					
		1.10		1.20		1.30		1.40		1.50		1.60		1.70		1.80		1.90		2.00	
cfm	rpm	bhp	rpm	bhp	rpm	bhp	rpm	bhp	rpm	bhp	rpm	bhp	rpm	bhp	rpm	bhp	rpm	bhp	rpm	bhp	
3-hp Oversized Motor & Drive																					
2400	1132	1.58	1161	1.68	1189	1.77	1216	1.86	1242	1.95	1268	2.04	1293	2.13	1318	2.23	1342	2.33	1364	2.42	
2700	1194	1.95	1222	2.05	1249	2.16	1276	2.26	1301	2.37	1327	2.48	1350	2.57	1374	2.68	1398	2.78	1421	2.88	
3000	1260	2.39	1286	2.50	1312	2.61	1337	2.72	1363	2.84	1387	2.96	1410	3.07	1434	3.19	1457	3.31	—	—	
3300	1328	2.90	1353	3.02	1378	3.14	1402	3.26	1426	3.39	—	—	—	—	—	—	—	—	—	—	
3600	—	—	—	—	—	—	—	—	—	—	—	—	—	—	—	—	—	—	—	—	
3-hp Oversized Motor & Field Supplied High Static Drive <sup>(b)</sup>																					

**Notes:**

1. For Standard Evaporator Fan Speed (rpm), reference [Table 137, p. 182](#).
2. Data includes pressure drop due to standard filters and wet coils. No accessories or options are included in pressure drop data.
3. Refer to [Table 144, p. 185](#) to determine additional static pressure drop due to other options/accessories.
4. 1-hp Fan Motor Heat (MBh) = 2.829 x Fan bhp + .4024. 3-hp Fan Motor Heat (MBh) = 2.900 x Fan bhp + .4750
5. Factory supplied motors, in commercial equipment, are definite purpose motors, specifically designed and tested to operate reliably and continuously at all cataloged conditions. Using the full horsepower range of our fan motors as shown in our tabular data will not result in nuisance tripping or premature motor failure. Our product's warranty will not be affected.

(a) Field Supplied Fan Sheave AK74 and Belt AX35  
 (b) Field Supplied Fan Sheave BK52 and Belt BX30



## Evaporator Fan Performance

**Table 69. Belt drive evaporator fan performance - 7½ tons standard efficiency - TSC092F3,4,W downflow airflow**

External Static Pressure (Inches of Water)																					
		0.10		0.20		0.30		0.40		0.50		0.60		0.70		0.80		0.90		1.00	
cfm	rpm	bhp	rpm	bhp	rpm	bhp	rpm	bhp	rpm	bhp	rpm	bhp	rpm	bhp	rpm	bhp	rpm	bhp	rpm	bhp	
1-hp Standard Motor & Field Supplied Low Static Drive <sup>(a)</sup>											1-hp Standard Motor & Drive										
2400	—	—	474	0.36	524	0.44	570	0.52	611	0.59	650	0.68	686	0.76	720	0.84	752	0.93	783	1.02	
2700	458	0.39	508	0.47	554	0.55	598	0.64	638	0.73	676	0.82	711	0.91	745	1.00	776	1.09	806	1.19	
3000	498	0.52	544	0.60	587	0.69	628	0.78	666	0.88	704	0.98	738	1.08	770	1.18	801	1.28	831	1.38	
3300	539	0.67	581	0.76	621	0.85	660	0.96	696	1.06	732	1.17	766	1.28	797	1.39	828	1.49	856	1.60	
3600	580	0.85	620	0.95	657	1.05	693	1.16	728	1.27	761	1.38	794	1.50	825	1.62	855	1.74	882	1.85	
											3-hp Oversized Motor & Drive <sup>(b)</sup>										

Continued

External Static Pressure (Inches of Water)																					
		1.10		1.20		1.30		1.40		1.50		1.60		1.70		1.80		1.90		2.00	
cfm	rpm	bhp	rpm	bhp	rpm	bhp	rpm	bhp	rpm	bhp	rpm	bhp	rpm	bhp	rpm	bhp	rpm	bhp	rpm	bhp	
1-hp Standard Motor Drive											3-hp Oversized Motor & Drive <sup>(b)</sup>										
2400	813	1.10	841	1.19	868	1.28	894	1.37	920	1.46	943	1.54	967	1.63	990	1.72	1012	1.81	1035	1.90	
2700	836	1.29	864	1.39	891	1.48	917	1.58	942	1.68	966	1.78	990	1.88	1012	1.97	1035	2.07	1056	2.17	
3000	860	1.49	887	1.60	914	1.70	940	1.81	964	1.92	988	2.03	1012	2.13	1035	2.24	1056	2.35	1079	2.46	
3300	885	1.72	911	1.83	938	1.94	963	2.06	988	2.18	1012	2.30	1035	2.42	1057	2.54	1079	2.65	1100	2.77	
3600	910	1.97	937	2.09	963	2.22	988	2.34	1012	2.46	1035	2.59	1059	2.72	1081	2.85	1104	2.98	1124	3.11	
											3-hp Oversized Motor & Field Supplied High Static Drive <sup>(c)</sup>										

**Notes:**

1. For Evaporator Fan Speed (rpm), reference [Table 137, p. 182](#).
2. Data includes pressure drop due to standard filters and wet coils. No accessories or options are included in pressure drop data.
3. Refer to [Table 144, p. 185](#) to determine additional static pressure drop due to other options/accessories.
4. 1-hp Fan Motor Heat (MBh) = 2.829 x Fan bhp + .4024. 3-hp Fan Motor Heat (MBh) = 2.900 x Fan bhp + .3800
5. Factory supplied motors, in commercial equipment, are definite purpose motors, specifically designed and tested to operate reliably and continuously at all cataloged conditions. Using the full horsepower range of our fan motors as shown in our tabular data will not result in nuisance tripping or premature motor failure. Our product's warranty will not be affected.

(a) BAYLSDR009A  
 (b) BAYHSMT400A  
 (c) Field Supplied AK56 x 1" Fan Sheave

## Evaporator Fan Performance

**Table 70. Belt drive evaporator fan performance - 7½ tons standard efficiency - TSC092F3,4,W horizontal airflow**

External Static Pressure (Inches of Water)																					
		0.10		0.20		0.30		0.40		0.50		0.60		0.70		0.80		0.90		1.00	
cfm	rpm	bhp	rpm	bhp	rpm	bhp	rpm	bhp	rpm	bhp	rpm	bhp	rpm	bhp	rpm	bhp	rpm	bhp	rpm	bhp	
1-hp Standard Motor & Field Supplied Low Static Drive <sup>(a)</sup>											1-hp Standard Motor & Drive										
2400	478	0.36	528	0.43	576	0.52	626	0.62	681	0.75	731	0.88	778	1.02	821	1.15	862	1.29	901	1.43	
2700	526	0.49	570	0.57	614	0.66	656	0.76	701	0.88	751	1.02	797	1.17	840	1.32	880	1.47	920	1.63	
3000	575	0.65	615	0.74	655	0.84	694	0.94	731	1.05	770	1.17	817	1.34	859	1.50	900	1.67	938	1.83	
3300	624	0.84	661	0.94	698	1.04	734	1.15	768	1.27	802	1.39	838	1.52	878	1.69	919	1.87	957	2.05	
3600	675	1.07	709	1.17	742	1.28	776	1.41	809	1.53	840	1.65	871	1.79	903	1.92	939	2.10	977	2.29	
											3-hp Oversized Motor & Drive <sup>(b)</sup>										

Continued

External Static Pressure (Inches of Water)																					
		1.10		1.20		1.30		1.40		1.50		1.60		1.70		1.80		1.90		2.00	
cfm	rpm	bhp	rpm	bhp	rpm	bhp	rpm	bhp	rpm	bhp	rpm	bhp	rpm	bhp	rpm	bhp	rpm	bhp	rpm	bhp	
											3-hp Oversized Motor & Drive <sup>(b)</sup>										
2400	938	1.57	973	1.71	1007	1.86	1038	1.99	1070	2.14	1101	2.29	1130	2.44	1159	2.59	1187	2.74	1214	2.89	
2700	956	1.78	991	1.93	1024	2.08	1057	2.25	1088	2.40	1119	2.56	1149	2.73	1177	2.89	1206	3.06	1233	3.22	
3000	975	2.00	1009	2.16	1044	2.34	1075	2.51	1108	2.69	1138	2.86	1167	3.03	1195	3.21	1222	3.38	—	—	
3300	994	2.24	1028	2.42	1063	2.61	1094	2.79	1126	2.98	1155	3.16	1185	3.35	—	—	—	—	—	—	
3600	1013	2.49	1048	2.69	1081	2.88	1114	3.09	1145	3.29	—	—	—	—	—	—	—	—	—	—	
											3-hp Oversized Motor & Field Supplied High Static Drive <sup>(c)</sup>										

**Notes:**

1. For Evaporator Fan Speed (rpm), reference [Table 137, p. 182](#).
2. Data includes pressure drop due to standard filters and wet coils. No accessories or options are included in pressure drop data.
3. Refer to [Table 144, p. 185](#) to determine additional static pressure drop due to other options/accessories.
4. 1-hp Fan Motor Heat (MBh) = 2.829 x Fan bhp + .4024. 3-hp Fan Motor Heat (MBh) = 2.900 x Fan bhp - .3800
5. Factory supplied motors, in commercial equipment, are definite purpose motors, specifically designed and tested to operate reliably and continuously at all cataloged conditions. Using the full horsepower range of our fan motors as shown in our tabular data will not result in nuisance tripping or premature motor failure. Our product's warranty will not be affected.

(a) BAYLSDR009A  
 (b) BAYHSMT400A  
 (c) Field Supplied AK56 x 1" Fan Sheave



## Evaporator Fan Performance

**Table 71. Belt drive evaporator fan performance - 7½ tons standard efficiency with gas heat YSC092F3,4,W low & medium heat downflow airflow**

External Static Pressure (Inches of Water)																					
		0.10		0.20		0.30		0.40		0.50		0.60		0.70		0.80		0.90		1.00	
cfm	rpm	bhp	rpm	bhp	rpm	bhp	rpm	bhp	rpm	bhp	rpm	bhp	rpm	bhp	rpm	bhp	rpm	bhp	rpm	bhp	
1-hp Standard Motor & Field Supplied Low Static Drive <sup>(a)</sup>											1-hp Standard Motor & Drive										
2400	—	—	500	0.39	549	0.47	594	0.55	636	0.63	674	0.71	709	0.80	742	0.88	772	0.96	800	1.04	
2700	493	0.44	533	0.50	584	0.60	626	0.69	666	0.78	704	0.87	739	0.96	772	1.05	802	1.15	830	1.24	
3000	536	0.58	575	0.65	620	0.75	661	0.86	698	0.95	734	1.05	769	1.15	802	1.25	832	1.35	861	1.46	
3300	580	0.75	620	0.84	653	0.91	696	1.05	732	1.16	766	1.26	799	1.37	831	1.48	862	1.59	891	1.70	
3600	625	0.96	665	1.07	693	1.13	730	1.25	768	1.39	800	1.51	832	1.62	861	1.74	891	1.86	920	1.98	
											3-hp Oversized Motor & Drive <sup>(b)</sup>										

Continued

External Static Pressure (Inches of Water)																					
		1.10		1.20		1.30		1.40		1.50		1.60		1.70		1.80		1.90		2.00	
cfm	rpm	bhp	rpm	bhp	rpm	bhp	rpm	bhp	rpm	bhp	rpm	bhp	rpm	bhp	rpm	bhp	rpm	bhp	rpm	bhp	
1-hp Standard Motor Drive											3-hp Oversized Motor & Drive <sup>(b)</sup>										
2400	828	1.12	855	1.20	881	1.29	905	1.37	928	1.45	952	1.53	974	1.61	996	1.69	1017	1.77	1038	1.86	
2700	858	1.33	884	1.42	909	1.51	933	1.60	957	1.69	980	1.79	1002	1.88	1024	1.97	1044	2.06	1066	2.15	
3000	888	1.56	913	1.66	939	1.77	963	1.87	986	1.97	1008	2.07	1032	2.17	1053	2.27	1073	2.37	1093	2.47	
3300	918	1.82	944	1.93	969	2.04	994	2.16	1016	2.26	1039	2.38	1061	2.49	1082	2.60	1103	2.71	1123	2.83	
3600	948	2.10	974	2.22	1000	2.35	1024	2.47	1046	2.59	1069	2.72	1091	2.84	1112	2.96	1133	3.08	1152	3.20	
											3-hp Oversized Motor & Field Supplied High Static Drive <sup>(c)</sup>										

**Notes:**

1. For Evaporator Fan Speed (rpm), reference [Table 137, p. 182](#).
2. Data includes pressure drop due to standard filters and wet coils. No accessories or options are included in pressure drop data.
3. Refer to [Table 144, p. 185](#) to determine additional static pressure drop due to other options/accessories.
4. 2-hp Fan Motor Heat (MBh) = 3.100 x Fan bhp + .200. 3-hp Fan Motor Heat (MBh) = 2.900 x Fan bhp - .3800
5. Factory supplied motors, in commercial equipment, are definite purpose motors, specifically designed and tested to operate reliably and continuously at all cataloged conditions. Using the full horsepower range of our fan motors as shown in our tabular data will not result in nuisance tripping or premature motor failure. Our product's warranty will not be affected.

(a) BAYLSDR009A  
 (b) BAYHSMT400A  
 (c) Field Supplied AK56 x 1" Fan Sheave

## Evaporator Fan Performance

**Table 72. Belt drive evaporator fan performance - 7½ tons standard efficiency with gas heat YSC092F3,4,W low & medium heat horizontal airflow**

External Static Pressure (Inches of Water)																					
		0.10		0.20		0.30		0.40		0.50		0.60		0.70		0.80		0.90		1.00	
cfm	rpm	bhp	rpm	bhp	rpm	bhp	rpm	bhp	rpm	bhp	rpm	bhp	rpm	bhp	rpm	bhp	rpm	bhp	rpm	bhp	
1-hp Standard Motor & Field Supplied Low Static Drive <sup>(a)</sup>											1-hp Standard Motor & Drive										
2400	527	0.43	573	0.51	615	0.59	656	0.68	693	0.77	728	0.86	760	0.95	791	1.04	819	1.13	847	1.22	
2700	581	0.59	624	0.68	663	0.77	699	0.86	736	0.96	770	1.07	801	1.17	830	1.27	859	1.37	886	1.47	
3000	636	0.78	675	0.88	712	0.98	747	1.09	779	1.19	812	1.30	843	1.42	872	1.53	899	1.64	926	1.75	
3300	692	1.02	728	1.13	763	1.24	795	1.35	827	1.47	856	1.58	886	1.70	915	1.83	942	1.95	968	2.08	
3600	748	1.30	782	1.42	814	1.54	845	1.66	874	1.78	903	1.91	929	2.04	957	2.17	985	2.30	1010	2.44	
3-hp Oversized Motor & Drive <sup>(b)</sup>																					

Continued

External Static Pressure (Inches of Water)																					
		1.10		1.20		1.30		1.40		1.50		1.60		1.70		1.80		1.90		2.00	
cfm	rpm	bhp	rpm	bhp	rpm	bhp	rpm	bhp	rpm	bhp	rpm	bhp	rpm	bhp	rpm	bhp	rpm	bhp	rpm	bhp	
1-hp Standard Motor & Drive											3-hp Oversized Motor & Drive <sup>(b)</sup>										
2400	873	1.31	899	1.40	923	1.48	946	1.57	969	1.66	992	1.75	1013	1.84	1034	1.93	1054	2.02	1074	2.11	
2700	912	1.57	937	1.67	961	1.77	984	1.87	1007	1.97	1028	2.07	1050	2.17	1071	2.27	1090	2.36	1110	2.47	
3000	951	1.86	976	1.97	1000	2.09	1023	2.20	1045	2.31	1067	2.42	1088	2.53	1107	2.64	1128	2.75	1147	2.86	
3300	992	2.20	1016	2.32	1040	2.44	1062	2.57	1084	2.68	1105	2.81	1126	2.93	1147	3.06	1166	3.17	1186	3.30	
3600	1034	2.57	1057	2.70	1081	2.84	1103	2.98	1124	3.11	1145	3.24	1165	3.37	—	—	—	—	—	—	
3-hp Oversized Motor & Field Supplied High Static Drive <sup>(c)</sup>																					

**Notes:**

1. For Evaporator Fan Speed (rpm), reference [Table 137, p. 182](#).
2. Data includes pressure drop due to standard filters and wet coils. No accessories or options are included in pressure drop data.
3. Refer to [Table 144, p. 185](#) to determine additional static pressure drop due to other options/accessories.
4. 1-hp Fan Motor Heat (MBh) = 2.829 x Fan bhp + .4024. 3-hp Fan Motor Heat (MBh) = 2.900 x Fan bhp - .3800
5. Factory supplied motors, in commercial equipment, are definite purpose motors, specifically designed and tested to operate reliably and continuously at all cataloged conditions. Using the full horsepower range of our fan motors as shown in our tabular data will not result in nuisance tripping or premature motor failure. Our product's warranty will not be affected.

(a) BAYLSDR009A

(b) BAYHSMT400A

(c) Field Supplied AK56 x 1" Fan Sheave



## Evaporator Fan Performance

**Table 73. Belt drive evaporator fan performance - 7½ tons standard efficiency with gas heat YSC092F3,4,W high heat downflow airflow**

External Static Pressure (Inches of Water)																					
		0.10		0.20		0.30		0.40		0.50		0.60		0.70		0.80		0.90		1.00	
cfm	rpm	bhp	rpm	bhp	rpm	bhp	rpm	bhp	rpm	bhp	rpm	bhp	rpm	bhp	rpm	bhp	rpm	bhp	rpm	bhp	
1-hp Standard Motor & Field Supplied Low Static Drive <sup>(a)</sup>											1-hp Standard Motor & Drive										
2400	—	—	508	0.40	556	0.48	603	0.56	645	0.65	683	0.73	718	0.81	751	0.90	782	0.98	811	1.06	
2700	500	0.45	549	0.54	592	0.61	635	0.70	676	0.80	714	0.89	749	0.99	782	1.08	812	1.17	842	1.27	
3000	545	0.60	591	0.70	630	0.78	669	0.87	707	0.97	744	1.08	780	1.18	812	1.28	843	1.39	873	1.49	
3300	591	0.77	632	0.88	672	0.98	706	1.07	741	1.18	776	1.29	810	1.40	842	1.52	874	1.63	903	1.75	
3600	637	0.98	675	1.10	713	1.22	747	1.32	778	1.42	810	1.53	843	1.65	874	1.78	904	1.90	933	2.03	
											3-hp Oversized Motor & Drive <sup>(b)</sup>										

Continued

External Static Pressure (Inches of Water)																					
		1.10		1.20		1.30		1.40		1.50		1.60		1.70		1.80		1.90		2.00	
cfm	rpm	bhp	rpm	bhp	rpm	bhp	rpm	bhp	rpm	bhp	rpm	bhp	rpm	bhp	rpm	bhp	rpm	bhp	rpm	bhp	
1-hp Standard Motor & Drive											3-hp Oversized Motor & Drive <sup>(b)</sup>										
2400	839	1.15	866	1.23	891	1.31	916	1.39	941	1.48	963	1.56	986	1.64	1008	1.73	1029	1.81	1050	1.89	
2700	869	1.36	895	1.45	921	1.54	946	1.64	969	1.73	992	1.82	1015	1.92	1037	2.01	1058	2.11	1078	2.20	
3000	900	1.59	926	1.70	952	1.80	975	1.90	999	2.01	1022	2.11	1044	2.22	1066	2.32	1088	2.43	1108	2.53	
3300	930	1.86	957	1.98	983	2.09	1007	2.21	1029	2.31	1053	2.43	1075	2.55	1096	2.66	1117	2.77	1137	2.88	
3600	961	2.15	987	2.28	1013	2.41	1037	2.53	1061	2.65	1083	2.78	1105	2.90	1127	3.03	1147	3.15	1168	3.28	
											3-hp Oversized Motor & Field Supplied High Static Drive <sup>(c)</sup>										

**Notes:**

1. For Evaporator Fan Speed (rpm), reference [Table 137, p. 182](#).
2. Data includes pressure drop due to standard filters and wet coils. No accessories or options are included in pressure drop data.
3. Refer to [Table 144, p. 185](#) to determine additional static pressure drop due to other options/accessories.
4. 1-hp Fan Motor Heat (MBh) = 2.829 x Fan bhp + .4024. 3-hp Fan Motor Heat (MBh) = 2.900 x Fan bhp - .3800
5. Factory supplied motors, in commercial equipment, are definite purpose motors, specifically designed and tested to operate reliably and continuously at all cataloged conditions. Using the full horsepower range of our fan motors as shown in our tabular data will not result in nuisance tripping or premature motor failure. Our product's warranty will not be affected.

- (a) BAYLSDR009A  
 (b) BAYHSMT400A  
 (c) Field Supplied AK56 x 1" Fan Sheave

## Evaporator Fan Performance

**Table 74. Belt drive evaporator fan performance - 7½ tons standard efficiency with gas heat YSC092F3,4,W high heat horizontal airflow**

External Static Pressure (Inches of Water)																					
		0.10		0.20		0.30		0.40		0.50		0.60		0.70		0.80		0.90		1.00	
cfm	rpm	bhp	rpm	bhp	rpm	bhp	rpm	bhp	rpm	bhp	rpm	bhp	rpm	bhp	rpm	bhp	rpm	bhp	rpm	bhp	
1-hp Standard Motor & Field Supplied Low Static Drive <sup>(a)</sup>											1-hp Standard Motor & Drive										
2400	548	0.47	593	0.56	635	0.64	674	0.74	709	0.82	744	0.92	777	1.01	808	1.10	837	1.20	865	1.29	
2700	605	0.65	647	0.74	686	0.84	721	0.94	756	1.04	787	1.14	818	1.24	849	1.35	878	1.45	905	1.56	
3000	663	0.86	702	0.97	737	1.08	772	1.18	803	1.29	834	1.41	864	1.52	891	1.63	919	1.74	946	1.86	
3300	722	1.12	757	1.24	791	1.36	823	1.48	853	1.59	882	1.72	911	1.85	938	1.97	964	2.09	988	2.21	
3600	782	1.44	814	1.56	846	1.69	875	1.82	905	1.95	933	2.08	959	2.21	985	2.35	1010	2.49	1034	2.62	
3-hp Oversized Motor & Drive <sup>(b)</sup>																					

Continued

External Static Pressure (Inches of Water)																					
		1.10		1.20		1.30		1.40		1.50		1.60		1.70		1.80		1.90		2.00	
cfm	rpm	bhp	rpm	bhp	rpm	bhp	rpm	bhp	rpm	bhp	rpm	bhp	rpm	bhp	rpm	bhp	rpm	bhp	rpm	bhp	
1-hp Standard Motor & Drive											3-hp Oversized Motor & Drive <sup>(b)</sup>										
2400	892	1.38	917	1.48	942	1.57	966	1.66	989	1.76	1012	1.85	1034	1.94	1055	2.04	1076	2.14	1096	2.23	
2700	931	1.66	957	1.77	982	1.87	1005	1.98	1027	2.08	1050	2.19	1072	2.29	1093	2.40	1113	2.50	1133	2.61	
3000	972	1.98	997	2.10	1021	2.21	1044	2.33	1067	2.45	1089	2.56	1111	2.68	1131	2.80	1152	2.91	1171	3.03	
3300	1014	2.34	1038	2.46	1062	2.59	1085	2.72	1107	2.85	1129	2.98	1151	3.11	1171	3.24	1192	3.37	—	—	
3600	1058	2.75	1081	2.88	1105	3.02	1127	3.16	1149	3.30	1171	3.45	—	—	—	—	—	—	—	—	
3-hp Oversized Motor & Field Supplied High Static Drive <sup>(c)</sup>																					

**Notes:**

1. For Evaporator Fan Speed (rpm), reference [Table 137, p. 182](#).
2. Data includes pressure drop due to standard filters and wet coils. No accessories or options are included in pressure drop data.
3. Refer to [Table 144, p. 185](#) to determine additional static pressure drop due to other options/accessories.
4. 1-hp Fan Motor Heat (MBh) = 2.829 x Fan bhp + .4024. 3-hp Fan Motor Heat (MBh) = 2.900 x Fan bhp - .3800
5. Factory supplied motors, in commercial equipment, are definite purpose motors, specifically designed and tested to operate reliably and continuously at all cataloged conditions. Using the full horsepower range of our fan motors as shown in our tabular data will not result in nuisance tripping or premature motor failure. Our product's warranty will not be affected.

(a) BAYLSDR009A

(b) BAYHSMT400A

(c) Field Supplied AK56 x 1" Fan Sheave



## Evaporator Fan Performance

**Table 75. Belt drive evaporator fan performance - 8½ tons standard efficiency - TSC102F3,4,W downflow airflow**

External Static Pressure (Inches of Water)																					
		0.10		0.20		0.30		0.40		0.50		0.60		0.70		0.80		0.90		1.00	
cfm	rpm	bhp	rpm	bhp	rpm	bhp	rpm	bhp	rpm	bhp	rpm	bhp	rpm	bhp	rpm	bhp	rpm	bhp	rpm	bhp	
<b>2-hp Standard Motor &amp; Field Supplied Low Static Drive Accessory Kit<sup>(a)</sup></b>																					
2720	—	—	539	0.44	584	0.53	626	0.64	668	0.76	708	0.88	746	1.00	781	1.12	814	1.26	845	1.40	
3060	—	—	583	0.58	626	0.68	665	0.78	703	0.90	740	1.04	775	1.17	810	1.30	843	1.44	875	1.58	
3400	—	—	628	0.72	669	0.84	706	0.96	741	1.08	775	1.21	809	1.36	841	1.51	873	1.65	904	1.81	
3740	641	0.81	677	0.92	713	1.04	749	1.17	781	1.30	813	1.43	845	1.58	875	1.73	905	1.89	935	2.06	
4080	693	1.03	726	1.15	758	1.27	792	1.41	824	1.56	854	1.69	883	1.83	912	1.99	940	2.16	968	2.33	
<b>2-hp Standard Motor &amp; Drive</b>																					

Continued

External Static Pressure (Inches of Water)																					
		1.10		1.20		1.30		1.40		1.50		1.60		1.70		1.80		1.90		2.00	
cfm	rpm	bhp	rpm	bhp	rpm	bhp	rpm	bhp	rpm	bhp	rpm	bhp	rpm	bhp	rpm	bhp	rpm	bhp	rpm	bhp	
<b>2-hp Standard Motor &amp; Drive</b>											<b>3-hp Oversized Motor &amp; Drive</b>										
2720	874	1.54	904	1.69	930	1.84	958	2.00	983	2.14	1010	2.30	1035	2.46	1060	2.62	1084	2.78	1109	2.95	
3060	905	1.73	933	1.89	960	2.05	986	2.20	1010	2.37	1035	2.54	1059	2.71	1083	2.89	1107	3.06	1131	3.24	
3400	933	1.96	962	2.11	990	2.27	1016	2.44	1041	2.62	1065	2.79	1089	2.97	1112	3.15	1134	3.34	—	—	
3740	964	2.22	992	2.39	1018	2.55	1045	2.72	1071	2.90	1095	3.08	1118	3.26	1141	3.45	—	—	—	—	
4080	995	2.51	1023	2.69	1048	2.86	1075	3.05	1100	3.23	1124	3.41	—	—	—	—	—	—	—	—	

**Notes:**

1. For Standard Evaporator Fan Speed (rpm), reference [Table 137, p. 182](#).
2. Data includes pressure drop due to standard filters and wet coils. No accessories or options are included in pressure drop data.
3. Refer to [Table 144, p. 185](#) to determine additional static pressure drop due to other options/accessories.
4. 1 hp Fan Motor Heat (MBh) = 2.829 x Fan bhp + .4024. 2-hp Fan Motor Heat (MBh) = 2.000 x Fan bhp + .5000. 3-hp Fan Motor Heat (MBh) = 2.900 x Fan bhp + .4750
5. Factory supplied motors, in commercial equipment, are definite purpose motors, specifically designed and tested to operate reliably and continuously at all cataloged conditions. Using the full horsepower range of our fan motors as shown in our tabular data will not result in nuisance tripping or premature motor failure. Our product's warranty will not be affected.

(a) BAYLSDR009A Required.



## Evaporator Fan Performance

**Table 76. Belt drive evaporator fan performance - 8½ tons standard efficiency - TSC102F3,4,W horizontal airflow**

External Static Pressure (Inches of Water)																					
		0.10		0.20		0.30		0.40		0.50		0.60		0.70		0.80		0.90		1.00	
cfm	rpm	bhp	rpm	bhp	rpm	bhp	rpm	bhp	rpm	bhp	rpm	bhp	rpm	bhp	rpm	bhp	rpm	bhp	rpm	bhp	
<b>2-hp Standard Motor &amp; Field Supplied Low Static Drive Accessory Kit<sup>(a)</sup></b>																					
2720	570	0.52	612	0.60	660	0.71	703	0.81	751	0.95	798	1.09	841	1.23	877	1.36	909	1.48	939	1.60	
3060	631	0.72	667	0.80	709	0.91	750	1.03	788	1.15	830	1.29	873	1.45	914	1.62	951	1.77	983	1.92	
3400	692	0.96	726	1.05	760	1.15	800	1.29	836	1.42	870	1.56	907	1.71	945	1.88	984	2.06	1020	2.24	
3740	754	1.26	786	1.36	815	1.46	850	1.59	886	1.74	918	1.88	949	2.03	980	2.19	1015	2.37	1052	2.57	
4080	817	1.61	848	1.72	874	1.83	903	1.95	935	2.10	968	2.26	998	2.42	1026	2.58	1054	2.75	1085	2.94	
<b>2-hp Standard Motor &amp; Drive</b>												<b>3-hp Standard Motor &amp; Drive</b>									

Continued

External Static Pressure (Inches of Water)																					
		1.10		1.20		1.30		1.40		1.50		1.60		1.70		1.80		1.90		2.00	
cfm	rpm	bhp	rpm	bhp	rpm	bhp	rpm	bhp	rpm	bhp	rpm	bhp	rpm	bhp	rpm	bhp	rpm	bhp	rpm	bhp	
<b>2-hp Standard Motor &amp; Drive</b>											<b>3-hp Oversized Motor &amp; Drive</b>										
2720	967	1.72	994	1.84	1018	1.96	1042	2.07	1066	2.19	1089	2.31	1112	2.43	1134	2.55	1155	2.67	1176	2.79	
3080	1012	2.06	1039	2.19	1065	2.32	1090	2.46	1113	2.59	1136	2.73	1158	2.86	1179	2.99	1199	3.12	1220	3.26	
3400	1052	2.41	1083	2.58	1109	2.73	1135	2.88	1159	3.04	1183	3.19	1204	3.33	—	—	—	—	—	—	
3740	1086	2.77	1119	2.96	1149	3.15	1178	3.34	—	—	—	—	—	—	—	—	—	—	—	—	
4080	1117	3.14	1151	3.36	—	—	—	—	—	—	—	—	—	—	—	—	—	—	—	—	

**Notes:**

1. For Standard Evaporator Fan Speed (rpm), reference [Table 137, p. 182](#).
2. Data includes pressure drop due to standard filters and wet coils. No accessories or options are included in pressure drop data.
3. Refer to [Table 144, p. 185](#) to determine additional static pressure drop due to other options/accessories.
4. 1 hp Fan Motor Heat (MBh) = 2.829 x Fan bhp + .4024. 2-hp Fan Motor Heat (MBh) = 2.000 x Fan bhp + .5000. 3-hp Fan Motor Heat (MBh) = 2.900 x Fan bhp + .4750
5. Factory supplied motors, in commercial equipment, are definite purpose motors, specifically designed and tested to operate reliably and continuously at all cataloged conditions. Using the full horsepower range of our fan motors as shown in our tabular data will not result in nuisance tripping or premature motor failure. Our product's warranty will not be affected.

(a) BAYLSDR009A required.



## Evaporator Fan Performance

**Table 77. Belt drive evaporator fan performance - 8½ tons standard efficiency with gas heat - YSC102F3,4,W\*L low heat downflow airflow**

External Static Pressure (Inches of Water)																					
		0.10		0.20		0.30		0.40		0.50		0.60		0.70		0.80		0.90		1.00	
cfm	rpm	bhp	rpm	bhp	rpm	bhp	rpm	bhp	rpm	bhp	rpm	bhp	rpm	bhp	rpm	bhp	rpm	bhp	rpm	bhp	
<b>2-hp Standard Motor &amp; Field Supplied Low Static Drive<sup>(a)</sup></b>																					
2720	—	—	—	—	621	0.62	662	0.74	703	0.86	741	0.98	777	1.11	810	1.24	841	1.38	871	1.52	
3060	587	0.58	630	0.69	668	0.79	707	0.92	743	1.05	779	1.18	814	1.32	846	1.45	878	1.60	907	1.75	
3400	643	0.77	683	0.89	718	1.00	753	1.13	787	1.26	820	1.41	853	1.56	884	1.71	915	1.86	944	2.02	
3740	699	0.99	736	1.12	770	1.25	802	1.38	833	1.52	864	1.67	894	1.83	925	2.00	953	2.16	982	2.33	
4080	757	1.26	790	1.40	823	1.55	853	1.69	882	1.83	910	1.98	938	2.15	967	2.32	994	2.50	1021	2.68	
<b>2-hp Standard Motor &amp; Drive</b>										<b>3-hp Oversized Motor &amp; Drive</b>											

Continued

External Static Pressure (Inches of Water)																					
		1.10		1.20		1.30		1.40		1.50		1.60		1.70		1.80		1.90		2.00	
cfm	rpm	bhp	rpm	bhp	rpm	bhp	rpm	bhp	rpm	bhp	rpm	bhp	rpm	bhp	rpm	bhp	rpm	bhp	rpm	bhp	
<b>2-hp Standard Motor &amp; Drive</b>										<b>3-hp Oversized Motor &amp; Drive</b>											
2720	900	1.67	927	1.82	954	1.97	980	2.12	1006	2.28	1032	2.44	1057	2.60	1082	2.76	1105	2.92	1129	3.09	
3060	936	1.90	962	2.06	989	2.22	1014	2.39	1039	2.56	1062	2.73	1085	2.90	1109	3.07	1133	3.25	1155	3.43	
3400	973	2.17	999	2.34	1025	2.51	1050	2.68	1074	2.86	1097	3.04	1120	3.22	1142	3.41	—	—	—	—	
3740	1010	2.50	1036	2.66	1062	2.84	1087	3.01	1110	3.19	1134	3.39	—	—	—	—	—	—	—	—	
4080	1047	2.86	1073	3.04	1098	3.22	1123	3.40	—	—	—	—	—	—	—	—	—	—	—	—	

**Notes:**

1. For Standard Evaporator Fan Speed (rpm), reference [Table 137, p. 182](#).
2. Data includes pressure drop due to standard filters and wet coils. No accessories or options are included in pressure drop data.
3. Refer to [Table 144, p. 185](#) to determine additional static pressure drop due to other options/accessories.
4. 2-hp Fan Motor Heat (MBh) = 2.000 x Fan bhp + .5000. 3-hp Fan Motor Heat (MBh) = 2.900 x Fan bhp + .4750
5. Factory supplied motors, in commercial equipment, are definite purpose motors, specifically designed and tested to operate reliably and continuously at all cataloged conditions. Using the full horsepower range of our fan motors as shown in our tabular data will not result in nuisance tripping or premature motor failure. Our product's warranty will not be affected.

(a) Field Supplied Fan Sheave AK79 and Belt AX38 required.

## Evaporator Fan Performance

**Table 78. Belt drive evaporator fan performance - 8½ tons standard efficiency with gas heat - YSC102F3,4,W\*L low heat horizontal airflow**

External Static Pressure (Inches of Water)																					
		0.10		0.20		0.30		0.40		0.50		0.60		0.70		0.80		0.90		1.00	
cfm	rpm	bhp	rpm	bhp	rpm	bhp	rpm	bhp	rpm	bhp	rpm	bhp	rpm	bhp	rpm	bhp	rpm	bhp	rpm	bhp	
2-hp Standard Motor & Field Supplied Low Static Drive <sup>(a)</sup>										2-hp Standard Motor & Drive											
2720	622	0.62	669	0.73	711	0.84	760	0.97	807	1.12	849	1.26	884	1.38	915	1.50	944	1.62	972	1.74	
3060	688	0.85	732	0.97	770	1.09	809	1.22	853	1.38	895	1.54	934	1.70	968	1.85	998	1.99	1026	2.13	
3400	756	1.14	795	1.27	832	1.40	866	1.54	901	1.69	941	1.86	979	2.04	1015	2.22	1049	2.40	1079	2.56	
3740	824	1.49	859	1.62	895	1.78	926	1.92	957	2.07	990	2.24	1025	2.42	1061	2.62	1095	2.82	1127	3.02	
4080	893	1.90	925	2.05	958	2.21	988	2.37	1017	2.53	1046	2.70	1075	2.88	1108	3.08	1140	3.29	—	—	
3-hp Oversized Motor & Drive																					

Continued

External Static Pressure (Inches of Water)																					
		1.10		1.20		1.30		1.40		1.50		1.60		1.70		1.80		1.90		2.00	
cfm	rpm	bhp	rpm	bhp	rpm	bhp	rpm	bhp	rpm	bhp	rpm	bhp	rpm	bhp	rpm	bhp	rpm	bhp	rpm	bhp	
2-hp Standard Motor & Drive										3-hp Oversized Motor & Drive											
2720	998	1.86	1024	1.98	1047	2.10	1071	2.22	1094	2.33	1115	2.45	1138	2.57	1159	2.69	1181	2.82	1201	2.94	
3060	1053	2.26	1078	2.39	1102	2.53	1125	2.66	1146	2.79	1169	2.93	1190	3.06	1210	3.19	1230	3.32	1250	3.45	
3400	1106	2.71	1131	2.86	1156	3.02	1179	3.16	1201	3.31	1223	3.45	—	—	—	—	—	—	—	—	
3740	1158	3.21	1185	3.39	—	—	—	—	—	—	—	—	—	—	—	—	—	—	—	—	
4080	—	—	—	—	—	—	—	—	—	—	—	—	—	—	—	—	—	—	—	—	

**Notes:**

1. For Standard Evaporator Fan Speed (rpm), reference [Table 137, p. 182](#).
2. Data includes pressure drop due to standard filters and wet coils. No accessories or options are included in pressure drop data.
3. Refer to [Table 144, p. 185](#) to determine additional static pressure drop due to other options/accessories.
4. 2-hp Fan Motor Heat (MBh) = 2.000 x Fan bhp + .5000. 3-hp Fan Motor Heat (MBh) = 2.900 x Fan bhp + .4750.
5. Factory supplied motors, in commercial equipment, are definite purpose motors, specifically designed and tested to operate reliably and continuously at all cataloged conditions. Using the full horsepower range of our fan motors as shown in our tabular data will not result in nuisance tripping or premature motor failure. Our product's warranty will not be affected.

(a) Field Supplied Fan Sheave AK79 and Belt AX38 required.



## Evaporator Fan Performance

**Table 79. Belt drive evaporator fan performance - 8½ tons with gas heat - YSC102F3,4,W\*M medium heat downflow airflow**

External Static Pressure (Inches of Water)																					
		0.10		0.20		0.30		0.40		0.50		0.60		0.70		0.80		0.90		1.00	
cfm	rpm	bhp	rpm	bhp	rpm	bhp	rpm	bhp	rpm	bhp	rpm	bhp	rpm	bhp	rpm	bhp	rpm	bhp	rpm	bhp	
<b>2-hp Standard Motor &amp; Field Supplied Low Static Drive<sup>(a)</sup></b>																					
2720	—	—	—	—	623	0.63	664	0.75	704	0.87	742	0.99	778	1.11	811	1.24	842	1.38	872	1.53	
3060	589	0.58	632	0.69	670	0.80	709	0.92	745	1.06	781	1.19	815	1.32	848	1.46	880	1.60	909	1.75	
3400	645	0.77	685	0.89	721	1.01	755	1.13	789	1.27	822	1.42	854	1.57	886	1.72	916	1.87	945	2.02	
3740	702	1.00	739	1.14	772	1.26	804	1.39	836	1.53	867	1.69	897	1.85	926	2.01	956	2.18	984	2.34	
4080	759	1.27	793	1.42	826	1.56	856	1.70	884	1.84	913	2.00	941	2.16	969	2.34	996	2.52	1024	2.70	
<b>2-hp Standard Motor &amp; Drive</b>										<b>3-hp Oversized Motor &amp; Drive</b>											

Continued

External Static Pressure (Inches of Water)																					
		1.10		1.20		1.30		1.40		1.50		1.60		1.70		1.80		1.90		2.00	
cfm	rpm	bhp	rpm	bhp	rpm	bhp	rpm	bhp	rpm	bhp	rpm	bhp	rpm	bhp	rpm	bhp	rpm	bhp	rpm	bhp	
<b>2-hp Standard Motor &amp; Drive</b>										<b>3-hp Oversized Motor &amp; Drive</b>											
2720	900	1.67	928	1.82	955	1.98	982	2.14	1008	2.29	1033	2.45	1057	2.60	1083	2.77	1107	2.94	1129	3.10	
3060	936	1.91	964	2.07	989	2.23	1015	2.39	1039	2.56	1063	2.73	1088	2.92	1111	3.09	1134	3.26	1157	3.44	
3400	974	2.18	1001	2.35	1027	2.52	1051	2.69	1075	2.87	1098	3.05	1121	3.23	1144	3.42	—	—	—	—	
3740	1011	2.50	1038	2.68	1064	2.85	1089	3.03	1113	3.22	1135	3.40	—	—	—	—	—	—	—	—	
4080	1050	2.87	1076	3.05	1101	3.24	1126	3.43	—	—	—	—	—	—	—	—	—	—	—	—	

**Notes:**

1. For Standard Evaporator Fan Speed (rpm), reference [Table 137, p. 182](#).
2. Data includes pressure drop due to standard filters and wet coils. No accessories or options are included in pressure drop data.
3. Refer to [Table 144, p. 185](#) to determine additional static pressure drop due to other options/accessories.
4. 2-hp Fan Motor Heat (MBh) = 2.000 x Fan bhp + .5000. 3-hp Fan Motor Heat (MBh) = 2.900 x Fan bhp + .4750
5. Factory supplied motors, in commercial equipment, are definite purpose motors, specifically designed and tested to operate reliably and continuously at all cataloged conditions. Using the full horsepower range of our fan motors as shown in our tabular data will not result in nuisance tripping or premature motor failure. Our product's warranty will not be affected.

(a) Field Supplied Fan Sheave AK79 and Belt AX38 required.

## Evaporator Fan Performance

**Table 80. Belt drive evaporator fan performance - 8½ tons with gas heat - YSC102F3,4,W\*M medium heat horizontal airflow**

External Static Pressure (Inches of Water)																					
		0.10		0.20		0.30		0.40		0.50		0.60		0.70		0.80		0.90		1.00	
cfm	rpm	bhp	rpm	bhp	rpm	bhp	rpm	bhp	rpm	bhp	rpm	bhp	rpm	bhp	rpm	bhp	rpm	bhp	rpm	bhp	
2-hp Standard Motor & Field Supplied Low Static Drive <sup>(a)</sup>										2-hp Standard Motor & Drive											
2720	625	0.62	671	0.73	714	0.84	763	0.98	809	1.13	851	1.27	885	1.39	917	1.51	946	1.63	974	1.75	
3060	691	0.86	734	0.98	772	1.10	812	1.23	856	1.39	897	1.55	936	1.71	970	1.86	1001	2.00	1028	2.14	
3400	759	1.15	798	1.28	835	1.41	868	1.55	904	1.70	943	1.87	982	2.05	1019	2.23	1052	2.41	1082	2.57	
3740	827	1.50	863	1.64	898	1.79	930	1.94	960	2.09	994	2.26	1029	2.44	1064	2.64	1098	2.84	1130	3.03	
4080	897	1.92	929	2.07	962	2.23	992	2.39	1021	2.55	1049	2.72	1079	2.90	1112	3.10	1144	3.31	—	—	
3-hp Oversized Motor & Drive																					

Continued

External Static Pressure (Inches of Water)																					
		1.10		1.20		1.30		1.40		1.50		1.60		1.70		1.80		1.90		2.00	
cfm	rpm	bhp	rpm	bhp	rpm	bhp	rpm	bhp	rpm	bhp	rpm	bhp	rpm	bhp	rpm	bhp	rpm	bhp	rpm	bhp	
2-hp Standard Motor & Drive										3-hp Oversized Motor & Drive											
2720	1000	1.87	1025	1.99	1048	2.10	1072	2.22	1095	2.34	1117	2.46	1139	2.58	1161	2.70	1182	2.82	1203	2.95	
3060	1054	2.27	1080	2.41	1103	2.53	1126	2.67	1149	2.80	1170	2.93	1192	3.07	1211	3.20	1231	3.33	—	—	
3400	1108	2.73	1134	2.88	1158	3.03	1181	3.17	1204	3.33	—	—	—	—	—	—	—	—	—	—	
3740	1160	3.23	1187	3.41	—	—	—	—	—	—	—	—	—	—	—	—	—	—	—	—	
4080	—	—	—	—	—	—	—	—	—	—	—	—	—	—	—	—	—	—	—	—	

**Notes:**

1. For Standard Evaporator Fan Speed (rpm), reference [Table 137, p. 182](#).
2. Data includes pressure drop due to standard filters and wet coils. No accessories or options are included in pressure drop data.
3. Refer to [Table 144, p. 185](#) to determine additional static pressure drop due to other options/accessories.
4. 2-hp Fan Motor Heat (MBh) = 2.000 x Fan bhp + .5000. 3-hp Fan Motor Heat (MBh) = 2.900 x Fan bhp + .4750
5. Factory supplied motors, in commercial equipment, are definite purpose motors, specifically designed and tested to operate reliably and continuously at all cataloged conditions. Using the full horsepower range of our fan motors as shown in our tabular data will not result in nuisance tripping or premature motor failure. Our product's warranty will not be affected.

(a) Field Supplied Fan Sheave AK79 and Belt AX38 required.



## Evaporator Fan Performance

**Table 81. Belt drive evaporator fan performance - 8½ tons standard efficiency with gas heat - YSC102F3,4,W\*H high heat downflow airflow**

External Static Pressure (Inches of Water)																					
		0.10		0.20		0.30		0.40		0.50		0.60		0.70		0.80		0.90		1.00	
cfm	rpm	bhp	rpm	bhp	rpm	bhp	rpm	bhp	rpm	bhp	rpm	bhp	rpm	bhp	rpm	bhp	rpm	bhp	rpm	bhp	
<b>2-hp Standard Motor &amp; Field Supplied Low Static Drive<sup>(a)</sup></b>																					
2720	—	—	590	0.55	633	0.66	674	0.77	713	0.89	750	1.01	786	1.14	818	1.28	850	1.42	879	1.56	
3060	602	0.62	643	0.72	682	0.83	719	0.96	756	1.09	791	1.23	825	1.36	857	1.50	889	1.65	917	1.80	
3400	660	0.82	698	0.94	733	1.05	767	1.18	801	1.32	834	1.48	866	1.62	897	1.77	927	1.92	956	2.08	
3740	718	1.06	754	1.19	787	1.32	818	1.45	849	1.60	880	1.76	910	1.92	939	2.08	968	2.24	996	2.41	
4080	777	1.35	811	1.49	841	1.63	870	1.77	899	1.92	928	2.08	956	2.26	983	2.43	1011	2.61	1037	2.79	
<b>2-hp Standard Motor &amp; Drive</b>												<b>3-hp Oversized Motor &amp; Drive</b>									

Continued

External Static Pressure (Inches of Water)																					
		1.10		1.20		1.30		1.40		1.50		1.60		1.70		1.80		1.90		2.00	
cfm	rpm	bhp	rpm	bhp	rpm	bhp	rpm	bhp	rpm	bhp	rpm	bhp	rpm	bhp	rpm	bhp	rpm	bhp	rpm	bhp	
<b>2-hp Standard Motor &amp; Drive</b>										<b>3-hp Oversized Motor &amp; Drive</b>											
2720	907	1.71	934	1.86	960	2.01	987	2.17	1014	2.33	1039	2.48	1063	2.64	1088	2.81	1112	2.97	1134	3.13	
3060	945	1.95	971	2.11	997	2.28	1022	2.45	1047	2.62	1070	2.79	1094	2.96	1117	3.14	1141	3.31	—	—	
3400	985	2.24	1010	2.40	1036	2.58	1060	2.76	1084	2.93	1106	3.11	1130	3.31	—	—	—	—	—	—	
3740	1023	2.58	1049	2.75	1075	2.93	1099	3.11	1122	3.29	—	—	—	—	—	—	—	—	—	—	
4080	1063	2.96	1089	3.15	1114	3.34	—	—	—	—	—	—	—	—	—	—	—	—	—	—	

**Notes:**

1. For Standard Evaporator Fan Speed (rpm), reference [Table 137, p. 182](#).
2. Data includes pressure drop due to standard filters and wet coils. No accessories or options are included in pressure drop data.
3. Refer to [Table 144, p. 185](#) to determine additional static pressure drop due to other options/accessories.
4. 2-hp Fan Motor Heat (MBh) = 2.000 x Fan bhp + .5000. 3-hp Fan Motor Heat (MBh) = 2.900 x Fan bhp + .4750
5. Factory supplied motors, in commercial equipment, are definite purpose motors, specifically designed and tested to operate reliably and continuously at all cataloged conditions. Using the full horsepower range of our fan motors as shown in our tabular data will not result in nuisance tripping or premature motor failure. Our product's warranty will not be affected.

(a) Field Supplied Fan Sheave AK79 and Belt AX38 required.

## Evaporator Fan Performance

**Table 82. Belt drive evaporator fan performance - 8½ tons standard efficiency with gas heat - YSC102F3,4,W\*H high heat horizontal airflow**

External Static Pressure (Inches of Water)																					
		0.10		0.20		0.30		0.40		0.50		0.60		0.70		0.80		0.90		1.00	
cfm	rpm	bhp	rpm	bhp	rpm	bhp	rpm	bhp	rpm	bhp	rpm	bhp	rpm	bhp	rpm	bhp	rpm	bhp	rpm	bhp	
2-hp Standard Motor & Field Supplied Low Static Drive <sup>(a)</sup>										2-hp Standard Motor & Drive											
2720	640	0.66	684	0.77	729	0.89	778	1.03	823	1.17	863	1.31	896	1.43	926	1.55	955	1.67	982	1.79	
3060	709	0.91	750	1.03	788	1.15	829	1.29	872	1.45	913	1.61	950	1.77	983	1.92	1011	2.05	1038	2.19	
3400	778	1.21	817	1.35	851	1.48	885	1.62	924	1.78	963	1.96	1000	2.14	1035	2.30	1067	2.49	1095	2.65	
3740	848	1.58	885	1.73	917	1.88	948	2.03	979	2.18	1014	2.36	1050	2.56	1084	2.76	1118	2.96	1148	3.15	
4080	919	2.02	952	2.18	984	2.35	1012	2.50	1041	2.67	1070	2.84	1102	3.04	1135	3.25	—	—	—	—	
3-hp Oversized Motor & Drive																					

Continued

External Static Pressure (Inches of Water)																					
		1.10		1.20		1.30		1.40		1.50		1.60		1.70		1.80		1.90		2.00	
cfm	rpm	bhp	rpm	bhp	rpm	bhp	rpm	bhp	rpm	bhp	rpm	bhp	rpm	bhp	rpm	bhp	rpm	bhp	rpm	bhp	
2-hp Standard Motor & Drive										3-hp Oversized Motor & Drive											
2720	1007	1.90	1032	2.02	1056	2.14	1079	2.26	1101	2.38	1124	2.50	1146	2.62	1167	2.74	1189	2.86	1209	2.98	
3060	1064	2.32	1090	2.46	1113	2.59	1135	2.72	1157	2.85	1178	2.98	1199	3.12	1220	3.26	1240	3.39	—	—	
3400	1121	2.80	1146	2.95	1170	3.10	1193	3.25	1215	3.40	—	—	—	—	—	—	—	—	—	—	
3740	1177	3.34	—	—	—	—	—	—	—	—	—	—	—	—	—	—	—	—	—	—	
4080	—	—	—	—	—	—	—	—	—	—	—	—	—	—	—	—	—	—	—	—	

**Notes:**

1. For Standard Evaporator Fan Speed (rpm), reference [Table 137, p. 182](#).
2. Data includes pressure drop due to standard filters and wet coils. No accessories or options are included in pressure drop data.
3. Refer to [Table 144, p. 185](#) to determine additional static pressure drop due to other options/accessories.
4. 2-hp Fan Motor Heat (MBh) = 2.000 x Fan bhp + .5000. 3-hp Fan Motor Heat (MBh) = 2.900 x Fan bhp + .4750
5. Factory supplied motors, in commercial equipment, are definite purpose motors, specifically designed and tested to operate reliably and continuously at all cataloged conditions. Using the full horsepower range of our fan motors as shown in our tabular data will not result in nuisance tripping or premature motor failure. Our product's warranty will not be affected.

(a) Field Supplied Fan Sheave AK79 and Belt AX38 required.



## Evaporator Fan Performance

**Table 83. Direct drive evaporator fan performance - 10 tons standard efficiency - TSC120F3,4,W downflow airflow**

cfm	External Static Pressure (Inches of Water)																			
	0.10		0.20		0.30		0.40		0.50		0.60		0.70		0.80		0.90		1.00	
	rpm	bhp	rpm	bhp	rpm	bhp	rpm	bhp	rpm	bhp	rpm	bhp	rpm	bhp	rpm	bhp	rpm	bhp	rpm	bhp
3200	1028	0.67	1054	0.74	1079	0.81	1105	0.88	1131	0.96	1157	1.04	1184	1.12	1209	1.21	1234	1.30	1258	1.38
3600	1150	0.93	1173	1.01	1196	1.09	1219	1.17	1242	1.25	1265	1.34	1288	1.43	1312	1.52	1335	1.61	1357	1.71
4000	1272	1.25	1294	1.34	1315	1.43	1335	1.52	1356	1.61	1376	1.70	1397	1.80	1418	1.90	1440	2.00	1460	2.09
4400	1395	1.65	1415	1.75	1435	1.84	1453	1.94	1472	2.04	1490	2.14	1509	2.24	1528	2.34	1547	2.45	1566	2.56
4800	1518	2.12	1537	2.23	1555	2.33	1572	2.44	1590	2.54	1606	2.65	1623	2.76	1641	2.87	1657	2.98	1675	3.10

Continued

cfm	External Static Pressure (Inches of Water)																			
	1.10		1.20		1.30		1.40		1.50		1.60		1.70		1.80		1.90		2.00	
	rpm	bhp	rpm	bhp	rpm	bhp	rpm	bhp	rpm	bhp	rpm	bhp	rpm	bhp	rpm	bhp	rpm	bhp	rpm	bhp
3200	1280	1.46	1302	1.54	1324	1.63	1347	1.71	1370	1.80	1392	1.89	1414	1.99	1436	2.09	1458	2.19	1479	2.28
3600	1379	1.80	1401	1.90	1422	2.00	1441	2.09	1461	2.18	1480	2.27	1501	2.36	1521	2.46	1542	2.57	1561	2.67
4000	1481	2.20	1501	2.30	1522	2.41	1542	2.52	1561	2.63	1579	2.73	1597	2.84	1614	2.94	1631	3.04	1649	3.14
4400	1585	2.67	1604	2.78	1623	2.89	1642	3.01	1660	3.12	1679	3.25	1696	3.36	—	—	—	—	—	—
4800	1693	3.22	—	—	—	—	—	—	—	—	—	—	—	—	—	—	—	—	—	—

**Notes:**

1. For Direct Drive Evaporator Fan Speed (rpm), reference [Table 142, p. 183](#).
2. Data includes pressure drop due to standard filters and wet coils. No accessories or options are included in pressure drop data.
3. Refer to [Table 144, p. 185](#) to determine additional static pressure drop due to other options/accessories.
4. Direct Drive Fan Motor Heat (MBH) = 2.8623 x Fan BHP - 0.1504
5. Factory supplied motors, in commercial equipment, are definite purpose motors, specifically designed and tested to operate reliably and continuously at all cataloged conditions. Using the full horsepower range of our fan motors as shown in our tabular data will not result in nuisance tripping or premature motor failure. Our product's warranty will not be affected.



## Evaporator Fan Performance

**Table 84. Direct drive evaporator fan performance - 10 tons standard efficiency - TSC120F3,4,W horizontal airflow**

External Static Pressure (Inches of Water)																					
		0.10		0.20		0.30		0.40		0.50		0.60		0.70		0.80		0.90		1.00	
cfm	rpm	bhp	rpm	bhp	rpm	bhp	rpm	bhp	rpm	bhp	rpm	bhp	rpm	bhp	rpm	bhp	rpm	bhp	rpm	bhp	
3200	1016	0.65	1044	0.72	1070	0.79	1097	0.87	1123	0.95	1148	1.03	1173	1.10	1197	1.18	1221	1.26	1245	1.34	
3600	1137	0.91	1162	0.99	1185	1.07	1209	1.15	1232	1.24	1256	1.32	1279	1.41	1301	1.49	1323	1.58	1344	1.66	
4000	1258	1.22	1280	1.31	1302	1.40	1323	1.49	1344	1.58	1366	1.68	1387	1.78	1408	1.87	1428	1.97	1448	2.06	
4400	1379	1.60	1400	1.70	1420	1.80	1439	1.90	1459	2.00	1478	2.10	1497	2.21	1517	2.32	1535	2.42	1554	2.52	
4800	1501	2.06	1520	2.17	1538	2.28	1557	2.38	1575	2.49	1592	2.60	1609	2.71	1627	2.83	1646	2.94	1663	3.06	

Continued

External Static Pressure (Inches of Water)																					
		1.10		1.20		1.30		1.40		1.50		1.60		1.70		1.80		1.90		2.00	
cfm	rpm	bhp	rpm	bhp	rpm	bhp	rpm	bhp	rpm	bhp	rpm	bhp	rpm	bhp	rpm	bhp	rpm	bhp	rpm	bhp	
3200	1269	1.43	1293	1.52	1317	1.61	1339	1.70	1361	1.78	1383	1.87	1404	1.96	1425	2.05	1447	2.14	1468	2.24	
3600	1366	1.75	1386	1.84	1408	1.94	1429	2.04	1451	2.15	1472	2.25	1492	2.35	1513	2.45	1532	2.54	1551	003	
4000	1467	2.15	1487	2.25	1506	2.34	1525	2.44	1544	2.55	1563	2.65	1582	2.76	1602	2.89	1620	3.00	1639	3.12	
4400	1573	2.63	1591	2.73	1609	2.84	1626	2.94	1643	3.04	1661	3.15	1679	3.26	1696	3.37	—	—	—	—	
4800	1681	3.18	1698	3.29	—	—	—	—	—	—	—	—	—	—	—	—	—	—	—	—	

**Notes:**

1. For Direct Drive Evaporator Fan Speed (rpm), reference [Table 142, p. 183](#).
2. Data includes pressure drop due to standard filters and wet coils.
3. Refer to [Table 144, p. 185](#) to determine additional static pressure drop due to other options/accessories.
4. Direct Drive Fan Motor Heat (MBH) = 2.8623 x Fan BHP - 0.1504
5. Factory supplied motors, in commercial equipment, are definite purpose motors, specifically designed and tested to operate reliably and continuously at all cataloged conditions. Using the full horsepower range of our fan motors as shown in our tabular data will not result in nuisance tripping or premature motor failure. Our product's warranty will not be affected.



## Evaporator Fan Performance

**Table 85. Direct drive evaporator fan performance - 10 tons standard efficiency with gas heat - YSC120F3,4,W\*L,M low & medium heat downflow airflow**

	External Static Pressure (Inches of Water)																			
	0.10		0.20		0.30		0.40		0.50		0.60		0.70		0.80		0.90		1.00	
cfm	rpm	bhp	rpm	bhp	rpm	bhp	rpm	bhp	rpm	bhp	rpm	bhp	rpm	bhp	rpm	bhp	rpm	bhp	rpm	bhp
3200	1055	0.73	1081	0.81	1105	0.88	1128	0.94	1152	1.01	1177	1.09	1202	1.17	1225	1.25	1249	1.33	1273	1.42
3600	1181	1.02	1204	1.10	1226	1.19	1248	1.27	1268	1.34	1289	1.42	1311	1.50	1333	1.59	1355	1.68	1376	1.77
4000	1307	1.38	1328	1.47	1348	1.56	1368	1.65	1388	1.74	1406	1.82	1425	1.91	1444	2.00	1464	2.10	1483	2.20
4400	1433	1.82	1453	1.92	1472	2.02	1490	2.12	1508	2.22	1525	2.32	1542	2.40	1559	2.49	1577	2.59	1594	2.69
4800	1560	2.34	1578	2.45	1595	2.56	1613	2.67	1629	2.77	1646	2.89	1662	2.99	1677	3.09	1692	3.18	—	—

Continued

	External Static Pressure (Inches of Water)																			
	1.10		1.20		1.30		1.40		1.50		1.60		1.70		1.80		1.90		2.00	
cfm	rpm	bhp	rpm	bhp	rpm	bhp	rpm	bhp	rpm	bhp	rpm	bhp	rpm	bhp	rpm	bhp	rpm	bhp	rpm	bhp
3200	1296	1.51	1319	1.61	1343	1.70	1366	1.81	1390	1.91	1415	2.02	1438	2.11	1461	2.21	1484	2.31	1506	2.41
3600	1397	1.86	1418	1.95	1439	2.05	1460	2.16	1480	2.27	1501	2.38	1522	2.49	1543	2.61	1564	2.72	1585	2.83
4000	1503	2.30	1522	2.39	1542	2.49	1561	2.60	1579	2.70	1598	2.81	1616	2.93	1635	3.05	1654	3.17	1673	3.29
4400	1612	2.80	1630	2.91	1647	3.02	1665	3.13	1683	3.24	1700	3.34	—	—	—	—	—	—	—	—
4800	—	—	—	—	—	—	—	—	—	—	—	—	—	—	—	—	—	—	—	—

**Notes:**

1. For Direct Drive Evaporator Fan Speed (rpm), reference [Table 142, p. 183](#).
2. Data includes pressure drop due to standard filters and wet coils.
3. Refer to [Table 144, p. 185](#) to determine additional static pressure drop due to other options/accessories.
4. Direct Drive Fan Motor Heat (MBH) = 2.8623 x Fan BHP - 0.1504
5. Factory supplied motors, in commercial equipment, are definite purpose motors, specifically designed and tested to operate reliably and continuously at all cataloged conditions. Using the full horsepower range of our fan motors as shown in our tabular data will not result in nuisance tripping or premature motor failure. Our product's warranty will not be affected.

## Evaporator Fan Performance

**Table 86. Direct drive evaporator fan performance - 10 tons standard efficiency with gas heat - YSC120F3,4,W\*L,M low & medium heat horizontal airflow**

External Static Pressure (Inches of Water)																					
		0.10		0.20		0.30		0.40		0.50		0.60		0.70		0.80		0.90		1.00	
cfm	rpm	bhp	rpm	bhp	rpm	bhp	rpm	bhp	rpm	bhp	rpm	bhp	rpm	bhp	rpm	bhp	rpm	bhp	rpm	bhp	
3200	1043	0.70	1072	0.78	1099	0.85	1128	0.94	1154	1.02	1179	1.10	1203	1.17	1227	1.26	1250	1.35	1274	1.44	
3600	1166	0.98	1192	1.06	1217	1.14	1241	1.23	1267	1.33	1291	1.42	1314	1.51	1335	1.59	1356	1.68	1378	1.78	
4000	1290	1.32	1314	1.41	1337	1.50	1359	1.60	1381	1.69	1404	1.80	1426	1.91	1447	2.01	1467	2.10	1486	2.20	
4400	1415	1.73	1436	1.83	1458	1.94	1478	2.04	1498	2.14	1518	2.25	1539	2.37	1560	2.49	1579	2.60	1597	2.70	
4800	1540	2.23	1560	2.34	1579	2.45	1598	2.56	1617	2.67	1635	2.79	1653	2.90	1672	3.03	1692	3.16	—	—	

Continued

External Static Pressure (Inches of Water)																					
		1.10		1.20		1.30		1.40		1.50		1.60		1.70		1.80		1.90		2.00	
cfm	rpm	bhp	rpm	bhp	rpm	bhp	rpm	bhp	rpm	bhp	rpm	bhp	rpm	bhp	rpm	bhp	rpm	bhp	rpm	bhp	
3200	1298	1.53	1323	1.63	1347	1.72	1370	1.82	1394	1.92	1416	2.02	1437	2.12	1459	2.22	1482	2.33	1503	2.43	
3600	1398	1.88	1419	1.98	1440	2.08	1462	2.19	1484	2.30	1505	2.40	1527	2.52	1547	2.62	1568	2.74	1587	2.84	
4000	1505	2.30	1524	2.41	1542	2.51	1562	2.63	1581	2.74	1600	2.85	1619	2.97	1639	3.09	1658	3.20	1677	3.32	
4400	1615	2.81	1633	2.91	1650	3.02	1667	3.14	1685	3.26	1700	3.38	—	—	—	—	—	—	—	—	
4800	—	—	—	—	—	—	—	—	—	—	—	—	—	—	—	—	—	—	—	—	

**Notes:**

1. For Direct Drive Evaporator Fan Speed (rpm), reference [Table 142, p. 183](#).
2. Data includes pressure drop due to standard filters and wet coils.
3. Refer to [Table 144, p. 185](#) to determine additional static pressure drop due to other options/accessories.
4. Direct Drive Fan Motor Heat (MBH) = 2.8623 x Fan BHP - 0.1504
5. Factory supplied motors, in commercial equipment, are definite purpose motors, specifically designed and tested to operate reliably and continuously at all cataloged conditions. Using the full horsepower range of our fan motors as shown in our tabular data will not result in nuisance tripping or premature motor failure. Our product's warranty will not be affected.



## Evaporator Fan Performance

**Table 87. Direct drive evaporator fan performance - 10 tons with standard efficiency gas heat -YSC120F3,4,W\*H high heat downflow airflow**

		External Static Pressure (Inches of Water)																			
		0.10		0.20		0.30		0.40		0.50		0.60		0.70		0.80		0.90		1.00	
cfm	rpm	bhp	rpm	bhp	rpm	bhp	rpm	bhp	rpm	bhp	rpm	bhp	rpm	bhp	rpm	bhp	rpm	bhp	rpm	bhp	
3200	1055	0.70	1082	0.79	1109	0.87	1132	0.93	1156	1.01	1180	1.09	1205	1.17	1228	1.25	1252	1.33	1275	1.41	
3600	1180	0.98	1205	1.07	1229	1.16	1252	1.25	1272	1.33	1293	1.40	1315	1.49	1337	1.59	1358	1.68	1379	1.77	
4000	1305	1.32	1328	1.42	1350	1.52	1372	1.63	1392	1.73	1410	1.80	1429	1.89	1448	1.99	1468	2.09	1488	2.19	
4400	1432	1.73	1452	1.84	1473	1.96	1493	2.07	1512	2.19	1530	2.29	1547	2.38	1564	2.47	1581	2.57	1599	2.68	
4800	1558	2.22	1577	2.34	1596	2.47	1615	2.59	1633	2.72	1650	2.84	1667	2.96	1683	3.06	1698	3.15	—	—	

Continued

		External Static Pressure (Inches of Water)																			
		1.10		1.20		1.30		1.40		1.50		1.60		1.70		1.80		1.90		2.00	
cfm	rpm	bhp	rpm	bhp	rpm	bhp	rpm	bhp	rpm	bhp	rpm	bhp	rpm	bhp	rpm	bhp	rpm	bhp	rpm	bhp	
3200	1298	1.49	1322	1.59	1348	1.69	1374	1.81	1398	1.91	1421	2.00	1443	2.10	1465	2.20	1488	2.30	1511	2.41	
3600	1400	1.86	1421	1.95	1441	2.04	1462	2.14	1483	2.24	1507	2.36	1530	2.48	1552	2.61	1574	2.72	1594	2.83	
4000	1507	2.29	1526	2.39	1544	2.49	1563	2.59	1582	2.69	1601	2.79	1619	2.90	1639	3.01	1657	3.13	1678	3.26	
4400	1617	2.79	1635	2.91	1652	3.02	1669	3.13	1687	3.23	—	—	—	—	—	—	—	—	—	—	
4800	—	—	—	—	—	—	—	—	—	—	—	—	—	—	—	—	—	—	—	—	

**Notes:**

1. For Direct Drive Evaporator Fan Speed (rpm), reference [Table 142, p. 183](#).
2. Data includes pressure drop due to standard filters and wet coils.
3. Refer to [Table 144, p. 185](#) to determine additional static pressure drop due to other options/accessories.
4. Direct Drive Fan Motor Heat (MBH) = 2.8623 x Fan BHP - 0.1504
5. Factory supplied motors, in commercial equipment, are definite purpose motors, specifically designed and tested to operate reliably and continuously at all cataloged conditions. Using the full horsepower range of our fan motors as shown in our tabular data will not result in nuisance tripping or premature motor failure. Our product's warranty will not be affected.

## Evaporator Fan Performance

**Table 88. Direct drive evaporator fan performance - 10 tons standard efficiency with gas heat -YSC120F3,4,W\*H high heat horizontal airflow**

External Static Pressure (Inches of Water)																					
		0.10		0.20		0.30		0.40		0.50		0.60		0.70		0.80		0.90		1.00	
cfm	rpm	bhp	rpm	bhp	rpm	bhp	rpm	bhp	rpm	bhp	rpm	bhp	rpm	bhp	rpm	bhp	rpm	bhp	rpm	bhp	
3200	1054	0.72	1084	0.79	1112	0.86	1141	0.95	1168	1.04	1193	1.12	1218	1.20	1242	1.28	1266	1.38	1289	1.48	
3600	1179	1.00	1205	1.08	1231	1.16	1256	1.24	1282	1.35	1306	1.45	1329	1.54	1352	1.63	1374	1.72	1395	1.82	
4000	1304	1.35	1328	1.44	1352	1.53	1375	1.62	1397	1.71	1420	1.83	1442	1.94	1463	2.04	1484	2.14	1504	2.24	
4400	1429	1.78	1452	1.88	1474	1.98	1495	2.07	1515	2.17	1536	2.27	1556	2.40	1577	2.53	1597	2.64	1616	2.75	
4800	1555	2.29	1576	2.40	1596	2.51	1616	2.61	1635	2.72	1654	2.82	1673	2.93	1692	3.07	—	—	—	—	

Continued

External Static Pressure (Inches of Water)																					
		1.10		1.20		1.30		1.40		1.50		1.60		1.70		1.80		1.90		2.00	
cfm	rpm	bhp	rpm	bhp	rpm	bhp	rpm	bhp	rpm	bhp	rpm	bhp	rpm	bhp	rpm	bhp	rpm	bhp	rpm	bhp	
3200	1314	1.57	1338	1.65	1362	1.74	1385	1.84	1407	1.93	1430	2.02	1453	2.12	1477	2.22	1498	2.32	1521	2.44	
3600	1416	1.92	1436	2.03	1458	2.14	1480	2.24	1501	2.33	1522	2.43	1543	2.54	1563	2.64	1583	2.74	1604	2.85	
4000	1524	2.35	1543	2.46	1562	2.56	1581	2.68	1600	2.80	1619	2.93	1638	3.04	1658	3.15	1677	3.26	1695	3.37	
4400	1635	2.87	1653	2.97	1671	3.09	1689	3.21	—	—	—	—	—	—	—	—	—	—	—	—	
4800	—	—	—	—	—	—	—	—	—	—	—	—	—	—	—	—	—	—	—	—	

**Notes:**

1. For Direct Drive Evaporator Fan Speed (rpm), reference [Table 142, p. 183](#).
2. Data includes pressure drop due to standard filters and wet coils.
3. Refer to [Table 144, p. 185](#) to determine additional static pressure drop due to other options/accessories.
4. Direct Drive Fan Motor Heat (MBH) = 2.8623 x Fan BHP - 0.1504
5. Factory supplied motors, in commercial equipment, are definite purpose motors, specifically designed and tested to operate reliably and continuously at all cataloged conditions. Using the full horsepower range of our fan motors as shown in our tabular data will not result in nuisance tripping or premature motor failure. Our product's warranty will not be affected.



## Evaporator Fan Performance

**Table 89. Belt drive evaporator fan performance - 3 tons high efficiency - THC036E3,E4 downflow airflow**

cfm	External Static Pressure (Inches of Water)																					
	0.10		0.20		0.30		0.40		0.50		0.60		0.70		0.80		0.90		1.00			
rpm	bhp	rpm	bhp	rpm	bhp	rpm	bhp	rpm	bhp	rpm	bhp	rpm	bhp	rpm	bhp	rpm	bhp	rpm	bhp	rpm	bhp	
<b>1-hp Standard Motor &amp; Low Static Drive Accessory Kit<sup>(a)</sup></b>												<b>1-hp Standard Motor &amp; Drive</b>										
600*	—	—	468	0.07	547	0.1	616	0.13	677	0.17	729	0.21	776	0.24	819	0.28	860	0.32	898	0.36		
720*	386	0.05	490	0.08	570	0.12	638	0.16	697	0.12	752	0.24	802	0.28	848	0.33	889	0.37	928	0.42		
840*	416	0.06	511	0.10	593	0.14	661	0.19	719	0.23	773	0.28	823	0.32	870	0.37	914	0.42	954	0.47		
960	449	0.08	534	0.12	614	0.17	683	0.22	742	0.27	795	0.32	845	0.37	891	0.42	935	0.47	977	0.53		
1080	483	0.11	561	0.15	635	0.20	704	0.25	765	0.30	818	0.36	868	0.42	913	0.47	957	0.53	998	0.59		
1200	518	0.14	592	0.18	658	0.23	725	0.29	786	0.35	842	0.41	891	0.47	936	0.53	979	0.59	1019	0.66		
1320	555	0.17	625	0.22	686	0.27	747	0.33	807	0.39	862	0.46	914	0.53	959	0.59	1002	0.66	1043	0.73		
1440	592	0.21	658	0.27	717	0.32	772	0.38	828	0.44	882	0.51	933	0.58	980	0.66	1025	0.73	1065	0.80		

Continued

cfm	External Static Pressure (Inches of Water)									
	1.10		1.20		1.30		1.40		1.50	
rpm	bhp	rpm	bhp	rpm	bhp	rpm	bhp	rpm	bhp	
<b>1-hp Standard Motor &amp; Drive</b>										
600*	934	0.41	968	0.45	1001	0.49	1034	0.54	1066	0.59
720*	965	0.46	999	0.51	1032	0.56	1065	0.61	1095	0.66
840*	992	0.53	1029	0.58	1063	0.63	1096	0.68	1125	0.74
960	1016	0.59	1054	0.65	1089	0.70	1124	0.76	1155	0.82
1080	1036	0.65	1075	0.72	1111	0.78	1146	0.84	1180	0.91
1200	1058	0.72	1095	0.78	1131	0.85	1167	0.92	1201	0.99
1320	1082	0.80	1119	0.87	1153	0.94	1188	1.01	1221	1.08
1440	1104	0.88	1141	0.95	1176	1.03	1211	1.10	1243	1.18
<b>1-hp Standard Motor &amp; Field Supplied High Static Drive<sup>(b)</sup></b>										

**Notes:**

1. For Standard Evaporator Fan Speed (rpm), reference [Table 137, p. 182](#).
  2. Data includes pressure drop due to standard filters and wet coils. Data does not include pressure drop due to reheat coil.
  3. Refer to [Table 145, p. 186](#) to determine additional static pressure drop due to other options/accessories.
  4. 1-hp Fan Motor Heat (MBh) = 2.7672 x Fan bhp + 0.4705.
  5. Factory supplied motors, in equipment, are definite purpose motors, specifically designed and tested to operate at all cataloged conditions. Using the full horsepower range of our fan motors as shown in our tabular data will not result in nuisance tripping or premature motor failure. Our product's warranty will not be affected.
- \* For 600, 720, and 840 CFM, unit application below 320 CFM/Ton are only applicable on T\_C models only (No Gas Heat). See below for restrictions.  
 \* Electric heaters restricted on applications below 320 CFM/Ton  
 \* Dehumidification (Hot Gas Reheat) or TXV with Froststat and Crankcase Heaters are required on applications below 320 CFM/Ton

(a) BAYLSDR006AB  
 (b) Field Supplied Fan Sheave AK41x3/4" required. Field Supplied Belt may be necessary.

## Evaporator Fan Performance

**Table 90. Belt drive evaporator fan performance - 3 tons high efficiency - THC036E3,E4 horizontal airflow**

cfm	External Static Pressure (Inches of Water)																					
	0.10		0.20		0.30		0.40		0.50		0.60		0.70		0.80		0.90		1.00			
rpm	bhp	rpm	bhp	rpm	bhp	rpm	bhp	rpm	bhp	rpm	bhp	rpm	bhp	rpm	bhp	rpm	bhp	rpm	bhp	rpm	bhp	
<b>1-hp Standard Motor &amp; Low Static Drive Accessory Kit<sup>(a)</sup></b>												<b>1-hp Standard Motor &amp; Drive</b>										
600*	372	0.04	472	0.06	552	0.09	619	0.12	678	0.15	730	0.18	778	0.22	823	0.25	865	0.29	904	0.32		
720*	398	0.05	496	0.08	575	0.11	643	0.15	702	0.18	756	0.22	805	0.26	849	0.29	892	0.33	931	0.37		
840*	422	0.06	524	0.10	598	0.13	665	0.17	726	0.22	780	0.26	829	0.30	875	0.34	918	0.39	957	0.43		
960	449	0.08	552	0.12	626	0.16	689	0.20	748	0.25	802	0.30	852	0.35	898	0.39	942	0.44	982	0.49		
1080	482	0.10	576	0.14	654	0.19	716	0.24	772	0.29	825	0.34	874	0.39	921	0.45	964	0.50	1005	0.55		
1200	517	0.13	600	0.17	681	0.23	744	0.28	799	0.33	850	0.39	898	0.44	943	0.50	987	0.56	1028	0.62		
1320	554	0.16	627	0.20	705	0.27	773	0.33	828	0.38	877	0.44	923	0.50	967	0.56	1010	0.62	1052	0.69		
1440	590	0.20	657	0.24	728	0.30	797	0.37	855	0.44	904	0.50	950	0.56	993	0.63	1034	0.69	1074	0.76		

Continued

cfm	External Static Pressure (Inches of Water)									
	1.10		1.20		1.30		1.40		1.50	
rpm	bhp	rpm	bhp	rpm	bhp	rpm	bhp	rpm	bhp	
<b>1-hp Standard Motor &amp; Drive</b>										
600*	941	0.36	977	0.4	1010	0.44	1042	0.48	1074	0.53
720*	969	0.41	1005	0.45	1040	0.5	1073	0.54	1105	0.5
840*	995	0.47	1031	0.52	1066	0.56	1100	0.61	1131	0.66
960	1020	0.54	1057	0.59	1092	0.64	1126	0.69	1158	0.74
1080	1045	0.61	1082	0.67	1116	0.72	1151	0.77	1183	0.83
1200	1067	0.68	1104	0.74	1141	0.80	1174	0.86	1207	0.92
1320	1091	0.75	1127	0.82	1163	0.88	1198	0.95	1230	1.02
1440	1112	0.83	1150	0.90	1186	0.97	1221	1.04	1254	1.11
<b>1-hp Standard Motor &amp; Field Supplied High Static Drive<sup>(b)</sup></b>										

**Notes:**

1. For Standard Evaporator Fan Speed (rpm), reference [Table 137, p. 182](#).
  2. Data includes pressure drop due to standard filters and wet coils. Data does not include pressure drop due to reheat coil.
  3. Refer to [Table 145, p. 186](#) to determine additional static pressure drop due to other options/accessories.
  4. 1-hp Fan Motor Heat (MBh) = 2.7672 x Fan bhp + 0.4705.
  5. Factory supplied motors, in equipment, are definite purpose motors, specifically designed and tested to operate at all cataloged conditions. Using the full horsepower range of our fan motors as shown in our tabular data will not result in nuisance tripping or premature motor failure. Our product's warranty will not be affected.
- \* For 600, 720, and 840 CFM, unit application below 320 CFM/Ton are only applicable on T\_C models only (No Gas Heat). See below for restrictions.  
 \* Electric heaters restricted on applications below 320 CFM/Ton  
 \* Dehumidification (Hot Gas Reheat) or TXV with Froststat and Crankcase Heaters are required on applications below 320 CFM/Ton

(a) BAYLSDR006AB  
 (b) Field Supplied Fan Sheave AK41x3/4" required. Field Supplied Belt may be necessary.



## Evaporator Fan Performance

**Table 91. Belt drive evaporator fan performance - 3 tons high efficiency - YHC036E3,E4\*L,M low & medium gas heat downflow airflow**

External Static Pressure (Inches of Water)																					
		0.10		0.20		0.30		0.40		0.50		0.60		0.70		0.80		0.90		1.00	
cfm	rpm	bhp	rpm	bhp	rpm	bhp	rpm	bhp	rpm	bhp	rpm	bhp	rpm	bhp	rpm	bhp	rpm	bhp	rpm	bhp	
1-hp Standard Motor & Field Supplied Low Static Drive <sup>(a)</sup>											1-hp Standard Motor & Drive										
960	—	—	—	—	605	0.15	671	0.19	730	0.23	784	0.27	835	0.31	881	0.36	924	0.41	965	0.45	
1080	—	—	563	0.14	630	0.17	693	0.22	751	0.26	804	0.31	854	0.35	901	0.40	946	0.46	986	0.50	
1200	—	—	596	0.17	659	0.21	718	0.25	773	0.30	825	0.35	875	0.40	921	0.45	964	0.51	1005	0.56	
1320	555	0.16	629	0.20	689	0.25	745	0.29	797	0.34	848	0.40	897	0.45	941	0.51	984	0.56	1026	0.62	
1440	593	0.20	663	0.25	721	0.29	775	0.34	824	0.39	873	0.45	919	0.51	963	0.57	1006	0.63	1046	0.69	

Continued

External Static Pressure (Inches of Water)											
		1.10		1.20		1.30		1.40		1.50	
cfm	rpm	bhp	rpm	bhp	rpm	bhp	rpm	bhp	rpm	bhp	
1-hp Standard Motor & Drive <sup>(b)</sup>											
960	1004	0.50	1039	0.55	1073	0.59	1105	0.64	1137	0.69	
1080	1025	0.56	1063	0.61	1098	0.66	1132	0.72	1163	0.77	
1200	1046	0.62	1082	0.67	1119	0.73	1153	0.79	1187	0.85	
1320	1064	0.68	1103	0.74	1139	0.80	1174	0.86	1207	0.93	
1440	1085	0.75	1123	0.81	1159	0.88	1193	0.94	—	—	
1-hp Standard Motor & Field Supplied High Static Drive <sup>(b)</sup>											

**Notes:**

1. For Standard Evaporator Fan Speed (rpm), reference [Table 137, p. 182](#).
2. Data includes pressure drop due to standard filters and wet coils. No accessories or options are included in pressure drop data.
3. Data does not include pressure drop due to reheat coil.
4. Refer to [Table 145, p. 186](#) to determine additional static pressure drop due to other options/accessories.
5. 1-hp Fan Motor Heat (MBh) = 2.7672 x Fan bhp + 0.4705.
6. Factory supplied motors, in equipment, are definite purpose motors, specifically designed and tested to operate at all cataloged conditions. Using the full horsepower range of our fan motors as shown in our tabular data will not result in nuisance tripping or premature motor failure. Our product's warranty will not be affected.

(a) Field Supplied Fan Sheave AK71x3/4" required. Field Supplied Belt may be necessary.  
 (b) Field Supplied Fan Sheave AK41x3/4" required. Field Supplied Belt may be necessary.



## Evaporator Fan Performance

**Table 92. Belt drive evaporator fan performance - 3 tons high efficiency - YHC036E3,E4\*L,M low & medium gas heat horizontal airflow**

External Static Pressure (Inches of Water)																					
		0.10		0.20		0.30		0.40		0.50		0.60		0.70		0.80		0.90		1.00	
cfm	rpm	bhp	rpm	bhp	rpm	bhp	rpm	bhp	rpm	bhp	rpm	bhp	rpm	bhp	rpm	bhp	rpm	bhp	rpm	bhp	
1-hp Standard Motor & Field Supplied Low Static Drive <sup>(a)</sup>											1-hp Standard Motor & Drive										
960	—	—	—	—	613	0.15	679	0.20	736	0.24	788	0.28	837	0.32	886	0.37	930	0.42	973	0.47	
1080	—	—	561	0.14	636	0.18	702	0.23	761	0.28	812	0.32	860	0.37	904	0.42	947	0.47	991	0.52	
1200	—	—	589	0.16	661	0.21	726	0.26	784	0.31	836	0.37	884	0.42	929	0.47	970	0.52	1011	0.58	
1320	—	—	619	0.20	687	0.25	750	0.30	807	0.36	859	0.41	909	0.47	953	0.53	995	0.59	1034	0.65	
1440	585	0.19	651	0.24	715	0.29	775	0.35	831	0.40	883	0.47	931	0.53	976	0.59	1019	0.66	1058	0.72	

Continued

External Static Pressure (Inches of Water)											
		1.10		1.20		1.30		1.40		1.50	
cfm	rpm	bhp	rpm	bhp	rpm	bhp	rpm	bhp	rpm	bhp	
1-hp Standard Motor & Drive											
960	1014	0.53	1051	0.58	1087	0.63	1121	0.68	1155	0.74	
1080	1031	0.58	1071	0.64	1108	0.69	1142	0.75	1177	0.81	
1200	1049	0.63	1087	0.69	1124	0.75	1161	0.82	1195	0.88	
1320	1071	0.70	1107	0.76	1143	0.82	1178	0.89	1213	0.96	
1440	1095	0.78	1130	0.84	1166	0.91	1199	0.97	—	—	
1-hp Standard Motor & Field Supplied High Static Drive <sup>(b)</sup>											

**Notes:**

1. For Standard Evaporator Fan Speed (rpm), reference [Table 137, p. 182](#).
2. Data includes pressure drop due to standard filters and wet coils. No accessories or options are included in pressure drop data.
3. Data does not include pressure drop due to reheat coil.
4. Refer to [Table 145, p. 186](#) to determine additional static pressure drop due to other options/accessories.
5. 1-hp Fan Motor Heat (MBh) = 2.7672 x Fan bhp + 0.4705.
6. Factory supplied motors, in equipment, are definite purpose motors, specifically designed and tested to operate reliably and continuously at all cataloged conditions. Using the full horsepower range of our fan motors as shown in our tabular data will not result in nuisance tripping or premature motor failure. Our product's warranty will not be affected.

(a) Field Supplied Fan Sheave AK71x3/4" required. Field Supplied Belt may be necessary.

(b) Field Supplied Fan Sheave AK41x3/4" required. Field Supplied Belt may be necessary.



## Evaporator Fan Performance

**Table 93. Belt drive evaporator fan performance - 3 tons high efficiency - YHC036E3,E4\*H high gas heat downflow airflow**

External Static Pressure (Inches of Water)																					
		0.10		0.20		0.30		0.40		0.50		0.60		0.70		0.80		0.90		1.00	
cfm	rpm	bhp	rpm	bhp	rpm	bhp	rpm	bhp	rpm	bhp	rpm	bhp	rpm	bhp	rpm	bhp	rpm	bhp	rpm	bhp	
1-hp Standard Motor & Field Supplied Low Static Drive <sup>(a)</sup>											1-hp Standard Motor & Drive										
960	—	—	—	—	609	0.15	671	0.19	730	0.24	785	0.28	835	0.33	881	0.37	924	0.42	966	0.47	
1080	—	—	572	0.14	638	0.18	697	0.23	752	0.27	805	0.32	855	0.37	900	0.42	945	0.47	986	0.53	
1200	—	—	606	0.18	668	0.22	725	0.26	778	0.31	827	0.36	876	0.42	922	0.47	964	0.52	1007	0.58	
1320	573	0.17	641	0.22	700	0.26	754	0.31	805	0.36	853	0.41	898	0.47	942	0.53	985	0.59	1026	0.65	
1440	613	0.21	677	0.27	733	0.31	786	0.36	835	0.42	881	0.47	925	0.53	966	0.59	1007	0.65	1047	0.71	

Continued

External Static Pressure (Inches of Water)											
		1.10		1.20		1.30		1.40		1.50	
cfm	rpm	bhp	rpm	bhp	rpm	bhp	rpm	bhp	rpm	bhp	
1-hp Standard Motor & Drive											
960	1004	0.52	1041	0.58	1076	0.63	1109	0.68	1142	0.73	
1080	1026	0.58	1063	0.64	1098	0.69	1133	0.75	1165	0.81	
1200	1046	0.64	1083	0.70	1120	0.76	1154	0.82	1187	0.88	
1320	1065	0.71	1103	0.77	1139	0.83	1175	0.90	1207	0.96	
1440	1086	0.78	1123	0.84	1160	0.91	1194	0.98	1227	1.05	
1-hp Standard Motor & Field Supplied High Static Drive <sup>(b)</sup>											

**Notes:**

1. For Standard Evaporator Fan Speed (rpm), reference [Table 137, p. 182](#).
2. Data includes pressure drop due to standard filters and wet coils. No accessories or options are included in pressure drop data.
3. Data does not include pressure drop due to reheat coil.
4. Refer to [Table 145, p. 186](#) to determine additional static pressure drop due to other options/accessories.
5. 1-hp Fan Motor Heat (MBh) = 2.7672 x Fan bhp + 0.4705.
6. Factory supplied motors, in equipment, are definite purpose motors, specifically designed and tested to operate at all cataloged conditions. Using the full horsepower range of our fan motors as shown in our tabular data will not result in nuisance tripping or premature motor failure. Our product's warranty will not be affected.

(a) Field Supplied Fan Sheave AK71x3/4" required. Field Supplied Belt may be necessary.  
 (b) Field Supplied Fan Sheave AK41x3/4" required. Field Supplied Belt may be necessary.

## Evaporator Fan Performance

**Table 94. Belt drive evaporator fan performance - 3 tons high efficiency -YHC036E3,E4\*H high gas heat horizontal airflow**

External Static Pressure (Inches of Water)																					
		0.10		0.20		0.30		0.40		0.50		0.60		0.70		0.80		0.90		1.00	
cfm	rpm	bhp	rpm	bhp	rpm	bhp	rpm	bhp	rpm	bhp	rpm	bhp	rpm	bhp	rpm	bhp	rpm	bhp	rpm	bhp	
1-hp Standard Motor & Field Supplied Low Static Drive <sup>(a)</sup>											1-hp Standard Motor & Drive										
960	—	—	—	—	621	0.15	685	0.20	745	0.24	799	0.29	849	0.33	894	0.38	936	0.42	975	0.47	
1080	—	—	580	0.14	649	0.19	711	0.23	768	0.28	821	0.32	871	0.38	917	0.43	960	0.48	1000	0.53	
1200	—	—	613	0.18	679	0.22	738	0.27	793	0.32	845	0.37	892	0.42	939	0.48	982	0.53	1024	0.59	
1320	574	0.17	647	0.22	710	0.26	767	0.31	820	0.37	870	0.42	917	0.48	962	0.53	1004	0.59	1046	0.66	
1440	612	0.21	682	0.26	742	0.31	797	0.37	849	0.42	897	0.48	943	0.54	986	0.60	1028	0.66	1068	0.72	

Continued

External Static Pressure (Inches of Water)											
		1.10		1.20		1.30		1.40		1.50	
cfm	rpm	bhp	rpm	bhp	rpm	bhp	rpm	bhp	rpm	bhp	
1-hp Standard Motor & Drive											
960	1012	0.52	1048	0.57	1082	0.62	1116	0.67	1148	0.72	
1080	1039	0.59	1075	0.64	1109	0.69	1142	0.74	1173	0.80	
1200	1063	0.65	1100	0.71	1134	0.77	1168	0.83	1199	0.88	
1320	1085	0.72	1122	0.78	1159	0.85	1193	0.91	1226	0.98	
1440	1107	0.79	1145	0.86	1181	0.93	1216	1.00	1248	1.07	
1-hp Standard Motor & Field Supplied High Static Drive <sup>(b)</sup>											

**Notes:**

1. For Standard Evaporator Fan Speed (rpm), reference [Table 137, p. 182](#).
2. Data includes pressure drop due to standard filters and wet coils. No accessories or options are included in pressure drop data.
3. Data does not include pressure drop due to reheat coil.
4. Refer to [Table 145, p. 186](#) to determine additional static pressure drop due to other options/accessories.
5. 1-hp Fan Motor Heat (MBh) = 2.7672 x Fan bhp + 0.4705.
6. Factory supplied motors, in equipment, are definite purpose motors, specifically designed and tested to operate at all cataloged conditions. Using the full horsepower range of our fan motors as shown in our tabular data will not result in nuisance tripping or premature motor failure. Our product's warranty will not be affected.

(a) Field Supplied Fan Sheave AK71x3/4" required. Field Supplied Belt may be necessary.  
 (b) Field Supplied Fan Sheave AK41x3/4" required. Field Supplied Belt may be necessary.



## Evaporator Fan Performance

**Table 95. Belt drive evaporator fan performance - 4 tons high efficiency - THC048E3,E4, F3, F4 downflow airflow**

cfm	External Static Pressure (Inches of Water)																					
	0.10		0.20		0.30		0.40		0.50		0.60		0.70		0.80		0.90		1.00			
rpm	bhp	rpm	bhp	rpm	bhp	rpm	bhp	rpm	bhp	rpm	bhp	rpm	bhp	rpm	bhp	rpm	bhp	rpm	bhp	rpm	bhp	
<b>1-hp Standard Motor &amp; Low Static Drive Accessory Kit<sup>(a)</sup></b>												<b>1-hp Standard Motor &amp; Drive</b>										
800*	—	—	444	0.06	526	0.09	598	0.13	663	0.16	720	0.20	772	0.24	820	0.28	863	0.32	905	0.36	959	0.41
960*	—	—	462	0.08	542	0.12	610	0.15	672	0.19	731	0.23	785	0.27	835	0.32	881	0.36	923	0.41	974	0.46
1120*	399	0.07	485	0.11	559	0.14	626	0.18	687	0.22	743	0.26	795	0.31	846	0.36	893	0.41	937	0.46	999	0.51
1280	429	0.10	510	0.14	581	0.17	644	0.21	703	0.26	757	0.30	809	0.35	857	0.40	903	0.45	947	0.51	1006	0.56
1440	459	0.12	537	0.17	604	0.21	665	0.26	722	0.30	774	0.35	823	0.40	871	0.45	916	0.51	959	0.56	1016	0.61
1600	492	0.16	567	0.21	630	0.26	689	0.31	742	0.36	793	0.41	842	0.46	887	0.51	932	0.57	974	0.63	1026	0.67
1760	526	0.20	597	0.26	658	0.31	713	0.36	765	0.42	814	0.47	860	0.53	905	0.58	947	0.64	989	0.70	1036	0.73
1920	561	0.25	627	0.31	687	0.37	739	0.43	790	0.49	838	0.55	882	0.60	924	0.66	966	0.72	1006	0.79	1056	0.85

Continued

cfm	External Static Pressure (Inches of Water)									
	1.10		1.20		1.30		1.40		1.50	
rpm	bhp	rpm	bhp	rpm	bhp	rpm	bhp	rpm	bhp	
<b>1-hp Standard Motor &amp; Drive</b>										
800*	942	0.40	980	0.44	1015	0.48	1047	0.53	1079	0.569
960*	964	0.46	1002	0.50	1038	0.55	1072	0.60	1105	0.65
1120*	979	0.51	1019	0.56	1055	0.62	1091	0.67	1125	0.725
1280	990	0.56	1031	0.62	1069	0.68	1105	0.74	1140	0.80
1440	999	0.62	1040	0.68	1079	0.75	1115	0.81	1152	0.87
1600	1014	0.69	1051	0.75	1089	0.82	1125	0.88	1162	0.95
1760	1028	0.77	1066	0.83	1104	0.90	1139	0.96	1175	1.04
1920	1044	0.85	1083	0.92	1118	0.99	1155	1.06	1188	1.13
<b>1-hp Standard Motor &amp; Field Supplied High Static Drive<sup>(b)</sup></b>										

**Notes:**

- For Standard Evaporator Fan Speed (rpm), reference [Table 137, p. 182](#).
  - Data includes pressure drop due to standard filters and wet coils. Data does not include pressure drop due to reheat coil.
  - Refer to [Table 145, p. 186](#) to determine additional static pressure drop due to other options/accessories.
  - 1-hp Fan Motor Heat (MBh) = 2.7672 x Fan bhp + 0.4705.
  - Factory supplied motors, in equipment, are definite purpose motors, specifically designed and tested to operate at all cataloged conditions. Using the full horsepower range of our fan motors as shown in our tabular data will not result in nuisance tripping or premature motor failure. Our product's warranty will not be affected.
- \* For 800, 960, and 1120 CFM, unit application below 320 CFM/Ton are only applicable on T\_C models only (No Gas Heat). See below for restrictions.  
 \* Electric heaters restricted on applications below 320 CFM/Ton  
 \* Dehumidification (Hot Gas Reheat) or TXV with Froststat and Crankcase Heaters are required on applications below 320 CFM/Ton

(a) BAYLSDR006AB  
 (b) Field Supplied Fan Sheave AK41x3/4" required. Field Supplied Belt may be necessary.

## Evaporator Fan Performance

**Table 96. Belt drive evaporator fan performance - 4 tons high efficiency - THC048E3,E4, F3, F4 horizontal airflow**

cfm	External Static Pressure (Inches of Water)																				
	0.10		0.20		0.30		0.40		0.50		0.60		0.70		0.80		0.90		1.00		
rpm	bhp	rpm	bhp	rpm	bhp	rpm	bhp	rpm	bhp	rpm	bhp	rpm	bhp	rpm	bhp	rpm	bhp	rpm	bhp	rpm	bhp
1-hp Standard Motor & Low Static Drive Accessory Kit <sup>(a)</sup>											1-hp Standard Motor & Drive										
800*	368	0.05	481	0.08	562	0.12	623	0.16	677	0.20	730	0.24	780	0.28	825	0.32	870	0.37	911	0.41	
960*	392	0.06	501	0.10	587	0.15	655	0.20	711	0.24	759	0.29	804	0.33	848	0.38	891.1	0.43	932	0.48	
1120*	420	0.08	519	0.13	607	0.18	679	0.23	740	0.29	792	0.34	837	0.39	879	0.45	918	0.50	955	0.55	
1280	449	0.11	541	0.16	625	0.21	700	0.27	764	0.33	819	0.40	868	0.46	912	0.52	951	0.58	989	0.64	
1440	482	0.14	567	0.19	644	0.25	718	0.32	783	0.38	841	0.45	892	0.52	939	0.59	982	0.66	1022	0.73	
1600	518	0.18	596	0.24	668	0.30	736	0.36	801	0.44	861	0.51	915	0.59	963	0.67	1007	0.74	1048	0.82	
1760	555	0.23	625	0.29	694	0.35	757	0.42	820	0.50	879	0.58	933	0.66	984	0.74	1030	0.83	1072	0.91	
1920	593	0.28	657	0.35	723	0.42	783	0.49	840	0.57	897	0.65	951	0.74	1001	0.83	1049	0.92	1093	1.01	
											1-hp Standard Motor & Field Supplied High Static Drive <sup>(b)</sup>										

Continued

cfm	External Static Pressure (Inches of Water)										
	1.10		1.20		1.30		1.40		1.50		
rpm	bhp	rpm	bhp	rpm	bhp	rpm	bhp	rpm	bhp	rpm	bhp
1-hp Standard Motor & Drive											
800*	950	0.46	986	0.51	1024	0.56	1057	0.602	1090	0.65	
960*	972	0.53	1009	0.58	1045	0.64	1080	0.692	1111	0.74	
1120*	994	0.61	1031	0.67	1067	0.73	1101	0.786	1134	0.85	
1280	1023	0.70	1057	0.76	1090	0.82	1123	0.89	1157	0.95	
1440	1057	0.80	1091	0.86	1123	0.93	1155	1.00	1184	1.07	
1600	1087	0.90	1123	0.97	1156	1.05	1187	1.12	1217	1.20	
1760	1113	1.00	1150	1.08	1184	1.17	1219	1.25	1250	1.34	
1920	1135	1.10	1174	1.19	1210	1.29	1244	1.38	1278	1.47	
1-hp Standard Motor & Field Supplied High Static Drive											

**Notes:**

1. For Standard Evaporator Fan Speed (rpm), reference [Table 137, p. 182](#).
  2. Data includes pressure drop due to standard filters and wet coils. Data does not include pressure drop due to reheat coil.
  3. Refer to [Table 145, p. 186](#) to determine additional static pressure drop due to other options/accessories.
  4. 1-hp Fan Motor Heat (MBh) = 2.7672 x Fan bhp + 0.4705.
  5. Factory supplied motors, in equipment, are definite purpose motors, specifically designed and tested to operate at all cataloged conditions. Using the full horsepower range of our fan motors as shown in our tabular data will not result in nuisance tripping or premature motor failure. Our product's warranty will not be affected.
- \* For 800, 960, and 1120 CFM, unit application below 320 CFM/Ton are only applicable on T\_C models only (No Gas Heat). See below for restrictions.  
 \* Electric heaters restricted on applications below 320 CFM/Ton  
 \* Dehumidification (Hot Gas Reheat) or TXV with Froststat and Crankcase Heaters are required on applications below 320 CFM/Ton

(a) BAYLSDR006AB  
 (b) Field Supplied Fan Sheave AK41x3/4" required. Field Supplied Belt may be necessary.



## Evaporator Fan Performance

**Table 97. Belt drive evaporator fan performance - 4 tons high efficiency - YHC048E3,E4,F3,F4\*L,M low & medium gas heat downflow airflow**

External Static Pressure (Inches of Water)																					
		0.10		0.20		0.30		0.40		0.50		0.60		0.70		0.80		0.90		1.00	
cfm	rpm	bhp	rpm	bhp	rpm	bhp	rpm	bhp	rpm	bhp	rpm	bhp	rpm	bhp	rpm	bhp	rpm	bhp	rpm	bhp	
1-hp Standard Motor & Field Supplied Low Static Drive <sup>(a)</sup>											1-hp Standard Motor & Drive										
1280	—	—	—	—	589	0.18	652	0.23	710	0.27	763	0.32	812	0.37	858	0.42	905	0.47	949	0.53	
1440	—	—	546	0.18	614	0.22	675	0.27	731	0.32	782	0.37	830	0.42	876	0.48	919	0.53	961	0.59	
1600	—	—	575	0.22	641	0.27	699	0.32	752	0.37	803	0.43	851	0.49	895	0.54	938	0.60	978	0.66	
1760	538	0.21	606	0.27	668	0.32	725	0.38	776	0.44	826	0.50	872	0.56	916	0.62	958	0.68	997	0.75	
1920	574	0.27	638	0.32	696	0.38	752	0.45	802	0.51	850	0.57	895	0.63	938	0.70	978	0.77	1018	0.84	

Continued

External Static Pressure (Inches of Water)											
		1.10		1.20		1.30		1.40		1.50	
cfm	rpm	bhp	rpm	bhp	rpm	bhp	rpm	bhp	rpm	bhp	
1-hp Standard Motor & Drive											
1280	993	0.58	1032	0.64	1070	0.70	1107	0.76	1143	0.82	
1440	1003	0.65	1043	0.71	1082	0.77	1118	0.84	1154	0.90	
1600	1017	0.72	1054	0.78	1092	0.85	1129	0.92	1165	0.98	
1760	1036	0.81	1073	0.88	1108	0.94	1142	1.01	1177	1.08	
1920	1056	0.91	1092	0.98	1127	1.04	1160	1.11	1193	1.19	
1-hp Standard Motor & Field Supplied High Static Drive <sup>(b)</sup>											

**Notes:**

1. For Standard Evaporator Fan Speed (rpm), reference [Table 137, p. 182](#).
2. Data includes pressure drop due to standard filters and wet coils. No accessories or options are included in pressure drop data.
3. Data does not include pressure drop due to reheat coil.
4. Refer to [Table 145, p. 186](#) to determine additional static pressure drop due to other options/accessories.
5. 1-hp Fan Motor Heat (MBh) = 2.7672 x Fan bhp + 0.4705.
6. Factory supplied motors, in equipment, are definite purpose motors, specifically designed and tested to operate at all cataloged conditions. Using the full horsepower range of our fan motors as shown in our tabular data will not result in nuisance tripping or premature motor failure. Our product's warranty will not be affected.

(a) Field Supplied Fan Sheave AK74x3/4" required. Field Supplied Belt may be necessary.  
 (b) Field Supplied Fan Sheave AK41x3/4" required. Field Supplied Belt may be necessary.

## Evaporator Fan Performance

**Table 98. Belt drive evaporator fan performance - 4 tons high efficiency -YHC048E3,E4,F3,F4\*L,M low & medium gas heat horizontal airflow**

External Static Pressure (Inches of Water)																					
		0.10		0.20		0.30		0.40		0.50		0.60		0.70		0.80		0.90		1.00	
cfm	rpm	bhp	rpm	bhp	rpm	bhp	rpm	bhp	rpm	bhp	rpm	bhp	rpm	bhp	rpm	bhp	rpm	bhp	rpm	bhp	
1-hp Standard Motor & Field Supplied Low Static Drive <sup>(a)</sup>										1-hp Standard Motor & Drive											
1280	—	—	554	0.16	622	0.21	685	0.26	741	0.31	794	0.36	842	0.42	888	0.47	931	0.53	973	0.59	
1440	—	—	590	0.21	652	0.26	712	0.31	767	0.36	818	0.42	866	0.48	911	0.54	953	0.60	995	0.67	
1600	561	0.21	628	0.26	686	0.32	741	0.37	794	0.43	844	0.49	890	0.55	935	0.62	976	0.68	1017	0.75	
1760	602	0.27	667	0.33	722	0.38	773	0.44	822	0.50	871	0.57	917	0.63	960	0.70	1001	0.77	1040	0.84	
1920	644	0.33	706	0.40	760	0.46	809	0.52	855	0.59	900	0.66	944	0.73	987	0.80	1027	0.87	1066	0.95 <sup>(b)</sup>	

Continued

External Static Pressure (Inches of Water)											
		1.10		1.20		1.30		1.40		1.50	
cfm	rpm	bhp	rpm	bhp	rpm	bhp	rpm	bhp	rpm	bhp	
1-hp Standard Motor & Drive											
1280	1012	0.65	1052	0.72	1090	0.78	1127	0.84	1162	0.91	
1440	1032	0.73	1070	0.80	1107	0.87	1142	0.94	1175	1.01	
1600	1055	0.82	1093	0.89	1128	0.96	1162	1.03	1195	1.11	
1760	1078	0.91	1114	0.99	1150	1.06	1183	1.14	1217	1.22	
1920	1103	1.02	1139	1.10	1174	1.18	1207	1.26	1239	1.34	
1-hp Standard Motor & Field Supplied High Static Drive <sup>(b)</sup>											

**Notes:**

1. For Standard Evaporator Fan Speed (rpm), reference [Table 137, p. 182](#).
2. Data includes pressure drop due to standard filters and wet coils. No accessories or options are included in pressure drop data.
3. Data does not include pressure drop due to reheat coil.
4. Refer to [Table 145, p. 186](#) to determine additional static pressure drop due to other options/accessories.
5. 1-hp Fan Motor Heat (MBh) = 2.7672 x Fan bhp + 0.4705.
6. Factory supplied motors, in equipment, are definite purpose motors, specifically designed and tested to operate at all cataloged conditions. Using the full horsepower range of our fan motors as shown in our tabular data will not result in nuisance tripping or premature motor failure. Our product's warranty will not be affected.

(a) Field Supplied Fan Sheave AK74x3/4" required. Field Supplied Belt may be necessary.

(b) Field Supplied Fan Sheave AK41x3/4" required. Field Supplied Belt may be necessary.



## Evaporator Fan Performance

**Table 99. Belt drive evaporator fan performance - 4 tons high efficiency - YHC048E3,E4,F3,F4\*H high gas heat downflow airflow**

External Static Pressure (Inches of Water)																					
		0.10		0.20		0.30		0.40		0.50		0.60		0.70		0.80		0.90		1.00	
cfm	rpm	bhp	rpm	bhp	rpm	bhp	rpm	bhp	rpm	bhp	rpm	bhp	rpm	bhp	rpm	bhp	rpm	bhp	rpm	bhp	
1-hp Standard Motor & Field Supplied Low Static Drive <sup>(a)</sup>											1-hp Standard Motor & Drive										
1280	—	—	528	0.15	600	0.19	661	0.23	717	0.28	771	0.33	821	0.38	870	0.43	915	0.48	959	0.54	
1440	—	—	556	0.18	626	0.23	687	0.28	740	0.33	790	0.38	839	0.43	886	0.49	930	0.54	974	0.61	
1600	—	—	586	0.22	651	0.28	712	0.34	766	0.39	814	0.44	860	0.50	904	0.55	947	0.61	990	0.68	
1760	554	0.22	619	0.28	680	0.33	738	0.39	792	0.46	841	0.52	884	0.58	926	0.63	967	0.69	1007	0.76	
1920	592	0.28	653	0.34	710	0.39	765	0.46	817	0.53	866	0.60	912	0.67	953	0.73	992	0.79	1028	0.85	

Continued

External Static Pressure (Inches of Water)											
		1.10		1.20		1.30		1.40		1.50	
cfm	rpm	bhp	rpm	bhp	rpm	bhp	rpm	bhp	rpm	bhp	
1-hp Standard Motor & Drive											
1280	1003	0.60	1045	0.66	1083	0.71	1121	0.77	1156	0.83	
1440	1013	0.66	1054	0.73	1094	0.79	1132	0.86	1168	0.92	
1600	1029	0.74	1069	0.81	1106	0.87	1142	0.94	1177	1.01	
1760	1046	0.82	1084	0.89	1121	0.96	1156	1.03	1191	1.11	
1920	1066	0.92	1103	0.99	1139	1.06	1174	1.14	1206	1.21	
1-hp Standard Motor & Field Supplied High Static Drive <sup>(b)</sup>											

**Notes:**

1. For Standard Evaporator Fan Speed (rpm), reference [Table 137, p. 182](#).
2. Data includes pressure drop due to standard filters and wet coils. No accessories or options are included in pressure drop data.
3. Data does not include pressure drop due to reheat coil.
4. Refer to [Table 145, p. 186](#) to determine additional static pressure drop due to other options/accessories.
5. 1-hp Fan Motor Heat (MBh) = 2.7672 x Fan bhp + 0.4705.
6. Factory supplied motors, in equipment, are definite purpose motors, specifically designed and tested to operate at all cataloged conditions. Using the full horsepower range of our fan motors as shown in our tabular data will not result in nuisance tripping or premature motor failure. Our product's warranty will not be affected.

(a) Field Supplied Fan Sheave AK74x3/4" required. Field Supplied Belt may be necessary.  
 (b) Field Supplied Fan Sheave AK41x3/4" required. Field Supplied Belt may be necessary.



## Evaporator Fan Performance

**Table 100. Belt drive evaporator fan performance - 4 tons high efficiency - YHC048E3,E4,F3,F4\*H high gas heat horizontal airflow**

																						External Static Pressure (Inches of Water)									
		0.10		0.20		0.30		0.40		0.50		0.60		0.70		0.80		0.90		1.00											
cfm	rpm	bhp	rpm	bhp	rpm	bhp	rpm	bhp	rpm	bhp	rpm	bhp	rpm	bhp	rpm	bhp	rpm	bhp	rpm	bhp											
1-hp Standard Motor & Field Supplied Low Static Drive <sup>(a)</sup>											1-hp Standard Motor & Drive																				
1280	—	—	561	0.16	626	0.20	684	0.25	739	0.29	792	0.34	842	0.39	890	0.45	935	0.50	977	0.56											
1440	—	—	595	0.20	659	0.25	715	0.30	766	0.35	816	0.40	864	0.45	909	0.51	953	0.57	995	0.63											
1600	561	0.20	628	0.25	694	0.31	748	0.36	798	0.41	843	0.47	888	0.52	932	0.58	974	0.64	1015	0.71											
1760	603	0.26	665	0.31	727	0.37	782	0.43	830	0.49	875	0.54	917	0.60	958	0.67	998	0.73	1038	0.80											
1920	646	0.32	705	0.38	761	0.44	816	0.52	864	0.58	908	0.63	949	0.70	988	0.76	1026	0.83	1063	0.90 <sup>(b)</sup>											

Continued

																						External Static Pressure (Inches of Water)				
		1.10		1.20		1.30		1.40		1.50																
cfm	rpm	bhp	rpm	bhp	rpm	bhp	rpm	bhp	rpm	bhp																
1-hp Standard Motor & Drive																										
1280	1018	0.62	1058	0.68	1095	0.74	1131	0.81	1166	0.87																
1440	1036	0.69	1075	0.76	1113	0.82	1148	0.89	1183	0.96																
1600	1055	0.77	1093	0.84	1130	0.91	1166	0.98	1201	1.05																
1760	1075	0.86	1113	0.93	1149	1.00	1184	1.08	1219	1.15																
1920	1100	0.97	1135	1.04	1171	1.11	1204	1.19	1237	1.26																
1-hp Standard Motor & Field Supplied High Static Drive <sup>(b)</sup>																										

**Notes:**

1. For Standard Evaporator Fan Speed (rpm), reference [Table 137, p. 182](#).
2. Data includes pressure drop due to standard filters and wet coils. No accessories or options are included in pressure drop data.
3. Data does not include pressure drop due to reheat coil.
4. Refer to [Table 145, p. 186](#) to determine additional static pressure drop due to other options/accessories.
5. 1-hp Fan Motor Heat (MBh) = 2.7672 x Fan bhp + 0.4705.
6. Factory supplied motors, in equipment, are definite purpose motors, specifically designed and tested to operate at all cataloged conditions. Using the full horsepower range of our fan motors as shown in our tabular data will not result in nuisance tripping or premature motor failure. Our product's warranty will not be affected.

(a) Field Supplied Fan Sheave AK74x3/4" required. Field Supplied Belt may be necessary.

(b) Field Supplied Fan Sheave AK41x3/4" required. Field Supplied Belt may be necessary.



## Evaporator Fan Performance

**Table 101. Belt drive evaporator fan performance - 5 tons high efficiency - THC060E3,E4,F3,F4 downflow airflow**

cfm	External Static Pressure (Inches of Water)																					
	0.10		0.20		0.30		0.40		0.50		0.60		0.70		0.80		0.90		1.00			
rpm	bhp	rpm	bhp	rpm	bhp	rpm	bhp	rpm	bhp	rpm	bhp	rpm	bhp	rpm	bhp	rpm	bhp	rpm	bhp	rpm	bhp	
1-hp Standard Motor & Low Static Drive Accessory Kit <sup>(a)</sup>													1-hp Standard Motor & Drive									
1000*	379	0.06	469	0.09	546	0.12	614	0.16	676	0.20	732	0.24	784	0.28	833	0.33	879	0.37	922	0.42		
1200*	416	0.09	498	0.12	571	0.158	635	0.20	694	0.24	749	0.28	800	0.33	849	0.38	894	0.43	938	0.48		
1400*	456	0.12	531	0.16	599	0.20	662	0.25	717	0.29	769	0.34	820	0.39	867	0.44	911	0.50	955	0.56		
1600	499	0.16	570	0.21	631	0.25	691	0.31	745	0.36	794	0.41	842	0.46	887	0.52	930	0.57	972	0.63		
1800	544	0.22	609	0.27	667	0.32	721	0.37	773	0.43	823	0.49	868	0.55	911	0.61	953	0.67	992	0.73		
2000	589	0.29	650	0.35	706	0.40	755	0.46	804	0.52	851	0.58	897	0.65	938	0.71	978	0.77	1017	0.84		
2200	636	0.37	692	0.43	745	0.50	793	0.56	838	0.62	882	0.68	925	0.75	967	0.83	1007	0.90	1044	0.97		
2400	683	0.47	736	0.54	785	0.61	833	0.68	875	0.74	916	0.81	956	0.88	996	0.95	1036	1.03	1073	1.11		

Continued

cfm	External Static Pressure (Inches of Water)									
	1.10		1.20		1.30		1.40		1.50	
rpm	bhp	rpm	bhp	rpm	bhp	rpm	bhp	rpm	bhp	
1-hp Standard Motor & Drive										
1000*	962	0.46	1002	0.51	1040	0.56	1076	0.61	1111	0.66
1200*	979	0.54	1018	0.50	1055	0.64	1091	0.70	1126	0.75
1400*	996	0.61	1035	0.67	1072	0.73	1107	0.79	1143	0.85
1600	1013	0.70	1051	0.76	1088	0.82	1124	0.89	1160	0.96
1800	1031	0.79	1070	0.86	1106	0.93	1142	1.00	1176	1.07
2000	1054	0.91	1091	0.98	1126	1.04	1161	1.12	1195	1.19
2200	1080	1.04	1115	1.11	1148	1.18	1183	1.26	1215	1.33
2400	1108	1.19	1142	1.27	1176	1.34	1207	1.42	1238	1.49
1-hp Standard Motor & Field Supplied High Static Drive <sup>(b)</sup>										

**Notes:**

1. For Standard Evaporator Fan Speed (rpm), reference [Table 137, p. 182](#).
  2. Data includes pressure drop due to standard filters and wet coils. Data does not include pressure drop due to reheat coil.
  3. Refer to [Table 145, p. 186](#) to determine additional static pressure drop due to other options/accessories.
  4. 1-hp Fan Motor Heat (MBh) = 2.7672 x Fan bhp + 0.4705.
  5. Factory supplied motors, in equipment, are definite purpose motors, specifically designed and tested to operate at all cataloged conditions. Using the full horsepower range of our fan motors as shown in our tabular data will not result in nuisance tripping or premature motor failure. Our product's warranty will not be affected.
- \* For 1000, 1200, and 1400 CFM, unit application below 320 CFM/Ton are only applicable on T\_C models only (No Gas Heat). See below for restrictions.  
 \* Electric heaters restricted on applications below 320 CFM/Ton  
 \* Dehumidification (Hot Gas Reheat) or TXV with Froststat and Crankcase Heaters are required on applications below 320 CFM/Ton

(a) BAYLSDR006AB  
 (b) Field Supplied Fan Sheave AK41x3/4" required. Field Supplied Belt may be necessary.

## Evaporator Fan Performance

**Table 102. Belt drive evaporator fan performance - 5 tons high efficiency - THC060E3,E4,F3,F4 horizontal airflow**

cfm	External Static Pressure (Inches of Water)																					
	0.10		0.20		0.30		0.40		0.50		0.60		0.70		0.80		0.90		1.00			
rpm	bhp	rpm	bhp	rpm	bhp	rpm	bhp	rpm	bhp	rpm	bhp	rpm	bhp	rpm	bhp	rpm	bhp	rpm	bhp	rpm	bhp	
<b>1-hp Standard Motor &amp; Low Static Drive Accessory Kit<sup>(a)</sup></b>											<b>1-hp Standard Motor &amp; Drive</b>											
1000*	412	0.07	517	0.10	601	0.15	664	0.19	716	0.23	764	0.27	810	0.31	853	0.35	897	0.40	939	0.44		
1200*	456	0.10	542	0.14	631	0.19	702	0.24	758	0.29	808	0.33	851	0.38	892	0.43	932	0.48	970	0.53		
1400*	502	0.14	580	0.18	654	0.23	730	0.29	795	0.35	848	0.41	893	0.46	936	0.52	974	0.58	1010	0.63		
1600	550	0.19	622	0.24	688	0.29	753	0.35	820	0.41	881	0.49	930	0.55	975	0.62	1015	0.68	1052	0.75		
1800	598	0.25	668	0.31	728	0.37	785	0.42	843	0.49	903	0.56	960	0.64	1010	0.72	1053	0.80	1092	0.87		
2000	648	0.33	714	0.39	771	0.46	824	0.52	875	0.58	927	0.66	982	0.74	1034	0.83	1082	0.91	1126	1.00		
2200	699	0.42	762	0.50	816	0.57	866	0.63	914	0.70	960	0.77	1006	0.85	1056	0.94	1106	1.03	1152	1.13		
2400	750	0.54	810	0.61	863	0.69	911	0.77	956	0.84	999	0.92	1042	1.00	1084	1.08	1130	1.17	1176	1.27		
											<b>1-hp Standard Motor &amp; Field Supplied High Static Drive<sup>(b)</sup></b>											

Continued

cfm	External Static Pressure (Inches of Water)									
	1.10		1.20		1.30		1.40		1.50	
rpm	bhp	rpm	bhp	rpm	bhp	rpm	bhp	rpm	bhp	
<b>1-hp Standard Motor &amp; Drive</b>										
1000*	977	0.49	1014	0.53	1049	0.58	1084	0.63	1118	0.68
1200*	1006	0.58	1042	0.63	1078	0.69	1112	0.74	1145	0.80
1400*	1045	0.69	1078	0.74	1111	0.8	1144	0.86	1174	0.92
1600	1087	0.81	1121	0.88	1152	0.94	1182	1.00	1213	1.07
1800	1129	0.95	1163	1.02	1195	1.09	1226	1.16	1255	1.23
2000	1165	1.08	1201	1.17	1236	1.25	1268	1.33	1298	1.41
2200	1196	1.23	1237	1.33	1271	1.42	1305	1.51	1338	1.60
2400	1219	1.37	1261	1.48	1301	1.58	1339	1.69	1373	1.79
<b>1-hp Standard Motor &amp; Field Supplied High Static Drive<sup>(b)</sup></b>										

**Notes:**

1. For Standard Evaporator Fan Speed (rpm), reference [Table 137, p. 182](#).
  2. Data includes pressure drop due to standard filters and wet coils. Data does not include pressure drop due to reheat coil.
  3. Refer to [Table 145, p. 186](#) to determine additional static pressure drop due to other options/accessories.
  4. 1-hp Fan Motor Heat (MBh) = 2.7672 x Fan bhp + 0.4705.
  5. Factory supplied motors, in equipment, are definite purpose motors, specifically designed and tested to operate at all cataloged conditions. Using the full horsepower range of our fan motors as shown in our tabular data will not result in nuisance tripping or premature motor failure. Our product's warranty will not be affected.
- \* For 1000, 1200, and 1400 CFM, unit application below 320 CFM/Ton are only applicable on T\_C models only (No Gas Heat). See below for restrictions.  
 \* Electric heaters restricted on applications below 320 CFM/Ton  
 \* Dehumidification (Hot Gas Reheat) or TXV with Froststat and Crankcase Heaters are required on applications below 320 CFM/Ton

(a) BAYLSDR006AB  
 (b) Field Supplied Fan Sheave AK41x3/4" required. Field Supplied Belt may be necessary.



## Evaporator Fan Performance

**Table 103. Belt drive evaporator fan performance - 5 tons high efficiency - YHC060E3,E4,F3,F4\*L,M low & medium gas heat downflow airflow**

External Static Pressure (Inches of Water)																					
		0.10		0.20		0.30		0.40		0.50		0.60		0.70		0.80		0.90		1.00	
cfm	rpm	bhp	rpm	bhp	rpm	bhp	rpm	bhp	rpm	bhp	rpm	bhp	rpm	bhp	rpm	bhp	rpm	bhp	rpm	bhp	
1-hp Standard Motor & Field Supplied Low Static Drive <sup>(a)</sup>											1-hp Standard Motor & Drive										
1600	—	—	583	0.22	648	0.27	705	0.32	755	0.37	804	0.42	852	0.47	897	0.53	941	0.59	982	0.65	
1800	—	—	623	0.28	683	0.34	740	0.40	790	0.45	835	0.50	879	0.56	922	0.62	964	0.68	1004	0.74	
2000	605	0.30	665	0.36	721	0.42	774	0.48	824	0.55	870	0.61	911	0.66	951	0.73	991	0.79	1028	0.86	
2200	653	0.39	709	0.45	762	0.51	812	0.58	859	0.65	905	0.72	948	0.79	986	0.86	1022	0.92	1057	0.99	
2400	701	0.49	756	0.56	803	0.63	851	0.70	896	0.77	939	0.85	982	0.93	1022	1.00	1057	1.07	1092	1.14	

Continued

External Static Pressure (Inches of Water)											
		1.10		1.20		1.30		1.40		1.50	
cfm	rpm	bhp	rpm	bhp	rpm	bhp	rpm	bhp	rpm	bhp	
1-hp Standard Motor & Drive											
1600	1024	0.71	1061	0.77	1099	0.83	1136	0.90	1170	0.96	
1800	1044	0.81	1081	0.87	1118	0.94	1155	1.01	1188	1.08	
2000	1067	0.93	1103	1.00	1139	1.07	1175	1.14	1209	1.22	
2200	1094	1.06	1129	1.13	1163	1.21	1197	1.29	1229	1.36	
2400	1124	1.21	1157	1.29	1189	1.37	1222	1.45	—	—	
1-hp Standard Motor & Field Supplied High Static Drive <sup>(b)</sup>											

**Notes:**

1. For Standard Evaporator Fan Speed (rpm), reference [Table 137, p. 182](#).
2. Data includes pressure drop due to standard filters and wet coils. No accessories or options are included in pressure drop data.
3. Data does not include pressure drop due to reheat coil.
4. Refer to [Table 145, p. 186](#) to determine additional static pressure drop due to other options/accessories.
5. 1-hp Fan Motor Heat (MBh) = 2.7672 x Fan bhp + 0.4705.
6. Factory supplied motors, in equipment, are definite purpose motors, specifically designed and tested to operate at all cataloged conditions. Using the full horsepower range of our fan motors as shown in our tabular data will not result in nuisance tripping or premature motor failure. Our product's warranty will not be affected.

(a) Field Supplied Fan Sheave AK69x3/4" required. Field Supplied Belt may be necessary.  
 (b) Field Supplied Fan Sheave AK41x3/4" required. Field Supplied Belt may be necessary.

## Evaporator Fan Performance

**Table 104. Belt drive evaporator fan performance - 5 tons high efficiency - YHC060E3,E4,F3,F4\*L,M low & medium gas heat horizontal airflow**

External Static Pressure (Inches of Water)																					
		0.10		0.20		0.30		0.40		0.50		0.60		0.70		0.80		0.90		1.00	
cfm	rpm	bhp	rpm	bhp	rpm	bhp	rpm	bhp	rpm	bhp	rpm	bhp	rpm	bhp	rpm	bhp	rpm	bhp	rpm	bhp	
1-hp Standard Motor & Field Supplied Low Static Drive <sup>(a)</sup>											1-hp Standard Motor & Drive										
1600	566	0.21	633	0.26	694	0.31	747	0.36	798	0.41	848	0.47	895	0.52	939	0.58	981	0.65	1021	0.71	
1800	621	0.28	681	0.33	739	0.39	790	0.45	837	0.51	884	0.57	929	0.63	971	0.69	1013	0.76	1052	0.82	
2000	676	0.37	731	0.43	785	0.49	836	0.56	880	0.62	923	0.69	966	0.75	1006	0.82	1046	0.89	1084	0.96	
2200	732	0.48	784	0.54	832	0.61	881	0.68	927	0.75	967	0.83	1005	0.90	1044	0.97	1082	1.04	1118	1.12	
2400	789	0.61	838	0.68	882	0.75	927	0.82	972	0.90	1012	0.98	1049	1.06	1085	1.14	1121	1.22	1155	1.30 <sup>(b)</sup>	

Continued

External Static Pressure (Inches of Water)											
		1.10		1.20		1.30		1.40		1.50	
cfm	rpm	bhp	rpm	bhp	rpm	bhp	rpm	bhp	rpm	bhp	
1-hp Standard Motor & Drive											
1600	1060	0.78	1097	0.84	1135	0.91	1169	0.98	1203	1.04	
1800	1090	0.89	1126	0.96	1161	1.04	1195	1.11	1229	1.19	
2000	1121	1.03	1156	1.10	1192	1.18	1224	1.26	1257	1.34	
2200	1155	1.19	1189	1.27	1223	1.34	1256	1.42	—	—	
2400	1190	1.38	1223	1.46	—	—	—	—	—	—	
1-hp Standard Motor & Field Supplied High Static Drive <sup>(b)</sup>											

**Notes:**

1. For Standard Evaporator Fan Speed (rpm), reference [Table 137, p. 182](#).
2. Data includes pressure drop due to standard filters and wet coils. No accessories or options are included in pressure drop data.
3. Data does not include pressure drop due to reheat coil.
4. Refer to [Table 145, p. 186](#) to determine additional static pressure drop due to other options/accessories.
5. 1-hp Fan Motor Heat (MBh) = 2.7672 x Fan bhp + 0.4705.
6. Factory supplied motors, in equipment, are definite purpose motors, specifically designed and tested to operate at all cataloged conditions. Using the full horsepower range of our fan motors as shown in our tabular data will not result in nuisance tripping or premature motor failure. Our product's warranty will not be affected.

(a) Field Supplied Fan Sheave AK69x3/4" required. Field Supplied Belt may be necessary.  
 (b) Field Supplied Fan Sheave AK41x3/4" required. Field Supplied Belt may be necessary.



## Evaporator Fan Performance

**Table 105. Belt drive evaporator fan performance - 5 tons high efficiency - YHC060E3,E4,F3,F4\*H high gas heat downflow airflow**

External Static Pressure (Inches of Water)																					
		0.10		0.20		0.30		0.40		0.50		0.60		0.70		0.80		0.90		1.00	
cfm	rpm	bhp	rpm	bhp	rpm	bhp	rpm	bhp	rpm	bhp	rpm	bhp	rpm	bhp	rpm	bhp	rpm	bhp	rpm	bhp	
1-hp Standard Motor & Field Supplied Low Static Drive <sup>(a)</sup>											1-hp Standard Motor & Drive										
1600	—	—	595	0.22	658	0.27	716	0.32	768	0.37	817	0.42	864	0.47	910	0.53	954	0.59	996	0.65	
1800	—	—	637	0.29	697	0.34	752	0.40	802	0.45	849	0.51	893	0.56	936	0.62	979	0.68	1019	0.75	
2000	621	0.31	680	0.36	737	0.42	790	0.49	838	0.55	884	0.61	927	0.67	967	0.73	1007	0.80	1046	0.86	
2200	671	0.40	726	0.46	779	0.52	829	0.59	876	0.66	919	0.72	962	0.79	1002	0.86	1039	0.93	1076	1.00	
2400	721	0.50	773	0.57	822	0.64	870	0.71	916	0.78	957	0.86	998	0.93	1036	1.00	1074	1.08	1109	1.15	

Continued

External Static Pressure (Inches of Water)											
		1.10		1.20		1.30		1.40		1.50	
cfm	rpm	bhp	rpm	bhp	rpm	bhp	rpm	bhp	rpm	bhp	
1-hp Standard Motor & Drive											
1600	1037	0.72	1076	0.78	1114	0.85	1151	0.91	1184	0.98	
1800	1058	0.82	1096	0.88	1133	0.95	1169	1.02	1204	1.10	
2000	1083	0.93	1120	1.00	1155	1.07	1189	1.15	1224	1.23	
2200	1111	1.07	1146	1.14	1181	1.22	1214	1.29	1248	1.37	
2400	1144	1.23	1177	1.30	1210	1.38	1241	1.46	1274	1.54	
1-hp Standard Motor & Field Supplied High Static Drive <sup>(b)</sup>											

**Notes:**

1. For Standard Evaporator Fan Speed (rpm), reference [Table 137, p. 182](#).
2. Data includes pressure drop due to standard filters and wet coils. No accessories or options are included in pressure drop data.
3. Data does not include pressure drop due to reheat coil.
4. Refer to [Table 145, p. 186](#) to determine additional static pressure drop due to other options/accessories.
5. 1-hp Fan Motor Heat (MBh) = 2.7672 x Fan bhp + 0.4705.
6. Factory supplied motors, in equipment, are definite purpose motors, specifically designed and tested to operate at all cataloged conditions. Using the full horsepower range of our fan motors as shown in our tabular data will not result in nuisance tripping or premature motor failure. Our product's warranty will not be affected.

(a) Field Supplied Fan Sheave AK69x3/4" required. Field Supplied Belt may be necessary.  
 (b) Field Supplied Fan Sheave AK41x3/4" required. Field Supplied Belt may be necessary.

## Evaporator Fan Performance

**Table 106. Belt drive evaporator fan performance - 5 tons high efficiency - YHC060E3,E4,F3,F4\*H high gas heat horizontal airflow**

External Static Pressure (Inches of Water)																					
		0.10		0.20		0.30		0.40		0.50		0.60		0.70		0.80		0.90		1.00	
cfm	rpm	bhp	rpm	bhp	rpm	bhp	rpm	bhp	rpm	bhp	rpm	bhp	rpm	bhp	rpm	bhp	rpm	bhp	rpm	bhp	
1-hp Standard Motor & Field Supplied Low Static Drive <sup>(a)</sup>										1-hp Standard Motor & Drive											
1600	570	0.21	639	0.26	703	0.32	760	0.37	809	0.41	854	0.46	894	0.52	936	0.58	977	0.64	1019	0.70	
1800	620	0.28	689	0.34	746	0.40	801	0.46	851	0.52	896	0.57	937	0.62	974	0.68	1011	0.75	1048	0.81	
2000	671	0.36	741	0.44	792	0.50	844	0.57	893	0.64	939	0.71	980	0.76	1019	0.82	1054	0.88	1087	0.95	
2200	723	0.46	791	0.55	843	0.62	889	0.69	936	0.77	981	0.85	1022	0.92	1061	0.99	1097	1.05	1131	1.11	
2400	776	0.58	841	0.68	895	0.76	937	0.84	981	0.91	1023	1.00	1064	1.09	1103	1.17	1140	1.25	1173	1.31 <sup>(b)</sup>	

Continued

External Static Pressure (Inches of Water)											
		1.10		1.20		1.30		1.40		1.50	
cfm	rpm	bhp	rpm	bhp	rpm	bhp	rpm	bhp	rpm	bhp	
1-hp Standard Motor & Drive											
1600	1057	0.76	1096	0.83	1133	0.90	1167	0.96	1201	1.03	
1800	1086	0.88	1123	0.95	1159	1.02	1192	1.09	1226	1.17	
2000	1119	1.02	1153	1.09	1188	1.17	1221	1.24	1253	1.32	
2200	1162	1.18	1193	1.25	1223	1.33	1253	1.41	1284	1.49	
2400	1206	1.38	1236	1.44	1266	1.52	1294	1.61	1320	1.69	
1-hp Standard Motor & Field Supplied High Static Drive <sup>(b)</sup>											

**Notes:**

1. For Standard Evaporator Fan Speed (rpm), reference [Table 137, p. 182](#).
2. Data includes pressure drop due to standard filters and wet coils. No accessories or options are included in pressure drop data.
3. Data does not include pressure drop due to reheat coil.
4. Refer to [Table 145, p. 186](#) to determine additional static pressure drop due to other options/accessories.
5. 1-hp Fan Motor Heat (MBh) = 2.7672 x Fan bhp + 0.4705.
6. Factory supplied motors, in equipment, are definite purpose motors, specifically designed and tested to operate at all cataloged conditions. Using the full horsepower range of our fan motors as shown in our tabular data will not result in nuisance tripping or premature motor failure. Our product's warranty will not be affected.

(a) Field Supplied Fan Sheave AK69x3/4" required. Field Supplied Belt may be necessary.  
 (b) Field Supplied Fan Sheave AK41x3/4" required. Field Supplied Belt may be necessary.



## Evaporator Fan Performance

**Table 107. Belt drive evaporator fan performance - 6 tons high efficiency - THC072F3,F4 downflow airflow**

External Static Pressure (Inches of Water)																					
		0.10		0.20		0.30		0.40		0.50		0.60		0.70		0.80		0.90		1.00	
cfm	rpm	bhp	rpm	bhp	rpm	bhp	rpm	bhp	rpm	bhp	rpm	bhp	rpm	bhp	rpm	bhp	rpm	bhp	rpm	bhp	
<b>1-hp Standard Motor &amp; Low Static Drive Accessory Kit<sup>(a)</sup></b>																					
1920	—	—	437	0.23	491	0.29	545	0.36	594	0.44	637	0.51	677	0.58	715	0.65	750	0.72	784	0.80	
2160	407	0.22	465	0.29	513	0.36	563	0.43	610	0.51	654	0.60	694	0.68	731	0.76	766	0.84	799	0.92	
2400	439	0.29	494	0.37	540	0.44	583	0.51	628	0.60	671	0.69	711	0.78	748	0.87	783	0.96	817	1.05	
2640	472	0.36	523	0.45	568	0.54	609	0.62	647	0.70	688	0.79	728	0.89	765	0.99	801	1.09	834	1.19	
2880	505	0.45	553	0.55	597	0.65	637	0.74	673	0.82	708	0.91	746	1.01	782	1.12	817	1.23	851	1.34	
<b>1-hp Standard Motor &amp; Drive</b>																					

Continued

External Static Pressure (Inches of Water)																					
		1.10		1.20		1.30		1.40		1.50		1.60		1.70		1.80		1.90		2.00	
cfm	rpm	bhp	rpm	bhp	rpm	bhp	rpm	bhp	rpm	bhp	rpm	bhp	rpm	bhp	rpm	bhp	rpm	bhp	rpm	bhp	
<b>1-hp Standard Motor &amp; Drive</b>																					
1920	815	0.87	847	0.94	875	1.01	903	1.08	930	1.16	958	1.23	984	1.31	1008	1.38	1033	1.46	1056	1.53	
2160	832	1.00	863	1.08	891	1.16	920	1.24	947	1.32	974	1.41	999	1.49	1024	1.57	1048	1.65	1071	1.73	
2400	848	1.14	878	1.23	908	1.32	935	1.41	963	1.50	989	1.59	1015	1.68	1040	1.77	1064	1.86	1088	1.95	
2640	865	1.29	895	1.39	924	1.48	953	1.59	979	1.68	1006	1.78	1031	1.88	1056	1.98	1080	2.08	1104	2.18	
2880	882	1.45	912	1.56	941	1.66	969	1.77	996	1.88	1021	1.98	1047	2.09	1072	2.20	—	—	—	—	
<b>2-hp Oversized Motor &amp; Drive</b>																					

**Notes:**

1. For Standard Evaporator Fan Speed (rpm), reference [Table 137, p. 182](#).
2. Data includes pressure drop due to standard filters and wet coils.
3. Refer to [Table 145, p. 186](#) to determine additional static pressure drop due to other options/accessories.
4. 1-HP Fan Motor Heat (MBH) = 2.829 x Fan BHP + .4024. 2-HP Fan Motor Heat (MBH) = 3.000 x Fan BHP + .5000.
5. Factory supplied motors, in equipment, are definite purpose motors, specifically designed and tested to operate at all cataloged conditions. Using the full horsepower range of our fan motors as shown in our tabular data will not result in nuisance tripping or premature motor failure. Our product's warranty will not be affected.

(a) BAYLSDR009AA



## Evaporator Fan Performance

**Table 108. Belt drive evaporator fan performance - 6 tons high efficiency - THC072F3,F4 horizontal airflow**

External Static Pressure (Inches of Water)																					
		0.10		0.20		0.30		0.40		0.50		0.60		0.70		0.80		0.90		1.00	
cfm	rpm	bhp	rpm	bhp	rpm	bhp	rpm	bhp	rpm	bhp	rpm	bhp	rpm	bhp	rpm	bhp	rpm	bhp	rpm	bhp	
1-hp Standard Motor & Low Static Drive Accessory Kit <sup>(a)</sup>														1-hp Standard Motor & Drive							
1920	422	0.21	490	0.28	551	0.37	595	0.44	634	0.51	670	0.59	704	0.66	735	0.74	765	0.82	794	0.89	
2160	461	0.28	514	0.35	581	0.46	629	0.55	667	0.62	702	0.70	735	0.78	767	0.87	796	0.96	824	1.04	
2400	501	0.37	547	0.44	604	0.54	661	0.66	701	0.75	735	0.84	768	0.93	798	1.02	827	1.11	855	1.21	
2640	541	0.47	584	0.55	629	0.64	685	0.77	734	0.90	769	1.00	800	1.09	831	1.19	860	1.29	886	1.39	
2880	582	0.59	623	0.69	661	0.76	708	0.88	759	1.03	803	1.17	834	1.28	864	1.39	892	1.49	919	1.59 <sup>(b)</sup>	

Continued

External Static Pressure (Inches of Water)																					
		1.10		1.20		1.30		1.40		1.50		1.60		1.70		1.80		1.90		2.00	
cfm	rpm	bhp	rpm	bhp	rpm	bhp	rpm	bhp	rpm	bhp	rpm	bhp	rpm	bhp	rpm	bhp	rpm	bhp	rpm	bhp	
1-hp Standard Motor & Drive														2-hp Oversized Motor & Drive							
1920	821	0.98	847	1.06	873	1.14	896	1.22	920	1.30	943	1.39	965	1.47	986	1.55	1006	1.64	1028	1.73	
2160	851	1.13	876	1.22	902	1.31	925	1.39	949	1.49	971	1.58	993	1.67	1014	1.76	1035	1.85	1055	1.95	
2400	881	1.30	907	1.40	932	1.49	955	1.59	978	1.69	1001	1.79	1022	1.88	1043	1.98	1064	2.09	1084	2.19	
2640	913	1.49	938	1.59	962	1.70	986	1.80	1009	1.91	1030	2.02	1052	2.12	1074	2.23	—	—	—	—	
2880	944	1.70	969	1.81	993	1.92	1016	2.04	1040	2.15	1061	2.26	—	—	—	—	—	—	—	—	

**Notes:**

1. For Standard Evaporator Fan Speed (rpm), reference [Table 137, p. 182](#).
2. Data includes pressure drop due to standard filters and wet coils.
3. Refer to [Table 145, p. 186](#) to determine additional static pressure drop due to other options/accessories.
4. 1-HP Fan Motor Heat (MBH) = 2.829 x Fan BHP + .4024. 2-HP Fan Motor Heat (MBH) = 3.000 x Fan BHP + .5000.
5. Factory supplied motors, in equipment, are definite purpose motors, specifically designed and tested to operate at all cataloged conditions. Using the full horsepower range of our fan motors as shown in our tabular data will not result in nuisance tripping or premature motor failure. Our product's warranty will not be affected.

(a) BAYLSDR009AA  
 (b) 2-HP Oversized Motor & Drive



## Evaporator Fan Performance

**Table 109. Belt drive evaporator fan performance - 6 tons high efficiency - YHC072F3,F4 low & medium gas heat downflow airflow**

External Static Pressure (Inches of Water)																					
		0.10		0.20		0.30		0.40		0.50		0.60		0.70		0.80		0.90		1.00	
cfm	rpm	bhp	rpm	bhp	rpm	bhp	rpm	bhp	rpm	bhp	rpm	bhp	rpm	bhp	rpm	bhp	rpm	bhp	rpm	bhp	
<b>1-hp Standard Motor &amp; Low Static Drive Accessory Kit<sup>(a)</sup></b>																					
1920	393	0.18	450	0.23	503	0.29	549	0.35	590	0.41	628	0.47	663	0.53	696	0.59	726	0.65	755	0.71	
2160	427	0.24	480	0.30	529	0.37	574	0.43	615	0.50	652	0.57	687	0.63	719	0.70	750	0.77	779	0.84	
2400	463	0.31	511	0.38	557	0.45	601	0.52	641	0.60	678	0.67	712	0.75	744	0.82	774	0.90	803	0.97	
2640	500	0.39	544	0.47	587	0.55	627	0.63	666	0.71	703	0.79	737	0.87	769	0.96	798	1.04	827	1.12	
2880	538	0.50	579	0.58	618	0.66	656	0.75	693	0.84	729	0.93	762	1.01	794	1.10	824	1.19	852	1.28	
<b>Continued</b>											<b>1-hp Standard Motor &amp; Drive</b>										
External Static Pressure (Inches of Water)																					
		1.10		1.20		1.30		1.40		1.50		1.60		1.70		1.80		1.90		2.00	
cfm	rpm	bhp	rpm	bhp	rpm	bhp	rpm	bhp	rpm	bhp	rpm	bhp	rpm	bhp	rpm	bhp	rpm	bhp	rpm	bhp	
<b>1-hp Standard Motor &amp; Drive</b>																					
1920	783	0.77	811	0.84	836	0.90	861	0.96	885	1.02	908	1.08	930	1.14	953	1.20	973	1.26	995	1.33	
2160	806	0.90	833	0.97	859	1.04	883	1.11	907	1.18	931	1.25	952	1.31	974	1.38	996	1.45	1016	1.52	
2400	830	1.05	856	1.12	883	1.20	906	1.27	930	1.35	952	1.42	976	1.50	998	1.58	1018	1.65	1039	1.73	
2640	854	1.20	880	1.29	906	1.37	930	1.45	953	1.53	976	1.62	998	1.70	1020	1.78	1041	1.86	1062	1.95	
2880	879	1.37	905	1.47	929	1.55	953	1.64	977	1.73	1000	1.83	1022	1.91	1044	2.01	1063	2.09	1084	2.18	
<b>2-hp Oversized Motor &amp; Drive</b>																					

**Notes:**

1. For Standard Evaporator Fan Speed (rpm), reference [Table 137, p. 182](#).
2. Data includes pressure drop due to standard filters and wet coils.
3. Refer to [Table 145, p. 186](#) to determine additional static pressure drop due to other options/accessories.
4. 1-HP Fan Motor Heat (MBH) = 2.829 x Fan BHP + .4024. 2-HP Fan Motor Heat (MBH) = 3.000 x Fan BHP + .5000.
5. Factory supplied motors, in equipment, are definite purpose motors, specifically designed and tested to operate at all cataloged conditions. Using the full horsepower range of our fan motors as shown in our tabular data will not result in nuisance tripping or premature motor failure. Our product's warranty will not be affected.

(a) BAYLSDR009AA

## Evaporator Fan Performance

**Table 110. Belt drive evaporator fan performance - 6 tons high efficiency - YHC072F3,F4 low & medium gas heat horizontal airflow**

External Static Pressure (Inches of Water)																					
		0.10		0.20		0.30		0.40		0.50		0.60		0.70		0.80		0.90		1.00	
cfm	rpm	bhp	rpm	bhp	rpm	bhp	rpm	bhp	rpm	bhp	rpm	bhp	rpm	bhp	rpm	bhp	rpm	bhp	rpm	bhp	
1-hp Standard Motor & Low Static Drive Accessory Kit <sup>(a)</sup>														1-hp Standard Motor & Drive							
1920	462	0.25	517	0.32	565	0.38	609	0.45	648	0.52	684	0.59	719	0.66	751	0.73	782	0.80	811	0.87	
2160	503	0.33	557	0.41	602	0.49	644	0.56	682	0.64	718	0.71	751	0.79	783	0.87	813	0.95	842	1.03	
2400	546	0.43	598	0.53	641	0.61	680	0.69	717	0.78	753	0.86	785	0.95	815	1.03	845	1.12	873	1.21	
2640	590	0.56	640	0.66	681	0.76	719	0.85	754	0.94	788	1.03	820	1.12	850	1.21	879	1.31	906	1.41	
2880	636	0.71	681	0.82	722	0.93	758	1.02	793	1.13	824	1.22	855	1.32	885	1.42	913	1.52	940	1.62 <sup>(b)</sup>	

Continued

External Static Pressure (Inches of Water)																					
		1.10		1.20		1.30		1.40		1.50		1.60		1.70		1.80		1.90		2.00	
cfm	rpm	bhp	rpm	bhp	rpm	bhp	rpm	bhp	rpm	bhp	rpm	bhp	rpm	bhp	rpm	bhp	rpm	bhp	rpm	bhp	
1-hp Standard Motor & Drive																					
1920	838	0.94	865	1.01	890	1.08	915	1.16	939	1.23	962	1.30	985	1.37	1007	1.45	1027	1.52	1049	1.59	
2160	870	1.11	895	1.19	920	1.27	945	1.35	969	1.43	991	1.51	1014	1.59	1035	1.67	1057	1.75	1077	1.83	
2400	901	1.30	926	1.38	952	1.47	975	1.56	999	1.65	1022	1.74	1044	1.82	1066	1.91	1086	2.00	1108	2.09	
2640	933	1.51	959	1.60	982	1.69	1007	1.79	1029	1.89	1053	1.99	1075	2.08	1096	2.18	1116	2.27	—	—	
2880	966	1.73	991	1.84	1015	1.94	1039	2.05	1062	2.16	1084	2.26	—	—	—	—	—	—	—	—	
2-hp Oversized Motor & Drive																					

**Notes:**

1. For Standard Evaporator Fan Speed (rpm), reference [Table 137, p. 182](#).
2. Data includes pressure drop due to standard filters and wet coils.
3. Refer to [Table 145, p. 186](#) to determine additional static pressure drop due to other options/accessories.
4. 1-HP Fan Motor Heat (MBH) = 2.829 x Fan BHP + .4024. 2-HP Fan Motor Heat (MBH) = 3.000 x Fan BHP + .5000.
5. Factory supplied motors, in equipment, are definite purpose motors, specifically designed and tested to operate at all cataloged conditions. Using the full horsepower range of our fan motors as shown in our tabular data will not result in nuisance tripping or premature motor failure. Our product's warranty will not be affected.

(a) BAYLSDR009AA  
 (b) 2-hp Oversized Motor & Drive



## Evaporator Fan Performance

**Table 111. Belt drive evaporator fan performance - 6 tons high efficiency - YHC072F3,F4 high gas heat, downflow airflow**

External Static Pressure (Inches of Water)																					
		0.10		0.20		0.30		0.40		0.50		0.60		0.70		0.80		0.90		1.00	
cfm	rpm	bhp	rpm	bhp	rpm	bhp	rpm	bhp	rpm	bhp	rpm	bhp	rpm	bhp	rpm	bhp	rpm	bhp	rpm	bhp	
1-hp Standard Motor & Low Static Drive Accessory Kit <sup>(a)</sup>															1-hp Standard Motor & Drive						
1920	412	0.20	472	0.26	524	0.32	571	0.38	612	0.44	651	0.51	686	0.57	719	0.64	750	0.71	779	0.77	
2160	454	0.27	504	0.33	553	0.40	599	0.47	640	0.54	678	0.61	712	0.68	745	0.75	776	0.83	805	0.90	
2400	495	0.36	534	0.41	585	0.50	627	0.57	668	0.65	705	0.73	739	0.81	771	0.88	802	0.96	831	1.05	
2640	535	0.46	570	0.52	617	0.61	657	0.69	696	0.77	732	0.86	767	0.95	799	1.03	829	1.12	858	1.20	
2880	575	0.58	612	0.65	646	0.72	690	0.83	725	0.92	761	1.01	795	1.11	827	1.20	857	1.29	884	1.38	

Continued

External Static Pressure (Inches of Water)																					
		1.10		1.20		1.30		1.40		1.50		1.60		1.70		1.80		1.90		2.00	
cfm	rpm	bhp	rpm	bhp	rpm	bhp	rpm	bhp	rpm	bhp	rpm	bhp	rpm	bhp	rpm	bhp	rpm	bhp	rpm	bhp	
1-hp Standard Motor & Drive															2-hp Oversized Motor & Drive						
1920	808	0.84	835	0.91	862	0.97	887	1.04	910	1.11	935	1.18	957	1.25	979	1.32	1001	1.39	1022	1.46	
2160	834	0.98	860	1.05	886	1.13	911	1.20	935	1.28	959	1.35	982	1.43	1004	1.51	1025	1.58	1046	1.66	
2400	859	1.13	886	1.21	912	1.29	936	1.37	960	1.45	984	1.54	1007	1.63	1028	1.71	1050	1.79	1071	1.88	
2640	885	1.29	911	1.38	937	1.47	962	1.56	985	1.65	1009	1.74	1032	1.84	1054	1.93	1074	2.01	1095	2.11	
2880	913	1.48	938	1.57	963	1.67	988	1.77	1012	1.86	1035	1.96	1057	2.06	1079	2.16	1099	2.26	—	—	

**Notes:**

1. For Standard Evaporator Fan Speed (rpm), reference [Table 137, p. 182](#).
2. Data includes pressure drop due to standard filters and wet coils.
3. Refer to [Table 145, p. 186](#) to determine additional static pressure drop due to other options/accessories.
4. 1-HP Fan Motor Heat (MBH) = 2.829 x Fan BHP + .4024. 2-HP Fan Motor Heat (MBH) = 3.000 x Fan BHP + .5000.
5. Factory supplied motors, in equipment, are definite purpose motors, specifically designed and tested to operate at all cataloged conditions. Using the full horsepower range of our fan motors as shown in our tabular data will not result in nuisance tripping or premature motor failure. Our product's warranty will not be affected.

(a) BAYLSDR009AA

## Evaporator Fan Performance

**Table 112. Belt drive evaporator fan performance - 6 tons high efficiency - YHC072F3,F4 high gas heat, horizontal airflow**

External Static Pressure (Inches of Water)																					
		0.10		0.20		0.30		0.40		0.50		0.60		0.70		0.80		0.90		1.00	
cfm	rpm	bhp	rpm	bhp	rpm	bhp	rpm	bhp	rpm	bhp	rpm	bhp	rpm	bhp	rpm	bhp	rpm	bhp	rpm	bhp	
1-hp Standard Motor & Low Static Drive Accessory Kit <sup>(a)</sup>												1-hp Standard Motor & Drive									
1920	476	0.27	528	0.34	575	0.40	619	0.47	660	0.54	697	0.62	731	0.69	763	0.77	793	0.84	821	0.92	
2160	520	0.36	571	0.44	614	0.51	655	0.59	694	0.67	731	0.75	765	0.83	796	0.91	826	1.00	854	1.08	
2400	566	0.47	615	0.56	656	0.65	694	0.73	730	0.81	765	0.90	799	0.99	830	1.08	860	1.17	888	1.27	
2640	612	0.61	659	0.71	698	0.81	734	0.89	769	0.98	802	1.08	834	1.17	865	1.27	894	1.37	922	1.47	
2880	660	0.77	703	0.88	742	0.99	777	1.09	808	1.18	840	1.28	870	1.38	899	1.49	929	1.60	957	1.70 <sup>(b)</sup>	

Continued

External Static Pressure (Inches of Water)																					
		1.10		1.20		1.30		1.40		1.50		1.60		1.70		1.80		1.90		2.00	
cfm	rpm	bhp	rpm	bhp	rpm	bhp	rpm	bhp	rpm	bhp	rpm	bhp	rpm	bhp	rpm	bhp	rpm	bhp	rpm	bhp	
1-hp Standard Motor & Drive																					
1920	849	0.99	876	1.07	900	1.14	925	1.22	949	1.30	972	1.38	994	1.45	1015	1.53	1037	1.61	1057	1.69	
2160	881	1.17	908	1.25	933	1.34	957	1.42	980	1.51	1003	1.59	1026	1.68	1046	1.76	1067	1.85	1088	1.94	
2400	915	1.36	941	1.46	966	1.55	990	1.64	1012	1.73	1035	1.83	1057	1.92	1079	2.02	1099	2.11	1119	2.21	
2640	949	1.57	975	1.67	999	1.78	1023	1.88	1045	1.98	1068	2.09	1090	2.19	1110	2.29	—	—	—	—	
2880	983	1.81	1009	1.92	1034	2.03	1056	2.14	1080	2.26	—	—	—	—	—	—	—	—	—	—	
2-hp Oversized Motor & Drive																					

**Notes:**

1. For Standard Evaporator Fan Speed (rpm), reference [Table 137, p. 182](#).
2. Data includes pressure drop due to standard filters and wet coils.
3. Refer to [Table 145, p. 186](#) to determine additional static pressure drop due to other options/accessories.
4. 1-HP Fan Motor Heat (MBH) = 2.829 x Fan BHP + .4024. 2-HP Fan Motor Heat (MBH) = 3.000 x Fan BHP + .5000.
5. Factory supplied motors, in equipment, are definite purpose motors, specifically designed and tested to operate at all cataloged conditions. Using the full horsepower range of our fan motors as shown in our tabular data will not result in nuisance tripping or premature motor failure. Our product's warranty will not be affected.

(a) BAYLSDR009AA  
 (b) 2-hp Oversized Motor & Drive



## Evaporator Fan Performance

**Table 113. Direct drive evaporator fan performance - 7½ tons high efficiency - THC092E3,E4 downflow airflow<sup>(a)</sup>**

cfm	External Static Pressure (Inches of Water)																			
	0.10		0.20		0.30		0.40		0.50		0.60		0.70		0.80		0.90		1.00	
	rpm	bhp	rpm	bhp	rpm	bhp	rpm	bhp	rpm	bhp	rpm	bhp	rpm	bhp	rpm	bhp	rpm	bhp	rpm	bhp
1500*	528	0.09	586	0.14	637	0.18	690	0.23	738	0.29	782	0.34	823	0.40	861	0.47	898	0.53	932	0.60
1800*	610	0.14	660	0.19	709	0.24	750	0.29	795	0.35	838	0.42	878	0.48	915	0.55	951	0.62	985	0.69
2100*	694	0.21	740	0.26	781	0.32	823	0.38	859	0.44	896	0.50	935	0.58	972	0.65	1007	0.73	1039	0.80
2400	780	0.29	822	0.35	860	0.42	895	0.48	933	0.55	966	0.62	996	0.69	1030	0.77	1063	0.85	1096	0.93
2700	867	0.40	905	0.47	941	0.54	974	0.61	1005	0.68	1038	0.76	1070	0.84	1097	0.92	1125	0.99	1155	1.08
3000	955	0.53	990	0.61	1024	0.68	1055	0.76	1084	0.84	1112	0.92	1142	1.01	1172	1.10	1198	1.19	1222	1.27
3300	1044	0.69	1076	0.77	1107	0.85	1137	0.94	1165	1.02	1191	1.11	1216	1.20	1243	1.29	1271	1.39	1297	1.50
3600	1133	0.87	1163	0.96	1191	1.06	1220	1.15	1247	1.24	1272	1.33	1296	1.42	1319	1.52	1343	1.62	1368	1.73

Continued

cfm	External Static Pressure (Inches of Water)																			
	1.10		1.20		1.30		1.40		1.50		1.60		1.70		1.80		1.90		2.00	
	rpm	bhp	rpm	bhp	rpm	bhp	rpm	bhp	rpm	bhp	rpm	bhp	rpm	bhp	rpm	bhp	rpm	bhp	rpm	bhp
1500*	965	0.66	997	0.73	1027	0.80	1056	0.88	1085	0.95	1112	1.03	1138	1.10	1165	1.18	1190	1.26	1214	1.35
1800*	1018	0.77	1048	0.84	1078	0.92	1108	1.00	1135	1.07	1163	1.16	1188	1.24	1214	1.32	1239	1.41	1264	1.50
2100*	1071	0.88	1102	0.96	1132	1.05	1160	1.13	1187	1.22	1214	1.30	1241	1.40	1265	1.48	1290	1.57	1314	1.67
2400	1127	1.02	1158	1.11	1187	1.20	1215	1.29	1242	1.38	1268	1.47	1294	1.57	1319	1.66	1343	1.76	1367	1.86
2700	1185	1.17	1215	1.27	1244	1.36	1270	1.46	1297	1.56	1324	1.66	1349	1.76	1373	1.86	1398	1.97	1422	2.07
3000	1247	1.35	1273	1.45	1302	1.55	1328	1.65	1354	1.75	1380	1.86	1405	1.97	1429	2.08	1453	2.19	1475	2.30
3300	1320	1.59	1342	1.68	1364	1.77	1389	1.87	1413	1.98	1438	2.09	1462	2.20	1486	2.32	1509	2.43	1533	2.55
3600	1393	1.84	1418	1.96	1438	2.06	1458	2.15	1478	2.25	1500	2.35	1522	2.47	1545	2.59	1569	2.71	1591	2.83

**Notes:**

1. For Direct Drive Fan Speed (RPM), reference [Table 142, p. 183](#).
  2. Data includes pressure drop due to standard filters and wet coils.
  3. Refer to [Table 145, p. 186](#) to determine additional static pressure drop due to other options/accessories.
  4. Direct Drive Fan Motor Heat (MBH) = 2.8623 x Fan BHP - 0.1504
  5. Factory supplied motors, in commercial equipment, are definite purpose motors, specifically designed and tested to operate reliably and continuously at all cataloged conditions. Using the full horsepower range of our fan motors as shown in our tabular data will not result in nuisance tripping or premature motor failure. Our product's warranty will not be affected.
- \* For 1500, 1800, and 2100 CFM, unit application below 320 CFM/Ton are only applicable on T\_C models only (No Gas Heat). See below for restrictions.  
 \* Electric heaters restricted on applications below 320 CFM/Ton  
 \* Dehumidification (Hot Gas Reheat) or TXV with Froststat and Crankcase Heaters are required on applications below 320 CFM/Ton

(a) Table for Dehumidification only.

## Evaporator Fan Performance

**Table 114. Direct drive evaporator fan performance - 7½ tons high efficiency - THC092F3,F4 downflow airflow**

External Static Pressure (Inches of Water)																						
		0.10		0.20		0.30		0.40		0.50		0.60		0.70		0.80		0.90		1.00		
cfm	rpm	bhp	rpm	bhp	rpm	bhp	rpm	bhp	rpm	bhp	rpm	bhp	rpm	bhp	rpm	bhp	rpm	bhp	rpm	bhp	rpm	bhp
2400	786	0.30	820	0.36	855	0.42	890	0.48	923	0.54	954	0.61	984	0.67	1014	0.73	1044	0.80	1074	0.87		
2700	876	0.42	907	0.48	937	0.54	968	0.61	999	0.68	1030	0.75	1058	0.82	1084	0.89	1110	0.96	1137	1.03		
3000	967	0.56	995	0.62	1022	0.69	1050	0.76	1078	0.84	1106	0.91	1133	0.99	1159	1.07	1184	1.15	1207	1.23		
3300	1058	0.73	1084	0.80	1108	0.87	1133	0.95	1159	1.03	1184	1.11	1209	1.19	1235	1.28	1259	1.37	1283	1.46		
3600	1150	0.93	1173	1.01	1196	1.09	1219	1.17	1242	1.25	1265	1.34	1288	1.43	1312	1.52	1335	1.61	1357	1.71		

Continued

External Static Pressure (Inches of Water)																						
		1.10		1.20		1.30		1.40		1.50		1.60		1.70		1.80		1.90		2.00		
cfm	rpm	bhp	rpm	bhp	rpm	bhp	rpm	bhp	rpm	bhp	rpm	bhp	rpm	bhp	rpm	bhp	rpm	bhp	rpm	bhp	rpm	bhp
2400	1103	0.95	1132	1.02	1162	1.09	1190	1.17	1217	1.25	1244	1.33	1269	1.41	1295	1.50	1319	1.58	1345	1.67		
2700	1164	1.11	1191	1.19	1217	1.27	1243	1.35	1268	1.43	1295	1.52	1321	1.61	1346	1.69	1369	1.78	1393	1.87		
3000	1231	1.30	1255	1.38	1280	1.47	1304	1.56	1328	1.65	1351	1.74	1375	1.83	1397	1.92	1420	2.01	1443	2.10		
3300	1305	1.54	1326	1.63	1348	1.71	1369	1.80	1391	1.88	1413	1.98	1435	2.08	1456	2.18	1479	2.28	1500	2.38		
3600	1379	1.80	1401	1.90	1422	2.00	1441	2.09	1461	2.18	1480	2.27	1501	2.36	1521	2.46	1542	2.57	1561	2.67		

**Notes:**

1. For Direct Drive Fan Speed (RPM), reference [Table 142, p. 183](#).
2. Data includes pressure drop due to standard filters and wet coils.
3. Refer to [Table 145, p. 186](#) to determine additional static pressure drop due to other options/accessories.
4. Direct Drive Fan Motor Heat (MBH) = 2.8623 x Fan BHP - 0.1504
5. Factory supplied motors, in commercial equipment, are definite purpose motors, specifically designed and tested to operate reliably and continuously at all cataloged conditions. Using the full horsepower range of our fan motors as shown in our tabular data will not result in nuisance tripping or premature motor failure. Our product's warranty will not be affected.



## Evaporator Fan Performance

**Table 115. Direct drive evaporator fan performance - 7½ tons high efficiency - THC092E3,E4 horizontal airflow<sup>(a)</sup>**

cfm	External Static Pressure (Inches of Water)																			
	0.10		0.20		0.30		0.40		0.50		0.60		0.70		0.80		0.90		1.00	
	rpm	bhp	rpm	bhp	rpm	bhp	rpm	bhp	rpm	bhp	rpm	bhp	rpm	bhp	rpm	bhp	rpm	bhp	rpm	bhp
1500*	546	0.11	618	0.16	682	0.22	741	0.29	794	0.35	842	0.42	887	0.49	929	0.56	970	0.64	1006	0.72
1800*	630	0.16	690	0.22	749	0.29	803	0.36	853	0.44	900	0.51	945	0.59	986	0.67	1025	0.76	1062	0.84
2100*	713	0.23	765	0.30	819	0.37	870	0.45	917	0.54	961	0.62	1003	0.71	1044	0.80	1082	0.89	1119	0.98
2400	797	0.32	852	0.40	894	0.48	940	0.57	984	0.66	1027	0.75	1066	0.85	1105	0.94	1141	1.04	1177	1.14
2700	882	0.43	934	0.52	976	0.61	1014	0.70	1055	0.80	1095	0.90	1133	1.01	1170	1.12	1204	1.22	1238	1.33
3000	970	0.57	1016	0.66	1059	0.77	1091	0.86	1129	0.97	1166	1.08	1203	1.19	1237	1.31	1271	1.42	1303	1.54
3300	1058	0.73	1100	0.83	1141	0.96	1179	1.07	1205	1.16	1240	1.28	1274	1.40	1308	1.53	1339	1.65	1370	1.78
3600	1147	0.93	1185	1.04	1224	1.16	1260	1.30	1293	1.42	1316	1.51	1349	1.65	1379	1.78	1410	1.91	1442	2.05

Continued

cfm	External Static Pressure (Inches of Water)																			
	1.10		1.20		1.30		1.40		1.50		1.60		1.70		1.80		1.90		2.00	
	rpm	bhp	rpm	bhp	rpm	bhp	rpm	bhp	rpm	bhp	rpm	bhp	rpm	bhp	rpm	bhp	rpm	bhp	rpm	bhp
1500*	1043	0.80	1077	0.88	1111	0.97	1142	1.05	1173	1.14	1203	1.23	1233	1.33	1261	1.42	1288	1.51	1315	1.61
1800*	1097	0.93	1132	1.02	1164	1.11	1196	1.21	1226	1.30	1256	1.40	1284	1.50	1313	1.60	1341	1.70	1367	1.80
2100*	1154	1.08	1187	1.18	1220	1.28	1250	1.37	1281	1.48	1310	1.58	1339	1.69	1367	1.80	1393	1.90	1420	2.02
2400	1212	1.25	1245	1.35	1277	1.46	1307	1.57	1338	1.68	1367	1.79	1394	1.91	1421	2.02	1448	2.14	1473	2.25
2700	1271	1.44	1304	1.55	1336	1.67	1366	1.79	1395	1.90	1424	2.03	1451	2.14	1479	2.27	1505	2.39	1531	2.52
3000	1334	1.66	1365	1.78	1395	1.90	1426	2.03	1454	2.15	1483	2.28	1509	2.41	1536	2.54	1563	2.68	1588	2.81
3300	1402	1.91	1431	2.04	1459	2.17	1486	2.29	1514	2.43	1542	2.57	1569	2.71	1596	2.85	1621	2.98	1647	3.13
3600	1470	2.19	1498	2.32	1527	2.47	1554	2.61	1579	2.75	1605	2.89	1631	3.03	1657	3.18	1681	3.33	—	—

**Notes:**

1. For Direct Drive Fan Speed (RPM), reference [Table 142, p. 183](#).
  2. Data includes pressure drop due to standard filters and wet coils.
  3. Refer to [Table 145, p. 186](#) to determine additional static pressure drop due to other options/accessories.
  4. Direct Drive Fan Motor Heat (MBH) = 2.8623 x Fan BHP - 0.1504
  5. Factory supplied motors, in commercial equipment, are definite purpose motors, specifically designed and tested to operate reliably and continuously at all cataloged conditions. Using the full horsepower range of our fan motors as shown in our tabular data will not result in nuisance tripping or premature motor failure. Our product's warranty will not be affected.
- \* For 1500, 1800, and 2100 CFM, unit application below 320 CFM/Ton are only applicable on T\_C models only (No Gas Heat). See below for restrictions.  
 \* Electric heaters restricted on applications below 320 CFM/Ton  
 \* Dehumidification (Hot Gas Reheat) or TXV with Froststat and Crankcase Heaters are required on applications below 320 CFM/Ton

(a) Table for Dehumidification only.



## Evaporator Fan Performance

**Table 116. Direct drive evaporator fan performance - 7½ tons high efficiency - THC092F3,F4 horizontal airflow**

External Static Pressure (Inches of Water)																					
		0.10		0.20		0.30		0.40		0.50		0.60		0.70		0.80		0.90		1.00	
cfm	rpm	bhp	rpm	bhp	rpm	bhp	rpm	bhp	rpm	bhp	rpm	bhp	rpm	bhp	rpm	bhp	rpm	bhp	rpm	bhp	
2400	778	0.30	814	0.35	849	0.41	882	0.47	914	0.53	946	0.59	977	0.66	1008	0.73	1037	0.79	1065	0.85	
2700	867	0.41	899	0.47	930	0.53	961	0.60	990	0.66	1019	0.73	1047	0.79	1076	0.87	1104	0.95	1131	1.02	
3000	956	0.54	985	0.61	1014	0.68	1042	0.75	1069	0.83	1096	0.90	1122	0.97	1147	1.04	1173	1.12	1198	1.21	
3300	1046	0.71	1073	0.78	1099	0.86	1125	0.94	1150	1.02	1175	1.09	1199	1.17	1222	1.25	1246	1.33	1269	1.41	
3600	1137	0.91	1162	0.99	1185	1.07	1209	1.15	1232	1.24	1256	1.32	1279	1.41	1301	1.49	1323	1.58	1344	1.66	

Continued

External Static Pressure (Inches of Water)																					
		1.10		1.20		1.30		1.40		1.50		1.60		1.70		1.80		1.90		2.00	
cfm	rpm	bhp	rpm	bhp	rpm	bhp	rpm	bhp	rpm	bhp	rpm	bhp	rpm	bhp	rpm	bhp	rpm	bhp	rpm	bhp	
2400	1093	0.92	1120	0.99	1149	1.07	1176	1.15	1204	1.22	1229	1.30	1256	1.38	1280	1.45	1303	1.52	1328	1.60	
2700	1157	1.09	1182	1.17	1207	1.24	1231	1.32	1257	1.40	1281	1.49	1307	1.57	1331	1.66	1354	1.74	1378	1.83	
3000	1223	1.29	1248	1.38	1272	1.46	1295	1.54	1318	1.62	1341	1.70	1362	1.79	1384	1.87	1406	1.97	1429	2.06	
3300	1292	1.50	1316	1.60	1339	1.69	1361	1.78	1383	1.87	1405	1.96	1427	2.05	1446	2.14	1467	2.23	1488	2.33	
3600	1366	1.75	1386	1.84	1408	1.94	1429	2.04	1451	2.15	1472	2.25	1492	2.35	1513	2.45	1532	2.54	1551	2.64	

**Notes:**

1. For Direct Drive Fan Speed (RPM), reference [Table 142, p. 183](#).
2. Data includes pressure drop due to standard filters and wet coils.
3. Refer to [Table 145, p. 186](#) to determine additional static pressure drop due to other options/accessories.
4. Direct Drive Fan Motor Heat (MBH) = 2.8623 x Fan BHP - 0.1504
5. Factory supplied motors, in commercial equipment, are definite purpose motors, specifically designed and tested to operate reliably and continuously at all cataloged conditions. Using the full horsepower range of our fan motors as shown in our tabular data will not result in nuisance tripping or premature motor failure. Our product's warranty will not be affected.



## Evaporator Fan Performance

**Table 117. Direct drive evaporator fan performance - 7½ tons high efficiency - YHC092E3,E4 low & medium gas heat, downflow airflow<sup>(a)</sup>**

	External Static Pressure (Inches of Water)																			
	0.10		0.20		0.30		0.40		0.50		0.60		0.70		0.80		0.90		1.00	
cfm	rpm	bhp	rpm	bhp	rpm	bhp	rpm	bhp	rpm	bhp	rpm	bhp	rpm	bhp	rpm	bhp	rpm	bhp	rpm	bhp
2400	795	0.30	827	0.36	864	0.42	898	0.48	930	0.55	964	0.62	995	0.69	1024	0.76	1053	0.83	1081	0.91
2700	886	0.41	915	0.48	946	0.55	978	0.62	1008	0.69	1037	0.76	1067	0.84	1095	0.91	1122	0.99	1149	1.07
3000	976	0.55	1005	0.62	1031	0.70	1060	0.77	1089	0.85	1116	0.93	1141	1.01	1168	1.09	1194	1.18	1220	1.26
3300	1066	0.71	1096	0.79	1118	0.87	1144	0.96	1170	1.04	1196	1.13	1221	1.21	1244	1.30	1269	1.39	1293	1.48
3600	1156	0.91	1186	1.00	1208	1.08	1229	1.17	1253	1.27	1278	1.36	1301	1.45	1325	1.54	1346	1.63	1368	1.73

Continued

	External Static Pressure (Inches of Water)																			
	1.10		1.20		1.30		1.40		1.50		1.60		1.70		1.80		1.90		2.00	
cfm	rpm	bhp	rpm	bhp	rpm	bhp	rpm	bhp	rpm	bhp	rpm	bhp	rpm	bhp	rpm	bhp	rpm	bhp	rpm	bhp
2400	1107	0.98	1132	1.06	1157	1.13	1181	1.21	1204	1.29	1226	1.37	1248	1.45	1270	1.53	1292	1.62	1313	1.71
2700	1175	1.15	1200	1.24	1224	1.32	1247	1.40	1270	1.49	1292	1.57	1313	1.66	1335	1.75	1356	1.84	1375	1.93
3000	1245	1.35	1269	1.44	1293	1.53	1315	1.62	1337	1.71	1359	1.80	1380	1.90	1401	1.99	1420	2.09	1441	2.18
3300	1317	1.58	1340	1.67	1363	1.77	1385	1.86	1407	1.97	1428	2.06	1447	2.16	1468	2.26	1487	2.36	1507	2.47
3600	1391	1.83	1413	1.94	1435	2.04	1456	2.14	1477	2.25	1497	2.35	1517	2.46	1537	2.56	1555	2.67	1575	2.78

**Notes:**

1. For Direct Drive Fan Speed (RPM), reference [Table 142, p. 183](#).
2. Data includes pressure drop due to standard filters and wet coils.
3. Refer to [Table 145, p. 186](#) to determine additional static pressure drop due to other options/accessories.
4. Direct Drive Fan Motor Heat (MBH) = 2.8623 x Fan BHP - 0.1504
5. Factory supplied motors, in commercial equipment, are definite purpose motors, specifically designed and tested to operate reliably and continuously at all cataloged conditions. Using the full horsepower range of our fan motors as shown in our tabular data will not result in nuisance tripping or premature motor failure. Our product's warranty will not be affected.

(a) Table for Dehumidification only.

## Evaporator Fan Performance

**Table 118. Direct drive evaporator fan performance - 7½ tons high efficiency - YHC092F3,F4 low & medium gas heat, downflow airflow**

	External Static Pressure (Inches of Water)																			
	0.10		0.20		0.30		0.40		0.50		0.60		0.70		0.80		0.90		1.00	
cfm	rpm	bhp	rpm	bhp	rpm	bhp	rpm	bhp	rpm	bhp	rpm	bhp	rpm	bhp	rpm	bhp	rpm	bhp	rpm	bhp
2400	806	0.33	839	0.39	870	0.44	903	0.50	935	0.56	966	0.62	997	0.70	1029	0.77	1061	0.85	1092	0.92
2700	899	0.46	929	0.52	956	0.57	985	0.64	1014	0.70	1042	0.77	1071	0.84	1098	0.92	1126	1.00	1153	1.09
3000	992	0.61	1020	0.68	1045	0.75	1070	0.81	1096	0.88	1122	0.95	1148	1.03	1173	1.10	1198	1.19	1224	1.27
3300	1086	0.80	1111	0.87	1135	0.95	1158	1.02	1181	1.09	1204	1.17	1229	1.25	1252	1.33	1275	1.41	1298	1.50
3600	1181	1.02	1204	1.10	1226	1.19	1248	1.27	1268	1.34	1289	1.42	1311	1.50	1333	1.59	1355	1.68	1376	1.77

Continued

	External Static Pressure (Inches of Water)																			
	1.10		1.20		1.30		1.40		1.50		1.60		1.70		1.80		1.90		2.00	
cfm	rpm	bhp	rpm	bhp	rpm	bhp	rpm	bhp	rpm	bhp	rpm	bhp	rpm	bhp	rpm	bhp	rpm	bhp	rpm	bhp
2400	1121	1.00	1151	1.07	1180	1.15	1209	1.24	1235	1.32	1262	1.40	1288	1.49	1314	1.58	1338	1.66	1361	1.75
2700	1183	1.18	1210	1.26	1238	1.35	1264	1.43	1291	1.52	1316	1.60	1342	1.69	1366	1.79	1390	1.88	1414	1.97
3000	1248	1.37	1273	1.46	1298	1.56	1325	1.65	1350	1.75	1374	1.84	1398	1.93	1422	2.03	1445	2.12	1468	2.23
3300	1321	1.59	1343	1.69	1366	1.79	1389	1.89	1412	2.00	1434	2.10	1458	2.21	1481	2.31	1503	2.41	1526	2.52
3600	1397	1.86	1418	1.95	1439	2.05	1460	2.16	1480	2.27	1501	2.38	1522	2.49	1543	2.61	1564	2.72	1585	2.83

**Notes:**

1. For Direct Drive Fan Speed (RPM), reference [Table 142, p. 183](#).
2. Data includes pressure drop due to standard filters and wet coils.
3. Refer to [Table 145, p. 186](#) to determine additional static pressure drop due to other options/accessories.
4. Direct Drive Fan Motor Heat (MBH) = 2.8623 x Fan BHP - 0.1504
5. Factory supplied motors, in commercial equipment, are definite purpose motors, specifically designed and tested to operate reliably and continuously at all cataloged conditions. Using the full horsepower range of our fan motors as shown in our tabular data will not result in nuisance tripping or premature motor failure. Our product's warranty will not be affected.



## Evaporator Fan Performance

**Table 119. Direct drive evaporator fan performance - 7½ tons high efficiency - YHC092E3,E4 low & medium gas heat, horizontal airflow<sup>(a)</sup>**

	External Static Pressure (Inches of Water)																			
	0.10		0.20		0.30		0.40		0.50		0.60		0.70		0.80		0.90		1.00	
cfm	rpm	bhp	rpm	bhp	rpm	bhp	rpm	bhp	rpm	bhp	rpm	bhp	rpm	bhp	rpm	bhp	rpm	bhp	rpm	bhp
2400	784	0.29	833	0.37	871	0.44	909	0.52	946	0.59	981	0.68	1018	0.77	1053	0.86	1086	0.95	1118	1.04
2700	869	0.40	916	0.48	954	0.56	987	0.65	1020	0.73	1054	0.82	1085	0.91	1117	1.00	1149	1.10	1180	1.21
3000	956	0.52	998	0.62	1037	0.71	1069	0.80	1099	0.89	1129	0.98	1159	1.08	1188	1.18	1216	1.28	1245	1.39
3300	1043	0.67	1082	0.78	1120	0.88	1152	0.98	1181	1.08	1207	1.18	1234	1.28	1262	1.39	1288	1.49	1315	1.61
3600	1131	0.86	1167	0.97	1202	1.08	1235	1.19	1263	1.30	1289	1.41	1313	1.52	1338	1.63	1364	1.74	1388	1.86

Continued

	External Static Pressure (Inches of Water)																			
	1.10		1.20		1.30		1.40		1.50		1.60		1.70		1.80		1.90		2.00	
cfm	rpm	bhp	rpm	bhp	rpm	bhp	rpm	bhp	rpm	bhp	rpm	bhp	rpm	bhp	rpm	bhp	rpm	bhp	rpm	bhp
2400	1149	1.14	1178	1.24	1206	1.34	1234	1.44	1261	1.55	1286	1.65	1312	1.76	1336	1.86	1360	1.98	1384	2.09
2700	1210	1.31	1239	1.41	1267	1.52	1294	1.63	1321	1.74	1346	1.86	1370	1.97	1395	2.09	1419	2.20	1441	2.32
3000	1274	1.50	1301	1.61	1329	1.73	1356	1.85	1381	1.96	1406	2.08	1431	2.21	1455	2.33	1478	2.45	1500	2.57
3300	1340	1.72	1367	1.84	1393	1.96	1420	2.09	1444	2.21	1468	2.34	1492	2.46	1516	2.60	1539	2.73	1561	2.86
3600	1413	1.98	1437	2.10	1460	2.22	1484	2.35	1509	2.49	1532	2.62	1555	2.75	1579	2.89	1602	3.03	1623	3.17

**Notes:**

1. For Direct Drive Fan Speed (RPM), reference [Table 142, p. 183](#).
2. Data includes pressure drop due to standard filters and wet coils.
3. Refer to [Table 145, p. 186](#) to determine additional static pressure drop due to other options/accessories.
4. Direct Drive Fan Motor Heat (MBH) = 2.8623 x Fan BHP - 0.1504
5. Factory supplied motors, in commercial equipment, are definite purpose motors, specifically designed and tested to operate reliably and continuously at all cataloged conditions. Using the full horsepower range of our fan motors as shown in our tabular data will not result in nuisance tripping or premature motor failure. Our product's warranty will not be affected.

(a) Table for Dehumidification only.

## Evaporator Fan Performance

**Table 120. Direct drive evaporator fan performance - 7½ tons high efficiency - YHC092F3,F4 low & medium gas heat, horizontal airflow**

	External Static Pressure (Inches of Water)																			
	0.10		0.20		0.30		0.40		0.50		0.60		0.70		0.80		0.90		1.00	
cfm	rpm	bhp	rpm	bhp	rpm	bhp	rpm	bhp	rpm	bhp	rpm	bhp	rpm	bhp	rpm	bhp	rpm	bhp	rpm	bhp
2400	799	0.32	836	0.38	872	0.44	904	0.50	936	0.57	967	0.63	1000	0.70	1032	0.78	1062	0.85	1091	0.93
2700	890	0.44	923	0.50	957	0.57	987	0.64	1015	0.71	1044	0.78	1072	0.86	1101	0.93	1129	1.01	1158	1.10
3000	982	0.59	1012	0.66	1041	0.73	1071	0.81	1098	0.88	1124	0.96	1149	1.04	1174	1.12	1200	1.20	1226	1.29
3300	1074	0.76	1102	0.84	1128	0.92	1156	1.00	1182	1.09	1207	1.17	1230	1.25	1253	1.33	1276	1.43	1300	1.52
3600	1166	0.98	1192	1.06	1217	1.14	1241	1.23	1267	1.33	1291	1.42	1314	1.51	1335	1.59	1356	1.68	1378	1.78

Continued

	External Static Pressure (Inches of Water)																			
	1.10		1.20		1.30		1.40		1.50		1.60		1.70		1.80		1.90		2.00	
cfm	rpm	bhp	rpm	bhp	rpm	bhp	rpm	bhp	rpm	bhp	rpm	bhp	rpm	bhp	rpm	bhp	rpm	bhp	rpm	bhp
2400	1120	1.01	1151	1.09	1180	1.18	1210	1.26	1239	1.35	1267	1.43	1294	1.52	1321	1.60	1346	1.68	1371	1.76
2700	1184	1.18	1210	1.26	1236	1.35	1263	1.44	1289	1.53	1316	1.63	1342	1.73	1368	1.82	1393	1.92	1418	2.01
3000	1251	1.38	1278	1.47	1302	1.57	1326	1.66	1349	1.75	1371	1.84	1395	1.94	1419	2.05	1445	2.16	1469	2.27
3300	1322	1.61	1346	1.71	1369	1.81	1393	1.91	1417	2.01	1439	2.11	1459	2.21	1481	2.32	1502	2.42	1522	2.53
3600	1398	1.88	1419	1.98	1440	2.08	1462	2.19	1484	2.30	1505	2.40	1527	2.52	1547	2.62	1568	2.74	1587	2.84

**Notes:**

1. For Direct Drive Fan Speed (RPM), reference [Table 142, p. 183](#).
2. Data includes pressure drop due to standard filters and wet coils.
3. Refer to [Table 145, p. 186](#) to determine additional static pressure drop due to other options/accessories.
4. Direct Drive Fan Motor Heat (MBH) = 2.8623 x Fan BHP - 0.1504
5. Factory supplied motors, in commercial equipment, are definite purpose motors, specifically designed and tested to operate reliably and continuously at all cataloged conditions. Using the full horsepower range of our fan motors as shown in our tabular data will not result in nuisance tripping or premature motor failure. Our product's warranty will not be affected.



## Evaporator Fan Performance

**Table 121. Direct drive evaporator fan performance - 7½ tons high efficiency - YHC092E3,E4 high gas heat, downflow airflow<sup>(a)</sup>**

	External Static Pressure (Inches of Water)																			
	0.10		0.20		0.30		0.40		0.50		0.60		0.70		0.80		0.90		1.00	
cfm	rpm	bhp	rpm	bhp	rpm	bhp	rpm	bhp	rpm	bhp	rpm	bhp	rpm	bhp	rpm	bhp	rpm	bhp	rpm	bhp
2400	806	0.31	836	0.37	871	0.43	905	0.50	938	0.56	969	0.63	1000	0.70	1030	0.77	1058	0.84	1085	0.91
2700	898	0.43	926	0.50	955	0.56	987	0.63	1017	0.70	1045	0.77	1073	0.85	1102	0.92	1129	1.00	1155	1.08
3000	990	0.57	1019	0.64	1042	0.72	1070	0.79	1098	0.87	1125	0.95	1151	1.03	1177	1.11	1202	1.19	1227	1.28
3300	1082	0.74	1111	0.82	1132	0.90	1155	0.99	1181	1.07	1207	1.15	1231	1.24	1255	1.33	1278	1.41	1302	1.50
3600	1175	0.95	1203	1.03	1225	1.12	1243	1.21	1266	1.31	1289	1.39	1313	1.49	1336	1.58	1358	1.67	1380	1.77

Continued

	External Static Pressure (Inches of Water)																			
	1.10		1.20		1.30		1.40		1.50		1.60		1.70		1.80		1.90		2.00	
cfm	rpm	bhp	rpm	bhp	rpm	bhp	rpm	bhp	rpm	bhp	rpm	bhp	rpm	bhp	rpm	bhp	rpm	bhp	rpm	bhp
2400	1110	0.99	1136	1.07	1160	1.14	1184	1.22	1206	1.30	1229	1.38	1251	1.46	1272	1.54	1293	1.63	1314	1.71
2700	1180	1.16	1204	1.25	1228	1.33	1251	1.41	1273	1.50	1295	1.58	1316	1.67	1337	1.76	1358	1.85	1378	1.94
3000	1252	1.37	1275	1.46	1298	1.54	1320	1.63	1342	1.72	1364	1.82	1384	1.91	1405	2.01	1424	2.10	1444	2.20
3300	1325	1.60	1347	1.69	1370	1.79	1392	1.89	1413	1.98	1434	2.08	1454	2.18	1474	2.29	1493	2.38	1512	2.48
3600	1401	1.87	1423	1.97	1444	2.07	1464	2.17	1485	2.27	1505	2.38	1524	2.48	1545	2.59	1563	2.70	1582	2.81

**Notes:**

1. For Direct Drive Fan Speed (RPM), reference [Table 142, p. 183](#).
2. Data includes pressure drop due to standard filters and wet coils.
3. Refer to [Table 145, p. 186](#) to determine additional static pressure drop due to other options/accessories.
4. Direct Drive Fan Motor Heat (MBH) = 2.8623 x Fan BHP - 0.1504
5. Factory supplied motors, in commercial equipment, are definite purpose motors, specifically designed and tested to operate reliably and continuously at all cataloged conditions. Using the full horsepower range of our fan motors as shown in our tabular data will not result in nuisance tripping or premature motor failure. Our product's warranty will not be affected.

(a) Table for Dehumidification only.

## Evaporator Fan Performance

**Table 122. Direct drive evaporator fan performance - 7½ tons high efficiency - YHC092F3,F4 high gas heat, downflow airflow**

	External Static Pressure (Inches of Water)																			
	0.10		0.20		0.30		0.40		0.50		0.60		0.70		0.80		0.90		1.00	
cfm	rpm	bhp	rpm	bhp	rpm	bhp	rpm	bhp	rpm	bhp	rpm	bhp	rpm	bhp	rpm	bhp	rpm	bhp	rpm	bhp
2400	807	0.32	841	0.38	873	0.44	905	0.50	937	0.56	967	0.62	1001	0.69	1035	0.77	1066	0.84	1095	0.92
2700	899	0.44	931	0.51	959	0.57	988	0.64	1017	0.70	1045	0.77	1073	0.84	1100	0.91	1130	0.99	1161	1.09
3000	992	0.59	1022	0.67	1049	0.74	1073	0.80	1099	0.88	1126	0.95	1151	1.03	1175	1.10	1200	1.18	1226	1.26
3300	1086	0.77	1113	0.85	1139	0.94	1162	1.01	1184	1.08	1208	1.16	1232	1.25	1255	1.33	1278	1.41	1301	1.49
3600	1180	0.98	1205	1.07	1229	1.16	1252	1.25	1272	1.33	1293	1.40	1315	1.49	1337	1.59	1358	1.68	1379	1.77

Continued

	External Static Pressure (Inches of Water)																			
	1.10		1.20		1.30		1.40		1.50		1.60		1.70		1.80		1.90		2.00	
cfm	rpm	bhp	rpm	bhp	rpm	bhp	rpm	bhp	rpm	bhp	rpm	bhp	rpm	bhp	rpm	bhp	rpm	bhp	rpm	bhp
2400	1125	0.99	1155	1.07	1184	1.16	1213	1.24	1240	1.32	1266	1.40	1293	1.48	1317	1.55	1342	1.63	1366	1.71
2700	1189	1.17	1215	1.25	1242	1.34	1268	1.42	1295	1.52	1320	1.60	1346	1.70	1371	1.79	1395	1.88	1420	1.97
3000	1252	1.35	1280	1.46	1307	1.56	1331	1.65	1354	1.73	1379	1.83	1402	1.92	1427	2.03	1450	2.13	1474	2.23
3300	1323	1.58	1345	1.67	1369	1.76	1395	1.88	1420	1.99	1444	2.10	1465	2.20	1487	2.30	1508	2.39	1529	2.50
3600	1400	1.86	1421	1.95	1441	2.04	1462	2.14	1483	2.24	1507	2.36	1530	2.48	1552	2.61	1574	2.72	1594	2.83

**Notes:**

1. For Direct Drive Fan Speed (RPM), reference [Table 142, p. 183](#).
2. Data includes pressure drop due to standard filters and wet coils.
3. Refer to [Table 145, p. 186](#) to determine additional static pressure drop due to other options/accessories.
4. Direct Drive Fan Motor Heat (MBH) = 2.8623 x Fan BHP - 0.1504
5. Factory supplied motors, in commercial equipment, are definite purpose motors, specifically designed and tested to operate reliably and continuously at all cataloged conditions. Using the full horsepower range of our fan motors as shown in our tabular data will not result in nuisance tripping or premature motor failure. Our product's warranty will not be affected.



## Evaporator Fan Performance

**Table 123. Direct drive evaporator fan performance - 7½ tons high efficiency - YHC092E3,E4 high gas heat, horizontal airflow<sup>(a)</sup>**

	External Static Pressure (Inches of Water)																			
	0.10		0.20		0.30		0.40		0.50		0.60		0.70		0.80		0.90		1.00	
cfm	rpm	bhp	rpm	bhp	rpm	bhp	rpm	bhp	rpm	bhp	rpm	bhp	rpm	bhp	rpm	bhp	rpm	bhp	rpm	bhp
2400	776	0.29	824	0.36	863	0.43	903	0.51	942	0.59	980	0.67	1017	0.76	1053	0.85	1087	0.95	1118	1.04
2700	860	0.39	906	0.47	944	0.55	978	0.63	1013	0.72	1048	0.81	1082	0.90	1116	1.00	1148	1.10	1180	1.20
3000	945	0.51	988	0.60	1026	0.69	1058	0.78	1089	0.87	1120	0.97	1152	1.07	1182	1.17	1213	1.27	1243	1.38
3300	1031	0.66	1071	0.75	1108	0.85	1140	0.95	1168	1.05	1196	1.16	1225	1.26	1254	1.37	1283	1.48	1310	1.59
3600	1118	0.83	1155	0.94	1190	1.05	1222	1.15	1250	1.26	1276	1.38	1302	1.49	1328	1.60	1354	1.72	1381	1.84

Continued

	External Static Pressure (Inches of Water)																			
	1.10		1.20		1.30		1.40		1.50		1.60		1.70		1.80		1.90		2.00	
cfm	rpm	bhp	rpm	bhp	rpm	bhp	rpm	bhp	rpm	bhp	rpm	bhp	rpm	bhp	rpm	bhp	rpm	bhp	rpm	bhp
2400	1150	1.14	1179	1.24	1208	1.34	1237	1.45	1264	1.56	1291	1.67	1317	1.78	1341	1.88	1365	2.00	1389	2.11
2700	1210	1.31	1239	1.41	1268	1.52	1296	1.64	1323	1.75	1348	1.86	1373	1.98	1399	2.10	1423	2.22	1446	2.34
3000	1273	1.50	1301	1.61	1329	1.73	1357	1.85	1383	1.97	1409	2.09	1433	2.21	1458	2.34	1481	2.46	1503	2.58
3300	1337	1.70	1366	1.83	1392	1.95	1419	2.08	1444	2.20	1469	2.33	1494	2.46	1517	2.59	1540	2.73	1564	2.87
3600	1406	1.96	1432	2.08	1456	2.20	1482	2.33	1507	2.47	1531	2.60	1555	2.74	1579	2.88	1602	3.02	1623	3.16

**Notes:**

1. For Direct Drive Fan Speed (RPM), reference [Table 142, p. 183](#).
2. Data includes pressure drop due to standard filters and wet coils.
3. Refer to [Table 145, p. 186](#) to determine additional static pressure drop due to other options/accessories.
4. Direct Drive Fan Motor Heat (MBH) = 2.8623 x Fan BHP - 0.1504
5. Factory supplied motors, in commercial equipment, are definite purpose motors, specifically designed and tested to operate reliably and continuously at all cataloged conditions. Using the full horsepower range of our fan motors as shown in our tabular data will not result in nuisance tripping or premature motor failure. Our product's warranty will not be affected.

(a) Table for Dehumidification only.



## Evaporator Fan Performance

**Table 124. Direct drive evaporator fan performance - 7½ tons high efficiency - YHC092F3,F4 high gas heat, horizontal airflow**

External Static Pressure (Inches of Water)																					
		0.10		0.20		0.30		0.40		0.50		0.60		0.70		0.80		0.90		1.00	
cfm	rpm	bhp	rpm	bhp	rpm	bhp	rpm	bhp	rpm	bhp	rpm	bhp	rpm	bhp	rpm	bhp	rpm	bhp	rpm	bhp	
2400	808	0.33	846	0.38	882	0.45	916	0.51	947	0.58	979	0.65	1011	0.71	1042	0.78	1073	0.85	1103	0.93	
2700	900	0.45	934	0.51	967	0.58	999	0.65	1028	0.72	1057	0.80	1085	0.88	1113	0.95	1141	1.03	1169	1.10	
3000	992	0.60	1024	0.67	1054	0.74	1083	0.82	1112	0.90	1138	0.97	1164	1.06	1189	1.14	1214	1.24	1240	1.32	
3300	1085	0.78	1114	0.86	1142	0.93	1169	1.02	1196	1.11	1221	1.19	1246	1.28	1270	1.36	1292	1.46	1315	1.55	
3600	1179	1.00	1205	1.08	1231	1.16	1256	1.24	1282	1.35	1306	1.45	1329	1.54	1352	1.63	1374	1.72	1395	1.82	

Continued

External Static Pressure (Inches of Water)																					
		1.10		1.20		1.30		1.40		1.50		1.60		1.70		1.80		1.90		2.00	
cfm	rpm	bhp	rpm	bhp	rpm	bhp	rpm	bhp	rpm	bhp	rpm	bhp	rpm	bhp	rpm	bhp	rpm	bhp	rpm	bhp	
2400	1133	1.01	1163	1.09	1193	1.18	1223	1.27	1252	1.36	1281	1.45	1309	1.54	1336	1.63	1363	1.72	1387	1.80	
2700	1196	1.18	1224	1.27	1250	1.35	1277	1.44	1303	1.54	1328	1.63	1357	1.74	1383	1.84	1409	1.94	1434	2.04	
3000	1266	1.40	1291	1.49	1315	1.57	1339	1.66	1363	1.75	1388	1.85	1412	1.95	1435	2.05	1459	2.16	1483	2.27	
3300	1338	1.65	1362	1.74	1385	1.84	1408	1.93	1430	2.02	1452	2.12	1475	2.22	1498	2.32	1519	2.42	1540	2.53	
3600	1416	1.92	1436	2.03	1458	2.14	1480	2.24	1501	2.33	1522	2.43	1543	2.54	1563	2.64	1583	2.74	1604	2.85	

**Notes:**

1. For Direct Drive Fan Speed (RPM), reference [Table 142, p. 183](#).
2. Data includes pressure drop due to standard filters and wet coils.
3. Refer to [Table 145, p. 186](#) to determine additional static pressure drop due to other options/accessories.
4. Direct Drive Fan Motor Heat (MBH) = 2.8623 x Fan BHP - 0.1504
5. Factory supplied motors, in commercial equipment, are definite purpose motors, specifically designed and tested to operate reliably and continuously at all cataloged conditions. Using the full horsepower range of our fan motors as shown in our tabular data will not result in nuisance tripping or premature motor failure. Our product's warranty will not be affected.



## Evaporator Fan Performance

**Table 125. Direct drive evaporator fan performance - 8½ tons high efficiency - THC102E3,E4, downflow airflow**

cfm	External Static Pressure (Inches of Water)																			
	0.10		0.20		0.30		0.40		0.50		0.60		0.70		0.80		0.90		1.00	
	rpm	bhp	rpm	bhp	rpm	bhp	rpm	bhp	rpm	bhp	rpm	bhp	rpm	bhp	rpm	bhp	rpm	bhp	rpm	bhp
1700*	582	0.13	634	0.17	684	0.22	729	0.27	776	0.33	819	0.39	859	0.45	897	0.52	933	0.59	967	0.66
2040*	677	0.19	724	0.25	766	0.30	808	0.36	845	0.42	885	0.49	924	0.56	960	0.63	995	0.70	1029	0.78
2380*	774	0.29	817	0.35	855	0.41	890	0.47	929	0.55	961	0.61	992	0.68	1026	0.76	1061	0.84	1093	0.93
2720	873	0.41	911	0.48	947	0.54	979	0.62	1010	0.69	1044	0.77	1075	0.86	1102	0.93	1129	1.00	1159	1.09
3060	973	0.56	1007	0.64	1040	0.71	1072	0.79	1100	0.87	1127	0.95	1156	1.04	1186	1.14	1213	1.23	1237	1.31
3400	1074	0.74	1105	0.83	1135	0.92	1164	1.01	1192	1.09	1218	1.18	1242	1.27	1268	1.36	1294	1.46	1321	1.57
3740	1175	0.97	1204	1.07	1232	1.16	1258	1.26	1285	1.35	1310	1.45	1334	1.54	1356	1.64	1378	1.74	1401	1.84
4080	1276	1.24	1303	1.34	1329	1.45	1354	1.55	1379	1.66	1403	1.76	1426	1.87	1448	1.97	1469	2.08	1489	2.18

Continued

cfm	External Static Pressure (Inches of Water)																			
	1.10		1.20		1.30		1.40		1.50		1.60		1.70		1.80		1.90		2.00	
	rpm	bhp	rpm	bhp	rpm	bhp	rpm	bhp	rpm	bhp	rpm	bhp	rpm	bhp	rpm	bhp	rpm	bhp	rpm	bhp
1700*	1000	0.73	1031	0.80	1061	0.88	1090	0.95	1119	1.03	1145	1.11	1172	1.19	1197	1.27	1223	1.36	1247	1.45
2040*	1061	0.86	1091	0.94	1121	1.02	1149	1.10	1177	1.19	1204	1.27	1230	1.36	1256	1.45	1281	1.54	1304	1.63
2380*	1124	1.01	1154	1.10	1183	1.19	1210	1.27	1238	1.37	1265	1.46	1290	1.55	1315	1.65	1340	1.75	1363	1.84
2720	1189	1.18	1219	1.28	1248	1.38	1275	1.47	1301	1.57	1327	1.67	1353	1.77	1377	1.87	1401	1.98	1425	2.09
3060	1260	1.39	1287	1.49	1313	1.59	1341	1.70	1366	1.80	1391	1.90	1416	2.01	1440	2.12	1463	2.23	1487	2.35
3400	1345	1.67	1367	1.77	1389	1.86	1411	1.96	1434	2.06	1458	2.17	1481	2.28	1507	2.41	1529	2.53	1553	2.65
3740	1426	1.96	1450	2.08	1474	2.20	1493	2.30	1513	2.40	1533	2.50	1553	2.61	1575	2.73	1596	2.85	1618	2.98
4080	1510	2.29	1532	2.41	1554	2.54	1576	2.66	1598	2.79	1617	2.91	1635	3.02	1653	3.13	1671	3.24	1690	3.36

**Notes:**

1. For Direct Drive Fan Speed (RPM), reference [Table 142, p. 183](#).
  2. Data includes pressure drop due to standard filters and wet coils.
  3. Refer to [Table 145, p. 186](#) to determine additional static pressure drop due to other options/accessories.
  4. Direct Drive Fan Motor Heat (MBH) = 2.8623 x Fan BHP - 0.1504
  5. Factory supplied motors, in commercial equipment, are definite purpose motors, specifically designed and tested to operate reliably and continuously at all cataloged conditions. Using the full horsepower range of our fan motors as shown in our tabular data will not result in nuisance tripping or premature motor failure. Our product's warranty will not be affected.
- \* For 1700, 2040, and 2380 CFM, unit application below 320 CFM/Ton are only applicable on T\_C models only (No Gas Heat). See below for restrictions.  
 \* Electric heaters restricted on applications below 320 CFM/Ton  
 \* Dehumidification (Hot Gas Reheat) or TXV with Frost and Crankcase Heaters are required on applications below 320 CFM/Ton

## Evaporator Fan Performance

**Table 126. Direct drive evaporator fan performance - 8½ tons high efficiency - THC102E3,E4, horizontal airflow**

External Static Pressure (Inches of Water)																					
		0.10		0.20		0.30		0.40		0.50		0.60		0.70		0.80		0.90		1.00	
cfm	rpm	bhp	rpm	bhp	rpm	bhp	rpm	bhp	rpm	bhp	rpm	bhp	rpm	bhp	rpm	bhp	rpm	bhp	rpm	bhp	
1700*	603	0.14	666	0.20	727	0.27	781	0.33	834	0.41	880	0.48	925	0.55	966	0.63	1006	0.72	1044	0.80	
2040*	696	0.21	750	0.28	806	0.36	856	0.43	903	0.51	949	0.60	991	0.68	1033	0.77	1071	0.86	1108	0.95	
2380*	791	0.31	846	0.40	889	0.47	936	0.56	980	0.65	1022	0.74	1061	0.84	1100	0.93	1138	1.03	1174	1.13	
2720	888	0.44	939	0.53	982	0.62	1019	0.71	1059	0.81	1100	0.91	1138	1.02	1174	1.13	1208	1.23	1243	1.34	
3060	987	0.60	1033	0.69	1075	0.81	1109	0.90	1144	1.00	1180	1.11	1217	1.23	1251	1.35	1284	1.47	1318	1.59	
3400	1088	0.80	1128	0.90	1169	1.02	1206	1.15	1234	1.24	1266	1.35	1298	1.48	1331	1.60	1363	1.74	1393	1.87	
3740	1189	1.04	1225	1.15	1262	1.27	1299	1.41	1332	1.54	1356	1.64	1383	1.76	1414	1.90	1443	2.04	1474	2.18	
4080	1290	1.32	1324	1.45	1358	1.57	1392	1.71	1424	1.87	1455	2.01	1477	2.12	1499	2.24	1529	2.40	1555	2.54	

Continued

External Static Pressure (Inches of Water)																					
		1.10		1.20		1.30		1.40		1.50		1.60		1.70		1.80		1.90		2.00	
cfm	rpm	bhp	rpm	bhp	rpm	bhp	rpm	bhp	rpm	bhp	rpm	bhp	rpm	bhp	rpm	bhp	rpm	bhp	rpm	bhp	
1700*	1080	0.89	1113	0.97	1147	1.06	1177	1.15	1209	1.25	1238	1.34	1266	1.43	1295	1.54	1323	1.64	1349	1.74	
2040*	1142	1.05	1176	1.14	1208	1.24	1239	1.34	1270	1.44	1299	1.55	1328	1.65	1356	1.76	1382	1.86	1409	1.98	
2380*	1208	1.23	1241	1.34	1272	1.45	1303	1.56	1334	1.67	1363	1.78	1391	1.89	1417	2.00	1444	2.12	1470	2.24	
2720	1276	1.45	1307	1.56	1339	1.68	1370	1.80	1399	1.92	1427	2.04	1454	2.16	1482	2.28	1508	2.41	1535	2.54	
3060	1347	1.71	1378	1.83	1408	1.95	1438	2.08	1466	2.21	1494	2.33	1522	2.47	1549	2.61	1574	2.74	1599	2.87	
3400	1424	2.00	1454	2.14	1481	2.27	1507	2.39	1536	2.53	1563	2.67	1590	2.81	1616	2.95	1642	3.10	1667	3.25	
3740	1503	2.33	1530	2.47	1557	2.61	1585	2.76	1612	2.91	1636	3.06	1660	3.20	1685	3.35	—	—	—	—	
4080	1583	2.69	1611	2.85	1637	3.01	1662	3.17	1688	3.32	—	—	—	—	—	—	—	—	—	—	

**Notes:**

1. For Direct Drive Fan Speed (RPM), reference [Table 142, p. 183](#).
  2. Data includes pressure drop due to standard filters and wet coils.
  3. Refer [Table 145, p. 186](#) to determine additional static pressure drop due to other options/accessories.
  4. Direct Drive Fan Motor Heat (MBH) = 2.8623 x Fan BHP - 0.1504
  5. Factory supplied motors, in commercial equipment, are definite purpose motors, specifically designed and tested to operate reliably and continuously at all cataloged conditions. Using the full horsepower range of our fan motors as shown in our tabular data will not result in nuisance tripping or premature motor failure. Our product's warranty will not be affected.
- \* For 1700, 2040, and 2380 CFM, unit application below 320 CFM/Ton are only applicable on T\_C models only (No Gas Heat). See below for restrictions.  
 \* Electric heaters restricted on applications below 320 CFM/Ton  
 \* Dehumidification (Hot Gas Reheat) or TXV with Frost and Crankcase Heaters are required on applications below 320 CFM/Ton



## Evaporator Fan Performance

**Table 127. Direct drive evaporator fan performance - 8½ tons high efficiency - YHC102E3,E4 low & medium gas heat, downflow airflow**

	External Static Pressure (Inches of Water)																			
	0.10		0.20		0.30		0.40		0.50		0.60		0.70		0.80		0.90		1.00	
cfm	rpm	bhp	rpm	bhp	rpm	bhp	rpm	bhp	rpm	bhp	rpm	bhp	rpm	bhp	rpm	bhp	rpm	bhp	rpm	bhp
2720	892	0.42	921	0.49	952	0.56	983	0.63	1014	0.70	1042	0.77	1071	0.85	1100	0.92	1128	1.00	1154	1.08
3060	994	0.58	1023	0.65	1048	0.73	1077	0.81	1105	0.89	1132	0.96	1157	1.05	1183	1.13	1209	1.22	1235	1.31
3400	1096	0.77	1126	0.86	1148	0.94	1172	1.03	1198	1.11	1223	1.20	1248	1.29	1272	1.38	1294	1.47	1317	1.56
3740	1199	1.01	1229	1.10	1251	1.19	1270	1.29	1293	1.38	1316	1.48	1340	1.58	1362	1.67	1384	1.76	1405	1.86
4080	1302	1.29	1332	1.40	1354	1.49	1372	1.59	1390	1.69	1411	1.80	1433	1.90	1454	2.01	1475	2.11	1496	2.22

Continued

	External Static Pressure (Inches of Water)																			
	1.10		1.20		1.30		1.40		1.50		1.60		1.70		1.80		1.90		2.00	
cfm	rpm	bhp	rpm	bhp	rpm	bhp	rpm	bhp	rpm	bhp	rpm	bhp	rpm	bhp	rpm	bhp	rpm	bhp	rpm	bhp
2720	1180	1.17	1205	1.25	1228	1.33	1251	1.42	1274	1.50	1296	1.59	1318	1.68	1338	1.76	1359	1.86	1379	1.94
3060	1259	1.39	1283	1.48	1306	1.57	1329	1.67	1350	1.76	1372	1.85	1394	1.95	1414	2.04	1434	2.14	1454	2.24
3400	1341	1.66	1364	1.76	1386	1.85	1408	1.95	1429	2.05	1450	2.15	1471	2.26	1491	2.36	1510	2.46	1529	2.57
3740	1426	1.96	1447	2.07	1469	2.18	1490	2.28	1510	2.39	1531	2.50	1551	2.61	1569	2.71	1588	2.82	1607	2.94
4080	1516	2.32	1535	2.43	1553	2.54	1573	2.65	1592	2.77	1612	2.89	1631	3.00	1650	3.12	1669	3.24	1687	3.36

**Notes:**

1. For Direct Drive Fan Speed (RPM), reference [Table 142, p. 183](#).
2. Data includes pressure drop due to standard filters and wet coils.
3. Refer to [Table 145, p. 186](#) to determine additional static pressure drop due to other options/accessories.
4. Direct Drive Fan Motor Heat (MBH) = 2.8623 x Fan BHP - 0.1504
5. Factory supplied motors, in commercial equipment, are definite purpose motors, specifically designed and tested to operate reliably and continuously at all cataloged conditions. Using the full horsepower range of our fan motors as shown in our tabular data will not result in nuisance tripping or premature motor failure. Our product's warranty will not be affected.

## Evaporator Fan Performance

**Table 128. Direct drive evaporator fan performance - 8½ tons high efficiency - YHC102E3,E4 low & medium gas heat, horizontal airflow**

External Static Pressure (Inches of Water)																					
		0.10		0.20		0.30		0.40		0.50		0.60		0.70		0.80		0.90		1.00	
cfm	rpm	bhp	rpm	bhp	rpm	bhp	rpm	bhp	rpm	bhp	rpm	bhp	rpm	bhp	rpm	bhp	rpm	bhp	rpm	bhp	
2720	875	0.40	921	0.49	960	0.57	992	0.65	1025	0.74	1059	0.83	1090	0.92	1121	1.02	1154	1.12	1185	1.22	
3060	973	0.55	1015	0.65	1054	0.74	1086	0.83	1115	0.93	1144	1.02	1173	1.12	1202	1.22	1230	1.32	1258	1.43	
3400	1072	0.73	1110	0.84	1147	0.94	1180	1.05	1208	1.15	1234	1.25	1260	1.36	1287	1.46	1313	1.57	1339	1.69	
3740	1172	0.95	1207	1.06	1241	1.18	1274	1.30	1302	1.41	1328	1.53	1352	1.64	1375	1.75	1400	1.87	1424	1.99	
4080	1272	1.21	1304	1.33	1336	1.46	1367	1.59	1396	1.71	1422	1.84	1446	1.97	1468	2.09	1489	2.21	1510	2.33	

Continued

External Static Pressure (Inches of Water)																					
		1.10		1.20		1.30		1.40		1.50		1.60		1.70		1.80		1.90		2.00	
cfm	rpm	bhp	rpm	bhp	rpm	bhp	rpm	bhp	rpm	bhp	rpm	bhp	rpm	bhp	rpm	bhp	rpm	bhp	rpm	bhp	
2720	1214	1.32	1243	1.43	1270	1.53	1298	1.64	1324	1.76	1350	1.87	1375	1.99	1399	2.10	1422	2.22	1445	2.34	
3060	1287	1.55	1315	1.66	1342	1.78	1368	1.89	1394	2.01	1419	2.13	1443	2.26	1467	2.38	1490	2.50	1513	2.63	
3400	1364	1.80	1389	1.92	1415	2.05	1441	2.17	1465	2.30	1489	2.43	1513	2.55	1537	2.69	1560	2.83	1582	2.96	
3740	1448	2.11	1470	2.23	1493	2.36	1516	2.49	1539	2.62	1562	2.76	1586	2.90	1609	3.04	1632	3.18	1652	3.32	
4080	1532	2.46	1555	2.59	1577	2.73	1598	2.86	1619	3.00	1640	3.14	1661	3.28	1682	3.43	—	—	—	—	

**Notes:**

1. For Direct Drive Fan Speed (RPM), reference [Table 142, p. 183](#).
2. Data includes pressure drop due to standard filters and wet coils.
3. Refer to [Table 145, p. 186](#) to determine additional static pressure drop due to other options/accessories.
4. Direct Drive Fan Motor Heat (MBH) = 2.8623 x Fan BHP - 0.1504
5. Factory supplied motors, in commercial equipment, are definite purpose motors, specifically designed and tested to operate reliably and continuously at all cataloged conditions. Using the full horsepower range of our fan motors as shown in our tabular data will not result in nuisance tripping or premature motor failure. Our product's warranty will not be affected.



## Evaporator Fan Performance

**Table 129. Direct drive evaporator fan performance - 8½ tons high efficiency - YHC102E3,E4 high gas heat, downflow airflow**

cfm	External Static Pressure (Inches of Water)																			
	0.10		0.20		0.30		0.40		0.50		0.60		0.70		0.80		0.90		1.00	
	rpm	bhp	rpm	bhp	rpm	bhp	rpm	bhp	rpm	bhp	rpm	bhp	rpm	bhp	rpm	bhp	rpm	bhp	rpm	bhp
2720	904	0.44	932	0.50	961	0.57	992	0.64	1022	0.71	1051	0.78	1079	0.86	1106	0.94	1133	1.01	1159	1.09
3060	1008	0.60	1038	0.68	1059	0.75	1087	0.83	1114	0.91	1141	0.99	1167	1.07	1192	1.15	1217	1.23	1242	1.32
3400	1113	0.81	1142	0.89	1163	0.97	1184	1.06	1209	1.14	1234	1.23	1258	1.32	1282	1.41	1305	1.50	1327	1.59
3740	1218	1.05	1246	1.14	1268	1.24	1286	1.33	1306	1.43	1329	1.52	1351	1.61	1374	1.71	1396	1.81	1417	1.90
4080	1323	1.35	1350	1.45	1373	1.55	1390	1.65	1406	1.75	1425	1.86	1447	1.96	1468	2.06	1488	2.16	1509	2.27

Continued

cfm	External Static Pressure (Inches of Water)																			
	1.10		1.20		1.30		1.40		1.50		1.60		1.70		1.80		1.90		2.00	
	rpm	bhp	rpm	bhp	rpm	bhp	rpm	bhp	rpm	bhp	rpm	bhp	rpm	bhp	rpm	bhp	rpm	bhp	rpm	bhp
2720	1185	1.18	1209	1.26	1233	1.34	1256	1.43	1278	1.51	1300	1.60	1321	1.69	1342	1.78	1363	1.87	1382	1.96
3060	1266	1.41	1289	1.50	1313	1.59	1335	1.68	1356	1.77	1377	1.87	1398	1.96	1419	2.06	1438	2.16	1457	2.25
3400	1350	1.68	1372	1.78	1394	1.88	1416	1.98	1437	2.08	1457	2.17	1477	2.28	1497	2.38	1517	2.49	1536	2.59
3740	1438	2.00	1458	2.11	1478	2.20	1499	2.31	1518	2.42	1539	2.53	1558	2.64	1578	2.75	1596	2.86	1615	2.97
4080	1529	2.38	1547	2.48	1567	2.59	1585	2.70	1604	2.81	1622	2.92	1641	3.04	1660	3.16	1677	3.27	1696	3.39

**Notes:**

1. For Direct Drive Fan Speed (RPM), reference [Table 142, p. 183](#).
2. Data includes pressure drop due to standard filters and wet coils.
3. Refer to [Table 145, p. 186](#) to determine additional static pressure drop due to other options/accessories.
4. Direct Drive Fan Motor Heat (MBH) = 2.8623 x Fan BHP - 0.1504
5. Factory supplied motors, in commercial equipment, are definite purpose motors, specifically designed and tested to operate reliably and continuously at all cataloged conditions. Using the full horsepower range of our fan motors as shown in our tabular data will not result in nuisance tripping or premature motor failure. Our product's warranty will not be affected.

## Evaporator Fan Performance

**Table 130. Direct drive evaporator fan performance - 8½ tons high efficiency - YHC102E3,E4 high gas heat, horizontal airflow**

cfm	External Static Pressure (Inches of Water)																			
	0.10		0.20		0.30		0.40		0.50		0.60		0.70		0.80		0.90		1.00	
	rpm	bhp	rpm	bhp	rpm	bhp	rpm	bhp	rpm	bhp	rpm	bhp	rpm	bhp	rpm	bhp	rpm	bhp	rpm	bhp
2720	866	0.39	912	0.47	949	0.56	984	0.64	1018	0.73	1053	0.82	1087	0.91	1120	1.01	1153	1.11	1185	1.21
3060	962	0.54	1004	0.63	1042	0.72	1075	0.81	1105	0.91	1135	1.00	1166	1.10	1197	1.21	1227	1.31	1256	1.42
3400	1060	0.71	1099	0.81	1135	0.91	1167	1.02	1196	1.12	1222	1.23	1250	1.33	1278	1.44	1306	1.55	1333	1.67
3740	1158	0.92	1194	1.04	1228	1.15	1260	1.26	1288	1.37	1314	1.49	1338	1.60	1364	1.72	1388	1.83	1414	1.96
4080	1257	1.17	1290	1.30	1322	1.42	1353	1.54	1381	1.66	1407	1.79	1430	1.91	1453	2.04	1475	2.17	1498	2.29

Continued

cfm	External Static Pressure (Inches of Water)																			
	1.10		1.20		1.30		1.40		1.50		1.60		1.70		1.80		1.90		2.00	
	rpm	bhp	rpm	bhp	rpm	bhp	rpm	bhp	rpm	bhp	rpm	bhp	rpm	bhp	rpm	bhp	rpm	bhp	rpm	bhp
2720	1215	1.32	1244	1.43	1272	1.54	1299	1.65	1326	1.76	1352	1.87	1377	1.99	1402	2.11	1426	2.23	1451	2.36
3060	1285	1.53	1314	1.65	1342	1.77	1369	1.89	1394	2.01	1420	2.13	1445	2.26	1468	2.38	1493	2.51	1516	2.64
3400	1360	1.79	1386	1.90	1414	2.03	1440	2.16	1464	2.29	1489	2.42	1514	2.55	1538	2.69	1561	2.82	1583	2.96
3740	1439	2.08	1465	2.21	1488	2.34	1513	2.47	1537	2.60	1561	2.74	1585	2.88	1608	3.03	1631	3.17	1652	3.31
4080	1522	2.42	1545	2.55	1568	2.69	1591	2.83	1613	2.97	1635	3.11	1657	3.25	1679	3.40	—	—	—	—

**Notes:**

1. For Direct Drive Fan Speed (RPM), reference [Table 142, p. 183](#).
2. Data includes pressure drop due to standard filters and wet coils.
3. Refer to [Table 145, p. 186](#) to determine additional static pressure drop due to other options/accessories.
4. Direct Drive Fan Motor Heat (MBH) = 2.8623 x Fan BHP - 0.1504
5. Factory supplied motors, in commercial equipment, are definite purpose motors, specifically designed and tested to operate reliably and continuously at all cataloged conditions. Using the full horsepower range of our fan motors as shown in our tabular data will not result in nuisance tripping or premature motor failure. Our product's warranty will not be affected.



## Evaporator Fan Performance

**Table 131. Direct drive evaporator fan performance - 10 tons high efficiency - THC120E3,E4, downflow airflow**

cfm	External Static Pressure (Inches of Water)																			
	0.10		0.20		0.30		0.40		0.50		0.60		0.70		0.80		0.90		1.00	
	rpm	bhp	rpm	bhp	rpm	bhp	rpm	bhp	rpm	bhp	rpm	bhp	rpm	bhp	rpm	bhp	rpm	bhp	rpm	bhp
2000*	666	0.19	713	0.24	756	0.29	799	0.35	836	0.41	876	0.47	916	0.54	953	0.62	988	0.69	1021	0.77
2400*	780	0.29	822	0.35	860	0.42	895	0.48	933	0.55	966	0.62	997	0.69	1030	0.77	1063	0.85	1096	0.93
2800*	897	0.44	933	0.51	969	0.58	1001	0.65	1031	0.73	1063	0.81	1094	0.90	1122	0.98	1148	1.05	1176	1.14
3200	1014	0.63	1047	0.71	1079	0.79	1110	0.88	1138	0.96	1164	1.04	1191	1.13	1219	1.22	1247	1.32	1272	1.42
3600	1133	0.87	1163	0.96	1191	1.06	1220	1.15	1247	1.24	1272	1.33	1296	1.42	1319	1.52	1343	1.62	1368	1.73
4000	1252	1.17	1280	1.28	1306	1.38	1332	1.48	1356	1.58	1381	1.68	1404	1.78	1426	1.89	1447	1.99	1468	2.10
4400	1372	1.54	1397	1.65	1422	1.76	1445	1.87	1468	1.99	1491	2.10	1514	2.21	1535	2.32	1555	2.44	1575	2.55
4800	1492	1.98	1516	2.10	1538	2.22	1560	2.34	1582	2.47	1603	2.59	1624	2.71	1644	2.83	1665	2.95	1684	3.08

Continued

cfm	External Static Pressure (Inches of Water)																			
	1.10		1.20		1.30		1.40		1.50		1.60		1.70		1.80		1.90		2.00	
	rpm	bhp	rpm	bhp	rpm	bhp	rpm	bhp	rpm	bhp	rpm	bhp	rpm	bhp	rpm	bhp	rpm	bhp	rpm	bhp
2000*	1053	0.84	1084	0.92	1114	1.00	1142	1.09	1170	1.17	1197	1.25	1224	1.34	1248	1.43	1273	1.52	1297	1.61
2400*	1127	1.02	1158	1.11	1187	1.20	1215	1.29	1242	1.38	1268	1.47	1294	1.57	1319	1.66	1343	1.76	1367	1.86
2800*	1205	1.23	1234	1.32	1262	1.42	1290	1.52	1317	1.62	1342	1.72	1367	1.83	1392	1.93	1416	2.04	1439	2.14
3200	1295	1.51	1317	1.59	1342	1.69	1368	1.79	1393	1.90	1418	2.01	1443	2.12	1468	2.24	1491	2.35	1514	2.47
3600	1393	1.84	1418	1.96	1438	2.06	1458	2.15	1478	2.25	1500	2.35	1522	2.47	1545	2.59	1569	2.71	1591	2.83
4000	1490	2.21	1512	2.33	1535	2.45	1558	2.58	1578	2.70	1597	2.81	1615	2.92	1634	3.03	1652	3.14	1672	3.26
4400	1594	2.67	1613	2.79	1632	2.90	1653	3.03	1673	3.16	1694	3.31	—	—	—	—	—	—	—	—
4800	—	—	—	—	—	—	—	—	—	—	—	—	—	—	—	—	—	—	—	—

**Notes:**

1. For Direct Drive Fan Speed (RPM), reference [Table 142, p. 183](#).
  2. Data includes pressure drop due to standard filters and wet coils.
  3. Refer to [Table 145, p. 186](#) to determine additional static pressure drop due to other options/accessories.
  4. Direct Drive Fan Motor Heat (MBH) = 2.8623 x Fan BHP - 0.1504
  5. Factory supplied motors, in commercial equipment, are definite purpose motors, specifically designed and tested to operate reliably and continuously at all cataloged conditions. Using the full horsepower range of our fan motors as shown in our tabular data will not result in nuisance tripping or premature motor failure. Our product's warranty will not be affected.
- \* For 2000, 2400, and 2800 CFM, unit application below 320 CFM/Ton are only applicable on T\_C models only (No Gas Heat). See below for restrictions.  
 \* Electric heaters restricted on applications below 320 CFM/Ton  
 \* Dehumidification (Hot Gas Reheat) or TXV with Froststat and Crankcase Heaters are required on applications below 320 CFM/Ton



## Evaporator Fan Performance

**Table 132. Direct drive evaporator fan performance - 10 tons high efficiency - THC120E3,E4, horizontal airflow**

cfm	External Static Pressure (Inches of Water)																			
	0.10		0.20		0.30		0.40		0.50		0.60		0.70		0.80		0.90		1.00	
	rpm	bhp	rpm	bhp	rpm	bhp	rpm	bhp	rpm	bhp	rpm	bhp	rpm	bhp	rpm	bhp	rpm	bhp	rpm	bhp
2000*	685	0.20	740	0.27	796	0.34	847	0.42	894	0.50	940	0.58	984	0.67	1024	0.75	1063	0.84	1099	0.93
2400*	797	0.32	852	0.40	894	0.48	940	0.57	984	0.66	1027	0.75	1066	0.85	1105	0.94	1141	1.04	1177	1.14
2800*	911	0.47	961	0.57	1005	0.67	1039	0.75	1079	0.85	1119	0.96	1155	1.06	1193	1.18	1226	1.28	1259	1.40
3200	1029	0.68	1072	0.77	1114	0.89	1151	1.00	1179	1.09	1215	1.21	1250	1.33	1285	1.45	1316	1.57	1348	1.70
3600	1147	0.93	1185	1.04	1224	1.16	1260	1.30	1293	1.42	1316	1.51	1349	1.65	1379	1.78	1410	1.91	1442	2.05
4000	1267	1.25	1300	1.38	1335	1.49	1370	1.64	1402	1.79	1433	1.93	1453	2.02	1479	2.16	1509	2.31	1535	2.45
4400	1386	1.64	1417	1.77	1449	1.90	1481	2.04	1512	2.21	1541	2.37	1569	2.53	1591	2.65	1609	2.76	1637	2.93
4800	1506	2.09	1536	2.24	1563	2.40	1593	2.53	1622	2.69	1651	2.88	1677	3.06	—	—	—	—	—	—

Continued

cfm	External Static Pressure (Inches of Water)																			
	1.10		1.20		1.30		1.40		1.50		1.60		1.70		1.80		1.90		2.00	
	rpm	bhp	rpm	bhp	rpm	bhp	rpm	bhp	rpm	bhp	rpm	bhp	rpm	bhp	rpm	bhp	rpm	bhp	rpm	bhp
2000*	1135	1.03	1169	1.12	1201	1.22	1233	1.32	1262	1.42	1292	1.52	1321	1.62	1349	1.73	1376	1.84	1402	1.94
2400*	1212	1.25	1245	1.35	1277	1.46	1307	1.57	1338	1.68	1367	1.79	1394	1.91	1421	2.02	1448	2.14	1473	2.25
2800*	1292	1.51	1324	1.62	1355	1.74	1386	1.87	1415	1.99	1443	2.11	1471	2.23	1497	2.35	1523	2.48	1550	2.61
3200	1380	1.83	1408	1.95	1437	2.07	1466	2.20	1495	2.34	1522	2.47	1550	2.61	1577	2.75	1602	2.88	1628	3.02
3600	1470	2.19	1498	2.32	1527	2.47	1554	2.61	1579	2.75	1605	2.89	1631	3.03	1657	3.18	1681	3.33	—	—
4000	1564	2.60	1592	2.76	1618	2.91	1644	3.07	1670	3.22	1695	3.38	—	—	—	—	—	—	—	—
4400	1661	3.09	1687	3.25	—	—	—	—	—	—	—	—	—	—	—	—	—	—	—	—
4800	—	—	—	—	—	—	—	—	—	—	—	—	—	—	—	—	—	—	—	—

**Notes:**

1. For Direct Drive Fan Speed (RPM), reference [Table 142, p. 183](#).
  2. Data includes pressure drop due to standard filters and wet coils.
  3. Refer to [Table 145, p. 186](#) to determine additional static pressure drop due to other options/accessories.
  4. Direct Drive Fan Motor Heat (MBH) = 2.8623 x Fan BHP - 0.1504
  5. Factory supplied motors, in commercial equipment, are definite purpose motors, specifically designed and tested to operate reliably and continuously at all cataloged conditions. Using the full horsepower range of our fan motors as shown in our tabular data will not result in nuisance tripping or premature motor failure. Our product's warranty will not be affected.
- \* For 2000, 2400, and 2800 CFM, unit application below 320 CFM/Ton are only applicable on T\_C models only (No Gas Heat). See below for restrictions.  
 \* Electric heaters restricted on applications below 320 CFM/Ton  
 \* Dehumidification (Hot Gas Reheat) or TXV with Frost and Crankcase Heaters are required on applications below 320 CFM/Ton



## Evaporator Fan Performance

**Table 133. Direct drive evaporator fan performance - 10 tons high efficiency - YHC120E3,E4 low & medium gas heat, downflow airflow**

	External Static Pressure (Inches of Water)																			
	0.10		0.20		0.30		0.40		0.50		0.60		0.70		0.80		0.90		1.00	
cfm	rpm	bhp	rpm	bhp	rpm	bhp	rpm	bhp	rpm	bhp	rpm	bhp	rpm	bhp	rpm	bhp	rpm	bhp	rpm	bhp
3200	1036	0.65	1065	0.73	1088	0.81	1116	0.89	1143	0.98	1169	1.06	1195	1.14	1218	1.23	1244	1.32	1268	1.41
3600	1156	0.91	1186	1.00	1208	1.08	1229	1.17	1253	1.27	1278	1.36	1301	1.45	1325	1.54	1346	1.63	1368	1.73
4000	1277	1.22	1307	1.32	1329	1.42	1348	1.51	1367	1.62	1389	1.72	1411	1.82	1432	1.93	1453	2.03	1474	2.13
4400	1399	1.60	1427	1.71	1450	1.82	1469	1.93	1485	2.03	1503	2.15	1522	2.26	1543	2.37	1562	2.49	1582	2.60
4800	1521	2.06	1547	2.18	1571	2.30	1590	2.41	1606	2.53	1621	2.65	1636	2.77	1655	2.89	1674	3.02	1692	3.14

Continued

	External Static Pressure (Inches of Water)																			
	1.10		1.20		1.30		1.40		1.50		1.60		1.70		1.80		1.90		2.00	
cfm	rpm	bhp	rpm	bhp	rpm	bhp	rpm	bhp	rpm	bhp	rpm	bhp	rpm	bhp	rpm	bhp	rpm	bhp	rpm	bhp
3200	1292	1.50	1317	1.59	1339	1.69	1361	1.78	1383	1.87	1403	1.97	1425	2.07	1445	2.17	1465	2.27	1484	2.37
3600	1391	1.83	1413	1.94	1435	2.04	1456	2.14	1477	2.25	1497	2.35	1517	2.46	1537	2.56	1555	2.67	1575	2.78
4000	1494	2.23	1514	2.34	1533	2.45	1553	2.56	1573	2.67	1592	2.79	1612	2.91	1631	3.02	1650	3.14	1668	3.26
4400	1602	2.71	1620	2.82	1638	2.93	1655	3.05	1673	3.17	1691	3.29	—	—	—	—	—	—	—	—
4800	—	—	—	—	—	—	—	—	—	—	—	—	—	—	—	—	—	—	—	—

**Notes:**

1. For Direct Drive Fan Speed (RPM), reference [Table 142, p. 183](#).
2. Data includes pressure drop due to standard filters and wet coils.
3. Refer to [Table 145, p. 186](#) to determine additional static pressure drop due to other options/accessories.
4. Direct Drive Fan Motor Heat (MBH) = 2.8623 x Fan BHP - 0.1504
5. Factory supplied motors, in commercial equipment, are definite purpose motors, specifically designed and tested to operate reliably and continuously at all cataloged conditions. Using the full horsepower range of our fan motors as shown in our tabular data will not result in nuisance tripping or premature motor failure. Our product's warranty will not be affected.

## Evaporator Fan Performance

**Table 134. Direct drive evaporator fan performance - 10 tons high efficiency - YHC120E3,E4 low & medium gas heat, horizontal airflow**

	External Static Pressure (Inches of Water)																			
	0.10		0.20		0.30		0.40		0.50		0.60		0.70		0.80		0.90		1.00	
cfm	rpm	bhp	rpm	bhp	rpm	bhp	rpm	bhp	rpm	bhp	rpm	bhp	rpm	bhp	rpm	bhp	rpm	bhp	rpm	bhp
3200	1014	0.62	1054	0.72	1092	0.82	1125	0.92	1153	1.01	1180	1.11	1209	1.21	1237	1.32	1265	1.42	1291	1.53
3600	1131	0.86	1167	0.97	1202	1.08	1235	1.19	1263	1.30	1289	1.41	1313	1.52	1338	1.63	1364	1.74	1388	1.86
4000	1248	1.14	1281	1.27	1314	1.39	1345	1.51	1374	1.64	1400	1.76	1423	1.88	1445	2.00	1467	2.12	1490	2.25
4400	1367	1.49	1397	1.63	1427	1.77	1456	1.90	1484	2.04	1510	2.17	1534	2.31	1556	2.44	1576	2.58	1597	2.71
4800	1485	1.91	1514	2.06	1541	2.21	1568	2.35	1595	2.50	1620	2.65	1645	2.80	1667	2.95	1687	3.10	—	—

Continued

	External Static Pressure (Inches of Water)																			
	1.10		1.20		1.30		1.40		1.50		1.60		1.70		1.80		1.90		2.00	
cfm	rpm	bhp	rpm	bhp	rpm	bhp	rpm	bhp	rpm	bhp	rpm	bhp	rpm	bhp	rpm	bhp	rpm	bhp	rpm	bhp
3200	1317	1.65	1345	1.76	1372	1.88	1398	2.00	1423	2.12	1448	2.25	1472	2.38	1496	2.50	1519	2.63	1541	2.76
3600	1413	1.98	1437	2.10	1460	2.22	1484	2.35	1509	2.49	1532	2.62	1555	2.75	1579	2.89	1602	3.03	1623	3.17
4000	1512	2.37	1535	2.50	1557	2.63	1579	2.77	1600	2.90	1621	3.04	1642	3.19	1664	3.33	1686	3.48	—	—
4400	1616	2.84	1637	2.98	1658	3.12	1678	3.26	1698	3.40	—	—	—	—	—	—	—	—	—	—
4800	—	—	—	—	—	—	—	—	—	—	—	—	—	—	—	—	—	—	—	—

**Notes:**

1. For Direct Drive Fan Speed (RPM), reference [Table 142, p. 183](#).
2. Data includes pressure drop due to standard filters and wet coils.
3. Refer to [Table 145, p. 186](#) to determine additional static pressure drop due to other options/accessories.
4. Direct Drive Fan Motor Heat (MBH) = 2.8623 x Fan BHP - 0.1504
5. Factory supplied motors, in commercial equipment, are definite purpose motors, specifically designed and tested to operate reliably and continuously at all cataloged conditions. Using the full horsepower range of our fan motors as shown in our tabular data will not result in nuisance tripping or premature motor failure. Our product's warranty will not be affected.



## Evaporator Fan Performance

**Table 135. Direct drive evaporator fan performance - 10 tons high efficiency -YHC120E3,E4 high gas heat, downflow airflow**

cfm	External Static Pressure (Inches of Water)																			
	0.10		0.20		0.30		0.40		0.50		0.60		0.70		0.80		0.90		1.00	
	rpm	bhp	rpm	bhp	rpm	bhp	rpm	bhp	rpm	bhp	rpm	bhp	rpm	bhp	rpm	bhp	rpm	bhp	rpm	bhp
3200	1051	0.68	1081	0.76	1102	0.84	1126	0.92	1153	1.00	1179	1.08	1204	1.17	1229	1.25	1252	1.34	1276	1.42
3600	1175	0.95	1203	1.03	1225	1.12	1243	1.21	1266	1.31	1289	1.39	1313	1.49	1336	1.58	1358	1.67	1380	1.77
4000	1299	1.27	1326	1.37	1348	1.47	1366	1.57	1382	1.67	1403	1.77	1424	1.87	1445	1.97	1466	2.07	1487	2.18
4400	1423	1.67	1448	1.78	1471	1.89	1490	2.00	1505	2.11	1519	2.22	1538	2.33	1557	2.44	1577	2.55	1596	2.66
4800	1548	2.15	1571	2.27	1593	2.38	1612	2.50	1629	2.62	1642	2.74	1655	2.86	1672	2.99	1689	3.11	—	—

Continued

cfm	External Static Pressure (Inches of Water)																			
	1.10		1.20		1.30		1.40		1.50		1.60		1.70		1.80		1.90		2.00	
	rpm	bhp	rpm	bhp	rpm	bhp	rpm	bhp	rpm	bhp	rpm	bhp	rpm	bhp	rpm	bhp	rpm	bhp	rpm	bhp
3200	1300	1.52	1323	1.61	1346	1.71	1368	1.80	1389	1.90	1410	1.99	1430	2.09	1450	2.19	1470	2.29	1489	2.38
3600	1401	1.87	1423	1.97	1444	2.07	1464	2.17	1485	2.27	1505	2.38	1524	2.48	1545	2.59	1563	2.70	1582	2.81
4000	1506	2.28	1526	2.39	1546	2.50	1564	2.60	1583	2.71	1602	2.82	1622	2.94	1640	3.06	1659	3.18	1676	3.29
4400	1615	2.77	1633	2.89	1652	3.01	1670	3.12	1687	3.24	—	—	—	—	—	—	—	—	—	—
4800	—	—	—	—	—	—	—	—	—	—	—	—	—	—	—	—	—	—	—	—

**Notes:**

1. For Direct Drive Fan Speed (RPM), reference [Table 142, p. 183](#).
2. Data includes pressure drop due to standard filters and wet coils.
3. Refer to [Table 145, p. 186](#) to determine additional static pressure drop due to other options/accessories.
4. Direct Drive Fan Motor Heat (MBH) = 2.8623 x Fan BHP - 0.1504
5. Factory supplied motors, in commercial equipment, are definite purpose motors, specifically designed and tested to operate reliably and continuously at all cataloged conditions. Using the full horsepower range of our fan motors as shown in our tabular data will not result in nuisance tripping or premature motor failure. Our product's warranty will not be affected.

## Evaporator Fan Performance

**Table 136. Direct drive evaporator fan performance - 10 tons high efficiency -YHC120E3,E4 high gas heat, horizontal airflow**

External Static Pressure (Inches of Water)																					
		0.10		0.20		0.30		0.40		0.50		0.60		0.70		0.80		0.90		1.00	
cfm	rpm	bhp	rpm	bhp	rpm	bhp	rpm	bhp	rpm	bhp	rpm	bhp	rpm	bhp	rpm	bhp	rpm	bhp	rpm	bhp	
3200	1002	0.60	1043	0.70	1081	0.80	1113	0.89	1142	0.99	1171	1.09	1200	1.19	1230	1.30	1259	1.41	1287	1.52	
3600	1118	0.83	1155	0.94	1190	1.05	1222	1.15	1250	1.26	1276	1.38	1302	1.49	1328	1.60	1354	1.72	1381	1.84	
4000	1234	1.11	1268	1.23	1300	1.35	1331	1.47	1359	1.59	1385	1.71	1408	1.83	1431	1.96	1454	2.08	1478	2.21	
4400	1350	1.45	1382	1.58	1412	1.72	1440	1.85	1468	1.98	1494	2.11	1517	2.24	1539	2.38	1560	2.52	1581	2.65	
4800	1467	1.85	1497	2.00	1524	2.15	1551	2.29	1578	2.43	1603	2.57	1626	2.72	1648	2.87	1669	3.01	1688	3.16	

Continued

External Static Pressure (Inches of Water)																					
		1.10		1.20		1.30		1.40		1.50		1.60		1.70		1.80		1.90		2.00	
cfm	rpm	bhp	rpm	bhp	rpm	bhp	rpm	bhp	rpm	bhp	rpm	bhp	rpm	bhp	rpm	bhp	rpm	bhp	rpm	bhp	
3200	1315	1.63	1344	1.75	1370	1.87	1398	2.00	1424	2.12	1449	2.25	1473	2.38	1497	2.50	1521	2.64	1543	2.76	
3600	1406	1.96	1432	2.08	1456	2.20	1482	2.33	1507	2.47	1531	2.60	1555	2.74	1579	2.88	1602	3.02	1623	3.16	
4000	1502	2.34	1526	2.47	1549	2.60	1573	2.74	1595	2.88	1617	3.01	1640	3.16	1663	3.31	1685	3.46	—	—	
4400	1602	2.79	1624	2.92	1645	3.06	1667	3.21	1689	3.36	—	—	—	—	—	—	—	—	—	—	
4800	—	—	—	—	—	—	—	—	—	—	—	—	—	—	—	—	—	—	—	—	

**Notes:**

1. For Direct Drive Fan Speed (RPM), reference [Table 142, p. 183](#).
2. Data includes pressure drop due to standard filters and wet coils.
3. Refer to [Table 145, p. 186](#) to determine additional static pressure drop due to other options/accessories.
4. Direct Drive Fan Motor Heat (MBH) = 2.8623 x Fan BHP - 0.1504
5. Factory supplied motors, in commercial equipment, are definite purpose motors, specifically designed and tested to operate reliably and continuously at all cataloged conditions. Using the full horsepower range of our fan motors as shown in our tabular data will not result in nuisance tripping or premature motor failure. Our product's warranty will not be affected.



# Fan Performance

**Table 137. Standard motor & sheave/fan speed (rpm)**

Tons	Unit Model Number	Fan Sheave	6 Turns Open	5 Turns Open	4 Turns Open	3 Turns Open	2 Turns Open	1 Turn Open	Closed
3	T/YSC036E	AK51x3/4"	N/A	765	835	905	975	1045	1115
4	T/YSC048E	AK49x3/4"	N/A	804	876	948	1020	1091	1163
5	T/YSC060E	AK44x3/4"	N/A	885	966	1049	1131	1212	1295
6	T/YSC072F	AK64x1"	N/A	723	779	835	890	946	1002
7½	T/YSC090F	AK59x1"	N/A	805	865	925	985	1045	1105
7½	T/YSC092F	AK59x1"	N/A	639	696	753	810	867	924
8½	T/YSC102F	AK59x1"	N/A	787	847	908	968	1029	1089
3	T/YHC036E	AK51x3/4"	N/A	765	835	905	975	1045	1115
4	T/YHC048E	AK54x3/4"	N/A	729	794	860	926	911	1057
4	T/YHC048F	AK54x3/4"	N/A	729	794	860	926	911	1057
5	T/YHC060E	AK49x3/4"	N/A	801	871	942	1012	1083	1154
5	T/YHC060F	AK49x3/4"	N/A	801	871	942	1012	1083	1154
6	T/YHC072F	AK64x1"	N/A	728	784	840	896	952	1008

**Note:** Factory set at 3 turns open.

**Table 138. Standard motor & low static drive accessory sheave/fan speed (rpm)**

Tons	Unit Model Number	Fan Sheave	6 Turns Open	5 Turns Open	4 Turns Open	3 Turns Open	2 Turns Open	1 Turn Open	Closed
3	T/YSC036E	AK71x3/4"	N/A	556	606	657	707	757	808
4	T/YSC048E	AK69x3/4"	N/A	N/A	624	675	727	779	832
5	T/YSC060E	AK61x3/4"	N/A	N/A	708	765	823	880	938
7½	T/YSC090F	AK74x1"	N/A	602	650	698	746	794	842
7½	TSC092F	AK99x1"	N/A	462	498	533	569	604	640
7½	TSC092F	AK79x1"	N/A	614	657	700	743	786	829
8½	TSC102F	AK99x1"	N/A	462	498	533	569	604	640
8½	TSC102F	AK79x1"	N/A	582	627	672	716	761	806
3	YHC036E	AK71x3/4"	N/A	556	607	657	707	758	808
3	THC036E	AK99x3/4"	N/A	385	424	462	501	539	578
4	YHC048E,F	AK71x3/4"	N/A	556	607	657	707	758	808
4	THC048E,F	AK99x3/4"	N/A	385	424	462	501	539	578
5	YHC060E,F	AK71x3/4"	N/A	556	607	657	707	758	808
5	THC060E,F	AK99x3/4"	N/A	385	424	462	501	539	578
6	YHC072F	AK79x1"	N/A	581	626	671	716	761	805
6	THC072F	AK99x1"	N/A	462	497	533	569	604	640

**Note:** Factory set at 3 turns open.

**Table 139. Standard motor & high static drive accessory sheave/fan speed (rpm)**

Tons	Unit Model Number	Fan Sheave	6 Turns Open	5 Turns Open	4 Turns Open	3 Turns Open	2 Turns Open	1 Turn Open	Closed
3	T/YSC036E	AK41x3/4"	N/A	967	1040	1113	1187	1228	N/A

continued on next page

**Table 139. Standard motor & high static drive accessory sheave/fan speed (rpm) (continued)**

Tons	Unit Model Number	Fan Sheave	6 Turns Open	5 Turns Open	4 Turns Open	3 Turns Open	2 Turns Open	1 Turn Open	Closed
4	T/YSC048E	AK41x3/4"	N/A	957	1033	1110	1187	1263	N/A
6	T/YSC072F	AK56x1"	N/A	831	895	959	1022	1086	1150
3	T/YHC036E	AK41x3/4"	N/A	N/A	967	1040	1113	1187	N/A
4	T/YHC048E,F	AK41x3/4"	N/A	N/A	966	1048	1132	1215	N/A
5	T/YHC060E,F	AK41x3/4"	N/A	N/A	961	1041	1122	1203	N/A

**Note:** Factory set at 3 turns open.

**Table 140. Oversized motor & drive sheave/fan speed (rpm)**

Tons	Unit Model Number	6 Turns Open	5 Turns Open	4 Turns Open	3 Turns Open	2 Turns Open	1 Turn Open	Closed
6	T/YSC072F	AK56x1"	N/A	958	1022	1086	1150	1214
7½	T/YSC090F	AK56x1"	N/A	958	1022	1086	1150	1214
7½	T/YSC092F	AK64x1"	860	910	960	1010	1060	1110
8½	T/YSC102F	AK56x1"	N/A	958	1022	1086	1150	1214
6	T/YHC072F	AK56x1"	N/A	885	948	1010	1073	1135

**Notes:** Factory set at 3 turns open.

\* Indicates both standard and high efficiency units and both ReliaTel™ and Electromechanical controls.

**Table 141. Oversized motor & high static drive sheave/fan speed (rpm)**

Tons	Unit Model Number	6 Turns Open	5 Turns Open	4 Turns Open	3 Turns Open	2 Turns Open	1 Turn Open	Closed
6	T/YSC072F	AK54x1"	N/A	995	1061	1128	1194	1261
7½	T/YSC090F	BK52x1"	N/A	1127	1197	1268	1338	1409
7½	T/YSC092F	AK56x1"	986	1043	1099	1156	1212	1269

**Notes:** Factory set at 3 turns open.

\* Indicates both standard and high efficiency units and both ReliaTel™ and Electromechanical controls.

**Table 142. Direct drive plenum fan settings (rpm vs. voltage)<sup>(a),(b)</sup>**

T/YHC092E, T/YHC092F, T/YHC102E, T/YSC120F, T/YHC120E	
Potentiometer Voltage	Motor RPM
1.25	217
1.5	312
1.75	362
2.0	427
2.25	479
2.50	543
2.75	605
3.00	668
3.25	732
3.50	797
3.75	863
4.00	929

continued on next page



## Fan Performance

**Table 142. Direct drive plenum fan settings (rpm vs. voltage)<sup>(a), (b)</sup> (continued)**

T/YHC092E, T/YHC092F, T/YHC102E, T/YSC120F, T/YHC120E	
Potentiometer Voltage	Motor RPM
4.25	995
4.50	1061
4.75	1126
5.00	1191
5.25	1253
5.50	1315
5.75	1374
6.00	1432
6.25	1487
6.50	1539
6.75	1588
7.00	1633
7.25	1675
7.50	1700

(a) See fan tables for unit rpm and cfm units.

(b) Factory setting is 5V.

**Table 143. Outdoor sound power level - dB (ref. 10 - 12 W)**

Tons	Unit Model Number	Octave Center Frequency								Overall dBA
		63	125	250	500	1000	2000	4000	8000	
3	T/YSC036E	79	85	79	79	77	71	67	58	81
4	T/YSC048E	82	84	83	80	76	72	66	58	82
5	T/YSC060E	85	82	81	81	77	72	67	61	82
6	T/YSC072F	91	95	90	87	84	79	75	68	89
7½	T/YSC090F	91	95	90	87	84	79	75	68	89
7½	T/YSC092F	92	96	92	89	85	80	76	69	91
8½	T/YSC102F	91	95	90	87	84	79	75	68	89
10	T/YSC120F	91	86	90	86	82	78	73	67	88
3	T/YHC036E	79	85	79	79	77	71	67	58	81
4	T/YHC048E	80	86	84	85	83	79	73	67	87
4	T/YHC048F	80	86	84	85	83	79	73	67	87
5	T/YHC060E	80	86	84	85	83	79	73	67	87
5	T/YHC060F	80	86	84	85	83	79	73	67	87
6	T/YHC072F	91	95	90	87	84	79	75	68	89
7½	T/YHC092E	89	87	91	85	80	77	73	66	87
7½	T/YHC092F	91	86	90	86	82	78	73	67	88
8½	T/YHC102E	89	87	91	85	80	77	73	66	87
10	T/YHC120E	89	87	91	85	80	77	73	66	87

**Note:** Tests follow ARI270-95.



**Table 144. Static pressure drop through accessories (inches water column) - 3-10 tons**

Tons	Unit Model Number	cfm	Standard Filters <sup>(d)</sup>			Economizer with OA/RA Dampers <sup>(a)</sup>				Electric Heater Accessory (kW) <sup>(b), (c)</sup>			
			Standard Filters <sup>(d)</sup>	2" MERV 7 Filter	2" MERV 13 Filter	100% OA Downflow	100% RA Downflow	100% OA Horizontal	100% RA Horizontal	5-6	9-18	23-36	54
3	T/YSC036E1	960	0.01	0.03	0.04	0.04	0.01	0.04	0.01	0.01	0.01	0.01	—
3	T/YSC036E1	1200	0.02	0.04	0.05	0.06	0.01	0.06	0.01	0.02	0.02	0.02	—
3	T/YSC036E1	1440	0.03	0.05	0.06	0.08	0.02	0.08	0.01	0.02	0.03	0.03	—
3	T/YSC036E3	960	0.01	0.03	0.04	0.04	0.01	0.04	0.01	0.01	0.01	0.01	—
3	T/YSC036E3	1200	0.02	0.04	0.05	0.06	0.01	0.06	0.01	0.02	0.02	0.02	—
3	T/YSC036E3	1440	0.03	0.05	0.06	0.08	0.02	0.08	0.01	0.02	0.03	0.03	—
4	T/YSC048E1	1280	0.03	0.05	0.06	0.09	0.02	0.09	0.01	0.02	0.03	0.03	—
4	T/YSC048E1	1600	0.04	0.07	0.07	0.13	0.04	0.13	0.02	0.04	0.05	0.05	—
4	T/YSC048E1	1920	0.06	0.10	0.08	0.17	0.06	0.17	0.02	0.05	0.06	0.08	—
4	T/YSC048E3	1280	0.03	0.05	0.06	0.09	0.02	0.09	0.01	0.02	0.03	0.03	—
4	T/YSC048E3	1600	0.04	0.07	0.07	0.13	0.04	0.13	0.02	0.04	0.05	0.05	—
4	T/YSC048E3	1920	0.06	0.10	0.08	0.17	0.06	0.17	0.02	0.05	0.06	0.08	—
5	T/YSC060E1	1600	0.04	0.07	0.07	0.13	0.04	0.13	0.02	0.04	0.05	0.05	—
5	T/YSC060E1	2000	0.06	0.10	0.09	0.18	0.07	0.18	0.02	0.06	0.07	0.08	—
5	T/YSC060E1	2400	0.08	0.13	0.10	0.25	0.11	0.25	0.03	0.08	0.10	0.12	—
5	T/YSC060E3	1600	0.04	0.07	0.07	0.13	0.04	0.13	0.02	0.04	0.05	0.05	—
5	T/YSC060E3	2000	0.06	0.10	0.09	0.18	0.07	0.18	0.02	0.06	0.07	0.08	—
5	T/YSC060E3	2400	0.08	0.13	0.10	0.25	0.11	0.25	0.03	0.08	0.10	0.12	—
6	T/YSC072F	1920	0.04	0.07	0.10	0.10	0.01	0.06	0.02	—	0.01	0.02	—
6	T/YSC072F	2400	0.06	0.09	0.13	0.11	0.02	0.08	0.02	—	0.02	0.03	—
6	T/YSC072F	2880	0.09	0.12	0.15	0.13	0.04	0.10	0.04	—	0.03	0.05	—
7½	T/YSC090F	2400	0.04	0.06	0.12	0.11	0.02	0.08	0.02	—	0.02	0.02	—
7½	T/YSC090F	3000	0.06	0.09	0.13	0.14	0.05	0.12	0.05	—	0.03	0.03	—
7½	T/YSC090F	3600	0.09	0.13	0.15	0.21	0.07	0.25	0.08	—	0.04	0.05	—
7½	T/YSC092F	2400	0.04	0.06	0.12	0.11	0.02	0.08	0.02	—	0.02	0.02	—
7½	T/YSC092F	3000	0.06	0.09	0.13	0.14	0.05	0.12	0.05	—	0.03	0.03	—
7½	T/YSC092F	3600	0.09	0.13	0.15	0.21	0.07	0.25	0.08	—	0.04	0.05	—
8½	T/YSC102F	2720	0.05	0.08	0.13	0.12	0.03	0.09	0.04	—	0.02	0.03	—
8½	T/YSC102F	3400	0.08	0.11	0.14	0.19	0.06	0.18	0.06	—	0.03	0.04	—
8½	T/YSC102F	4080	0.12	0.16	0.16	0.30	0.07	0.31	0.09	—	0.05	0.06	—
10	T/YSC120F	3200	0.07	0.10	0.14	0.17	0.05	0.14	0.05	—	0.02	0.03	0.05
10	T/YSC120F	4000	0.11	0.15	0.16	0.26	0.07	0.30	0.08	—	0.02	0.03	0.05
10	T/YSC120F	4800	0.16	0.20	0.18	0.34	0.09	0.35	0.10	—	0.03	0.04	0.06

(a) OA = Outside Air and RA = Return Air.

(b) Nominal kW ratings at 240, 480, 600 volts. Heaters only available on T units.

(c) Electric heaters restricted on applications below 320 cfm/Ton.

(d) Tested with standard filters. Difference in pressure drop should be considered when utilizing optional 2" MERV 7 and MERV 13 filters.



## Fan Performance

**Table 145. Static pressure drop through accessories (inches water column) - 3-10 tons**

Ton s	Unit Model Number	cfm	Standard Filters <sup>(d)</sup>	2" MERV 7 Filter	2" MERV 13 Filter	Reheat Coil	Economizer with OA/RA Dampers <sup>(a)</sup>				Electric Heater Accessory (kW) <sup>(b), (c)</sup>			
							100% OA		100% RA		5-6	9-18	23-36	54
							Downflow	Horizontal	Downflow	Horizontal				
3	T/YHC036E1	960	0.01	0.03	0.04	—	0.04	0.01	0.04	0.01	0.01	0.01	0.01	—
3	T/YHC036E1	1200	0.02	0.04	0.05	—	0.06	0.01	0.06	0.01	0.02	0.02	0.02	—
3	T/YHC036E1	1440	0.03	0.05	0.06	—	0.08	0.02	0.08	0.01	0.02	0.03	0.03	—
3	T/YHC036E3,4	600	0.01	0.02	0.03	0.04	0.03	0.01	0.03	0.01	—	—	—	—
3	T/YHC036E3,4	960	0.01	0.03	0.04	0.08	0.04	0.01	0.04	0.01	0.01	0.01	0.01	—
3	T/YHC036E3,4	1200	0.02	0.04	0.05	0.10	0.06	0.01	0.06	0.01	0.02	0.02	0.02	—
3	T/YHC036E3,4	1440	0.03	0.05	0.06	0.14	0.08	0.02	0.08	0.01	0.02	0.03	0.03	—
4	T/YHC048F1	1280	0.02	0.04	0.03	—	0.08	0.00	0.04	0.01	0.01	0.00	0.01	—
4	T/YHC048F1	1600	0.03	0.06	0.05	—	0.09	0.01	0.05	0.02	0.02	0.01	0.02	—
4	T/YHC048F1	1920	0.05	0.08	0.07	—	0.10	0.01	0.07	0.02	0.02	0.01	0.03	—
4	T/YHC048E/F3,4	800	0.01	0.03	0.04	0.03	0.06	0.00	0.03	0.01	—	—	—	—
4	T/YHC048E/F3,4	1280	0.02	0.04	0.03	0.07	0.08	0.00	0.04	0.01	0.01	0.00	0.01	—
4	T/YHC048E/F3,4	1600	0.03	0.06	0.05	0.09	0.09	0.01	0.05	0.02	0.02	0.01	0.02	—
4	T/YHC048E/F3,4	1920	0.05	0.08	0.07	0.12	0.10	0.01	0.07	0.02	0.02	0.01	0.03	—
5	T/YHC060F1	1600	0.03	0.06	0.08	—	0.09	0.01	0.05	0.02	0.02	0.01	0.02	—
5	T/YHC060F1	2000	0.05	0.08	0.11	—	0.11	0.01	0.07	0.02	0.02	0.02	0.03	—
5	T/YHC060F1	2400	0.07	0.10	0.13	—	0.12	0.03	0.09	0.03	0.03	0.02	0.04	—
5	T/YHC060E/F3,4	1000	0.01	0.04	0.03	0.05	0.06	0.01	0.06	0.01	—	—	—	—
5	T/YHC060E/F3,4	1600	0.03	0.06	0.08	0.09	0.09	0.01	0.05	0.01	0.02	0.01	0.02	—
5	T/YHC060E/F3,4	2000	0.05	0.08	0.11	0.13	0.11	0.01	0.07	0.02	0.02	0.02	0.03	—
5	T/YHC060E/F3,4	2400	0.07	0.10	0.13	0.17	0.12	0.03	0.09	0.04	0.03	0.02	0.04	—
6	T/YHC072F	1920	0.04	0.07	0.10	—	0.10	0.01	0.06	0.02	—	0.01	0.02	—
6	T/YHC072F	2400	0.06	0.09	0.13	—	0.11	0.02	0.08	0.02	—	0.02	0.03	—
6	T/YHC072F	2880	0.09	0.12	0.15	—	0.13	0.04	0.10	0.04	—	0.03	0.05	—
7½	T/YHC092E/F	1500	0.02	0.03	0.08	0.03	0.07	0.01	0.04	0.01	—	—	—	—
7½	T/YHC092E/F	2400	0.04	0.06	0.12	0.06	0.11	0.02	0.08	0.02	—	0.01	0.01	—
7½	T/YHC092E/F	3000	0.06	0.09	0.13	0.08	0.14	0.05	0.12	0.05	—	0.01	0.02	—
7½	T/YHC092E/F	3600	0.09	0.13	0.15	0.11	0.21	0.07	0.25	0.08	—	0.02	0.03	—
8½	T/YHC102E	1700	0.02	0.50	0.11	0.04	0.07	0.01	0.05	0.02	—	—	—	—
8½	T/YHC102E	2720	0.05	0.08	0.13	0.07	0.12	0.03	0.09	0.04	—	0.01	0.02	—
8½	T/YHC102E	3400	0.08	0.11	0.14	0.10	0.19	0.06	0.18	0.06	—	0.02	0.02	—
8½	T/YHC102E	4080	0.12	0.16	0.16	0.13	0.30	0.07	0.31	0.09	—	0.03	0.03	—
10	T/YHC120E	2000	0.03	0.06	0.11	0.05	0.80	0.03	0.07	0.02	—	—	—	—
10	T/YHC120E	3200	0.07	0.10	0.14	0.09	0.17	0.05	0.14	0.05	—	0.02	0.03	0.05
10	T/YHC120E	4000	0.11	0.15	0.16	0.12	0.26	0.07	0.30	0.08	—	0.02	0.03	0.05
10	T/YHC120E	4800	0.16	0.20	0.18	0.16	0.34	0.09	0.35	0.10	—	0.03	0.04	0.06

(a) OA = Outside Air and RA = Return Air.

(b) Nominal kW ratings at 240, 480, 600 volts. Heaters only available on T units.

(c) Electric heaters restricted on applications below 320 cfm/Ton.

(d) Tested with standard filters. Difference in pressure drop should be considered when utilizing optional 2" MERV 7 and MERV 13 filters.

**Table 146. Gas fired heating capacities - standard efficiency**

Tons	Unit Model Number	Heating Input MBh <sup>(a)</sup>	Heating Output MBh	Air Temp. Rise, F
3	YSC036E1*(L,X)	60	48	25-55
3	YSC036E1*(M,Y)	80	65	35-65
3	YSC036E1*(H,Z)	120	96	55-85
3	YSC036E(3,4,W)*(L,X)	60	48	25-55
3	YSC036E(3,4,W)*(M,Y)	80	64	35-65
3	YSC036E(3,4,W)*(H,Z)	120	96	55-85
4	YSC048E1*(L,X)	60	49	15-45
4	YSC048E1*(M,Y)	80	65	20-50
4	YSC048E1*(H,Z)	120	96	40-70
4	YSC048E(3,4,W)*(L,X)	60	48	15-45
4	YSC048E(3,4,W)*(M,Y)	80	64	20-50
4	YSC048E(3,4,W)*(H,Z)	120	96	40-70
5	YSC060E1*(L,X)	60	48	10-40
5	YSC060E1*(M,Y)	80	65	15-45
5	YSC060E1*(H,Z)	130	104	35-65
5	YSC060E(3,4,W)*(L,X)	60	48	10-40
5	YSC060E(3,4,W)*(M,Y)	80	64	15-45
5	YSC060E(3,4,W)*(H,Z)	130	104	35-65
6	YSC072F(3,4,W)*(L,X)	80	64	15-45
6	YSC072F(3,4,W)*(M,Y)	120	96	20-50
6	YSC072F(3,4,W)*(H,Z)	150/105	120/84	25-55
7½	YSC090F(3,4,W)*(L,X)	120	96	20-50
7½	YSC090F(3,4,W)*(M,Y)	150/105	120/84	25-55
7½	YSC090F(3,4,W)*(H,Z)	200/140	160/112	35-65
7½	YSC092F(3,4,W)*(L,X)	120	96	20-50
7½	YSC092F(3,4,W)*(M,Y)	150/105	120/84	25-55
7½	YSC092F(3,4,W)*(H,Z)	200/140	160/112	35-65
8½	YSC102F(3,4,W)*(L,X)	120	96	15-45
8½	YSC102F(3,4,W)*(M,Y)	150/105	120/84	20-50
8½	YSC102F(3,4,W)*(H,Z)	200/140	160/112	35-65
10	YSC120F(3,4,W)*(L,X)	150/105	120/84	20-50
10	YSC120F(3,4,W)*(M,Y)	200/140	160/112	25-55
10	YSC120F(3,4,W)*(H,Z)	250/175	200/140	35-65

**Note:** Ratings shown are for elevations up to 2,000 ft. For higher elevations, reduce ratings at a rate of 4% per 1,000 ft. elevation.

(a) For two stage heaters (input or output), Second stage is total heating capacity. Second Stage/First Stage.

**Table 147. Gas fired heating capacities - high efficiency**

Tons	Unit Model Number	Heating Input MBh	Heating Output MBh	Air Temp. Rise, F
3	YHC036E1*(L,X)	60	48	25-55
3	YHC036E1*(M,Y)	80	65	35-65
3	YHC036E1*(H,Z)	120	96	55-85

continued on next page



## Fan Performance

**Table 147. Gas fired heating capacities - high efficiency (continued)**

Tons	Unit Model Number	Heating Input MBh	Heating Output MBh	Air Temp. Rise, F
3	YHC036E(3,4)*(L,X)	60	48	25-55
3	YHC036E(3,4)*(M,Y)	80	64	35-65
3	YHC036E(3,4)*(H,Z)	120	96	55-85
4	YHC048F1*(L,X)	60	49	10-40
4	YHC048F1*(M,Y)	80	64	20-50
4	YHC048F1*(H,Z)	120	96	40-70
4	YHC048E(3,4)*(L,X)	60	48	10-40
4	YHC048E(3,4)*(M,Y)	80	64	20-50
4	YHC048E(3,4)*(H,Z)	120	96	40-70
4	YHC048F(3,4)*(L,X)	60	48	10-40
4	YHC048F(3,4)*(M,Y)	80	64	20-50
4	YHC048F(3,4)*(H,Z)	120	96	40-70
5	YHC060F1*(L,X)	60	49	10-40
5	YHC060F1*(M,Y)	80	64	15-45
5	YHC060F1*(H,Z)	130	104	35-65
5	YHC060E(3,4)*(L,X)	60	48	10-40
5	YHC060E(3,4)*(M,Y)	80	64	15-45
5	YHC060E(3,4)*(H,Z)	130	104	35-65
5	YHC060F(3,4)*(L,X)	60	48	10-40
5	YHC060F(3,4)*(M,Y)	80	64	15-45
5	YHC060F(3,4)*(H,Z)	130	104	35-65
6	YHC072F(3,4)*(L,X)	80	64	15-45
6	YHC072F(3,4)*(M,Y)	120	96	20-50
6	YHC072F(3,4)*(H,Z)	150/105	120/84	25-55
7½	YHC092E(3,4)*(L,X)	120	96	20-50
7½	YHC092E(3,4)*(M,Y)	150/105	120/84	25-55
7½	YHC092E(3,4)*(H,Z)	200/140	160/112	35-65
7½	YHC092F(3,4)*(L,X)	120	96	20-50
7½	YHC092F(3,4)*(M,Y)	150/105	120/84	20-50
7½	YHC092F(3,4)*(H,Z)	200/140	160/112	25-55
8½	YHC102E(3,4)*(L,X)	120	96	15-45
8½	YHC102E(3,4)*(M,Y)	150/105	120/84	20-50
8½	YHC102E(3,4)*(H,Z)	200/140	160/112	35-65
10	YHC120E(3,4)*(L,X)	150/105	120/84	20-50
10	YHC120E(3,4)*(M,Y)	200/140	160/112	25-55
10	YHC120E(3,4)*(H,Z)	250/175	200/140	35-65

**Note:** Ratings shown are for elevations up to 2,000 ft. For higher elevations, reduce ratings at a rate of 4% per 1,000 ft. elevation.

Table 148. Auxiliary electric heat capacity

Tons	Unit Model Number	Total <sup>(a)</sup>		No. of Stages	Stage 1		Stage 2	
		kW Input <sup>(b)</sup>	MBh Output		kW Input	MBh Output	kW Input	MBh Output
3	T*C036E1	5.00	17.07	1	5.00	17.07	—	—
3	T*C036E1	10.00	34.14	2	5.00	17.07	5.00	17.07
3	T*C036E1	13.80	47.11	2	5.00	17.07	8.80	30.04
3	T*C036E3, E4, EW <sup>(c)</sup>	6.00	20.48	1	6.00	20.48	—	—
3	T*C036E3, E4, EW <sup>(c)</sup>	12.00	40.97	2	6.00	20.48	6.00	20.48
3	T*C036E3, E4, EW <sup>(c)</sup>	17.40	59.40	2	8.70	29.70	8.70	29.70
4	T*C048*1	5.00	17.07	1	5.00	17.07	—	—
4	T*C048*1	10.00	34.14	2	5.00	17.07	5.00	17.07
4	T*C048*1	13.80	47.11	2	5.00	17.07	8.80	30.04
4	T*C048*1	17.60	60.09	2	8.80	30.04	8.80	30.04
4	T*C048*3, *4, EW <sup>(c)</sup>	6.00	20.48	1	6.00	20.48	—	—
4	T*C048*3, *4, EW <sup>(c)</sup>	12.00	40.97	2	6.00	20.48	6.00	20.48
4	T*C048*3, *4, EW <sup>(c)</sup>	17.40	59.40	2	8.70	29.70	8.70	29.70
5	T*C060*1	5.00	17.07	1	5.00	17.07	—	—
5	T*C060*1	10.00	34.14	2	5.00	17.07	5.00	17.07
5	T*C060*1	13.80	47.11	2	5.00	17.07	8.80	30.04
5	T*C060*1	17.60	60.09	2	8.80	30.04	8.80	30.04
5	T*C060*3, *4, EW <sup>(c)</sup>	6.00	20.48	1	6.00	20.48	—	—
5	T*C060*3, *4, EW <sup>(c)</sup>	12.00	40.97	2	6.00	20.48	6.00	20.48
5	T*C060*3, *4, EW <sup>(c)</sup>	17.40	59.40	2	8.70	29.70	8.70	29.70
5	T*C060*3, *4, EW <sup>(c)</sup>	23.00	78.52	2	8.70	29.70	14.30	48.82
6	TSC072F3,4,W	9.00	30.73	1	9.00	30.73	—	—
6	TSC072F3,4,W	18.00	61.45	1	18.00	61.45	—	—
6	TSC072F3,4,W	27.00	92.18	2	18.00	61.45	9.00	30.73
6	TSC072F3,4,W	36.00	122.90	2	18.00	61.45	18.00	61.45
6	THC072F3,4	9.00	30.73	1	9.00	30.73	—	—
6	THC072F3,4	18.00	61.45	1	18.00	61.45	—	—
6	THC072F3,4	27.00	92.18	2	18.00	61.45	9.00	30.73
6	THC072F3,4	36.00	122.90	2	18.00	61.45	18.00	61.45
7½	TSC090F3,4,W	9.00	30.73	1	9.00	30.73	—	—
7½	TSC090F3,4,W	18.00	61.45	1	18.00	61.45	—	—
7½	TSC090F3,4,W	27.00	92.18	2	18.00	61.45	9.00	30.73
7½	TSC090F3,4,W	36.00	122.90	2	18.00	61.45	18.00	61.45
7½	TSC092F3,4,W	9.00	30.73	1	9.00	30.73	—	—
7½	TSC092F3,4,W	18.00	61.45	1	18.00	61.45	—	—
7½	TSC092F3,4,W	27.00	92.18	2	18.00	61.45	9.00	30.73
7½	TSC092F3,4,W	36.00	122.90	2	18.00	61.45	18.00	61.45
7½	THC092E3,4	9.00	30.73	1	9.00	30.73	—	—
7½	THC092E3,4	18.00	61.45	1	18.00	61.45	—	—
7½	THC092E3,4	27.00	92.18	2	18.00	61.45	9.00	30.73
7½	THC092E3,4	36.00	122.90	2	18.00	61.45	18.00	61.45

continued on next page



## Fan Performance

**Table 148. Auxiliary electric heat capacity (continued)**

Tons	Unit Model Number	Total <sup>(a)</sup>			Stage1		Stage 2	
		kW Input <sup>(b)</sup>	MBh Output	No. of Stages	kW Input	MBh Output	kW Input	MBh Output
7½	THC092F3,4	9.00	30.73	1	9.00	30.73	—	—
7½	THC092F3,4	18.00	61.45	1	18.00	61.45	—	—
7½	THC092F3,4	27.00	92.18	2	18.00	61.45	9.00	30.73
7½	THC092F3,4	36.00	122.90	2	18.00	61.45	18.00	61.45
8½	TSC102F3,4,W	9.00	30.73	1	9.00	30.73	—	—
8½	TSC102F3,4,W	18.00	61.45	1	18.00	61.45	—	—
8½	TSC102F3,4,W	27.00	92.18	2	18.00	61.45	9.00	30.73
8½	TSC102F3,4,W	36.00	122.90	2	18.00	61.45	18.00	61.45
8½	THC102E3,4	9.00	30.73	1	9.00	30.73	—	—
8½	THC102E3,4	18.00	61.45	1	18.00	61.45	—	—
8½	THC102E3,4	27.00	92.18	2	18.00	61.45	9.00	30.73
8½	THC102E3,4	36.00	122.90	2	18.00	61.45	18.00	61.45
10	TSC120F3,4,W	18.00	61.45	1	18.00	61.45	—	—
10	TSC120F3,4,W	27.00	92.18	2	18.00	61.45	9.00	30.73
10	TSC120F3,4,W	36.00	122.90	2	18.00	61.45	18.00	61.45
10	TSC120F3,4,W	54.00	184.36	2	36.00	122.90	18.00	61.45
10	THC120E3,4	18.00	61.45	1	18.00	61.45	—	—
10	THC120E3,4	27.00	92.18	2	18.00	61.45	9.00	30.73
10	THC120E3,4	36.00	122.90	2	18.00	61.45	18.00	61.45
10	THC120E3,4	54.00	184.36	2	36.00	122.90	18.00	61.45

(a) Heaters are rated at 240V,380V,480V and 600V. For other than rated voltage, CAP= (voltage/rated voltage)<sup>2</sup> x rated cap.

(b) All input/output does not include indoor fan power or heat.

(c) 600V is not available on high efficiency units.

**Table 149. Electric heater voltage correction factors (applicable to auxiliary heat capacity)**

Nominal Voltage	Distribution Voltage	Capacity Multiplier
240	208	0.751
240	230	0.918
240	240	1.000
480	440	0.840
480	460	0.918
480	480	1.000
600	540	0.810
600	575	0.918
600	600	1.000

**Table 150. Air temperature rise across electric heaters (°F)**

kW	Stages	3 Tons <sup>(a)</sup> 1200 cfm		4 Tons 1600 cfm		5 Tons <sup>(b)</sup> 2000 cfm	
		Single Phase	Three Phase	Single Phase	Three Phase	Single Phase	Three Phase
		T*C036E1	T*C036E3,E4, EW <sup>(c)</sup>	T*C048E/F1	T*C048E/F3, E/F4, EW <sup>(c)</sup>	T*C060E/F1	T*C060E/F3, E/F4, EW <sup>(c)</sup>
5.00	1	13.8	—	10.5	—	8.5	—
6.00	1	—	18.5	—	10.5	—	11.4
10.00	2	26.8	—	20.3	—	16.3	—
12.00	2	—	36.2	—	22.3	—	21.5
13.80	2	36.9	—	27.8	—	22.3	—
17.40	2	—	48.2	—	33.0	—	30.0
17.60	2	—	—	35.5	—	28.3	—
23.0	2	—	—	—	—	—	38.8

**Notes:**

1. For minimum design airflow, see airflow performance table for each unit.
2. To calculate temp rise at different airflow, use the following formula: Temp. rise across Electric Heater = kWx3414/1.08xCFM.

- (a) The minimum allowable airflow for a 3 ton with a 17.4 kW heater is 1080 cfm.  
 (b) The minimum allowable airflow for a 5 ton unit with a 23.0 kW heater is 1900 cfm.  
 (c) 600V is not available on high efficiency units.

**Table 151. 6-10 tons air temperature rise across electric heaters (°F)**

kW	Stages	6 Tons 2000 cfm	7½ Tons 3000 cfm	8½ Tons 3400 cfm	10 Tons 4000 cfm <sup>(a)</sup>
		TSC072F3,4,W THC072F3,4	TSC090F3,4,W TSC092F3,4,W THC092* or E/F,3,4	TSC102F3,4,W THC102E3,4	TSC120F3,4,W THC120E3
9.0	1	14.2	9.5	8.4	—
18.0	1	28.5	19.0	16.7	14.2
27.0	2	42.7	28.5	25.1	21.3
36.0	2	56.9	37.9	33.5	28.5
54.0	2	—	—	—	42.7

**Notes:**

1. For minimum design airflow, see airflow performance table for each unit.
2. To calculate temp rise at different airflow, use the following formula:  
Temp. rise across Electric Heater = kWx3414/1.08xcfm.

(a) Minimum allowable airflow with a 54 kW heater for the TSC120F and THC120E is 3400 cfm.

**Table 152. Reheat temperature rise table**

Leaving Evaporator Dry Bulb									
Tons	Unit Model No.	CFM	35	40	45	50	55	60	65
3	THC	600	33.5	31.6	29.7	27.7	25.8	23.8	21.8
3	THC	720	30.8	29.1	27.4	25.6	23.9	22.1	20.3
3	THC	840	28.5	27.0	25.4	23.8	22.1	20.5	18.8
3	T/YHC	960	26.8	25.3	23.8	22.2	20.7	19.1	17.6
3	T/YHC	1080	25.3	23.8	22.4	20.9	19.4	18.0	16.5
3	T/YHC	1200	23.9	22.5	21.2	19.8	18.4	17.0	15.6
3	T/YHC	1320	22.7	21.4	20.0	18.7	17.4	16.1	14.8

continued on next page



## Fan Performance

**Table 152. Reheat temperature rise table (continued)**

Leaving Evaporator Dry Bulb									
Tons	Unit Model No.	CFM	35	40	45	50	55	60	65
3	T/YHC	1440	21.8	20.5	19.2	17.9	16.6	15.3	14.1
4	THC	800	32.9	30.9	29.0	27.0	25.0	23.0	21.1
4	THC	960	30.4	28.6	26.8	25.0	23.2	21.4	19.6
4	THC	1120	28.3	26.6	24.9	23.3	21.6	19.9	18.2
4	T/YHC	1280	26.6	25.1	23.5	21.9	20.3	18.6	17.0
4	T/YHC	1440	25.1	23.6	22.1	20.7	19.2	17.7	16.2
4	T/YHC	1600	23.7	22.3	21.0	19.6	18.2	16.8	15.3
4	T/YHC	1760	22.7	21.3	20.0	18.6	17.3	15.9	14.5
4	T/YHC	1920	21.8	20.4	19.1	17.8	16.5	15.2	13.9
5	THC	1000	33.2	31.4	29.6	27.7	25.9	24.0	22.1
5	THC	1200	30.6	28.9	27.3	25.6	23.9	22.2	20.4
5	THC	1400	28.3	26.8	25.3	23.8	22.2	20.7	19.1
5	T/YHC	1600	26.5	25.1	23.6	22.2	20.7	19.3	17.8
5	T/YHC	1800	24.9	23.6	22.2	20.9	19.5	18.1	16.7
5	T/YHC	2000	23.5	22.2	21.0	19.7	18.4	17.1	15.8
5	T/YHC	2200	22.2	21.0	19.9	18.7	17.5	16.3	15.0
5	T/YHC	2400	21.1	20.0	18.9	17.8	16.6	15.5	14.3
7½	THC	1500	30.0	30.9	31.8	32.5	33.2	33.8	34.3
7½	THC	1800	25.6	26.6	27.4	28.1	28.7	29.3	29.9
7½	THC	2100	22.2	23.1	23.9	24.6	25.2	25.8	26.3
7½	T/YHC	2400	19.5	20.4	21.2	22.0	22.6	23.2	23.8
7½	T/YHC	2700	17.3	18.2	19.0	19.8	20.4	21.0	21.5
7½	T/YHC	3000	15.5	16.4	17.3	18.0	18.7	19.3	19.8
7½	T/YHC	3300	14.0	14.9	15.7	16.4	17.1	17.6	18.2
7½	T/YHC	3600	12.7	13.6	14.4	15.1	15.7	16.3	16.8
8½	THC	1700	30.1	31.2	32.1	33.0	33.8	34.5	35.1
8½	THC	2040	25.5	26.5	27.3	28.1	28.8	29.5	30.1
8½	THC	2380	22.2	23.2	24.1	24.9	25.6	26.3	26.9
8½	T/YHC	2720	19.5	20.4	21.3	22.0	22.7	23.3	23.9
8½	T/YHC	3060	17.3	18.3	19.1	19.8	20.5	21.1	21.6
8½	T/YHC	3400	15.5	16.5	17.3	18.0	18.6	19.2	19.8
8½	T/YHC	3740	14.1	15.0	15.8	16.5	17.1	17.7	18.3
8½	T/YHC	4080	12.8	13.7	14.4	15.1	15.8	16.4	16.9
10	THC	2000	30.0	31.0	31.8	32.6	33.3	33.9	34.5
10	THC	2400	25.4	26.3	27.1	27.9	28.5	29.1	29.7
10	THC	2800	22.0	22.9	23.7	24.4	25.1	25.7	26.2
10	T/YHC	3200	19.3	20.2	21.0	21.7	22.3	22.8	23.4
10	T/YHC	3600	17.2	18.1	18.8	19.5	20.1	20.6	21.1
10	T/YHC	4000	15.4	16.3	17.0	17.7	18.3	18.8	19.3
10	T/YHC	4400	14.0	14.8	15.5	16.2	16.7	17.3	17.7
10	T/YHC	4800	12.8	13.6	14.3	14.9	15.5	16.0	16.5



# Controls

## ReliaTel™ Controlled Units

Zone Sensors are the building occupant's comfort control devices. The following zone sensor options are available for Precedent units with ReliaTel control:

### Differential Enthalpy

Differential Enthalpy replaces the standard dry bulb control with two enthalpy sensors that compare total heat content of the indoor air and outdoor air to determine the most efficient air source. This control option offers the highest level of comfort control, plus energy efficiency, available.

### Differential Pressure Switches

This factory or field-installed option allows individual fan failure and dirty filter indication. The fan failure switch will disable all unit functions and "flash" the Service LED on the zone sensor. The dirty filter switch will light the Service LED on the zone sensor and will allow continued unit operation.

#### Manual Changeover

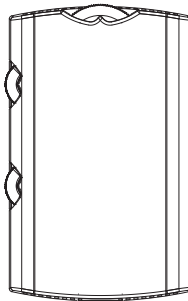

Heat, Cool or Off System Switch. Fan Auto or Off Switch. One temperature setpoint lever.

#### Manual/Automatic Changeover

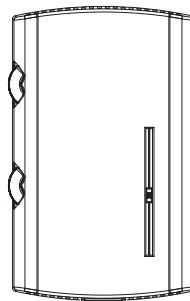

Auto, Heat, Cool or Off System Switch. Fan Auto or Off Switch. Two temperature setpoint levers.

#### Manual/Automatic Changeover

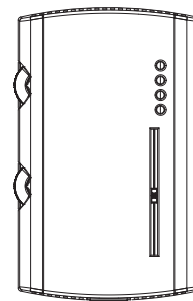

Auto, Heat, Cool or Off System Switch. Fan Auto or Off Switch. Two temperature setpoint levers. Status Indication LED lights, System On, Heat, Cool, or Service.

#### Manual/Automatic Changeover

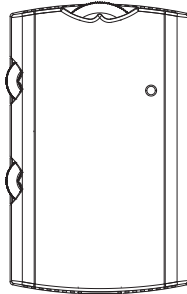

Auto, Heat, Cool or Off System Switch. Fan Auto or Off Switch. Two temperature setpoint levers.

#### Remote Sensor

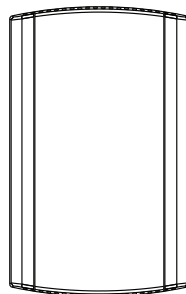

Sensor(s) available for all zone sensors to provide remote sensing capabilities.

#### Integrated Comfort™ System

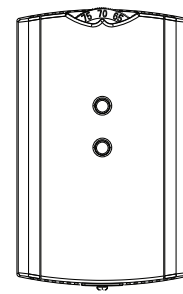

Sensor(s) available with optional temperature adjustment and override buttons to provide central control through a Trane Integrated Comfort™ system.

## Controls

---

### Digital Display Programmable Thermostat (1H/1C)

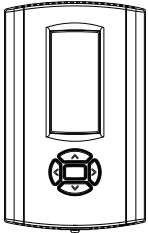

One heat/One Cool Auto changeover digital display thermostat.

### Digital Display Thermostat (3H/2C)

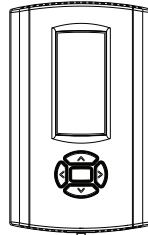

Three Heat, Two Cool Auto changeover digital display thermostat.

### Digital Display Programmable Thermostat (3H/2C)

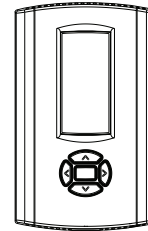

Three Heat/Two Cool Auto changeover digital display thermostat. 7-day programmable stat with night setback is available.

### Programmable Night Setback

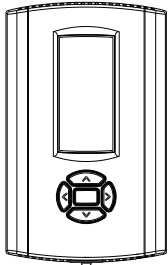

Auto or manual changeover with seven-day programming. Keyboard selection of Heat, Cool, Fan, Auto, or On. All programmable sensors have System On, Heat, Cool, Service LED/indicators as standard. Night Setback Sensors have one (1) Occupied, one (1) Un-occupied, and one (1) Override program per day.

### Wireless Zone Sensor

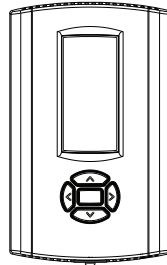

LCD display that provides heat, cool, auto or off. Includes two temperature setpoints and a lockable setting with °F or °C indicators.

### CO<sub>2</sub> Sensing

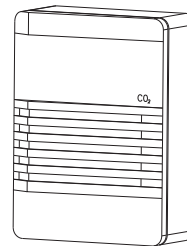

The CO<sub>2</sub> sensor shall have the ability to monitor the concentration (parts per million, ppm) of CO<sub>2</sub> (Carbon Dioxide) in the air. As the CO<sub>2</sub> concentration changes, the outside air damper modulates to meet the current ventilation needs of the zone.

### Humidity Sensor

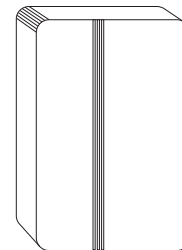

Field installed, wall-mounted or duct-mounted humidity sensor is used to control activation of the hot gas reheat dehumidification option. The humidity sensor can be set for humidity levels between 40% and 60% relative humidity by adjusting the ReliaTel Options Module.

### Touchscreen Programmable Thermostat (2H/2C)

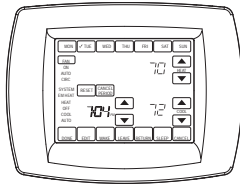

Two Heat/Two Cool programmable thermostat with touch screen digital display. Menu-driven programming. Effortless set-up. Program each day separately with no need to copy multiple days. All programming can be done on one screen. Easy to read and use. Large, clear backlit digital display.

### Digital Display Programmable Thermostat with Built-In Relative Humidity Sensing (3H/2C)

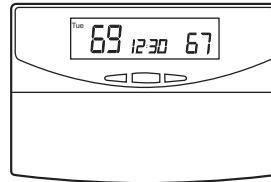

Three Heat, Two Cool digital display thermostat with built-in humidity control and display. This thermostat combines both humidity and dry bulb into one. Fully programmable with night setback.

### Economizer Controls

The standard equipment offering is a fixed dry bulb changeover control. In addition, there are two optional controls, Enthalpy and Differential Enthalpy Control.

#### Enthalpy Control

Replaces the dry bulb control with a wet bulb changeover controller which has a fully adjustable setpoint. Enthalpy control offers a higher level of comfort control, along with energy savings potential, than the standard dry bulb control. This is due to the additional wet bulb sensing capability.

#### RA Remote Sensor

Return Air Remote Sensor which can be mounted in the return air duct to report return air temperature.

#### Room Remote Sensor

Space Remote Sensor which can be mounted on the wall to report/control from a remote location in the space.

#### Remote Potentiometer

Minimum position setting of economizer can be remotely adjusted with this accessory.

### Trane Communication Interface (TCI)

This factory or field-installed micro-processor interface allows the unit to communicate to Trane's Integrated Comfort™ system.

### BACnet™ Communication Interface

This option shall be provided to allow the unit to communicate directly with a generic open protocol BACnet MS/TP Network Building Automation System Controls.



# Electrical Data

**Table 153. Unit wiring - standard efficiency**

Tons	Unit Model Number	Voltage Range	Standard Indoor Fan Motor <sup>(a)</sup>		Oversized Indoor Fan Motor	
			MCA	Max Fuse Size or Max Circuit Breaker	MCA	Max Fuse Size or Max Circuit Breaker
3	T/YSC036E1	187-253	28.8	45	—	—
3	T/YSC036E3	187-253	23.0	35	—	—
3	T/YSC036E4	414-506	11.7	15	—	—
3	T/YSC036EW	517-633	9.4	15	—	—
4	T/YSC048E1	187-253	36.8	50	—	—
4	T/YSC048E3	187-253	24.1	35	—	—
4	T/YSC048E4	414-506	11.5	15	—	—
4	T/YSC048EW	517-633	8.6	15	—	—
5	T/YSC060E1	187-253	43.8	70	—	—
5	T/YSC060E3	187-253	29.5	45	—	—
5	T/YSC060E4	414-506	15.5	25	—	—
5	T/YSC060EW	517-633	10.1	15	—	—
6	T/YSC072F3	187-253	36.5	50	37.8	60
6	T/YSC072F4	414-506	18.2	25	19.4	25
6	T/YSC072FW	517-633	12.7	20	13.5	20
7½	T/YSC090F3	187-253	38.2	60	44.0	60
7½	T/YSC090F4	414-506	19.5	30	22.4	35
7½	T/YSC090FW	517-633	14.7	20	16.7	25
7½ <sup>(b)</sup>	T/YSC092F3	187-253	39.3	50	45.1	50
7½ <sup>(b)</sup>	T/YSC092F4	414-506	18.5	20	21.4	25
7½ <sup>(b)</sup>	T/YSC092FW	517-633	15.5	20	17.8	20
8½	T/YSC102F3	187-253	43.3	50	46.4	60
8½	T/YSC102F4	414-506	21.4	25	22.4	25
8½	T/YSC102FW	517-633	16.8	20	18.0	20
10	T/YSC120F3	187-253	49.6	60	—	—
10	T/YSC120F4	414-506	22.7	30	—	—
10	T/YSC120FW	517-633	18.9	25	—	—

(a) No optional motors available for 3-5 tons. The standard motor for the 1-phase models is a Multispeed Direct Drive Motor. The standard motor for 3-phase (3-8½ ton models) is a Belt Drive Motor.

(b) Dual refrigeration system.

**Table 154. Unit wiring with electric heat (single point connection) - standard efficiency**

Tons	Unit Model Number	Heater Model Number	Heater kW Rating <sup>(a)</sup>	Control Stages	Standard Indoor Motor	Oversized Indoor Motor		
					MCA	Max Fuse Size or Max Circuit Breaker	MCA	Max Fuse Size or Max Circuit Breaker
<b>208/230 Volts Single Phase</b>								
3	TSC036E1	BAYHTRE105*	3.8/5.0	1	30.1/33.5	45.0/45.0	—	—
3	TSC036E1	BAYHTRE110*	7.5/10.0	2	52.6/59.6	60.0/60.0	—	—
3	TSC036E1	BAYHTRE114*	10.4/13.8	2	69.8/79.4	70.0/80.0	—	—
4	TSC048E1	BAYHTRE105*	3.8/5.0	1	36.8/36.8	50.0/50.0	—	—
4	TSC048E1	BAYHTRE110*	7.5/10.0	2	54.6/61.6	60.0/70.0	—	—
4	TSC048E1	BAYHTRE114*	10.4/13.8	2	71.8/81.4	80.0/90.0	—	—
4	TSC048E1	BAYHTRE118*	13.2/17.6	2	89.0/101.1	90.0/110.0	—	—
5	TSC060E1	BAYHTRE105*	3.8/5.0	1	43.8/43.8	70.0/70.0	—	—
5	TSC060E1	BAYHTRE110*	7.5/10.0	2	54.6/61.6	70.0/70.0	—	—
5	TSC060E1	BAYHTRE114*	10.4/13.8	2	71.8/81.4	80.0/90.0	—	—
5	TSC060E1	BAYHTRE118*	13.2/17.6	2	89.0/101.1	90.0/110.0	—	—
<b>208/230 Volts Three Phase</b>								
3	TSC036E3	BAYHTRE306*	4.5/6.0	1	23.0/24.3	35.0/35.0	—	—
3	TSC036E3	BAYHTRE312*	9.0/12.0	2	37.5/42.4	40.0/45.0	—	—
3	TSC036E3	BAYHTRE318*	13.1/17.4	2	51.6/58.6	60.0/60.0	—	—
4	TSC048E3	BAYHTRE306*	4.5/6.0	1	24.1/24.3	35.0/35.0	—	—
4	TSC048E3	BAYHTRE312*	9.0/12.0	2	37.5/42.4	40.0/45.0	—	—
4	TSC048E3	BAYHTRE318*	13.1/17.4	2	51.6/58.6	60.0/60.0	—	—
5	TSC060E3	BAYHTRE306*	4.5/6.0	1	29.5/29.5	45.0/45.0	—	—
5	TSC060E3	BAYHTRE312*	9.0/12.0	2	37.5/42.4	45.0/45.0	—	—
5	TSC060E3	BAYHTRE318*	13.1/17.4	2	51.6/58.6	60.0/60.0	—	—
5	TSC060E3	BAYHTRE323*	17.3/23.0	2	66.3/75.4	70.0/80.0	—	—
6	TSC072F3	BAYHTRS309*	6.8/9.0	1	36.5/36.5	50/50	37.8/37.8	60/60
6	TSC072F3	BAYHTRS318*	13.5/18.0	1	53.1/60.4	60/70	54.8/62.0	60/70
6	TSC072F3	BAYHTRS327*	20.3/27.0	2	76.6/87.5	80/90	78.3/89.1	80/90
6	TSC072F3	BAYHTRS336*	27.0/36.0	2	100.1/114.5	110/125	101.8/116.1	110/125
7½	TSC090F3	BAYHTRW309*	6.8/9.0	1	38.2/38.2	60/60	44.0/44.0	60/60
7½	TSC090F3	BAYHTRW318*	13.5/18.0	1	51.4/58.6	60/60	58.6/65.9	60/70
7½	TSC090F3	BAYHTRW327*	20.3/27.0	2	74.9/85.8	80/90	82.1/93.0	90/100
7½	TSC090F3	BAYHTRW336*	27.0/36.0	2	98.4/112.8	100/125	105.6/120.0	110/125
7½(b)	TSC092F3	BAYHTRT309*	6.8/9.0	1	39.3/39.3	50/50	45.1/45.1	50/50
7½(b)	TSC092F3	BAYHTRT318*	13.5/18.0	1	51.4/58.6	60/60	58.6/65.9	60/70
7½(b)	TSC092F3	BAYHTRT327*	20.3/27.0	2	74.9/85.8	80/90	82.1/93.0	90/100
7½(b)	TSC092F3	BAYHTRT336*	27.0/36.0	2	98.4/112.8	100/125	105.6/120.0	110/125
8½	TSC102F3	BAYHTRT309*	6.8/9.0	1	43.3/43.3	50/50	46.4/46.4	60/60
8½	TSC102F3	BAYHTRT318*	13.5/18.0	1	54.8/62.0	60/70	58.6/65.9	60/70
8½	TSC102F3	BAYHTRT327*	20.3/27.0	2	78.3/89.1	80/90	82.1/93.0	90/100
8½	TSC102F3	BAYHTRT336*	27.0/36.0	2	101.8/116.1	110/125	105.6/120.0	110/125
10	TSC120F3	BAYHTRA318*	13.5/18.0	1	57.5/64.8	60/70	—/—	—/—

continued on next page



## Electrical Data

**Table 154. Unit wiring with electric heat (single point connection) - standard efficiency (continued)**

Tons	Unit Model Number	Heater Model Number	Heater kW Rating <sup>(a)</sup>	Control Stages	Standard Indoor Motor		Oversized Indoor Motor	
					MCA	Max Fuse Size or Max Circuit Breaker	MCA	Max Fuse Size or Max Circuit Breaker
<b>208/230 Volts Three Phase</b>								
10	TSC120F3	BAYHTRA327*	20.3/27.0	2	81.0/91.9	90/100	—/—	—/—
10	TSC120F3	BAYHTRA336*	27.0/36.0	2	104.5/118.9	110/125	—/—	—/—
10	TSC120F3	BAYHTRA354*	40.6/54.0	2	151.4/140.5	175/150	—/—	—/—
<b>460 Volts Three Phase</b>								
3	TSC036E4	BAYHTRE406*	6.0	1	12.1	15	—	—
3	TSC036E4	BAYHTRE412*	12.0	2	21.1	25	—	—
3	TSC036E4	BAYHTRE418*	17.4	2	29.3	30	—	—
4	TSC048E4	BAYHTRE406*	6.0	1	12.1	15	—	—
4	TSC048E4	BAYHTRE412*	12.0	2	21.1	25	—	—
4	TSC048E4	BAYHTRE418*	17.4	2	29.3	30	—	—
5	TSC060E4	BAYHTRE406*	6.0	1	15.5	25	—	—
5	TSC060E4	BAYHTRE412*	12.0	2	21.1	25	—	—
5	TSC060E4	BAYHTRE418*	17.4	2	29.3	30	—	—
5	TSC060E4	BAYHTRE423*	23.0	2	37.8	40	—	—
6	TSC072F4	BAYHTRS409*	9.0	1	18.2	25	19.3	25
6	TSC072F4	BAYHTRS418*	18.0	1	30.3	35	31.6	35
6	TSC072F4	BAYHTRS427*	27.0	2	43.8	45	45.1	50
6	TSC072F4	BAYHTRS436*	36.0	2	57.3	60	58.6	60
7½	TSC090F4	BAYHTRW409*	9.0	1	19.5	30	22.4	35
7½	TSC090F4	BAYHTRW418*	18.0	1	29.3	30	32.9	35
7½	TSC090F4	BAYHTRW427*	27.0	2	42.8	45	46.4	50
7½	TSC090F4	BAYHTRW436*	36.0	2	56.3	60	59.9	60
7½ <sup>(b)</sup>	TSC092F4	BAYHTRT409*	9.0	1	18.5	20	21.4	25
7½ <sup>(b)</sup>	TSC092F4	BAYHTRT418*	18.0	1	29.3	30	32.9	35
7½ <sup>(b)</sup>	TSC092F4	BAYHTRT427*	27.0	2	42.8	45	46.4	50
7½ <sup>(b)</sup>	TSC092F4	BAYHTRT436*	36.0	2	56.3	60	59.9	60
8½	TSC102F4	BAYHTRT409*	9.0	1	21.4	25	22.4	25
8½	TSC102F4	BAYHTRT418*	18.0	1	31.6	35	32.9	35
8½	TSC102F4	BAYHTRT427*	27.0	2	45.1	50	46.4	50
8½	TSC102F4	BAYHTRT436*	36.0	2	58.6	60	59.9	60
10	TSC120F4	BAYHTRA418*	18.0	1	32.5	35	—	—
10	TSC120F4	BAYHTRA427*	27.0	2	46.0	50	—	—
10	TSC120F4	BAYHTRA436*	36.0	2	59.5	60	—	—
10	TSC120F4	BAYHTRA454*	54.0	2	70.4	80	—	—
<b>575 Volts Three Phase</b>								
3	TSC036EW	BAYHTREW06*	6.0	1	9.4	15	—	—
3	TSC036EW	BAYHTREW12*	12.0	2	16.5	20	—	—
3	TSC036EW	BAYHTREW18*	17.4	2	23.0	25	—	—
4	TSC048EW	BAYHTREW06*	6.0	1	9.4	15	—	—
4	TSC048EW	BAYHTREW12*	12.0	2	16.5	20	—	—

continued on next page

## Electrical Data

**Table 154. Unit wiring with electric heat (single point connection) - standard efficiency (continued)**

Tons	Unit Model Number	Heater Model Number	Heater kW Rating <sup>(a)</sup>	Control Stages	Standard Indoor Motor		Oversized Indoor Motor	
					MCA	Max Fuse Size or Max Circuit Breaker	MCA	Max Fuse Size or Max Circuit Breaker
<b>575 Volts Three Phase</b>								
4	TSC048EW	BAYHTREW18*	17.4	2	23.0	25	—	—
5	TSC060EW	BAYHTREW06*	6.0	1	10.1	15	—	—
5	TSC060EW	BAYHTREW12*	12.0	2	16.5	20	—	—
5	TSC060EW	BAYHTREW18*	17.4	2	23.0	25	—	—
5	TSC060EW	BAYHTREW23*	23.0	2	29.8	30	—	—
6	TSC072FW	BAYHTRSW09*	9.0	1	13.0	20	14.0	20
6	TSC072FW	BAYHTRSW18*	18.0	1	23.8	25	24.8	25
6	TSC072FW	BAYHTRSW27*	27.0	2	34.6	35	35.6	40
6	TSC072FW	BAYHTRSW36*	36.0	2	45.4	50	46.4	50
7½	TSC090FW	BAYHTRWW18*	18.0	1	23.4	25	25.9	30
7½	TSC090FW	BAYHTRWW27*	27.0	2	34.3	35	36.8	40
7½	TSC090FW	BAYHTRWW36*	36.0	2	45.0	45	47.5	50
7½ <sup>(b)</sup>	TSC092FW	BAYHTRTW18*	18.0	1	23.4	25	26.3	30
7½ <sup>(b)</sup>	TSC092FW	BAYHTRTW27*	27.0	2	34.3	35	37.1	40
7½ <sup>(b)</sup>	TSC092FW	BAYHTRTW36*	36.0	2	45.0	45	47.9	50
8½	TSC102FW	BAYHTRTW18*	18.0	1	24.8	25	26.3	30
8½	TSC102FW	BAYHTRTW27*	27.0	2	35.6	40	37.1	40
8½	TSC102FW	BAYHTRTW36*	36.0	2	46.4	50	47.9	50
10	TSC120FW	BAYHTRAW18*	18.0	1	27.0	30	—	—
10	TSC120FW	BAYHTRAW36*	36.0	2	48.6	50	—	—
10	TSC120FW	BAYHTRAW54*	54.0	2	57.4	60	—	—

(a) No optional motors available for 3-5 tons. The standard motor for 1-phase models is a Multispeed, Direct Drive Motor. The Standard Motor for the 3-phase (3-8½ ton models) is a Belt Drive Motor.

(b) Dual refrigeration system.

**Table 155. Electrical characteristics - compressor motor and condenser motor - 60 cycle - standard efficiency**

Tons	Unit Model Number	No.	Compressor Motors						Condenser Fan Motors					
			Volts	Phase	hp <sup>(b)</sup>	rpm	Amps <sup>(a)</sup>		No.	Volts	Phase	hp	Amps <sup>(a)</sup>	
							RLA	LRA					FLA	LRA
3	T/YSC036E1	1	208-230	1	2.7	3500	16.7	79.0	1	208-230	1	0.33	2.0	6.6
3	T/YSC036E3	1	208-230	3	2.8	3500	12.8	95.0	1	208-230	1	0.33	2.0	6.6
3	T/YSC036E4	1	460	3	2.8	3500	6.4	45.0	1	460	1	0.33	1.2	2.5
3	T/YSC036EW	1	575	3	2.8	3500	5.4	38.0	1	575	1	0.33	0.9	1.3
4	T/YSC048E1	1	208-230	1	3.6	3500	21.8	117.0	1	208-230	1	0.33	2.0	6.6
4	T/YSC048E3	1	208-230	3	3.6	3500	13.7	83.1	1	208-230	1	0.33	2.0	6.6
4	T/YSC048E4	1	460	3	3.6	3500	6.2	41.0	1	460	1	0.33	1.2	2.5
4	T/YSC048EW	1	575	3	3.5	3500	4.8	33.0	1	575	1	0.33	0.9	1.3
5	T/YSC060E1	1	208-230	1	4.4	3500	25.0	134.0	1	208-230	1	0.40	2.5	6.6
5	T/YSC060E3	1	208-230	3	4.3	3500	15.9	110.0	1	208-230	1	0.40	2.5	6.6
5	T/YSC060E4	1	460	3	4.3	3500	7.1	52.0	1	460	1	0.40	1.0	2.8

continued on next page



## Electrical Data

**Table 155. Electrical characteristics - compressor motor and condenser motor - 60 cycle - standard efficiency (continued)**

Tons	Unit Model		Compressor Motors							Condenser Fan Motors					
			No.	Volts	Phase	hp <sup>(b)</sup>	rpm	Amps <sup>(a)</sup>		No.	Volts	Phase	hp	Amps <sup>(a)</sup>	
								RLA	LRA					FLA	LRA
5	T/YSC060EW	1	575	3	4.3	3500	5.1	39.5	1	575	1	0.40	0.8	2.0	
6	T/YSC072F3	1	208-230	3	5.6	3500	22.4	149.0	1	208-230	1	.70	3.5	10.9	
6	T/YSC072F4	1	460	3	5.6	3500	10.6	75.0	1	460	1	.70	2.4	6.6	
6	T/YSC072FW	1	575	3	5.6	3500	7.7	54.0	1	575	1	.70	1.4	3.6	
7½	T/YSC090F3	2	208-230	3	6.7	3500	25.0	164.0	1	208-230	1	.70	3.3	9.5	
7½	T/YSC090F4	2	460	3	6.7	3500	12.8	100.0	1	460	1	.70	1.8	5.5	
7½	T/YSC090FW	2	575	3	6.7	3500	9.6	78.0	1	575	1	.70	1.3	3.2	
7½	T/YSC092F3	2	208-230	3	3.7/3.1	3500/3500	14.5/13.6	98.0/83.0	1	208-230	1	.75	4.0	9.4	
7½	T/YSC092F4	2	460	3	3.7/3.1	3500/3500	6.3/6.1	55.0/41.0	1	460	1	.75	2.8	6.8	
7½	T/YSC092FW	2	575	3	3.7/3.1	3500/3500	6.0/4.2	41.0/33.0	1	575	1	.75	2.4	6.2	
8½	T/YSC102F3	2	208-230	3	3.7/3.7	3500/3500	15.9/13.1	110.0/83.0	1	208-230	1	.75	4.0	9.4	
8½	T/YSC102F4	2	460	3	3.7/3.7	3500/3500	7.1/6.1	52.0/41.0	1	460	1	.75	2.8	6.8	
8½	T/YSC102FW	2	575	3	3.7/3.7	3500/3500	6.0/4.4	41.0/33.0	1	575	1	.75	2.4	6.2	
10	T/YSC120F3	2	208-230	3	4.8/3.7	3500/3500	20.5/16.0	155.0/91.0	1	208-230	1	.75	4.0	9.4	
10	T/YSC120F4	2	460	3	4.8/3.7	3500/3500	9.6/7.1	75.0/46.0	1	460	1	.75	2.8	6.8	
10	T/YSC120FW	2	575	3	4.8/3.7	3500/3500	7.6/5.6	54.0/37.0	1	575	1	.75	2.4	6.2	

(a) Amp draw for each motor; multiply value by number of motors to determine total amps.

(b) hp for each compressor.

**Table 156. Electrical characteristics - standard evaporator fan motor - 60 cycle - direct or belt drive standard efficiency**

Tons	Unit Model		Direct or Belt				Amps		
			Drive	No.	Volts	Phase	hp	FLA	LRA
3	T/YSC036E1	Direct Drive	1	208-230	1	0.75	6.0	—	
3	T/YSC036E3	Belt Drive	1	208-230	3	1.00	5.0	32.2	
3	T/YSC036E4	Belt Drive	1	460	3	1.00	2.5	16.1	
3	T/YSC036EW	Belt Drive	1	575	3	1.00	1.7	13.2	
4	T/YSC048E1	Direct Drive	1	208-230	1	1.00	7.6	—	
4	T/YSC048E3	Belt Drive	1	208-230	3	1.00	5.0	32.2	
4	T/YSC048E4	Belt Drive	1	460	3	1.00	2.5	16.1	
4	T/YSC048EW	Belt Drive	1	575	3	1.00	1.7	13.2	
5	T/YSC060E1	Direct Drive	1	208-230	1	1.00	7.6	—	
5	T/YSC060E3	Belt Drive	1	208-230	3	1.00	5.0	32.2	
5	T/YSC060E4	Belt Drive	1	460	3	1.00	2.5	16.1	
5	T/YSC060EW	Belt Drive	1	575	3	1.00	1.7	13.2	
6	T/YSC072F3	Belt Drive	1	208-230	3	1.00	5.0	32.2	
6	T/YSC072F4	Belt Drive	1	460	3	1.00	2.5	16.1	
6	T/YSC072FW	Belt Drive	1	575	3	1.00	1.7	13.2	
7½	T/YSC090F3	Belt Drive	1	208-230	3	1.00	3.6-3.5	12.5	
7½	T/YSC090F4	Belt Drive	1	460	3	1.00	1.7	12.5	
7½	T/YSC090FW	Belt Drive	1	575	3	1.00	1.4	10.0	
7½	T/YSC092F3	Belt Drive	1	208-230	3	1.00	3.6-3.5	12.5	

continued on next page



## Electrical Data

**Table 156. Electrical characteristics - standard evaporator fan motor - 60 cycle - direct or belt drive standard efficiency (continued)**

Tons	Unit Model		No.	Volts	Phase	hp	Amps	
	Number	Direct or Belt Drive					FLA	LRA
7½	T/YSC092F4	Belt Drive	1	460	3	1.00	1.7	12.5
7½	T/YSC092FW	Belt Drive	1	575	3	1.00	1.4	10.0
8½	T/YSC102F3	Belt Drive	1	208-230	3	2.00	6.3	48.0
8½	T/YSC102F4	Belt Drive	1	460	3	2.00	3.6	24.0
8½	T/YSC102FW	Belt Drive	1	575	3	2.00	2.5	18.2
10	T/YSC120F3	Direct Drive	1	208-230	3	3.80	8.5-8.5	—
10	T/YSC120F4	Direct Drive	1	460	3	3.60	4.3	—
10	T/YSC120FW <sup>(a)</sup>	Direct Drive	1	575	3	3.60	4.3	—

(a) T/YSC120FW utilizes a 460V evaporator motor.

**Table 157. Electrical characteristics - oversized evaporator fan motor - 60 cycle - belt drive - standard efficiency**

Tons	Unit Model		No.	Volts	Phase	hp	Amps	
	Number						FLA	LRA
6	T/YSC072F3		1	208-230	3	2.00	6.30	48.0
6	T/YSC072F4		1	460	3	2.00	3.6	24.0
6	T/YSC072FW		1	575	3	2.00	2.50	18.2
7½	T/YSC090F3		1	208-230	3	3.00	9.40-9.20	52.4
7½	T/YSC090F4		1	460	3	3.00	4.60	26.3
7½	T/YSC090FW		1	575	3	3.00	3.40	29.4
7½	T/YSC092F3		1	208-230	3	3.00	9.40	83.0
7½	T/YSC092F4		1	460	3	3.00	4.60	42.0
7½	T/YSC092FW		1	575	3	3.00	3.70	31.0
8½	T/YSC102F3		1	208-230	3	3.00	9.40	83.0
8½	T/YSC102F4		1	460	3	3.00	4.60	42.0
8½	T/YSC102FW		1	575	3	3.00	3.70	31.0

**Table 158. Electrical characteristics — power exhaust (cooling and gas/electric)**

Tons	Volts	Phase	hp	rpm	FLA	LRA
3-5	208-230	1	0.33	1075	2.2	3.9
3-5	460	1	0.33	1075	1.1	2.0
3-5	575	1	0.33	1075	1.0	1.8
6-10	208-230	1	0.87	1075 <sup>(a)</sup>	5.7	13.6
6-10	460	1	0.87	1075 <sup>(a)</sup>	3.3	6.8
6-10	575	1	0.87	1075 <sup>(a)</sup>	2.3	5.4

(a) Two speed.



## Electrical Data

**Table 159. Electrical characteristics - inducer motor**

Unit Model Number	Stages	hp	rpm	Volts	Phase	LRA
YSC(036-060)E**(L,M,X,Y)	1	1/35	3000	208-230	1	0.6
YSC(036-060)E**(H,Z)	1	1/15	3300	208-230	1	0.4
YSC072F**(L,M,X,Y) YSC(090-102)F**(L,X)	1	1/35	3000	208-230	1	0.6
YSC072F**(H,Z) YSC(090-102)F**(M,H,Y,Z) YSC120F	2	1/15	2800/3350	208-230	1	0.4

**Table 160. Unit wiring - high efficiency**

Tons	Unit Model Number	Voltage Range	Standard Indoor Fan Motor		Optional Belt Drive Indoor Fan Motor <sup>(a)</sup>	
			MCA	Max Fuse Size or Max Circuit Breaker	MCA	Max Fuse Size or Max Circuit Breaker
3	T/YHC036E1	187-253	28.3	45	<sup>(a)</sup>	<sup>(a)</sup>
3	T/YHC036E3	187-253	20.6	30	19.6	30
3	T/YHC036E4	414-506	11.0	15	10.3	15
4	T/YHC048F1	187-253	37.3	50	<sup>(a)</sup>	<sup>(a)</sup>
4	T/YHC048E3	187-253	28.3	40	25.7	40
4	T/YHC048E4	414-506	13.8	20	12.3	15
4	T/YHC048F3	187-253	27.2	40	24.6	40
4	T/YHC048F4	414-506	12.8	15	11.3	15
5	T/YHC060F1	187-253	41.4	60	<sup>(a)</sup>	<sup>(a)</sup>
5	T/YHC060E3	187-253	30.0	45	27.4	40
5	T/YHC060E4	414-506	13.8	20	12.3	20
5	T/YHC060F3	187-253	30.0	45	27.4	45
5	T/YHC060F4	414-506	13.8	20	12.3	20
Tons	Unit Model Number	Voltage Range	Standard Indoor Fan Motor		Optional Belt Drive Indoor Fan Motor <sup>(b)</sup>	
			MCA	Max Fuse Size or Max Circuit Breaker	MCA	Max Fuse Size or Max Circuit Breaker
6	T/YHC072F3	187-253	32.3	50	33.6	50
6	T/YHC072F4	414-506	15.1	20	15.7	20
7½	T/YHC092E3	187-253	42.7	50	—	—
7½	T/YHC092E4	414-506	19.8	25	—	—
7½	T/YHC092F3	187-253	41.9	50	—	—
7½	T/YHC092F4	414-506	19.9	25	—	—
8½	T/YHC102E3	187-253	44.7	60	—	—
8½	T/YHC102E4	414-506	22.9	30	—	—
10	T/YHC120E3	187-253	50.3	60	—	—
10	T/YHC120E4	414-506	24.9	30	—	—

(a) No optional motors available for 3-5 tons. The standard motor for the 1-phase models is a Multispeed Direct Drive Motor.

(b) No optional motors available for 3-5 tons. The standard motor for the 1-phase models is a Multispeed Direct Drive Motor.

## Electrical Data

**Table 161. Unit wiring with electric heat (single point connection) - high efficiency - 3-5 tons**

Tons	Unit Model Number	Heater Model Number	Heater kW Rating <sup>(a)</sup>	Control Stages	Standard Indoor Motor		Optional Belt Drive Indoor Motor	
					MCA	Max Fuse Size or Max Circuit Breaker	MCA	Max Fuse Size or Max Circuit Breaker
<b>208/230 Volts Single Phase</b>								
3	THC036E1	BAYHTRE105*	3.8/5.0	1	30.1/33.5	45/45	—	—
3	THC036E1	BAYHTRE110*	7.5/10.0	2	52.6/59.6	60/60	—	—
3	THC036E1	BAYHTRE114*	10.4/13.8	2	69.8/79.4	70/80	—	—
4	THC048F1	BAYHTRX105*	3.8/5.0	1	37.3/37.3	50/50	—	—
4	THC048F1	BAYHTRX110*	7.5/10.0	2	54.6/61.6	60/70	—	—
4	THC048F1	BAYHTRX114*	10.4/13.8	2	71.8/81.4	80/90	—	—
4	THC048F1	BAYHTRX118*	13.2/17.6	2	89.0/101.1	90/110	—	—
5	THC060F1	BAYHTRX105*	3.8/5.0	1	41.1/41.4	60/60	—	—
5	THC060F1	BAYHTRX110*	7.5/10.0	2	54.6/61.6	60/70	—	—
5	THC060F1	BAYHTRX114*	10.4/13.8	2	71.8/81.4	80/90	—	—
5	THC060F1	BAYHTRX118*	13.2/17.6	2	89.0/101.1	90/110	—	—
<b>208/230 Volts Three Phase</b>								
3	THC036E3	BAYHTRE306*	4.5/6.0	1	23.1/25.5	30/30	21.9/24.3	30/30
3	THC036E3	BAYHTRE312*	9.0/12.0	2	38.8/43.6	40/45	37.5/42.4	40/45
3	THC036E3	BAYHTRE318*	13.1/17.4	2	52.9/59.9	60/60	51.6/58.6	60/60
4	THC048E3	BAYHTRX306*	4.5/6.0	1	28.3/28.3	40/40	25.7/25.7	40/40
4	THC048E3	BAYHTRX312*	9.0/12.0	2	40.8/45.6	45/50	37.5/42.4	40/45
4	THC048E3	BAYHTRX318*	13.1/17.4	2	54.9/61.9	60/70	51.6/58.6	60/60
4	THC048F3	BAYHTRX306*	4.5/6.0	1	27.2/27.5	40/40	24.6/24.6	35/35
4	THC048F3	BAYHTRX312*	9.0/12.0	2	40.8/45.6	45/50	37.5/42.4	40/45
4	THC048F3	BAYHTRX318*	13.1/17.4	2	54.9/61.9	60/70	51.6/58.6	60/60
5	THC060E3	BAYHTRX306*	4.5/6.0	1	30.0/30.0	45/45	27.4/27.4	40/40
5	THC060E3	BAYHTRX312*	9.0/12.0	2	40.8/45.6	45/50	37.5/42.4	40/45
5	THC060E3	BAYHTRX318*	13.1/17.4	2	54.9/61.9	60/70	51.6/58.6	60/60
5	THC060E3	BAYHTRX323*	17.3/23.0	2	69.5/78.6	70/80	66.3/75.4	70/80
5	THC060F3	BAYHTRX306*	4.5/6.0	1	30.0/30.0	45/45	27.4/27.4	40/40
5	THC060F3	BAYHTRX312*	9.0/12.0	2	40.8/45.6	45/50	37.5/42.4	40/45
5	THC060F3	BAYHTRX318*	13.1/17.4	2	54.9/61.9	60/70	51.6/58.6	60/60
5	THC060F3	BAYHTRX323*	17.3/23.0	2	69.5/78.6	70/80	66.3/75.4	70/80
<b>460 Volts Three Phase</b>								
3	THC036E4	BAYHTRE406*	6.0	1	13.0	15	12.1	15
3	THC036E4	BAYHTRE412*	12.0	2	22.0	25	21.1	25
3	THC036E4	BAYHTRE418*	17.4	2	30.1	35	29.3	30
4	THC048E4	BAYHTRX406*	6.0	1	14.0	20	12.3	15
4	THC048E4	BAYHTRX412*	12.0	2	23.0	25	21.1	25
4	THC048E4	BAYHTRX418*	17.4	2	31.1	35	29.3	30
4	THC048F4	BAYHTRX406*	6.0	1	14.0	15	12.3	15
4	THC048F4	BAYHTRX412*	12.0	2	23.0	25	21.1	25
4	THC048F4	BAYHTRX418*	17.4	2	31.1	35	29.3	30

continued on next page



## Electrical Data

**Table 161. Unit wiring with electric heat (single point connection) - high efficiency - 3-5 tons (continued)**

Tons	Unit Model Number	Heater Model Number	Heater kW Rating <sup>(a)</sup>	Control Stages	Standard Indoor Motor		Optional Belt Drive Indoor Motor	
					MCA	Max Fuse Size or Max Circuit Breaker	MCA	Max Fuse Size or Max Circuit Breaker
5	THC060E4	BAYHTRX406*	6.0	1	14.0	20	12.3	15
5	THC060E4	BAYHTRX412*	12.0	2	23.0	25	21.1	25
5	THC060E4	BAYHTRX418*	17.4	2	31.1	35	29.3	30
5	THC060E4	BAYHTRX423*	23.0	2	39.6	40	37.8	40
5	THC060F4	BAYHTRX406*	6.0	1	14.0	20	12.3	15
5	THC060F4	BAYHTRX412*	12.0	2	23.0	25	21.1	25
5	THC060F4	BAYHTRX418*	17.4	2	31.1	35	29.3	30
5	THC060F4	BAYHTRX423*	23.0	2	39.6	40	37.8	40

(a) Heater kW ratings are at 208/240V for 208/230V units, 480V for 460V units.

**Table 162. Unit wiring with electric heat (single point connection) - high efficiency - 6-10 tons**

Tons	Unit Model Number	Heater Model Number	Heater kW Rating <sup>(a)</sup>	Control Stages	Standard Indoor Motor		Oversize Indoor Motor	
					MCA	Max Fuse Size or Max Circuit Breaker	MCA	Max Fuse Size or Max Circuit Breaker
<b>208/230 Volts Three Phase</b>								
6	THC072F3	BAYHTRU309*	6.8/9.0	1	32.3/33.4	50/50	33.6/35.0	50/50
6	THC072F3	BAYHTRU318*	13.5/18.0	1	53.1/60.4	60/70	54.8/62.0	60/70
6	THC072F3	BAYHTRU327*	20.3/27.0	2	76.6/87.5	80/90	78.3/89.1	80/90
6	THC072F3	BAYHTRU336*	27.0/36.0	2	100.1/114.5	110/125	101.8/116.1	125/110
7½	THC092E3	BAYHTRD309*	6.8/9.0	1	42.7/42.7	50/50	—/—	—/—
7½	THC092E3	BAYHTRD318*	13.5/18.0	1	57.5/64.8	60/70	—/—	—/—
7½	THC092E3	BAYHTRD327*	20.3/27.0	2	81.0/91.9	90/100	—/—	—/—
7½	THC092E3	BAYHTRD336*	27.0/36.0	2	104.5/118.9	110/125	—/—	—/—
7½	THC092F3	BAYHTRA309*	6.8/9.0	1	41.9/41.9	50/50	—/—	—/—
7½	THC092F3	BAYHTRA318*	13.5/18.0	1	57.5/64.8	60/70	—/—	—/—
7½	THC092F3	BAYHTRA327*	20.3/27.0	2	81.0/91.9	90/100	—/—	—/—
7½	THC092F3	BAYHTRA336*	27.0/36.0	2	104.5/118.9	110/125	—/—	—/—
8½	THC102E3	BAYHTRD309*	6.8/9.0	1	44.7/44.7	60/60	—/—	—/—
8½	THC102E3	BAYHTRD318*	13.5/18.0	1	57.5/64.8	60/70	—/—	—/—
8½	THC102E3	BAYHTRD327*	20.3/27.0	2	81.0/91.9	90/100	—/—	—/—
8½	THC102E3	BAYHTRD336*	27.0/36.0	2	104.5/118.9	110/125	—/—	—/—
10	THC120E3	BAYHTRD318*	13.5/18.0	1	57.5/64.8	60/70	—/—	—/—
10	THC120E3	BAYHTRD327*	20.3/27.0	2	81.0/91.9	90/100	—/—	—/—
10	THC120E3	BAYHTRD336*	27.0/36.0	2	104.5/118.9	110/125	—/—	—/—
10	THC120E3	BAYHTRD354*	40.6/54.0	2	151.4/140.5	175/150	—/—	—/—
<b>460 Volts Three Phase</b>								
6	THC072F4	BAYHTRU409*	9.0	1	16.6	20	17.4	20
6	THC072F4	BAYHTRU418*	18.0	1	30.3	35	31.0	35

continued on next page

## Electrical Data

**Table 162. Unit wiring with electric heat (single point connection) - high efficiency - 6-10 tons (continued)**

Tons	Unit Model Number	Heater Model Number	Heater kW Rating <sup>(a)</sup>	Control Stages	Standard Indoor Motor		Oversize Indoor Motor	
					MCA	Max Fuse Size or Max Circuit Breaker	MCA	Max Fuse Size or Max Circuit Breaker
6	THC072F4	BAYHTRU427*	27.0	2	43.8	45	44.5	45
6	THC072F4	BAYHTRU436*	36.0	2	57.3	60	58.0	60
7½	THC092E4	BAYHTRD409*	9.0	1	19.8	25	—	—
7½	THC092E4	BAYHTRD418*	18.0	1	32.5	35	—	—
7½	THC092E4	BAYHTRD427*	27.0	2	46.0	50	—	—
7½	THC092E4	BAYHTRD436*	36.0	2	59.5	60	—	—
7½	THC092F4	BAYHTRA409*	9.0	1	19.9	25	—	—
7½	THC092F4	BAYHTRA418*	18.0	1	32.5	35	—	—
7½	THC092F4	BAYHTRA427*	27.0	2	46.0	50	—	—
7½	THC092F4	BAYHTRA436*	36.0	2	59.5	60	—	—
8½	THC102E4	BAYHTRD409*	9.0	1	22.9	30	—	—
8½	THC102E4	BAYHTRD418*	18.0	1	32.5	35	—	—
8½	THC102E4	BAYHTRD427*	27.0	2	46.0	50	—	—
8½	THC102E4	BAYHTRD436*	36.0	2	59.5	60	—	—
10	THC120E4	BAYHTRD418*	18.0	1	32.5	35	—	—
10	THC120E4	BAYHTRD427*	27.0	2	46.0	50	—	—
10	THC120E4	BAYHTRD436*	36.0	2	59.5	60	—	—
10	THC120E4	BAYHTRD454*	54.0	2	70.4	80	—	—

(a) Heater kW ratings are at 208/240V for 208/230V units, 480V for 460V units.

**Table 163. Electrical characteristics - compressor motor and condenser fan motor - 60 cycle - high efficiency**

Tons	Unit Model Number	No.	Compressor Motors						Condenser Fan Motors					
			Volts	Phase	hp	rpm	RLA	LRA	No.	Volts	Phase	hp	FLA	LRA
3	T/YHC036E1	1	208-230	1	2.7	3500	16.7	79.0	1	208-230	1	0.20	1.5	2.4
3	T/YHC036E3	1	208-230	3	2.7	3500	10.4	73.0	1	208-230	1	0.20	1.5	2.4
3	T/YHC036E4	1	460	3	2.7	3500	5.8	38.0	1	460	1	0.20	0.6	1.3
4	T/YHC048F1	1	208-230	1	3.6	3500	21.8	117.0	1	208-230	1	0.40	2.5	6.6
4	T/YHC048E3	1	208-230	3	3.6	3500	14.6	91.0	1	208-230	1	0.40	2.5	6.6
4	T/YHC048E4	1	460	3	3.6	3500	7.1	46.0	1	460	1	0.40	1.0	2.8
4	T/YHC048F3	1	208-230	3	3.5	3500	13.7	83.1	1	208-230	1	0.40	2.5	6.6
4	T/YHC048F4	1	460	3	3.5	3500	6.2	41.0	1	460	1	0.40	1.0	2.8
5	T/YHC060F1	1	208-230	1	4.4	3500	25.0	134.0	1	208-230	1	0.40	2.5	6.6
5	T/YHC060E3	1	208-230	3	4.1	3500	17.7	110.1	1	208-230	1	0.40	2.5	6.6
5	T/YHC060E4	1	460	3	4.1	3500	7.9	52.0	1	460	1	0.40	1.0	2.8
5	T/YHC060F3	1	208-230	3	4.3	3500	15.9	110.0	1	208-230	1	0.40	2.5	6.6
5	T/YHC060F4	1	460	3	4.3	3500	7.1	52.0	1	460	1	0.40	1.0	2.8
6	T/YHC072F3	1	208-230	3	4.9	3500	19.2	136.0	1	208-230	1	0.70	3.3	9.5
6	T/YHC072F4	1	460	3	4.9	3500	8.7	66.0	1	460	1	0.70	1.8	5.5
7½	T/YHC092E3	2	208-230	3	3.8/2.8	3500/3500	16.0/11.5	91.0/77.0	1	208-230	3	0.75	2.7	9.8
7½	T/YHC092E4	2	460	3	3.8/2.7	3500/3500	7.1/5.1	46.0/35.0	1	460	3	0.75	1.5	4.8

continued on next page



## Electrical Data

**Table 163. Electrical characteristics - compressor motor and condenser fan motor - 60 cycle - high efficiency**

Unit Model			Compressor Motors						Condenser Fan Motors					
Tons	Number	No.	Volts	Phase	hp	rpm	RLA	LRA	No.	Volts	Phase	hp	FLA	LRA
7½	T/YHC092F3	2	208-230	3	3.8/2.8	3500/3500	15.9/10.0	110.0/71.0	1	208-230	1	0.75	3.5	9.3
7½	T/YHC092F4	2	460	3	3.8/2.7	3500/3500	7.1/4.7	52.0/38.0	1	460	1	0.75	2.0	6.2
8½	T/YHC102E3	2	208-230	3	4.3/2.8	3500/3500	17.6/11.5	123.0/77.0	1	208-230	3	0.75	2.7	9.8
8½	T/YHC102E4	2	460	3	4.3/2.7	3500/3500	9.6/5.1	62.0/46.0	1	460	3	0.75	1.5	4.8
10	T/YHC120E3	2	208-230	3	4.9/3.3	3500/3500	20.5/13.5	123.0/77.0	1	208-230	3	0.75	2.7	9.8
10	T/YHC120E4	2	460	3	4.9/3.3	3500/3500	9.6/7.1	75.0/46.0	1	460	3	0.75	1.5	4.8

**Table 164. Electrical characteristics - evaporator fan motor - 60 cycle - direct drive - high efficiency<sup>(a)</sup>**

Unit Model			Motor						
Tons	Number	Volts	Hz	Phase	No.	FLA	LRA	bhp	
3	T/YHC036E1	208-230	60	1	1	6.0	—	0.75	
3	T/YHC036E3	208-230	60	1	1	6.0	—	0.75	
3	T/YHC036E4	460	60	1	1	3.2	—	0.75	
4	T/YHC048F1	208-230	60	1	1	7.6	—	1.00	
4	T/YHC048E3	208-230	60	1	1	7.6	—	1.00	
4	T/YHC048E4	460	60	1	1	4.0	—	1.00	
4	T/YHC048F3	208-230	60	3	1	7.6	—	1.00	
4	T/YHC048F4	460	60	3	1	4.0	—	1.00	
5	T/YHC060F1	208-230	60	1	1	7.6	—	1.00	
5	T/YHC060E3	208-230	60	1	1	7.6	—	1.00	
5	T/YHC060E4	460	60	1	1	4.0	—	1.00	
5	T/YHC060F3	208-230	60	3	1	7.6	—	1.00	
5	T/YHC060F4	460	60	3	1	4.0	—	1.00	

(a) Belt drive indoor motor is standard equipment on T/YHC036E-T/YHC060E with optional dehumidification.

**Table 165. Electrical characteristics - evaporator fan motor - 60 cycle - optional belt drive - high efficiency<sup>(a)</sup>**

Unit Model			Motor					
Tons	Number	Volts	Hz	Phase	No.	FLA	LRA	bhp
3	T/YHC036E3	208-230	60	3	1	5.0	32.2	1.00
3	T/YHC036E4	460	60	3	1	2.5	16.1	1.00
4	T/YHC048E3	208-230	60	3	1	5.0	32.2	1.00
4	T/YHC048E4	460	60	3	1	2.5	16.1	1.00
4	T/YHC048F3	208-230	60	3	1	5.0	32.2	1.00
4	T/YHC048E4	460	60	3	1	2.5	16.1	1.00
5	T/YHC060E3	208-230	60	3	1	5.0	32.2	1.00
5	T/YHC060E4	460	60	3	1	2.5	16.1	1.00
5	T/YHC060F3	208-230	60	3	1	5.0	32.2	1.00
5	T/YHC060F4	460	60	3	1	2.5	16.1	1.00

(a) Belt drive indoor motor is standard equipment on T/YHC036E-T/YHC060E with optional dehumidification.

**Table 166. Electrical characteristics - standard evaporator fan motor - 60 cycle - direct or belt drive - high efficiency**

Tons	Unit Model	Direct or	Volts	Hz	Phase	hp	FLA	LRA
	Number	Belt Drive						
6	T/YHC072F3	Belt Drive	208-230	60	3	1.0	4.0-5.0	24.5
6	T/YHC072F4	Belt Drive	460	60	3	1.0	2.5	12.3
7½	T/YHC092E3	Direct Drive	208-230	60	3	3.8	8.5-8.5	—
7½	T/YHC092E4	Direct Drive	460	60	3	3.6	4.3	—
7½	T/YHC092F3	Direct Drive	208-230	60	3	3.8	8.5-8.5	—
7½	T/YHC092F4	Direct Drive	460	60	3	3.6	4.3	—
8½	T/YHC102E3	Direct Drive	208-230	60	3	3.8	8.5-8.5	—
8½	T/YHC102E4	Direct Drive	460	60	3	3.6	4.3	—
10	T/YHC120E3	Direct Drive	208-230	60	3	3.8	8.5-8.5	—
10	T/YHC120E4	Direct Drive	460	60	3	3.6	4.3	—

**Table 167. Electrical characteristics - oversize evaporator fan motor - 60 cycle - direct or belt drive - high efficiency**

Tons	Unit Model	Direct or	Volts	Hz	Phase	hp	FLA	LRA
	Number	Belt Drive						
6	T/YHC072F3	Belt Drive	208-230	60	3	2.0	6.3-6.2	48.0
6	T/YHC072F4	Belt Drive	460	60	3	2.0	3.1	24.0

**Table 168. Electrical characteristics - inducer motor**

Unit Model Number	Stages	hp	rpm	Volts	Phase	LRA
YHC036E(L,M,X,Y) YHC(048,060)E, F	1	1/35	3000	208-230	1	0.6
YHC036E(H,Z)	1	1/15	3300	208-230	1	0.4
YHC072F(L,M,X,Y) YHC(092-102)**(L,X)	1	1/35	3000	208-230	1	0.6
YHC072(H,Z) YHC(092-102)(M,H,Y,Z) YHC120	2	1/15	3350	208-230	1	0.4

# Jobsite Connections

**Table 169. Typical Number of Wires**

Zone Sensors		
A	Manual Changeover.....	4
	Manual/Auto Changeover.....	5
	Manual/Auto Changeover with Status Indication LED's.....	10
	Programmable Night Setback with Status Indication LED's.....	7
Thermostats		
A	3 Wires, 24V, Cooling only	
	4 Wires, 24V, with Electric Heat	
B	3 Power Wires + 1 Ground Wire (3-phase)	
	2 Power Wires + 1 Ground Wire (1-phase)	

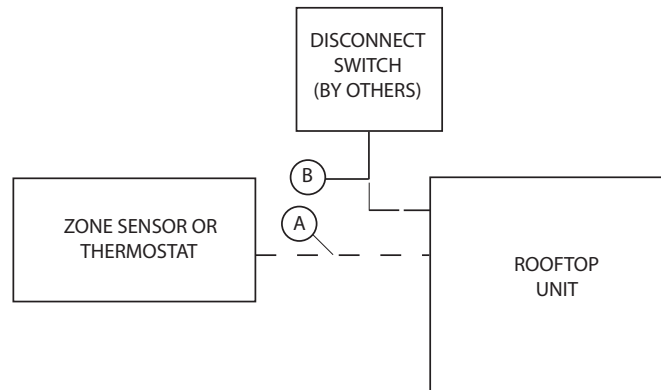

For specific wiring information, see the installation instructions.  
 All wiring except power wire is low voltage.  
 All customer supplied wiring to be copper and must conform to applicable electrical codes (such as NEC or CEC) and local electric codes. Wiring shown dotted is to be furnished and installed by the customer.



# Dimensional Data

**Figure 3. Cooling and gas/electric - 3-5 tons standard efficiency, 3 tons high efficiency**

**Notes:**

1. All dimensions are in inches/millimeters.
2. 1/2 NPT Gas Connection = (Y\_C Models only); 2" Electrical Connection: Single Point Power When Heat Installed (T\_C Models only.)

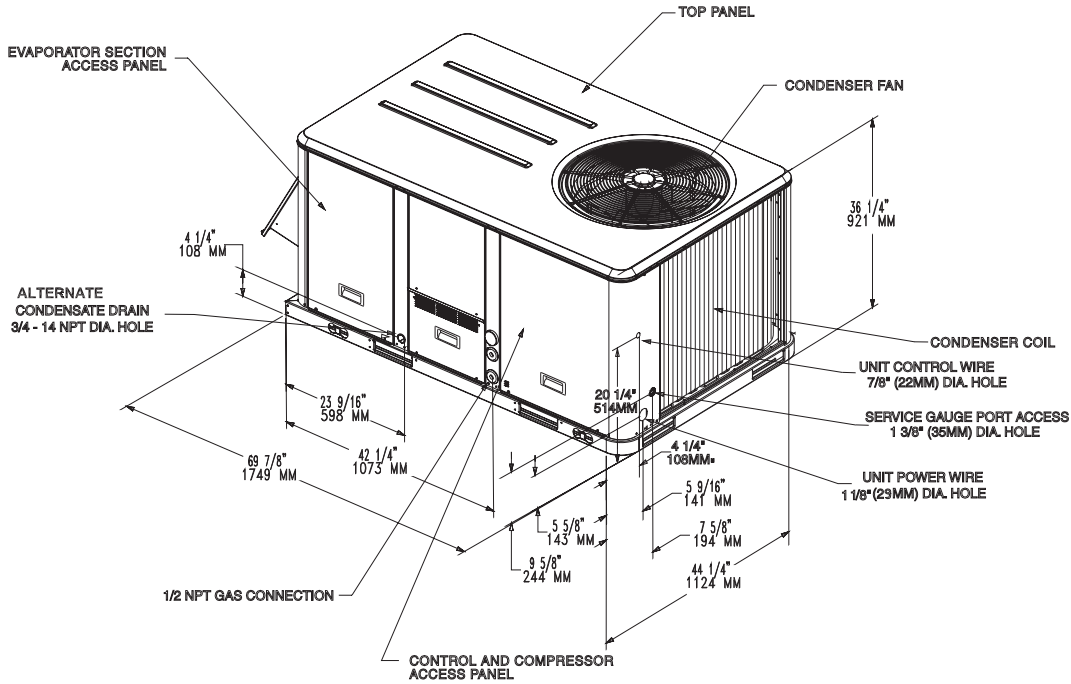

**Figure 4. Cooling and gas/electric - 3-5 tons standard efficiency, 3 tons high efficiency downflow airflow supply/return - through the base utilities**

**Note:** All dimensions are in inches/millimeters.

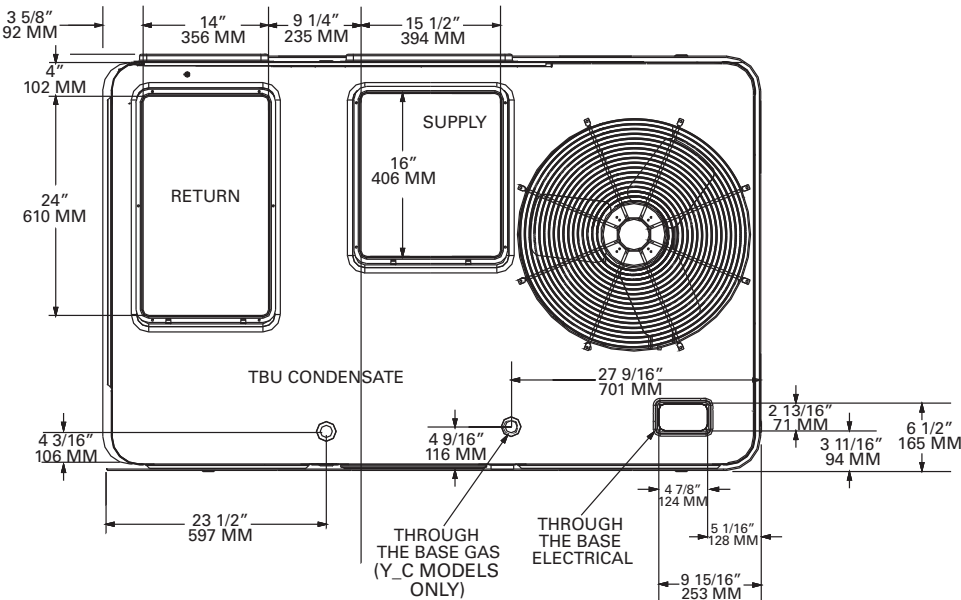



## Dimensional Data

**Figure 5. Cooling and gas/electric - 3-5 tons standard efficiency, 3 tons high efficiency horizontal airflow supply/return**

**Note:** All dimensions are in inches/millimeters.

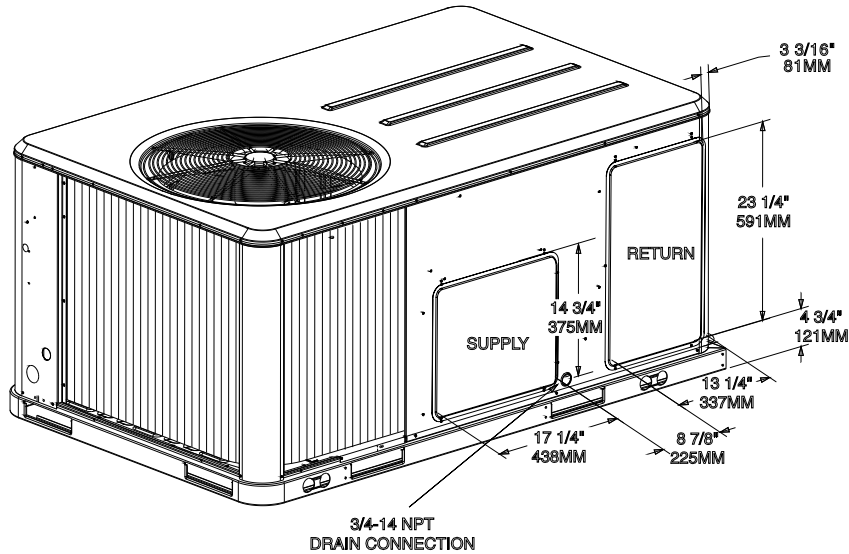

**Figure 6. Cooling and gas/electric - 3-5 tons standard efficiency, 3 tons high efficiency unit clearance and roof opening**

**Note:** All dimensions are in inches/millimeters.

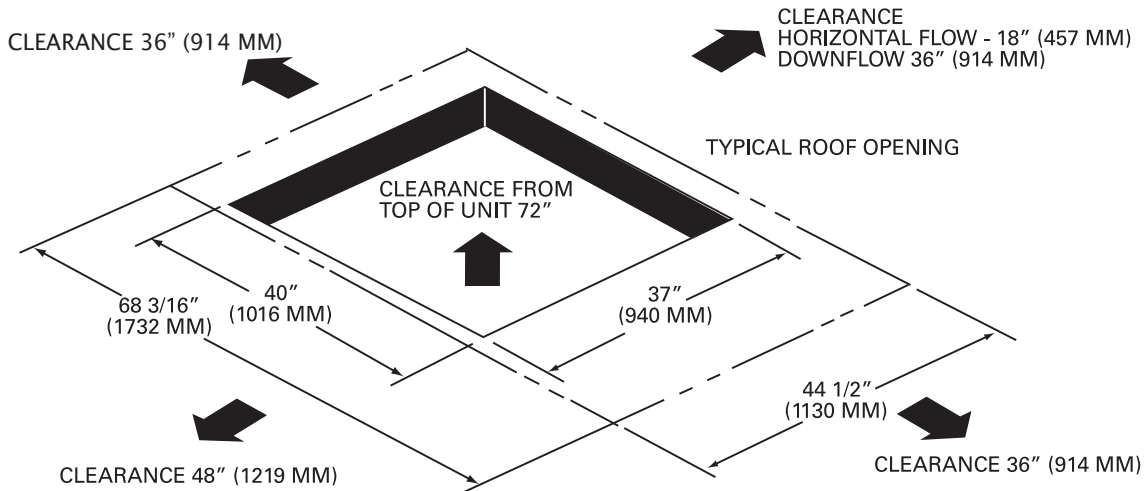

**Figure 7. Cooling and gas/electric - 3-5 tons standard efficiency, 3 tons high efficiency - roof curb**

Note: All dimensions are in inches/millimeters.

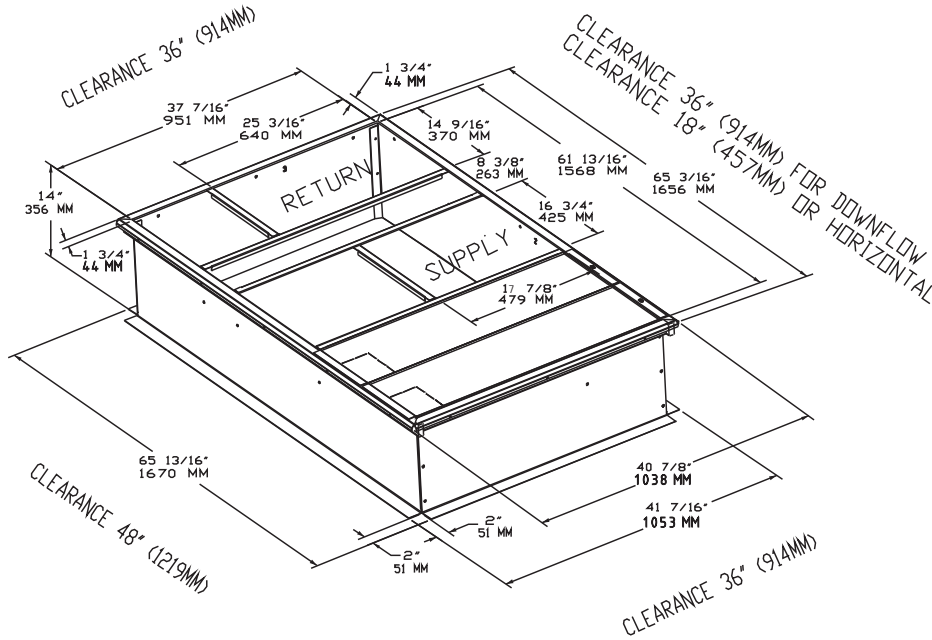

**Figure 8. Cooling and gas/electric - 3-5 tons standard efficiency; 3 tons high efficiency downflow duct connections - field fabricated**

Note: All dimensions are in inches/millimeters.

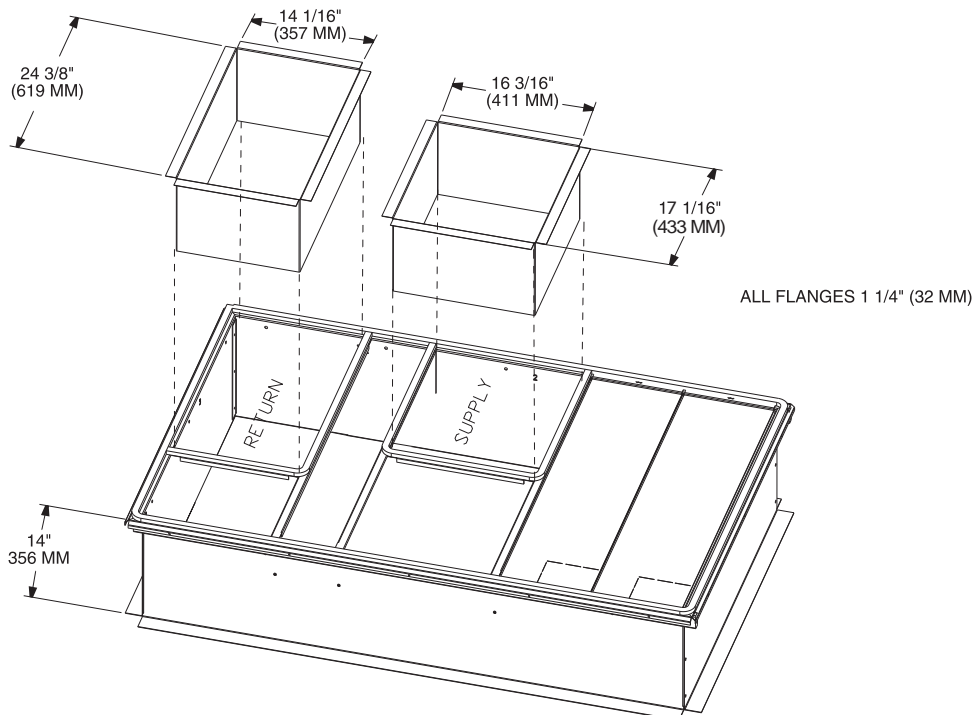

## Dimensional Data

**Figure 9. Cooling and gas/electric - 3-5 tons standard efficiency, 3 tons high efficiency economizer, manual or motorized fresh air damper; power exhaust**

**Note:** All dimensions are in inches/millimeters.

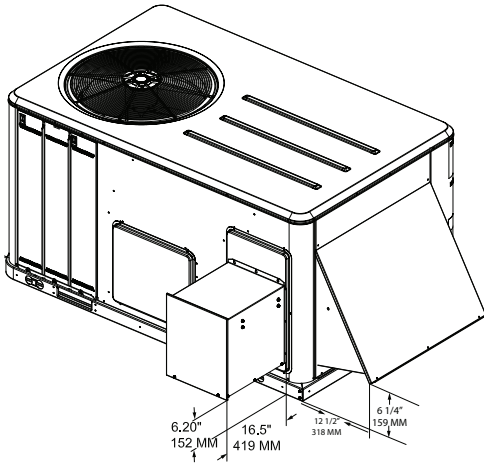

**Figure 10. Cooling and gas/electric - 3-5 tons standard efficiency, 3 tons high efficiency economizer & barometric relief damper hood**

**Note:** All dimensions are in inches/millimeters.

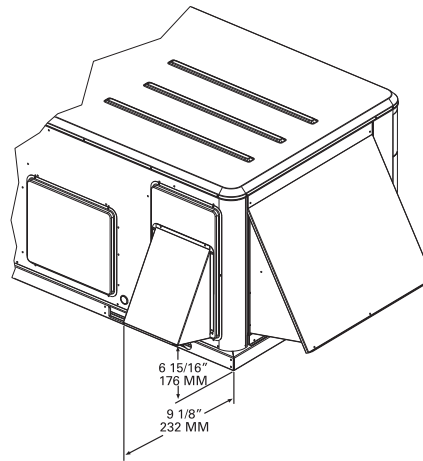

**Figure 11. Cooling and gas/electric models - 3-5 tons standard efficiency, 3 tons high efficiency swing diameter for hinged door(s) option**

**Note:** All dimensions are in inches/millimeters.

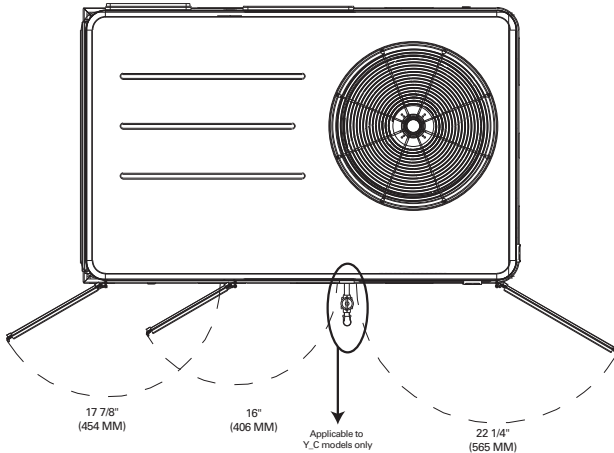

**Figure 12. Gas/electric models - 3-5 tons standard efficiency, 3 tons high efficiency height of gas pipe required from inside base of unit to gas shut off assembly (factory provided) - Y,C models only**

**Note:** All dimensions are in inches/millimeters.

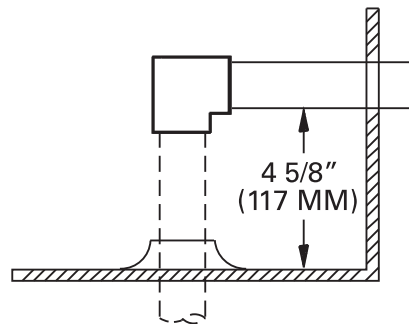

**Figure 13. Cooling and gas/electric - 6, 7½ (single) tons standard efficiency, 4-5 tons high efficiency**

**Note:** All dimensions are in inches/millimeters.

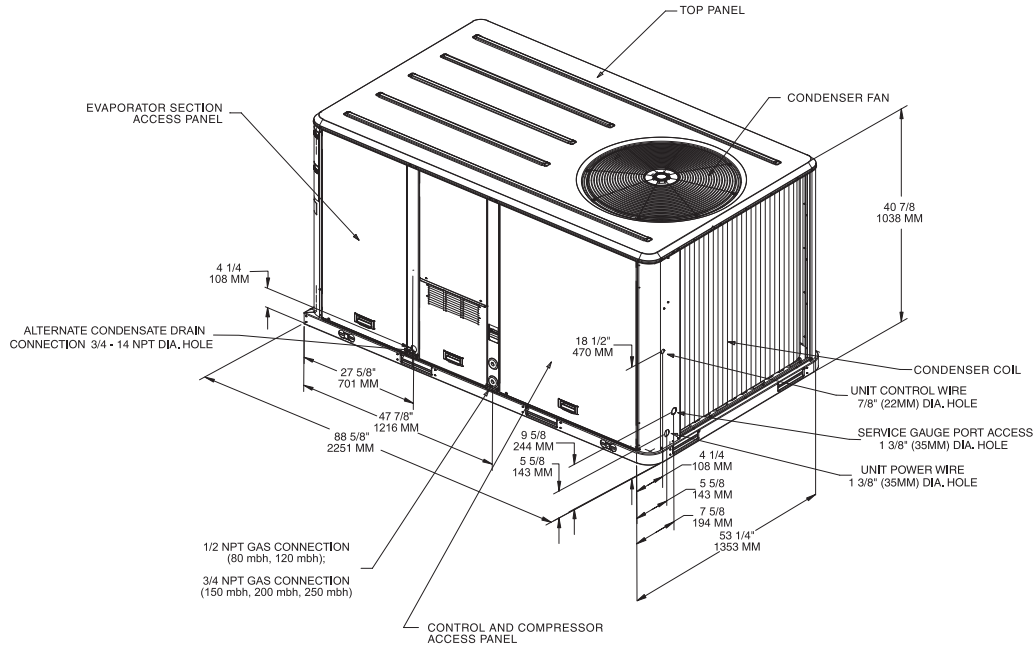

**Figure 14. Cooling and gas/electric - 6, 7½ (single) tons standard efficiency, 4-5 tons high efficiency downflow airflow supply/return - through the base utilities**

**Note:** All dimensions are in inches/millimeters.

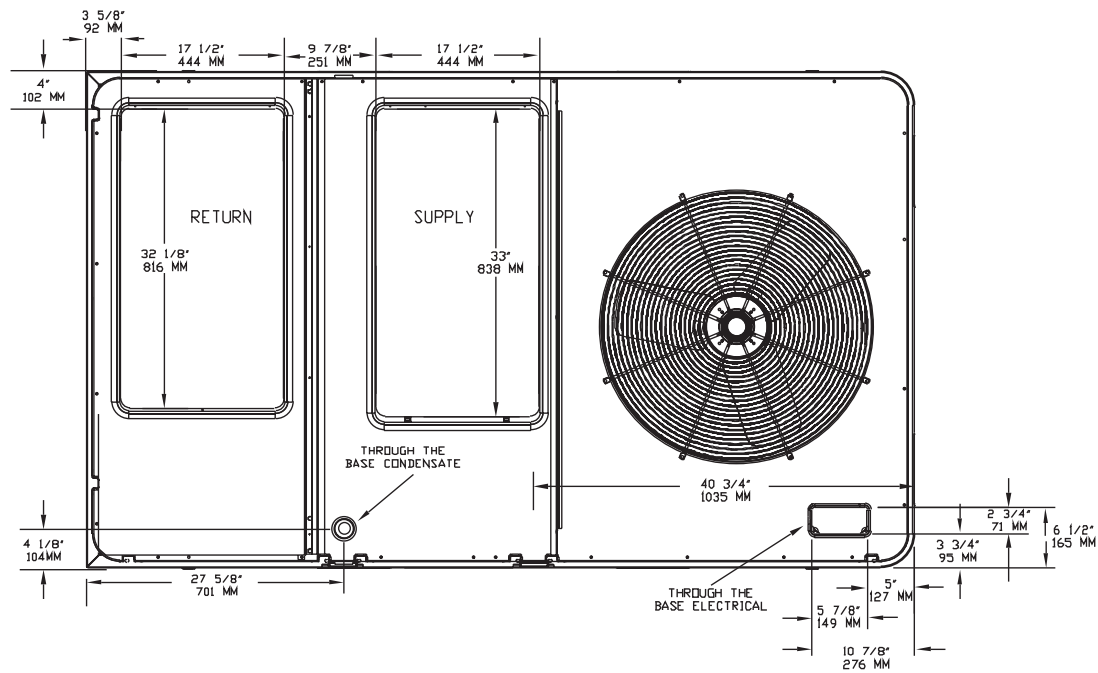

## Dimensional Data

**Figure 15. Cooling and gas/electric - 6, 7½ (single) tons standard efficiency, 4-5 tons high efficiency horizontal airflow supply and return**

**Note:** All dimensions are in inches/millimeters.

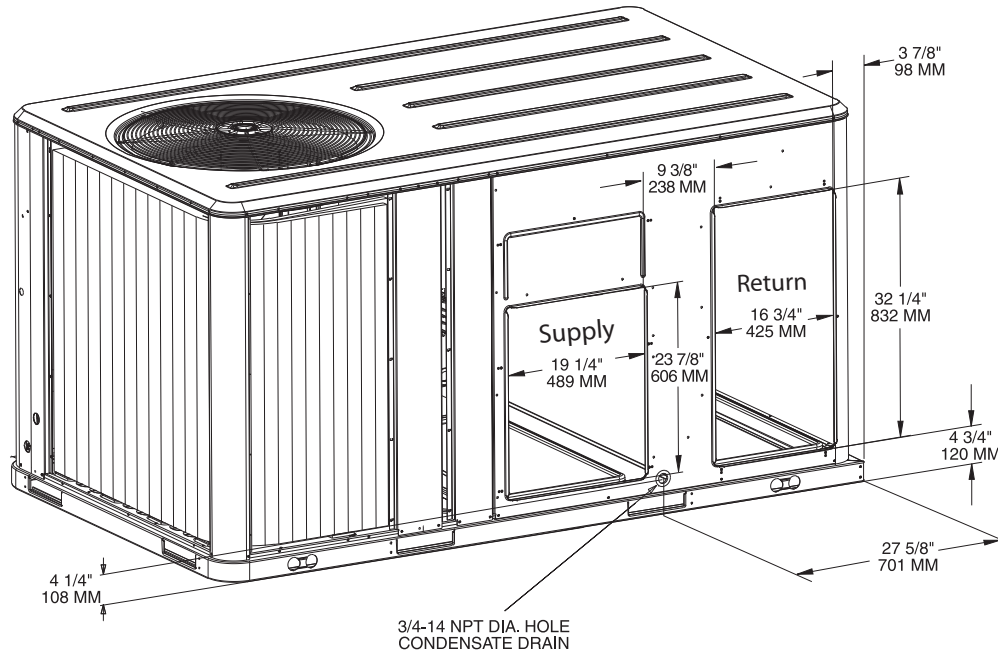

**Figure 16. Cooling and gas/electric - 6, 7½ (single) tons standard efficiency, 4-5 tons high efficiency unit clearance and roof opening**

**Note:** All dimensions are in inches/millimeters.

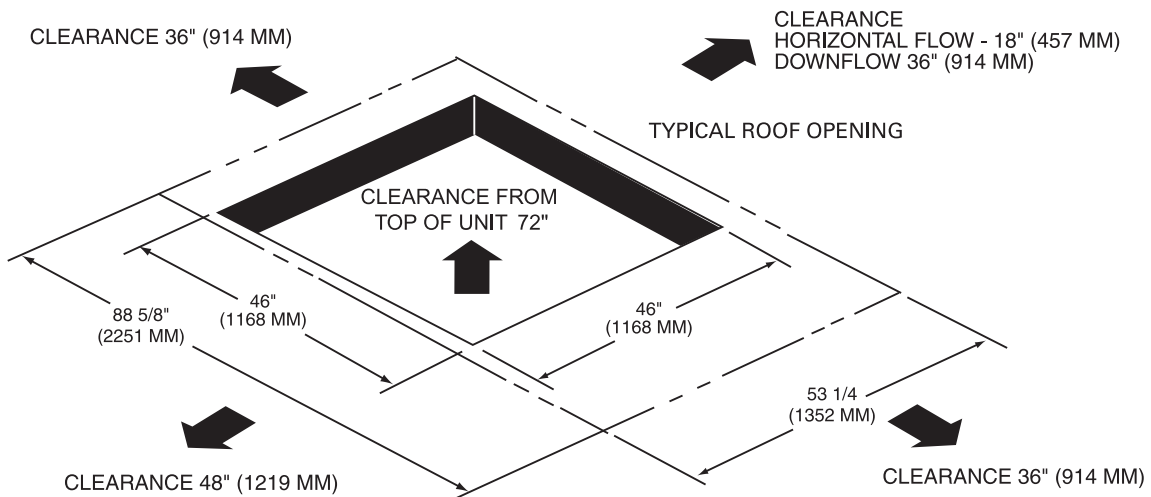

**Figure 17. Cooling and gas/electric - 6, 7½ (single) tons standard efficiency, 4-5 tons high efficiency - roof curb**

Note: All dimensions are in inches/millimeters.

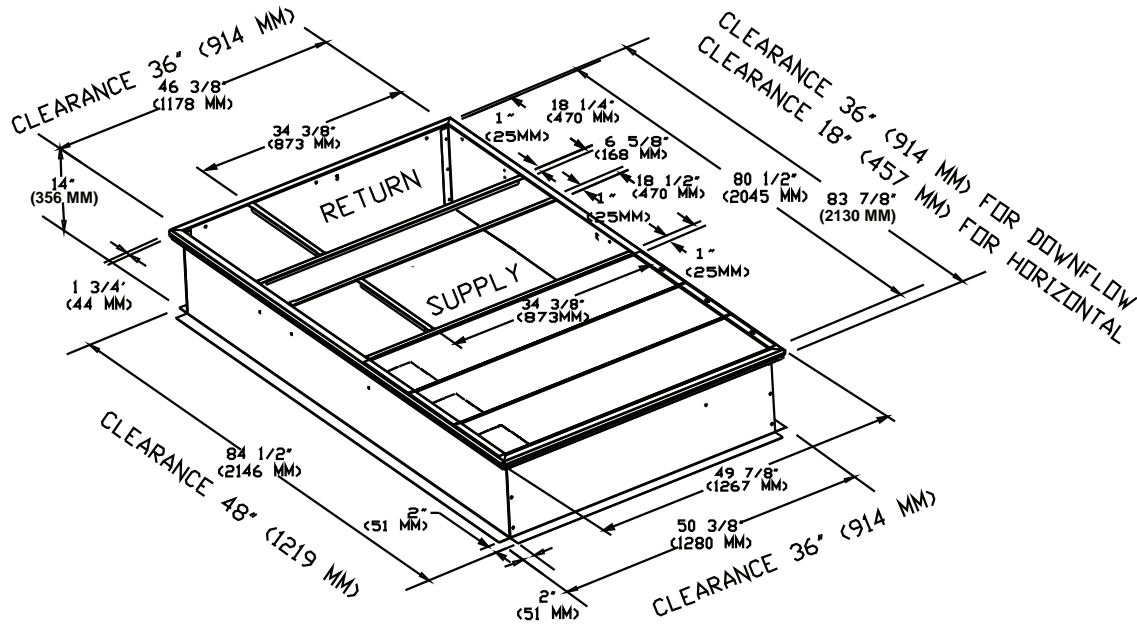

**Figure 18. Cooling and gas/electric - 6, 7½ (single) tons standard efficiency, 4-5 tons high efficiency downflow duct connections field fabricated**

Note: All dimensions are in inches/millimeters.

Note: See "Clearance required from duct to combustible surfaces (inches)," p. 17 for duct clearance to combustible materials.

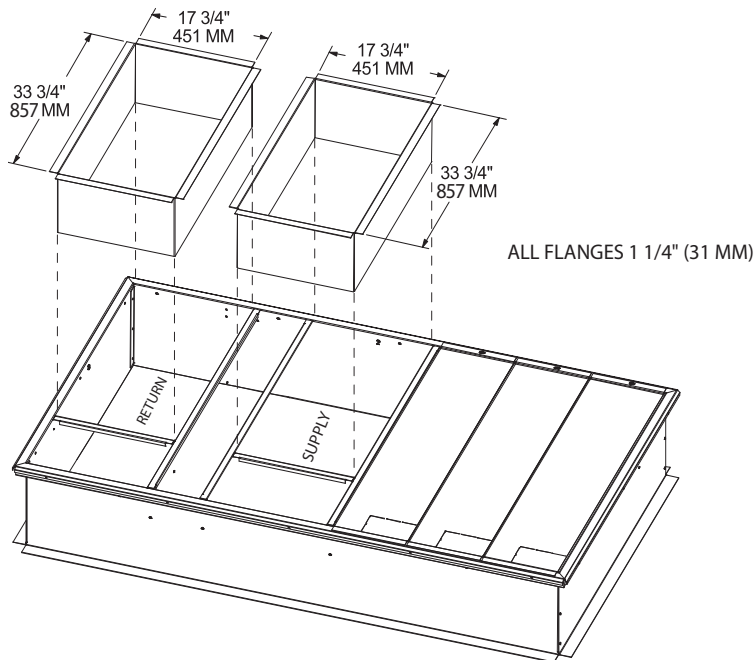

## Dimensional Data

**Figure 19. Cooling and gas/electric - 6, 7½ (single) tons standard efficiency, 4-5 tons high efficiency economizer, manual or motorized fresh air damper**

**Note:** All dimensions are in inches/millimeters.

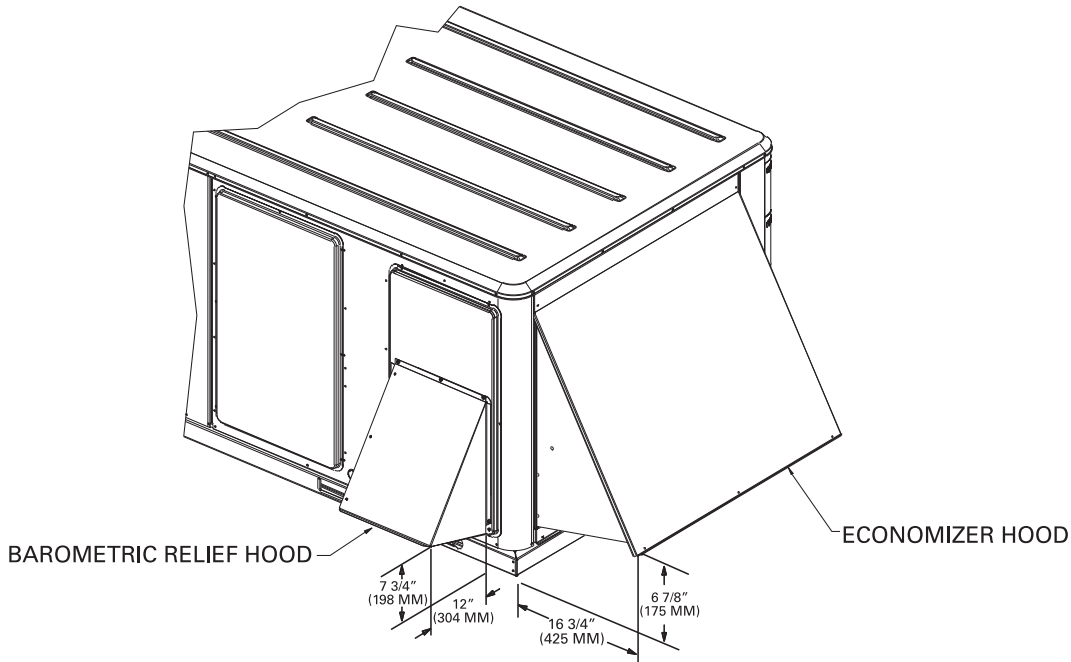

**Figure 20. Cooling and gas/electric - 6, 7½ (single) tons standard efficiency, 4-5 tons high efficiency swing diameter for hinged door(s) option**

**Note:** All dimensions are in inches/millimeters.

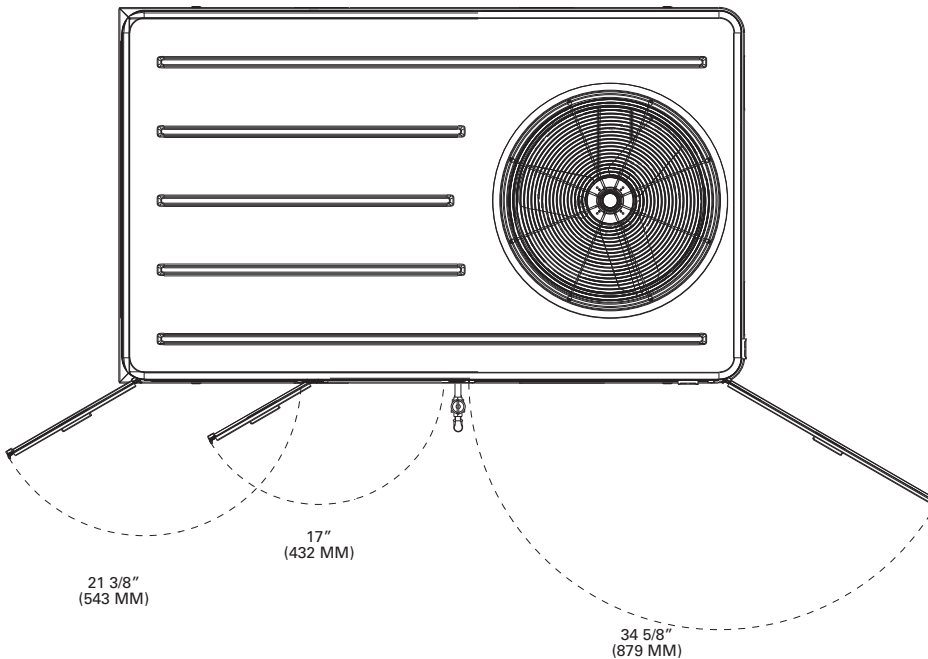



**Figure 21. Cooling and gas/electric - 7½ tons (dual compressor standard efficiency) - 10 tons standard efficiency, 6 tons high efficiency; 7½ tons (microchannel) high efficiency**

**Note:** All dimensions are in inches/millimeters.

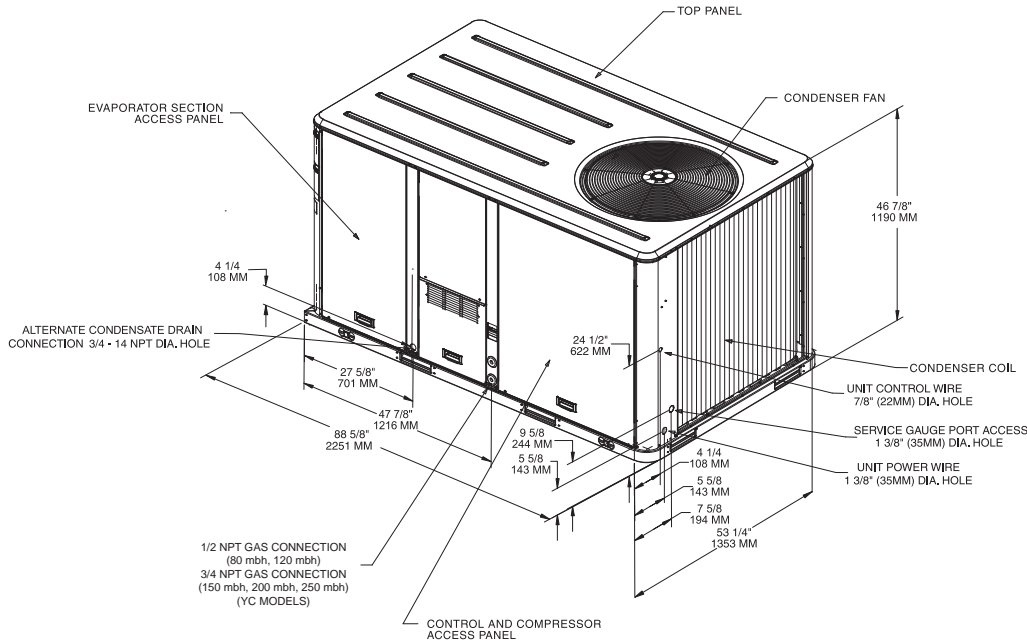

**Figure 22. Cooling and gas/electric - 7½ tons (dual compressor standard efficiency) - 10 tons standard efficiency, 6 tons high efficiency, 7½ tons (microchannel) high efficiency; downflow airflow supply/return through the base utilities**

**Note:** All dimensions are in inches/millimeters.

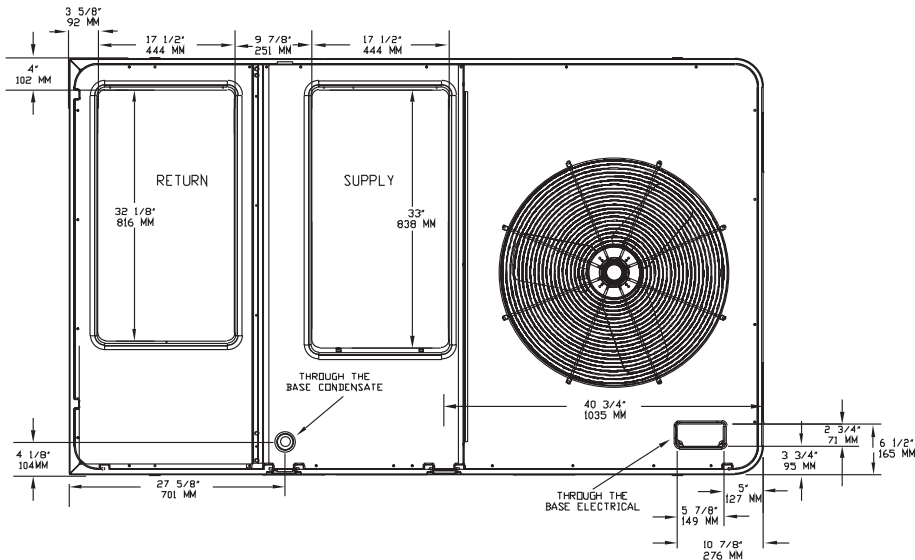

## Dimensional Data

**Figure 23. Cooling and gas/electric - 7½ tons (dual compressor standard efficiency) - 10 tons standard efficiency, 6 tons high efficiency; 7½ tons (microchannel) high efficiency; horizontal airflow supply and return**

**Note:** All dimensions are in inches/millimeters.

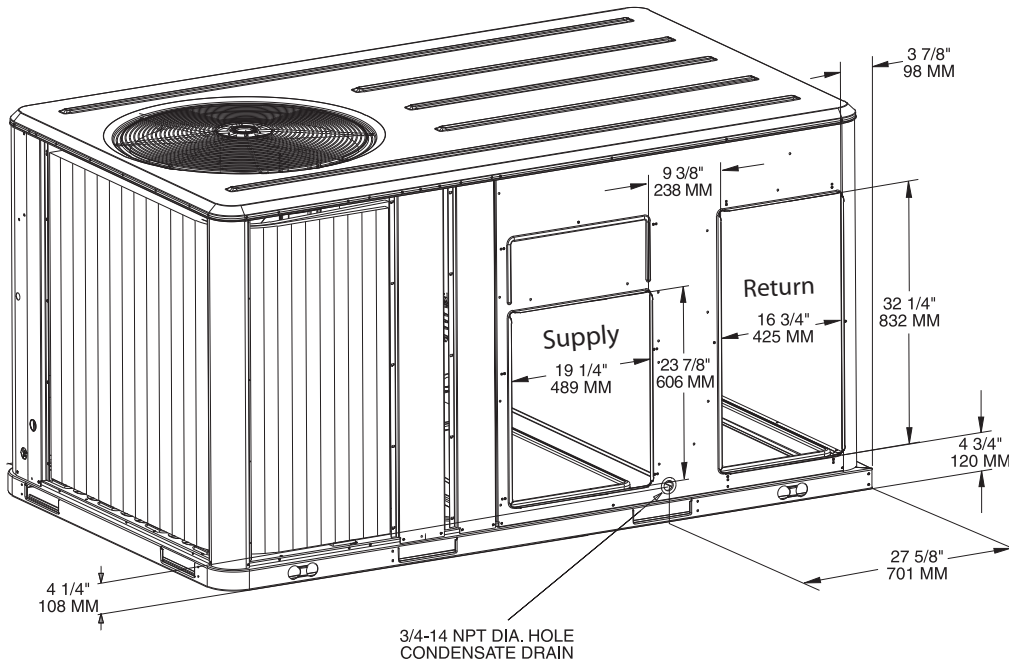

**Figure 24. Cooling and gas/electric - 7½ tons (dual compressor standard efficiency), 10 tons standard efficiency, 6 tons high efficiency, 7½ tons (microchannel) high efficiency; unit clearance and roof opening**

**Note:** All dimensions are in inches/millimeters.

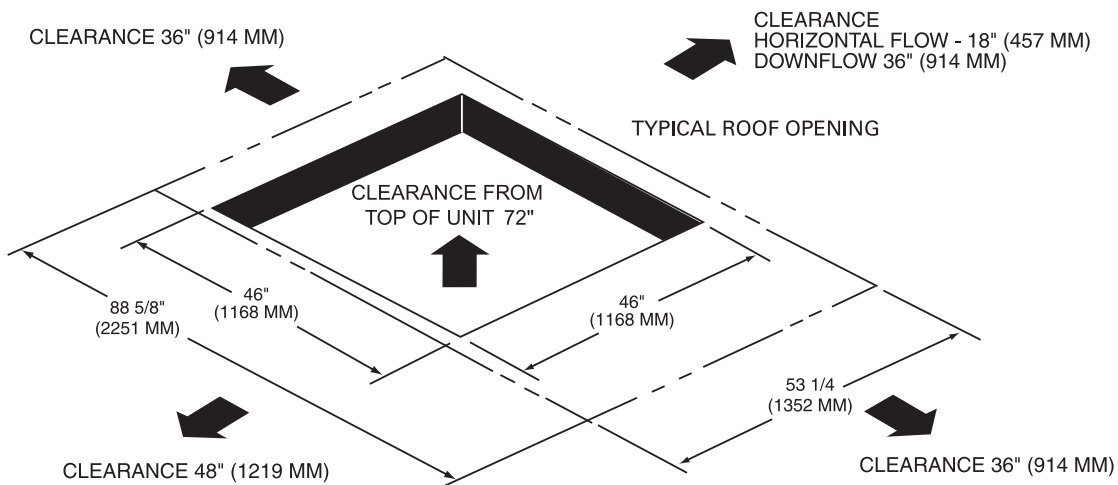

**Figure 25. Cooling and gas/electric - 7½ tons (dual compressor standard efficiency), 10 tons standard efficiency, 6 tons high efficiency, 7½ tons (microchannel) high efficiency; roof curb**

Note: All dimensions are in inches/millimeters.

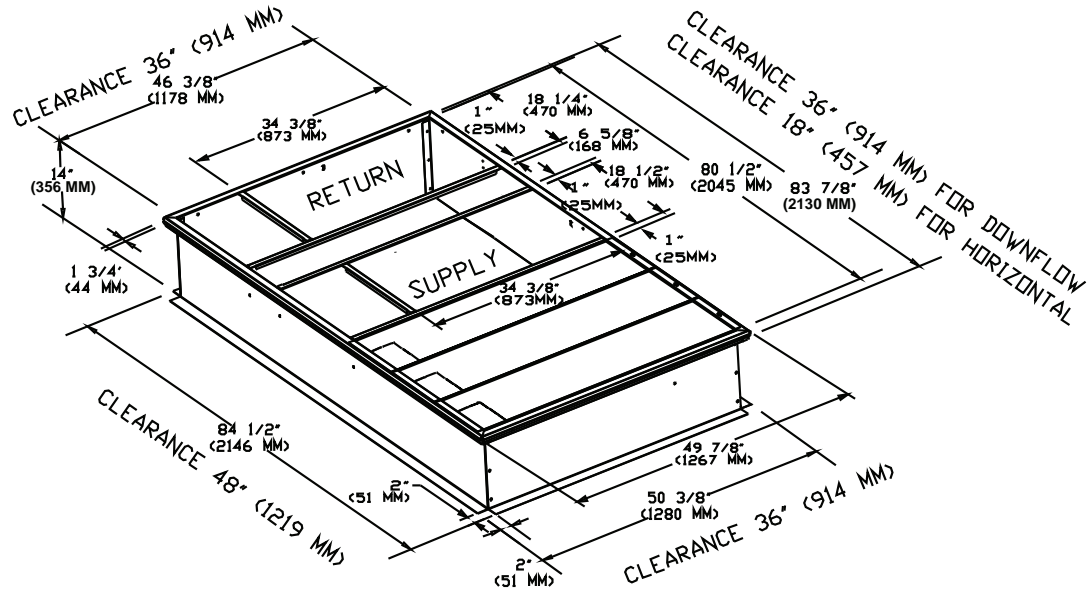

**Figure 26. Cooling and gas/electric - 7½ tons (dual compressor standard efficiency), 10 tons standard efficiency downflow, 6 tons high efficiency, 7½ tons (microchannel) high efficiency; duct connections field fabricated**

Note: All dimensions are in inches/millimeters.

Note: See "Clearance required from duct to combustible surfaces (inches)," p. 17 for duct clearance to combustible materials.

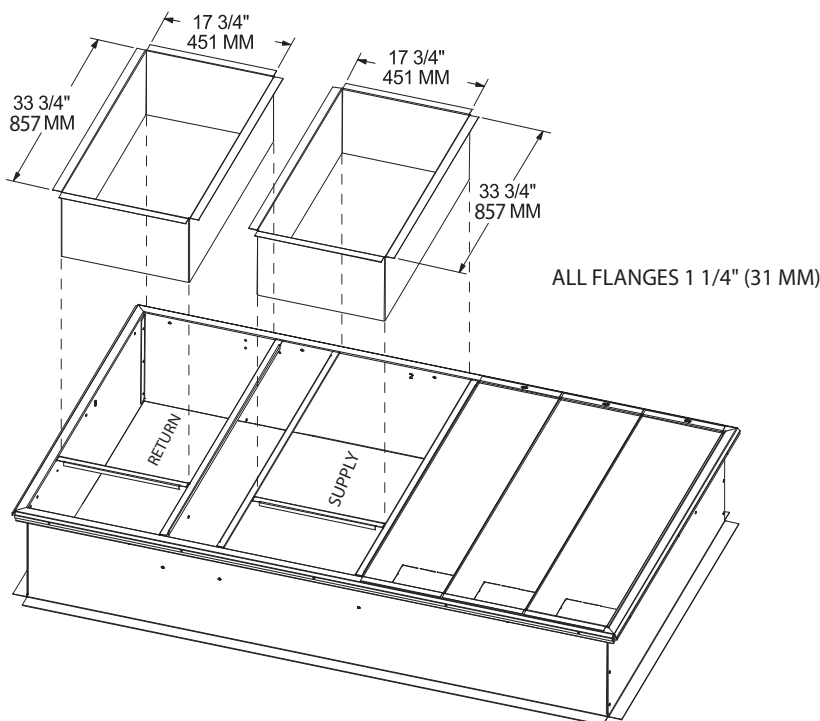

## Dimensional Data

**Figure 27. Cooling and gas/electric - 7½ tons (dual compressor standard efficiency), 10 tons standard efficiency, 6 tons high efficiency, 7½ tons (microchannel) high efficiency; power exhaust**

**Note:** All dimensions are in inches/millimeters.

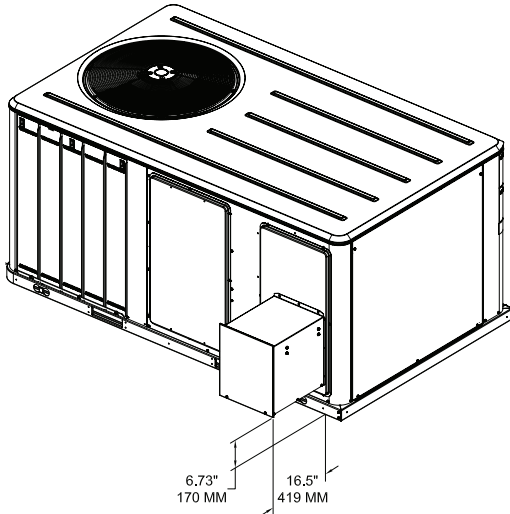

**Figure 28. Cooling and gas/electric - 7½ tons (dual compressor standard efficiency), 10 tons standard efficiency, 6 tons high efficiency, 7½ tons (microchannel) high efficiency; swing diameter for hinged door(s) option**

**Note:** All dimensions are in inches/millimeters.

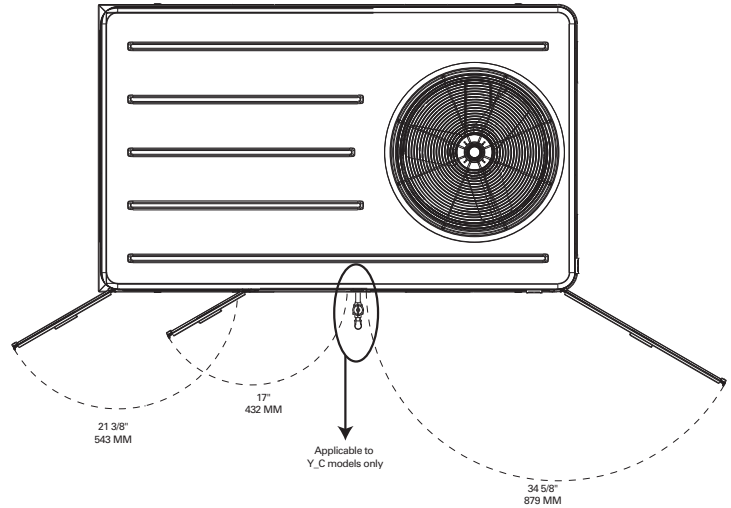

**Figure 29. Cooling and gas/electric - 6-10 tons standard efficiency, 4-6 tons high efficiency, 7½ tons (microchannel) high efficiency; economizer, manual or motorized fresh air damper**

**Note:** All dimensions are in inches/millimeters.

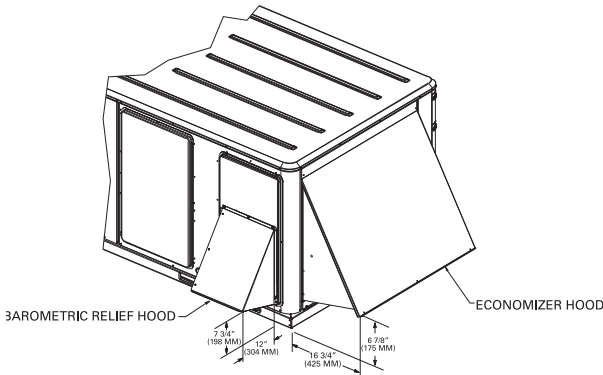

**Figure 30. Gas/electric - 6-10 tons standard efficiency, 4-6 tons high efficiency, 7½ tons (microchannel) high efficiency; height of gas pipe required from inside base of unit to gas shut off assembly (factory provided) - Y\_C models only**

**Note:** All dimensions are in inches/millimeters.

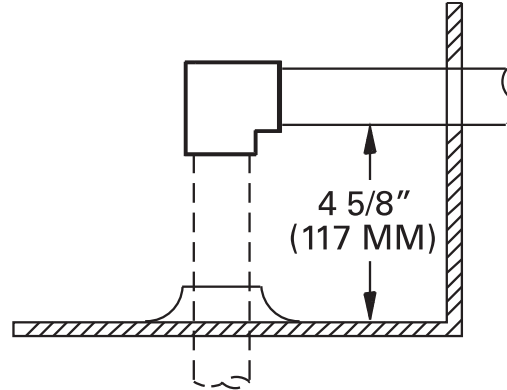

**Figure 31. Cooling and gas/electric - 7½ tons (dehumidification) high efficiency, 8½-10 tons high efficiency**

**Notes:**

1. All dimensions are in inches/millimeters.
2. ½ or ¾ NPT Gas Connection = (Y\_C Models only); 2" Electrical Connection: Single Point Power When Heat Installed (T\_C Models only.)

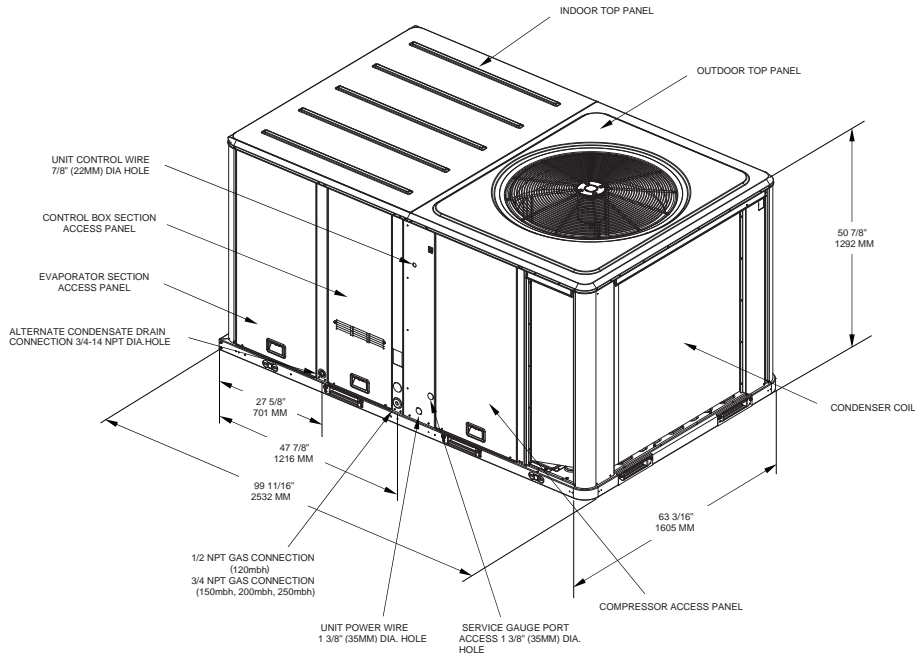

**Figure 32. Cooling and gas/electric - 7½ tons (dehumidification) high efficiency, 8½-10 tons high efficiency; downflow airflow supply/return, through the base utilities**

**Notes:**

1. All dimensions are in inches/millimeters.
2. ½ or ¾ NPT Gas Connection = (Y\_C Models only); 2" Electrical Connection: Single Point Power When Heat Installed (T\_C Models only.)

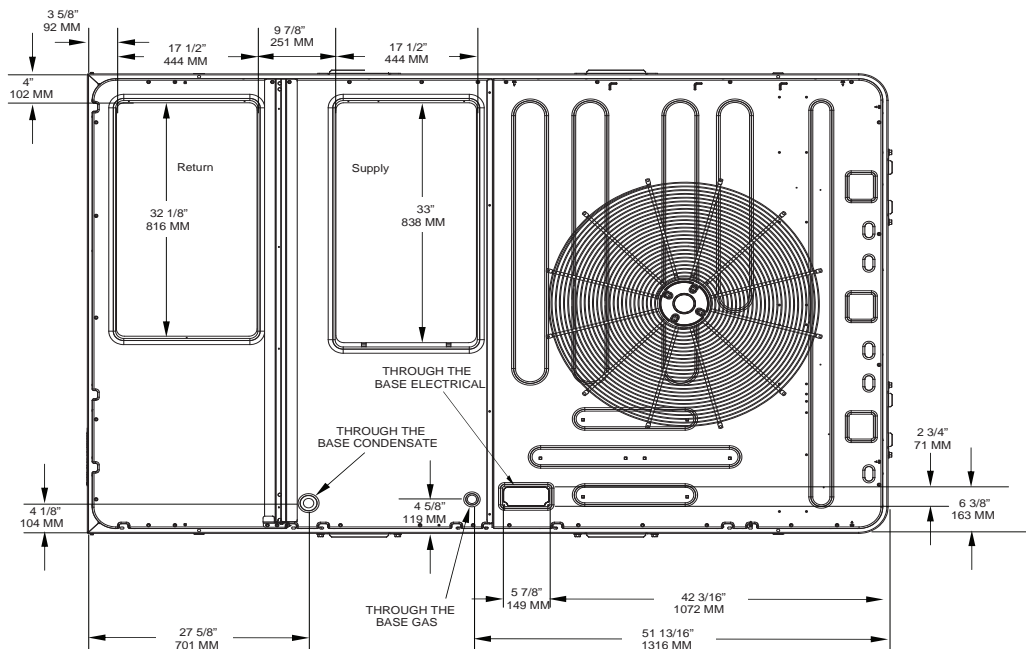

## Dimensional Data

**Figure 33. Cooling and gas/electric - 7½ tons (dehumidification) high efficiency, 8½-10 tons high efficiency; horizontal airflow supply/return**

**Notes:**

1. All dimensions are in inches/millimeters.
2. ½ or ¾ NPT Gas Connection = (Y\_C Models only); 2" Electrical Connection: Single Point Power When Heat Installed (T\_C Models only.)

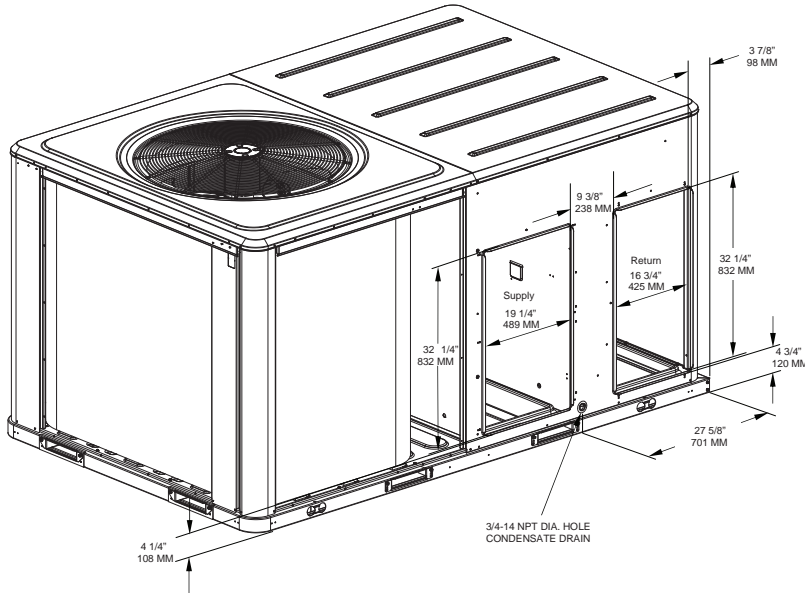

**Figure 34. Cooling and gas/electric - 7½ tons (dehumidification) high efficiency, 8½-10 tons high efficiency; unit clearance and roof opening**

**Notes:**

1. All dimensions are in inches/millimeters.
2. ½ or ¾ NPT Gas Connection = (Y\_C Models only); 2" Electrical Connection: Single Point Power When Heat Installed (T\_C Models only.)

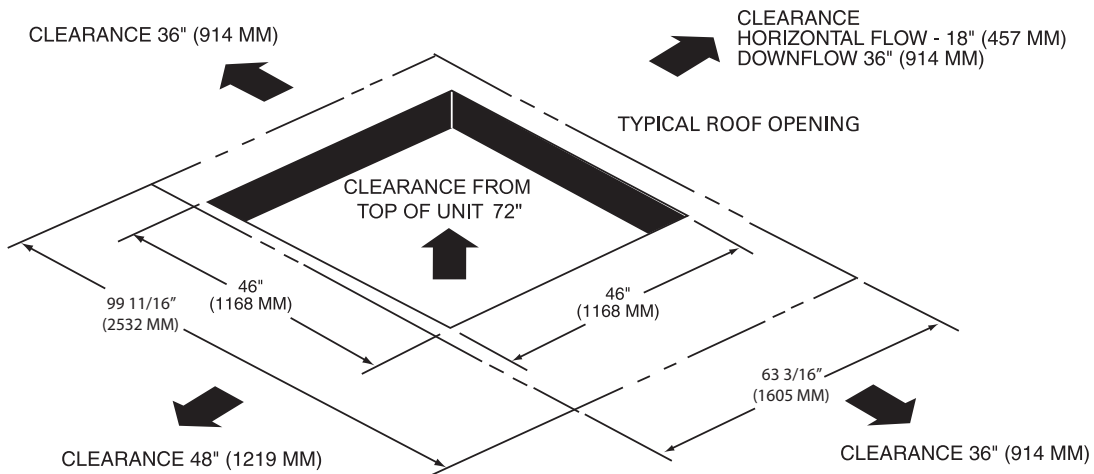

**Figure 35. Cooling and gas/electric - 7½ tons (dehumidification) high efficiency, 8½-10 tons high efficiency - roof curb**

**Notes:**

1. All dimensions are in inches/millimeters.
2. ½ or ¾ NPT Gas Connection = (Y\_C Models only); 2" Electrical Connection: Single Point Power When Heat Installed (T\_C Models only.)

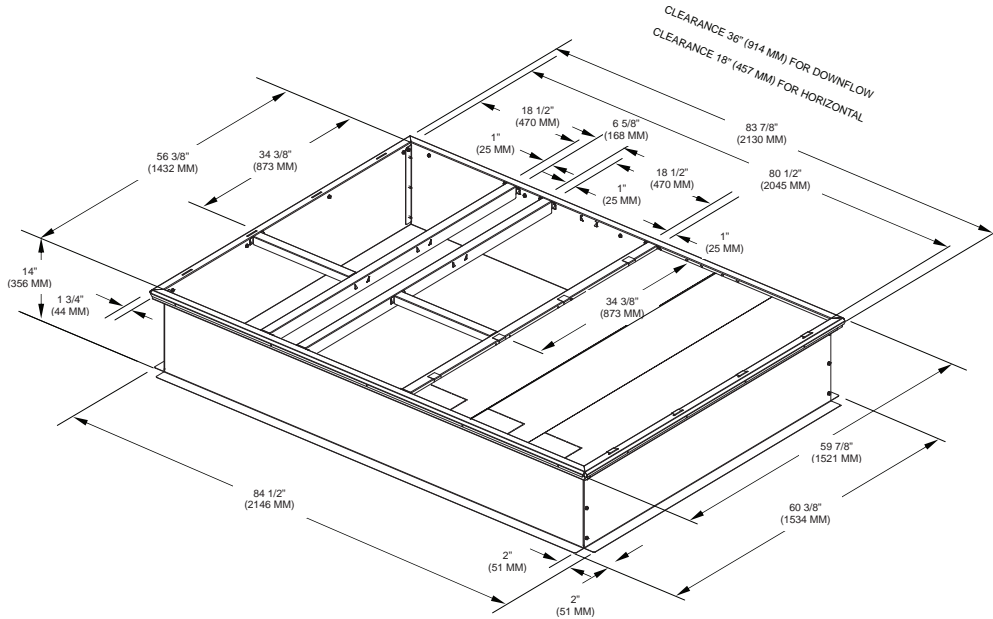

**Figure 36. Cooling and gas/electric - 7½ tons (dehumidification) high efficiency, 8½-10 tons high efficiency; duct connections field fabricated**

**Notes:**

1. All dimensions are in inches/millimeters.
2. ½ or ¾ NPT Gas Connection = (Y\_C Models only); 2" Electrical Connection: Single Point Power When Heat Installed (T\_C Models only.)
3. See "Clearance required from duct to combustible surfaces (inches)," p. 17 for duct clearance to combustible materials.

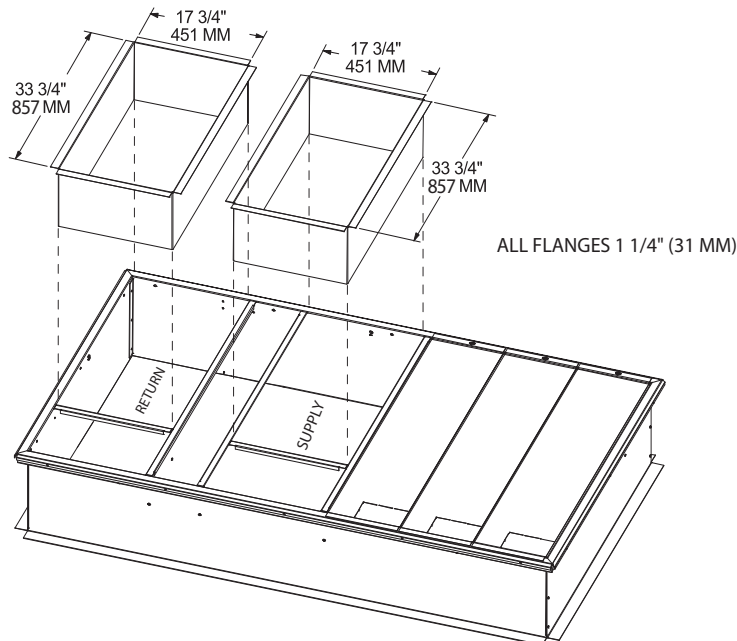

## Dimensional Data

**Figure 37. Cooling and gas/electric - 7½ tons (dehumidification) high efficiency, 8½-10 tons high efficiency - power exhaust**

**Note:** All dimensions are in inches/millimeters.

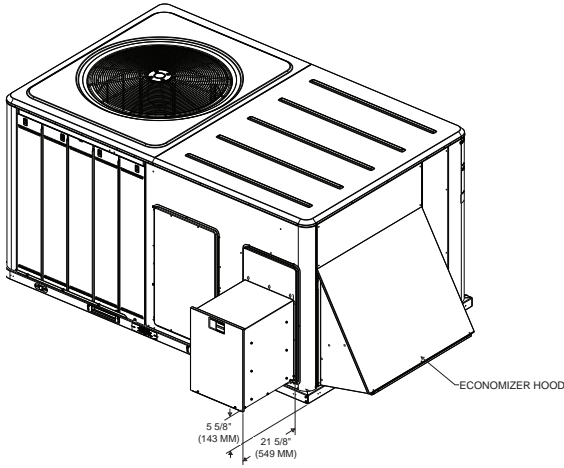

**Figure 38. Cooling and gas/electric - 7½ tons (dehumidification) high efficiency, 8½-10 tons high efficiency; swing diameter for hinged door(s) option**

**Note:** All dimensions are in inches/millimeters.

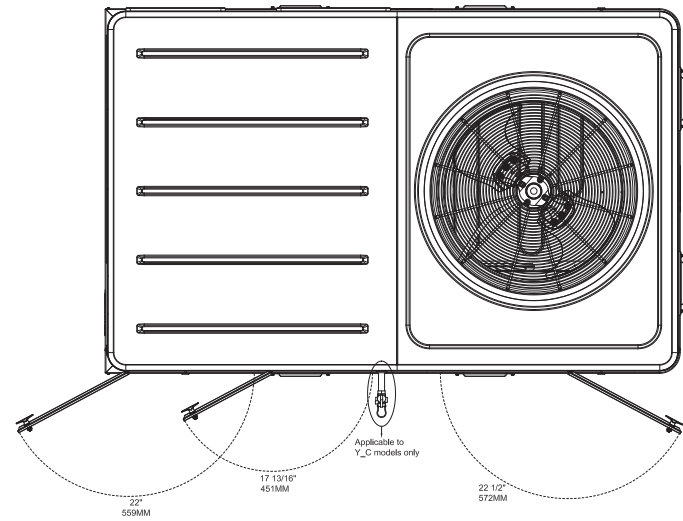

**Figure 39. Cooling and gas/electric - 7½ tons (dehumidification) high efficiency, 8½-10 tons high efficiency - economizer, manual or motorized fresh air damper**

**Note:** All dimensions are in inches/millimeters.

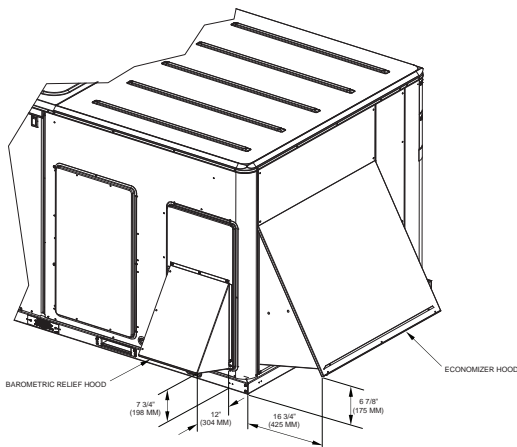

**Figure 40. Gas/electric - 7½ tons (dehumidification) high efficiency, 8½-10 tons high efficiency - height of gas pipe required from inside base of unit to gas shut off assembly (factory provided) - Y\_C models only**

**Note:** All dimensions are in inches/millimeters.

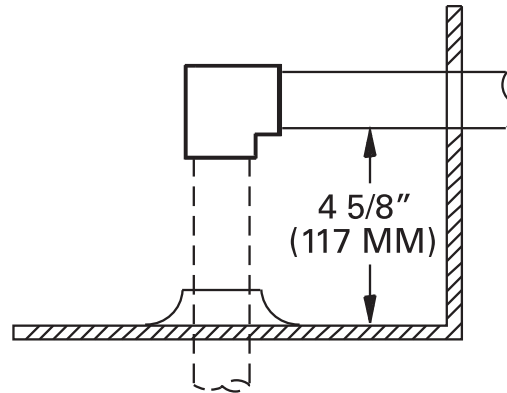



# Weights

**Table 170. Maximum unit & corner weights (lbs) and center of gravity dimensions (in.) - cooling models**

Tons	Unit Model No.	Maximum Model Weights <sup>(a)</sup>		Corner Weights <sup>(b)</sup>				Center of Gravity (in.)	
		Shipping	Net	A	B	C	D	Length	Width
3	TSC036E	555	481	157	122	95	107	31	19
4	TSC048E	586	511	167	129	101	114	31	19
5	TSC060E	636	561	183	142	111	125	31	19
6	TSC072F	762	667	218	186	131	132	44	21
7½	TSC090F	781	686	222	195	136	134	44	21
7½	TSC092F	940	797	249	235	163	149	46	21
8½	TSC102F	999	856	264	239	177	175	45	22
10	TSC120F	1058	960	320	218	233	189	40	24
3	THC036E	555	481	157	122	95	107	31	19
4	THC048E	787	692	220	178	132	163	40	23
4	THC048F	737	642	208	177	128	130	44	22
5	THC060E	841	746	241	193	139	173	39	22
5	THC060F	774	679	219	189	135	137	43	21
6	THC072F	883	740	228	219	155	138	47	21
7½	THC092E	1421	1227	346	330	269	282	49	28
7½	THC092F	1026	928	315	209	224	180	40	24
8	THC102E	1436	1242	360	337	268	287	48	28
10	THC120E	1446	1252	355	334	268	285	48	28

(a) Weights are approximate.

(b) Corner weights are given for information only.

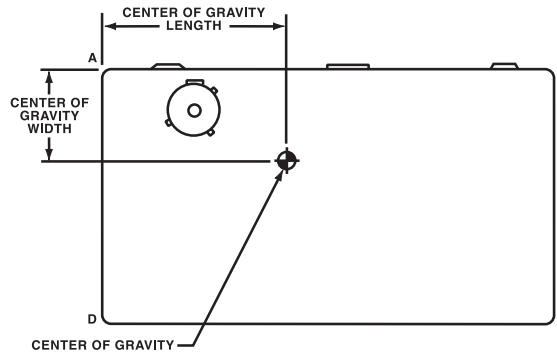

**Table 171. Maximum unit & corner weights (lbs) and center of gravity dimensions (in.) - gas/electric models**

Tons	Unit Model No.	Maximum Model Weights <sup>(a)</sup>		Corner Weights <sup>(b)</sup>				Center of Gravity (in.)	
		Shipping	Net	A	B	C	D	Length	Width
3	YSC036E	607	532	165	137	95	134	31	19
4	YSC048E	638	563	175	145	101	142	31	19
5	YSC060E	688	613	190	158	110	155	31	19
6	YSC072F	805	710	222	217	121	150	41	22
7½	YSC090F	862	767	243	221	155	149	45	21
7½	YSC092F	990	847	265	249	173	160	46	21

continued on next page



## Weights

**Table 171. Maximum unit & corner weights (lbs) and center of gravity dimensions (in.) - gas/electric models (continued)**

Tons	Unit Model No.	Maximum Model Weights <sup>(a)</sup>		Corner Weights <sup>(b)</sup>				Center of Gravity (in.)	
		Shipping	Net	A	B	C	D	Length	Width
8½	YSC102F	1047	904	279	252	187	186	44	22
10	YSC120F	1156	1058	345	242	258	213	41	23
3	YHC036E	607	532	165	137	95	134	31	19
4	YHC048E	858	763	238	200	148	176	40	23
4	YHC048F	806	711	226	199	144	143	44	22
5	YHC060E	917	822	261	218	156	187	40	22
5	YHC060F	850	755	239	214	152	151	44	21
6	YHC072F	965	822	250	245	174	153	47	21
7½	YHC092E	1528	1334	373	368	295	299	50	28
7½	YHC092F	1124	1026	340	233	249	204	41	23
8½	YHC102E	1553	1359	387	375	294	303	49	28
10	YHC120E	1563	1369	386	379	299	305	49	28

(a) Weights are approximate.

(b) Corner weights are given for information only.

**Table 172. Factory installed options (fiops)/accessory net weights (lbs)<sup>(a),(b)</sup>**

Accessory	T/YSC036E-060E	T/YHC048E-060E	T/YSC072F-102F	T/YSC120F	T/YHC102E-120E
	T/YHC036E	T/YHC048F-060F	T/YHC072F	T/YHC092F	
	Net Weight	Net Weight	Net Weight	Net Weight	Net Weight
	3-5 Tons	4-5 Tons	6-10 Tons	7½, 10	8½-10
Barometric Relief	7	10	10	10	10
Belt Drive Option (3 phase only)	31	31	—	—	—
Coil Guards	12	20	20	20	30
Economizer	26	36	36	36	36
Electric Heaters <sup>(c)</sup>	15	30	30	40	40
Hinged Doors	10	12	12	12	12
Manual Outside Air Damper	16	26	26	26	26
Motorized Outside Air Damper	20	30	30	30	30
Novar Control	8	8	8	8	8
Oversized Motor	5	8	8	—	—
Powered Convenience Outlet	38	38	38	38	50
Powered Exhaust	40	40	80	80	80
Reheat Coil	15	25	—	—	53
Roof Curb	61	78	78	78	89
Smoke Detector, Supply	5	5	5	5	5
Smoke Detector, Return	7	7	7	7	7
Stainless Steel Heat Exchanger <sup>(d)</sup>	4	6	6	6	6
Through the Base Electrical	8	13	13	13	13
Through the Base Gas	5	5	5	5	5
Unit Mounted Circuit Breaker	5	5	5	5	5
Unit Mounted Disconnect	5	5	5	5	5

(a) Weights for options not listed are <5 lbs.

(b) Net weight should be added to unit weight when ordering factory-installed accessories.

(c) Applicable to Cooling units only.

(d) Applicable to Gas/Electric units only.



# Mechanical Specifications

## General

The units shall be convertible airflow. The operating range shall be between 115°F and 0°F in cooling as standard from the factory for units with microprocessor controls. Operating range for units with electromechanical controls shall be between 115°F and 40°F. Cooling performance shall be rated in accordance with ARI testing procedures. All units shall be factory assembled, internally wired, fully charged with R-410A, and 100 percent run tested to check cooling operation, fan and blower rotation, and control sequence before leaving the factory. Wiring internal to the unit shall be colored and numbered for simplified identification. Units shall be cULus listed and labeled, classified in accordance for Central Cooling Air Conditioners.

## Casing

Unit casing shall be constructed of zinc coated, galvanized steel. Exterior surfaces shall be cleaned, phosphatized, and finished with a weather-resistant baked enamel finish. Unit's surface shall be tested 672 hours in a salt spray test in compliance with ASTM B117. Cabinet construction shall allow for all maintenance on one side of the unit. Service panels shall have lifting handles and be removed and reinstalled by removing two fasteners while providing a water and air tight seal. All exposed vertical panels and top covers in the indoor air section shall be insulated with a cleanable foil-faced, fire-retardant permanent, odorless glass fiber material. The base of the unit shall be insulated with 1/8 inch, foil-faced, closed-cell insulation. All insulation edges shall be either captured or sealed. The unit's base pan shall have no penetrations within the perimeter of the curb other than the raised 1 1/8 inch high downflow supply/return openings to provide an added water integrity precaution, if the condensate drain backs up. The base of the unit shall have provisions for forklift and crane lifting, with forklift capabilities on three sides of the unit.

## Compressors

All units shall have direct-drive, hermetic, scroll type compressors with centrifugal type oil pumps. Motor shall be suction gas-cooled and shall have a voltage utilization range of plus or minus 10 percent of unit nameplate voltage. Internal overloads shall be provided with the scroll compressors.

Crankcase heaters shall be included on 6-10 ton units.

Dual compressors are outstanding for humidity control, light load cooling conditions and system back-up applications. Dual compressors are available on 7½-10 ton models and allow for efficient cooling utilizing 3-stages of compressor operation for all high efficiency models.

## Controls

Unit shall be completely factory-wired with necessary controls and contactor pressure lugs or terminal block for power wiring. Unit shall provide an external location for mounting a fused disconnect device.

A choice of microprocessor or electromechanical controls shall be available.

Microprocessor controls provide for all 24V control functions. The resident control algorithms shall make all heating, cooling, and/or ventilating decisions in response to electronic signals from sensors measuring indoor and outdoor temperatures. The control algorithm maintains accurate temperature control, minimizes drift from set point, and provides better building comfort. A centralized microprocessor shall provide anti-short cycle timing and time delay between compressors to provide a higher level of machine protection.

24-volt electromechanical control circuit shall include control transformer and contactor pressure lugs for power wiring. Units shall have single point power entry as standard.

## Evaporator and Condenser Coils

Internally finned, 5/16" copper tubes mechanically bonded to a configured aluminum plate fin shall be standard. The microchannel type condenser coil is standard for all 6-10 ton standard efficiency models and 4,5,6 and 7½ ton high efficiency models. The microchannel type condenser coil is not



## Mechanical Specifications

---

offered on the 4,5 and 7½ ton dehumidification model. Due to flat streamlined tubes with small ports, and metallurgical tube-to-fin bond, microchannel coil has better heat transfer performance. Microchannel condenser coil can reduce system refrigerant charge by up to 50% because of smaller internal volume, which leads to better compressor reliability. Compact all-aluminum microchannel coils also help to reduce the unit weight. These all aluminum coils are recyclable. Galvanic corrosion is also minimized due to all aluminum construction. Strong aluminum brazed structure provides better fin protection. In addition, flat streamlined tubes also make microchannel coils more dust resistant and easier to clean. Coils shall be leak tested at the factory to ensure the pressure integrity. The evaporator coil and condenser coil shall be leak tested to 600 psig. The assembled unit shall be leak tested to 465 psig. The condenser coil shall have a patent pending 1+1+1 hybrid coil designed with slight gaps for ease of cleaning. A removable, reversible, double-sloped condensate drain pan with through the base condensate drain is standard.

### Filters

Throwaway filters shall be standard on all units. Optional 2-inch MERV 7 and MERV 13 filters shall also be available.

### Gas Heating Section

The heating section shall have a progressive tubular heat exchanger design using stainless steel burners and corrosion resistant steel throughout. An induced draft combustion blower shall be used to pull the combustion products through the firing tubes. The heater shall use a direct spark ignition (DSI) system. On initial call for heat, the combustion blower shall purge the heat exchanger for 20 seconds before ignition. After three unsuccessful ignition attempts, the entire heating system shall be locked out until manually reset at the thermostat/zone sensor. Units shall be suitable for use with natural gas or propane (field-installed kit) and also comply with the California requirement for low NOx emissions (Gas/Electric Only).

### High Pressure Control

All units include High Pressure Cutout as standard.

### Indoor Fan

The following units shall be equipped with a direct drive plenum fan design (T/YSC120F, T/YHC092E/F, T/YHC102E, 120E). Plenum fan design shall include a backward-curved fan wheel along with an external rotor direct drive variable speed indoor motor. All plenum fan designs will have a variable speed adjustment potentiometer located in the control box.

3-5 ton units (standard efficiency 3-phase or high efficiency 3-phase with optional motor) are belt driven, FC centrifugal fans with adjustable motor sheaves. 3-5 ton units (1-phase or high efficiency 3-phase) have multispeed, direct drive motors. All 6-8½ ton units (standard efficiency) shall have belt drive motors with an adjustable idler-arm assembly for quick-adjustment to fan belts and motor sheaves. All motors shall be thermally protected. All 10 tons and 7½-8½ (high efficiency) have variable speed direct drive motors. All indoor fan motors meet the U.S. Energy Policy Act of 1992 (EPACT).

### Outdoor Fans

The outdoor fan shall be direct-drive, statically balanced, draw-through in the vertical discharge position. The fan motor shall be permanently lubricated and shall have built-in thermal overload protection.

### Phase Monitoring Protection

Precedent™ units with 3-phase power are equipped with phase monitoring protection as standard. These devices protect motors and compressors against problems caused by phase loss, phase imbalance and phase reversal indication.

### **Plenum Fan**

All 10 tons and 7½-8½ ton high efficiency units shall be equipped with a direct drive plenum fan design. Plenum fan design shall include a backward-curved fan wheel along with an external rotor direct drive variable speed indoor motor. All plenum fan designs will have a variable speed adjustment potentiometer located in the control box.

### **Refrigerant Circuits**

Each refrigerant circuit offer thermal expansion valve as standard. Service pressure ports, and refrigerant line filter driers are factory-installed as standard. An area shall be provided for replacement suction line driers.

### **Unit Top**

The top cover shall be one piece construction or where seams exist, it shall be outside the indoor air-conditioned section. The ribbed top adds extra strength and prevents water from pooling on unit top.

## **Factory Installed Options**

### **Black Epoxy Pre-Coated Coils<sup>1</sup>**

The black epoxy coils have a thermoset vinyl coating that is bonded to the aluminum fin stock prior to the fin-stamping process. The pre-coated coils are an economical option for protection in mildly corrosive environments.

### **CompleteCoat™ Coils**

The cathodic epoxy type electrodisposition coating is formulated for high edge build to plate fin and tube heat exchangers. The coating is selected to provide excellent resistance and durability to corrosive effects of alkalies, acids, alcohols, petroleum, seawater, salt air and corrosive environments. This option is available for the plate fin-tube condenser coil and the microchannel type condenser coil.

The option shall be equipped with crankcase heater(s), low pressure switch(es), Froststat™, and a thermostatic expansion valve(s) (TXV) as standard.

### **Heat Exchanger**

The compact cabinet features a tubular heat exchanger in low, medium and high heat capacities.

The heat exchanger is fabricated using stainless steel burners and corrosion-resistant aluminized steel tubes as standard on all models. It has an induced draft blower to pull the gas mixture through the burner tubes. The heater has a direct spark ignition system which doubles as a safety device to prove the flame.

Gas/Electric Precedent models exceed all California seasonal efficiency requirements. They also perform better than required to meet the California NOx emission requirements.

### **Hinged Access Doors**

Sheet metal hinges are available on the Filter/Evaporator, Supply Fan/Heat, and the Compressor/Control Access Doors.

### **Novar Return Air Zone Sensor**

This option, when used in conjunction with Novar Controls, will contain a factory provided and wired zone temperature sensor located in the return air stream.

---

<sup>1</sup> Not available on microchannel condenser coils.

## Mechanical Specifications

---

### Novar Unit Controls

Optional Novar rooftop unit controls shall be installed and tested. The Novar electronic thermostat module will interface to the unit microprocessor and will control the unit to the desired stage of cooling or heating.

### Powered or Unpowered Convenience Outlet

This is a GFCI, 120V/15amp, 2 plug, convenience outlet, either powered or unpowered. When the convenience outlet is powered, a service receptacle disconnect will be available. The convenience outlet is powered from the line side of the disconnect or circuit breaker, and therefore will not be affected by the position of the disconnect or circuit breaker. This option can only be ordered when the Through the Base Electrical with either the Disconnect Switch or Circuit Breaker option is ordered.

### Single Zone VAV – One Zone Variable Air Volume Mode

Single zone VAV is designed for use in single zone applications like gymnasiums, auditoriums, manufacturing facilities, retail box stores, and any large open spaces, where there is a lot of diversity in the load profile. Single Zone VAV (SZ VAV) is an ideal replacement to “yesterday’s” constant volume (CV) systems, by reducing operating costs while improving occupant comfort. SZ VAV systems combine Trane application, control and system integration knowledge to exactly match fan speed with cooling and heating loads, regardless of the operating condition. Trane algorithms meet/exceed ASHRAE 90.1- 2010, SZ VAV energy-saving recommendations, and those of CA Title 24. The result is an optimized balance between zone temperature control and system energy savings. Depending on your specific application, energy savings can be as much as 20+%.

**Note:** *Building system modeling in energy simulation software like TRACE is recommended to evaluate performance improvements for your application.*

SZ VAV is fully integrated into the ReliaTel Control system and is available today. It provides the simplest and fastest commissioning in the industry through proven factory-installed, wired, and tested system controllers. All control modules, logic and sensors are factory installed, and tested to assure the highest quality and most reliable system available. This means no special programming of algorithms, or hunting at the jobsite for sensors, boards, etc. that need to be installed in the field. Single zone VAV is a quick and simple solution for many applications and is available from your most trusted rooftop VAV system solution provider - Trane.

### Multi-Speed Indoor Fan System

Multi-speed indoor fan system is designed for use in applications for meeting the minimum requirement of CA Title 24.

This system incorporates a multi-speed fan control to change the speed of the fan to 67% of full airflow based off of compressor stages.

### Stainless Steel Heat Exchanger

The optional stainless steel heat exchanger is constructed of 409 stainless steel. It is resistant to corrosion and oxidation and easy to clean.

The high strength to weight ratio allows for high ventilation rates with gas units. It is an excellent option to compliment the dehumidification option as a high outside air ventilation unit.

With this option, a 10-year stainless steel heat exchanger warranty is standard.

### Supply and/or Return Air Smoke Detector

With this option, if smoke is detected, all unit operation will be shut down. Reset will be manual at the unit. Return Air Smoke Detectors require minimum allowable airflow when used with certain models. See the Installation, Operation, and Maintenance (IOM) manual for the models affected and the minimum allowable airflow required.

### **Thermal Expansion Valve**

Thermal Expansion Valve is standard for all models.

### **Through the Base Electrical Access**

An electrical service entrance shall be provided allowing electrical access for both control and main power connections inside the curb and through the base of the unit. Option will allow for field installation of liquid-tight conduit and an external field-installed disconnect switch.

### **Through the Base Electrical with Circuit Breaker**

This option is a thermal magnetic, molded case, HACR Circuit Breaker with provisions for through the base electrical connections. The circuit breaker will be installed in a water tight enclosure in the unit with access through a swinging door. Wiring will be provided from the switch to the unit high voltage terminal block. The circuit breaker will provide overcurrent protection, be sized per NEC and cULus guidelines, and be agency recognized by cULus.

### **Through the Base Electrical with Disconnect Switch**

This 3-pole, molded case, disconnect switch with provisions for through the base electrical connections are available. The disconnect switch will be installed in the unit in a water tight enclosure with access through a swinging door. Wiring will be provided from the switch to the unit high voltage terminal block. The switch will be cULus agency recognized.

**Note:** *The disconnect switch will be sized per NEC and cULus guidelines but will not be used in place of unit overcurrent protection.*

### **Through the Base Gas Piping**

The unit shall include a standard through the base gas provision. This option shall have all piping necessary including, black steel, manual gas shut-off valve, elbows, and union. The manual shut-off valve shall include a 1/8" NPT pressure tap. This assembly will require minor field labor to install (Gas/Electric Only).

### **Two-Inch Filters**

Two-inch MERV 7 and MERV 13 media filters shall be available on all models.

## **Factory or Field Installed Options**

### **Clogged Filter/Fan Failure Switch**

A dedicated differential pressure switch is available to achieve active fan failure indication and/or clogged filter indication. These indications will be registered with either a zone sensor with status indication lights or an Integrated Comfort™ System. This option is available for microprocessor controlled units.

### **Differential Pressure Switches**

These sensors allow individual fan failure and dirty filter indication for microprocessor controlled units. The fan failure switch will disable all unit functions and "flash" the Service LED on the zone sensor. The dirty filter switch will light the Service LED on the zone sensor and will allow continued unit operation.

### **Discharge Air Sensing**

This option provides true discharge air sensing in heating models. This sensor is a status indicator readable through Tracer™ or Tracker™. This option is available for microprocessor controlled units.

### **Economizer**

This accessory shall be available with or without barometric relief. The assembly includes fully modulating 0-100 percent motor and dampers, minimum position setting, preset linkage, wiring



## Mechanical Specifications

---

harness with plug, spring return actuator and fixed dry bulb control. The barometric relief shall provide a pressure operated damper that shall be gravity closing and shall prohibit entrance of outside air during the equipment "off" cycle. Optional solid state or differential enthalpy control shall be available for either factory or field installation. The economizer arrives in the shipping position and shall be moved to the operating position by the installing contractor.

### Electric Heaters

Electric heat modules shall be available for installation within basic unit. Electric heater elements shall be constructed of heavy-duty nickel chromium elements internally delta connected for 240V, wye connected for 480V and 600 V. Staging shall be achieved through ReliaTel™. Each heater package shall have automatically reset high limit control operating through heating element contactors. All heaters shall be individually fused from the factory, where required, and shall meet all NEC and CEC requirements when properly installed. Power assemblies shall provide single-point connection. Electric heat modules shall be cULus listed.

### Frostat

This option is to be utilized as a safety device. The Frostat opens when temperatures on the evaporator coil fall below 10°F. The temperature will need to rise to 50°F before closing. This option should be utilized in low airflow or high outside air applications (cooling only).

### LonTalk® Communication Interface

This option shall be provided to allow the unit to communicate as a Tracer™ LCI-R device or directly with generic LonTalk Network Building Automation System Controls.

### BACnet™ Communication Interface

This option shall be provided to allow the unit to communicate directly with a generic open protocol BACnet MS/TP Network Building Automation System Controls.

### Reference or Comparative Enthalpy

Reference Enthalpy is used to measure and communicate outdoor humidity. The unit receives and uses this information to provide improved comfort cooling while using the economizer. Comparative Enthalpy measures and communicates humidity for both outdoor and return air conditions, and return air temperature. The unit receives and uses this information to maximize use of economizer cooling, and to provide maximum occupant comfort control. Reference or Comparative Enthalpy option shall be available when a factory or field installed Downflow Economizer is ordered. This option is available on all downflow models.

### Tool-less Hail Guards

Tool-less, hail protection guards are available for condenser coil protection.

### Trane Communication Interface

This option shall be provided to interface ReliaTel™ controlled units with the Trane Integrated Comfort™ systems.

## Field Installed Options

### CO<sub>2</sub> Sensor

The CO<sub>2</sub> sensor shall have the ability to monitor the concentration (parts per million, ppm) of CO<sub>2</sub> (Carbon Dioxide) in the air. As the CO<sub>2</sub> concentration changes, the outside air damper modulates to meet the current ventilation needs of the zone.

### Duct Mounted Humidity Sensor

This duct-mounted humidity sensor is used to control activation of the hot gas reheat dehumidification option. The humidity sensor can be set for humidity levels between 40% and 60% relative humidity by adjusting the ReliaTel Options Module.



**High Static Drive**

The high static drive option shall allow the standard motor to operate with improved external static capabilities.

**Manual Outside Air Damper**

This rain hood and screen shall provide up to 50 percent outside air.

**Motorized Outside Air Damper**

Manually set outdoor air dampers shall provide up to 50 percent outside air. Once set, outdoor air dampers shall open to set position when indoor fan starts. The damper shall close to the full closed position when indoor fan shuts down.

**Powered Exhaust**

The powered exhaust, available for 3-10 ton units, shall provide exhaust of return air, when using an economizer, to maintain better building pressurization.

**Programmable Night Setback**

Auto or manual changeover with seven-day programming. Keyboard selection of Heat, Cool, Fan, Auto, or On. All programmable sensors have System On, Heat, Cool, Service LED/indicators as standard. Night Setback Sensors have one (1) Occupied, one (1) Un-occupied, and one (1) Override program per day.

**Remote Potentiometer**

The minimum position setting of the economizer shall be adjusted with this accessory.

**Roof Curb**

The roof curb shall be designed to mate with the unit's downflow supply and return and provide support and a water tight installation when installed properly. The roof curb design shall allow field-fabricated rectangular supply/return ductwork to be connected directly to the curb. Curb shall be shipped knocked down for field assembly and shall include wood nailer strips.

**Thermostat**

Two stage heating and cooling operation or one stage heating and cooling shall be available in either manual or automatic changeover. Automatic programmable electronic with night set back shall also be available.

**Ventilation Override Accessory**

With the Ventilation Override Accessory installed, the unit can be set to transition up to 3 different pre-programmed sequences for Smoke Purge, Pressurization, and Exhaust. The transition occurs when a binary input on the RTOM is closed (shorted). This would typically be a hard wired relay output from a smoke detector or fire control panel. The ventilation override accessory shall be available as field installed.

**Wall Mounted Humidity Sensor**

This wall-mounted humidity sensor is used to control activation of the hot gas reheat dehumidification option. The humidity sensor can be set for humidity levels between 40% and 60% relative humidity by adjusting the ReliaTel Options Module.

**Wireless Zone Sensor**

LCD display that provides heat, cool, auto or off. Includes two temperature setpoints and a lockable setting with °F or °C indicators.



## Mechanical Specifications

---

### **Zone Sensor**

This control shall be provided to interface with the Micro equipped units and shall be available in either manual, automatic programmable with night setback, with system malfunction lights, or remote sensor options.





Trane optimizes the performance of homes and buildings around the world. A business of Ingersoll Rand, the leader in creating and sustaining safe, comfortable and energy efficient environments, Trane offers a broad portfolio of advanced controls and HVAC systems, comprehensive building services, and parts. For more information, visit [www.Trane.com](http://www.Trane.com).

Trane has a policy of continuous product and product data improvement and reserves the right to change design and specifications without notice.

© 2012 Trane All rights reserved  
RT-PRC023-EN 16 May 2012  
Supersedes RT-PRC023-EN (02 Dec 2011)

We are committed to using environmentally  
conscious print practices that reduce waste.

