

MANUFACTURER OF
ENGINEERED PRODUCTS

SPECIALIZED IN

**TEETH, ADAPTERS
SHROUDS AND
LOCKING**

WWW.BUCKETTEETH.NET
CATALOGUE 2014





INDEX

INSTRUCTIONS	01-05
QUICK REFERENCES	06-09
CAT	10-45
KOMATSU	46-58
ESCO-SUPER-V	59-75
DOOSAN	76-79
DOOSAN- 2014 NEW SYSTEM	80
ESCO	81-85
VOLVO	86-87
KOBLECO	88-89
HYUNDAI	90-93
BOFOR	94-97
JCB	98
MINI Fork Tip	99
FIAT KOMATSU	100
FIAT HITACHI	101
HL	102
LIEBHERR	103
FAIT	104
UNI-Z	105
LEHNOFF	106
HENSLEY	107-109
TATA HITACHI INDIAN	110
JOHN DEER INDIAN	111
INDIAN FORK TEETH	112
INDIAN CASE	113



INDEX

INDIAN CAT	114
KOBLECO-NEW MACHINE	115
FIAT KOBELCO	116
FAIT HITACHI	117
HIDROMEK	118
KAWASAKI	119
ADCO	120
BOBCAT	121
KAWASAK	122
NON-KNOW BRAND- FORK TIP	123
HIATICHI -FORK TIP	124
BRASIL -G.E.T SYSTEM	125
NON-KNOW BRANDS SIDE CUTTER	126
SANYI	127-128
CASE	129-131
CHINA MACHINE(XGMA, XCMG, LIUGONG,SDLG)	132-134
SINGLE BEVEL CUTTING EDGE	134-142
BULLDOZER END BITS	143-145
GRADER END BITS	146-152
PIN AND LOCKS	153-159
BOLT AND NUT	160-161
PIN AND LOCKS	162-169



INSTRUCTIONS

ENGINEERED PRODUCTS

TURBO OFFERS A COMPLETE LINE FOR CATERPILLAR G.E.T. SYSTEM

CAT SIZE	J200	J220	J250	J300	J350	J400	J450	J460	J550	J600	J700	J800
	LIGHT CONSTRUCTION			CONSTRUCTION			HEAVY CONSTRUCTION			MINING		
MACHINE SIZE (TONS)	J200	J220	J250	J300	J350	J400	J450	J460	J550	J600	J700	J800
	6	9	11	20	30	40	60	63	80	140	250	300

LIGHT CONSTRUCTION MARKET

- For backhoe loaders, mini excavators and other compact machines.
- Sizes J200, J220 and J250 offer selection of adapters and point shapes to fit all applications
- Both weld-on and bolt-on adapters for wheel loaders.

CONSTRUCTION MARKET

- For mid range wheel loaders and excavators.
- Sizes J300, J350 and J400 offer one of the widest selections of points and adapters to service applications from general purpose to extreme service
- Both weld-on and bolt-on adapters for most wheel loaders.

HEAVY CONSTRUCTION MARKET

- For large wheel loaders, excavators and face shovels.
- Sizes J450, J550 and J600 offer a complete range of points and adapters.
- Designed and manufactured to perform in the toughest conditions, from pipeline work in rock to demanding quarry applications.

MINING MARKET

- For wheel loaders, excavators, face shovels and shovel dippers used in mining applications.
- Sizes J700, J800 have a comprehensive offer of points and adapters to cover a wide range of heavy duty to extreme duty applications.
- All components are designed for maximum strength, reliability and service life to increase productivity and reduce the overall cost of ownership.

CATERPILLAR BUCKET TIP ADAPTERS

PROVIDE DIFFERENT PERFORMANCE FOR DIFFERENT JOBS

ROCK BUCKET ADAPTERS



BOTTOM-STRAP WELD-ON ADAPTER

- Provides the largest offset for the most aggressive digging.
- Thick bottom strap provides the greatest protection of base edge.
- Promotes fast loading; permits easy, complete dumping.
- Available for 910 through 992 Loaders.

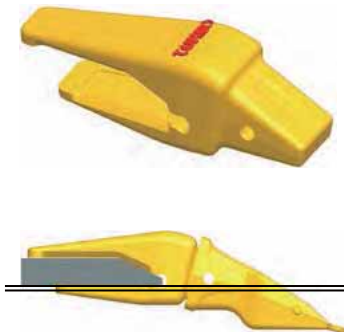

TWO-STRAP WELD-ON ADAPTER

- Provides best retention in high-impact work.
- For general loading, where adapter retention is a concern.
- Protects the base edge well.
- Available for 966, 980, 988, 990, 992 and 994 Loaders.



HEAVY DUTY TWO-STRAP WELD-ON ADAPTER

- Thicker to provide increased adapter strength.
- Weld-groove enlarged for easier welding, which enhances adapter retention.
- Bottom strap is thicker for longer wear life and greater base-edge protection.
- Shouldered to provide rear tip protection and improved retention.
- Available for 966 through 992 Loaders.



FLUSHMOUNT WELD-ON ADAPTER

- Provides smooth bucket footprint, leaving a clean, unrutted work surface.
- Extends tire life.
- Available for 910 through 992 Loaders.



TWO-STRAP WELD-ON

- Provides size-up tip option without increasing thickness.
- Stronger, more protection.
- Available for 980, 988, 990, 992 and 994 Loaders.

CATERPILLAR BUCKET TIP ADAPTERS

PROVIDE DIFFERENT PERFORMANCE FOR DIFFERENT JOBS

CATERPILLAR CORNER GUARD ADAPTER SYSTEMS

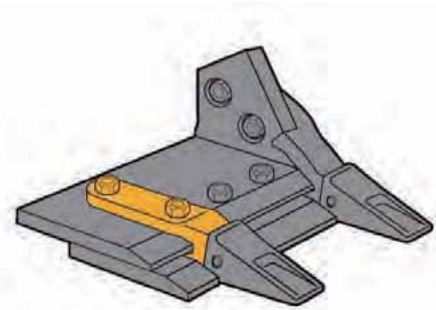
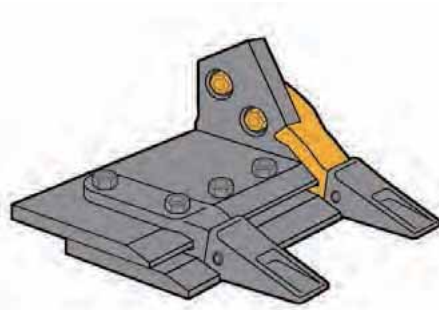
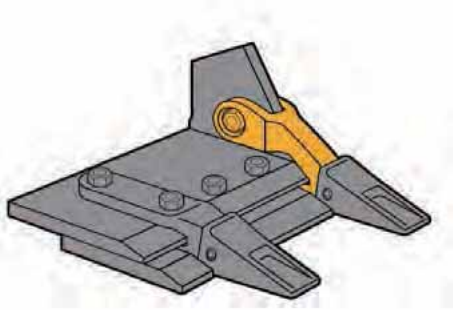

SINGLE-BOLT CORNER ADAPTER

- Puts wear material under the base edge and on the front inside and outside of the corner.
- Easy to install, remove and replace.
- Available for 910 and 988 Wheel Loaders and all Track Loaders

TWO-BOLT CORNER ADAPTER

- Keeps adapter securely attached; won't shift in demanding applications
- Reduces stress, adding service life in high-wear applications
- Easy to retrofit and convert your old buckets to the two-bolt design with a simple welding operation
- Available for 916 through 980 Wheel Loaders

CENTER BOLT-ON CORNER ADAPTER

- Used in general loading work, where leaving a smooth work surface isn't needed
- Provides good base-edge protection
- Easy to install, remove and replace
- Available for 910 through 992 Loaders

CATERPILLAR EXCAVATOR ADAPTERS



CATERPILLAR EXCAVATOR ADAPTERS

All Cat excavator buckets come with two strapweld-on adapters. (Ditch-cleaning buckets come with bare base edge) The adapters are designed especially for excavator work, but they accept the same tips used on Caterpillar loader buckets.

TIP SELECTION GUIDE

WHAT TO CONSIDER WHEN YOU'RE CHOOSING TIPS BUCKET

ALL TURBO BUCKET TIPS ARE MADE FROM ONE OF TWO SPECIAL STEEL ALLOYS:
F2, which resists softening in applications that generate high heat.
F4, which is through-hardened to provide consistently low wear rates throughout the life of the tip.

TIPS COME IN SO MANY DIFFERENT SHAPES AND SIZES, YOU MIGHT THINK IT TAKES AN EXPERT TO PICK THE RIGHT ONE. NOT SO. IT CAN ALL BE REDUCED TO A FEW SIMPLE GUIDELINES.

STRENGTH:

The ability to withstand digging and penetrating shocks and high breakout forces ■

PENETRATION:

The ability to penetrate tough material, when it's tightly compacted, rocky or frozen ■

WEAR LIFE:

The ability to withstand wearing, scouring, and abrasive action of the material being handled ■

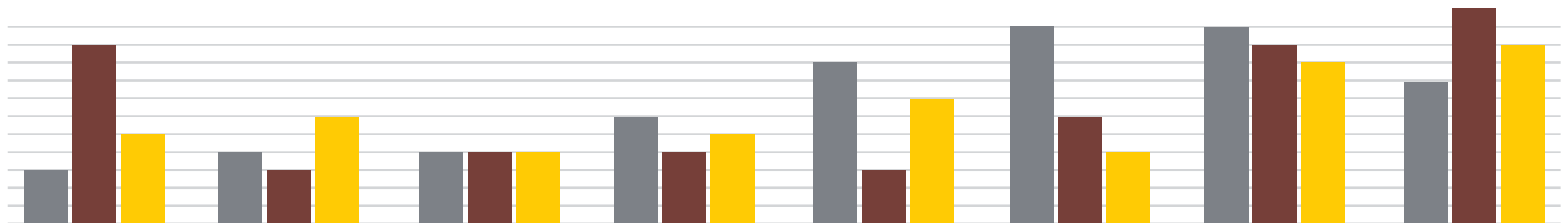

PENETRATION:

- Use in densely compacted material such as clay.
- Gives maximum penetration.
- Self-sharpening.



SHORT:

- Use in high-impact and pry-out work such as rock.
- Extremely strong.



LONG:

- Use in most general applications where breakage is not a problem.
- Extremely strong.



HEAVY DUTY LONG:

- Use in general loading and excavation work.
- Has extended wear strength.



HEAVY DUTY ABRASION:

- Use when working in sand, gravel and shot rock.
- Maximum wear material.



HEAVY DUTY LONG LIFE:

- Use to increase wear life and penetration. As the Heavy Duty
- Long Life tip wears, ease of penetration.



HEAVY DUTY PENETRATION:

- Use in high-impact, hard-to-penetrate material.
- Extended wear life.



ROCK CHISEL:

- 3 to 5 times more wear life than standard.

TIPS FOR SPECIAL APPLICATIONS



UNITOOTH:

- A one-piece tip and adapter that bolts to the bucket.
- Use in light-to medium-duty work.



CENTER SHARP:

- Fitted to central part of the bucket cutting edge.
- Provides maximum gouging and penetration capabilities.
- Unlike competitive tips, it features a single center rib that keeps tips sharp for life.



WIDE:

- Use on excavators to increase capacity in light materials.
- Reduces bucket spillage.
- Leaves a smoother floor



CORNER SHARP:

- Install on bucket corners.
- Provides maximum gouging and penetration capabilities.
- Can be used on either side of the bucket edge.



TWIN SHARP:

- Provides more wear material, increased strength, enhanced fracture capabilities.
- Opposite corner tips may be exchanged to prolong wear.























QUICK REFERENCES

CATERPILLAR SIDE PIN TEETH CHART

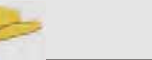
EXCAVATOR

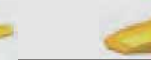
EXCAVATOR										
J200	1U3209	1U3202SYL	1U3202V	1U3202	1U3202RC	1U3202TL · 9W8209	220-3202	1U3201	1U3202R	1U3202WTL · 135-8208
J220		6Y3222SYL	6Y3222V	6Y3222	6Y3222RC		220-3202	1U3201	1U3202R	1U3202WTL · 135-8208
J250	9J4259	1U3252SYL	1U3252V	1U3252	1U3252RC	1U3252TL · 9W8259	220-3222			
J300	9J4309	1U3302SYL	1U3302V · 183-5300	1U3302	1U3302RC	1U3302TL · 9W8309	220-3252	1U3251	1U3252R	1U3252WTL · 135-8258
J350	9J4359	1U3352SYL	1U3352V · 168-1359	1U3352	1U3352RC	1U3352TL · 9W8359	220-3302	1U3301	1U3302R	1U3302WTL · 135-9308
J400	7T3409	7T3402SYL	7T3402V · 168-1409	7T3402	7T3402RC	7T3402TL · 6Y5409	220-3352	1U3351	1U3352R	1U3352WTL · 135-9357
J450	9W8459	9W8452SYL	9W8452V · 159-0459	9W8452	9W8452RC 9W8452RC 1U3452RC	9W8452TL · 7T8459	220-3402	7T3401	7T3402R	7T3402WTL · 135-9408
J550	9W8559	9W8552SYL	1U3552V · 159-0559	9W8552		9W8552TL · 9W6559	220-8452	9W8451	9W8452R	9W8452WTL · 138-6458
J600	717609			616602		616602TL · 107-8609	220-8552	9W8551	9W8552R	9W8552WTL · 138-6558
J700	4T4709			4T4702			220-6602	616601	616602R	616602WTL · 135-9608
J800					618802RC					

LOADER

LOADER									
J200				4T2203 · 9J4203					1U3202
J220									
J250	9N4253			4T2253 · 9J4253				9N4252	1U3252
J300	9N4303	1U3302PT		4T2303 · 9J4303	135-9300		4T2303RP2	9N4302	1U3302
J350	9N4353	1U3352PT		4T2353 · 9J4353	144-1358		4T2353RP2	9N4352HD	1U3352
J400		7T3402PT		7T3403 · 9J4403	135-9400		7T3403RP2	8E4402	7T3402
J450	9N4453	9W8452PT		9W1453 · J4453	138-6451		9W1453RP2	9N4452HD	9W8452
J550	6Y2553	9W8552PT		9W1553 · 9J4553	138-6551 138-6552		9W1553RP2	9N4552	9W8552
J600	616603	616602PT			135-9600		616602RP2	7Y0602	616602
J700	4T4703	4T4702PT			135-9700				4T4702
J800	618803	618802PT							

EXCAVATOR G.E.T. CHART



EXCAVATOR

EDGE THICKNESS	EDGE DEGREE	SIZE	WELD ON ADAPTERS	TEETH	PIN	RETAINERS	HEEL SHROUD	CONNER LIPS	SIDE CUTTER	PROTECTOR	MACHINE MOLDES
20	23°	J200	8J7525	1U3202	8E6208	8E6209	*		*		416 · 446
22	23°	J220	6Y3224	6Y3222	6Y3228	8E6209	*		*	*	416 · 4426
25	23°	J250	6Y3254	1U3252	8E6258	8E6259	HS1140-110		7Y0203 · 7Y0204	*	E200 · 205 · 214 · 206 213 · 311 · 312
30	23°	J300	3G6304	1U3302	9J2308	8E6259	HS1175-140	HZ-50-150-23°	7Y0203 · 7Y0204	*	E180 · E200 · 215 · 219 311 · 312 · 320 · 325
30	23°	J300	8E9490	1U3302	9J2308	8E6259	HS1175-140	HZ-50-150-23°	7Y0203 · 7Y0204	*	E180 · E200 · 215 · 219 311 · 312 · 320 · 325
40	35°	J350	3G8354HD	1U3352	8E6358	8E6359	ES6697-2-185		096-4747 · 096-4748	*	225 · 219 · 215 · 320 E200 · E240
40	23°	J350	8J4310(6I6354)	1U3352	8E6358	8E6359	ES6697-2-185	HZ-50-150-23°	096-4747 · 096-4748	*	225 · 219 · 215 · 320 E200 · E240
45	23°	J400	6I6404	7T3042	7T3408	8E8409	ES6697-2-185	HZ-50-150-23°	096-4747 · 096-4748	*	235FS · 231SD · 300 · 231D
50	23°	J450	6I6464	9W8452	8E0468	8E0469	ES6697-2-185	HZ-70-250-23°	7Y0357 · 7Y0358 8J9825 · 8J9826	166-2877	225 · 235 · 245 · 320 325 · 330 · E30
60	23°	J550	6I6554	9W8552	6Y8558	8E5559	ES6697-2-185	HZ-70-250-23°	*		245 · 330
70	23°	J600	6I6604	6I6602	6I6608	6I6609	ES6697-5-250		*		375 · 365 · 374
90	23°	J700	4T4704		4T4708	4T4707	ES6697-5-250		*		375

LOADERS G.E.T. CHART



LOADERS







EDGE THICKNESS	EDGE DEGREE	SIZE	WELD ON ADAPTERS	TEETH	BOLT	NUT	CONNER ADAPTER 2 HOLES	CONNER ADAPTER	SEGMENT	MACHINE MOLDES
20	23°	J200	8E2184	4T2303	5J4771	2J3506	6I9250 · 6I9251	1U2208 · 1U2209		910 · 914 · 931 · 933 · 935 IT12 · 416 · 426 · 428 · 436
25	23°	J250	1U0257	9N4253	4F3656	4K0367	6I9250 · 6I9251	3G4258 · 3G4259	132-1037 · 4T6694 4T6692 · 4T6691	916 · 920 · 924 · 926 · 928 · 930 · 931 933 · 935 · 936 · 939941 · 943 · 953 · 95
30	23°	J300	1U0307	9N4303	8J2928	8J2933	8E5308 · 8E5309	3G4308 · 3G4309	4T6693 · 4T6694 · 132-1037	950 · 955 · 960 · 963
40	23°	J350	3G3357	9N4353	5P8361	5P8361	3G5358 · 3G5359	3G5358 · 3G5359	4T3015 · 4T9123 · 4T91234	960 · 963 · 966 · 966C · 966G 970 · 972G · 973 · 977
45	23°	J400	6I9898		5P8361	5P8361		1U1358 · 1U1359		
50	23°	J450	8E2467	9N4453	5P8361	5P8361	8E3468 · 8E3469	6I8242 · 6I8243		980
60	23°	J550					6I8242 · 6I8243			
70	23°	J600					8E3468 · 8E3469			
90	23°	J700								
100	23°	J800							*	

EDGE THICKNESS	EDGE DEGREE	SIZE	WELD ON ADAPTERS	TEETH	PIN	RETAINERS	HALF ARROW	SEGMENT	MACHINE MOLDES
20	23°	J200	9J7525	4T2303	8E6208	8E6209			
25	23°	J250	3G0169	9N4253	8E6258	8E6259			
30	23°	J300	9J8929	9N4303	9J2308	8E6259			
40	23°	J350	135-9354	9N4353	8E6358	8E6359	135-9544/9545/9546	135-9544/45/46	966
45	23°	J400	125-8404		7T3408	8E8409	113-3140/3141/3142	116-7460/7461/7462	980
50	23°	J450	114-0464	9N4453	8E0468	8E0469	109-9080/9081/9082	116-7460/7461/7462 101-9435/9436/9437	983 988
60	23°	J550	107-3554	6Y2553	6Y8558	8E5559	195-7190/7191/7192	4T6760/6761/6762	922C · 992B 245 · 990
70	23°	J600	119-8604	6I6603	6I6608	6I6609	109-2675/2676/2677	4T6760/6761/6762	375 · 992
90	23°	J700	133-0704	4T4703	4T4708	4T4707	109-9030/9031/9032	4T6760/6761/6762	992 · 994
100	23°	J800	6I8804	6I8803	4T4708	4T4707	109-9033/9034/9035		994 · 998

DOZER G.E.T. CHART











DOZERS

 MACHINE	 SHANK ASSEMBLY	 REPAIR SEGMENT	REPAIR NOSE	 SHANK GUARD PART NUMBER	 SHANK GUARD UPPER FASTENER(S)	 SHANK GUARD LOWER FASTENER(S)	 TOOTH SERIES
D11 (SS)	8E0467 · 8E1466 · 7T6020 · 9W0259	104-9279 · 6Y9473	N/A	9N4621	8E2229P 8E2230 (pin & retainer)	8E2229P · 8E2230 (pin & retainer)	R550
D11 (MS) · D10 · D9L	6Y6138 · 8E8411 · 6Y6141 · 8E8414 · 6Y6144 · 8E8415 6Y6147 · 8E8416 · 8E8417 · 109-9114 · 114-4503	103-8115	107-3361	9W8365	6Y3909/4T4707 (pin & retainer) 3G0500	6Y3909/4T4707 (pin & retainer) 3G0500	R500
D10	6Y4679 · 8E8412 · 118-2140 · 109-3135 · 6Y5616 · 8E8413	103-8115	107-3361	6Y8960 · 6Y8960H	6Y3909/4T4707 (pin & retainer) 3G0500	6Y3909/4T4707 (pin & retainer)	R500
D10	1V4592 · 7T5130 · 3G8566 · 9W4427 · 3G2088 · 9W4426 9J5954 · 1U4873 · 7T5131	1U3630*	103-8114	6Y9704	8J4889 (weld-on retainer)	6Y3909/4T4707 (pin & retainer) 3G0500	R500
	3G5707 · 3G6507	1U3630*	103-8114	1U3644 · 1U3644H		6Y3909P/4T4707W · 3G0500P*	R500
D9 · D8	107-3485 · 107-3486 · 4T0134 · 4T0135 · 4T0136 · 4T8988 4T8989 · 4T8990 · 7J1792 · 7J1793 8E5339 · 8E5340 8E5341 · 8E5345 · 8E5346 · 8E5347 · 8E5348 · 9W6167	8E8418 7J1791	9U9694 4T9776	6J8814 · 8E1848	6J8811	6Y3394/8E5559 · 7J9600	R450
D7H · 983	9W7382 · 7J6671		9W7488				R350
D7 · D6 · D5 · 973 977	9J3139 (straight) · 9J8923 (curved)	9J3139					R350 9J8920 (old style)
D4 · 941 · 951 · 955 · 963	9J6586 (straight) · 9J8913 (curved)		8E7350				R300
953 943	1U1257		9J4254				J250
D3 931	8J5299		8J7525				J200
4 · 12 · 14 · 112 · 130 · 140	9F5124 · 5B6251 (Scarifier Shanks)						2D5572 · 6Y5230

COMPACTOR G.E.T. CHART



COMPACTOR

 MACHINE	 TAMPING FOOT	 HD ROCK FOOT	 BOLT	 NUT	 WASHER	 FINGER SHANK	 TEETH	 PIN
815 815B	8K9189 · 2V7053	4V3851	8K9183	7H3607	5S0581	5V4311	3G8250	9J2258 · 3G9609
825 835	8k9171 · 2V6628 · 7K2939	4V0668	8K9164	7H3609	4D6194			



CAT



EXCAVATOR

K: K+J SERIES

SIZE	TURBO PART N°	DESCRIPTION	WEIGHT							
J200	220-3202	k+J series	1.3	4T1204	8J7525	*	*	9J4297 8E2184	8E6208	8E6209
J220	220-3222	k+J series	2.2	*	*	*	*	*	8E6258	8E6259
J250	220-3252	k+J series	3	1U1254	3G0169	*	6Y3254	1U0257	8E6258	8E6259
J300	220-3302	k+J series	4.5	1U1304	9J8929	*	3G6304	4T4307 1U0307 3G9307	9J2308	8E6259
J350	220-3352	k+J series	6.5	1U1354	1U1350	135-9354/55/56 113-0354/55/56	3G8354	3G3357 1U1357	8E6358	8E6359
J400	220-3402	k+J series	9	*	*	125-8404/05/06	6I6404	6I9898	7T3408	8E8409
J450	220-8452	k+J series	12	8E0464	*	114-0464/65/66	6I6464	8E2467	8E8468	8E8469
J550	220-8552	k+J series	18.5	7J9554	*	107-3554/55/56	6I6554	*	6Y8558	8E8559
J600	220-6602	k+J series	29	*	*	119-8604/05/06	6I6604	*	6I6608	6I6609



EXCAVATOR



LOADER

Long-Standard Version

SIZE	TURBO PART N°	DESCRIPTION	WEIGHT							
J200	1U3202	Long-new desgin	1.3	4T1204	8J7525	*	*	9J4297 8E2184	8E6208	8E6209
J220	6Y3222	Long-new desgin	2.2	*	*	*	6Y3224	*	8E6258	8E6259
J250	1U3252	Long-new desgin	3	1U1254	3G0169	*	6Y3254	1U0257	8E6258	8E6259
J300	1U3302	Long-new desgin	4.5	1U1304	9J8929	*	3G6304	4T4307 1U0307 3G9307	9J2308	8E6259
J350	1U3352	Long-new desgin	6.6	1U1354	1U1350	135-9354/55/56 113-0354/55/56	3G8354	3G3357 1U1357	8E6358	8E6359
J400	7T3402	Long-new desgin	9.4	*	*	125-8404/05/06	6I6404	6I9898	7T3408	8E8409
J450	9W8452 1U3452	Long-new desgin	12.45	8E0464	*	114-0464/65/66	6I6464	8E2467	8E8468	8E8469
J550	9W8552 1U3552	Long-new desgin	18.45	7J9554	*	107-3554/55/56	6I6554	*	6Y8558	8E8559
J600	6I6602	Long-new desgin	30.3	*	*	119-8604/05/06	6I6604	*	6I6608	6I6609
J700	4T4702	Long-new desgin	41	*	4T4704	*	*			



Long-Light Weight Version



SIZE	TURBO PART N°	DESCRIPTION	WEIGHT							
J300	1U3302	Long-Light Verson	4,1	1U1304	9J8929	*	3G6304	4T4307 1U0307 3G9307	9J2308	8E6259
J350	1U3352	Long-Light Verson	6.1	1U1354	1U1350	135-9354/55/56 113-0354/55/56	3G8354	3G3357 1U1357	8E6358	8E6359
J450	9W8452	Long-Light Verson	11.4	8E0464	*	114-0464/65/66	6I6464	8E2467	8E8468	8E8469



Long -Old Design Version









DISCONTINUE D:
AVAILABLE IN
RCROCK CHISEL
2011 VERSION

SIZE	TURBO PART N°	DESCRIPTION	WEIGHT							
JJ200	1U3202	Long -Old Version	1.2	4T1204	8J7525	*	*	9J4297 8E2184	8E6208	8E6209
J220	6Y3222	Long -Old Version	1.9	*	*	*	6Y3224	*	8E6258	8E6259
J250	1U3252	Long -Old Version	3	1U1254	3G0169	*	6Y3254	1U0257	8E6258	8E6259
J300	1U3302	Long -Old Version	4.1	1U1304	9J8929	*	3G6304	4T4307 1U0307 3G9307	9J2308	8E6259
J350	1U3352	Long -Old Version	6	1U1354	1U1350	135-9354/55/56 113-0354/55/56	3G8354	3G3357 1U1357	8E6358	8E6359
J350	1U3352	Long -Old Version	6.6	1U1354	1U1350	135-9354/55/56 113-0354/55/56	3G8354	3G3357 1U1357	8E6358	8E6359
J400	7T3402	Long -Old Version	9.3	*	*	125-8404/05/06	6I6404	6I9898	7T3408	8E8409
J450	9W8452	Long -Old Version	11.4	8E0464	*	114-0464/65/66	6I6464	8E2467	8E8468	8E8469
J450	1U3452	Long -Old Version	12.4	8E0464	*	114-0464/65/66	6I6464	8E2467	8E8468	8E8469
J550	9W8552	Long -Old Version	18.95	7J9554	*	107-3554/55/56	6I6554	*	6Y8558	8E8559



EXCAVATOR

Rock Chisel

SIZE	TURBO PART N°	DESCRIPTION	WEIGHT							
J200	1U3202RC	LRock Chisel	1.3	44T1204	8J7525	*	*	9J4297 8E2184	8E6208	8E6209
J220	6Y3222RC	Rock Chisel	2.8	*	*	*	6Y3224	*	8E6258	8E6259
J250	1U3252RC	Rock Chisel	3.7	1U1254	3G0169	*	6Y3254	1U0257	8E6258	8E6259
J300	1U3302RC	Rock Chisel	4.8	1U1304	9J8929	*	3G6304	4T4307 1U0307 3G9307	9J2308	8E6259
J300	1U3302RC	Rock Chisel	5.6	1U1304	9J8929	135-9354/55/56 113-0354/55/56	3G6304	4T4307 1U0307 3G9307	9J2308	8E6259
J350	1U3352RC-2014	Rock Chisel	7.6	1U1354	1U1350	135-9354/55/56 113-0354/55/56	3G8354	3G3357 1U1357	8E6358	8E6359
J350	1U3352RC	Rock Chisel	8.2	1U1354	1U1350	125-8404/05/06	3G8354	3G3357 1U1357	8E6358	8E6359
J400	7T3402RC	Rock Chisel	10.4	*	*	114-0464/65/66	6I6404	6I9898	7T3408	8E8409
J450	1U3452RC	Rock Chisel	14.1	8E0464	*	114-0464/65/66	6I6464	8E2467	8E8468	8E8469
J450	9W8452RC	Rock Chisel	14.1	8E0464	*	107-3554/55/56	6I6464	8E2467	8E8468	8E8469
J550	9W8552RC	Rock Chisel	23.5	7J9554	*	107-3554/55/56	6I6554	*	6Y8558	8E8559
J550	1U3552RC	Rock Chisel	23.5	7J9554	*	107-3554/55/56	6I6554	*	6Y8558	8E8559
J550	9W8552PV	Rock Chisel	18.7	7J9554	*	119-8604/05/06	6I6554	*	6Y8558	8E8559
J600	6I6602RC	Rock Chisel	38.8	*	*	*	6I6604	*	6I6608	6I6609
J700	4T4702RC	Rock Chisel	48	*	4T4704	*	*	*		
J800	6I8803RC (390RC)	Rock Chisel	68.5	*	6I8804	*	*	*		











EXCAVATOR

Rock Chisel- Steel









SIZE	TURBO PART N°	DESCRIPTION	WEIGHT							
J220	1U3202RC	Rock Chisel- Steel	1.3	*	*	*	6Y3224	*		
J220	6Y3222RC	Rock Chisel- Steel	2.8	*	*	*	6Y3224	*	8E6258	8E6259
J250	1U3252RC-2013	Rock Chisel- Steel	3.5	1U1254	3G0169	*	6Y3254	1U0257	8E6258	8E6259
J300	1U3302RC	Rock Chisel- Steel	5.5	1U1304	9J8929	*	3G6304	4T4307 1U0307 3G9307	9J2308	8E6259
J350	1U3352RC-3	Rock Chisel- Steel	7.9	1U1354	1U1350	135-9354/55/56 113-0354/55/56	3G8354	3G3357 1U1357	9J2308	8E6259
J350	1U3352RC-2014	Rock Chisel- Steel	7.6	1U1354	1U1350	135-9354/55/56 113-0354/55/56	3G8354	3G3357 1U1357	8E6358	8E6359
J350	1U3352RC	Rock Chisel- Steel	8.2	1U1354	1U1350	135-9354/55/56 113-0354/55/56	3G8354	3G3357 1U1357	8E6358	8E6359
J400	7T3402RC	Rock Chisel- Steel	10.25	*	*	125-8404/05/06	6I6404	6I9898	7T3408	8E8409
J450	1U3452RC	Rock Chisel- Steel	13.9	8E0464	*	114-0464/65/66	6I6464	8E2467	8E8468	8E8469
J450	9W8452RC	Rock Chisel- Steel	13.9	8E0464	*	114-0464/65/66	6I6464	8E2467	8E8468	8E8469



EXCAVATOR

Rock Chisel Heavy Dute



SIZE	TURBO PART N°	DESCRIPTION	WEIGHT							
J300	1U3302HD-2014	Rock Chisel Heavy dute	6.5	1U1304	*9J8929	*	3G6304	4T4307 1U0307 3G9307	9J2308	8E6259
J350	1U3352HD-2014	Rock Chisel Heavy dute	9.8	1U1354	1U1350	135-9354/55/56 113-0354/55/56	3G8354	3G3357 1U1357	8E6358	8E6359
J400	7T3402HD-2014	Rock Chisel Heavy dute	12.5	*	*	125-8404/05/06	6I6404	6I9898	7T3408	8E8409
J450	9W8452HD-2014	Rock Chisel Heavy dute	15.3	8E0464	*	114-0464/65/66	6I6464	8E2467	8E8468	8E8469
J550	9W8552HD-2014	Rock Chisel Heavy dute	25	7J9554	*	107-3554/55/56	6I6554	*		



EXCAVATOR

Rock Chisel-V Type/Light Dute



SIZE	TURBO PART N°	DESCRIPTION	WEIGHT							
J200	1U3202V	Rock Chisel-V type / Light dute	1.2	4T1204	8J7525	*	*	9J4297 8E2184	8E6208	8E6209
J250	1U3252V	Rock Chisel-V type / Light dute	2.6	1U1254	3G0169	*	6Y3254	1U0257	8E6258	8E6259
J300	1U3302V 1835300	Rock Chisel-V type / Light dute	4.5	1U1304	9J8929	*	3G6304	4T4307 1U0307 3G9307	9J2308	8E6259
J350	1U3352V 1681359	Rock Chisel-V type / Light dute	6.1	1U1354	1U1350	35-9354/55/56 113-0354/55/56	3G8354	3G3357 1U1357	8E6358	8E6359
J400	7T3402V 1681409	Rock Chisel-V type / Light dute	8.5	*	*	125-8404/05/06	6I6404	6I9898	7T3408	8E8409
J450	9W8452V 1590459	Rock Chisel-V type / Light dute	14.3	8E0464	*	114-0464/65/66	6I6464	8E2467	8E8468	8E8469
J550	1U3552V 1590559	Rock Chisel-V type / Light dute	21.5	7J9554	*	107-3554/55/56	6I6554	3G3357 1U1357	6Y8558	8E8559



EXCAVATOR

Twin Tiger









SIZE	TURBO PART N°	DESCRIPTION	WEIGHT							
J200	1U3202WTL 135-8208	Twin Tiger	1.4	4T1204	8J7525	*	*	9J4297 8E2184	8E6208	8E6209
J250	1U3252WTL 135-8258	Twin Tiger	3.6	1U1254	3G0169	*	6Y3254	1U0257	8E6258	8E6259
J300	1U3302WTL 135-9308	Twin Tiger	4.7	1U1304	9J8929	*	3G6304	T4307 1U0307 3G9307	9J2308	8E6259
J350	1U3352WTL 135-9357	Twin Tiger	6.75	1U1354	1U1350	135-9354/55/56 113-0354/55/56	3G8354	3G3357 1U1357	8E6358	8E6359
J400	7T3402WTL 135-9408	Twin Tiger	9.9	*	*	125-8404/05/06	6I6404	6I9898	7T3408	8E8409
J450	9W8452WTL 138-6458	Twin Tiger	15.7	8E0464	*	114-0464/65/66	6I6464	8E2467	8E8468	8E8469
J550	9W8552WTL 138-6558 1U3552WTL	Twin Tiger	18.7	7J9554	*	107-3554/55/56	6I6554	*	6Y8558	8E8559
J600	6I6602WTL 135-9608	Twin Tiger	37	*	*	119-8604/05/06	6I6604	*	6I6608	6I6609



EXCAVATOR







Tiger-Central Sharp

SIZE	TURBO PART N°	DESCRIPTION	WEIGHT							
J200	1U3202L 9W8209	Tiger	1.3	4T1204	8J7525	*	*	9J4297 8E2184	48E6208	8E6209
J250	1U3252TL 9W8259	Tiger	2.7	1U1254	3G0169	*	6Y3254	1U0257	8E6258	8E6259
J300	1U3302TL 9W8309	Tiger	4.5	1U1304	9J8929	*	3G6304	4T4307 1U0307 3G9307	9J2308	8E6259
J350	1U3352TL 1U3352VIP 9W8359	Tiger	5.5	1U1354	1U1350	135-9354/55/56 113-0354/55/56	3G8354	3G3357 1U1357	8E6358	8E6359
J400	7T3402TL 7T3402VIP 6Y5409	Tiger	11.8	*	*	125-8404/05/06	6I6404	6I9898	7T3408	8E8409
J450	9W8452TL 1U3452VIP 7T8459	Tiger	12.8	8E0464	*	114-0464/65/66	6I6464	8E2467	8E8468	8E8469
J550	9W8552TL 1U3552TL 9W6559	Tiger	16.4	7J9554	*	107-3554/55/56	6I6554	*	6Y8558	8E8559
J600	6I6602TL 107-8609	Tiger	31.6	*	*	119-8604/05/06	6I6604	*	6I6608	6I6609



EXCAVATOR

Tiger

SIZE	TURBO PART N°	DESCRIPTION	WEIGHT							
J250	HZ250TL	Tiger	2.7	1U1254	3G0169	*	6Y3254	1U0257	8E6258	8E6259
J300	HZ300TL	Tiger	4.8	1U1304	9J8929	*	3G6304	4T4307 1U0307 3G9307	9J2308	8E6259
J350	HZ350TL	Tiger	6.2	1U1354	1U1350	135-9354/55/56 113-0354/55/56	3G8354	3G3357 1U1357	8E6358	8E6359
J400	HZ400TL	Tiger	12.2	*	*	125-8404/05/06	6I6404	6I9898	7T3408	8E8409
J450	HZ450TL	Tiger	13.4	8E0464	*	114-0464/65/66	6I6464	8E2467	8E8468	8E8469
J550	HZ550TL	Tiger	17.6	7J9554	*	107-3554/55/56	6I6554	*	6Y8558	8E8559
J600	HZ600TL	Tiger	37	*	*	119-8604/05/06	6I6604	*	6I6608	6I6609





EXCAVATOR

Short



SIZE	TURBO PART N°	DESCRIPTION	WEIGHT							
J200	1U3201	Short	1.2	4T1204	8J7525	*	*	9J4297 8E2184	8E6208	8E6209
J250	1U3251	Short	2.7	1U1254	3G0169	*	6Y3254	1U0257	8E6258	8E6259
J300	1U3301	Short	4.1	1U1304	9J8929	*	3G6304	4T4307 1U0307 3G9307	9J2308	8E6259
J350	1U3351	Short	5.5	1U1354	1U1350	135-9354/55/56 113-0354/55/56	3G8354	3G3357 1U1357	8E6358	8E6359
J450	9W8451	Short	10.4	*	*	125-8404/05/06	6I6404	6I9898	7T3408	8E8409
J550	9W8551	Short	16	8E0464	*	114-0464/65/66	6I6464	8E2467	8E8468	8E8469



EXCAVATOR

Peneration



SIZE	TURBO PART N°	DESCRIPTION	WEIGHT							
J200	1U3209	Peneration	1.2	4T1204	8J7525	*	*	9J4297 8E2184	8E6208	8E6209
J220	6Y8229	Peneration	1.7	*	*	*	6Y3224	*	8E6258	8E6259
J250	9J4259	Peneration	2.6	1U1254	3G0169	*	6Y3254	1U0257	8E6258	8E6259
J300	9J4309	Peneration	3.5	1U1304	9J8929	*	3G6304	4T4307 1U0307 3G9307	9J2308	8E6259
J350	9J4359	Peneration	5.8	1U1354	1U1350	135-9354/55/56 113-0354/55/56	3G8354	3G3357 1U1357	8E6358	8E6359
J400	6Y7409	Peneration	8.6	*	*	125-8404/05/06	6I6404	6I9898	7T3408	8E8409
J450	9W8459	Peneration	10.4	8E0464	*	114-0464/65/66	6I6464	8E2467	8E8468	8E8469
J550	9W8559	Peneration	14.8	7J9554	*	107-3554/55/56	6I6554	*	6Y8558	8E8559
J600	7I7609	Peneration	29.6	*	*	119-8604/05/06	6I6604	*	6I6608	6I6609
J700	4T4709	Peneration	38	*	4T4704	*	*	*		



EXCAVATOR

Symmetrical

SIZE	TURBO PART N°	DESCRIPTION	WEIGHT							
J200	1U3202SYL	Symmetrical	1.3	4T1204	8J7525	*	*	9J4297 8E2184	8E6208	8E6209
J250	1U3252SYL	Symmetrical	3.1	1U1254	3G0169	*	6Y3254	1U0257	8E6258	8E6259
J300	1U3302SYL	Symmetrical	5.5	1U1304	9J8929	*	3G6304	4T4307 1U0307 3G9307	9J2308	8E6259
J350	1U3352SYL	Symmetrical	7.6	1U1354	1U1350	135-9354/55/56 113-0354/55/56	3G8354	3G3357 1U1357	8E6358	8E6359
J400	7T3402SYL	Symmetrical	11.2	*	*	125-8404/05/06	6I6404	6I9898	8E6258	8E6259
J450	9W8452SYL	Symmetrical	13.5	8E0464	*	114-0464/65/66	6I6464	8E2467	7T3408	8E8409
J550	9W8552SYL	Symmetrical	22	7J9554	*	107-3554/55/56	6I6554	*	8E8468	8E8469
J600	6I6602SYL	Symmetrical	33	*	*	119-8604/05/06	6I6604	*	6Y8558	8E8559



EXCAVATOR



LOADER

Heavy Dute Long New design

SIZE	TURBO PART N°	DESCRIPTION	WEIGHT							
J200	8E4222	Heavy Dute Long New design	2.8	4T1204	8J7525	*	*	9J4297 8E2184	8E6208	8E6209
J250	9N4252	Heavy Dute Long New design	3.8	1U1254	3G0169	*	6Y3254	1U0257	8E6258	8E6259
J300	9N4302	Heavy Dute Long New design	5.6	1U1304	9J8929	*	3G6304	4T4307 1U0307 3G9307	9J2308	8E6259
J350	9N4352	Heavy Dute Long New design	8.8	1U1354	1U1350	135-9354/55/56 113-0354/55/56	3G8354	3G3357 1U1357	8E6358	8E6359
J450	9N4452	Heavy Dute Long New design	16	8E0464	*	114-0464/65/66	6I6464	8E2467	8E8468	8E8469
J550	9N4552	Heavy Dute Long New design	26	7J9554	*	107-3554/55/56	6I6554	*	6Y8558	8E8559
J600	7Y0602	Heavy Dute Long New design	42	*	*	119-8604/05/06	6I6604	*	6I6608	6I6609





LOADER

Abrasion



SIZE	TURBO PART N°	DESCRIPTION	WEIGHT							
J200	4T2203 9J4203	Abrasion	1.4	4T1204	8J7525	*	*	9J4297 8E2184	8E6208	8E6209
J250	4T2253 9J4253	Abrasion	3.6	1U1254	3G0169	*	6Y3254	1U0257	8E6258	8E6259
J300	4T2303 9J4303	Abrasion	5.2	1U1304	9J8929	*	3G6304	4T4307 1U0307 3G9307	9J2308	8E6259
J350	4T2353 9J4353	Abrasion	7.1	1U1354	1U1350	135-9354/55/56 113-0354/55/56	3G8354	3G3357 1U1357	8E6358	8E6359
J400	7T3403 9J4403	Abrasion	13.45	*	*	125-8404/05/06	6I6404	6I9898	7T3408	8E8409
J450	9W1453 9J4453	Abrasion	15.9	8E0464	*	114-0464/65/66	6I6464	8E2467	8E8468	8E8469
J450	9W1553 9J4553	Abrasion	22	8E0464	*	114-0464/65/66	6I6464	8E2467	8E8468	8E8469



EXCAVATOR

Tip R



SIZE	TURBO PART N°	DESCRIPTION	WEIGHT							
J200	1U3202R	Tip R	1.3	4T1204	8J7525	*	*	9J4297 8E2184	8E6208	8E6209
J220	6Y3222R	Tip R	2.1	*	*	*	6Y3224	*	8E6258	8E6259
J250	1U3252R	Tip R	2.6	1U1254	3G0169	*	6Y3254	1U0257	8E6258	8E6259
J300	1U3302R	Tip R	4	1U1304	9J8929	*	3G6304	4T4307 1U0307 3G9307	9J2308	8E6259
J350	1U3352R	Tip R	5.7	1U1354	1U1350	135-9354/55/56 113-0354/55/56	3G8354	3G3357 1U1357	8E6358	8E6359
J400	7T3402R	Tip R	8.9	*	*	125-8404/05/06	6I6404	6I9898	7T3408	8E8409
J450	9W8452R	Tip R	11.2	8E0464	*	114-0464/65/66	6I6464	8E2467	8E8468	8E8469
J550	9W8552R	Tip R	18.5	7J9554	*	107-3554/55/56	6I6554	*	6Y8558	8E8559
J600	6I6602R	Tip R	32	*	*	119-8604/05/06	6I6604	*	6I6608	6I6609



LOADER

Heavy Dute Abrasion



SIZE	TURBO PART N°	DESCRIPTION	WEIGHT							
J250	9N4253	Heavy Dute Abrasion	4.6	1U1254	3G0169	*	6Y3254	1U0257	8E6258	8E6259
J300	9N4303	Heavy Dute Abrasion	7.3	1U1304	9J8929	*	3G6304	4T4307 1U0307 3G9307	9J2308	8E6259
J350	9N4353	Heavy Dute Abrasion	10.5	1U1354	1U1350	135-9354/55/56 113-0354/55/56	3G8354	3G3357 1U1357	8E6358	8E6359
J450	9N4453	Heavy Dute Abrasion	21	8E0464	*	114-0464/65/66	6I6464	8E2467	8E8468	8E8469
J550	6Y2553	Heavy Dute Abrasion	30.4	7J9554	*	107-3554/55/56	6I6554	*	6Y8558	8E8559
J600	6I6603	Heavy Dute Abrasion	57.5	*	*	119-8604/05/06	6I6604	*	6I6608	6I6609
J700	4T4703	Heavy Dute Abrasion	68.5	*	4T4704	*	*	*		
J800	6I8803	Heavy Dute Abrasion	104	*	6I8804	*	*	*		



LOADER

Rock Penetration



SIZE	TURBO PART N°	DESCRIPTION	WEIGHT							
J200	1U3202PT	Rock Penetration	1.9	4T1204	8J7525	*	*	9J4297 8E2184	8E6208	8E6209
J250	1U3252PT	Rock Penetration Old design	5	1U1254	3G0169	*	6Y3254	1U0257	8E6258	8E6259
J300	1U3302PT	Rock Penetration	7.6	1U1304	9J8929	*	3G6304	4T4307 1U0307 3G9307	9J2308	8E6259
J350	1U3352PT	Rock Penetration	11	1U1354	1U1350	135-9354/55/56 113-0354/55/56	3G8354	3G3357 1U1357	8E6358	8E6359
J400	7T3402PT	Rock Penetration	15.5	*	*	125-8404/05/06	6I6404	6I9898	7T3408	8E8409
J450	9W8452PT	Rock Penetration	21.2	8E0464	*	114-0464/65/66	6I6464	8E2467	8E8468	8E8469
J550	9W8552PT	Rock Penetration	29.2	7J9554	*	107-3554/55/56	6I6554	*	6Y8558	8E8559
J600	6I6602PT	Rock Penetration	48	*	*	119-8604/05/06	6I6604	*	6I6608	6I6609
J700	4T4702PT	Rock Penetration	67	*	4T4704	*	*	*		
J600	6I8802PT	Rock Penetration	110	*	6I8804	*	*	*		



LOADER

Rock Penetration HD



SIZE	TURBO PART N°	DESCRIPTION	WEIGHT							
J300	135-9300	Rock Penetration HD	8.3	1U1304	9J8929	*	3G6304	4T4307 1U0307 3G9307	9J2308	8E6259
J350	144-1358	Rock Penetration HD	12.7	1U1354	1U1350	135-9354/55/56 113-0354/55/56	3G8354	3G3357 1U1357	8E6358	8E6359
J400	135-9400	Rock Penetration HD	16.9	*	*	125-8404/05/06	6I6404	6I9898	7T3408	8E8409
J450	138-6451	Rock Penetration HD	21.95	8E0464	*	114-0464/65/66	6I6464	8E2467	8E8468	8E8469
J550	138-6552	Rock Penetration HD	30.2	7J9554	*	107-3554/55/56	6I6554	*	6Y8558	8E8559
J600	135-9600	Rock Penetration HD	52.2	*	*	119-8604/05/06	6I6604	*	6I6608	6I6609
J700	135-9700	Rock Penetration HD	72	*	4T4704	*	*	*		
J700	135-9800	Rock Penetration HD	100	*	6I8804	*	*	*		



LOADER

Rock Penetration













SIZE	TURBO PART N°	DESCRIPTION	WEIGHT							
J300	4T2303RP2	Rock Penetration 2	8.6	Rock Penetration 2	Rock Penetration 2	*	3G6304	4T4307 1U0307 3G9307	9J2308	8E6259
J350	4T2353RP2	Rock Penetration 2	11.9	Rock Penetration 2	Rock Penetration 2	135-9354/55/56 113-0354/55/56	3G8354	3G3357 1U1357	8E6358	8E6359
J400	7T3403RP2	Rock Penetration 2	17.8	Rock Penetration 2	Rock Penetration 2	125-8404/05/06	6I6404	6I9898	7T3408	8E8409
J450	9W1453RP2	Rock Penetration 2	23	Rock Penetration 2	Rock Penetration 2	114-0464/65/66	6I6464	8E2467	8E8468	8E8469
J550	9W1553RP2	Rock Penetration 2	27.6	Rock Penetration 2	Rock Penetration 2	107-3554/55/56	6I6554	*	6Y8558	8E8559



EXCAVATOR

Tip long













 SIZE	 TURBO PART N°	 DESCRIPTION	 WEIGHT							
J200	195-9209	Tip long	1.4	4T1204	8J7525	*	*	9J4297 8E2184 1U1357	8E6208	8E6209
J350	168-1351	Tip long	6.9	1U1354	1U1350	135-9354/55/56 113-0354/55/56	3G8354	3G3357 1U1357	8E6358	8E6359
J400	168-1401	Tip long	8.8	*	*	125-8404/05/06	6I6404	6I9898	7T3408	8E8409
J450	168-1451	Tip long	11	8E0464	*	114-0464/65/66	6I6464	8E2467	8E8468	8E8469



EXCAVATOR

Wide



 SIZE	 TURBO PART N°	 DESCRIPTION	 WEIGHT							
J200	109-9200	Wide	1.5	4T1204	8J7525	*	*	9J4297 8E2184	8E6208	8E6209
J250	3G8250	Wide	3.4	1U1254	3G0169	*	6Y3254	1U0257	8E6258	8E6259
J300	4T1300 107-3300	Wide	5.3	1U1304	9J8929	*	3G6304	4T4307 1U0307 3G9307	9J2308	8E6259
J350	8J3350 107-3350	Wide	7.9	1U1354	1U1350	135-9354/55/56 113-0354/55/56	3G8354	3G3357 1U1357	8E6358	8E6359
J400	7T3400 107-3400	Wide	11.7	*	*	125-8404/05/06	6I6404	6I9898	7T3408	8E8409
J450	8J1450 107-3450	Wide	15.9	8E0464	*	114-0464/65/66	6I6464	8E2467	8E8468	8E8469
J550	7J-9550	Wide	23.2	7J9554	*	107-3554/55/56	6I6554	*	6Y8558	8E8559



EXCAVATOR



Top Pin Tip

SIZE	TURBO PART N°	DESCRIPTION	WEIGHT	P-23		P-18			
J910 920	4K6936	Top Pin Tip	1.4	8J2930 6K3125	*	*			
J930 944	4K0034	Top Pin Tip	2	8J2929 6K2563 5K8287 6K1965	*	*			



LOADER



UniTip-Fork Tip

SIZE	TURBO PART N°	DESCRIPTION	WEIGHT	BLADE SIZE	BOLT	NUT		
J10	132-4720	UniTip	1.9	*	*	*	*	*
J10	6Y6335	UniTip	3.4	19	4K0367	4F3656	*	*
J10	6Y6335	UniTip	3.5	19	4K0367	4F3656	*	*
J10	9W1879	UniTip	3.4	19	4K0367	4F3656	*	*
J10	135-8203	UniTip	3.4	19	4K0367	4F3656	*	*
J10	8J6207	UniTip	4.6	20	2J3506	5J4771	*	*
	6Y0649	Cat- fork tip	28.5	38	*	*	*	*
J15	1U1857	UniTip	9.9	25	2J3507	8J2928	*	*
J15	1U1867	UniTip	16.2	32	8J2933	8J2928	*	*
J30	1U1877	UniTip	12.5	25	8J2933	8J2928	*	*
J30	1U1877HD	UniTip	17	25	8J2933	8J2928	*	*
	8J2936	CAT(UniTip)	18.25	32	*	*	*	*



EXCAVATOR

Flush Mount Adapter



SIZE	TURBO PART N°	DESCRIPTION	WEIGHT	BLADE SIZE	PIN/RETAINER	MACHINE MODEL
J200	4T1204	Flush Mount Adapter	2.1	13-25	8E6208 8E6209	935 · 931 · 910 · IT12 · 428 · 426 · 416
J250	1U1254	Flush Mount Adapter	5.5	25-30	8E6258 8E6259	953 951 943 941 936 930 926 920 916 IT28 IT18
J300	1U1304	Flush Mount Adapter	8	25-30	9J2308 8E6259	966C · 963 · 955 · 950 · 944
J350	1U1354	Flush Mount Adapter	13.2	32-45	8E6358 8E6359	980 · 977 · 973 · 966D
J440	8E0464	Flush Mount Adapter	20	45-51	8E0468 8E0469	988 · 983 · 980 · 973 · 966D
J450	8E0465	Flush Mount Adapter	23.5	45-51	8E0468 8E0469	988 · 983 · 980 · 973 · 966D
J450	8E0466	Flush Mount Adapter	23.5	45-51	8E0468 8E0469	988 · 983 · 980 · 973 · 966D
J550	7J9554 3G4554	Flush Mount Adapter	34	51-64	6Y8558 8E5559	988 · 992



EXCAVATOR

Bottom Strap Adapter



SIZE	TURBO PART N°	DESCRIPTION	WEIGHT	BLADE SIZE	PIN/RETAINER	MACHINE MODEL
J200	8J7525	Bottom Strap Adapter	1.75	13-25	8E6208 8E6209	935 · 931 · 910 · IT12 · 428 · 426 · 416
J250	3G0169	Bottom Strap Adapter	4.2	19-32	8E6258 8E6259	953 951 943 941 936 930 926 920 96 IT28 IT18
J300	9J8929	Bottom Strap Adapter	6.82	25-30	9J2308 8E6259	966C · 963 · 955 · 950 · 944
J350	1U1350	Bottom Strap Adapter	9.5	32-45	8E6358 8E6359	980 · 977 · 973 · 966D
J350	1U1351	Bottom Strap Adapter	10.2	32-45	8E6358 8E6359	980 · 977 · 973 · 966D
J350	1U1352	Bottom Strap Adapter	10.2	32-45	8E6358 8E6359	980 · 977 · 973 · 966D



EXCAVATOR

Loder Adapter



SIZE	Nº TURBO PART Nº	DESCRIPTION	WEIGHT kg	BLADE SIZE	PIN/RETAINER	MACHINE MODEL
J300	8E9490	Loder Adapter	7.5	38	9J2308 8E6259	E-180 · E-200 · 215
J350	6I6354	Loder Adapter	9.9	40	8E6358 8E6359	320 · 325 · 225 · 219 · 215 · 320 · E200 · E240 · B/C/S
J350	6I6355	Loder Adapter	9.6	40	8E6358 8E6359	320 · 325 · 225 · 219 · 215 · 320 · E200 · E240 · B/C/S
J350	6I6356	Loder Adapter	9.6	40	8E6358 8E6359	225 · 219 · 215 · 320 · E200 · E240 · B/C/S
J350	135-9354	Loder Adapter	14	40	8E6358 8E6359	966
J350	135-9355	Loder Adapter	14.5	40	8E6358 8E6359	966
J350	135-9356	Loder Adapter	14.5	40	8E6358 8E6359	966
J400	107-3404	Loder Adapter	19.2	40	7T3408 8E8409	980
J400	125-8404	Loder Adapter	18.7	45	7T3408 8E8409	980
J400	125-8405	Loder Adapter	19.7	45	7T3408 8E8409	980
J400	125-8406	Loder Adapter	19.7	45	7T3408 8E8409	980
J450	114-0464	Loder Adapter	20.8	50	8E0468 8E0469	983 · 988
J450	114-0465	Loder Adapter	22.5	50	8E0468 8E0469	983 · 988
J450	114-0466	Loder Adapter	22.5	50	8E0468 8E0469	983 · 988
J550	107-3554	Loder Adapter	42.9	64	6Y8558 8E5559	922C · 992B · 245 Frontal · 990
J550	107-3555	Loder Adapter	42.9	64	6Y8558 8E5559	922C · 992B · 245 Frontal · 991
J550	107-3556	Loder Adapter	42.9	64	6Y8558 8E5559	922C · 992B · 245 Frontal · 992
J600	119-8604	Loder Adapter	71	70	6I6608 6I6609	375 · 992
J600	119-8605	Loder Adapter	72	70	6I6608 6I6609	375 · 992
J600	119-8606	Loder Adapter	72	70	6I6608 6I6609	375 · 992
J700	4T4704	Loder Adapter	75	76	4T4708 4T4707	992C · 994
J700	4T4705	Loder Adapter	72	76	4T4708 4T4707	992C · 995
J700	4T4706	Loder Adapter	72	76	4T4708 4T4707	992C · 996
J700	132-4704	Loder Adapter	74	80	4T4708 4T4707	
J800	6I8804	Loder Adapter	112	100	1341808 1341809	994 · 998



EXCAVATOR

Excavator Adapter

SIZE	TURBO PART N°	DESCRIPTION	WEIGHT	BLADE SIZE	PIN/RETAINER	MACHINE MODEL
J200	119-3204	Excavator Adapter	1.8	25	8E6208 8E6209	416 · 426
J250	119-3205	Excavator Adapter	1.8	20	8E6258 8E6259	416 · 446
J250	119-3253	Excavator Adapter	4.2	32	8E6258 8E6259	E200 · 205 · 214 · 206 · 213 · 311 · 312
J250	6Y3254HD	Excavator Adapter	4.2	25	8E6258 8E6259	E200 · 205 · 214 · 206 · 213 · 311 · 312
J250	6Y3254	Excavator Adapter	4.2	32	8E6258 8E6259	E200 · 205 · 214 · 206 · 213 · 311 · 312
J250	6Y3254	Excavator Adapter	4.2	25	8E6258 8E6259	E200 · 205 · 214 · 206 · 213 · 311 · 313
J300	3G6304	Excavator Adapter	7.2	32	9J2308 8E6259	E-180 · E-200 · 215 · 219 · 311 · 312 · 315 · 320 · 325
J300	9W1304	Excavator Adapter	7.2	32	9J2308 8E6259	E-180 · E-200 · 215 · 219 · 311 · 312 · 315 · 320 · 325
J300	3G6304	Excavator Adapter	7.2	30	9J2308 8E6259	E-180 · E-200 · 215 · 219 · 311 · 312 · 315 · 320 · 325
J300	8E9490	Excavator Adapter	7.5	36	9J2308 8E6259	E-180 · E-200 · 215 · 219 · 311 · 312 · 315 · 320 · 325
J350	3G8354HD	Excavator Adapter	9.1	40	8E6358 8E6359	225 · 219 · 215 · 320 · E200 · E240 · B/C/S
J350	3G8354HD-A	Excavator Adapter (35 Degree angle Blade)-Remooned use	9	40	8E6358 8E6359	225 · 219 · 215 · 320 · E200 · E240 · B/C/S
J400	6I6404	Excavator Adapter	12.9	45	7T3408 8E8409	235FS · 231SD · Series · 300 · 231D · C/D/S
J450	6I6464	Excavator Adapter	19.9	50	8E0468 8E0469	225 · 235 · 245 · 320 · 325 · 330 · E30 · D/E/F
J450	159-0464	Excavator Adapter	19.9	50	8E0468 8E0471	225 · 235 · 245 · 320 · 325 · 330 · E32 · D/E/F
J450	8E6464	Excavator Adapter	20.6	50	8E0468 8E0473	225 · 235 · 245 · 320 · 325 · 330 · E34 · D/E/F
J550	1U1553	Excavator Adapter	43	60	6Y8558 8E5559	245 · E/F/G/H · 330
J550	6I6554	Excavator Adapter	32	60	6Y8558 8E5559	245 · E/F/G/H · 330
J550	6I6554	Excavator Adapter	32	65	6Y8558 8E5559	245 · E/F/G/H · 330
J600	113-9604	Excavator Adapter	53	80	6I6608 6I66089	375H/J
J600	6I6604	Excavator Adapter	53	70	6I6608 6I66089	375H/J
J600	6I6604	Excavator Adapter	50.5	75	6I6608 6I66089	375H/J
J700	222-7700	Excavator Adapter	90	90	4T4708 4T4707	
J700	100-7416HD	Excavator Adapter	101	100	4T4708 4T4707	
J800	357-6516-100	Excavator Adapter	101	100	1341808 1341809	





EXCAVATOR

Excavator Adapter Heavy Dute



SIZE	TURBO PART N°	DESCRIPTION	WEIGHT	BLADE SIZE	PIN/RETAINER	MACHINE MODEL
J300	3G6304C	Excavator Adapter-Heavy dute	7.5	30	9J2308 8E6259	E-180 · E-200 · 215 · 219 · 311 · 312 · 315 · 320 · 325
J350	6I6354C	Loder Adapter HD	11.8	40	8E6358 8E6359	219 · 311 · 312 · 315 · 225 · 219 · 215 · 320 · E200 · E240 · B/C/S
J400	6I6404C	Excavator Adapter heavy dute	15.8	45	7T3408 8E8409	235FS · 231SD · Series · 300 · 232D · C/D/S
J450	6I6464C	Excavator Adapter heavy dute	21.5	50	8E0468 8E0470	225 · 235 · 245 · 320 · 325 · 330 · E31 · D/E/F
J450	159-0464C	Excavator Adapter heavy dute	21.5	50	8E0468 8E0472	225 · 235 · 245 · 320 · 325 · 330 · E33 · D/E/F
J550	6I6554C	Excavator Adapter	36.5	65	6Y8558 8E5559	245 · E/F/G/H · 330
J600	6I6604C	Excavator Adapter heavy dute	54.5	75	6I6608 6I66089	375H/J



EXCAVATOR

Excavator Adapter Straght Blade



SIZE	TURBO PART N°	DESCRIPTION	WEIGHT	BLADE SIZE	PIN/RETAINER	MACHINE MODEL
J220	6Y3224V	Excavator Adapter	2.9	25	8E6258 8E6259	E312 · E70
J250	6Y3254V	Excavator Adapter	3.9	25	8E6258 8E6259	E200 · 205 · 214 · 206 · 213 · 311 · 312
J350	3G8354V	Excavator Adapter	9.1	40	8E6358 8E6359	225 · 219 · 215 · 320 · E200 · E240 · B/C/S
J350	3G8354V-2	Excavator Adapter	9.3	40	8E6358 8E6359	225 · 219 · 215 · 320 · E200 · E240 · B/C/S
J400	6I6404V	Excavator Adapter	12.9	45	7T3408 8E8409	235FS · 231SD · Series · 300 · 231D · C/D/S
J400	6I6404V	Excavator Adapter	12.8	50	7T3408 8E8409	235FS · 231SD · Series · 300 · 231D · C/D/S
J450	6I6464V	Excavator Adapter	19.9	50	8E0468 8E0469	225 · 235 · 245 · 320 · 325 · 330 · E30 · D/E/F
J450	6I6464V	Excavator Adapter	19.5	55	8E0468 8E0469	225 · 235 · 245 · 320 · 325 · 330 · E30 · D/E/F
J450	6I6464HD	Excavator Adapter	21.6	60	8E0468 8E0469	225 · 235V245 · 320 · 325 · 330 · E30 · D/E/F
J550	6I6554HD	Excavator Adapter	33.2	65	6Y8558 8E5559	245 · E/F/G/H · 330
J550	6I6554HD	Excavator Adapter	32.6	70	6Y8558 8E5559	245 · E/F/G/H · 330



EXCAVATOR

Excavator Adapter- Left/Right Hand



SIZE	TURBO PART N°	DESCRIPTION	WEIGHT	BLADE SIZE	PIN/RETAINER	MACHINE MODEL
J300	3G6305	Excavator Adapter	7.6	32	9J2308 8E6259	180 · 200 · 215 · 219 · 311 · 312 · 315 · 320
J300	3G6306	Excavator Adapter	7.6	32	9J2308 8E6259	180 · 200 · 215 · 219 · 311 · 312 · 315 · 320
J350	3G8355	Excavator Adapter	8.7	40	8E6358 8E6359	225 · 219 · 215 · 320 · E200 · E240
J350	3G8356	Excavator Adapter	8.7	40	8E6358 8E6359	225 · 219 · 215 · 320 · E200 · E240
J450	8E6465 6I6465	Excavator Adapter	17.4	50	8E0468 8E0469	225 · 235 · 245 · 320 · 325 · 330 · E300 D/E/F
J450	8E6466 6I6466	Excavator Adapter	17.4	50	8E0468 8E0469	225 · 235 · 245 · 320 · 325 · 330 · E300 D/E/F
J400	6I6405	Excavator Adapter	13.5	45	7T3408 8E8409	235FS · 231SD · Series · 300 · 231D · C/D/S
J400	6I6406	Excavator Adapter	13.5	45	7T3408 8E8409	235FS · 231SD · Series · 300 · 231D · C/D/S
J550	6I6555	Excavator Adapter	33.5	60	6Y8558 8E5559	245 · E/F/G/H · 330
J550	6I6556	Excavator Adapter	33.5	60	6Y8558 8E5559	245 · E/F/G/H · 330
J600	6I6605	Excavator Adapter	59.5	75	6I6608 6I6609	375H/J
J600	6I6606	Excavator Adapter	59.5	75	6I6608 6I6609	375H/J



LOADER

2 Holes Bolt Adapter



SIZE	TURBO PART N°	DESCRIPTION	WEIGHT	BLADE SIZE	BOLT/NUT	MACHINE MODEL
J200	9J4207	2 Holes Bolt Adapter	3	20	5J4771 2J3506	910 · 914 · 931 · 933 · 935 · IT12
J250	8E2184	2 Holes Bolt Adapter	2.6	20	4F3656 4K0367	416 · 426 · 428 · 436
J250	1U0257	2 Holes Bolt Adapter	8.9	25	8J2928 8J2933	916 · 920 · 924 · 926 · 928 · 930 · 931 · 933 · 935 · 936 · 939 · 941 · 943 · 951 · 953
J300	1U0307	2 Holes Bolt Adapter	10.3	25	8J2928 8J2933	955 · 950
J300	4T4307	2 Holes Bolt Adapter	13.2	32	8J2928 8J2933	955 · 950 · 960 · 963
J300	3G9307	2 Holes Bolt Adapter	14.7	32	5P8361 5P8362	966C
J350	3G7357	2 Holes Bolt Adapter	20.9	32	5P8361 5P8362	966C · 963B



LOADER

2 Holes Bolt Adapter



SIZE	TURBO PART N°	DESCRIPTION	WEIGHT	BLADE SIZE	BOLT/NUT	MACHINE MODEL
J350	3G3357	2 Holes Bolt Adapter	16.9	38	5P8361 5P8361	960 · 966 · 970 · 973 · 977 · 972G · 966G
J350	1U1357	2 Holes Bolt Adapter	19.8	45	5P8361 5P8361	980
J350	3G1357	2 Holes Bolt Adapter	19.8	45	5P8361 5P8361	980
J450	6I9898	2 Holes Bolt Adapter	27.5	45	5P8361 5P8361	980C · 980F
J550	9J0174	adapter	32	*	*	*



LOADER

3 Holes Bolt Adapter



SIZE	TURBO PART N°	DESCRIPTION	WEIGHT	BLADE SIZE	BOLT/NUT	MACHINE MODEL
J300	3G5307	3Holes Bolt Adapter	14	38	8J2928 8J2933	966C
J450	8E2467	3Holes Bolt Adapter	25.5	45	5P8362 5P8362	988 980



LOADER

Bolt on Conner Adapter



SIZE	TURBO PART N°	DESCRIPTION	WEIGHT	BLADE SIZE	BOLT/NUT	MACHINE MODEL
J200	1U2208	Bolt on Adapter	4.1	20	5G2807 5G2806	910 · 914 · 931 · 933 · 935 · IT12 · 416 · 426 · 428 · 436
J250	1U2209	Bolt on Adapter	4.1	20	5G2807 5G2806	910 · 914 · 931 · 933 · 935 · IT12 · 416 · 426 · 428 · 436
J250	3G4258	Bolt on Adapter	10.4	25	4V1544 4V1545	916 · 920 · 924 · 926 · 928 · 930 · 931 · 933 · 935 · 936 · 939 · 941 · 943 · 953 · 950
J250	3G4259	Bolt on Adapter	10.4	25	4V1544 4V1545	916 · 920 · 924 · 926 · 928 · 930 · 931 · 933 · 935 · 936 · 939 · 941 · 943 · 953 · 950
J300	3G4308	Bolt on Adapter	15.5	25	5V7396 5V7395	950 · 955 · 960 · 963
J300	3G4309	Bolt on Adapter	15.5	25	5V7396 5V7395	950 · 955 · 960 · 963
J300	3G8308	Bolt on Adapter	16.5	38	5V2772 5V2773	966C
J300	3G8309	Bolt on Adapter	16.5	38	5V2772 5V2773	966C
J350	3G5358	Bolt on Adapter	20.4	38	5V2772 5V2773	960 · 963 · 966 · 966C · 966G · 970 · 972G · 973 · 977
J350	3G5359	Bolt on Adapter	20.4	38	4V7175 4V7174	960 · 963 · 966 · 966C · 966G · 970 · 972G · 973 · 977



LOADER

Bolt on Fork Adapter



SIZE	TURBO PART N°	DESCRIPTION	WEIGHT	BLADE SIZE	BOLT/NUT	MACHINE MODEL
J350	1U1358	Bolt on Adapter	26	35	5V2772 5V2773	
J350	1U1359	Bolt on Adapter	26	35	4V7175 4V7174	
J300	1U1858	Bolt on Adapter	14.2	25	5V7396 5V7395	950 · 955 · 960 · 963
J300	1U1859	Bolt on Adapter	14.2	25	5V7396 5V7395	950 · 955 · 960 · 963
J300	1U1878	Bolt on Adapter	24.3	30	5V2772 5V2773	966C
J300	1U1879	Bolt on Adapter	24.3	30	5V2772 5V2773	966C
J350	1u1888	Bolt on Adapter	38	38	5V2772 5V2773	960 · 963 · 966 · 966C · 966G · 970 · 972G · 973 · 977
J350	1u1889	Bolt on Adapter	38	38	4V7175 4V7174	960 · 963 · 966 · 966C · 966G · 970 · 972G · 973 · 978



LOADER

Bolt on 2 holes Conner Adapter



SIZE	TURBO PART N°	DESCRIPTION	WEIGHT	BLADE SIZE	BOLT/NUT	MACHINE MODEL
J200	6I9250	Bolt on Adapter	12.7	25	6I8319 6I8311	916 · 920 · 924 · 926 · 928 · 930 · 931 · 933 · 935 · 936 · 939 · 941 · 943 · 951 · 953
J250	6I9251	Bolt on Adapter	12.7	25	6I8319 6I8311	910 · 914 · 931 · 933 · 935 · IT12 · 416 · 426 · 428 · 436
J300	8E5308	Bolt on Adapter	18.4	32	8E5302 8E5303	950 · 955 · 960 · 963 · 966C
J300	8E5309	Bolt on Adapter	18.4	32	8E5300 8E5301	950 · 955 · 960 · 963 · 966C
J350	8E5358	Bolt on Adapter	26.3	35	8E5320 8E5321	960 · 963B · 966 · 966C · 966G · 970 · 972G · 973 · 977 · 980
J350	8E5359	Bolt on Adapter	26.3	35	8E5310 8E5311	960 · 963B · 966 · 966C · 966G · 970 · 972G · 973 · 977 · 980



LOADER

Top Pin Adapter



SIZE	TURBO PART N°	DESCRIPTION	WEIGHT	BLADE SIZE	BOLT/NUT	MACHINE MODEL
	P-23	Cat Top Pin Adapter	2.4	13-20	4k0043 4k0041	910 · 920 · 922 · 931 · 933
	P-18	Cat Top Pin Adapter	3.3	25	4k0043 4k0041	930 · 944 · 950 · 951 · 955



LOADER

Scarifier Shanks

SIZE	TURBO PART N°	DESCRIPTION	WEIGHT	SCARIFIER TIP	BOLT/NUT	MACHINE MODEL
	9F5124	Cat Scarifier Shanks-3holes	5.4	6Y5230	5K1458 5K1459	112 · 130 · 140
	5B6251	Cat Scarifier Shanks-3holes	4.3	6Y5230	5K1458 5K1459	112 · 130 · 140
	9F5124-101	Cat Scarifier Shanks-Universal 5 holes	5.4	6Y5230	5K1458 5K1459	112 · 130 · 140
	H31280	Cat Scarifier Shanks	5.9	H31281		



LOADER

Scarifier Tips

SIZE	TURBO PART N°	DESCRIPTION	WEIGHT	SCARIFIER TIP	BOLT/NUT	MACHINE MODEL
	2D5572	Cat Scarifier Tips	1.5	9F5124 5B6251	5K1458 5K1459	112 · 130 · 140
	6Y5230	Cat Scarifier Tips	1.5	9F5124 5B6251	5K1458 5K1459	112 · 130 · 140
	2D5572	Cat Scarifier Tips	1.5	9F5124 5B6251	5K1458 5K1459	112 · 130 · 140
	6Y5230	Cat Scarifier Tips	1.5	9F5124 5B6251	5K1458 5K1459	112 · 130 · 140
	H31281	Cat Scarifier Tips	1.4	H31280		



MACHINE

Shanks

SIZE	TURBO PART N°	DESCRIPTION	WEIGHT	REPAIRE NOSE	RIPPER TEETH	PROTECTOR	PIN/RETAINER	MACHINE MODEL
	9J6586	CAT-Shanks	22.9	8E7300	6Y0309	*	9J6583 1U2405	D4 · 941 · 951 · 955 · 963
	9J8923	CAT-Shanks	60.5	8E7350	6Y0359	6J8814	8E6358 1U2405	D7 · D6 · D5 · 973 · 977
	9J3139	CAT-Shanks	55	8E7350	4T4352 6Y0359	6J8814	8E6358 1U2405	16 · 973 · 977 · D5 · D6
	8J5299	CAT-Shanks	8	*	1U3209 1U3201 9W8209 1U3202	*	8E6208 8E6209	D3 · 931 · 933 · 939 D4C · 135-H · 120-H



Shanks Nose



SIZE	TURBO PART N°	DESCRIPTION	WEIGHT	SHANK	RIPPER TEETH	PROTECTOR	PIN/RETAINER	MACHINE MODEL
	8E7350	Welding nose-J350-CAT	2.5	9J6586	4T4352 6Y0359	6J8814	8E6358 1U2405	16 · 973 · 977 · D5 · D6 · D7 · 983
	8E7300	Welding nose-J300-CAT	5.6	9J9139	4T4302 9W7309 6Y0309	6J8814	9J6583 1U2405	D4 · 941 · 951 · 955 · 963 · 12 14 · 130 · 140 · 143H · 160H
	8E8418	CAT-Shanks Nose	14.5	7J1795	9W2451 9W2452	8E1848	6Y3394/8E4743	D8K · D8L · D8N · D9H · D9N
	9U9694	CAT-Shanks Nose	19.11	*			6Y3394 8E4743	D8N · D8K · D8L · D9H · D9N
	9J4354WN	CAT-Shanks Nose	4.8					
	3G4454WN	CAT-Shanks Nose	9					
	107-3361	CAT-Shanks Nose	45	6Y6138 · 6Y6144 · 6Y6141 8E8414 · 8E8415 · 8E8416 6Y4679 · 6Y5616 · 8E8412 8E8413 · 9W8366 · 6Y6147 8E8411 · 8E8417	4T4501 · 4T4502 · 4T4502ST 4T4503 · 4T5501 · 4T5502 4T5503 · 8E5572		6Y3909 4T4707	D9L · D10 · D10N · D11 · D11N
	103-8114	CAT-Shanks Nose	50	3G2088 · 3G6507 · 9W4427 1V4592 · 9J5954 · 1U4873 3G5707 · 6Y6138	4T4501 · 4T4502 · 4T4502ST 4T4503 · 4T5501 · 4T5502 4T5503 · 8E5572		6Y3909 4T4707	D9L · D10 · D10N · D11 · D11N
	103-8115	CAT-Shanks Nose	81	6Y6138 · 6Y6144 · 6Y6141 8E8414 · 8E8415 · 8E8416 6Y4679 · 6Y5616 · 8E8412 8E8413 · 9W8366 · 6Y6147 8E8411 · 8E8417	4T4501 · 4T4502 · 4T4502ST 4T4503 · 4T5501 · 4T5502 4T5503 · 8E5572		6Y3909 4T4707	D9L · D10 · D10N · D11 · D11N



Ripper Tip



SIZE	TURBO PART N°	DESCRIPTION	WEIGHT	SHANK	PROTECTOR	PIN/RETAINER	MACHINE MODEL
R300	4T4302	Ripper Tip	5.5	6Y0865 · 9J8913 9J6586 · 8E7300		8J1433 · 9J6583 · 1U2405	D4 · 963 · 14 · 12
R300	7K0037	Ripper Tip	5.5	5K1428		4K0043 · 5K1426	D4 · 963 · 14 · 12
R300	6Y0309	Ripper Tip new design	5.4	6Y0865 · 9J8913 9J6586 · 8E7300		8J1433 · 9J6583 · 1U2405	D4 · 963 · 14 · 12
R350	6Y0352	Ripper Tip	10.4	9J8923 · 9J3139 · 8J8215 9W7382 · 7J6671 · 8E7350		7J9600 · 8E6358 · 1U2405	D5 · D6 · D7 · 16 · 973 · 977
R350	6Y0359	Ripper Tip new design	11.5	9J8923 · 9J3139 · 8J8215 9W7382 · 7J6671 · 8E7350		8E6358 · 1U2405	D5 · D6 · 16 · 973 · 977 · 983 · D7
R350	6Y0359	Ripper Tip Old Design	11.3	9J8923 · 9J3139 · 8J8215 9W7382 · 7J6671 · 8E7350		8E6358 · 1U2405	D5 · D6 · 16 · 973 · 977 · 983 · D7



Ripper Tip



SIZE	TURBO PART N°	DESCRIPTION	WEIGHT	SHANK	PROTECTOR	PIN/RETAINER	MACHINE MODEL
R350	7J3309	Ripper Tip	11.6	7J2514 · 7J2515 7J2459 · 7J2587		7J9600 · 6Y3394 · 1U2405	D7 · D8 · D9
R350	7J3310	Ripper Tip	11.68	7J2514 · 7J2515 7J2459 · 7J2587		7J9600 · 6Y3394 · 1U2405	D7 · D8 · D9
R350	7J3312	Ripper Tip	14.5	7J2514 · 7J2515 7J2459 · 7J2587		7J9600 · 6Y3394 · 1U2405	D7 · D8 · D9
R450	9W2451A	Ripper Tip new design	15.4	7J1792 · 7J1793 · 7J1795 107-3485 · 107-3486 · 8E5346 4T0134 · 4T0135 · 4T0136 4T8989 · 4T8990 · 8E5340 8E5346 · 8E5347 · 7J1794 8E5345 · 9W6167 · 4T8988 8E5339 · 8E5348 · 7J1791	6J8814	7J9600 · 6Y3394 · 8E4743	D8 · D8L · D8N · D9H D9N · D8K · D8C
R450	9W2452A	Ripper Tip new design	17.9	7J1792 · 7J1793 · 7J1795 107-3485 · 107-3486 · 8E5346 4T0134 · 4T0135 · 4T0136 4T8989 · 4T8990 · 8E5340 8E5346 · 8E5347 · 7J1794 8E5345 · 9W6167 · 4T8988 8E5339 · 8E5348 · 7J1791	6J8814	7J9600 · 6Y3394 · 8E4743	D8 · D8L · D8N · D9H D9N · D8K · D8C
R450	9W2452ST	Ripper Tip	17.5	7J1792 · 7J1793 · 7J1795 107-3485 · 107-3486 · 8E5346 4T0134 · 4T0135 · 4T0136 4T8989 · 4T8990 · 8E5340 8E5346 · 8E5347 · 7J1794 8E5345 · 9W6167 · 4T8988 8E5339 · 8E5348 · 7J1791	6J8814	7J9600 · 6Y3394 · 8E4743	D8 · D8L · D8N · D9H D9N · D8K · D8C
R450	114-0453	Ripper Tip	20.5	7J1792 · 7J1793 · 7J1795 107-3485 · 107-3486 · 8E5346 4T0134 · 4T0135 · 4T0136 4T8989 · 4T8990 · 8E5340 8E5346 · 8E5347 · 7J1794 8E5345 · 9W6167 · 4T8988 8E5339 · 8E5348 · 7J1791	6J8814	7J9600 · 6Y3394 · 8E4743	D8 · D8L · D8N · D9H D9N · D8K · D8C
R450	4T5451	Ripper Tip	14.7	7J1791 · 7J1792 · 7J1793 7J1795 · 107-3845 · 4T9776 107-3846 · 8E5346 · 4T1304 4T1305 · 4T1306 · 8E5340 8E5341 · 8E5342 · 4T8989 4T0134 · 4T8990 · 8E5347 8E5340 · 7J1794 · 8E5345 9W6167 · 4T8988 · 4T8990	6J8814	7J9600 · 6Y3394 · 8E4743	D8K · D8L · D8N D9N · D9H
R450	4T4453	Ripper Tip	19.2	7J1791 · 7J1792 · 7J1793 7J1795 · 107-3845 · 4T9776 107-3846 · 8E5346 · 4T1304 4T1305 · 4T1306 · 8E5340 8E5341 · 8E5342 · 4T8989 4T0134 · 4T8990 · 8E5347 8E5340 · 7J1794 · 8E5345 9W6167 · 4T8988 · 4T8990	6J8814	7J9600 · 6Y3394 · 8E4743	D8 · D8L · D9 · D8N D9H · D9N · D8K · D8C





Ripper Tip



SIZE	TURBO PART N°	DESCRIPTION	WEIGHT	SHANK	PROTECTOR	PIN/RETAINER	MACHINE MODEL
R450	4T5452	Ripper Tip	17	7J1791 · 7J1792 · 7J1793 7J1795 · 107-3845 · 4T9776 107-3846 · 8E5346 · 4T1304 4T1305 · 4T1306 · 8E5340 8E5341 · 8E5342 · 4T8989 4T0134 · 4T8990 · 8E5347 8E5340 · 7J1794 · 8E5345 9W6167 · 4T8988 · 4T8990	6J8814	7J9600 · 6J8811 · 6Y3394 · 8E4743	D8K · D8L · D8N · D9N · D9H
R500	4T4501	Ripper Tip	27.2	3G6507 · 9J5954 · 6Y6138 6Y6144 · 6Y6141 · 8E8414 8E8415 · 8E8416 · 3G6707 3G5707 · 1V4592 · 1U4873 6Y4679 · 6Y5616 · 8E8412 8E8413 · 6Y6138 · 9W4427 9J5954 · 9W8366 · 6Y6147 6Y5616 · 6Y6141 · 8E8411 8E8415 · 8E8417	6J8814	3G0500 · 6Y3909 · 4T4707	D9L · D10 · D10N · D11 · D11N
R500	4T4502	Ripper Tip	29	3G6507 · 9J5954 · 6Y6138 6Y6144 · 6Y6141 · 8E8414 8E8415 · 8E8416 · 3G6707 3G5707 · 1V4592 · 1U4873 6Y4679 · 6Y5616 · 8E8412 8E8413 · 6Y6138 · 9W4427 9J5954 · 9W8366 · 6Y6147 6Y5616 · 6Y6141 · 8E8411 8E8415 · 8E8417	6J8814	3G0500 · 6Y3909 · 4T4707	D9L · D10 · D10N · D11 · D11N
R500	4T4502ST	Ripper Tip	30.5	3G6507 · 9J5954 · 6Y6138 6Y6144 · 6Y6141 · 8E8414 8E8415 · 8E8416 · 3G6707 3G5707 · 1V4592 · 1U4873 6Y4679 · 6Y5616 · 8E8412 8E8413 · 6Y6138 · 9W4427 9J5954 · 9W8366 · 6Y6147 6Y5616 · 6Y6141 · 8E8411 8E8415 · 8E8417	6J8814	3G0500 · 6Y3909 · 4T4707	D9L · D10 · D10N · D11 · D11N
R500	4T4503	Ripper Tip	32	3G6507 · 9J5954 · 6Y6138 6Y6144 · 6Y6141 · 8E8414 8E8415 · 8E8416 · 3G6707 3G5707 · 1V4592 · 1U4873 6Y4679 · 6Y5616 · 8E8412 8E8413 · 6Y6138 · 9W4427 9J5954 · 9W8366 · 6Y6147 6Y5616 · 6Y6141 · 8E8411 8E8415 · 8E8417	6J8814	3G0500 · 6Y3909 · 4T4707	D9L · D10 · D10N · D11 · D11N



Ripper Tip

SIZE	TURBO PART N°	DESCRIPTION	WEIGHT	SHANK	PROTECTOR	PIN/RETAINER	MACHINE MODEL
	4T5501	Ripper Tip	26.5	3G6507 · 9J5954 · 6Y6138 6Y6144 · 6Y6141 · 8E8414 8E8415 · 8E8416 · 3G6707 3G5707 · 1V4592 · 1U4873 6Y4679 · 6Y5616 · 8E8412 8E8413 · 6Y6138 · 9W4427 9J5954 · 9W8366 · 6Y6147 6Y5616 · 6Y6141 · 8E8411 8E8415 · 8E8417	6J8814	3G0500 · 6Y3909 · 4T4707	D9L · D10 · D10N · D11 · D11N
	4T5502A	Ripper Tip	29	3G6507 · 9J5954 · 6Y6138 6Y6144 · 6Y6141 · 8E8414 8E8415 · 8E8416 · 3G6707 3G5707 · 1V4592 · 1U4873 6Y4679 · 6Y5616 · 8E8412 8E8413 · 6Y6138 · 9W4427 9J5954 · 9W8366 · 6Y6147 6Y5616 · 6Y6141 · 8E8411 8E8415 · 8E8417	6J8814	3G0500 · 6Y3909 · 4T4707	D9L · D10 · D10N · D11 · D11N
	4T5502	Ripper Tip	32	3G6507 · 9J5954 · 6Y6138 6Y6144 · 6Y6141 · 8E8414 8E8415 · 8E8416 · 3G6707 3G5707 · 1V4592 · 1U4873 6Y4679 · 6Y5616 · 8E8412 8E8413 · 6Y6138 · 9W4427 9J5954 · 9W8366 · 6Y6147 6Y5616 · 6Y6141 · 8E8411 8E8415 · 8E8417	6J8814	3G0500 · 6Y3909 · 4T4707	D9L · D10 · D10N · D11 · D11N
	4T5502VIP	Ripper Tip Tiger	27.5	3G6507 · 9J5954 · 6Y6138 6Y6144 · 6Y6141 · 8E8414 8E8415 · 8E8416 · 3G6707 3G5707 · 1V4592 · 1U4873 6Y4679 · 6Y5616 · 8E8412 8E8413 · 6Y6138 · 9W4427 9J5954 · 9W8366 · 6Y6147 6Y5616 · 6Y6141 · 8E8411 8E8415 · 8E8417	6J8814	3G0500 · 6Y3909 · 4T4707	D9L · D10 · D10N · D11 · D11N



Ripper Tip

SIZE	TURBO PART N°	DESCRIPTION	WEIGHT	SHANK	PROTECTOR	PIN/RETAINER	MACHINE MODEL
R500	4T5503	Ripper Tip	34.2	3G6507 · 9J5954 · 6Y6138 6Y6144 · 6Y6141 · 8E8414 8E8415 · 8E8416 · 3G6707 3G5707 · 1V4592 · 1U4873 6Y4679 · 6Y5616 · 8E8412 8E8413 · 6Y6138 · 9W4427 9J5954 · 9W8366 · 6Y6147 6Y5616 · 6Y6141 · 8E8411 8E8415 · 8E8417	6J8814	3G0500 · 6Y3909 · 4T4707	D9L · D10 · D10N D11 · D11N
R550	9W4551	Ripper Tip	46.5	7T6020 · 9W0259 · 8E0467 8E1466 · 6Y9473 · 6Y9473EXT 104-9279 · 104-9279EXT	9N4621	9W1821 · 8E2229 · 8E2230	D10N · D11 · D11N
R550	9W4552	Ripper Tip	47.5	7T6020 · 9W0259 · 8E0467 8E1466 · 6Y9473 · 6Y9473EXT 104-9279 · 104-9279EXT	9N4621	9W1821 · 8E2229 · 8E2230	D10N · D11 · D11N
R550	6Y3552	Ripper Tip	50	7T6020 · 9W0259 · 8E0467 8E1466 · 6Y9473 · 6Y9473EXT 104-9279 · 104-9279EXT	9N4621	9W1821 · 8E2229 · 8E2230	D10N · D11 · D11N
R550	6Y3552A	Ripper Tip Heavy Dute	52	7T6020 · 9W0259 · 8E0467 8E1466 · 6Y9473 · 6Y9473EXT 104-9279 · 104-9279EXT	9N4621	9W1821 · 8E2229 · 8E2230	D10N · D11 · D11N



Ripper Protector

SIZE	TURBO PART N°	DESCRIPTION	WEIGHT	BLADE SIZE	SHANK	RIPPER TEETH	PIN/RETAINER	MACHINE MODEL
	6J8814	CAT-Ripper Proctor	13.9	75	7J1792	9w2451	7J9600 · 6J8811 · 6Y3394 · 8E4743	D8K · D8L · D8N · D9N · D9H
	132-4716	CAT-Ripper Proctor	23.5	75	7J1792	9w2451	7J9600 · 6J8811 · 6Y3394 · 8E4743	D8K · D8L · D8N · D9N · D9H
	8E1848	CAT-Ripper Proctor	23.7	75	9W6167	9w2451	7J9600 · 6J8811 · 6Y3394 · 8E4743	D8K · D8L · D9N · D9H
	3G9594	CAT-Ripper Proctor	*	90	3G5707	4T4502	3G0500 · 1U3630	D10 · D11 · D11N
	9W8365	CAT-Ripper Proctor-standard	41.5	90	6Y6138	4T4502	3G0500 · 6Y3909 · 4T4707	D9L · D10N





Ripper Protector

SIZE	Nº	DESCRIPTION	WEIGHT	BLADE SIZE	SHANK	RIPPER TEETH	PIN/RETAINER	MACHINE MODEL
	9W8365EXT	CAT-Ripper Proctor-long version	47.5	90	6Y6138	4T4502	3G0500 · 6Y3909 · 4T4707	D9L · D10N
	6Y8960	CAT-Ripper Proctor-standard	38.7	100	118-2140	4T4502	3G0500 · 6Y3909 · 4T4707	D9L · D10N
	6Y8960EXT	CAT-Ripper Proctor-long version	56.8	100	118-2140	4T4502	3G0500 · 6Y3909 · 4T4707	D9L · D10N
	9N4621	CAT-Ripper Proctor	80.3	110	7T6020	6Y3552	9W1821 · 8E2229 · 8E2230	D9L · D10 · D10N · D11 · D11N
	1U3644	CAT-Ripper Proctor	40.5	90	1U3630	4T4502	3G0500 · 1U3630	D9L · D10 · D10N · D11 · D11N
	6Y-9704	CAT-Ripper Proctor	55.1	90	1U4873	4T4502	3G0500 · 8J4889	D9L · D10 · D10N · D11 · D11N



Bucket Protector

SIZE	Nº	DESCRIPTION	WEIGHT	BLADE SIZE	PIN/RETAINER	MACHINE MODEL
	9J9600	CAT-Protector	18	35	135-9350 · 152-0027	980 · 988
	1U0740	CAT-Protector	22.4	52	133-0738 · 107-8559	988 · 990 · 992
	8J4143	CAT-Protector	20.2	35	9J8441 · 8E5559	620 · 630 · 650 · 992B · 992C
	125-0800	CAT-Protector	62	65	8E4708 · 4T4707	994
	135-8246	CAT-PROTECTOR	10.2	25.5	135-9292 · 114-0359	620 · 630 · 650 · 992
	166-2877	CAT- Excavator Protector Blade 36mm	18.8	36	132-0988 · 132-0999	330
	112-2489	CAT-Excavator Protector Blade 32mm	18.8	32	112-2490 · 132-0999	330



Segment-Casted

SIZE	Nº	DESCRIPTION	WEIGHT	BOLT NUT	MACHINE MODEL
	4T6694	CAT-Segment	10.6	4F4042 · 2J3507	963 953 951 941 930 926 920
	4T6695	CAT-Segment	12.7	4F4042 · 2J3507	950 936
	4T6696	CAT-Segment	13.8	5P8823 · 3K9770	977
	4T6699	CAT-Segment	21	5P8823 · 3K9770	970 966



Bucket Side Cutter

SIZE	TURBO PART N°	DESCRIPTION	WEIGHT	BOLT NUT	MACHINE MODEL
	7Y0203(E120BR)	CAT-Side Cutter	7.8	093-7676 096-7074	312
	7Y0204(E120BL)	CAT-Side Cutter	7.8	093-7676 096-7074	312
	096-4747(E200BR)	CAT-Side Cutter	11.4	8T0380 7X0851	320
	096-4748(E200BL)	CAT-Side Cutter	11.4	8T0380 7X0851	320
	112-2487	CAT-Side Cutter	26.5	1D4635 2J3507 3K5234	320 330
	112-2488	CAT-Side Cutter	26.5	1D4635 2J3507 3K5234	320 330
	2322147	CAT-Side Cutter	25	*	320 330
	2322148	CAT-Side Cutter	25	*	320 330
	8J9614	CAT-Side Cutter	23.4	7Y2146 2J3507	320 330
	8J9615	CAT-Side Cutter	23.4	7Y2146 2J3507	320 330
	2568690	CAT-Side Cutter	42	*	320 330
	2568691	CAT-Side Cutter	42	*	320 330
	7Y0357	CAT-Side Cutter	20.3	6I6371 2J3507	330
	7Y0358	CAT-Side Cutter	20.3	6I6371 2J3507	330
	9J1855	CAT-Side Cutter	11.5	4F7827 2J3506	*
	9J1866	CAT-Side Cutter	11.5	4F7827 2J3506	*
	8J9825	CAT-Side Cutter	32	7Y1136 2J3507 3K5234	*
	8J9826	CAT-Side Cutter	32	7Y1136 2J3507 3K5234	*
	174-8044	CAT-Side Cutter	25.2	*	*
	2322140	CAT-Side Cutter	26	*	*
	2322140	CAT-Side Cutter	25	*	*



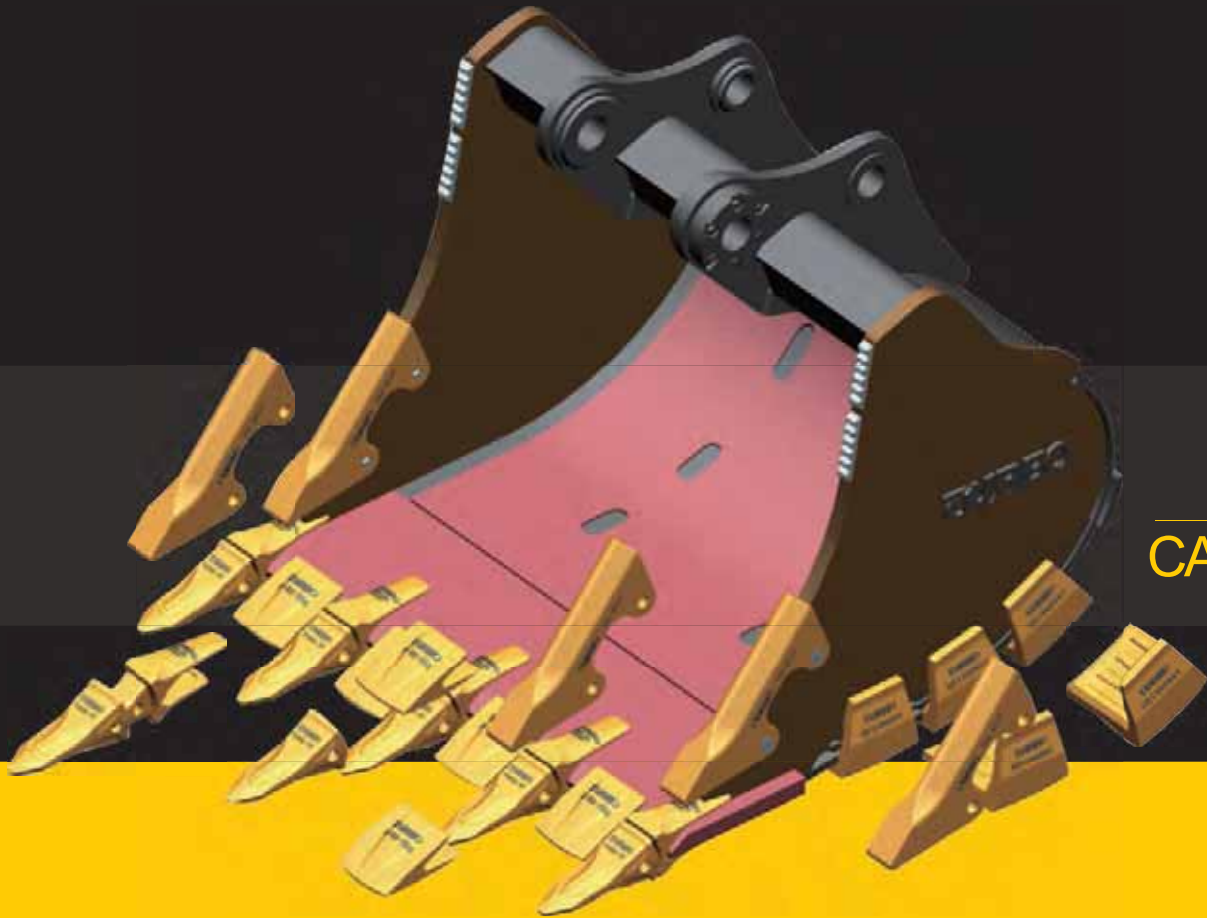

CAT

CAT BUCKET PROTECTION SYSTEM





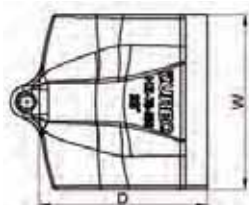
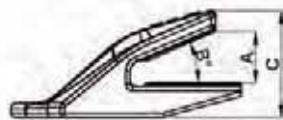

Hell Shroud

N° TURBO PART N°	TYPE	R	A	C	D	E	kg Kg
157-1019	Straight	\	250	50	270	200	29.8
157-1027	Curved	R800	250	50	270	200	29.2
138-6529	Straight	\	175	40	205	150	13.2
HS138-6551	Curved	R600	200	51	222	186	18
HS140-110	Curved	R1000	110	30	140	110	4.6
HS175-140	Curved	R1000	140	40	175	115	10.6
HS230-190	Curved	R1000	190	45	230	165	19.8
HS290-240	Curved	R1000	240	50	290	220	40.2
ES6697	Curved	R940	150	50	210	130	14
ES6697-2	Curved	R850	188	50	250	200	22.5
ES6697-3	Curved	R800	188	38	200	150	13.8
ES6697-4	Curved	R800	188	32	175	135	10.2
ES6697-5	Curved	R850	250	50	300	235	40.3
ES6697-7	Curved	R850	250	100	350	235	83
PDE6250							\



Lip Conner

 TURBO PART N°	 TYPE	 BLADE SIZE	A	C	D	E	 Kg
HZ-50-150-23°	Centre	40-50	45	95	190	150	7.7
HZ-50-150-30°	Centre	40-50	45	80	205	150	7.7
HZ-70-250-30°	Centre	60-75	66	112	250	250	22
HZ-70-250-30°-L	Left	60-75	66	112	250	250	23
HZ-70-250-30°-R	Right	60-75	66	112	250	250	23
HZ-70-250-23°	Centre	60-75	73.5	132	230	250	21.5
HZ-70-250L-23°	Left	60-75	73.5	132	230	240	22.6
HZ-70-250R-23°	Right	60-75	73.5	132	230	240	22.6
HZ-90-360-30°	Centre	80-100	95	145	254	360	36
HZ-90-360-30°-L	Left	80-100	95	145	254	360	37.5
HZ-90-360-30°-R	Right	80-100	95	145	254	360	37.5
HZ-90-360-35°	Centre	80-100	95	165	254	360	35
HZ-90-360-35°-L	Left	80-100	95	165	254	360	37
HZ-90-360-35°-R	Right	80-100	95	165	254	360	37
HZ-120-320-30°	Centre	100-120	115	180	280	320	40
HZ-120-320-30°-L	Left	100-120	115	180	280	320	42
HZ-120-320-30°-R	Right	100-120	115	180	280	320	42

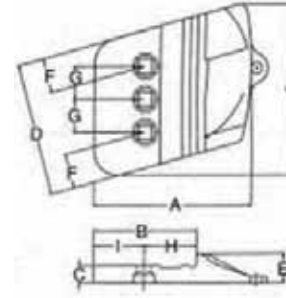
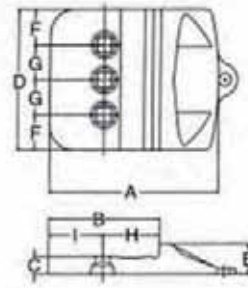
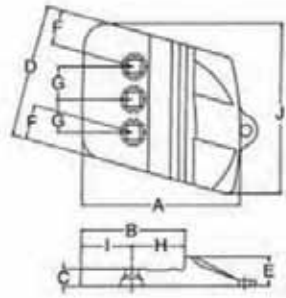

Half Arrow

^{Nº} TURBO PART Nº	HOLES	ANGLE	A	B	D	D	E	F	G
109-9030	5	0	593	437	440	440	140	50	85
109-9031R	5	15	593	437	440	440	140	56	85
109-9032L	5	15	593	437	440	440	140	56	85
109-9033	5	0	593	437	622	622	140	141	85
117-6805R	5	15	633.5	437	440	440	140	56	85
117-6806L	5	15	633.5	437	440	440	140	56	85
109-2675	4	0	536	360	410	410	115	70	90
109-2676R	4	15	536	360	436	436	115	73	100
109-2677L	4	15	536	360	436	436	115	73	100
119-9600	4	0	495	330	410	410	100	70	90

Half Arrow

N° TURBO PART N°	HOLES	ANGLE	A	B	D	D	E	F	G
119-9601R	4	15	480	330	436	436	100	73	100
119-9602L	4	15	480	330	436	436	100	73	100
109-9080	3	0	420	275	342	342	75	86	85
109-9081R	3	15	420	275	342	342	75	89	85
109-9082L	3	15	420	275	342	342	75	89	85
116-7460	3	0	420	275	312	312	75	71	85
116-7461R	3	15	420	275	312	312	75	74	85
116-7462L	3	15	420	275	312	312	75	74	85
113-3140	2		400	261	288	288	71	77	134
113-3141R	2	14	416	261	328	328	71	99	134
113-3142L	2	14	416	261	328	328	71	99	134
135-9544	2	0	400	262	300	300	71	90	60
135-9545R	2	15	400	262	304	304	71	55	100
135-9546L	2	15	400	262	304	304	71	55	100
195-7190	*	*	*	*	*	*	*	*	*
195-7191	*	*	*	*	*	*	*	*	*
195-7192	*	*	*	*	*	*	*	*	*
4T8101HA	*	*	*	*	*	*	*	*	*
1441281	*	*	*	*	*	*	*	*	*
1441282	*	*	*	*	*	*	*	*	*
2755460	*	*	*	*	*	*	*	*	*
2755461	*	*	*	*	*	*	*	*	*
2755462	*	*	*	*	*	*	*	*	*



CAT-Clean Bar



N° TURBO PART N°	DESCRIPTION	WEIGHT kg	LOCK	MACHINE MODEL
1062047	CAT-Tamping Feet	9.3	3G8250	815B
141-7407	CAT-Clean Bar	5	3G8250	815B
3G8250	CAT-Clean Bar Tip	3.4		



Bucket Conner Shroud



 TURBO PART N°	 DESCRIPTION	 WEIGHT	MACHINE MODEL	BASE EDGE	ADAPTERS
618310	CAT-Shroud	6.2	938	105-2345	1U0257 · 3G4259/8
618311	CAT-Shroud	6.2	938	105-2345	1U0257 · 3G4259/8
8J7210	CAT-Shroud	8.7	938	110-4712	1U0257 · 3G4259/8
8J7211	CAT-Shroud	8.7	938	110-4712	1U0257 · 3G4259/8
4V7174	CAT-Shroud	9	977	6W2983	3G3357 · 3G5359/8
4V7175	CAT-Shroud	9	977	6W2983	3G3357 · 3G5359/8
4V1544	CAT-Shroud	5.2	953	9V6570	1U0257 · 3G4259/8
4V1545	CAT-Shroud	5.2	953	9V6570	1U0257 · 3G4259/8
8E5300	CAT-Shroud	7	950	9V6573	4T4307 · 8E5309/8
8E5301	CAT-Shroud	7	950	9V6573	4T4307 · 8E5309/8



Bucket Side Bar Proection

 TURBO PART N°	 DESCRIPTION	 WEIGHT	MACHINE MODEL
VS450	CAT-Side Bar Proection	20.8	
VS500	CAT-Side Bar Proection	31	
VS550	CAT-Side Bar Proection	40	
VSM100WN	CAT-Side Bar Adapter	5.4	
VSM200WN	CAT-Side Bar Adapter	5.7	
VSM150WN	CAT-Side Bar Adapter	5.8	

Bucket Wear Plate



TURBO PART N°	DESCRIPTION	WEIGHT	Bolt/Nut	MACHINE MODEL
100-4015	Wear plate	235	6V8360 · 3K9770 · 4K0684	994
9W6749	bucket wear plate	31.64	5J4773 · 2J3506 5P8248	970
9W6748	bucket wear plate	19.2	5J4773 · 2J3506 · 5P8248	970
9W6747	bucket wear plate	19.2	5J4773 · 2J3506 · 5P8248	970
195-7097	cover plate	24.5	*	*
195-7098	cover plate	24.5	*	*
195-7096	cover plate	22.3	*	*

Compactor Cap



TURBO PART N°	DESCRIPTION	WEIGHT	BASE	MACHINE MODEL
47021	Tamping Foot	5.3	*	*
2V7053	Tamping Foot	3.7	7K7071	815F
2V6628	Tamping Foot	5.4	7K7071	825C
4V3851	Rock Tamping Foot	4.4	7K6908	825C
4V0668	Rock Tamping Foot	7.2	7K7071	825C
8K9189	Rock Tamping Foot	3.5	7K6908	815F
8K9171	Rock Tamping Foot	6.4	7K7071	835
7K2939	Rock Tamping Foot	6.9	9S1645	835
7K6908	Base	4.2	*	815F
7K7071HD	Base	9	*	835





Clean bars



TURBO PART N°	DESCRIPTION	WEIGHT	TAMPING FOOT	MACHINE MODEL
3S3228	Sheepsfoot	7	4S7928	835
3S3225	CAT-Plate	22	*	*
4S7928	Tamping Foot	6	3S3228	835



Router Bits



 TURBO PART N°	 DESCRIPTION	 WEIGHT	 Bolt/Nut	MACHINE MODEL
4J8665	Router Bits-Standard	25	4F4042 2J3507	666 651
7J3023	Router Bits-Heavy duty	35.8	4F4042 2J3507	666 651
4T0668	Router Bits	40.2	5P8823 3K9770 4K0684	657
15002210	Router Bits	34		
15002211	Router Bits	34		
220-9150	Router Bits	58		
8F7232	Router Bits	*	5J4773 2J3506	80
9F1831	Router Bits	*	4F3654 4K0367	60
1J3599	Router Bits	*	5J4771 5J4771 2J3506	491 470
4T4336	Router Bits	*	8S9092 4K0367 5P8247	613

End bit-Casted



 TURBO PART N°	 DESCRIPTION	 WEIGHT	MACHINE MODEL
6Y4410	CAT-End Bit-Cast	27	
6Y4411	CAT-End Bit-Cast	27	
4T3051	CAT-End Bit-Cast	9	
4T3052	CAT-End Bit-Cast	9	
3G8319	CAT-End Bit-Cast	19	
3G8320	CAT-End Bit-Cast	19	
3G8301	CAT-End Bit-Cast	34.5	
3G8302	CAT-End Bit-Cast	34.5	
4J8261	CAT-End Bit-Cast	16	
4J8262	CAT-End Bit-Cast	16	
4J8443	CAT-End Bit-Cast	25.2	
4J8844	CAT-End Bit-Cast	25	
8E4193	CAT-End Bit-Cast	60.2	
8E4194	CAT-End Bit-Cast	60.2	
8E4196	CAT-End Bit-Cast	75.8	

End bit-Casted

N° TURBO PART N°	DESCRIPTION	WEIGHT kg	MACHINE MODEL
8E4197	CAT-End Bit-Cast	75.8	
8E4198	CAT-End Bit-Cast	112.8	
8E4199	CAT-End Bit-Cast	112.8	
8E4537	CAT-End Bit-Cast	75.3	
8E4538	CAT-End Bit-Cast	75.3	
8E4539	CAT-End Bit-Cast	79	
8E4540	CAT-End Bit-Cast	79	
8E9378	CAT-End Bit-Cast	12.5	
8E9379	CAT-End Bit-Cast	12.5	
3G8279	CAT-End Bit-Cast	40.6	
3G8280	CAT-End Bit-Cast	40.6	
3G8281	CAT-End Bit-Cast	74	
3G8282	CAT-End Bit-Cast	74	
3G8287	CAT-End Bit-Cast	41.1	
3G8288	CAT-End Bit-Cast	41.1	
3G8289	CAT-End Bit-Cast	58.5	
3G8290	CAT-End Bit-Cast	58.5	
3G8301	CAT-End Bit-Cast	30.5	
3G8302	CAT-End Bit-Cast	30.5	
3G8315	CAT-End Bit-Cast	26.4	
3G8316	CAT-End Bit-Cast	26.4	
3G8319	CAT-End Bit-Cast	16.2	
3G8320	CAT-End Bit-Cast	16.2	



STEP

N° TURBO PART N°	DESCRIPTION	WEIGHT kg	MACHINE MODEL
7T5140	Cat-Step	9.6	





KOMATSU

Rock Chisel



SIZE	TURBO PART N°	DESCRIPTION	WEIGHT	STRATGHIT BLADE	BEVEL BLADE	LOCK	MACHINE MODEL
PC60	PC60RC 201-70-24140RC	Rock Chisel	1.7	PC60-20 · PC60-A		20X-70-00150	PC60
PC100	PC100RC 20X-70-14160RC	Rock Chisel	2.5	PC100-25 · 20X-70-14151		20X-70-00100	PC70 PC100
PC120	202-70-12130RC	Rock Chisel	5.3	202-70-12140		09244-02489	PC120
PC200	PC200RC-2013 205-70-19570RC-2013	Rock Chisel	5.5	20Y-70-14520 · 205-939-7120(A)	205-70-68141	09244-02496	PC100 · PC100L-5 · PC120-5 PC130 · PC200-5
PC300	PC300RC-2013 207-70-14151RC-2013	Rock Chisel	8.8	207-939-3120 · 207-939-5120 · 207-939-3120HD 207-934-7120 · 207-939-3120ST	207-70-14142	09244-02516	PC300
PC400	PC400RC-NEW 208-70-14152RC-NEW	Rock Chisel	13.6	208-939-3120 · 208-939-3120ST 208-939-3120HD	208-70-14143	09244-03036	PC400 · PC400-5 PC450 · PC450(新款)
PC400	PC450RC	Rock Chisel - (Heavy Dute)	14.9	208-939-3120 · 208-939-3120ST 208-939-3120HD	208-70-14143	09244-03036	PC400 · PC400-5 PC450 · PC450(新款)
PC650	209-70-54210RC-2014	Rock Chisel	32		209-70-74140	209-70-54240	PC650 · PC750
PC1250	21N-72-14290RC-2014	Rock Chisel	54.5		21N-70-14140	21N-72-14330	PC1000 · PC1100 PC1200

Standard



SIZE	TURBO PART N°	DESCRIPTION	WEIGHT	STRATGHIT BLADE	BEVEL BLADE	LOCK	MACHINE MODEL
PC60	PC60 201-70-24140	Standard	1.8	PC60-20 · PC60-A		20X-70-00150	PC60
PC100	PC100 20X-70-14160	Standard	2.3	PC100-25 · 20X-70-14151		20X-70-00100	PC70 · PC100
PC120	202-70-12130	Standard	4.2	202-70-12140		09244-02489	PC120 · WA300 · WA320
PC200	205-70-19570	Standard	4.1	20Y-70-14520 · 205-939-7120(A)	205-70-68141	09244-02496	PC100 · PC100L-5 · PC120-5, PC130 · PC200-5
PC200	205-70-19570HD	Standard -heavy duty	4.5	20Y-70-14520 · 205-939-7120(A)	205-70-68141	09244-02496	PC100 · PC100L-5 · PC120-5, PC130 · PC200-5
PC300	207-70-14151	Standard	6.6	207-939-3120 · 207-939-5120 · 207-939-3120HD 207-934-7120 · 207-939-3120ST	207-70-14142	09244-02516	PC220 · PC240 · PC280 · PC290 PC300 · PC340 · PC360 · PC380
PC300	207-70-14151HD	Standard -heavy duty	6.8	207-939-3120 · 207-939-5120 · 207-939-3120HD 207-934-7120 · 207-939-3120ST	207-70-14142	09244-02516	PC220 · PC240 · PC280 · PC290 PC300 · PC340 · PC360 · PC380
PC400	208-70-14152	Standard	9.5	208-939-3120 · 208-939-3120ST · 208-939-3120HD	208-70-14143	09244-03036	PC400 · PC400-5 PC450 · PC450
PC400	208-70-14152HD	Standard -heavy duty	10.2	208-939-3120 · 208-939-3120ST · 208-939-3120HD	208-70-14143	09244-03036	PC400 · PC400-5 PC450 · PC450

Standard



TURBO SIZE	TURBO PART N°	DESCRIPTION	WEIGHT	STRATGHIT BLADE	BEVEL BLADE	LOCK	MACHINE MODEL
PC650	209-70-54210	Standard	28				PC650 · PC750
PC1250	21N-72-14290	Standard	43				PC1000 · PC1100 · PC1200

Short Rock Chisel



TURBO SIZE	TURBO PART N°	DESCRIPTION	WEIGHT	STRATGHIT BLADE	BEVEL BLADE	LOCK	MACHINE MODEL
PC200	205-70-19570TR	Short Rock Chisel	4.9				PC100 · PC100L-5 · PC120-5, PC130 · PC200-5
PC300	207-70-14151TR	Short Rock Chisel	8				PC220 · PC240 · PC280 · PC290 PC300 · PC340 · PC360 · PC380
PC400	208-70-14152TR	Short Rock Chisel	12.5				PC400 · PC400-5 PC450 · PC450

Rock Chisel Heavy



TURBO SIZE	TURBO PART N°	DESCRIPTION	WEIGHT	STRATGHIT BLADE	BEVEL BLADE	LOCK	MACHINE MODEL
PC200	205-70-19570RCHD	Rock Chisel Heavy	6.6				PC100 · PC100L-5 · PC120-5, PC130 · PC200-5
PC300	207-70-14151RCHD	Rock Chisel Heavy	10.5				PC220 · PC240 · PC280 · PC290 PC300 · PC340 · PC360 · PC380
PC400	208-70-14152RCHD	Rock Chisel Heavy	16				PC400 · PC400-5 PC450 · PC450

Heavy Dute Standard



TURBO SIZE	TURBO PART N°	DESCRIPTION	WEIGHT	STRATGHIT BLADE	BEVEL BLADE	LOCK	MACHINE MODEL
PC200	205-70-68260	Heavy dute standard	6.2				PC100 · PC100L-5 · PC120-5, PC130 · PC200-5
PC300	207-70-14280	Heavy dute standard	8.7				PC220 · PC240 · PC280 · PC290 PC300 · PC340 · PC360 · PC380
PC300	207-70-14280HD	Heavy dute standard	9.3				PC220 · PC240 · PC280 · PC290 PC300 · PC340 · PC360 · PC380
PC400	208-70-14270	Heavy dute standard	14				PC400 · PC400-5 PC450 · PC450

Tiger Long



SIZE	TURBO PART N°	DESCRIPTION	WEIGHT	STRATGHIT BLADE	BEVEL BLADE	LOCK	MACHINE MODEL
PC200	PC200TL	Tiger Long	5	20Y-70-14520 · 205-939-7120(A)	205-70-68141	09244-02496	PC100 · PC100L-5 · PC120-5 PC130 · PC200-5
PC300	PC300TL	Tiger Long	8.4	207-939-3120 · 207-939-5120 · 207-939-3120HD 207-934-7120 · 207-939-3120ST	207-70-14142	09244-02516	PC220 · PC240 · PC280 · PC290 PC300 · PC340 · PC360 · PC380
PC400	PC400TL	Tiger Long	12.4	208-939-3120 · 208-939-3120ST 208-939-3120HD	208-70-14143	09244-03036	PC400 · PC400-5 PC450 · PC450
PC400	PC400TL	Tiger Long-light dute	11.4	208-939-3120 · 208-939-3120ST 208-939-3120HD	208-70-14143	09244-03036	PC400 · PC400-5 PC450 · PC450
PC650	PC650TL	Tiger Long	27.3		209-70-74140	209-70-54240	PC650 · PC750
PC1250	PC1200TL	Tiger Long	44		21N-70-14140	21N-72-14330	PC1000 · PC1100 · PC1200

Tiger Long-Central sharp



SIZE	TURBO PART N°	DESCRIPTION	WEIGHT	STRATGHIT BLADE	BEVEL BLADE	LOCK	MACHINE MODEL
PC200	PC200VIP 205-70-19570VIP	Tiger Long	5	20Y-70-14520 · 205-939-7120(A)	205-70-68141	09244-02496	PC100 · PC100L-5 · PC120-5 PC130 · PC200-5
PC300	PC300VIP 207-70-14151VIP	Tiger Long	8	207-939-3120 · 207-939-5120 · 207-939-3120HD 207-934-7120 · 207-939-3120ST	207-70-14142	09244-02516	PC220 · PC240 · PC280 · PC290 PC300 · PC340 · PC360 · PC380
PC400	PC400VIP 208-70-14152VIP	Tiger Long	13.1	208-939-3120 · 208-939-3120ST 208-939-3120HD	208-70-14143	09244-03036	PC400 · PC400-5 PC450 · PC450-LC
PC650	PC650VIP 209-70-54210VIP	Tiger Long	28		209-70-74140	209-70-54240	PC650 · PC750

Symmetrical



SIZE	TURBO PART N°	DESCRIPTION	WEIGHT	STRATGHIT BLADE	BEVEL BLADE	LOCK	MACHINE MODEL
PC200	205-70-19570SYL	Symmetrica	4.15	20Y-70-14520 · 205-939-7120(A)	205-70-68141	09244-02496	PC100 · PC100L-5 · PC120-5 PC130,PC200-5
PC300	207-70-14151SYL	Symmetrical	7.8	207-939-3120 · 207-939-5120 · 207-939-3120HD 207-934-7120 · 207-939-3120ST	207-70-14142	09244-02516	PC220 · PC240 · PC280 · PC290 PC300 · PC340 · PC360 · PC380
PC400	208-70-14152SYL	Symmetrical	11.6	208-939-3120 · 208-939-3120ST 208-939-3120HD	208-70-14143	09244-03036	PC400 · PC400-5 PC450 · PC450

ESCO standard Komatsu



Blade Size	TURBO PART N°	DESCRIPTION	WEIGHT (kg)	STRAIGHTHIT BLADE	BEVEL BLADE	LOCK	MACHINE MODEL
PC60	20X-70-23161(25S)	ESCO standard	2.3	20X-70-23150-25		25-30PN · 25-30LK	PC60
PC100	203-70-43150(30S)	ESCO standard	2.5	855-30		25-30PN · 25-30LK	PC70 PC100
PC200	205-70-74272(35S)	ESCO standard	4.3	3807-35		35-PN · 35-LK	PC100 · PC100L-5 · PC120-5 PC130 · PC200-5
PC300	206-70-54221(40S)	ESCO standard	7.5	3809-40		40-PN · 40-LK	PC220 · PC240 · PC280 · PC290 PC300 · PC340 · PC360 · PC380
PC400	208-70-34211(45S)	ESCO standard	10.1	208-70-34220		45-PN · 45-LK	PC400 · PC400-5 PC450 · PC450LC

Loader Tip



Blade Size	TURBO PART N°	DESCRIPTION	WEIGHT (kg)	STRAIGHTHIT BLADE	BEVEL BLADE	LOCK	MACHINE MODEL
WA300	202-70-12130	Loader Tip	4.2	419-847-1111		09244-02496	WA300 · WA320
WA380	423-847-1140	Loader Tip	8.6	423-847-1111		09244-02516	WA380 · WA400 · WA420 · WA450
WA500	426-847-1110	Loader Tip	12.5	426-847-1121		09244-03036	WA500 · WA600
WA700	427-70-13731	Loader Tip	31	427-70-13743		427-70-13790	WA700 · WA800 · WA900
WA800	427-70-13780	Loader Tip	50	427-70-13743		427-70-13790	WA700 · WA800 · WA900

Fork Loader



Blade Size	TURBO PART N°	DESCRIPTION	WEIGHT (kg)	BLADE SIZE	LOCK	Machine Model
	417-70-13261	komatsu- fork teeth				WA120
	417-70-13271	komatsu- fork teeth				WA120
	417-70-13251	komatsu- fork teeth				WA120
WA130	418-70-13150 (417-70-B1390)	Fork Tip Loader	7	30	423-70-13180 · 02290-11422	WA180 · WA200 · WA250
WA130	418-70-13160	Fork Tip Loader	10.9	30	423-70-13180 · 02290-11422	WA180 · WA200 · WA250

Fork Loader



SIZE	TURBO PART N°	DESCRIPTION	WEIGHT	BLADE SIZE	LOCK	MACHINE MODEL
WA130	418-70-13170	Fork Tip Loader	10.9	30	423-70-13180 02290-11422	WA180 · WA200 · WA250
WA250	419-70-13114	Fork Tip Loader	15	28	09208-12290 09218-12219	WA300 · WA320 · WA350 · WA380 · WA400 · WA420 · WA460 · WA470
WA250	419-70-13164	Fork Tip Loader	21	28	09208-12290 09218-12219	WA300 · WA320 · WA350 · WA380 · WA400 · WA420 · WA460 · WA470
WA250	419-70-13174	Fork Tip Loader	21	28	09208-12290 09218-12219	WA300 · WA320 · WA350 · WA380 · WA400 · WA420 · WA460 · WA470
WA380/420	77Z-70-10201 423-70-13114	Fork Tip Loader	17	35		WA350.420
WA380/420	423-70-13154	Fork Tip Loader	23.5	35		WA350.420
WA380/420	423-70-13144	Fork Tip Loader	23.5	35		WA350.420
	20T-70-13130	Fork Tip Loader-Blade 16mm	2.5	16		
	20W-70-15130	Fork Tip Loader-Blade 10mm	1.3	10		
	10E-70-22211	Fork Tip Loader-Blade 14mm	1.7	14		



Ripper Tip



TURBO PART N°	DESCRIPTION	WEIGHT	SHANK	PPER PROTECTOR	LOCK	MACHINE MODEL
131-78-31190	KOM-Ripper Tip-D30	9.1	131-78-31180		09244-02496	D40 · D45 · D50 · D60
141-78-11253	KOM-Ripper	12.2	141-78-11241		09244-02508	D60 · D65 · D75 · D85
141-78-11330	Tip-D40-D50-D70	*	141-78-11241		09244-02508	D60 · D65 · D75 · D85
141-78-11254	KOM-Ripper Tip	12.7	141-78-11241		09244-02508	D60 · D65 · D75 · D85
175-78-31230	KOM-Ripper Tip	15.2	175-78-21613 175-78-21614	195-78-21320	09244-02508	D85 · D135 · D150 · D155
175-78-31230 2013	KOM-Ripper Tip-D85 High wear life	13.9	175-78-21613 175-78-21614	195-78-21320	09244-02508	D85 · D135 · D150 · D155
175-78-31230 TL D85VIP	KOM-RipperTip-D85 High penetration-new design	13.3	175-78-21613 175-78-21614	195-78-21320	09244-02508	D85 · D135 · D150 · D155

Ripper Tip



N° TURBO PART N°	DESCRIPTION	kg WEIGHT	 SHANK	 PPER PROTECTOR	 LOCK	MACHINE MODEL
175-78-34131	KOM-Ripper Tip	*	175-78-21613 175-78-21614	195-78-21320	09244-02508	D85 · D135 · D150 · D155
175-78-61660	KOM-Ripper Tip	*	175-78-21613 175-78-21614	195-78-21320	09244-02508	D85 · D135 · D150 · D155
175-78-31293	KOM-Ripper Tip	15.4	175-78-21613 175-78-21614	195-78-21320	09244-02508	D85 · D135 · D150 · D155
175-78-34141	KOM-Ripper Tip	*	175-78-21613 175-78-21614	195-78-21320	09244-02508	D85 · D135 · D150 · D155
175-78-61670	KOM-Ripper Tip	*	175-78-21613 175-78-21614	195-78-21320	09244-02508	D85 · D135 · D150 · D155
175-78-31231	KOM-Ripper Tip	*	175-78-21613 175-78-21614	195-78-21320	09244-02508	D85 · D135 · D150 · D155
195-78-21331	KOM-Ripper Tip-D155-D255	16	195-79-31140 195-79-41190	195-78-21320 195-78-21580	09244-02508	D275 · D355 · D455
195-78-29130	KOM-Ripper Tip	*	195-79-31140 195-79-41190	195-78-21320 195-78-21580	09244-02508	D275 · D355 · D455
195-78-71440	KOM-Ripper Tip	*	195-79-31140 195-79-41190	195-78-21320 195-78-21580	09244-02508	D275 · D355 · D455
195-78-29140	KOM-Ripper Tip	21.8	195-79-31140 195-79-41190	195-78-21320 195-78-21580	09244-02508	D275 · D355 · D455
195-78-71450	KOM-Ripper Tip	*	195-79-31140 195-79-41190	195-78-21320 195-78-21580	09244-02508	D275 · D355 · D455
195-78-21333	KOM-Ripper Tip	*	195-79-31140 195-79-41190	195-78-21320 195-78-21580	09244-02508	D275 · D355 · D455
195-78-71140	KOM-Ripper Tip	*	195-78-71120	195-78-71111	09244-02508	
195-78-71240	KOM-Ripper Tip	*	195-78-71120	195-78-71111	09244-02508	
195-78-71250	KOM-Ripper Tip	*	195-78-71120	195-78-71111	09244-02508	
195-78-71260	KOM-Ripper Tip	*	195-78-71120	195-78-71111	09244-02508	
195-78-71420	KOM-Ripper Tip	*	195-78-71120	195-78-71111	09244-02508	D375-A
195-78-71320	KOM-Ripper Tip-D350	26	195-79-51110	195-78-72410	09244-02508	D375-A
195-78-71370	KOM-Ripper Tip	*	195-79-51110	195-78-72410	09244-02508	D375-A
195-78-71340	KOM-Ripper Tip	*	195-79-51110	195-78-72410	09244-02508	D375-A
195-78-71350	KOM-Ripper Tip	*	195-79-51110	195-78-72410	09244-02508	D375-A
195-78-71300	KOM-Ripper Tip	*	195-79-51110	195-78-72410	09244-02508	D375-A

Ripper Tip



TURBO PART N°	DESCRIPTION	WEIGHT	SHANK	PPER PROTECTOR	LOCK	MACHINE MODEL
198-79-11560	KOM-Ripper Tip	*	198-79-11630	198-79-11640	09244-03036	D455
198-79-11551	KOM-Ripper Tip	*	198-79-11630	198-79-11640	09244-03036	D455
198-78-21420	KOM-Ripper Tip	*	198-78-21340	198-78-21330	09244-03036	D475-A
198-78-21340RPL	KOM- Ripper Tip-D470	44	198-78-21340	198-78-21330	09244-03036	D475-A
198-78-21350	KOM- Ripper Tip	*	198-78-21340	198-78-21330	09244-03036	D475-A
198-78-21380	KOM- Ripper Tip	*	198-78-21340	198-78-21330	09244-03036	D475-A

Dozer Protector



TURBO PART N°	DESCRIPTION	WEIGHT	BLADE SIZE	LOCK	MACHINE MODEL
195-78-21320	KOM-Dozer Protector	15.4	75	09244-02508	D85 · D135 · D150 · D155 · D275 · D355 · D455
195-78-21580	KOM- Dozer Protector	23.6	75	09244-02508	D275 · D355 · D455
195-78-21580HD	KOM- Dozer Protector-Long version	30	75	09244-02508	D275 · D355 · D455
195-78-71111-B	KOM-Dozer Protector	21.3	75	09244-02508	D375-A(NEW)
195-78-72410	KOM- Dozer Protector	52.8	80	09244-02508	D375-A
198-78-21330	KOM-Dozer Protector	42	85	09244-03036	D475-A

Excavator Protector



TURBO PART N°	DESCRIPTION	WEIGHT	BLADE SIZE	MACHINE MODEL
209-70-54610(4006)	KOM-Excavator Protector	28	*	PC300
208-934-7131	KOM-Excavator Protector	14	40	PC400 PC400-5 PC450

Bucket Side Cutter



TURBO PART N°	DESCRIPTION	WEIGHT kg	MACHINE MODEL
201-70-74170 L	KOM- Side Cutter-PC60	5.7	PC70 · PC100 · PC60
201-70-74171 R	KOM-Side Cutter-PC60	5.7	PC70 · PC100 · PC60
21K-70-14180	Side cutter	11.3	
21K-70-14190	Side cutter	11.3	
PC100L	KOM-Side Cutter-PC100	7.3	PC100 · PC120
PC100R	KOM-Side Cutter-PC100	7.3	PC100 · PC120
202-70-63160L	KOM-Side Cutter-PC120	7.5	PC120 · WA300 · WA320
202-70-63171R	KOM-Side Cutter-PC120	7.5	PC120 · WA300 · WA320
205-70-74180 L	KOM- Side Cutter-PC200	14.8	PC100 · PC100L-5 · PC120-5 · PC130 · PC200-5
205-70-74190 R	KOM- Side Cutter-PC200	14.8	PC100 · PC100L-5 · PC120-5 · PC130 · PC200-5
207-70-34160 L	KOM- Side Cutter-PC300	15.7	PC220 · PC240 · PC280 · PC290 · PC300 · PC340 · PC360 · PC380
207-70-34170 R	KOM-Side Cutter-PC300	15.7	PC220 · PC240 · PC280 · PC290 · PC300 · PC340 · PC360 · PC380
208-70-34160 L	KOM-Side Cutter-PC400	22.7	PC400 · PC400-5PC450 · PC450LC
208-70-34170 R	KOM-Side Cutter-PC400	22.7	PC400 · PC400-5PC450 · PC450LC

Bucket Protector



TURBO PART N°	DESCRIPTION	WEIGHT kg	MACHINE MODEL
208-934-Z170	KOM-Blade Protector	2.8	
209-939-5170	KOM-Blade Protector	4	

Excavator Adapter



SIZE	TURBO PART N°	DESCRIPTION	WEIGHT	BLADE SIZE	TEETH	PIN	MACHINE MODEL
PC60	PC60 Adapter	Excavator Adapter	2.4	16	PC60	20X-70-00150	PC60
PC60	PC60 Adapter	Excavator Adapter	2.3	20	PC60	20X-70-00150	PC60
PC100	PC100-25	Excavator Adapter	2.8	25	PC100	20X-70-00100	PC70 · PC100
PC100	20X-70-14151	Excavator Adapter	2.8	18	PC100	20X-70-00100	PC70 · PC100
PC120	202-70-12140	Excavator Adapter	6.8	25	202-70-12130	09244-02489	PC120 · WA300 · WA320
PC200	20Y-70-14520	Excavator Adapter	7.25	35	202-70-12130	09244-02496	PC100 · PC100L-5 · PC120-5 · PC130 · PC200-5
PC200	205-939-7120	Excavator Adapter	6.6	32	202-70-12130	09244-02496	PC100 · PC100L-5 · PC120-5 · PC130 · PC200-5
PC200	205-939-7120	Excavator Adapter	7.5	40	202-70-12130	09244-02496	PC100 · PC100L-5 · PC120-5 · PC130 · PC200-5
PC200	205-939-7120	Excavator Adapter	7.6	35	202-70-12130	09244-02496	PC100 · PC100L-5 · PC120-5, PC130, PC200-5
PC200	205-939-7120	Excavator Adapter	7.8	32	202-70-12130	09244-02496	PC100 · PC100L-5 · PC120-5, PC130, PC200-5
PC300	206-939-5120	Excavator Adapter	10.2	40	207-70-14151	09244-02516	PC220 · PC240 · PC280 · PC290 · PC300 · PC340 · PC360 · PC380
PC300	207-939-3120	Excavator Adapter	14.3	40	207-70-14151	09244-02516	PC220 · PC240 · PC280 · PC290 · PC300 · PC340 · PC360 · PC380
PC300	207-939-3120ST	Excavator Adapter	13.4	40	207-70-14151	09244-02516	PC220 · PC240 · PC280 · PC290 · PC300 · PC340 · PC360 · PC380
PC300	207-939-3120ST	Excavator Adapter	13.2	45	207-70-14151	09244-02516	PC220 · PC240 · PC280 · PC290 · PC300 · PC340 · PC360 · PC380
PC400	208-939-3120ST	Excavator Adapter	23.7	50	207-70-14152	09244-03036	PC400 · PC400-5 · PC450 · PC450-LC
PC400	208-939-3120ST	Excavator Adapter	23.2	55	207-70-14152	09244-03036	PC400 · PC400-5 · PC450 · PC450-LC
PC400	208-939-3120ST	Excavator Adapter	22.8	60	207-70-14152	09244-03036	PC400 · PC400-5 · PC450 · PC450-LC

Excavator Adapter Heavy



SIZE	TURBO PART N°	DESCRIPTION	WEIGHT	BLADE SIZE	TEETH	PIN	MACHINE MODEL
PC200	20Y-939-1180	Excavator Adapter Heavy	9.2	32	202-70-12130	09244-02496	PC100 · PC100L-5 · PC120-5 · PC130 · PC200-5
PC200	20Y-939-1180	Excavator Adapter Heavy	9	35	202-70-12130	09244-02496	PC100 · PC100L-5 · PC120-5 · PC130 · PC200-5
PC200	20Y-939-1180	Excavator Adapter Heavy	9.1	40	202-70-12130	09244-02496	PC100 · PC100L-5 · PC120-5 · PC130 · PC200-5
PC300	207-934-7120	Excavator Adapter Heavy	18.8	55	207-70-14151	09244-02516	PC220 · PC240 · PC280 · PC290 · PC300 · PC340 · PC360 · PC380
PC300	207-934-7120	Excavator Adapter Heavy	18.8	60	207-70-14151	09244-02516	PC220 · PC240 · PC280 · PC290 · PC300 · PC340 · PC360 · PC380
PC300	207-939-3120HD	Excavator Adapter Heavy	14.3	50	207-70-14151	09244-02516	PC220 · PC240 · PC280 · PC290 · PC300 · PC340 · PC360 · PC380
PC400	208-939-3120HD	Excavator Adapter Heavy	26.1	55	207-70-14152	09244-03036	PC400 · PC400-5 · PC450 · PC450-LC
PC400	208-939-3120HD	Excavator Adapter Heavy	26.1	60	207-70-14152	09244-03036	PC400 · PC400-5 · PC450 · PC450-LC

Excavator Adapter- Belvel



SIZE	TURBO PART N°	DESCRIPTION	WEIGHT	BLADE SIZE	TEETH	PIN	MACHINE MODEL
PC200	205-70-68141	Excavator Adapter Heavy	7.5	40	205-70-19570	09244-02496	PC100 · PC100L-5 · PC120-5 · PC130 · PC200-5
PC300	207-70-14142	Excavator Adapter Heavy	14.8	50	207-70-14151	09244-02516	PC220 · PC240 · PC280 · PC290 · PC300 · PC340 · PC360 · PC380
PC400	208-70-14143	Excavator Adapter Heavy	21.3	65	207-70-14151	09244-03036	PC220 · PC240 · PC280 · PC290 · PC300 · PC340 · PC360 · PC380
PC600	209-70-74140	Excavator Adapter Heavy	44.5	80	209-70-54210	209-70-54240	PC650 · PC750
PC1000	21N-70-14140	Excavator Adapter Heavy	76.8	90	21N-70-14520	21N-72-14330	PC1000 · PC1100 · PC1200

Excavator Adapter- ESCO



SIZE	TURBO PART N°	DESCRIPTION	WEIGHT	BLADE SIZE	TEETH	PIN	MACHINE MODEL
PC60	20X-70-23150(3806-25)	Excavator Adapter	5.5	25	20X-70-23161(25S)	25-30PN 25-30LK	PC60
PC100	203-70-43150(3807-30)	Excavator Adapter	7.5	30	203-70-43150(30S)	25-30PN 25-30LK	PC70 · PC100
PC200	20Y-70-14180(3808-35)	Excavator Adapter	6.6	35	205-70-74272(35S)	35-PN 35-LK	PC100 · PC100L-5 · PC120-5 · PC130 · PC200-5 (新款-A)
PC300	206-70-54221(3809-40)	Excavator Adapter	11.4	40	206-70-54221(40S)	40-PN 40-LK	PC220 · PC240 · PC280 · PC290 · PC300 · PC340 · PC360 · PC380
PC400	208-70-34211(3810-45)	Excavator Adapter		45	208-70-34211(45S)	45-PN 45-LK	PC400 · PC400-5 · PC450 · PC450LC

Loader Adapter



SIZE	TURBO PART N°	DESCRIPTION	WEIGHT	BLADE SIZE	TEETH	PIN	MACHINE MODEL
PC200	417-847-1140	Loader Adapter	*	20	201-70-24140	25-30PN	WA100 · WA120 · WA150
PC250	418-847-1120	Loader Adapter	*	20	20X-70-14160	25-30LK	WA180 · WA200 · WA250
WA300	419-847-1111	Loader Adapter	10.5	25	202-70-12130	25-30PN	WA300 · WA320
WA300	419-847-1121	Loader Adapter	9.75	25	202-70-12130	25-30LK	WA300 · WA320
WA300	419-847-1131	Loader Adapter	9.75	25	202-70-12130	35-PN 35-LK	WA300 · WA320
WA420	423-847-1111	Loader Adapter	15.9	35	423-847-1140	40-PN 40-LK	WA380 · WA400 · WA420 · WA450
WA420	423-847-1121	Loader Adapter	15.9	35	423-847-1140	45-PN 45-LK	WA380 · WA400 · WA420 · WA450
WA420	423-847-1131	Loader Adapter	15.9	35	423-847-1140		WA380 · WA400 · WA420 · WA450
WA500	426-847-1121	Loader Adapter	25.2	35	426-847-1110		WA500 · WA600
WA500	427-70-13743	Loader Adapter	44	70	427-70-13780		WA500 · WA600
WA250	202-70-12140	Loader Adapter	6.8	35	202-70-12130		WA500 · WA600
WA500	423-847-1110	Loader Adapter	18	35	423-847-1140		WA380 · WA400 · WA420 · WA450
WA500	426-847-1121	Loader Adapter	23.8	60	426-847-1110		WA500 · WA600

SUPER V SYSTEM

SUPER Vzahnssystem

LIGHT CONSTRUCTION

Light Construction



&



&



STD HD
Tonne

XHD
Tonne

STD HD
Tonne

XHD
Tonne

V13	Breakout force	3.6	2.9	5.9	4.5
	Machine Weight	3.4	5.9	4.5	
V17	Breakout force	5.3	4.2	8.7	6.8
	Machine Weight	5.4	8.7	6.8	
V19	Breakout force	7	5.6	11.5	8.9
	Machine Weight	10	7.6	11.5	8.9

CONSTRUCTION

Construction



STD HD
Tonne

XHD
Tonne

STD HD
Tonne

XHD
Tonne

V23	Breakout force	10.1	8.1	16.7	12.9
	Machine Weight	15.7	12	16.7	12.9
V29	Breakout force	13.2	10.5	25	19.5
	Machine Weight	21.7	16.3	25	19.5
V33	Breakout force	17	13.5	32.6	25
	Machine Weight	29.4	22.1	33.8	25
V39	Breakout force	21.8	17.4	39.9	32.3
	Machine Weight	39.9	30.2	46.9	33.4

SUPER V SYSTEM

SUPER Vzahnssystem

HEAVY CONSTRUCTION

Heavy Construction



		STD HD Tonne	XHD Tonne	STD HD Tonne	XHD Tonne	STD HD Tonne	XHD Tonne
V43	Breakout force	27	21.8	49.2	39.3		
	Machine Weight	53.3	39.9	63.6	46.9		
V51	Breakout force	31.8	27	59.1	49.2	37.3	31.6
	Machine Weight	67.4	53.3	81.2	63.6	62.2	48.6
V59	Breakout force	39.1	31.8	71.7	59.1	46.1	37.3
	Machine Weight	88.8	67.4	103.7	81.2	82.9	62.2

MINING

Mining



		STD HD Tonne	XHD Tonne	STD HD Tonne	XHD Tonne	STD HD Tonne	XHD Tonne
V61	Breakout force	48.7	39.1	92.2	71.7	57.4	46.1
	Machine Weight	119.4	88.8	144.1	103.7	110	82.9
V69	Breakout force	62.5	50.9	116.2	90.4	71.8	60.3
	Machine Weight	188	129.9	248.4	136.4	161.1	120.4
V71	Breakout force	79.1	62.5	138.5	107.7	88.1	71.8
	Machine Weight	270.5	188	345.1	211.3	218.5	161.1
V81	Breakout force	105.6	80.1			121.1	91.9
	Machine Weight	402.2	275.2			334.5	231.9



ESCO-SUPER-V

SUPER V Teeth for excavators

SYL

SYL means a standard tooth with a long Y-shaped rib for excavator buckets. Its symmetrical design allows us to keep the profile always sharp for best penetration. The Y-shaped rib makes it a very robust product, with plenty of wear metal. It is the best choice for general applications.



RYL

RYL is a tooth with Y-shaped rib for rocky grounds. This short tooth is most suitable for high-impact rock applications or any application where violent thrusts cause longer teeth to break.



SDX

SDX is a sharp Delta-shaped tooth. The chisel tip allows better penetration, while offering a more robust product and more wear metal than the VY shape.



SHV

SHV stands for Sharp, Heavy, V-shaped rib. It is suitable for extreme or abrasive applications, where more wear metal is required.



VY (VYH)

VY is V-shaped tooth with a non-symmetrical Y-shaped rib. It is used when maximum penetration is needed, such as in frozen ground or argillite. It has a longer lifespan than teeth of other shapes and stays sharp for longer. The model VYH offers higher robustness than the VY one.



TVY (TVYH)

TVY is a Twin, V-shaped tooth, with non-symmetrical Y-shaped rib and excellent penetration capacity. It has been conceived to be used in angular position with VY teeth, with a view to making clearance for the bucket. The TVYH is the most robust version.



SUPER V Teeth for excavators

FLARED

Sunk and tapered tooth for cleaning jobs.
Excellent for ditches and foundation work.



TYLCE

CE means Continuous Edge. The cavity of the tooth does not have a screw shape, so that it can be mounted without being rotated over the nose and so that a blade can be welded on to it resulting in a continuous edge bucket suitable to clear-up open spaces, flatten the ground and dig evenly.



Teeth for loaders

TYL

TYL is a two-way tooth, with Y-shaped rib and a long tip. It is used for adherence to level ground (without furrows) in standard applications. The upper part can be rotated downwards for a more energetic digging. The non-symmetrical shape is ideal to replace the long CAT tooth.



AD

AD is a Delta-shaped FEL tooth for extremely abrasive applications requiring the maximum penetration. It is an optimum choice for quarry work.



ADH

Robust shape, specifically designed to be used on a quarry Loadmaster. The wide wear shoe guarantees an even quarry floor and long wear (only available in size V43).



AR-ARL

AR is a FEL tooth for Rocky and highly Abrasive applications. It offers added wear metal for a longer life and better cost-effectiveness. The ARL version is available in various sizes.



AG

AG is a General Abrasion tooth, with a wide base to guarantee maximum strength in heavy-duty applications. Its slender contours offer very good penetration.



ARH

ARH has been specifically developed for abrasive applications such as the handling of Hot Slag. ARH has a sturdy base, thicker ear flaps and a thicker cavity wall for better adherence to the nose even in the most demanding applications. It can be used in a range of applications, apart from the handling of hot slag, requiring a higher amount of wear metal.



Teeth for loaders



TYLCE

CE means Continuous Edge. The cavity of the tooth does not have a screw shape, so that it can be mounted without being rotated over the nose and so that a blade can be welded on to it resulting in a continuous edge bucket suitable to clear-up open spaces, flatten the ground and dig evenly.





General Purpose Long CL



 TURBO PART N°	 DESCRIPTION	 WEIGHT	ADAPTER	PIN	Machine Model
V13SYL	Super V-General Purpose Long CL	0.8	833-V13	V13	
V17SYL	Super V-General Purpose Long CL	1.2	833-V17	V17	
V18SYL	Super V-General Purpose Long CL	1.7		V18	
V19SYL	Super V-General Purpose Long CL	2.3	833-V19	V19	
V23SYL	Super V-General Purpose Long CL	3.1	3870-V23	V23	
V29SYL	Super V-General Purpose Long CL	4.4	8833-V29	V29	
V33SYL	Super VL-General Purpose Long CL	6.8	3872A-V33	V33	
V39SYL	Super V-General Purpose Long CL	9.6	3892-V39	V39	
V43SYL	Super V-General Purpose Long CL	13	8837-V43	V43	
V51SYL	Super V-General Purpose Long CL	16.8	8814-V51	V51	
V61SYL	Super V-General Purpose Long CL	24	3811-V61	V61	



Standard Rock CL



 TURBO PART N°	 DESCRIPTION	 WEIGHT	ADAPTER	PIN	Machine Model
V29RYL	Super V-Standard Rock CL	4.5	8833-V29	V29	
V33RYL	Super V-Standard Rock CL	6.3	3872A-V33	V33	
V39RYL	Super V-Standard Rock CL	9	3892-V39	V39	
V43RYL	Super V-Standard Rock CL	12	8837-V43	V43	
V51RYL	Super V-Standard Rock CL	15	8814-V51	V51	
V59RYL	Super V-Standard Rock CL	20	8811-V59	V59	
V61RYL	Super V-Standard Rock CL	22	3811-V61	V61	
V69RYL	Super V-Standard Rock CL	37.5	6803-V69	V69	
V71RYL	Super V-Standard Rock CL	44	5897-V71	V71	
V81RYL	Super V-Standard Rock CL	70	6806-V81	V81	



Chesil Heavy CL



 TURBO PART N°	 DESCRIPTION	 WEIGHT	ADAPTER	PIN	Machine Model
V29SDX	Super V-Chesil Heavy CL	5	8833-V29	V29	
V33SDX	Super V-Chesil Heavy CL	6.9	3872A-V33	V33	
V39SDX	Super V-Chesil Heavy CL	9.6	3892-V39	V39	
V43SDX	Super V-Chesil Heavy CL	15	8837-V43	V43	
V51SDX	Super V-Chesil Heavy CL	18	8814-V51	V51	
V59SDX	Super V-Chesil Heavy CL	23.5	8811-V59	V59	
V61SDX/SD	Super V-Chesil Heavy CL	29	3811-V61	V61	
V69SD	Super V-Chesil Heavy CL	37.5	6803-V69	V69	
V71SD/SDX	Super V-Chesil Heavy CL	46	5897-V71	V71	
V81SD	Super V-Chesil Heavy CL	75	6806-V81	V81	



Rock Chesil



 TURBO PART N°	 DESCRIPTION	 WEIGHT	ADAPTER	PIN	Machine Model
V19RC	Super V-Rock Chesil	\	833-V19	V19	
V23RC	Super V-Rock Chesil	3.5	3870-V23	V23	
V29RC	Super V-Rock Chesil	4.5	8833-V29	V29	
V33RC	Super V-Rock Chesil	6.5	3872A-V33	V33	
V39RC	Super V-Rock Chesil	8.8	3892-V39	V39	
V43RC	Super V-Rock Chesil	13	8837-V43	V43	
V51RC	Super V-Rock Chesil	18	8814-V51	V51	
V61RC	Super V-Rock Chesil	28	3811-V61	V61	
V69RC	Super V-Rock Chesil	36	6803-V69	V69	
V71RC	Super V-Rock Chesil	45	5897-V71	V71	
V81RC	Super V-Rock Chesil	73	6806-V81	V81	



Petration Abrasion CL



 TURBO PART N°	 DESCRIPTION	 WEIGHT	ADAPTER	PIN	Machine Model
V23SHV	Super V-Penetration Abrasion CL	\	3870-V23	V23	
V29SHV	Super V-Penetration Abrasion CL	5.5	8833-V29	V29	
V33SHV	Super V-Penetration Abrasion CL	8	3872A-V33	V33	
V39SHV	Super V-Penetration Abrasion CL	9	3892-V39	V39	
V43SHV	Super V-Penetration Abrasion CL	16	8837-V43	V43	
V51SHV	Super V-Penetration Abrasion CL	22	8814-V51	V51	
V59SHV	Super V-Penetration Abrasion CL	\	8811-V59	V59	
V61SHV	Super V-Penetration Abrasion CL	31.3	3811-V61	V61	



Pick NCL



 TURBO PART N°	 DESCRIPTION	 WEIGHT	ADAPTER	PIN	Machine Model
V17VY	Super V-Pick NCL	1.1	833-V17	V17	
V19VY	Super V-Pick NCL	2	833-V19	V19	
V23VY	Super V-Pick NCL	2.8	3870-V23	V23	
V29VY/VYH	Super V-Pick NCL	3.8	8833-V29	V29	
V33VY/VYH	Super V-Pick NCL	5.4	3872A-V33	V33	
V39VY/VYH	Super V-Pick NCL	8	3892-V39	V39	
V43VY/VYH	Super V-Pick NCL	11	8837-V43	V43	
V51VY	Super V-Pick NCL	14.3	8814-V51	V51	
V59VY/VYH	Super V-Pick NCL	19.1	8811-V59	V59	



Penetration CL



 TURBO PART N°	 DESCRIPTION	 WEIGHT	ADAPTER	PIN	Machine Model
V43VX	Super V-Penetration CL	15.4	8837-V43	V43	
V61VX	Super V-Penetration CL	22.5	3811-V61	V61	
V69VX	Super V-Penetration CL	33.5	6803-V69	V69	
V71VX	Super V-Penetration CL	41	5897-V71	V71	
V81VX	Super V-Penetration CL	73.5	6806-V81	V81	

Tiger Long NCL



 TURBO PART N°	 DESCRIPTION	 WEIGHT	ADAPTER	PIN	Machine Model
V39VIP	Super V-Tiger Long NCL	8.8	3892-V39	V39	
V43VIP	Super V-Tiger Long NCL	11.8	8837-V43	V43	
V51VIP	Super V-Tiger Long NCL	15.5	8814-V51	V51	
V59VIP	Super V-Tiger Long NCL	\	8811-V59	V59	
V61VIP	Super V-Tiger Long NCL	\	3811-V61	V61	
V69VIP	Super V-Tiger Long NCL	\	6803-V69	V69	
V71VIP	Super V-Tiger Long NCL	\	5897-V71	V71	
V81VIP	Super V-Tiger Long NCL	\	6806-V81	V81	

Twin Pick NCL



TURBO PART N°	DESCRIPTION	WEIGHT	ADAPTER	PIN	Machine Model
V17TVY	Super V-Twin Pick NCL	1.2	833-V17	V17	
V23TVY	Super V-Twin Pick NCL	3.3	3870-V23	V23	
V29TVYH	Super V-Twin Pick NCL	4.3	8833-V29	V29	
V33TVYH	Super V-Twin Pick NCL	6	3872A-V33	V33	
V39TVYH	Super V-Twin Pick NCL	9.3	3892-V39	V39	
V43TVYH	Super V-Twin Pick NCL	12	8837-V43	V43	
V51TVYH	Super V-Twin Pick NCL	17	8814-V51	V51	
V59TVYH	Super V-Twin Pick NCL	21.5	8811-V59	V59	
V61TVP	Super V-Twin Pick NCL	\	3811-V61	V61	

Abrasion Petration NCL



TURBO PART N°	DESCRIPTION	WEIGHT	ADAPTER	PIN	Machine Model
V19AD	Super V-Abrasion Petration NCL	3	833-V19	V19	
V23AD	Super V-Abrasion Petration NCL	4.7	3870-V23	V23	
V29AD	Super V-Abrasion Petration NCL	6.2	8833-V29	V29	
V33AD	Super V-Abrasion Petration NCL	9	3872A-V33	V33	
V39AD	Super V-Abrasion Petration NCL	12.8	3892-V39	V39	
V43AD	Super V-Abrasion Petration NCL	18	8837-V43	V43	
V51AD	Super V-Abrasion Petration NCL	22	8814-V51	V51	
V59AD	Super V-Abrasion Petration NCL	28	8811-V59	V59	
V61AD	Super V-Abrasion Petration NCL	33.5	3811-V61	V61	
V69ADB	Super V-Abrasion Petration NCL	57	6803-V69	V69	
V69ADHL	Super V-Abrasion Petration NCL	67.5	6803-V69	V69	
V71ADB	Super V-Abrasion Petration NCL	70	5897-V71	V71	
V71ADHL	Super V-Abrasion Petration NCL	91	5897-V71	V71	

Abrasion Heavy NCL



TURBO PART N°	DESCRIPTION	WEIGHT	ADAPTER	PIN	Machine Model
V51AG	Super V-Abrasion Heavy NCL	23	8814-V51	V51	
V59AG	Super V-Abrasion Heavy NCL	29	8811-V59	V59	
V61AG	Super V-Abrasion Heavy NCL	35	3811-V61	V61	
V69AG	Super V-Abrasion Heavy NCL	49	6803-V69	V69	
V71AG	Super V-Abrasion Heavy NCL	55	5897-V71	V71	

Abrasion Rock NCL



TURBO PART N°	DESCRIPTION	WEIGHT	ADAPTER	PIN	Machine Model
V23AR	Super V-Abrasion Rock NCL	5.6	3870-V23	V23	
V29AR	Super V-Abrasion Rock NCL	7.7	8833-V29	V29	
V33AR	Super V-Abrasion Rock NCL	11	3872A-V33	V33	
V39AR	Super V-Abrasion Rock NCL	16	3892-V39	V39	
V43AR	Super V-Abrasion Rock NCL	22	8837-V43	V43	
V51AR	Super V-Abrasion Rock NCL	\	8814-V51	V51	
V59AR	Super V-Abrasion Rock NCL	\	8811-V59	V59	

Abrasion Rock Heavy NCL



TURBO PART N°	DESCRIPTION	WEIGHT	ADAPTER	PIN	Machine Model
V43ARH	Super V-Abrasion Rock Heavy NCL	\	8837-V43	V43	
V51ARH	Super V-Abrasion Rock Heavy NCL	34	8814-V51	V51	
V59ARH	Super V-Abrasion Rock Heavy NCL	44	8811-V59	V59	

Abrasion Rock Long NCL



TURBO PART N°	DESCRIPTION	WEIGHT	ADAPTER	PIN	Machine Model
V61ARL	Super V-Abrasion Rock Long NCL	37	3811-V61	V61	
V69ARL	Super V-Abrasion Rock Long NCL	53	6803-V69	V69	
V71ARL	Super V-Abrasion Rock Long NCL	62	5897-V71	V71	

Flare CL



TURBO PART N°	DESCRIPTION	WEIGHT	ADAPTER	PIN	Machine Model
V19TF	Super V-Flare CL	2.7	833-V19	V19	
V23S5F	Super V-Flare CL	3.9	3870-V23	V23	
V29S6F	Super V-Flare CL	6.2	8833-V29	V29	
V29S7F	Super V-Flare CL	9	8833-V29	V29	
V39S8F	Super V-Flare CL	13	3892-V39	V39	
V43S9F	Super V-Flare CL	17.5	8837-V43	V43	
V51S10F	Super V-Flare CL	23.5	8814-V51	V51	

Twist Long GP NCL



TURBO PART N°	DESCRIPTION	WEIGHT	ADAPTER	PIN	Machine Model
V19TYCE	Super V-Non-Twist Long GP NCL		833-V19	V19	
V23TYCE	Super V-Non-Twist Long GP NCL		3870-V23	V23	
V29TYCE	Super V-Non-Twist Long GP NCL		8833-V29	V29	
V33TYCE	Super V-Non-Twist Long GP NCL		8833-V29	V29	
V39TYCE	Super V-Non-Twist Long GP NCL		3892-V39	V39	
V43TYCE	Super V-Non-Twist Long GP NCL		8837-V43	V43	

General Purpose NCL



TURBO PART N°	DESCRIPTION	WEIGHT	ADAPTER	PIN	Machine Model
V17TYL	Super V-General Purpose NCL	1.2	833-V17	V17	
V18TY	Super V-General Purpose NCL	\			
V19TY	Super V-General Purpose NCL	2.2	833-V19	V19	
V23TY	Super V-General Purpose NCL	3.4	3870-V23	V23	
V29TYL	Super V-General Purpose NCL	4.8	8833-V29	V29	

General Purpose NCL





TURBO PART N°	DESCRIPTION	WEIGHT	ADAPTER	PIN	Machine Model
T33TYL	Super V-General Purpose NCL	7.2	3872A-V3	V33	
V39TYL	Super V-General Purpose NCL	10	3	V39	
V43TYL	Super V-General Purpose NCL	14	3892-V39	V43	
V51TYL	Super V-General Purpose NCL	18	8837-V43	V51	
V71RXL	Super V-General Purpose NCL	56	8814-V51	V71	
V81RXL	Super V-General Purpose NCL	81	5897-V71	V81	
V71RMX	Super V-General Purpose NCL	65	6806-V81	V71	
V81RMX	Super V-General Purpose NCL	94	5897-V71	V81	
V71RMHL	Super V-General Purpose NCL	76	6806-V81	V71	
V81RXXL	Super V-General Purpose NCL	93	5897-V71	V81	
			6806-V81		

Bottom Leg



TURBO PART N°	DESCRIPTION	WEIGHT	ADAPTER	PIN	Machine Model
833-V13	Super V Adapter-Bottom Leg Blade 15mm	1	15	30	V13
833-V17	Super V Adapter-Bottom Leg Blade 20mm	1.7	20	30	V17
833-v18	Super V Adapter-Bottom Leg Blade 20mm	1.8			
833-V19	Super V Adapter-Bottom Leg Blade 25mm	3	25	30	V19
8872-V19	Super V Adapter-Bottom Leg Blade 25-38mm	6	25-38	45	V19
8873-V19	Super V Adapter-Bottom Leg Blade 25-38mm	6	25-38	45	V19
3870-V23	Super V Adapter-Bottom Leg Blade 30-32mm	4.5	30-32	30	V23
3871-V29	Super V Adapter-Bottom Leg Blade 30-35mm	6.4	30-35	30	V29
3872A-V33	Super V Adapter-Bottom Leg Blade 35-40mm	12.5	35-40	30	V33



Fushmount

 TURBO PART N°	 DESCRIPTION	 WEIGHT	ADAPTER		PIN	Machine Model
8843-V13	Super V Adapter-Fushmount Blade 15mm	1.1	15	30	V13	
8806-V17	Super V Adapter-Fushmount Blade 20mm	2	20	25	V17	
3891-V17	Super V Adapter-Fushmount Blade 20mm	2.2	20	25	V17	
8806-V19	Super V Adapter-Fushmount Blade 20mm	4.1	20	25	V19	
8802-V19	Super V Adapter-Fushmount Blade 25mm	4.1	25	25	V19	
8830-V23	Super V Adapter-Fushmount Blade 35mm	6.4	35	25	V23	
8803-V23	Super V Adapter-Fushmount Blade 25-35mm	6.4	25-35	25	V23	
3829A-V29	Super V Adapter-Fushmount Blade 40mm	9	40	22-25	V29	
8831-V29	Super V Adapter-Fushmount Blade 40-45mm	9.3	40-45	22-25	V29	
4882-V33	Super V Adapter-Fushmount Blade 38-40mm	11	38-40	30	V33	
8831-V33	Super V Adapter-Fushmount Blade 50mm	13	50	22-25	V33	
3892-V33	Super V Adapter-Fushmount Blade 45-50mm	13	45-50	22-25	V33	
3892-V39	Super V Adapter-Fushmount Blade 45-50mm	16	45-50	22-25	V39	
1836-V39	Super V Adapter-Fushmount Blade 51mm	16	51	30	V39	
8837-V43	Super V Adapter-Fushmount Blade 65mm	21	65	30	V43	
1852-V43	Super V Adapter-Fushmount Blade 60-65mm	23	60-65	25-30	V43	
4883-V43	Super V Adapter-Fushmount Blade 60mm	25	60	25-30	V43	
1836-V43	Super V Adapter-Fushmount Blade 50mm	24	50	25-30	V43	
3892-V43	Super V Adapter-Fushmount Blade 51mm	23	51	22-25	V43	
1852-V51	Super V Adapter-Fushmount Blade 60-65mm	30	60-65	30	V51	





1/2 Bottom Leg



 TURBO PART N°	 DESCRIPTION	 WEIGHT	ADAPTER	PIN	Machine Model
1610T-V13	Super V Adapter-1-1/2 Bottom Leg Blade 16mm	1	16	30	V13
5854-V19	Super V Adapter-1-1/2 Bottom Leg Blade 25mm	3.8	25	30	V19
5854-V23	Super V Adapter-1-1/2 Bottom Leg Blade 25mm	5.7	25	30	V23
5849-V23	Super V Adapter-1-1/2 Bottom Leg Blade 30mm	5.7	30	30	V23
5849-V29	Super V Adapter-1-1/2 Bottom Leg Blade 30mm	8	30	30	V29
5850-V29	Super V Adapter-1-1/2 Bottom Leg Blade 38-40mm	7.7	38-40	30	V29
5855-V33	Super V Adapter-1-1/2 Bottom Leg Blade 38-40mm	11.3	38-40	30	V33
5856-V39	Super V Adapter-1-1/2 Bottom Leg Blade 51mm	16	51	30	V39
5856-V43	Super V Adapter-1-1/2 Bottom Leg Blade 51mm	22.7	51	30	V43
5857A-V51	Super V Adapter-1-1/2 Bottom Leg Blade 63.5mm	27.5	63.5	30	V51
8814-V51	Super V Adapter-1-1/2 Bottom Leg Blade 63.5mm	28	63.5	22-25	V51
5857A-V59	Super V Adapter-1-1/2 Bottom Leg Blade 63.5mm	36	63.5	30	V59
8814A-V59	Super V Adapter-1-1/2 Bottom Leg Blade 63.5mm	36	63.5	30	V59



1-1/2 Top Leg



 TURBO PART N°	 DESCRIPTION	 WEIGHT	ADAPTER	PIN	Machine Model
8842-V13	Super V Adapter-1-1/2 Top Leg Blade 25mm	1.4	25	23	V13
8841-V17	Super V Adapter-1-1/2 Top Leg Blade 20mm	1.8	20	30	V17
8842-V17	Super V Adapter-1-1/2 Top Leg Blade 25mm	2.4	25	23	V17
8822-V19	Super V Adapter-1-1/2 Top Leg Blade 25mm	4.5	25	30	V19
3877-V19	Super V Adapter-1-1/2 Top Leg Blade 30mm	4.2	30	30	V19
3880-V23	Super V Adapter-1-1/2 Top Leg Blade 30mm	6	30	30	V23
3808-V23	Super V Adapter-1-1/2 Top Leg Blade 35mm	6	35	30	V23
8835-V23	Super V Adapter-1-1/2 Top Leg Blade 30mm	6.9	30	22-25	V23

1-1/2 Top Leg



 TURBO PART N°	 DESCRIPTION	 WEIGHT	ADAPTER		PIN	Machine Model
8834-V23	Super V Adapter-1-1/2 Top Leg Blade 35mm	6.6	35	22-25	V23	
3882A-V29	Super V Adapter-1-1/2 Top Leg Blade 40mm	7.6	40	30	V29	
3881A-V29	Super V Adapter-1-1/2 Top Leg Blade 35mm	7.6	35	30	V29	
8833-V29	Super V Adapter-1-1/2 Top Leg Blade 40mm	9	40	22-25	V29	
3882A-V33	Super V Adapter-1-1/2 Top Leg Blade 40mm	11.5	40	30	V33	
3810A-V33	Super V Adapter-1-1/2 Top Leg Blade 45mm	14.5	45	30	V33	
3882A-V39	Super V Adapter-1-1/2 Top Leg Blade 40mm	16.2	40	30	V39	
3810A-V39	Super V Adapter-1-1/2 Top Leg Blade 45mm	16	45	30	V39	
1837A-V39	Super V Adapter-1-1/2 Top Leg Blade 51mm	18	51	30	V39	
3892A-V39	Super V Adapter-1-1/2 Top Leg Blade 51mm	17	51	22	V39	
8801-V43	Super V Adapter-1-1/2 Top Leg Blade 51mm	21.5	51	30	V43	
8801-V51	Super V Adapter-1-1/2 Top Leg Blade 51mm	27	51	30	V51	
3811-V51	Super V Adapter-1-1/2 Top Leg Blade 63.5mm	27.5	63.5	30	V51	
8811-V59	Super V Adapter-1-1/2 Top Leg Blade 60mm	43	60	22.5	V59	
5869A-V59	Super V Adapter-1-1/2 Top Leg Blade 63.5mm	42	63.5	22-25	V59	
3811-V59	Super V Adapter-1-1/2 Top Leg Blade 60mm	34	60	30	V59	
3858-V59	Super V Adapter-1-1/2 Top Leg Blade 70mm	34	70	30	V59	
3811-V61	Super V Adapter-1-1/2 Top Leg Blade 60mm	47.6	60	30	V61	
3858A-V61	Super V Adapter-1-1/2 Top Leg Blade 70mm	47.6	70	30	V61	
5898-V61	Super V Adapter-1-1/2 Top Leg Blade 80mm	56	80	30	V61	
2878-V61	Super V Adapter-1-1/2 Top Leg Blade 90mm	59	90	30	V61	
6803-V69	Super V Adapter-1-1/2 Top Leg Blade 90mm	76	90	30	V69	
6804-V69	Super V Adapter-1-1/2 Top Leg Blade 100mm	74	100	30	V69	
5898-V69	Super V Adapter-1-1/2 Top Leg Blade 80mm	70	80	30	V69	
5897-V71	Super V Adapter-1-1/2 Top Leg Blade 100mm	115	100	30	V71	
6804-V71	Super V Adapter-1-1/2 Top Leg Blade 100mm	115	100	30	V71	
2837-V71	Super V Adapter-1-1/2 Top Leg Blade 90mm	118	90	30	V71	
6810-V71	Super V Adapter-1-1/2 Top Leg Blade 120mm	132	120	30	V71	
3869B-V81	Super V Adapter-1-1/2 Top Leg Blade 120mm	175	120	30	V81	
6806-V81	Super V Adapter-1-1/2 Top Leg Blade 140mm	183	140	30	V81	

1/2 Cornr Straddle Leg



TURBO PART N°	DESCRIPTION	WEIGHT	ADAPTER		PIN	Machine Model
5870A-V51	Super V Adapter-1-1/2 Cornr Straddle Leg Blade 63.5mm	35	63.5	25	V51	
5870A-V59	Super V Adapter-1-1/2 Cornr Straddle Leg Blade 63.5mm	47	63.5	25	V59	
5870A-V61	Super V Adapter-1-1/2 Cornr Straddle Leg Blade 63.5mm	50	63.5	25	V61	
6831-V69	Super V Adapter-1-1/2 Cornr Straddle Leg Blade 76mm	93	76	30	V69	
5893L-V69	Super V Adapter-1-1/2 Cornr Straddle Leg Blade 102mm	87	102	30	V69	
5899-V71	Super V Adapter-1-1/2 Cornr Straddle Leg Blade 102mm	120	102	30	V71	
5893-V71	Super V Adapter-1-1/2 Cornr Straddle Leg Blade 102mm	120	102	30	V71	
5895-V81	Super V Adapter-1-1/2 Cornr Straddle Leg Blade 121mm	183	121	30	V81	
6808-V81	Super V Adapter-1-1/2 Cornr Straddle Leg Blade 140mm	195	140	30	V81	



2 Leg 2 Bolt



TURBO PART N°	DESCRIPTION	WEIGHT	ADAPTER		PIN	Machine Model
8716-V19	Super V Adapter-2 Leg 2 Bolt Blade 30mm	6	30	27.6	V19	
5775-V19	Super V Adapter-2 Leg 2 Bolt Blade 20mm	5	20	25	V19	
5776-V19	Super V Adapter-2 Leg 2 Bolt Blade 25mm	5.1	25	25	V19	
5733A-V23	Super V Adapter-2 Leg 2 Bolt Blade 30mm	6.6	30	25	V23	
5734A-V23	Super V Adapter-2 Leg 2 Bolt Blade 35mm	8.2	35	25	V23	
8719-V29	Super V Adapter-2 Leg 2 Bolt Blade 38-40mm	11.2	38-40	25	V29	
8719-V33	Super V Adapter-2 Leg 2 Bolt Blade 40mm	12	40	25	V33	
5774A-V23	Super V Adapter-2 Leg 2 Bolt Blade 35-38mm	6.6	35-38	25	V23	
5773A-V29	Super V Adapter-2 Leg 2 Bolt Blade 38mm	15	38	25	V29	
5773-V33	Super V Adapter-2 Leg 2 Bolt Blade 38mm	17	38	25	V33	

Super V -Pin



 TURBO PART N°	 DESCRIPTION	 WEIGHT	ADAPTER	PIN	Machine Model
V13	Super V -Pin	0.04			
V17	Super V -Pin	0.04			
V19	Super V -Pin	0.05			
V23	Super V -Pin	0.05			
V29	Super V -Pin	0.12			
V33	Super V -Pin	0.13			
V39	Super V -Pin	0.17			
V43	Super V -Pin	0.23			
V51	Super V -Pin	0.43			
V59	Super V -Pin	0.43			
V61	Super V -Pin	0.46			
V69	Super V -Pin	0.93			
V71	Super V -Pin	1.05			
V81	Super V -Pin	1.24			



DOOSAN

TURBO MANUFACTURER OF ENGINEERED PRODUCTS · SPARE PARTS · CATALOG 2014

Standard



TURBO PART N°	DESCRIPTION	WEIGHT	STRATGHIT BLADE	LOCK	MACHINE MODEL
2713-9050	Standard	1.1	2713-9051		DH55 · DH60
2713-1221	Standard	3.5	2713-1222	2705-1022 · 2114-1859	DH130 · DH150
2713-1272	Standard	3.5	2713-1222	2705-1022 · 2114-1859	DH130 · DH150
2713-1217	Standard	5.5	2713-1218	2705-1020 · 2114-1848A	DH210 · DH220 · DH225
2713-1269	Standard	5.5	2713-1218	2705-1020 · 2114-1848A	DH210 · DH220 · DH225
2713-1219	Standard	6.7	2713-1218	2705-1021 · 2114-1849	DH300
2713-1270	Standard	6.7	2713-1218	2705-1021 · 2114-1849	DH300
713-00054	Standard	7.8		2705-1021 · 2114-1849	DH300
713-00032	Standard	9.2	713-00033	705-00006 · 114-00246	DH370
2713-1234	Standard	9.2	713-00033	705-00006 · 114-00246	DH370
2713-1271	Standard	17.2	2713-1273	2705-1034 · 2114-1931	DH420
2713-1236	Standard	17.2	2713-1237	2705-1034 · 2114-1931	DH420

Standard-Old Machine



TURBO PART N°	DESCRIPTION	WEIGHT	STRATGHIT BLADE	LOCK	MACHINE MODEL
18S	Standard	1.1	1619-18	18PN 18LK	DH55 · DH60
2713-9061	Standard	1.5	2713-9062		DH55 · DH60
2713-9041	Standard	6.6	2713-9042	2705-1020 · 2114-1848A	DH210 · DH220 · DH225
2713-9038(E262-3046)	Standard	7.2	2713-9037	E262-5004 · 61E5-11150	DH300
2713-9038(E262-3046)	Standard	6.8	2713-9037	E262-5004 · 61E5-11150	DH300
2173-9044	Standard	9.1	2713-9043	61E5-11150	DH320

Rock Chisel



TURBO PART N°	DESCRIPTION	WEIGHT	STRATGHIT BLADE	LOCK	MACHINE MODEL
18RC	Rock Chisel	1.2	1619-18	18PN - 18LK	DH55 - DH60
2713-1221RC	Rock Chisel	3.8	2713-1222	2705-1022 - 2114-1859	DH130 - DH150
2713-1217RC-2013	Rock Chisel	5.5	2713-1218	2705-1020 - 2114-1848A	DH210 - DH220 - DH225
2713-1219RC(PV)-2013	Rock Chisel	7.6	2713-1220	2705-1021 - 2114-1849	DH300
713Y00032RC-2013	Rock Chisel	9.3	713-00033	705-00006 - 114-00246	DH370
2713-1236RC	Rock Chisel	13.9	2713-1237	2705-1034 - 2114-1931	DH420

Rock Chisel Heavy Dute



TURBO PART N°	DESCRIPTION	WEIGHT	STRATGHIT BLADE	LOCK	MACHINE MODEL
2713-1217RC	Rock Chisel Heavy dute	6.6	2713-1218	2705-1020 - 2114-1848A	DH210 - DH220 - DH225
2713-1219RC	Rock Chisel Heavy dute	8.9	2713-1220	2705-1021 - 2114-1849	DH300
713-00032RC	Rock Chisel Heavy dute	11	713-00033	705-00006 - 114-00246	DH370
2713-1236RC	Rock Chisel Heavy dute	17.2	2713-1237	2705-1034 - 2114-1931	DH420

Rock Chisel-Old Machine



TURBO PART N°	DESCRIPTION	WEIGHT	STRATGHIT BLADE	LOCK	MACHINE MODEL
2713-9041RC	Rock Chisel	7.6	2713-9042	2705-1020 - 2114-1848A	DH210 - DH220 - DH225
2713-9041RC	Rock Chisel	7.6	2713-9042	2705-1020 - 2114-1848A	DH210 - DH220 - DH225
2713-9038RC	Rock Chisel	7.6	2713-9037	E262-5004 - 61E5-11150	DH300
2173-9044RC	Rock Chisel	9.2	2713-9043	61E5-11150	DH320

Tiger







TURBO PART N°	DESCRIPTION	WEIGHT	STRATGHIT BLADE	LOCK	MACHINE MODEL
2713-1219TL (VIP)	Tiger	7.1	2713-1220	2705-1021 · 2114-1849	DH300
DH360VIP(713-00032VIP)	Tiger	10.5	713-00033	705-00006 · 114-00246	DH370
DH450VIP (2713-1236VIP)	Tiger	14.8	2713-1237	2705-1034 · 2114-1931	DH420

Side Cutter



TURBO PART N°	DESCRIPTION	WEIGHT	STRATGHIT BLADE	LOCK	MACHINE MODEL
55 L	Side Cutter	2			DH55 · DH60
55 R	Side Cutter	2			DH55 · DH60
2713-1228 L	Side Cutter	8.9			DH130 · DH150
2713-1228 R	Side Cutter	8.9			DH130 · DH150
2713-1059 L-6 holes	Side Cutter	14.5			DH210 · DH220 · DH225
2713-1060 R-6 holes	Side Cutter	14.5			DH210 · DH220 · DH225
2713-6034 L	Side Cutter	16.8			DH300
2713-6035 R	Side Cutter	16.8			DH300
713-00028 L	Side Cutter	18.9			DH370
713-00029 R	Side Cutter	18.9			DH370
2713-1241 L	Side Cutter	27			DH420
2713-1241 R	Side Cutter	27			DH420

Standard

 TURBO PART N°	 DESCRIPTION	 WEIGHT	 BLADE SIZE	TEETH	 PIN	MACHINE MODEL
2713-1222	Excavator Adapter	5.5	32	2713-1221	2705-1022 · 2114-1859	S130
2713-1218	Excavator Adapter	8.6	35	2713-1217	2705-1020 · 2114-1848A	S220
2713-1218	Excavator Adapter	8.5	40	2713-1217	2705-1020 · 2114-1848A	S220
2713-1220	Excavator Adapter	10.9	40	2713-1219	2705-1021 · 2114-1849	S280
2713-1220	Excavator Adapter	10.7	45	2713-1219	2705-1021 · 2114-1849	S280
2713-1220	Excavator Adapter	12	50	2713-1219	2705-1021 · 2114-1849	S280
713-00033	Excavator Adapter	17.6	50	713-00032	705-00006 · 114-00246	S360
713-00033	Excavator Adapter	17.3	55	713-00032	705-00006 · 114-00246	S360
713-00033-A	Excavator Adapter	19.2	60	713-00032	705-00006 · 114-00246	S360
2713-1273 (2713-1237)	Excavator Adapter	24	55	2713-1236	2705-1034 · 2114-1931	S420
2713-1273 (2713-1237)	Excavator Adapter	23	60	2713-1236	2705-1034 · 2114-1931	S420
2713-9062	Excavator Adapter	2.3	*	2713-9051		S55
2713-9042	Excavator Adapter	10.3	40	2713-9041		S220
2713-9037	Excavator Adapter	12.4	40	2713-9038		S280
2713-9043	Excavator Adapter	17.2	40	2713-9044		S360





DOOSAN- 2014 NEW SYSTEM

MANUFACTURER OF ENGINEERED PRODUCTS · SPARE PARTS · CATALOG 2014

Standard



TURBO PART N°	DESCRIPTION	WEIGHT	STRATGHIT BLADE	LOCK	MACHINE MODEL
23011-00089	Standard	4.2	430203-00022	2705-1022 2114-1859	DX140
23011-00090	Standard	7.5	430203-00024	2705-1021 2114-1849A	DX170/180 DX225/255/DX300
230111-00092	Standard	12.3	430203-00036	705-00006 114-00246	DX340 DX420
230111-00093	Standard	20	430203-00037-60	2705-1034 2114-1931	DX480/520
230111-00094	Standard	25.5	430203-00038	K1052231 K1052892	DX700

Adapter



TURBO PART N°	DESCRIPTION	WEIGHT	BLADE SIZE	LOCK	MACHINE MODEL
430203-00022	Adapter		32	2705-1022 2114-1859	DX140
430203-00024	Adapter	12.5	40	2705-1021 2114-1849A	DX170/180 DX225/255/DX300
430203-00036	Adapter		50	705-00006 114-00246	DX340 DX420
430203-00037-60	Adapter	30	60	2705-1034 2114-1931	DX480/520
430203-00038	Adapter	51	70	K1052231 K1052892	DX700



ESCO

MANUFACTURER OF ENGINEERED PRODUCTS · SPARE PARTS · CATALOG 2014

ESCO



Nº TURBO PART Nº	DESCRIPTION	WEIGHT	ADAPTER	ADAPTER	LOCK	MACHINE MODEL
18S	ESCO-18(Conical Standard) Tip	1.1	18-800	833-18	18PN · 18LK	DH55
22S	ESCO-22(Conical Standard) Tip	1.4	22SA	22SA	22PN · 22LK	EX70
25S(20X-70-23160)	ESCO-25(Conical Standard) Tip	2.4	3806-25	855-25	25-30PN · 25-30LK	EX100
30S(203-70-43180)	ESCO-30(Conical Standard) Tip	2.5	3808-30 · 3807-30	855-30	25-30PN · 25-30LK	EX200
35S(205-70-74272)	ESCO-35(Conical Standard) Tip	4.3	3808-35	3803-35	35PN · 35LK	EX300
40S	ESCO-40(Conical Standard) ESCO original Tip	5.7	3809-40	3803-40	40PN · 40Lk	EX300
40S	ESCO-40(Conical Standard) Tip	6.8	3809-40	3803-40	40PN · 40Lk	EX300
45S	ESCO-45(Conical Standard) Tip	10.2	3809-40	3803-40	40PN · 40Lk	EX400



Conical TL Tip

Nº TURBO PART Nº	DESCRIPTION	WEIGHT	ADAPTER	ADAPTER	LOCK	MACHINE MODEL
18TL	Conical TL Tip	1.1	18-800	833-18	18PN · 18LK	DH55
18VIP	Conical TL Tip	1.1	18-800	833-18	18PN · 18LK	DH55

Conical Tiger VIP



Nº TURBO PART Nº	DESCRIPTION	WEIGHT	ADAPTER	ADAPTER	LOCK	MACHINE MODEL
30VIP	Conical Tiger VIP	3.3	3808-30 3807-30	855-30	25-30PN · 25-30LK	EX200
25VIP	Conical Tiger VIP	3	3806-25	855-25	25-30PN · 25-30LK	EX100
35VIP	Conical Tiger VIP	4.1	3808-35	3803-35	35PN · 35LK	EX300
40VIP	Conical Tiger VIP	7.1	3809-40	3803-40	40PN · 40Lk	EX300
45VIP	Conical Tiger VIP	7.8	3809-40	3803-40	40PN · 40Lk	EX300

Conical Dual Purpose



Nº TURBO PART Nº	DESCRIPTION	WEIGHT	ADAPTER	ADAPTER	LOCK	MACHINE MODEL
25T	Conical Dual Purpose	2.2	3806-25	855-25	25-30PN · 25-30LK	EX100
30T	Conical Dual Purpose	3.5	3808-30 · 3807-30	855-30	25-30PN · 25-30LK	EX100
35T	Conical Dual Purpose	4.1	3808-35	3803-35	35PN · 35LK	EX200
40T	Conical Dual Purpose	7	3809-40	3803-40	40PN · 40Lk	EX300



Twin Tiger

Nº TURBO PART Nº	DESCRIPTION	WEIGHT	ADAPTER	ADAPTER	LOCK	MACHINE MODEL
18WTL(TVC)	Twin Tiger	1.2	18-800	833-18	18PN · 18LK	DH55



Conical Twin Tiger V

Nº TURBO PART Nº	DESCRIPTION	WEIGHT	ADAPTER	ADAPTER	LOCK	MACHINE MODEL
30TVC	Conical Twin Tiger V	3.35	3808-30 · 3807-30	855-30	25-30PN · 25-30LK	EX100
35TVC	Conical Twin Tiger V	5.1	3808-35	3803-35	35PN · 35LK	EX200
40TVC	Conical Twin Tiger V	7.1	3809-40	3803-40	40PN · 40Lk	EX300



Hellok SYL

Nº TURBO PART Nº	DESCRIPTION	WEIGHT	ADAPTER	ADAPTER	LOCK	MACHINE MODEL
21SYL	Hellok SYL	3.2		RC21R	RC21R	21-LK
27SYL	Hellok SYL	4.6	27WN	RC27R	RC27R	27-LK
37SYL	Hellok SYL	6.6	3882V-37	R-37R	R-37R	37-LK
47SYL	Hellok SYL	11.8	3810-47	R-47R	R-47R	47-LK

Helilok VIP



N° TURBO PART N°	DESCRIPTION	WEIGHT	ADAPTER	ADAPTER	LOCK	MACHINE MODEL
21VIP	Helilok VIP	3.1		RC21R	RC21R	21-LK
27VIP	Helilok VIP	3.6	27WN	RC27R	RC27R	27-LK
37VIP	Helilok VIP	6.3	3882V-37	R-37R	R-37R	37-LK
47VIP	Helilok VIP	10.8	3810-47	R-47R	R-47R	47-LK

Helilok TVIP



N° TURBO PART N°	DESCRIPTION	WEIGHT	ADAPTER	ADAPTER	LOCK	MACHINE MODEL
27TVIP	Helilok TVIP	4.5	27WN	RC27R	RC27R	27-LK
37TVIP	Helilok TVIP	7.3	3882V-37	R-37R	R-37R	37-LK
47TVIP	Helilok TVIP	12.2	3810-47	R-47R	R-47R	47-LK

Helilok SD



N° TURBO PART N°	DESCRIPTION	WEIGHT	ADAPTER	ADAPTER	LOCK	MACHINE MODEL
37SD	Helilok SD	7.6	3882V-37	R-37R	R-37L	37-LK

Supverconical FP tip



N° TURBO PART N°	DESCRIPTION	WEIGHT	ADAPTER	ADAPTER	LOCK	MACHINE MODEL
66FP	ESCO-Supverconical FP tip	25.8	3858-66	66-LK 66-PN		
76FP	ESCO-Supverconical FP tip	35.5	2878-76	76-LK 76-PN		

Ripper Tip



Nº TURBO PART Nº	DESCRIPTION	WEIGHT kg	WELDING NOSE	PIN	MACHINE MODEL
22R10	Ripper Tip	4.1	22RNSEF	22RPG · 22RBG	
25R10	Ripper Tip	5.7	25RNSPF	25RPG · 25RBG	
25R11	Ripper Tip	4.9	25RNSPF	25RPG · 25RBG	
25R12	Ripper Tip	5.6	25RNSPF	25RPG · 25RBG	
25RC12HD	Ripper Tip	6.5			
25RC10	Ripper Tip	5	25RNSPF	25RPG · 25RBG	
25RC10	Ripper Tip	6.5	25RNSPF	25RPG · 25RBG	
35R14	Ripper Tip	13.6	35RNSEF	35RPG · 25RBG	
35R14B	Ripper Tip	14.2	35RNSEF	35RPG · 25RBG	
35R15	Ripper Tip	14.2	35RNSEF	35RPG · 25RBG	
39R16A	Ripper Tip	19.5	39RWNS1A	39RPG · 39RBG	
39R17E	Ripper Tip	19.5	39RWNS1A	39RPG · 39RBG	
39RH16A	Ripper Tip	19.5	39RWNS1A	39RPG · 39RBG	
39RH17E	Ripper Tip	19.5	39RWNS1A	39RPG · 39RBG	



Superconical FP Adapter

Nº TURBO PART Nº	DESCRIPTION	WEIGHT kg	BLADE SIZE	TEETH	PIN	MACHINE MODEL
S9114T-76 (2878-76)	ESCO-Superconical 76FP adapter	76	75	76FP	76-LK 76-PN	







Two Strap Adapter

Nº TURBO PART Nº	DESCRIPTION	WEIGHT kg	BLADE SIZE	TEETH	PIN	MACHINE MODEL
833-18	Bottom Strap Adapter	1.6	18	18S	18PN 18LK	DH55
855-25	Bottom Strap Adapter	3.5	25	25S	25PN 25LK	EX100
855-30	Bottom Strap Adapter	3.7	30	30S	30PN 30LK	EX100



Two Strap Adapter



 TURBO PART N°	 DESCRIPTION	 WEIGHT	 BLADE SIZE	TEETH	PIN	MACHINE MODEL
18SA (1617-18)	Two Strap Adapter	2.3	18	18S	18PN 18LK	EX70
22SA	Two Strap Adapter	2.8	20	22S	25PN 25LK	EX70
3806-25	Two Strap Adapter	6.6	25	25S	25PN 25LK	EX100
1306-25	Two Strap Adapter	3.8	25	25S	25PN 25LK	EX100
3807-30	Two Strap Adapter	6.5	30	30S	30PN 30LK	EX100
1899-35	Two Strap Adapter	10	35	35S	35PN 35LK	EX200
3808-35	Two Strap Adapter	6.7	35	35S	35PN 35LK	EX200
3840-35	Two Strap Adapter	11	35	35S	35PN 35LK	EX200
3809-40	Two Strap Adapter	11.5	40	40S	40PN 40LK	EX300
3809-40	Two Strap Adapter	11.6	45	45S	45PN 45LK	EX400
3810-45	Two Strap Adapter	19	45	45S	45PN 45LK	EX400

Ripper Nose



 TURBO PART N°	 DESCRIPTION	 WEIGHT	Adapter	Lock	MACHINE MODEL
22RN	Ripper Nose	5.8	22R10	22RPG - 22RBG	
25RN	Ripper Nose	8.8	25R10	25RPG - 25RBG	
2849-25R	Ripper Nose	11.6	25R10	25RPG - 25RBG	
3806-25RC	Ripper Nose	13	25R10	25RPG - 25RBG	
35RWN	Ripper Nose	15.2	35R	35RPG - 35RBG	
39RNSEF	Ripper Nose	22.8	39R	39RPG - 39RBG	
39RWNS1A	Ripper Nose		39R	39RPG - 39RBG	



VOLVO

TURBO MANUFACTURER OF ENGINEERED PRODUCTS · SPARE PARTS · CATALOG 2014

Standard



TURBO PART N°	DESCRIPTION	WEIGHT	ADAPTER	LOCK	MACHINE MODEL
1171-00041	Standard	4.3	1171-00042	V140	EC140B
14527863	Standard	3.8	14527865	V140	EC140B
14530544 1171-00371	Standard	6.6	1171-01620	V210	EC210B
1171-01910	Standard	10.4	1171-01900	V290	EC290B
T55GP 14553243	Standard	14.8	EC360B (14556404)	V360	EC360B
VOE460B 14537843	Standard	18.9	EC460 (14537826)	V460	EC460B

Rock Chisel



TURBO PART N°	DESCRIPTION	WEIGHT	ADAPTER	LOCK	MACHINE MODEL
11171-00041RC	Rock Chisel	5.3	1171-00042	V140	EC140
14530544RC	Rock Chisel	6.7	1171-01620	V210	EC210
1171-01910RC	Rock Chisel	14.1	1171-01900	V290	EC290
T55GPRC	Rock Chisel	14.6	EC360B (14556404)	V360	EC360

Tiger(Vip)



TURBO PART N°	DESCRIPTION	WEIGHT	ADAPTER	LOCK	MACHINE MODEL
VOV210VIP-A	Tiger	6	11171-01620	V210	EC210B
VOV360VIP-A	Tiger (T55GPVIP)	13.1	EC360B (14556404)	V360	EC360
VOV360VIP-A-TOP	Tiger	12.5	EC360B (14556404)	V360	EC360

Adapter



TURBO PART N°	DESCRIPTION	WEIGHT	BLADE SIZE	TEETH	PIN	MACHINE MODEL
114527865-EC140A	Adapter	5.4	32	114527863-EC140T	V140	EC140B
1171-01620	Adapter	11.9	30	14530544	V210	EC210B
1171-01900	Adapter	20.6	50	1171-01910	V290	EC290B
14556464	Adapter	24.8	50	T55GP	V360	EC360B
14556464	Adapter	24.8	60	T55GP	V360	EC360B
14537826	Adapter	24.2	60	VOE460B	V460	EC460B



Ripper Teeth

TURBO PART N°	DESCRIPTION	WEIGHT
CH9937	VOLVO GRADER RIPPER TIP	3.4

Side Cutter



TURBO PART N°	DESCRIPTION	WEIGHT	ADAPTER	LOCK	MACHINE MODEL
LOV210L	TSide Cutter	12.2			EC210B
LOV210R	Side Cutter	12.2			EC210B
1171-01170	Side Cutter	20			EC260B
1171-01180	Side Cutter	20			EC260B



KOBLECO

TURBO MANUFACTURER OF ENGINEERED PRODUCTS · SPARE PARTS · CATALOG 2014



Standard Tip

TURBO PART N°	DESCRIPTION	WEIGHT	ADAPTER	LOCK	MACHINE MODEL
SK200-2014	Standard Tip	5	BF01L	SK200	SK200
AF02L	Standard Tip	7.6	AF01L	SK230	SK230



Rock Chisel Tip

TURBO PART N°	DESCRIPTION	WEIGHT	ADAPTER	LOCK	MACHINE MODEL
SK200RC	Rock Chisel Tip	5.5	1 BF01L	SK200	SK200
AF02RC	Rock Chisel Tip	7.9	AF01L	SK230	SK230



Tiger Tip

TURBO PART N°	DESCRIPTION	WEIGHT	ADAPTER	LOCK	MACHINE MODEL
SK200TL (VIP)	Tiger Tip	6.3	BF01L	SK200	SK200

Adapter



TURBO PART N°	DESCRIPTION	WEIGHT	BLADE SIZE	TEETH	PIN	MACHINE MODEL
BF01L	Adapter	9.6	32	SK200-2014 SK200RC SK200TL (VIP)	SK210	SK200
SK200YS35	Adapter	8.8	32	SK200-2014 SK200RC SK200TL (VIP)	SK210	SK200
SK200YS35	Adapter	8.8	35	SK200-2014 SK200RC SK200TL (VIP)	SK210	SK200
SK200YS35	Adapter	8.8	40	SK200-2014 SK200RC SK200TL (VIP)	SK210	SK200
AF01L	Adapter	12.4	40	AF02L AF02RC	SK230	SK230
AF01L	Adapter	12.7	35	AF02L AF02RC	SK230	SK230

Side Cutter



TURBO PART N°	DESCRIPTION	WEIGHT	ADAPTER	LOCK	MACHINE MODEL
2412N278D1	Side Cutter	8.9			SK200-8
2412N278D2	Side Cutter	8.9			SK200-8
2412N289D1	Side Cutter	15.6			SK230
2412N289D2	Side Cutter	15.6			SK230
14538012	Side Cutter/ Side Protector 3 holes	10.9			SK260

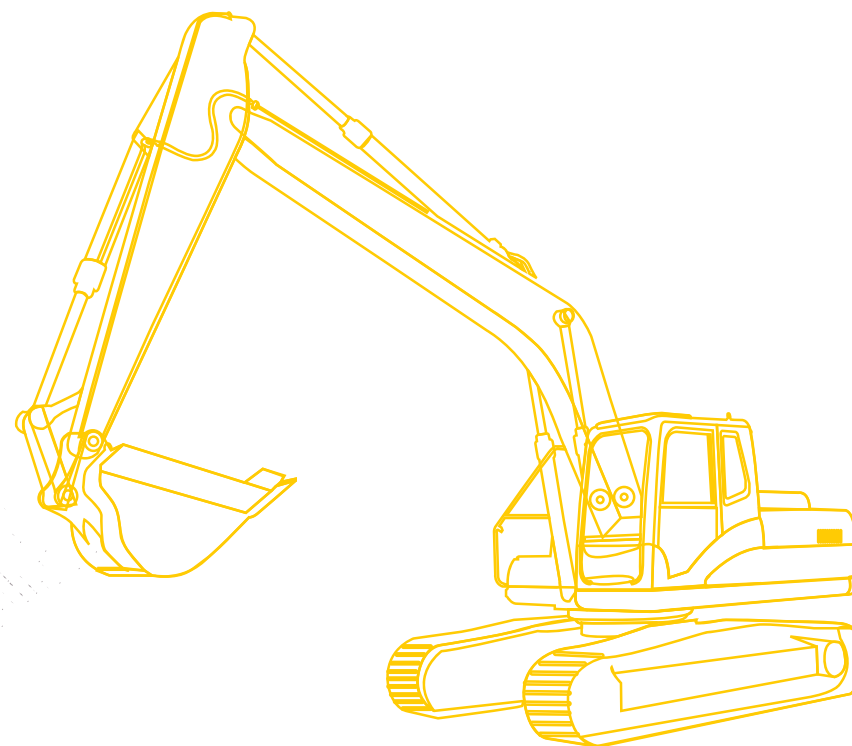



HYUNDAI

STANDARD



N° TURBO PART N°	DESCRIPTION	WEIGHT kg	ADAPTER	LOCK	MACHINE MODEL
E161-3027	Tip	4.4	1 E161-3017	E161-3035 S411-180002	R215 R225
E262-3046(2713-9038)	Tip	7.2	E262-3027	E262-5004 61E5-11150	R305
E262-3046(2713-9038)	Tip	6.8	E262-3027	E262-5004 61E5-11150	R305
61E70101	Tip	11	61E70100	61E7-0105 61EH-11150	R460 R420 R450 R360

Standard Heavy Duty-New Type



N° TURBO PART N°	DESCRIPTION	WEIGHT kg	ADAPTER	LOCK	MACHINE MODEL
61N4-31210	TStandard Heavy Duty	4.5	61N4-31320	66N4-30350 66N4-11150	R210-7
61N6-31310	Standard Heavy Duty	6.8	61N6-31320	E161-3035 S411-180002	R210-7
61Q6-31310	Standard Heavy Duty	7.2	61Q6-31320	E161-3035 S411-180002	R210-9
61N6DA0020	Standard Tip	4.6			
61N8-31310	Standard Heavy Duty	9.4	61N8-31320	E262-5004 61E5-11150	R290-7
61NA-31310	Standard Heavy Duty	13.5	61NA-31320	61EH-70105 61EH-11150	R360-7
61QA-31310	Standard Heavy Duty	13.8	61QA-31320		R 360LC-9
61NB-31310	Standard Heavy Duty	21.5	61NB-31320	61E7-04620 61E7-04630	R450
66NB-31310	Standard Heavy Duty	18.5	62NB-31320	66NB-31340 66NB-31350	R500
61EQ-30030	Standard Heavy Duty	28.5	61EQ-30040	61EQ-30460 61EQ-30510	R6500



Rock Chisel

N° TURBO PART N°	DESCRIPTION	WEIGHT kg	ADAPTER	LOCK	MACHINE MODELL
E161-3027RC	Rock Chisel	5.2	E161-3017	E161-3035 S411-180002	R215 R225
E262-3046RC	Rock Chisel	7.5	E262-3027	61E5-11150 E262-5004	R305

Rock Chisel-New Type



TURBO PART N°	DESCRIPTION	WEIGHT	ADAPTER	LOCK	MACHINE MODEL
61Q6-31310RC	Rock Chisel	5.7	61Q6-31320	E161-3035 S411-180002	R210-9
67N6-31310RC	Rock Chisel	5.7	61Q6-31320	E161-3035 S411-180002	R210-7
61EQ-30030RC	Rock Chisel	32	61EQ-30030	61EQ-30460 61EQ-30510	

Tiger



TURBO PART N°	DESCRIPTION	WEIGHT	ADAPTER	LOCK	MACHINE MODEL
61Q6-31310VIP 61Q6-31310TL	Tiger	5.2	61Q6-31320	E161-3035 S411-180002	R215
E262-3046TL	Tiger	7.5	E262-3027	E262-5004 61E5-11150	R305
2713-9038TL	Tiger	7.5	E262-3027	E262-5004 61E5-11150	R305

Adapter-Bevel



TURBO PART N°	DESCRIPTION	WEIGHT	BLADE SIZE	TEETH	LOCK	MACHINE MODEL
E161-3017	Adapter	6.8	32	E161-3027	E161-3035 S411-180002	R215 R225
E262-3027	Adapter	12.5	40	E262-3046	61E5-11150 E262-5004	R305
61E7-0100	Adapter	14.2	40	61E7-0101	61E7-0105 61EH-11150	R460 R420 R450 R360

Adapter-Stratight Blade



TURBO PART N°	DESCRIPTION	WEIGHT	BLADE SIZE	TEETH	PIN	MACHINE MODEL
E161-3017-32mm	Adapter	6.5	32	E161-3027	E161-3035 S411-180002	R215 R225
E161-3017-35mm	Adapter	6.5	35	E161-3027	E161-3035 S411-180002	R215 R225
E161-3017-40mm	Adapter	6.7	40	E161-3027	E161-3035 S411-180002	R215
E262-3027	Adapter	10.8	40	E262-3046	61E5-11150 E262-5004	R305

Adapter-New Type Stratight Blade



TURBO PART N°	DESCRIPTION	WEIGHT	BLADE SIZE	TEETH	PIN	MACHINE MODEL
61N4-31200	Adapter	6	32	61N6-31310	66N4-30350 66N4-11150	R210-7
61N6-31320	Adapter	9.7	35	61N6-31310	E161-3035 S411-180002	R210-7
61Q6-31320	Adapter	10.4	35	61Q6-31310	E161-3035 S411-180002	R210LC
61Q6-31320	Adapter	10.4	40	61Q6-31310	E161-3035 S411-180002	R211LC
61N8-31320	Adapter	15.3	40	61N8-31310	E262-5004 61E5-11150	R290-7
61NA-31320	Adapter	19.7	45	61NA-31310	61EH-70105 61EH-11150	R360-7
61QA-31320	Adapter	19	50	61QA-31310	*	R360LC-9
62NB-31320	Adapter	30	50	61NB-31310	61E7-04620 61E7-04630	R450

Adapter-New Type Bevel



TURBO PART N°	DESCRIPTION	WEIGHT	BLADE SIZE	TEETH	PIN	MACHINE MODEL
61Q6-31320	Adapter	10.3	40	61Q6-31310	E161-3035 S411-180002	R210-9
67N6-31320	Adapter	10.4	40	61Q6-31310	E161-3035 S411-180002	R210LC
66NB-31320	Adapter	32.5	70	66NB-31310	66NB-31340 66NB-31350	R500
61EQ-30040	Adapter	56.5	80	61EQ-30030	61EQ-30460 61EQ-30510	R6500

Side Cutter



N° TURBO PART N°	DESCRIPTION	WEIGHT kg	MACHINE MODEL
CLZ-01-D (1m5-30270)	HYUNDA-Side Cutter	2.7	R60
CLZ-01-L (1m5-30280)	HYUNDA-Side Cutter	2.7	R60
DH55R	HYUNDA-Side Cutter	2.1	R50
DH55L	HYUNDA-Side Cutter	2.1	R50
61E3-3033	HYUNDA- Side Cutter	14.8	R130 R220
61E3-3034	HYUNDA- Side Cutter	14.8	R130 R220
63E1-3533C	HYUNDA- Side Cutter	18.7	R210 R200 R280
63E1-3534C	HYUNDA- Side Cutter	18.7	R210 R200 R280
61E7-0101	HYUNDA-Side Cutter	32	R360
63E7-0102	HYUNDA-Side Cutter	32	R360

Loder Fork Tip



N° TURBO PART N°	DESCRIPTION	WEIGHT kg	BLADE SIZE	TEETH	PIN	MACHINE MODEL
61L3-0169	Hyundai fork tip - Center Loder Nr 2	11.6	25.4			
61L3-0170	Hyundai fork tip - Left Loder Nr 2	15.2	25.4			
61L3-0171	Hyundai fork tip - Right Loder Nr 1	15.2	25.4			
61L1-3022	Hyundai fork tip - Center Loder Nr 1	21	36			
61L1-3028	Hyundai fork tip - Left Loder Nr 1	23	36			
61L1-3029	Hyundai fork tip - Right Loder Nr 1	23	36			



BOFOR

Loader Tip

N° TURBO PART N°	DESCRIPTION	WEIGHT kg	ADAPTER	LOCK	MACHINE MODEL
4047166 -30101	A Loader Tip	2.7	4046816	V 6254673	
4047167 -31102	Loader Tip	4.8	4046797	6254675	
4047168 -31106	Loader Tip	4.57	4046797	6254675	
3031537 32101	Loader Tip	8.4	4046819	6254677	
3031538- 32104	Loader Tip		4046819	6254677	
3031539 -33102	Loader Tip	12.6	4046862	6254682	
3031542 -34102	Loader Tip	22	4044339	6254682	
3031386 -35102	Loader Tip	38	3031387	6254697	
4038279	Loader Tip	2.2	4038219	M-10090	
4038208	Loader Tip	3.5	4038223	M-10090	
3027580	Loader Tip	6.1	4038210	M-10090	
3000FN	Loader Tip	2.27	H-300	5-ST	
4000FN	Loader Tip	3.9	H-400	10-ST	
5000-FN	Loader Tip	4	H-500		
7500-FN	Loader Tip	7.15	H-750	15-ST	
8000-FN	Loader Tip	8.1	G-800		
10000-FN	Loader Tip	10.5	H-1000	20-ST	



Excavator Tip



N° TURBO PART N°	DESCRIPTION	WEIGHT kg	ADAPTER	LOCK	MACHINE MODEL
4044336 31101	Excavator Tip	4.9	3031434	6254675	
4044428 32102	Excavator Tip	8.95	3031394	6254677	
3031334 33101	Excavator Tip	14	3031395	6254682	
3031335 34101	Excavator Tip	18.7	3031396	6254682	
3031336 35101	Excavator Tip	27	3031397	6254679	
3000BT	Excavator Tip	2	H-300	5-ST	
4000BT	Excavator Tip	3.3	H-400	10-ST	
7500BT	Excavator Tip		H-750	15-ST	
4046818 30104	Excavator Tip	2.3	4046816	6254673	
4046799 31104	Excavator Tip	3.7	4046797	6254675	
4046961 31105	Excavator Tip	5.8	4046797	6254675	
3032682 32105	Excavator Tip	7.5	4046819	6254677	
3031354 33104	Excavator Tip	11.2	4046862	6254682	

Chamsheel Tip



N° TURBO PART N°	DESCRIPTION	WEIGHT kg	ADAPTER	LOCK	MACHINE MODEL
4044291 30103	Chamsheel Tip	2	4046816	6254673	
4044388 31103	Chamsheel Tip	3.7	4046797	6254675	
3031362	Chamsheel Tip	6	4046819	6254677	
4037988	Chamsheel Tip	5	4043608	200-14-OL	
4046729*	Chamsheel Tip	7.2	130-02	200-14-OL	
4046663	Chamsheel Tip	10	3031112	200-18-OL	
4038207	Chamsheel Tip	12	3031112	200-18-OL	
3027689 38104	Chamsheel Tip	14.5	3031113	200-18-OL	
3027512 38101	Chamsheel Tip	21.6	3031265	200-18-OL	



Excavator Tip

TURBO PART N°	DESCRIPTION	WEIGHT	ADAPTER	LOCK	MACHINE MODEL
3027538	Excavator Tip	26	3031113		
3027524	Excavator Tip	32	3031265		



B-Clock Adapter

TURBO PART N°	DESCRIPTION	WEIGHT	ADAPTER	LOCK	MACHINE MODEL
34046816 31006	B-Clock adapter	1	4047166	6254673	
4046797 31004	B-Clock adapter	1.9	4047167	6254675	
4046819 32004	B-Clock adapter	3.5	3031537	6254677	
4046862 33004	B-Clock adapter	5	3031539	6254682	
4044339 -34004	B-Clock adapter	8.7	3031542	6254682	
3031387 -35003	B-Clock adapter	16	3031386	6254679	



B-Clock Adapter

TURBO PART N°	DESCRIPTION	WEIGHT	ADAPTER	LOCK	MACHINE MODEL
4038219	Side Pin adapter		4038279	TM-010	
4038223	Side Pin adapter	1.5	4038208	TM-010	
4038210	Side Pin adapter	4.6	3027580	TM-010	

B-Clock Adapter



TURBO PART N°	DESCRIPTION	WEIGHT	ADAPTER	LOCK	MACHINE MODEL
4043608	Clamshell Adapter	5.2	4037988		
3031112	Clamshell Adapter	11	4038261		
3031113	Clamshell Adapter	15.4	4038207		
3031265	Clamshell Adapter	19.6	4038257		
3031434	Clamshell Adapter	7	4044336	6254675	
3031394	Clamshell Adapter	9.5	4044428	6254677	
3031395	Clamshell Adapter	12.5	3031334	6254682	
3031396	Clamshell Adapter	18	3031335	6254682	
3031397	Clamshell Adapter	27	3031336	6254679	

Rear Clock Adapter



TURBO PART N°	DESCRIPTION	WEIGHT	ADAPTER	LOCK	MACHINE MODEL
300-H	Rear Clock adapter	1.25	3000-BT	5-ST	
400-H	Rear Clock adapter	2.3	4000-BT	10-ST	
500-H	Rear Clock adapter	*	5000 BT	10-ST	
750-H	Rear Clock adapter	*	7500-BT	15-ST	



JCB

Adapter



TURBO PART N°	DESCRIPTION	WEIGHT	BLADE SIZE	BOLT	NUT	MACHINE MODEL
53103205	5Center Tip	2.5	22	5J4773 (826/00303)	6V774 (21340/0701Z)	JCB-3CX
53103205HD	Center Tip-Heavy duty	2.9	22	5J4773 (826/00303)	6V774 (21340/0701Z)	JCB-3CX
53103205	Center Tip-standard	2.3	22	5J4773 (826/00303)	6V774 (21340/0701Z)	JCB-3CX
53103208	Side Cutter Tip-Light duty	4.6	22	1305/0714	1340/0701	JCB-3CX
53103209	Side Cutter Tip-Light duty	4.6	22	1305/0714	1340/0701	JCB-3CX
53103208	Side Cutter Tip	4.8	22	1305/0714	1340/0701	JCB-3CX
53103209	Side Cutter Tip	4.8	22	1305/0714	1340/0701	JCB-3CX
53103209HD	Side Cutter Tip-Heavy duty	5.2	22	1305/0714	1340/0701	JCB-3CX
53103208HD	Side Cutter Tip-Heavy duty	5.2	22	1305/0714	1340/0701	JCB-3CX
53103206	Side Cutter Tip	4.5	22	1305/0714	1340/0701	JCB-3CX
53103207	Side Cutter Tip	4.5	22	1305/0714	1340/0701	JCB-3CX



Shark-JCB

TURBO PART N°	DESCRIPTION	WEIGHT	BLADE SIZE	BOLT	NUT	MACHINE MODEL
332-C4388	Center Tip-Shark	2.65	22	1305/0714	1340/0701	JCB-3CX
332-C4389	Side Cutter Tip-Shark	5.45	22	1305/0714	1340/0701	JCB-3CX
332-C4390	Side Cutter Tip-Shark	5.45	22	1305/0714	1340/0701	JCB-3CX

Side Cutter Welding



TURBO PART N°	DESCRIPTION	WEIGHT	BLADE SIZE	BOLT	NUT	MACHINE MODEL
150LS	JCB-Side cutter welding	1.7				
151LS	JCB-Side cutter welding	3.9				
153LS	JCB-Side cutter welding	5				
154LS	JCB-Side cutter welding	9.6				
155LS	JCB-Side cutter welding	10.6				



MINI Fork Tip

MINI Fork Tip

N° TURBO PART N°	DESCRIPTION	WEIGHT kg	BLADE SIZE	BOLT	NUT	MACHINE MODEL
Mini-00	MINI- Fork Tip	1.1	16			
Mini-01	MINI- Fork Tip	1.2	16			
Mini-02	MINI- Fork Tip	1.6	16			
112-12	MINI- Fork Tip	1.3	16			
7-17	MINI- Fork Tip	1.3	16			
1462201M1	MINI- Fork Tip	2.8	21			
1462201M2	MINI- Fork Tip	2.5	21			
1462201M3	MINI- Fork Tip	2.5	21			
468049	MINI- Fork Tip	1.2	16			
467334	MINI- Fork Tip	1.6	16			
HM054	MINI- Fork Tip	1.5	22			
IMP113-14BT	Fork Tip	2.8	*			
IMP113-14	Fork Tip	2.5	*			
IMP113-14LH	Fork Tip	5.5	*			
IMP113-14RH	Fork Tip	5.5	*			
IMP122/14	Fork Tip	1.7	*			
IMP123/14LH	Fork Tip	2.9	*			
IMP123/14RH	Fork Tip	2.9	*			
M20.4	Fork Tip	1.8	*			
M20.7	Fork Tip	1.8	*			
M20.LOC	Fork Tip	1.8	*			
M30.3	Fork Tip	3	*			









FIAT KOMATSU

TURBO MANUFACTURER OF ENGINEERED PRODUCTS · SPARE PARTS · CATALOG 2014

FIAT KOMATSU



 TURBO PART N°	 DESCRIPTION	 WEIGHT	 BLADE SIZE	BOLT	NUT	MACHINE MODEL
312204052	FIAT KOMATSU- Fork Tip	6.4	20	3F5108	4K0367	SYNTH-TER 90-P6 SYNTH-ESIS 555-692-698 SYNTH-LOAD 555-556-692-698
312204053	FIAT KOMATSU- Fork Tip	6.4	20	3F5108	4K0367	SYNTH-TER 90-P6 SYNTH-ESIS 555-692-698 SYNTH-LOAD 555-556-692-698
312204054	FIAT KOMATSU- Fork Tip	4	20	3F5108	4K0367	SYNTH-TER 90-P6 SYNTH-ESIS 555-692-698 SYNTH-LOAD 555-556-692-698







FIAT HITACHI

TURBO MANUFACTURER OF ENGINEERED PRODUCTS · SPARE PARTS · CATALOG 2014

FIAT HITACHI



 TURBO PART N°	 DESCRIPTION	 WEIGHT	 BLADE SIZE	BOLT	NUT	MACHINE MODEL
85801109	FIAT HITACHI-Fork Tip	3.8	20	3F5108	4K0367	TERNE · BACK-Hoe · LOADERS BAGGERLADER · TRANTO-PELES FB-90 FB-100
85801377	FIAT HITACHI-Fork Tip	4.9	20	3F5108	4K0367	TERNE · BACK-Hoe · LOADERS BAGGERLADER · TRANTO-PELES FB-90 FB-100
85801376	FIAT HITACHI-Fork Tip	4.9	20	3F5108	4K0367	TERNE · BACK-Hoe · LOADERS BAGGERLADER · TRANTO-PELES FB-90 FB-100



HL



HXL tip

TURBO PART N°	DESCRIPTION	WEIGHT	ADAPTER	PIN	LOCK	MACHINE MODEL
230ST	HL-23-HXL tip	1.2	834-23	2740-23	23-PN	



Light Tip

TURBO PART N°	DESCRIPTION	WEIGHT	ADAPTER	PIN	LOCK	MACHINE MODEL
230SP	HL- Light Tip	1.2	834-23	2740-23	23-PN	
240SP	HL- Light Tip	1.7	3000-24	2740-24	24-PN	



Tiger Long tip

TURBO PART N°	DESCRIPTION	WEIGHT	ADAPTER	PIN	LOCK	MACHINE MODEL
23TL	HL-Tiger Long tip	1.1	834-23	2740-23	23-PN	
24TL	HL-Tiger Long tip	1.3	3000-24	2740-24	24-PN	



Twin Tiger tip

TURBO PART N°	DESCRIPTION	WEIGHT	ADAPTER	PIN	LOCK	MACHINE MODEL
23WTL	HL- Twin Tiger tip	1.2	834-23	2740-23	23-PN	
24WTL	HL- Twin Tiger tip	1.5	3000-24	2740-24	24-PN	



Excavator Adapter

TURBO PART N°	DESCRIPTION	WEIGHT	ADAPTER	PIN	LOCK	MACHINE MODEL
2740-23	HL-Excavator Adapter Blade 16/22/25mm	1.9	16 22 25	230-S	23-PN	
2740-24	HL-Excavator Adapter Blade 16/22/25mm	2.2	16 22 25	240-S	24-PN	
U43792	HL-Excavator Adapter Blade 16/22/25mm	1.76	16 22 25		23-PN	
834-23	HL-Excavator Adapter Blade 16/22/25mm	1.6	16 22 25	230-S	23-PN	
3000-24	HL-Excavator Adapter Blade 16/22/25mm		16 22 25	240-S	24-PN	



LIEBHERR

TURBO MANUFACTURER OF ENGINEERED PRODUCTS · SPARE PARTS · CATALOG 2014

Standard Tip



Nº	DESCRIPTION	WEIGHT	ADAPTER	PIN	LOCK	MACHINE MODEL
TURBO PART Nº						
3001127	LIEBHERR-Standard Tip R904	5.8	R904 (3001250)	3001286	3001157	
3001288	LIEBHERR-Standard Tip R914	7	R914(3001248 ,3001249)	3001286	3001157	
3001318	LIEBHERR-Standard Tip R924	10.2	R924 (3001255)	3001286	3001114	R924
3001319	LIEBHERR- Standard Tip R944	15.6	R944 (3001255)	3001289	3001158	R944
3001130	LIEBHERR- Standard Tip R974	23	R974(3001150)	3001289	3001159	R974

Excavator adapter



Nº	DESCRIPTION	WEIGHT	BLADE SIZE	BOLT	NUT	MACHINE MODEL
TURBO PART Nº						
3001250	LIEBHERR- excavator adapter R904	8				
3001248 · 3001249	LIEBHERR- excavator adapter R914	8				
3001255	LIEBHERR- excavator adapter R924	19.2				R924
3001255	LIEBHERR excavator adapter R944	28.1				R944
3001150	LIEBHERR- excavator adapter R944	41				R974



FAIT

TURBO MANUFACTURER OF ENGINEERED PRODUCTS · SPARE PARTS · CATALOG 2014

SYMMETRICAL



TURBO PART N°	DESCRIPTION	WEIGHT	ADAPTER	PIN	MACHINE MODEL
7042-25SYL	FAIT- Tip SYL	3.2	6042-91 (7042-36)	P01206-01N	POCLAIN:60,61,70 75,85, CASE:688,888
7042-27SYL	FAIT- Tip SYL	6	6042-74	P01206-02N	

Excavator Adapter



TURBO PART N°	DESCRIPTION	WEIGHT	BLADE SIZE	TEETH	PIN	MACHINE MODEL
6042-91 (7042-36)	FAIT-excavator adapter Blade 35mm	6.1	35	7042-25SYL	P01206-01N	POCLAIN:60,61,70 75,85 CASE:688,888
6042-74	FAIT-excavator adapter Blade 40mm	14	40	7042-27SYL	P01206-02N	



UNI-Z

Standard



Nº	DESCRIPTION	WEIGHT	ADAPTER	PIN	MACHINE MODEL
TURBO PART Nº					
UNI-Z I	UNI-Z-Standard Tip	1.2	UNI-Z I	62380	
UNI-ZII	UNI-Z-Standard Tip	1.8	UNI-ZII	26334	
UNI-Z III	UNI-Z-Standard Tip	3.2	UNI-Z III	62379	
UNI-ZIV	UNI-Z-Standard Tip	4.7	UNI-ZIV	62378	
UNI-Z V	UNI-Z-Standard Tip	10.4	UNI-Z V	63684	

Excavator adapter



Nº	DESCRIPTION	WEIGHT	BLADE SIZE	TEETH	PIN	MACHINE MODEL
TURBO PART Nº						
UNI-Z I	UNI-Z-excavator adapter	1.7	UNI-Z I			
UNI-ZII	UNI-Z-excavator adapter	2.9	UNI-ZII			
UNI-Z III	UNI-Z-excavator adapter	4	UNI-Z III			
UNI-Z IV	UNI-Z-excavator adapter	7.7	UNI-ZIV			
UNI-Z V	UNI-Z-excavator adapter	14.4	UNI-Z V			



TURBO MANUFACTURER OF ENGINEERED PRODUCTS · SPARE PARTS · CATALOG 2014

LEHNOFF



Nº	DESCRIPTION	WEIGHT	ADAPTER	PIN	MACHINE MODEL
400 F	LEHNOFF- excavator Tip	1.5	001 HS	62380	
411 F	LEHNOFF- excavator Tip	2.4	011 HS	26334	
301 B	LEHNOFF- excavator Tip	1.8		62379	
001 HS	LEHNOFF- excavator adapter	1.6	400 F	62378	
011 HS	LEHNOFF- excavator adapter	1.3	411 F	63684	



Hensley

Standard



N° TURBO PART N°	DESCRIPTION	WEIGHT kg	ADAPTER	PIN	MACHINE MODEL
X156	Standard	0.9	155X156-28	K156S	
X220	Standard	3.1	103X220-25	K220S	
X290	Standard	4.2	127X290-32	K290S	
X310	Standard	4.6	158X310-35	K310S	
X330	Standard	6.2	158X330-38	K330S	
X370	Standard	9	937X370-45	K370S	
X400	Standard	7.5	802X400-50	K400S	
X410	Standard	11.7	940X410-50	K410S	
X335	Standard	5.7	*	K335S	
X385	Standard	10	*	K385S	
X435	Standard	13.5	*	K435S	
X475	Standard	18	*	K475	
X485	Standard	23.6	*	K485	

Extra Longer



N° TURBO PART N°	DESCRIPTION	WEIGHT kg	ADAPTER	PIN	MACHINE MODEL
X156L	Extra Longer	0.9	155X156-28	K156S	
X156LP	Extra Longer	1.8	155X156-28	K156S	

Twin Tiger Long



Nº	DESCRIPTION	WEIGHT	ADAPTER	PIN	MACHINE MODEL
TURBO PART Nº	DESCRIPTION	WEIGHT	ADAPTER	PIN	MACHINE MODEL
X156WTL	Twin Tiger Long	1.7	155X156-28	K156S	
X220WTL	Twin Tiger Long	3.8	103X220-25	K220S	
X290WTL	Twin Tiger Long	4.8	127X290-32	K290S	
X310WTL	Twin Tiger Long	6	158X310-35	K310S	
X330WTL	Twin Tiger Long	6.5	158X330-38	K330S	
X370WTL	Twin Tiger Long	9.6	937X370-45	K370S	
X400WTL	Twin Tiger Long	11.2	802X400-50	K400S	
X410WTL	Twin Tiger Long	12.8	940X410-50	K410S	

Tiger



Nº	DESCRIPTION	WEIGHT	ADAPTER	PIN	MACHINE MODEL
TURBO PART Nº	DESCRIPTION	WEIGHT	ADAPTER	PIN	MACHINE MODEL
X156T	Tiger	1.0	155X156-28	K156S	
X220T	Tiger	2.9	103X220-25	K220S	
X290T	Tiger	3.9	127X290-32	K290S	
X310T	Tiger	4.5	158X310-35	K310S	
X330T	Tiger	5.7	158X330-38	K330S	
X370T	Tiger	8.2	937X370-45	K370S	
X400T	Tiger	7.6	802X400-50	K400S	
X410T	Tiger	10.3	940X410-50	K410S	

Rock Chisel



N° TURBO PART N°	DESCRIPTION	kg WEIGHT	ADAPTER	PIN	MACHINE MODEL
X290RC	Rock Chisel	5.2	127X290-32	K290S	
X330RC	Rock Chisel	7.6	158X330-38	K310S	
X370RC	Rock Chisel	9.7	937X370-45	K330S	
X410RC	Rock Chisel	13.9	802X400-50	K400S	

Welding Adapter



N° TURBO PART N°	DESCRIPTION	kg WEIGHT	BLADE SIZE	TEETH	PIN	MACHINE MODEL
X156WN	X156 Hensley welding nose	1	*	X156	K156S	
155X156	welding Adapte	2.3	28	X156	K156S	
230X156	welding Adapte	1.7	16	X156	K156S	
552X156	welding Adapte	2.1	20	X156	K156S	
103X220	welding Adapte	7.2	25	X220	K220S	
109X220	welding Adapte	6.4	32	X220	K220S	
127X290	welding Adapte	10	32	X290	K290S	
158X290	welding Adapte	10	38	X290	K290S	
158X330	welding Adapte	16	38	X330	K330S	
937X330	welding Adapte	15.1	45	X330	K330S	
937X370	welding Adapte	18.6	45	X370	K370S	
940X370	welding Adapte	15.2	52	X370	K370S	
802X400	welding Adapte	23.2	50	X440	K400S	
940X410	welding Adapte	21.6	50	X410	K410S	



TATA HITACHI Indian

Standard



N° TURBO PART N°	DESCRIPTION	WEIGHT kg	ADAPTER	PIN	MACHINE MODEL
EX60	TATA HITACHI EX60	1.7	EX60	EX600	Indian-TATA HITACHI EX60
TB00395	Standard Tip (PC100 Tip)	2.2	PC100-25	EX70	Indian-TATA HITACHI EX70
TB00705HD	Standard-Heavy duty Tip	8.9	TB00704	EX200	Indian-TATA HITACHI EX200
TB00705	Standard-light duty Tip	7.4	TB00704	EX200	Indian-TATA HITACHI EX200
TB00822	Standard Tip	11.5	TB00821	EX300	Indian-TATA HITACHI EX300
TD08460	excavator teeth	20	TD08459	EX600	Indian-TATA HITACHI EX600



Rock Chisel

N° TURBO PART N°	DESCRIPTION	WEIGHT kg	ADAPTER	PIN	MACHINE MODEL
TB00705RC	Rock Chisel Tip	7.5	TB00704	EX200	Indian-TATA HITACHI EX200

Excavator adapter



N° TURBO PART N°	DESCRIPTION	WEIGHT kg	BLADE SIZE	TEETH	PIN	MACHINE MODEL
TC00593 PC100-25	excavator adapter (PC100-25 Adapter)	2.8	25	TB00395	EX70	TATA HITACHI EX70
TB070205	excavator adapter	12.3	40	TB00705	EX200	TATA HITACHI EX200
TB00704	excavator adapter- back side Blade type	12.3	40	TB00705	EX200	TATA HITACHI EX200
TB00821	excavator adapter	25.2	60	TB00822	EX300	TATA HITACHI EX300
TD08459	excavator adapter	40.2	65	TD08460	EX600	TATA HITACHI EX600



JOHN DEER INDIAN

TURBO MANUFACTURER OF ENGINEERED PRODUCTS · SPARE PARTS · CATALOG 2014

JOHN DEER Indian



TURBO PART N°	DESCRIPTION	WEIGHT	ADAPTER	PIN	MACHINE MODEL
TF23	Indian Market (JOHN DEER)-Tip	1.85	U43792	23PN	

ADAPTER

TURBO PART N°	DESCRIPTION	WEIGHT	BLADE SIZE	TEETH	PIN	MACHINE MODEL
U43792	Indian Market (JOHN DEER)-t excavator adapter	1.7	25	TF23	23PN	



INDIAN FORK TEETH

TURBO MANUFACTURER OF ENGINEERED PRODUCTS · SPARE PARTS · CATALOG 2014

Indian Fork Teeth



TURBO PART N°	DESCRIPTION	WEIGHT	BLADE SIZE	TEETH	PIN	MACHINE MODEL
HC00002	Indian Market case fork Tip	4.4	20			







INDIAN CASE

TURBO MANUFACTURER OF ENGINEERED PRODUCTS · SPARE PARTS · CATALOG 2014

Indian Case



 TURBO PART N°	 DESCRIPTION	 WEIGHT	 BLADE SIZE	TEETH	PIN	MACHINE MODEL
BU0420001	Indian Market case fork Tip	2.7	22			
BU0630302	Indian Market case fork Tip	5.3	22			
BU0630302	Indian Market case fork Tip	5.3	22			



INDIAN CAT

TURBO MANUFACTURER OF ENGINEERED PRODUCTS · SPARE PARTS · CATALOG 2014



Indian Cat

TURBO PART N°	DESCRIPTION	WEIGHT	BLADE SIZE	TEETH	PIN	MACHINE MODEL
6Y6335	Center	3.5	22			
277-8664	Side cutter	5.5	22			
277-8665	Side cutter	5.5	22			



Indian Fork Teeth

TURBO PART N°	DESCRIPTION	WEIGHT	BLADE SIZE	TEETH	PIN	MACHINE MODEL
WD00010	Indian Market case fork Tip	13.8				
WD00011	Indian Market case fork Tip	12.8				
WD00012	Indian Market case fork Tip	13.6				



KOBLECO-NEW MACHINE

TURBO MANUFACTURER OF ENGINEERED PRODUCTS · SPARE PARTS · CATALOG 2014

Kobleco-New Machine



TURBO PART N°	DESCRIPTION	WEIGHT	ADAPTER	PIN	MACHINE MODEL
SK60RC	Tip Kobleco SK 60- OEM-LE100-8	1.6	SK60-20	*	SK 60
2412U16S1	Tip Kobleco SK 140/SK135	4.5	2412U47	B12P0015E12 B12P0015E3-L	SK 140/SK135
B12P0015E12	Pin Kobleco SK 140/SK135	0.25			SK 140/SK135
B12P0015E3-L	Retainer Kobleco SK 140/SK135	0.04			SK 140/SK135
YN69S001L	Tip Kobleco SK 210	7.8	YN61B01020PIL-SK210A	YN69B00008S002-L YN69B00008S003-L	SK 210
YN69B00008S002-L	Kobleco SK 210	0.25			SK 210
YN69B00008S003-L	Retainer Kobleco SK 210	0.04			SK 210
LC6901S1L	Tip Kobleco SK 350A	12.7	LC61B01001PIL-SK350A	LC69B00001S2-L LC69B00001S3-1	SK 350A
LC69B00001S2-L	Pin Kobleco SK 350A	0.25			SK 350A
LC69B00001S3-1	Kobleco SK 350A	0.04			SK 350A

Kobleco-New Machine



TURBO PART N°	DESCRIPTION	WEIGHT	BLADE SIZE	PIN	MACHINE MODEL
SK60-20	Adapter Kobleco SK 60 blade 20mm	2.8	20mm	*	SK 60
2412U47	Adapter Kobleco SK 140/SK135		32mm	B12P0015E12 B12P0015E3-L	SK 140/SK135
YN61B01020PIL-SK210A	Adapter Kobleco SK 210	13.7	40	YN69B00008S002-L YN69B00008S003-L	SK 210
LC61B01001PIL-SK350A	Adapter Kobleco SK 350A	17.6	51	LC69B00001S2-L LC69B00001S3-1	SK 350A





FIAT KOBELCO

TURBO MANUFACTURER OF ENGINEERED PRODUCTS · SPARE PARTS · CATALOG 2014





FIAT KOBELCO



 TURBO PART N°	 DESCRIPTION	 WEIGHT	ADAPTER	ADAPTER LH	ADAPTER RH	MACHINE MODEL
76028588	Tip-FR 160 - 2 / W 190-FIAT ALLIS - FIAT KOBELCO	3.60	79069599	79069597	79069598	FR 160 - 2 / W 190-FIAT ALLIS - FIAT KOBELCO
76052987	Tip- W130-FIAT ALLIS - FIAT KOBELCO	2.20	76052985	76052986	76052984	W130-FIAT ALLIS - FIAT KOBELCO
8290419	Tip FL 10 -FIAT ALLIS - FIAT KOBELCO	8.00	*	*	*	FL 10 -FIAT ALLIS - FIAT KOBELCO
79069603	Tip FR 220 -FIAT ALLIS - FIAT KOBELCO	18.60	79069601	79070396		FR 220 -FIAT ALLIS - FIAT KOBELCO
79069594	Tip - RH FR 130 FIAT ALLIS - FIAT KOBELCO	8	76052985	76052986	76052984	FR 130 FIAT ALLIS - FIAT KOBELCO
79069595	Tip - LF FR 130 FIAT ALLIS - FIAT KOBELCO	8	76052985	76052986	76052984	FR 130 FIAT ALLIS - FIAT KOBELCO

FIAT KOBELCO



 TURBO PART N°	 DESCRIPTION	 WEIGHT	 BLADE SIZE	TEETH	PIN	MACHINE MODEL
79069599	Adapter-FR 160 - 2 / W 190	12.40	*	76028588	*	FR 160 - 2 / W 190-FIAT ALLIS
79069597	Adapter- RH FR 160 FIAT ALLIS - FIAT KOBELCO	14.2	*	76028588	*	FR 160 FIAT ALLIS - FIAT KOBELCO
79069598	Adapter- LH FR 160 FIAT ALLIS - FIAT KOBELCO	14.2	*	76028588	*	FR 160 FIAT ALLIS - FIAT KOBELCO
76052985	Adapter- W130-FIAT ALLIS - FIAT KOBELCO	7.7	*	76052987	*	W130-FIAT ALLIS - FIAT KOBELCO
76052986	Adapter Right- W130-FIAT ALLIS - FIAT KOBELCO	8.5	*	76052987	*	W130-FIAT ALLIS - FIAT KOBELCO
76052984	Adapter Left- W130-FIAT ALLIS - FIAT KOBELCO	8.5	*	76052987	*	W130-FIAT ALLIS - FIAT KOBELCO
79069601	Adapter FR 220 -FIAT ALLIS - FIAT KOBELCO	25.90	*	79069603	*	FR 220 -FIAT ALLIS - FIAT KOBELCO
79070396	Adapter FR 220 -FIAT ALLIS - FIAT KOBELCO	25.90	*	79069603	*	FR 220 -FIAT ALLIS - FIAT KOBELCO



FAIT HITACHI

TURBO MANUFACTURER OF ENGINEERED PRODUCTS · SPARE PARTS · CATALOG 2014

Fait Hitachi



TURBO PART N°	DESCRIPTION	WEIGHT	ADAPTER	ADAPTER LH	ADAPTER RH	MACHINE MODEL
71467241	Tip-Fait Hitachi FH120/FH150	2.80	*	*	*	Fait Hitachi FH120/FH150
71417992	Tip-Fait Hitachi FH200-2	4.70	*	*	*	Fait Hitachi FH200-2
71465120	Tip-Fait Hitachi FH200-3	5.90	*	*	*	Fait Hitachi FH200-3
71421565	Tip-Fait Hitachi FH270-330	8.4	71421566	71421567	71421568	Fait Hitachi FH270-330
71464186	Tip-Fait Hitachi FH220-270-300	6.40	71421566	71421567	71421568	Fait Hitachi FH220-270-300
71468101	Tip -Fait Hitachi FH 400-3 / 450-3	11.60	71468102	71468103	71468104	Fait Hitachi FH 400-3 / 450-3
71432195	Tip -Fait Hitachi FH 400LCH-2	13.4	71432196	*	*	Fait Hitachi FH 400LCH-2

Fait Hitachi



TURBO PART N°	DESCRIPTION	WEIGHT	BLADE SIZE	TEETH	PIN	MACHINE MODEL
71421566	Adapter-Fait Hitachi FH270-330	16.5	*	71421565	*	Fait Hitachi FH270-330
71421567	Right Adapter-Fait Hitachi FH270-330	23.8	*	71421565	*	Fait Hitachi FH270-330
71421568	Left Adapter-Fait Hitachi FH270-330	23.8	*	71421565	*	Fait Hitachi FH270-330
71464187	ADAPTER Fait Hitachi FH220-270-300	13.9	*	71464186	*	Fait Hitachi FH220-270-300
71468102	CENTER ADAPTER -Fait Hitachi FH 400-3 / 45	20.7	*	71464186	*	Fait Hitachi FH220-270-300
71468103	Right ADAPTER -Fait Hitachi FH 400-3 / 450-3	42.5	*	71468101	*	Fait Hitachi FH 400-3 / 450-3
71468104	Left ADAPTER -Fait Hitachi FH 400-3 / 450-3	42.5	*	71468101	*	Fait Hitachi FH 400-3 / 450-3
71432196	Adapter Fait Hitachi FH 400LCH-2	21.5	*	71432195	*	Fait Hitachi FH 400-3 / 450-3



HIDROMEK

TURBO MANUFACTURER OF ENGINEERED PRODUCTS · SPARE PARTS · CATALOG 2014



Fork Tip

TURBO PART N°	DESCRIPTION	WEIGHT	BLADE SIZE	PIN	MACHINE MODEL
81010600	HIDROMEK-CENTER Tip HMK FB190-100T	3.4	20		HMK FB190-100T
81010630	HIDROMEK-SIDE CUTTER-RIGHT HMK FB190-100T	6.7	20		HMK FB190-100T
81010640	HIDROMEK-SIDE CUTTER-LEFT HMK FB190-100T	6.7	20		HMK FB190-100T

Standrd Teeth and Adpater



TURBO PART N°	DESCRIPTION	WEIGHT	ADAPTER	PIN	MACHINE MODEL
345302800	HIDROMEK Tip	6.2	345302601		HIDROMEK HMK220
H345302801 HMK220T2	HIDROMEK Tip	4.9	H345302602		HIDROMEK HMK200
H255302801 HMK300T	HIDROMEK Tip	7.5	H255302601		HIDROMEK HMK300
375302800 HMK370T	HIDROMEK Tip	9.9	375302600		HIDROMEK HMK370A

HIDROMEK







TURBO PART N°	DESCRIPTION	WEIGHT	BLADE SIZE	TEETH	PIN	MACHINE MODEL
H345302602 HMK220A	HIDROMEK Adapter	11	35	H345302801		Adapter HMK200
345302601	HIDROMEK Adapter	10.6	35	345302800		Adapter HMK220
H255302601 HMK300A	HIDROMEK Adapter	10.6	40	H255302801		Adapter HMK300
375302600 HMK370A	HIDROMEK Adapter	17.7	45	375302800		Adapter HMK370A



KAWASAKI

MANUFACTURER OF ENGINEERED PRODUCTS · SPARE PARTS · CATALOG 2014

Kawasaki

 TURBO PART N°	 DESCRIPTION	 WEIGHT	 BLADE SIZE	TEETH	PIN	MACHINE MODEL
03C1160L001	Tip - CENTER kawasaki 60Z2 70Z2 80Z3	11.00	25.4	76028588	*	60 Z2,70 Z2 ,3,5 80 Z3,5
03C1170L001	Tip - CENTER kawasaki 80Z4	14.5	32	76028588	*	70B,D,Z3,85 Z3 CO,80 ZS,80 Z4
03C1180L001	Tip - CENTER kawasaki 90Z3	23.50	38	76028588	*	KSS 85Z- 90Z - 95Z
03C1190L001	Tip - CENTER kawasaki 95Z	25.40	45	76052987	*	KSS 95Z-II,4
36815-20040	Tip Right - CENTER kawasaki 60Z2 70Z2 80Z3	19.20	32	76052987	*	60 Z2, 70 Z2,3,5 80 Z3,5
36815-20030	Tip Left - CENTER kawasaki 60Z2 70Z2 80Z3	19.20	32	76052987	*	60 Z2, 70 Z2,3,5 80 Z3,5
03C3660L001	Tip - right kawasaki 80Z4	20.00	32	79069603	*	70B,D,Z3,85 Z3 CO,80 ZS,80 Z4
03C3650L001	Tip - left kawasaki 80Z4	20.00	32	79069603	*	70B,D,Z3,85 Z3 CO,80 ZS,80 Z4
03C3661L001	Tip -right kawasaki 90Z3	26.70	38			KSS 85Z- 90Z - 95Z
03C3651L001	Tip -left kawasaki 90Z3	26.70	38			KSS 85Z- 90Z - 95Z
03C3700L001	Tip - right kawasaki 95Z	31	40			KSS 95Z-II,4
03C3690L001	Tip - left kawasaki 95Z	31	40			KSS 95Z-II,4





ADCO

MANUFACTURER OF ENGINEERED PRODUCTS · SPARE PARTS · CATALOG 2014

ADCO



TURBO PART N°	DESCRIPTION	WEIGHT	ADAPTER	PIN	MACHINE MODEL
100	ADCO Center Tip	1.4	110	*	
200	ADCO Center Tip	2.6	210		
100 RH	ADCO RH/LH Tip	1.5	110		
100 LH	ADCO RH/LH Tip	1.5	110		
200 RH	ADCO RH/LH Tip	3	210		
200 LH	ADCO RH/LH Tip	3	210		

ADCO



TURBO PART N°	DESCRIPTION	WEIGHT	BLADE SIZE	TEETH	PIN	MACHINE MODEL
110	ADCO Center Adapter	3.08	*		*	
210	ADCO Center Adapter	3.96	*			
210 RH	ADCO RH/LH Adapter	4.8	*			
210 LH	ADCO RH/LH Adapter	4.8	*			
3-868(Ateco) 9937(Champion, Volvo)	Ateco-Center Tip	3.6	*			





BOBCAT

TURBO MANUFACTURER OF ENGINEERED PRODUCTS · SPARE PARTS · CATALOG 2014

Bobcat







 TURBO PART N°	 DESCRIPTION	 WEIGHT	ADAPTER	PIN	MACHINE MODEL
6737325	Bobcat Tip	1	6737324		
6737324	Bobcat adapter	1.9	6737325		

KAWASAK

TURBO MANUFACTURER OF ENGINEERED PRODUCTS · SPARE PARTS · CATALOG 2014



KAWASAK





 TURBO PART N°	 DESCRIPTION	 WEIGHT	 BLADE SIZE	TEETH	PIN	MACHINE MODEL
5421114	KAWASAK-Fork Tip Blade 20mm	8.6	20			
5421115	KAWASAK-Fork Tip Blade 20mm	8.6	20			
5420402	KAWASAK-Fork Tip Blade 20mm	4.2	20			

NON-KNOW BRAND- FORK TIP

MANUFACTURER OF ENGINEERED PRODUCTS · SPARE PARTS · CATALOG 2014

Non-know brand- Fork Tip



 TURBO PART N°	 DESCRIPTION	 WEIGHT	 BLADE SIZE	TEETH	PIN	MACHINE MODEL
11000SX-L	Fork Tip	2.1				
1000SX-R	Fork Tip	2.1				
2900402	Fork Tip	4.2				
2901114	Fork Tip	8.5				
2901115	Fork Tip	8.5				



MANUFACTURER OF ENGINEERED PRODUCTS · SPARE PARTS · CATALOG 2014

Hiatchi -Fork Tip



Nº TURBO PART N°	DESCRIPTION	kg WEIGHT	BLADE SIZE	TEETH	PIN	MACHINE MODEL
205-70-T4272	Komatsu fork Tip-Turkey market-Blade 38mm	16	38			
207-70-T4212	Komatsu fork Tip-Turkey market-Blade 38mm	15.7	40			
56600-51382	Tip - CENTER Hiatchi ZW180 / 220	17.5	36			ZW 180 / 220
56600-51482	Tip - RIGHT SIDE Hiatchi ZW 180 / 220	23.5	36			ZW 180 / 220
56600-51492	Tip - LEFT SIDE Hiatchi ZW 180 / 220	23.5	36			ZW 180 / 220
56700-50372	Tip - CENTER Hiatchi ZW 250 / 310	24	45			ZW 250 / 310
56700-50382	Tip - RIGHT SIDE Hiatchi ZW 250 / 310	40	45			ZW 250 / 310
56700-50392	Tip - LEFT SIDE Hiatchi ZW 250 / 310	40	45			ZW 250 / 310



BRASIL -G.E.T SYSTEM

Brasil -G.E.T System



N° TURBO PART N°	DESCRIPTION	kg WEIGHT	ADAPTER	BLADE SIZE	PIN	MACHINE MODEL
846602	Tip Maxion	3.3				
862740	Tip Maxion	2.8				
3201071	Tip	10.2				
3302877	Tip	9.3				
234-785-1121	Tip	5.7				
D027748	Tip	1				
E157559	Tip	10.4				
75216654	tooth Flat	6				
TBM-01	tooth Flat	10.3				
D39093	Tip Maxion	1.1				
E61652-1	W18/20B 1"	10.4				
E61652-5/8	Tip	10.4				
75238350	RETRO 5/8 2F	2.6				
232-70-13130	komatsu-Shank	6.6				



NON-KNOW BRANDS SIDE CUTTER

MANUFACTURER OF ENGINEERED PRODUCTS · SPARE PARTS · CATALOG 2014



Non-Know Brands Side Cutter

Nº TURBO PART Nº	DESCRIPTION	WEIGHT kg	ADAPTER	PIN	MACHINE MODEL
E72958L	side cutter	10.2	38		
E72958R	side cutter	10.2	40		
E72959	side cutter center	5.1	36		
ES124-L	Side cutter	3.8	36		
ES125-R	Side cutter	3.8	36		
1010517	Hitachi 400 side cutter	20.2	45		
1010518	Hitachi 400 side cutter	20.2	45		
CE 17748L3	Esco-side cutter	20.3	45		
CE 17748R3	Esco-side cutter	20.3	45		
CA05	Tip	0.6			



SANY

Standard tip



TURBO PART N°	DESCRIPTION	WEIGHT	ADAPTER	PIN	MACHINE MODEL
12076675	standard tip	1.7	12076693	12076709 12076732	SY55/60
12076809	standard tip	2.4	12076804	12076815 12076820	SY65/75/95
60154445	standard tip	3	60154444	60154443 60154446	SY115
12076847	standard tip	/	12076838	12077349 12077355	SY135
12164234	standard tip	/	12076838	12077349 12077355	SY155
11912709	standard tip	5.7	11902150	2705-1020 2114-1848A	SY205/215
60116436	standard tip	9.2	60116435	705-0000 114-00246	SY285/335 SY365
60142870	standard tip	17.2	60142870	2705-1034 2114-1931	SY465

Side Cutter



TURBO PART N°	DESCRIPTION	WEIGHT	ADAPTER	PIN	MACHINE MODEL
A229900002159	Side cutter	6.4	12076693		SY55/60
A229900007313		6.4	12076804		65/75
2713-1228 L	Side cutter	8.6	60154444		SY95/115
2713-1228 R		8.6	12076838		135/155
11280631	Side cutter	16	12076838		SY235
60040991	Side cutter	22	11902150		SY285
60040992		22	60116435		
A820403000889	Side cutter	27.7	60142870		SY335

Adapter



N° TURBO PART N°	DESCRIPTION	WEIGHT kg	ADAPTER	PIN	MACHINE MODEL
12076693	Adapter	2.4	12076675	12076709/12076732	SY55/60
12076804	Adapter	3.6	12076809	12076815/12076820	SY65/75/95
60154444	Adapter	4.8	60154445	60154443/60154446	SY115
12076838	Adapter	/	12076847	12077349/12077355	SY135
12076838	Adapter	/	12164234	12077349/12077355	SY155
11902150	Adapter	8.6	11902148	2705-1020 2114-1848A	SY195/215/235
60116435	Adapter	17.7	60116437	705-0000 114-00246	SY285/335S Y365
60142870	Adapter	24	60142873	2705-1034 2114-1931	SY465



Rock Chisel

N° TURBO PART N°	DESCRIPTION	WEIGHT kg	ADAPTER	PIN	MACHINE MODEL
11902148	Rock Chisel	6.8	111902150	2705-1020 2114-1848A	SSY195/215/235
60116437	Rock Chisel	11	60116435	705-0000 114-00246	SY285/335 SY365
60142873	Rock Chisel	14.2	60142870	2705-1034 2114-1931	SY465



Lip Conner

N° TURBO PART N°	DESCRIPTION	WEIGHT kg	ADAPTER	PIN	MACHINE MODEL
60154446	Lip conner	61.2			SY95
A820403000698	Lip conner	1.4			SY215/23 5285/335
A820403000893	Lip conner	2.8			SY335



CASE

MANUFACTURER OF ENGINEERED PRODUCTS · SPARE PARTS · CATALOG 2014

Case



TURBO PART N°	DESCRIPTION	WEIGHT	ADAPTER	PIN	MACHINE MODEL
87430710	SYL Teeth	0.8			
87344351	VY Twin Pick	1			
87430711	Pin	0.2			
87430711	Pin	0.2			
87344354	TVY Twin Pick	1.2			
87344353	AR/ARH Penetration Abrasion	*			
87344356	VY Pick	1.1			
87430854	TY/TYL General Purpose	1			
233792A1	Pin	0.2			
P3882188U	SYL General Purpose Long	2.3			
372138A1	TVY Twin Pick	2			
254823A1	VY Pick	2			
127555A1	TY/TYL General Purpose	2.2			
233792A1	PN Pin	0.2			
127558A1	SYL General Purpose Long	3.1			
241813A1	TVY Twin Pick	3.3			
241814A1	VY Pick	2.8			
254814A1	TY/TYL General Purpose	3.4			
254816A1	AD Abrasion Penetration	4.7			
241812A1	Flare	3.9			
233799A1	PN Pin	0.2			
233798A1	SYL General Purpose Long	6.8			



Case



N° TURBO PART N°	DESCRIPTION	WEIGHT kg	ADAPTER	PIN	MACHINE MODEL
241818A1	TVY Twin Pick	6			
233796A1	VY Pick	5.4			
241819A1	Flare	*			
372150A1	SHV Penetration Abrasion	8			
378944A1	RYL Standard Rock	6.3			
372149A1	SDX Chisel Heavy	6.9			
372152A1	TYLCE Non-Twist Long GP	*			
254098A1	Pin	0.1			
254093A1	SYL General Purpose Long	9.6			
254096A1	TVY Twin Pick	9.3			
254094A1	VY Pick	8.8			
254097A1	Flare	13			
372155A1	SHV Penetration Abrasion	9			
378945A1	RYL Standard Rock	9			
372154A1	SDX Chisel Heavy	9.6			
372156A1	TYLCE Non-Twist Long GP	*			
254104A1	PN Pin	0.2			
254100A1	SYL General Purpose Long	13			
254102A1	TVY Twin Pick	12			
254101A1	VY Pick	11.8			
254103A1	Flare	17.5			
372157A1	SDX Chisel Heavy	15			

Case



 TURBO PART N°	 DESCRIPTION	 WEIGHT	ADAPTER	PIN	MACHINE MODEL
372159A1	TYLCE Non-Twist Long GP	*			
372044A1	Pin	0.2			
372042A1	SYL General Purpose Long	16.8			
372161A1	TVY Twin Pick	17			
372160A1	VY Pick	15.5			
372164A1	TY/TYL General Purpose	18			
378965A1	Flare	23.5			
372163A1	SHV Penetration Abrasion	22			
378959A1	RYL Standard Rock	15			
372162A1	SDX Chisel Heavy	16.8			
378961A1	SDX Chisel Heavy	23.5			
233795A1	Pin	0.1			
233794A1	SYL General Purpose Long	6			
241816A1	TVY Twin Pick	4.3			
241817A1	VY Pick	3.8			
254807A1	TY/TYL General Purpose	4.8			
254811A1	AD Abrasion Penetration	6.2			
254810A1	AR Abrasion Rock	7.7			
241815A1	Flare	9			
372147A1	SHV Penetration Abrasion	5.5			
378943A1	RYL Standard Rock	4.5			
372145A1	SDX Chisel Heavy	5			
372148A1	TYLCE Non-Twist Long GP	*			



XG50

CHINA MACHINE(XGMA, XCMG, LIUGONG,SDLG)

TURBO MANUFACTURER OF ENGINEERED PRODUCTS · SPARE PARTS · CATALOG 2014



ChengGong

Nº	DESCRIPTION	WEIGHT	ADAPTER	PIN	MACHINE MODEL
TURBO PART N°					
CQ30	成工30	4.5			CQ30C



ChangLin

Nº	DESCRIPTION	WEIGHT	ADAPTER	PIN	MACHINE MODEL
TURBO PART N°					
CL50	常林 50	10.1			
CLB50 L	常林 50	11			XG50
CLB50 R	常林 50	11			



XGMA

Nº	DESCRIPTION	WEIGHT	ADAPTER	PIN	MACHINE MODEL
TURBO PART N°					
XIA50	夏工 50XGMA	8.5			
XB50 L	夏工 50XGMA	17.5			XG50
XB50 R	夏工 50XGMA	17.5			



ShangGong

Nº	DESCRIPTION	WEIGHT	ADAPTER	PIN	MACHINE MODEL
TURBO PART N°					
YSW30T	山工 30	3.1	YSW30A		SG30
YSW50T	山工 30	6.9	YSW50A		SG50
YSW30A	山工 30		30	YSW30T	SG30
YSW50A	山工 30		40	YSW50T	SG50



XCMG

TURBO PART N°	DESCRIPTION	WEIGHT	ADAPTER	PIN	MACHINE MODEL
XU30	徐工 30XCMG	5.4			XG30
XUB30	徐工 30XCMG	5.6			
XU50	徐工 30XCMG	8.5			XG50
XUB50	徐工 30XCMG	13			



Liugong

TURBO PART N°	DESCRIPTION	WEIGHT	ADAPTER	PIN	MACHINE MODEL
LG40-B	柳工 40/50Liugong	4.5	1LUM40		ZL40B/LG50C
LG50C	柳工 40/50Liugong	5.1	LUM40		
LG40-T	柳工 40/50Liugong	6.3	LUM40		
LUM40	柳工 40/50Liugong	10.5			
LUB40 L	柳工 40/50Liugong	12.5			
LUB40 R	柳工 40/50Liugong	12.5			
LU50	柳工 40/50Liugong	7.4			
LU50H	柳工 40/50Liugong	1.5			



LongKing

TURBO PART N°	DESCRIPTION	WEIGHT	ADAPTER	PIN	MACHINE MODEL
2713-9061	福田/龙工 60	1.5	2713-9062		福田/龙工 60
2713-9062	福田/龙工 60	1.5	20	2713-9061	龙工 60

SDLG



TURBO PART N°	DESCRIPTION	WEIGHT	ADAPTER	PIN	MACHINE MODEL
SDLG50	SDLG- Loder 50 conner tip	9.2			
SDLG50R	SDLG- Loder 50 conner tip- Right	13.2			ZL40B/LG50C
SDLG50L	SDLG- Loder 50 conner tip-LIGHT	13.2			
291700 36961	SDLG 30 东方红机器 -FORK TIP	5			
291700 36981	SDLG 30 东方红机器 -FORK TIP	6.2			
291700 36971	SDLG 30 东方红机器 -FORK TIP	6.2			ZL40B/LG30C
XG932	XCMG-For teeth- Loder 932	8			



CUTTING EDGES

TURBO MANUFACTURER OF ENGINEERED PRODUCTS · SPARE PARTS · CATALOG 2014

TURBO BUCKET TEETH

CUTTING EDGES

TURBO PART N°	DESCRIPTION	WEIGHT
3G6289	Cutting Edges	36.8
4T6386	Cutting Edges	78
8K8162	Cutting Edges	118
9J9606	Cutting Edges	38.7
9W6608	Cutting Edges	89.3
9W6615	Cutting Edges	88.4
8294269	19*203*1060	30
8294669	19*203*756	21.3
8294271		
8294669	19*203*756	21.3
11082664-11		
11082666-6	30*380*1818	155
100-4015		
100-4043	45*265*556	48.6
100-4044		
100-6356	45*330*1162	127.8
100-6664		
100-6666	30*293*359	23.4
100-6668		
10120745	30*360*1403.4	110
10120752		
10120757	25*280*820	40

CUTTING EDGES

TURBO PART N°	DESCRIPTION	WEIGHT
10127292	35*254*806	45.6
101-9435	38*346*482	47.5
101-9436	38*354*482	50
101-9437	38*354*482	50
106-0956	19*254*1380	48.5
106-9290	35*227*510	28.5
107-3381	30*360*1240	93.2
107-3383	75*545*556	182
107-3474	45*254*910	75.65
107-3477	45*254*1520	127.74
107-3479	45*254*1034	86.81
107-3483	45*254*1095	92.12
107-3490	45*312*482	50
107-3528	45*354*482	56.3
107-3537	45*354*482	56.3
107-3538	45*354*482	56.3
107-3746	25*280*1179	59
109-9019	30*315*360	22.3
109-9212	35*406*1450	153.7
109-9215	35*254*627	41.3
109-9230	45*406*1451	190.2
111-80-00016	16*160*273	5.45



CUTTING EDGES

Nº	DESCRIPTION	WEIGHT
TURBO PART Nº		
111-80-00017	16*160*1114.8	322.4
112-2471	45*330*803	88.37
112-2472	45*330*1353	149
112-80-00016	16*160*758.6	12
112-83-00017	16*160*437.4	6.65
112-83-00018	16*160*758.4	12
112-83-00019	16*160*474.8	7.4
112-946-1510	16*152*370	6.2
118-7110		
122-80-00002		
122-80-00013		
122-80-00017		
122-80-00019		
122-9227	25*254*894	42
122-946-1510		
128-2872	19*203*323	
128-2873		
11G-71-31170	16*160*380	7
12F-70-31251		
12F-70-31261	16*160*914	16.9
12F-70-31281		
13F-Z27-1510	19*203*1430	40

CUTTING EDGES

Nº	DESCRIPTION	WEIGHT
TURBO PART Nº		
130-70-41130	19*203*1350	38.2
130-70-61170	19*203*1535	43.4
130-920-2180	19*203*1199	33.5
130-Z20-1510	19*203*1255	35
132-1033	35*170*496	20.65
132-1035	35*225*280	15
132-1037	35*265*280	17.5
132-4715	35*278*305	20.5
134-72-61410	19*203*1350	37.6
134-72-61420	19*203*1255	35
135-6537	25*280*1108	58.4
135-9294	40*300*330	30.8
135-9295	40*315*330	32.3
135-9296	40*315*330	32.3
135-9647	30*265*360	18.8
135-9648	30*210*360	14.9
135-9649	30*265*360	18.8
138-0865	40*344*482	
138-0866	40*354*482	
138-0867	40*354*482	
138-6470	35*312*482	
138-6471	35*323*482	



CUTTING EDGES

Nº	DESCRIPTION	WEIGHT
TURBO PART Nº		
138-6472	35*323*482	
139-9230	30*360*1280	101
140-0983	16*203*914	21
140-2187	16*165*1008	18,5
140-6862	35*256*360	
140-6863	35*265*360	
140-6864	35*265*360	
140-6865		
140-6866		
140-6867	35*240*360	
140-6868		
140-6869	35*253*360	
140-6870		
140-7601	30*360*292	21,6
140-80-00001		
140-80-00006	19*203*773	30
144-70-11131		
144-871-5130	20*254*1594	57,4
144-920-1120		
14X-71-11310	19*203*1383	40
154-70-11313		
154-70-11314	25*254*1156	54,5



CUTTING EDGES

Nº	DESCRIPTION	WEIGHT
TURBO PART Nº		
154-71-43190	25*254*850	39,2
154-72-11151	25*254*910	44
154-81-11190	25*254*838	39,5
154-81-11191	25*254*838	39,5
156-82-00001	25*254*844	40
175-70-21115	25*254*1397	65,7
175-70-26310	25*254*1062	50
17A-71-11351	35*330*764 POINT	55,9
	30*330*764 POINT	54
17A-71-11654	32*330*761	54
17A-71-45210	32*330*1064	80,8
17A-71-45220	35*330*530	33
17A-71-45230	40*330*530	33
	30*330*1090	78,3
17M-71-21550	35*330*1090	90,5
	38*330*1091	98,3
17M-72-21160	30*330*781	55,5
195-70-12492	30*330*1327	99,7
	30*330*1064	79,9
17M-71-21550	35*330*1064	90,5
195-71-61550	40*406*887	108,4
198-71-11181	40*406*1192	145,8

CUTTING EDGES

Nº TURBO PART Nº	DESCRIPTION	kg WEIGHT
198-71-21830	40*406*1190	146.63
198-71-31540	45*406*861	108
198-71-31550	45*406*1192	157
198-72-11181	40*406*862	102.2
419-904-1121	25*254*1255.8	58
421-70-12122	35*225*3050	185
421-70-12430	35*225*3170	192.1
421-815-1121	35*330*546	46.5
421-815-1221	35*330*592	
421-815-2110	35*330*2070	177
421-815-2211	30*330*1382	
421-815-2220	30*196*445	22.6
421-825-3210	35*330*1302	
421-825-3220	35*278*455	32.77
423-815-1111	35*330*1617	
423-815-2210	30*330*1249	107
423-904-1131	25*254*1217.6	
424-70-H2D60	30*330*650	45.5
424-815-1211	35*330*1860	
	30*330*1861	136
1U0292	25*280*1162	
1U0295	25*280*1025	49.4



CUTTING EDGES

Nº TURBO PART Nº	DESCRIPTION	kg WEIGHT
1U0593	30*360*1319	98.6
1U0601	30*360*1210	91.5
1U0761	40*556*265	43
1U0762	35*406*1406	148.6
1U1192	19*254*913	31.8
1U1909	30*360*1260	94.1
1U2211	19*203*1396	39
1U2406	30*360*1230.5	94.1
1U4930	35*254*856	55.6
1U4931	32*254*1095	65.5
3G4282	19*203*1152	32.2
3G4285	19*203*425	12
3G6395	35*200*510	25.6
3G9306	16*203*884	22
4T2236	25*203*2438	90
4T2315	19*203*1558	43.5
4T2887	22*406*1530	96.5
4T2895	30*406*1528.6	131
4T2921	19*254*1063	36.99
4T2922	19*254*758	26.38
4T2923	19*254*1029	35.78
4T2945	19*254*708	25

CUTTING EDGES

N° TURBO PART N°	DESCRIPTION	WEIGHT kg
4T6513		
4T6514	25*254*1558	71.4
4T6515	25*254*1773	83.3
4T6531	25*254*1520	69
4T6532	25*254*910	44.5
4T6568	25*406*1429	90.3
4T6592	35*406*858	92
4T6594	35*406*1542	164.1
4T6611		
4T6612	25*330*748	44.3
4T6613		
4T6614		
4T6648		
4T6659	19*203*1052	29.4
4T6692		
4T-6693,132-1036	25*210*280	9.8
4T6694		
4T6695	25*265*280	12.5
4T6696		
4T6697	30*210*360	15
4T6698		
4T6699	30*270*360	19.7

CUTTING EDGES

N° TURBO PART N°	DESCRIPTION	WEIGHT kg
4T-6700	30*290*360	21.5
4T6760		69
4T6761		76
4T6762		76
4T8077	16*203*2382	54.75
4T8091	25*160*342	9.5
4T8101	30*170*496	18
4T8317	35*254*2438	160.4
4T8796	19*254*1238	43.4
4T8799	25*254*998.4	45.4
4T8940	16*203*1193.8	27.33
4T9585/6Y5540	30*330*803	57
4T9586	30*330*1695	122.2
4T9587/6Y5540	30*330*802	57
4T9836	35*330*1695	144
5G2809	19*200*2080	57.8
5J6832		43.3
5J6839	19*254*802	28.2
5J6849		50
5J6888	19*254*1063	38.2
	25*254*1063	49.3
5V4661	25*245*2408	106



CUTTING EDGES

TURBO PART N°	DESCRIPTION	WEIGHT
5V4696	32*282*2736	174
5V7276	25*245*2616	123.3
5V7410	25*245*2471	121.2
5V7423	25*245*2439	106.9
6J1406		42.5
6J7116	25*254*1533	72.1
6W2985	25*245*2639	114.3
6W2987	25*245*2615	113.2
6W2989		
6W2990	30*282*2856	175.1
6Y3840		
6Y5539	30*330*1787	130
6Y5540/4T9587		
7J2959	40*330*900	90
7J2980		
7J3025		47
7T3495		
7T5701		
7T5702		
7T6589	25*280*1095	58.3
7T6592		
7T6678	25*280*894	47.6



CUTTING EDGES

TURBO PART N°	DESCRIPTION	WEIGHT
7T6936	125*280*908	43.12
7T9125	35*330*803	68.2
	30*330*803	58.5
7T9126	35*330*1353.2	114.8
7T9127	35*330*824.1 POINT	
7T9976		40
7T9977	25*203*1019	38.3
7T9978	25*203*658	24.8
7V1490	40*300*3033	246
7V6844	40*300*2914	260.2
8294271	19*203*912	26.1
8E2085	60*406*992	180
8E2086	60*406*859	155.5
8E2087	60*406*848	153.5
8E4567	25*280*1102	53.2
8E4569	25*247*280	12.5
8J1489		22.3
		18.8
8J1490		24
		20
8J8118	25*254*1034	48.4
8J9668	25*254*1215	56.2

CUTTING EDGES

TURBO PART N°	DESCRIPTION	WEIGHT
8K8161		113
8K9754		181.3
		345
9J4369	35*406*1580	162
		190.8
9R4672	20*150*2262	50.6
		58
9U8057	19*203*627	17.5
9V0170	40*580*3085	437
		158
9V6574	45*305*3314	361
		271
9W1375	35*406*1524	161.5
		43.2
9W3927	45*330*800	88
		184
9W4398	35*330*800	68
		182.3
9W4494	60*406*1020	182
		192.9
9W4500	35*330*1040	88.5



CUTTING EDGES

TURBO PART N°	DESCRIPTION	WEIGHT
9W4502	35*330*1223	104
9W4507	40*330*1354	135.18
9W4508	40*330*1223	131.4
9W4902	35*406*908	92.9
9W5232	30*330*825	60
9W5432	30*330*1241	85.5
9W5730		41
9W5734	35*312*483	40
9W5737	35*323*483	41
9W6092	35*330*900	76.5
9W6608	35*406*859	89.3
9W6609	35*406*992	103
9W6656	45*406*995	133.9
9W6657	45*402*859	115.7
9W7043	45*330*1787	196.4
9W8215	19*203*1130	31.9
9W9098	35*330*1240	105.2
9W9702	45*406*908	120.4
U17519		
U18064		
U18400		
U18197		
U17689		



BULLDOZER END BITS

TURBO MANUFACTURER OF ENGINEERED PRODUCTS · SPARE PARTS · CATALOG 2014

TURBO BUCKET TEETH

BULLDOZER END BITS

Nº TURBO PART Nº	DESCRIPTION	kg WEIGHT
73117713/14	25MM THICKNESS	
8294274	25MM THICKNESS	16.2
8294681/82	25MM THICKNESS	19.9
8E4198	End Bit	112.8
8E4199	End Bit	112.8
17A-71-45712	End Bit	76.2
17A-71-45722	End Bit	76.2
9W8874	End Bit	20
9W8875		
3G8294	End Bit	23.7
8E9379		
1U1546	End Bit	67.6
112-70-31120/30		
112-817-1110	16MM THICKNESS FLAT	6.9
112-946-1510		
11G-71-31170	16MM THICKNESS FLAT	7.1
120-Y46-5162/72		
124-70-21330/40	20MM THICKNESS	9.8
12F-929-2170(2)		
13F-Z27-1581/71	25MM THICKNESS FLAT	14.4
13F-Z27-1582/72		
140-70-11130/40	20MM THICKNESS	9.6

BULLDOZER END BITS

Nº TURBO PART Nº	DESCRIPTION	kg WEIGHT
140-70-11131/41	25MM THICKNESS	15.7
140-70-11170/80	25MM THICKNESS	15
140-70-11170/80RF	30MM THICKNESS FLAT	18.2
144-70-11180/90	25MM THICKNESS	12.6
144-70-11250/60	25MM THICKNESS	15.5
144-70-11251/61	30MM THICKNESS	17.8
144-952-1120/30	25MM THICKNESS	14.5
14X-71-11330/40	30MM THICKNESS	17.86
150-70-21343/53	30MM THICKNESS	25
150-70-21344/54	30MM THICKNESS	25
150-70-21345/55	30MM THICKNESS	25
150-70-21346/56	30MM THICKNESS	25
154-926-1120/30	30MM THICKNESS FLAT	25
175-70-21123/33	38MM THICKNESS	27.5
175-70-21125/35	38MM THICKNESS	27.5
175-70-21126/36	35MM THICKNESS	33
175-70-21126/36	38MM THICKNESS	40.5
175-71-11170/80	38MM THICKNESS	45
175-71-11172/82	38MM THICKNESS	45
175-71-22271/81	38MM THICKNESS	45
175-71-22271/81	30MM THICKNESS	30
175-71-22272/82	38MM THICKNESS	40.1



BULLDOZER END BITS

BULLDOZER END BITS



Nº TURBO PART N°	DESCRIPTION	kg WEIGHT
175-71-22241/51	38MM THICKNESS	45
17M-71-21930/40	40MM THICKNESS	71.6
195-70-12610/20	40MM THICKNESS	64.2
195-71-11173/83	40MM THICKNESS	73.4
195-71-21350/60	40MM THICKNESS	67
195-71-61930/40	50MM THICKNESS	117.4
198-71-31520	60MM THICKNESS	130
198-71-31530	60MM THICKNESS	130
1T14036		
1T14033		37.65
1U1545/46		
1U4925/26	51MM THICKNESS	106.5
3G4285(2)		
3G8277/78 7J3459/60	40MM THICKNESS	40.6
3G8279/80 9J1473/72		
3G8281/82 7J3461/62	40MM THICKNESS	74
3G8283/84 7J3463/64		
3G8285/86 7J3457/58	40MM THICKNESS	41.1
3G8287/88 9J1475/74		
3G8289/90 7J6713/14	35MM THICKNESS	64.5
3G8291/92 7J67711/12		
3G8293/94	25MM THICKNESS	23.7

Nº TURBO PART N°	DESCRIPTION	kg WEIGHT
3G8295/96 6J0893/94	125MM THICKNESS	17.4
3G8297/98	25MM THICKNESS	16.4
3G8299/300 5J8769/70	30MM THICKNESS	30
3G8301/02 9J1479/80	30MM THICKNESS	30
3G8315/16	30MM THICKNESS	26.4
3G8317/18 8J8105/20	30MM THICKNESS	30.8
3G8319/20 6J0275/76	25MM THICKNESS	18
3G-8321/22	25MM THICKNESS	17.4
4J8723/24 1J9055/56	35MM THICKNESS	50.8
4T3041/42	19MM THICKNESS FLAT	10.1
4T3043/44	20MM THICKNESS FLAT	8.3
4T3045/46 8J7162/63	19MM THICKNESS FLAT	10.7
4T3051/52 5J6923/24	19MM THICKNESS FLAT	10
	19MM THICKNESS FLAT	9.5
	25MM THICKNESS FLAT	12.5
4T4435/36	25MM THICKNESS FLAT	13.3
4T4454/55		22.8
4T5407/08	30MM THICKNESS	24.5
4T6229(2) 8J6412(2)	16MM THICKNESS FLAT	6.5
4T6239/40 9J1539/40	25MM THICKNESS FLAT	21.5
4T6505/06	25MM THICKNESS FLAT	22.5
4T6667/68 5J6921/22	25MM THICKNESS FLAT	21.5

BULLDOZER END BITS



Nº TURBO PART Nº	DESCRIPTION	WEIGHT kg
14T8090	30MM THICKNESS FLAT	24.5
5A4565/66	20MM THICKNESS FLAT	8.8
5J1279/80 1J1985/86	35MM THICKNESS	50
5J8767/68	30MM THICKNESS	32
6J0275/76	25MM THICKNESS	17.4
6Y4278	40MM THICKNESS	52.5
6Y-5839	16*165*350(310) FLAT	6.5
6Y-5840	16*165*350(310) FLAT	6.5
7T4092/93	55MM THICKNESS	70
7T4688/89	60MM THICKNESS	99
8E4193/94 7T9089/90	35MM THICKNESS	60.2
8E4196/97 9W6193/92	50MM THICKNESS	75.8
8E4537/38	50MM THICKNESS	75.3

BULLDOZER END BITS

Nº TURBO PART Nº	DESCRIPTION	WEIGHT kg
8E4539/40 9W6195/94	145MM THICKNESS	79
8E4541/42 7T4097/96	45MM THICKNESS	108.3
8E4543/44	60MM THICKNESS	157
8E7078/79	19*203*451 FLAT	12
8E9378/79	25*203*476 FLAT	18
	19*203*476 FLAT	12.5
9J1479/80	38MM THICKNESS	36.8
9W1875/76	30MM THICKNESS	27
9W-6198/99	35MM THICKNESS	46.5
	38MM THICKNESS	50.5
9W-8874/75	25MM THICKNESS FLAT	20
9W9010/11	25MM THICKNESS	20
9W9014/15 5J1419/20	25MM THICKNESS	21.5



GRADER BLADES

TURBO MANUFACTURER OF ENGINEERED PRODUCTS · SPARE PARTS · CATALOG 2014

TURBO BUCKET TEETH

GRADER BLADES

Nº	DESCRIPTION	WEIGHT
TURBO PART Nº		kg
040100020	GRADER END BIT	9
040100050	G/BLADE 3/4**8**7.5(14#5/8")	55.5
232-70-12143	G/BLADE 5/8**6**6(13#5/8")	30
233-70-12141		20
		31
234-70-12193	G/BLADE 5/8**6**7	34
235-70-12140	G/BLADE 3/4**8**8	66
238-70-12220	G/BLADE 5/8**6**5(11#5/8")	24.5
3G7966		
4T2231		70
4T2233		
4T2236	G/BLADE 1**8**8(17#3/4")	90
4T2242		
4T2243	G/BLADE 1**8**6(13#5/8")	68.8
4T2244		
4T3036/5J6973		60.4
4T3007/5J6970		
4T6511	G/BLADE 1**10**8(17#3/4")	116.6
4T8317		
4Z8055	G/BLADE 1**10**7 (15#3/4")	97.4
4Z8056		
5B5564	G/BLADE 5/8**6**6(8#5/8")	30.3

GRADER BLADES

Nº	DESCRIPTION	WEIGHT
TURBO PART Nº		kg
5D9553	G/BLADE 5/8**6**6(13#5/8")	30
5D9554	G/BLADE 5/8**6**7(15#5/8")	35
5D9556	G/BLADE 3/4**6**6(13#5/8")	37
5D9557	G/BLADE 3/4**6**7(15#5/8")	42
5D9558	G/BLADE 3/4**8**6(13#5/8")	50
5D9559	G/BLADE 3/4**8**7(15#5/8")	59
5D9562	G/BLADE 5/8**8**6(13#5/8")	42.3
5D9732		66
5J6970		51
5J6973		59.6
7D1158	G/BLADE 5/8**8**7(15#3/4")	48.5
7D1576	G/BLADE 3/4**8**6(13#3/4")	50
7D1577	G/BLADE 3/4**8**7(15#3/4")	59
7D1949	G/BLADE 3/4**8**8(17#3/4")	66
7D4508	G/BLADE 5/8**6**5(11#5/8")	25
7T1623		60
7T1634		51.5
8D2786		24
8D2787	G/BLADE 1/2**6**7(15#5/8")	27.6
8J4043		
8J9821		56.5
9J3657		30





GRADER BLADES

TURBO PART N°	DESCRIPTION	WEIGHT
9J3658		35
9J7701	G/BLADE 5/8**8**6'(13#3/4")	42.3
HK 19*203*1790	G/BLADE 3/4**8**6'(9#5/8")	50
234-70-12710	Grader Blades	48.5
4T2237	Grader Blades	91
9W2301	Grader Blades	33.6
9W2299	Grader Blades	29.4

GRADER BLADES

TURBO PART N°	DESCRIPTION	WEIGHT
7D4509	Grader Blades	34.5
6G8623	Grader Blades	17
7T1627	Grader Blades	66.7
5B5562	Grader Blades	35.3
7T1645	Grader Blades	35.3
7T1633	Grader Blades	30.3

GRADER END BITS

TURBO PART N°	DESCRIPTION	WEIGHT
232-70-52180		7.7
232-70-52190	13MM THICKNESS	11.5
232-70-12150	13MM THICKNESS	9
232-70-12160	13MM THICKNESS	9
234-70-32230		11.5
234-70-32240	16MM THICKNESS	20
6D1904	13*230*470	9.5
	16MM THICKNESS	14.5
6D1948	12MM THICKNESS	10.5
	13MM THICKNESS	12.1
6Y2805	16MM THICKNESS	



GRADER END BITS

TURBO PART N°	DESCRIPTION	WEIGHT
7D9999	13*230*600	13.7
7D2052	16*152*474	7.6
8E5531		8.1
8E5529		8.3
9J4405		8.2
9J4406		8.2
9W1767	12mm THICKNESS	11.7
	12mm THICKNESS	11.7
9W1768	16mm THICKNESS	14.4

LOADER END BITS

Nº TURBO PART Nº	DESCRIPTION	kg WEIGHT
100-4043	45*265*556	48.6
100-6668	30*360*1399.5	111
107-3746	25*280*1179	59
109-9212	35*406*1450	153.3
118-7110	19*203*1199	33.8
139-9230	30*360*1280	101
424-70-H2D60	30*330*650	45.5
100-6664	30*253*360	
100-6666	30*293*359	
101-9435	38*346*482	45.3
101-9436	38*354*482	
101-9437	38*354*482	46.1
106-9290	35*227*510	
107-3490	45*312*482	
107-3528	45*354*482	
107-3537	45*354*482	56.3
109-9019	30*315*360	
128-2872	19*203*323	
128-2873	19*203*265	
132-1035	35*225*280	
132-1037	35*265*280	
132-4715		



LOADER END BITS

Nº TURBO PART Nº	DESCRIPTION	kg WEIGHT
135-9294	G40*300*330	30.8
135-9295	40*315*330	
135-9296	40*315*330	32.3
135-9647	30*265*360	
135-9647/49	30*360*355	
135-9648	30*360*210	
135-9648	30*210*360	
135-9649	30*265*360	
138-0865	40*344*482	
138-0866	40*354*482	
138-0867	40*354*482	
138-6470	35*312*482	
138-6471	35*323*482	
138-6472	35*323*482	
140-6862	35*256*360	
140-6863	35*265*360	
140-6864	35*265*360	
140-6865		
140-6866	35*210*360	
140-6867	35*240*360	
140-6868	35*270*360	
140-6869	35*253*360	

LOADER END BITS

Nº TURBO PART Nº	DESCRIPTION	kg WEIGHT
140-6870	35*293*360	
140-7601	30*360*292	21.6
4T-3015	30*360*256	
4T-6691	25*175*280	8.2
4T-6692	25*195*280	9.5
4T-6693,132-1036	25*210*280	9.8
4T-6694	25*225*280	10.9
4T-6694,132-1035	25*225*280	11.7
4T-6695	25*265*280	12.9
4T-6696	30*190*360	14.1
4T-6697	30*210*360	15.7
4T-6698	30*240*360	19.2
4T-6699	30*270*360	19.7
4T-6700	30*290*360	21.5
4T-7139	30*305*360	
4T-7139	30*305*360	
4T-7140	30*305*360	
4T-8091	25*160*342	10
4T-8101	30*170*496	17.5
4T-9123,132-1039	30*265*360	
4T-9124,132-1040	30*265*360	
9W-5730	35*323*483	41

LOADER END BITS

Nº TURBO PART Nº	DESCRIPTION	kg WEIGHT
9W-5734	G35*312*483	340
9W-5737	35*323*483	41
9W-8367	35*367*483	
9W-8368	35*367*483	
SEG-25	25*280*265	14.5
SEG-30	30*360*300	25.5
SUB-30	30*360*1400	118.7



BULLDOZER SEGMENT GROUP



TURBO PART N°	DESCRIPTION	WEIGHT
131-27-61710	3 Teeth	6
10Y-18-00013	5 Teeth	10.2
141-27-32411	3 Teeth	8.1
14X-27-15112	3 Teeth	8.2
154-27-12273	3 Teeth	7.4
154-27-12283	2 Teeth	10.8
155-27-00151	5 Teeth	15.6
175-27-22325	3 Teeth	11.85

BULLDOZER SEGMENT GROUP

TURBO PART N°	DESCRIPTION	WEIGHT
195-27-12467	3 Teeth	16.8
195-27-33110	5 Teeth	33
1171616	5 Teeth	11.85
6T4179	5 Teeth	
6Y2931	5 Teeth	11.8
8E4675	5 Teeth	14.6
6T6782	3 Teeth	12.1

RIPPER SHANK



TURBO PART N°	DESCRIPTION	WEIGHT
1U3630	Gadaptor	96
175-78-21693		97
195-78-71380		56
10Y-84-50000	SD13 3 TEETH SHANK	57.3
16Y-84-30000	D60 3 TEETH SHANK	105.8
23Y-89-00100	D85 SOLE TEETH SHANK	211.5

RIPPER SHANK

TURBO PART N°	DESCRIPTION	WEIGHT
154-78-14348	D85 3 TEETH SHANK	96162.7
15A-79-11120	D155 SOLE TEETH SHANK	465.78
175-78-21615	D155 3 TEETH SHANK	288.6
195-79-31141	D355	586
195-79-51151	D375	576



GRADER BLADES

TURBO MANUFACTURER OF ENGINEERED PRODUCTS · SPARE PARTS · CATALOG 2014

TURBO BUCKET TEETH

SINGLE BEVEL CUTTING EDGE

N°	DESCRIPTION	WEIGHT
TURBO PART N°		
16*150*1900		34.0
16*203*2200		55.1
20*200*1100		47.9
20*150*2200		32.5
25*250*1600		72.4
SB25*250*3000		138.2
SB25*250*3150		173.8
SB30*300*3000		199
SB30*300*3150		208.5
SB30*300*3500		232
SB40*300*3150		
SB40*300*3300		291

SINGLE BEVEL CUTTING EDGE

N°	DESCRIPTION	WEIGHT
TURBO PART N°		
SB40*300*3500		3
SB40*300*3750		
P45161501800	16*150*1800	31.2
P45161502500	16*150*2500	43.33
P45161503000	16*150*3000	52
P45201501800	20*150*1800	39
P45201502500	20*150*2500	54.17
P45201503000	20*150*3000	65
P45202002400	20*200*2400	69.33
P45202002500	20*200*2500	72.22
P45202003000	20*200*3000	86.66



CHOCKY BARS

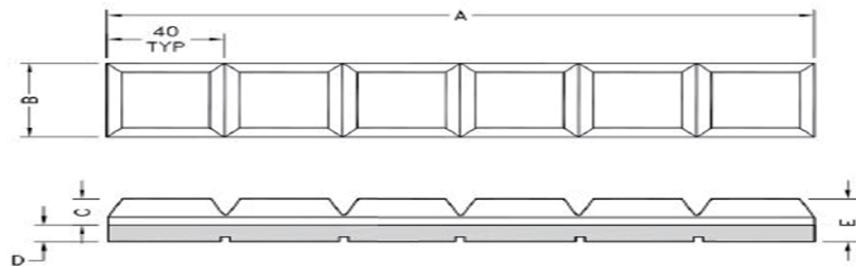

Chocky Bars

Nº TURBO PART Nº	A	C	D	E	WEIGHT kg
CB 25	240	17	8	25	1.1
CB 40	240	17	8	25	1.7
CB 50	240	17	8	25	2.2
CB 65	240	17	8	25	2.8
CB 90	240	17	8	25	4.2
CB 100	240	17	8	25	4.4
CB 130	240	17	8	25	5.6

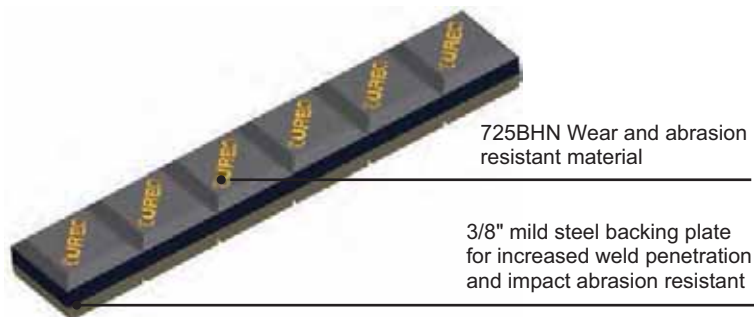

- Turbo chocky bars are made of highly abrasive chrome white iron material that
- The mild steel backing plate is 3/8" thick which provides more weldable surface allowing for tougher impact and gouging abrasion application
- The bars can be shaped to fit convex and concave surfaces

- These products were developed with the customer in mind to combat wear in any application
- The size selection and ease of use allows them to be used in any area that sees excessive wear
- Turbo Chocky bars and buttons are a cost-effective solution to wear areas in all applications
- They perform best in high abrasion to lower impact applications
- Product is easy to install and provides protection to your base structure thus lengthening its life cycle. It has a hardness of 725 BHN

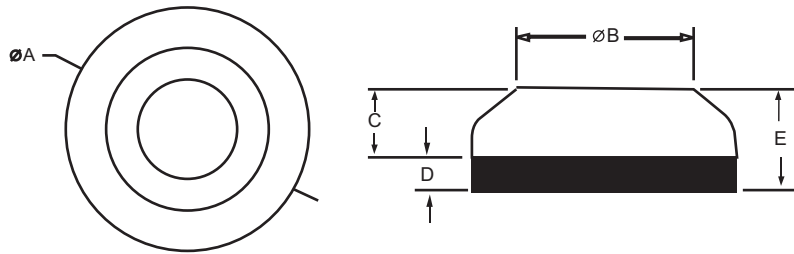

Wear Buttons

Nº TURBO PART Nº	A	C	D	E	kg WEIGHT
WB60	60	120	10	30	0.7
WB75	75	20	10	30	1
WB90	90	20	10	30	1.5
WB115	115	20	12	32	2.5
WB150	150	25	16	41	5.7

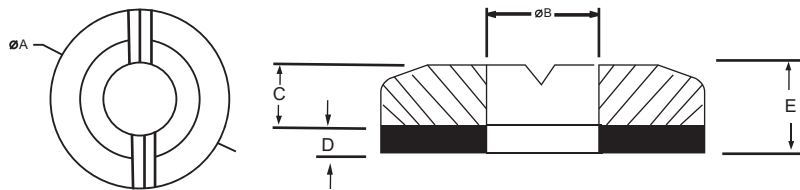

Wear Buttons

Nº TURBO PART Nº	A	C	D	E	kg WEIGHT
DLP1920	75	17	8	25	0.7
DLP1921	100	17	8	25	1
DLP1994	100	24	8	32	1
DLP2196	130	15	8	23	1.3

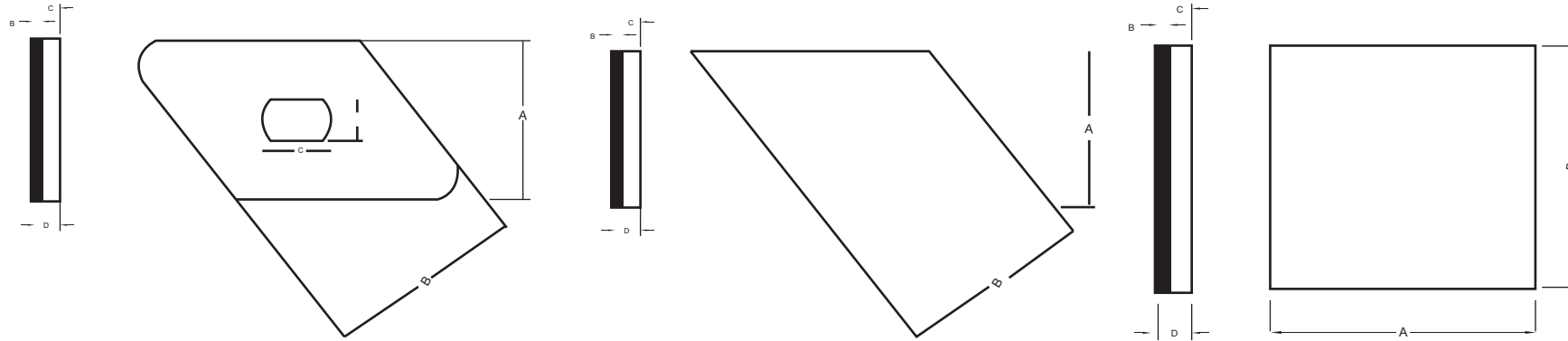

Standard Wear Plates

N° TURBO PART N°	TYPE	A	C	D	E	kg WEIGHT
DLP995	3	150	18	6	24	8.7
DLP1213	3	200	18	10	28	13.3
DLP352	3	203	38	20	58	19
DLP727	3	294	20	8	28	19
DLP1(MOD)	3	300	20	10	30	21.2
DLP2	3	372	20	8	28	30.4
DLP692	3	294	20	8	28	28.8
DLP667	3	445	19	6	25	38.9
DLP1935	1	212.5	17	8	25	10
DLP2002	2	290.5	22	8	30	19.5

Standard Wear Bars

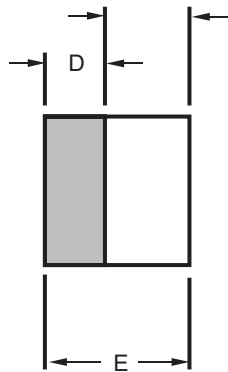

^{Nº} TURBO PART Nº	A	C	D	E	^{kg} WEIGHT
DLP919	1200	15	610	25	1
DLP1191	300	15	10	25	1.5
DLP515	195	20	10	30	1.1
DLP200	102	25	8	33	0.9
DLP295	153	25	8	33	1.51
DLP4	300	25	8	33	3
DLP271	203	12	8	20	1.6
DLP270	254	12	8	20	2
DLP508	190	20	10	30	2.2
DLP2265	115	38	12	50	2.3
DLP337	127	38	10	48	2.4
DLP1101	150	40	10	50	2.9
DLP343	190	40	10	50	3.7
DLP369	210	38	12	50	4.1
DLP125	230	38	12	50	4.5
DLP453	294	40	10	50	5.8
DLP2017	300	40	10	50	5.9
DLP201A	432	38	12	50	8.5
DLP2230	600	38	12	50	11.8
DLP965	250	12	8	20	2.4
DLP184	150	29	10	39	3.4
DLP528	150	40	10	50	4.4
DLP619	150	50	10	60	5.3
DLP451	194	38	12	50	6.1
DLP450	294	38	12	50	9.2
DLP392/20	241	38	20	58	11

Skid Edge

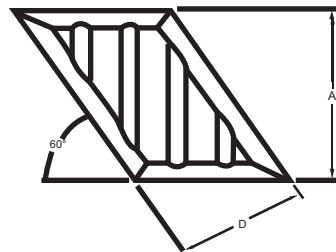
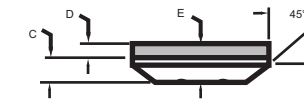
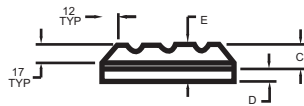
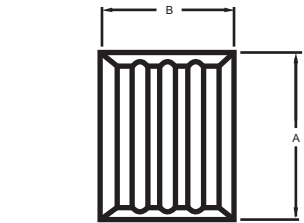

RETANGULAR	TYPE	B	C	D	E	WEIGHT ^{kg}
SB403	1	101	122	112	34	5.1
SB406	1	101	22	12	34	7.3
SB409	1	101	22	12	34	3.7
SB205	1	75	22	12	34	6.1

Herringbone

RETANGULAR	TYPE	B	C	D	E	WEIGHT ^{kg}
SB404L	2	1101	22	112	34	5.9
SB405R	2	101	22	12	34	5.9
SB407L	2	101	22	12	34	8.4
SB408R	2	101	22	12	34	8.4
SB410L	2	101	22	12	34	4.2
SB411R	2	101	22	12	34	4.2

Domed Edge

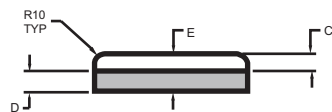
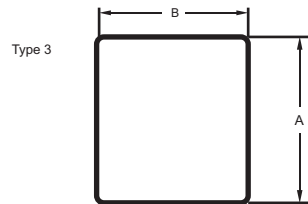

RETANGULAR	TYPE	B	C	D	E	WEIGHT ^{kg}
SB412	3	150	20	25	45	13.1
SB413	3	150	20	25	45	10.5
SB414	3	250	20	25	45	21.9

Knife Edges

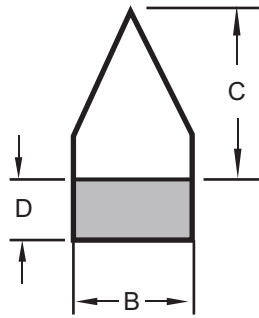

Type 1

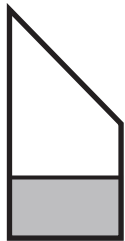

Type 2

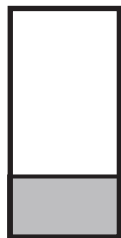

Type 3

ARROWHEAD	TYPE	B	C	D	E	WEIGHT ^{kg}
DLP 1065-16	1	16	238	12	50	0.9
DLP 1065-19	1	19	38	12	50	1.1
DLP 1065-22	1	22	38	12	50	1.3
DLP 1065-25	1	25	38	12	50	1.5
DLP 1265-16	1	16	38	12	50	1.4
DLP 1265-19	1	19	38	12	50	1.6
DLP 1265-22	1	22	38	12	50	1.9
DLP 1265-25	1	25	38	12	50	2.2

HALF ARROWHEAD	TYPE	B	C	D	E	WEIGHT ^{kg}
DLP 1065A-16	2	16	138	12	50	1
DLP 1065A-25	2	25	50	12	62	1.7
DLP 1265A-25	2	25	40	16	56	2.5

BLUNT	TYPE	B	C	D	E	WEIGHT ^{kg}
DLP 1301-19	3	119	38	12	50	1.6
DLP 1301-25	3	25	38	12	50	2.1
DLP 1301-28	3	28	38	12	50	2.3

Grizzly Bars

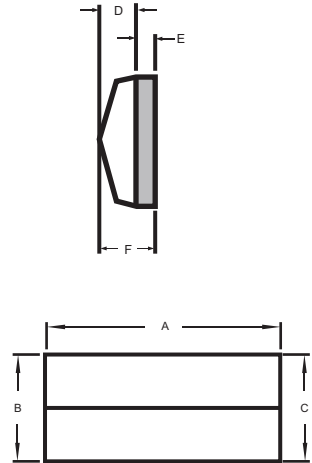

ARROWHEAD	TYPE	B	C	D	E	WEIGHT ^{kg}
DLP 2067	305	137.5	38	12	50	13.6
DLP 2068	305	125	38	12	50	12.5
DLP 2069	305	112.5	38	12	50	11.2
DLP 2070	305	100	38	12	50	10
DLP 2071	305	87.5	38	12	50	8.8
DLP 2072	305	75	38	12	50	7.5
DLP 2073	305	62.5	38	12	50	6.3
DLP 2074	305	50	38	12	50	5.1

Shredder/Grinder Tips

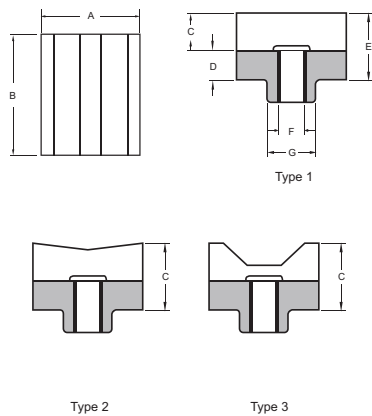

^{NP} TURBO PART N°	TYPE	B	C	D	E	WEIGHT ^{kg}
PLAIN						
DLP 653	1	190	25	20	45	2.9
DLP 920	1	50	25	20	45	1.6
DLP 996	1	50	20	18	38	0.7
DLP 1052	1	80	25	20	45	2.4
DLP 1115	1	100	25	20	45	3.6
DLP 1208	1	64	20	20	40	1.2
DLP 1340	1	56	25	20	45	1.6

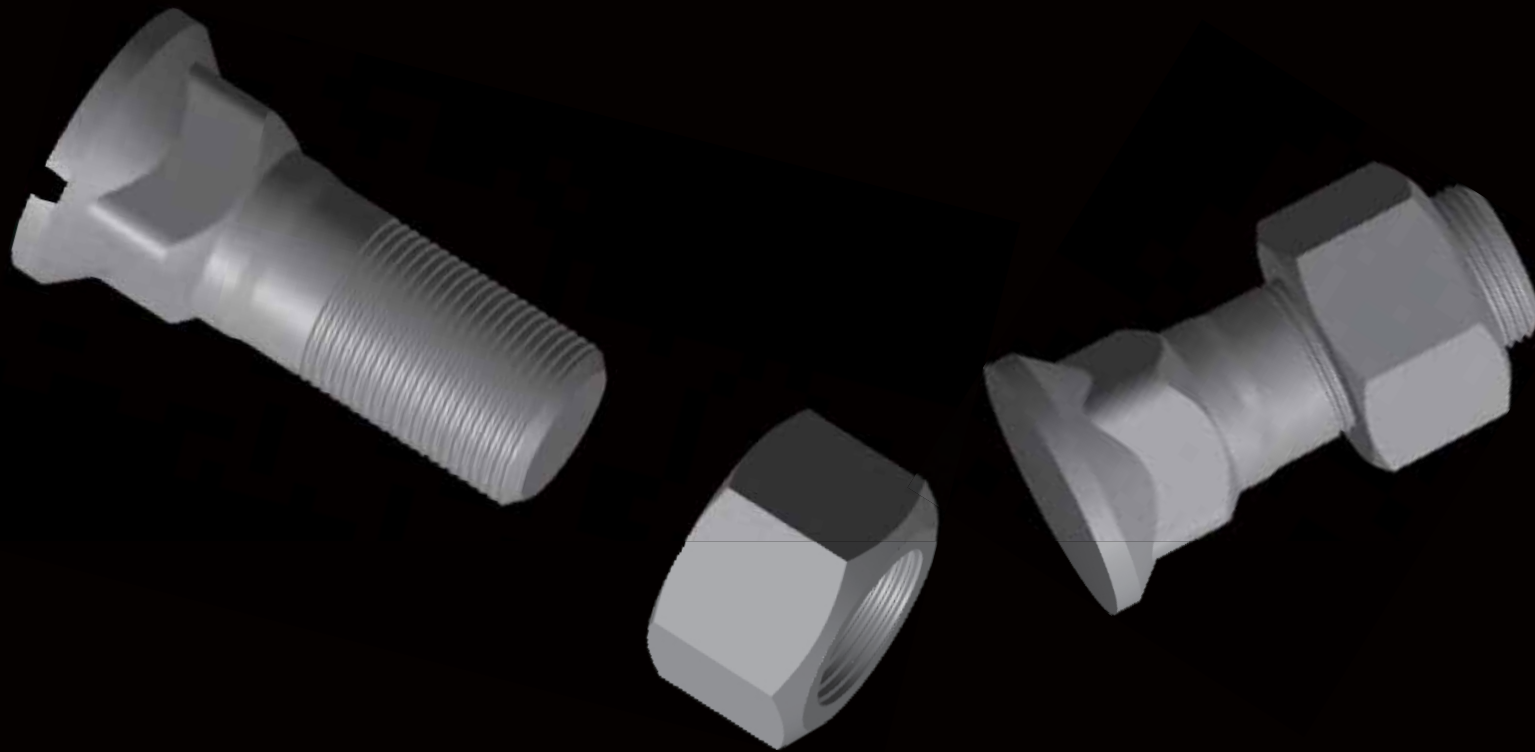



BOLT AND NUT



TURBO MANUFACTURER OF ENGINEERED PRODUCTS · SPARE PARTS · CATALOG 2014

TURBO BUCKET TEETH

Bolt And Nut

 TURBO PART N°	 DESCRIPTION	 WEIGHT
821002	5/8 PLOW BOLT 3/4 HEAD 2 3/4 LENGTH	0.135
178-32-11220	24MM SQUARE TRACK NUT 1.50 PITCH	0.154
195-32-61210	TRACK SHOE BOLT, M30 x 2, L = 96MM	0.850
198-71-21720	1-1/4" UNC-7X5-3/4" PLOW BOLT	1.01
1F7958	NUT HEX GRADE 8 1/2 NC X 7/16	0.018
1J0962	PLOW BOLT 3/4 NC x 4 1/4	0.240
1J3527	1" UNC-8X4-1/2" PLOW BOLT	0.51
1J4948	1" UNC-8X3-3/4" PLOW BOLT	0.43
1J5607	PLOW BOLT 1 NC x 2 3/4	0.320
1J6762	PLOW BOLT 3/4 NC X 3 1/8	0.200
1M1408	5/8" SQUARE TRACK NUT	0.062
1S1859	3/4" X 2 5/32" TRACK BOLT	0.200
1S1860	3/4" SQUARE TRACK NUT	0.090
208-32-11220	22MM SQUARE TRACK NUT 1.50 PITCH	0.120
2A3223	1/2" X 1 7/8" TRACK BOLT	0.070
2J2548	7/8" UNC-9X4-1/4" PLOW BOLT	0.35
2J3505	HEX NUT 7/8 NC	0.008
2J3506	NUT HEX 3/4 NC X 41/64	0.050
2J3507	NUT PLOW 1" UNC	0.125
2J5458	7/8" UNC-9X4-1/4" PLOW BOLT LONG	0.350
2M5656	TRACK NUT 1 X 1	0.160
2P9670	3/4" X 4 3/8" SML BOLT	0.350

Bolt And Nut

 TURBO PART N°	 DESCRIPTION	 WEIGHT
2S2140	nut 7/8-14unf	0.13
3F5108	PLOW BOLT 5/8 NC X 2 1/4	0.110
3K9770		0.25
3S0336	SEGMENT BOLT 3/4 2 3/8	0.210
3S8182	SEGMENT BOLT 5/8 NF X 1 7/8	0.130
4F0138	3/4" UNC-10X3" PLOW BOLT	0.20
4F3654		0.10
4F3656	PLOW BOLT 5/8 NC x 2 1/2	0.125
4F3657	PLOW BOLT 5/8 X 2 3/4 USE 4F3658	0.130
4F3658	PLOW BOLT 5/8 NC X 3	0.140
4F3665	PLOW BOLT 5/8 NC x 3 1/2	0.160
4F3672		0.14
4F7827	PLOW BOLT 3/4 NC X 2 1/4	0.150
4J9058	PLOW BOLT 1 NC X 3 1/4	0.360
4J9208	PLOW BOLT 1 x 3 1/2	0.380
4K0367	NUT-FULL 5/8 UNC"HEX	0.030
4K0684	FLAT WASHERΦ1-1/4"	0.09
4K7038	9/16" X 1 5/8" TRACK BOLT	0.095
5A4104	5/8" X 3 3/8" TRACK BOLT	0.180
5F8933	PLOW BOLT 3/4NC x 3 3/4	0.230
5J2409		0.27
5J4771	PLOW BOLT 3/4NC X 2 3/4	0.180

Bolt And Nut

Nº	DESCRIPTION	WEIGHT
TURBO PART Nº		
5J4772	PLOW BOLT 7/8 NC x 2 1/2	0.230
5J4773	PLOW BOLT 3/4 NC x 2 1/2	0.165
	SEGMENT BOLT 3/4 NF 2 5/8 CHAMFER TYPE	0.240
5P4684	9/16" X 2 7/8" SML BOLT	0.130
	BOLT SPROCKET SEGMENT	0.550
5P8136	PLOW BOLT 1 NC X 4	0.430
	1 1/8" SQUARE TRACK NUT	0.320
5P8248	WASHER	0.035
	WASHER	0.055
5P8250	WASHER	0.083
	PLOW BOLT 1 1/4 x 4 15/16	0.890
5P8362		0.25
	PLOW BOLT 1 1/4 NC x 4 1/8	0.750
6F0196		0.25
	ROLLER BOLT	0.390
6T8853	BOLT-TRACK (1-3/8) D11N/R	1.300
	SEGMENT BOLT 5/8 NF X 2 7/64	0.130
6V1724	7/8" X 3 25/32" SML BOLT	0.420
	7/8" X 5 5/64" SML BOLT	0.530
6V1726	1" X 3 13/16" TRACK BOLT	0.590
6V1728	1" X 5 21/64" SML BOLT	0.820
6V1792	3/4" X 2 13/32" TRACK BOLT	0.230
9W9058	7/8" X 4 1/2" MASTER PAD BOLT	0.490
8U2703	5/8" 18UNF x 51 12.9	0.129
1M1408/5W98285/8 "		0.062
205-32-51120	M16X1,5X46	0.130
CR6388	M16X1,5X16	0.062
HT530	M22x1,5x24	0.130

Bolt And Nut

Nº	DESCRIPTION	WEIGHT
TURBO PART Nº		
6V1793	3/4" X 3 9/64" SML BOLT D6H	0.260
6V8360	PLOW BOLT 1 1/4 NC x 4 1/2	0.820
6Y0846	20MM X 64.5MM TRACK BOLT 1.50 PITCH	0.250
6Y9024	TRACK BOLT 22.5MM GRIP O.D.M22MMX1.50X66MM	0.320
7H3597	5/8" X 2 3/32" TRACK BOLT	0.140
7H3598	bolt3/4x-16unfx61	0.24
7H3599	bolt 7/8-14unfx67	0.363
7H3607	TRACK NUT HEX 5/8 NF	0.044
7H3608	TRACK NUT HEX 3/4 UNF	0.070
7T0998	1 1/8" X 6 15/32" SML BOLT	1.160
7T0999	1 1/8" X 5 1/4" SML BOLT	0.95
7X2565	BOLT M20 X 100MM	0.300
7X2575	BOLT M24 X 60MM	0.330
8H7504	TRACK BOLT 1/2" x 1 1/2"	0.070
8J2928	PLOW BOLT 1 NC X 3 3/4	0.430
8J2933	NUT 1" NC	0.125
9G3110	5/8" X 2 3/32" TRACK BOLT	0.140
9S1838	3/4" X 4 1/8" SML BOLT	0.320
9S8752	NUT HEX 3/8 NC X 21/64- FULL	0.070
9W3361	NUT TRACK M20 X 1.50" PITCH	0.100
9W3619	20MM X 55MM TRACK BOLT 1.50 PITCH	0.240
9W4381	TRACK NUT SQ M22 x 1.50 x 22MM	0.120
79039443	M18X1,5X55	0.170
79039445	M18X1,5X19	0.072
4F4042	1" UNC-8X3" 刀角螺栓	0.35
1D4637	1"UNC-8X3-1/4" 六角螺栓	0.46
8T9079	1-1/4" UNC-7X3-3/8" PLOW BOLT	
4F0391		0.16



PIN AND LOCKS

TURBO MANUFACTURER OF ENGINEERED PRODUCTS · SPARE PARTS · CATALOG 2014

Pin&Lock&Retianer CAT

Nº TURBO PART N°	DESCRIPTION	WEIGHT kg
8E6208	CAT-J200 Lock 1U4208/9W7112	0.045
8E6209	CAT-J200 Retainer 4T0001	0.015
132-4762	CAT-J225 Lock 6Y3228 (Heavy Duty Style)	0.1
149-5733	CAT-J225 Retainer (Heavy Duty Style)	0.03
8E6258	CAT-J250 Lock 9J2258	0.12
8E6259	CAT-J225/250/300 Retainer 3G9609	0.03
132-4763	CAT-J250 Lock (Heavy Duty Style)	0.03
133-0699	CAT-J250 Retainer (Heavy Duty Style)	0.02
9J2308	CAT-J300 Lock 107-3308/132-4766	0.12
132-4763	CAT-J300 Lock (Heavy Duty Style)	0.03
149-5733	CAT-J300 Retainer (Heavy Duty Style)	0.03
8E6358	CAT-J350 Lock 9J2358	0.23
8E6359	CAT-J350 Retainer 3G9549	0.05
114-0358	CAT-J350 Lock (Heavy Duty Style)	0.23
114-0359	CAT-J350 Retainer (Heavy Duty Style)	0.05
7T3408	CAT-J400 Lock	0.37
8E8409	CAT-J400 Retainer 7T3409	0.03
116-7408	CAT-J400 Lock (Heavy Duty Style)	0.32
116-7409	CAT-J400 Retainer (Heavy Duty Style)	0.05
9W8296	CAT-J450 Lock 4T1458/6Y2527/1U1458	0.5
8E0468	CAT-J460 Lock	0.48
8E8469	CAT-J460 Retainer 8E0469	0.05

Pin&Lock&Retianer CAT

Nº TURBO PART N°	DESCRIPTION	WEIGHT kg
114-0468	CAT-J460 Lock (Heavy Duty Style)	0.46
107-3469	CAT-J460 Retainer (Heavy Duty Style)	0.03
6Y8558	CAT-J550 Lock 1U1558/9W9026	0.64
8E5559	CAT-J550 Retainer 3G9559	0.23
107-3378	CAT-J550 Lock (Heavy Duty Style)	0.64
107-8559	CAT-J550 Retainer (Heavy Duty Style)	0.05
6I6608	CAT-J600 Lock	1.1
6I6609	CAT-J600 Retainer	0.08
6I6608(42CrMo)	CAT-J600 Lock- High strength	1.1
6I6609(60Si2Mn)	CAT-J600 Retainer- High strength	0.08
113-9608	CAT-J600 Lock (Heavy Duty Style)	1.1
113-9609	CAT-J600 Retainer (Heavy Duty Style)	0.05
4T4708	CAT-J700 Lock 9U9616	1.25
4T4707	CAT-J700 Retainer	0.3
113-4708	CAT-J700 Lock (Heavy Duty Style)	1.25
113-4709	CAT-J700 Retainer (Heavy Duty Style)	0.1
113-4708(42CrMo)	CAT-J700 Lock (Heavy Duty Style)- High strength	1.25
113-4709(60Si2Mn)	CAT-J700 Retainer (Heavy Duty Style)- High strength	0.26
134-1808	CAT-J800 Lock 102-0101 (Heavy Duty Style)	1.25
134-1809	CAT-J800 Retainer 101-2874 (Heavy Duty Style)	0.1
8J1433	CAT-R300 Ripper Teeth Pin P295/6Y0309中卡	0.25
9W2668	CAT-R300 Ripper Teeth lock 1368308/9J6583	0.23



Pin&Lock&Retianer CAT

Nº	DESCRIPTION	WEIGHT
TURBO PART N°		
1U2405	CAT-R300 Ripper Teeth Retainer 3G9459	0.05
4K0043	CAT-R300 Ripper tooth Vertical Pin 4K6936	0.1
4K0041	CAT-R300 Loader tooth Rubber 4K6936/40034	0.05
5K1426	CAT-R300 Ripper tooth Rubber	0.2
7J9600	CAT-R350/400/450 Ripper Teeth Pin P385 D85 中卡	0.45
9W2678	CAT-R350 Ripper Teeth lock	0.24
1U2405	CAT-R350 Ripper Teeth Retainer 3G9459	0.05
8E6358	CAT-R350/400 Ripper Teeth Lock	0.23
1U2405	CAT-R350/400 Ripper Teeth Retainer 3G9459	0.05
4K0032	CAT-R350 Ripper tooth Vertical Pin	0.12
4K0008	CAT-R350 Loader tooth Rubber	0.07
5K1425	CAT-R350 Ripper tooth Rubber	0.08
4K0033	CAT-966 Loader tooth Vertical Pin	0.15
4K0006	CAT-966 Loader tooth Rubber	0.08
8E4708H	CAT-994 Loader Sidebar Protector 125-0800/8E3814 Lock	0.8
4T4707	CAT-994 Loader Sidebar Protector 125-0800/8E3814 Retainer	0.3
6J8811	CAT-R350/400/450 Ripper Teeth Pin Assembly(Lower Protector)	0.73
4T2479	CAT-R450 Ripper Teeth Pin Assembly(Tip & Upper Protector) P385 D85 中卡	0.54
6Y3394	CAT-R450 Ripper Teeth&Protector Lock (Bucket Style) D85 边卡	0.52
8E4743	CAT-R450 Ripper Teeth&Protector Retainer (Bucket Style)	0.3
3G0500	CAT-R500 Ripper Teeth Pin Assembly (102-9062 Pin Assembly) D9 中卡	1.1
6Y3909	CAT-R500 Ripper Teeth Lock (Bucket Style) D9边卡	1.2
7K9535	CAT Tamping Feet 7K-2939 Fastener Pin	0.23
112195	Pin	0.09
112196	Retainer	0.025

Pin&Lock&Retianer CAT

Nº	DESCRIPTION	WEIGHT
TURBO PART N°		
4T4707	CAT-R500 Ripper Teeth Retainer (Bucket Style)	0.3
6Y1204	CAT-R500 Ripper Teeth&Protector Lock (Impact Ripper Style)	1.1
6Y1202	CAT-R500 Ripper Teeth&Protector Retainer Assembly (Impact Ripper Style)	0.2
138-6508	CAT-R500 Ripper Teeth Lock (Heavy Duty Style)=Can use 6Y3909 Lock	0.3
113-4709	CAT-R500 Ripper Teeth Retainer Assembly(Heavy Duty Style)	0.1
9W1821	CAT-R550 Ripper Teeth Pin Assembly	1.66
6Y2443	CAT-R550 Ripper Teeth Pin Assembly	
8E2229	CAT-R550 Ripper Teeth Lock (Bucket Style)	1.3
8E2230	CAT-R550 Ripper Teeth Retainer (Bucket Style)	0.36
9N4245	CAT-R550 Ripper Teeth&Protector Lock (Impact Ripper Style)	1.5
6Y1205	CAT-R550 Ripper Teeth&Protector RetainerAssembly (Impact Ripper Style)	0.4
159-0558	CAT-R550 Ripper Teeth Lock(Heavy Duty Style)	
134-1809	CAT-R550 Ripper Teeth Retainer Assembly(Heavy Duty Style)	0.1
133-0738	Sidebar Protector 1U0740/112-8996 Pin	0.67
107-8559	Sidebar Protector 1U0740/112-8996 Retainer Assembly	0.05
9J8442	Sidebar Protector 8J6399 lock	0.21
8E6359	Sidebar Protector 8J6399 Retainer Assembly	0.05
135-9350	Sidebar Protector 9J9600 Lock	0.23
114-0359	Sidebar Protector 9J9600 Retainer Assembly	0.05
2011238	CAT DRS 230 Pin	0.05
2011239	CAT DRS 230 Retainer	0.02
2K6413	CAT Ripper Shank 9J6586 Pin	2.2
EM1003	Pin	0.19
EM1004	Retainer	0.08



Cat Motor Grader Components

 TURBO PART N°	 DESCRIPTION	 WEIGHT
5K1458	Cat Motor Grader 6Y5230/2D5572 Rubber	0.01
5K1459	Cat Motor Grader 6Y5230/2D5572 Pin	0.31

Komatsu Pin

 TURBO PART N°	 DESCRIPTION	 WEIGHT
201-70-00150	Komatsu-PC60 Pin 201-70-24150	0.15
20X-70-00100	Komatsu-PC100/20X-70-14160 Pin 20X-70-14170	0.2
09244-02489	Komatsu-PC120 Pin	0.35
09244-02496	Komatsu-PC200 Pin 205-70-19610/205-70-69130	0.38
09244-02508	Komatsu-PC220 Pin 175-78-21740	0.43
09244-02516	Komatsu-PC300 Pin 175-78-21810	0.48
09244-03036	Komatsu-PC400 Pin 198-79-11320/A03-78-11730/426-847-1130	0.8
209-70-54240	Komatsu-PC650 Pin	1.35
21N-72-14330	Komatsu-PC1200 Pin 21N-70-00060	1.7
21T-72-74320	Komatsu-PC1600 Pin	3
427-70-13770	Komatsu-WA700 Pin	1.8
427-70-13790	Komatsu-WA800 Pin	2.5
195-78-71360	Komatsu-D375 Pin	0.95
198-78-21410	Komatsu-D475 Pin 198-78-21340	0.9
19N-78-11371	Komatsu-D575 Pin 19M-78-11370 D11中卡	1.4

Hensley

 TURBO PART N°	 DESCRIPTION	 WEIGHT
K290S	Hensley-290 size Steel Keeper Standard Pin	0.14
K330S	Hensley-330 size Steel Keeper Standard Pin	0.19
K370S	Hensley-370 size Steel Keeper Standard Pin	0.48
K400S	Hensley-400 size Steel Keeper Standard Pin	0.52
K410K	Hensley-410 size Steel Keeper Standard Pin	0.59
K450S	Hensley-450 size Steel Keeper Standard Pin	0.65
K500S	Hensley-500 size Steel Keeper Standard Pin	0.88
K550S	Hensley-550 size Steel Keeper Standard Pin	1.4
P156	Hensley 156 Roll Pin \varnothing 10*51	0.01
P160	Hensley 160 Roll Pin \varnothing 13*76	0.02
X220	Hensley 220 Roll Pin \varnothing 13*76	0.05
P290	Hensley 290 Flex Pin(Optional)	0.2
P330	Hensley 330 Flex Pin(Optional)	0.38
P370	Hensley 370 Flex Pin(Optional)	0.42
P400HD	Hensley 400 Flex Pin(Optional)	0.22
P410	Hensley 410 Flex Pin(Optional)	0.36
P450	Hensley 450 Flex Pin(Optional)	0.52
P475P	Hensley 475 Flex Pin(Optional)	0.56
P500	Hensley 500 Flex Pin(Optional)	0.77
P290STP	Hensley 290 Solid Rubber Pin	0.2
P330STP	Hensley 330 Solid Rubber Pin	0.35
P370STP	Hensley 370 Solid Rubber Pin	0.18
P400STP	Hensley 400 Solid Rubber Pin	0.21
P410STP	Hensley 410 Solid Rubber Pin	0.24
P450STP	Hensley 450 Solid Rubber Pin	0.39

DOSSAN-DH

Nº	DESCRIPTION	WEIGHT
TURBO PART Nº		
2705-1022	DH130/DX140 Pin 2705-9014, 2713-1221	0.2
2114-1859	DH130/DX140 Retainer 2709-9015, 2713-1221	0.08
2705-1020	DH220/DX225/S180 Pin 2713-1217/2713-9041	0.23
2114-1848A	DH220/DX225/S180 Retainer 2705-9008, 2713-1217/2713-9041	0.03
2705-9010	DH280 Pin 2713-9044	0.28
2705-9008	DH280 Retainer 2713-9044	0.04
2705-1021	DH300/DX300 Pin 2705-9012, 2713-1219	0.28
2114-1849	DH300/DX300 Retainer 2713-1219	0.05
2705-1022(DH360)		0.51
2114-1859(DH360)		0.12
705-00006	DH360/DX340 Pin 713-00032	0.51
114-00246	DH360/DX340 Retainer 713-00032	0.12
2705-1034	DH420/S500 Pin 2713-1236	0.69
2114-1931	DH420/S500 Retainer 2713-1236	0.14

HYUNDAI

Nº	DESCRIPTION	WEIGHT
TURBO PART Nº		
66N4-30350	HYUNDAI140LC-7(61N4-31310)	0.24
66N4-11150	HYUNDAI140LC-7(61N4-31310)	0.04
E161-3035	HYUNDAI210-(E161-3027)61N6-31310	0.24
61E5-11150	HYUNDAI210-(E161-3027)S411-180002	0.04
E161-3035	HYUNDAI225-9(E161-3027)67N6-31310/61Q6-31310	0.32
61E5-11150	HYUNDAI225-9(E161-3027)67N6-31310/61Q6-31310	0.08
E262-5004	HYUNDAI290-(E262-3046) HYUNDAI-290-7(61N8-31310)	0.28
61E5-11150	HYUNDAI290-(E262-3046) HYUNDAI-290-7(61N8-31310)	0.08
61EH-70105	HYUNDAI360-7(61NA-31310)	0.5
61EH-11150	HYUNDAI360-7(61NA-31310)	0.08
61E7-0105	HYUNDAI450(61E7-0101)	0.5
61EH-11150	HYUNDAI450(61E7-0101)	0.08
61E7-04620	HYUNDAI450-7/500(61NB-31310)	0.5
61E7-04630	HYUNDAI450-7/500(61NB-31310)	0.08
66NB-31340 R500	HYUNDAI500(66NB-31310)	0.72
66NB-31350 R500	HYUNDAI500(66NB-31310)	0.12

Esco Conical Teeth Pin

Nº TURBO PART Nº	DESCRIPTION	kg WEIGHT
18PN	Esco 18S/TL/MIP/WTL Standard Lock	0.03
18LK	Esco 18S/TL/MIP/WTL Standard Rubber	0.03
22PN	Esco 22S Standard Lock	0.035
22LK	Esco 22S Standard Rubber	0.05
25-30PN	Esco 25-30S/STD/MIP/R/RDX/T Standard Lock	0.1
25-30LK	Esco 25-30S/STD/MIP/R/RDX/T Standard Rubber	0.03
35PN	Esco 35S/P/AP/MIP/R/TVIP/T Standard Rubber	0.13
40PN	Esco 40S/STD/MIP/R/RDX/T Standard Lock	0.22
35-40LK	Esco 40S/STD/MIP/R/RDX/T Standard Rubber	0.03
45PN	Esco 45S/MIP/R/RDX Standard Lock	0.38
45LK	Esco 45S/MIP/R/RDX Standard Rubber	0.22
50PN	Esco 50S/MIP/R/RDX Standard Lock	0.5
50LK	Esco 50S/VIPL/R/RDX Standard Rubber	0.22
55PN	Esco 55VIPL/R/RDX Standard Lock	0.65
55LK	Esco 55VIPL/R/RDX Standard Rubber	0.26
77PN	Esco 77-HBP Standard Lock	0.8
77LK	Esco 77-HBP Standard Rubber	0.55
18PNR	Esco 18S/TL/MIP/WTL Reinforced Lock	0.042
18LKR	Esco 18S/TL/MIP/WTL Reinforced Rubber	0.03
25-30PNR	Esco 25-30S/STD/MIP/R/RDX/T Reinforced Lock	0.13
25-30LKR	Esco 25-30S/STD/MIP/R/RDX/T Reinforced Rubber	0.03
35PNR	Esco 35S/STD/MIP/R/T Reinforced Lock	0.2
35-40LKR	Esco 35S/STD/MIP/R/T Reinforced Rubber	0.05
40PNR	Esco 40S/STD/MIP/R/RDX/T Reinforced Lock	0.22
35-40LKR	Esco 40S/STD/MIP/R/RDX/T Reinforced Rubber	0.05
45PNR	Esco 45S/MIP/R/RDX Reinforced Lock	0.38
45LKR	Esco 45S/MIP/R/RDX Reinforced Rubber	0.03
50PNR	Esco 50S/MIP/R/RDX Reinforced Lock	0.45
50LKR	Esco 50S/VIPL/R/RDX Reinforced Rubber	0.33
55PNR	Esco 55VIPL/R/RDX Reinforced Lock	0.48
55LKR	Esco 55VIPL/R/RDX Reinforced Rubber	0.33
77PNR	Esco 77-HBP/CLP/CRMHL/CRXX Reinforced Lock	0.62
77LKR	Esco 77-HBP/CLP/CRMHL/CRXX Reinforced Rubber	0.46



Esco Superconical Teeth Pin

Nº TURBO PART Nº	DESCRIPTION	kg WEIGHT
36PN	Esco Superconical Teeth 36-FP/MIP Lock R2PN	0.42
36LK	Esco Superconical Teeth 36-FP/MIP Rubber R2LK	0.12
46PN	Esco Superconical Teeth 46-FP/MIP Lock	0.5
46LK	Esco Superconical Teeth 46-FP/MIP Rubber	0.14
56PN	Esco Superconical Teeth 56-FP/RDX/MIP Lock	0.55
56LK	Esco Superconical Teeth 56-FP/RDX/MIP Rubber	0.2
66PN	Esco Superconical Teeth 66-FP/LP/R/RDX/MIP Lock	0.6
66LK	Esco Superconical Teeth 66-FP/LP/R/RDX/MIP Rubber	0.23
76PN	Esco Superconical Teeth 76-FP/LP/R/RDX/MIP Lock	0.7
76LK	Esco Superconical Teeth 76-FP/LP/R/RDX/MIP Rubber	0.28
86PN	Esco Superconical Teeth 86-FP/LP/RDX/MIP/SD Lock	0.92
86LK	Esco Superconical Teeth 86-FP/LP/RDX/MIP/SD Rubber	0.4



Esco Dragline Pick Teeth

Nº TURBO PART Nº	DESCRIPTION	kg WEIGHT
44DPN	Esco Dragline Pick Teeth 44-D14 Lock	0.7
44DLK	Esco Dragline Pick Teeth 44-D14 Rubber	0.26
54DPN	Esco Dragline Pick Teeth 54-D16 Lock	0.89
54DLK	Esco Dragline Pick Teeth 54-D16 Rubber	0.48

Esco Ripper Pin

 TURBO PART N°	 DESCRIPTION	 WEIGHT
22RPG	22R Pin	0.12
22RBG	22R Bushing/Rubber	0.05
25RPG	25R Pin	0.13
25RBG	25R Bushing/Rubber	0.02
25RC-PN	25RC Pin	0.23
25RC-LKSR	25RC Bushing/Rubber	0.05
35RPG	35R Pin	0.2
35RBG	35R Bushing/Rubber	0.025
35RPH	35R Pin	0.22
49SR	35R Washer	0.02
35RSP	35R Uni-Lock Pin	0.62
39RPG	39R Pin	0.4
39RBG	39R Bushing/Rubber	0.03
39-49RPH	39R Pin 49RP	0.4
49SR	39R Washer	0.02
39SPH	39R Pin	0.46
39SRH	39R Washer	0.08
39RSP	39R Uni-Lock Pin	0.12
49RSP	49R Uni-Lock Pin	0.95

Bofor

 TURBO PART N°	 DESCRIPTION	 WEIGHT
6254673/30201	Bofor 4047166/31006 Fastener Pin	0.12
6257675/31201	Bofor 4047167/4047168-31102/31106 Fastener Pin	0.2
6254677/32201	Bofor 3031537/3031538-32101/32104 Fastener Pin	0.25
6254682/33201	Bofor 3031539/3031542-33102/34102 Fastener Pin	0.3
6254679/35201	Bofor 3031386/35102 Fastener Pin	0.38
6220086/36203	Bofor 2019245/36101 Fastener Pin	0.45
6737326	Bobcat Pin =FLEX-PIN 23FP	0.05
5-ST	Bofor 3000FN/BT Fastener Pin	0.18
10-ST	Bofor 4000FN/BT-5000FN Fastener Pin	0.22
15-ST	Bofor 7500FN/BT-8000FN Fastener Pin	0.24
20-ST	Bofor 10000FN Fastener Pin	0.33
BF-2073	Bofor 4044336/4044428-31101/32102 O&K Vertical Pin	0.2
BF-2886	Bofor 3031334/3031335-33101/34101 O&K Vertical Pin	0.42
BF-3097	Bofor 3031336/35101 O&K Vertical Pin	0.53

FIAT

TURBO PART N°	DESCRIPTION	WEIGHT
2MF-22P	Fiat-Hitachi Old System Teeth 71407828 Pin	0.1
2MF-21/22R	Fiat-Hitachi Old System Teeth 71407828 Washer	0.04
2MF24P	Fiat-Hitachi Old System Teeth 71417992 Pin	0.18
2MF24R	Fiat-Hitachi Old System Teeth 71417992 Washer	0.05
2MF26P	Fiat-Hitachi Old System Teeth 71421565 Pin	0.23
2MF28P	Fiat-Hitachi Old System Teeth 71432195 Pin	0.3
2MF26/28R	Fiat-Hitachi Old System Teeth 71421565/71432195 Washer	0.06
76028389	FIAT Teeth 240S/76026615 Pin	0.1
79073185	FIAT Teeth 252S/76026619 Pin	0.04
76028388	FIAT Teeth 272S/76026621 Pin	0.24

Esco Vertalok Pins and Plugs

TURBO PART N°	DESCRIPTION	WEIGHT
27VPN&27VPL	Esco 27 Series Vertalok	0.12
37VPN&27VPL	Esco 37 Series Vertalok	0.16
47VPN&27VPL	Esco 47 Series Vertalok	0.23
57VPN&27VPL	Esco 57 Series Vertalok	0.3

Lehnoff Pin

TURBO PART N°	DESCRIPTION	WEIGHT
11S	Lehnoff Teeth 411 F Pin	0.08

ESCO-Super V

TURBO PART N°	DESCRIPTION	WEIGHT
V13-V17PN	Super V13-17 Pin	0.04
V18-V23PN	Super V18-23 Pin	0.05
V29PN	Super V29 Pin	0.13
V33PN	Super V33 Pin	0.16
V39PN	Super V39 Pin	0.24
V43PN	Super V43 Pin	0.32
V51PN	Super V51 Pin	0.36
V59PN	Super V59 Pin	0.43
V61PN	Super V61 Pin	0.46
V69PN	Super V69 Pin	0.73
V71PN	Super V71 Pin	0.8
V81PN	Super V81 Pin	1.4

Esco Helilok Teeth Pin

TURBO PART N°	DESCRIPTION	WEIGHT
21LK	21 Series Lock	0.37
27LK	27 Series Lock	0.11
37LK	37 Series Lock	0.14
47LK	47 Series Lock	0.22
57LK	57 Series Lock	0.29

VOLVO

Nº	DESCRIPTION	WEIGHT
TURBO PART Nº		
V210(1070-13030/40)	VOL 210	0.28
V290(1171-01920/30)	VOL 290 1070-61320/9213-18000 绿色编号不确认	0.48
V360(14550967/68)	VOL 360	0.9
V460	VOL 460	1.35

LIEBHRE Pin

Nº	DESCRIPTION	WEIGHT
TURBO PART Nº		
3001288	Liebhre 914 Pin	0.14
3001319	Liebhre 944 Pin	0.29
3001359	Liebhre 954 Pin	0.65

Kobleco Pin

Nº	DESCRIPTION	WEIGHT
TURBO PART Nº		
SK200	SK200 Pin	0.36
SK230	SK230 Pin	0.43

Case Poclain Teeth Pin

Nº	DESCRIPTION	WEIGHT
TURBO PART Nº		
P01206-01N	Case Poclain Teeth 7042 Pin	0.16
P01206-02N	Case Poclain Teeth 7042 Pin	0.31
T1236129/30	Case Poclain Teeth 16040 Pin	0.43
P1236125	Case Poclain Teeth 15040 Pin	0.62

H&L

Nº	DESCRIPTION	WEIGHT
TURBO PART Nº		
23PN	H&L 230S/ST/HXL/TL/WTL Teeth Pin 23FP	0.05
TF23(F/P)	TATA HITACHI Pin TF23/U43792	0.07
24PN	H&L 240S Teeth Pin 24FP/FLEX-PIN 24	0.06
25PN	H&L 252S Teeth Pin	0.19
27PN	H&L 272S Teeth Pin 27FP/FLEX-PIN 27	0.24
4EP	Pin	0.25
5EB	Pin	0.36
C3/13306	Combi Part Fastener Pin	0.14
C4/14306	Combi Part Fastener Pin	0.25

UNI-Z Pin

Nº	DESCRIPTION	WEIGHT
TURBO PART Nº		
UNI-Z	UNI-Z /4317-1460 Pin-Type1(c 15*53)	
UNI-Z	UNI-Z Pin-Type2(c 15*65)	
UNI-Z		
UNI-Z		

Tata Hitachi

Nº	DESCRIPTION	WEIGHT
TURBO PART Nº		
EX200	Hitachi-200 Pin TB00705 c 19*118, c 32*8	0.3
EX200	China Hitachi-200 新款 Pin EX200RC c 20*118, c 32*8 DH280 老款一样	0.3
EX300	Hitachi-300 Pin TB00822 c 20*148	0.5
EX300	China Hitachi-300新款 Pin EX300RC c 23*132 与DH360一样	0.5
EX460	Hitachi-460 Pin	0.7

TEL:0086-574-88540655 FAX:0086-574-88535198

www.buchetteeth.net
info@bucketteeth.net