

PAB SERIES

3 thru 6-1/3 Ton

Belt Drive



10 SEER

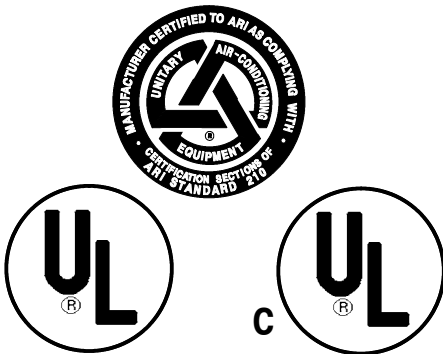

CONVERTIBLE SINGLE PACKAGE AIR CONDITIONING UNIT

SINGLE PACKAGE

- Electric cooling, self contained for year-round comfort. Systems can be installed on roof top or ground level with the new convertible design. 6-¹/₃ Ton unit has two-stage cooling.

CABINET

- Triple-coated steel, consisting of a Polyester top coat, a urethane primer coat preceded by an oxide pretreatment. Access panels for easy service. Side by side supply and return. Heavy gauge base with rails.

INTEGRAL BASE RAILS

- Fork-lift access on three sides. Holes provided for lifting lugs makes rooftop installation easier.

IMPROVED INSULATION

- Dual density insulation improves temperature separation.

INDOOR BLOWER

- Belt drive blower to meet a wide range of applications.
- "No Difference" Design - Unit will operate at the same rated External Static Pressure in the down shot or horizontal duct position.

INTERNAL AIR FILTERS

- Easy access air filters to maintain a clean evaporator coil.

COPPER TUBE/ALUMINUM FIN COILS

- Enhanced aluminum fins mechanically bonded to 3/8" copper tubes for improved heat transfer.

FILTER DRIERS

- To insure refrigerant cleanliness.

COMPRESSORS

- Scroll compressors on 4 and 5 ton models, Recip compressor on 3 and 6-1/3 ton models.

HIGH & LOW PRESSURE SWITCHES

- To provide excellent compressor protection.

FREEZE THERMOSTAT

- Mounted to evaporator, prevents coil freeze up.

EXTERNALLY-MOUNTED GAUGE PORTS

- Allows for more accurate reading of operating conditions while servicing.

PRE-WIRED FOR ECONOMIZER

- Designed for slide in, plug in economizer installation.

ELECTRIC HEAT ACCESSORY

- 5 thru 30KW

65VA TRANSFORMER

- Standard 65 VA transformer has built-in secondary circuit breaker standard on all models.

RESIDENTIAL AND COMMERCIAL SYSTEMS • SPLIT SYSTEMS • PACKAGED AIR CONDITIONERS
• COMBINATION GAS / ELECTRIC UNITS • HEAT PUMPS • AIR HANDLERS • MANUFACTURED
HOME AIR CONDITIONERS • GAS, OIL AND ELECTRIC FURNACES

International Comfort Products
650 Heil-Quaker Avenue, Lewisburg, TN 37091

513 11 1601 01
06/01

UNIT SPECIFICATIONS

MODEL NUMBER	Electrical Data			Condenser Data								
	Voltage Phase - Hz	HACR Max. Fuse	Ampacity	Coil			Fan Motor			Fan		
				Total Face Area Sq. Feet (Sq. Meters)	Fins Per In. / Rows	Tube Diameter In.(mm.)	Horsepower / Amps	Full Load Amps	RPM (Max.)	Size Diameter In.(mm)	Degree Pitch	CFM (Max.)
PAB036N2H	208/230-3-60	25	17.6	12.5 (1.16)	20 / 1	3/8 (9.52)	.75 / 2.6	2.6	1120	22(558.8)	28	3500
PAB036N2L	460-3-60	15	8.5				.75 / 1.4	1.4	1120			
PAB036N2S	575-3-60	15	7.8				.75 / 1.2	1.2	1120			
PAB048N2H	208/230-3-60	35	24.0	17.2 (1.6)	20 / 1	3/8 (9.52)	.75 / 2.6	2.6	1140	22(558.8)	28	4500
PAB048N2L	460-3-60	20	12.9				.75 / 1.4	1.4	1140			
PAB048N2S	575-3-60	15	10.3				.75 / 1.2	1.2	1140			
PAB060N2H	208/230-3-60	45	30.2	17.2 (1.6)	20 / 1	3/8 (9.52)	.75 / 2.6	2.6	1140	22(558.8)	28	4500
PAB060N2L	460-3-60	20	15.6				.75 / 1.4	1.4	1140			
PAB060N2S	575-3-60	15	12.4				.75 / 1.2	1.2	1140			
PAB075N2H	208/230-3-60	40	33.7	17.2 (1.6)	20 / 2	3/8 (9.52)	.75 / 2.6	2.6	1140	22(558.8)	28	4000
PAB075N2L	460-3-60	20	14.7				.75 / 1.4	1.4	1140			
PAB075N2S	575-3-60	15	12.4				.75 / 1.2	1.2	1140			

NOTES: PAB075 models have two compressors with 2 individual circuits. (Two-Stage Cooling).

MODEL NUMBER	Evaporator Coil									Compressor		Factory Refrigerant Charge R-22 Oz.(Ltr)	Sound Rating (Bels)	Ship. Weight Lbs.(Kg)
	Coil			Motor		Blower			Rated Load Amps	Locked Rotor Amps				
	Total Face Area Sq. Feet (Sq. Meters)	Fins Per In. / Rows	Tube Diameter In.(mm)	Blower H.P. - Speeds	Full Load Amps	RPM	Type & Size	RPM (Max)			CFM Rated			
PAB036N2H	8.2 (.76)	15 / 2	3/8 (9.52)	3/4 - 1	5.4 / 5.5	1140	BD10-8	1090	1200	10.26	77	104 (3.07)	8.0	590(267.6)
PAB036N2L					1.4	1140				5.13	39			590(267.6)
PAB036N2S					1.3	1140				4.23	31			590(267.6)
PAB048N2H	8.2 (.76)	15 / 2	3/8 (9.52)	3/4 - 1	5.4 / 5.5	1725	BD11-11	1075	1600	13.5	99	126 (3.72)	7.8	620(281.2)
PAB048N2L					1.7	1725				7.4	49.5			620(281.2)
PAB048N2S					1.3	1725				5.8	40.0			620(281.2)
PAB060N2H	8.2 (.76)	14 / 3	3/8 (9.52)	1 - 1	14.0 / 7.0	1725	BD11-11	1120	2000	17.3	123	129 (3.81)	8.0	640(290.3)
PAB060N2L					1.5	1750				9.0	62			640(290.3)
PAB060N2S					1.1	1750				7.1	50			640(290.3)
PAB075N2H	8.2 (.76)	14 / 4	3/8 (9.52)	2 - 1	6.8	1725	BD11-11A	1365	2500	10.5 ea	75 ea	128/128 (3.78/3.78)	--	735(334.0)
PAB075N2L					3.0	1725				4.6 Ea	37 Ea			735(334.0)
PAB075N2S					2.4	1725				3.9 Ea	31 Ea			735(334.0)

PERFORMANCE DATA: COOLING

MODEL NUMBER	Rated Capacity BTUH**	S / T Ratio	S.E.E.R.	E.E.R.	Power Input Watts	Evaporator Rated Airflow (SCFM)
PAB036	34,500	.77	10.2	9.05	3812	1200
PAB048	45,000	.78	10	8.75	5085	1600
PAB060	58,500	.76	10	8.55	7090	2000
PAB075	74,000	.78	----	9.15	8090	2500

NOTES: PAB075 models have two compressors with 2 individual circuits. (Two-Stage Cooling), IPLV 9.12.

** Rated Capacity @ ARI Standards 95° Amb, 80° DB, / 67° WB, 230 Volts. For applications at 208 volts deduct 1000 BTU.

MODEL NUMBER IDENTIFICATION GUIDE

MODEL NUMBER	P	A	B	036	N	2	H
Product Family P = Single Package							Electrical Characteristics H = 208 / 230-3-60 L = 460-3-60 S = 575-3-60
Fuel Type A = Air Conditioner							
Design Series B = Architectural Stone Color, HSP Ignition System							Blower Options 1 = Standard Direct Drive 2 = Standard Belt Drive
Capacity (Nominal BTU) 036 = 3 Ton 060 = 5 Ton 048 = 4 Ton 075 = 6-1/3 Ton							Electric Heat Accessory Available

ELECTRICAL DATA - ELECTRIC HEAT ACCESSORY

Heater Model #	Use With	Supply Voltage (Volts-Phase-Hz)	Nominal Btu/h	1 st / 2 nd Stage kW Rating	Supply Circuit Number	Heater Amps	Minimum Circuit Ampacity	Max. Fuse or NEC HACR Breaker (Amps)		
AEB010CHA	3 to 6-1/3 Ton	240-3-60	34,130	10.0	L4-L5-L6	24.1	30.1	35		
		208-3-60	25,598	7.5	L4-L5-L6	20.8	26.1	30		
AEB015CHA	3 to 6-1/3 Ton	240-3-60	51,195	15.0	L4-L5-L6	36.1	45.2	50		
		208-3-60	38,567	11.3	L4-L5-L6	31.4	39.3	40		
AEB020CHA	3 to 6-1/3 Ton	240-3-60	68,260	10.0 / 20.0	L4-L5-L6 L7-L8-L9	24.1 24.1	30.1 30.1	35 35		
			208-3-60	51,195	15.0	L4-L5-L6 L7-L8-L9	20.8 20.8	26.1 26.1	30 30	
		240-3-60		85,325	12.5 / 25.0	L4-L5-L6 L7-L8-L9	30.1 30.1	37.6 37.6	40 40	
			208-3-60	64,164	9.4 / 18.8	L4-L5-L6 L7-L8-L9	26.1 26.1	32.7 32.7	35 35	
AEB030CHA	4 to 6-1/3 Ton	240-3-60		102,390	15.0 / 30.0	L4-L5-L6 L7-L8-L9	36.1 36.1	45.2 45.2	50 50	
			208-3-60	76,793	11.25 / 22.5	L4-L5-L6 L7-L8-L9	31.4 31.4	39.3 39.3	40 40	
		AEB010CLA		3 to 6-1/3 Ton	480-3-60	34,130	10.0	L4-L5-L6	12.0	15.0
			51,195			15.0	L4-L5-L6	18.1	22.6	25
AEB020CLA	3 to 6-1/3 Ton	480-3-60	68,260	10.0 / 20.0	L4-L5-L6 L7-L8-L9	12.0	15.0	15		
						12.0	15.0	15		
AEB025CLA	4 to 6-1/3 Ton	480-3-60	85,325	12.5 / 25.0	L4-L5-L6 L7-L8-L9	15.1	18.8	20		
						15.1	18.8	20		
AEB030CLA	4 to 6-1/3 Ton	480-3-60	102,390	15.0 / 30.0	L4-L5-L6 L7-L8-L9	18.1	22.6	25		
						18.1	22.6	25		
AEB010CSA	3 to 6-1/3 Ton	600-3-60	34,130	10.0	L4-L5-L6	9.6	12.0	15		
AEB015CSA	3 to 6-1/3 Ton	600-3-60	51,195	15.0	L4-L5-L6	14.5	18.1	20		
AEB020CSA	3 to 6-1/3 Ton	600-3-60	68,260	10.0 / 20.0	L4-L5-L6 L7-L8-L9	9.6	12.0	15		
						9.6	12.0	15		
AEB025CSA	4 to 6-1/3 Ton	600-3-60	85,325	12.5 / 25.0	L4-L5-L6 L7-L8-L9	12.1	15.1	20		
						12.1	15.1	20		
AEB030CSA	4 to 6-1/3 Ton	600-3-60	102,390	15.0 / 30.0	L4-L5-L6 L7-L8-L9	14.5	18.1	25		
						14.5	18.1	25		

BELT DRIVE BLOWER PERFORMANCE DATA - 3 TON UNITS - 208 VOLTS

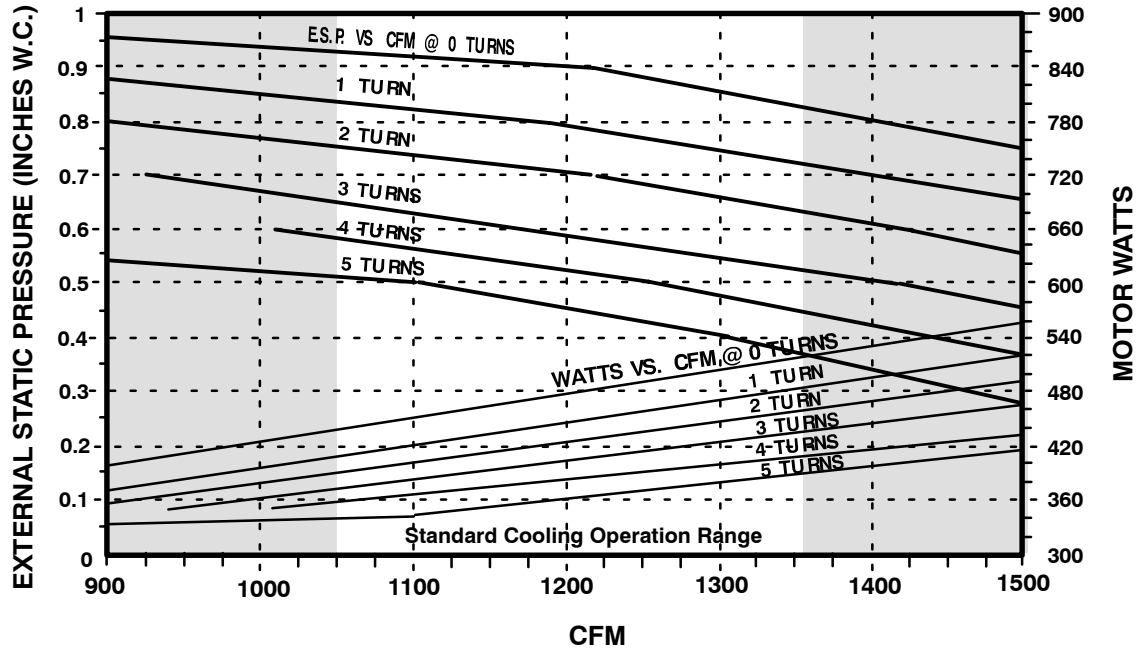

NOTES: 1) Maximum motor Watts is 787 Watts. 2) Maximum blower speed is 1400 RPM. 3) Contact factory for applications requiring operation outside standard cooling operating range. 4) Airflow data is based on dry coil with filters. 5) Pulley turns refers to turns out. In other words, 0 turns is a narrower sheave than 5 turns. 6) Blower speed MUST be set to give the correct air temperature rise through the unit as marked on the Rating Plate.

NUMBER OF TURNS	EXTERNAL STATIC PRESSURE IN INCHES WATER COLUMN														
	.2			.4			.6			.8			1.0		
	CFM	WATTS	RPM	CFM	WATTS	RPM	CFM	WATTS	RPM	CFM	WATTS	RPM	CFM	WATTS	RPM
0										1421	535	920			
1							1614	552	880	1183	448	888			
2							1418	470	844						
3				1587	478	804	1206	399	809						
4				1446	419	766									
5	1615	433	724	1301	375	727									

PULLEY TURNS OPEN	0	1	2	3	4	5
RPM WITH .75 HP STD PULLEY	909	878	842	807	768	730

FACTORY SETTING TURNS OPEN	
.75 HP STD PULLEY	5

BELT DRIVE BLOWER PERFORMANCE DATA - 3 TON UNITS - 230, 460, 575 VOLTS

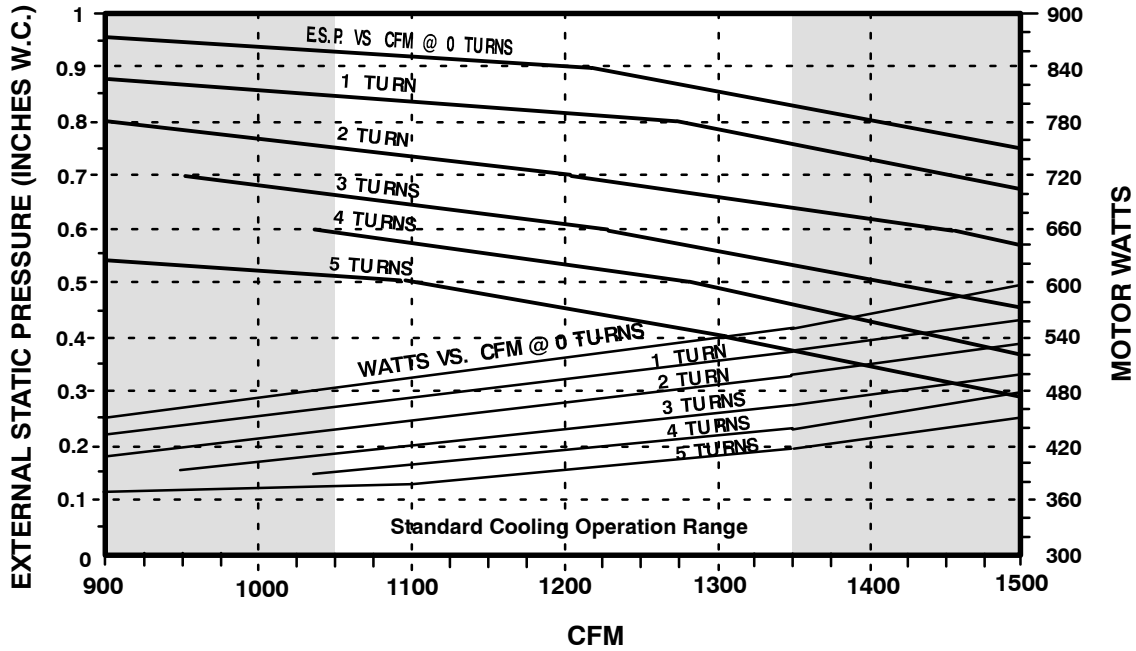

NOTES: 1) Maximum motor Watts is 808 Watts. 2) Maximum blower speed is 1400 RPM. 3) Contact factory for applications requiring operation outside standard cooling operating range. 4) Airflow data is based on dry coil with filters. 5) Pulley turns refers to turns out. In other words, 0 turns is a narrower sheave than 5 turns. 6) Blower speed MUST be set to give the correct air temperature rise through the unit as marked on the Rating Plate.

NUMBER OF TURNS	EXTERNAL STATIC PRESSURE IN INCHES WATER COLUMN														
	.2			.4			.6			.8			1.0		
	CFM	WATTS	RPM	CFM	WATTS	RPM	CFM	WATTS	RPM	CFM	WATTS	RPM	CFM	WATTS	RPM
0										1420	575	925			
1							1623	594	885	1264	509	891			
2							1453	521	848						
3				1599	520	807	1222	442	811						
4				1455	467	769	1032	393	772						
5	1604	467	727	1318	418	730									

PULLEY TURNS OPEN	0	1	2	3	4	5
RPM WITH .75 HP STD PULLEY	915	883	846	809	771	732

FACTORY SETTING TURNS OPEN	
.75 HP STD PULLEY	5

BELT DRIVE BLOWER PERFORMANCE DATA - 4 TON UNITS - 208 VOLTS

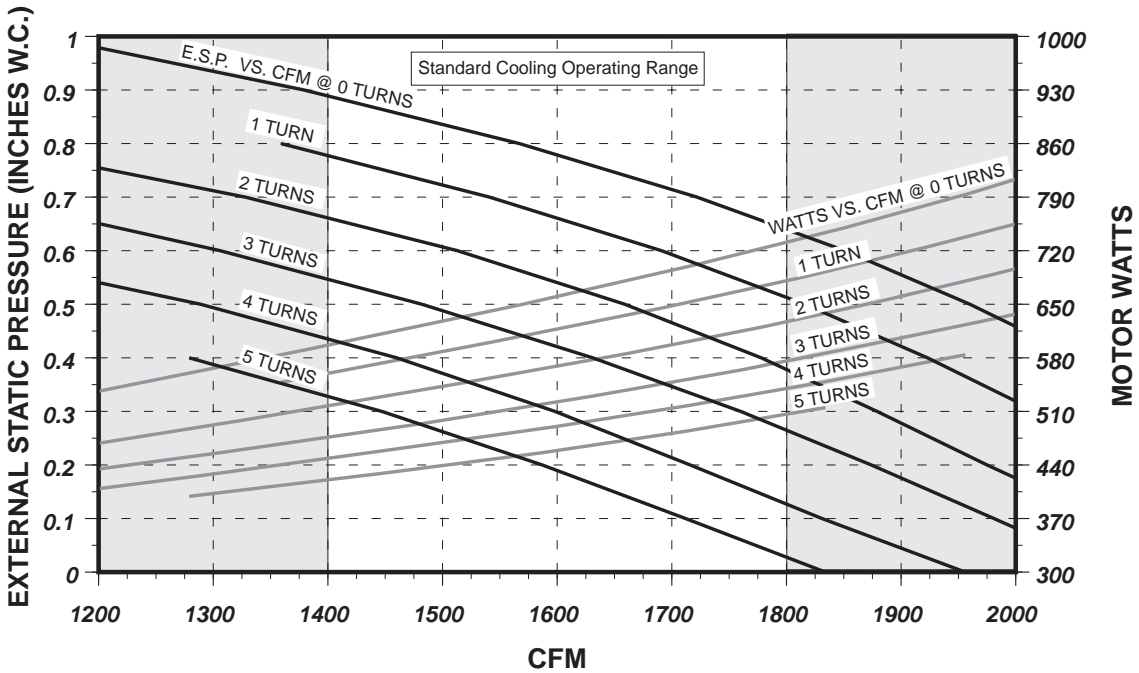

NOTES: 1) Maximum motor Watts is 928 Watts. 2) Maximum blower speed is 1400 RPM. 3) Contact factory for applications requiring operation outside standard cooling operating range. 4) Airflow data is based on dry coil with filters. 5) Pulley turns refers to turns out. In other words, 0 turns is a narrower sheave than 5 turns. 6) Blower speed MUST be set to give the correct air temperature rise through the unit as marked on the Rating Plate.

NUMBER OF TURNS	EXTERNAL STATIC PRESSURE IN INCHES WATER COLUMN														
	.2			.4			.6			.8			1.0		
	CFM	WATTS	RPM	CFM	WATTS	RPM	CFM	WATTS	RPM	CFM	WATTS	RPM	CFM	WATTS	RPM
0							1851	750	952	1567	649	960			
1							1691	645	913	1359	548	920			
2				1778	620	867	1513	546	871						
3				1631	530	822									
4	1716	518	774	1460	461	777									
5	1587	456	725												

PULLEY TURNS OPEN	0	1	2	3	4	5
RPM WITH .75 HP STD PULLEY	950	910	870	825	780	730

FACTORY SETTING TURNS OPEN	
.75 HP STD PULLEY (PGMG48H135)	2

BELT DRIVE BLOWER PERFORMANCE DATA - 4 TON UNITS - 230, 460, 575 VOLTS

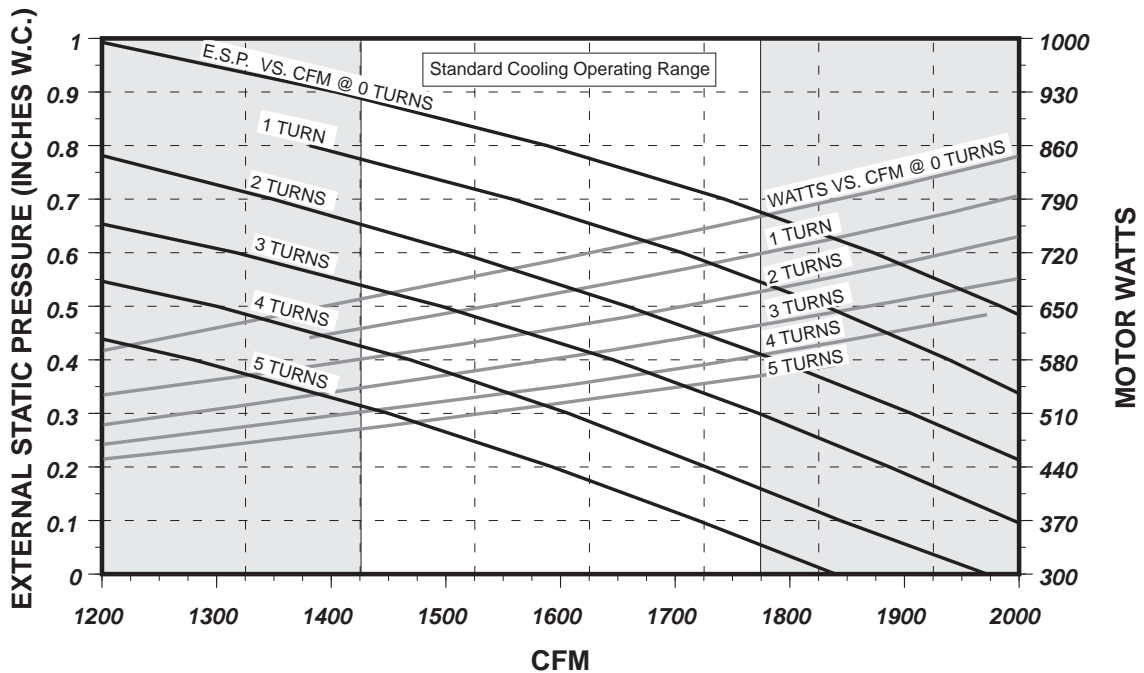

NOTES: 1) Maximum motor Watts is 962 Watts. 2) Maximum blower speed is 1400 RPM. 3) Contact factory for applications requiring operation outside standard cooling operating range. 4) Airflow data is based on dry coil with filters. 5) Pulley turns refers to turns out. In other words, 0 turns is a narrower sheave than 5 turns. 6) Blower speed MUST be set to give the correct air temperature rise through the unit as marked on the Rating Plate.

NUMBER OF TURNS	EXTERNAL STATIC PRESSURE IN INCHES WATER COLUMN														
	.2			.4			.6			.8			1.0		
	CFM	WATTS	RPM	CFM	WATTS	RPM	CFM	WATTS	RPM	CFM	WATTS	RPM	CFM	WATTS	RPM
0							1873	800	959	1588	708	965			
1							1706	698	919	1381	609	925			
2				1788	673	870	1512	600	874						
3				1646	593	825	1317	519	829						
4	1727	574	776	1469	520	778									
5	1593	522	728												

PULLEY TURNS OPEN	0	1	2	3	4	5
RPM WITH .75 HP STD PULLEY	960	920	875	825	780	730

FACTORY SETTING TURNS OPEN	
.75 HP STD PULLEY (PGMG48H/F135)	2

BELT DRIVE BLOWER PERFORMANCE DATA - 5 TON UNITS - 208 VOLTS

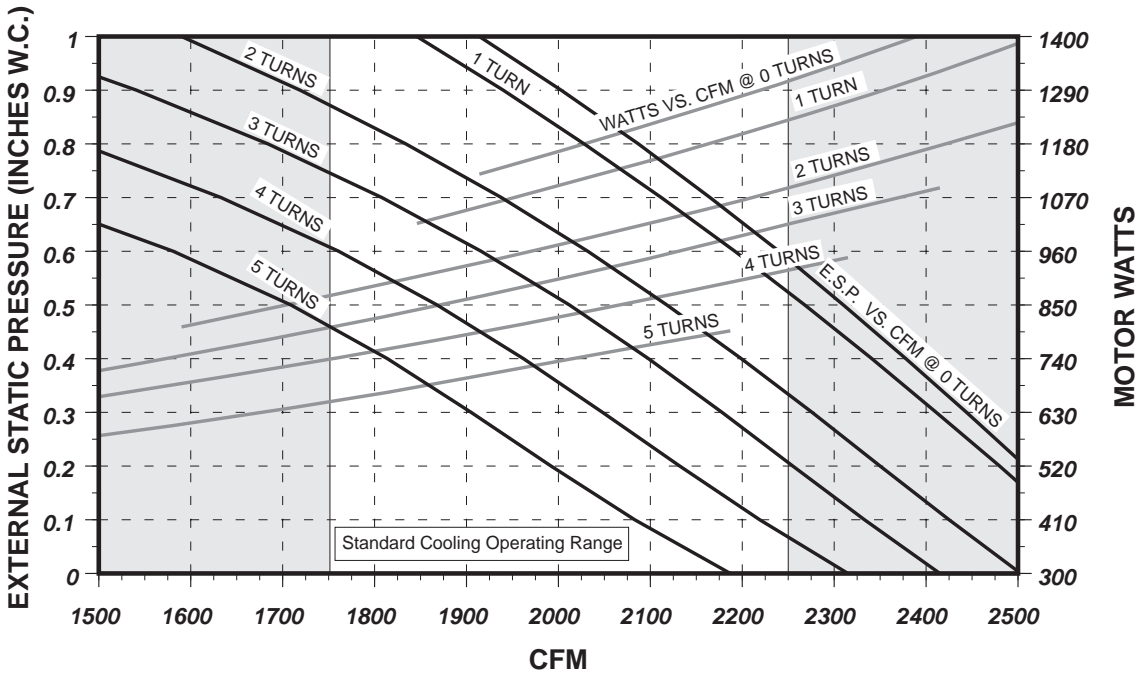

NOTES: 1) Maximum motor Watts is 1486 Watts. 2) Maximum blower speed is 1400 RPM. 3) Contact factory for applications requiring operation outside standard cooling operating range. 4) Airflow data is based on dry coil with filters. 5) Pulley turns refers to turns out. In other words, 0 turns is a narrower sheave than 5 turns. 6) Blower speed MUST be set to give the correct air temperature rise through the unit as marked on the Rating Plate.

NUMBER OF TURNS	EXTERNAL STATIC PRESSURE IN INCHES WATER COLUMN														
	.2			.4			.6			.8			1.0		
	CFM	WATTS	RPM	CFM	WATTS	RPM	CFM	WATTS	RPM	CFM	WATTS	RPM	CFM	WATTS	RPM
0							2240	1302	1153	2087	1213	1163	1914	1118	1174
1							2192	1196	1127	2028	1109	1137	1846	1017	1145
2				2199	1064	1074	2032	987	1082	1834	903	1089			
3	2255	1018	1025	2098	945	1031	1916	868	1037						
4	2132	875	982	1962	811	986	1761	742	991						
5	1992	732	938	1814	671	942									

PULLEY TURNS OPEN	0	1	2	3	4	5
RPM WITH 1 HP STD PULLEY	1145	1120	1080	1035	990	945

FACTORY SETTING TURNS OPEN	
1 HP STD PULLEY	2.5

BELT DRIVE BLOWER PERFORMANCE DATA - 5 TON UNITS - 230, 460, 575 VOLTS

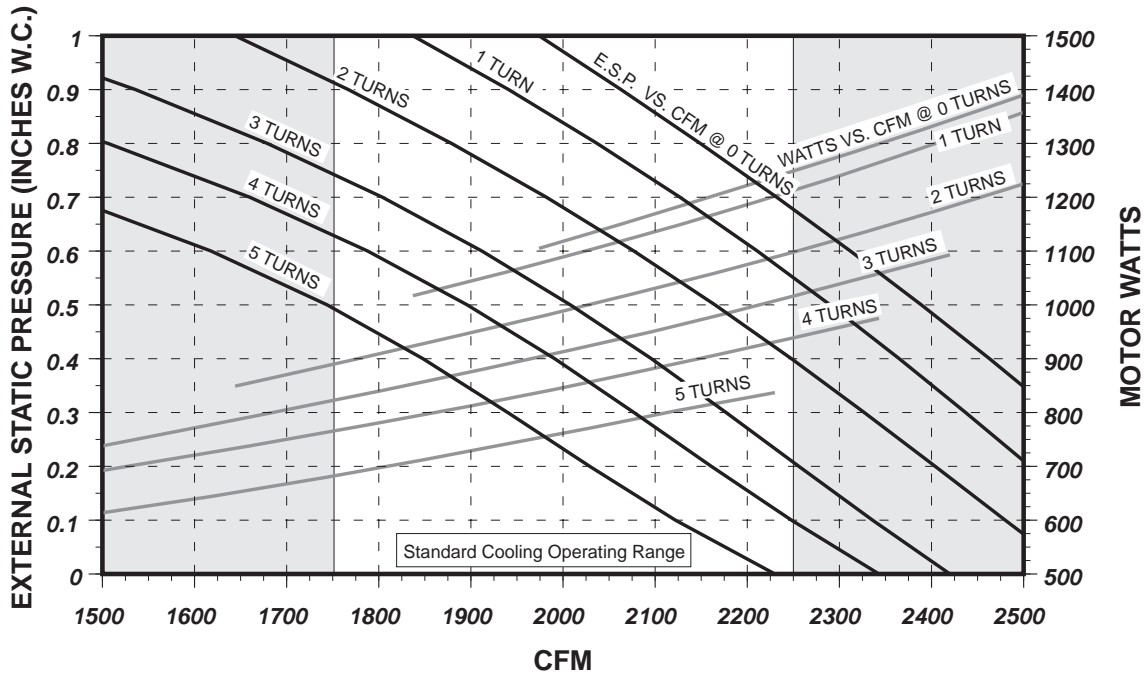

NOTES: 1) Maximum motor Watts is 1454 Watts. 2) Maximum blower speed is 1400 RPM. 3) Contact factory for applications requiring operation outside standard cooling operating range. 4) Airflow data is based on dry coil with filters. 5) Pulley turns refers to turns out. In other words, 0 turns is a narrower sheave than 5 turns. 6) Blower speed MUST be set to give the correct air temperature rise through the unit as marked on the Rating Plate.

NUMBER OF TURNS	EXTERNAL STATIC PRESSURE IN INCHES WATER COLUMN														
	.2			.4			.6			.8			1.0		
	CFM	WATTS	RPM	CFM	WATTS	RPM	CFM	WATTS	RPM	CFM	WATTS	RPM	CFM	WATTS	RPM
0							2312	1282	1179	2149	1195	1186	1974	1105	1193
1							2211	1192	1147	2037	1106	1153	1837	1017	1158
2				2248	1097	1087	2077	1021	1091	1879	940	1096			
3	2256	1019	1037	2096	950	1042	1912	880	1046						
4	2161	905	990	1991	843	993	1788	777	996						
5	2029	771	944	1848	712	946									

PULLEY TURNS OPEN	0	1	2	3	4	5
RPM WITH 1 HP STD PULLEY	1175	1145	1090	1045	1000	950

FACTORY SETTING TURNS OPEN	
1 HP STD PULLEY	2.5

BELT DRIVE BLOWER PERFORMANCE DATA - 6-1/3 TON UNITS - 208 VOLTS

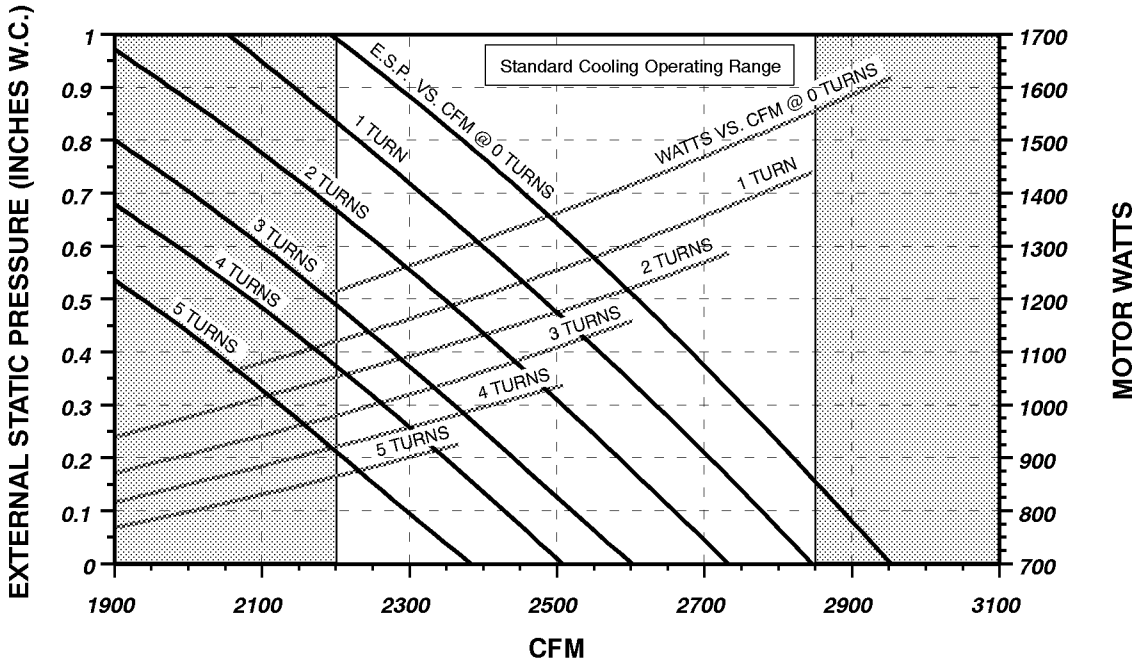

NOTES: 1) Maximum motor Watts is 1538 Watts. 2) Maximum blower speed is 1400 RPM. 3) Contact factory for applications requiring operation outside standard cooling operating range. 4) Airflow data is based on dry coil with filters. 5) Pulley turns refers to turns out. In other words, 0 turns is a narrower sheave than 5 turns. 6) Blower speed MUST be set to give the correct air temperature rise through the unit as marked on the Rating Plate.

NUMBER OF TURNS	EXTERNAL STATIC PRESSURE IN INCHES WATER COLUMN														
	.2			.4			.6			.8			1.0		
	CFM	WATTS	RPM	CFM	WATTS	RPM	CFM	WATTS	RPM	CFM	WATTS	RPM	CFM	WATTS	RPM
0	2820	1538	1239	2682	1460	1242	2534	1380	1246	2372	1298	1249			
1	2707	1361	1198	2558	1283	1200	2399	1207	1203	2231	1133	1205			
2	2584	1213	1154	2429	1145	1156	2262	1077	1158						
3	2441	1081	1108	2278	1011	1110									
4	2348	976	1061												
5	2211	863	1014												

NOTE: For entering air flow correction factors and voltage correction factors for cooling and heating, see page 7. Will operate at rated ESP in either horizontal or downflow duct position.

PULLEY TURNS OPEN	0	1	2	3	4	5
RPM WITH 2 HP STD PULLEY	1245	1202	1157	1111	1064	1017

FACTORY SETTING TURNS OPEN	
2 HP STD PULLEY	2

BELT DRIVE BLOWER PERFORMANCE DATA 6-1/3 TON UNITS - 240, 460 & 575 VOLTS

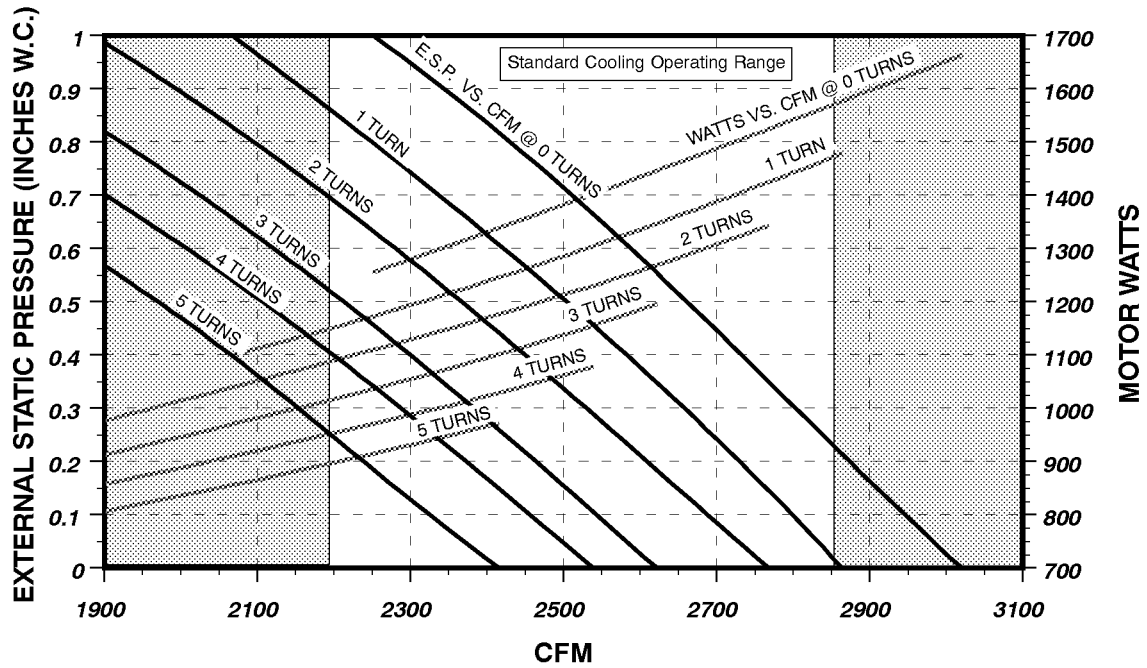

NOTES: 1) Maximum motor Watts is 1582 Watts. 2) Maximum blower speed is 1400 RPM. 3) Contact factory for applications requiring operation outside standard cooling operating range. 4) Airflow data is based on dry coil with filters. 5) Pulley turns refers to turns out. In other words, 0 turns is a narrower sheave than 5 turns. 6) Blower speed MUST be set to give the correct air temperature rise through the unit as marked on the Rating Plate.

NUMBER OF TURNS	EXTERNAL STATIC PRESSURE IN INCHES WATER COLUMN														
	.2			.4			.6			.8			1.0		
	CFM	WATTS	RPM	CFM	WATTS	RPM	CFM	WATTS	RPM	CFM	WATTS	RPM	CFM	WATTS	RPM
0				2733	1505	1250	2588	1428	1253	2430	1346	1255	2251	1255	1258
1	2730	1404	1205	2583	1327	1207	2422	1248	1209	2250	1172	1211			
2	2609	1263	1159	2450	1191	1161	2281	1121	1163						
3	2464	1122	1112	2300	1055	1114									
4	2373	1013	1065	2199	953	1067									
5	2239	910	1017												

NOTE: For entering air flow correction factors and voltage correction factors for cooling and heating, see page 7. Will operate at rated ESP in either horizontal or downflow duct position.

PULLEY TURNS OPEN	0	1	2	3	4	5
RPM WITH 2 HP STD PULLEY	1255	1210	1165	1115	1070	1020

FACTORY SETTING TURNS OPEN	
2 HP STD PULLEY	2

UNIT DIMENSIONS

Note: Duct connections for downflow discharge are made to roof curb only.

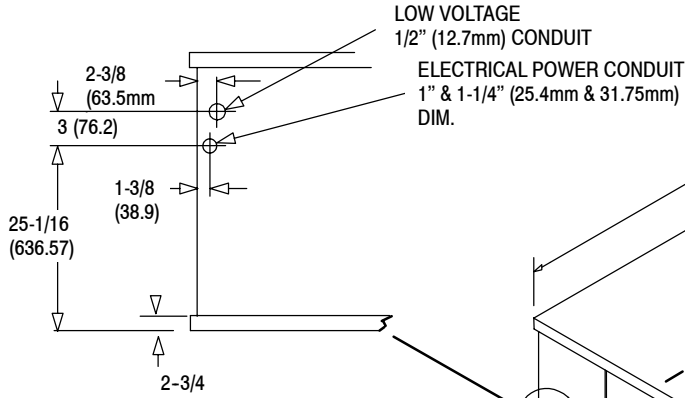

ALL DIMENSIONS IN INCHES (MM)

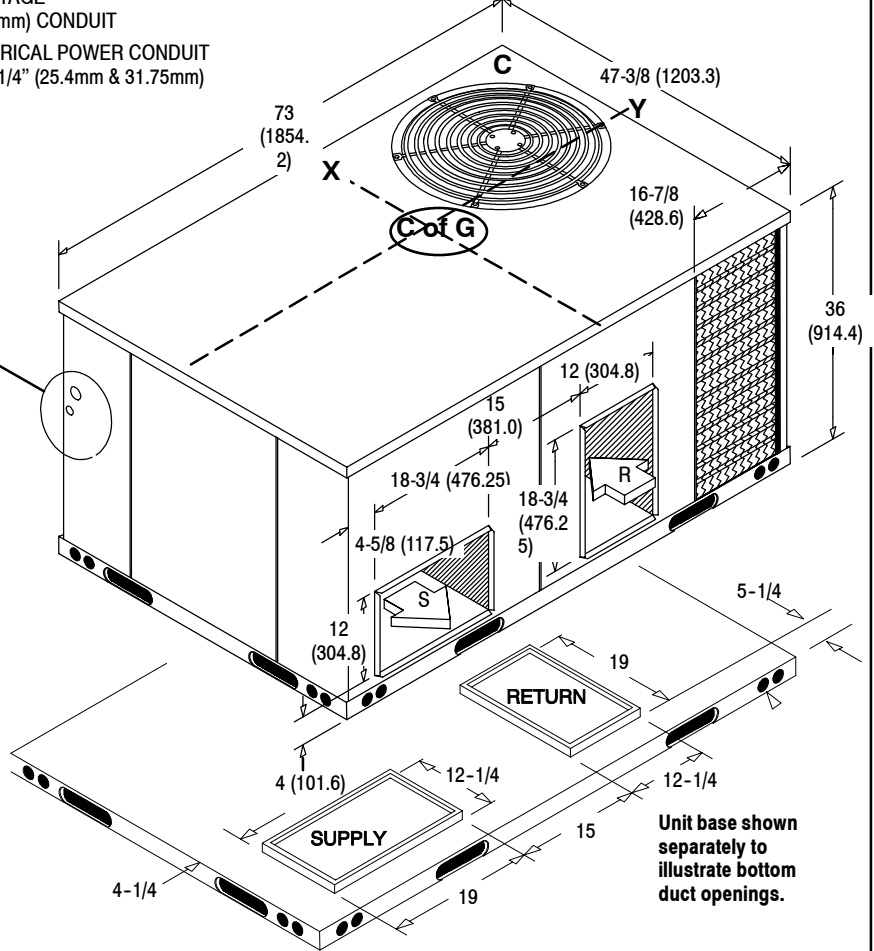

Unit base shown separately to illustrate bottom duct openings.

Center of Gravity (Inches)		
Model	X axis	Y axis
PAB036	35	21
PAB048	34	20
PAB060	34	20
PAB075	33	19

Note: To determine Center of Gravity, get appropriate measurements from the table above, then measure from the corner of the unit marked "C", making sure to use the correct measurement for the axis you are measuring. See example of typical center of gravity determination on dimensional drawing to the right.

ACCESSORIES

ROOF CURB

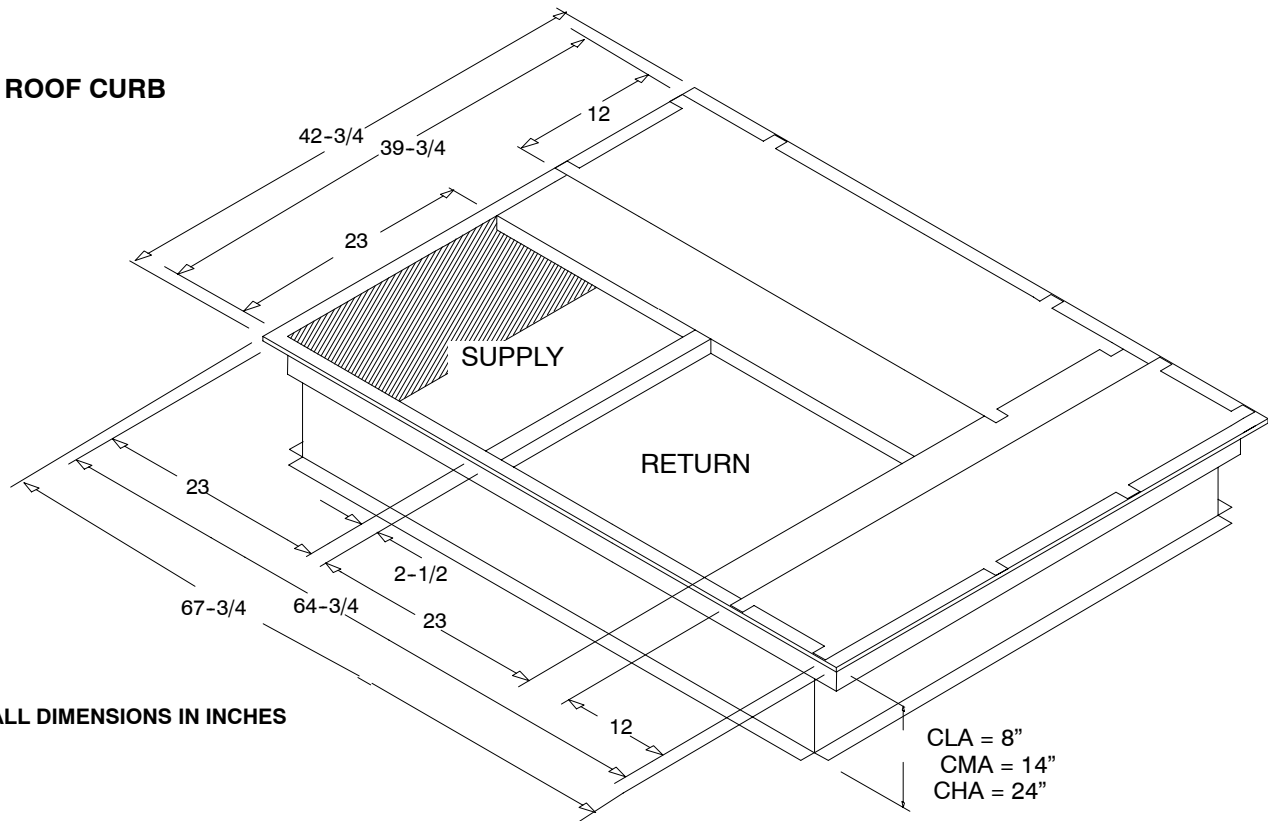

ALL DIMENSIONS IN INCHES

CLA = 8"
CMA = 14"
CHA = 24"

ROOF CURBS

Description	Model Number	Used on
8"	AXB030CLA	3 - 6 1/3 Ton
14"	AXB030CMA	3 - 6 1/3 Ton
24"	AXB030CHA	3 - 6 1/3 Ton

LOW AMBIENT CONTROLS

Description	Service Parts Number*	Used on
To 0° F	1148233	3 - 5 Ton
To 0° F	1071675	6 1/3 Ton

OUTDOOR AIR DAMPERS

Description	Model Number	Used on
Manual - 25%	AXB030FAC	3 - 6 1/3 Ton
Motorized - 25%	AXB030FMC	3 - 6 1/3 Ton

COIL PROTECTION

Description	Service Parts Number *	Used on
Coil Guard	1149486	3 - 6 1/3 Ton
Hail Guard	1065342	3 - 6 1/3 Ton

CONCENTRIC DUCT KIT

Description	Mainline Model Number	Used on
Roof Curb Transition Square to Round	AXB030CTA	3 to 6 1/3 Ton
Grille, Flush Mount	AXB030CFA	3 to 5 Ton
Grille, Step Down	AXB030CSA	3 to 5 Ton
Grille, Flush Mount	AXB040CFA	6 1/3 Ton
Grille, Step Down	AXB040CSA	6 1/3 Ton

ECONOMIZERS/DOWNFLOW

ALL DIMENSIONS IN INCHES

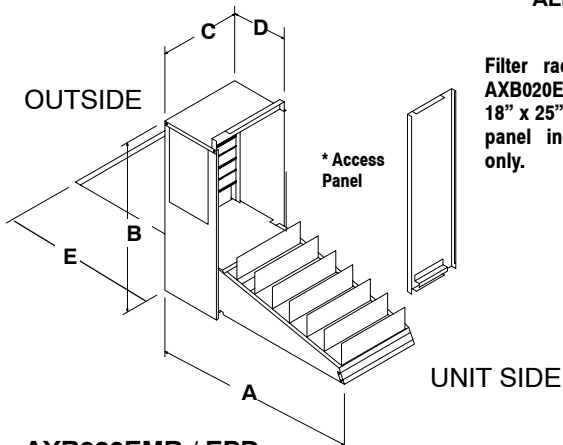

Filter racks are included with AXB020E**. Economizers require 18" x 25" x 1" or 2" filters. Access panel included with AXB030E** only.

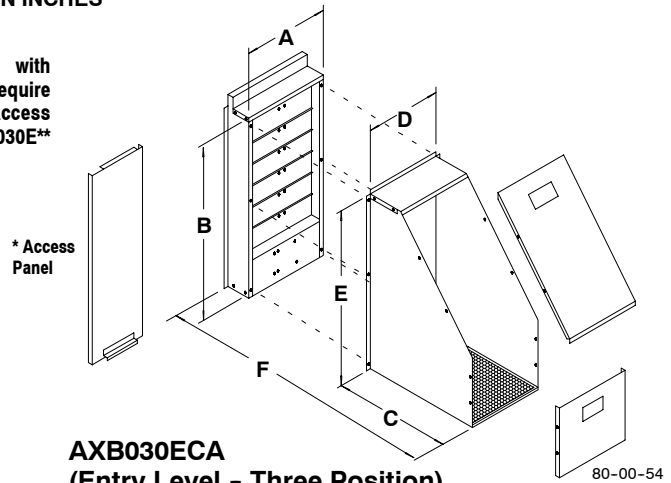

AXB030EMB / EPD (Modulating or Three Position)

Economizer Model No.	A	B	C	D	E
AXB030EMC/PD	35	31	14-3/4	10-7/8	22

AXB030ECA (Entry Level - Three Position)

Economizer Model No.	A	B	C	D	E	G
AXB030ECA	14-3/4	31	20-1/4	13	30	24

All Economizers Feature Enthalpy and/or ambient temperature control providing outdoor air ventilation and "free cooling" when outdoor conditions are favorable.

Return Air and Pressure Relief dampers for proper air balance, on most models.

Interconnecting wiring furnished.

Center controlled dual action dampers with gaskets to provide proper seal.

Description	Model Number	Used on
Fully Modulating (1)	AXB030EMC	3 to 6-1/3 Ton
Three Position (2)	AXB030EPD	
Entry Level Three Position (3)	AXB030ECA	

NOTES:

- (1) - Ambient/Enthalpy Control; Includes Return Air Damper & Relief Damper.
- (2) - Ambient Control Only; Includes Return Air Damper & Relief Damper.
- (3) - Ambient Control Only; No Return Air Damper; No Relief Damper.
- (4) - On AXB030, Filters not supplied. Filter retainers and filters can be ordered thru Service Parts, retainer part number 1054517. Filters (20x30x2) part number 1054503.

ECONOMIZERS/HORIZONTAL

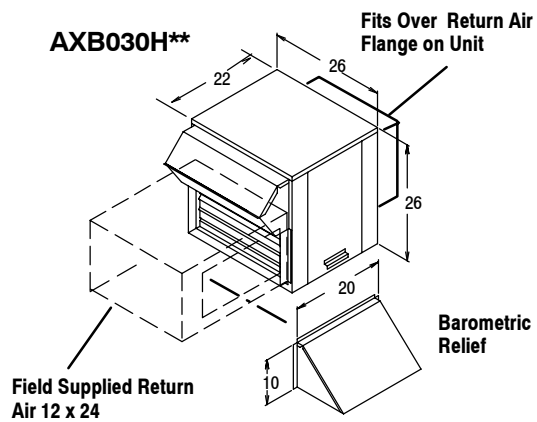

Description	Model Number	Used on
Fully Modulating (1)	AXB030HEC	3 to 6-1/3 Ton
Three Position (2)	AXB030HPD	

NOTES:

- (1) - Ambient/Enthalpy Control; Includes Return Air Damper & Relief Damper.
- (2) - Ambient Control Only; Includes Return Air Damper & Relief Damper.

GUIDE SPECIFICATION

CABINET

The cabinet is made of sturdy G-90 galvanized steel, Triple-coated, consisting of a Polyester top coat, a urethane primer coat preceded by an oxide pretreatment. Access panels for easy service. Base rails are 18 gauge steel with fork lift slots and holes provided for lifting shackles. Unit is designed for convertible airflow and is shipped ready for downflow application. Conversion to horizontal airflow is accomplished by relocating two panels.

Return air compartments are insulated with 1" (25.4mm) of water resistant coated glass fiber and 1" (25.4mm) of aluminum foil faced glass fiber in the furnace/supply compartments.

COOLING SECTION

Units are factory charged and operationally ready. Each refrigerant circuit has a compressor with internal overload protection, high and low pressure switches, filter drier, and copper tube/aluminum fin evaporator and condenser coils. The 6-1/3 ton units are two stage cooling.

Units are capable of cooling operation down to 40°F (17.4°C) as shipped from the factory.

COILS

The evaporator and condenser coils are fabricated with aluminum fins mechanically bonded to copper tubing. Both coils are pressure tested prior to assembly into the unit and electronically leak tested after assembly into the unit. The evaporator coil is protected from dust and debris on the return air side by factory installed 2" (50.8mm) air filters.

CONDENSER FAN

The unit has a single direct drive propeller fan/motor assembly mounted directly to a vertical-discharge grille panel that is easily removable. Motors are 1075 RPM with permanently lubricated sleeve bearings and inherent overload protection.

EVAPORATOR BLOWER

The PAB036-075 units have belt drive blowers for high static applications. The evaporator blower system has the capability to operate against the same rated external static pressure in downflow or horizontal duct designs.

HEATING SECTION

The heating compartment shall be easily accessible and accept the optional slide-in electric heat accessory packages.

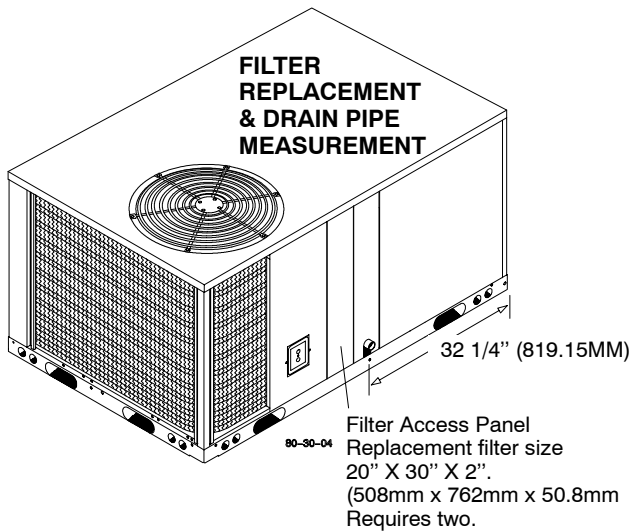

RIGGING DETAILS

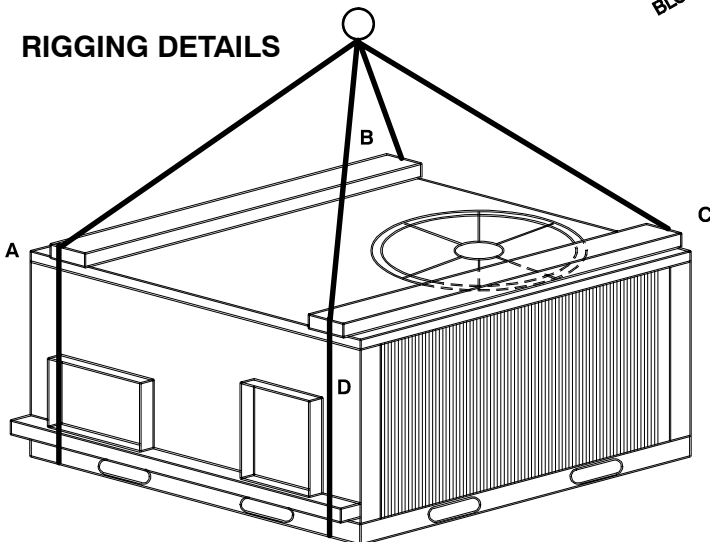

INSTALLATION CLEARANCES

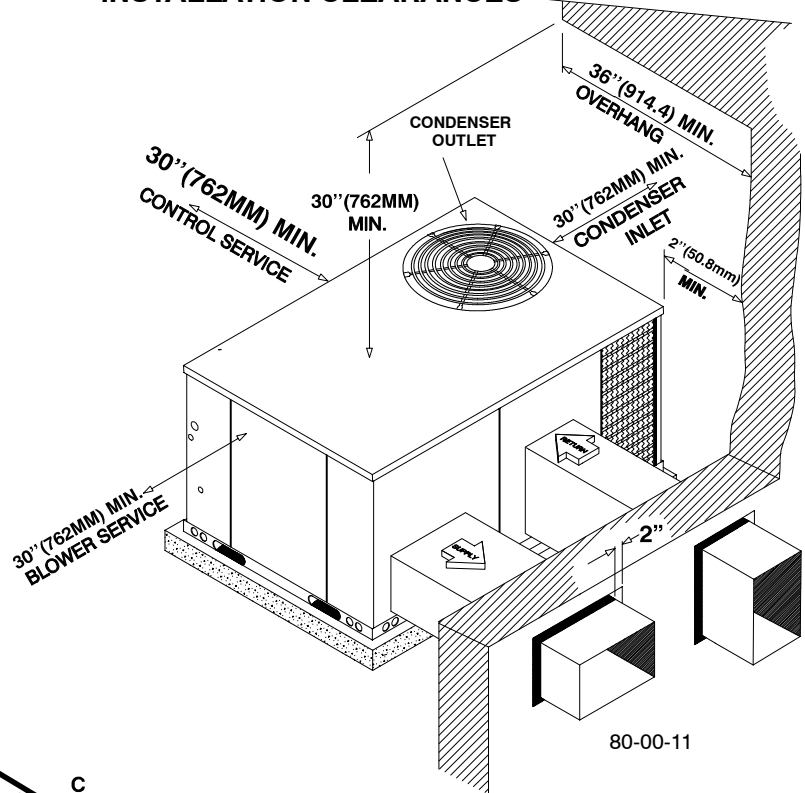

CORNER WEIGHTS (LBS)

Unit Size (Ton)	A	B	C	D	OPERATING WEIGHT TOTAL
3	129	140	176	163	608
4	136	146	185	171	638
5	140	151	191	176	658
6-1/3	161	174	220	201	758