

200S OSCILLATOR

OPERATING AND SERVICE MANUAL



HP Archive

This vintage Hewlett Packard document was
preserved and distributed by

[www. hparchive.com](http://www.hparchive.com)

Please visit us on the web !

Scanned by on-line curator: Tony Gerbic

**** For FREE Distribution Only *****



OPERATING AND SERVICE MANUAL

(HP PART NO. 00200-91902)

**MODEL 200S
OSCILLATOR**

SERIALS PREFIXED: 332-

Appendix C, Manual Backdating Changes,
adapts this manual to Serials Prefixed: 229-,
129-, 103-, 001-.

Copyright Hewlett-Packard Company 1959
P. O. Box 301, Loveland, Colorado, 80537 U. S. A.

TABLE OF CONTENTS

Section	Page	Section	Page
I GENERAL DESCRIPTION	1-1	IV MAINTENANCE	4-1
1-1. General	1-1	4-1. Introduction	4-1
1-2. Instrument Identification	1-1	4-2. Test Equipment Required	4-1
1-3. Power Cable	1-1	4-3. Performance Check	4-1
1-4. 230-Volt Operation	1-1	4-4. Cabinet Removal	4-2
1-5. Incoming Inspection	1-1	4-5. 230-Volt Operation	4-2
II OPERATING INSTRUCTIONS	2-1	4-6. Periodic Maintenance	4-2
2-1. Operating Procedure	2-1	4-7. Adjustment Procedure	4-2
2-2. Output Circuit Options	2-1	4-8. Troubleshooting	4-5
III THEORY OF OPERATION	3-1	4-9. Repair and Replacement	4-5
3-1. General	3-1	V REPLACEABLE PARTS	5-1
3-2. Frequency-Controlling Bridge	3-1	5-1. Introduction	5-1
3-3. Amplifier	3-1	5-2. Ordering Information	5-1
3-4. Output Circuit	3-1		

- Appendix
A CODE LIST OF MANUFACTURERS
B SALES AND SERVICE OFFICES
C MANUAL BACKDATING CHANGES

LIST OF ILLUSTRATIONS

Number	Title	Page	Number	Title	Page
1-1.	Model 200S Oscillator	1-0	4-2.	Calibration Test Setup	4-3
2-1.	Controls and Terminals	2-0	4-3.	Alternate Calibration Setup	4-3
2-2.	Typical Output Connections	2-1	4-4.	Distortion Test Setup	4-4
3-1.	Model 200S Block Diagram	3-0	4-5.	Range Switch Detail	4-7
4-1.	230-Volt Operation	4-2	4-6.	Left Side View Model 200S	4-8
			4-7.	Right Side View Model 200S	4-9
			4-8.	Servicing Etched Circuit Boards	4-10
			4-9.	Voltage and Resistance Diagram	4-11
			4-10.	Model 200S Oscillator	4-12

LIST OF TABLES

Number	Title	Page
4-1.	Test Instruments Required	4-0
4-2.	Frequency/Period Conversion	4-1
4-3.	Distortion Test Frequencies	4-2
4-4.	Troubleshooting	4-5
4-5.	Replacement of Critical Parts	4-6
5-1.	Replaceable Parts	5-1

SPECIFICATIONS

FREQUENCY RANGE:	5 cps to 600 kc in 5 ranges.
DIAL ACCURACY:	±2%.
FREQUENCY RESPONSE:	±1 db, 1000 cps reference.
MAXIMUM OUTPUT:	3 V rms into 50 ohms.
ATTENUATOR:	Approximately 10 db range.
DISTORTION:	Less than 0.5% below 500 kc; less than 1% above 500 kc.
HUM VOLTAGE:	Less than 0.1% of rated output.
POWER:	115/230 volt, ±10%, 50-1000 cps, 75 watts.
ACCESSORIES AVAILABLE:	<p>Ⓢ11000A Cable Assembly, terminated by dual banana plugs.</p> <p>Ⓢ11001A Cable Assembly, as above, but with one BNC connector.</p>
DIMENSIONS:	<p>Cabinet Mount: 7-1/2" wide, 11-1/2" high, 14-1/4" deep.</p> <p>Rack Mount:</p>

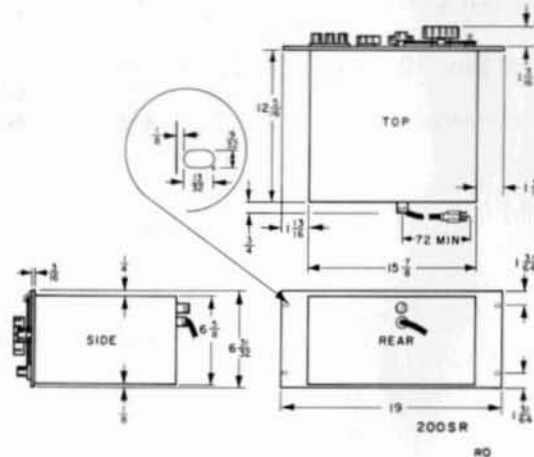

WEIGHT:	Cabinet Mount:	Net 23 lbs., shipping 29 lbs.
	Rack Mount:	Net 27 lbs., shipping 35 lbs.

SECTION I

GENERAL DESCRIPTION

1-1. GENERAL.

The Model 200S is specifically designed to provide the low frequency signals required by the Φ Model 739A Frequency Response Test Set. The oscillator covers the range between 5 cps and 600 kc in five overlapping ranges and will provide at least 3 volts into a 50 ohm load. Since the instrument was developed for a specific application, the output amplitude control has a limited range. The minimum output into a 50 ohm load is between 1 and 2 volts.

The Model 200S with the Model 739A Frequency Response Test Set may be used to check the frequency response of voltmeters, oscilloscopes, amplifiers, or filters between 5 cps and 10 mc.

To help eliminate ground loops, the output terminals are ungrounded. If a grounded output is desirable, a link is provided to connect one of the output terminals to the chassis.

1-2. INSTRUMENT IDENTIFICATION.

Hewlett-Packard uses a two-section eight-digit serial number (e. g. , 000-00000). If the first three digits of the serial number on your instrument do not agree with those on the title page of this manual, change sheets supplied with the manual will define differences between your instrument and the Model 200S described in this manual.

1-3. POWER CABLE.

For the protection of operating personnel, the National Electrical Manufacturers' Association (NEMA) recommends that the instrument panel and cabinet be grounded. This instrument is equipped with a three-conductor power cable, which, when plugged into an appropriate receptacle, grounds the instrument. The offset pin on the power cable three-prong connector is the ground pin.

To preserve the protection feature when operating the instrument from a two-contact outlet, use a three-prong to two-prong adapter and connect the green pigtail on the adapter to ground.

1-4. 230-VOLT OPERATION.

This instrument is normally wired for operation from a nominal 115 volt supply. Operation from a 230 volt source is easily accomplished by reconnecting the dual primary windings on the power transformer in series. Refer to paragraph 4-5 for connection procedures.

1-5. INCOMING INSPECTION.

Upon receipt of your 200S, check the contents against the packing list and inspect the instrument for any obvious damage received in transit. To facilitate re-shipment, keep the packing material until an operational check has been performed (see paragraph 4-3). If there is any apparent damage, file a claim with the carrier and refer to the warranty page in this manual.

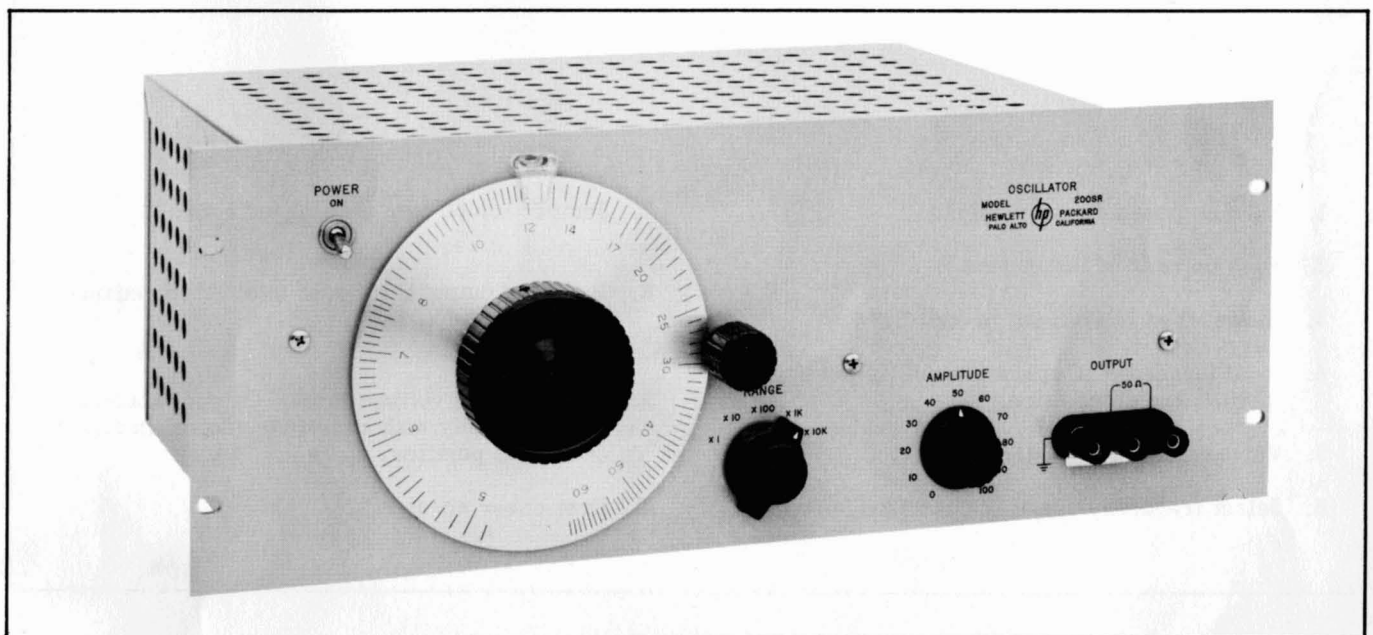
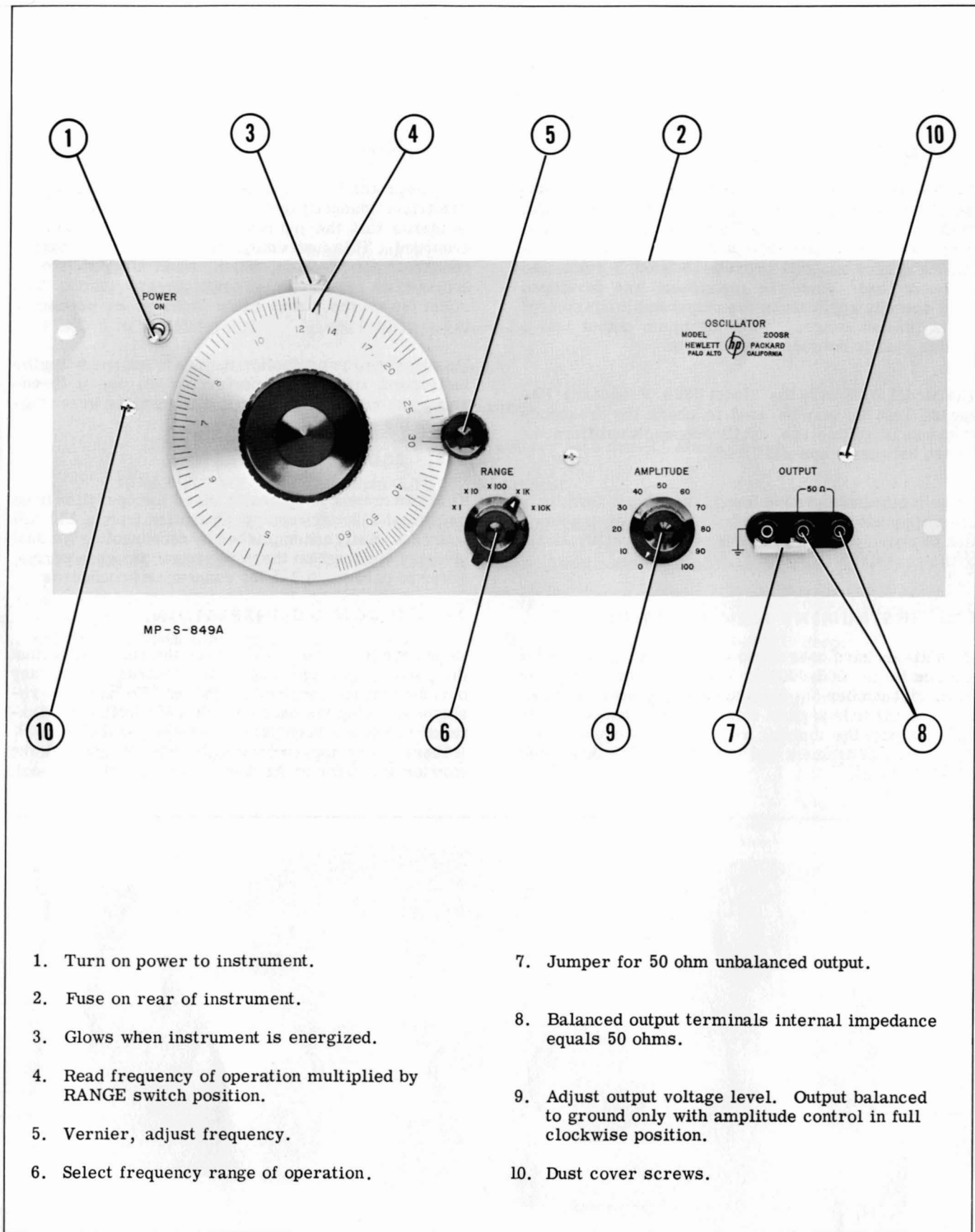

Figure 1-1. Model 200S Oscillator



1. Turn on power to instrument.
2. Fuse on rear of instrument.
3. Glows when instrument is energized.
4. Read frequency of operation multiplied by RANGE switch position.
5. Vernier, adjust frequency.
6. Select frequency range of operation.
7. Jumper for 50 ohm unbalanced output.
8. Balanced output terminals internal impedance equals 50 ohms.
9. Adjust output voltage level. Output balanced to ground only with amplitude control in full clockwise position.
10. Dust cover screws.

Figure 2-1. Controls and Terminals

SECTION II

OPERATING INSTRUCTIONS

2-1. OPERATING PROCEDURE.

1) With the instrument plugged into a power source of specified voltage and frequency, and the power switch at ON, allow a warm-up period of approximately five minutes. Where maximum accuracy is desired, this warm-up period should be extended at least to thirty minutes.

NOTE

If a 230 volt power source is used, check (a) that power transformer T3 is strapped for 230-volt operation (strapping options shown on schematic diagram) and (b) that fuse F1 is the correct size for 230-volt operation. (See Table of Replaceable Parts for value.)

2) The frequency of the output voltage is determined by (a) the setting of the frequency dial and (b) the setting of the RANGE switch. For example, to obtain a 1000-cycle output, set the frequency dial at 10 and the RANGE switch at X100 (10 x 100 is 1000).

3) Make the connection between the Model 200S and the equipment to be driven at the terminals designated 50 Ω . (Connections are discussed in paragraph 2-2.)

4) Adjust the AMPLITUDE control to obtain the desired output level.

2-2. OUTPUT CIRCUIT OPTIONS.

The output circuit of the Model 200S may be arranged for balanced or unbalanced operation. Typical connections for each are indicated in figure 2-2.

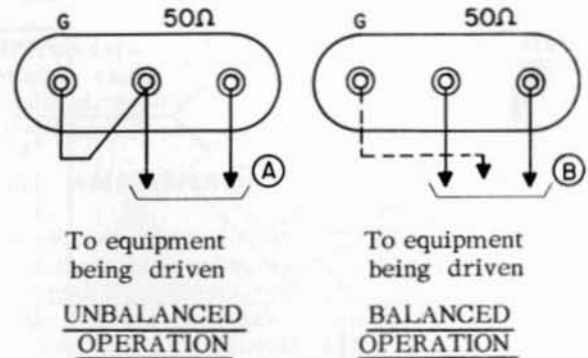

Figure 2-2. Model 200S Typical
Output Connections

- A. UNBALANCED OPERATION. To operate with one side grounded, a strap is placed between the G terminal and the center terminal, as indicated in figure 2-2A.
- B. BALANCED OPERATION. Connections for balanced operation are indicated in figure 2-2B. (The broken line from the ground terminal indicates the output circuit is balanced to ground, with the AMPLITUDE control at maximum.)

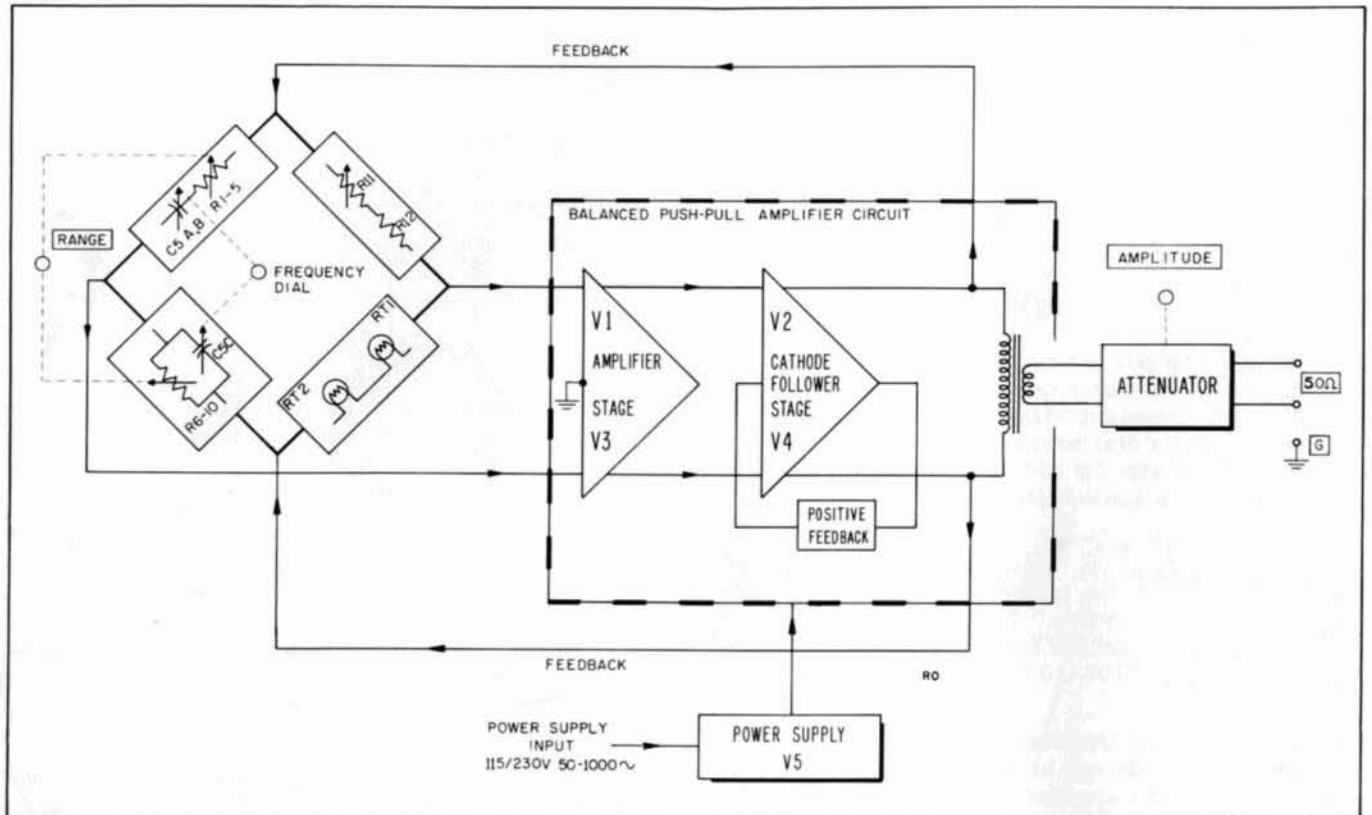

Figure 3-1. Model 200S Block Diagram

SECTION III

THEORY OF OPERATION

3-1. GENERAL.

The Model 200S Oscillator uses a balanced (push-pull) oscillator circuit from which the output is taken directly, avoiding the complication and possible distortion of an isolating amplifier. Reaction of the load on the oscillator is minimized by the use of a low impedance output stage. This arrangement results in a simple, trouble-free circuit having low distortion and high stability over the entire frequency range.

Functionally, the circuits of the Model 200S include a frequency-controlling bridge and balanced push-pull amplifier which constitute the oscillator circuit, an output circuit which may be arranged either for balanced or unbalanced operation, and a power-supply circuit. These are shown in block diagram form in figure 3-1 and in detail in the schematic diagram.

3-2. FREQUENCY-CONTROLLING BRIDGE.

The frequency-controlling circuit is arranged as a floating bridge, symmetrical with respect to ground. With no connection to ground on any terminal of the bridge, stability of calibration is assured since any stray capacity and leakage to ground present at the bridge output terminals do not shunt either the frequency-controlling or amplitude-stabilizing arms of the bridge. The frequency-controlling components (RC networks which are varied by operation of the RANGE switch and frequency dial) comprise two arms of the bridge, while the amplitude-stabilizing components (a voltage divider which includes a thermally-sensitive resistance) comprise the other two arms. The amplitude is stabilized at such a level that the amplifier tubes are operated in the substantially linear portion of their characteristics, which, together with the large negative feedback at harmonic frequencies, results in a very pure sine wave oscillation.

The bridge is fed by the balanced voltage developed at the cathodes of V2 and V4 in the output of the balanced amplifier. The output of the frequency-controlling branch of the bridge is applied to the grid of V3 and the output of the amplitude-stabilizing branch is applied to the grid of V1. The manner in which the voltage-versus-frequency and phase-versus-frequency characteristics of an RC network can be utilized with an amplifier of proper design to achieve an oscillator

which delivers a voltage of excellent stability and waveform is well covered in texts such as Terman & Pettit's Electronic Measurements.

Variable resistor R11 is provided for adjustment of the maximum output amplitude.

Variable capacitors C3, C6, and C7 are adjusted for optimum calibration and frequency response. They should not require adjustment unless the RANGE switch is replaced.

3-3. AMPLIFIER.

The oscillator amplifier is a balanced push-pull circuit which includes a voltage-amplifier stage (V1, V3) and a special cathode-follower stage (V2, V4). Criss-cross positive feedback is used in the cathode-follower stage to provide a low output impedance as seen by the cathode-to-cathode load. The feedback paths are from the plate of V2 to the control grid and screen of V4, and from the plate of V4 to the control grid and screen of V2. The degree of the positive feedback is a function of the load and increases as the load impedance decreases, thus tending to maintain the output constant regardless of load.

Capacitors C10, C11, and C12, and coils L2 and L3 are part of the frequency-compensating circuitry.

The output from the cathode-follower stage (1) returns feedback to the frequency-controlling bridge and (2) supplies the primary winding of the output transformers, which couple the oscillator output to the output circuit.

3-4. OUTPUT CIRCUIT.

Transformer coupling provides isolation between the oscillator circuit and the output circuit, and allows the output to be obtained either balanced or unbalanced. Since a single transformer will operate suitably over only a part of the frequency range covered by the 200S, two transformers are provided. Connections between cathode-followers V2 and V4 and the proper transformer for the band in use are set up by the RANGE switch. The secondary windings of the coupling transformers supply the output attenuator, the setting of which is adjusted by operation of the AMPLITUDE control on the front panel.

Table 4-1. Test Instruments Required

Instrument Type	Minimum Required Specifications	Recommended Instruments
DC Electronic Voltmeter	Sensitivity: 1 volt full scale minimum Input resistance: 10 megohms or higher	Model 410B or 412A Vacuum Tube Voltmeter
AC Electronic Voltmeter	Input impedance: 2 megohms shunted by 40 pf (below the 0.3 volt range) Accuracy: $\pm 3\%$ from 5 cps to 500 kc	Model 403A Transistor Voltmeter
AC Electronic Voltmeter	Input impedance: 10 megohms shunted by 25 pf (below the 0.3 volt range) Accuracy: $\pm 2\%$ from 20 cps to 1 mc	Model 400D/H/L Vacuum Tube Voltmeter
Distortion Analyzer		Model 330B Distortion Analyzer
50-ohm Resistor	50 ohms $\pm 1\%$ to 100 kc	Not Available
Electronic Counter	Frequency and period readings available. Frequency measuring capabilities to at least 600 kc	Models 523C/CR, D/DR or 524C/D Electronic Counters
—or— Frequency Standard	Frequencies available: a) 10 cps b) 100 cps c) 1 kc d) 100 kc Output voltage: 5 volts rms minimum Frequency accuracy: $\pm 0.05\%$	100ER Precision Frequency Standard
—and— (Optional - recommended) Oscilloscope	Frequency range: flat from 5 cps to at least 600 kc	Models 150A, 160B, 170A Oscilloscopes

SECTION IV MAINTENANCE

4-1. INTRODUCTION.

This section contains test and maintenance information for the 200S Oscillator. Included is a quick performance check that may be made with the instrument in its cabinet, as a part of routine maintenance or as a part of your incoming quality control inspection.

The maintenance data provided in this section assumes that maintenance personnel are familiar with the operating procedures and circuit theory given in section II and III respectively.

The 200S should require little maintenance, since all component parts are operated well within the recommended ratings. Should failure occur, however, a troubleshooting paragraph, 4-8, has been included to assist you in quickly localizing the problem.

Tube replacement will probably correct a majority of the difficulties which may develop, however, some readjustment will be necessary after replacement of tubes, stabilization lamps (RT1 and RT2), and other critical parts. Refer to table 4-5 for any necessary adjustment after replacement of these parts.

Small errors may be introduced in the 200S because of the capacitance added to the circuit after cabinet replacement. Therefore, if any adjustments are required in the 200S throughout this section, slide the cabinet over the instrument after the adjustment, and check instrument performance.

4-2. TEST EQUIPMENT REQUIRED.

Table 4-1 lists the test equipment required for maintenance and repair of the 200S. If equipment other than the recommended types are used in the following procedures, make sure it meets the minimum specifications listed in table 4-1.

4-3. PERFORMANCE CHECK.

The following procedure is to verify proper operation and should be accomplished with the instrument in its cabinet. A complete adjustment procedure is given in paragraph 4-7. Proceed as follows:

NOTE

To isolate troubles in the 200S, turn to paragraph 4-7 and follow all steps and note indications, but DO NOT adjust anything. Then refer to table 4-4 for possible causes of readings that are beyond test limits.

A. FREQUENCY RESPONSE.

- 1) Connect the 200S to an ac voltmeter and a 523D Electronic Counter as shown in figure 4-2. Substitute a 403A for the 400D/H/L in figure 4-2.
- 2) Set 200S RANGE to X100, frequency dial to 10. Terminate output in 50 ohms.
- 3) Adjust 200S AMPLITUDE for a convenient reference around 0.9 on the voltmeter scale.
- 4) Starting with the X1 range, rotate the frequency dial across the band while observing the meter.
- 5) Repeat this process for each range. The voltmeter indication should not vary more than ± 1 db throughout the ranges checked.

B. DIAL ACCURACY.

- 1) Set 200S RANGE to X10K, frequency dial to 60. Observe the frequency reading on the 523D Counter.
- 2) Check the frequency at 40, 20, 10 and 5 on the dial.
- 3) Repeat this procedure for the remaining ranges. The frequency should be correct within $\pm 2\%$.

NOTE

For the lower end of the X10 range and the entire X1 range, it will be advantageous to measure the frequency indirectly by switching the 523D FUNCTION SELECTOR to 10 PERIOD AVERAGE. Table 4-2 lists the specifications in terms of period readings for each point on the X1 range. To check X10 range, divide the period limit in table 4-2 by 10.

Table 4-2. Frequency/Period Conversion

Frequency (cps)	Frequency Limits	Period Limits
5	5.1	196.0 ms
	4.9	204.0 ms
10	10.2	98.0 ms
	9.8	102.0 ms
20	20.4	49.0 ms
	19.6	51.0 ms
40	40.8	24.5 ms
	39.2	25.5 ms
60	61.2	16.3 ms
	58.8	17.0 ms

C. DISTORTION.

- 1) Connect the 200S to a 330B Distortion Analyzer as shown in figure 4-4.
- 2) Set 200S RANGE switch and frequency dial to one of the frequencies indicated in table 4-3.
- 3) The 330B switches should be set to the following positions:
 - a. AF-RF to AF
 - b. FREQUENCY to incoming frequency selected in step 2
 - c. Selector switch to SET LEVEL
 - d. RMS VOLTS-DB switch set to +20 db.
- 4) Adjust 330B INPUT control for a zero db reference on the 330B meter.
- 5) Switch selector to DISTORTION.
- 6) Adjust BALANCE and FREQUENCY controls for a dip on the meter.
- 7) Turn RMS VOLTS-DB switch counterclockwise while continually adjusting 330B BALANCE and FREQUENCY until the lowest possible dip is obtained. Specifications are listed in table 4-3.
- 8) Check the remaining frequencies listed in table 4-3 by following steps 1 through 7.

Table 4-3. Distortion Test Frequencies

Range	Frequency	Specifications
X10	100 cps	46 db
X100	1000 cps	46 db
X100	6 kc	46 db
X1K	5 kc	46 db

4-4. CABINET REMOVAL.

To remove the 200S cabinet, proceed as follows:

- 1) Disconnect the 200S from the power source.
- 2) Remove the two screws at the rear of the cabinet. The 200SR rack mount unit has two additional screws on the front panel which must be removed.
- 3) Carefully slide the instrument forward, out of the cabinet.

4-5. 230-VOLT OPERATION.

The following describes circuit modifications necessary to change the 200S power transformer primary from 115-volt operation to 230-volt operation. Figure 4-1 further illustrates this procedure.

- 1) Remove the cabinet as per paragraph 4-4.

- 2) Remove the two bare wire jumpers from the terminal strip as indicated in figure 4-1.
- 3) Add an insulated jumper from the green/black transformer primary wire to the black/yellow one.
- 4) Replace fuse F1 with a 0.6 amp slow-blow fuse (see table 5-1, Replaceable Parts).

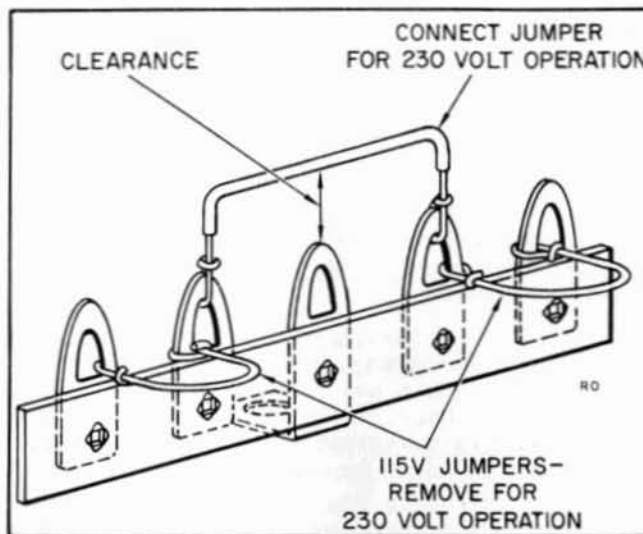

Figure 4-1. 230-Volt Operation

4-6. PERIODIC MAINTENANCE.

The 200S should require a minimum of maintenance, since there are few moving parts. The following procedure performed once or twice a year should insure smooth operation.

- 1) Put one drop of oil in each of the three oil holes on the tuning drive mechanism.
- 2) Place a small amount of high quality contact cleaner on the RANGE switch contacts. Rotate the switch back and forth several times.
- 3) Using compressed air, gently blow any accumulated dust out of the tuning capacitor plates (C5).

4-7. ADJUSTMENT PROCEDURE.

The following is a complete adjustment procedure. Adjustments should be made only if it has been definitely determined that the 200S is not operating within specifications. If the instrument fails to perform within any of the limits given in the following procedure, refer to table 4-4 for possible cause and corrective action.

This procedure can also be an aid in troubleshooting. Simply follow the procedure until the trouble manifests itself as a reading that exceeds the test limit, and then refer to table 4-4 for possible causes.

NOTE: The test indications and limits given in this paragraph are NOT formal performance specifications. Specifications are given in the front of the manual.

In order to minimize the effects of hand capacity, a "tuning wand" or tuning screwdriver with a plastic shank should be used for all adjustments.

A. **TERMINOLOGY.** When the expression "Slip the dial" is used in this text, it has the meaning here specified:

- 1) Remove center knob on frequency dial.
- 2) Loosen the four screws which secure the dial plate to the drive shaft.
- 3) Reset dial to position indicated in the text.
- 4) Tighten the four securing screws. (Center knob may be replaced at the end of this procedure.)

B. **PRELIMINARY CHECKS.** The following basic tests are given to avoid possible unnecessary adjustment of the 200S. If the instrument fails any of these tests, some component is probably at fault and should be replaced before attempting any adjustments. Proceed as follows:

- 1) Power Supply:
 - a. With the instrument turned off, check the resistance from C13 to ground and the resistance across C13. This resistance is typically many megohms. A very low reading (below 100K) indicates a shorted or leaky capacitor between the B+ line and ground.
 - b. Turn the instrument on, and allow it to warm up for at least 15 minutes.
 - c. Check to see that all tubes are glowing.
 - d. Using the 412A, 410B Electronic Voltmeters, or other suitable voltmeter, measure the positive and negative power supply voltages using ground as a reference. The positive voltage (approximately 225 volts) may be measured between the chassis and C14. The negative voltage (approximately 155 volts) is measured from the chassis to the junction of R30, R31 and R40 (figure 4-7). The difference between the negative and positive voltage should be 380 volts \pm 75 volts.

2) Recovery Time:

- a. Switch RANGE to X10K and frequency to 50 kc.
- b. Connect the output of the 200S to an oscilloscope.

- c. Switch from range to range, observing the oscilloscope pattern after each range switching.
- d. The oscilloscope presentation should become stable within 5 seconds after switching ranges.

C. **CALIBRATION.** Calibration procedure for the 200S is divided into two basic parts. The first procedure is intended to effect a flat frequency response for the 200S and is accomplished with the instrument set on the X10 range. The second, accomplished on the X100 range, is given to produce correct frequency dial tracking. Proceed as follows:

1) Frequency Response Adjustments:

- a. Turn 200S RANGE to X10, frequency dial to 5.
- b. Connect the 200S to a 400D/H/L AC Voltmeter and a frequency measuring device (counter or frequency standard) as shown in figures 4-2 or 4-3.
- c. Using 200S AMPLITUDE, set a reference around .9 volts as read on the 400D/H/L meter.
- d. Turn the frequency dial to 60. The 400D/H/L should read within $\pm 1/4$ db of the reference in step C1c and the frequency should be correct within 2%.

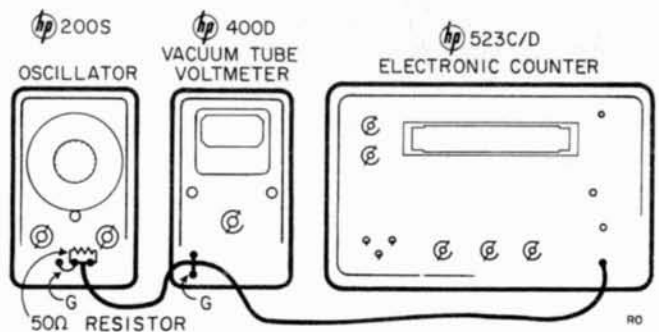

Figure 4-2. Calibration Test Setup

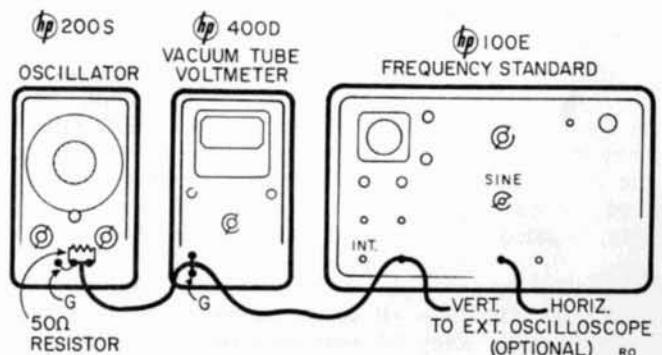

Figure 4-3. Alternate Calibration Setup

- e. If 600 cps is off more than 2%, set the frequency on with C6.

NOTE: Since replacing the cabinet raises the frequency slightly, it is advisable to set the frequency slightly low (e. g., 599 cps) when making this adjustment.

- f. Observe the output voltage and determine how much it differs from the reference.
- g. Adjust C3 to correct for half this difference. Then adjust C6 so that the output frequency is again 600 cps.
- h. Observe the output voltage. If it is more than $\pm 1/4$ db from the reference in step C1c repeat steps C1c through C1h until a flat response is obtained with 600 cps set on frequency (see note above).

2) Frequency Dial Tracking:

- a. Switch 200S RANGE to X100. Connect the equipment as shown in figures 4-2 or 4-3.
- b. Check the frequency at 5. The frequency reading should be 500 cps $\pm 2\%$. If the frequency is off more than $\pm 2\%$ slip the dial to put it on frequency.
- c. If it was necessary to slip the dial, repeat steps C1a through C1h.
- d. If step C2c was necessary, repeat step C2b. It is possible that the entire dial will now track without further adjustment.
- e. Check all numbered points on the dial, beginning at the high end. If some points exceed test limits ($\pm 2\%$), try to equalize the error by slipping the dial to get all points within these limits.
- f. Switch RANGE to X10K, and set the 200S frequency dial to 60.
- g. Adjust C7 to put 600 kc on frequency.
- h. Check calibration on the remaining ranges. Calibration should be correct to $\pm 2\%$.

NOTE: It will be advantageous to set the counter FUNCTION SELECTOR to 10 PERIOD AVERAGE when measuring frequency on the X1 range (refer to table 4-2).

Finally, if the above procedures do not result in correct calibration, start over by adjusting C3 and/or C6 as in step C1 a through h. Then work toward the low end by setting the dial to the next numbered point and bending one of the outer rotor plates in each section of C5 at the point of mesh. Continue this procedure to the low end of the dial to obtain approximately correct frequencies. Repeat the bending procedure from the high end, this time making fine adjustments of frequency with the other outer rotor plates. In this way, bending of any one plate is minimized.

When bending rotor plates, observe the following precautions: (1) Keep all bends as near the shaft as possible. (2) Keep all segments in line. The rotor plates should taper gradually inward or outward, depending on whether you must compress or expand the

frequency range. This gradual taper is essential for linearity. (3) Bending of plates near the high frequency end should be unnecessary.

D. DISTORTION

- 1) Connect the 200S to a 330B Distortion Analyzer as shown in figure 4-4.
 - 2) Set 200S RANGE to X1 and the frequency dial to 20.
 - 3) The 330B switches should be in the following positions:
 - a. AF-RF to AF
 - b. FREQUENCY to 20
 - c. Selector switch to SET LEVEL
 - d. RMS VOLTS-DB switch set to the +20 db position
 - 4) Adjust 330B INPUT control for a zero db reference on the 330B meter.
 - 5) Switch selector to DISTORTION
 - 6) Adjust BALANCE and FREQUENCY controls for a dip on the meter.
 - 7) Turn RMS VOLTS-DB switch counterclockwise while continually adjusting 330B BALANCE and INPUT until the lowest possible dip is obtained.
 - 8) Adjust R50 (dynamic balance) for a dip (minimum distortion) on the 330B meter. Repeat steps 7 and 8 until the lowest possible dip is obtained.
- NOTE: For optimum results use lowest frequency setting of the 200S Wide Range Oscillator.
- 9) Repeat steps 1 through 8, adjusting all 330B controls for 50 cps (60 cps if 50 cps line frequency is being used) instead of 1000 cps.
 - 10) Adjust R51 (Hum Balance) instead of Dynamic Balance on step 8.

E. OUTPUT VOLTAGE.

- 1) Connect the 200S, loaded, to a 400D AC Voltmeter.
- 2) Turn 200S AMPLITUDE fully clockwise, and adjust R11 for 3.5 volts on the 400D meter.

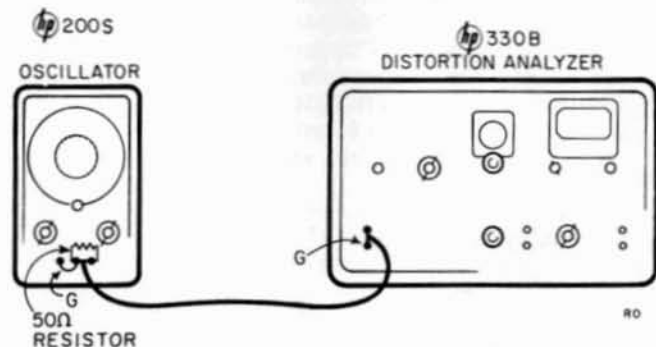

Figure 4-4. Distortion Test Setup

4-8. TROUBLESHOOTING.

The following is intended as a guide to assist in localizing troubles that may occur in the 200S. A good way to locate troubles is to follow the test procedure until the problem appears as a reading that does not meet the test limit. Then refer to table 4-4 for possible causes. The following suggestions are offered to save time in trouble isolation.

A. **POWER SUPPLY.** If the fuse has blown, replace it with a new slow-blow fuse of correct rating. See table 5-1. If the new one does not blow, it is possible that the fuse was defective or the failure was due to a line surge. If the fuse blows again, turn the 200S off, short C14 to ground, and measure the resistance from B+ and B- to ground (observe polarity). This resistance is typically many megohms.

If the resistance is 100K or more, remove V5 and replace the fuse. If it blows again, the trouble is either in T3 or the heater circuit. If the fuse does not

blow, the problem is either a shorted tube or a high voltage breakdown of one of the capacitors between B+ and B-, or B+ and ground (usually C13 or C14).

B. **AMPLIFIER.** In the rest of the instrument, tube failure will most likely be the cause of trouble. DO NOT indiscriminately make adjustments in the 200S. If the instrument is not operating within specifications, try replacing tubes or RT1 and RT2 first. Check tubes by substitution. Results obtained through the use of a "tube checker" may be erroneous and misleading. Mark original tubes so if they are not replaced, they may be returned to the same socket. If tubes are replaced, refer to table 4-5 for required adjustments.

4-9. REPAIR AND REPLACEMENT.**A. SERVICING PRINTED CIRCUIT BOARDS.**

Servicing parts on the etched circuit board requires special care to avoid excessive heat that might

Table 4-4. Troubleshooting

Symptom	Probable Cause	Symptom	Probable Cause
Resistance to ground less than 100K ohms	C13A, B, C leaky C14 leaky C10, 11 shorted	Impossible to set low end on frequency Dial springs back when turned counterclockwise against the stop	Tuning capacitor open too far when fully meshed
Tubes not glowing, pilot light out	Blown fuse F1 S2 defective	Calibration bad on one range only	Dirty RANGE switch contacts C1, C2, C7, or C16 need adjusting One RANGE switch resistor has changed resistance
One or more tubes not glowing, pilot light on	One or more tubes burned out	Excessive distortion on X1-X100 ranges	R50 or R51 adjusted T2 defective
Power supply voltage variation exceeds test limit	C13A, B, C or C14 breaking down under high voltage V5 defective V1-V4 shorted	Excessive distortion on X1K-X10K ranges	R50 or R51 mis-adjusted T1 defective
Turning AMPLITUDE control causes jumpy output	R39 (AMPLITUDE control) defective	Excessive distortion on all ranges	V1-V4 defective RT1-RT2 defective Dust between tuning capacitor plates
Recovery time exceeds test limit	V1, V3 defective RT1, RT2 defective	Impossible to set 3.5 v out with 200S terminated with 50 ohms (adjustment procedure)	RT1, RT2 defective V1-V4 weak
200S obviously microphonic	V1-V4 defective RT1, RT2 defective Tuning capacitor dirty or defective		
Dial springs back when turned clockwise against the stop	Tuning capacitor closed too far when fully meshed		

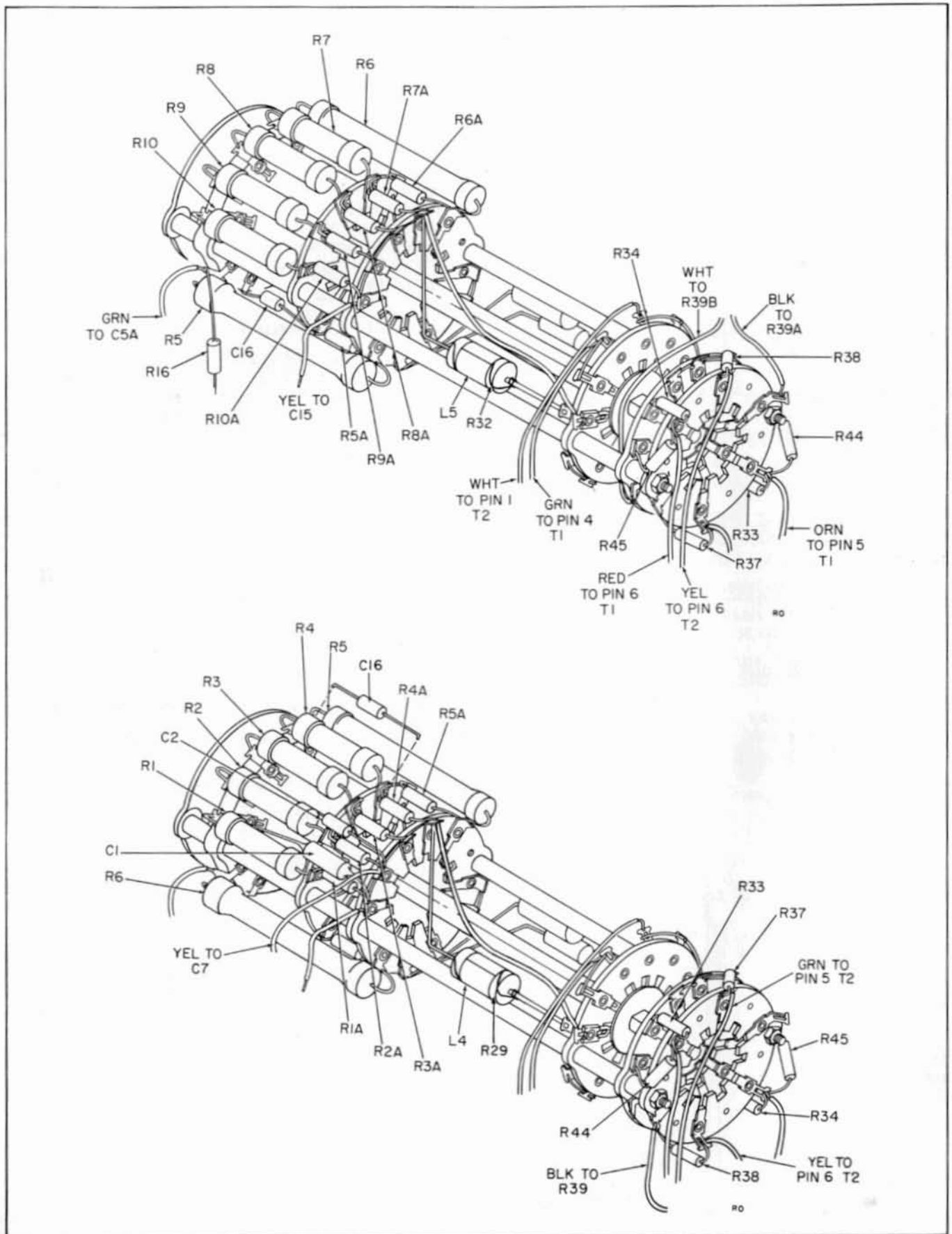

Figure 4-5. Range Switch Detail

damage the board. Refer to figure 4-9 for information concerning parts replacement on etched circuit boards.

B. **TUBE REPLACEMENT.** If V2 or V4 are changed, be careful to replace the special tube shields in their original positions since they also function to increase tube reliability by lowering the operating temperature of the output tubes. When replacing tubes in the 200S, be sure to use the correct replacements as specified in the parts list (table 5-1). Refer to table 4-5 for any necessary adjustments after replacement.

C. **TUNING CAPACITOR REPAIR.** The tuning capacitor should not be loosened unless absolutely necessary, since doing so may cause misalignment of the tuning capacitor shaft with the shaft extension to the gears. If C5A, B, C has been removed or loosened for any reason, it should be readjusted mechanically before any electrical adjustment is attempted. In some cases, due to slippage, the tuning capacitor will not mesh far enough to allow perfect calibration at the extreme low end of the dial. When correctly set, the edge of the insulation protruding from the rotor plate spacer on C5 should line up with the topmost stator spacer when the dial is set fully clockwise.

D. **RANGE SWITCH REPAIR.** Resistor values on S1 have been carefully bridged and adjusted at the factory to the exact value required for proper tracking

on all ranges. If one range is found to be badly out of calibration and all other possibilities have been exhausted (especially dirty RANGE switch contacts) try adjusting the value of C1, C2, C7 or C16 (depending on the range affected) slightly. If any part of the RANGE switch is found to be defective, it is recommended that the switch be replaced as an assembly. Figure 4-6 shows all wiring detail for replacement.

Table 4-5. Replacement of Critical Parts

Ref.	Function	Required Checks or Adjustments
V1, V3	Voltage Amplifier	Recheck Calibration and distortion. Reset output voltage. See paragraph 4-7.
V2, V4	Cathode Followers	Recheck distortion, paragraph 4-7C. Reset output voltage, paragraph 4-7E.
V5	Rectifier	Check power supply voltage (par. 4-7B1).
RT1, RT2	Amplitude Stabilization lamps	Reset output voltage, paragraph 4-7E.

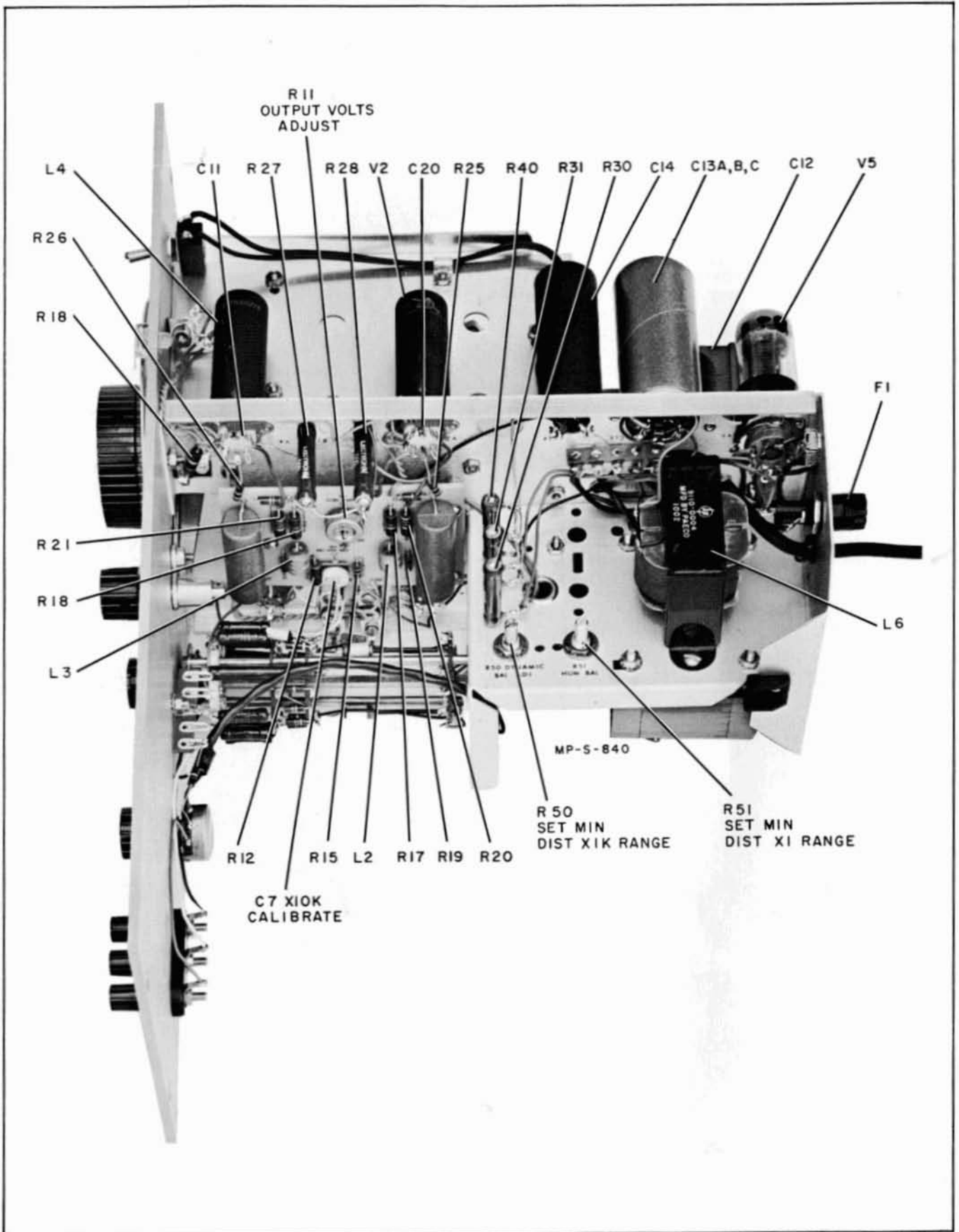

Figure 4-6. Left Side View Model 200S

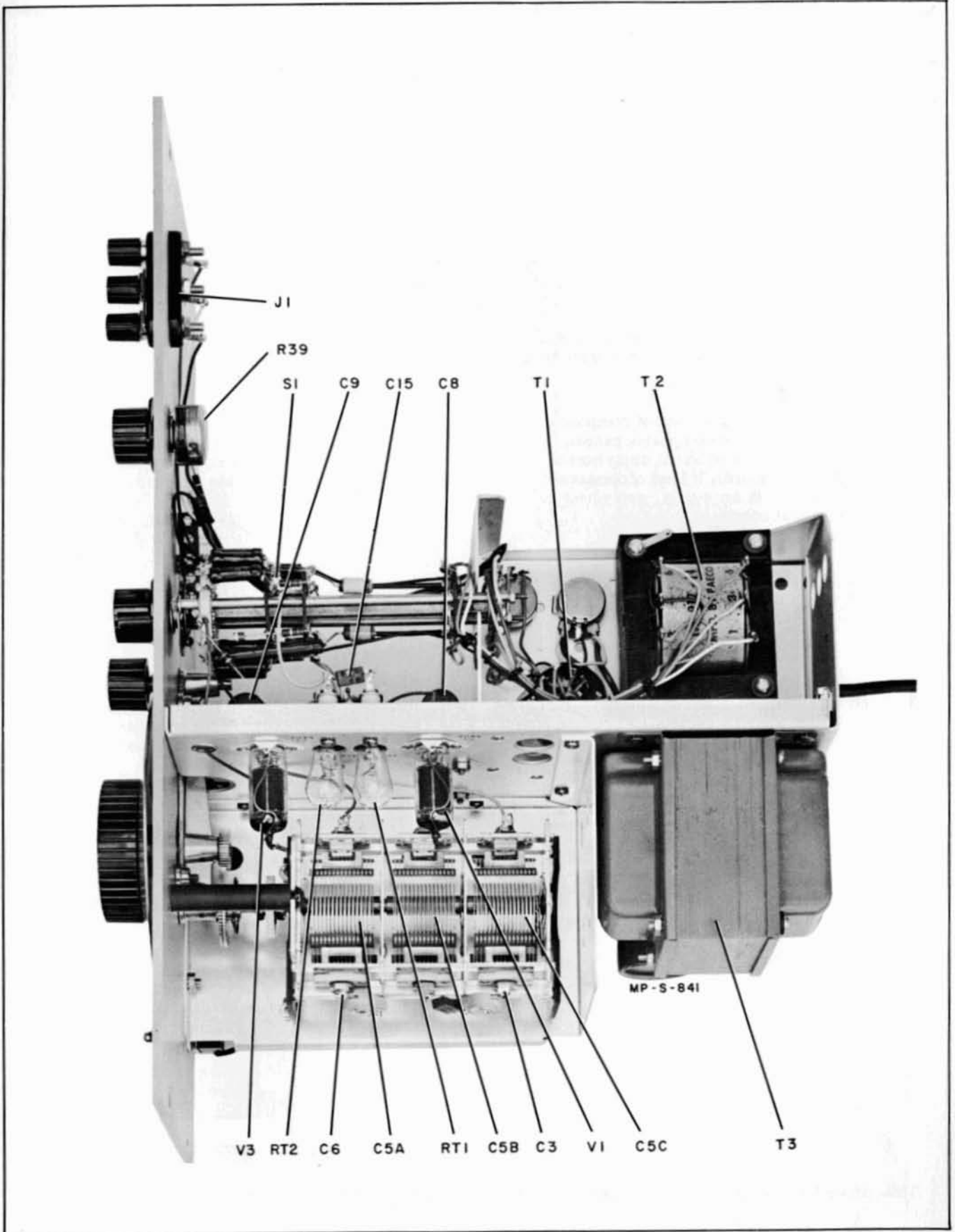

Figure 4-7. Right Side View Model 200S

SERVICING ETCHED CIRCUIT BOARDS

Excessive heat or pressure can lift the copper strip from the board. Avoid damage by using a low power soldering iron (50 watts maximum) and following these instructions. Copper that lifts off the board should be cemented in place with a quick drying acetate base cement having good electrical insulating properties.

A break in the copper should be repaired by soldering a short length of tinned copper wire across the break.

Use only high quality rosin core solder when repairing etched circuit boards. NEVER USE PASTE FLUX. After soldering, clean off any excess flux and coat the repaired area with a high quality electrical varnish or lacquer.

When replacing components with multiple mounting pins such as tube sockets, electrolytic capacitors, and potentiometers, it will be necessary to lift each pin slightly, working around the components several times until it is free.

WARNING: If the specific instructions outlined in the steps below regarding etched circuit boards without eyelets are not followed, extensive damage to the etched circuit board will result.

1. Apply heat sparingly to lead of component to be replaced. If lead of component passes through an eyelet in the circuit board, apply heat on component side of board. If lead of component does not pass through an eyelet, apply heat to conductor side of board.
2. Reheat solder in vacant eyelet and quickly insert a small awl to clean inside of hole. If hole does not have an eyelet, insert awl or a #57 drill from conductor side of board.

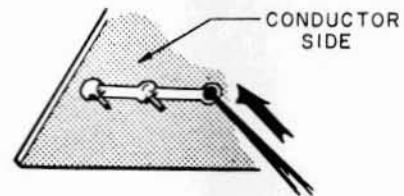
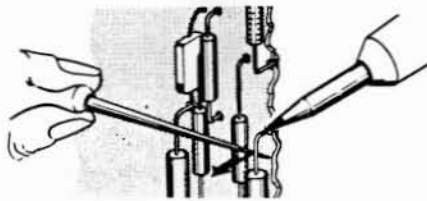

3. Bend clean tinned leads on new part and carefully insert through eyelets or holes in board.
4. Hold part against board (avoid overheating) and solder leads. Apply heat to component leads on correct side of board as explained in step 1.

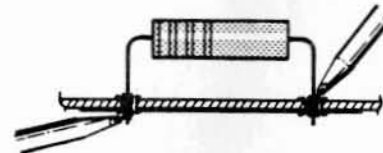
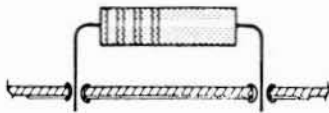

In the event that either the circuit board has been damaged or the conventional method is impractical, use method shown below. This is especially applicable for circuit boards without eyelets.

1. Clip lead as shown below.
2. Bend protruding leads upward. Bend lead of new component around protruding lead. Apply solder using a pair of long nose pliers as a heat sink.

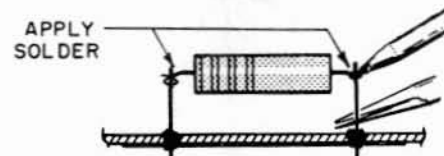
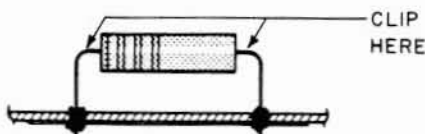

This procedure is used in the field only as an alternate means of repair. It is not used within the factory.

Figure 4-8. Servicing Etched Circuit Boards

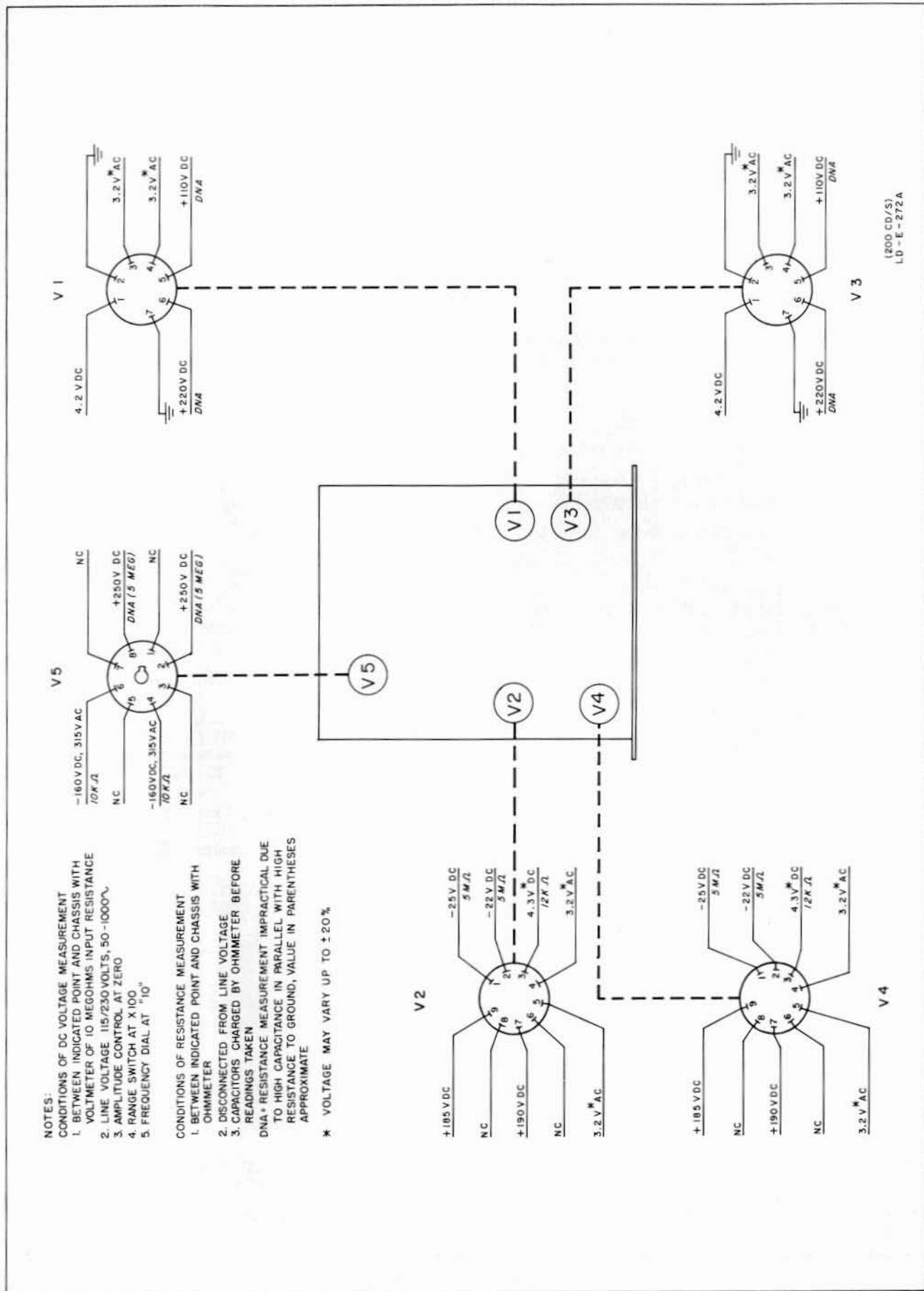
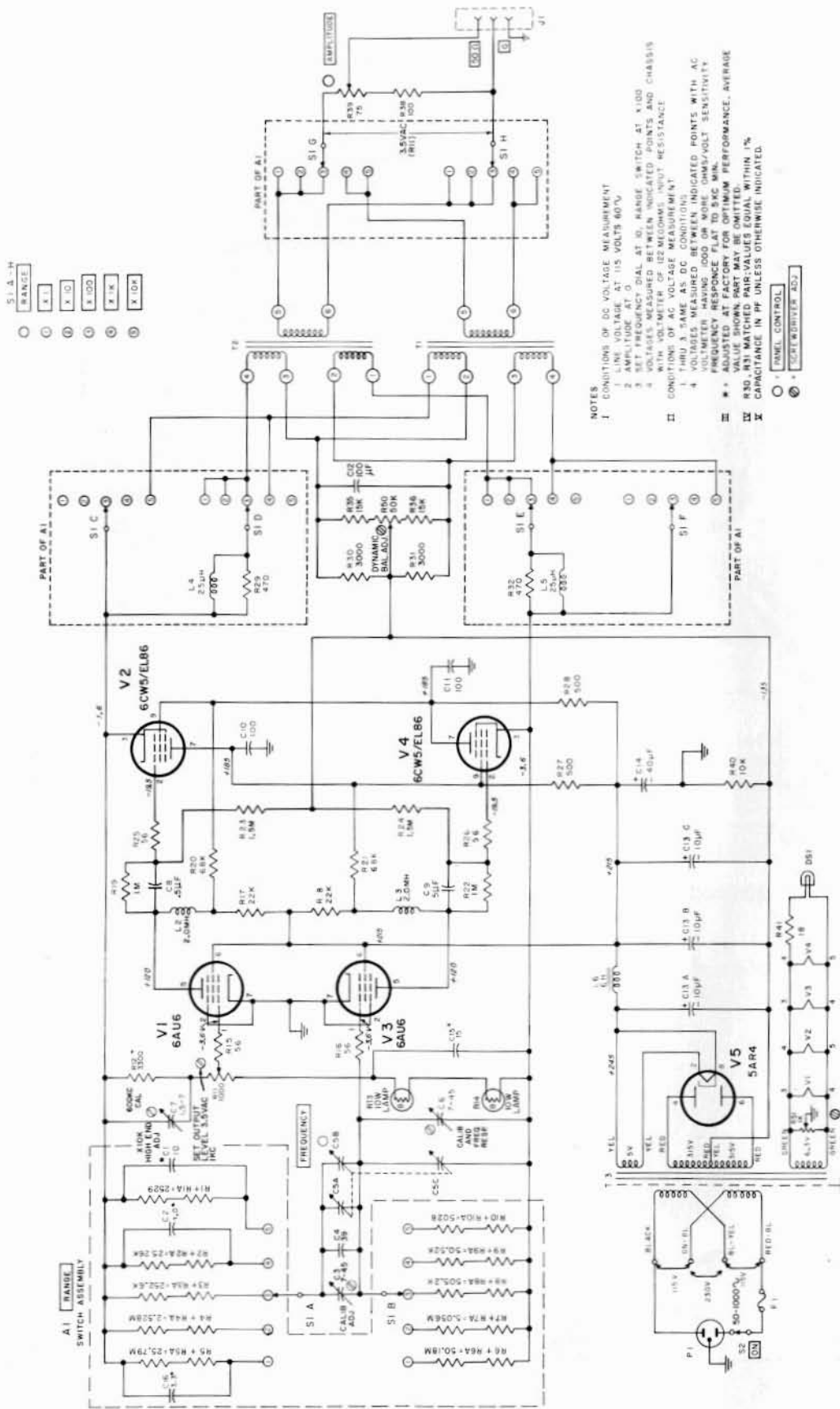

Figure 4-9. Model 200S Voltage and Resistance Diagram



- NOTES
- 1 LINE VOLTAGE AT 115 VOLTS 60%
 - 2 AMPLITUDE AT 0
 - 3 SET FREQUENCY DIAL AT 10 RANGE SWITCH AT X100
 - 4 VOLTAGES MEASURED BETWEEN INDICATED POINTS AND CHASSIS WITH VOLTMETER OF 10Z MEDIUM INPUT RESISTANCE
 - 5 VOLTAGES MEASURED BETWEEN INDICATED POINTS WITH AC VOLTMETER HAVING 1000 OHM OR MORE OHMS/VOLT SENSITIVITY
 - 6 ** ADJUSTED AT FACTORY FOR OPTIMUM PERFORMANCE. AVERAGE FREQUENCY RESPONSE FLAT TO 5KC MIN.
 - 7 500 MA MAXIMUM. MAY BE OBTAINED WITHIN 1% CAPACITANCE IN PF UNLESS OTHERWISE INDICATED.

Figure 4-10. Model 200S Oscillator

SECTION V

REPLACEABLE PARTS

5-1. INTRODUCTION.

This section contains information for ordering replacement parts for the Model 200S Wide Range Oscillator.

Table 5-1 lists replaceable parts in alpha-numerical order of their reference designators. Detailed information on a part used more than once in the instrument is listed opposite the first reference designator applying to the part. Other reference designators applying to the same part refer to the initial designator. Miscellaneous parts are included at the end of the list. Detailed information includes the following:

- 1) Reference designator.
- 2) Full description of the part.
- 3) Manufacturer of the part in a five-digit code; see list of manufacturers in appendix.
- 4) Hewlett-Packard stock number.
- 5) Total quantity used in the instrument (TQ column).

5-2. ORDERING INFORMATION.

To order a replacement part, address order or inquiry either to your authorized Hewlett-Packard sales office (see lists in appendix) or to

CUSTOMER SERVICE
Hewlett-Packard Company
395 Page Mill Road
Palo Alto, California,

or, in Western Europe, to

Hewlett-Packard S. A.
54 Route del Acacias
Geneva, Switzerland.

Specify the following information for each part:

- 1) Model and complete serial number of instrument.
- 2) Hewlett-Packard stock number.
- 3) Circuit reference designator.
- 4) Description.

To order a part not listed in table 5-1, give a complete description of part and include function and location.

Table 5-1. Replaceable Parts (Sheet 1 of 4)

Ckt Ref.	Description	Mfr	hp Stock No.	TQ			
A1	Assembly, range switch Consists of the following: C1, C2, C16, R1 thru R10, S1	28480	200S-19W	1			
C1, 2	Part of Range Switch Assembly A1 components not recommended for field replacement.						
C3	Capacitor: variable, ceramic, 7-45pf, 500 vdcw	72982	0130-0001	2			
C4	Capacitor: fixed, silver mica, 39pf $\pm 2\%$, 500 vdcw	76433	0140-0116	1			
C5	Capacitor: variable, 3 sections, 14-617 pf/sect.	28480	0121-0018	1			
C6	Same as C3						
C7	Capacitor: variable, ceramic, 1.5 - 7pf, 500 vdcw	72982	0130-0011	1			
C8, 9	Capacitor: fixed, mylar, 0.5uf $\pm 10\%$, 400 vdcw	14655	0160-0024	2			
C10, 11	Capacitor: fixed, mica, 100pf $\pm 10\%$, 500 vdcw	76433	0140-0054	2			

Table 5-1. Replaceable Parts (Sheet 2 of 4)

Ckt Ref.	Description	Mfr *	hp Stock No.	TQ*			
C12	Capacitor: fixed, electrolytic, 100uf, 100 vdcw	56289	0180-0013	1			
C13A/B/ C	Capacitor: fixed, electrolytic, 3 sections, 10uf/sect., 450 vdcw	56289	0180-0017	1			
C14	Capacitor: fixed, electrolytic, 40uf, 450 vdcw	56289	0180-0024	1			
C15	Capacitor: fixed, mica, 15pf $\pm 10\%$, 300 vdcw Optimum value selected at factory. Average value shown.	00853	0140-0004	1			
C16	Part of Range Switch Assembly A1; component not recommended for field replacement.						
F1	Fuse, cartridge: 1.25 amp, slow-blow, for 115V operation or Fuse, cartridge: 0.6 amp, slow-blow, for 230V operation	71400 75915	2110-0021 2110-0016	1			
I1	Lamp, incandescent: 6-8V, 0.15 amp, #47	24455	2140-0009	1			
L1	Not assigned						
L2, 3	Inductor, fixed: 2.0 mh	28480	200CD-60C	2			
L4, 5	Coil, R. F., filter: 25uh	28480	200CD-60B	2			
L6	Reactor, filter, choke: 6h	98734	9110-0004	1			
P1	Power cord	70903	8120-0050	1			
R1 thru R10	Part of Range Switch Assembly A1; components not recommended for field replacement.						
R11	Resistor: variable, composition, linear taper, 1000 ohms, $\pm 30\%$, 3/10 W	11237	2100-0154	1			
R12	Resistor: fixed, composition, 3000 ohms $\pm 5\%$, 1 W Optimum value selected at factory. Average value shown.	01121	0689-3025	1			
R13, 14	Lamp, Mazda, 10W	24455	2140-0007	2			
R15, 16	Resistor: fixed, composition, 56 ohms $\pm 10\%$, 1/2 W	01121	0687-5601	4			
R17, 18	Resistor: fixed, composition, 22,000 ohms $\pm 10\%$, 1 W	01121	0690-2231	2			

* See introduction to this section

Table 5-1. Replaceable Parts (Sheet 3 of 4)

Ckt Ref.	Description	Mfr *	Stock No.	TQ*			
R19	Resistor: fixed, composition, 1 megohm $\pm 5\%$, 1/2 W	01121	0686-1055	2			
R20, 21	Resistor: fixed, composition, 68,000 ohms $\pm 10\%$, 1 W	01121	0690-6831	2			
R22	Same as R19						
R23, 24	Resistor: fixed, composition, 1.5 Megohms $\pm 10\%$, 1/2 W	01121	0687-1551	2			
R25, 26	Same as R15						
R27, 28	Resistor: fixed, wirewound, 500 ohms $\pm 10\%$, 10 W	35434	0816-0003	2			
R29	Resistor: 470 ohms, part of L4						
R30, 31	Resistor: fixed, wirewound, 3000 ohms, $\pm 10\%$, 10 W	35434	0816-0002	2			
R32	Resistor: 470 ohms, part of L5						
R33, 34	Not assigned						
R35, 36	Resistor: fixed, composition, 15,000 ohms $\pm 10\%$, 1 W	01121	0690-1531	1			
R37	Not assigned						
R38	Resistor: fixed, composition, 100 ohms $\pm 10\%$, 1/2 W	01121	0687-1011	1			
R39	Resistor: variable, composition, 75 ohms $\pm 10\%$	01121	2100-0076	1			
R40	Resistor: fixed, wirewound, 10,000 ohms $\pm 10\%$, 10 W	35434	0816-0008	1			
R41	Resistor: fixed, composition, 18 ohms $\pm 10\%$, 1 W	01121	0690-1801	1			
R42 thru R49	Not assigned						
R50	Resistor: variable, composition, linear taper, 50,000 ohms $\pm 20\%$, 1/2 W	71590	2100-0013	1			
R51	Resistor: variable, composition, linear taper, 1000 ohms	71590	2100-0036	1			
S1	Part of Range Switch Assembly A1; component not recommended for field replacement.						
S2	Switch, toggle: SPST	04009	3101-0001	1			
T1	Transformer, output: high frequency	28480	200S-9	1			
T2	Transformer, output: low frequency	98734	9120-0049	1			

* See introduction to this section

Table 5-1. Replaceable Parts (Sheet 4 of 4)

Ckt Ref.	Description	Mfr *	Ⓢ Stock No.	TQ*			
T3	Transformer, power	98734	9100-0036	1			
V1	Tube, electron: 6AU6	80131	1923-0021	2			
V2	Tube, electron: 6CW5/EL86	80131	1923-0044	2			
V3	Same as V1						
V4	Same as V2						
V5	Tube, electron: 5AR4	80131	1930-0003	1			
XV2, 4	Socket, tube: 9-pin, ceramic	91662	1200-0072	2			
	<u>MISCELLANEOUS</u>						
	Binding Post Assembly ground with link	28480	5060-0625	1			
	Binding Post Assembly: black	28480	5060-0632	1			
	Binding Post Assembly: red	28480	5060-0633	2			
	Coupler, Yoke; 1/4" shaft	76487	1500-0002	2			
	Disc Ass'y, vernier drive	28480	5040-0607	1			
	Bearing, Capacitor Drive	28480	5020-0618	1			
	Insulator, flexible coupling	28480	5040-0212	1			
	Fuseholder	75915	1400-0084	1			
	Gear Assembly	28480	5060-0020	1			
	Gear Assembly	28480	5060-0021	1			
	Insulator, binding post: black	28480	0340-0087	1			
	Knob: AMPLITUDE	28480	0370-0032	1			
	Knob: RANGE	28480	0370-0035	1			
	Knob: frequency dial vernier	28480	0370-0028	1			
	Knob: frequency dial	28480	0370-0045	1			
	Shield, tube (for V1 and V3)	98978	1220-0029	2			
	Spring, Thrust	28480	5000-0637	1			
	Window, dial	28480	5040-0600	1			

*See introduction to this section

APPENDIX
CODE LIST OF MANUFACTURERS (Sheet 1 of 2)

The following code numbers are from the Federal Supply Code for Manufacturers Cataloging Handbooks H4-1 (Name to Code) and H4-2 (Code to Name) and their latest supplements. The date of revision and the date of the supplements used appear at the bottom of each page. Alphabetical codes have been arbitrarily assigned to suppliers not appearing in the H4 handbooks.

Table with 6 columns: Code No., Manufacturer, Address, Code No., Manufacturer, Address, Code No., Manufacturer, Address, Code No., Manufacturer, Address. Contains multiple entries for various manufacturers and their locations.

APPENDIX CODE LIST OF MANUFACTURERS (Sheet 2 of 2)

Code No.	Manufacturer	Address	Code No.	Manufacturer	Address	Code No.	Manufacturer	Address	Code No.	Manufacturer	Address
81349	Military Specification	85474	R. M. Bracamonte & Co.	San Francisco, Calif.	93929	G. V. Controls	Livingston, N. J.	98220	Francis L. Mosley	Pasadena, Calif.
81415	Wikor Products, Inc.	Cleveland, Ohio	85660	Koiled Kords, Inc.	New Haven, Conn.	93983	Insuline-Van Norman Ind., Inc.	98278	Microdot, Inc.	So. Pasadena, Calif.
81453	Raytheon Mfg. Co., Industrial Components Div., Industr. Tube Operations	Newton, Mass.	85911	Seamless Rubber Co.	Chicago, Ill.	94137	Electronic Division	Manchester, N. H.	98291	Sealectro Corp.	Mamaroneck, N. Y.
81483	International Rectifier Corp.	El Segundo, Calif.	86197	Clifton Precision Products	Clifton Heights, Pa.	94144	General Cable Corp.	Bayonne, N. J.	98405	Carad Corp.	Redwood City, Calif.
81541	The Airpax Products Co.	Cambridge, Mass.	86579	Precision Rubber Products Corp.	Dayton, Ohio	94144	Raytheon Mfg. Co., Industrial Components Div., Receiving Tube Operation	Quincy, Mass.	98731	General Mills	Minneapolis, Minn.
81860	Barry Controls, Inc.	Watertown, Mass.	86684	Radio Corp. of America, RCA Electron Tube Div.	Harrison, N. J.	94145	Raytheon Mfg. Co., Semiconductor Div., California Street Plant	Newton, Mass.	98821	North Hills Electric Co.	Minneapolis, Minn.
82042	Carter Parts Co.	Skokie, Ill.	87216	Philco Corporation (Lansdale Division)	Lansdale, Pa.	94148	Scientific Radio Products, Inc.	98925	Clevite Transistor Prod. Div. of Clevite Corp.	Waltham, Mass.
82142	Jeffers Electronics Division of Spear Carbon Co.	Du Bois, Pa.	87473	Western Fibrous Glass Products Co.	San Francisco, Calif.	94154	Tung-Sol Electric, Inc.	Loveland, Colo.	98978	International Electronic Research Corp.	Burbank, Calif.
82170	Allen B. DuMont Labs. Inc.	Clifton, N. J.	87664	Van Waters & Rogers Inc.	Seattle, Wash.	94197	Curtiss-Wright Corp., Electronics Div.	East Paterson, N. J.	99109	Columbia Technical Corp.	New York, N. Y.
82209	Maguire Industries, Inc.	Greenwich, Conn.	87930	Tower Mfg. Corp.	Providence, R. I.	94222	Southco Div. of S. Chester Corp.	Lester, Pa.	99313	Varian Associates	Palo Alto, Calif.
82219	Sylvania Electric Prod. Inc. Electronic Tube Div.	Emporium, Pa.	88140	Cutler-Hammer, Inc.	Lincoln, Ill.	94310	Tru Ohm Prod. Div. of Model Engineering and Mfg. Co.	Chicago, Ill.	99515	Marshall Industries, Electron Products Division	Pasadena, Calif.
82376	Astron Co.	East Newark, N. J.	88220	Gould-National Batteries, Inc.	St. Paul, Minn.	94330	Wire Cloth Products Inc.	Chicago, Ill.	99707	Control Switch Division, Controls Co. of America	El Segundo, Calif.
82389	Switchcraft, Inc.	Chicago, Ill.	88698	General Mills, Inc.	Buffalo, N. Y.	94682	Worcester Pressed Aluminum Corp.	Worcester, Mass.	99800	Delevan Electronics Corp.	East Aurora, N. Y.
82647	Metals and Controls, Inc., Div. of Texas Instruments, Inc., Spencer Prods.	Attleboro, Mass.	89231	Graybar Electric Co.	Oakland, Calif.	95023	Philbrick Researchers, Inc.	Boston, Mass.	99848	Wilco Corporation	Indianapolis, Ind.
82866	Research Products Corp.	Madison, Wis.	89462	Waldes Kohinoor, Inc.	Cambridge, Mass.	95236	Allies Products Corp.	Miami, Fla.	99934	Renbrandt, Inc.	Boston, Mass.
82877	Rotron Manufacturing Co., Inc.	Woodstock, N. Y.	89636	Carter Parts Div. of Economy Baler Co.	Schenectady, N. Y.	95238	Continental Connector Corp.	Woodside, N. Y.	99942	Hoffman Semiconductor Div. of Hoffman Electronics Corp.	Evanston, Ill.
82893	Vector Electronic Co.	Glendale, Calif.	89665	United Transformer Co.	Chicago, Ill.	95263	Leecraft Mfg. Co., Inc.	New York, N. Y.	99957	Technology Instrument Corp of Calif.	Newbury Park, Calif.
83053	Western Washer Mfr. Co.	Los Angeles, Calif.	90179	U.S. Rubber Co., Mechanical Goods Div.	Passaic, N. J.	95264	Lerco Electronics, Inc.	Burbank, Calif.			
83058	Carr Fastener Co.	Cambridge, Mass.	90970	Bearing Engineering Co.	San Francisco, Calif.	95265	National Coil Co.	Sheridan, Wyo.			
83086	New Hampshire Ball Bearing, Inc.	Peterborough, N. H.	91260	Connor Spring Mfg. Co.	San Francisco, Calif.	95275	Vitramon, Inc.	Bridgeport, Conn.			
83125	Pyramid Electric Co.	Darlington, S. C.	91345	Miller Dial & Nameplate Co.	El Monte, Calif.	95348	Gordas Corp.	Bloomfield, N. J.			
83148	Electro Cords Co.	Los Angeles, Calif.	91418	Radio Materials Co.	Chicago, Ill.	95354	Methode Mfg. Co.	Chicago, Ill.			
83186	Victory Engineering Corp.	Springfield, N. J.	91506	Augat Brothers, Inc.	Attleboro, Mass.	95712	Dage Electric Co., Inc.	Franklin, Ind.			
83298	Bendix Corp., Red Bank Div.	Red Bank, N. J.	91637	Dale Electronics, Inc.	Columbus, Nebr.	95987	Weckesser Co.	Chicago, Ill.			
83315	Hubbell Corp.	Mundelein, Ill.	91662	Elco Corp.	Philadelphia, Pa.	96067	Huggins Laboratories	Sunnyvale, Calif.			
83330	Smith, Herman H., Inc.	Brooklyn, N. Y.	91737	Gremer Mfg. Co., Inc.	Wakefield, Mass.	96095	Hi-Q Division of Aerovox	Olean, N. Y.			
83385	Central Screw Co.	Chicago, Ill.	91827	K F Development Co.	Redwood City, Calif.	96256	Thordarson-Meissner Div. of Maguire Industries, Inc.	Mt. Carmel, Ill.			
83501	Gavitt Wire and Cable Co., Div. of Amerace Corp.	Brookfield, Mass.	91929	Minneapolis-Honeywell Regulator Co., Microswitch Div.	Freeport, Ill.	96296	Solar Manufacturing Co.	Los Angeles, Calif.			
83594	Burroughs Corp., Electronic Tube Div.	Plainfield, N. J.	91961	Nahm-Bros. Spring Co.	Oakland, Calif.	96330	Carlton Screw Co.	Chicago, Ill.			
83740	Eveready Battery	New York, N. Y.	92180	Tru-Connector Corp.	Peabody, Mass.	96341	Microwave Associates, Inc.	Burlington, Mass.			
83777	Model Eng. and Mfg., Inc.	Huntington, Ind.	92196	Universal Metal Prod., Inc.	Bassett Puente, Calif.	96501	Excel Transformer Co.	Oakland, Calif.			
83821	Loyd Scruggs Co.	Festus, Mo.	92367	Elgeet Optical Co., Inc.	Rochester, N. Y.	97464	Industrial Retaining Ring Co.	Irvington, N. J.			
84171	Arco Electronics, Inc.	New York, N. Y.	92607	Tinsolite Insulated Wire Co.	Tarrytown, N. Y.	97539	Automatic and Precision Mfg. Co.	Yonkers, N. Y.			
84396	A. J. Giesener Co., Inc.	San Francisco, Calif.	93332	Sylvania Electric Prod. Inc., Semiconductor Div.	Woburn, Mass.	97966	CBS Electronics, Div. of C. B. S., Inc.	Danvers, Mass.			
84411	Good All Electric Mfg. Co.	Ogallala, Neb.	93369	Robbins and Myers, Inc.	New York, N. Y.	97979	Reon Resistor Corp.	Yonkers, N. Y.			
84970	Sarkes Tarzian, Inc.	Bloomington, Ind.	93410	Stevens Mfg. Co., Inc.	Mansfield, Ohio	98141	Axel Brothers Inc.	Jamaica, N. Y.			
85454	Bonton Molding Company	Bonton, N. J.	93788	Howard J. Smith Inc.	Port Monmouth, N. J.	98159	Rubber Teck, Inc.	Gardena, Calif.			
85471	A. B. Boyd Co.	San Francisco, Calif.									

THE FOLLOWING H-P VENDORS HAVE NO NUMBER ASSIGNED IN THE LATEST SUPPLEMENT TO THE FEDERAL SUPPLY CODE FOR MANUFACTURERS HANDBOOK.

J0000	Winchester Electronics, Inc.	Santa Monica, Calif.
0000F	Malco Tool and Die	Los Angeles, Calif.
0000M	Western Coil Div. of Automatic Ind., Inc.	Redwood City, Calif.
0000P	Ty-Car Mfg. Co., Inc.	Holliston, Mass.
0000Z	Willow Leather Products Corp.	Newark, N. J.
000AA	British Radio Electronics Ltd.	Washington, D. C.
000AB	ETA	England
000AC	Indiana General Corp., Elect. Div.	Indiana
000BB	Precision Instrument Components Co.	Van Nuys, Calif.
000MM	Rubber Eng. & Development	Hayward, Calif.
000NN	A "N" D Manufacturing Co.	San Jose 27, Calif.
000QQ	Cooltron	Oakland, Calif.
000SS	Control of Elgin Watch Co.	Burbank, Calif.
000WW	California Eastern Lab.	Burlingame, Calif.
000YY	S. K. Smith Co.	Los Angeles 45, Calif.

MANUAL BACKDATING CHANGES

MODEL 200S

WIDE RANGE OSCILLATOR

Manual Serial Prefixed: 332-
-hp- Part No. 00200-91902

This manual backdating sheet makes this manual applicable to earlier instruments. Instrument-component values that differ from those in the manual, yet are not listed in the backdating sheet, should be replaced using the part number given in the manual.

Instrument Serial Prefix	Make Manual Changes	Instrument Serial Prefix	Make Manual Changes
229-	1		
129-	1, 2		
103-	1, 2, 3		
001-	1, 2, 3, 4		

NOTE: -hp- Part No. and  Stock No. are synonymous.

CHANGE #1

Table of Replaceable Parts, under miscellaneous,

Add the following:

- Disc, vernier drive 5020-0236
- Disc, vernier drive 5040-0211
- Spring, compression 1460-0019

Delete the following:

- Disc Ass'y Vernier Drive; -hp- Part No. 5040-0607; Mfr. 28480; TQ 1.
- Bearing, Capacitor Drive; -hp- Part No. 5020-0618; Mfr. 28480; TQ 1.
- Spring Thrust; -hp- Part No. 5000-0637; Mfr. 28480; TQ 1.

CHANGE #2

Table 5-1, under miscellaneous,

Add: Coupler, flexible, for 1/4" shaft; -hp- Part No. 1500-0009 and delete the following: Coupler, yoke; -hp- Part No. 1500-0002; Mfr. Millen; TQ 2.

CHANGE #3

R30, 31: Change to resistor, fixed, matched pair, 2500 ohms; -hp- Part No. 200J-26.

R35: Delete.

R50: Change to resistor, variable, composition, 250,000 ohms $\pm 20\%$, 1/4W; -hp- Part No. 2100-0175.

CHANGE #4

Section IV, Paragraph 4-7,

Change step D to read:

CHECK FOR CAUSE OF DISTORTION

A. GENERAL

To check for the cause of distortion, the dc voltage between the cathodes of V2 and V4 should be measured. There should be less than 1 volt between the V2-V4 cathodes, and the voltage read with the RANGE switch on X100 should be the same as that read with the switch on X10. A 20,000 ohms-per-volt, or better, voltmeter may be used for making the measurements. Proceed as follows:

- 1) Set the RANGE switch on X10. Turn the frequency dial to "20".
- 2) Allow a five-minute warm-up period before making the voltage measurements. Connect one terminal of the voltmeter to pin 3 of V2 and the other to pin 3 of V4.

Instrument Serial Prefix	Make Manual Changes	Instrument Serial Prefix	Make Manual Changes
229-	1		
129-	1, 2		
103-	1, 2, 3		
001-	1, 2, 3, 4		

B. EXCESSIVE GRID CURRENT IN V3

- 1) Note the voltmeter reading with the RANGE switch on X10.
- 2) Set the RANGE switch on X100, and note the meter reading: if it differs from that obtained with the switch on X10, excessive grid current in V3 is indicated.
 - a. Before replacing V3 with a new tube, interchange V1 and V3, and again measure the voltage between the V2-V4 cathodes with the RANGE switch on X10 and X100.
 - b. If the V1-V3 interchange has not corrected the trouble, replace V3.

To determine whether the replacement tube has the proper characteristics for the oscillator circuit again measure the distortion.

C. BAD TUBE IN OSCILLATOR

If more than 1 volt is measured between the V2-V4 cathodes, a bad tube in the oscillator is indicated.

To determine which tube is not operating properly, substitute another tube of corresponding JEDEC standard characteristics for each tube, in turn. After each tube substitution, measure the distortion.

NOTE

It is recommended that substitution be made first for V1 or V3 since the characteristics of these tubes more greatly affect the distortion in the output waveform than the characteristics of V2 and V4.

C7: Change to capacitor, variable, ceramic, 1.5-7 pf, 500 vdcw; -hp- Part No. 0130-0003.

C8 and C9: Change to capacitor, fixed, paper, 0.047 μ f \pm 10%, 600 vdcw; -hp- Part No. 0160-0005.

R11: Change to resistor, variable, composition, 1000 ohms \pm 20%, 1/2W; -hp- Part No. 2100-0036.

RT1, RT2: Change to R13, R14 lamp, incandescent, 250V, 10W; -hp- Part No. 2140-0007.

R19, R22: Change to resistor, fixed, composition, 10 megohms \pm 5%, 1/2W; -hp- Part No. 0686-1065.

R23, R24: Change to resistor, fixed, composition, matched pairs, 8.2 megohms, 1/2W; -hp- Part No. 200CD-67.

R50, R51: Delete.

V1, V3: Change to tube, electron, 6SH7; -hp- Part No. 1923-0036.

V2-4: Change to tube, electron, 6AU5GT; -hp- Part No. 1923-0020.

