

181T/TR

# OSCILLOSCOPE

OPERATING  
AND SERVICE  
MANUAL

HEWLETT  PACKARD

COLORADO SPRINGS DIVISION

# HP Archive

This vintage Hewlett Packard document was  
preserved and distributed by

**[www. hparchive.com](http://www.hparchive.com)**

Please visit us on the web !

Scanned by on-line curator: Tony Gerbic

**\*\* For FREE Distribution Only \*\*\***



OPERATING AND SERVICE MANUAL

**MODEL 181T/TR  
OSCILLOSCOPE  
(Including Option 003)**

**SERIAL NUMBERS**

This manual applies directly to instruments with serial numbers prefixed 1503A thru 1531A.

HEWLETT-PACKARD COMPANY/COLORADO SPRINGS DIVISION  
1900 GARDEN OF THE GODS ROAD, COLORADO SPRINGS, COLORADO, U.S.A.

Manual Part Number 00181-90915  
Microfiche Part Number 00181-90815

**PRINTED: MAY 1976**

## TABLE OF CONTENTS

Section	Page	Section	Page
<b>I GENERAL INFORMATION</b> .....	1-1	<b>V PERFORMANCE AND ADJUSTMENTS</b> ...	5-1
1-1. Introduction .....	1-1	5-1. Introduction .....	5-1
1-4. Description .....	1-1	5-3. Equipment Required .....	5-1
1-12. Warranty .....	1-1	5-6. Performance Checks .....	5-1
1-14. Accessories Furnished .....	1-1	5-8. Performance Check Record .....	5-1
1-16. Accessories Available .....	1-1	5-10. Adjustments .....	5-1
1-21. Instrument and Manual Identification .....	1-2	5-12. Performance Check Procedures .....	5-1
1-23. Inquiries .....	1-2	5-13. Preliminary Setup .....	5-1
<b>II INSTALLATION</b> .....	2-1	5-14. Calibrator .....	5-1
2-1. Introduction .....	2-1	5-16. Magnifier .....	5-3
2-3. Initial Inspection .....	2-1	5-18. Bandwidth .....	5-3
2-6. Preparation for Use .....	2-1	5-20. Beam Finder .....	5-3
2-7. Power Requirements .....	2-1	5-22. Persistence and Write Rate .....	5-3
2-9. Three Conductor Power Cable .....	2-1	5-24. Adjustments .....	5-5
2-10. Rack Mounting .....	2-1	5-26. Cover Removal .....	5-5
2-11. Claims .....	2-2	5-27. Preliminary Adjustment Setup .....	5-5
2-13. Repacking for Shipment .....	2-2	5-28. Low Voltage Power Supply (LVPS) .....	5-5
<b>III OPERATION</b> .....	3-1	5-29. High Voltage Power Supply (HVPS) .....	5-5
3-1. Introduction .....	3-1	5-30. Astigmatism .....	5-5
3-3. Controls and Connectors .....	3-1	5-31. Intensity Limit .....	5-5
3-5. Focus and Astigmatism .....	3-1	5-34. Trace Alignment .....	5-6
3-6. Store .....	3-1	5-35. Gate Amplifier Response .....	5-6
3-7. View .....	3-1	5-36. DC Balance .....	5-6
3-8. Norm .....	3-1	5-37. Vernier Balance .....	5-7
3-9. Write .....	3-1	5-38. Horizontal Gain .....	5-7
3-10. Max W. ....	3-1	5-39. Phase Adj .....	5-7
3-11. Erase .....	3-1	5-40. Transient Response .....	5-8
3-12. Persistence and Intensity .....	3-1	5-41. Horizontal Linearity .....	5-8
3-13. Trace Align .....	3-1	5-42. Pulse Circuit .....	5-9
3-14. Find Beam .....	3-1	5-43. Writing Rate .....	5-9
3-15. Display .....	3-3	5-44. Writing Rate Max .....	5-10
3-16. Magnifier .....	3-3	5-45. Calibrator Frequency .....	5-10
3-17. Calibrator .....	3-3	<b>VI REPLACEABLE PARTS</b> .....	6-1
3-18. Aux Outputs .....	3-3	6-1. Introduction .....	6-1
3-19. Z-axis Input .....	3-3	6-3. Ordering Information .....	6-1
3-20. AC Line Input .....	3-3	<b>VII MANUAL CHANGES AND OPTIONS</b> .....	7-1
3-21. Operating Information .....	3-3	7-1. Introduction .....	7-1
<b>IV PRINCIPLES OF OPERATION</b> .....	4-1	7-3. Manual Changes .....	7-1
4-1. Introduction .....	4-1	7-5. Standard Options .....	7-4
4-3. General .....	4-1	<b>VIII SCHEMATICS AND TROUBLE-</b>	
4-14. Variable Persistence and Storage .....	4-3	<b>SHOOTING</b> .....	8-1
4-15. Storage Principles .....	4-3	8-1. Introduction .....	8-1
4-25. Variable Persistence .....	4-4	8-3. Schematics .....	8-1
4-28. Normal .....	4-5	8-9. Reference Designators .....	8-1
4-31. Detailed Description .....	4-5	8-13. Component Locations .....	8-1
4-33. LVPS .....	4-5	8-15. Board Connections .....	8-1
4-44. HVPS and CRT .....	4-6	8-16. Semiconductor Replacement .....	8-1
4-53. Gate Amplifier and Calibrator .....	4-7	8-17. Troubleshooting .....	8-1
4-61. Horizontal Amplifier .....	4-8	8-21. Repair and Replacement .....	8-3
4-67. Pulse Circuit .....	4-8	8-23. High Voltage Supply Repair .....	8-3
4-69. Write .....	4-9	8-24. Heat Sink Removal .....	8-3
4-71. Max W. ....	4-9	8-25. CRT Removal and Replacement .....	8-3
4-73. Norm .....	4-9	8-26. Servicing Circuit Boards .....	8-4
4-74. Store .....	4-9	8-28. Troubleshooting Trees .....	8-4
4-77. View .....	4-9		
4-78. Erase .....	4-9		
4-82. Storage Protection .....	4-9		

### LIST OF ILLUSTRATIONS

Figure	Title	Page	Figure	Title	Page
1-1.	Instrument Serial Number .....	1-2	8-1.	Semiconductor Terminal Identification ...	8-2
2-1.	Power Receptacles .....	2-1	8-2.	Chassis Mounted Component Identification .....	8-9
2-2.	Bench/Rack Mount Conversion .....	2-2	8-3.	Component Identification, Assembly A1 .	8-10
2-3.	Light Shield Removal .....	2-3	8-4.	Component Identification, Assembly A2 .	8-10
3-1.	Front and Rear Panel Controls and Connectors .....	3-2	8-5.	Gate Amplifier Circuit Waveforms .....	8-11
3-2.	Fade Positive and Background Illumination .....	3-4	8-6.	Output and Gate Amplifier .....	8-11
4-1.	Overall Block Diagram .....	4-2	8-7.	Component Identification, Assembly A11 .....	8-12
4-2.	Simplified Storage Construction .....	4-3	8-8.	Component Identification, Assembly A3 .....	8-12
4-3.	Secondary Emission Ratio .....	4-3	8-9.	Horizontal Amplifier Circuit Waveforms .....	8-13
4-4.	Storage Mesh and Surface Potentials During Erasure .....	4-4	8-10.	Horizontal Amplifier .....	8-13
4-5.	Variable Persistence Accomplished Through Erasure .....	4-4	8-11.	Component Identification, Assembly A6 .....	8-14
5-1.	Bright Spots in CRT Display .....	5-4	8-12.	Component Identification, Assembly A10 .....	8-15
5-2.	Phase Adj. Test Setup .....	5-8	8-13.	Pulse Circuit Waveforms .....	8-15
5-3.	Transient Response Adj. Setup .....	5-8	8-14.	Pulse Circuit .....	8-15
5-4.	Pulse Board Adjustments .....	5-9	8-15.	Vertical and Horizontal CRT Connections .....	8-16
5-5.	Typical CRT Display .....	5-11	8-16.	Component Identification, Assemblies A4, A5, and A9 .....	8-16
5-6.	Location of Adjustments and Test Points .....	5-11	8-17.	HV Oscillator Circuit Waveforms .....	8-17
6-1.	Model 181T/TR Mechanical Parts Identification .....	6-0	8-18.	High Voltage Power Supply .....	8-17
			8-19.	Component Identification, Assembly A7 .....	8-18
			8-20.	Component Identification, Assembly A8 .....	8-18
			8-21.	Low Voltage Power Supply .....	8-19
			8-22.	Interconnection Jack (J3) .....	8-20

### LIST OF TABLES

Table	Title	Page	Table	Title	Page
1-1.	Specifications .....	1-2	6-2.	Replaceable Parts .....	6-2
1-2.	Reference Designators and Abbreviations .....	1-4	6-3.	Lists of Manufacturers' Codes .....	6-11
2-1.	Shipping Carton Test Strength .....	2-2	7-1.	Manual Changes .....	7-1
4-1.	LVPS Current Capabilities .....	4-6	8-1.	Schematic Diagram Notes .....	8-0
5-1.	Recommended Test Equipment .....	5-2	8-2.	Troubleshooting Tree .....	8-5
5-2.	Low Voltage Adjustments .....	5-5	8-3.	Troubleshooting Tree .....	8-6
6-1.	Abbreviations for Replaceable Parts List .....	6-1	8-4.	Troubleshooting Tree .....	8-7
			8-5.	Troubleshooting Tree .....	8-7
			8-6.	Troubleshooting Tree .....	8-8
			8-7.	Waveform and DC Voltage Measurement Conditions .....	8-11

## SECTION I

### GENERAL INFORMATION

#### 1-1. INTRODUCTION

1-2. This manual provides operating and service information for Hewlett-Packard Models 181T and TR oscilloscope mainframes. The manual is divided into eight sections, each covering a specific topic or aspect of the instrument. All schematics are located in Section VIII.

#### NOTE

This manual does not apply to the plug-ins. The appropriate plug-in Operating and Service Manual should be referred to.

1-3. This section contains a description of Model 181T/181TR. Instrument specifications are listed in table 1-1. Table 1-2 lists abbreviations used throughout this manual, except in Section VI. The parts list in Section VI is a computer printout and uses computer-supplied abbreviations.

#### 1-4. DESCRIPTION.

1-5. Models 181T and TR are general purpose, variable persistence storage oscilloscope mainframes with plug-in capability. The instruments, as shipped from the factory, are intended for bench use. The Model 181TR can be rack mounted as described in Section II.

1-6. The storage feature can be used to store single-shot occurrences for later viewing or photographing. Comparison of waveforms can be accomplished by storing several separate occurrences and later viewing them simultaneously.

1-7. The horizontal amplifier has a direct-coupled bandwidth of dc to 5 MHz. The ac-coupled bandwidth is 5 Hz to 5 MHz with a dynamic range of  $\pm 20$  volts. The amplifier has front-panel selectable deflection factor ranges of 1 V/div (X1), 0.2 V/div (X5) and 0.1 V/div (X10). A vernier control provides continuous adjustment between ranges. A front-panel BNC connector permits the use of external deflection signals. The external input impedance is 1 megohm shunted by approximately 30 pF.

1-8. A rear-panel BNC connector (Z-Axis Input) is provided for external control of CRT blanking. A signal of approximately +2 V, 50-ns pulse width ( $\ll 10$  MHz) will blank a trace of normal intensity.

1-9. Four rear-panel BNC connectors provide recorder outputs for use with spectrum analyzer plug-ins.

Since these outputs are dependent upon the plug-ins utilized, the appropriate plug-in Operating and Service Manual should be referred to for identification of the output signals available.

#### NOTE

These outputs should not be used when a standard 1800-series plug-in is installed in the oscilloscope.

1-10. A 10 V, 1-kHz square-wave signal is available at the front panel for calibration purposes.

1-11. The cathode ray tube has an internal graticule and P31 aluminized phosphor. Variable persistence and storage are provided by internal elements.

#### 1-12. WARRANTY.

1-13. This instrument is certified and warranted as described inside the front cover of this manual. The CRT is covered by a separate warranty. The CRT warranty and warranty claim form are located at the rear of this manual. Should the CRT fail within the time specified on the warranty, process the warranty claim through your nearest Hewlett-Packard Sales/Service Office.

#### CAUTION

The warranty may be void for instruments having a mutilated serial tag.

#### 1-14. ACCESSORIES FURNISHED.

1-15. The standard Model 181T/TR oscilloscope is supplied with a mesh contrast filter, blue plastic light filter, and a detachable power cord. Also included with the Model 181TR is a rack-mounting kit.

#### 1-16. ACCESSORIES AVAILABLE.

1-17. A series of mobile test stands are available for the Models 181T and 181TR. The Model 1002B Testmobile is intended for use with the cabinet Model 181T. The Model 1117B Testmobile is intended for use with rack-model instruments such as the Model 181TR.

1-18. A front-panel protection cover, Model 10166A, is available for the cabinet Model 181T. A similar cover, HP Part No. 5060-0437, is available for the rack Model 181TR.

1-19. Cameras, probes, viewing hoods, terminations and other accessory items are available for specialized requirements. Information concerning accessories may be obtained from Hewlett-Packard Sales/Service Offices listed in the rear of this manual.

## 1-20. INSTRUMENT AND MANUAL IDENTIFICATION.

1-21. This manual applies directly to Model 181T/TR instruments with serial prefix number as listed on the manual title page. The serial prefix number is the first group of digits in the instrument serial number (figure 1-1). The instrument serial-number tag is located on the rear panel.

1-22. Check the serial prefix number of the instrument. If the serial prefix number is different from that listed on the title page of this manual, refer to Section VII for instructions to adapt this manual for proper instrument coverage.

## 1-23. INQUIRIES.

1-24. Refer any questions regarding the manual, the Manual Changes sheet, or the instrument to the nearest Hewlett-Packard Sales/Service Office. Always identify the instrument by model number, complete name, and complete serial number in all correspondence. Refer to the inside rear cover of this manual for a world-wide listing of Hewlett-Packard Sales/Service Offices.



Figure 1-1. Instrument Serial Number

Table 1-1. Specifications

<p><b>HORIZONTAL AMPLIFIER</b></p> <p><b>EXTERNAL INPUT</b></p> <p><b>Bandwidth:</b> dc-coupled, dc to 5 MHz; ac coupled, 5 Hz to 5 MHz.</p> <p><b>Deflection Factor:</b> 1 V/div, <math>\pm 5\%</math> on X1; 0.2 V/div, <math>\pm 5\%</math> on X5; 0.1 V/div, <math>\pm 5\%</math> on X10. Vernier provides continuous adjustment between ranges. Dynamic Range <math>\pm 20</math> V.</p> <p><b>Input RC:</b> 1 megohm shunted by approximately 30 pF.</p> <p><b>Sweep Magnifier:</b> X5, X10; accuracy <math>\pm 5\%</math>.</p> <p><b>CALIBRATOR</b></p> <p><b>TYPE:</b> approximately 1-kHz square wave, <math>&lt; 3 \mu\text{s}</math> rise time.</p> <p><b>VOLTAGE:</b> 10 V p-p into <math>&gt; 1</math> megohm accuracy <math>\pm 1\%</math>.</p> <p><b>CATHODE-RAY TUBE AND CONTROLS</b></p> <p><b>TYPE:</b> post-accelerator storage tube, 8.5 kV accelerating potential, aluminized P31 phosphor.</p> <p><b>GRATICULE:</b> 8 x 10 div internal graticule, 1 div = 0.95 cm. Subdivisions of 0.2 div on major axes. Front panel adjustment aligns trace with graticule.</p> <p><b>WRITING SPEED:</b> Write mode <math>&lt; 20</math> div/ms. Max write mode <math>&gt; 1</math> div/<math>\mu\text{s}</math>.</p> <p><b>ERASE:</b> Pushbutton erasure takes approximately 300 ms.</p> <p><b>BRIGHTNESS:</b> <math>&gt; 100</math> fL.</p> <p><b>PERSISTENCE:</b> continuously variable from <math>&lt; 0.2</math> s to more than one minute, or normal P31 persistence of approximately 40 <math>\mu\text{s}</math>.</p> <p><b>STORAGE TIME:</b> from WRITE mode to STORE, trace may be stored at reduced intensity for <math>&gt; 1</math> hour. To VIEW mode, traces may be viewed at normal intensity for <math>&gt; 1</math> minute. For MAX</p>	<p>WRITE mode to STORE, trace may be stored at reduced intensity for <math>&gt; 5</math> minutes. To VIEW mode, trace may be stored at normal intensity for <math>&gt; 15</math> seconds.</p> <p><b>INTENSITY MODULATION:</b> approximately +2 V, <math>&gt; 50</math> ns pulse width (<math>&lt; 10</math> MHz sine wave), will blank trace of normal intensity. Input resistance = 5100 ohms.</p> <p><b>BEAM FINDER:</b> pressing FIND BEAM control when operating in any mode except STORE or VIEW brings trace on CRT screen regardless of setting of horizontal or vertical controls.</p> <p><b>OUTPUTS</b></p> <p>Four rear-panel BNC jacks provide recorder outputs for use with spectrum analyzer. Maximum current available is <math>\pm 3</math> mA. Will drive impedances <math>&gt; 1000</math> ohms without distortion.</p> <p><b>GENERAL</b></p> <p><b>ENVIRONMENT</b></p> <p><b>Temperature:</b> <math>0^\circ\text{C}</math> to <math>+55^\circ\text{C}</math>.</p> <p><b>Humidity:</b> to 95% relative humidity to <math>40^\circ\text{C}</math>.</p> <p><b>Altitude:</b> to 4.6 km (15 000 ft).</p> <p><b>Vibration:</b> vibrated in three planes for 15 min. each with 0.254 mm (0.010 in.) excursion, 10 to 55 Hz.</p> <p><b>POWER:</b> 115 Vac or 230 Vac, <math>\pm 10\%</math>, 48-440 Hz, <math>&lt; 225</math> VA max with plug-ins, convection cooled.</p> <p><b>WEIGHT:</b> (without plug-ins) Model 181T: net, 10.9 kg (24 lb); shipping, 18.1 kg (40 lb), Model 181TR (rack): net, 11.8 kg (26 lb); shipping, 18.1 kg (40 lb).</p> <p><b>ACCESSORIES FURNISHED:</b> blue plastic light filter, mesh contrast filter, detachable power cord, and rack mounting hardware (Model 181TR only).</p>
-------------------------------------------------------------------------------------------------------------------------------------------------------------------------------------------------------------------------------------------------------------------------------------------------------------------------------------------------------------------------------------------------------------------------------------------------------------------------------------------------------------------------------------------------------------------------------------------------------------------------------------------------------------------------------------------------------------------------------------------------------------------------------------------------------------------------------------------------------------------------------------------------------------------------------------------------------------------------------------------------------------------------------------------------------------------------------------------------------------------------------------------------------------------------------------------------------------------------------------------------------------------------------------------------------------------------------------------------------------------------------------------------------------------------------------------------------------------------------------------------------------------------------------------------------------------------------------------------------------------------------------------------------------------------------------------------------------------------------------------------------------------	-----------------------------------------------------------------------------------------------------------------------------------------------------------------------------------------------------------------------------------------------------------------------------------------------------------------------------------------------------------------------------------------------------------------------------------------------------------------------------------------------------------------------------------------------------------------------------------------------------------------------------------------------------------------------------------------------------------------------------------------------------------------------------------------------------------------------------------------------------------------------------------------------------------------------------------------------------------------------------------------------------------------------------------------------------------------------------------------------------------------------------------------------------------------------------------------------------------------------------------------------------------------------------------------------------------------------------------------------------------------------------------------------------------------------------------------------------------------------------------------------------------------------------------------------------------------------------------------------------------------------------------------------------------------------------------------------------------------------------

NOTES:

DIMENSIONS IN MILLIMETERS AND (INCHES)  
 EIA RACK HEIGHT (INCLUDING FILLER STRIP)  
 FOR CABINET HEIGHT (INCLUDING FEET) ADD  
 8 (5/16) TO EIA RACK HEIGHT

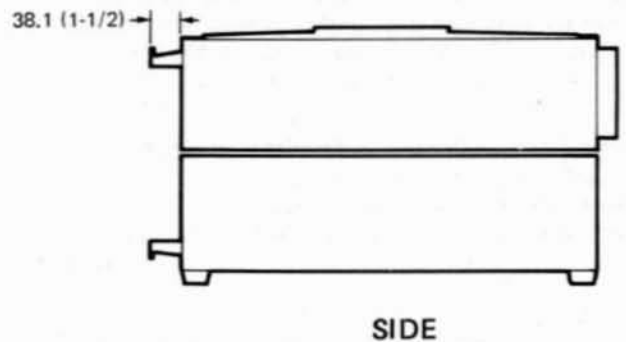
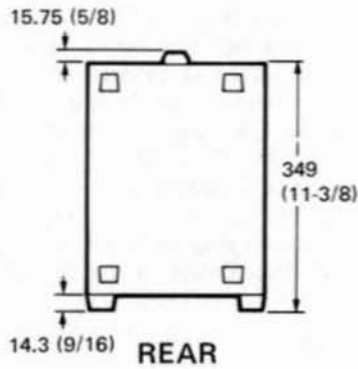
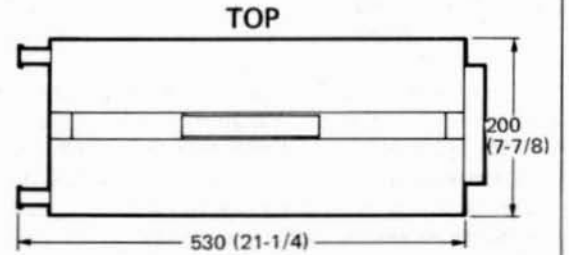
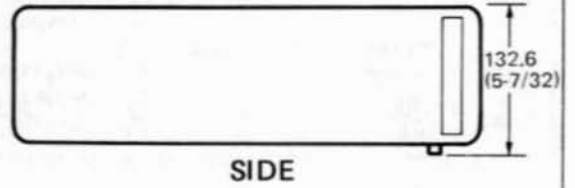
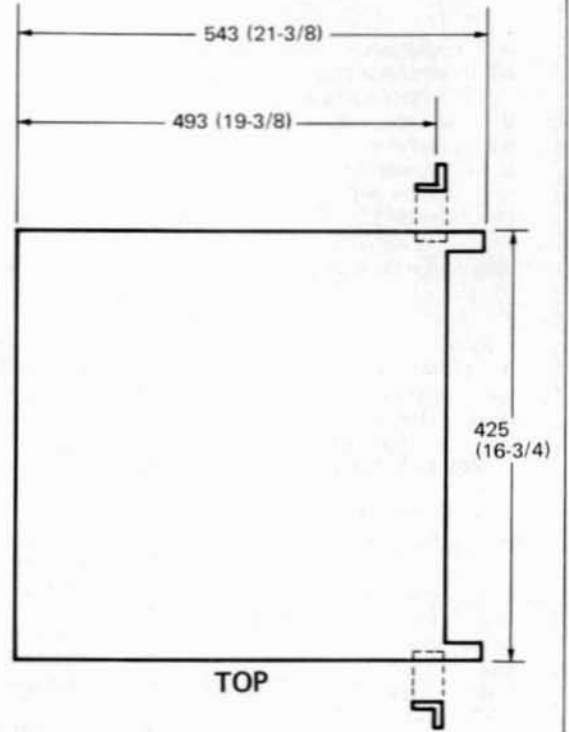
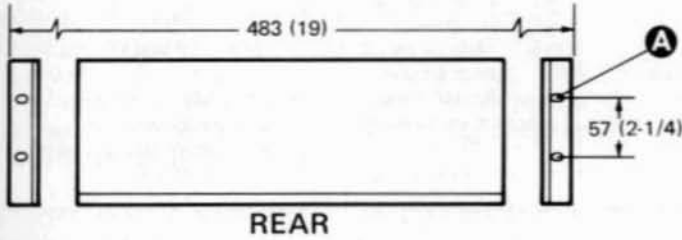
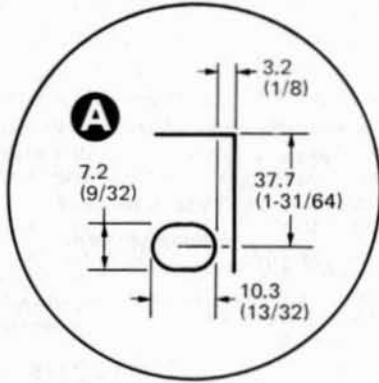



Table 1-2. Reference Designators and Abbreviations

REFERENCE DESIGNATIONS							
<b>A</b>	ASSEMBLY	<b>E</b>	MISC. ELECTRICAL PART	<b>P</b>	PLUG	<b>U</b>	INTEGRATED CIRCUIT (UNREPAIRABLE)
<b>AT</b>	ATTENUATOR RESISTIVE TERMINATION	<b>F</b>	FUSE	<b>PS</b>	POWER SUPPLY	<b>V</b>	VACUUM TUBE, NEON BULB, PHOTOCELL, ETC.
<b>B</b>	MOTOR, FAN	<b>FL</b>	FILTER	<b>Q</b>	TRANSISTOR	<b>VR</b>	VOLTAGE REGULATOR (DIODE)
<b>BT</b>	BATTERY	<b>H</b>	HARDWARE	<b>R</b>	RESISTOR	<b>W</b>	CABLE
<b>C</b>	CAPACITOR	<b>J</b>	JACK	<b>RT</b>	THERMISTOR	<b>X</b>	SOCKET
<b>CP</b>	COUPLING	<b>K</b>	RELAY	<b>S</b>	SWITCH	<b>Y</b>	CRYSTAL
<b>CR</b>	DIODE	<b>L</b>	INDUCTOR	<b>T</b>	TRANSFORMER	<b>Z</b>	NETWORK
<b>DL</b>	DELAY LINE	<b>LS</b>	SPEAKER	<b>TB</b>	TERMINAL BOARD		
<b>DS</b>	DEVICE SIGNALING (LAMP)	<b>M</b>	METER	<b>TP</b>	TEST POINT		
		<b>MP</b>	MECHANICAL PART				
ABBREVIATIONS							
<b>A</b>	AMPERE(S)	<b>F</b>	FARAD(S)	<b>n</b>	NANO ( $10^{-9}$ )	<b>rfi</b>	RADIO FREQUENCY INTERFERENCE
<b>At</b>	AMPERE TURN(S)	<b>FET</b>	FIELD-EFFECT TRANSISTOR(S)	<b>nc</b>	NORMALLY CLOSED	<b>rms</b>	ROOT MEAN SQUARE
<b>ampl</b>	AMPLIFIER(S)	<b>G</b>	GIGA ( $10^9$ )	<b>no.</b>	NORMALLY OPEN	<b>rwv</b>	REVERSE WORKING VOLTAGE
<b>assy</b>	ASSEMBLY	<b>gnd</b>	GROUND(ED)	<b>npn</b>	NEGATIVE-POSITIVE-NEGATIVE	<b>SCR</b>	SILICON CONTROLLED RECTIFIER
<b>ampltd</b>	AMPLITUDE	<b>H</b>	HENRY(IES)	<b>ns</b>	NANOSECOND	<b>s</b>	SECOND(S)
<b>bd</b>	BOARD(S)	<b>h</b>	HOUR(S)	<b>p</b>	PICO ( $10^{-12}$ )	<b>std</b>	STANDARD
<b>bp</b>	BANDPASS	<b>HP</b>	HEWLETT-PACKARD	<b>pc</b>	PRINTED (ETCHED) CIRCUIT(S)	<b>trmr</b>	TRIMMER
<b>c</b>	CENTI ( $10^{-2}$ )	<b>Hz</b>	HERTZ	<b>pk</b>	PEAK	<b><math>\mu</math></b>	MICRO ( $10^{-6}$ )
<b>ccw</b>	COUNTERCLOCKWISE	<b>if.</b>	INTERMEDIATE FREQ.	<b>pnv</b>	POSITIVE-NEGATIVE-POSITIVE	<b><math>\mu</math>s</b>	MICROSECOND
<b>coax.</b>	COAXIAL	<b>intl</b>	INTERNAL	<b>p/o</b>	PART OF	<b>V</b>	VOLTS
<b>coef</b>	COEFFICIENT	<b>k</b>	KILO ( $10^3$ )	<b>p-p</b>	PEAK-TO-PEAK	<b>var</b>	VARIABLE
<b>com</b>	COMMON	<b>kg</b>	KILOGRAM	<b>prgm</b>	PROGRAM	<b>w/</b>	WITH
<b>CRT</b>	CATHODE-RAY TUBE	<b>lpf</b>	LOW-PASS FILTER(S)	<b>prv</b>	PEAK INVERSE VOLTAGE(S)	<b>w/o</b>	WITHOUT
<b>cw</b>	CLOCKWISE	<b>m</b>	MILLI ( $10^{-3}$ )	<b>ps</b>	PICOSECOND	<b>wiv</b>	WORKING INVERSE VOLTAGE
<b>d</b>	DECI ( $10^{-1}$ )	<b>M</b>	MEGA ( $10^6$ )	<b>pwv</b>	PEAK WORKING VOLTAGE		
<b>dB</b>	DECIBEL	<b>ms</b>	MILLISECOND	<b>rf</b>	RADIO FREQUENCY		
<b>ext</b>	EXTERNAL						

## SECTION II

### INSTALLATION

#### 2-1. INTRODUCTION.

2-2. This section contains instruction for performing an initial inspection of the Model 181T/TR. Installation procedures and precautions are presented in step-by-step order. The procedures for making claim for warranty repairs and for repacking the instrument for shipment are also described in this section.

#### WARNING

Read the Safety Summary at the front of this manual before installing or operating the instrument.

#### 2-3. INITIAL INSPECTION.

2-4. The instrument was inspected mechanically and electrically before shipment. Upon receipt, inspect it for damage that may have occurred in transit. Check for broken knobs, bent or broken connectors, and dents or scratches. If damage is found, refer to the claims paragraph in this section. Retain the packing material for possible future use.

2-5. Check the electrical performance of the instrument immediately after receipt. Refer to Section V for the performance check procedure. The performance check will determine whether or not the instrument is operating within the specifications listed in table 1-1. Initial performance and accuracy of the instrument are certified as stated in the front of this manual. If the instrument does not operate as specified, refer to the claims paragraph in this section.

#### 2-6. PREPARATION FOR USE.

**2-7. POWER REQUIREMENTS.** The power cord required depends on, (1) the ac input voltage, and (2) the country in which the instrument is to be used. Figure 2-1 illustrates the standard power receptacle (wall outlet) configurations that are used throughout the United States and in other countries. The HP part number shown directly above each receptacle drawing is the part number for a power cord equipped with the appropriate mating plug for that receptacle. If the appropriate power cord is not included with the instrument, notify the nearest HP Sales/Service Office and a replacement cord will be provided.

2-8. The instrument can operate on either 115 Vac or 230 Vac  $\pm 10\%$ , single phase, 48 Hz to 440 Hz that

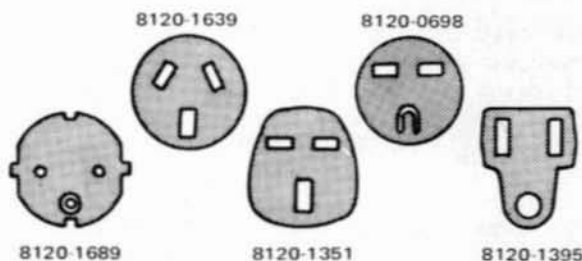

Figure 2-1. Power Receptacles

can deliver approximately 225 volt-amperes. The instrument is normally shipped from the factory set to operate at 115 Vac. To operate from a 230 Vac source, proceed as follows:

- Remove power cord (if connected).
- Set switch on rear panel to 230 V position.

#### NOTE

It is not necessary to replace the 115 volt fuse. Positioning the 115/230 switch selects the proper fuse.

- Install power cord.

**2-9. THREE-CONDUCTOR AC POWER CABLE.** For the protection of operating personnel, Hewlett-Packard Company recommends that the instrument panel and cabinet be grounded. This instrument is equipped with a three-conductor ac power cable that, when connected to an appropriate receptacle, grounds the instrument through the offset pin. The power jack and mating plug of the power cord meet International Electro-technical Commission (IEC) safety standards. To preserve this protection feature when operating from a two-contact outlet, use a three-conductor to two-conductor adapter, and connect the adapter wire to ground at the power outlet.

**2-10. RACK MOUNTING.** A kit for converting the Model 181TR to a rack mount is supplied with each instrument. Instructions for making the conversion are given below. Refer to figure 2-2 for parts identification.

- Detach tilt stand by pressing it away from front feet. Remove all plastic feet by pressing metal button and sliding feet free.

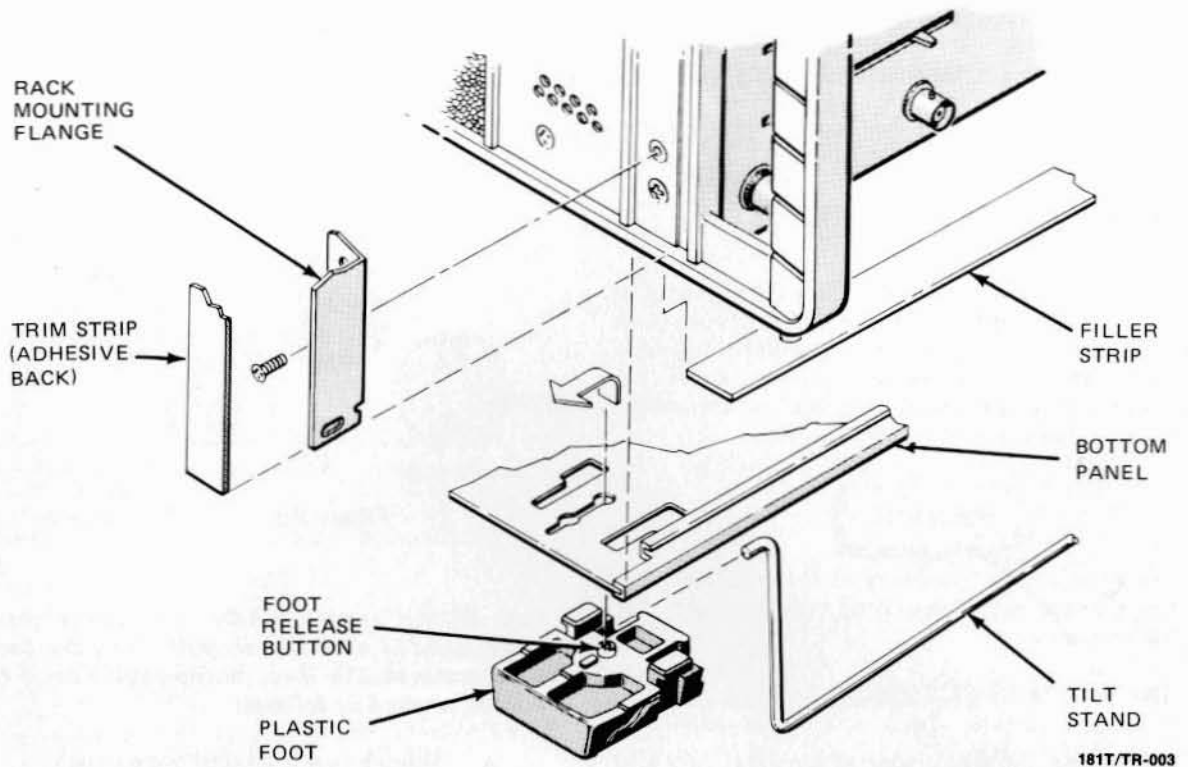

Figure 2-2. Bench/Rack-Mount Conversion

b. Remove aluminum trim strip from each side of instrument with a thin blade tool.

c. Attach rack mounting flange in space from which trim strip was removed (use screws provided with kit). Large notch of flange should be positioned at bottom of instrument.

**2-11. CLAIMS.**

2-12. The warranty statement applicable to this instrument is printed at the front of this manual. The CRT warranty and claims form is located at the rear of this manual. If damage is found or if performance is not as specified, notify the carrier and the HP Sales/Service Office immediately. Refer to the back of this manual for addresses. The HP Sales/Service Office will arrange for repair or replacement without waiting for settlement of a claim with the carrier.

**2-13. REPACKING FOR SHIPMENT.**

2-14. If the instrument is to be shipped to an HP Sales/Service Office for service or repair, attach a

tag showing owner (with address), instrument serial number, and a description of the service required.

2-15. Use the original shipping carton and packing material, if available. If not available, the HP Sales/Service Office will provide information and recommendations on material to be used. Materials for shipping an instrument normally include the following:

- a. A double-walled carton. Refer to table 2-1.
- b. Heavy paper or sheets of cardboard to protect all instrument surfaces; use a nonabrasive material such as Kimpak around all projecting parts.

Table 2-1. Shipping Carton Test Strength

Gross Weight (lb)	Carton Test Strength (lb)
up to 10	200
up to 30	275
30 to 120	350
120 to 140	500
140 to 160	600

c. At least 4 inches of tightly packed, industry-approved, shock-absorbing material such as extra-firm polurethane foam.

## SECTION III

### OPERATION

#### 3-1. INTRODUCTION.

3-2. This section provides general operating instructions and applications information for Model 181T/TR. Front- and rear-panel controls and connectors are identified and briefly described in figure 3-1.

#### 3-3. CONTROLS AND CONNECTORS.

3-4. The following paragraphs provide detailed description of controls and connectors.

3-5. **FOCUS AND ASTIGMATISM.** These controls provide sharp and uniform display over the entire CRT viewing area. To adjust, press WRITE pushbutton and (with a low-intensity spot on the CRT screen) adjust FOCUS and ASTIG controls for a small, round, sharply focused spot.

#### NOTE

It may be necessary to adjust for best average in center area of CRT.

3-6. **STORE.** To store the CRT display, press the STORE pushbutton. The signal will be stored at reduced intensity, resulting in a storage time of greater than one hour. The INTENSITY, PERSISTENCE, FOCUS, ERASE, and HORIZONTAL POSITION controls do not affect the presentation in the STORE mode.

3-7. **VIEW.** To observe a previously stored display, press the VIEW pushbutton. The stored display will be intensified to a brightness level established by the intensity and persistence values selected during the write process. The INTENSITY, PERSISTENCE, FOCUS, ERASE, and POSITION controls do not affect the display.

3-8. **NORM.** This operating mode disables the variable persistence and storage features of the instrument. It will now function as a conventional, general purpose, oscilloscope. The PERSISTENCE control does not function in this mode.

#### CAUTION

Always adjust INTENSITY in WRITE mode with minimum PERSISTENCE for no blooming, then switch to NORM. Do not increase intensity beyond this level while in NORM.

3-9. **WRITE.** Pressing the WRITE pushbutton establishes the CRT in a condition for variable persistence display of a signal which can later be stored. Use the minimum INTENSITY and maximum PERSISTENCE required to obtain the desired display.

3-10. **MAX W.** Operation in the max write mode (MAX W.) provides a more rapid build-up and display of fast single-shot signals. Because the background illumination also increases more rapidly, the CRT contrast level and storage time are reduced.

3-11. **ERASE.** Pressing the ERASE pushbutton will remove stored signals from the CRT when either the WRITE or MAX W. pushbutton is pressed. ERASE should always be pressed after switching to WRITE or MAX W. to condition the CRT.

3-12. **PERSISTENCE AND INTENSITY.** These controls determine the viewing time of a signal being displayed. The INTENSITY control sets brightness of the trace as it is written. The PERSISTENCE control is used to establish the desired duration of signal viewing without rewriting. It accomplishes this by varying the rate which the displayed signal decays.

#### CAUTION

Excessive intensity for long duration will damage the CRT storage mesh. The INTENSITY setting for any sweep speed should be at minimum usable intensity.

3-13. **TRACE ALIGN.** The TRACE ALIGN adjustment compensates for external magnetic fields which may affect the alignment of the horizontal trace with the graticule. The alignment should be checked and adjusted if necessary, when the instrument is moved to a new location.

3-14. **FIND BEAM.** Off-screen positioning of the CRT beam may occur due to improper control settings or a very high dc input signal. The beam may be brought back on screen by pressing the FIND BEAM pushbutton. While pressing FIND BEAM adjust the horizontal and vertical position controls to center the display (refer to the plug-in manuals). Adjust the INTENSITY control to obtain a visible trace.

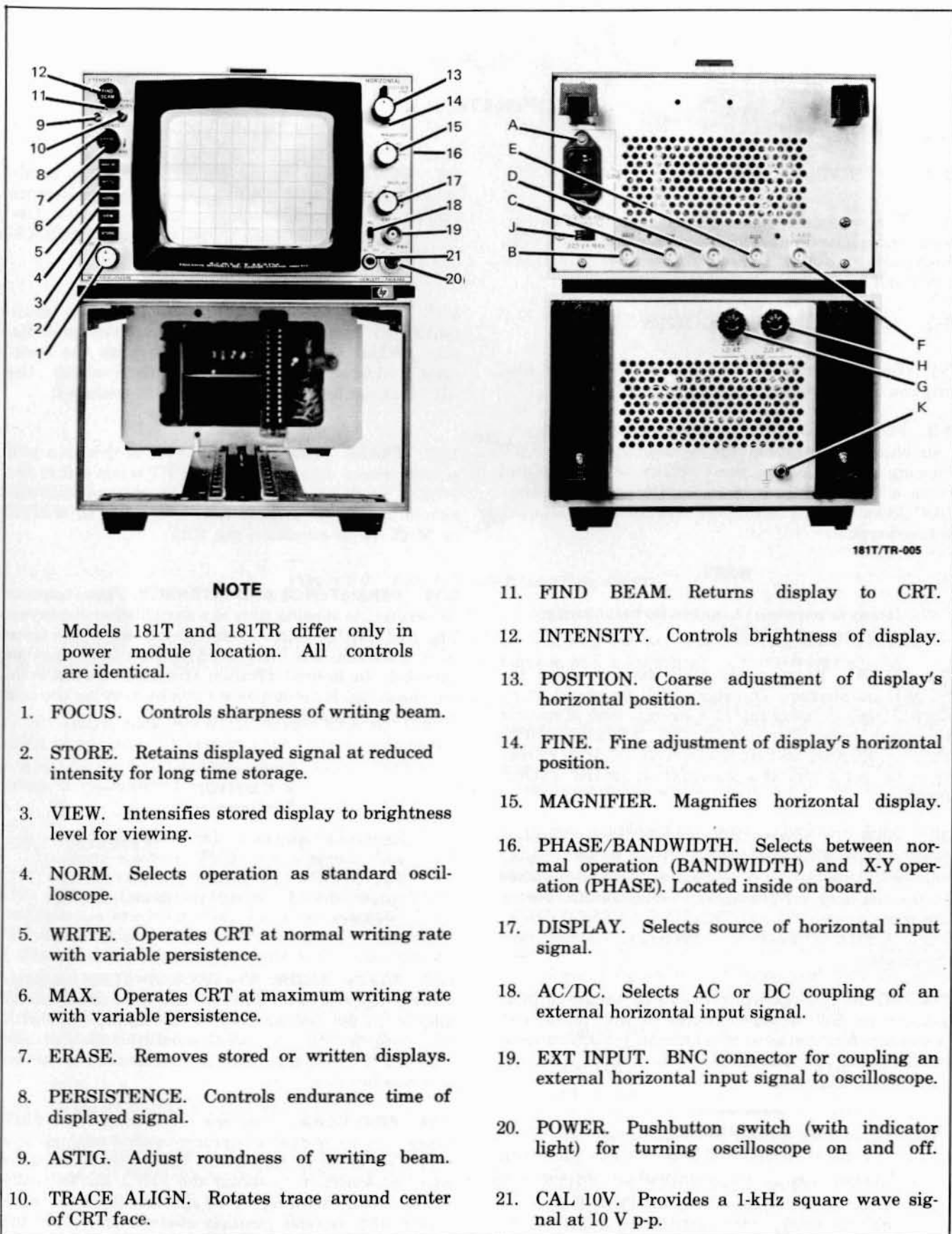

Figure 3-1. Front and Rear Panel Controls and Connectors

REAR PANEL	
A. AC INPUT. 3-wire ac power line input jack.	F. Z-AXIS INPUT. BNC for connecting external intensification or blanking signal.
B. AUX A. BNC for connecting recorder output.	G. FUSE. AC line fuse for 230 Vac operation.
C. AUX B. BNC for connecting recorder output.	H. FUSE. AC line fuse for 115 Vac operation.
D. AUX C. BNC for connecting recorder output.	I. LINE SWITCH. Input power switch for selection of 115 Vac or 230 Vac operation.
E. AUX D. BNC for connecting recorder output.	J. GROUNDING CONNECTOR. 3-way connector jack for instrument grounding.

Figure 3-1. Front and Rear Panel Controls and Connectors (Cont'd)

**3-15. DISPLAY.** This control selects the input signal to the horizontal amplifier. With the DISPLAY control set to EXT CAL, the external horizontal input signal is coupled directly to the horizontal amplifier. As the DISPLAY control is rotated ccw, the external signal is increasingly attenuated to at least 10 V (div in X1). When the DISPLAY control is fully ccw (INT), the external input signal is disconnected and the internal sweep is coupled directly to the horizontal amplifier.

**3-16. MAGNIFIER.** The MAGNIFIER provides selected gain levels in the horizontal amplifier of X1, X5, or X10. In the X5 or X10 positions, horizontal gain is increased to provide a magnified display of five or ten times, respectively. The MAGNIFIER is usable in both internal and external sweep modes.

**3-17. CALIBRATOR.** A square-wave signal of approximately 10 V, 1 kHz can be used for vertical sensitivity calibration and for probe compensation adjustment. The CALIBRATOR output amplitude is accurate within  $\pm 1\%$ . Rise time of the square-wave output is less than 3  $\mu$ s.

**3-18. AUX OUTPUTS.** Four rear-panel BNC connectors provide recorder output for use with spectrum analyzer plug-ins. Refer to the plug-in operating and service manual for information about the use of these outputs.

#### NOTE

These outputs should not be used when a standard 1800-series plug-in is installed in the oscilloscope, or calibrated performance of the plug-in will be degraded due to loading.

**3-19. Z-AXIS INPUT.** An external signal can be utilized for control of CRT intensity. A rear-panel BNC connector permits a direct connection to the CRT intensity gate amplifier. A signal of approximately +2 V, 50-ns pulse width ( $\leq 10$  MHz) will blank a trace of normal intensity. Input of a negative signal can be used for beam intensification.

**3-20. AC LINE INPUT.** A three-conductor ac input jack is provided for power input. Also located on the rear panel is the 115 V - 230 V slide switch and required fuses for either 115 Vac or 230 Vac operation.

#### 3-21. OPERATING INFORMATION.

3-22. The following paragraphs provide additional information concerning the use of Model 181T/TR functions.

3-23. For normal persistence operation, press WRITE pushbutton and turn PERSISTENCE control fully ccw. Slowly rotate INTENSITY cw to a point where no trace blooming occurs. Press NORM pushbutton; do not increase INTENSITY while in NORM mode. If sweep speed is changed, always check for proper intensity using the above procedure.

#### CAUTION

When not actively using the oscilloscope, switch to STORE or VIEW mode. This turns off the write gun and eliminates the possibility of burning the storage mesh. When in WRITE, NORM, or MAX W. mode, any visible trace may cause permanent damage to the CRT if the display is left for prolonged periods of time. To prevent such damage, periodically erase the display, or switch to STORE mode if image retention is desired.

3-24. For variable persistence operation, press WRITE pushbutton. Use minimum INTENSITY and maximum PERSISTENCE compatible with display.

3-25. Use MAX W. mode only for fast sweep time, single shot display, or to improve uniformity of trace intensity. The MAX W. mode causes more rapid positive fading (figure 3-2A) on CRT and persistence or storage time of display is reduced.

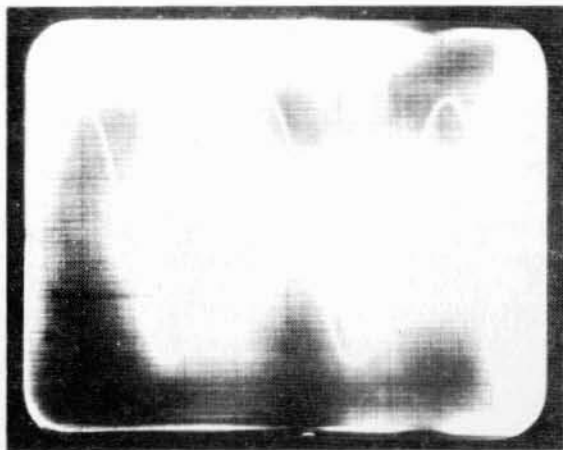
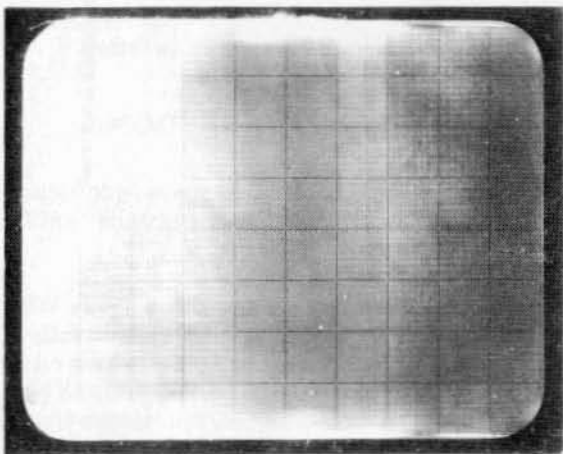
AB

181T/TR-006

Figure 3-2. Fade Positive and Background Illumination

3-26. To store a display, press WRITE pushbutton, adjust INTENSITY and PERSISTENCE for desired display, and then press STORE pushbutton.

3-27. To store more than one display, press WRITE pushbutton, set PERSISTENCE fully ccw and INTENSITY as required; allow first display to be stored on CRT. Set INTENSITY fully ccw and con-

nect second signal to be stored. Reset vertical POSITION if second display is not to be superimposed on first. Slowly rotate INTENSITY cw until second display appears and then press STORE pushbutton.

3-28. A display that is stored when power is turned off will remain stored for several days. To redisplay stored waveform, press STORE pushbutton and turn POSITION controls fully ccw before turning power on. Apply power and allow 5 minutes warm-up. Press VIEW pushbutton to observe waveform.

3-29. To erase all persistent or stored displays, set mode to WRITE or MAX W. Press ERASE pushbutton.

3-30. If only a portion of a slow sweep display is desired, press STORE pushbutton when trace has been written to desired point: write gun is blanked and written portion is stored.

3-31. To write or store single-shot phenomena, a trial setting of INTENSITY is the best approach. Amplitude of phenomena and sweep-time required to display them will affect persistence. For example, with maximum PERSISTENCE and some setting of INTENSITY, a single-shot straight-line may bloom (figure 3-2A). A single-shot signal with amplitude variations may not cause blooming. To determine best INTENSITY setting, connect a signal that approximates sweep time and amplitude of single-shot signal to be written. Set PERSISTENCE fully cw and trigger a single sweep of test signal. Set INTENSITY as high as possible without causing blooming. Repeat this procedure, varying INTENSITY, until proper display is obtained. This should give maximum persistence to single-shot display. After signal has been written, press STORE pushbutton to retain display.

3-32. Single-shot signals that require a sweep time faster than 20 microseconds per division can be written with more brightness by switching to the MAX W. mode. The screen will be unevenly illuminated after erasing when in MAX W. (figure 3-2B). INTENSITY however, can be set high enough to make display visible through illumination. A display written in MAX W. will be obscured more rapidly by positive fading than a signal written in WRITE.

## SECTION IV

### PRINCIPLES OF OPERATION

#### 4-1. INTRODUCTION.

4-2. This section provides circuit theory analysis of the Model 181T/TR oscilloscope. An overall block diagram description keyed to figure 4-1 is presented first, followed by a detailed description of the individual circuits. Because variable persistence and storage techniques may be somewhat unfamiliar to the reader, basic theory of operation will be explained following the block diagram description.

#### 4-3. GENERAL.

4-4. The Model 181T/TR oscilloscope mainframe consists of a low-voltage power supply, a high-voltage power supply, a CRT, a gate amplifier, and a horizontal amplifier similar to a standard oscilloscope. In addition, there is a pulse circuit to initiate the variable persistence and storage functions. The mainframe also contains a calibrator to compensate probes and check sensitivity should standard vertical and horizontal plug-ins be installed. There are four rear-panel outputs from the frequency domain plug-ins that can be used to drive an external recorder. These outputs should not be used if standard plug-ins are installed.

4-5. The instrument may be operated as a variable persistence and storage oscilloscope, or as a conventional oscilloscope when operated in NORM mode. However, the write gun beam must still pass through the storage mesh in NORM, thus the presentation will be dimmer than for a conventional oscilloscope. Any attempts to make the trace as bright as a conventional oscilloscope may damage the storage surface of the CRT.

4-6. Three basic signals are necessary to obtain a usable CRT display, horizontal deflection, vertical deflection, and intensity (or unblanking). The circuitry for horizontal and intensity signals will be explained in the following paragraphs, referenced to figure 4-1. The vertical deflection signal is coupled directly to the CRT plates from the frequency domain or vertical plug-in. These plug-ins are covered by separate manuals.

4-7. The low-voltage power supply produces seven dc voltages. Three of these are used only in the mainframe and four are used both in the mainframe and the plug-ins.

4-8. The high-voltage power supply produces operating potentials for the CRT grid and cathode. In addition, there is a multiplier assembly that increases the voltage to  $\approx 7$  kV for the CRT post accelerator.

4-9. The CRT contains a standard write gun assembly to initiate and form a beam, and deflection plates to control the beam. In addition, there are two flood guns and two added meshes for the variable persistence and storage functions. To help form the flood electrons in the variable persistence and storage mode, a collimation voltage is tied to the aquadag coating in the CRT funnel. The post-accelerator voltage is tied to a silver ring around the inner face of the CRT.

4-10. The unblanking gate amplifier unblanks the normally off CRT. Internal inputs to the gate amplifier include; an unblanking gate from the frequency domain or time base plug-in, or chopped blanking from a frequency domain or vertical plug-in. These inputs are summed with a current level from the front-panel INTENSITY control to adjust the beam level. If EXT (external) display is selected,  $-100V$  is disconnected from the plug-in, so no unblanking gate can be initiated and applied to the amplifier input to give a level similar to an unblanking gate. This is summed with the intensity level to control the beam. Chopped blanking, as well as Z-axis, may also be applied in the external display mode. Input to the gate amplifier from the storage pulse circuit is normally off, except when STORE, VIEW, or ERASE is selected. When on, this input inhibits any other inputs from unblanking the beam.

4-11. There are two outputs from the gate amplifier. One is a positive pulse that controls the CRT grid. The other is a negative spike generated on the trailing edge of the gate and is used by the plug-in as an ALT signal for switching between vertical input channels.

4-12. If INT is selected by the HORIZONTAL DISPLAY switch, the sweep is coupled from the frequency domain or time base plug-in to the horizontal amplifier input. This sweep is summed with a current from the POSITION control, amplified, and changed to a differential signal to provide horizontal deflection. When EXT is selected horizontal drive is supplied by an external input thru the horizontal impedance converter.

4-13. Pushbuttons on the front panel allow selection of the various functions available. The switches control circuitry on the pulse board, which in turn controls elements within the CRT to give the variable persistence, storage, or conventional modes of operation. Pulses from the calibration circuit are transferred to the pulse circuit to be shaped for use by the CRT elements in the variable persistence and storage modes.



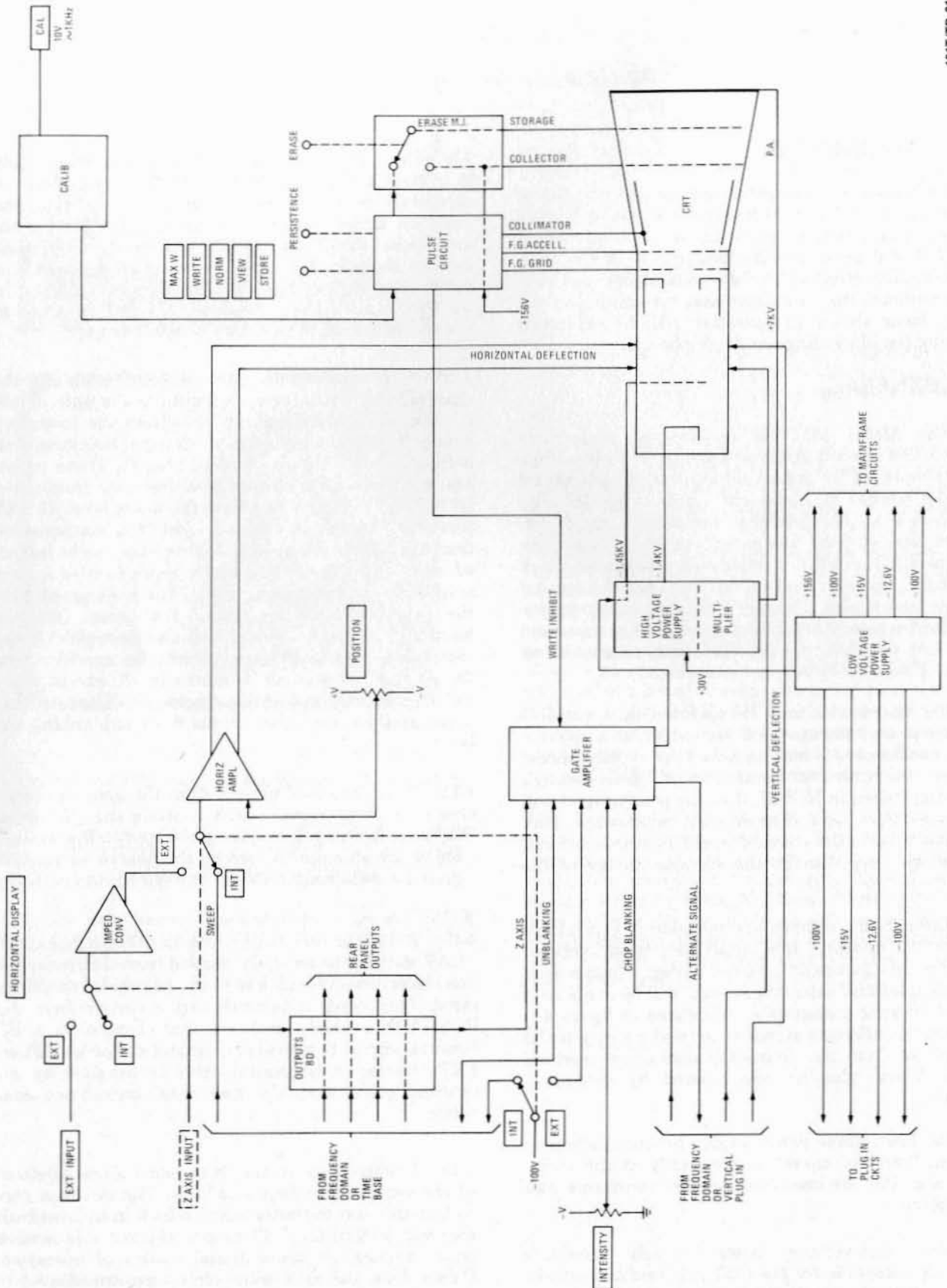

Figure 4-1. Overall Block Diagram

#### 4-14. VARIABLE PERSISTENCE AND STORAGE.

**4-15. STORAGE PRINCIPLES.** The Model 181T/TR storage CRT consists of a conventional electron gun with deflection plates (write gun), an aluminized phosphor viewing screen, two flood guns, flood-beam collimator, collector mesh, and a storage mesh as shown in figure 4-2.

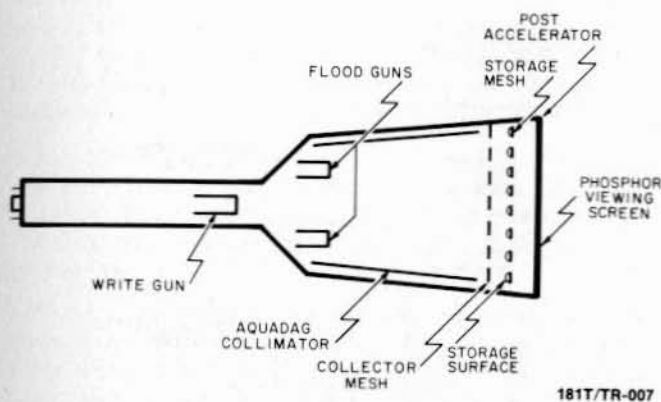

Figure 4-2. Simplified Storage Construction

4-16. The wire gun functions as a conventional electrostatic deflection gun, delivering high velocity electrons to selected points on the phosphor viewing screen. The elements that provide storage and variable persistence are located between the write gun and the phosphor.

4-17. The flood guns are physically located just outside the horizontal deflection plates. A cloud of electron is emitted by each flood-gun cathode. These electron clouds are combined, shaped, and accelerated by two control grids. Under certain conditions the two electron clouds will appear as light areas on the viewing screen when the instrument is first turned on. The combined electron cloud is further shaped and accelerated by the collimator (a coating on the inside of the funnel section of the glass). The positive voltage on the collimator is adjusted so that the flood-gun electron cloud just fills the CRT viewing screen. The cloud is further accelerated toward the storage mesh and viewing screen by the collector mesh, the flood electrons are further controlled by potentials on the storage mesh and surface.

4-18. The storage mesh is located between the collector mesh and the phosphor. The back side of this mesh is coated with a layer of non-conductive material. The storage of information takes place on the surface of this non-conductive material (storage surface).

4-19. The basis for storage of information on the non-conductive material is the secondary emission ratio

curve shown in figure 4-3. This curve shows the ratio of the number of electrons leaving the surface to the energy of the electrons striking the surface. At an energy of about 40 electron/volts (eV) the number of electrons leaving the surface is equal to the number arriving. The point where the secondary emission ratio is equal to unity is called "first crossover". If the surface is bombarded with electrons having less than 40 eV of energy, the surface potential decreases because there are fewer electrons leaving than arriving.

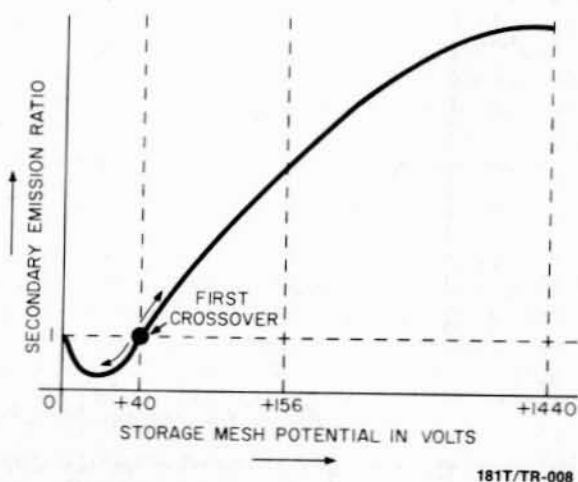
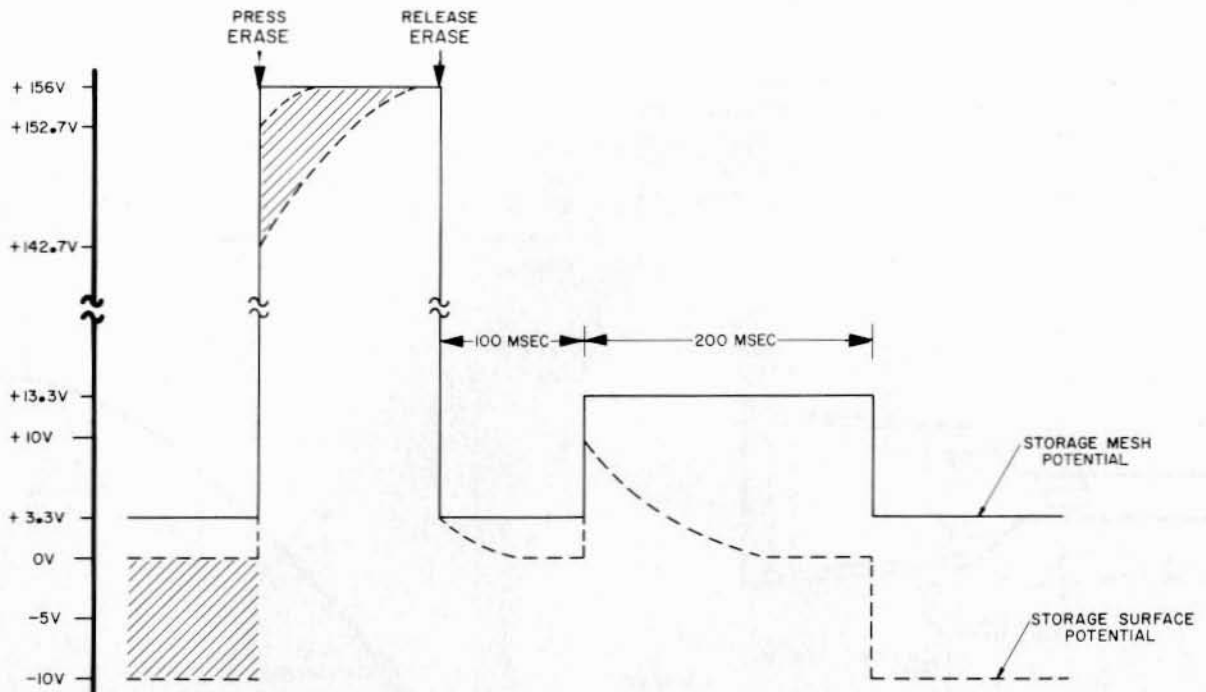

Figure 4-3. Secondary Emission Ratio

4-20. When the ERASE pushbutton is pressed, the storage mesh is charged to the same potential as the collector mesh (+156 V). The storage surface is also charged to approximately this same potential by capacitive coupling. Since the surface is then being bombarded by electrons with energy levels much higher than first crossover energy, the entire storage potential becomes equal to +156 volts. The surface potential cannot increase beyond +156 volts because the collector mesh would then repel the electrons back to the storage surface, tending to decrease the surface potential.

4-21. When the ERASE pushbutton is released (figure 4-4), the storage mesh is now charged to ~+4 volts and the storage surface follows to the same potential by capacitive coupling. The surface potential then decays to zero volt by action of the flood-gun electrons (surface below first crossover, brought to flood-gun cathode potential). After 100 ms, the storage mesh is raised to ~+4 volts and held there for 200 ms. The storage surface follows to +10 volts by capacitive coupling, but immediately starts decaying toward zero volt by capturing flood-gun electrons. At the end of the 200 ms, the storage mesh is brought back to ~+4 volts. The storage surface is consequently reduced from zero volt to -10 volts by capacitive coupling.



181T/TR-009

Figure 4-4. Storage Mesh and Surface Potentials During Erasure

4-22. Since the write gun electrons reach the storage surface with energy levels much higher than first crossover energy, they charge the surface in a positive direction wherever they strike. This charge pattern on the storage surface remains for a considerable length of time since the storage material is a very good insulator.

4-23. Those areas of the storage surface that are charged to near zero volt allow the field created by the high positive potential on the post accelerator to capture flood gun electrons, accelerating them to strike the phosphor viewing screen, causing the phosphor to emit light. Thus, the pattern of charge on the storage surface is made visible.

4-24. The secondary electrons emitted by the storage surface where the write gun electrons strike must charge the surface from its erased potential to about -5 volts before flood electrons can be captured by the post accelerator. The writing speed of the CRT can be enhanced by erasing the surface to just below cutoff level. This is the MAX W. mode. Operating in this mode reduces storage time and contrast ratio. The cut-off potentials of various areas of the storage surface may not be exactly the same. Thus, the background illumination may not be uniform when the storage surface is erased in the MAX W. mode.

**4-25. VARIABLE PERSISTENCE.** Figure 4-5 represents the method of obtaining variable persistence. The unwritten storage surface after erasure is at approxi-

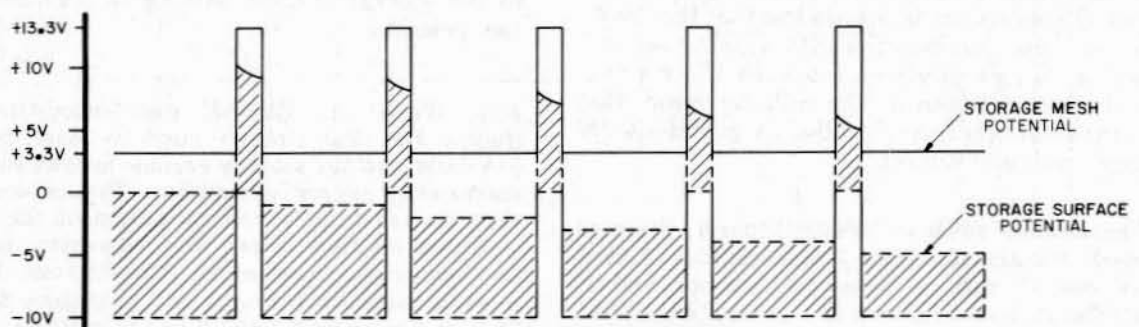

181T/TR-010

Figure 4-5. Variable Persistence Accomplishment Through Pulsed Erasure

mately -10 volts. Those areas of the storage surface that are struck by electrons from the write gun become charged to near zero volt. A +10-volt pulse applied to the storage mesh charges the unwritten areas of the storage surface to approximately zero volt and the written areas to +10 volts. While at this potential, the written areas of the storage surface attract and capture flood gun electrons, this tends to lower the potential of these areas. When the storage mesh returns to its normal level, the storage surface drops 10 volts. The unwritten areas of the storage surface return to -10 volts and the written areas return to a slightly negative potential, somewhat lower (more negative) than their initial value. This decrease in potential reduces the acceleration potential, preventing the capture of flood electrons which slightly reduces the trace brightness.

4-26. When this procedure is repeated many times, the stored trace will eventually be erased. The time required to accomplish this erasure is controlled by varying the pulse width of the pulses applied to the storage mesh.

4-27. During the time the storage mesh is pulsed positive, flood electrons are allowed through to the phosphor viewing screen. This creates a light background glow that is visible when the CRT is used in the variable persistence mode.

4-28. **NORMAL.** When the storage mesh potential is reduced to -50 volts it acts as a control grid to flood-gun electrons and prevents them from reaching the phosphor. However, it has little effect on write gun electrons, allowing some of them to reach the phosphor viewing screen. Some of the write gun electrons strike the storage surface, charging it positively toward zero volt wherever they strike. The CRT appears to act as a conventional CRT without variable persistence or storage. However, when the storage mesh is charged to +4 volts, the areas of the storage surface that have been struck by write gun electrons allow flood electrons to be captured by the post accelerator field. This displays the pattern that was written on the phosphor when the storage mesh was at -50 volts.

4-29. To view a stored trace for one minute or more, the storage mesh is held at +4 volts. This is accomplished by reducing the width of the variable persistence erase pulses to zero (corresponding to maximum persistence), or by disconnecting the pulses from the storage mesh. The write gun may be turned off if desired, to prevent additional writing on the storage surface.

4-30. The viewing time is limited by fade positive of the storage surface (entire screen illuminated). This is caused by positive ions reaching the storage surface and charging it positively. The positive ions are generated by flood-gun electrons striking residual gas molecules in the CRT. To obtain an extended storage time, the flood guns should be turned off. This is done in the STORE mode; however, the flood guns are turned on occasionally to permit viewing of the stored trace at a reduced intensity.

## 4-31. DETAILED DESCRIPTION.

4-32. The following paragraphs provide a more detailed description of the circuits of the Model 181T/TR oscilloscope. Refer to the schematics in Section VIII while reading the theory of operation.

4-33. **LVPS. (See figure 8-21.)** The Low Voltage Power Supply produces seven dc voltages and four ac voltages for use in both the mainframe and the plug-ins. These include: +156 volts for use in variable persistence and storage circuits, +100 volts used both in the mainframe and the plug-ins, +30 volts used by the high-voltage oscillator and pilot light, +15 volts, -12.6 volts and -100 volts are used in both the mainframe and the plug-ins. Two 115-volt lines transfer primary power to the plug-ins for use as necessary, ~20 V p-p from one secondary is transferred to the time base plug-in for line sync, and 6.3 Vac for the CRT write gun filament.

4-34. Ac input power is transferred via J1, F1 and switch S5 (POWER) to the primary windings of T1. These windings are connected by switch S6 (VOLTS AC). For 115-Vac operation, the windings are in parallel and for 230-Vac operation, the windings are in series. When switched to 230 Vac, F2 is inserted for primary protection. RF filtering is provided by ferrite beads L4 and L5 and capacitors C7 and C8. Lines parallel with each primary winding transfers 115 Vac to the Plug-ins. Secondary windings provide: 6.3 Vac to the CRT filament and various outputs to bridge rectifiers for rectified dc outputs. A tap off the winding for the +15 V supply goes to the time base plug-ins for line sync.

4-35. Four full-wave rectified outputs are applied to regulating circuits for the -100 V-, -12.6 V-, +15 V- and +100 V-supplies. Approximately +30 V is tapped off the +15 V supply (before regulation) for use in the high-voltage oscillator and for lamp DS1. A fifth full-wave rectified output is stacked on top of the +100 V output and regulated by break down diodes to provide +105 V (current source for the +100 V differential amplifier) and +156 V for the variable persistence and storage functions. These outputs will only be +105 V and +156 V if the +100 V supply is correct. The -100 V-, 12.6 V-, +15 V-, +100 V- supplies are fused by F3, F4, F5, F6 and A7R3/R5 to protect T1 from burnout due to overloads.

4-36. The -100 V is used as a reference voltage for the -12.6 V-, +15 V- and +100 V-supplies as well as being used by other mainframe and plug-in circuits. It will be discussed first.

4-37. The output of bridge rectifier A7CR17-A7CR20, is prefiltered by A7R6 and C4, and applied across divider network A8R35/R36/R37 and the load to ground. Variations in this output (ripple and drift) are sensed at the base of A8Q12, one half of a differential amplifier. These variations are compared

to a fixed level generated at the base of A8Q11 by voltage reference tube A8V2. The difference between these levels is amplified and used to control the conduction of series regulator Q4 by way of driver A8Q10. Q4 is in the return path to the bridge rectifier and controls the current across the divider network and load and thus the voltage output. The level of the output is controlled by  $-100$  V Adj A8R36. Capacitor A8C10, across the output, provides filtering of load signals from returning to the supply. Should F6 open CR10 clamps the voltage to ground to prevent damaging A8C10. A8C9 and A8R34 provide a short time constant path to couple fast transients to the base of A8Q12 for regulation. Diodes A8CR8 and A8CR9 provide protection against excessive reverse bias during turn on and turn off. A8CR12 provides protection for A8Q11 and A8Q12 during short duration line transients coupled into the supply.

4-38. A8C8 and A8R29, from the base of A8Q10 to ground, are to keep the supply from oscillating. Avalanche diode A8VR3 and A8R28 provide protection from excessive reverse breakdown voltages during short circuit conditions. The 54.9 volts will not normally be measured across VR3 except for a brief period when a short circuit in the load occurs, and then only until F6 opens.

4-39. The  $+100$  V supply functions similarly to the  $-100$  V supply. Output from the bridge rectifier is supplied to the series regulator, then to the load to ground in parallel with the divider network A8R9/R10/R11 back to the  $-100$  V. Variations are sensed at the base of A8Q3, compared with the fixed reference of A8V1 at the base of A8Q2, and the amplified difference controls conduction of series regulator Q1 by way of driver A8Q1. A8C3 filters load signals while A8CR3 clamps excessive negative voltages from destroying A8C3. A8CR1/CR2 provide turn-on and turn-off protection and A8CR11 protects Q1 and A8Q1 during line transients. A8R3 and A8C1, from the base of A8Q1 to  $+100$  V, presents the supply from oscillating. A8R2 and A8VR2 provide short circuit protection.

4-40. Current source for the  $+100$  V differential amplifier, A8Q3, is the auxiliary  $+105$  V supply. The value of this current source voltage is relatively unimportant as long as it is more positive than the output. The  $+100$  V supply then becomes the current source for the other supplies. If F3 in the  $+100$  V supply opens, none of the other supplies will be correct.

4-41. The  $-12.6$  V supply functions similar to the  $-100$  V supply with the following exceptions. The regulated  $-100$  V is used as a reference on divider network A8R25/R26/R27 and the regulated  $+100$  V is used as a current source for A8Q9. Variations in the output are amplified by A8Q9 and applied to series regulator Q3 by way of driver A8Q7. A8C7 performs as A8C3/C10, but there is no protection diode for A8C7. A8CR6 provides turn on protection for A8Q9. A8CR7, with the opposite temperature coefficient of A8Q9

provides thermal stability in the absence of a differential amplifier. A8R20 and A8C6, from the base of A8Q7 to ground, prevents the supply from oscillating. A8Q8, in conjunction with A8R22, provides output current limit protection. A8Q8 is normally off, but as current exceeds the design limit, the voltage drop across A8R22 turns on A8Q8, which in turn tends to shut Q3 off. Thus, the output voltage will decrease to a lower level maintaining a maximum-current limitation. If the output load becomes a short circuit, output voltage will decrease to 0 V. Should A8Q8/R22 fail to function, F5 will open and protect the main transformer.

4-42. The  $+15$  V supply functions essentially the same as the  $-12.6$ -volt supply.

4-43. It should be noted that there are certain interrelations within the low voltage power supplies. The  $-100$  V will not function without the  $+100$  V. The  $+100$  V;  $+15$  V; and  $-12.6$  V supplies rely on the  $-100$  V supply as reference. The  $+15$  V and  $-12.6$  V supplies also need  $+100$  V as a current source.  $+105$  V and  $+156$  V will not be correct if the  $+100$  V is not correct. Since  $-100$  V is used as a reference for the other voltage sources it should be adjusted properly first. Test points are provided on the regulator board for voltage measurements.

**4-44. HVPS AND CRT.** (See figure 8-18.) The high-voltage power supply provides operating potentials for the CRT. These include  $-1.44$  kV for the cathode,  $\sim -1.5$  kV for the grid and  $\sim +7$  kV for the post accelerator. These values are produced by a Hartley oscillator and a high ratio step up transformer. The outputs are half-wave rectified and filtered before application to the CRT elements.

4-45. When line power is applied,  $+30$  V is applied to the collector of high-voltage oscillator Q5 and the primary of high voltage transformer A5T1. Current is drawn through Q5 and the transformer primary producing a magnetic field. This field is coupled back to the base of Q5 by one secondary winding and turns on Q5 harder, producing more field and feedback to the base of Q5. This continues until the transformer core saturates and Q5 draws less current causing the field to collapse. The collapsing field is fed back to the base of Q5 as a turn off signal, causing oscillation. The frequency of oscillation is about 40 kHz and is controlled by the values of the transformer primary, A4L1 and A4C2.

4-46. The oscillations are also applied to two more secondary windings with high step-up ratios. The center tap of the cathode winding provides about 100:1 step-up ratio, the grid winding approximately 102:1, and the full winding output for the post accelerator about 170:1.

4-47. Negative half cycles are rectified by A5CR1, filtered by A5C1/C2/R3, and applied to the CRT grid. The grid supply is not referenced directly to ground,

but is stacked on top of the gate amplifier output. The dc component of the gate amplifier output sets the grid more or less negative in respect to the cathode and controls the beam intensity. The ac component (unblanking gate) is coupled to the grid thru capacitors A1C21/C22/C23.

4-48. Negative half cycles are also rectified by A5CR2, filtered by A5C3/C4 and A1R52/C24/C25/C26, and applied to the CRT cathode. A sample of this output is fed back to the regulating circuit of A1Q8/Q9/Q10 thru feedback resistor A1R50 to control the cathode supply, similar to a standard dc feedback supply. Any variations in the supply output are fed back through A1Q8/Q9/Q10 to the base of Q5 as a changing bias level. Superimposed on this bias level are the oscillations induced in the base secondary. This turns on Q5 for a shorter or longer time as necessary to alter the field energy and keep the supply output constant. High Voltage Adj A1R38 sets the operating point of the circuit and the supply outputs. A4CR1 and CR1 protect Q5 from excessive back bias on the negative swings of oscillation. Intensity limit A5R2 sets the desired difference voltage between grid and cathode to compensate for different cutoff levels in each CRT. A1V1/V2 limit the maximum difference between grid and cathode to a safe limit for the CRT elements should one supply fail. A1C20 and A1R58 keep the supply from oscillating (double moding).

4-49. The full output of the cathode winding is applied to tripler assembly A9. Positive half cycles are rectified, tripled, and filtered to provide +7 kV for the CRT post accelerator. The four capacitors, three diodes, and two resistors that comprise the HV tripler are potted in an insulating material and are not separately replaceable.

4-50. A divider network from the cathode supply to ground (comprised of A1R53/R54, with FOCUS potentiometer R5) provides the necessary high voltage for the CRT focusing anode. R6, between the CRT cathode and filament, increases the filament to the cathode potential to forestall arcing between these elements. A1VR3/R55 produce the proper potential for the accelerating anode while R7, from +100 V to ground, provides a variable potential for the astigmatism anode. A1R56, from +100 V to ground, provides adjustment for the pattern anode. Dual flood gun filaments are tied from -12.6 V to ground and the remaining elements are controlled by outputs from the pulse circuitry.

4-51. Since the CRT is rectangular it will not rotate for trace alignment, thus coils are placed around the CRT neck inside the CRT mu-metal shield to affect beam alignment. By adjusting the voltage applied through these coils, a field is altered to align the traces with the graticule markings. The X alignment adjustment is brought to the front panel and called TRACE ALIGN. The Y alignment is an internal adjustment. Trace alignment can be affected by magnetic fields in the area where the oscilloscope is operated, as well as by the earth's terrestrial magnetic field and may need readjustment as the instrument is relocated.

4-52. The cathode supply (with feedback regulation) can supply about 1 mA of current, normal operation draws less than 100  $\mu$ A. The grid and post accelerator supplies (with no regulation) can supply about 1  $\mu$ A before the supply output begins to deteriorate. Although grid current normally is less than 1  $\mu$ A at full beam intensity grid-cathode leakage will cause excessive grid current, thus lowering the grid voltage toward the cathode potential and turn the beam on full with no control.

**4-53. GATE AMPLIFIER AND CALIBRATOR.** (See figure 8-6) Input transistor A1Q1 is a common-base stage that controls amplifier gain, which is dependent on the current taken from the emitter-base junction. The emitter-base junction is a low impedance point that is used as a current summing point. Several inputs may be summed at once to provide the desired CRT unblanking. Normally, the input is an unblanking gate from the frequency domain or time base plug-in. The unblanking gate is summed with the current through the INTENSITY control. This establishes the desired amount of CRT unblanking (beam intensity). If the plug-in is in chopped operation at this time, chopped blanking is also included. Z-axis modulation can also be applied as further beam control.

4-54. If EXT display is selected, -100 V is removed from the plug-in by switch S1 (so the plug-in will not form an unblanking gate) and applied through A1R6/R7 to the summing point to simulate the level of an unblanking gate. This level is summed with current through the INTENSITY control to establish the desired CRT intensity. Chopped blanking and Z-axis can also be induced at this point.

4-55. Diode A1CR15 is normally off. When it is desired to inhibit the CRT beam (during VIEW, STORE, and ERASE modes) A1CR15 is turned on by A6Q15 and current is injected into the summing point. Less current is taken from the emitter-base junction of A1Q1 and the beam is inhibited (blanked).

4-56. A1CR1 limits the amount of positive voltage that can be applied to A1Q1, while A1CR2/CR3/CR4 limit the possible saturation of the circuit. After amplification by A1Q1 the signal is applied to A1Q3/Q4 via emitter-follower A1Q2. Since A1Q3 is a PNP and A1Q4 is an NPN, the signal from A1Q2 turns one transistor on and turns the other off. This insures the quick turn on and turn off, that is necessary for fast sweep speeds with standard time base plug-ins. Feedback from A1Q3/Q4 collectors to the base of A1Q2, aids this fast turn on - turn off, stabilizing circuit gain.

4-57. Should the high-negative voltage of the HVPS arc to ground it will appear at the cathode of A1CR10 as a positive excursion. A1CR10 will turn off and protect A1Q3/Q4. Should any of this energy pass through A1CR10 it will be absorbed by R57 or bypassed through A1CR8 to protect A1Q3. Any large negative excursions will be clamped to ground by A1CR7.

4-58. A1C13 and A1R23, from Q3 and Q4 collectors to ground, differentiates both transitions of the unblanking gate. A1Q5 conducts only on the negative differentiation and this spike is passed through A1CR11 and A1R27 to the frequency domain or vertical plug-in as an ALT trigger signal. The amplitude of this trigger signal depends on the amplitude of the unblanking gate, and some plug-ins may not alternate at very low intensity.

4-59. The calibrator consists of a free-running multivibrator A1Q6/Q7 and associated components. Values have been chosen for a frequency of approximately 1 kHz. When either transistor is on, it is essentially a saturated switch, with little voltage drop. From the collector of A1Q7 to ground there is a divider network consisting of A1R35/R36 that have 0.1% tolerance ratings. If the -100 V supply is set up properly the calibrator output will be accurate within the 1% tolerance specified. An output is taken from the collector of A1Q6 and applied to the storage pulse circuit for use in initiating the variable persistence and storage pulses. As a storage tube ages, a point in time can be reached where the mechanical resonance of the storage mesh matches the calibrator frequency. At this time the CRT may produce an audible note (singing). This resonance can be stopped by changing the calibrator frequency using A1R59.

4-60. The calibrator output is a fast-rise square wave. It is primarily a source for matching probe compensation to the input compensation of the vertical amplifier. It may also be used as a check of vertical or horizontal sensitivity, but should not be considered accurate enough to be a calibration source. Frequency is not controlled accurately enough to use it for a timing check.

#### 4-61. HORIZONTAL AMPLIFIER. (See figure 8-10.)

The horizontal amplifier will accept a sweep input from either an internal or external source. The inputs are amplified and converted to differential signals for CRT deflection. Gain is adjustable to match the varying deflection sensitivities of different CRT's.

4-62. In INT (internal) a linear ramp comes from either a frequency domain or time base plug-in to the emitter-base junction of common base amplifier A3Q3. The signal is summed with current from POSITION potentiometers R2 and R3, amplified, and applied to emitter follower A3Q4. Output from A3Q4 is applied to the base of A3Q6 (one-half of a differential driver). The base of A3Q7 (the other half of the driver) is held at a fixed level by emitter follower A3Q5 through the common emitters of A3Q6 and A3Q7. When A3Q6 is turned on, A3Q7 is turned off, and when A3Q6 is turned off, A3Q7 is turned on. Thus, the collector signals of A3Q6 and A3Q7 produce a differential signal. Gain is selected by MAGNIFIER switch S4. Adjustments A3R30/R32/R34 are used to maintain gain accuracy with different CRT sensitivities.

4-63. The outputs of A3Q6/Q7 are applied to emitter-followers A3Q8/Q11 through diodes A3CR2/CR4/CR7/CR8. These diodes limit the maximum output excursion to the CRT plates regardless of the input amplitude. A3CR3/CR6 act as clamps to shunt any possible negative swings from A3Q6/Q7 to ground. A3CR7/CR8 are biased on through the FIND BEAM switch. When FIND BEAM is pressed the diodes bias off and gain is essentially cut in half to bring any presentation on screen.

4-64. The signals from emitter-followers A3Q8/Q11 are applied to the base circuits of A3Q9/Q10 and A3Q12/Q13. This arrangement is the same as the gate amplifier output. The signal that turns A3Q9/Q12 on, turns A3Q10/Q13 off, and vice versa. This ensures proper turn on and turn off at very fast sweep speeds. Feedback paths from the collectors to the bases maintain bandwidth and linearity. Adjustments in the feedback paths match amplifier linearity to CRT linearity.

4-65. When EXT is selected, an external signal can be applied to deflect the CRT beam. An impedance converter is employed to maintain a high impedance to the external circuit and convert to the low impedance necessary to drive A3Q3. The stage has no gain and the vernier can adjust the output to give the desired deflection. When in EXT CAL, gain is 1 volt/div (X1), 0.2 volt/div (X5), and 0.1 volt/div (X10). A3R1/R2/R55 maintain a constant 1 megohm input impedance while providing X4 input attenuation to achieve  $\pm 20$  V of dynamic range. A3C1 adjusts input compensation for precise attenuation at high frequencies.

4-66. The EXT input may also be used in conjunction with a vertical channel to make X-Y measurements. Since most verticals for this system employ delay lines, a means is provided to lag the horizontal input for phase measurements. When Phase/Bandwidth switch, A3S1, is placed in Phase position capacitors A3C2/C3 are inserted into the signal path to ground. This delays the input signal. A3C2 can be used to adjust this delay to equal the delay of a 160-ns delay line (up to 100 kHz). Switch A3S1 must be returned to the Bandwidth position for signals above 100 kHz.

4-67. PULSE CIRCUIT. (See figure 8-14.) To achieve variable persistence and storage the pulse circuit is used to apply various voltage levels and/or pulses to certain elements in the CRT. Mode selection is made by switch assembly A10, which controls circuitry on board assembly A6.

4-68. The calibrator provides a 1-kHz signal that is applied to the base of A6Q3. The resultant square wave at the collector of Q3 is passed through A6CR2 and differentiated by A6C2 and A6R13. The amplitude of the pulses at the anode of A6CR3 is established by the ratio of A6R12 and the PERSISTENCE control R9, and by the charging time constant of A6C2/R13. The resultant variable-amplitude signal passed through A6CR3 is sensed as a variation in width at the base of A6Q4, which determines conduction time. The

variable width pulses from the collector of A6Q4 are passed through A6CR5/CR6 to the CRT storage mesh to establish persistence. Write Adj, A6R18, sets the conduction level of A6CR5. This effectively changes the amplitude of the pulses to meet the specific needs of each CRT. A6R18 also affects the preset level of the mesh at the same time.

**4-69. Write.** The following describes how the variable persistence pulses are derived and applied to the storage mesh in the WRITE mode. Maximum width pulses give maximum erasure with minimum persistence. Minimum width pulses (or no pulses) gives maximum persistence (at least 1 minute). Ground is applied through the WRITE switch to the cathode of A6CR11, which turns A6Q17 on. With A6Q17 on, zero volt is applied to the bases of A6Q8/Q18/Q19. Zero volt holds A6Q8 off, which turns A6Q9 on, applying voltage to activate Write Coll Adj, A6R9. A6R9 is adjusted to set the conduction of A6Q10 to preset the desired collimation level as needed by a particular CRT.

4-70. A6Q18/Q19 are held off, which removes Max Write Adj, A6R17, and Max Write Coll Adj, A6R29, from the circuit. Ground is also applied to the base of A6Q14, which holds off A6Q14 and in turn holds A6Q15 on. This clamps A1CR15 off and allows the CRT beam to operate.

**4-71. Max Write.** When MAX W. is chosen, ground is applied to the cathode of A6CR10, which turns A6Q16 on and A6Q17 off. With A6Q17 off a positive potential is applied to the bases of A6Q8/Q18/Q19. With A6Q8 on, A6Q9 is turned off removing Write Coll Adj, A6R9, from the circuit. With A6Q19 on, Max Write Coll Adj, A6R29, is inserted to preset the desired collimation level. When A6Q18 is turned on, Max Write Adj, A6R17, is placed in parallel with A6R18 to preset the mesh level. This lowers the amplitude of the variable persistence pulses to the storage mesh. As in the WRITE mode, ground is on A6Q14 base and A6Q15 is conducting to allow the CRT beam to operate.

4-72. A6Q16/Q17 comprise a one-shot multivibrator. When one transistor is turned on the other is turned off and the circuit remains in this state until the opposite transistor is turned on. This memory type circuit is employed so the proper write and collimation levels are retained in VIEW mode after a signal has been STORED.

**4-73. Norm.** When NORM (normal or conventional operation) is selected +156 volts is removed from the junction of A6R16/R19. This turns off A6CR5 and stops the variable persistence pulses. The divider network of A6R19/R16/CR6/R20 sets a level of approximately -50 volts on the storage mesh. This high-negative potential on the mesh blocks all flood gun electrons and allows only CRT beam electrons to pass through to the phosphor. This negative potential detracts somewhat from the beam efficiency and the trace will not be as bright as a conventional oscillo-

scope while in NORM. Another section of the NORM switch applies ground to the base of A6Q14 and enables the CRT beam to operate. This same section of the switch removes ground from the ERASE switch so the erase circuit cannot be enabled.

**4-74. Store.** A signal written in MAX W., WRITE, or NORM can be stored by selecting the STORE mode. This removes ground from the ERASE switch so the erase mode cannot operate and applies ground to the base of A6Q1, turning it off. With A6Q1 turned off, ground is removed from the junction of A6R22/R23/R40. This applies a positive potential to the base of A6Q14, turning it on and A6Q15 off. With A6Q15 off, A1CR15 is turned on and current is applied to the gate amplifier summing point to hold A1Q1 off and inhibit the beam. The same positive level applied to A6Q14 base is applied to A6Q4 base holding it on so that a fixed level is applied to the storage mesh. This positive level holds A6CR3 off, blocking the variable persistence pulses.

4-75. When A6Q1 turns off, A6Q2 turns on and the square waves at A6Q3 collector (differentiated by C1 and R2) are now passed through A6CR1 to the base of A6Q2. The time constant of A6C1/R2 forms a fixed-width pulse of approximately 50  $\mu$ s. The resultant pulse at the collector of A6Q2 is applied to the flood gun accelerator.

4-76. The flood gun accelerator had previously been held on, allowing steady flood gun electron passage. The flood gun electrons are now allowed to pass only about 50  $\mu$ s of each millisecond square-wave period. The stored image is displayed at a diminished level and retained for approximately one hour then written in WRITE mode (5 minutes when written in MAX W. mode). Normal flood gun emission is selected by Flood Gun Adj, A6R42.

**4-77. View.** To observe the stored image at an increased level, the VIEW mode may be selected. Ground is removed from the ERASE switch to inhibit erasure and from the junction of A6R22/R23/R40, which inhibits the write gun beam. Ground is also removed from the base of A6Q1, turning it on and turning off A6Q2. The flood gun accelerator level allows full passage of flood electrons. The positive potential on A6Q4 holds it on and A6CR3 off, blocking variable persistence pulses to the mesh.

**4-78. Erase.** (See figures 4-4 and 8-14.) To prepare the storage mesh for receipt of a new signal, and/or remove a previously written signal, requires activation of the ERASE cycle. Since ground is applied to the ERASE switch only in the MAX W. or WRITE modes, erasure cannot be activated in any other mode. Excessive erasure can cause the CRT to appear gassy to the storage principle, thereby degrading specifications for writing speed and storage time. A monostable multivibrator circuit has been added to ensure a specified time of erasure.



4-79. Monostable multivibrator A10Q1/Q2 is biased so A10Q2 is normally on. With A10Q2 on, A10Q3/Q4 are held off. When ERASE is activated, ground is placed at the junction of A10R4/R5. This turns A10Q1 on and A10Q2 off. When A10Q2 is turned off, A10Q3 is turned on. This turns A10Q4 on. With A10Q4 on, +156 V is applied to the storage mesh through A6R3. After approximately 100 ms, A10Q2 turns on and +156 V is removed from the mesh.

4-80. While +156 V is on the storage mesh, A6CR6 is back biased blocking the variable persistence pulses. A positive potential turns A6Q13 on which turns off A6Q12. This allows A6C6 to charge and A6Q14 turns on. With A6Q14 on, A6Q15 is off and the CRT beam is inhibited. At the end of the approximately 100-ms time constant from the monostable multivibrator, +156 V is removed from the mesh and A6CR6 and the level set by A6R18 (or A6R18/R17) is applied to the mesh. A6Q13 is turned off and A6C6 begins to discharge, which turns A6Q11 on. A6Q11 holds A6Q14 on to continue inhibiting the CRT beam and A6C5 begins to charge. With A6Q11/Q8 turned on, A6Q9 is turned off. This turns A6Q10 on very hard and approximately +120 V is applied to the collimator to assist in uniform erasure.

4-81. The discharge time of A6C6 is approximately 100 ms, at which time A6Q11 turns off and A6C5 begins to discharge. This turns A6Q7 on, holding A6Q14 on. This inhibits the beam, and turns A6Q6 on, which turns A6Q4 off. With A6Q4 off, pulse are blocked and the level of the storage mesh increases to levels determined by A6R18. The discharge time of A6C5 is approximately 200 ms, after which time A6Q7 turns on, A6Q6 turns off, and A6Q4 turn on. This brings the mesh back to about +4 V and variable persistence pulses are again applied. A6Q14 is turned off, A6Q15 turns on and back biases A1CR15, and A1C6 discharges through A1R10 to insure the beam is inhibited until the cycle is ready to start again.

**4-82. STORAGE PROTECTION.** The mode selector switches can be inadvertently manipulated so that multiple functions or no function may be selected. Should more than one switch be pushed in, or all switches out, ground is removed from the junction of A6R22/R23/R40. This applies a positive potential on A6Q14 base, turning it on, and inhibiting the CRT beam. It also turns A6Q4 on, to clamp the storage mesh to approximately +4 V, and back biases A6CR3 to block the variable persistence pulses.

## SECTION V

### PERFORMANCE CHECK AND ADJUSTMENTS

#### 5-1. INTRODUCTION.

5-2. This section contains step-by-step procedures for checking instrument performance and making all internal adjustments. Performance checks should be made in numerical sequence for best results.

5-3. The Model 181T and 181TR are intended for use with a number of different plug-ins. These plug-ins are classified as real time, sampling and TDR, and frequency domain. Certain features of the mainframe apply only to real time plug-ins. The performance checks and adjustment procedures note when these differences occur and indicate which group of plug-ins listed below are covered by the procedures.

Group A Real Time Plug-ins Model Numbers	Group B Sampling and TDR, Frequency Domain Plug-ins Model Numbers
1801A, 1802A, 1803A, 1804A, 1805A, 1806A, 1807A, 1808A, 1809A, 1820A, 1820B, 1820C, 1821A, 1822A, 1824A, 1825A	1810A, 1811A, 1815A, 1818A, 8558B, 8755A

#### 5-4. EQUIPMENT REQUIRED.

5-5. Test equipment required is listed in table 5-1. Test equipment equivalent to that recommended may be substituted provided it meets the required characteristics listed in table 5-1. For best results use recently calibrated test equipment.

#### 5-6. PERFORMANCE CHECKS.

5-7. The performance checks given in this section are suitable for incoming inspections, preventative maintenance, and troubleshooting. The checks are designed to verify the published instrument specifications.

#### 5-8. PERFORMANCE CHECK RECORD.

A performance Check Record is provided at the end of this section for recording the results of the perform-

ance checks. This record lists all of the tested specifications and their acceptable limits. The record can be removed from the manual and retained as a permanent record of the incoming inspection or routine maintenance performed on the instrument.

#### 5-10. ADJUSTMENTS.

5-11. The adjustment procedures are arranged in a recommended sequence. While most adjustments may be made independently, it is recommended that adjustments be made sequentially as a number of adjustments are directly related to preceding or following adjustments.

#### 5-12. PERFORMANCE CHECK PROCEDURES.

5-13. **PRELIMINARY SETUP.** Perform preliminary setup as follows:

- a. Install plug-in units into mainframe.
- b. Set INTENSITY control fully ccw.
- c. Set PERSISTENCE control fully ccw.
- d. Press WRITE pushbutton.
- e. Apply power to instrument. Entire screen should be evenly illuminated after approximately three minutes.
- f. Allow 15 minutes warm-up time.

**CAUTION**

To operate Models 181T and 181TR in NORM mode, the following precautions should be taken. Set PERSISTENCE fully ccw and press WRITE pushbutton. Rotate INTENSITY control cw until required intensity is obtained without blooming. Press NORM pushbutton. Do not increase intensity while in NORM as CRT mesh may be damaged.

5-14. **CALIBRATOR.** The calibrator function is normally used with group A plug-ins only. This check can be eliminated when using group B plug-ins.

Specification: the calibrator output is a 10 V, 1-kHz square-wave with a rise time of less than 3  $\mu$ s. The

Table 5-1. Recommended Test Equipment

Instrument		Required Characteristics	Required For
Type	Model		
Voltmeter Calibrator	HP Model 745A or 6920B	1, 2, 10 V p-p $\pm 0.2\%$	Calibrator Check Magnifier Check
Test Oscilloscope	HP Model 1740A	Sensitivity 1 V/div Sweep Speed 1 $\mu$ s Rise Time 3 $\mu$ s Sweep Output	Calibrator Check Gate Ampl Response
Divider Probe	HP Model 10004D	Ratio 10:1 $\pm 3\%$	Gate Ampl Response
Test Oscillator	HP Model 652A	50 kHz - 5 MHz at 10 V p-p	Bandwidth Check Trace Alignment Adj Pulse Circuit Adj
Digital Voltmeter	HP Model 3465A	$\pm 100$ Vdc $\pm 0.5\%$ 2.5 mA $\pm 2\%$	LVPS Adj HVPS Adj
Divider Probe	HP Model K05-3440A	Ratio 1000:1 3000 Vdc, $\pm 0.1\%$	HVPS Adj
Square-wave Generator		200-kHz 1 V, p-p Rise Time 30 $\mu$ s	Horiz Transient Response
Time-mark Generator	HP Model 226A	1-ms markers 50 MHz	Horiz Amplifier Gain Adj Linearity

calibrator is checked by comparing it with a signal of known amplitude.

5-15. Perform calibration check as follows:

a. Set Model 181T/TR controls as follows:

CRT Mode ..... WRITE  
MAGNIFIER ..... X5  
HORIZONTAL DISPLAY ..... EXT CAL  
HORIZONTAL EXT INPUT coupling .. AC

b. Apply 10 V p-p signal from voltmeter calibrator to HORIZONTAL EXT INPUT connector.

c. Adjust INTENSITY, POSITION, and FOCUS controls to obtain horizontal trace.

d. Adjust HORIZONTAL DISPLAY and POSITION controls for 10-division display.

e. Disconnect voltmeter calibrator and connect CALIBRATOR output to HORIZONTAL EXT INPUT connector, adjusting INTENSITY for single dot at each side of display.

f. Space between dots should be 10 div  $\pm 0.1$  div.

g. Set INTENSITY control fully ccw.

h. Monitor Model 181T/TR CALIBRATOR output with test oscilloscope.

i. Rise time of calibrator waveform should be  $\leq 3 \mu\text{s}$ .

**5-16. MAGNIFIER.** This check is applicable when using either group A or group B plug-ins, however calibration is relatively unimportant when using group B plug-ins.

Specification: sweep magnifier increases gain by factors of X1, X5, and X10. The magnifier is checked by applying a known signal and verifying that the multiple of the switch setting is displayed on CRT screen.

5-17. Perform magnifier check as follows:

a. Set MAGNIFIER control to X1 and HORIZONTAL DISPLAY control to EXT CAL.

b. Apply 10 V p-p signal from voltmeter calibrator to HORIZONTAL EXT INPUT connector, and adjust INTENSITY for visible display.

c. Deflection should be 10 div  $\pm 0.5$  div.

d. Set MAGNIFIER control to X5.

e. Apply 2 V p-p signal from voltmeter calibrator to HORIZONTAL EXT INPUT connector.

f. Deflection should be 10 div  $\pm 0.5$  div.

g. Set MAGNIFIER control to X10.

h. Apply 1 V p-p signal from voltmeter calibrator to HORIZONTAL EXT INPUT connector.

i. Deflection should be 10 div  $\pm 0.5$  div.

**5-18. BANDWIDTH.** This check is applicable when using group A plug-ins in high frequency X-Y applications. Bandwidth is relatively unimportant when using group B plug-ins.

Specification: dc coupled, dc to 5 MHz; ac coupled 5 Hz to 5 MHz. To check bandwidth, a test oscillator is used to apply 50-kHz, 10-div display. The frequency is then increased to 5 MHz. The signal amplitude should always be 7.1 div or greater.

5-19. Perform bandwidth check as follows:

a. Apply a 50-kHz signal from test oscillator to HORIZONTAL EXT INPUT connector.

b. Set MAGNIFIER control to X1 and adjust INTENSITY for visible display.

c. Adjust test oscillator amplitude and Model 181T/TR POSITION controls for a 10-div display.

d. Note indication on test oscillator output meter.

e. Increase test oscillator output frequency to 5 MHz.

f. Increase test oscillator output to that noted in step d.

g. Display deflection should be  $\geq 7.1$  div.

h. If deflection is less than 7.1 div verify Phase Bandwidth switch, A3S1 is in Bandwidth position.

**5-20. FIND BEAM.** This check is applicable when using either group A or B plug-ins.

Specification: display returns to viewing area of CRT when FIND BEAM is pressed. To check, the display is positioned off screen and when FIND BEAM pushbutton is pressed display returns to screen.

5-21. Perform beam finder check as follows:

a. Adjust INTENSITY and POSITION controls to obtain visible display.

b. Set POSITION controls fully ccw.

c. Press FIND BEAM pushbutton.

d. Beam should appear on screen.

**5-22. PERSISTENCE AND WRITE RATE.** This check can only be made when using group A plug-ins. Although applicable to both groups, persistence and write rate cannot be checked or adjusted using group B plug-ins. Actual sweep speeds of group B plug-ins will never exceed capabilities of the Model 181T/TR.

Specification: persistence is continuously variable from less than 0.2 second to more than one minute. Write rate, 20 div/ms in WRITE and 1 div/ $\mu$ s in MAX W.

5-23. Perform persistence and write check as follows:

- a. Set Model 181T/TR controls as follows:

HORIZONTAL DISPLAY .....	INT
MAGNIFIER .....	X1
CRT Mode .....	WRITE
PERSISTENCE .....	fully ccw

- b. Set vertical plug-in controls as follows:

Display .....	A
Channel A Volts/Div .....	0.5
Input coupling .....	AC

- c. Set horizontal plug-in controls as follows:

Sweep Display (if applicable) .....	MAIN
Time/div (main sweep) .....	0.2 s/div
Sweep Mode (main sweep) .....	AUTO
Trigger Source (main sweep) .....	INT
Trigger Coupling (main sweep) .....	AC

- d. Slowly rotate INTENSITY control cw until moving spot just appears.

- e. Observe tail on spot. Tail shall be no longer than 1 major div anywhere on screen.

- f. Rotate PERSISTENCE control cw. Length of tail shall increase as persistence is increased. Allow full trace or more to be written.

- g. Rotate INTENSITY control fully ccw. Display should remain visible for one minute.

- h. Press VIEW pushbutton. Display intensity should remain same as in WRITE mode.

- i. Press WRITE pushbutton and ERASE pushbutton. Screen should be dark, except for possibly few small spots (figure 5-1).

- j. Rotate INTENSITY control slowly cw until display has normal intensity, then fully ccw.

- k. Rotate PERSISTENCE control fully ccw. CRT background should become illuminated and display should disappear; rotate PERSISTENCE control fully cw and screen should be dark.

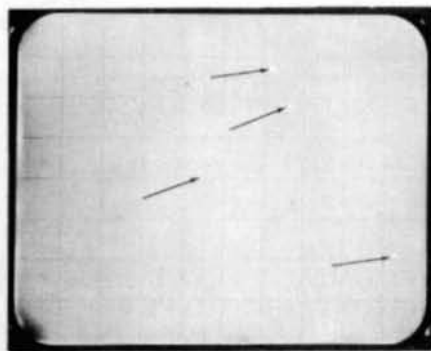

181T/TR-016

Figure 5-1. Bright Spots in CRT Display

- l. Set horizontal plug-in time/div to 50  $\mu$ s.
- m. Set horizontal plug-in sweep mode control to single.
- n. Rotate INTENSITY control fully cw. Press ERASE pushbutton.
- o. Press horizontal plug-in RESET pushbutton.
- p. Rotate trigger level (main) control fully cw and then fully ccw to trigger sweep. Display should be visible. It may be necessary to adjust FOCUS and retrigger sweep to obtain sharpest trace.
- CAUTION**
- Do not return sweep mode switch to auto or normal while INTENSITY is fully cw. Adjust FOCUS control slightly and press ERASE pushbutton. Retrigger sweep and observe display. Repeat as necessary.
- q. Press STORE pushbutton. Low intensity display should be visible, and remain visible for one hour.
- r. Rotate INTENSITY control fully ccw.
- s. Press MAX W pushbutton.
- t. Set horizontal plug-in time/div (main) control to 1  $\mu$ s and sweep mode control to single.
- u. Rotate INTENSITY control fully cw.
- v. Press ERASE pushbutton. CRT background may not be uniformly illuminated. Both dark and bright areas may appear. Mesh pattern may also be visible (figure 5-5F).
- w. Press horizontal plug-in RESET pushbutton.
- x. Rotate trigger level (main) control fully cw and then fully ccw to trigger sweep. Display should be

visible. It may be necessary to readjust FOCUS and retrigger sweep to obtain sharpest trace.

**CAUTION**

Do not set sweep mode switch to auto or normal while INTENSITY is fully cw. Adjust FOCUS control slightly and press ERASE pushbutton. Repeat as necessary.

y. Press WRITE pushbutton. Rotate INTENSITY and PERSISTENCE controls fully ccw.

## 5-24. ADJUSTMENTS.

**WARNING**

Read the Safety Summary at the front of this manual before performing adjustment procedures.

5-25. The required test equipment is listed in table 5-1. Test equipment with similar characteristics may be substituted if necessary. Figure 5-6 shows the location of adjustments in both Models 181T and 181TR.

5-26. **COVER REMOVAL.** The covers of the Model 181TR can be removed by removing the appropriate screws and lifting the cover free. To remove the covers from the Model 181T, proceed as follows: Lower tilt stand and place instrument on rear panel. Remove screws on each cover along the side of the instrument (where the panels meet); lift the cover along the side of the instrument and rotate toward top or bottom.

5-27. **PRELIMINARY ADJUSTMENT SETUP.** Install plug-ins in Model 181T/TR mainframe. Set INTENSITY and PERSISTENCE controls fully ccw. Press WRITE pushbutton. Apply power and allow to warm-up for 15 minutes. Verify that Phase/Bandwidth switch is in Bandwidth position.

5-28. **LOW VOLTAGE POWER SUPPLY (LVPS).** This adjustment is applicable when using either group A or group B plug-ins. Perform LVPS adjustments as follows:

a. Using digital voltmeter measure voltages at test points listed in table 5-2.

**NOTE**

Tolerance listed in table 5-2 are not critical to actual instrument operation, but should be adhered to if plug-in interchangeability among mainframes is desired.

5-29. **HIGH VOLTAGE POWER SUPPLY (HVPS).** This adjustment is applicable when using either group A or

Table 5-2. Low Voltage Adjustments

Test Point	Measure	Adjust
A8TP4	-100 V $\pm$ 0.1 V	A8R36
A8TP1	+100 V $\pm$ 0.1 V	A8R10
A8TP3	-12.6 V $\pm$ 0.1 V	A8R26
A8TP2	+15 V $\pm$ 0.1 V	A8R18

group B plug-ins. Tight voltage tolerance is only necessary to single sweep applications of group A plug-ins. Perform HVPS adjustment as follows:

**WARNING**

Contact with high voltage power supply voltage can result in injury or death.

a. Monitor -100 V at A8TP4 with dc voltmeter using 1000:1 divider probe.

b. Observe voltage reading and note result.

c. Multiply +1.440 by result obtained in step b.

d. Monitor voltage at A1TP1 with dc voltmeter using 1000:1 divider probe.

e. Adjust A1R38 to obtain same voltage reading as calculated in step c.

5-30. **ASTIGMATISM.** This adjustment is applicable when using either group A or group B plug-ins. When using group B plug-ins adjust vertical controls so spot contains no appreciable noise. Perform astigmatism adjustment as follows:

a. Set HORIZONTAL DISPLAY control to EXT CAL and vertical plug-in display to A.

b. Slowly rotate INTENSITY control cw until spot appears. Set POSITION control as necessary.

c. Adjust FOCUS and ASTIGMATISM for small round spot.

5-31. **INTENSITY LIMIT.** This adjustment is applicable using either group A or group B plug-ins. The intensity limit normally needs adjustment at time of CRT replacement only. Adjustment is only important to single sweep application with group A plug-ins.

5-32. **Group A plug-ins.** Perform intensity limit adjustment as follows:

a. Obtain a baseline display.

b. Set baseline to first vertical graticule line using POSITION control.

c. Set HORIZONTAL DISPLAY control to INT and PERSISTENCE control fully cw.

- d. Press MAX W. pushbutton.
- e. Set sweep mode control on plug-in to single sweep.
- f. Press ERASE pushbutton.
- g. Slowly rotate INTENSITY control until spot appears on until INTENSITY control is fully cw. If spot appears prior to full cw rotation of INTENSITY control, adjust intensity limit, A5R2 (under hv cover), slightly ccw.

h. Press ERASE pushbutton. Continue rotating INTENSITY control cw and adjusting intensity limit, A5R2, until spot is just extinguished with INTENSITY control fully cw. Press ERASE pushbutton each time A5R2 is adjusted. Spot should not appear with INTENSITY control fully cw.

**5-33. Group B Plug-ins.** Perform intensity limit adjustment as follows:

- a. Set HORIZONTAL DISPLAY to EXT.
- b. Set INTENSITY CONTROL to 12 o'clock position.
- c. Adjust intensity limit, A5R2, until spot is just extinguished.

**5-34. TRACE ALIGNMENT.** This adjustment is applicable when using either group A or group B plug-ins. When using group B plug-ins, the front panel TRACE ALIGN can be set using any free-running trace or an input into the external horizontal input. Y align can be set with any vertical information inserted with horizontal in EXT and no external input applied. Perform trace alignment adjustment as follows:

- a. Set MAGNIFIER to X1.
- b. Set horizontal plug-in sweep mode control to auto and sweep time/div control to 0.1  $\mu$ s/div.
- c. Rotate INTENSITY control slowly cw until display appears. Center trace horizontally, and position display on center graticule line using vertical position control.
- d. Adjust TRACE ALIGN, R8 (front panel), so that display is parallel with center graticule line.
- e. Set HORIZONTAL DISPLAY control to EXT CAL and apply 1-kHz signal from test oscillator to channel A input.
- f. Set vertical plug-in controls as follows:

Channel A Polarity .....	+UP
Channel A Volts/Div .....	1
Channel A Vernier .....	CAL
Channel A Coupling .....	AC

g. Adjust INTENSITY, POSITION, and test oscillator amplitude for an 8-div display on vertical line. Adjust Y Align, A3R53, so that display is parallel with graticule center line.

h. Adjust Pattern Adj, A1R56, for straightest line when positioned to left and right sides of graticule.

i. Set INTENSITY control fully ccw, and disconnect test oscillator from vertical input.

**5-35. GATE AMPLIFIER RESPONSE.** This adjustment is applicable only when using group A plug-ins at fast sweep speeds. Perform gate amplifier response adjustment as follows:

- a. Set Model 181T/TR controls as follows:

CRT Mode .....	WRITE
PERSISTENCE .....	fully ccw
HORIZONTAL DISPLAY .....	INT

b. Set vertical plug-in channel A position control fully ccw.

- c. Set horizontal plug-in controls as follows:

Time/Div (main) .....	0.1 $\mu$ s
Vernier (main) .....	CAL
Sweep Mode (main) .....	AUTO
Sweep Display (if applicable) .....	MAIN
Delayed Time/Div (if applicable) .....	OFF

- d. Set test oscilloscope controls as follows:

Volts/Div .....	1
Input Coupling .....	DC
Time/Div .....	0.1 $\mu$
Trigger Source .....	INT
SLOPE .....	+

e. Observe signal at collector of A1Q3 using 10:1 divider probe.

f. Rotate INTENSITY control cw until bottom of waveform on test oscilloscope rises 0.2 div.

g. Adjust A1C8 and A1C9 for best rise time and flattest response.

h. Rotate INTENSITY control fully ccw.

i. Disconnect probe from A1Q3.

**5-36. DC BALANCE.** This adjustment is applicable when using either group A or group B plug-ins and may be performed with no plug-ins installed if desired. Perform dc balance adjustment as follows:

a. Set HORIZONTAL DISPLAY control to EXT CAL.

b. Center vertical plug-in channel A position control.

- c. Rotate INTENSITY control slowly cw until spot just appears.
- d. Set MAGNIFIER control to X10 and center spot using HORIZONTAL POSITION control.
- e. Set MAGNIFIER control to X1 and recenter spot by adjusting Int Dc Bal, A3R37.
- f. Repeat steps d and e until spot does not shift when MAGNIFIER control is switched from X10 to X1.

**5-37. VERNIER BALANCE.** This adjustment is applicable when using either group A or group B plug-ins and may be performed with no plug-ins installed if desired. Perform vernier balance adjustment as follows:

- a. Set MAGNIFIER control to X10.
- b. Rotate HORIZONTAL DISPLAY control ccw until it is just out of INT.
- c. Center spot using HORIZONTAL POSITION control.
- d. Rotate HORIZONTAL DISPLAY control to EXT CAL and adjust Ext Dc Bal, A3R7, to recenter spot.
- e. Repeat steps b thru d until spot does not shift when HORIZONTAL DISPLAY control is rotated from just out of INT to EXT CAL.

**5-38. HORIZONTAL GAIN.** This adjustment is applicable when using either group A or group B plug-ins but critical only to interchangeability of time bases of group A. When using group B plug-ins gain is not critical and adjustment may be accomplished by inserting any known peak to peak voltage into EXT HORIZONTAL INPUT. Perform horizontal gain as follows:

- a. Set controls as follows:
 

DISPLAY.....	EXT CAL
MAGNIFIER .....	X1
PERSISTENCE.....	fully ccw
Operating Mode.....	STD
- b. Check +100 V supply for +100 V ±0.1 V.
- c. Adjust HORIZONTAL POSITION to center spot exactly on left-hand vertical graticule line.
- d. Connect 40-kilohm, 0.1%, 1/2 W resistor between +100 V supply and emitter of A3Q3. Keep connection lead lengths short as possible to avoid stray pickup or oscillations. Do not leave resistor connected throughout adjustment as thermal rise will shift current reference.



+100 V is present at open lead of resistor.

- e. While alternately connecting and disconnecting resistor to emitter of A3Q3, adjust X1 Gain Adj, A3R34, for exactly 10-major divisions of separation between spot positions.
- f. Set DISPLAY to INT.
- g. Set time base for 1 ms/div sweep speed.
- h. Apply 1-ms markers from time-mark generator to input of vertical plug-in.
- i. Adjust time base 1-ms calibration adjustment to obtain precisely one marker per division.
- j. Set MAGNIFIER to X5.
- k. Adjust X5 Gain Adj, A3R32, to obtain exactly 1 marker every 5 divisions.
- l. Set MAGNIFIER to X10.
- m. Adjust X10 Gain Adj, A3R30, to obtain exactly 1 marker every 10 divisions.
- n. Disconnect time-mark generator.
- o. Disconnect 40-kilohm resistor from +100 V supply.

**5-39. PHASE ADJ.** This adjustment is applicable only when using group A plug-ins for X-Y application. Perform phase adjustment as follows:

- a. Set controls as follows:
 

Phase/Bandwidth Switch .....	PHASE
HORIZONTAL MAGNIFIER .....	X1
HORIZONTAL DISPLAY.....	EXT CAL
Channel A Coupling .....	DC

b. Connect 10-kHz sine-wave output of test oscillator to HORIZONTAL EXT INPUT and to vertical plug-in channel A input (figure 5-2).

**NOTE**

Adjust phase in channel normally used.

- c. Adjust test oscillator output to obtain an 8-div display.
- d. Adjust attenuator Input Comp, A3C1, for display of single diagonal line (no phase shift).
- e. Set test oscillator for output of 100-kHz.
- f. Adjust Phase, A3C2, for display of single diagonal line (no phase shift).
- g. Disconnect test oscillator.
- h. Return Phase/Bandwidth switch to Bandwidth position.



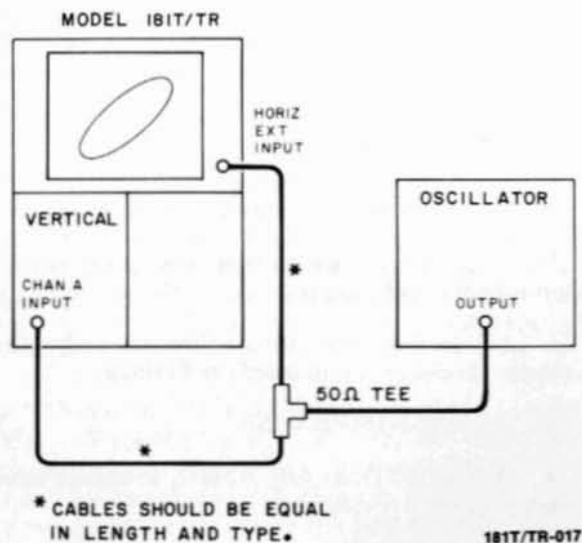

Figure 5-2. Phase Adj. Test Setup

**5-40. TRANSIENT RESPONSE.** This adjustment is applicable when using group A plug-ins and only after major repairs or complete board replacement has been made. Omit this adjustment procedure for normal calibration and perform the Horizontal Linearity adjustment. Perform transient response adjustment as follows:

- a. Use test setup (figure 5-3).

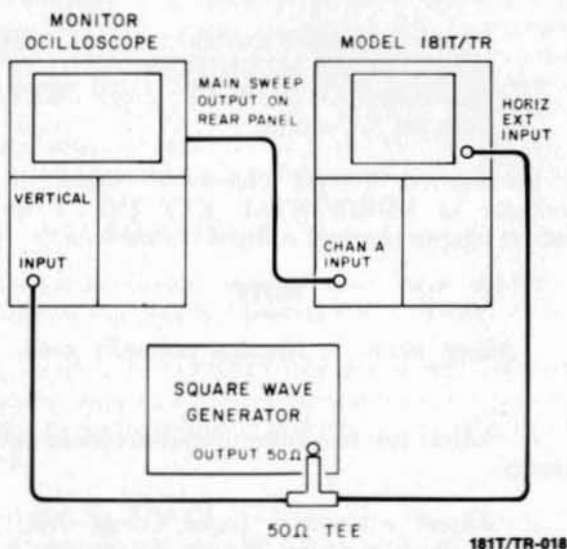

Figure 5-3. Transient Response Adj. Test Setup

- b. Set DISPLAY to EXT CAL.
- c. Connect main sweep output from monitor oscilloscope to vertical input of Model 181T/TR.
- d. Adjust vertical plug-in Volts/Div and vernier controls to obtain 8-div display.

e. Connect 1 V p-p square wave at 200-kHz repetition rate from square-wave generator to HORIZONTAL EXT INPUT and to monitor oscilloscope vertical input (figure 5-3).

f. Set monitor oscilloscope to operate at sweep of  $1\mu\text{s}/\text{div}$  and synchronize monitor oscilloscope with 200-kHz signal.

g. Using POSITION controls and varying frequency of square-wave generator, position lower right-hand corner of sideways square wave so that it is on screen.

#### NOTE

A spot at the lower right edge of the display may tend to bloom. If so, position the entire display so that the spot is off screen.

h. With viewing mode switch in NORM and intensity level set low, observe display waveform. At this stage of adjustment waveform will typically exhibit 5% (approximately  $1/2$  div) overshoot. If overshoot is greater, adjust HF Adj No. 1, A3C6, HF Adj No. 2, A3C9, and HF Adj No. 3, A3C19, to obtain flat-top response with approximately 5% overshoot on lower right-hand corner of displayed pulse.

#### NOTE

Capacitors for HF Adj No. 1, A3C6, and HF Adj No. 3, A3C19, should be adjusted so their slugs are equally extended.

**5-41. HORIZONTAL LINEARITY.** This adjustment is applicable only when using group A plug-ins at fast sweep speeds. Before proceeding with this adjustment, check linearity and if magnified sweep timing is within specifications do not perform this adjustment. Perform horizontal linearity adjustment as follows:

#### NOTE

Ensure that time base has been properly calibrated before proceeding with this adjustment.

- a. Set HORIZONTAL DISPLAY to INT.
- b. Set HORIZONTAL MAGNIFIER to X10.
- c. Connect 4 V p-p, 50-MHz sine-wave output from time-mark generator to vertical input.
- d. Select fastest sweep speed ( $0.05$  or  $0.1\mu\text{s}/\text{div}$ ) and obtain display.
- e. Adjust HF Adj No. 1, A3C6, HF Adj No. 2, A3C9, and HF Adj No. 3, A3C19, for best overall linearity of center 80 divisions of available display. Use HORIZONTAL POSITION control to permit viewing right, center, and left portions of display. HF

Adj No. 1 affect right portion, HF Adj No. 2 affects center portion, and HF Adj No. 3 affects left portion of sweep.

f. Disconnect time-mark generator.

**5-42. PULSE CIRCUIT.** This adjustment can only be made when using group A plug-ins. Although applicable to both groups, pulse adjustment cannot be checked or adjusted using group B plug-ins. Sweep speeds of group B plug-ins will never exceed capabilities of Model 181T/TR. Perform pulse circuit adjustment as follows:

a. Set Model 181T/TR controls as follows:

CRT Mode .....	WRITE
HORIZONTAL DISPLAY .....	INT
INTENSITY .....	fully ccw
PERSISTENCE .....	fully ccw
Max Write Rate Adjust A6R17 ....	fully cw
Write Adjust A6R18 .....	fully cw
Floodgun Adjust A6R42 .....	fully cw
Write Collimation Adjust A6R9...	fully ccw
Max Write Collimation Adjust A6R29 .....	fully ccw

b. Press ERASE PUSHBUTTON. Display should resemble figure 5-5A. If display does not resemble figure 5-5A, but instead fills entire screen, omit steps c and d and proceed with step e. See figure 5-4 for location of adjustment.

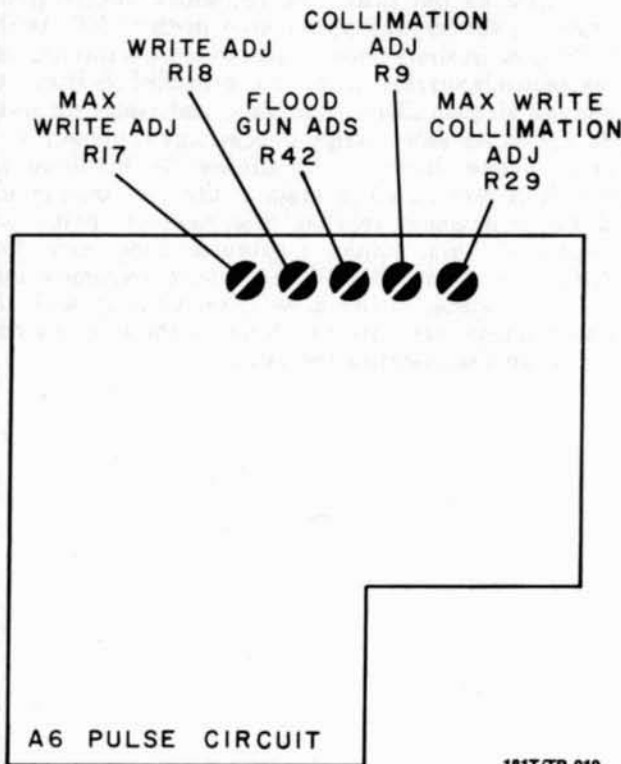

Figure 5-4. Pulse Board Adjustments

c. Adjust Floodgun Adjust, A6R42, ccw until background illumination just reaches maximum height.

**NOTE**

This variation in height is very small and may be less than 0.1 div.

d. Press ERASE pushbutton.

e. Adjust WRITE Collimation Adjust, A6R9, until background illumination just fills CRT graticule area as shown in figure 5-5C. Disregard slight dimple areas at top and bottom of display. These may cause slight blank area when rest of CRT graticule is filled.

f. Press ERASE pushbutton. If display looks normal as shown in figure 5-C, proceed with writing rate adjustment. If bright areas appear in any or all corners of CRT, adjust Write Collimation Adjust, A6R9, cw in small increments, pressing ERASE pushbutton after each change of A6R9, until bright areas just disappear.

**5-43. WRITING RATE.** Perform write rate (norm) adjustment as follows:

a. Set time base plug-in controls as follows:

Sweep Mode (main) .....	AUTO
Time/Div (main) .....	1 ms/div
Trigger Source (main) .....	INT

b. Connect 800-Hz signal from test oscillator to channel A INPUT.

c. Rotate INTENSITY control slowly cw until trace just appears. Adjust test oscillator output and channel A V/div control for 8-div vertical display.

d. Set time base plug-in sweep mode control to single.

e. Set trigger level (main) fully ccw.

f. Rotate INTENSITY control to 3 o'clock position and PERSISTENCE control fully cw.

g. Press ERASE pushbutton.

h. Press RESET pushbutton to arm single sweep. Rotate trigger level until single sweep is triggered. 800-Hz sine-wave display should be observed (figure 5-5D). It may be necessary to adjust FOCUS to obtain sharp trace.

**CAUTION**

Do not set sweep mode switch to NORM or AUTO. Adjust FOCUS control slightly, press ERASE pushbutton, retrigger sweep and observe display. Repeat until sharpest display is obtained. Press ERASE pushbutton before retriggering sweep.

i. Figure 5-5D shows display stored with non-uniform brightness across screen, with some areas fading faster than others. Adjust Write Adjust, A6R18, ccw in small increments until uniform storing is obtained (figure 5-5E).

j. Press ERASE pushbutton and retrigger sweep each time A6R18 is changed. At least 80% of display should be visible after 1 minute.

k. Press ERASE pushbutton. Background should be completely dark except for possibly few small spots (figure 5-1). If some background illumination is present, adjust A6R18 slightly cw and press ERASE pushbutton. Repeat as necessary until background is dark.

**5-44. WRITING RATE (MAX).** Perform write rate (max) adjustment as follows:

a. Press MAX W. pushbutton and rotate PERSISTENCE and INTENSITY fully ccw.

b. Press ERASE pushbutton. Display should resemble figure 5-5A. Adjust Max Write Collimation Adjust, A6R29, cw until background illumination just fills CRT graticule area. Display should be like figure 5-5A, within 1/2 div of outer graticule line.

c. Rotate PERSISTENCE fully cw. Press ERASE pushbutton. Adjust Max Write Rate Adjust, A6R17, ccw in small increments, pressing ERASE pushbutton after each change of A6R17. Obtain background illumination with best compromise between minimum background light (may not be uniform). Mesh pattern may also be visible (figure 5-5F).

d. Set time base controls as follows:

Sweep Mode (main) ..... AUTO  
Time Div (main) ..... 20  $\mu$ s/div

e. Connect 200-kHz sine-wave signal from test oscillator to vertical INPUT.

f. Rotate PERSISTENCE fully ccw and rotate INTENSITY control slowly cw until trace just appears.

g. Adjust test oscillator output and channel A V/div control for 8-div vertical display.

h. Set time base plug-in sweep mode control to single.

i. Set trigger level (main) fully ccw.

j. Rotate INTENSITY and PERSISTENCE controls fully cw.

k. Press ERASE pushbutton.

l. Press RESET pushbutton to arm single sweep. Rotate trigger level until single sweep is triggered. 200-kHz sine-wave should be observed. It may be necessary to adjust FOCUS to obtain sharp trace. At least 80% of display should be visible after 10 seconds.

#### NOTE

If display fades positive too fast, Adjust A6R17 slightly cw and repeat Writing Rate adjustment. If display is not stored over entire area adjust A6R17 slightly ccw and repeat.

**5-45. CALIBRATOR FREQUENCY.** This adjustment is applicable when using either group A or group B plug-ins.

5-46. This adjustment varies the calibrator frequency approximately  $\pm 25\%$  and is set at the factory as close to 1 kHz as practical. The calibrator circuit is the source of the storage pulses used in the CRT. As the CRT ages, in some cases a point of electro/mechanical resonance is reached within the tube that results in an audible singing. This resonance and resulting noise do not cause any change in instrument operation or performance; however, if allowed to continue indefinitely mechanical damage to the CRT may result. If the instrument reaches this resonant point and begins to sing, adjust Calibrator Frequency Adj, A1R59, cw to increase the calibrator frequency until the noise stops. If the noise does not stop with the potentiometer set fully cw, decrease the frequency by adjusting the potentiometer ccw.

**PERFORMANCE CHECK RECORD  
MODEL 181T/TR**

Instrument Serial Number \_\_\_\_\_

Date \_\_\_\_\_

Check	Specification	Measured
Screen Illumination	Light Green Illumination	_____
Calibrator Amplitude Rise Time	10 ±0.5 div  < 3 μs	_____  _____
Magnifier  X1 X5 X10	10 ±0.5 div  10 ±0.5 div  10 ±0.5 div	_____  _____  _____
Bandwidth  AC Coupling	> 7.1 div	_____
Beam Finder	On Screen Display	_____
Persistence and Write Rate  Minimum  Maximum	< 1 div  > 1 minute	_____  _____

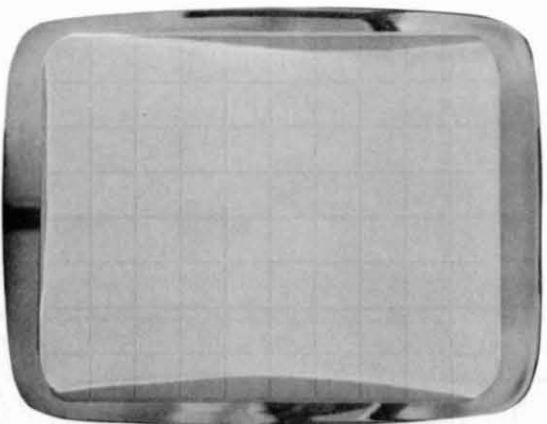

A.

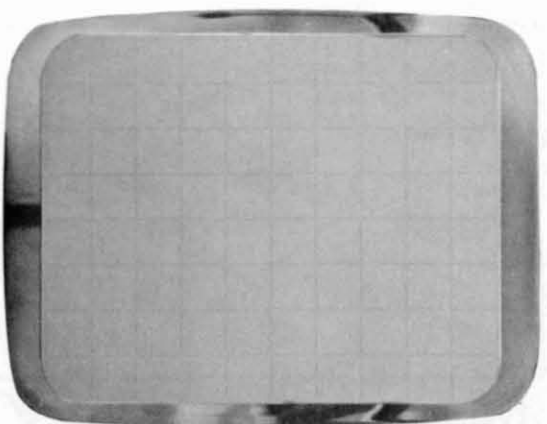

B.

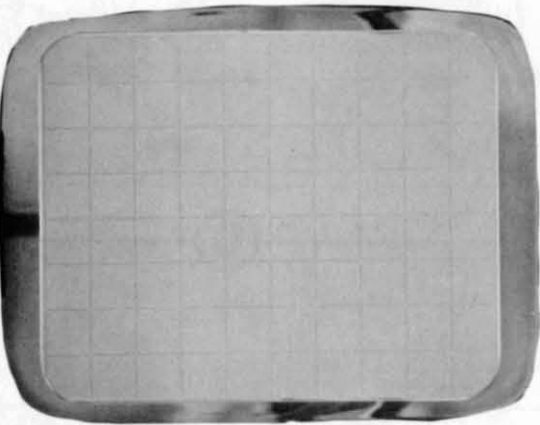

C.

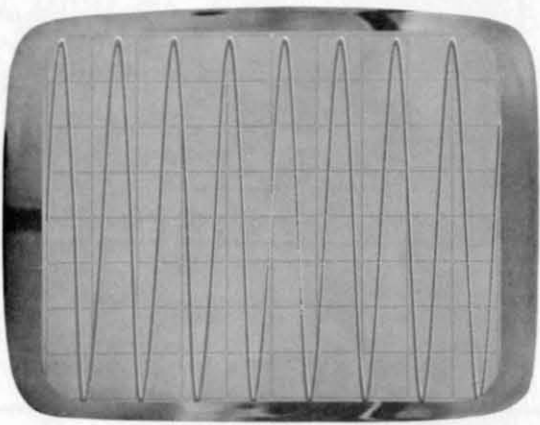

D.

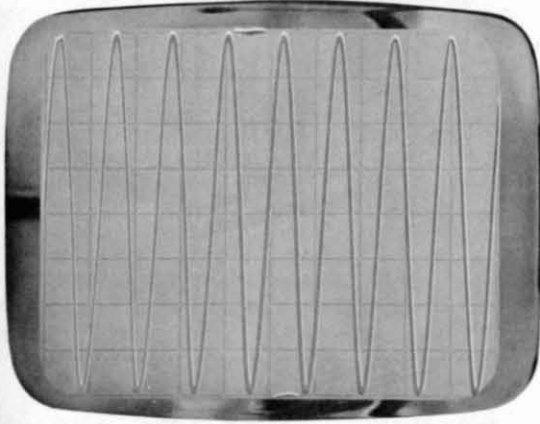

E.

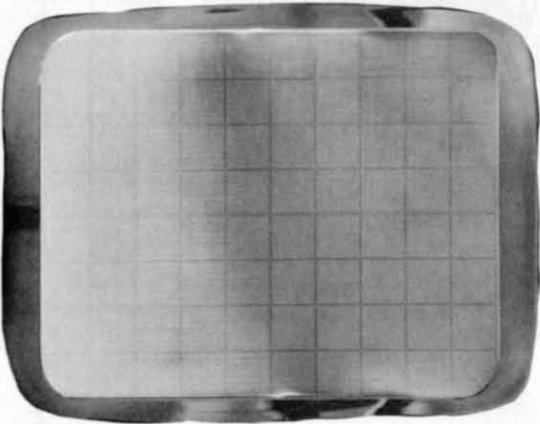

F.

Figure 5-5. Typical CRT Display

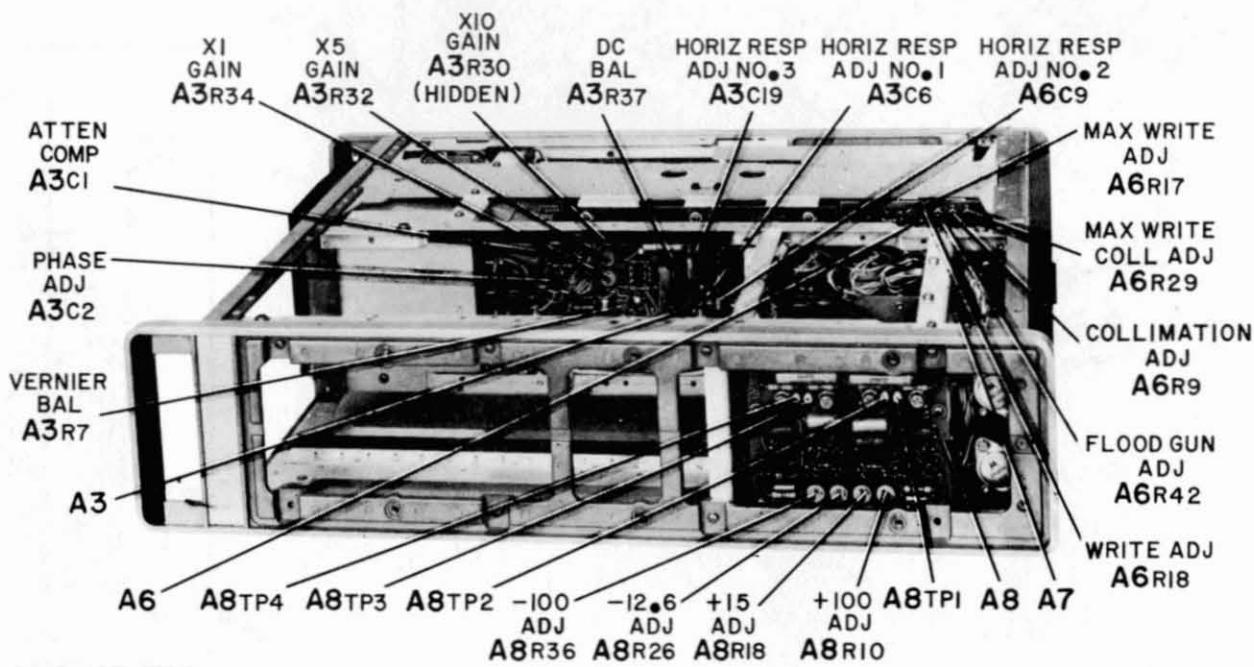
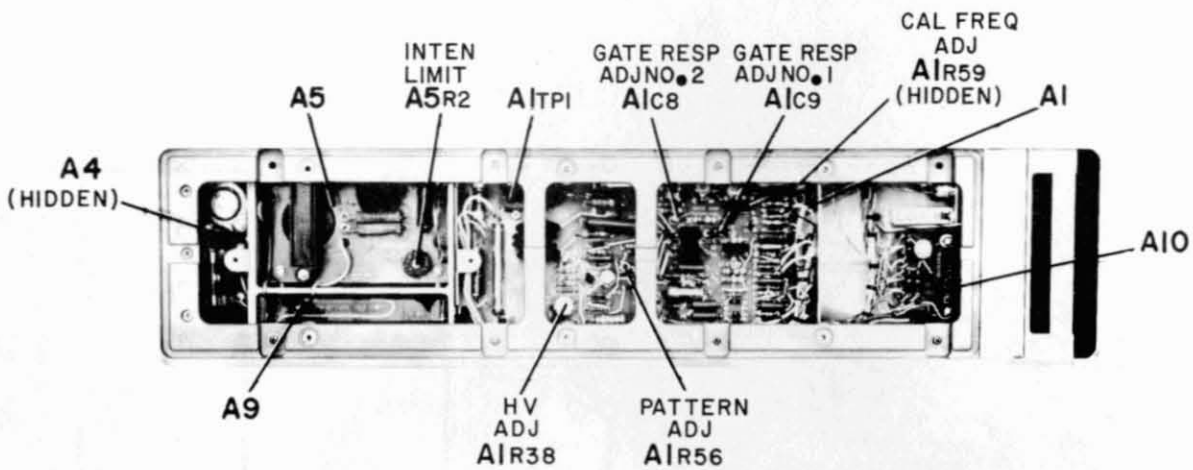

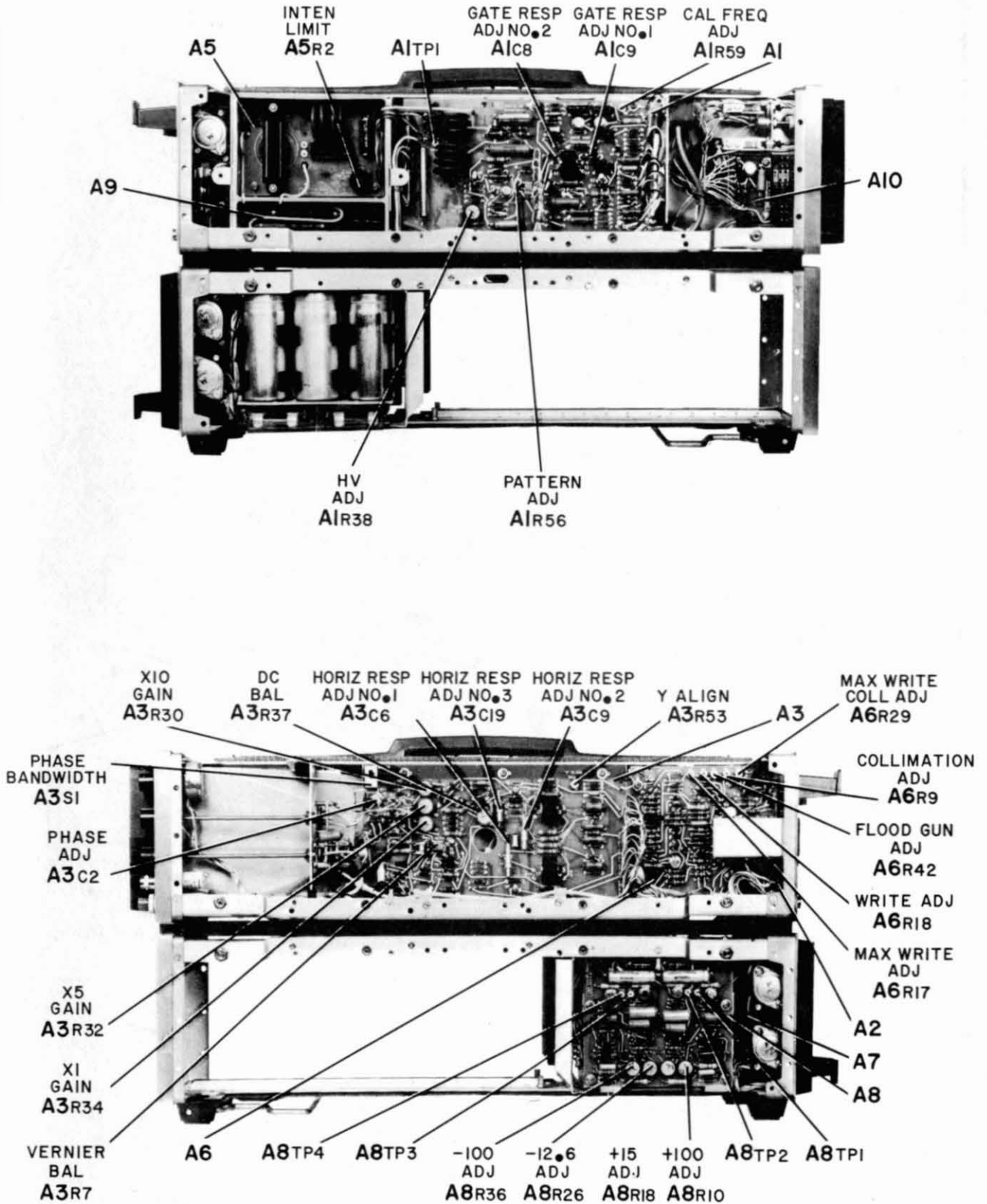
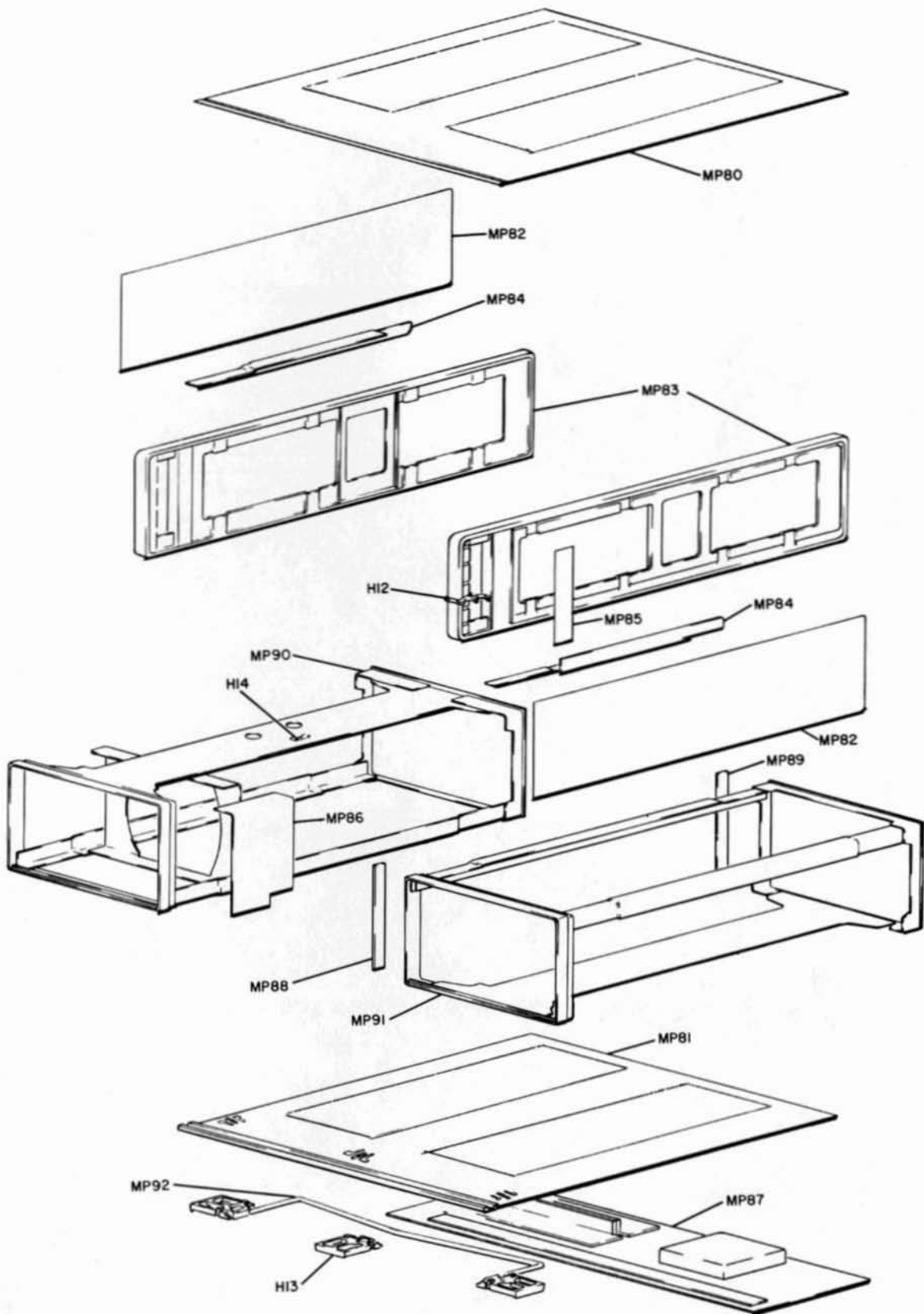

Figure 5-6.  
Location of Adjustment and Test Points





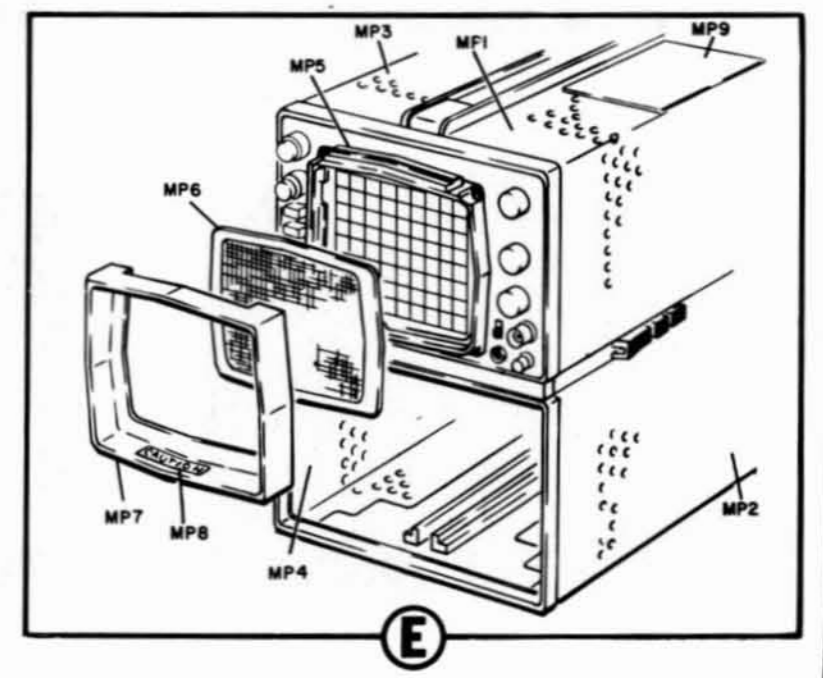
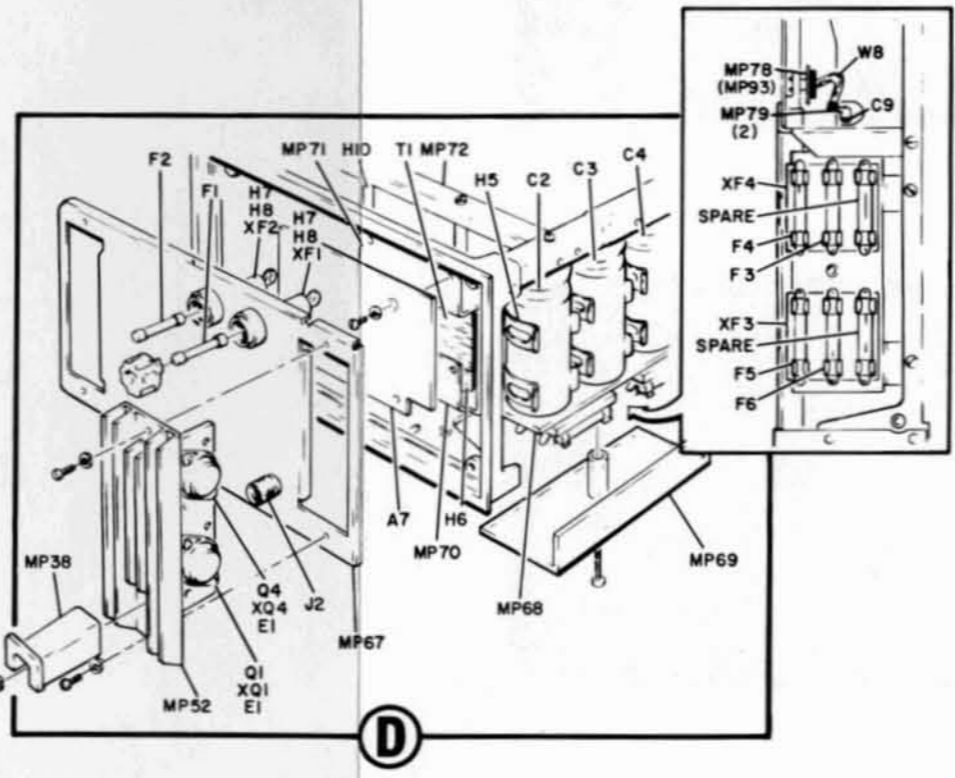
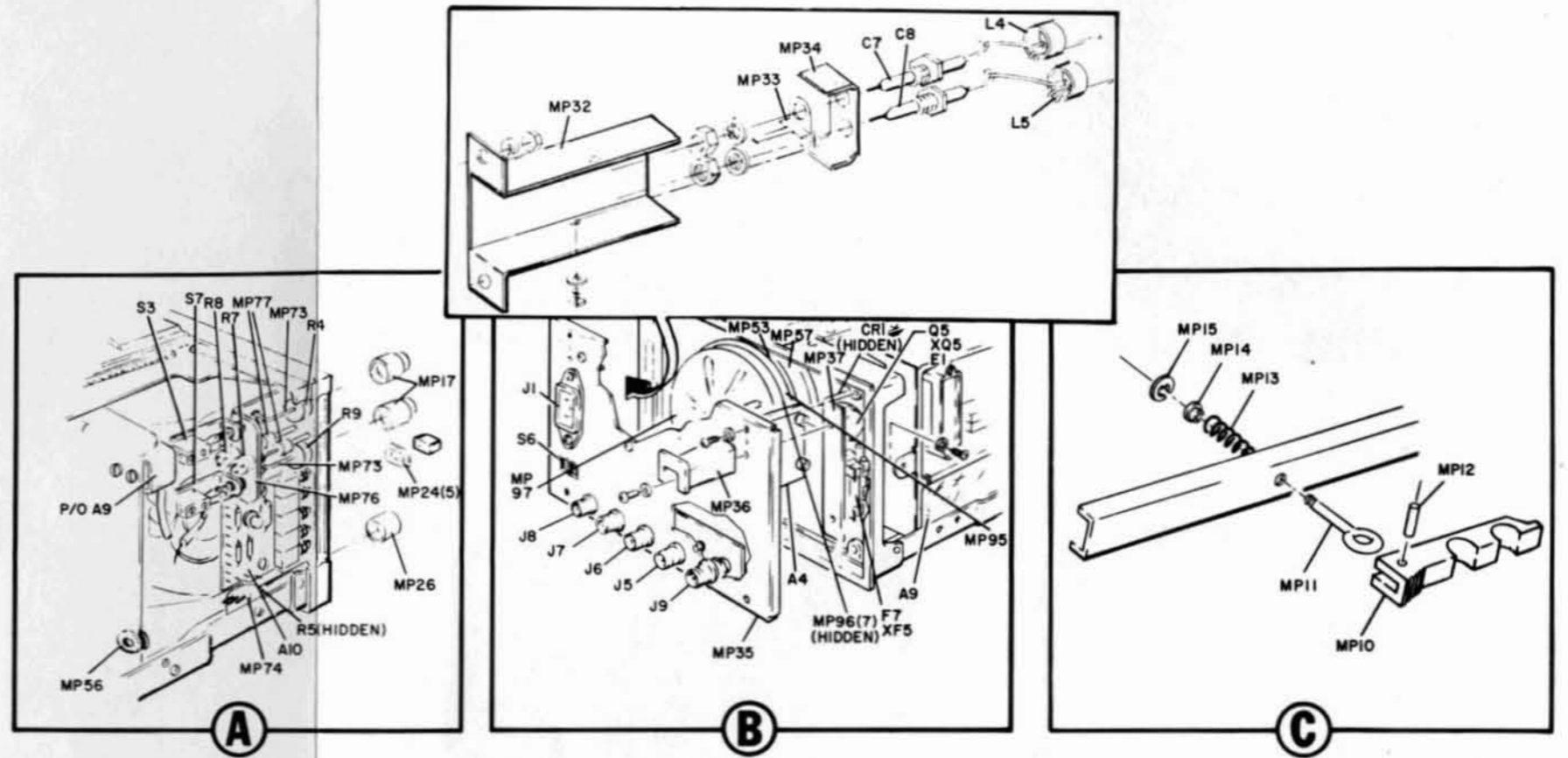
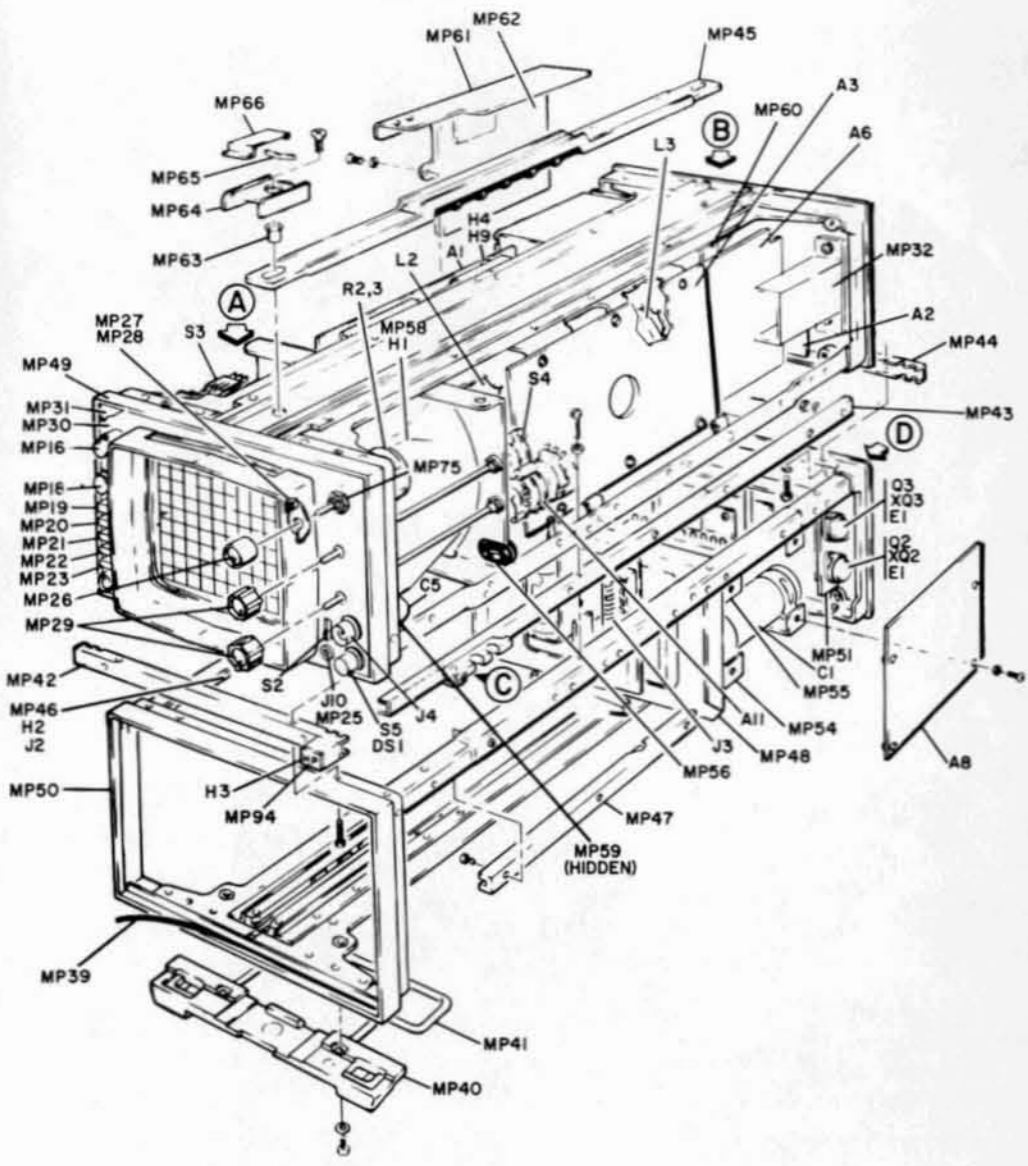

Figure 6-1. Model 181T/TR Mechanical Parts Identification

## SECTION VI

### REPLACEABLE PARTS

#### 6-1. INTRODUCTION.

6-2. This section contains information for ordering replacement parts. The abbreviations used in the parts list are described in table 6-1. Table 6-2 lists the parts in alphanumeric order by reference designation and includes the manufacturer and manufacturer's part number. Table 6-3 contains the list of manufacturers' codes.

#### 6-3. ORDERING INFORMATION.

6-4. To obtain replacement parts from Hewlett-Packard, address order or inquiry to the nearest Hewlett-Packard Sales/Service Office and supply the following information:

- a. Instrument model and serial number.
  - b. HP part number of item(s).
  - c. Quantity of part(s) desired.
  - d. Reference designation of part(s).
- 6-5. To order a part not listed in the table, provide the following information:
- a. Instrument model and serial number.
  - b. Description of the part, including function and location in the instrument.
  - c. Quantity desired.

Table 6-1. Abbreviations for Replaceable Parts List

<b>A</b>	AMPERE(S)	<b>H</b>	HENRY(IES)	<b>NPN</b>	NEGATIVE-POSITIVE-NEGATIVE	<b>RWV</b>	REVERSE WORKING VOLTAGE
<b>ASSY</b>	ASSEMBLY	<b>HG</b>	MERCURY	<b>NSR</b>	NOT SEPARATELY REPLACEABLE	<b>S-B</b>	SLOW-BLOW
<b>BD</b>	BOARD(S)	<b>HP</b>	HEWLETT-PACKARD			<b>SCR</b>	SILICON CONTROLLED RECTIFIER
<b>BH</b>	BINDER HEAD	<b>HZ</b>	HERTZ			<b>SE</b>	SELENIUM
<b>BP</b>	BANDPASS	<b>IF</b>	INTERMEDIATE FREQ.	<b>OBD</b>	ORDER BY DESCRIPTION	<b>SEC</b>	SECOND(S)
<b>C</b>	CENTI (10 <sup>-2</sup> )	<b>IMPG</b>	IMPREGNATED	<b>OH</b>	OVAL HEAD	<b>SECT</b>	SECTION(S)
<b>CAR</b>	CARBON	<b>INCD</b>	INCANDESCENT	<b>OX</b>	OXIDE	<b>SI</b>	SILICON
<b>CCW</b>	COUNTERCLOCKWISE	<b>INCL</b>	INCLUDE(S)	<b>P</b>	PEAK	<b>SIL</b>	SILVER
<b>CER</b>	CERAMIC	<b>INS</b>	INSULATION(ED)	<b>PC</b>	PRINTED (ETCHED) CIRCUIT(S)	<b>SL</b>	SLIDE
<b>CMO</b>	CABINET MOUNT ONLY	<b>INT</b>	INTERNAL	<b>PF</b>	PICOFARADS	<b>SP</b>	SINGLE POLE
<b>COAX</b>	COAXIAL	<b>K</b>	KILO (10 <sup>3</sup> )	<b>PHL</b>	PHILLIPS	<b>SPL</b>	SPECIAL
<b>COEF</b>	COEFFICIENT	<b>KG</b>	KILOGRAM	<b>PIV</b>	PEAK INVERSE VOLTAGE(S)	<b>ST</b>	SINGLE THROW
<b>COMP</b>	COMPOSITION	<b>LB</b>	POUND(S)	<b>PIV</b>	PEAK INVERSE VOLTAGE(S)	<b>STD</b>	STANDARD
<b>CONN</b>	CONNECTOR(S)	<b>LH</b>	LEFT HAND	<b>PNP</b>	POSITIVE-NEGATIVE-POSITIVE	<b>TA</b>	TANTALUM
<b>CRT</b>	CATHODE-RAY TUBE	<b>LIN</b>	LINEAR TAPER	<b>P/O</b>	PART OF	<b>TD</b>	TIME DELAY
<b>CW</b>	CLOCKWISE	<b>LOG</b>	LOGARITHMIC TAPER	<b>PORC</b>	PORCELAIN	<b>TFL</b>	TEFLON
<b>D</b>	DECI (10 <sup>-1</sup> )	<b>LPF</b>	LOW-PASS FILTER(S)	<b>POS</b>	POSITION(S)	<b>TGL</b>	TOGGLE
<b>DEPC</b>	DEPOSITED CARBON	<b>LVR</b>	LEVER	<b>POT</b>	POTENTIOMETER(S)	<b>THYR</b>	THYRISTOR
<b>DP</b>	DOUBLE POLE	<b>M</b>	MILLI (10 <sup>-3</sup> )	<b>P-P</b>	PEAK-TO-PEAK	<b>TI</b>	TITANIUM
<b>DT</b>	DOUBLE THROW	<b>MEG</b>	MEGA (10 <sup>6</sup> )	<b>PRGM</b>	PROGRAM	<b>TNLDIO</b>	TUNNEL DIODE(S)
<b>ELECT</b>	ELECTROLYTIC	<b>MET FILM</b>	METAL FILM	<b>PS</b>	POLYSTYRENE	<b>TOL</b>	TOLERANCE
<b>ENCAP</b>	ENCAPSULATED	<b>MET OX</b>	METAL OXIDE	<b>PWV</b>	PEAK WORKING VOLTAGE	<b>TRIM</b>	TRIMMER
<b>EXT</b>	EXTERNAL	<b>MFR</b>	MANUFACTURER			<b>U</b>	MICRO (10 <sup>-6</sup> )
<b>F</b>	FARAD(S)	<b>MINAT</b>	MINIATURE	<b>RECT</b>	RECTIFIER(S)	<b>V</b>	VOLTS
<b>FET</b>	FIELD-EFFECT TRANSISTOR(S)	<b>MOM</b>	MOMENTARY	<b>RF</b>	RADIO FREQUENCY	<b>VAR</b>	VARIABLE
<b>FH</b>	FLAT HEAD	<b>MTG</b>	MOUNTING	<b>RFI</b>	RADIO FREQUENCY INTERFERENCE	<b>VDCW</b>	DC WORKING VOLT(S)
<b>FIL H</b>	FILLISTER HEAD	<b>MY</b>	MYLAR	<b>RH</b>	ROUND HEAD OR	<b>W</b>	WATT(S)
<b>FXD</b>	FIXED	<b>N</b>	NANO (10 <sup>-9</sup> )			<b>W/</b>	WITH
<b>G</b>	GIGA (10 <sup>9</sup> )	<b>N/C</b>	NORMALLY CLOSED	<b>RMS</b>	RIGHT HAND	<b>WIV</b>	WORKING INVERSE VOLTAGE
<b>GE</b>	GERMANIUM	<b>NE</b>	NEON			<b>W/O</b>	WITHOUT
<b>GL</b>	GLASS	<b>N/O</b>	NORMALLY OPEN	<b>RMO</b>	RACK MOUNT ONLY	<b>WW</b>	WIREWOUND
<b>GRD</b>	GROUNDED	<b>NOF</b>	NEGATIVE POSITIVE ZERO (ZERO TEMPERATURE COEFFICIENT)				

Table 6-2. Replaceable Parts

Reference Designation	HP Part Number	Qty	Description	Mfr Code	Mfr Part Number
CHASSIS PARTS					
A1	00181-66512	1	ASSY: CALIBRATOR, GATE AND HV CONTROL BOARD	28480	00181-66512
A2	00180-66551	1	ASSY: AUXILIARY OUTPUT BOARD	28480	00180-66551
A3	00181-66514	1	ASSY: HORIZONTAL AMPLIFIER BOARD	28480	00181-66514
A4	00180-66532	1	ASSY: HIGH VOLTAGE OSCILLATOR BOARD	28480	00180-66532
A5	00181-66502	1	ASSY: HIGH VOLTAGE RECTIFIER BOARD	28480	00181-66502
A6	00181-66518	1	ASSY: PULSE CIRCUIT BOARD	28480	00181-66518
A7	00181-66503	1	ASSY: LOW VOLTAGE RECIFIER BOARD	28480	00181-66503
A8	00181-66509	1	ASSY: LOW VOLTAGE POWER SUPPLY BOARD	28480	00181-66509
A9	00181-61101	1	ASSY: HIGH VOLTAGE TRIPLER (MODEL 181T ONLY)	28480	00181-61101
A9	00181-61102	1	ASSY: HIGH VOLTAGE TRIPLER (MODEL 181TR ONLY)	28480	00181-61102
A10	00181-66517	1	ASSY: MODE SWITCH	28480	00181-66517
A11	00180-61904	1	ASSY: SWITCH DISPLAY	28480	00180-61904
C1	0180-1808		C:FXD ELECT 430 UF +50-10% 200VDCW	56289	32D431F200AC2A-DQC
C2	0180-1865		C:FXD ELECT 2100 UF +75-10% 40VDCW	56289	32D212G040AB2A-DQC
C3	0180-1809		C:FXD ELECT 3400 UF +75-10% 25VDCW	56289	32D342G025AB2A-DQC
C4	0180-1807		C:FXD ELECT 290 UF +50-10% 200VDCW	56289	32D291F200AB2A-DQC
C5	0170-0022		C:FXD MY 0.1UF 20% 600VDCW	09134	TYPE 24
C6		1	DELETED		
C7	0160-3484	1	C:FXD CER 1000 PF 20% 1000VDCW	72982	2432
C8	0160-3484	1	C:FXD CER 1000 PF 20% 1000VDCW	72982	2432
CR1	1901-0040	1	DIODE:SILICON 30MA 30WV	07263	FDG1088
DS1	2140-0245		LAMP:INCANDESCENT 28V 0.04A	71744	CM 387
E1	1200-0043	2	INSULATOR:TRANSISTOR MOUNTING	71785	293011
E2	00181-00601	1	SHIELD-CRT	28480	00181-00601
E3	5020-0495	152	PIN-SQUARE	28480	5020-0495
E4	0362-0116	10	TERMINAL:CRIMP, 18 GA (USED WITH E3)	91886	2611225-6
E5	1251-2039	28	CONNECTOR:TEST POINT, CORD JACK	28480	1251-2039
E6	0362-0264	113	TERMINAL:CRIMP, 24 GA (USED WITH E3)	91886	2611225-14
E7	1251-2039	9	TERMINAL:CRIMP (USED ON CRT NECK PINS)	07557	3367-1-03
F1	2110-0006	1	FUSE-CARTRIDGE 2.0 AMP (SLOW-BLOW)	75915	313002
F2	2110-0007	1	FUSE-CARTRIDGE 1.0 AMP (SLOW-BLOW)	75915	313001
F3	2110-0012	3	FUSE-CARTRIDGE 0.5 AMP	75915	312500
F4	2110-0002	3	FUSE-CARTRIDGE 2 AMP	75915	312002
F5	2110-0002		FUSE-CARTRIDGE 2 AMP	75915	312.002
F6	2110-0067	1	FUSE-0.30A 250V	28480	2110-0067
F7	2110-0012		FUSE-CARTRIDGE 0.5A	28480	2110-0012
H1	00180-09105	1	CLIP-GROUND	28480	00180-09105
H2	00180-09104	1	CLIP-GROUND	28480	00180-09104
H3	00180-44701	1	SPACER:TRADEMARK	28480	00180-44701
H4	00180-24702	1	STANDOFF-GATE BOARD	28480	00180-24702
H5	1400-0091	8	CLIP:COMPONENT FOR 1-3/8" DIA	37942	TH25
H6	00180-24701	4	STANDOFF:TRANSFORMER	28480	00180-24701
H7	1400-0090	2	WASHER:RUBBER 5/8" OD	00000	0BD
H8	2950-0038	2	NUT:HEX SST 1/2-24 X 11/16	75915	903-12
H9	0570-0031	1	SCREW:NYLON	00000	0BD
H10	0380-0724	2	SPACER:POST TYPE	00000	0BD
H11	1205-0063	1	HEAT SINK:SEMICONDUCTOR	05820	NF224
H12	5040-0464	1	HANGER:PROBE	28480	5040-0464
H13	5060-0767	5	FOOT ASSY:(RACK PART)	28480	5060-0767
H14	00180-41208	1	CLIP:HORIZONTAL (RACK PART)	28480	00180-41208
J1	1251-2357	1	CONNECTOR:POWER 3 PIN MALE	87930	1251-2357
J2	1510-0038	1	BINDING POST	28480	1510-0038
J3	00180-27601	1	RECEPTACLE:32 CONTACT	02660	26-4200-32S
J4	1250-0083	6	CONNECTOR:BNC	02660	31-221-1020
J5	1250-0083		CONNECTOR:BNC	02660	31-221-1020
J6	1250-0083		CONNECTOR:BNC	02660	31-221-1020
J7	1250-0083		CONNECTOR:BNC	02660	31-221-1020
J8	1250-0083		CONNECTOR:BNC	02660	31-221-1020
J9	1250-0083		CONNECTOR:BNC	02660	31-221-1020
J10	00180-21702	1	CONNECTOR:BANANA, FEMALE	28480	00180-21702
J11	0363-0006	2	CONTACT:CONNECTOR, VERTICAL, PLUG-IN	28480	0363-0006
L1			DELETED		
L2	5060-0443	1	COIL:TRACE ALIGNMENT	28480	5060-0443
L3	00191-66004	1	COIL:ALIGNMENT, Y AXIS	28480	00191-66004
L4	9170-0013	2	COIL:CORE, TOROID, GREEN	72656	CF-102-H
L5	9170-0013		COIL:CORE, TOROID, GREEN	72656	CF-102-H
MP1	00180-04134	1	COVER:TOP RIGHT (CABINET PART)	28480	00180-04134
MP2	00180-04130	1	COVER:BOTTOM RIGHT (CABINET PART)	28480	00180-04130
MP3	00180-04136	1	COVER:TOP LEFT (CABINET PART)	28480	00180-04136
MP4	00180-04132	1	COVER:BOTTOM LEFT (CABINET PART)	28480	00180-04132
MP5	5020-0476	1	BEZEL	28480	5020-0476
MP6	10178A	1	FILTER:CONTRAST	28480	10178A
MP7	5040-0444	1	SHIELD-LIGHT, BLACK NYLON	28480	5040-0444
MP8		1	NOT USED		
MP9		1	NOT USED		
MP10	5040-0463	2	HANGER:PROBE (CABINET PART)	28480	5040-0463
MP11	5020-0499	2	HINGE:PROBE HANGER (CABINET PART)	28480	5020-0499
MP12	0510-0705	1	PIN:SPRING	00287	0BD
MP13	1460-0706	6	SPRING:COMPRESSION (CABINET PART)	00000	0BD
MP14	3050-0441	1	WASHER:SHOULDER	28480	3050-0441

See introduction to this section for ordering information

Table 6-2. Replaceable Parts (Cont'd)

Reference Designation	HP Part Number	Qty	Description	Mfr Code	Mfr Part Number
MP15	0510-0952	6	RING:RETAINING	79136	X5133-9-S-MD
MP16	00180-67405	1	KNOB:RND BLK (FIND BEAM)	28480	00180-67405
MP17	0370-0348	2	KNOB:RND BLK	28480	0370-0348
MP18	01201-67401	1	PUSHBUTTON (ERASE)	28480	01201-67401
MP19	00181-67402	1	PUSHBUTTON (MAX WRITE)	28480	00181-67402
MP20	01331-67402	1	PUSHBUTTON ASSY (WRITE)	28480	01331-67402
MP21	00181-67401	1	PUSHBUTTON (NORM)	28480	00181-67401
MP22	01331-67403	1	PUSHBUTTON (VIEW)	28480	01331-67403
MP23	01331-67404	1	PUSHBUTTON ASSY (STORE)	28480	01331-67404
MP24	0370-0451	5	BEZEL:PUSHBUTTON KNOW BLK NYLON	28480	0370-0451
MP25	00180-45403	3	INSULATOR:BUSHING, CALIBRATOR	28480	00180-45403
MP26	00180-67402	2	KNOB ASSY:POSITION	28480	00180-67402
MP27	0370-0432	1	KNOB:LEVER	28480	0370-0432
MP28	00180-05002	1	LEVER:HORIZONTAL POSITION	28480	00180-05002
MP29	00180-67404	2	KNOB ASSY:BAR WITH BLACK ARROW	28480	00180-67404
MP30	00181-00215	1	PANEL:FRONT (181T ONLY)	28480	00181-00215
MP30	00181-00216	1	PANEL:FRONT (181TR ONLY)	28480	00181-00216
MP31	00181-00202	1	PANEL:FRONT SUB	28480	00181-00202
MP32	00182-00601	1	SHIELD:LINE FILTER	28480	00182-00601
MP33	00180-01246	1	BRACKET:GROUND LINE FILTER	28480	00180-01246
MP34	00182-01209	1	BRACKET:LINE FILTER (CAP)	28480	00182-01209
MP35	00181-00214	1	PANEL:REAR (INCLUDES J1 AND MP32)	28480	00181-00214
MP36	5040-0447	2	FOOT:REAR, (LONG) (CABINET PART)	28480	5040-0447
MP37	00180-01206	1	BRACKET:TRANSISTOR	28480	00180-01206
MP38	5040-0446	2	FOOT:REAR (SHORT) (CABINET PART)	28480	5040-0446
MP39	4320-0231	1	RUBBER:RF1	00000	08D
MP40	5040-0445	2	FOOT:BOTTOM (CABINET PART)	28480	5040-0445
MP41	1490-0710	1	STAND:TILT (CABINET PART)	28480	1490-0710
MP42	5020-0551	1	SPACER:FRONT (CABINET PART)	28480	5020-0551
MP43	5020-0552	2	SPACER:SIDE (CABINET PART)	28480	5020-0552
MP44	5020-0553	1	SPACER:REAR (CABINET PART)	28480	5020-0553
MP45	5040-0459	1	HANDLE	28480	5040-0459
MP46	0403-0128	1	GUIDE:PLUG-IN LEFT	28480	0403-0128
MP47	0403-0129	1	GUIDE:PLUG-IN RIGHT	28480	0403-0129
MP48	00180-01209	1	BRACKET:CONNECTOR PLUG-IN	28480	00180-01209
MP49	00180-60117	1	CHASSIS:DISPLAY (CABINET PART)	28480	00180-60117
MP50	00180-60116	1	CHASSIS:POWER (CABINET PART)	28480	00180-60116
MP51	00180-61104	1	TRANSISTOR:HEAT SINK LH	28480	00180-61104
MP52	00180-61103	1	TRANSISTOR:HEAT SINK RH	28480	00180-61103
MP53	00180-41207	2	BRACKET:PLASTIC, CRT	28480	00180-41207
MP54	00180-01210	1	BRACKET:TRANSFORMER (FRONT)	28480	00180-01210
MP55	00180-01214	1	BRACKET:TRANSFORMER (FRONT)	28480	00180-01214
MP56	0400-0010	2	GROMMET:VINYL 0.250" ID	00000	08D
MP57	1400-0028	1	CLAMP:STAINLESS STEEL	66295	36H
MP58	00181-00601	1	SHIELD:CRT	28480	00181-00601
MP59	00181-00602	1	SHIELD:CALIBRATOR	28480	00181-00602
MP60	00181-01201	1	BRACKET:CRT CLAMP	28480	00181-01201
MP61	00180-04128	1	COVER:PLATE HVPS	28480	00180-04128
MP62	00180-25402	1	PLEXIGLASS:HV	28480	00180-25402
MP63	00180-24718	2	SPACER:HANDLE (CABINET PART)	28480	00180-24718
MP64	00180-22301	2	KEEPER:HANDLE (CABINET PART)	28480	00180-22301
MP65	00180-09103	2	SPRING:INSERT (CABINET PART)	28480	00180-09103
MP66	00180-07201	2	INSERT:KEEPER (CABINET PART)	28480	00180-07201
MP67	00181-00211	1	PANEL:REAR, POWER	28480	00181-00211
MP68	00180-01212	1	BRACKET:CAPACITOR	28480	00180-01212
MP69	00181-44101	1	COVER:FUSE	28480	00181-44101
MP70	00180-01215	1	BRACKET:TRANSFORMER (REAR)	28480	00180-01215
MP71	00180-01211	1	BRACKET:TRANSFORMER (REAR)	28480	00180-01211
MP72	00180-04703	1	SUPPORT:TRANSFORMER	28480	00180-04703
MP73	00180-23701	2	SHAFT:BEAM FINDER	28480	00180-23701
MP74	5040-0453	1	COVER:POTENTIOMETER (FOCUS)	28480	5040-0453
MP75	00180-24301	1	NUT:HORIZONTAL POSITION POT	28480	00180-24301
MP76	00181-01202	1	BRACKET:CRT CONTROL MOUNTING	28480	00181-01202
MP77	00181-23201	2	COUPLER:SHAFT	28480	00181-23201
MP78	00180-01249	1	BRACKET:VERTICAL LEADS (CABINET PART)	28480	00180-01249
MP79			NOT USED		
MP80	00180-04138	1	COVER:TOP (RACK PART)	28480	00180-04138
MP81	00180-64110	1	COVER:BOTTOM (RACK PART)	28480	00180-64110
MP82	00180-04137	2	COVER:SIDE (RACK PART)	28480	00180-04137
MP83	5060-0431	2	FRAME ASSY:SIDE (RACK PART)	28480	5060-0431
MP84	00180-01217	2	BRACKET:COVER (RACK PART)	28480	00180-01217
MP85	5000-0051	2	TRIM STRIP (RACK PART)	28480	5000-0051
MP86	00180-00601	1	SHIELD:POST ACCELERATOR (RACK PART)	28480	00180-00601
MP87	5060-0552	1	KIT:5 H RACK MOUNT (RACK PART)	28480	00180-0552
MP88	5000-0449	1	SPACER:FRONT (RACK PART)	28480	5000-0449
MP89	5000-0469	1	SPACER:REAR (RACK PART)	28480	5000-0469
MP90	00180-60103	1	CHASSIS ASSY:DISPLAY (RACK PART)	28480	00180-60103
MP91	00180-60104	1	CHASSIS ASSY:POWER (RACK PART)	28480	00180-60104
MP92	1490-0030	1	STAND:TILT (RACK PART)	28480	1490-0030
MP93	00180-01250	1	BRACKET:VERTICAL LEADS (RACK PART)	28480	00180-01250
MP94	7120-1254	1	TRADEMARK (HP)	28480	7120-1254

See introduction to this section for ordering information

Table 6-2. Replaceable Parts (Cont'd)

Reference Designation	HP Part Number	Qty	Description	Mfr Code	Mfr Part Number
MP95	1200-0037	1	SOCKET:CRT TUBE	72825	97097
MP96	1200-0050	7	CONTACT:CRT SOCKET	72825	9553-1
MP97	1200-0408	1	COVER:CRT SOCKET	28480	1200-0408
MP98	5060-0548	1	KIT:CONTRAST FILTER-BLUE	28480	5060-0548
Q1	1854-0063	4	TSTR:SI NPN	80131	2N3055
Q2	1854-0063		TSTR:SI NPN	80131	2N3055
Q3	1854-0063		TSTR:SI NPN	80131	2N3055
Q4	1854-0063		TSTR:SI NPN	80131	2N3055
Q5	1854-0291	1	TSTR:SI NPN	28480	1854-0291
R1			DELETED		
R2	2100-3287	1	R:VAR COMP 2 X 100K OHM 20% LIN	28480	2100-3287
R3			N.S.R. PART OF R2		
R4	2100-2602	1	R:VAR COMP 10K OHM 20% LIN 1/4W	28480	2100-2602
R5	2100-2563	1	R:VAR COMP 5 MEGOHM 20% LIN 1/2W	28480	2100-2563
R6	0683-1045	1	R:FXD COMP 100K OHMS 5% 1/4W	01121	CB 1045
R7	2100-1717	1	R:VAR COMP 50K OHM 20% LIN 1/2W	28480	2100-1717
R8	2100-2086	1	R:VAR COMP 5K OHM 20% LIN 1/2W	28480	2100-2086
R9	2100-2608	1	R:VAR COMP 10K OHM 20% LOG 1/4W	28480	2100-2608
S1			DELETED		
S2	3101-0070	1	SWITCH:SLIDE	79727	G-126
S3	3101-0977	2	SWITCH:PUSHBUTTON DPDT	82389	125-1032
S4	3100-1345	1	SWITCH:ROTARY 1 SECTION 3 POSITION	28480	3100-1345
S5	3101-0965	1	SWITCH:PUSHBUTTON SPDT (INCLUDES DSI)	87034	54-61681-27-387
S6	3101-1237	1	SWITCH:SLIDE DPDT (115/230V OPERATION)	82389	3101-1237
S7	3101-0977		SWITCH:PUSHBUTTON DPDT (ERASE)	82389	125-1032
T1	9100-1117	1	TRANSFORMER:POWER	28480	9100-1117
V1	5083-1952	1	CATHODE RAY TUBE:(P31 PHOSPHOR) STANDARD	28480	5083-1952
W1	8120-1538	1	CABLE ASSY:POWER CORD (181T)	28480	8120-1538
	8120-1545	1	CABLE ASSY:POWER CORD (181TR)	28480	00181-61620
W2	00181-61620	1	CABLE ASSY:T1 (181T ONLY)	28480	00181-61617
W3			CABLE ASSY:COAX, DISPLAY SWITCH (RACK)	28480	00180-61617
W4			NOT ASSIGNED	28480	
W5	00180-61657	1	CABLE ASSY:HORIZONTAL MAGNIFIER	28480	00180-61657
W6	00181-61606	1	CABLE:HORIZONTAL CRT CONNECTION (RACK)	28480	00181-61606
W7			NOT ASSIGNED		
W8	00180-61685	1	CABLE:CRT VERTICAL	28480	00180-61685
W9			DELETED		
W10			NOT ASSIGNED		
W11	00180-61807	1	CABLE:AUXILIARY OUTPUT	28480	00180-61807
W12	00180-61682	1	CABLE ASSY: T1 PRIMARY (INCLUDES L4)	28480	00180-61682
W13	00180-61683	1	CABLE ASSY:LINE (INCLUDES L5)	28480	00180-61683
W14	00181-61634	1	CABLE ASSY:MAIN HARNESS (RACK)	28480	00181-61634
W15			NOT ASSIGNED		
W16	00180-61653	1	CABLE ASSY:LOW VOLTAGE POWER SUPPLY	28480	00180-61653
W17	00181-61617	1	CABLE ASSY:LOW VOLTAGE TRANSFORMER	28480	00181-61617
W18	00180-61652	1	CABLE:COAX, DISPLAY	28480	00180-61652
XF1	1400-0084	2	FUSEHOLDER:EXTRACTOR POST TYPE	75915	342014
XF2	1400-0084		FUSEHOLDER:EXTRACTOR POST TYPE	75915	342014
XF3	1400-0123	2	FUSEHOLDER:3 POLE FOR 1/4" DIA	75915	35 7003
XF4	1400-0123		FUSEHOLDER:3 POLE FOR 1/4" DIA	75915	35 7003
XF5	1400-0008	1	FUSEHOLDER:BRONZE CLIP	95915	3610-11
XQ1	1200-0041	5	SOCKET:TRANSISTOR	71785	133-32-10-013
XQ2	1200-0041		SOCKET:TRANSISTOR	71785	133-32-10-013
XQ3	1200-0041		SOCKET:TRANSISTOR	71785	133-32-10-013
XQ4	1200-0041		SOCKET:TRANSISTOR	71785	133-32-10-013
XQ5	1200-0041		SOCKET:TRANSISTOR	71785	133-32-10-013

See introduction to this section for ordering information

Table 6-2. Replaceable Parts (Cont'd)

Reference Designation	HP Part Number	Qty	Description	Mfr Code	Mfr Part Number
A1	00181-66512	1	ASSY:CALIBRATOR, GATE & HV CONTROL BD.	28480	00181-66512
A1C1	0160-0162	12	C:FXD MY 0.022 UF 10% 200VDCW	56289	192P22392-PTS
A1C2	0160-0162		C:FXD MY 0.022 UF 10% 200VDCW	56289	192P22392-PTS
A1C3	0160-0162		C:FXD MY 0.022 UF 10% 200VDCW	56289	192P22392-PTS
A1C4	0160-0207	1	C:FXD MYLAR 0.01UF 5% 200VDCW	28480	0160-0207
A1C5	0160-0162		C:FXD MY 0.022 UF 10% 200VDCW	56289	192P22392-PTS
A1C6	0180-0374	2	C:FXD ELECT 10.0 UF 10% 20VDCW	56289	1500106X902082-76
A1C7	0150-0059	1	C:FXD CER 3.3-0.25 PF 500VDCW	72982	301-000-COJ0-339C
A1C8	0121-0168	5	C:VAR TEFLON 0.25-1.50 PF 600VDCW	28480	0121-0168
A1C9	0132-0004	1	C:VAR POLY 0.7-3.0 PF 350VDCW	72982	535-009-4R
A1C10	0140-0180	1	C:FXD MICA 2000 PF 2%	28480	0140-0180
A1C11	0160-0162		C:FXD MY 0.022 UF 10% 200VDCW	56289	192P22392-PTS
A1C12	0160-0303	1	C:FXD MYLAR .15 UF 10% 200VDCW	28480	0160-0303
A1C13	0160-2150	1	C:FXD MICA 33 PF 5%	28480	0160-2150
A1C14	0160-2961	2	C:FXD MICA 5825 PF 2% 300VDCW	04062	RDM20F(5825)G3C
A1C15	0160-2961		C:FXD MICA 5825 PF 2% 300VDCW	04062	RDM20F(5825)G3C
A1C16	0180-0089	1	C:FXD ELECT 10 UF -10%+100% 150VDCW	56289	300106G150DF4
A1C17	0180-0155	3	C:FXD ELECT 2.2 UF 20% 20VDCW	56289	1500225X0020A2-DYS
A1C18	0180-0045	1	C:FXD ELECT 20 UF 25VDCW	56289	300206-G0-2508-6M1
A1C19	0160-3008	5	C:FXD CER 4700 PF 20% 4K VDCW (LEFT FRONT LEAD)	72982	3888-024-Y550-472M
A1C20	0160-0380	2	C:FXD MY 0.22 UF 10% 200VDCW	28480	0160-0380
A1C21	0160-3007	6	C:FXD CER 4700 PF 20% 4K VDCW (RIGHT FRONT LEAD)	72982	3888-024-Y550-472M
A1C22	0160-3008		C:FXD CER 4700 PF 20% 4K VDCW (LEFT FRONT LEAD)	72982	3888-024-Y550-472M
A1C23	0160-3007		C:FXD CER 4700 PF 20% 4K VDCW (RIGHT FRONT LEAD)	72982	3888-024-Y550-472M
A1C24	0160-3007		C:FXD CER 4700 PF 20% 4K VDCW (RIGHT FRONT LEAD)	72982	3888-024-Y550-472M
A1C25	0160-3008		C:FXD CER 4700 PF 20% 4K VDCW (LEFT FRONT LEAD)	72982	3888-024-Y550-472M
A1C26	0160-3007		C:FXD CER 4700 PF 20% 4K VDCW (RIGHT FRONT LEAD)	72982	3888-024-Y550-472M
A1CR1	1901-0040	34	DIODE:SILICON 30MA 30VW	07263	FDG1088
A1CR2	1901-0040		DIODE:SILICON 30MA 30VW	07263	FDG1088
A1CR3	1901-0040		DIODE:SILICON 30MA 30VW	07263	FDG1088
A1CR4	1901-0040		DIODE:SILICON 30MA 30VW	07263	FDG1088
A1CR5	1901-0179	1	DIODE:SILICON 15VW	28480	1901-0179
A1CR6	1901-0040		DIODE:SILICON 30MA 30VW	07263	FDG1088
A1CR7	1901-0029	2	DIODE:SILICON 600 PIV	28480	1901-0029
A1CR8	1901-0029		DIODE:SILICON 600 PIV	28480	1901-0029
A1CR9			NOT ASSIGNED		
A1CR10	1901-0487	1	DIODE:SILICON 1500 PIV	28480	1901-0487
A1CR11	1901-0040		DIODE:SILICON 30MA 30VW	07263	FDG1088
A1CR12	1901-0096	4	DIODE:SILICON 120V	01295	UG-888
A1CR13	1901-0096		DIODE:SILICON 120V	01295	UG-888
A1CR14	1901-0096		DIODE:SILICON 120V	01295	UG-888
A1CR15	1901-0040		DIODE:SILICON 30MA 30VW	07263	FDG1088
A1L1	9100-1653	7	COIL/CHOKE 910 UH 5%	28480	9100-1653
A1L2	9140-0179		COIL/CHOKE 22.0 UH 10%	28480	9140-0179
A1Q1	1854-0019	5	TSTR:SI NPN	28480	1854-0019
A1Q2	1854-0019		TSTR:SI NPN	28480	1854-0019
A1Q3	1853-0038	3	TSTR:SI PNP	28480	1853-0038
A1Q4	1854-0271	1	TSTR:SI NPN	28480	1854-0271
A1Q5	1853-0036	1	TSTR:SI PNP	80131	2N3906
A1Q6	1854-0234	2	TSTR:SI NPN	80131	2N3440
A1Q7	1854-0234		TSTR:SI NPN	80131	2N3440
A1Q8	1854-0023	1	TSTR:SI NPN (SELECTED FROM 2N2484)	28480	1854-0023
A1Q9	1854-0071	25	TSTR:SI NPN (SELECTED FROM 2N3704)	28480	1854-0071
A1Q10	1854-0039	3	TSTR:SI NPN	80131	2N3053
A1R1	0757-0407	7	R:FXD MET FLM 200 OHM 1% 1/8W	14674	ORDER BY DESCRIPTION
A1R2	0757-0407		R:FXD MET FLM 200 OHM 1% 1/8W	14674	ORDER BY DESCRIPTION
A1R3	0757-0401	9	R:FXD MET FLM 100 OHM 1% 1/8W	14674	ORDER BY DESCRIPTION
A1R4	0757-0401		R:FXD MET FLM 100 OHM 1% 1/8W	14674	ORDER BY DESCRIPTION
A1R5	0757-0401		R:FXD MET FLM 100 OHM 1% 1/8W	14674	ORDER BY DESCRIPTION
A1R6	0757-0401		R:FXD MET FLM 100 OHM 1% 1/8W	14674	ORDER BY DESCRIPTION
A1R7	0757-0458	1	R:FXD MET FLM 51.1K OHM 1% 1/8W	91637	MF-1/10-32
A1R8	0757-0281	4	R:FXD MET FLM 2.74K OHM 1% 1/8W	28480	0757-0281
A1R9	0757-0274	1	R:FXD MET FLM 1.21K OHM 1% 1/8W	28480	0757-0274
A1R10	0757-0281		R:FXD MET FLM 2.74K OHM 1% 1/8W	28480	0757-0281
A1R11	0757-0290	1	R:FXD MET FLM 6.19K OHM 1% 1/8W	28480	0757-0290
A1R12	0757-0462	1	R:FXD MET FLM 75K OHM 1% 1/8W	28480	0757-0462
A1R13	0757-0724	1	R:FXD FLM 392 OHM 1% 1/4W	28480	0757-0724
A1R14	0757-0727	1	R:FXD MET FLM 562 OHM 1% 1/4W	28480	0757-0727
A1R15	0757-0757	2	R:FXD FLM 15K OHM 1% 1/4W	28480	0757-0757
A1R16	0757-0469	2	R:FXD FLM 150K OHM 1% 1/8W	28480	0757-0469
A1R17	0757-0757		R:FXD FLM 15K OHM 1% 1/4W	28480	0757-0757
A1R18	0757-0407		R:FXD MET FLM 200 OHM 1% 1/8W	14674	ORDER BY DESCRIPTION
A1R19	0757-0280	8	R:FXD MET FLM 1K OHM 1% 1/8W	14674	ORDER BY DESCRIPTION
A1R20	0757-0190	3	R:FXD MET FLM 20K OHM 1% 1/2W	28480	0757-0190
A1R21	0757-0416	1	R:FXD MET FLM 511 OHM 1% 1/8W	14674	ORDER BY DESCRIPTION
A1R22	0757-0441	2	R:FXD MET FLM 8.25K 1% 1/8W	14674	ORDER BY DESCRIPTION
A1R23	0757-0426	2	R:FXD FLM 1.3K OHM 1% 1/8W	28480	0757-0426
A1R24	0761-0083	1	R:FXD MET OX 68K OHM 5% 1W	28480	0761-0083
A1R25	0757-0438	8	R:FXD MET FLM 5.11K 1% 1/8W	14674	ORDER BY DESCRIPTION
A1R26	0757-0283	10	R:FXD MET FLM 2.00K OHM 1% 1/8W	28480	0757-0283

See introduction to this section for ordering information

Table 6-2. Replaceable Parts (Cont'd)

Reference Designation	HP Part Number	Qty	Description	Mfr Code	Mfr Part Number
A1R27	0757-0424	1	R:FXD MET FLM 1.1K OHM 1% 1/8W	28480	0757-0424
A1R28	0757-0760	1	R:FXD FLM 20K OHM 1% 1/4W	28480	0757-0760
A1R29	0757-0466	3	R:FXD MET FLM 110K OHM 1% 1/8W	28480	0757-0466
A1R30	0757-0466		R:FXD MET FLM 110K OHM 1% 1/8W	28480	0757-0466
A1R31	0684-0271	2	R:FXD COMP 2.7 OHM 10% 1/4W	01121	CB 27G1
A1R32	0757-0283		R:FXD MET FLM 2.00K OHM 1% 1/8W	28480	0757-0283
A1R33	0757-0393	1	R:FXD FLM 47.5 OHM 1% 1/8W	28480	0757-0393
A1R34	0757-0841	3	R:FXD MET FLM 12.1K OHM 1% 1/2W	28480	0757-0841
A1R35	0698-6612	1	R:FXD MET FLM 2K OHM 0.1% 1/8W	28480	0698-6612
A1R36	0698-5421	1	R:FXD MET FLM 17.82K OHM 0.1% 1/2W	28480	0698-5421
A1R37	0684-0271		R:FXD COMP 2.7 OHM 10% 1/4W	01121	CB 27G1
A1R38	2100-0943	1	R:VAR MET FLM 100K 20% LIN 3/4W	75042	CT150
A1R39	0727-0263	1	R:FXD DEPC 950K OHM 1% 1/2W	28480	0727-0263
A1R40	0757-0442	3	R:FXD MET FLM 10.0K 1% 1/8W	14674	ORDER BY DESCRIPTION
A1R41	0757-0442		R:FXD MET FLM 10.0K 1% 1/8W	14674	ORDER BY DESCRIPTION
A1R42	0757-0438		R:FXD MET FLM 5.11K 1% 1/8W	14674	ORDER BY DESCRIPTION
A1R43	0698-3553	1	R:FXD FLM 2.49 MEGOHM 1% 1/2W	28480	0698-3553
A1R44	0757-0283		R:FXD MET FLM 2.00K OHM 1% 1/8W	28480	0757-0283
A1R45	0757-0280		R:FXD MET FLM 1K OHM 1% 1/8W	14674	ORDER BY DESCRIPTION
A1R46	0757-0465	8	R:FXD MET FLM 100K 1% 1/8W	14674	ORDER BY DESCRIPTION
A1R47	0757-0814	1	R:FXD MET FLM 511 OHM 1% 1/2W	28480	0757-0814
A1R48	0757-0401		R:FXD MET FLM 100 OHM 1% 1/8W	14674	ORDER BY DESCRIPTION
A1R49	0757-0465		R:FXD MET FLM 100K 1% 1/8W	14674	ORDER BY DESCRIPTION
A1R50	0698-8220	1	R:FXD FLM 15 MEGOHM 1% 3W	28480	0698-8220
A1R51	0687-1051	1	R:FXD COMP 1 MEGOHM 10% 1W	01121	EB 1051
A1R52	0687-4721	1	R:FXD COMP 4700 OHM 10% 1/2W	01121	EB 4721
A1R53	0698-5353	1	R:FXD FLM 8.25 MEGOHM 5% 1W	28480	0698-5353
A1R54	0698-6580	1	R:FXD FLM 16.25 MEGOHM 5% 1W	28480	0698-6580
A1R55	0757-0460	2	R:FXD MET FLM 61.9K OHM 1% 1/8W	28480	0757-0460
A1R56	2100-2031	4	R:VAR 50K OHM 10% LIN 1/2W	28480	2100-2031
A1R57	0687-1011	1	R:FXD COMP 100 OHM 10% 1/2W	01121	EB 1011
A1R58	0698-3510	1	R:FXD MET FLM 453 OHM 1% 1/8W	28480	0698-3510
A1R59	2100-2030	2	R:VAR FLM 20K OHM 10% LIN 1/2W	28480	2100-2030
A1TP1	1251-0206	5	CONNECTOR:SOCKET (TEST JACK)	98291	SKT-400
A1V1	2140-0018	2	LAMP:GLOW 1/10W	24455	NE 2E1
A1V2	2140-0018		LAMP:GLOW 1/10W	24455	NE 2E1
A1VR1	1902-0045	1	DIODE BREAKDOWN:7.32V 2% 400 MW	28480	ORDER BY DESCRIPTION
A1VR2	1902-0025	1	DIODE BREAKDOWN:10.0V 5% 400 MW	28480	1902-0025
A1VR3	1902-0038	1	DIODE BREAKDOWN:45.3V 5% 400 MW	28480	1902-0038
A2	00180-66551	1	AUXILIARY OUTPUT BOARD	28480	00180-66551
A2C1	0160-3446	1	C:FXD CER 220 PF 10% 1000VDCW	28480	0160-3446
A2E1	0360-1514	10	TERMINAL:P11V	28480	0360-1514
A2R1	0757-0438	3	R:FXD MET FLM 5110 OHM 1% 1/8W	28480	0757-0438
A2R2	0757-0438		R:FXD MET FLM 5110 OHM 1% 1/8W	28480	0757-0438
A2R3	0757-0438		R:FXD MET FLM 5110 OHM 1% 1/8W	28480	0757-0438
A3	00181-66514	1	ASSY:HORIZONTAL AMPLIFIER BOARD	28480	00181-66514
A3C1	0121-0059	1	C:VAR CER 2-8 PF 300VDCW	72982	538-006-C0P0-89R
A3C2	0121-0105	1	C:VAR CER 9-35 PF	72982	538-006D-9-35
A3C3	0160-2201	1	C:FXD MICA 51 PF 300VDCW	72136	RDM15E510J1C
A3C4	0160-0162		C:FXD MY 0.022 UF 10% 200VDCW	56289	192P22392-PTS
A3C5	0160-0162		C:FXD MY 0.022 UF 10% 200VDCW	56289	192P22392-PTS
A3C6	0132-0007	3	C:VAR POLY 0.7 TO 3.0 PF 350VDCW	72982	535-033-4R
A3C7	0160-0162		C:FXD MY 0.022 UF 10% 200VDCW	56289	192P22392-PTS
A3C8	0170-0040	2	C:FXD MY 0.047 UF 10% 200VDCW	56289	192P47392-PTS
A3C9	0132-0007		C:VAR POLY 0.7 TO 3.0 PF 350VDCW	72982	535-033-4R
A3C10	0160-2235	1	C:FXD CER 0.75 PF 500VDCW	72982	301-000-C0K0-758C
A3C11	0160-0162		C:FXD MY 0.022 UF 10% 200VDCW	56289	192P22392-PTS
A3C12	0160-0162		C:FXD MY 0.022 UF 10% 200VDCW	56289	192P22392-PTS
A3C13	0180-0197	4	C:FXD ELECT 2.2 UF 10% 20VDCW	56289	1500225X9020A2-DYS
A3C14	0180-0197		C:FXD ELECT 2.2 UF 10% 20VDCW	56289	1500225X9020A2-DYS
A3C15	0160-0162		C:FXD MY 0.022 UF 10% 200VDCW	56289	192P22392-PTS
A3C16	0180-0197		C:FXD ELECT 2.2 UF 10% 20VDCW	56289	1500225X9020A2-DYS
A3C17	0180-0197		C:FXD ELECT 2.2 UF 10% 20VDCW	56289	1500225X9020A2-DYS
A3C18	0180-0218	1	C:FXD ELECT 0.15 UF 10% 35VDCW	28480	0180-0218
A3C19	0132-0007		C:VAR POLY 0.7 TO 3.0 PF 350VDCW	72982	535-033-4R
A3C20	0160-0162		C:FXD MY 0.022 UF 10% 200VDCW	56289	192P22392-PTS
A3C21	0170-0040		C:FXD MY 0.047 UF 10% 200VDCW	56289	192P47392-PTS
A3C22	0160-2250		C:FXD CER 5.1 PF	72982	301-000-C0H0-519C
A3CR1	1901-0040		DIODE:SILICON 30MA 30WV	07263	FDG 1088
A3CR2	1901-0040		DIODE:SILICON 30MA 30WV	07263	FDG 1088
A3CR3	1901-0040		DIODE:SILICON 30MA 30WV	07263	FDG 1088
A3CR4	1901-0040		DIODE:SILICON 30MA 30WV	07263	FDG 1088
A3CR5	1901-0040		DIODE:SILICON 30MA 30WV	07263	FDG 1088
A3CR6	1901-0040		DIODE:SILICON 30MA 30WV	07263	FDG 1088
A3CR7	1901-0040		DIODE:SILICON 30MA 30WV	07263	FDG 1088
A3CR8	1901-0040		DIODE:SILICON 30MA 30WV	07263	FDG 1088
A3CR9	1901-0040		DIODE:SILICON 30MA 30WV	07263	FDG 1088
A3L1	9140-0179		COIL/CHOKE 22.0 UH 10%	28480	9140-0179
A3L3	9140-0179		COIL/CHOKE 22.0 UH 10%	28480	9140-0179
A3L4	9170-0029	1	CORE:FERRITE BEAD	02114	56-590-65A2/4A

See introduction to this section for ordering information

Table 6-2. Replaceable Parts (Cont'd)

Reference Designation	HP Part Number	Qty	Description	Mfr Code	Mfr Part Number
A3Q1	1855-0062	1	TSTR-SI FET	17856	FN578
A3Q2	1854-0215	1	TSTR-SI NPN	04713	SPS3611
A3Q3	1850-0158	1	TSTR-GE PNP	80131	2N2635
A3Q4	1854-0019		TSTR-SI NPN	28480	1854-0019
A3Q5	1854-0071		TSTR-SI NPN(SELECTED FROM 2N3704)	28480	1854-0071
A3Q6	1854-0019		TSTR-SI NPN	28480	1854-0019
A3Q7	1854-0019		TSTR-SI NPN	28480	1854-0019
A3Q8	1853-0009	2	TSTR-SI PNP	28480	1853-0009
A3Q9	1854-0419	2	TSTR-SI NPN	80131	1854-0419
A3Q10	1853-0038		TSTR-SI PNP	28480	1853-0038
A3Q11	1853-0009		TSTR-SI PNP	28480	1853-0009
A3Q12	1854-0419		TSTR-SI NPN	80131	1854-0419
A3Q13	1853-0038		TSTR-SI PNP	28480	1853-0038
A3R1	0698-5539	1	R:FXD MET FLM 2 MEG 1% 1/2W	75042	CEC, T-O
A3R2	0757-0156	1	R:FXD MET FLM 1.5 MEG 1% 1/2W	75042	CEC, T-O
A3R3	0757-0401		R:FXD MET FLM 100 OHM 1% 1/8W	14674	ORDER BY DESCRIPTION
A3R4	0757-0367	1	R:FXD MET FLM 100K 1% 1/2W	75042	CEC, T-O
A3R5	0757-0280		R:FXD MET FLM 1K 1% 1/8W	75042	CEA, T-O
A3R6	0761-0074	1	R:FXD METOX 15K 5% 1W	14674	C32
A3R7	2100-2514	1	R:VAR CERMET 20K 10% LIN 1/2W	73138	62-228-1
A3R8	0698-3153	1	R:FXD MET FLM 3.83K 1% 1/8W	19701	MF4C-T-O
A3R9	0757-0426		R:FXD MET FLM 1.3K 1% 1/8W	19701	MF5C-T-O
A3R10	0757-0463	2	R:FXD MET FLM 82.5K 1% 1/8W	14674	ORDER BY DESCRIPTION
A3R11	0757-0441		R:FXD MET FLM 8.25K 1% 1/8W	14674	ORDER BY DESCRIPTION
A3R12	0757-0792	1	R:FXD MET FLM 681K OHM 1% 1/4W	28280	0757-0792
A3R13	0757-0401		R:FXD MET FLM 100 OHM 1% 1/8W	14674	ORDER BY DESCRIPTION
A3R14	0757-0460		R:FXD MET FLM 61.9K OHM 1% 1/8W	28480	0757-0460
A3R15	0757-0401		R:FXD MET FLM 100 OHM 1% 1/8W	14674	ORDER BY DESCRIPTION
A3R16	0757-0283		R:FXD MET FLM 2.00K OHM 1% 1/8W	28480	0757-0283
A3R17	0757-0764	3	R:FXD FLM 33.2K OHM 1% 1/4W	28480	0757-0764
A3R18	0757-0741	2	R:FXD MET FLM 2.43K OHM 1% 1/4W	28480	0757-0741
A3R19	0757-0281		R:FXD MET FLM 2.74K OHM 1% 1/8W	28480	0757-0281
A3R20	0757-0443	2	R:FXD MET FLM 11.0K OHM 1% 1/8W	91637	MF-1/10-32
A3R21	0757-0434	4	R:FXD MET FLM 3.65K OHM 1% 1/8W	28480	0757-0434
A3R22	0757-0736	2	R:FXD MET FLM 1.50K OHM 1% 1/4W	28480	0747-0736
A3R23	0757-0846	2	R:FXD MET FLM 22.1K OHM 1.0% 1/2W	28480	0757-0846
A3R24	0757-0413	2	R:FXD MET FLM 392 OHM 1% 1/8W	28480	0757-0413
A3R25	0757-0407		R:FXD MET FLM 200 OHM 1% 1/8W	14674	ORDER BY DESCRIPTION
A3R26	0757-0841		R:FXD MET FLM 12.1K OHM 1% 1/2W	28480	0757-0841
A3R27	0757-0448	1	R:FXD MET FLM 18.2K OHM 1% 1/8W	28480	0757-0448
A3R28	0683-0275		R:FXD COMP 2.7 OHM 5% 1/4W	01121	CB 27G5
A3R29	0757-0388	5	R:FXD FLM 30.1 OHM 1% 1/8W	28480	0757-0388
A3R30	2100-1770	1	R:VAR WW 100 OHM 5% TYPE H 1W	28480	2100-1770
A3R31	0757-0284	1	R:FXD MET FLM 150 OHM 1% 1/8W	28480	0757-0284
A3R32	2100-1771	1	R:VAR WW 200 OHM 5% TYPE H 1W	28480	2100-1771
A3R33	0757-0411	1	R:FXD MET FLM 332 OHM 1% 1/8W	28480	0757-0411
A3R34	2100-1773	2	R:VAR WW 1K OHM 5% TYPE H 1W	28480	2100-1773
A3R35	0757-0428	1	R:FXD MET FLM 1.62K 1% 1/8W	14674	ORDER BY DESCRIPTION
A3R36	0698-3416	3	R:FXD MET FLM 21.5K OHM 1% 1/2W	28480	0698-3416
A3R37	2100-1775	1	R:VAR WW 5K OHM 5% 1W	28480	2100-1775
A3R38	0698-3416		R:FXD MET FLM 21.5K OHM 1% 1/2W	28480	0698-3416
A3R39	0757-0468	1	R:FXD FLM 130K OHM 1% 1/8W	28480	0757-0468
A3R40	0757-0440		R:FXD MET FLM 7.50K 1% 1/8W	14674	ORDER BY DESCRIPTION
A3R41	0757-0427	1	R:FXD MET FLM 1.5K 1% 1/8W	14674	ORDER BY DESCRIPTION
A3R42	0757-0741		R:FXD MET FLM 2.43K OHM 1% 1/4W	28480	0757-0741
A3R43	0757-0281		R:FXD MET FLM 2.74K OHM 1% 1/8W	28480	0757-0281
A3R44	0757-0200	4	R:FXD MET FLM 5.62K OHM 1% 1/8W	14674	ORDER BY DESCRIPTION
A3R45	0757-0443		R:FXD MET FLM 11.0K OHM 1% 1/8W	91637	MF-1/10-32
A3R46	0757-0434		R:FXD MET FLM 3.65K OHM 1% 1/8W	28480	0757-0434
A3R47	0757-0736		R:FXD MET FLM 1.50K OHM 1% 1/4W	28480	0757-0736
A3R48	0757-0413		R:FXD MET FLM 392 OHM 1% 1/8W	28480	0757-0413
A3R49	0757-0846		R:FXD MET FLM 22.1K OHM 1.0% 1/2W	28480	0757-0846
A3R50	0757-0407		R:FXD MET FLM 200 OHM 1% 1/8W	14674	ORDER BY DESCRIPTION
A3R51	0757-0841		R:FXD MET FLM 12.1K OHM 1% 1/2W	28480	0757-0841
A3R52	0757-0280		R:FXD MET FLM 1K OHM 1% 1/8W	14674	ORDER BY DESCRIPTION
A3R53	2100-2030		R:VAR FLM 20K OHM 10% LIN 1/2W	28480	2100-2030
A3R54	0757-0280		R:FXD MET FLM 1K OHM 1% 1/8W	14674	ORDER BY DESCRIPTION
A3R55	0757-0344	1	R:FXD MET FLM 1.0 MEG 1% 1/4W	19701	MF52C-T-O
A3R56	0757-0447	1	R:FXD MET FLM 16.2K 1% 1/8W	19701	MF4C-T-O
A3R57	0757-0401	1	R:FXD MET FLM 100 OHM 1% 1/8W	19701	MF4C-T-O
A3R58	0757-0407	1	R:FXD MET FLM 200 OHM 1% 1/8W	19701	MF4C-T-O
A3S1	3101-0982	1	SWITCH-SLIDE SPST 0.5A 125V	79727	GF 124-0007
A4	00180-66523	1	ASSY-HV OSC BOARD	28480	00180-66523
A4C1	0180-0097	3	C:FXD ELECT 47 UF 10% 35VDCW	56289	159D476X903552-DYS
A4C2	0160-0380		C:FXD MY 0.22 UF 10% 200VDCW	28480	0160-0380
A4CR1	1901-0049	1	DIODE-SILICON 0.75A 50PIV	04713	SR1358-6
A4L1	9140-0071	1	COL:FXD RF: 22UH	28480	9140-0071
A5	00181-66502	1	ASSY-HIGH VOLTAGE RECTIFIER BOARD	28480	00181-66502
A5C1	0160-3008		C:FXD CER 4700 PF (LEFT FRONT LEAD)	72982	3888-024-Y550-472M
A5C2	0160-3007		C:FXD CER 4700 PF (RIGHT FRONT LEAD)	72982	3888-024-Y550-472M



Table 6-2. Replaceable Parts (Cont'd)

Reference Designation	HP Part Number	Qty	Description	Mfr Code	Mfr Part Number
A5C3	0160-3007		C:FXD CER 4700 PF (RIGHT FRONT LEAD)	72962	3888-024-Y550-472M
A5C4	0160-3008		C:FXD CER 4700 PF (LEFT FRONT LEAD)	72962	3888-024-Y550-472M
A5CR1	1901-0341	2	DIODE-SI 7000 PIV 50MA	29480	1901-0341
A5CR2	1901-0341		DIODE-SI 7000 PIV 50MA	29480	1901-0341
A5R1	0687-2231	1	R:FXD COMP 22K OHM 10% 1/2W	01121	EB 2231
A5R2	2100-0918	1	R:VAR COMP 1 MEGOHM 20% LIN 1/5W	29480	2100-0918
A5R3	0836-0003	1	R:FXD FLM 29 MEGOHM 10% 1W	29480	0836-0003
A5T1	00181-60801	1	TRANSFORMER-HIGH VOLTAGE ASSY	29480	00181-60801
A6	00181-66518	1	ASSY-PULSE CIRCUIT BOARD	29480	00181-66518
A6C1	0160-2216	1	C:FXD MICA 820 PF 5%	29480	0160-2216
A6C2	0160-0154	1	C:FXD MICA MY 0.0022 UF 10% 200VDCW	56289	192P22292-PTS
A6C3	0140-0176	1	C:FXD MICA 100 PF 2%	29480	0140-0176
A6C4	0160-2930	3	C:FXD CER 0.01 UF +80-20% 100VDCW	91418	TA
A6C5	0180-0374		C:FXD ELECT 10.0 UF 10% 20VDCW	56289	1500106X9020B2-76
A6C6	0180-0100	3	C:FXD ELECT 4.7 UF 10% 35VDCW	56289	1500475X9035B2-DYS
A6C7	0160-2930		C:FXD CER 0.01 UF +80-20% 100VDCW	91418	TA
A6C8	0160-2930		C:FXD CER 0.01 UF +80-20% 100VDCW	91418	TA
A6CR1	1901-0040		DIODE-SILICON 30MA 30WV	07263	FDG1088
A6CR2	1901-0040		DIODE-SILICON 30MA 30WV	07263	FDG1088
A6CR3	1901-0040		DIODE-SILICON 30MA 30WV	07263	FDG1088
A6CR4	1901-0040		DIODE-SILICON 30MA 30WV	07263	FDG1088
A6CR5	1901-0025	1	DIODE-SILICON 100MA/1V	07263	FD 2387
A6CR6	1901-0026	6	DIODE-SILICON 0.75A 200PIV	04713	SR1358-8
A6CR7	1901-0040		DIODE-SILICON 30MA 30WV	07263	FDG1088
A6CR8	1901-0040		DIODE-SILICON 30MA 30WV	07263	FDG1088
A6CR9	1901-0040		DIODE-SILICON 30MA 30WV	07263	FDG1088
A6CR10	1901-0026		DIODE-SILICON 0.75A 200PIV	04713	SR1358-8
A6CR11	1901-0026		DIODE-SILICON 0.75A 200PIV	04713	SR1350-8
A6CR12	1901-0026		DIODE-SILICON 0.75A 200PIV	04713	SR1358-8
A6Q1	1854-0071		TSTR-SI NPN(SELECTED FROM 2N3704)	29480	1854-0071
A6Q2	1854-0022	4	TSTR-SI NPN	07263	S17843
A6Q3	1854-0071		TSTR-SI NPN(SELECTED FROM 2N3704)	29480	1854-0071
A6Q4	1854-0071		TSTR-SI NPN(SELECTED FROM 2N3704)	29480	1854-0071
A6Q5			NOT USED		
A6Q6	1854-0071		TSTR-SI NPN(SELECTED FROM 2N3704)	29480	1854-0071
A6Q7	1854-0071		TSTR-SI NPN(SELECTED FROM 2N3704)	29480	1854-0071
A6Q8	1854-0071		TSTR-SI NPN(SELECTED FROM 2N3704)	29480	1854-0071
A6Q9	1854-0022		TSTR-SI NPN	07263	S17843
A6Q10	1854-0022		TSTR-SI NPN	07263	S17843
A6Q11	1854-0071		TSTR-SI NPN(SELECTED FROM 2N3704)	29480	1854-0071
A6Q12	1854-0071		TSTR-SI NPN(SELECTED FROM 2N3704)	29480	1854-0071
A6Q13	1854-0071		TSTR-SI NPN(SELECTED FROM 2N3704)	29480	1854-0071
A6Q14	1854-0071		TSTR-SI NPN(SELECTED FROM 2N3704)	29480	1854-0071
A6Q15	1854-0071		TSTR-SI NPN(SELECTED FROM 2N3704)	29480	1854-0071
A6Q16	1854-0071		TSTR-SI NPN(SELECTED FROM 2N3704)	29480	1854-0071
A6Q17	1854-0071		TSTR-SI NPN(SELECTED FROM 2N3704)	29480	1854-0071
A6Q18	1854-0071		TSTR-SI NPN(SELECTED FROM 2N3704)	29480	1854-0071
A6Q19	1854-0022		TSTR-SI NPN	07263	S17843
A6R1	0687-2241	1	R:FXD COMP 220K OHM 10% 1/2W	01121	EB 2241
A6R2	0687-4741	7	R:FXD COMP 470K OHM 10% 1/2W	01121	EB 4741
A6R3	0687-4731	4	R:FXD COMP 47K OHM 10% 1/2W	01121	EB 4731
A6R4	0757-0767	1	R:FXD CLM 43.2K OHM 1% 1/4W	29480	0757-0767
A6R5	0757-0446	1	R:FXD MET FLM 15.0K OHM 1% 1/8W	29480	0757-0446
A6R6	0757-0469		R:FXD FLM 150K OHM 1% 1/8W	29480	0757-0469
A6R7	0757-0466		R:FXD MET FLM 110K OHM 1% 1/8W	29480	0757-0466
A6R8	0687-4741		R:FXD COMP 470K OHM 10% 1/2W	01121	EB 4741
A6R9	2100-2650	2	R:VAR FLM 200K OHM 10% LIN 1/2W	29480	2100-2650
A6R10	0687-8231	1	R:FXD COMP 82K OHM 10% 1/2W	01121	EB 8231
A6R11	0687-4731		R:FXD COMP 47K OHM 10% 1/2W	01121	EB 4731
A6R12	0687-5631	1	R:FXD COMP 56K OHM 10% 1/2W	01121	EB 5631
A6R13	0687-4741		R:FXD COMP 470K OHM 10% 1/2W	01121	EB 4741
A6R14	0757-0479	1	R:FXD MET FLM 392K OHM 1% 1/8W	29480	0757-0479
A6R15	0757-0442		R:FXD MET FLM 10.0K 1% 1/8W	14674	ORDER BY DESCRIPTION
A6R16	0757-0469	1	R:FXD MET FLM 150K OHM 1% 1/8W	29480	0757-0469
A6R17	2100-2031		R:VAR 50K OHM 10% LIN 1/2W	29480	2100-2031
A6R18	2100-2031		R:VAR 50K OHM 10% LIN 1/2W	29480	2100-2031
A6R19	0757-0135		R:FXD MET FLM 511K OHM 1% 1/2W	29480	0757-0135
A6R20	0757-0352	1	R:FXD MET FLM 150K OHM 1% 1/2W	29480	0757-0352
A6R21			NOT USED		
A6R22	0687-1841	2	R:FXD COMP 180K OHM 10% 1/2W	01121	EB 1841
A6R23	0687-1031	5	R:FXD COMP 10K OHM 10% 1/2W	01121	EB 1031
A6R24	0687-1031		R:FXD COMP 10K OHM 10% 1/2W	01121	EB 1031
A6R25	0687-1041	5	R:FXD COMP 100K OHM 10% 1/2W	01121	EB 1041
A6R26	0757-0482	2	R:FXD MET FLM 511K OHM 1% 1/8W	29480	0757-0482
A6R27	0687-1041		R:FXD COMP 100K OHM 10% 1/2W	01121	EB 1041
A6R28	0687-1041		R:FXD COMP 100K OHM 10% 1/2W	01121	EB 1041
A6R29	2100-2650		R:VAR FLM 200K OHM 10% LIN 1/2W	29480	2100-2650
A6R30	0687-1041		R:FXD COMP 100K OHM 10% 1/2W	01121	EB 1041
A6R31	0757-0770	2	R:FXD FLM 56.2K OHM 1% 1/4W	29480	0757-0770
A6R32	0757-0482		R:FXD MET FLM 511K OHM 1% 1/8W	29480	0757-0482

See introduction to this section for ordering information

Table 6-2. Replaceable Parts (Cont'd)

Reference Designation	HP Part Number	Qty	Description	Mfr Code	Mfr Part Number
A6R33	0757-0770		R:FXD FLM 56.2K OHM 1% 1/4W	28480	0757-0770
A6R34	0687-4741		R:FXD COMP 470K OHM 10% 1/2W	01121	EB 4741
A6R35	0687-4741		R:FXD COMP 470K OHM 10% 1/2W	01121	EB 4741
A6R36	0687-4741		R:FXD COMP 470K OHM 10% 1/2W	01121	EB 4741
A6R37	0757-0283		R:FXD MET FLM 2.00K OHM 1% 1/8W	28480	0757-0283
A6R38	0757-0283		R:FXD MET FLM 2.00K OHM 1% 1/8W	28480	0757-0283
A6R39	0687-1031		R:FXD COMP 10K OHM 10% 1/2W	01121	EB 1031
A6R40	0687-1031		R:FXD COMP 10K OHM 10% 1/2W	01121	EB 1031
A6R41	0687-1841		R:FXD COMP 180K OHM 10% 1/2W	01121	EB 1841
A6R42	2100-2031		R:VAR 50K OHM 10% LIN 1/2W	28480	2100-2031
A6R43	0757-0190		R:FXD MET FLM 20K OHM 1% 1/2W	28480	0757-0190
A6R44	0757-0283		R:FXD MET FLM 2.00K OHM 1% 1/8W	28480	0757-0283
A6R45	0757-0283		R:FXD MET FLM 2.00K OHM 1% 1/8W	28480	0757-0283
A6R46	0757-0431		R:FXD MET FLM 2.43K OHM 1% 1/8W	28480	0757-0431
A6R47	0757-0431		R:FXD MET FLM 2.43K OHM 1% 1/8W	28480	0757-0431
A6R48	0757-0465		R:FXD MET FLM 100K 1% 1/8W	14674	ORDER BY DESCRIPTION
A6R49	0757-0465		R:FXD MET FLM 100K 1% 1/8W	14674	ORDER BY DESCRIPTION
A6R50	0687-4731		R:FXD COMP 47K OHM 10% 1/2W	01121	EB 4731
A6R51	0687-1041		R:FXD COMP 100K OHM 10% 1/2W	01121	EB 1041
A6R52	0687-4731		R:FXD COMP 47K OHM 10% 1/2W	01121	EB 4731
A6R53	0757-0453	1	R:FXD MET FLM 30.1K OHM 1% 1/8W	28480	0757-0453
A6R54	0757-0774	1	R:FXD FLM 82.5K OHM 1% 1/4W	28480	0757-0774
A6R55	0687-1031	1	R:FXD COMP 10K OHM 10% 1/2W	01121	EB 1031
A7	00181-66503	1	ASSY:LOW VOLTAGE RECTIFIER BOARD	28480	00181-66503
A7C1	0180-0091	1	C:FXD ELECT 10 UF +50-10% 100VDCW	56289	30D106F100DC2-DSM
A7CR1	1901-0028	12	DIODE:SILICON 0.75A 400PIV	04713	SR1358-9
A7CR2	1901-0028		DIODE:SILICON 0.75A 400PIV	04713	SR1358-9
A7CR3	1901-0028		DIODE:SILICON 0.75A 400PIV	04713	SR1358-9
A7CR4	1901-0028		DIODE:SILICON 0.75A 400PIV	04713	SR1358-9
A7CR5	1901-0028		DIODE:SILICON 0.75A 400PIV	04713	SR1358-9
A7CR6	1901-0028		DIODE:SILICON 0.75A 400PIV	04713	SR1358-9
A7CR7	1901-0028		DIODE:SILICON 0.75A 400PIV	04713	SR1358-9
A7CR8	1901-0028		DIODE:SILICON 0.75A 400PIV	04713	SR1358-9
A7CR9	1901-0415	8	DIODE:SILICON 50 PIV 3A	28480	1901-0415
A7CR10	1901-0415		DIODE:SILICON 50 PIV 3A	28480	1901-0415
A7CR11	1901-0415		DIODE:SILICON 50 PIV 3A	28480	1901-0415
A7CR12	1901-0415		DIODE:SILICON 50 PIV 3A	28480	1901-0415
A7CR13	1901-0415		DIODE:SILICON 50 PIV 3A	28480	1901-0415
A7CR14	1901-0415		DIODE:SILICON 50 PIV 3A	28480	1901-0415
A7CR15	1901-0415		DIODE:SILICON 50 PIV 3A	28480	1901-0415
A7CR16	1901-0415		DIODE:SILICON 50 PIV 3A	28480	1901-0415
A7CR17	1901-0028		DIODE:SILICON 0.75A 400PIV	04713	SR1358-9
A7CR18	1901-0028		DIODE:SILICON 0.75A 400PIV	04713	SR1358-9
A4CR19	1901-0028		DIODE:SILICON 0.75A 400PIV	04713	SR1358-9
A7CR20	1901-0028		DIODE:SILICON 0.75A 400PIV	04713	SR1358-9
A7R1	0760-0016	1	R:FXD MET OX 2700 OHM 2% 1W	14674	C-32 OBD
A7R2	0757-0060	3	R:FXD MET FLM 24.3K OHM 1% 1/2W	28480	0757-0060
A7R3	0811-1788	1	R:FXD WW 15 OHM 5% 2W	28480	0811-1788
A7R4	0757-0465		R:FXD MET FLM 100K 1% 1/8W	14674	ORDER BY DESCRIPTION
A7R5	0811-1678	1	R:FXD WW 10 OHM 5% 2W	28480	0811-1678
A7R6	0757-0465		R:FXD MET FLM 100K 1% 1/8W	14674	ORDER BY DESCRIPTION
A7VR1	1902-0597	1	DIODE BREAKDOWN 56.2V 5% 1W	28480	1902-0597
A8	00181-66509	1	ASSY:LOW VOLTAGE POWER SUPPLY BOARD	28480	00181-66509
ABC1	0160-0168	6	C:FXD MY 0.1 UF 10% 200VDCW	56289	192P10492-PTS
ABC2	0180-0100		C:FXD ELECT 4.7 UF 10% 35VDCW	56289	150D475X903582-DYS
ABC3	0180-1810	2	C:FXD ELECT 18 UF +50-10% 150VDCW	56289	600D186F150DG4-DHE
ABC4	0160-0168		C:FXD MY 0.1 UF 10% 200VDCW	56289	192P10492-PTS
ABC5	0180-0097		C:FXD ELECT 47 UF 10% 35VDCW	56289	159D476X903552-DYS
ABC6	0160-0168		C:FXD MY 0.1 UF 10% 200VDCW	56289	192P10492-PTS
ABC7	0180-0097		C:FXD ELECT 47 UF 10% 35VDCW	56289	159D476X903552-DYS
ABC8	0160-0168		C:FXD MY 0.1 UF 10% 200VDCW	56289	192P10492-PTS
ABC9	0180-0100		C:FXD ELECT 4.7 UF 10% 35VDCW	56289	150D475X903582-DYS
ABC10	0180-1810		C:FXD ELECT 18 UF +50-10% 150VDCW	56289	600D186F150DG4-DHE
ABCR1	1901-0040		DIODE:SILICON 30MA 30WV	07263	FDG 1088
ABCR2	1901-0040		DIODE:SILICON 30MA 30WV	07263	FDG 1088
ABCR3	1901-0026		DIODE:SILICON 0.75A 200PIV	04713	SR1358-8
ABCR4	1901-0040		DIODE:SILICON 30MA 30WV	07263	FDG 1088
ABCR5	1901-0040		DIODE:SILICON 30MA 30WV	07263	FDG 1088
ABCR6	1901-0040		DIODE:SILICON 30MA 30WV	07263	FDG 1088
ABCR7	1901-0040		DIODE:SILICON 30MA 30WV	07263	FDG 1088
ABCR8	1901-0040		DIODE:SILICON 30MA 30WV	07263	FDG 1088
ABCR9	1901-0040		DIODE:SILICON 30MA 30WV	07263	FDG 1088
ABCR10	1901-0026		DIODE:SILICON 0.75A 200PIV	04713	SR1358-8
ABCR11	1901-0040		DIODE:SILICON 30MA 30WV	07263	FDG 1088
ABCR12	1901-0040		DIODE:SILICON 30MA 30WV	07263	FDG 1088
ABQ1	1854-0090	2	TSTR-SI NPN(SIMILAR TO 2N3053)	28480	1854-0090
ABQ2	1854-0067	2	TSTR-SI NPN	80131	2N3417
ABQ3	1854-0071		TSTR-SI NPN(SELECTED FROM 2N3704)	28480	1854-0071
ABQ4	1854-0039		TSTR-SI NPN	80131	2N3053
ABQ5	1854-0071		TSTR-SI NPN(SELECTED FROM 2N3704)	28480	1854-0071

See introduction to this section for ordering information

Table 6-2. Replaceable Parts (Cont'd)

Reference Designation	HP Part Number	Qty	Description	Mfr Code	Mfr Part Number
ABQ6	1854-0071		TSTR:SI NPN(SELECTED FROM 2N3704)	28480	1854-0071
ABQ7	1854-0039		TSTR:SI NPN	80131	2N3053
ABQ8	1854-0071		TSTR:SI NPN(SELECTED FROM 2N3704)	28480	1854-0071
ABQ9	1854-0071		TSTR:SI NPN(SELECTED FROM 2N3704)	28480	1854-0071
ABQ10	1854-0090		TSTR:SI NPN(SIMILAR TO 2N3053)	28480	1854-0090
ABQ11	1854-0087		TSTR:SI NPN	80131	2N3417
ABQ12	1854-0071		TSTR:SI NPN(SELECTED FROM 2N3704)	28480	1854-0071
ABR1	0757-0280		R:FXD MET FLM 1K OHM 1% 1/8W	14674	ORDER BY DESCRIPTION
ABR2	0757-0280		R:FXD MET FLM 1K OHM 1% 1/8W	14674	ORDER BY DESCRIPTION
ABR3	0757-0407		R:FXD MET FLM 200 OHM 1% 1/8W	14674	ORDER BY DESCRIPTION
ABR4	0757-0848	3	R:FXD MET FLM 30.1K OHM 1.0% 1/2W	28480	0757-0848
ABR5	0757-0200		R:FXD MET FLM 5.62K OHM 1% 1/8W	14674	ORDER BY DESCRIPTION
ABR6	0757-0438		R:FXD MET FLM 5.11K 1% 1/8W	14674	ORDER BY DESCRIPTION
ABR7	0757-0764		R:FXD FLM 33.2K OHM 1% 1/4W	28480	0757-0764
ABR8	0757-0388		R:FXD FLM 30.1 OHM 1% 1/8W	28480	0757-0388
ABR9	0757-0200		R:FXD MET FLM 5.62K OHM 1% 1/8W	14674	ORDER BY DESCRIPTION
ABR10	2100-1774	1	R:VAR WW 2K OHM 5% TYPE H 1W	28480	2100-1774
ABR11	0757-0855	1	R:FXD MET FLM 68.1K OHM 1% 1/2W	28480	0757-0855
ABR12	0757-0388		R:FXD FLM 30.1 OHM 1% 1/8W	28480	0757-0388
ABR13	0757-0044	1	R:FXD MET FLM 33.2K OHM 1% 1/2W	28480	0757-0044
ABR14	0811-1746	2	R:FXD WW 0.36 OHM 5% 2W	28480	0811-1746
ABR15	0757-0463		R:FXD MET FLM 82.5K 1% 1/8W	14674	ORDER BY DESCRIPTION
ABR16	0757-0480	1	R:FXD FLM 432K OHM 1% 1/8W	28480	0757-0480
ABR17	0757-0434		R:FXD MET FLM 3.65K OHM 1% 1/8W	28480	0757-0434
ABR18	2100-1772	2	R:VAR WW 500 OHM 5% TYPE H 1W	28480	2100-1772
ABR19	0757-0060		R:FXD MET FLM 24.3K OHM 1% 1/2W	28480	0757-0060
ABR20	0757-0388		R:FXD FLM 30.1 OHM 1% 1/8W	28480	0757-0388
ABR21	0757-0848		R:FXD MET FLM 30.1K OHM 1.0% 1/2W	28480	0757-0848
ABR22	0811-1746		R:FXD WW 0.36 OHM 5% 2W	28480	0811-1746
ABR23	0757-0965	1	R:FXD FLM 51K 2% 1/8W	14674	ORDER BY DESCRIPTION
ABR24	0757-0477	1	R:FXD MET FLM 332K OHM 1% 1/8W	28480	0757-0477
ABR25	0757-0434		R:FXD MET FLM 3.65K OHM 1% 1/8W	28480	0757-0434
ABR26	2100-1772		R:VAR WW 500 OHM 5% TYPE H 1W	28480	2100-1772
ABR27	0757-0060		R:FXD MET FLM 24.3K OHM 1% 1/2W	28480	0757-0060
ABR28	0757-0280		R:FXD MET FLM 1K OHM 1% 1/8W	14674	ORDER BY DESCRIPTION
ABR29	0757-0399	1	R:FXD MET FLM 82.5 OHM 1% 1/8W	28480	0757-0399
ABR30	0757-0848		R:FXD MET FLM 30.1K OHM 1.0% 1/2W	28480	0757-0848
ABR31	0757-0200		R:FXD MET FLM 5.62K OHM 1% 1/8W	14674	ORDER BY DESCRIPTION
ABR32	0757-0764		R:FXD FLM 33.2K OHM 1% 1/4W	28480	0757-0764
ABR33	0757-0465		R:FXD MET FLM 100K 1% 1/8W	14674	ORDER BY DESCRIPTION
ABR34	0757-0388		R:FXD FLM 30.1 OHM 1% 1/8W	28480	0757-0388
ABR35	0757-0435	1	R:FXD FLM 3920 OHM 1% 1/8W	28480	0757-0435
ABR36	2100-1773		R:VAR WW 1K OHM 5% TYPE H 1W	28480	2100-1773
ABR37	0698-3416		R:FXD MET FLM 21.5K OHM 1% 1/2W	28480	0698-3416
ABTP1	1251-0206		CONNECTOR:SOCKET (TEST JACK)	98291	SKT-400
ABTP2	1251-0206		CONNECTOR:SOCKET (TEST JACK)	98291	SKT-400
ABTP3	1251-0206		CONNECTOR:SOCKET (TEST JACK)	98291	SKT-400
ABTP4	1251-0206		CONNECTOR:SOCKET (TEST JACK)	98291	SKT-400
ABV1	1940-0025	2	ELECTRON TUBE:VOLTAGE REF. 83.0V+/-1.0V	74276	Z83R4A
ABV2	1940-0025		ELECTRON TUBE:VOLTAGE REF. 83.0V+/-1.0V	74276	Z83R4A
A3VR1	1902-3096	1	DIODE BREAKDOWN:5.23V 5% 400 MW	28480	1902-3096
ABVR2	1902-3354	2	DIODE BREAKDOWN:54.9V 5% 400 MW	28480	1902-3354
ABVR3	1902-3354		DIODE BREAKDOWN:54.9V 5% 400 MW	28480	1902-3354
A9	00181-61103	1	ASSY:HIGH VOLTAGE TRIPLER BOARD (CABINET)	28480	00181-61103
A9	00181-61104	1	ASSY:HIGH VOLTAGE TRIPLER BOARD (RACK)	28480	00181-61104
A9C1			N.S.R. PART OF A9		
A9C2			N.S.R. PART OF A9		
A9C3			N.S.R. PART OF A9		
A9C4			N.S.R. PART OF A9		
A9CR1			N.S.R. PART OF A9		
A9CR2			N.S.R. PART OF A9		
A9CR3			N.S.R. PART OF A9		
A9R1			N.S.R. PART OF A9		
A9R2			N.S.R. PART OF A9		
A10	00181-66517	1	ASSY:MODE SWITCH	28480	00181-66517
A10C1	0180-0168		C:FXD MY 0.1 UF 10% 200VDCW	56289	192P10492-PTS
A10C2	0180-3443	2	C:FXD CER 0.1 UF +80-20% 50VDCW	72982	8131-050-651-104Z
A10C3	0180-1746	3	C:FXD ELECT 15 UF 10% 20VDCW	56289	0180-1746
A10C4	0180-0197		C:FXD ELECT 2.2 UF 10% 20VDCW	56289	150D225X9020A2-DYS
A10C5	0160-3443		C:FXD CER 0.1 UF +80-20% 50VDCW	72982	8131-050-651-104Z
A10CR1	1901-0418		DIODE:SILICON 400PIV 1N5000	04713	1N5000
A10CR2	1901-0040		DIODE:SI 30 MA 30 WV	07263	FDG1088
A10CR3	1901-0028	1	DIODE:SI 0.75A 400PIV	04713	SR 1358-9
A10Q1	1854-0215	1	TSTR:SI NPN	80131	2N3904
A10Q2	1854-0215		TSTR:SI NPN	80131	2N3904
A10Q3	1854-0232		TSTR:SI NPN (SELECTED FROM 2N3440)	28480	1854-0232
A10Q4	1853-0336		TSTR:SI PNP	04713	SPS 6781
A10R1	0684-1021	3	R:FXD COMP 1K OHM 10% 1/4W	01121	CB 1021
A10R2	0684-1021		R:FXD COMP 1K OHM 10% 1/2W	01121	CB 1021
A10R3	0684-1021		R:FXD COMP 1K OHM 10% 1/2W	01121	CB 1021
A10R4	0684-1041		R:FXD COMP 100K OHM 10% 1/4W	01121	CB 1041

See introduction to this section for ordering information

Table 6-2. Replaceable Parts (Cont'd)

Reference Designation	HP Part Number	Qty	Description	Mfr Code	Mfr Part Number
A10R5	0684-5631		R:FXD COMP 56K OHM 10% 1/4W	01121	CB 5631
A10R6	0684-5631		R:FXD COMP 56K OHM 10% 1/4W	01121	CB 5631
A10R7	0684-1541		R:FXD COMP 150K OHM 10% 1/4W	01121	CB 1541
A10R8	0684-2231		R:FXD COMP 22K OHM 10% 1/4W	01121	CB 2231
A10R9	0684-2231		R:FXD COMP 22K OHM 10% 1/4W	01121	CB 2231
A10R10	0684-1541		R:FXD COMP 150K OHM 10% 1/4W	01121	CB 1541
A10R11	0684-5631		R:FXD COMP 56K OHM 10% 1/4W	01121	CB 5631
A10S1	3101-1167		SWITCH	28480	3101-1167
A11	00180-61904		ASSY:SWITCH DISPLAY	28480	00180-61904
A11C6	0180-0168		C:FXD MY 0.1 UF 10% 200VDCW	56289	192P10492-PTS
A11L1	9140-0179		COIL/CHOKE 22.0 UH 10%	28480	9140-0179
A11R1			N.S.R. PART OF A11S1		
A11S1	3100-1344		SWITCH:ROTARY, DISPLAY	28480	3100-1344
W11	00180-61807	1	CABLE:AUXILIARY OUTPUT	28480	00180-61807

Table 6-3. List of Manufacturers' Codes

MFR NO.	MANUFACTURER NAME	ADDRESS	ZIP CODE
00000	U.S.A. COMMON	ANY SUPPLIER OF U.S.A.	
00053	SANGAMU ELECTRIC CO. PICKENS DIV.	PICKENS, S.C.	29671
01121	ALLEN BRADLEY CO.	MILWAUKEE, WIS.	53204
01295	TEXAS INSTRUMENTS INC. SEMICONDUCTOR COMPONENTS DIV.	DALLAS, TEX.	75231
01538	SMALL PARTS INC.	COSTA MESA, CALIF.	92626
02114	FERNOXCORP CORP.	SAUGERTIES, N.Y.	12477
02660	AMPHENOL CORP.	BROADVIEW, ILL.	60153
04713	MOTOROLA SEMICONDUCTOR PROD. INC.	PHOENIX, ARIZ.	85008
05820	WAKEFIELD ENGINEERING INC.	WAKEFIELD, MASS.	01880
07263	FAIRCHILD CAMERA & INST. CORP. SEMICONDUCTOR DIV.	MOUNTAIN VIEW, CALIF.	74040
08717	SLCAN CO. THE	SUN VALLEY, CALIF.	91352
09134	TEXAS CAPACITOR CO. INC.	HOUSTON, TEX.	77042
09353	C E K COMPONENTS INC.	NEWTON, MASS.	02158
12881	METER CORP.	FOISON, N.J.	08817
14655	CORNELL DUBLIER ELECT. DIV. FEDERAL PACIFIC ELECT. CO.	NEWARK, N.J.	07105
17117	ELECTRONIC MOLDING CORP.	PAWTUCKET, R.I.	02860
27264	MULEX PROD. CO.	DOWNS GROVE, ILL.	60515
28480	HEWLETT-PACKARD CO. CORPORATE HQ	YOUR NEAREST HP OFFICE	
56289	SPRAGUE ELECTRIC CO.	N. ADAMS, MASS.	01247
59730	THOMAS & BETTS CO. THE	ELIZABETH, N.J.	07207
66295	WITTEK MFG. CO.	CHICAGO, ILL.	60673
71400	BUSSMANN MFG. DIV. MC GRAM-EDISON CO.	ST. LOUIS, MO.	63017
71590	GLUBE UNION INC. CENTRALAB DIV.	MILWAUKEE, WISC.	53201
71616	COMMERCIAL PLASTICS CO.	MUNDELEIN, ILL.	60060
71744	CHICAGO MINIATURE LAMP WORKS	CHICAGO, ILL.	60640
71785	CINCH MFG. CO. DIV TRW INC.	ELK GROVE VILLAGE, ILL.	
72136	ELECTRO MOTIVE MFG. CO. INC.	WILLMANTIC, CONN.	06226
72656	INDIANA GENERAL CORP. ELECTRONIC DIV.	KEASBEY, N.J.	08837
72825	ERY FUGH M. INC.	PHILADELPHIA, PA.	19144
72982	ERIE TECHNOLOGICAL PROD. INC.	ERIE, PA.	16512
75915	LITTELFUSE INC.	DES PLAINES, ILL.	60016
78486	STACKPOLE CARBON CO.	ST. MARYS, PA.	15857
79727	CONTINENTAL-AMIK ELECTRONICS CORP.	WARMINSTER, PA.	18974
80131	ELECTRONIC INDUSTRIES ASSOCIATION	WASHINGTON D.C.	20006
82389	SWITCHCRAFT INC.	CHICAGO, ILL.	60630
91506	AUGAT INC.	ATTLEBORO, MASS.	02703
91896	MALCO MFG. CO. INC.	CHICAGO, ILL.	60650
95354	METHUEN MFG. CO.	ROLLING MEADOWS, ILL.	60008
95487	WECKLESER CO. INC.	CHICAGO, ILL.	60641
96291	SEALECTIC CORP.	MAMARONECK, N.Y.	10544
99600	DELEVAN ELECTRONICS CORP.	E. AURORA, N.Y.	14052

## SECTION VII

### MANUAL CHANGES AND OPTIONS

#### 7-1. INTRODUCTION.

7-2. This section contains information required to backdate or update this manual for a specific instrument. Description of standard options are also in this section.

#### 7-3. MANUAL CHANGES.

7-4. This manual applies directly to the instrument having the same serial prefix shown on the manual title page. If the serial prefix of the instrument is not the same as the one on the title page, find your serial prefix in table 7-1 and make the changes to the manual that are listed for that serial prefix. When making changes listed in table 7-1, make the change with the highest number first. Example: if backdating changes 1, 2, and 3 are required for your serial prefix, do change 3 first, then change 2, and finally change 1. If the serial prefix of the instrument is not listed either in the title page or in table 7-1, refer to an enclosed MANUAL CHANGES sheet for updating information. Also, if a MANUAL CHANGES sheet is supplied, make all indicated ERRATA corrections.

Table 7-1. Manual Changes

Serial Prefix	Make Changes
No backdating changes are required at this time.	

#### 7-5. STANDARD OPTIONS.

7-6. Standard options are modifications installed on HP instruments at the factory and are available on

request. Contact the nearest Hewlett-Packard Sales/Service Office for information concerning standard options. Standard Options for the 181T/TR are as follows:

**OPTION 003.** The Model 181T/TR, Option 003 is the same as the standard instrument except that the low voltage transformer primary winding has been rewired to operate from a source of 100 V or 200 V input power. See figure below for proper transformer primary wiring for this option.



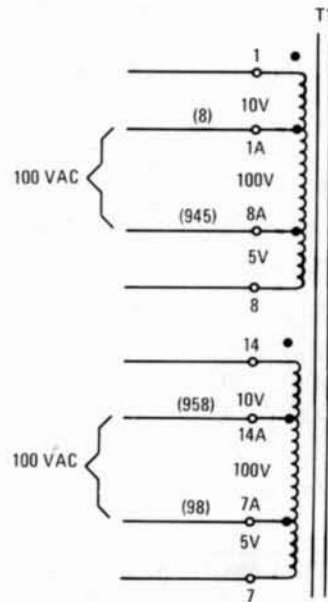







Add: The following parts to table 6-2 when using Option 003: HP Part No. 7120-4106, LABEL: CAUTION, Mfr Code 28480, Mfr Part No. 7120-4106; and HP Part No. 7120-4453, TAG: 100 VOLT, Mfr Code 28480, Mfr Part No. 7120-4453.





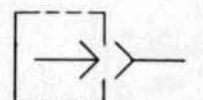
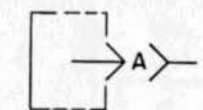
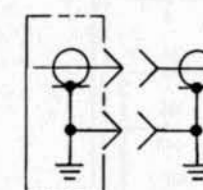
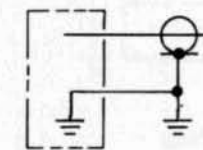

Option 003 Wiring

Table 8-1. Schematic Notes

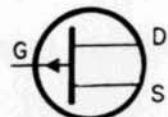
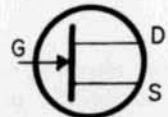
Refer to MIL-STD-15-1A and MIL-STD-806 for schematic symbols not listed in this table.

	ETCHED CIRCUIT BOARD
	FRONT-PANEL MARKING
	REAR-PANEL MARKING
	FRONT-PANEL CONTROL
	SCREWDRIVER ADJUSTMENT
	ELECTRICAL TEST POINT TP (WITH NUMBER)
	WAVEFORM TEST POINT (WITH NUMBER)
	SINGLE-PIN CONNECTOR ON BOARD
	PIN OF A PLUG-IN BOARD (WITH LETTER OR NUMBER)
	COAXIAL CABLE CONNECTED TO SNAP-ON JACK
	COAXIAL CABLE CONNECTED DIRECTLY TO BOARD
	MAIN SIGNAL PATH
	PRIMARY FEEDBACK PATH
	SECONDARY FEEDBACK PATH
P/O	PART OF
NC	NO CONNECTION
CW	CLOCKWISE END OF VARIABLE RESISTOR

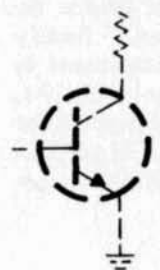
	FIELD-EFFECT TRANSISTOR (P-TYPE BASE)
	FIELD-EFFECT TRANSISTOR (N-TYPE BASE)
	BREAKDOWN DIODE (VOLTAGE REGULATOR)
	TUNNEL DIODE
	STEP-RECOVERY DIODE
	CIRCUITS OR COMPONENTS DRAWN WITH DASHED LINES (PHANTOM) SHOW FUNCTION ONLY AND ARE NOT INTENDED TO BE COMPLETE. THE CIRCUIT OR COMPONENT IS SHOWN IN DETAIL ON ANOTHER SCHEMATIC.

<b>6</b>	SIGNAL REFERENCE	<b>2</b>	SCHEMATIC REFERENCE
(925)		WIRE COLORS ARE GIVEN BY NUMBERS IN PARENTHESES USING THE RESISTOR COLOR CODE	

- [ (925) IS WHT-RED-GRN ]
- |            |            |
|------------|------------|
| 0 - BLACK  | 5 - GREEN  |
| 1 - BROWN  | 6 - BLUE   |
| 2 - RED    | 7 - VIOLET |
| 3 - ORANGE | 8 - GRAY   |
| 4 - YELLOW | 9 - WHITE  |

\* OPTIMUM VALUE SELECTED AT FACTORY, TYPICAL VALUE SHOWN; PART MAY HAVE BEEN OMITTED.

UNLESS OTHERWISE INDICATED:  
RESISTANCE IN OHMS  
CAPACITANCE IN PICOFARADS  
INDUCTANCE IN MICROHENRIES

## SECTION VIII

### SCHEMATICS AND TROUBLESHOOTING

#### 8-1. INTRODUCTION.

8-2. This section contains schematics, repair and replacement information, component-identification illustrations, waveforms, test conditions and overall troubleshooting trees. Tables 8-2 through 8-6 provide a guide to locating possible problems. A disassembly procedure for removing the CRT is also contained in this section.

#### 8-3. SCHEMATICS.

8-4. Schematics are printed on fold-out pages for easy reference to the text and figures in other sections. The schematics are drawn to show the electronic function of the circuits. Any one schematic may include all or part of several different physical assemblies. Non MIL-standard symbols and conventions used in the schematics are defined in table 8-1.

8-5. The schematics are numbered in sequence with a bold number in the lower right-hand corner of each page. These numbers are used to cross reference signal connections between schematics. At each circuit breaking point a number in a circle is shown along with a number in bold type. The bold number indicates the associated schematic that contains the source or destination of the signal and the circled number indicates the signal. To find the source or destination of any signal on a given schematic, turn to the schematic referred to by the bold-type number and find the number of the signal in question.

8-6. A reference designations table on each schematic lists all components shown on the schematic. Component reference designators which have been deleted from the schematic are listed below the table.

8-7. All components within the bordered areas of the schematic are physically located on etched circuit boards. Components not physically located on an etched circuit board are shown in the open areas of the schematic.

8-8. Transistors and diodes packaged in metal cans having one lead in common with the can will have the connection shown on the schematic by a heavy dot.

#### 8-9. REFERENCE DESIGNATIONS.

8-10. The unit system of reference designations used in this manual is in accordance with the provisions of USA Standard Y32.16-1968, Reference Designations for Electrical and Electronics Parts and Equipments,

dated March 1, 1968. Minor variations from the standard, due to design and manufacturing practices, may be noted.

8-11. Each electrical component is assigned a class letter and number. This letter-number combination is the basic reference designation. Components which are not part of an assembly have only the basic reference designation. Components which are part of an assembly have, in addition to the basic designation, a prefix designation indicating the assembly of which the component is a part (resistor R23 on assembly A1 is called A1R23).

8-12. Assemblies are numbered consecutively. If an assembly reference designation is assigned and later deleted, that number is not reused.

#### 8-13. COMPONENT LOCATIONS.

8-14. Locations of components on assemblies and subassemblies are illustrated in figures adjacent to the schematics. Since the schematics are drawn to show function, portions of a particular assembly may appear on several different schematics. The component-location figure is printed next to the schematic that shows most of the circuitry on the assembly. Components located on the chassis are identified in figure 8-2. The location of all adjustments are shown in Section V. An exploded-view drawing that shows mechanical (and some electrical) parts is located in Section VI.

8-15. **BOARD CONNECTIONS.** Square-pin connectors are identified on circuit boards by the color code of the connecting wire.

8-16. **SEMICONDUCTOR REPLACEMENT.** Figure 8-1 is included to help identify the leads of the common shapes and sizes of semiconductor devices. When removing a semiconductor, use long-nosed pliers as a heat sink between the device and the soldering iron. When replacing a semiconductor, ensure sufficient lead length to dissipate the soldering heat by using the same length of exposed lead as was used for the original part.

#### 8-17. TROUBLESHOOTING.

#### WARNING

Read the Safety Summary at the front of this manual before troubleshooting the instrument.

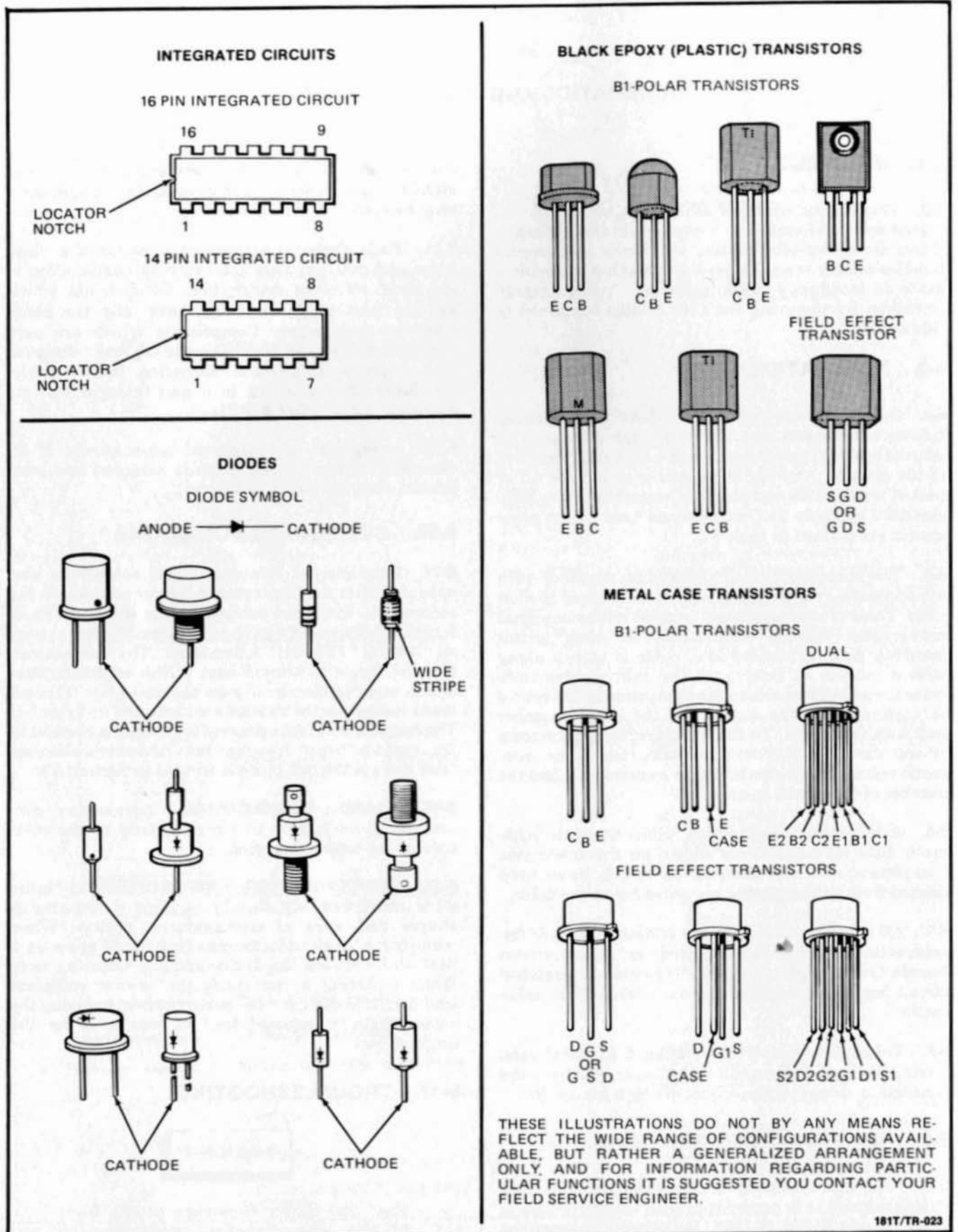

Figure 8-1. Semiconductor Terminal Identification



8-18. Two important prerequisites for successful troubleshooting are understanding how the instrument is designed to operate and correct use of front-panel controls. Suspected malfunctions may be caused by improper control settings or circuit connections. Before doing the test or troubleshooting procedures, read Section III (Operation) for an explanation of controls and general operating considerations, and Section IV (Principles of Operation) for an explanation of circuit theory.

8-19. If trouble is suspected, visually inspect the instrument. Look for loose or burned components that might suggest a source of trouble. Check to see that all circuit board connections are making good contact and are not shorting to an adjacent circuit. If no obvious trouble is found, check the power supply voltages in the unit. Prior to any extensive troubleshooting, check the external power sources also. Tables 8-2, 8-3, 8-4, 8-5 and 8-6 list several of the most common malfunctions and probable sources of trouble.

8-20. Dc voltages are indicated on the schematics for active components (transistors, etc). Conditions for making the voltage measurements are given in table 8-7. Waveform measurement points ( $\nabla$  with a number enclosed) are placed on the schematics along main signal paths. The numbers inside the measurement point symbols are keyed to corresponding waveforms adjacent to each schematic. Conditions for making the waveform measurements are given in table 8-7.

## 8-21. REPAIR AND REPLACEMENT.

8-22. The following paragraphs provide procedures for replacing components in the instrument and basic considerations when repairing etched circuit boards. Section VI provides a parts list to allow ordering of replacement parts. If satisfactory repair cannot be obtained, contact the nearest HP Sales/Service Office (addresses at rear of this manual). If shipment of the instrument to the Sales/Service Office for repair is recommended, refer to Section II of this manual for repackaging and shipping information.

8-23. **HIGH VOLTAGE SUPPLY REPAIR.** The following procedures should be used when replacing the high voltage rectifier assembly (A5), and the high voltage tripler assembly (A9).

### CAUTION

To prevent CRT damage when troubleshooting the high voltage supply, disconnect the CRT socket and disconnect second anode connection (high voltage connector block). This will leave the capacitive load of the tripler on the high voltage transformer and maintain the normal 40-kHz oscillation.

- a. Remove top left side cover of Model 181T or top cover and left side cover of Model 181TR.
- b. Remove two screws from HVPS cover and lift up.
- c. Remove four screws holding rear panel of display chassis and let panel hang.
- d. Unsolder five wires from small printed circuit board mounted to A5T1.
- e. Remove white, gray, red/blue, and red/white wires from printed circuit board A1 (HV Control Assembly).

### NOTE

To remove A5 and A9 as a unit, omit steps f through h.

- f. Remove four screws from HV Rectifier Assembly (A5).
- g. Remove gray wire and yellow wire coming from HV Tripler Assembly (A9).
- h. A5 Assembly can now be removed by pulling out and toward front of instrument.
- i. Unsolder wires on high voltage connector block mounted on chassis.

8-24. **HEAT SINK REMOVAL.** There are two types of heat sinks used in the instrument. The friction type heat sink is used on A1 and A3 assemblies. The transistors can be removed from the heat sink by carefully pulling the transistors from heat sink with a pair of long-nosed pliers. A heat dissipater casting type of heat sink is used in the low voltage power supply. It is shown in the exploded view in Section VI. The transistors may be removed by removing the two screws that secure them to their sockets.

## 8-25. CRT REMOVAL AND REPLACEMENT.

### WARNING

To prevent personal injury, wear a face mask or goggles when handling the CRT. Wear protective gloves and handle the CRT carefully.

- a. Remove plug-ins from oscilloscope.
- b. Remove all four covers from Model 181T or the top and bottom covers from Model 181TR.
- c. On Model 181TR, remove shield next to CRT post accelerator lead (shield is between CRT and plug-in compartment).

- d. Remove flexible three conductor CRT lead from connector block.
- e. Remove connections from neck pins on CRT (use long-nosed pliers through access holes).
- f. Remove rear display panel.
- g. Loosen clamp at rear of CRT.
- h. Carefully remove CRT socket.
- i. Remove front-panel CRT light shield by squeezing at midpoint, top and bottom.
- j. Remove CRT bezel by removing four retaining screws.



Do not place CRT face down after removing. This may cause damage to CRT by placing charged particles on storage mesh of tube.

- k. Place one hand on face of CRT and, with other hand, slide the CRT forward and out of instrument. Be careful not to catch neck pins on trace align coil.
- l. To install a CRT, reverse the above procedure. After CRT is installed, perform adjustment procedure in Section V.

**8-26. SERVICING CIRCUIT BOARDS.**

8-27. Etched circuit boards in this instrument have components mounted on one side of the boards, conductive surfaces on both sides, and plated-through component mounting holes. Hewlett-Packard Service Note M-20E contains useful information on servicing etched circuit boards. Some important considerations are as follows:

- a. Use 37- to 47.5-watt chisel tip soldering iron with tip diameter of 1/16 to 1/8 inch, and small diameter resin core solder.
- b. Components may be removed by placing soldering iron on component leads on either side of board and pulling component straight away from board.

c. If component is obviously damaged or faulty, clip leads close to component and then unsolder leads from board.

d. Large components, such as potentiometers, may be removed by rotating soldering iron from lead to lead and applying steady pressure to lift part free. The alternative is to clip leads of damaged part and remove them individually.

e. Excessive heat or force will destroy laminate bond between metal plated surface (conductor) and board. If this problem should occur, lifted conductor may be cemented down with small amount of quick-drying acetate base cement having good insulating properties. Another method of repair is to solder a section of good conducting wire along damaged area.

f. Before replacing a component, heat remaining solder in component hole and remove with desoldering tool. Sharp pointed metallic tools are not recommended since they may loosen eyelets in boards or remove plating from inside of holes on plated-through etched circuit boards.

g. Tin and shape replacement component leads to fit existing holes.

h. Install replacement component in same position as original. Heat damage may be minimized by gripping lead with long-nose pliers between soldering iron and component.

**8-28. TROUBLESHOOTING TRES.**

8-29. Tables 8-2 through 8-6 provide a guide to locating possible problems.

a. Set Model 181T/TR controls as follows:

Power .....	ON
INTENSITY .....	12 o'clock position
Mode .....	WRITE
PERSISTENCE.....	full ccw
FOCUS .....	as necessary
FIND BEAM .....	as directed
Horizontal DISPLAY .....	EXT
Horizontal MAGNIFIER.....	X1
Horizontal POSITION .....	centered
Vertical POSITION .....	centered
Vertical INPUT.....	none

b. Allow instrument to warm up and then proceed to table 8-2.

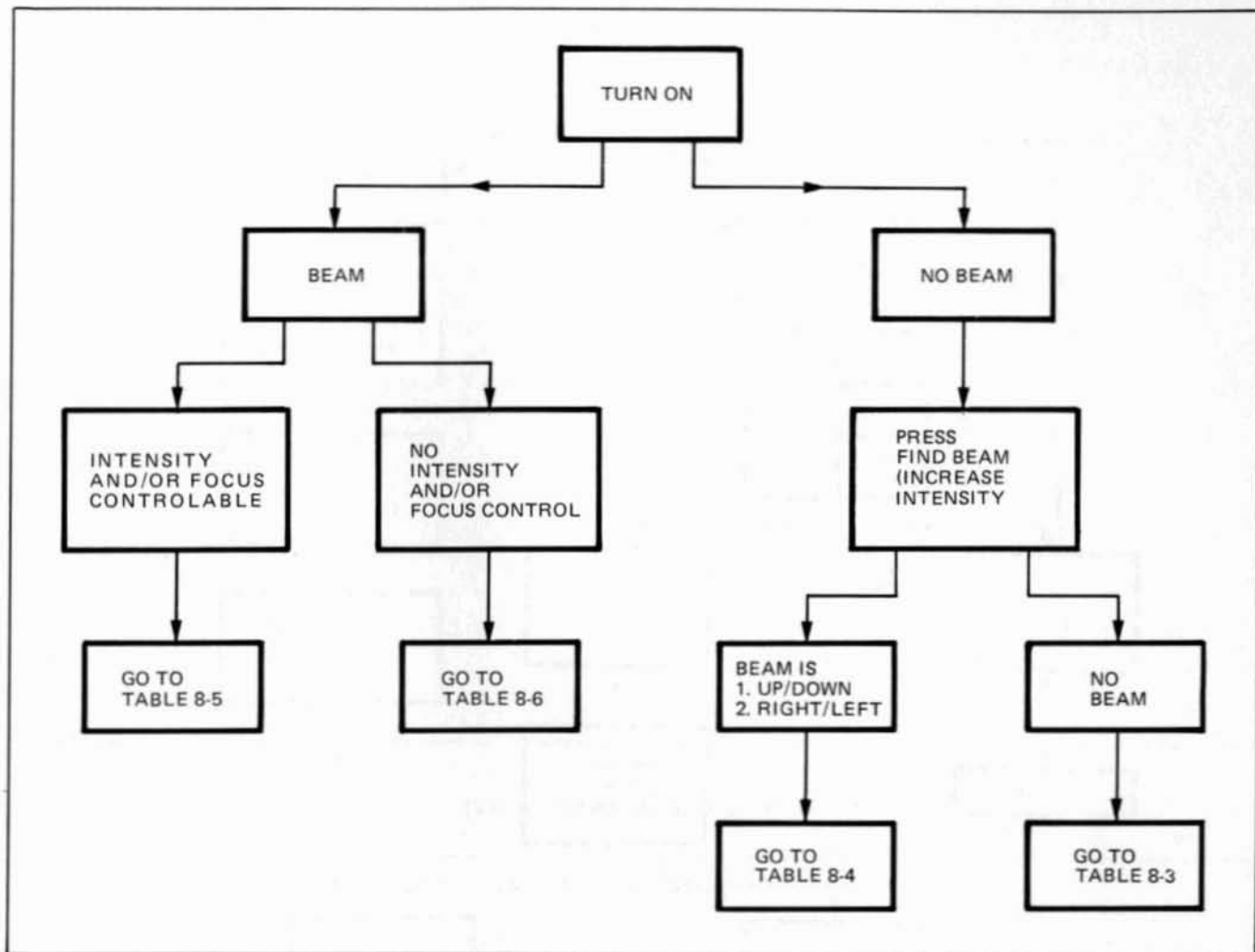

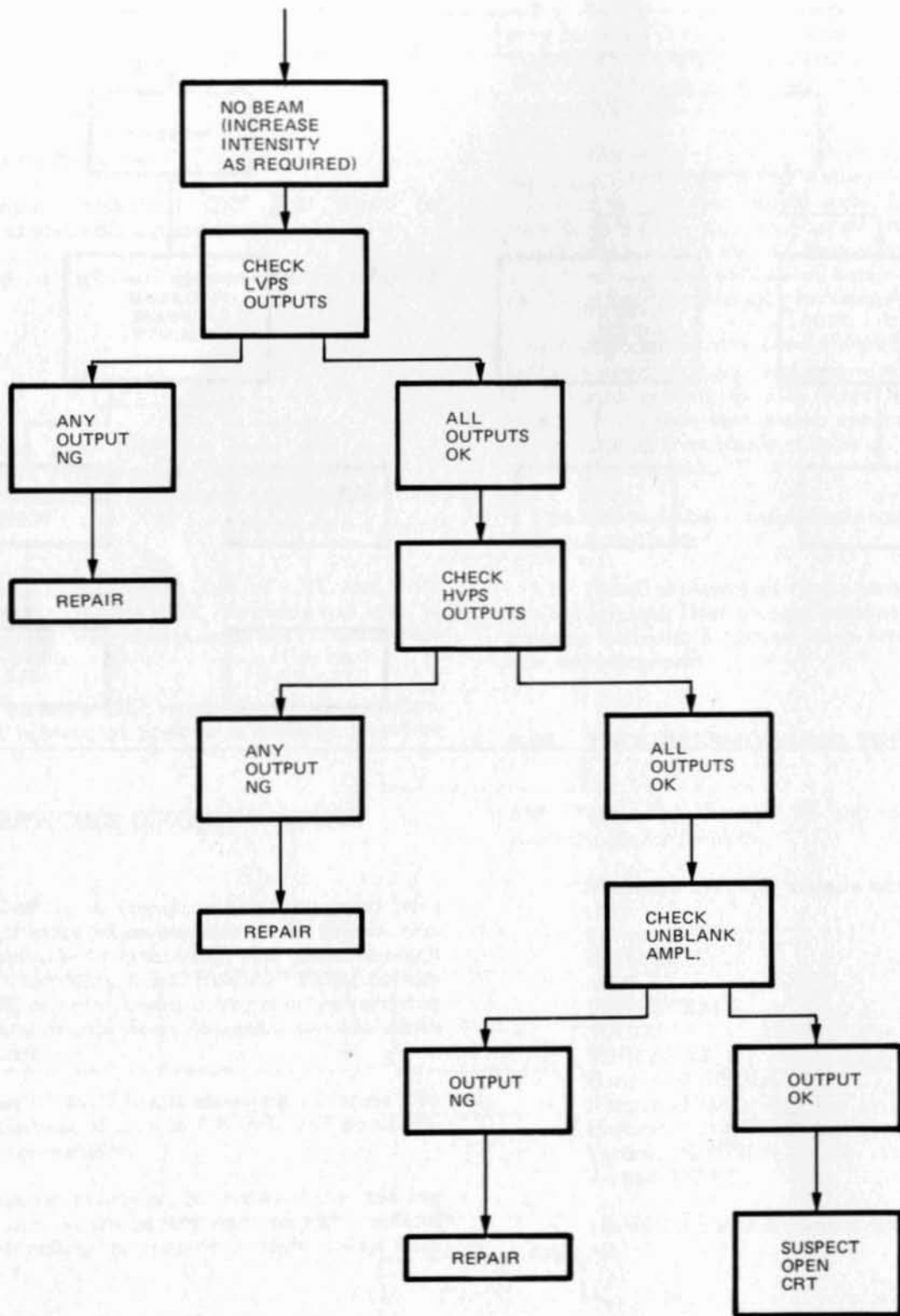

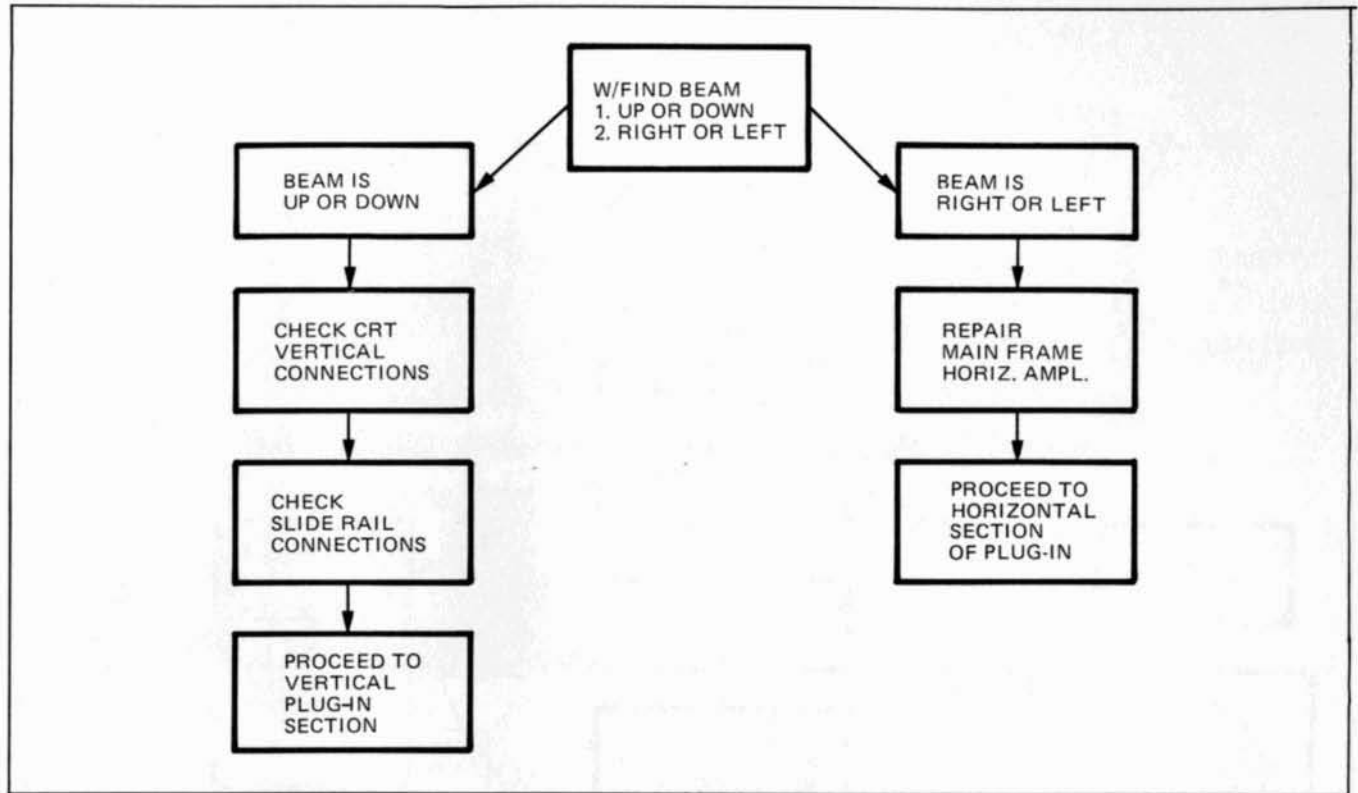
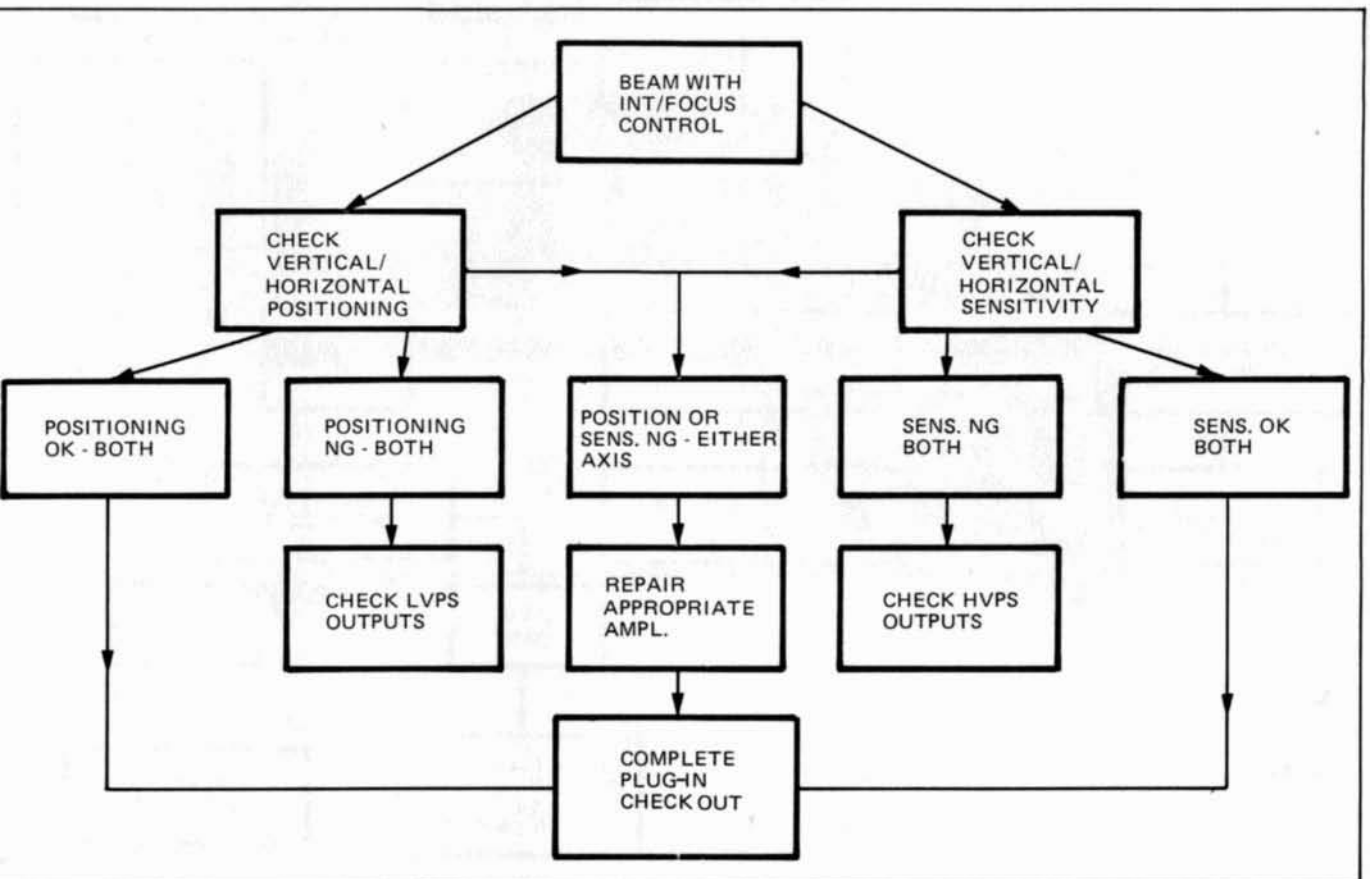
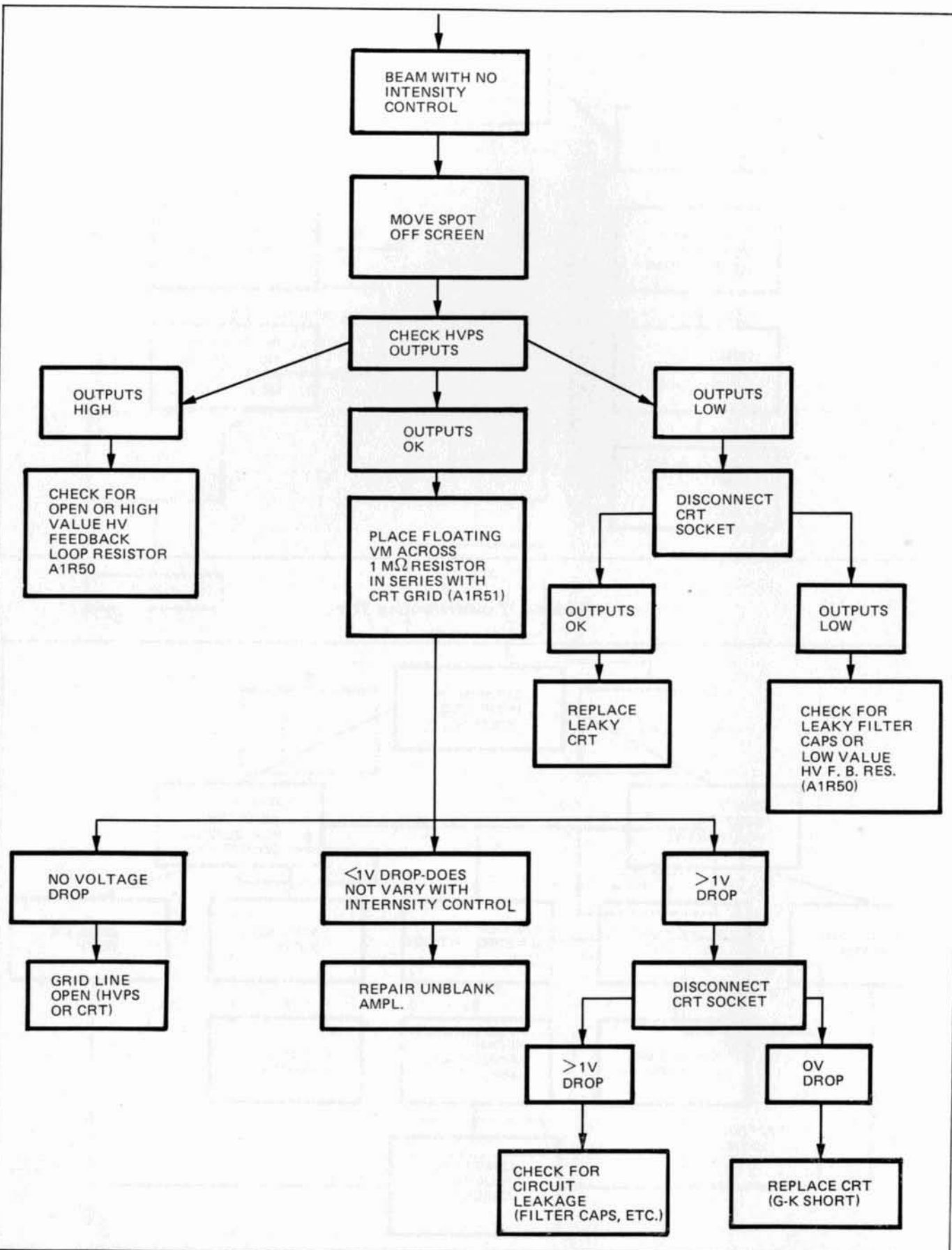
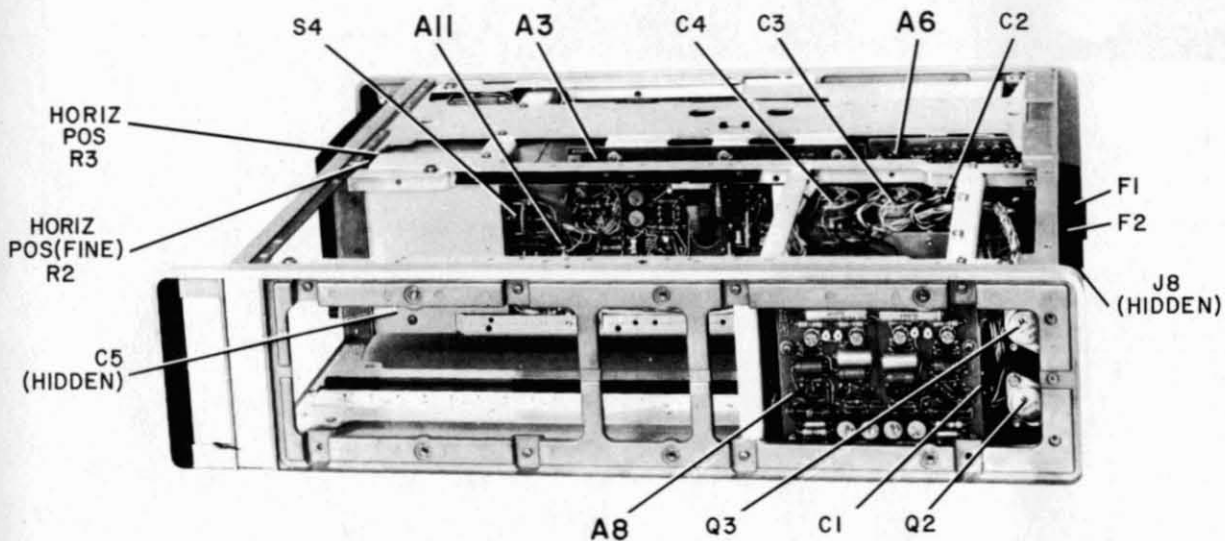
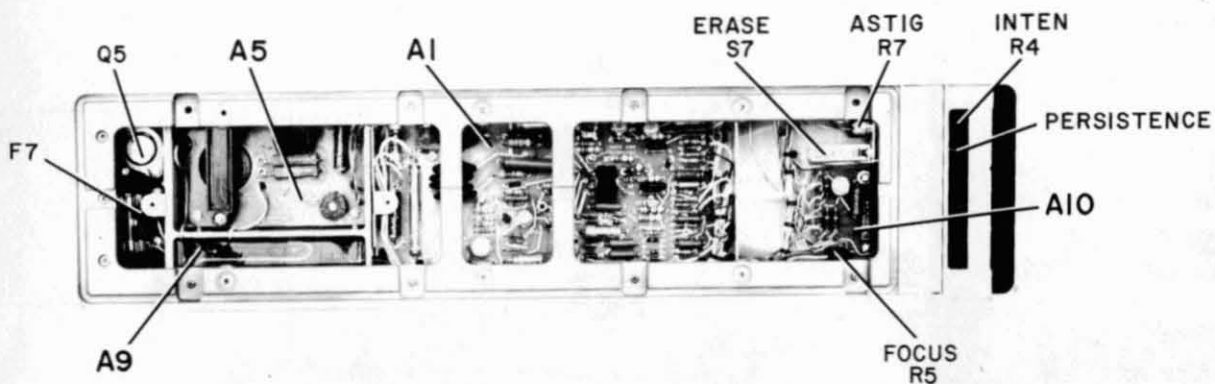
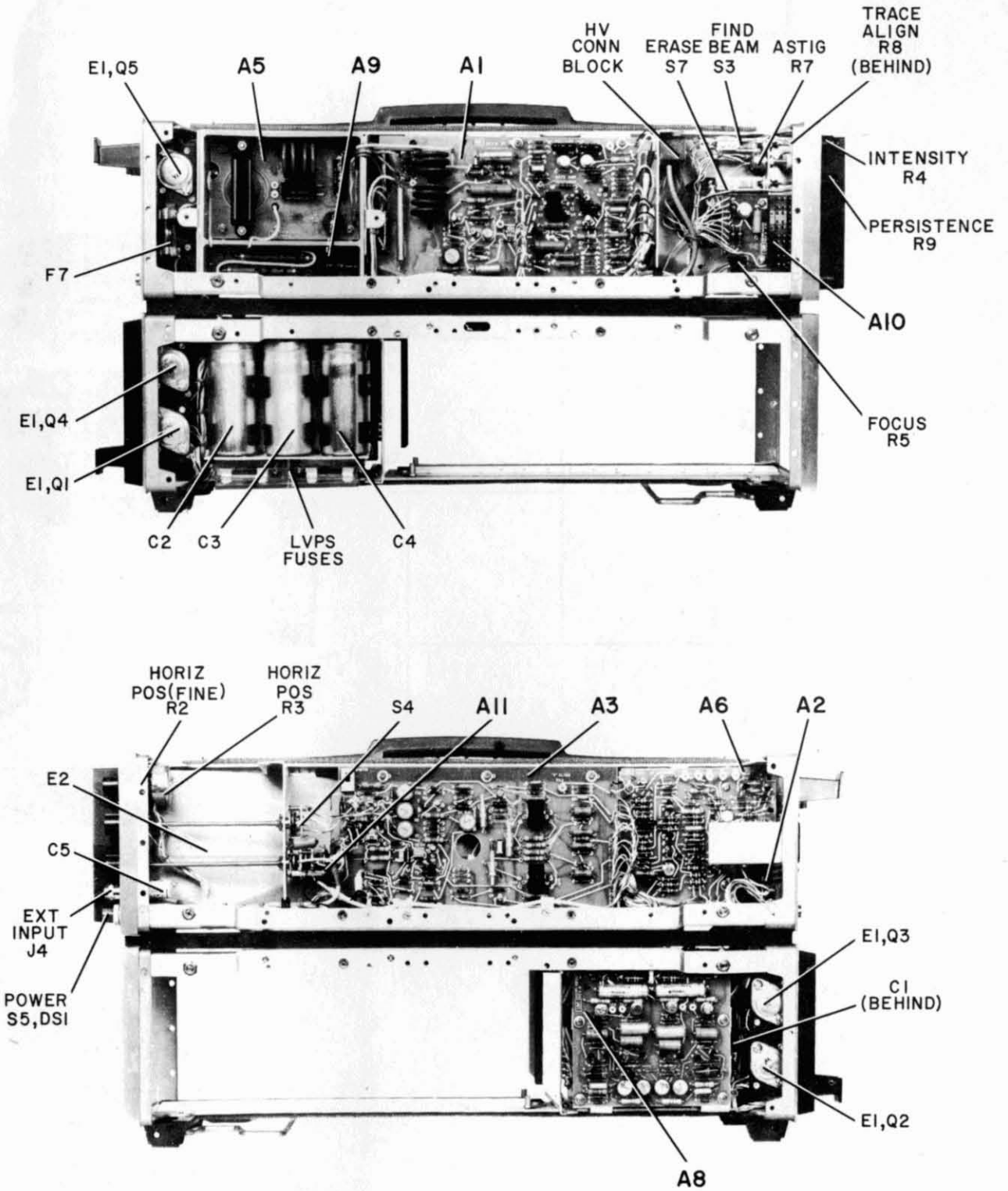

Table 8-5. Troubleshooting Tree









181T/TR-024

Figure 8-2.  
Chassis Mounted Component Identification  
8-9



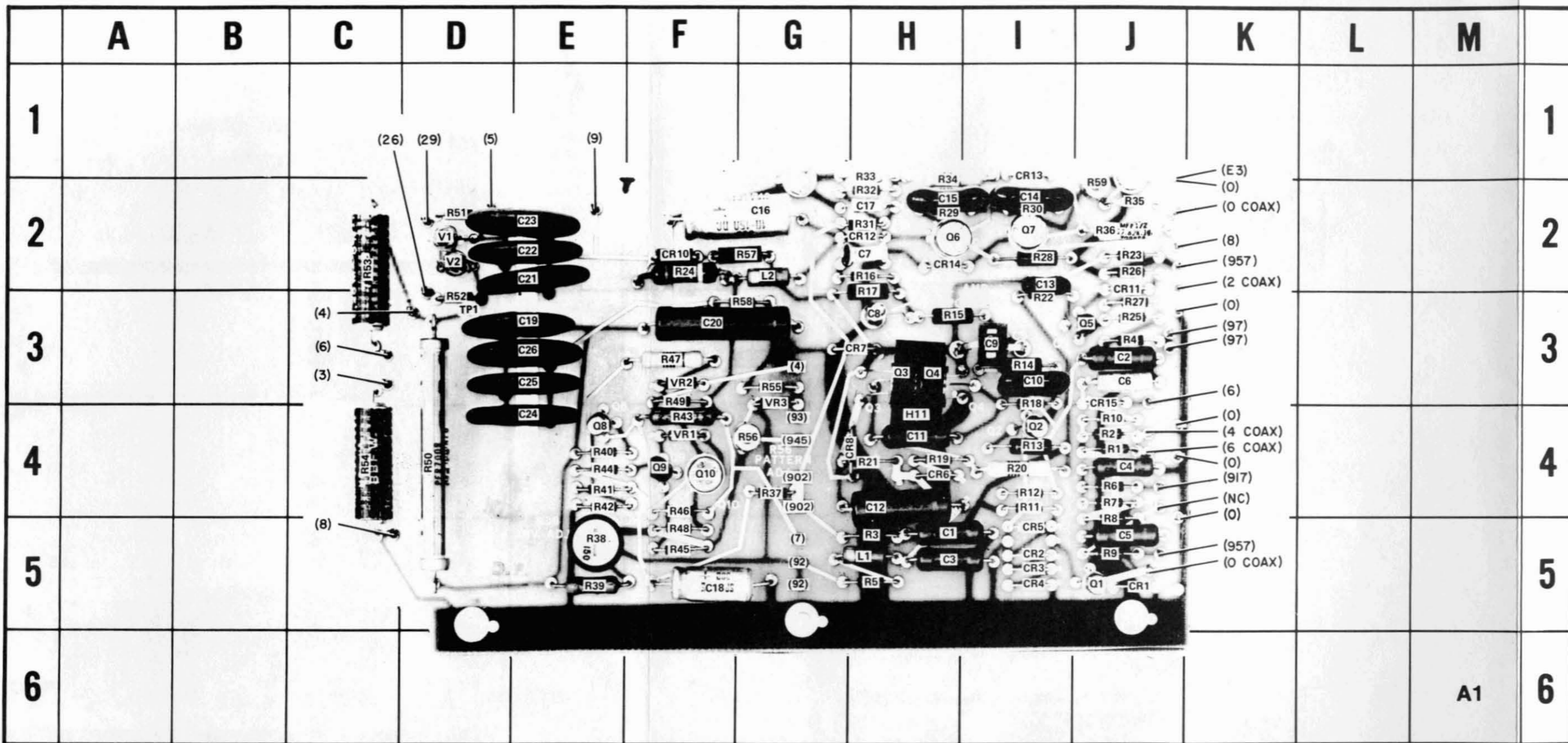

REF DESIG	GRID LOC	REF DESIG	GRID LOC	REF DESIG	GRID LOC	REF DESIG	GRID LOC	REF DESIG	GRID LOC	REF DESIG	GRID LOC	REF DESIG	GRID LOC	REF DESIG	GRID LOC
C1	H-5	C16	G-2	CR5	I-5	Q4	H-3	R9	J-5	R23	J-2	R37	G-4	R51	D-2
C2	J-3	C17	H-2	CR6	H-4	Q5	J-3	R10	J-4	R24	F-2	R38	E-5	R52	D-3
C3	H-5	C18	F-5	CR7	H-3	Q6	H-2	R11	I-4	R25	J-3	R39	E-5	R53	C-2
C4	J-4	C19	E-3	CR8	H-4	Q7	I-2	R12	I-4	R26	J-2	R40	E-4	R54	C-4
C5	J-5	C20	F-3	CR10	F-2	Q8	E-4	R13	I-4	R27	J-3	R41	E-4	R55	G-3
C6	J-3	C21	E-2	CR11	J-3	Q9	F-4	R14	I-3	R28	I-2	R42	E-4	R56	G-4
C7	H-2	C22	E-2	CR12	H-2	Q10	F-4	R15	H-3	R29	H-2	R43	F-4	R57	G-2
C8	H-3	C23	E-2	CR13	I-2	R1	J-4	R16	H-2	R30	I-2	R44	E-4	R58	G-3
C9	I-3	C24	E-4	CR14	H-2	R2	J-4	R17	H-3	R31	H-2	R45	F-5	R59	J-2
C10	I-3	C25	E-3	CR15	J-4	R3	H-5	R18	I-4	R32	H-2	R46	F-4	TP1	D-3
C11	H-4	C26	E-3	L1	H-5	R4	J-3	R19	H-4	R33	H-2	R47	F-3	V1	D-2
C12	H-4	CR1	J-5	L2	G-2	R5	H-5	R20	I-4	R34	H-2	R48	F-5	V2	D-2
C13	I-2	CR2	I-5	Q1	J-5	R6	J-4	R21	H-4	R35	J-2	R49	F-4	VR1	F-4
C14	I-2	CR3	I-5	Q2	I-4	R7	J-4	R22	I-3	R36	J-2	R50	D-4	VR2	F-3
C15	H-2	CR4	I-5	Q3	H-3	R8	J-5							VR3	G-4

Figure 8-3. Component Identification, Assembly A1

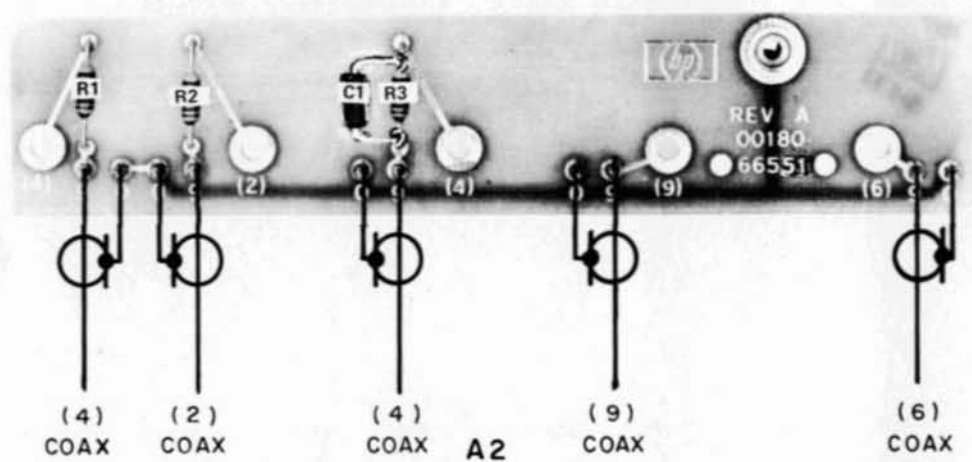

181T/TR-026

Figure 8-4. Component Identification, Assembly A2

**WAVEFORMS**

The test point waveforms, as given in figures preceding the schematic diagrams, were taken under the following conditions:

**MODEL 181T/TR OSCILLOSCOPE**

Mode..... WRITE  
 PERSISTENCE..... MINIMUM  
 DISPLAY..... INT  
 INTENSITY..... MINIMUM  
 HORIZONTAL  
 Time/Div..... 20 $\mu$  sec  
 VERTICAL  
 Polarity..... +UP  
 Display..... ALT  
 TRIGGERING  
 Trigger Mode..... AUTO  
 Trigger..... INT  
 Slope..... +

**MODEL 180A/AR (MONITOR OSCILLOSCOPE)**

DISPLAY..... INT  
 MAGNIFIER..... X1  
 HORIZONTAL  
 Triggering..... INT  
 Slope..... +  
 Sweep Mode..... AUTO  
 VERTICAL  
 Polarity..... +UP  
 Display..... channel A  
 Input..... AC

## Note

Any exceptions to these conditions are noted adjacent to the applicable waveform photo.

**DC VOLTAGES**

The DC voltage readings, as given on the schematic diagrams, were taken under the conditions listed below.

Mode..... WRITE  
 PERSISTENCE..... MINIMUM  
 HORIZONTAL POSITION..... CENTERED  
 DISPLAY..... INT  
 INTENSITY..... MINIMUM  
 MAGNIFIER..... X1  
 Line Voltage..... 115V

**NO PLUG-INS**

Exceptions (if any) are noted in the waveform figure preceding the individual schematic.

All voltages measured with reference to chassis ground.

Voltage readings are considered normal if within 10% of voltage given on schematic.

See Table 8-7 for Measurement Conditions

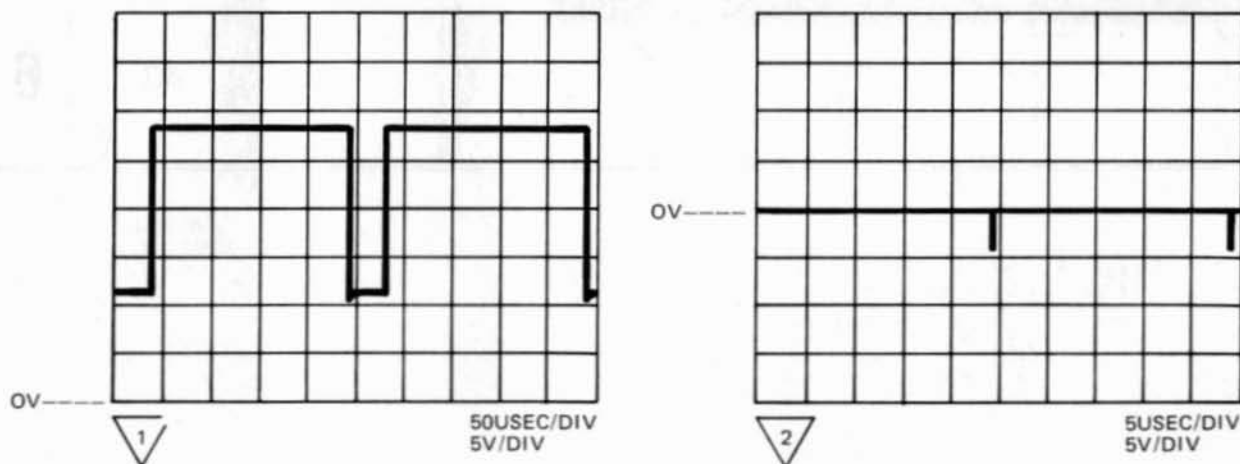
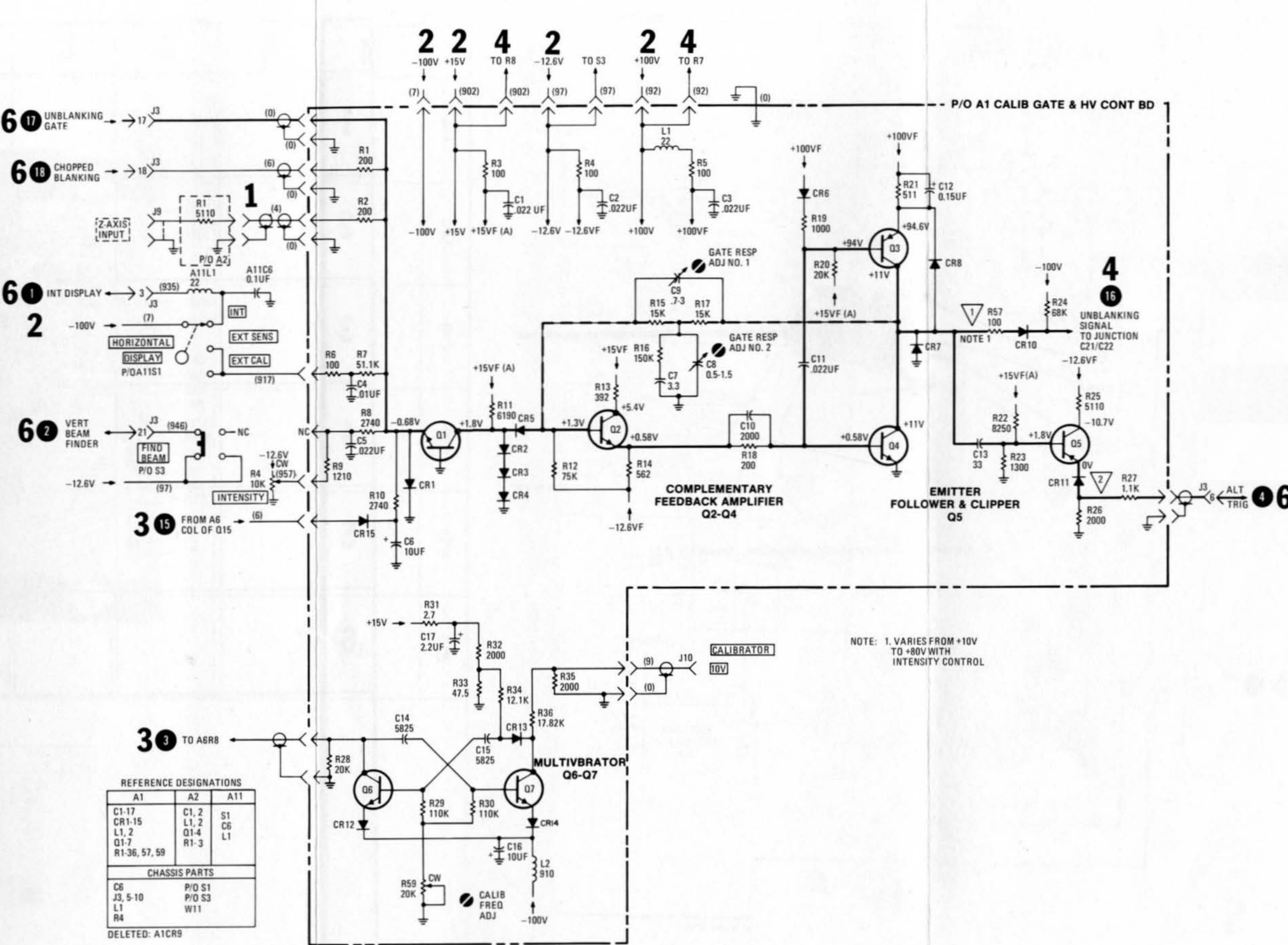

Figure 8-5. Gate Amplifier Circuit Waveform



6 17 UNBLANKING GATE → J3 (17)

6 18 CHOPPED BLANKING → J3 (18)

6 1 INT DISPLAY → J3 (935)

2 -100V → J3 (7)

6 2 VERT BEAM FINDER → J3 (946)

-12.6V → J3 (97)

3 15 FROM A6 COL OF Q15 → J3 (6)

3 3 TO A6R8 → J3 (3)

2 2 4 2 2 4  
 -100V +15V TO R8 -12.6V TO S3 +100V TO R7  
 (7) (902) (902) (97) (97) (92) (92)

P/O A1 CALIB GATE & HV CONT BD

4 16

4 6

COMPLEMENTARY FEEDBACK AMPLIFIER Q2-Q4

EMITTER FOLLOWER & CLIPPER Q5

MULTIVRATOR Q6-Q7

NOTE: 1. VARIES FROM +10V TO +80V WITH INTENSITY CONTROL

REFERENCE DESIGNATIONS

A1	A2	A11
C1-17	C1, 2	S1
CR1-15	L1, 2	C6
L1, 2	Q1-4	L1
Q1-7	R1-3	
R1-36, 57, 59		

CHASSIS PARTS

C6	P/O S1
J3, 5-10	P/O S3
L1	W11
R4	

DELETED: A1CR9

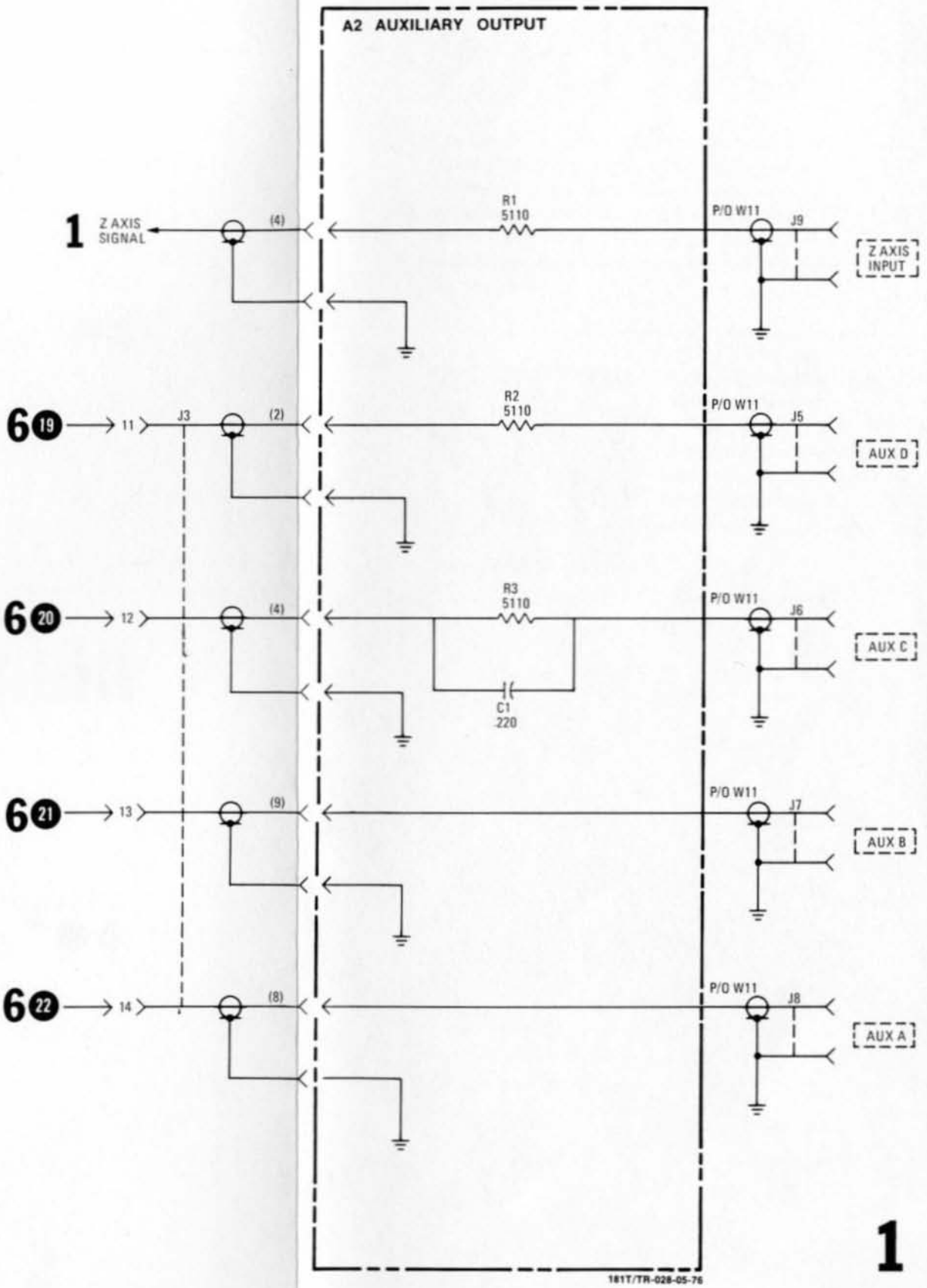

1811/TR-028-05-76

Figure 8-6.  
Output and Gate Amplifier  
8-11

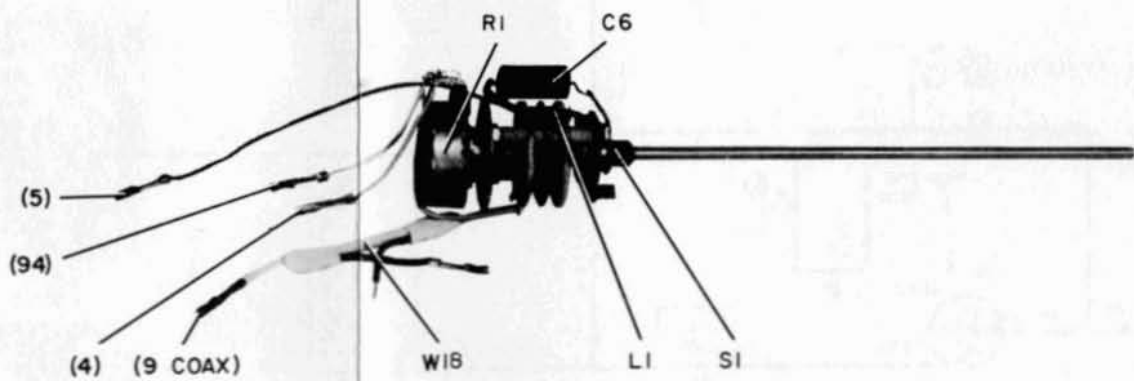

181T/TR-029

*Figure 8-7. Component Identification, Assembly A11*

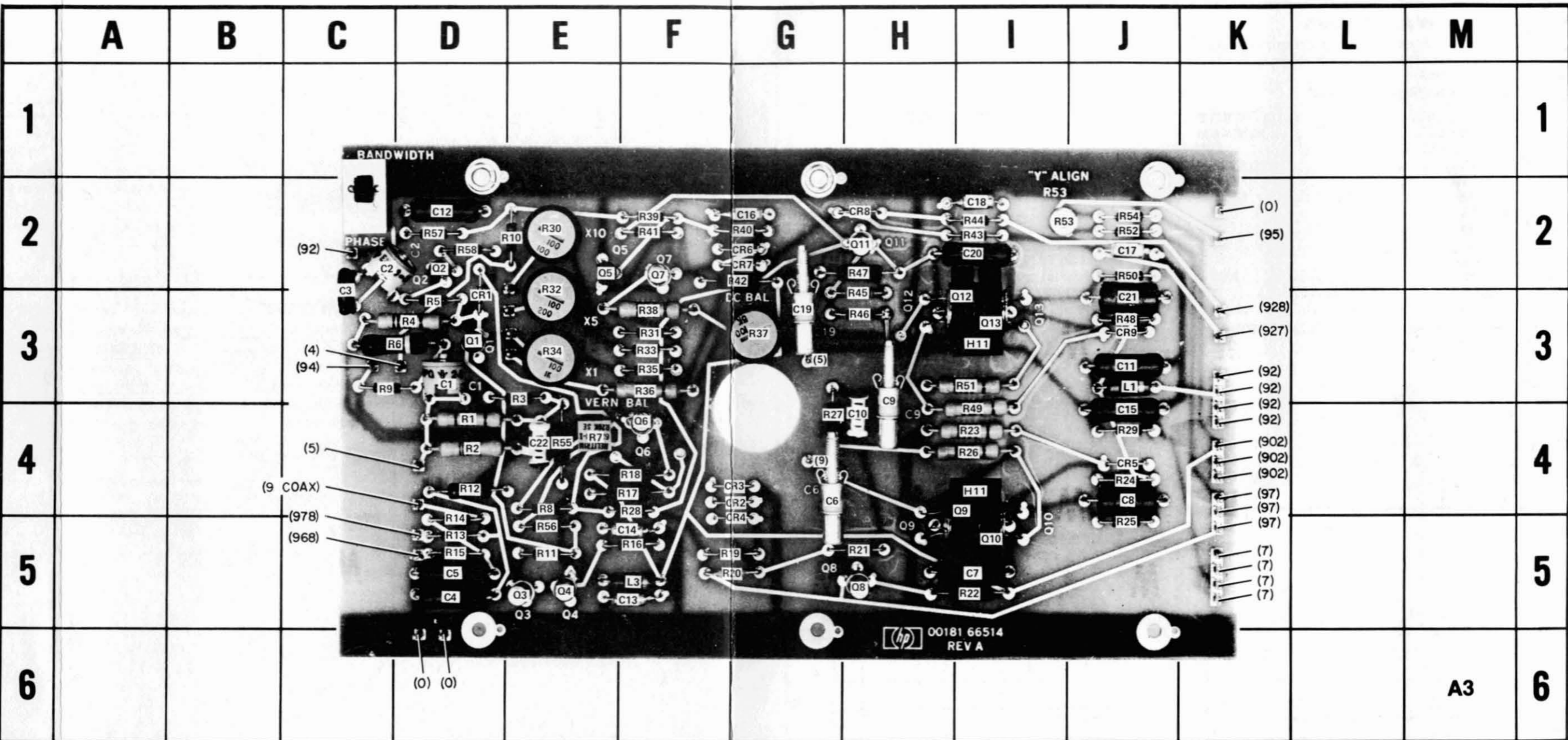

REF DESIG	GRID LOC	REF DESIG	GRID LOC	REF DESIG	GRID LOC	REF DESIG	GRID LOC	REF DESIG	GRID LOC	REF DESIG	GRID LOC	REF DESIG	GRID LOC	REF DESIG	GRID LOC
C1	D-3	C14	F-5	CR5	J-4	Q7	F-2	R7	E-4	R20	G-5	R33	F-3	R46	H-3
C2	C-2	C15	J-4	CR6	G-2	Q8	H-5	R8	E-4	R21	H-5	R34	E-3	R47	H-2
C3	C-3	C16	G-2	CR7	G-2	Q9	I-4	R9	D-3	R22	I-5	R35	F-3	R48	J-3
C4	D-5	C17	J-2	CR8	H-2	Q10	I-5	R10	E-2	R23	I-4	R36	F-3	R49	I-4
C5	D-5	C18	I-2	CR9	J-3	Q11	H-2	R11	E-5	R24	J-4	R37	G-3	R50	J-2
C6	G-4	C19	G3	L1	J-3	Q12	I-2	R12	D-4	R25	J-4	R38	F-3	R51	I-3
C7	I-5	C20	I-2	L3	F-5	Q13	H-3	R13	D-5	R26	I-4	R39	F-2	R52	J-2
C8	J-4	C21	J-3	Q1	D-3	R1	D-4	R14	D-5	R27	G-4	R40	G-2	R53	I-2
C9	H-3	C22	E-4	Q2	D-2	R2	D-4	R15	D-5	R28	F-4	R41	F-2	R54	J-2
C10	H-4	CR1	D-3	Q3	E-5	R3	E-3	R16	F-5	R29	J-4	R42	G-2	R55	E-4
C11	J-3	CR2	G-4	Q4	E-5	R4	D-3	R17	F-4	R30	E-2	R43	I-2	R56	E-5
C12	D-2	CR3	G-4	Q5	E-2	R5	D-3	R18	F-4	R31	F-3	R44	I-2	R57	D-2
C13	F-5	CR4	G-4	Q6	F-4	R6	D-3	R19	G-5	R32	E-2	R45	H-2	R58	D-2

Figure 8-8. Component Identification, Assembly A3

See Table 8-7 for Measurement Conditions

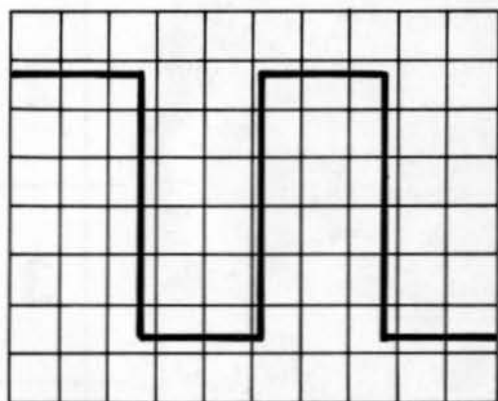

3  
 DISPLAY....EXT CAL  
 APPLY 10V CAL SIGNAL TO  
 EXT HORIZ INPUT  
 0.2MS/DIV  
 2V/DIV

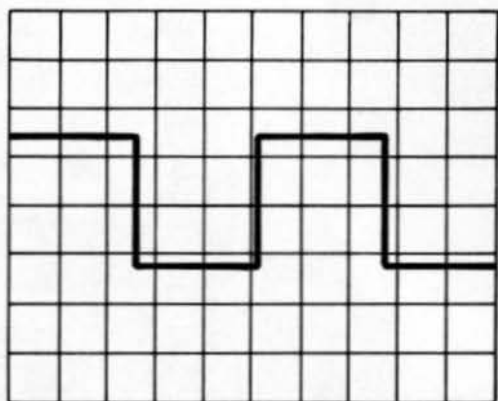

4  
 DISPLAY....EXT CAL  
 APPLY 10V CAL SIGNAL TO  
 EXT HORIZ INPUT  
 0.2MS/DIV  
 2V/DIV

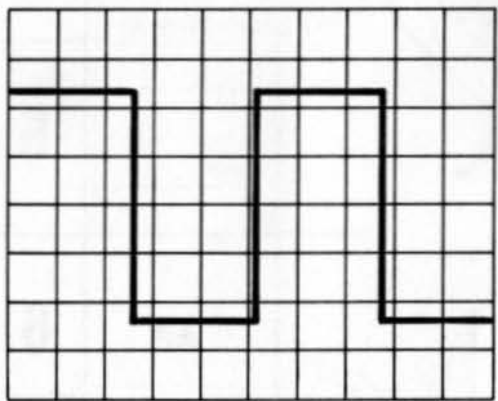

5  
 DISPLAY....EXT CAL  
 SLOPE....+  
 APPLY 10V CAL SIGNAL TO  
 EXT HORIZ INPUT  
 0.2MS/DIV  
 10V/DIV

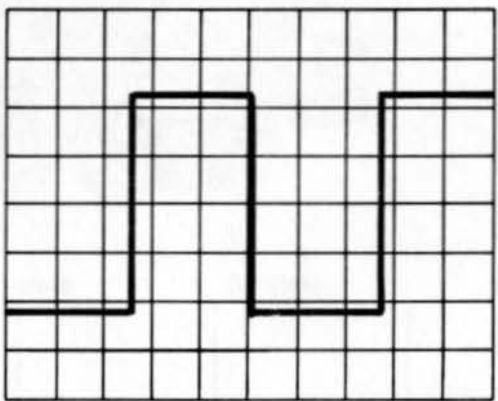

6  
 DISPLAY....EXT CAL  
 SLOPE....-  
 APPLY 10V CAL SIGNAL TO  
 EXT HORIZ INPUT  
 0.2MS/DIV  
 10V/DIV

181T/TR-031

Figure 8-9. Horizontal Amplifier Circuit Waveforms



6 5

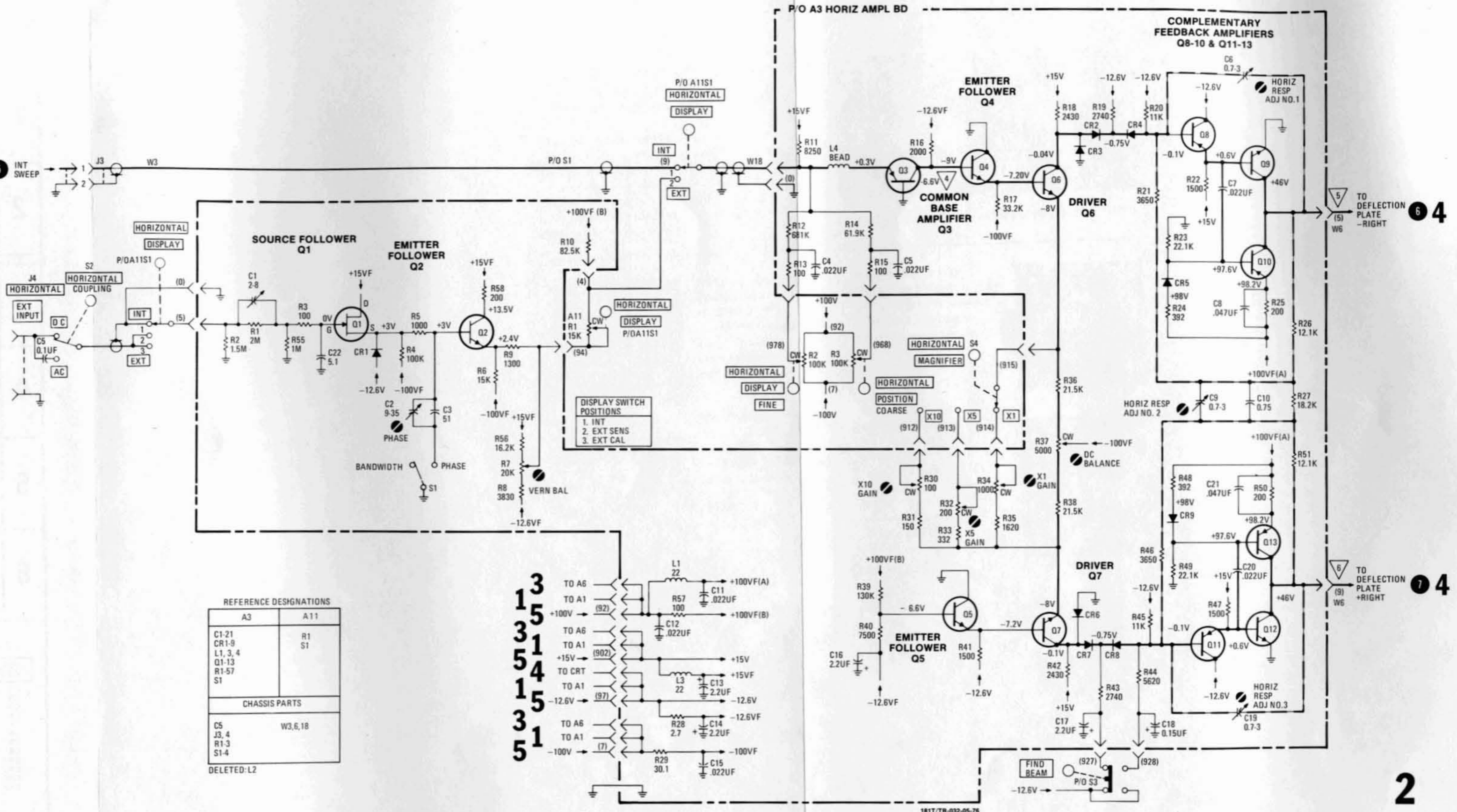

6 4

7 4

2

Figure 8-10.  
Horizontal Amplifier  
8-13

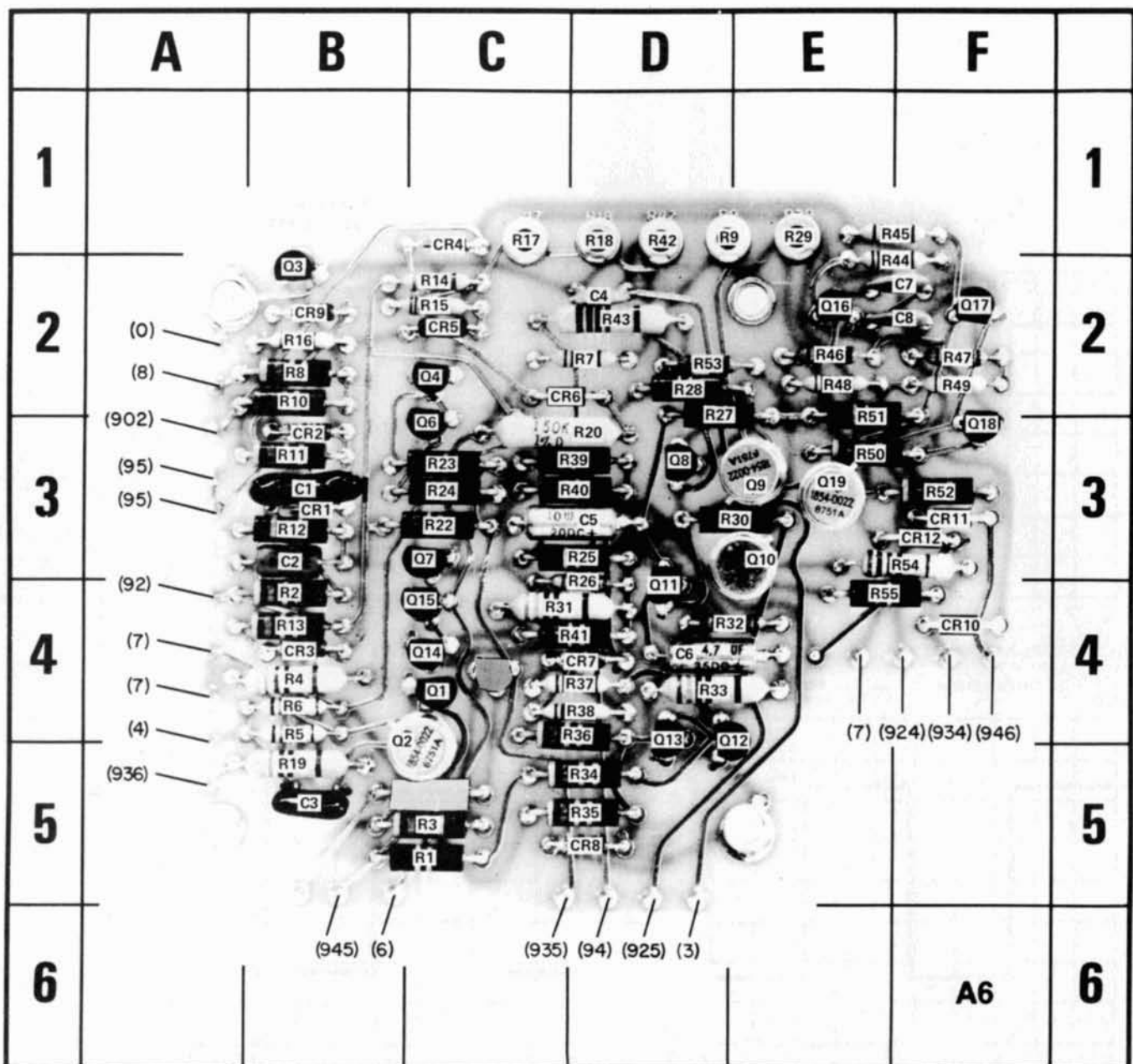

REF DESIG	GRID LOC	REF DESIG	GRID LOC	REF DESIG	GRID LOC	REF DESIG	GRID LOC	REF DESIG	GRID LOC	REF DESIG	GRID LOC	REF DESIG	GRID LOC	REF DESIG	GRID LOC
C1	B-3	CR5	C-2			Q17	F-2	R10	B-2	R22	C-3	R34	D-5	R45	F-1
C2	B-3	CR6	C-2	Q6	C-3	Q18	F-3	R11	B-3	R23	C-3	R35	D-4	R46	E-2
C3	B-5	CR7	D-4	Q7	C-3	Q19	E-3	R12	B-3	R24	C-3	R36	D-5	R47	F-2
C4	D-2	CR8	D-5	Q8	D-3	R1	C-5	R13	B-4	R25	D-3	R37	D-4	R48	E-2
C5	D-3	CR9	B-2	Q9	E-3	R2	B-4	R14	C-2	R26	D-3	R38	D-4	R49	F-2
C6	D-4	CR10	F-4	Q10	E-3	R3	C-5	R15	C-2	R27	D-2	R39	D-3	R50	E-3
C7	F-2	CR11	F-3	Q11	D-4	R4	B-4	R16	B-2	R28	D-2	R40	D-3	R51	E-3
C8	F-2	CR12	F-3	Q12	E-4	R5	B-4	R17	C-1	R29	E-1	R41	D-4	R52	F-3
CR1	B-3	Q1	C-4	Q13	D-4	R6	B-4	R18	D-1	R30	E-3	R42	D-1	R53	D-2
CR2	B-3	Q2	C-5	Q14	C-4	R7	D-2	R19	B-5	R31	C-4	R43	D-2	R54	F-3
CR3	B-4	Q3	B-2	Q15	C-4	R8	B-2	R20	D-3	R32	D-4	R44	F-2	R55	E-4
CR4	C-1	Q4	C-2	Q16	E-2	R9	D-1								

Figure 8-11. Component Identification, Assembly A6

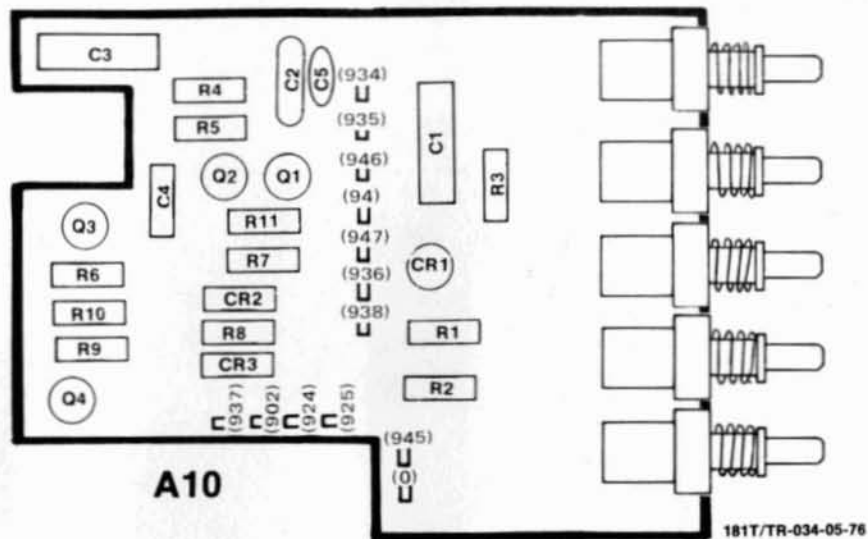

Figure 8-12. Component Identification, Assembly A10

See Table 8-7 for Measurement Conditions

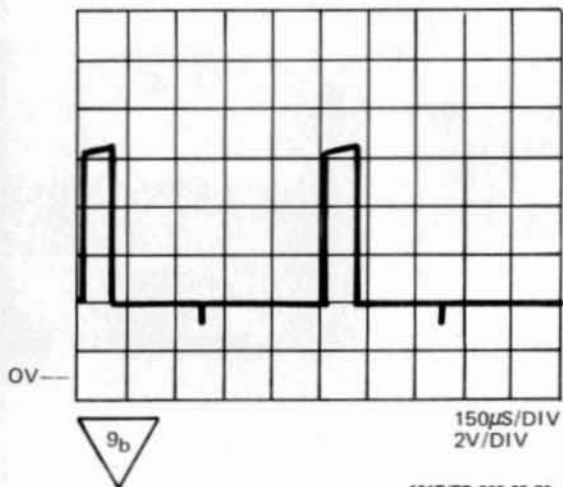
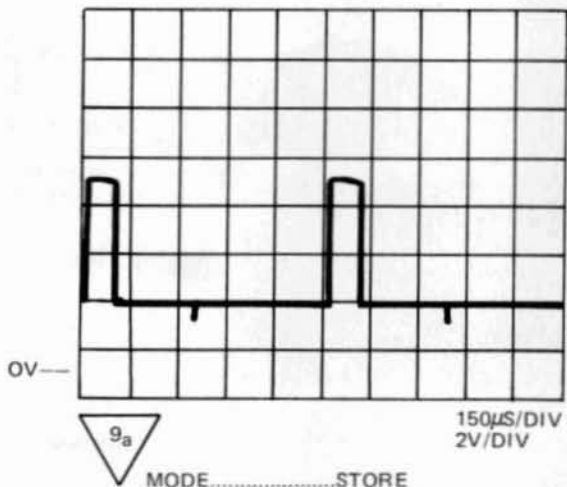
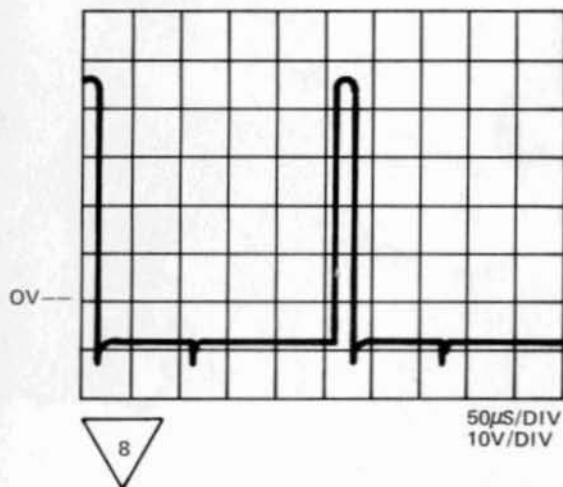
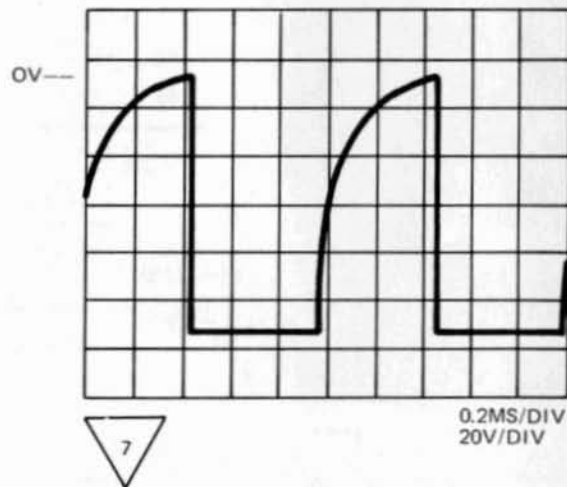
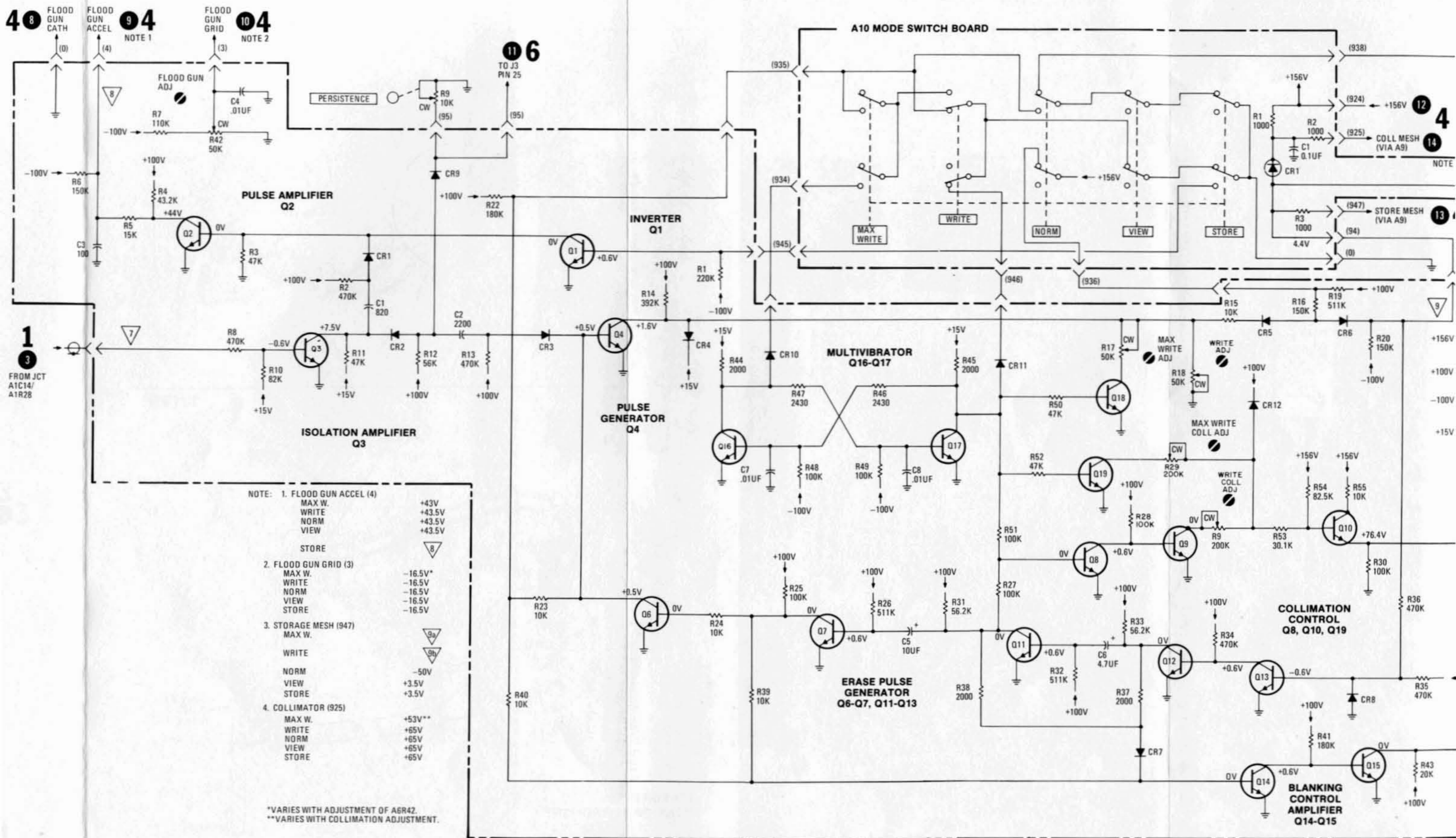

Figure 8-13. Pulse Circuit Waveforms



NOTE: 1. FLOOD GUN ACCEL (4)

MAX W.	+43V
WRITE	+43.5V
NORM	+43.5V
VIEW	+43.5V
STORE	8

2. FLOOD GUN GRID (3)

MAX W.	-16.5V*
WRITE	-16.5V
NORM	-16.5V
VIEW	-16.5V
STORE	-16.5V

3. STORAGE MESH (947)

MAX W.	9a
WRITE	9b
NORM	-50V
VIEW	+3.5V
STORE	+3.5V

4. COLLIMATOR (925)

MAX W.	+53V**
WRITE	+65V
NORM	+65V
VIEW	+65V
STORE	+65V

\*VARIES WITH ADJUSTMENT OF A6R42.  
 \*\*VARIES WITH COLLIMATION ADJUSTMENT.

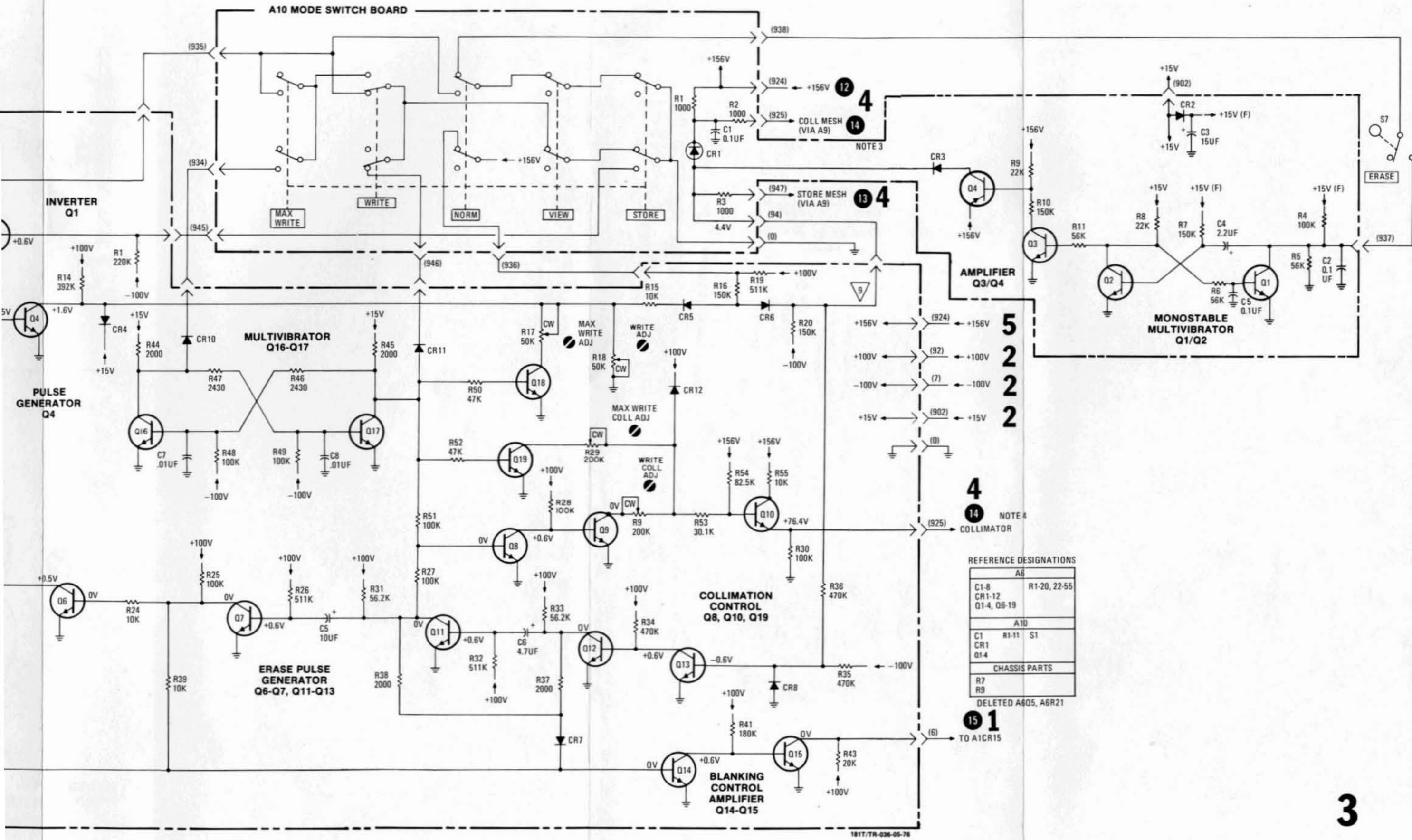

3

Figure 8-14.  
Pulse Circuit  
8-15

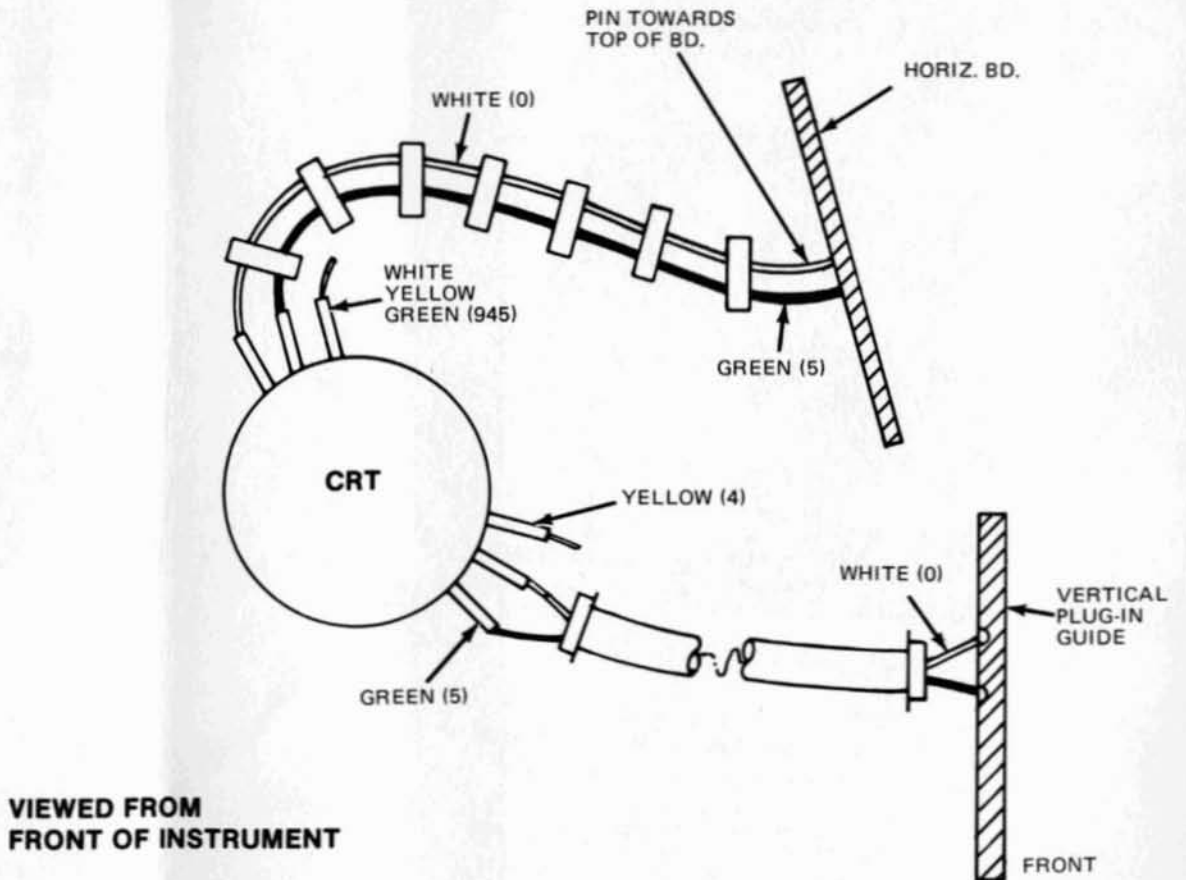
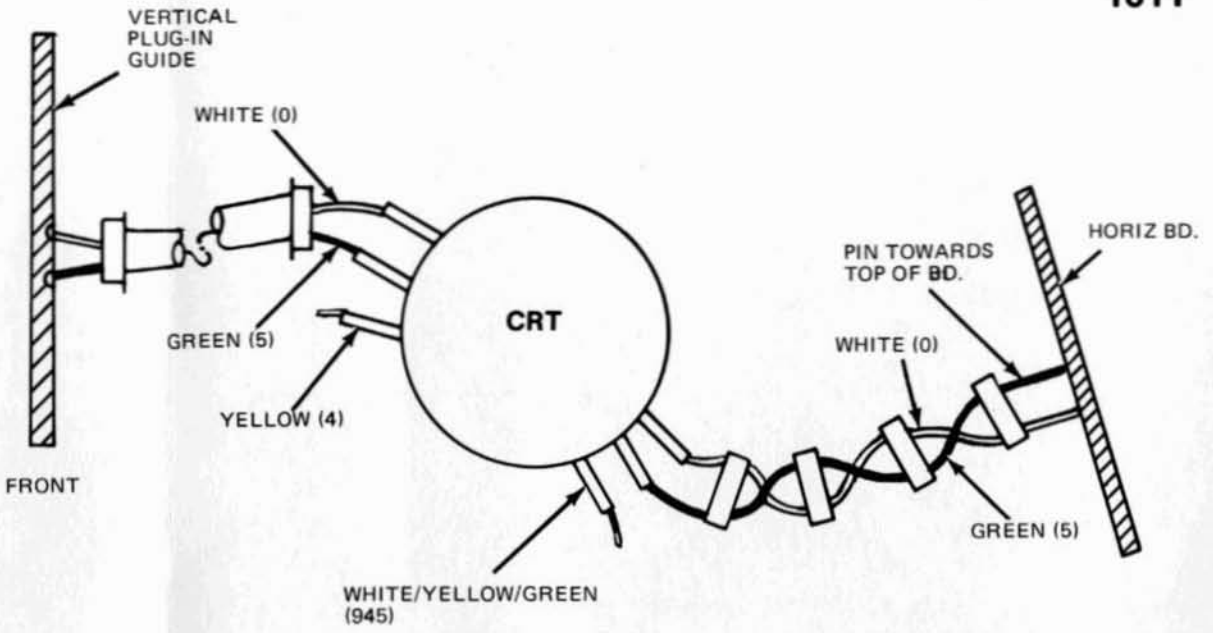

VIEWED FROM  
FRONT OF INSTRUMENT

Figure 8-15. Vertical and Horizontal CRT Connections

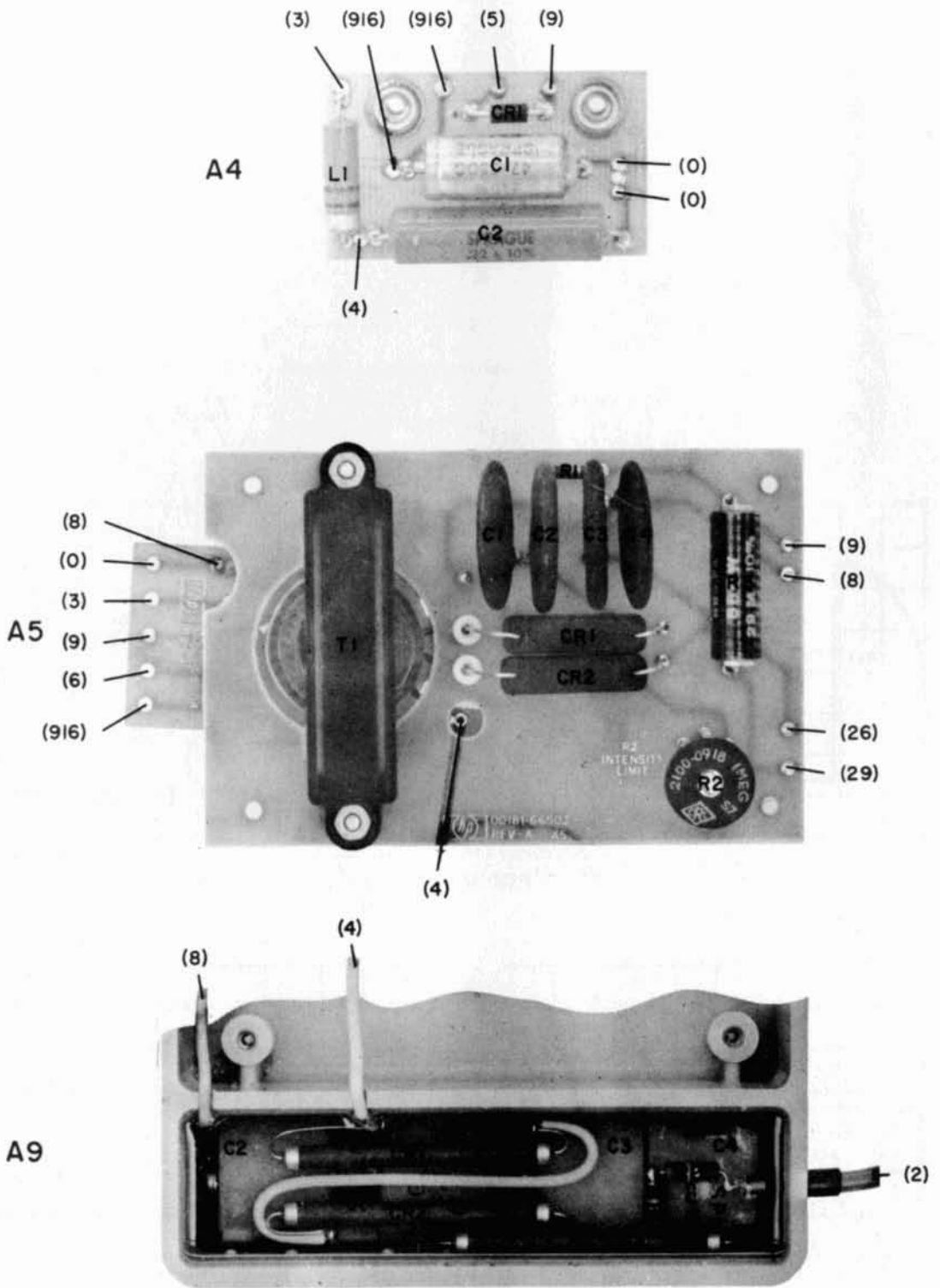

181T/TR-038

Figure 8-16. Component Identification, Assemblies A4, A5, and A9

See Table 8-7 for Measurement Conditions

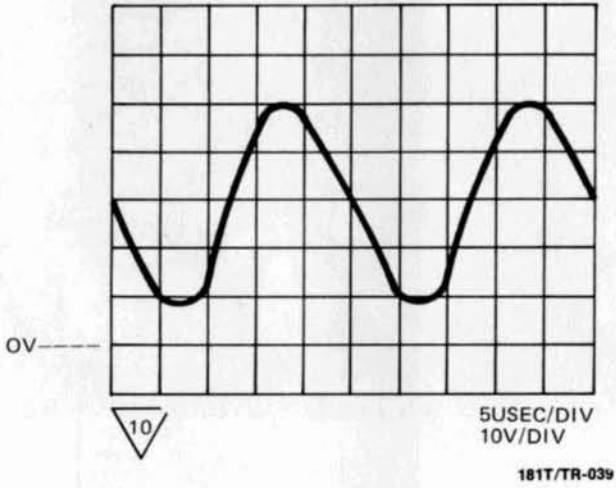
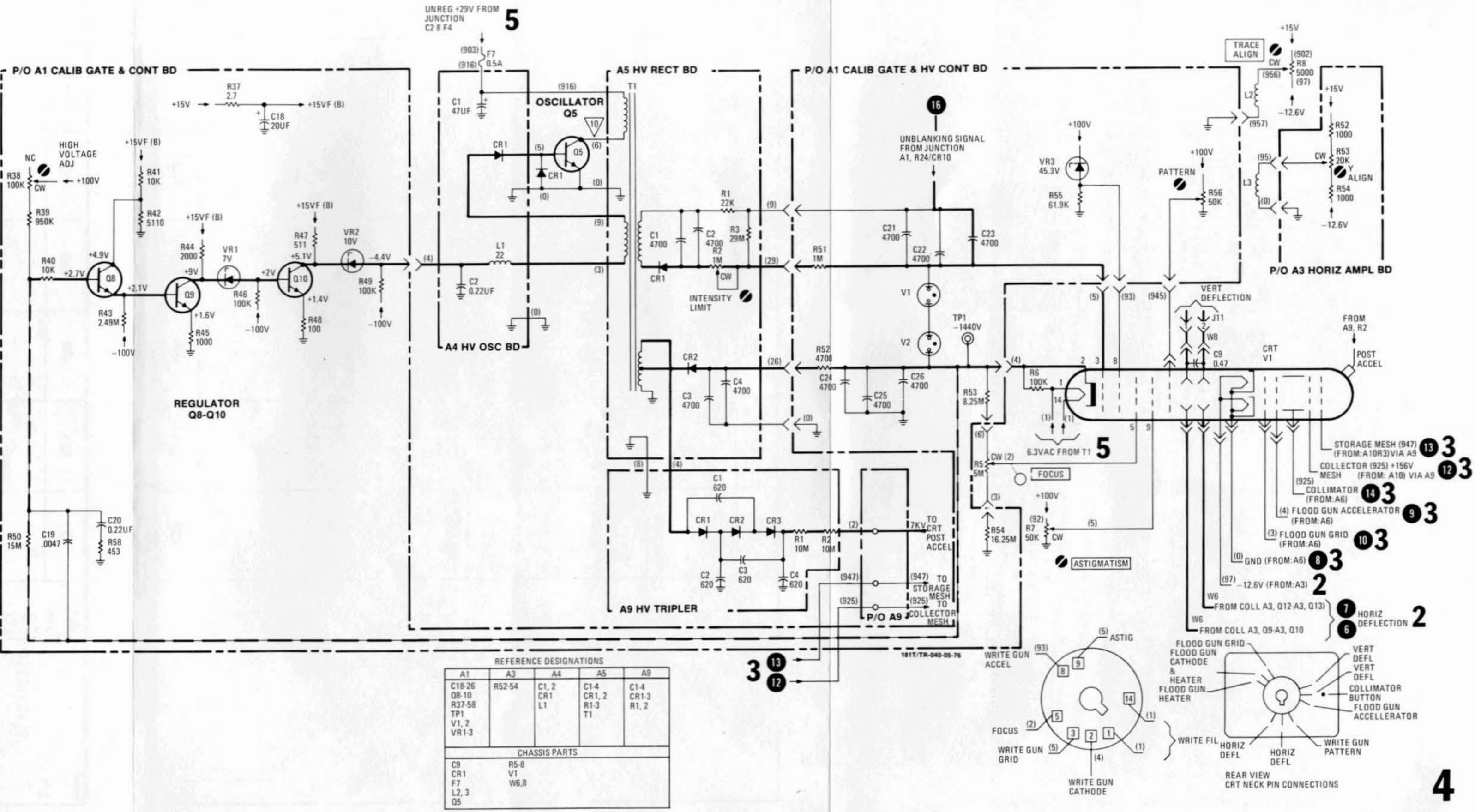

Figure 8-17. HV Oscillator Circuit Waveform





4

Figure 8-18.  
High Voltage Power Supply  
8-17

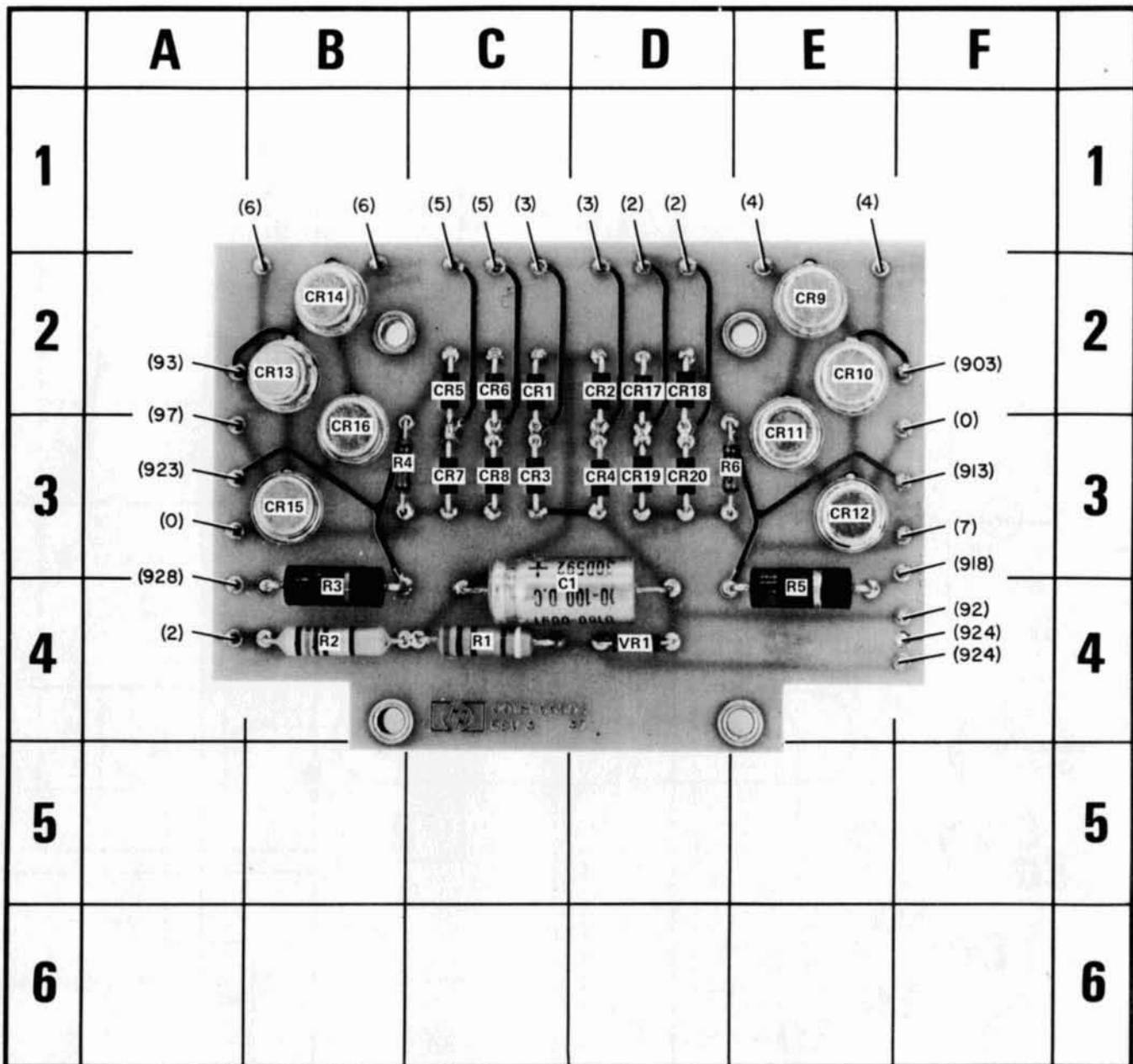

REF DESIG	GRID LOC	REF DESIG	GRID LOC	REF DESIG	GRID LOC	REF DESIG	GRID LOC
C1	C-4	CR7	C-3	CR14	B-2	R1	C-4
CR1	C-2	CR8	C-3	CR15	B-3	R2	B-4
CR2	D-2	CR9	E-2	CR16	B-3	R3	B-4
CR3	C-3	CR10	E-2	CR17	D-2	R4	B-3
CR4	D-3	CR11	E-3	CR18	D-2	R5	E-4
CR5	C-2	CR12	E-3	CR19	D-3	R6	D-3
CR6	C-2	CR13	B-2	CR20	D-3	VR1	D-4

Figure 8-19. Component Identification, Assembly A7

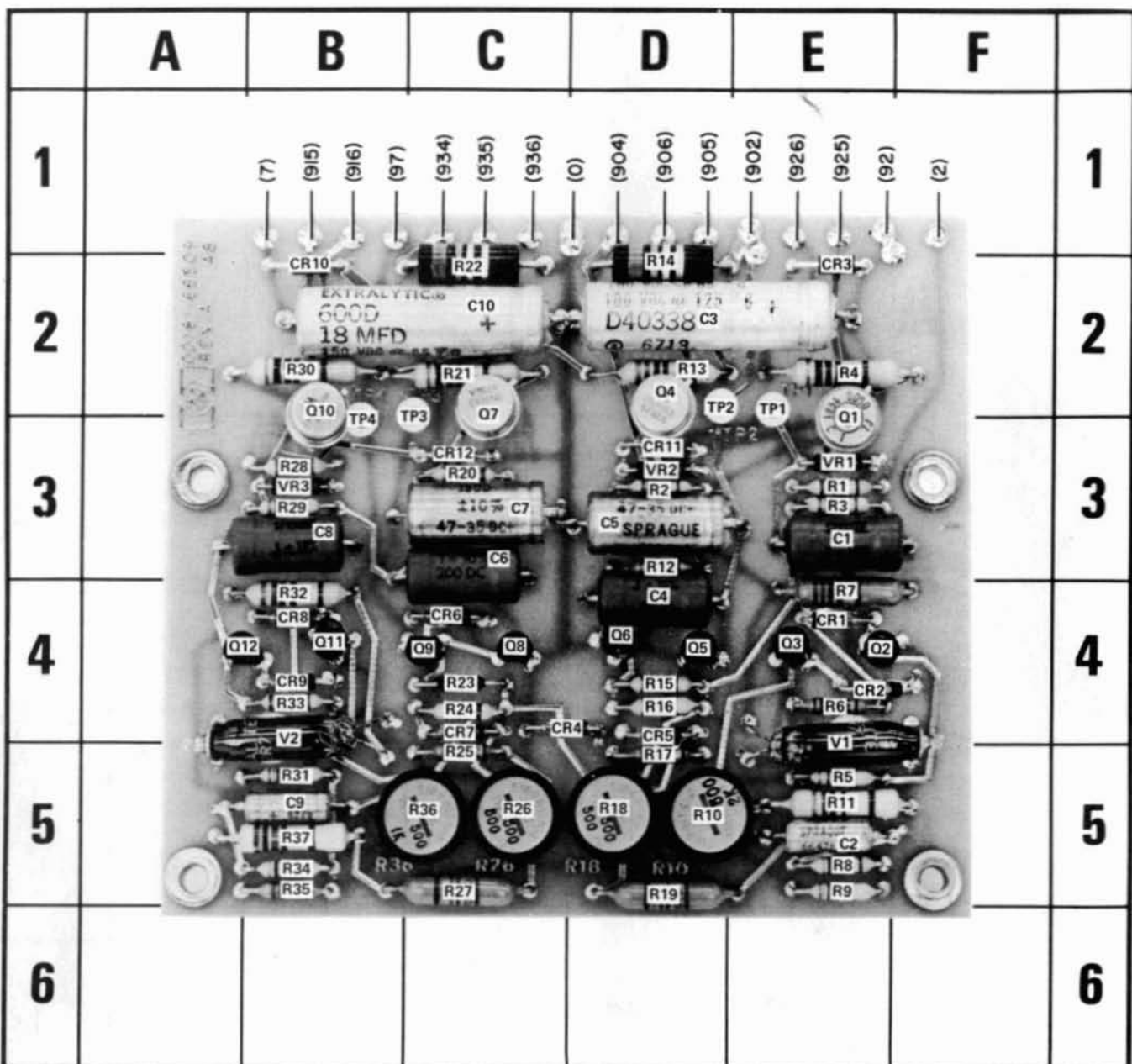

REF DESIG	GRID LOC	REF DESIG	GRID LOC	REF DESIG	GRID LOC	REF DESIG	GRID LOC	REF DESIG	GRID LOC	REF DESIG	GRID LOC	REF DESIG	GRID LOC
C1	E-3	CR3	E-2	Q3	E-4	R3	E-3	R14	D-2	R25	C-5	R36	C-5
C2	E-5	CR4	C-4	Q4	D-2	R4	E-2	R15	D-4	R26	C-5	R37	B-5
C3	D-2	CR5	D-4	Q5	D-4	R5	E-5	R16	D-4	R27	C-5	TP1	E-2
C4	D-4	CR6	C-4	Q6	D-4	R6	E-4	R17	D-5	R28	B-3	TP2	D-2
C5	D-3	CR7	C-4	Q7	C-2	R7	E-4	R18	D-5	R29	B-3	TP3	C-2
C6	C-3	CR8	B-4	Q8	C-4	R8	E-5	R19	D-5	R30	B-2	TP4	B-3
C7	C-3	CR9	B-4	Q9	C-4	R9	E-5	R20	C-3	R31	B-5	V1	E-4
C8	B-3	CR10	B-2	Q10	B-2	R10	D-5	R21	C-2	R32	B-4	V2	B-4
C9	B-5	CR11	D-3	Q11	B-4	R11	E-5	R22	C-2	R33	B-4	VR1	E-3
C10	C-2	CR12	C-3	Q12	A-4	R12	D-3	R23	C-4	R34	B-5	VR2	D-3
CR1	E-4	Q1	E-3	R1	E-3	R13	D-2	R24	C-4	R35	B-5	VR3	B-3
CR2	E-4	Q2	E-4	R2	D-3								

Figure 8-20. Component Identification, Assembly A8

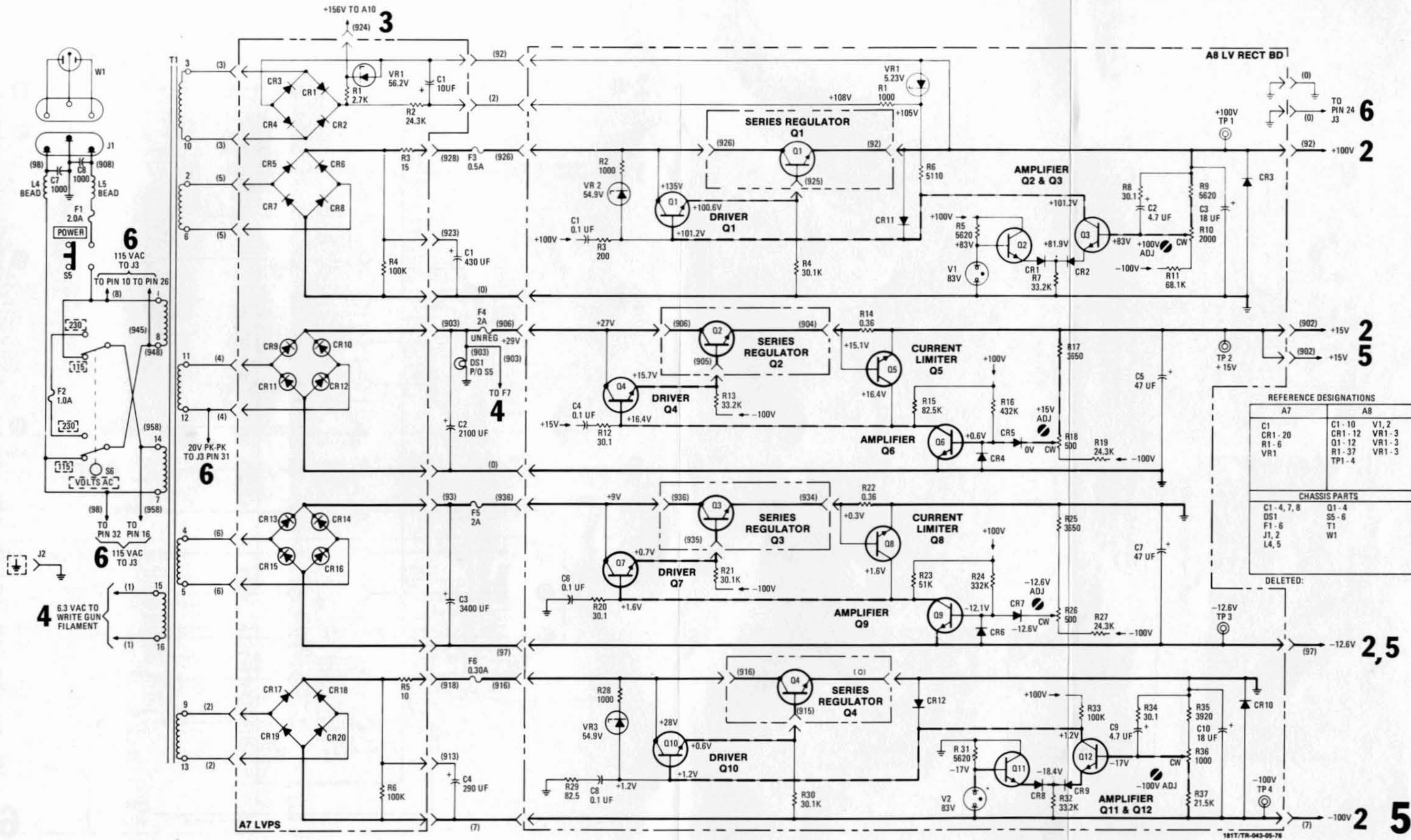
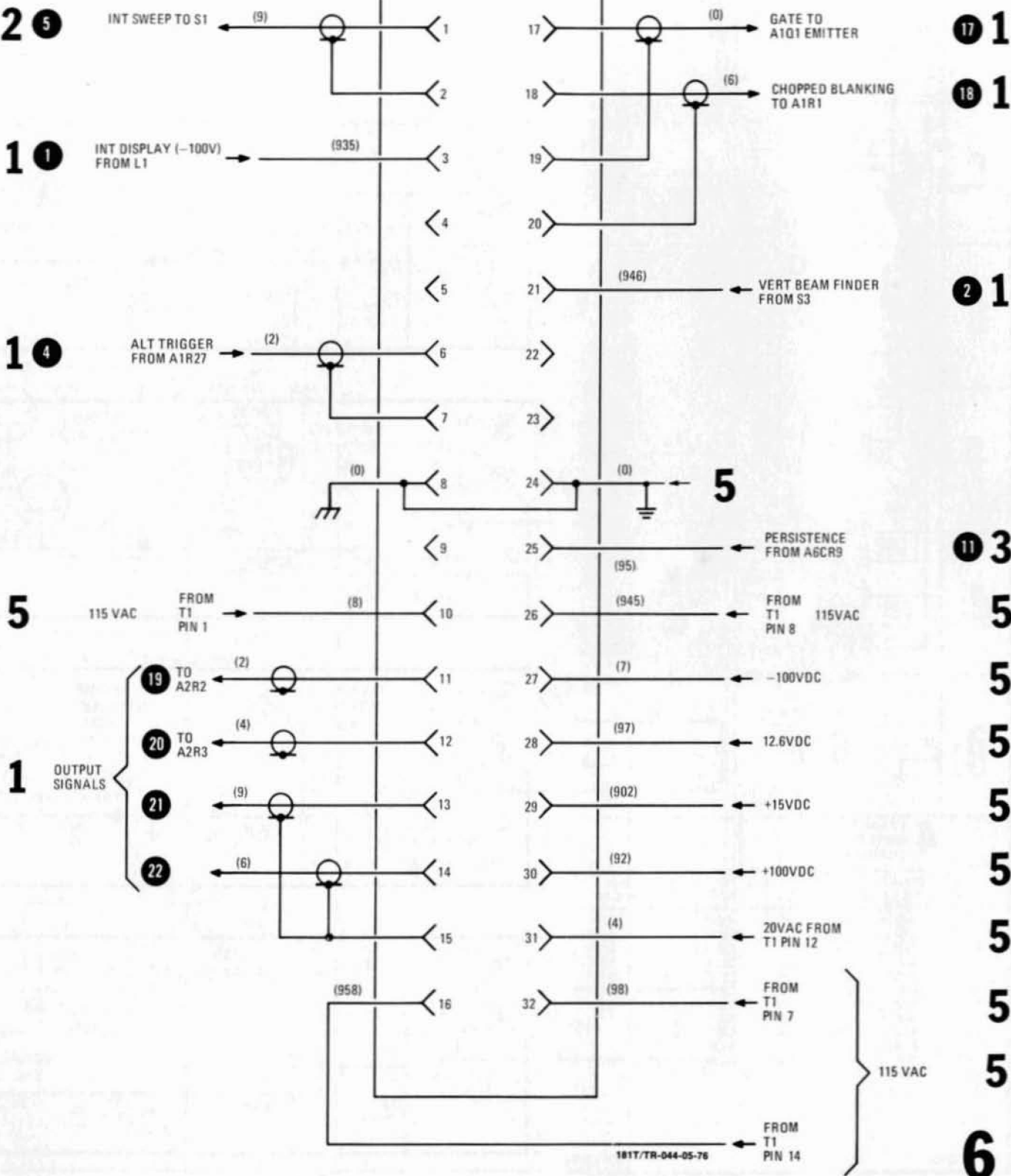

Figure 8-21. Low Voltage Power Supply 8-19

J3 WIRING SIDE



# MANUAL CHANGES

## MANUAL IDENTIFICATION

**Model Number:** 181T/TR  
**Date Printed:** May 1976  
**Part Number:** 00181-90915

This supplement contains important information for correcting manual errors and for adapting the manual to instruments containing improvements made after the printing of the manual.

To use this supplement:

Make all ERRATA corrections.

Make all appropriate serial number related changes indicated in the tables below.

Serial Prefix or Number	Make Manual Changes	Serial Prefix or Number	Make Manual Changes
1638A (181TR)	1	2112A	1, 2, 3, 4, 5
1640A (181T)	1		
1706A (181TR)	1,2		
1709A (181T)	1,2		
1919A	1,2,3		
2034A (181T) 2035A (181TR)	1, 2, 3, 4		

### ▲ NEW ITEM

## ERRATA

Paragraph 5-33. Group B Plug-ins.

Change step b to:

- b. Set INTENSITY CONTROL to 2 o'clock position.

▲ Paragraph 5-44. WRITING RATE (MAX),

Change frequency in steps d and l from 200 kHz to 40 kHz.

Table 6-2,

Change: MP35 (REAR PANEL), HP and Mfr Part No to 00181-00225.

Delete: XF1 and XF2.

Add: XF1A and XF2A, HP Part No. 2110-0470, Qty 2, FUSE HOLDER BODY EXTR PST; BAYONET; TND, Mfr Code 75915, Mfr Part No. 345003-010.

Add: XF1B and XF2B, HP Part No. 2110-0465, Qty 2, FUSE HOLDER CAP EXTR PST; BAYONET; 20A Mfr Code 75915, Mfr Part No. 345001-020.

Add: XF1C and XF2C, HP Part No. 2110-0467, Qty 2, NUT-HEX 1/2-28 THD 0.688 A/F, Mfr Code 75915, Mfr Part No. 903-070.

## NOTE

Manual change supplements are revised as often as necessary to keep manuals as current and accurate as possible. Hewlett-Packard recommends that you periodically request the latest edition of this supplement. Free copies are available from all HP offices. When requesting copies quote the manual identification information from your supplement, or the model number and print date from the title page of the manual.

19 MARCH 1981

Page 1 of 6

HEWLETT  PACKARD

**▲ CHANGE 5**

Page 6-2, Table 6-2. Replaceable Parts,  
Change A8 HP and Mfr Part Number to 00181-66523.

Page 6-9, Table 6-2. Replaceable Parts,  
Change A8 HP and Mfr Part Number to 00181-66523.  
Change A8C2 to HP Part Number 0180-0269, C:FXD ELECT 1UF +50-10% 150 VDCW, Mfr Code 56289,  
Mfr Part Number 30D105G150BA2-DSM.  
Add A8C11, HP and Mfr Part Number 0140-0176, C:FXD MICA 100PF 2% 300 VDCW, Mfr Code 28480.  
Add A8C12, HP and Mfr Part Number 0140-0176, C:FXD MICA 100PF 2% 300 VDCW, Mfr Code 28480.

Page 6-10, Table 6-2. Replaceable Parts,  
Change A8R5 to HP and Mfr Part Number 0757-0060, R:FXD MET FLM 24.3K OHM 1% 1/2 W, Mfr Code 28480.  
Change A8R8 to HP and Mfr Part Number 0757-0060, R:FXD MET FLM 24.3K OHM 1% 1/2 W, Mfr Code 28480.  
Change A8R9 to HP and Mfr Part Number 0757-0435, R:FXD MET FLM 3920 OHM 1% 1/8 W, Mfr Code 28480.  
Change A8R10 to HP and Mfr Part Number 2100-1773, R:VAR WW 1000 OHM 5% TYPE H 1W, Mfr Code 28480.  
Change A8R11 to HP and Mfr Part Number 0757-0767, R:FXD MET FLM 43.2K OHM 1% 1/4 W, Mfr Code 28480.  
Delete A8R31.  
Add A8R38, HP and Mfr Part Number 0757-0770, R:FXD MET FLM 56.2K OHM 1% 1/4 W, Mfr Code 28480.  
Add A8R39, HP and Mfr Part Number 0757-0766, R:FXD MET FLM 39.2K OHM 1% 1/4 W, Mfr Code 28480.  
Delete A8V1 and A8V2.  
Add A8VR4, HP Part Number 1902-0787, DIODE BREAKDOWN:9.0V 5% 500MW, Mfr Code 04713, Mfr Part Number 1N937.

Page 8-18, Figure 8-20,  
Replace A8 Component Identification with Figure 2 of this manual change sheet.

Page 8-19, Figure 8-21,  
Make changes shown in Figure 3 of this manual change sheet.

**ERRATA (Cont'd)**

Add:XF1D and XF2D, HP Part No. 1400-0090, Qty 2, WASHER-FUSEHOLDER .625 OD .5 ID, Mfr Code 75915, Mfr Part No. 901-129.

Change: A1R38, HP Part No. 2100-3214, Qty 1, RESISTOR-TRMR 100K 10% C TOP-ADJ 1-TRN, Mfr Code 32997, Mfr Part No. 3386P-Y46-104.

Change: A10CR1, HP Part No. 1901-0036, DIODE-HV RECT 1KV 600MA D0-29, Mfr Code 04713, Mfr Part No. SR 1358-12.

**CHANGE 1**

Table 6-2,

Change MP26 to 00182-67401.

Change MP29 to 00180-67406, KNOB ASSY:BAR WITH WHITE ARROW.

Change MP30 (181T only) to 00181-00219.

Change MP30 (181TR only) to 00181-00220.

**CHANGE 2**

The name of Model 181T/TR instruments has been changed from OSCILLOSCOPE to DISPLAY.

Table 6-2,

MP30 (181T): Change HP Part No. and Mfr Part No. to 00181-00221.

MP30 (181TR): Change HP Part No. and Mfr Part No. to 00181-00222.

MP35: Change HP Part No. and Mfr Part No. to 00181-00223.

**CHANGE 3**

Table 6-2,

Add: H15, HP Part No. 2190-0018, Qty 2, WASHER-LK HCLC NO. 6 .141-IN-ID, Mfr Code 28480, Mfr Part No. 2190-0018.

Add: H16, HP Part No. 2360-0195, Qty 2, SCREW-MACH 6-32 .312-IN-LG PAN-HD-POZI, Mfr Code 28480, Mfr Part No. 2360-0195.

Add: H17, HP Part No. 3050-0010, Qty 2, WASHER-FL MTLC NO. 6 .147-IN-ID, Mfr Code 28480, Mfr Part No. 3050-0010.

Change: L3, HP and Mfr Part Nos. to 01741-66001.

Change: MP58, HP and Mfr Part Nos. to 00181-00605.

**CHANGE 4**

Table 6-2, Replaceable Parts,

Change A7, HP Part No. and Mfr Part No. to 00181-66522.

Add: A7C2, HP Part No. 0160-2903, Qty 2, C:FXD CER .05UF  $\pm 20\%$  500VDCW, Mfr Code 28480, Mfr Part No. 0160-2903.

Add: A7C3, HP Part No. 0160-3494, Qty 2, C:FXD ELECT .47UF  $\pm 5\%$  200VDCW, Mfr Code 28480, Mfr Part No. 0160-3494.

Add: A7C4, HP Part No. 0160-3494, C:FXD ELECT .47UF  $\pm 5\%$  200VDCW, Mfr Code 28480, Mfr Part No. 0160-3494.

Add: A7C5, HP Part No. 0160-2903, C:FXD CER .05UF  $\pm 20\%$  500VDCW, Mfr Code 28480, Mfr Part No. 0160-2903.

Figure 8-21. Schematic 5,

Make changes shown in figure 1 of this manual change sheet.



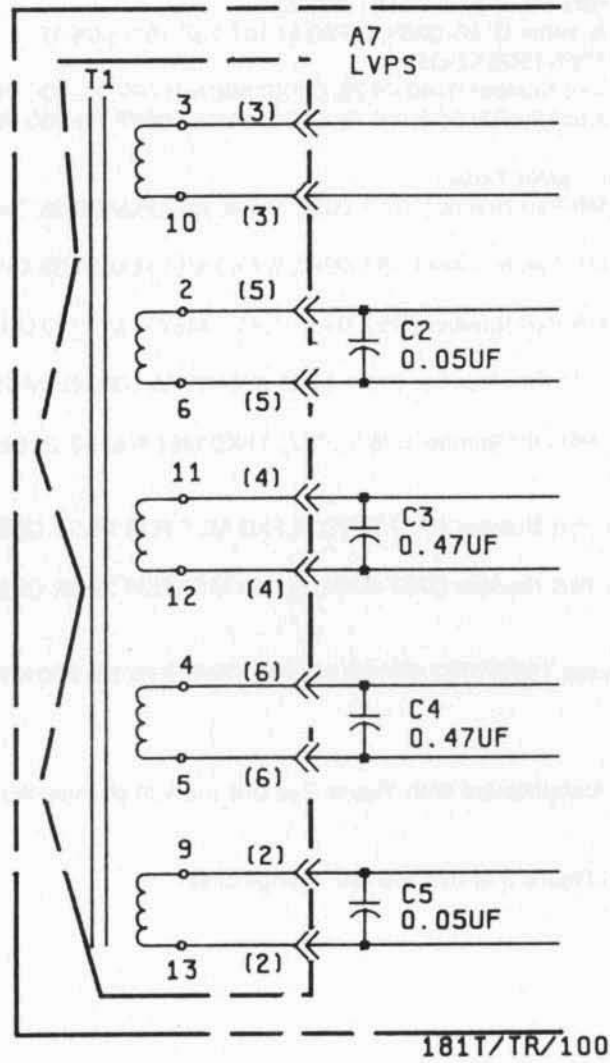

Figure 1. Additions to Figure 8-21 (Schematic 5)

HEWLETT  PACKARD