

NOT  
MEASUREMENT  
SENSITIVE

MIL-STD-188-141B  
1 MARCH 1999

---

SUPERSEDING  
MIL-STD-188-141A  
15 SEPTEMBER 1988

# DEPARTMENT OF DEFENSE INTERFACE STANDARD

INTEROPERABILITY AND PERFORMANCE STANDARDS  
FOR MEDIUM AND HIGH FREQUENCY  
RADIO SYSTEMS



AMSC N/A

AREA TCSS

DISTRIBUTION STATEMENT : Approved for public release; distribution unlimited.

## FOREWORD

1. This standard is approved for use by all Departments and Agencies of the Department of Defense (DoD).
2. In accordance with DoD Instruction 4630.8, it is DoD policy that all forces for joint and combined operations be supported through compatible, interoperable, and integrated Command, Control, Communications, and Intelligence (C3I) systems. Furthermore, all C3I systems developed for use by U.S. forces are considered to be for joint use. The director of the Defense Information Systems Agency (DISA) serves as DoD's single point of contact for developing information technology standards to achieve interoperability and compatibility. All C3I systems and equipment shall conform to technical and procedural standards for interface, interoperability, and compatibility, as recommended by DISA.
3. MIL-STDs in the 188 series (MIL-STD-188-XXX) address telecommunication design parameters based on proven technologies. These MIL-STDs are to be used in all new DoD systems and equipment, or major upgrades thereto, to ensure interoperability. The MIL-STD-188 series is subdivided into a MIL-STD-188-100 series, covering common standards for tactical and long-haul communications; a MIL-STD-188-200 series, covering standards for tactical communications only; and a MIL-STD-300 series, covering standards for long-haul communications only. Emphasis is being placed on the development of common standards for tactical and long-haul communications (the MIL-STD-188-100 series). The MIL-STD-188 series may be based on, or make reference to, Joint Technical Architecture, American National Standards Institute (ANSI) standards, International Telecommunications Union - Telecommunication Standardization Sector (ITU-T) recommendations, North Atlantic Treaty Organization (NATO) Standardization Agreements (STANAG), and other standards wherever applicable.
4. This document contains technical standards and design objectives for medium- and high-frequency radio systems. Included are: (1) the basic radio parameters to support both conventional and adaptive radio communications; and (2) technical parameters for automatic link establishment (ALE), linking protection, and other advanced adaptive features and functions.
5. The technical parameters in certain identified paragraphs have not (as of the date of publication) been verified by testing or implementation. These parameters have, however, been subjected to rigorous simulation and computer modeling. The DoD working group and the Technical Advisory Committee (TAC) are confident that these features, functions, and parameters are technically valid. The un-tested portion of the technology are marked (NT) following the title of each paragraph containing un-tested material.
6. Users of this MIL-STD should note that there is no proprietary or otherwise restricted use material in this document. This document is for unrestricted DoD, federal, and industry use.

## TABLE OF CONTENTS

<u>PARAGRAPH</u>	<u>PAGE</u>
1. SCOPE.....	1
1.1 <u>Scope</u> .....	1
1.2 <u>Applicability</u> .....	1
1.3 <u>Application guidance</u> .....	1
2. APPLICABLE DOCUMENTS.....	1
2.1 <u>General</u> .....	1
2.2 <u>Government documents</u> .....	1
2.2.1 <u>Specifications, standards, and handbooks</u> .....	1
2.2.2 <u>Other Government documents, drawings, and publications</u> .....	2
2.3 <u>Non-Government publications</u> .....	2
2.4 <u>Order of precedence</u> .....	3
3. DEFINITIONS.....	3
3.1 <u>Terms</u> .....	3
3.2 <u>Abbreviations and acronyms</u> .....	4
4. GENERAL REQUIREMENTS.....	5
4.1 <u>General</u> .....	5
4.1.1 <u>Equipment parameters</u> .....	6
4.1.2 <u>Basic HF radio parameters</u> .....	6
4.2 <u>Equipment operation mode</u> .....	7
4.2.1 <u>Baseline mode</u> .....	7
4.2.2 <u>Push-to-talk operation</u> .....	8
4.2.3 <u>ALE mode</u> .....	8
4.2.4 <u>Anti-jam (AJ) mode</u> .....	8
4.2.5 <u>Linking protection (LP)</u> .....	8
4.3 <u>Interface parameters</u> .....	9
4.3.1 <u>Electrical characteristics of digital interfaces</u> .....	9
4.3.2 <u>Electrical characteristics of analog interfaces</u> .....	9
4.3.3 <u>Modulation and data signaling rates</u> .....	9
4.4 <u>NATO and Quadripartite interoperability requirements</u> .....	9
4.4.1 <u>Single-channel communications systems</u> .....	9
4.4.2 <u>Maritime air communications systems</u> .....	9
4.4.3 <u>High-performance HF data modems</u> .....	10
4.4.4 <u>QSTAGs</u> .....	10
4.5 <u>Adaptive communications</u> .....	10
4.6 <u>Linking protection</u> .....	10
4.7 <u>HF data link protocol</u> .....	11
4.8 <u>Networking functions</u> .....	11
4.8.1 <u>Indirect calling and relaying</u> .....	11
4.8.2 <u>Network management</u> .....	11
4.9 <u>Application protocols for HF radio networks</u> .....	11

**TABLE OF CONTENTS**  
(continued)

<u>PARAGRAPH</u>	<u>PAGE</u>
5. DETAILED REQUIREMENTS.....	13
5.1 <u>General</u> .....	13
5.1.1 <u>Introduction</u> .....	13
5.1.2 <u>Signal and noise relationships</u> .....	13
5.2 <u>Common equipment characteristics</u> .....	14
5.2.1 <u>Displayed frequency</u> .....	14
5.2.2 <u>Frequency coverage</u> .....	14
5.2.3 <u>Frequency accuracy</u> .....	14
5.2.4 <u>Phase stability</u> .....	14
5.2.5 <u>Phase noise</u> .....	14
5.2.6 <u>Bandwidths</u> .....	17
5.2.7 <u>Overall channel responses</u> .....	17
5.2.8 <u>Absolute delay</u> .....	19
5.3 <u>Transmitter characteristics</u> .....	19
5.3.1 <u>Noise and distortion</u> .....	19
5.3.2 <u>Spectral purity</u> .....	21
5.3.3 <u>Carrier suppression</u> .....	23
5.3.4 <u>Automatic level control (ALC)</u> .....	23
5.3.5 <u>Attack and release time delays</u> .....	25
5.3.6 <u>Signal input interface characteristics</u> .....	25
5.3.7 <u>Transmitter output load impedance</u> .....	25
5.4 <u>Receiver characteristics</u> .....	27
5.4.1 <u>Receiver rf characteristics</u> .....	27
5.4.2 <u>Receiver distortion and internally generated spurious outputs</u> .....	28
5.4.3 <u>Automatic gain control (AGC) characteristic</u> .....	29
5.4.4 <u>Receiver linearity</u> .....	29
5.4.5 <u>Interface characteristics</u> .....	29
5.5 <u>ALE</u> .....	30
5.5.1 <u>Basic ALE (2G)</u> .....	30
5.5.2 <u>3G ALE</u> .....	30
5.6 <u>LP</u> .....	30
5.7 <u>ALE control functions (orderwire functions)</u> .....	30
5.8 <u>Networking functions</u> .....	30
5.9 <u>Network management</u> .....	30
5.10 <u>HF application interface</u> .....	30
5.11 <u>Data link protocol</u> .....	31
5.12 <u>Anti-jam capability</u> .....	31
5.13 <u>Automatic repeat request (ARQ) protocol</u> .....	31

**TABLE OF CONTENTS**  
(continued)

<b><u>PARAGRAPH</u></b>	<b><u>PAGE</u></b>
6. NOTES.....	31
6.1 <u>Intended use</u> .....	31
6.2 <u>Interaction matrix</u> .....	31
6.3 <u>Issue of DODISS</u> .....	34
6.4 <u>Subject term (key word) listing</u> .....	34
6.5 <u>International standardization agreements</u> .....	35
6.6 <u>Electromagnetic compatibility (EMC) requirements</u> .....	35

**TABLES**

TABLE I. <u>Relaying alternative notes</u> .....	13
TABLE II. <u>Bandwidths</u> .....	17
TABLE III. <u>Out-of-band power spectral density limits for radio transmitters</u> .....	21
TABLE IV. <u>Interaction matrix: General features</u> .....	32

**FIGURES**

FIGURE 1. <u>Physical layer with transceiver and modem elements</u> .....	7
FIGURE 2. <u>Radio subsystems interface points</u> .....	9
FIGURE 3. <u>Relaying alternatives</u> .....	12
FIGURE 4. <u>Phase noise limit mask for fixed site and transportable long-haul radio transmitters</u> .....	15
FIGURE 5. <u>Phase noise limit mask for tactical radio transmitters</u> .....	16
FIGURE 6. <u>Overall channel response for single-channel or dual-channel equipment</u> .....	18
FIGURE 7. <u>Overall channel characteristics (four-channel equipment)</u> .....	20
FIGURE 8. <u>Out-of-band power spectral density for HF transmitters</u> .....	22
FIGURE 9. <u>Discrete spurious emissions limit for HF transmitters</u> .....	24
FIGURE 10. <u>Output power vs. VSWR for transmitters with broadband output impedance networks</u> .....	26

**APPENDICES**

Appendix A. Automatic Link Establishment System.....	36
Appendix B. Linking Protection.....	231
Appendix C. Third Generation HF Link Automation.....	264
Appendix D. HF Radio Networking.....	440
Appendix E. Application Protocols for HF Radio Networks.....	488
Appendix F. Anti-jam and Anti-interference Techniques.....	499
Appendix G. HF Data Link Protocol.....	509
Appendix H. Management Information Base for Automated HF Radio Networks.....	512

## 1. SCOPE.

### 1.1 Scope.

The purpose of this document is to establish technical performance and interface parameters in the form of firm requirements and optional design objectives (DO) that are considered necessary to ensure interoperability and interface of new long-haul and tactical radio systems in the medium frequency (MF) band and in the high frequency (HF) band. It is also the purpose of this document to establish a level of performance for new radio equipment as is considered necessary to satisfy the requirements of the majority of users. These technical parameters, therefore, represent a minimum set of interoperability, interface, and performance standards. The technical parameters of this document may be exceeded in order to satisfy certain specific requirements, provided that interoperability is maintained. That is, the capability to incorporate features such as additional standard and nonstandard interfaces is not precluded.

### 1.2 Applicability.

This standard is approved for use within the Department of Defense (DoD) in the design and development of new MF and HF radio systems. It is not intended that existing equipment and systems be immediately converted to comply with the provisions of this standard. New equipment and systems, and those undergoing major modification or rehabilitation, should conform to this standard. If deviation from this standard is required, the user should contact the lead standardization activity for waiver procedures.

### 1.3 Application guidance.

The terms “system standard” and “design objective” are defined in FED-STD-1037. In this document, the word “shall” identifies firm requirements. The word “should” identifies design objectives that are desirable but not mandatory.

## 2. APPLICABLE DOCUMENTS.

### 2.1 General.

The documents listed in this section are specified in sections 3, 4, and 5 of this standard. This section does not include documents cited in other sections of this standard, those recommended for additional information, or those used as examples. While every effort has been made to ensure the completeness of this list, document users are cautioned that they must meet all specified requirements documents cited in sections 3, 4, and 5 of this standard, whether or not they are listed.

### 2.2 Government documents.

#### 2.2.1 Specifications, standards, and handbooks.

The following specifications, standards, and handbooks form a part of this document to the extent specified herein. Unless otherwise specified, the issues of these documents are those listed in the issue of the Department of Defense Index of Specifications and Standards (DODISS) and supplement thereto cited in the solicitation (see paragraph 6.3).

STANDARDS

FEDERAL

FED-STD-1037            Telecommunications: Glossary of  
Telecommunications Terms

DEPARTMENT OF DEFENSE

MIL-STD-188-110       Interoperability and Performance Standards for HF  
Data Modems

MIL-STD-188-114       Electrical Characteristics of Digital Interface  
Circuits

MIL-STD-188-148       (S) Interoperability Standard for Anti-Jam (AJ)  
Communications in the High Frequency Band  
(2-30 MHz) (U)

(Unless otherwise indicated, copies of the above specifications, standards, and handbooks are available from the Standardization Document Order Desk, 700 Robbins Ave. Building 4D, Philadelphia, PA 19111-5094.)

2.2.2 Other Government documents, drawings, and publications.

The following other Government documents, drawings, and publications form a part of this document to the extent specified herein. Unless otherwise specified, the issues are those cited in the solicitation.

U.S. DEPARTMENT OF COMMERCE

National Telecommunications and Information Administration (NTIA)

NTIA Manual of Regulations and Procedures for Federal Radio Frequency  
Management

(Applications for copies should be addressed to the U.S. Department of Commerce, NTIA, Room 4890, 14th and Constitution Ave. N.W., Washington, DC 20230.)

2.3 Non-Government publications.

The following documents form a part of this document to the extent specified herein. Unless otherwise specified, the issues of the documents which have been adopted by DoD are those listed in the issues of the DODISS cited in the solicitation. Unless otherwise specified, the issues of the documents not listed in the DODISS are the issues of the documents cited in the solicitation (see paragraph 6.3).

## INTERNATIONAL STANDARDIZATION DOCUMENTS

### North Atlantic Treaty Organization (NATO) Standardization Agreements (STANAGs)

STANAG 4203	Technical Standards for Single Channel HF Radio Equipment
STANAG 5035	Introduction of an Improved System for Maritime Air Communications on HF, LF, and UHF

(Applications for copies should be addressed to: Standardization Document Order Desk, 700 Robbins Ave. Building 4D, Philadelphia, PA 19111-5094.)

### Quadripartite Standardization Agreements (QSTAGs)

QSTAG 733	Technical Standards for Single Channel High Frequency Radio Equipment
-----------	---

(Application for copies should be addressed to: Standardization Document Order Desk, 700 Robbins Ave. Building 4D, Philadelphia, PA 19111-5094.)

### International Telecommunications Union (ITU), Radio Regulations

CCIR Recommendations 455-2	Improved Transmission System for HF Radiotelephone Circuits
----------------------------	---

(Application for copies should be addressed to the General Secretariat, International Telecommunications Union, Place des Nations, CH-1211 Geneva 20, Switzerland.)

(Non-Government standards and other publications are normally available from the organizations that prepare or distribute the documents. These documents also may be available in or through libraries or other informational services.)

## 2.4 Order of precedence.

In the event of a conflict between the text of this document and the references cited herein, the text of this document takes precedence. Nothing in this document, however, supersedes applicable laws and regulations unless a specific exemption has been obtained.

## 3. DEFINITIONS.

### 3.1 Terms.

Definitions of terms used in this document should be as specified in the current edition of FED-STD-1037, except where inconsistent with the use in this standard. In addition, the following definitions are applicable for the purpose of this standard.



High-performance HF data modem. High-speed (capable of at least 1200 bits per second) or robust data modes which incorporate sophisticated techniques for correcting or reducing the number of raw (over-the-air induced) errors.

Phase noise (dBc/Hertz (Hz)). The amount of single-sided phase noise, contained in a 1-Hz bandwidth, produced by a carrier (signal generation) source, and referenced in decibels below the full (unsuppressed) carrier output power.

Second generation automatic link establishment (2G ALE). ALE as first technically described in Appendix A of this document.

Third generation automatic link establishment (3G ALE). ALE as first technically described in Appendix C of this document.

### 3.2 Abbreviations and acronyms.

The abbreviations and acronyms used in this document are defined below. Those listed in the current edition of FED-STD-1037 have been included for the convenience of the reader.

2G ALE	second generation automatic link establishment
3G ALE	third generation automatic link establishment
ABCA	American, British, Canadian, Australian
AGC	automatic gain control
AJ	Anti-Jam
ALC	automatic level control
ALE	automatic link establishment
ANSI	American National Standards Institute
ARQ	automatic repeat request
b/s	bits per second
Bd	baud
C3I	Command, Control, Communications, and Intelligence
CCIR	International Radio Consultative Committee
dB	decibels
dBc	decibels referenced to full-rated peak envelope power
DII	Defense Information Infrastructure
DISA	Defense Information Systems Agency
DISAC	Defense Information Systems Agency Circular
DO	design objective
DoD	Department of Defense
DODISS	Department of Defense Index of Specifications and Standards
EMC	electromagnetic compatibility
FDM	frequency division multiplex
FEC	forward error correction
FSK	frequency-shift keying
HF	high frequency
HFNC	HF Network Controller

Hz	Hertz
ICW	interrupted continuous wave
IF	intermediate frequency
IMD	intermodulation distortion
ISB	independent sideband
ITU-T	International Telecommunications Union - Telecommunication Standardization Sector
kHz	kiloHertz
LP	link protection
LQA	link quality analysis
LSB	lower sideband
MF	medium frequency
MHz	megahertz
ms	millisecond
NATO	North Atlantic Treaty Organization
NBFM	narrowband frequency modulation
NSA	National Security Agency
NT	not tested
NTIA	National Telecommunications and Information Administration
PEP	peak envelope power
PI	protection interval
PQM	path quality matrix
PTT	push-to-talk
QSTAG	Quadripartite Standard Agreement
RF	radio frequency
RT	routing table
SINAD	signal-plus-noise-plus-distortion to noise-plus-distortion ratio
SSB	single-sideband
STANAG	Standard Agreement
TAC	Technical Advisory Committee
TOD	time of day
uncl	unclassified
USB	upper sideband
VSWR	voltage standing wave ratio

#### 4. GENERAL REQUIREMENTS.

##### 4.1 General.

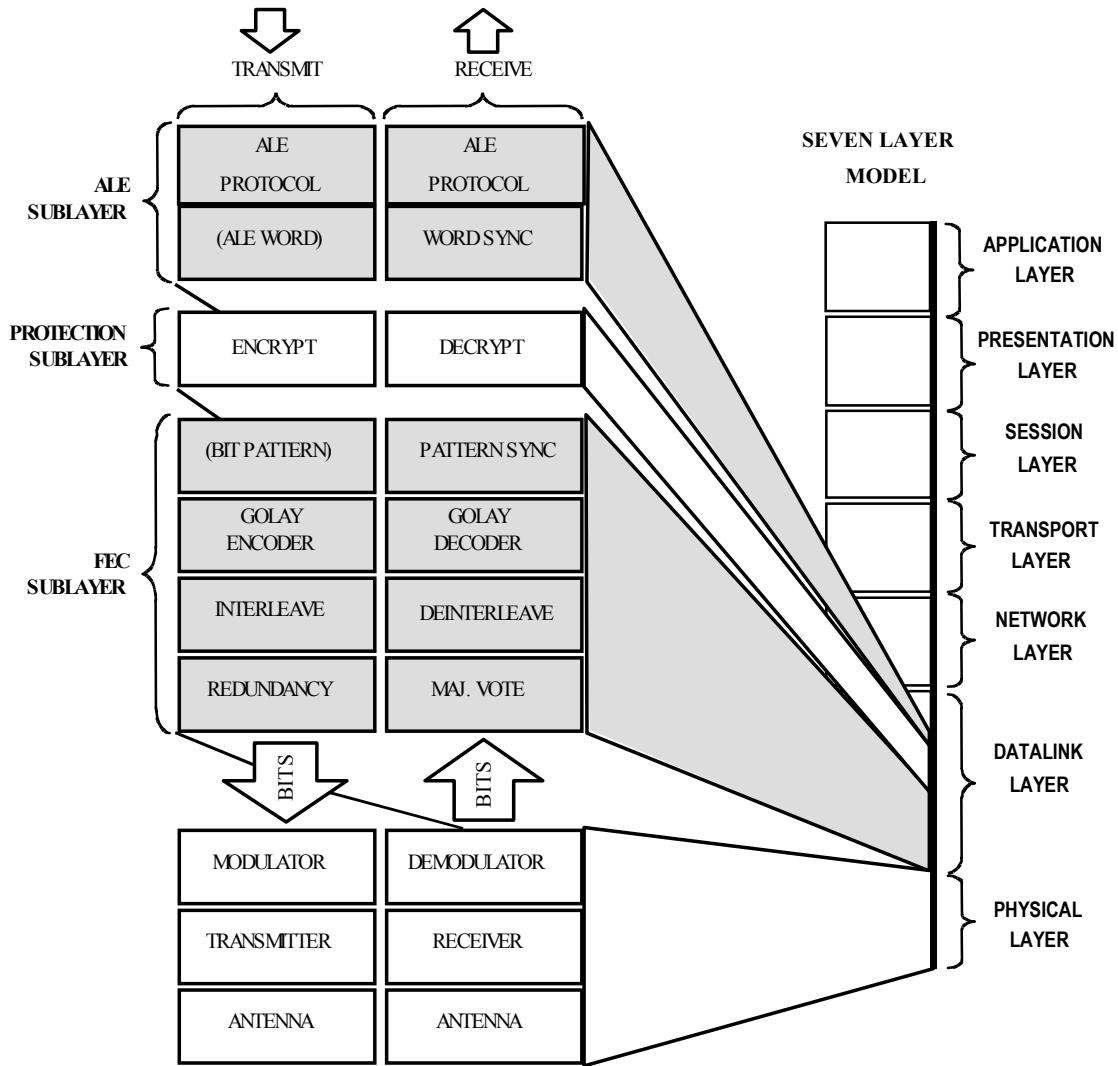
By convention, frequency band allocation for the MF band is from 0.3 megahertz (MHz) to 3 MHz and the HF band is from 3 MHz to 30 MHz. However, for military purposes, equipment designed for HF band use has been historically designed with frequency coverage extending into the MF band. For new HF equipment, HF band standard parameters shall apply to any portion of the MF band included as extended coverage. Currently there are no known military requirements below 1.5 MHz. Consequently, this portion of the MF band is not standardized.

#### 4.1.1 Equipment parameters.

Equipment parameters will be categorized using functional use groups for radio assemblages/sets. Historically, these groups have been fixed (long-haul) installations and tactical systems. The tactical sets are subgrouped further into vehicle transportable and manpack versions. Although these distinctions still exist in principle, the former lines of distinction have become somewhat blurred. The mobility of current military forces dictates that a significant number of long-haul requirements will be met with transportable systems, and in some cases, such systems are implemented with design components shared with manpack radios. When such “tactical” equipment is used to meet a long-haul requirement, the equipment shall meet long-haul minimum performance standards.

#### 4.1.2 Basic HF radio parameters.

Basic HF radio parameters are contained in this section and in section 5. HF technology going beyond the basic radio is contained in the appendices. Figure 1 shows the relationship of the functional aspects of current HF technology in terms of the Seven Layer Reference Model. The shaded area in figure 1 indicates coverage in this section and section 5.



**FIGURE 1. Physical layer with transceiver and modem elements.**

4.2 Equipment operation mode.

4.2.1 Baseline mode.

Frequency control of all new HF equipment, except manpack, shall be capable of being stabilized by an external standard. Should multiple-frequency (channel) storage be incorporated, it shall be of the programmable-memory type and be capable of storing/initializing the operational mode (see paragraphs 4.2.1.1 and 4.2.1.2 below, and paragraph A.4.3.1 of Appendix A) associated with each particular channel.

4.2.1.1 Single-channel.

All new single-channel HF equipment shall provide, as a minimum, the capability for the following one-at-a-time selectable operational modes:

- a. One nominal 3-kiloHertz (kHz) channel upper sideband (USB) or lower sideband (LSB) (selectable).
- b. One (rate-dependent bandwidth) interrupted continuous wave (ICW) channel.\*
- c. A narrowband frequency modulation (NBFM) channel capability should be included as a DO.

\*Not mandatory for radios designed for ALE.

#### 4.2.1.2 Multichannel.

All new multichannel HF equipment shall provide a single channel capability as set forth in paragraph 4.2.1.1, as a minimum, and one or more of the following modes, selectable one at a time:

- a. Two nominal 3-kHz channels in the USB and LSB (two independent channels in the same sideband--sideband selectable).
- b. One nominal 6-kHz channel in the USB or LSB (selectable).
- c. Two nominal 3-kHz channels in the USB and two in the LSB (four independent 3-kHz channels – two in each sideband).
- d. One nominal 6-kHz channel in the USB and one in the LSB (two independent 6-kHz channels--one in each sideband).
- e. One nominal 3-kHz channel in the USB and one in the LSB (two independent 3-kHz channels--one in each sideband).

#### 4.2.2 Push-to-talk operation.

Push-to-talk (PTT) operation is the most common form of interaction with MF/HF single sideband (SSB) radios, especially for tactical use by minimally trained, “noncommunicator” operators. Manual control with PTT shall be conventional; that is, the operator pushes the PTT button to talk and releases it to listen.

#### 4.2.3 ALE mode.

Should an ALE capability be included, it shall be of the channel-scanning type and shall provide for contact initiation by either or both manual and automated control. Detailed requirements are in Appendix A. See 4.5 for the list of features required to support this operational mode.

#### 4.2.4 Anti-jam (AJ) mode.

If AJ is to be implemented, the AJ capabilities and features for HF radios shall be in accordance with MIL-STD-188-148 and Appendix F, Anti-jam and Anti-interference Techniques.

#### 4.2.5 Linking protection (LP).

If LP is to be implemented, the LP capabilities and features for HF radios shall be in accordance with Appendix B.

### 4.3 Interface parameters.

#### 4.3.1 Electrical characteristics of digital interfaces.

As a minimum, any incorporated interfaces for serial binary data shall be in accordance with the provisions of MIL-STD-188-114, and any other interfaces specified by the contracting agencies. Such interfaces shall include provisions for request-to-send and clear-to-send signaling. The capability to accept additional standard interfaces is not precluded.

#### 4.3.2 Electrical characteristics of analog interfaces.

See 5.3.6 and 5.4.5.

#### 4.3.3 Modulation and data signaling rates.

The modulation rate (expressed in baud (Bd)) or the data signaling rate (expressed in bits per second (b/s)) at interface points A and A' in figure 2 shall include those contained in MIL-STD-188-110.

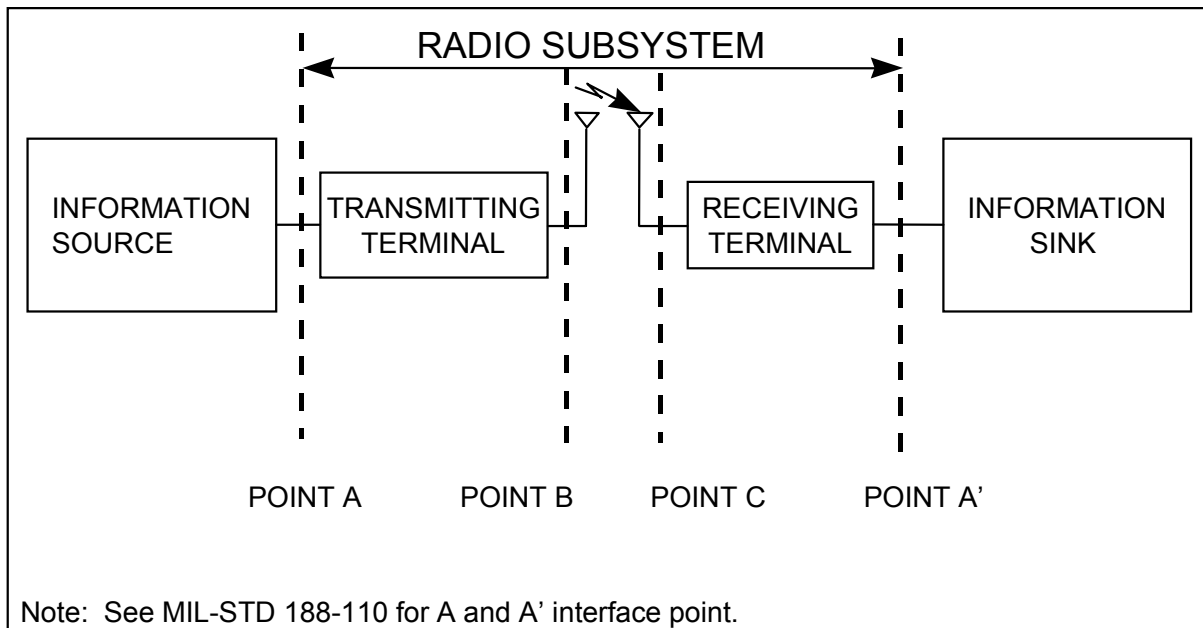
### 4.4 NATO and Quadripartite interoperability requirements.

#### 4.4.1 Single-channel communications systems.

If interoperation with NATO member nations is required for land, air, and maritime applications, single-channel HF radio equipment shall comply with the applicable requirements of the current edition of STANAG 4203.

#### 4.4.2 Maritime air communications systems.

If interoperation with NATO member nations is required, HF maritime air communications shall comply with the applicable requirements of the current edition of STANAG 5035.



**FIGURE 2. Radio subsystems interface points.**

#### 4.4.3 High-performance HF data modems.

If interoperation with NATO member nations is required, land, air, and maritime, single-channel HF radio equipment shall comply with the applicable requirements of the appropriate STANAG.

#### 4.4.4 QSTAGs.

If interoperation among American, British, Canadian, Australian (ABCA), and New Zealand Armies is required, HF combat net radio equipment shall comply with the applicable requirements of the current edition of QSTAG 733.

#### 4.5 Adaptive communications.

Adaptive HF describes any HF communications system that has the ability to sense its communications environment, and, if required, to automatically adjust operations to improve communications performance. Should the user elect to incorporate adaptive features, they shall be in accordance with the requirements for those features stated in this document.

The essential adaptive features are:

- a. Channel (frequency) scanning capability.
- b. ALE using an embedded selective calling capability. A disabling capability and a capability to inhibit responses shall be included.
- c. Automatic sounding (station-identifiable transmissions). A capability to disable sounding and a capability to inhibit responses shall be included.
- d. Limited link quality analysis (LQA) for assisting the ALE function:
  - (1) Relative data error assessment.
  - (2) Relative signal-plus-noise-plus-distortion to noise-plus-distortion ratio (SINAD).
  - (3) Multipath/distortion assessment (DO) (optional).
- e. Automatic link maintenance
- f. Channel occupancy

#### 4.6 Linking protection.

LP refers to the protection of the linking function required to establish, control, maintain, and terminate the radio link. Because this protection is applied to the link establishment function, LP is a data link layer function in terms of the Seven Layer Reference Model. Figure B-1, Appendix B shows a conceptual model of the MIL-STD-188-141 data link layer functions, showing the placement within the data link layer at which linking protection shall be implemented. Voice transmissions or data transmissions from external modems are not affected by the LP. The LP application levels and their corresponding protection interval (PI) are defined in Appendix B, paragraphs B 4.1.1 through B 4.1.1.5.

#### 4.7 HF data link protocol.

See Appendix G, HF Data Link Protocol and MIL-STD-188-110.

#### 4.8 Networking functions.

- a. MIL-STD-188-141 establishes the technology baseline needed for establishing and maintaining links among HF radio stations. Networking technology augments this direct connection capability with the ability to find and use indirect routes.
- b. The functions performed at the network layer may be grouped into two broad categories: routing functions and data management functions. Routing functions select paths through the network for voice and data traffic, using stored information (provided by operators, local data link controllers, and remote networking controllers) about the quality of available links to other stations. Data management functions acquire and communicate that (and other) information.
- c. Link-level error statistics directly characterize the quality of single-link paths and are used to compute end-to-end path quality for multiple-link paths through relays. These results are stored in a path quality matrix (PQM), which is organized to provide the path quality to any reachable destination via each directly-reachable relay station. From this path quality data, a routing table (RT) is formed. This table lists the best path to each reachable station for various types of communication (e.g., voice and data).

##### 4.8.1 Indirect calling and relaying.

When a station cannot directly link with a desired destination, other stations may be employed to assist in getting the message through. The simplest option is to have the local link controller or the HF Network Controller (HFNC) establish a link with a station other than the desired destination so that the station operators can manually communicate (using either voice or data orderwire) after the fashion of a torn-tape relay. When the equipment at the intermediate station is able to automatically establish an indirect path to the destination, this is termed relaying. A variety of relaying techniques are possible, some of which are shown in figure 3. These techniques are differentiated where the cross-connection occurs in the protocol stack. Each alternative is briefly discussed in table I.

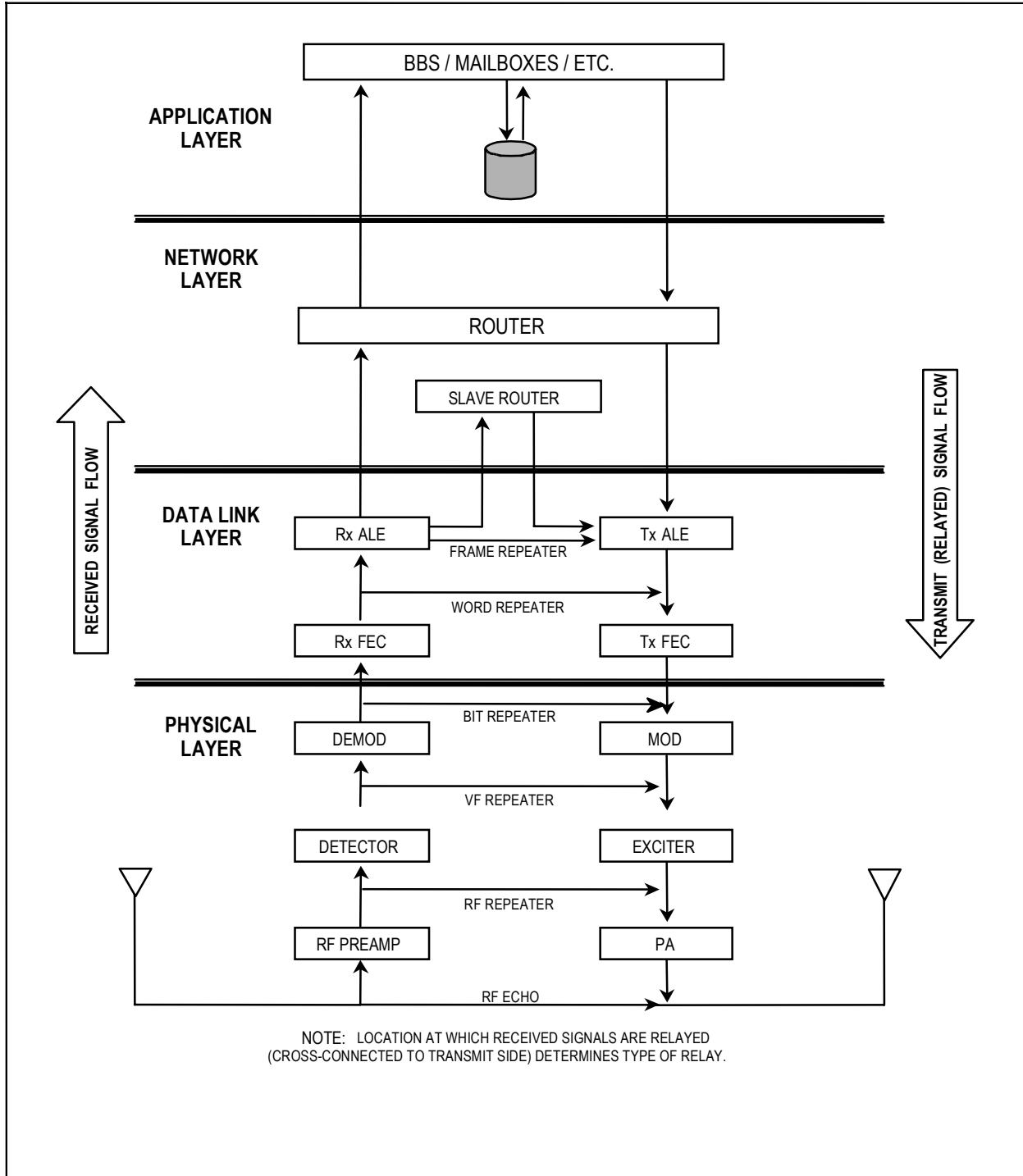
##### 4.8.2 Network management.

See Appendix D, HF Radio Networking, and Appendix H, Management Information Base

#### 4.9 Application protocols for HF radio networks.

See Appendix E, Application Protocols for HF Radio Networks.





**FIGURE 3. Relaying alternatives.**

**TABLE I. Relaying alternative notes.**

Type	Description
Radio Frequency (RF) echo	No radios required. Examples: float a large aluminized balloon or use a billboard reflector.
RF repeater	Formed by connecting an RF amplifier between two antennas. Uses different radio frequencies by heterodyning or translating the received frequencies.
VF repeater	Formed by connecting two radios back-to-back through the audio ports. This and all following relays can easily use different radio frequencies.
Bit repeater	Formed by connecting data ports of modems. Regenerates audio and bit timing.
Word repeater	Occurs just above forward error correction (FEC) sublayer (and below LP). Corrects errors in data words but does not examine those words or otherwise manipulate their contents. Introduces one word time delay.
Frame repeater	Occurs within data link protocol sublayer. Like word repeater, but buffers an entire frame before retransmitting it; introduces delay of frame time plus time to detect the end of the frame. This and all following relays require only one radio, but can use more if available
Slave router	Occurs just above data link layer. Effectively connects data links in tandem as directed by indirect addresses in data link frames. Makes no routing decisions; merely implements the routing scheme specified in frames that it receives (hence the name).
Router	Network layer function. Determines where to send each received frame using local routing information; this routing information may be entirely static or it may include real-time data (in an adaptive router). Uses network layer message header; normally has access only to message section of data link layer (e.g., ALE) frame. May buffer data when no path currently exists to destination.
Mailbox	Application layer function. Stores messages for later retrieval by specified recipient.
BBS	Application layer function. Stores messages for later retrieval by anyone with access to that bulletin board system.

## 5. DETAILED REQUIREMENTS.

### 5.1 General.

#### 5.1.1 Introduction.

This section provides detailed performance standards for MF and HF radio equipment. These performance standards shall apply over the appropriate frequency range from 2.0 MHz to 29.9999 MHz (DO: 1.5 MHz to 29.9999 MHz).

#### 5.1.2 Signal and noise relationships.

The signal and noise relationships are expressed as SINAD, unless otherwise identified. Unless otherwise specified, when the ratio is stated, the noise bandwidth is 3 kHz.

## 5.2 Common equipment characteristics.

These characteristics shall apply to each transmitter and to each receiver unless otherwise specified.

### 5.2.1 Displayed frequency.

The displayed frequency shall be that of the carrier, whether suppressed or not.

### 5.2.2 Frequency coverage.

The radio equipment shall be capable of operating over the frequency range of 2.0 MHz to 29.9999 MHz in a maximum of 100-Hz frequency increments (DO: 10-Hz) for single-channel equipment, and 10-Hz frequency increments (DO: 1-Hz) for multichannel equipment.

### 5.2.3 Frequency accuracy.

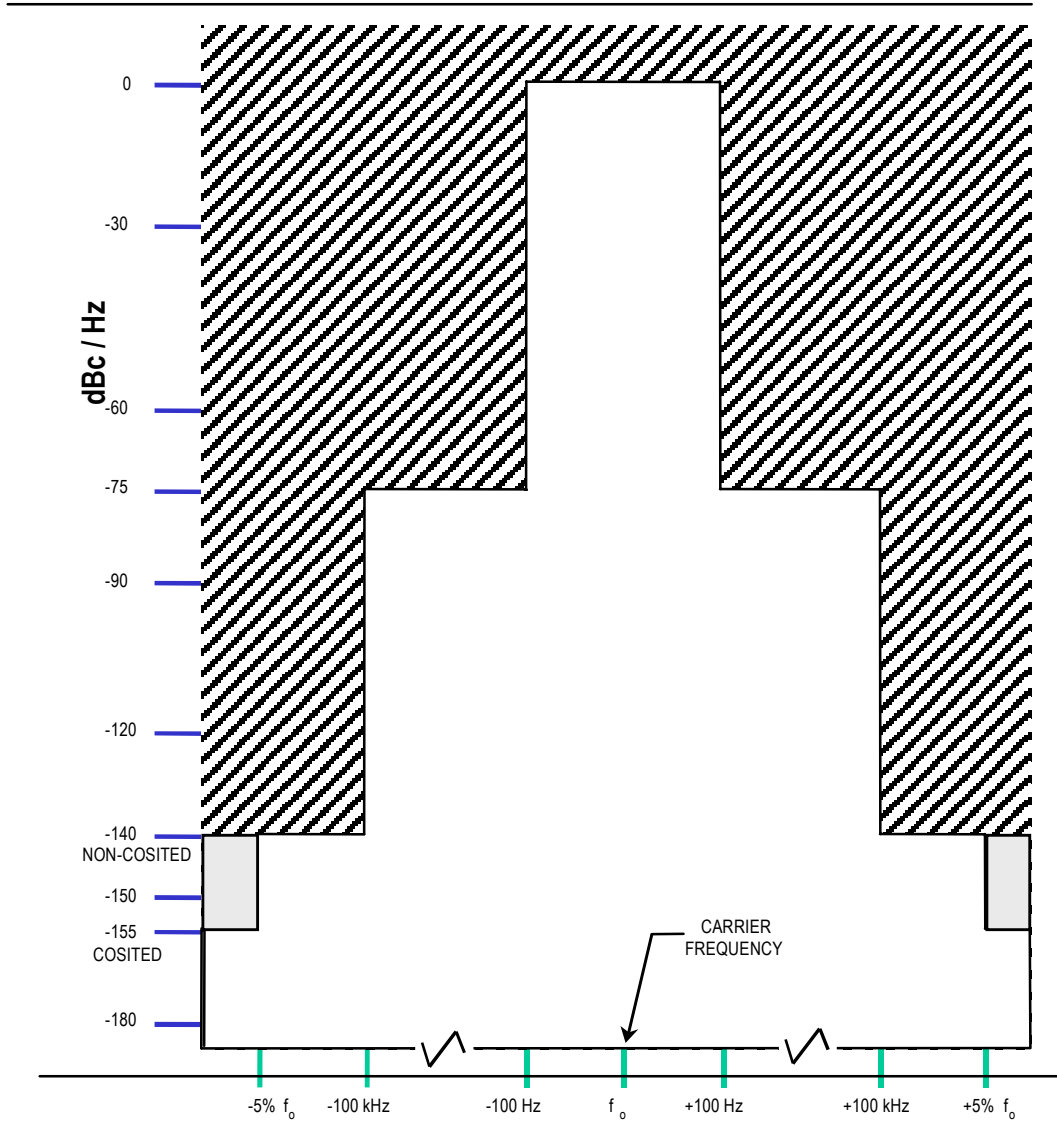
The accuracy of the radio carrier frequency, including tolerance and long-term stability, but not any variation due to doppler shift, shall be within  $\pm 30$  Hz for tactical application and within  $\pm 10$  Hz for all others, during a period of not less than 30 days. If tactical system include long haul interoperability mission, tactical equipment must meet  $\pm 10^\circ$  Hz radio carrier frequency specification.

### 5.2.4 Phase stability.

The phase stability shall be such that the probability that the phase difference will exceed 5 degrees over any two successive 10 millisecond (ms) periods (13.33-ms periods may also be used) shall be less than 1 percent. Measurements shall be performed over a sufficient number of adjacent periods to establish the specified probability with a confidence of at least 95 percent.

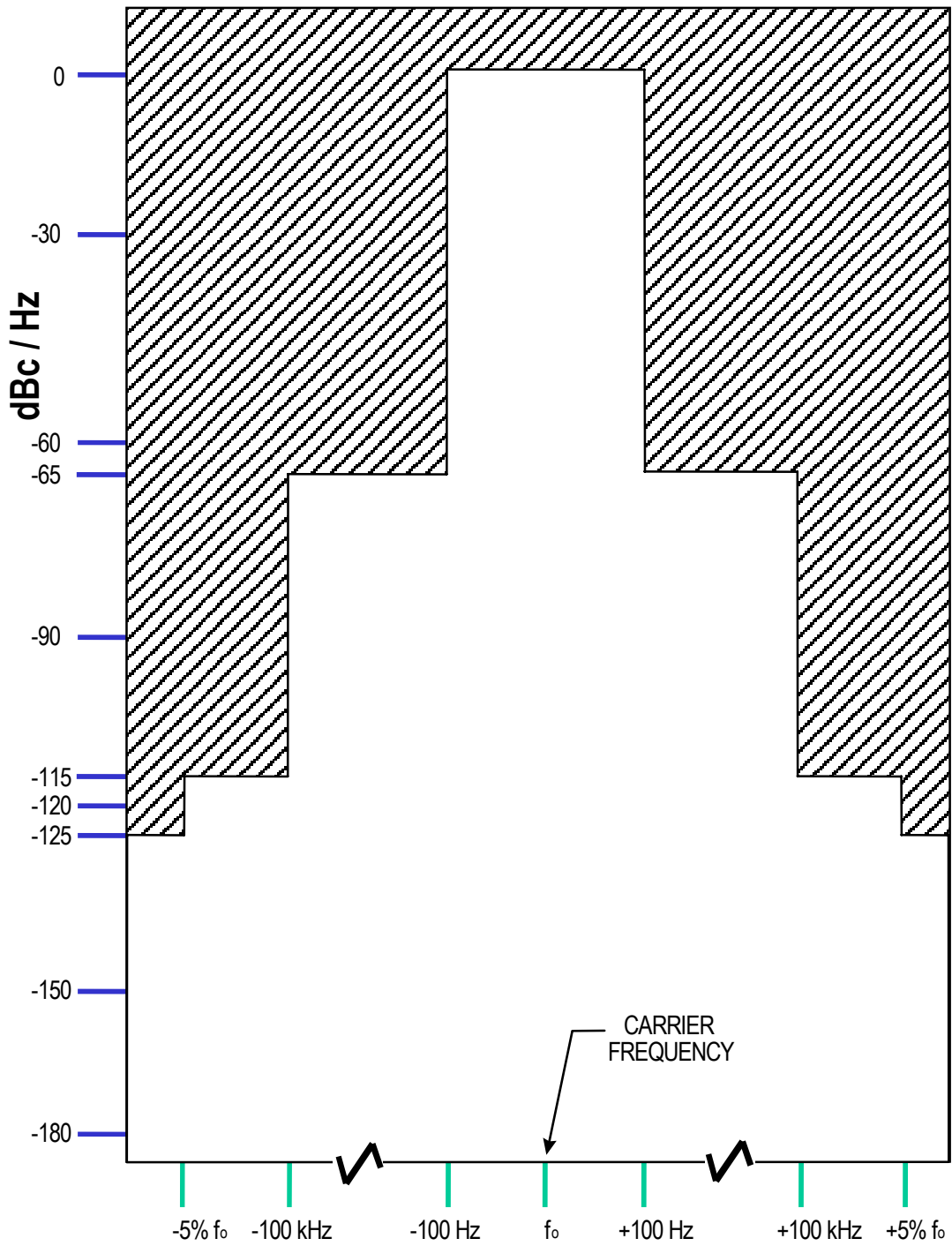
### 5.2.5 Phase noise.

The synthesizer and mixer phase-noise spectrum at the transmitter output shall not exceed those limits as depicted in figures 4 and 5 under continuous carrier single-tone output conditions. Figure 4 depicts the limits of phase noise for cosited and non-cosited fixed-site and transportable long-haul radio transmitters. Figure 5 depicts the limits for tactical radio transmitters. If tactical system include long haul interoperability mission, tactical equipment must meet  $\pm 10^\circ$  Hz radio carrier frequency specification.



NOTE: dBc = DECIBELS REFERENCED TO FULL RATED PEP.

**FIGURE 4. Phase noise limit mask for fixed site and transportable long-haul radio transmitters.**



NOTE: dBc = DECIBELS REFERENCED TO FULL RATED PEP.

**FIGURE 5. Phase noise limit mask for tactical radio transmitters.**

### 5.2.6 Bandwidths.

The bandwidths for high frequency band emissions shall be as shown in table II. Use of other HF band emissions is optional, however, if selected, shall be as shown in table II. Other high frequency band emissions, which may be required to satisfy specific user requirements, can be found in the NTIA Manual of Regulations and Procedures for Federal Radio Frequency Management.

**TABLE II. Bandwidths.**

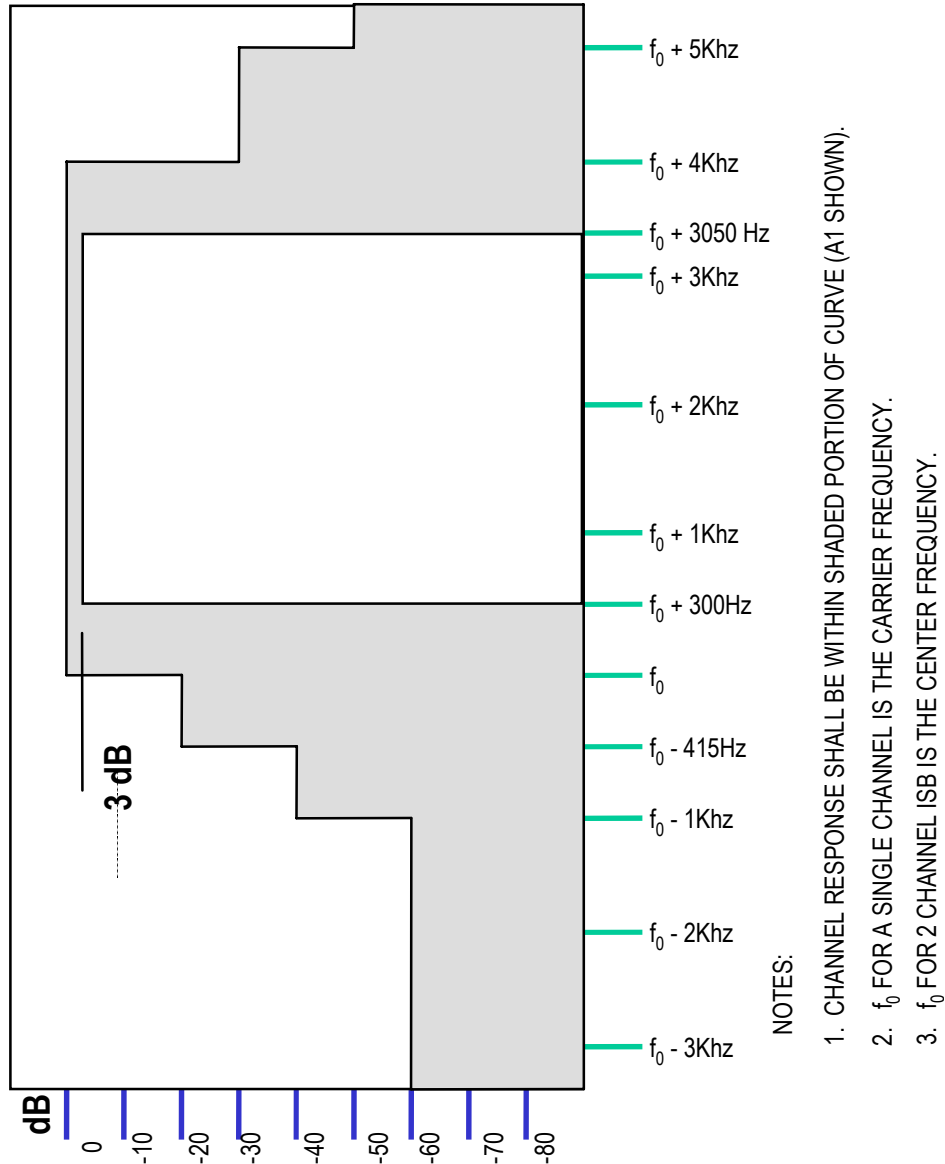
<b>Emission type</b>	<b>Maximum Allowable 3 decibels (dB) Bandwidth (kHz)</b>	<b>Mandatory Req.</b>
ICW	0.5	Yes*
Frequency-shift keying (FSK) (85-Hz shift)	0.3	No
FSK (850-Hz shift)	1.1	No
SSB modulation single-channel	see 5.2.7.1	Yes
Independent-sideband (ISM) modulation		
two channels	see 5.2.7.1	No
four channels	see 5.2.7.2	No
* Not mandatory for radios designed for ALE.		

### 5.2.7 Overall channel responses.

#### 5.2.7.1 Single-channel or dual-channel operation.

The amplitude vs. frequency response between ( $f_0 + 300$  Hz) and ( $f_0 + 3050$  Hz) shall be within 3 dB (total) where  $f_0$  is the carrier frequency. The attenuation shall be at least 20 dB from  $f_0$  to ( $f_0 - 415$  Hz), at least 40 dB from ( $f_0 - 415$  Hz) to ( $f_0 - 1000$  Hz), and at least 60 dB below ( $f_0 - 1000$  Hz). Attenuation shall be at least 30 dB from ( $f_0 + 4000$  Hz) to ( $f_0 + 5000$  Hz) and at least 60 dB above ( $f_0 + 5000$  Hz). See figure 6. Group delay time shall not vary by more than 1.0 ms over 80 percent of the passband of 300 Hz to 3050 Hz (575-2775 Hz). Measurements shall be performed end-to-end (transmitter audio input to receiver audio output) with the radio equipment configured in a back-to-back test setup.

NOTE: Although the response values given are for single-channel USB operation, an identical shape, but inverted channel response, is required for LSB or the inverted channel of a dual-channel independent sideband operation.



**FIGURE 6. Overall channel response for single-channel or dual-channel equipment.**

#### 5.2.7.2 Four-channel operation.

When four-channel independent sideband operation is employed, the four individual 3-kHz channels shall be configured as shown in figure 7, which also shows the amplitude response for these four channels. Channels A2 and B2 shall be inverted and displaced with respect to channels A1 and B1 as shown on the figure. This can be accomplished by using subcarrier frequencies of 6290 Hz above and below the center carrier frequency, or by other suitable techniques that produce the required channel displacements and inversions.

The suppression of any subcarriers used shall be at least 40 dB (DO: 50 dB) below the level of a single tone in the A2 or B2 channel modulating the transmitter to 25 percent of peak envelope power (PEP). See figure 7. The rf amplitude versus frequency response for each ISB channel shall be within 2 dB (DO: 1 dB) between 250 Hz and 3100 Hz, referenced to each channel's carrier (either actual or virtual). Referenced from each channel's carrier, the channel attenuation

shall be at least 40 dB at 50 Hz and 3250 Hz, and at least 60 dB at -250 Hz and 3550 Hz. Group delay distortion shall not exceed 1500 microseconds over the ranges 370 Hz to 750 Hz and 3000 Hz to 3100 Hz. The distortion shall not exceed 1000 microseconds over the range 750 Hz to 3000 Hz. Group delay distortion shall not exceed 150 microseconds for any 100-Hz frequency increment between 570 Hz and 3000 Hz. Measurements shall be performed end-to-end (transmitter audio input to receiver audio output) with the radio equipment configured in a back-to-back test setup.

#### 5.2.8 Absolute delay.

The absolute delay shall not exceed 10 ms (DO: 5 ms) over the frequency range of 300 Hz to 3050 Hz. Measurements shall be performed back-to-back as in paragraph 5.2.7.1.

### 5.3 Transmitter characteristics.

#### 5.3.1 Noise and distortion.

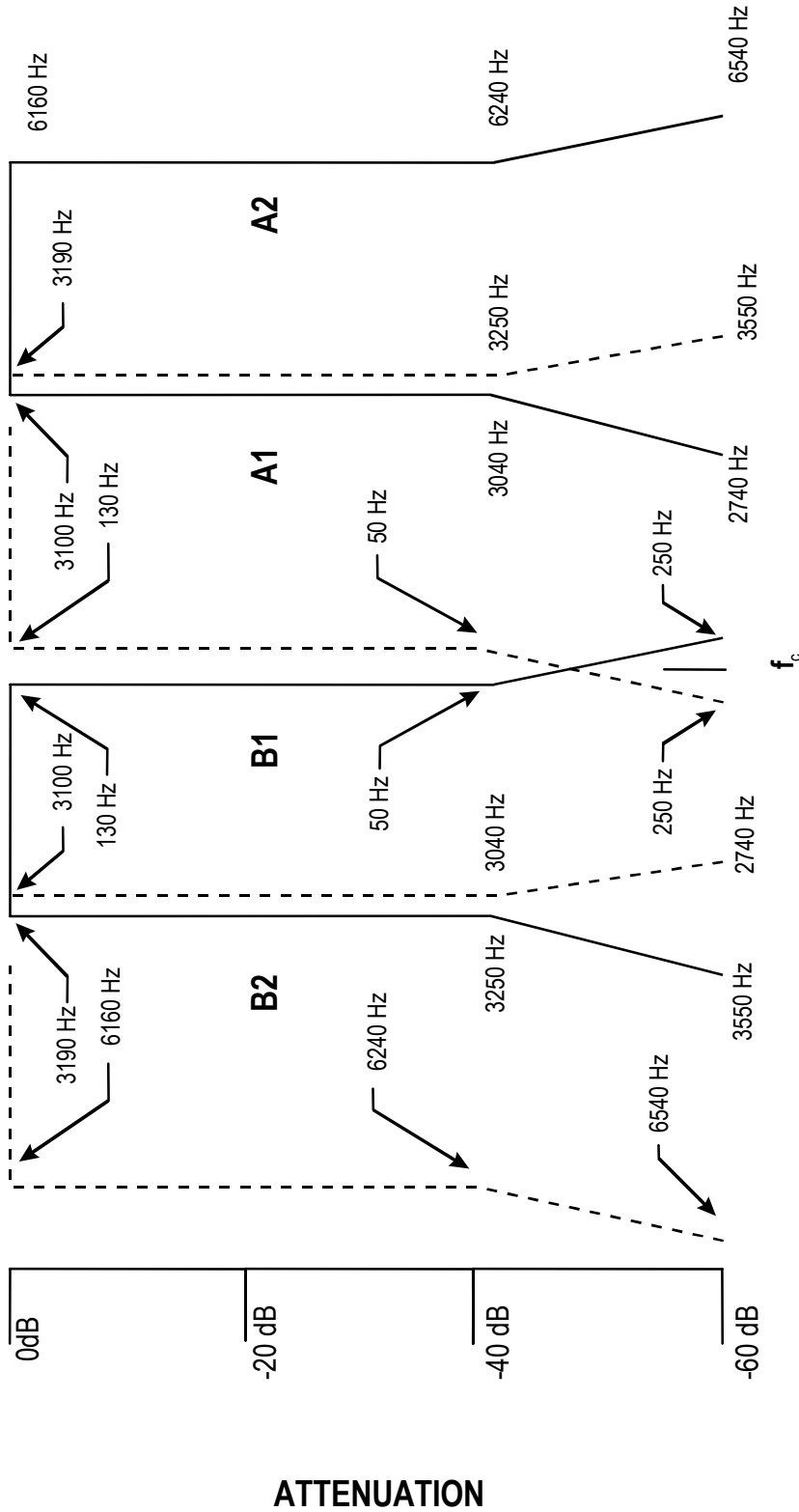
##### 5.3.1.1 In-band noise.

Broadband noise in a 1-Hz bandwidth within the selected sideband shall be at least 75 decibels referenced to full-rated peak envelope power (dBc) below the level of the rated PEP of the HF transmitter for fixed station application and 65 dBc below the level of the rated PEP of the HF transmitter for tactical application.

##### 5.3.1.2 Intermodulation distortion (IMD).

The IMD products of HF transmitters produced by any two equal-level signals within the 3 dB bandwidth (a single-frequency audio output) shall be at least 30 dB below either tone for fixed station application and 24 dB below either tone for tactical application when the transmitter is operating at rated PEP. The frequencies of the two audio test signals shall not be harmonically or subharmonically related and shall have a minimum separation of 300 Hz.





- NOTES:**
1. THE VIRTUAL SUBCARRIER FOR THE A2 AND B2 INVERTED CHANNELS SHALL BE  $f_c + 6290$  HZ.
  2. FREQUENCIES SHOWN ARE AT THE FILTER dB (BREAK POINT) LEVELS NOTED.

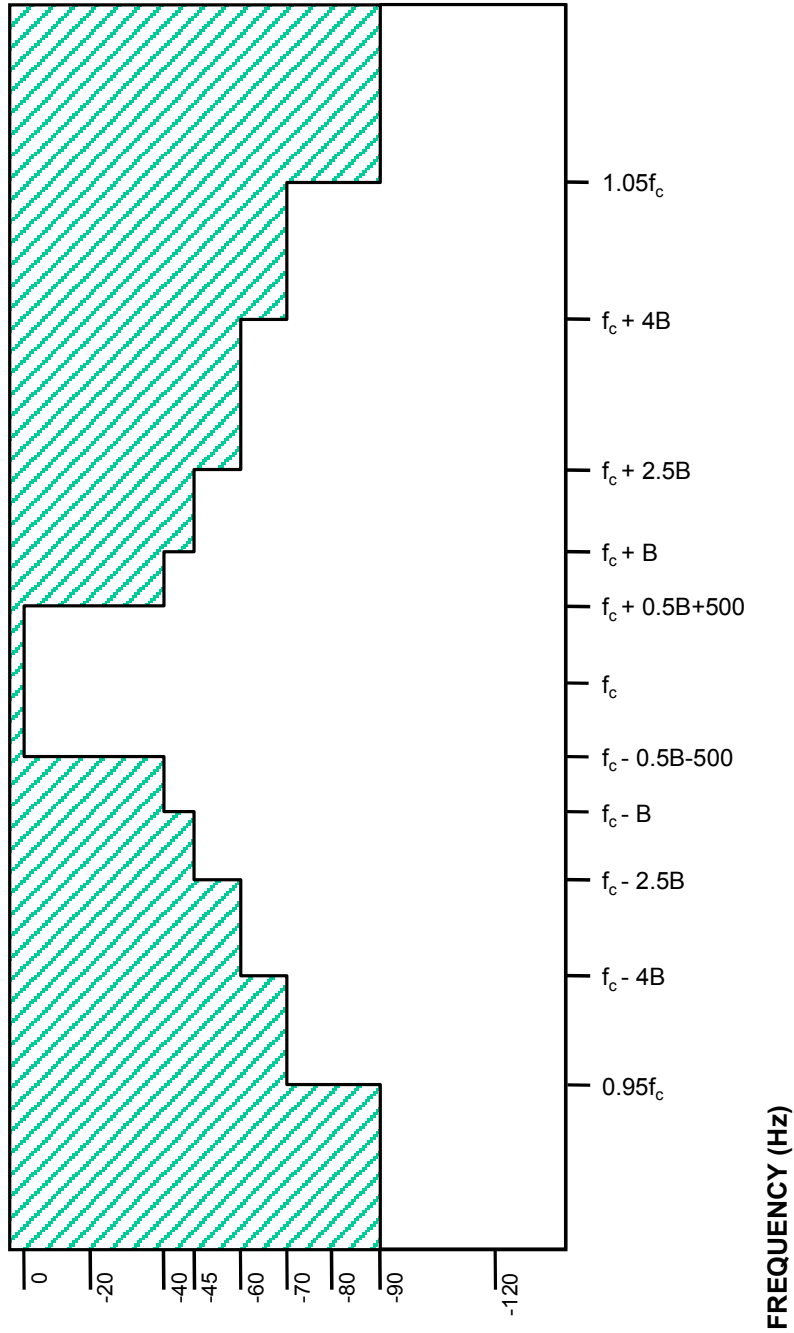
**FIGURE 7. Overall channel characteristics (four-channel equipment).**

5.3.2 Spectral purity.5.3.2.1 Broadband emissions.

When the transmitter is driven with a single tone to the rated PEP, the power spectral density of the transmitter broadband emission shall not exceed the level established in table III and as shown in figure 8. Discrete spurs shall be excluded from the measurement, and the measurement bandwidth shall be 1 Hz.

**TABLE III. Out-of-band power spectral density limits for radio transmitters.**

Frequency (Hz)	Attenuation Below In-Band Power Density (dBc)
$f_m = f_c \pm (0.5 B + 500)$	40 (DO: 43)
$f_m = f_c \pm 1.0 B$	45 (DO: 48)
$f_m = f_c \pm 2.5 B$	60 (DO: 80)
$(f_c + 4.0 B) \leq f_m \leq 1.05 f_c$ $0.95 f_c \leq f_m \leq (f_c - 4.0 B)$	70 (DO: 80)
$f_m \leq 0.95 f_c$ $f_m \geq 1.05 f_c$	90 (DO: 120)
Where: $f_m$ = frequency of measurement (Hz) $f_c$ = center frequency of bandwidth (Hz) B = bandwidth (Hz)	



**FIGURE 8. Out-of-band power spectral density for HF transmitters.**

5.3.2.2 Discrete frequency spurious emissions.

For HF transmitters, when driven with a single tone to produce an rf output of 25 percent rated PEP, all discrete frequency spurious emissions shall be suppressed as follows:

- a. For fixed application

- Between the carrier frequency  $f_c$  and  $f_c \pm 4B$  (where  $B$  = bandwidth), at least 40 dBc.
- Between  $f_c \pm 4B$  and  $\pm 5$  percent of  $f_c$  removed from the carrier frequency, at least 60 dBc.
- Beyond  $\pm 5$  percent removed from the carrier frequency, at least 80 dBc.
- Harmonic performance levels shall not exceed -63 dBc.

See figure 10a.

b. For tactical application

- Between the carrier frequency  $f_c$  and  $f_c \pm 4B$  (where  $B$  = bandwidth), at least 40 dBc.
- Beyond  $f_c \pm 4B$  at least 50 dBc.
- Harmonic performance levels shall not exceed -40 dBc.

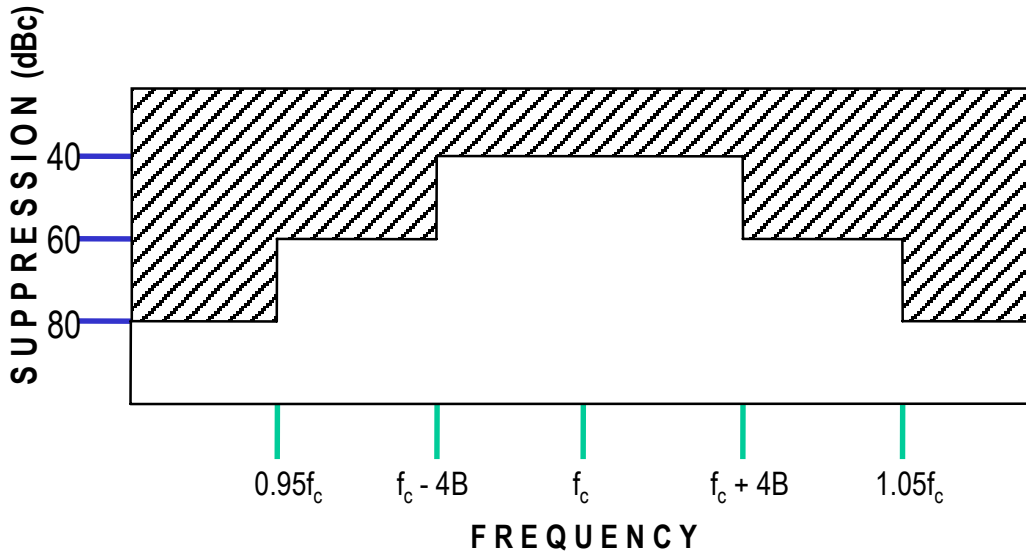
See figure 9.

5.3.3 Carrier suppression.

The suppressed carrier for tactical applications shall be at least 40 dBc (DO: 60 dBc) below the output level of a single tone modulating the transmitter to rated PEP. The suppressed carrier for fixed site applications shall be at least 50 dBc (DO: 60 dBc) below the output level of a single tone modulating the transmitter to rated PEP.

5.3.4 Automatic level control (ALC).

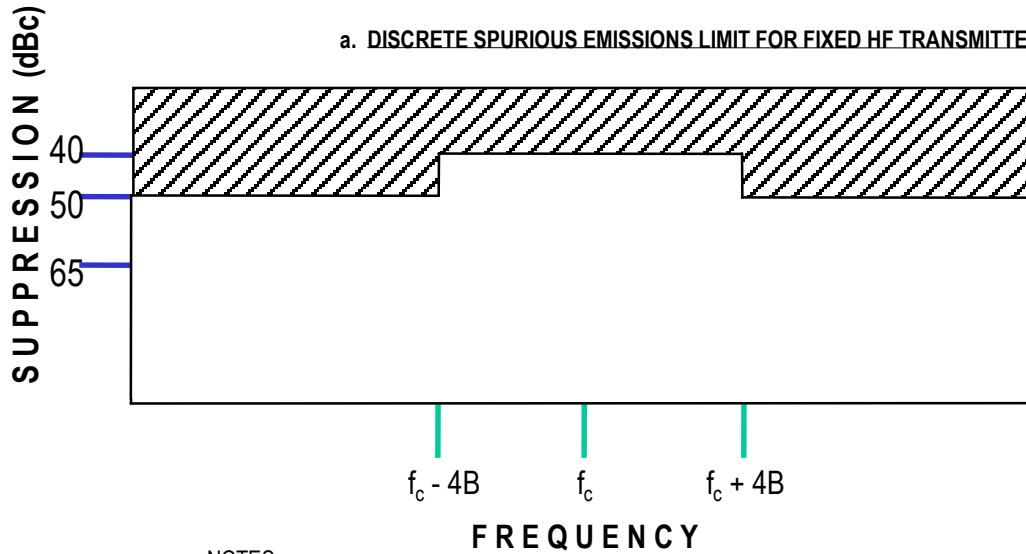
Starting at ALC threshold, an increase of 20 dB in audio input shall result in less than a 1 dB increase in average rf power output.



NOTES:

1. EMISSIONS SHALL FALL WITHIN THE UNSHADED PORTION OF THE CURVE.
2. HARMONIC PERFORMANCE LEVELS FOR FIXED TRANSMITTERS SHALL NOT EXCEED -63dBc.

**a. DISCRETE SPURIOUS EMISSIONS LIMIT FOR FIXED HF TRANSMITTERS.**



NOTES:

1. EMISSIONS SHALL FALL WITHIN THE UNSHADED PORTION OF THE CURVE.
2. HARMONIC PERFORMANCE LEVELS FOR TACTICAL TRANSMITTERS SHALL NOT EXCEED -40dBc.

**b. DISCRETE SPURIOUS EMISSIONS LIMIT FOR TACTICAL HF TRANSMITTERS.**

**FIGURE 9. Discrete spurious emissions limit for HF transmitters.**

### 5.3.5 Attack and release time delays.

#### 5.3.5.1 Attack-time delay.

The time interval from keying-on a transmitter until the transmitted rf signal amplitude has increased to 90 percent of its steady-state value shall not exceed 25 ms (DO: 10 ms). This delay excludes any necessary time for automatic antenna tuning.

#### 5.3.5.2 Release-time delay.

The time interval from keying-off a transmitter until the transmitted rf signal amplitude has decreased to 10 percent of its key-on steady-state value shall be 10 ms or less.

### 5.3.6 Signal input interface characteristics.

#### 5.3.6.1 Input signal power.

Input signal power for microphone or handset input is not standardized. When a line-level input is provided (see paragraph 5.3.6.2), rated transmitter PEP shall be obtainable for single tone amplitudes from -17 dBm to +6 dBm (manual adjustment permitted).

#### 5.3.6.2 Input audio signal interface.

##### 5.3.6.2.1 Unbalanced interface.

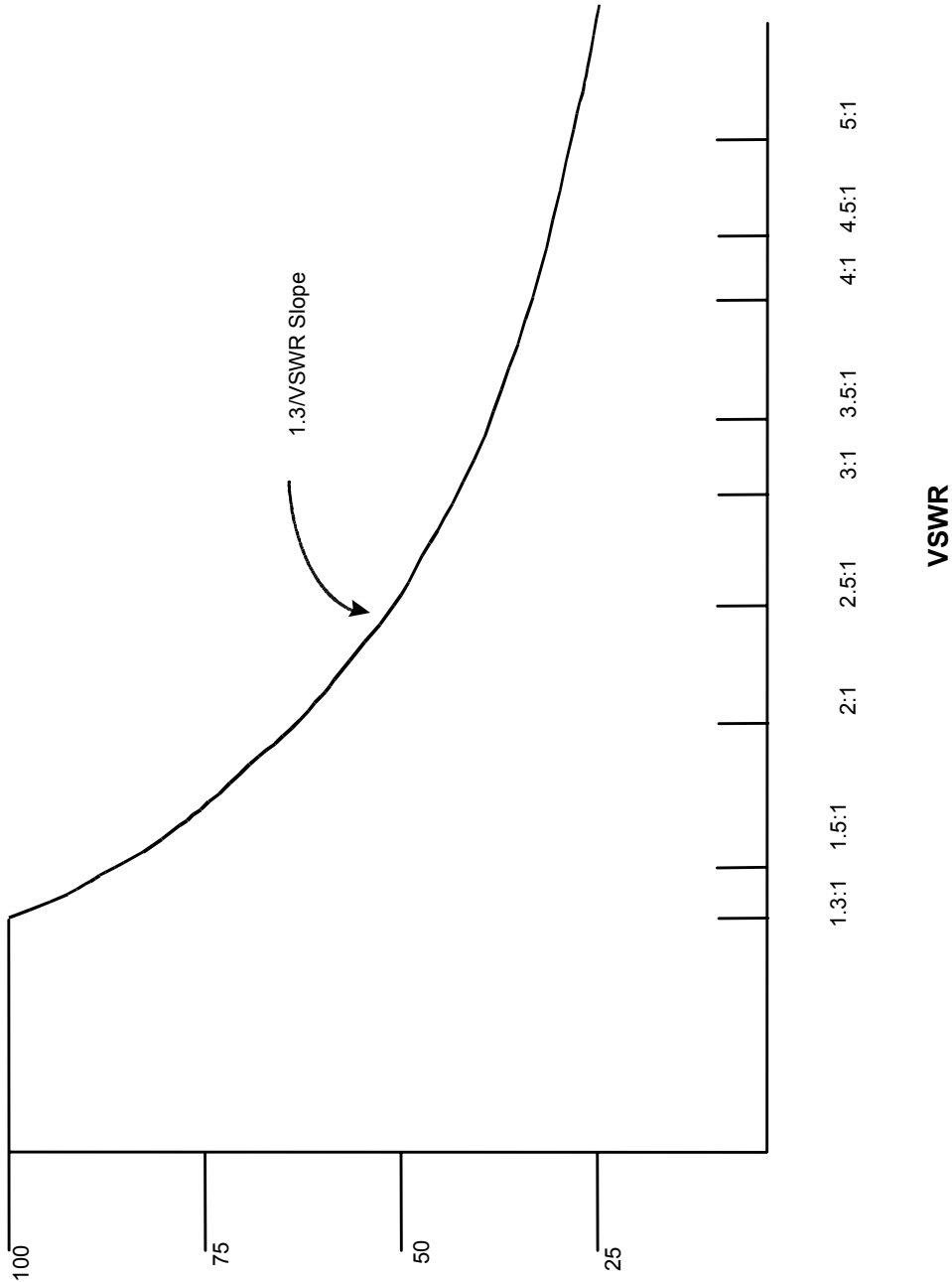
When an unbalanced interface is provided, it shall have an audio input impedance of a nominal 150 ohms, unbalanced with respect to ground, with a minimum return loss of 20 dB against a 150-ohm resistance over the nominal 3 kHz passband.

##### 5.3.6.2.2 Balanced interface.

When a balanced interface is provided, the audio input impedance shall be a nominal 600 ohms, balanced with respect to ground, with a minimum return loss of 26 dB against a 600-ohm resistance over the frequency range of 300 Hz to 3050 Hz. The electrical symmetry shall be sufficient to suppress longitudinal currents at least 40 dB below the reference signal level.

### 5.3.7 Transmitter output load impedance.

The nominal rf output load impedance at interface point B in figure 2 shall be 50 ohms, unbalanced with respect to ground. Transmitters shall survive any voltage standing wave ratio (VSWR) at point B, while derating the output power as a function of increasing VSWR. However, the transmitter shall deliver full rated forward power into a 1.3:1 VSWR load. Figure 11 is a design objective for the derating curve. The VSWR between an exciter and an amplifier shall be less than 1.5:1. The VSWR between an amplifier and an antenna coupler shall be less than 1.5:1 for fixed applications and less than 2.0:1 for tactical application.



**FIGURE 10. Output power vs. VSWR for transmitters with broadband output impedance networks.**

NOTE: The full-rated output power of a transmitter over the operating frequency range is defined to be (a) the rated PEP when the transmitter is driven by a two-tone signal consisting of equal amplitude tones, and (b) the rated average power when driven by a single tone. The output rating shall be determined with the transmitter operating into a 50-ohm load.

## 5.4 Receiver characteristics.

### 5.4.1 Receiver rf characteristics.

All receiver input amplitudes are in terms of available power in dBm from a 50-ohm source impedance signal generator.

#### 5.4.1.1 Image rejection.

The rejection of image signals shall be at least 70 dB for tactical HF receivers and 80 dB for all other HF receivers (DO: 100 dB).

#### 5.4.1.2 Intermediate frequency (IF) rejection.

Spurious signals at the IF (frequencies) shall be rejected by at least 70 dB for tactical HF receivers and 80 dB for all other HF receivers (DO: 100 dB).

#### 5.4.1.3 Adjacent-channel rejection.

The receiver shall reject any signal in the undesired sideband and adjacent channel in accordance with figure 6.

#### 5.4.1.4 Other signal-frequency external spurious responses.

Receiver rejection of spurious frequencies, other than IF and image, shall be at least 65 dB (55 dB for tactical application) for frequencies from +2.5 percent to +30 percent, and from -2.5 percent to -30 percent of the center frequency, and at least 80 dB (70 dB for tactical application) for frequencies beyond  $\pm 30$  percent of the center frequency.

#### 5.4.1.5 Receiver protection.

The receiver, with primary power on or off, shall be capable of survival without damage with applied signals of up to +43 dBm (DO: +53 dBm) available power delivered from a 50-ohm source for a duration of 5 minutes for fixed site applications and 1 minute for tactical applications.

#### 5.4.1.6 Desensitization dynamic range.

The following requirement shall apply to the receiver in an SSB mode of operation with an IF passband setting providing at least 2750 Hz (nominal 3 kHz bandwidth) at the 2 dB points. With the receiver tuning centered on a sinusoidal input test signal and with the test signal level adjusted to produce an output SINAD of 10 dB, a single interfering sinusoidal signal, offset from the test signal by an amount equal to  $\pm 5$  percent of the carrier frequency, is injected into the receiver input. The output SINAD shall not be degraded by more than 1 dB as follows:

- a. For fixed site radios, the interfering signal is equal to or less than 100 dB above the test signal level.
- b. For tactical radios, the interfering signal is equal to or less than 90 dB above the test signal level.



#### 5.4.1.7 Receiver sensitivity.

The sensitivity of the receiver over the operating frequency range, in the sideband mode of operation (3-kHz bandwidth), shall be such that a -111 dBm (DO: -121 dBm) unmodulated signal at the antenna terminal, adjusted for a 1000 Hz audio output, produces an audio output with a SINAD of at least 10 dB over the operating frequency range.

#### 5.4.1.8 Receiver out-of-band IMD.

Second-order and higher-order responses shall require a two-tone signal amplitude with each tone at -30 dBm or greater (-36 dBm or greater for tactical applications), to produce an output SINAD equivalent to a single -110 dBm tone. This requirement is applicable for equal-amplitude input signals with the closest signal spaced 30 kHz or more from the operating frequency.

#### 5.4.1.9 Third-order intercept point.

Using test signals within the first IF passband, the worst-case third-order intercept point shall not be less than +10 dBm (+1 dBm for tactical applications).

### 5.4.2 Receiver distortion and internally generated spurious outputs.

#### 5.4.2.1 Overall IMD (in-channel).

The total of IMD products, with two equal-amplitude, in-channel tones spaced 110 Hz apart, present at the receiver rf input, shall meet the following requirements. However, for frequency division multiplex (FDM) service, the receiver shall meet the requirements for any tone spacing equal to or greater than the minimum between adjacent tones in any FDM library. The requirements shall be met for any rf input amplitude up to 0 dBm PEP (-6 dBm/tone) at rated audio output. All IMD products shall be at least 35 dB (DO: 45 dB) below the output level of either of the two tones.

#### 5.4.2.2 Adjacent-channel IMD.

For multiple-channel equipment, the overall adjacent-channel IMD in each 3 kHz channel being measured shall not be greater than -35 dBm at the 3 kHz channel output with all other channels equally loaded with 0 dBm unweighted white noise.

#### 5.4.2.3 Audio frequency total harmonic distortion.

The total harmonic distortion produced by any single-frequency rf test signal, which produces a frequency within the frequency bandwidth of 300 Hz to 3050 Hz shall be at least 25 dB (DO: 35 dB) below the reference tone level with the receiver at rated output level. The rf test signal shall be at least 35 dB above the receiver noise threshold.

#### 5.4.2.4 Internally generated spurious outputs.

For 99 percent of the available 3 kHz channels, internally generated spurious signals shall not exceed -112 dBm. For 0.8 percent of the available 3 kHz channels, spurious signals shall not exceed -100 dBm for tactical applications and -106 dBm for fixed applications. For 0.2 percent of the available 3 kHz channels, spurious signals may exceed these levels.

### 5.4.3 Automatic gain control (AGC) characteristic.

The steady-state output level of the receiver (for a single tone) shall not vary by more than 3 dB over an rf input range from -103 dBm to +13 dBm for fixed application or -103 dBm to 0 dBm for tactical application.

#### 5.4.3.1 AGC attack time (nondata modes).

The receiver AGC attack time shall not exceed 30 ms.

#### 5.4.3.2 AGC release time (nondata modes).

The receiver AGC release time shall be between 800 and 1200 ms for SSB voice and ICW operation. This shall be the period from rf signal downward transition until audio output is within 3 dB of the steady-state output. The final steady-state audio output is simply receiver noise being amplified in the absence of any rf input signal.

#### 5.4.3.3 AGC requirements for data service.

In data service, the receiver AGC attack time shall not exceed 10 ms. The AGC release time shall not exceed 25 ms.

### 5.4.4 Receiver linearity.

The following shall apply with the receiver operating at maximum sensitivity, and with a reference input signal that produces a SINAD of 10 dB at the receiver output. The output SINAD shall increase monotonically and linearly within  $\pm 1.5$  dB for a linear increase in input signal level until the output SINAD is equal to at least 30 dB (DO: 40 dB). When saturation occurs, the output SINAD may vary  $\pm 3$  dB for additional increase in signal level. This requirement shall apply over the operating frequency range of the receiver.

### 5.4.5 Interface characteristics.

#### 5.4.5.1 Input impedance.

The receiver rf input impedance shall be nominally 50 ohms, unbalanced with respect to ground. The input VSWR, with respect to 50 ohms, shall not exceed 2.5:1 over the operating frequency range.

#### 5.4.5.2 Output impedance and power.

When a balanced output is provided, the receiver output impedance shall be a nominal 600 ohms, balanced with respect to ground, capable of delivering 0 dBm to a 600-ohm load. Electrical symmetry shall be sufficient to suppress longitudinal currents at least 40 dB below reference signal level. The receiver output signal power for operation with a headset or handset shall be adjustable at least over the range from -30 dBm to 0 dBm. For operation with a speaker, the output level shall be adjustable at least over the range of 0 dBm to +30 dBm. As a DO, an additional interface can accommodate speakers ranging from 4 to 16 ohms impedance should be provided.

## 5.5 ALE.

### 5.5.1 Basic ALE (2G).

If ALE is to be implemented, it shall be in accordance with appendix A. The ALE requirements include selective calling and handshake, link quality analysis and channel selection, scanning, and sounding. These requirements are organized in Appendix A as follows:

- a. Requirements for ALE implementation are given in sections A-1 through A-4.
- b. Detailed requirements on ALE waveform, signal structure protocols, and ALE control function (orderwire messages) are contained in section A-5.

### 5.5.2 3G ALE.

This improved more capable ALE may be implemented in addition to, but not in lieu of, Basic ALE. The technical requirements for 3G ALE are contained in Appendix C.

## 5.6 LP.

If linking protection is required to be implemented, it shall be in accordance with appendix B. These requirements are organized in Appendix B as follows:

- a. General requirements for LP implementation are given in sections B-1 through B-4.
- b. Detailed requirements on how to implement LP are given in section B-5.
- c. The unclassified application level (AL-1) is the lowest level of LP and is mandatory for all protected radios implementing LP.
- d. The unclassified enhanced application level (AL-2) is the highest level of LP covered in Appendix B. The algorithms for the higher levels of LP, application levels AL-3 and AL-4, are defined in National Security Agency (NSA) classified documents.
- e. The 24-bit encryption algorithm for linking protection applies to 2nd generation systems (Appendix B, Annex A) and the SODARK algorithm applies to 3rd generation systems (Appendix B, Annex B).

## 5.7 ALE control functions (orderwire functions).

See Appendix A, paragraphs A 5.6 and A 5.7.

## 5.8 Networking functions.

See Appendix D.

## 5.9 Network management.

See Appendix D.

## 5.10 HF application interface.

See Appendix E.

5.11 Data link protocol.

See Appendix F.

5.12 Anti-jam capability.

See Appendix G.

5.13 Automatic repeat request (ARQ) protocol.

See Appendix H.

6. NOTES.

This section contains information of a general or explanatory nature that may be helpful, but is not mandatory.

6.1 Intended use.

- a. This standard contains requirements to ensure interoperability of new radio equipment with long-haul and tactical application in the medium frequency (MF) band and in the high frequency (HF) band.
- b. There is no requirement for linking protection to be a part of a user's acquisition unless the user has an identified need. Optional levels of linking protection are identified and detailed. Options AL-1 and AL-2 provide an inexpensive, least protected mode, and AL-3 and AL-4 provide more sophisticated protection modes. The users should establish their application level based on minimum essential requirements.
- c. There is no requirement for the user to acquire any of the advanced technology defined in the appendices to this document unless the user has an identified requirement.

6.2 Interaction matrix.

The complexity of the adaptive features and functions may be confusing to the user of this standard. Certain parts of the technical features are dependent on other features defined within this standard and MIL-STD-187-721. This dependency is not always apparent to the user or the acquisition activity. The matrix shown in Table IV provides the interaction dependencies known, as of the publication date.

**TABLE IV. Interaction matrix: General features.**

Feature	Paragraph	Requires	Notes
1. Automated Network Management	Appendix D MIL-STD-188-141 D.4.4 and D.5.3	HNMP [28] and HF MIB [29]	
2. Remote Control Of Station Equipment	*	HNMP [28] and HF MIB [29]	*Feature supported, but no paragraph with this title.
3. Remote Data Fill		HNMP [28] and HF MIB [29]	*Feature supported, but no paragraph with this title
4. Any-Media Networking	Appendix D MIL-STD-188-141 D.4.5 and D.5.5	IP [14], AME [24] (for use of HF) HRMP [26] and HSSP [27] (for topology monitoring) Robust networking using all available media CONEX [19] is also useful.	Robust networking using all available media; CONEX [19] is also useful.
5. Fully-Automated Message Handling	*	Message Store and Forward [22], Route Selection [20]	*Level 2 HFNC [16] provides the features for fully-automated (but not adaptive) message handling.
6. Adaptive Routing	*	Routing Queries [7]	*Path Quality Matrix [18] and CONEX [19] provide increased functionality, with increased overhead.
7. Routing Queries	MIL-STD-188-141 D.5.2.6.6.1	HRMP [26]	
8. Connectivity Monitoring	MIL-STD-188-141 D.5.2.6.6.3	HRMP [26]	HSSP [27] recommended also.
9. Repeater Control	MIL-STD-188-141 D.5.2.6.6.2	HRMP [26]	
10. Full-Duplex Independent Operation	5.6.3	Frequency Select Command [35]	
11. Internet Services	*	TCP [12]	*For example, FTP, SMTP, Telnet (defined in RFCs)
12. TCP	*	IP [14] and either 3G Data Link Protocol [62] (preferred) or HFDLP [32]	*Defined in RFC-793 Do not use over HF channels without an ARQ protocol.
13. UDP	*	IP [14]	*Defined in RFC-768
14. IP	*	AME [24] For use of HF, HFNC [16]	*Defined in RFC-791 (ICMP in RFC-792)
15. Indirect Calling	4.8 and D.5.2.2	ALE controller (for Link Establishment)	Level 2 (or higher) HFNC [16] recommended for selection alternate station.
16. HFNC	D.4.2	(See Table D-II for levels of functional capability) Requires at least one link controller, including ALE, HFDLP [32], or other media.	SDLP [31] recommended for link controller interface. FED-STD-1052 modem and HFDLP [32] recommended for message transfer over HF links (versus ALE modem with DTM [49] or DBM [48])
17. Routing Table	D.4.2.1.1 D.5.2.1.2	HFNC [16]	
18. Path Quality Matrix	D.4.2.1.2 D.5.2.1.1	HFNC [16]	CONEX [19] may be used to dynamically update path qualities.
19. Conex	D.5.2.4	Network Layer Header [21]	Normally uses Path Quality Matrix [18]; may instead use only link control.
20. Route Selection	D.4.2.1.3	Routing Table [17]	
21. Network Layer Header	5.7.3	HFNC [16]	

**Interaction matrix: General features (continued).**

Feature	Paragraph	Requires	Notes
22. Message Store And Forward	D.4.2.3 D.5.2.5.2	AME [24]	
23. Null Store And Forward	D.5.2.5.3	AME [24]	
24. AME	D.4.2.4	AME Protocol [25], and either Message Store and Forward [22] or Null Store and Forward [23]	Automatic Message Exchange
25. AME Protocol	D.5.2.5.1 D.5.2.5.4	Network Layer Header [21]	Automatic Message Exchange. Works best with 3G modems and protocols [60] or FED-STD-1052 modem and HFDLP [32].
26. HRMP	D.5.2.6	Network Layer Header [21]	HF Relay Management Protocol. Works best with 3G modems and protocols [60] or FED-STD-1052 modem and HFDLP [32].
27. HSSP	D.5.2.7	Network Layer Header [21]	HF Station Status Protocol. Works best with 3G modems and protocols [60] or FED-STD-1052 modem and HFDLP [32].
28. HNMP	D.5.3.2	AME [24] for HF Links; UDP [13] and IP [14] when using Internet; UDP+IP+AME when internetworking via HF.	HF Network Management Protocol. Works best with 3G modems and protocols [60] or FED-STD-1052 modem and HFDLP [32].
29. HF MIB	D.5.3.3 and Appendix H		
30. Interface to Link Controllers	4.2.8		SDLP [31] recommended protocol for interface to link controllers.
31. SDLP	D.5.4		Station Data Link Protocol
32. HFDLP	Appendix H	MIL-STD-188-110-serial-tone modem. FS-1052	HF Data Link Protocol will work over other modems, but is optimized for the MIL-STD-188-110 serial-tone modem.
33. LP	B.4.1, B.4.1.1, B.5.1, B.5.2 B.5.2.2.2	Time Exchange Protocol [34] (for synchronization).	
34. Time Exchange Protocol	B.4.1, B.4.1.1, B.5.1, B.5.2		Time service protocol is usually sufficient for LP.
35. Frequency Select Command	5.6.3	ALE Controller, Frequency Designators [36]	
36. Frequency Designators	A.5.6.4.1	ALE Controller	
37. Channel Designators	5.3b A.5.6.4.1	ALE Controller	
38. LQA Matrix	5.4.1	At least one source of data: Basic LQA [51], Polling [41], LQA Reporting [45], or ALQA [47].	LQA Matrix is required in MIL-STD-188-141 ALE controllers.
39. Passive LQA	5.4.1	ALE Controller	
40. Sounding	4.4.2	ALE Controller	
41. Polling	5.4.2	At least one Polling Protocol from [24-26]	
42. Individual Poll	5.4.3.1	ALE Controller	
43. Multistation, Single-channel Polling	5.4.3.2	ALE Controller that supports Star Net Calls [53] or Star Group Calls [52]	

**Interaction matrix: General features (continued)**

Feature	Paragraph	Requires	Notes
44. Two-station, Single-channel Polling	5.4.3.3	ALE Controller	Frequency Designators [36] or Channel Designator [37] required to select channels outside current scan list.
45. ALQA Reporting	4.4.3	LQA Report Protocol [46]	
46. LQA Report Protocol	5.4.4	MIL-STD-188-141 ALE Controller with LQA Matrix [38], and either DTM [49] OR DBM [48].	Frequency Designators [36] or Channel Designators [37] required to report channels outside current scan list.
47. ALQA	4.5, 5.5	ALE Controller	Advanced LQA
48. DBM	A.5.7.4	ALE Controller	Data Block Message Greater throughput than DTM [49], but less than FED-STD-1052
49. DTM	A.5.7.3	ALE Controller	Data Text Message.
50. AMD	A.5.7.2	ALE Controller	Automatic Message Display
51. LQA	A.5.4.1 A.5.4.2	ALE Controller	Link Quality Analysis
52. Star Group Calls	A.5.5.4	ALE Controller	
53. Star Net Calls	A.5.5.3	ALE Controller	
54. Individual Calls	A.5.5.2	ALE Controller	
55. Allcalls	A.5.5.5	Individual Calls	
56. Anycalls	A.5.5.6	Individual Calls	
57. Wildcard Addressing	A.5.2.4.8	Individual Calls	
58. Sounding	A.5.3	ALE Controller	
59. HF E-mail	E.4.2	TCP [12] and/or 3G protocols [60]	Electronic mail over HF
60. 3G Link Automation	Appendix C	3G ALE [61], 3G Data Link Protocols [62], and 3G Modem [63]	High performance protocol suite for large networks and data applications.
61. 3G ALE	C.4.6, C.5.2	3G Modem (BW0) [63]	3G ALE.
62. 3G Data Link	C.4.7	3G ALE [61], 3G TM [64], 3G ARQ [65], 3G CLC [66], 3G Modem [63]	High performance data link protocols, including ability to engage NATO protocols
63. 3G Modem	C.5.1	Radio	Scalable suite of waveforms for various channel conditions.
64. 3G TM	C.5.3	3G ALE [61], 3G Modem (BW1) [63]	Traffic Management protocol; coordinates transitions from ALE to traffic protocol.
65. 3G ARQ	C.5.4, C.5.5	3G ALE [61], 3G TM [64], 3G Modem (BW1-4) [63]	High rate and robust automatic repeat request (reliable) data link protocols.
66. 3G CLC	C.5.6	3G ALE [61], 3G TM [64]	Circuit Link Control (for circuit or "hard" links).

**6.3 Issue of DODISS.**

When this standard is used in acquisition, the applicable issue of the DODISS must be cited in the solicitation (see 2.2.1 and 2.2.2).

**6.4 Subject term (key word) listing.**

Adaptive communications  
AJ mode  
ALE  
ALE control functions  
ALE message protocol  
ALE mode

ALE  
 Automatic sounding  
 Baseline mode  
 Deep interleaving  
 Forward error correction  
 Golay coding  
 Leading redundant word  
 Linking protection  
 LQA  
 Network functions  
 Network management  
 Protection interval  
 Radio frequency scanning  
 Selective calling  
 Slotted responses  
 Star net and group  
 Triple redundant words  
 Word phase

#### 6.5 International standardization agreements.

Certain provisions of this standard in paragraphs 4.2, 4.4, 5.2, 5.3, and 5.4 are the subject of international standardization agreements, STANAGs 4203 and 5035, and QSTG 733. When change notice, revision, or cancellation of this standard is proposed that will modify the international agreement concerned, the preparing activity will take appropriate action through international standardization channels, including departmental standardization offices, to change the agreement or make other appropriate accommodations.

#### 6.6 Electromagnetic compatibility (EMC) requirements.

All services and agencies are responsible for their own EMC programs, which are driven by their user requirements and doctrine.

HF radio has significant inherent EMC implications that requires serious consideration by designers, users, and acquisition personnel. It is strongly recommended that all users of this standard refer to the following documents prior to design or acquisition of HF radio systems or equipment:

- a. MIL-STD-461, Requirements for the Control of Electromagnetic Interface Emissions and Susceptibility.
- b. MIL-STD-462, Measurement of Electromagnetic Interference Characteristics.
- c. MIL-HDBK-237, Electromagnetic Compatibility Management Guide for Platform, Systems and Equipment.

The applicable portions of these documents should be included in any acquisition actions for HF radio systems or equipment.



APPENDIX A  
AUTOMATIC LINK ESTABLISHMENT SYSTEM  
(SECOND GENERATION (2G) )

**TABLE OF CONTENTS**

<b><u>PARAGRAPH</u></b>	<b><u>PAGE</u></b>
A.1 GENERAL.....	48
A.1.1 <u>Scope</u> .....	48
A.1.2 <u>Applicability</u> .....	48
A.2 APPLICABLE DOCUMENTS.....	48
A.2.1 <u>General</u> .....	48
A.2.2 <u>Government documents</u> .....	48
A.2.2.1 <u>Specifications, standards, and handbooks</u> .....	48
A.2.3 <u>Non-Government publications</u> .....	49
A.3 DEFINITIONS.....	50
A.3.1 <u>Terms</u> .....	50
A.3.2 <u>Abbreviations and acronyms</u> .....	50
A.3.3 <u>Definitions of timing symbols</u> .....	52
A.4 GENERAL REQUIREMENTS.....	52
A.4.1 <u>ALE introduction</u> .....	52
A.4.1.1 <u>ALE addresses</u> .....	53
A.4.1.2 <u>Scanning</u> .....	53
A.4.1.3 <u>Calling</u> .....	54
A.4.1.4 <u>Channel evaluation</u> .....	54
A.4.1.5 <u>Channel quality display</u> .....	54
A.4.2 <u>System performance requirements</u> .....	55
A.4.2.1 <u>Scanning rate</u> .....	55
A.4.2.1.1 <u>Alternative Quick Call (AQC) (NT)</u> .....	55
A.4.2.1.2 <u>Recommendation</u> .....	55
A.4.2.2 <u>Occupancy detection - not tested (NT)</u> .....	55
A.4.2.3 <u>Linking probability</u> .....	56
A.4.2.3.1 <u>AQC-ALE linking probability</u> .....	58
A.4.2.3.2 <u>AQC-ALE linking performance</u> .....	58
A.4.3 <u>Required data structures</u> .....	58
A.4.3.1 <u>Channel memory</u> .....	58
A.4.3.2 <u>Self address memory</u> .....	59
A.4.3.3 <u>Other station table</u> .....	61
A.4.3.3.1 <u>Other station address storage</u> .....	61
A.4.3.3.2 <u>Link quality memory</u> .....	63
A.4.3.3.3 <u>Other station settings storage</u> .....	63
A.4.3.4 <u>Operating parameters</u> .....	63
A.4.3.5 <u>Message memory</u> .....	63
A.4.4 <u>ALE operational rules</u> .....	64

## TABLE OF CONTENTS

(continued)

<u>PARAGRAPH</u>	<u>PAGE</u>
A.4.5 <u>Alternate Quick Call ALE (AQC-ALE) (NT)</u> .....	64
A.4.5.1 <u>Introduction</u> .....	64
A.4.5.2 <u>General signaling strategies</u> .....	64
A.4.5.3 <u>Features supported by AQC-ALE</u> .....	65
A.4.5.4 <u>Features not provided by AQC-ALE</u> .....	66
A.5. DETAILED REQUIREMENTS.....	66
A.5.1 <u>ALE modem waveform</u> .....	66
A.5.1.1 <u>Introduction</u> .....	66
A.5.1.2 <u>Tones</u> .....	66
A.5.1.3 <u>Timing</u> .....	67
A.5.1.4 <u>Accuracy</u> .....	67
A.5.2 <u>Signal structure</u> .....	69
A.5.2.1 <u>Introduction</u> .....	69
A.5.2.2 <u>FEC</u> .....	69
A.5.2.2.1 <u>General</u> .....	69
A.5.2.2.2 <u>Golay coding</u> .....	69
A.5.2.2.2.1 <u>Encoding</u> .....	69
A.5.2.2.2.2 <u>Decoding</u> .....	69
A.5.2.2.3 <u>Interleaving and deinterleaving</u> .....	73
A.5.2.2.4 <u>Redundant words</u> .....	74
A.5.2.3 <u>Word structures</u> .....	74
A.5.2.3.1 <u>ALE word format</u> .....	74
A.5.2.3.1.1 <u>Structure</u> .....	78
A.5.2.3.1.2 <u>Word types</u> .....	79
A.5.2.3.1.3 <u>Preambles</u> .....	79
A.5.2.3.2 <u>Address words</u> .....	79
A.5.2.3.2.1 <u>TO</u> .....	79
A.5.2.3.2.2 <u>THIS IS (TIS)</u> .....	80
A.5.2.3.2.3 <u>THIS WAS (TWAS)</u> .....	80
A.5.2.3.2.4 <u>THRU</u> .....	80
A.5.2.3.2.5 <u>FROM</u> .....	81
A.5.2.3.3 <u>Message words</u> .....	81
A.5.2.3.3.1 <u>CMD</u> .....	81
A.5.2.3.4 <u>Extension words</u> .....	81
A.5.2.3.4.1 <u>DATA</u> .....	81
A.5.2.3.4.2 <u>REP</u> .....	82
A.5.2.4 <u>Addressing</u> .....	82

**TABLE OF CONTENTS**  
**(continued)**

<u>PARAGRAPH</u>	<u>PAGE</u>
A.5.2.4.1 <u>Introduction</u> .....	82
A.5.2.4.2 <u>Basic 38 ASCII subset</u> .....	83
A.5.2.4.3 <u>Stuffing</u> .....	83
A.5.2.4.4 <u>Individual addresses</u> .....	84
A.5.2.4.4.1 <u>Basic size</u> .....	86
A.5.2.4.4.2 <u>Extended size</u> .....	86
A.5.2.4.5 <u>Net addresses</u> .....	88
A.5.2.4.6 <u>Group addresses</u> .....	88
A.5.2.4.7 <u>Allcall addresses</u> .....	88
A.5.2.4.8 <u>AnyCalls</u> .....	89
A.5.2.4.9 <u>Wildcards</u> .....	89
A.5.2.4.10 <u>Self addresses</u> .....	90
A.5.2.4.11 <u>Null address</u> .....	91
A.5.2.4.12 <u>In-link address</u> .....	91
A.5.2.5 <u>Frame structure</u> .....	91
A.5.2.5.1 <u>Calling cycle</u> .....	93
A.5.2.5.2 <u>Message section</u> .....	96
A.5.2.5.3 <u>Conclusion</u> .....	98
A.5.2.5.4 <u>Valid sequences</u> .....	101
A.5.2.5.5 <u>Basic frame structure examples</u> .....	101
A.5.2.6 <u>Synchronization</u> .....	105
A.5.2.6.1 <u>Transmit word phase</u> .....	105
A.5.2.6.2 <u>Receiver word sync</u> .....	106
A.5.2.6.3 <u>Synchronization criteria</u> .....	106
A.5.3 <u>Sounding</u> .....	107
A.5.3.1 <u>Introduction</u> .....	107
A.5.3.2 <u>Single channel</u> .....	108
A.5.3.3 <u>Multiple channels</u> .....	108
A.5.3.4 <u>Optional handshake</u> .....	113
A.5.4 <u>Channel selection</u> .....	115
A.5.4.1 <u>LQA</u> .....	115
A.5.4.1.1 <u>BER</u> .....	115
A.5.4.1.2 <u>SINAD</u> .....	116
A.5.4.1.3 <u>MP (optional)</u> .....	116
A.5.4.1.4 <u>Operator display (optional)</u> .....	116
A.5.4.2 <u>Current channel quality report (LQA CMD)</u> .....	116
A.5.4.2.1 <u>BER field in LQA CMD</u> .....	116

**TABLE OF CONTENTS**  
**(continued)**

<b><u>PARAGRAPH</u></b>	<b><u>PAGE</u></b>
A.5.4.2.2 <u>SINAD</u> .....	116
A.5.4.2.3 <u>MP</u> .....	116
A.5.4.3 <u>Historical LQA report</u> .....	118
A.5.4.4 <u>Local noise report CMD (optional)</u> .....	118
A.5.4.5 <u>Single-station channel selection</u> .....	119
A.5.4.5.1 <u>Single-station channel selection for link establishment</u> .....	119
A.5.4.5.2 <u>Single-station channel selection for one-way broadcast</u> .....	121
A.5.4.5.3 <u>Single-station channel selection for listening</u> .....	121
A.5.4.6 <u>Multiple-station channel selection</u> .....	121
A.5.4.7 <u>Listen before transmit</u> .....	122
A.5.4.7.1 <u>Listen-before-transmit duration</u> .....	122
A.5.4.7.2 <u>Modulations to be detected</u> .....	122
A.5.4.7.3 <u>Listen before transmit override</u> .....	122
A.5.5 <u>Link establishment protocols</u> .....	122
A.5.5.1 <u>Manual operation</u> .....	122
A.5.5.2 <u>ALE</u> .....	123
A.5.5.2.1 <u>Timing</u> .....	123
A.5.5.2.2 <u>ALE states</u> .....	123
A.5.5.2.3 <u>ALE channel selection</u> .....	123
A.5.5.2.3.1 <u>Rejected channel</u> .....	124
A.5.5.2.3.2 <u>Busy channel</u> .....	124
A.5.5.2.3.3 <u>Exhausted channel list</u> .....	124
A.5.5.2.4 <u>End of frame detection</u> .....	124
A.5.5.3 <u>One-to-one calling</u> .....	127
A.5.5.3.1 <u>Sending an individual call</u> .....	127
A.5.5.3.2 <u>Receiving an individual call</u> .....	128
A.5.5.3.3 <u>Response</u> .....	129
A.5.5.3.4 <u>Acknowledgment</u> .....	130
A.5.5.3.5 <u>Link termination</u> .....	131
A.5.5.3.5.1 <u>Manual termination</u> .....	131
A.5.5.3.5.2 <u>Automatic termination</u> .....	131
A.5.5.3.6 <u>Collision detection</u> .....	132
A.5.5.4 <u>One-to-many calling</u> .....	132
A.5.5.4.1 <u>Slotted responses</u> .....	132
A.5.5.4.1.1 <u>Slotted response frames</u> .....	133
A.5.5.4.1.2 <u>Slot widths</u> .....	133
A.5.5.4.1.3 <u>Slot wait time formula</u> .....	133

**TABLE OF CONTENTS**  
**(continued)**

<b><u>PARAGRAPH</u></b>	<b><u>PAGE</u></b>
A.5.5.4.1.4 <u>Slotted response example</u> .....	134
A.5.5.4.2 <u>Star net calling protocol</u> .....	134
A.5.5.4.2.1 <u>Star net call</u> .....	134
A.5.5.4.2.2 <u>Star net response</u> .....	134
A.5.5.4.2.3 <u>Star net acknowledgment</u> .....	135
A.5.5.4.3 <u>Star group calling protocol</u> .....	135
A.5.5.4.3.1 <u>Star group scanning call</u> .....	135
A.5.5.4.3.2 <u>Star group leading call</u> .....	136
A.5.5.4.3.3 <u>Star group call conclusion</u> .....	136
A.5.5.4.3.4 <u>Receiving a star group call</u> .....	136
A.5.5.4.3.5 <u>Star group slotted responses</u> .....	137
A.5.5.4.3.6 <u>Star group acknowledgment</u> .....	137
A.5.5.4.3.7 <u>Star group call example</u> .....	137
A.5.5.4.3.8 <u>Multiple self addresses in group call</u> .....	137
A.5.5.4.4 <u>Allcall protocol</u> .....	138
A.5.5.4.5 <u>AnyCall protocol</u> .....	138
A.5.5.4.6 <u>Wildcard calling protocol</u> .....	139
A.5.6. <u>ALE control functions (CMDs other than AMD, DTM, and DBM)</u> .....	140
A.5.6.1 <u>CRC</u> .....	142
A.5.6.2 <u>Power control (optional)</u> .....	144
A.5.6.3 <u>Channel related functions</u> .....	145
A.5.6.3.1 <u>Channel designation</u> .....	145
A.5.6.3.2 <u>Frequency designation</u> .....	146
A.5.6.3.3 <u>Full-duplex independent link establishment (optional)</u> .....	147
A.5.6.3.4 <u>LQA polling (optional)</u> .....	147
A.5.6.3.5 <u>LQA reporting (optional)</u> .....	147
A.5.6.3.6 <u>LQA scan with linking (optional)</u> .....	147
A.5.6.3.7 <u>Advanced LQA (optional)</u> .....	147
A.5.6.4 <u>Time-related functions</u> .....	147
A.5.6.4.1 <u>Tune and wait</u> .....	147
A.5.6.4.2 <u>Scheduling commands</u> .....	148
A.5.6.4.3 <u>Time exchange word formats</u> .....	151
A.5.6.4.3.1 <u>Command words</u> .....	152
A.5.6.4.3.2 <u>Time Is command</u> .....	152
A.5.6.4.3.3 <u>Time Request command</u> .....	152
A.5.6.4.3.4 <u>Other encodings</u> .....	152
A.5.6.4.4 <u>Coarse time word</u> .....	152

**TABLE OF CONTENTS**  
**(continued)**

<b><u>PARAGRAPH</u></b>	<b><u>PAGE</u></b>
A.5.6.4.5 <u>Authentication word</u> .....	153
A.5.6.4.6 <u>Time quality</u> .....	153
A.5.6.5 <u>Mode control functions (optional)</u> .....	155
A.5.6.5.1 <u>Modem negotiation and handoff</u> .....	155
A.5.6.5.1.1 <u>Modem selection CMD</u> .....	156
A.5.6.5.1.2 <u>Modem negotiating</u> .....	156
A.5.6.5.2 <u>Crypto negotiation and handoff</u> .....	157
A.5.6.6 <u>Capabilities reporting functions</u> .....	158
A.5.6.6.1 <u>Version CMD (mandatory)</u> .....	158
A.5.6.6.2 <u>Capabilities function (mandatory)</u> .....	159
A.5.6.6.2.1 <u>Capabilities query</u> .....	159
A.5.6.6.2.2 <u>Capabilities report CMD</u> .....	160
A.5.6.6.2.3 <u>Data format</u> .....	160
A.5.6.7 <u>Do not respond CMD</u> .....	163
A.5.6.8 <u>Position report (optional)</u> .....	163
A.5.6.9 <u>User unique functions (UUFs)</u> .....	163
A.5.7 <u>ALE message protocols</u> .....	165
A.5.7.1 <u>Overview</u> .....	165
A.5.7.2 <u>AMD mode (mandatory)</u> .....	165
A.5.7.2.1 <u>Expanded 64-channel subset</u> .....	165
A.5.7.2.2 <u>AMD protocol</u> .....	166
A.5.7.2.3 <u>Maximum AMD message size</u> .....	167
A.5.7.3 <u>DTM mode</u> .....	167
A.5.7.4 <u>DBM mode</u> .....	178
A.5.8 <u>AQC (optional) (NT)</u> .....	190
A.5.8.1 <u>Signaling structure (NT)</u> .....	191
A.5.8.1.1 <u>AQC-ALE word structure (NT)</u> .....	191
A.5.8.1.1.1 <u>Packed address (NT)</u> .....	191
A.5.8.1.1.2 <u>Address differentiation flag (NT)</u> .....	192
A.5.8.1.2 <u>Preambles (NT)</u> .....	193
A.5.8.1.2.1 <u>TO (NT)</u> .....	193
A.5.8.1.2.2 <u>THIS IS (TIS) (NT)</u> .....	193
A.5.8.1.2.3 <u>THIS WAS (TWAS) (NT)</u> .....	193
A.5.8.1.2.4 <u>PART2 (NT)</u> .....	193
A.5.8.1.2.5 <u>INLINK (NT)</u> .....	193
A.5.8.1.2.6 <u>COMMAND (NT)</u> .....	194
A.5.8.1.2.7 <u>DATA (NT)</u> .....	194

## TABLE OF CONTENTS

(continued)

<u>PARAGRAPH</u>	<u>PAGE</u>
A.5.8.1.2.8 <u>REPEAT (NT)</u> .....	194
A.5.8.1.3 <u>AQC-ALE address characteristics (NT)</u> .....	194
A.5.8.1.3.1 <u>Address size (NT)</u> .....	194
A.5.8.1.3.2 <u>Address character set (NT)</u> .....	194
A.5.8.1.3.3 <u>Support of ISDN (option) (NT)</u> .....	194
A.5.8.1.3.4 <u>Over-the-air address format (NT)</u> .....	194
A.5.8.1.4 <u>Address formats by call type (NT)</u> .....	194
A.5.8.1.4.1 <u>Unit addresses (NT)</u> .....	194
A.5.8.1.4.2 <u>StarNet addresses (NT)</u> .....	194
A.5.8.1.4.3 <u>Group addresses (NT)</u> .....	194
A.5.8.1.4.4 <u>AllCall address (NT)</u> .....	195
A.5.8.1.4.5 <u>AnyCall address (NT)</u> .....	195
A.5.8.1.5 <u>Data exchange field (NT)</u> .....	195
A.5.8.1.5.1 <u>DE(1) no data available (NT)</u> .....	195
A.5.8.1.5.2 <u>DE(2) number of to's left in calling cycle (NT)</u> .....	195
A.5.8.1.5.3 <u>DE(3) Inlink resource list (NT)</u> .....	196
A.5.8.1.5.4 <u>DE(4) local noise report (NT)</u> .....	196
A.5.8.1.5.5 <u>DE(5) LQA variation (NT)</u> .....	198
A.5.8.1.5.6 <u>DE(6) LQA measurement (NT)</u> .....	198
A.5.8.1.5.7 <u>DE(7) number of Tis/Twas left in sounding cycle (NT)</u> .....	199
A.5.8.1.5.8 <u>DE(8) inlink data definition from INLINK (NT)</u> .....	199
A.5.8.1.5.9 <u>DE(9) Inlink data definition from PART2 (NT)</u> .....	200
A.5.8.1.6 <u>PSK tone sequence (optional) (NT)</u> .....	201
A.5.8.1.6.1 <u>PSK tone sequence placement (NT)</u> .....	201
A.5.8.1.6.2 <u>PSK tone sequence generation (NT)</u> .....	201
A.5.8.2 <u>AQC-ALE frame structure and protocols (NT)</u> .....	201
A.5.8.2.1 <u>Calling cycle (NT)</u> .....	201
A.5.8.2.2 <u>Unit call structure (NT)</u> .....	203
A.5.8.2.3 <u>Star net call structure (NT)</u> .....	203
A.5.8.2.4 <u>AllCall frame formats (NT)</u> .....	204
A.5.8.2.5 <u>AnyCall frame formats (NT)</u> .....	205
A.5.8.2.6 <u>Sounding (NT)</u> .....	206
A.5.8.2.7 <u>Inlink transactions (NT)</u> .....	206
A.5.8.2.7.1 <u>Inlink transaction as an acknowledgement (NT)</u> .....	207
A.5.8.2.7.2 <u>CRC for Inlink event sequences (NT)</u> .....	207
A.5.8.2.7.3 <u>Use of address section (NT)</u> .....	207



**TABLE OF CONTENTS**  
**(continued)**

<b><u>PARAGRAPH</u></b>	<b><u>PAGE</u></b>
A.5.8.2.7.4 <u>Slotted responses in an Inlink state (NT)</u> .....	208
A.5.8.3 <u>AQC-ALE orderwire functions (optional) (NT)</u> .....	208
A.5.8.3.1 <u>Operator ACK/NAK transaction command section (optional) (NT)</u> .....	208
A.5.8.3.2 <u>AQC-ALE control message section (optional) (NT)</u> .....	209
A.5.8.3.2.1 <u>AMD dictionary message (NT)</u> .....	209
A.5.8.3.2.2 <u>Channel definition (NT)</u> .....	212
A.5.8.3.2.3 <u>Slot assignment (NT)</u> .....	213
A.5.8.3.2.4 <u>List content of database (NT)</u> .....	213
A.5.8.3.2.5 <u>List database activation time (NT)</u> .....	213
A.5.8.3.2.6 <u>Set database activation time (NT)</u> .....	213
A.5.8.3.2.7 <u>Define database content (NT)</u> .....	214
A.5.8.3.2.8 <u>Database content listing (NT)</u> .....	215
A.5.8.4 <u>AQC-ALE linking protection (NT)</u> .....	215

**TABLES**

TABLE A-I. <u>Occupancy detection probability (2G and 3G)</u> .....	55
TABLE A-II. <u>Probability of linking</u> .....	57
TABLE A-III. <u>Channel memory example</u> .....	60
TABLE A-IV. <u>Self address memory example</u> .....	61
TABLE A-V. <u>ALE operational rules</u> .....	64
TABLE A-VI. <u>2/3 Majority vote decoding</u> .....	77
TABLE A-VII. <u>Majority word construction</u> .....	77
TABLE A-VIII. <u>ALE word types (preambles)</u> .....	79
TABLE A-IX. <u>Use of “@” utility symbol</u> .....	85
TABLE A-X. <u>Basic (38) address structures</u> .....	87
TABLE A-XI. <u>Use of “?” wildcard symbol</u> .....	90
TABLE A-XII. <u>Limits to frames</u> .....	101
TABLE A-XIII. <u>Approximate BER values</u> .....	117
TABLE A-XIV. <u>Link quality analysis structure</u> .....	118
TABLE A-XV. <u>Timing</u> .....	125
TABLE A-XVI. <u>Summary of CMD functions</u> .....	141
TABLE A-XVII. <u>Cyclic redundancy check structure</u> .....	144
TABLE A-XVIII. <u>Power control CMD bits (KP<sub>1-3</sub>)</u> .....	145
TABLE A-XIX. <u>Tune and wait structure</u> .....	149
TABLE A-XX. <u>Time values</u> .....	150
TABLE A-XXI. <u>Time-related CMD functions</u> .....	151
TABLE A-XXII. <u>Time quality</u> .....	154
TABLE A-XXIII. <u>Modem codes</u> .....	157

**TABLE OF CONTENTS**  
**(continued)**

<b><u>TABLE</u></b>	<b><u>PAGE</u></b>
TABLE A-XXIV. <u>Crypto codes</u> .....	158
TABLE A-XXV. <u>Component selection</u> .....	159
TABLE A-XXVI. <u>Format selection</u> .....	159
TABLE A-XXVII. <u>Capabilities report data fields (ALE timing)</u> .....	161
TABLE A-XXVIII. <u>Capabilities report data fields (mode settings)</u> .....	161
TABLE A-XXIX. <u>Capabilities report data field (feature capabilities)</u> .....	162
TABLE A-XXX. <u>User unique functions structure</u> .....	164
TABLE A-XXXI. <u>ALE message protocols</u> .....	165
TABLE A-XXXII. <u>DTM characteristics</u> .....	169
TABLE A-XXXIII. <u>DTM structure</u> .....	172
TABLE A-XXXIV. <u>DBM characteristics</u> .....	180
TABLE A-XXXV. <u>DBM structures</u> .....	185
TABLE A-XXXVI. <u>AQC address character ordinal value</u> .....	192
TABLE A-XXXVII. <u>AQC-ALE word types (and preambles)</u> .....	193
TABLE A-XXXVIII. <u>Data exchange definitions</u> .....	195
TABLE A-XXXIX. <u>Inlink resource list</u> .....	196
TABLE A-XL. <u>Local noise report</u> .....	197
TABLE A-XLI. <u>Magnitude of minimum SNR from mean SNR</u> .....	198
TABLE A-XLII. <u>LQA scores</u> .....	199
TABLE A-XLIII. <u>Valid combinations of ACK-This and I'm Inlink</u> .....	200
TABLE A-XLIV. <u>DE(9) inlink transaction identifier</u> .....	201
TABLE A-XLV. <u>Scanning part duration using automated calculation</u> .....	202
TABLE A-XLVI. <u>Operator ACK/NAK command</u> .....	208
TABLE A-XLVII. <u>AQC-ALE control message section word sequences</u> .....	209
TABLE A-XLVIII. <u>Lookup tables for packed AMD messages</u> .....	211
TABLE A-IL. <u>Adding spaces during AMD unpacking</u> .....	212

**FIGURES**

FIGURE A-1. <u>Data link with ALE and FEC sublayers</u> .....	54
FIGURE A-2. <u>Occupancy detection test setup</u> .....	56
FIGURE A-3. <u>System performance measurements test setup</u> .....	56
FIGURE A-4. <u>Connectivity and LQA memory example</u> .....	62
FIGURE A-5. <u>ALE symbol library</u> .....	68
FIGURE A-6. <u>Generator matrix for (24, 12) extended Golay code</u> .....	70
FIGURE A-7. <u>Parity-check matrix for (24, 12) extended Golay code</u> .....	71
FIGURE A-8. <u>Golay word encoding example</u> .....	72
FIGURE A-9. <u>Golay FEC coding examples</u> .....	73

**TABLE OF CONTENTS**  
**(continued)**

<b><u>FIGURE</u></b>	<b><u>PAGE</u></b>
FIGURE A-10. <u>Word bit coding and interleaving</u> .....	75
FIGURE A-11. <u>Bit and word decoding</u> .....	76
FIGURE A-12. <u>ALE basic word structure</u> .....	78
FIGURE A-13. <u>Basic 38 ASCII subset (unshaded areas)</u> .....	83
FIGURE A-14. <u>Valid word sequences</u> .....	92
FIGURE A-15. <u>Calling cycle sequence</u> .....	94
FIGURE A-16. <u>Message sequence</u> .....	97
FIGURE A-17. <u>Conclusion (terminator) sequences</u> .....	99
FIGURE A-18. <u>Valid word sequence (calling cycle section)</u> .....	102
FIGURE A-19. <u>Valid word sequence (message section)</u> .....	103
FIGURE A-20. <u>Valid word sequence (conclusion section)</u> .....	104
FIGURE A-21. <u>Basic frame structure examples</u> .....	105
FIGURE A-22. <u>Basic sounding structure</u> .....	109
FIGURE A-23. <u>Call rejection scanning sounding protocol</u> .....	110
FIGURE A-24. <u>Call acceptance scanning sounding protocol</u> .....	111
FIGURE A-25. <u>Scanning sounding with optional handshake protocol</u> .....	114
FIGURE A-26. <u>Local noise report (optional)</u> .....	119
FIGURE A-27. <u>LQA memory example</u> .....	120
FIGURE A-28. <u>Link establishment states</u> .....	123
FIGURE A-29. <u>Individual calls</u> .....	127
FIGURE A-30. <u>Response frame</u> .....	129
FIGURE A-31. <u>Acknowledgment frame</u> .....	130
FIGURE A-32. <u>Slotted responses</u> .....	133
FIGURE A-33. <u>2G ALE slotted responses</u> .....	134
FIGURE A-34. <u>Net call</u> .....	134
FIGURE A-35. <u>Group call</u> .....	135
FIGURE A-36. <u>Power control CMD format</u> .....	145
FIGURE A-37. <u>Frequency select CMD format</u> .....	146
FIGURE A-38. <u>Time exchange CMD word</u> .....	153
FIGURE A-39. <u>Coarse time and authentication words</u> .....	154
FIGURE A-40. <u>Mode control CMD format</u> .....	155
FIGURE A-41. <u>Modem selection CMD format</u> .....	156
FIGURE A-42. <u>Crypto selection CMD format</u> .....	158
FIGURE A-43. <u>Version CMD format</u> .....	158
FIGURE A-44. <u>Capabilities query CMD format</u> .....	160
FIGURE A-45. <u>Capabilities report CMD and DATA format</u> .....	160
FIGURE A-46. <u>Expanded 64 ASCII subset (shown unshaded)</u> .....	166

**TABLE OF CONTENTS****(continued)**

<b><u>FIGURE</u></b>	<b><u>PAGE</u></b>
FIGURE A-47. <u>DTM structure example</u> .....	170
FIGURE A-48. <u>Data test message reconstruction (overlay)</u> .....	175
FIGURE A-49. <u>Data test message structure and ARQ example</u> .....	181
FIGURE A-50. <u>DBM interleaver and deinterleaver</u> .....	182
FIGURE A-51. <u>DBM example</u> .....	183
FIGURE A-52. <u>AQC-ALE data exchange word</u> .....	192
FIGURE A-53. <u>Example of unit call format</u> .....	203
FIGURE A-54. <u>Example of StarNet format</u> .....	204
FIGURE A-55. <u>Example AllCall frame format</u> .....	205
FIGURE A-56. <u>Example AnyCall frame formats</u> .....	205
FIGURE A-57. <u>Example sounding frame format</u> .....	206
FIGURE A-58. <u>Example inlink transaction TRW sequences</u> .....	207
FIGURE A-59. <u>Generalized AQC-ALE control message format</u> .....	209
FIGURE A-60. <u>AQC-ALE dictionary lookup message</u> .....	210
FIGURE A-61. <u>Channel definition and meet-me function</u> .....	212
FIGURE A-62. <u>AQC-ALE slot assignment</u> .....	213
FIGURE A-63. <u>List content of database</u> .....	213
FIGURE A-64. <u>Set database activation time</u> .....	214
FIGURE A-65. <u>Define database content</u> .....	214

**ANNEXES**

ANNEX A. DEFINITIONS OF TIMING SYMBOLS.....	216
ANNEX B. TIMING.....	219
ANNEX C. SUMMARY OF ALE SIGNAL PARAMETERS.....	229

## **AUTOMATIC LINK ESTABLISHMENT SYSTEM**

### A.1 GENERAL.

#### A.1.1 Scope.

This appendix provides details of the prescribed waveform, signal structures, protocols, and performance requirements for the second generation (2G) automatic link establishment (ALE) system.

#### A.1.2 Applicability.

This appendix is a mandatory part of MIL-STD-188-141 whenever ALE is a requirement to be implemented into the high frequency (HF) radio system. The functional capability described herein includes automatic signaling, selective calling, automatic answering, and radio frequency (rf) scanning with link quality analysis (LQA). The capability for manual operation of the radio in order to conduct communications with existing, older generation, non-automated manual radios, shall not be impaired by implementation of these automated features.

### A.2 APPLICABLE DOCUMENTS.

#### A.2.1 General.

The documents listed in this section are specified in A.3, A.4, and A.5 of this standard. This section does not include documents cited in other sections of this standard or recommended for additional information or as examples. While every effort has been made to ensure the completeness of this list, document users are cautioned that they must meet all specified requirements documents cited in A.3, A.4, and A.5 of this standard, whether or not they are listed.

#### A.2.2 Government documents.

##### A.2.2.1 Specifications, standards, and handbooks.

The following specifications, standards, and handbooks form a part of this document to the extent specified herein. Unless otherwise specified, the issues of these documents are those listed in the issue of the Department of Defense Index of Specifications and Standards (DODISS) and supplement thereto, cited in the solicitation.

### STANDARDS

#### FEDERAL

##### Federal Information Processing Standards

FIPS PUB 1-1      Publication Code: for Information Interchange

MIL-STD-188-141B  
APPENDIX A

FEDERAL STANDARDS

FED-STD-1003	Telecommunications: Synchronous Bit Orientation Data Link Control Procedures (Advanced Data Communications Control Procedures)
FED-STD-1037	Telecommunications: Glossary of Telecommunications Terms

DEPARTMENT OF DEFENSE

MIL-STD-188-110	Interoperability and Performance Standards for HF Data Modems
-----------------	---

(Copies of Federal Information Processing Standards (FIPS) are available at Standardization Document Order Desk, 700 Robbins Avenue, Building #4, Section D, Philadelphia, PA 19111-5094. Non-Department of Defense (DoD) users must request copies of FIPS from the National Technical Information Service, 5285 Port Royal Road, Springfield, VA 22161-2171.)

A.2.3 Non-Government publications.

The following documents form a part of this appendix to the extent specified:

INTERNATIONAL STANDARDIZATION DOCUMENTS

North Atlantic Treaty Organization (NATO) Standardization Agreements (STANAGs)

STANAG 4285	Characteristics of 1200/2400/3600 bps Single Tone Modems for HF Radio Links
STANAG 4529	Characteristics of Single Tone Modulators/Demodulators for Maritime HF Radio Links with 1240 Hz Bandwidth

International Telecommunications Union (ITU),  
Radio Regulations

ITU-R F.520-2	Recommendation for Fixed Service, use of High Frequency Ionospheric Channel Simulators
---------------	--

(Application for copies should be addressed to the General Secretariat, International Organization for Standardization (ISO) 1, Rue de Varembe, CH-1211 Geneva 20, Switzerland.)

Other Publications

NMSU-EE-CD-001	Wireless Network Waveform Samples
----------------	-----------------------------------

(Application for copies should be addressed to New Mexico State University, Klipsch School of Electrical and Computer Engineering, University Park, NM 88003, Attn: Dr. E. E. Johnson.)

(Non-Government standards and other publications are normally available from the organizations that prepare or distribute the documents. These documents also may be available in or through libraries or other informational services.)

### A.3 DEFINITIONS.

#### A.3.1 Terms.

Definitions of terms used in this document shall be as specified in the current edition of FED-STD-1037 except where inconsistent with the use in this standard. In addition, the following definitions are applicable for the purpose of this standard.

- **Available State.** An ALE controller is in the available state when it does not currently have a link with any other station, and is not in the process of establishing a link. An ALE controller that is programmed for multichannel scanning operation will be scanning when it is in the available state. Single-channel controllers will remain tuned to the assigned channel regardless of their state.
- **Exclusive OR..** Used as a check, the condition that exits when each resulting bit is a “1” if the two input bits do not match, or the resulting bit is a “0” when the two input bits match.
- **Linking State.** An ALE controller enters the linking state from the available state when it sends or receives an ALE call frame. Scanning controllers stop scanning when they enter the linking state. An ALE controller returns to the available state if the linking attempt does not complete successfully. Upon successful completion of a three-way handshake, controllers in the linking state enter the linked state.
- **Linked State.** An ALE controller is considered to be in the linked state if it has successfully completed link establishment with one or more stations, and at least one link to which it is party has not been terminated. While in the linked state, a wait-for-activity timer will be running (if not disabled by the operator). Controllers programmed to scan will not be scanning while in the linked state. After link establishment, communication among linked stations normally is carried by additional three-way handshakes, but controllers remain in the linked state during these handshakes.

#### A.3.2 Abbreviations and acronyms.

The abbreviations and acronyms used in this document are defined below. Those listed in the current edition of FED-STD-1037 have been included for the convenience of the reader.

2G ALE	second generation automatic link establishment
3G ALE	second generation automatic link establishment
ACK	acknowledge character

AGC	automatic gain control
ALE	automatic link establishment
AMD	automatic message display
AQC	Alternative Quick Call
AQC	Alternative Quick Call
AQC-ALE	Alternative Quick Call Automatic Link Establishment
ARQ	automatic repeat request
ASCII	American Standard Code for Information Interchange
AWGN	Additive white gaussian noise
b/s	bits per second
BCD	binary coded decimal
BER	bit error ratio
CCIR	International Radio Consultative Committee
chps	channels per second
CMD	ALE preamble word COMMAND
CRC	cyclic redundancy check
dB	Decibel
DBM	data block message
dBw	dB referred to 1 W (watt)
DC	data code
DCE	data circuit-terminating equipment
DO	design objective
DoD	Department of Defense
DODISS	Department of Defense Index of Specifications and Standards
DTE	data terminal equipment
DTM	data text message
e.g.	for example
FCS	frame check sequence
FEC	forward error correction
FIPS	Federal Information Processing Standards
FSK	frequency shift keying
HF	high frequency
HFNC	high frequency node controller
Hz	hertz
ID	identification
IFF	if and only if
ISDN	Integrated Services Digital Network
ISO	Organization of Standardization
ITU	International Telecommunications Union
kHz	Kilohertz
LP	linking protection
LQA	link quality analysis



MIL-STD-188-141B  
APPENDIX A

LSB	(1) lower sideband (2) least significant bit
MF	medium frequency
MHz	megahertz
MP	multipath
ms	millisecond
MSB	most significant bit
NAK	negative-acknowledge character
NATO	North Atlantic Treaty Organization
NT	Not Tested
PL	probability of linking
PPM	parts per million
REP	ALE preamble word REPEAT
rf	radio frequency
RX	receive
s	second
SCTY	Security
SINAD	signal-plus-noise-plus-distortion to noise-plus-distortion ratio
SN	Slot Number
SNR	signal to noise ratio
SPS	symbols per second
SSB	single-sideband [transmission]
TDMA	time-division multiple access
TIS	ALE preamble word THIS IS
TOD	time of day
TWAS	ALE preamble word THIS WAS
TX	transmit
UI	unique index
USB	upper sideband
UUF	user unique function
UUT	units under test
WRTT	wait for response and tune timeout
WS	AQC-ALE Word Sync word

A.3.3 Definitions of timing symbols.

The abbreviations and acronyms used for timing symbols are contained in annex A to this appendix.

A.4 GENERAL REQUIREMENTS.

A.4.1 ALE introduction.

The techniques specified in this appendix employ a robust modem and forward error correction coding and constitutes a digital ALE data link. The exchange of such ALE words according to

the specified protocols supports channel evaluation, selective calling, and passing data messages and constitute an ALE data link layer. (The ALE modem, radio, coupler, antenna, and so on constitute the corresponding physical layer.)

The ALE data link layer contains three sublayers, as shown in figure A-1: a lower sublayer concerned with error correction and detection (forward error correction [FEC] sublayer), an upper sublayer containing the ALE protocol (ALE sublayer), and a linking protection (LP) sublayer between. Within the FEC sublayer are redundancy and majority voting, interleaving, and Golay coding applied to the 24-bit ALE words which constitute the (FEC sublayer) service-data-unit, in terms of the Seven Layer Reference Model. The ALE sublayer specifies protocols for link establishment, data communication, and rudimentary LQA based on the capability of exchanging ALE words. The shaded area of figure A-1 indicates the contents of this appendix.

The following paragraphs specify the general requirements for ALE operation.

#### A.4.1.1 ALE addresses.

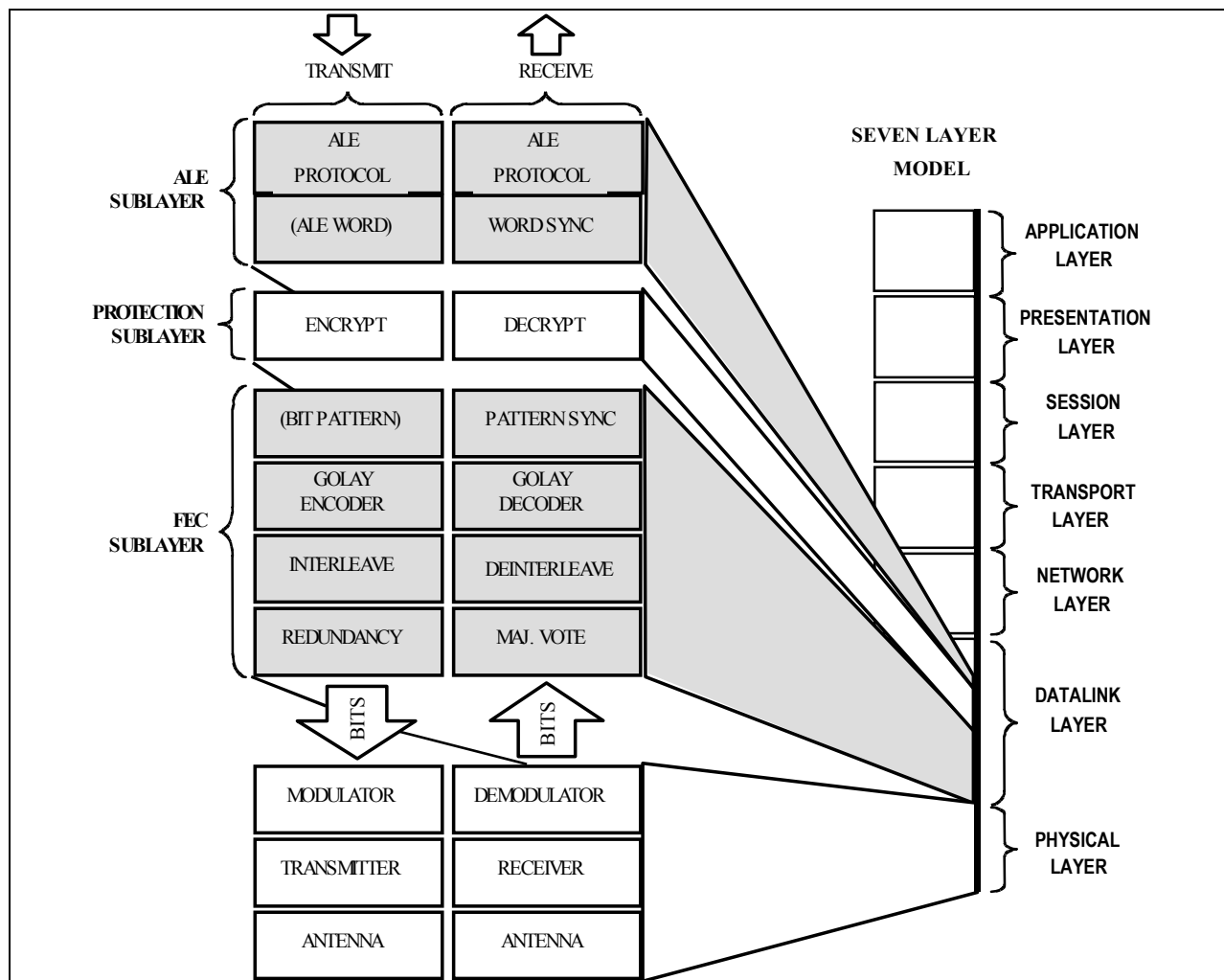
Stations designed to this appendix shall employ the addressing structure specified in A.5.2.4 to identify individual stations and collections of stations (nets and groups).

#### A.4.1.2 Scanning.

The radio system shall be capable of repeatedly scanning selected channels stored in memory (in the radio or controller) under either manual control or under the direction of any associated automated controller. The radio shall stop scanning and wait on the most recent channel upon the occurrence of any of the following selectable events:

- Automatic controller decision to stop scan (the normal mode of operation)
- Manual input of stop scan
- Activation of external stop-scan line (if provided)

The scanned channels should be selectable by groups (often called “scan lists”) and also individually within the groups, to enable flexibility in channel and network scan management.



**FIGURE A-1. Data link with ALE and FEC sublayers.**

**A.4.1.3 Calling.**

Upon request by the operator or an external automated controller, the radio system shall execute the appropriate calling protocol specified in A.5.5.

**A.4.1.4 Channel evaluation.**

The radio system shall be capable of automatically transmitting ALE sounding transmissions in accordance with A.5.3, and shall automatically measure the signal quality of ALE receptions in accordance with A.5.4.1.

**A.4.1.5 Channel quality display.**

If an operator display is provided, the display shall have a uniform scale, 0-30 with 31 being unknown all based on signal-plus-noise-plus-distortion to noise-plus-distortion (SINAD).

**A.4.2 System performance requirements.**

Stations designed to this appendix shall demonstrate an overall system performance equal to or exceeding the following requirements.

**A.4.2.1 Scanning rate.**

Stations designed to this appendix shall incorporate selectable scan rates of two and five channels per second, and may also incorporate other scan rates (design objective (DO): 10 channels per second).

**A.4.2.1.1 Alternative Quick Call (AQC) (NT).**

In the optional AQC-ALE protocol, the system shall be capable of variable dwell rates while scanning such that traffic can be detected in accordance with table A-II Probability of Linking.

**A.4.2.1.2 Recommendation.**

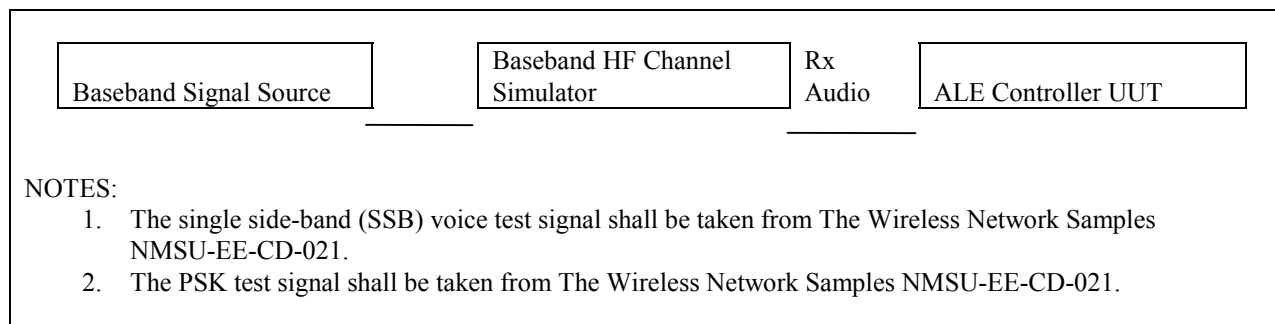
Radios equipped with the optional AQC-ALE shall provide scanning at scan rates of two channels per second or five channels per second for backward compatibility to non-AQC-ALE networks.

**A.4.2.2 Occupancy detection - not tested (NT).**

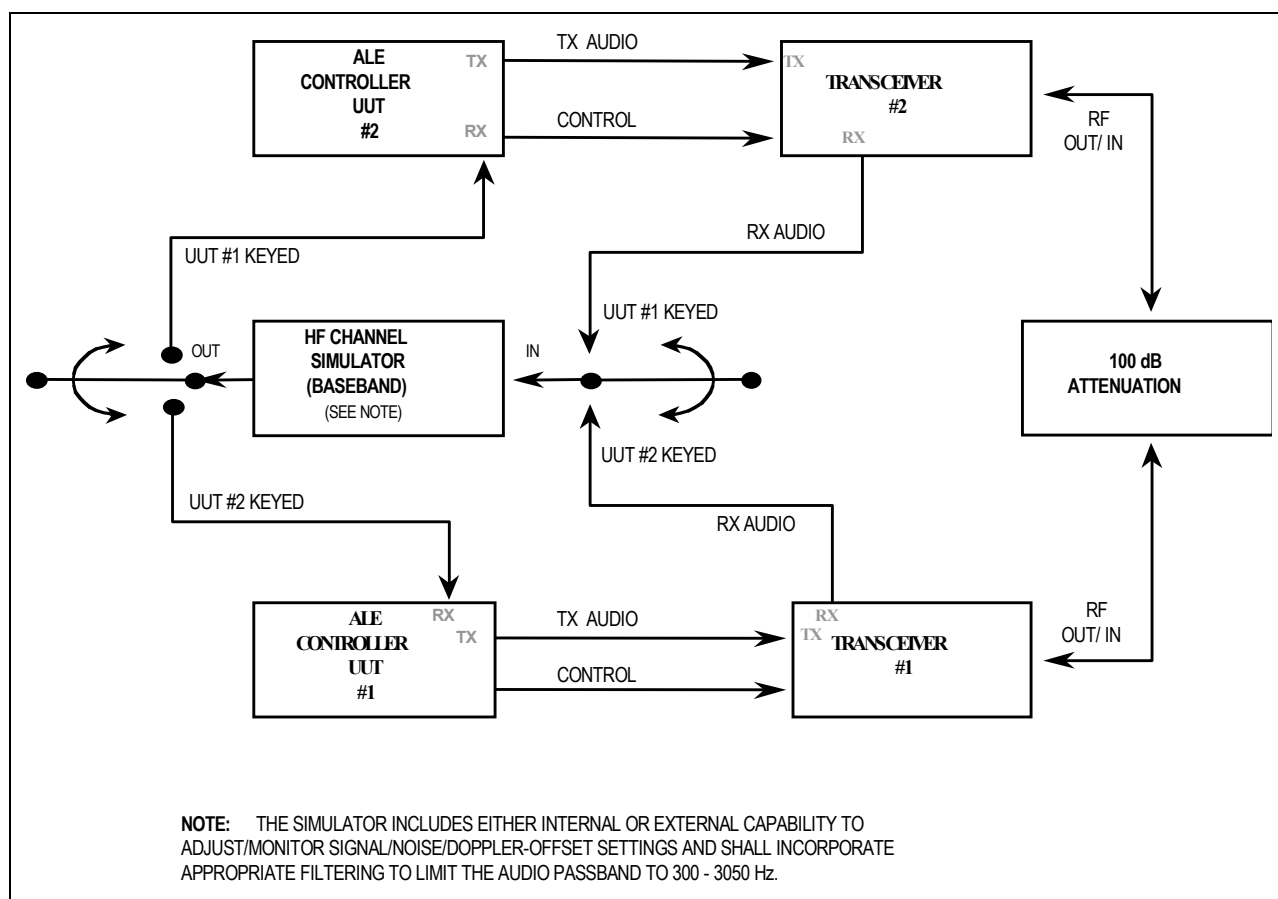
Stations designed to this appendix shall achieve at least the following probability of detecting the specified waveforms (See A.5.4.7) under the indicated conditions, with false alarm rates of no more than 1 percent. The channel simulator shall provide additive white gaussian noise (AWGN) without fading or multipath (MP). See table A-I.

**TABLE A-I. Occupancy detection probability (2G and 3G).**

Waveform	SNR (dB in 3 kHz)	Dwell Time (s)	Detection Prob
ALE	0	2.0	0.80
	6	2.0	0.99
SSB Voice	6	2.0	0.80
	9	2.0	0.99
MIL-STD-188-110 (Serial Tone PSK)	0	2.0	0.80
	6	2.0	0.99
STANAG 4529	0	2.0	0.80
	6	2.0	0.99
STANAG 4285	0	2.0	0.80
	6	2.0	0.99



**FIGURE A-2. Occupancy detection test setup.**



**FIGURE A-3. System performance measurements test setup.**

A.4.2.3 Linking probability.

Linking attempts made with a test setup configured as shown in figure A-3, using the specified ALE signal created in accordance with this appendix, shall produce a probability of linking as shown in table A-II.

**TABLE A-II. Probability of linking.**

Probability of Linking (Pl)	Signal-to-noise ratio (dB in 3 kHz)		
	Gaussian Noise Channel	Modified CCIR Good Channel	Modified CCIR Poor Channel
≥ 25%	-2.5	+0.5	+1.0
≥ 50%	-1.5	+2.5	+3.0
≥ 85%	-0.5	+5.5	+6.0
≥ 95%	0.0	+8.5	+11.0
Multipath (millisecond)	0.0	0.52	2.2
Doppler spread (Hertz)	0.0	0.10	1.0

The receive audio input to the ALE controller shall be used to simulate the three channel conditions. The modified International Radio Consultative Committee (CCIR) good channel shall be characterized as having 0.52 millisecond (ms) (modified from 0.50ms) MP delay and a fading (two sigma) bandwidth of 0.1 hertz (Hz). The modified CCIR poor channel, normally characterized as consisting of a circuit having 2.0 ms MP delay with a fading (two sigma) bandwidth of 1.0 Hz, shall be modified to have 2.2 ms MP delay and a fading (two sigma) bandwidth of 1.0 Hz. Doppler shifts of  $\pm 60$  Hz shall produce no more than a 1.0 decibel (dB) performance degradation from the requirements of table A-II for the modified CCIR good and poor channels.

NOTE: This modification is necessary due to the fact that the constant 2-ms MP delay (an unrealistic fixed condition) of the CCIR poor channel results in a constant nulling of certain tones of the ALE tone library. Other tone libraries would also have some particular MP value, which would result in continuous tone cancellation during simulator testing.

Each of the signal-to-noise (SNR) ratio values shall be measured in a nominal 3-kiloHertz (kHz) bandwidth. Performance tests of this capability shall be conducted in accordance with ITU-R F.520-2 Use of High Frequency Ionospheric Channel Simulators employing the C.C. Watterson Model. This test shall use the individual scanning calling protocol described in A.5.5.3. The time for performance of each link attempt shall be measured from the initiation of the calling transmission until the successful establishment of the link. Performance testing shall include the following additional criteria:

- a. The protocol used shall be the individual scanning calling protocol with only TO and TIS preambles.
- b. Addresses used shall be alphanumeric, one word (three characters) in length from the 38-character basic American Standard Code for Information Interchange (ASCII) subset.
- c. Units under test (UUTs) shall be scanning 10 channels at two channels per second, and repeated at five channels per seconds.

- d. Call initiation shall be performed with the UUT transmitter stopped and tuned to the calling frequency.
- e. Maximum time from call initiation (measured from the start of UUT rf transmission -- not from activation of the ALE protocol) to link establishment shall not exceed 14.000 seconds, plus simulator delay time. The call shall not exceed 23 redundant words, the response three redundant words and the acknowledgment three redundant words. (See A.5.2.2.4 and Annex A).

NOTE: Performance at the higher scan rates shall also meet the foregoing requirements and shall meet or exceed the probability of linking as shown in table A-II.

#### A.4.2.3.1 AQC-ALE linking probability.

When the optional AQC-ALE protocol (see details in Section A.5.8) is implemented, the probability of linking shall conform to table A-II with the following additional criteria:

- a. The protocol used shall be quick AQC individual calling protocol with no message passing.
- b. Addresses shall be one to six characters in the 38-character basic ASCII subset.
- c. Units being called shall be scanning 10 channels.
- d. Call initiation shall be performed with the UUT transmitter stopped and tuned to the calling frequency.
- e. The initial call probe shall not exceed  $10 T_{rw}$ , the call response shall not exceed  $4T_{rw}$ , and the acknowledgment shall not exceed  $2 T_{rw}$ .

#### A.4.2.3.2 AQC-ALE linking performance.

AQC-ALE linking performance shall not be degraded in LP level 1 or 2. Scan rates of two or five channels per second may degrade performance because insufficient redundant words are emitted during the call probe.

### A.4.3 Required data structures.

#### A.4.3.1 Channel memory.

The equipment shall be capable of storing, retrieving, and employing at least 100 different sets of information concerning channel data to include receive and transmit frequencies with associated mode information. See table A-III. The channel data storage shall be nonvolatile.

The mode information normally includes:

- transmit power level
- traffic or channel use (voice, data, etc.)

- sounding data
- modulation type (associated with frequency)
- transmit/receive modes
- filter width (DO)
- automatic gain control (AGC) setting (DO)
- input/output antenna port selection (DO)
- input/output information port selection (DO)
- noise blanker setting (DO)
- security (DO)
- sounding self address(es) SA....n(DO)

Any channel (a) shall be capable of being recalled manually or under the direction of any associated automated controller, and (b) shall be capable of having its information altered after recall without affecting the original stored information settings.

#### A.4.3.2 Self address memory.

The radio shall be capable of storing, retrieving, and employing at least 20 different sets of information concerning self addressing. The self-address information storage shall be nonvolatile.

These sets of information include self (its own personal) address(es), valid channels which are associated for use, and net addressing.

Net addressing information shall include (for each “net member” self address, as necessary) the net address and the associated slot wait time (in multiples of  $T_w$ ). See table A-IV. (Slotted responses and related concepts are defined in A.5.5.4.1.) The slot wait time values are  $T_{swt}(\text{slot number (SN)})$  from the formula,  $T_{swt}(\text{SN}) = T_{sw} \times \text{SN}$ .

Stations called by their net call address shall respond with their associated self (net member) address with the specified delay ( $T_{swt}(\text{SN})$ ). For example, the call is “GUY,” thus the response is “BEN.”

Stations called individually by one of their self addresses (even if a net member address) shall respond immediately and with that address, as specified in the individual scanning calling protocol.

Stations called by one of their self addresses (even if a net member address) within a group call shall respond in the derived slot, and with that address, as specified in the star group scanning protocol. If a station is called by one of its net addresses and has no associated net member



address, it shall pause and listen but shall not respond (unless subsequently called separately with an available self or net member address), but shall enter the linked state.

**TABLE A-III. Channel memory example.**

Channel	Frequency TX (MHz)	Frequency RX (MHz)	Mode TX	Mode RX	T/R	(2) SCAN	(2) SCTY	(3) Next Sound	Sound Interval	(2) SA	(1) AN	(1) PW	(1) US	Example Comments
C-1	17,777.7	17,777.7	USB	USB	T/R	Y	C	14 min	40 min	2	1	LO	V	Typical simplex channel, low power voice, clear
C-2	22,222.2	22,222.2	USB	USB	R	Y	C	---	---				V	Same, but receive only at this time
C-3	10,333.0	10,333.0	USB	LSB	T/R	Y	CS	1 min	60 min	2	2	HI	V	Half-duplex, uses another antenna, high power, clear and secure
C-4	13,111.0	13,999.0	LSB	LSB	T/R	Y	CS	22 min	60 min	5	1	HI	D	Typical voice or data, half-duplex, high power, clear and secure
C-5	9,900.0	9,900.0	USB	LSB	T/R	N	S	---	---	5	2	LO		Typical, simplex, non-scan, data only, secure
C-100	0.0	5,000.0	---	AM	R	N	C	---	---	-	1	-	D	Receive only, non-scan, clear

**NOTES:**

- Optional storage of antenna selection(s) "ANT"; power output "PWR"; and usage "USE".
- Y=yes, N=no, C-clear, S-secure, V-voice, D-data, SA -Self address. "next sound" indicates time until next sounding on channel and is periodically decremented until "zero" value triggers sounding.
- It is reset to "sound interval" value when a sound is sent.
- Values shown for example only.

**TABLE A-IV. Self address memory example.**

Index	Self (or Net Member) Address	Net Address	$T_{swt}(SN)=$ Slot Wait Time ( $T_w$ )	(4) Valid Channels	Example Comments
SA1	SAM	--	--	All	simple individual address, 1-word, all channels
SA2	BOBBIE	--	--	C1,2,3	simple individual address, 2-word, limited channels
SA3	JIM	--	--	C7	simple individual address, 1-word, single channel
SA4	BEN	GUY	14	All	net and individual addresses, 1-word, all channels, preset slot unit time (slot 1)
SA5	CLAUDETTE	GAL	80	C3-C7	net and 3-word individual addresses, limited channels, preset slot wait-time (slot 4)
SA6	JOE	PEOPLE	17	C1-C9	2-word net and 1-word individual addresses, limited channels preset slot wait-time
×	×	×	×	×	
×	×	×	×	×	
×	×	×	×	×	
SA20	--	PARTY	--	C5-C12	2-word net only address, therefore receive only if called

NOTES:

1. The self address number "SA#" index is included for clarity. Indexes may be useful for efficient memory management.
2. If a net address is associated with a self address, the self address should be referred to as a "net member" address.
3. Addresses and values shown for example only.
4. Valid channels are the channels on which this address is planned, or permitted, to be used.

#### A.4.3.3 Other station table.

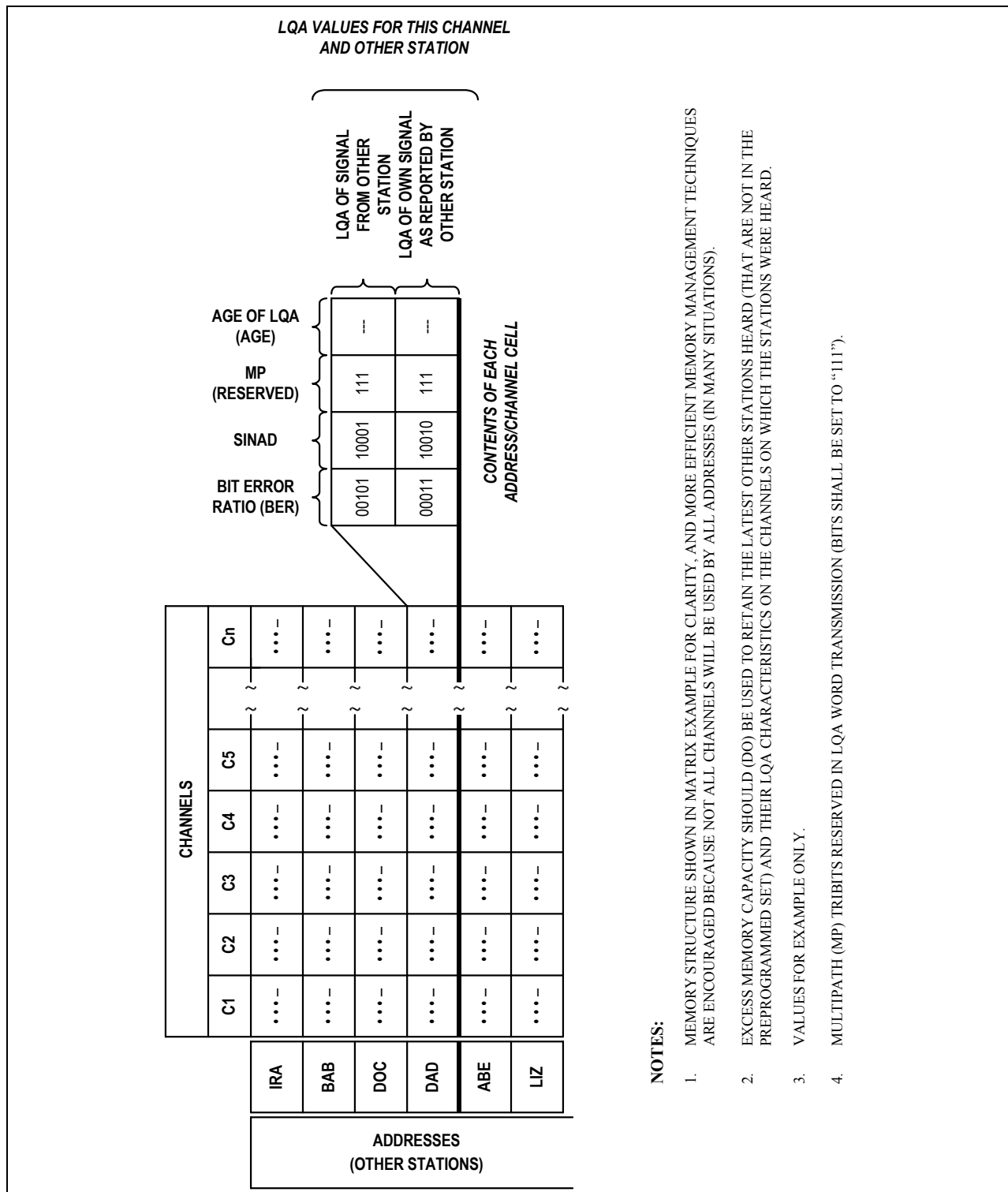
The radio shall be capable of storing, retrieving, and employing at least 100 different sets of information concerning the addresses of other stations and nets, channel quality data to those stations and nets (measurements or predictions), and equipment settings specific to links with each station or net.

DO: any excess capacity which is not programmed with preplanned other station information should be automatically filled with any addresses heard on any of the scanned or monitored channels. When the excess capacity is filled, it should be kept current by replacing the oldest heard addresses with the latest ones heard. This information should be used for call initiation to stations (if needed), and for activity evaluation.

##### A.4.3.3.1 Other station address storage.

Individual station addresses shall be stored in distinct table entries, and shall be associated with a specific wait for reply time ( $T_{wr}$ ) if not the default value. Net information shall include own net and net member associations, relative slot sequences, and own net wait for reply times ( $T_{wrn}$ ) for use when calling. See figure A-4. The storage for addresses and settings shall be nonvolatile.

MIL-STD-188-141B  
APPENDIX A



**FIGURE A-4. Connectivity and LQA memory example.**

A.4.3.3.2 Link quality memory.

The equipment shall be capable of storing, retrieving, and employing at least 4000 (DO: 10,000) sets of connectivity and LQA information associated with the channels and the other addresses in an LQA memory. The connectivity and LQA information storage shall be retained in memory for not less than one hour during power down or loss of primary power. The information in each address/channel “cell” shall include as a minimum, bilateral SINAD values of (a) the signals received at the station, and (b) the station’s signals received at, and reported by, the other station.

It shall also include either an indicator of the age of the information (for discounting old data), or an algorithm for automatically reducing the weight of data with time, to compensate for changing propagation conditions. (DO: the cells of the LQA memory should also include bilateral bit-error ratio (BER) and bilateral MP information derived by suitably equipped units.) The information within the LQA memory shall be used to select channels and manage networks as stated in this document. See figure A-4.

A.4.3.3.3 Other station settings storage.

DO: Equipment settings for use in linking with specific stations or nets should be stored in nonvolatile memory. Such settings may include antenna selection and azimuth, channels authorized for that station or net, power limits for the relevant net, and so on.

A.4.3.4 Operating parameters.

The following ALE operating parameters shall be programmable by the operator or an external automated controller. Complete definitions of the parameters are provided in Appendix H.

ScanRate	RequestLQA	OtherAddr	LqaStatus
MaxScanChan	AutoPowerAdj	OtherAddrStatus	LqaAge
MaxTuneTime	SelfAddrTable	OtherAddrNetMembers	LqaMultipath
TurnAroundTime	SelfAddrEntry	OtherAddrValidChannels	LqaSINAD
ActivityTimeout	SelfAddr	OtherAddrAnt	LqaBER
ListenTime	SelfAddrStatus	OtherAddrAntAzimuth	ScanSet
AcceptAnyCall	NetAddr	OtherAddrPower	ConnectionTable
AcceptAllcall	SlotWaitTime	LqaMatrix	ConnectionEntry
AcceptAMD	SelfAddrValidChannels	LqaEntry	ConnectedAddr
AcceptDTM	OtherAddrTable	LqaAddr	ConnectionStatus
AcceptDBM	OtherAddrEntry	LqaChannel	

A.4.3.5 Message memory.

Storage for preprogrammed, operator entered, and incoming messages shall be provided in the equipment. This storage shall be retained in memory for not less than one hour during power down or loss of primary power. Storage for at least 12 messages (DO: 100 messages), and a total capacity of at least 1000 characters (DO: 10,000 characters) shall be provided.

A.4.4 ALE operational rules.

The ALE system shall incorporate the basic operational rules listed in table A-V. Some of these rules may not be applicable in certain applications. For example, “always listening” is not possible while transmitting with a transceiver or when using a common antenna with a separate transmitter and receiver.

**TABLE A-V. ALE operational rules.**

1) Independent ALE receive capability (in parallel with other modems and similar audio receivers) (critical).
2) Always listening (for ALE signals) (critical).
3) Always will respond (unless deliberately inhibited).
4) Always scanning (if not otherwise in use).
5) Will not interfere with active channel carrying detectable traffic in accordance with table A-I (unless this listen call function is overridden by the operator or other controller).
6) Always will exchange LQA with other stations when requested (unless inhibited), and always measures the signal quality of others.
7) Will respond in the appropriate time slot to calls requiring slotted responses.
8) Always seek (unless inhibited) and maintain track of their connectivities with others.
9) Linking ALE stations employ highest mutual level of capability.
10) Minimize transmit and receive time on channel.
11) Automatically minimize power used (if capable).
NOTE : Listed in order of precedence.

A.4.5 Alternate Quick Call ALE (AQC-ALE) (NT).

A.4.5.1 Introduction.

This feature may be implemented in addition to the basic ALE functionality described in this appendix. The AQC-ALE provides a link establishment technique that requires significantly less time to link than the baseline ALE system. This is accomplished by some additional technology and trading-off some of the lesser used functions of the baseline system, for a faster linking process. The AQC-ALE shall always be listening for the baseline ALE call and shall automatically respond and operate in that mode when called.

A.4.5.2 General signaling strategies.

The AQC-ALE format employs the following characteristics:

- a. Packs three address characters (21 bits) into a 16-bit value
- b. Addresses are reduced from a maximum of 15 characters to 6 characters
- c. Six (6) address characters are sent in every transaction
- d. Replaces two seldom used preambles as follows:
  - FROM preamble becomes PART2 indicating the 2nd address word

- THRU preamble becomes INLINK indicating a linked transaction
- e. Isolates station addresses from message portion of the signaling structure:
  - TO, TIS, TWAS, INLINK, PART2 preambles used for addressing
  - CMD, DATA, and REP are used for messaging
- f. Easy separation of second generation basic ALE and AQC-ALE protocols:
  - Fixes 1 bit of any address word
  - Prevents legitimate addresses in AQC-ALE from being legitimate addresses in second generation basic ALE.
- g. Provides at least eight information bits per transmission

#### A.4.5.3 Features supported by AQC-ALE.

The following basic ALE features are fully implemented using the AQC-ALE protocol.

NOTE: A station operating in AQC-ALE can respond to any call type, but a station equipped with only second generation basic ALE will not respond to AQC-ALE protocol forms.

- a. Linking protection levels 0, 1, 2, 3
- b. Unit calls
- c. Star Net calls
- d. Allcalls
- e. AnyCalls
- f. LQA Exchange as part of the call handshake
- g. Supports Orderwire and Relay features while in a link:
  - automatic message display (AMD), data text message (DTM) or DBM
  - User Unique Functions (UUF) when in a link
  - Call Relay features
  - Time of day and Network Management
- h. Sound:
  - Sounds are shortened to include scan time + 50percent
  - Sounds may include a PSK signal to enhance LQA data

#### A.4.5.4 Features not provided by AQC-ALE.

- a. Group call. As an alternative, a controller can use the calling protocol to add on additional members. Behavior of the system is more akin to setting up a call and then conferencing in a third party.
- b. AMD, DTM, DBM are not provided during link set up. Primary focus of AQC-ALE is to establish a link between two or more stations as rapidly as possible. Once linked, information can be exchanged in the most efficient manner as is common between stations.
- c. Early identification of transmitter's address during orderwire traffic or additional addressing identification for relay addresses. The need for this is eliminated because the call setup is significantly reduced. Orderwire messages are not allowed during the call setup.

### A.5. DETAILED REQUIREMENTS.

#### A.5.1 ALE modem waveform.

##### A.5.1.1 Introduction.

The ALE waveform is designed to pass through the audio passband of standard SSB radio equipment. This waveform shall provide for a robust, low-speed, digital modem capability used for multiple purposes to include selective calling and data transmission. This section defines the waveform including the tones, their meanings, the timing and rates, and their accuracy.

##### A.5.1.2 Tones.

The waveform shall be an 8-ary frequency shift-keying (FSK) modulation with eight orthogonal tones, one tone (or symbol) at a time. Each tone shall represent three bits of data as follows (least significant bit (LSB) to the right):

- 750 Hz        000
- 1000 Hz      001
- 1250 Hz      011
- 1500 Hz      010
- 1750 Hz      110
- 2000 Hz      111
- 2250 Hz      101
- 2500 Hz      100

The transmitted bits shall be encoded and interleaved data bits constituting a word, as described in paragraphs A.5.2.2 and A.5.2.3. The transitions between tones shall be phase continuous and shall be at waveform maxima or minima (slope zero).

MIL-STD-188-141B  
APPENDIX A

A.5.1.3 Timing.

The tones shall be transmitted at a rate of 125 tones (symbols) per second, with a resultant period of 8 ms per tone. Figure A-5 shows the frequency and time relationships. The transmitted bit rate shall be 375 bits per second (b/s). The transitions between adjacent redundant (tripled) transmitted words shall coincide with the transitions between tones, resulting in an integral 49 symbols (or tones) per redundant (tripled) word. The resultant single word period ( $T_w$ ) shall be 130.66... ms (or 16.33... symbols), and the triple word (basic redundant format) period ( $3 T_w$ ) shall be 392 ms.

A.5.1.4 Accuracy.

At baseband audio, the generated tones shall be within  $\pm 1.0$  Hz. At rf, all transmitted tones shall be within the range of 2.0 dB in amplitude. Transmitted symbol timing, and therefore, the bit and word rates shall be within ten parts per million.



MIL-STD-188-141B  
APPENDIX A

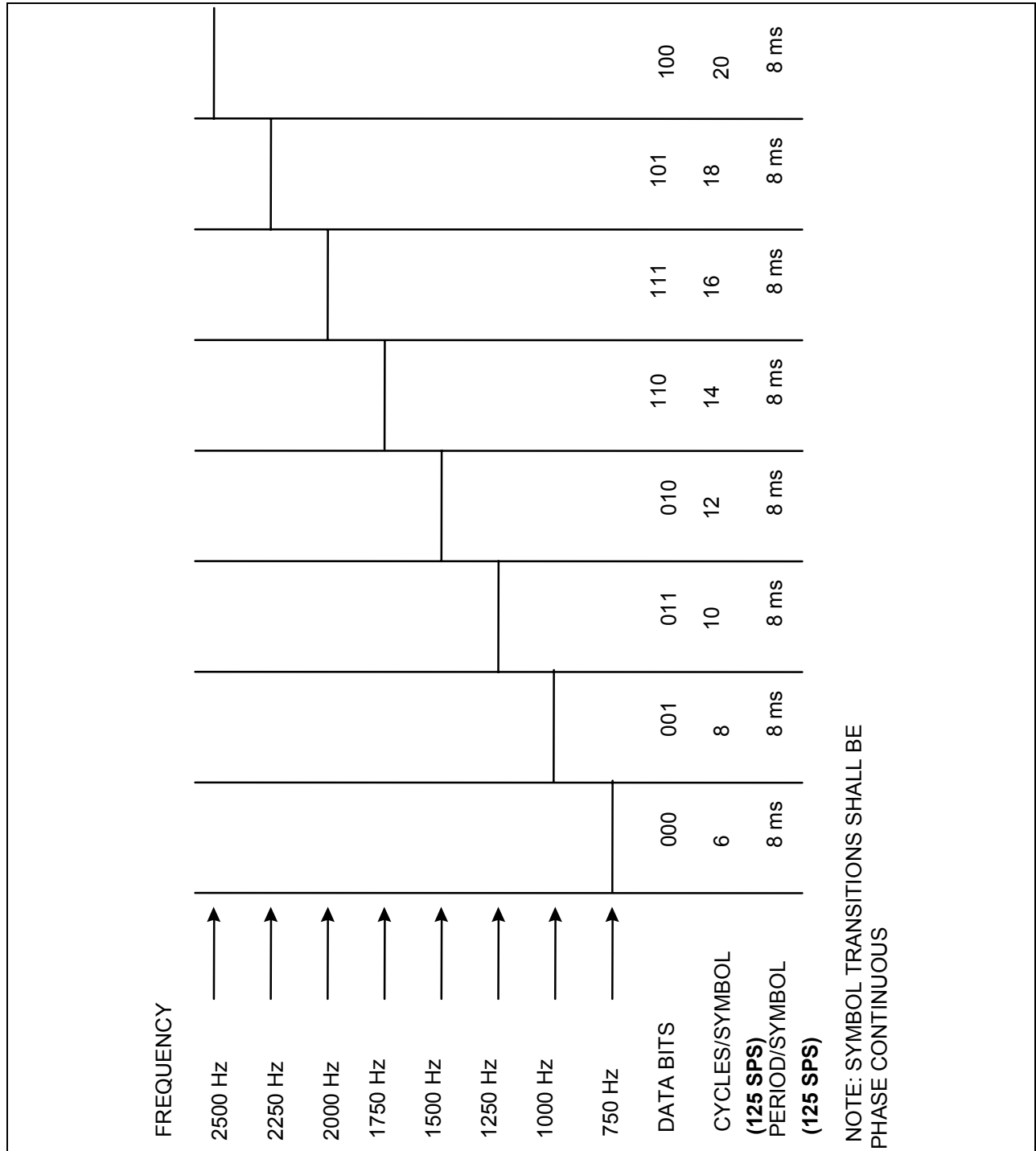


FIGURE A-5. ALE symbol library.

## A.5.2 Signal structure.

### A.5.2.1 Introduction.

This section provides definition of the ALE signal structure. Included are: forward error correction, word structure, addressing, frame structure, and synchronization. Also described in this section are: addressing, signal quality analysis, and the functions of the standard word preambles associated with the signal structure.

### A.5.2.2 FEC.

#### A.5.2.2.1 General.

The effective performance of stations, while communicating over adverse rf channels, relies on the combined use of forward error correction, interleaving, and redundancy. These functions shall be performed within the transmit encoder and receive decoder.

#### A.5.2.2.2 Golay coding.

The Golay (24, 12, 3) FEC code is prescribed for this standard. The FEC code generator polynomial shall be:

$$g(x) = x^{11} + x^9 + x^7 + x^6 + x^5 + x + 1$$

The generator matrix G, derived from g(x), shall contain an identity matrix I<sub>12</sub> and a parity matrix P as shown in figure A-6. The corresponding parity check matrix H shall contain a transposed matrix p<sup>T</sup> and an identity matrix I<sub>12</sub> as shown in figure A-7.

#### A.5.2.2.2.1 Encoding.

Encoding shall use the fundamental formula  $x = uG$ , where the code word x shall be derived from the data word u and the generator matrix G. Encoding is performed using the G matrix by summing (modulo-2) the rows of G for which the corresponding information bit is a "1." See figures A-6, A-8, and A-9a.

#### A.5.2.2.2.2 Decoding.

Decoding will implement the equation

$$s = y H^T$$

where  $y = x + e$  is a received vector which is the modulo-2 sum of a code word x and an error vector e, s is a vector of "n - k" bits called the syndrome. See figure A-9. See figure A-7 for the value of H. Each correctable/detectable error vector e results in a unique vector s. Because of this, s is computed according to the equation above and is used to index a look-up of the corresponding e, which is then added modulo-2 to y to give the original code word x. Flags are set according to the number of errors being corrected. The uses of the flags are described in A.5.2.6. If s is not equal to 0 and e contains more ones than the number of errors being corrected by decoding mode, a detected error is indicated and the appropriate flag is set.

MIL-STD-188-141B  
APPENDIX A

		$I_{12}$				:	$P$			
$G =$		100	000	000	000	:	101	011	100	011
		010	000	000	000	:	111	110	010	010
		001	000	000	000	:	110	100	101	011
		000	100	000	000	:	110	001	110	110
		000	010	000	000	:	110	011	011	001
		000	001	000	000	:	011	001	101	101
		000	000	100	000	:	001	100	110	111
		000	000	010	000	:	101	101	111	000
		000	000	001	000	:	010	110	111	100
		000	000	000	100	:	001	011	011	110
		000	000	000	010	:	101	110	001	101
		000	000	000	001	:	010	111	000	111

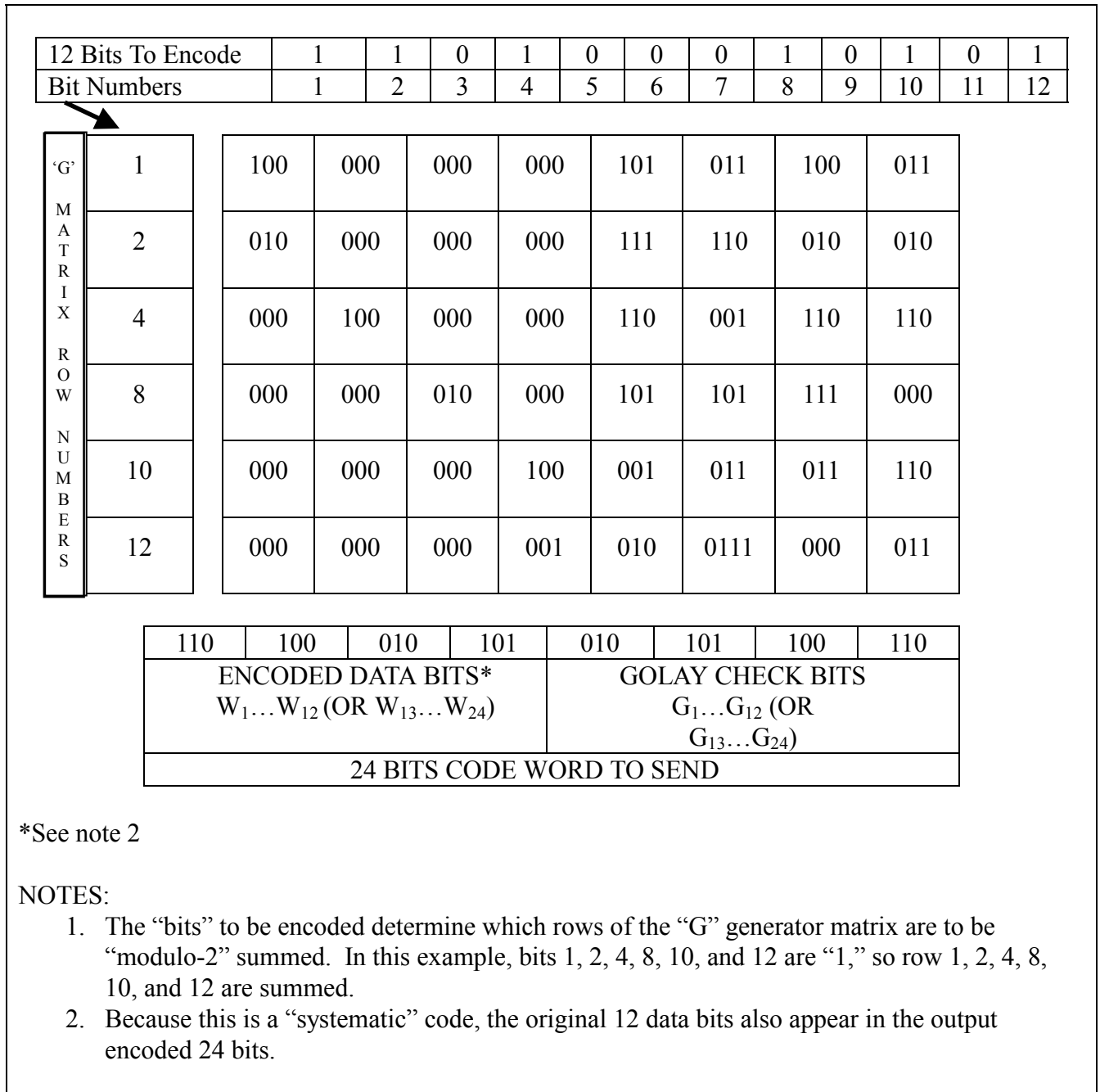
**FIGURE A-6. Generator matrix for (24, 12) extended Golay code.**

MIL-STD-188-141B  
APPENDIX A

$P^T$					$I_{12}$				
H=	111	110	010	010	:	100	000	000	000
	011	111	001	001	:	010	000	000	000
	110	001	110	110	:	001	000	000	000
	011	000	111	011	:	000	100	000	000
	110	010	001	111	:	000	010	000	000
	100	111	010	101	:	000	001	000	000
	101	101	111	000	:	000	000	100	000
	010	110	111	100	:	000	000	010	000
	001	011	011	110	:	000	000	001	000
	000	101	101	111	:	000	000	000	100
	111	100	100	101	:	000	000	000	010
	101	011	100	011	:	000	000	000	001

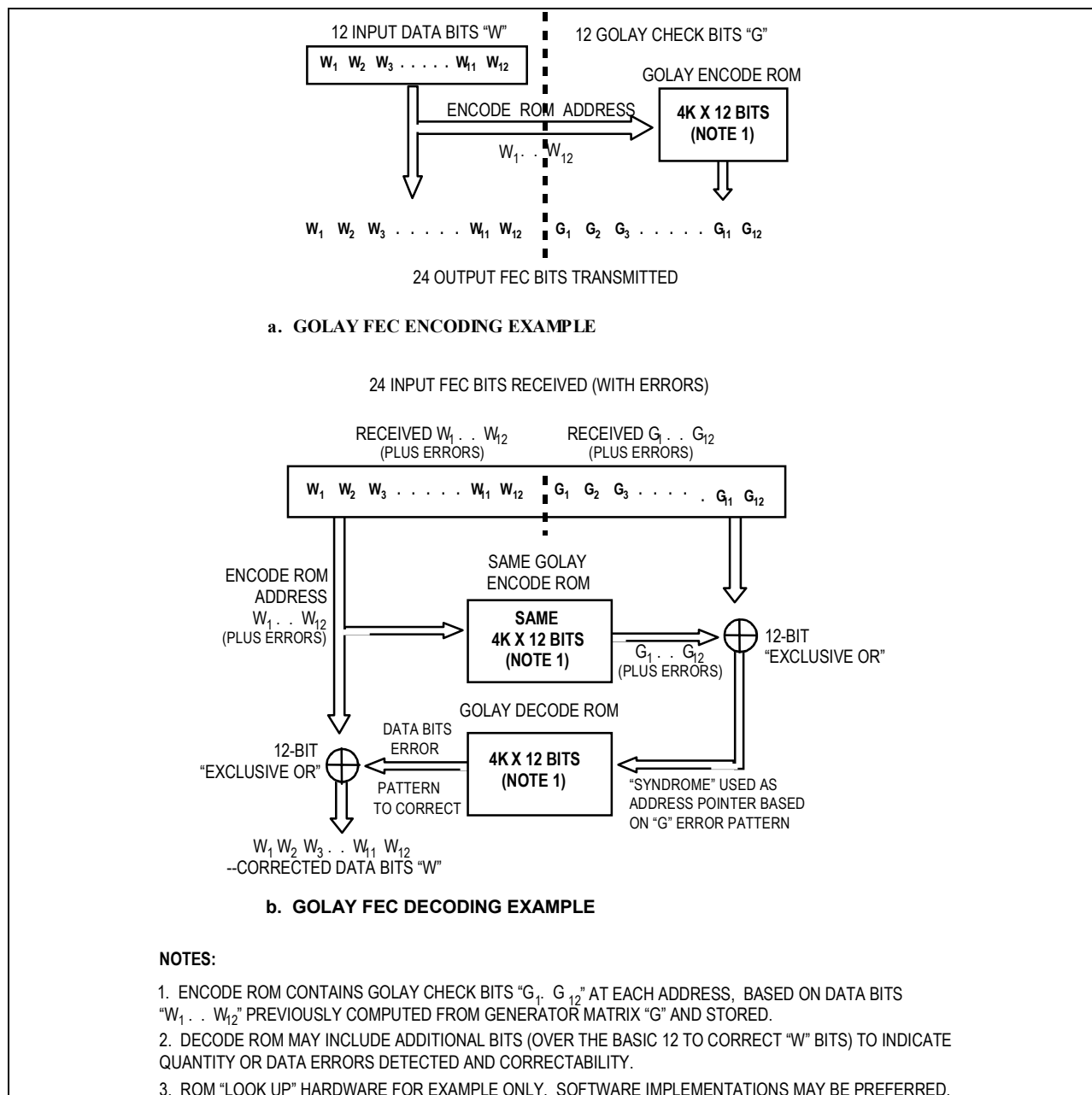
**FIGURE A-7. Parity-check matrix for (24, 12) extended Golay code.**

MIL-STD-188-141B  
APPENDIX A



**FIGURE A-8. Golay word encoding example.**

MIL-STD-188-141B  
APPENDIX A



**FIGURE A-9. Golay FEC coding examples.**

**A.5.2.2.3 Interleaving and deinterleaving.**

The basic word bits  $W_1$  (most significant bit (MSB)) through  $W_{24}$  (LSB), and resultant Golay FEC bits  $G_1$  through  $G_{24}$  (with  $G_{13}$  through  $G_{24}$  inverted), shall be interleaved, before transmission using the pattern shown in figure A-10. The 48 interleaved bits plus a 49th stuff bit  $S_{49}$ , (value = 0) shall constitute a transmitted word and they shall be transmitted  $A_1, B_1, A_2, B_2 \dots A_{24}, B_{24}, S_{49}$  using 16-1/3 symbols (tones) per word ( $T_w$ ) as described in A.5.1.3. At the

receiver, and after 2/3 voting (see A.5.2.2.4), the first 48 received bits of the majority word (including remaining errors) shall be deinterleaved as shown in figure A-10 and then Golay FEC decoded to produce a correct(ed) 24-bit basic word (or an uncorrected error flag). The 49th stuff bit (S49) is ignored.

#### A.5.2.2.4 Redundant words.

Each of the transmitted 49-bit (or 16-1/3 symbol) ( $T_w$ ) words shall be sent redundantly (times 3) to reduce the effects of fading, interference, and noise. An individual (or net) routing word (TO...), used for calling a scanning (multichannel) station (or net), shall be sent redundantly as long as required in the scan call ( $T_{sc}$ ) to ensure receipt, as described in A.5.5.2. However, when the call is a non-net call to multiple scanning stations (a group call, using THRU and REPEAT (REP) alternately), the first individual routing word (THRU) and all the subsequent individual routing words (REP, THRU, REP,...) shall be sent three adjacent times ( $T_{rw}$ ). These triple words for the individual stations shall be rotated in group sequence as described in A.5.5.3. See figure A-11. At bit time intervals (approximately  $T_w/49$ ), the receiver shall examine the present bit and past bit stream and perform a 2/3 majority vote, on a bit-by-bit basis, over a span of three words.

See tables A-VI and A-VII. The resultant 48 (ignoring the 49th bit) most recent majority bits constitute the latest majority word and shall be delivered to the deinterleaver and FEC decoder. In addition, the number of unanimous votes of the 48 possible votes associated with this majority word are temporarily retained for use as described in A.5.2.6.

#### A.5.2.3 Word structures.

##### A.5.2.3.1 ALE word format.

The basic ALE word shall consist of 24 bits of information, designated W1 (MSB) through W24 (LSB). The bits shall be designated as shown in figure A-12.

MIL-STD-188-141B  
APPENDIX A

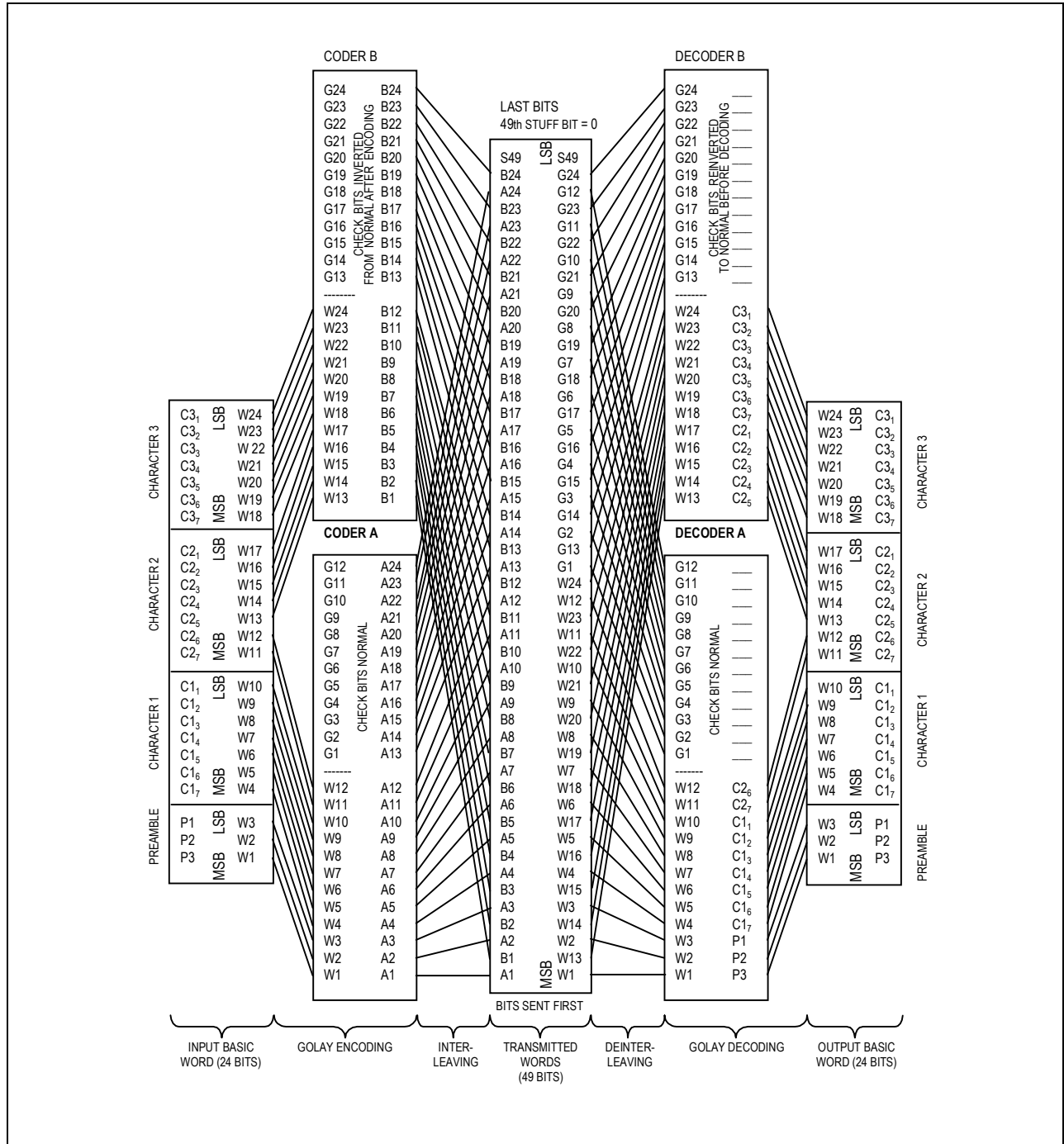


FIGURE A-10. Word bit coding and interleaving.



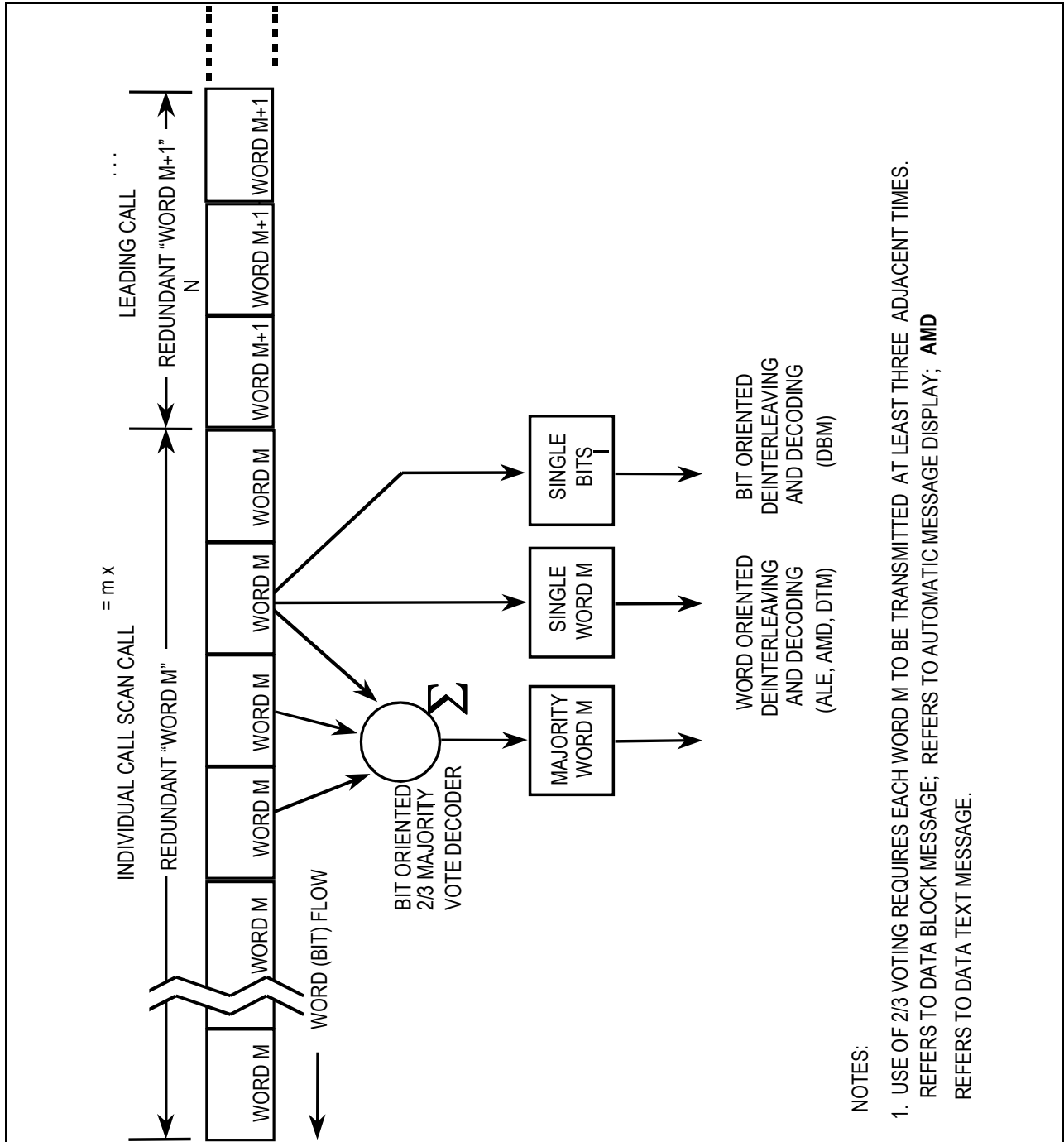


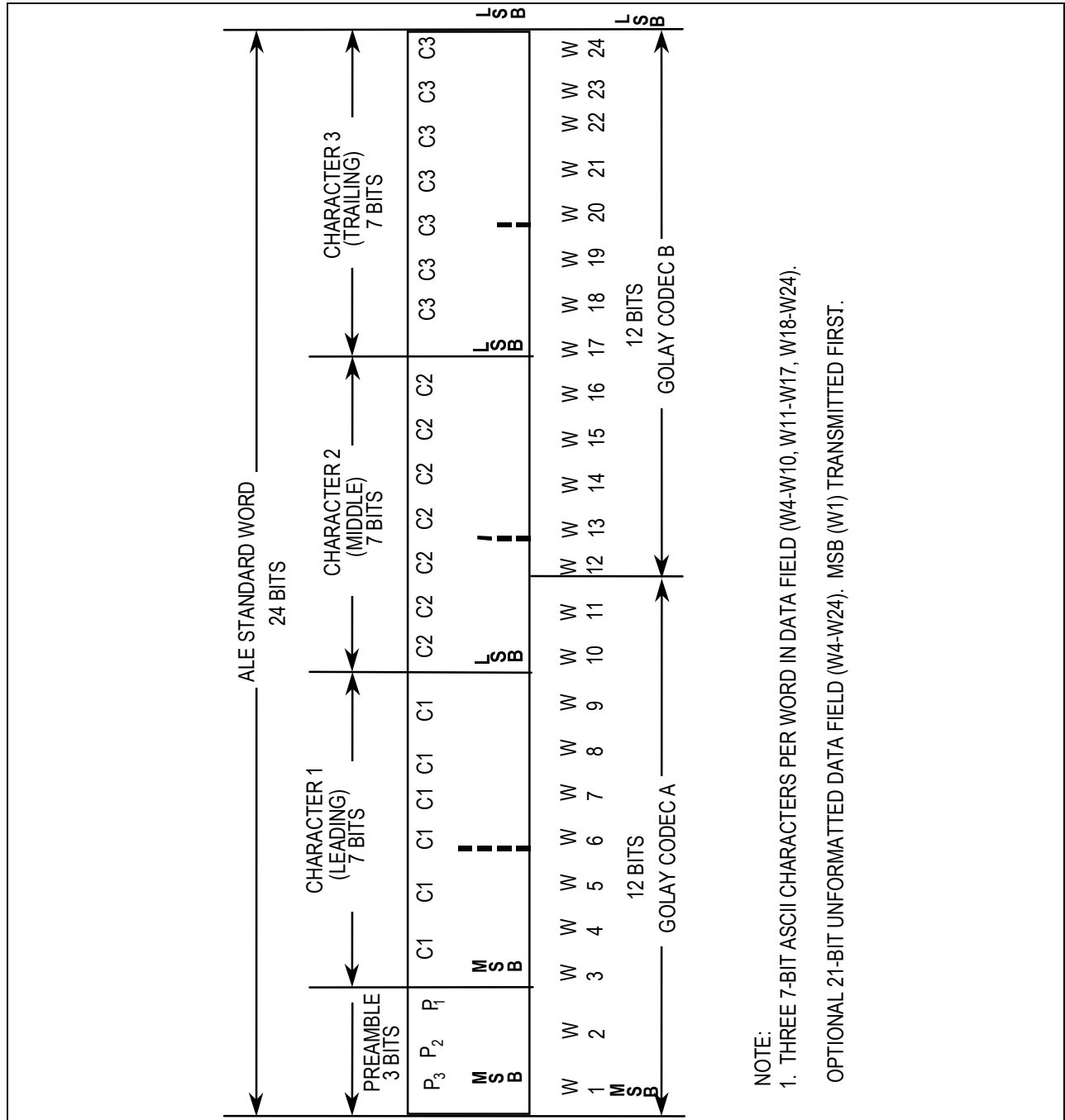
FIGURE A-11. Bit and word decoding.

**TABLE A-VI. 2/3 Majority vote decoding.**

Received Bit R	Received Time	Eight Possible Bit Combinations							
R (n) (now)	T	0	0	0	0	1	1	1	1
R(n-49) ( $T_w$ old)	T-130.66... ms	0	0	1	1	0	0	1	1
R(n-98) ( $2 T_w$ old)	T-261.33... ms	0	1	0	1	0	1	0	1
Resultant majority bit M:		0	0	0	1	0	1	1	1
Possible error flag:		0	1	1	1	1	1	1	0
0 = error unlikely 1 = error likely									

**TABLE A-VII. Majority word construction.**

Relative Time	Received Bits R (Time) for 2/3 Voting			Majority Words Bit M	Used as Decoder Bits
Stuff bits	R(n)	R(n-49)	R(n-98)	M(n)	S49 ignored
Recent (LSB)	R(n-1)	R(n-50)	R(n-99)	M(n-1)	B24 (LSB)
	R(n-2)	R(n-51)	R(n-100)	M(n-2)	A24
	R(n-3)	R(n-52)	R(n-101)	M(n-3)	B23
	R(n-4)	R(n-53)	R(n-102)	M(n-4)	A23
	•	•	•	•	•
	•	•	•	•	•
	•	•	•	•	•
	R(n-46)	R(n-95)	R(n-144)	M(n-46)	A2
	R(n-47)	R(n-96)	R(n-145)	M(n-47)	B1
	Older (MSB)	R(n-48)	R(n-97)	R(n-146)	M(n-48)
NOTES:					
1. "n" indicates present bit time					
2. "n-m" indicates bit received at "m" bit times earlier					



NOTE:  
1. THREE 7-BIT ASCII CHARACTERS PER WORD IN DATA FIELD (W<sub>4</sub>-W<sub>10</sub>, W<sub>11</sub>-W<sub>17</sub>, W<sub>18</sub>-W<sub>24</sub>).  
OPTIONAL 21-BIT UNFORMATTED DATA FIELD (W<sub>4</sub>-W<sub>24</sub>). MSB (W<sub>1</sub>) TRANSMITTED FIRST.

FIGURE A-12. ALE basic word structure.

A.5.2.3.1.1 Structure.

The word shall be divided into two parts: a 3-bit preamble and a 21-bit data field (which often contains three 7-bit characters). The MSB for all parts, and the word, is to the left in figure A-12 and is sent earliest. Before transmission, the word shall be divided into two 12-bit halves (Golay code A and B in figure A-10) for FEC encoding as described in 5.2.2.

The optional AQC-ALE word packs the address data. Details of this can be found in A.5.8.1.1, AQC-ALE Address Word Structure.

A.5.2.3.1.2 Word types.

The leading three bits, W1 through W3, are designated preamble bits P3 through P1, respectively. These preamble bits shall be used to identify one of eight possible word types.

A.5.2.3.1.3 Preambles.

The word types (and preambles) shall be as shown in table A-VIII and as described herein.

Optional AQC-ALE preambles are defined in A.5.8.1.2.

**TABLE A-VIII. ALE word types (preambles).**

Word Type	Code Bits	Functions	Significance
<u>THRU</u>	001	multiple (and indirect routing)	present multiple direct destinations for group calls (and future indirect relays, reserved)
<u>TO</u>	010	direct routing	present direct destination for individual and net calls
<u>CMD</u>	110	orderwire control and status	ALE system-wide station (and operator) orderwire for coordination, control, status, and special functions
<u>FROM</u>	100	identification (and indirect routing)	identification of present transmitter without termination (and past originator and relayers, reserved)
<u>TIS</u>	101	terminator and identification continuing	identification of present transmitter, signal terminations, protocol continuation
<u>TWAS</u>	011	terminator and identification quitting	identification of present transmitter, signal and protocol termination
<u>DATA</u>	000	extension and information	extension of data field of the previous ALE work, or information defined by the previous <u>CMD</u>
<u>REP</u>	111	duplication and information	duplication of the previous preamble, or information defined by the previous <u>CMD</u>

P3                  P2                  P1

MSB                                  LSB

W1                  W2                  W3

A.5.2.3.2 Address words.

A.5.2.3.2.1 TO.

The TO word (010) shall be used as a routing designator which shall indicate the address of the present destination station(s) which is (are) to directly receive the call. TO shall be used in the individual call protocols for single stations and in the net call protocols for multiple net-member stations which are called using a single net address. The TO word itself shall contain the first three characters of an address. For extended addresses, the additional address words (and characters) shall be contained in alternating DATA and REP words, which shall immediately

follow. The sequence shall be TO, DATA, REP, DATA, and REP, and shall be only long enough to contain the address, up to a maximum capacity of five address words (15 characters).

A.5.2.3.2.2 THIS IS (TIS).

The TIS word (101) shall be used as a routing designator which shall indicate the address of the present calling (or sounding) station which is directly transmitting the call (or sound). Except for the use of TWAS, TIS shall be used in all ALE protocols to terminate the ALE frame and transmission. It shall indicate the continuation of the protocol or handshake, and shall direct, request, or invite (depending on the specific protocol) responses or acknowledgments from other called or receiving stations. The TIS shall be used to designate the call acceptance sound. The TIS word itself shall contain the first three characters of the calling stations address. For extended addresses, the additional address words (and characters) shall be contained in alternating DATA and REP words which shall immediately follow, exactly as described for whole addresses using the TO word and sequence. The entire address (and the required portion of the TIS, DATA, REP, DATA, REP sequence, as necessary) shall be used only in the conclusion section of the ALE frame (or shall constitute an entire sound). TWAS shall not be used in the same frame as TIS, as they are mutually exclusive.

A.5.2.3.2.3 THIS WAS (TWAS).

The TWAS word (011) shall be used as a routing designator exactly as the TIS, with the following variations. It shall indicate the termination of the ALE protocol or handshake, and shall reject, discourage, or not invite (depending on the specific protocol) responses or acknowledgments from other called or receiving stations. The TWAS shall be used to designate the call rejection sound. TIS shall not be used in the same frame as TWAS, as they are mutually exclusive.

A.5.2.3.2.4 THRU.

The THRU word (001) shall be used in the scanning call section of the calling cycle only with group call protocols. The THRU word shall be used alternately with REP, as routing designators, to indicate the address first word of stations that are to be directly called. Each address first word shall be limited to one basic address word (three characters) in length. A maximum of five different address first words shall be permitted in a group call. The sequence shall only be alternations of THRU, REP. The THRU shall not be used for extended addresses, as it will not be used within the leading call section of the calling cycle. When the leading call starts in the group call, the entire group of called stations shall be called with their whole addresses, which shall be sent using the TO preambles and structures, as described in A.5.2.3.2.1.

NOTE: 1. The THRU word is also reserved for future implementation of indirect and relay protocols, in which cases it may be used elsewhere in the ALE frame and with whole addresses and other information. Stations designed in compliance with this nonrelay standard should ignore calls to them which employ their address in a THRU word in other than the scanning call.

NOTE: 2. The THRU preamble value is also reserved for the AQC-ALE protocol.

#### A.5.2.3.2.5 FROM.

The FROM word (100) is an optional designator which shall be used to identify the transmitting station without using an ALE frame termination, such as TIS or TWAS. It shall contain the whole address of the transmitting station, using the FROM, and if required, the DATA and REP words, exactly as described in the TO address structure in A.5.2.3.2.1. It should be used only once in each ALE frame, and it shall be used only immediately preceding a command (CMD) in the message section. Under direction of the operator or controller, it should be used to provide a “quick ID” of the transmitting station when the normal conclusion may be delayed, such as when a long message section is to be used in an ALE frame.

NOTE: 1. The FROM word is also reserved for future implementation of indirect and relay protocols, in which cases it may be used elsewhere in the ALE frame and with multiple addresses and other information. Stations designed in compliance with this nonrelay standard should ignore sections of calls to them that employ FROM words in any other sequence than immediately before the CMD word.

NOTE: 2. The FROM preamble value is also reserved for the AQC-ALE protocol.

#### A.5.2.3.3 Message words.

All message words (orderwire messages) begin with a word with the CMD preamble.

##### A.5.2.3.3.1 CMD.

The CMD word (110) is a special orderwire designator which shall be used for system-wide coordination, command, control, status, information, interoperation, and other special purposes. CMD shall be used in any combination between ALE stations and operators. CMD is an optional designator which is used only within the message section of the ALE frame, and it shall have (at some time in the frame) a preceding call and a following conclusion, to ensure designation of the intended receivers and identification of the sender. The first CMD terminates the calling cycle and indicates the start of the message section of the ALE frame. The orderwire functions are directed with the CMD itself, or when combined with the REP and DATA words. See A.5.6 for message words (orderwire messages) and functions.

#### A.5.2.3.4 Extension words.

##### A.5.2.3.4.1 DATA.

The DATA word (000) is a special designator which shall be used to extend the data field of any previous word type (except DATA itself) or to convey information in a message. When used with the routing designators TO, FROM, TIS, or TWAS, DATA shall perform address extension from the basic three characters to six, nine, or more (in multiples of three) when alternated with REP words. The selected limit for address extension is a total of 15 characters. When used with

CMD, its function is predefined as specified in A.5.6 for message words (orderwire messages) and functions.

#### A.5.2.3.4.2 REP.

The REP word (111) is a special designator which shall be used to duplicate any previous preamble function or word meaning while changing the data field contents (bits W4 through W24). See table A-VIII. Any change of words or data field bits requires a change of preamble bits ( $P_3$  through  $P_1$ ) to preclude uncertainty and errors. If a word is to change, even if the data field is identical to that in the previous word, the preamble shall be changed, thereby clearly designating a word change. When used with the routing designator TO, REP performs address expansion, which enables more than one address to be specified. See A.5.2.3.2.4 for use with THRU. With DATA, REP may be used to extend and expand address, message, command, and status fields. REP shall be used to perform these functions, and it may directly follow any other word type except for itself, and except for TIS or TWAS, as there cannot be more than one transmitter for a specific call at a given time.

NOTE 1. REP is used in  $T_{sc}$  of group calls directed to units with different first word addresses.

NOTE 2. REP is not used in  $T_{sc}$  of calls directed to groups with same first word addresses. Also REP is not used in  $T_{sc}$  of calls directed to individuals and nets.

#### A.5.2.4 Addressing.

##### A.5.2.4.1 Introduction.

The ALE system deploys a digital addressing structure based upon the standard 24-bit (three character) word and the Basic 38 character subset. As described below, ALE stations have the capability and flexibility to link or network with one or many prearranged or as-needed single or multiple stations. All ALE stations shall have the capacity to store and use at least 20 self addresses of up to 15 characters each in any combination of individual and net calls. There are three basic addressing methods which will be presented:

- Individual station
- Multiple station
- Special modes

NOTE: Certain alphanumeric address combinations may be interpreted to have special meanings for emergency or specific functions, such as "SOS," "MAYDAY," "PANPAN," "SECURITY," "ALL," "ANY," and "NULL." These should be carefully controlled or restricted.

A.5.2.4.2 Basic 38 ASCII subset.

The Basic 38 ASCII subset shall include all capital alphabets (A-Z) and all digits (0-9), plus designated utility and wildcard symbols “@” and “?” as shown in figure A-13. The Basic 38 ASCII subset shall be used for all basic addressing functions. To be a valid basic address, the word shall contain a routing preamble from A.5.2.3.2 (such as TO...), plus three alphanumeric characters (A-Z, 0-9) from the Basic 38 ASCII subset in any combination. In addition, the “@” and “?” symbols shall be used for special functions. Digital discrimination of the Basic 38 ASCII subset shall not be limited to examination of only the three MSBs (b<sub>7</sub> through b<sub>5</sub>), as a total of 48 digital bit combinations would be possible (including ten invalid symbols which would be improperly accepted).

BITS					0 0 0	0 0 1	0 1 0	0 1 1	1 0 0	1 0 1	1 1 0	1 1 1				
b <sub>7</sub>	b <sub>6</sub>	b <sub>5</sub>	b <sub>4</sub>	b <sub>3</sub>	b <sub>2</sub>	b <sub>1</sub>	COLUMN	ROW	0	1	2	3	4	5	6	7
0	0	0	0	0	0	0	NUL	DLE	SP	0	@	P	'	p		
0	0	0	1	1	1	1	SOH	DC1	!	1	A	Q	a	q		
0	0	1	0	2	2	2	STX	DC2	"	2	B	R	b	r		
0	0	1	1	3	3	3	ETX	DC3	#	3	C	S	c	s		
0	1	0	0	4	4	4	EOT	DC4	\$	4	D	T	d	t		
0	1	0	1	5	5	5	ENQ	NAK	%	5	E	U	e	u		
0	1	1	0	6	6	6	ACK	SYN	&	6	F	V	f	v		
0	1	1	1	7	7	7	BEL	ETB	'	7	G	W	g	w		
1	0	0	0	8	8	8	BS	CAN	(	8	H	X	h	x		
1	0	0	1	9	9	9	HT	EM	)	9	I	Y	i	y		
1	0	1	0	10	10	10	LF	SUB	*	:	J	Z	j	z		
1	0	1	1	11	11	11	VT	ESC	+	;	K		k	{		
1	1	0	0	12	12	12	FF	FS	,	<	L	\	l			
1	1	0	1	13	13	13	CR	GS	-	=	M		m	}		
1	1	1	0	14	14	14	SO	RS	.	>	N	^	n	~		
1	1	1	1	15	15	15	SI	US	/	?	O	?	o	DEL		

FIGURE A-13. Basic 38 ASCII subset (unshaded areas).

A.5.2.4.3 Stuffing.

The ALE basic address structure is based on single words which, in themselves, provide multiples of three characters. The quantity of available addresses within the system, and the flexibility of assigning addresses, are significantly increased by the use of address character stuffing. This technique allows address lengths that are not multiples of three to be compatibly contained in the standard (multiple of three characters) address fields by “stuffing” the empty trailing positions with the utility symbol “@.” See table A-IX. “Stuff-1” and “Stuff-2” words



MIL-STD-188-141B  
APPENDIX A

shall only be used in the last word of an address, and therefore should appear only in the leading call ( $T_{lc}$ ) of the calling cycle ( $T_{cc}$ ).

NOTE: As an example of proper usage, a call to the address "MIAMI" would be structured "TO MIA," "DATA MI@."

A.5.2.4.4 Individual addresses.

The fundamental address element in the ALE system is the single routing word, containing three characters, which forms the basic individual station address. This basic address word, used primarily for intranet and slotted operations, may be extended to multiple words and modified to provide increased address capacity and flexibility for internet and general use. An address which is assigned to a single station (within the known or used network) shall be termed an "individual" address. If it consists of one word (that is, no longer than three characters) it shall be termed a "basic" size, and if it exceeds one word, it shall be termed an "extended" size.

**TABLE A-IX. Use of “@” utility symbol.**

Pattern	Function	Guidance
<u>TO</u> A B C	“Standard” three character address structure “ABC”	Any position in address and sequences
<u>TO</u> A B @	“Stuff-1” reduced address fields; adds characters “A, B”	Only last word in address; anywhere in sequences
<u>TO</u> A @ @	“Stuff-2” reduced address fields; adds character “A”	Only last word in address; anywhere in sequences
<u>TO</u> @ ? @	“Allcall” global address; all stop and listen (unless inhibited), none respond	Exclusive member of calling cycle; single <u>TO</u> only
<u>TO</u> @ A @	<u>REP</u> @ B @ (option)	“Selective AllCall;” global address; all with same last character “A” (or “B”) stop and listen (unless inhibited), none respond Alone, or with additional different AllCall selections, for “group selective AllCall;” only in calling cycle; must use <u>TO</u> , <u>REP</u> alternately never <u>DATA</u> , if more than one*
<u>TO</u> @ @ ?	“AnyCall” global address; all stop and respond in PRN slots (unless inhibited), none respond	Exclusive member of calling cycle; single <u>TO</u> only
<u>TO</u> @ @ A	<u>REP</u> @ B @ (option)	“Selective AnyCall;” all with same last character(s) “A” (or “B”) stop and respond in PRN slots (unless inhibited), using own addresses Alone or with additional different AnyCall selections, for “group selective AnyCall;” only in calling cycle; must use <u>TO</u> , <u>REP</u> alternately (never <u>DATA</u> ), if more than one*
<u>TO</u> @ A B	<u>REP</u> @ C D (option)	“Double selective AnyCall;” all with same last characters “AB” (or “CD”) stop and respond in PRN slots (unless inhibited), using own addresses Alone or with additional different AnyCall selections, for “group selective AnyCall;” only in calling cycle; must use <u>TO</u> , <u>REP</u> alternately (never <u>DATA</u> ), if more than one*
<u>TO</u> @ @ @	“Null” address; all ignore, test and maintenance use, or extra “buffer” slot	Any position in address sequence (omit from T <sub>sc</sub> if group call) except never in conclusion (terminator), or <u>REP</u> , only if following <u>TO</u>
NOTES:		
<ol style="list-style-type: none"> <li>1. All patterns not shown here are reserved and shall be considered invalid until standardized.</li> <li>2. “@” indicates special utility character (1000000); “?” wildcard (0111111).</li> <li>3. “A,” “B,” “C,” or “D” indicates any alphanumeric member of Basic 38 ASCII subset other than “@,” or “?,” that is “A-Z” and “0-9.”</li> </ol>		
* <u>THRU</u> , <u>REP</u> in T <sub>sc</sub> if group call.		

A.5.2.4.4.1 Basic size.

The basic address word shall be composed of a routing preamble (TO, or possibly a REP which follows a TO, in  $T_{1c}$  of group call, or a TIS or TWAS) plus three address characters, all of which shall be alphanumeric numbers of the Basic 38 ASCII subset. The three characters in the basic individual address provide a Basic 38-address capacity of 46,656, using only the 36 alphanumerics. This three-character single word is the minimum structure. In addition, all ALE stations shall associate specific timing and control information with all own addresses, such as prearranged delays for slotted net responses. As described in A.5.5, the basic individual addresses of various station(s) may be combined to implement flexible linking and networking.

NOTE: All ALE stations shall be assigned at least one (DO: several) single-word address for automatic use in one-word address protocols, such as slotted (multistation type) responses. This is a mandatory user requirement, not a design requirement. However, nothing in the design shall preclude using longer addresses.

A.5.2.4.4.2 Extended size.

Extended addresses provide address fields which are longer than one word (three characters), up to a maximum system limit of five words (15 characters). See table A-X. This 15-character capacity enables Integrated Services Digital Network (ISDN) address capability. Specifically, the ALE extended address word structure shall be composed of an initial basic address word, such as TO or TIS, as described above, plus additional words as necessary to contain the additional characters in the sequence DATA, REP, DATA, REP, for a maximum total of five words. All address characters shall be the alphanumeric members of the Basic 38 ASCII subset.

NOTE 1: All ALE stations shall be assigned at least one (DO: several) two-word address(es) for general use, plus an additional address(es) containing the station's assigned call sign(s). This is a mandatory user requirement, not a design requirement. However, nothing in the design shall preclude using longer addresses.

NOTE 2: The recommended standard address size for intranet, internet, and general non-ISDN use is two words. Any requirement to operate with address sizes larger than six characters must be a network management decision. As examples of proper usage, a call to "EDWARD" would be "TO EDW," "DATA ARD," and a call to "MISSISSIPPI" would be "TO MIS," "DATA SIS," "REP SIP," "DATA PI@."

MIL-STD-188-141B  
APPENDIX A

**TABLE A-X. Basic (38) address structures.**

Words		Address Characters	Types
B	1	1	Stuff-2
A			
S	1	2	Stuff-1
I			
C	1	3	Basic
E X T E N D E D	2	4	Basic + Stuff-2
	2	5	Basic + Stuff-1
	2	6	2 Basic
	3	7	2 Basic + Stuff-2
	3	8	2 Basic + Stuff-1
	3	9	3 Basic
	4	10	3 Basic + Stuff-2
	4	11	3 Basic + Stuff-1
	4	12	4 Basic
	5	13	4 Basic + Stuff-2
5	14	4 Basic + Stuff-1	
5 (limit)	15 (limit)	5 Basic (limit)	
NOTES:			
1. Basic : ABC			
2. Stuff-2: A@@			
3. Stuff-1: AB@			

A.5.2.4.5 Net addresses.

The purpose of a net call is to rapidly and efficiently establish contact with multiple prearranged (net) stations (simultaneously if possible) by the use of a single net address, which is an additional address assigned to all net members in common. When a net address type function is required, a calling ALE station shall use an address structure identical to the individual station address, basic or extended as necessary. For each net address at a net member's station, there shall be a response slot identifier, plus a slot width modifier if directed by the specific standard protocol. As described in paragraphs A.5.5.3 and A.5.5.4, additional information concerning the assigned response slots (and size) must be available, and the mixing of individual, net, and group addresses and calls is restricted

A.5.2.4.6 Group addresses.

The purpose of a group call is to establish contact with multiple nonprearranged (group) stations (simultaneously if possible) rapidly and efficiently by the use of a compact combination of their own addresses which are assigned individually. When a group address type function is required, a calling ALE station shall use a sequence of the actual individual station addresses of the called stations, in the manner directed by the specific standard protocol. A station's address shall not appear more than once in a group calling sequence, except as specifically permitted in the group calling protocols described in A.5.5.4.

NOTE: The group feature is not available in the AQC-ALE protocol.

A.5.2.4.7 Allcall addresses.

An "AllCall" is a general broadcast that does not request responses and does not designate any specific address. This mechanism is provided for emergencies ("HELP!"), broadcast data exchanges, and propagation and connectivity tracking. The global AllCall address is "@?@." The AllCall protocol is discussed in A.5.5.4.4. As a variation on the AllCall, the calling station can organize (or divide) the available but unspecified receiving stations into logical subsets, using a selective AllCall address. A selective AllCall is identical in structure, function, and protocol to the AllCall except that it specifies the last single character of the addresses of the desired subgroup of receiving stations (1/36 of all). By replacing the "?" with an alphanumeric, the selective AllCall special address pattern is "TO @A@" (or possibly "THRU @A@" and "REP @B@" if more than one subset is desired), where "A" (and "B," if applicable) in this notation represents any of the 36 alphanumerics in the Basic-38 subset. "A" and "B" may represent the same or different character from the subset, and specifically indicate which character(s) must be last in a station's address in order to stop scan and listen.

NOTE: For ACQ-ALE, the Part2 address portion shall contain the same three characters used in the TO word of the call.

#### A.5.2.4.8 AnyCalls.

An “AnyCall” is a general broadcast that requests responses without designating any specific addressee(s). It is required for emergencies, reconstitution of systems, and creation of new networks. An ALE station may use the AnyCall to generate responses from essentially unspecified stations, and it thereby can identify new stations and connectivities. The global AnyCall address is “@@?” The AnyCall protocol is discussed in A.5.5.4.5. If too many responses are received to an AnyCall, or if the caller must organize the available but unspecified responders into logical subsets, a selective AnyCall protocol is used. The selective AnyCall address is identical in structure, function, and protocol to the global AnyCall, except that it specifies the last single character of the addresses of the desired subset of receiving station (1/36 of all). By replacing the “?” with an alphanumeric, the global AnyCall becomes a selective AnyCall whose special address pattern is “TO @@A.” If even narrower acceptance and response criteria are required, the double selective AnyCall should be used. The double selective AnyCall is an operator selected general broadcast which is identical to the selective AnyCall described above, except that its special address (using “@AB” format) specifies the last two characters that the desired subset of receiving stations must have to initiate a response.

NOTE: For ACQ-ALE, the Part2 address portion shall contain the same three characters used in the TO word of the call.

#### A.5.2.4.9 Wildcards.

A “wildcard” is a special character that the caller uses to address multiple-station addresses with a single-call address. The receivers shall accept the wildcard character as a substitute for any alphanumeric in their self addresses in the same position or positions. Therefore, each wildcard character shall substitute for any of 36 characters (A to Z, 0 to 9) in the Basic 38-character subset. The total lengths of the calling (wildcard) address, and the called addresses shall be the same. The special wildcard character shall be “?” (0111111). It shall substitute for any alphanumeric in the Basic 38-character subset. It shall substitute for only a single-address character position in an address, per wildcard character. See table A-XI for examples of acceptable patterns.

**TABLE A-XI. Use of “?” wildcard symbol.**

A B C	BASIC “STANDARD,” 1 CASE EACH
A B ?    A ? C    ? B C	“STANDARD” “WILD-1,” 36 CASES EACH
A ? ?    ? B ?    ? ? C	“STANDARD” “WILD-2,” 1296 CASES EACH
? ? ?	“STANDARD” “WILD-3,” 46656 CASES EACH
A B @	“STUFF-1,” 1 CASE EACH
A ? @    ? B @	“WILD-1” “STUFF-1,” 36 CASES EACH
? ? @	“WILD-2” “STUFF-2,” 1296 CASES EACH
A @ @	“STUFF-2,” 1 CASE EACH
? @ @	“WILD-1” “STUFF-2,” 36 CASES EACH
@ A B	“DOUBLE SELECTIVE ANYCALL,” (“DSA”) 1/1296 CASES
@ A ?	“DSA” “WILD-1,” 1/36 CASES
@ ? B	NOT PERMITTED. USE “SELECTIVE ANYCALL”
@ ? ?	NOT PERMITTED. USE “GLOBAL ANYCALL”
@ @ A	“SELECTIVE ANYCALL”
@ @ ?	“GLOBAL ANYCALL”
@ A ?	“SELECTIVE ALL CALL”
@ ? @	“GLOBAL ALL CALL”
? @ ?	“IN LINK ADDRESS”

**A.5.2.4.10 Self addresses.**

For self test, maintenance, and other purposes, stations shall be capable of using their own self addresses in calls. When a self-addressing type function is required, ALE stations shall use the following self-addressing structures and protocols. Any ALE calling structures and protocols permissible within this standard, and containing a specifically addressed calling cycle (such as

“TO ABC,” but not AllCall or AnyCall), shall be acceptable, except that the station may substitute (or add) any one (or several) of its own calling addresses into the calling cycle.

#### A.5.2.4.11 Null address.

For test, maintenance, buffer times, and other purposes, the station shall use a null address that is not directed to, accepted by, or responded to by any station. When an ALE station requires a null address type function, it shall use the following null address protocol. The null address special address pattern shall be “TO @@@,” (or “REP @@@”), if directly after another TO. The null address shall only use the TO (or REP), and only in the calling cycle ( $T_{cc}$ ). Null addresses may be mixed with other addresses (group call), in which case they shall appear only in the leading call ( $T_{lc}$ ), and not in the scanning call ( $T_{sc}$ ). Nulls shall never be used in conclusion (terminator) (TIS or TWAS). If a null address appears in a group call, no station is designated to respond in the associated slot; therefore, it remains empty (and may be used as a buffer for tune-ups, or overflow from the previous slot’s responder, etc.).

#### A.5.2.4.12 In-link address.

The inlink address feature is used by a system to denote that all members in the established link are to act upon the information sent in the frame containing the inlink address. The inlink address shall be ‘?@?’. When a radio enters the linked condition with one or more stations, the radio shall expand the set of recognized self addresses to include the inlink address (‘?@?’). When a frame is transmitted by any member of the link using the inlink address, all members are thus addressed publicly and are to use the frame information. Thus, if a linked member sent an AMD message, all members would present that message to their user. If the member sent a frame terminated with a TWAS preamble, then all members would note that the transmitting station just ‘left’ the link. Short messages of ‘to-F?@?’, ‘to-?@?’, ‘tis-TALKINGMEMBER’ would act as a keep-alive function and cause the receiving radio to extend any link termination timer.

#### A.5.2.5 Frame structure.

All ALE transmissions are based on the tones, timing, bit, and word structures described in paragraphs A.5.1 and A.5.2.3. All calls shall be composed of a “frame,” which shall be constructed of contiguous redundant words in valid sequence(s) as described in figure A-14, as limited in table A-VII, and in formats as described in A.5.5. There are three basic frame sections: calling cycle, message, and conclusion. See A.5.2.5.5 for basic frame structure examples.



MIL-STD-188-141B  
APPENDIX A

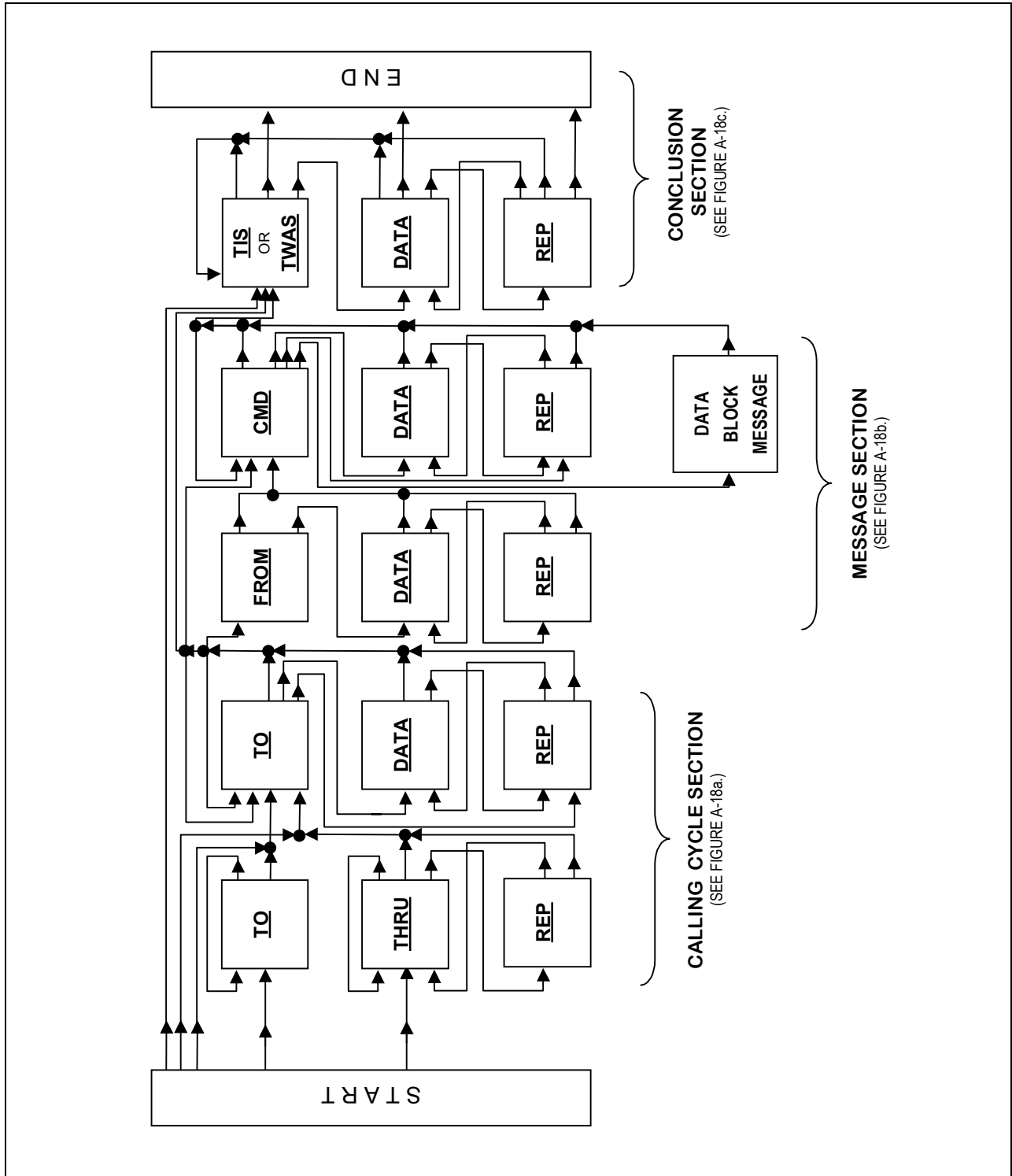


FIGURE A-14. Valid word sequences.

A.5.2.5.1 Calling cycle.

The initial section of all frames (except sounds) is termed a calling cycle ( $T_{cc}$ ), and it is divided into two parts: a scanning call ( $T_{sc}$ ) and a leading call ( $T_{lc}$ ). The scanning call shall be composed of TO words if an individual or net call (or THRU and REP words, alternating, if a group call), which contain only the first word(s) of the called station(s) or net address. The leading call shall be composed of TO (and possibly DATA and REP) words containing the whole address(es) for the called station(s), from initiation of the leading call until the start of the message section or the conclusion (thus the end of the calling cycle). See figure A-15. The use of REP and DATA is described in A.5.2.4. The set of different address first words ( $T_{cl}$ ) may be repeated as necessary for scanning calling ( $T_{sc}$ ), to exceed the scan period ( $T_s$ ). There is no unique “flag word” or “sync word” for frame synchronization (as discussed below). Therefore, stations may acquire and begin to read an ALE signal at any point after the start. The transmitter shall have reached at least 90 percent of the selected rf power within 2.5 ms of the first tone transmission following call initiation. The end of the calling cycle may be indicated by the start of the optional quick-ID, which occupies the first words in the message section, after the leading call and before the start of the rest of the message (or conclusion, if no message) section.

NOTE 1: The frame time may need to be delayed (equipment manufacturer dependent) to avoid loss of the leading words if the transmitter attack time is significantly long.

Alternatively, the modem may transmit repeated duplicates of the scanning cycle (set of) first word(s) to be sent (not to be counted in the frame) as the transmitter rises to full power (and may even use the ALE signal momentarily instead of a tuning tone for the tuner), and then start the frame when the power is up.

NOTE 2: The 2.5-ms permissible delay of the first ALE tone, after the transmitter has reached 90 percent of selected power, is in addition to the allowable attack time delay specified in 5.3.5.1.

NOTE 3: Non-compliance with the 90 percent of power parameter will impact the probability of linking. Compliance testing for this can be construed to be met if the probability of linking criteria is met (see table A-I).

MIL-STD-188-141B  
APPENDIX A

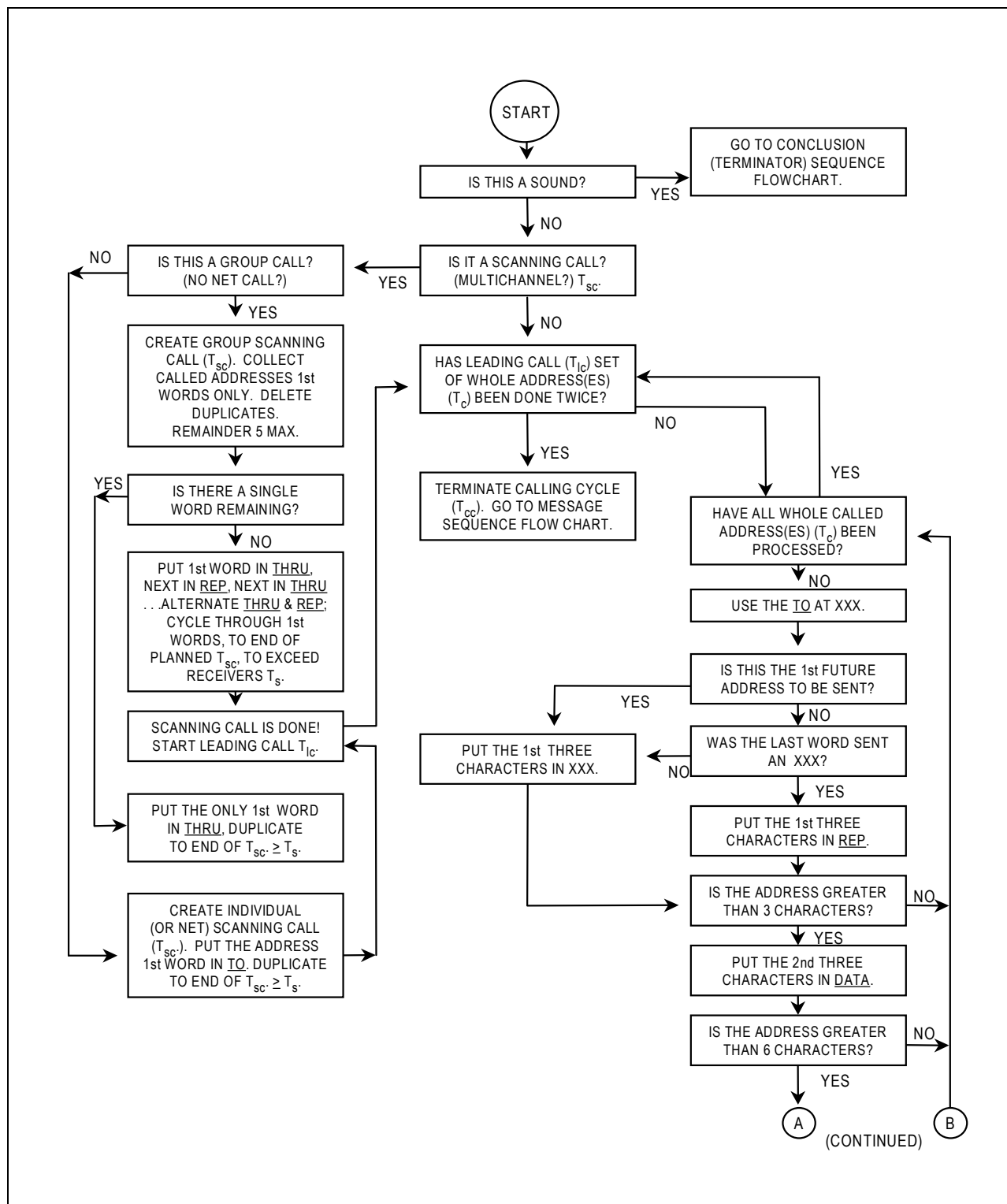
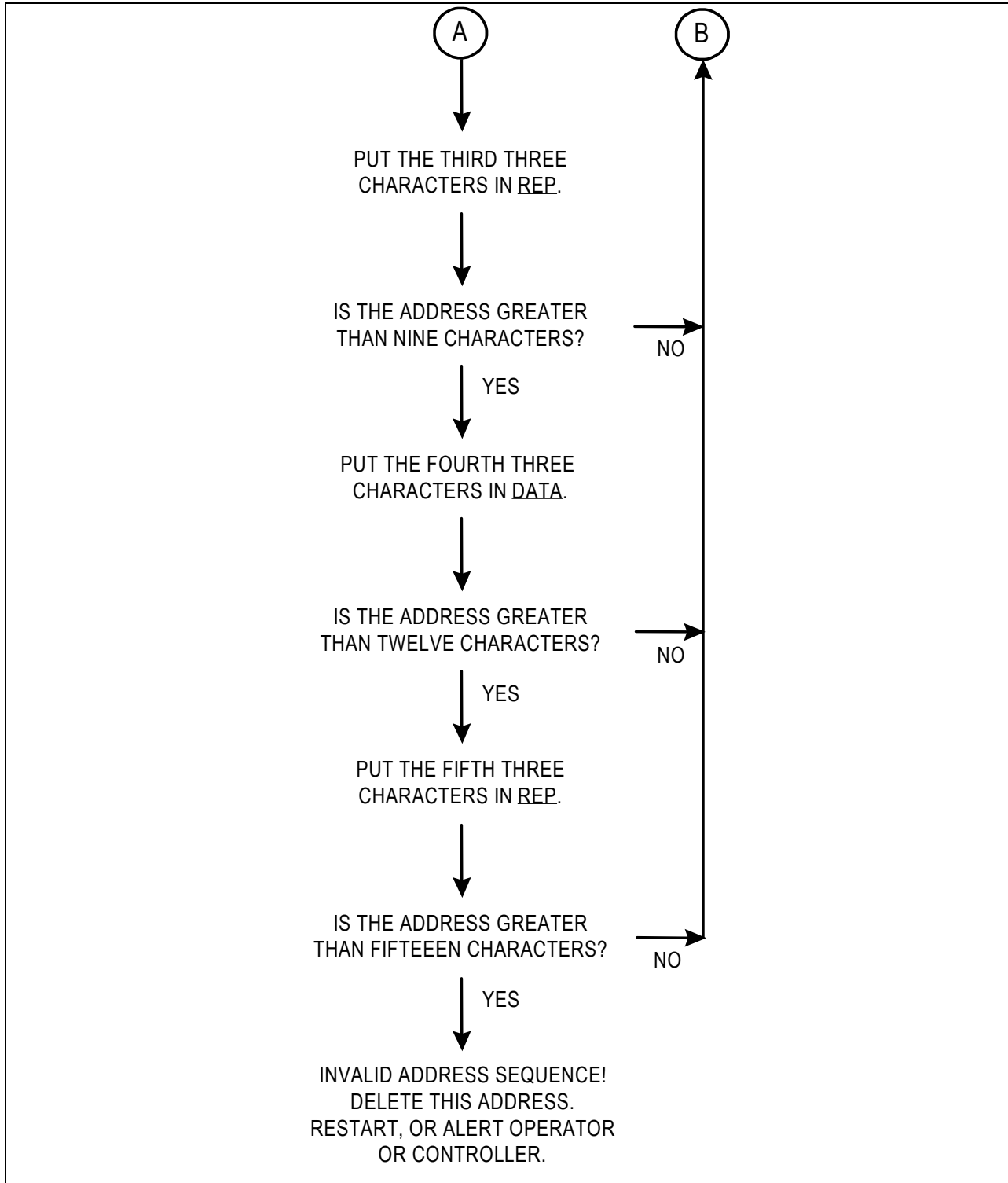


FIGURE A-15. Calling cycle sequence.



**FIGURE A-15. Calling cycle sequence (continued).**

A.5.2.5.2 Message section.

The second and optional section of all frames (except sounds) is termed a “message.” Except for the quick-ID, it shall be composed of CMD (and possibly REP and DATA) words from the end of the calling cycle until the start of the conclusion (thus the end of the message). The optional quick-ID shall be composed of FROM (and possibly REP and DATA) word(s), containing the transmitter’s whole address. It shall only be used once at the start of the CMD message section sequences. The quick-ID enables prompt transmitter identification and should be used if the message section length is a concern. It is never used without a following (CMD...) message(s). The message section shall always start with the first CMD (or FROM with later CMD(s)) in the call. See figure A-16. The use of REP and DATA is described in A.5.7.3. The message section is not repeated within the call (although messages or information itself, within the message section, may be).

For AQC-ALE, the message section in AQC-ALE is available when in a link. The acknowledgement leg (third leg) of a call may be used as an inlink entry condition. See A.5.8.2.3.

MIL-STD-188-141B  
APPENDIX A

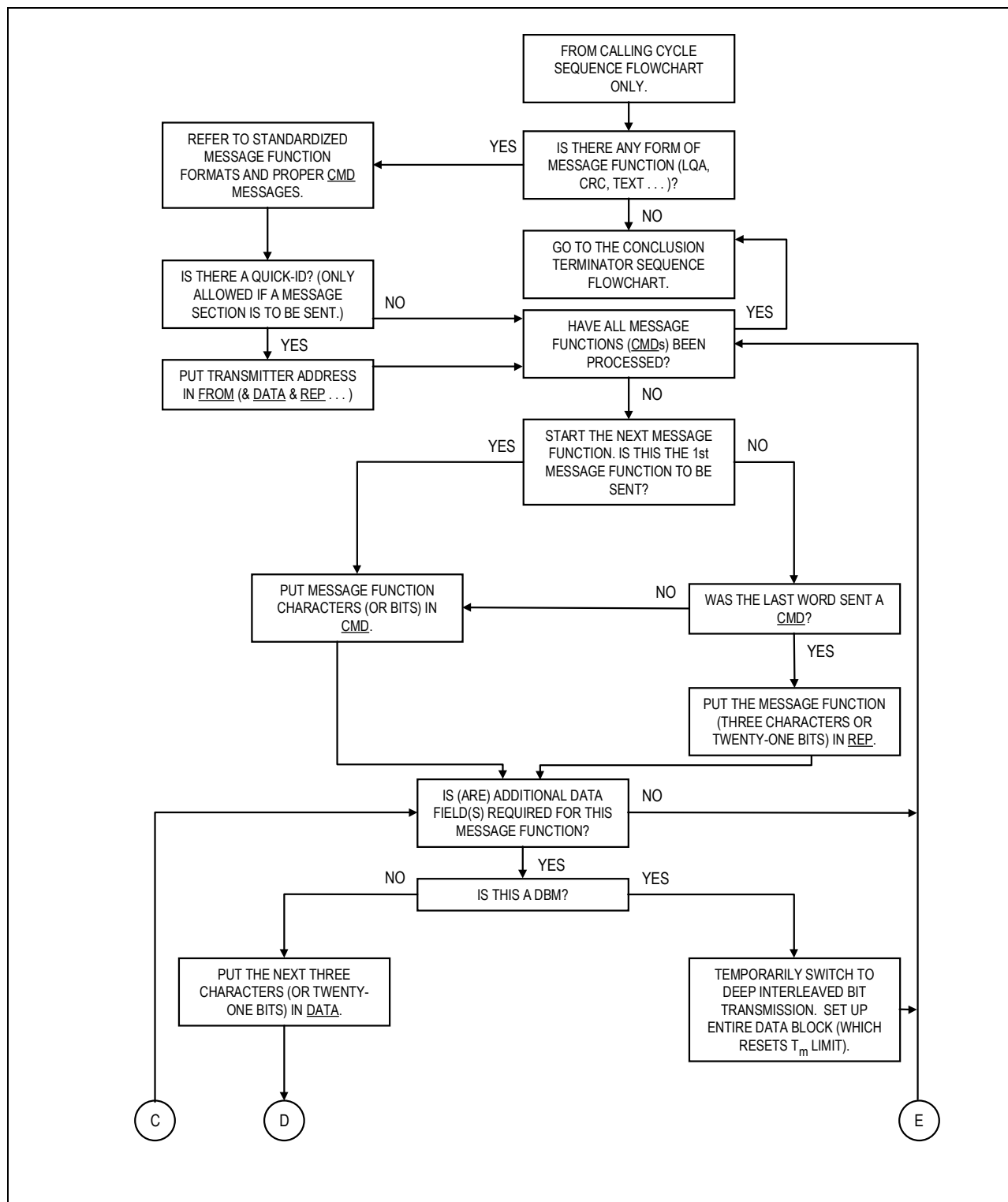
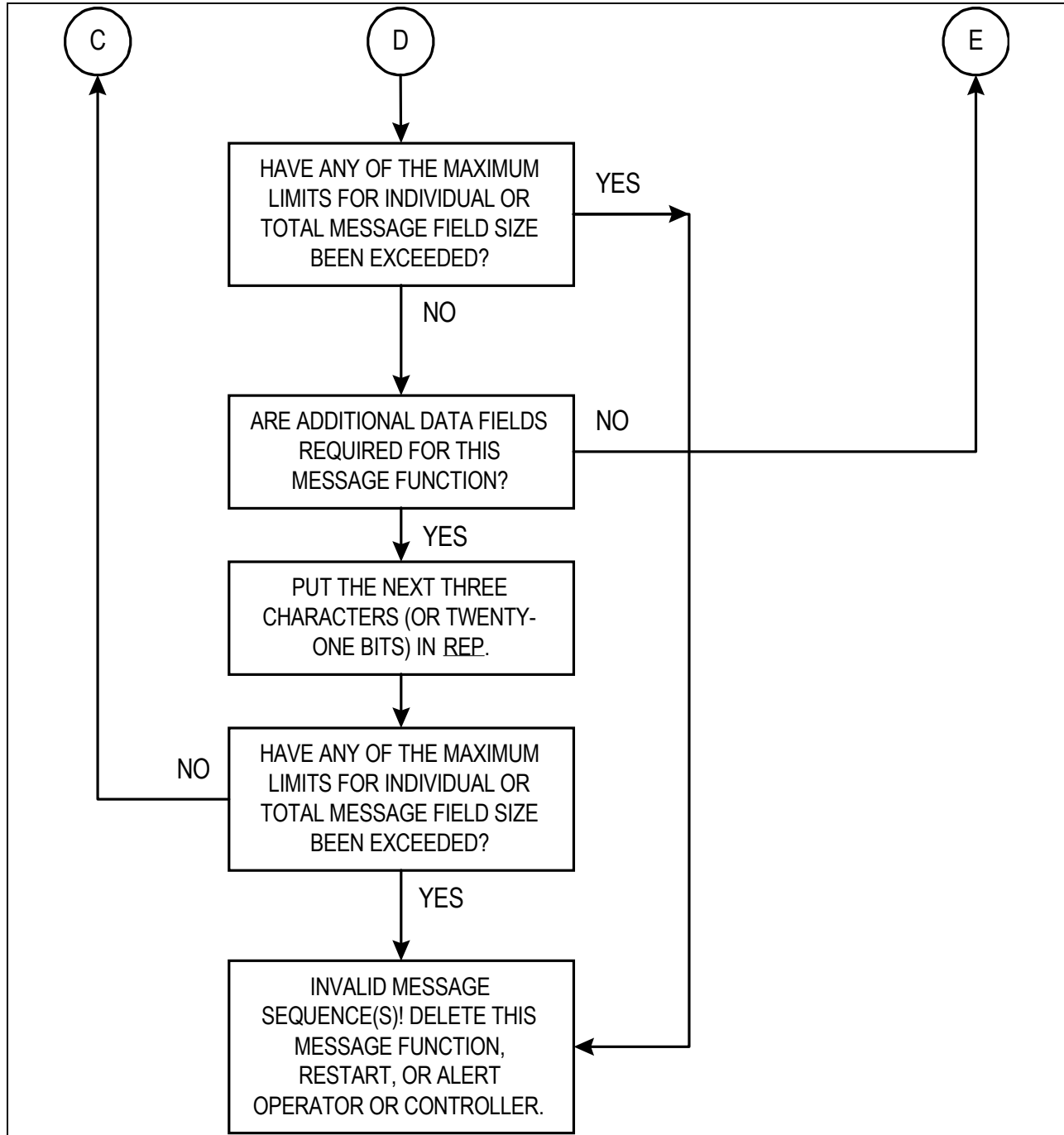


FIGURE A-16. Message sequence.



**FIGURE A-16. Message sequence (continued).**

**A.5.2.5.3 Conclusion.**

The third section of all frames is termed a “conclusion.” It shall be composed of either TIS or TWAS (but not both) (and possibly DATA and REP) words, from the end of the message (or calling cycle sections, if no message) until the end of the call. See figure A-17. Sounds and

MIL-STD-188-141B  
APPENDIX A

exception shall start immediately with TIS (or TWAS) words as described in A.5.3. REP shall not immediately follow TIS or TWAS. Both conclusions and sounds contain the whole address of the transmitting station.

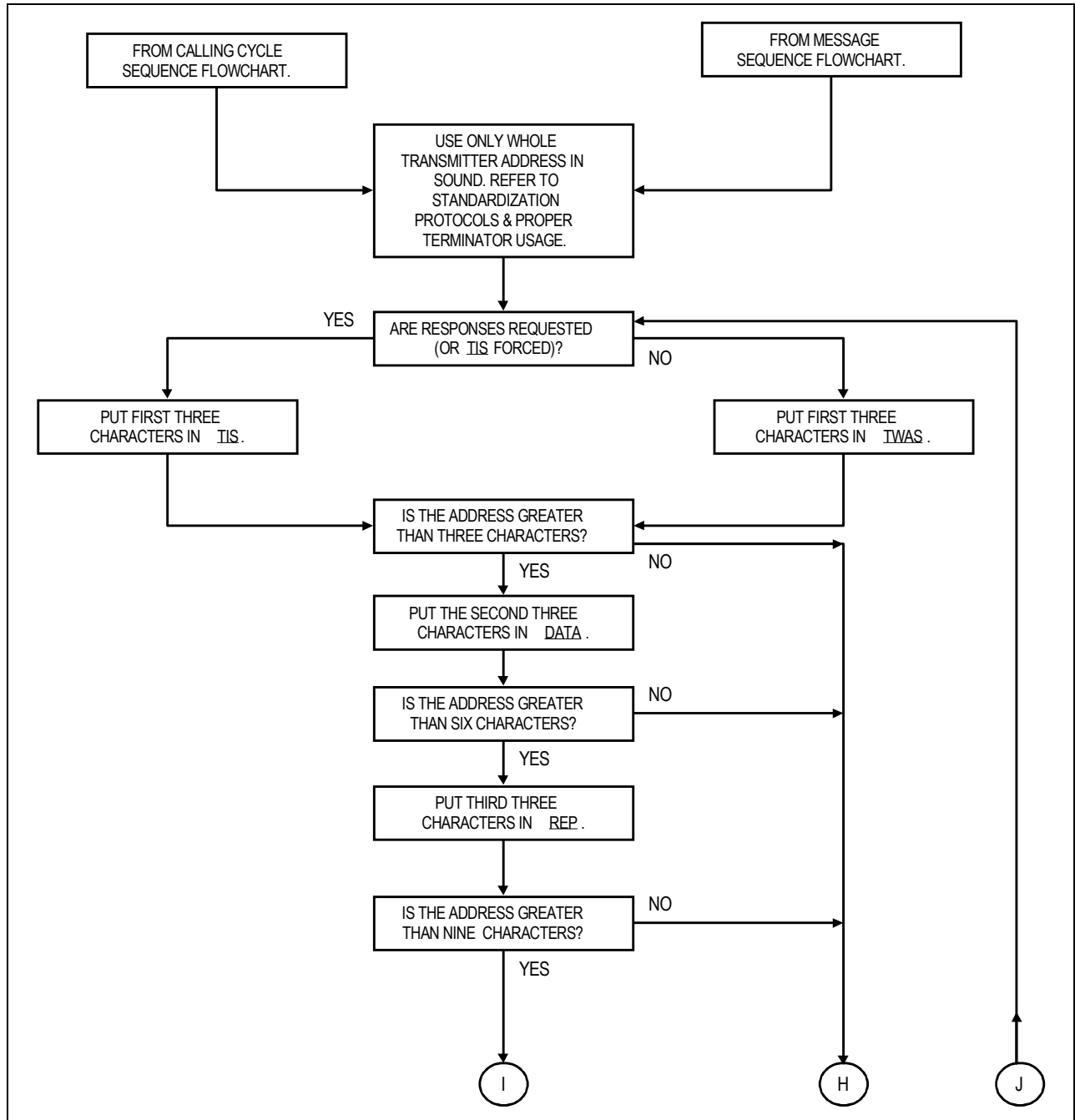


FIGURE A-17. Conclusion (terminator) sequences.



MIL-STD-188-141B  
APPENDIX A

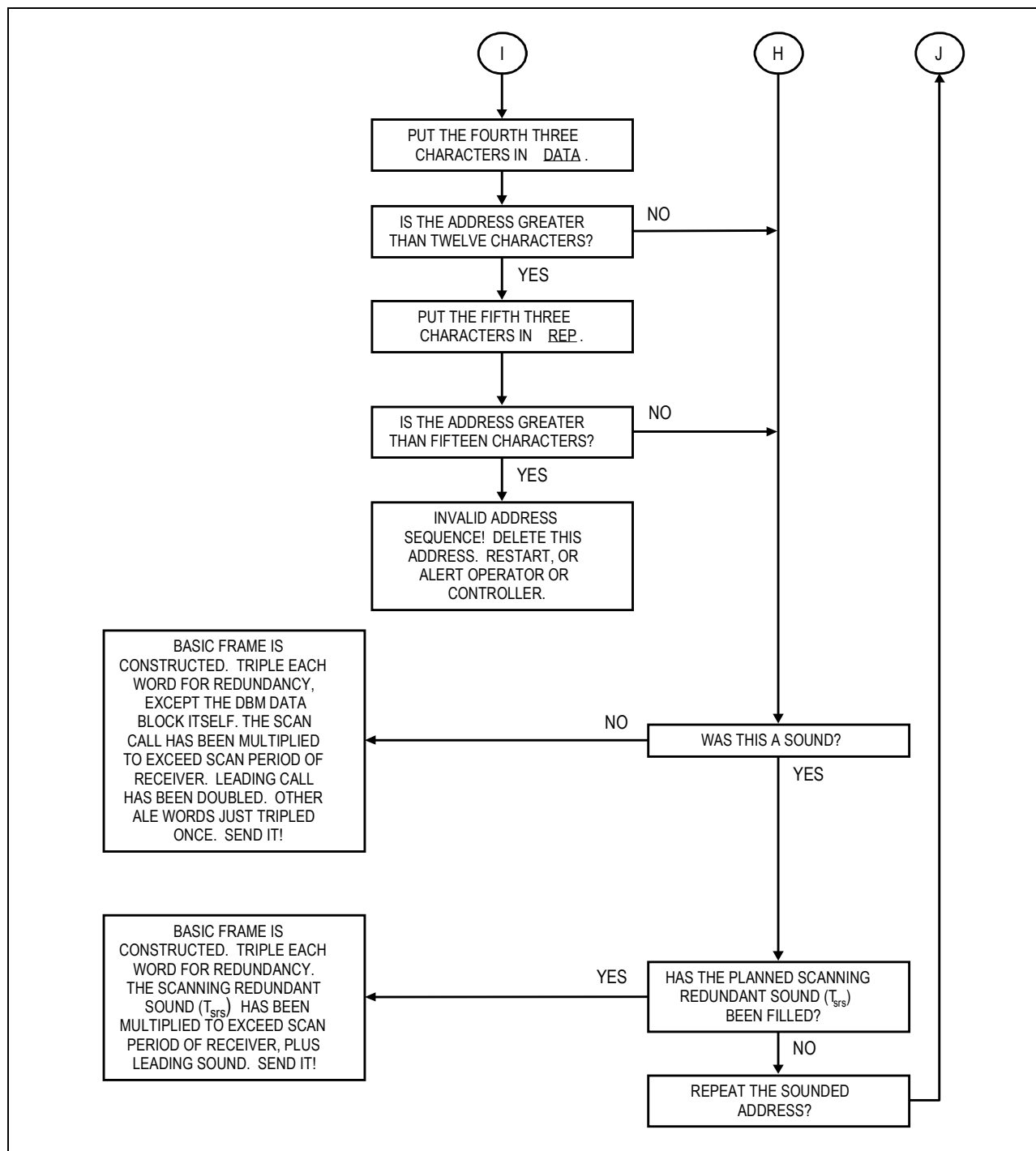


FIGURE A-17. Conclusion (terminator) sequences (continued).

A.5.2.5.4 Valid sequences.

The eight ALE words types that have been described shall be used to construct frames and messages only as permitted in figures A-18, A-19, and A-20. The size and duration of ALE frames, and their parts, shall be limited as described in table A-XII.

**TABLE A-XII. Limits to frames.**

<b>Calls</b>	<b>Limit</b>
Address size (5 words) ( $T_{a \max}$ )	1960 ms
Call time maximum $T_c$ (one-half of $T_{lc} = 12 \text{ words}_{\max}$ )	4704 ms
Scan period ( $T_s \max$ )	50 s
Message section basic time ( $T_{m \max \text{ basic}}$ ) (unless modified by AMD extension, or by <u>CMD</u> such as DTM or DBM)	11.76 s
Message section, time limit of AMD (90 characters) ( $T_{m \max \text{ AMD}}$ )	11.76 s
Message section time, DTM (1053 characters) ( $T_{m \max \text{ DTM}}$ )	2.29 min (entire data block)
Message section time, DBM (37377 characters) ( $T_{m \max \text{ DBM}}$ )	23.26 min (entire deeply interleaved block)

A.5.2.5.5 Basic frame structure examples.

Contained in figure A-21 are basic examples (does not include the optional message section) of frame construction. Included are single-word and multiple-word examples of either single or multiple called station address(es) for non-scan (single-channel) and scanning (multiple-channel) use in individual, net, or group calls.

MIL-STD-188-141B  
APPENDIX A

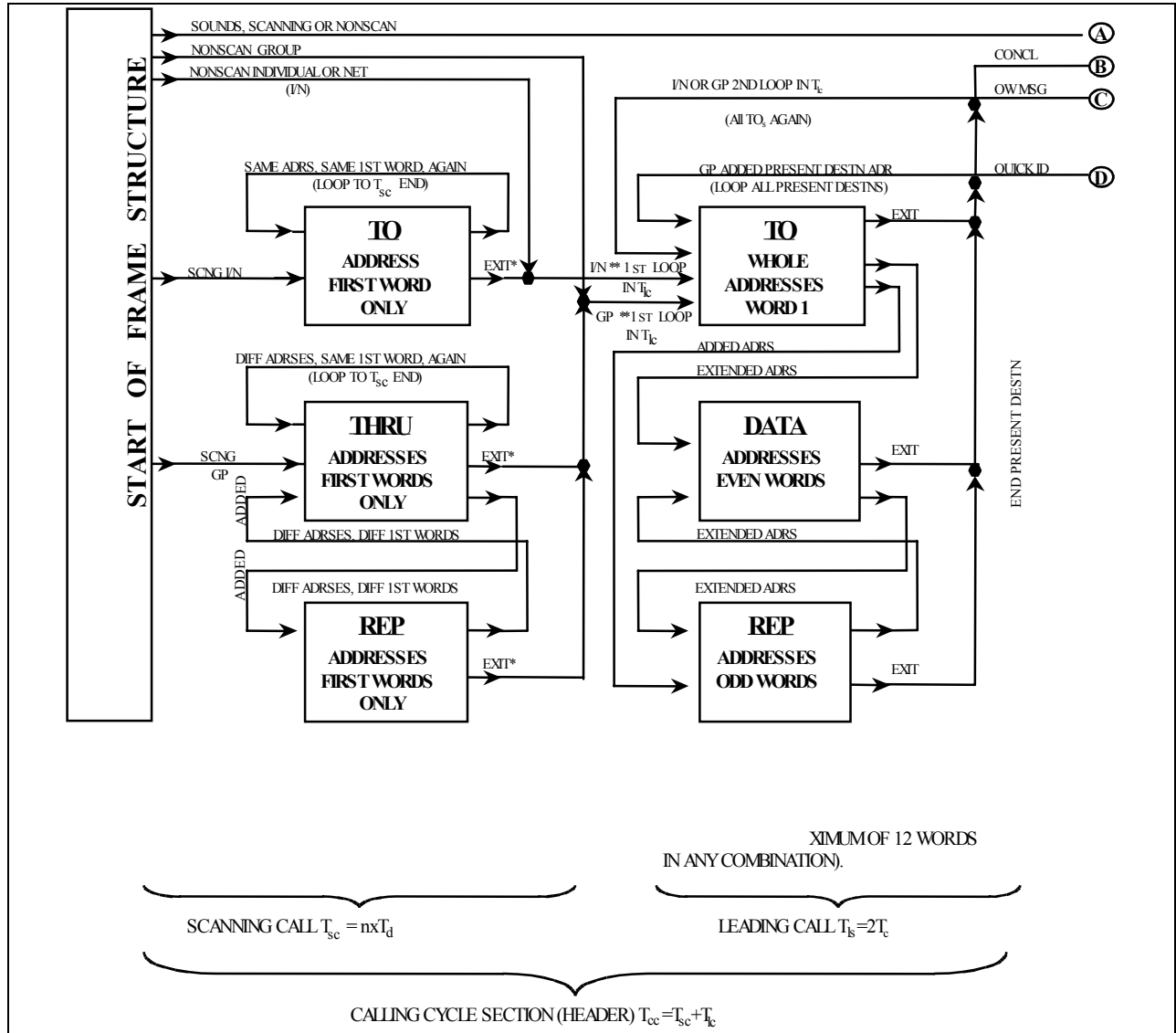
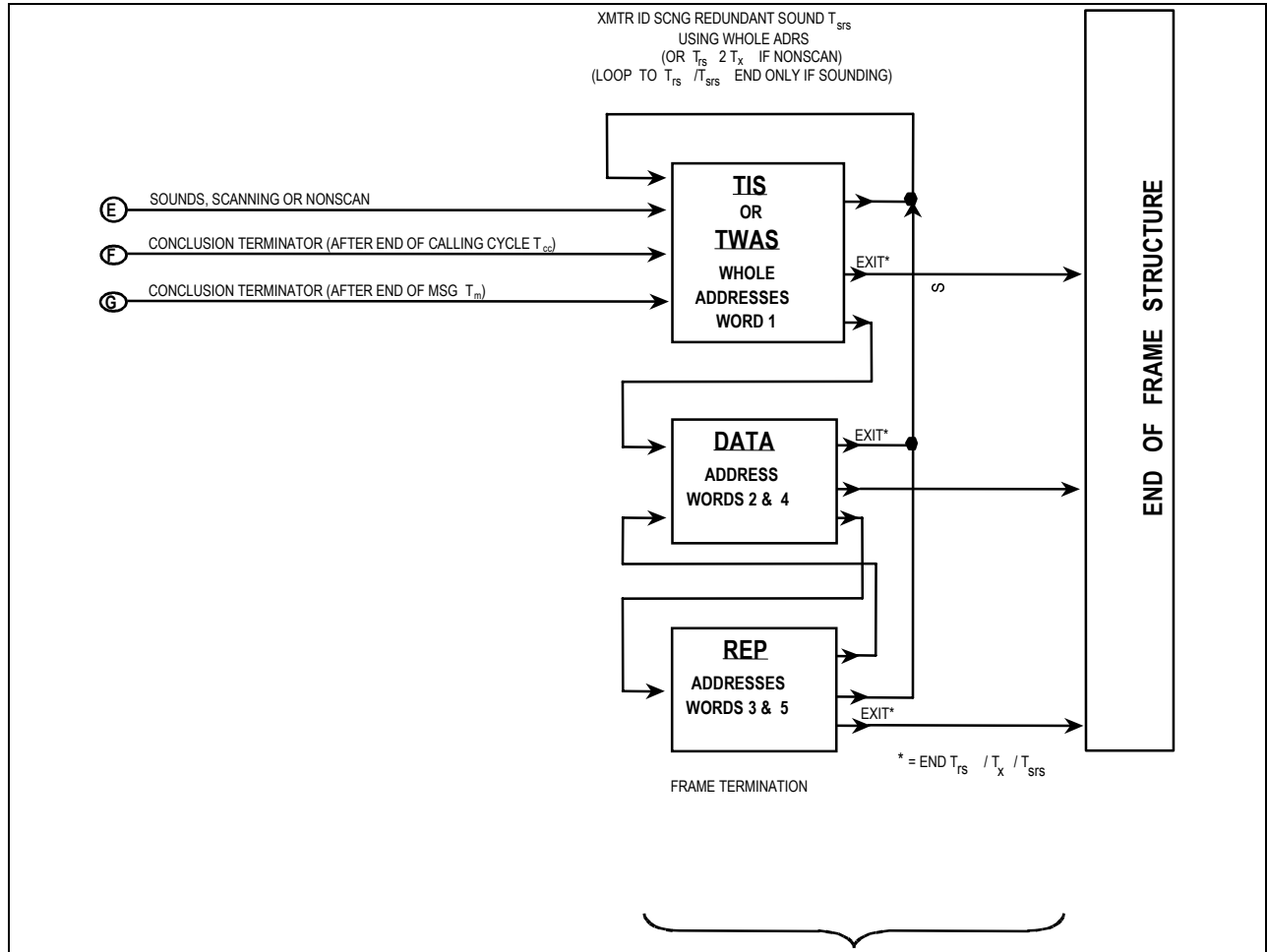


FIGURE A-18. Valid word sequence (calling cycle section).

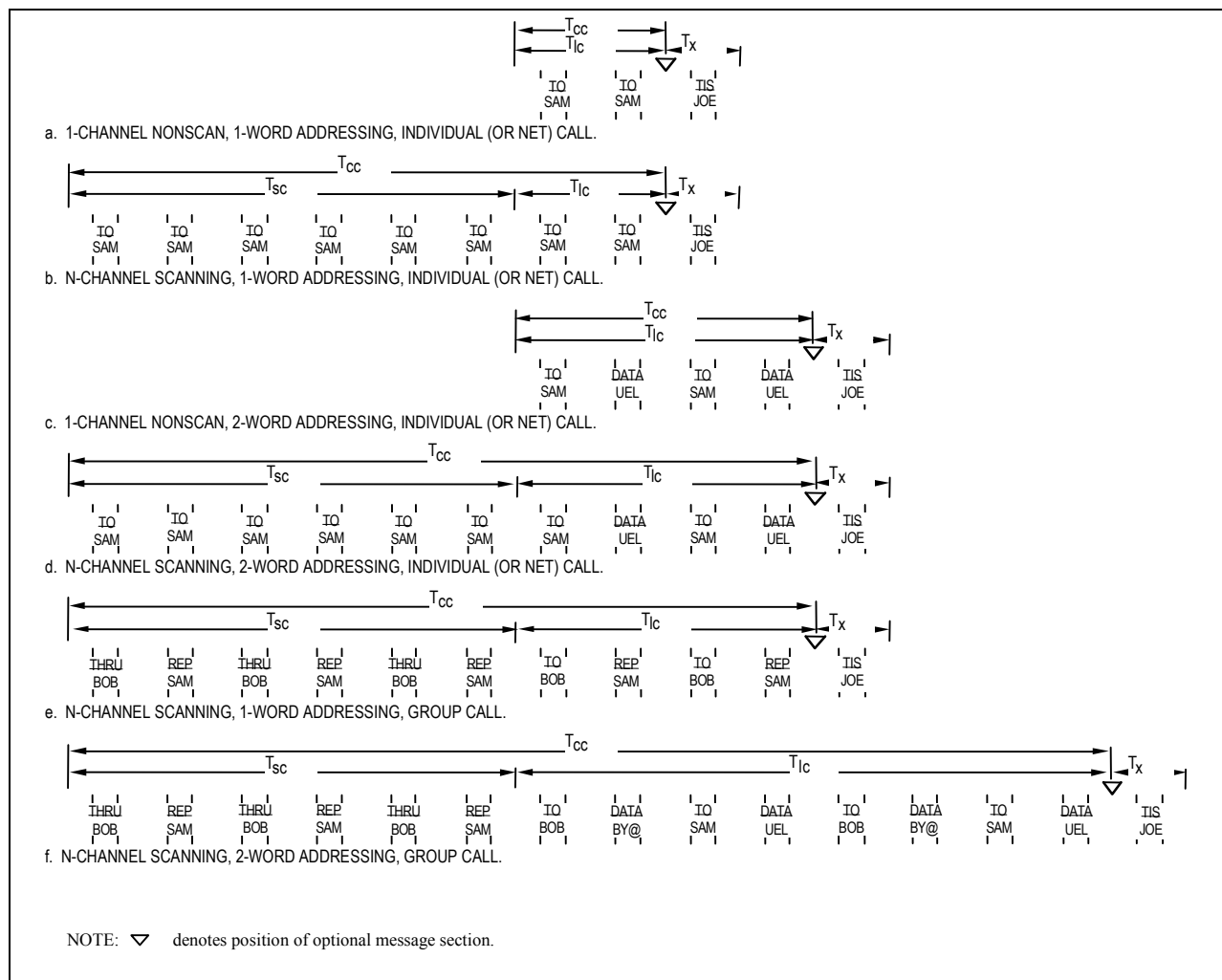


MIL-STD-188-141B  
APPENDIX A



**FIGURE A-20. Valid word sequence (conclusion section).**

MIL-STD-188-141B  
APPENDIX A



**FIGURE A-21. Basic frame structure examples.**

**A.5.2.6 Synchronization.**

The ALE system is inherently asynchronous and does not require any form of system synchronization, although it is compatible with such techniques. Within a frame, the imbedded timing and structure of the system provide the necessary “hooks” for achieving and maintaining word synchronization (word sync) during linking, orderwire, and anti-interference functions, as described herein.

**A.5.2.6.1 Transmit word phase.**

The ALE transmit modulator accepts digital data from the encoder and provides modulated baseband audio to the transmitter. The signal modulation is strictly timed as described in A.5.1.3 and A.5.1.4. After the start of the first transmission by a station, the ALE transmit modulator shall maintain a constant phase relationship, within the specified timing accuracy, among all

transmitted triple redundant words at all times until the final frame in the transmission is terminated. Specifically,

$$T_{(\text{later triple redundant word})} - T_{(\text{early triple redundant word})} = n \times T_{\text{rw}}$$

where  $T_{()}$  is the event time of a given triple redundant word within any frame,  $T_{\text{rw}}$  is the period of three words (392 ms), and  $n$  is any integer.

NOTE: Word phase tracking will only be implemented within a transmission and not between transmissions.

The internal word phase reference of the transmit modulator shall be independent of the receiver (which tracks incoming signals) and shall be self timed (within its required accuracy). See A.5.1.4.

NOTE: In some applications, a single transmission may contain several frames.

#### A.5.2.6.2 Receiver word sync.

The receive demodulator accepts baseband audio from the receiver; acquires, tracks, and demodulates ALE signals; and provides the recovered digital data to the decoders. See figure A-11. In data block message (DBM) mode, the receive demodulator shall also be capable of reading single data bits for deep deinterleaving and decoding.

#### A.5.2.6.3 Synchronization criteria.

The decoder accepts digital data from the receive demodulator and performs deinterleaving, decoding, FEC, and data checking. During initial and continuing synchronization, all of the following criteria should be used to discriminate and read every ALE word:

- Must meet or exceed a threshold of unanimous votes in the 2/3 majority voter decoder
- Successful Golay decode of "A" word bits
- Successful Golay decode of "B" word bits
- Acceptable preamble according to valid word sequences as shown in figure A-14
- Acceptable first character bits (of Basic 38 ASCII subset)
- Acceptable second character bits (of Basic 38 ASCII subset)
- Acceptable third character bits (of Basic 38 ASCII subset)
- History, status, expectations, and protocol
- Correct triple redundant word phase

The number of unanimous votes provides an easily adjustable BER signal quality discrimination, and the threshold should be chosen by the manufacturer to optimize performance. A successful

Golay decode indicates that all detected bit errors were corrected within the power of the FEC code; that is, the errors were within correctable limits and therefore, the uncorrectable error flag(s) did not occur. The correction power (mode) of the Golay code should be chosen by the manufacturer to optimize performance using any of the four modes: (3/4, 2/5, 1/6, 0/7) where n/m indicates up to “n” errors detected and corrected, or up to “m” errors detected but not correctable. Acceptable preambles, as described here and defined in A.5.2.3.1.3, refer to those preambles which are within the limits of this standard. As a DO, automatic adjustment of the unanimous vote threshold and Golay mode should be provided to optimize performance under varying conditions.

NOTE: The application of each preamble is dependent on the recent signaling history of the stations heard, the active status of the machine, the handshake(s) expected, and the protocol being used, if any. For example, an uncommitted station, awaiting calls, would accept TO if individual or net call (and possibly THRU or REP if group call) as valid preambles for calls to it. It would reject CMD as being irrelevant (because it missed the preceding and required calling cycle  $T_{cc}$ ). It might also reject TIS or TWAS (unless collecting sounding information). Acceptable characters means that each character is within the appropriate ASCII subset. Note that all criteria, together, must be satisfied to accept a word. For example, all three characters would have to be within the Basic 38 ASCII subset if a routing preamble such as a TO was decoded. Likewise, any bit combination would be conditionally acceptable if an initial REP was received, but in most cases, without the necessary knowledge of the previous word, it would be considered irrelevant and should be rejected.

### A.5.3 Sounding.

#### A.5.3.1 Introduction.

The sounding signal is a unilateral, one-way transmission performed at periodic intervals on unoccupied channels. To implement, a timer is added to the controller to periodically initiate sounding signals (if the channel is clear). Sounding is not an interactive, bilateral technique, such as polling. However, the identification of connectivity from a station by hearing its sounding signal does indicate a high probability (but not guarantee) of bilateral connectivity and it may be done passively at the receiver. Sounding uses the standard ALE signaling, any station can receive sounding signals. As a minimum, the signal (address) information shall be displayed to the operator and, for stations equipped with connectivity and LQA memories, the information shall be stored and used later for linking. If a station has had recent transmissions on any channels that are to be sounded on, it may not be necessary to sound on those channels again until the sounding interval, as restarted from those last transmissions, has elapsed. In addition, if a net (or group) of stations is polled, their responses shall serve as sounding signals for the other net (or group) receiving stations. All stations shall be capable of performing periodic sounding on clear prearranged channels. The sounding capability may be selectively activated by, and the period between sounds shall be adjustable by the operator or controller, according to system requirements. When available, and not otherwise committed or directed by the operator or



controller, all ALE stations shall automatically and temporarily display the addresses of all stations heard, with an operator selectable alert.

The structure of the sound is virtually identical to that of the basic call; however, the calling cycle is not needed and there is no message section. It is only necessary to send the conclusion (terminator) that identifies the transmitting station. See figure A-22. The type of word, either TIS or TWAS (but never both), indicates whether potential callers are encouraged or ignored, respectively. The minimum redundant sound time ( $T_{rs}$ ) is equal to the standard one-word address leading call time ( $T_{lc}$ )=784 ms. Described below are both single-channel and multiple-channel protocols, plus detailed timing and control information, for designing stations.

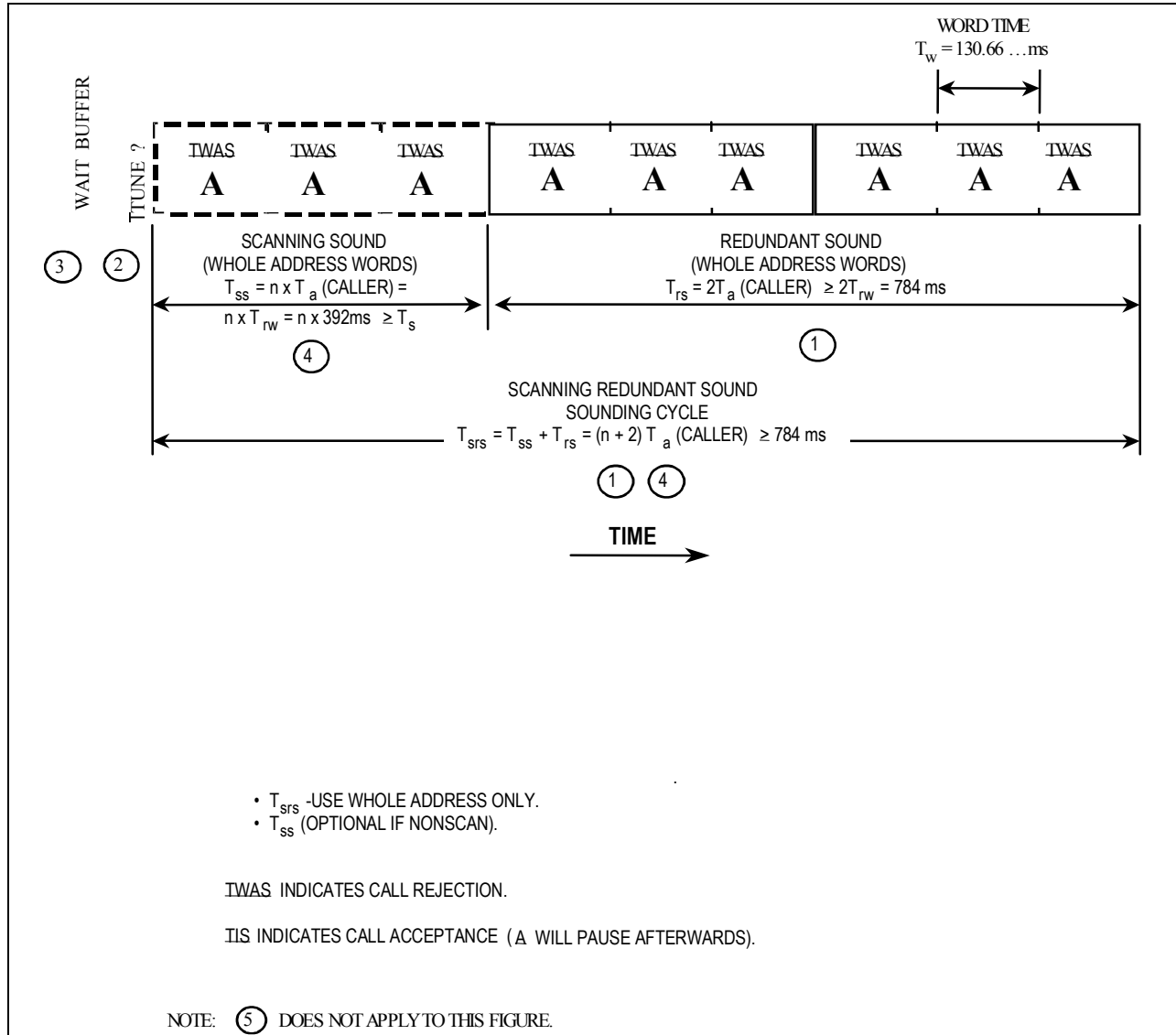
#### A.5.3.2 Single channel.

The fundamental capability to automatically sound on a channel shall be in accordance with the sounding protocol as shown in figure A-22. As an option, stations may employ this protocol for single-channel sounding, connectivity tracking, and the broadcast of their availability for calls and traffic. The basic protocol consists of only one part: the sound. The sound contains its own address (“TIS A”). If “A” is encouraging calls and receives one, “A” shall follow the sound with the optional handshake protocol described in A.5.3.4. If “A” plans to ignore calls, it shall use the TWAS, which advises “B” and the others not to attempt calls, and then “A” shall immediately return to normal “available.” In some systems it is necessary for a multichannel station “A” to periodically sound to a single-channel network, usually to inform them that he is active and available on that channel, although scanning. Upon receipt of “A’s” sound, “B” (see figure A-23) and the other stations shall display “A’s” address as a received sound and, if they have an LQA and connectivity memory, they shall store the connectivity information.

#### A.5.3.3 Multiple channels.

Sounding must be compatible with the scanning timing. All stations shall be capable of performing the scanning sounding protocols described herein, even if operating on a fixed frequency. See figures A-22, A-23, and A-24. These protocols establish and positively confirm unilateral connectivity between stations on any available mutually scanned channel, and they assist in establishment of links between stations waiting for contact. Stations shall employ these protocols for multichannel sounding, connectivity tracking, and the broadcast of their availability for calls and traffic.

MIL-STD-188-141B  
APPENDIX A



**FIGURE A-22. Basic sounding structure.**

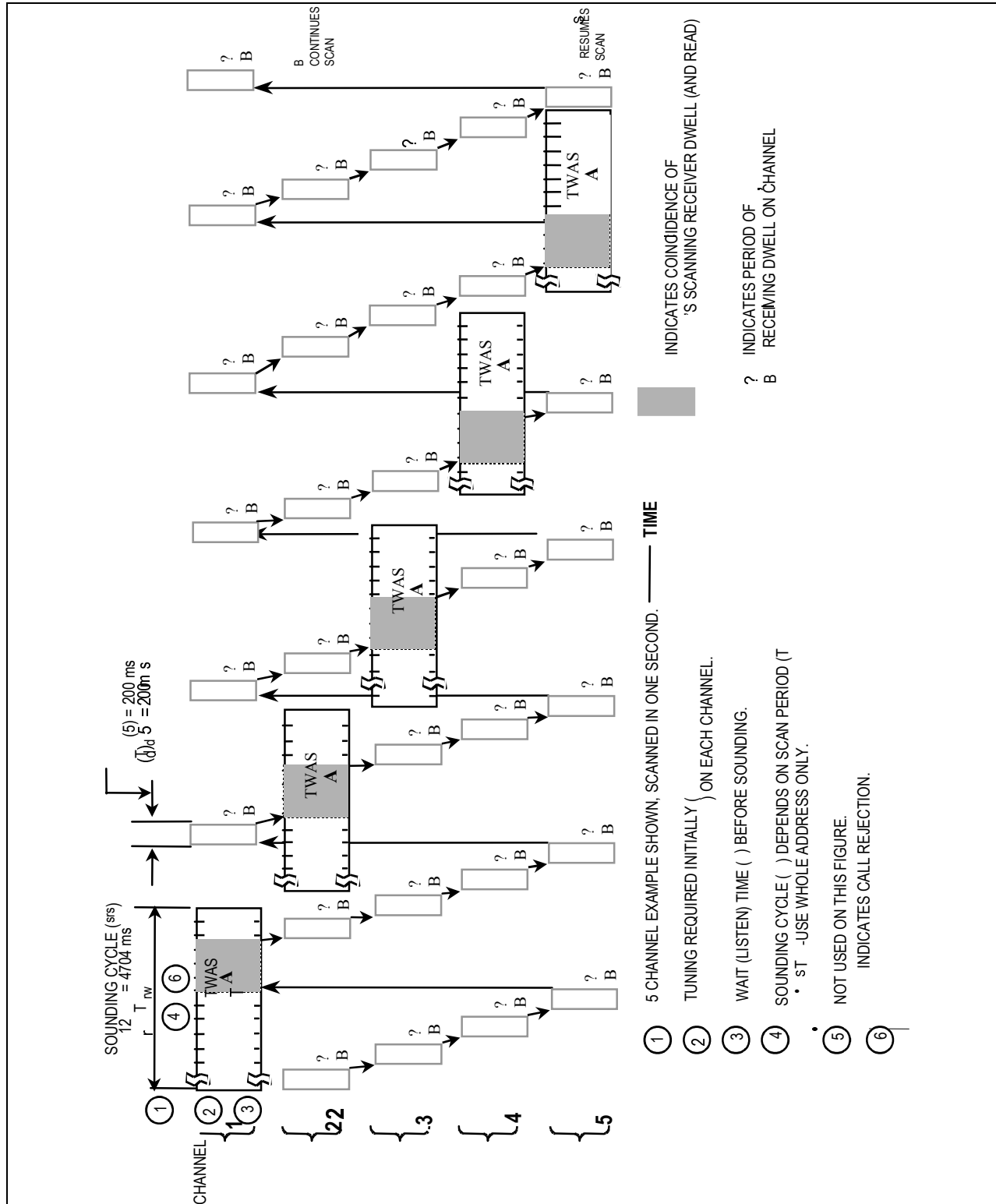


FIGURE A-23. Call rejection scanning sounding protocol.

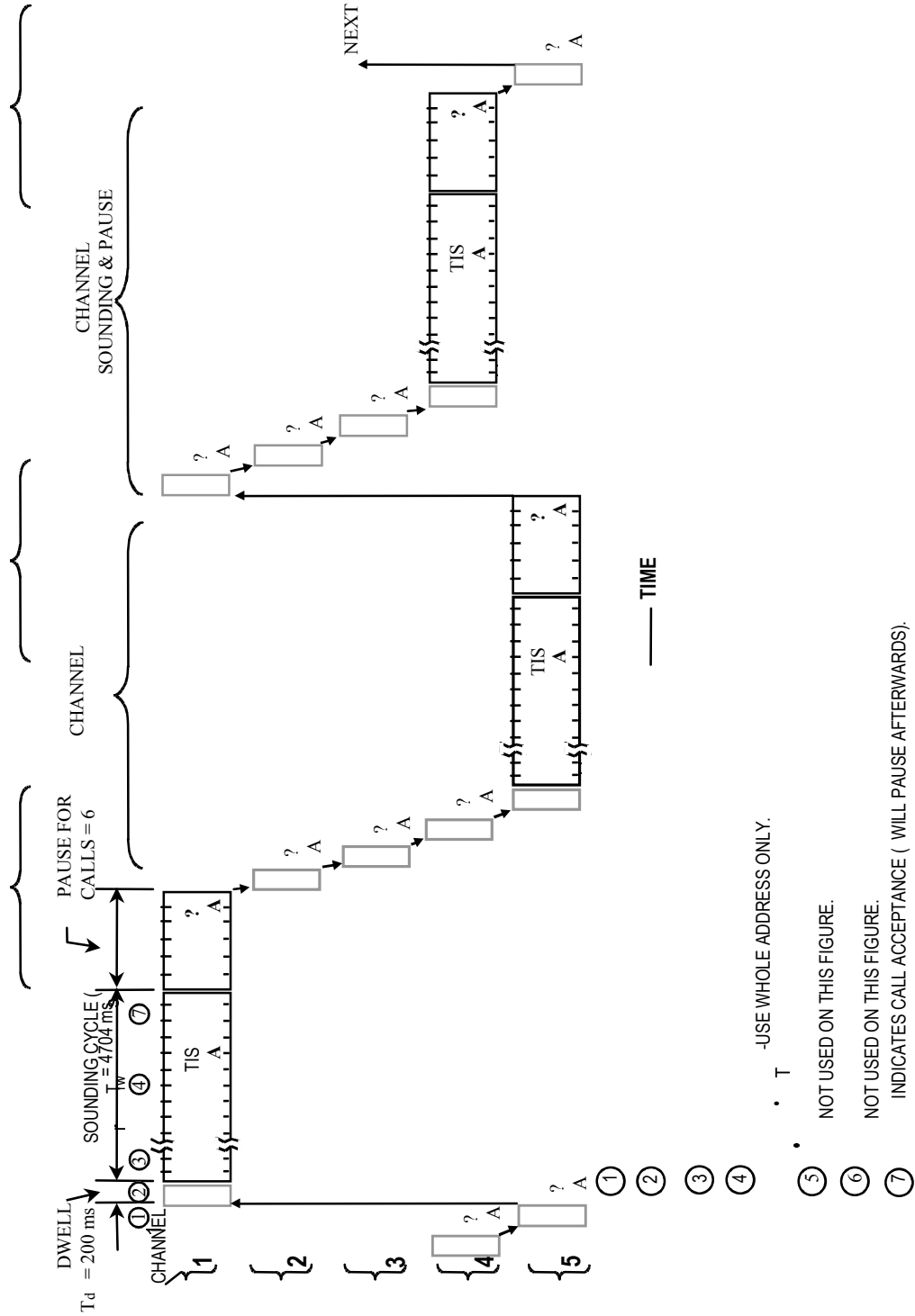


FIGURE A-24. Call acceptance scanning sounding protocol.

All timing considerations and computations for individual scanning calling shall apply to scanning sounding, including sounding cycle times and (optional) handshake times.

NOTE: The scanning sound is identical to the single-channel sound except for the extension of the redundant sound time ( $T_{rs}$ ) by adding words to the scan sounding time ( $T_{ss}$ ) to form a scanning redundant sound time ( $T_{srs}$ ); that is  $T_{srs} = T_{ss} + T_{rs}$ . The scan sounding time ( $T_{ss}$ ) is identical in purpose to the scan calling time ( $T_{sc}$ ) for an equivalent scanning situation, but it only uses the whole address of the transmitter.

The channel-scanning sequences and selection criteria for individual scanning calling shall also apply to scanning sounding. The channels to be sounded are termed a “sound set,” and usually are identical to the “scan set” used for scanning. See figure A-23. In this illustration, station “A” is sounding and station “B” is scanning normally. If a station “A” plans to ignore calls (from “B”), which may follow “A’s” sound, the following call rejection scanning sounding protocol shall be used. In a manner identical to the previously described individual scanning call, “A” lands on the first channel in the scan set (1), waits ( $T_{wt}$ ) to see if the channel is clear (3), tunes ( $T_t$ ) its coupler, comes to full power, and initiates the frame of the scanning redundant sound times ( $T_{srs}$ ). This scanning sound is computed to exceed “B’s” (and any others) scan period ( $T_s$ ) by at least a redundant sound time ( $T_{rs}$ ), which will ensure an available detection period exceeding  $T_{drw} = 784$  ms. In this five-channel example, with “B” scanning at 5 chps, “A” sounds for at least  $12 T_{rw}$  (4704 ms). “A” also uses “TWAS A,” redundantly to indicate that calls are not invited. Upon completion of the scanning sounding frame transmission, “A” immediately leaves the channel and goes to the next channel in the sound set. This procedure repeats until all channels have been sounded, or skipped if occupied. When the calling ALE station has exhausted all the prearranged sound set channels, it shall automatically return to the normal “available” receive scan mode. As shown in figure A-23, the timing of both “A” and “B” have been prearranged to ensure that “B” has at least one opportunity, on each channel, to arrive and “capture” “A’s” sound. Specifically, “B” arrives, detects sounds, waits for good words, reads at least three (redundant) “TWAS A” (in 3 to 4  $T_w$ ), stores the connectivity information (if capable), and departs immediately to resume scan.

There are several specific protocol differences when station “A” plans to welcome calls after the sound. See figure A-24. In this illustration, “A” is sounding and “B” is scanning normally. If station “A” plans to welcome calls (from “B”), which may follow his sound, the following call acceptance scanning sounding protocol shall be used. In this protocol, “A” sounds for the same time period as before. However, since “A” is receptive to calls, he shall use his normal scanning dwell time ( $T_d$ ) or his preset wait before transmit time ( $T_{wt}$ ), whichever is longer, to listen for both channel activity and calls before sounding. If the channel is clear, “A” shall initiate the scanning sound identically to before, but with “TIS A.” At the end of the sounding frame, “A” shall wait for calls identically to the wait for reply and tune time ( $T_{wrt}$ ) in the individual scanning calling protocol, in this case shown to be 6  $T_w$  (for fast-tuning stations). During this wait, “A” shall (as always) be listening for calls that may coincidentally arrive even though unassociated

with “A’s” sound, plus any other sound heard, which “A” shall store as connectivity information if polling-capable. If no calls are received, “A” shall leave the channel.

#### A.5.3.4 Optional handshake.

In the previous descriptions, one alternative action is the implementation of an optional handshake with a station immediately after its sound. This protocol is identical in all regards to the single channel individual call protocol, except that it is manually or automatically (operator or controller) triggered by acquisition of connectivity from the station that is to be called. See figure A-25. In this illustration, “A” is scanning sounding and is receptive to calls, and “B” is receive scanning (or waiting in ambush on a channel) and requires contact with “A” if heard. “A” uses the standard call acceptance scanning sound, including the “TIS A” and the pause for calls. In this case “B” calls “A.” When ALE stations are scanning sounding and receptive to calls, or required contact with such a station, the optional handshake protocol should be used. The calling station should immediately initiate the call upon the determination that the station to be called has terminated its transmission. A wait time before transmit time is not required. Therefore, if “B” hears “A’s” sound and is seeking “A,” “B” calls immediately using the simple single-channel call. Also, if “B’s” operator or controller identifies “A’s” address it can attempt the optional handshake.

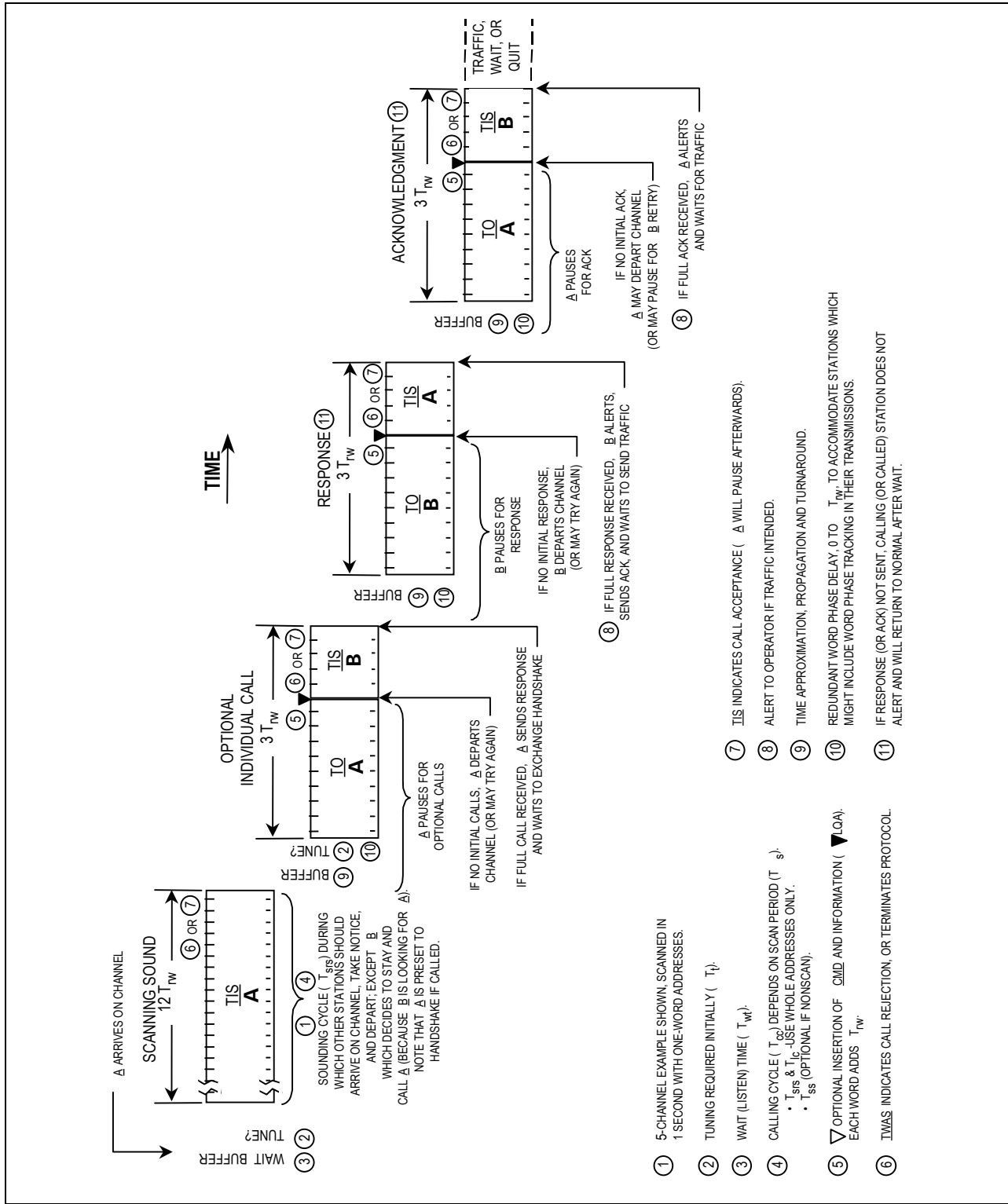


FIGURE A-25. Scanning sounding with optional handshake protocol.

#### A.5.4 Channel selection.

Channel selection is based on the information stored within the LQA memory (such as BER, SINAD, and MP) and this information is used to speed connectivity and to optimize the choice of quality channels. When initiating scanning (multichannel) calling attempts, the sequence of channels to be tried shall be derived from information in the LQA memory with the channel(s) with the “best score(s)” being tried first (unless otherwise directed by the operator or controller) until all the LQA scored channels are tried. However, if LQA or other such information is unavailable (or it has been exhausted and other valid channels remain available and untried) the station shall continue calling on those channels until successful or until all the remaining (untried valid) channels have been tried.

##### A.5.4.1 LQA.

LQA data shall be used to score the channels and to support selection of a “best” (or an acceptable) channel for calling and communication. LQA shall also be used for continual monitoring of the link(s) quality during communications that use ALE signaling. The stored values shall be available to be transmitted upon request, or as the network manager shall direct. Unless specifically and otherwise directed by the operator or controller, all ALE stations shall automatically insert the CMD LQA word (▼) in the message section of their signals and handshakes when requested by the handshaking station(s), when prearranged in a network, or when specified by the protocol. See A.5.4.2. If an ALE station requires, and is capable of using LQA information (polling-capable), it may request the data from another station by setting the control bit KA1 to “1” in the CMD LQA word. If an ALE station, which is sending CMD LQA in response to a request is incapable of using such information itself (not polling-capable), it shall set the control bit KA1 to “0.” It will be a network management decision to determine if the LQA is to be active or passive. For human factor considerations, LQA scores that may be presented to the operator should have higher (number) scores for better channels.

##### A.5.4.1.1 BER.

Analysis of the BER on rf channels, with respect to poor channels and the 8-ary modulation, plus the design and use of both redundancy and Golay FEC, shows that a coarse estimate of BER may be obtained by counting the number of non-unanimous (2/3) votes (out of 48) in the majority vote decoder. The range of this measure is 0 through 48. Correspondence to actual BER values is shown in table A-XIII.

After an ALE receiver achieves word synchronization (see A.5.2.6.2), all received words in a frame shall be measured, and a linear average BER/LQA shall be computed as follows:

- If the Golay decoder reports no uncorrectable errors in both halves of the ALE word, the number of non-unanimous votes detected in the word shall be added to the total.
- If at least one half of the ALE word contained uncorrectable errors, the number of non-unanimous votes detected shall be discarded, and 48 (the maximum value) shall be added to the total.



At the end of the transmission, the total shall be divided by the number of words received, and the total shall be stored in the Link Quality Memory as the most current BER code for the station sending the measured transmission and the channel that carried it.

A.5.4.1.2 SINAD.

The signal to noise and distortion measurement shall be a SINAD measurement  $((S+N+D)/(N+D))$  averaged over the duration of each received ALE signal. The SINAD values shall be measured on all ALE signals.

A.5.4.1.3 MP (optional).

Measurement of MP using received ALE signals is optional.

A.5.4.1.4 Operator display (optional).

Display of SINAD values shall be in dB.

A.5.4.2 Current channel quality report (LQA CMD).

This mandatory function is designed to support the exchange of current LQA information among ALE stations. The CMD LQA word shall be constructed as shown in table A-XIV. The preamble shall be CMD (110) in bits P3 through P1 (W1 through W3). The first character shall be "a" (1100001) in bits C1-7 through C1-1 (W4 through W10), which shall identify the LQA function "analysis." It carries three types of analysis information (BER, SINAD, and MP) which are separately generated by the ALE analysis capability. Note that when the control bit KA1 (W11) is set to "1," the receiving station shall respond with an LQA report in the handshake. If KA1 is set to "0," the report is not required.

A.5.4.2.1 BER field in LQA CMD.

Measurement and reporting of BER is mandatory. The BER field in the LQA CMD shall contain five bits of information, BE5 through BE1 (W20 through W24). Refer to table A-XIII for the assigned values.

A.5.4.2.2 SINAD.

SINAD shall be reported in the CMD LQA word as follows. The SINAD is represented as five bits of information SN5 through SN1 (W15 through W19). The range is 0 to 30 dB in 1-dB steps. 00000 is 0 dB or less, and 11111 is no measurement.

A.5.4.2.3 MP.

If implemented, MP measurements shall be reported in CMD LQA words in the three bits, MP3 through MP1 (W12 through W14). The measured value in ms shall be reported rounded to the nearest integer, except that values greater than 6 ms shall be reported as 6 (110). When MP is not measured, the reported MP value shall be 7 (111).

MIL-STD-188-141B  
APPENDIX A

**TABLE A-XIII. Approximate BER values.**

Average 2/3 Votes Counted	LQA Transmission Bits					Approximate BER
	MSB		LSB			
	BE5	BE4	BE3	BE2	BE1	
0	0	0	0	0	0	0.0
1	0	0	0	0	1	0.006993
2	0	0	0	1	0	0.01409
3	0	0	0	1	1	0.02129
4	0	0	1	0	0	0.02860
5	0	0	1	0	1	0.03602
6	0	0	1	1	0	0.04356
7	0	0	1	1	1	0.05124
8	0	1	0	0	0	0.05904
9	0	1	0	0	1	0.06699
10	0	1	0	1	0	0.07508
11	0	1	0	1	1	0.08333
12	0	1	1	0	0	0.09175
13	0	1	1	0	1	0.1003
14	0	1	1	1	0	0.1091
15	0	1	1	1	1	0.1181
16	1	0	0	0	0	0.1273
17	1	0	0	0	1	0.1368
18	1	0	0	1	0	0.1464
19	1	0	0	1	1	0.1564
20	1	0	1	0	0	0.1667
21	1	0	1	0	1	0.1773
22	1	0	1	1	0	0.1882
23	1	0	1	1	1	0.1995
24	1	1	0	0	0	0.2113
25	1	1	0	0	1	0.2236
26	1	1	0	1	0	0.2365
27	1	1	0	1	1	0.2500
28	1	1	1	0	0	0.2643
29	1	1	1	0	1	0.2795
30 (or more)	1	1	1	1	0	0.3 (or more)
--	1	1	1	1	1	no value available

**TABLE A-XIV. Link quality analysis structure.**

	LQA Bits		Word Bits	
<u>CMD</u> Preamble	MSB	P3=1 P2=1 P1=0	MSB	W1 W2 W3
First Character “a”	MSB	C1-7=1 C1-6=1 C1-5=0 C1-4=0 C1-3=0 C1-2=0		W4 W5 W6 W7 W8 W9
	LSB	C1-1=1		W10
Control		KA1		W11
MP Bits	MSB	MP3 MP2		W12 W13
	LSB	MP1		W14
SINAD Bits	MSB	SN5 SN4 SN3 SN2		W15 W16 W17 W18
	LSB	SN1		W19
BER Bits	MSB	BE5 BE4 BE3 BE2		W20 W21 W22 W23
	LSB	BE1	LSB	W24
NOTES: 1. Command LQA first character is “a” (1100001) for “analysis.” 2. Control bit KA1 (W11) requests an LQA within the handshake from the called station, if set to “1,” and suppresses LQA if set to “0.”				

**A.5.4.3 Historical LQA report.**

See MIL-STD-187-721.

**A.5.4.4 Local noise report CMD (optional).**

The Local Noise Report CMD provides a broadcast alternative to sounding that permits receiving stations to approximately predict the bilateral link quality for the channel carrying the report. An example application of this optional technique is networks in which most stations are silent but need to have a high probability of linking on the first attempt with a base station. A station receiving a Local Noise Report can compare the noise level at the transmitter to its own local noise level, and thereby estimate the bilateral link quality from its own LQA measurement of the received noise report transmission. The CMD reports the mean and maximum noise power measured on the channel in the past 60 minutes.

The Local Noise Report CMD shall be formatted as shown in figure A-26. Units for the Max and Mean fields are dB relative to 0.1  $\mu$ V 3 KHz noise. If the local noise measurement to be reported is 0 dB or less, a 0 is sent. For measured noise ratios of 0 dB to +126 dB, the ratio in dB is rounded to an integer and sent. For noise ratios greater than +126 dB, 126 is sent. The code 127 (all 1s) is sent when no report is available for a field. By comparing the noise levels reported by a distant station on several channels, the station receiving the noise reports can select a channel for linking attempts based upon knowledge of both the propagation characteristics and the interference situation at that destination.

3	7	7	7
<u>CMD</u>	Noise Report (ASCII 'n')	Max	Mean
110	1101110		

**FIGURE A-26. Local noise report (optional).**

A.5.4.5 Single-station channel selection.

All stations shall be capable of selecting the (recent) best channel for calling or listening for a single station based on the values in the LQA memory.

A.5.4.5.1 Single-station channel selection for link establishment.

When selecting a channel for a two-way link, link quality measurements for both directions on each frequency must be considered. Figure A-27 represents a simple LQA memory example. For each address/channel cell, the measured LQA (upper section) and reported LQA values (lower section) are stored. Bilateral (handshake) scores in this example are the sum of the two LQA values.

NOTE 1: For operator viewing, LQA values for better channels should be displayed as higher numbers, and values for poorer channels should be displayed as lower numbers.

NOTE 2: In the example shown in figure A-27, if a handshake is required with station "B," channel C3 would be the best because the "round trip" (bilateral) score would be 5 (1+4), thus the lowest, channel C4 is next best with a score of 6 (3+3), the C5 with 7, C2 with 12, and C6 with 18. Linking attempts should be made in that order (C3, C4, C5, C2, and C6).

C1 is left until last because of the "x", which indicates that a recent attempted handshake on that channel failed to link. Similarly, an attempt to call "A" would yield the sequence C3(3), C5(12), C2(12), C1(24), C6(26), and C4(x). In this case, C5 was equal to C2 (both are 12), but C5 was chosen first because the paths were more balanced (LQA values were more equal).

MIL-STD-188-141B  
APPENDIX A

			CHANNELS					
			C1	C2	C3	C4	C5	C6
ADDRESSES (OTHER STATIONS)	A	FROM	10	4	1	0	5	15
		TO	14	8	2	X	7	11
	B	FROM	9	5	1	3	2	6
		TO	X	7	4	3	5	12
	C	FROM	30	22	13	8	3	18
		TO	X	-	17	6	2	-
	D	FROM	1	2	5	12	20	-
		TO	-	4	7	15	21	-
	E	FROM	-	2	6	7	10	-
		TO	X	14	6	9	12	X

LQA SCORE

NOTES:

- Upper value is LQA measurement on received signal from other stations.
- Lower value is LQA measure on transmitted signal to other station as received and reported back.
- Example shows range of 0 to 30 for LQA "scores," with a smaller value being better.
  - LQA = "0" is excellent, ranging down to "30" which is very poor.
  - LQA = "x" indicates none available after handshake attempt.
  - LQA = "-" indicates none available but handshake not tried.

**FIGURE A-27. LQA memory example.**

A.5.4.5.2 Single-station channel selection for one-way broadcast.

If only a one-way transmission to a station is required instead of a handshake, the scores reported by the destination station (TO section in figure A-27) should be given greater weight than the scores measured on transmissions from that station.

NOTE: In the example, to reach “B,” the sequence would be C4(3), C3(4), C5(5), C2(7), C6(12), and C1(x) as a last resort.

A.5.4.5.3 Single-station channel selection for listening.

When selecting a channel to listen for another station, the scores measured on transmissions from that station (FROM section in figure A-27) should be given greater weight than the scores reported by the destination station.

NOTE: In the example, to listen for “A,” channel C4(0) would be best, and if only three channels were to be scanned, they should be C4, C3, and C2.

A.5.4.6 Multiple-station channel selection.

A station shall also be capable of selecting the (recent) best channel to call or listen for multiple stations, based on the values in the LQA memory.

NOTE: In the example shown in figure A-27, if a multiple-station handshake is required with stations “B” and “C,” C5 is the best choice as the total score is 12 (2+5+3+2), followed by C4 (20) and C3 (35). Next would be C2 (34+) and C6 (36+), this ranking being due to their unknown handshake capability (which had not been tried). C1(x) is the last to be tried because recent handshake attempts had failed for both “B” and “C.” To call the three stations “A,” “B,” and “C,” the sequence would be C5 (24), C3 (38), C2 (46+), C6 (62+), C4 (one x) (recently failed attempt), and finally C1 (two x).

If an additional selection factor is used, it will change the channel selection sequence.

NOTE: In the example, to call “D” and “E,” the sequence would be C2, C3, C4, C5, C1, and C6. If a maximum limit of  $LQA \leq 14$  is imposed on any path (to achieve a minimum circuit quality), only C2 and C3 would be initially selected for the linking attempt. Further, if the LQA limit was “lowered” to 10, C3 would be selected before C2 for the linking attempt.

If a broadcast to multiple stations is required, the TO section (“to” the station) scores are given priority.

NOTE: In the example, to broadcast to “B” and “C,” the sequence would be C5(7), C4(9), C3(21), C2(7+), C6(12+), and C1(two x).

To select channels for listening for multiple stations, the FROM section (“from” the station) scores are given priority.

NOTE: In the example, to listen for “A” and “B,” channel C2 (2) would be best, and if only four channels could be scanned, they should be C2, C3, C4, and C5.

#### A.5.4.7 Listen before transmit.

Before initiating a call or a sound on a channel, an ALE controller shall listen for a programmable time ( $T_{wt}$ ) for other traffic, and shall not transmit on that channel if traffic is detected. Normally, a sound aborted due to detected traffic will be rescheduled, while for a call another channel shall be selected.

##### A.5.4.7.1 Listen-before-transmit duration.

The duration of the listen-before-transmit pause shall be programmable by the network manager. When the selected channel is known to be used only for ALE transmissions, the listen-before-transmit delay need be no longer than  $2 T_{rw}$ . For other channels, at least 2 seconds shall be used. When an ALE controller was already listening on the channel selected for a transmission, the time spent listening on the channel may be included in the listen-before-transmit time.

##### A.5.4.7.2 Modulations to be detected.

The listen-before-transmit function shall detect traffic on a channel in accordance with A.4.2.2. This may be accomplished using any combination of internal signal detection and external devices that provide a channel busy signal to the ALE controller.

##### A.5.4.7.3 Listen before transmit override.

The operator shall be able to override both the listen-before-transmit pause and the transmit lockout (for emergency use).

#### A.5.5 Link establishment protocols.

An ALE controller shall control an attached HF SSB radio to support both manual and automatic link operation as described in the following paragraphs.

##### A.5.5.1 Manual operation.

The ALE controller shall support emergency control by the operator. Each ALE controller shall provide a manual control capability to permit an operator to directly operate the basic SSB radio in emergency situations. At all other times, the radio shall be under automated control, and the operator should operate the radio through its associated controller. The ALE controller’s receiving and passive collection capability to be “always listening,” such as monitoring for sounding signals or alerting the operator, shall not be impaired.

NOTE: This does not abrogate the manual push-to-talk operation required by 4.2.2.

A.5.5.2 ALE.

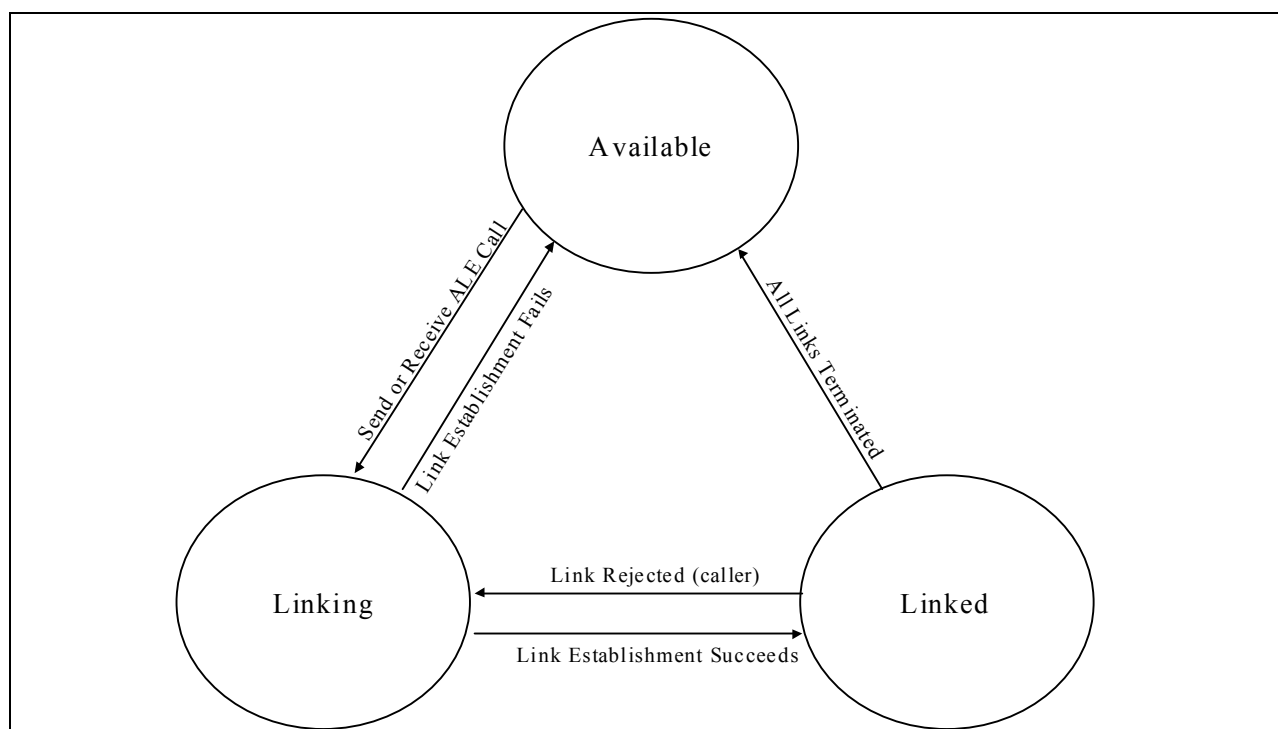
The fundamental protocol exchange for link establishment shall be the three-way handshake (see Appendix I for overview of Selective Calling). A three-way handshake is sufficient to establish a link between a calling station and a responding station. With the addition of slotted responses (described in A.5.5.4.2), the same call/response/acknowledgment sequence can also link a single calling station to multiple responding stations.

A.5.5.2.1 Timing.

The ALE system depends on a selection of timing functions for optimizing the efficiency and effectiveness of ALE. The primary timing functions and values as listed in table A-XV. Annex A defines the timing symbols and Annex B explains the timing analysis and computation.

A.5.5.2.2 ALE states.

An ALE controller may be referred to as being in one of three conceptual “states.” See figure A-28.



**FIGURE A-28. Link establishment states.**

A.5.5.2.3 ALE channel selection.

A scanning calling station shall send ALE calls on its scanned channels in the order dictated by its channel selection algorithm. It shall link on the first channel it tries that supports a handshake with the called station(s).



A.5.5.2.3.1 Rejected channel.

If a channel is rejected after linking by the operator or controller as unsuitable, the ALE controller shall terminate the link in accordance with A.5.5.3.5 and shall update LQA data using measurements obtained during linking.

A.5.5.2.3.2 Busy channel.

During the scanning-calling cycle, a caller may encounter occupied channels and shall skip them to avoid interference to traffic and activity. After all available channels have been tried, if no contact has been successful, the caller should revisit the previously occupied channels and, if they are free, attempt to call.

A.5.5.2.3.3 Exhausted channel list.

If a calling station has exhausted all of its prearranged scan set channels and failed to establish a link, it shall immediately return to normal receive scanning (the available state). It shall also alert the operator (and networking controller if present) that the calling attempt was unsuccessful.

A.5.5.2.4 End of frame detection.

ALE controllers shall identify the end of a received ALE signal by the following methods. The controller shall search for a valid conclusion (TIS or TWAS, possibly followed by DATA and REP for a maximum of five words, or  $T_{x \text{ max}}$ ). The conclusion must maintain constant redundant word phase within itself (if a sound) and with associated previous words. The controller shall examine each successive redundant word phase ( $T_{rw}$ ) following the TIS (or TWAS) for the first (of up to four) non-readable or invalid word(s). Failure to detect a proper word (or detection of an improper word) or detection of the last REP, plus the last word wait delay time, ( $T_{lww}$  or  $T_{rw}$ ), shall indicate the end of the received transmission. The maximal acceptable terminator sequence is TIS (or TWAS), DATA, REP, DATA, REP.

**TABLE A-XV. Timing.**

NOTE: Refer to annex A and annex B for details.

Basic system timing

- Tone rate = 125 symbols per second (sps)
- Tone period =  $T_{\text{tone}} = 8$  ms
- On-air rate = 375 b/s
- On-air word:  $T_w = 130.66\dots$  ms
- On-air redundant word:  $T_{\text{rw}} = 3 T_w = 392$  ms
- On-air leading redundant words:  $T_{\text{lrw}} = 2 T_{\text{rw}} = 784$  ms
- On-air individual (net) address time:  $T_a = m \times T_{\text{rw}}$  for  $m = 1$  to  $5_{\text{max}}$  words.  
 $T_a = 392$  ms to 1960 ms
- Propagation:  $T_p = 0$  to 70 ms

System timing limits

- Address size limit 5 words:  $T_{a \text{ max}} = 1960$  ms
- Address first word limit:  $T_{\text{al}} = 392$  ms
- Call time maximum:  $T_c = 4704$  ms (one-half of  $T_{\text{lc}} = 12$  words  $_{\text{max}}$ )
- Group addresses first word limit:  $T_{\text{cl}} = 1960$  ms
- Maximum scan period:  $T_{s \text{ max}} = 50$  s
- Message section basic time (unless modified by AMD extension, or by CMD (such as DTM or DBM)):  $T_{m \text{ max}} \text{ basic} = 11.76\text{s}$
- Message section time limit, AMD (90 characters):  $T_{m \text{ max}} \text{ AMD} = 11.76\text{s}$
- Message section time limit, DTM (1053 characters):  $T_{m \text{ max}} \text{ DTM} = 2.29$  min (entire data block)
- Message section time limit, DBM, (37377 characters):  $T_{m \text{ max}} \text{ DBM} = 23.26$  min (entire deeply interleaved block with CMD)
- Termination time limit:  $T_{x \text{ max}} = 1960$  ms

If an ALE (orderwire) protocol such as AMD, DTM, or DBM is used to extend the basic message section, it shall start no later than the start of the 30th word (11.368 s). Such extension of the message section shall be determined by the length of the extended ALE protocol, and the message section shall terminate at the end of the orderwire without additional extension. The conclusion shall start at the end of the message section.

Individual calling

- Minimum dwell time:  $T_d (5)_{\text{min}} = 200$  ms, basic receive scanning (5 channels per second)
- Minimum dwell time:  $T_d (2)_{\text{min}} = 500$  ms minimum receive scanning (2 channels per second (chps))
- Probable maximum dwell per channel, for channel, for  $T_s$  computations, let  $T_d = T_{\text{drw}} = 784$  ms
- Number of channels:  $C$
- Scan period:  $T_s = C \times T_d$
- Call time:  $T_c = T_a$  (one or more whole addresses as required  $\sum T_a$ ) in  $T_{\text{lc}}$
- Call time (Group Call):  $T_{\text{cl}} = T_{\text{al}}$  (one or more different first words,  $\sum T_{\text{al}}$ ) in  $T_{\text{sc}}$
- Leading call time:  $T_{\text{lc}} = 2 T_c$
- Redundant call time:  $T_{\text{rc}} = T_{\text{lc}} + T_x$
- Scanning call time:  $T_{\text{sc}} = n \times T_{\text{cl}} \geq T_s$
- Calling cycle time:  $T_{\text{cc}} = T_{\text{sc}} + T_{\text{lc}} \geq T_s + T_{\text{lc}}$
- Scanning redundant call time:  $T_{\text{src}} = T_{\text{sc}} + T_{\text{rc}}$
- Last word wait delay:  $T_{\text{lw}} = T_{\text{rw}} = 392$  ms

**TABLE A-XV. Timing (continued).**

- Wait for response time delay:  $T_{wr} = T_{ld} + T_p + T_{lww} + T_{ta} + T_{rwp}$  (if not first transmission...) +  $T_{ld} + T_p + T_{rd}$
- Late detect delay:  $T_{ld} = T_w = 130.66...ms$
- Redundant word phase delay:  $T_{rwp} = 0$  to  $T_{rw}$  (0 to 392 ms)
- Turnaround time:  $T_{ta} = T_{rd} + T_{dek} + T_{enk} + T_{tc} + T_{tk} + T_{ld}$
- Wait for calling cycle end time:  $T_{wce} = 2 \times \text{own } T_s$  (default)
- Tune time:  $T_t$  (as required by slowest tuner)
- Wait for reply and tune time:  $T_{wrt} = T_{wr} + T_t$
- Detect signaling period:  $T_{ds} \leq (T_d(5) = 200 \text{ ms})$
- Detect redundant word period:  $T_{drw} = T_{rw} + \text{spare } T_{rw} = 784 \text{ ms}$
- Detect rotating redundant word period:  $T_{drrw} = 2 T_{rw} + \text{spare } T_{rw} = 1176 \text{ ms}$

Sounding

- Redundant sound time (similar to  $T_{lc}$ ):  $T_{rs} = 2 T_a$  (caller)
- Scanning sound time (similar to  $T_{sc}$ ):  $T_{ss} = n \times T_a$  (caller)  $\geq T$
- Scanning redundant sound time (similar to  $T_{cc}$ ):  $T_{srs} = T_{ss} + T_{rs} \geq T_s + T_{rs}$

Star calling

- Minimum standard slot widths:  $T_{sw \text{ min}} = 14, 17 T_w$  for 1st handshake slots, or 17, 20 for subsequent handshake slots, or other  $T_w$  as set by CMD.
- Slot widths:  $T_{sw} = 14, 17, 9$ , or other  $T_w$
- Slot number: SN
- Slot wait time:  $T_{swt} = T_{sw} \times SN$  (uniform case)
- Slot wait time (delay to start reply):  $T_{swt}$  for each slot is the sum of all the previous slot times and so must be different for each slot and is cumulative.  $T_{swt}(SN) = T_{sw} \times SN$  for uniform slots or generally  $T_{swt}(SN) = SN \times [5 T_w + 2 T_a \text{ (caller)} + (\text{optional LQA})T_{rw} + (\text{optional message})T_m] + T_a \text{ (caller)} + [(\text{sum of all previous called addressed})_{m=SN-1} \sum T_a(m) \text{ (called)}]_{m=1}$
- Number of slots: NS
- Wait for net reply (at calling station):  $T_{wrn} = (T_{sw} \times NS)$  for uniform slots, or generally  $T_{wrn} = T_{swt}(NS)$
- Wait for net acknowledgment (at called stations):  $T_{wan} = T_{wrn} + T_{drw}$
- Turnaround and tune limits:  $T_{ta} + T_t \leq 360, 2100$ , or 1500 ms, depending on whether slot 0, 1, or others
- Maximum star group wait for acknowledgment:  $T_{wan \text{ max}} = 107 T_w + 27 T_a \text{ (caller)} + 13 T_{rw}$  (optional LQA) + 13  $T_m$  (optional message)
- For late arrival stations, if caller uses one word addresses and no message calling:  $T_{wan \text{ max}} = 188 T_w$ , or 227  $T_w$  if LQA

Programmable timing parameters: typical values

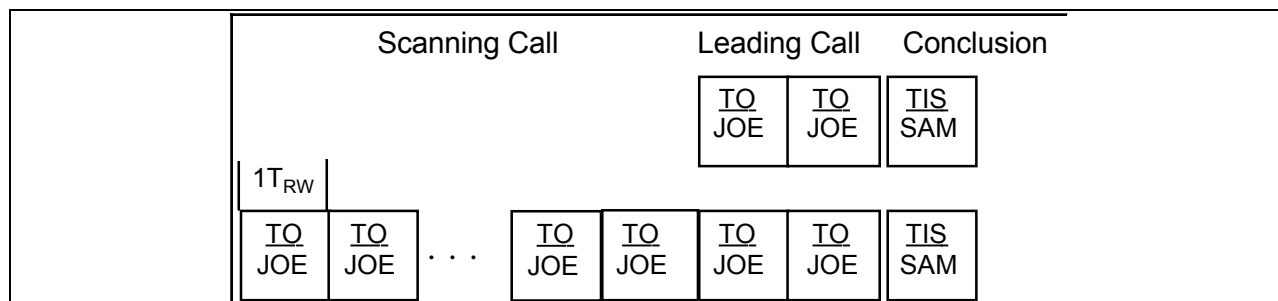
- Wait (listen first):  $T_{wt} = 2$  seconds, general uses; = 784 ms, ALE/data only channels
- Tune time:  $T_t = 8 T_w = 1045.33...ms$  (default), "blind" first call; = 20 seconds, next try
- Automatic sounding:  $T_{ps} = 30$  minutes
- Wait for activity:  $T_{wa} = 30$  seconds

A.5.5.3 One-to-one calling.

The protocol for establishing a link between two individual stations shall consist of three ALE frames: a call, a response, and an acknowledgment. The sequence of events, and the timeouts involved, are discussed in the following paragraphs using a calling station SAM and a called station JOE.

A.5.5.3.1 Sending an individual call.

After selecting a channel for calling, the calling station (SAM) shall begin the protocol by first listening on the channel to avoid “disturbing active channels,” and then tuning. If the called station (JOE) is known to be listening on the chosen channel (not scanning), the calling station shall transmit a single-channel call that contains only a leading call and a conclusion (see upper frame in figure A-29). Otherwise, it shall send a longer calling cycle that precedes the leading call with a scanning call of sufficient length to capture the called station’s receiver as it scans (lower frame in figure A-29). The duration of this scanning call shall be  $2 T_{rw}$  for each channel that the called station is scanning. The scanning call section shall contain only the first word of the called station address, using a TO preamble, and repeated as necessary until the end of the scanning call section.



**FIGURE A-29. Individual calls.**

The entire called station address shall be used in the leading call section, and shall be sent twice (see figure A-29) using a TO preamble each time the first word is sent and DATA and REP as required for additional words.

Any message section CMDs shall be sent immediately following the leading call, followed by a conclusion containing the complete calling station address (“TIS SAM”). The calling station shall then wait a preset reply time to start to receive the called station’s response. In the single-channel case, the wait for reply time shall be  $T_{wr}$ , which includes anticipated round trip propagation delay and the called station’s turnaround time. In the multi-channel case, the calling station shall wait through a wait for reply and tune time ( $T_{wrt}$ ), which also includes time for the called station to tune up on the chosen channel.

If the expected reply from the called station does not start to arrive within the preset wait for reply time ( $T_{wr}$ ) or wait for reply and tune time ( $T_{wrt}$ ), the linking attempt on this channel has failed. At this point, if other channels in the scan set have not been tried, the linking attempt will normally start over on a new channel. Otherwise, the ALE controller shall return to the available state, and the calling station's operator or networking controller shall be notified of the failed linking attempt.

#### A.5.5.3.2 Receiving an individual call.

When the called station (JOE) arrives on channel, sometime during its scan period  $T_s$ , and therefore during the calling station SAM's longer scan calling time  $T_{sc}$ , the called station shall attempt to detect ALE signaling within its dwell time. If ALE signaling is detected, and the controller achieves word sync, it shall examine the received word to determine the appropriate action.

If JOE reads "TO JOE" (or an acceptable equivalent according to protocols), the ALE controller shall stop scan, enter the linking state, and continue to read ALE words while waiting a preset, limited time  $T_{wce}$  for the calling cycle to end and the message or conclusion to begin.

- If the received word is potentially from a sound or some other protocol, the ALE controller shall process the word in accordance with that protocol.
- Otherwise, the ALE controller shall resume its previous state (e.g., available if it was scanning, linked if it was linked to another station).

While reading a call in the linking state, the called station shall evaluate each new received word. The controller shall immediately abort the handshake and return to its previous state upon the occurrence of any of the following:

- It does not receive the start of a quick-ID, message, or frame conclusion within  $T_{wce}$ , or the start of a conclusion within  $T_{mmax}$  after the start of the message section;
- Any invalid sequence of ALE word preambles is received, except that during receipt of a scanning call, up to three contiguous words containing uncorrectable errors shall be tolerated without causing rejection of the frame;
- The end of the conclusion is not detected within  $T_{lww}$ , (plus the additional multiples of  $T_{rw}$  if an extended address) after the first word of the conclusion.

If a quick-ID or a message section starts within  $T_{wce}$ , the called station, (JOE) shall attempt to read one or more complete messages within a new preset, limited time  $T_{mmax}$

If a frame conclusion starts "TIS SAM," the called station shall wait and attempt to read the calling station's address (SAM) within a new preset, limited time  $T_{xmax}$ .

If an acceptable conclusion sequence with TIS is read, the called station shall start a "last word wait" timeout  $T_{lww} = T_{rw}$  while searching for additional address words (if any) and the end of the frame (absence of a detected word), which shall trigger its response. The called station will also expect the calling station to continue the handshake (with an acknowledgment) within the called

station's reply window,  $T_{wr}$ , after its response. If TWAS is read instead, the called station shall not respond but shall return to its previous state immediately after reading the entire calling station address.

If all of the above criteria for responding are satisfied, the called station shall initiate an ALE response immediately after detecting the end of the call, unless otherwise directed by the operator or controller.

#### A.5.5.3.3 Response.

Upon receipt of a call that is addressed to one of its own self addresses (JOE), and which contains a valid calling station address in a TIS conclusion (SAM), the called station shall listen for other traffic on the channel. If the channel is not in use, the station shall tune up, send a response (figure A-30), and start its own reply timer  $T_{wr}$ . (The longer  $T_{wrt}$  timeout is not necessary unless the calling station will send its acknowledgment on a different channel than the one carrying the call, requiring re-tuning.) If the channel is in use, the ALE controller shall ignore the call and return to its previous state unless otherwise programmed.



**FIGURE A-30. Response frame.**

If the calling station (SAM) successfully reads the beginning of an appropriate response (“TO SAM”) starting within its timeout (either  $T_{wr}$  or  $T_{wrt}$ ), it shall process the rest of the frame in accordance with the checks and timeouts described above for the call until it either aborts the handshake or receives the appropriate conclusion, which in this example is “TIS JOE.”

Specifically, the calling station shall immediately abort the handshake upon the occurrence of any of the following:

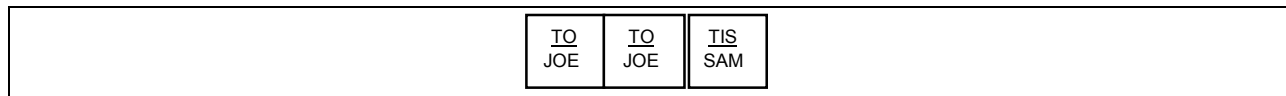
- It does not receive an appropriate response calling cycle (“TO SAM”) starting within the timeout;
- An invalid sequence of ALE word preambles occurs;
- It does not receive the appropriate conclusion (“TIS JOE”) starting within  $T_{lc}$  (plus  $T_{m\ max}$ , if message included);
- The end of the conclusion is not detected within  $T_{lww}$ , (plus the additional multiples of  $T_{rw}$  if an extended address).

After aborting a handshake for any of the above reasons, the calling station will normally restart the calling protocol, usually on another channel.

If the calling station receives the proper conclusion from the called station (“TIS JOE”) starting within  $T_{lc}$  (plus  $T_{m\ max}$ , if message included), it shall set a last word wait timeout as above and prepare to send an acknowledgment. If, instead, “TWAS JOE” is received, the called station has rejected the linking attempt, the calling station ALE controller shall abort the linking attempt and inform the operator of the rejected attempt.

A.5.5.3.4 Acknowledgment.

If all of the above criteria for an acceptable response are satisfied, and if not otherwise directed by the operator or networking controller, the calling station ALE controller shall alert its operator that a correct response has been received, send an ALE acknowledgment (see figure A-31), enter the linked state with the called station (JOE), and unmute the speaker.



**FIGURE A-31. Acknowledgment frame.**

A “wait for activity” timer  $T_{wa}$  shall be started (with a typical timeout of 30 seconds) that shall cause the link to be dropped if the link remains unused for extended periods (see A.5.5.3.5).

If the called station (JOE) successfully reads the beginning of an appropriate acknowledgment (“TO JOE”) starting within its  $T_{wr}$  timeout, it shall process the rest of the frame in accordance with the checks and timeouts described above for the response until it either aborts the handshake or receives the appropriate conclusion, which in this example is “TIS SAM” or “TWAS SAM.” Specifically, the calling station shall immediately abort the handshake upon the occurrence of any of the following:

- It does not receive an appropriate response calling cycle (“TO JOE”) starting within its  $T_{wr}$  timeout;
- An invalid sequence of ALE word preambles occurs;
- It does not receive the appropriate conclusion starting within  $T_{lc}$  after the start of the frame (plus  $T_{m\ max}$ , if message included);
- The end of the conclusion is not detected within  $T_{lww}$ , (plus the additional multiples of  $T_{rw}$  if an extended address).

If the handshake is aborted for any of the above reasons, the handshake has failed, and the called station ALE controller shall return to its pre-linking state. The called station shall notify the operator or controller of the failed linking attempt.

Otherwise, the called station shall enter the linked state with the calling station (“SAM”), alert the operator (and network controller if present), unmute the speaker, and set a wait-for-activity timeout  $T_{wa}$ .

NOTE 1: Although SAM's acknowledgment to JOE appears identical to a single-channel individual call from SAM to JOE, it does not cause JOE to provide another response to the acknowledgment (resulting in an endless "ping-pong" handshake) because SAM's acknowledgment arrives within a narrow time window ( $T_{wr}$ ) after JOE's response, and an acknowledge (ACK) from SAM is expected within this window. If SAM's acknowledgment arrives late (after  $T_{wr}$ ), however, then JOE must treat it as a new individual call (and shall therefore send a new response, if SAM concludes the frame with TIS).

NOTE 2: A typical one-to-one scanning call three-way handshake takes between 9 and 14 seconds.

#### A.5.5.3.5 Link termination.

Termination of a link after a successful linking handshake shall be accomplished by sending a frame concluded with TWAS to any linked station(s) which is (are) to be terminated. For example, "TO JOE, TO JOE, TWAS SAM" (when sent by SAM) shall terminate the link between stations SAM and JOE. JOE shall immediately mute and return to the available state, unless it still retains a link with any other stations on the channel. Likewise, SAM shall also immediately mute and return to the available state, unless it retains a link with any other stations on the channel.

##### A.5.5.3.5.1 Manual termination.

A means shall be provided for operators to manually reset a station, which shall mute the speaker(s), return the ALE controller to the available state, and send a link terminating (TWAS) transmission, as specified above, to all linked stations, unless this latter feature is overridden by the operator. (DO: provide a manual disconnect feature that drops individual links while leaving others in place.)

##### A.5.5.3.5.2 Automatic termination.

If no voice, data, or control traffic is sent or received by a station within a preset time limit for activity ( $T_{wa}$ ), the ALE controller shall automatically mute the speaker, terminate the linked state with any linked stations, and return to the available state. The wait for the activity timer is mandatory, but shall also be capable of being disabled by the operator or network manager. This timed reset is not required to cause a termination (TWAS) transmission, as specified above. However, it is recommended that a termination be sent to reset the other linked stations(s) to immediately return them to the available state.

Termination during a handshake or protocol by the use of TWAS (or a timer) should cause the receiving (or timed-out) station to end the handshake or protocol, terminate the link with that station, re-mute, and immediately return to the available state unless it still retains a link with another station.



#### A.5.5.3.6 Collision detection.

While receiving an ALE signal, it is possible for the continuity of the received signal to be lost (due to such factors as interference or fading) as indicated by failure to detect a good ALE word at a  $T_{rw}$  boundary. When one or both Golay words of a received ALE word contain uncorrectable errors, the ALE controller shall attempt to regain word sync, with a bias in favor of words that arrive with the same word phase as the interrupted frame.

If word sync is reacquired but at a new word phase, this indicates that a collision has occurred. The interrupted frame shall be discarded, and the interrupting signal processed as a new ALE frame.

NOTE: Stations should be able to read interfering ALE signals, as they may contain useful (or critical) information, for which the station is “always listening.”

#### A.5.5.4 One-to-many calling.

One station may simultaneously establish a multi-way link with multiple other stations using the protocols described in the following subparagraphs.

##### A.5.5.4.1 Slotted responses.

The simple three-way handshake used for individual links cannot be used for one-to-many calling because the responses from the called stations would collide with each other. Instead, a time-division multiple access (TDMA) scheme is used. Each responding station shall send its response in an assigned or computed time slot as described later for the particular one-to-many protocol.

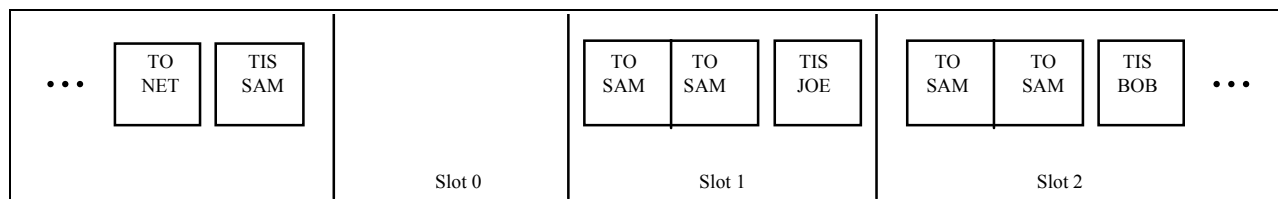
At the end of a one-to-many call frame, the following events shall take place:

- The calling station shall set a wait-for-response-and-tune timeout (WRTT) that shall trigger its acknowledgment after the last response slot time has expired. The time allowed is denoted  $T_{wrn}$ . The value of  $T_{wrn}$  is described later for each one-to-many protocol.
- The called stations shall set their own WRTTs that bound their waiting times for an acknowledgment. To allow time for acquiring word sync during the leading call of the acknowledgment, the waiting time shall be set to  $T_{wan} = T_{wrn} + 2 T_{rw}$ .
- Each called station shall also set a slot wait timeout  $T_{swt}$  that shall trigger its response.
- The called stations shall tune as required during the slot immediately following the end of the call frame, called slot 0.

As each station's slot wait timer expires, it shall send its response and continue to await the expiration of its WRTT. Should that timer expire before the start of an acknowledgment from the calling station, the called station shall abort the linking attempt, and return to its pre-linking state.

A.5.5.4.1.1 Slotted response frames.

Slotted response frames shall be formatted identically to responses in the one-to-one calling protocol (see figure A-32), including a leading call, an optional message section, and a frame conclusion. A responding station shall conclude its response with TIS to accept the call, or TWAS to reject it. When the calling and responding addresses are one-word (as shown), slots are each  $14 T_w$ , or about 1.8 seconds.



**FIGURE A-32. Slotted responses.**

A.5.5.4.1.2 Slot widths.

Unless otherwise specified, all slots shall be  $14 T_w$  in duration, which allows response frames with single-word addresses to propagate to and from the other side of the globe and use commonly available HF transceivers and tuners. When any slot is extended, all following slots shall be delayed commensurately.

- When the calling station address is longer than one word, every slot shall be extended by two  $T_{rw}$  (six  $T_w$ ) per additional address word.
- When a called station address is longer than one word, its slot shall be extended by one  $T_{rw}$  (three  $T_w$ ) per additional address word.
- Slots shall be extended by one  $T_{rw}$  (three  $T_w$ ) for each ALE word to be sent in the message section of responses (including LQA CMD).

A.5.5.4.1.3 Slot wait time formula.

The general formula for determining the correct timing for slotted responses in nonminimum or nonuniform cases is as follows for a selected slot number denoted SN:

$$T_{swt}(SN) = SN \times [5 T_w + 2 T_a(\text{caller}) + (\text{optional message}) T_m] + T_a(\text{caller}) +$$

$$m = SN - 1$$

$$\sum_{m=1} T_a(m) (\text{called})$$

Where  $T_a(\text{caller})$  is the address length (an integer multiple of  $T_{rw}$ ) of the calling station, (optional message)  $T_m$  is an optional message section (same size for all slots), present if and only if requested in the call.  $T_a(m)$  (called) is the address length of the station that will respond in slot  $m$ . (Note that the length of slot 0 is determined by using the address length of the calling station.) The formula for the calling station wait for net reply timeout ( $T_{wnr}$ ) is

$$T_{wrn} = T_{swt} (NS + 1)$$

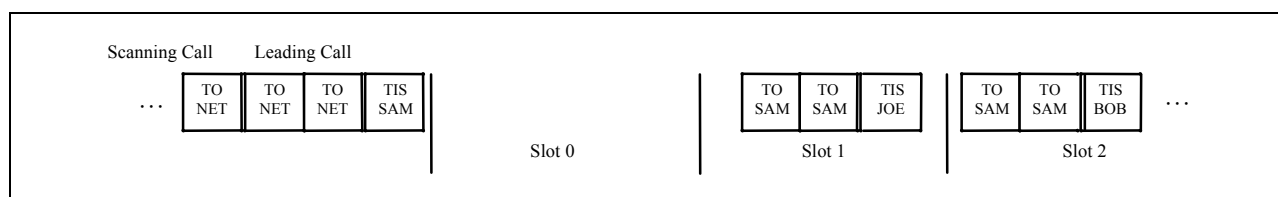
where NS is the total number of slots; one is added to include slot zero.

The formula for the called station acknowledgment timer is

$$T_{wan} = T_{wrn} + 2 T_{rw}$$

#### A.5.5.4.1.4 Slotted response example.

The slotted response example is shown in figure A-33.



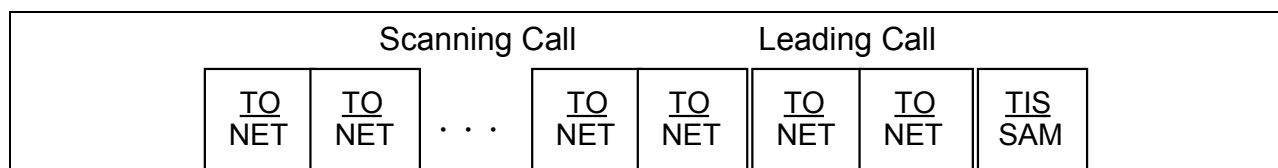
**FIGURE A-33. 2G ALE slotted responses.**

#### A.5.5.4.2 Star net calling protocol.

A net address is assigned to a set of net member stations, as described in A.5.2.4.4. The slot number and address to be used by each net member are preassigned and known to all net members.

##### A.5.5.4.2.1 Star net call.

A star net call is identical to a one-to-one call, except that the called station address is a net address, as shown in figure A-34. The calling station address shall be an individual station address (not a net or other collective address).



**FIGURE A-34. Net call.**

##### A.5.5.4.2.2 Star net response.

When an ALE controller receives a call that is addressed to a net address that appears in its self address memory (see A.4.3.2), it shall process the call using the same checks and timeouts as an individual call (see A.5.5.3.2). If the call is acceptable, it shall respond in accordance with A.5.5.4.1 using its assigned net member address and slot number for the net address that was called.

A.5.5.4.2.3 Star net acknowledgment.

A star net acknowledgment is identical to a one-to-one acknowledgment, except that the called station address is a net address.

An ALE controller that has responded to a net call shall process the acknowledgment from the calling station in accordance with A.5.5.3.4, except that the wait-for-response timeout value shall be the  $T_{wan}$  timeout from A.5.5.4.1.3. A TWAS acknowledgment from the calling station shall return the called ALE controller to its pre-linking state. If a TIS acknowledgment is received from the calling station, the called ALE controller shall enter the linked state with the calling station (SAM in this example), alert the operator (and network controller if present), unmute the speaker, and set a wait-for-activity timeout  $T_{wa}$ .

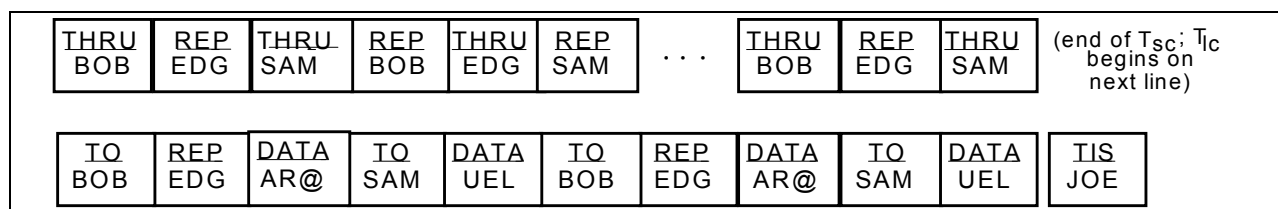
A.5.5.4.3 Star group calling protocol.

The group calling protocol extends the power of one-to-many calling to ad hoc collections of stations that have not been preprogrammed as a net. Nothing need be known about the stations except their individual addresses and scanned frequencies. Because a group is not set up in advance, stations must be able to derive group membership and slot parameters on the fly. Group membership is limited as follows:

- The total length of group member station addresses cannot exceed 12 ALE words.
- The set of unique first address words among group members cannot exceed five words.

A.5.5.4.3.1 Star group scanning call.

A group address is produced by combining individual addresses of the stations that are to form the group. During a scanning call, only the first word(s) of addresses shall be sent, just as for individual or net calls. The set of unique first address words for the group members shall be sent repeatedly in rotation until the end of  $T_{sc}$ . These address words shall alternate between THRU and REP preambles (see figure A-35 for a sample group consisting of BOB, EDGAR, and SAM).



**FIGURE A-35. Group call.**

When group member addresses share a common first word, that word shall be sent only once during  $T_{sc}$ . A limit of five unique first words may be sent in rotation during  $T_{sc}$ .

A.5.5.4.3.2 Star group leading call.

During  $T_{lc}$ , the complete addresses of the prospective group members shall be sent, using TO preambles as usual. Up to 12 address words total are allowed for the full addresses of group members, so  $T_{lc}$  in a group call may last up to  $24 T_{rw}$ . Note in figure A-34 that when a TO word would follow another TO word, a REP preamble must be used, but when a TO follows any other word it shall remain a TO.

A.5.5.4.3.3 Star group call conclusion.

The optional message section and the conclusion of a star group call shall be in accordance with A.5.2.5.

A.5.5.4.3.4 Receiving a star group call.

Slots shall be derived for group call responses by noting the order in which individual addresses appear in the call.

a. When an ALE controller pauses on a channel carrying a group scanning call, it will read either a THRU or a REP preamble. If the address word in this first received word matches the first word of one of its individual addresses, the ALE controller shall stay to read the leading call. Otherwise, it shall continue to read first address words until it finds:

- a match with the first word of a self address, or
- a repetition of a word it has already seen, or
- five unique words.

(In the latter two cases, the station is not being called and the ALE controller shall return to the available or linked state as appropriate.)

b. When  $T_{lc}$  starts, an ALE controller potentially addressed in the scanning call shall watch for its complete address. If found, a slot counter shall be set to 1 and incremented for each address that follows it. If that address is found again (as it should be, because the address list is repeated in  $T_{lc}$ ), the counter shall be then reset to 1, and incremented for each following address as before. The number of words in each following address shall also be noted for use in computing  $T_{swt}$ .

c. The message section (if any) and the frame conclusion shall be processed in accordance with A.5.5.3.2.

In the event that an addressed ALE controller arrives on channel too late to identify the size of the called group, it will be unable to compute the correct  $T_{wan}$ . In this situation, it shall use a default value for  $T_{wan}$ , which is equal to the longest possible group call of twelve one-word addresses. It will, however, have computed its correct slot number because to have received its own address it must also have received the addresses that followed that self address in the leading call.

A.5.5.4.3.5 Star group slotted responses.

Slotted responses shall be sent and checked in accordance with A.5.5.4.1, using the derived slot numbers and the self address contained in the leading call.

A.5.5.4.3.6 Star group acknowledgment.

The acknowledgment in a group call handshake shall be addressed to any subset of the members originally called, and is usually limited to those whose responses were heard by the calling station. The leading call of the acknowledgment shall include the full addresses of the stations addressed, sent twice, using the same syntax as in the call (A.5.5.4.3.2).

An ALE controller that responded to a group call shall await acknowledgment and process an incoming acknowledgment in accordance with A.5.5.3.4, with the following exceptions:

- The wait-for-response timeout value shall be the  $T_{wan}$  timeout from A.5.5.4.1.3, not  $T_{wr}$ .
- Self address detection shall search through the entire leading call group address.

An ALE controller that responded but was not named in the acknowledgment shall return to its pre-linking state. An ALE controller that is addressed in the acknowledgment shall proceed as follows:

- A TWAS acknowledgment from the calling station shall return the called ALE controller to its pre-linking state.
- If a TIS acknowledgment is received from the calling station, the called ALE controller shall enter the linked state with the calling station (SAM in this example), alert the operator (and network controller if present), unmute the speaker, and set a wait-for-activity timeout  $T_{wa}$ .

A.5.5.4.3.7 Star group call example.

In the example group call in figure A-35, SAMUEL will respond in slot 1, with  $T_{swt} = 14 T_w$  (the one-word address JOE causes slot 0 to be  $14 T_w$ ). EDGAR will respond in slot 2, with  $T_{swt} = 14 + 17 T_w = 31 T_w$  (slot 1 is  $17 T_w$  because of SAMUEL's two-word address). BOB will respond in slot 3, with  $T_{swt} = 48 T_w$ . JOE will send an acknowledgment after  $62 T_w$ .

A.5.5.4.3.8 Multiple self addresses in group call.

If a station is addressed multiple times in a group call, even by different addresses, it shall properly respond to at least one address.

NOTE: The fact that the called station has multiple addresses may not be known to the caller. In some cases, it would be confusing or inappropriate to respond to one but not another address. Redundant calling address conflicts can be resolved after successful linking, if there is a problem.

#### A.5.5.4.4 Allcall protocol.

An AllCall requests all stations hearing it to stop and listen, but not respond. The AllCall special address structure(s) (see A.5.2.4.7) shall be the exclusive member(s) of the scanning call and the leading call, and shall not be used in any other address field or any other part of the handshake. The global AllCall address shall appear only in TO words. Selective AllCalls with more than one selective AllCall address, however, shall be sent using group addressing, using THRU during the scanning call and TO during the leading call.

An AllCall pertains to an ALE controller when it is a global AllCall, or when a selective AllCall specifies a character that matches the last character of any self address assigned to that station. Upon receipt of a pertinent AllCall, an ALE controller shall temporarily stop scanning and listen for a preset limited time,  $T_{cc\ max}$ .

- If a message section or frame conclusion does not arrive within  $T_{cc\ max}$ , the controller shall automatically resume scanning.
- If a quick-ID (an address beginning with a FROM word immediately after the calling cycle) arrives, the pause for the message section shall be extended for no more than five words ( $5 T_{rw}$ ), and if a CMD does not arrive, the controller shall resume scanning.
- If a message arrives (indicated by receipt of a CMD), the controller shall pause for a preset limited time,  $T_{m\ max}$  to read the message. If the frame conclusion does not arrive within  $T_{m\ max}$ , the controller shall automatically resume scanning. If a conclusion arrives (indicated by receipt of a TIS or TWAS), the controller shall pause (for a preset limited time,  $T_{x\ max}$ ) to read the caller's address. If the end of the signal does not arrive within  $T_{x\ max}$ , the controller shall automatically resume scanning.

If a pertinent AllCall frame is successfully received and is concluded with a TIS, the controller shall enter the linked state, alert the operator, unmute its speaker and start a wait-for-activity timeout. If an AllCall is successfully received with a TWAS conclusion, the called controller shall automatically resume scanning and not respond (unless otherwise directed by the operator or controller).

If a station receiving an AllCall desires to attempt to link with the calling station, the operator may initiate a handshake within the pause after a TIS conclusion. Note that in all handshakes (the initial AllCall does not constitute a handshake), the AllCall address shall not be used. To minimize possible adverse effects resulting from overuse or abuse of AllCalls, controllers shall have the capability to ignore AllCalls. Normally AllCall processing should be enabled.

#### A.5.5.4.5 AnyCall protocol.

An AnyCall is similar to an AllCall, but it instead requests responses. Use of the AnyCall special address structures is identical to that for the AllCall special address structures. Upon receipt of a pertinent AnyCall, an ALE controller shall temporarily stop scanning and examine the call identically to the procedure for AllCalls, including the  $T_{cc\ max}$ ,  $T_{m\ max}$ , and  $T_{x\ max}$  limits.

If the AnyCall is successfully received, and is concluded with TIS, the controller shall enter the linking state and automatically generate a slotted response in accordance with A.5.5.4.1 and the following special procedure:

- Because neither preprogrammed nor derived slot data are available, the controller shall randomly select a slot number, 1 through 16.
- Each slot shall be  $20 T_w$  (2613.33...ms) wide, unless the calling station requests LQA responses, in which case the slots shall expand by  $3 T_w$  to  $23 T_w$  to accommodate the CMD LQA message section.
- The controller shall compute values for  $T_{swt}$  and  $T_{wan}$  using this slot width and its random slot number.
- Slot 0 shall be used for tuning, as usual for slotted response protocols.
- Upon expiration of its  $T_{swt}$  timeout, the controller shall send a standard star net response consisting of TO (with the address of the caller) and TIS (with the address of the responder), with the LQA CMD included if requested. Responders shall use a self address no longer than five words minus twice the caller address length. (For example, if the caller address is two words, the responder shall use a one-word address.) The AnyCall special address shall not be sent.

In this protocol, collisions are expected and tolerated. The station sending the AnyCall shall attempt to read the best response in each slot.

Upon receipt of the slotted responses, the calling station shall transmit an ACK to any subset of stations whose responses were read, using an individual or group address. The AnyCall special address shall not be used in the acknowledgment. The caller selects the conclusion of its ACK to either maintain the link for additional interoperation and traffic with the responders (TIS), or return everyone to scan (TWAS), as appropriate to the caller's original purpose.

An ALE controller that responded to an AnyCall shall await and process the acknowledgment in accordance with A.5.5.4.3.6.

To minimize possible adverse effects resulting from overuse or abuse of AnyCalls, controllers shall have the capability to ignore AnyCalls. Normally AnyCall processing should be enabled.

#### A.5.5.4.6 Wildcard calling protocol.

Wildcard addresses shall be the exclusive members of a calling cycle in a call, and shall not be used in any other address sequence in the ALE frame or handshake. The span (number of cases possible) of the wildcard(s) used should be minimized to only the essential needs of the user(s).

Calls to wildcard addresses that conclude with TWAS shall be processed identically to the AllCall protocol.



Responses to wildcard calls that conclude with TIS shall be sent in pseudorandomly-selected slots in accordance with the AnyCall protocol.

As in both the AllCall and AnyCall, the controller shall be programmable to ignore wildcard calls, but wildcard call processing should normally be enabled.

A.5.6. ALE control functions (CMDs other than AMD, DTM, and DBM).

In addition to automatically establishing links, stations shall have the capability to transfer information within the orderwire, or message, section of the frame. This section describes these messages, including data, control, error checking, networking, and special purpose functions. Table A-XVI provides a summary of the CMD functions.

NOTE: For critical orderwire messages that require increased protection from interference and noise, several ALE techniques are available. Any message may be specially encoded off-line and then transmitted using the full 128 ASCII CMD data DTM mode (which also accepts random data bits). Larger blocks of information may be Golay FEC coded and deeply interleaved using the CMD DBM mode. Both modes have an automatic repeat request (ARQ) error-control capability. Integrity of the data may be ensured using the CMD cyclic redundancy check (CRC) mode (see A.5.6.1). In addition, once a link has been established, totally separate equipment, such as heavily coded and robust modems, may be switched onto the rf link in the normal circuit (traffic-bearing) mode.

MIL-STD-188-141B  
APPENDIX A

**TABLE A-XVI. Summary of CMD functions.**

First Character	Second Character	Function
Any of the extended-64 character set		AMD
“	1100000	Advanced LQA
a	1100001	LQA
b	1100010	Data block analysis
c	1100011	Channels
d	1100100	DTM
f	1100110	Frequency
m	1101101	Mode selection commands
	a	1100001 Analog port Selection
	c	1100011 Crypto negotiation
	d	1100100 Data port selection
	n	1101110 Modem negotiation
	q	1110001 Digital squelch
n	1101110	Noise report
p	1110000	Power control
r	1110010	LQA report
t	1110100	Scheduling commands
	a	1100001 Adjust slot width
	b	1100010 Station busy
	c	1100011 Channel busy
	d	1100100 Set dwell time
	h	1101000 Halt and wait
	l	1101100 Contact later
	m	1101101 Meet me
	n	1101110 Poll operator (default NAK)
	o	1101111 Request operator ACK
	p	1110000 Schedule periodic function
	q	1110001 Quiet contact
	r	1110010 Respond and wait
	s	1110011 Set sounding interval
	t	1110100 Tune and wait
	w	1110111 Set slot width
	x	1111000 Do not respond
	y	1111001 Year and date
	z	1111010 Zulu time
v	1110110	c 1100011 Capabilities
	s	1110011 Versions
x	1111000	CRC*
y	1111001	CRC*
z	1111010	CRC*
{	1111011	CRC*
	1111100	User-unique functions
~	1111110	Time exchange

\*(16-bit CRC overflows into the two least-significant bits of the first two character)

#### A.5.6.1 CRC.

This special error-checking function is available to provide data integrity assurance for any form of message in an ALE call.

NOTE: The CRC function is optional, but mandatory when used with the DTM or DBM modes.

The 16-bit frame check sequence (FCS) and method as specified by FED-STD 1003 shall be used herein. The FCS provides a probability of undetected error of  $2^{-16}$ , independent of the number of bits checked. The generator polynomial is

$$X^{16} + X^{12} + X^5 + 1$$

and the sixteen FCS bits are designated

$$(\text{MSB}) X^{15}, X^{14}, X^{13}, X^{12} \dots X^1, X^0 (\text{LSB})$$

The ALE CRC is employed two ways: within the DTM data words, and following the DBM data field, described in paragraphs A.5.7.3 and A.5.7.4, respectively. The first, and the standard, usages are described in this section.

The CMD CRC word shall be constructed as shown in table A-XVII. The preamble shall be CMD (110) in bits P3 through P1 (W1 through W3). The first character shall be “x” (1111000), “y” (1111001), “z” (1111010), or “{” (1111011) in bits C1-7 through C1-1 (W4 through W10). Note that four identifying characters result from FCS bits  $X^{15}$  and  $X^{14}$  which occupy C1-2 and C1-1 (W9 and W10) in the first character field respectively. The conversion of FCS bits to and from ALE CRC format bits shall be as described in table A-XVII where  $X^{15}$  through  $X^0$  correspond to W9 through W24.

The CMD CRC message should normally appear at the end of the message section of a transmission, but it may be inserted within the message section (but not within the message being checked) any number of times for any number of separately checked messages, and at any point except the first word (except as noted below). The CRC analysis shall be performed on all ALE words in the message section that precede the CMD CRC word bearing the FCS information, and which are bounded by the end of the calling cycle, or the previous CMD CRC word, whichever is closest. The selected ALE words shall be analyzed in their non-redundant and unencoded (or FEC decoded) basic ALE word (24-bit) form in the bit sequence (MSB) W1, W2, W3, W4...W24 (LSB), followed by the unencoded bits W1 through W24 from the next word sent (or received), followed by the bits of the next word, until the first CMD CRC is inserted (or found). Therefore, each CMD CRC inserted and sent in the message section ensures the data integrity of all the bits in the previous checked ALE words, including their preambles. If it is necessary to check the ALE words in the calling cycle (TO) preceding the message section, an optional calling cycle

CMD CRC shall be used as the calling cycle terminator (first FROM or CMD), shall therefore appear first in the message section, and shall analyze the calling cycle words in their simplest ( $T_c$ ), nonredundant and nonrotated form. If it is necessary to check the words in a conclusion (TIS or TWAS), an optional conclusion CRC shall directly precede the conclusion portion of the call, shall be at the end of the message section, and shall itself be directly preceded by a separate CMD CRC (which may be used to check the message section or calling cycle, as described herein). Stations shall perform CRC analysis on all received ALE transmissions and shall be prepared to compare analytical FCS values with any CMD CRC words which may be received. If a CRC FCS comparison fails, an ARC (or operator initiated) or other appropriate procedure may be used to correct the message.

MIL-STD-188-141B  
APPENDIX A

**TABLE A-XVII. Cyclic redundancy check structure.**

	CRC bits		Word bits		
CMD preamble	MSB	P3-1	MSB	W1	
		P2-1		W2	
	LSB	P1-0		W3	
First characters “x,y,z, {”	(c)	MSB		CL-7-1	W4
				CL-6-1	W5
				CL-5-1	W6
				CL-4-1	W7
				CL-3-0	W8
	(x)	MSB	CL-2-x <sup>15</sup>		W9
	(c)	LSB	CL-1-x <sup>14</sup>		W10
			X <sup>13</sup>		W11
			X <sup>12</sup>		W12
			X <sup>11</sup>		W13
		X <sup>10</sup>		W14	
		X <sup>9</sup>		W15	
		X <sup>8</sup>		W16	
		X <sup>7</sup>		W17	
		X <sup>6</sup>		W18	
		X <sup>5</sup>		W19	
		X <sup>4</sup>		W20	
		X <sup>3</sup>		W21	
		X <sup>2</sup>		W22	
		X <sup>1</sup>		W23	
	(x)	LSB	X <sup>0</sup>	LSB	W24

NOTES:

1. CMD CRC first character is one of four, “x” (1111000), “y” (1111001), “z” (1111010), or “{” (1111011), depending on CRC bits x<sup>15</sup> and x<sup>14</sup>, which are also C1-2 and C1-1, respectively.
2. “x” indicates FCS bits.

**A.5.6.2 Power control (optional).**

The power control orderwire function is used to advise parties to a link that they should raise or lower their rf power for optimum system performance. The power control CMD word format shall be as shown in figure A-36. The KP control bits shall be used as shown in table XVIII.

3	7	3	6	5
<u>CMD</u>	1110000 (‘p’: power control)	KP1-3	Power	(reserved)

**FIGURE A-36. Power control CMD format.**

**TABLE A-XVIII. Power control CMD bits (KP<sub>1-3</sub>).**

Bit	Value	Meaning
KP <sub>3</sub> (MSB)	1	Request to adjust power
	0	Report of current power level
KP <sub>2</sub>	1	Relative Power (in dB)
	0	Absolute Power (in dBW)
KP <sub>1</sub> (LSB)	1	Relative Power (dB) is positive
	0	Relative Power (dB) is negative

The procedure shall be:

- a. When KP<sub>3</sub> is set to 1, the power control command is a request to adjust the power from the transmitter. If KP<sub>2</sub> is 1, the adjustment is relative to the current operating power, i.e., to raise (KP<sub>1</sub> = 1) or lower (KP<sub>1</sub> = 0) power by the number of dB indicated in the relative power field. If KP<sub>2</sub> is 0, the requested power is specified as an absolute power in dBW.
- b. When KP<sub>3</sub> is set to 0, the power control command reports the current power output of the transmitter, in dB relative to nominal power if KP<sub>2</sub> is 1, or in absolute dBW if KP<sub>2</sub> is 0.
- c. KP<sub>1</sub> shall be set to 0 whenever KP<sub>2</sub> is 0.
- d. Normally, a station receiving a power control request (KP<sub>3</sub> = 1) should approximate the requested effect as closely as possible, and respond with a power report (KP<sub>3</sub> = 0) indicating the result of its power adjustment.

#### A.5.6.3 Channel related functions.

The channel related functions are defined in the following subparagraphs.

##### A.5.6.3.1 Channel designation.

When two or more stations need to explicitly refer to channels or frequencies other than the one(s) in use for a link, the following encodings shall be used. A frequency is designated using binary-coded-decimal (BCD). The standard frequency designator is a five-digit string (20 bits), in which the first digit is the 10 megahertz (MHz) digit, followed by 1 MHz, 100 kilohertz (kHz), 10 kHz, and 1 kHz digits. A frequency designator is normally used to indicate an absolute frequency. When a bit in the command associated with a frequency designator indicates that a

frequency offset is specified instead, the command shall also contain a bit to select either a positive or a negative frequency offset.

**A.5.6.3.2 Frequency designation.**

A channel differs from a frequency in that a channel is a logical entity that implies not only a frequency (or two frequencies for a full-duplex channel), but also various operating mode characteristics, as defined in A.4.3.1. As in the case of frequency designators, channels may be specified either absolutely or relatively. In either case, a 7-bit binary integer shall be used that is interpreted as an unsigned integer in the range 0 through 127. Bits in the associated command shall indicate whether the channel designator represents an absolute channel number, a positive offset, or a negative offset.

- a. The frequency select CMD word shall be formatted as shown in figure A-37. A frequency designator (in accordance with A.5.6.3.1) is sent in a DATA word immediately following the frequency select CMD; bit W4 of this DATA word shall be set to 0, as shown.

3	7	6	4	4
<u>CMD</u>	1100110 (‘f’: frequency)	Control	100 Hz	10 Hz

3	1	4	4	4	4	4
DATA	0	Frequency Designator				
		10 MHz	1 MHz	100 kHz	10 kHz	1 kHz

**FIGURE A-37. Frequency select CMD format.**

- b. The 100 Hz and 10 Hz fields in the frequency select CMD word contain BCD digits that extend the precision of the standard frequency designator. These digits shall be set to 0 except when it is necessary to specify a frequency that is not an even multiple of 1 kHz (e.g., when many narrowband modem channels are allocated within a 3 kHz voice channel).
- c. The control field shall be set to 000000 to specify a frequency absolutely, to 100000 to specify a positive offset, or to 110000 to specify a negative offset.
- d. A station receiving a frequency select CMD word shall make whatever response is required by an active protocol on the indicated frequency.

A.5.6.3.3 Full-duplex independent link establishment (optional).

Full duplex independent link establishment is an optional feature; however, if this option is selected the transmit and receive frequencies for use on a link shall be negotiated independently as follows:

- a. The caller shall select a frequency believed to be propagating to the distant station (the prospective responder) and places a call on that frequency. The caller embeds a frequency select CMD word in the call to ask the responder to respond on a frequency chosen for good responder-to-caller propagation (probably from sounding data in the caller's LQA matrix).
- b. If the responder hears the call, it shall respond on the second frequency, asking the caller to switch to a better caller-to-responder frequency by embedding a frequency select CMD word in its response (also based upon sounding data).
- c. The caller shall send an acknowledgment on the frequency chosen by the responder (the original frequency by default), and the full duplex independent link is established.

A.5.6.3.4 LQA polling (optional).

See MIL-STD-187-721.

A.5.6.3.5 LQA reporting (optional).

See MIL-STD-187-721.

A.5.6.3.6 LQA scan with linking (optional).

See MIL-STD-187-721.

A.5.6.3.7 Advanced LQA (optional).

See MIL-STD-187-721.

A.5.6.4 Time-related functions.

A.5.6.4.1 Tune and wait.

The CMD tune and wait special control function directs the receiving station(s) to perform the initial parts of the handshake, up through tune-up, and wait on channel for further instructions during the specified time limit. The time limit timer is essentially the WRTT as used in net slotted responses where its value  $T_{wm}$  is set by the timing information in the special control instruction, and it starts from the detected end of the call. The CMD tune and wait instruction shall suppress any normal or preset responses. Except for the tune-up itself, the receiving station(s) shall make no additional emissions, and they shall quit the channel and resume scan if no further instructions are received.

NOTE: This special control function enables very slow tuning stations, or stations that must wait for manual operator interaction, to effectively interface with automated networks.



The CMD tune and wait shall be constructed as follows and as shown in table A-XIX. The preamble shall be CMD (110) in bits P3 through P1 (W1 through W3). The first character (C1) shall be “t” (1110100) in bits C1-7 through C1-1 (W4 through W10) and “t” (1110100) in bits C2-7 through C2-1 (W11 through W17), for “time, tune-up.” The “T” time bits TB7 through TB1 (W18 through W24) shall be values selected from table A-XX, and limited as shown in table A-XXI. The lowest value (00000) shall cause the tuning to be performed immediately, with zero waiting time, resulting in immediate return to normal scan after tuning.

#### A.5.6.4.2 Scheduling commands.

These special control functions permit the manipulation of timing in the ALE system. They are based on the standard “T” time values, presented in table A-XX, which have the following ranges based on exact multiples of  $T_w$  (130.66...ms) or  $T_{rw}$  (392 ms).

- 0 to 4 seconds in 1/8 second ( $T_w$ ) increments
- 0 to 36 seconds in 1 second ( $3 T_{rw}$ ) increments
- 0 to 31 minutes in 1 minute ( $153 T_{rw}$ ) increments
- 0 to 29 hours in 1 hour ( $9184 T_{rw}$ ) increments

There are several specific functions that utilize these special timing controls. All shall use the CMD (110) preamble in bits P3 through P1 (W1 through W3). The first character is “t” (1110100) for “time.” The second character indicates the function as shown in table A-XXI. The basic structure is the same as in table A-XIX.

MIL-STD-188-141B  
APPENDIX A

**TABLE A-XIX. Tune and wait structure.**

	Tune and Wait Bits		Word Bits	
<u>CMD</u> Preamble	MSB	P3 = 1 P2 = 1	MSB	W1 W2
	LSB	P1 = 0		W3
First Character “t”	MSB	C1-7 = 1 C1-6 = 1 C1-5 = 1 C1-4 = 0 C1-3 = 1 C1-2 = 0		W4 W5 W6 W7 W8 W9
	LSB	C1-1 = 0		W10
Second Character “t”	MSB	C2-7 = 1 C2-6 = 1 C2-5 = 1 C2-4 = 0 C2-3 = 1 C2-2 = 0		W11 W12 W13 W14 W15 W16
	LSB	C2-1 = 0		W17
Time Bits “T”	MSB	TB7 TB6 TB5 TB4 TB3 TB2		W18 W19 W20 W21 W22 W23
	LSB	TB1	LSB	W24
NOTES: 1. <u>CMD</u> tune and wait first two characters are “t” (1110100) and “t” (1110100) for “time tune-up.” 2. Time bits TB7 through TB1 from table A-XX.				

MIL-STD-188-141B  
APPENDIX A

**TABLE A-XX. Time values.**

<b>MULTIPLIER: MSBs</b>										
MSB TB7 (W18)	TB6 (W19)	Exact increment				Approximate increment	Approximate range of "T" values			
0	0	$T_w$ 130.66 . . ms				1/8 second	0 - 4 seconds			
0	1	$3 T_{rw}$ 1176 ms				1 second	0 - 36 seconds			
1	0	153 $T_{rw}$ 59.976 sec				1 minute	0 - 31 minutes			
1	1	9184 $T_{rw}$ 60.002min				1 hour	0 - 29 hours			
INDEX: Least significant Bits (LSBs)										
TB5 (W20)	TB4 (W21)	TB3 (W22)	TB2 (W23)	LBS TB1 (W24)	INDEX VALUE	"T" VALUE FOR MSB=00	"T" VALUE FOR MSB=01	"T" VALUE FOR MSB=10	"T" VALUE FOR MSB=11	
0	0	0	0	0	0	0(1)	0	0	0	
0	0	0	0	1	1	130.66 ms	1.176 s	1.00 min	1.00 hr	
0	0	0	1	0	2	261.33 ms	2.352 s	2.00 min	2.00 hr	
0	0	0	1	1	3	392.0 ms	3.528 s	3.00 min	3.00 hr	
0	0	1	0	0	4	523.66 ms	4.204 s	4.00 min	4.00 hr	
0	0	1	0	1	5	653.33 ms	5.880 s	5.00 min	5.00 hr	
•	•	•	•	•	•	•	•	•	•	
•	•	•	•	•	•	•	•	•	•	
1	1	1	0	1	29	3789.3 ms	34.10 s	29.0 min	29.0 hr	
1	1	1	1	0	30	3920.0 ms	35.28 s	30.0 min	(3)	
1	1	1	1	1	31	4050.7 ms	36.46 s	31.0 min	(2)	
NOTES:										
<ol style="list-style-type: none"> <li>1. The minimum value "0" (TB = 0000000) is interpreted as "do immediately" if a delay, or "zero size" if a time width, as specified in usage.</li> <li>2. The maximum value "127" (TB = 1111111) is interpreted as "do it at time or date following," as specified in next <u>CMD</u>.</li> <li>3. The next maximum value "126" (TB = 1111110) is interpreted as "indefinite time," unlimited except by other <u>CMD</u> or timeout protocol.</li> </ol>										

**TABLE A-XXI. Time-related CMD functions.**

Identification	First Character	Second Character	Function
Adjust Slot Width	“t”	“a” (1100001)	Add T to width of all slots for this response. TB=0, normal. TB7=0 as 36 second limit.
Halt and Wait	“t”	“h” (1101000)	Stop scan on channel, do not tune or respond, wait T for instruction; quit and resume scan if nothing. TB=0, quit after call. TB7=0 as 36 second limit.
Operator NAK	“t”	“n” (1101110)	Same as “t,o” operator ACK, except that at T, if no input, automatic tune-up and respond NAK ( <u>TIS</u> ), in slots if any. TB=0, NAK now.
Operator ACK	“t”	“o” (1101111)	Stop scan, alert operator to manually input ACK (or NAK), which causes tune-up (if needed) and ACK response <u>TWAS</u> , or <u>TIS</u> ; if no input by operator by T, simply quit. TB=0, ACK now. TB7=0 as 36 second time limit. TB=1111111, do at date/time following.
Respond and Wait	“t”	“r” (1110010)	Stop scan, tune-up and respond as normal, wait T for instructions, quit and resume scan if nothing. TB=0, quit after response. TB7=0 as 36 second limit. TB=1111111, do at date/time following.
Tune and Wait	“t”	“t” (1110100)	Stop scan, tune-up, do not respond, wait T for Instructions, quit and resume scan if nothing. TB=0, quit after tune-up. TB7=0 as 36 second limit.
Width of Slots	“t”	“w” (1110111)	Set all slots to T wide for this response. TB=0, no responses. TB7=0 as 36 second limit.
<p>NOTES:</p> <ol style="list-style-type: none"> <li>1. Preamble is <u>CMD</u> (110).</li> <li>2. First character is “t” (1110100) for all.</li> <li>3. Third-character field is binary bits TB7 through TB1 (W18 through W24), designating a time interval “T” as a standard value in table A-XX.</li> <li>4. When the optional UUF is implemented, the STAY command function is required.</li> <li>5. This second ASCII character will vary, depending on the resulting binary value.</li> </ol>			

**A.5.6.4.3 Time exchange word formats.**

The mandatory time protocols employ the following three types of ALE words: (1) command words, (2) coarse time words, and, (3) authentication words, in the formats listed below.

A.5.6.4.3.1 Command words.

Time exchange command words Time Is and Time Request that are used to request and to provide time of day (TOD) data, shall be formatted as shown in figure A-38. The three most-significant bits (W1-3) shall contain the standard CMD preamble (110). The next seven bits (W4-10) shall contain the ASCII character '~'(1111110), indicating the magnitude of time uncertainty at the sending station in accordance with A.5.6.4.6.

A.5.6.4.3.2 Time Is command.

The Time Is command word carries the fine time current at the sending station as of the start of transmission of the word following the Time Is command word, and is used in protected time requests and all responses. In a Time Is command word, the seconds field shall be set to the current number of seconds elapsed in the current minute intervals which have elapsed in the current second (0-24). The time quality shall reflect the sum of the uncertainty of the local time and the uncertainty of the time of transmission of the Time Is command, in accordance with table A-XXII and A.5.6.4.6. When a protocol requires transmission of the Time Is command word, but no time value is available, a NULL Time Is command word shall be sent, containing a time quality of 7 and the seconds and ticks fields both set to all 1s.

A.5.6.4.3.3 Time Request command.

The Time Request command word shall be used to request time when no local time value is available, and is used only in non-protected transmissions. In a Time Request command word, time quality shall be set to 7, the seconds field to all 1s, and the ticks field set to 30 (11110).

A.5.6.4.3.4 Other encodings.

All encodings of the seconds and ticks fields not specified here are reserved, and shall not be used until standardized.

A.5.6.4.4 Coarse time word.

Coarse time words shall be formatted as shown in figure A-39, and shall contain the coarse time current as of the beginning of that word.

Time Service Example  Date=8 May Time=15:57:34:12 Time Quality=4				
3	7	3	6	5
<u>CMD</u>	Time Exchange	Time Quality	Seconds	40 ms ticks
110	1111110	100	100010	00011
“TIME IS” Command				

**FIGURE A-38. Time exchange CMD word.**

A.5.6.4.5 Authentication word.

Authentication words, formatted as shown in figure A-39, shall be used to authenticate the times exchanged using the time protocols. The 21-bit authenticator shall be generated by the sender as follows:

- a. All 24-bit words in the time exchange message preceding the authentication word (starting with the Time Is or Time Request command word which begins the message) shall be exclusive-or'd.
- b. If the message to be authenticated is in response to a previous time exchange message, the authenticator from that message shall be exclusive-or'd with the result of (1).
- c. The 21 least significant bits of the final result shall be used as the authenticator.

A.5.6.4.6 Time quality.

Every time exchange command word transmitted shall report the current uncertainty in TOD at the sending station, whether or not time is transmitted in the command word. The codes listed in table A-XXII shall be employed for this purpose. The time uncertainty windows on the table are upper bounds on total uncertainty (with respect to coordinated universal time).

**TABLE A-XXII. Time quality.**

Time Quality Code	Time Uncertainty Window
0	none
1	20 ms
2	100 ms
3	500 ms
4	2 s
5	10 s
6	60 s
7	unbounded
NOTE: Time quality "0" shall be used only by UTC time standard stations.	

**Time Service Example**

**Date = 8 May**  
**Time = 15:57:34:12**  
**Time Quality = 4**

	<b>3</b>	<b>1</b>	<b>4</b>	<b>5</b>	<b>11</b>
<b>DATA</b>	<b>0</b>	<b>Month</b>	<b>Day</b>	<b>Minute</b>	
<b>000</b>	<b>0</b>	<b>0101</b>	<b>01000</b>	<b>011101111101</b>	

**Coarse Time Word**

<b>3</b>	<b>21</b>
<b>REP</b>	<b>Authenticator</b>
<b>111</b>	<b>110101110011111111110</b>

**Authenticator Word  
(over CMD and Coarse Time Words)**

**FIGURE A-39. Coarse time and authentication words.**

For example, an uncertainty of  $\pm 6$  seconds is 12 seconds total and requires a transmitted time quality value of 6. Stations shall power up from a cold start with a time quality of 7. Time

uncertainty is initialized when time is entered (see B.5.2.2.1) and shall be maintained thereafter as follows:

- a. The uncertainty increases at a rate set by oscillator stability (e.g., 72 ms per hour with a  $\pm 10$  parts per million (ppm) time base).
- b. Until the uncertainty is reduced upon the acceptance of time with less uncertainty from an external source after which the uncertainty resumes increasing at the above rate.

A station accepting time from another station shall add its own uncertainty due to processing and propagation delays to determine its new internal time uncertainty. For example, if a station receives time of quality 2, it adds to the received uncertainty of 100 ms ( $\pm 50$  ms) its own processing delay uncertainty of, say  $\pm 100$  ms, and a propagation delay bound of  $\pm 35$  ms, to obtain a new time uncertainty of  $\pm 185$  ms, or 370 ms total, for a time quality of 3. With a  $\pm 10$  ppm time source, this uncertainty window would grow by 72 ms per hour, so after two hours, the uncertainty becomes 514 ms, and the time quality has dropped to 4. If a low-power clock is used to maintain time while the rest of the unit is powered off, the quality of this clock shall be used to assign time quality upon resumption of normal operation. For example, if the backup clock maintains an accuracy of  $\pm 100$  ppm under the conditions expected while the station is powered off, the time uncertainty window shall be increased by 17 seconds per day. Therefore, such a radio, which has been powered-off for much over three days, shall not be presumed to retain even coarse sync, despite its backup clock, and may require manual entry of time.

#### A.5.6.5 Mode control functions (optional).

If any of these features are selected, however, they shall be implemented in accordance with this standard. Many of the advanced features of an ALE controller are “modal” in the sense that when a particular option setting is selected, that selection remains in effect until changed or reset by some protocol event. The mode control CMD is used to select many of these operating modes, as described in the following paragraphs. The CMD word shall be formatted as shown in figure A-40. The first character shall be ‘m’ to identify the mode control command; the second character identifies the type of mode selection being made; the remaining bits specify the new setting for that mode.

3	7	7	7
<u>CMD</u>	1101101 (‘m’: mode control)	Mode ID	Mode Selection

**FIGURE A-40. Mode control CMD format.**

#### A.5.6.5.1 Modem negotiation and handoff.

An ALE data link can be used to negotiate a modem to be used for data traffic by exchanging modem negotiation messages. A modem negotiation message shall contain one modem selection command.



NOTE: This function may best be implemented in a high frequency node controller (HFNC) to avoid retrofit to existing ALE controllers, and for the greater flexibility inherent in network management information bases.

A.5.6.5.1.1 Modem selection CMD.

The modem selection CMD word shall be formatted as shown in figure A-41, and may be followed by one or more DATA words, as described below. The defined modem codes are listed in table A-XXIII. Codes not defined are reserved, and shall not be used until standardized.

3	7	7	7
<u>CMD</u>	1101101 (‘m’: mode control)	1101110 (‘n’: modem select)	Modem Code

**FIGURE A-41. Modem selection CMD format.**

A.5.6.5.1.2 Modem negotiating.

Modem negotiating shall employ modem negotiation messages in the following protocol:

- a. The station initiating the negotiation will send a modem selection CMD word containing the code of the modem it wants to use.
- b. The responding station(s) may either accept this modem selection or suggest alternatives. A station accepting a suggested modem shall send a modem selection CMD word containing the code of that modem.
- c. A station may negotiate by sending a modem selection CMD word containing all 1s in the modem code field, followed by one or more DATA words containing the codes of one or more suggested modems. Modem codes shall be listed in order of preference in the DATA word(s). Unused positions in the DATA word(s) shall be filled with the all 1s code.
- d. The negotiation is concluded when the most recent modem negotiation message from all participating stations contains an identical modem selection CMD word with the same modem code (not all 1s). When this occurs, the station that initiated the negotiation will normally begin sending traffic using the selected modem.

MIL-STD-188-141B  
APPENDIX A

**TABLE A-XXIII. Modem codes.**

Code		Modem Type
	0000000	(Reserved)
	0000001	ALE modem
	0000010	Serial-tone HF data modem (MIL-STD-188-110)
	0000011	16-tone DPSK HF data modem (MIL-STD-188-110)
	0000100	39-Tone HF data modem (MIL-STD-188-110)
	0000101	ANDVT
	0000110	FSK 170 Hz shift (MIL-STD-188-110)
	0000111	FSK 850 Hz shift (MIL-STD-188-110)
Short intlv (010xxxx) long intlv		STANAG 4285
0100000	0101000	75 b/s
0100001	0101001	150 b/s
0100010	0101010	300 b/s
0100011	0101011	600 b/s
0100100	0101100	1200 b/s
0100101	0101101	2400 b/s
0100110	0101110	4800 b/s
	(011xxxx)	STANAG 4529:
0110000	0111000	75 b/s
0110001	0111001	150 b/s
0110010	0111010	300 b/s
0110011	0111011	600 b/s
0110100	0111100	1200 b/s
0110101	0111101	2400 b/s
0110110	0111110	4800 b/s
1111111		Reserved to indicate no modem code. (All others reserved until defined)

A.5.6.5.2 Crypto negotiation and handoff.

When crypto negotiation and handoff are required, the following applies:

- a. An ALE data link can also be used to negotiate an encryption device to be used for voice or data traffic by exchanging crypto negotiation messages. The crypto selection CMD word is formatted as shown in figure A-42. The defined crypto codes are listed in table A-XXIV. Codes not defined are reserved, and shall not be used until standardized.

NOTE: This function may best be implemented in an HFNC to avoid retrofit to existing ALE controllers, and for the greater flexibility inherent in network management information bases.

3	7	7	7
<u>CMD</u>	1101101 (‘m’: mode control)	1100011 (‘c’: crypto select)	Crypto Code

**FIGURE A-42. Crypto selection CMD format.**

**TABLE A-XXIV. Crypto codes.**

Code	Crypto Type
0000000	No encryption
1111111	Reserved to indicate no crypto code (All others reserved until defined)

b. Crypto negotiation shall employ crypto negotiation messages in the protocol described above for modem negotiation.

**A.5.6.6 Capabilities reporting functions.**

**A.5.6.6.1 Version CMD (mandatory).**

The version CMD function is used to request ALE controller version identification. The first character is ‘v’ to indicate the version family of ALE CMD word functions. The second character shall be set to ‘s’ to select a summary report.

NOTE: The capabilities function in A.5.6.6.2 is a variant of this function that provides more detailed information.

a. The response to a version CMD is a printable ASCII message in manufacturer-specific format that indicates a manufacturers’ identification, the version(s) of hardware, operating firmware and software, and/or management firmware and software of the responding ALE controller, as requested by control bits KVC<sub>1-3</sub> of the version CMD format (see figure A-43 and table A- XXV).

3	7	7	3	4
<u>CMD</u>	1110110 (‘v’: version <u>CMD</u> )	1110011 (‘s’: summary)	Comps (KVC)	Formats (KVF)

**FIGURE A-43. Version CMD format.**

**TABLE A-XXV. Component selection.**

Bit	Component whose version is requested when bit set to 1
KVC3 (MSB)	ALE controller hardware
KVC2	ALE controller operating firmware
KVC1 (LSB)	ALE controller network management firmware (i.e., HNMP)

b. The requesting station specifies acceptable formats for the response in control bits  $KVF_{1-4}$  in accordance with table A-XXVI. A controller responding to a version function shall attempt to maximize the utility of its response and:

- (1) Shall report the version(s) of all of the components requested by the KVC control bits that are present in the controller.
- (2) Shall use the ALE message format that represents the highest level of mutual capability of itself and the requesting station by comparing the message types that it can generate with those desired by the requesting station, and selecting the message type in the intersection of these two sets that correspond to the highest-numbered KVF bit.

**TABLE A-XXVI. Format selection.**

Bit	Reporting format desired when bit set to 1
KVF4 (MSB)	Reserved (always set to 0)
KVF3	DBM
KVF2	DTM
KVF1 (LSB)	AMD Message

**A.5.6.6.2 Capabilities function. (mandatory).**

The capabilities function is used to obtain a compact representation of the features available in a remote ALE controller. This function uses a variant of the version CMD word, as shown in figures A-44 and A-45.

**A.5.6.6.2.1 Capabilities query.**

The capabilities query, shown in figure A-44, consists of a single ALE CMD word. The second character position shall be set to 'c' to select a full capabilities report (rather than a summary as in the version CMD). The third character position shall be set to 'q' in a capabilities query to request a capabilities report.

MIL-STD-188-141B  
APPENDIX A

3	7	7	7
<u>CMD</u>	1110110 (‘v’: version <u>CMD</u> )	1100011 (‘c’: capability)	1110001 (‘q’: query)

**FIGURE A-44. Capabilities query CMD format.**

A.5.6.6.2.2 Capabilities report CMD.

The capabilities report shall consist of a CMD word followed by five DATA words, as shown in figure A-45. The second character position of the capabilities report CMD word shall be set to ‘c’ and the third character position shall be set to ‘r’. (The DATA preamble in the second and fourth DATA words shall be replaced by REP for transmission, as required by the ALE protocol).

3	7	7	7
<u>CMD</u>	1110110 (‘v’: version <u>CMD</u> )	1100011 (‘c’: capability)	1110010 (‘r’: report)
3	5	8	8
<u>DATA</u>	Scan Rate (SR <sub>1-5</sub> )	Channels Scanned (CS <sub>1-8</sub> )	Max Tune Time (TT <sub>1-8</sub> )
3	6	7	8
<u>DATA</u>	LP Time (LPT <sub>1-6</sub> )	ALE Protocols (VAP <sub>1-7</sub> )	ALQA (ALQA <sub>1-8</sub> )
3	8	8	5
<u>DATA</u>	Orderwire (OW <sub>1-8</sub> )	Reserved	Reserved
3	21		
<u>DATA</u>	Scheduling (SCH <sub>1-21</sub> )		

**FIGURE A-45. Capabilities report CMD and DATA format.**

A.5.6.6.2.3 Data format.

The format of the DATA words in a capabilities report is constant, regardless of the capabilities reported, to simplify the software that implements the capabilities command. The data fields of the capabilities report shall be encoded in accordance with tables A-XXVII, A-XXVIII, and A-XXIX. The values encoded shall represent the current operational capabilities of the responding

MIL-STD-188-141B  
APPENDIX A

ALE controller, i.e., the timing or functions currently programmed. All timing fields shall be encoded as unsigned integers.

**TABLE A-XXVII. Capabilities report data fields (ALE timing).**

Group	Field	Value	Units	Parameter from table A-XV "Timing"
ALE Timing	SR <sub>1-5</sub>	Scan rate	Channels/s	1/T <sub>d</sub>
	CS <sub>1-8</sub>	Chan. scanned	100 ms	C
	TT <sub>1-8</sub>	Max tune time	100 ms	T <sub>t</sub>
	TTA <sub>1-4</sub>	Turnaround time	log <sub>2</sub> s	T <sub>ta</sub>
	TWA <sub>1-4</sub>	Activity timeout Listen time	1 s	T <sub>wa</sub> *
	TWT <sub>1-3</sub>			T <sub>wt</sub>
* T <sub>wa</sub> =log <sub>2</sub> n where n is the number of seconds of no detected activity before timeout.				

**TABLE A-XXVIII. Capabilities report data fields (mode settings).**

Group	Bit	Set to 1 if and only if (iff)	Cross Ref: MIL-STD	
ALE Protocols	VAP <sub>7</sub> (MSB)	Accepting ALL calls	188-141 (Allcalls)	
	VAP <sub>6</sub>	Accepting ANY calls	188-141 (AnyCalls)	
	VAP <sub>5</sub>		Accepting AMD 2msgs	188-141 (AMD mode)
				188-141 (DTM mode)
	VAP <sub>4</sub>	Accepting DTM msgs	188-141 (DBM mode)	
	VAP <sub>3</sub>	Accepting DBM msgs	188-141 (DTM mode)	
	VAP <sub>2</sub>	DTM capabilities	188-141 (DBM mode)	
VAP <sub>1</sub> (LSB)	DBM capabilities			
LP Levels	LPL <sub>5</sub> (MSB)	Capable of other LP		
	LPL <sub>4</sub>	Capable of AL-4 LP	188-141 Appendix B	
	LPL <sub>3</sub>	Capable of AL-3 LP	188-141 Appendix B	
	LPL <sub>2</sub>	Capable of AL-2 LP	188-141 Appendix B	
	LPL <sub>1</sub> (LSB)	Capable of AL-1 LP	188-141 Appendix B	
Time Exchange	LPT <sub>6</sub> (MSB)	Acting as time server	188-141 (Time service response, Time service response (non-protected))	
	LPT <sub>5</sub>	Active time acq. enable	188-141 (Active time acquisition (protected), Active time acquisition (non-protected))	
			188-141 (Passive time acquisition)	
	LPT <sub>4</sub>	Passive time acq. enable	188-141 (Time broadcast)	
	LPT <sub>3</sub>	Will send time broadcasts	(not yet standardized)	
	LPT <sub>2</sub>	Time iteration capable	(not yet standardized)	
LPT <sub>1</sub> (LSB)	Precision time capable	(not yet standardized)		

MIL-STD-188-141B  
APPENDIX A

**TABLE A-XXIX. Capabilities report data field (feature capabilities).**

Group	Bit	Set to 1 iff Feature Implemented	Cross Ref: MIL-STD (paragraph)
Polling	PP <sub>5</sub> (MSB)	Full Net Poll	187-721 (Full Net Poll)
	PP <sub>4</sub>	Full Group Poll	187-721 (Full Group Poll)
	PP <sub>3</sub>	Channel Scan <u>CMD</u>	187-721 (Two Station- Multiple Channel Polling)
	PP <sub>2</sub>	LQA Report	187-721 (LQA Report Protocol)
	PP <sub>1</sub> (LSB)	Local Noise Report	188-141 (Local Noise Report)
ALQA	ALQA <sub>8</sub> (MSB)	Reserved (always set to 0)	
	ALQA <sub>7</sub>	ALQA SINAD	187-721 (SINAD and PBER)
	ALQA <sub>6</sub>	ALQA PBER	187-721 (SINAD and PBER)
	ALQA <sub>5</sub>	ALQA AI	187-721 (Articulation Index)
	ALQA <sub>4</sub>	ALQA SD	187-721 (Spectral Distortion)
	ALQA <sub>3</sub>	ALQA EFI	187-721 (Error-free Interval)
	ALQA <sub>2</sub>	ALQA AVQ	187-721 (Achievable Voice Quality)
	ALQA <sub>1</sub> (LSB)	ALQA ADC	187-721 (Available Data Capacity)
Orderwire	OW <sub>8</sub> (MSB)	Frequency Select <u>CMD</u>	187-721 (Frequency Select Command)
	OW <sub>7</sub>	Channel Select <u>CMD</u>	(not yet standardized)
	OW <sub>6</sub>	Modem Negotiation	188-141 (Modem Negotiation and Handoff)
	OW <sub>5</sub>	Crypto Negotiation	188-141 (Crypto Negotiation and handoff)
	OW <sub>4</sub>	Analog Port Selection	187-721 (Analog Port Selection)
	OW <sub>3</sub>	Data Port selection	187-721 (Data Port Selection)
	OW <sub>2</sub>	Digital Squelch	187-721 (Digital Squelch)
	OW <sub>1</sub> (LSB)	Power Control	188-141 (Power Control)
Scheduling	SCH <sub>21</sub> (MSB)	Reserved (always set to 0)	
	SCH <sub>20</sub>	Adjust Slot Width	187-721 (Adjust Slot Width)
	SCH <sub>19</sub>	Station Busy	187-721 (Station Busy)
	SCH <sub>18</sub>	Channel Busy	187-721 (Channel Busy)
	SCH <sub>17</sub>	Set Dwell Time	187-721 (Set Dwell Time)
	SCH <sub>16</sub>	Halt and Wait	187-721 (Halt and Wait)
	SCH <sub>15</sub>	Contact Later	187-721 (Contact Later)
	SCH <sub>14</sub>	Meet Me	187-721 (Meet Me)
	SCH <sub>13</sub>	Poll Operator (default NAK)	187-721 (Poll Operator(default NAK))
	SCH <sub>12</sub>	Request Operator ACK	187-721 (Request Operator ACK)
	SCH <sub>11</sub>	Schedule Periodic Function	187-721 (Schedule Periodic Function)
	SCH <sub>10</sub>	Quiet Contact	187-721 (Quiet Contact)
	SCH <sub>9</sub>	Respond and Wait	187-721 (Respond and Wait)
	SCH <sub>8</sub>	Set Sounding Interval	187-721 (Set Sounding Interval)
	SCH <sub>7</sub>	Tune and wait	187-721 (Tune and Wait)
	SCH <sub>6</sub>	Set Slot Width	187-721 (Set Slot Width)
	SCH <sub>5</sub>	Year and Date	187-721 (Year and Date)
	SCH <sub>4</sub>	Zulu Time	187-721 (Zulu Time)
	SCH <sub>3</sub>	Do Not Respond	188-141 (Do Not Respond)
	SCH <sub>2</sub>	Reserved (always set to 0)	
	SCH <sub>1</sub> (LSB)	Reserved (always set to 0)	

A.5.6.7 Do not respond CMD.

When an ALE controller receives this CMD in a transmission, it shall not respond unless a response is specifically required by some other CMD in the transmission (e.g., an LQA request or a DTM or DBM with ARQ requested). In a Do Not Responds CMD, no three-way ALE handshake needs to be completed.

A.5.6.8 Position report (optional).

See MIL-STD-187-721.

A.5.6.9 User unique functions (UUFs).

UUFs are for special uses, as coordinated with specific users or manufacturers, which use the ALE system in conjunction with unique, nonstandard, or non-ALE, purposes. There are 16384 specific types of CMD UUF codes available, as indicated by a 14-bit (or two-character) unique index (UI). Each unique type of special function that employs a UUF shall have a specific UI assigned to it to ensure interoperability, compatibility, and identification. The UI shall be assigned for use before any transmission of the UUF or the associated unique activity, and the ALE UUF shall always include the appropriate UI when sent.

The UUF shall be used only among stations that are specifically addressed and included within the protocol, and shall be used only with stations specifically capable of participating in the UUF activity, and all other (non-participating) stations should be terminated. There are two exceptions for stations that are not capable of participating in the UUF and are required to be retained in the protocol until concluded. They shall be handled using either of the two following procedures. First, the calling station shall direct all the addressed and included stations to stay linked for the duration of the UUF, to read and use anything that they are capable of during that time, and to resume acquisition and tracking of the ALE frame and protocol after the UUF ends. To accomplish this, and immediately before the CMD UUF, the sending station shall send the CMD STAY, which shall indicate the time period (T) for which the receiving stations shall wait for resumption of the frame and protocol. Second, the sending station shall use any standard CMD function to direct the non-participating stations to wait or return later, or do anything else appropriate and controllable through the standard orderwire functions.

If a CMD UUF is included within an ALE frame, it shall only be within the message section. The UUF activity itself should be conducted completely outside of the frame and should not interfere with the protocols. If the UUF activity itself must be conducted within the message section, will occupy time on the channel, and is incompatible with the ALE system, that activity shall be conducted immediately after the CMD UUF and it shall be for a limited amount of time (T). A CMD STAY shall precede the UUF instruction, as described herein, to indicate that time (T). The sending station shall resume the same previous redundant word phase when the frame and protocol resumes, to ensure synchronization. The STAY function preserves maintenance of the frame and link. It instructs the stations to wait, because the amount of time occupied by the UUF activity or its signaling may conflict with functions such as the wait-for-activity timer ( $T_{wa}$ ). This may interfere with the protocols or maintenance of the link. In any case, the users of the



MIL-STD-188-141B  
APPENDIX A

UUF shall be responsible for noninterference with other stations and users, and also for controlling their own stations and link management functions to avoid these conflicts.

The UUF shall be constructed as follows and as shown in table A-XXX. The UUF word shall use the CMD (110) preamble in bits P3 through P1 (W1 through W3). The character in the first position shall be the pipe “|” or vertical bar “|” (1111100) in bits C1-7 through C1-1 (W4 through W10), which shall identify the “unique” function. The user or manufacturer-specific UI shall be a 14-bit (or two-character, 7-bit ASCII) code using bits UI-14 through UI-1 (W11 through W24). All unassigned UI codes shall be reserved and shall not be used until assigned for a specific use.

**TABLE A-XXX. User unique functions structure.**

	<b>User Unique Function Bits</b>		<b>Word Bits</b>	
<u>CMD</u> Preamble	MSB	P3=1	MSB	W1
		P2=1		W2
	LSB	P1=0		W3
First Character	MSB	C1 (bit-7) =1		W4
		C1 (bit-6)=1		W5
		C1 (bit-5) =1		W6
		C1 (bit-4) =1		W7
		C1 (bit-3) =1		W8
		C1 (bit-2) =0		W9
	LSB	C1 (bit-1) =0		W10
First UI Character	MSB	UI-1-7		W11
		UI-1-6		W12
		UI-1-5		W13
		UI-1-4		W14
		UI-1-3		W15
		UI-1-2		W16
Second UI Character	LSB	UI-1-1		W17
	MSB	UI-2-7		W18
		UI-2-6		W19
		UI-2-5		W20
		UI-2-4		W21
		UI-2-3		W22
		UI-2-2		W23
LSB	UI-2-1	LSB	W24	
NOTES:				
1. <u>CMD</u> user unique functions first character is “ ” (1111100) for “unique.”				
2. Unique index (UI) characters UI-1 and UI-2 from central registry and assignment.				

A.5.7 ALE message protocols.

A.5.7.1 Overview.

Three message protocols are available for carrying user data using the ALE waveform and signal structure. The characteristics of these three protocols are summarized in the table A-XXXI. All ALE controllers complying with this appendix shall implement the AMD protocol.

**TABLE A-XXXI. ALE message protocols.**

<b>Protocol</b>	<b>Mandatory</b>	<b>Character Set</b>	<b>Peak Throughput</b>	<b>ARQ</b>
AMD	Y	Expanded 64	55 b/s	N
DTM	N	unrestricted	61 b/s	Opt
DBM	N	unrestricted	187 b/s	Opt

A.5.7.2 AMD mode (mandatory).

The operators and controllers shall be able to send and receive simple ASCII text messages using only the existing station equipment.

A.5.7.2.1 Expanded 64-channel subset.

The expanded 64 ASCII subset shall include all capital alphabets (A-Z), all digits (0-9), the utility symbols “@” and “?,” plus 26 other commonly used symbols. See figure A-46. The expanded 64 subset shall be used for all basic orderwire message functions, plus special functions as may be standardized. For orderwire message use, the subset members shall be enclosed within a sequence of DATA (and REP) words and shall be preceded by an associated CMD (such as DTM). The CMD designates the usage of the information that follows, and shall also be preceded by a valid and appropriate calling cycle using the Basic 38 ASCII subset addressing. Digital discrimination of the expanded 64 ASCII subset may be accomplished by examination of the two MSBs (b<sub>7</sub> and b<sub>6</sub>), as all of the members within the “01” and “10” MSBs are acceptable. No parity bits are transmitted because the integrity of the information is protected by the basic ALE FEC and redundancy and may be ensured by optional use of the CMD CRC as described in A.5.6.1. The station shall have the capability to both send and receive AMD messages from and to both the operator and the controller. The station shall also have the capability to display any received AMD messages directly to the operator and controller upon arrival, and to alert them. The operator and controller shall have the capability to disable the display and the alarm when their functions would be operationally inappropriate.

MIL-STD-188-141B  
APPENDIX A

BITS					0 0 0	0 0 1	0 1 0	0 1 1	1 0 0	1 0 1	1 1 0	1 1 1				
b <sub>7</sub>	b <sub>6</sub>	b <sub>5</sub>	b <sub>4</sub>	b <sub>3</sub>	b <sub>2</sub>	b <sub>1</sub>	COLUMN	ROW	0	1	2	3	4	5	6	7
0	0	0	0	0	0	0			NUL	DLE	SP	0	@	P	`	p
0	0	0	1	1	1	1			SOH	DC1	!	1	A	Q	a	q
0	0	1	0	0	2	2			STX	DC2	"	2	B	R	b	r
0	0	1	1	1	3	3			ETX	DC3	#	3	C	S	c	s
0	1	0	0	0	4	4			EOT	DC4	\$	4	D	T	d	t
0	1	0	1	1	5	5			ENQ	NAK	%	5	E	U	e	u
0	1	1	0	0	6	6			ACK	SYN	&	6	F	V	f	v
0	1	1	1	1	7	7			BEL	ETB	,	7	G	W	g	w
1	0	0	0	0	8	8			BS	CAN	(	8	H	X	h	x
1	0	0	1	1	9	9			HT	EM	)	9	I	Y	i	y
1	0	1	0	0	10	10			LF	SUB	*	:	J	Z	j	z
1	0	1	1	1	11	11			VT	ESC	+	;	K	[	k	{
1	1	0	0	0	12	12			FF	FS	,	<	L	\	l	
1	1	0	1	1	13	13			CR	GS	-	=	M	]	m	}
1	1	1	0	0	14	14			SO	RS	.	>	N	^	n	~
1	1	1	1	1	15	15			SI	US	/	?	O	?	o	DEL

FIGURE A-46. Expanded 64 ASCII subset (shown unshaded).

A.5.7.2.2 AMD protocol.

When an ASCII short orderwire AMD type function is required, the following CMD AMD protocol shall be used, unless another protocol in this standard is substituted. An AMD message shall be constructed in the standard word format, as described herein, and the AMD message shall be inserted in the message section of the frame. The receiving station shall be capable of receiving an AMD message contained in any ALE frame, including calls, responses, and acknowledgments. Within the AMD structure, the first word shall be a CMD AMD word, which shall contain the first three characters of the message. It shall be followed by a sequence of alternating DATA and REP words that shall contain the remainder of the message. The CMD, DATA, and REP words shall all contain only characters from the expanded ASCII 64 subset, which shall identify them as an AMD transmission. Each separate AMD message shall be kept intact and shall only be sent in a single frame, and in the exact sequence of the message itself. If one or two additional characters are required to fill the triplet in the last word sent, the position(s) shall be “stuffed” with the “space” character (0100000) automatically by the controller, without operator action. The end of the AMD message shall be indicated by the start of the frame conclusion, or by the receipt of another CMD. Multiple AMD messages may be sent within a frame, but they each shall start with their own CMD AMD with the first three characters.

A.5.7.2.3 Maximum AMD message size.

Receipt of the CMD AMD word shall warn the receiving station that an AMD message is arriving and shall instruct it to alert the operator and controller and display the message, unless they disable these outputs. The station shall have the capability to distinguish among, and separately display, multiple separate AMD messages that were in one or several transmissions. The AMD word format shall consist of a CMD (110) in bits P3 through P1 (W1 through W3), followed by the three standard character fields C1, C2, and C3. In each character field, each character shall have its most significant bits (MSBs) bit 7 and bit 6 (C1-7 and C1-6, C2-7 and C2-6, and C3-7 and C3-6) set to the values of "01" or "10" (that is, all three characters are members of the expanded ASCII 64 subset). The rest of the AMD message shall be constructed identically, except for the alternating use of the DATA and REP preambles.

Any quantity of AMD words may be sent within the message section of the frame within the  $T_{m \max}$  limitation of 30 words (90 characters).  $T_{m \max}$  shall be expanded from 30 words, to a maximum of 59 words, with the inclusion of CMD words within the message section. The maximum AMD message shall remain 30 words, exclusive of additional CMD words included within the message section of the frame. The maximum number of CMD words within the message section shall be 30. The message characters within the AMD structure shall be displayed verbatim as received. If a detectable information loss or error occurs, the station shall warn of this by the substitution of a unique and distinct error indication, such as all display elements activated (like a "block"). The display shall have a capacity of at least 20 characters (DO: at least 40). The AMD message storage capacity, for recall of the most recently received message(s), shall be at least 90 characters plus sending station address. (DO: at least 400). By operator or controller direction, the display shall be capable of reviewing all messages in the AMD memory and shall also be capable of identifying the originating station's address. If words are received that have the proper AMD format but are within a portion of the message section under the control of another message protocol (such as DTM), the other protocol shall take precedence and the words shall be ignored by the station's AMD function.

NOTE: If higher data integrity or reliability is required, the CMD DTM and DBM protocols should be used.

A.5.7.3 DTM mode.

The DTM ALE (orderwire) message protocol function enables stations to communicate (full ASCII or unformatted binary bits) messages to and from any selected station(s) for direct output to and input from associated data terminals or other data terminal equipment (DTE) devices through their standard data circuit-terminating equipment (DCE) ports. The DTM data transfer function is a standard speed mode (like AMD) with improved robustness, especially against weak signals and short noise bursts. When used over medium frequency (MF)/HF by the ALE system, DTM orderwire messages may be unilateral or bilateral, and broadcast or acknowledged. As the DTM data blocks are of moderate sizes, this special orderwire message function enables utilization of the inherent redundancy and FEC techniques to detect weak HF signals and tolerate short noise bursts.

MIL-STD-188-141B  
APPENDIX A

The DTM data blocks shall be fully buffered at each station and should appear transparent to the using DTEs or data terminals. As a DO, and under the direction of the operator or controller, the stations should have the capability of using the DTM data traffic mode (ASCII or binary bits) to control switching of the DTM data traffic to the appropriate DCE port or associated DTE equipment, such as to printers and terminals (if ASCII mode), or computers and cryptographic devices (if binary bits mode). As an operator or controller selected option, the received DTM message may also be presented on the operator display similar to the method for AMD in A.5.7.2.

There are four CMD DTM modes: BASIC, EXTENDED, NULL, and ARQ. The DTM BASIC block ranges over a moderate size and contains a variable quantity of data, from zero to full as required, which is exactly measured to ensure integrity of the data during transfer. The DTM EXTENDED blocks are variable over a larger range of sizes, in integral multiples of the ALE basic word, and are filled with integral multiples of message data. The DTM NULL and ARQ modes are used for both link management, and error and flow control. The characteristics of the CMD DTM orderwire message functions are listed in table A-XXXII and are summarized below:

CMD DTM Mode	BASIC	EXTENDED	ARQ NULL
Maximum Size, Bits	651	7371	0
Cyclic Redundancy Check	16 Bits	16 Bits	0
Data Capacity, ASCII	0-93	3-1053, by 3	0
Data Capacity, Bits	1-651	21-7371, by 21	0
ALE Word Redundancy	3 Fixed	3 Fixed	0
Data Transmission	392 ms - 12.152 sec	392 ms - 2.29 min	0

MIL-STD-188-141B  
APPENDIX A

**TABLE A-XXXII. DTM characteristics.**

	WORD BITS		DTM CODE (DC) DECIMAL (n)	DATA WORDS (w)	BINARY BITS DATA	ASCII CHAR DATA	DATA TIME	TOTAL DTM ( $T_{TW}$ )
	W 15----W 19	W 20----W 24						
	DTM CODE BITS							
	DC 10----DC 6	DC 5----DC 1						
DTM NULL*	0 0 0 0 0	0 0 0 0 0	0	0*	0	0	0	1*
DTM EXTENDED (FULL)	0 0 0 0 0 0 0 0 0 0 0 0 0 0 0 ↓ ↓ ↓ ↓ ↓ 0 1 0 1 0 1 1 1 1 0 0 1 0 1 0	0 0 0 0 1 0 0 0 1 0 ↓ ↓ ↓ ↓ ↓ 1 1 1 1 0 1 1 1 1 1	1 2 350 351	1 2 n 350 351	21 42 21n 7350 7371	3 6 3n 1050 1053	392 ms 784 ms nx392 ms 2.28 min 2.29 min	3 4 n+2 352 353
DTM ARQ*	0 1 0 1 1	0 0 0 0 0	352	0*	0	0	0	1*
(RESERVED)*	(12 ≤ m ≤ 31)	0 0 0 0 0	32m	---	---	---	---	---
DTM BASIC (EXACT)	0 1 0 1 1 0 1 1 0 0 ↓ ↓ ↓ ↓ ↓ 1 1 1 1 0 1 1 1 1 1 (11 ≤ m ≤ 31)	(01 ≤ p ≤ 31) ↓ ↓ ↓ ↓ ↓ (01 ≤ p ≤ 31)	352+p 384+p 32m+p 960+p 992+p	p ↓ p	(21p+m-31) ↓ (21p+m-31)	3(p-1 to p) ↓ 3(p-1 to p)	px392 ms ↓ px392 ms	p + 2 ↓ p + 2 w + 2 ↓ w + 2
	(11 ≤ m ≤ 31) ↓ ↓ ↓ ↓ ↓ (11 ≤ m ≤ 31)	0 0 0 0 1 0 0 0 1 0 ↓ ↓ ↓ ↓ ↓ 1 1 1 1 0 1 1 1 1 1	32m+1 32m+2 32m+p 32m+30 32m+31	1 2 p 30 31	1-21 22-42 (21p+m-31) 610-630 631-651	0-3 3-6 3(p-1 to p) 87-90 90-93	392 ms 784 ms px392 ms 11.760 s 12.152 s	w + 2 ↓ w + 2

NOTE:  
1. \* - NO CMD CRC USED.  
2. m - BINARY BITS IN LAST WORD + 10.  
3. p = DTM DATA WORDS.

When an ASCII, or binary bit, digital data message function is required, the following CMD DTM orderwire structures and protocols shall be used as specified herein, unless another standardized protocol is substituted. The DTM structure shall be inserted within the message section of the standard ALE frame. A CMD DTM word shall be constructed in the standard 24-bit format, using the CMD preamble (see table A-XXXIII). The message data to be transferred shall also be inserted in words, using the DATA and REP preambles. The words shall then be Golay FEC encoded and interleaved, and then shall be transmitted immediately following the CMD DTM word. A CMD CRC shall immediately follow the data block words, and it shall carry the error control CRC FCS.

When the DTM structure transmission time exceeds the maximum limit for the message section ( $T_{m \max}$ ), the DTM protocol shall take precedence and shall extend the  $T_m$  limit to accommodate the DTM. The DTM mode preserves the required consistency of redundant word phase during the transmission. The message expansion due to the DTM is always a multiple of one  $T_{rw}$ , as the basic ALE word structure is used. The transmission time of the DTM data block (DTM words x 392 ms) does not include the  $T_{rw}$  for the preceding CMD DTM word or the following CMD CRC. Figure A-47 shows an example of a DTM message structure.

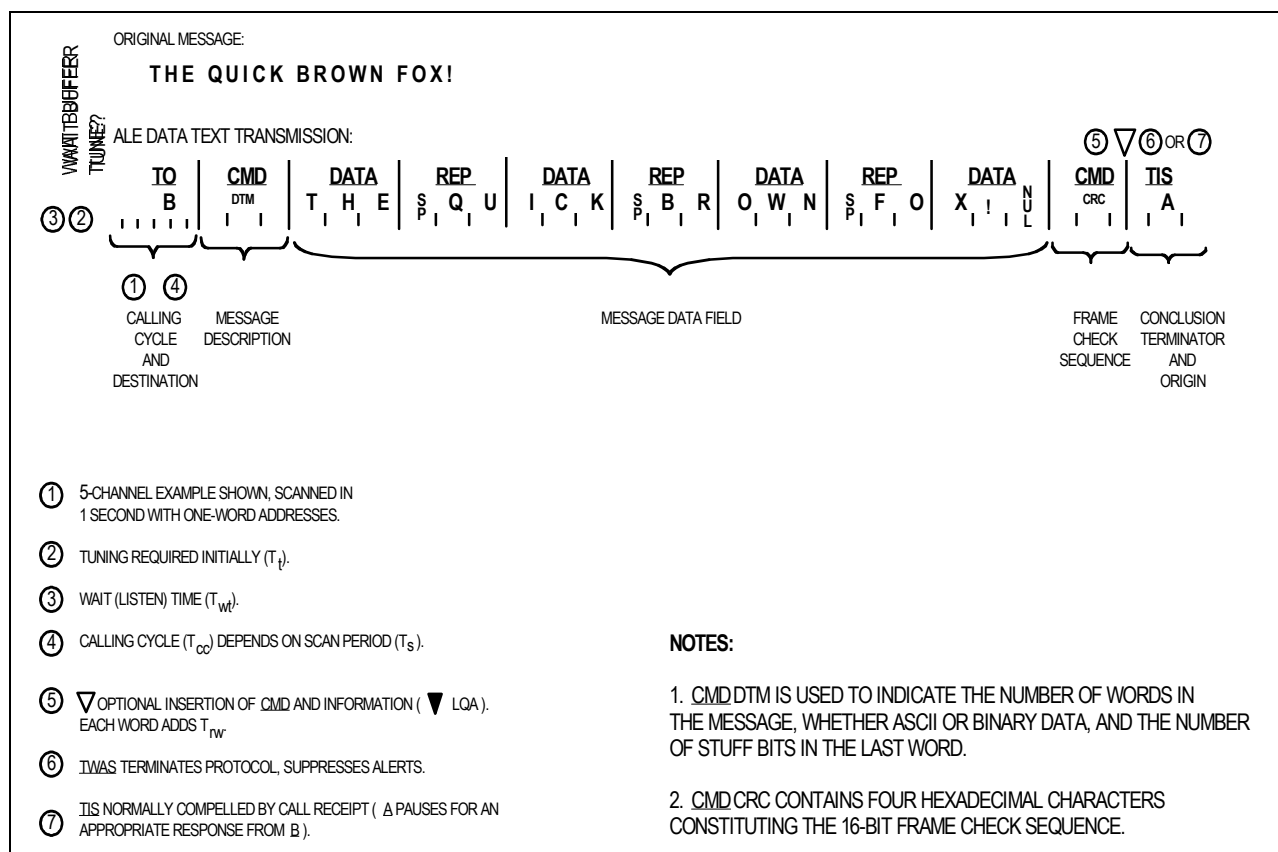


FIGURE A-47. DTM structure example.

The DTM protocol shall be as described herein. The CMD DTM BASIC and EXTENDED formats (herein referred to as DTM data blocks) shall be used to transfer messages and information among stations. The CMD DTM ARQ format shall be used to acknowledge other CMD DTM formats and for error and flow control, except for non-ARQ and one-way broadcasts. The CMD DTM NULL format shall be used to (a) interrupt (“break”) the DTM and message flow, (b) to interrogate station to confirm DTM capability before initiation of the DTM message transfer protocols, and (c) to terminate the DTM protocols while remaining linked. When used in ALE handshakes and subsequent exchanges, the protocol frame terminations for all involved stations shall be TIS until all the DTM messages are successfully transferred, and all are acknowledged if ARQ error control is required. The only exceptions shall be when the protocol is a one-way broadcast or the station is forced to abandon the exchange by the operator or controller, in which cases the termination should be TWAS.

Once a CMD DTM word of any type has been received by a called (addressed) or linked station, the station shall remain on channel for the entire specified DTM data block time (if any), unless forced to abandon the protocol by the operator or controller. The start of the DTM data block itself shall be exactly indicated by the end of the CMD DTM BASIC or EXTENDED word itself. The station shall attempt to read the entire DTM data block information in the DATA and REP words, and the following CMD CRC, plus the expected frame continuation, which shall contain a conclusion (possibly preceded by additional functions in the message section, as indicated by additional CMD words).

With or without ARQ, identification of each DTM data block and its associated orderwire message (if segmented into sequential DTM data blocks) shall be achieved by use of the sequence and message control bits, KD1 and KD2, (as shown in table A-XXXIII), which shall alternate with each DTM transmission and message, respectively. The type of data contained within the data block (ASCII or binary bits) shall be indicated by KD3 as a data identification bit. Activation of the ARQ error control protocol shall use the ARQ control bit KD4. If no ARQ is required, such as in one-way broadcasts, multiple DTM data blocks may be sent in the same frame, but they shall be in proper sequential order if they are transferring a segmented message.

When ARQ error or flow control is required, the CMD DTM ARQ shall identify the acknowledged DTM data block by the use of the sequence and message control bits KD1 and KD2, which shall be set to the same values as the immediately preceding and referenced DTM data block transmission. Control bit KD3 shall be used as the DTM flow control to pause or continue (or resume) the flow of the DTM data blocks. The ACK and request-for-repeat (NAK) functions shall use the ARQ control bit KD4. If no ARQ has been required by the sending station, but the receiving station needs to control the flow of the DTM data blocks, it shall use the DTM ARQ to request a pause in, and resumption of, the flow.



MIL-STD-188-141B  
APPENDIX A

**TABLE A-XXXIII. DTM structure.**

	DTM Bits		Word Bits	
<u>CMD</u> preamble	MSB	P3=1 P2=1	MSB	W1 W2
	LSB	P1=0		W3
First character “d”	MSB	C1 (bit-7) = 1 C1 (bit-6) = 1 C1 (bit-5) = 0 C1 (bit-4) = 0 C1 (bit-3) = 1 C1 (bit-2) = 0		W4 W5 W6 W7 W8 W9
	LSB	C1 (bit-1) = 0		W10
Control bits	MSB	KD4 KD3 KD2		W11 W12 W13
	LSB	KD1		W14
DTM data code bits	MSB	DC10 DC9 DC8 DC7 DC6 DC5 DC4 DC3 DC2		W15 W16 W17 W18 W19 W20 W21 W22 W23
	LSB	DC1	LSB	W24

NOTES:

1. CMD DTM and DTM ARQ first character is “d” for “data”.
2. With DTM transmission, control bit KD4 (W11) is set to “0” for no ACK request, and “1” for ACK request.
3. If a DTM ARQ transmission, control bit KD4 (W11) is set to “0” for binary bits, and “1” for 7-bit ASCII characters.
4. With DTM transmission, control bit KD3 (W12) is set to “0” for binary bits and “1” for 7-bit ASCII characters.
5. If a DTM ARQ transmission, control bit KD3 (W12) is set to “0” for flow continue, and “1” for flow pause.
6. With DTM transmissions, control bit KD2 (W13) is set (a) the same (“0” or “1”) as the sequentially adjacent DTM(s) if the transmitted data field is to be reintegrated as part of a larger DTM, and (b) alternately different if independent from the prior adjacent DTM data field(s).
7. If a DTM ARQ transmission, control bit KD2 (W13) is set the same as the referenced DTM transmission.
8. With DTM transmission, control bit KD1 (W14) is set alternately to “0” and “1” in any sequence of DTMs, as a sequence control.
9. If a DTM ARQ transmission, control bit KD1 (W14) is set the same as the referenced DTM transmission.
10. Data Code (DC) bits are from table A-XXXII.

MIL-STD-188-141B  
APPENDIX A

When data transfer ARQ error and flow control is required, the DTM data blocks shall be sent individually, in sequence, and each DTM data block shall be acknowledged before the next DTM data block is sent. Therefore, with ARQ there shall be only one DTM data block transmission in each ALE frame. If the transmitted DTM data block causes a NAK in the returned DTM ARQ, as described below, or if ACK or DTM ARQ is detected in the returned frame, or if no ALE frame is detected at all, the sending station shall resend an exact duplicate of the unacknowledged DTM data block. It shall send and continue to resend duplicates (which should be up to at least seven) one at a time and with appropriate pauses for responses, until the involved DTM data block is specifically acknowledged by a correct DTM ARQ. Only then shall the next DTM data block in the sequence be sent. If the sending station is frequently or totally unable to detect ALE frame or DTM ARQ responses, it should abort the DTM transfer protocol, terminate the link, and relink and reinitiate the DTM protocol on a better channel, under operator or controller direction.

Before initiation of the DTM data transfer protocols, the sending stations should confirm the existence of the DTM capability in the intended receiving stations, if not already known. When a DTM interrogation function is required, the following protocol shall be used. Within any standard protocol frame (using TIS), the sending station shall transmit a CMD DTM NULL, with ARQ required, to the intended station(s). These receiving stations shall respond with the appropriate standard frame and protocol, with the following variations. They shall include a CMD DTM ARQ if they are DTM capable, and they shall omit it if they are not DTM capable. The sending station shall examine the ALE and DTM ARQ responses for existence, correctness, and the status of the DTM KD control bits, as described herein. The transmitted CMD DTM NULL shall have its control bits set as follows: KD1 and KD2 set opposite of any subsequent and sequential CMD DTM BASIC or EXTENDED data blocks, which will be transmitted next; KD3 set to indicate the intended type of traffic, and KD4 set to require ARQ. The returned CMD DTM ARQ shall have its control bits set as follows: KD1 and KD2 set to match the interrogating DTM NULL; KD3 set to indicate if the station is ready for DTM data exchanges, or if a pause is requested; and KD4 set to ACK if the station is ready to accept DTM data transmissions with the specified traffic type, and NAK if it cannot or will not participate, or it failed to read the DTM NULL.

The sending (interrogating) station shall handle any and all stations that return a NAK, or do not return a DTM ARQ at all, or do not respond at all, in any combination of the following three ways, and for any combination of these stations. The specific actions and stations shall be selected by the operator or controller. The sending station shall: (a) terminate the link with them, using an appropriate and specific call and the TWAS terminator; or (b) direct them to remain and stay linked during the transmissions, using the CMD STAY protocol in each frame immediately before each CMD DTM word and data block sent; or (c) redirect them to do anything else that is controllable using the CMD functions described within this standard.

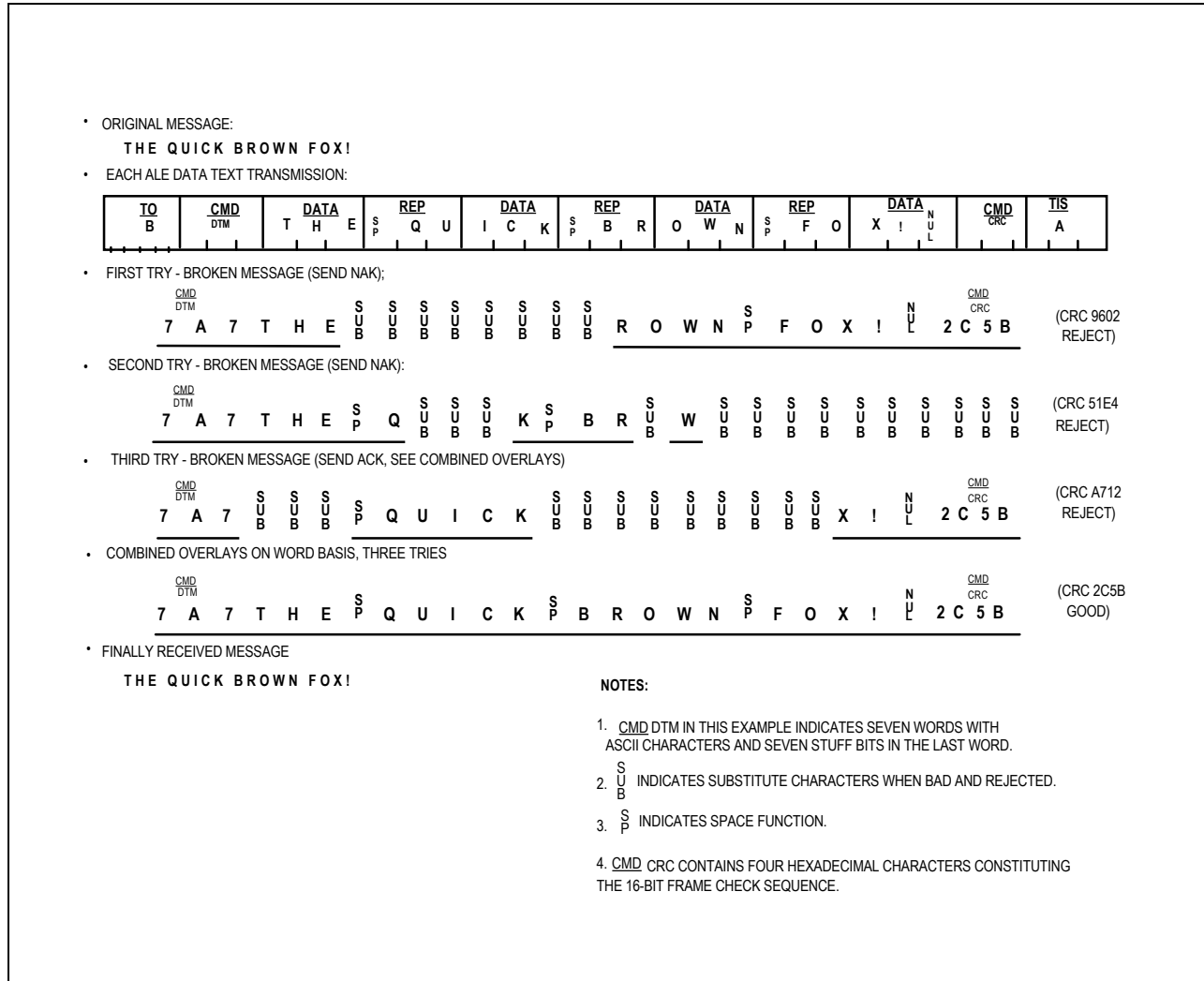
Each received DTM data block shall be examined using the CRC data integrity test included within the mandatory associated CMD CRC that immediately follows the DTM data block

MIL-STD-188-141B  
APPENDIX A

structure. If the data block passes the CRC test, the data shall be passed through to the appropriate DCE port (or normal output as directed by the operator or controller). If the data block is part of a larger message segmented before DTM transfer, it shall be recombined before output. If any DTM data blocks are received and do not pass the CRC data integrity test, any detectable but uncorrectable errors or areas likely to contain errors and should be tagged for further analysis, error control, or inspection by the operator or controller.

If ARQ is required, the received but unacceptable data block shall be temporarily stored, and a DTM ARQ NAK shall be returned to sender, who shall retransmit an exact duplicate DTM data block. Upon receipt of the duplicate, the receiving station shall again test the CRC. If the CRC is successful, the data block shall be passed through as described before, the previously unacceptable data block should be deleted, and a DTM ARQ ACK shall be returned. If the CRC fails again, both the duplicate and the previously stored data blocks shall be used to correct, as possible, errors and to create an "improved" data block. See figure A-48 for an example of data block reconstruction. The "improved" data block shall then be CRC tested. If the CRC is successful, the "improved" data block is passed through, the previously unacceptable data blocks should be deleted, and a DTM ARQ ACK shall be returned. If the CRC test fails, the "improved" data block shall be stored and a DTM ARQ NAK shall be returned. This process shall be repeated until: (a) a received duplicate, or an "improved" data block passes the CRC test (the data block is passed through, and a DTM ARQ ACK is returned); (b) the maximum number of duplicates (such as seven or more) have been sent without success (with actions by the sender as described above); or (c) the operators or controllers terminate or redirect the DTM protocol.

MIL-STD-188-141B  
APPENDIX A



**FIGURE A-48. Data test message reconstruction (overlay).**

During reception of ALE frames and DTM data blocks, it is expected that fades, interferences, and collisions will occur. The receiving station shall have the capability to maintain synchronization with the frame and the DTM data block transmission, once initiated. It shall also have the capability to read and process any colliding and significantly stronger (that is, readable) ALE signals without confusing them with the DTM signal (basic ALE reception in parallel, and always listening). Therefore, useful information that may be derived from readable collisions of ALE signals should not be arbitrarily rejected or wasted. The DTM structures, especially the DTM EXTENDED, can tolerate weak signals, short fades, and short noise bursts. For these cases and for collisions, the DTM protocol can detect DTM words that have been damaged and "tag" them for error correction or repeats. The DTM constructions are described herein. Within the DTM data block structure, the CMD DTM word shall be placed ahead of the DTM data block itself. The DTM word shall alert the receiving station that a DTM data block is arriving, how

MIL-STD-188-141B  
APPENDIX A

long it is, what type of traffic it contains, what its message and block sequence is, and if ARQ is required. It shall also indicate the exact start of the data block (the end of the CMD DTM word), and shall initiate the reception, tracking, decoding, reading, and checking of the message data contained within the data block, which itself is within the DATA and REP words. The message data itself shall be either one of two types, binary bits or ASCII.

The ASCII characters (typically used for text) shall be the standard 7-bit length, and the start, stop, and parity bits shall be removed at the sending (and restored at the receiving) station. The binary bits (typically used for other character formats, computer files, and cryptographic devices) may have any (or no) pattern or format, and they shall be transferred transparently (that is, exactly as they were input to the sending station) with the same length and without modification.

The size of the DTM BASIC or EXTENDED data block shall be the smallest multiple of DATA and REP words that will accommodate the quantity of the ASCII or binary bits message data to be transferred in the DTM data block. If the message data to be transferred does not exactly fit the unencoded data field of the DTM block size selected, the available empty positions shall be “stuffed” with ASCII “DEL” (111111) characters or all “1” bits. The combined message and “stuff” data in the uncoded DTM data field shall then be checked by the CRC for error control in the DTM protocol. The resulting 16-bit CRC word shall always be inserted into the CMD CRC word that immediately follows the DTM data block words themselves. All the bits in the data field shall then be inserted into standard DATA and REP words on a 21-bit or three-character basis and Golay FEC encoded, interleaved, and tripled for redundancy. Immediately after the CMD DTM word, the DTM DATA and REP words shall follow standard word format, and the CMD CRC shall be at the end.

The DTM BASIC data block has a relatively compact range of sizes from 0 to 31 words and shall be used to transfer any quantity of message data between zero and the maximum limits for the DTM BASIC structure, which is up to 651 bits or 93 ASCII characters. It is capable of counting the exact quantity of message data it contains, on a bit-by-bit basis. It should be used as a single DTM for any message data within this range. It shall also be used to transfer any message data in this size range that is an “overflow” from the larger size (and increments) DTM EXTENDED data blocks, which shall immediately precede the DTM BASIC in the DTM sequence of sending.

The DTM EXTENDED data blocks are also variable in size in increments of single ALE words up to 351. They should be used as a single, large DTM to maximize the advantages of DTM throughput. The size of the data block should be selected to provide the largest data field size that can be totally filled by the message data to be transferred. Any “overflow” shall be in a message data segment sent within an immediately following and appropriately sized DTM EXTENDED or BASIC data block. Under operator or controller direction, multiple DTM EXTENDED data blocks, with smaller than the maximum appropriate ID sizes, should be selected if they will optimize DTM data transfer throughput and reliability. However, these multiple data blocks will require that the message data be divided into multiple segments at the sending station, that they be sent only in the exact order of the segments in the message, and that

MIL-STD-188-141B  
APPENDIX A

the receiving stations recombine the segments into a complete received message. When binary bits are being transferred, the EXTENDED data field shall be filled exactly to the last bit. When ASCII characters are being transferred, there are no stuff bits as the 7-bit characters fit the ALE word 21-bit data field exactly.

If stations are exchanging DTM data blocks and DTM ARQs, they may combine both functions in the same frames, and they shall discriminate based on the direction of transmission and the sending and destination addressing. If ARQ is required in a given direction, only one DTM data block shall be allowed within any frame in that direction, and only one DTM ARQ shall be allowed in each frame in the return direction. If no ARQ is required in a given direction, multiple DTM data blocks may be included in frames in that direction, and multiple DTM ARQ's may be included in the return direction.

As always throughout the DTM protocol, any sequence of DTM data blocks to be transferred shall have the KD1 sequence control bits alternating with the preceding and following DTM data blocks (except duplicates for ARQ, which shall be exactly the same as the originally transmitted DTM data block).

Also, all multiple DTM data blocks transferring multiple segments of a larger data message shall all have their KD2 message control bits set to the same value, and opposite of the preceding and following messages. If a sequence of multiple but unrelated DTM data blocks are sent (such as several independent and short messages within several DTM BASIC data blocks), they may be sent in any sequence. However, the KD1 or KD2 sequence and message control bits shall alternate with those in the adjacent DTM data blocks.

The CMD DTM words shall be constructed as shown in table A-XXXIII. The preamble shall be CMD (110) in bits P3 through P1 (W1 through W3). The first character shall be "d" (1100100) in bits C1-7 through C1-1) (W4 through W10), which shall identify the DTM "data" function.

For DTM BASIC, EXTENDED, and NULL, when the "ARQ" control bit KD4 (W11) is set to "0," no correct data receipt acknowledgment is required; and when set to "1," it is required. For DTM ARQ, "ARQ" control bit KD4 is set to "0" to indicate acknowledgment or correct data block receipt (ACK); and when set to "1," it indicates a failure to receive the data and is therefore a request-for-repeat (NAK). For DTM ARQ responding to a DTM NULL interrogation, KD4 "0" indicates non-participation in the DTM protocol or traffic type, and KD4 "1" indicates affirmative participation in both the DTM protocol and traffic type.

For DTM BASIC, EXTENDED, and NULL, when the "data type" control bit KD3 (W12) is set to "0," the message data contained within the DTM data block shall be binary bits with no required format or pattern; and when KD3 is set to "1" the message data is 7-bit ASCII characters. For DTM ARQ, "flow" control bit KD3 is set to indicate that the DTM transfer flow should continue, or resume; and when KD3 is set to "1" it indicates that the sending station should pause (until another and identical DTM ARQ is returned, except that KD3 shall be "0").

For DTM BASIC, EXTENDED, and NULL, when the “message” control bit KD2 (W13) is set to the same value as the KD2 in any sequentially adjacent DTM data block, the message data contained within those adjacent blocks (after individual error control) shall be recombined with the message data within the present DTM data block segment-by-segment to reconstitute the original whole message, and when KD2 is set opposite to any sequentially adjacent DTM data blocks, those data blocks contain separate message data and shall not be combined. For DTM ARQ, “message” control bit KD2 shall be set to match the referenced DTM data block KD2 value to provide message confirmation.

For DTM BASIC, EXTENDED, and NULL, the “sequence” control bit KD1 (W14) shall be set opposite to the KD1 value in the sequentially adjacent DTM BASIC, EXTENDED, or NULLs to be sent (the KD1 values therefore alternate, regardless of their message dependencies). When KD1 is set to the same value as any sequentially adjacent DTM sent, it indicates that it is a duplicate (which shall be exactly the same). For DTM ARQ, “sequence” control bit KD1 shall be set to match the referenced DTM data block or NULL KD1 value to provide sequence confirmation.

When used for the DTM protocols, the ten DTM data code (DC) bits DC10 through DC1 (W15 through W24) shall indicate the DTM mode (BASIC, EXTENDED, ARQ, or NULL). They shall also indicate the size of the message data and the length of the data block. The DTM NULL DC value shall be “0” (0000000000), and it shall designate the single CMD DTM NULL word. The DTM EXTENDED DC values shall range from “1” (0000000001) to “351” (0101011111), and they designate the CMD DTM EXTENDED word and the data block multiple of DATA and REP words that define the variable data block sizes. The EXTENDED sizes shall range from 1 to 351 words, with a range of 21 to 7371 binary bits, in increments of 21; or three to 1053 ASCII characters, in increments of three. The DTM BASIC DC values shall range from “353” (0101100001) to “1023” (1111111111), and they shall designate the CMD DTM BASIC word and the exact size of the message data in compact and variable size data blocks, with up to 651 binary bits or 93 ASCII characters. The DTM ARQ DC value shall be “352” (0101100000), and it shall designate the single CMD DTM ARQ word. The DC values “384” (0110000000) and all higher multiples of “32m” (m x 100000) shall be reserved until standardized. See table A-XXXII for DC values and DTM block sizes and other characteristics.

#### A.5.7.4 DBM mode.

The DBM ALE (orderwire) message protocol function enables ALE stations to communicate either full ASCII, or unformatted binary bit messages to and from any selected ALE station(s) for direct output to and input from associated data terminal or other DTE devices through their standard DCE ports. This DBM data transfer function is a high-speed mode (relative to DTM and AMD) with improved robustness, especially against long fades and noise bursts. When used over MF/HF by the ALE system, DBM orderwire messages may be unilateral or bilateral, and broadcast or acknowledged. As the DBM data blocks can be very large, this special orderwire

MIL-STD-188-141B  
APPENDIX A

message function enables exploitation of deep interleaving and FEC techniques to penetrate HF-channel long fades and large noise bursts.

The DBM data blocks shall be fully buffered at each station and should appear transparent to the using DTEs or data terminals. As a design objective and under the direction of the operator or controller, the stations should have the capability of using the DBM data traffic mode (ASCII or binary bits) to control switching of the DBM data traffic to the appropriate DCE port or associated DTE equipment, such as to printers and terminals (if ASCII mode) or computers and cryptographic devices (if binary bits mode). As an operator or controller-selected option, the received DBM message may also be presented on the operator display, similar to the method for AMD in table A.5.7.2.

There are four CMD DBM modes: BASIC, EXTENDED, NULL, and ARQ. The DBM BASIC block is a fixed size and contains a variable quantity of data, from zero to full as required, which is exactly measured to ensure integrity of the data during transfer. The DBM EXTENDED blocks are variable in size in integral multiples of the BASIC block, and are filled with integral multiples of message data. The DBM NULL and ARQ modes are used for both link management, and error and flow control. The characteristics of the CMD DBM orderwire message functions are listed in table A-XXXIV, and they are summarized below:

<u>CMD DBM Mode</u>	<u>BASIC</u>	<u>EXTENDED</u>	<u>ARQ NULL</u>
Maximum Size, Bits	588	262836	0
CRC	16 Bits	16 Bits	0
Data Capacity, ASCII	0-81	81-37377, by 84	0
Data Capacity, Bits	0-572	572-261644, by 588	0
ALE Word	49 Fixed	49-21805, by 49	0
Redundancy			
Data Transmission	3.136 Sec	3.136 sec - 23.26 min, by 3.136 sec increments	0



**TABLE A-XXXIV. DBM characteristics.**

WORD BITS		DBM CODE (DC) DECIMAL (n)	INTER- LEAVE DEPTH (ID)	BINARY BITS DATA	ASCII CHAR DATA	BLOCK TIME	TOTAL DBM ( $T_{rw}$ )
W 15-----W 24							
DBM CODE BITS							
BC 10-----BC 1							
DBM NULL*	0000000000	0	0	0	0	0*	1*
DBM EXTENDED (FULL)	0000000001 0000000010 ↓ ↓ ↓ ↓ ↓ ↓ ↓ ↓ ↓ ↓ 0110111100 0110111101 0110111110 0110111111	1 2 n 444 445 446 447	49 98 49n 21756 21805 --- ---	572 1160 12ID-16 261056 261644 --- ---	81 165 BITS+7 37293 37377 --- ---	3.136s 6.272s IDx64ms 23.21min 23.26min --- ---	9 17 8n+1 3553 3561 --- ---
(RESERVED)							
DBM BASIC (EXACT)	0111000000 0111000001 0111000011 ↓ ↓ ↓ ↓ ↓ ↓ ↓ ↓ ↓ ↓ 1111111011 1111111100	448 449 450 ↓ 1019 1020	49 ↓ 49	0 1 2 n-448 571 572	0 0 0 BITS+7 81 81	3.136s ↓ 3.136s	9 ↓ 9
DBM ARQ*	1111111101	1021	0	0	0	0*	1*
(RESERVED)*	1111111110	1022	---	---	---	---	---
(RESERVED)*	1111111111	1023	---	---	---	---	---

NOTE:  
\*NO INTERNAL CRC USED.

When an ASCII, or binary bit, digital data message function is required, the following CMD DBM orderwire structures and protocols shall be used as specified herein, unless another standardized protocol is substituted. The DBM structure shall be inserted within the message section of the standard frame. A CMD DBM word shall be constructed in the standard format. The data to be transferred shall be Golay FEC encoded, interleaved (for error spreading during decoding), and transmitted immediately following the CMD DBM word.

When the DBM structure transmission time exceeds the maximum for the message section ( $T_{m \max}$ ), the DBM protocol shall take precedence and shall extend the  $T_m$  limit to accommodate the DBM. The DBM mode preserves the required consistency of redundant word phase during the transmission. The message expansion due to the DBM is always a multiple of  $8 T_{rw}$ , as the interleaver depth is always a multiple of 49. The transmission time of the DBM data block ( $T_{dbm}$ ) itself is equal to (interleaver depth x 64ms), not including the  $T_{rw}$  for the preceding CMD DBM word. Figure A-49 shows an example of an exchange using the DBM orderwire to transfer

and acknowledge messages. Figure A-50 shows an example of a DBM data interleaver, and figure A-51 shows the transmitted DBM bit-stream sequence.

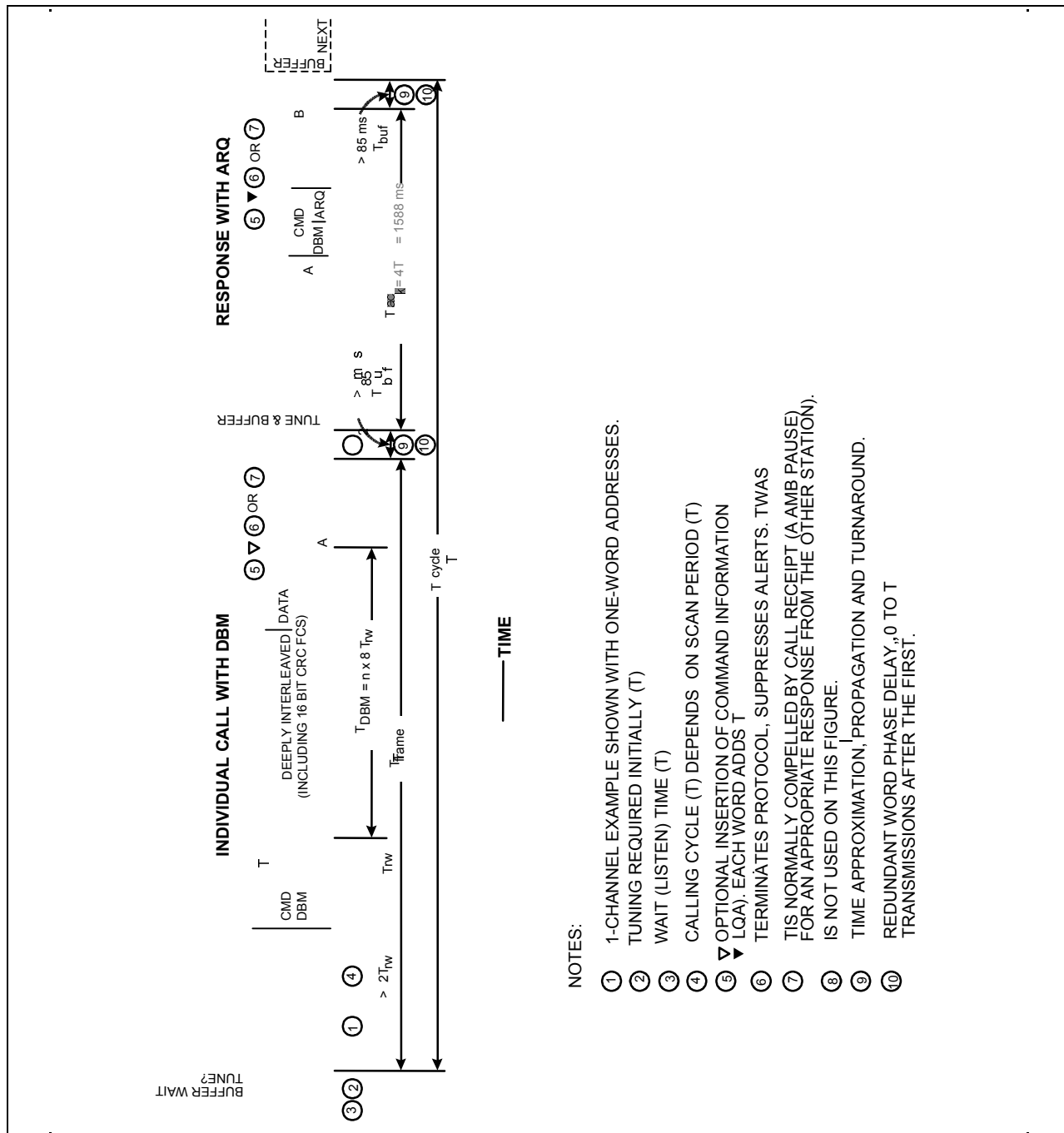


FIGURE A-49. Data test message structure and ARQ example.

MIL-STD-188-141B  
APPENDIX A

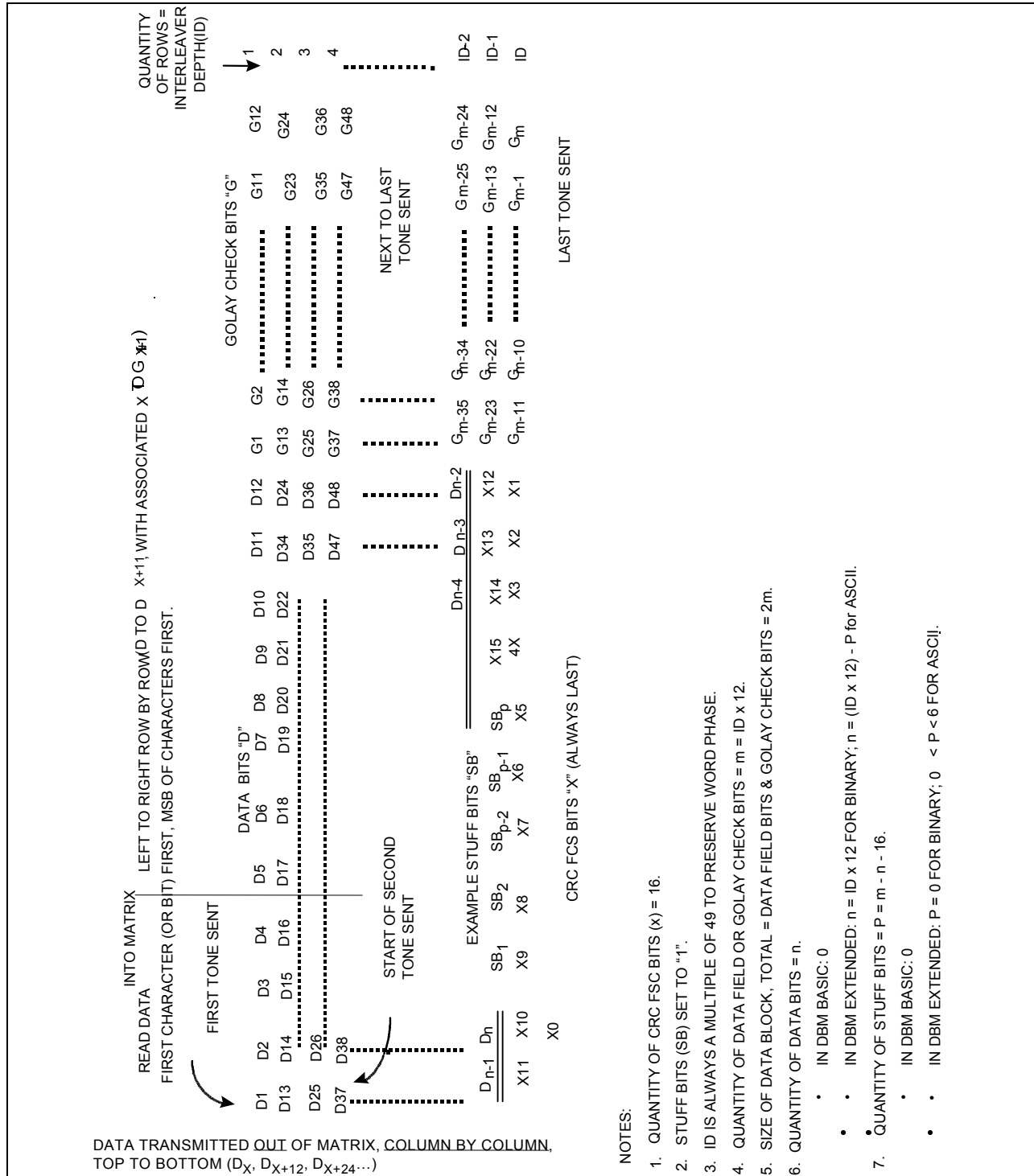
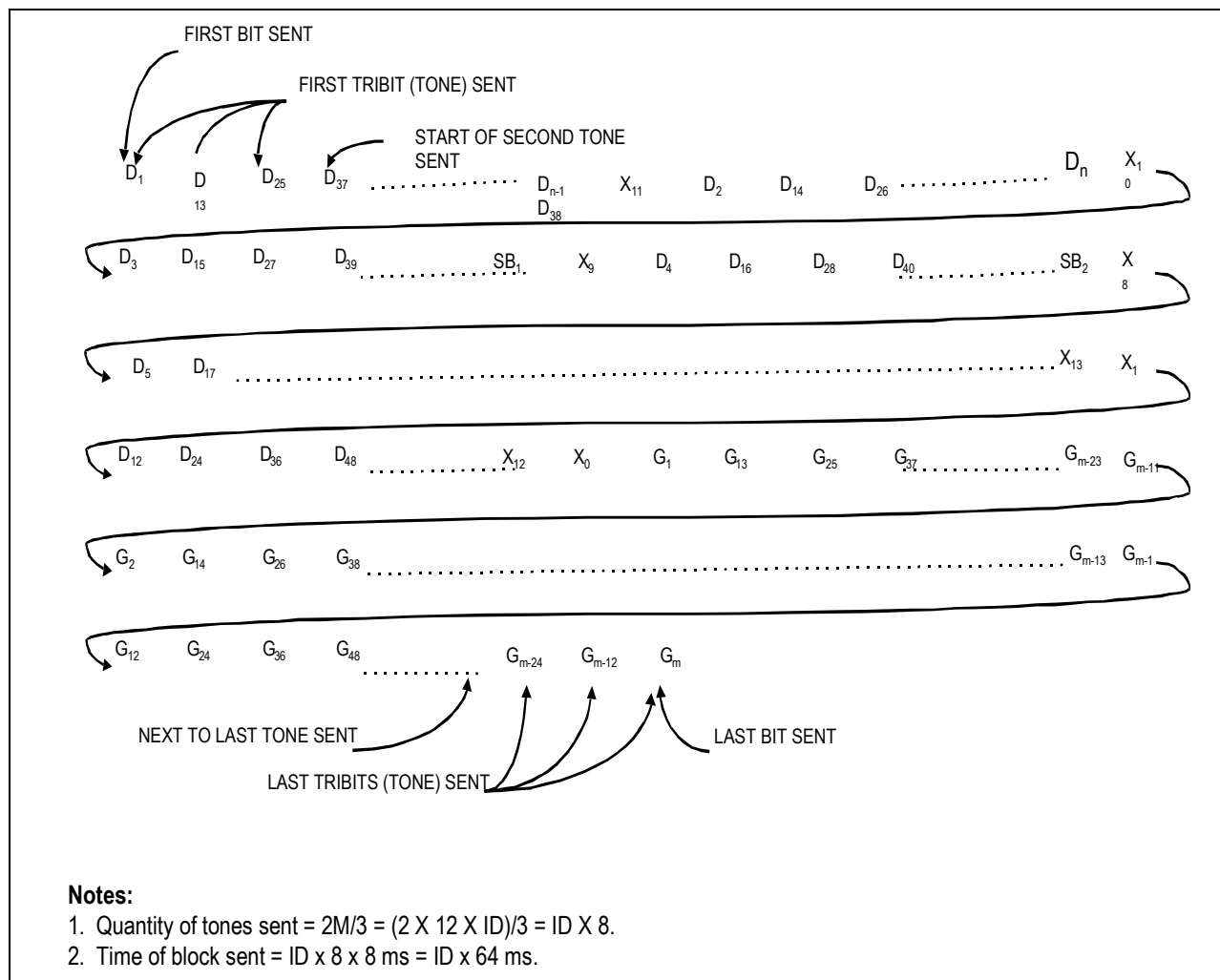


FIGURE A-50. DBM interleaver and deinterleaver.

MIL-STD-188-141B  
APPENDIX A



**FIGURE A-51. DBM example.**

The DBM protocol shall be as described herein. The CMD DBM BASIC and EXTENDED formats (herein referred to as DBM data blocks) shall be used to transfer messages in information among ALE stations. The CMD DBM ARQ format shall be used to acknowledge other CMD DBM formats and for error and flow control, except for non-ARQ and one-way broadcasts. The CMD DBM NULL format shall be used to: (a) interrupt (“break”) the DBM and message flow; (b) to interrogate stations to confirm DBM capability before initiation of the DBM message transfer protocols; and (c) to terminate the DBM protocols while remaining linked. When used in handshakes and subsequent exchanges, the protocol frame terminations for all involved stations shall be TIS until all the DBM messages are successfully transferred, and all are acknowledged if ARQ error control is required. The only exceptions shall be when the protocol is a one-way broadcast or the station is forced to abandon the exchange by the operator or controller, in which cases the termination should be TWAS.

MIL-STD-188-141B  
APPENDIX A

Once a CMD DBM word of any type has been received by a called (addressed) or linked station, the station shall remain on channel for the entire specified DBM data block time (if any), unless forced to abandon the protocol by the operator or controller. The start of the DBM data block itself shall be exactly indicated by the end of the CMD DBM BASIC or EXTENDED word itself. The station shall attempt to read the entire DBM data block information, plus the expected frame continuation, which shall contain a conclusion (possibly preceded by additional functions in the message section, as indicated by additional CMD words).

With or without ARQ, identification of each DBM data block and its associated orderwire message (if segmented into sequential DBM data blocks) shall be achieved by use of the sequence and message control bits, KB1 and KB2, (see table A-XXXV) which shall alternate with each DBM transmission and message, respectively. The type of data contained within the data block (ASCII or binary bits) shall be indicated by KB3 as a data identification bit. Activation of the ARQ error-control protocol shall use the ARQ control bit KB4. If no ARQ is required, such as in one-way broadcasts, multiple DBM data blocks may be sent in the same frame, but they shall be in proper sequence if they are transferring a segmented message.

MIL-STD-188-141B  
APPENDIX A

**TABLE A-XXXV. DBM structures.**

	DBM Bits		Word Bits	
CMD preamble	MSB	P3 = 1 P2 = 1 P1 = 0	MSB	W3 W1 W2
First character "b"	MSB	C1 (bit-7) = 1 C1 (bit-6) = 1 C1 (bit-5) = 0 C1 (bit-4) = 0 C1 (bit-3) = 0 C1 (bit-2) = 1 C1 (bit-1) = 0		W4 W5 W6 W7 W8 W9 W10
Control bits	MSB	KB4 KB3 KB2		W11 W12 W13
	LSB	KB1		W14
DTM data code bits	MSB	BC10 BC9 BC8 BC7 BC6 BC5 BC4 BC3 BC2		W15 W16 W17 W18 W19 W20 W21 W22 W23
	LSB	BC1	LSB	W24

NOTES:

1. CMD DBM and DBM ARQ first character is "b" for "block."
2. With DBM transmission, control bit KB4 (W11) is set to "0" for no ACK request, and "1" for ACK request.
3. If a DBM ARQ transmission, control bit KB4 (W11) is set to "0" for ACK, and "1" for NAK.
4. With DBM transmissions, control bit KB3 (W12) is set to "0" for binary bits and "1" for 7-bit ASCII characters.
5. If a DBM ARQ transmission, control bit KB3 (W12) is set to "0" for flow continue, and "1" for flow pause.
6. With DBM transmissions, control bit KB2 (W13) is set: (a) the same ("0" or "1") as the sequentially adjacent DBM(s) if the transmitted data field is to be reintegrated as part of a larger DBM, and (b) alternately different if independent from the prior adjacent DBM data field(s).
7. If a DBM ARQ transmission, control bit KB2 (W13) is set the same as the referenced DBM transmission.
8. With DBM transmissions, control bit KB1 (W14) is set alternately to "0" and "1" in any sequence of DBMs as a sequence control.
9. If a DBM ARQ transmission, control bit KB1 (W14) is set the same as the referenced DBM transmission.
10. Block code (BC) bits are from table A-XXXIV.

MIL-STD-188-141B  
APPENDIX A

When ARQ error or flow control is required, the CMD DBM ARQ shall identify the acknowledged DBM data block by the use of the sequence and message control bits KB1 and KB2, which shall be set to the same values as the immediately preceding and referenced DBM data block transmission. Control bit KB3 shall be used as the DBM flow control to pause or continue (or resume) the flow of the DBM data blocks. The ACK and NAK functions shall use the ARQ control bit KB4. If no ARQ has been required by the sending station, but the receiving station needs to control the flow of the DBM data blocks, it shall use the DBM ARQ to request a pause in, and resumption of, the flow.

When data transfer ARQ error and flow control is required, the DBM data blocks shall be sent individually and in sequence. Each DBM data block shall be individually acknowledged before the next DBM data block is sent. Therefore, with ARQ there shall be only one DBM data block transmission in each frame. If the transmitted DBM data block causes a NAK in the returned DBM ARQ, as described below, or if no ACK or DBM ARQ is detected in the returned frame, or if no frame is detected at all, the sending station shall resend an exact duplicate of the unacknowledged DBM data block. It shall continue to resend duplicates (which should be at least seven), one at a time and with appropriate pauses for responses, until the involved DBM data block is specifically acknowledged by a correct DBM ARQ. Only then shall the next DBM data block in the sequence be sent. If the sending station is frequently or totally unable to detect frame or DBM ARQ responses, it should abort the DBM transfer protocol, terminate the link and relink and reinitiate the DBM protocol on a better channel (under operator or controller direction).

Before initiation of the DBM data transfer protocols, the sending stations should confirm the existence of the DBM capability in the intended receiving stations, if not already known. When a DBM interrogation function is required, the following protocol shall be used. Within any standard protocol frame (using TIS), the sending station shall transmit a CMD DBM NULL, with ARQ required, to the intended station(s). These receiving stations shall respond with the appropriate standard frame and protocol, with the following variations. They shall include a CMD DBM ARQ if they are DBM capable, and they shall omit it if they are not DBM capable. The sending station shall examine the ALE and DBM ARQ responses for existence, correctness, and the status of the DBM KB control bits, as described herein. The transmitted CMD DBM NULL shall have its control bits set as follows: KB1 and KB2 set opposite of any subsequent and sequential CMD DBM BASIC or EXTENDED data blocks which will be transmitted next; KB3 set to indicate the intended type of traffic; and KB4 set to require ARQ. The returned CMD DBM ARQ shall have its control bits set as follows: KB1 and KB2 set to match the interrogating DBM NULL; KB3 set to indicate if the station is ready for DBM data exchanges, or if a pause is requested; and KB4 set to ACK if the station is ready to accept DBM data transmissions with the specified traffic type, and NAK if it cannot or will not participate, or if it failed to read the DBM NULL.

The sending (interrogating) station shall handle any stations which return a NAK, or do not return a DBM ARQ, or do not respond, in any combination of the following, and for any

combination of these stations. The specific actions and stations shall be selected by the operator or controller. The sending station shall: (a) terminate the link with these stations, using an appropriate and specific call and the TWAS terminator; (b) direct the stations to remain and stay linked during the transmissions, using the CMD STAY protocol in each frame immediately before each CMD DBM word and data block sent; or (c) redirect them to do anything else which is controllable using the CMD functions described within this standard.

Each received DBM data block shall be examined using the CRC data integrity test which is embedded within the DBM structure and protocol. If the data block passes the CRC test, the data shall be passed through to the appropriate DCE port (or normal output as directed by the operator or controller). If the data block is part of a larger message which was segmented before DBM transfer, it shall be recombined before output. If any DBM data blocks are received and do not pass the CRC data integrity test, any detectable but uncorrectable errors; or areas likely to contain errors, should be tagged for further analysis, error control, or inspection by the operator or controller.

If ARQ is required, the received but unacceptable data block shall be temporarily stored, and a DBM ARQ NAK shall be returned to the sender, who shall retransmit an exact duplicate DBM data block. Upon receipt of the duplicate, the receiving station shall again test the CRC. If the CRC is successful, the data block shall be passed through as described before, the previously unacceptable data block should be deleted, and a DBM ARQ ACK shall be returned. If the CRC fails again, both the duplicate and the previously stored data blocks shall be used to correct, as possible, errors and to create an "improved" data block. See figure A-48 for an example of data block reconstruction. The "improved" data block shall then be CRC tested. If the CRC is successful, the "improved" data block is passed through, the previously unacceptable data blocks should be deleted, and a DBM ARQ ACK shall be returned. If the CRC test fails, the "improved" data block shall also be stored and a DBM ARQ NAK shall be returned. This process shall be repeated until: (a) a received duplicate, or an "improved" data block passes the CRC test (and the data block is passed through, and a DBM ARQ ACK is returned); (b) the maximum number of duplicates (such as seven or more) have been sent without success (with actions by the sender as described above); or (c) the operators or controllers terminate or redirect the DBM protocol.

During reception of frames and DBM data blocks, it is expected that fades, interferences, and collisions will occur. The receiving station shall have the capability to maintain synchronization with the frame and the DBM data block transmission, once initiated. It shall also have the capability to read and process any colliding and significantly stronger (that is, readable) ALE signals without confusing them with the DBM signal (basic ALE reception in parallel, and always listening). The DBM structures, especially the DBM EXTENDED, can tolerate significant fades, noise bursts, and collisions. Therefore, useful information which may be derived from readable collisions of ALE signals should not be arbitrarily rejected or wasted.



MIL-STD-188-141B  
APPENDIX A

The DBM constructions shall be as described herein. Within the DBM data block structure, a CMD DBM word shall be placed ahead of the encoded and interleaved data block itself. The DBM word shall alert the receiving station that a DBM data block is arriving, how long it is, what type of traffic it contains, what its interleaver depth is, what its message and block sequence is, and if ARQ is required. It shall also indicate the exact start of the data block itself (the end of the CMD DBM word itself) and shall initiate the reception, tracking, deinterleaving, decoding, and checking of the data contained within the block. The message data itself shall be either one of two types, binary bits or ASCII. The ASCII characters (typically used for text) shall be the standard 7-bit length, and the start, stop, and parity bits shall be removed at the sending (and restored at the receiving) station. The binary bits (typically used for other character formats, computer files, and cryptographic devices) may have any (or no) pattern or format, and they shall be transferred transparently, that is, exactly as they were input to the sending station, with the same length and without modification. The value of the interleaver depth shall be the smallest (multiple of 49) which will accommodate the quantity of ASCII or binary bits message data to be transferred in the DBM data block. If the message data to be transferred does not exactly fit the uncoded data field of the DBM block size selected (except for the last 16 bits, which are reserved for the CRC), the available empty positions shall be “stuffed” with ASCII “DEL” characters or all “1” bits. The combined message and “stuff” data in the uncoded DBM data field shall then be checked by the CRC for error control in the DBM protocol. The resulting 16-bit CRC word shall always occupy the last 16 bits in the data field. All the bits in the field shall then be Golay FEC encoded, on a 12-bit basis, to produce rows of 24-bit code words, arranged from top to bottom in the interleaver matrix (or equivalent), as shown in figure A-50. The bits in the matrix are then read out by columns (of length equal to the interleaver depth) for transmission. Immediately after the CMD DBM word, the encoded and interleaved data blocks bits shall follow in bit format, three bits per symbol (tone).

The DBM BASIC data block has a fixed size (interleaver depth 49) and shall be used to transfer any quantity of message data between zero and the maximum limits for the DBM BASIC structure, which is up to 572 bits or 81 ASCII characters. It is capable of counting the exact quantity of message data which it contains, on a bit-by-bit basis. It should be used as a single DBM for any message data within this range. It shall also be used to transfer any message data in this size range which is an “overflow” from the larger size (and increments) DBM EXTENDED data blocks (which shall immediately precede the DBM BASIC in the DBM sequence of sending).

The DBM EXTENDED data blocks are variable in size, in increments of 49 times the interleaver depth. They should be used as a single, large DBM to maximize the advantages of DBM deep interleaving, FEC techniques, and higher speed (than DTM or AMD) transfer of data. The interleaver depth of the EXTENDED data block should be selected to provide the largest data field size which can be totally filled by the message data to be transferred. Any “overflow” shall be in a message data segment sent within an immediately following DBM EXTENDED or BASIC data block. Under operator or controller direction, multiple DBM EXTENDED data blocks, with smaller than the maximum appropriate interleaver depth sizes, should be selected if

they will optimize DBM data transfer throughput and reliability. However, these multiple data blocks will require that the message data be divided into multiple segments at the sending station and sent only in the exact order of the segments in the message. The receiving stations must recombine the segments into a complete received message. When binary bits are being transferred, the EXTENDED data field shall be filled exactly to the last bit. When ASCII characters are being transferred, the EXTENDED data field may have 0 to 6 “stuff” bits inserted. Individual ASCII characters shall not be split between DBM data blocks and the receiving station shall read the decoded data field on a 7-bit basis, and it shall discard any remaining “stuff” bits (modulo-7 remainder).

If stations are exchanging DBM data blocks and DBM ARQs, they may combine both functions in the same frames. They shall discriminate based on the direction of transmission and the sending and destination addressing. If ARQ is required in a given direction, only one DBM data block shall be allowed within any frame in that direction, and only one DBM ARQ shall be allowed in each frame in the return direction. If no ARQ is required in a given direction, multiple DBM data blocks may be included in frames in that direction, and multiple DBM ARQs may be included in the return direction.

As always throughout the DBM protocol, any sequence of DBM data blocks to be transferred shall have their KB1 sequence control bits alternating with the preceding and following DBM data blocks (except duplicates for ARQ, which shall be exactly the same as their originally transmitted DBM data block). Also, all multiple DBM data blocks transferring multiple segments of a large data message shall all have their KB2 message control bits set to the same value, and opposite of the preceding and following messages. If a sequence of multiple but unrelated DBM data blocks are sent (such as several independent and short messages within several DBM BASIC data blocks), they may be sent in any sequence. However, when sent, the associated KB1 and KB2 sequence and message control bits shall alternate with those in the adjacent DBM data blocks.

The CMD DBM words shall be constructed as shown in table A-XXXV. The preamble shall be CMD (110) in bits P3 through P1 (W1 through W3). The first character shall be “b” (1100010) in bits C1-7 through C1-1 (W4 through W10), which shall identify the DBM “block” function.

For DBM BASIC, EXTENDED, and NULL, when the ARQ control bit KB4 (W11) is set to “0,” no correct data receipt acknowledgment is required; and when set to “1,” it is required. For DBM ARQ, ARQ control bit KB4 is set to “0” to indicate acknowledgment or correct data block receipt (ACK); and when set to “1,” it indicates a failure to receive the data and is therefore a request-for-repeat (NAK). For DBM ARQ responding to a DBM NULL interrogation, KB4 “0” indicates non-participation in the DBM protocol or traffic type, and KB4 “1” indicates affirmative participation in both the DBM protocol and traffic type.

For DBM BASIC, EXTENDED, and NULL, when the data type control bit KB3 (W12) is set to “0,” the message data contained within the DBM data block shall be binary bits with no required

format or pattern; and when KB3 is set to “1” the message data is 7-bit ASCII characters. For DBM ARQ, flow control bit KB3 is set to “0” to indicate that the DBM transfer flow should continue or resume; and when KB3 is set to “1” it indicates that the sending station should pause (until another and identical DBM ARQ is returned, except that KB3 shall be “0”).

For DBM BASIC, EXTENDED, and NULL, when the “message” control bit KB2 (W13) is set to the same value as the KB2 in any sequentially adjacent DBM data block, the message data contained within those adjacent blocks (after individual error control) shall be recombined with the message data within the present DBM data block to reconstitute (segment-by-segment) the original whole message; and when KB2 is set opposite to any sequentially adjacent DBM data blocks, those data blocks contain separate message data and shall not be combined. For DBM ARQ, “message” control bit KB2 shall be set to match the referenced DBM data block KB2 value to provide message confirmation.

For DBM BASIC, EXTENDED, and NULL, the sequence control bit KB1 (W14) shall be set opposite to the KB1 value in the sequentially adjacent DBM BASIC, EXTENDED, or NULLs be sent (the KB1 values therefore alternate, regardless of their message dependencies). When KB1 is set the same as any sequentially adjacent DBM sent, it indicates a duplicate. For DBM ARQ, sequence control bit KB1 shall be set to match the referenced DBM data block or NULL KB1 value to provide sequence confirmation.

When used for the DBM protocols, the ten DBM data code (BC) bits BC10 through BC1 (W15 through W24) shall indicate the DBM mode (BASIC, EXTENDED, ARQ, or NULL). They shall also indicate the size of the message data and the length of the data block. The DBM NULL BC value shall be “0” (0000000000), and it shall designate the single CMD DBM NULL word. The DBM EXTENDED BC values shall range from “1” (0000000001) to “445” (0110111101), and they shall designate the CMD DBM EXTENDED word and the data block multiple (of 49 INTERLEAVER DEPTH) which defines the variable data block sizes, in increments of 588 binary bits or 84 ASCII characters. The DBM BASIC BC values shall range from “448” (0111000000) to “1020” (1111111100), and they shall designate the CMD DBM BASIC word and the exact size of the message data in a fixed size (INTERLEAVER DEPTH = 49) data block, with up to 572 binary bits or 81 ASCII characters. The DBM ARQ BC value shall be “1021” (1111111101), and it shall designate the single CMD DBM ARQ word.

NOTES:

1. The values “446” (0110111110) and “447” (0110111111) are reserved.
2. The values “1022” (1111111110) and “1023” (1111111111) are reserved until standardized (see table A-XXXIV).

A.5.8 AQC (optional) (NT).

AQC-ALE is designed to use shorter linking transmissions than those of baseline second generation ALE (2G ALE) described previously in this appendix. AQC-ALE uses an extended

version of the 2G ALE signaling structure to assure backward compatibility to already fielded radios. Special features of AQC-ALE include the following:

- The signaling structure separates the call attempt from the inlink-state transactions. This allows radios that are scanning to detect and exit a channel that is carrying traffic that is of no interest.
- The address format is a fixed form to allow end of address detection without requiring the last word wait timeout.
- Control features distinguish call setup channels from traffic carrying channels.
- Local Noise Reports are inherent in the sound and call setup frames to minimize the need to sound as frequently.
- Resources that are needed during the linked state can be identified and bid for during the link setup. This provides a mechanism to bid for needed resources during linking.

#### A.5.8.1 Signaling structure (NT).

The AQC-ALE signaling structure is identical to that described previously in this appendix, except as provided below and in the remaining subsections of this section:

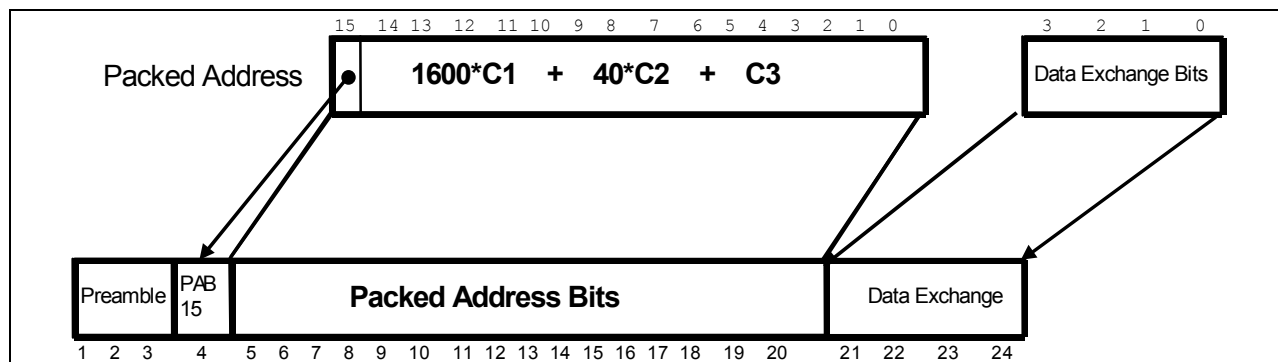
- The AQC-ALE word is encoded differently (see A.5.8.1.1).
- A PSK tone sequence may optionally be inserted between AQC-ALE words during calling handshakes or sounds (see A.5.8.1.6). All compliant implementation of AQC-ALE shall correctly process the AQC-ALE words in calling handshakes and sounds whether or not such PSK tone sequences are present, and whether or not the implementation can extract useful channel data from such PSK tone sequences.

##### A.5.8.1.1 AQC-ALE word structure (NT).

The AQC-ALE word shall consist of a three-bit preamble, an address differentiation flag, a 16-bit packed address field, and a 4-bit Data Exchange field. These fields shall be formatted and used as described in the following paragraphs. Every AQC-ALE word shall have the form shown in figure A-52, AQC-ALE Word. The data values associated with a particular AQC-ALE word are defined by the context of the frame transmission (see A.5.8.2).

##### A.5.8.1.1.1 Packed address (NT).

AQC-ALE packs the 21 bits representing three address characters in the 38-character ASCII subset into 16 bits. This is performed by assigning an ordinal value between 0 and 39 to each member of the 38-character subset. Base 40 arithmetic is used to pack the mapped data into a 16-bit number. The ASCII characters used for addressing shall be mapped to the values defined in table A-XXXVI, Address Character Ordinal Values, with character 1's value multiplied by 1600, Character 2's value multiplied by 40, and Character 3's value multiplied by 1. The sum of the three values shall be used as the 16-bit packed address (see example below).



**FIGURE A-52. AQC-ALE data exchange word.**

**TABLE A-XXXVI. AQC address character ordinal value.**

Character	Value
*	0
0 to 9	1 to 10
?	11
@	12
A to Z	13 to 38
_ (Underscore)	39

Note: The “\*” and “\_” characters are not part of the standard ALE ASCII-38 character set. These characters shall not be used in station addresses in any network that is required to interoperate with stations that support only baseline 2G ALE.

Example:

Using table A-XXXVI, the address 'ABC' would be computed as:

$$\begin{aligned}
 & (\text{Value('A')} * 1600) + (\text{Value('B')} * 40) + \text{Value('C')} \\
 & \text{which is} \\
 & ( 13 * 1600 ) + ( 14 * 40 ) + 15 = 21,375
 \end{aligned}$$

The smallest valued legal address is "000" for a packed value of → 1,641  
 A legal address such as "ABC" would have a packed value of → 21,375  
 The largest valued legal address is "ZZZ" for a packed value of → 62,358

A.5.8.1.1.2 Address differentiation flag (NT).

Bit 4 of the AQC-ALE word shall be a copy of the most significant bit of the 16-bit packed address. This combination results in no legal address in AQC-ALE being legal in baseline 2G ALE and vice versa. The packed address shall occupy the next 16 bits of the 21-bit data portion of the address.

A.5.8.1.2 Preambles (NT).

The preambles shall be as shown in table A-XXXVII AQC-ALE word types (and preambles)

**TABLE A-XXXVII. AQC-ALE word types (and preambles).**

<b>Word Type</b>	<b>Code Bits</b>	<b>Functions</b>	<b>Significance</b>
<b><u>INLINK</u></b>	001	direct routing	Transaction for linked members
<b><u>TO</u></b>	010	--	See table A-VIII
<b><u>CMD</u></b>	110	--	See table A-VIII
<b><u>PART2</u></b>	100	direct routing	indicates this is the second part of the full AQC-ALE address
<b><u>TIS</u></b>	101	--	See table A-VIII
<b><u>TWAS</u></b>	011	--	See table A-VIII
<b><u>DATA</u></b>	000	extension of information	Used only in message section to extend information being sent
<b><u>REP</u></b>	111	duplication and extension of information	Used only in message section to extend information being sent

A.5.8.1.2.1 TO (NT).

This preamble shall have a binary value of 010 and is functionally identical to the TO preamble in A.5.2.3.2.1. The AQC-ALE TO preamble shall represent the first of two words identifying the address of the station or net.

A.5.8.1.2.2 THIS IS (TIS) (NT).

This preamble shall have a binary value of 101. The preamble is functionally identical to the TIS preamble in A.5.2.3.2.2. The AQC-ALE TIS preamble identifies the AQC-ALE word as containing the first three characters of the of the calling or sounding station address.

A.5.8.1.2.3 THIS WAS (TWAS) (NT).

This preamble shall have a binary value of 011. This preamble is functionally identical to the TWAS preamble in A.5.2.3.2.3. The AQC-ALE TWAS preamble identifies the AQC-ALE word as containing the first three characters of the of the calling or sounding station address.

A.5.8.1.2.4 PART2 (NT).

This preamble shall have a binary value of 100. This preamble is shared with the baseline 2G ALE preamble of FROM. This preamble identifies the second set of three characters in an AQC-ALE address. This preamble shall be used for the second word of every AQC-ALE packed address transmission.

A.5.8.1.2.5 INLINK (NT).

This preamble shall have a binary value of 001. This preamble is shared with the baseline 2G ALE preamble of THRU. This preamble shall be used by AQC-ALE whenever a transmission to stations already in an established link is required. This preamble identifies the AQC-ALE word as containing the first three characters of the transmitting station address. This preamble may also be used in the acknowledgement frame of a three-way handshake as described in A.5.8.2.3.

A.5.8.1.2.6 COMMAND (NT).

No Change to A.5.2.3.3.1

A.5.8.1.2.7 DATA (NT).

See A.5-2.3.4.1. In the AQC-ALE word, this preamble never applies to a station address.

A.5.8.1.2.8 REPEAT (NT).

See A.5-2.3.4.2. In the AQC-ALE word, this preamble never applies to a station address.

A.5.8.1.3 AQC-ALE address characteristics (NT).

A.5.8.1.3.1 Address size (NT).

Addresses shall be from 1 to 6 characters.

A.5.8.1.3.2 Address character set (NT).

The address character set shall be the same ASCII-38 character set as for baseline 2G ALE.

A.5.8.1.3.3 Support of ISDN (option) (NT).

To support an ISDN address requirement, the station shall be capable of mapping any 15 character address to and from a 6 character address for displaying or calling. This optional mapping shall be available for at least one Self Address and all programmed Other Addresses in the radio.

A.5.8.1.3.4 Over-the-air address format (NT).

A two AQC-ALE word sequence shall be broadcast for any AQC-ALE address. The “@” shall be used as the stuff character to complete an address that contains fewer than six characters. The sequence shall be an AQC-ALE word with the preamble TO, TIS, TWAS, or INLINK for the first three characters of the address followed by an AQC-ALE word with the preamble PART2 for the last three address characters.

A.5.8.1.4 Address formats by call type (NT).

A.5.8.1.4.1 Unit addresses (NT).

A unit or other address shall be from one to six characters.

A.5.8.1.4.2 StarNet addresses (NT).

A StarNet address shall be from one to six characters.

A.5.8.1.4.3 Group addresses (NT).

This feature is not applicable to AQC-ALE.

A.5.8.1.4.4 AllCall address (NT).

AQC-ALE AllCall address shall be six characters. The second three characters of the AllCall address shall be the same as the first three characters. Thus, a global AllCall sequence would look like:

TO-@?@|PART2-@?@.

A.5.8.1.4.5 AnyCall address (NT).

AQC-ALE AnyCall address shall be six characters. The second three characters of the AnyCall address shall be the same as the first three characters. Thus, a global AnyCall sequence would look like:

TO-@@?|PART2-@@?.

A.5.8.1.5 Data exchange field (NT).

The 4-bit data exchange field shall be encoded as described in table A\_XXXVIII and the following paragraphs. The use of the various encodings DE(1) through (9) shall be as shown in the figures for the Sound, Unit call, Starnet call, All call, and Any call in the respective subsections of A.5.8.2.

NOTE: A station may use the contents of the data exchange field to further validate the correctness of a given frame.

**TABLE A-XXXVIII. Data exchange definitions.**

	Bit 3	Bit 2	Bit 1	Bit 0	Description
DE(1)	1	1	1	1	No Data Available
DE(2)	x	x	x	x	Number of TOs Left in Calling Cycle Section
DE(3)	x	x	x	x	Inlink Resource List Expected
DE(4)	x	x	x	x	Local Noise Index
DE(5)	LQA Variance	0	< LQA Minimum from LQA Mean >		1 bit spare, 3 bits of LQA variance data
DE(6)	x	x	x	x	LQA Measurement Index
DE(7)	x	x	x	x	Number of Tis/Twas left in Sound
DE(8)	Ack This	<# of Command Preambles>			Most Significant Bits of the Inlink Transaction Code
DE(9)	I'm Inlink	< Transaction Code >			Least significant 4 bits of Inlink

A.5.8.1.5.1 DE(1) no data available (NT).

DE(1) shall be sent in the TIS word in the conclusion of a Call frame. All data bits shall be set to 1s.

A.5.8.1.5.2 DE(2) number of to's left in calling cycle (NT).

DE(2) shall be sent in every AQC-ALE word that contains a TO preamble. In a Call frame, the DE(2) field shall indicate the remaining number of TO preambles that remain in the frame. This is an inclusive number and when set to a value of 1 the next address shall be the caller's address



using a TIS or TWAS preamble. When the remaining call duration would require a count greater than 15, a count of 15 shall be used.

A value of 0 shall be used in in the Response frame and Acknowledgement frame when a single address in required. DE(2) shall count down to 1 whenever multiple addresses are transmitted in an address section.

**A.5.8.1.5.3 DE(3) Inlink resource list (NT).**

DE(3) shall be sent in the PART 2 word that follows each TO word. The DE(3) field shall indicate the type of traffic to be conveyed during the Inlink state, using the encodings in table AXXXIX. Values not specified in the table are reserved, and shall not be used until standardized.

Upon receipt of the INLINK Resource List in the Call, the called station shall determine whether the station can operate with the desired resource. When responding to the call, the called station shall honor the requested resource whenever possible. If the resource requested is unavailable, the called unit shall respond with an alternate resource that is the best possible alternative resource available to the receiver. This information is provided in the Response frame of a handshake.

By definition, when the calling station enters an Inlink state with the called station, the calling station accepted the Inlink resource that the called station can provide.

**TABLE A-XXXIX. Inlink resource list.**

Value	Meaning	Alternate Resource
0	Clear Voice	15
1	Digital Voice	0
2	High Fidelity Digital (HFD) Voice	1 or 0
3	Reserved	NA
4	Secure Digital Voice	2, 1, 0
5	Secure HFD Voice	4, 2, 1, 0
6	Reserved	NA
7	Reserved	NA
8	ALE Messaging	15
9	PSK Messaging	0 or 15
10	39 Tone Messaging	0 or 15
11	HF Email	9, 8, 0
12	KY-100 Data Security Active	9
13	Reserved	NA
14	Reserved	NA
15	Undeclared Traffic. Usually a mixture.	Always Acceptable

**A.5.8.1.5.4 DE(4) local noise report (NT).**

DE(4) shall be sent in the PART 2 word that concludes a Call frame and in every PART 2 word in a Sounding frame. The Local Noise Report contains information which describes the type of

MIL-STD-188-141B  
APPENDIX A

local noise at the sender's location. The Local Noise Report provides a broadcast alternative to sounding that permits receiving stations to approximately predict the bilateral link quality for the channel carrying the report. An example application of this technique is networks in which most stations are silent but which need to have a high probability of linking on the first attempt with a base station. A station receiving a Local Noise Report can compare the noise level at the transmitter to its own local noise level, and thereby estimate the bilateral link quality from its own LQA measurement of the received noise report transmission. The report includes a mean and maximum noise power measured on the channel in the past 60 minutes with measurement intervals at least once per minute.

The Local Noise Report shall be formatted as shown in figure A.5.8-5. Units for the Max and Mean fields are dB relative to 0.1  $\mu$ V 3 kHz noise. The Max noise level shall be the amount of distance from the Mean that the local noise was measured against. When averaging is used, standard rounding rules to the integer shall apply. By comparing the noise levels reported by a distant station on several channels, the station receiving the noise reports can select a channel for linking attempts based upon knowledge of both the propagation characteristics and the interference situation at that destination. For a more detailed local noise report, a station may broadcast the ALE Local Noise Report command in the message section. When deriving the average noise floor, signals which can be recognized shall be excluded from the power measurement.

**TABLE A-XL. Local noise report.**

Value	Delta Max Noise from Mean	Mean Noise Level
0	0 <= Noise < 6 dB	Mean <= 6 dB
1	6 <= Noise < 12 dB	Mean <= 6 dB
2	Noise >= 12 dB	Mean <= 6 dB
3	0 <= Noise < 6 dB	6 < Mean <= 15 dB
4	6 <= Noise < 12 dB	6 < Mean <= 15 dB
5	Noise >= 6 dB	6 < Mean <= 15 dB
6	0 <= Noise < 6 dB	15 < Mean <= 40 dB
7	6 <= Noise < 12 dB	15 < Mean <= 40 dB
8	Noise >= 12 dB	15 < Mean <= 40 dB
9	0 <= Noise < 6 dB	40 < Mean <= 60 dB
10	6 <= Noise < 12 dB	40 < Mean <= 60 dB
11	Noise >= 12db	40 < Mean <= 60 dB
12	No Definition	60 < Mean <= 80 dB
13	No Definition	80 < Mean <= 100 dB
14	No Definition	Mean > 100 dB
15	No Data	No Data

A.5.8.1.5.5 DE(5) LQA variation (NT).

DE(5) shall be sent in the TIS or TWAS word in the conclusion of AQC-ALE Response and Acknowledgement frames. It shall report the signal quality variation measured on the immediately preceding transmission of the handshake.

Whenever an AQC-ALE or ALE word is received, a signal noise ratio (SNR) sample shall be computed. This measurement can be used to determine the capacity of the channel to handle traffic. Because several types of signaling protocols may be used while in the linked state, it is important that this measurement be applicable to a wide variety of signaling structures. The DE(5) LQA Data Exchange word provides feedback as to the value of the measured signal.

During receipt of a AQC-ALE or ALE signal, an SNR measurement shall be taken at least every Tw (non-redundant word period). Three characteristics shall be collected:

1. A Mean SNR signal shall be derived
2. A Minimum SNR value during the frame shall be recorded
3. Rapid Change Boolean, when set 1, shall indicate more than 40 percent of the measurements varied greater than  $\pm 3$  dB from the mean SNR.

	Bit 3	Bit 2	Bit 1	Bit 0	Description
DE(5)	Rapid Change	0	< LQA Minimum from LQA Mean >		one bit spare, 3 bits of LQA variation data

Items 2 and 3 of the LQA calculation are reported in this data exchange field. This field shall be set to all 1's when the LQA measurement value in DE(6) indicates that no SNR value was taken.

Table A-XLT shall be used to encode the magnitude of lowest value SNR difference from the Mean.

**TABLE A-XLI. Magnitude of minimum SNR from mean SNR.**

Value	Magnitude from SNR MEAN
0	difference $\leq 6$ dB
1	$6 < \text{difference} \leq 12$ dB
2	$12 < \text{difference} \leq 18$ dB
3	$> 18$ dB drop from SNR Mean

A.5.8.1.5.6 DE(6) LQA measurement (NT).

DE(6) shall be sent in the PART 2 word in the conclusion of AQC-ALE Response and Acknowledgement frames. The Link Quality Measurement contains the predicted quality of the channel to handle traffic. This value may be used as a first approximation to setting data rates for data transmission, determining that propagation conditions could carry voice traffic, or directing the station to continue to search for a better channel. (See A.5.8.1.5.5 for a description of the LQA.) This can also be used to determine which channels are more likely to provide sufficient propagation characteristics for the intended Inlink state traffic. Table

A-XLII shall be used to encode the measured mean SNR value. An additional column is provided suggesting possible channel usage for the given SNR value.

**TABLE A-XLII. LQA scores.**

Value	Measured SNR	Potential Channel Usage
0	SNR $\leq$ -6	Choose another channel
1	-6 < SNR $\leq$ -3	use 50 to 75 bps data
2	-3 < SNR $\leq$ 0	use 50 to 75 bps data
3	0 < SNR $\leq$ 3	use 150 bps data
4	3 < SNR $\leq$ 6	use 300 bps data
5	6 < SNR $\leq$ 9	use 300 bps data
6	9 < SNR $\leq$ 12	use 1200 bps data, could carry voice, digital voice, KY-100 data, secure digital voice
7	12 < SNR $\leq$ 15	use 1200 bps data, could carry voice
8	15 < SNR $\leq$ 18	use 2400 bps data, could carry voice
9	18 < SNR $\leq$ 21	use 2400 bps data, could carry good quality voice, HFD Voice, Secure HFD Voice
10	21 < SNR $\leq$ 24	use 4800 bps data, could carry high quality voice
11	24 < SNR $\leq$ 27	use 4800 bps data, could carry poor quality voice
12	27 < SNR $\leq$ 30	Very high data rates can be supported (9600 baud)
13	30 < SNR $\leq$ 33	
14	SNR > 33	
15	No Measurement Taken	Value in DE(5) shall be ignored

**A.5.8.1.5.7 DE(7) number of Tis/Twas left in sounding cycle (NT).**

While transmitting the sounding frame, DE(7) shall be sent in each TIS/TWAS word to identify the remaining number of TIS/TWAS words that will be transmitted in the frame. This is an inclusive number and when set to a value of 1, only one PART2 word remains in the frame.

When the sound duration would require an initial count greater than 15, a count of 15 shall be used until the count can correctly decrement to 14. From this point, DE(7) shall count down to 1.

**A.5.8.1.5.8 DE(8) inlink data definition from INLINK (NT).**

Inlink Event transaction definitions are defined by 2 data exchange words. DE(8) shall be used when the INLINK preamble is used, while DE(9) shall be used for the second half of the address begun with the INLINK preamble.

	Bit 3	Bit 2	Bit 1	Bit 0	Description
DE(8)	AckThis	<# of Command Preambles>			Most Significant Bits of the Inlink Transaction Code

**A.5.8.1.5.8.1 Acknowledge this frame (NT).**

Data Bit3, ACK-THIS, when set to 1, shall indicate that the stations which are linked to the transmitting station are to generate an ACK Inlink message in response to this frame. If the

address section of an Inlink transaction is present, then only the addressed stations in the link are to respond. The responding station Inlink event shall return a NAK if any CRC in the received message fails, otherwise the Inlink event shall be an ACK. When Data Bit3 is set to 0, the transmitting station is broadcasting the information and no response by the receiving stations is required.

**A.5.8.1.5.8.2 Identify command section count (NT).**

Data Bits 0-2 represent the number of command sections that are present in the frame. A value of 0 indicates no command sections are present, i.e., the frame is complete when the immediately following PART2 address word is received. A value of 1 indicates that 1 command section is present. Up to seven command sections can be transmitted in one Inlink event transaction.

**A.5.8.1.5.9 DE(9) Inlink data definition from PART2 (NT).**

Inlink Event transaction definitions are defined by 2 data exchange words. DE(9) is used for the second half of the address begun with the INLINK preamble.

	Bit 3	Bit 2	Bit 1	Bit 0	Description
DE(9)	I'm Inlink	<	Transaction Code	>	Least significant 4 bits of Inlink

**A.5.8.1.5.9.1 I AM remaining in a link state (NT).**

Data Bit3, I'mInlink, when set to 1, shall indicate that the transmitting station will continue to be available for Inlink transactions. When set to 0, the station is departing the linked state with all associated stations. It shall be the receiver's decision to return to scan or perform other overhead functions when a station departs from a link state. All Inlink event transactions should set this to '1' when the members of the link are to remain in the linked state.

Valid combinations of data bit ACK-THIS and I'mInlink are defined in table A-XLIII.

**TABLE A-XLIII. Valid combinations of ACK-This and I'm Inlink.**

Ack This Value	I'm Inlink Value	Description
0	0	Station departing linked state
0	1	Station remaining in linked state
1	0	Not valid. A station cannot leave a link and expect a response
1	1	Acknowledge this transmission.

**A.5.8.1.5.9.2 Inlink event transaction code (NT).**

Data Bits 0-2 represent the type of Inlink event that is being transmitted. Table A-XLIV shall be used to encode the types of Inlink events. The Operator ACK/NAK and AQC-ALE Control Message sections are described in A.5.8.3.

**TABLE A-XLIV. DE(9) inlink transaction identifier.**

Value	Notes	Meaning	Message Section Count
0		Reserved	0
1		MS_141A Section Definition. Each section shall be terminated with a CRC	1 to 7
2		ACK'ng Last Transaction	0
3		NAK'ng Last Transaction	0
4	(1)	Directed Link Terminate	0
5	(1) (2)	Operator ACK/NAK	1
6	(1) (2)	AQC-ALE Control Message	1 to 7
7		Reserved	0
<ol style="list-style-type: none"> <li>1. Requires that an address section (To,Part2) was received in the frame.</li> <li>2. Optional Transaction Code.</li> </ol>			

**A.5.8.1.6 PSK tone sequence (optional) (NT).**

In any frame of a calling handshake or sounding transmission, the transmitting station may emit an optional PSK tone sequence to provide an early measurement of the channel characteristics relative to a PSK type signaling waveform.

**A.5.8.1.6.1 PSK tone sequence placement (NT).**

The optional PSK tone sequence for link quality may be inserted after the last tone associated with any PART2 AQC-ALE word and prior to the first FSK tone of the following AQC-ALE word (if any). The 26.67 ms PSK tone sequence shall be preceded by 8 ms of guard time and followed by 21.33 ms of guard time, for a total duration of 56 ms (seven symbol periods of the 2G ALE FSK waveform).

**A.5.8.1.6.2 PSK tone sequence generation (NT).**

The PSK tone sequence shall be identical to the 26.67 ms preamble for Burst Waveform 2 (see C.5.1.5).

**A.5.8.2 AQC-ALE frame structure and protocols (NT).**

**A.5.8.2.1 Calling cycle (NT).**

The calling cycle frame is used when the caller is attempting to reach a station that is scanning. Sufficient address words are repeated continuously until the scanning radio has had ample opportunity to stop on the channel. Other receivers, upon hearing an address, may recognize the presence of an ongoing call and skip processing the channel until the handshake is completed.

The calling cycle shall be composed of the target address broadcast for at least the period defined as the call duration for the radio, followed by the target address followed by the caller's (source) address. Data exchange values shall be per the specific type of call being attempted. When the call duration is not evenly divisible by 2 Trw, then an additional full address may be transmitted. When an entire address is not used to complete a fractional portion of the call duration, the caller

MIL-STD-188-141B  
APPENDIX A

shall begin the transmission with the second half of the target address using the PART2 preamble. In this case, the LP word number shall be 1.

When the radio is programmed to automatically derive the call duration, the equation shall be:

$$\text{Number of Channels} * 0.196$$

Table A-XLV specifies minimum and maximum number of words used for the scanning cycle section of a call. The total number of words used for calling is four additional words. The unit call time column presents the maximum time to complete a unit call as measured from the first tone transmitted by the caller to the last tone transmitted by the caller in the Acknowledgement frame. Users will see times greater than these due to call setup time, caller tune time, listen before call, and link notification delay; these may add several seconds to the response time seen by a user.

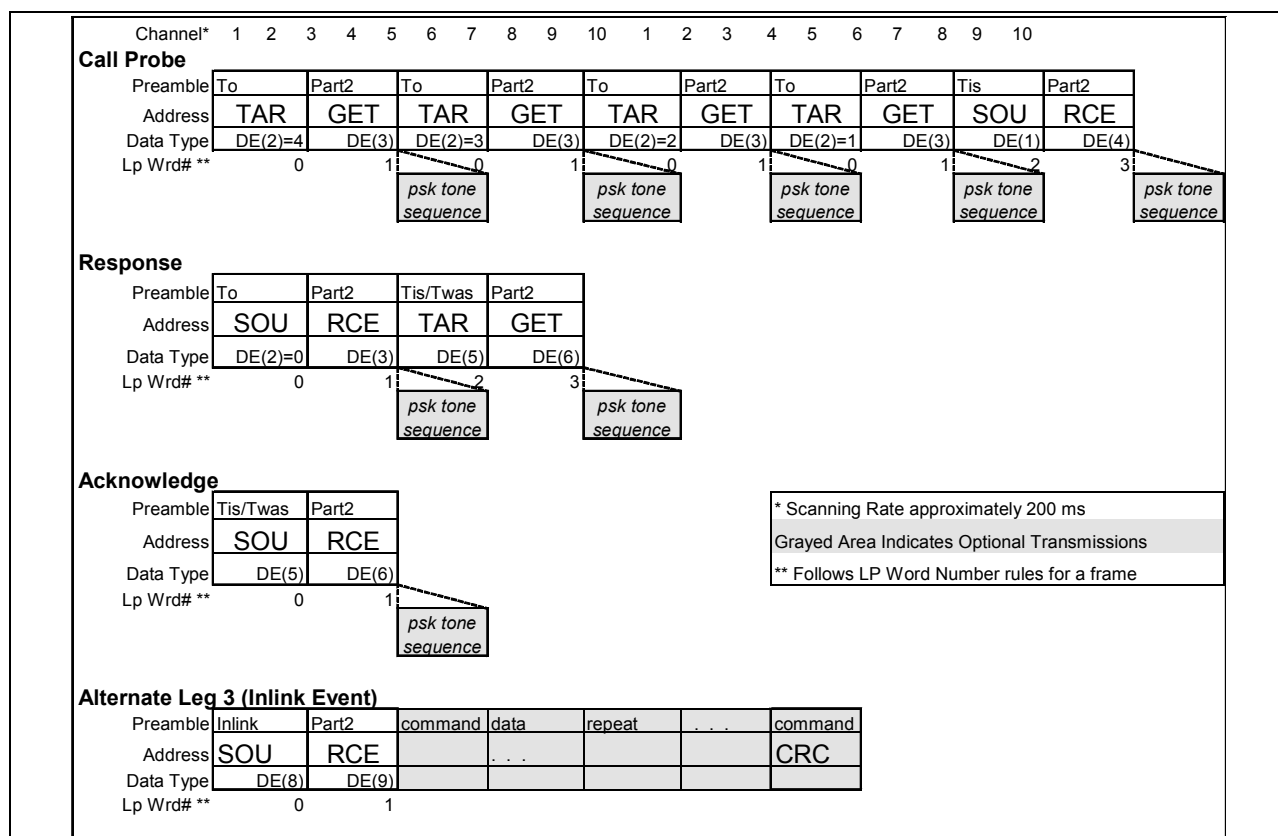
**TABLE A-XLV. Scanning part duration using automated calculation.**

Channels	AQC-ALE Minimum Scan Trw	AQC-ALE Maximum Scan Trw	Call Time in Seconds
1	0	0	4.8
2	1	2	5.6
3	2	2	5.6
4	2	2	5.6
5	3	4	6.4
6	3	4	6.4
7	4	4	6.4
8	4	4	6.4
9	5	6	7.2
10	5	6	7.2
11	6	6	7.2
12	6	6	7.2
13	7	8	8.0
14	7	8	8.0
15	8	8	8.0
16	8	8	8.0
17	9	10	8.8
18	9	10	8.8
19	10	10	8.8
20	10	10	8.8

A.5.8.2.2 Unit call structure (NT).

A unit call in AQC-ALE follows the same principles as a standard ALE unit call with the following changes. In the Leading Call section of the Call and Response, the address shall appear once instead of twice. In the Acknowledgement frame, only the conclusion section shall be sent. See figure A-53 for an example of a unit call sequence from SOURCE to TARGET.

- See A.5.8.2.1, Calling Cycle to determine the maximum number of words to send during the scanning call portion of the Call.
- The optional PSK tone sequence shall be available during any leg of the handshake.
- An Inlink Event Transaction shall be used in lieu of the Acknowledgement frame when ALE data traffic is available for the Inlink State in AQC-ALE.



**FIGURE A-53. Example of unit call format.**

A.5.8.2.3 Star net call structure (NT).

The call probe shall be identical to a Unit call where the star net address replaces the unit address. The Slotted Response portion shall always use a two word address for the TO and TIS addresses. Just as in Baseline 2G ALE, the slotted response shall be 5 Tw wider than the 6 Tw needed to transmit the TIS/TWAS address. Slot 0 shall be 17 Tw to accommodate a non-net member participating in the call. Slot 1 and all remaining slots shall be 11 Tw wide. No LQA



MIL-STD-188-141B  
APPENDIX A

information shall be emitted in the Acknowledgement portion of the Start Net Call except as provided through the data exchange bits. The optional PSK tone sequence shall be available during any frame of the handshake. The slot width does not change, even when the optional PSK tone sequence is used.

The Data Exchange values shall be per figure A-54.

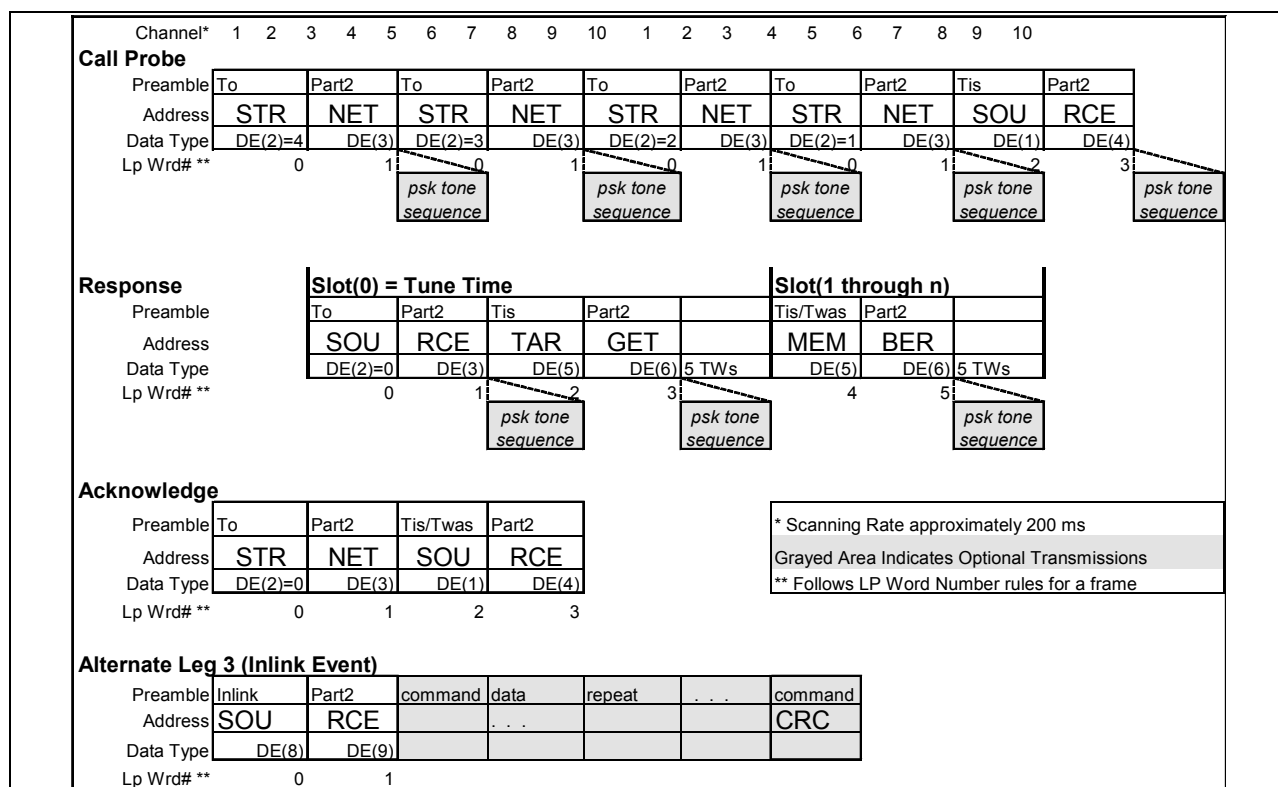


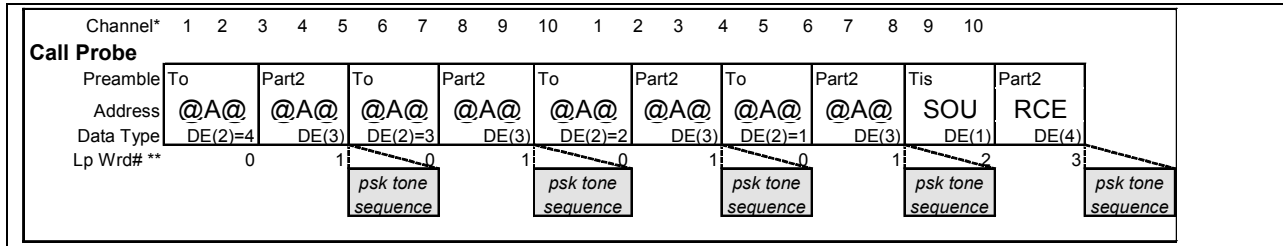
FIGURE A-54. Example of StarNet format.

An Inlink Event frame may be used for the Acknowledgement frame. Slots 1 and beyond may be expanded by fixed number of Trw for certain types of AQC-ALE Inlink Messages.

A.5.8.2.4 AllCall frame formats (NT).

A station placing an AllCall shall issue the call using the calling cycle definition in A.5.8.2.1. The actions taken shall be as described for baseline 2G ALE AllCalls. The Data Exchange values shall be per figure A.-55, AllCall Frame Format. Selective AllCall shall be supported.

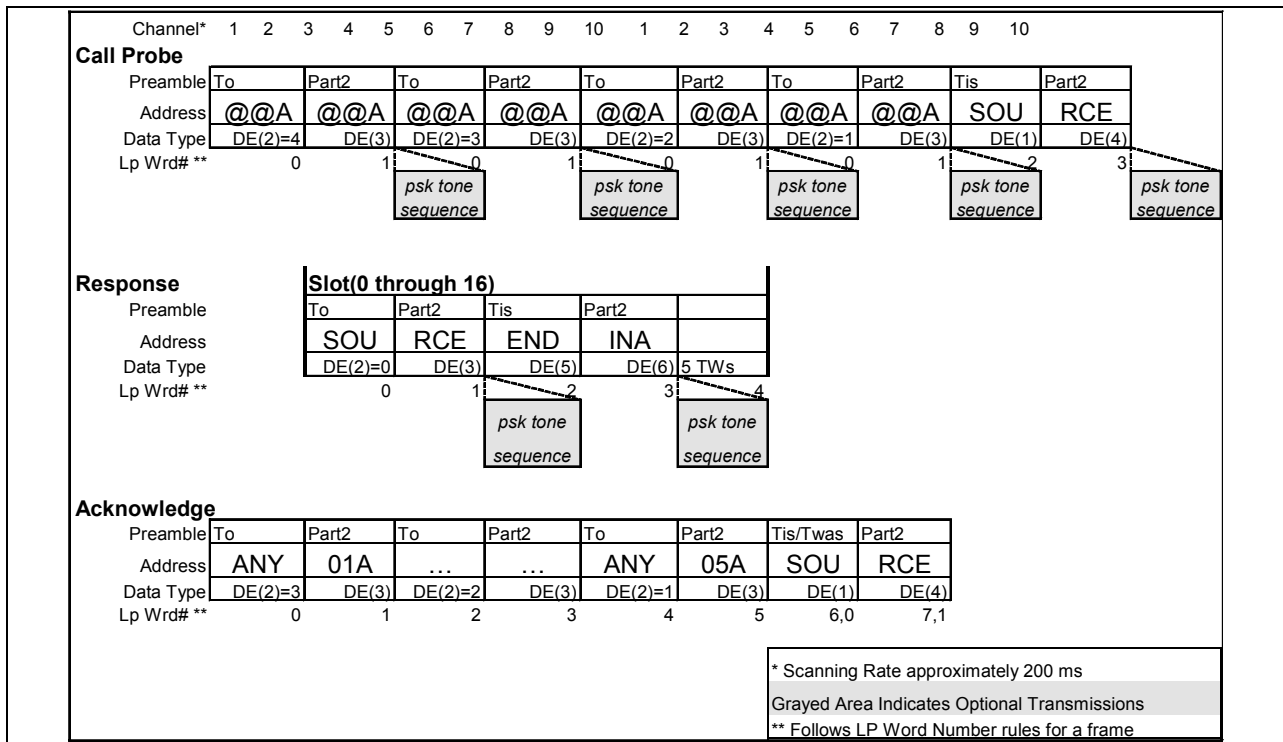
MIL-STD-188-141B  
APPENDIX A



**FIGURE A-55. Example AllCall frame format.**

A.5.8.2.5 AnyCall frame formats (NT).

A station placing an AnyCall shall issue the call using the calling cycle definition in A.5.8.2.1. The actions taken shall be as described for baseline 2G ALE AnyCalls except that the Slot width shall be fixed at 17 Tw. The leading address section and conclusion shall be used for each slotted response. The Data Exchange values shall be per figure A-56. Selective AnyCall and Double Selective AnyCall shall be supported.



**FIGURE A-56. Example AnyCall frame formats.**

An Inlink Event frame shall not be used for the Acknowledgement frame.

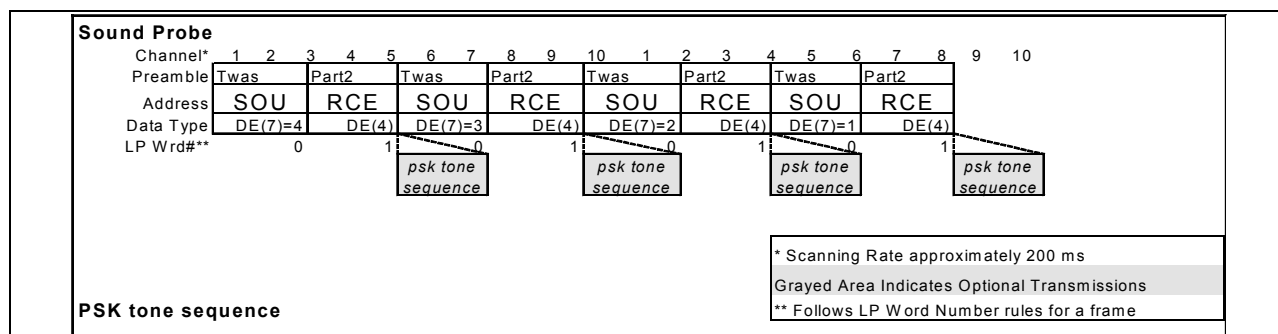
A.5.8.2.6 Sounding (NT).

The sounding cycle shall be composed of the station's address broadcast for at least the period defined as the sound duration for the radio. Data exchange values shall be as denoted in figure A-57. When the call duration is not evenly divisible by 2 triple-redundant word times, then an additional full address may be transmitted. When an entire address is not used to complete a fractional portion of the sound duration, the caller shall begin the transmission with the second half of the target address using the PART2 preamble. In this case, the LP word number shall be 1. As shown in figure A-57, the LP word number shall toggle between 0 and 1.

When the radio is programmed to automatically derive the sound duration, the equation shall be:

$$\text{Number of Channels} * 0.196 + 0.784$$

See table A-58 for the minimum and maximum number of Trw to broadcast automatically.



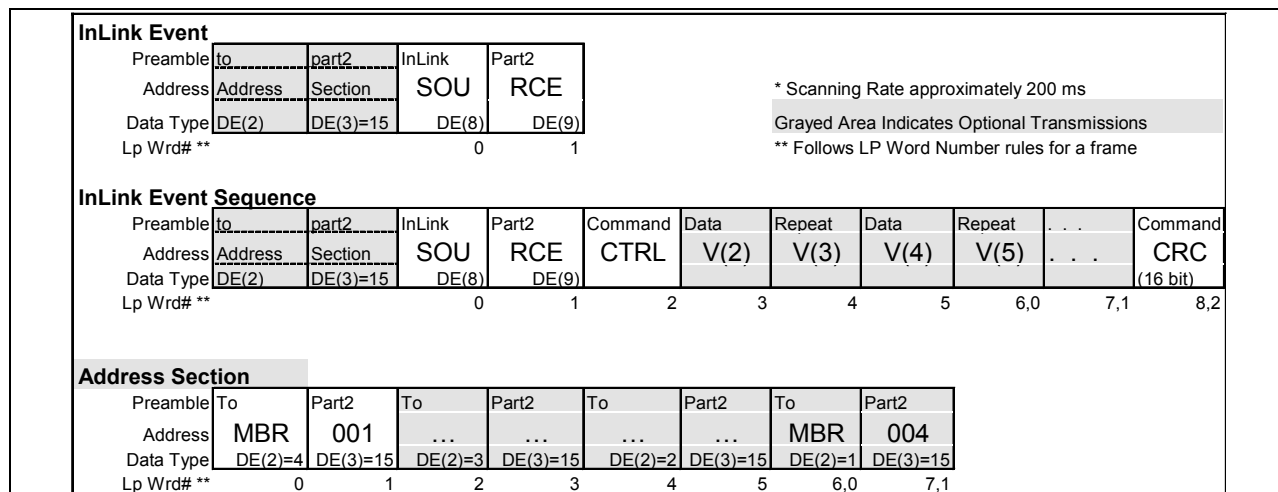
**FIGURE A-57. Example sounding frame format.**

A.5.8.2.7 Inlink transactions (NT).

AQC-ALE stations shall have the capability to transfer information within the Inlink state of the radio. A special purpose frame is defined for the purpose of separating link establishment transactions from transactions that occur during the Inlink state. Two types of Inlink transactions are defined, Inlink Event and Inlink Event Sequence. Either transaction can have an optional address section appended to the beginning of the frame. This optional address section indicates that the transaction is targeted at the addresses defined in this section of the frame.

The Inlink frame uses Data Exchange DE(8) and DE(9). DE(8) informs the recipient of the type of transaction and whether this frame needs to be acknowledged. See A.5.8.3.8. DE(9) data content indicates to the caller the exact form of the data and identifies if the sender intends to remain in the linked state with all those represented in the address section of the frame. When the address section is omitted, the frame shall be targeted to all stations currently linked with the transmitting station. See A.5.8.3.9.

The data Exchange values shall be per figure A-58. This figure outlines the general format of both types of Inlink transaction events.



**FIGURE A-58. Example inlink transaction TRW sequences.**

**A.5.8.2.7.1 Inlink transaction as an acknowledgement (NT).**

The Inlink Event or the Inlink Event Sequence shall be used as the Acknowledgement frame of a handshake whenever the calling radio has a message for the radios entering the Inlink state. If the INLINK preamble is replacing a TIS preamble indicating that the radios were to remain in an Inlink state, then the I'M LINKED bit shall be set to 1. If a TWAS preamble would normally be used for this transmission, the I'M LINKED bit shall be set to 0. Thus, the calling station can minimize over the air time for any transaction by judicious use of Inlink state and associated control bits.

**A.5.8.2.7.2 CRC for Inlink event sequences (NT).**

As seen in figure A-58, a command section of an Inlink event sequence shall consist of the COMMAND preamble, followed by the data associated with the command using the preambles DATA and REPEAT. The Inlink event sequence frame shall be terminated with a COMMAND preamble containing the CRC of the data contained in all words starting with the first COMMAND preamble. This CRC shall be computed exactly as the CRC for a standard ALE DTM (See A.5.6.1). The receiver shall maintain a history of failed CRC. The history may be displayed to the operator or used in channel selection algorithms for follow-on traffic.

**A.5.8.2.7.3 Use of address section (NT).**

The address section of a Inlink transaction, when present, shall indicate that the addressed stations in the link are to react to the information contained in the message section.

**A.5.8.2.7.4 Slotted responses in an Inlink state (NT).**

When an acknowledgement has been requested, each radio in the address section shall be assigned a response slot in the same manner as a standard ALE group call. The slot width shall be as specified for AQC-ALE StarNet call, A.5.8.2.4. When the address section contains a StarNet address, the slot assignments shall be per the StarNet definition. When no slot assignment can be determined and an acknowledgement is requested, the receiving radio shall respond as quickly as possible.

Slotted responses shall use an Inlink transaction frame beginning with the INLINK preamble. The address section shall not be permitted in the slotted response. When a the transmitting station issues a message that requires a responding message, such as time-request to Time-is, the slot widths for slot 1 and greater shall automatically expand by a fixed number of Trw to satisfy the response.

When a response could be variable in length, the maximum slot width shall be used. The maximum width in Tw for an Inlink transaction shall be 44 Tw. This could represent an AMD message of up to 27 characters.

**A.5.8.3 AQC-ALE orderwire functions (optional) (NT).**

The Operator ACK/NAK and AQC-ALE Control Message sections are described below. These functions may only appear in frames containing INLINK transactions, and may never be used in baseline 2G ALE frames.

**A.5.8.3.1 Operator ACK/NAK transaction command section (optional) (NT).**

This optional message section is a means to poll every station to determine if a site is currently manned. The operator must respond to the request for acknowledgement in a timely manner. AMD messages formatted in accordance with table A.5.8-11 Operator ACK/NAK shall be used to define the values and meaning of the message. When a request for ACK is received, the operator shall have 15 seconds to respond. The ACK message shall be sent immediately as an Inlink Event if the operator responds. If no response from the operator occurs the receiving station shall emit an Operator NAK response Inlink Event.

**TABLE A-XLVI. Operator ACK/NAK command.**

AMD Message Section Content	Action to be Taken
"REQ"	Receiving station should notify operator that a response to this message is required. The response must occur within 15 seconds.
"ACK"	The operator acknowledges receipt of last Inlink event.
"NAK"	The operator failed to respond to the last Inlink event.

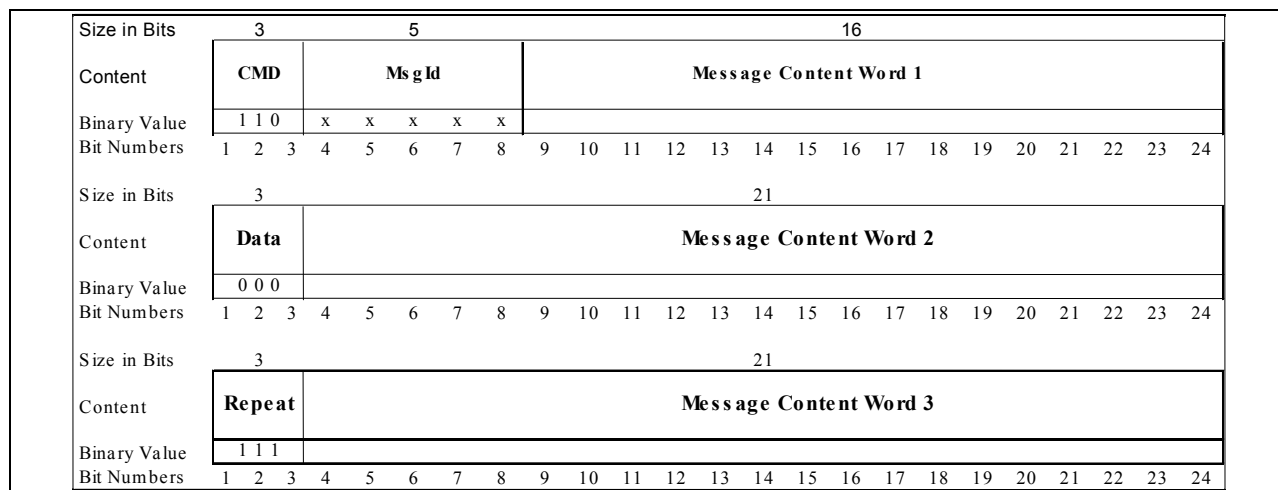
A.5.8.3.2 AQC-ALE control message section (optional) (NT).

Table A-XLVII defines the values used to declare a AQC-ALE control message. When sending these commands, all commands in the frame shall be AQC-ALE control messages. Table A-XLVI defines which message types in an AQC-ALE message section are mandatory for all implementations of AQC-ALE and which messages are optional for AQC-ALE implementations.

**TABLE A-XLVII. AQC-ALE control message section word sequences.**

MsgId Value	# Words	Description	Handle Message Section
0	n	AMD Dictionary Message	Mandatory
1	3	Channel Definition	Mandatory
2	1	Slot Assignment	Mandatory
3	1	List Content of Database	Optional
4	1	List Database Activation Time	Optional
5	2	Set Database Activation Time	Optional
6	n	Define Database Content	Optional
7	n	Database Content Listing	Optional

As seen in figure A-59, each word with a COMMAND preamble contains a 5-bit MsfID field to define the type of control message present. Because ALE orderwire functions are still allowed, MsgID values greater than 7 are not allowed, as these would overlap with existing ALE orderwire commands.



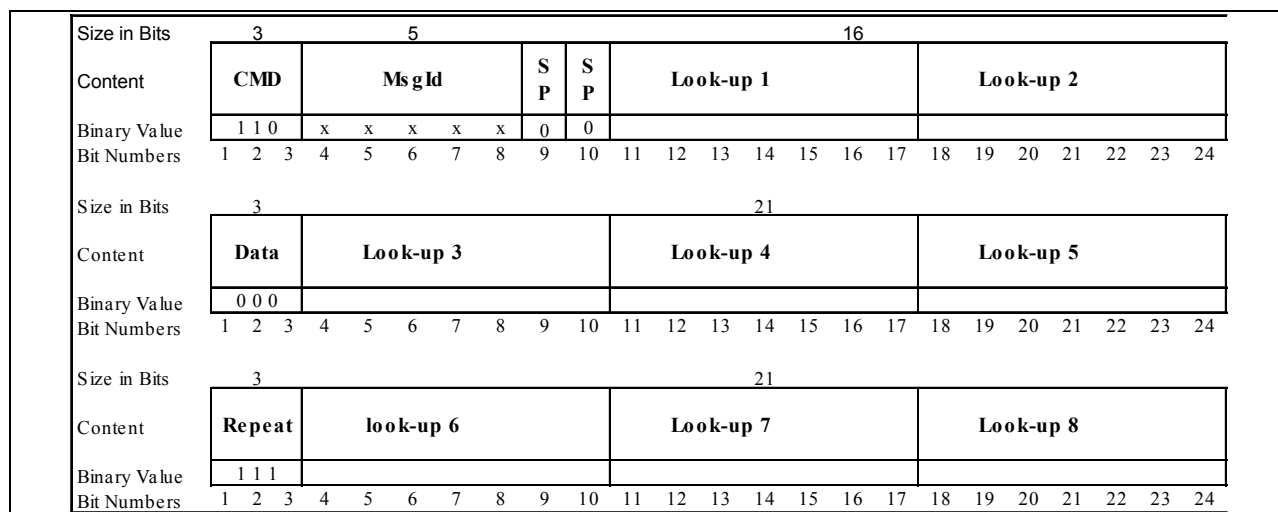
**FIGURE A-59. Generalized AQC-ALE control message format.**

A.5.8.3.2.1 AMD dictionary message (NT).

When a message section can be translated into a dictionary and all stations linked are using AQC-ALE, an AMD message may use the dictionary word as provided in table A-XLVIII. Each character in the AMD message will represent itself or a word/phrase found in one of three look up tables. Because messages are short, when a transmission word is lost, the complete message could be rendered meaningless if a bit packing approach was used. This method shall consist of

a series of 7-bit values. This is the same size as currently used for an AMD message. At a minimum, a radio shall provide lookups for values 2 through 95. A mapped entry can be of any length. Every radio communicating with packed AMD formats must use the same programmed values for words or confusion in the message will result. Messages should be displayed in their unpacked form as looked up or optionally with curly braces around the numeric value of the lookup, i.e. {2.5} would indicate word is in Dictionary Set 2 at index position 5. (See figure A-60 for the format of an AQC-ALE Packed AMD message.)

The two dictionaries sets provide a means to identify the most frequently used words communication for a mission. Dictionary Set 1 shall be the initial dictionary used for values 96 through 127. When a character with value 1 is received in a Packed AMD Message, then Dictionary Set 2 shall be the word list for character values 96 through 127 until the end of that message or receipt of a character with value 0 in that message, after which Dictionary Set 1 shall again be used, and so on.



**FIGURE A-60. AQC-ALE dictionary lookup message.**

A network manager might choose to minimize air time and provide some unique information using Dictionary Set 1 by placing tactical user phrases in the dictionary, such as "**AT WAY POINT**". To identify where the a unit is, the AMD message "**AT WAY POINT 1**" would be entered. What would be transmitted in the Packed AMD message would be a 4 TRW Inlink event transmission consisting of INLINK, PART2, COMMAND, REPEAT preambles. That is the entire message would fit in one COMMAND TRW as:

1. Message Type = AQC-ALE Packed AMD Message
2. Look-up 1 = Index into Dictionary Set 1 for "**AT WAY POINT**"
3. Look-up 2 = The character "**1**"

MIL-STD-188-141B  
APPENDIX A

No spaces are needed because the lookup table transform shall place spaces into the expanded message as defined in table A-II.

**TABLE A-XLVIII. Lookup tables for packed AMD messages.**

ASCII Ordinal Value	Dictionary Set 0 (0 to 31)	ASCII 64 Character Set (32 to 63)	ASCII 64 Character Set (64 to 95)	Dictionary Set 1 (96 to 127)	Dictionary Set 2 (96 to 127)
0	(Use Set 1)	Space	@	Programmable	Programmable
1	(Use Set 2)	!	A	Programmable	Programmable
2	A	"	B	Programmable	Programmable
3	AN	#	C	Programmable	Programmable
4	AND	\$	D	Programmable	Programmable
5	ARE	%	E	Programmable	Programmable
6	AS	&	F	Programmable	Programmable
7	BE	'	G	Programmable	Programmable
8	CAN	(	H	Programmable	Programmable
9	EACH	)	I	Programmable	Programmable
10	EAST	*	J	Programmable	Programmable
11	FOR	+	K	Programmable	Programmable
12	FROM	,	L	Programmable	Programmable
13	IN	-	M	Programmable	Programmable
14	IS	.	N	Programmable	Programmable
15	NORTH	/	O	Programmable	Programmable
16	NOT	0	P	Programmable	Programmable
17	OF	1	Q	Programmable	Programmable
18	ON	2	R	Programmable	Programmable
19	OR	3	S	Programmable	Programmable
20	SIZE	4	T	Programmable	Programmable
21	SOUTH	5	U	Programmable	Programmable
22	SYSTEM	6	V	Programmable	Programmable
23	THAT	7	W	Programmable	Programmable
24	THE	8	X	Programmable	Programmable
25	THIS	9	Y	Programmable	Programmable
26	TO	:	Z	Programmable	Programmable
27	USE	;	[	Programmable	Programmable
28	WEST	<	\	Programmable	Programmable
29	WILL	=	]	Programmable	Programmable
30	WITH	>	^	Programmable	Programmable
31	YOU	?	—	Programmable	Programmable



**TABLE A-IL. Adding spaces during AMD unpacking.**

	Message Value is in a Dictionary	Message Value is in ASCII-64 and not Alphanumeric	Message is Value is Alphanumeric
First Character of Message	No Leading Space	No Leading Space	No Leading Space
Last Expanded Character from Lookup	Add Leading Space	No Leading Space	Add Leading Space
Last Expanded Character is ASCII-64	Add Leading Space	No Leading Space	No Leading Space

**A.5.8.3.2.2 Channel definition (NT).**

The channel definition provides a system to reprogram the radio with a different frequency or to cause stations in a link to move to a traffic channel. This allows the radios to listen for general propagation characteristics in a common area and then move to a nearby channel to manage the inlink state transactions. By allowing a channel to be reprogrammed, the radio can adapt to a wide variety of conditions that may occur on a mission. If congestion is experienced on the assigned frequency, the stations shall return to the normal scan list and reestablish the call.

The channel index number is specified from a range of 0 to 255. A radio shall have at least 100 channels available for reprogramming. A channel index of 0 shall indicate that the receive and transmit frequencies are to be used for the remainder of this link. Other channel index numbers indicate that the new assignment shall be entered into the channel table.

Size in Bits	3	5	16																			
Content	<b>CMD</b>	<b>Ms gld</b>	<b>Channel Number 0 - 255</b>													<b>Emission Mode</b>		<b>Spare</b>				
Binary Value	1 1 0	x x x x x																				
Bit Numbers	1 2 3	4 5 6 7 8	9 10 11 12 13 14 15 16	17 18 19 20	21 22 23 24																	
Size in Bits	3	21																				
Content	<b>Data</b>	<b>Receive Frequency in 100 hz Steps</b>																				
Binary Value	0 0 0																					
Bit Numbers	1 2 3	4 5 6 7 8	9 10 11 12 13 14 15 16	17 18 19 20	21 22 23 24																	
Size in Bits	3	21																				
Content	<b>Repeat</b>	<b>Trans mit Frequency in 100 hz Steps</b>																				
Binary Value	1 1 1																					
Bit Numbers	1 2 3	4 5 6 7 8	9 10 11 12 13 14 15 16	17 18 19 20	21 22 23 24																	

**FIGURE A-61. Channel definition and meet-me function.**

Frequencies shall be specified as a 21-bit values with each step being 100 Hz. See figure A-61 for an example format of this message. A 2-bit value 0 for emission mode shall indicate upper side band and a value of 1 shall indicate a value of lower side band. Bits 17-18 refer to the receive frequency, bits 19-20 to the transmit frequency.

A.5.8.3.2.3 Slot assignment (NT).

The slot assignment feature allows a control station to dynamically assign response slots for stations with which it is linked. In this manner, when a response is required from several stations in an inlink state, orderly responses can be generated. The slot width shall be in Tw. When set to 11 or less, the radio shall respond with the shortest form possible allowing for 5 Tw as timing error. Figure A-62 depicts the format of a slot assignment.

Size in Bits	3			5					16															
Content	<b>CMD</b>			<b>Msgld</b>					<b>Slot Number</b>				<b>Number of TWs in Slot</b>											
Binary Value	1	1	0	x	x	x	x	x																
Bit Numbers	1	2	3	4	5	6	7	8	9	10	11	12	13	14	15	16	17	18	19	20	21	22	23	24

**FIGURE A-62. AQC-ALE slot assignment.**

Examples of this usage would be setting up a link to several stations and then periodically polling them with an operator ACK/NAK request or a position report request. Each radio would respond at a specified time following that transmission. This form of time division multiplexing is self-synchronizing to minimize the need for time of day clock synchronization. If more traffic is required on a channel, slot widths can be expanded.

A.5.8.3.2.4 List content of database (NT).

The list content of database (FIGURE a-63) shall display the programmable values of a scanning radio such that the receiver can inter-operate with that station in the best possible manner. This command requests the contents to be displayed. The Database identifier shall be the ASCII36 character set plus the characters “\*” and “\_”.

Size in Bits	3			5					16															
Content	<b>CMD</b>			<b>Msgld</b>					<b>Packed ALE Address Indicating Database Identification. This may include the "*" and "_" Characters</b>															
Binary Value	1	1	0	x	x	x	x	x																
Bit Numbers	1	2	3	4	5	6	7	8	9	10	11	12	13	14	15	16	17	18	19	20	21	22	23	24

**FIGURE A-63. List content of database.**

A.5.8.3.2.5 List database activation time (NT).

This function requests the time stamp of a database. Its format is identical to that shown in figure A-64.

A.5.8.3.2.6 Set database activation time (NT).

This function (figure A-64) sets or displays the time stamp of a database. The first word format of the command is identical to the List Content of Database. The second word contains the time of day that the database is to be active. Only one database shall be active at a time. When the SET bit=1, the command represents the time to assert when the database becomes active. When the SET bit=0, this is a report of the current time set value.

MIL-STD-188-141B  
APPENDIX A

A network control station can program or select preprogrammed channel sets and then cause all mission participants to switch to a new set of channels to operate upon. Other uses would include moving from one area of the world to another may cause the user to move into a different set of allocated frequencies.

Size in Bits	3			5					16															
Content	<b>CMD</b>			<b>Msgld</b>					<b>Packed ALE Address Indicating Database Identification.</b> <b>This may include the "*" and "_" Characters</b>															
Binary Value	1 1 0			x x x x x																				
Bit Numbers	1	2	3	4	5	6	7	8	9	10	11	12	13	14	15	16	17	18	19	20	21	22	23	24
Size in Bits	3								21															
Content	<b>Data</b>			<b>Activation Day</b>					<b>Activation Month</b>					<b>S E T</b>		<b>Activation Hour</b>					<b>Activation Minute</b>			
Binary Value	0 0 0																							
Bit Numbers	1	2	3	4	5	6	7	8	9	10	11	12	13	14	15	16	17	18	19	20	21	22	23	24

**FIGURE A-64. Set database activation time.**

A.5.8.3.2.7 Define database content (NT).

This function defines a database over the air. The first TRW format of the command is identical to the List Content of Database. Subsequent words contain association of existing information into a dataset that the radio may operate against. As shown in figure A-65.

Size in Bits	3			5					16															
Content	<b>CMD</b>			<b>Msgld</b>					<b>Packed ALE Address Indicating Database Identification.</b> <b>This may include the "*" and "_" Characters</b>															
Binary Value	1 1 0			x x x x x																				
Bit Numbers	1	2	3	4	5	6	7	8	9	10	11	12	13	14	15	16	17	18	19	20	21	22	23	24
Size in Bits	3								21															
Content	<b>Data</b>			<b>LP Level</b>		<b>L</b>	<b>LP Key Number</b>		<b>Spare</b>			<b>Number of Channels</b>					<b>Spare</b>							
Binary Value	0 0 0																							
Bit Numbers	1	2	3	4	5	6	7	8	9	10	11	12	13	14	15	16	17	18	19	20	21	22	23	24
Size in Bits	3								21															
Content	<b>Repeat</b>			<b>Spare</b>					<b>Channel Number 1</b>							<b>Channel Number 2</b>								
Binary Value	1 1 1																							
Bit Numbers	1	2	3	4	5	6	7	8	9	10	11	12	13	14	15	16	17	18	19	20	21	22	23	24
Size in Bits	3								21															
Content	<b>Data</b>			<b>Spare</b>					<b>Channel Number 3</b>							<b>Channel Number n+3</b>								
Binary Value	0 0 0																							
Bit Numbers	1	2	3	4	5	6	7	8	9	10	11	12	13	14	15	16	17	18	19	20	21	22	23	24

**FIGURE A-65. Define database content.**

Word 2 of the message shall consist of:

1. 3 bits of LP Level number. Values range from 0 through 4.
2. 1 bit for Lower Level Linking. When set to 1, the radio shall honor lower level link attempts.
3. 3 bits for LP Key number identification. A value of 0 indicates no key assignment. When an LP level greater than 0 exists, this would be a non-operational condition. If more than one type of key is used between LP levels, they must use the same key index. When a radio does not have a key present for a given LP Key, a value of NOKEY shall be used.
4. 5 bits for the number of channels. Immediately following this word shall be (number\_of\_Channels/2) words containing the channel numbers to use. Earlier commands defining channel numbers or a preprogrammed value define the actual frequencies used.
5. 6 bits for defining the words from a dictionary into the 64 words. The mapping of a dictionary into a database dictionary allows a specific set of words that yield a higher frequency hit rate to the dictionary. A value of 0 indicates using the original programmed dictionary. The mapping of the dictionary is contained in the Trw that follow the channel association.

#### A.5.8.3.2.8 Database content listing (NT)

This command shall have the same format as the Define Database Content.

#### A.5.8.4 AQC-ALE linking protection (NT).

When operating in LP with AQC-ALE, every 24-bit AQC-ALE word shall be scrambled in accordance with Appendix B. The same rules for LP in baseline 2G ALE shall be applied to AQC-ALE with the following exceptions:

- The word number for all TO AQC-ALE words during the scanning call shall be 0, and the word number for all PART 2 AQC-ALE words during the scanning call shall be 1. The TIS or TWAS word that concludes a scanning call shall use word number 2 and the following PART 2 word shall use word number 3.
- The AQC-ALE response frame shall use word numbers 0, 1, 2, and 3.
- A 2-word AQC-ALE acknowledgement shall use word numbers 0 and 1. The TOD shall be later than that used at the end of the scanning call.

MIL-STD-188-141B  
APPENDIX A  
ANNEX A

**ANNEX A. DEFINITIONS OF TIMING SYMBOLS**

C	Number of channels in sequence
H	Handshake. Completed sequence of call, response, and acknowledgment
n	Integer
NA	Number of addresses
NAm	Number of addresses with “m” words
NAW	Number of original individual address words
NS	Number of slots in response period, total
s	Seconds
SN	Slot number identification
T	Time
T <sub>a</sub>	Individual station (or net) whole address time
T <sub>al</sub>	Individual station (or net) address first word time
T <sub>a max</sub>	Maximum individual station (or net) whole address time limit
T <sub>c</sub>	Call time, combination of whole address(es), which is usually repeated as a leading call T <sub>1c</sub>
T <sub>c1</sub>	Combined different first words of group station address
T <sub>cc</sub>	Calling cycle time
T <sub>c max</sub>	Maximum call time limit
T <sub>d</sub>	Basic dwell time on each channel during scan. Sometimes shown with channels per second scanning rate in ( ) e.g. T <sub>d</sub> (5).
T <sub>dbm</sub>	DBM time
T <sub>dek</sub>	Decode time
T <sub>drw</sub>	Detect rotating redundant word time
T <sub>drw</sub>	Detect redundant word time
T <sub>ds</sub>	Detect signaling (tones and timing) time
T <sub>enk</sub>	Encode time

MIL-STD-188-141B  
APPENDIX A  
ANNEX A

$T_{lc}$	Leading call time
$T_{ld}$	Late detect word additional time
$T_{lrw}$	on-air leading redundant words
$T_{lww}$	Last word wait delay
$T_m$	Orderwire message section time
$T_{m\ max}$	Maximum orderwire message section time limit
$T_p$	Propagation time
$T_{ps}$	Periodic sounding interval
$T_{rc}$	Redundant call time
$T_{rd}$	Receiver internal signal delay time
$T_{rs}$	Redundant sound time
$T_{rsc}$	scanning redundant call time
$T_{rw}$	Redundant word time (392 ms)
$T_{rwp}$	Redundant word phase delay (0 to $T_{rw}$ )
$T_s$	Scan period
$T_{sc}$	Scan calling time, same as $T_{ss}$
$T_{s\ max}$	Maximum scan period
$T_{s\ min}$	Minimum scan period
$T_{src}$	Scanning redundant call time
$T_{srs}$	Scanning redundant sound time
$T_{ss}$	Scan sounding time, same as $T_{sc}$
$T_{sw}$	Slot width time
$T_{swt}$	Slot wait time delay after end of call, until slotted response starts
$T_t$	Tuneup time delay of antenna tuner or coupler
$T_{ta}$	Turnaround time, receipt of end of signal to start of reply
$T_{tc}$	Transmitter command (to transmit) time
$T_{td}$	Transmitter internal signal delay time

MIL-STD-188-141B  
APPENDIX A  
ANNEX A

$T_{tk}$	Transmitter acknowledgment (that is transmitting) time
$T_{tone}$	Tone (8 ms)
$T_w$	Word time (130.66...ms)
$T_{wa}$	Wait for activity time
$T_{wan}$	Wait for net acknowledgment time (for called stations)
$T_{wan\ max}$	Maximum limit group call wait for reply time (for late arrival called stations)
$T_{wce}$	Wait for calling cycle end (message or terminator stations)
$T_{wr}$	Wait for reply time
$T_{wrn}$	Wait for net/group reply time (for calling stations)
$T_{wrt}$	Wait for reply and tune (scanning) time
$T_{wt}$	Wait (listen first) time before tune or transmit
$T_x$	Termination section time
$T_{x\ max}$	Maximum termination section time limit
WRT	Wait for reply timer (load with $T_{wr}$ )
WRTT	Wait for response and tune timer (load with $T_{wrn}$ or $T_{wrt}$ )

## ANNEX B. TIMING

NOTE: Refer to annex A and table A-XV.

### Basic system timing

- Tone (symbol) rate = 125 symbols per second
- Tone period:

$$T_{\text{tone}} = 8 \text{ ms per symbol}$$

- On-air bit-rate = 375 bits per second
- On-air individual word period (never sent alone):

$$T_w = 16.33... \text{ symbols} \times T_{\text{tone}} = 130.66... \text{ms}$$

- On-air (triple) redundant word period:

$$T_{\text{rw}} = 3T_w = 49 \text{ tone} = 392 \text{ ms}$$

- On-air individual (or net) address time for  $m = 1$  to 5 words:

$$T_a = m \times T_{\text{rw}} = 392 \text{ ms to } 1960 \text{ ms}$$

- Propagation time, range divided by speed of wave, for MF/HF signals, local to global:

$$T_p = 0 \text{ to } 70 \text{ ms}$$

### System timing limits

- Maximum individual station (or net address time limit), based on 15-character (or 5-word) maximum:

$$T_{a \text{ max}} = 5 T_{\text{rw}} = 1,960 \text{ ms}$$

- Individual (or net) address first word, used in scan call  $T_{\text{sc}}$ :

$$T_{\text{al}} = T_{\text{rw}} = 392 \text{ ms}$$

- Maximum group combined addresses different first words time limit, maximum 5 first words, in scan call  $T_{\text{sc}}$ :

$$T_{\text{cl}} = \Sigma T_{\text{al}} \text{ (different)}$$



MIL-STD-188-141B  
APPENDIX A  
ANNEX B

$$T_{cl \max} = 5 T_{al} = 5 T_{rw} = 1960 \text{ ms}$$

- Maximum call time limit, based on 12-word maximum, chole addresses in  $T_{lc}$ :

$$T_c \max = 12 T_{rw} = 4,704 \text{ ms}$$

- Maximum scan cycle period limit, based on 2 channels per second and 100 channels:

$$T_s \max = 50 \text{ s}$$

- Maximum message (orderwire) section time limit, unless adjusted by CMD:

$$T_m \max \text{ basic} = 30 T_{rw} = 11.76 \text{ s}$$

$$T_m \max \text{ including } T_m \max \text{ AMD} = 29 T_{rw}^* + 30 T_{rw} = 23.128 \text{ s}$$

$$T_m \max \text{ including } T_m \max \text{ DTM} = 29 T_{rw}^* + 353 T_{rw} = 382 T_{rw} \\ (149.744\text{s})$$

$$T_m \max \text{ including } T_m \max \text{ DBM} = 29 T_{rw}^* + 3560 T_{rw} = 3589 \\ T_{rw} (1406.888\text{s})$$

\*NOTE:  $T_{m \max}$  basic equals  $29 T_{rw}$  when combined with AMD, DTM, or DBM. This is due to the requirement to commence the AMD, DTM, or DBM transmission one  $T_{rw}$  (392) ms prior to the close of  $T_{m \max}$  basic which effectively reduces the value of  $T_{m \max}$  basic to  $29 T_{rw}$  in these equations.

- Maximum termination section time limit, same as  $T_{a \max}$ :

$$T_x \max = T_a \max = 1,960\text{ms}$$

### Individual calling

- Initial and minimum dwell time on each channel by receiving station during normal receive scanning; inverse of scanning rate; not including extended pause to read word:

$$T_d(5)_{\min} = 200 \text{ ms at 5 channels per second basic scan rate, or}$$

$$T_d(2)_{\min} = 500 \text{ ms at 2 channels per second minimum scan rate}$$

$$T_d(10)_{\min} = 100 \text{ ms at 10 channels per second (DO)}$$

MIL-STD-188-141B  
APPENDIX A  
ANNEX B

- Scan period for receiving station to scan all scanned channels during normal receive scanning, where “C” is the number of scanned channels; not including extended pause to read words:

$$T_{s \text{ min}} = C \times T_{d \text{ min}}$$

For example,

$$\begin{aligned} T_{s \text{ min}} &= 0 \text{ for single-channel, nonscan case, or} \\ &= 2 \text{ seconds for typical } C = 10 \text{ at 5 chps, or} \\ &= 5 \text{ seconds for } C = 10 \text{ 2 chps minimum rate} \\ &= 1 \text{ seconds for } C = 10 \text{ at chps (DO)} \end{aligned}$$

- For scan call  $T_{sc}$  computations, use  $T_s$  based on probable maximum pause on each channel ( $T_d$ , to read words) of  $T_{drw} = 2 T_{rw}$  ( $T_d$  may be adjusted by net managers for best system performance):

$$T_s = C \times T_d = C \times T_{drw}$$

For example,

$$T_s = 7,840 \text{ ms for } C = 10 \text{ channels and } T_d = T_{drw}$$

- Call time, the called whole address (or combination of called whole addresses, if a group call), which may be repeated in the leading call  $T_{lc}$ ; maximum limit 12 one-word addresses:

$$\begin{aligned} T_c &= T_c \text{ (called) for single-station (or net) calls, or} \\ &= T_a \text{ (first)} + T_a \text{ (second)} + T_a \text{ (last) if group call} \end{aligned}$$

- First-word call time, the called address first word (or combination of addresses first words, if a group call), which is repeated in the scanning call  $T_{sc}$ ; maximum limit 5 different first words:

$$\begin{aligned} T_{lc} &= T_{al} \text{ (called) for single-station (or net) calls, or} \\ &= T_{al} \text{ (first)} + T_{al} \text{ (second different)} + T_{al} \text{ (last different) if group call} \end{aligned}$$

- Leading call time, composed of two complete repetitions of  $T_c$ , which contains the whole address(es):

MIL-STD-188-141B  
APPENDIX A  
ANNEX B

$$T_{1c} = 2T_c = 2T_a \text{ (called) for single-station (or net) calls, or}$$

$$= 2(T_a \text{ (first)} + T_a \text{ (second)} + T_a \text{ (last)}, \text{ if group call})$$

- Scanning call time, consisting of repetitions of only the first word(s)  $T_{a1}$  of the called address (or combination of addresses, if a group call), for calling station to “capture” scanning receivers during normal scanning calling. Therefore,  $T_{sc}$  is a multiple  $T_{c1}$  (group of  $T_{a1}$ ’s if a group call) of words, which is  $\geq$  the receiver’s scan period  $T_s$ , where  $n$  is any integer such that  $T_{sc} \geq T_s$ :

$$T_{sc} = n \times T_{c1} \geq T_s = C \times T_d$$

For example,

$$T_{sc} = 0 \text{ for single-channel individual call case, or}$$

$$\geq 20 T_{rw} = 7840 \text{ ms if } C = 10 \text{ and } T_d = T_{drw}$$

- Calling cycle time for calling station to both “capture” scanning receivers and ensure reading the called station address(es), consisting of scan calling time ( $T_{sc}$ ) plus leading call time ( $T_{1c}$ ), respectively:

$$T_{cc} = T_{sc} + T_{1c} \geq T_s + T_{1c}$$

For example,

$$T_{cc} = T_{1c} = 2T_a \text{ (called)} = 784 \text{ ms for single-channel one-word address individual (or net) call case } (T_s = 0), \text{ or}$$

$$= T_{sc} + T_{1c} = (20 + 2) T_{rw} + 8624 \text{ ms if } C = 10 \text{ and } T_d = T_{drw}$$

- Single-channel redundant call time, consisting of individual (or net) leading call  $T_{1c}$  (with TO) plus terminator  $T_a$  (with TIS or TWAS), not including any message section time:

$$T_{rc} = T_{1c} + T_x = 2T_c + T_x = 2T_a \text{ (called)} + T_a \text{ (caller)}$$

$$= 3 T_{rw \text{ min}} = 1176 \text{ ms minimum, for individual station}$$

(or net) call using one-word addresses.

$$= 15 T_{rw \text{ min}} = 5880 \text{ ms max for 5-word addresses}$$

- Scanning redundant call time, consisting of scanning call time  $T_{sc}$ , and redundant call time  $T_{rc}$ , respectively:

MIL-STD-188-141B  
APPENDIX A  
ANNEX B

$$T_{\text{rsc}} = T_{\text{sc}} + T_{\text{rc}}$$

For example, using one-word addresses:

$$T_{\text{src}} = (20 + 3) T_{\text{rw}} = 9016 \text{ ms if } C = 10 \text{ and } T_{\text{d}} = T_{\text{drw}}$$

- Last word wait additional fixed delay at replying or receiving station, after (possibly early) detected end of received call and before start of reply, to avoid on-air overlap, loss of additional termination (caller address) words, and to allow for transmitter turnaround for reception:

$$T_{\text{1ww}} = T_{\text{rw}} = 392 \text{ ms}$$

- Late word detection additional fixed delay at calling station, to increase wait for reply time in case of possibly late detection at called station:

$$T_{\text{1d}} = T_{\text{w}} = 130.66... \text{ms}$$

- Redundant word phase delay. To synchronize a transmission to any recently preceding transmissions, and used on all but first transmission of a handshake or exchange until terminated period:

$$T_{\text{rwp}} = 0 \text{ to } 392 \text{ ms} \leq T_{\text{rw}}$$

- Turnaround time at replying station, measured at rf port(s); from end of received signal to start of transmitted reply, not including delays such as  $T_{\text{1ww}}$  internal signal delays,  $T_{\text{rd}}$  and  $T_{\text{td}}$ ; decode and encode times,  $T_{\text{dek}}$  and  $T_{\text{enk}}$ ; and transmitter command and acknowledgment delays,  $T_{\text{tc}}$  and  $T_{\text{tk}}$ :

$$T_{\text{ta}} = T_{\text{rd}} + T_{\text{dek}} + T_{\text{enk}} + T_{\text{tc}} + T_{\text{tk}} + T_{\text{td}}$$

For example, approximations:

$$\begin{aligned} T_{\text{ta}} &= 0 \text{ for new, fast equipment, or} \\ &= 2 T_{\text{w}} = 261.33... \text{ms estimated allowance for old slower equipment} \end{aligned}$$

- Wait for calling cycle end time at receiving station, is delineated by receipt of start of message, terminator, or quick-ID section:

$$T_{\text{wce}} = 2 \times T_{\text{s}} \text{ (of own station) as default value}$$

- Wait for reply time at calling station, from end of transmitter signal to start of received reply detection periods ( $T_{\text{ds}}$ ,  $T_{\text{drw}}$ , and  $T_{\text{drw}}$ , below); including propagation,  $T_{\text{p}}$ ; last word wait,  $T_{\text{1ww}}$ ; late word detection,  $T_{\text{1d}}$ ; turnaround,  $T_{\text{ta}}$ ; redundant word phase delay (if not first transmission in handshake or exchange),  $T_{\text{rwp}}$ ; and receiver and transmitter internal

MIL-STD-188-141B  
APPENDIX A  
ANNEX B

signal delays,  $T_{rd}$  and  $T_{td}$ ; in a single-channel case without tune times, or multi-channel scanning case after first tune and transmission:

$$T_{wr} = T_{td} + T_p + T_{lww} + T_{lww} + T_{ta} + T_{rwp} \text{ (if not first)} + T_{ld} + T_p + T_{rd}$$

For example, approximations:

$$\begin{aligned} T_{wr} &= 5 T_w = 653.33... \text{ ms for fast equipment, or} \\ &= 7 T_w = 914.66... \text{ ms for slower equipment, maximum} \\ &= 8 T_w = 1045.33... \text{ ms for fast equipment if not first} \\ &= 10 T_w = 1306.66... \text{ ms for slower equipment if not first} \end{aligned}$$

- Tune time delay, after issuance of tune-up command and before ready to transmit the reply signal:

$$T_t = \text{maximum tune-up delay for slowest tuner in system (or net/group being called)}$$

For example, typical allowance ranges are:

$$\begin{aligned} T_t &\geq T_w = 130.66... \text{ ms for fast (solid state) tuners or} \\ &\geq 8 T_w = 1,045.33... \text{ ms for fast relay tuners, or} \\ &\geq 20 \text{ seconds for old electromechanical (servo drive) tuners, or as required by available equipment} \end{aligned}$$

NOTE: If tune time(s) of called station(s) is unknown, first try default value shall be  $8 T_w$  and second try default value shall be at least 20 seconds.

- Wait for response and tune time, same as wait for reply  $T_{wr}$ , plus tune time  $T_t$  in scanning cases, and relevant only to first transmission on a channel (which requires tuning time):

$$T_{wrt} = T_{wr} + T_t$$

For example, typical allowance ranges are:

$$T_{wrt} = 6 T_w = 784 \text{ ms for fast tuners, or}$$

MIL-STD-188-141B  
APPENDIX A  
ANNEX B

$15 T_w = 1,960$  ms for slower tuners, or adjusted as required by available equipment

NOTE: If tune time(s) of called station(s) is unknown, first try default value shall be  $15 T_w$  and second try default value shall be at least 20 seconds.

- Detect signaling tones and timing (of call or reply) detection period; after arrival on channel during normal receive scanning, or after end of wait for reply time  $T_{wr}$  or  $T_{wrt}$  during normal calling, and before automatic return to normal receive scanning; used to identify channel vacancy or occupancy with standard ALE signaling.

$$T_{ds} \leq T_d(5) = 200 \text{ ms}$$

- Detect redundant words detection period, starting same as  $T_{ds}$ , and used to continue beyond  $T_{ds}$  if tones and timing are detected, before automatic return to normal receive scanning; used for acceptance of basic single-word (and address first work) addressing and to real calls:

$$T_{drw} = T_{rw} + \text{spare } T_{rw} = 6 T_w = 784 \dots \text{ms}$$

- Detect rotating redundant words detection period, starting same time as  $T_{ds}$ , and used to continue beyond  $T_{drw}$  if redundant words are detected, before automatic return to normal receive scanning; used for acceptance of extended (multiword) addressing and/or group calls:

$$T_{drrw} = 2 T_{rw} + \text{spare } T_{rw} = 9 T_w = 1,176 \text{ ms}$$

### Sounding

- Single-channel redundant sound time, like leading call  $T_{1c}$ , but with only the “TIS” or “TWAS” terminator, using twice the whole address:

$$T_{rs} = 2T_a \text{ (caller)}$$

For example,

$T_{rs} = 2T_{rw} = 784$  ms minimum, individual single-word address sound on a single channel

MIL-STD-188-141B  
APPENDIX A  
ANNEX B

- Scanning sound time. Like  $T_{sc}$ , but using whole address only (not just first word of address):

$$T_{ss} = n \times T_a(\text{caller}) \geq T_s$$

- Scanning redundant sound time, like calling cycle time,  $T_{cc}$ , consisting of redundant sound time  $T_{rs}$ , with addition of scanning sounding time  $T_{ss}$  (which is identical to  $T_{sc}$ ):

$$T_{srs} = T_{ss} + T_{rs} = (2 + n)T_a(\text{caller}) \geq T_s + T_{rs}$$

For example,

$$T_{srs} = (20 + 2) T_{rw} = 8,624 \text{ ms if } C = 10, \text{ and } T_d = T_{drw}$$

### Star calling

- Minimum uniform slot width for automatic slotted responses in normal single-word address star net and group calling protocols (but may be modified by CMD):

$$\begin{aligned} T_{sw}(\text{min}) &= 14 T_w = 1,829.33... \text{ ms for standard replies, or} \\ &= 17 T_w = 2,221.33... \text{ ms for LQA replies, or} \\ &= 9 T_w = 1,176 \text{ ms for only fixed "tight slot" replies, or} \\ &= n \times T_w \text{ by CMD} \end{aligned}$$

NOTE: Replies above are for first transmissions; if not,  $T_{sw \text{ min}} = 17, 20, \text{ and } 12 T_w$  respectively, (due to redundant word-phase delay).

- Slot wait time before start of slotted response and after detection of end of calling signal, where SN is the assigned (or derived) slot number, for group or preset net calling:

$$T_{swt}(\text{SN}) = T_{sw} \times \text{SN for uniform slot widths}$$

(by CMD or net manager), or if non-uniform (customized) slot width

$$T_{swt}(\text{SN}) = \text{SN} [5 T_w + 2T_a(\text{caller}) + (\text{optional LQA}) T_{rw} (\text{optional message}) T_m] + T_a(\text{caller}) + [(\text{sum of all previous } w_a \text{ called addresses})]$$

$$m = \text{SN}-1$$

$$\Sigma T_a(m)(\text{called})$$

MIL-STD-188-141B  
APPENDIX A  
ANNEX B

$$m = 1$$

as the general case.

For example,

$$T_{\text{swt}}(5) = 14 T_w \times 5 = 70 T_w = 9,146.66\dots\text{ms delay for start of normal 5th slot response, first time, no LQA, single word address.}$$

- Wait for net reply buffer time at calling station, after end of star net or group call, until responses should be received and an acknowledgment can be started, where “NS” is the total number of slots (including slot 0):

$$T_{\text{wrn}}(\text{calling}) = (T_{\text{sw}} \times \text{Ns}) \text{ for uniform slots or generally, } T_{\text{swt}}(\text{NS})$$

- Wait for net acknowledge buffer time at called stations, to receive acknowledgment after end of star net or group call:

$$\begin{aligned} T_{\text{wan}}(\text{called}) &= (T_{\text{sw}} \times \text{NS}) + T_{\text{drw}} \\ &= T_{\text{wrn}}(\text{calling}) + 2T_{\text{rw}} \end{aligned}$$

- Turnaround plus tune time totals for slotted responses have the following limits (not including  $T_{\text{lw}}(w)$ ):

$$\begin{aligned} T_{\text{ta}} + T_{\text{t}} & \quad 1500 \text{ ms for standard slots, except} \\ & \quad 2100 \text{ ms for slot 1 only, or} \\ & \quad 360 \text{ ms for slot 0 emergency or interrupt} \end{aligned}$$

- Maximum star group wait for acknowledgment time at called stations:

$$\begin{aligned} T_{\text{wan max}} = & \quad 107 T_w + 27 T_a(\text{caller}) + 13 T_{\text{rw}}(\text{optional LQA}) + \\ & \quad 13 T_m(\text{optional message}) \end{aligned}$$

- Default maximum star group wait for acknowledgment time for late arrival, called stations, not knowing the size of the group. There are two default maximum waiting values, before automatically returning to normal receive scanning, if no message and caller uses single-word address:

$$\begin{aligned} T_{\text{wan max}} = & \quad 188 T_w = 24,563.33\dots\text{ms if standard or,} \\ & \quad 277 T_w = 29,661.33\dots\text{ms if LQA requested} \end{aligned}$$



MIL-STD-188-141B  
APPENDIX A  
ANNEX B

Programmable timing parameters

Unless otherwise programmed by the network manager, the following typical timing values are recommended:

- Dwell time per channel, basic receive scanning:

$$T_d(5) = 200 \text{ ms for 5 chps basic scan rate}$$

- Dwell time per channel, minimum receive scanning:

$$T_d(2) = 500 \text{ ms for 2 chps minimum scan rate}$$

- Dwell time for calculations of  $T_s$  (and  $T_{sc}$ ), based on probable maximum typical pause (may be adjusted by net manager for best system performance):

$$T_d = T_{drw} = 2T_{rw} = 784 \text{ ms}$$

Wait (listen first) time before tune or transmit:

$$\begin{aligned} T_{wt} &= 2 \text{ seconds for voice or general purpose channels or,} \\ &= T_{drw} = 784 \text{ ms for ALE and data only channels} \end{aligned}$$

Tune time allowance for wait for response time is normally set for slowest known tuner in associated network; except if unknown parameter (such as in blind internet calls to “strangers”):

$$\begin{aligned} T_t &= 8T_w = 1045.33\dots\text{ms for first call, and} \\ &= 20 \text{ seconds for next try} \end{aligned}$$

- Automatic periodic sounding intervals (when channels are clear):

$$T_{ps} = 45 \text{ minutes when enabled (} T_{ps} \text{ must be capable of being disabled).}$$

Wait for activity time after linking or use, before automatic return to normal receive scanning:

$$T_{wa} = 30 \text{ seconds when enabled (} T_{wa} \text{ must be capable of being disabled).}$$

MIL-STD-188-141B  
APPENDIX A  
ANNEX C

**ANNEX C. SUMMARY OF ALE SIGNAL PARAMETERS**

ALE occupied bandwidth	500-2750 Hz
Quantity of tones	8 (one per symbol period)
Tone frequencies	750; 1000; 1250; 1500; 1750; 2000; 2250; 2500 Hz
Tone values	000 001 011 010 110 111 101 100
Symbol changes	Tone transitions are phase continuous
Symbol structure	3 bits of binary coded data
Symbol rate; period	125 symbols per second (sps); 8 ms
Uncoded data rate	375 bits per second (b/s) transmitted
Forward error correction	Golay (24, 12, 3) half-rate coding (4 modes of (FEC) correct/delect; 3/4, 2/5, 1/6, or 0/7)
Auxiliary coding (DTM,	Redundant x 3, with 2/3 majority vote (with 49 AMD, basic ALE) transmitted bits)
Auxiliary coding (DBM)	Interleaving depth (ID) = 49 to 21805 = (n x 49)
Coded data rate (DTM, AMD, basic ALE)	61.22 b/s
Coded data rate (DBM)	187.5 b/s
Coded data bits per basic ALE word (DTM, AMD)	24 (21 (3 characters) plus 3 preamble), per word
Coded data bits per message (DTM)	From 0 to 7371 bits per block
Coded data bits per message (DBM)	From 0 to 261644 bits per block, plus 16 bits CRC (DBM)
Throughput, maximum data rate (DTM, AMD, basic ALE)	53.57 b/s data bits
Throughput maximum data rate (DBM)	187.5 b/s data bits

MIL-STD-188-141B  
 APPENDIX A  
 ANNEX C

Characters per word (AMD or basic ALE)	0 to 3 expanded 64 or full ASCII
Character per message (DTM)	0 to 1053 ASCII characters per block
Character per message (DBM)	0 to 37377 full ASCII characters per block
Character rate (DTM, AMD, basic ALE)	7.653 cps
Character rate (DBM)	26.79 cps
Equivalent throughput maximum word rate (DTM, AMD)	76.53 words per minute (wpm) (5 character plus space per word)
Equivalent throughput maximum word rate (DBM)	267.9 wpm (5 character + space per word)
Unit period (DTM, AMD, or ALE word)	130.66 ... ms per word ( $T_{rw}$ ) or 392 ms per triple redundant word ( $T_{rw}$ )
Message period (DTM)	0 to 2.29 minutes per block
Message period (DBM)	0 to 23.26 minutes per block
Minimum sound time	784 ms ( $2 T_{rw}$ )
Minimum call time	1176 ms ( $3 T_{rw}$ )
Minimum handshake time	3528 ms ( $9 T_{rw}$ ) three-way linking
Preamble (word types)	8 (3 bits)
Character sets or random bits	ASCII (Basic 38, expanded 64, full 128),
Link quality analysis (LQA)	ALE (BER, SINAD, and MP)

APPENDIX B  
LINKING PROTECTION

**TABLE OF CONTENTS**

<b><u>PARAGRAPH</u></b>	<b><u>PAGE</u></b>
B.1 GENERAL.....	234
B.1.1 <u>Scope</u> .....	234
B.1.2 <u>Applicability</u> .....	234
B.2 APPLICABLE DOCUMENTS.....	234
B.2.1 <u>General</u> .....	234
B.2.2 <u>Government documents</u> .....	234
B.2.2.1 <u>Specifications, standards, and handbooks</u> .....	234
B.2.2.2 <u>Other Government documents, drawings, and publications</u> .....	235
B.3 DEFINITIONS.....	235
B.3.1 <u>Standard abbreviations and acronyms</u> .....	235
B.3.2 <u>Definitions of timing signals</u> .....	236
B.4 GENERAL REQUIREMENTS.....	236
B.4.1 <u>LP overview</u> .....	236
B.4.1.1 <u>Linking protection application levels</u> .....	238
B.4.1.1.1 <u>AL-0</u> .....	238
B.4.1.1.2 <u>AL-1</u> .....	239
B.4.1.1.3 <u>AL-2</u> .....	239
B.4.1.1.4 <u>AL-3</u> .....	239
B.4.1.1.5 <u>Classified application level AL-4</u> .....	239
B.4.2 <u>Protocol transparency</u> .....	239
B.4.3 <u>Transmit processing</u> .....	239
B.4.4 <u>Receive Processing</u> .....	239
B.4.5 <u>Time of day (TOD) synchronization</u> .....	240
B.5 DETAILED REQUIREMENTS.....	241
B.5.1 <u>Linking protection</u> .....	241
B.5.2 <u>LPCM</u> .....	241
B.5.2.1 <u>Scrambler interfaces</u> .....	241
B.5.2.2 <u>TOD</u> .....	241
B.5.2.2.1 <u>TOD entry</u> .....	241
B.5.2.2.2 <u>Time exchange protocols</u> .....	242
B.5.2.3 <u>Seed format</u> .....	242
B.5.3 <u>Procedure for 2G ALE</u> .....	242
B.5.3.1 <u>Transmitting station</u> .....	244
B.5.3.2 <u>Receiving station</u> .....	246
B.5.3.3 <u>Message sections</u> .....	247
B.5.3.4 <u>Data block message (DBM) mode</u> .....	247
B.5.4 <u>Procedure for 3G ALE - not tested (NT)</u> .....	247

**TABLE OF CONTENTS**  
**(continued)**

<b><u>PARAGRAPH</u></b>	<b><u>PAGE</u></b>
B.5.4.1 <u>Encryption of 3G protocol data units (PDU)</u> .....	247
B.5.4.2 <u>Procedure for synchronous-mode 3G ALE</u> .....	247
B.5.4.3 <u>Procedure for asynchronous-mode 3G ALE</u> .....	248
B.5.4.3.1 <u>Protected 3G asynchronous-mode scanning call</u> .....	248
B.5.4.3.2 <u>Protected 3G asynchronous-mode response</u> .....	248
B.5.4.4 <u>Protected 3G PI progression</u> .....	248
B.5.5 <u>Time protocols</u> .....	248
B.5.5.1 <u>Time exchange word format</u> .....	248
B.5.5.2 <u>Active time acquisition (protected)</u> .....	248
B.5.5.2.1 <u>Time Request call (protected)</u> .....	248
B.5.5.2.2 <u>Time Service response (protected)</u> .....	249
B.5.5.2.3 <u>Time Server request (protected)</u> .....	249
B.5.5.2.4 <u>Authentication and adjustment (protected)</u> .....	250
B.5.5.3 <u>Active time acquisition (non-protected)</u> .....	250
B.5.5.3.1 <u>Time Request call (non-protected)</u> .....	250
B.5.5.3.2 <u>Time Service response (non-protected)</u> .....	250
B.5.5.3.3 <u>Authentication and adjustment (non-protected mode)</u> .....	251
B.5.5.4 <u>Passive time acquisition (optional)</u> .....	251
B.5.5.5 <u>Time broadcast</u> .....	251
B.5.5.6 <u>Advanced time distribution protocols</u> .....	252
B.5.6 <u>The Lattice Algorithm</u> .....	252
B.5.6.1 <u>Encryption using the Lattice Algorithm</u> .....	252
B.5.6.2 <u>Decryption using the Lattice Algorithm</u> .....	252
B.5.6.4 <u>Lattice Algorithm examples</u> .....	257
B.5.7.1 <u>Encryption using the SoDark-3 Algorithm</u> .....	259
B.5.7.2 <u>Decryption using the SoDark-3 Algorithm</u> .....	259
B.5.7.3 <u>Encryption using the SoDark-6 Algorithm</u> .....	260
B.5.7.4 <u>Decryption using the SoDark-6 Algorithm</u> .....	262

**TABLES**

TABLE B-I. <u>Encryption table</u> .....	255
TABLE B-II. <u>Decryption table</u> .....	256

**FIGURES**

FIGURE B-1. <u>Data link layer with linking protection sublayer</u> .....	237
FIGURE B-2. <u>Data flow in a protected radio</u> .....	238
FIGURE B-3. <u>Seed formats</u> .....	243
FIGURE B-4. <u>Transmitting and receiving stations state diagram</u> .....	245
FIGURE B-5. <u>Lattice Algorithm schematic diagram (encryption)</u> .....	254
FIGURE B-6. <u>SoDark-3 Algorithm schematic diagram (encryption)</u> .....	261
FIGURE B-7. <u>SoDark-6 Algorithm schematic diagram (encryption)</u> .....	263

## LINKING PROTECTION

### B.1 GENERAL.

#### B.1.1 Scope.

This appendix contains the requirements for the prescribed protocols and directions for the implementation and use of high frequency (HF) automatic link establishment (ALE) radio linking protection.

#### B.1.2 Applicability.

This appendix is a mandatory part of MIL-STD-188-141 whenever linking protection (LP) is a requirement for the HF radio implementation. The functional capability herein described includes linking protection, linking protection application levels, and timing protocols. The capability for manual operation of the radio in order to conduct communications with existing, older generation, non-automated radios shall not be impaired by implementation of these automated procedures.

### B.2 APPLICABLE DOCUMENTS.

#### B.2.1 General.

The documents listed in this section are specified in B. 3, B. 4, and B. 5 of this standard. This section does not include documents cited in other sections of this standard or recommended for additional information or as examples. While every effort has been made to ensure the completeness of this list, document users are cautioned that they must meet all specified requirements documents cited in B. 3, B. 4, and B. 5 of this standard, whether or not they are listed.

#### B.2.2 Government documents.

##### B.2.2.1 Specifications, standards, and handbooks.

The following specifications, standards, and handbooks form a part of this document to the extent specified herein. Unless otherwise specified, the issues of these documents are those listed in the issue of the Department of Defense Index of Specifications and Standards (DODISS) and supplement thereto.

## STANDARDS

### FEDERAL

FED-STD-1037

Telecommunications: Glossary of  
Telecommunication Terms

(Unless otherwise indicated, copies of federal and military specifications, standards, and handbooks are available from the Standardization Document Order Desk, 700 Robbins Avenue, Building #4, Section D, Philadelphia, PA 19111-5094.)

B.2.2.2 Other Government documents, drawings, and publications.

The following other Government documents, drawings, and publications form a part of this document to the extent specified herein. Unless otherwise specified, the issues are those cited in the solicitation.

None.

B.3 DEFINITIONS.

B.3.1 Standard abbreviations and acronyms.

The abbreviations and acronyms used in this document are defined below. Those listed in the current edition of FED-STD-1037 have been included for the convenience of the reader.

2G	second generation
3G	third generation
2G ALE	second generation automatic link establishment
3G ALE	third generation automatic link establishment
AL-0	unprotected application level
AL-1	unclassified application level
AL-2	unclassified enhanced application level
AL-3	unclassified but sensitive application level
AL-4	classified application level
ALE	automatic link establishment
AMD	automatic message display
ASCII	American Standard Code for Information Interchange
BW1	Burst Waveform 1
CMD	ALE preamble word COMMAND
CRC	cyclic redundancy check
DBM	data block message
DO	design objective
DODISS	Department of Defense Index of Specifications and Standards
DTM	data text message
FEC	forward error correction
HF	high frequency
ICD	interface control document
LP	linking protection
LPCM	linking protection control module
ms	millisecond
NSA	National Security Agency
NT	Not Tested
PDU	protocol data unit
PI	protection interval
REP	Repeat preamble in 2G ALE
TOD	time of day



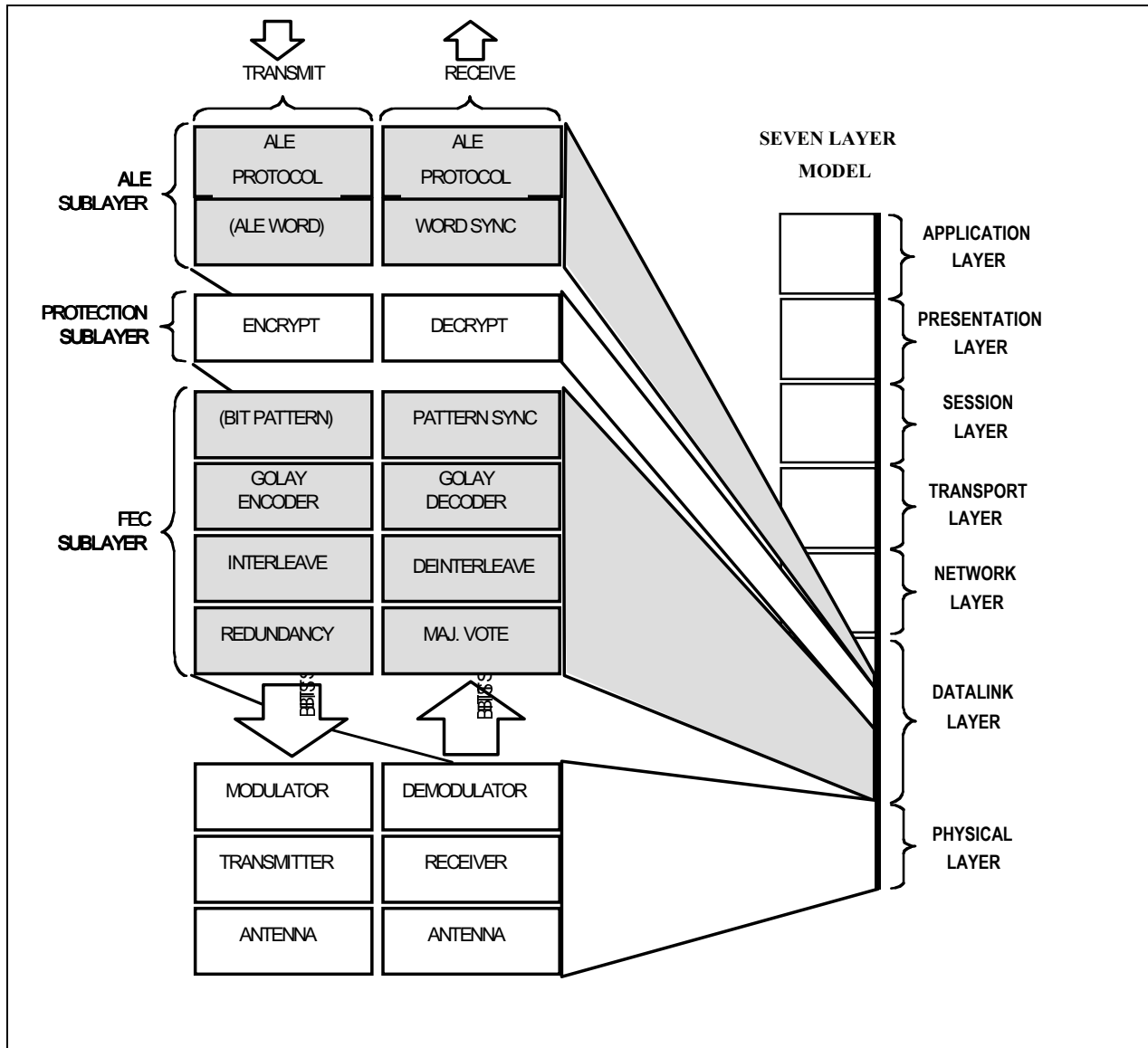
### B.3.2 Definitions of timing signals.

The abbreviations and acronyms used for timing symbols are contained in Annex A to Appendix A.

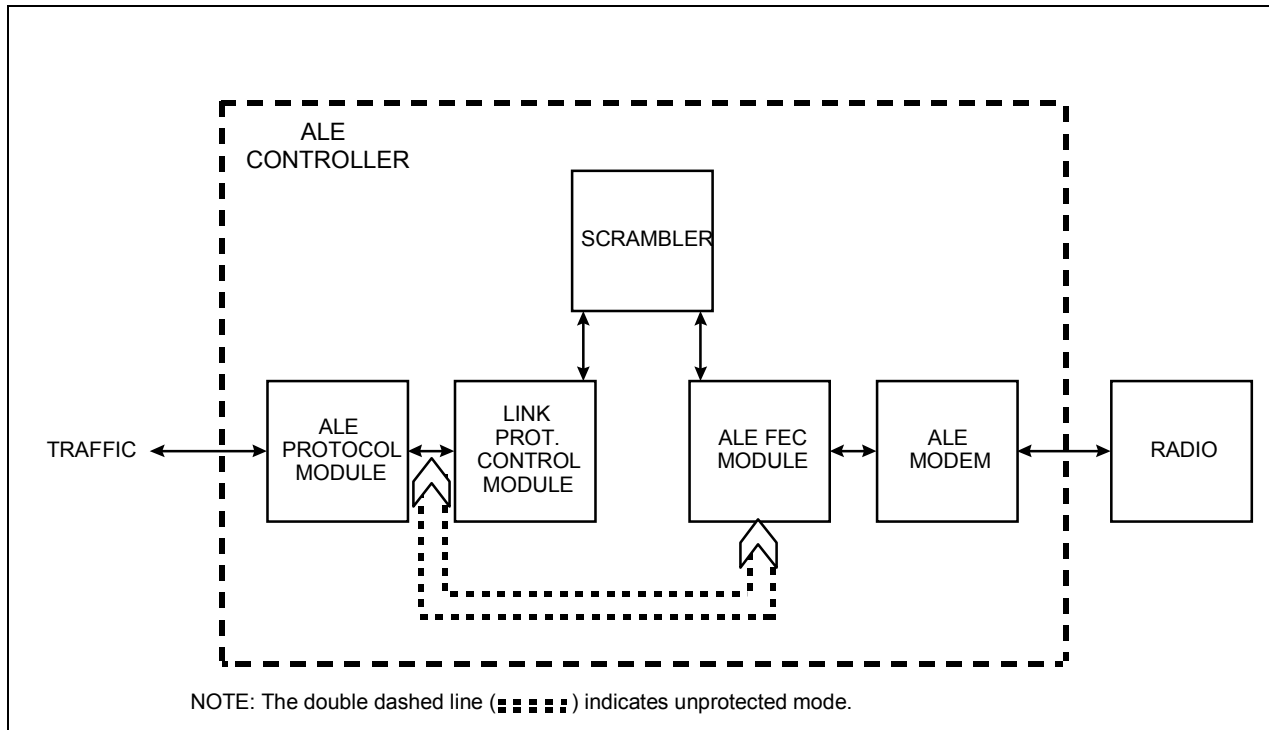
## B.4 GENERAL REQUIREMENTS.

### B.4.1 LP overview.

The LP procedures specified herein shall be implemented as distinct functional entities for control functions and bit randomization functions. (Unless otherwise indicated, distinct hardware for each function is not required.) Figure B-1 shows a conceptual model of the MIL-STD-188-141 data link layer functions, showing the placement within the data link layer at which LP shall be implemented. The linking protection control module (LPCM) shall perform all control functions specified herein and interface to the ALE controller as shown on figure B-2. Scrambler(s) shall perform all cryptographic operations on ALE words, under the control of the LPCM. Use of LP shall neither increase the time to establish a link compared to the non-protected radio, nor degrade the probability of linking below the standard set for non-protected linking in Appendix A, table A-II. A means shall be provided to disable the LP functions and operate the radio in the clear unprotected application level (AL-0). Hardware scramblers shall be removable without impairment of the unprotected application level functionality of a radio.



**FIGURE B-1. Data link layer with linking protection sublayer.**



**FIGURE B-2. Data flow in a protected radio.**

**B.4.1.1 Linking protection application levels.**

The application levels of LP are defined herein. The classified application level (AL-4), which offers the highest degree of protection, and the unclassified but sensitive application level (AL-3) use National Security Agency (NSA) controlled algorithms described in classified documents. This standard can only make reference to these documents with very little other descriptive material. All protected radios shall be capable of operation at the unclassified application level (AL-1). A means shall be provided to disable automatic linking at linking protection application levels less secure than the application level in use by the station being called. For example, a station which is operating at unclassified enhanced application level (AL-2) shall be able to disable the receiver from listening for linking attempts at unprotected application level (AL-0) and AL-1. (Design objective (DO): Alert the operator but do not link automatically when a valid call is received from a transmitter with a lower linking protection application level.) This mechanism shall not preclude the operator from manually initiating ALE using a disabled application level. This manual override is required for interoperability.

**B.4.1.1.1 AL-0.**

Assignment of the AL-0 indicates that no linking protection is being employed. No protection is provided against interfering, unintentional, or malicious linking attempts. All protected HF radios shall be capable of operation in the AL-0 mode.

B.4.1.1.2 AL-1.

The AL-1 unclassified application level is mandatory for all protected radio systems, and therefore, provides protected interoperability within the U.S. Government. All protected radios shall be capable of operation in the AL-1 mode even if they also provide application levels with greater protection. The AL-1 scrambler shall employ the lattice encryption algorithm as specified in B.5.6, and may be implemented in hardware or software with manufacturer-specified interfaces. This scrambler is for general U.S. Government and commercial use. The AL-1 protection interval (PI) is 60 seconds, which provides slightly lower protection than any of the other available protected modes but allows for relaxed synchronization requirements.

B.4.1.1.3 AL-2.

The AL-2 scrambler shall employ the same algorithm as specified for the AL-1, and may be implemented in hardware or software, with manufacturer-specific interfaces. This scrambler is for general U.S. Government and commercial use. The AL-2 PI is 2 seconds.

B.4.1.1.4 AL-3.

AL-3 shall use distinct hardware scramblers and shall employ an algorithm and the corresponding interface control document (ICD) developed by the NSA. Systems employing the AL-3 LP shall meet NSA security requirements. The AL-3 PI is a maximum of 2 seconds.

B.4.1.1.5 Classified application level AL-4.

AL-4 shall use distinct hardware scramblers and shall employ an algorithm and the corresponding ICD developed by NSA. An AL-4 scrambler may be used to protect classified orderwire traffic. Systems employing classified application level LP shall meet NSA security requirements. The AL-4 PI is a maximum of 1 second.

B.4.2 Protocol transparency.

A principal consideration in implementing LP is that the presence of an LP module in a radio (or its controller) shall have no impact on any protocols outside of the protection sublayer in the datalink layer. In particular, this means that achieving and maintaining crypto sync shall occur transparently to the ALE waveform and protocols, and that scanning radios shall be able to acquire crypto sync at any point in the scanning call portion of a protected transmission if this transmission was encrypted under the key in use by the receiving station. Thus, LP modules shall not insert sync bits into the data stream, and shall acquire crypto sync without the use of synchronization preambles or message indicator bits.

B.4.3 Transmit processing.

The LP module in a sending station shall encrypt each 24-bit ALE word to be sent using the seed data then in use (frequency, PI number, word number, etc. See B.5.2.3.) and delivers the encrypted word to the FEC module. (Data Block Mode is a special case. See B. 5. 3. 4.)

B.4.4 Receive Processing.

The receiver side of an LP module is responsible for achieving crypto sync with transmitting stations, and for decrypting protected ALE words produced by Golay decoder. In operation, when a scanning receiver arrives at a channel carrying valid tones and timing, the FEC sublayer

(majority voter, de-interleaver, and Golay decoder) shall process the output of the ALE modem and alert the LP receive module when an acceptable candidate word has been received. (This occurs roughly once every 8 milliseconds (ms) when the Golay decoders are correcting three errors, or once every 78 ms when correcting one error per Golay word.)

The receive LP module shall then decipher the candidate word, and pass it to the receiving ALE module, which will determine whether word sync has been achieved by checking for acceptable preamble and ASCII subset. This task is complicated by the possibility that the received word (even if properly aligned) may have been encrypted using a different PI than that at the receiver, requiring the receiving LP module to decrypt each candidate word under several seeds.

A further complication is the possibility, though small, that a word may satisfy the preamble and character set checks under multiple seeds. When this occurs, the valid successors to all seeds, which produced valid words, are used to decrypt the next word, and each result is evaluated in the context of the corresponding first word. The probability is vanishingly small that multiple PI possibilities will exist after this second word is checked.

For example, if during a scanning call (or sound), a received word decrypts to "TO SAM" using seed A, and to "DATA SNV" using seed B, the next word is decrypted using the successors to those seeds, denoted A' and B'. If the result of decrypting this next word under A' is not "TO SAM," the first decrypt under seed A was invalid because the word following a TO word in a scanning call must be the same TO word. To be valid in a scanning call or sound, a word following "DATA SNV" must have three ASCII-38 characters and a THRU, REPEAT, TIS or TWAS preamble. All valid preamble sequences may be found in Appendix A (table A-VIII).

#### B.4.5 Time of day (TOD) synchronization.

Because LP employs PIs (which are time-based), all stations must maintain accurate TOD clocks. Practical considerations suggest that station local times may differ by significant fractions of a minute unless some means is employed to maintain tighter synchronization. Because the effectiveness of LP increases as the length of the PI decreases, there is a trade-off between protection and the cost of implementing and using a time synchronization protocol.

The approach taken here is to rely on operators to get station times synchronized to within 1 minute (plus or minus 30 seconds), and then to employ a protocol to synchronize stations to within 1 or 2 seconds (fine sync) for full linking protection. While it is possible to operate networks with only coarse (1 minute) time synchronization, this reduces the protection offered by this system against playback (tape recorder) attacks.

Synchronization of local times for LP requires some cooperation between the protocol entity and the LP time base. For this reason, the LP module, which already has access to the time base for its normal operations, appears to be the logical entity to execute the synchronization protocols, although these protocols are logically at a higher layer in the protocol stack than the LP procedure. In this case, the LP module would need to examine the contents of received transmissions to extract relevant message sections.

If, instead, the synchronization protocols are executed by the ALE entity, the division of function by level of abstraction is cleaner. One concept of how the coordination across the ALE-LP sublayer boundary may be effected in this case is as follows:

- a. TOD is maintained by the ALE entity, and is provided to the LP entity as required.
- b. The transmit LP entity uses the TOD provided by the transmit ALE entity to form seeds during  $T_{sc}$  and for the initial time setting for  $T_{lc}$ . Thereafter, the TOD from ALE is ignored, and the transmit LP entity sequences seeds in accordance with the state diagram in figure B-4.
- c. On the receive side, seed sequencing is performed by the functions responsible for achieving and maintaining word sync. These functions may be implemented within either the LP or the ALE module, but must know the current phase of the ALE protocol (e.g.,  $T_{sc}$ ,  $T_{lc}$ , and so on).
- d. For authentication of clear mode time exchanges, the ALE module must be able to call upon the LP module to encrypt and decrypt individual ALE words "off line."

## B.5 DETAILED REQUIREMENTS

### B.5.1 Linking protection.

The following requirements apply to both second generation automatic link establishment (2G ALE) and third generation automatic link establishment (3G ALE) unless otherwise stated.

### B.5.2 LPCM.

The LPCM shall execute the LP procedure specified in B.5.3 and control the attached scrambler(s) as specified below.

#### B.5.2.1 Scrambler interfaces.

The LPCM shall interact with the scrambler(s) in accordance with the circuits and protocols specified in the interface control document (ICD) for each scrambler (see B.4.1.1.4 and B.4.1.1.5). For AL-1, the ICD is prepared and controlled by the manufacturer.

#### B.5.2.2 TOD.

The LPCM requires accurate time and date for use in the LP procedure. The local time base shall not drift more than  $\pm 1$  second per day when the station is in operation.

##### B.5.2.2.1 TOD entry.

A means shall be provided for entry of TOD (date and time) via either an operator interface or an electronic fill port or time receiving port (DO: provide both operator interface and electronic port). This interface should also provide for the entry of the uncertainty of the time entered. If time uncertainty is not provided, a default time uncertainty shall be used. Defaults for the various time fill ports may be separately programmable. Default time uncertainty shall be determined by the procuring agency or manufacturer. Default uncertainty of  $\pm 15$  seconds is suggested.

#### B.5.2.2.2 Time exchange protocols.

After initialization of TOD, the LPCM shall execute the time protocols of B.5.5 as required, to maintain total time uncertainty less than the PI length of the most secure LP mode it is using. The LPCM shall respond to time requests in accordance with B.5.5.3 unless this function is disabled by the operator.

#### B.5.2.3 Seed format.

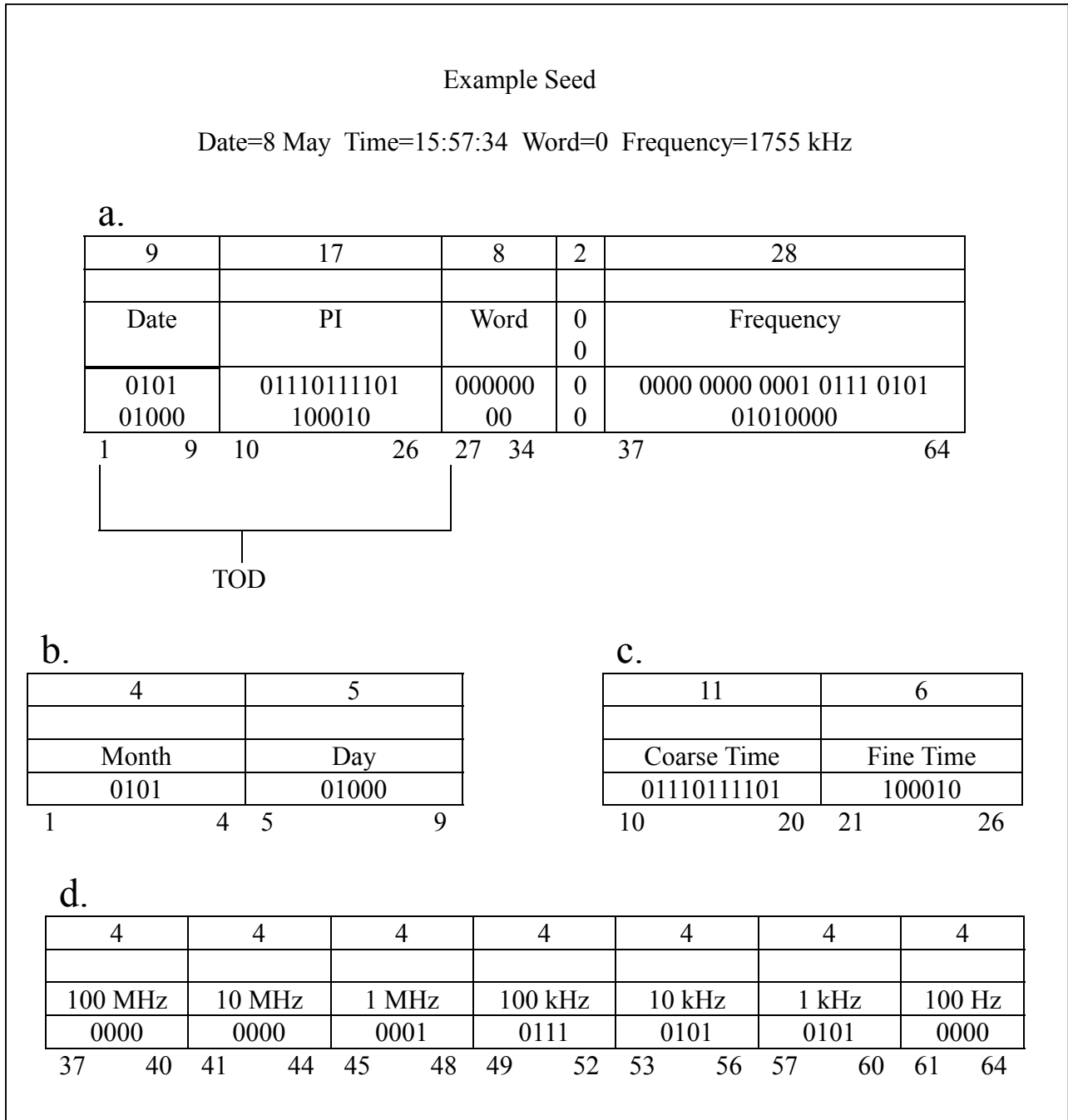
The LPCM shall maintain randomization information for use by the scrambler(s), and shall provide this information, or “seed,” to each scrambler in accordance with the applicable ICD. The 64-bit seed shall contain the frequency, the current PI number, the date, and a word number in the format shown on figure B-3, where the most significant bits of the seed and of each field are on the left. The TOD portion of the seed shall be monotonically non-decreasing. The remaining bits are not so constrained. The date field shall be formatted in accordance with figure B-3. The month field shall contain a 4-bit integer for the current month (1 for January through 12 for December). The day field shall contain a 5-bit integer for the current day of the month (1 through 31). A mechanism shall be provided to accommodate leap years. The PI field shall be formatted in accordance with figure B-3. The coarse time field shall contain an 11-bit integer which counts minutes since midnight (except that temporary discrepancies may occur as discussed in B.5.3). The 6-bit fine time field shall be set to all 1s when time is not known more accurately than within 1 minute (i.e., time quality of six or seven). When a time synchronization protocol (see B.5.5) is employed to obtain more accurate time, the fine time field shall be set to the time obtained using this protocol and incremented as described in B.5.3. The fine time field shall always be a multiple of the PI length, and shall be aligned to PI boundaries (e.g., with a 2-second PI, fine time shall always be even). The word field shall be used to count words within a PI, as specified in B.5.3. The frequency field shall be formatted in accordance with figure B-3. Each 4-bit field shall contain one binary-coded decimal digit of the frequency of the current protected transmission. Regardless of time quality, the fine time field shall be set all 1s for the unclassified application level of LP.

#### B.5.3 Procedure for 2G ALE.

The procedure to be employed in protecting transmissions consisting entirely of 24-bit ALE words is presented in B.5.3.1 and B.5.3.2. When a radio is neither transmitting nor receiving, the PI number shall be incremented as follows. When using linking protection level AL-2 and local time quality (see Appendix A, A.5.6.4.6) is “5” or better, the fine time field shall be incremented at the end of each PI by the length of the PI, modulo 60. When the fine time field rolls over to “0,” the coarse time field shall be incremented, modulo 1440. At midnight, the coarse and fine time fields shall be set to “0,” and the date and month fields updated. When using linking protection level AL-1, or when the local time quality (see appendix A, A.5.6.4.6) is “6” or “7,” the fine time field shall contain all “1s,” and the coarse time field shall be incremented once per minute, modulo 1440. At midnight, the coarse time field shall be set to “0,” and the date and month fields updated. Whenever the local time uncertainty is greater than the PI, the system shall:

- a. Present an alarm to the operator.

b. Optionally, also attempt resynchronization (if enabled). The first attempt at resynchronization shall use the current fine seed. If this fails, the system shall use a coarse seed for subsequent attempts.



**FIGURE B-3. Seed formats.**

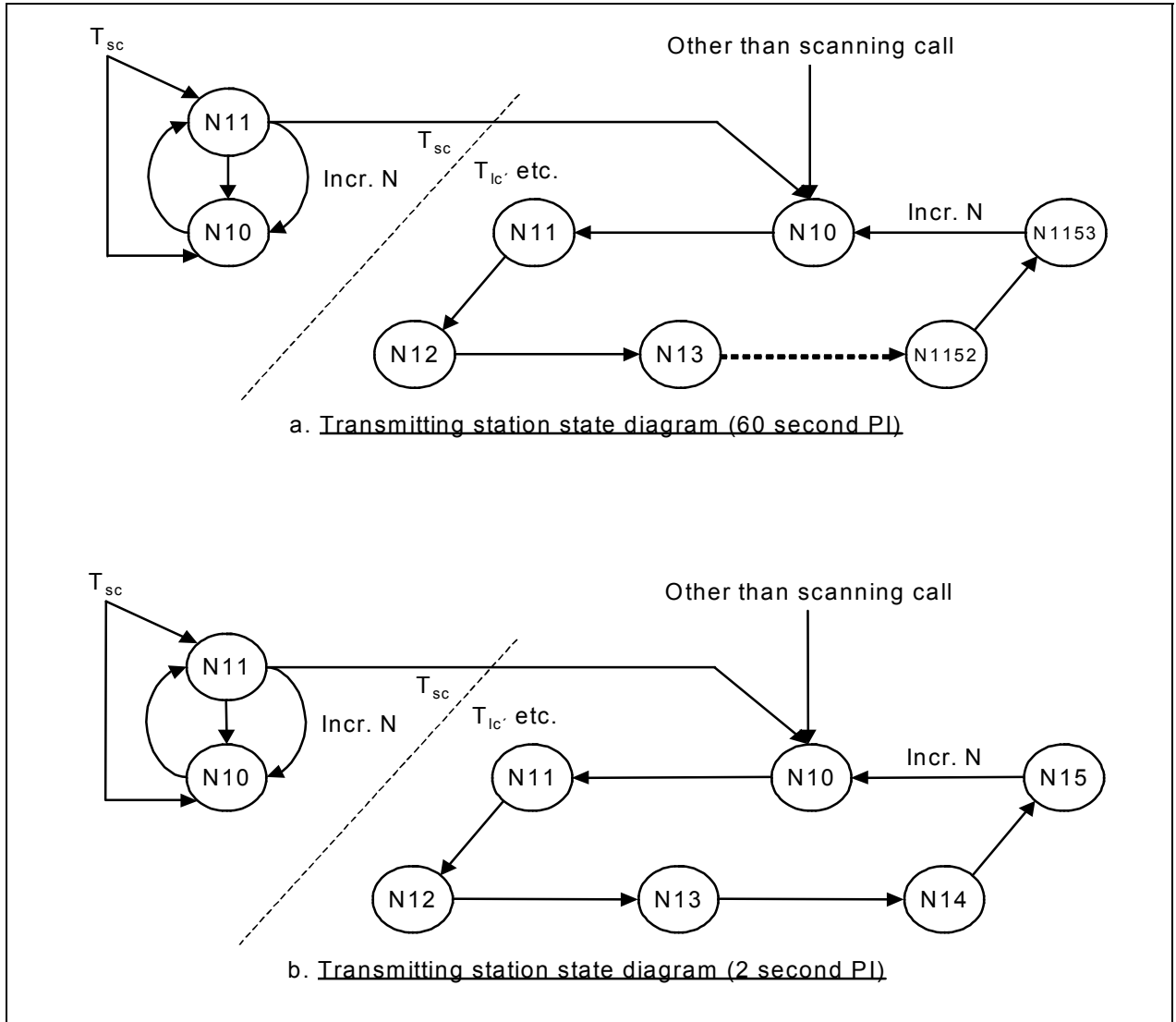


B.5.3.1. Transmitting station.

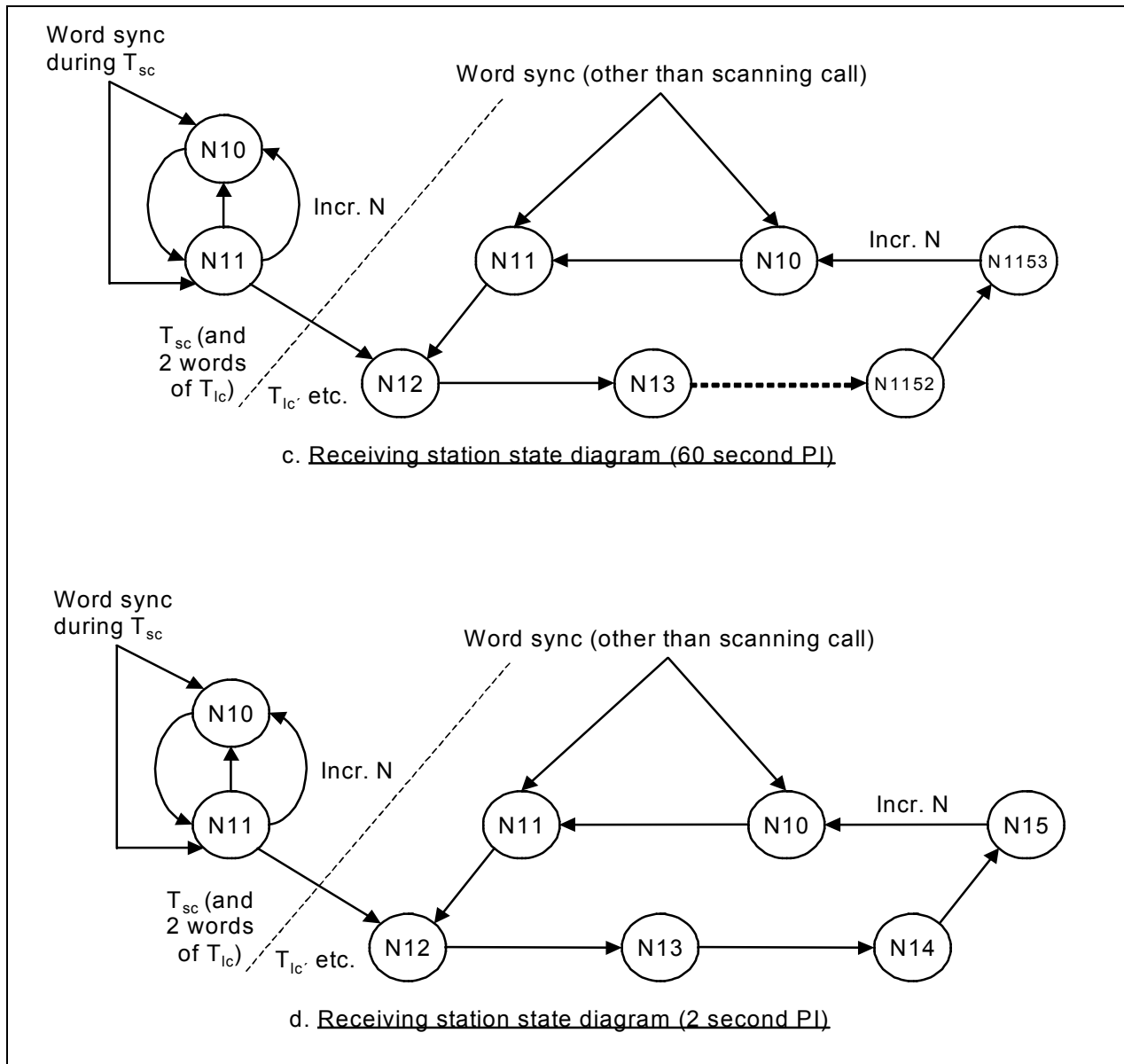
Each word to be transmitted shall be encrypted by the scrambler using the current seed information. In the course of a transmission, the protocol described below may cause a discrepancy between the TOD fields in the seed and the real time. Such discrepancy shall be allowed to persist until the conclusion of each transmission, whereupon the TOD fields of the seed shall be corrected. The word number field “w” shall be as follows:

- a. During the scanning call phase ( $T_{sc}$ ) of a call, or throughout a sound, the calling stations shall alternate transmission of words encrypted using  $w = 0$  and  $w = 1$ . The first word of  $T_{sc}$  shall begin with  $w = 0$  or  $w = 1$ , as required, such that the last word of  $T_{sc}$  is encrypted using  $w = 1$ . The TOD used during  $T_{sc}$  shall change as required to keep pace with real time, except that TOD shall only change when  $w = 0$ . Words encrypted with  $w = 1$  shall use the same TOD as the preceding word.
- b. At the beginning of the leading call phase ( $T_{lc}$ ) of a call (which is the beginning of a single-channel), the first word shall be encrypted using  $w = 0$  and the correct TOD for the time of transmission of that word.
- c. All succeeding words of the call shall use succeeding word numbers up to and including  $w = w_{max}$ . For the word following a word encrypted with  $w = w_{max}$ , the TOD shall be incremented and  $w$  shall be reset to 0.
  - (1)  $W_{max} = 2$  for a 1-second PI.
  - (2)  $W_{max} = 5$  for a 2-second PI.
  - (3)  $W_{max} = 153$  for a 60-second PI.
- d. Responses and all succeeding transmissions shall start with  $w = 0$  and the current (corrected) TOD, with these fields incremented as described in paragraph c above for each succeeding word.

Figure B-4 illustrates the permissible TOD with combinations for a transmitting station using a 60 second ( $w_{max}=153$ ) and a 2-second PI ( $w_{max} = 5$ ), and the permissible sequences of these combinations. Sounds are protected in the same fashion with  $T_{rs}$  in place of  $T_{lc}$ .



**FIGURE B-4. Transmitting and receiving stations state diagram.**



**FIGURE B-4. Transmitting and receiving stations state diagram (continued).**

**B.5.3.2 Receiving station.**

Because of the possibility of acceptable decodes under multiple TOD/word number combinations, receivers shall attempt to decode received words under all allowed combinations (the current and adjacent PIs (future and past), and both  $w = 0$  and  $w = 1$ ) when attempting to achieve word synchronization with a calling station (six combinations). Stations prepared to accept time requests (see B.5.5.2.2) shall also attempt to decode received words using coarse TOD (fine time = all 1s, correct coarse time only) with both  $w = 0$  and  $w = 1$  (eight combinations total). All valid combinations shall be checked while seeking word sync. After achieving word sync, the number of valid combinations is greatly reduced by the link protection

protocol. Figure B-4 illustrates the permissible TOD/w sequences for a receiving station using a 60-second PI and a 2-second PI respectively, after word sync is achieved. Note that unlike the transmitter, the receiving station state machine may be non-deterministic. For example, when in  $T_{sc}$  and in state  $N/1$ , a received word may yield valid preambles and ASCII when decrypted using all of the valid combinations:  $N/0$ ,  $(N + 1)/0$ , and  $N/2$  (the latter implying that  $T_{lc}$  started two words previously), and will therefore, be in three states at once until the ambiguity is resolved by evaluating the decrypted words for compliance with the LP and ALE protocols under the valid successor states to these three states. Stations using a PI of 2 seconds or less shall not accept more than one transmission encrypted using a given TOD, and need not check combinations using that TOD. For example, if a call is decrypted using  $TOD = N$ , no TOD before  $N+1$  is valid for the acknowledgment.

#### B.5.3.3 Message sections.

All ALE words shall be protected including message text.

#### B.5.3.4 Data block message (DBM) mode.

- a. A DBM data block contains an integral number of 12-bit words, the last of which comprises the least significant 12 bits of a cyclic redundancy check (CRC). These 12-bit words shall be encrypted in pairs, with the first 12-bit word presented to the LPCM by the ALE protocol module as the more significant of the two. When a data block contains an odd number of 12-bit words (i.e., basic DBM data block and extended DBM data blocks with odd  $N$ ), the final 12-bit word shall not be encrypted, but shall be passed directly to the FEC sublayer.
- b. The word number field “w” of the seed shall be incremented only after three pairs of 12-bit words have been encrypted (rather than after every 24-bit word as in normal operation), except that the word number “w” shall be incremented exactly once after the last pair of 12-bit words in a DBM data block is encrypted, whether or not it was the third pair to use that word number. As usual, TOD shall be incremented whenever “w” rolls over to 0.

#### B.5.4 Procedure for 3G ALE - not tested (NT).

Linking protection for 3G ALE shall employ the same algorithms, seed format, and procedures as for 2G, except as specified in the following paragraphs. For definitions of terms used here that are specific to 3G ALE, see Appendix C.

##### B.5.4.1 Encryption of 3G protocol data units (PDU).

The first 2 bits of each 26-bit third-generation ALE PDU shall be sent without encrypting. The remaining 24 bits shall be encrypted in the same manner as 24-bit 2G ALE words. AL-1 and AL-2 shall use the SoDark-3 Algorithm (see B.5.7.1 and B.5.7.2) for encrypting 3G ALE PDUs. 3G traffic manager, synchronization manager, and link maintenance PDUs shall be encrypted using the SoDark-6 algorithm (see B.5.7.3 and B.5.7.4).

##### B.5.4.2 Procedure for synchronous-mode 3G ALE.

When a network is operating in synchronous mode, stations are inherently synchronized to within 50 ms. The protection interval for synchronous mode 3G ALE is therefore the length of one slot

(800 ms). The PI field in the seed shall be used as a 17-bit integer rather than as an 11-bit coarse time and a 6-bit fine time field. This 17-bit PI field shall contain the number of 800 ms slots that have elapsed since midnight (network time). The word number field in the seed shall always be 00000000. The date fields shall reflect the current network date. The frequency field shall indicate the frequency on which the protected PDU is sent. Synchronous-mode 3G ALE nodes shall ignore any synchronous-mode Probe PDU (i.e., a Probe PDU that is not preceded by Scanning Call PDUs) which is not encrypted using the current PI number.

#### B.5.4.3 Procedure for asynchronous-mode 3G ALE.

Asynchronous 3G handshakes shall be protected using the procedure in B.5.3 that has been modified as follows.

##### B.5.4.3.1 Protected 3G asynchronous-mode scanning call.

The probe PDU that concludes a 3G asynchronous-mode call shall be encrypted using word number = 2. Scanning call PDUs shall be encrypted using alternating word numbers 0 and 1. The word number used in encrypting the first scanning call PDU shall be selected so that the scanning call PDU sent immediately before the probe PDU is encrypted using word number = 1.

##### B.5.4.3.2 Protected 3G asynchronous-mode response.

The handshake PDU that follows an asynchronous-mode call shall be encrypted using the current TOD with word number = 3.

##### B.5.4.4 Protected 3G PI progression.

3G ALE nodes shall not accept PDU sequences in which the TOD used to encrypt a PDU is earlier than the TOD used to encrypt a preceding PDU of that sequence.

#### B.5.5 Time protocols.

The following shall be employed to synchronize LP time bases. The time service protocols for active time acquisition, both protected (B.5.5.2) and non-protected (B.5.5.3), are mandatory for all implementations of LP.

##### B.5.5.1 Time exchange word format.

See Appendix A, A.5.6.4.3.

##### B.5.5.2 Active time acquisition (protected).

A station that knows the correct date and time to within 1 minute may attempt to actively acquire time from any station with which it can communicate in protected mode by employing the protocol in the following paragraphs. The quality of time so acquired is necessarily at least one grade more uncertain than that of the selected time server. A station that does not know the correct date and time to within 1 minute may nevertheless employ this protected protocol by repeatedly guessing the time until it successfully communicates with a time server.

##### B.5.5.2.1 Time Request call (protected).

A station requiring fine time shall request the current value of the network time by transmitting a Time Request call, formatted as follows. (In principle, any station may be asked for the time, but

some stations may not be programmed to respond, and others may have poor time quality. Thus, multiple servers may need to be tried before sufficient time quality is achieved.)

TO <time server> CMD Time Is <time> DATA <coarse time>  
REP <authenticator> TIS <requester>.

The Time Is command shall be immediately followed by a coarse time word and an authentication word. The authenticator shall be generated by the exclusive-or of the command word and the coarse time word, as specified in Appendix A, A.5.6.4.4. The Time Request call transmission shall be protected using the procedure specified in B.5.3.1 and B.5.3.2. When acquiring time synchronization, the coarse seed (fine time field in the seed set to all 1s) current at the requesting station shall be used. When used to reduce the time uncertainty of a station already in time sync, the current fine seed shall be used.

#### B.5.5.2.2 Time Service response (protected).

A station which receives and accepts a Time Request call shall respond with a Time Service response formatted as follows:

TO <requester> CMD Time Is <time> DATA <coarse time>  
REP <authenticator> TWAS <time server>.

The Time Is command shall be immediately followed by a coarse time word and an authentication word. The authenticator shall be generated by the three-way exclusive-or of the command word and the coarse time word from this transmission and the authentication word (including the REP preamble) from the requester, as specified in Appendix A, A.5.6.4.5. The entire Time Service response shall be protected as specified in B.5.3.1 and B.5.3.2 using the time server's current coarse seed if the request used a coarse seed, or the current fine seed otherwise. The seed used in protecting a Time Service response may differ from that used in the request that caused the response. A time server shall respond only to the first Time Request call using each fine or coarse seed; i.e., one coarse request per minute and one fine request per fine PI. Acceptance of time request may be disabled by the operator. Stations prepared to accept coarse Time Request commands shall decrypt the initial words of incoming calls under eight (vs. six) possible seeds:  $w = 0$  and  $w = 1$  with the current coarse TOD, and with the current fine  $TOD \pm 1$  PI. (Note that only one coarse TOD is checked vs. three fine TODs.)

#### B.5.5.2.3 Time Server request (protected).

A time server may request authenticated time from the original requestor by returning a Time Server request, which is identical to the Time Service response as given above except that the TWAS termination is replaced by TIS. The original requester shall then respond with a Time Service response, as above, with an authenticator generated by the three-way exclusive-or of the command word and the coarse time word from its Time Service response and the authentication word (including the REP preamble) from the Time Server request, as specified in Appendix A, A.5.6.4.5.

B.5.5.2.4 Authentication and adjustment (protected).

A station awaiting a Time Service response shall attempt to decrypt received words under the appropriate seeds. If the request used a coarse seed, the waiting station shall try the coarse seeds used to encrypt its request, with  $w = 0$  and  $w = 1$ , and those corresponding to 1 minute later. If the request used a fine seed, the waiting station shall try the usual six seeds:  $w = 0$  and  $w = 1$ , and those corresponding to 1 minute later. If the request used a fine seed, the waiting station shall try the usual six seeds:  $w = 0$  and  $w = 1$  with the current fine  $TOD \pm 1$  PI. Upon successful decryption of a Time Service response, the requesting station shall exclusive-or the received command and coarse time words with the authentication word it sent in its request. If the 21 least significant bits of the result match the corresponding 21 bits of the received authentication word, the internal time shall be adjusted using the time received in the Time Is command and coarse time word, and the time uncertainty shall be set in accordance with Appendix A, A.5.6.4.6.

B.5.5.3 Active time acquisition (non-protected).

A station that does not know the correct date and time to within 1 minute may attempt to actively acquire time from any station with which it can communicate in non-protected mode by employing the protocol in the following paragraphs. Because time is not known in this case with sufficient accuracy to employ LP, the entire exchange takes place in the clear, with the authentication procedure as the only barrier against decryption.

B.5.5.3.1 Time Request call (non-protected).

A station requiring time shall request the current value of the network time by transmitting a non-protected Time Request call, formatted as follows:

TO <time server> CMD Time Request DATA <coarse time>  
REP <random #> TIS <requestor>.

The Time Request command shall be immediately followed by a coarse time word, followed by an authentication word containing a 21-bit number, generated by the requesting station in such a fashion that future numbers are not predictable from recently used numbers from any net member. Encrypting a function of a radio-unique quantity and a sequence number that is incremented with each use (and is retained while the radio is powered off) may meet this requirement.

B.5.5.3.2 Time Service response (non-protected).

A station that receives and accepts a non-protected Time Request call shall respond with a non-protected Time Service response formatted as follows:

TO <requestor> CMD Time Is <time> DATA <coarse time>  
REP <authenticator> TWAS <time server>.

The Time Is command shall be immediately followed by a coarse time word and an authentication word. The 21-bit authenticator shall be generated by encrypting the 24-bit result of the three-way exclusive-or of the command word and the coarse time word from this

transmission and the entire random number word (including the REP preamble) from the requester, as specified in Appendix A, A.5.6.4.5. The encryption shall employ the AL-1 and AL-2 algorithm and a seed containing the time sent and  $w = \text{all } 1\text{s}$ . The least-significant 21 bits of this encryption shall be used as the authenticator. A time server shall respond only to the first error-free non-protected Time Request call received each minute (according to its internal time). Acceptance of non-protected time requests may be disabled by the operator.

#### B.5.5.3.3 Authentication and adjustment (non-protected mode).

Upon receipt of a non-protected Time Service response, the requesting station shall exclusive-or the received coarse time word with the received Time Is command word. Then exclusive-or the result with the entire random number word it sent in its Time Request call, and encrypt this result using  $w = \text{all } 1\text{s}$  and the coarse time contained in the Time Service response. If the 21 least significant bits of the result match the corresponding 21 bits of the received authentication word, the internal time shall be adjusted using the received coarse and fine time, and the time uncertainty shall be set in accordance with Appendix A, A.5.6.4.6.

#### B.5.5.4 Passive time acquisition (optional).

As an alternative to the active time acquisition protocols specified above, stations may attempt to determine the correct network time passively by monitoring protected transmissions. Regardless of the technique used to otherwise accept or reject time so acquired, passive time acquisition shall include the following constraints:

- a. Local time may only be adjusted to times within the local window of uncertainty. Received transmissions using times outside of the local uncertainty window shall be ignored.
- b. Local time quality shall be adjusted only after receipt of transmissions from at least two stations, both of which include time quality values, and whose times are consistent with each other within the windows implied by those time qualities.

A passive time acquisition mechanism may also be used to maintain network synchronization once achieved. Passive time acquisition is optional, and if provided, the operator shall be able to disable it.

#### B.5.5.5 Time broadcast.

To maintain network synchronization, stations shall be capable of broadcasting unsolicited Time Is commands to the network, periodically or upon request by the operator:

```
TO <net> CMD Time Is <time> DATA <coarse time>  
REP <authenticator> TWAS <time server>.
```

The Time Is command shall be immediately followed by a coarse time word and an authentication word. The authenticator shall be generated by the exclusive-or of the command word and the coarse time word from this transmission as specified in Appendix A, A.5.6.4.4. If the broadcast is made without LP (i.e., in the clear), the authenticator must be encrypted as described in Appendix A, A.5.6.4.5 to provide any authentication. The use of an authenticator that does not depend on a challenge from a requesting station provides no protection against



playback of such broadcasts. A station receiving such broadcasts must verify that the time and the time uncertainty that the broadcasts contain are consistent with the local time and uncertainty before such received time is at all useful.

#### B.5.5.6 Advanced time distribution protocols.

Advanced time exchange protocols for application levels 3 and 4 will be addressed as required with future upgrades of MIL-STD-188-141.

#### B.5.6 The Lattice Algorithm.

The Lattice Algorithm is designed specifically for the encryption of 24-bit ALE words. It uses a 56-bit key (7 bytes), and the 8-byte seed described in B.5.2.3, Seed format.

NOTE: The author makes no claim of proprietary rights in this algorithm. All are free to implement it without royalty.

##### B.5.6.1 Encryption using the Lattice Algorithm.

A schematic representation of the algorithm is shown in figure B-5. The algorithm operates on each of the 3 bytes of the 24-bit word individually. At each step, here termed one "round" of processing, each byte is exclusive-ored with one or both of the other data bytes, a byte of key, and a byte of seed, and the result is then translated using the 256x8 bit substitution table ("S-box") listed in table B-I. Eight rounds shall be performed. Mathematically, the encryption algorithm works as follows:

1. Let  $f(\bullet)$  be an invertible function mapping  $\{0..255\} \rightarrow \{0..255\}$ .
2. Let  $V$  be a vector of key variable bytes and  $S$  be a vector of TOD/frequency "seed" bytes. Starting with the first byte in each of  $V$  and  $S$ , perform eight "rounds" of the sequence in 4 below, using the next byte from  $V$  and  $S$  (modulo their lengths) each time a reference to  $V[ ]$  and  $S[ ]$  is made.
3. Let  $A$  be the most significant of the three-byte input to each round of encryption,  $B$  be the middle byte, and  $C$  be the least significant byte, and  $A'$ ,  $B'$ , and  $C'$  be the corresponding output bytes of each round.
4. Then for each round,  
$$A' = f(A + B + V[ ] + S[ ])$$
$$C' = f(C + B + V[ ] + S[ ])$$
$$B' = f(A' + B + C' + V[ ] + S[ ])$$

The 24-bit output of the encryption algorithm consists of, in order of decreasing significance, the bytes  $A'$ ,  $B'$ , and  $C'$  resulting from the eighth round of encryption.

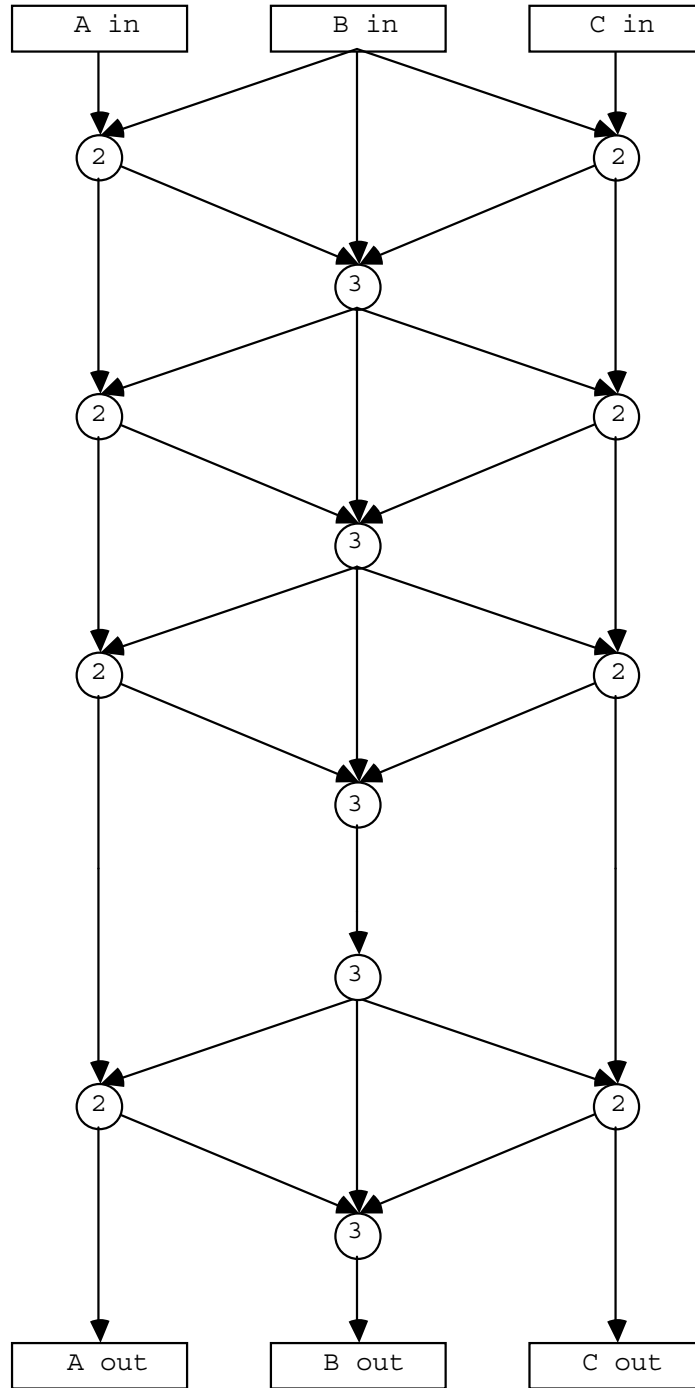
##### B.5.6.2 Decryption using the Lattice Algorithm.

The decryption algorithm simply inverts the encryption algorithm. Note that the starting point in the  $V$  and  $S$  vectors must be pre-computed, and that the  $V$  and  $S$  bytes are used in reverse order.

1. Let  $g(\bullet)$  be the inverse of the  $f(\bullet)$  used for encryption (see table B-II).

2. Starting with the last elements of the V and S vectors used in encryption, perform eight rounds of the following decryption steps, working backward through the V and S vectors.
3. Let A' be the most significant of the 3-byte input to each round of decryption, B' be the middle byte, and C' be the least significant byte, and A, B, and C be the corresponding output bytes of each round.
4.  $B = g(B') + A' + C' + V[ ] + S[ ]$   
 $C = g(C') + B + V[ ] + S[ ]$   
 $A = g(A') + B + V[ ] + S[ ]$

The 24-bit output of the decryption algorithm consists of, in order of decreasing significance, the bytes A, B, and C resulting from the eighth round of decryption.



**FIGURE B-5. Lattice Algorithm schematic diagram (encryption).**

**B.5.6.3 Encryption and decryption tables.**

The 256 -> 256 mapping tables B-I and B-II for use in linking protection are given below. To use these tables, use the most significant 4 bits of the input byte to select a row in the table, and the least significant 4 bits to select a column. The output byte is contained at the selected location.

**TABLE B-I. Encryption table**

9c	f2	14	c1	8e	cb	b2	65	97	7a	60	17	92	F9	78	41
07	4c	67	6d	66	4a	30	7d	53	9d	b5	bc	c3	ca	f1	04
03	ec	d0	38	B0	ed	ad	c4	dd	56	42	bd	a0	de	1b	81
55	44	5a	e4	50	DC	43	63	09	5c	74	cf	0e	ab	1d	3d
6b	02	5d	28	e7	c6	ee	b4	d9	7c	19	3e	5e	6c	d6	6e
2a	13	a5	08	b9	2d	BB	a2	d4	96	39	e0	ba	d7	82	33
0d	5f	26	16	fe	22	af	00	11	c8	9e	88	8b	a1	7b	87
27	E6	c7	94	d1	5b	9b	f0	9f	db	e1	8d	d2	1f	6a	90
f4	18	91	59	01	b1	FC	34	3c	37	47	29	e2	64	69	24
0a	2f	73	71	a9	84	8c	a8	a3	3b	E3	E9	58	80	a7	D3
b7	c2	1c	95	1e	4d	4f	4E	fb	76	fd	99	c5	C9	e8	2e
8a	df	f5	49	f3	6f	8f	e5	EB	F6	25	d5	31	c0	57	72
aa	46	68	0b	93	89	83	70	ef	a4	85	f8	0f	b3	AC	10
62	cc	61	40	f7	fa	52	7f	ff	32	45	20	79	ce	ea	be
cd	15	21	23	D8	b6	0c	3f	54	1A	bf	98	48	3a	75	77
2b	ae	36	da	7e	86	35	51	05	12	b8	a6	9a	2C	06	4b

MIL-STD-188-141B  
APPENDIX B

**TABLE B-II. Decryption table.**

67	84	41	20	1f	f8	fe	10	53	38	90	c3	e6	60	3c	cc
cf	68	f9	51	02	e1	63	0b	81	4a	E9	2e	a2	3e	a4	7d
db	e2	65	E3	8f	ba	62	70	43	8b	50	f0	Fd	55	af	91
16	bc	D9	5f	87	F6	F2	89	23	5a	ed	99	88	3f	4b	e7
d3	0f	2a	36	31	da	c1	8a	ec	b3	15	ff	11	a5	A7	a6
34	f7	d6	18	e8	30	29	BE	9c	83	32	75	39	42	4c	61
0a	d2	d0	37	8d	07	14	12	c2	8e	7e	40	4d	13	4f	b5
c7	93	bf	92	3a	EE	a9	ef	0e	dc	09	6e	49	17	f4	d7
9d	2f	5e	c6	95	ca	F5	6f	6b	c5	b0	6c	96	7b	04	b6
7F	82	0c	c4	73	a3	59	08	EB	ab	fc	76	00	19	6a	78
2c	6d	57	98	c9	52	fb	9e	97	94	c0	3d	CE	26	f1	66
24	85	06	cd	47	1a	e5	a0	fa	54	5c	56	1b	2b	df	ea
bd	03	a1	1c	27	ac	45	72	69	AD	1d	05	d1	e0	dd	3b
22	74	7c	9F	58	bb	4e	5d	E4	48	f3	79	35	28	2d	b1
5b	7a	8c	9A	33	b7	71	44	ae	9B	de	B8	21	25	46	c8
77	1e	01	b4	80	b2	B9	d4	cb	0D	d5	a8	86	aa	64	d8

B.5.6.4 Lattice Algorithm examples.

Key variable = c2284a1ce7be2f

seed = 543bd88000017550 (w=0)  
Encrypt 54e0cd ( <TO> SAM )

Step	A	B	C
0	54	E0	CD
1	D0	72	1D
2	1D	48	3C
3	41	DB	0C
4	98	7C	6D
5	39	10	3D
6	13	AA	E4
7	FC	82	27
8	C0	D7	05

Result: C0D705

seed = 543bd88040017550 (w=1)  
Encrypt 54E0CD ( <TO> SAM )

Step	A	B	C
0	54	E0	CD
1	D0	72	1D
2	1D	3D	EF
3	E1	F8	6B
4	11	A0	A2
5	6E	32	A0
6	B0	B4	E2
7	CF	CB	11
8	70	84	34

Result: 708434

seed = 543bd88080017550 (w=2)  
Encrypt b2a7c5 ( <TIS> JOE )

Step	A	B	C
0	B2	A7	C5
1	59	47	E6
2	91	BF	83
3	D1	B8	E8
4	53	ED	A9
5	F4	55	9E
6	32	25	FA
7	DD	5D	15
8	28	ED	4A

Result: 28ED4A

MIL-STD-188-141B  
APPENDIX B

Decrypt C0D705

Step	A	B	C
0	C0	D7	05
1	FC	82	27
2	13	AA	E4
3	39	10	3D
4	98	7C	6D
5	41	DB	0C
6	1D	48	3C
7	D0	72	1D
8	54	E0	CD

Result: 54E0CD

Decrypt 708434

Step	A	B	C
0	70	84	34
1	CF	CB	11
2	B0	B4	E2
3	6E	32	A0
4	11	A0	A2
5	E1	F8	6B
6	1D	3D	EF
7	D0	72	1D
8	54	E0	CD

Result: 54E0CD

Decrypt 28ED4A

Step	A	B	C
0	28	ED	4A
1	DD	5D	15
2	32	25	FA
3	F4	55	9E
4	53	ED	A9
5	D1	B8	E8
6	91	BF	83
7	59	47	E6
8	B2	A7	C5

Result: B2A7C5

### B.5.7 The SoDark Algorithm (NT).

The SoDark Algorithm is designed specifically for the encryption of 3G control PDUs. It uses a 56-bit key (7 bytes), and the 8-byte seed described in B.5.2.3 Seed format. The SoDark-3 variant is designed for 24-bit words, while the SoDark-6 variant is designed for 48-bit words.

NOTE: The author makes no claim of proprietary rights in this algorithm. All are free to implement it without royalty.

#### B.5.7.1 Encryption using the SoDark-3 Algorithm.

The SoDark-3 Algorithm is designed specifically for the encryption of 3G ALE PDUs. It shall be applied to the 24 least-significant bits of each such PDU. A schematic representation of the SoDark-3 algorithm is shown in figure B-6. The algorithm operates on each of the 3 bytes of the 24-bit word individually. At each step, here termed one "round" of processing, each byte is exclusive-ored with one or both of the other data bytes, a byte of key, and a byte of seed, and the result is then translated using the 256x8 bit substitution table ("S-box") listed in table B-I. Sixteen rounds shall be performed.

Mathematically, the encryption algorithm works as follows:

1. Let  $f(\bullet)$  be an invertible function mapping  $\{0..255\} \rightarrow \{0..255\}$ .
2. Let  $V$  be a vector of key variable bytes and  $S$  be a vector of TOD/frequency "seed" bytes. Starting with the first byte in each of  $V$  and  $S$ , perform sixteen "rounds" of the sequence in 4 below, using the next byte from  $V$  and  $S$  (modulo their lengths) each time a reference to  $V[ ]$  and  $S[ ]$  is made.
3. Let  $A$  be the most significant of the 3-byte input to each round of encryption,  $B$  be the middle byte, and  $C$  be the least significant byte, and  $A'$ ,  $B'$ , and  $C'$  be the corresponding output bytes of each round.
4. Then for each round,  
$$A' = f(A + B + V[ ] + S[ ])$$
$$C' = f(C + B + V[ ] + S[ ])$$
$$B' = f(A' + B + C' + V[ ] + S[ ])$$

The 24-bit output of the encryption algorithm consists of, in order of decreasing significance, the bytes  $A'$ ,  $B'$ , and  $C'$  resulting from the sixteenth round of encryption.

#### B.5.7.2 Decryption using the SoDark-3 Algorithm.

The decryption algorithm simply inverts the encryption algorithm. Note that the starting point in the  $V$  and  $S$  vectors must be pre-computed, and that the  $V$  and  $S$  bytes are used in reverse order.

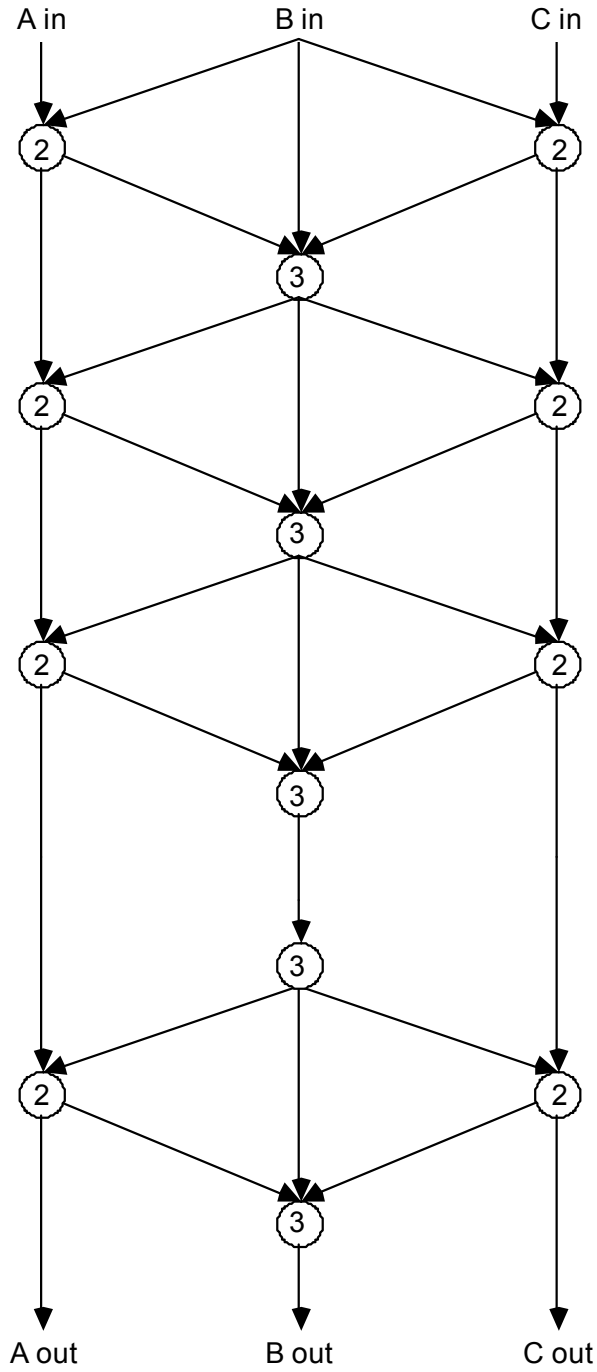


1. Let  $g(\bullet)$  be the inverse of the  $f(\bullet)$  used for encryption (see table B-II).
2. Starting with the last elements of the V and S vectors used in encryption, perform sixteen rounds of the following decryption steps, working backward through the V and S vectors.
3. Let A' be the most significant of the 3-byte input to each round of decryption, B' be the middle byte, and C' be the least significant byte, and A, B, and C be the corresponding output bytes of each round.
4.  $B = g(B') + A' + C' + V[ ] + S[ ]$   
 $C = g(C') + B + V[ ] + S[ ]$   
 $A = g(A') + B + V[ ] + S[ ]$

The 24-bit output of the decryption algorithm consists of, in order of decreasing significance, the bytes A, B, and C resulting from the sixteenth round of decryption.

#### B.5.7.3 Encryption using the SoDark-6 Algorithm.

The SoDark-6 Algorithm is designed specifically for the encryption of 3G PDUs that use Burst Waveform 1 (BW1), including traffic setup, synchronization management, and link maintenance PDUs. It shall be applied to the 48 bits of each such PDU. A schematic representation of the SoDark-6 algorithm is shown in figure B-7. The algorithm operates on each of the 6 bytes of the 48-bit PDU individually. At each step, here termed one "round" of processing, each byte is exclusive-ored with two of the other data bytes, a byte of key, and a byte of seed, and the result is then translated using the 256x8 bit substitution table ("S-box") listed in table B-I. Sixteen rounds shall be performed.



**FIGURE B-6. SoDark-3 Algorithm schematic diagram (encryption).**

Mathematically, the encryption algorithm works as follows:

1. Let  $f(\bullet)$  be an invertible function mapping  $\{0..255\} \rightarrow \{0..255\}$ .
2. Let  $V$  be a vector of key variable bytes and  $S$  be a vector of TOD/frequency "seed" bytes. Starting with the first byte in each of  $V$  and  $S$ , perform sixteen "rounds" of the sequence in 4 below, using the next byte from  $V$  and  $S$  (modulo their lengths) each time a reference to  $V[ ]$  and  $S[ ]$  is made.
3. Let  $A$  be the most significant of the 6-byte input to each round of encryption,  $B$ ,  $C$ ,  $D$ , and  $E$  be the middle bytes in descending order of significance, and  $F$  be the least significant byte, and  $A'$ ,  $B'$ ,  $C'$ ,  $D'$ ,  $E'$  and  $F'$  be the corresponding output bytes of each round.
4. Then for each round,
 
$$A' = f(A + B + F + V[ ] + S[ ])$$

$$C' = f(B + C + D + V[ ] + S[ ])$$

$$E' = f(E + D + F + V[ ] + S[ ])$$

$$B' = f(A' + B + C' + V[ ] + S[ ])$$

$$D' = f(C' + D + E' + V[ ] + S[ ])$$

$$F' = f(E' + F + A' + V[ ] + S[ ])$$

The 48-bit output of the encryption algorithm consists of, in order of decreasing significance, the bytes  $A'$ ,  $B'$ ,  $C'$ ,  $D'$ ,  $E'$  and  $F'$  resulting from the sixteenth round of encryption.

#### B.5.7.4 Decryption using the SoDark-6 Algorithm.

The decryption algorithm simply inverts the encryption algorithm. Note that the starting point in the  $V$  and  $S$  vectors must be pre-computed, and that the  $V$  and  $S$  bytes are used in reverse order.

1. Let  $g(\bullet)$  be the inverse of the  $f(\bullet)$  used for encryption (see table B-II).
2. Starting with the last elements of the  $V$  and  $S$  vectors used in encryption, perform sixteen rounds of the following decryption steps, working backward through the  $V$  and  $S$  vectors.
3. Let  $A'$  be the most significant of the 6-byte input to each round of decryption,  $B'$ ,  $C'$ ,  $D'$ , and  $E'$  be the middle bytes in descending order of significance, and  $F'$  be the least significant byte, and  $A$ ,  $B$ ,  $C$ ,  $D$ ,  $E$  and  $F$  be the corresponding output bytes of each round.
4.
 
$$B = g(B') + A' + C' + V[ ] + S[ ]$$

$$D = g(D') + C' + E' + V[ ] + S[ ]$$

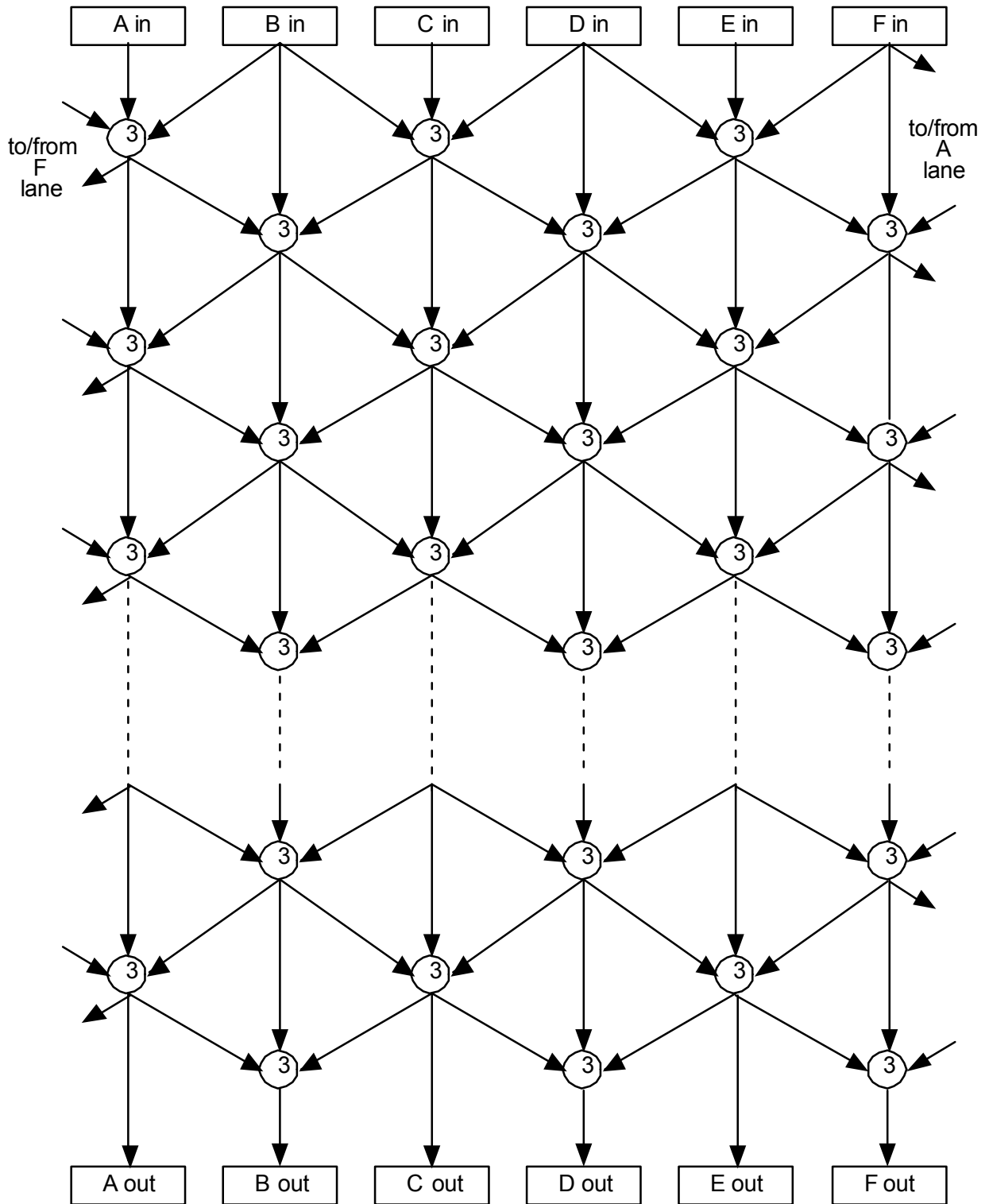
$$F = g(F') + E' + A' + V[ ] + S[ ]$$

$$E = g(E') + D + F + V[ ] + S[ ]$$

$$C = g(C') + B + D + V[ ] + S[ ]$$

$$A = g(A') + F + B + V[ ] + S[ ]$$

The 48-bit output of the decryption algorithm consists of, in order of decreasing significance, the bytes  $A$ ,  $B$ ,  $C$ ,  $D$ ,  $E$ , and  $F$  resulting from the sixteenth round of decryption.



**FIGURE B-7. SoDark-6 Algorithm schematic diagram (encryption).**

APPENDIX C  
THIRD-GENERATION HF LINK AUTOMATION

**TABLE OF CONTENTS**

<b><u>PARAGRAPH</u></b>	<b><u>PAGE</u></b>
C.1 GENERAL.....	271
C.1.1 <u>Scope</u> .....	271
C.1.2 <u>Applicability</u> .....	271
C.2 APPLICABLE DOCUMENTS.....	271
C.2.1 <u>General</u> .....	271
C.2.2 <u>Government documents</u> .....	272
C.2.2.1 <u>Specifications, standards, and handbooks</u> .....	272
C.2.2.2 <u>Other Government documents, drawings, and publications</u> .....	272
C.2.3 <u>Non-Government publications</u> .....	272
C.2.4 <u>Order of precedence</u> .....	273
C.3 DEFINITIONS.....	273
C.3.1 <u>Standard definitions and acronyms</u> .....	273
C.3.2 <u>Abbreviations and acronyms</u> .....	273
C.3.3 <u>Operating parameters</u> .....	274
C.4 GENERAL REQUIREMENTS.....	275
C.4.1 <u>Overview</u> .....	275
C.4.2 <u>Frequency management</u> .....	276
C.4.2.1 <u>Calling and traffic channels</u> .....	276
C.4.2.2 <u>External frequency management</u> .....	276
C.4.3 <u>Network synchronization</u> .....	276
C.4.3.1 <u>External synchronization</u> .....	276
C.4.3.2 <u>Over-the-air synchronization</u> .....	277
C.4.4 <u>Scanning</u> .....	277
C.4.4.1 <u>Synchronous mode</u> .....	277
C.4.4.2 <u>Asynchronous mode</u> .....	277
C.4.5 <u>3G addresses</u> .....	277
C.4.5.1 <u>Synchronous mode address structure</u> .....	277
C.4.5.2 <u>Net entry addresses</u> .....	278
C.4.5.3 <u>Multicast addresses</u> .....	278
C.4.5.4 <u>Node address assignments</u> .....	278
C.4.5.5 <u>Multicast address assignments</u> .....	278
C.4.6 <u>ALE</u> .....	278
C.4.6.1 <u>System performance requirements</u> .....	279
C.4.6.2 <u>Calling channel selection</u> .....	280
C.4.6.3 <u>Interoperability with 2G systems</u> .....	281
C.4.6.4 <u>MIL-STD-188-148A functionality</u> .....	281
C.4.7 <u>Data link protocol</u> .....	281
C.4.8 <u>Automatic link maintenance</u> .....	281

**TABLE OF CONTENTS**  
**(continued)**

<b><u>PARAGRAPH</u></b>	<b><u>PAGE</u></b>
C.4.9 <u>Network management interface</u> .....	281
C.4.10 <u>Order of transmission</u> .....	281
C.4.11 <u>3G ALE data structures</u> .....	281
C.4.11.1 <u>Station self address</u> .....	282
C.4.11.2 <u>Station table</u> .....	282
C.4.11.3 <u>Channel table</u> .....	282
C.4.12 <u>Cyclic Redundancy Check (CRC) computation procedure</u> .....	282
C.5 <u>DETAILED REQUIREMENTS</u> .....	284
C.5.1 <u>Constituent waveforms</u> .....	284
C.5.1.1 <u>Service primitives</u> .....	285
C.5.1.2 <u>Burst waveform interleaving</u> .....	288
C.5.1.3 <u>Burst Waveform 0 (BW0)</u> .....	290
C.5.1.4 <u>Burst Waveform 1 (BW1)</u> .....	296
C.5.1.5 <u>Burst Waveform 2 (BW2)</u> .....	301
C.5.1.6 <u>Burst Waveform 3 (BW3)</u> .....	309
C.5.1.7 <u>Burst Waveform 4 (BW4)</u> .....	314
C.5.1.8 <u>Burst waveform modulation</u> .....	317
C.5.2 <u>3G-ALE protocol definition</u> .....	318
C.5.2.1 <u>3G-ALE service primitives</u> .....	319
C.5.2.2 <u>3G-ALE PDUs</u> .....	320
C.5.2.3 <u>Synchronous dwell structure</u> .....	324
C.5.2.4 <u>3G-ALE protocol behavior</u> .....	325
C.5.2.5 <u>Notification protocol behavior</u> .....	347
C.5.2.6 <u>Calling into a 3G network</u> .....	348
C.5.2.7 <u>Synchronization management protocol (not tested)</u> .....	349
C.5.3 <u>TM protocol</u> .....	355
C.5.3.1 <u>Overview</u> .....	355
C.5.3.2 <u>Data object types</u> .....	356
C.5.3.3 <u>Service primitives</u> .....	357
C.5.3.4 <u>PDUs</u> .....	361
C.5.3.5 <u>Protocol behavior</u> .....	364
C.5.4 <u>HDL protocol</u> .....	402
C.5.4.1 <u>Overview</u> .....	402
C.5.4.2 <u>Data object types</u> .....	402
C.5.4.3 <u>Service primitives</u> .....	403
C.5.4.4 <u>PDUs</u> .....	403
C.5.4.5 <u>Protocol behavior</u> .....	407
C.5.5 <u>LDL protocol</u> .....	414
C.5.5.1 <u>Overview</u> .....	414

**TABLE OF CONTENTS**  
**(continued)**

<u>PARAGRAPH</u>	<u>PAGE</u>
C.5.5.2 <u>Data object types</u> .....	415
C.5.5.3 <u>Service primitives</u> .....	415
C.5.5.4 <u>PDU</u> s .....	417
C.5.5.5 <u>Protocol behavior</u> .....	419
C.5.6 <u>CLC</u> .....	426
C.5.6.1 <u>Overview</u> .....	426
C.5.6.2 <u>Service primitives</u> .....	427
C.5.6.3 <u>PDU</u> s .....	429
C.5.6.4 <u>Protocol behavior</u> .....	429
C.5.7 <u>Examples</u> .....	435

**TABLES**

TABLE C-I. <u>Linking probability requirements (3 kiloHertz (kHz) signal to noise ratio (SNR) decibels (dB))</u> .....	279
TABLE C-II. <u>Synchronous-mode occupancy detection requirements (3 kHz SNR dB)</u> .....	280
TABLE C-III. <u>Burst waveform characteristics</u> .....	284
TABLE C-IV. <u>Burst Waveform (BWn) service primitives</u> .....	286
TABLE C-V. <u>TLC/AGC guard sequence symbol values</u> .....	291
TABLE C-VI. <u>BW0 acquisition preamble symbol values</u> .....	292
TABLE C-VII. <u>BW0 interleaver parameters</u> .....	294
TABLE C-VIII. <u>Walsh modulation of coded bits to tritbit sequences</u> .....	294
TABLE C-IX. <u>BW0 PN spreading sequence</u> .....	295
TABLE C-X. <u>TLC/AGC guard sequence symbol values</u> .....	297
TABLE C-XI. <u>BW1 acquisition preamble symbol values</u> .....	298
TABLE C-XII. <u>Interleaver parameters for BW1</u> .....	300
TABLE C-XIII. <u>BW1 PN spreading sequence</u> .....	301
TABLE C-XIV. <u>Gray coding table</u> .....	307
TABLE C-XV. <u>BW3 preamble symbol values</u> .....	311
TABLE C-XVI. <u>Interleaver parameters for BW3</u> .....	313
TABLE C-XVII. <u>BW3 PN spreading sequence</u> .....	313
TABLE C-XVIII. <u>Walsh modulation of BW4 payload bits to tritbit sequences</u> .....	315
TABLE C-XIX. <u>BW4 PN spreading sequence</u> .....	316
TABLE C-XX. <u>8-ary PSK signal space</u> .....	318
TABLE C-XXI. <u>3G-ALE service primitives</u> .....	319
TABLE C-XXII. <u>Call type field encodings</u> .....	322
TABLE C-XXIII. <u>Command field encodings</u> .....	323
TABLE C-XXIV. <u>Reason field encodings</u> .....	323
TABLE C-XXV. <u>Caller status field encodings</u> .....	324



**TABLE OF CONTENTS**  
**(continued)**

<b><u>TABLE</u></b>	<b><u>PAGE</u></b>
TABLE C-XXVI. <u>3G-ALE protocol data</u> .....	326
TABLE C-XXVII. <u>3G-ALE protocol events</u> .....	327
TABLE C-XXVIII. <u>3G-ALE protocol actions</u> .....	328
TABLE C-XXIXa. <u>Probability of slot selection for LE call PDUs</u> .....	329
TABLE C-XXIXb. <u>Probability of slot selection for LE broadcast and LE notification PDUs</u> .....	329
TABLE C-XXX. <u>3G-ALE synchronous mode protocol behavior</u> .....	333
TABLE C-XXXI. <u>3G-ALE asynchronous mode protocol behavior</u> .....	343
TABLE C-XXXII. <u>3G-ALE synchronization management time quality codes</u> .....	350
TABLE C-XXXIII. <u>3G-ALE synchronization management sync offset codes</u> .....	352
TABLE C-XXXIV. <u>TM data object types</u> .....	356
TABLE C-XXXV. <u>TM service primitives</u> .....	357
TABLE C-XXXVI. <u>TM PDU format</u> .....	362
TABLE C-XXXVII. <u>Argument field values</u> .....	363
TABLE C-XXXVIII. <u>TM events</u> .....	365
TABLE C-XXXIX. <u>TM actions</u> .....	368
TABLE C-XL. <u>TM data items</u> .....	372
TABLE C-XLI. <u>TM state transition table</u> .....	379
TABLE C-XLII. <u>Protocol time-intervals</u> .....	386
TABLE C-XLIII. <u>HDL data object types</u> .....	402
TABLE C-XLIV. <u>HDL service primitives</u> .....	404
TABLE C-XLV. <u>Data packet format</u> .....	405
TABLE C-XLVI. <u>Sequence number field definition</u> .....	405
TABLE C-XLVII. <u>HDL_ACK PDU format</u> .....	406
TABLE C-XLVIII. <u>HDL_EOM PDU</u> .....	406
TABLE C-XLIX. <u>HDL events</u> .....	409
TABLE C-L. <u>HDL actions</u> .....	410
TABLE C-LI. <u>HDL data items</u> .....	412
TABLE C-LII. <u>HDL state transition table</u> .....	414
TABLE C-LIII. <u>LDL data object types</u> .....	415
TABLE C-LIV. <u>LDL service primitives</u> .....	416
TABLE C-LV. <u>Data packet format</u> .....	417
TABLE C-LVI. <u>Sequence number field definition</u> .....	418
TABLE C-LVII. <u>LDL_ACK PDU format</u> .....	418
TABLE C-LVIII. <u>LDL_EOM PDU format</u> .....	419
TABLE C-LIX. <u>LDL events</u> .....	421
TABLE C-LX. <u>LDL actions</u> .....	422
TABLE C-LXI. <u>LDL data items</u> .....	424
TABLE C-LXII. <u>LDL state transition table</u> .....	426

**TABLE OF CONTENTS**  
**(continued)**

<b><u>TABLE</u></b>	<b><u>PAGE</u></b>
TABLE C-LXIII. <u>CLC service primitives</u> .....	427
TABLE C-LXIV. <u>CLC events</u> .....	430
TABLE C-LXV. <u>CLC actions</u> .....	431
TABLE C-LXVI. <u>CLC data items</u> .....	432
TABLE C-LXVII. <u>Backoff interval duration probabilities</u> .....	432

**FIGURES**

<b><u>FIGURE</u></b>	<b><u>PAGE</u></b>
FIGURE C-1. <u>Scope of 3G technology</u> .....	271
FIGURE C-2. <u>3G HF protocol suite</u> .....	275
FIGURE C-3. <u>Synchronous mode address structure</u> .....	278
FIGURE C-4. <u>CRC computation structure</u> .....	283
FIGURE C-5. <u>BW0 timing</u> .....	290
FIGURE C-7. <u>BW1 timing</u> .....	296
FIGURE C-8. <u>Rate 1/3, constraint length 9 convolutional encoder</u> .....	299
FIGURE C-9. <u>BW2 waveform structure and timing characteristics</u> .....	303
FIGURE C-10. <u>Data packet extension with encoder flush bits</u> .....	304
FIGURE C-11. <u>Rate 1/4, constraint length 8 convolutional encoder</u> .....	306
FIGURE C-12. <u><math>2^{16} - 1</math> maximum-length sequence generator</u> .....	308
FIGURE C-13. <u>BW3 timing</u> .....	309
FIGURE C-14. <u>BW3 rate 1/2, k=7 convolutional encoder</u> .....	312
FIGURE C-15. <u>BW4 timing</u> .....	314
FIGURE C-16. <u>Carrier modulation</u> .....	318
FIGURE C-17. <u>3G-ALE PDUs</u> .....	321
FIGURE C-18. <u>Synchronous dwell structure</u> .....	325
FIGURE C-19. <u>Example 3G-ALE synchronous link establishment</u> .....	338
FIGURE C-20. <u>3G-ALE asynchronous mode link establishment</u> .....	346
FIGURE C-21. <u>TM state diagram: packet</u> .....	374
FIGURE C-22. <u>TM state diagram: point-to-point circuit</u> .....	375
FIGURE C-23. <u>TM state diagram: multicast circuit (master)</u> .....	376
FIGURE C-24. <u>TM state diagram: multicast circuit (slave)</u> .....	377
FIGURE C-25. <u>TM state diagram: broadcast circuit</u> .....	378
FIGURE C-26. <u>Point-to-point packet link timing example for <math>T_{\text{deltaTOD}} = 0, T_{\text{prop}} = T_{\text{prop.max}}</math></u> .....	392
FIGURE C-27. <u>Point-to-point packet link timing example for <math>T_{\text{deltaTOD}} = -T_{\text{sug}}, T_{\text{prop}} = T_{\text{prop.max}}</math></u> .....	393
FIGURE C-28. <u>Point-to-point packet link timing example for <math>T_{\text{deltaTOD}} = T_{\text{sug}}, T_{\text{prop}} = T_{\text{prop.max}}</math></u> .....	394
FIGURE C-29. <u>Point-to-point packet link timing example for <math>T_{\text{deltaTOD}} = -T_{\text{sug}}, T_{\text{prop}} = 0</math></u> .....	395
FIGURE C-30. <u>Point-to-point packet link timing example for <math>T_{\text{deltaTOD}} = T_{\text{sug}}, T_{\text{prop}} = 0</math></u> .....	396
FIGURE C-31. <u>Point-to-point circuit link timing example</u> .....	398

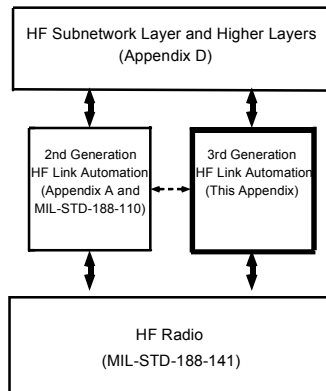
**TABLE OF CONTENTS**  
**(continued)**

<b><u>FIGURE</u></b>		<b><u>PAGE</u></b>
FIGURE C-32.	<u>Multicast circuit link timing example</u> .....	401
FIGURE C-33.	<u>HDL data transfer overview</u> .....	408
FIGURE C-34.	<u>HDL link termination scenario overview</u> .....	408
FIGURE C-35.	<u>HDL state diagram</u> .....	413
FIGURE C-36.	<u>LDL data transfer overview</u> .....	420
FIGURE C-37.	<u>LDL link termination scenario overview</u> .....	420
FIGURE C-38.	<u>LDL state diagram</u> .....	425
FIGURE C-39.	<u>CLC state diagram</u> .....	434
FIGURE C-40.	<u>ALE/TSU scenarios: packet and point-to-point circuit links</u> .....	435
FIGURE C-41.	<u>ALE/TSU scenario: multicast circuit links</u> .....	436
FIGURE C-42.	<u>Packet traffic link termination scenarios</u> .....	437
FIGURE C-43.	<u>Two-way packet link scenarios</u> .....	437
FIGURE C-44.	<u>Link termination scenarios: multicast circuit links</u> .....	438
FIGURE C-45.	<u>Packet linking and traffic exchange: on-air signalling overview</u> .....	439

## C.1 GENERAL.

### C.1.1 Scope.

This appendix contains the requirements for the prescribed protocols and directions for the implementation and use of third generation (3G) high frequency (HF) radio technology including advanced automatic link establishment (ALE), automatic link maintenance, and high-performance data link protocols. The inter-relationship of the technology specified in this appendix to other HF automation standards is shown in figure C-1.



**FIGURE C-1. Scope of 3G technology.**

### C.1.2 Applicability.

3G technology provides advanced technical capabilities for automated HF radio systems. This advanced technology improves on the performance of similar techniques described elsewhere in this standard. Thus, 3G technology may not be required by some users of HF radio systems. However, if the user has a requirement for the features and functions described herein, they shall be implemented in accordance with the technical parameters specified in this appendix.

## C.2 APPLICABLE DOCUMENTS.

### C.2.1 General.

The documents listed in this section are specified in C.4 and C.5 of this appendix. This section does not include documents cited in other sections of this standard or recommended for additional information or as examples. While every effort has been made to ensure the completeness of this list, document users are cautioned that they must meet all specified requirements documents cited in C.4 and C.5 of this appendix, whether or not they are listed here.

C.2.2 Government documents.

C.2.2.1 Specifications, standards, and handbooks.

The following specifications, standards, and handbooks form a part of this document to the extent specified herein. Unless otherwise specified, the issues of these documents are those listed in the issue of the Department of Defense Index of Specifications and Standards (DODISS) and supplement thereto, cited in the solicitation.

STANDARDS

FEDERAL

FED-STD-1037      Telecommunications: Glossary of  
Telecommunication Terms

MILITARY

MIL-STD-188-110      Interoperability and Performance Standards  
for HF Data Modems

Unless otherwise indicated, copies of federal and military specifications, standards, and handbooks are available from the Naval Publications and Forms Center, ATTN: NPODS, 5801 Tabor Avenue, Philadelphia, PA 19120-5099.

C.2.2.2 Other Government documents, drawings, and publications.

The following other Government documents, drawings, and publications form a part of this document to the extent specified herein. Unless otherwise specified, the issues are those cited in the solicitation.

None.

C.2.3 Non-Government publications.

The following documents form a part of this document to the extent specified herein. Unless otherwise specified, the issues of the documents which are DoD adopted are those listed in the issues of the DODISS cited in the solicitation. Unless otherwise specified, the issues of the documents not listed in the DODISS are the issues of the documents cited in the solicitation (see 6.3).

INTERNATIONAL STANDARDIZATION DOCUMENTS

North Atlantic Treaty Organization (NATO) Standardization Agreements  
(STANAGs)

STANAG 4285      Characteristics of 1200/2400/3600 bits per second  
Single Tone modulators/demodulators for HF  
Radio Links

STANAG 4197      Modulation and Coding Characteristics that Must  
be Common to Assure Interoperability of 2400 BPS  
Linear Predictive Encoded Digital Speech  
Transmitted Over HF Radio Facilities

STANAG 4198 Parameters and Coding Characteristics That Must  
be Common to Assure Interoperability of 2400 BPS  
Linear Predictive Encoded Digital Speech

International Telecommunications Union (ITU)  
Radio Regulations Recommendation for Fixed Service, Use of High  
ITU-R F.520-2 Frequency Ionospheric Channel Simulators

C.2.4 Order of precedence.

In the event of a conflict between the text of this document and the references cited herein, the text of this document takes precedence. Nothing in this document, however, supersedes applicable laws and regulations unless a specific exemption has been obtained.

C.3 DEFINITIONS.

C.3.1 Standard definitions and acronyms.

C.3.2 Abbreviations and acronyms.

The abbreviations and acronyms used in this document are defined below. Those listed in the current edition of FED-STD-1037 have been included for the convenience of the reader.

a	2G	second generation
b	2G ALE	second generation automatic link establishment
c	3G	third generation
d	3G ALE	third generation automatic link establishment
e	ACK	acknowledgment
f	ACQ-ALE	alternative quick call -automatic link establishment
g	AGC	automatic gain control
h	ALE	automatic link establishment
i	ALM	automatic link maintenance
j	ARQ	automatic repeat request
k	ASCII	American Standard Code for Information Interchange
l	AWGN	additive white gaussian noise
m	bps	bits per second
n	BW0	Burst Waveform 0
o	BW1	Burst Waveform 1
p	BW2	Burst Waveform 2
q	BW3	Burst Waveform 3
r	BW4	Burst Waveform 4
s	CLC	circuit link controller
t	CM	Connection Manager
u	CMD	ALE preamble word COMMAND
v	CONF	confirm
w	CRC	cyclic redundancy check
x	CSU	Call SetUp

MIL-STD-188-141B  
APPENDIX C

y	dB	decibel
z	DO	design objective
aa	EMCON	Emission Control
bb	EOM	End of Message
cc	FEC	forward error correction
dd	FSK	frequency shift keying
ee	GPS	Global Positioning System
ff	HF	high frequency
gg	HDL	high-rate data link protocol
hh	HNMP	HF Network Management Protocol
ii	Hz	Hertz
jj	LDL	low-rate data link protocol
kk	lsb	least-significant bit
ll	kHz	kiloHertz
mm	MHZ	megahertz
nn	ms	millisecond
oo	msb	most-significant bit
pp	NAK	negative acknowledgment
qq	PDU	protocol data unit
rr	PN	pseudo noise
ss	REQ	request
tt	rx	receive
uu	s	second
vv	SDU	service data unit
ww	SNMP	simple network management protocol
xx	SSB	Single SideBand
yy	TERM	Terminate
zz	TLC	Transmit Level Control
aaa	TM	traffic management
bbb	TOD	time of day
ccc	TRF	Traffic
ddd	TSU	Traffic SetUp
eee	TWAS	ALE preamble word THIS WAS
fff	tx	transmit
ggg	UNL	unlink

### C.3.3 Operating parameters.

The operating parameters used in this appendix are collected here for the convenience of the reader.

<u>Symbol</u>	<u>Parameter Name</u>	<u>Default Value</u>
$T_{\text{sym}}$	PSK symbol time	1/2400 s _ 417 $\mu$ s
$T_{\text{slot}}$	Slot time	800 milliseconds (ms)
C	Number of scanned channels	

MIL-STD-188-141B  
APPENDIX C

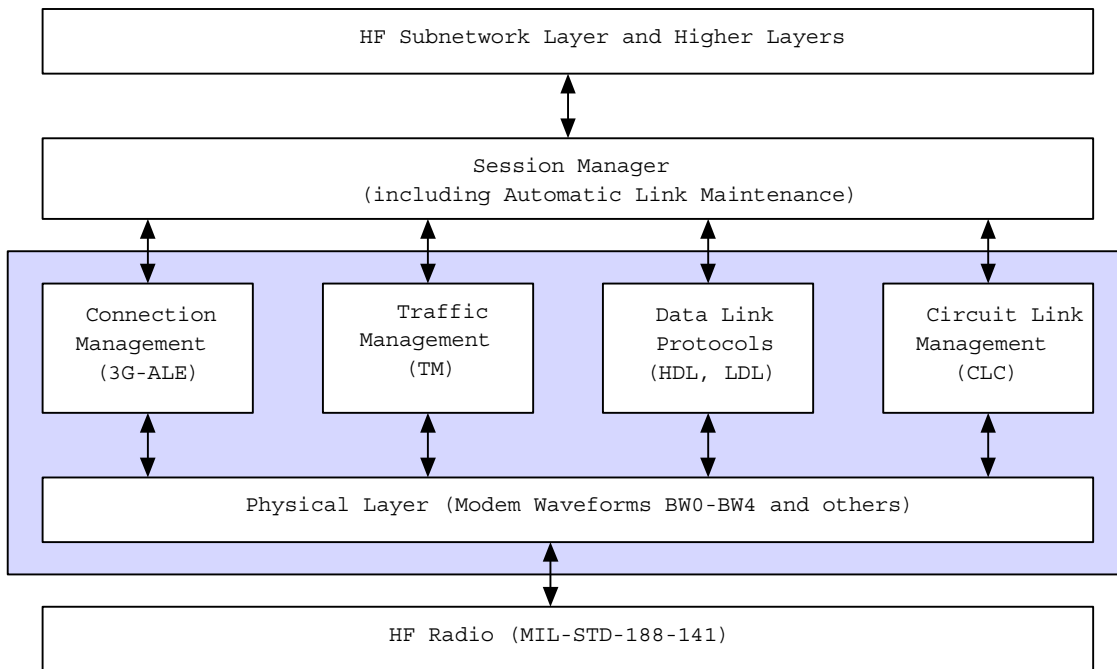
M	Number of repetitions of protocol data units (PDUs) per channel in asynchronous networks	1.3
T <sub>sc</sub>	Time for an asynchronous mode scanning call	
T <sub>tlc</sub>	Time for transmit level control settling	256/2400 s _ 106.7 ms
T <sub>BW0 pre</sub>	Time for Burst Waveform 0 preamble	384/2400 s = 160.0 ms
T <sub>BW0 data</sub>	Time for Burst Waveform 0 data	832/2400 s _ 346.7 ms
D	Current dwell channel	
T	Seconds since midnight (network time)	
G	Dwell group number	

Also see table C-XXV 3G-ALE Protocol Data for additional operating parameters.

C.4 GENERAL REQUIREMENTS.

C.4.1 Overview.

The third-generation automatic link establishment (3G-ALE) protocol, the Traffic Management (TM) protocol, the High-Rate Data Link (HDL) and Low-Rate Data Link (LDL) protocols, and the circuit link management (CLC) protocol form a mutually-dependent protocol suite (see figure C-2). Compliance with this appendix requires compliant implementations of all of the protocols defined in this appendix (shown in shaded box in figure C-2).



**FIGURE C-2. 3G HF protocol suite.**



## C.4.2 Frequency management.

### C.4.2.1 Calling and traffic channels.

Frequencies assigned for use in 3G networks will be designated for use in calling, traffic, or both. Network managers should observe the following principles in assigning channels in these networks:

- Use of a channel for both calling and traffic reduces performance in networks subject to heavy traffic loads.
- Traffic channels should be assigned near calling channels so that the propagation characteristics of traffic channels are similar to those of the calling channels.
- Calling channels should be assigned to scan lists (see Scanning below) in non-monotonic frequency order so that the available frequency range is covered several times during a single scan. For example, frequencies 3, 4, 5, 6, 8, 10, 11, 13, 18, and 23 MHz might be scanned in the order 3, 6, 11, 23, 5, 10, 18, 4, 8, 13.

Calling channels shall be assigned to the lowest-numbered channels, starting with channel 0. When C calling channels are scanned, the highest-numbered calling channel shall be C-1.

### C.4.2.2 External frequency management.

Systems shall provide for management of frequency use via the network management interface (see Section 4.9). This capability shall include at least the following:

- Assignment of frequencies to channels
- Enabling and disabling of calling and traffic on each channel
- Assignment of channels to scan list
- Entry of channel quality data

NOTE: The network manager must assign the first three items uniformly network-wide.

## C.4.3 Network synchronization.

3G systems shall include mechanisms to maintain synchronization among all local time bases in a network. When 3G-ALE is operating in synchronous mode, the difference between the earliest time and the latest time among the stations must not exceed 50 ms. In asynchronous networks, the permissible range of network times is determined by the current level of linking protection, if any.

### C.4.3.1 External synchronization.

A means shall be provided to set the local time from a source such as a Global Positioning System (GPS) receiver. The internal time base shall differ by no more than 1 ms from the external source immediately after such a time update. Time base drift shall not exceed 1 part per million.

#### C.4.3.2 Over-the-air synchronization.

When an external source of synchronization is not available, 3G systems shall maintain synchronization using the synchronization management protocol of C.5.2.7.

#### C.4.4 Scanning.

When not engaged in any of the 2G or 3G protocols, 3G systems shall continuously scan assigned channels, listening for 2G and 3G calls. They shall leave the scanning state when called or when placing a call, in accordance with the protocol behaviors specified in C.5.2.4 and C.5.2.5.

##### C.4.4.1 Synchronous mode.

3G ALE synchronous-mode receivers shall scan at a synchronized rate of 4 seconds per channel. Stations shall be assigned to dwell groups by the network manager. Each dwell group shall listen on a different channel during each 4-second dwell period, in accordance with the following formula:

$$D = ((T / 4) + G) \text{ mod } C$$

where D = Dwell channel

T = Seconds since midnight (network time)

G = Dwell group number

C = Number of channels in scan list

Note that this yields channel numbers in the range 0 to C-1 in accordance with C.4.2.1.

##### C.4.4.2 Asynchronous mode.

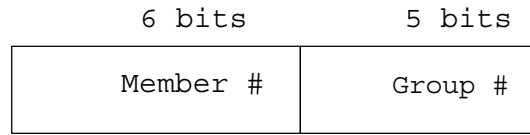
3G systems using asynchronous mode 3G ALE shall scan assigned calling channels at a rate of at least 1.5 channels per second. (design objective (DO): scan at 10 channels per second, in which case the corresponding dwell period of 100 ms may be extended to up to 667 ms as required when evaluating received signals. If a BW0 preamble has not been detected within 667 ms, the system shall resume scanning.)

#### C.4.5 3G addresses.

3G systems use 11-bit binary addresses in the over-the-air protocols. These addresses shall be translated to and from second-generation addresses (call signs of up to 15 American Standard Code for Information Interchange (ASCII)-36 characters) for operator use.

##### C.4.5.1 Synchronous mode address structure.

The synchronous mode 3G-ALE protocol defines further structure within the 11-bit address space: the 5 least-significant bits (LSBs) of the address shall contain the dwell group number of the node, and the 6 most-significant bits (MSBs) shall contain the node's member number within that group (see figure C-3).



**FIGURE C-3. Synchronous mode address structure.**

**C.4.5.2 Net entry addresses.**

The member numbers from 111100 through 111111 (addresses 11110000000 through 11111111111) are reserved for temporary use by stations calling into a network, and shall not be assigned to any network member.

**C.4.5.3 Multicast addresses.**

Multicast addresses form a distinct 6-bit address space, and shall be distinguished from individual addresses by their use only in multicast calls. When computing link IDs for use in multicast calls, the multicast address shall be placed in the most-significant six bits (member number portion in figure C-1), and the group number bit positions shall be filled with five bits set to 1.

**C.4.5.4 Node address assignments.**

Each node in a network shall be assigned a single 11-bit address that is distinct from all other node addresses in the network. This address shall be recognized by that node in individual and unicast calls.

NOTE: When it is desired to be able to reach all network members with a single call, and network traffic is expected to be light, up to 60 network member stations may be assigned to one dwell group. However, this arrangement is subject to calling channel congestion. To support heavier call volume than the single-group scheme will support, the network members should be distributed into multiple dwell groups.

**C.4.5.5 Multicast address assignments.**

A 3G system shall be programmable to subscribe to (recognize) at least 10 multicast addresses in addition to its individual node address. Multicast addresses have network-wide scope.

**C.4.6 ALE.**

3G ALE provides functionality similar to second-generation ALE (2G ALE) as described in Appendix A, but with improved ability to link in stressed channels, to link more quickly, and to operate efficiently in large, data-oriented networks.

3G ALE systems shall be capable of operation in both asynchronous and synchronous modes in accordance with C.5.2.4 and C.5.2.5. A system operating in synchronous mode shall recognize asynchronous-mode scanning calls addressed to it and respond to such calls in accordance with the asynchronous-mode protocol.

After a link is established using 3G-ALE, the system shall wait no more than a programmable time, ( $T_{\text{traf\_wait}}$  Time or `trafWaitTimeMcast` as appropriate), for traffic setup to begin, and shall return to scanning if traffic setup has not begun within that time.

C.4.6.1 System performance requirements.

Requirements for linking probability and occupancy detection are specified in the following paragraphs.

C.4.6.1.1 Linking probability.

3G ALE systems shall meet or exceed the linking probability requirements of table C-I while operating in synchronous or asynchronous mode. The test procedure of A.4.2.3 shall be employed, with the following modifications:

- The multipath delay settings shall be 0.5 ms for the Good channel and 2.0 ms for the Poor channel.
- Units under test shall scan 3 calling channels ( $C = 3$ ).
- The requested traffic type shall be packet data.
- A link will be declared successful if, in response to the first Call PDU sent, the 3G-ALE controllers complete an individual call handshake and both tune to the traffic channel specified in the handshake PDU to begin traffic setup.

Additional requirements are listed in the following paragraphs that are specific to operation in synchronous or asynchronous mode.

**TABLE C-I. Linking probability requirements (3 kiloHertz (kHz) signal to noise ratio (SNR) decibels (dB)).**

Prob Link Success	Gaussian	ITU-R	
		F.250-2 Good	F.250-2 Poor
25%	-10	-8	-6
50%	-9	-6	-3
85%	-8	-3	0
95%	-7	1	3

C.4.6.1.1.1 Linking probability for synchronous operation.

3G ALE systems operating in synchronous mode shall meet or exceed the linking probability requirements of table C-I.

NOTE: Synchronous-mode systems will normally link within 4 seconds if the call is placed on the first channel scanned, but may defer calling until a later dwell if the current channel has been recorded as non-propagating.

C.4.6.1.1.2 Linking probability for asynchronous operation.

3G ALE systems operating in asynchronous mode shall meet or exceed the linking probability requirements of table C-I.

C.4.6.1.2 Occupancy detection.

3G ALE systems shall detect occupied channels as specified below for synchronous or asynchronous operation, and shall not send ALE PDUs on channels that appear to be occupied without operator intervention. The probability of declaring a channel occupied when it carries only additive white gaussian noise (AWGN) shall be less than 1percent.

C.4.6.1.2.1 Occupancy detection for synchronous operation.

3G ALE systems operating in synchronous mode shall correctly recognize that a channel is occupied at least as reliably as indicated in table C-II during the Listen portion of Slot 0 (see C.5.2.3, Synchronous dwell structure). The test procedure of A.4.2.2 shall be used. Systems shall also meet or exceed the requirements of table C-II for detecting calling channels in use while listening before calling during Slots 1 through 3.

C.4.6.1.2.2 Occupancy detection for asynchronous operation.

3G ALE systems operating in asynchronous mode shall meet the occupancy detection requirements of A.4.2.2, using the test procedure specified in A.4.2.2. Such systems shall also meet the 3G-ALE and 3G-HDL occupancy detection requirements of table C-II.

**TABLE C-II. Synchronous-mode occupancy detection requirements (3 kHz SNR dB).**

Waveform	AWGN 3 kHz SNR (dB)	Minimum Required Detection Probability
2G-ALE	0	50%
	6	90%
3G-ALE (BW0)	-9	50%
	-6	95%
3G-HDL (BW2)	0	30%
	6	70%
single sideband (SSB) Voice	6	50%
	9	75%
MIL-STD-188-110 or	0	30%
FED-STD-1052 PSK modem	6	70%
STANAG 4285 or	0	30%
STANAG 4529 PSK modem	6	70%

C.4.6.2 Calling channel selection.

The 3G ALE calling protocols inherently evaluate channels during link establishment. However, informed selection of the initial calling channel can reduce calling overhead (in both synchronous

and asynchronous modes) and result in faster linking (in asynchronous mode). 3G ALE systems should use all available channel quality data to select the initial channel for calling:

- Calling channel link quality measurements collected from all received PDUs.
- Occupancy of traffic channels monitored during Slot 0 of each scanning dwell.
- Data from prediction programs and other external sources stored in the channel quality data in the 3G ALE Station table (e.g., via the network management interface).

#### C.4.6.3 Interoperability with 2G systems.

A 3G ALE system shall always listen for 2G signalling when it is listening for 3G calls. 2G sounds shall be evaluated, and the results shall be stored for use in placing 2G calls.

#### C.4.6.4 MIL-STD-188-148A functionality.

When establishing a link while operating in MIL-STD-188-148A frequency-hopping mode, a 3G ALE system shall spread each PDU over multiple hops in accordance with Appendix F. Linking performance when linking while hopping shall meet or exceed the requirements of Appendix F.

#### C.4.7 Data link protocol.

When a link has been established for packet data transfer, using 3G-ALE or other means, the TM protocol in accordance with C.5.4 shall be used to coordinate use of the HDL and LDL protocols in accordance with C.5.5 and C.5.6 to transfer data messages. When a link has been established for data virtual circuit operation, the CLC protocol (C.5.7) shall be used.

#### C.4.8 Automatic link maintenance.

The Relink and Restart commands of C.5.3 shall be used to initiate changes in frequency or data link operating mode when such changes would result in higher performance.

#### C.4.9 Network management interface.

3G systems should provide a network management interface in accordance with Appendix D to facilitate interoperability with common network management systems.

#### C.4.10 Order of transmission.

Unless otherwise specified, all PDUs shall be serialized as follows:

- Fields within a PDU shall be sent in left-to-right order.
- Bits within fields shall be sent most-significant bit (MSB) first.

NOTE: The MSB of each field is shown as the leftmost bit in each figure in this appendix.

#### C.4.11 3G ALE data structures.

3G systems shall implement the following data structures at the network management interface (if provided).

C.4.11.1 Station self address.

The “self address” of each 3G ALE station table shall be an index into the station table (see below).

C.4.11.2 Station table.

The 3G ALE station table shall be capable of storing at least 128 entries. Each entry shall contain at least the following fields:

- Station call sign in accordance with 2G format (up to 15 ASCII-36 characters)
- 3G address (11 bits, including dwell group number)
- Multicast subscription flag (indicates whether the associated address of this entry is a multicast to which this station listens)
- Channels on which address is valid
- Link quality measurements from that station on each calling and traffic channel including time of measurement
- Current station status

Entries for all network members shall be locked in the table. Other table entries shall store data obtained from received PDUs, with the oldest such entry replaced when new data is available and the table is full.

C.4.11.3 Channel table.

The channel table shall provide storage for at least 128 channel entries. Individual flags for each channel shall indicate whether that channel may be used for 3G link establishment, for 2G link establishment, and for traffic. Each entry shall also include transmit and receive frequencies, antenna selection and settings, power limits, and modulation type.

C.4.12 Cyclic Redundancy Check (CRC) computation procedure.

A CRC (Cyclic Redundancy Check) is a sequence of bits computed in a specific manner from a sequence of input bits. The CRC is concatenated with the string of input bits and the entire sequence is transmitted over a channel. At the receive side of the channel, the CRC is used to attempt to determine whether the channel caused there to be any errors in the concatenated sequence. The input sequence of bits is said to be covered by the CRC. A suitably chosen method for generating the CRC sequence can reduce the probability of undetected random channel errors to approximately  $(\frac{1}{2})^K$  where K is the number of bits comprising the CRC. All of the CRCs used in the protocols defined in this Appendix shall be computed using the procedure defined below.

When a CRC is to be computed from the non-CRC bits of a given PDU, the following must be known:

$U_0, U_1, \dots, U_{N-1}$  the  $N$  non-CRC bits contained in the PDU, in the order in which they will be coded, modulated, and transmitted, so that  $U_0$  will be the first bit input to the PDU coding and modulation processing.

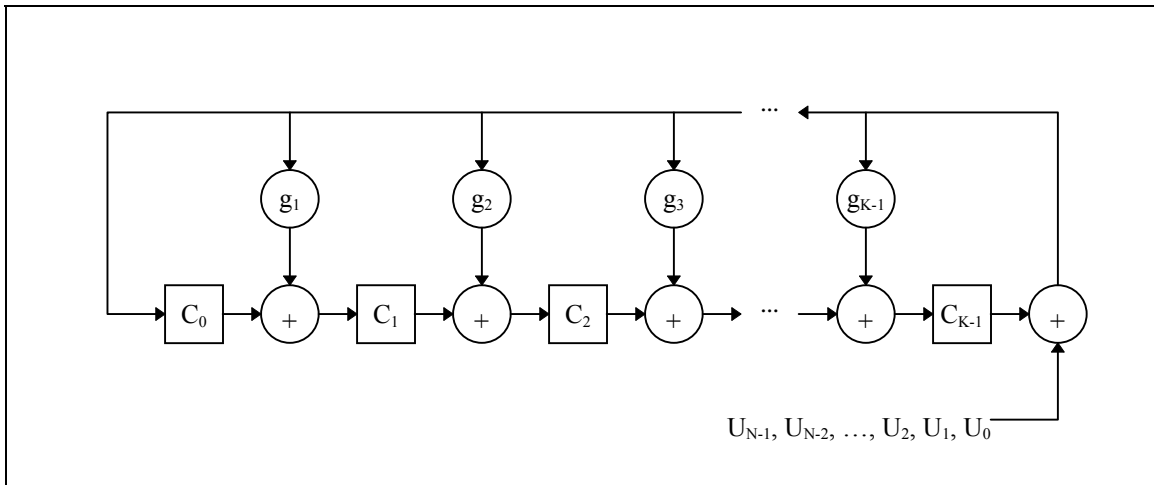
$g(X)$  A  $K^{\text{th}}$  order polynomial with binary coefficients of form:

$$1 + g_1 * X + g_2 * X^2 + \dots + g_{K-2} * X^{K-2} + g_{K-1} * X^{K-1} + X^K$$

NOTE: 1. The order  $K$  of this polynomial indicates the number of bits comprising the CRC.

NOTE: 2. The zero<sup>th</sup> and  $K^{\text{th}}$  coefficients,  $g_0$  and  $g_k$ , are equal to one.

The following diagram indicates the operations necessary to compute the CRC. The addition operation pictured is binary addition (exclusive-or). The multipliers pictured represent binary multiplication (or binary and); specifically, each circle containing the name of one of the polynomial coefficients multiplies its input by the coefficient value (0 or 1) to produce its output.



**FIGURE C-4. CRC computation structure.**

The above structure is used by the transmitter to produce a CRC sequence from the  $N$  user bits  $U_0$  through  $U_{N-1}$  via the following procedure:

1. Initialize binary memory elements  $C_0$  through  $C_{K-1}$  with 0.
2. Apply each of the  $N$  user bits in order, starting with  $U_0$ , to the binary adder at the far right of the diagram, and perform the other indicated binary additions and multiplications.
3. After each of the  $N$  user bits has been applied to the indicated adder, the memory elements  $C_0$  through  $C_{K-1}$  contain the CRC.
4. The  $K$  bit CRC is read out and appended to bits  $U_0$  through  $U_{N-1}$  of the PDU in right-to-left order, starting with  $C_{K-1}$  and finishing with  $C_0$ , so that the entire PDU with CRC is the bit-sequence  $(U_0, \dots, U_{N-1}, C_{K-1}, \dots, C_0)$ , with  $U_0$  being the first bit and  $C_0$  the last.



NOTE: The structure can be viewed as a feedback shift register with feedback connections corresponding to the coefficients of the polynomial: the feedback connection labeled 'g<sub>i</sub>' is present if and only if the coefficient g<sub>i</sub> is equal to one.

## C.5 DETAILED REQUIREMENTS.

### C.5.1 Constituent waveforms.

This section defines the constituent waveforms used by the Third Generation HF Automation protocols. Burst waveforms are defined for the various kinds of signalling required in the system, so as to meet their distinctive requirements as to payload, duration, time synchronization, and acquisition and demodulation performance in the presence of noise, fading, and multipath. All of the burst waveforms use the basic 8-ary PSK serial tone modulation of an 1800 hertz (Hz) carrier at 2400 symbols per second that is also used in the MIL-STD-188-110 serial tone modem waveform. Table C-III summarizes the characteristics of the waveforms and their uses within this standard.

**TABLE C-III. Burst waveform characteristics.**

Wave Form	used for	burst duration	payload	preamble	FEC coding	inter-leaving	data format	effective code rate <sup>1</sup>
BW0	3G-ALE PDUs	613.33 ms 1472 PSK symbols	26 bits	160.00 ms 384 PSK symbols	rate = 1/2, k = 7 convolutional (no flush bits)	4x13 block	16-ary orthogonal Walsh function	1 / 96
BW1	Traffic Management PDUs; HDLacknowledgement PDUs	1.30667 seconds 3136 PSK symbols	48 bits	240.00 ms 576 PSK symbols	rate = 1/3, k = 9 convolutional (no flush bits)	16x9 block	16-ary orthogonal Walsh function	1 / 144
BW2	HDLtraffic data PDUs	640 + (n*400) ms 1536 + (n*960) PSK symbols, n = 3, 6, 12, or 24	n*1881 bits	26.67 ms 64 PSK symbols (for equalizer training)	rate = 1/4, k = 8 convolutional (7 flush bits)	none	32 unknown/ 16 known	variable: 1 / 1 to 1 / 4
BW3	LDL traffic data PDUs	373.33 + (n*13.33) ms 32n + 896 PSK symbols, n = 64, 128, 256, or 512	8n+25 bits	266.67 ms 640 PSK symbols	rate = 1/2, k = 7 convolutional (7 flush bits) <sup>2</sup>	24x24, 32x34, 44x48, or 64x65 convolutional block	16-ary orthogonal Walsh function	variable: 1 / 12 to 1 / 24
BW4	LDL acknowledgement PDUs	640.00 ms 1536 PSK symbols	2 bits	none	none	none	4-ary orthogonal Walsh function	1 / 1920

Notes:

1. Reflects Forward Error Correction (FEC) and Walsh-function coding only; does not include known data or convolutional encoder flush bits.
2. In this case, the number of flush bits exceeds by one the minimum number required to flush the convolutional encoder; this makes the number of coded bits a multiple of four as is required for the Walsh-function modulation format.

Other waveforms, including the MIL-STD-188-110 serial tone modem waveform, can be used to deliver data and digitized voice signalling on circuit links established using the 3G-ALE and TM protocols.

C.5.1.1 Service primitives.

Table C-IV defines the service primitives exchanged between the Burst Waveform (physical layer) entities and the higher-layer user processes that use Burst Waveform services. Note that there is no requirement that implementations of the waveforms and protocols defined in this Appendix contain precisely these service primitives; nor are the services primitives defined below necessarily all of the service primitives that would be required in an implementation of these waveforms and protocols.

**TABLE C-IV. Burst Waveform (BWn) service primitives.**

Primitive name	Attribute	Values	Description
BW0_Send	Overview	Invoked by a user process to send a 26-bit data payload using the BW0 robust burst signalling format	
	Parameters	payload	an ordered sequence of 26 bits of data to be modulated and transmitted using the BW0 signalling format
	Originator	Connection Management (CM)	
	Preconditions		
BW0_Receive	Overview	Issued by BW0 Receiver when it has received a BW0 transmission.	
	Parameters	payload	the 26 bits of payload data received in the incoming BW0 transmission. The payload value can contain undetected errors due to channel noise, fading, multipath, etc.; however, on a perfect channel, the payload value would be identical to the payload parameter-value of the original BW0_Send primitive at the remote station.
	Originator	BW0 Receiver	
	Preconditions	BW0 Receiver is active.	
BW0_Pre_Detect	Overview	Issued by BW0 Receiver when it has detected a BW0 acquisition preamble.	
	Parameters	none	
	Originator	BW0 Receiver	
	Preconditions	BW0 Receiver is active.	
BW1_Send	Overview	Invoked by a user process to send a 48-bit data payload using the BW1 robust burst signalling format	
	Parameters	payload	an ordered sequence of 48 bits of data to be modulated and transmitted using the BW1 signalling format
	Originator	<ul style="list-style-type: none"> <li>• HDL protocol</li> <li>• TM</li> </ul>	
	Preconditions		
BW1_Receive	Overview	Issued by BW1 Receiver when it has received a BW1 transmission.	
	Parameters	payload	the 48 bits of payload data received in the incoming BW1 transmission. The payload value can contain undetected errors due to channel noise, fading, multipath, etc.; however, on a perfect channel, the payload value would be identical to the payload parameter-value of the original BW1_Send primitive at the remote station.
	Originator	BW1 Receiver	
	Preconditions	BW1 Receiver is active.	
BW1_Pre_Detect	Overview	Issued by BW1 Receiver when it has detected a BW1 acquisition preamble.	
	Parameters	none	
	Originator	BW1 Receiver	
	Preconditions	BW1 Receiver is active.	
BW2_Send	Overview	Invoked by a user process to send a sequence of data packets to a remote station, using the BW2 high-rate burst signalling format	
	Parameters	tx frame	a <i>BW2 tx frame</i> , consisting of an ordered sequence of NumPkts data packets to be modulated and transmitted using the BW2 signalling format, where NumPkts = 3, 6, 12, or 24. Each data packet contains an ordered sequence of 1881 bits of payload data.

**TABLE C-IV. Burst Waveform (BWn) service primitives (continued).**

Primitive name	Attribute	Values	Description
		reset	boolean value; reset = TRUE indicates to the BW2 transmitter that it should reset its Forward Transmission counter, <i>FTcount</i> .
	Originator	HDL protocol	
	Preconditions	<p>A previous signalling exchange has established the time at which transmission of the current BW2 burst is to start, and the time at which the receiver should expect it to arrive.</p> <p>If reset = FALSE, the value of NumPkts for the current invocation of BW2_Send (i.e., the number of data packets in the forward transmission frame, payload) must be equal to the value of NumPkts in the preceding invocation of BW2_Send. (reset = TRUE in the first invocation of BW2_Send for a new datagram, at which time the value of NumPkts for all invocations of BW2_Send throughout the duration of the datagram transfer is determined.)</p>	
BW2_Receive	Overview	Issued by the BW2 Receiver when it has received a BW2 transmission.	
	Parameters	rx frame	<p>a <i>BW2 rx frame</i> containing NumRcvd indexed data packets, where <math>0 \leq \text{NumRcvd} \leq \text{NumPkts}</math>. An indexed data packet contains</p> <ul style="list-style-type: none"> <li>• payload: a data packet containing 1881 bits of payload data; identical to the corresponding data packet in the transmitted <i>tx</i> frame.</li> <li>• index: the position at which the indexed data packet occurred in the forward transmission (BW2 tx frame) in which it was received, where <math>0 \leq \text{index} \leq \text{NumPkts}</math>. index = 0 indicates that the packet was in the first packet-slot in the forward transmission.</li> </ul> <p>Only data packets received with no errors (as indicated by checking the 32-bit CRC added to each packet by BW2) are passed to the user process in a BW2 rx frame.</p>
	Originator	BW2 Receiver	
	Preconditions	<p>BW2 Receiver is active.</p> <p>The arrival time of the incoming BW2 burst has been estimated, based on the observed arrival time of previous received signalling from the remote station.</p>	
BW3_Send	Overview	Invoked by a user process to send a data packet to a remote station, using the BW3 low-rate burst signalling format.	
	Parameters	payload	an ordered sequence of 537, 1049, 2073, or 4121 bits of data to be modulated and transmitted using the BW3 signalling format. ( <b>Note:</b> these payload lengths are chosen so as to accommodate the four possible forward transmission lengths of the LDL; see section C.5.5.)
		reset	boolean value; reset = TRUE indicates to the BW3 modulator that it should reset its Forward Transmission counter, <i>FTcount</i> .
	Originator	LDL protocol	
Preconditions	A previous signalling exchange has established the time at which transmission of the current BW3 burst is to start, and the time at which the receiver should expect it to arrive.		
BW3_Receive	Overview	Issued by the BW3 Receiver when it has successfully received a BW3 transmission without errors.	

**TABLE C-IV. Burst Waveform (BWn) service primitives (continued).**

Primitive name	Attribute	Values	Description
	Parameters	payload	537, 1049, 2073, or 4121 bits of BW3 data demodulated and received without errors by the Burst Waveform Modem, as determined by the CRC check performed by the BW3 receiver; identical to the payload parameter-value of the original BW3_Send primitive at the remote station.
	Originator	BW3 Receiver	
	Preconditions	BW3 Receiver is active. The arrival time of the incoming BW3 burst has been estimated, based on the observed arrival time of previous received signalling from the remote station.	
BW4_Send	Overview	Invoked by a user process to send two bits of payload data using the BW4 robust burst signalling format.	
	Parameters	payload	two bits of data to be modulated and transmitted using the BW4 signalling format.
	Originator	LDL protocol	
	Preconditions	A previous signalling exchange has established the time at which transmission of the current BW4 burst is to start, and the time at which the receiver should expect it to arrive.	
BW4_Receive	Overview	Issued by the BW4 Receiver when it has received a BW4 transmission.	
	Parameters	payload	two bits of BW4 data received and demodulated by the Burst Waveform Modem. The payload value can contain undetected errors due to channel noise, fading, multipath, etc.; however, on a perfect channel, the payload value would be identical to the payload parameter-value of the original BW4_Send primitive at the remote station.
	Originator	BW4 Receiver	
	Preconditions	BW4 Receiver is active.	
		The arrival time of the incoming BW4 burst has been estimated, based on the observed arrival time of previous received signalling from the remote station.	

#### C.5.1.2 Burst waveform interleaving.

A block interleaver is used to improve FEC performance for certain of the burst waveforms described below. This interleaver is based on a single interleave matrix having R rows and C columns, and hence accommodating up to (R \* C) bits.

The particular interleaver used in each burst waveform is defined by the values assigned to the following set of interleaver parameters:

R	• Number of rows
C	• Number of columns
$i_{rs}$	• Row increment, stuff
$i_{cs}$	• Column increment, stuff
$\Delta i_{rs}$	• Delta row increment, stuff. Applied only when stuff count is an integer multiple of the number of columns.
$\Delta i_{cs}$	• Delta column increment, stuff. Applied only when stuff count is an integer multiple of the number of rows.
$i_{rf}$	• Row increment, fetch
$i_{cf}$	• Column increment, fetch
$\Delta i_{rf}$	• Delta row increment, fetch. Applied only when fetch count is an integer multiple of the number of columns.
$\Delta i_{cf}$	• Delta column increment, fetch. Applied only when fetch count is an integer multiple of the number of rows.

The parameter-values for each burst waveform are given in the sections of this document describing the individual burst waveforms.

Irrespective of the particular values assigned to these parameters, each of the interleavers is operated in the following way. Starting with the matrix empty,  $(R * C)$  input bits are stuffed one by one into the matrix using the algorithm:

```

initialize s (stuff count),  $r_s$ , and  $c_s$  to zero
while  $s < (R * C)$ 
    matrix[ $r_s, c_s$ ] = input bit
    increment s
    if  $(s \bmod R) == 0$ 
         $c_s = (c_s + i_{cs} + \Delta i_{cs}) \bmod C$ 
    else
         $c_s = (c_s + i_{cs}) \bmod C$ 
    end if
    if  $(s \bmod C) == 0$ 
         $r_s = (r_s + i_{rs} + \Delta i_{rs}) \bmod R$ 
    else
         $r_s = (r_s + i_{rs}) \bmod R$ 
    end if
end while

```

NOTE: using '=' to denote assignment, and '==' to denote the equality predicate.

Once the matrix has been filled, the  $(R * C)$  output bits are fetched one by one from the matrix in interleaved order, using the algorithm:

```

initialize f (fetch count), rf, and cf to zero
while f < (R * C)
  output bit = matrix[rf,cf]
  increment f
  if (f mod R) == 0
    cf = (cf + icf + Δicf) mod C
  else
    cf = (cf + icf) mod C
  end if
  if (f mod C) == 0
    rf = (rf + irf + Δirf) mod R
  else
    rf = (rf + irf) mod R
  end if
end while

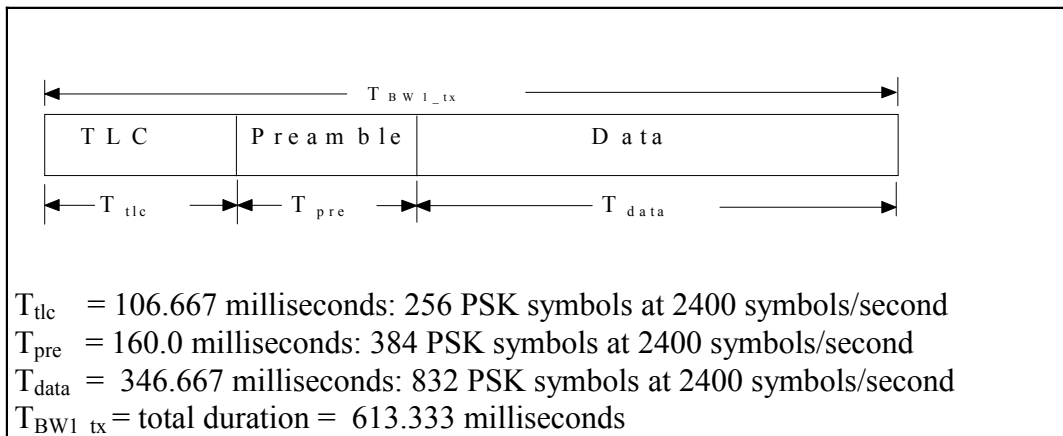
```

### C.5.1.3 Burst Waveform 0 (BW0).

Burst Waveform 0 (BW0) is used to convey all 3G-ALE (connection management) PDUs. Figure C-5 summarizes the structure and timing characteristics of the BW0 waveform. Higher layer protocols cause the generation of a BW0 burst by invoking the BW0\_Send primitive. The BW0\_Send primitive has one parameter:

- payload: the 26-bit data packet to be transmitted.

C.5.2 describes the manner in which the user process assigns values to the payload parameter.



**FIGURE C-5. BW0 timing.**

The description of the BW0 waveform generation will proceed as follows:

- C.5.1.3.1 and C.5.1.3.2 will discuss generation of raw tribit values for the first two waveform components: Gain control loop compensation and Preamble.

NOTE: A tribit number can take on the values 0,1,...,7.

- C.5.1.3.3, C.5.1.3.4, and C.5.1.3.5 will discuss the mapping of input bits to the raw tribit values for the data waveform component via FEC, interleaving, and orthogonal Walsh symbol formation.
- C.5.1.3.6 will discuss generation of tribit values for the pseudo noise (PN) spreading sequence and the combining of raw tribit values and PN spreading sequence tribit values.
- C.5.1.3.7 will discuss carrier modulation using combined tribit values.

C.5.1.3.1 TLC/AGC guard sequence.

The TLC/AGC guard sequence portion of the BW0 waveform provides an opportunity for both the transmitting radio's Transmit Level Control process (TLC) and the receiving radio's Automatic Gain Control process (AGC) to reach steady states before the BW0 preamble appears at their respective inputs, minimizing the distortion to which the preamble can be subjected by these processes. The TLC/AGC guard sequence is a sequence of 256 pseudo-random tribit symbols having the values shown in table C-V. The tribit symbols are transmitted in the order shown in table C-V, starting at the top left and moving from left to right across each row, and from top to bottom through successive rows.

**TABLE C-V. TLC/AGC guard sequence symbol values.**

2,6,1,6, 1,6,3,0, 6,0,1,1, 5,0,0,6, 2,6,2,1, 6,2,3,2, 7,6,4,3, 0,2,3,5, 2,7,5,1, 5,1,7,6, 1,7,1,5, 4,4,0,7, 2,2,6,2, 2,2,6,3, 3,3,7,7, 3,2,4,5,
0,7,4,7, 7,7,2,3, 1,6,7,6, 5,7,0,5, 1,0,7,6, 2,4,0,2, 7,5,5,4, 1,5,1,5, 6,7,3,0, 2,7,6,6, 4,0,7,4, 3,2,2,6, 6,7,4,7, 2,0,2,7, 2,1,5,4, 6,2,3,2,
1,6,0,7, 1,1,2,6, 2,2,0,2, 2,3,6,7, 1,7,1,7, 1,5,7,7, 2,2,2,0, 4,3,4,2, 0,6,7,6, 0,5,0,7, 1,7,4,1, 2,3,4,6, 7,2,2,0, 6,4,4,6, 6,4,2,2, 6,5,3,4,
2,3,5,7, 7,1,0,0, 0,3,1,2, 0,1,6,2, 7,4,4,3, 2,5,4,5, 6,4,2,5, 6,2,2,4, 7,0,6,2, 3,7,2,5, 4,2,4,1, 5,5,3,6, 1,1,3,2, 7,5,7,0, 7,3,5,0, 0,1,2,0

The TLC/AGC guard sequence symbols are modulated directly as described in C.5.1.3.7, without undergoing PN spreading as described in C.5.1.3.6.



C.5.1.3.2 Acquisition preamble.

The BW0 acquisition preamble provides an opportunity for the receiver to detect the presence of the waveform and to estimate various parameters for use in data demodulation. The preamble component of BW0 is the sequence of 384 tritbit symbols shown in C-VI. The preamble symbols are modulated directly as described in C.5.1.3.7, without undergoing PN spreading as described in C.5.1.3.6. The preamble symbols are transmitted in the order shown in table C-VI, starting at the top left and moving from left to right across each row, and from top to bottom through successive rows.

When it detects a BW0 acquisition preamble, the BW0 receiver issues a BW0\_Pre\_Detect service primitive, as described in table C-IV.

**TABLE C-VI. BW0 acquisition preamble symbol values.**

7,7,7,7,	5,4,3,1,	1,2,0,2,	7,2,2,0,	1,3,4,7,	5,3,7,7,	4,3,1,0,	1,1,5,2,
1,6,0,0,	4,7,6,2,	2,3,6,0,	5,1,7,6,	1,6,1,7,	6,6,6,1,	7,3,0,4,	7,1,2,2,
3,3,6,7,	7,1,7,3,	1,5,0,3,	3,4,5,2,	5,2,5,3,	1,7,2,1,	5,7,6,1,	2,5,3,5,
3,6,2,0,	7,5,6,6,	0,1,4,2,	5,4,1,1,	7,0,0,6,	6,7,5,6,	3,7,4,0,	2,6,3,6,
4,5,1,0,	0,4,5,5,	4,7,1,5,	1,5,6,7,	3,3,5,2,	2,2,7,2,	3,3,0,4,	1,4,1,3,
6,0,7,2,	6,1,5,0,	1,4,1,1,	7,0,7,4,	0,2,4,5,	3,0,0,3,	1,2,6,4,	6,5,2,6,
0,0,7,3,	5,3,4,0,	6,2,7,2,	3,3,7,6,	7,1,0,0,	6,7,3,1,	5,5,0,2,	3,4,2,7,
7,4,5,2,	1,6,1,0,	4,7,1,6,	1,2,4,0,	3,6,5,4,	5,4,4,6,	1,2,5,1,	3,6,2,7,
2,6,7,4,	7,3,0,1,	5,0,5,3,	4,5,0,7,	3,2,7,0,	3,2,7,0,	6,1,6,7,	7,1,4,2,
6,7,7,4,	2,7,2,7,	3,7,6,3,	2,6,5,6,	6,3,6,6,	4,1,0,6,	2,6,4,1,	5,5,4,3,
3,4,6,3,	5,2,4,1,	1,7,5,3,	7,1,6,5,	4,6,6,2,	3,4,2,3,	3,7,4,1,	4,4,5,4,
6,1,3,4,	6,1,7,4,	1,3,5,2,	6,5,5,4,	2,1,5,1,	6,1,2,7,	1,4,4,2,	3,4,7,3

C.5.1.3.3 Forward error correction.

BW0 carries a payload of 26 protocol bits. The 26 protocol bits are encoded using the  $r = 1/2$ ,  $k = 7$  convolutional encoder shown in figure C-6, creating 52 coded bits. A ‘tail-biting’ convolutional encoding approach is used as follows:

1. Initialize the six memory cells  $x^1 \dots x^6$  of the encoder with the last six bits of the payload sequence,  $p_{20} \dots p_{25}$ , so that cell  $x^1$  contains  $p_{20}$  and cell  $x^6$  contains  $p_{25}$ .
2. Shift the first bit of the payload sequence,  $p_0$ , into cell  $x^6$ .
3. Extract the two coded output bits  $b_0$  and  $b_1$ , in that order, as shown in figure C-6.
4. Shift the next payload bit into cell  $x^6$ , then extract the two coded output bits  $b_0$  and  $b_1$ .
5. Repeat step 4 until a total of 52 coded bits have been produced.

No flush bits are necessary for the encoding process.

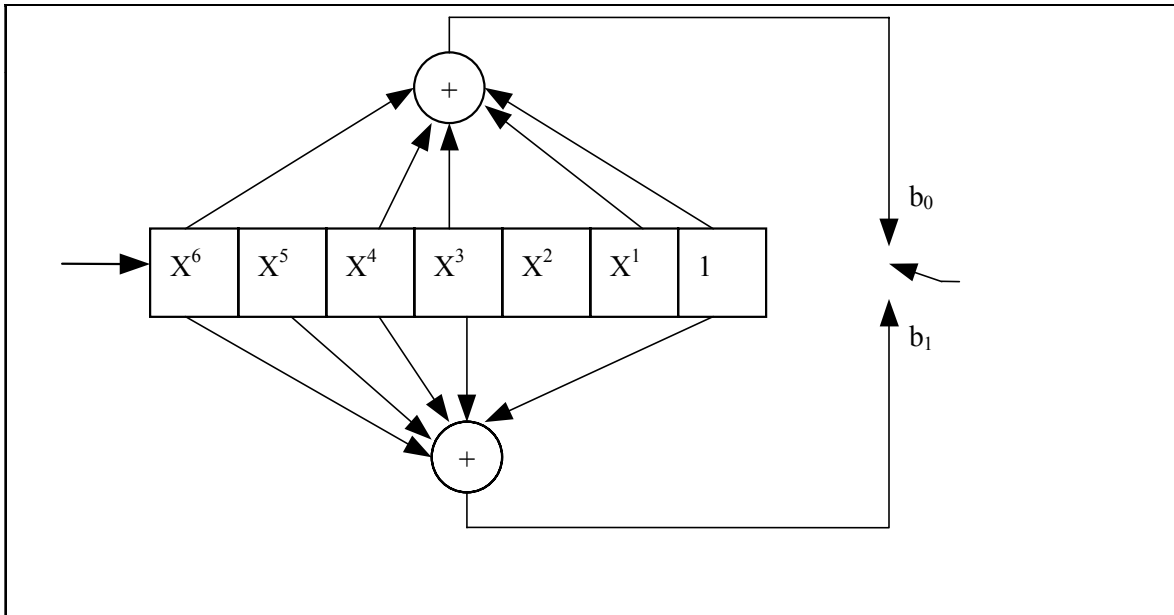


FIGURE C-6. Rate 1/2, constraint length 7 convolutional encoder.

The polynomials used are:

- $b_0 = x^6 + x^4 + x^3 + x^1 + 1$
- $b_1 = x^6 + x^5 + x^4 + x^3 + 1$

where  $x^6$  corresponds to the most recent encoder input bit.

#### C.5.1.3.4 Interleaving.

BW0 utilizes a simple block interleaver structure which can be viewed as a 4 by 13 element rectangular array. See C.5.1.2 for a description of the interleaving process. The interleaver parameters for BW0 are as follows:

**TABLE C-VII. BW0 interleaver parameters.**

R	4
C	13
$i_{rs}$	0
$i_{cs}$	1
$\Delta i_{rs}$	1
$\Delta i_{cs}$	0
$i_{rf}$	1
$i_{cf}$	0
$\Delta i_{rf}$	0
$\Delta i_{cf}$	1

**C.5.1.3.5 Orthogonal symbol formation.**

The interleaver fetch process removes 4 coded bits at a time from the interleaver matrix. These four coded bits are mapped into a 16-tribit sequence using the mapping given in table C-VIII. Note that each of the four-bit sequences in the Coded Bits column of the table is of the form  $b_3b_2b_1b_0$ , where  $b_3$  is the first bit fetched from the interleaver matrix. The 16-tribit sequence thus obtained is repeated 4 times to obtain a 64-tribit sequence. The tribit values are placed in the output tribit sequence in the order in which they appear in the corresponding row of table C-VIII, moving from left to right across the row.

**TABLE C-VIII. Walsh modulation of coded bits to tribit sequences.**

Coded Bits (shown as $b_3b_2b_1b_0$ )	Tribit Sequence
0000	0000 0000 0000 0000
0001	0404 0404 0404 0404
0010	0044 0044 0044 0044
0011	0440 0440 0440 0440
0100	0000 4444 0000 4444
0101	0404 4040 0404 4040
0110	0044 4400 0044 4400
0111	0440 4004 0440 4004
1000	0000 0000 4444 4444
1001	0404 0404 4040 4040
1010	0044 0044 4400 4400
1011	0440 0440 4004 4004
1100	0000 4444 4444 0000
1101	0404 4040 4040 0404
1110	0044 4400 4400 0044
1111	0440 4004 4004 0440

This process repeats for a total of 13 iterations (one for each group of four coded bits) to produce 832 raw tribit values.

C.5.1.3.6 Pseudo noise (PN) spreading sequence generation and application.

A sequence of 832 pseudo-random tribit values  $s_i$  is generated by extracting 64-tribit sequences from table C-IX,  $832/64 = 13$  times. The tribit values are extracted in the order shown in table C-IX, starting at the top left and moving from left to right across each row, and from top to bottom through successive rows. The table contains 256 values; therefore, the PN spreading sequence is repeated every 4 blocks of 64 tribit sequences.

**TABLE C-IX. BW0 PN spreading sequence.**

0,2,4,3,	3,6,4,5,	7,6,7,0,	5,5,4,3,	5,4,3,7,	0,7,6,2,	6,2,4,6,	7,2,4,7,
5,5,7,0,	7,3,3,3,	7,3,3,1,	4,2,3,7,	0,2,7,7,	3,5,1,0,	1,4,0,5,	0,0,0,0,
6,5,0,1,	2,7,6,5,	5,2,7,3,	3,3,2,1,	2,5,6,1,	3,4,2,1,	0,1,2,3,	6,4,7,5,
2,2,6,2,	7,6,5,2,	4,6,5,4,	7,2,5,1,	0,0,7,7,	3,5,4,2,	1,4,2,7,	0,3,4,0,
0,0,7,7,	3,5,4,2,	1,4,2,7,	0,3,4,0,	1,0,5,2,	6,0,3,5,	1,0,5,1,	5,2,5,6,
3,2,3,7,	1,2,2,0,	7,1,3,6,	4,2,6,2,	7,4,3,7,	6,7,2,3,	1,7,4,1,	5,1,5,4,
7,1,1,2,	3,6,7,7,	6,6,1,2,	2,4,1,7,	7,5,5,4,	7,7,5,0,	7,3,7,5,	7,7,5,0,
6,6,6,1,	3,4,4,4,	0,3,3,2,	1,4,5,4,	5,3,1,1,	1,2,5,1,	7,1,5,7,	2,0,0,6

The 832 tribit values  $s_i$  of the PN sequence are then combined with the 832 raw tribit values  $r_i$  produced by the orthogonal symbol formation process described in the previous section. Each symbol of the PN sequence  $s_i$  is combined with the corresponding symbol  $r_i$  of the raw tribit sequence to form a channel symbol  $c_i$ , by adding  $s_i$  to  $r_i$  modulo 8. For instance, if  $s_i = 7$ ,  $r_i = 4$ , then  $c_i = 7 \oplus 4 = 3$ , where the symbol  $\oplus$  represents modulo-8 addition.

The process can be summarized:

$$\begin{bmatrix} c_0 \\ \vdots \\ c_{2303} \end{bmatrix} = \begin{bmatrix} r_0 \\ \vdots \\ r_{2303} \end{bmatrix} \oplus \begin{bmatrix} s_0 \\ \vdots \\ s_{2303} \end{bmatrix}$$

where  $r$  is the vector of data raw tribit values,  $s$  is the vector of PN sequence tribit values,  $c$  is the resulting vector of combined tribit values, and the symbol  $\oplus$  represents component-wise modulo-8 addition.

C.5.1.3.7 Modulation.

The sequence of channel symbols consisting of

- the TLC/AGC guard sequence of 256 tribit symbols described by C.5.1.3.1 (on which no PN-spreading has been performed), followed by

- the acquisition preamble sequence of 384 tribit symbols described by C.5.1.3.2 (on which no PN-spreading has been performed), followed by
- the 832-length sequence of BW1 channel symbols (data symbols), PN-spread as described in C.5.1.3.6,

is used to PSK modulate an 1800 Hz carrier signal at 2400 channel symbols/sec.

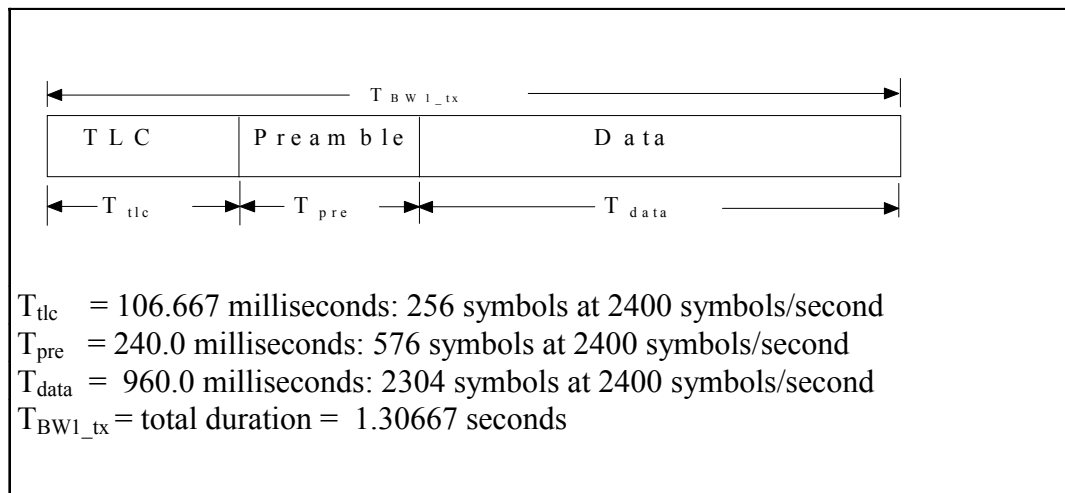
See C.5.1.8 for a description of how the channel symbol values are mapped to carrier phases and the subsequent carrier modulation process.

#### C.5.1.4 Burst Waveform 1 (BW1).

Burst Waveform 1 (BW1) is used to convey all TM PDUs and the HDL protocol's HDL\_ACK PDU. Figure C-7 summarizes the structure and timing characteristics of the BW1 waveform. Higher layer protocols cause the generation of a BW1 waveform by invoking the BW1\_Send primitive. The BW1\_Send primitive has one parameter:

- payload: the 48-bit data packet to be transmitted.

Sections C.5.2 and C.5.3 describe the manner in which the user processes assign values to the payload parameter.



**FIGURE C-7. BW1 timing.**

The description of the BW1 waveform generation will proceed as follows:

- C.5.1.4.1 and C.5.1.4.2 will discuss generation of raw tribit values for the first two waveform components: Gain control loop compensation and Preamble.

NOTE: A tribit number can take on the values 0,1,...,7.

- C.5.1.4.3, C.5.1.4.4, and C.5.1.4.5 will discuss the mapping of input bits to the raw tribit values for the data waveform component via FEC, interleaving, and orthogonal Walsh symbol formation.
- C.5.1.4.6 will discuss generation of tribit values for the PN spreading sequence and the combining of raw tribit values and PN spreading sequence tribit values.
- C.5.1.4.7 will discuss carrier modulation using combined tribit values.

C.5.1.4.1 TLC/AGC guard sequence.

The TLC/AGC guard sequence portion of the BW1 waveform provides an opportunity for both the transmitting radio's Transmit Level Control process (TLC) and the receiving radio's Automatic Gain Control process (AGC) to reach steady states before the BW1 preamble appears at their respective inputs, minimizing the distortion to which the preamble can be subjected by these processes. The TLC/AGC guard sequence is a sequence of 256 pseudo-random tribit symbols having the values shown in table C-X. The tribit symbols are transmitted in the order shown in table C-X, starting at the top left and moving from left to right across each row, and from top to bottom through successive rows. For convenience of implementation, the length of the TLC/AGC guard sequence (256 PSK symbols) has been chosen so as to be an integral multiple of the length (64 PSK symbols) of the Walsh-function modulated orthogonal symbols described in C.5.1.4.5.

**TABLE C-X. TLC/AGC guard sequence symbol values.**

2,6,1,6, 1,6,3,0, 6,0,1,1, 5,0,0,6, 2,6,2,1, 6,2,3,2, 7,6,4,3, 0,2,3,5, 2,7,5,1, 5,1,7,6, 1,7,1,5, 4,4,0,7, 2,2,6,2, 2,2,6,3, 3,3,7,7, 3,2,4,5,
0,7,4,7, 7,7,2,3, 1,6,7,6, 5,7,0,5, 1,0,7,6, 2,4,0,2, 7,5,5,4, 1,5,1,5, 6,7,3,0, 2,7,6,6, 4,0,7,4, 3,2,2,6, 6,7,4,7, 2,0,2,7, 2,1,5,4, 6,2,3,2,
1,6,0,7, 1,1,2,6, 2,2,0,2, 2,3,6,7, 1,7,1,7, 1,5,7,7, 2,2,2,0, 4,3,4,2, 0,6,7,6, 0,5,0,7, 1,7,4,1, 2,3,4,6, 7,2,2,0, 6,4,4,6, 6,4,2,2, 6,5,3,4,
2,3,5,7, 7,1,0,0, 0,3,1,2, 0,1,6,2, 7,4,4,3, 2,5,4,5, 6,4,2,5, 6,2,2,4, 7,0,6,2, 3,7,2,5, 4,2,4,1, 5,5,3,6, 1,1,3,2, 7,5,7,0, 7,3,5,0, 0,1,2,0.

The TLC/AGC guard sequence symbols are modulated directly as described in C.5.1.4.7, without undergoing PN spreading as described in C.5.1.4.6.

C.5.1.4.2 Acquisition preamble.

The BW1 acquisition preamble provides an opportunity for the receiver to detect the presence of the waveform and to estimate various parameters for use in data demodulation. The preamble component of BW1 is a sequence of 576 tribit symbols having the values shown in table C-XI. The preamble symbols are transmitted in the order shown in table C-XI, starting at the top left and moving from left to right across each row, and from top to bottom through successive rows. The preamble symbols are modulated directly as described in C.5.1.4.7, without undergoing PN spreading as described in C.5.1.4.6.

When it detects a BW1 acquisition preamble, the BW1 receiver issues a BW1\_Pre\_Detect service primitive, as described in table C-IV.

**TABLE C-XI. BW1 acquisition preamble symbol values.**

4,4,7,3, 7,7,1,0, 4,7,1,6, 6,5,5,0, 6,4,0,6, 0,1,6,2, 2,7,3,5, 1,5,4,5, 5,6,6,0, 2,0,4,0, 7,0,2,6, 3,7,1,5, 2,3,2,3, 7,1,1,7, 0,0,0,7, 4,5,2,3,
2,3,7,3, 1,0,3,4, 2,5,6,6, 6,5,2,3, 2,7,6,7, 6,6,1,0, 1,2,6,5, 6,5,1,4, 3,5,2,6, 5,6,5,2, 5,2,0,0, 2,6,7,0, 4,2,2,5, 0,2,5,1, 5,2,1,2, 3,4,1,7,
4,1,0,5, 1,1,4,1, 6,2,6,5, 2,2,3,1, 7,1,0,6, 0,4,6,2, 3,3,6,1, 5,0,4,2, 5,1,4,6, 7,2,1,5, 4,1,4,7, 7,1,5,4, 1,7,0,2, 6,2,4,7, 1,1,3,0, 6,4,2,1,
7,3,2,5, 4,0,4,4, 5,4,6,7, 7,2,6,7, 1,1,4,6, 0,5,1,6, 6,1,2,3, 2,5,3,4, 5,2,0,4, 1,4,6,5, 2,6,3,2, 2,3,0,7, 7,0,2,2, 1,6,6,6, 0,5,1,3, 4,5,1,6,
7,2,2,2, 1,3,7,5, 7,0,6,6, 5,7,2,4, 0,3,0,6, 1,4,3,4, 0,1,5,4, 5,1,5,7, 6,5,6,4, 7,7,0,1, 4,3,5,6, 1,5,7,1, 5,3,1,0, 5,5,0,4, 2,2,2,5, 2,4,5,3,
6,2,6,3, 5,0,4,0, 0,7,3,5, 1,4,5,5, 2,5,2,6, 6,3,7,6, 0,2,7,1, 4,3,5,2, 6,1,2,0, 6,5,1,7, 1,0,6,3, 0,4,7,6, 0,5,0,4, 1,5,7,0, 4,6,6,1, 7,0,5,1,
6,0,6,4, 6,6,1,4, 6,3,3,2, 1,4,4,1, 4,6,7,2, 6,2,4,6, 1,0,5,0, 4,0,5,4, 4,2,5,2, 7,2,4,4, 7,3,6,4, 7,5,6,5, 6,5,5,3, 2,3,4,7, 5,7,2,7, 1,5,5,3,
0,3,5,4, 2,1,3,7, 1,5,4,4, 3,7,5,5, 5,4,7,0, 7,7,1,0, 5,4,7,0, 4,6,7,1, 0,0,3,4, 5,4,7,0, 3,3,2,2, 2,0,3,2, 7,0,0,3, 0,5,3,7, 1,4,2,3, 5,3,5,7,
1,3,3,1, 0,1,1,6, 5,1,5,1, 5,0,7,0, 2,5,7,6, 7,7,3,1, 0,3,1,4, 2,3,5,1, 4,0,2,1, 7,1,1,7, 4,5,0,1, 0,0,3,6, 6,6,6,3, 7,3,2,6, 0,3,7,5, 1,0,1,6.

#### C.5.1.4.3 Forward error correction.

BW1 carries a payload of 48 protocol bits. The 48 protocol bits are coded using the  $r = 1/3$ ,  $k = 9$  convolutional encoder shown in figure C-8, creating 144 coded bits. A ‘tail-biting’ convolutional encoding approach is used as follows:

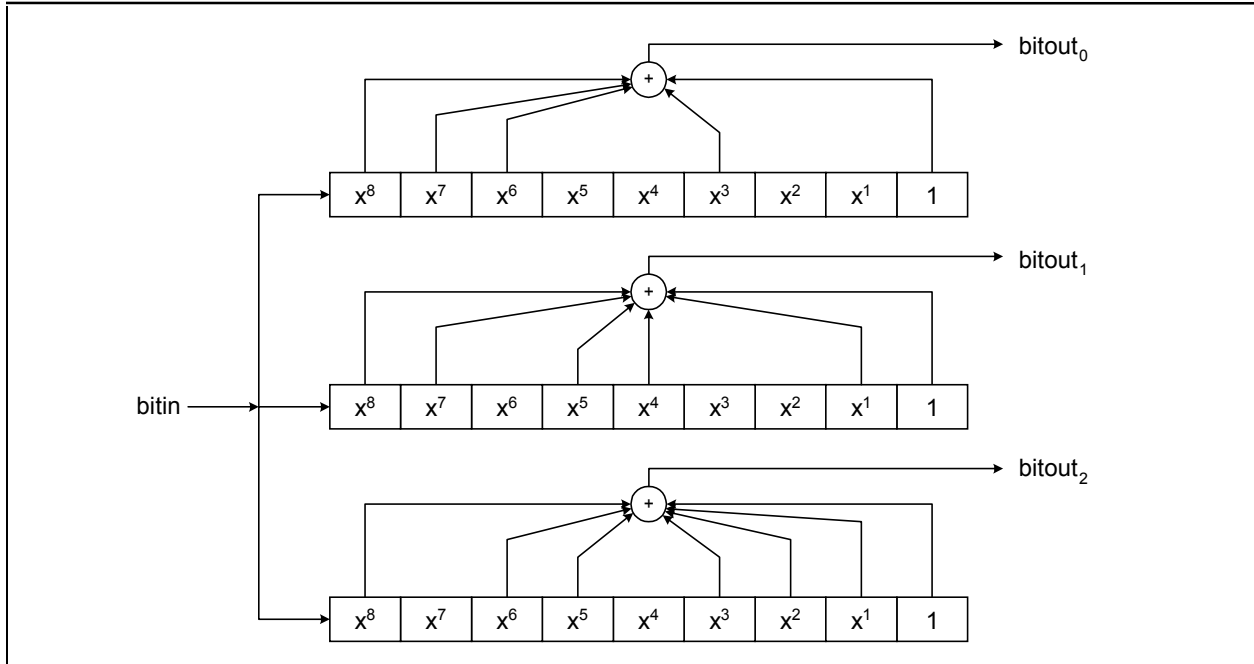
1. Initialize the eight memory cells  $x^1 \dots x^8$  of the encoder with the last eight bits of the payload sequence,  $p_{40} \dots p_{47}$ , so that cell  $x^1$  contains  $p_{40}$  and cell  $x^8$  contains  $p_{47}$ .
2. Shift the first bit of the payload sequence,  $p_0$ , into cell  $x^8$ .
3. Extract the first three coded output bits  $bitout_0$ ,  $bitout_1$ , and  $bitout_2$ , in that order, as shown in figure C-8.
4. Shift the next payload bit into cell  $x^8$ , then extract the three coded output bits  $bitout_0$ ,  $bitout_1$ , and  $bitout_2$ .
5. Repeat step 4 until a total of 144 coded bits have been produced.

No flush bits are necessary for the encoding process. The polynomials used are:

- $\text{Bitout}_0 = x^8 + x^7 + x^6 + x^3 + 1$
- $\text{Bitout}_1 = x^8 + x^7 + x^5 + x^4 + x^1 + 1$
- $\text{Bitout}_2 = x^8 + x^6 + x^5 + x^3 + x^2 + x^1 + 1$

where  $x^8$  corresponds to the most recent encoder input bit.

The order of output to the interleaving process is  $\text{Bitout}_0$  then  $\text{Bitout}_1$  then  $\text{Bitout}_2$ .



**FIGURE C-8. Rate 1/3, constraint length 9 convolutional encoder.**

C.5.1.4.4 Interleaving.

See C.5.1.2 for a description of the interleaving process. The interleaver parameters for BW1 are as follows:



**TABLE C-XII. Interleaver parameters for BW1.**

R	16
C	9
$i_{rs}$	0
$i_{cs}$	1
$\Delta i_{rs}$	1
$\Delta i_{cs}$	0
$i_{rf}$	1
$i_{cf}$	0
$\Delta i_{rf}$	0
$\Delta i_{cf}$	1

See C.5.1.2 for a complete description of the block interleaving process used by the various burst waveforms.

**C.5.1.4.5 Orthogonal symbol formation.**

The interleaver fetch process removes 4 coded bits at a time from the interleaver matrix. These 4 coded bits are mapped into a 16-tribit sequence using the mapping given in table C-VIII. Note that each of the four-bit sequences in the Coded Bits column of the table is of the form  $b_3b_2b_1b_0$ , where  $b_3$  is the first bit fetched from the interleaver matrix. The tribit values are placed in the output tribit sequence in the order in which they appear in the corresponding row of table C-VIII, moving from left to right across the row. The 16-tribit sequence thus obtained is repeated 4 times to obtain a 64-tribit sequence. This process repeats for a total of 36 iterations to produce 2304 raw tribit values.

**C.5.1.4.6 PN spreading sequence generation and application.**

A sequence of 2304 pseudo-random tribit values  $s_i$  is generated by repeating the 256-tribit sequence presented in table C-XIII,  $2304 / 256 = 9$  times. The tribit values are used in the order shown in table C-XIII, starting at the top left and moving from left to right across each row, and from top to bottom through successive rows.

**TABLE C-XIII. BW1 PN spreading sequence.**

0,2,4,3, 3,6,4,5, 7,6,7,0, 5,5,4,3, 5,4,3,7, 0,7,6,2, 6,2,4,6, 7,2,4,7, 5,5,7,0, 7,3,3,3, 7,3,3,1, 4,2,3,7, 0,2,7,7, 3,5,1,0, 1,4,0,5, 0,0,0,0,
6,5,0,1, 2,7,6,5, 5,2,7,3, 3,3,2,1, 2,5,6,1, 3,4,2,1, 0,1,2,3, 6,4,7,5, 2,2,6,2, 7,6,5,2, 4,6,5,4, 7,2,5,1, 0,0,7,7, 3,5,4,2, 1,4,2,7, 0,3,4,0,
0,0,7,7, 3,5,4,2, 1,4,2,7, 0,3,4,0, 1,0,5,2, 6,0,3,5, 1,0,5,1, 5,2,5,6, 3,2,3,7, 1,2,2,0, 7,1,3,6, 4,2,6,2, 7,4,3,7, 6,7,2,3, 1,7,4,1, 5,1,5,4,
7,1,1,2, 3,6,7,7, 6,6,1,2, 2,4,1,7, 7,5,5,4, 7,7,5,0, 7,3,7,5, 7,7,5,0, 6,6,6,1, 3,4,4,4, 0,3,3,2, 1,4,5,4, 5,3,1,1, 1,2,5,1, 7,1,5,7, 2,0,0,6.

The 2304 tribit values  $s_i$  of the PN sequence are then combined with the 2304 raw tribit values  $r_i$  produced by the orthogonal symbol formation process described in the previous section. Each symbol of the PN sequence  $s_i$  is combined with the corresponding symbol  $r_i$  of the raw tribit sequence to form a channel symbol  $c_i$ , by adding  $s_i$  to  $r_i$  modulo 8. For instance, if  $s_i = 7$ ,  $r_i = 4$ , then  $c_i = 7 \oplus 4 = 3$ , where the symbol  $\oplus$  represents modulo-8 addition.

The process can be summarized:

$$\begin{bmatrix} c_0 \\ \vdots \\ c_{2303} \end{bmatrix} = \begin{bmatrix} r_0 \\ \vdots \\ r_{2303} \end{bmatrix} \oplus \begin{bmatrix} s_0 \\ \vdots \\ s_{2303} \end{bmatrix}$$

where  $r$  is the vector of data raw tribit values,  $s$  is the vector of PN sequence tribit values,  $c$  is the resulting vector of combined tribit values, and the symbol  $\oplus$  represents component-wise modulo-8 addition.

#### C.5.1.4.7 Modulation.

The sequence of channel symbols consisting of

- the TLC/AGC guard sequence of 256 tribit symbols described by C.5.1.4.1 (on which no PN-spreading has been performed), followed by
- the acquisition preamble sequence of 576 tribit symbols described by C.5.1.4.2 (on which no PN-spreading has been performed), followed by
- the 2304-length sequence of BW1 channel symbols (data symbols), PN-spread as described in C.5.1.4.6,

is used to PSK modulate an 1800 Hz carrier signal at 2400 channel symbols/sec.

See C.5.1.8 for a description of how the channel symbol values are mapped to carrier phases and the subsequent carrier modulation process.

#### C.5.1.5 Burst Waveform 2 (BW2).

Burst Waveform 2 (BW2) is used for transfers of traffic data by the HDL protocol. Figure C-9 summarizes the structure and timing characteristics of the BW2 waveform.

BW2 is used to transmit a sequence of data packets from a transmitting station to a receiving station, where a data packet is defined as a fixed-length sequence of precisely 1913 data bits. The HDL protocol process (described in C.5.2) causes BW2 to modulate a Forward Transmission containing a sequence of data packets by invoking the BW2\_Send primitive. The BW2\_Send primitive has two parameters:

- payload: a sequence of NumPKTs data packets, where NumPKTs = 3, 6, 12, or 24; and
- reset: a boolean parameter which is set to TRUE by the HDL protocol for the first Forward Transmission performed in delivering a datagram, and set to FALSE at all other times. reset = TRUE causes counters used in BW2's FEC encoding and PN spreading processes to be reinitialized.

C.5.2 describes the manner in which the HDL protocol determines the values assigned to these parameters.

The total duration of the Forward Transmission phase of the HDL protocol is  $0.64 + (0.40 * \text{NumPKTs})$  seconds, and includes a constant-length portion and a variable-length portion. The constant-length portion has a fixed duration of 0.64 seconds ( $T_{\text{FORWARD}} - T_{\text{DATA}}$ ), which includes:

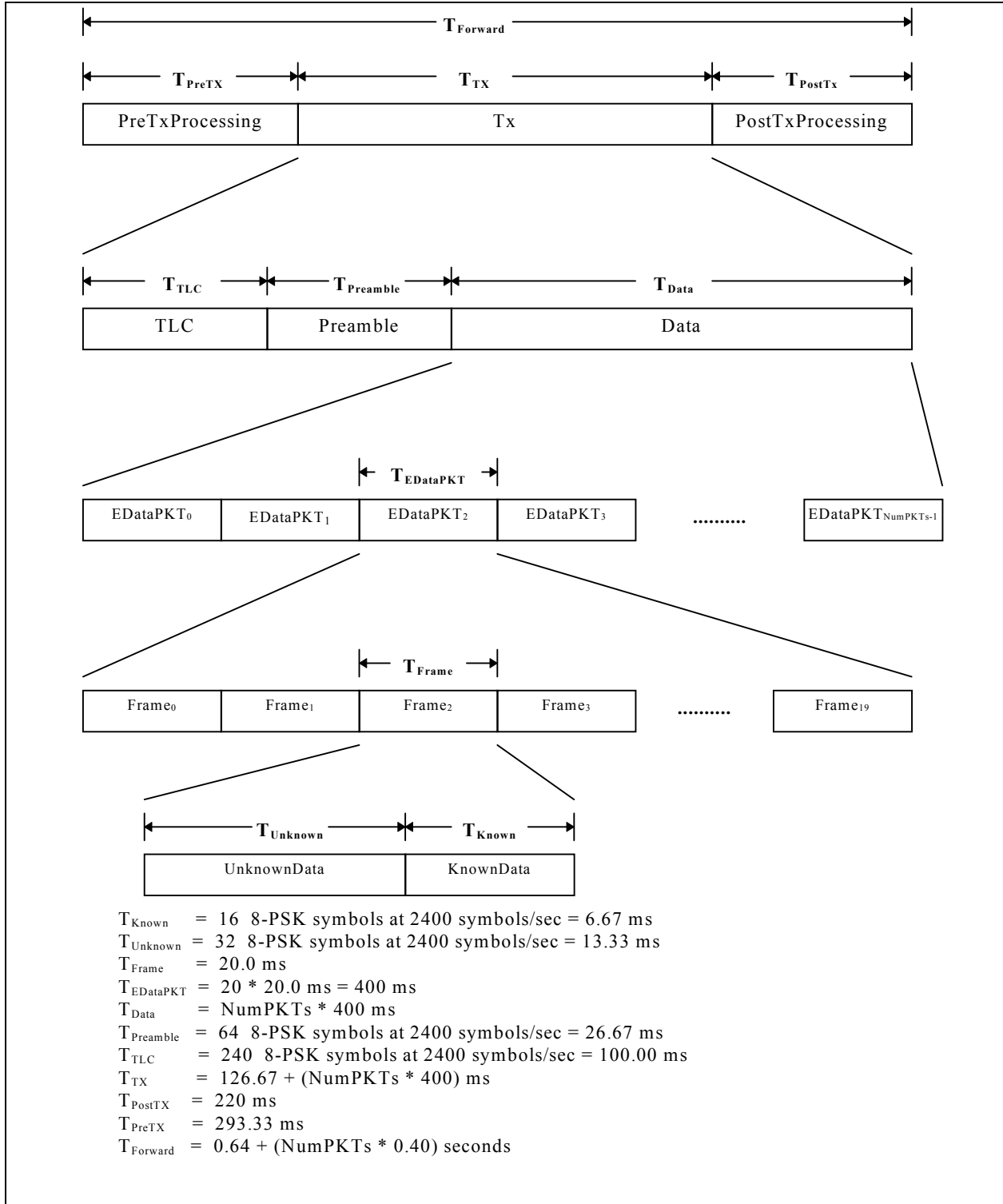
- a PreTxProcessing interval of 293.33 ms (704 PSK symbol times, at 2400 symbols per second), in which no waveform is transmitted or received
- a PostTxProcessing interval of 220 ms (528 PSK symbol times, at 2400 symbols per second), in which no waveform is transmitted or received
- a TLC/AGC guard sequence of 240 PSK symbols, with a duration of 100 ms ( $T_{\text{TLC}}$ )
- a BW2 acquisition preamble sequence of 64 PSK symbols, with a duration of 26.67 ms ( $T_{\text{PRE}}$ ).

The variable-length portion has a duration ( $T_{\text{DATA}}$ ) of  $400 * \text{NumPKTs}$  milliseconds (equal to  $960 * \text{NumPKTs}$  PSK symbol times).

The BW2 modulation process uses a count variable, FTcount, to keep track of how many Forward Transmissions have occurred in transmitting the current datagram. At the start of each Forward Transmission, FTcount is initialized to zero if and only if the reset parameter of the current invocation of BW2\_Send is TRUE. At the end of each Forward Transmission, FTcount is incremented. The value of FTcount is used in FEC encoding (as described in C.5.1.5.5), in rotating the modulation symbols containing FEC-coded data (as described in C.5.1.5.8), and in generating the spreading symbol sequence used to PN-spread the BW2 gray-coded modulation symbols (as described in C.5.1.5.8).

The subsections of this describe the manner in which the values of the symbols in the TLC/AGC guard sequence, the preamble sequence, and the variable-length data portion of each Forward Transmission are determined, and then describe the manner in which the resulting symbol sequence is PN-spread and modulated.

MIL-STD-188-141B  
APPENDIX C



**FIGURE C-9. BW2 waveform structure and timing characteristics.**

C.5.1.5.1 TLC/AGC guard sequence.

The TLC/AGC guard sequence portion of the BW2 waveform provides an opportunity for both the transmitting radio's Transmit Level Control process (TLC) and the receiving radio's Automatic Gain Control process (AGC) to reach steady states before the BW2 preamble appears at their respective inputs, minimizing the distortion to which the preamble can be subjected by these processes. The BW2 TLC/AGC guard sequence is composed of the first 240 of the pseudo-random tribit symbol values shown in table C-X. The tribit symbols are transmitted in the order shown in table C-X, starting at the top left and moving from left to right across each row, and from top to bottom through successive rows.

For convenience of implementation, the length of the TLC/AGC guard sequence (240 PSK symbols) has been chosen so as to be an integral multiple of the length of an unknown/known symbol frame as described in C.5.1.5.7.

The TLC/AGC guard sequence symbols are modulated directly as described in C.5.1.5.9, without undergoing PN spreading as described in C.5.1.5.8.

C.5.1.5.2 Acquisition preamble.

The BW2 acquisition preamble is a sequence of 64 tribit symbols all having values of zero (000). The BW2 acquisition preamble symbols undergo PN spreading as described in C.5.1.5.8; the PN-spread preamble symbols are then modulated as described in C.5.1.5.9.

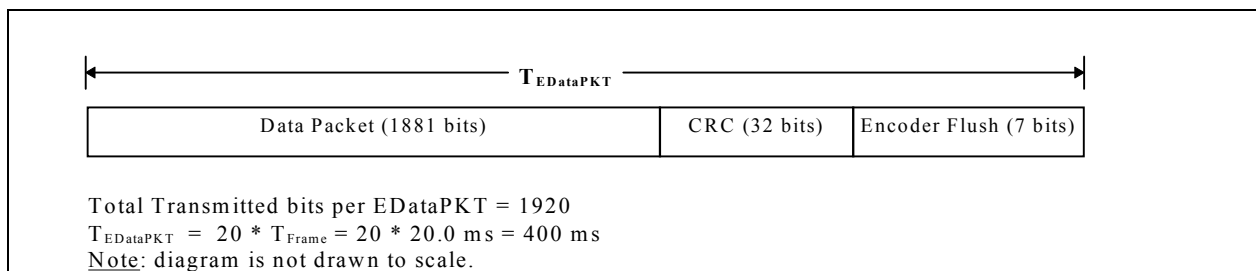
C.5.1.5.3 CRC computation.

A 32-bit Cyclic Redundancy Check (CRC) value is computed across the 1881 payload data bits in each data packet, and is then appended to the data packet. The generator polynomial used in computing the CRC is:

$$X^{32} + X^{26} + X^{23} + X^{22} + X^{16} + X^{12} + X^{11} + X^{10} + X^8 + X^7 + X^5 + X^4 + X^2 + X^1 + 1.$$

Other details of the CRC computation procedure are as defined in C.4.1.

C.5.1.5.4 Data packet extension.

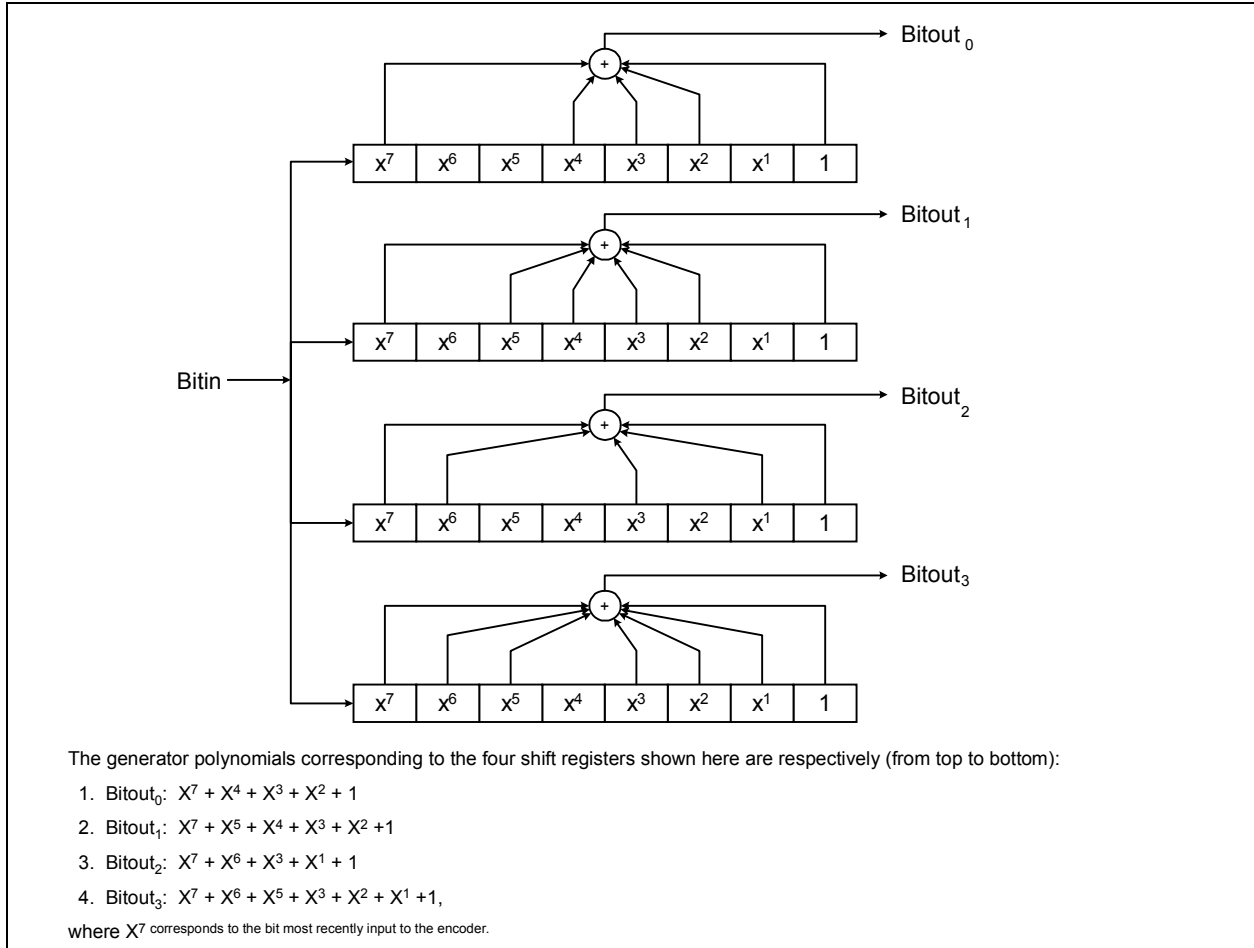


**FIGURE C-10. Data packet extension with encoder flush bits.**

As is shown in figure C-10, seven encoder flush bits with values of zero are appended to the 1913 payload and CRC bits of each data packet to produce an extended data packet, known henceforth as an 'EDataPkt' (i.e., an "Extended Data Packet"). Note that the further processing (FEC, symbol formation, and frame formation) of each EDataPKT is not affected by the presence of the CRC and flush bits in the EDataPKT; in these processes, each EDataPKT is treated as an arbitrary sequence of 1920 bits. As described below, each 1920-bit EDataPKT is transformed into 20 frames of 48 PSK symbols each. Each of the 32 known 8-PSK symbols in a frame carries three data bits, so that each frame carries 96 of the 1920 bits in an EDataPKT.

#### C.5.1.5.5 Forward error correction.

The 1920 bits in each EDataPkt are convolutionally encoded using the rate 1/4, constraint length 8, non-systematic convolutional encoder shown in figure C-11. The encoder produces 4 encoded bits:  $Bitout_0$ ,  $Bitout_1$ ,  $Bitout_2$ , and  $Bitout_3$ , for each single input bit. As each EDataPkt is encoded, the coded bits from each of the four coded bit streams are accumulated into a block of 1920 coded bits. This produces a total of four Encoded Blocks of 1920 bits each ( $EBlk_0$  through  $EBlk_3$ , where each  $EBlk_k$  is composed solely of output bits from  $Bitout_k$ ). Only one of the four Encoded Blocks resulting from the encoding of each EDataPkt is transmitted in each Forward Transmission. Which of the four Encoded Blocks is transmitted is determined by the value of the BW2 modulation process's FTcount variable: the Encoded Block transmitted is  $EBlk_n$  (containing coded data bits from  $Bitout_n$ ), where  $n = FTcount \bmod 4$ . For instance, the sixth Forward Transmission of a datagram contains  $EBlk_1$  (since  $FTcount = 5$  and  $5 \bmod 4 = 1$ ) for every EDataPkt in the Forward Transmission. Each successive retransmission of a EDataPkt contains a different Encoded Block derived from the EDataPkt contents, providing the decoder at the remote station with additional information as to the contents of the EDataPkt.



**FIGURE C-11. Rate 1/4, constraint length 8 convolutional encoder.**

The seven zeroes in the Encoder Flush field at the end of each EDataPkt return the convolutional encoder to its initial (all-zero) state before it starts to encode the contents of the next EDataPkt.

#### C.5.1.5.6 Modulation Symbol formation.

Once the NumPKTs encoded blocks for each forward transmission have been produced, the contents of the encoded blocks are formed into three-bit modulation symbols. Each modulation symbol is formed by taking three bits one at a time from the current Encoded Block, starting with the first bit of the first Encoded Block, and shifting them successively into the modulation symbol's least significant bit-position (so that the first bit of the three is eventually placed in the most significant bit-position). This continues until  $1920/3 = 640$  modulation symbols have been formed for each Encoded Block.

The modulation symbols for all Encoded Blocks are then rotated toward the least significant bit-position (so that  $M_2M_1M_0$  becomes  $M_0M_2M_1$ ), FTcount mod 3 times. This causes each successive transmission of an Encoded Block to have its data contents mapped onto different modulation symbol values. After this rotation has been performed, the rotated modulation symbols are gray-coded as shown in table C-XIV, yielding a sequence of gray-coded modulation symbols.

**TABLE C-XIV. Gray coding table.**

<b>Input Data (Modulation Symbol)</b>	<b>Output Data (Gray-Coded Modulation Symbol)</b>
000	000
001	001
010	011
011	010
100	111
101	110
110	100
111	101

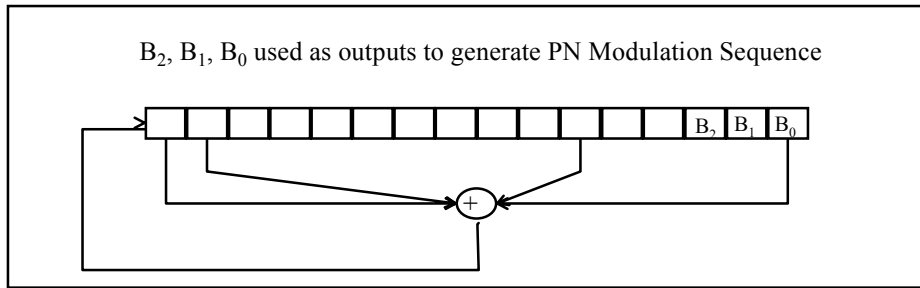
**C.5.1.5.7 Frame formation.**

Once the NumPKTs Encoded Blocks have been formed into modulation symbols, rotated, and gray-coded, the resulting gray-coded modulation symbols are formed into Frames. Each Frame (as shown on figure C-9) is formed by taking the next 32 consecutive gray-coded modulation symbols (known as “unknown symbols” because they contain coded payload data not known a priori) from the sequence produced as described in the previous section, and appending to them 16 known symbols having symbol values equal to zero (000). The 640 gray-coded modulation symbols for each Encoded Block are incorporated into the unknown sections of 20 Frames (since  $640/32 = 20$ ). For a Forward Transmission containing NumPKTs EDataPkts, there will therefore be  $(20 * \text{NumPKTs})$  Frames, each containing 32 gray-coded modulation symbols (unknown symbols) derived from encoded payload data, followed by 16 known symbols having values of zero.

**C.5.1.5.8 PN spreading sequence generation and application.**

The length  $2^{16}-1$  Maximum-Length Sequence Generator shown in figure C-12 is used to PN-spread the sequence of modulation symbols (tribits) consisting of the 64 symbols of the BW2 acquisition preamble described by C.5.1.5.2, followed by the  $(960 * \text{NumPKTs})$  gray-coded modulation symbols generated as described in sections C.5.1.5.3 through C.5.1.5.7.





**FIGURE C-12.  $2^{16} - 1$  maximum-length sequence generator.**

The Forward Transmission count variable FTcount (described in C.5.1.5) is used in initializing the state of the sequence generator: at the start of each Forward Transmission, the state of the generator is initialized to  $(0xAB91 + FTcount) \bmod 0x10000$ .

The outputs of the sequence generator are used to PN-spread the modulation symbols as follows:

1. For each input symbol (preamble symbol or gray-coded modulation symbol), a three-bit spreading symbol is formed by cycling the PN generator three times, and then taking the three least significant bits B<sub>2</sub>, B<sub>1</sub>, and B<sub>0</sub> (as shown in figure C-12) from the shift register, with B<sub>2</sub> becoming the most significant bit of the spreading symbol.
2. The spreading symbol is then summed modulo 8 with the input symbol to form a three-bit channel symbol.

This is performed for each of the 64 preamble symbols and each of the  $(960 * \text{NumPKTs})$  gray-coded modulation symbols. Note that since all of the preamble symbols and the known modulation symbols were filled with zero values (000), and the Gray-coding of zero yields zero, the preamble channel symbols and the known channel symbols actually contain the spreading symbols.

#### C.5.1.5.9 Modulation.

The sequence of channel symbols consisting of:

- the TLC/AGC guard sequence described by C.5.1.5.1 (on which no gray-coding or PN-spreading has been performed), followed by
- the 64-length sequence of BW2 acquisition preamble symbols described by C.5.1.5.2, PN-spread as described in C.5.1.5.8; followed by
- the  $(960 * \text{NumPKTs})$  gray-coded modulation symbols generated as described in C.5.1.5.3 through C.5.1.5.7, and PN-spread as described in C.5.1.5.8,

is used to PSK modulate an 1800 Hz carrier signal at 2400 channel symbols/sec.

See C.5.1.8 for a description of how the channel symbol values are mapped to carrier phases and the subsequent carrier modulation process.

C.5.1.6 Burst Waveform 3 (BW3).

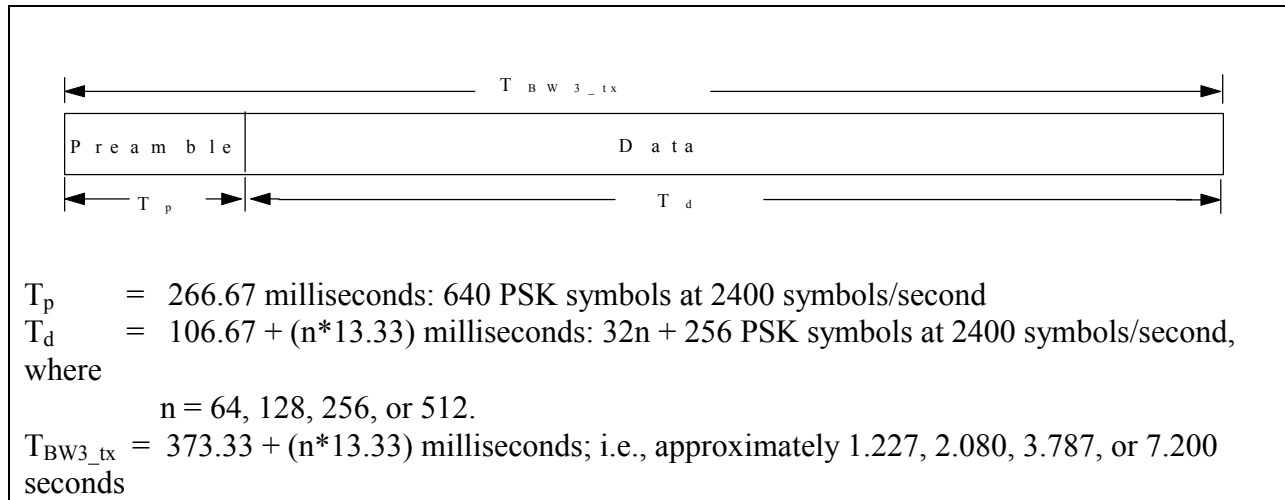
Burst Waveform 3 (BW3) is used for transfers of traffic data by the LDL protocol. Figure C-13 summarizes the structure and timing characteristics of the BW3 waveform.

BW3 is used to transmit a single data packet from a transmitting station to a receiving station, where a data packet is defined as a fixed-length sequence of 537, 1049, 2073, or 4121 bits. The number of bits in a BW3 data packet is of the form  $8n+25$ , where  $n = 64, 128, 256, \text{ or } 512$ . The value 'n' used throughout this section refers to the number of payload data bytes (or octets) carried by each LDL protocol forward transmission; the additional 25 bits of payload in each BW3 transmission are LDL overhead. BW3 is used only to deliver forward transmissions of the LDL protocol described in C.5.5.

The LDL protocol process causes the generation of a BW3 waveform by invoking the BW3\_Send primitive. The BW3\_Send primitive has two parameters:

- payload: the  $(8n+25)$ -bit data packet to be transmitted; and
- reset: a boolean parameter which is set to TRUE by the LDL protocol for the first Forward Transmission performed in delivering a datagram, and set to FALSE at all other times. reset = TRUE causes the Forward Transmission counter FTcount used in BW3's FEC encoding process to be reinitialized.

C.5.5 describes the manner in which the LDL protocol determines the values assigned to these parameters.



**FIGURE C-13. BW3 timing.**

The BW3 modulation process maintains a count variable, FTcount, to keep track of how many forward transmissions have occurred in transmitting the current datagram. FTcount is initialized to zero upon reception of a BW3\_Send PDU having its reset parameter set to TRUE. At the end of each BW3 forward transmission, FTcount is incremented by one. The value of FTcount is used in FEC encoding as described in C.5.1.6.3.

The description of BW3 waveform generation will proceed as follows:

- Section C.5.1.6.1 will discuss generation of tribit values for the Preamble waveform component.
- Sections C.5.1.6.2, C.5.1.6.3, C.5.1.6.4, and C.5.1.6.5 will discuss the mapping of input bits to raw tribit values for the data waveform component via CRC computation, FEC, interleaving, and orthogonal Walsh symbol formation.
- Section C.5.1.6.6 will discuss the generation of tribit values for the PN spreading sequence and the combining of these PN spreading sequence tribit values with the raw tribit values for the data waveform component.
- Section C.5.1.6.8 will discuss carrier modulation using the preamble and PN-spread data tribit values.

#### C.5.1.6.1 Preamble.

This portion of the burst waveform provides an opportunity for both the transmitting radio's Transmit Level Control process (TLC) and the receiving radio's Automatic Gain Control process (AGC) to reach steady states, and provides an opportunity for the receiver to detect the presence of the waveform and to estimate various channel parameters for use in data demodulation. The preamble component of BW3 is a sequence of 640 tribit values having the values shown in table C-XV. The preamble symbols are transmitted in the order shown in table C-XV, starting at the top left and moving from left to right across each row, and from top to bottom through successive rows. The preamble symbols are modulated directly as described in section C.5.1.4.7, without undergoing PN spreading as described in section C.5.1.6.6.

A TLC/AGC guard sequence is not provided as an explicit part of the BW3 waveform, since the correlation-based receive processing of the BW3 waveform is relatively insensitive to such signal perturbations as are likely to be introduced by the TLC and AGC processes. The duration of the BW3 preamble includes sufficient time for preamble acquisition to be performed after the TLC and AGC processes have settled.

**TABLE C-XV. BW3 preamble symbol values.**

7,2,3,5, 7,5,0,6, 7,5,3,5, 6,3,5,4, 7,1,4,5, 7,7,3,5, 0,5,1,6, 0,3,1,0, 2,7,6,2, 4,4,2,0, 0,7,2,0, 2,3,7,4, 1,1,3,0, 1,3,6,3, 0,1,3,1, 5,4,5,6, 3,2,5,2, 6,0,6,6, 0,4,6,3, 7,1,7,0, 6,2,1,5, 5,2,2,5, 3,3,3,2, 1,4,7,0, 0,2,0,2, 5,7,5,7, 7,5,3,6, 2,2,1,6, 4,4,7,1, 5,4,7,2, 7,5,6,1, 1,5,0,0,
1,4,0,5, 3,4,7,3, 6,2,2,5, 4,0,2,7, 6,2,7,1, 6,5,5,3, 2,3,2,5, 7,7,3,7, 3,2,2,2, 4,0,0,7, 5,4,5,3, 5,0,3,3, 3,0,6,4, 6,5,6,4, 2,7,6,2, 6,6,1,0, 5,1,0,7, 1,4,2,7, 6,0,1,6, 7,5,6,1, 1,7,5,1, 0,0,1,0, 3,1,7,4, 5,4,4,5, 4,3,2,0, 4,1,6,6, 2,7,6,4, 4,6,2,2, 3,0,3,5, 2,1,1,6, 2,7,6,2, 2,5,7,1,
2,5,5,6, 4,0,7,1, 7,2,3,2, 5,2,0,2, 2,2,0,3, 6,6,6,2, 5,5,5,6, 0,0,2,3, 6,7,6,5, 7,2,2,4, 5,5,2,5, 7,3,2,7, 0,3,0,1, 4,1,6,2, 5,7,0,1, 6,0,1,6, 5,1,3,6, 5,4,2,0, 4,4,2,1, 2,6,1,1, 0,1,1,3, 5,7,5,0, 4,3,1,5, 3,0,0,4, 5,6,7,5, 7,6,1,5, 5,1,2,7, 5,0,3,6, 3,5,2,7, 0,6,6,0, 6,5,4,2, 7,5,6,0,
4,1,7,0, 4,7,4,7, 3,1,2,3, 7,2,2,6, 7,5,1,6, 6,7,2,5, 6,4,0,3, 0,4,7,1, 6,2,5,4, 3,6,0,6, 6,5,3,3, 4,4,5,1, 2,6,7,3, 1,3,0,7, 7,4,6,2, 5,2,0,7, 3,6,7,6, 3,6,3,1, 4,4,6,3, 7,7,6,4, 4,5,2,2, 5,4,7,4, 5,6,2,6, 0,2,4,6, 3,3,4,3, 5,5,0,7, 6,3,1,6, 0,2,2,0, 4,2,6,7, 7,2,0,5, 1,3,7,6, 3,7,2,0,
1,6,3,5, 1,0,3,7, 5,4,6,7, 2,4,0,0, 2,2,7,1, 2,6,3,3, 7,1,7,7, 4,1,2,2, 5,4,0,3, 3,5,6,1, 0,4,5,6, 7,1,2,0, 3,1,6,2, 4,6,1,5, 6,7,7,2, 6,3,7,6, 7,2,3,4, 4,4,6,0, 4,3,7,7, 1,5,7,1, 3,4,5,6, 6,3,2,3, 4,4,0,1, 4,0,3,6, 7,3,5,0, 3,0,7,1, 0,5,4,5, 4,4,3,7, 6,1,1,5, 0,1,1,1, 4,6,0,7, 2,5,4,3.

#### C.5.1.6.2 CRC computation.

A 32-bit Cyclic Redundancy Check (CRC) value is computed across the payload data bits in the data packet, and is then appended to the data packet. The generator polynomial used in computing the CRC is:

$$X^{32} + X^{26} + X^{23} + X^{22} + X^{16} + X^{12} + X^{11} + X^{10} + X^8 + X^7 + X^5 + X^4 + X^2 + X^1 + 1.$$

Other details of the CRC computation procedure are as defined in C.4.1.

#### C.5.1.6.3 Forward error correction.

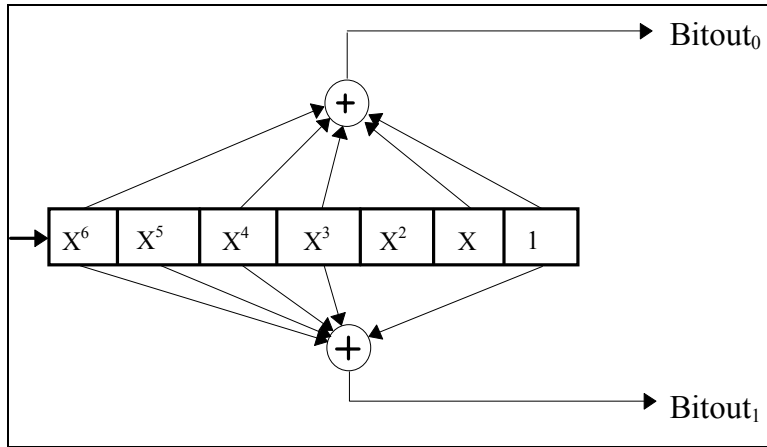
7 flush bits having the value 0 are appended to the (8n+57) bits of the data packet with CRC to ensure that the encoder is in the all-zero state upon encoding the last flush bit. The data and CRC bits and the 7 flush bits are coded using the  $r = 1/2$ ,  $k = 7$  convolutional encoder shown in C-14.

NOTE 1. Since BW3 uses a  $k=7$  convolutional code, only 6 bits are literally needed to flush the encoder. The seventh 'flush bit' is added purely for convenience -- to make the number of coded bits per BW3 transmission a multiple of four, so that each group of four bits can then be mapped to an orthogonal symbol as described below.

NOTE 2. The generator polynomials corresponding to Bitout0 and Bitout1 are:

- Bitout<sub>0</sub>:  $X^6 + X^4 + X^3 + X + 1$

- Bitout<sub>1</sub>:  $X^6+X^5+X^4+X^3+1$
- where  $X^6$  corresponds to the most recent input bit.



**FIGURE C-14. BW3 rate 1/2, k=7 convolutional encoder.**

This encoder produces two encoded bits, Bitout<sub>0</sub> and Bitout<sub>1</sub>, for each single input bit. Encoding an entire sequence of  $(8n+57)$  data and CRC bits followed by 7 flush bits results in two encoded blocks of  $(8n+64)$  coded bits each, EBlk<sub>0</sub> and EBlk<sub>1</sub>, where each EBlk<sub>k</sub> is made up solely of output bits from Bitout<sub>k</sub>. In each forward transmission, only coded bits from EBlk <sub>$(FTcount \text{ mod } 2)$</sub>  are passed forward to the interleaving process, where FTcount is the forward transmission count variable described in C.5.1.6; the encoded bits from the other encoded block are retained to possibly be transmitted in one or more subsequent forward transmissions. For instance, the fourth forward transmission of a data packet contains the coded bits from EBlk<sub>1</sub> (since  $FTcount = 3$  and  $3 \text{ mod } 2 = 1$ ).

#### C.5.1.6.4 Interleaving.

See C.5.1.2 for a description of the interleaving process. The interleaver parameters for BW3 depend on the value  $\underline{n}$  (which determines the BW3 payload size), as shown in table C-XVI.

**TABLE C-XVI. Interleaver parameters for BW3.**

n	64	128	256	512
R	24	32	44	64
C	24	34	48	65
$i_{rs}$	7	7	7	7
$i_{cs}$	0	0	0	0
$\Delta i_{rs}$	0	0	0	0
$\Delta i_{cs}$	1	1	1	1
$i_{rf}$	1	1	1	1
$i_{cf}$	-7	-7	-7	-7
$\Delta i_{rf}$	0	0	0	0
$\Delta i_{cf}$	-7	-7	-7	-7

**C.5.1.6.5 Orthogonal symbol formation.**

The interleaver fetch process removes 4 coded bits at a time from the interleaver matrix. These 4 coded bits are mapped into a 16-tribit sequence using the mapping given in tabel C-VIII. Note that each of the four-bit sequences in the Coded Bits column of the table is of the form  $b_3b_2b_1b_0$ , where  $b_3$  is the first bit fetched from the interleaver matrix. The tribit values are placed in the output tribit sequence in the order in which they appear in the corresponding row of table C-VIII, moving from left to right across the row. This process repeats for a total of  $2n+16$  iterations to produce the  $32n+256$  raw tribit values of the data portion of BW3.

**C.5.1.6.6. PN spreading sequence generation and application.**

A sequence of  $32n+896$  pseudo-random tribit values  $s_i$  is generated by repeating the 32-tribit sequence presented in table C-XVII,  $(32n+256) / 32 = n+8$  times. The tribit values are used in the order shown in table C-XVII, starting at the top left and moving from left to right across each row, and from top to bottom through successive rows.

**TABLE C-XVII. BW3 PN spreading sequence.**

$0,0,0,0, 0,2,4,6, 0,4,0,4, 0,6,4,2,$ $0,0,0,0, 1,3,5,7, 2,6,2,6, 3,1,7,5.$
--

The  $32n+256$  tribit values  $s_i$  of the PN sequence are then combined with the  $32n+256$  raw tribit values  $r_i$  produced by the orthogonal symbol formation process described in the preceding section. Each symbol of the PN sequence  $s_i$  is combined with the corresponding symbol  $r_i$  of the raw tribit (data) sequence to form a channel symbol  $c_i$ , by adding  $s_i$  to  $r_i$  modulo 8. For instance, if  $s_i = 7, r_i = 4$ , then  $c_i = 7 \oplus 4 = 3$ , where the symbol  $\oplus$  represents modulo-8 addition.

The process can be summarized:

$$\begin{bmatrix} c_0 \\ \vdots \\ c_{32n+255} \end{bmatrix} = \begin{bmatrix} r_{d0} \\ \vdots \\ r_{d_{32n+255}} \end{bmatrix} \oplus \begin{bmatrix} s_0 \\ \vdots \\ s_{32n+255} \end{bmatrix}$$

where  $r_d$  is the vector of data raw tritbit values,  $s$  is the vector of PN sequence tritbit values,  $c$  is the resulting vector of combined tritbit values, and the symbol  $\oplus$  represents component-wise modulo-8 addition.

#### C.5.1.6.7 Modulation.

The sequence of channel symbols consisting of

- the preamble sequence of 640 tritbit symbols described by section C.5.1.6.1 (on which no PN-spreading has been performed), followed by
- the sequence of  $(32n+256)$  BW3 channel symbols (data symbols), PN-spread as described in section C.5.1.6.6,

is used to PSK modulate an 1800 Hz carrier signal at 2400 Channel Symbols/sec. See section C.5.1.8 for a description of how combined tritbit values are mapped to carrier phases and the subsequent carrier modulation process.

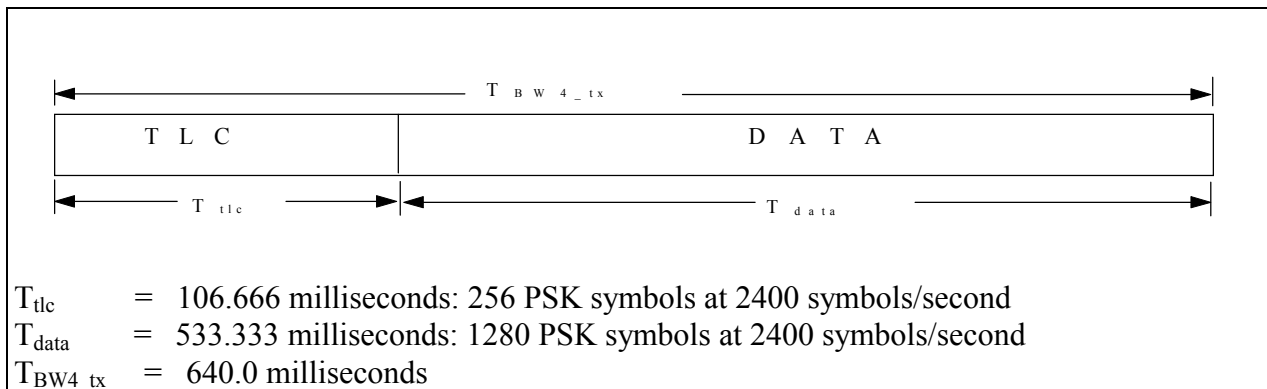
#### C.5.1.7 Burst Waveform 4 (BW4).

Burst Waveform 4 (BW4) is used to convey the LDL protocol's LDL\_ACK PDU. Figure C-15 summarizes the structure and timing characteristics of the BW4 waveform.

A user process (the LDL protocol) causes the generation of a BW4 waveform by issuing a BW4\_Send primitive. The BW4\_Send primitive has one parameter:

- payload: the two bits of payload data to be transmitted.

C.5.5 describes the manner in which values are assigned to the payload parameter.



**FIGURE C-15. BW4 timing.**

The description of the BW4 waveform generation will proceed as follows:

- C.5.1.7.1 will discuss generation of raw tribit values for the TLC/AGC guard sequence
- C.5.1.7.2 will discuss the mapping of input bits to the raw tribit values for the Data waveform component.
- C.5.1.7.3 will discuss the combining of raw tribit values with the PN spreading sequence tribit values.
- C.5.1.7.4 will discuss carrier modulation using combined tribit values.

**C.5.1.7.1 TLC/AGC guard sequence.**

The TLC/AGC guard sequence portion of the BW4 waveform provides an opportunity for both the transmitting radio's Transmit Level Control process (TLC) and the receiving radio's Automatic Gain Control process (AGC) to reach steady states before the BW4 preamble appears at their respective inputs, minimizing the distortion to which the preamble can be subjected by these processes. The TLC/AGC guard sequence is a sequence of 256 pseudo-random tribit symbols having the values shown in table C-X. The tribit symbols are transmitted in the order shown in table C-X, starting at the top left and moving from left to right across each row, and from top to bottom through successive rows.

The TLC/AGC guard sequence symbols are modulated directly as described in C.5.1.7.4, without undergoing PN spreading as described in C.5.1.7.3.

**C.5.1.7.2 Orthogonal symbol formation.**

BW4 carries a payload of two protocol bits. The two protocol bits are mapped into a 16-tribit sequence using the mapping given in table C-XVIII. Note that each of the two-bit sequences in the Payload Bits column of the table is of the form  $b_1b_0$ , where  $b_1$  is the first payload bit. The tribit values are placed in the output tribit sequence in the order in which they appear in the corresponding row of table C-XVIII, moving from left to right across the row. The 16-tribit sequence thus obtained is repeated 80 times to produce 1280 tribit values.

**TABLE C-XVIII. Walsh modulation of BW4 payload bits to tribit sequences.**

Payload Bits (shown as $b_1b_0$ )	Tribit Sequence
00	0000 0000 0000 0000
01	0404 0404 0404 0404
10	0044 0044 0044 0044
11	0440 0440 0440 0440

**C.5.1.7.3 PN spreading sequence generation and application.**

The BW4 PN spreading sequence is the sequence of 1280 pseudo-random tribit values  $s_i$  shown in table C-XIX. The tribit values are used in the order shown in table C-XIX, starting at the top left and moving from left to right across each row, and from top to bottom through successive rows.



**TABLE C-XIX. BW4 PN spreading sequence.**

5,2,0,7,	1,3,2,5,	0,4,5,3,	3,0,7,3,	5,3,2,3,	7,4,7,5,	0,4,1,0,	5,7,6,5,
2,6,4,1,	7,1,6,6,	0,1,2,2,	1,6,7,6,	3,7,1,3,	5,0,6,4,	6,6,5,2,	2,3,5,2,
3,5,7,2,	5,4,6,0,	6,1,0,7,	5,2,0,2,	6,6,2,4,	6,0,2,0,	7,3,0,1,	5,0,2,1,
6,2,2,7,	4,3,1,1,	4,6,3,5,	1,3,6,1,	6,3,3,0,	5,5,7,1,	7,4,7,6,	1,7,1,7,
1,5,3,7,	3,7,5,3,	3,6,6,3,	3,4,6,6,	4,1,0,5,	5,3,3,1,	2,6,2,1,	1,5,3,2,
4,7,7,1,	5,5,7,3,	7,2,0,4,	0,7,0,5,	6,4,1,4,	3,0,7,6,	3,0,0,5,	1,3,4,4,
2,1,5,1,	3,0,3,0,	2,3,6,6,	7,6,0,0,	2,6,2,7,	7,1,0,3,	5,1,0,0,	0,1,2,0,
2,1,7,0,	3,6,3,5,	7,5,2,6,	5,2,3,4,	3,1,5,5,	7,1,7,2,	1,6,4,0,	6,2,4,7,
4,2,0,7,	4,4,5,3,	5,4,2,4,	0,4,5,2,	2,6,6,4,	3,6,2,0,	3,2,7,0,	4,2,6,0,
7,1,4,7,	2,6,0,3,	5,5,4,2,	1,1,5,7,	0,2,3,2,	2,0,5,2,	2,0,7,1,	4,3,0,4,
0,1,7,0,	5,5,1,2,	3,1,5,1,	6,6,6,1,	0,5,6,1,	2,6,2,0,	4,4,4,4,	4,4,3,7,
6,4,5,3,	2,5,5,1,	6,4,0,4,	2,3,5,2,	2,1,0,7,	4,5,1,2,	5,2,6,5,	6,0,2,0,
2,7,1,7,	2,2,1,6,	6,5,3,6,	1,4,4,4,	4,3,3,6,	3,5,4,1,	5,0,4,3,	7,4,2,7,
5,3,4,6,	0,4,5,1,	3,1,3,0,	1,0,2,2,	3,2,3,6,	3,1,5,3,	3,6,0,3,	7,1,1,4,
3,6,3,1,	2,5,2,3,	6,3,0,2,	6,2,3,4,	6,5,7,5,	5,0,4,0,	2,7,0,4,	2,7,2,2,
5,5,4,7,	7,4,4,3,	6,7,3,4,	1,6,1,1,	5,3,1,7,	6,4,5,4,	7,2,6,4,	1,1,3,0,
5,0,5,7,	7,4,2,5,	1,5,3,5,	3,3,7,5,	7,3,0,0,	5,5,7,0,	5,3,0,2,	3,3,6,6,
3,2,2,5,	4,5,7,5,	6,3,7,1,	1,5,2,0,	0,0,5,3,	2,7,2,4,	1,7,1,5,	4,7,2,3,
6,6,1,0,	5,5,2,4,	4,6,5,2,	4,4,6,5,	5,2,1,6,	1,7,3,1,	4,6,5,2,	6,5,7,0,
7,2,4,6,	1,1,2,4,	4,2,7,4,	4,5,3,5,	0,7,1,5,	5,5,5,6,	2,5,3,3,	7,0,5,7,
0,3,1,0,	6,3,1,0,	7,2,5,3,	6,6,5,2,	6,4,2,0,	5,5,3,3,	7,3,4,3,	0,3,3,5,
3,6,7,1,	0,2,0,3,	5,3,5,2,	7,6,1,6,	1,5,6,2,	1,6,2,4,	2,4,1,7,	4,2,2,2,
7,0,7,7,	5,6,2,0,	5,3,5,1,	4,0,7,1,	2,6,2,7,	5,5,5,4,	1,4,0,7,	2,4,6,6,
7,5,5,4,	3,0,6,2,	3,1,3,1,	2,0,3,7,	6,6,2,1,	2,4,3,1,	1,4,6,2,	0,4,2,2,
3,2,2,3,	1,3,6,0,	2,7,3,4,	7,5,3,5,	2,2,3,0,	3,3,6,7,	1,3,0,0,	0,6,0,3,
2,2,6,1,	3,6,0,2,	7,5,5,6,	3,3,7,0,	2,3,3,5,	2,2,7,2,	3,1,3,2,	0,4,4,0,
1,3,6,0,	5,0,5,2,	0,0,1,0,	2,3,6,5,	5,6,6,3,	1,7,7,6,	0,5,2,5,	2,7,7,2,
3,3,6,3,	7,6,0,7,	1,1,1,3,	7,1,1,2,	5,0,7,3,	4,1,3,4,	7,0,5,5,	3,2,6,1,
5,6,4,1,	6,4,2,7,	4,3,5,2,	6,4,1,1,	3,4,0,1,	2,7,0,1,	4,4,6,6,	1,7,7,0,
2,5,0,1,	6,4,3,6,	3,0,5,0,	3,3,2,3,	2,4,7,7,	0,4,7,3,	2,6,7,5,	5,3,1,0,
1,5,3,6,	4,4,6,5,	4,5,0,1,	2,1,3,7,	3,4,5,5,	4,2,5,0,	5,4,7,4,	7,5,0,0,
1,7,2,1,	7,0,5,0,	2,4,2,5,	3,1,6,7,	7,6,4,3,	6,6,4,2,	7,2,2,5,	0,1,4,0,
3,7,5,1,	5,1,7,3,	5,2,2,0,	6,3,2,1,	3,6,4,5,	1,5,7,6,	7,0,6,6,	0,1,7,3,
7,5,1,0,	0,7,0,7,	7,0,7,6,	1,5,2,1,	5,5,1,2,	6,2,5,6,	2,0,1,2,	1,1,4,0,
3,6,5,4,	6,0,0,3,	3,7,3,3,	2,5,6,2,	6,4,2,1,	7,2,6,0,	0,5,0,0,	5,1,0,0,
6,6,5,7,	5,4,1,0,	4,1,0,0,	0,1,5,1,	2,6,1,1,	6,4,3,7,	6,0,2,5,	0,4,1,0,
4,6,1,5,	3,2,2,7,	1,2,7,0,	2,7,6,1,	2,7,2,4,	4,6,5,5,	4,7,1,5,	3,6,2,4,
4,0,0,2,	3,2,4,1,	2,7,0,2,	1,7,5,0,	4,4,2,7,	5,6,5,2,	3,0,1,0,	0,2,3,3,
5,4,4,5,	1,6,4,0,	2,0,2,1,	4,4,7,4,	2,0,5,1,	6,2,5,6,	6,3,1,7,	6,1,3,4,
0,2,2,4,	4,5,0,4,	2,1,3,6,	6,2,4,1,	7,4,2,6,	7,5,0,0,	5,6,7,6,	1,4,5,5.

The 1280 tritbit values  $s_i$  of the PN sequence are combined with the 1280 raw tritbit values  $r_i$  produced by the orthogonal symbol formation process described in the previous section. Each

symbol of the PN sequence  $s_i$  is combined with the corresponding symbol  $r_i$  of the raw tribit sequence to form a channel symbol  $c_i$ , by adding  $s_i$  to  $r_i$  modulo 8. For instance, if  $s_i = 7$ ,  $r_i = 4$ , then  $c_i = 7 \oplus 4 = 3$ , where the symbol  $\oplus$  represents modulo-8 addition.

The process can be summarized:

$$\begin{bmatrix} c_0 \\ \vdots \\ c_{1279} \end{bmatrix} = \begin{bmatrix} r_0 \\ \vdots \\ r_{1279} \end{bmatrix} \oplus \begin{bmatrix} s_0 \\ \vdots \\ s_{1279} \end{bmatrix}$$

where  $r$  is the vector of data raw tribit values,  $s$  is the vector of PN sequence tribit values,  $c$  is the resulting vector of combined tribit values, and the symbol  $\oplus$  represents component-wise modulo-8 addition.

#### C.5.1.7.4 Modulation.

The sequence of channel symbols consisting of:

- the TLC/AGC guard sequence of 256 tribit symbols described by C.5.1.7.1 (on which no PN-spreading has been performed), followed by
- the 1280-length sequence of BW4 channel symbols (data symbols), PN-spread as described in C.5.1.7.3,

is used to PSK modulate an 1800 Hz carrier signal at 2400 channel symbols/sec.

See C.5.1.8 for a description of how combined tribit values are mapped to carrier phases and the subsequent carrier modulation process.

#### C.5.1.8 Burst waveform modulation.

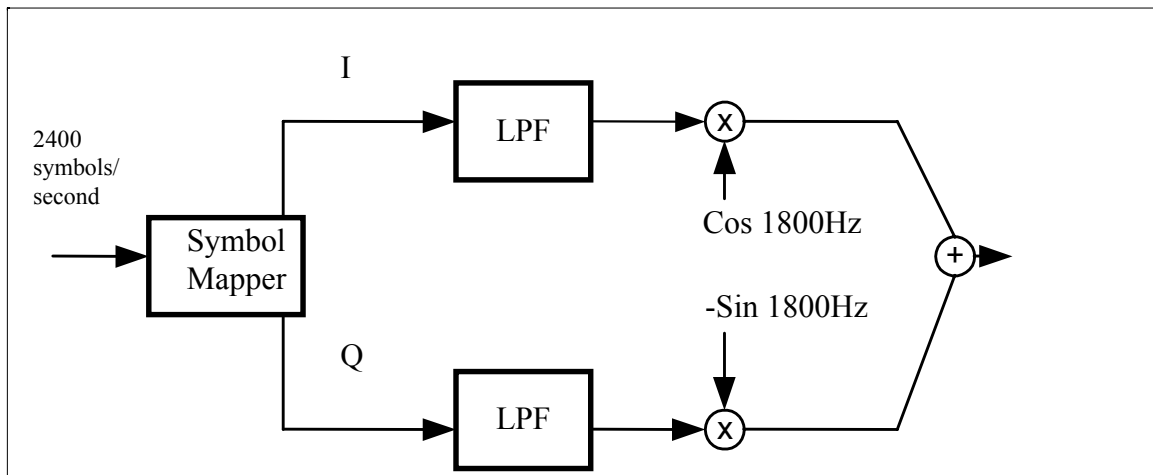
The burst waveform descriptions have thus far only discussed the mapping of protocol bits to tribit values. This section will describe the process by which the tribit values are used to create the transmitted signal.

The transmitted signal consists of a 8-ary phase-shift-keyed 1800Hz single-tone carrier modulated at a constant 2400 symbols per second. The phase shift of the signal relative to that of the unmodulated carrier is a function of the tribit values as given in the tribit-value-to-carrier-phase mapping of table C-XX:

**TABLE C-XX. 8-ary PSK signal space.**

Tribit Value	Phase Shift	In-Phase (I)	Quadrature (Q)
0	0	1.0	0.0
1	$\pi/4$	$1/\sqrt{2}$	$1/\sqrt{2}$
2	$\pi/2$	0.0	1.0
3	$3\pi/4$	$-1/\sqrt{2}$	$1/\sqrt{2}$
4	$\pi$	-1.0	0.0
5	$5\pi/4$	$-1/\sqrt{2}$	$-1/\sqrt{2}$
6	$3\pi/2$	0.0	-1.0
7	$7\pi/4$	$1/\sqrt{2}$	$-1/\sqrt{2}$

The transmitted waveform is generated as illustrated in C-16. The tribit values are converted to the complex 8-PSK resulting in separate In-Phase [I] and Quadrature [Q] waveforms as given in C-XX. These waveforms are interpolated and independently filtered by equivalent low pass filters to provide spectral containment and image rejection. Finally, the interpolated and filtered In-phase and Quadrature waveforms are used to modulate the 1800 Hz sub-carrier. The accuracy of the clock linked with the generation of the sub-carrier frequency is 1 part in  $10^5$ .



**FIGURE C-16. Carrier modulation.**

**C.5.2 3G-ALE protocol definition.**

3G-ALE shall be implemented as defined in the following paragraphs.

C.5.2.1 3G-ALE service primitives.

Table C-XXI describes an example set of service primitives exchanged between the 3G-ALE entity and a user process at the 3G-ALE entity upper interface. Note that there is no requirement that implementations of 3G-ALE contain precisely these service primitives; nor are the service primitives defined below necessarily all of the service primitives that would be required in an implementation of this protocol.

**TABLE C-XXI. 3G-ALE service primitives.**

Name	Attribute	Values	Description
LE_Link_Req	Overview		LE_Link_Req: issued by ALE user process (usually connection manager) to request establishment of a link
	Parameters	destAddr	11-bit 3G address of the station to be called
		callType	one of INDIVIDUAL, UNICAST, MULTICAST, BROADCAST
		trafType	Identifies the type of traffic for which the link is requested; one of: Packet Data, Modem Circuit (for HF data modems only), Voice Circuit (for analog voice or non-HF modems), High-Quality Circuit
		pri	Priority of the traffic for which the link is requested; one of Highest, High, Routine, Low
		callChan	Optional calling channel number (for override)
		trafChan	Optional traffic channel number (for override)
	Originator	user process	
Preconditions	none		
LE_Link_Ind	Overview		LE_Link_Ind: issued by ALE process to indicate the establishment of link as responder
	Parameters	addr	11-bit 3G address of the station or multicast to which link has been established
		callType	Identifies the type of link that has been established; same values as above
	Originator	ALE entity	
Preconditions	none		
LE_Link_Confirm	Overview		LE_Link_Confirm: issued by ALE process to indicate establishment of link as caller
	Parameters	addr	11-bit 3G address of the station or multicast to which link has been established
	Originator	ALE entity	
	Preconditions	link has been requested or established	
LE_Status_Ind	Overview		LE_Status_Ind: issued by ALE process to indicate its current status
	Parameters	status	Current ALE status; one of: SCANNING, CALLING, LINKED
	Originator	ALE entity	
	Preconditions	none	
LE_Link_Det_Ind	Overview		LE_Link_Det_Ind: issued by ALE process to report detection of the establishment or termination of a link between remote stations
	Parameters	status	One of LINKED, AVAILABLE
		trafChan	Traffic channel used by link

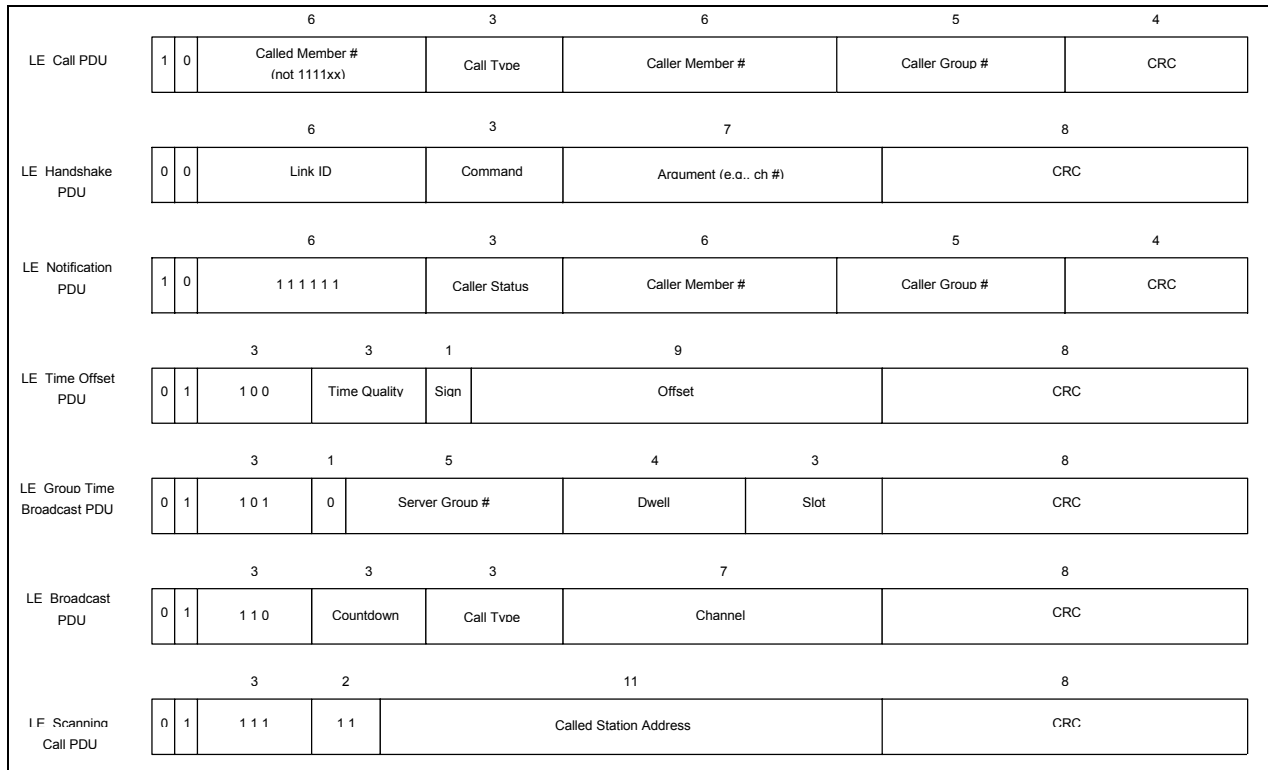
**TABLE C-XXI. 3G-ALE service primitives (continued).**

Name	Attribute	Values	Description
		caller	11-bit 3G address of the calling station
		responder	11-bit 3G address of the responding station
	Originator	ALE entity	
	Preconditions	none	
LE_Link_Fail_Ind	Overview		LE_Link_Fail_Ind: issued by ALE process to indicate the failure of a link
	Parameters	reason	Reason for link failure; one of: NO_RESPONSE, REJECTED, NO_TRAF_CHAN, LOW_QUALITY
	Originator	ALE entity	
	Preconditions		link has been requested or established
LE_ReturnToScan	Overview		LE_ReturnToScan: issued by user process to request termination of link and return to scanning operation; also used to reject an incoming link
	Parameters	none	
	Originator	user process	
	Preconditions		link has been requested or established
LE_McastUpdate	Overview		LE_McastUpdate: issued by user process to add or delete a dwell group from a multicast
	Parameters	multicast	affected multicast address (same address used as member number in calls to all dwell groups)
		group	affected dwell group number
		status	one of: INCLUDED, EXCLUDED
	Originator	user process	
	Preconditions		none

**C.5.2.2 3G-ALE PDUs.**

The link establishment protocol data units (LE-PDUs) are shown in figure C-17. Unused encodings are reserved, and shall not be used until standardized. Order of transmission shall be as specified in C.4.10 Order of transmission. For example, the LE\_Broadcast PDU shall begin 0, 1, 1, 1, 0.

MIL-STD-188-141B  
APPENDIX C



**FIGURE C-17. 3G-ALE PDUs.**

C.5.2.2.1 LE Call PDU.

The LE\_Call PDU shall be formatted as shown in figure C-17. It conveys necessary information to the responder so that that station will know whether to respond, and what quality of traffic channel will be needed.

The Call Type field in the LE\_Call PDU shall be encoded as specified in table C-XXII.

- A call type of Packet Data shall be used only when the 3G data link protocol will be used to deliver a message after link establishment.
- The call type shall be Modem Circuit when an HF data modem using waveforms other than BW0-BW5 will be used to convey traffic after link establishment.
- The Voice Circuit call type requests a minimum link SNR suitable for orderwire voice operation (for example, 10 dB or better).
- The High-Quality Circuit call type requests a substantially better SNR than an orderwire Voice Circuit (for example, 20 dB or better).
- The unicast and multicast call types are used when the calling station will specify the traffic channel used for a link.
- The link release call type shall be used only when releasing, rather than establishing, a link.

**TABLE C-XXII. Call type field encodings.**

Code	Call Type	Second PDU From
0	3G ARQ Packet Data	Responder
1	HF Modem Circuit	Responder
2	Analog Voice Circuit	Responder
3	High-Quality Circuit	Responder
4	Unicast ARQ Packet	Caller
5	Unicast Circuit	Caller
6	Multicast Circuit	Caller
7	Control	Caller

C.5.2.2.2 LE\_Handshake PDU.

The LE\_Handshake PDU shall be formatted as shown in figure C-17. The link ID shall be computed as follows from the 11-bit addresses of the caller (node sending LE\_Call PDU) and responder (node addressed in LE\_Call PDU):

1. temp1 = <caller address> \* 0x13C6EF
2. temp2 = <responder address> \* 0x13C6EF
3. LinkID = ( (temp1 >> 4) + (temp2 >> 15) ) & 0x3f

where ‘\*’ indicates 32-bit unsigned multiplication, ‘>> n’ indicates right shift by n bits, and ‘&’ indicates bitwise AND. Example LinkID computations are shown below.

Caller	Responder	temp1	temp2	result	result
1	2	0013c6ef	00278dde	3D	61
1	3	0013c6ef	003b54cd	24	36
2	1	00278dde	0013c6ef	4	4
3	1	003b54cd	0013c6ef	33	51
1951	1	96b91771	0013c6ef	1E	30
(decimal)	(decimal)	(hexadecimal)	(hexadecimal)	(hexadecimal)	(decimal)

The Command field shall be encoded as shown in table C-XXIII. Unused encodings are reserved, and shall not be used until standardized.

**TABLE C-XXIII. Command field encodings.**

Code	Command	Description	Argument
0	Continue Handshake	The handshake will continue for at least another two-way handshake (on the next assigned called station dwell frequency when operating in synchronous mode).	Reason
1	Commence Traffic Setup	This is the final command sent on a calling channel. The argument is the channel number on which the responding station will (or should) listen for traffic setup. Following this command, all stations proceed to that traffic channel.	Channel
2	Voice Traffic	This command directs called station(s) to tune to a traffic channel and commence voice traffic. The argument is the channel number. Following this command, the calling station will be first to speak. (Uni- and multicast only)	Channel
3	Link Release	This command informs all listening stations that the specified traffic channel is no longer in use by the sending station.	Channel
4	Sync Check	This command directs the called station to measure and report synchronization offset back to the calling station. Used in synchronization management protocol (C.5.2.7).	Quality   Slot
6	Data	This command is reserved for special-purpose protocols. The argument carries previously requested data.	Data
7	Abort Handshake	This command immediately terminates the handshake and needs no response. It is analogous to the TWAS preamble in 2G ALE.	Reason

The Argument field shall contain a channel number, a reason code, or 7 bits of data, as indicated in table C-XXIII. Reasons shall be encoded as 7-bit integers with values selected from table C-XXIV. Unused encodings are reserved, and shall not be used until standardized.

**TABLE C-XXIV. Reason field encodings.**

Code	Reason
0	NO_RESPONSE
1	REJECTED
2	NO_TRAF_CHAN
3	LOW_QUALITY

**C.5.2.2.3 LE Notification PDU.**

The LE\_Notification PDU shall be formatted as shown in figure C-17, and shall be used as specified in C.5.2.5 Notification Protocol Behavior. The Caller Member Number and Caller Group Number fields shall contain the address of the station sending the PDU. The Caller Status field shall be encoded as shown in table C-XXV. Unused encodings are reserved, and shall not be used until standardized.



**TABLE C-XXV. Caller status field encodings.**

Code	Station Status
0	Nominal
1	Time server
6	Commencing EMCON
7	Leaving network

**C.5.2.2.4 LE\_Broadcast PDU.**

The LE\_Broadcast PDU shall be formatted as shown in figure C-17, and shall be used as specified in C.5.2.4.4.5 3G-ALE synchronous mode broadcast calling.

The Call Type field shall describe the traffic to be sent:

- Analog Voice Circuit if the receiving stations are to deliver the received audio directly.
- HF Modem Circuit if an HF modem is to be engaged to process received traffic.
- High-Quality Circuit if a non-HF modem is to be engaged to process received traffic.
- 3G ARQ Packet Data if the link will be used in bidirectional mode using the CLC(see C.5.6) for channel access control.

The Countdown field shall be used as specified in C.5.2.4.4.5 3G-ALE synchronous mode broadcast calling and in C.5.2.4.5.6 3G-ALE asynchronous mode broadcast call.

**C.5.2.2.5 Scanning call PDU.**

The LE\_Scanning\_Call PDU shall be formatted as shown in figure C-17, and shall be used as specified in C.5.2.4.5.2 3G-ALE asynchronous mode scanning call.

**C.5.2.2.6 CRC computation for 3G-ALE PDUs.**

Each LE\_PDU contains either a 4-bit or an 8-bit CRC. The 4-bit CRC shall be computed in accordance with C.4.12 using the polynomial  $x^4 + x^3 + x + 1$ . The 8-bit CRC shall be computed in accordance with C.4.12 using the polynomial  $x^8 + x^7 + x^4 + x^3 + x + 1$ .

**C.5.2.3 Synchronous dwell structure.**

When scanning in synchronous mode, 3G systems shall dwell on each assigned channel for 4 seconds. Each synchronous dwell time is divided into five slots of 800 ms each, which shall be used as follows (see figure C-18).

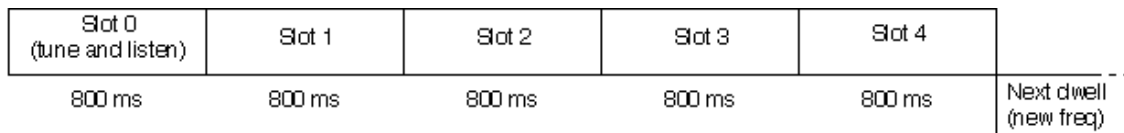
Slot 0: Tune and Listen Time. During Slot 0, radio frequency (RF) components shall be retuned to the frequency on which the node may transmit during that dwell.

- A scanning station shall tune to the assigned calling channel for that dwell, computed in accordance with C.4.4.1. Couplers are normally not retuned while scanning.

- A station that will place a call during that dwell shall instead tune to the channel on which it will call during that dwell. The coupler may be retuned either in slot 0 or immediately before transmitting.

Following tuning, every receiver shall sample a traffic frequency in the vicinity of the new calling channel, attempting to detect traffic. (This provides recent traffic channel status before stations get involved in a handshake.)

Calling Slots. The remainder of the dwell time is divided into four 800 ms calling slots. These slots shall be used for the synchronous exchange of PDUs on calling channels. A two-way handshake shall not begin in the last slot of a dwell. The last slot of every dwell is reserved for LE\_Handshake, LE\_Notification, and LE\_Broadcast PDUs.



**FIGURE C-18. Synchronous dwell structure.**

#### C.5.2.4 3G-ALE protocol behavior.

The behavior of the 3G-ALE protocol is specified in the following paragraphs in terms of data structures, states, events, actions, and state transitions. Note that these data structures, states, events, actions, and state transitions are not requirements of a compliant implementation, but only serve to illustrate the required over-the-air behavior of compliant systems. The data structures, events, and actions are listed in a single set of tables, which are used by both the synchronous-mode and asynchronous-mode protocol definitions. Separate behavior tables are specified for the two modes.

##### C.5.2.4.1 3G-ALE protocol data.

The internal variables used in the description of the 3G-ALE protocol are defined in table C-XXVI. These are for illustrative use only, and are not mandatory in implementations of 3G-ALE except as required elsewhere.

**TABLE C-XXVI. 3G-ALE protocol data.**

<b>Data item</b>	<b>Description</b>
myIndivAddr	11-bit address of this station
myMulticastAddresses	list of 11-bit addresses for multicasts to which this station subscribes
networkTime	coordinated network time (may be synchronized to UTC or GPS)
myCurrentDwellChannel	calling channel on which this station listens for calls
myCurrentTrafficChannel	traffic channel on which this station monitors occupancy
channelOccupancy	array of channel occupancy records: result, time measured
callingChannel	current dwell channel of destination station
destStation	ID of destination station (indiv, mcast, or bcast)
linkID	Link ID value computed for current handshake
linkQualityTable	array of link quality records for all stations and channels
prefTrafChan	preferred traffic channel for current handshake partner
myCallingSlot	slot in which call will be sent
bcastCount	LE_Broadcast PDU countdown (use varies between sync and async modes)
announcedBroadcastChannel	channel specified in LE_Broadcast PDU
numScanChan	number of calling channels in scan list
scanCallCountdown	number of times LE_Scanning_Call PDU is sent
scanSoundCountdown	number of times LE_Notification PDU is sent when sounding
trafWaitTime	time called station will wait for traffic to start after link is established
trafWaitTimeMcast	time called station will wait for traffic to start after link is established (longer time allowed for multicasts)

C.5.2.4.2 3G-ALE protocol events.

Table C-XXVII defines the events to which the 3G-ALE entity responds. The event names are used in the state transition tables in C.5.2.4.4.7 and C.5.2.4.5.9 which define the behavior of the 3G-ALE protocol.

**TABLE C-XXVII. 3G-ALE protocol events.**

Event name	Description
End of dwell	A boundary between dwells has occurred
TuningComplete	Tuning has been completed in all RF components
FinishedListening	The occupancy check of a channel has been completed
D: LE_Link_Req(destAddr, callType, pri, [chan])	An LE_Link_Req primitive was received from the user process (Connection Manager); chan is optional
D: LE_ReturnToScan	An LE_ReturnToScan primitive was received from the user process (Connection Manager)
R: LE_Call(destAddr, srcAddr, callType)	received an LE_Call PDU
R: LE_ScanCall(destAddr)	received an LE_Scanning_Call PDU for indicated destination address
R: LE_Hshake(ID, CMD, ARG)	received an LE_Handshake PDU
R: LE_Bcast(countdown, callType, chan)	received an LE_Broadcast PDU
FinishedSendingPDU	occurs at end of slot (synchronous mode) or end of PDU (asynchronous mode)
SlotAvailable	Occupancy check of preceding slot(s) and analysis of any received PDUs indicates that no handshake in progress will extend into the slot now beginning
SlotOccupied	Occupancy check of preceding slot(s) and analysis of any received PDUs indicates that a handshake in progress will extend into the slot now beginning
ResponseTimeout	No response arrived within the timeout previously set
ScanCallTimeout	End of scanning call did not occur within allowed timeout
ScanCallDropout	Unable to identify BW0 preamble for three consecutive PDUs during scanning call timeout period
TrafWaitTimeout	Traffic did not begin within the timeout previously set
TimeToSound(channel)	Time to sound on indicated channel

**C.5.2.4.3 3G-ALE protocol actions.**

Table C-XXVIII defines the actions which the 3G-ALE entity can perform. The action name is used in the state transition tables used below to define the behavior of the 3G-ALE protocol.

**TABLE C-XXVIII. 3G-ALE protocol actions.**

Action name	Description
ComputeDwellChannel(addr)	Computes the current dwell channel for specified station at current networkTime
SelectCallingChannel(addr)	Selects calling channel for best estimated connectivity to individual station using linkQualityTable (async mode only)
SelectMulticastChannels(addr)	Selects calling and traffic channels for best estimated connectivity to multicast subscribers using linkQualityTable
SelectBroadcastChannels	Selects calling and traffic channels for best estimated connectivity to network members using linkQualityTable
InitBroadcastCount	Initializes broadcastCount to number of times LE_Broadcast PDU will be sent
InitBcastCountdown(number)	Sets broadcastCount to number
TuneToNewChannel(chan)	Retune transceiver, PA, coupler, etc to specified channel; TuningComplete event when done
SelectTrafficChannel(chan)	Selects a traffic channel "near" specified channel, considering age of channel measurements
ListenOnChannel(chan)	Listen for occupancy on specified channel; FinishedListening event after preset interval
RecordOccupancy(chan)	store results of listening on chan in channelOccupancy array
ListenForCalls(chan)	Listen for 2G and 3G calls on specified channel; EndOfDwell event at end of current dwell
SelectSlot(pri)	Compute myCallingSlot using pri
WaitForSlot(slot)	Listens on myCurrentTrafficChannel until end of slot-1; SlotAvailable event if channel believed vacant, otherwise SlotOccupied (or R: xxx) event
U: LE_Link_Ind(callerAddr, callType)	Inform user process (Connection Manager) that a link has been established by a calling station
U: LE_Link_Confirm(destAddr)	Inform user process that link has been established to destAddr
U: LE_Status_Ind(status)	Inform user process (Connection Manager) of ALE status
U: LE_Link_Det_Ind(status, trafChan, caller, dest)	Inform user process that a change in link status between caller and dest has been detected (link established or terminated)
U: LE_Link_Fail_Ind(reason)	Inform user process (Connection Manager) that link has failed
S: LE_Call(destAddr, srcAddr, trafType, pri)	Send an LE_Call PDU
S: LE_Bcast(countdown, trafType, pri, chan)	Send an LE_Broadcast PDU
S: LE_Hshake(ID, CMD, ARG)	Send an LE_Handshake PDU
InitResponseTimeout	Set timeout for end of next slot

**TABLE C-XXVIII. 3G-ALE protocol actions (continued).**

Action name	Description
InitScanCallTimeout	Set timeout for maximum allowed scanning call duration
RestartSoundingTimer(chan, time)	Set timer to prompt next sound on channel
InitAsyncCount	Initialize asynchronous-mode broadcast countdown
InitTrafWaitTimeout(time)	Set timeout (trafWaitTime or trafWaitTimeMcast) to bound time waiting for traffic to start

**C.5.2.4.4 3G-ALE synchronous mode protocol.**

The synchronous-mode link establishment protocol shall comply with the following requirements as observed over the air. Precise definitions of the protocols are presented following overviews of the individual, multicast, and broadcast calling protocols.

**C.5.2.4.4.1 3G-ALE synchronous mode slot selection.**

The probability of selecting a slot for sending an LE\_Call, LE\_Broadcast, or LE\_Notification PDU shall randomized over all usable slots, but the probabilities for higher-priority calls shall be skewed toward the early slots while lower-priority calls are skewed toward the later slots. (Such a scheme will operate reasonably well in all situations, while hard partitioning of early slots for high and late slots for low priorities would exhibit inordinate congestion in crisis and/or routine times.) Suggested sets of probabilities are shown in table C-XXIXa for LE\_Call PDUs and table C-XXIXb for LE\_Broadcast and LE\_Notification PDUs.

**TABLE C-XXIXa. Probability of slot selection for LE call PDUs.**

Call Priority	Slot 1	Slot 2	Slot 3
Highest	65%	30%	5%
High	40%	35%	25%
Routine	25%	35%	40%
Low	5%	30%	65%

**TABLE C-XXIXb. Probability of slot selection for LE broadcast and LE notification PDUs.**

Probability of Slot Selection for LE Broadcast and LE Notification PDUs.				
Call Priority	Slot 1	Slot 2	Slot 3	Slot 4
Highest	50%	30%	15%	5%
High	30%	50%	15%	5%
Routine	5%	15%	50%	30%
Low	5%	15%	30%	50%

A new random slot shall be selected for each dwell in which a call will be placed. Random number generation for slot selection shall be essentially independent from one dwell to the next, and among different stations, so that systems that select the same slot in one dwell will not have a higher than expected probability of continuing to select identical slots in subsequent dwells.

C.5.2.4.4.2 3G-ALE synchronous mode individual calling overview.

The one-to-one linking protocol identifies a frequency for traffic use relatively quickly (i.e., within a few seconds), and minimizes channel occupancy during this link establishment process. A station shall commence the link establishment protocol immediately upon receiving a request to establish a link with another station, unless it defers the start of calling until the called station will be listening on a channel believed to be propagating. The latter option serves to reduce channel occupancy, and does not preclude calling on the bypassed channels later if the link cannot be established on the favored channel.

When a station needs to establish a link with another station, it shall send LE\_Call PDUs on the frequencies monitored by the called station until it receives a response, or until it has called on all calling channels at least once. The Call Type in the LE\_Call PDU shall not be Unicast or Multicast in the individual calling protocol. In each dwell, the calling station shall do the following:

- select a slot in accordance with C.5.2.4.4.1 3G-ALE synchronous mode slot selection;
- listen on an associated traffic channel (if any) during Slot 0;
- listen for occupancy on the calling slot channel during the slot immediately preceding its calling slot, if not calling in Slot 1;
- defer its call as necessary until it believes the channel will not be occupied by a response PDU;
- send its LE\_Call PDU.

A station that receives an LE\_Call PDU addressed to its node address shall respond in the immediately following slot with an LE\_Handshake PDU that either aborts the call, names a traffic channel, or defers naming a channel but continues the handshake. When a suitable frequency for traffic to the responding station has been found, the stations shall enter the Traffic state. If additional negotiation is required (e.g., to set up a full duplex circuit using a second frequency), the ALM protocol shall be employed on the traffic channel.

C.5.2.4.4.3 3G-ALE synchronous mode unicast calling.

A unicast call is used to contact an individual station and direct it to a traffic channel selected by the calling station.

1. An LE\_Call PDU shall be sent as usual, containing the individual responding-station address. The Call Type field shall be Unicast. No station shall respond to a Unicast-type LE\_Call PDU.

2. The caller shall send an LE\_Handshake PDU in the immediately following response slot that directs the called station to a traffic channel.
3. The called station shall tune to that channel and listen for modem traffic if the command in the LE\_Handshake PDU is Commence Traffic Setup. If the command is Voice Traffic, the called station shall tune to the channel and prepare for voice traffic (e.g., unmute the speaker). If the announced traffic does not begin to arrive within the traffic wait timeout, the called station shall return to scan.
4. After sending the LE\_Handshake PDU, the caller shall tune to the specified channel and initiate the type of traffic indicated in the LE\_Handshake PDU.

Note that a unicast call may be used to set up a link for bidirectional traffic.

#### C.5.2.4.4.4 3G-ALE synchronous mode multicast calling.

A multicast call is used to contact selected stations concurrently and direct them to a traffic channel selected by the calling station.

1. An LE\_Call PDU shall be sent as usual, but it shall contain a multicast responding-station address. The Call Type field shall be Multicast. No station shall respond to a Multicast-type LE\_Call PDU.
2. The caller shall send an LE\_Handshake PDU in the immediately following response slot that directs the called stations to a traffic channel. The link ID field shall be computed in accordance with C.4.5.3 Multicast addresses.
3. The called stations shall tune to that channel and listen for modem traffic if the command in the LE\_Handshake PDU is Commence Traffic Setup. If the command is Voice Traffic, the called stations shall tune to the channel and prepare for voice traffic (e.g., unmute the speaker). If the announced traffic does not begin to arrive within the multicast traffic wait timeout, the called stations shall return to scan. (This timeout should be set to accommodate calls to the maximum number of dwell groups whose members may subscribe to the multicast.)
4. When the stations subscribing to a multicast are assigned to more than one dwell group, the multicast call (both PDUs) shall be sent repeatedly by the caller. The caller should select the timing (and possible redundancy) of its transmissions to minimize calling channel occupancy while maximizing the probability of reaching called stations.
5. After sending the (final) LE\_Handshake PDU, the caller shall tune to the specified channel and initiate the type of traffic indicated in the LE\_Handshake PDU.

#### C.5.2.4.4.5 3G-ALE synchronous mode broadcast calling - not tested (NT)

An LE\_Broadcast PDU directs every station that receives it to a particular traffic channel, where another protocol (possibly voice) will be used. A means shall be provided for operators to disable execution of the broadcast protocol.



- The Call Type field in the LE\_Broadcast PDU shall be encoded as in the LE\_Call PDU, except that only the circuit call types may be used.
- The Countdown field shall indicate of the number of dwells that will occur between the end of the current dwell and the start of the broadcast. A Countdown value of 0 shall indicate that the broadcast will begin in Slot 1 of the following dwell. Other Countdown field values  $n \neq 0$  indicate that the broadcast will begin no later than  $4n+3$  dwell times in the future.
- The Channel field shall indicate the channel that will carry the broadcast.

Slot selection for LE\_Broadcast PDUs shall use the same probabilistic approach as for LE\_Call PDUs. However, a station may send an LE\_Broadcast PDU in every slot in a dwell starting with the randomly selected slot. It may also change frequencies every slot to reach a new dwell group. The calling station shall check occupancy on the new calling channel before transmitting on that channel. A split-site station with a fast tuner may be able to send an LE\_Broadcast PDU on a new channel in every slot by listening on the next channel each time and tuning at the start of the slot. A means shall be provided to override listen-before-transmit for highest-priority broadcasts that will permit transmission of an LE\_Broadcast PDU on a new channel in every slot.

Stations that receive an LE\_Broadcast PDU and tune to the indicated traffic channel shall return to scan if the announced traffic does not begin within the traffic wait timeout period after the announced starting time of the broadcast.

#### C.5.2.4.4.6 3G-ALE synchronous mode link release.

At the conclusion of an individual or unicast link, the caller shall send a link release. The link release shall be an LE\_Call PDU containing the original called station address, with a type of Control, followed by an LE\_Handshake PDU that identifies the traffic channel and contains a link release command.

The link release shall be sent on the calling channel on which the handshake that set up the link occurred. The calling station shall attempt to send the link release during the first dwell after the link is terminated during which the called dwell group is listening on that calling channel. The calling station need not attempt to send a link release later if calling channel occupancy during that dwell prevents transmission of the link release.

#### C.5.2.4.4.7 3G-ALE synchronous mode protocol behavior.

Implementations of 3G-ALE operating in synchronous mode shall exhibit the same over-the-air behavior as that described in table C-XXX.

**TABLE C-XXX. 3G-ALE synchronous mode protocol behavior.**

State	Event	Condition	Action	Next State	
Scanning	End of dwell		ComputeDwellChannel(myIndivAddr) + TuneToNewChannel(myCurrentDwellChannel)	S_Tune	
	D: LE_Link_Req(dest, INDIV or UCAST, trafType, pri)		ComputeDwellChannel(dest) + TuneToNewChannel(callingChannel) + SelectSlot(pri)	C_Slot_Wait	
	D: LE_Link_Req(dest, MCAST, trafType, pri)		SelectMulticastChannel(dest) + TuneToNewChannel(callingChannel) + SelectSlot(pri)	C_Slot_Wait	
	D: LE_Link_Req(dest, BCAST, trafType, pri)		SelectBroadcastChannel + InitBroadcastCount + TuneToNewChannel(callingChannel) + SelectSlot(pri)	C_Slot_Wait	
	R: LE_Call(myIndivAddr, srcAddr, callType is packet or circuit)	willing to link w/srcAddr & good traffic channel known		ComputeLinkID(srcAddr, myIndivAddr) + R_Commence S:LE_Hshake(linkID, COMMENCE, prefTrafChan)	
		not willing to link with srcAddr		ComputeLinkID(srcAddr, myIndivAddr) + R_Abort S:LE_Hshake(linkID, ABORT, UNAVAILABLE)	
		willing to link w/srcAddr but no traffic channel known		ComputeLinkID(srcAddr, myIndivAddr) + R_Continue S:LE_Hshake(linkID, CONTINUE, NO_CHANNEL)	
	R: LE_Call(myIndivAddr, srcAddr, UNICAST)		InitResponseTimeout	R_Unicast	
	R: LE_Call(dest, srcAddr, MULTICAST)	dest addr is in myMulticastAddresses		InitResponseTimeout	R_Multicast
	R: LE_Call(dest, srcAddr, LinkRelease)			InitResponseTimeout	R_Release
R: LE_Bcast(countdown, trafType, pri, chan)	broadcasts accepted		InitBcastCountdown(countdown) + broadcastPriority=pri + announcedBroadcastChannel = chan + ListenForCalls(myCurrentDwellChannel)	R_Bcast	
others			none	Scanning	
S_Tune	TuningComplete		SelectTrafficChannel(myCurrentDwellChannel) + ListenOnChannel(myCurrentTrafficChannel)	S_Listen	
	others		queue or ignore	S_Tune	
S_Listen	FinishedListening		RecordOccupancy(myCurrentTrafficChannel) + ListenForCalls(myCurrentDwellChannel)	Scanning	
	others		queue or ignore	S_Listen	
R_Release	R: LE_Hshake(id, cmd, arg)	id is correct, cmd=LinkRelease	U: LE_Link_Det_Ind(Available, arg, srcAddr, dest) + ListenForCalls(myCurrentDwellChannel)	Scanning	
		wrong id or other command	ListenForCalls(myCurrentDwellChannel)	Scanning	

**TABLE C-XXX. 3G-ALE synchronous mode protocol behavior (continued).**

State	Event	Condition	Action	Next State
	ResponseTimeout		ListenForCalls(myCurrentDwellChannel)	Scanning
	others		none	R_Release
C_Slot_Wait	TuningComplete		ListenOnChannel(myCurrentTrafficChannel)	C_Slot_Wait
	FinishedListening		WaitForSlot(myCallingSlot)	C_Slot_Wait
	SlotAvailable	individual call	S: LE_Call(destAddr, myIndivAddr, callType)	SEND_CALL
		unicast or multicast call	S: LE_Call(destAddr, myIndivAddr, callType)	SEND_CALL
		broadcast call	S: LE_Bcast(myCurrentTrafficChannel, callType)	SEND_BCAST
	SlotOccupied	myCallingSlot < 4	increment myCallingSlot + WaitForSlot(myCallingSlot)	C_Slot_Wait
		myCallingSlot >= 4	compute/select next channel + TuneToNewChannel(callingChannel) + SelectSlot(pri)	C_Slot_Wait
	R: 2G_Call	2G calls accepted	U: 2G_Call_Ind	Offline
	others		queue or ignore	S_Listen
		unicast or multicast call	ComputeLinkID(myIndivAddr, destAddr) + N_Commence S:LE_Hshake(linkID, COMMENCE or VOICE, myCurrentTrafficChannel)	
	others		none	SEND_CALL
ListenFor Response	R: LE_Hshake(id, cmd, arg)	id is correct, cmd=Commence	myCurrentTrafficChannel = arg + TuneToNewChannel(myCurrentTrafficChannel)	T_Tune
		id is correct, cmd = AbortU: LE_Link_Fail_Ind(reason = arg)		Scanning
		wrong id or other command	ComputeNextDwellChannel(indivDest) + TuneToNewChannel(callingChannel) + SelectSlot(pri)	C_Slot_Wait
	ResponseTimeout	ComputeNextDwellChannel(indivDest) + TuneToNewChannel(callingChannel) + SelectSlot(pri)	C_Slot_Wait	
	others		none	ListenFor Response
T_Tune	TuningComplete		U: LE_Link_Ind(CALLER, indivDest, trafType, pri)	LinkedAsCaller
	others		none	T_Tune
N_Commence	FinishedSendingPDU		TuneToNewChannel(myCurrentTrafficChannel)	N_Tune
	others		none	N_Commence

**TABLE C-XXX. 3G-ALE synchronous mode protocol behavior (continued).**

State	Event	Condition	Action	Next State
N_Tune	TuningComplete		U: LE_Link_Ind(NCS, mcastDest, trafType, pri)	LinkedOneToMany
	others		none	N_Tune
SEND_BCAS T	FinishedSendingPDU	broadcastCount = 1	TuneToNewChannel(myCurrentTrafficChannel)	A_Tune
		broadcastCount > 1, currentSlot < 4	TuneToNewChannel(nextCallingChannel) + decrement broadcastCount	B_Tune
		broadcastCount > 1, currentSlot >= 4	TuneToNewChannel(nextCallingChannel) + SelectSlot(pri) + decrement broadcastCount	C_Slot_Wait
	others		none	SEND_BCAST
A_Tune	TuningComplete		U: LE_Link_Ind(NCS, Broadcast, callType)	LinkedOneToMany
	others		none	A_Tune
B_Tune	TuningComplete		S: LE_Bcast(myCurrentTrafficChannel, callType)	SEND_BCAST
	others		none	B_Tune
R_Commence	FinishedSendingPDU		TuneToNewChannel(myCurrentTrafficChannel)	R_Tune
	others		none	R_Commence
R_Abort	FinishedSendingPDU		none	Scanning
	others		none	R_Abort
R_Continue	FinishedSendingPDU		none	Scanning
	others		none	R_Continue
R_Unicast	R: LE_Hshake(id, cmd, arg)	id is correct, cmd = Commence or Voice	myCurrentTrafficChannel = arg + TuneToNewChannel(myCurrentTrafficChannel)	R_Tune
		wrong id or other command	ComputeDwellChannel(myIndivAddr) + ListenForCalls(myCurrentDwellChannel)	Scanning
	ResponseTimeout		ComputeDwellChannel(myIndivAddr) + ListenForCalls(myCurrentDwellChannel)	Scanning
	others		none	R_Unicast
R_Multicast	R: LE_Hshake(id, cmd, arg)	id is correct, cmd = Commence or Voice	myCurrentTrafficChannel = arg + TuneToNewChannel(myCurrentTrafficChannel)	M_Tune
		wrong id or other command	ComputeDwellChannel(myIndivAddr) + ListenForCalls(myCurrentDwellChannel)	Scanning
	ResponseTimeout		ComputeDwellChannel(myIndivAddr) + ListenForCalls(myCurrentDwellChannel)	Scanning

**TABLE C-XXX. 3G-ALE synchronous mode protocol behavior (continued).**

State	Event	Condition	Action	Next State	
	others		none	R_Multicast	
R_Bcast	EndOfDwell	broadcastCount = 1	TuneToNewChannel(announcedBroadcastChannel)	M_Tune	
		broadcastCount > 1	ComputeDwellChannel(myIndivAddr) + TuneToNewChannel(myCurrentDwellChannel) + decrementbroadcastCount	R_Bcast	
	TuningComplete		SelectTrafficChannel(myCurrentDwellChannel) + ListenOnChannel(myCurrentTrafficChannel)	R_Bcast	
	FinishedListening		RecordOccupancy(myCurrentTrafficChannel)	R_Bcast	
	R: 2G_Call	2G calls accepted	U: 2G_Call_Ind	Offline	
	others		none	R_Bcast	
R_Tune	TuningComplete		U: LE_Link_Ind(RESPONDER, srcAddr, callType) + InitTrafWaitTimeout(trafWaitTime)	LinkedAsResponder	
	others		none	R_Tune	
M_Tune	TuningComplete		U: LE_Link_Ind(MEMBER, srcAddr, callType) + InitTrafWaitTimeout(trafWaitTimeMcast)	LinkedOneOfMany	
	others		none	M_Tune	
LinkedAsCaller	D: LE_ReturnToScan		TuneToNewChannel(callingChannel) + SelectSlot(pri)	LinkReleaseWait	
	others		none	LinkedAsCaller	
LinkedOneToMany	D: LE_ReturnToScan		TuneToNewChannel(callingChannel) + SelectSlot(pri)	LinkReleaseWait	
	others		none	LinkedOneToMany	
LinkReleaseWait	EndOfDwell	dest group will dwell on callingChannel	WaitForSlot(myCallingSlot)	LinkReleaseWait	
		dest group will dwell on another channel	none	LinkReleaseWait	
	SlotAvailable		S: LE_Call(destAddr, myIndivAddr, LinkRelease1 LinkRelease)		
	SlotOccupied	myCallingSlot < 4		increment myCallingSlot + WaitForSlot(myCallingSlot)	LinkReleaseWait
		myCallingSlot >= 4		ComputeDwellChannel(myIndivAddr) + ListenForCalls(myCurrentDwellChannel)	Scanning
	others		queue or ignore	S_Listen	

**TABLE C-XXX. 3G-ALE synchronous mode protocol behavior (continued).**

State	Event	Condition	Action	Next State
LinkRelease1	FinishedSendingPDU		ComputeLinkID(myIndivAddr, destAddr) + S:LE_Hshake(linkID, LinkRelease, myCurrentTrafficChannel)	LinkRelease2
	others		none	LinkRelease1
LinkRelease2	FinishedSendingPDU		ComputeDwellChannel(myIndivAddr) + ListenForCalls(myCurrentDwellChannel)	Scanning
	others		none	LinkRelease2
LinkedAs Responder	D: LE_ReturnToScan		ComputeDwellChannel(myIndivAddr) + ListenForCalls(myCurrentDwellChannel)	Scanning
	TrafWaitTimeout		ComputeDwellChannel(myIndivAddr) + ListenForCalls(myCurrentDwellChannel) + U:LE_Link_Fail_Ind(NORESPONSE))	Scanning
	others		none	LinkedAsResponder
LinkedOneOf Many	D: LE_ReturnToScan		ComputeDwellChannel(myIndivAddr) + ListenForCalls(myCurrentDwellChannel)	Scanning
	TrafWaitTimeout		ComputeDwellChannel(myIndivAddr) + ListenForCalls(myCurrentDwellChannel) + U:LE_Link_Fail_Ind(NORESPONSE))	Scanning
	others		none	LinkedOneOf Many
Offline	D: LE_ReturnToScan		ComputeDwellChannel(myIndivAddr) + ListenForCalls(myCurrentDwellChannel)	Scanning
	others		none	Offline

**C.5.2.4.4.8 3G-ALE synchronous mode protocol examples.**

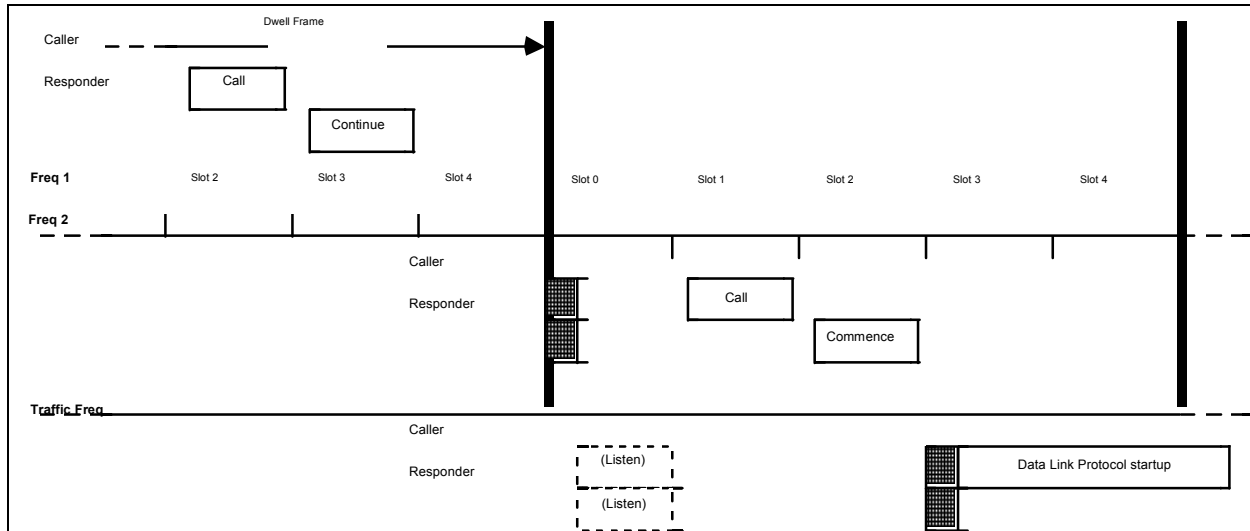
An example of synchronous mode 3G-ALE protocol behavior is shown in figure C-19. The first call occurs in Slot 2. The responder receives the call, but has not identified a suitable traffic channel for the requested traffic, and therefore sends an LE\_Handshake PDU containing a Continue Handshake command.

In the next dwell, both stations tune during Slot 0, then listen for occupancy on a nearby traffic frequency. The caller selects Slot 1 this time, and the responder has determined that the traffic channel was available. When the LE\_Call PDU is received by the responder, the measured channel quality is sufficient for the offered traffic, and the responder sends an LE\_Handshake PDU containing a Commence Traffic Setup command that indicates the traffic channel to be used. Both stations tune to that channel in the following slot, and the caller initiates the traffic setup protocol.

**C.5.2.4.4.9 3G-ALE synchronous mode timing characteristics.**

Synchronous-mode 3G-ALE timing is specified in terms of  $T_{\text{sym}}$ , where  $2400 T_{\text{sym}} = 1$  s. The time at which each type of 3G-ALE\_PDU shall be sent is specified in the following paragraphs. In each case of sending a PDU, the transmitter shall have reached 90 percent of steady-state

power at the time that the PDU begins. Unless otherwise stated, deviation from specified timing shall not exceed  $\pm 10$  percent.



**FIGURE C-19. Example 3G-ALE synchronous link establishment.**

**C.5.2.4.4.9.1 3G-ALE synchronous mode tuning time.**

All emanations for tuning the RF components in a synchronous-mode 3G-ALE system shall occur only during the first  $256 T_{sym}$  (approximately 106.7 ms) of Slot 0, or between the start of a calling slot and the beginning of a PDU sent by that station in that slot. (Emanations required for the initial or learning tuning of a coupler with presets may occur at any time.)

**C.5.2.4.4.9.2 3G-ALE synchronous mode traffic channel evaluation timing.**

Synchronous-mode 3G-ALE systems shall listen for occupancy of a traffic channel during most of the remainder of Slot 0 during each scanning dwell, and shall meet the requirements of C.4.6.1.2 Occupancy detection. Normally, at least 640 ms should be available for this function, but no minimum time is required. The receiver shall be re-tuned to the calling channel in time to receive a PDU that begins coincident with the start of Slot 1. (NOTE: a PDU may arrive this early due to differences in local time bases.)

**C.5.2.4.4.9.3 3G-ALE synchronous mode call, broadcast, and notification timing.**

LE\_Call, LE\_Broadcast, and LE\_Notification PDUs shall be sent during slots selected in accordance with C.5.2.4.4.1 3G-ALE synchronous mode slot selection. The PDU shall begin at the later of the following two instants:

1.  $128 T_{\text{sym}}$  (approximately 53.3 ms) has elapsed since the start of the selected slot.
2. If and only if a PDU was received in the preceding slot,  $256 T_{\text{sym}}$  (approximately 106.7 ms) has elapsed since the end of that PDU.

#### C.5.2.4.4.9.4 3G-ALE synchronous mode response timing

A responding station shall commence transmission of an LE\_Handshake PDU at the later of the two following instants:

1.  $128 T_{\text{sym}}$  (approximately 53.3 ms) has elapsed since the start of the response slot at the responding station.
2.  $256 T_{\text{sym}}$  (approximately 106.7 ms) has elapsed since the end of the received LE\_Call PDU. C.5.2.4.4.9.5 3G-ALE synchronous mode unicast, multicast, and link release command timing

When a 3G-ALE system is sending a unicast or multicast call, or a link release, the LE\_Handshake PDU that designates the traffic channel shall be sent in the slot that immediately follows the LE\_Call PDU. The transmitter shall be keyed when  $128 T_{\text{sym}}$  (approximately 53.3 ms) has elapsed since the start of that slot.

#### C.5.2.4.5 3G-ALE asynchronous mode protocol.

When a 3G-ALE network is operating in asynchronous mode, calls shall be extended to capture scanning receivers (similar to 2G-ALE) as described in C.5.2.4.5.2 3G-ALE asynchronous mode scanning call. The remainder of the handshake shall be self-timed as described in C.5.2.4.5.3 3G-ALE asynchronous mode handshake.

##### C.5.2.4.5.1 3G-ALE asynchronous mode listen before transmit.

Systems operating in 3G-ALE asynchronous mode shall listen on the calling channel before sending a scanning call or a sound. The duration of this listen before transmit period shall be programmable, with a default value of 2 s.

##### C.5.2.4.5.2 3G-ALE asynchronous mode scanning call.

The LE\_Scanning\_Call PDU shall be sent repeatedly to capture scanning receivers, followed by an LE\_Call PDU. The number of times the LE\_Scanning\_Call PDU is sent shall be a programmable multiple of the number of channels scanned (denoted C). By default, the multiplier M shall be 1.3. The number of LE\_Scanning\_Call PDUs sent shall be the smallest integer that is at least equal to the product of C and M.

During a scanning call, only the first LE\_Scanning\_Call PDU shall include  $T_{\text{tlc}}$  (used for transmitter level control and receiver AGC settling). All succeeding LE\_Scanning\_Call PDUs and the LE\_Call PDU shall omit  $T_{\text{tlc}}$ , and include only the BW0 preamble ( $T_{\text{pre}}$ ) and data ( $T_{\text{data}}$ ) portions.



C.5.2.4.5.3 3G-ALE asynchronous mode handshake.

The asynchronous mode 3G-ALE handshake is self-timed. The responding station shall

1. Decode an LE\_Call PDU when it is received,
2. Tune its RF components (if necessary),
3. Listen on a traffic channel for approximately 640 ms to determine occupancy, and
4. Key its transmitter for its response, in accordance with C.5.2.4.5.11.2 3G-ALE asynchronous mode handshake timing.

The use of LE\_Handshake PDU commands shall be the same as in the synchronous mode.

If the calling station receives a Commence Traffic Setup command in the responding LE\_Handshake PDU, it shall commence the data link protocol (or ALM protocol, if required) starting  $4 T_{\text{slot}} = 3.2$  s after the beginning of its LE\_Call PDU.

C.5.2.4.5.4 3G-ALE asynchronous mode unicast call.

A unicast call is used to contact an individual station and direct it to a traffic channel selected by the calling station. An asynchronous-mode unicast call shall consist of a scanning call in accordance with C.5.2.4.5.2 3G-ALE asynchronous mode scanning call, with a Call Type of Unicast ARQ Packet, Unicast Circuit, or Control in the LE\_Call PDU, followed immediately by an LE\_Handshake PDU that contains the following:

- A link ID (C.5.2.2) computed from the called station address and the calling station address.
- A Voice Traffic command if requesting a link for analog voice traffic, or a Commence Traffic Setup command if requesting a link for other traffic types.
- The channel number for the traffic channel that will be used for traffic.

This LE\_Handshake PDU shall not include  $T_{\text{tlc}}$ , but only the BW0 preamble ( $T_{\text{pre}}$ ) and data ( $T_{\text{data}}$ ) portions.

C.5.2.4.5.5 3G-ALE asynchronous mode multicast call.

A multicast call is used to contact selected stations concurrently and direct them to a traffic channel selected by the calling station. An asynchronous-mode multicast call shall consist of a scanning call in accordance with C.5.2.4.5.2 3G-ALE asynchronous mode scanning call, with a Call Type of Multicast in the LE\_Call PDU, followed immediately by an LE\_Handshake PDU that contains the following:

- A link ID (C.5.2.2) computed from the multicast address and the calling station address, in accordance with C.4.5.3 Multicast addresses.

- A Voice Traffic command if the link is for analog voice, otherwise a Commence Traffic Setup command.
- The channel number for the traffic channel that will be used for the multicast.

This LE\_Handshake PDU shall not include  $T_{tlc}$ , but only the BW0 preamble ( $T_{pre}$ ) and data ( $T_{data}$ ) portions.

#### C.5.2.4.5.6 3G-ALE asynchronous mode broadcast call.

The asynchronous-mode broadcast call shall consist of at least  $M C + 1$  repetitions of an LE\_Broadcast PDU, where  $C$  is the number of calling channels scanned by the stations being called, and  $M$  is the multiplier defined in C.5.2.4.5.2 3G-ALE asynchronous mode scanning call. The Call Type and Channel fields shall be used as specified in C.5.2.4.4.5 3G-ALE synchronous mode broadcast calling. The Countdown field shall be used as follows:

1. A repetition factor  $R$  shall be computed as the smallest integer that is greater than or equal to  $M C / 7$ . For example, if  $M = 1.2$  and  $C = 10$ ,  $R$  shall be 2.
2. The initial value of the Countdown field shall be the smallest integer that is greater than or equal to  $M C / R$ . For example if  $M = 1.2$  and  $C = 10$ , the initial Countdown value shall be 6.
3.  $R$  identical repetitions of the LE\_Broadcast PDU shall be sent, after which the Countdown field shall be decremented.
4. Step 3 shall be repeated until the decremented value of the Countdown field is 0. A single instance of the LE\_Broadcast PDU with Countdown = 0 shall be sent.
5. The broadcast shall commence on the indicated channel  $2 T_{slot}$  after the end of the final LE\_Broadcast PDU.

During an asynchronous-mode broadcast call, only the first LE\_Broadcast PDU shall include  $T_{tlc}$  (used for transmitter level control settling). All succeeding LE\_Broadcast PDUs shall omit  $T_{tlc}$ , and include only the BW0 preamble ( $T_{pre}$ ) and data ( $T_{data}$ ) portions.

A means shall be provided for operators to disable execution of the asynchronous-mode broadcast protocol.

#### C.5.2.4.5.7 3G-ALE asynchronous mode link release.

Transmission of link releases is optional when operating in asynchronous mode. When used, an asynchronous-mode link release shall be sent after termination of a link on the calling channel that was used in establishing the link. Asynchronous-mode link releases shall begin with a scanning call addressed to the called station in accordance with C.5.2.4.5.2 3G-ALE asynchronous mode scanning call, with a Call Type of Link Release in the LE\_Call PDU, followed immediately by an LE\_Handshake PDU that contains the following:

- A link ID computed from the called address and the calling station address.

- A Link Release command.
- The channel number for the traffic channel that is being released.

This LE\_Handshake PDU shall not include  $T_{tlc}$ , but only the BW0 preamble ( $T_{pre}$ ) and data ( $T_{data}$ ) portions.

C.5.2.4.5.8 3G-ALE asynchronous mode entry to synchronous networks.

Stations not synchronized to network time may link with synchronous mode stations by sending either normal (C.5.2.4.5.2) or extended scanning calls addressed to those stations. The duration of an extended scanning call is 4 C seconds, which ensures that the destination station will dwell on the calling channel during the call.

C.5.2.4.5.9 3G-ALE asynchronous mode protocol behavior.

Implementations of 3G-ALE operating in asynchronous mode shall exhibit the same over-the-air behavior as that described in table C-XXXI.

MIL-STD-188-141B  
APPENDIX C

**TABLE C-XXXI. 3G-ALE asynchronous mode protocol behavior.**

State	Event	Condition	Action	Next State
Scanning	End of dwell		ComputeDwellChannel(myIndivAddr) + ListenForCalls(myCurrentDwellChannel)	Scanning
	D: LE_Link_Req( indivDest, trafType, pri)		SelectCallingChannel(indivDest) + ListenOnChannel(callingChannel)	C_Listen
	D: LE_Link_Req( mcastDest, trafType, pri)		SelectMulticastChannels(mcastDest) + ListenOnChannel(callingChannel)	C_Listen
	D: LE_Link_Req( Broadcast, trafType, pri)		SelectBroadcastChannels + InitBroadcastCount + ListenOnChannel(callingChannel)	C_Listen
	R: LE_Scan_Call(addr)	addr is myIndivAddr or is subscribed multicast or listening for LinkReleases	InitScanCallTimeout	ListenToCall
	R: LE_Bcast(countdown, trafType, pri, chan)	broadcasts accepted	InitBcastCountdown(countdown) + broadcastPriority=pri + announcedBroadcastChannel = chan	R_Bcast
	TimeToSound(channel)	sounding enabled	callingChannel = channel + ListenOnChannel(myCurrentTrafficChannel)	S_Listen
	others		none	Scanning
S_Listen	FinishedListening	channel occupied	RecordOccupancy(callingChannel) + RestartSoundingTimer(callingChannel, soundRetryDelay) + ListenForCalls(myCurrentDwellChannel)	Scanning
		channel vacant	TuneToNewChannel(callingChannel) + RestartSoundingTimer(callingChannel, soundingInterval)	S_Tune
	others		queue or ignore	S_Listen
S_Tune	TuningComplete		S: LE_Notification(myIndivAddr, NOMINAL) + scanSoundCountdown = 1.2 * numScanChan	SendSound
	others		queue or ignore	S_Tune
Send Sound	FinishedSendingPDU	scanSoundCountdown > 1	S: LE_Notification(myIndivAddr, NOMINAL) + scanSoundCountdown = scanSoundCountdown - 1	SendSound
		scanSoundCountdown <= 1	ComputeDwellChannel(myIndivAddr) + ListenForCalls(myCurrentDwellChannel)	Scanning
	others		queue or ignore	SendSound
ListenTo Call	R: LE_Call(myIndivAddr, srcAddr, pkt or ckt call)		TuneToNewChannel(myCurrentDwellChannel)	L_Tune
	R: LE_Call(myIndivAddr, srcAddr, UNICAST)		InitResponseTimeout	R_Unicast
	R: LE_Call(destAddr, srcAddr, MULTICAST)	destAddr is in myMulticastAddresses	InitResponseTimeout	R_Multicast
	R: LE_Call(dest, srcAddr, LinkRelease)		InitResponseTimeout	R_Release
	ScanCallTimeout		ComputeDwellChannel(myIndivAddr) + ListenForCalls(myCurrentDwellChannel)	Scanning
	ScanCallDropout		ComputeDwellChannel(myIndivAddr) + ListenForCalls(myCurrentDwellChannel)	Scanning
	others		queue or ignore	ListenToCall

**TABLE C-XXXI. 3G-ALE asynchronous mode protocol behavior (continued).**

State	Event	Condition	Action	Next State
L_Tune	TuningComplete	willing to link w/srcAddr	SelectTrafficChannel(myCurrentDwellChannel) + ListenOnChannel(myCurrentTrafficChannel)	R_Listen
		not willing to link with srcAddr	ComputeLinkID(srcAddr, myIndivAddr) + S:LE_Hshake(linkID, ABORT, REJECTED)	R_Abort
	others		queue or ignore	L_Tune
R_Release	R: LE_Hshake(id, cmd, arg)	id is correct, cmd=LinkRelease	U: LE_Link_Det_Ind(Available, arg, srcAddr, dest) + ListenForCalls(myCurrentDwellChannel)	Scanning
		wrong id or other command	ListenForCalls(myCurrentDwellChannel)	Scanning
	ResponseTimeout		ListenForCalls(myCurrentDwellChannel)	Scanning
	others		none	R_Release
R_Listen	FinishedListening	traffic channel occupied	ComputeLinkID(srcAddr, myIndivAddr) + S:LE_Hshake(linkID, CONTINUE, NO_CHANNEL)	R_Continue
		traffic channel vacant	ComputeLinkID(srcAddr, myIndivAddr) + S:LE_Hshake(linkID, COMMENCE, prefTrafChan)	R_Commence
	others		queue or ignore	R_Listen
R_Commence	FinishedSendingPDU		TuneToNewChannel(myCurrentTrafficChannel)	R_Tune
	others		none	R_Commence
R_Abort	FinishedSendingPDU		none	Scanning
	others		none	R_Abort
R_Continue	FinishedSendingPDU		none	Scanning
	others		none	R_Continue
R_Unicast	R: LE_Hshake(id, cmd, arg)	id is correct, cmd = Commence or Voice	myCurrentTrafficChannel = arg + TuneToNewChannel(myCurrentTrafficChannel)	R_Tune
		wrong id or other command	ComputeDwellChannel(myIndivAddr) + ListenForCalls(myCurrentDwellChannel)	Scanning
	ResponseTimeout		ComputeDwellChannel(myIndivAddr) + ListenForCalls(myCurrentDwellChannel)	Scanning
	others		none	R_Multicast
R_Multicast	R: LE_Hshake(id, cmd, arg)	id is correct, cmd = Commence or Voice	myCurrentTrafficChannel = arg + TuneToNewChannel(myCurrentTrafficChannel)	M_Tune
		wrong id or other command	ComputeDwellChannel(myIndivAddr) + ListenForCalls(myCurrentDwellChannel)	Scanning
	ResponseTimeout		ComputeDwellChannel(myIndivAddr) + ListenForCalls(myCurrentDwellChannel)	Scanning
	others		none	R_Multicast
R_Bcast	R: LE_Bcast(countdown, trafType, pri, chan)	countdown = 0	TuneToNewChannel(chan)	M_Tune
		countdown > 0	none	R_Bcast
	others		none	R_Bcast
R_Tune	TuningComplete		U: LE_Link_Ind(RESPONDER, srcAddr, trafType, pri)	LinkedAsResponder

**TABLE C-XXXI. 3G-ALE asynchronous mode protocol behavior (continued).**

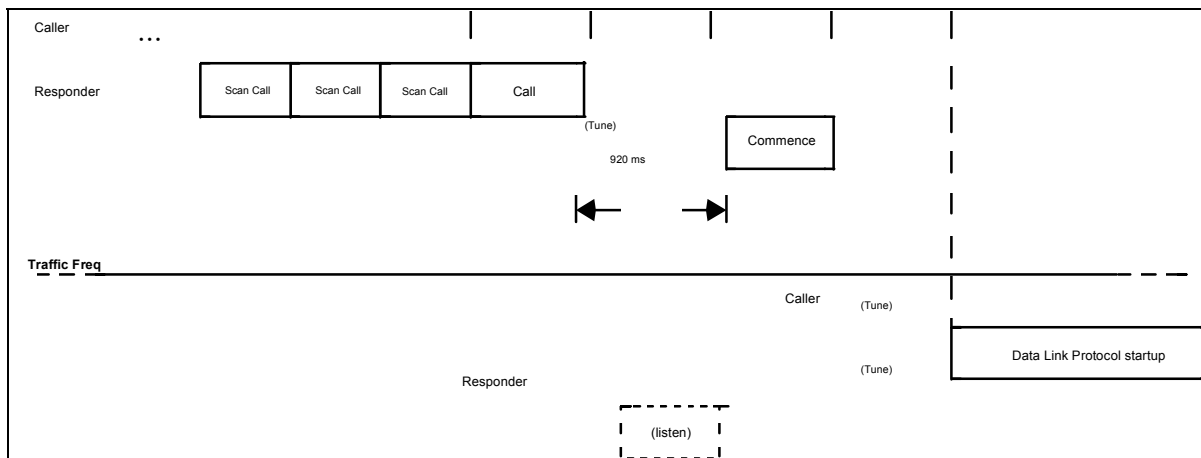
State	Event	Condition	Action	Next State
	others	none		R_Tune
M_Tune	TuningComplete		U: LE_Link_Ind(MEMBER, srcAddr, trafType, pri)	LinkedOneOfMany
	others	none		M_Tune
LinkedAs Caller	D: LE_ReturnToScan		ComputeDwellChannel(myIndivAddr) + ListenForCalls(myCurrentDwellChannel)	Scanning
	others	none		LinkedAs Caller
LinkedOneTo Many	D: LE_ReturnToScan		ComputeDwellChannel(myIndivAddr) + ListenForCalls(myCurrentDwellChannel)	Scanning
	others	none		LinkedOneTo Many
LinkedAs Responder	D: LE_ReturnToScan		ComputeDwellChannel(myIndivAddr) + ListenForCalls(myCurrentDwellChannel)	Scanning
	others	none		LinkedAs Responder
C_Listen	FinishedListening	channel vacant	TuneToNewChannel(callingChannel)	C_Tune
		channel occupied	RecordOccupancy(callingChannel) + SelectCallingChannel(indivDest) + ListenOnChannel(callingChannel)	C_Listen
	others	queue or ignore		C_Listen
C_Tune	TuningComplete	individual call	S: LE_Scan_Call(destAddr)	SendScanCall
		multicast call	S: LE_Scan_Call(mcastAddr)	SendScanCall
		broadcast call	InitAsyncCount + S: LE_Bcast(bcastCount, trafType, pri, myCurrentTrafficChannel)	BroadcastCall
	others	queue or ignore		S_Listen
SendScanCall	FinishedSendingPDU	individual call	ComputeLinkID(myIndivAddr, indivDest) + InitResponseTimeout	ListenForResponse
		multicast call	ComputeLinkID(myIndivAddr, mcastDest) + S:LE_Hshake(linkID, COMMENCE or VOICE, myCurrentTrafficChannel)	N_Commence
	others	none		SendScanCall
ListenFor Response	R: LE_Hshake(id, cmd, arg)	id is correct, cmd=Commence	myCurrentTrafficChannel = arg + TuneToNewChannel(myCurrentTrafficChannel)	T_Tune
		id is correct, cmd=Abort	U: LE_Link_Rejected(reason = arg)	Scanning
		wrong id or other command	RecordCallFailure(indivDest, callingChannel) + SelectCallingChannel(indivDest) + ListenOnChannel(callingChannel)	C_Listen
	ResponseTimeout		RecordCallFailure(indivDest, callingChannel) + SelectCallingChannel(indivDest) + ListenOnChannel(callingChannel)	C_Listen
	others	none		ListenFor Response
T_Tune	TuningComplete		U: LE_Link_Ind(Caller, indivDest, trafType, pri)	LinkedAsCaller
	others	none		T_Tune

**TABLE C-XXXI. 3G-ALE asynchronous mode protocol behavior (continued).**

State	Event	Condition	Action	Next State
N_Commerce	FinishedSendingPDU		TuneToNewChannel(myCurrentTrafficChannel)	N_Tune
	others		none	N_Commerce
N_Tune	TuningComplete		U: LE_Link_Ind(NCS, mcastDest, trafType, pri)	LinkedOneToMany
	others		none	N_Tune
BroadcastCall	FinishedSendingPDU	countdown = 0	TuneToNewChannel(myCurrentTrafficChannel)	A_Tune
		countdown > 0	update bcastCount + S: LE_Bcast(bcastCount, trafType, pri, myCurrentTrafficChannel)	BroadcastCall
	others		none	BroadcastCall
A_Tune	TuningComplete		U: LE_Link_Ind(NCS, Broadcast, trafType, pri)	LinkedOneToMany
	others		none	A_Tune

C.5.2.4.5.10 3G-ALE asynchronous mode protocol example.

The asynchronous mode 3G-ALE protocol is illustrated in figure C-20. The called station (“Responder”) receives a scanning call and evaluates the channel quality of the calling channel using the received LE\_Scanning\_Call and LE\_Call PDUs. Having determined that the channel quality is sufficient for the type of traffic announced in the LE\_Call PDU, the Responder tunes on the calling channel for sending a response, listens on a nearby traffic channel, finds the traffic channel unoccupied, and therefore sends a Commence Traffic Setup command in an LE\_Handshake PDU.



**FIGURE C-20. 3G-ALE asynchronous mode link establishment.**

C.5.2.4.5.11 3G-ALE asynchronous mode timing characteristics.

Asynchronous mode timings are referenced only to the start of the scanning call, not to any global timing system. Unless otherwise stated, deviation from specified timing shall not exceed ±10 percent.

C.5.2.4.5.11.1 3G-ALE asynchronous mode scanning call timing.

The duration of a 3G-ALE asynchronous-mode scanning call (including LE\_Scanning\_Call PDUs and the LE\_Call PDU) shall be as follows, where C is the number of scanned channels, and M is the multiplier of C.5.2.4.5.2 3G-ALE asynchronous mode scanning call.

$$\begin{aligned} T_{sc} &= T_{tlc} + (M C + 1) (T_{BW0\ pre} + T_{BW0\ data}) \\ &= 2.640\ s \text{ when } C = 3 \text{ calling channels, and } M = 1.3 \end{aligned}$$

When an LE\_Handshake PDU is appended to the LE\_Call PDU,  $T_{sc}$  is increased by  $T_{BW0\ pre} + T_{BW0\ data}$  or approximately 506.7 ms.

C.5.2.4.5.11.2 3G-ALE asynchronous mode handshake timing.

When an LE\_Handshake PDU is sent by a responding station, it shall begin  $32 T_{sym}$  (approximately 13.3 ms) after the transmitter is keyed. Total elapsed time from end of LE\_Call PDU until start of LE\_Handshake PDU shall be  $2208 T_{sym}$  (920 ms), measured at the responding station.

The duration of a 3G-ALE asynchronous-mode handshake, from the start of the scanning call through the start of traffic setup on the traffic channel is as follows:

$$\begin{aligned} T_{handshake} &= T_{tlc} + M C (T_{BW0\ pre} + T_{BW0\ data}) + 4 T_{slot} \\ &= 5.333\ s \text{ when } C = 3 \text{ calling channels, and } M = 1.3 \end{aligned}$$

C.5.2.5 Notification protocol behavior.

Sending LE\_Notification PDUs is optional. Network managers may wish to enable the notification protocol when the use of channel time for this overhead function provides a worthwhile return in tracking station and channel status.

C.5.2.5.1 Station status notification.

When station status notification is enabled, stations shall broadcast an LE\_Notification PDU when one of the following occurs:

- Station status changes (or is about to change to a non-communicative state).
- A periodic timer prompts a notification.

A notification shall be sent on one or more channels selected to efficiently inform other network members of station status.

C.5.2.5.2 Sounding.

Sounding will normally be unnecessary in 3G-ALE systems. Knowledge of propagating channels can be used in synchronous networks to delay the start of calling and thereby reduce calling channel occupancy. However, with synchronous scanning, knowledge of propagating channels will have only slight effect on linking latency unless non-propagating channels are removed from the scan list (see Calling Channel Management, above).



In asynchronous 3G-ALE networks, sounding may be desired if propagation data is unobtainable by other means. In this case, periodic transmissions of a repeated LE\_Notification PDU indicating Nominal station status may be employed.

#### C.5.2.5.3 Synchronous mode notifications.

In networks operating in synchronous mode, LE\_Notification PDUs shall be sent singly in randomly selected slots using the same procedure as for LE\_Call PDUs, including slot selection and listening before transmitting.

#### C.5.2.5.4 Asynchronous mode notifications.

In networks operating in asynchronous mode, LE\_Notification PDUs shall be sent  $M C + 1$  times, after listening before transmitting, where  $C$  is the number of scanned channels, and  $M$  is the multiplier of C.5.2.4.5.2 3G-ALE asynchronous mode scanning call.

#### C.5.2.6 Calling into a 3G network.

Stations that have not been assigned an address in a network may call into that network by randomly selecting a Net Entry address (C.5.2.6.1) and placing a call using that address in accordance with an appropriate calling protocol. The call may be placed on any frequency known to be monitored by the network to be entered. Networks that support net entry by non-member stations should assign a well-known address (e.g., all 0's) to field such calls. Linking protection should be employed when spoofing is a concern.

Net entry calling and acceptance of net entry calls shall be supported by all 3G systems. A means shall be provided for operators to disable acceptance of net entry calls.

##### C.5.2.6.1 Net entry addresses.

Net Entry addresses are of the form 1111xxxxxx. A station placing a net entry call shall randomly select one of these 128 addresses for use in a 3G-ALE calling protocol and subsequent protocols until it is assigned a member address.

##### C.5.2.6.2 Link establishment for net entry.

A station calling into a network operating in synchronous or asynchronous mode shall place an asynchronous-mode unicast call to a well-known address in accordance with C.5.2.4.5.4 3G-ALE asynchronous mode unicast call. When the calling station does not know the channel assignments in the foreign network, it should specify channel 127 which results in linking for traffic on the calling channel. When more than one of the frequencies scanned by the destination network are known, calling attempts should be placed on each channel in rotation until a link is established.

If the calling station seeks only a one-time analog voice link, the Call Type should be "Unicast Circuit" and the LE\_Handshake PDU should carry a Commence Voice command. Otherwise, the TM protocol will normally be engaged after linking, so the Call Type should be "Unicast ARQ Packet" and the LE\_Handshake PDU should carry a Commence Traffic Setup command.

#### C.5.2.6.3 Acquisition of operating data.

When a station calling into a network is to begin regular operation as a network member, the 3G packet protocol and the network management protocol of Appendix D should be used to transfer the following network operating data to the entering station:

- A station self address for use in the newly entered network (not a net entry address). Normally the calling station will provide its call sign and receive a 3G ALE (11 bit ) address in return.
- Channel table (frequencies, usage flags, and power limits); see C.4.11.3.

This transfer may be accomplished during the traffic phase of the initial net entry call, using the net entry address.

Synchronization of the entering station with network time shall comply with C.4.3 Network synchronization. If over-the-air synchronization will be required, it is recommended that operating data be set up in the new network member before the net entry synchronization protocol of C.5.2.7.6 is executed.

#### C.5.2.7 Synchronization management protocol (not tested).

3G networks operating in synchronous mode are intended to maintain synchronization using external means such as GPS receivers. This section describes a synchronization management protocol that is intended to serve as a fallback mechanism for use when external time references are unavailable or their use is otherwise impractical. Network managers should avoid use of this protocol when other alternatives are available because it requires use of the HF channels for this overhead function.

The synchronization management protocol supports the following tasks:

- Synchronization maintenance to compensate for time base drift
- Time service for late net entry
- Initial distribution of time to network member stations

This is an optional protocol. However, all 3G networks that must operate without external synchronization available to every station should implement these functions.

#### C.5.2.7.1 Synchronization data.

For successful operation in synchronous mode, third generation systems must maintain time base accuracy in accordance with C.4.3. The formula used by synchronous-mode stations to compute their current dwell channels in C.4.4.1 includes the time since midnight (network time). Network time is conceptually stored as a GPS week counter (week 0 was the week beginning 00:00 6 January 1980), a day of the week, elapsed seconds in the current day, and elapsed Tsym within the current second. A dwell counter is extracted from the seconds counter by dropping the two least-significant bits. Note that GPS time runs at the same rate as coordinated universal time

(UTC), but GPS time does not add leap seconds and therefore differs by a small number of seconds from UTC.

In addition to a local estimate of network time, each station shall maintain a bound on the uncertainty (loss of accuracy) of this time base. This uncertainty value shall be set when the time base is adjusted, as described later, and shall increase steadily until the next time base update at a rate determined by the accuracy of the time base oscillator. When the oscillator has an accuracy of 1 part per million, the time base may drift by  $\pm 3.6$  ms per hour, so the total width of time base uncertainty shall be increased by 7.2 ms per hour.

**C.5.2.7.2 Time quality.**

When one station sends a time update to another station, the uncertainty at the sending station shall be encoded as a Time Quality code in accordance with table C-XXXII. Note that only UTC sites may claim Time Quality 0. Stations that receive regular updates from a local GPS receiver or other stable time base that maintains their uncertainty below 1 ms shall report Time Quality 1. Other stations shall use the smallest code whose corresponding uncertainty value is greater than or equal to the local total uncertainty width.

**TABLE C-XXXII. 3G-ALE synchronization management time quality codes.**

SM Time Quality Code	Total Time Uncertainty
0 (000)	none: UTC station
1 (001)	1 ms: local GPS receiver or equiv.
2 (010)	2 ms or stand-alone master station
3 (011)	5 ms
4 (100)	10 ms
5 (101)	20 ms
6 (110)	50 ms
7 (111)	unbounded or unknown

NOTE: When a network is operating in stand-alone mode (i.e., no network member has access to UTC, GPS, or equivalent time), one network member station should be designated as the master time reference, and that station should always use Time Quality 2. Of all station that have suitably stable oscillators, the designated station may be selected as the one with the lowest 3G-ALE address (e.g., a designated net entry server, with address zero).

**C.5.2.7.3 Synchronization management PDUs.**

The LE\_PDUs (see figure C-17) used in synchronization management are described in the following paragraphs.

**C.5.2.7.3.1 Group time broadcast PDU.**

The group time broadcast PDU (LE\_GTB PDU) conveys limited-precision time to any station that receives it. It is sent singly as described later in this section. The Server Group Number shall contain the dwell group number portion of the sending station address. The Dwell Number

field shall contain the four least-significant bits of the counter of dwell periods since midnight network time. The Slot Number field shall indicate the slot in which the PDU is sent. (The Slot Number field is set to 7 during initial time distribution, as described in C.5.2.7.5.)

An LE\_GTB PDU shall always be sent starting 128 Tsym after the beginning of the indicated slot at the sender. However, receiving stations may not know the propagation delay from sender to receiver, so this PDU by itself is insufficient to synchronize stations to meet the requirements of C.4.3.

NOTE: each day contains an even multiple of 16 dwells so the four Dwell Number bits sent in this PDU increment naturally from 1111 to 0000 at midnight. The time indicated by this PDU should never be ambiguous unless (and only when) network time adds a leap second. For this reason, GPS time may be preferred over UTC.

#### C.5.2.7.3.2 Sync check PDU.

The Sync Check PDU is an LE\_Handshake PDU containing a Sync Check command. It is sent following a Control-type LE\_Call PDU during a sync check handshake, and shall always be sent 128 Tsym after the beginning of its slot at the sending station.

The most-significant bit of the Argument field shall be 0. The next three bits shall contain the time quality code from table C-XXXII corresponding to the total time uncertainty at the station sending the PDU. The three least-significant bits shall contain the number of the slot in which the PDU is sent: 001, 010, 011, or 100.

The Argument field may be set to all 1's when used in Late Net Entry Sync Acquisition (see C.5.2.7.6).

#### C.5.2.7.3.3 Sync offset PDU.

The LE\_Sync Offset PDU is used to compensate for time base drift and propagation delay among stations during a Sync Check Handshake. It shall be sent by the responding station 256 Tsym (+/- 1 ms) after the end of a Sync Check PDU. The Quality field shall contain the time quality of the responding station in accordance with C.5.2.7.2. The Offset field shall indicate the magnitude of the difference between the time when the end of the Sync Check PDU arrives at the responding station and the "ideal time" when a PDU sent by the responding station in that same slot would have ended (i.e., beginning of the slot plus 128 Tsym plus 613 ms, which is 1600 Tsym or 666.7 ms into the slot). The Offset field shall be encoded in accordance with table C-XXXIII. The Sign bit shall be 1 if the PDU arrived early (before the ideal time), 0 if it arrived after the ideal time.

**TABLE C-XXXIII. 3G-ALE synchronization management sync offset codes.**

Sync Offset Code	Magnitude of Offset (ms)
0 - 400	2 x Code
401 - 420	(reserved; do not use)
421 - 511	40 x (Code - 400)

**C.5.2.7.4 Sync check handshake.**

The sync check handshake is used to update the time base at the station that initiates the handshake. It consists of a Control-type LE\_Call PDU, followed by an LE\_Sync Check PDU from the initiator. The called station then responds with an LE\_Sync Offset PDU. The initiating station shall compute its new local time and total time uncertainty as follows after receiving the LE\_Sync Offset PDU:

1. The initiator shall measure the elapsed time between the end of its Sync Check PDU and the time of arrival of the end of the LE\_Sync Offset PDU. The propagation delay  $T_{pd}$  shall be computed as  $T_{pd} = (\text{Elapsed time} - 720 \text{ ms}) / 2$ .
2. If the LE\_Sync Offset PDU Sign field is 0 (initiator is behind), the initiator shall subtract  $T_{pd}$  from the Offset field and add the result to its local time. Otherwise (Sign field = 1), the initiator shall add  $T_{pd}$  to the Offset field and subtract the result from its local time.
3. The initiator shall set its time base uncertainty to the value corresponding to the Quality code in the LE\_Sync Offset PDU plus 5 ms to allow for unmeasured fluctuations in time of PDU release and in propagation delay.

A sync check handshake shall begin with equal probability in slot 1 or slot 2, and shall not begin in later slots.

**C.5.2.7.5 Synchronization maintenance.**

Stations operating in synchronous mode should request a time base update whenever their total time uncertainty will increase past the maximum allowed tolerance (C.4.3) within 60 minutes. A sync check handshake should then be initiated with the time server in its group. If no response (or a garbled response) is received, the initiating station should try again  $C + 1$  dwells later on the next channel, and so on.

If a station's time uncertainty grows past the limit of C.4.3, it must cease synchronous operation and attempt to reacquire network synchronization using the Late Net Entry procedure specified in C.5.2.7.6.

**C.5.2.7.6 Synchronization for late net entry.**

A station that is not synchronized to a network but whose time base is within +/- 30 s of network time may request and synchronize to network time using the following protocol. The protocol is

more robust if the unsynchronized station knows the channel assignments of the network (see step 3), but may be used by a station that knows only one frequency that is monitored by the network stations.

1. The unsynchronized station (caller) initiates the protocol by sending an asynchronous Control call to a time server or other known address. The caller may use either a Net Entry address (C.5.2.6.1) or a network member address assigned as described in C.5.2.6.3. The call shall consist of LE\_Scanning Call PDUs addressed to the called station (responder), a Control type LE\_Call PDU addressed to the responder, and an LE\_Sync Check PDU with the Argument field set to all 1s. This special value in the Argument field indicates that the call is a time request rather than a sync maintenance request.
2. In response to an LE\_Sync Check PDU with the Argument field set to all 1s, the responder will return an LE\_GTB PDU rather than a Sync Offset PDU. The LE\_GTB PDU shall be sent 128 Tsym after the slot boundary that follows the end of the received LE\_Sync Check PDU, and shall report the slot number of the slot it occupies (which may be slot 0). The LE\_GTB PDU shall be sent on the frequency that carried the call. After sending the LE\_GTB PDU, the responder shall remain on the same frequency, ignore the next slot and check the slot after that for an LE\_Call PDU.
3. The caller should correct its local time using the time contained in the LE\_GTB PDU, with the assumption that propagation time from the responder was zero, and set its time uncertainty to 70 ms. It should then initiate the synchronization maintenance protocol described above (C.5.2.7.4) in the second slot after the LE\_GTB PDU. If no response (or a garbled response) is received, the station may continue to attempt Sync Check handshakes with the responder on the responder's assigned dwell channels using the formula in C.4.4.1 if it knows the calling channels in use in the network. Otherwise it must restart this protocol at step 1.
4. If the responder receives error-free LE\_Call and LE\_Handshake PDUs containing the expected fields for a Sync Check handshake from the entering station, it shall complete the handshake by sending an LE\_Sync Offset PDU as described in C.5.2.7.3.3. After sending this PDU, or after failing to receive the appropriate PDUs, the responder shall return to the Scanning state on its then-current assigned dwell channel.

An entering station shall not place any other synchronous call to the network until this synchronization is completed.

#### C.5.2.7.7 Initial time distribution.

Before a network is synchronized, stations should be scanning in asynchronous mode. Initial time distribution to a network begins with an asynchronous mode notification sequence, followed by an LE\_GTB PDU from the master time station for the network (e.g., station 0). The repeated LE\_Notification PDU shall contain the master time station address and a status of Time Server. The LE\_GTB PDU shall contain a Slot Number value of seven, which indicates that the initial

time distribution protocol is commencing. The PDU sequence that ends in this LE\_GTB PDU shall be timed such that the LE\_GTB PDU occurs the final slot of a dwell (according to what will be network time), and the call shall be sent on the channel that the master time station would be monitoring during that dwell in synchronous mode.

Following receipt of this transmission, each station in the network shall compute the limited-precision time implied by the LE\_GTB PDU, temporarily set its time base to this time, set its total time uncertainty to 70 ms and commence scanning its assigned channels in synchronous mode. In the following dwells, each dwell group will in turn monitor the channel that carried the time distribution transmission. During that dwell, the time server in each dwell group shall execute a Sync Check handshake with the network master time station to refine its time and set its time uncertainty.

After 32 dwells have elapsed since the end of the initial LE\_GTB transmission, all stations shall stop scanning and remain on their current calling channel. Each dwell group will be on a distinct channel, and the time server in each group should have completed a Sync Check handshake with the master time station. Each such dwell group time server shall then transmit identical LE\_Notification PDUs in slots 1, 2, and 3 of the dwell, followed by an LE\_GTB PDU in slot 4. The Slot Number field in this LE\_GTB PDU shall be 4. Dwell group members shall perform Sync Check handshakes with their respective group time servers in the following 60 dwells, starting with member number 0 in the first dwell after this normal LE\_GTB PDU, member number 1 in the next dwell and so on. After 60 dwells, all stations shall resume scanning on their assigned channels.

Breakdowns in this protocol are handled as follows:

1. Any dwell group time server that has not received the expected LE\_Notification/LE\_GTB sequence from the master time station within 8 minutes after the expected startup of the time distribution protocol should initiate the late net entry synchronization protocol from C.5.2.7.6, calling the master time station and, if it receives no response after calling on all channels, calling designated alternate master time station(s) and other group time servers.
2. Any dwell group member that received the initial LE\_Notification/LE\_GTB sequence from the master time station, but does not receive the expected LE\_Notification/LE\_GTB sequence from the group time server after listening for 60 dwells should attempt late net entry synchronization calling its dwell group time server first, followed by calls to the master and alternate master time stations.
3. Any dwell group member that does not receive the initial LE\_Notification/LE\_GTB sequence from the master time station within 10 minutes after the expected startup of the time distribution protocol should initiate the late net entry synchronization protocol from C.5.2.7.6, calling its group time server first, followed by calls to the master and alternate master time stations.

As each station achieves synchronization, it commences synchronous operation.

### C.5.3 TM protocol.

#### C.5.3.1 Overview.

The TM protocol is used to coordinate traffic exchanges on connections established using the Third Generation ALE (3G-ALE) protocol. Following the end of the ALE phase in which a connection is established, the stations participating in the connection enter the Traffic Set-Up (TSU) phase in which the TM protocol is used to establish a traffic link on which traffic can be delivered.

Once a connection has been established, the stations participating in it have determined:

1. the identities of the stations intended to participate in the connection;
2. the connection topology: point-to-point, multicast, or broadcast;
3. the link mode: packet or circuit (“hard link”);
4. the HF frequency (or “traffic channel”) that will be used for signalling within the connection.

In addition, each participating station knows whether or not it initiated the connection (even though stations other than the initiator do not always know which station originated the connection, as in broadcast connections), so that the initiating station knows it can transmit a TM PDU in the first transmit time-slot of the TSU phase.

During the TSU phase, the participating stations exchange TM PDUs in order to determine:

1. whether the connection will be used to deliver data or voice traffic, if it is a circuit connection;
2. which data link protocol(s), waveform(s), and/or baseband modulation formats will be used to deliver traffic on the connection;
3. the priority of the traffic to be delivered;
4. the fine time synchronization required for the HDL and LDL protocols, on traffic links established for packet traffic.

If the traffic link is a multicast circuit link (has a multicast topology), the participating stations initially conduct a roll-call procedure to determine which of the stations in the multicast group received the 3G-ALE signalling and are now present on the traffic frequency. A second roll-call can be conducted on the traffic link just before the traffic link is torn-down and the participating stations resume scanning. This allows a station sending information on a Multicast circuit link to know whether the intended recipients of the information were on the traffic frequency to receive



it, and allows the station initiating the traffic link to drop the current link and attempt to re-establish it if desired stations are absent from the link.

When traffic exchanges have been completed on a traffic link, the TM protocol is used to coordinate the participating stations' departure from the traffic link.

C.5.3.2 Data object types.

The terms defined in table C-XXXIV are used to refer to specific types of data objects in defining the TM protocol.

**TABLE C-XXXIV. TM data object types.**

Data object type	Definition																		
traffic type	<p>identifies a kind of traffic that can be delivered on a traffic link established using the TM protocol. The defined traffic types and their meanings are as follows:</p> <table border="1" data-bbox="380 747 1466 1182"> <thead> <tr> <th data-bbox="380 747 570 779">value</th> <th data-bbox="570 747 1466 779">description</th> </tr> </thead> <tbody> <tr> <td data-bbox="380 779 570 810">HDL_n</td> <td data-bbox="570 779 1466 810">HDL (HDL), n data packets per forward transmission (n = 24, 12, 6, or 3)</td> </tr> <tr> <td data-bbox="380 810 570 842">LDL_n</td> <td data-bbox="570 810 1466 842">LDL, n payload data bytes per LDL forward transmission (n = 512, 256, 128, or 64)</td> </tr> <tr> <td data-bbox="380 842 570 894">ANDVT</td> <td data-bbox="570 842 1466 894">Digitized voice using the ANDVT digitized voice coding method and modem waveforms defined by STANAG 4197 and STANAG 4198.</td> </tr> <tr> <td data-bbox="380 894 570 978">DGTL_VOICE</td> <td data-bbox="570 894 1466 978">Digitized voice using a non-ANDVT digitized voice coding method and/or modem waveform. The receiving station is assumed to be able to detect the voice coding and modem waveform and apply the appropriate receive processing.</td> </tr> <tr> <td data-bbox="380 978 570 1010">ANLG_VOICE</td> <td data-bbox="570 978 1466 1010">Analog voice traffic.</td> </tr> <tr> <td data-bbox="380 1010 570 1062">SER_110</td> <td data-bbox="570 1010 1466 1062">Bit-pipe data traffic delivered using the MIL-STD-188-110 serial tone modem signalling format.</td> </tr> <tr> <td data-bbox="380 1062 570 1115">HQ_n</td> <td data-bbox="570 1062 1466 1115">Bit-pipe data traffic delivered using a high-rate data modem signalling format at n bits per second (n = 9600, 6400, 4800, or 3200).</td> </tr> <tr> <td data-bbox="380 1115 570 1182">SER_4285</td> <td data-bbox="570 1115 1466 1182">Bit-pipe data traffic delivered using the STANAG 4285 serial tone modem signalling format.</td> </tr> </tbody> </table>	value	description	HDL_n	HDL (HDL), n data packets per forward transmission (n = 24, 12, 6, or 3)	LDL_n	LDL, n payload data bytes per LDL forward transmission (n = 512, 256, 128, or 64)	ANDVT	Digitized voice using the ANDVT digitized voice coding method and modem waveforms defined by STANAG 4197 and STANAG 4198.	DGTL_VOICE	Digitized voice using a non-ANDVT digitized voice coding method and/or modem waveform. The receiving station is assumed to be able to detect the voice coding and modem waveform and apply the appropriate receive processing.	ANLG_VOICE	Analog voice traffic.	SER_110	Bit-pipe data traffic delivered using the MIL-STD-188-110 serial tone modem signalling format.	HQ_n	Bit-pipe data traffic delivered using a high-rate data modem signalling format at n bits per second (n = 9600, 6400, 4800, or 3200).	SER_4285	Bit-pipe data traffic delivered using the STANAG 4285 serial tone modem signalling format.
value	description																		
HDL_n	HDL (HDL), n data packets per forward transmission (n = 24, 12, 6, or 3)																		
LDL_n	LDL, n payload data bytes per LDL forward transmission (n = 512, 256, 128, or 64)																		
ANDVT	Digitized voice using the ANDVT digitized voice coding method and modem waveforms defined by STANAG 4197 and STANAG 4198.																		
DGTL_VOICE	Digitized voice using a non-ANDVT digitized voice coding method and/or modem waveform. The receiving station is assumed to be able to detect the voice coding and modem waveform and apply the appropriate receive processing.																		
ANLG_VOICE	Analog voice traffic.																		
SER_110	Bit-pipe data traffic delivered using the MIL-STD-188-110 serial tone modem signalling format.																		
HQ_n	Bit-pipe data traffic delivered using a high-rate data modem signalling format at n bits per second (n = 9600, 6400, 4800, or 3200).																		
SER_4285	Bit-pipe data traffic delivered using the STANAG 4285 serial tone modem signalling format.																		
	<table border="1" data-bbox="380 1182 1466 1579"> <tbody> <tr> <td data-bbox="380 1182 570 1297">PKT</td> <td data-bbox="570 1182 1466 1297">packet traffic: refers to any traffic type that can be delivered on a packet traffic link: i.e., any of the HDL_n or LDL_n traffic types. Is used in contexts in which a station knows that a packet link is required, but not the specific type of packet traffic to be delivered on the link.</td> </tr> <tr> <td data-bbox="380 1297 570 1413">CKT</td> <td data-bbox="570 1297 1466 1413">circuit traffic: refers to any traffic type that can be delivered on a circuit traffic link, including all of the defined traffic types except HDL_n and LDL_n (which are delivered only on packet traffic links). Is used in contexts in which a station knows that a circuit link is required, but not the specific type of traffic to be delivered on the circuit link.</td> </tr> <tr> <td data-bbox="380 1413 570 1476">NO_TR</td> <td data-bbox="570 1413 1466 1476">no traffic: the sender has no traffic to deliver, and will await traffic from the other participant(s) in the traffic link.</td> </tr> <tr> <td colspan="2" data-bbox="380 1476 1466 1579"><u>Note:</u> In the TM behavior definitions, 'pktTraf' is used as an abbreviation for a traffic type of either HDL_n or LDL_n, which can be delivered only on a packet traffic link, or for 'NO_TR' (no traffic). 'cktTraf' is used as an abbreviation for any traffic type other than HDL_n or LDL_n -- i.e., any traffic type that can be delivered on a circuit traffic link -- or for 'NO_TR' (no traffic).</td> </tr> </tbody> </table>	PKT	packet traffic: refers to any traffic type that can be delivered on a packet traffic link: i.e., any of the HDL_n or LDL_n traffic types. Is used in contexts in which a station knows that a packet link is required, but not the specific type of packet traffic to be delivered on the link.	CKT	circuit traffic: refers to any traffic type that can be delivered on a circuit traffic link, including all of the defined traffic types except HDL_n and LDL_n (which are delivered only on packet traffic links). Is used in contexts in which a station knows that a circuit link is required, but not the specific type of traffic to be delivered on the circuit link.	NO_TR	no traffic: the sender has no traffic to deliver, and will await traffic from the other participant(s) in the traffic link.	<u>Note:</u> In the TM behavior definitions, 'pktTraf' is used as an abbreviation for a traffic type of either HDL_n or LDL_n, which can be delivered only on a packet traffic link, or for 'NO_TR' (no traffic). 'cktTraf' is used as an abbreviation for any traffic type other than HDL_n or LDL_n -- i.e., any traffic type that can be delivered on a circuit traffic link -- or for 'NO_TR' (no traffic).											
PKT	packet traffic: refers to any traffic type that can be delivered on a packet traffic link: i.e., any of the HDL_n or LDL_n traffic types. Is used in contexts in which a station knows that a packet link is required, but not the specific type of packet traffic to be delivered on the link.																		
CKT	circuit traffic: refers to any traffic type that can be delivered on a circuit traffic link, including all of the defined traffic types except HDL_n and LDL_n (which are delivered only on packet traffic links). Is used in contexts in which a station knows that a circuit link is required, but not the specific type of traffic to be delivered on the circuit link.																		
NO_TR	no traffic: the sender has no traffic to deliver, and will await traffic from the other participant(s) in the traffic link.																		
<u>Note:</u> In the TM behavior definitions, 'pktTraf' is used as an abbreviation for a traffic type of either HDL_n or LDL_n, which can be delivered only on a packet traffic link, or for 'NO_TR' (no traffic). 'cktTraf' is used as an abbreviation for any traffic type other than HDL_n or LDL_n -- i.e., any traffic type that can be delivered on a circuit traffic link -- or for 'NO_TR' (no traffic).																			

C.5.3.3 Service primitives.

Table C-XXXV describes the service primitives exchanged between the TM entity and a user process at TM's upper interface. Note that there is no requirement that implementations of the waveforms and protocols defined in this Appendix contain precisely these service primitives; nor are the services primitives defined below necessarily all of the service primitives that would be required in an implementation of these waveforms and protocols.

**TABLE C-XXXV. TM service primitives.**

Name	Attribute	Value	Description
TM_Connect_Req	Overview	TM Connect Request: issued to TM by the user process to request establishment of a traffic link.	
	Parameters	topology	Identifies the topology of the traffic link being established; one of: <ul style="list-style-type: none"> <li>• P2P (point-to-point): the traffic link will contain the initiating station and a single called station.</li> <li>• MC (multicast): the traffic link will contain the initiating station together with all members (or as many as possible) of a defined multicast group.</li> <li>• BC (broadcast): the traffic link will contain the initiating station together with all other stations in the net that receive the ALE Broadcast PDUs used to place the broadcast call.</li> </ul> The topology value must be 'P2P' if trafficType is any of the 3G data link traffic types HDL_n or LDL_n.
		trafficType	Identifies the type of traffic for which the traffic link is being established; value can be any of the traffic type values defined in table C-XXXIV.
		role	role of the local station in the established traffic link: MASTER (initiator of the link) or SLAVE.
		priority	priority level of the traffic (at the initiating station) for which the traffic link is being requested: HIGHEST, HIGH, ROUTINE, or LOW.
		addr	address of the station or group of stations to be included with the local station in the requested traffic link: an individual or multicast address, or a null (ignored) address for broadcast traffic links.
		reqIntvl	the duration of the time-interval through which TM should wait to receive a TM_REQ PDU from the initiating station before timing-out. The reqIntvl parameter-value is used only by slave stations in broadcast circuit links; it is ignored in all other cases.
	Originator	user process	
Preconditions	<ol style="list-style-type: none"> <li>1. A connection has just been established by 3G-ALE, with this station as a participant.</li> <li>2. No traffic link is established. I.e., the most recent service primitive (if any) passed between TM and the user process was a TM_Disconnect_Req, a TM_Disconnect_Ind, or a TM_Disconnect_Conf.</li> </ol>		
TM_Connect_Ind	Overview	TM Connect Indication: issued to the user process to indicate that a traffic link has been established at the request of a remote station, with the local station as a participant.	
	Parameters	trafficType	Identifies the type of traffic for which the traffic link is being established; value can be any of the traffic type values defined in table C-XXXIV. Obtained from the Argument (Traffic type) field of the TM_REQ PDU sent by the initiating station.
		priority	priority level of the traffic for which the traffic link has been established: HIGHEST, HIGH, ROUTINE, or LOW. This value is obtained from the Priority field-value of the TM_REQ PDU sent by the link master station to initiate the establishment of the link.

**TABLE C-XXXV. TM service primitives (continued).**

Name	Attribute	Value	Description
		srcAddr	station address of the station that initiated establishment of the link (the link master). Obtained from the Source Addr field-value of the TM_REQ PDU sent by the initiating station.
		responses	list of addresses of the members of the multicast group (for multicast links) from which a valid roll-call response was received; null (ignored) for point-to-point and broadcast links (on which no roll-call is performed).
	Originator	TM	
	Preconditions	No traffic link is established. I.e., the most recent service primitive (if any) passed between TM and the user process was a TM_Disconnect_Req, a TM_Disconnect_Ind, or a TM_Disconnect_Conf.	
TM_Connect_Conf	Overview	TM Connect Confirm: issued to the user process by TM, to confirm that a traffic link has been established as requested by a preceding TM_Connect_Req service primitive.	
	Parameters	responses	list of addresses of the members of the multicast group (for multicast links) from which a valid roll-call response was received; null (ignored) for point-to-point and broadcast links (on which no roll-call is performed).
	Originator	TM	
	Preconditions	Either a traffic link is being established at the request of the local user process; i.e., the most recent service primitive passed between TM and the user process was a TM_Connect_Req; or an established traffic link is being reversed after successful delivery of packet data; i.e., the most recent service primitive passed between TM and the user process was a TM_Connect_Ind.	
TM_Disconnect_Req	Overview	TM Disconnect Request: issued to TM by the user process, to request that the local station cease to participate in the current traffic link, and if the local station is the link master, that the traffic link be terminated entirely, with all of the remaining participants leaving the traffic frequency (or frequencies).	
	Parameters	reason	reason for disconnection. Value is one of: <ul style="list-style-type: none"> <li>• RELINK: requests that the traffic link be re-established on a different channel. Used only on point-to-point traffic links.</li> <li>• SIGN_OFF: requests that the local station sign-off a multicast or broadcast circuit link, without necessarily causing the link to be terminated: other stations may stay linked. Used only at slave stations on multicast and broadcast circuit links.</li> <li>• ABORT: requests that the traffic link be immediately terminated. In broadcast or multicast circuit connections, can be issued only by the user process of the circuit master: the station that initiated the circuit.</li> <li>• UNLINK: requests that a multicast traffic link be terminated with a final roll call occurring just before the link is dropped. Used only on multicast circuit links; can be issued only at the master station: the station that initiated the circuit.</li> </ul>
		period	on point-to-point circuit and multicast circuit links, the maximum amount of time that TM can wait for the link to become available so that the TM_TERM PDU sent as the station departs from the link does not collide with other traffic. After TM waits this amount of time, if the CLC still indicates that the link is busy, TM sends a TM_TERM PDU and drops the link regardless of any ongoing link activity. The period parameter-value is ignored (not used) on packet and broadcast circuit links.
	Originator	user process	
Preconditions	A traffic link is currently established or is being established. I.e., TM has accepted a TM_Connect_Req service primitive since the most recent time at which it issued a TM_Disconnect_Ind or a TM_Disconnect_Conf, or accepted a TM_Disconnect_Req.		

**TABLE C-XXXV. TM service primitives (continued).**

Name	Attribute	Value	Description	
TM_Disconnect_Ind	Overview	TM Disconnect Indication: issued to the user process to indicate that the local station has ended its participation in a traffic link for a reason other than the user process' having issued a TM_Disconnect_Req primitive.		
	Parameters	reason	<p>reason for disconnection. Value is one of:</p> <ul style="list-style-type: none"> <li>• SIGN_OFF: indicates that the local station has left a traffic link due to another station's having signed-off the link — the other station in a unicast link, or the last remaining station in a multicast or broadcast circuit of which the local station was master.</li> <li>• ABORT: the local station has left a traffic link due to the link master station's having aborted the link.</li> <li>• EOM: the local station has left a packet traffic link due to successful completion of the packet data transfer and the absence of any packet traffic pending in the reverse direction.</li> <li>• RELINK: the remote station has initiated a re-link operation in which the participating stations will attempt to re-establish the traffic link on a different channel, by sending a TM_TERM PDU to the local station with Reason = RELINK. Used only on point-to-point traffic links.</li> <li>• REQ_TIMEOUT: the local station has left a traffic link due to failure to receive a TM_REQ PDU in the time period in which one was expected. If the traffic link being established was a unicast link, the two stations will attempt to re-link.</li> <li>• CONF_TIMEOUT: the local station has left a traffic link due to failure to receive a TM_CONF PDU in the time period in which one was expected. If the traffic link being established was a unicast link, the two stations will attempt to re-link.</li> <li>• TRF_TIMEOUT: the local station has left a circuit traffic link, due to the CLC's (CLC's) having detected no traffic on the circuit link over a time interval equal to its traffic timeout period.</li> <li>• UNLINK: the remote master station of the currently-established multicast circuit has requested that the circuit link be dropped after a final roll call ("unlink") is performed. A TM_Disconnect_Ind service primitive with reason = UNLINK requests that the user process respond with a TM_Disconnect_Resp service primitive indicating whether the local station has succeeded or failed in receiving the traffic delivered on the circuit link.</li> </ul>	
	Originator	TM		
	Preconditions	A traffic link is currently established or is being established. I.e., TM has accepted a TM_Connect_Req service primitive since the most recent time at which it issued a TM_Disconnect_Ind or a TM_Disconnect_Conf, or accepted a TM_Disconnect_Req.		
	Originator	TM		
TM_Disconnect_Resp	Overview	TM Disconnect Response: issued to TM by the user process to acknowledge that a currently-active multicast circuit is being "unlinked": i.e., dropped after a final roll call is performed.		
	Parameters	ackNak	<p>Positive or negative acknowledgement of having received the traffic delivered on the multicast circuit. Possible values are</p> <ul style="list-style-type: none"> <li>• ACK: the traffic delivered on the multicast circuit was received successfully (with the user process determining what counts as "success")</li> <li>• NAK: the traffic delivered on the multicast circuit was not detected or received containing (an excessive quantity of) errors.</li> </ul>	
		watch	Boolean: if TRUE, TM will wait on the traffic channel to hear the unlink roll call responses from the other circuit participants. Otherwise, the station will wait only long enough to transmit its own roll call response in its unlink roll call time slot, and will immediately afterward return to 3G-ALE scanning.	
	Originator	TM		
	Preconditions	<ol style="list-style-type: none"> <li>1. A multicast circuit link is presently active.</li> <li>2. TM has just issued a TM_Disconnect_Ind service primitive to the user process with reason = UNLINK.</li> </ol>		

**TABLE C-XXXV. TM service primitives (continued).**

Name	Attribute	Value	Description
TM_Disconnect_Conf	Overview	TM Disconnect Confirm: issued to the user process by TM to acknowledge that a currently-active traffic link is being dropped as a result of a TM_Disconnect_Req service primitive.	
	Parameters	reason	The reason for which the traffic link is being dropped. Possible values and their meanings are the same as for the reason parameter of the TM_Disconnect_Req service primitive, as described above.
		responses	list of responses to an optional unlink roll-call performed at the conclusion of a multicast circuit connection, in which each response is in the form of an ordered pair (indAddr, ackNak), where indAddr is the address of a station whose roll call response was heard, and ackNak is the Reason field-value of the TM_TERM PDU sent as the station's response: UNL_ACK or UNL_NAK. The responses parameter has a value only when a multicast circuit link has been concluded with an unlink roll call. The list of responses can be incomplete for either of two reasons: <ol style="list-style-type: none"> <li>at a slave station, the user process has requested that the station remain in the circuit link only long enough to transmit its own roll call response, by setting the watch parameter of its TM_Disconnect_Resp primitive to FALSE. In this case, the reason parameter has the value UNLINK; and responses are not included in the list from those stations whose roll call time slots fall after the local station's time slot.</li> <li>at either the master station or a slave station, the user process may have cut short the station's participation in the roll call, by issuing a TM_Disconnect_Req service primitive while the roll call is in progress. In this case, the reason parameter-value will be ABORT at the master station, or SIGN_OFF at a slave station; the response list will include only responses received before the TM_Disconnect_Req was accepted.</li> </ol> <p>The responses parameter is shown in the state diagrams only where it is used: where a multicast circuit link is being dropped with a concluding unlink roll call operation.</p>
	Originator	TM	
Preconditions			
TM_Suspend_Req	Overview	TM Suspend Request: issued to TM by the user process, to suspend the current multicast circuit link. This primitive can be issued by the user process at the station which has initiated a multicast circuit link, when the responses to a just-completed roll call indicate that not all members of the multicast group are present in the circuit link. In response to the TM_Suspend_Req service primitive, the TM entity sends a TM_TERM PDU with reason = SUSPEND to hold the stations that answered the roll call on the traffic channel, then repeats the 3G-ALE multicast calling process in order to bring as many as possible of the remaining stations into the multicast circuit link.	
	Parameters	(none)	
	Originator	user process	
	Preconditions	A multicast circuit link initiated by the local station is currently active. I.e., since any other exchange of TM service primitives, TM has issued a TM_Connect_Conf service primitive to the user process whose responses parameter identifies those multicast group member stations which responded to the most recent multicast circuit roll call.	
TM_Resume_Req	Overview	TM Resume Request: issued to TM by the user process, to cause the current multicast circuit link to be resumed after it has been suspended by means of a TM_Suspend_Req service primitive. In response to the TM_Resume_Req, TM sends a TM_REQUEST PDU on the traffic channel, to initiate an additional roll call and determine which of the multicast group members are now present on the traffic channel.	
	Parameters	(none)	
	Originator	user process	
	Preconditions	<ol style="list-style-type: none"> <li>A multicast circuit link is currently suspended.</li> <li>Since the multicast circuit link was suspended by means of a TM_Suspend_Req PDU, an additional 3G-ALE multicast call has been completed.</li> </ol>	

#### C.5.3.4 PDUs.

The sub-sections of this section describe the PDUs exchanged between a TM entity and its remote peer entities. All TM PDUs have the common format and contents shown in table C-XXXVI. Behavioral descriptions of the TM protocol refer to three kinds of PDUs: TM\_REQ, TM\_CONF, and TM\_TERM. These PDUs all have the format shown in table XXXVI, and are distinguished from one another by the values of their Type fields:

- a “TM\_REQ PDU” is a TM PDU having Type = TM\_REQUEST (0)
- a “TM\_CONF PDU” is a TM PDU having Type = TM\_CONFIRM (1)
- a “TM\_TERM PDU” is a TM PDU having Type = TM\_TERM (2)

The field-values of each TM PDU are transmitted in order of their occurrence in table XXXVI, starting with the protocol field. The bits of each field-value are transmitted in order of significance, starting with the most significant bit.

All of the TM PDUs are sent and received using the burst waveform BW1 described in section C.5.1.4. Each outgoing PDU is used as the Payload parameter value for a BW1\_Send service primitive as described in table C-IV; each incoming PDU is received as the value of the Payload parameter of a BW1\_Receive service primitive (see table C-XXXVII).

The TM entity at each station remains active while the station is exchanging voice or data traffic with other stations on an established traffic link, so as to be ready to drop the link on request. On traffic links established for packet traffic delivered using the HDL protocol (C.5.2) or the LDL protocol (C.5.5), the user process can terminate the data link transfer and use the next data link transmission time slot in either direction — i.e., the time slot for the xDL\_DATA or the xDL\_ACK PDU — to instead send a TM\_TERM PDU (by issuing a TM\_Disconnect\_Req primitive) as many times as will fit within the data link PDU time-slot. This means that while a data link transfer is in progress, each station must be simultaneously attempting to demodulate TM\_TERM PDUs conveyed by the BW1 waveform as it is attempting to demodulate and receive data link signalling conveyed by BW2, BW3, or BW4. Similarly, on a circuit link, each station must attempt to detect and demodulate TM\_TERM PDUs conveyed by the BW1 waveform at all times when the station is not transmitting.

**TABLE C-XXXVI. TM PDU format.**

Field name	Size (bits)	Values	Description
Protocol	3	001 <sub>2</sub> (fixed)	distinguishes TM PDUs from HDL_ACK and HDL_EOM PDUs
Priority	2		In all TM_REQ and some TM_CONF PDUs (i.e., TM PDUs having Type = TM_REQUEST or TM_CONFIRM), indicates the priority level of the traffic (if any) that the sender of the PDU intends to send on the traffic link once it is established. In TM_CONF PDUs, this field is used only when the Argument field value refers to one of the High-Rate ('HDL_n') or LDL ('LDL_n') traffic types as shown in table C-XXXVII. The field-value is set to 3 (LOW) in all other TM_CONF PDUs and in all TM_TERM PDUs, and must be ignored by the receiver.
		0	HIGHEST: highest priority
		1	HIGH
		2	ROUTINE
		3	LOW: lowest priority
Dest Addr	11	any	address of the station to which this PDU is being sent. Dest Addr can be the individual address of a single intended recipient station (abbreviated 'indAddr' below), a multicast address designating a multicast group ('MCaddr'), or all ones on a broadcast traffic link ('BCaddr') (see note). When the destination address is a multicast address, the lowest-order five bits of the address (corresponding to the dwell group number in an individual address) shall be all ones.
Source Addr	11	any	address of the station that is sending this PDU. Is always the station address of a single station — never a multicast or broadcast address.
Type	3		Type of PDU, indicating its role in the TM protocol. Note that the state diagrams and other materials refer to, for instance, a "TM_REQ PDU"; this is a TM PDU whose Type field value is 0 (TM_REQUEST).
		0	TM_REQUEST: A PDU with Type = TM_REQUEST is sent in order to request that a traffic link be established between the station sending the TM_REQUEST and the other stations specified by the PDU's destination address.
		1	TM_CONFIRM: A PDU with Type = TM_CONFIRM is sent in response to a received TM_REQUEST PDU, to confirm the sender's readiness to participate in a traffic link.
		2	TM_TERM: a PDU with Type = TM_TERM is sent in order to terminate the station's participation in a traffic link (during or after link establishment), and when sent by the link master, to terminate the link as a whole.
		3..7	reserved
Argument	6		variant field whose usage and meaning depend on the value of the Type field; see TABLE XXXVII.
CRC	12	any	12-bit Cyclic Redundancy Check (CRC) computed across the remaining 36 bits of each TM PDU, using the generator polynomial $X^{12} + X^{11} + X^9 + X^8 + X^7 + X^6 + X^3 + X^2 + X^1 + 1$ , and the procedure described in C.4.1.
NOTE: The destination address has no significance on broadcast links; this field is set to all-ones purely by convention. The all-ones address vaule is not a reserved broadcast address, and hence can also be used as an individual or multicast address.			

MIL-STD-188-141B  
APPENDIX C

**TABLE C-XXXVII. Argument field values.**

Type field Value	Field name	Values	Description
TM_REQUEST or TM_CONFIRM	Traffic Type	Indicates the type of traffic that the sender expects to send or receive on the traffic link once it is established. Each argument field-value represents one of the traffic type values defined in TABLE C-XXXIV. In a TM_REQUEST PDU, the Traffic Type field-value serves to stipulate the type of traffic that will be delivered on the traffic link. The sender of a TM_CONFIRM PDU places in this field the value of the Traffic Type field in the TM_REQUEST PDU it has recently received; in this case, the field-value serves as an acknowledgement of the traffic type specified in the TM_REQUEST.	
		0	HDL_24
		1	HDL_12
		2	HDL_6
		3	HDL_3
		4	LDL_512
		5	LDL_256
		6	LDL_128
		7	LDL_64
		8	ANDVT
		9	DGTL_VOICE
		10	ANLG_VOICE
		11	SER_110
		12	HQ_9600
		13	HQ_6400
		14	HQ_4800
		15	HQ_3200
		16	SER_4285
		17-60	reserved
		61	PKT
62	CKT		
63	NO_TR		
TM_TERM	Reason	Indicates the reason why the sending station is terminating its participation in the traffic link, and the intended result of its doing so.	
		0 ("ABORT")	Immediately terminate the traffic link, with all participating stations leaving the traffic frequency (-ies) assigned to the link. Reason = ABORT indicates nothing about any measures that may be taken to resume any data transfer that may have been in progress.
		1 ("RELINK")	Immediately terminate the traffic link, with all participating stations leaving the traffic frequency (-ies) assigned to the link. Reason = RELINK indicates that the user process will attempt to resume the data transfer, possibly on a different frequency or frequencies.
		2 ("SIGN_OFF")	The station sending the TM_TERM PDU is departing the multicast circuit link, of which it is not the master. If two or more stations remain on the link, they may continue to exchange traffic.
		3 ("UNLINK")	Is sent by the initiator of a multicast circuit link, to cause the link to be torn-down after a final roll call is performed.
		4 ("UNL_ACK")	Is sent by a participant in a multicast circuit link in response to a TM_TERM PDU with Reason = UNLINK, to indicate that the station has successfully received all traffic sent on the multicast circuit (see note).
		5 ("UNL_NAK")	Is sent by a participant in a multicast circuit link in response to a TM_TERM PDU with Reason = UNLINK, to indicate that the station is still present in the multicast circuit, but has not received all traffic sent on the multicast circuit successfully.
		6 ("SUSPEND")	Suspends the current multicast circuit link while the link initiator repeats the 3G-ALE multicast call in order to retrieve as many as possible of the multicast group members that were found to be absent in the most recent roll call. Stations receiving the TM_TERM PDU with Reason = SUSPEND are expected to remain on the traffic channel for a time period sufficient to allow the link initiator to complete the 3G-ALE multicast call, return to the traffic channel, and send a TM_REQ PDU to start another roll call.
7 - 63	reserved		
NOTE: Whether the traffic has been received successfully, and what this means, are determined by the user process and not by TM.			



#### C.5.3.5 Protocol behavior.

The following sections define the behavior of the TM protocol:

- C.5.3.5.1 identifies and defines the events to which the TM entity responds;
- C.5.3.5.2 identifies and defines the actions taken by the TM entity in response to these events;
- C.5.3.5.3 describes the data items used and maintained by a TM entity;
- C.5.3.5.4 provides state diagrams and a state transition table specifying the behavior of the TM entity in terms of these events, actions, and data items; and
- C.5.3.5.5 provides additional information on the timing characteristics of TM protocol behavior.

##### C.5.3.5.1 Events.

Table C-XXXVIII defines the events to which the TM entity responds. The event names are used in the state diagrams or state transition tables in C.5.3.5, which define the behavior of the TM protocol. Some event names refer to the receipt of PDUs from the TM entity at a remote station; in these cases, either the PDU definition in C.5.3.4 or the ‘description’ field of the table entry describes the manner in which the arrival of a PDU is accomplished through TM’s accepting one or more service primitives from lower-layer entities at the local station. The prefix ‘R:’ in the name of an event indicates that the event is the receipt of a PDU from the remote station. The prefix ‘D:’ indicates that the event is the TM entity’s accepting a service primitive from a higher-layer entity (the primitive is passed ‘downward’), while the prefix ‘U:’ indicates that the event is the TM entity’s accepting a service primitive from a lower-layer entity (the primitive is passed ‘upward’). Event names are used in the state diagrams and the transition table precisely as shown here, with the following exception: italicized words in the event names shown here are substitution variables for which explicit parameter- or field-values are substituted when these event names are used in the state diagrams and the transition table.

**TABLE C-XXXVIII. TM events.**

Event name	Description
ConfirmTimeout	A TM_CONF PDU was not received in the time period in which it was expected, in the two-way handshake performed to establish a point-to-point traffic link for packet or circuit traffic, as indicated by a timeout of ConfirmTimer.
D:TM_Connect_Req (topology, trafficType, role, addr, reqIntvl)	<p>A TM_Connect_Req service primitive was received from the user process, with the indicated values for the topology, trafficType, role, addr, and reqIntvl parameters. In the state diagrams and state transition table,</p> <ul style="list-style-type: none"> <li>• <i>'topology'</i> is replaced by 'P2P' (point-to-point), 'MC' (multicast), or 'BC' (broadcast), indicating the topology of the traffic link being established</li> <li>• <i>'role'</i> is replaced by 'MASTER' or 'SLAVE', where the link master is the station initiating the traffic link</li> <li>• <i>'trafficType'</i> is replaced by one of the traffic type values defined in table C-XXXIV. The values 'PKT' and 'CKT' are used whenever role = SLAVE, since the slave station does not yet know the specific type of traffic that is to be delivered on the traffic link (as this information is not conveyed by 3G-ALE). 'pktTraf' is used as an abbreviation for any of the HDL_n or LDL_n traffic types which can be delivered on a packet traffic link; 'cktTraf' is used for any traffic type other than HDL_n or LDL_n, which can be delivered on a circuit traffic link.</li> <li>• <i>'addr'</i> is replaced by either 'indAddr' (the remote station participating in a packet or point-to-point circuit link), 'MCaddr' (the address of the called multicast group), or 'BCaddr' (the all-ones broadcast address). Note that addr is ignored whenever topology = BC; although an all-ones broadcast value is transmitted in TM PDUs, this address value has no significance.</li> <li>• <i>'reqIntvl'</i> is used only at slave stations participating in broadcast circuit links. The value of reqIntvl is based on the Countdown field-value of the received LE_BROADCAST PDU.</li> </ul>
D:TM_Disconnect_Req (reason) D:TM_Disconnect_Req (reason, period)	<p>A TM_Disconnect_Req service primitive was received from the user process, having the indicated value, or one of the provided list of values, as its reason parameter. <i>'reason'</i> may be either a single parameter value (e.g., "ABORT") or a list of two or more possible reason values separated by 'pipe' characters (' ') (e.g., "ABORT RELINK"). An event name containing the word 'reason' instead of a specific parameter-value applies to any TM_Disconnect_Req service primitive containing any value for the reason parameter.</p> <p>The value of the period parameter determines the maximum length of time that TM will wait for the link to become available before sending a TM_TERM PDU, if the link is busy (as determined by CLC) at the time the TM_Disconnect_Req service primitive is accepted from the user process. The period parameter is shown on the state diagrams only in those situations in which it is used: i.e., on circuit traffic links after the link has been established (and hence could be busy). In all other contexts, the period parameter-value is ignored.</p>
D:TM_Suspend_Req	A TM_Suspend_Req service primitive was received from the user process.
D:TM_Resume_Req	A TM_Resume_Req service primitive was received from the user process.
DropTimeout	The time limit limiting the period through which TM can wait for the traffic link to become idle before sending a TM_TERM PDU in response to a TM_Disconnect_Req has been exceeded, as indicated by a timeout of DropTimer.

**TABLE C-XXXVIII. TM events (continued).**

Event name	Description
EndOfMCRollCall	Indicates that the time period in which stations participating in a multicast circuit link are expected to transmit their roll-call responses has ended, as indicated by the RollCallTimer.
EndOfUnlink	Indicates that the time period in which stations participating in a multicast circuit link are expected to transmit their unlink roll-call responses has ended, as indicated by the UnlinkRollCallTimer.
MyRCSlot	Indicates that the time-slot allocated to the local station for transmission of its roll call response has arrived, as indicated by the RollCallTimer. See C.5.3.5.5 for a specification of the timing of the multicast roll-call operation. Roll call time slots are assigned to multicast group member stations in the following manner: <ol style="list-style-type: none"> <li>1. The individual addresses of the multicast group member stations are placed in a list.</li> <li>2. If the link master (the station that initiated the link) is a member of the multicast group, its individual address is removed from the list (see note).</li> <li>3. The list of addresses is sorted by increasing dwell group number, and, for stations in the same dwell group, by increasing member number (so that, for instance, {group #4, member#5} precedes {group #5, member #2}, and {group #5, member #2} precedes {group #5, member #4}).</li> <li>4. The station whose address is first in the list is assigned the first roll call slot (the slot immediately following the transmission of the TM_REQUEST PDU that initiated the roll call), the one whose address is second gets the second slot, and so forth.</li> </ol>
other	Refers to any event not corresponding to any of the explicit event labels on transitions leaving the current state.
R:other	Refers to the receipt of any PDU not described explicitly by any of the event labels on transitions leaving the current state.
R:TM_CONF (pktTraf, srcAddr) R:TM_CONF (cktTraf, srcAddr)	A TM_CONF PDU was received from the station with individual address srcAddr, confirming establishment of the traffic link requested by a preceding TM_REQ PDU. The Traffic Type field value (represented by 'pktTraf' or 'cktTraf') should be identical to that of the TM_REQ PDU sent most recently by the local station; received TM_CONF PDUs in which this is not the case shall be ignored. If the requested traffic link is a multicast circuit link, then the TM_CONF PDU is a roll call response, which should be received in the correct roll call time-slot of the station having srcAddr as its individual address; any TM_CONF PDU having an incorrect source address for the roll call time slot in which it was received shall be ignored. On point-to-point links, the TM_CONF PDU should be received immediately following the transmission of the TM_REQ PDU to which it is a response; otherwise, a ConfirmTimeout occurs.
R:TM_REQ (pktTraf, srcAddr) R:TM_REQ (cktTraf, srcAddr)	A TM_REQ PDU was received from the station with individual address srcAddr, requesting establishment of a traffic link for delivery of the traffic type represented by 'pktTraf' (HDL_n or LDL_n traffic) or 'cktTraf' (circuit traffic: i.e., neither HDL_n nor LDL_n).
R:TM_REQ (cktTraf, srcAddr, MCaddr)	A TM_REQ PDU was received from the station with individual address srcAddr, requesting establishment of a multicast circuit link containing members of the multicast group having address MCaddr, for delivery of the traffic type represented by 'cktTraf' (circuit traffic).
R:TM_TERM (reason)	A TM_TERM PDU, having RELINK, ABORT, or SIGN_OFF as the value of its reason parameter, was received from the remote station participating in a point-to-point link.

**TABLE C-XXXVIII. TM events (continued).**

Event name	Description
R:TM_TERM (ABORT, srcAddr)	A TM_TERM PDU was received from the station with address 'srcAddr', with reason = ABORT: the sending station is dropping a currently-established circuit link of which it was the master participant.
R:TM_TERM (SIGN_OFF, srcAddr)	A TM_TERM PDU was received from the station with address 'srcAddr', with reason = SIGN_OFF: the sending station is signing-off a currently-established circuit link in which it was a slave participant.
R:TM_TERM (SUSPEND, srcAddr)	A TM_TERM PDU was received from the station with address 'srcAddr', with reason = SUSPEND: the sending station is suspending a currently-established multicast circuit link of which it was the master participant, while it repeats the multicast call so as to attempt to include additional stations in the circuit link.
R:TM_TERM (UNLINK, srcAddr)	A TM_TERM PDU was received from the station with address 'srcAddr', with reason = UNLINK: the sending station is dropping a currently-established multicast circuit link in which it was the master station, and requesting that the stations present in the circuit respond to an unlink roll-call as they leave the circuit.
R:TM_TERM (ackNak, srcAddr)	A TM_TERM PDU was received from the station with address 'srcAddr', with reason = UNL_ACK or UNL_NAK: the sending station is leaving the current multicast circuit link, and indicating that it did (if reason = UNL_ACK) or did not (if reason = UNL_NAK) successfully receive the traffic transmitted on the circuit.
RequestTimeout	A TM_REQ PDU was not received in the time period in which it was expected, in the course of an attempt to establish a traffic link, as indicated by a timeout of RequestTimer.
ReversalTimeout	A TM_REQ PDU was not received in the time period in which it was expected, in the course of an potential packet traffic link reversal, as indicated by a timeout of ReversalTimer.
U:CLC_Avail_Ind	A CLC_Avail_Ind service primitive was received from the CLC, indicating that the traffic link is available for new traffic (i.e., not busy).
U:CLC_Busy_Ind	A CLC_Busy_Ind service primitive was received from the CLC, indicating that the traffic link is busy (i.e., not available for new traffic).
U:CLC_Idle_Ind	A CLC_Idle_Ind service primitive was received from the CLC, indicating that a traffic timeout occurred: no outgoing or incoming traffic was detected on the circuit link over a time period equal to the traffic timeout interval.
U:xDL_Rcv_Ind	An HDL_Rcv_Ind or LDL_Rcv_Ind service primitive was received from, respectively, the High-Rate or LDL, indicating that the data link has just successfully completed an incoming datagram transfer.
U:xDL_Send_Conf	An HDL_Send_Conf or LDL_Send_Conf service primitive was received from, respectively, the High-Rate or LDL, indicating that the data link has just successfully completed an outgoing datagram transfer.
NOTE: It is considered unnecessary for the link master to respond to the roll call, since it has indicated its presence by sending the original TM_REQUEST. No roll call response time slot is assigned to the link master at all, since assigning one and leaving it unused could cause a listening station to erroneously declare the channel unused (and hence available) if it were to listen on the channel during the unused time slot.	

**C.5.3.5.2 Actions.**

Table C-XXXIX defines the actions which the TM entity can perform. The action name is used in the state diagrams and/or state transition tables used below to define the behavior of the TM protocol. Some action names refer to sending PDUs to the TM entity at a remote station; in these cases, the PDU definition in C.5.3.4 or the 'description' field of the table entry describes the manner in which sending of the PDU is accomplished by issuing one or more service primitives

to subordinate entities at the local station. Action names are used in the state diagrams and the transition table precisely as shown here, with the following exception: italicized words in the action names shown here are substitution variables for which explicit parameter- or field-values are substituted when these action names are used in the state diagrams and the transition table.

**TABLE C-XXXIX. TM actions.**

Action name	Description
D:CLC_Active_Req	Issue a CLC_Active_Req service primitive to the CLC, requesting that it begin monitoring and arbitrating access to the newly-established circuit link.
D:CLC_Idle_Req	Issue a CLC_Idle_Req service primitive to the CLC, requesting that it cease monitoring and arbitrating access to the circuit link.
D:CLC_Set_Priority (prio)	Issue a CLC_Set_Priority service primitive, giving it a new priority value for pending outgoing traffic (if any) for the current circuit link. Where the word 'prio' occurs in place of an explicit value for the prio parameter, this indicates that the prio parameter has assigned to it the value of the priority parameter of the TM_Connect_Req primitive that caused the current traffic link to be established.
InitRollCall	Initialize (empty) RollCallResponses; initialize and start RollCallTimer.
InitUnlink	Initialize (empty) UnlinkResponses; initialize and start UnlinkRollCallTimer.
InitWaitForConfirm	Initialize ConfirmTimer to start timing the time-interval in which an incoming TM_CONFIRM PDU is expected in the establishment of a packet or point-to-point circuit link. The timeout interval duration is $T_{BW1} + 2T_{prop,max} + T_{BW1enc} + 2T_{BW1proc}$ following the emission of the last sample of an outgoing TM_REQUEST PDU, where the 'T <sub>x</sub> ' duration constants are as defined in C.5.3.5.5.
InitWaitForRequest	Initialize RequestTimer to start timing the time-interval in which an incoming TM_REQUEST PDU is expected in the establishment of a packet or point-to-point circuit traffic link. The timeout interval duration is $T_{tune} + 2T_{sug} + T_{prop,max} + T_{BW1} + T_{BW1proc}$ following the end of the 3G-ALE time slot in which the LE_HANDSHAKE PDU was transmitted or received, where the 'T <sub>x</sub> ' duration constants are as defined in C.5.3.5.5.
InitWaitForRequest (MC)	Initialize RequestTimer to start timing the time-interval in which an incoming TM_REQUEST PDU is expected in the establishment of a multicast circuit traffic link. The timeout interval duration is $T_{traf\_wait\_mcast} + T_{tune} + 2T_{sug} + T_{prop,max} + T_{BW1} + T_{BW1proc}$ following the end of the 3G-ALE slot in which the LE_HANDSHAKE PDU specifying the traffic channel for the circuit link was received, where $T_{traf\_wait\_mcast}$ is an initial set-up parameter, and the remaining 'T <sub>x</sub> ' duration constants are as defined in C.5.3.5.5.
InitWaitForRequest (SUSPEND)	Initialize RequestTimer to start timing the time-interval in which an incoming TM_REQUEST PDU is expected after an established multicast circuit traffic link has been suspended. The timeout interval duration is $2T_{BW1} + T_{BW1proc} + T_{traf\_wait\_mcast} + 2T_{dwell} + T_{tune} + 2T_{sug} + T_{prop,max} + T_{BW1} + T_{BW1proc}$ following the instant in which the last sample of the TM_TERM(SUSPEND) PDU was received, where $T_{traf\_wait\_mcast}$ is an initial set-up parameter, and the remaining 'T <sub>x</sub> ' duration constants are as defined in C.5.3.5.5.
InitWaitForRequest (reqIntvl)	Initialize RequestTimer to start timing the time-interval in which an incoming TM_REQUEST PDU is expected in the establishment of a broadcast traffic link. The value of reqIntvl is supplied by the user process as the reqIntvl parameter-value of the TM_Connect_Req service primitive, and is based on the countdown field-value of the received LE_BROADCAST PDU.

**TABLE C-XXXIX. TM actions (continued).**

Action name	Description
InitWaitForReversal	Initialize ReversalTimer to start timing the time-interval in which an incoming TM_REQUEST PDU is expected at the former sending station in a packet traffic link reversal. The timeout interval duration is $T_{BW1} + T_{BW1proc}$ following the instant at which the arrival of the first sample of an xDL_ACK PDU would have been expected if the preceding data link transfer had not been already completed. In this case, if a request timeout occurs, TM assumes that the remote station did not attempt to reverse the packet traffic link; it is up to the user process at the remote station to set-up a new traffic link (via 3G-ALE and TM) to deliver any packet traffic it has, if an attempted packet link reversal fails.
MarkAbsent (srcAddr)	Record in RollCallResponses the fact that no roll call response was received from the station with address srcAddr.
MarkLinkAvail	Set LinkBusy to FALSE (since the link is “available”).
MarkLinkBusy	Set LinkBusy to TRUE.
MarkPresent (srcAddr)	Record in RollCallResponses the fact that a roll call response was received from the station with address srcAddr.
MarkReverseTrafficPending	Set ReverseTrafficPending to TRUE.
none	No action.
RecordUnlinkResponse (ackNak, srcAddr)	Add an entry to UnlinkResponses representing a received unlink roll call response from the station whose individual address is srcAddr, and ackNak is the Reason field value of the response (TM_TERM) PDU: UNL_ACK or UNL_NAK.
S:TM_CONF (pktTraf, srcAddr) S:TM_CONF (cktTraf, srcaddr)	Send a TM_CONF (“Confirm”) PDU with destAddr = the individual address of the station that initiated the traffic link being established by sending a TM_REQ PDU, and trafficType = the traffic type announced in the TM_REQ PDU. ‘pktTraf’ represents an announced packet traffic type (HDL_n or LDL_n); ‘cktTraf’ represents an announced circuit traffic type (neither HDL_n nor LDL_n).
S:TM_CONF (cktTraf, MCaddr)	Send a TM_CONF PDU in the local station’s roll call time slot., with destAddr = the multicast address of the multicast group for which the circuit link is being established, and trafficType equal to the circuit traffic type value announced in the TM_REQ PDU sent by the link master to initiate the roll call operation.
S:TM_REQ (trafficType, destAddr)	Send a TM_REQ PDU requesting establishment of a traffic link, with trafficType = the type of traffic to be delivered on the requested link, and destAddr identifying the stations intended to participate in the link. In the state diagrams and transition table, ‘pktTraf’ is used to refer to any form of packet traffic delivered by either the High-Rate (‘HDL_n’) or the LDL (‘LDL_n’); ‘cktTraf’ is used to refer to any traffic type that can be delivered on a circuit link: i.e., any type other than HDL_n or LDL_n. For circuit links, the type of destination address depends on whether the requested link is a point-to-point, multicast, or broadcast link; this is signified in the state diagrams and transition table by the use of the abbreviations ‘indAddr’, ‘MCaddr’, and ‘BCaddr’.

**TABLE C-XXXIX. TM actions (continued).**

Action name	Description
S:TM_TERM (reason, addr, howMany)	<p>Send one or more TM_TERM PDUs having the indicated values for the Reason and Dest Addr fields. addr is the station address of the remote participant in a point-to-point link (circuit or packet), the multicast address of the multicast group participating in a multicast circuit link, or the all-ones broadcast address. The howMany term (which does not refer to a PDU field) indicates how many times the TM_TERM PDU is to be sent:  once, if no explicit howMany value is provided;  three times, if howMany = '3x'; and  as many times as possible within a High-Rate or LDL forward transmission interval, if howMany = 'nx':  once, for traffic type HDL_3 or HDL_6;  three times, for traffic type HDL_12;  seven times, for traffic type HDL_24;  once, for traffic type LDL_64 or LDL_128;  two times, for traffic type LDL_256; and  five times, for traffic type LDL_512.</p> <p>When 'reason' occurs in the state diagrams or transition table in place of an explicit Reason field-value, this indicates that this field is to be given the value of the Reason parameter of the TM_Disconnect_Req service primitive most recently received from the user process. When 'ackNak' is shown in the reason position, this indicates that the Reason field-value is to be either UNL_ACK or UNL_NAK, depending on whether the station successfully received the traffic transmitted on the multicast circuit which is now being dropped. In this case, the Reason field-value should be the same as the ackNak parameter-value of the TM_Disconnect_Resp service primitive just accepted from the user process.</p>
ScheduleAbort	Set ScheduledAbort to TRUE.
ScheduleSignoff	Set ScheduledSignoff to TRUE.
SetDropTimeout (period)	Set DropTimer to time out and generate a DropTimeout event after an interval of duration period has elapsed.
SetupUnlink (ackNak, watch)	Record whether the traffic transmitted on the multicast circuit now being dropped was received successfully, as indicated by the ackNak parameter-value of the TM_Disconnect_Resp service primitive just accepted from the user process. Also record whether the local station is to remain on the traffic channel long enough to hear all of the unlink roll call responses from the participants in the multicast circuit.
U:TM_Connect_Conf U:TM_Connect_Conf (responses)	Issue a TM_Connect_Conf service primitive to the user process, confirming establishment of the requested traffic link, of which the local station is now link master. If the established link is a multicast circuit link, the 'responses' parameter identifies the stations from which roll call responses were received; this parameter is omitted when the link is a point-to-point or broadcast link.

**TABLE C-XXXIX. TM actions (continued).**

Action name	Description
U:TM_Connect_Ind (trafficType, srcAddr, responses)	Issue a TM_Connect_Ind service primitive to the user process, indicating that a traffic link has been established of which the local station is a non-master participant. The trafficType parameter identifies the type of traffic for which the traffic link is being established, and should have the same value as the Argument (Traffic Type) field of the TM_REQ PDU that was sent by the station initiating the traffic link. The srcAddr parameter is the individual address of the station that initiated the traffic link. If the established link is a multicast circuit link, the responses parameter identifies the stations from which roll call responses were received; this parameter is omitted when the link is a point-to-point or broadcast link.
U:TM_Disconnect_Conf (reason) U:TM_Disconnect_Conf (reason, responses)	Issue a TM_Disconnect_Conf service primitive with its reason parameter having the indicated value to the user process. Where the word 'reason' occurs in place of an explicit value for the reason parameter, this indicates that the reason parameter has assigned to it the value of the reason parameter of the TM_Disconnect_Req primitive to which the TM_Disconnect_Conf primitive is a response. The responses parameter is present only if the link being dropped is a multicast circuit link and if an unlink roll call has been performed; in this case, the value of the responses parameter is a list of the unlink roll call responses received by the local station.
U:TM_Disconnect_Ind (reason)	Issue a TM_Disconnect_Ind service primitive with its reason parameter having the indicated value to the user process. Where the word 'reason' occurs in place of an explicit value for the reason parameter, this indicates that the reason parameter has assigned to it the value of the 'reason' field of a just-received TM_TERM PDU.

C.5.3.5.3 Data.

Table C-XL defines the data items used and maintained by the TM entity, including buffers, counters, timers, configuration parameters, and so forth. These data items are referred to by the names assigned to them here, in the definitions of TM events and actions presented in the preceding sections. These data items are used in this specification only as expository devices; it is not required for compliance that an implementation contain these data items in the forms described here.



**TABLE C-XL. TM data items.**

<b>Data item</b>	<b>Description</b>
ConfirmTimer	Timer timing the period in which receipt of a TM_CONF PDU is expected in response to a TM_REQ PDU just sent.
DropTimer	Timer timing the interval TM waits for the traffic link to become available (no longer busy) as indicated by CLC, so that TM can send a TM_TERM PDU in response to a TM_Disconnect_Req.
LinkBusy	Boolean condition variable: is TRUE if and only if CLC has declared the current circuit link to be busy (without since then having declared it to be non-busy — i.e., available for new traffic).
RequestTimer	Timer timing the period in which receipt of a TM_REQ PDU is expected, when the local station is a slave participant in a connection which has just been established by 3G-ALE. The timeout period varies depending on the traffic link topology; see the descriptions of the InitWaitForRequest() actions for further details.
ReversalTimer	Timer timing the period in which receipt of a TM_REQ PDU is expected, when the local station has just completed an outgoing data link transfer on a packet traffic link, and is waiting for an indication that the remote station has data link traffic to send on the traffic link.
ReverseTrafficPending	Boolean condition variable; when TRUE, indicates that the non-master participant in a packet traffic link has packet traffic to send to the link initiator, and hence that the link direction will be reversed once delivery of the link initiator's packet traffic has been completed.
RollCallResponses	List of the system addresses of stations intended to participate in the current multicast circuit link (multicast group members) from which valid roll call responses have been received.
RollCallTimer	Timer timing each station's participation in the roll call performed in establishing a multicast circuit link. Provides two time signals (interrupts) to the local station: one when it is time for the local station to send its own roll call response, the other when the time interval for all roll call responses by all participating stations has expired.
ScheduledSignoff	Boolean condition variable; when TRUE, causes the local station (non-master participant in a multicast circuit link) to send a TM_TERM PDU signing-off from the circuit link as soon as the roll call currently in progress is completed.
ScheduledAbort	Boolean condition variable; when TRUE, causes the local station (master of a multicast circuit link) to send a TM_TERM PDU dropping the circuit link as soon as the roll call currently in progress is completed.
UnlinkResponses	List of responses to the optional unlink roll-call performed at the conclusion of a multicast circuit connection, in which each response is in the form of an ordered pair (indAddr, ackNak), where indAddr is the address of a station whose roll call response was heard, and ackNak is the Reason field-value of the TM_TERM PDU sent as the station's response: UNL_ACK or UNL_NAK.
UnlinkRollCallTimer	Timer timing each station's participation in the optional roll call that can be performed just before a multicast circuit link is dropped. Provides two time signals (interrupts) to the local station: one when it is time for the local station to send its own unlink roll call response (if any), the other when the time interval for all unlink roll call responses by all participating stations has expired.

C.5.3.5.4 Behavior definition.

For the reader's convenience, two equivalent representations of the behavior of the TM protocol are provided in this section: the state transition table in table C-XLI, and the state diagrams figures C-21 through C-25. Due to the complexity of the state-machine behavior, it has been

found necessary to represent this behavior on four different state diagrams. Note that the Idle state shown on all four diagrams is the same single state: each diagram depicts only a subset of the transitions entering and leaving the Idle state.

Both the state diagrams and the transition table specify the behavior of the TM entity in terms of the events defined in C.5.3.5.1 and the actions defined in C.5.3.5.2. The conditions gating certain transitions are specified in terms of the data items defined in C.5.3.5.3.

In the state diagrams, each state transition is labeled with an event, an optional condition, and zero or more actions. This indicates that the state transition occurs whenever the event occurs and the condition obtains (is TRUE), causing the associated actions to be performed. In the diagram,

- the name of each event is shown in square brackets preceded by the letter ‘E’;
- the description of each condition is shown in square brackets preceded by the letter ‘C’;  
and
- the names of the actions associated with a transition are shown in square brackets preceded by the letter ‘A’.

Where a transition is labeled with two or more events, this indicates that the transition occurs whenever any of the events occurs.

In the state diagrams and the state transition table, text within text boxes or braces (“{}”) is commentary and not part of the formal state machine definition.

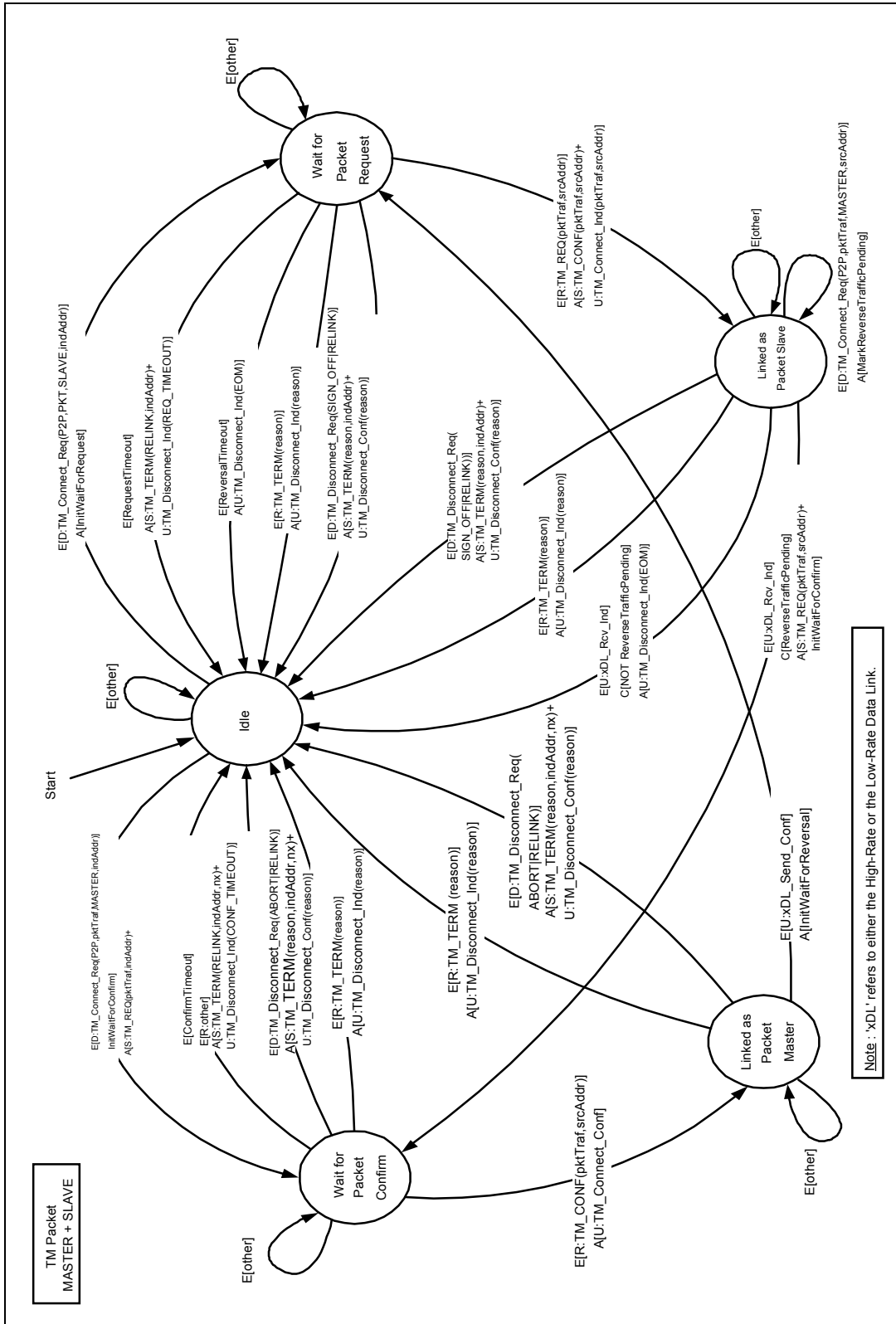


FIGURE C-21. TM state diagram: packet.

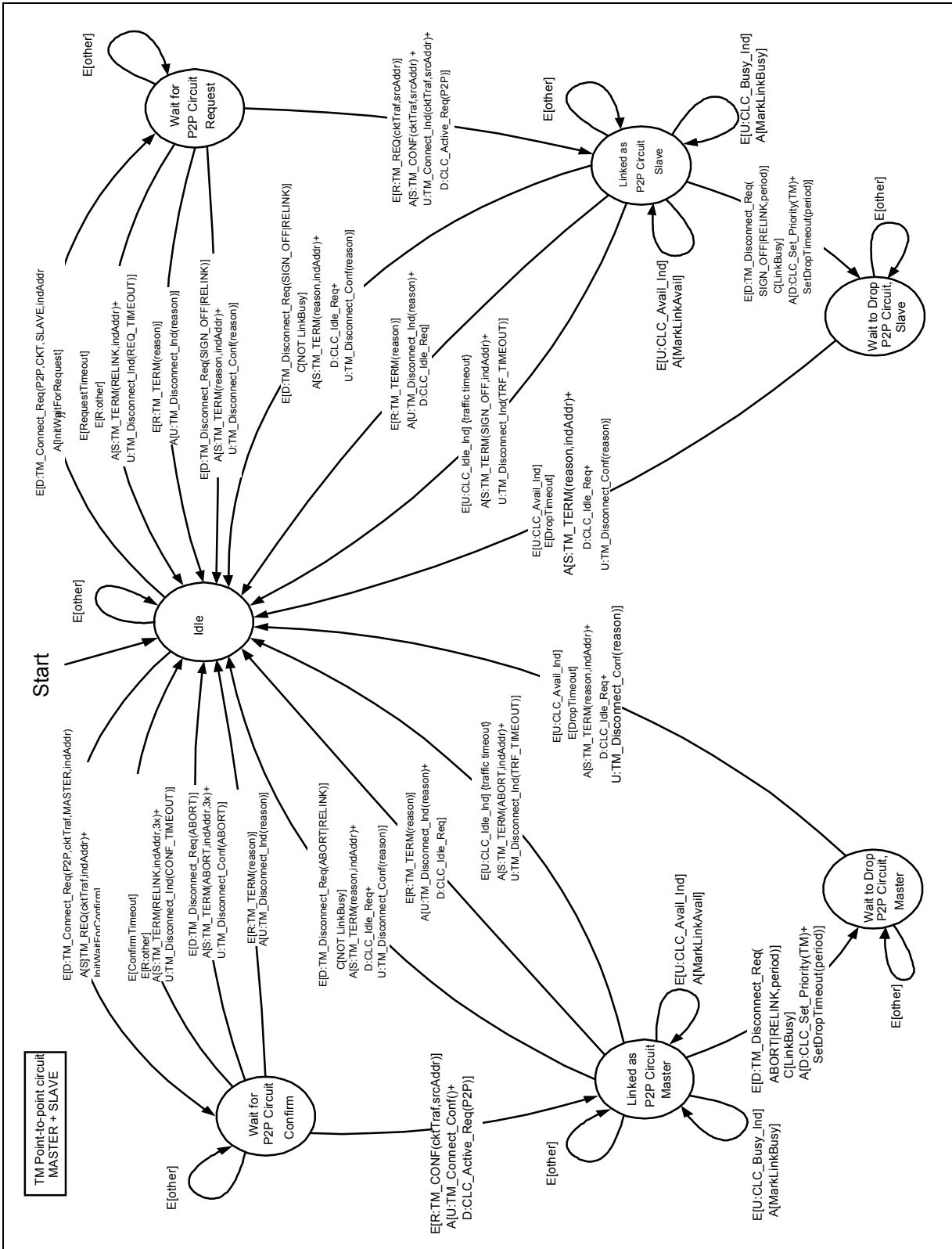


FIGURE C-22. TM state diagram: point-to-point circuit.

MIL-STD-188-141B  
APPENDIX C

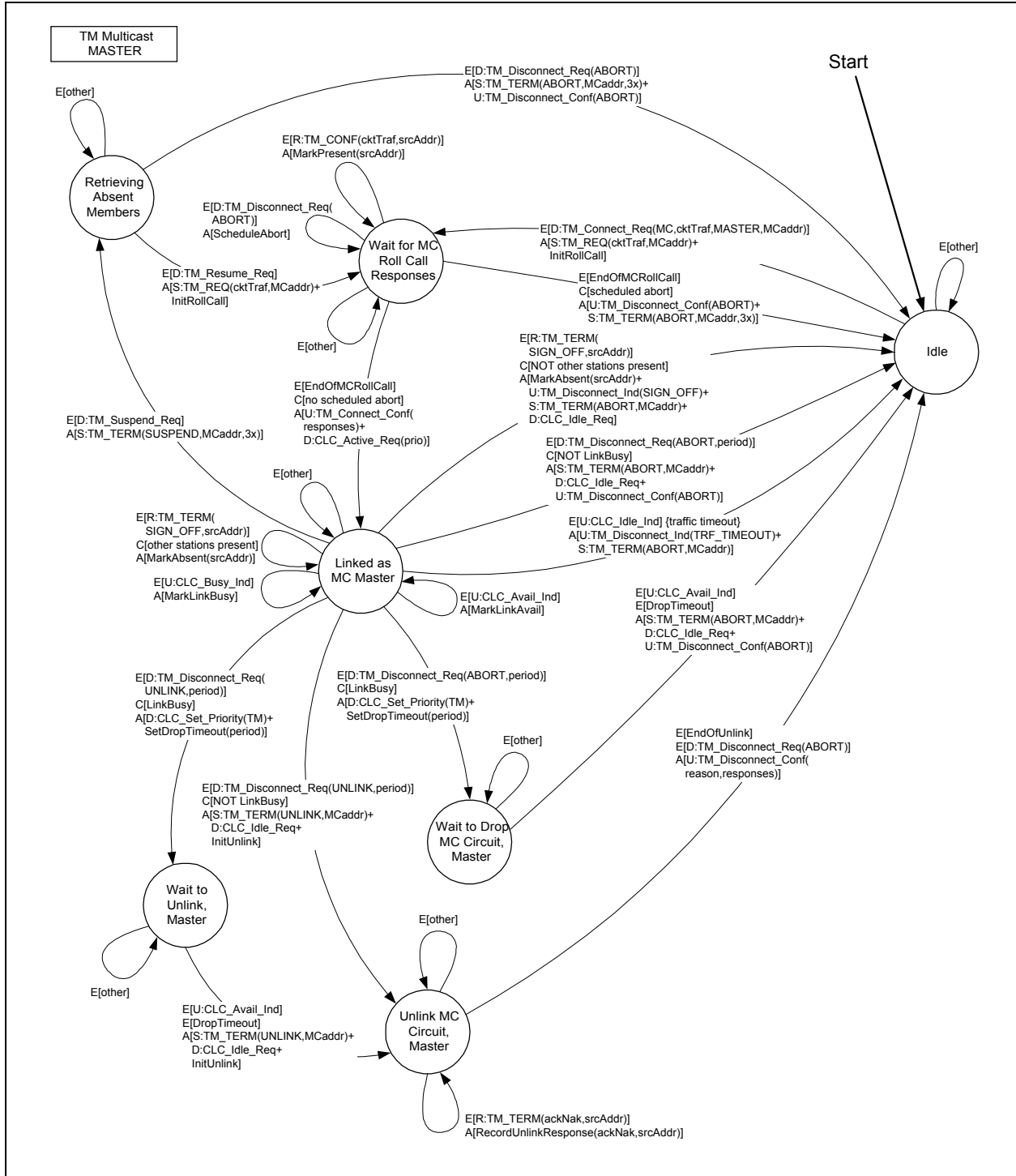


FIGURE C-23. TM state diagram: multicast circuit (master).

MIL-STD-188-141B  
APPENDIX C

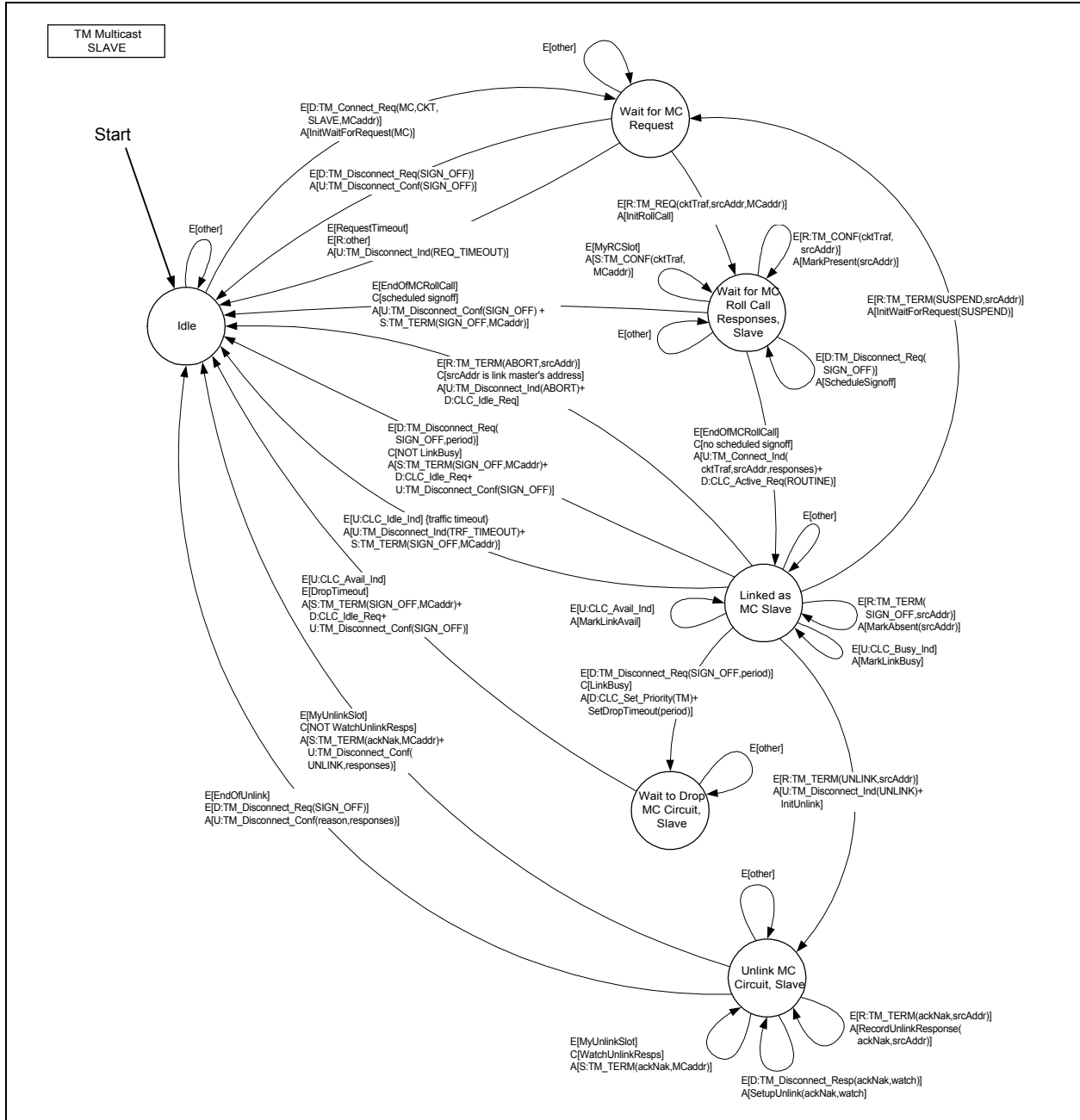


FIGURE C-24. TM state diagram: multicast circuit (slave).

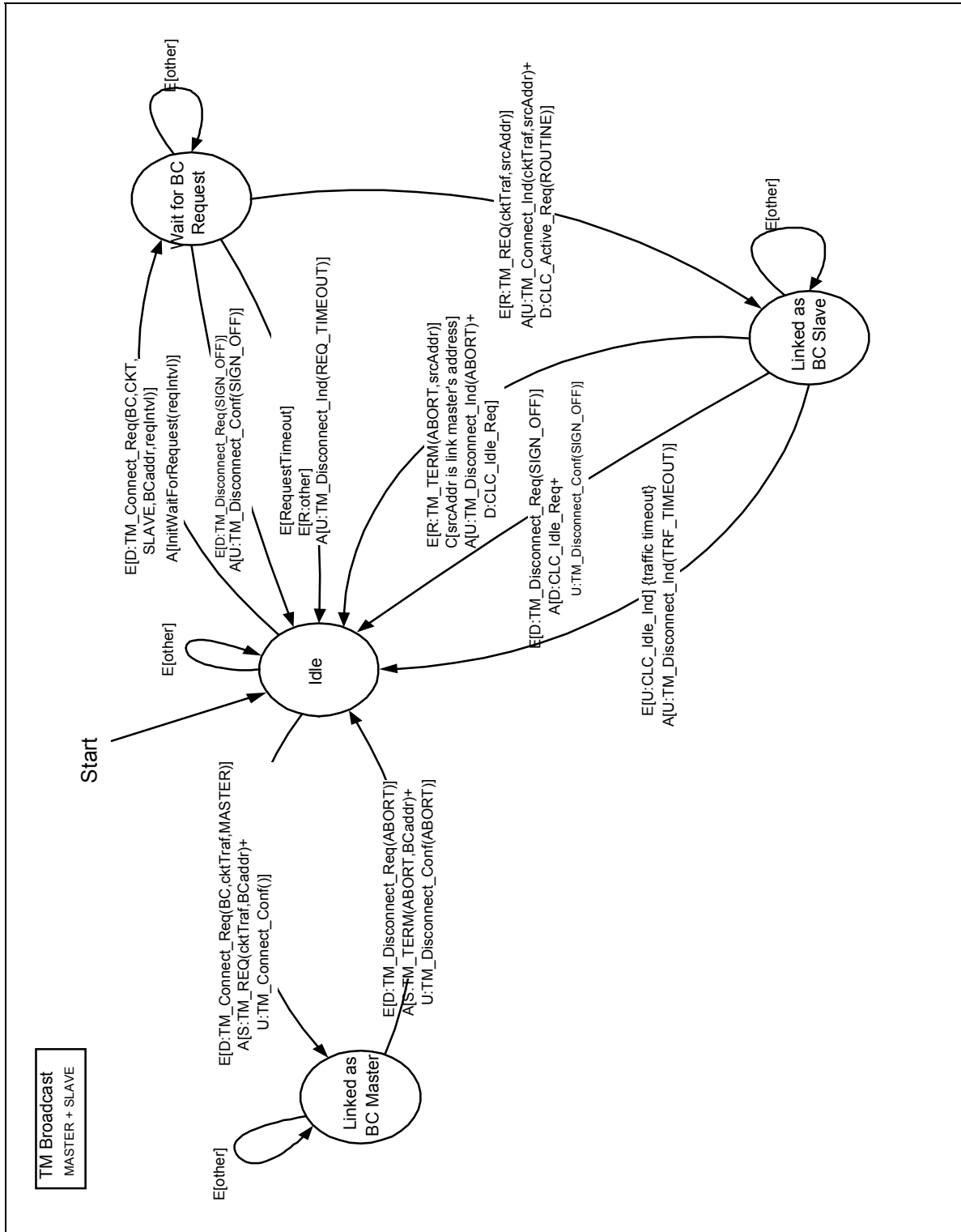


FIGURE C-25. TM state diagram: broadcast circuit.

**TABLE C-XLI. TM state transition table.**

State	Event	Condition	Action	Next State
Idle	D:TM_Connect_Req (P2P, pktTraf, MASTER, indAddr)		S:TM_REQ (pktTraf, indAddr)+ InitWaitForConfirm	Wait for Packet Confirm
	D:TM_Connect_Req (P2P, PKT, SLAVE, indAddr)		InitWaitForRequest	Wait for Packet Request
	D:TM_Connect_Req (P2P, cktTraf, MASTER, indAddr)		S:TM_REQ (cktTraf, indAddr)+ InitWaitForConfirm	Wait for P2P Circuit Confirm
	D:TM_Connect_Req (P2P, CKT, SLAVE, indAddr)		InitWaitForRequest	Wait for P2P Circuit Request
	D:TM_Connect_Req (MC, cktTraf, MASTER, MCaddr)		S:TM_REQ (cktTraf, MCaddr)+ InitRollCall	Wait for MC Roll Call Responses
	D:TM_Connect_Req (MC, CKT, SLAVE, MCaddr)		InitWaitForRequest(MC)	Wait for MC Request
	D:TM_Connect_Req (BC, cktTraf, MASTER)		S:TM_REQ (cktTraf, BCaddr)+ U:TM_Connect_Conf	Linked as BC Master
	D:TM_Connect_Req (BC, CKT, SLAVE, BCaddr reqIntvl)		InitWaitForRequest (reqIntvl)	Wait for BC Request
	other		none	Idle
Wait for Packet Confirm	R:TM_CONF (pktTraf, srcAddr)		U:TM_Connect_Conf	Linked as Packet Master
	ConfirmTimeout R:other		S:TM_TERM (RELINK, indAddr, nx)+ U:TM_Disconnect_Ind (CONF_TIMEOUT)	Idle
	D:TM_Disconnect_Req (ABORT   RELINK)		S:TM_TERM (reason, indAddr, nx)+ U:TM_Disconnect_Conf (reason)	Idle
	R:TM_TERM (reason)		U:TM_Disconnect_Ind (reason)	Idle
	other		none	Wait for Packet Confirm
Linked as Packet Master	U:xDL_Send_Conf		InitWaitForReversal	Wait for Packet Request
	D:TM_Disconnect_Req (ABORT   RELINK)		S:TM_TERM (reason, indAddr, nx)+ U:TM_Disconnect_Conf (reason)	Idle
	R:TM_TERM (reason)		U:TM_Disconnect_Ind (reason)	Idle
	other		none	Linked as Packet Master
Wait for Packet Request	R:TM_REQ (pktTraf, srcAddr)		S:TM_CONF (pktTraf, srcAddr)+ U:TM_Connect_Ind (pktTraf, srcAddr)	Linked as Packet Slave
	D:TM_Disconnect_Req (SIGN_OFF   RELINK)		S:TM_TERM (reason, indAddr)+ U:TM_Disconnect_Conf (reason)	Idle
	R:TM_TERM (reason)		U:TM_Disconnect_Ind (reason)	Idle
	RequestTimeout		S:TM_TERM (RELINK, indAddr)+ U:TM_Disconnect_Ind (REQ_TIMEOUT)	Idle
	ReversalTimeout		U:TM_Disconnect_Ind (EOM)	Idle



**TABLE C-XLI. TM state transition table (continued).**

State	Event	Condition	Action	Next State
Linked as Packet Slave	other		none	Wait for Packet Request
	U:xDL_Rcv_Ind	NOT Reverse Traffic Pending	U:TM_Disconnect_Ind (EOM)	Idle
	U:xDL_Rcv_Ind	Reverse Traffic Pending	S:TM_REQ (pktTraf, srcAddr)+ InitWaitForConfirm	Wait for Packet Confirm
	D:TM_Disconnect_Req (SIGN_OFF   RELINK)		S:TM_TERM (reason, indAddr)+ U:TM_Disconnect_Conf (reason)	Idle
	R:TM_TERM (reason)		U:TM_Disconnect_Ind (reason)	Idle
	D:TM_Connect_Req (P2P, pktTraf, MASTER, srcAddr)		MarkReverseTrafficPending	Linked as Packet Slave
	other		none	Linked as Packet Slave
Wait for P2P Circuit Confirm	R:TM_CONF (cktTraf, srcAddr)		U:TM_Connect_Conf+ D:CLC_Active_Req (P2P)	Linked as P2P Circuit Master
	D:TM_Disconnect_Req (ABORT)		S:TM_TERM (ABORT, indAddr, 3x)+ U:TM_Disconnect_Conf (ABORT)	Idle
	R:TM_TERM (reason)		U:TM_Disconnect_Ind (reason)	Idle
	ConfirmTimeout R:other		S:TM_TERM (RELINK, indAddr, 3x)+ U:TM_Disconnect_Ind (CONF_TIMEOUT)	Idle
	other		none	Wait for P2P Circuit Confirm
Linked as P2P Circuit Master	R:TM_TERM (reason)		U:TM_Disconnect_Ind (reason)+ D:CLC_Idle_Req	Idle
	D:TM_Disconnect_Req (ABORT   RELINK)	NOT LinkBusy	S:TM_TERM (reason, indAddr)+ D:CLC_Idle_Req+ U:TM_Disconnect_Conf (reason)	Idle
	D:TM_Disconnect_Req (ABORT   RELINK, period)	LinkBusy	D:CLC_Set_Priority (TM)+ SetDropTimeout (period)	Wait to Drop P2P Circuit, Master
	U:CLC_Idle_Ind {traffic timeout}		S:TM_TERM (ABORT, indAddr)+ U:TM_Disconnect_Ind (TRF_TIMEOUT)	Idle
	U:CLC_Busy_Ind		MarkLinkBusy	Linked as P2P Circuit Master
	U:CLC_Avail_Ind		MarkLinkAvail	Linked as P2P Circuit Master
	other		none	Linked as P2P Circuit Master

**TABLE C-XLI. TM state transition table (continued).**

State	Event	Condition	Action	Next State
Wait to Drop P2P Circuit, Master	U:CLC_Avail_Ind DropTimeout		S:TM_TERM (reason, indAddr)+ D:CLC_Idle_Req+ U:TM_Disconnect_Conf (reason)	Idle
	other		none	Wait to Drop P2P Circuit, Master
Wait for P2P Circuit Request	R:TM_REQ (cktTraf, srcAddr)		S:TM_CONF (cktTraf, srcAddr)+ U:TM_Connect_Ind (cktTraf, srcAddr)+ D:CLC_Active_Req (P2P)	Linked as P2P Circuit Slave
	RequestTimeout R:other		S:TM_TERM (RELINK, indAddr)+ U:TM_Disconnect_Ind (REQ_TIMEOUT)	Idle
	D:TM_Disconnect_Req (SIGN_OFF   RELINK)		S:TM_TERM (reason, indAddr)+ U:TM_Disconnect_Conf (reason)	Idle
	R:TM_TERM (reason)		U:TM_Disconnect_Ind (reason)	Idle
	other		none	Wait for P2P Circuit Request
Linked as P2P Circuit Slave	D:TM_Disconnect_Req (SIGN_OFF   RELINK)	NOT LinkBusy	S:TM_TERM (reason, indAddr)+ D:CLC_Idle_Req+ U:TM_Disconnect_Conf (reason)	Idle
	R:TM_TERM (reason)		U:TM_Disconnect_Ind (reason)+ D:CLC_Idle_Req	Idle
	U:CLC_Idle_Ind {traffic timeout}		S:TM_TERM (SIGN_OFF, indAddr)+ U:TM_Disconnect_Ind (TRF_TIMEOUT)	Idle
	D:TM_Disconnect_Req (SIGN_OFF   RELINK, period)	LinkBusy	D:CLC_Set_Priority (TM)+ SetDropTimeout (period)	Wait to Drop P2P Circuit, Slave
	U:CLC_Busy_Ind		MarkLinkBusy	Linked as P2P Circuit Slave
	U:CLC_Avail_Ind		MarkLinkAvail	Linked as P2P Circuit Slave
	other		none	Linked as P2P Circuit Slave
Wait to Drop P2P Circuit, Slave	U:CLC_Avail_Ind DropTimeout		S:TM_TERM (reason, indAddr)+ D:CLC_Idle_Req+ U:TM_Disconnect_Conf (reason)	Idle
	other		none	Wait to Drop P2P Circuit, Slave
Wait for MC Roll Calls Responses	EndOfMCRollCall	NOT Scheduled Abort	U:TM_Connect_Conf (responses)+ D:CLC_Active_Req (prio)	Linked as MC Master
	R:TM_CONF (cktTraf, srcAddr)		MarkPresent (srcAddr)	Wait for MC Roll Call Responses

**TABLE C-XLI. TM state transition table (continued).**

State	Event	Condition	Action	Next State
	D:TM_Disconnect_Req (ABORT)		ScheduleAbort	Wait for MC Roll Call Responses
	other		none	Wait for MC Roll Call Responses
	EndOfMCRollCall	Scheduled Abort	U:TM_Disconnect_Conf (ABORT)+ S:TM_TERM (ABORT, MCaddr, 3x)	Idle
Linked as MC Master	R:TM_TERM (SIGN_OFF, srcAddr)	other stations present	MarkAbsent (srcAddr)	Linked as MC Master
	R:TM_TERM (SIGN_OFF, srcAddr)	NOT other stations present	MarkAbsent (srcAddr)+ U:TM_Disconnect_Ind (SIGN_OFF)+ S:TM_TERM (ABORT, MCaddr)+ D:CLC_Idle_Req	Idle
	D:TM_Disconnect_Req (ABORT, period)	NOT LinkBusy	S:TM_TERM (ABORT, MCaddr)+ D:CLC_Idle_Req+ U:TM_Disconnect_Conf (ABORT)	Idle
	D:TM_Disconnect_Req (ABORT, period)	LinkBusy	D:CLC_Set_Priority (TM)+ SetDropTimeout(period)	Wait to Drop MC Circuit, Master
	U:CLC_Idle_Ind {traffic timeout}		U:TM_Disconnect_Ind (TRF_TIMEOUT)+ S:TM_TERM (ABORT, MCaddr)	Idle
	U:CLC_Busy_Ind		MarkLinkBusy	Linked as MC Master
	U:CLC_Avail_Ind		MarkLinkAvail	Linked as MC Master
	D:TM_Suspend_Req		S:TM_TERM (SUSPEND, MCaddr, 3x)	Retrieving Absent Members
	D:TM_Disconnect_Req (UNLINK, period)	NOT LinkBusy	S:TM_TERM (UNLINK, MCaddr)+ D:CLC_Idle_Req+ InitUnlink	Unlink MC Circuit, Master
	D:TM_Disconnect_Req (UNLINK, period)	LinkBusy	D:CLC_Set_Priority (TM)+ SetDropTimeout (period)	Wait to Unlink, Master
	other		none	Linked as MC Master
Retrieve Absent Members	D:TM_Resume_Req		S:TM_REQ (cktTraf, MCaddr)+ InitRollCall	Wait for MC Roll Call Responses
	D:TM_Disconnect_Req (ABORT)		S:TM_TERM (ABORT, MCaddr, 3x)+ U:TM_Disconnect_Conf (ABORT)	Idle
	other		none	Retrieve Absent Members
Wait to Drop MC Circuit, Master	U:CLC_Avail_Ind DropTimeout		S:TM_TERM (ABORT, MCaddr)+ D:CLC_Idle_Req+ U:TM_Disconnect_Conf (ABORT)	Idle
	other		none	Wait to Drop MC Circuit, Master
Unlink MC Circuit, Master	R:TM_TERM (ackNak, srcAddr)		RecordUnlinkResponse (ackNak, srcAddr)	Unlink MC Circuit, Master

**TABLE C-XLI. TM state transition table (continued).**

State	Event	Condition	Action	Next State
	EndOfUnlink D:TM_Disconnect_Req (ABORT)		U:TM_Disconnect_Conf (reason, responses)	Idle
	other		none	Unlink MC Circuit, Master
Wait to Unlink, Master	U:CLC_Avail_Ind DropTimeout		S:TM_TERM (UNLINK, MCaddr)+ D:CLC_Idle_Req+ InitUnlink	Unlink MC Circuit, Master
	other		none	Wait to Unlink, Master
Wait for MC Request	R:TM_REQ (cktTraf, srcAddr, MCaddr)		InitRollCall	Wait for MC Roll Call Responses, Slave
	RequestTimeout R:other		U:TM_Disconnect_Ind (REQ_TIMEOUT)	Idle
	D:TM_Disconnect_Req (SIGN_OFF)		U:TM_Disconnect_Conf (SIGN_OFF)	Idle
	other		none	Wait for MC Request
Wait for MC Roll Call Response s, Slave	EndOfMCRollCall	NOT Scheduled Signoff	U:TM_Connect_Ind (cktTraf, srcAddr, responses)+ D:CLC_Active_Req (ROUTINE)	Linked as MC Slave
	R:TM_CONF (cktTraf, srcAddr)		MarkPresent (srcAddr)	Wait for MC Roll Call Responses, Slave
	MyRCSlot		S:TM_CONF (cktTraf, MCaddr)	Wait for MC Roll Call Responses, Slave
	D:TM_Disconnect_Req (SIGN_OFF)		ScheduleSignoff	Wait for MC Roll Call Responses, Slave
	other		none	Wait for MC Roll Call Responses, Slave
	EndOfMCRollCall	Scheduled Signoff	U:TM_Disconnect_Conf (SIGN_OFF)+ S:TM_TERM (SIGN_OFF, MCaddr)	Idle
Linked as MC Slave	R:TM_TERM (SIGN_OFF, srcAddr)		MarkAbsent (srcAddr)	Linked as MC Slave
	D:TM_Disconnect_Req (SIGN_OFF, period)	NOT LinkBusy	S:TM_TERM (SIGN_OFF, MCaddr)+ D:CLC_Idle_Req+ U:TM_Disconnect_Conf (SIGN_OFF)	Idle
	D:TM_Disconnect_Req (SIGN_OFF, period)	LinkBusy	D:CLC_Set_Priority (TM)+ SetDropTimeout (period)	Wait to Drop MC Circuit, Slave
	R:TM_TERM (ABORT, srcAddr)	srcAddr is link master's address	U:TM_Disconnect_Ind (ABORT)+ D:CLC_Idle_Req	Idle

**TABLE C-XLI. TM state transition table (continued).**

State	Event	Condition	Action	Next State
	U:CLC_Idle_Ind {traffic timeout}		U:TM_Disconnect_Ind (TRF_TIMEOUT) + S:TM_TERM (SIGN_OFF, MCaddr)	Idle
	U:CLC_Busy_Ind		MarkLinkBusy	Linked as MC Slave
	U:CLC_Avail_Ind		MarkLinkAvail	Linked as MC Slave
	R:TM_TERM (SUSPEND, srcAddr)		InitWaitForRequest(SUSPEND)	Wait for MC Request
	R:TM_TERM (UNLINK, srcAddr)		U:TM_Disconnect_Ind (UNLINK)+ InitSlaveUnlink	Unlink MC Circuit, Slave
	other		none	Linked as MC Slave
Wait to Drop MC Circuit, Slave	U:CLC_Avail_Ind DropTimeout		S:TM_TERM (SIGN_OFF, MCaddr)+ D:CLC_Idle_Req+ U:TM_Disconnect_Conf (SIGN_OFF)	Idle
	other		none	Wait to Drop MC Circuit, Slave
Unlink MC Circuit, Slave	D:TM_Disconnect_Resp (ackNak, watch)		SetupUnlink (ackNak, watch)	Unlink MC Circuit, Slave
	R:TM_TERM (ackNak, srcAddr)		RecordUnlinkResponse (ackNak, srcAddr)	Unlink MC Circuit, Slave
	MyUnlinkSlot	WatchUnlink Resps	S:TM_TERM (ackNak, MCaddr)	Unlink MC Circuit, Slave
	MyUnlinkSlot	NOT Watch UnlinkResps	S:TM_TERM (ackNak, MCaddr)+ U:TM_Disconnect_Conf (UNLINK, responses)	Idle
	EndOfUnlink D:TM_Disconnect_Req (SIGN_OFF)		U:TM_Disconnect_Conf (reason, responses)	Idle
	other		none	Unlink MC Circuit, Slave
Linked as BC Master	D:TM_Disconnect_Req (ABORT)		S:TM_TERM (ABORT, BCaddr)+ U:TM_Disconnect_Conf (ABORT)	Idle
	other		none	Linked as BC Master
Wait for BC Request	R:TM_REQ (cktTraf, srcAddr)		U:TM_Connect_Ind (cktTraf, srcAddr)+ D:CLC_Active_Req (ROUTINE) {CLC used only for traffic timeout}	Linked as BC Slave

**TABLE C-XLI. TM state transition table (continued).**

State	Event	Condition	Action	Next State
	RequestTimeout R:other		U:TM_Disconnect_Ind (REQ_TIMEOUT)	Idle
	D:TM_Disconnect_Req (SIGN_OFF)		U:TM_Disconnect_Conf(SIGN_OFF)	Idle
	other		none	Wait for BC Request
Linked as BC Slave	D:TM_Disconnect_Req (SIGN_OFF)		D:CLC_Idle_Req+ U:TM_Disconnect_Conf(SIGN_OFF)	Idle
	R:TM_TERM (ABORT, srcAddr)	srcAddr is link master's address	U:TM_Disconnect_Ind (ABORT)+ D:CLC_Idle_Req	Idle
	U:CLC_Idle_Ind (traffic timeout}		U:TM_Disconnect_Ind (TRF_TIMEOUT)	Idle
	other		none	Linked as BC Slave

**C.5.3.5.5 Timing characteristics.**

The protocol timing characteristics vary depending on which kind of traffic link is being established. The sub-sections of this section describe the timing characteristics applying to establishment and execution of, respectively, point-to-point packet traffic links, point-to-point circuit links, and multicast circuit links.

Table C-XLII gives definitions of time intervals used in presenting the protocol timing characteristics.

**TABLE C-XLII. Protocol time-intervals.**

Interval	# 32 Frames	# 48 Frames	# PSK Symbol times	Duration (ms., approx.)	Description
T <sub>slot</sub>	60		1920	800	Duration of 3G-ALE slot.
T <sub>dwell</sub>	300		9600	4000	Duration of 3G-ALE dwell.
T <sub>sug</sub>	4		128	53.33	LE sync uncertainty guard interval
T <sub>tune</sub>	45		1600	666.67	TM coupler tune allowance
T <sub>prop,max</sub>	6		192	80.00	maximum propagation delay
T <sub>BW0proc</sub>	8		128	53.33	BW0 processing time (after last sample is received)
T <sub>BW1enc</sub>	5		160	66.67	BW1 encoding time (prior to emission of first sample)
T <sub>BW1</sub>	98		3136	1306.67	BW1 transmission duration (TLC+preamble+data)
T <sub>BW1proc</sub>	10		320	133.33	BW1 processing time (after last sample is received)
T <sub>BW2enc</sub>	22		704	293.33	BW2 encoding time (prior to emission of first sample)
T <sub>BW2</sub>	2	5+20n	304+960n	126.67+ (n*400.00)	BW2 transmission duration -- n packets per transmission (n = 3, 6, 12, or 24)
T <sub>BW2(3)</sub>	2	65	3184	1326.67	BW2 transmission duration (3 packets per transmission)
T <sub>BW2(6)</sub>	2	125	6064	2526.67	BW2 transmission duration (6 packets per transmission)
T <sub>BW2(12)</sub>	2	245	11824	4926.67	BW2 transmission duration (12 packets per transmission)
T <sub>BW2(24)</sub>	2	485	23344	9726.67	BW2 transmission duration (24 packets per transmission)
T <sub>BW2proc</sub>		11	528	220.00	BW2 processing time (after last sample is received)
T <sub>BW3enc</sub>	5		160	66.67	BW3 encoding time (prior to emission of first sample)
T <sub>BW3</sub>	28+n		896+32n	373.33+ (n*13.33)	BW3 transmission duration (preamble+data) – n payload bytes per transmission (n = 64, 128, 256, or 512)
T <sub>BW3(64)</sub>	92		2944	1226.67	BW3 transmission duration (preamble+data) – 64 payload bytes per transmission
T <sub>BW3(128)</sub>	156		4992	2080.00	BW3 transmission duration (preamble+data) – 128 payload bytes per transmission
T <sub>BW3(256)</sub>	284		9088	3786.67	BW3 transmission duration (preamble+data) – 256 payload bytes per transmission
T <sub>BW3(512)</sub>	540		17280	7200.00	BW3 transmission duration (preamble+data) – 512 payload bytes per transmission
T <sub>BW3proc</sub>	5		160	66.67	BW3 processing time (after last sample is received)
T <sub>BW4enc</sub>	5		160	66.67	BW4 encoding time (prior to emission of first sample)
T <sub>BW4</sub>	48		1536	640.00	BW4 transmission duration (TLC+data)

**TABLE C-XLII. Protocol time-intervals (continued).**

Interval	# 32 Frames	# 48 Frames	# PSK Symbol times	Duration (ms., approx.)	Description
$T_{BW4proc}$	5		160	66.67	BW4 processing time (after last sample is received)
$T_{TM,Master}$					Duration of the initial TM handshake at the link master station. $T_{TM,Master} = T_{sug} + 2T_{BW1} + 2T_{prop,max} + 2T_{BW1proc} + T_{BW1enc}$ .
$T_{RTFD, HDL}$					Time from start of TM_REQUEST PDU to start of first HDL_DATA PDU. $T_{RTFD, HDL} = 2T_{BW1} + 2T_{prop,max} + 2T_{BW1proc} + T_{BW1enc} + T_{BW2enc}$ .
$T_{CTFA(n), HDL}$					Time from start of TM_CONFIRM PDU to start of first HDL_ACK PDU. $T_{CTFA, HDL} = T_{BW1} + T_{BW1proc} + 2T_{prop,max} + T_{BW2enc} + T_{BW2(n)} + T_{BW2proc} + T_{BW1enc}$ .
$T_{HDL(n)}$					Period of HDL protocol. $T_{HDL(n)} = T_{BW2enc} + T_{BW2(n)} + 2T_{prop,max} + T_{BW2proc} + T_{BW1enc} + T_{BW1} + T_{BW1proc}$ .
$T_{RTFD, LDL}$					Time from start of TM_REQUEST PDU to start of first LDL_DATA PDU. $T_{RTFD, LDL} = 2T_{BW1} + 2T_{prop,max} + 2T_{BW1proc} + T_{BW1enc} + T_{BW3enc}$ .
$T_{CTFA(n), LDL}$					Time from start of TM_CONFIRM PDU to start of first LDL_ACK PDU. $T_{CTFA, LDL(n)} = T_{BW1} + T_{BW1proc} + 2T_{prop,max} + T_{BW3enc} + T_{BW3(n)} + T_{BW3proc} + T_{BW4enc}$ .
$T_{LDL(n)}$					Period of LDL protocol. $T_{LDL(n)} = T_{BW3enc} + T_{BW3(n)} + 2T_{prop,max} + T_{BW3proc} + T_{BW4enc} + T_{BW4} + T_{BW4proc}$ .
$T_{rc slot, TM}$					Duration of TM roll call slot. $T_{rc slot, TM} = T_{BW1enc} + T_{BW1} + 2 * T_{prop,max} + T_{BW1proc}$
$T_{CLenc}$	15		2400	1000.00	MIL-STD-188-110 serial tone (see note) modem transmit startup delay: the permitted time interval between presentation of the first bit of data to the modem for modulation (when RTS is asserted), and emission of the first time-sample of the modem preamble. Note that this delay is not required for encoding per se, since MIL-STD-188-110 modems typically start emitting the modem preamble simultaneously with encoding the first bit of traffic data. The modem startup delay defined here is a characteristic of modem implementations rather than of the MIL-STD-188-110 standard.



**TABLE C-XLII. Protocol time-intervals (continued).**

Interval	# 32 Frames	# 48 Frames	# PSK Symbol times	Duration (ms., approx.)	Description
T <sub>CLpre</sub>	15		480	200.00	Duration of a single period of the Mil-Std-188-110A serial tone modem preamble: the minimum portion of the modem preamble that must be received and processed to successfully detect and acquire sync with an incoming modem transmission.
T <sub>CLproc</sub>	15		480	200.00	Mil-Std-188-110A serial tone modem acquisition processing delay: the processing time required following receipt of the last sample of a 200 ms. Preamble period, before the receiving modem can declare modem signal presence based on having acquired the preamble.

NOTE: Timing analyses for circuit links assume that these links are used for bit-pipe delivery of data using MIL-STD-188-110 serial tone modems; the timings used for delivery of other kinds of traffic on circuit links are the same.

**C.5.3.5.5.1 Point-to-point packet link.**

This section will first provide a description of point-to-point packet link timing. Following this, point-to-point packet link timing requirements will be given.

**C.5.3.5.5.1.1 Point-to-point packet link timing description.**

The contents of this section are for informational purposes only.

The TM phase of the point-to-point packet link is considered to begin at the end of the 3G-ALE time-slot in which the LE\_COMMENCE PDU (see note) is transmitted. Since only a two-way TM handshake is performed, it is not possible for both stations to estimate the propagation delay between them. Instead, in each direction, the TM handshake signalling is used to establish the timing for all subsequent signalling in that direction. In the forward direction, the first xDL\_DATA PDU (High-Rate or Low-Rate) is sent at a fixed time interval known a priori to both stations, following the transmission of the TM\_REQUEST PDU. Likewise, in the reverse direction, the first xDL\_ACK PDU is sent at a fixed time interval known a priori to both stations, following the transmission of the TM\_CONFIRM PDU. The entire process is depicted on figure C-26 through figure C-30, and analyzed in further detail below, using the HDL protocol for the purpose of illustration.

Note: I.e., an LE\_HANDSHAKE PDU in which the Command field's value is "Commence Traffic".

The linking activity proceeds as follows:

- First, an LE handshake is performed. This handshake establishes a link time reference, T<sub>link</sub>, for both the Master and the Slave. This time reference is defined as the start of the LE slot immediately following the LE slot in which the LE\_COMMENCE PDU was transmitted. If TOD offset exists between the Master and the Slave (i.e. T<sub>deltaTOD</sub> ≠ 0), T<sub>link</sub> will not be the same for Master and Slave, and so we introduce individual T<sub>link</sub>

values for each station,  $T_{\text{link,Master}}$  and  $T_{\text{link,Slave}}$ . Figure C-27 through figure C-30 show examples of  $T_{\text{deltaTOD}}$  having a non-zero value, and thus  $T_{\text{link,Master}} \neq T_{\text{link,Slave}}$ .  $T_{\text{link,Master}}$  and  $T_{\text{link,Slave}}$  can differ by no more than  $T_{\text{sug}}$ .

- Next, Master and Slave are given an opportunity to change to the traffic channel and tune, if necessary. This opportunity lasts  $T_{\text{tune}}$  seconds.
- Next, a TM handshake is performed. As was done for LE timing, the Master begins emission of the TM\_REQUEST PDU  $T_{\text{sug}}$  seconds into the TM time slot. (The reason for this is shown on figure C-30.) Unlike CM handshakes, the response (in this case the TM\_CONFIRM) is always emitted a fixed duration after reception of the first TM PDU of the handshake. As shown in the figures, this fixed response latency is  $T_{\text{BW1proc}} + T_{\text{BW1enc}}$ . Combining this fixed response latency with the duration of the two BW1 waveforms, a second processing delay for the Master to process the response, the sync uncertainty guard time, and worst-case propagation delay gives the duration of  $T_{\text{TM,Master}}$  as defined in table C-XLI and as shown in the figures. Note that  $T_{\text{TM,Master}}$  is fixed in duration, but  $T_{\text{TM,Slave}}$  is not.  $T_{\text{TM,Slave}}$  is equal to  $T_{\text{TM,Master}} - T_{\text{deltaTOD}} + T_{\text{prop}}$ . The fact that  $T_{\text{TM,Slave}}$  is variable does not complicate matters for the Slave station, however, since the TM\_REQUEST and the first forward transmission of the data link protocol are separated by a fixed amount of time,  $T_{\text{RTFD, HDL}}$ . As a result, the Slave need only measure the time of arrival of the TM\_REQUEST PDU to know when to expect the first forward transmission of the data link protocol and thus  $T_{\text{TM,Slave}}$ . ( $T_{\text{TM,Slave}}$  terminates  $T_{\text{BW2enc}}$  seconds prior to the expected arrival of the first forward transmission.) Similarly, the Master need only measure the time of arrival of the TM\_CONFIRM PDU to know when to expect the first HDL\_ACK PDU, as these two events will be delayed by  $T_{\text{CTFA(n), HDL}}$ .
- Next, the data link protocol executes a succession of forward transmission / acknowledge handshakes. These handshakes occur with a period of  $T_{\text{HDL(n)}}$ .  $T_{\text{HDL(n)}}$  is designed to account for waveform encoding and processing delays, and for worst-case propagation delay.  $T_{\text{HDL(n)}}$  is defined in table C-III.  $T_{\text{HDL(n)}}$  depends on the size of the forward transmission as established in the TM handshake. Note that the data link protocol time slots of the Slave are delayed  $T_{\text{prop}}$  with respect to the data link protocol time slots of the Master.
- Finally, the data link protocol concludes when the Master issues HDL\_EOM PDU(s) (as many as can be concatenated without exceeding  $T_{\text{BW2(n)}}$ ). If reverse traffic is pending, the Slave issues a TM\_REQUEST PDU starting at the same time it would have issued an HDL\_ACK PDU, the roles of Master and Slave reverse, and the timing proceeds as just described.

A similar analysis defines the timing structure for point-to-point packet traffic links using the LDL protocol, with the following substitutions:

- $T_{\text{BW2enc}}$  is replaced by  $T_{\text{BW3enc}}$
- $T_{\text{BW2(n)}}$  is replaced by  $T_{\text{BW3(n)}}$

- TBW2proc is replaced by TBW3proc
- TBW1enc is replaced by TBW4enc
- TBW1 is replaced by TBW4
- TBW1proc is replaced by TBW4proc
- THDL(n) is replaced by TLDL(n)
- TRTFD, HDL is replaced by TRTFD, LDL
- TCTFA(n), HDL is replaced by TCTFA(n), LDL

C.5.3.5.5.1.2 Point-to-point packet link timing requirements.

The following requirements apply to point-to-point packet link timing:

1. Stations shall reckon the start of a link as the start of the 3G-ALE slot immediately following the slot in which the LE\_COMMENCE PDU was transmitted.
2. For  $T_{\text{tune}}$  seconds after the start of the link, stations shall change to the traffic channel, if necessary, and tune, if necessary.
3. The Master shall begin emission of the TM\_REQUEST PDU  $T_{\text{tune}} + T_{\text{sug}}$  seconds after the start of the link.
4. The Slave shall begin emission of its response TM PDU  $T_{\text{BW1proc}} + T_{\text{BW1enc}}$  seconds after the end of the TM\_REQUEST PDU as observed by the Slave.
5. The Master shall begin emission of the first data link protocol HDL\_DATA PDU  $T_{\text{RTFD, HDL}}$  seconds after emission of the TM\_REQUEST PDU began. Thereafter, the Master shall begin emissions of HDL\_DATA PDUs  $T_{\text{HDL}(n)}$  seconds after the emission of the previous HDL\_DATA PDU began.
6. The Slave shall begin emission of the first data link protocol HDL\_ACK PDU  $T_{\text{CTFA}(n), \text{HDL}}$  seconds after emission of its response TM PDU began. Thereafter, the Slave shall begin emissions of HDL\_ACK PDUs  $T_{\text{HDL}(n)}$  seconds after the emission of the previous HDL\_ACK PDU began.
7. The Master shall begin emission of the first HDL\_EOM PDU  $T_{\text{HDL}(n)}$  seconds after the emission of the previous HDL\_DATA PDU began.
8. If reverse traffic is pending, the Slave shall begin emission of the TM\_REQUEST PDU  $T_{\text{HDL}(n)}$  seconds after the emission of the previous HDL\_ACK PDU began. At this point the roles of Master and Slave reverse, and point-to-point packet link timing requirements 4-7 apply.

9. The Master shall begin emission of the first data link protocol LDL\_DATA PDU  $T_{RTFD, LDL}$  seconds after emission of the TM\_REQUEST PDU began. Thereafter, the Master shall begin emissions of LDL\_DATA PDUs  $T_{LDL(n)}$  seconds after the emission of the previous LDL\_DATA PDU began.
10. The Slave shall begin emission of the first data link protocol LDL\_ACK PDU  $T_{CTFA(n), LDL}$  seconds after emission of its response TM PDU began. Thereafter, the Slave shall begin emissions of LDL\_ACK PDUs  $T_{LDL(n)}$  seconds after the emission of the previous LDL\_ACK PDU began.
11. The Master shall begin emission of the first LDL\_EOM PDU  $T_{LDL(n)}$  seconds after the emission of the previous LDL\_DATA PDU began.
12. If reverse traffic is pending, the Slave shall begin emission of the TM\_REQUEST PDU  $T_{LDL(n)}$  seconds after the emission of the previous LDL\_ACK PDU began. At this point the roles of Master and Slave reverse, and point-to-point packet link timing requirements 4 and 9-11 apply.

MIL-STD-188-141B  
APPENDIX C

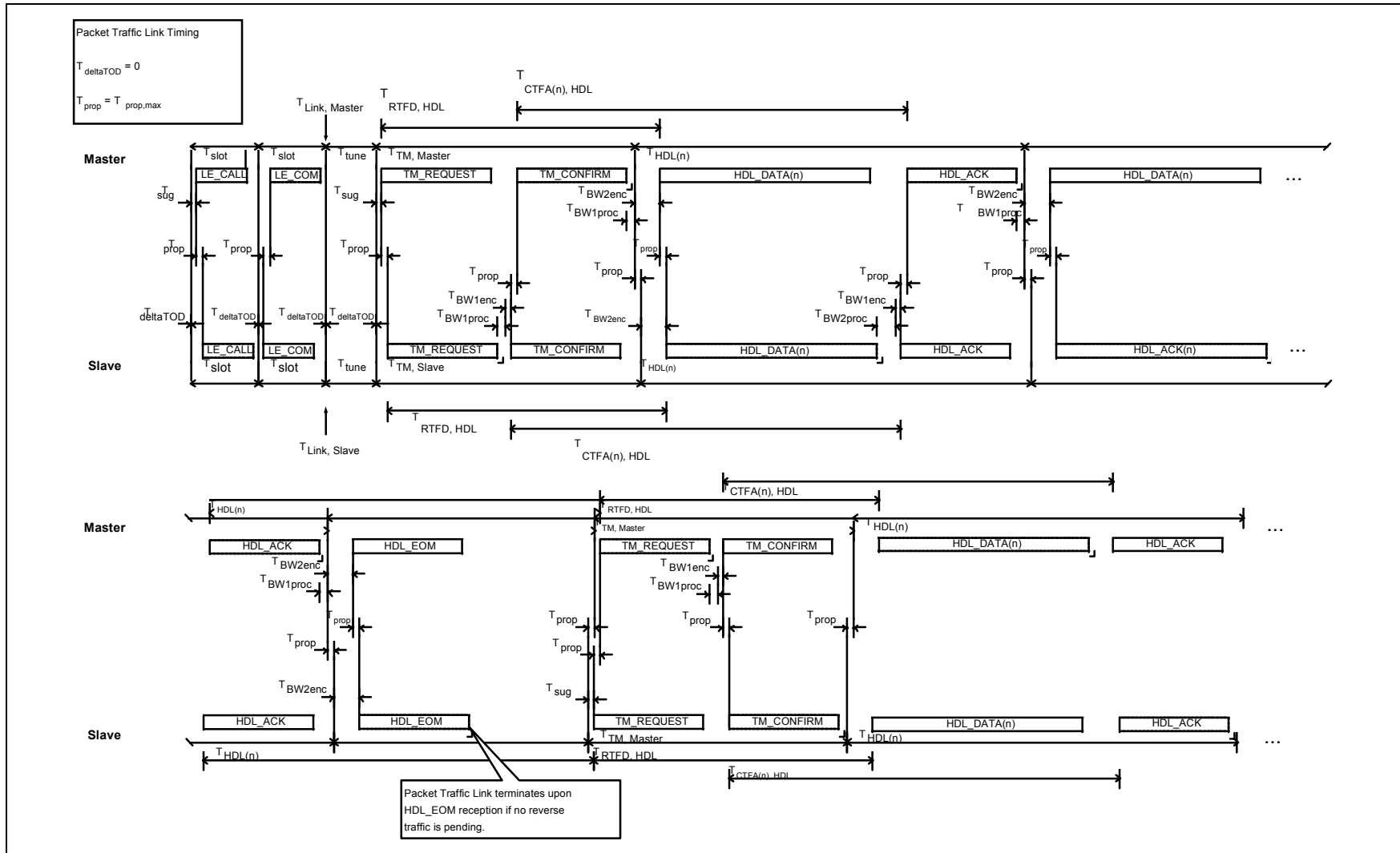
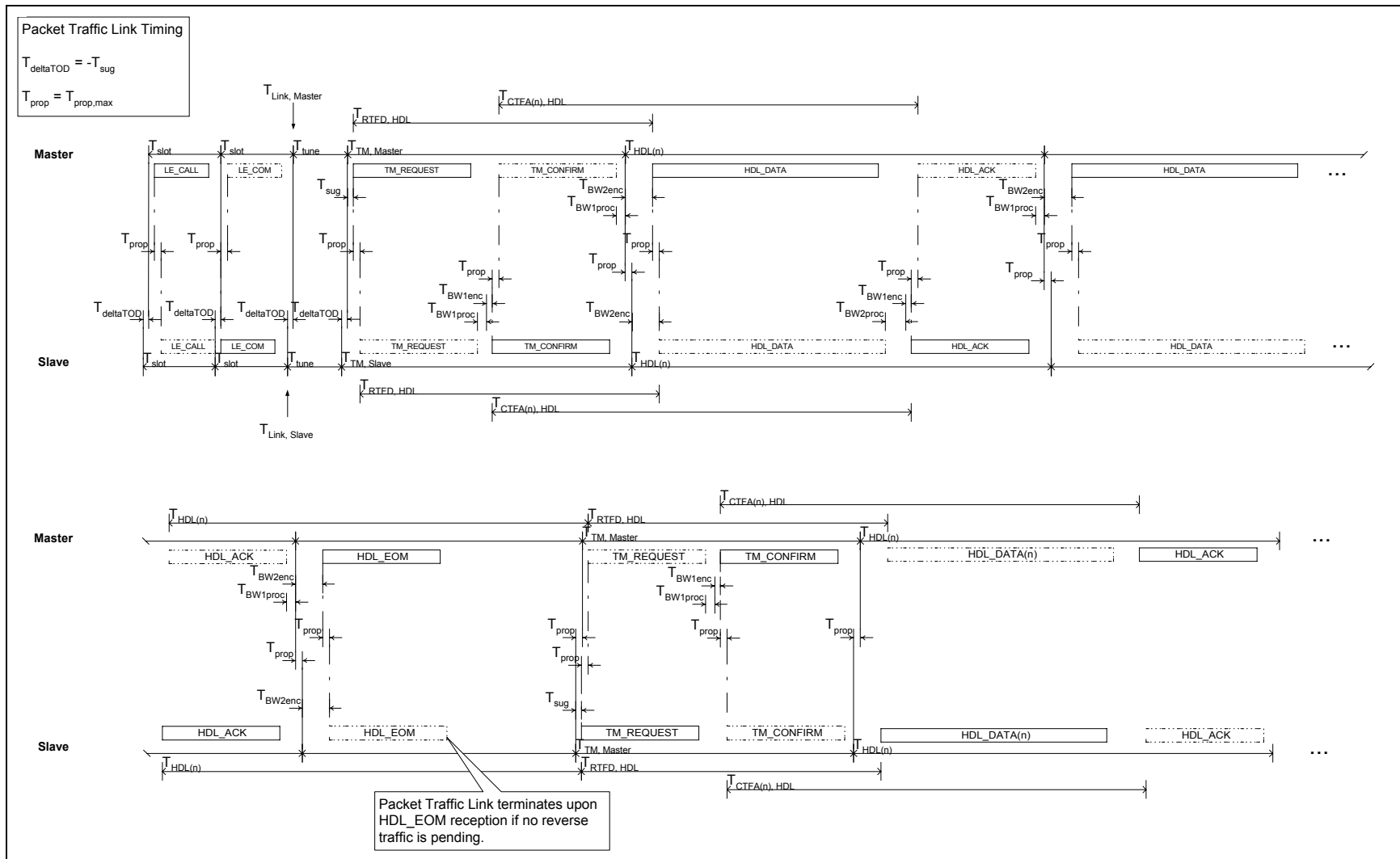


FIGURE C-26. Point-to-point packet link timing example for  $T_{\text{deltaTOD}}=0$ ,  $T_{\text{prop}}=T_{\text{prop,max}}$ .

MIL-STD-188-141B  
APPENDIX C



**FIGURE C-27. Point-to-point packet link timing example for  $T_{\text{deltaTOD}} = -T_{\text{sug}}$ ,  $T_{\text{prop}} = T_{\text{prop,max}}$ .**

MIL-STD-188-141B  
APPENDIX C

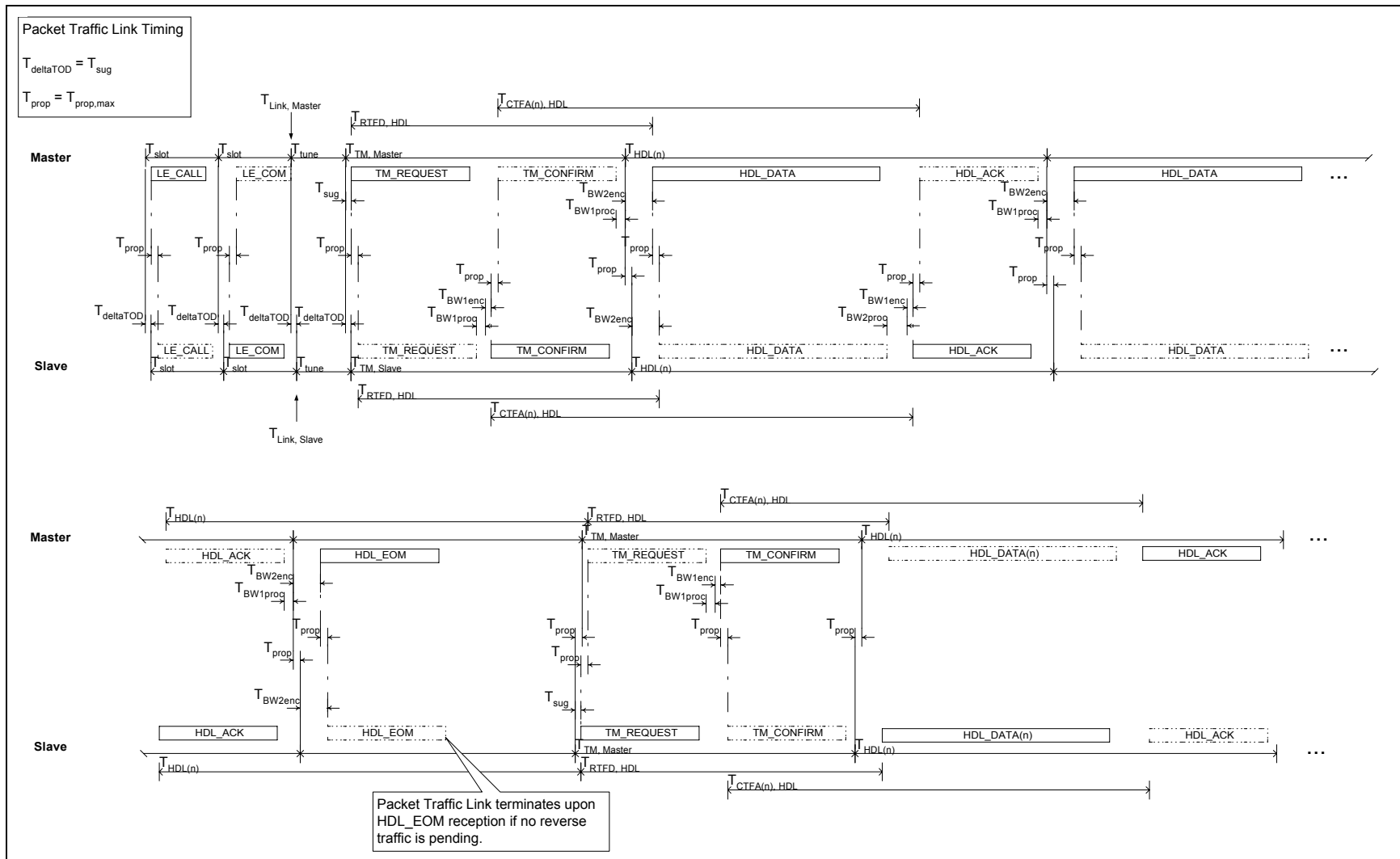


FIGURE C-28. Point-to-point packet link timing example for  $T_{\text{deltaTOD}} = T_{\text{sug}}$ ,  $T_{\text{prop}} = T_{\text{prop,max}}$ .

MIL-STD-188-141B  
APPENDIX C

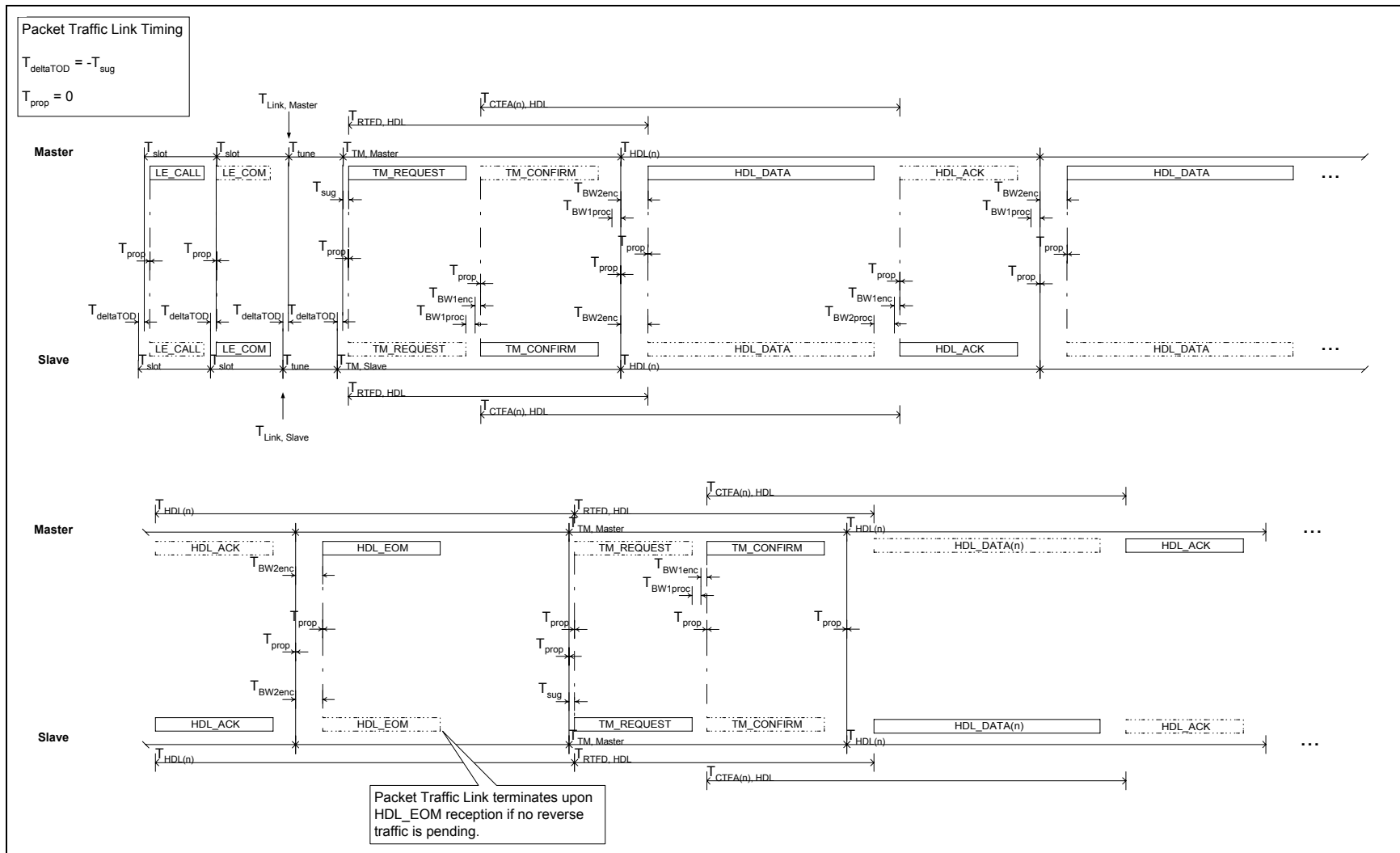
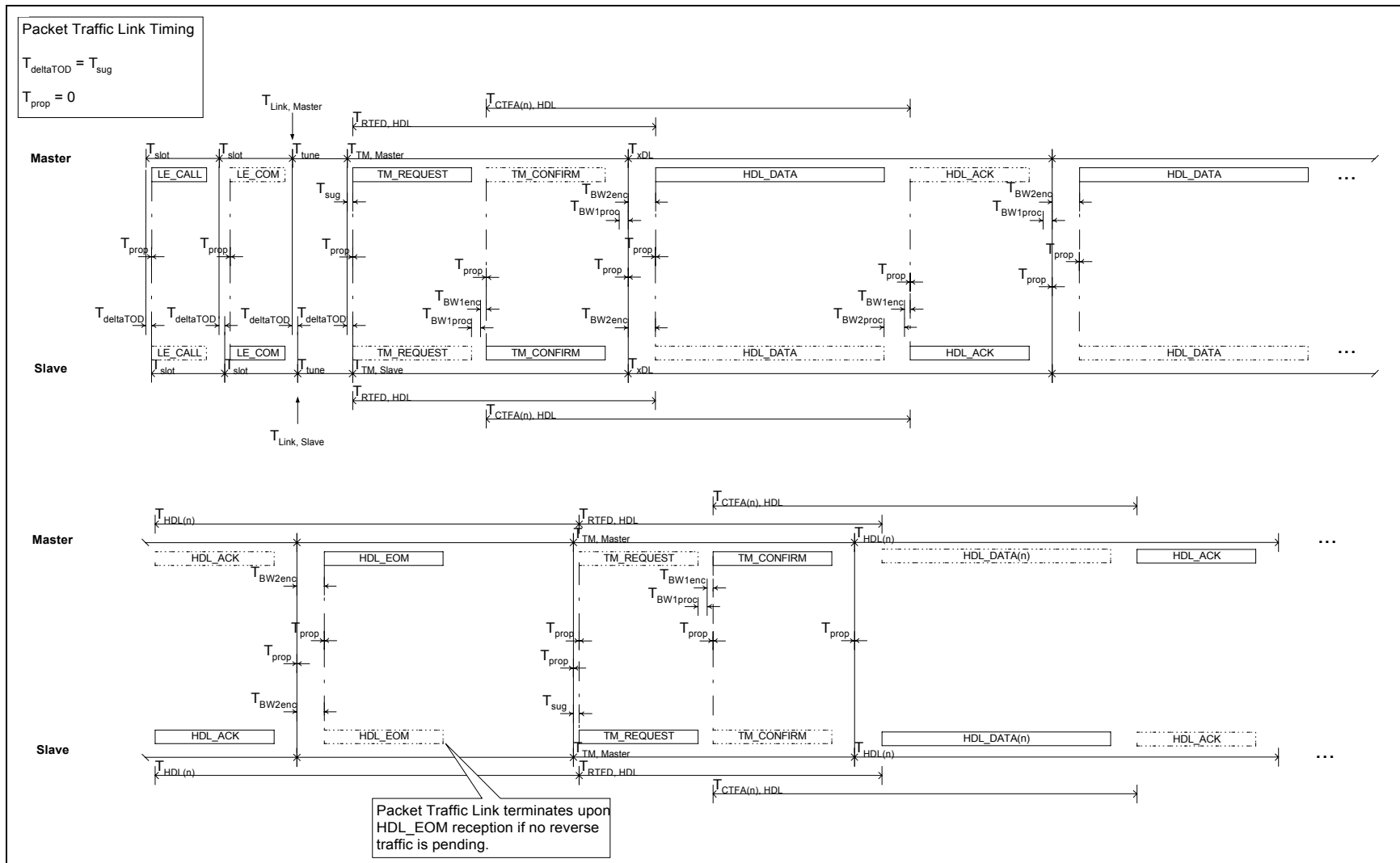


FIGURE C-29. Point-to-point packet link timing example for  $T_{\text{deltaTOD}} = -T_{\text{sug}}$ ,  $T_{\text{prop}} = 0$ .



MIL-STD-188-141B  
APPENDIX C



**FIGURE C-30. Point-to-point packet link timing example for  $T_{\text{deltaTOD}} = T_{\text{sug}}$ ,  $T_{\text{prop}} = 0$ .**

#### C.5.3.5.5.2 Point-to-point circuit links.

This section will first provide a description of point-to-point circuit link timing. Following this, point-to-point circuit link timing requirements will be given.

##### C.5.3.5.5.2.1 Point-to-point circuit link timing description.

The contents of this section are for informational purposes only.

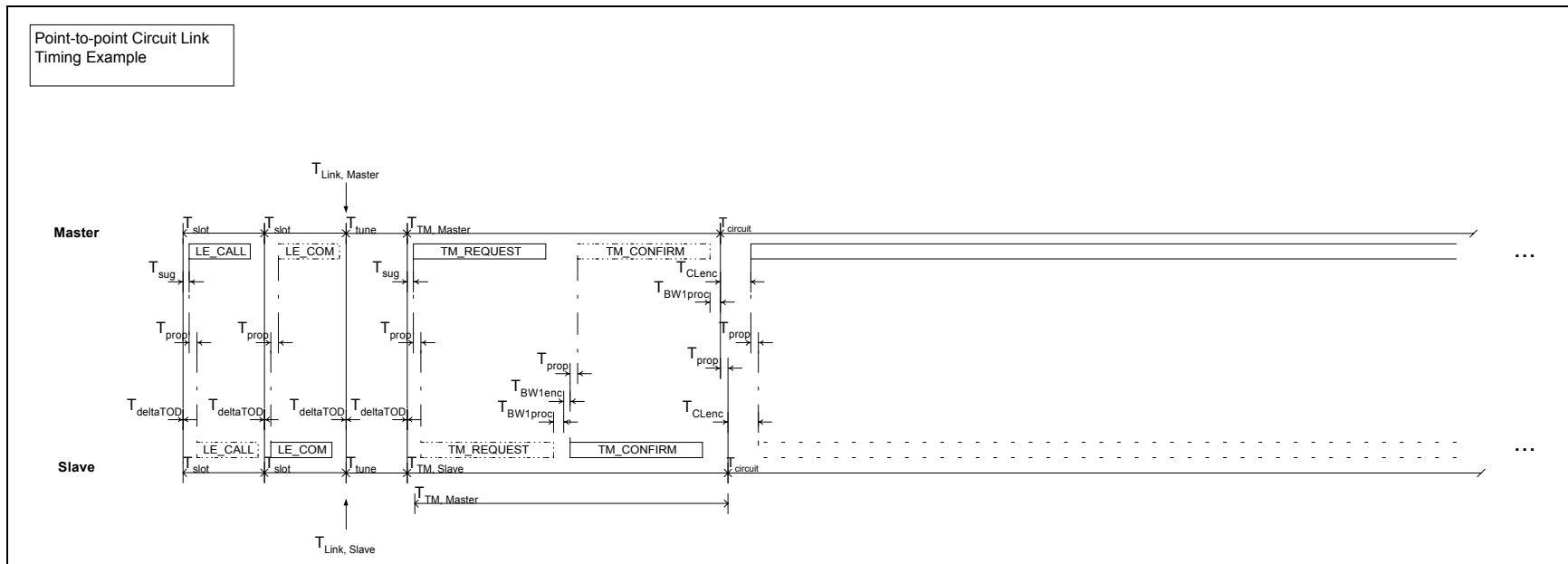
Figure C-31 provides an example point-to-point circuit link. The linking activity proceeds as follows:

- First, an LE handshake is performed. See the section on point-to-point packet link timing for further explanation.
- Next, Master and Slave are given an opportunity to change to the traffic channel and tune, if necessary. This opportunity lasts  $T_{\text{tune}}$  seconds.
- Next, a TM handshake is performed. This handshake is identical to that performed for point-to-point packet links. The Slave is able to determine when to expect the start of the Master's transmission based on when it receives the TM\_REQUEST PDU from the Master (the Master's transmission starts  $-T_{\text{BW1}} - T_{\text{sug}} + T_{\text{TM,Master}} + T_{\text{CLenc}}$  after the end of the TM\_REQUEST PDU as observed by the Slave).
- Finally, the Master transmits its message.

##### C.5.3.5.5.2.2 Point-to-point circuit link timing requirements.

The following requirements apply to point-to-point circuit link timing:

1. Stations shall reckon the start of a link as the start of the 3G-ALE slot immediately following the slot in which the LE\_COMMENCE PDU was transmitted.
2. For  $T_{\text{tune}}$  seconds after the start of the link, stations shall change to the traffic channel, if necessary, and tune, if necessary.
3. The Master shall begin emission of the TM\_REQUEST PDU  $T_{\text{tune}} + T_{\text{sug}}$  seconds after the start of the link.
4. The Slave shall begin emission of its response TM PDU  $T_{\text{BW1proc}} + T_{\text{BW1enc}}$  seconds after the end of the TM\_REQUEST PDU as observed by the Slave.
5. The Master shall begin transmission of its message  $T_{\text{tune}} + T_{\text{TM,Master}} + T_{\text{CLenc}}$  seconds after the start of the link.



**FIGURE C-31. Point-to-point circuit link timing example.**

### C.5.3.5.5.3 Multicast circuit link.

This section will first provide a description of multicast circuit link timing. Following this, multicast circuit link timing requirements will be given.

#### C.5.3.5.5.3.1 Multicast circuit link timing description.

The contents of this section are for informational purposes only. Figure C-32 shows an example multicast circuit link involving a Master and 3 Slaves. The linking activity for this example proceeds as follows:

- First, an LE handshake is performed. This handshake establishes a link time reference,  $T_{link}$ , for both the Master and the Slaves. This time reference is defined as the start of the LE slot immediately following the LE slot in which the LE\_COMMENCE PDU was transmitted.
- Next, Master and Slaves are given an opportunity to change to the traffic channel and tune, if necessary. This opportunity lasts  $T_{tune}$  seconds.
- Next, a TM roll-call handshake is performed. The roll-call handshake begins with a two-way handshake between the Master and Slave 1 which is identical to the two-way handshake performed for point-to-point links. The remaining Slaves determine roll call slot timing based on when they receive the TM\_REQUEST PDU from the Master (the first roll call slot starts  $-T_{BW1} - T_{sug} + T_{TM,Master}$  after the end of the TM\_REQUEST PDU as observed by each Slave). Each roll call slot  $T_{rc\ slot, TM}$  seconds in duration. This roll call slot timing is designed to allow Slaves the time required to process a PDU arriving in the roll call slot immediately preceding the Slave's own roll call slot. (See figure C-32. Observe that Slave 3 is given  $T_{BW1proc}$  seconds to process the preceding PDU.)
- Finally, the multicast is transmitted by the Master  $T_{CLenc}$  seconds after the end of the last roll call slot.

#### C.5.3.5.5.3.2 Multicast circuit link timing requirements.

The following requirements apply to multicast circuit link timing:

1. Stations shall reckon the start of a link as the start of the 3G-ALE slot immediately following the slot in which the LE\_COMMENCE PDU was transmitted.
2. For  $T_{tune}$  seconds after the start of the link, stations shall change to the traffic channel, if necessary, and tune, if necessary.
3. The Master shall begin emission of the TM\_REQUEST PDU  $T_{tune} + T_{sug}$  seconds after the start of the link.
4. Slave 1 shall begin emission of its response TM PDU  $T_{BW1proc} + T_{BW1enc}$  seconds after the end of the TM\_REQUEST PDU as observed by Slave 1.

MIL-STD-188-141B  
APPENDIX C

5. Slaves 2 through n, where n is the number of members of the multicast group, shall begin emission of their respective response PDUs  $2 * T_{BW1proc} + 2 * T_{BW1enc} + T_{BW1} + 2 * T_{prop,max} + (m-2) * T_{rc\ slot, TM}$  seconds after the end of the TM\_REQUEST PDU as observed by the Slave, where m is the position of the Slave in the multicast group (e.g. m = 2 for Slave 2).
6. If, following the roll call, the Master elects to proceed with the multicast, the Master shall begin the multicast  $T_{tune} + T_{TM, Master} + (n-1) * T_{rc\ slot, TM} + T_{CLenc}$  seconds after the start of the link. Otherwise, if the Master elects to transmit TM protocol PDU(s), the Master shall begin emission of such PDUs  $T_{tune} + T_{TM, Master} + (n-1) * T_{rc\ slot, TM} + T_{BW1enc}$  seconds after the start of the link. Again, n is the number of members in the multicast group.

MIL-STD-188-141B  
APPENDIX C

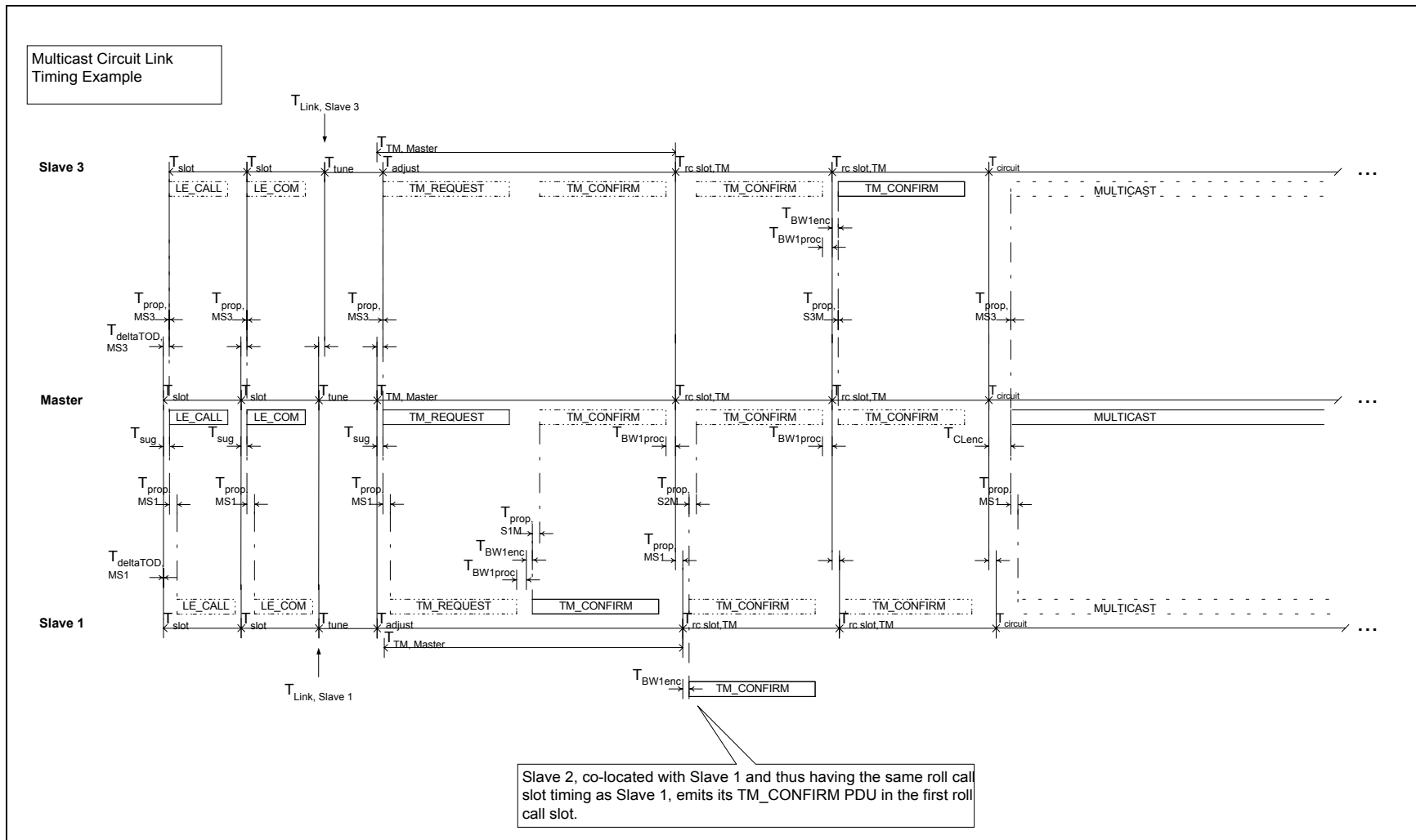


FIGURE C-32. Multicast circuit link timing example.

C.5.4 HDL protocol.

C.5.4.1 Overview.

The HDL is used to provide acknowledged point-to-point delivery of datagrams from a transmitting station to a receiving station across an already-established HF link, with selective retransmission (ARQ) of data received in error. The datagram passed to the HDL for delivery is a finite-length ordered sequence of 8-bit data bytes (octets). The HDL protocol is best suited to delivering relatively large datagrams under good to fair HF channel conditions. By contrast, the LDL protocol described in section C.5.5 provides better performance for all datagram lengths under fair to very poor HF channel conditions, and under all channel conditions for short datagrams.

C.5.4.2 Data object types.

The terms defined in table C-XLIII are used to refer to specific types of data objects in defining the HDL protocol.

**TABLE C-XLIII. HDL data object types.**

<b>Data object type</b>	<b>Definition</b>
datagram	an ordered sequence of 8-bit data bytes (octets) of length $dl$ , where $1 \leq dl \leq 7,634,944$ (equal to $(233 * 32,768) - 233$ payload data bytes per data packet, and 32,768 data packets per datagram).
data segment	an ordered sequence of 8-bit data bytes (octets) that occur consecutively within a datagram, of length $sl$ where $1 \leq sl \leq 233$ .
sequence number	a 17-bit data object having the format defined in table C-XLVI, which indicates the position occupied by a data segment within a datagram, and, when the data segment includes the last data byte of the datagram, the number of bytes of payload data from the datagram in the data segment.
data packet	the combination of a data segment with the sequence number indicating its position within a datagram. If the data segment is of length less than 233 bytes (because it includes the last data byte of the datagram), a sequence of null data bytes (of value zero) is appended to the data segment so as to extend it to length 233 in constructing the data packet, and the value of the sequence number indicates how many of the 233 bytes in the extended data segment contain payload data from the datagram.
tx frame	a sequence of $np$ data packets, where $np = 24, 12, 6, \text{ or } 3$ , and the value of $np$ is determined by the numPkts parameter of the most recent HDL_Send_Req or HDL_Rcv_Req service primitive. Same as an HDL_DATA PDU as defined in C.5.4.4.1.
packet index	a number indicating the ordinal position of a data packet within a <i>tx frame</i> , such that packet <i>index</i> = 0 indicates that the data packet occupies the first position in the <i>tx frame</i> .
indexed packet	the combination of a data packet with the packet index indicating the data <i>packet's</i> ordinal position within a specific <i>tx frame</i> .
rx frame	a sequence of $np$ indexed packets, where $0 \leq np \leq 24$ , which includes an indexed packet containing each data packet that was received without errors (as determined by checking its CRC) in an incoming <i>tx frame</i> . $np$ is never greater than the value of the numPkts parameter of the most recent HDL_Rcv_Req service primitive, but may be less due to packets' having been omitted from the <i>rx frame</i> (by the BW2 receiver) due to their having been received containing errors.

#### C.5.4.3 Service primitives.

Table C-XLIV describes the service primitives exchanged between the HDL protocol entity HDL and one or more user processes at HDL's upper interface. These service primitives are used in this specification only as expository devices, and are not required to be present in any compliant implementation of the protocol. Note that there is no requirement that implementations of the waveforms and protocols defined in this Appendix contain precisely these service primitives; nor are the services primitives defined below necessarily all of the service primitives that would be required in an implementation of these waveforms and protocols.

#### C.5.4.4 PDU's.

The sub-sections of this section describe the PDUs exchanged between a HDL protocol HDL entity and its remote peer entities.

##### C.5.4.4.1 HDL\_DATA.

An HDL\_DATA PDU is a tx frame as defined in table C-XLIII, in which the format and contents of each data packet are as shown in table C-XLV. Table C-XLVI specifies the format and contents of the Sequence Number field of each data packet.



**TABLE C-XLIV. HDL service primitives.**

Name	Attribute	Values	Description
HDL_Send_Req	Overview	HDL Send Request: generated by the user process when it has a datagram to send on an already-established HF link.	
	Parameters	datagram	datagram to be delivered, as described in table C-XLIII.
		numPkts	the number <i>np</i> of data packets to be transmitted in each forward transmission by BW2 (i.e., each tx frame), where $np = 24, 12, 6, \text{ or } 3$ .
	Originator	User process	
Preconditions	TM has just completed a successful point-to-point HF link establishment with the intended datagram recipient.		
HDL_Rcv_Req	Overview	HDL Receive Request: generated by the user process to request that HDL perform the processing required to receive an expected incoming datagram.	
	Parameters	numPkts	the number <i>np</i> of data packets that will be received in each incoming transmission by BW2, where $np = 24, 12, 6, \text{ or } 3$ .
		Originator	User process
	Preconditions	TM has just completed a successful point-to-point HF link establishment with the expected datagram sender.	
HDL_Rcv_Ind	Overview	HDL Receive Indication: issued by HDL when HDL has a successfully-received datagram to give to the local user process.	
	Parameters	datagram	datagram just received, as described in table C-XLIII; identical to the original datagram parameter-value of the HDL_Send_Req primitive at the remote station.
	Originator	HDL	
	Preconditions	HDL has received an HDL_Rcv_Req since the last outgoing or incoming datagram transfer.	
HDL_Send_Conf	Overview	HDL Send Confirm: Issued by HDL when HDL has completed successful delivery of a datagram to the remote station.	
	Parameters	(none)	
	Originator	HDL	
	Preconditions	HDL was requested to deliver the datagram by the user process by means of an HDL_Send_Req service primitive.	
HDL_Abort_Req	Overview	HDL Abort Request: used by the user process to terminate a HDL protocol data transfer that is currently in progress. The purpose of this service primitive is only to cause the HDL entity to cease attempting to send or receive the current datagram; coordinating the data transfer termination with the remote station is the responsibility of TM.	
	Parameters	(none)	
	Originator	User process	
	Preconditions	Either an outgoing or an incoming data transfer is in progress, using the HDL protocol.	
HDL_Failure_Ind	Overview	HDL Failure Indication: Issued by HDL when HDL is unable to complete delivery of an outgoing or incoming datagram.	
	Parameters	(none)	
	Originator	HDL	
	Preconditions	Either an outgoing or an incoming data transfer is in progress, using the HDL protocol.	

**TABLE C-XLV. Data packet format.**

Field name	Size (bits)	Values	Description
Payload	1864 (fixed)	any	Contains a data segment as defined in table C-XLIII, followed by however many zero bytes are needed to fill the Payload field to length 233 bytes. Whenever the field contains fewer than 233 bytes of payload data (from the outgoing datagram), the value of the Sequence Number field indicates how many bytes of payload data are present.
Sequence Number	17 (fixed)	As defined by table C-XLVI.	

The bytes of the Payload field are transmitted in the order of their occurrence in the datagram; the bits of each byte are transmitted in order of significance, starting with the most significant bit.

HDL\_DATA PDUs are transmitted using the BW2 burst waveform described by section C.5.1.5.

**TABLE C-XLVI. Sequence number field definition.**

Case	bit 16 (EOM)	bit 15 (SOM)	bits 14-9	bits 8 - 0
only packet in datagram	1	1	0	Payload field byte count: the number of bytes (octets) of datagram data present in the Payload field of the packet.
last packet in datagram	1	0	0	Payload field byte count (see above)
first packet in datagram	0	1	number of packets required to convey the data contents of the datagram, minus one: equal to (the least integer greater than or equal to (datagram length in bytes / 233)) - 1.	
packet in interior of datagram	0	0	down-counting packet sequence number: the number of packets in the current datagram, following the current packet.	

Following the last bit of the Payload field-value, the bits of the Sequence Number field are transmitted in order of significance within the 17-bit field-value, starting with the most significant bit (bit 16).

#### C.5.4.4.2 HDL\_ACK.

The HDL\_ACK PDU is used to transfer selective acknowledgements, in the form of an ack bit-mask containing a single bit for each data packet in an HDL\_DATA PDU, from the receiving station to the sending station in a HDL transfer. Table C-XLVII specifies the format and contents of the HDL\_ACK PDU.

**TABLE C-XLVII. HDL ACK PDU format.**

Field name	Size (bits)	Values	Description
Protocol	3	000 <sub>2</sub> = HDL	identifies this PDU as an HDL PDU
Type	1	0 <sub>2</sub> = ACK	Identifies this PDU as an HDL_ACK PDU
Ack Bit-Mask	24	any	Contains one ack bit for each of the data packets that can be received in an HDL_DATA PDU. Each bit indicates whether the corresponding data packet was received without errors; 1 = ACK (was received successfully); 0 = NAK (not received successfully).
Reserved	4	0000 <sub>2</sub> (fixed)	Reserved for future use.
CRC	16	any	16-bit Cyclic Redundancy Check (CRC) computed across the values of the Type and Ack Bit-Mask fields, using the generator polynomial $X^{16} + X^{15} + X^{11} + X^8 + X^6 + X^5 + X^4 + X^3 + X^1 + 1$ , and the procedure described in C.4.1.

The fields of the HDL\_ACK PDU are transmitted in the order of their occurrence in table C-XLVII, protocol field first. Bits of the Ack Bit-Mask field are transmitted in the order in which the corresponding data packets were transmitted in the HDL\_DATA PDU that is being acknowledged; for instance, the first ack bit acknowledges the first data packet.

HDL\_ACK PDUs are transmitted using the BW1 burst waveform described by section C.5.1.4.

#### C.5.4.4.3 HDL\_EOM.

The HDL\_EOM PDU is sent from the sending station to the receiving station in a HDL transfer, to indicate that the sending station has received acknowledgements from the receiving station of every data packet in the datagram being transferred, and hence will send no more HDL\_DATA PDUs for the current datagram. The HDL\_EOM PDU is sent as many times as possible within the time interval defined for a forward transmission (based on the value of numPkts), to maximize the probability of its being received without errors. Table C-XLVIII specifies the format and contents of the HDL\_EOM PDU.

**TABLE C-XLVIII. HDL EOM PDU.**

Field name	size (bits)	Values	Description
Protocol	3	000 <sub>2</sub> = HDL	identifies this PDU as an HDL PDU
Type	1	1 <sub>2</sub> = EOM	Identifies this PDU as an HDL_EOM PDU.
Check	44	0xA5A5A5A5 A5A	Unused, but should be inspected by the recipient to verify that it contains the correct bit-pattern specified here.

The fields of the HDL\_EOM PDU are transmitted in the order of their occurrence in table C-XLVIII, protocol field first. The bits of the Check field are transmitted following the single bit of the Type field in order of significance, most significant bit first, so that the first four bits transmitted from the Check field are 1, 0, 1, 0.

HDL\_EOM PDUs are transmitted using the BW1 burst waveform described by section C.5.1.4.

On traffic links established for packet traffic delivered using the HDL protocol, the user process can terminate the data link transfer and use the next data link transmission time slot in either direction — i.e., the time slot for the HDL\_DATA or the HDL\_ACK PDU — to instead send one or more TM PDUs (described in C.5.3.4) within the data link PDU time-slot. This means that while a HDL transfer is in progress, the receiving station must be simultaneously attempting to demodulate TM PDUs conveyed by the BW1 waveform as it is attempting to demodulate and receive HDL\_DATA PDUs conveyed by BW2. The sending station may receive a TM PDU conveyed by BW1 in place of an HDL\_ACK PDU (also BW1), and must ensure that this PDU is received and processed by its TM sublayer.

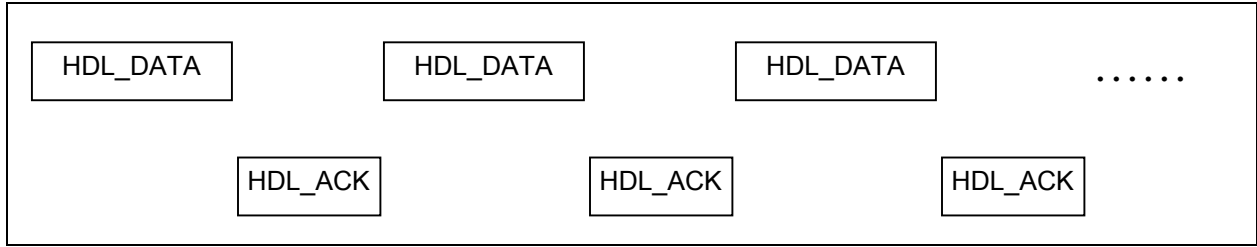
#### C.5.4.5 Protocol behavior.

This section provides an informal overview of the behavior of the HDL protocol. The following sections define this behavior precisely:

- C.5.4.5.1 identifies and defines the events to which HDL responds;
- C.5.4.5.2 identifies and defines the actions taken by HDL in response to these events;
- C.5.4.5.3 describes the data items used and maintained by HDL;
- C.5.4.5.4 provides a state diagram and a state transition table specifying the behavior of HDL in terms of these events, actions, and data items; and
- C.5.4.5.5 provides additional information on the timing characteristics of HDL behavior.

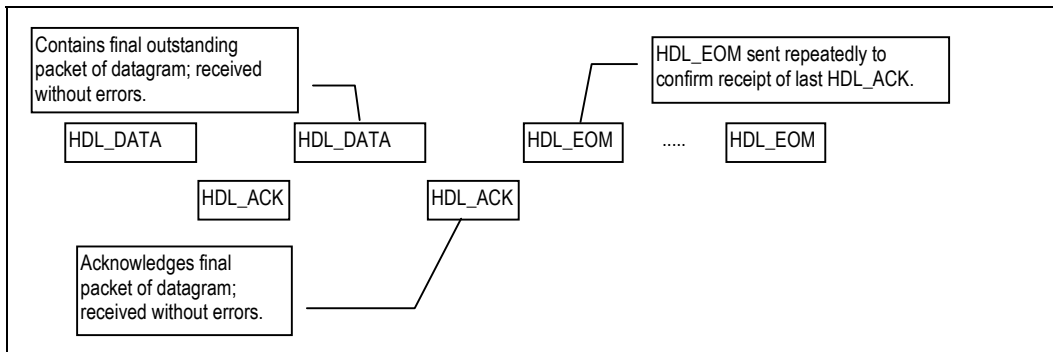
Data transfer by HDL begins after the TM sublayer has already established the data link connection, in so doing negotiating the fact that HDL will be used (as opposed to LDL or some other mechanism), the number of data packets to be sent in each HDL\_DATA PDU, and the precise time synchronization of data link transmissions.

In an HDL data transfer, the sending station and the receiving station alternate transmissions in the manner depicted in figure C-33, the sending station transmitting HDL\_DATA PDUs containing payload data packets, and the receiving station transmitting HDL\_ACK PDUs containing acknowledgements of the data packets received without errors in the preceding HDL\_DATA PDU. If either station fails to receive a PDU at the expected time, it sends its own next outgoing PDU at the same time as if the incoming PDU had been received successfully. The times at which the burst waveforms conveying HDL\_DATA, HDL\_ACK, and HDL\_EOM PDUs may be emitted are precisely stipulated; see C.5.4.5.5 for details.



**FIGURE C-33. HDL data transfer overview.**

The end of a data transfer is reached when the sending station has transmitted HDL\_DATA PDUs containing all of the payload data in the delivered datagram, and the receiving station has received these data without errors and has acknowledged their successful delivery. When the sending station receives an HDL\_ACK PDU indicating that the entire contents of the datagram have been delivered successfully, it sends an HDL\_EOM PDU repeated as many times as possible within the duration of an HDL\_DATA PDU, starting at the time at which it would have otherwise transmitted the next HDL\_DATA PDU, to indicate to the receiving station that the data transfer will be terminated. This link termination scenario is depicted in figure C-34.



**FIGURE C-34. HDL link termination scenario overview.**

The definition of HDL behavior presented in the following sections includes mechanisms for dealing appropriately with the following occurrences:

- excessive number of consecutive failures to receive an expected HDL\_DATA PDU;
- excessive number of consecutive failures to receive an expected HDL\_ACK PDU;
- immediate termination of an ongoing data link transfer requested by the TM sublayer.

#### C.5.4.5.1 Events.

Table C-XLIX defines the events to which the HDL entity responds. The event names are used in the state diagram and the state transition table in C.5.4.5.4, which define the behavior of the HDL protocol. Some event names refer to the receipt of PDUs from the HDL entity at a remote

station; in these cases, the ‘description’ field of the table entry describes the manner in which the arrival of a PDU is accomplished through HDL’s accepting one or more service primitives from lower-layer entities at the local station. The prefix ‘R:’ in the name of an event indicates that the event is the receipt of a PDU from the remote station. ‘D:’ indicates that the event is an HDL service primitive passed down to HDL from a higher-layer entity; ‘U:’ indicates a lower-layer service primitive passed *up* to HDL from a lower-layer entity.

**TABLE C-XLIX. HDL events.**

<b>Event name</b>	<b>Description</b>
R:HDL_DATA PDU	A BW2_Receive primitive containing an HDL_DATA PDU was accepted.
R:HDL_ACK PDU	A BW1_Receive primitive containing an HDL_ACK PDU was accepted, and the HDL_ACK PDU was found to be free of errors by checking its CRC.
R:HDL_EOM PDU	A BW1_Receive primitive containing a HDL_EOM PDU was accepted, and the HDL_EOM PDU was found to be free of errors by comparing the received PDU against the known HDL_EOM bit pattern specified in table C-XLVIII.
D:HDL_Send_Req	An HDL_Send_Req primitive was accepted from the user process.
D:HDL_Abort_Req	An HDL_Abort_Req primitive was accepted from the user process.
AckTimeout	A valid HDL_ACK PDU was not received within the time period in which it was expected.
DataTimeout	An HDL_DATA PDU was not received within the time period in which it was expected.

#### C.5.4.5.2 Actions.

Table C-L defines the actions which the HDL entity can perform. The action name is used in the state diagrams and/or state transition tables used below to define the behavior of the HDL protocol. Some action names refer to sending PDUs to the HDL entity at a remote station; in these cases, the ‘description’ field of the table entry describes the manner in which sending of the PDU is accomplished by issuing one or more service primitives to lower-layer entities at the local station.

#### C.5.4.5.3 Data.

Table C-LI defines the data items used and maintained by HDL, including buffers, counters, timers, configuration parameters, and so forth. These data items are referred to by the names assigned to them here, in the definitions of HDL events and actions presented in the preceding sections. These data items are used in this specification only as expository devices, and are not required to be present in any compliant implementation of the protocol.

**TABLE C-L. HDL actions.**

Action name	Description
TxInit	Set NumPktsTx to the value of the numPkts parameter of the HDL_Send_Req primitive. Insert the outgoing datagram into TxDatagramBuf. Clear TxFrameBuf. Reset MissedAckCount to zero.
S:HDL_DATA	<p>For each of the first NumPktsTx data packet positions in TxFrameBuf, if the data packet position is empty, construct a new outgoing data packet (as described by table C-XLV) in this position:</p> <ol style="list-style-type: none"> <li>1. Get the next data segment (the next 233 consecutive data bytes to be transmitted) from TxDatagramBuf; place these in the Payload field of the data packet. If fewer than 233 data bytes remain to be transmitted, place these bytes at the beginning of the Payload field; fill the remainder of the field with zero bytes.</li> <li>2. Construct a sequence number value as specified in table C-XLVI; write this value into the packet's Sequence Number field.</li> </ol> <p>If TxDatagramBuf is completely emptied of payload data before all packet positions in TxFrameBuf have been filled with new packets, fill the remaining packet positions with repetitions of packets already residing in other positions of TxFrameBuf. <b>Note:</b> The HDL transmitter is at liberty to select packets from the current datagram to repeat as it pleases; the HDL receiver must inspect the sequence number of each packet received without errors, and use this information to discard duplicate packets. <b>Note:</b> Whenever a packet is retransmitted, it is always placed in the same packet position within the Tx frame that it occupied in the previous transmission.</p> <p>Send an HDL_DATA PDU containing the tx frame in TxFrameBuf, using a BW2_Send primitive. Set the primitive's reset parameter to TRUE if this is the first tx frame transmitted for the current datagram, and to FALSE otherwise.</p> <p>Reset the AckTimeout timer. If an AckTimeout has occurred, increment MissedAckCount.</p>
ProcessAck	<p>Check the HDL_ACK PDU's CRC. If the CRC is valid:</p> <ol style="list-style-type: none"> <li>1. Copy the Ack Bit-Mask field value to RxAck.</li> <li>2. For each <math>i, 0 \leq i \leq (\text{NumPktsTx} - 1)</math>, if RxAck[i] is 1, clear the <math>i^{\text{th}}</math> position of TxFrameBuf. (Each unacknowledged packet is retained in its current position in TxFrameBuf, and will be retransmitted in the same position that it occupied in the previous transmission.)</li> <li>3. If TxDatagramBuf is not empty, set the condition MoreToSend to TRUE; otherwise set it to FALSE.</li> </ol>
S:HDL_EOM	<p>Send an HDL_EOM PDU to the remote station using BW1_Send, as many times as possible within the duration of an HDL_DATA PDU. The number of times the HDL_EOM PDU is sent depends on the value of NumPktsTx as follows:</p> <ul style="list-style-type: none"> <li>• if NumPktsTx = 3, the HDL_EOM PDU is transmitted <i>once</i></li> <li>• if NumPktsTx = 6, the HDL_EOM PDU is transmitted <i>once</i></li> <li>• if NumPktsTx = 12, the HDL_EOM PDU is transmitted <i>three</i> times</li> <li>• if NumPktsTx = 24, the HDL_EOM PDU is transmitted <i>seven</i> times.</li> </ul> <p>Disable AckTimeout timer.</p>
U:HDL_Send_Conf	Issue an HDL_Send_Conf primitive to the user process that requested the outgoing data transfer.
AbortTransmit	Disable AckTimeout timer; reset MissedAckCount to zero.
RxInit	<p>Set NumPktsRx to the value of the numPkts parameter of the HDL_Rcv_Req primitive. Clear RxDatagramBuf, and RxFrameBuf. Reset MissedTxFrameCount to zero. Set CompleteDatagramRcvd to FALSE.</p>

**TABLE C-L. HDL actions (continued).**

Action name	Description
S:HDL_ACK(ack/nak)	<p>Clear TxAck to all zeroes. Reset MissedTxFrameCount to zero. <u>if</u> CompleteDatagramRcvd is FALSE <u>then</u>     For each indexed packet received from the BW2 receiver,         1. Insert a data packet containing the Payload and Sequence Number field values from the indexed packet into RxFrameBuf[i], where i = the Index value from the indexed packet (the packet's position in the transmitted HDL_DATA PDU).         2. Set TxAck[i] to 1.         3. Move the Payload field contents of RxFrameBuf[i] to the position in RxDatagramBuf indicated by the Sequence Number field-value.         4. If all packets for the current datagram have been received without errors, set CompleteDatagramRcvd to TRUE. <u>else</u> (CompleteDatagramRcvd is TRUE)     Set the first NumPktsRx bits of TxAck to 1. <u>end if</u> Send an HDL_ACK PDU containing TxAck, using BW1_Send. Reset the DataTimeout timer. <b>Note:</b> An implementation of HDL can, without impairing compliance to this standard, provide segments of a partially-received datagram to the user process, in order of their occurrence in the original datagram at the sending station, before the entire datagram has been received. Doing so would allow a higher-layer protocol to abort an ongoing data transfer, then resume it at a later time, without having to retransmit the entire portion of the current datagram that was already delivered successfully. <b>Note:</b> The HDL transmitter can send duplicate packets either as a result of missing an HDL_ACK PDU, or at the end of a datagram, in order to fill the (otherwise unused) packet positions of an HDL_DATA PDU. The HDL receiver is required to inspect the sequence number of each data packet received without errors, and to use the sequence numbers to identify and discard duplicate packets.</p>
S:HDL_ACK(naks)	<p>Reset the DataTimeout timer. Clear TxAck to all zeroes. Send an HDL_ACK PDU containing TxAck using BW1_Send. If a DataTimeout has occurred, increment MissedTxFrameCount.</p>
U:HDL_Rcv_Ind	<p>Issue an HDL_Rcv_Ind primitive containing the received datagram to the user process.</p>
AbortReceive	<p>Disable DataTimeout timer; reset MissedTxFrameCount to zero.</p>



**TABLE C-LI. HDL data items.**

<b>Data item</b>	<b>Description</b>
NumPktsTx	the number of data packets in each tx frame, as negotiated during the Traffic Set-Up (TSU) phase.
TxDatagramBuf	buffer storing the data contents of an outgoing datagram which have not yet been inserted into a tx frame for transmission.
TxFrameBuf	buffer storing the sequence of NumPkts data packets contained in an outgoing tx frame (an HDL_DATA PDU).
NumPktsRx	the maximum number of data packets in each incoming rx frame, as negotiated during the Traffic Set-Up (TSU) phase.
RxDatagramBuf	buffer storing the data contents of an incoming datagram which have been received thus far, in which the complete incoming datagram is re-assembled in correct order.
RxFrameBuf	buffer storing those incoming data packets of an rx frame which were received without errors (as determined by the CRC check performed by the BW2 receiver).
TxAck	ack flag sequence to be transmitted to the remote station. Contains one bit-flag for each data packet in a maximum-length tx frame; TxAck[i] = 1 indicates that the i <sup>th</sup> data packet in the most recently received rx frame was received without errors.
RxAck	ack flag sequence received in an HDL_ACK PDU from the remote station. Contains one bit-flag for each data packet in a maximum-length tx frame; RxAck[i] = 1 indicates that the remote station received the i <sup>th</sup> data packet in the previously-transmitted rx frame without errors.
MissedAckCount	count of consecutive failures to receive an HDL_ACK PDU in the time period in which one was expected.
MissedTxFrameCount	count of consecutive failures to receive an HDL_DATA PDU (a tx frame) in the time period in which one was expected.
AckTimeout	timer used to time the duration of the interval in which receipt of an HDL_ACK PDU is expected; fires when the interval expires.
DataTimeout	timer used to time the duration of the interval in which receipt of an HDL_DATA PDU is expected; fires when the interval expires.
MAX_MISSED_ACKS	HDL configuration parameter specifying the maximum number of consecutive missed HDL_ACK PDUs that can occur without causing the HDL transmitter to terminate the data link transfer. The value of this parameter is not stipulated by this specification, since it is not required for interoperability that this parameter have identical values in both the sending and receiving stations.
MAX_MISSED_TX_FRAME S	HDL configuration parameter specifying the maximum number of consecutive missed HDL_DATA PDUs that can occur without causing the HDL receiver to terminate the data link transfer. The value of this parameter is not stipulated by this specification, since it is not required for interoperability that this parameter have identical values in both the sending and receiving stations.
MoreToSend	Boolean condition variable: is TRUE if and only if an outgoing datagram transfer is in progress, and there are one or more data packets in the datagram for which the local station has not yet received an acknowledgement of their receipt without errors by the remote station.
CompleteDatagramRcvd	Boolean condition variable: is TRUE if and only if an incoming datagram transfer has been successfully completed (all contents of the datagram received without errors), but an HDL_Rcv_Ind primitive has not yet been issued to the user process.

C.5.4.5.4 Behavior definition.

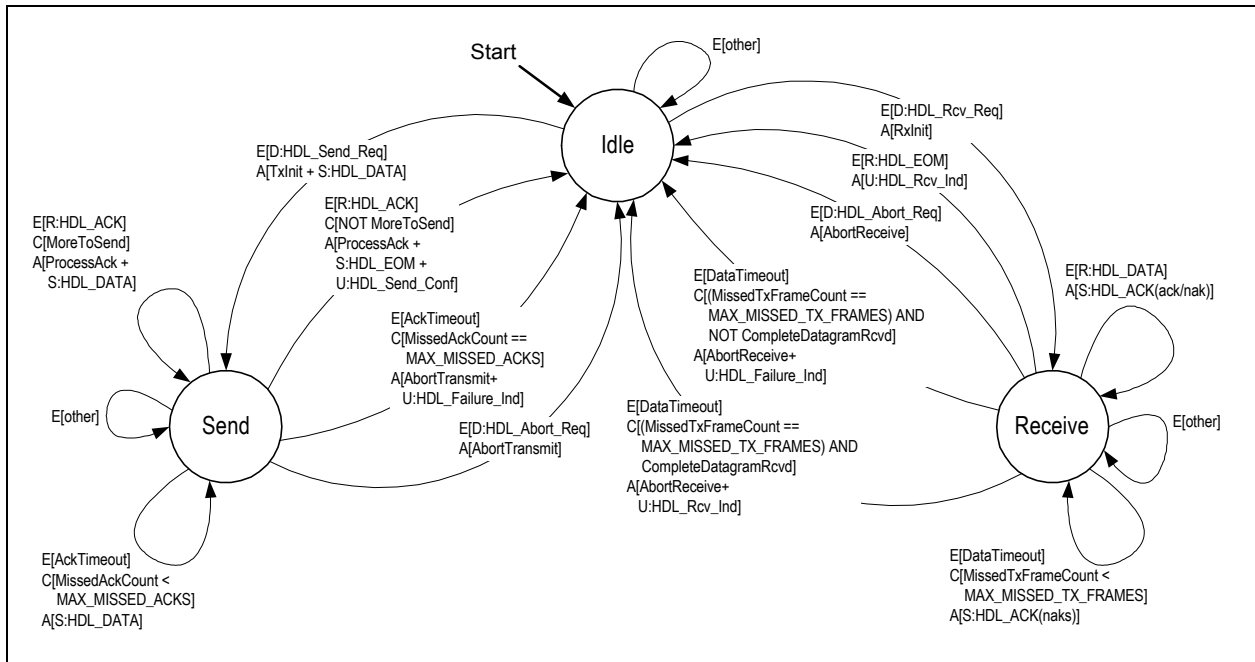
For the reader's convenience, two equivalent representations of the behavior of the HDL protocol are provided in this section: the state transition table in table C-LII, and the state diagram in figure C-35.

Both table C-LII and figure C-35 specify the behavior of HDL in terms of the events defined in C.5.4.5.1 and the actions defined in C.5.4.5.2. The conditions gating certain transitions are specified in terms of the data items defined in C.5.4.5.3.

In the state diagram, each state transition is labeled with an event, an optional condition, and zero or more actions. This indicates that the state transition occurs whenever the event occurs and the condition obtains (is TRUE), causing the associated actions to be performed. In the diagram,

- the name of each event is shown in brackets preceded by the letter 'E';
- the description of each condition is shown in brackets preceded by the letter 'C'; and
- the names of the actions associated with a transition are shown in brackets preceded by the letter 'A'.

Where a transition is labeled with two or more events, this indicates that the transition occurs whenever any of the events occurs.



**FIGURE C-35. HDL state diagram.**

**TABLE C-LII. HDL state transition table.**

State	Event	Condition	Action	Next State
Idle	D:HDL_Send_Req		TxInit + S:HDL_DATA	Send
	D:HDL_Rcv_Req		RxInit	Receive
	other		none	Idle
Send	R:HDL_ACK	MoreToSend	ProcessAck + S:HDL_DATA	Send
	R:HDL_ACK	NOT MoreToSend	ProcessAck + S:HDL_EOM + U:HDL_Send_Conf	Idle
	AckTimeout	MissedAckCount < MAX_MISSED_ACKS	S:HDL_DATA	Send
	AckTimeout	MissedAckCount == MAX_MISSED_ACKS	AbortTransmit + U:HDL_Failure_Ind	Idle
	D:HDL_Abort_Req		AbortTransmit	Idle
	other		none	Send
Receive	R:HDL_DATA		S:HDL_ACK(ack/nak)	Receive
	R:HDL_EOM		U:HDL_Rcv_Ind	Idle
	DataTimeout	MissedTxFrameCount < MAX_MISSED_TX_FRAMES	S:HDL_ACK(naks)	Receive
	DataTimeout	(MissedTxFrameCount == MAX_MISSED_TX_FRAMES) AND NOT CompleteDatagramRcvd	AbortReceive + U:HDL_Failure_Ind	Idle
	DataTimeout	(MissedTxFrameCount == MAX_MISSED_TX_FRAMES) AND CompleteDatagramRcvd	AbortReceive + U:HDL_Rcv_Ind	Idle
	D:HDL_Abort_Req		AbortReceive	Idle
	other		none	Receive

#### C.5.4.5.5 Timing characteristics.

See C.5.3.5.5, which includes an analysis of the timing of the HDL protocol in conjunction with TM protocol timing.

### C.5.5 LDL protocol.

#### C.5.5.1 Overview.

The LDL protocol is used to provide reliable acknowledged point-to-point delivery of datagrams from a transmitting station to a receiving station across an already-established HF link. The datagram passed to the LDL protocol entity for delivery is a finite-length ordered sequence of 8-bit data bytes (octets). The LDL protocol provides improved performance for all datagram

lengths under fair to very poor HF channel conditions, and under all channel conditions for short datagram lengths.

C.5.5.2 Data object types.

The terms defined in table C-LIII are used to refer to specific types of data objects in defining the LDL protocol.

**TABLE C-LIII. LDL data object types.**

<b>Data object type</b>	<b>Definition</b>
datagram	an arbitrary sequence of 8-bit data bytes (octets) of length $dl$ , where $1 \leq dl \leq 16,777,216$ (equal to $512 * 32,768$ ): i.e., 512 payload data bytes per data packet times a maximum of 32,768 data packets per datagram).
data segment	a sequence of 8-bit data bytes (octets) that occur consecutively within a datagram, of length $sl$ where $1 \leq sl \leq 512$ .
filled segment	a data segment of length $sl \leq pl$ bytes, followed by a sequence of $pl - sl$ fill bytes having value 0, where $pl$ is the packet length established for the current LDL transfer (64, 128, 256, or 512).
sequence number	a 17-bit data object having the format defined in table C-LVI, which indicates the position occupied by a data segment within a datagram, and, when the data segment includes the last data byte of the datagram, the number of bytes of payload data from the datagram in the data segment.
control field	an 8-bit data object reserved for future use.
data packet	the combination of a filled segment with a corresponding sequence number and control field. If the data segment contained in the filled segment is of length less than $pl$ bytes (because it includes the last data byte of the datagram), the value of the sequence number indicates how many of the $pl$ bytes in the extended data segment contain payload data from the datagram – i.e., the value of $sl$ for the data segment contained in the filled segment.
tx frame	a single data packet. Same as an LDL_DATA PDU as defined in table C-LV.
rx frame	a single data packet that was received without errors, as determined by the CRC check performed by the BW3 receiver.

C.5.5.3 Service primitives.

Table C-LIV describes the service primitives exchanged between the LDL protocol entity and one or more user processes at LDL's upper interface. Note that there is no requirement that implementations of the waveforms and protocols defined in this Appendix contain precisely these service primitives; nor are the services primitives defined below necessarily all of the service primitives that would be required in an implementation of these waveforms and protocols.

**TABLE C-LIV. LDL service primitives.**

Name	Attribute	Values	Description
LDL_Send_Req	Overview	LDL Send Request: generated by the user process when it has a datagram to send on an already-established HF link using the LDL protocol.	
	Parameters	datagram	datagram to be delivered, as described in table C-LIII.
		pktLength	the number <i>pl</i> of payload data bytes and fill bytes to be transmitted in each data packet transmitted using BW3, where <i>pl</i> = 64, 128, 256, or 512. The value of <i>pktLength</i> should correspond to the TrafficType field-value of the TM_REQUEST PDU sent in establishing the packet traffic link: e.g., <i>pktLength</i> should be 64 if and only if the TrafficType field of the TM_REQUEST PDU had the value LDL_64. (See C.5.3.4.1.)
	Originator	User process	
	Preconditions	TM has just completed a successful point-to-point HF link establishment with the intended datagram recipient.	
LDL_Rcv_Req	Overview	LDL Receive Request: generated by the user process to request that LDL perform the processing required to receive an expected incoming datagram.	
	Parameters	pktLength	the number <i>pl</i> of payload data bytes or fill bytes expected to be present in each incoming data packet received by the BW3 receiver, where <i>pl</i> = 64, 128, 256, or 512. The value of <i>pktLength</i> should correspond to the TrafficType field-value of the TM_REQUEST PDU received when the packet traffic link was established: e.g., <i>pktLength</i> should be 512 if and only if the TrafficType field of the TM_REQUEST PDU had the value LDL_512. (See C.5.3.4.1.)
		Originator	User process
	Preconditions	TM has just completed a successful point-to-point HF link establishment with the expected datagram sender.	
	LDL_Rcv_Ind	Overview	LDL Receive Indication: issued by LDL when LDL has a successfully-received datagram to give to the local user process.
Parameters		datagram	datagram just received, as described in table C-LIII; identical to the datagram parameter-value of the original LDL_Send_Req primitive at the remote station.
Originator		LDL	
Preconditions		LDL has accepted an LDL_Rcv_Req service primitive from a higher-layer entity since the last outgoing or incoming datagram transfer.	
LDL_Send_Conf		Overview	LDL Send Confirm: Issued by LDL when LDL has completed successful delivery of a datagram to the remote station.
	Parameters	(none)	
	Originator	LDL	
	Preconditions	LDL was requested to deliver the datagram by the user process by means of an LDL_Send_Req service primitive.	

**TABLE C-LIV. LDL service primitives (continued).**

Name	Attribute	Values	Description
LDL_Abort_Req	Overview	LDL Abort Request: used by the user process to terminate an LDL protocol data transfer that is currently in progress. The purpose of this service primitive is only to cause the LDL entity to cease attempting to send or receive the current datagram; coordinating the data transfer termination with the remote station is the responsibility of TM.	
	Parameters	(none)	
	Originator	User process	
	Preconditions	Either an outgoing or an incoming data transfer is in progress, using the LDL protocol.	
LDL_Failure_Ind	Overview	LDL Failure Indication: Issued by LDL when LDL is unable to complete delivery of an outgoing or incoming datagram.	
	Parameters	(none)	
	Originator	LDL	
	Preconditions	Either an outgoing or an incoming data transfer is in progress, using the LDL protocol.	

#### C.5.5.4 PDUs.

The sub-sections of this section describe the PDUs exchanged between an LDL protocol entity and its remote peer entities.

The LDL\_ACK and LDL\_EOM PDUs are conveyed using BW4 and thus require no special distinction from TM PDUs which are conveyed using BW1. The LDL\_ACK and LDL\_EOM PDUs are distinguished from one another by context: any PDU sent using BW4 in the forward direction is an LDL\_EOM PDU, while any PDU sent using BW4 in the reverse direction is an LDL\_ACK PDU.

##### C.5.5.4.1 LDL DATA.

An LDL\_DATA PDU is a tx frame as defined in table C-LIII, in which the format and contents of each data packet are as shown in table C-LV. Table C-LVI specifies the format and contents of the Sequence Number field of each data packet.

**TABLE C-LV. Data packet format.**

Field name	Size (bits)	Values	Description
Payload	512, 1024, 2048, or 4096 (fixed for each datagram transfer)	any	Contains a filled segment as defined in table C-LIII: i.e., a data segment followed by however many zero bytes are needed to fill the Payload field to the length given by PacketLength as defined in table C-LXI. Whenever the field contains fewer than PacketLength bytes of payload data from the datagram being delivered (the remainder being fill bytes with value 0), the value of the Sequence Number field indicates how many bytes of payload data are present.
Sequence Number	17 (fixed)	As defined by table C-LXVI.	
Control	8 (fixed)	Reserved (set to zero); must be ignored by the receiving station.	

The fields of the LDL\_DATA PDU are transmitted in order of their occurrence in table C-LV, Payload field first. The bytes of the Payload field are transmitted in the order of their occurrence in the datagram; the bits of each byte are transmitted in order of significance, starting with the most significant bit. Following the last bit of the Payload field-value, the bits of the Sequence Number field are transmitted in order of significance within the 17-bit field-value, starting with the most significant bit (bit 16). Finally, the bits of the Control field are transmitted in order of significance, most significant bit first.

LDL\_DATA PDUs are transmitted using the BW3 burst waveform described by section C.5.1.6.

**TABLE C-LVI. Sequence number field definition.**

Case	Bit 16 (EOM)	Bit 15 (SOM)	Bits 14 - 10	Bits 9 - 0
only packet in datagram	1	1	0	Payload field byte count: the number of bytes (octets) of datagram data present in the Payload field of the packet.
last packet in datagram	1	0	0	Payload field byte count (see above)
first packet in datagram	0	1	number of packets required to convey the data contents of the datagram, minus one: equal to (the least integer greater than or equal to (datagram length in bytes / PacketLength (as defined in table C-LXI)) - 1.	
packet in interior of datagram	0	0	down-counting packet sequence number: the number of packets in the current datagram, following the current packet.	

**C.5.5.4.2 LDL ACK.**

The LDL\_ACK PDU is used to transfer acknowledgement, in the form of an ack bit for the data packet in the immediately preceding LDL\_DATA PDU, from the receiving station to the sending station in an LDL transfer. Table C-LVII specifies the format and contents of the LDL\_ACK PDU.

**TABLE C-LVII. LDL ACK PDU format.**

Field name	Size (bits)	Values	Description
Ack Bit	1	any	Contains one ack bit for the data packet received in an LDL_DATA PDU. The bit indicates whether the corresponding data packet was received without errors; 1 = ACK (was received successfully); 0 = NAK (not received successfully).
CompleteDatagramRcvd	1	any	Contains one bit to indicate that the data packet received in the immediately previous LDL_DATA PDU is understood by the receiving station to be the last data packet of the datagram; 1 = complete datagram received; 0 = complete datagram not received.

Of the two bits of the LDL\_ACK PDU, the Ack Bit is transmitted first.

LDL\_ACK PDUs are transmitted using the BW4 burst waveform described by section C.5.1.7.

C.5.5.4.3 LDL EOM.

The LDL\_EOM PDU is sent from the sending station to the receiving station in an LDL transfer, to indicate that the sending station has received acknowledgements from the receiving station of every data packet in the datagram being transferred, and hence will send no more LDL\_DATA PDUs for the current datagram. The LDL\_EOM PDU is sent as many times as possible within the time interval defined for a forward transmission, to maximize the probability of its being received without errors. Table C-LVIII specifies the format and contents of the LDL\_EOM PDU.

**TABLE C-LVIII. LDL EOM PDU format.**

Field name	Size (bits)	Values	Description
Unused	1	1 (fixed)	Must be set to 1.
EOM	1	1 (fixed)	Must be set to 1.

Of the two bits of the LDL\_EOM PDU, the Unused bit is transmitted first.

LDL\_EOM PDUs are transmitted using the BW4 burst waveform described by section C.5.1.7.

On traffic links established for packet traffic delivered using the LDL protocol, the user process can terminate the data link transfer and use the next data link transmission time slot in either direction — i.e., the time slot for the LDL\_DATA or the LDL\_ACK PDU — to instead send one or more TM PDUs (described in C.5.3.4) within the data link PDU time-slot. This means that while an LDL transfer is in progress, the receiving station must be simultaneously attempting to demodulate TM PDUs conveyed by the BW1 waveform as it is attempting to demodulate and receive LDL\_DATA PDUs conveyed by BW3. The sending station must likewise simultaneously attempt to demodulate and receive TM PDUs conveyed by the BW1 waveform as it is attempting to demodulate and receive LDL\_ACK PDUs conveyed by BW4. Since the duration of the BW1 burst is longer than that of the BW4 burst, if the sending station detects a BW1 preamble during the LDL\_ACK time-slot, it must skip the transmission of the next LDL\_DATA PDU in order to be able to receive the remainder of the BW1 burst. If the received BW1 burst is a TM PDU, then the sending station must ensure that this PDU is received and processed by its TM sublayer.

C.5.5.5 Protocol behavior.

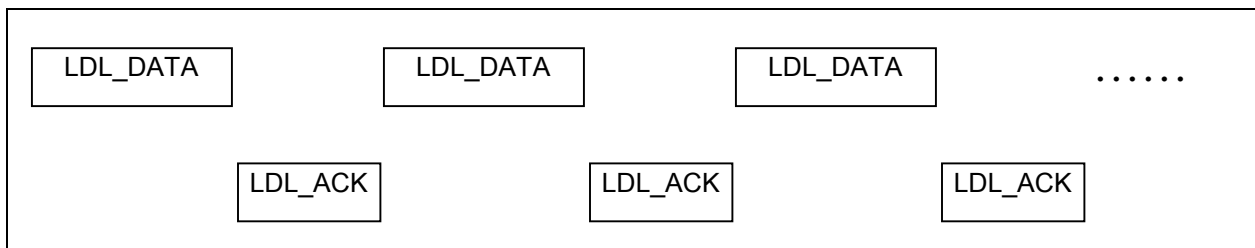
This section provides an informal overview of the behavior of the LDL protocol. The following paragraphs define this behavior precisely:

- C.5.5.5.1 identifies and defines the events to which LDL responds;
- C.5.5.5.2 identifies and defines the actions taken by LDL in response to these events;
- C.5.5.5.3 describes the data items used and maintained by LDL;
- C.5.5.5.4 provides a state diagram and an equivalent state transition table specifying the behavior of LDL in terms of these events, actions, and data items; and
- C.5.5.5.5 provides additional information on the timing characteristics of LDL behavior.



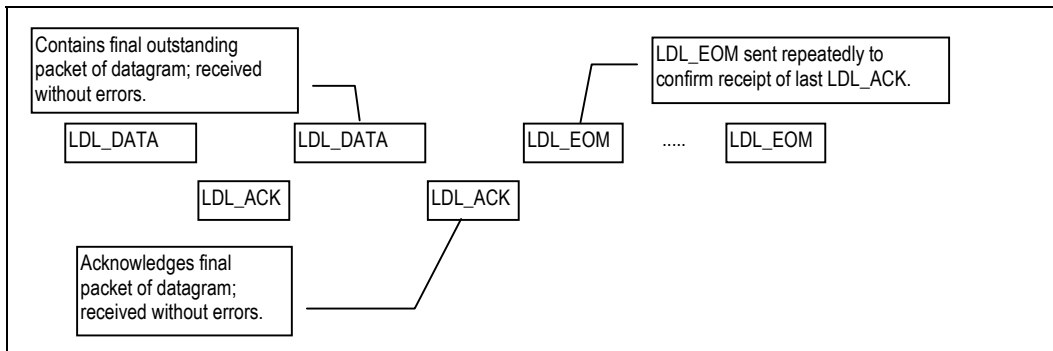
Data transfer by LDL begins after the TM sublayer has already established the data link connection, in so doing negotiating the fact that LDL will be used (as opposed to HDL or some other mechanism), and the precise time synchronization of data link transmissions.

In an LDL data transfer, the sending station and the receiving station alternate transmissions in the manner depicted in figure C-36, the sending station transmitting LDL\_DATA PDUs containing payload data packets, and the receiving station transmitting LDL\_ACK PDUs containing acknowledgement of whether or not the data packet in the preceding LDL\_DATA PDU was received without error. If either station fails to receive a PDU at the expected time, it sends its own next outgoing PDU at the same time as if the incoming PDU had been received successfully. The times at which the burst waveforms conveying LDL\_DATA, LDL\_ACK, and LDL\_EOM PDUs may be emitted are precisely stipulated. See C.5.5.5.5 for details.



**FIGURE C-36. LDL data transfer overview.**

The end of a data transfer is reached when the sending station has transmitted LDL\_DATA PDUs containing all of the payload data in the delivered datagram, and the receiving station has received these data without errors and has acknowledged their successful delivery. When the sending station receives an LDL\_ACK PDU indicating that the entire contents of the datagram have been delivered successfully, it sends an LDL\_EOM PDU repeated as many times as possible within the duration of an LDL\_DATA PDU, starting at the time at which it would have otherwise transmitted the next LDL\_DATA PDU, to indicate to the receiving station that the data transfer will be terminated. This link termination scenario is depicted in figure C-37. See C.5.5.5.5 for timing details.



**FIGURE C-37. LDL link termination scenario overview.**

The definition of LDL behavior presented in the following sections includes mechanisms for dealing appropriately with the following occurrences:

- excessive number of consecutive failures to receive an expected LDL\_DATA PDU;
- excessive number of consecutive failures to receive an expected LDL\_ACK PDU;
- immediate termination of an ongoing data link transfer requested by the TM sublayer.

#### C.5.5.5.1 Events.

Table C-LIX defines the events to which the LDL entity responds. The event names are used in the state diagram and the state transition table in C.5.5.5.4, which define the behavior of the LDL protocol. Some event names refer to the receipt of PDUs from the LDL entity at a remote station; in these cases, the ‘description’ field of the table entry describes the manner in which the arrival of a PDU is accomplished through LDL’s accepting one or more service primitives from lower-layer entities at the local station. The prefix ‘R:’ in the name of an event indicates that the event is the receipt of a PDU from the remote station. ‘D:’ indicates that the event is an LDL service primitive passed down to LDL from a higher-layer entity; ‘U:’ indicates a lower-layer service primitive passed up to LDL from a lower-layer entity.

#### C.5.5.5.2 Actions.

Table C-LX defines the actions which the LDL entity can perform. The action name is used in the state diagrams and/or state transition tables used below to define the behavior of the LDL protocol. Some action names refer to sending PDUs to the LDL entity at a remote station; in these cases, the ‘description’ field of the table entry describes the manner in which sending of the PDU is accomplished by issuing one or more service primitives to lower-layer entities at the local station.

**TABLE C-LIX. LDL events.**

<b>Event name</b>	<b>Description</b>
R:LDL_DATA PDU	A BW3_Receive primitive containing an LDL_DATA PDU was accepted.
R:LDL_ACK PDU	A BW4_Receive primitive containing an LDL_ACK PDU was accepted.
R:LDL_EOM PDU	A BW4_Receive primitive containing an LDL_EOM PDU was accepted, and the LDL_EOM PDU was found to be free of errors by comparing the received PDU against the known LDL_EOM bit pattern specified in C.5.5.4.3.
D:LDL_Send_Req	An LDL_Send_Req primitive was accepted from the user process.
D:LDL_Abort_Req	An LDL_Abort_Req primitive was accepted from the user process.
U:BW1_Pre_Detect	A BW1_Pre_Detect primitive was received, indicating that the BW1 Receiver has detected the BW1 acquisition preamble, with the likely implications that the remote station has sent a TM PDU in the current LDL_ACK time slot.
AckTimeout	A valid LDL_ACK PDU was not received within the time period in which it was expected.
DataTimeout	An LDL_DATA PDU was not received within the time period in which it was expected.

**TABLE C-LX. LDL actions.**

Action name	Description
TxInit	Insert the outgoing datagram into TxDatagramBuf. Clear TxFrameBuf. Reset MissedAckCount to zero. Set PacketLength to the value of the pktLength parameter of the LDL_Send_Req service primitive just accepted by LDL.
S:LDL_DATA	If the TxFrameBuf is clear, construct a new outgoing data packet (as described by table C-LV) in the following manner: <ol style="list-style-type: none"> <li>1. Get the next data segment (the next PacketLength consecutive data bytes to be transmitted) from TxDatagramBuf; place these in the Payload field of the data packet. If fewer than PacketLength data bytes remain to be transmitted, place these bytes at the beginning of the Payload field; fill the remainder of the field with zero-valued bytes so that the Payload field contains a filled segment.</li> <li>2. Construct a sequence number value as specified in table C-LVI; write this value into the packet's Sequence Number field.</li> <li>3. Construct a control field with all 8 bits set to zero.</li> <li>4. Place the data packet generated in steps 1-3 into the TxFrameBuf.</li> </ol> Send an LDL_DATA PDU containing the tx frame in TxFrameBuf, using a BW3_Send primitive. Set the primitive's reset parameter to TRUE if this is the first transmission of a tx frame for the current datagram, and to FALSE otherwise. If an AckTimeout has occurred, increment MissedAckCount. Reset AckTimeout timer.
ProcessAck	Copy the Ack Bit-Mask field value to RxAck. If RxAck is 1, clear the TxFrameBuf. If TxDatagramBuf is not empty, set the condition MoreToSend to TRUE; otherwise set it to FALSE.
S:LDL_EOM	Send an LDL_EOM PDU to the remote station using BW4_Send, as many times as possible within the duration of an LDL_DATA PDU. The number of times the LDL_EOM PDU is sent depends on the value of PacketLength as follows: <ul style="list-style-type: none"> <li>• if PacketLength = 64, the LDL_EOM PDU is transmitted <i>once</i></li> <li>• if PacketLength = 128, the LDL_EOM PDU is transmitted <i>three</i> times</li> <li>• if PacketLength = 256, the LDL_EOM PDU is transmitted <i>five</i> times</li> <li>• if PacketLength = 512, the LDL_EOM PDU is transmitted <i>eleven</i> times.</li> </ul> Disable AckTimeout timer.
Skip LDL_DATA slot	Do not send an LDL_DATA PDU in the next LDL_DATA time slot, so that an incoming BW1 burst can be received. However, continue the LDL slot timing, and be prepared to send an LDL_DATA PDU in the slot after the next one.
U:LDL_Send_Conf	Issue an LDL_Send_Conf primitive to the user process that requested the outgoing data transfer.
AbortTransmit	Disable AckTimeout timer; reset MissedAckCount to zero.
RxInit	Clear RxDatagramBuf, and RxFrameBuf. Reset MissedTxFrameCount to zero. Reset CompleteDatagramRcvd. Reset DataTimeout timer. Set PacketLength to the value of the pktLength parameter of the LDL_Rcv_Req service primitive just accepted by LDL.

**TABLE C-LX. LDL actions (continued).**

Action name	Description
S:LDL_ACK(ack)	<p>Reset MissedTxFrameCount to zero.            Insert the received data packet containing the Payload and Sequence Number field into RxFrameBuf.            Set TxAck to 1.            Move the Payload field contents of RxFrameBuf to the position in RxDatagramBuf indicated by the Sequence Number field-value. In doing this, move only payload data bytes into RxDatagramBuf; discard any fill bytes. Use the Sequence Number field-value to determine which bytes contain payload data and which are fill bytes.            If the entire datagram has been received, set CompleteDatagramRcvd.            Reset DataTimeout timer.            Send an LDL_ACK PDU containing the TxAck and CompleteDatagramRcvd values, using BW4_Send.            Note: An implementation of LDL can, without impairing compliance to this standard, provide segments of a partially-received datagram to the user process, in order of their occurrence in the original datagram at the sending station, before the entire datagram has been received. Doing so would allow a higher-layer protocol to abort an ongoing data transfer, then resume it at a later time, without having to retransmit the entire portion of the current datagram that was already delivered successfully.            Note: The LDL transmitter can send duplicate packets either as a result of missing an LDL_ACK PDU, or at the end of a datagram, in order to fill the (otherwise unused) packet positions of an LDL_DATA PDU. The LDL receiver is required to inspect the sequence number of each data packet received without errors, and to use the sequence numbers to identify and discard duplicate packets.</p>
S:LDL_ACK(nak)	<p>Clear TxAck.            Send an LDL_ACK PDU containing the TxAck and CompleteDatagramRcvd values, using BW4_Send.            If a DataTimeout has occurred, increment MissedTxFrameCount.            Reset the DataTimeout timer.</p>
U:LDL_Rcv_Ind	<p>Send an LDL_Rcv_Ind service primitive to the user process.</p>
AbortReceive	<p>Disable DataTimeout timer; reset MissedTxFrameCount to zero.</p>

**C.5.5.5.3 Data.**

Table C-LXI defines the data items used and maintained by LDL, including buffers, counters, timers, configuration parameters, and so forth. These data items are referred to by the names assigned to them here, in the definitions of LDL events and actions presented in the preceding sections.

**C.5.5.5.4 Behavior definition.**

For the reader's convenience, two equivalent representations of the behavior of the LDL protocol are provided in this section: the state transition table in table C-LXII, and the state diagram in figure C-38.

Both table C-LXII and figure C-38 specify the behavior of LDL in terms of the events defined in C.5.5.5.1 and the actions defined in C.5.5.5.2. The conditions gating certain transitions are specified in terms of the data items defined in C.5.5.5.3.

**TABLE C-LXI. LDL data items.**

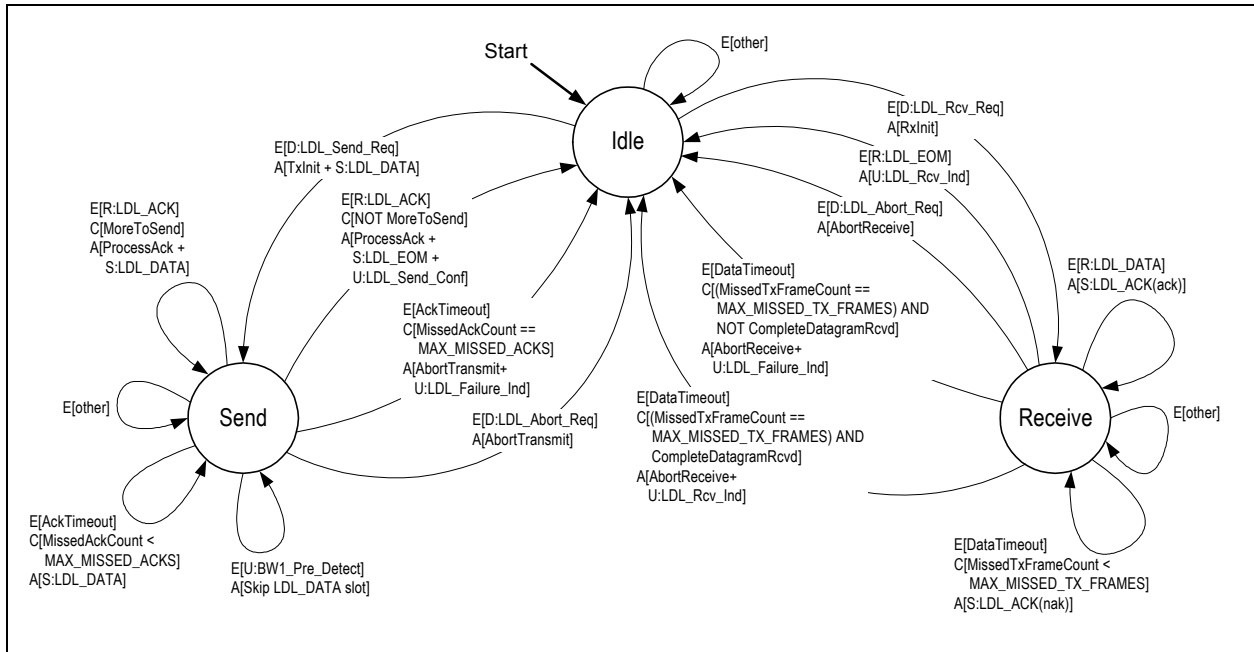
<b>Data item</b>	<b>Description</b>
TxDatagramBuf	buffer storing the data contents of an outgoing datagram which have not yet been inserted into a tx frame for transmission.
TxFrameBuf	buffer storing the outgoing tx frame (an LDL_DATA PDU).
RxDatagramBuf	buffer storing the data contents of an incoming datagram which have been received thus far, in which the complete incoming datagram is re-assembled in correct order.
RxFrameBuf	buffer storing the most recent rx frame that was received without errors (as determined by the CRC check performed by the BW3 receiver).
TxAck	ack flag to be transmitted to the remote station. TxAck = 1 indicates that the data packet in the most recently received rx frame was received without errors.
RxAck	ack flag received in an LDL_ACK PDU from the remote station. RxAck = 1 indicates that the remote station received the data packet in the previously-transmitted frame without errors.
MissedAckCount	count of consecutive failures to receive an LDL_ACK PDU in the time period in which one was expected.
MissedTxFrameCount	count of consecutive failures to receive an LDL_DATA PDU (a tx frame) in the time period in which one was expected.
AckTimeout	timer used to time the duration of the interval in which receipt of an LDL_ACK PDU is expected; fires when the interval expires.
DataTimeout	timer used to time the duration of the interval in which receipt of an LDL_DATA PDU is expected; fires when the interval expires.
MAX_MISSED_ACKS	LDL configuration parameter specifying the maximum number of consecutive missed LDL_ACK PDUs that can occur without causing the LDL transmitter to terminate the data link transfer. The value of this parameter is not stipulated by this specification, since it is not required for interoperability that this parameter have identical values in both the sending and receiving stations.
MAX_MISSED_TX_FRAMES	LDL configuration parameter specifying the maximum number of consecutive missed LDL_DATA PDUs that can occur without causing the LDL receiver to terminate the data link transfer. The value of this parameter is not stipulated by this specification, since it is not required for interoperability that this parameter have identical values in both the sending and receiving stations.
CompleteDatagramRcvd	flag maintained by the receiving station indicating whether or not the entire datagram has been successfully received.
MoreToSend	Boolean condition variable: is TRUE if and only if an outgoing datagram transfer is in progress, and there are one or more data packets in the datagram for which the local station has not yet received an acknowledgement of their receipt without errors by the remote station.
PacketLength	number of payload data bytes and fill bytes (if any) carried within each LDL forward transmission in the current datagram transfer; possible values are 64, 128, 256, and 512. The value of PacketLength is determined by the pktLength parameter of the LDL_Send_Req or LDL_Rcv_Req service primitive that was accepted by LDL just prior to the start of the datagram transfer.

In the state diagram, each state transition is labeled with an event, an optional condition, and zero or more actions. This indicates that the state transition occurs whenever the event occurs and the condition obtains (is TRUE), causing the associated actions to be performed. On figure C-38,

- the name of each event is shown in brackets preceded by the letter 'E';

MIL-STD-188-141B  
APPENDIX C

- the description of each condition is shown in brackets preceded by the letter ‘C’; and
- the names of the actions associated with a transition are shown in brackets preceded by the letter ‘A’.



**FIGURE C-38. LDL state diagram.**

Where a transition is labeled with two or more events, this indicates that the transition occurs whenever any of the events occurs.

**TABLE C-LXII. LDL state transition table.**

State	Event	Condition	Action	Next State
Idle	D:LDL_Send_Req		TxInit + S:LDL_DATA	Send
	D:LDL_Rev_Req		RxInit	Receive
	other		none	Idle
Send	R:LDL_ACK	MoreToSend	ProcessAck + S:LDL_DATA	Send
	R:LDL_ACK	NOT MoreToSend	ProcessAck + S:LDL_EOM + U:LDL_Send_Conf	Idle
	U:BW1_Pre_Detect		Skip LDL_Data slot	Send
	AckTimeout	MissedAckCount < MAX_MISSED_ACKS	S:LDL_DATA	Send
	AckTimeout	MissedAckCount == MAX_MISSED_ACKS	AbortTransmit + U:LDL_Failure_Ind	Idle
	D:LDL_Abort_Req		AbortTransmit	Idle
	other		none	Send
Receive	R:LDL_DATA		S:LDL_ACK(ack)	Receive
	R:LDL_EOM		U:LDL_Rev_Ind	Idle
	DataTimeout	MissedTxFrameCount < MAX_MISSED_TX_FRAMES	S:LDL_ACK(nak)	Receive
	DataTimeout	(MissedTxFrameCount == MAX_MISSED_TX_FRAMES) AND NOT CompleteDatagramRcvd	AbortReceive + U:LDL_Failure_Ind	Idle
	DataTimeout	(MissedTxFrameCount == MAX_MISSED_TX_FRAMES) AND CompleteDatagramRcvd	AbortReceive + U:LDL_Rev_Ind	Idle
	D:LDL_Abort_Req		AbortReceive	Idle
	other		none	Receive

C.5.5.5.5 Timing characteristics.

See C.5.3.5.5, which includes an analysis of the timing of the LDL protocol in conjunction with TM protocol timing.

C.5.6 CLC.

C.5.6.1 Overview.

The CLC monitors and coordinates traffic on an established circuit link. It provides a simple listen-before-transmit access control mechanism:

- Transmission of new outgoing traffic is inhibited whenever the CLC detects that the circuit link is busy, due to either traffic being received from another station, or traffic currently being transmitted by the local station.
- At the end of each outgoing or incoming traffic transmission, the CLC continues to inhibit transmission of new outgoing traffic for the duration of a backoff interval.

In addition, the CLC provides a traffic timeout indication when an interval of a specified duration elapses in which no outgoing or incoming traffic is detected on the circuit link, allowing the traffic link to be terminated when no longer required.

The CLC is employed only on circuit links.

#### C.5.6.2 Service primitives.

Table C-LXIII describes the service primitives exchanged between the CLC and one or more user processes at the CLC's upper interface. Note that there is no requirement that implementations of the waveforms and protocols defined in this Appendix contain precisely these service primitives; nor are the services primitives defined below necessarily all of the service primitives that would be required in an implementation of these waveforms and protocols.

**TABLE C-LXIII. CLC service primitives.**

Name	Attribute	Values	Description
CLC_Active_Req	Overview	CLC Active Request: issued to CLC by the user process to request that CLC begin monitoring and arbitration of access to the currently-established circuit link, using the indicated priority level in its backoff mechanism. CLC sets its data item TrafficPriority to the value of the <i>prio</i> parameter.	
	Parameters	prio	priority level of waiting outgoing traffic (if any); value is one of <ul style="list-style-type: none"> <li>• P2P: a point-to-point circuit link is being established, which is treated as a special case by CLC: the backoff delay depends on which station has just transmitted, rather than on traffic priority</li> <li>• TM: TM is waiting to send a TM-PDU</li> <li>• HIGHEST: highest priority level for user traffic</li> <li>• HIGH</li> <li>• ROUTINE</li> <li>• LOW: lowest priority level for user traffic; also serves as default value when no outgoing traffic is pending.</li> </ul>
	Originator	user process	
	Preconditions	CLC is Idle; a circuit link was just established by the Traffic Manager.	
CLC_Idle_Req	Overview	CLC Idle Request: issued to CLC by the user process to request that CLC cease to monitor and arbitrate access to the current circuit link.	
	Parameters	none	
	Originator	user process	
	Preconditions	CLC is presently active: i.e., not presently residing in its Idle state.	



**TABLE C-LXIII. CLC service primitives (continued).**

Name	Attribute	Values	Description
CLC_Set_Priority	Overview	issued to CLC by the user process to request that CLC use the indicated outgoing traffic priority level in its backoff mechanism. CLC sets its data item TrafficPriority to the value of the <i>prio</i> parameter.	
	Parameters	prio	priority level of waiting outgoing traffic (if any); value is one of <ul style="list-style-type: none"> <li>• P2P: a point-to-point circuit link is being established, which is treated as a special case by CLC: the backoff delay depends on which station has just transmitted, rather than on traffic priority</li> <li>• TM: TM is waiting to send a TM-PDU</li> <li>• HIGHEST: highest priority level for user traffic</li> <li>• HIGH</li> <li>• ROUTINE</li> <li>• LOW: lowest priority level for user traffic; also serves as default value when no outgoing traffic is pending.</li> </ul>
	Originator	user process	
	Preconditions	none: can be accepted by CLC in any state.	
CLC_Idle_Ind	Overview	CLC Idle Indication: issued to the user process by CLC, to indicate that CLC is ceasing to monitor and arbitrate access to the current circuit link due to occurrence of a traffic timeout (no link traffic detected over a time interval of a specific duration).	
	Parameters	none	
	Originator	CLC	
	Preconditions	CLC is presently active: i.e., not presently residing in its Idle state.	
CLC_Busy_Ind	Overview	CLC Busy Indication: issued to the user process by CLC, to indicate that CLC considers the circuit link to be busy — i.e., unavailable for new traffic because of a traffic exchange currently in progress, or because a backoff period following a traffic exchange has not yet expired.	
	Parameters	none	
	Originator	CLC	
	Preconditions	CLC is either <ul style="list-style-type: none"> <li>• newly-activated: i.e., the most recent service primitive passed between CLC and the user process was a CLC_Active_Req primitive; or</li> <li>• indicating that the traffic link is available: i.e., the most recent service primitive passed between CLC and the user process was a CLC_Avail_Ind primitive.</li> </ul>	
CLC_Avail_Ind	Overview	CLC Available Indication: issued to the user process by CLC, to indicate that CLC considers the circuit link to be available for new traffic.	
	Parameters	none	
	Originator	CLC	
	Preconditions	CLC is indicating that the traffic link is busy: i.e., the most recent service primitive passed between CLC and the user process was a CLC_Busy_Ind primitive.	

### C.5.6.3 PDUs.

The CLC does not exchange PDUs with a remote peer entity.

### C.5.6.4 Protocol behavior.

The following paragraphs define the behavior of the CLC:

- C.5.6.4.1 identifies and defines the events to which the CLC responds;
- C.5.6.4.2 identifies and defines the actions taken by the CLC in response to these events;
- C.5.6.4.3 describes the data items used and maintained by the CLC; and
- C.5.6.4.4 provides a state diagram specifying the behavior of the CLC in terms of these events, actions, and data.

#### C.5.6.4.1 Events.

Table C-LXIV defines the events to which the CLC responds. The event names are used in the state diagram in C.5.6.4.4, which defines the behavior of the CLC.

#### C.5.6.4.2 Actions.

Table C-LXV defines the actions which the CLC can perform. The action name is used in the state diagram used below to define the behavior of the CLC.

**TABLE C-LXIV. CLC events.**

event name	description
D:CLC_Active_Req (prio)	CLC_Active_Req primitive issued by user process, with the indicated value for its <i>prio</i> parameter.
D:CLC_Idle_Req	CLC_Idle_Req primitive issued by user process.
D:CLC_Set_Priority (prio)	CLC_Set_Priority primitive issued by user process, with the indicated value for its <i>prio</i> parameter. CLC sets its data item TrafficPriority to the value of the <i>prio</i> parameter.
ModemRTS	signal indicating that the local station's modem is starting to modulate data to be transmitted the current circuit link.
AudioRTS	signal indicating presence of an outgoing audio signal to be transmitted on the current circuit link, such as a handset keyline assertion.
ModemEOTx	signal indicating that a transmission of modem data by the local station has been completed.
AudioEOTx	signal indicating that transmission of an outgoing audio signal has ended due to, for instance, de-assertion of the handset keyline.
ModemDetect	signal indicating that the local station's modem has detected incoming data signalling; equivalent to a signal presence indication. As a minimum requirement for compliance with this standard, the CLC shall employ a signal detector capable of detecting MIL-STD-188-110 serial tone modem signalling, including both the preamble and data portions of the modem waveform. As a design objective, it is also desirable that the signal detector be able to detect as many as possible of the signalling types corresponding to the traffic types enumerated in table C-XXXIV, as well as the following: <ul style="list-style-type: none"> <li>• CW signalling</li> <li>• frequency shift keying (FSK) signalling.</li> </ul>
AudioDetect	signal indicating that the local station has detected incoming audio (typically voice) signalling on the circuit link. The capability to detect SSB analog voice is a requirement for compliance with this standard.
ModemEORx	signal indicating that the local station's modem has detected the MIL-STD-188-110 serial tone End-Of-Message (EOM) sequence.
ModemSigLoss	signal indicating that the local station's modem has declared signal absence after previously having acquired an incoming modem transmission, without having detected the modem's EOM sequence.
AudioSigLoss	signal indicating that the local station has determined that an incoming audio signal on the circuit link has ceased to be present.
TrafficTimeout	timeout event generated by TrafficTimer when the local station has not detected incoming or outgoing traffic on the current circuit link within an interval of duration $\geq$ TRAFFIC_TIMEOUT_INTVL
BackoffTimeout	timeout event generated by BackoffTimer when the backoff interval following the most recent detected incoming or outgoing traffic transmission has expired.
ReacqTimeout	timeout event generated by ReacqTimer when the local station has not detected resumption of reception of an interrupted incoming modem or audio signal within an interval of duration $\geq$ REACQ_TIMEOUT_INTVL.

**TABLE C-LXV. CLC actions.**

Action name	Description
SetPriority	Set TrafficPriority to the value of the <i>prio</i> parameter of a CLC_Active_Req or CLC_Set_Priority service primitive.
StartTrafficTimer	Set TrafficTimer to TRAFFIC_TIMEOUT_INTVL.
StopTrafficTimer	Disable TrafficTimer.
StartBackoffTimer	Set BackoffTimer to BACKOFF_TIMEOUT_INTVL.
StopBackoffTimer	Disable BackoffTimer.
StartReacqTimer	Set ReacqTimer to REACQ_TIMEOUT_INTVL.
StopReacqTimer	Disable ReacqTimer.
U:CLC_Idle_Ind	Issue a CLC_Idle_Ind service primitive to the user process.
U:CLC_Avail_Ind	Issue a CLC_Avail_Ind service primitive to the user process.
U:CLC_Busy_Ind	Issue a CLC_Busy_Ind service primitive to the user process.

C.5.6.4.3 Data.

Table C-LXVI defines the data items used and maintained by CLC, including buffers, counters, timers, configuration parameters, and so forth. These data items are referred to by the names assigned to them here, in the definitions of CLC events and actions presented in the preceding sections. These data items are used in this specification only as expository devices; it is not required for compliance that an implementation contain these data items in the form described here.

**TABLE C-LXVI. CLC data items.**

<b>Data item</b>	<b>Description</b>
BackoffTimer	down-counting timer used to time BackoffTimeouts. Is set with a duration value and, unless reset before the timeout interval expires, counts down to zero, then generates a BackoffTimeout event.
ReacqTimer	down-counting timer used to time ReacqTimeouts. Is set with a duration value and, unless reset before the timeout interval expires, counts down to zero, then generates a ReacqTimeout event.
TrafficTimer	down-counting timer used to time TrafficTimeouts. Is set with a duration value and, unless reset before the timeout interval expires, counts down to zero, then generates a TrafficTimeout event.
TrafficPriority	the priority level of the pending outgoing traffic, if any.
TRAFFIC_TIMEOUT_INTVL	constant configuration parameter: duration of the time interval after which a traffic timeout will occur if no incoming or outgoing traffic is detected on the current circuit link. The value of this parameter is not stipulated as a requirement for interoperability.
BACKOFF_TIMEOUT_INTVL	duration of the time interval after which a backoff timeout will occur if no incoming traffic is detected on the current circuit link. Determines the interval following each outgoing or incoming transmission on the circuit link during which the local station will listen for traffic on the circuit before transmitting. The interval duration is always zero for pending analog or digital voice traffic (preventing annoying delays in voice answer-back operation). For data traffic, the interval duration is selected randomly from one of five values; the relative probabilities of the possible duration values are determined by the priority level of the pending outgoing data traffic (if any), as specified in table C-LXVII. If no traffic is pending, the interval duration is set to zero.
REACQ_TIMEOUT_INTVL	constant configuration parameter: duration of the time interval after which a reacquisition timeout will occur if an incoming modem or audio traffic signal is not detected on the traffic circuit. The value of this parameter is not stipulated as a requirement for interoperability; a suggested default value is 800 milliseconds.

**TABLE C-LXVII. Backoff interval duration probabilities.**

<b>Priority</b>	<b>0 ms</b>	<b>250 ms</b>	<b>450 ms</b>	<b>650 ms</b>	<b>850 ms</b>
P2P (after transmit or on start of link if not initiator)					100%
P2P (after receive or on start of link if initiator)	100%				
TM	50%	50%			
HIGHEST	50%	50%			
HIGH		50%	50%		
ROUTINE			50%	50%	
LOW				50%	50%

The backoff scheme using these interval durations is intended to accomplish the following:

- on a broadcast or multicast link, at the end of each transmission, stations having traffic of higher priority get earlier opportunities to seize the link. Mapping each priority level

to two backoff interval durations serves to reduce congestion when multiple stations have pending traffic at the same priority level.

- TM PDUs (expected to be TM\_TERM ABORT or SIGN\_OFF PDUs) are treated as being of priority equal to the HIGHEST priority level for user traffic.
- Point-to-point traffic links are used fairly: at the end of each transmission, the receiving station gets the first opportunity to seize the link, based on the expectation that point-to-point link users will tend to want to send traffic in an alternating fashion.
- When a circuit traffic link is initially established, the initiator of the link gets the first opportunity to transmit on it.

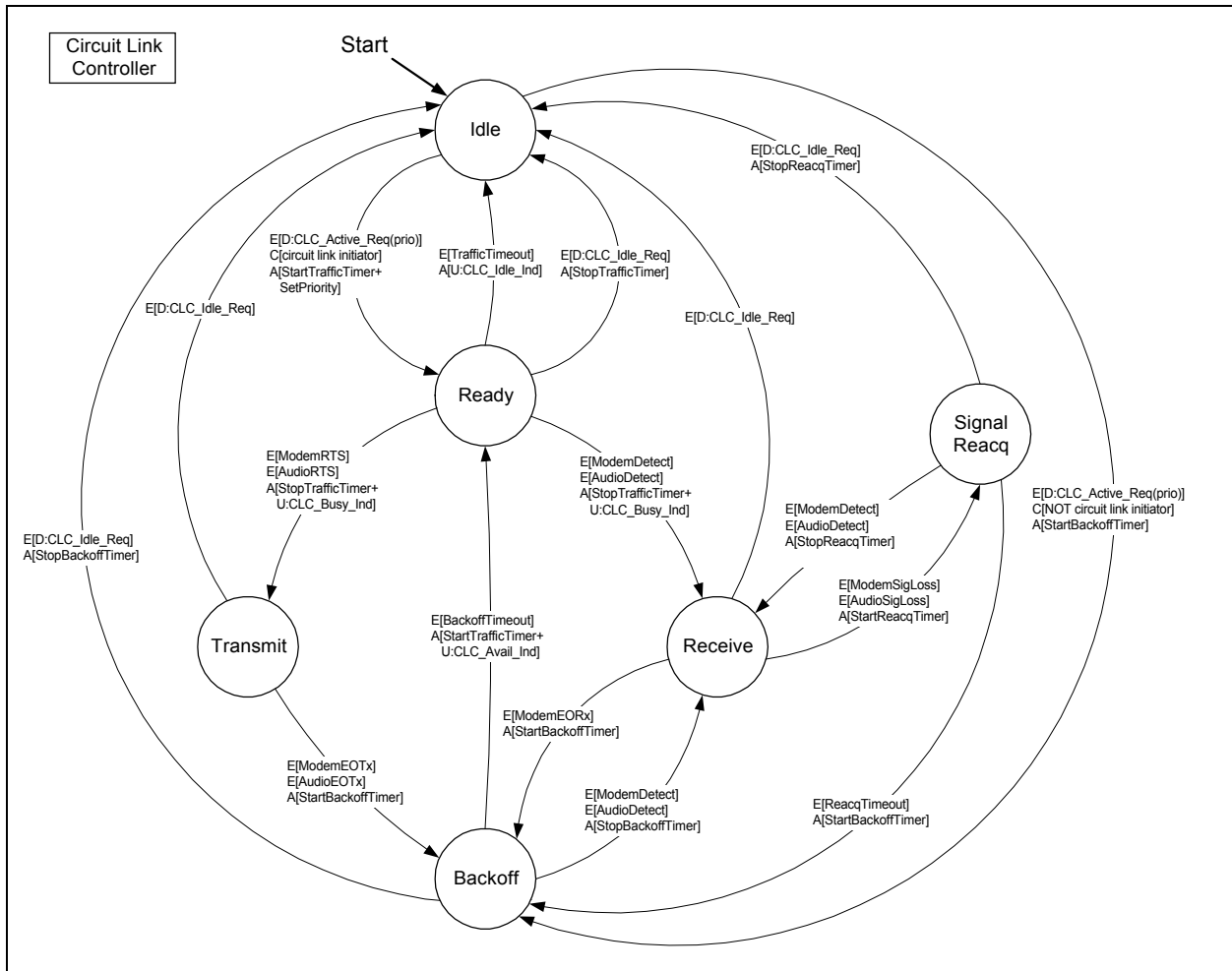
#### C.5.6.4.4 Behavior definition.

The state diagram in figure C-39 specifies the behavior of the CLC in terms of the events defined in C.5.6.4.1 and the actions defined in C.5.6.4.2.

In the state diagram, each state transition is labeled with an event, an optional condition, and zero or more actions. This indicates that the state transition occurs whenever the event occurs and the condition obtains (is TRUE), causing the associated actions to be performed. In the diagram,

- the name of each event is shown in square brackets preceded by the letter 'E';
- the description of each condition is shown in square brackets preceded by the letter 'C';  
and
- the names of the actions associated with a transition are shown in square brackets preceded by the letter 'A'.

Where a transition is labeled with two or more events, this indicates that the transition occurs whenever any of the events occurs.



**FIGURE C-39. CLC state diagram.**

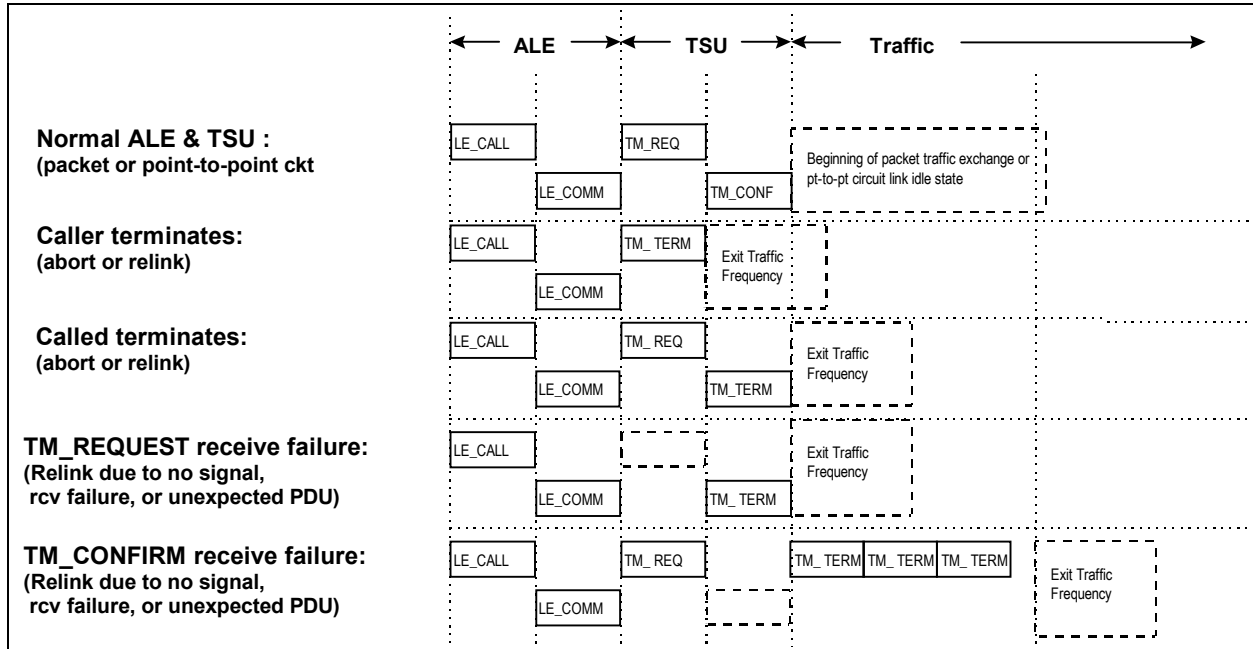
In its Idle state, the CLC does not monitor link traffic or control access to the link. When a circuit link is established, the CLC of the station that initiated the link is placed in its Ready state and begins to monitor traffic on the circuit link. From Ready it proceeds to its Transmit or its Receive state, respectively, when outgoing or incoming traffic is detected. When the traffic ends, the CLC proceeds into its Backoff state where it waits for the duration of a backoff interval before returning to its ready state. If incoming signal presence is lost during reception of incoming modem signalling, the CLC enters its Signal Reacq state, where it remains until either incoming signal presence is reacquired, or a ReacqTimeout event occurs causing the CLC to decide that the incoming traffic has ended and proceed to its Backoff state.

When a circuit link is established, the CLC of each station that did not initiate the link enters its Backoff state, giving the link initiator the first opportunity to transmit on the circuit link.

Note that on the occurrence of any event not shown here, the CLC will take no action and remain in its current state.

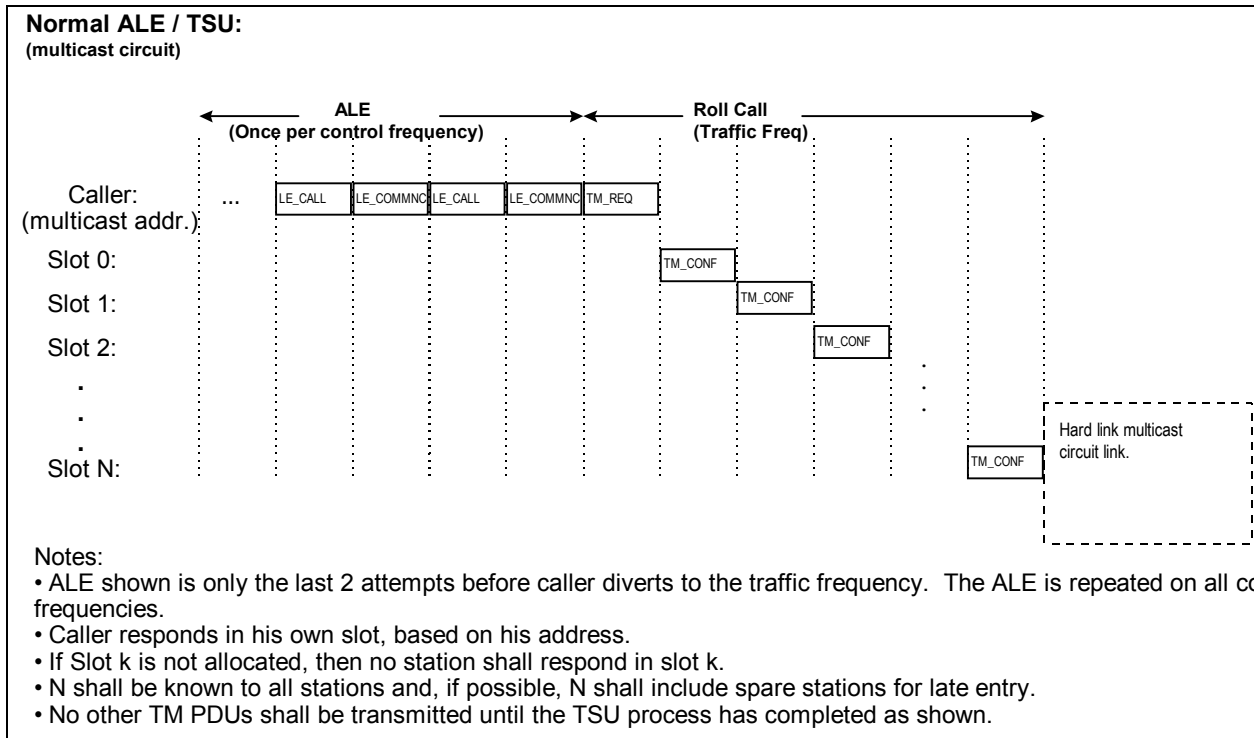
C.5.7 Examples.

Figure C-40 through figure C-45 illustrate the operation of the protocols described in this appendix.

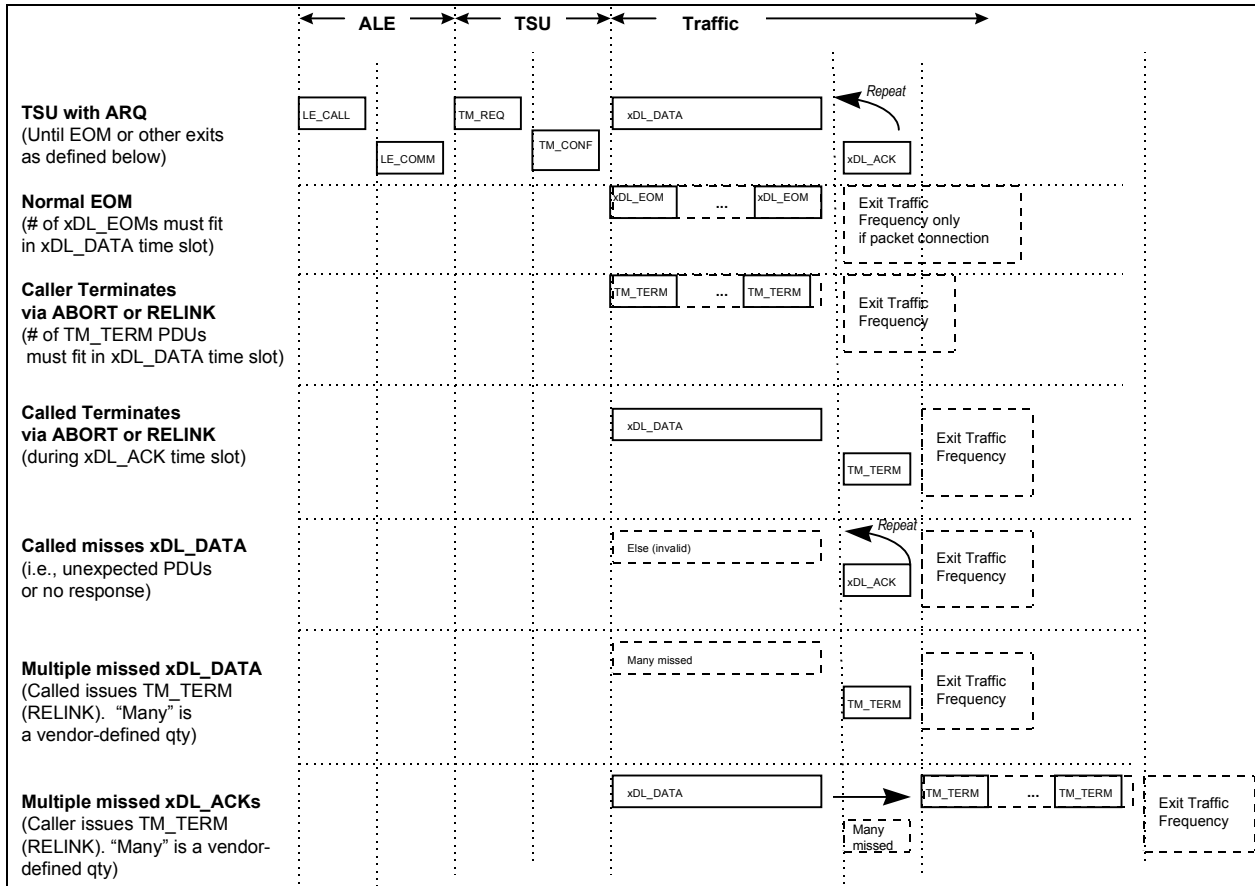


**FIGURE C-40. ALE/TSU scenarios: packet and point-to-point circuit links.**

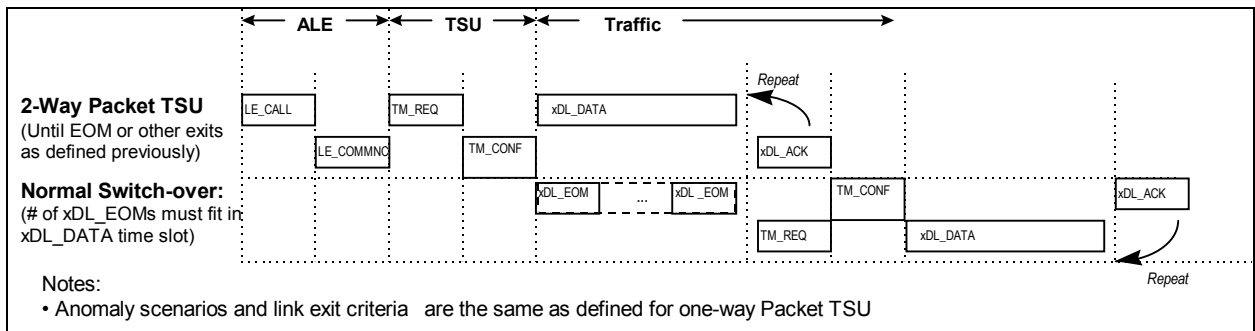




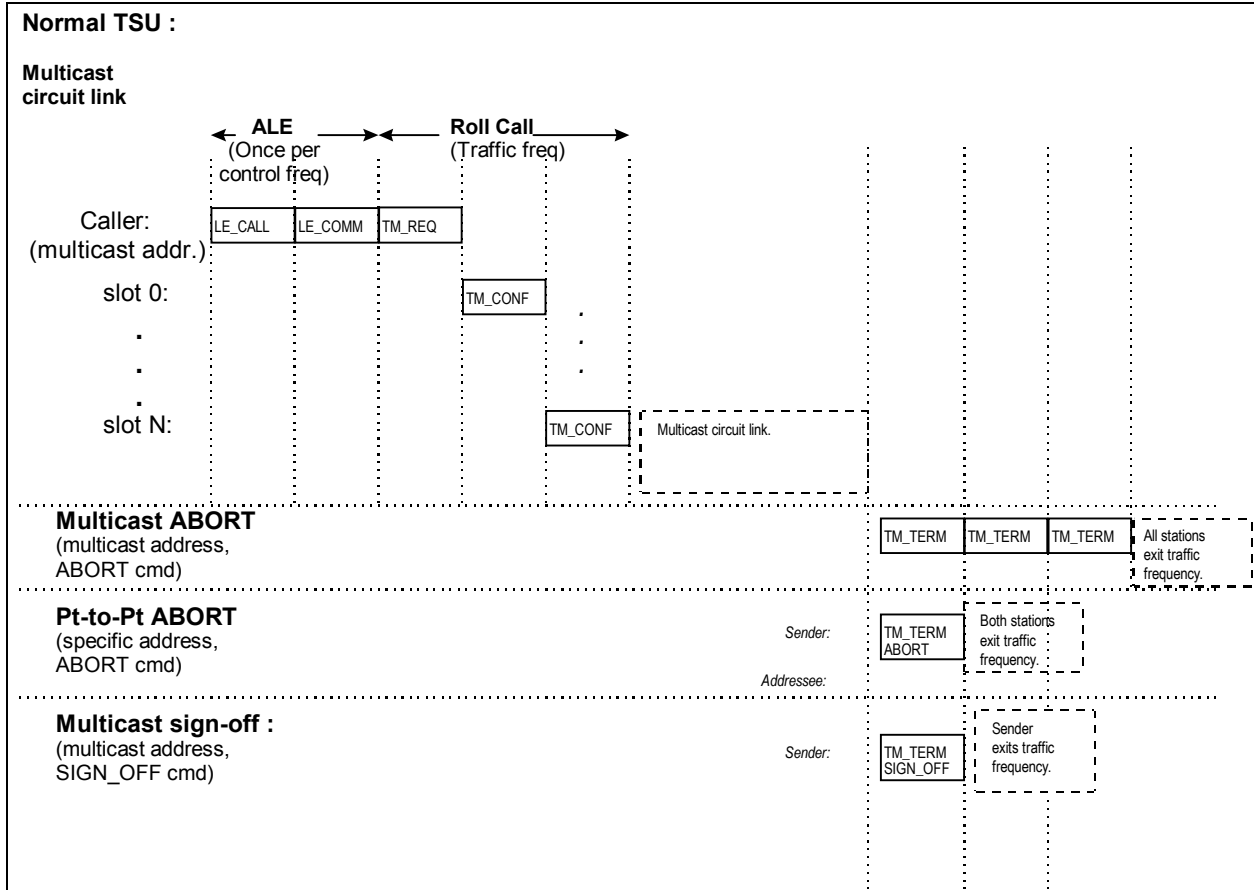
**FIGURE C-41. ALE/TSU scenario: multicast circuit links.**



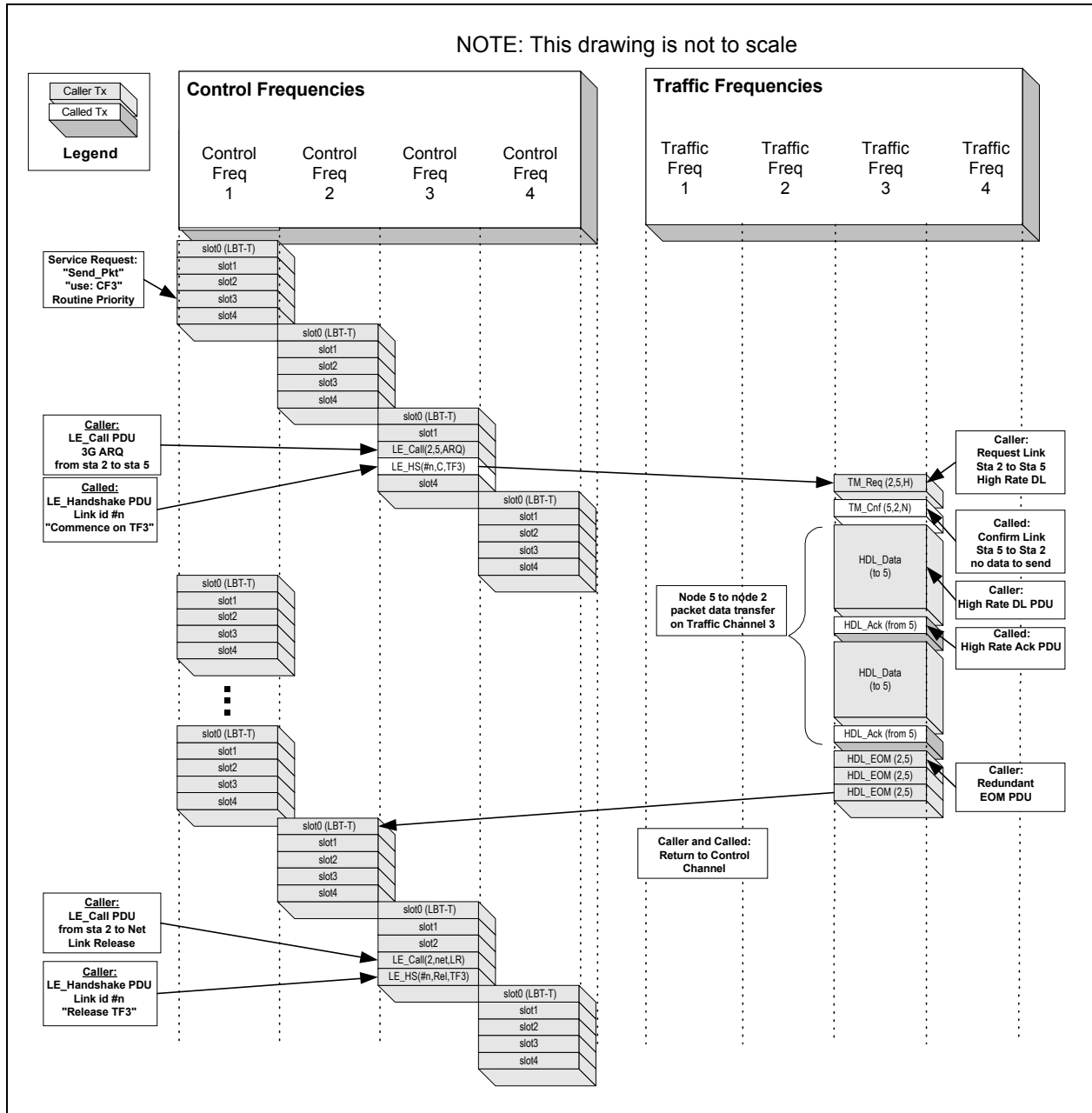
**FIGURE C-42. Packet traffic link termination scenarios.**



**FIGURE C-43. Two-way packet link scenarios.**



**FIGURE C-44. Link termination scenarios: multicast circuit links.**



**FIGURE C-45. Packet linking and traffic exchange: on-air signalling overview.**

APPENDIX D  
HF RADIO NETWORKING

TABLE OF CONTENTS

<u>PARAGRAPH</u>	<u>PAGE</u>
D.1 GENERAL.....	444
D.1.1 <u>Scope</u> .....	444
D.1.2 <u>Applicability</u> .....	444
D.2 APPLICABLE DOCUMENTS.....	444
D.2.1 <u>General</u> .....	444
D.2.2 <u>Government documents</u> .....	444
D.2.2.1 <u>Specifications, standards, and handbooks</u> .....	444
D.2.2.2 <u>Other Government documents, drawings, and publications</u> .....	445
D.2.3 <u>Non-Government publications</u> .....	445
D.2.4 <u>Order of precedence</u> .....	447
D.3 DEFINITIONS.....	447
D.3.1 <u>Standard definitions</u> .....	447
D.3.2 <u>Abbreviations and acronyms</u> .....	447
D.4 GENERAL REQUIREMENTS.....	449
D.4.1 <u>Introduction</u> .....	449
D.4.2 <u>Networking controller</u> .....	449
D.4.2.1 <u>Data structures</u> .....	450
D.4.2.2 <u>Route selection</u> .....	450
D.4.2.3 <u>Message store and forward</u> .....	451
D.4.2.4 <u>Automatic message exchange (AME)</u> .....	451
D.4.2.5 <u>Connectivity exchange</u> .....	451
D.4.2.6 <u>Standard levels of capability</u> .....	451
D.4.2.7 <u>Link selection</u> .....	451
D.4.2.8 <u>Interface to link controllers</u> .....	452
D.4.3 <u>Interface to other media</u> .....	453
D.4.4 <u>Network management</u> .....	453
D.4.4.1 <u>Network management functions</u> .....	453
D.4.4.2 <u>Network management application program capabilities</u> .....	453
D.4.4.3 <u>Simple Network Management Protocol (SNMP)</u> .....	454
D.4.5 <u>Multiple-media networks</u> .....	454
D.5 DETAILED REQUIREMENTS.....	455
D.5.1 <u>Introduction</u> .....	455
D.5.2 <u>Networking functions</u> .....	455
D.5.2.1 <u>Route and link selection</u> .....	455
D.5.2.2 <u>Indirect calling</u> .....	459
D.5.2.3 <u>Network layer header</u> .....	459
D.5.2.4 <u>Connectivity exchange</u> .....	459
D.5.2.5 <u>Message delivery</u> .....	466
D.5.2.6 <u>Relay management protocol</u> .....	469
D.5.2.7 <u>Station status protocol</u> .....	475
D.5.2.8 <u>Network broadcast address</u> .....	476

**TABLE OF CONTENTS**  
**(continued)**

<b><u>PARAGRAPH</u></b>	<b><u>PAGE</u></b>
D.5.2.9 <u>Checksum computation</u> .....	476
D.5.2.10 <u>Data transmission order</u> .....	476
D.5.3 <u>Network management</u> .....	476
D.5.3.1 <u>Terminology</u> .....	477
D.5.3.2 <u>Management protocol</u> .....	477
D.5.3.3 <u>Management information</u> .....	478
D.5.3.4 <u>Proxy management</u> .....	479
D.5.3.5 <u>Access control</u> .....	480
D.5.3.6 <u>Traps</u> .....	481
D.5.4 <u>HFNC interface to local equipment (station data bus)</u> .....	482
D.5.4.1 <u>Station network message format</u> .....	483
D.5.4.2 <u>Station data link protocol</u> .....	483
D.5.4.3 <u>Station physical layer</u> .....	485
D.5.4.4 <u>Examples</u> .....	485
D.5.5 <u>Multiple-media operation</u> .....	487
D.6 NOTES .....	487

**TABLES**

TABLE D-I. <u>Levels of HF networking controller functional capability</u> .....	452
TABLE D-II. <u>Network layer header characters</u> .....	459
TABLE D-III. <u>Voice path quality cascading</u> .....	461
TABLE D-IV. <u>Examples of data path quality computations</u> .....	463
TABLE D-V. <u>Age field encoding</u> .....	465
TABLE D-VI. <u>Port numbers in AME header</u> .....	467
TABLE D-VII. <u>Relay management commands</u> .....	471
TABLE D-VIII. <u>Encoding of HRMP arguments</u> .....	472
TABLE D-IX. <u>Station status codes</u> .....	475

**FIGURES**

FIGURE D-1. <u>Functional block diagram of an automated HF station</u> .....	449
FIGURE D-2. <u>Networking controller</u> .....	450
FIGURE D-3. <u>Network connectivity example</u> .....	456
FIGURE D-4. <u>Path quality matrix example</u> .....	457
FIGURE D-5. <u>Routing table example</u> .....	458
FIGURE D-6. <u>Structure of CONEX message</u> .....	463
FIGURE D-7. <u>CONEX header</u> .....	464
FIGURE D-8. <u>CONEX station or network ID</u> .....	464
FIGURE D-9. <u>CONEX report</u> .....	465
FIGURE D-10. <u>Example AME message header and address record</u> .....	467
FIGURE D-11. <u>HF relay management protocol message format</u> .....	470

**TABLE OF CONTENTS**  
**(continued)**

<b><u>FIGURE</u></b>		<b><u>PAGE</u></b>
FIGURE D-12.	<u>Station status message format.</u> .....	475
FIGURE D-13.	<u>Event time encoding.</u> .....	475
FIGURE D-14.	<u>Interrelationship of protocols.</u> .....	478
FIGURE D-15.	<u>Station data bus.</u> .....	482
FIGURE D-16.	<u>SDLP frame structure.</u> .....	483
FIGURE D-17.	<u>Station network message format.</u> .....	483
FIGURE D-18.	<u>Station data bus example.</u> .....	486
FIGURE D-19.	<u>Menu-driven remote tech control.</u> .....	487



## HF RADIO NETWORKING

### D.1 GENERAL.

#### D.1.1 Scope.

This appendix contains the requirements, prescribed protocols, and directions for the implementation of adaptive networking functions for high frequency (HF) radio. Networking represents the more advance technical capabilities of automated HF radio.

#### D.1.2 Applicability.

This appendix is a mandatory part of MIL-STD-188-141 whenever networking is a requirement to be implemented into the HF radio system. None of the features and functions described in this appendix are mandatory requirements for the user in the acquisition of an HF radio systems, however, if the user has a requirement for the features and functions described herein, they shall be implemented in accordance with the technical parameters specified in this appendix.

### D.2 APPLICABLE DOCUMENTS.

#### D.2.1 General.

The documents listed in this section are specified in D. 3, D. 4, and D. 5 of this standard. This section does not include documents cited in other sections of this standard or recommended for additional information or as examples. While every effort has been made to ensure the completeness of this list, document users are cautioned that they must meet all specified requirements documents cited in D. 3, D. 4, and D. 5 of this standard, whether or not they are listed.

#### D.2.2 Government documents.

##### D.2.2.1 Specifications, standards, and handbooks.

The following specifications, standards, and handbooks form a part of this document to the extent specified herein. Unless otherwise specified, the issues of these documents are those listed in the issue of the Department of Defense Index of Specifications and Standards (DODISS) and supplement thereto, cited in the solicitation.

### STANDARDS

#### FEDERAL

FED-STD-1037	Telecommunications: Glossary of Telecommunication Terms
--------------	--

#### DEPARTMENT OF DEFENSE

MIL-STD-188-110	Interoperability and Performance Standards for HF Data Modems
-----------------	--

MIL-STD-187-721	Interoperability and Performance Standards for Advanced Adaptive HF Radio
-----------------	--

Unless otherwise indicated, copies of federal and military specifications, standards, and handbooks are available from the Naval Publications and Forms Center, ATTN: NPODS, 5801 Tabor Avenue, Philadelphia, PA 19120-5099.

D.2.2.2 Other Government documents, drawings, and publications.

The following other Government documents, drawings, and publications form a part of this document to the extent specified herein. Unless otherwise specified, the issues are those cited in the solicitation.

None.

D.2.3 Non-Government publications.

STANDARDS

EIA/RS-485      Electrical characteristics of generators and receivers for use in balanced digital multipoint systems

Application for copies should be addressed to the EIA, Engineering Dept., 2001 Pennsylvania Ave., N.W., Washington, D.C. 20006.

ISO/IEC 3309:1991      Information Technology-Telecommunications and Information Exchange Between Systems-High Level Data Link Control (HDLC) Procedures-Frame Structure

ISO/IEC 8824      Information Technology-Open Systems Interconnection-Specification of Abstract Syntax Notation One (ASN.1)

ISO/IEC 8825      Information Technology-Open Systems Interconnection-Specification of Basic Encoding Rules for Abstract Notation One (ASN.1)

Application for copies should be addressed to the International Organization for Standardization, Geneva, Switzerland.

IEEE STANDARDS

IEEE 802.2      Logical Link Control (LLC) and Medium Access Control (MAC)

IEEE 802.3      Carrier Sense Multiple Access with Collision Detection (CSMA/CD)

Application for copies should be addressed to the IEEE, Inc., 345 East 47 Street, New York, NY 10017.

INTERNET DOCUMENTS

RFC-768	User Datagram Protocol
RFC-1321	MD5 Messafe - Digest Algorithm
RFC-1441	Introduction to Version 2 of the Internet-standard Network Management Framework
RFC-1442	Structure of Management Information for Version 2 of the Simple Network Management Protocol (SNMPv2)
RFC-1443	Textual Conventions for Version 2 of the Simple Network Management Protocol (SNMPv2)
RFC-1444	Conformance Statements for Version 2 of the Simple Network Management Protocol (SNMPv2)
RFC-1445	Administrative Model for Version 2 of the Simple Network Management Protocol (SNMPv2)
RFC-1446	Security Protocols for Version 2 of the Simple Network Management Protocol (SNMPv2)
RFC-1447	Party MIB for Version 2 of the Simple Network Management Protocol (SNMPv2)
RFC-1448	Protocol Operations for Version 2 of the Simple Network Management Protocol (SNMPv2)
RFC-1449	Transport Mappings for Version 2 of the Simple Network Management Protocol (SNMPv2)
RFC-1450	Management Information Base for Version 2 of the Simple Network Management Protocol (SNMPv2)
RFC-1451	Manager-to-Manager Management Information Base

RFC-1452	Coexistence Between Version 1 and Version 2 of the Internet-Standard Network Management Framework
RFC-1570	Internet Official Protocol Standard
RFC-1662	PPP in HDLC-Like Framing

May be obtained by anonymous ftp from nis.nsf.net or nic.ddn.mil.

#### D.2.4 Order of precedence.

In the event of a conflict between the text of this document and the references cited herein, the text of this document takes precedence. Nothing in this document, however, supersedes applicable laws and regulations unless a specific exemption has been obtained.

### D.3 DEFINITIONS.

#### D.3.1 Standard definitions.

None.

#### D.3.2 Abbreviations and acronyms.

The abbreviations and acronyms used in this document are defined below. Those listed in the current edition of FED-STD-1037 have been included for the convenience of the reader.

ACK	acknowledge character
ALE	automatic link establishment
ALQA	Advanced Link Quality Assessment
AME	automatic message exchange
ARQ	automatic retransmission request
ASCII	American Standard Code for Information Interchange
ASN.1	Abstract Syntax Notation One
b/s	bits per second
BER	bit error ratio
CLNP	Connectionless Network Protocol
CONEX	connectivity exchange
CRC	cyclic redundancy check
CSMA/CD	carrier sense multiple access with collision detection
dB	decibel
DBM	data block message
DII	Defense Information Infrastructure
DoD	Department of Defense
DTM	data terminal message
HDLC	high-level data link control

MIL-STD-188-141B  
APPENDIX D

HF	high frequency
HFDLP	HF Data Link Protocol
HF MIB	HF Management Information Base
HFNC	HF Networking Controller
HFTP	HF Transport Protocol
HNMP	HF network management protocol
HRMP	HF relay management protocol
HSSP	HF station status protocol
ICMP	Internet Control Message Protocol
ID	identification
IP	internet protocol
LCP	link control protocol
LQA	link quality analysis
MRU	Maximum Received Unit
MSB	most significant bit
NAK	negative-acknowledge character
NRM	Normal Response Mode
NSAP	network service access point
OSI	open systems interconnections
P/F	poll/final
PIN	personal identification number
PPP	point-to-point protocol
QOS	quality of service
SDLP	station data link protocol
SINAD	signal-plus-noise-plus-distortion to noise-plus-distortion ratio
SNMP	Simple Network Management Protocol
SNMPv2	Simple Network Management Protocol version 2
SNRM	Set Normal response mode
UA	unnumbered acknowledge
UDP	User Datagram Protocol
UTC	universal time, coordinated

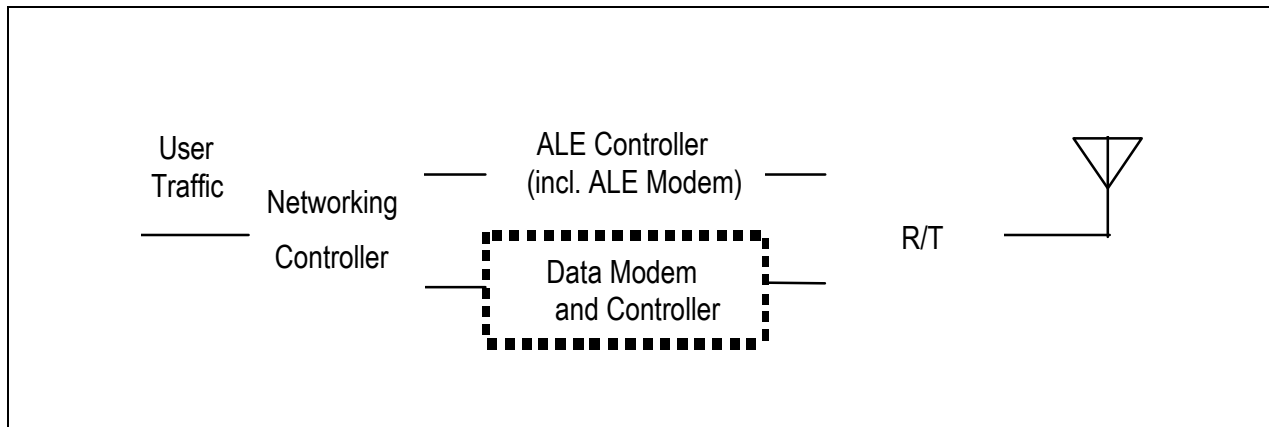
#### D.4 GENERAL REQUIREMENTS.

##### D.4.1 Introduction.

Networked operation supports indirect routing to deliver traffic when propagation does not support direct links.

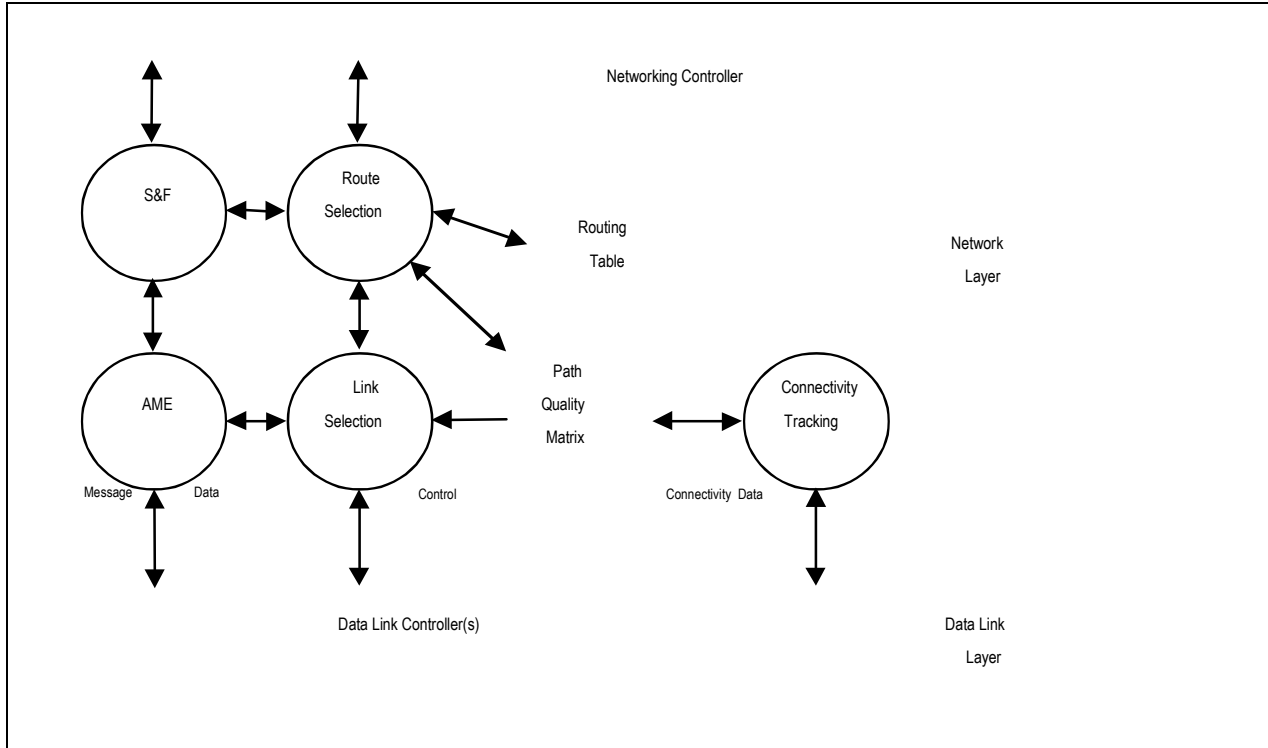
##### D.4.2 Networking controller.

A networking controller performs the network-layer functions relating to traffic routing and relaying. In the simplest case, the network layer functions reside within a radio and have access only to the links achievable by that radio. A more advanced radio may include both ALE and HF data modems, along with a networking controller that is capable of establishing links using the ALE modem and protocols and is capable of switching to the data modem for data communication (see figure D-1). Such a networking controller could use either of the modems (via its respective data link layer entity) to carry traffic for the local user or to relay others' traffic within the network. A still more sophisticated networking controller could manage several radios in a major communications hub, routing traffic through the radio that has the best path to the destination. Such a networking controller could be generalized to act as a multiple-media gateway, routing traffic over media such as wire, fiber, microwave, and satellite links as well as HF links.



**FIGURE D-1. Functional block diagram of an automated HF station.**

The principal functions performed within the networking controller are route selection and link selection, automatic message exchange (AME) and message store and forward, and connectivity tracking. Note that the connectivity tracking function employs the connectivity exchange protocol described in D.5.2.4 and the connectivity monitoring protocol described in D.5.2.6.6.3. The interactions among the various functions and data structures within the networking controller are shown on figure D-2.



**FIGURE D-2. Networking controller.**

**D.4.2.1 Data structures.**

Depending upon the level of functional capability of a networking controller (see D.4.2.6), it shall implement one or both of the following data structures.

**D.4.2.1.1 Routing table.**

The networking controller shall maintain a routing table that stores the preferred route from that station to other reachable stations (DO: also alternate routes); specifically, for each reachable station the routing table shall indicate how traffic destined for that station should be routed. Separate entries shall be maintained for voice and for data traffic. The routing table entries shall be individually programmable as static (entered manually by the operator or downloaded verbatim from other stations) or adaptive (computed automatically by the networking controller using the path quality matrix). See D.5.2.1.2 for detailed requirements for the routing table.

**D.4.2.1.2 Path quality matrix.**

The central data structure supporting adaptive routing is the path quality matrix. This matrix shall be organized to separately record voice and data path quality to any reachable destination via each directly-reachable relay station. These path quality estimates shall be based upon link quality measurements reported by the link controllers in accordance with D.5.2.1.1.

**D.4.2.2 Route selection.**

The route selection function routes voice and data traffic through networks using direct or indirect paths as required. While accomplishing this, it uses and maintains the routing table

discussed in D.4.2.1.1. The route selection function supports both indirect calling and various types of relaying, including analog repeaters, frame repeaters, and message store and forward.

#### D.4.2.3 Message store and forward.

The message store and forward function provides message delivery service for users or transport-layer processes (the term transport message is used in all cases). This function may buffer in-transit messages for varying periods of time depending upon the storage facilities available within the network controller.

The store and forward process at each networking controller employs the route selection function to determine routes through the network for messages, and employs the automatic message exchange process to actually deliver messages over HF links. When full store and forward functionality is not required, a null store and forward function provides the interface to automatic message exchange (see D.5.2.5.3).

#### D.4.2.4 Automatic message exchange (AME).

Automatic message exchange refers to the network layer function that accepts network messages from the store and forward function for delivery to a specified directly reachable station (relay or final destination), and automatically delivers each message when a link is available to that station. When a link cannot be established to the requested station, the automatic message exchange function may either reject the network message, allowing the store and forward function to attempt delivery by alternate means, or it may store the message for future delivery when the desired link is established (so-called “discovery mode”).

#### D.4.2.5 Connectivity exchange.

Information about routes to stations that are not directly reachable, and which have not routed traffic through the local station recently, can sometimes be obtained from the connectivity data stored by a directly reachable station. This data may be shared either upon request or by periodic broadcast. When stations report their path quality matrix contents to other stations, this is termed connectivity exchange (CONEX). When, on the other hand, a station asks for replies from stations with connectivity to a specified destination this is termed query routing (e.g., “Who can reach Joe?”). Protocols for both functions are specified in D.5.

#### D.4.2.6 Standard levels of capability.

The standard levels of functional capability listed in table D-I are defined for HF Networking Controller (HFNC). Note that each level includes the capabilities of all lower-numbered levels.

#### D.4.2.7 Link selection.

The link selection function of the network controller shall interact with local data link controllers to request the establishment and status of links. It shall use data from the path quality matrix to select among available data link controllers for data transfer to the distant station. The link selection function makes no routing decisions per se.



**TABLE D-I. Levels of HF networking controller functional capability.**

Functional Level	Capabilities
Level 1 Minimal HFNC (No routing table)  (No path quality matrix)	Controls ALE radio (including indirect calling) Remote data fill support Automatic message exchange Null store and forward Internet protocol (optional) Controls HF data modem (optional)
Level 2  Basic HFNC  (No path quality matrix)	(All capabilities of Level 1 HFNC) -plus- Route selection using static routing table Message store and forward Routing table data fill Routing queries Repeater control (optional) Connectivity monitoring Controls multiple radios and modems (optional)
Level 3  Adaptive HFNC	(All capabilities of Level 2 HFNC) -plus- Path quality matrix Connectivity exchange (CONEX) Adaptive routing
Level 4  Multiple-media gateway	(All capabilities of Level 3 HFNC) -plus- Routing via alternate media Internet protocol (mandatory) Internet gateway

#### D.4.2.8 Interface to link controllers.

The following functions form a minimal interface between a networking controller and the link controllers that it uses. Because of the wide range of implementations possible, the specifics of this interface are not yet fully standardized.

##### D.4.2.8.1 Link control.

The networking controller shall be able to request the establishment and termination of links, specifying desired destinations using the appropriate link-level addresses. However, artifacts of particular link controllers (e.g., padding ALE addresses on the right with “@” characters) shall not be required of networking controllers. Link controllers should report the success or failure of link establishment and the identities of linked stations (e.g., stations responding to an ALE net call).

##### D.4.2.8.2 Link quality reporting.

The networking controller requires reports from the link controllers regarding the quality of links to other stations available from each link controller. These reports shall specify the data necessary for path quality matrix entries (e.g., BER and SINAD), but shall not contain data such as channel numbers that are relevant only to the link controller.

##### D.4.2.8.3 Network messages.

Messages to be sent from one networking controller to another over a link shall be delivered to a link controller in two parts: a network message (which is handled transparently by the link controller); and control information which specifies to the link controller the data-link layer

addressee of the message as well as other requirements for the transmission. The link controller is presumed to assume custody of each message that it accepts for transmission. Received messages delivered by link controllers to an HFNC shall be accompanied by the link layer address of the sender of the message.

#### D.4.3 Interface to other media.

The HF networking controller is capable of providing a subnetwork service to Internet routers. This subnetwork need not consist solely of HF links. When other media links are included in a subnetwork, the networking controller should route calls and traffic to optimize use of each type of link.

#### D.4.4 Network management.

##### D.4.4.1 Network management functions.

Automated network management functions support the efficient control of automated HF networks. The tools for network management specified in D.5 include protocols for the following functions:

- a. Monitoring and reporting network status (e.g., topology, capabilities, congestion, and faults).
- b. Downloading ALE controller data.
- c. Updating network routing tables.
- d. Identifying software versions and updating the software in ALE and networking controllers.
- e. Re-keying linking protection scramblers.
- f. Remotely controlling station operations.
- g. Adjusting transmitter power of linked stations.
- h. Hand-off from ALE modems to other modems.
- i. Transition among security modes.

##### D.4.4.2 Network management application program capabilities.

The network management application program (often running on networking controller hardware) integrates the monitoring, reporting, and control capabilities of attached networking and link controllers to allow the network manager to view and adjust the operation of a network. These capabilities include the LQA, ALQA, Version, and Capabilities functions of the ALE controller, and the CONEX function of the networking controller. Network management programs employ the data communication capabilities of networking and link controllers to exchange network management messages.

#### D.4.4.3 Simple Network Management Protocol (SNMP).

All HF radio equipment should implement the SNMP, as specified in Request for Comments 1441-1452 (RFC-1441) with the HF-specific enhancement specified in D.5.3.2. This combination of SNMP with HF radio enhancements is hereafter denoted HF network management protocol (HNMP). Equipment not implementing HNMP may be managed through the use of proxy agents, which translate between HNMP commands and equipment-specific commands.

NOTE: An HFNC is the platform for proxy agents because of its connections to most other equipment at a station.

Every HFNC that implements HNMP shall also implement the HF AME protocol if carrying traffic over HF.

#### D.4.5 Multiple-media networks.

Multiple-media networks support the efficient integration of all available transmission media for end-to-end communications.

- a. From a user's perspective, a communication system should seamlessly integrate any available media to provide end-to-end service. In addition to this general requirement for static multiple-media interoperability, many Government systems (especially military and law enforcement agency systems) require robust networks that can sustain communications in the face of widespread loss of assets, and that can be rapidly extended into new locales using any available facilities. It is this dynamic element that distinguishes so called "any media" networks from the more common multiple-media networks.
- b. Because of the dynamic characteristics of ionospheric propagation, HFNCs are designed specifically to cope with fluctuating connectivity. This makes the HFNC especially suitable for service as a router in any-media networks.
- c. HF radio may be integrated with other media in two complementary ways:
  - (1) A network of HFNCs may contain not only HF links, but also wireline, microwave, tropo- or meteor-scatter, and satellite links. Such HF networks use HF links for mobile or remote stations and for contingencies, with other media used as dictated by tactics and economics.
  - (2) A network of HFNCs may serve as a subnetwork in a larger internet (such as the Internet). Such an "HF" subnetwork may of course employ any of the media listed above. The HF component of such internets provides an inexpensive means to extend the network to remote or mobile users. Examples include Defense Information Infrastructure (DII) entry and providing access to the commercial telephone system from remote regions of the world (e.g., northern Canada).

When multiple media or any media networking is required, the other media shall be interconnected to HF assets via HFNCs. For fully automatic internetworking, the HFNC level of

functional capability must be level 2 or above (see table D-I). A level 4 HFNC is required for internet gateways in the case of paragraph D.4.5.b above.

## D.5 DETAILED REQUIREMENTS.

### D.5.1 Introduction.

HF networking technology includes HFNC functions, the HF Network Management Protocol, and a data link protocol for use within automated HF stations.

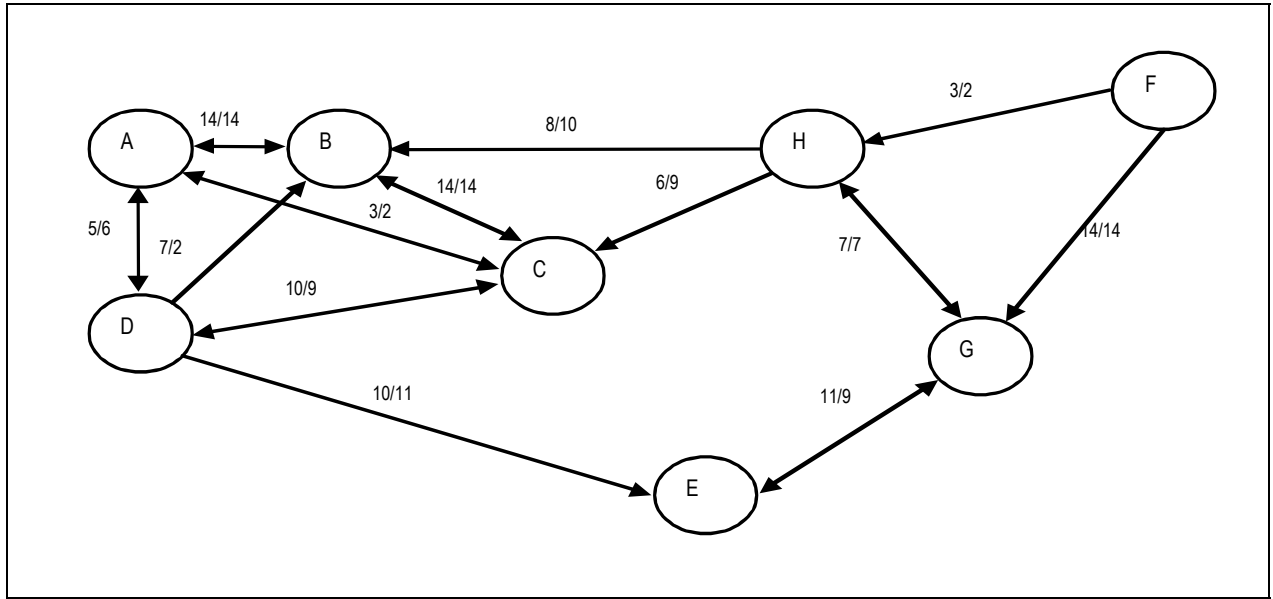
### D.5.2 Networking functions.

The functions implemented within a networking controller include automatic route and link selection, indirect calling, connectivity monitoring, connectivity exchange, routing queries, repeater control, message store and forward, automatic message exchange, and station status reporting.

#### D.5.2.1 Route and link selection.

The router is the central entity of the networking controller, in the sense that almost every other networking function either relies upon it or supports it. The router performs two functions: route selection and link selection. The route selection function finds routes through networks for user and orderwire traffic, using connectivity data from the path quality matrix, operator entries, and broadcast queries to maintain the routing table. The link selection function simply chooses the best data link available to each destination selected by the route selector.

The following examples of network-layer operations refer to the hypothetical network connectivity from station A shown on figure D-3. The arrows indicate the direction(s) of connectivity; the pair of numbers on each arrow indicates voice and data path quality, respectively (in accordance with the link quality functions in MIL-STD-187-721, paragraph on Link Quality Functions).



**FIGURE D-3. Network connectivity example.**

**D.5.2.1.1 Path quality matrix.**

The path quality matrix is organized with a row for each directly reachable relay station, and a column for each destination of interest. When multiple data link controllers are available to the networking controller, a separate path quality matrix may be maintained for each, or a single path quality matrix may be maintained. The single path quality matrix contains the best path scores over all link controllers, along with indications of the specific link controller to use for each path.

A path quality matrix is needed by every networking controller that provides adaptive routing for locally-originated messages, whether or not the station intends to relay messages for other stations.

Figure D-4 illustrates how the network connectivity on figure D-3 may be summarized in the path quality matrix at station A. The path qualities are computed in accordance with the algorithms given in D.5.2.4.1 and D.5.2.4.2. Note that unidirectional path qualities (A to destination) are shown. Normally, path qualities in both directions will be stored and used.

MIL-STD-188-141B  
APPENDIX D

DESTINATION:	B	C	D	E	F	G	H
RELAY:							
B*	14 14 0 1 s	13 13 1 59 m	9 8 2 5 hr	7 7 3 5 hr	- - - -	6 6 4 5 hr	4 5 5 1 d
C*	1 1 1 5 hr	3 2 0 30 m	1 1 1 5 hr	0 0 2 5 hr	- - - -	0 0 3 5 hr	0 0 4 5 hr
D*	4 1 1 2 hr	4 5 1 3 hr	5 6 0 12 hr	4 5 1 5 m	- - - -	3 4 2 5 hr	1 3 3 5 hr
E*	- - - -	- - - -	- - - -	- - - -	- - - -	- - - -	- - - -
F*	- - - -	- - - -	- - - -	- - - -	- - - -	- - - -	- - - -
G*	- - - -	- - - -	- - - -	- - - -	- - - -	- - - -	- - - -
H*	- - - -	- - - -	- - - -	- - - -	- - - -	- - - -	- - - -

\*KEY: Voice Quality, Data Quality, Relays, Age

**FIGURE D-4. Path quality matrix example.**

D.5.2.1.2 Routing table.

A routing table is maintained by the networking controller for use in route selection. An example routing table is shown on figure D-5, corresponding to the path quality matrix example on figure D-4.

DESTINATION	B	C	D	E	F	G	H
ROUTE VOICE TRAFFIC VIA *	B 14 0 1 s	B 13 1 59 m	B 9 2 5 hr	B 7 3 5 hr	- - - -	B 6 4 5 hr	B 4 5 1 d
ROUTE DATA TRAFFIC VIA *	B 14 0 1 s	B 13 1 59 m	B 8 2 5 hr	B 7 3 5 hr	- - - -	B 6 4 5 hr	B 5 5 1 d
*KEY: Relay Address Path Quality Relays Age							

**FIGURE D-5. Routing table example.**

**D.5.2.1.2.1 Organization.**

The routing table is organized for quickly determining where to send traffic destined for any reachable station. It is indexed by a reachable station address. The entry for each station contains (at least) the best relay(s) for voice and data traffic destined for that station. In addition, routing table entries may contain alternate relays and candidates for indirect calls when no relays are available.

**D.5.2.1.2.2 Manual entries.**

A means shall be provided for operator entry of routing table data. These entries shall be retained in non-volatile storage when the network controller is powered off and shall not be overwritten by automatic updates to the routing table from path quality matrix data; this may be implemented by flagging non-adaptive routing table entries. The operator shall also be able to view, edit, and delete manual routing table entries. The requirements of this paragraph do not apply when the mission, power, or weight limitations contraindicate.

**D.5.2.1.2.3 Automatic updates.**

When adaptive routing is employed, alternative routes to reachable destinations shall be re-evaluated whenever new path quality data arrives (e.g., via CONEX), and the routing table shall be updated as appropriate.

D.5.2.2 Indirect calling.

When a link controller fails to establish a link requested by the networking controller, the routing table (and path quality matrix as required) may be used to identify candidate station(s) for indirect calling. Initiation of an indirect call by the networking controller may be automatic upon linking failure or it may be initiated by the operator. When an automatic indirect call succeeds in establishing a link with a candidate station, the operator should be notified that the link established is to a third party rather than to the desired destination.

D.5.2.3 Network layer header.

All messages sent from one networking controller to another shall be preceded by a single ASCII character denoting the type of message to follow. When a networking controller receives a message, it examines this one-character header to determine the format and protocol to use in interpreting the remainder of the message. (See D.4.2.)

The defined network layer header characters are listed in table D-II. Header characters not listed are reserved and shall not be used until standardized.

**TABLE D-II. Network layer header characters.**

Header	Message Type
C	Connectivity exchange
M	User message (with AME header)
R	Relay management
S	Station status message

D.5.2.4 Connectivity exchange.

The CONEX protocol allows relay stations to exchange lists of other stations they can contact. However, CONEX exacts a price in overhead channel usage that may be unacceptable under many conditions. Normally, relay stations use static routing table entries with notification-based protocols (see D.5.2.6.6.3 and D.5.2.7) and HF network management requests. CONEX is useful only for those relay stations equipped with a Level 3 or 4 HFNC (see table D-I), and is recommended only for those networks that cannot use normal routing table maintenance (also see D.5.2.4.1b).

- a. Networking controllers exchange the contents of their path quality matrices using the following CONEX protocol. Note that CONEX messages may be carried on any type of data link that connects the parties to the exchange. Because these messages may be relatively large, a high speed modem should be used for CONEX whenever possible; the ALE modem should only be used when no other data link is available.
- b. A CONEX report pertains to the path from one station to another, which may consist of a single link (a “direct path”) or of multiple links (an “indirect path”) through one or more intermediate (relay) station(s). In all cases, each CONEX report includes the number of relay stations included in the path, estimates of the path quality for voice and for data, and the age of the oldest data used to estimate these path qualities.



D.5.2.4.1 Voice path quality.

The voice quality for a path is an estimate of the end-to-end SINAD of the path. For SINAD less than 2 dB, the voice path quality is 0; for 2 through 26 dB, the quality is 1/2 SINAD (in dB); for SINAD greater than 27 dB, the quality is 14; and when the end-to-end SINAD is unknown, the quality is 15 (1111) (default value). Voice quality shall be computed as follows:

- a. For a single-link path, the mean SINAD for that link (median SINAD if ALQA data is available) shall be obtained from the link controller and converted directly to a path quality code.
- b. For a multilink path, the voice quality obtained in a CONEX report from the best relay station for the ultimate destination shall be combined with the quality of the best link to that station to obtain the resulting voice path quality as specified in table D-III. (Note that a multilink path will never have quality 14.) The “best relay” is the station among all potential relays that gives the highest result quality after the qualities of links to those stations have been included.

D.5.2.4.2 Data path quality.

- a. The data quality for a path is an estimate of the efficiency of the path in passing data traffic. The data path quality code used is based upon estimates of the time required to pass messages over each link in the path; the resulting code reflects several measures of importance to data networks: data throughput, message latency, and resource utilization (stations and channels).

**TABLE D-III. Voice path quality cascading.**

Quality 1	Quality 2	Result Quality	Quality 1	Quality 2	Result Quality
0	Any	0	6	11	5
1	Any	0	6	12	5
2	Any	0	6	13	5
3	3	0	6	14	5
3	4	1	7	7	5
3	5	1	7	8	5
3	6	1	7	9	6
3	7	1	7	10	6
3	8	1	7	11	6
3	9	1	7	12	6
3	10	1	7	13	6
3	11	1	7	14	6
3	12	1	8	8	6
3	13	1	8	9	6
3	14	1	8	10	7
4	4	2	8	11	7
4	5	3	8	12	7
4	6	3	8	13	7
4	7	3	8	14	7
4	8	3	9	9	7
4	9	3	9	10	7
4	10	3	9	11	8
4	11	3	9	12	8
4	12	3	9	13	8
4	13	3	9	14	8
4	14	3	10	10	8
5	5	3	10	11	8
5	6	3	10	12	9
5	7	4	10	13	9
5	8	4	10	14	9
5	9	4	11	11	9
5	10	4	11	12	9
5	11	4	11	13	10
5	12	4	11	14	10
5	13	4	12	12	10
5	14	4	12	13	10
6	6	4	12	14	11
6	7	4	13	13	11
6	8	5	13	14	12
6	9	5	14	14	13
6	10	5	15	Any	15

b. Computing the end-to-end data path quality through one or more relay stations shall proceed as follows. Assume that station “A” receives a CONEX report from “B” about the best data path from “B” to “X.” Station “A” computes its path quality to “X” through “B” by combining the quality of its link to “B” with the report from “B” about “B’s” best path to “X.”

(1) Station “A” computes the quality of its link to “B” as described in paragraph e below, and compares the result to the quality of the path from “B” to “X” as reported by “B.”

(2) If either quality is 0, the result is 0. Likewise, if either is 31 (unknown), the result is 31.

(3) In all other cases, the quality of the path from “A” to “X” through “B” is 1 less than the lower path quality of the two components.

c. The quality of a single data link is computed from the nominal data rate and measured error characteristics of that link obtained from the link controller. The result of the following formula shall be truncated to an integer in the range of 0 through 30, inclusive (e.g., if the result is less than zero, 0 shall be used).

$$\text{Data link quality} = 7 + \text{Nominal Speed} - \text{ARQ Repeats.}$$

d. The “nominal speed” term in the formula is obtained from the nominal data rate (in bits per second (b/s)) as follows. The result shall be rounded to the nearest integer. Note that the logarithm is taken with a base of 2.

$$\text{Nominal speed} = \log_2 (\text{data rate}/75 \text{ b/s}).$$

e. The “ARQ repeats” term in the formula is the mean number of error-induced retransmissions per message of the messages sent over that link during the past hour. If no messages were sent over the link during the past hour, the ARQ repeats term may be estimated using the BER of the link (measured before error correction):

<u>BER</u>	<u>ARQ Repeats Estimate</u>
<0.1	0
0.1 < BER < 0.199	$\frac{\text{BER} - 0.1}{0.2 - \text{BER}}$
> 0.199	100 (link unusable)

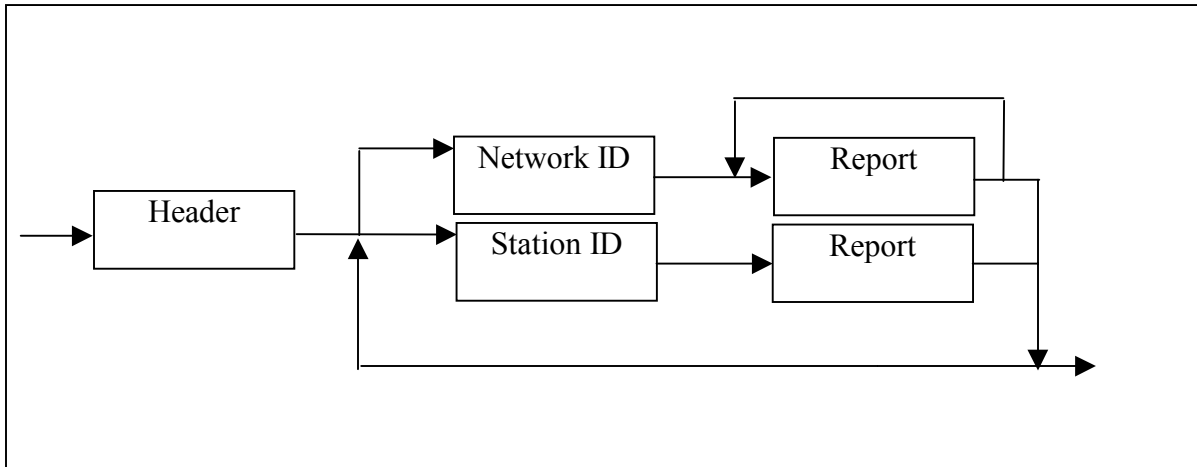
Table D-IV illustrates the use of this formula:

**TABLE D-IV. Examples of data path quality computations.**

Link Type	Nominal Data Rate	Nominal Speed	ARQ Repeats (measured)	BER	ARQ Repeats (estimated)	Data Link Quality
DTM (ALE Modem)	53.6	0	0			7
	53.6	0		0.1181	0.22	6
HF Data Modem	2400	5	0.1			11
	2400	5		0.167	2.03	9
Wireline Modem	9600	7		0.0105	0.00	14
	9600	7	1.2			12

D.5.2.4.3 CONEX message format (Optional).

a. A CONEX message consists of a header, identifier(s) of the net or specific stations reported, and reports of path quality to those stations. When a net is named, the reports for the stations in the net are listed in the standard order for that net, without sending the individual station identifiers. A flow diagram for the structure of a CONEX message is shown on figure D-6. CONEX messages are formatted in even multiples of 8 bits to simplify the insertion of these reports into the natural data blocks of the links likely to be available.

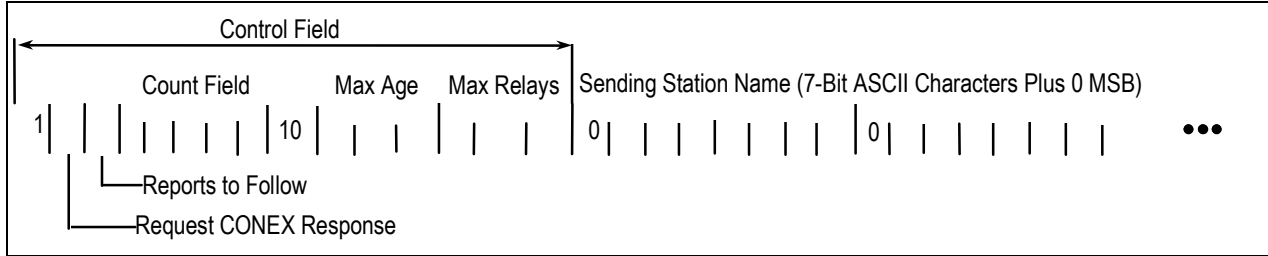


**FIGURE D-6. Structure of CONEX message.**

b. The CONEX message header contains a 16-bit Control field, followed by the name of the sending station, as shown on figure D-7. The first bit is set to 1. The second bit is set to 1 to request CONEX from responding stations, or to 0 to suppress such responses. The third bit is set to 1 to indicate that CONEX reports follow the sending station name; if this bit is 0, no reports are included in this message. The next five bits in the Control field contain a count of the characters in the sending station name (a count of 0 indicates a 32-character address).

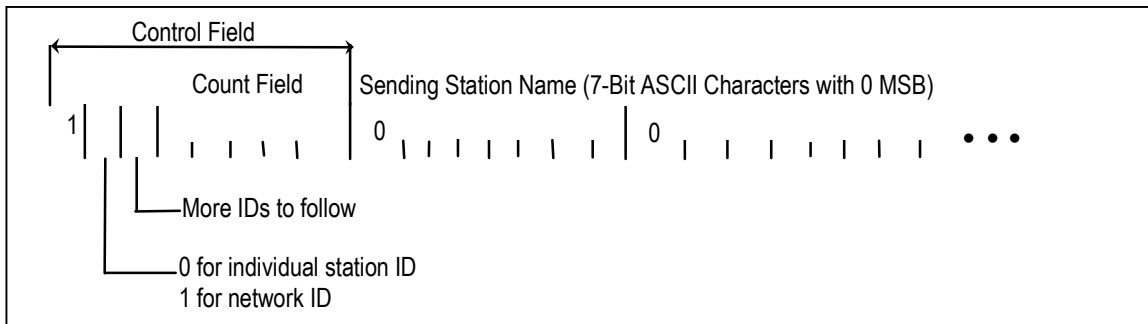
The second 8 bits of the header begin with 2 bits set to 1 and 0 respectively, followed by the Max Age and Max Relays fields. The Max Age and Max Relays fields apply to CONEX requests; the

responding station shall only return reports whose Age and Relays fields do not exceed these limits (all 1's in a field means no limit). The Control field is followed by the number of ASCII characters indicated in the Count field, with a 0 most significant bit (MSB) placed before each 7-bit character.



**FIGURE D-7. CONEX header.**

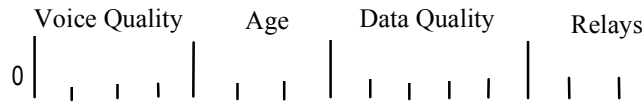
c. Station and network IDs have a structure similar to the CONEX header. Each begins with an 8-bit Control field, which is followed by the ASCII characters composing the name of that station or network (see figure D-8). The first bit is set to 1. The second bit is set to 0 for an individual station identifier, and to 1 for a network identifier. The third bit is set to 0 in the last ID in the CONEX message, and to 1 for all of the preceding station and network IDs. The last five bits in the Control field contain a count of the characters in the station or network name. The Control field is followed by the number of ASCII characters indicated in this count, with a 0 MSB placed before each 7-bit character.



**FIGURE D-8. CONEX station or network ID.**

d. Each report in a CONEX message refers to the best path from the sending station to a specified destination. When the report is preceded by a station ID, the report pertains to the best path to that station. When the report is one of a sequence of reports following a network ID, the destination station is known implicitly from the position of the report in that sequence.

e. Each report contains four fields as shown on figure D-9: the minimum number of relays between the sending station and the destination station (3 bits); end-to-end quality of the best path(s) to the destination for voice or data use (4 bits for voice quality and 5 bits for data quality); and the age of the oldest data used to compute the voice and data path qualities (3 bits). Note that the first bit is always set to 0.



**FIGURE D-9. CONEX report.**

f. The Age field uses the encoding as shown in table D-V. For 0 through 5 relays in the path, the Relays field contains the number of relays. For 6 or more relays, the Relays field contains 110 (6). When the number of relays is unknown, the Relays field is set to 111 (7).

**TABLE D-V. Age field encoding.**

Age Field	Age of Reported Data
001	0 - 15 min
001	15 - 30 min
010	30 - 60 min
011	1 - 2 hr
100	2 - 4 hr
101	4 - 23 hr
110	23 - 25 hr
111	>25 or unknown

**D.5.2.4.4 CONEX broadcast.**

a. Stations may periodically broadcast CONEX messages containing reports of path quality to selected destinations (e.g., net control stations, gateways to other networks, or distant network members that are difficult for some members to reach). The rate of such broadcasts, the channels used, and the stations included in the CONEX report may be selected by the operator or may be determined adaptively by the networking controller. A CONEX broadcast will typically use an ALE scanning call to a net or group. The CONEX message may be sent using DTM or DBM with the ALE modem; however, an HF data modem should always be used when available.

b. A station receiving a CONEX broadcast should update its path quality matrix using the data received along with link quality data from the link controller receiving the broadcast, as described above.

**D.5.2.4.5 CONEX handshake.**

A CONEX handshake is used to exchange connectivity data among networking controllers. The request bit is set to 1 to request connectivity, and the Max Age and Max Relays fields may be used to restrict the number of reports received. ALE is used to establish the link(s) used, as required; the CONEX messages may be conveyed using either the ALE modem (with DTM or DBM) or a data modem.

#### D.5.2.5 Message delivery.

In the seven layer reference model, the network layer performs end-to-end message delivery, using one or more data links in tandem to carry each message. When HF links are employed, the inherent error rates involved require the use of connection-oriented data links for efficient use of the medium. Such data link protocols guarantee that those blocks of a message that are delivered to the network layer at the destination arrive in order and without duplication. (The DTM and DBM ALE protocols using CRC and ARQ satisfy these requirements, as do other data link protocols used in advanced modems.)

However, data links occasionally fail, so the data link layer cannot guarantee message delivery within a bounded time. A mechanism is required at the network or transport layer to detect and deal with data link failures through the use of retransmission, alternate routing, etc. In the existing DoD internet, this function is performed in the transport layer. Therefore, the HF network layer need only provide datagram service, and its principal function is message routing.

##### D.5.2.5.1 AME header.

The AME header (see D.4.2.4) carries the information used by the network layer for message routing and delivery. This header immediately follows the single-character network layer header (which will be 'M' to indicate that an AME header follows). The AME header contains the following fields:

Quality of Service (QOS)	A single bit indicating whether to emphasize speed of delivery (QOS = 0) or minimum probability of loss or error (QOS = 1) in handling the message.
Precedence	A 3-bit code with 0 as lowest precedence. Used for queuing at relay nodes and determining order of link establishment, order of delivery, etc.
Port	A 4-bit code designating destination port within network controller, analogous to network service access point (NSAP) in the seven layer model. Assigned port numbers are listed in table D-VI.
Header Length	An 8-bit count of the bytes in the AME header, starting with the precedence/port byte and ending with the last character of the source address record.
Message Length	A 16-bit count of the bytes in the transport message following the AME header (does not include the network layer header or AME header bytes).
Relay(s)	Zero or more address records (see address record format description). When relays are specified, they may be either suggested relays or mandatory relays. When mandatory relays are specified, the message must be routed through the relays listed in the order given. Suggested

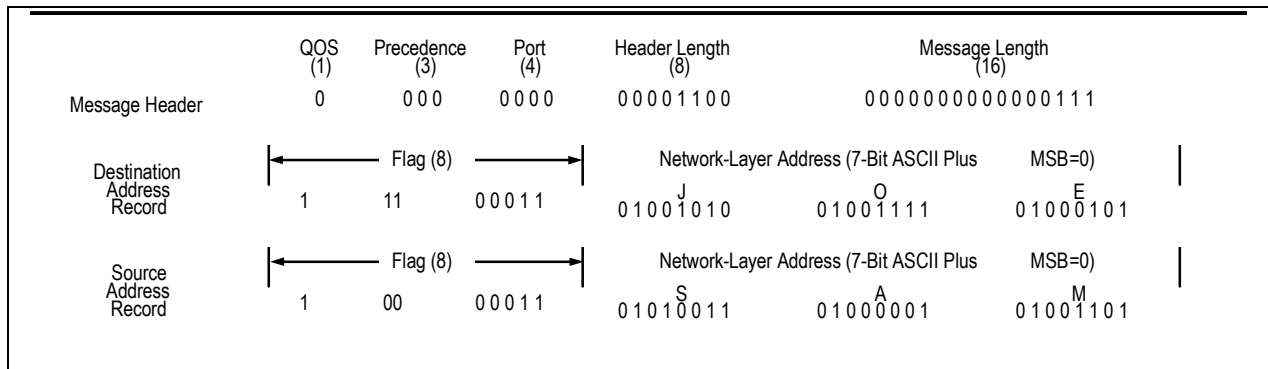
relays are offered for consideration by the route selector in addition to alternatives found in the routing table.

Destination(s)	One or more address records. The message body should be delivered to all destination addressees.
Source	One address record, specifying the address of the station that originated the message.

An address record is structured as an 8-bit flag, followed by a network layer address of ASCII characters with a 0 MSB placed before each 7-bit character. The MSB of the flag is a 1. The next two bits encode the record type: 0 for a source address record, 1 for a mandatory relay, 2 for a suggested relay, and 3 for a destination. The five least-significant bits contain a count of the characters in the address. Address characters have MSB = 0. An example of an AME header and address record is shown on figure D-10.

**TABLE D-VI. Port numbers in AME header.**

Port Number	Transport Message Destination
0	Operator Terminal
1	Automatic Message Exchange Control Channel
2	Operator Storage
3	HF Transport Protocol (HFTP)
4	Connectionless Network Protocol (CLNP)
5	Internet Protocol (IP)
6	HF Network Management Protocol (HNMP)
All Others	Reserved Until Standardized



**FIGURE D-10. Example AME message header and address record.**

**D.5.2.5.2 Message store and forward.**

The store and forward process accepts messages from, and delivers messages to, users (or transport-level processes). Each transport message to be sent is accompanied by the network layer addresses of its destination(s). For each transport message to be sent, the store and forward function groups the network layer destination address(es) according to the first relay on the path to each addressee (obtained from the route selection function), or the final destination if a direct path is the best path. For each such group, an AME header is formed. The header contains the



destinations that share an initial relay station. The transport message is appended to this header to compose a network message. These network messages are passed to the local AME process for delivery.

As network messages arrive from other stations and are delivered to the store and forward function by the local AME process, the AME header of each is removed and processed as follows:

- a. If any of the destination addresses in the header are self addresses, the embedded transport message is delivered locally as specified in other fields (precedence and port) of the header.
- b. All self addresses are removed from the header.
- c. If any destinations remain, those addresses and the transport message are handled as discussed above for a new outgoing message.

#### D.5.2.5.3 Null store and forward function.

A null store and forward function may be used in place of the message store and forward process described above when automatic message routing is not needed. The null store and forward function shall form AME headers for outgoing messages and process the AME headers from incoming messages as follows.

##### D.5.2.5.3.1 Outgoing messages.

For each outgoing message, the null store and forward function shall create an AME header with pre-programmed values in all fields, except that the header length and message length fields shall be computed for the actual message and AME header. The user (or transport layer process) shall be able to override the default values. Normally, the user will override only the default destination address, the precedence, and the port fields. A user may insert relay addresses for manual source-routing. If the user is able to override the source address, this capability should normally be restricted to selecting one of a set of pre-programmed addresses (to preclude impersonation of other stations).

##### D.5.2.5.3.2 Incoming messages.

The destination and relay address records in the AME header of each incoming message shall be examined. If a self address is found in any of these address records, the message and the AME header shall be delivered to the user. (This permits users to manually relay messages.)

#### D.5.2.5.4 AME.

AME is the network layer function concerned with single-link message delivery. It works with either a full store and forward process or a null store and forward process. In the following paragraphs, the term “store and forward process” refers to either implementation of the store and forward functionality.

NOTE: AME provides a simple datagram service, with no acknowledgments, error checking, or flow control.

#### D.5.2.5.4.1 Outgoing messages.

Each network message passed to the AME process from the store and forward process contains an AME header and a transport message. The AME process shall interpret the first address record in the AME header as the desired destination for that message.

Outgoing messages from the store and forward process shall be queued by the AME process for transmission in order of precedence. The AME process requests a link to the destination of each message from the link selection function. When the link selection function indicates that a link to that destination is available, the AME process shall attach a network layer header (the character "M") to the front of the message, translate the network layer address to a data link layer address appropriate for the selected data link controller, and provide the network message and the translated address to that controller for transmission.

If a direct link cannot be established to the destination, the AME process shall take one of two actions:

- a. Return the message to the store and forward process as undeliverable (appropriate if the store and forward process can attempt alternate routing).
- b. Store the message for later delivery when a link can be established.

In the latter case, messages should be stored in separate queues for each destination so that only one series of linking retries is made for each destination (rather than one for each queued message). The first retry shall be made after a time sufficient for a busy station to have resumed listening for linking attempts. To minimize use of the spectrum for futile linking attempts, subsequent retries shall occur at intervals sufficient for propagation to have measurably improved. (The retry interval may be shortened when a queue contains high-priority messages.)

When contact is eventually made with the desired destination, whether through a successful linking retry or through connectivity discovered by reception of a message from that station, messages queued for that destination shall be sent in decreasing priority order.

#### D.5.2.5.4.2 Incoming messages.

Incoming messages are delivered to the AME process when their network layer header is "M" (user messages). The AME process shall simply strip this single-character network layer header and pass each received message to the store and forward process for processing.

#### D.5.2.6 Relay management protocol.

The HF relay management protocol (HRMP) shall be used by HF networking controllers to inquire about connectivity through prospective relay stations, to manage repeater operation, and to preempt repeater circuits, as described in D.5.2.6.6. HRMP is a connectionless protocol, although it can be used to set up analog tandem circuits or data virtual circuits.

Every HRMP message refers to three stations: the first is the Relay station (actual or potential); the second is the Control station managing the relay; the third is the Distant station to which

access is provided by the relay. HRMP messages are exchanged between the Control station and the Relay station.

HRMP messages shall be formatted as shown on figure D-11. The fields in HRMP messages shall be encoded as described in the following paragraphs.

Msg. Dest.	Msg. Source	Desired Dest.	Msg. ID	Msg. Length	Command	Arguments	Checksum
------------	-------------	---------------	---------	-------------	---------	-----------	----------

**FIGURE D-11. HF relay management protocol message format.**

**D.5.2.6.1 HRMP address field.**

Three station addresses are present in every HRMP message: that of the station sending the message (Msg. Source), that of the station to which an indirect path is sought or desired (Desired Dest.), and that of the station receiving the message (Msg. Dest.). The Desired Dest. shall always be the Distant station. The Msg. Source and Msg. Dest. shall be the Control and Relay stations, respectively, for Control-to-Relay messages, and vice versa for Relay-to-Control messages.

The addresses of all three stations shall be encoded as AME address records in accordance with D.5.2.5.1.

**D.5.2.6.1.1 Message destination.**

The Msg. Dest. field on figure D-11 shall contain the address of the Relay station, with a suggested Relay flag, when the message direction is Control-to-Relay. For Relay-to-Control messages, the Msg. Dest. field shall contain the address of the Control station with a source flag.

**D.5.2.6.1.2 Message source.**

The Msg. Source field on figure D-11 shall contain the address of the Control station, with a source flag when the message direction is Control-to-Relay. For Relay-to-Control messages, the Msg. Source field shall contain the address of the Relay station with a suggested Relay flag.

**D.5.2.6.1.3 Desired destination.**

The Desired Dest. field on figure D-11 shall always contain the address of the Distant station, with a Destination flag.

**D.5.2.6.2 HRMP message identification field.**

The Msg. ID on figure D-11 field shall contain an 8-bit number used by the Control station to match responses with requests. Responses from the Relay station shall contain the same Msg. ID as is found in the corresponding Request from the Control station. Messages from the Relay station other than responses shall set this field to all 1s.

**D.5.2.6.3 HRMP length field.**

The Msg. Length field on figure D-11 shall contain the number of bytes in the entire HRMP message, from the first byte of the Msg. Dest. field through the last byte of the Checksum.

D.5.2.6.4 HRMP commands.

The HRMP command field on figure D-11 shall contain one of the 8-bit codes listed in table D-VII. (Unlisted codes are reserved and shall not be used until standardized.) The use of these commands is described in D.5.2.6.6.

**TABLE D-VII. Relay management commands.**

Code	Command	Arguments
0	ACK	(None)
1	Query	Type, QOS, precedence
2	Query-response	Type, QOS, precedence
4	Connectivity-change	Connectivity code
5	Monitor-connectivity	Cx Monitor
8	Repeater-status	Rept. No., type, QOS, status
9	Repeater-request	Type, QOS, precedence
10	Repeater-lost	Rept No., reason code
11	Repeater-status-request	Repeater number
13	Release-repeater	Repeater number
255	NAK	Reason code

The encoding of the arguments to these commands is given in table D-VIII. (Unlisted codes are reserved and shall not be used until standardized.) Arguments shall be sent in the order listed in table D-VIII.

**TABLE D-VIII. Encoding of HRMP arguments.**

<b>Argument</b>	<b>Format</b>	<b>Encoding</b>
Reason code	8-bit unsigned	0 - No connectivity 1 - Precedence too low 2 - Inappropriate 255 - Not equipped
Type	2-bit unsigned	0 - Analog repeater 1 - Digital repeater (Usually frame repeater) 2 - Store and forward
QOS	6-bit field	Each bit independently selects a quality-of-service aspect; if bit = 1, better than normal performance in this aspect is requested QOS1: (MSB) Delay QOS2: Throughput QOS3: Reliability QOS4: Noise QOS5: (Reserved) QOS6: (LSB) (Reserved)
Precedence	8-bit unsigned	0 - Routine (lowest) 64 - Priority 128 - Immediate 192 - Flash 250 - Flash override 254 - Reserved for inter-network control use 255 - Reserved for network control use*
Connectivity	8-bit unsigned	0 - Discovered direct connectivity 1 - Discovered indirect connectivity 254 - Lost direct connectivity (have indirect) 255 - Lost all connectivity
CX Monitor	8-bit unsigned	0 - Broadcast all changes of connectivity to distant stations 1 - Broadcast only lose or discovery of connectivity: do not report transactions between direct and indirect
		128 - Report all changes in connectivity 129 - Do not report connectivity changes
Repeater No.	8-bit unsigned	Repeater reference number assigned by relay station
Status	8-bit unsigned	0 - Repeater fully operational 1 - Requesting link to distant station 2 - Link to distant station failed; attempting to re-establish link 3 - Repeater preempted 255 - Repeater not available
<p>* NOTE: Any number from 1 through 253, except those standardized herein (0, 64, 128, 192, and 250) may be used for user unique precedence requirements.</p>		

#### D.5.2.6.5 Checksum.

The 16-bit Checksum shall be computed in accordance with D.5.2.9.

#### D.5.2.6.6 HRMP operation.

Allowed exchanges are listed in the following paragraphs for each of the classes of relay control actions supported by the HRMP. HRMP exchanges are one of two types:

- a. Request-response. A control station sends a request to a Relay station and starts a timer. If a response is received before the timer expires, the protocol completes successfully. Otherwise, the Control station should abort the exchange. Lack of a response indicates loss of connectivity to the Relay station; thus, a retransmission should not be initiated until sufficient time has elapsed for connectivity to be restored (either improved propagation or resumption of operations at the Relay station).
- b. Notification. A Relay station sends an unsolicited message to a Control station to announce an event asynchronously. Such events include preemption of a repeater in use by the Control station or loss of connectivity to a Distant station being monitored at the request of the Control station.

##### D.5.2.6.6.1 Routing queries.

A station seeking to find an indirect path to a Distant station sends a query to prospective relay(s). A station receiving a query shall respond with a NAK in any of the following cases:

- a. It lacks the facilities to provide the services requested (reason code = not equipped).
- b. It has facilities, but they are not available for a request of the stated precedence (reason code = precedence too low).
- c. It has available facilities, but has no connectivity to the requested Distant station (reason code = no connectivity).

A station having available facilities that at least approximate the requested service and having connectivity to the requested Distant station, shall return a query response that describes the type and quality of service it can provide. Note that routing queries may be made for either message store and forward service or repeater service.

##### D.5.2.6.6.2 Repeater control.

Both analog and digital repeaters may be remotely controlled through the use of the Repeater control commands. When a repeater is engaged using HRMP, the Relay station shall assign a repeater number (analogous to a virtual circuit number) for unambiguous reference to the circuit established.

- a. A repeater request shall specify the type and quality of service desired (just as in a query). If the repeater can be engaged, the Relay station shall return a repeater status response which contains the assigned repeater number and type and quality of service actually provided. Otherwise, (see conditions in D.5.2.6.6.1) a NAK shall be returned.

NOTE: A repeater request specifying store and forward shall elicit a NAK with a reason code of “inappropriate” because the store and forward function cannot be seized.

b. A repeater status request sent by a Control station to inquire about the operational status of a previously engaged repeater shall carry the repeater number assigned when it engaged that repeater. The Relay station shall respond with a NAK if the specific repeater is not currently assigned to the Control and Distant stations specified in the message; otherwise, it shall respond with a repeater status message that describes the type, quality of service, and current status of the specific repeater.

c. A Control station shall release an engaged repeater by sending a release repeater message. The Relay station shall send a NAK under the conditions described above for repeater status requests; otherwise, the Relay station shall terminate the link to the Distant station, disengage the repeater, and return a repeater status message containing a status code of “repeater not available.”

d. When a Relay station cannot sustain a previously engaged repeater service, it shall send a repeater lost message to the affected Control and Distant stations. For each intended recipient of the repeater lost message, the address of that station shall be encoded as the Msg Dest using a source address record, and the third party to the repeater service shall be encoded as the Desired Dest using a Destination address record. If the repeater service is terminated because of loss of connectivity, the reason code shall be “no connectivity.” If the repeater was preempted, the reason code shall be “precedence too low.”

Loss of a link to one party of a repeater service shall not result in a repeater lost message and termination of the repeater service until attempts to automatically re-establish the link have failed. During link re-establishment, the repeater status shall be reported as code 2 in responses to repeater status requests.

#### D.5.2.6.6.3 Connectivity monitoring.

Connectivity monitoring is a notification-based alternative to connectivity exchange (D.5.2.4). A Monitor Connectivity message requests that the named Relay station monitor (or cease monitoring) its connectivity to the named Distant station. Notification options include broadcasting connectivity changes to all stations, or reporting changes to a named control station, or cease reporting changes in its ability to reach that Distant station. If the Distant Station field contains the network broadcast address (D.5.2.8), the Relay station shall perform the indicated command for all stations.

Notification of a change in connectivity shall be sent in a connectivity change message. A connectivity change message may be broadcast by addressing it to the network broadcast address (D.5.2.8). The arguments defined for the monitor connectivity and connectivity change

messages support two levels of detail in this service: notification only of loss and discovery of connectivity, or notification of transitions between direct and indirect connectivity as well.

D.5.2.7 Station status protocol.

The HF station status protocol (HSSP) shall be used to notify network members of changes in the operating mode of a station. HSSP messages shall be formatted as shown on figure D-12.

Source Addr	D	New Status	Event Time	Duration	Checksum
-------------	---	------------	------------	----------	----------

**FIGURE D-12. Station status message format.**

- a. The Source Addr field shall contain the address of the station sending the message, encoded in an address record (see D.5.2.5.1) with a source flag.
- b. The “D” bit shall be set to 1 if and only if the Duration field is present.
- c. The 7-bit New Status field shall report the new status of the reporting station as of the date and time indicated in the Event Time field, using the codes listed in table D-IX.

**TABLE D-IX. Station status codes.**

Code	New Status
0	Normal operations
1	Assumed net control (from non-net control stations)
2	Relinquishing net control (from net control station)
3	Radio silence
4	Reduced power
5	Alternate scan set 1
6	Alternate scan set 2
7	Alternate scan set 3
127	Out of service

- d. The Event Time field (24 bits) shall contain the date and time that the new status will be effective for the station in accordance with figure D-13, except that an Event Time field containing all 1’s indicates that the new status is effective immediately after the message was sent. The Event Time shall be encoded in Zulu time (i.e., universal time, coordinated (UTC)), with the year digit holding the least-significant digit of the event year.

4	4	5	5	6
Year (0 - 9)	Month	Day	Hour	Minute

**FIGURE D-13. Event time encoding.**

- e. The optional Duration field (24 bits) shall be encoded in accordance with figure D-13 to indicate the expected duration of the status change.
- f. The 16-bit Checksum shall be computed in accordance with D.5.2.9.



NOTE: No length field is needed to determine the number of bytes contained in an HSSP message because the only variable-length field in the message is the Source address record, which contains an internal length field.

#### D.5.2.8 Network broadcast address.

Where permitted by network layer protocols, the broadcast address “@ ? @” (identical to ALE Allcall address) may be used to collectively refer to all reachable stations.

#### D.5.2.9 Checksum computation.

The 16-bit Checksum in network layer messages shall be computed as the 16-bit 1's complement of the one's complement sum of all relevant 16-bit words (either all words in the AME header or all words in the message for HRMP or HSSP). If the Checksum is to be computed over an odd number of bytes, the final byte shall be padded on the right with a 0-filled byte. For purposes of computing the checksum, the Checksum field itself shall be filled with 0 bits.

#### D.5.2.10 Data transmission order.

The order of transmission of the headers and data composing the messages described in this section (i.e., connectivity exchange, AME, relay management, and station status messages) is resolved to the octet or character level.

The bytes of these messages shall be transferred in the order left-to-right then top-to-bottom, just as English words are read. In the case of multibyte fields, this means that the most significant (i.e., left-most) byte is transferred first.

CONEX messages consist of 7-bit “characters” while messages from the other protocols consist of 8-bit bytes. In all cases, the bytes (or characters) of these messages shall be transferred in the order left-to-right then top-to-bottom, just as English words are read. In the case of multibyte (multicharacter) fields, this means that the most-significant (i.e., left-most byte (character) is transferred first.

NOTE: The order of bit transmission within these units is determined by the data link protocol used and is transparent to network layer protocols. For example, ALE conveys data most significant bit first, while the HF Data Link Protocol (HFDLP) and most computer serial ports convey data least significant bit first. The HFDLP is contained in Appendix G. Although this data link protocol orders multibyte values within its own header least significant byte first, network layer messages are conveyed to data link protocols as individual bytes (i.e., multibyte fields appear only as a sequence of bytes to the data link protocol), and are carried on the data link in the order determined by the network layer entity.

#### D.5.3 Network management.

Programs that provide network management functionality are not standardized. Interoperation among such network management systems, however, requires the standardization of protocols for examining and changing the state of network elements, and of the abstract data objects

(management information) manipulated using the HNMP protocol. The protocol requirements are identified in D.5.3.2, and the management information requirements are defined in D.5.3.3.

#### D.5.3.1 Terminology.

Managed network elements (e.g., radios, ALE controllers, data modems, and networking controllers) are monitored and controlled by embedded network management agents (processes) which have access to the operating data of the elements and can initiate actions in those elements. Network management stations communicate with the agents to request the values of operating data, and to request that operating data be changed. Actions in management elements are produced as side effects when operating data are changed. For example, changing the antenna Mode value for a rotatable antenna causes the antenna to rotate (see Management Information Base (MIB), Appendix H, for the definition of antenna mode).

#### D.5.3.2 Management protocol.

SNMPv2, in accordance with RFC 1441 through 1452 shall be employed for HF network management, with the following additional requirements (see D.4.4.3).

- a. An agent receiving a SetRequest that selects a non-existent row in a table shall automatically create the requested row subject to resource availability, setting column objects in the new row to their default values unless other valid values are specified in the SetRequest message. However, if any value in the SetRequest message specifies an invalid value for any column object in the new row, the new row shall not be created, and a GetResponse message shall be returned indicating the erroneous variable binding.
- b. Table rows invalidated by a SetRequest shall not be reported in responses to GetNextRequests (i.e., from the point of view of management stations, invalidated rows are deleted from the table).
- c. Object identifiers for objects defined in the HF MIB (see Appendix H) may be encoded for transmission within HF networks only using the truncated encoding scheme of D.5.3.3.2. Gateways that connect HF networks to non-HF networks, however, shall ensure that object identifier encodings in messages entering non-HF networks use the full encoding of ISO/International Electrotechnical Commission (IEC) 8825; SNMP messages entering HF networks may be translated to use truncated encodings.
- d. Retransmission timeouts in network management programs shall be adjusted to allow time for link establishment, and for the transmission of requests and responses over modems that may be able to achieve throughputs of 100 b/s or less.

##### D.5.3.2.1 Inside local HF station.

The relationship of the network management protocol to the other protocols in use within an HF station is shown on figure D-14. HNMP requires only a connectionless datagram transport service (e.g., the UDP). Consequently, figure D-14 shows HNMP using UDP for a Transport-layer protocol, IP for an Internet-layer protocol, and the HF AME protocol (D.5.2.5) as the Network-layer protocol. IP datagrams sent through the HF AME protocol shall use port number 5 in the network message header (AME header). Figure D-14 also shows integration of IEEE

802 protocols as an illustration of the use of HNMP over an Ethernet local area network. Other network protocols may be integrated similarly.

D.5.3.2.2 Outside local HF station.

When interoperation with management stations outside the local HF sub-network is not required, UDP and IP may be eliminated to reduce the overhead of network management messages. In this case, messages shall be directed to AME port number 6, which is a direct connection to HNMP.

Application	HNMP		
Presentation			
Session			
Transport	UDP		
Internet	IP		
Network	AME		
Data Link	ALE	HFDLP Appendix G	IEEE 802.2
Physical	ALE Modem	MIL-STD-188-110 Modem	IEEE 802.3 (CSMA/CD)
	MIL-STD-188-141 Radio		

**FIGURE D-14. Interrelationship of protocols.**

D.5.3.3 Management information.

SNMP functions by reading and writing data structures defined for each item of controlled equipment. These data structures are defined using an abstract syntax so that the details of how the data are stored by individual network components are hidden. For example, aleScanRate (the rate at which an ALE controller scans channels as defined in the HF MIB, Appendix H) is simply defined to be an integer, with no indication of byte order, or even the number of bytes used to represent it on any particular ALE controller.

- a. Furthermore, some ALE controllers may store channel dwell time instead of scan rate, in which case a conversion from dwell time to or from scan rate is made whenever aleScanRate is read or written. This illustrates the fact that the objects manipulated by a network management station need not correspond directly to the internal data structures of managed elements. A principal function of agents in managed elements is the translation between the

abstract objects used in the management protocol and the actual data structures used in equipment.

- b. The objects that may be read and written using HNMP are defined in modules using Abstract Syntax Notation One (ASN.1), ISO/IEC 8824. RFC-1450 defines the objects commonly used to manage TCP/IP internets. The standard objects for HF network management are identified in the HF MIB, D.5.3.3.1. Objects specific to each manufacturer's equipment are specified in a MIB provided by that manufacturer. A management station integrates MIB modules from the elements it manages, resulting in access to a wide-ranging and dynamic set of management data. The structure of MIBs is defined in RFC-1442.
- c. When data is exchanged over the air (or some other medium), all parties involved in the exchange shall use the same encodings for the data. The HNMP encoding rules are specified in D.5.3.3.2.

#### D.5.3.3.1 HF Management information base (MIB).

The HF MIB is contained in Appendix H. The MIB module contains groups of objects for radios (and related RF equipment), ALE controllers, linking protection, HF data modems (and associated data link controllers), and networking controllers. HF equipment complying with this paragraph shall implement the corresponding group of objects from the HF MIB, although access to these objects may be provided by proprietary protocols rather than HNMP (requiring proxy management, D.5.3.4). As a DO, new equipment should support HNMP directly.

#### D.5.3.3.2 Encoding rules.

Object names and values sent in HNMP messages shall be encoded in accordance with the Basic Encoding Rules for ASN.1, found in ISO/IEC 8825, with an optional truncated encoding for OBJECT IDENTIFIERS of objects from the HF MIB, as specified in the following text. Such truncated encodings shall not be used in messages outside HF networks.

- a. The object names used in variable bindings in HNMP messages are OBJECT IDENTIFIERS, which authoritatively identify each object named by specifying the location of its definition in a tree of standards. For objects defined in the HF MIB, the OBJECT IDENTIFIER may employ a truncated path that begins in the HF MIB, using the unique code 123 (decimal) to indicate that the path to the definition begins in the HF MIB. For example, the ALE self address table may be identified as 123.2.16.
- b. For an object defined for general use (i.e., not HF-specified), HNMP messages shall carry the normal OBJECT IDENTIFIER for the object. For example, the sysDescr object shall be identified as 1.3.6.1.2.1.1.1 (which traces the following path: iso(1) org(3) dod(6) internet(1) mgmt(2) mib-2(1) sys(1) sysDescr(1)).

#### D.5.3.4 Proxy management.

When elements do not implement HNMP, they may still be managed by using proxy agents that translate the standard HNMP messages into proprietary messages understood by the non-HNMP ("foreign") elements.

NOTE: As HNMP management of HF radio networks is phased in, few network elements will initially implement HNMP. Proxy agents will be needed to extend the management capability to current-generation equipment. As a general rule, the proxy agent for any foreign network element should reside in the lowest-level controller (see figure D-14) that has a control path to that element.

- a. In operation, HNMP traffic that is directed to a foreign element will be delivered to the proxy agent. The proxy agent shall translate the request into an appropriate message for the target element, in terms of the native control protocol for that element, and pass the translated message to the foreign element over any available control circuit. Responses received from the foreign agent shall be translated into HNMP messages and passed to the requesting management station.
- b. For efficiency purposes, proxy agents may cache frequently requested variables from foreign elements so that some traffic on the control paths within a station is eliminated.

NOTE: Variable caching necessitates messages from the foreign element to the caching proxy agent to either update or invalidate cached copies when cached variables are changed by other than the proxy agent (e.g., from an element front panel).

#### D.5.3.5 Access control.

Access to the management information of network elements is controlled in HNMP at two levels.

- a. The first level is an administrative model that restricts the objects at each element that are accessible to other parties and the operations that may be performed by those parties.
- b. The second level of access control is authentication of messages, that is, determination that a message actually comes from the party named in the message.

##### D.5.3.5.1 Administrative model.

HNMP agents and management applications shall employ the administrative model of RFC-1445. Object identifiers for parties and contexts shall be assigned by network administrators, who shall in turn obtain space in the tree of object identifiers from the preparing activity of this standard. Transport domain identifiers specific to HF networks are defined in the HF MIB.

##### D.5.3.5.2 Authentication.

The following three authentication schemes should cover the range of requirements for HF networks. Management stations shall employ only the trivial authentication protocol in HNMP messages, unless the addressed party is known to support a more secure authentication protocol. All HNMP agents must therefore support the trivial authentication protocol, although the access permitted trivially-authenticated parties to management information may be restricted.

NOTE: Since HNMP uses a broadcast medium, it is susceptible to injection of false messages by hostile forces. HF networks should strive for the highest possible level of authentication necessary for the mission to minimize this risk.

#### D.5.3.5.2.1 Trivial authentication.

When trivial authentication is employed, an agent receiving an HNMP message shall compare the Transport-layer address of the originator of the message to a list of authentic Transport-layer addresses for the party sending the message. If a match is found, the agent shall assume the message is authentic. When Transport-layer addresses are not used, agents may either use lower-layer addresses for authentication, or simply assume that all messages are authentic, as determined by network management policy for each network.

#### D.5.3.5.2.2 Personal identification number (PIN) authentication.

An intermediate level of security may be achieved through the use of PIN authentication. When PIN authentication is employed, network management programs shall prompt the station operator to enter a PIN. The network management program shall then insert this PIN as the authInfo in every SnmpAuthMsg that carries a request protocol data unit (PDU). Agents receiving these requests shall compare this PIN to a list of authentic PINs for the named party as in D.5.3.5.2.1 above.

Response and trap messages from agents shall carry the serial number of the responding device in place of a PIN. These serial numbers should be verified using a local table before assuming that a response or trap message is authentic.

NOTE: This scheme can be easily spoofed by duplicating PINs and serial numbers intercepted from prior traffic. Because SetRequests may be more important to authenticate than responses and traps, the lists of valid PINs should be varied with time to heighten protection against bogus request messages.

#### D.5.3.5.2.3 Cryptographic authentication.

A secure authentication scheme for SNMP is specified in RFC-1446, section 3. This digest authentication protocol includes a digest of each authenticated message at the beginning of the message (authInfo in the SnmpAuthMsg). This digest is computed from the message contents and a secret initialization vector in such a way that it is considered computationally infeasible to “spoof” the authentication system. A time-of-day mechanism is included as well to limit the effects of replay attacks.

When cryptographic authentication of HNMP traffic is required, the digest authentication protocol of RFC-1446 shall be employed, using the MD-5 Message Digest Algorithm of RFC-1321. Initialization vector distribution is beyond the scope of this standard.

#### D.5.3.6 Traps.

HNMP messages containing traps are sent by managed elements to management applications to announce exceptional events, such as equipment failures or degradation of operating parameters beyond programmed thresholds. Trap messages may be used to reduce the required rate of polling for most such events.

**D.5.4 HFNC interface to local equipment (station data bus).**

The protocols specified in this section provides an optional interoperable mechanism to support the functionality specified in D.4.2.8.1 through D.4.2.8.3 for interconnecting an HFNC to one or more external link controllers (see figure D-15), as well as to other external equipment.

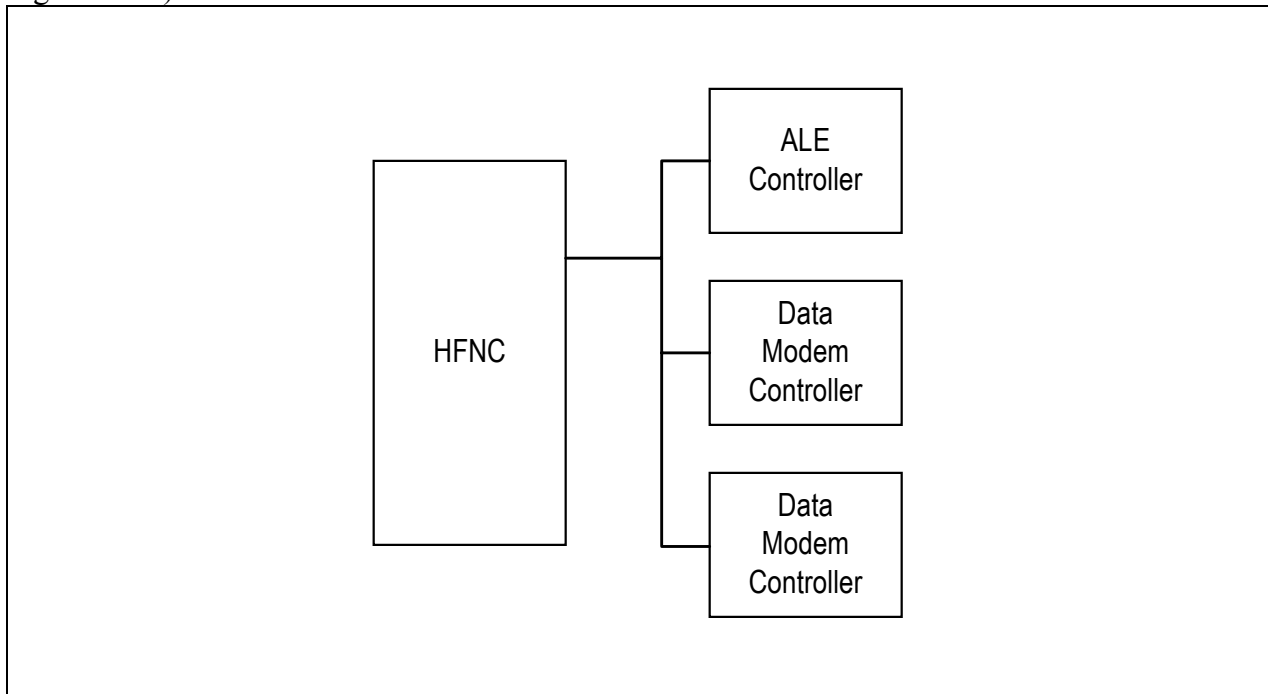
NOTE: Use of this optional communication interface is dependent on the system configuration and performance requirements. This interface will not normally be used between devices interconnected by a high-speed “backplane” bus.

The specific functions specified in D.4.2.8.1 and D.4.2.8.2 should be implemented using HNMP and the following objects from the HF MIB:

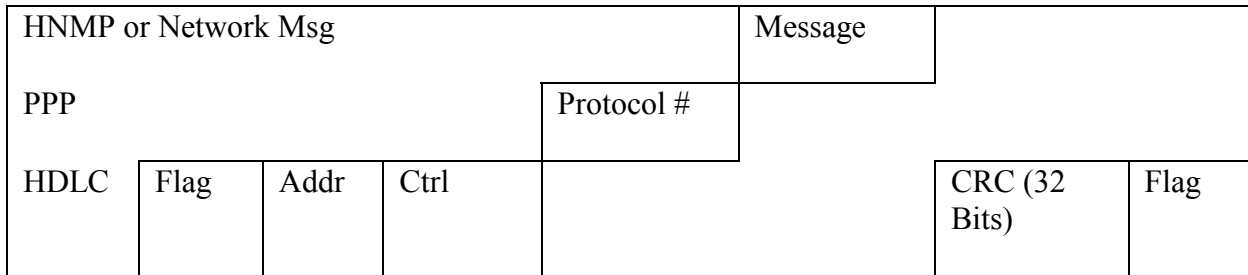
- a. Link control should use the aleConnectionTable for management of ALE links, and hfdlpLinkState and hfdlpOtherAddress for management of HFDLP links.
- b. Link quality reporting should use the aleLqaMatrix for link quality data.

Access to these MIB objects in local equipment shall employ HNMP messages sent directly to those devices using the station data link protocol specified in D.5.4.2. These messages will not use the network-layer header, AME header, and optional IP and UDP headers that are needed for sending messages through the network. That is, these are not “network messages.”

Network messages (messages sent to other stations) should use the station network message format specified in D.5.4.1. Network messages in this format are carried over the station data bus (D.5.4.3) within the data link frames of the Station Data Link Protocol (see D.5.4.2 and figure D-16).



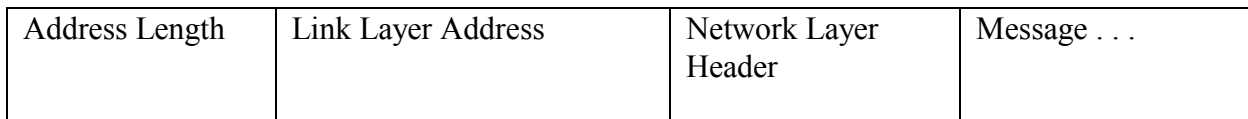
**FIGURE D-15. Station data bus.**



**FIGURE D-16. SDLP frame structure.**

**D.5.4.1 Station network message format.**

The standard format for network messages passing between HFNCs and link controllers is shown on figure D-17. The first octet contains a count of the number of address octets in the link layer address of the distant station (destination of a message from HFNC to link controller, or source of a message from link controller to HFNC). This is followed by the indicated number of address octets, which is in turn followed by the network layer header and the remainder of the body of the network message.



**FIGURE D-17. Station network message format.**

When a link controller receives a network message that specifies a destination to which it is not currently linked, a request to establish that link should be inferred.

**D.5.4.2 Station data link protocol.**

The point-to-point protocol (PPP) HDLC-like framing in accordance with RFC-1662 is recommended for use as a station data link protocol (SDLP) to carry traffic among devices in a station. In this scheme, HNMP and network messages are encapsulated within PPP packets, which are in turn carried in the Information field in HDLC frames (see figure D-16).

Some modifications to this scheme are necessary for SDLP, as detailed below. Padding at the end of the PPP packet is neither necessary nor desirable, and shall not be inserted.

NOTE: Padding can complicate the task of the receiving device.

**D.5.4.2.1 HDLC mode for SDLP.**

Links established by the HFNC shall operate in HDLC Normal Response Mode (NRM) in accordance with ISO/IEC 3309:1991, in which the HFNC acts as the “primary” device and polls the other “secondary” devices. The full range of HDLC frame types is used for SDLP, rather than solely Unnumbered Information frames as specified in RFC-1662.



Octet stuffing in accordance with RFC-1662 shall be used for transparency. This eliminates the need for bit stuffing (commonly required in other implementations of HDLC).

NOTE: The underlying physical layer will normally be asynchronous (rather than octet or bit-synchronous).

#### D.5.4.2.2 Bus arbitration.

Devices within the station shall be assigned one-octet HDLC addresses (the LSB must be 1), with address 1 reserved for the HFNC. The address field in the HDLC frames shall always contain the address of the secondary device (not the HFNC).

PPP links within a station shall be established only by the HFNC; other devices shall transmit frames on the station data bus only in response to "poll" frames from the HFNC (i.e., frames from the HFNC having the poll/final (P/F) bit in the HDLC Control field set to 1).

#### D.5.4.2.3 PPP numbers.

HNMP messages directed to local devices shall be sent using the network control PPP number assigned for HF (see Assigned Numbers RFC). Note that HNMP messages directed to remote devices will be embedded within network messages, following AME and possibly other headers.

Network messages shall use the network-layer PPP number assigned for HF AME.

#### D.5.4.2.4 PPP configuration options.

The following options (at least) should be configured during SDLP link establishment:

- a. Cyclic Redundancy Check (CRC). Default is 16-bit CRC. SDLP implementations should negotiate use of 32-bit CRC in accordance with RFC-1570.
- b. Maximum Received Unit (MRU). Default is 1500 octets. SDLP implementations should negotiate an MRU appropriate to the station error environment.

#### D.5.4.2.5 SDLP link establishment.

The following sequence of frames shall be sent on the station data bus to establish a link from the HFNC to a link controller.

- a. The HFNC selects a link controller by sending a Set Normal response mode (SNRM) HDLC frame addressed to that link controller with the P/F bit set to 1.
- b. The link controller responds with an unnumbered acknowledge (UA) HDLC frame with the P/F bit set to 1.
- c. The HFNC attempts to open a PPP connection by sending an Information HDLC frame that contains a link control protocol (LCP) Configure-Request packet. This packet will specify the PPP configuration options (if any) that the HFNC wishes to change from their default values.

- d. The link controller responds with an Information HDLC frame that carries its response to the Configure-Request (often a Configure-ACK). The HDLC frame from the HFNC is acknowledged in the HDLC header of the response.
- e. Additional PPP LCP packets may be exchanged to continue to negotiate, or to authenticate the link establishment. (The details of HDLC Normal Response Mode are implied and not repeated here.)

The SDLP link is established when LCP Configure-Ack packets have been sent and received. Thereafter, HDLC Information frames are used to carry PPP packets carrying HNMP and network messages as described in D.5.4.3.

NOTE: Because the HFNC must poll a link controller before the link controller may transmit, links may remain in existence between uses, and this link establishment procedure need not be executed before each message is transferred.

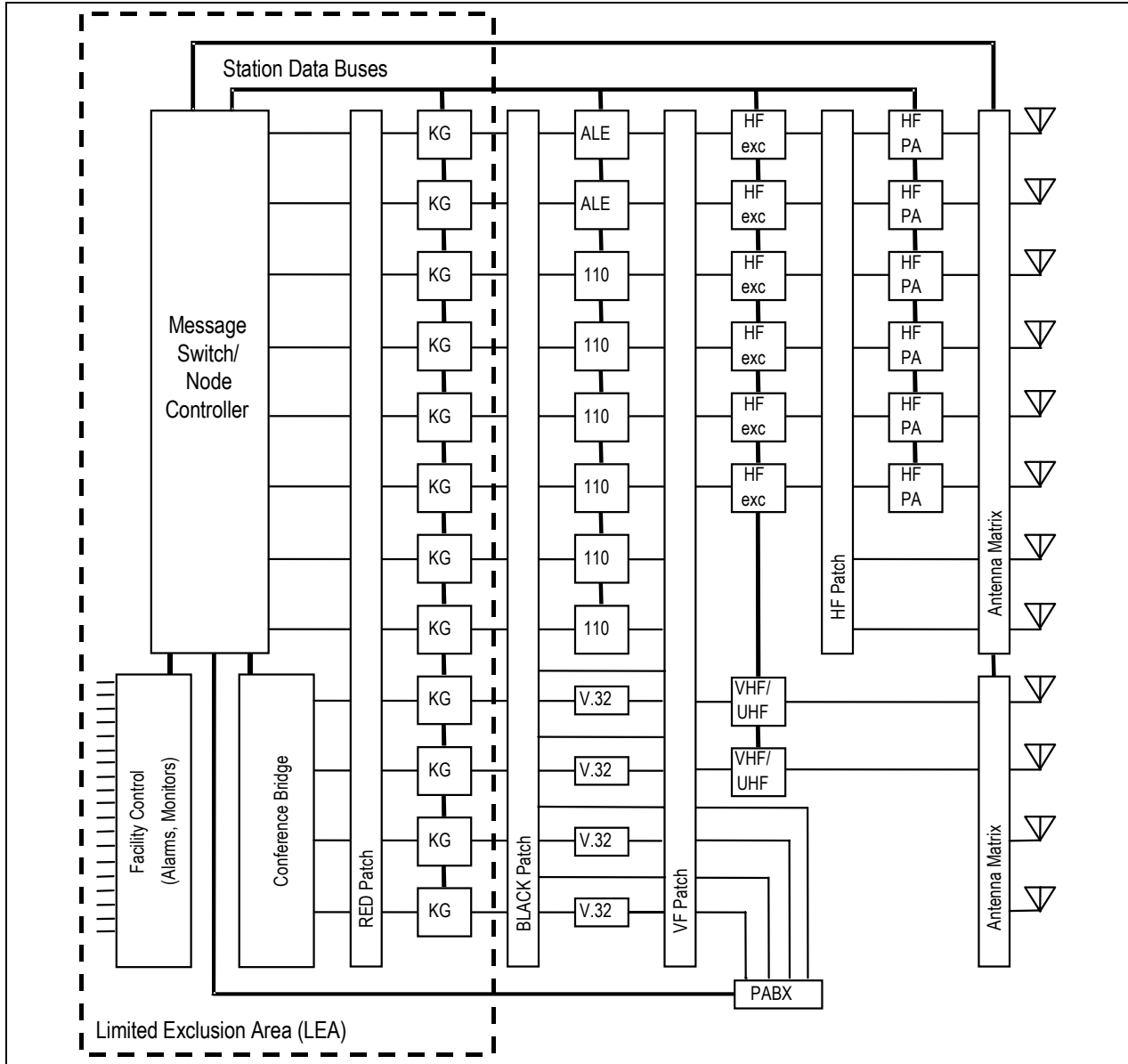
#### D.5.4.3 Station physical layer.

The physical layer protocol of the station data bus employs full duplex asynchronous transmission of 8-bit characters (octets) with no parity and one stop bit. The least significant bit of each octet shall be sent first. All devices should support a data rate of 9600 b/s; other data rates are optional (DO: automatically send and adapt to the data rate in use).

The electrical interface shall be RS-485. The only circuits required are Transmitted Data (balanced), Received Data (balanced), Signal Ground, and Protective Ground. The HFNC shall drive the Transmitted Data circuit, and the other devices shall drive the Received Data circuit.

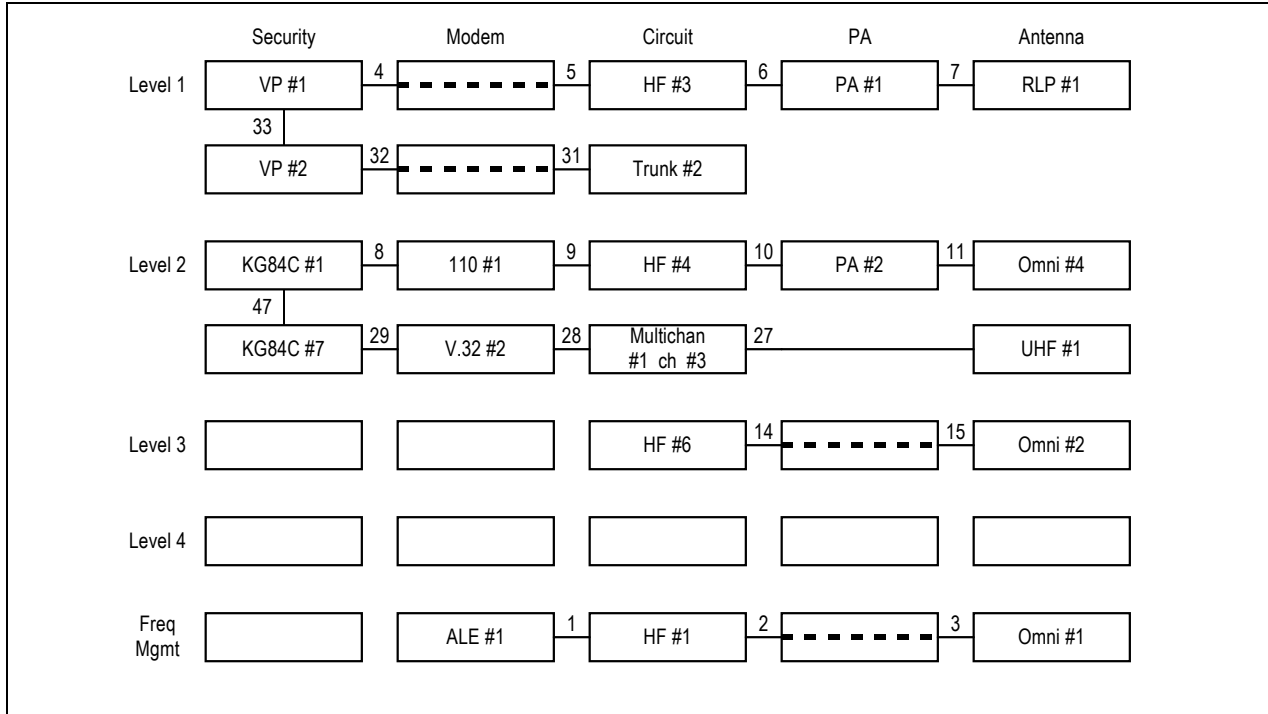
#### D.5.4.4 Examples.

Figure D-18 shows an example application of the station data bus concept in a large, unmanned (lights out) communication station. Because of electrical loading, more than a single station data bus would be required to connect the Message Switch/Node Controller to all of the assets shown.



**FIGURE D-18. Station data bus example.**

Figure D-19 shows a conceptual “pop-up menu” oriented user interface for remotely controlling such a station. For each “level” of equipment, the operator selects devices by choosing from a menu of available devices of each type (e.g., crypto, modems, and radios), and links them together by clicking a mouse button between the rectangles shown. Each connection displayed is numbered with the index of the corresponding entry in the connection figure for the site (see HF MIB).



**FIGURE D-19. Menu-driven remote tech control.**

**D.5.5 Multiple-media operation.**

HFNCs (level 2 or above) shall be capable of automatically routing voice and data traffic via any available data link(s).

- a. Level 2 HFNCs (with static routing tables) must be programmed to use specific media for each destination node. This may be accomplished by any combination of manual or remote programming (e.g., using HNMP).
- b. Level 3 and above HFNCs shall automatically evaluate links of any medium for adaptive routing using the Path Quality formulas (paragraphs D.5.2.1 and D.5.2.4.2).

NOTE: The CONEX messages that carry the data necessary for path quality calculations will be less costly in terms of overhead on high-band-width alternate media than on HF links. In many applications, connectivity exchanges should be restricted to such high-bandwidth links, with query and notification-based protocols employed generally to discover and adapt to changing network topology and connectivity (see D.5.2.6.6.1 Routing Queries, D.5.2.6.6.3 Connectivity Monitoring, and D.5.2.7 Station Status Protocol).

- c. Level 4 HFNCs shall implement the IP and the Internet Control Message Protocol (ICMP), and shall be capable of routing traffic via any available subnet.

**D.6 NOTES.**

None.

APPENDIX E

APPLICATION PROTOCOLS FOR HF RADIO NETWORKS

**TABLE OF CONTENTS**

<b><u>PARAGRAPH</u></b>	<b><u>PAGE</u></b>
E.1 GENERAL.....	491
E.1.1 <u>Scope</u> .....	491
E.1.2 <u>Applicability</u> .....	491
E.2 APPLICABLE DOCUMENTS.....	491
E.2.1 <u>General</u> .....	491
E.2.2 <u>Government documents</u> .....	491
E.2.2.1 <u>Specifications, standards, and handbooks</u> .....	491
E.2.2.2 <u>Other Government documents, drawings, and publications</u> .....	492
E.2.3 <u>Non-Government publications</u> .....	492
E.2.4 <u>Order of precedence</u> .....	492
E.3 DEFINITIONS.....	492
E.3.1 <u>Standard definitions and acronyms</u> .....	492
E.3.2 <u>Abbreviations and acronyms</u> .....	492
E.4 GENERAL REQUIREMENTS.....	493
E.4.1 <u>Introduction</u> .....	493
E.4.1.1 <u>Required HF subnetwork protocols</u> .....	494
E.4.1.2 <u>Support for Internet applications</u> .....	494
E.4.1.3 <u>Security</u> .....	495
E.4.2 <u>Electronic mail transfer</u> .....	496
E.4.2.1 <u>Mail transfer within HF networks</u> .....	496
E.4.2.2 <u>Mail retrieval by call-in users</u> .....	496
E.4.3 <u>Digital imagery transfer</u> . (not yet standardized).....	496
E.4.4 <u>Digital voice operation</u> . (not yet standardized).....	496
E.4.5 <u>Other applications</u> .....	496
E.5 DETAILED REQUIREMENTS.....	497
E.5.1 <u>Introduction</u> .....	497
E.5.2 <u>Electronic mail protocols</u> .....	497
E.5.2.1 <u>HF mail transfer protocol</u> .....	497
E.5.2.1.1 <u>HMTTP command grouping</u> .....	497
E.5.2.1.2 <u>HMTTP over TCP</u> .....	497
E.5.2.1.3 <u>HMTTP without TCP</u> .....	497
E.5.2.2 <u>HF mail retrieval protocols</u> .....	497
E.5.3 <u>Digital imagery protocol</u> .....	498
E.5.4 <u>Digital voice protocol</u> .....	498
E.5.5 <u>Radio facsimile protocol</u> .....	498
E.6 NOTES.....	498

**TABLE OF CONTENTS**  
**(continued)**

<b><u>PARAGRAPH</u></b>	<b>FIGURES</b>	<b><u>PAGE</u></b>
FIGURE E-1. <u>HF application interoperation</u> .....		493
FIGURE E-2. <u>Application interoperation via internet gateway</u> .....		494
FIGURE E-3. <u>Application-layer mail gateway</u> .....		495

## APPLICATION PROTOCOLS FOR HF RADIO NETWORKS

### E.1 GENERAL.

#### E.1.1 Scope.

This appendix contains the requirements for the prescribed protocols and directions for the implementation and use of various communications applications in HF radio networks.

#### E.1.2 Applicability.

Applications provide advanced technical capabilities of automated HF radio. None of the features and functions described in this appendix are mandatory requirements for the user in the acquisition of an HF radio system. However, if the user requires the features and functions described herein, they shall be provided in accordance with the technical parameters specified in this appendix.

### E.2 APPLICABLE DOCUMENTS.

#### E.2.1 General.

The documents listed in this section are specified in sections E.3, E.4, and E.5 of this standard. This section does not include documents cited in other sections of this standard or recommended for additional information or as examples. While every effort has been made to ensure the completeness of this list, document users are cautioned that they must meet all specified requirements documents cited in sections E.3, E.4, and E.5 of this standard, whether or not they are listed.

#### E.2.2 Government documents.

##### E.2.2.1 Specifications, standards, and handbooks.

The following specifications, standards, and handbooks form a part of this document to the extent specified herein. Unless otherwise specified, the issues of these documents are those listed in the issue of the Department of Defense Index of Specifications and Standards (DoDISS) and supplement thereto, cited in the solicitation.

### STANDARDS

#### FEDERAL

FED-STD-1037      Telecommunications: Glossary of  
Telecommunication Terms

Unless otherwise indicated, copies of federal and military specifications, standards, and handbooks are available from the Naval Publications and Forms Center, ATTN: NPODS, 5801 Tabor Avenue, Philadelphia, PA 19120-5099.



E.2.2.2 Other Government documents, drawings, and publications.

The following other Government documents, drawings, and publications form a part of this document to the extent specified herein. Unless otherwise specified, the issues are those cited in the solicitation.

None

E.2.3 Non-Government publications.

The following documents form a part of this document to the extent specified herein. Unless otherwise specified, the issues of the documents which are DoD adopted are those listed in the issues of the DODISS cited in the solicitation. Unless otherwise specified, the issues of the documents not listed in the DODISS are the issues of the documents cited in the solicitation (see 6.3).

INTERNET DOCUMENTS

RFC-854	Telnet Protocol specification
RFC-821	Simple Mail Transfer Protocol
RFC-959	File Transfer Protocol
RFC-1651	SMTP Service Extensions
RFC-1730	Internet Message Access Protocol - Version 4
RFC-1854	SMTP Service Extensions for Command Pipelining
RFC-1939	Post Office Protocol - Version 3
RFC-2068	Hypertext Transfer Protocol - HTTP/1.1

(Internet documents may be obtained by anonymous file transfer protocol (ftp) from nis.nsf.net or nic.ddn.mil.)

E.2.4 Order of precedence.

In the event of a conflict between the text of this document and the references cited herein, the text of this document takes precedence. Nothing in this document, however, supersedes applicable laws and regulations unless a specific exemption has been obtained.

E.3 DEFINITIONS.

E.3.1 Standard definitions and acronyms.

None.

E.3.2 Abbreviations and acronyms.

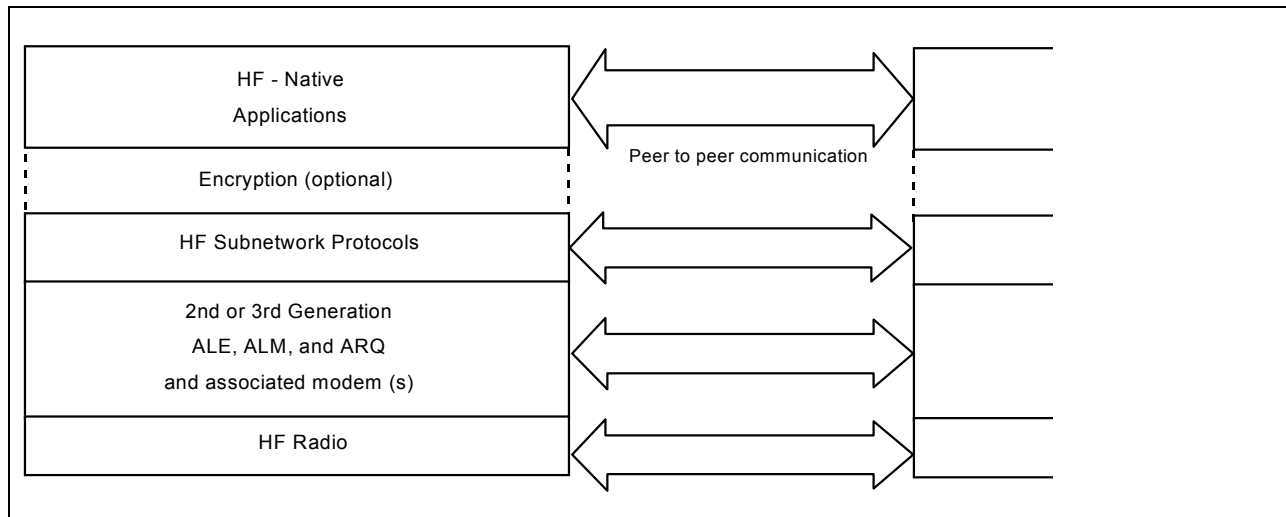
The abbreviations and acronyms used in this document are defined below. Those listed in the current edition of FED-STD-1037 have been included for the convenience of the reader.

ALE	automatic link establishment
ALM	automatic link maintenance
ARQ	automatic repeat request
COMSEC	Communications Security
e-mail	electronic mail
FTP	file transfer protocol
HF	high frequency
HMTP	HF mail transport protocol
HTTP	hypertext transfer protocol
IMAP4	Internet Mail Access Protocol - version 4
IP	Internet Protocol
NSAP	network service access point
PDU	protocol data unit
POP3	Post Office Protocol - version 3
SMTP	simple mail transfer protocol
TCP	transmission control protocol
UDP	user datagram protocol

#### E.4 GENERAL REQUIREMENTS

##### E.4.1 Introduction.

Figure E-1 illustrates the relationship of application-layer protocols to the protocols defined elsewhere in this standard. Interoperation among applications in use at different stations requires that the applications *and all supporting protocols* at the stations interoperate. Performance will then be determined by how well the protocol stacks work with each other and with the HF medium.



**FIGURE E-1. HF application interoperation.**

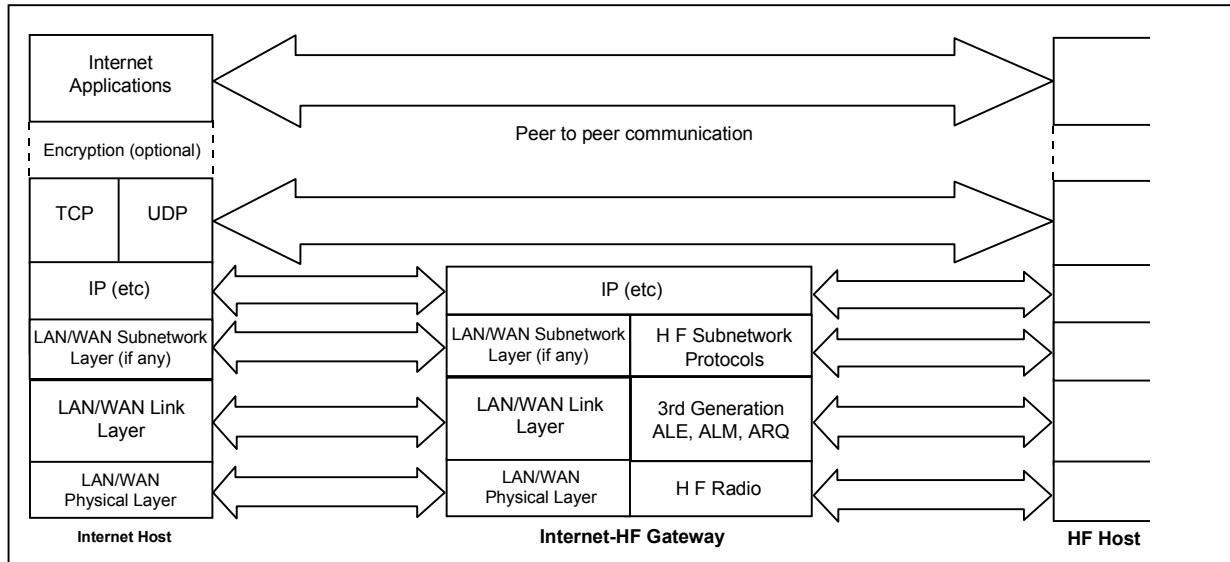
E.4.1.1 Required HF subnetwork protocols.

To simplify the task of ensuring interoperability among applications using the HF medium, a small number of protocols is approved for use with the application protocols specified in this appendix. Systems that implement any application from this appendix shall use the following protocols to convey the corresponding application protocol data units (PDUs) over the HF medium:

- HF subnetwork in accordance with Appendix D
- ALE in accordance with Appendix A and ALM and ARQ in accordance with Appendix G (the second-generation suite), OR ALE, ALM, and ARQ in accordance with Appendix C (the third-generation suite)
- HF radio in accordance with MIL-STD-188-141.

E.4.1.2 Support for Internet applications.

When an HF subnetwork is connected to other subnetworks using the Internet Protocol (IP) suite, Internet applications can use the resulting Internet as illustrated in figure E-2. For Internet applications, the third-generation link-layer suite (shown in figure E-2) will generally provide higher performance than the second-generation suite.

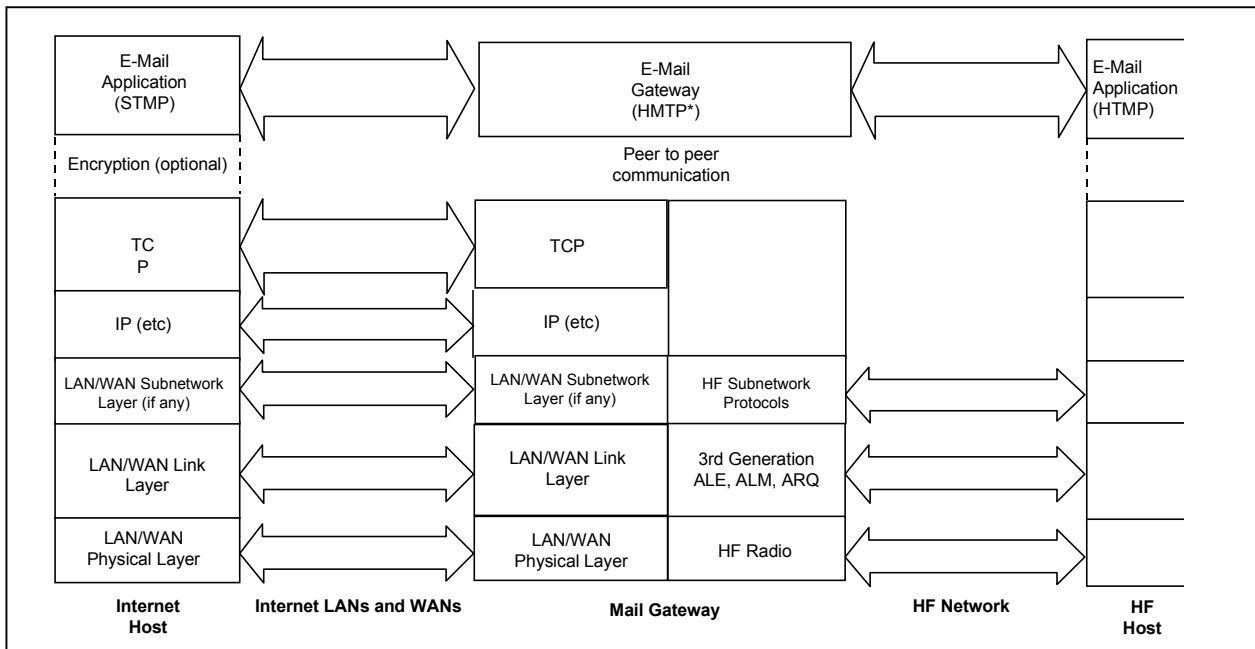


**FIGURE E-2. Application interoperation via internet gateway.**

When a host computer is connected to the Internet via an HF network (e.g., HF Host in figure E-2), most Internet applications will call upon the Transmission Control Protocol (TCP) or the User Datagram Protocol (UDP) for end-to-end transport service to the distant Internet Host. These two protocols, in turn, require the services of IP for routing packets through the Internet. HF network designers should be aware of several potential performance problems that arise when TCP and IP are used in an HF network:

- a. The two protocols together add 40 bytes of overhead to each application PDU sent.
- b. TCP connection setup requires an additional three-way handshake after the link establishment handshake and data link protocol startup. Each link turnaround consumes at least three interleaver times; when the MIL-STD-188-110 serial-tone modem is using its 4.8 s interleaver, this three-way handshake will add at least 43 s to the time to establish a link (at least 58 s if the data rate is 75 bps).
- c. The TCP congestion avoidance mechanisms can significantly reduce throughput each time the HF data link throughput changes abruptly.

For electronic mail (e-mail) transport through HF networks, an application-layer mail gateway can be employed at the boundary of the HF network that will eliminate the need for TCP *within the HF network* (see figure E-3). However, interactive applications (e.g., remote terminals, file transfer, and web browsing) will generally require the use of TCP.



**FIGURE E-3. Application-layer mail gateway.**

#### E.4.1.3 Security.

Figures E-1, E-2, and E-3 show optional encryption of application data. If Communications Security (COMSEC) is implemented in this way, the control information conveyed to lower layers shall bypass encryption using an approved method. Link layer encryption may also be used. Further COMSEC considerations are beyond the scope of this appendix.

E.4.2 Electronic mail transfer.

An HF e-mail system will be found to comply with this appendix if it conveys e-mail through HF networks using the required HF subnetwork protocols (see Required HF subnetwork protocols above) and the HF Mail Transfer Protocol (HMTP) described in E.5.2.1 (HF Mail Transfer Protocol).

E.4.2.1 Mail transfer within HF networks.

Mail shall be transferred within HF networks using HMTP, except as provided in the next paragraph. Wherever possible, application-layer mail gateways (see figure E-3) shall be employed to translate between SMTP and HMTP at the boundaries of the HF subnetwork, so that TCP is not used to convey mail over HF links.

E.4.2.2 Mail retrieval by call-in users.

When connectivity to a user is too infrequent to use HMTP to push messages to that user's host computer, a mail drop should be created at a host that can usually be reached by that user over a single HF link. One of the mail retrieval protocols from E.5.2.2 (HF mail retrieval protocols) shall be used to pull mail from the mail drop host to the user's host.

E.4.3 Digital imagery transfer. (not yet standardized)

E.4.4 Digital voice operation. (not yet standardized)

E.4.5 Other applications.

Interactive applications such as file transfer and hypertext transfer (in support of the worldwide web) shall employ the usual Internet application protocols for those applications:

<u>Application</u>	<u>Protocol</u>	<u>Reference</u>
Remote terminal	telnet	RFC-854
File transfer	File Transfer Protocol (FTP)	RFC-959
Hypertext transfer	Hypertext Transfer Protocol (HTTP)	RFC-2068

TCP shall be implemented at the client and server hosts that support these applications. IP and related protocols shall be implemented at client and server hosts and at subnetwork gateways (often termed "routers") that interconnect HF subnetworks with other subnetworks (see figure E-2). Neither TCP nor IP is needed at other HF nodes.

## E.5 DETAILED REQUIREMENTS.

### E.5.1 Introduction.

The functions supported by the protocols specified in this section are optional. However, when the functionality provided by one of these protocols is required, that protocol shall be implemented as specified to provide that functionality.

### E.5.2 Electronic mail protocols.

The HMTP shall be used to “push” e-mail messages through HF networks from one mail server to the next. The Post Office Protocol version 3 (POP3) or the Internet Mail Access Protocol version 4 (IMAP4) shall be used within HF networks to retrieve (“pull”) e-mail messages from servers.

#### E.5.2.1 HF mail transfer protocol.

The HF Mail Transfer Protocol (HMTP) is an extended version of the Simple Mail Transfer Protocol (SMTP). HMTP clients and servers shall implement SMTP in accordance with RFC 821, the SMTP service extension (“EHLO”) protocol in accordance with RFC 1651, and command pipelining in accordance with RFC 1854.

##### E.5.2.1.1 HMTP command grouping.

When connected to a server that supports command pipelining, HMTP clients shall group commands to the maximum extent permitted in RFC 1854:

- a. All setup commands, including RSET (if required), MAIL, RCPT, and DATA, for each message shall be sent as a single group.
- b. Multiple messages sent to a single server shall be chained by appending the setup commands for each subsequent message to the message body of the preceding message.

When connected to a server that does not support command pipelining, HMTP clients shall execute SMTP in its basic interlocked mode in accordance with RFC 821.

##### E.5.2.1.2 HMTP over TCP.

When HMTP uses TCP transport services, it shall listen on TCP port 25 (the well-known SMTP port), and, in general, use TCP in the same manner as does SMTP.

##### E.5.2.1.3 HMTP without TCP.

When TCP is not used to transport HMTP data, the HMTP server shall listen for calls on network service access point (NSAP) 8 of the HF subnetwork service.

### E.5.2.2 HF mail retrieval protocols.

When a user is usually not reachable (i.e., the user connects sporadically to pick up e-mail), HMTP will not be appropriate for delivery of mail *to* that user. In such cases, POP3 in accordance with RFC 1939 or IMAP4 in accordance with RFC 1730 shall be used to retrieve

mail from a mail drop server (see E.4.2.2). Messages *sent* by such users shall be conveyed to the server using HMTP.

E.5.3 Digital imagery protocol.  
(not yet standardized)

E.5.4 Digital voice protocol.  
(not yet standardized)

E.5.5 Radio facsimile protocol.  
(not yet standardized)

E.6 NOTES.

None.

APPENDIX F  
ANTI-JAM AND ANTI-INTERFERENCE TECHNIQUES



**TABLE OF CONTENTS**

<b><u>PARAGRAPH</u></b>	<b><u>PAGE</u></b>
F.1 GENERAL.....	502
F.1.1 <u>Scope</u> .....	502
F.1.2 <u>Applicability</u> .....	502
F.2 APPLICABLE DOCUMENTS.....	502
F.2.1 <u>General</u> .....	502
F.2.2 <u>Government documents</u> .....	502
F.2.2.1 <u>Specifications, standards, and handbooks</u> .....	502
F.2.2.2 <u>Other Government documents, drawings, and publications</u> .....	503
F.3 DEFINITIONS.....	503
F.3.1 <u>Standard definitions and acronyms</u> .....	503
F.3.2 <u>Abbreviations and acronyms</u> .....	503
F.3.3 <u>Operating parameters</u> .....	503
F.4 GENERAL REQUIREMENTS.....	504
F.4.1 <u>Overview</u> .....	504
F.4.2 <u>Hop sets</u> .....	504
F.4.3 <u>System performance requirements</u> .....	505
F.4.3.1 <u>Linking probability: link before hopping</u> .....	505
F.4.3.2 <u>Linking probability: link while hopping</u> .....	505
F.4.3.3 <u>Occupancy detection: link before hopping</u> .....	505
F.4.3.3 <u>Occupancy detection: link while hopping</u> .....	506
F.5 DETAILED REQUIREMENTS.....	506
F.5.1 <u>Linking before hopping</u> .....	506
F.5.2 <u>Linking while hopping</u> .....	506
F.5.2.1 <u>Hopping synchronous slot duration</u> .....	507
F.5.2.2 <u>Hopping synchronous dwell structure</u> .....	507
F.5.2.3 <u>Hopping PDU transmission</u> .....	507
F.5.2.3.1 <u>Hopping PDU transmit level control sequence</u> .....	507
F.5.2.3.2 <u>Hopping 3G-ALE PDU transmission during data time</u> .....	507
F.5.2.3.3 <u>Hopping transmission of other PDUs during data time</u> .....	508
F.6 NOTES.....	508

**TABLE OF CONTENTS**  
**(continued)**

**TABLES**

<b><u>TABLE</u></b>	<b><u>PAGE</u></b>
TABLE F-I. <u>Modes of operation</u> .....	504
TABLE F-II. <u>Linking probability requirements for linking while hopping (3 kiloHertz (kHz) SNR dB)</u> .....	505
TABLE F-III. <u>Occupancy detection requirements for linking while hopping (3 kHz SNR dB)</u> .....	506

**FIGURES**

FIGURE F-1. <u>Hopping PDU transmission</u> .....	507
---	-----

## F.1 GENERAL

### F.1.1 Scope.

This appendix contains the requirements for implementation of third generation (3G) HF link automation when frequency hopping is used in anti-jam and anti-interference applications.

### F.1.2 Applicability.

Frequency hopping operation with 3G HF link automation may not be required for some users of HF radio systems. However, if the user has a requirement for the features and functions described herein, they shall be implemented in accordance with the technical parameters specified in this appendix.

## F.2 APPLICABLE DOCUMENTS

### F.2.1 General.

The documents listed in this section are specified in F.3, F.4 and F.5 of this appendix. This section does not include documents cited in other sections of this standard or recommended for additional information or as examples. While every effort has been made to ensure the completeness of this list, document users are cautioned that they must meet all specified requirements documents cited in F.3, F.4 and F.5 of this appendix, whether or not they are listed here.

### F.2.2 Government documents.

#### F.2.2.1 Specifications, standards, and handbooks.

The following specifications, standards, and handbooks form a part of this document to the extent specified herein. Unless otherwise specified, the issues of these documents are those listed in the issue of the Department of Defense Index of Specifications and Standards (DODISS) and supplement thereto, cited in the solicitation.

## STANDARDS

### FEDERAL

FED-STD-1037	Telecommunications: Glossary of Telecommunications Terms
--------------	--

### MILITARY

MIL-STD-188-148	(S) Interoperability Standard for Anti-Jam (AJ) Communications in the High Frequency Band 2 - 30 megahertz (MHz) (U)
-----------------	--

(Unless otherwise indicated, copies of the above specifications, standards, and handbooks are available from the Standardization Document Order Desk, 700 Robbins Ave. Building 4D, Philadelphia, PA 19111-5094.)

F.2.2.2 Other Government documents, drawings, and publications.

The following other Government documents, drawings, and publications form a part of this document to the extent specified herein. Unless otherwise specified, the issues are those cited in the solicitation.

NTIA Report 98-348      Software Implementation of a Wideband HF Channel  
Transfer Function

(Applications for copies should be addressed to the U.S. Department of Commerce, NTIA, Room 4890, 14th and Constitution Ave. N.W., Washington, DC 20230.)

F.3 DEFINITIONS

F.3.1 Standard definitions and acronyms.

None.

F.3.2 Abbreviations and acronyms.

The abbreviations and acronyms used in this document are defined below. Those listed in the current edition of FED-STD-1037 have been included for the convenience of the reader.

a	3G	third generation
b	AJ	Anti-Jam
c	ALE	Automatic Link Establishment
d	ALM	Automatic Link Maintenance
e	AWGN	additive white Gaussian noise
f	DODISS	Department of Defense Index of Specifications and Standards
g	HF	high frequency
h	kHz	kiloHertz
i	MHz	megahertz
j	PDU	Protocol Data Unit

F.3.3 Operating parameters.

The operating parameters used in this appendix are collected here for the convenience of the reader.

<u>Symbol</u>	<u>Parameter Name</u>	<u>Default Value</u>
$T_{\text{sym}}$	PSK symbol time	1/2400 s _ 417 $\mu$ s
$T_{\text{bit}}$	32 $T_{\text{sym}}$ ; quantum of 3G PSK signaling	~13.333 ms
$T_{\text{prop}}$	Maximum propagation delay among network members	70 ms
$T_{\text{hop}}$	Duration of hopping dwell	*

$T_{\text{guard}}$	Guard time at hop boundary for radio tuning	*
$T_{\text{data}}$	Portion of hopping dwell used for data transmission ( $T_{\text{hop}} - T_{\text{guard}}$ )	*
$T_{\text{disc}}$	Maximum discrepancy among synchronized, hopping radios	*
$T_{\text{slot}}$	Duration of slot in synchronous mode 3G ALE	*
$N_{\text{bph}}$	Number of data bits sent per hop	*
$H_{\text{bw0}}$	Number of hops necessary to send a 3G ALE PDU while hopping	*
C	Number of calling hop sets scanned by radio that links while hopping	

\* depends on specific hopping scheme in use

## F.4 GENERAL REQUIREMENTS

### F.4.1 Overview.

Systems employing both 3G HF link automation (see Appendix C) and frequency hopping may operate in any of the following five modes listed in table F-I.

**TABLE F-I. Modes of operation.**

Mode	Hopping Mode	Linking Mode	Scanning Mode
1A	MIL-STD-188-148	Link before hopping	Async
1B	MIL-STD-188-148	Link before hopping	Sync
2	MIL-STD-188-148	Link while hopping	Sync
3A	Army enhanced	Link before hopping	Async
3B	Army enhanced	Link before hopping	Sync

### F.4.2 Hop sets.

An ordered list of frequencies, along with timing specifications that determine when each frequency is used, is termed a hop set. When 3G protocols are used in a frequency-hopping network, hop sets take the place of channels. Thus, in 3G systems that support frequency hopping, the channel table specified in C.4.11.3 Channel table shall be extended to store a hop set specification in each entry, and channel numbers in 3G automatic link establishment (ALE) and 3G automatic link maintenance (ALM) protocol data units (PDUs) shall refer to hop sets.

F.4.3 System performance requirements.

F.4.3.1 Linking probability: link before hopping.

When linking before hopping (Mode 1A, 1B, 3A, or 3B), 3G ALE systems shall meet or exceed the linking probability requirements of C.4.6.1.1 Linking probability and the appropriate sub-paragraph for linking in synchronous or asynchronous mode.

F.4.3.2 Linking probability: link while hopping.

When linking while hopping (Mode 2), 3G ALE systems shall meet or exceed the linking probability requirements of table F-II. The test procedure of A.4.2.3 shall be employed, with the following modifications:

- The multipath delay settings shall be 0.5 ms for the Good channel and 2.0 ms for the Poor channel. (NOTE: testing is performed using a narrowband simulator because parameters have not yet been established for testing using the wideband model described in NTIA Report 98-348. Testing using a wideband channel simulator may be required in future revisions of this standard.)
- Units under test shall hop in a single calling hop set ( $C = 1$ ).
- The requested traffic type shall be packet data.
- A link will be declared successful if, in response to the first Call PDU sent, the 3G-ALE controllers complete an individual call handshake and both commence hopping on the traffic hop set specified in the Handshake PDU.
- The time limit for each successful link shall be 6 seconds, measured from the time the request is presented at the operator interface until the start of the traffic setup PDU preamble.

**TABLE F-II. Linking probability requirements for linking while hopping  
(3 kiloHertz (kHz) SNR dB).**

Prob Link Success	Gaussian	CCIR Good	CCIR Poor
25%	-7	-5	-3
50%	-6	-3	0
85%	-5	0	3
95%	-4	4	6

F.4.3.3 Occupancy detection: link before hopping.

When linking before hopping (Mode 1A, 1B, 3A, or 3B), 3G ALE systems shall meet or exceed the occupancy detection requirements of C.4.6.1.2 Occupancy detection and the appropriate sub-paragraph for synchronous or asynchronous operation.

F.4.3.3 Occupancy detection: link while hopping.

3G ALE systems operating in link-while-hopping mode (Mode 2) shall correctly recognize that a traffic hop set is occupied at least as reliably as indicated in table C-II during the Listen portion of Slot 0 (see F.5.2.2, Hopping synchronous dwell structure). The test procedure of A.4.2.2 shall be used. Systems shall also meet or exceed the requirements of table F-III for detecting calling hop sets in use while listening before calling during Slots 1 through 3. The probability of declaring a hop set occupied when each hop dwell contains only additive white Gaussian noise (AWGN) shall be less than 1percent.

**TABLE F-III. Occupancy detection requirements for linking while hopping (3 kHz SNR dB).**

Waveform	AWGN 3 kHz SNR (dB)	Minimum Required Detection Probability
2G-ALE	1	50%
3G-ALE (BW0)	-8	50%
3G-HDL (BW2)	1	30%
SSB Voice	7	50%
MIL-STD-188-110 or FED-STD-1052 PSK modem	1 7	30% 70%
STANAG 4285 PSK modem	1	30%

F.5 DETAILED REQUIREMENTS

F.5.1 Linking before hopping.

When 3G ALE systems link before hopping, the ALE protocols of Appendix C shall be employed with the following modification: hopping synchronization and startup shall occur at the point in the respective protocol at which traffic startup would occur in non-hopping operation. Traffic startup shall commence upon completion of hopping startup.

F.5.2 Linking while hopping.

When linking while hopping, a 3G ALE system shall operate in the modified synchronous mode specified below. The following timing parameters are used:

- The hopping dwell period, denoted  $T_{hop}$ , is the reciprocal of the hopping rate.
- Each dwell comprises a guard time  $T_{guard}$ , during which the radio is changing frequency, and a user data time  $T_{data}$ , during which user data may be sent.  $T_{hop} = T_{guard} + T_{data}$ .
- Stations are synchronized while hopping. The maximum discrepancy among network member time bases is  $T_{disc}$ .
- The maximum propagation delay among network member stations is  $T_{prop}$ .
- The duration of the transmit level control, preamble, and data portions of the 3G-ALE PDU are  $T_{tlc}$ ,  $T_{BW0\ pre}$ , and  $T_{BW0\ data}$ , respectively

F.5.2.1 Hopping synchronous slot duration.

When the network hopping rate is such that an entire 3G-ALE PDU can be sent during  $T_{data}$ , the slot time  $T_{slot}$  shall be equal to  $T_{hop}$ . Otherwise, the 3G-ALE  $T_{slot}$  shall be extended to the smallest integral multiple of  $T_{hop}$  greater than or equal to  $T_{prop}$  plus the time to send an entire 3G-ALE PDU using the procedure specified in F.5.2.3 Hopping PDU transmission.

F.5.2.2 Hopping synchronous dwell structure.

The dwell structure for 3G ALE while hopping shall comprise five slots, each of duration  $T_{slot}$ :

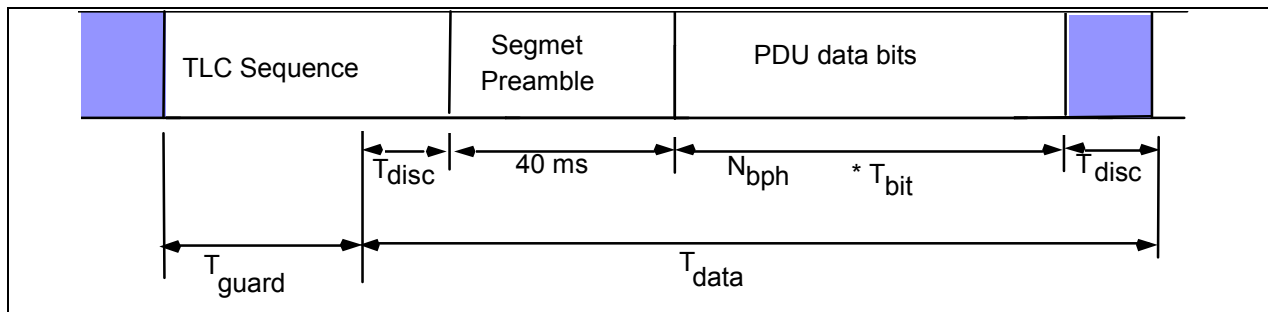
- Slot 0, during which stations shall synchronously check a traffic hop set for occupancy;
- Slots 1-4, during which stations initiate calls and other protocols in accordance with Appendix C.

F.5.2.3 Hopping PDU transmission.

When any 3G PDU cannot be sent during a single hop, it shall be spread over multiple hops as described below.

F.5.2.3.1 Hopping PDU transmit level control sequence.

The transmit level control portion of a PDU shall be sent by the controller to the transmitter during  $T_{guard}$  and the first portion of  $T_{data}$ , with symbols dropped from the beginning of the sequence if necessary so that the end of the  $T_{tlc}$  sequence shall occur at time  $T_{disc}$  after the end of the guard time (see figure F-1). Some of the symbols may be dropped by the transmitter while it is changing frequency.



**FIGURE F-1. Hopping PDU transmission.**

F.5.2.3.2 Hopping 3G-ALE PDU transmission during data time.

When  $T_{data} \geq T_{BW0_{pre}} + T_{BW0_{data}} + 2 T_{disc}$ , the 3G-ALE PDU shall be sent during a single hop, with the preamble beginning immediately after the end of the  $T_{tlc}$  sequence.

Otherwise, the preamble and data portions of the 3G ALE PDU shall be split over multiple hops. The transmissions during each  $T_{hop}$  shall be (a portion of) the  $T_{tlc}$  sequence as described above, followed immediately by a 40 ms (96 symbol) segment of the preamble, followed immediately by up to  $N_{bph}$  PDU data bits:



$$N_{bph} = \left\lceil \frac{T_{data} - 40ms - 2T_{disc}}{T_{bit}} \right\rceil$$

Transmissions should cease during the period from the final symbol of the PDU data bits until the first symbol of the next  $T_{tlc}$  sequence. This will reduce interference levels. The number of hops required to send the 26 data bits that compose a 3G ALE PDU is  $H_{BW0}$ :

$$H_{BW0} = \left\lceil \frac{26}{N_{bph}} \right\rceil$$

Preamble segments shall be sent in order in successive hops, with the specified symbol sequence cycling back to the beginning if necessary in the later hops. If the unused PDU data bit positions in the final hop do not exceed  $T_{prop}$ , an extra hop must be included in  $T_{slot}$  to allow for propagation to all network stations.

F.5.2.3.3 Hopping transmission of other PDUs during data time.  
The other 3G PDUs shall be sent similarly to the 3G ALE PDUs.

F.6 NOTES  
None.

APPENDIX G  
HF DATA LINK PROTOCOL

**TABLE OF CONTENTS**

<b><u>PARAGRAPH</u></b>	<b><u>PAGE</u></b>
G.1 GENERAL .....	511
G.1.1 <u>Scope</u> .....	511
G.1.2 <u>Applicability</u> .....	511
G.2 APPLICABLE DOCUMENTS.....	511
G.2.1 <u>General</u> .....	511
G.2.2 <u>Government documents</u> .....	511
G.3 DEFINITIONS .....	511
G.4 GENERAL REQUIREMENTS .....	511
G.5 DETAILED REQUIREMENTS .....	511
G.6 NOTES.....	511

## G.1 GENERAL

### G.1.1 Scope.

The purpose of this appendix is to specify the requirements for an additional data link protocol to be used with implementations of second generation (2G) HF link automation.

### G.1.2 Applicability.

2G HF link automation inherently includes data transfer protocols that use the frequency-shift keyed modem specified in Appendix A. The data link protocol specified in this appendix shall be used in 2G HF networks that employ data modems complying with MIL-STD-188-110.

## G.2 APPLICABLE DOCUMENTS

### G.2.1 General.

This section does not include documents cited in other sections of this standard or recommended for additional information or as examples.

### G.2.2 Government documents.

The following standard forms a part of this document to the extent specified herein. Unless otherwise specified, the issues of these documents are those listed in the issue of the Department of Defense Index of Specifications and Standards (DODISS) and supplement thereto cited in the solicitation.

## STANDARDS

### DEPARTMENT OF DEFENSE

MIL-STD-188-110	Interoperability and Performance Standards for Data Modems
-----------------	--

(Unless otherwise indicated, copies of the above standard are available from the Standardization Document Order Desk, 700 Robbins Ave. Building 4D, Philadelphia, PA 19111-5094.)

## G.3 DEFINITIONS

None.

## G.4 GENERAL REQUIREMENTS

The data link protocol for 2G HF link automation is specified in MIL-STD-188-110.

## G.5 DETAILED REQUIREMENTS

None.

## G.6 NOTES

The earliest version of MIL-STD-188-110 that specifies a data link protocol is MIL-STD-188-110B.

APPENDIX H  
MANAGEMENT INFORMATION BASE  
FOR  
AUTOMATED HF RADIO NETWORK

**TABLE OF CONTENTS**

<b><u>PARAGRAPH</u></b>	<b><u>PAGE</u></b>
H.1 General.....	514
H.1.1 <u>Scope</u> .....	514
H.1.1.2 <u>Applicability</u> .....	514
H.2. APPLICABLE DOCUMENTS.....	514
H.2.1 <u>General</u> .....	514
H.2.2 <u>Government documents</u> .....	514
H.2.3 <u>Non-Government publications</u> .....	514
H.3 Definitions.....	515
H.3.1 <u>Standard definitions</u> .....	515
H.3.2 <u>Abbreviations and acronyms</u> .....	515
H.4 General Requirements.....	516
H.4.1 <u>Introduction</u> .....	516
H.4.1.1 <u>Network Connectivity and equipment status</u> .....	516
H.4.1.2 <u>Internet suite of protocols</u> .....	516
H.4.2 <u>SNMP</u> .....	517
H.5 Detailed Requirements.....	518
H.5.1 <u>SNMP function</u> .....	518
H.5.1.1 <u>Encoding rules</u> .....	518
H.5.1.2 <u>HNMP</u> .....	518
H.5.2 <u>HNMP Performance</u> .....	519
H.5.3 <u>Network management MIBs and HNMP definitions</u> .....	521

**TABLES**

TABLE H-I. <u>Over the air transfers</u> .....	521
TABLE H-II. <u>HF management information base</u> .....	522

**FIGURES**

FIGURE H-1. <u>Station data bus example</u> .....	520
---	-----

## H.1 GENERAL.

### H.1.1 Scope.

The scope of this appendix is limited to the Management Information Base (MIB) for automatic high frequency (HF) radio networks.

### H.1.1.2 Applicability.

This appendix defines the MIB for automated HF radio networks. Management of HF radio networks through the use of the Simple Network Management Protocol (SNMP) requires the formal definition of the data objects to be remotely read and written by a network management program.

## H.2. APPLICABLE DOCUMENTS.

### H.2.1 General.

The documents listed in this section are specified in H.4 and H.5 of this standard. This section does not include documents cited in other sections of this standard or recommended for additional information or as examples. While every effort has been made to ensure the completeness of this list, document users are cautioned that they must meet all specified requirements documents cited in H.4, and H.5 of this standard, whether or not they are listed.

### H.2.2 Government documents.

MIL-STD-187-721	Interoperability and Performance Standards for Advanced Adaptive HF Radio
-----------------	--

### H.2.3 Non-Government publications.

The following documents form a part of this document to the extent specified herein. Unless otherwise specified, the issues of the documents which are Department of Defense (DoD) adopted are those listed in the issues of the Department of Defense Index of Specifications and Standards (DODISS) cited in the solicitation. Unless otherwise specified, the issues of the documents not listed in the DODISS are the issues of the documents cited in the solicitation (see 6.3).

## INTERNET DOCUMENTS

RFC-1155	Structure and Identification of Management Information
RFC-1157	A Simple Network Management Protocol (SNMP)
RFC-1213	Management Information Base for Network Management of TCP/IP-based Internets: MIB-II
RFC-1441	Introduction to Version 2 of the Internet-standard Network Management Framework
RFC-1442	Structure of Management Information for Version 2 of the Simple Network Management Protocol (SNMPv2)
RFC-1443	Textual Conventions for Version 2 of the Simple Network Management Protocol (SNMPv2)
RFC-1444	Conformance Statements for Version 2 of the Simple Network Management Protocol (SNMPv2)
RFC-1445	Administrative Model for Version 2 of the Simple Network Management Protocol (SNMPv2)
RFC-1446	Security Protocols for Version 2 of the Simple Network Management Protocol (SNMPv2)
RFC-1447	Party MIB for Version 2 of the Simple Network Management Protocol (SNMPv2)
RFC-1448	Protocol Operations for Version 2 of the Simple Network Management Protocol (SNMPv2)
RFC-1449	Transport Mappings for Version 2 of the Simple Network Management Protocol (SNMPv2)
RFC-1450	Management Information Base for Version 2 of the Simple Network Management Protocol (SNMPv2)
RFC-1451	Manager-to-Manager Management Information Base
RFC-1452	Coexistence between Version 1 and Version 2 of the Internet-standard Network Management Framework

May be obtained by anonymous ftp from nis.nsf.net or nic.ddn.mil.

### H.3 DEFINITIONS.

#### H.3.1 Standard definitions.

None.

#### H.3.2 Abbreviations and acronyms.

The abbreviations and acronyms used in this document are defined below. Those listed in the current edition of FED-STD-1037 have been included for the convenience of the reader.



ALE	automatic link establishment
AME	automatic message exchange
ARPANET	Advanced Research Projects Agency Network
ASN.1	abstract syntax notation 1
bps	bits per second
DoD	Department of Defense
HF	high frequency
HFDLP	HF Data Link Protocol
HNMP	HF Network Management Protocol
LP	linking protection
MIB	Management Information Base
PIN	personal identification number
PDU	protocol data unit
SNMP	Simple Network Management Protocol
SNMPv2	Version 2 of the Simple Network Management Protocol
TCP/IP	transmission control protocol/internet protocol
UDP	user datagram protocol

#### H.4 GENERAL REQUIREMENTS.

##### H.4.1 Introduction.

Automation of HF radio networks to date has simplified the tasks related to establishing links using HF radios. However, the automatic link establishment (ALE) technology that hides the complexities of linking has generated a new problem in radio network management: the automatic controllers use a number of intricate data structures that must be kept consistent throughout a network if operations are to proceed smoothly. Some steps toward reducing the impact of this problem have been included in MIL-STD-187-721.

##### H.4.1.1 Network Connectivity and equipment status.

An aspect of network management that has not been addressed by the current HF standards is the need to observe network connectivity and equipment status from network control sites so that corrective action can be initiated promptly when malfunctions or other disruptions occur. Managers of packet networks have been at work on network management problems for some time, so it makes sense to look at the procedures used in these more mature automated networks to see whether they have technology that could be usefully applied to the management of HF networks.

##### H.4.1.2 Internet suite of protocols.

Perhaps the best-known of the packet network technologies is the Internet suite of protocols (including the transmission control protocol (TCP) / internet protocol (IP)), which grew out of the DoD-sponsored Advanced Research Projects Agency Network (ARPANET) research. The network management approach used in the Internet and associated sub-networks is based upon the Internet-standard Network Management Framework developed in the late 1980s. This technology is more often referred to by the protocol that it employs for managing network nodes, the SNMP [RFC-1157].

#### H.4.2 SNMP.

SNMP was designed so that it explicitly minimizes the number and complexity of management functions realized by the management agent itself. That is, the development costs of including SNMP in managed equipment are minimized at the expense of (perhaps) increasing the complexity of the software for network management stations. However, the ratio of managed nodes to management stations is large so the benefit of widespread implementation has greatly outweighed the cost of implementing the management software.

To briefly summarize the salient points of the SNMP approach:

- a. Network management stations monitor and control network elements by communicating with agents in those elements.
- b. This interaction uses SNMP [RFC-1157] to get and set the values of defined data objects. Agents may also send trap messages to management stations to announce important events asynchronously.
- c. The defined data objects are described in the MIB [RFC-1213], which is currently strongly oriented toward the TCP/IP protocol suite, but is easily extensible. Object definitions are expressed formally in abstract syntax notation 1 (ASN.1) [ISO 8824].
- d. Object names and values are encoded in accordance with a set of ASN.1 Basic Encoding Rules [ISO 8825].
- e. When elements do not implement SNMP, they may still be managed by using proxy agents that translate the standard SNMP messages into proprietary messages understood by the non-SNMP elements.
- f. Authentication is included in the standard, although current practice uses only trivial authentication. The mechanism is extensible using ideas similar to HF linking protection.
- g. SNMP requires only a connectionless datagram transport service (e.g., the user datagram protocol (UDP) in the Internet, or a similar protocol on top of HF automatic message exchange (AME) in MIL-STD-187-721).
- h. SNMPv2, in accordance with RFC 1441-1452 shall be employed for HF network management with the following additional requirements:
  - (1) An agent receiving a SetRequest that selects a non-existent row in a table shall automatically create the requested row subject to resource availability, setting column objects in the new row to their default values unless other valid values are specified in the SetRequest message. However, if any value in the SetRequest message specifies an invalid value for any column object in the new row, the new row shall not be created, and a GetResponse message shall be returned indicating the erroneous variable binding.
  - (2) Table rows invalidated by a SetRequest shall not be reported in responses to GetNextRequests; that is, from the point of view of management stations, invalidated rows are deleted from the table.

- (3) Object identifiers for objects defined in the MIB may be encoded for transmission within HF networks only using the truncated encoding scheme. Gateways that connect HF networks to non-HF networks, however, shall ensure that object identifier encodings in messages entering non-HF networks use the full encoding of ISO/IEC 8825; SNMP messages entering HF networks may be translated to use truncated encodings.
- (4) Retransmission timeouts in network management programs shall be adjusted to allow time for link establishment and for the transmission of requests and responses over modems that may be able to achieve throughputs of 100 bits per second (bps) or less.

## H.5 DETAILED REQUIREMENTS.

### H.5.1 SNMP function.

SNMP functions by reading and writing data structures defined for each item of controlled equipment. These data structures are defined using an abstract syntax (ASN.1) so that the details of how the data are stored by individual network components are hidden.

For example, aleScanRate (the rate at which an ALE controller scans channels) is simply defined to be an integer, with no indication of byte order, or even the number of bytes used to represent it on any particular ALE controller. Furthermore, some ALE controllers may store channel dwell time instead of scan rate, in which case a conversion from dwell time to or from scan rate is made whenever aleScanRate is read or written.

#### H.5.1.1 Encoding rules.

When data are exchanged over the air (or some other medium), it is necessary that all parties to the exchange use the same encodings for the data.

The ASN.1 encoding rules [ISO 8825] name each object by tracing a path through a tree of standards to finally reach the leaf that defines that object. It seems reasonable, while within an HF network, to truncate this path to that portion that lies within the HF MIB, and use a special flag (i.e., the octet 123) to denote this. This is expected to reduce, by 4, the number of bytes needed to name each object, without compromising the interoperability of the proposed HF radio networks implementation of SNMP, described in this appendix.

#### H.5.1.2 HNMP.

SNMP version 2 (SNMPv2) modified for use in HF networks is called the HF Network Management Protocol (HNMP). The variations on SNMPv2 introduced for HF use are intended to reduce the amount of overhead bandwidth consumed by the network management protocol. These variations are as follows:

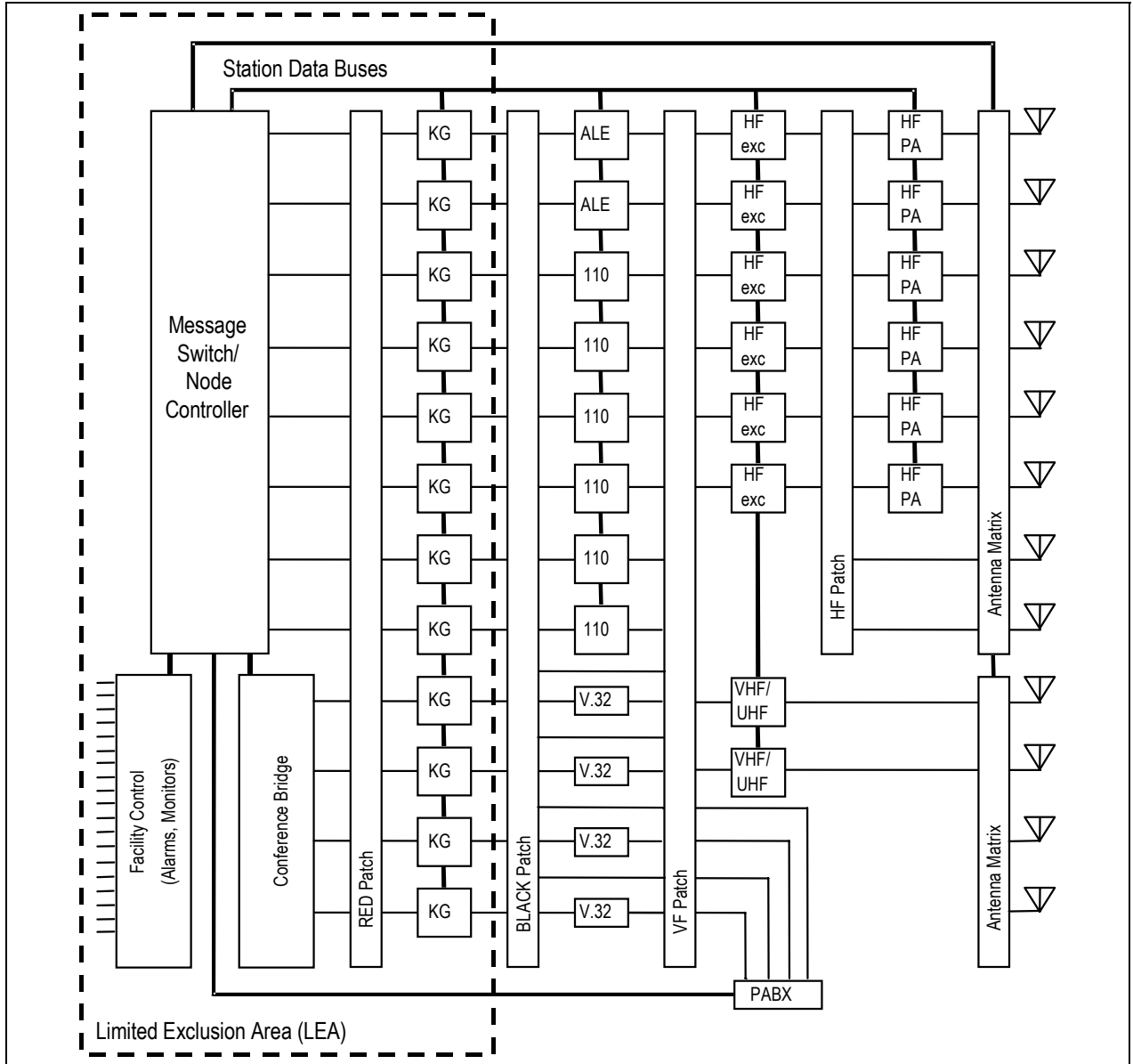
- a. Object identifiers for objects defined in the HF MIB shall be encoded for transmission using the truncated encoding scheme described above.
- b. A GetRows variant of the GetBulk message is used for efficient retrieval of rows of tables.
- c. A personal identification number (PIN) authentication is available. MD5 authentication is optional.

The GetRows operation is similar to the SNMPv2 GetBulk operation, except that the response to a GetRows is a new protocol data unit (PDU) format. A GetRows response includes the object Identify only of the first object in each row, followed by the values of all objects requested in that row.

#### H.5.2 HNMP Performance.

The performance of HNMP may be gauged by how many bits are transferred to perform common operations. A fairly complex station such as that shown schematically in figure 1, is used for computing some example bit counts. In this case, the station is postulated to contain one ALE controller, seven radios, 10 antennas, six HF Data Link Protocol (HFDLP) controllers, one antenna matrix, and one BLACK patch panel. A complete over-the-air load of ALE operating data using HNMP will transfer the following objects:

- 14 scalar values
- Six Self Address Table entries
- 14 individual and threenet entries in the Other Address Table
- 30 entries in the Channel Table
- Three entries in the Channel Set Table



**FIGURE H-1. Station data bus example.**

Using HNMP, this transfer will require 2,831 octets. Using this as a baseline, the number of octets to load the remaining equipment is estimated on the following table:

**TABLE H-1. Over the air transfers.**

Radios	15,000
Antennas	500
HFDLP	200
Antenna matrix	500
BLACK patch	500
Total	20,000 (est)

**H.5.3 Network management MIBs and HNMP definitions.**

Table H-2 contains MIBs for network management of automated HF radio networks. This MIB is merely a subset of the management information that will be needed for a full implementation of automated HF radio network management. Additional objects may be defined in equipment-specific MIBs as described in the structure of Management Information [RFC-1442].

**TABLE H-II. HF management information base.**

(ABSTRACT SYNTAX NOTATION (HF-MIB DEFINITIONS))

HF-MIB DEFINITIONS ::= BEGIN

IMPORTS

experimental, OBJECT-TYPE, MODULE-IDENTITY, Counter32, Gauge32,  
TimeTicks

FROM SNMPv2-SMI-- RFC 1442

DisplayString, RowStatus, TimeStamp, TruthValue

FROM SNMPv2-TC; -- RFC 1443

hf MODULE-IDENTITY

LAST-UPDATED "9408310212Z"

ORGANIZATION "U.S. Army Information Systems Engineering Command"

CONTACT\_INFO

" Eric E. Johnson

Postal: New Mexico State University  
Dept 3-O, (Electrical Computer Engineering)  
Las Cruces, NM 88003-0001  
USA

Tel: +1 505 646 4739

Fax: +1 505 646 1435

E-mail: ejohnson@nmsu.edu"

DESCRIPTION "The MIB module for MIL/FED-STD automated HF radio networks"

::= { 2 43 } -- (encoded as the single octet 123)

admin OBJECT IDENTIFIER ::= { hf 1 } -- subtree for party context IDs...

security OBJECT IDENTIFIER ::= { hf 2 } -- subtree for security features,  
-- including ECCM and multi-level security

enterprises OBJECT IDENTIFIER ::= { hf 3 } -- subtree for enterprise-specific MIBs

hfSystem OBJECT IDENTIFIER ::= { hf 4 } -- generally applicable objects

patch OBJECT IDENTIFIER ::= { hf 5 } -- interconnection systems such as  
-- antenna matrices and patch panels

antenna OBJECT IDENTIFIER ::= { hf 6 } -- antennas, couplers, etc.

radio OBJECT IDENTIFIER ::= { hf 7 } -- radios

ale OBJECT IDENTIFIER ::= { hf 8 } -- automatic link establishment controllers

lp OBJECT IDENTIFIER ::= { hf 9 } -- linking protection

modem OBJECT IDENTIFIER ::= { hf 10 } -- modems

hfdlp **OBJECT IDENTIFIER** ::= { hf 11 } -- HF data link protocol  
ame **OBJECT IDENTIFIER** ::= { hf 12 } -- automatic message exchange  
hrmp **OBJECT IDENTIFIER** ::= { hf 13 } -- relay management protocol  
hssp **OBJECT IDENTIFIER** ::= { hf 14 } -- station status protocol  
hftp **OBJECT IDENTIFIER** ::= { hf 15 } -- HF transport protocol  
hnmp **OBJECT IDENTIFIER** ::= { hf 16 } -- HF network management protocol  
-- the HF system group

hfControlMode **OBJECT-TYPE**

**SYNTAX INTEGER** {  
    other (1)  
    local (2),         -- device is under local control  
    remote (3)        -- remote control enabled  
}  
**MAX-ACCESS** read-only  
**STATUS** current  
**DESCRIPTION**  
    "locus of control"  
::= { hfSystem 1 }

hfSelfTestMode **OBJECT-TYPE**

**SYNTAX INTEGER**  
**MAX-ACCESS** read-write  
**STATUS** current  
**DESCRIPTION**  
    "0 indicates device not performing self test; other values correspond to particular self  
    tests; these values and their meanings vary from device to device"  
::= { hfSystem 2 }

hfLastTestResult **OBJECT-TYPE**

**SYNTAX INTEGER**  
**MAX-ACCESS** read-write  
**STATUS** current  
**DESCRIPTION**  
    "0 indicates self test completed successfully; -1 indicates that no self test has been  
    performed; positive values indicate failures with device-specific meanings;  
    negative values are reserved for standardized fault codes."  
::= { hfSystem 3 }

hfLastFault **OBJECT-TYPE**

**SYNTAX INTEGER** (0..65535)  
**MAX-ACCESS** read-only  
**STATUS** current  
**DESCRIPTION**  
    "last fault code returned by device; 0 for no fault"  
::= { hfSystem 4 }



**hfLastMessage OBJECT-TYPE**

**SYNTAX** DisplayString  
**MAX-ACCESS** read-only  
**STATUS** current  
**DESCRIPTION**

"last diagnostic message returned by device; 0-length string if none"  
 ::= { hfSystem 5 }

**hfNoChange OBJECT-TYPE**

**SYNTAX** TruthValue  
**MAX-ACCESS** read-only  
**STATUS** current  
**DESCRIPTION**

"True if no change has occurred to hfLastTestResult, hgLastFault and hfLastMessage since each was last read. False if any has changed."  
 ::= { hfSystem 6 }

**hfNativeControlPort OBJECT-TYPE**

**SYNTAX** OCTET STRING (SIZE (1..65535))  
**MAX-ACCESS** read-write  
**STATUS** current  
**DESCRIPTION**

"This object implements a transparent pass-through to built-in proprietary control interfaces. Strings written to this object are effectively injected into the local control port of the device. Reading this object returns the status message(s), in order, returned by the device in response to the latest write to this object. All are in the native format of the device."  
 ::= { hfSystem 7 }

- the Device Ports and Ranks Tables
- The ports described in these tables are strictly physical.
- For "logical ports" use the interfaces group in MIB-II

**hfPortRanksTable OBJECT-TYPE**

**SYNTAX SEQUENCE OF** HfRankEntry  
**MAX-ACCESS** not-accessible  
**STATUS** current  
**DESCRIPTION**

"Table describing the groups, or ranks, of ports on a device. A rank may either be a logical rank of ports (as in a patch panel), or a group of similar ports (such as the audio inputs on a radio)."  
 ::= { hfSystem 8 }

**hfRankEntry OBJECT-TYPE**

**SYNTAX** HfRankEntry

**MAX-ACCESS** not-accessible

**STATUS** current

**DESCRIPTION**

"an entry in the device port ranks table describing one rank of ports"

**INDEX** { hfRankIndex }

::= { hfPortRanksTable 1 }

HfRankEntry ::=

**SEQUENCE** {

hfRankIndex

**INTEGER,**

hfRankType

**INTEGER,**

hfRankDescr

DisplayString

}

hfRankIndex **OBJECT-TYPE**

**SYNTAX** INTEGER

**MAX-ACCESS** not-accessible

**STATUS** current

**DESCRIPTION**

"rank number; auxiliary variable used to identify one rank of ports in the device port ranks table"

::= { hfRankEntry 1 }

hfRankType **OBJECT-TYPE**

**SYNTAX** INTEGER {

other (1), -- none of the following

unused (2), -- an unused rank

binRed (3), -- binary ports for classified data

binBlk (4), -- binary ports for unclassified data

vfRed (5), -- analog ports for classified signals

vfBlack (6), -- analog ports for unclas signals

rfLow (7), -- radio-frequency ports (up to 300 W)

rfHigh (8), -- radio-frequency ports (over 300 W)

}

**MAX-ACCESS** read-only

**STATUS** current

**DESCRIPTION**

"type of ports in rank"

::= { hfRankEntry 2 }

hfRankDescr **OBJECT-TYPE**

**SYNTAX** DisplayString

**MAX-ACCESS** read-write  
**STATUS** current  
**DESCRIPTION**  
"description of rank of ports; for display to user"  
::= { hfRankEntry 3 }

hfPortsTable **OBJECT-TYPE**  
**SYNTAX SEQUENCE OF** HfPortEntry  
**MAX-ACCESS** not-accessible  
**STATUS** current  
**DESCRIPTION**  
"table of ports in a rank"  
::= { hfSystem 9 }

hfPortEntry **OBJECT-TYPE**  
**SYNTAX** HfPortEntry  
**MAX-ACCESS** not-accessible  
**STATUS** current  
**DESCRIPTION**  
"an entry in the ports table describing one port"  
**INDEX** { hfPortRankIndex hfPortIndex }  
::= { hfPortsTable 1 }

HfPortEntry ::=

```
SEQUENCE {
    hfPortRankIndex
        INTEGER,
    hfPortIndex
        INTEGER,
    hfPortStatus
        INTEGER,
    hfPortDescr
        DisplayString
}
```

hfPortRankIndex **OBJECT-TYPE**  
**SYNTAX** INTEGER  
**MAX-ACCESS** not-accessible  
**STATUS** current  
**DESCRIPTION**  
"rank number; auxiliary variable used to identify rank number of an entry in the  
Ports Table; corresponds to the rank number in the hfPortRanksTable"  
::= { hfPortEntry 1 }

hfPortIndex **OBJECT-TYPE**  
**SYNTAX** INTEGER  
**MAX-ACCESS** not-accessible

**STATUS** current

**DESCRIPTION**

"port number; auxiliary variable used to identify an entry in the Ports Table in which port in the rank)"

::= { hfPortEntry 2 }

hfPortStatus **OBJECT-TYPE**

**SYNTAX INTEGER** {

down (1), -- inoperative  
avail (2), -- available for normal operation  
inUse (3), -- in use for normal operation  
test (4), -- in some test mode; not available for use

}

**MAX-ACCESS** read-only

**STATUS** current

**DESCRIPTION**

"current operational status of port"

::= { hfPortEntry 3 }

hfPortDescr **OBJECT-TYPE**

**SYNTAX** DisplayString

**MAX-ACCESS** read-write

**STATUS** current

**DESCRIPTION**

"name of equipment or circuit attached to this port; for display to user"

::= { hfPortEntry 4 }

-- the Channel Table

-- for any equipment that uses channel numbers to refer to operating frequencies

-- and modes, e.g., radios and ALE controllers

hfChannelTable **OBJECT-TYPE**

**SYNTAX SEQUENCE OF** HfChannelEntry

**MAX-ACCESS** not-accessible

**STATUS** current

**DESCRIPTION**

"table of channel characteristics"

::= { hfSystem 10 }

hfChannelEntry **OBJECT-TYPE**

**SYNTAX** HfChannelEntry

**MAX-ACCESS** not-accessible

**STATUS** current

**DESCRIPTION**

"an entry in the channel table"

**INDEX** { hfChannelIndex }

::= { hfChannelTable 1 }

HfChannelEntry ::=

```
SEQUENCE {  
    hfChannelIndex  
        INTEGER,  
    hfChannelType  
        INTEGER,  
    hfChannelRxFreq  
        INTEGER,  
    hfChannelRxMode  
        HfModulation,  
    hfChannelTxFreq  
        INTEGER,  
    hfChannelTxMode  
        HfModulation,  
    hfChannelAntenna  
        INTEGER,  
    hfChannelPower  
        INTEGER,  
    hfChannelStatus  
        RowStatus  
}
```

**hfChannelIndex OBJECT-TYPE**

**SYNTAX INTEGER**

**MAX-ACCESS** not-accessible

**STATUS** current

**DESCRIPTION**

"channel number; auxiliary variable used to identify an entry in the Channel Table"

::= { hfChannelEntry 1 }

**hfChannelType OBJECT-TYPE**

**SYNTAX INTEGER {**

other (1), -- none of the following

unused (2), -- an unused channel

duplex (3), -- a channel in duplex service (both directions simultaneously)

simplex (4), -- a channel in simplex service (both directions, but one at  
a time)

listen (5), -- a channel in receive-only service

**}**

**MAX-ACCESS** read-create

**STATUS** current

**DESCRIPTION**

"operating mode of channel"

**DEFVAL** { simplex }

::= { hfChannelEntry 2 }

**hfChannelRxFreq OBJECT-TYPE**

**SYNTAX INTEGER**

**UNITS** "Hz"

**MAX-ACCESS** read-create

**STATUS** current

**DESCRIPTION**

"frequency for this channel"

**DEFVAL** { 0 }

::= { hfChannelEntry 3 }

**hfChannelRxMode OBJECT-TYPE**

**SYNTAX** HfModulation

**MAX-ACCESS** read-create

**STATUS** current

**DESCRIPTION**

"receiving modulation for this channel"

**DEFVAL** { usb }

::= { hfChannelEntry 4 }

**hfChannelTxFreq OBJECT-TYPE**

**SYNTAX INTEGER**

**UNITS "Hz"**

**MAX-ACCESS** read-create

**STATUS** current

**DESCRIPTION**

"transmitting frequency for this channel"

**DEFVAL** { 0 }

::= { hfChannelEntry 5 }

**hfChannelTxMode OBJECT-TYPE**

**SYNTAX** HfModulation

**MAX-ACCESS** read-create

**STATUS** current

**DESCRIPTION**

"transmitting modulation for this channel"

**DEFVAL** { usb }

::= { hfChannelEntry 6 }

**hfChannelAntenna OBJECT-TYPE**

**SYNTAX INTEGER**

**MAX-ACCESS** read-create

**STATUS** current

**DESCRIPTION**

"antenna number (local significance: index into site antenna table)"

**DEFVAL** { 1 }

::= { hfChannelEntry 7 }

**hfChannelPower OBJECT-TYPE**

**SYNTAX INTEGER** {

full (1),

reduced (2)

}

**MAX-ACCESS** read-create

**STATUS** current

**DESCRIPTION**

"full or reduced transmitter power used on this channel?"

**DEFVAL** { 1 }

::= { hfChannelEntry 8 }

**hfChannelStatus OBJECT-TYPE**

**SYNTAX** RowStatus

**MAX-ACCESS** read-create

**STATUS** current

**DESCRIPTION**

"The status column used for creating, modifying, and deleting Channel Table entries"

**DEFVAL** { active }  
 ::= { hfChannelEntry 9 }

HfModulation ::=  
 **INTEGER** {  
     cw (1),  
     afsk (2),             -- incl RATT  
     am (3),             -- incl AME  
     usb (4),  
     lsb (5),  
     isb2 (6),  
     isb4 (7),  
     mcw (8),  
     fm (9),  
     fsk (10),  
     psk (11)  
 }

-- the Channel Set Table

hfChannelSetTable **OBJECT-TYPE**  
 **SYNTAX SEQUENCE OF** HfChannelSet  
 **MAX-ACCESS** not-accessible  
 **STATUS** current  
 **DESCRIPTION**  
     "contains sets of channels for efficient reference to scan lists, etc."  
 ::= { hfSystem 11 }

hfChannelSet **OBJECT-TYPE**  
 **SYNTAX** HfChannelSet  
 **MAX-ACCESS** not-accessible  
 **STATUS** current  
 **DESCRIPTION**  
     "an entry in the Channel Set Table"  
 **INDEX** { hfChannelSetIndex }  
 ::= { hfChannelSetTable 1 }

HfChannelSet ::=  
 **SEQUENCE** {  
     hfChannelSetIndex  
     **INTEGER**,  
     hfChannelSetMembers  
     **BIT STRING**,



```
        hfChannelSetStatus
            RowStatus
    }
```

hfChannelSetIndex **OBJECT-TYPE**

**SYNTAX INTEGER**

**MAX-ACCESS** not-accessible

**STATUS** current

**DESCRIPTION**

"auxiliary variable to identify an entry in Channel Set Table"

::= { hfChannelSet 1 }

hfChannelSetMembers **OBJECT-TYPE**

**SYNTAX BIT STRING**

**MAX-ACCESS** read-create

**STATUS** current

**DESCRIPTION**

"Bit string that indicates which channels are in set. Bit number corresponds to channel number. A bit set to 1 indicates that the corresponding channel is in the set, while a bit set to 0 indicates that the corresponding bit is not in the set. The bit string need be no longer than the highest-numbered channel that is in the set plus one bit. (Bit 0 is always 0, unless equipment supports a channel numbered 0.)"

::= { hfChannelSet 2 }

hfChannelSetStatus **OBJECT-TYPE**

**SYNTAX** RowStatus

**MAX-ACCESS** read-create

**STATUS** current

**DESCRIPTION**

"The status column used for creating, modifying, and deleting Channel Set Table entries"

**DEFVAL** { active }

::= { hfChannelSet 3 }

-- the Patch group

-- the Patch Connections Table

patchConnectionsTable **OBJECT-TYPE**

**SYNTAX SEQUENCE OF** PatchConnectionEntry

**MAX-ACCESS** not-accessible

**STATUS** current

**DESCRIPTION**

"table of connections among patch ports in automated patch panel"

::= { patch 1 }

**patchConnectionEntry OBJECT-TYPE**

**SYNTAX** PatchConnectionEntry

**MAX-ACCESS** not-accessible

**STATUS** current

**DESCRIPTION**

"an entry in the patch connections table"

**INDEX** { patchRankA patchPortA patchRankB patchPortB }

::= { patchConnectionsTable 1 }

PatchConnectionEntry ::=

**SEQUENCE** {

patchRankA

**INTEGER,**

patchPortA

**INTEGER,**

patchRankB

**INTEGER,**

patchPortB

**INTEGER,**

patchConnectionStatus

**INTEGER**

}

**patchRankA OBJECT-TYPE**

**SYNTAX** INTEGER

**MAX-ACCESS** not-accessible

**STATUS** current

**DESCRIPTION**

"rank of first end of a patch connection; auxiliary variable used to identify an entry  
in Patch Connections Table"

::= { patchConnectionEntry 1 }

**patchPortA OBJECT-TYPE**

**SYNTAX** INTEGER

**MAX-ACCESS** not-accessible

**STATUS** current

**DESCRIPTION**

"port of first end of a patch connection; auxiliary variable used to identify an entry  
in Patch Connections Table"

::= { patchConnectionEntry 2 }

**patchRankB OBJECT-TYPE**

**SYNTAX** INTEGER

**MAX-ACCESS** not-accessible

**STATUS** current

**DESCRIPTION**

"rank of second end of a patch connection; auxiliary variable used to identify an entry in Patch Connections Table"

::= { patchConnectionEntry 3 }

patchPortB **OBJECT-TYPE**

**SYNTAX INTEGER**

**MAX-ACCESS** not-accessible

**STATUS** current

**DESCRIPTION**

"port of second end of a patch connection; auxiliary variable used to identify an entry in Patch Connections Table"

::= { patchConnectionEntry 4 }

patchConnectionStatus **OBJECT-TYPE**

**SYNTAX INTEGER** {

free (1), -- written to release a connection,  
-- freeing the ports;

-- read only in response to freeing SET

seized (2), -- written to establish a connection; read when -- established

reserved (3), -- written to capture ports without making the  
-- connection;

-- read when both ports have been reserved

}

**MAX-ACCESS** read-create

**STATUS** current

**DESCRIPTION**

"current status of connection; an appropriate error code is returned when a connection cannot be established, reserved, or freed as requested, or in response to a get request for a non-existent connection"

**DEFVAL** { seized }

::= { patchConnectionEntry 5 }

-- the antenna system group

-- the antenna

tableantennaTable **OBJECT-TYPE**

**SYNTAX SEQUENCE OF** AntennaEntry

**MAX-ACCESS** not-accessible

**STATUS** current

**DESCRIPTION**

"Table of antennas under the control of the addressed device (antennas are not addressed directly)"

::= { antenna 1 }

antennaEntry **OBJECT-TYPE**

**SYNTAX** AntennaEntry

**MAX-ACCESS** not-accessible

**STATUS** current

**DESCRIPTION**

"An entry in the antenna table"

**INDEX** { antennaIndex }

::= { antennaTable 1 }

AntennaEntry ::=

**SEQUENCE** {

antennaIndex

**INTEGER,**

antennaType

**INTEGER,**

antennaPolar

**INTEGER,**

antennaModel

DisplayString,

antennaMode

**INTEGER,**

antennaMaxPower

**INTEGER,**

antennaAzimuth,

**INTEGER**

}

antennaIndex **OBJECT-TYPE**

**SYNTAX** INTEGER

**MAX-ACCESS** not-accessible

**STATUS** current

**DESCRIPTION**

"Antenna number; auxiliary variable used to identify an entry in the Antenna  
Table"

::= { antennaEntry 1 }

antennaType **OBJECT-TYPE**

**SYNTAX** INTEGER {

other (1), -- none of the following

whip (2),

dipole (3),

longwire (4),

loop (5),

omni (6), -- omnidirectional

rlp (7), -- rotatable log-periodic

beam (8), -- any other multi-element assembly  
rhombic (9),  
slopingv (10),  
nvis (11)  
}  
**MAX-ACCESS** read-only  
**STATUS** current  
**DESCRIPTION**  
"Type of antenna. When more than one of the types listed is applicable, use the  
most specific."  
::= { antennaEntry 2 }

antennaPolar **OBJECT-TYPE**  
**SYNTAX INTEGER** {  
other (1), -- none of the following  
horizontal (2),  
vertical (3),  
circular (4)  
}  
**MAX-ACCESS** read-only  
**STATUS** current  
**DESCRIPTION**  
"Polarization of antenna"  
::= { antennaEntry 3 }

antennaModel **OBJECT-TYPE**  
**SYNTAX** DisplayString  
**MAX-ACCESS** read-only  
**STATUS** current  
**DESCRIPTION**  
"Manufacturer and model of antenna"  
::= { antennaEntry 4 }

antennaMode **OBJECT-TYPE**  
**SYNTAX INTEGER** {  
other (1), -- none of the following  
RxOnly (2),  
TxOnly (3),  
RxTx (4)  
}  
**MAX-ACCESS** read only  
**STATUS** current  
**DESCRIPTION**  
"Operating mode capability."  
::= { antennaEntry 5 }

**antennaMaxPower OBJECT-TYPE**

**SYNTAX INTEGER** (-128..127)

**UNITS** "dBW"

**MAX-ACCESS** read only

**STATUS** current

**DESCRIPTION**

"Maximum operating power of antenna. When rounding computed dBW to integer, round down."

::= { antennaEntry 6 }

**antennaAzimuth OBJECT-TYPE**

**SYNTAX INTEGER** (0..359)

**UNITS** "degrees"

**MAX-ACCESS** read-write

**STATUS** current

**DESCRIPTION**

"Current magnetic azimuth of antenna. Always 0 for omni antennas."

::= { antennaEntry 7 }

-- the radio group

**radioChannel OBJECT-TYPE**

**SYNTAX INTEGER**

**MAX-ACCESS** read-write

**STATUS** current

**DESCRIPTION**

"Index into Channel Table for the radio of its current operating channel. If its current frequencies and modes do not exactly correspond to an entry in that table, equal to -1."

::= { radio 1 }

**radioKeyed OBJECT-TYPE**

**SYNTAX** TruthValue

**MAX-ACCESS** read-write

**STATUS** current

**DESCRIPTION**

"1 if transmitter is keyed, 0 otherwise. Writing a 1 keys transmitter."

::= { radio 2 }

**radioTxPower OBJECT-TYPE**

**SYNTAX INTEGER** (-128..127)

**UNITS** "dBW"

**MAX-ACCESS** read-write

**STATUS** current

**DESCRIPTION**

"Nominal PA output power, as adjusted by power management commands. For example, a 100W radio returns 20 when operating at full rated power. Writing 10 to radioTxPower should cause this radio to reduce its power output by 10 dB to a nominal 10W. Power adjustments will usually be approximations of the output power requested; the actual output power resulting from adjustment should be reported in the response to a set. (-128 dBW indicates no power.)"

::= { radio 3 }

radioTxFreq **OBJECT-TYPE**

**SYNTAX INTEGER**

**UNITS "Hz"**

**MAX-ACCESS read-write**

**STATUS current**

**DESCRIPTION**

"Current transmitting frequency."

::= { radio 4 }

radioTxMode **OBJECT-TYPE**

**SYNTAX HfModulation**

**MAX-ACCESS read-write**

**STATUS current**

**DESCRIPTION**

"Current transmitter modulation setting."

::= { radio 5 }

radioRxFreq **OBJECT-TYPE**

**SYNTAX INTEGER**

**UNITS "Hz"**

**MAX-ACCESS read-write**

**STATUS current**

**DESCRIPTION**

"Current receiving frequency."

::= { radio 6 }

radioRxMode **OBJECT-TYPE**

**SYNTAX HfModulation**

**MAX-ACCESS read-write**

**STATUS current**

**DESCRIPTION**

"Current receiver modulation setting."

::= { radio 7 }

radioTuned **OBJECT-TYPE**

**SYNTAX TruthValue**

**MAX-ACCESS read-write**

**STATUS** current

**DESCRIPTION**

"1 if radio and coupler tuned for radioTxFreq, 0 otherwise. Writing a 1 causes tuning (0 will be read until tuning is completed)."

::= { radio 8 }

radioPABypass **OBJECT-TYPE**

**SYNTAX** TruthValue

**MAX-ACCESS** read-write

**STATUS** current

**DESCRIPTION**

"true for bypass; false for normal"

::= { radio 9 }

radioCouplerBypass **OBJECT-TYPE**

**SYNTAX** TruthValue

**MAX-ACCESS** read-write

**STATUS** current

**DESCRIPTION**

"true for bypass; false for normal"

::= { radio 10 }

radioActiveAntenna **OBJECT-TYPE**

**SYNTAX** INTEGER

**MAX-ACCESS** read-write

**STATUS** current

**DESCRIPTION**

"Index into antennaTable indicating the antenna currently in use (or ready for use)."

::= { radio 11 }

radioPreselectorBypass **OBJECT-TYPE**

**SYNTAX** TruthValue

**MAX-ACCESS** read-write

**STATUS** current

**DESCRIPTION**

"true for bypass; false for normal"

::= { radio 12 }

radioFrontEndAtten **OBJECT-TYPE**

**SYNTAX** INTEGER (0..255)

**UNITS** "dB"

**MAX-ACCESS** read-write

**STATUS** current

**DESCRIPTION**

"attenuation at front end"



::= { radio 13 }

**radioRFMute OBJECT-TYPE**

**SYNTAX** TruthValue

**MAX-ACCESS** read-write

**STATUS** current

**DESCRIPTION**

"true if RF is muted, false if unmuted"

::= { radio 14 }

**radioRFGain OBJECT-TYPE**

**SYNTAX INTEGER** (-128..127)

**UNITS** "dB"

**MAX-ACCESS** read-write

**STATUS** current

**DESCRIPTION**

"gain of receiver RF amplifier relative to nominal"

::= { radio 15 }

**radioVFO OBJECT-TYPE**

**SYNTAX INTEGER**

**UNITS** "Hz"

**MAX-ACCESS** read-write

**STATUS** current

**DESCRIPTION**

"frequency of VFO; 0 is off"

::= { radio 16 }

**radioNoiseBlanker OBJECT-TYPE**

**SYNTAX INTEGER** (0..9)

**UNITS** "arbitrary"

**MAX-ACCESS** read-write

**STATUS** current

**DESCRIPTION**

"noise blanker level; the range of levels supported by the radio shall be mapped into the range 0 through 9, with 9 being the highest level; 0 disables noise blanker"

::= { radio 17 }

**radioNotchFilterMode OBJECT-TYPE**

**SYNTAX INTEGER** {

off (1),

manual (2),

automatic (3)

}

**MAX-ACCESS** read-write

**STATUS** current

**DESCRIPTION**

"operating mode of notch filter; in automatic mode, notch frequency tracks the interfering signal automatically"

::= { radio 18 }

radioNotchFilterFrequency **OBJECT-TYPE**

**SYNTAX INTEGER**

**UNITS "Hz"**

**MAX-ACCESS** read-write

**STATUS** current

**DESCRIPTION**

"center frequency of notch filter; read only when mode is automatic"

::= { radio 19 }

radioAGCMode **OBJECT-TYPE**

**SYNTAX INTEGER** {

off (1),

fast (2),

medium (3),

slow (4),

external (5),

coherent (6),

data (7)

}

**MAX-ACCESS** read-write

**STATUS** current

**DESCRIPTION**

"AGC speed and mode"

::= { radio 20 }

radioAudioClipEnable **OBJECT-TYPE**

**SYNTAX** TruthValue

**MAX-ACCESS** read-write

**STATUS** current

**DESCRIPTION**

"true if audio peak filter is on, false if off"

::= { radio 21 }

radioAudioClipLevel **OBJECT-TYPE**

**SYNTAX INTEGER**

**UNITS "dB"**

**MAX-ACCESS** read-write

**STATUS** current

**DESCRIPTION**

"level relative to nominal"

::= { radio 22 }

**radioAudioPassband OBJECT-TYPE**

**SYNTAX INTEGER**

**UNITS "Hz"**

**MAX-ACCESS** read-write

**STATUS** current

**DESCRIPTION**

"width of audio passband"

::= { radio 23 }

**radioPassbandTuning OBJECT-TYPE**

**SYNTAX INTEGER**

**UNITS "Hz"**

**MAX-ACCESS** read-write

**STATUS** current

**DESCRIPTION**

"variation of passband center frequency from nominal; 0 means passband tuning is off"

::= { radio 24 }

**radioBFO OBJECT-TYPE**

**SYNTAX INTEGER**

**UNITS "Hz"**

**MAX-ACCESS** read-write

**STATUS** current

**DESCRIPTION**

"frequency of beat frequency oscillator; 0 is off"

::= { radio 25 }

**radioSquelch OBJECT-TYPE**

**SYNTAX INTEGER (0..9)**

**UNITS "arbitrary"**

**MAX-ACCESS** read-write

**STATUS** current

**DESCRIPTION**

"squelch level; 0 is off"

::= { radio 26 }

**radioSpeakerMute OBJECT-TYPE**

**SYNTAX** TruthValue

**MAX-ACCESS** read-write

**STATUS** current

**DESCRIPTION**

"true if speaker is muted, false if unmuted"

::= { radio 27 }

radioMicGain **OBJECT-TYPE**

**SYNTAX INTEGER**

**UNITS "dB"**

**MAX-ACCESS read-write**

**STATUS current**

**DESCRIPTION**

"gain of microphone input"

::= { radio 28 }

radioSpeechProcEnable **OBJECT-TYPE**

**SYNTAX TruthValue**

**MAX-ACCESS read-write**

**STATUS current**

**DESCRIPTION**

"true if speech processor is on, false if off"

::= { radio 29 }

radioSpeechProcInputLevel **OBJECT-TYPE**

**SYNTAX INTEGER**

**UNITS "dB"**

**MAX-ACCESS read-write**

**STATUS current**

**DESCRIPTION**

"level relative to nominal"

::= { radio 30 }

radioSpeechProcOutputLevel **OBJECT-TYPE**

**SYNTAX INTEGER**

**UNITS "dB"**

**MAX-ACCESS read-write**

**STATUS current**

**DESCRIPTION**

"level relative to nominal"

::= { radio 31 }

radioAudioGain **OBJECT-TYPE**

**SYNTAX INTEGER**

**UNITS "dB"**

**MAX-ACCESS read-write**

**STATUS current**

**DESCRIPTION**

"level relative to nominal"

::= { radio 32 }

radioVoxEnable **OBJECT-TYPE**

**SYNTAX TruthValue**

**MAX-ACCESS** read-write  
**STATUS** current  
**DESCRIPTION**  
"true if VOX is on, false if off"  
::= { radio 33 }

radioVoxGain **OBJECT-TYPE**  
**SYNTAX INTEGER**  
**UNITS** "dB"  
**MAX-ACCESS** read-write  
**STATUS** current  
**DESCRIPTION**  
"gain relative to nominal"  
::= { radio 34 }

radioVoxAntiTrip **OBJECT-TYPE**  
**SYNTAX INTEGER** (0..9)  
**UNITS** "arbitrary"  
**MAX-ACCESS** read-write  
**STATUS** current  
**DESCRIPTION**  
"VOX circuit anti-trip setting"  
::= { radio 35 }

radioVoxDelay **OBJECT-TYPE**  
**SYNTAX INTEGER**  
**UNITS** "ms"  
**MAX-ACCESS** read-write  
**STATUS** current  
**DESCRIPTION**  
"VOX delay"  
::= { radio 36 }

radioZeroize **OBJECT-TYPE**  
**SYNTAX** TruthValue  
**MAX-ACCESS** read-write  
**STATUS** current  
**DESCRIPTION**  
"set to true to zeroize; reads as true if radio is zeroized"  
::= { radio 37 }

radioScanSet **OBJECT-TYPE**  
**SYNTAX SEQUENCE OF INTEGER**  
**MAX-ACCESS** read-write  
**STATUS** current  
**DESCRIPTION**  
"list of channel set indices in scan set"

::= { radio 38 }

radioScanRate **OBJECT-TYPE**

**SYNTAX INTEGER**

**UNITS** "channels per second"

**MAX-ACCESS** read-write

**STATUS** current

**DESCRIPTION**

"rate at which receiver scans channels"

::= { radio 39 }

radioStopScanThreshold **OBJECT-TYPE**

**SYNTAX INTEGER**

**UNITS** "dB"

**MAX-ACCESS** read-write

**STATUS** current

**DESCRIPTION**

"level relative to nominal"

::= { radio 40 }

-- the radio gauges

radioGauges **OBJECT-TYPE**

**SYNTAX SEQUENCE OF** RadioGaugeEntry

**MAX-ACCESS** not-accessible

**STATUS** current

**DESCRIPTION**

"Table of read-only radio gauges. Organized in no particular order, each is identified by a name, and has integer-valued readings in specified units."

::= { radio 41 }

radioGaugeEntry **OBJECT-TYPE**

**SYNTAX** RadioGaugeEntry

**MAX-ACCESS** not-accessible

**STATUS** current

**DESCRIPTION**

"An abstract radio gauge"

**INDEX** { radioGaugeIndex }

::= { radioGauges 1 }

RadioGaugeEntry ::= **SEQUENCE** {  
    radioGaugeIndex  
        **INTEGER**,  
    radioGaugeName  
        DisplayString,  
    radioGaugeUnits  
        DisplayString,  
    radioGaugeReading  
        Gauge,  
    radioGaugeTrapHigh  
        Gauge,  
    radioGaugeTrapLow  
        Gauge  
}

radioGaugeIndex **OBJECT-TYPE**  
**SYNTAX** INTEGER  
**MAX-ACCESS** not-accessible  
**STATUS** current  
**DESCRIPTION**  
    "gauge number; auxiliary variable used to identify an entry in the table of radio gauges"  
::= { radioGaugeEntry 1 }

radioGaugeName **OBJECT-TYPE**  
**SYNTAX** DisplayString  
**MAX-ACCESS** read-only  
**STATUS** current  
**DESCRIPTION**  
    "Name of the quantity whose value is displayed on the gauge."  
::= { radioGaugeEntry 2 }

radioGaugeUnits **OBJECT-TYPE**  
**SYNTAX** DisplayString  
**MAX-ACCESS** read-only  
**STATUS** current  
**DESCRIPTION**  
    "Units of the value displayed on the gauge. Should be selected so that integer readings are useful."  
::= { radioGaugeEntry 3 }

radioGaugeReading **OBJECT-TYPE**  
**SYNTAX** Gauge  
**UNITS** "specified in radioGaugeUnits"  
**MAX-ACCESS** read-only

**STATUS** current

**DESCRIPTION**

"Most recent value of the quantity named in radioGaugeName"

::= { radioGaugeEntry 4 }

radioGaugeTrapHigh **OBJECT-TYPE**

**SYNTAX** Gauge

**UNITS** "specified in radioGaugeUnits"

**MAX-ACCESS** read-write

**STATUS** current

**DESCRIPTION**

"threshold above which a trap will be generated automatically"

::= { radioGaugeEntry 5 }

radioGaugeTrapLow **OBJECT-TYPE**

**SYNTAX** Gauge

**UNITS** "specified in radioGaugeUnits"

**MAX-ACCESS** read-write

**STATUS** current

**DESCRIPTION**

"threshold below which a trap will be generated automatically"

::= { radioGaugeEntry 6 }

-- the ALE group

aleScanRate **OBJECT-TYPE**

**SYNTAX** INTEGER

**UNITS** "channels per second"

**MAX-ACCESS** read-write

**STATUS** current

**DESCRIPTION**

"rate at which ALE receiver scans channels"

::= { ale 1 }

aleMaxScanChan **OBJECT-TYPE**

**SYNTAX** INTEGER

**MAX-ACCESS** read-write

**STATUS** current

**DESCRIPTION**

"maximum number of channels scanned for network"

::= { ale 2 }

aleMaxTuneTime **OBJECT-TYPE**

**SYNTAX** INTEGER

**UNITS** "100 ms"



**MAX-ACCESS** read-write  
**STATUS** current  
**DESCRIPTION**  
    "maximum tune time for network"  
::= { ale 3 }

aleTurnAroundTime **OBJECT-TYPE**  
    **SYNTAX** INTEGER  
    **UNITS** "100 ms"  
    **MAX-ACCESS** read-write  
    **STATUS** current  
    **DESCRIPTION**  
        "maximum Tta for network"  
::= { ale 4 }

aleActivityTimeout **OBJECT-TYPE**  
    **SYNTAX** INTEGER  
    **UNITS** "seconds"  
    **MAX-ACCESS** read-write  
    **STATUS** current  
    **DESCRIPTION**  
        "wait-for-activity timeout Twa"  
::= { ale 5 }

aleListenTime **OBJECT-TYPE**  
    **SYNTAX** INTEGER  
    **UNITS** "seconds"  
    **MAX-ACCESS** read-write  
    **STATUS** current  
    **DESCRIPTION**  
        "listen before transmit time Twt"  
::= { ale 6 }

aleAcceptAnycall **OBJECT-TYPE**  
    **SYNTAX** INTEGER {  
        respond (1),  
        ignore (2)  
    }  
    **MAX-ACCESS** read-write  
    **STATUS** current  
    **DESCRIPTION**  
        "will ALE controller respond to anycalls"  
::= { ale 7 }

aleAcceptAllcall **OBJECT-TYPE**  
    **SYNTAX** INTEGER {

```
    accept (1),
    ignore (2)
}
MAX-ACCESS read-write
STATUS current
DESCRIPTION
    "will ALE controller detect and stop scan for allcalls "
 ::= { ale 8 }
```

```
aleAcceptAMD OBJECT-TYPE
  SYNTAX INTEGER {
    display (1),
    store (2),
    displayAndStore (3),
    ignore (4)          -- doesn't require return to scan
  }
  MAX-ACCESS read-write
  STATUS current
  DESCRIPTION
    "ALE controller action(s) upon receipt of AMD message"
 ::= { ale 9 }
```

```
aleAcceptDTM OBJECT-TYPE
  SYNTAX INTEGER {
    accept (1),
    ignore (2)
  }
  MAX-ACCESS read-write
  STATUS current
  DESCRIPTION
    "ALE controller action upon receipt of data text message"
 ::= { ale 10 }
```

```
aleAcceptDBM OBJECT-TYPE
  SYNTAX INTEGER {
    accept (1),
    ignore (2)
  }
  MAX-ACCESS read-write
  STATUS current
  DESCRIPTION
    "ALE controller action upon receipt of data block message"
 ::= { ale 11 }
```

```
aleRequestLQA OBJECT-TYPE
  SYNTAX INTEGER {
```

always (1), -- request LQA in every ALE transmission  
callOnly (2), -- request LQA only in ALE call  
never (3)

}

**MAX-ACCESS** read-write

**STATUS** current

**DESCRIPTION**

"ALE protocol phases in which ALE controller will request an LQA report"

::= { ale 12 }

aleAutoPowerAdj **OBJECT-TYPE**

**SYNTAX INTEGER** {

always (1), -- evaluate every received ALE transmission, but  
-- request power adjustment only when needed

callOnly (2), -- negotiate power only during link

-- establishment

never (3)

}

**MAX-ACCESS** read-write

**STATUS** current

**DESCRIPTION**

"ALE protocol phases in which ALE controller will generate power adjust  
commands to distant station, based upon measurement of received signal  
strength"

::= { ale 13 }

AleAddress ::= OCTET STRING (SIZE (1..15))

-- one to fifteen characters from [A-Z, 0-9]

-- the ALE Self Address Table

aleSelfAddrTable **OBJECT-TYPE**

**SYNTAX SEQUENCE OF** AleSelfAddrEntry

**MAX-ACCESS** not-accessible

**STATUS** current

**DESCRIPTION**

"table of 'self' addresses for ALE controller, along with ALE information relevant  
to each self address"

**REFERENCE** "see MIL-STD-188-141"

::= { ale 14 }

aleSelfAddrEntry **OBJECT-TYPE**

**SYNTAX** AleSelfAddrEntry

**MAX-ACCESS** not-accessible

**STATUS** current

**DESCRIPTION**

"an entry in the ALE Self Address Table"

**INDEX** { IMPLIED aleSelfAddr }  
 ::= { aleSelfAddrTable 1 }

AleSelfAddrEntry ::= **SEQUENCE** {  
    aleSelfAddr  
        AleAddress,  
    aleSelfAddrStatus  
        **INTEGER**,  
    aleNetAddr  
        AleAddress,  
    aleSlotWaitTime  
        **INTEGER**,  
    aleSelfAddrValidChannels  
        **INTEGER**  
}

aleSelfAddr **OBJECT-TYPE**  
**SYNTAX** AleAddress  
**MAX-ACCESS** not-accessible  
**STATUS** current  
**DESCRIPTION**  
    "ALE self address; one to fifteen characters from [A-Z, 0-9]; auxiliary variable  
        that uniquely identifies one entry in the ALE Self Address Table"  
 ::= { aleSelfAddrEntry 1 }

aleSelfAddrStatus **OBJECT-TYPE**  
**SYNTAX** RowStatus  
**MAX-ACCESS** read-create  
**STATUS** current  
**DESCRIPTION**  
    "The status column used for creating, modifying, and deleting ALE self address  
        table entries"  
**DEFVAL** { active }  
 ::= { aleSelfAddrEntry 2 }

aleNetAddr **OBJECT-TYPE**  
**SYNTAX** AleAddress  
**MAX-ACCESS** read-create  
**STATUS** current  
**DESCRIPTION**  
    "ALE address of net to which this self address belongs"  
**DEFVAL** { "" }  
 ::= { aleSelfAddrEntry 3 }

aleSlotWaitTime **OBJECT-TYPE**

**SYNTAX INTEGER**

**UNITS** "ALE word time Tw (130.667 ms)"

**MAX-ACCESS** read-only

**STATUS** current

**DESCRIPTION**

"slot wait time for responding to net call"

::= { aleSelfAddrEntry 4 }

aleSelfAddrValidChannels **OBJECT-TYPE**

**SYNTAX INTEGER**

**MAX-ACCESS** read-create

**STATUS** current

**DESCRIPTION**

"index into channel set table (0 means all channels valid)"

**DEFVAL** { 0 }

::= { aleSelfAddrEntry 5 }

-- the ALE Other Address Table

aleOtherAddrTable **OBJECT-TYPE**

**SYNTAX SEQUENCE OF** AleOtherAddrEntry

**MAX-ACCESS** not-accessible

**STATUS** current

**DESCRIPTION**

"ALE addresses of other stations and nets known to this ALE controller"

**REFERENCE** "see MIL-STD-188-141"

::= { ale 15 }

aleOtherAddrEntry **OBJECT-TYPE**

**SYNTAX** AleOtherAddrEntry

**MAX-ACCESS** not-accessible

**STATUS** current

**DESCRIPTION**

"an entry in the ALE Other Address Table"

**INDEX** { IMPLIED aleOtherAddr }

::= { aleOtherAddrTable 1 }

AleOtherAddrEntry ::=

**SEQUENCE** {

aleOtherAddr

AleAddress,

aleOtherAddrStatus

**INTEGER,**

aleOtherAddrNetMembers

**OCTET STRING,**

aleOtherAddrValidChannels

**INTEGER,**  
aleOtherAddrAnt  
**INTEGER,**  
aleOtherAddrAntAzimuth  
**INTEGER,**  
aleOtherAddrPower  
**INTEGER**  
}

aleOtherAddr **OBJECT-TYPE**

**SYNTAX** AleAddress

**MAX-ACCESS** not-accessible

**STATUS** current

**DESCRIPTION**

"ALE address; one to fifteen characters from [A-Z, 0-9]; auxiliary variable that uniquely identifies one entry in the ALE Other Address Table"

::= { aleOtherAddrEntry 1 }

**aleOtherAddrStatus OBJECT-TYPE**

**SYNTAX** RowStatus

**MAX-ACCESS** read-create

**STATUS** current

**DESCRIPTION**

"The status column used for creating, modifying, and deleting ALE Other Address Table entries"

**DEFVAL** { active }

::= { aleOtherAddrEntry 2 }

**aleOtherAddrNetMembers OBJECT-TYPE**

**SYNTAX SEQUENCE OF** AleAddress

**MAX-ACCESS** read-create

**STATUS** current

**DESCRIPTION**

"List of ALE addresses of net members, in slot order. Empty list if this other address is not a net address. Unknown net member addresses set to '@' "

**DEFVAL** { } -- empty sequence

::= { aleOtherAddrEntry 3 }

**aleOtherAddrValidChannels OBJECT-TYPE**

**SYNTAX INTEGER**

**MAX-ACCESS** read-create

**STATUS** current

**DESCRIPTION**

"index into channel set table (0 means all channels valid)"

**DEFVAL** { 0 }

::= { aleOtherAddrEntry 4 }

**aleOtherAddrAnt OBJECT-TYPE**

**SYNTAX INTEGER**

**MAX-ACCESS** read-create

**STATUS** current

**DESCRIPTION**

"Antenna number (antennaIndex) to use in links with this station or net. 0 means default to antenna specified for channel in hfChannelTable"

**DEFVAL** { 0 }

::= { aleOtherAddrEntry 5 }

**aleOtherAddrAntAzimuth OBJECT-TYPE**

**SYNTAX INTEGER**

**MAX-ACCESS** read-create

**STATUS** current

**DESCRIPTION**

"Azimuth of rotatable antenna to use in links with this station or net. 0 is default."

**DEFVAL** { 0 }

::= { aleOtherAddrEntry 6 }

aleOtherAddrPower **OBJECT-TYPE**

**SYNTAX INTEGER** {

default (0),

full (1),

reduced (2)

}

**MAX-ACCESS** read-create

**STATUS** current

**DESCRIPTION**

"Power to use in links with this station or net. 0 means default to power specified  
for channel in hfChannelTable"

**DEFVAL** { 0 }

::= { aleOtherAddrEntry 7 }

-- the LQA matrix

aleLqaMatrix **OBJECT-TYPE**

**SYNTAX SEQUENCE OF** AleLqaEntry

**MAX-ACCESS** not-accessible

**STATUS** current

**DESCRIPTION**

"table of link quality measurements"

::= { ale 16 }

aleLqaEntry **OBJECT-TYPE**

**SYNTAX** AleLqaEntry

**MAX-ACCESS** not-accessible

**STATUS** current

**DESCRIPTION**

"an entry in the ALE Other Address Table"

**INDEX** { **IMPLIED** aleLqaAddr aleLqaChannel }

::= { aleLqaMatrix 1 }

AleLqaEntry ::=

**SEQUENCE** {

aleLqaAddr

AleAddress,

aleLqaChannel

**INTEGER,**

aleLqaStatus

**INTEGER,**

aleLqaAge

**INTEGER,**



```
aleLqaMultipath
    INTEGER,
aleLqaSINAD
    INTEGER,
aleLqaBER
    INTEGER
}
aleLqaAddr OBJECT-TYPE
    SYNTAX AleAddress
    MAX-ACCESS not-accessible
    STATUS current
    DESCRIPTION
        "ALE address; one to fifteen characters from [A-Z, 0-9]; auxiliary variable that
        identifies (along with channel number) one entry in the ALE LQA Matrix"
    ::= { aleLqaEntry 1 }

aleLqaChannel OBJECT-TYPE
    SYNTAX INTEGER
    MAX-ACCESS not-accessible
    STATUS current
    DESCRIPTION
        "Channel number of LQA measurement; auxiliary variable that identifies (along
        with aleLqaAddr) one entry in the ALE LQA Matrix"
    ::= { aleLqaEntry 2 }

aleLqaStatus OBJECT-TYPE
    SYNTAX RowStatus
    MAX-ACCESS read-create
    STATUS current
    DESCRIPTION
        "The status column used for creating, modifying, and deleting LQA Matrix
        entries"
    DEFVAL { active }
    ::= { aleLqaEntry 3 }

aleLqaAge OBJECT-TYPE
    SYNTAX INTEGER {
        lqaFifteen (0),    -- 0-15 minutes
        lqaThirty (1),    -- 15-30 minutes
        lqaSixty (2),     -- 30-60 minutes
        lqaTwoHr (3),     -- 1-2 hours
        lqaFourHr (4),    -- 2-4 hours
        lqaToday (5),     -- 4-23 hours
        lqaYesterday (6), -- 23-25 hours
        lqaTooOld (7)    -- over 25 hours or unknown
    }
}
```

**MAX-ACCESS** read-create  
**STATUS** current  
**DESCRIPTION**  
    "Age of LQA measurement"  
::= { aleLqaEntry 4 }

aleLqaMultipath **OBJECT-TYPE**  
    **SYNTAX INTEGER** (0..7)  
    **UNITS** "ms"  
    **MAX-ACCESS** read-create  
    **STATUS** current  
    **DESCRIPTION**  
        "multipath measurement; 7 means unknown"  
::= { aleLqaEntry 5 }

aleLqaSINAD **OBJECT-TYPE**  
    **SYNTAX INTEGER** (0..31)  
    **UNITS** "dB"  
    **MAX-ACCESS** read-create  
    **STATUS** current  
    **DESCRIPTION**  
        "SINAD measurement; 31 means unknown"  
::= { aleLqaEntry 6 }

aleLqaBER **OBJECT-TYPE**  
    **SYNTAX INTEGER** (0..31)  
    **MAX-ACCESS** read-create  
    **STATUS** current  
    **DESCRIPTION**  
        "pseudo-BER measurement; 31 means unknown"  
::= { aleLqaEntry 7 }

-- the ALE controls

aleScanSet **OBJECT-TYPE**  
    **SYNTAX SEQUENCE OF INTEGER**  
    **MAX-ACCESS** read-write  
    **STATUS** current  
    **DESCRIPTION**  
        "list of channel set indices in scan set"  
::= { ale 16 }

aleConnectionTable **OBJECT-TYPE**  
    **SYNTAX SEQUENCE OF** AleConnectionEntry  
    **MAX-ACCESS** not-accessible

**STATUS** current

**DESCRIPTION**

"table of currently-linked stations"

::= { ale 17 }

aleConnectionEntry **OBJECT-TYPE**

**SYNTAX** AleConnectionEntry

**MAX-ACCESS** not-accessible

**STATUS** current

**DESCRIPTION**

"an entry in the ALE Connection Table"

**INDEX** { IMPLIED aleConnectedAddr }

::= { aleConnectionTable 1 }

AleConnectionEntry ::=

**SEQUENCE** {

aleConnectedAddr

AleAddress,

aleConnectionStatus

**INTEGER**

}

aleConnectedAddr **OBJECT-TYPE**

**SYNTAX** AleAddress

**MAX-ACCESS** not-accessible

**STATUS** current

**DESCRIPTION**

"ALE address of station or net to which connected; auxiliary variable that uniquely identifies one entry in the ALE Connection Table"

::= { aleConnectionEntry 1 }

aleConnectionStatus **OBJECT-TYPE**

**SYNTAX** RowStatus

**MAX-ACCESS** read-create

**STATUS** current

**DESCRIPTION**

"The status column used for creating, modifying, and deleting ALE Connection Table entries. Management stations may initiate link establishment by setting aleConnectionStatus to createAndGo. During link establishment, the connection status will be notInService, changing to active when the link is established. Management stations may initiate link termination by setting aleConnectionStatus to destroy."

**DEFVAL** { notInService }

::= { aleConnectionEntry 2 }

-- the LP (linking protection) group

lpLevelsAvail **OBJECT-TYPE**

**SYNTAX BIT STRING** {

unprotected (0), -- no linking protection  
al1 (1), -- unclassified application level AL-1  
al2 (2), -- unclassified enhanced application level AL-2  
al3 (3), -- unclassified but sensitive application level AL-3  
al4 (4), -- classified application level AL-4  
other (5) -- any AL not identified in MIL-STD-188-141

}

**MAX-ACCESS** read-only

**STATUS** current

**DESCRIPTION**

"Reports available linking protection (LP) application levels. Because AL-1 is the defined interoperability level, the al1 bit may be 0 only if all bits other than bit 0 are also set to 0, indicating no LP capability."

**REFERENCE** "see MIL-STD-188-141, Linking protection application levels"

::= { lp 1 }

-- the modem group

modemStatus **OBJECT-TYPE**

**SYNTAX INTEGER** {

other (1), -- none of the following  
available (2), -- "on hook"  
connecting (3), -- "off hook" but no received carrier  
carrier (4), -- "off hook" and receiving carrier  
dataSync (5), -- "off hook," receiving carrier, and  
-- achieved data synchronization  
fault (6) -- failure detected

}

**MAX-ACCESS** read-write

**STATUS** current

**DESCRIPTION**

"modem status; only the following values are valid in a set operation: available (2) forces the modem on-hook or resets a fault, and connecting (3) initiates a (re)connection attempt"

::= { hf modem 1 }

modemMode **OBJECT-TYPE**

**SYNTAX INTEGER** {

other (1), -- none of the following  
hfSerialTone (2),  
hf16Tone (3),  
hf39Tone (4),

fsk170 (5), -- 170 Hz shift  
fsk850 (6), -- 850 Hz shift  
stanag4285 (7),  
be11103 (8), -- 300 bps  
be11212a (9), -- 1200 bps  
v21 (10), -- 300 bps  
v22 (11), -- 1200 bps  
v22bis (12), -- 2400 bps  
v32 (13), -- 4800/9600 bps  
v32bis (14) -- 7200/9600/12000/14400 bps

}

**MAX-ACCESS** read-write

**STATUS** current

**DESCRIPTION**

"modem operating mode; a set operation that specifies an unavailable mode shall not change the operating mode"

::= { hf modem 2 }

modemAvailableModes **OBJECT-TYPE**

**SYNTAX** BIT STRING {

other (1), -- none of the following  
hfSerialTone (2),  
hf16Tone (3),  
hf39Tone (4),  
fsk170 (5), -- 170 Hz shift  
fsk850 (6), -- 850 Hz shift  
stanag4285 (7)  
be11103 (8), -- 300 bps  
be11212a (9), -- 1200 bps  
v21 (10), -- 300 bps  
v22 (11), -- 1200 bps  
v22bis (12), -- 2400 bps  
v32 (13), -- 4800/9600 bps  
v32bis (14) -- 7200/9600/12000/14400 bps

}

**MAX-ACCESS** read-only

**STATUS** current

**DESCRIPTION**

"available operating modes"

::= { hf modem 3 }

modemMaxDataRate **OBJECT-TYPE**

**SYNTAX** INTEGER

**UNITS** "bps"

**MAX-ACCESS** read-only

**STATUS** current

**DESCRIPTION**

"maximum data rate supported by modem"  
::= { hf modem 4 }

**modemTxDataRate OBJECT-TYPE**

**SYNTAX INTEGER**

**UNITS "bps"**

**MAX-ACCESS read-write**

**STATUS current**

**DESCRIPTION**

"data rate for data sent by modem; set operation causes data rate change at next logical opportunity"  
::= { hf modem 5 }

**modemTxInterleaver OBJECT-TYPE**

**SYNTAX INTEGER**

**UNITS "100 ms"**

**MAX-ACCESS read-write**

**STATUS current**

**DESCRIPTION**

"interleaver length used in sending data; 0 means no interleaver; a set operation that specifies an unavailable length should result in use of the nearest available length to that specified"  
::= { hf modem 6 }

**modemRxDataRate OBJECT-TYPE**

**SYNTAX INTEGER**

**UNITS "bps"**

**MAX-ACCESS read-only**

**STATUS current**

**DESCRIPTION**

"rate of data currently (or most recently) received by modem"  
::= { hf modem 7 }

**modemRxInterleaver OBJECT-TYPE**

**SYNTAX INTEGER**

**UNITS "100 ms"**

**MAX-ACCESS read-only**

**STATUS current**

**DESCRIPTION**

"interleaver length used for data currently (or most recently) received by modem"  
::= { hf modem 8 }

**modemRxSNR OBJECT-TYPE**

**SYNTAX INTEGER**

**UNITS "dB"**

**MAX-ACCESS** read-only

**STATUS** current

**DESCRIPTION**

"signal-to-noise ratio measured for data currently (or most recently) received by  
modem"

::= { hf modem 9 }

modemRxFreqOffset **OBJECT-TYPE**

**SYNTAX INTEGER**

**UNITS "Hz"**

**MAX-ACCESS** read-only

**STATUS** current

**DESCRIPTION**

"measured data carrier offset for data currently (or most recently) received by  
modem"

::= { hf modem 10 }

modemLoopbackMode **OBJECT-TYPE**

**SYNTAX INTEGER** {

none (1), -- no loopback  
digital (2), -- transmit data connected to receive data  
analog (3) -- transmit analog signal connected to  
-- receive analog input

}

**MAX-ACCESS** read-write

**STATUS** current

**DESCRIPTION**

"modem loopback mode; a set operation that specifies an unavailable mode shall  
effect no change"

::= { hf modem 11 }

modemDuplexMode **OBJECT-TYPE**

**SYNTAX INTEGER** {

other (1), -- none of the following  
simplex (2), -- send and receive alternately  
duplex (3), -- send and receive simultaneously  
-- ("full" duplex)  
sendOnly (4),  
rcvOnly (5)

}

**MAX-ACCESS** read-write

**STATUS** current

**DESCRIPTION**

"modem duplex mode; a set operation that specifies an unavailable mode shall  
effect no change"

::= { hf modem 12 }

**modemARQProtocol OBJECT-TYPE**

**SYNTAX INTEGER {**

none (1),            -- no ARQ protocol  
other (2),           -- none of the following  
hfdlp (3),  
v42 (4),  
lapm (5),  
mnp (6),  
mnp10 (7)

**}**

**MAX-ACCESS** read-write

**STATUS** current

**DESCRIPTION**

"modem ARQ protocol; a set operation that specifies an unavailable mode shall effect no change"

::= { hf modem 13 }

**modemCompressionProtocol OBJECT-TYPE**

**SYNTAX INTEGER {**

none (1),            -- no compression  
other (2),           -- none of the following  
mnp (3),  
v42bis (4)

**}**

**MAX-ACCESS** read-write

**STATUS** current

**DESCRIPTION**

"modem compression protocol; a set operation that specifies an unavailable mode shall effect no change"

::= { hf modem 14 }

-- the HF data link protocol group

**hfdlpProtocolVersion OBJECT-TYPE**

**SYNTAX INTEGER**

**MAX-ACCESS** read-only

**STATUS** current

**DESCRIPTION**

"version of protocol in use by terminal"

::= { hfdlp 1 }

**hfdlpControlMode OBJECT-TYPE**

**SYNTAX INTEGER {**

varFrameARQ (1),-- variable-length control frames with ARQ



broadcast (2), -- fixed-length control frames with no ARQ  
circuitARQ (3), -- variable-length control frames with ARQ  
-- and "keep-alive"  
fixedFrameARQ (4) -- fixed-length control frames with ARQ

}

**MAX-ACCESS** read-write

**STATUS** current

**DESCRIPTION**

"control mode currently (or most recently) in use on link; set operation determines preference, but other terminal in a link can override varFrameARQ (1) or circuitARQ (3) to force fixedFrameARQ (4)"

::= { hfdlp 2 }

hfdlpNegotiationMode **OBJECT-TYPE**

**SYNTAX INTEGER** {

normal (1), -- negotiate changes only

everySeries (2) -- negotiate between every data series

}

**MAX-ACCESS** read-write

**STATUS** current

**DESCRIPTION**

"negotiation mode currently (or most recently) in use on link; set operation determines preference, but other terminal in a link can override normal (1) to force everySeries (2)"

::= { hfdlp 3 }

hfdlpSelfAddress **OBJECT-TYPE**

**SYNTAX OCTET STRING** (SIZE (2..18))

**MAX-ACCESS** read-write

**STATUS** current

**DESCRIPTION**

"address of this terminal"

::= { hfdlp 4 }

hfdlpOtherAddress **OBJECT-TYPE**

**SYNTAX OCTET STRING** (SIZE (0..18))

**MAX-ACCESS** read-write

**STATUS** current

**DESCRIPTION**

"address of other terminal in link; zero-length string if no link; all 1s if broadcast"

::= { hfdlp 5 }

hfdlpLinkState **OBJECT-TYPE**

**SYNTAX INTEGER** {

idle (1),

calling (2),

callAcknowledge (3),  
sending (4), -- transmit terminal in link-up state  
receiving (5), -- receive terminal in link-up state  
circuitIdle (6) -- link-up state, but no traffic in progress  
-- (ARQ Circuit Mode only)

}

**MAX-ACCESS** read-write

**STATUS** current

**DESCRIPTION**

"link establishment state of HFDLP terminal; only the following values are valid in a set operation:

idle (1) forces terminal to drop link

calling (2) initiates a (re)connection attempt

sending (4) initiates Immediate mode message transfer"

::= { hfdlp 6 }

hfdlpMaxRetries **OBJECT-TYPE**

**SYNTAX INTEGER** (0..7)

**MAX-ACCESS** read-write

**STATUS** current

**DESCRIPTION**

"maximum number of times transmit terminal will resend control frames; 0 means no retransmissions (set ignored by receive terminal)"

::= { hfdlp 7 }

hfdlpRetryCountdown **OBJECT-TYPE**

**SYNTAX INTEGER** (0..7)

**MAX-ACCESS** read-only

**STATUS** current

**DESCRIPTION**

"remaining number of times terminal will send current control frame"

::= { hfdlp 8 }

hfdlpLinkTimeout **OBJECT-TYPE**

**SYNTAX INTEGER**

**UNITS** "100 ms"

**MAX-ACCESS** read-only

**STATUS** current

**DESCRIPTION**

"link timeout value in use by a transmit terminal or receive terminal"

::= { hfdlp 9 }

hfdlpFrameLength **OBJECT-TYPE**

**SYNTAX INTEGER**

**MAX-ACCESS** read-write

**STATUS** current

**DESCRIPTION**

"data bytes per data frame in use by transmit terminal (set ignored by receive terminal)"  
::= { hfdlp 10 }

**hfdlpSeriesLength OBJECT-TYPE**

**SYNTAX INTEGER**

**MAX-ACCESS** read-write

**STATUS** current

**DESCRIPTION**

"frames per data series in use by transmit terminal (set ignored by receive terminal)"  
::= { hfdlp 11 }

-- the AME group

**ameForwarding OBJECT-TYPE**

**SYNTAX INTEGER** {

relay (1), -- entity forwards messages

terminal (2) -- entity does not forward messages

}

**MAX-ACCESS** read-write

**STATUS** current

**DESCRIPTION**

"Enables or disables message relay in networking controller"  
::= { ame 1 }

**ameAdaptiveRouting OBJECT-TYPE**

**SYNTAX INTEGER** {

adaptive (1), -- entity automatically updates Routing

-- Table from local data, HRMP, or HSSP

static (2) -- entity doesn't automatically update Routing Table

}

**MAX-ACCESS** read-write

**STATUS** current

**DESCRIPTION**

"Enables or disables adaptive routing in networking controller. (Always reads as static if no Routing Table.)"  
::= { ame 2 }

**ameAlternateMedia OBJECT-TYPE**

**SYNTAX INTEGER** {

hfOnly (1), -- entity routes messages only via HF links

allMedia (2) -- entity routes messages via any available links

}

**MAX-ACCESS** read-write

**STATUS** current

**DESCRIPTION**

"Enables or disables multi media routing in networking controller. (Always reads as hfOnly if no Routing Table.)"

::= { ame 3 }

ameRetryCount **OBJECT-TYPE**

**SYNTAX** INTEGER

**MAX-ACCESS** read-write

**STATUS** current

**DESCRIPTION**

"Maximum number of delivery attempts before a message is discarded"

::= { ame 4 }

ameRetryInterval **OBJECT-TYPE**

**SYNTAX** INTEGER

**UNITS** "seconds"

**MAX-ACCESS** read-write

**STATUS** current

**DESCRIPTION**

"Initial retry interval for message delivery; subsequent intervals are larger"

::= { ame 5 }

ameInReceives **OBJECT-TYPE**

**SYNTAX** Counter32

**MAX-ACCESS** read-only

**STATUS** current

**DESCRIPTION**

"Messages received by AME entity"

::= { ame 6 }

ameInForwMsgs **OBJECT-TYPE**

**SYNTAX** Counter32

**MAX-ACCESS** read-only

**STATUS** current

**DESCRIPTION**

"Messages forwarded by AME entity"

::= { ame 7 }

**ameInUnknPorts OBJECT-TYPE**

**SYNTAX** Counter32

**MAX-ACCESS** read-only

**STATUS** current

**DESCRIPTION**

"Messages received by AME entity, but discarded due to unknown AME port numbers"

::= { ame 8 }

**ameInDelivers OBJECT-TYPE**

**SYNTAX** Counter32

**MAX-ACCESS** read-only

**STATUS** current

**DESCRIPTION**

"Messages received by AME entity and delivered to higher-layer protocol"

::= { ame 9 }

**ameOutRequests OBJECT-TYPE**

**SYNTAX** Counter32

**MAX-ACCESS** read-only

**STATUS** current

**DESCRIPTION**

"Messages from higher-layer protocol passed to AME entity for delivery."

::= { ame 10 }

**ameOutDiscards OBJECT-TYPE**

**SYNTAX** Counter32

**MAX-ACCESS** read-only

**STATUS** current

**DESCRIPTION**

"Messages from higher-layer protocol discarded by AME entity after maximum retries"

::= { ame 11 }

-- the AME Routing Table

**ameRoutingTable OBJECT-TYPE**

**SYNTAX SEQUENCE OF** AmeRouteEntry

**MAX-ACCESS** not-accessible

**STATUS** current

**DESCRIPTION**

"The AME Routing Table"

**REFERENCE** "see MIL-STD-187-721"

::= { ame 12 }

**ameRouteEntry OBJECT-TYPE**

**SYNTAX** AmeRouteEntry

**MAX-ACCESS** not-accessible

**STATUS** current

**DESCRIPTION**

"An entry in the AME Routing Table"

**INDEX** { IMPLIED ameRouteDest ameRouteRank }

::= { ameRoutingTable 1 }

AmeRouteEntry ::=

**SEQUENCE** {

ameRouteDest  
AleAddress,  
ameRouteRank  
**INTEGER**,  
ameRouteIfIndex  
**INTEGER**,  
ameRouteNextHop  
AleAddress,  
ameRouteHops  
**INTEGER**,  
ameRouteStatus  
RowStatus

}

**ameRouteDest OBJECT-TYPE**

**SYNTAX** AleAddress

**MAX-ACCESS** not-accessible

**STATUS** current

**DESCRIPTION**

"Address of station to which message is to be routed"

::= { ameRouteEntry 1 }

**ameRouteRank OBJECT-TYPE**

**SYNTAX** INTEGER

**MAX-ACCESS** read-create

**STATUS** current

**DESCRIPTION**

"Order of this route among all listed routes to the destination (1 is highest ranking).

Routes should be ranked in order of preference"

**DEFVAL** { 1 }

::= { ameRouteEntry 2 }

**ameRouteIfIndex OBJECT-TYPE**

**SYNTAX** INTEGER

**MAX-ACCESS** read-create

**STATUS** current

**DESCRIPTION**

"interface (link layer controller) to use for this route"

**DEFVAL** { 1 }

::= { ameRouteEntry 3 }

ameRouteNextHop **OBJECT-TYPE**

**SYNTAX** AleAddress

**MAX-ACCESS** read-create

**STATUS** current

**DESCRIPTION**

"address of relay (or destination if a direct route)"

::= { ameRouteEntry 4 }

ameRouteHops **OBJECT-TYPE**

**SYNTAX** INTEGER

**MAX-ACCESS** read-create

**STATUS** current

**DESCRIPTION**

"number of hops (links) in this route to destination"

**DEFVAL** { 1 }

::= { ameRouteEntry 5 }

ameRouteStatus **OBJECT-TYPE**

**SYNTAX** RowStatus

**MAX-ACCESS** read-create

**STATUS** current

**DESCRIPTION**

"The status column used for creating, modifying, and deleting AME Routing Table entries"

**DEFVAL** { active }

::= { ameRouteEntry 6 }

END

APPENDIX B

ABSTRACT SYNTAX NOTATION (HNMP DEFINITIONS)

HNMP DEFINITIONS ::= BEGIN

IMPORTS

ObjectName, ObjectSyntax, Integer32, **MODULE-IDENTITY**  
FROM SNMPv2-SMI; -- RFC 1442

hnmp **MODULE-IDENTITY**

**LAST-UPDATED** "9408021914Z"

**ORGANIZATION** "U.S. Army Information Systems Engineering Command"

**CONTACT\_INFO**

" Eric E. Johnson

Postal: New Mexico State University  
Dept 3-O, (Electrical Computer Engineering)  
Las Cruces, NM 88003-0001  
USA

Tel: +1 505 646 4739

Fax: +1 505 646 1435

E-mail: ejohnson@nmsu.edu"

**DESCRIPTION** "The HF Network Management Protocol for MIL/FED-STD automated  
HF radio networks"

::= { hf 15 } -- normally encoded as { 2 43 15 }

HfObjID ::=

[**PRIVATE 0**]

**IMPLICIT OBJECT IDENTIFIER**

HfObjectName ::=

**CHOICE** {

long-form -- uses full path to the root

ObjectName,

short-form -- uses truncated path starting with HF MIB flag { 2 43 }

encoded as 123

HfObjID



```
}  
  
HfObjectSyntax ::=  
    CHOICE {  
        smi-object-value    -- universal and application types from SMI  
            ObjectSyntax,  
        hfObjID-value      -- truncated object ID starting with HF MIB flag { 2 43 }  
            HfObjID  
    }  
encoded as  
  
-- protocol data units  
  
PDUs ::=  
    CHOICE {  
        get-request  
            GetRequest-PDU,  
  
        get-next-request  
            GetNextRequest-PDU,  
  
        get-bulk-request  
            GetBulkRequest-PDU,  
  
        get-rows-request  
            GetRowsRequest-PDU,  
  
        response  
            Response-PDU,  
  
        get-rows-response  
            GetRowsResponse-PDU,  
  
        set-request  
            SetRequest-PDU,  
  
        inform-request  
            InformRequest-PDU,  
  
        snmpV2-trap  
            SNMPv2-Trap-PDU
```

}

--PDUs

GetRequest-PDU::=  
    [0]  
    **IMPLICIT PDU**

GetNextRequest-PDU::=  
    [1]  
    **IMPLICIT PDU**

Response-PDU::=  
    [2]  
    **IMPLICIT PDU**

SetRequest-PDU::=  
    [3]  
    **IMPLICIT PDU**

-- [4] is obsolete

GetBulkRequest-PDU::=  
    [5]  
    **IMPLICIT BulkPDU**

InformRequest-PDU::=  
    [6]  
    **IMPLICIT PDU**

SNMPv2-Trap-PDU::=  
    [7]  
    **IMPLICIT PDU**

GetRowsRequest-PDU::=  
    [28]  
    **IMPLICIT BulkPDU**

GetRowsResponse-PDU::=  
    [29]  
    **IMPLICIT RowsPDU**

max-bindings

**INTEGER**::=2147483647

PDU::=

**SEQUENCE** {

request-id  
Integer32,

error-status -- sometimes ignored

**INTEGER** {

noError(0),  
tooBig(1),  
noSuchName(2), -- for proxy compatibility  
badValue(3), -- for proxy compatibility  
readOnly(4), -- for proxy compatibility  
genErr(5),  
noAccess(6),  
wrongType(7),  
wrongLength(8),  
wrongEncoding(9),  
wrongValue(10),  
noCreation(11),  
inconsistentValue(12),  
resourceUnavailable(13),  
commitFailed(14),  
undoFailed(15),  
authorizationError(16),  
notWritable(17),  
inconsistentName(18)

},

err-index -- sometimes ignored

**INTEGER** (0..max-bindings),

variable-bindings -- values are sometimes ignored

VarBindList

}

BulkPDU::= -- MUST be identical in

**SEQUENCE** { -- structure to PDU

MIL-STD-188-141B  
APPENDIX H

```
request-id
  Integer32,

non-repeaters
  INTEGER (0..max-bindings),

max-repetitions
  INTEGER (0..max-bindings),

variable-bindings    -- values are ignored
  VarBindList
}
```

```
RowsPDU ::=    -- MUST be identical in
SEQUENCE {    -- structure to PDU
  request-id
    Integer32,

  non-repeaters
    INTEGER (0..max-bindings),

  max-repetitions
    INTEGER (0..max-bindings),

  non-repeater-bindings
    VarBindList,

  row-bindings
    RowBindList
}
```

-- variable binding

```
VarBind ::=
    SEQUENCE {
        name
            HfObjectName,

        CHOICE {
            value
                HfObjectSyntax,
            unSpecified          -- inretrieval requests
                NULL,
                -- exceptions in responses
            noSuchObject[0]
                IMPLICIT NULL,

            noSuchInstance[1]
                IMPLICIT NULL,

            endOfMibView[2]
                IMPLICIT NULL
        }
    }
```

-- variable-binding list

```
VarBindList ::=
    SEQUENCE (SIZE (0..max-bindings)) OF
        VarBind
```

MIL-STD-188-141B  
APPENDIX H

-- row-binding

```
RowBind ::=
  SEQUENCE {
    name          -- object name of first object only
    HfObjectName,

    SEQUENCE OF  -- followed by values of all objects request in row
    CHOICE { -- containing first object
      value
        HfObjectSyntax,
        -- exceptions in responses
      noSuchObject[0]
        IMPLICIT NULL,

      noSuchInstance[1]
        IMPLICIT NULL,

      endOfMibView[2]
        IMPLICIT NULL,

      wrongRow[3]
        IMPLICIT NULL
    }
  }
```

-- row-binding list

```
RowBindList ::=
  SEQUENCE OF
  RowBind
```

**END**

CONCLUDING MATERIAL

Custodians:

Air Force - 90

Navy - EC

Review activities:

Navy- MC

DoD - DC, NS

Preparing activity:

Army - CR

(Project TCSS-0018)

# STANDARDIZATION DOCUMENT IMPROVEMENT PROPOSAL

## INSTRUCTIONS

1. The preparing activity must complete blocks 1, 2, 3, and 8. In block 1, both the document number and revision letter should be given.
2. The submitter of this form must complete blocks 4, 5, 6, and 7, and send to preparing activity.
3. The preparing activity must provide a reply within 30 days from receipt of the form.

NOTE: This form may not be used to request copies of documents, nor to request waivers, or clarification of requirements on current contracts. Comments submitted on this form do not constitute or imply authorization to waive any portion of the referenced document(s) or to amend contractual requirements.

<b>I RECOMMEND A CHANGE:</b>	1. DOCUMENT NUMBER MIL-STD-188-141B	2. DOCUMENT DATE (YYMMDD) 990301
3. DOCUMENT TITLE Interoperability and Performance Standards for Medium and High Frequency Radio Systems		
4. NATURE OF CHANGE <i>(Identify paragraph number and include proposed rewrite, if possible. Attach extra sheets as needed.)</i>		
5. REASON FOR RECOMMENDATION		
6. SUBMITTER		
a. NAME <i>(Last, First, Middle Initial)</i>	b. ORGANIZATION	
c. ADDRESS <i>(Include Zip Code)</i>	d. TELEPHONE <i>(Include Area Code)</i> (1) Commercial  (2) AUTOVON <i>(If applicable)</i>	7. DATE SUBMITTED (YYMMDD)
8. PREPARING ACTIVITY		
a. NAME Headquarters Department of the Army	b. TELEPHONE <i>(Include Area Code)</i> (1) Commercial (703) 614-6180 (2) AUTOVON 224-6180	
c. ADDRESS <i>(Include Zip Code)</i> ATTN: SAIS-PAA-M Washington, DC 20310-0107	<b>IF YOU DO NOT RECEIVE A REPLY WITHIN 45 DAYS, CONTACT:</b> Defense Standardization Program Office (DLSC-LM) 8725 John J. Kingman Road, Suite 2533 Ft. Belvoir, VA 22060-2533 Telephone (703) 767-6888 AUTOVON 427-6888	