

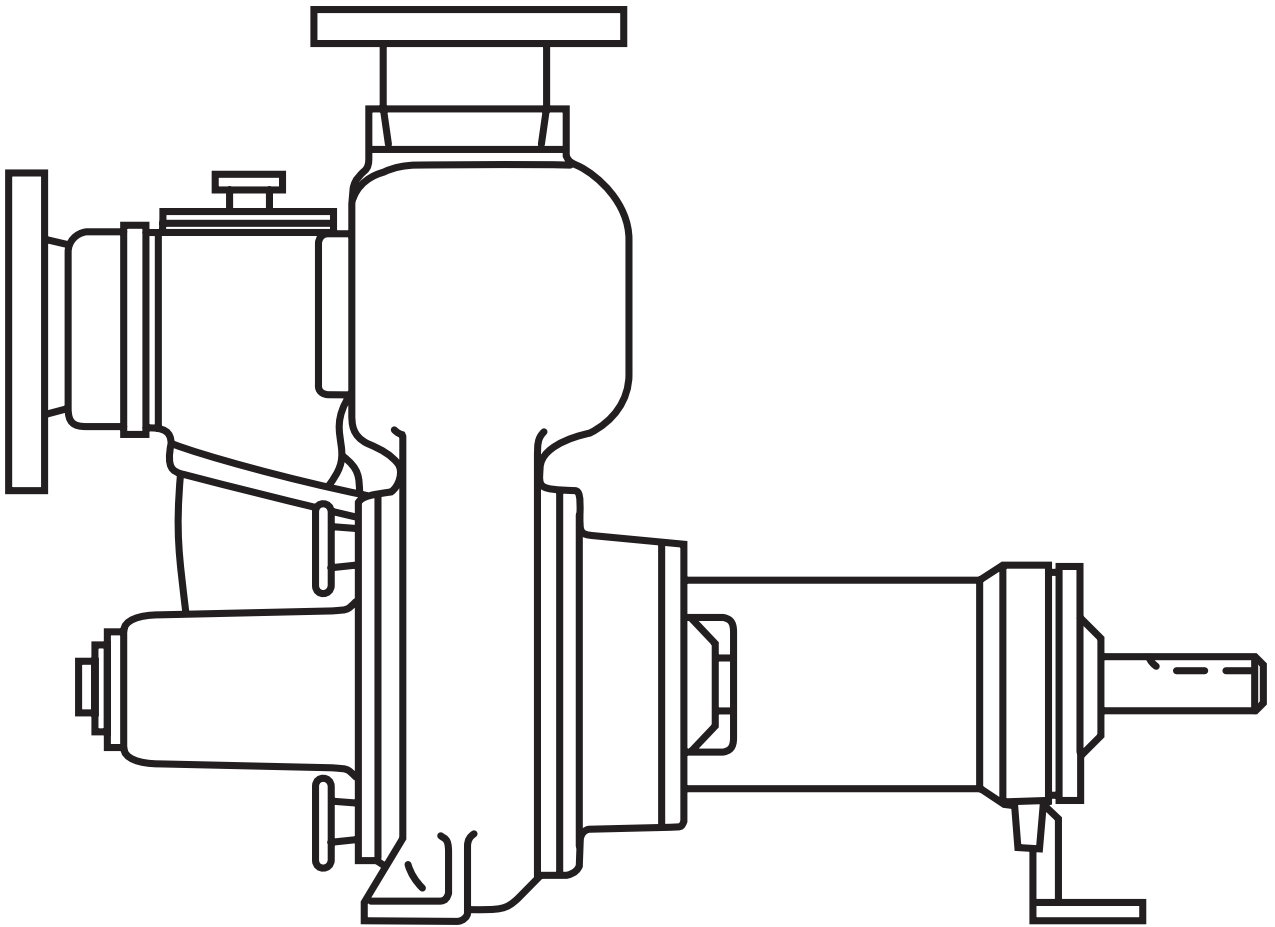

HYDROMATIC®



MODEL MPS **SELF-PRIMING SEWAGE AND TRASH PUMPS**

INSTALLATION AND SERVICE MANUAL

NOTE! To the installer: Please make sure you provide this manual to the owner of the equipment or to the responsible party who maintains the system.

General Information

The MPS self-priming centrifugal pump has a semiopen impeller and suction flap valve. Pump is designed to handle raw unscreened sewage, mild industrial waste and slurries containing entrained solids. The material of construction is a cast iron volute case and bearing frame, ductile iron impeller and wear plate.

Thank you for purchasing your Hydromatic® self-priming pump. If there are any additional questions not covered in this manual please contact the Hydromatic representative or Hydromatic Pump.

Before Operation:

Read the following instructions carefully. Reasonable care and safe methods should be practiced for installation and operation of pump. Check all local codes and requirements before installation.

Attention:

This manual contains important information for the safe use of this product. Read this manual completely before using this product and refer to it often for continued safe product use. **DO NOT THROW AWAY OR LOSE THIS MANUAL.** Keep it in a safe place so that you may refer to it often.

Unpacking Pump:

Remove pump from pallet. When unpacking unit, check for concealed damage. Claims for damage must be made at the receiving end through the delivery

carrier. Damage claims cannot be processed from the factory. Check for and tighten all loose attaching hardware. Check oil levels and lubricate as necessary.

WARNING: Before handling these pumps and controls, always disconnect the power first. Do not smoke or use sparkable electrical devices or flames in a septic (gaseous) or possible septic area.

CALIFORNIA PROPOSITION 65 WARNING:

▲WARNING This product and related accessories contain chemicals known to the State of California to cause cancer, birth defects or other reproductive harm.

Pump Not Operating or in Storage:

If pump is not put into service immediately, it must be properly stored to prevent damage. Store unit in a dry warm location. Never store unit in the open even if it is protected with plastic or other covering. The bearing housing and motor will draw moisture, which may result in pump failure after being put in operation.

While in storage pumps with carbon ceramic seals must have impellers manually rotated (6 to 12 revolutions) after setting non-operational for 3 months or longer and prior to electrical start-up.

Pumps with tungsten carbide seals must have impellers manually rotated (6 to 12 revolutions) after setting non-operational for 3 weeks or longer and prior to electrical start-up.

Motors:

Pump unit may be shipped less the motor for customer to supply and mount.

Motor Types:

Pumps can be driven by standard drip-proof, totally enclosed fan-cooled, totally enclosed hazardous location or drip-proof motor with encapsulated windings for moisture protection. If motor is to operate in the open or in a dusty location, a totally enclosed fan-cooled motor must be used. If pump is to operate in a damp location, a motor with encapsulated winding should be used. Motors are to be sized so that no overload will exist in the operating range of the pump.

NOTE: When pump units are mounted at the factory, the driver and pump are aligned before shipment. During transit and handling of pump and components misalignment may occur. Before operation the drive alignment should be checked.

Shaft Couplings:

We recommend using Wood's flexible coupling to prevent misalignment and noise that can be caused by other couplings. The extra cost of the coupling is easily saved in installation and field service that can result from coupling problems.

V-belt Drive:

Where V-belts are used, keep belts tight by adjusting motor base screws. Belts should run cool. If belts heat up it will indicate slipping. The V-belts should be fiddle-string tight.

CAUTION: The belt guards and coupling guards must be properly installed before operating pump unit.

Electrical Starting Equipment:

If electrical starting equipment is not furnished with pump, certain precautions must be observed in selecting motor starter.

Type of Starter:

For three phase power a magnetic starter with 3-leg overload protection is recommended to prevent motor burnout that can occur from single phasing or transformer faults on three phase systems. For single-phase motors a standard starter with 2-leg overload protection is recommended.

Electrical:

1. For motor overload protection the magnetic starter trip amp rating should not be more than 1.25 times the full load amps of the motor. Hydromatic recommends a rating of 1.15 times the full load amps of the motor.
2. Always use fused disconnect switch or circuit breaker ahead of magnetic starter for short circuit protection. When duplex pumps are used and are operated from single disconnect switch be sure disconnect switch is large enough to withstand the starting current of both pumps coming on at once. This can occur after a power failure. This is important as a blown fuse or tripped circuit breaker can make both pumps and an alarm system inoperative resulting in flooding or other damage.

Ground:

Connect a ground wire to motors, control box and other related controls. Ground wires should be sized to the National Electric Code article 250-95. Ground wire must be connected to a driven ground stake or to a ground wire from the supply service. If a ground stake is used it must be driven at least 8 feet into the ground.

Codes:

All local wiring codes must be observed and any exceptions to data given must be followed in accordance with the local code. Consult the local inspector before installation to avoid costly delays that can occur due to rejection after the job is finished.

Pump Installation

Pump Installation Foundation:

Pump frame or base should be installed on a concrete floor with proper shims and grout. Use hardwood tapered shims to drive under base to level. Base should be about 1 to 1 1/2" off the floor. Build form around the base and fill base inside cavity with grout. Foundation bolts can be set in the grout or set in the concrete floor with expansion bolts.

Grout should be made with 1 part cement and 2 parts sand. Mixture should be fluid enough to run under base. Wood shim blocks can be removed after grout has set and holes filled with quick set concrete.

Piping:

All piping to suction and discharge openings of pump must be supported to remove stress from the pump case and bearing frame.

Suction Pipe:

1. Suction pipe should be the same size as pump opening. DO NOT use larger suction pipe as priming time will be increased and velocity may not be high enough to properly carry solids.
2. Pump should be installed as close to the liquid being pumped as possible with a minimum of elbows or fittings.
3. To avoid air pockets suction pipe must be as short and direct as possible. Suction pipe must always slope upward to the pump from the source of the liquid being pumped.
4. The suction pipe should be installed at a distance equal to 1 1/2 times the diameter of the suction pipe from the wall of the wet well, minimum.
5. The suction pipe should be installed at a distance equal to one half the diameter of the suction pipe or 3" from the floor of the wet well, minimum.
6. If more than one suction pipe is to be installed in the same wet well, a distance equal to at least 3 times the diameter of the suction pipe should separate them, minimum.
7. Submergence of the suction pipe is critical to efficient pump operations. See the following chart for recommended minimum submergence vs. velocity. Submergence may be reduced by installing a standard pipe increaser fitting at the end of the suction pipe. The larger opening size will reduce the inlet velocity and required submergence. See Fig. 1.

Vertical Suction Lift:

Vertical lift should not be more than 15 feet. This is for starting level only. After pump primes,

Pump Installation

level can be pumped down to 18 to 20 feet if desired, but sump level must rise up to the original level for restart. All suction line joints must be airtight as a leak in the suction pipe can cause pump to lose prime or not prime at all. Always check N.P.S.H. calculations for available atmosphere pressure before applying pump.

Discharge Lines:

If the discharge line ends at a level lower than the liquid being pumped, a siphon breaker must be installed in the discharge line. Otherwise, siphoning action may cause damage to the pump.

The discharge line should include a system check valve, with an outside weight or spring, to protect the pump from excessive shock pressure and reverse rotation when pump is stopped. Do not depend on the check valve at pump suction to hold discharge pressure. The discharge line should include an isolation valve, plug valve or gate valve, to isolate the pump from the discharge line. This will allow maintenance to be performed on the pump or check valve without draining the discharge line.

Air Bleed Pipe:

A $\frac{3}{4}$ " or 1" bleed line with ball valve or gate valve must be installed between the pump discharge flange and discharge check valve. The bleed line should be installed as close to the discharge check valve as possible, the end extending a minimum of 6" below low water offset point

in the wet well. The valve in the bleed line is to be fully open at initial start-up of pump. After initial start-up the valve is to be left partially open at all times. This will allow any trapped air or gas to be vented back to the wet well. Be sure vent line is under water at all times. This is important. See installation drawings (Fig. 2). Self-priming pumps will not compress air to any extent. Pump may not prime if the bleed line is not used or closed and may not reprime if pump loses prime after discharge line is full of water and a discharge check valve is used.

Drain Line from Pump Case:

A pipe should be installed in the lower drain tapping of volute case and be piped back to the wet well. Install a shut-off valve, ball valve or gate valve, in this line. This will permit draining of pump case if necessary to remove suction elbow/plate to clean impeller or perform maintenance on the pump.

Electrical Connections:

Connect power lines to motor from magnetic starter. Turn pump shaft by hand to be sure it is free before attempting to start motor. Turn power on and off quickly to check rotation. If motor is three phase, interchanging any two lines to motor can reverse rotation. If motor is single-phase, consult literature supplied with the motor for specific instructions. Correct pump rotation is clockwise when looking at pulley or coupling end (power end) of pump. Direction arrow is cast on bearing housing.

Priming:

For initial prime, remove priming cap from suction inlet casting and fill pump housing with water.

Fully open the air bleed valve in the bleed line. Replace cap, being sure gasket is in place and that seat is clean. Start motor and allow sufficient timing for priming. Priming time is dependent on pump speed, impeller diameter and vertical suction lift.

Cleaning Impeller:

If impeller gets clogged at any time, suction elbow/plate can be removed by unscrewing 4 hand knobs or nuts. Drain pump case before removing suction elbow/plate. Tap on knobs with hammer to loosen. Be sure O-ring gaskets are in place before replacing suction elbow/plate. Use grease on machined faces to make removal easier at a later date. Tap on hand knobs with hammer to retighten.

Adjusting Impeller Clearance:

Impeller face vanes must be within .015" of suction wear plate for most efficient operation.

When wear plate or impeller wears, it can be readjusted to proper clearance from the outboard bearing end without the use of shims or disturbing the pump case or piping. Loosen the 3 screws with the jam nuts. Tighten the other 3 screws evenly until the impeller just drags on the suction wear plate when the shaft is turned by hand. Back off the 3 screws and place a .015 shim under the head of the screw. Turn screw up against the shim, then remove shim. Repeat this operation on each of the 3 pushing screws. Now retighten the 3 screws with jam nuts, pushing the housing up against the 3 adjusting screws. Retighten the jam nuts and pump is ready to operate with the impeller face .015" from suction wear plate.

This clearance should be checked at least once a year and more often if water containing abrasives is being pumped. When impeller face wear exceeds $\frac{1}{8}$ ", impeller, wear plate and volute lip plate should be replaced.

WARNING: Before handling these pumps and controls, always disconnect the power first. Do not smoke or use sparkable electric devices or flames in a septic (gaseous) or possible septic area. Be sure all V-belt guards or coupling guards are in place before operating unit.

Pump Lubricating

Shaft Seals:

All Hydromatic self-priming sewage pumps use two shaft seals with an oil chamber between the seals. The oil in the seal chamber should be checked every six months or every three months if water containing abrasives is being pumped. Remove hex head plug from top of seal chamber and loosen hex plug at bottom of seal chamber. Place a container under the lower plug, then remove lower plug and allow oil to drain into container. After all oil is removed, pour used oil into a glass container so that it can be observed. If the oil is clean it will indicate seals are in good condition. If a small amount of water shows in the oil, this will also indicate satisfactory seal operation. If considerable water and some dirt shows in the oil, it will indicate the inboard seal is worn and should be replaced before outboard seal is damaged. If seals are in good order, refill the seal chamber with #30 non-detergent automotive oil. About

one quart is required. Fill with funnel or tube so that the air can escape. Oil chamber must have a 1" air gap; do not overfill oil chamber. See sectional drawing (Fig. 3).

Pump Bearings Grease Lubricated:

Bearings should be lubricated every six months or more often if pump is operated 24 hours a day. Do not overgrease bearings as heat will build up that can damage the bearings. Bearing housing is fitted with grease gun pressure fittings at both bearing locations and grease relief fittings. Add grease until a small amount comes from relief fitting. See sectional drawing (Fig. 3). The same basic instructions apply to lubricating motor bearings, but consult motor manufacturer's data on lubricating bearings. Use high quality ball bearing grease or high temperature grease. Bearings can run quite hot to the hand without damage to the bearing. Outside temperature of the housing should not exceed 130° F for long bearing life.

Pump Maintenance

Replacing Impeller and Volute Lip Plate:

Disconnect power from the motor before attempting to work on pump. Drain pump volute case and oil from seal chamber. Remove suction elbow/plate with wear plate attached. Clean any trash out of pump volute. Clean all machined surfaces and wipe all ports clean.

The following pertains to the 3" and 4" MPS pumps. Remove stainless steel socket head impeller screw that locks impeller to the shaft. This screw has a right-hand

thread. Remove impeller lock washer with pin. Block impeller vane with a piece of hardwood and unscrew impeller by turning pump shaft counterclockwise. Impeller shaft has a right-hand thread. Use large crescent wrench or strap wrench on shaft, pulling against the key. A pipe wrench can be used if care is used not to damage shaft. It may be necessary to tap on impeller vanes with hammer to break impeller loose, especially if pump has been in service for a long period of time.

All 6" pumps, MP and MPH, built after July, 1967 use a taper fit impeller shaft. If impeller is held to the shaft with a taper fit, remove the stainless steel nut on the end of shaft, then remove washer. A taper fit shaft can be identified by the key that drives the impeller. To remove impeller, loosen 3 holding screws at outboard bearing cap and tighten up on back-off screws. This will pull the impeller loose from the shaft. After impeller is removed, retighten screws to bring bearing cap back to original position. It will be necessary to readjust the impeller clearance after impeller is reinstalled. See adjusting instructions. (Page 4)

After impeller is removed, unscrew 3 or 4 stainless steel socket head screws that hold volute lip plate in place. Tap on plate to loosen and remove through volute case inlet opening. The inboard seal now can be removed for inspection by sliding sleeve from pump shaft. If faces are worn, the seal should be replaced. See seal replacement instructions. Clean pump casing thoroughly, removing any rust or dirt from all machined surfaces.

Install lip plate with lip in the one o'clock position. Use a pipe compound or NEVER SEEZ® on all machined faces. NEVER SEEZ is a graphite compound

* NEVER-SEEZ® is a registered trademark of Bostik Findley, Inc.
* Permatex® is a registered trademark of Permatex, Inc.

Pump Maintenance

that will not wash away with water and is highly recommended for all repair work for use on machine faces. This compound can be obtained from Hydromatic Pump if not available at local supply houses.

The following pertains to the 3" and 4" MPS pumps. Use Permatex® on the 3 stainless steel screws that hold volute lip plate in place. Reinstall the lip plate and tighten the screws. Install seal on shaft and place seal spring in place. Block impeller vane with a piece of hardwood and screw impeller on by turning pump shaft clockwise. Use large crescent wrench or strap wrench on shaft, pulling against key to retighten. A pipe wrench can be used if care is used not to damage shaft. Replace impeller lock washer with pin and stainless lock screw.

All 6" pumps, MPS, built after July, 1967 use a taper fit impeller shaft. Use Permatex on the 4 stainless steel screws that hold volute lip plate in place. Reinstall the lip plate and tighten the screws. Install seal on shaft and place seal spring in place, then install key and impeller. Caution must be taken to be sure impeller is seated on the shaft and not on the key. Replace impeller lock washer and stainless lock bolt.

Replace suction elbow/plate with wear plate attached. Check impeller clearance, adjusting if necessary as described under Adjusting Instructions. Refill seal chamber as described under Lubricating Instructions.

Replacing Inboard Seal:

Use all steps outlined under impeller removal. Slide seal and shaft sleeve from shaft. It may be necessary to tap on sleeve with plastic hammer to loosen. After rotating part of seal is removed, use wire hook and pull stationary seal seat from casting. Wipe seal pocket clean, then install new stationary seat. Use grease on rubber cap and push in place with fingers, then wipe the seal face clean. Place new rotating seal part on sleeve and to push sleeve onto shaft. Be sure O-ring gasket is in place at end of stainless steel shaft sleeve.

Reinstall volute lip plate, put seal spring in place and install impeller. Install impeller washer, impeller lock screw or nut, and suction elbow/plate. Check impeller clearance, adjusting if necessary as described under Adjusting Instructions. Refill seal chamber with #30 non-detergent automotive oil.

Replacing Both Inboard and Outboard Seals:

When it is necessary to replace both seals, which will be indicated by water leaking from the seal chamber, it is recommended that the complete rotating assembly be removed so that it can be worked on more easily.

Drain pump and seal chamber as described above. Then loosen or remove the pump coupling or remove V-belt components, if belt driven. Remove motor bolts and move motor to one side. Remove bolts in bearing bracket support foot and remove 6 nuts from studs in seal housing. Tap on housing with hammer to loosen, then pull complete assembly from case. Remove impeller and lip plate; see Replacing Impeller and Lip Plate. Remove inboard seal by

sliding sleeve from shaft. Use two screws in tapped holes of seal plate and pry out plate with pinch bar under heads of pull bolts. Remove snap ring from shaft and pull outboard rotating assembly from shaft. Use wire hooks to pull ceramic stationary seal seat from housing. It may be necessary to break the ceramic seal ring. Ceramic ring can be easily broken by tapping with screwdriver. Ring is broken only if worn and needs to be replaced.

Wipe housing clean and replace ceramic stationary ring. Use grease on rubber cap to push into housing. Push in stationary seal seat with fingers only, then wipe the seal face clean. Push new rotating seal part onto shaft. Replace seal spring and holding washer, then install snap ring.

Replace seal plate. Be sure O-ring is in place and that flat rubber gasket is in place on backside of seal plate. Use grease on O-ring and push plate into position in seal housing. Replace the 3 socket head stainless steel screws. Use Permatex on bolt threads. Replace new inboard stationary seal face. Now replace rotating seal part mounted on shaft sleeve. Replace volute lip plate with the 3 or 4 socket head stainless screws. Use Permatex on screw threads. Install seal spring and then screw impeller onto shaft. Lock impeller on with washer and stainless steel socket head screw. If shaft has a taper fit, be sure key is in place and in notch of shaft sleeve. Unit is now ready to reinstall in casing. Use NEVER SEEZ® on machine faces and be sure case O-ring is in place on flange. Replace nuts and bearing bracket support foot. Reset motor and connect coupling or reinstall belts if unit is belt-driven. Refill seal chamber with #30 non-detergent automotive grade oil. Replace top fill plugs.

Replacing Shaft Bearings:

Both inboard and outboard shaft bearings are single row type and are the same size for any given pump. Grease-lubricated bearings are single shield.

To replace bearings, remove the impeller, seal plate and seals as described previously. Remove holding screws from outboard bearing cap and pull shaft and bearing assembly from housing. It may be necessary to tap on end of shaft with plastic or rubber hammer to loosen shaft bearings from housing. After shaft is removed take snap ring off end bearing cap and push shaft and bearing from housing.

Use Arbor press to press bearings from shaft. **ALWAYS SUPPORT OR PRESS ON INNER FACE OF BEARING. NEVER PRESS ON OUTER FACE AS THIS CAN DAMAGE THE BEARING.** Be sure housing and all parts are thoroughly cleaned before installing new bearings. Use care in pushing shaft through lip seals that seal shaft in bearing housing and bearing cap. Clean all old grease from housing and cap and pack bearing level full with grease before reinstalling. **DO NOT** add any extra grease to housing after assembly, as this grease pack is sufficient for at least 6 months use. After shaft is reassembled, install seals and impeller and adjust clearance of impellers as described previously.

Pump Troubleshooting

WARNING: Before handling these pumps and controls, always disconnect the power first. Do not smoke or use sparkable electrical devices or flames in a septic (gaseous) or

possible septic area. Be sure all belt guards and exposed coupling guards are in place before operating unit.

WARNING: If the pump has overheated, allow pump to cool before servicing. Do not remove plates, cover, gauges or fittings from an overheated pump. Liquid inside the pump case can reach the boiling point, and vapor pressure within the pump case may cause parts to be ejected with great force. Drain pump case only after pump has been allowed to cool. Use care to prevent personnel from touching the hot liquid.

Pump will not prime.

1. Pump discharge does not have air bleed line installed. See pump installation instructions for air bleed line.
2. Vertical suction lift is too high. Vertical lift for priming should not be more than 15 feet.
3. Allow sufficient time for priming. On high lifts and at low pump speeds priming time may take 5 minutes or longer.
4. Suction line has an air leak. Install a vacuum gauge at pump suction flange and start pump. After a vacuum is established, stop pump and see if gauge holds. If gauge hand drops, it will indicate an air leak at some connection below the gauge tap.
5. Check pump rotation. Pump must turn clockwise when looking at the power end of pump.
6. Not enough liquid in pump casing; add water to the case. Pump needs water in the pump case to prime.
7. Suction check valve damaged or contaminated; replace check valve.

8. Leaking or worn seal or pump gasket; check pump case vacuum and replace leaking or worn seals or gaskets.

Pump primed OK initially but occasionally loses prime and will not reprime without adding water.

IMPORTANT: Drain pump case and close the discharge gate valve before removing the inspection cover.

1. Air bleed line is not installed properly as specified or is plugged. See installation instructions.
2. Check priming port for plugging. Remove inspection cover on right side of case when facing power end of pump. Check priming port hole in case below inspection plate for plugging.
3. Impeller may be worn, leaving too much clearance between impeller face and suction wear plate. Adjust impeller as described under Adjusting Instructions. If impeller and volute lip plate are worn, they must be replaced to regain original priming efficiency.

Pump makes a loud crackling noise when operating.

1. If pump has been operating satisfactorily and this noise suddenly starts, it may indicate that some large object is lodged in the suction check valve, suction elbow/plate or impeller causing the pump to be noisy. Remove debris from these areas of the pump.
2. If noise exists when suction pipe, check valve and suction elbow are clear, it may indicate

Pump Troubleshooting

too high of capacity being delivered for a given suction lift, causing suction cavitation. If pump is allowed to operate under these conditions, the impeller will be damaged. Using a smaller impeller or reducing the pump speed if a belt drive is used may alleviate the cavitation. Consult factory for recommendations.

3. If cracking noise is pronounced when pump is operating at low capacity it may indicate pump is operating too near the shut-off head. Increasing the impeller diameter or increasing pump speed may alleviate this condition. Consult factory for recommendations.
4. Performance curves show maximum/minimum capacity that the pump will deliver at a given condition point and the allowable suction lift without cavitation. Use vacuum gauge at pump suction to check total suction lift when pump is operating. Use discharge pressure gauge at pump discharge to check discharge head. Total the two-gauge reading to determine the total dynamic head the pump must operate against.
5. Entrained air may be present and is being pumped. Find source of air and eliminate.
6. The pump or drive is not securely mounted. Retighten all components.

Pump does not deliver rated capacity.

1. Total head may be higher than calculated. Pump capacity

is based on total head. Total dynamic head is arrived at by adding the suction gauge reading, in feet, to the discharge gauge reading, in feet. These readings should be taken at the suction flange and at the pump discharge flange connections. Reading should be taken as close to the flange fittings and pump case as possible. To convert psi, pressure per square inch, to feet, multiply the total psi readings by 2.31. This will equal total dynamic head in feet.

2. Pump impeller may be worn on the vane faces or the clearance between the impeller and wear plate may be greater than .015". Adjust impeller to wear plate clearances for proper clearance as described under Adjusting Instructions. If impeller, suction wear plate and volute lip plate are badly worn, they must be replaced.
3. Pump speed may be too slow. Check drive assembly, V-belts or coupling, for slippage.
4. Possible air leak in the suction piping; eliminate the leak.
5. Suction head may be too high. Reduce lift by raising on/off levels in the wet well or reduce friction losses due to suction piping arrangement.
6. Suction line not submerged at proper levels. Correct suction pipe submergence.
7. Blockage in the suction pipe or discharge pipe; remove blockage. Where the blockage is can be determined by gauge readings.
8. Impeller clogged; remove debris.

Motor starter overload trips after pump has operated for a short period.

1. Rags or trash may be caught in the impeller, causing extra

load. Remove suction elbow/plate and clean impeller. Pump shaft must turn freely by hand after cleaning impeller.

2. Overload heater may be too small. Check heater size with full load amps of motor. See an electrical table for proper size.
3. Total head may be lower than calculated, causing extra load on the motor. Reducing impeller diameter or reducing speed if belt driven, will lower motor load. Consult factory for recommendations.
4. Pump may be pumping a liquid heavier than water or a liquid with higher viscosity than water, such as heavy oil. Consult factory for power required to pump oils or liquids other than water.
5. Bearings may be damaged, causing excessive motor load.
6. Pump speed may be too high. Check drive output to see if they are sized properly.

Pump clogs frequently.

1. Liquid solution being pumped is too thick; dilute if possible.
2. Discharge velocity too slow; open discharge valves to fully open, and increase pump speed.

Bearing running too hot.

1. Drive is misaligned; realign drive.
2. Low or incorrect lubricant; use proper type and level of lubricant.
3. Suction and/or discharge pipe not supported properly. Check piping installation for proper support, taking strain off the pump case and bearing frame.

Entrance Velocity in Feet/Second Submergence Requirements

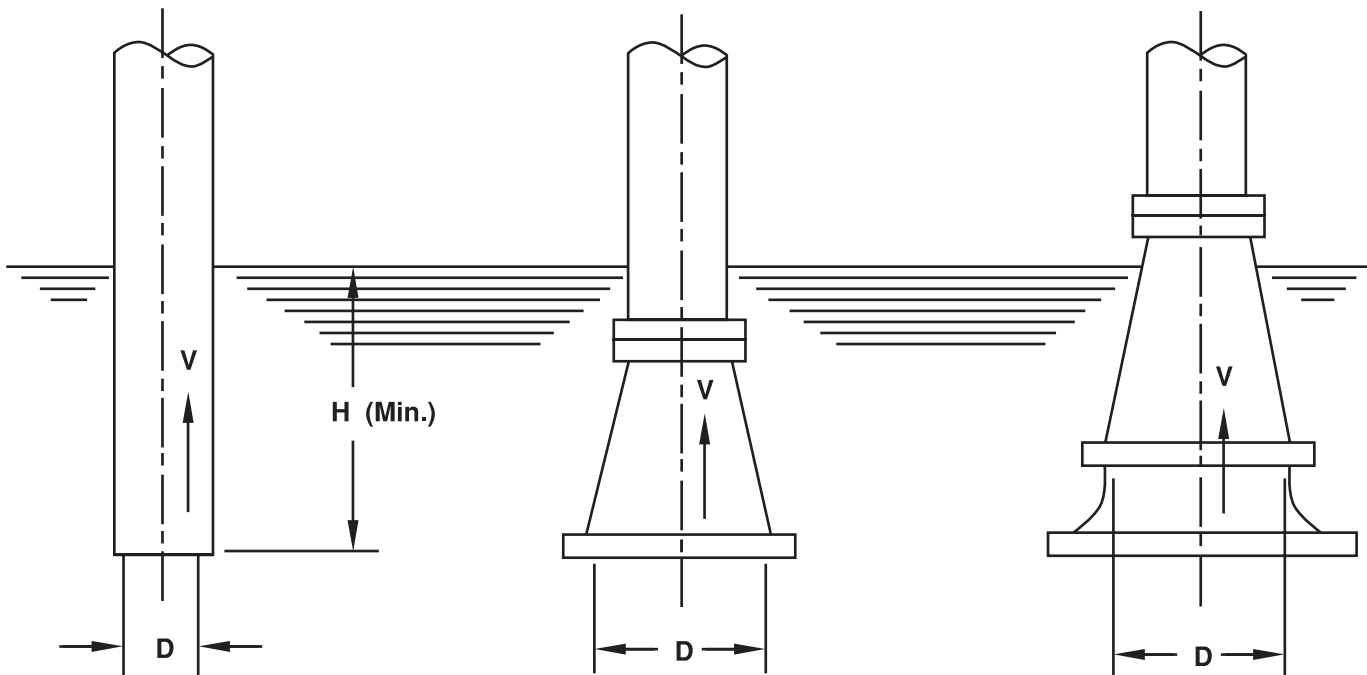

V = Entrance Velocity
In Feet/Second

$$V = \frac{\text{G.P.M.} \times .41}{D^2}$$

Where D = Dia. (Inches)

V = Velocity (F.P.S.)	H = Submergence (Feet)
2	1.0
3	1.5
4	2.0
5	2.5
6	3.0
7	4.0
8	4.5
9	5.5
10	6.0
11	7.5
12	9.0
15	14.0

(V) Inlet Velocity vs Minimum Submergence (H)

FIGURE 1

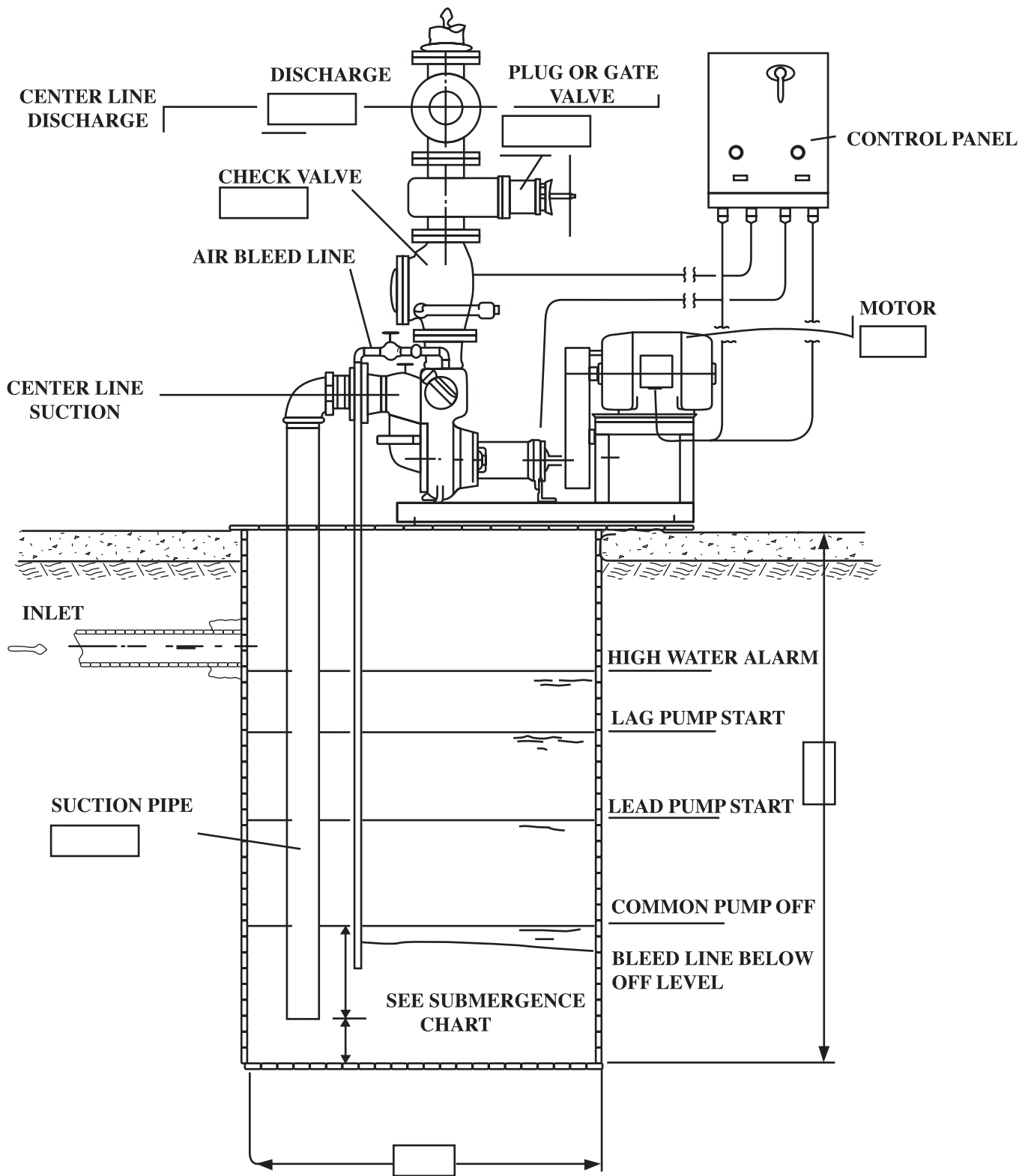

FIGURE 2

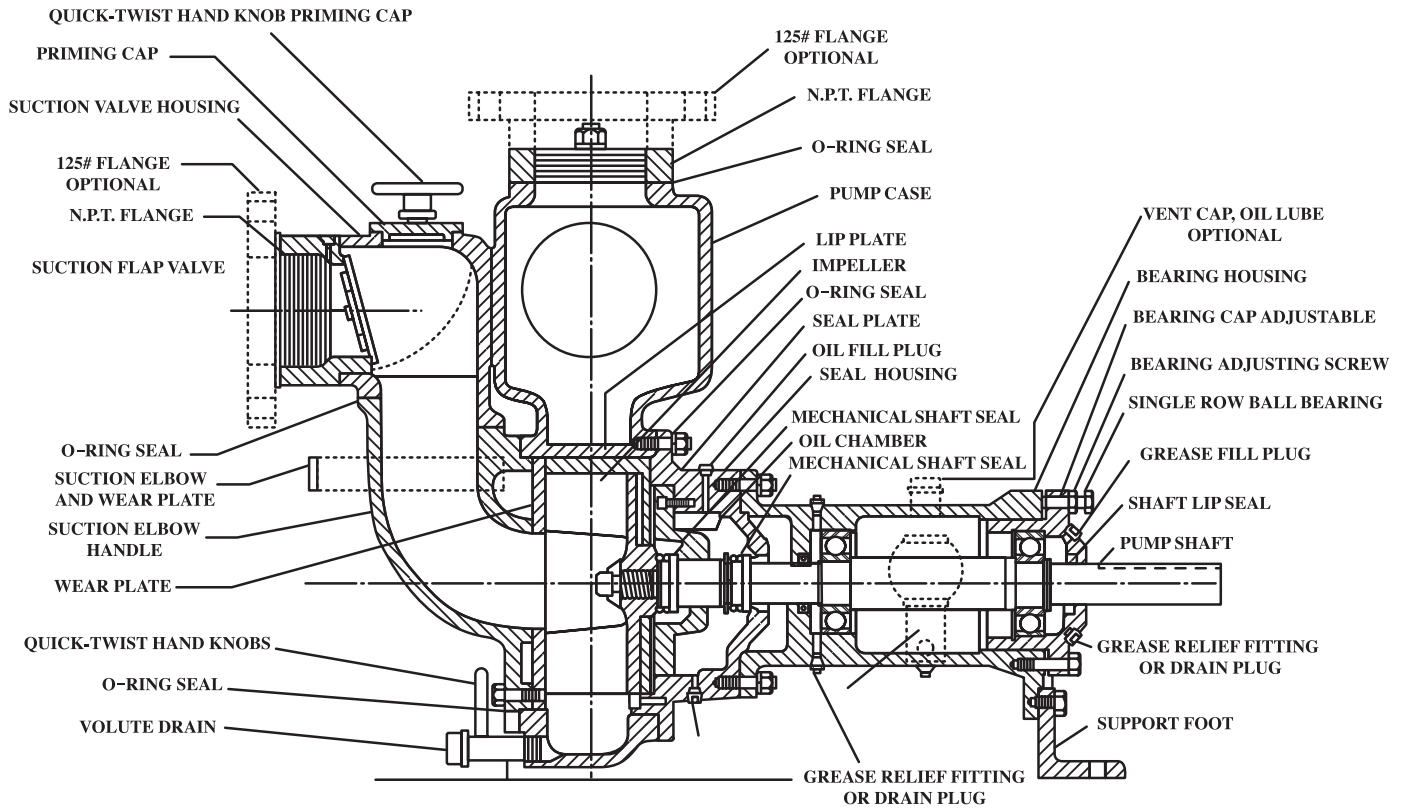

FIGURE 3

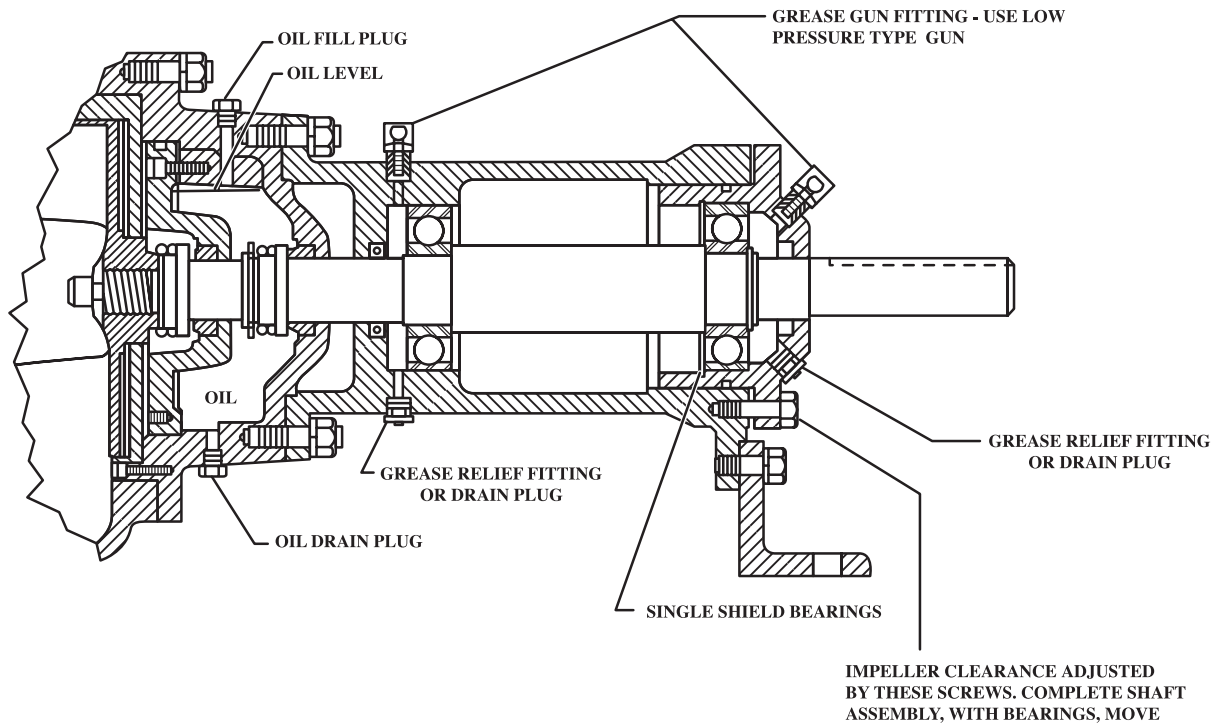
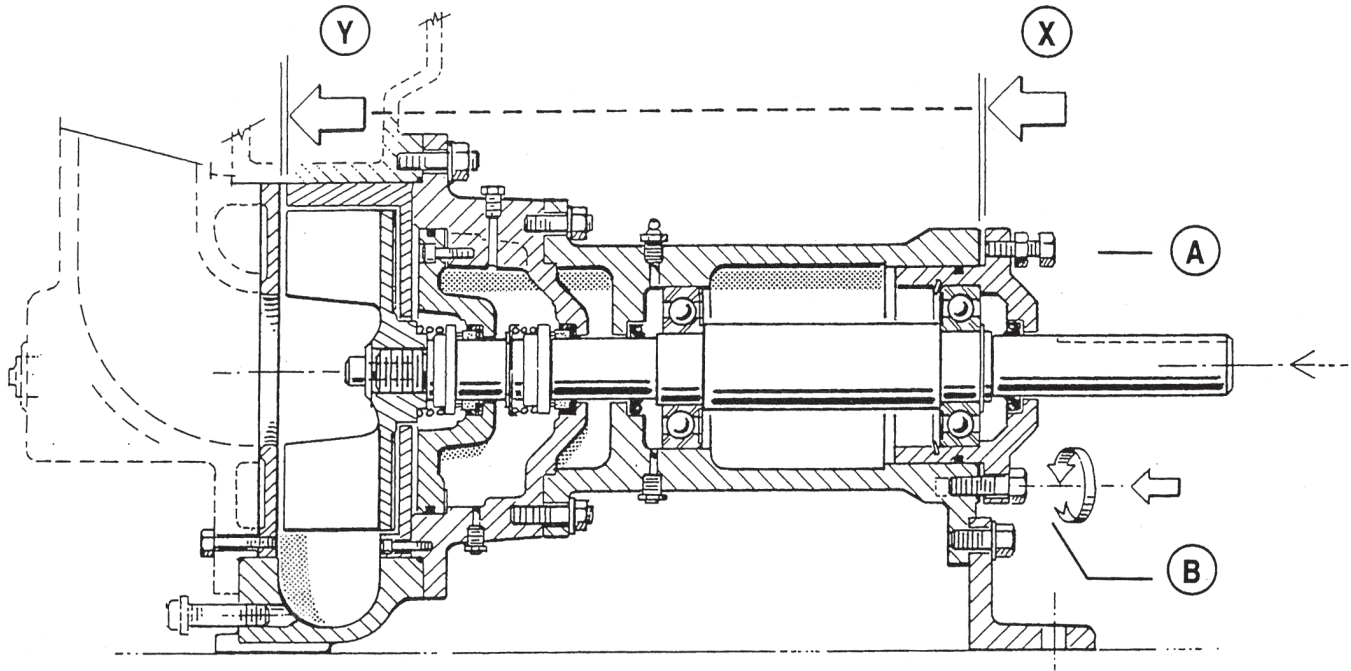

FIGURE 3 CONTINUED

CLEARANCE ADJUSTMENT OF IMPELLER TO WEAR PLATE

In normal operation the pump passes solids of all types. This includes sand, grit and other abrasive material, resulting in abrasion between the impeller and wear plate.



In order to reestablish the normal running clearance of 15 thousandths:

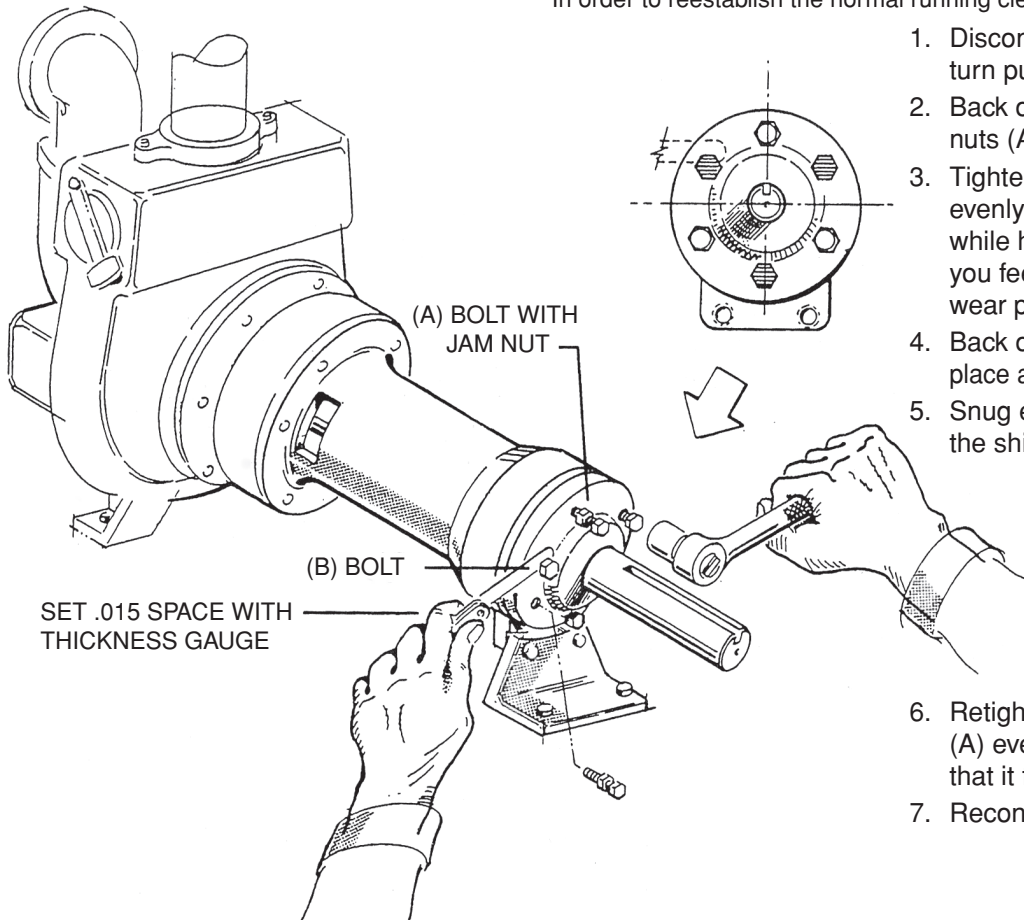

1. Disconnect coupling to driver and turn pump shaft by hand.
2. Back off the three bolts with jam nuts (A).
3. Tighten the other three bolts (B) evenly against the bearing cap while hand turning the shaft until you feel the impeller drag on the wear plate.
4. Back off the three bolts (B) and place a .015 shim under each head.
5. Snug each bolt (B) up against the shim, then remove shim.

6. Retighten each bolt with jam nut (A) evenly to pull the bearing cap so that it fits firmly against bolt (B).
7. Reconnect coupling to driver.

30MPS Parts List

ORDERING REPLACEMENT PARTS: Product improvements are made from time to time. The latest part design will be furnished as long as it is interchangeable with the old part. When ordering replacement parts, always furnish the following information: (1) pump serial number, (2) pump model and size, (3) part description, (4) part number, (5) impeller diameter (if ordering impeller), (6) quantity required, and (7) shipping instructions.

Ref. No.	Part No.	Part Description	Qty.
1	00120-004-1	Pipe Plug	2
2	04128-316-2	Discharge Flange 3"	1
3	00905-316-2	Clamp Handle	1
4	01027-006-1	Stud	2
5	19109A018	Nut	1
6	01071-316-2	Clamp Arm	1
7	00896-316-2	Priming Cover	1
8	00150-108-1	O-Ring	1
9	00119-006-1	Pipe Plug	2
10	01342-316-2	Suction Flange, 3"	1
11	01074-002-1	Flap Valve	1
12	00101-021-1	Bolt	1
13	00156-038-1	Washer	1
14	01079-008-1	Stud	4
15	05454A024	Lockwasher	10
16	01085-003-1	Nut, SST	10
17	01058-316-2	Suction Box	1
18	00241-104-1	O-Ring	1
19	01075-316-2	Weight	1
20	01124-004-1	Nut	2
21	05454A027	Lockwasher	2
22	01030-010-1	Stud	2
23	01059-316-2	Suction Elbow	1
24	01060-316-2	Wear Plate	1
25	00238-023-1	Socket Head Screw	2
26	02922-002-1	Stat-O-Seal	2
27	00905-317-2	Clamp Handle	4
28	01024-012-1	Stud	4

Ref. No.	Part No.	Part Description	Qty.
29	00119-007-1	Pipe Plug	1
30	01024-015-1	Stud	1
31	05223-003-1	Impeller Washer	1
32	01061-321-2	Impeller 8-13/32" Dia	1
	01061-322-2	Impeller 7-3/4" Dia	1
	01061-323-2	Impeller 7-7/16" Dia	1
	01061-324-2	Impeller 7" Dia	1
	01061-325-2	Impeller 6-1/2" Dia	1
33	00079-107-1	O-Ring (Optional)	1
34	01509-316-3	Sleeve (Optional)	1
35	00150-123-1	O-Ring	3
36	04130-011-5	Shaft (Optional)	1
37	01063-316-2	Lip Plate, 8-13/32" Imp Dia	1
	09756-318-2	Lip Plate, 7-3/4" Imp Dia	1
	09756-317-2	Lip Plate, 7-7/16" Imp Dia	1
	09755-317-2	Lip Plate, 7" Imp Dia	1
	09755-316-2	Lip Plate, 6-1/2" Imp Dia	1
38	19102A021	Bolt	4
39	00119-005-1	Pipe Plug	2
40	08168-000-2	Seal Housing	1
41	00975-003-1	Snap Ring	1
42	01345-000-1	Relief Fitting	2
43	01079-002-1	Stud	4
44	05454A005	Lockwasher	4
45	01085-001-1	Nut	7
46	00065-007-1	Bearing	2
47	01065-001-3	Support Foot	1
48	05454A004	Lockwasher	2

Ref. No.	Part No.	Part Description	Qty.
49	00239-003-1	Bolt	2
50	19102A002	Bolt	3
51	00975-004-1	Snap Ring	1
52	04130-010-5	Shaft w/stud	1
53	01090-001-1	Lip Seal	2
54	06205-000-1	Grease Fitting	1
56	01083-002-1	Bolt	3
57	01066-000-2	Bearing Cap	1
58	00974-000-1	Snap Ring	1
59	00150-013-1	O-Ring	1
60	01064-000-2	Bearing Housing	1
61	05218-000-1	Grease Fitting	1
62	00920-001-1	Seal	1
63	00920-007-1	Seal	1
64	08908-001-1	Key	1
65	01079-007-1	Stud	6
66	13425-029-1	Nameplate	1
67	04580-001-1	Drivescrews	4
68	01057-316-2	Volute	1
69	00241-106-1	O-Ring	1
70	00177-018-1	Lockwasher	2
71	19109A084	Nut	2
72	01024-010-1	Stud	2
73	05219-000-1	Cap - Grease Fitting	2
74	00852-007-1	Impeller Nut	1
75	00156-048-1	Washer	1

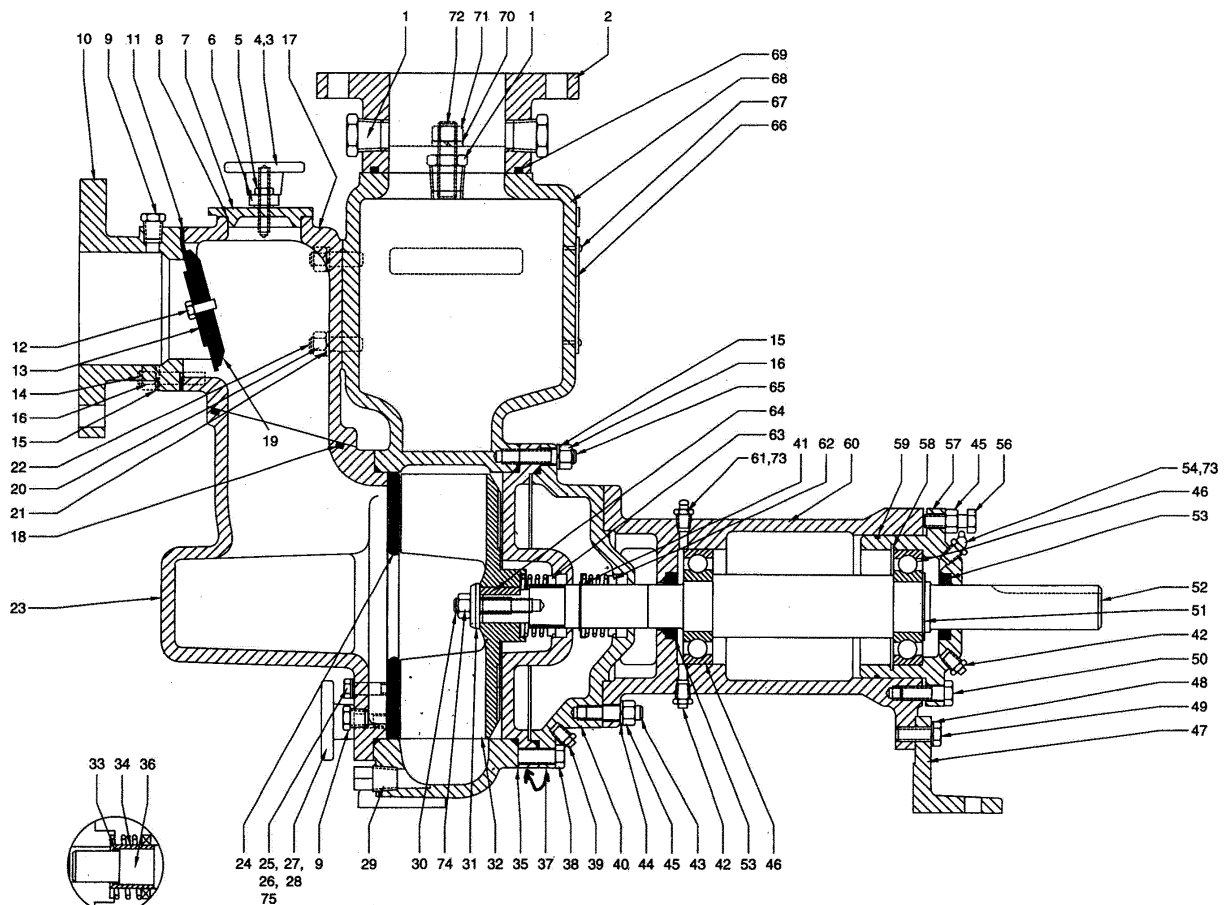

40MPS Parts List

ORDERING REPLACEMENT PARTS: Product improvements are made from time to time. The latest part design will be furnished as long as it is interchangeable with the old part. When ordering replacement parts, always furnish the following information: (1) pump serial number, (2) pump model and size, (3) part description, (4) part number, (5) impeller diameter (if ordering impeller), (6) quantity required, and (7) shipping instructions.

Ref. No.	Part No.	Part Description	Qty.
1	01124-004-1	Hex Nut	2
2	05454A027	Lockwasher, SS	2
3	01030-009-1	Stud, SS	2
4	00905-316-2	Clamp Handle	1
5	01027-006-1	Stud	2
6	19109A018	Nut	1
7	01071-316-2	Clamp Arm	1
8	00896-316-2	Priming Cover	1
9	00150-108-1	O-Ring	1
10	00890-316-2	Flap Valve Housing	1
11	00903-316-2	Flap Valve Weight	1
12	00119-006-1	Pipe Plug	2
13	01309-316-2	Suction Flange	1
14	00947-003-1	Flap Valve	1
15	00101-021-1	Cap Screw	1
16	00156-037-1	Flap Valve Washer	1
17	01024-010-1	Stud	4
18	00177-018-1	Lockwasher	14
19	19109A084	Nut, SS	14
20	01024-013-1	Stud, SS	8
21	00241-107-1	O-Ring	1
22	00889-316-2	Suction Elbow	1
23	01024-015-1	Stud	1
24	05223-003-1	Impellar Washer	1
25	00891-316-2	Suction Wear Plate	1
26	00238-023-1	Capscrew	2
27	02922-002-1	Stat-O-Seal	2

Ref. No.	Part No.	Part Description	Qty.
28	00905-317-2	Clamp Handle	4
29	00150-124-1	O-Ring	3
30	00924-004-1	Pipe Plug	1
31	00888-321-2	Impeller 9-5/32" Dia	1
	00888-322-2	Impeller 8-1/2" Dia	1
	00888-323-2	Impeller 8-5/32" Dia	1
	00888-324-2	Impeller 7-3/4" Dia	1
	00888-325-2	Impeller 7-3/16" Dia	1
32	00079-107-1	O-Ring (Optional)	1
33	01509-316-1	Sleeve (Optional)	1
34	19103A061	Capscrew	2
35	08917-000-2	Seal Housing	1
36	00920-001-1	Seal	1
37	00920-007-1	Seal, Ceramic (Standard)	1
	00920-009-1	Seal, Carbide (Optional)	1
38	00119-005-1	Pipe Plug	2
39	01345-000-1	Relief Fitting	2
40	01024-002-1	Stud, SS	4
41	05454A004	Lockwasher	6
42	19109A030	Hex Nut	4
43	00946-017-5	Shaft (Opt) w/stud	1
44	00947-003-1	Snap Ring	1
45	00945-002-3	Support Foot	1
46	00852-007-1	Nut	1
47	100-012112-273	Hex Head Capscrew	8
48	00975-005-1	Snap Ring	1
49	01090-001-1	Lip Seal	2

Ref. No.	Part No.	Part Description	Qty.
50	00946-016-5	Shaft w/ Stud	1
51	06205-000-1	Grease Fitting	1
53	00899-000-2	Bearing Cap	1
54	00065-005-1	Bearing	2
55	00150-014-1	O-Ring	1
56	00898-000-2	Bearing Housing	1
57	00975-003-1	Snap Ring	1
58	05218-000-1	Grease Fitting	1
60	08908-001-1	Key, SS	1
61	01024-011-1	Stud	6
62	00901-316-2	Lip Plate, 9-5/32" Imp Dia	1
	09758-318-2	Lip Plate, 8-1/2" Imp Dia	1
	09758-317-2	Lip Plate, 8-5/32" Imp Dia	1
	09757-318-2	Lip Plate, 7-3/4" Imp Dia	1
	09757-317-2	Lip Plate, 7-3/16" Imp Dia	1
63	13425-029-1	Nameplate	1
64	04580-001-1	Drivescrews	4
65	00887-316-2	Valve Case	1
66	08889-001-1	O-Ring	1
67	00120-004-1	Pipe Plug	2
68	01308-316-2	Discharge Flange	1
69	05219-000-1	Cap, Grease Fitting	2
70	00156-048-1	Washer	2
71	00568-009-1	Capscrew Old Style	1
72	05223-003-1	Imp Washer Old Style	1

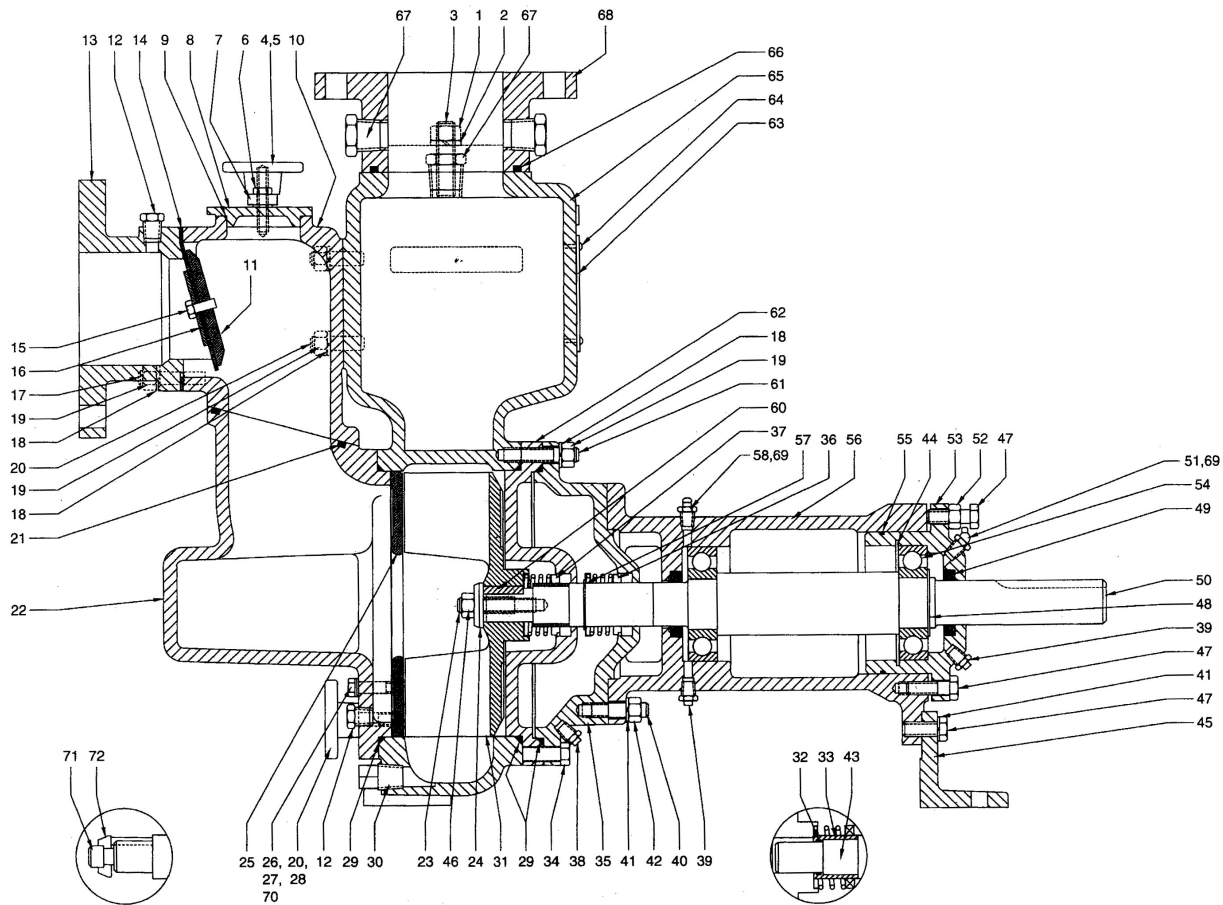

THIS PAGE INTENTIONALLY LEFT BLANK

STANDARD LIMITED WARRANTY

Pentair Hydromatic® warrants its products against defects in material and workmanship for a period of 12 months from the date of shipment from Pentair Hydromatic or 18 months from the manufacturing date, whichever occurs first – provided that such products are used in compliance with the requirements of the Pentair Hydromatic catalog and technical manuals for use in pumping raw sewage, municipal wastewater or similar, abrasive-free, noncorrosive liquids.

During the warranty period and subject to the conditions set forth, Pentair Hydromatic, at its discretion, will repair or replace to the original user, the parts that prove defective in materials and workmanship. Pentair Hydromatic reserves the right to change or improve its products or any portions thereof without being obligated to provide such a change or improvement for prior sold and/or shipped units.

Start-up reports and electrical schematics may be required to support warranty claims. Submit at the time of start up through the Pentair Hydromatic website: <http://forms.pentairliterature.com/startupform/startupform.asp?type=h>. Warranty is effective only if Pentair Hydromatic authorized control panels are used. All seal fail and heat sensing devices must be hooked up, functional and monitored or this warranty will be void. Pentair Hydromatic will cover only the lower seal and labor thereof for all dual seal pumps. Under no circumstance will Pentair Hydromatic be responsible for the cost of field labor, travel expenses, rented equipment, removal/reinstallation costs or freight expenses to and from the factory or an authorized Pentair Hydromatic service facility.

This limited warranty will not apply: (a) to defects or malfunctions resulting from failure to properly install, operate or maintain the unit in accordance with the printed instructions provided; (b) to failures resulting from abuse, accident or negligence; (c) to normal maintenance services and parts used in connection with such service; (d) to units that are not installed in accordance with applicable local codes, ordinances and good trade practices; (e) if the unit is moved from its original installation location; (f) if unit is used for purposes other than for what it is designed and manufactured; (g) to any unit that has been repaired or altered by anyone other than Pentair Hydromatic or an authorized Pentair Hydromatic service provider; (h) to any unit that has been repaired using non factory specified/OEM parts.

Warranty Exclusions: PENTAIR HYDROMATIC MAKES NO EXPRESS OR IMPLIED WARRANTIES THAT EXTEND BEYOND THE DESCRIPTION ON THE FACE HEREOF. PENTAIR HYDROMATIC SPECIFICALLY DISCLAIMS THE IMPLIED WARRANTIES OF MERCHANTABILITY AND FITNESS FOR ANY PARTICULAR PURPOSE.

Liability Limitation: IN NO EVENT SHALL PENTAIR HYDROMATIC BE LIABLE OR RESPONSIBLE FOR CONSEQUENTIAL, INCIDENTAL OR SPECIAL DAMAGES RESULTING FROM OR RELATED IN ANY MANNER TO ANY PENTAIR HYDROMATIC PRODUCT OR PARTS THEREOF. PERSONAL INJURY AND/OR PROPERTY DAMAGE MAY RESULT FROM IMPROPER INSTALLATION. PENTAIR HYDROMATIC DISCLAIMS ALL LIABILITY, INCLUDING LIABILITY UNDER THIS WARRANTY, FOR IMPROPER INSTALLATION. PENTAIR HYDROMATIC RECOMMENDS INSTALLATION BY PROFESSIONALS.

Some states do not permit some or all of the above warranty limitations or the exclusion or limitation of incidental or consequential damages and therefore such limitations may not apply to you. No warranties or representations at any time made by any representatives of Pentair Hydromatic shall vary or expand the provision hereof.



HYDROMATIC®

740 EAST 9TH STREET
ASHLAND, OHIO, USA 44805
419-289-1144

490 PINEBUSH ROAD, UNIT #4
CAMBRIDGE, ONTARIO, CANADA N1T 0A5
800-363-PUMP

WWW.HYDROMATIC.COM