



**ATARI**<sup>®</sup>  
GAMES

TM-320  
1st printing

**TOBIN**

**Operators  
Manual**

with Illustrated Parts Lists

## For technical assistance:

If reading through this manual does not lead to solving your game maintenance or repair problem, call TELE-HELP® at one of these Atari Games Customer Service offices:

### UNITED STATES

Atari Games Corporation  
California Customer Service Office  
737 Sycamore Drive

P.O. Box 361110  
Milpitas, CA 95035

Fax (408) 434-3945

Telex 5101007850

☎ (408) 434-3950

(Monday-Friday, 7:30 a.m.-4:00 p.m. Pacific time)

### EUROPE

Atari Games Ireland Limited  
European Customer Service Office  
Tipperary Town, Ireland

Fax 062-51702

Telex 70665

☎ 062-52155

(Monday-Friday, 9:00 a.m.-5:30 p.m. GMT)



# Toobin'™ Operators Manual

with ~~Illustrated~~ Parts Lists



© 1988 by Atari Games Corporation.

All rights reserved.

No part of this publication may be reproduced by any mechanical, photographic or electronic process, or in the form of a phonographic recording, nor may it be stored in a retrieval system, transmitted, or otherwise copied for public or private use, without permission from the publisher.

The game play, all graphic designs, this technical manual, its accompanying schematic diagrams, and the display manual are protected by the U.S. Copyright Act of 1976.

This Act provides for substantial penalties for violating federal copyright laws. Courts can impound infringing articles while legal action is pending. If infringers are convicted, courts can order destruction of the infringing articles.

In addition, the Act provides for payment of statutory damages of up to \$50,000 per infringing transaction in certain cases. Infringers may also have to pay costs and attorneys' fees and face an imprisonment of up to five years as well as fines of up to \$250,000 in the case of individuals and up to \$500,000 in the case of corporations.

Atari Games Corporation will aggressively enforce its copyrights against infringers. We will use all legal means to immediately halt any manufacture, distribution, or operation of a copy of video games made by us. Anyone who purchases such copies risks forfeiting such a game.

Published by:  
Atari Games Corporation  
675 Sycamore Drive  
P.O. Box 361110  
Milpitas, California 95035

Printed in the U.S.A      6S

Produced by the Atari Games Technical Publications Department

## Notice Regarding Non-Atari® Parts

### WARNING

Use of non-Atari parts or modifications of any Atari game circuitry may adversely affect the safety of your game, and may cause injury to you and your players.

You may void the game warranty (printed on the inside back cover of this manual) if you do any of the following:

- Substitute non-Atari parts in the game.
- Modify or alter any circuits in the game by using kits or parts *not* supplied by Atari Games Corporation.

### NOTE

This equipment generates, uses, and can radiate radio frequency energy, and if not installed and used in accordance with the instruction manual, may cause interference to radio communications. It has been tested and found to comply with the limits for a Class A computing device pursuant to Subpart J of Part 15 of Federal Communications Commission (FCC) Rules, which are designed to provide reasonable protection against such interference when operated in a commercial environment. Operation of this equipment in a residential area or modification to this equipment is likely to cause interference, in which case the user, at his own expense, will be required to take whatever measures may be required to correct the interference. If you suspect interference from an Atari game at your location, check the following:

- All ground wires in the game are properly connected as shown in the game wiring diagram.
- The power cord is properly plugged into a grounded three wire outlet.
- On games provided with an Electromagnetic Interference (EMI) ground plane, be sure the game printed-circuit boards (PCBs) are properly installed on the EMI Ground Plane. If you are still unable to solve the interference problem, please contact Customer Service at Atari Games Corporation. See the inside front cover of this manual for service in your area.

# Table of Contents

<b>1</b>	<b>Set-Up</b>	
	How to Use This Manual.....	1-1
	Inspecting the Game.....	1-2
	Control and Switch Locations.....	1-2
	Setting the Coin and Game Options.....	1-2
	Game Play.....	1-2
	Maximizing Earnings.....	1-4
<b>2</b>	<b>Self-Test</b>	
	RAM/ROM Test.....	2-2
	Control Test.....	2-2
	Alphanumeric Test.....	2-3
	Coin Options.....	2-3
	Game Options.....	2-4
	Statistics.....	2-5
	Histograms.....	2-6
	Playfield Scroll Test.....	2-6
	Motion Object Test.....	2-6
	Color Test.....	2-7
	Color Purity Test.....	2-7
	Convergence Test.....	2-7
	Intensity Test.....	2-8
	Sound Test.....	2-8
<b>3</b>	<b>Maintenance</b>	
	<b>Preventive Maintenance</b> .....	3-2
	Preventive-Maintenance Intervals.....	3-2
	Maintaining the Attraction Drum.....	3-2
	Cleaning the Coin Mechanism.....	3-2
	Cleaning the Interior Components.....	3-2
	<b>Corrective Maintenance</b> .....	3-4
	Removing the Video Display.....	3-4
	Replacing the Video Display.....	3-4
	Removing the Game PCB.....	3-5
	Replacing Static-Sensitive Devices.....	3-6
	Replacing Snap-Action Switches.....	3-6
	Removing the Fluorescent Lights.....	3-7
	Removing the Speaker.....	3-7
	Replacing the Attraction Drum Motor.....	3-8
<b>4</b>	<b>Illustrated Parts Lists</b>	
	<b>Toobin' Statistics</b>	
	<b>Glossary</b>	
	<b>Warranty</b>	

# List of Illustrations

Figure 1-1	Control and Switch Locations .....	1-3
Figure 2-1	Failing RAM Test .....	2-2
Figure 2-2	Failing ROM Test .....	2-2
Figure 2-3	Control Test.....	2-2
Figure 2-4	Alphanumeric Test.....	2-3
Figure 2-5	Coin Options.....	2-3
Figure 2-6	Game Options.....	2-4
Figure 2-7	Statistics Screen.....	2-5
Figure 2-8	Histograms .....	2-6
Figure 2-9	Playfield Scroll Test .....	2-6
Figure 2-10	Motion Object Test .....	2-6
Figure 2-11	Color Test.....	2-7
Figure 2-12	Color Purity Test.....	2-7
Figure 2-13	Convergence Test .....	2-7
Figure 2-14	Intensity Test.....	2-8
Figure 2-15	Sound Test Screen .....	2-8
<del>Figure 3-1</del>	Lubricating the Attraction Drum .....	3-3
Figure 3-2	Control Panel, Video Display, and Speaker Removal.....	3-5
Figure 3-3	Replacing Snap-Action Switches .....	3-6
Figure 4-1	Cabinet-Mounted Assemblies.....	4-2
Figure 4-2	Control Panel Assembly .....	4-6
Figure 4-3	Attraction Drum Assembly .....	4-7
Figure 4-4	Switching/Linear (SL) Power Supply Assembly .....	4-8
Figure 4-5	Coin Acceptors, Inc. Coin Door Assembly.....	4-12
Figure 4-6	Toobin' Game PCB Assembly .....	4-15
Figure 4-7	Stand-Alone Audio PCB Assembly.....	4-24

# List of Tables

Table 1-1	Game Specifications .....	1-2
Table 2-1	Faulty RAM Locations.....	2-2
Table 2-2	Faulty ROM Locations .....	2-2
Table 2-3	Coin Options .....	2-3
Table 2-4	Game Options .....	2-5
Table 2-5	Faulty Sound RAM and ROM Locations.....	2-9
Table 3-1	Recommended Preventive-Maintenance Intervals.....	3-2

# Safety Summary

The following safety precautions apply to all game operators and service personnel. Specific warnings and cautions will be found in this manual whenever they apply.

## WARNING

**Properly Ground the Game.** Players may receive an electrical shock if this game is not properly grounded! To avoid electrical shock, do not plug in the game until it has been inspected and properly grounded. This game should be only be plugged into a grounded three-wire outlet. If you have only a two-wire outlet, we recommend you hire a licensed electrician to install a three-wire grounded outlet. If the control panel is not properly grounded, players may receive an electrical shock! After servicing any part on the control panel, check that the grounding wire is firmly secured to the inside of the control panel. After you have checked this, lock up the game.

**AC Power Connection.** Before you plug in the game, be sure that the game's power supply can accept the AC line voltage in your location. The line voltage requirements are listed in the first chapter of this manual.

**Disconnect Power During Repairs.** To avoid electrical shock, disconnect the game from the AC power before removing or repairing any part of the game. If you remove or repair the video display, be very careful to avoid electrical shock. High voltages continue to exist even after power is disconnected in the display circuitry and the cathode-ray tube (CRT). Do not touch the internal parts of the display with your hands or with metal objects! Always discharge the high voltage from the CRT before servicing it. Do this after you disconnect it from the power source. First, attach one end of a large, well-insulated, 18-gauge jumper wire to ground. Then momentarily touch the free end of the grounded jumper wire to the CRT anode by sliding the wire under the anode cap. Wait two minutes and do this again.

**Use Only Atari Parts.** To maintain the safety of your Atari game, use only Atari parts when you repair it. Using non-Atari parts or modifying the game circuitry may be dangerous, and could injure you and your players.

**Handle the CRT With Care.** If you drop the CRT and it breaks, it may implode! Shattered glass from the implosion can fly six feet or more.

**Use the Proper Fuses.** To avoid electrical shock, use replacement fuses which are specified in the parts list for this game. Replacement fuses must match those replaced in fuse type, voltage rating, and current rating. In addition, the fuse cover must be in place during game operation.

## CAUTION

**Properly Attach All Connectors.** Make sure that the connectors on each printed circuit board (PCB) are properly plugged in. The connectors are keyed to fit only one way. If they do not slip on easily, do not force them. If you reverse a connector, it may damage your game and void your warranty.

**Ensure the Proper AC Line Frequency.** Video games manufactured for operation on 60 Hz line power (used in the United States) must not be operated in countries with 50 Hz line power (used in Europe). If a 60 Hz machine operates on 50 Hz line power, the fluorescent line ballast transformer will overheat and cause a potential fire hazard. Check the product identification label on your machine for the line frequency required.

## ABOUT NOTES, CAUTIONS, AND WARNINGS

In Atari publications, notes, cautions and warnings have the following meaning:

**NOTE**—A highlighted piece of information.

**CAUTION**—Equipment and/or parts can be damaged or destroyed if instructions are not followed. You will void the warranty on Atari printed-circuit boards, parts thereon, and video displays if equipment or parts are damaged or destroyed due to failure of following instructions.

**WARNING**—Players and/or technicians can be killed or injured if instructions are not followed.



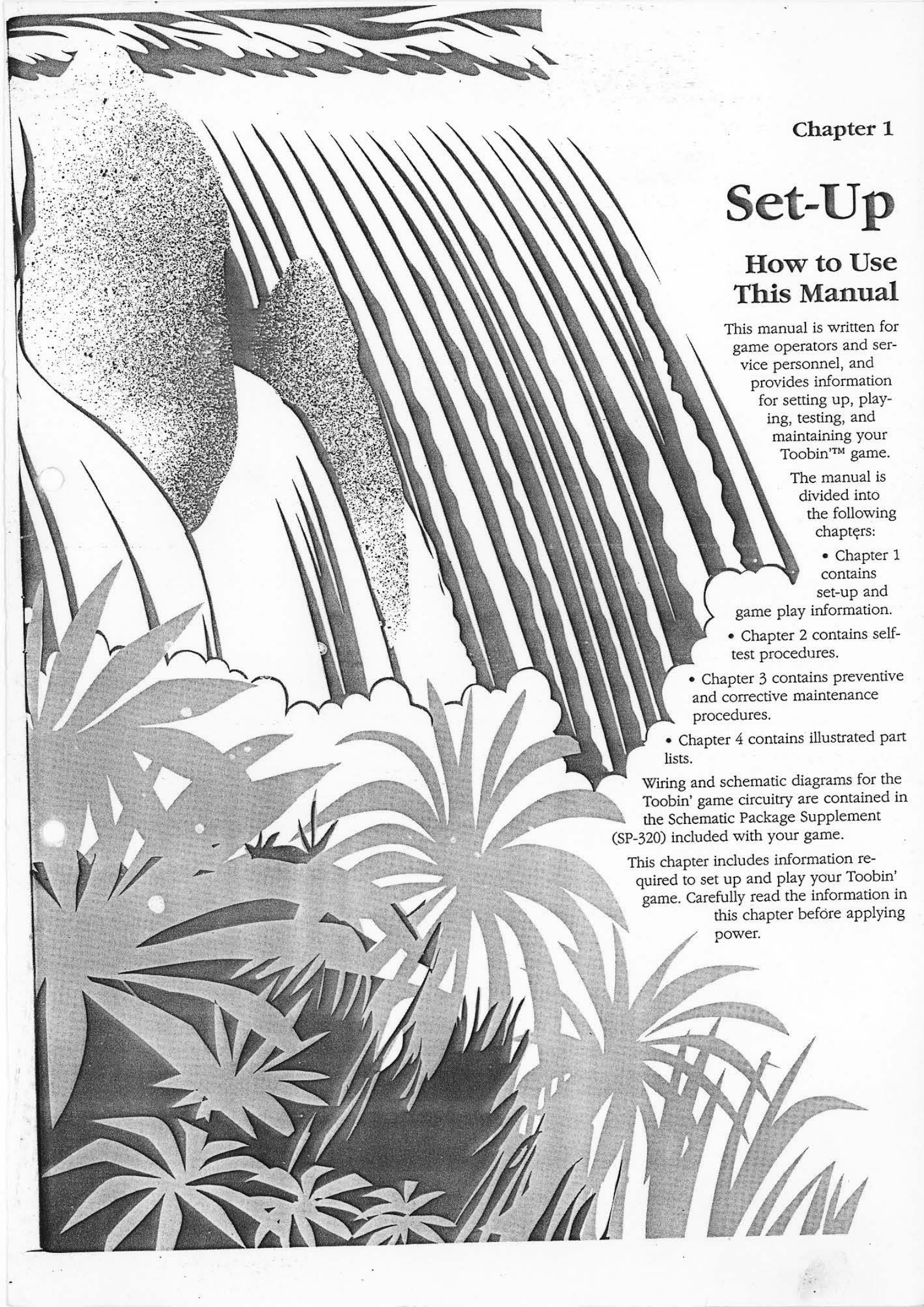

## Chapter 1

# Set-Up

## How to Use This Manual

This manual is written for game operators and service personnel, and provides information for setting up, playing, testing, and maintaining your Toobin™ game.

The manual is divided into the following chapters:

- Chapter 1 contains set-up and game play information.
- Chapter 2 contains self-test procedures.
- Chapter 3 contains preventive and corrective maintenance procedures.
- Chapter 4 contains illustrated part lists.

Wiring and schematic diagrams for the Toobin' game circuitry are contained in the Schematic Package Supplement (SP-320) included with your game.

This chapter includes information required to set up and play your Toobin' game. Carefully read the information in this chapter before applying power.

**WARNING**

To avoid electrical shock, do not plug in the cabinet until it has been properly inspected and set up for the line voltage in your area.

This cabinet should be connected to a grounded three-wire outlet only. If you have only a two-wire outlet, we recommend that you hire a licensed electrician to install a grounded outlet. Players can receive an electrical shock if the cabinet is not properly grounded.

**Inspecting the Game****WARNING**

Do not plug in the game until you have completed the following inspection steps.

Please inspect your Toobin' game carefully to ensure that the game is complete and was delivered to you in good condition. Figure 5-1 shows the locations of the component parts of the game. Table 1-1 lists space, power, and environmental requirements.

Inspect the factory-assembled game as follows:

1. Examine the exterior of the cabinet for dents, chips, or broken parts.
2. Unlock and open the rear access panel. Unlock and open the coin doors. Inspect the interior of the cabinet as follows:
  - a. Ensure that all plug-in connectors (on the cabinet harnesses) are firmly plugged in. Do not force connectors together. The connectors are keyed so they fit only in the proper orientation. *A reversed edge connector can damage a printed-circuit board (PCB) and will void your warranty.*

**Table 1-1 Game Specifications**

Characteristic	Specification
Power Consumption	150 V-A, 110 W RMS
Temperature	+5° to +50° C (+37° to +122° F)
Humidity	Not to exceed 95% relative
Line Voltage	102 to 132 VAC (U.S. games)
Width	25.25 in. (64 cm)
Depth	34.75 in. (88 cm)
Height	72 in. (183 cm)
Weight	270 lbs. (123 kg)

- b. Ensure that all plug-in integrated circuits on each PCB are firmly plugged into their sockets.
- c. Inspect the power cord for any cuts or dents in the insulation.
- d. Inspect the power supply. Make sure that the correct fuses are installed. Check that the harness is plugged in correctly and that the fuse block cover is mounted in place. Check that the green ground wires are connected.
- e. Inspect other major sub-assemblies, such as the video display, printed-circuit boards (PCBs), and speaker. Make sure that they are mounted securely and that the ground wires are connected.

**Control and Switch Locations****Power On/Off Switch**

The power on/off switch is located at the bottom rear of the cabinet. (See Figure 4-1.)

**Volume Control**

The volume control is located on the Audio PCB behind the upper coin door. (See Figure 1-1.) The volume control adjusts the level of sound produced by the game.

**Self-Test Switch**

The self-test switch is located on the corner of the Audio PCB behind the upper coin door. (See Figure 1-1.) The self-test switch selects the Self-Test Mode to check game operation. Refer to Chapter 2 for a complete description of self-test operation.

**Coin Counter**

The coin counter is located on the shelf inside the upper coin door. The coin counter records the number of coins deposited.

**Setting the Coin and Game Options**

The Toobin' coin and game options are set in the Self-Test Mode. Refer to Chapter 2 for the recommended settings and the procedure for setting the options.

**Game Play**

This part of the manual describes the theme and game play of the Toobin' game.

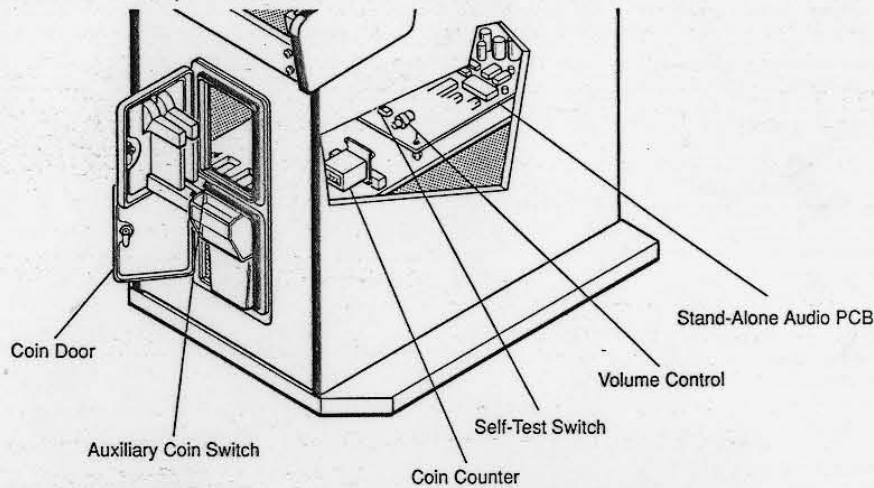

**Figure 1-1 Control and Switch Locations**

### Introduction

Toobin' is a unique fantasy-adventure game. One or two players can race Bif and Jet, the Toobin' dudes, in their inner tubes, down 45 different rivers. The players try to keep Jet and Bif afloat, avoiding sharp objects, gaining points, and throwing cans at obstacles. Toobin' appeals to both males and females of all ages who both find it just "fun to play."

Toobin' has a continuous buy-in feature so players can join in at any time. Toobin' has a color-coded control panel and players can identify Jet in the yellow inner tube and Bif in the black inner tube and red shorts.

Each player has a set of four buttons to steer Bif or Jet forwards, backwards, and sideways. Pressing the two Paddle Forward buttons moves the inner tube forward. Pressing the two Back Paddle buttons moves the inner tube backwards. Pressing only one Paddle button makes the inner tube turn. The player uses the Throw Can button to destroy obstacles in the river and stun riverside pests.

Toobin' players can enjoy amusing game play and an incredible variety of rivers and environments for their long-term enjoyment.

### Play Mode

The player races Bif or Jet against other players, or against the game, down Toobin's 45 different rivers, paddling through six classes of play, and cruising the 15 unique river environments. The player can choose almost 200 courses through the rivers, finding his own way through rapids, obstacles, riverside pests and waterfalls.

The player has to guide Bif or Jet around obstacles, go through gates and pick up treasure to accumulate points to get more inner tube patches, collect cans to throw at obstacles and to stun riverside pests, and paddle fast enough to avoid the big 'gator lurking in all the rivers.

At the finish line, players are treated to a party. Each party grows in size until the player reaches the final super party at the end of the game.

**Inner-Tube Patches:** At the beginning of each game, the player has a certain number of inner-tube patches, which represent game lives. A player receives extra patches by scoring the number of points required for another patch. The number of points required changes from level to level, and is displayed in the lower left and right corners of the playfield. A player can also receive more patches by picking up patches floating in the rivers.

**Points:** The player can score points by:

- *Time of Travel:* The player receives points simply for traveling down the river.
- *Passing through Gates:* The player receives points for passing through the gates in the river. Different-colored gates are worth different amounts of points. The green gates give the lowest points, then the red, gold, and finally crystal gates give the highest points.

If a player "swishes" a gate, that is, paddles through it without hitting the poles, he adds to his Score Multiplier. (This is described in *Score Multiplier* below.) For maximum points, the player should be the first through the gate and swish the gate. Each time the gate poles are hit, the point value of the gate falls.

- *Score Multiplier:* If a player "swishes" the gate, the score is multiplied. Each gate that is swished adds to the multiplier. For example, if the player has a "2X" multiplier, each point scored is multiplied by 2.

Every point the player scores is multiplied by the score multiplier. The score multiplier is shown in the upper left and right of the playfield, underneath the game scores. The minimum multiplier is 1 and the maximum is 5. The player must pass through every gate (whether he swishes it or not) to maintain the score multiplier. If

the player misses a gate, the score multiplier is reduced by one. As long as the player passes through the gate, even if he bumps it, the score multiplier is maintained. However, if a player's tube is punctured, his score multiplier falls to one.

- **Treasures:** The player can pick up treasures floating on the river or hidden under obstacles to gain extra points. The lowest-value treasure is green, next is red, and gold is the highest.
- **Warp:** The warp feature moves the player to the intermediate or advanced play classes. When the player warps, he is rewarded with warp bonus points. Warping is a good way to quickly score points.

**Cans:** The player must accumulate cans to throw at obstacles and pests. All cans are the same value. The player can pick up individual cans floating in all the rivers or six-packs hidden under obstacles or in back waters. (Six packs give unlimited cans.) The player throws the cans by pointing Bif or Jet at the obstacle and pressing the Throw Can button.

Most of the obstacles in the river can be eliminated by hitting them with a can.

**Dangers:** The player must avoid or eliminate dangers in the river and stun pests on the river banks. The dangers in the river include:

- |                           |                     |
|---------------------------|---------------------|
| • Falling rocks           | • Floating logs     |
| • Deadly falling coconuts | • Icebergs          |
| • Mines                   | • Stampeding cattle |
| • Snakes                  | • Crocodiles        |
| • Barbed wire             | • Thorny bushes     |

Dangerous riverside pests throw and shoot objects at Bif and Jet. The player can stun most of these objectionable characters with a can thrown in their direction. These pests include:

- |                     |                |
|---------------------|----------------|
| • Casting fishermen | • Hillbillies  |
| • Terrorists        | • Devils       |
| • Martians          | • Street punks |
| • Pistoleros        | • Natives      |
| • Penguins          | • Bears        |
| • Dinosaurs         | • Cavemen      |

**Big 'Gator :** If a player is slow, the big 'gator comes up from behind to discourage slow play and hurry the player through the gates. A loud thumping sound warns the player of its presence. One escape from the big 'gator is to quickly paddle downstream or pass through a gate. If the gator catches Bif or Jet, one inner-tube patch is lost.

## Maximizing Earnings

Operator options on this game have been kept very simple. You should thoroughly read Chapter 2, Self-Test, for information on the Coin Options, Game Options, Histogram, and Statistics screens so that you can

effectively use the available options. Use the Self-Test screens showing Statistics and Histogram to evaluate game data, and the Game Options screen to make adjustments. (Refer also to the Self-Test chapter for more information on setting options.)

The key to maximum earnings is striking a midpoint on game times. Game times must be short enough so that player turnover is high. Conversely, game times must be long enough to give players a good value and ensure repeat play. (Repeat play is crucial to longevity.) The Toobin' software gives the operator the flexibility to tune game difficulty and enough statistics to intelligently make adjustments.

If collections seem low or are dropping off, check all player controls and coin mechanisms for proper operation.

If earnings seem low, the game is technically sound, and the average game time per quarter is under 150 seconds, try changing the game-difficulty option to an easier setting. This change will give players more game time for their money.

If the average game time per quarter is over 270 seconds, first try changing the game difficulty to a harder setting. If the average game time per quarter is still over 270 seconds after a few weeks, try an even harder setting.

After changing the game-difficulty settings, it is a good idea to reset the game statistics and the histograms. The game statistics can be cleared in the self-test by pressing all the Back Paddle buttons simultaneously. The histograms can be cleared by pressing all the Back Paddle buttons simultaneously while you are on the seventh histogram screen.

## Special Contest Feature

Every Toobin' game in the U.S has a special contest. A player can win a free Toobin' t-shirt just for playing the game and finding and picking up all seven characters to spell the word *Toobin'* (including the apostrophe). These characters are hidden in the river below obstacles and hazards. The letters collected by the player are shown at the beach party at the end of the run. For more contest details, see the game.

# Self-Test

The Toobin™ game tests itself and provides visual and audible indications of the condition of the game circuitry and controls. Self-test information is displayed on the screen and through the sound system. No additional equipment is required.

We suggest that you perform a self-test when you first set up the game, each time you collect the money, or when you suspect

game failure.

The self-test screens provide information about the game circuits and controls. The game enters the self-test mode after the self-test switch is turned on. The following self-test screens are arranged in the sequence in which they occur when the self-test switch is turned on. After the sound test, the sequence starts over with the control test. If you turn off the self-test switch at any time during the self-test mode, the game returns to the attract mode.

The self-test switch is located on the front corner of the Stand-Alone Audio board, inside the coin door.

## RAM/ROM Test

The RAM/ROM Test screens are shown in Figures 2-1 and 2-2.

If the game has errors in the RAM, ROM, or associated circuitry, this test provides information about the location of the error. If the RAMs and ROMs pass the test, the self-test advances to the Control Test.

The RAM/ROM Test is divided into two sections. The RAM Test is performed first. If the RAM Test passes after a six-second delay, the self-test skips to the ROM Test without displaying any message. If the RAM fails, a message is displayed on the screen as shown in Figure 2-1. See Table 2-1 for information about RAM problems.

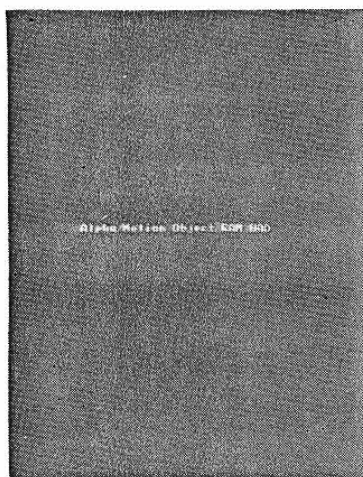

Figure 2-1 Failing RAM Test

If no errors occur, the ROM Test displays no messages and advances to the Switch Test. If a ROM fails, a message is displayed as shown in Figure 2-2. Refer to Table 2-2 for the location of the failing ROM. If you get a message on the screen, press the left player Start button to advance to the Switch Test.

Error Address	Location on Game PCB	
00000	U = 1J	L = 1F
20000	U = 2J	L = 2F
40000	U = 4J	L = 4F
60000	U = 5J	L = 5F

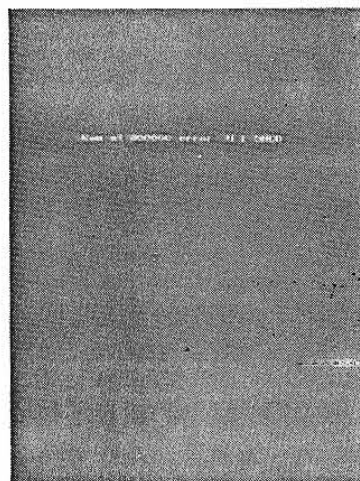

Figure 2-2 Failing ROM Test

## Control Test

The control test is shown in Figure 2-3. Use this test to check the condition of the buttons. As you press each button, the corresponding position on the screen turns red if it is operating correctly. Press both Start buttons to go to the next test.

RAM Type	Location	Video Display Characteristic
CPU	7J, 7F	Background color is red.
PF	1E, 3E, 4/5E	Background color is green.
AL/MO	17D, 18D	Background color is blue.
COL	8J, 9J	Background color varies between red, white, and blue.

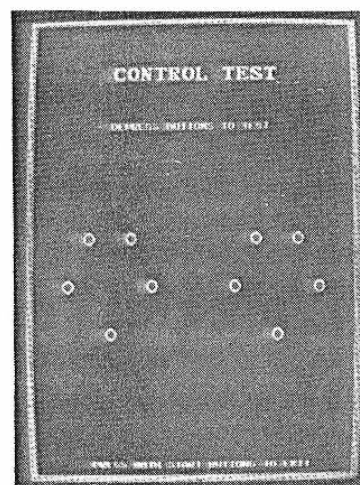

Figure 2-3 Control Test

# Alphanumeric Test

The alphanumeric test checks the condition of the alphanumericics in the game. The screen is shown in Figure 2-4.

If you see an error on the screen, check the EPROM at 20H.

Press the left Start button to go to the next test.

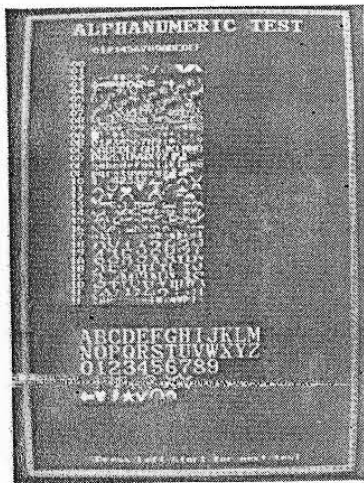

Figure 2-4 Alphanumeric Test

# Coin Options

Check and select the coin options on this screen. The screen is shown in Figure 2-5.

The coin option setting defaults are shown in green. The coin option that you are changing is shown in a blue box.

Press the left player Back Paddle buttons to move up and down the screen.

Change any of the option settings by pressing either left player Paddle Forward button. Exit the screen by pressing the left Start button. To save your changes, you must press the left Start button before you leave the Self-Test.

Change all the option settings back to the factory defaults by pressing the furthest right Paddle Forward button. To return to your original option settings, press the right Start button.

The coin options are as follows:

*Coin Mode* has a blue box around it when the screen first appears. The blue box means that you can change this option. The coin mode settings you can choose are:

- One coin equals one credit (default)
- Two coins equal one credit

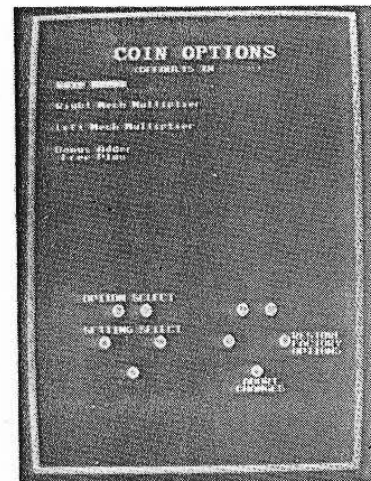

Figure 2-5 Coin Options

- Three coins equal one credit
- Four coins equal one credit

*Right Mech Multiplier* is the next option. Move to this option by pressing the right Paddle Forward button for the left player. Change the setting of this option when it has a blue box around it. The settings you can choose are:

- One coin counts as one coin (default)
- Six coins count as one coin
- Five coins count as one coin
- Four coins count as one coin

*Left Mech Multiplier* is the next option. Move to this option by pressing a Paddle Forward button for the

<i>Coin Mode</i>	One coin equals one credit ♦ Two coins equal one credit Three coins equal one credit Four coins equal one credit
<i>Right Mech Multiplier</i>	One coin counts as one coin ♦ Six coins count as one coin Five coins count as one coin Four coins count as one coin
<i>Left Mech Multiplier</i>	One coin counts as one coin ♦ One coin counts as two coins
<i>Bonus Adder</i>	No bonus adder ♦ 2 coins give 1 extra coin 4 coins give 1 extra coin 4 coins give 2 extra coins 5 coins give 1 extra coin 3 coins give 1 extra coin Free Play (for demonstration mode)

♦ Manufacturer's recommended settings

left player. Change the setting on this option when it has a blue box around it. You can choose these settings:

- One coin counts as one coin (default)
- One coin counts as two coins

*Bonus Adder* is the next option. To move to this option, press down either Paddle Forward button on the left player side. Change the setting on this option when it has a blue box around it. You can choose these settings:

- No bonus adder (default)
- 2 coins give 1 extra coin
- 4 coins give 1 extra coin
- 4 coins give 2 extra coins
- 5 coins give 1 extra coin
- 3 coins give 1 extra coin
- Free play (for demonstration mode)

To go to the game options screen, press the left Start button.

## Game Options

Use this screen to check and select the game options. The screen is shown in Figure 2-6.

The game option setting defaults are shown in green. You can change the setting when the option has a blue box around it.

Press the left player Back Paddle buttons to move up or down the option list.

Change any option setting by pressing either left player Paddle Forward button. Exit the screen by pressing the left Start button. To save your changes you must press the left Start button before leaving the Self-Test.

Change the options to the factory defaults by pressing the furthest right Paddle Forward button. To return to your original option settings, press the right Start button.

The game option settings are as follows.

*Difficulty Level* has a blue box around it when the screen first appears. Choose the player difficulty level. The levels are:

- Easiest
- Easier
- Easy
- Medium (default)
- Medium Hard
- Hard
- Harder
- Hardest

*Clear High Score Table* is the next option. Move to this option by pressing the left player's right Paddle Forward button. Use this option to clear the high score table displayed in the attract mode.

- Yes
- No (default)

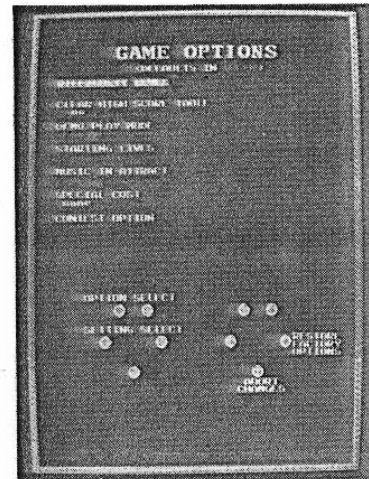

Figure 2-6 Game Options

*Demo/Play Mode* is the next option. Move to this option by pressing the left player's right Paddle Forward button. Use this option to choose the play mode or the demonstration mode.

- Playable Game Mode (default)
- Demonstration Only Mode

*Starting Lives* is the number of times a player's inner tube can be punctured before sinking.

The settings are:

- 2
- 3 (default)
- 4
- 5

*Music in Attract Mode* turns the music on or off in the attraction mode.

- Yes (default)
- No

*Special Cost* allows you to choose either 2 credits to start and 1 to continue, or the standard coin setting.

- 2 credits to start, 1 to continue (default)
- None



**Table 2-4 Game Option Settings**

Option Name	Settings	
Difficulty Setting	Easiest	Easier
	Easy	Medium ♦
	Medium Hard	Hard
	Harder	Hardest
Clear High Score Table	Yes	No ♦
	Demo Play Mode	
Starting Lives	2	3 ♦
	4	5
Music in Attract Mode	Yes ♦	No
Special Cost	2 credits to start, 1 to continue ♦ None	
Contest	Enabled (default for U.S. games)♦	
	Disabled (default for European games)	

♦ *Manufacturer's recommended settings*

*Contest* is the last game option. For U.S. games, the default is that the contest is enabled, but for European games, the default is disabled. The contest is briefly described at the end of Chapter 1.

- Enabled (default for U.S. games)
- Disabled (default for European games)

Exit the screen by pressing the left Start button.

## Statistics

Use the statistics shown on this screen and on the histogram screens to track your game use. Record the statistics on the Toobin' statistics sheet found in the back of this manual.

The statistics screen is shown in Figure 2-7. The information on the screen is accumulated from the last time the statistics were reset.

Also on this screen is the date the program was created. If you call Atari Games Customer Service with a problem, you may need this information.

To reset the statistics screen, simultaneously press all of the Back Paddle buttons. Exit the screen by pressing the left Start button.

The statistics screen shows the following information:

- *Left Coins* shows the number of coins deposited in the left coin mechanism.

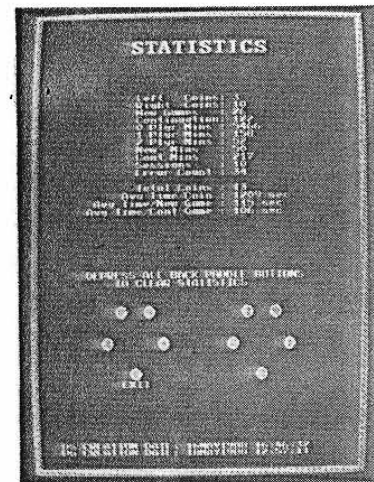
**Figure 2-7 Statistics Screen**

- *Right Coins* shows the number of coins deposited in the right coin mechanism.
- *New Games* shows the number of new games started.
- *Continuation* shows the number of games continued.
- *0 Plyr Mins* shows the number of minutes the game had no players.
- *1 Plyr Mins* shows the number of minutes the game was played by one player.
- *2 Plyr Mins* shows the number of minutes the game was played by two players.
- *New Mins* shows the number of minutes the game was played as a new game.
- *Cont Mins* shows the number of minutes the game was played as a continued game.
- *Sessions* shows the number of sessions played. A session starts when the first coin is put in and ends when the last player leaves the game.
- *Error Count* shows the number of errors counted in the erasable memory. This should have a count of less than 75 per week. If it has more, then the game should be repaired.
- *Total Coins* shows the number of coins deposited.
- *Avg Time/Coin* shows the average number of seconds per coin.
- *Avg Time/New Game* shows the average number of seconds per new game. (This calculates the average time correctly whether or not you are using the 2 coins to start, 1 coin to continue setting.)

- *Avg Time/Cont Game* shows the average number of seconds per continued game. (This calculates the average time correctly whether or not you are using the 2 coins to start, 1 coin to continue setting.)

## Histograms

This game has seven histogram (horizontal bar graph) screens. The first one is shown in Figure 2-8. The histogram information is accumulated from the last time the screens were cleared.

You can clear all the histogram screens by pressing all the Back Paddle buttons at the same time when you are in the seventh histogram screen. To move through the screens, press the left Start button.

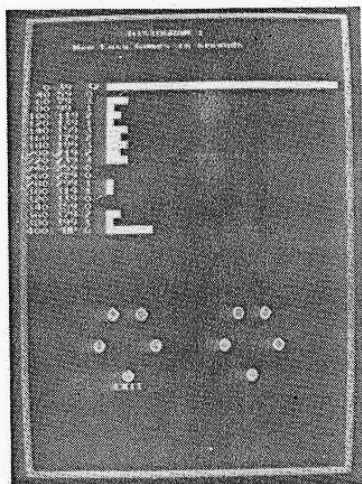

Figure 2-8 Histograms

The seven histogram screens show the following:

- New easy games in seconds
- New medium games in seconds
- New hard games in seconds
- Easy continuation games in seconds
- Medium continuation games in seconds
- Hard continuation games in seconds
- Sessions in minutes

## Playfield Scroll Test

You can test the playfield scrolling circuitry in this screen. Use the left player buttons to move left, right, up, and down. The screen is shown in Figure 2-9.

Exit the screen by pressing the left Start button.

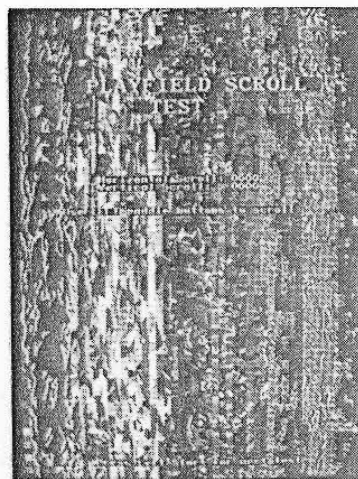

Figure 2-9 Playfield Scroll Test

## Motion Object Test

The motion object test screen is shown in Figure 2-10. This tests the movement and color of various game objects.

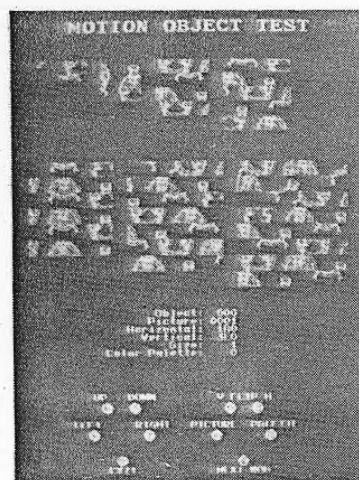

Figure 2-10 Motion Object Test

Use the left player paddle buttons to move the objects left, right, up and down. The left player Start button is the Exit button as usual.

Use the right player buttons to do the following:

- Press the left Back Paddle button to flip the object vertically.
- Press the right Back Paddle button to flip the object horizontally.
- Press the left Paddle Forward button to change the picture in the object.
- Press the right Paddle Forward button to change the color of the object.
- Press the Start button to choose the next object.

## Color Test

This test indicates the condition of the video display color circuits. The screen is shown in Figure 2-11.

The screen changes from white at the bottom to black in the middle. The last black line in the middle should be definitely black. Above the black line, red, green, and blue become darker and darker, with the colors and the black border blending into each other at the top of the screen.

If the screen does not fit this description, see the video display manual included with the game for adjustments.

Exit the screen by pressing the left Start button.

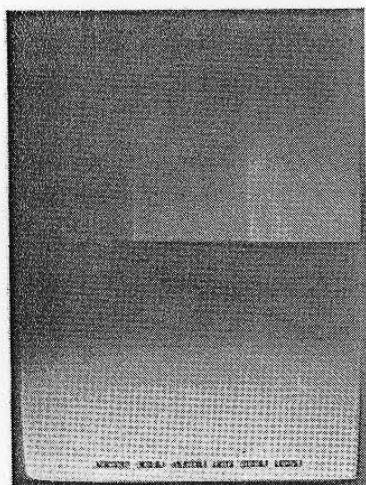

Figure 2-11 Color Test

## Color Purity Test

The color purity test has five screens. The first screen is shown in Figure 2-12.

These screens show the condition of the color purity circuit in the video display. Each screen should display a rectangle of color, with no curving at the corners and no lines in the display. The screens are red, green,

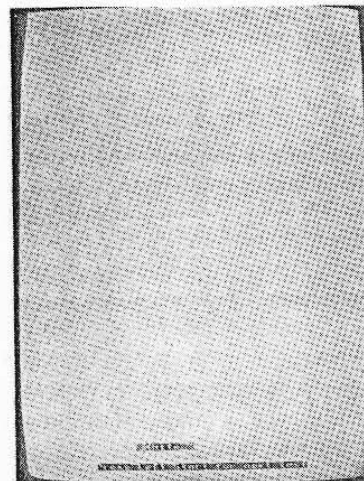

Figure 2-12 Color Purity Test

blue, white and gray.

If the screens are not correct, see the video display manual included with the game for adjustments.

Exit each screen by pressing the left Start button.

## Convergence Test

The convergence test is shown in Figure 2-13. This test has three screens. The first is white, the second is purple, and the last is green.

Check the following on the screens:

- The grid lines should be straight within 3.0 mm and the lines should not pincushion or barrel.
- The convergence of the lines on the violet and white screens should be within 2.0 mm.

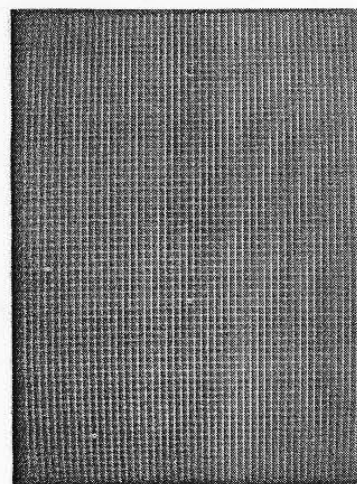

Figure 2-13 Convergence Test

If these screens do not meet these criteria, see the video display manual for suggested adjustments.

Exit the screen by pressing the left Start button.

## Intensity Test

This test checks the intensity circuit and the interrupt circuit of the video display. The screen is shown in Figure 2-14.

You should see a number of grey vertical bars from light to dark across the display. If these bars do not appear, there is problem in either the intensity or the interrupt circuit.

You can determine which circuit is the problem by going into the play mode. If the screen does not fade out when the the game goes into play mode, then something is wrong with the intensity circuit. If the game does not display anything at all, then something is wrong with the interrupt circuit.

Exit the screen by pressing the left Start button.

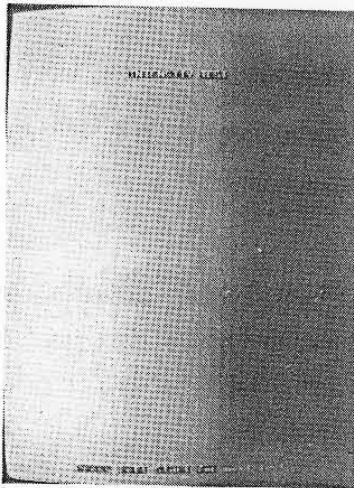

Figure 2-14 Intensity Test

## Sound Test

The sound test indicates the condition of the music and sound effects circuits. The sound test screen is shown in Figure 2-15. The sound microprocessor resets at the beginning of the test. You will hear the first sound three seconds after the test starts.

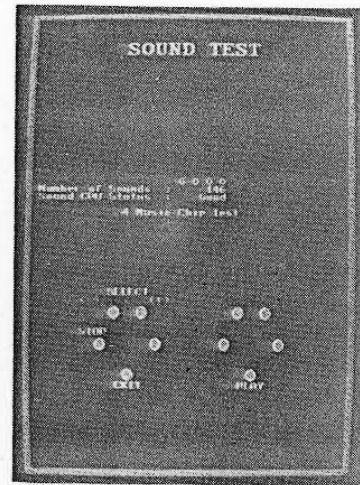

Figure 2-15 Sound Test Screen

After the microprocessor is reset and you hear the first sound, the number of game sounds and the sound CPU status information appear. If the CPU is good, the word "Good" appears.

The test cycles through the following tests:

- Music Chip Test
- Effects Chip Test
- SCOM Reset Test



Table 2-5 Faulty Sound RAM and ROM Locations

Error Message	Location on Stand-Alone Audio PCB	Cause or Comment
Music Chip Time Out	2F	
Sound CPU Interrupt Error	2F, 5K, Transistor Q8	
Sound CPU RAM 1 Error	2H	
Sound CPU ROM 1 Error	2K	If displayed when entering test, then sound processor cannot run further. Press the Left Player Start button to go to the next test.
Communications Error #1	1M	Will count number of errors caused by either the Stand-Alone Audio PCB or Game PCB. This error message usually means that the SCOM chip (part no. 137526-001) on one of these boards is bad.
<b>CAUTION</b>		
The SCOM chip is a CMOS IC and is static sensitive. If you do not handle it properly, you can permanently damage this chip. See the section <i>Replacing Static-Sensitive Devices</i> , in Chapter 3 of this manual, for more information.		
Communications Error #2		A probable disconnection of the Stand-Alone Audio PCB from the Game PCB, or the chip at 1M is not inserted into its socket.
Sound Processor Not Responding Alone		A major problem with the Stand-Alone Audio PCB. If you cannot enter the self-test, the cause may be a harness disconnection between the Stand-Audio Board and the Game PCB.

After these tests, the 4th Music Chip Test begins. Use the buttons on the control panel to select sounds in the test and listen to them.

Use the player buttons to do the following:

- Press the left player Back Paddle buttons to move forward and back through the sound list.
- Press the left player left Paddle Forward button to stop the sound.
- Press the right player Start button to play the sound.
- Press the left player Start button to exit the sound test. You return to the first test in the self-test series.



# N O T E S



## Chapter 3

# Maintenance

This chapter includes preventive and corrective maintenance procedures for the Toobin™ game components that are subject to the most use. To assure maximum trouble-free operation from this game, we recommend that preventive maintenance be performed as described in this chapter.

Removal, disassembly, re-assembly, and replacement procedures are provided for components that might require corrective maintenance. Appropriate references are provided to Chapter 4, Illustrated Parts Lists, to help locate the parts of this game that are mentioned, but not illustrated, in the maintenance procedures.

# Preventive Maintenance

Preventive maintenance includes cleaning, lubricating, and tightening hardware. How often preventive maintenance is performed depends upon the game environment and frequency of play. However, for those components listed in Table 3-1, Recommended Preventive-Maintenance Intervals, we recommend that preventive maintenance be performed at the intervals specified.

## WARNING

To avoid possible electrical shock, turn off the game before performing any maintenance procedures.

## Preventive-Maintenance Intervals

The preventive-maintenance intervals specified in Table 3-1 are the recommended minimum requirements for the components listed.

**Table 3-1 Recommended Preventive-Maintenance Intervals**

<b>Attraction Drum</b>	Lubricate and tighten hardware at least every three months.
<b>Coin Mechanism</b>	Inspect whenever you collect coins. Clean at least every three months.

## Maintaining the Attraction Drum

Preventive maintenance on the attract drum consists of:

- Lubricating the five points shown in Figure 3-2.
- Tightening the screws on the left side of the frame that hold the drum shafts in place.

### Lubricating the Attraction Drum

1. Remove the two screws on the top of the game cabinet that secure the retainer. Take off the retainer.
2. Remove the inner and outer attraction shields and attraction graphics.
3. Lightly oil the plastic bearings that hold the drum shafts in the frame. Do this at each of the five locations shown on Figure 3-1.

### Tightening the Attraction Drum

1. Tighten the hex-head screws that hold the attraction drums in place. You will not be able to reach all of the screws, but tighten the ones you can reach.
2. Tighten the screws that hold the frame to the cabinet and that hold the light fixture on the frame.
3. If you take out the frame to replace the motor or the light fixture, tighten all the nuts at that time.
4. When you are done, replace the retainer and tighten the two screws that hold the retainer on the cabinet.

## Cleaning the Coin Mechanism

Use a soft-bristled brush to remove loose dust or foreign material from the coin mechanism. A toothbrush can be used to remove any stubborn build-up of residue in the coin path. After cleaning the coin mechanism, blow out all of the dust with compressed air.

## Cleaning the Interior Components

### WARNING

Turn off the game power, but do not unplug the power cord before cleaning inside the cabinet. The power cord provides a ground path for stray static voltages that can be present on the cleaning tools.

Perform the following procedure to clean the components inside the cabinet.

1. Unlock and open the rear access panel and display service panel.
2. Discharge the high voltage from the cathode-ray tube (CRT) before proceeding. The display assembly contains a circuit for discharging the high voltage to ground when power is removed. However, to make certain, always discharge the display as follows:
  - a. Attach one end of a large, well-insulated, 18-gauge jumper wire to ground.
  - b. Momentarily touch the free end of the grounded jumper to the CRT anode by sliding it under the anode cap.



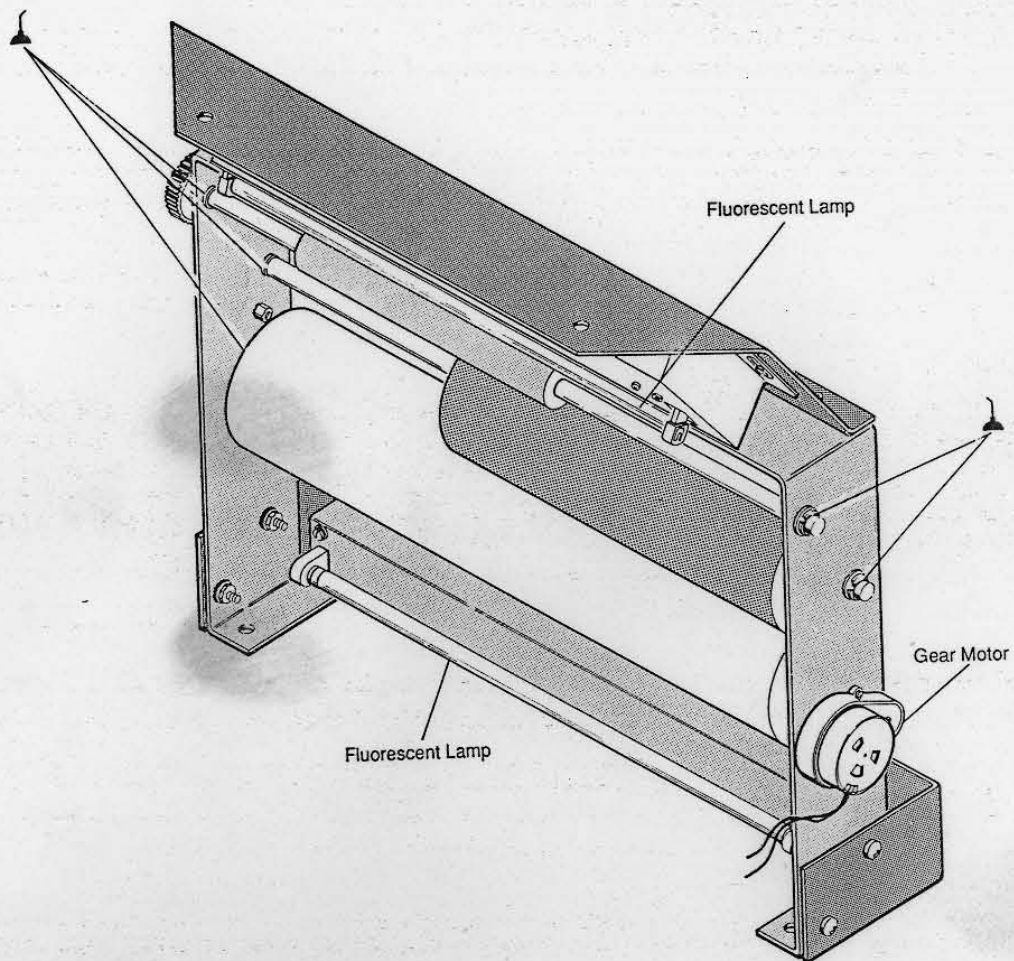

**Figure 3-1 Lubricating the Attraction Drum**

c. Wait two minutes and repeat part b.

**CAUTION**

Be extremely careful when cleaning the electrical components inside the cabinet. Avoid touching the electrical components with any solid object other than the soft bristles of the vacuum attachment or paint brush.

3. Use a vacuum cleaner with a soft long-bristled brush attachment or use a soft-bristled paint brush to remove loose dirt and dust accumulated on the inside of the cabinet. Be sure to clean the electrical components thoroughly (power supplies, PCB assemblies, display, etc.).

## Corrective Maintenance

Corrective maintenance consists of removal, disassembly, re-assembly, and replacement of game components. The following procedures are provided for components that may require corrective maintenance.

### Removing the Video Display

Perform the following procedure to remove/replace the video display. (See Figure 3-2.)

1. Turn the game power off and wait two minutes. Unplug the power cord.

#### WARNING

##### *High Voltage*

The video display contains lethal high voltages. To avoid injury, do not attempt to service this display until you observe all precautions necessary for working on high-voltage equipment.

##### *X-Radiation*

The video display has been designed to minimize X-radiation. However, to avoid possible exposure to soft X-radiation, never modify the high-voltage circuitry.

##### *Implosion Hazard*

The cathode-ray tube may implode if struck or dropped. Shattered glass may cause injury within a 6-foot radius. Use care when handling the display.

2. Open the coin door. Reach up through the coin door to the control panel and unlatch the latches on both sides of the it. Tilt the control panel up and disconnect the harness connectors. Remove the control panel.
3. Use the finger hole below the video display to help you remove the video display shield.
4. Carefully remove the bezel from the protective foam tape.
5. Open the rear access panel.
6. Be sure that the game power is turned off before discharging the high voltage from the cathode-ray tube (CRT). The display assembly contains a circuit for discharging the high voltage to ground when power is removed. However, to make certain, always discharge the display as follows:
  - a. Attach one end of a large, well-insulated, 18-gauge jumper wire to ground.
  - b. Momentarily touch the free end of the grounded jumper to the CRT anode by sliding it under the anode cap.
  - c. Wait two minutes and repeat part b.
7. From the rear of the cabinet, disconnect the display harness connectors from the display.
8. Remove the two wood cleats on the left and right sides of the cabinet. Use a Phillips screwdriver to remove the 2 screws on each side.
9. Use a 3/8-inch nut driver to remove the four hex head-washer bolts holding the display onto the metal mounting brackets in the cabinet.
10. Carefully lift the display out through the front of the cabinet.

#### WARNING

To avoid dropping the video display, use extreme care when removing the display from the cabinet. We recommend that no one weighing less than 150 pounds should attempt to remove the display. In addition, we recommend that you wear gloves to protect your hands from the sheet-metal edges.

11. Replace the video display as described in the following procedure.

### Replacing the Video Display

Perform the following procedure to replace the video display in the cabinet. (See Figure 3-2.)

#### NOTE

Whenever the cathode-ray tube and yoke are replaced as a single unit, readjust the brightness, size, and centering as described in the display manual. Also check the purity and convergence according to the display manual instructions, but adjust both only if required.

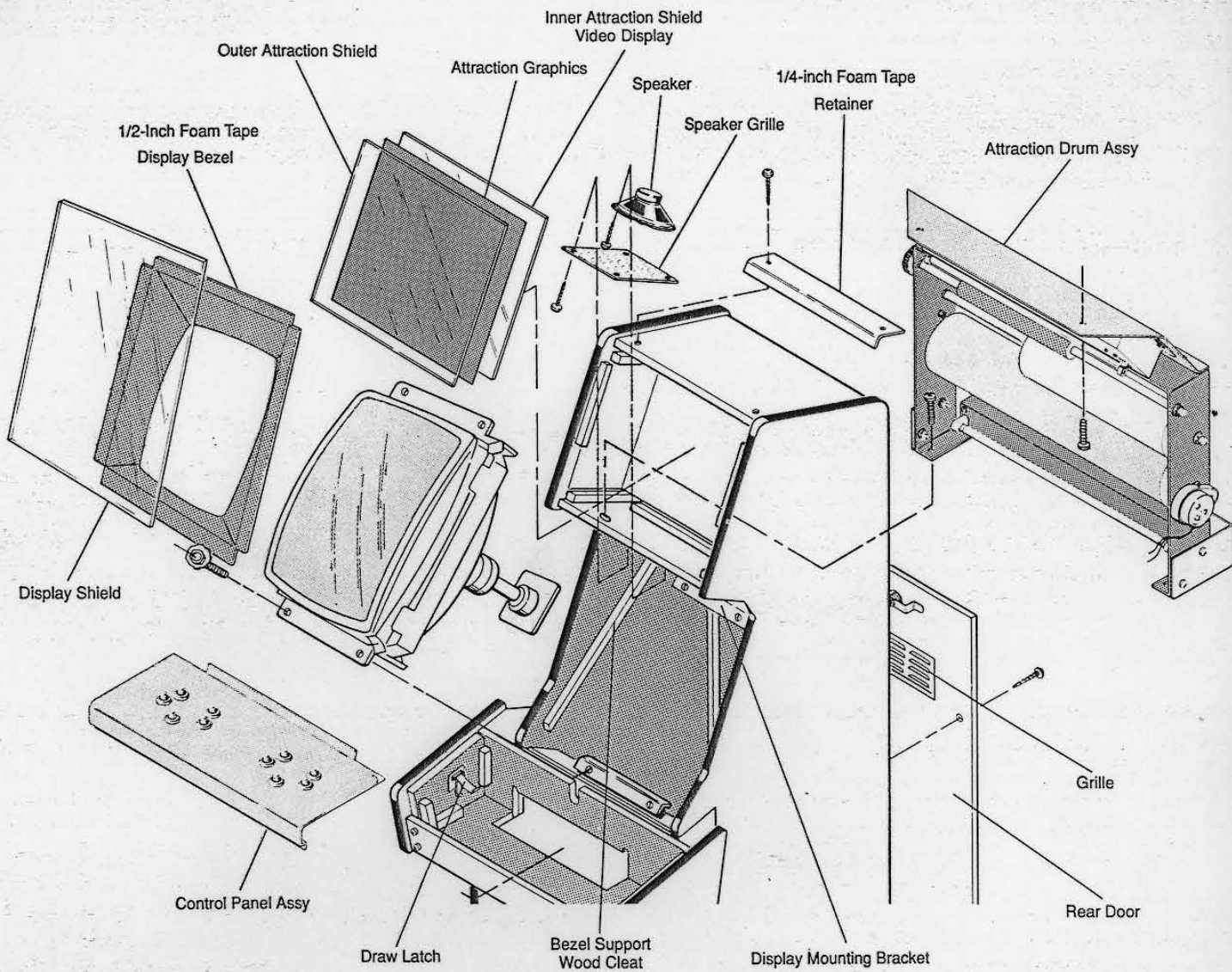

**Figure 3-2 Control Panel, Video Display, and Speaker Removal**

1. Carefully lift the video display through the front of the cabinet.
2. Position the display so that the four holes in the video display mounting brackets align with the four holes in the top and bottom metal bracket.
3. Install the four hex head-washer bolts through the display frame and mounting brackets.
4. Use a 3/8-inch nut driver to tighten the bolts. Be sure that the display is centered horizontally.
5. Connect the display harnesses to the display.
6. Install the two cleats that support the bezel and the display shield.
6. Replace the bezel and display shield.

## Removing the Game PCB

Perform the following procedure to remove or replace the Toobin' Game PCB.

1. Turn the game power off.
2. Unlock and remove the rear access panel from the cabinet.
3. Disconnect the harness connectors from the Game PCB.
4. Use a Phillips screwdriver to remove the two screws and washers holding the Game PCB to the cabinet.
5. Grasp the edge of the Game PCB and gently lift it out of the slotted guide.
6. Replace the Game PCB in the reverse order of removal.

## Replacing Static-Sensitive Devices

Be careful when you are working with static-sensitive devices, such as microprocessors, field-effect transistors (FET), complementary metal-oxide semiconductors (CMOS), and other large-scale integration (LSI) devices that use metal-oxide semiconductor (MOS) technology.

Static charge that has built up in your body can cause a static-sensitive device to fail. Leakage from an improperly grounded soldering iron can also cause a static-sensitive device to fail.

Before you handle a static-sensitive device or a PCB with such devices attached to it, ground any static voltage that may have accumulated in your body by touching an object that has been earth grounded. A bare wire wrapped around your wrist and attached to an earth ground is effective when working extensively with static-sensitive devices.

When you solder a static-sensitive device, use a solder-

ing iron with a properly grounded three-wire cord.

Before you replace a static-sensitive device, make sure it is actually defective. A static-sensitive device can appear defective due to leakage on a PCB. To make sure a device is defective, ground static voltages as described in the paragraph above. Clean both sides of the PCB with flux remover or an eraser. For discrete FETs, clean thoroughly between the gate, drain, and source leads. Then test the device.

New static-sensitive devices can be packaged in conductive foam or can have a protective shorting wire attached to the pins. Remove the conductive foam just prior to inserting the device into its socket or soldering it to a PCB. Remove the shorting wire only *after* the device is inserted into its socket or *after* all the leads are soldered in place.

## Replacing Snap-Action Switches

Perform the following procedure to replace any of the snap-action switches. (See Figure 3-3.)

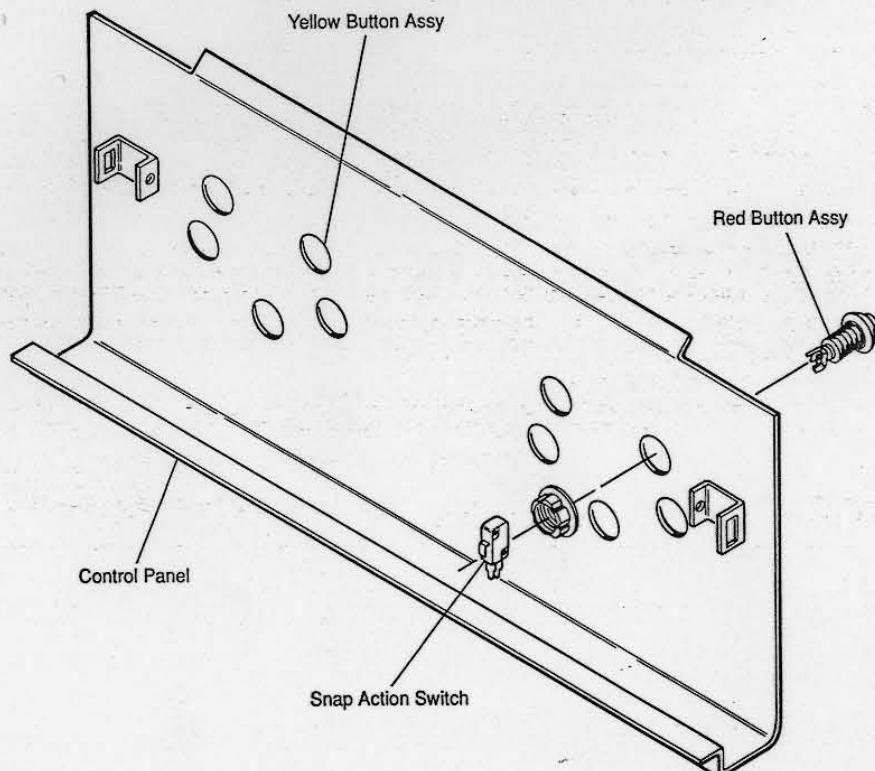

Figure 3-3 Replacing Snap-Action Switches

1. Open the coin door.
2. Reach up through the coin door to the control panel. Unlatch the latches on both sides of the control panel that hold it in place.
3. Disconnect the control panel harness connector and remove the control panel from the cabinet.
4. Remove the two connectors on the switch.
5. Remove the switch by twisting and pulling the switch to release it from the plastic pegs in the bottom of the button assembly.
6. Push a new switch into the holder. Make sure the pegs on the button assembly go into the two holes in the side of the switch.
7. Push the electrical connectors onto the switch.
8. Replace the control panel in the cabinet.

## Removing the Fluorescent Lights

Perform the following procedure to remove or replace the fluorescent lights. (See Figure 3-3.)

1. Turn the game power off.
2. Remove the two screws holding the retainer on the top of the cabinet. Remove the retainer.
3. Remove the attraction shields and attraction graphics.
4. Remove the fluorescent light from the light fixture.
5. To remove the entire light fixture, take out the attract drum frame. Remove the four screws in the top and bottom that hold the frame on the cabinet.
6. Disconnect the motor and light connectors from the cabinet harness. Take out the attract drum frame.
7. Unscrew the two screws that hold the light fixture on the frame. Take the wire out of the tie wrap on the side. Remove the light fixture.
8. Replace the light fixture and put new tie wraps around the wires on the side.

9. Replace the attract drum frame in the cabinet.
10. Replace the attraction shields with the attraction graphics between them. Replace the retainer.

## Removing the Speaker

Perform the following procedure to remove the speaker. (See Figure 3-2.)

1. Turn the game power off.
2. Remove the four screws holding the speaker grille to the cabinet. Remove the grille.

### CAUTION

Do not touch the speaker cone when handling the speaker. The cone material is fragile and can be easily damaged.

3. Use a Phillips screwdriver to remove the four screws holding the speaker to the cabinet. Do not let the speaker fall.
4. Lower the speaker just far enough to disconnect the two speaker wires.

### CAUTION

Do not rest the speaker against the video display. The magnet in the speaker will cause color impurity. You may have to re-adjust the video display if you put the speaker on the screen.

5. Replace the speaker in the reverse order of removal. Be sure that you hook up the wires correctly.

The signal wire on the speaker should be attached to the speaker tab marked with color, a "+" sign, or a round dot. (The signal wire is shown on the game wiring diagram; refer to the Schematic Package included with the game.)



## Replacing the Attraction Drum Motor

Perform the following procedure to replace the attraction drum motor. (See Figure 3-2.)

1. Turn the game power off.
2. Remove the two screws that secure the retainer on the top of the cabinet. Remove the retainer.
3. Remove the attraction shields and attraction graphics.
4. Remove the four screws on the top and bottom that hold the frame in the cabinet.
5. Disconnect the motor and light connectors from the cabinet harness. Take out the attraction drum frame.
6. Take the wire out of the tie wrap on the side.
7. Loosen the set screw that holds the drum onto the motor shaft.
8. Using a 1/4-inch Allen wrench, remove the hex head nuts that hold the motor onto the frame.
9. Replace the motor, and replace the hex-head nuts. Tighten the set screw that holds the drum onto the motor shaft.
10. Put new tie wraps around the wires on the side.
11. Replace the attraction drum frame.



# Illustrated Parts Lists

This chapter provides information you need to order parts for your game.

Common hardware parts, such as screws, nuts, washers, and so on are not in the parts lists.

The PCB parts lists are arranged in alphabetical order by component.

Each component section is arranged alphanumerically by reference designator.

Other parts lists are arranged alphanumerically by Atari part number. In these parts lists, all A-prefix numbers come first. Next come part numbers with a two-number designation followed by a hyphen (00- through 99-). Ending the list are part numbers with six numbers followed by a hyphen (000598- through 201000-).

When you order parts, give the part number, part name, the number of this manual, and the serial number of your game.

With this information, we can fill your order rapidly and correctly.

We hope this will create less downtime and more profit from your game.

Atari Customer Service phone numbers are listed on the

inside front cover of this manual.

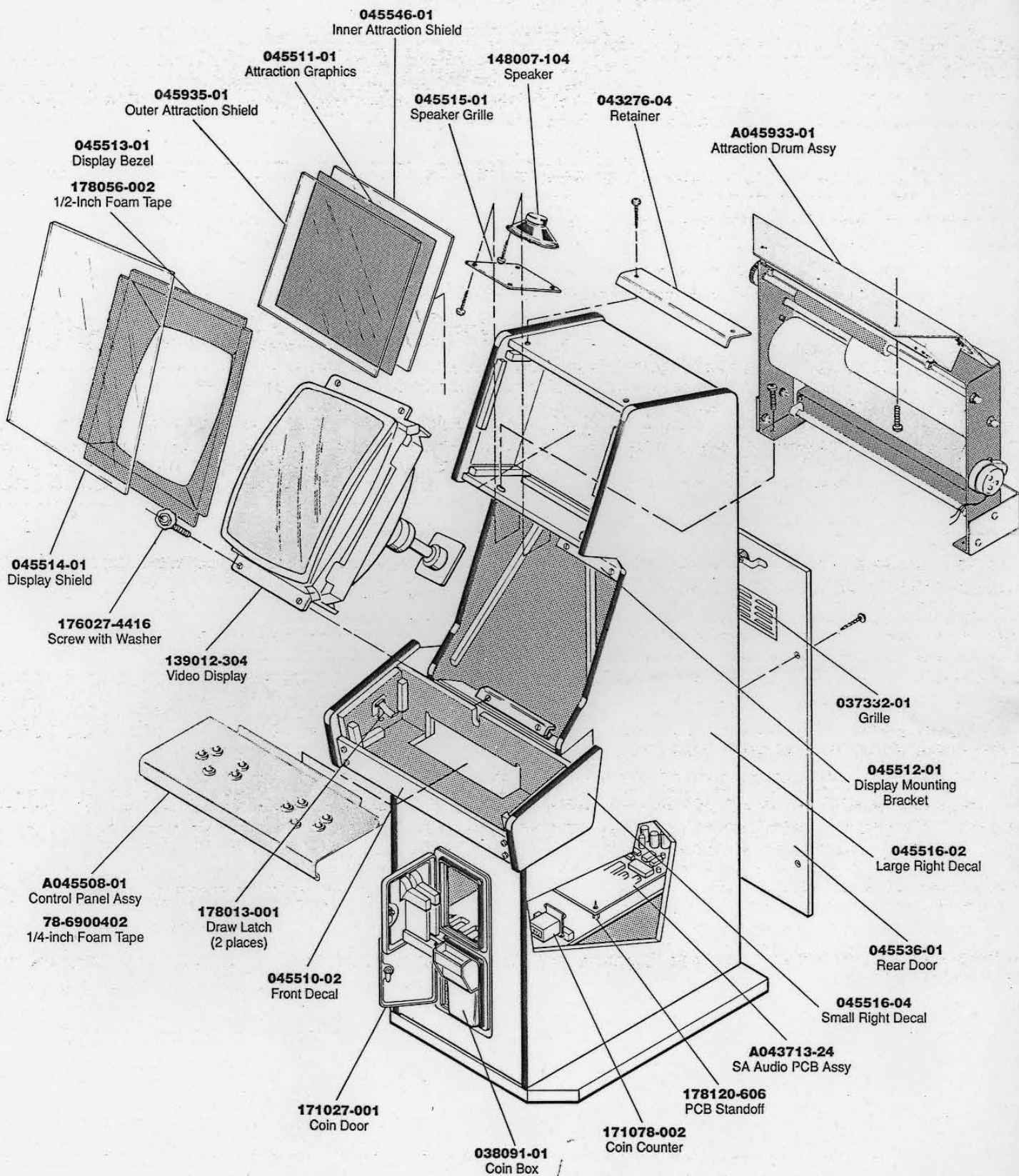
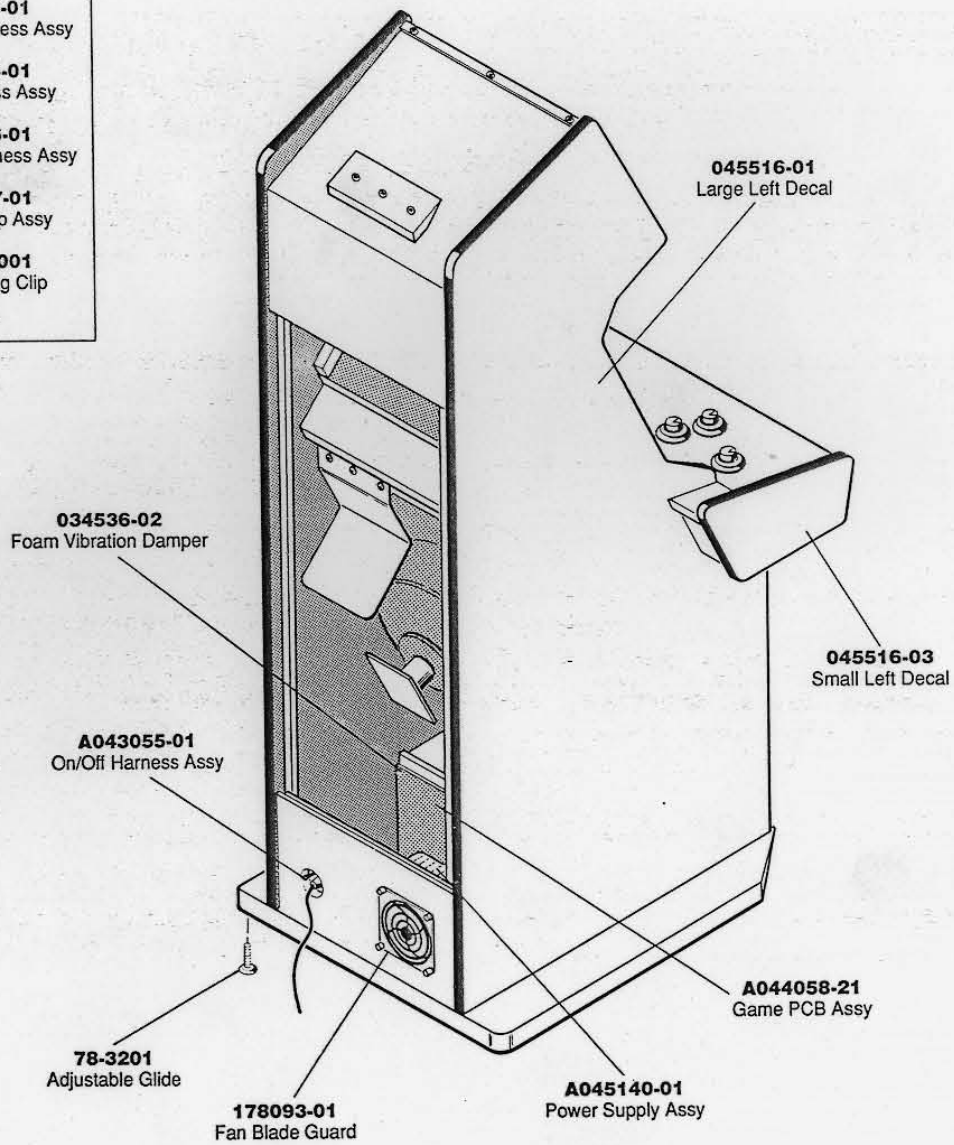

Figure 4-1 Cabinet Mounted Assemblies  
A045504-01 B



- Not Shown**
- A043909-02**  
+5 Volt Harness Assy
  - A045549-01**  
Speaker Harness Assy
  - A045571-01**  
Cabinet Harness Assy
  - A045572-01**  
Power Harness Assy
  - A045573-01**  
AC Power Harness Assy
  - A045574-01**  
Video Harness Assy
  - A045576-01**  
Com./Aud. Harness Assy
  - A045577-01**  
Ground Strap Assy
  - 178129-001**  
Wire Routing Clip



**Figure 4-1 Cabinet-Mounted Assemblies, Continued**

## Cabinet-Mounted Assemblies Parts List

Part No.	Description
A043055-01	On/Off Harness Assembly
A043713-24	Stand-Alone Audio PCB Assembly (see Figure 4-7)
A043909-02	+5 Volt Harness Assembly
A044058-21	Toobin' Game PCB Assembly (see Figure 4-6)
A045140-01	SL Power Supply Assembly (see Figure 4-4)
A045508-01	Control Panel Assembly (see Figure 4-2)
A045549-01	Speaker Harness Assembly
A045571-01	Cabinet Harness Assembly
A045572-01	Power Harness Assembly
A045573-01	AC Power Harness Assembly
A045574-01	Video Harness Assembly
A045576-01	Com./Aud. Harness Assembly
A045577-01	Ground Strap Assembly
A045933-01	Attraction Drum Assembly (see Figure 4-3)
034536-02	Foam Vibration Damper
037332-01	Louvered Grille
038091-01	Molded Coin Box
043276-04	Retainer
045511-01	Attraction Graphics
045512-01	Display Mounting Bracket
045513-01	Display Bezel
045514-01	Display Shield
045515-01	Speaker Grille
045516-01	Upper Left Side Decal
045516-02	Upper Right Side Decal
045516-03	Left Decal Next to Control Panel
045516-04	Right Decal Next to Control Panel
045510-02	Front Decal
045935-01	Attraction Shield
045536-01	Rear Door
045546-01	Textured Inner Attraction Shield
045548-01	Light Reflector
139012-304	Wells-Gardner 19-inch Medium Resolution Video Display
148007-104	4 1/2-inch Round Shielded Speaker
171027-001	Over/Under 25¢/25¢ USA Coin Door (see Figure 4-5)
171078-002	Non-Resettable 12V DC Coin Counter
175008-002	#10 White Nylon Washer
176019-220	#8 Cross Recessed Screw
176027-4016	#10 Hex Head Screw with Washer
176027-4416	1/4 Hex Head Screw with Washer
178013-001	Draw Latch
178056-002	1/2-inch Wide, 4-inch Long Foam Tape
178093-01	Fan Blade Guard
178120-606	PCB Standoff
178129-001	Wire Routing Clip
78-3201	Adjustable Glide

## Cabinet-Mounted Assemblies Parts List, Continued

---

Part No.	Description
78-6900402	1/4-inch Wide, 40-inch Long Foam Tape

---

*These items are the technical information supplements to the game:*

SP-320	Toobin' Schematic Package
ST-320	Toobin' Self-Test Label
TM-320	Toobin' Operators Manual
TM-321	Wells-Gardner (Model #19K7635) 19-inch Color Video Display Service Manual

---



**Not Shown**  
**A045575-01**  
 Control Harness Assy

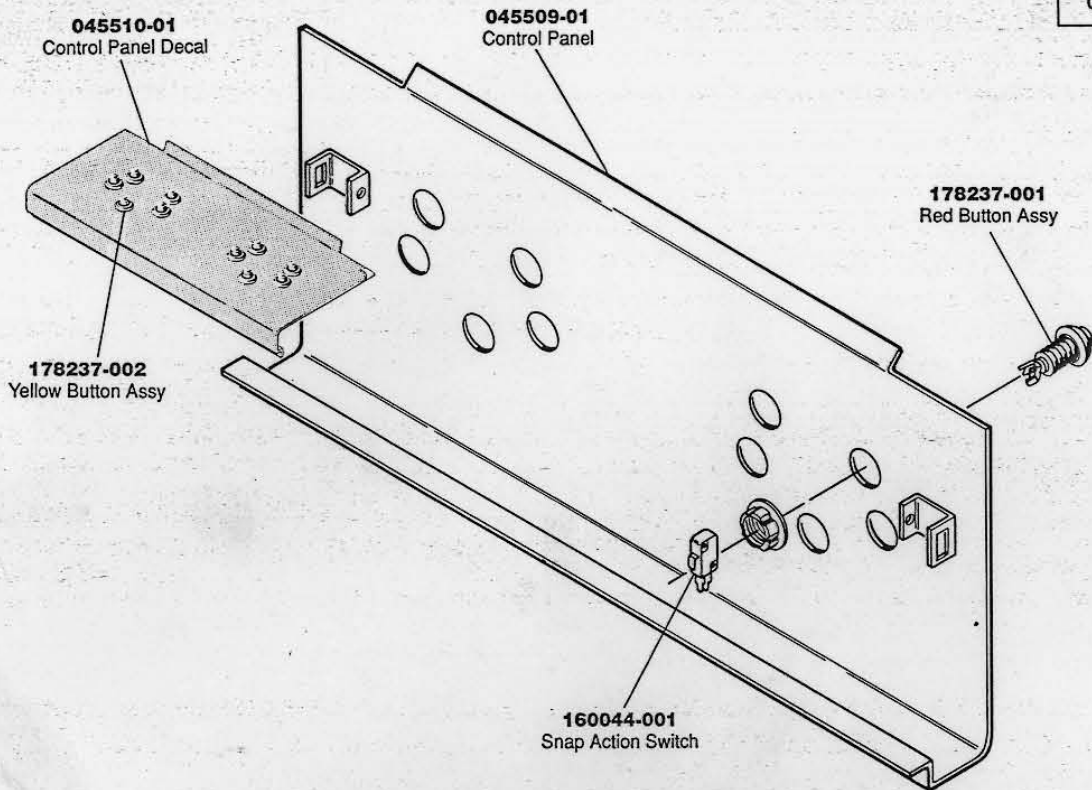

**Figure 4-2 Control Panel Assembly**  
**A045508-01 A**

**Control Panel Assembly**  
**Parts List**

Part No.	Description
A045575-01	Control Harness Assembly
045509-01	Control Panel
045510-01	Control Panel Decal
160044-001	Snap-Action Switch
178237-001	Red Button Assembly
178237-002	Yellow Button Assembly

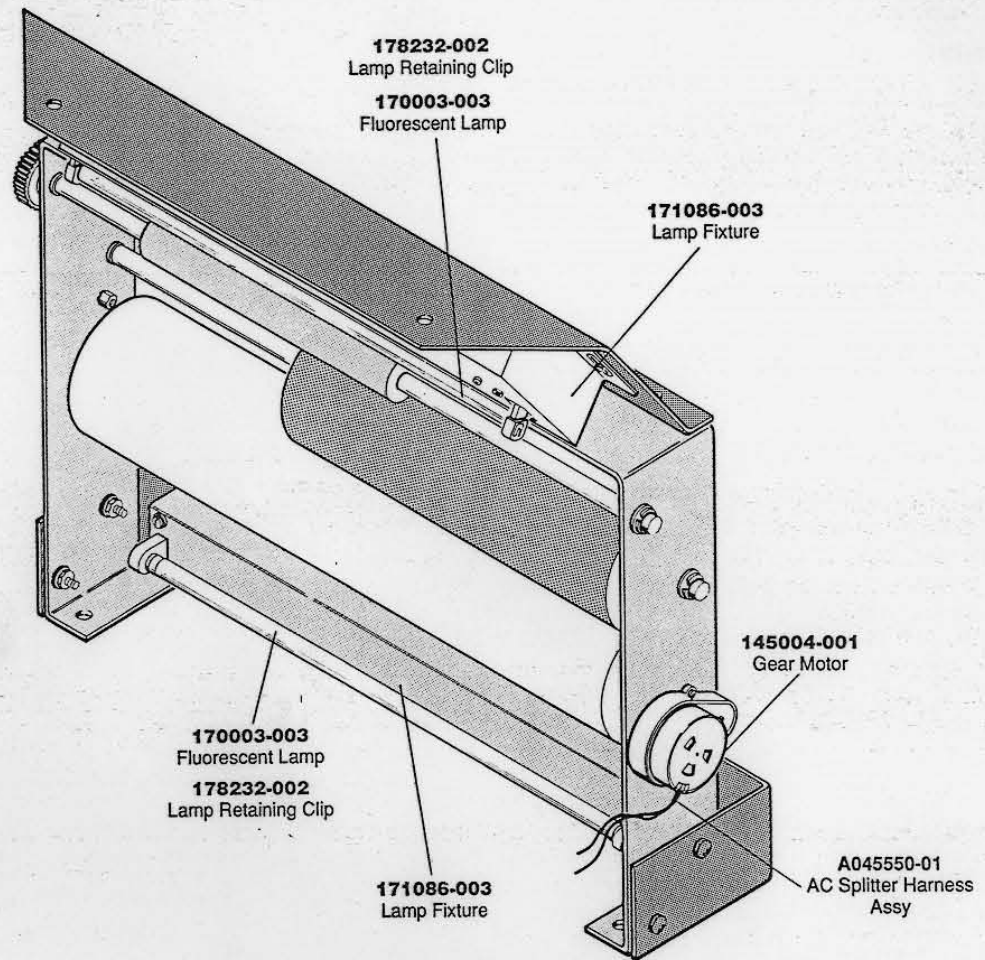

### Attraction Drum Assembly Parts List

Part No.	Description
A045550-01	AC Splitter Harness Assembly
107013-001	Light Oil Lubricant
145004-001	120 VAC, 16 RPM, CW Gear Motor
17003-003	8W 12-inch Long Fluorescent Lamp
171086-003	118V, 60Hz, 12-inch Long Electrical Lamp Fixture (Acceptable substitute is part no. 171086-004)
178232-002	Lamp Retaining Clip

**▲ WARNING ▲**  
 The switching power supply has high voltages on it when power is turned on. Therefore, be sure you do not touch this power supply unless you have turned off the power to the game.

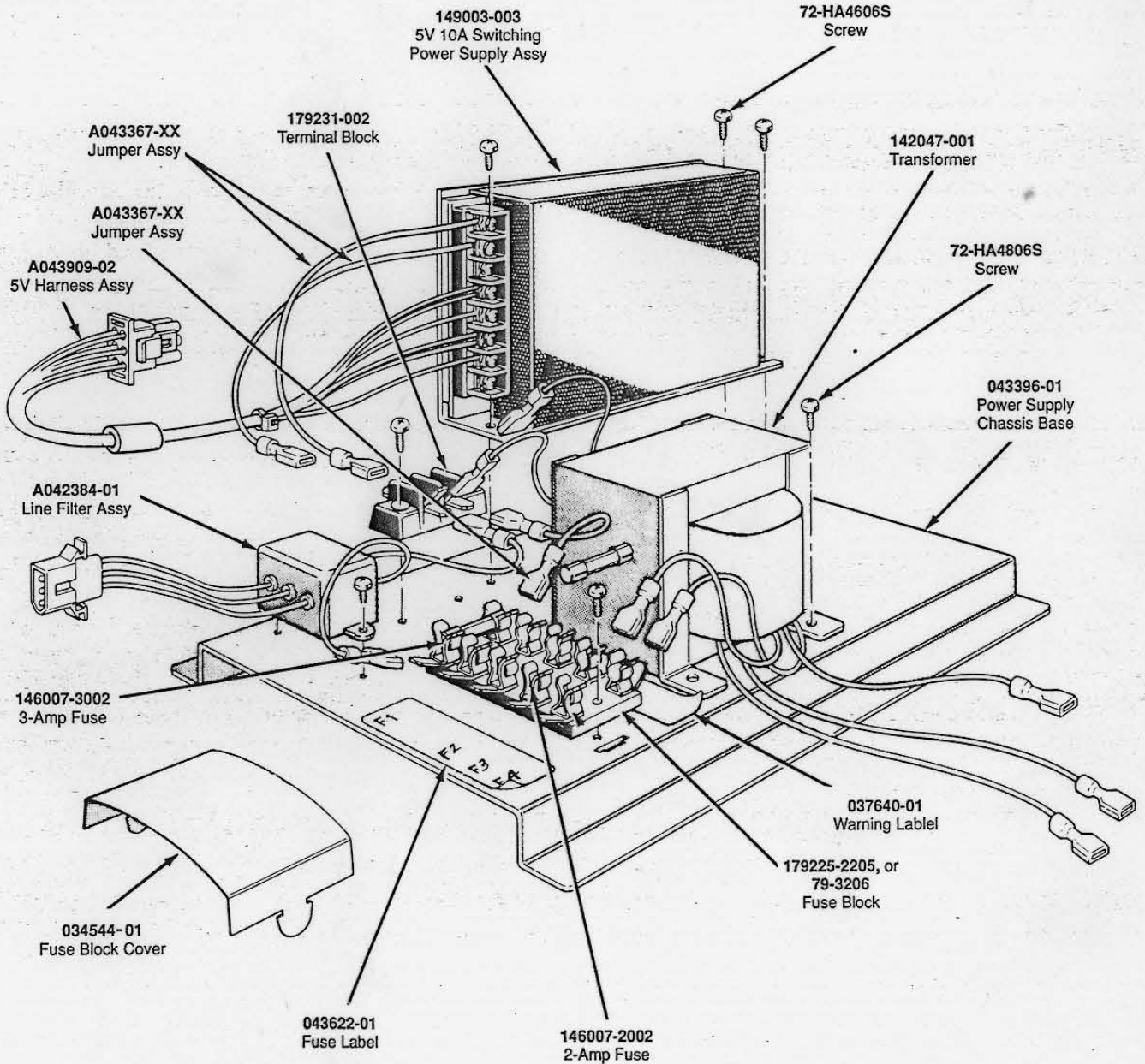

**Figure 4-4 Switching/Linear (SL) Power Supply Assembly  
 A045140-01 A**

### *Switching/Linear Power Supply Assembly Parts List*

Part No.	Description
A042384-01	Line Filter Assembly
A043367-01	Jumper Assembly
A043367-02	6-Inch Black Jumper Assembly
A043367-03	6-Inch White Jumper Assembly
72-HA4606s	#6-32 Thread-Forming Screw
72-HA4806s	#8-32 Thread-Forming Screw
034544-01	Fuse Block Cover
037640-01	Power Supply Warning Label
043396-01	Power Supply Base Chassis
043622-01	Power Supply Fuse Label
142047-001	Power Transformer
146007-2022	2-Amp 250 V 3AG Slow Blow Fuse
146007-3022	3-Amp 250 V 3AG Slow Blow Fuse
149003-003	Hitron 5V 10A Switching Power Supply (see below)
179225-2205	5-Position Fuse Block (Acceptable substitute is part no. 79-3206)
179231-002	2-Position Terminal Block

### *Hitron 5-Volt Power Supply Sub-Assembly Model HSA-122B(S) Parts List*

Designator	Description	Part No.
<b>Capacitors</b>		
C1	Capacitor, Metal Film, 0.047 $\mu$ F, 250 V	99-211036
C2	Capacitor, Metal Film, 0.1 $\mu$ F, 400 V	99-211038
C3, C4	Capacitor, Ceramic, 4700 $\mu$ F, 400 V	99-211049
C5, C6	Capacitor, Electrolytic, 100 $\mu$ F, 200 V	99-211046
C7	Capacitor, Metal Film, 0.1 $\mu$ F, 400 V	99-211038
C8	Capacitor, Ceramic, 0.001 $\mu$ F, 2 kV	99-211042
C9	Capacitor, Ceramic, 0.01 $\mu$ F, 1 kV, Z5U	99-211041
C10	Capacitor, Electrolytic, 220 $\mu$ F, 25 V	99-211045
C11	Capacitor, Metal Film, 0.22 $\mu$ F, 100 V	99-211037
C12	Capacitor, Metal Film, 0.022 $\mu$ F, 100 V	99-211039
C13	Capacitor, Metal Film, 0.22 $\mu$ F, 100 V	99-211037
C14	Capacitor, Ceramic, 1800 PF, 2 kV, Z5 V	99-211040
C17	Capacitor, Electrolytic, 470 $\mu$ F, 25 V	99-211044
C19	Capacitor, Electrolytic, 2200 $\mu$ F, 16 V	99-211048
C20	Capacitor, Electrolytic, 1000 $\mu$ F, 25 V	99-211047
C21	Capacitor, Ceramic, 470 PF, 1 kV, Z5P	99-211043
C22	Capacitor, Electrolytic, 2200 $\mu$ F, 16 V	99-211048
C23	Capacitor, Electrolytic, 1000 $\mu$ F, 25 V	99-211047
C24	Capacitor, Electrolytic, 2200 $\mu$ F, 16 V	99-211048
<b>Diodes</b>		
D1, D2	Diode, Fast Recovery, RPG10K	99-211010
D3	Diode, Fast Recovery, RPG15B	99-211011
D4	Diode, Fast Recovery, RPG10B	99-211009
D5-D7	Diode, Switching, 1N4148	99-211012

**Hitron 5-Volt Power Supply Sub-Assembly  
Model HSA-122B(S) Parts List, Continued**

Designator	Description	Part No.
D9	Diode, Fast Recovery, 30DF1	99-211006
D11, D12	Diode, Schottky, S10SC4M	99-211005
D13.-D16	Diode, Rectifier, 1N4006	99-211008
<b>Inductors</b>		
L1	Inductor, 15 mH	99-211052
L3	Inductor, 7 $\mu$ H (Acceptable substitute is part no. 99-211051)	99-211050
L4	Inductor, 2.2 $\mu$ H	99-211054
L5	Inductor, 1.5 mH	99-211053
<b>Resistors</b>		
R1, R2	Resistor, Carbon Film, 180 K Ohm, $\pm$ 5%, 1 W	99-211034
R3	Resistor, Wirewound, 120 Ohm, $\pm$ 5%, 2 W	99-211019
R4	Resistor, Wirewound, 0.47 Ohm, $\pm$ 5%, 2 W	99-211018
R5	Resistor, Wirewound, 33 Ohm, $\pm$ 5%, 2 W	99-211017
R6, R7	Resistor, Carbon Film, 5.6 Ohm, $\pm$ 5%, 1/4 W	99-211027
R8	Resistor, Wirewound, 0.47 Ohm, $\pm$ 5%, 2 W	99-211018
R9	Resistor, Carbon Film, 10 Ohm, $\pm$ 5%, 1/4 W	99-211029
R10	Resistor, Carbon Film, 1 K Ohm, $\pm$ 5%, 1/4 W	99-211032
R11	Resistor, Carbon Film, 47 Ohm, $\pm$ 5%, 1/4 W	99-211025
R12	Resistor, Carbon Film, 5.6 Ohm, $\pm$ 5%, 1/4 W	99-211027
R13	Resistor, Carbon Film, 330 Ohm, $\pm$ 5%, 1/4 W	99-211026
R14	Resistor, Carbon Film, 270 Ohm, $\pm$ 5%, 1/2 W	99-211023
R15	Resistor, Carbon Film, 330 Ohm, $\pm$ 5%, 1/2 W	99-211022
R16	Resistor, Carbon Film, 8.2 Ohm, $\pm$ 5%, 1/4 W	99-211028
R17, R18	Resistor, Carbon Film, 56 Ohm, $\pm$ 5%, 1/4 W	99-211031
R19	Resistor, Carbon Film, 39 Ohm, $\pm$ 5%, 1/4 W	99-211030
R20	Resistor, Carbon Film, 2 K Ohm, $\pm$ 5%, 1/4 W	99-211035
R21	Resistor, Carbon Film, 470 Ohm, $\pm$ 5%, 1/4 W	99-211024
R22	Resistor, 2.2 K Ohm, $\pm$ 2%, 1/4 W	99-211021
R23	Resistor, Metal Film, 2 K Ohm, $\pm$ 2%, 1/4 W	99-211033
R25	Resistor, Carbon Film, 10 Ohm, $\pm$ 5%, 1/4 W	99-211029
R26	Resistor, Wirewound, 50 Ohm, $\pm$ 5%, 2 W	99-211015
R27	Resistor, Carbon Film, 47 Ohm, $\pm$ 5%, 1/4 W	99-211025
R31	Resistor, Wirewound, 150 Ohm, $\pm$ 5%, 2 W	99-211016
<b>Transistors</b>		
Q1	Transistor, NPN, 2SC1413A	99-211002
Q3	Transistor, NPN, PE8050B	99-211003
Q3	Transistor, PNP, PE8550B	99-211004
<b>Miscellaneous</b>		
F1	Fuse, 2 A, 250 V, SEMKO	99-211058
IC1	Regulator, UA431AWC	99-211001
SCR1	Thyristor, SCR	99-211013
T1	Transformer	99-211055
TR1	Thermistor, 0.5 Ohm, $\pm$ 5%, 5 W	99-211020
VR1	Potentiometer, Trimming, 3 K Ohm	99-211014
ZD1	Diode, Zener, 1N752A	99-211007
	Fuse, 2 A, 250 V	99-211056
	Fuse Holder, 6.35 mm	99-211060
	Terminal Block, 8 Ckt	99-211057
	Heat Sink	99-211059
	Heat Sink, 1.5 mm	99-211061



# N O T E S

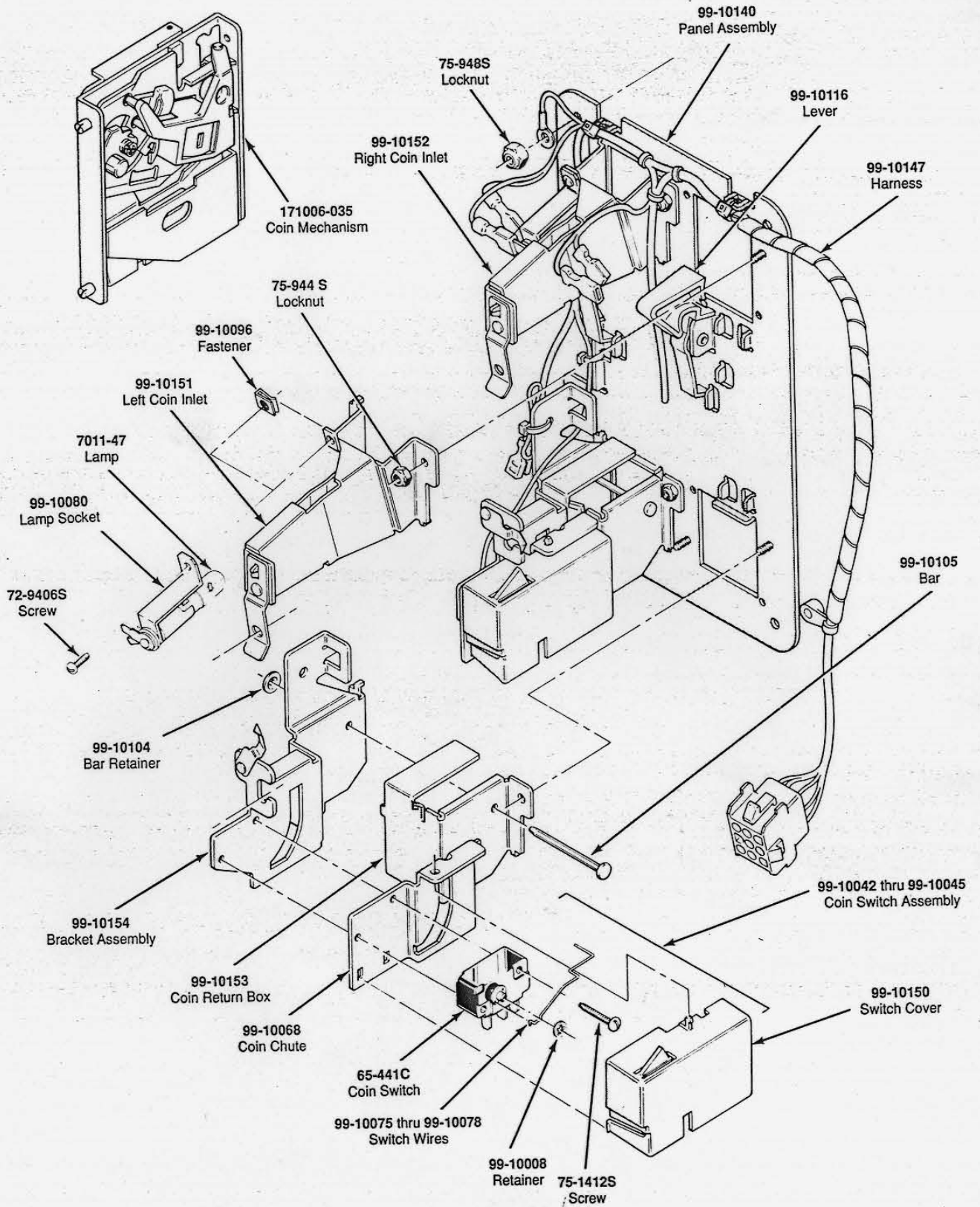

**Figure 4-5 Coin Acceptors, Inc. Coin Door Assembly  
171027-001 A**

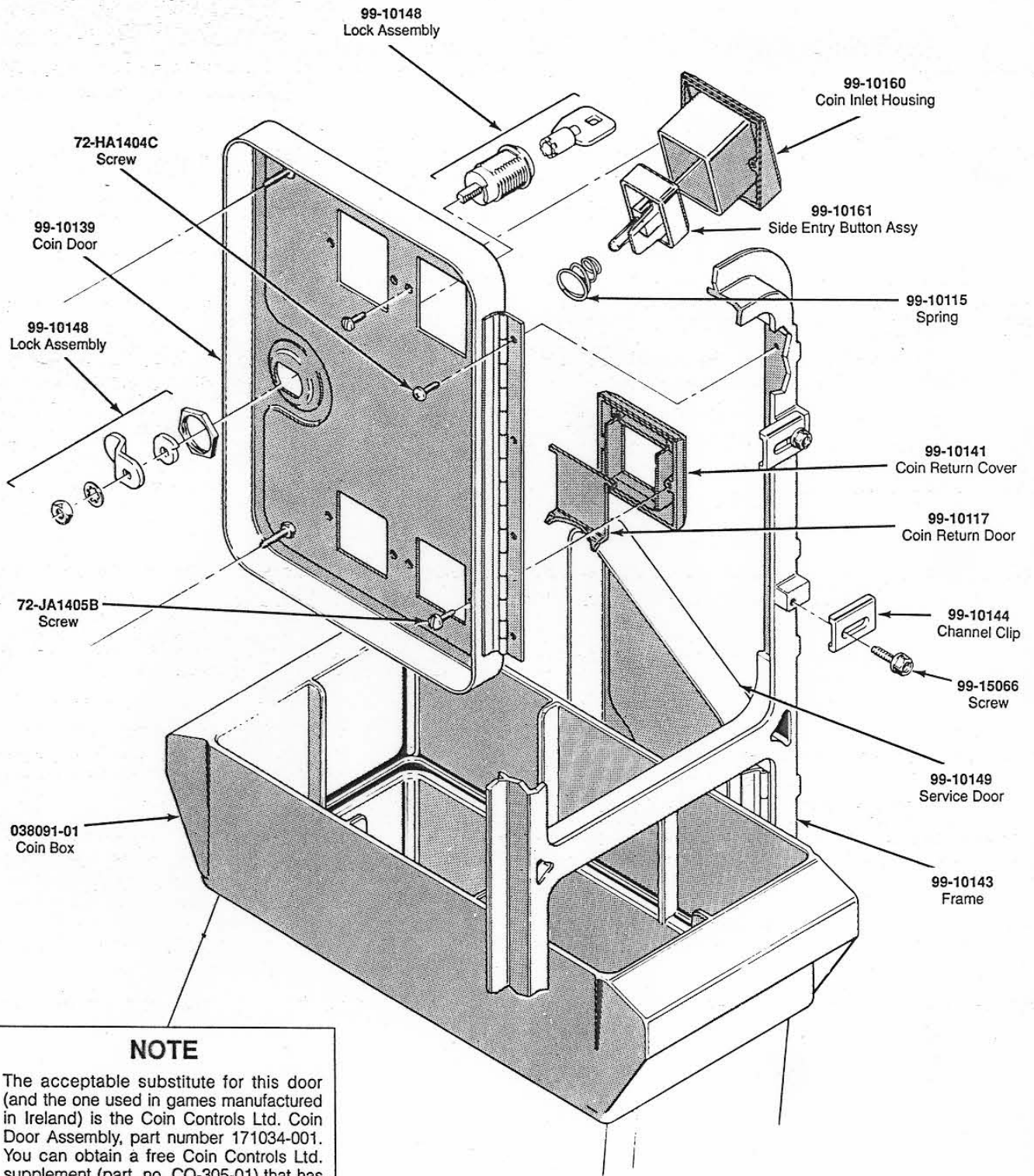

**NOTE**

The acceptable substitute for this door (and the one used in games manufactured in Ireland) is the Coin Controls Ltd. Coin Door Assembly, part number 171034-001. You can obtain a free Coin Controls Ltd. supplement (part. no. CO-305-01) that has illustrations and a parts list. Write to Atari Games Ireland Limited, Tipperary Town, Ireland. Telephone 062-52155.

Figure 4-5 Coin Acceptors, Inc. Coin Door Assembly, Continued

## Coin Acceptors, Inc. Coin Door Assembly Parts List

Part No.	Description
65-441C	Coin Switch
70-11-47	Miniature Bayonet Lamp
72-9406S	#4-40 x 3/8-Inch Truss-Head Screw
72-HA1404C	#4-40 x 1/4-Inch Pan-Head Screw
72-JA1405B	#4-40 x .31-Inch Pan-Head Screw
75-1412S	#4-40 x 3/4-Inch Pan-Head Screw
75-994S	#4-40 Locknut
99-10008	Retainer
99-10042	Coin Switch Assembly for Belgian 5 Fr and U.S. 25¢
99-10043	Coin Switch Assembly for German 1 DM, Japanese 100 Yen, Swiss 1 Fr
99-10044	Coin Switch Assembly for German 2 DM, Italian 100 L, U.S. \$1.00
99-10045	Coin Switch Assembly for Australian \$.20, German 5 DM, British 10 P
99-10068	Coin Return Chute
99-10075	Switch Wire (included in coin switch assembly 99-10043)
99-10076	Switch Wire (included in coin switch assembly 99-10042)
99-10077	Switch Wire (included in coin switch assembly 99-10044)
99-10078	Switch Wire (included in coin switch assembly 99-10045)
99-10080	Lamp Socket
99-10081	Key Holder
99-10096	Fastener
99-10104	Bar Retainer
99-10105	Bar
99-10115	Spring
99-10116	Plastic Coin Return Lever
99-10117	Steel Coin Return Door
99-10139	Coin Door
99-10140	Coin Door Inner-Panel Assembly
99-10141	Die-Cast Coin Return Cover
99-10143	Coin Door Frame
99-10144	Channel Clip
99-10147	Harness
99-10148	Lock Assembly
99-10149	Service Door
99-10150	Switch Cover
99-10151	Left Coin Inlet
99-10152	Right Coin Inlet
99-10153	Coin Return Box
99-10154	Bracket Assembly
99-10160	1-Inch Wide Die-Cast Coin Inlet Housing
99-10161	25¢ Amber Side-Entry Coin Button Assembly
99-15066	Screw for Clamp
171006-035	Metal Coin Mechanism for U.S. 25¢

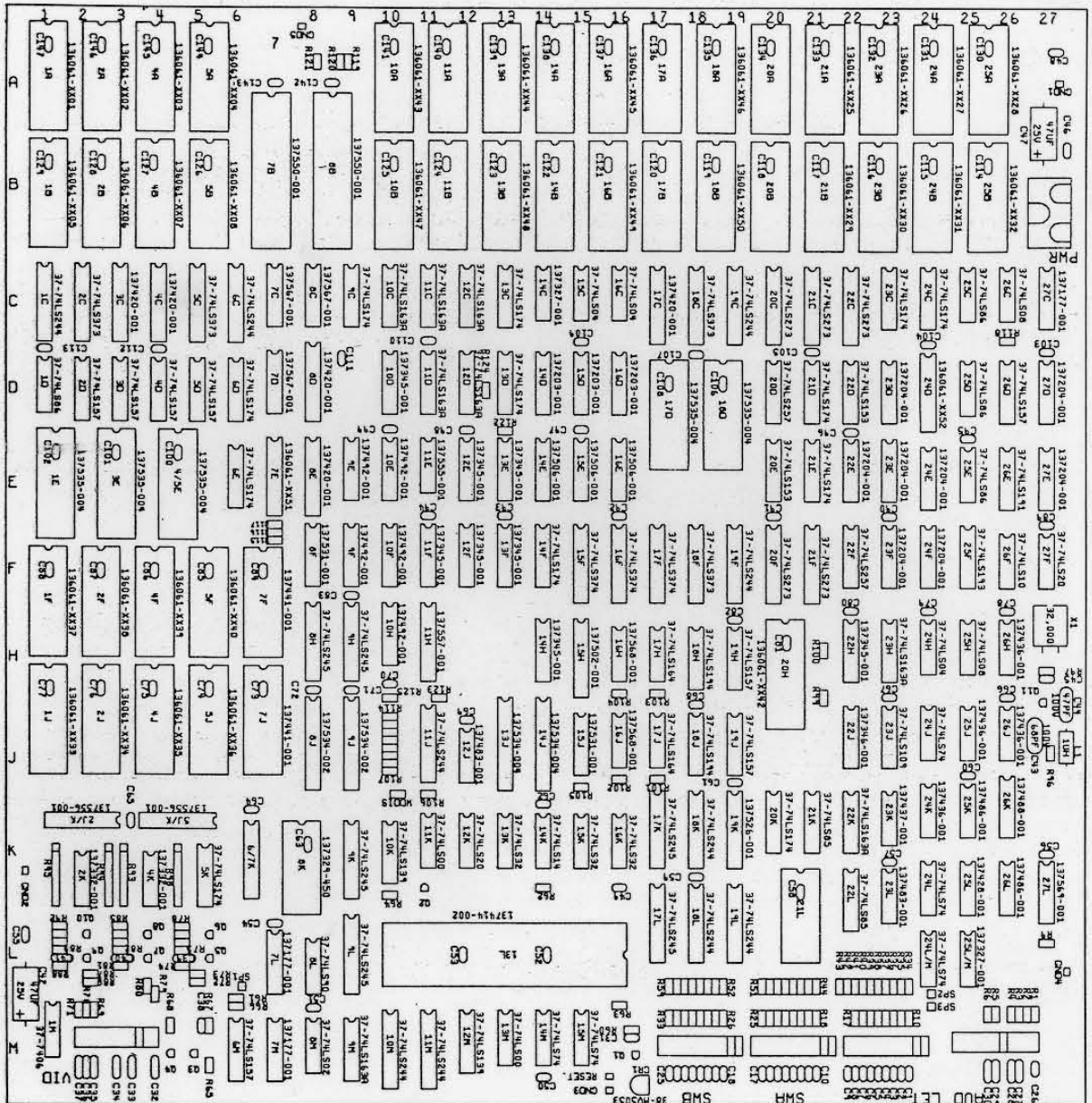

Figure 4-6 Toobin' Game PCB Assembly  
A044058-01 C

## Toobin' Game PCB Assembly Parts List

Designator	Description	Part No.
<b>Integrated Circuits</b>		
1A	Integrated Circuit, EPROM, 27512-200	136061-1101
1B	Integrated Circuit, EPROM, 27512-200	136061-1105
1C	Integrated Circuit, 74LS244	37-74LS244
1D	Integrated Circuit, 74LS86	37-74LS86
1E	Integrated Circuit, RAM, 8Kx8, 100 nsec	137535-004
1F	Integrated Circuit, EPROM, 27512-300	136061-1137
1J	Integrated Circuit, EPROM, 27512-300	136061-1133
1M	Integrated Circuit, 7406	37-7406
2A	Integrated Circuit, EPROM, 27512-200	136061-1102
2B	Integrated Circuit, EPROM, 27512-200	136061-1106
2C	Integrated Circuit, 74LS373	37-74LS373
2D	Integrated Circuit, 74LS157	37-74LS157
2F	Integrated Circuit, EPROM, 27512-300	136061-1138
2J	Integrated Circuit, EPROM, 27512-300	136061-1134
2J/K	Integrated Circuit, 74HC273	137556-001
2K	Integrated Circuit, 74LS260	137332-001
3C	Integrated Circuit, 74F374	137420-001
3D	Integrated Circuit, 74LS157	37-74LS157
3E, 4/5E	Integrated Circuit, RAM, 8Kx8, 100 nsec	137535-004
4A	Integrated Circuit, EPROM, 27512-200	136061-1103
4B	Integrated Circuit, EPROM, 27512-200	136061-1107
4C	Integrated Circuit, 74F374	137420-001
4D	Integrated Circuit, 74LS157	37-74LS157
4F	Integrated Circuit, EPROM, 27512-300	136061-1139
4J	Integrated Circuit, EPROM, 27512-300	136061-1135
4K	Integrated Circuit, 74LS260	137332-001
5A	Integrated Circuit, EPROM, 27512-200	136061-1104
5B	Integrated Circuit, EPROM, 27512-200	136061-1108
5C	Integrated Circuit, 74LS373	37-74LS373
5D	Integrated Circuit, 74LS157	37-74LS157
5F	Integrated Circuit, EPROM, 27512-300	136061-1140
5J	Integrated Circuit, EPROM, 27512-300	136061-1136
5J/K	Integrated Circuit, 74HC273	137556-001
5K	Integrated Circuit, 74LS174	37-74LS174
6C	Integrated Circuit, 74LS244	37-74LS244
6D, 6E	Integrated Circuit, 74LS174	37-74LS174
6M	Integrated Circuit, 74LS157	37-74LS157
7B	Integrated Circuit, SOS	137550-001
7C, 7D	Integrated Circuit, 74F219	137567-001
7E	Integrated Circuit, PAL, 16L8 A	136061-1151
7F, 7J	Integrated Circuit, RAM, 8Kx8, 150 nsec	137441-001
7L, 7M	Integrated Circuit, 74LS138	137177-001
8B	Integrated Circuit, SOS	137550-001
8C	Integrated Circuit, 74F219	137567-001

### Toobin' Game PCB Assembly Parts List

Designator	Description	Part No.
8D, 8E	Integrated Circuit, 74F374	137420-001
8F	Integrated Circuit, 74F174	137531-001
8H	Integrated Circuit, 74LS245	37-74LS245
8J	Integrated Circuit, RAM, 2Kx8, 45 nsec	137534-002
8K	Integrated Circuit, 2804 A-45, 450 nsec	137329-450
8L	Integrated Circuit, 74LS90	37-74LS90
8M	Integrated Circuit, 74LS02	37-74LS02
9C	Integrated Circuit, 74LS174	37-74LS174
9E, 9F	Integrated Circuit, 74F153	137492-001
9H	Integrated Circuit, 74LS245	37-74LS245
9J	Integrated Circuit, RAM, 2Kx8, 45 nsec	137534-002
9K, 9L	Integrated Circuit, 74LS245	37-74LS245
9M	Integrated Circuit, 74LS163 A	37-74LS163A
10A	Integrated Circuit, 1M Bit, Mask ROM, LH231000	136061-1143
10B	Integrated Circuit, 1M Bit, Mask ROM, LH231000	136061-1147
10C	Integrated Circuit, 74LS163 A	37-74LS163A
10D	Integrated Circuit, 74F163	137345-001
10E, 10F, 10H	Integrated Circuit, 74F153	137492-001
10K	Integrated Circuit, 74LS139	37-74LS139
10M	Integrated Circuit, 74LS244	37-74LS244
11C, 11D	Integrated Circuit, 74LS163 A	37-74LS163A
11E	Integrated Circuit, 74F21	137555-001
11F	Integrated Circuit, 74F163	137345-001
11H	Integrated Circuit, 74F398	137557-001
11J	Integrated Circuit, 74LS244	37-74LS244
11K	Integrated Circuit, 74LS00	37-74LS00
11M	Integrated Circuit, 74LS244	37-74LS244
12C, 12D	Integrated Circuit, 74LS163 A	37-74LS163A
12E, 12F	Integrated Circuit, 74F163	137345-001
12J	Integrated Circuit, 74F08	137483-001
12K	Integrated Circuit, 74LS20	37-74LS20
12M	Integrated Circuit, 74LS139	37-74LS139
13A	Integrated Circuit, 1M Bit, Mask ROM, LH231000	136061-1144
13B	Integrated Circuit, 1M Bit, Mask ROM, LH231000	136061-1148
13C, 13D	Integrated Circuit, 74LS174	37-74LS174
13E, 13F	Integrated Circuit, 74F163	137345-001
13K	Integrated Circuit, 74LS32	37-74LS32
13L	Integrated Circuit, 68010	137414-002
13M	Integrated Circuit, 74LS00	37-74LS00
14C	Integrated Circuit, 74F00	137327-001
14D	Integrated Circuit, 74LS158	137203-001
14E	Integrated Circuit, 74F283	137506-001
14F	Integrated Circuit, 74LS174	37-74LS174
14H	Integrated Circuit, 74F163	137345-001
14K	Integrated Circuit, 74LS14	37-74LS14
14M	Integrated Circuit, 74LS74	37-74LS74

## Toobin' Game PCB Assembly Parts List

Designator	Description	Part No.
15C	Integrated Circuit, 74LS04	37-74LS04
15D	Integrated Circuit, 74LS158	137203-001
15E	Integrated Circuit, 74F283	137506-001
15F	Integrated Circuit, 74LS374	37-74LS374
15H	Integrated Circuit, 74F244	137502-001
15J	Integrated Circuit, 74F174	137531-001
15K	Integrated Circuit, 74LS32	37-74LS32
15M	Integrated Circuit, 74LS74	37-74LS74
16A	Integrated Circuit, 1M Bit, Mask ROM, LH231000	136061-1145
16B	Integrated Circuit, 1M Bit, Mask ROM, LH231000	136061-1149
16C	Integrated Circuit, 74LS04	37-74LS04
16D	Integrated Circuit, 74LS158	137203-001
16E	Integrated Circuit, 74F283	137506-001
16F	Integrated Circuit, 74LS374	37-74LS374
16H, 16J	Integrated Circuit, 74F164	137568-001
16K	Integrated Circuit, 74LS32	37-74LS32
17C	Integrated Circuit, 74F374	137420-001
17D	Integrated Circuit, RAM, 8Kx8, 100 nsec	137535-004
17F	Integrated Circuit, 74LS374	37-74LS374
17H, 17J	Integrated Circuit, 74LS164	37-74LS164
17K, 17L	Integrated Circuit, 74LS245	37-74LS245
18A	Integrated Circuit, 1M Bit, Mask ROM, LH231000	136061-1146
18B	Integrated Circuit, 1M Bit, Mask ROM, LH231000	136061-1150
18C	Integrated Circuit, 74LS373	37-74LS373
18D	Integrated Circuit, RAM, 8KX8, 100 nsec	137535-004
18F	Integrated Circuit, 74LS373	37-74LS373
18H, 18J	Integrated Circuit, 74LS194 A	37-74LS194
18K, 18L, 19C, 19F	Integrated Circuit, 74LS244	37-74LS244
19H, 19J	Integrated Circuit, 74LS157	37-74LS157
19K	Integrated Circuit, SCOM	137526-001
19L	Integrated Circuit, 74LS244	37-74LS244
20C	Integrated Circuit, 74LS273	37-74LS273
20D	Integrated Circuit, 74LS257	37-74LS257
20E	Integrated Circuit, 74LS153	37-74LS153
20F	Integrated Circuit, 74LS273	37-74LS273
20H	Integrated Circuit, EPROM, 27128-200	136061-1142
20K	Integrated Circuit, 74LS174	37-74LS174
21A	Integrated Circuit, EPROM, 27512-200	136061-1125
21B	Integrated Circuit, EPROM, 27512-200	136061-1129
21C	Integrated Circuit, 74LS273	37-74LS273
21D, 21E	Integrated Circuit, 74LS174	37-74LS174
21F	Integrated Circuit, 74LS273	37-74LS273
21K	Integrated Circuit, 74LS85	37-74LS85
22C	Integrated Circuit, 74LS273	37-74LS273
22D	Integrated Circuit, 74LS153	37-74LS153
22E	Integrated Circuit, 74LS283	137204-001



## Toobin' Game PCB Assembly Parts List

Designator	Description	Part No.
22F	Integrated Circuit, 74LS257	37-74LS257
22H	Integrated Circuit, 74F163	137345-001
22J	Integrated Circuit, 74F162	137346-001
22K	Integrated Circuit, 74LS163 A	37-74LS163A
22L	Integrated Circuit, 74LS85	37-74LS85
23A	Integrated Circuit, EPROM, 27512-200	136061-1126
23B	Integrated Circuit, EPROM, 27512-200	136061-1130
23C	Integrated Circuit, 74LS174	37-74LS174
23D, 23E, 23F	Integrated Circuit, 74LS283	137204-001
23H	Integrated Circuit, 74LS163 A	37-74LS163A
23J	Integrated Circuit, 74LS109	37-74LS109
23K	Integrated Circuit, 74F04	137437-001
23L	Integrated Circuit, 74F08	137483-001
24A	Integrated Circuit, EPROM, 27512-200	136061-1127
24B	Integrated Circuit, EPROM, 27512-200	136061-1131
24C	Integrated Circuit, 74LS174	37-74LS174
24D	Integrated Circuit, PROM, 82S147	136061-1152
24E, 24F	Integrated Circuit, 74LS283	137204-001
24H	Integrated Circuit, 74LS04	37-74LS04
24J	Integrated Circuit, 74LS74	37-74LS74
24K	Integrated Circuit, 74F74	137436-001
24L, 24L/M	Integrated Circuit, 74LS74	37-74LS74
25A	Integrated Circuit, EPROM, 27512-200	136061-1128
25B	Integrated Circuit, EPROM, 27512-200	136061-1132
25C, 25D, 25E	Integrated Circuit, 74LS86	37-74LS86
25F	Integrated Circuit, 74LS193	37-74LS193
25H	Integrated Circuit, 74LS08	37-74LS08
25J	Integrated Circuit, 74F74	137436-001
25K	Integrated Circuit, 74F32	137486-001
25L	Integrated Circuit, 74F10	137428-001
25L/M	Integrated Circuit, 74F00	137327-001
26C	Integrated Circuit, 74LS08	37-74LS08
26D	Integrated Circuit, 74LS157	37-74LS157
26E	Integrated Circuit, 74LS191	37-74LS191
26F	Integrated Circuit, 74LS10	37-74LS10
26H, 26J	Integrated Circuit, 74F74	137436-001
26K	Integrated Circuit, 74F139	137488-001
26L	Integrated Circuit, 74F32	137486-001
27C	Integrated Circuit, 74LS138	137177-001
27D, 27E	Integrated Circuit, 74LS283	137204-001
27F	Integrated Circuit, 74LS20	37-74LS20
27L	Integrated Circuit, 74F112	137569-001
<b>EPROM Substitutes for Mask ROMs</b>		
<i>Substitute for Mask ROM at 10A</i>		
10A	Integrated Circuit, EPROM, 27512-200	136061-1109
11A	Integrated Circuit, EPROM, 27512-200	136061-1110

## Toobin' Game PCB Assembly Parts List

Designator	Description	Part No.
	<i>Substitute for Mask ROM at 13A</i>	
13A	Integrated Circuit, EPROM, 27512-200	136061-1111
14A	Integrated Circuit, EPROM, 27512-200	136061-1112
	<i>Substitute for Mask ROM at 16A</i>	
16A	Integrated Circuit, EPROM, 27512-200	136061-1113
17A	Integrated Circuit, EPROM, 27512-200	136061-1114
	<i>Substitute for Mask ROM at 18A</i>	
18A	Integrated Circuit, EPROM, 27512-200	136061-1115
20A	Integrated Circuit, EPROM, 27512-200	136061-1116
	<i>Substitute for Mask ROM at 10B</i>	
10B	Integrated Circuit, EPROM, 27512-200	136061-1117
11B	Integrated Circuit, EPROM, 27512-200	136061-1118
	<i>Substitute for Mask ROM at 13B</i>	
13B	Integrated Circuit, EPROM, 27512-200	136061-1119
14B	Integrated Circuit, EPROM, 27512-200	136061-1120
	<i>Substitute for Mask ROM at 16B</i>	
16B	Integrated Circuit, EPROM, 27512-200	136061-1121
17B	Integrated Circuit, EPROM, 27512-200	136061-1122
	<i>Substitute for Mask ROM at 18B</i>	
18B	Integrated Circuit, EPROM, 27512-200	136061-1123
20B	Integrated Circuit, EPROM, 27512-200	136061-1124
	<b>Capacitors</b>	
C10-C26	Capacitor, .1 $\mu$ F, 50 V, Ceramic	122002-104
C27-C30	Capacitor, 100 pF, 100 V, Ceramic	122016-101
C31	Capacitor, .1 $\mu$ F, 50 V, Ceramic	122002-104
C32-C34	Capacitor, 100 pF, 100 V, Ceramic	122016-101
C35-C37	Capacitor, .001 $\mu$ F, 50 V, Ceramic	122002-102
C38	Capacitor, 33 pF, 50 V, Ceramic	121015-330
C39-C41	Capacitor, 100 pF, 100 V, Ceramic	122016-101
C42	Capacitor, 47 $\mu$ F, 25 V, Electrolytic	124009-476
C43	Capacitor, 68 pF, 100 V, Mica	128002-680
C44	Capacitor, 47 pF, 100 V, Mica	128002-470
C45, C46	Capacitor, .1 $\mu$ F, 50 V, Ceramic	122002-104
C47	Capacitor, 47 $\mu$ F, 25 V, Electrolytic	124009-476
C48-C147	Capacitor, .1 $\mu$ F, 50 V, Ceramic	122002-104
	<b>Inductor</b>	
L1	Inductor, 1 $\mu$ H, 830 mA	141007-001
	<b>Transistors</b>	
Q1	Transistor, 2N5306	133033-001
Q2-Q11	Transistor, 2N3904	34-2N3904
	<b>Resistors</b>	
R1	Resistor, 1 K Ohm, $\pm$ 5%, 1/8 W	110027-102
R2-R6	Resistor, 470 Ohm, $\pm$ 5%, 1/8 W	110027-471
R9	Resistor, 1 K Ohm, $\pm$ 5%, 1/8 W	110027-102
R18-R33	Resistor, 470 Ohm, $\pm$ 5%, 1/8 W	110027-471
R44-R59	Resistor, 1 K Ohm, $\pm$ 5%, 1/8 W	110027-102
R60	Resistor, 100 K Ohm, $\pm$ 5%, 1/8 W	110027-104
R61, R62	Resistor, 1 K Ohm, $\pm$ 5%, 1/8 W	110027-102
R63	Resistor, 240 Ohm, $\pm$ 5%, 1/8 W	110027-241
R64	Resistor, 10 K Ohm, $\pm$ 5%, 1/8 W	110027-103

## Toobin' Game PCB Assembly Parts List

Designator	Description	Part No.
R65	Resistor, 4.7 K Ohm, $\pm 5\%$ , 1/8 W	110027-472
R66	Resistor, 1 K Ohm, $\pm 5\%$ , 1/8 W	110027-102
R67	Resistor, 10 K Ohm, $\pm 5\%$ , 1/8 W	110027-103
R68-R71	Resistor, 220 Ohm, $\pm 5\%$ , 1/8 W	110027-221
R72	Resistor, 100 Ohm, $\pm 5\%$ , 1/8 W	110027-101
R73	Resistor, 10 Ohm, $\pm 5\%$ , 1/8 W	110027-100
R74	Resistor, 3.3 K Ohm, $\pm 5\%$ , 1/8 W	110027-332
R75	Resistor, 1 K Ohm, $\pm 5\%$ , 1/8 W	110027-102
R76	Resistor, 300 Ohm, $\pm 5\%$ , 1/8 W	110027-301
R77	Resistor, 2.4 K Ohm, $\pm 5\%$ , 1/8 W	110027-242
R78	Resistor, 1 K Ohm, $\pm 5\%$ , 1/8 W	110027-102
R79	Resistor, 100 Ohm, $\pm 5\%$ , 1/8 W	110027-101
R80	Resistor, 10 Ohm, $\pm 5\%$ , 1/8 W	110027-100
R81	Resistor, 3.3 K Ohm, $\pm 5\%$ , 1/8 W	110027-332
R82	Resistor, 1 K Ohm, $\pm 5\%$ , 1/8 W	110027-102
R83	Resistor, 300 Ohm, $\pm 5\%$ , 1/8 W	110027-301
R84	Resistor, 2.4 K Ohm, $\pm 5\%$ , 1/8 W	110027-242
R85	Resistor, 1 K Ohm, $\pm 5\%$ , 1/8 W	110027-102
R86	Resistor, 100 Ohm, $\pm 5\%$ , 1/8 W	110027-101
R87	Resistor, 10 Ohm, $\pm 5\%$ , 1/8 W	110027-100
R88	Resistor, 3.3 K Ohm, $\pm 5\%$ , 1/8 W	110027-332
R89	Resistor, 1 K Ohm, $\pm 5\%$ , 1/8 W	110027-102
R90	Resistor, 300 Ohm, $\pm 5\%$ , 1/8 W	110027-301
R91	Resistor, 2.4 K Ohm, $\pm 5\%$ , 1/8 W	110027-242
R92	Resistor, 1 K Ohm, $\pm 5\%$ , 1/8 W	110027-102
R93-R95	Resistor, SIP Network, 1K/2K Ohm, $\pm 2\%$	118016-001
R96	Resistor, 68, $\pm 5\%$ , 1/8 W	110027-680
R97	Resistor, 10 K Ohm, $\pm 5\%$ , 1/8 W	110027-103
R98	Resistor, SIP Network, 1K/2K Ohm, $\pm 2\%$	118016-001
R99, R100	Resistor, 1 K Ohm, $\pm 5\%$ , 1/8 W	110027-102
R101	Resistor, 680 Ohm, $\pm 5\%$ , 1/8 W	110027-681
R102	Resistor, 470 Ohm, $\pm 5\%$ , 1/8 W	110027-471
R103	Resistor, 680 Ohm, $\pm 5\%$ , 1/8 W	110027-681
R104	Resistor, 470 Ohm, $\pm 5\%$ , 1/8 W	110027-471
R105-R115	Resistor, 1 K Ohm, $\pm 5\%$ , 1/8 W	110027-102
R116	Resistor, 470 Ohm, $\pm 5\%$ , 1/8 W	110027-471
R117	Resistor, 680 Ohm, $\pm 5\%$ , 1/8 W	110027-681
R118	Resistor, 1 K Ohm, $\pm 5\%$ , 1/8 W	110027-102
R119	Resistor, 680 Ohm, $\pm 5\%$ , 1/8 W	110027-681
R120	Resistor, 470 Ohm, $\pm 5\%$ , 1/8 W	110027-471
R121	Resistor, 1 K Ohm, $\pm 5\%$ , 1/8 W	110027-102
R122, R123	Resistor, 470 Ohm, $\pm 5\%$ , 1/8 W	110027-471
R124, R125	Resistor, 680 Ohm, $\pm 5\%$ , 1/8 W	110027-681

### Toobin' Game PCB Assembly Parts List, Continued

Designator	Description	Part No.
<b>Sockets</b>		
	Socket, 28 Pin, .600	179257-028
	Socket, 24 Pin, .600	179257-024
	Socket, 64 Pin, .900	179256-064
	Socket, 20 Pin, .300	179259-020
<b>Connectors</b>		
AUD	Connector, 11 Ckt, Header, .100-Inch Ctr, Key 5	179118-011
PWR	Connector, 6 Ckt, Header, .250 Ctr	179069-006
SWA	Connector, 11 Ckt, Header, .100-Inch Ctr, Key 2	179118-011
SWB	Connector, 11 Ckt, Header, .100-Inch Ctr, Key 2	179118-011
VID	Connector, 11 Ckt, Header, .100-Inch Ctr, Key 3	179118-011
<b>Miscellaneous</b>		
X1	Crystal, 32.000 MHz	144000-010
CR1	Diode, MV5053, Light Emitting	38-MV5053
	Test Point	179051-001



# N O T E S

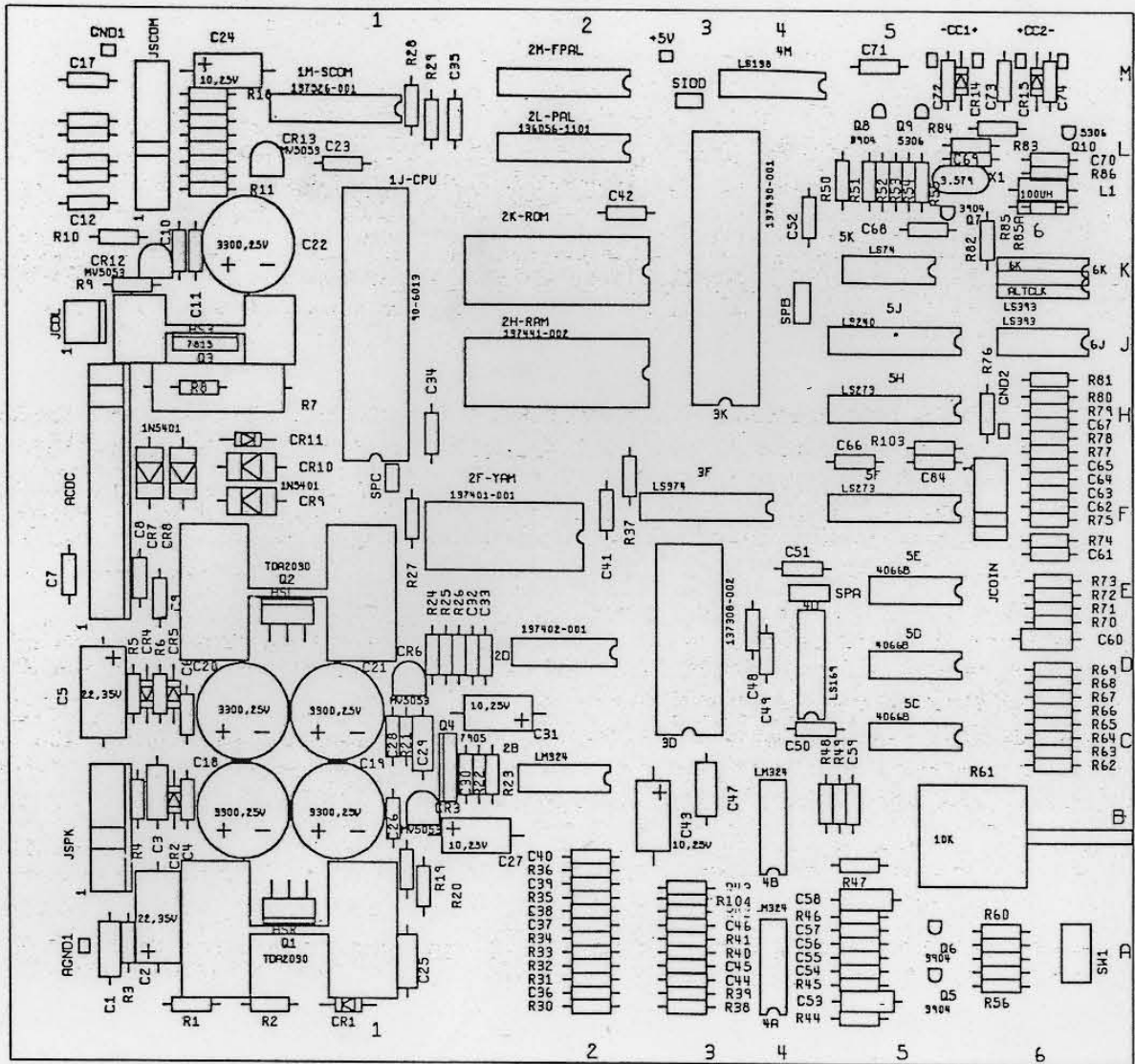

Figure 4-7 Stand-Alone Audio PCB Assembly  
A043713-24 B

## Stand-Alone Audio PCB Assembly Parts List

Location	Description	Part No.
<b>Integrated Circuits</b>		
1J-CPU	Integrated Circuit, 6502 A	90-6013
1M-SCOM	Integrated Circuit, SCOM	137526-001
2B	Integrated Circuit, LM324	37-LM324
2F-YAM	Integrated Circuit, YM2151	137401-001
2H-RAM	Integrated Circuit, 6264-15, 150 nsec	137441-002
2K-ROM	Integrated Circuit, 27512, 300 nsec	136061-1141
2L-PAL	Integrated Circuit, Programmed PAL16L8 A, 25 ns	136056-2101
3F	Integrated Circuit, 74LS374	37-74LS374
3K	Integrated Circuit, POKEY	137430-001
4A, 4B	Integrated Circuit, LM324	37-LM324
4M	Integrated Circuit, 74LS138	137177-001
5C, 5E	Integrated Circuit, 4066B	37-4066
5F, 5H	Integrated Circuit, 74LS273	37-74LS273
5J	Integrated Circuit, 74LS240	137251-001
5K	Integrated Circuit, 74LS74	37-74LS74
6J	Integrated Circuit, 74LS393	37-74LS393
ALTCLK	Integrated Circuit, 74LS393	37-74LS393
<b>Capacitors</b>		
C1	Capacitor, .22 $\mu$ F, 50 V, Ceramic	122015-224
C2	Capacitor, 22 $\mu$ F, 35 V, Electrolytic	24-350226
C3	Capacitor, .22 $\mu$ F, 50 V, Ceramic	122015-224
C4	Capacitor, .1 $\mu$ F, 50 V, Ceramic	122002-104
C5	Capacitor, 22 $\mu$ F, 35 V, Electrolytic	24-350226
C6-C9, C12	Capacitor, .1 $\mu$ F, 50 V, Ceramic	122002-104
C13-C16	Capacitor, 100 pF, 100 V, Ceramic	122016-101
C17	Capacitor, .1 $\mu$ F, 50 V, Ceramic	122002-104
C18-C21	Capacitor, 3300 $\mu$ F, 25 V, Electrolytic, Radial	123003-338
C23	Capacitor, .1 $\mu$ F, 50 V, Ceramic	122002-104
C24	Capacitor, 10 $\mu$ F, 25 V, Electrolytic	24-250106C25
C25	Capacitor, .22 $\mu$ F, 50 V, Ceramic	122015-224
C26	Capacitor, .1 $\mu$ F, 50 V, Ceramic	122002-104
C27	Capacitor, 10 $\mu$ F, 25 V, Electrolytic	24-250106
C28	Capacitor, .1 $\mu$ F, 50 V, Ceramic	122002-104
C29	Capacitor, .22 $\mu$ F, 50 V, Ceramic	122015-224
C30	Capacitor, .1 $\mu$ F, 50 V, Ceramic	122002-104
C31	Capacitor, 10 $\mu$ F, 25 V, Electrolytic	24-250106
C32, C33	Capacitor, .001 $\mu$ F, 50 V, Ceramic	122002-102
C34, C35	Capacitor, .1 $\mu$ F, 50 V, Ceramic	122002-104
C37	Capacitor, .047 $\mu$ F, 100 V, Ceramic	122015-473
C38, C39	Capacitor, .1 $\mu$ F, 50 V, Ceramic	122002-104
C40	Capacitor, .001 $\mu$ F, 50 V, Ceramic	122002-102
C41, C42	Capacitor, .1 $\mu$ F, 50 V, Ceramic	122002-104
C43	Capacitor, 10 $\mu$ F, 25 V, Electrolytic	24-250106
C47	Capacitor, .22 $\mu$ F, 50 V, Ceramic	122015-224
C48-C52	Capacitor, .1 $\mu$ F, 50 V, Ceramic	122002-104

## Stand-Alone Audio PCB Assembly Parts List, Continued

Location	Description	Part No.
C53	Capacitor, .0022 $\mu$ F, 50 V, Axial Ceramic	122015-222
C54	Capacitor, .0027 $\mu$ F, 50 V, Ceramic	122015-272
C55	Capacitor, .001 $\mu$ F, 50 V, Ceramic	122002-102
C56	Capacitor, .0027 $\mu$ F, 50 V, Ceramic	122015-272
C57	Capacitor, .001 $\mu$ F, 50 V, Ceramic	122002-102
C58	Capacitor, .0022 $\mu$ F, 50 V, Axial Ceramic	122015-222
C61-C68	Capacitor, .1 $\mu$ F, 50 V, Ceramic	122002-104
C69	Capacitor, 39 pF, 100 V, Ceramic	122016-390
C70	Capacitor, 100 pF, 100 V, Ceramic	122016-101
C71-C74, C84	Capacitor, .1 $\mu$ F, 50 V, Ceramic	122002-104
<b>Diodes</b>		
CR1, CR2	Diode, 1N4001	131048-001
CR3	Diode, MV5053, Light-Emitting	131027-002
CR4, CR5	Diode, 1N4001	131048-001
CR6	Diode, MV5053, Light-Emitting	131027-002
CR7-CR10	Diode, 1N5401	131051-002
CR13	Diode, MV5053, Light-Emitting	131027-002
CR14, CR15	Diode, 1N4001	131048-001
<b>Inductor</b>		
L1	Inductor, 100 $\mu$ H	141024-001
<b>Transistors</b>		
Q1, Q2	Integrated Circuit, TDA2030	137301-001
Q4	Integrated Circuit, 7905, Standup	37-7905
Q5-Q8	Transistor, 2N3904	34-2N3904
Q9, Q10	Transistor, 2N5306	133033-001
<b>Resistors</b>		
R1	Resistor, 1 K Ohm, $\pm$ 5%, 1/4 W	110000-102
R2	Resistor, 10 K Ohm, $\pm$ 5%, 1/4 W	110000-103
R3, R4	Resistor, 1 Ohm, $\pm$ 5%, 1/4 W	110000-010
R5	Resistor, 1 K Ohm, $\pm$ 5%, 1/4 W	110000-102
R6	Resistor, 10 K Ohm, $\pm$ 5%, 1/4 W	110000-103
R10	Resistor, 0 Ohm, 1/4 W	110005-001
R11	Resistor, 1 K Ohm, $\pm$ 5%, 1/4 W	110000-102
R12	Resistor, 470 Ohm, $\pm$ 5%, 1/4 W	110000-471
R13	Resistor, 1 K Ohm, $\pm$ 5%, 1/4 W	110000-102
R14	Resistor, 470 Ohm, $\pm$ 5%, 1/4 W	110000-471
R15	Resistor, 1 K Ohm, $\pm$ 5%, 1/4 W	110000-102
R16	Resistor, 470 Ohm, $\pm$ 5%, 1/4 W	110000-471
R17, R18	Resistor, 10 K Ohm, $\pm$ 5%, 1/4 W	110000-103
R19	Resistor, 22 K Ohm, $\pm$ 5%, 1/4 W	110000-223
R20	Resistor, 1 K Ohm, $\pm$ 5%, 1/4 W	110000-102
R21	Resistor, 22 K Ohm, $\pm$ 5%, 1/4 W	110000-223



### Stand-Alone Audio PCB Assembly Parts List, Continued

Location	Description	Part No.
R22	Resistor, 10 Ohm, $\pm 5\%$ , 1/4 W	110000-100
R23	Resistor, 560, $\pm 5\%$ , 1/4 W	110000-561
R24	Resistor, 1 K Ohm, $\pm 5\%$ , 1/4 W	110000-102
R26, R27	Resistor, 10 Ohm, $\pm 5\%$ , 1/4 W	110000-100
R28	Resistor, 10 K Ohm, $\pm 5\%$ , 1/4 W	110000-103
R29	Resistor, 1 K Ohm, $\pm 5\%$ , 1/4 W	110000-102
R33, R34	Resistor, 470 Ohm, $\pm 5\%$ , 1/4 W	110000-471
R35	Resistor, 75 K Ohm, $\pm 5\%$ , 1/4 W	110000-753
R36, R37	Resistor, 10 K Ohm, $\pm 5\%$ , 1/4 W	110000-103
R38	Resistor, 47 K Ohm, $\pm 5\%$ , 1/4 W	110000-473
R43-R48	Resistor, 12 K Ohm, $\pm 5\%$ , 1/4 W	110000-123
R49	Resistor, 10 K Ohm, $\pm 5\%$ , 1/4 W	110000-103
R50	Resistor, 1 K Ohm, $\pm 5\%$ , 1/4 W	110000-102
R51, R52	Resistor, 10 K Ohm, $\pm 5\%$ , 1/4 W	110000-103
R53, R54	Resistor, 1 K Ohm, $\pm 5\%$ , 1/4 W	110000-102
R55, R56	Resistor, 150 K Ohm, $\pm 5\%$ , 1/4 W	110000-154
R58	Resistor, 1 K Ohm, $\pm 5\%$ , 1/4 W	110000-102
R59	Resistor, 150 K Ohm, $\pm 5\%$ , 1/4 W	110000-154
R60	Resistor, 1 K Ohm, $\pm 5\%$ , 1/4 W	110000-102
R61	Potentiometer, 10 K Ohm, Horizontal, Dual	119011-103
R62	Resistor, 7.5 K Ohm, $\pm 5\%$ , 1/4 W	110000-752
R63	Resistor, 30 K Ohm, $\pm 5\%$ , 1/4 W	110000-303
R64	Resistor, 15 K Ohm, $\pm 5\%$ , 1/4 W	110000-153
R65	Resistor, 12 K Ohm, $\pm 5\%$ , 1/4 W	110000-123
R70	Resistor, 75 K Ohm, $\pm 5\%$ , 1/4 W	110000-753
R71	Resistor, 150 K Ohm, $\pm 5\%$ , 1/4 W	110000-154
R74-R81	Resistor, 1 K Ohm, $\pm 5\%$ , 1/4 W	110000-102
R82	Resistor, 470 Ohm, $\pm 5\%$ , 1/4 W	110000-471
R83	Resistor, 150 K Ohm, $\pm 5\%$ , 1/4 W	110000-154
R84	Resistor, 0 Ohm, 1/4 W	110005-001
R85A	Resistor, 470 Ohm, $\pm 5\%$ , 1/4 W	110000-471
R86	Resistor, 220 Ohm, $\pm 5\%$ , 1/4 W	110000-221
R103	Resistor, 150 K Ohm, $\pm 5\%$ , 1/4 W	110000-154
R104	Resistor, 12 K Ohm, $\pm 5\%$ , 1/4 W	110000-123
<b>Sockets</b>		
1J-CPU	Socket, 40 Pin	179257-040
1M-SCOM	Socket, 20 Pin	179259-020
2D	Socket, 16 Pin	179259-016
2F-YAM	Socket, 24 Pin	179257-024
2H-RAM, 2K-ROM	Socket, 28 Pin	179257-028
3K	Socket, 40 Pin	179257-040
<b>Connectors</b>		
JACDC	Connector, 12 Ckt, Header, .156-Inch Ctr, Key 11	179213-012
JCDL	Connector, 2 Ckt, Header, .156-Inch Ctr	179213-002
JCOIN	Connector, 6 Ckt, Header, .100-Inch Ctr, Key 2	179118-006

### Stand-Alone Audio PCB Assembly Parts List, Continued

Location	Description	Part No.
JSCOM	Connector, 11 Ckt, Header, .100-Inch Ctr, Key 5	179118-011
JSPK	Connector, 6 Ckt, Header, .156-Inch Ctr, Key 3	179213-006
<b>Miscellaneous</b>		
HSL	Heat Sink, TDA2030	178190-032
HSR	Heat Sink, TDA2030	178190-032
SW1	Switch, Slide, SPDT	160040-001
X1	Crystal, 3.579 MHz Standup	144007-001
	Test Point	179051-001



# Toobin'™ Statistics: Date \_\_\_\_\_

## Game Statistics

(Refer to Chapter 2 of the operators manual for clarification of these terms)

Left Coins	_____	Cont Mins	_____
Right Coins	_____	Sessions	_____
New Games	_____	Error Count	_____
Continuation	_____	Total Coins	_____
0 Plyr Mins	_____	Avg Time/Coin	_____
1 Plyr Mins	_____	Avg Time/New Game	_____
2 Plyr Mins	_____	Avg Time/Cont Game	_____
New Mins	_____		

## Histogram Information

### New Easy Games

Length of Game in Seconds	Number of Games	Length of Game in Seconds	Number of Games	Length of Game in Seconds	Number of Games
0-39	_____	160-179	_____	300-319	_____
40-59	_____	180-199	_____	320-339	_____
60-79	_____	200-219	_____	340-359	_____
80-99	_____	220-239	_____	360-379	_____
100-119	_____	240-259	_____	380-399	_____
120-139	_____	260-279	_____	400 & Up	_____
140-159	_____	280-299	_____		

### New Medium Games

Length of Game in Seconds	Number of Games	Length of Game in Seconds	Number of Games	Length of Game in Seconds	Number of Games
0-39	_____	160-179	_____	300-319	_____
40-59	_____	180-199	_____	320-339	_____
60-79	_____	200-219	_____	340-359	_____
80-99	_____	220-239	_____	360-379	_____
100-119	_____	240-259	_____	380-399	_____
120-139	_____	260-279	_____	400 & Up	_____
140-159	_____	280-299	_____		

### New Hard Games

Length of Game in Seconds	Number of Games	Length of Game in Seconds	Number of Games	Length of Game in Seconds	Number of Games
0-39	_____	160-179	_____	300-319	_____
40-59	_____	180-199	_____	320-339	_____
60-79	_____	200-219	_____	340-359	_____
80-99	_____	220-239	_____	360-379	_____
100-119	_____	240-259	_____	380-399	_____
120-139	_____	260-279	_____	400 & Up	_____
140-159	_____	280-299	_____		

**Continued Easy Games**

Length of Game in Seconds	Number of Games	Length of Game in Seconds	Number of Games	Length of Game in Seconds	Number of Games
0-39	_____	160-179	_____	300-319	_____
40-59	_____	180-199	_____	320-339	_____
60-79	_____	200-219	_____	340-359	_____
80-99	_____	220-239	_____	360-379	_____
100-119	_____	240-259	_____	380-399	_____
120-139	_____	260-279	_____	400 & Up	_____
140-159	_____	280-299	_____		

**Continued Medium Games**

Length of Game in Seconds	Number of Games	Length of Game in Seconds	Number of Games	Length of Game in Seconds	Number of Games
0-39	_____	160-179	_____	300-319	_____
40-59	_____	180-199	_____	320-339	_____
60-79	_____	200-219	_____	340-359	_____
80-99	_____	220-239	_____	360-379	_____
100-119	_____	240-259	_____	380-399	_____
120-139	_____	260-279	_____	400 & Up	_____
140-159	_____	280-299	_____		

**Continued Hard Games**

Length of Game in Seconds	Number of Games	Length of Game in Seconds	Number of Games	Length of Game in Seconds	Number of Games
0-39	_____	160-179	_____	300-319	_____
40-59	_____	180-199	_____	320-339	_____
60-79	_____	200-219	_____	340-359	_____
80-99	_____	220-239	_____	360-379	_____
100-119	_____	240-259	_____	380-399	_____
120-139	_____	260-279	_____	400 & Up	_____
140-159	_____	280-299	_____		

**Session Length**

Length of Game in Seconds	Number of Games	Length of Game in Seconds	Number of Games	Length of Game in Seconds	Number of Games
0-39	_____	160-179	_____	300-319	_____
40-59	_____	180-199	_____	320-339	_____
60-79	_____	200-219	_____	340-359	_____
80-99	_____	220-239	_____	360-379	_____
100-119	_____	240-259	_____	380-399	_____
120-139	_____	260-279	_____	400 & Up	_____
140-159	_____	280-299	_____		

# Glossary

## **AC**

Alternating current; from zero it rises to a maximum positive level, then passes through zero again to a maximum negative level.

## **ACTIVE STATE**

The true state of a signal. For example: The active state for is low.

## **ADDRESS**

A value that identifies a specific location of data in memory; normally expressed in hexadecimal notation.

## **ANALOG**

Measurable in an absolute quantity (as opposed to on or off). Analog devices are volume controls, light dimmers, stereo amplifiers, etc.

## **ANODE**

The positive (arrow) end of a diode.

## **AMPLIFIER**

A device used to increase the strength of an applied signal.

## **AMPLITUDE**

The maximum instantaneous value of a waveform pulse from zero.

## **ASTABLE**

Having no normal state. An astable device will free-run or oscillate as long as operating voltage is applied. The oscillation frequency is usually controlled by external circuitry.

## **AUXILIARY COIN SWITCH**

A momentary-contact pushbutton switch with a black cap located on the utility panel. The auxiliary coin switch adds credits to the game without activating a coin counter.

## **BEZEL**

A cut, formed, or machined retention device, such as the conical device used to mount a pushbutton switch to a control panel, or the formed device used to frame the video display screen.

## **BIDIRECTIONAL**

Able to send or receive data on the same line (e.g., the data bus of a microprocessor).

## **BINARY**

A number system that expresses all values by using two digits (0 and 1).

## **BIT**

A binary digit; expressed as 1 or 0.

## **BLANKING**

Turning off the beam on a cathode-ray tube during retrace.

## **BLOCK DIAGRAM**

A drawing in which functional circuitry units are represented by blocks. Very useful during initial troubleshooting.

## **BUFFER**

1. An isolating circuit designed to eliminate the reaction of a driven circuit on the circuits driving it (e.g., a buffer amplifier).

2. A device used to supply additional drive capability.

## **BUS**

An electrical path over which information is transferred from any of several sources to any of several destinations.

## **CAPACITOR**

A device capable of storing electrical energy. A capacitor blocks the flow of DC current while allowing AC current to pass.

## **CATHODE**

The negative end of a diode.

## **CHIP**

An integrated circuit comprising many circuits on a single wafer slice.

## **CLOCK**

A repetitive timing signal for synchronizing system functions.

## **COINCIDENCE**

Occurring at the same time.

## **COIN COUNTER**

A 6-digit electromechanical device that counts the coins inserted in the coin mechanism(s).

## **COIN MECHANISM**

A device on the inside of the coin door that inspects the coin to determine if the correct coin has been inserted.

## **COMPLEMENTARY**

Having opposite states, such as the outputs of a flip-flop.

## **COMPOSITE SYNC**

Horizontal and vertical synchronization pulses that are bused together into a single signal. This signal provides the timing necessary to keep the display in synchronization with the game circuitry.

## **COMPOSITE VIDEO**

Complete video signal from the game system to drive the display circuitry, usually comprising H SYNC, V SYNC, and the video.

## **CREDIT**

One play for one person based on the game switch settings.

## **CRT**

Cathode-ray tube.

## **DATA**

General term for the numbers, letters, and symbols that serve as input for device processing.

## **DARLINGTON**

A two-transistor amplifier that provides extremely high gain.

## **DC**

Direct current, meaning current flowing in one direction and of a fixed value.

## **DEFLECTION YOKE**

Electromagnetic coils around the neck of a cathode-ray tube. One set of coils deflects the electron beam horizontally and the other set deflects the beam vertically.

## **DIAGNOSTICS**

A programmed routine for checking circuitry. For example: the self-test is a diagnostic routine.

## **DIODE**

A semiconductor device that conducts in only one direction.

## **DISCRETE**

Non-integrated components, such as resistors, capacitors, and transistors.

## **DMA**

Direct memory access. DMA is a process of accessing memory that bypasses the microprocessor logic. DMA is normally used for transferring data between the input/output ports and memory.

## **DOWN TIME**

The period during which a game is malfunctioning or not operating correctly due to machine failure.

## **EAROM**

Electrically alterable read-only memory (see ROM). The EAROM is a memory that can be changed by the application of high voltage.

**FLYBACK**

A step-up transformer used in a display to provide the high voltage.

**GATE**

1. A circuit with one output that responds only when a certain combination of pulses is present at the inputs.
2. A circuit in which one signal switches another signal on and off.
3. To control the passage of a pulse or signal.

**HARNESS**

A prefabricated assembly of insulated wires and terminals ready to be attached to a piece of equipment.

**HEXADECIMAL**

A number system using the equivalent of the decimal number 16 as a base. The symbols 0-9 and A-F are usually used.

**IMPLODE**

To burst inward; the inward collapse of a vacuum tube.

**I/O**

Input/Output.

**IRQ**

Interrupt request. IRQ is a control signal to the microprocessor that is generated by external logic. This signal tells the microprocessor that external logic needs attention. Depending on the program, the processor may or may not respond.

**LED**

The abbreviation for a light-emitting diode.

**LOCKOUT COIL**

Directs coins into the coin return box when there is no power to the game.

**LOGIC STATE**

The binary (1 or 0) value at the node of a logic element or integrated circuit during a particular time. Also called the logic level. The list below shows the voltage levels corresponding to the logic states (levels) in a TTL system.

*Logic 0, Low* = 0 VDC to +0.8 VDC

*Grey Area (Tri-State Level)* = +0.8 VDC to +2.4 VDC

*Logic 1, High* = +2.4 VDC to +5 VDC

**MULTIPLEXER**

A device that takes several low-speed inputs and combines them into one high-speed data stream for simultaneous transmission on a single line.

**NMI**

Non-maskable interrupt. NMI is a request for service by the microprocessor from external logic. The microprocessor cannot ignore this interrupt request.

**PAGE**

A subsection of memory. A read-only memory device (see ROM) is broken into discrete blocks of data. These blocks are called pages. Each block has X number of bytes.

**PCB**

The abbreviation for a printed-circuit board.

**PHOTOTRANSISTOR**

A transistor that is activated by an external light source.

**POTENTIOMETER**

1. A resistor that has a continuously moving contact which is generally mounted on a moving shaft. Used chiefly as a voltage divider. Also called a pot (slang).

2. An instrument for measuring a voltage by balancing it against a known voltage.

**RAM**

Random-access memory. A device for the temporary storage of data.

**RASTER-SCAN DISPLAY**

A display system whereby images are displayed by continuously scanning the cathode-ray tube horizontally and vertically with an electron beam. The display system controls the intensity of the electron beam.

**RETRACE**

In a raster-scan display, retrace is the time during which the cathode-ray tube electron beam is resetting either from right to left or from bottom to top.

**RESISTOR**

A device designed to have a definite amount of resistance. Used in circuits to limit current flow or to provide a voltage drop.

**ROM**

Read-only memory. A device for the permanent storage of data.

**SIGNATURE ANALYSIS**

A process of isolating digital logic faults at the component level by means of special test equipment called signature analyzers. Basically, signature analyzers

(e.g., the ATARI® CAT Box) convert lengthy bit streams into four-digit hexadecimal signatures. The signature read by the analyzer at each circuit node is then compared with the known good signature for that node. This process continues until a fault is located.

**TROUBLESHOOT**

The process of locating and repairing a fault.

**VECTOR**

A line segment drawn between specific X and Y coordinates on a cathode-ray tube.

**WATCHDOG**

A counter circuit designed to protect the microprocessor

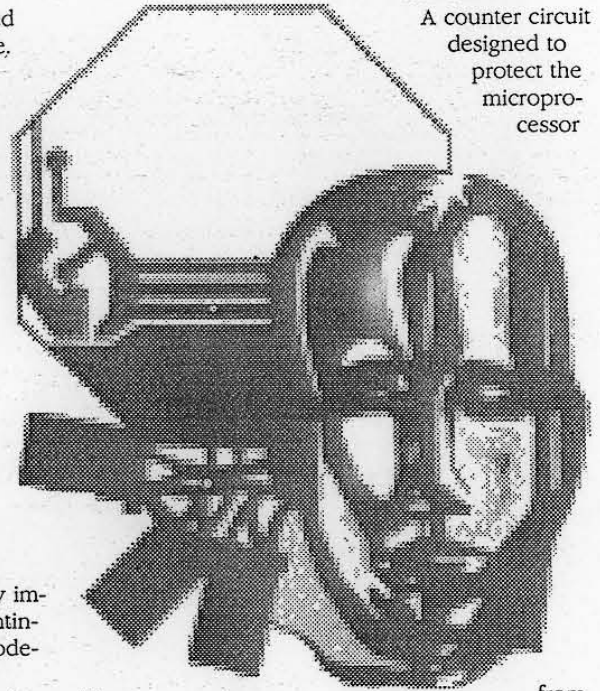

from self-destruction if a program malfunction occurs. If a malfunction does occur, the counter applies continuous pulses to the reset line of the microprocessor, which causes the microprocessor to keep resetting.

**X-Y DISPLAY**

A display system whereby images are displayed with vectors.

**ZENER DIODE**

A special diode used as a regulator. Its main characteristic is breaking down at a specified reverse-bias (Zener) voltage.

# Warranty

Seller warrants that its printed-circuit boards and parts thereon are free from defects in material and workmanship under normal use and service for a period of ninety (90) days from date of shipment. Seller warrants that its video displays and laser-video disc players (in games supplied with displays and video-disc players) are free from defects in material and workmanship under normal use and service for a period of thirty (30) days from date of shipment. None of the Seller's other products or parts thereof are warranted.

If the products described in this manual fail to conform to this warranty, Seller's sole liability shall be, at its option, to repair, replace, or credit Buyer's account for such products which are returned to Seller during said warranty period, provided:

- (a) Seller is promptly notified in writing upon discovery by Buyer that said products are defective;
- (b) Such products are returned prepaid to Seller's plant; and
- (c) Seller's examination of said products discloses to Seller's satisfaction that such alleged defects existed and were not caused by accident, misuse, neglect, alteration, improper repair, installation, or improper testing.

In no event shall Seller be liable for loss of profits, loss of use, incidental or consequential damages.

*Except for any express warranty set forth in a written contract between Seller and Buyer which contract supersedes the terms herein, this warranty is expressed in lieu of all other warranties expressed or implied, including the implied warranties of merchantability and fitness for a particular purpose, and of all other obligations or liabilities on the Seller's part, and it neither assumes nor authorizes any other person to assume for the Seller any other liabilities in connection with the sale of products by Seller.*

The use of any non-Atari parts may void your warranty, according to the terms of the warranty. The use of any non-Atari parts may also adversely affect the safety of your game and cause injury to you and others. Be very cautious in using non-Atari-supplied components with our games, in order to ensure your safety.

Atari distributors are independent, being privately owned and operated. In their judgment they may sell parts or accessories other than Atari parts or accessories. Atari Games Corporation cannot be responsible for the quality, suitability or safety of any non-Atari part or any modification including labor which is performed by such distributor.





# TOOBIN'

## Schematic Package

Supplement to the Operators Manual

**NOTE** This staple temporarily holds the schematic package together. Remove the staple when you use the schematics.



# Table of Contents

Faulty RAM/ROM Tables .....	Sheet 1
Toobin™ Game PCB Assembly Schematic Diagram.....	Sheets 1-16
Toobin' Memory Map .....	Sheet 17
Toobin' Main Wiring Diagram.....	Sheet 18
Stand-Alone Audio PCB Assembly Schematic Diagram .....	Sheet 19-22
Wiring Diagrams for Switching/Linear (SL) Power Supply, Hitron 5V 10A Switching Power Supply, and Coin Door.....	Sheet 23

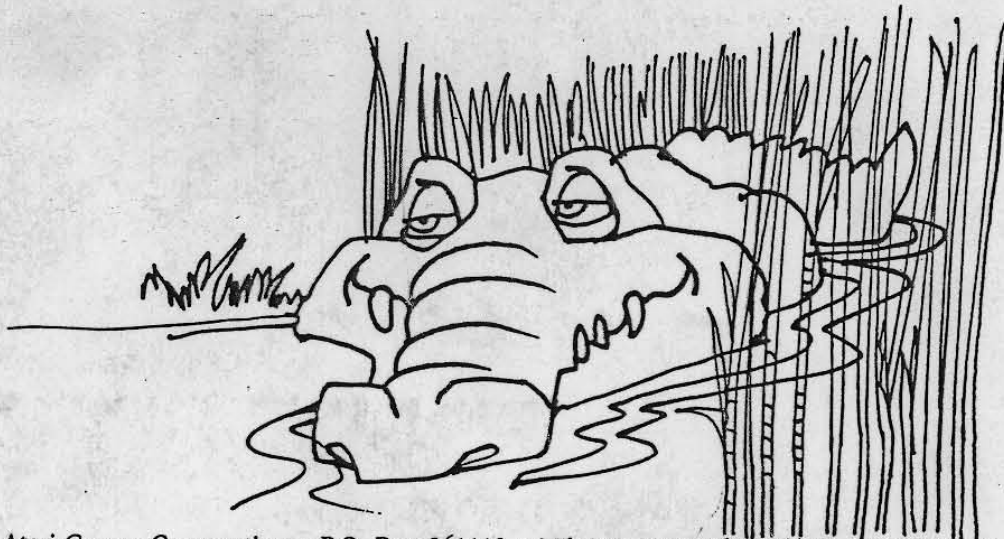

# Faulty RAM/ROM Tables

**Table 1 Faulty RAM Locations**

Ram Type	Location	Video Display Characteristic
CPU	7J, 7F	Background color is red.
PF	1E, 3E, 4/5E	Background color is green.
AL/MO	17D, 18D	Background color is blue.
COL	8J, 9J	Background color varies between red, white, and blue.

**Table 2 Faulty ROM Locations**

Error Address	Location on Game PCB	
00000	U = 1J	L = 1F
20000	U = 2J	L = 2F
40000	U = 4J	L = 4F
60000	U = 5J	L = 5F

**NOTICE TO ALL PERSONS  
RECEIVING THIS DRAWING**

CONFIDENTIAL: Reproduction forbidden without the specific written permission of Atari Games Corporation, Milpitas, CA. This drawing is only conditionally issued and neither receipt nor possession thereof confers or transfers any right in, or license to use, the subject matter of the drawing or any design or technical information shown thereon, nor any right to reproduce this drawing, or any part thereof. Except for manufacture by vendors of Atari Games Corporation, and for manufacture under the corporation's written license, no right is granted to reproduce this drawing or the subject matter thereof, unless by written agreement with or written permission from the corporation.

**Toobin™ Game PCB Assembly  
Schematic Diagram, Faulty RAM/ROM Tables**



© 1988 Atari Games Corporation

SP-320 Sheet 1  
1st printing

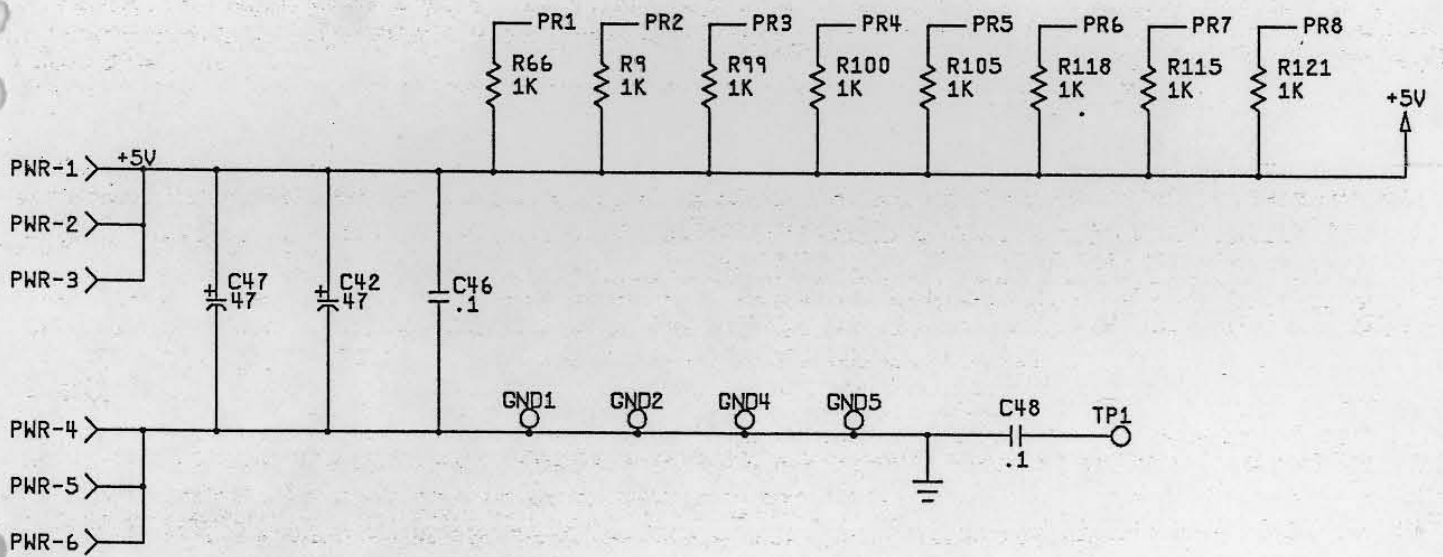

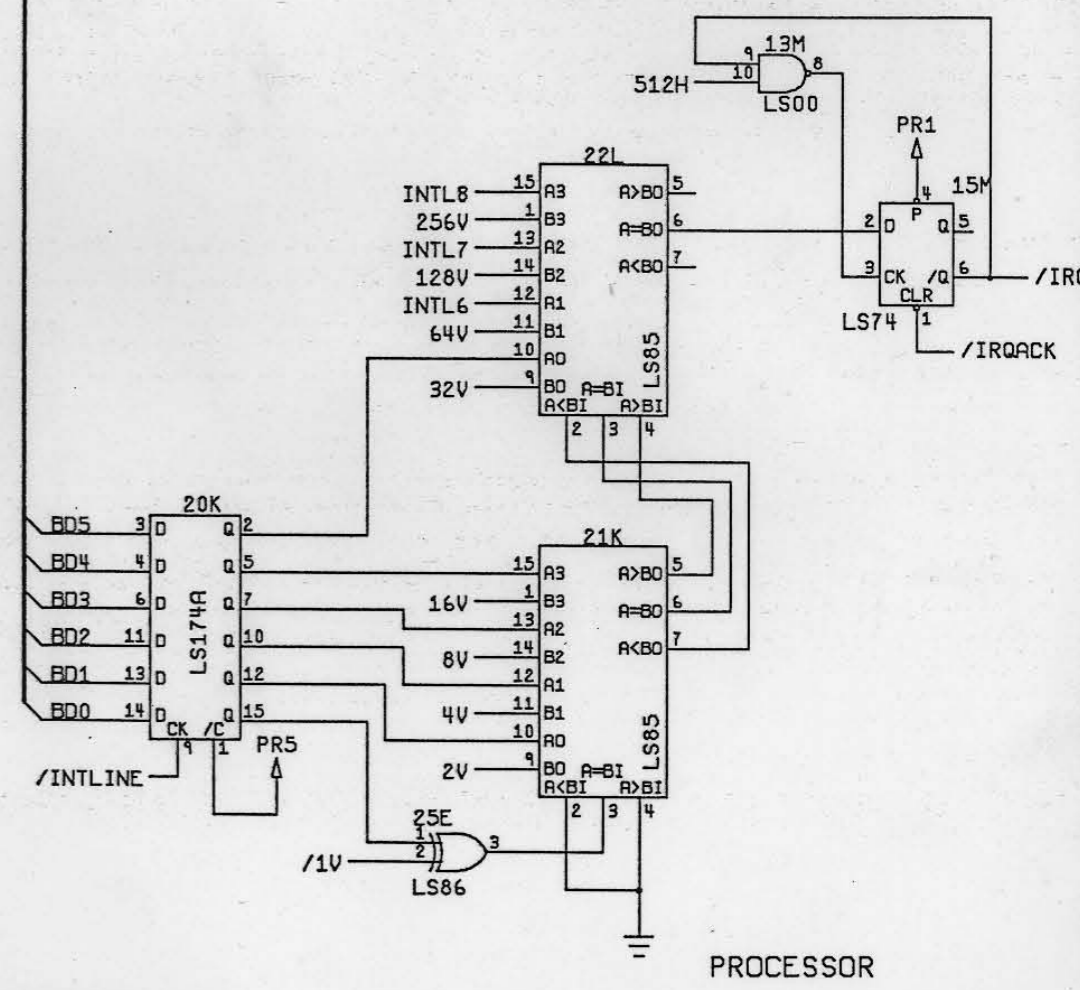
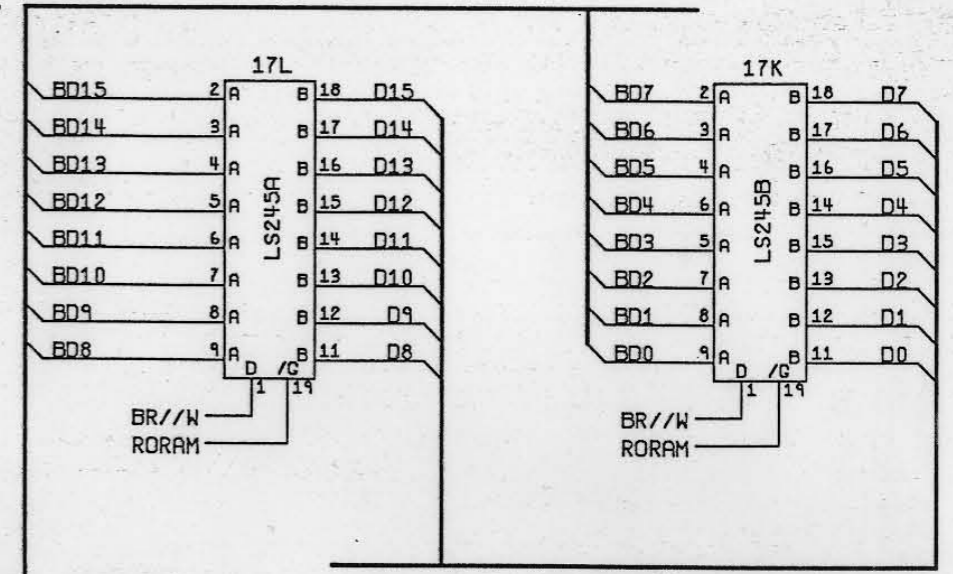
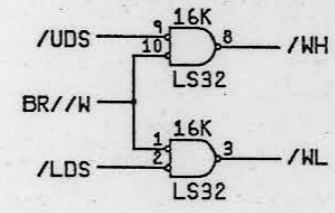
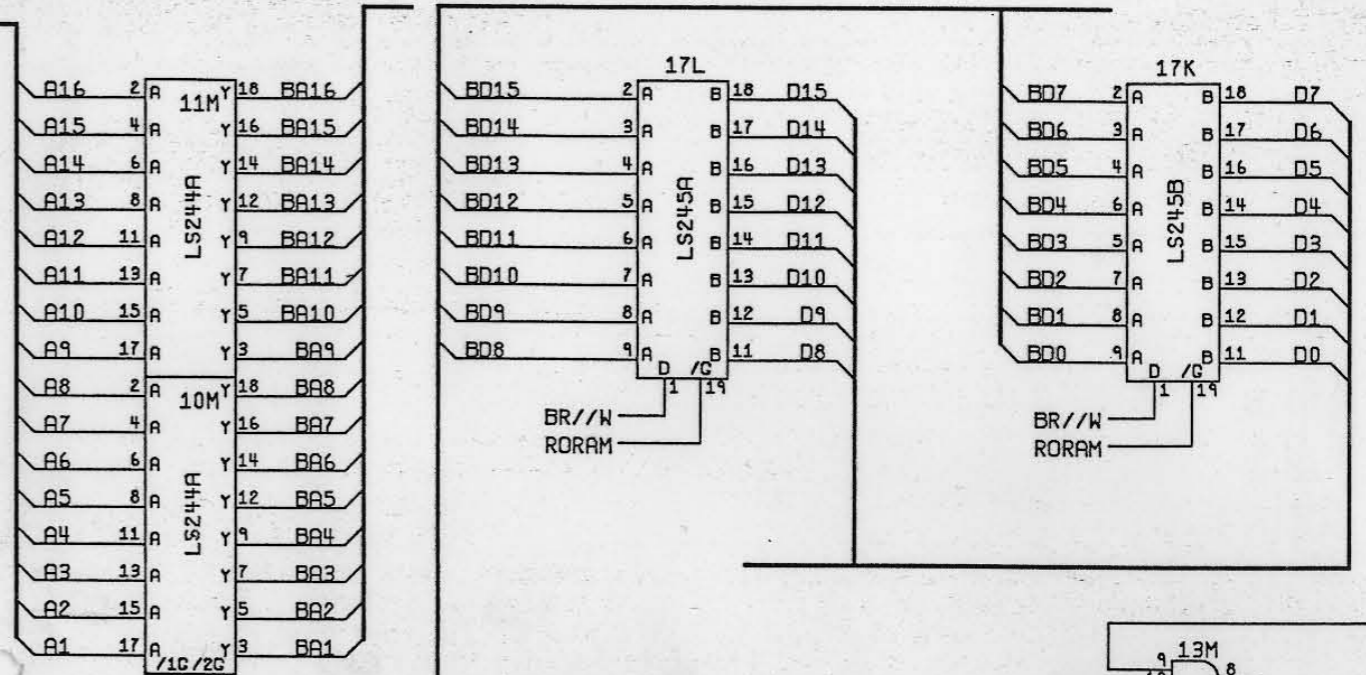
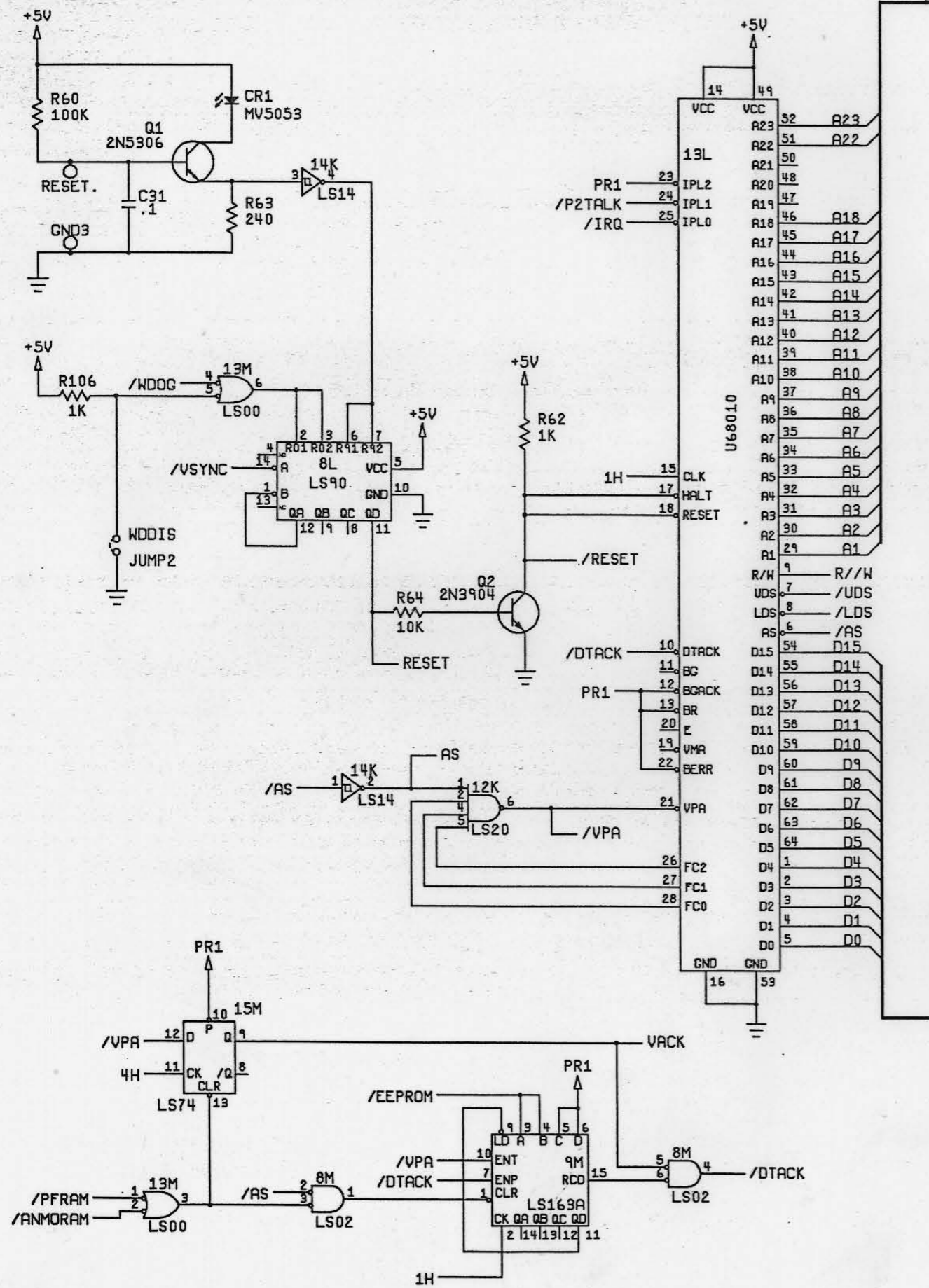

NOTICE TO ALL PERSONS RECEIVING THIS DRAWING  
 CONFIDENTIAL: Reproduction forbidden without the specific written permission of Atari Games Corporation, Milpitas, CA. This drawing is only conditionally issued and neither receipt nor possession thereof confers or transfers any right in, or license to use, the subject matter of the drawing or any design or technical information shown thereon, nor any right to reproduce this drawing, or any part thereof. Except for manufacture by vendors of Atari Games Corporation, and for manufacture under the corporation's written license, no right is granted to reproduce this drawing or the subject matter thereof, unless by written agreement with or written permission from the corporation.

**Toobin™ Game PCB Assembly Schematic Diagram**

**ATARI GAMES**

© 1988 Atari Games Corporation

SP-320 Sheet 2  
1st printing

044402-xx A

Not Stuffed

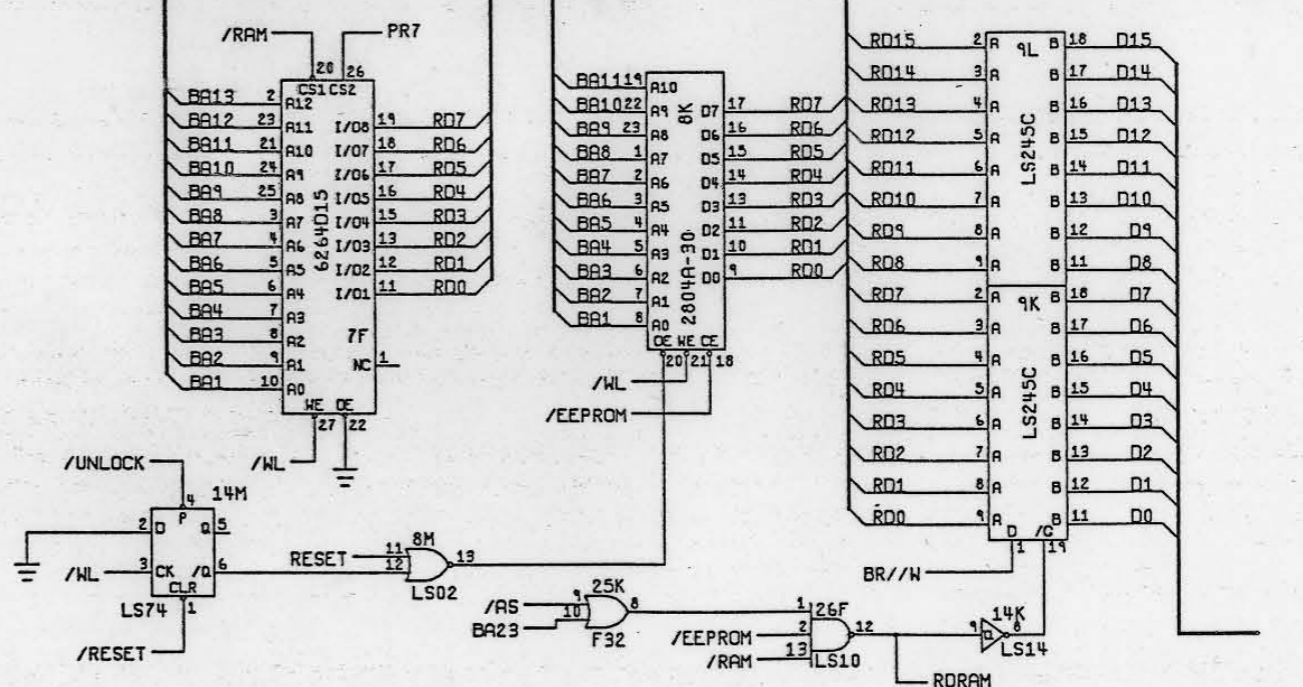
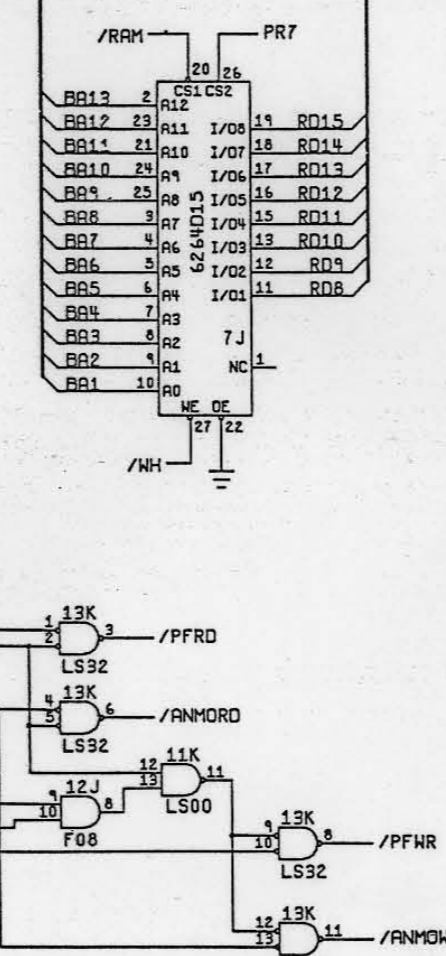
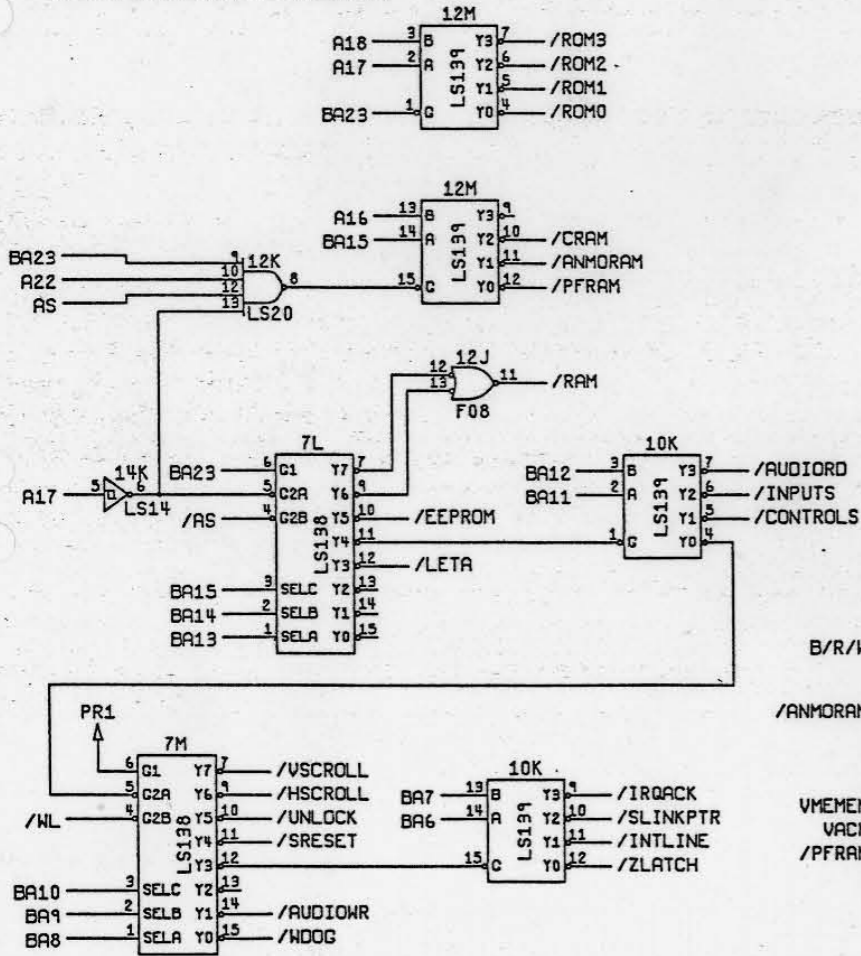
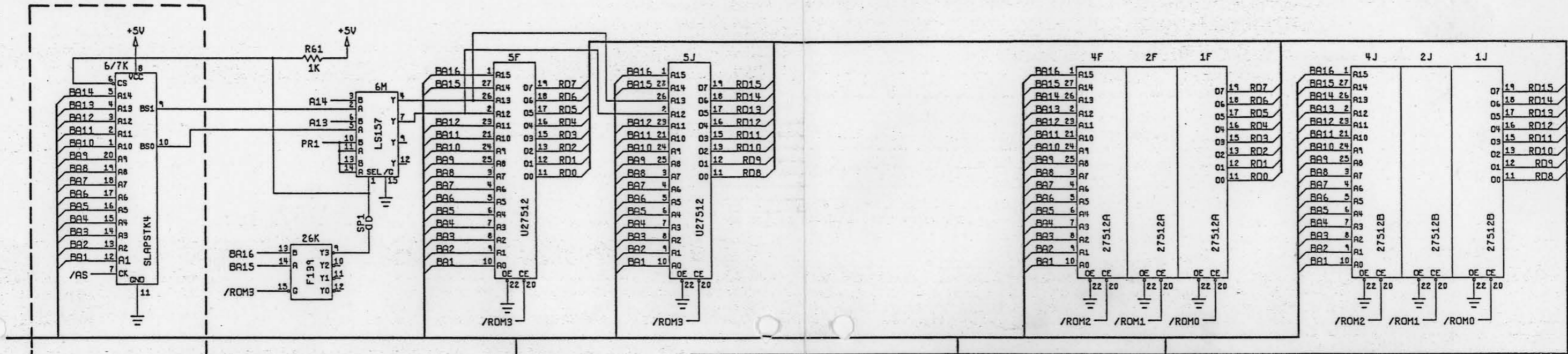

RAM, ROM, ADDRESS DECODES

**NOTICE TO ALL PERSONS RECEIVING THIS DRAWING**  
 CONFIDENTIAL: Reproduction forbidden without the specific written permission of Atari Games Corporation, Milpitas, CA. This drawing is only conditionally issued and neither receipt nor possession thereof confers or transfers any right in, or license to use, the subject matter of the drawing or any design or technical information shown thereon, nor any right to reproduce this drawing, or any part thereof. Except for manufacture by vendors of Atari Games Corporation, and for manufacture under the corporation's written license, no right is granted to reproduce this drawing or the subject matter thereof, unless by written agreement with or written permission from the corporation.

**Toobin™ Game PCB Assembly Schematic Diagram**

**ATARI GAMES**

© 1988 Atari Games Corporation  
 044402-xx A

SP-320 Sheet 3  
 1st printing

Not Stuffed

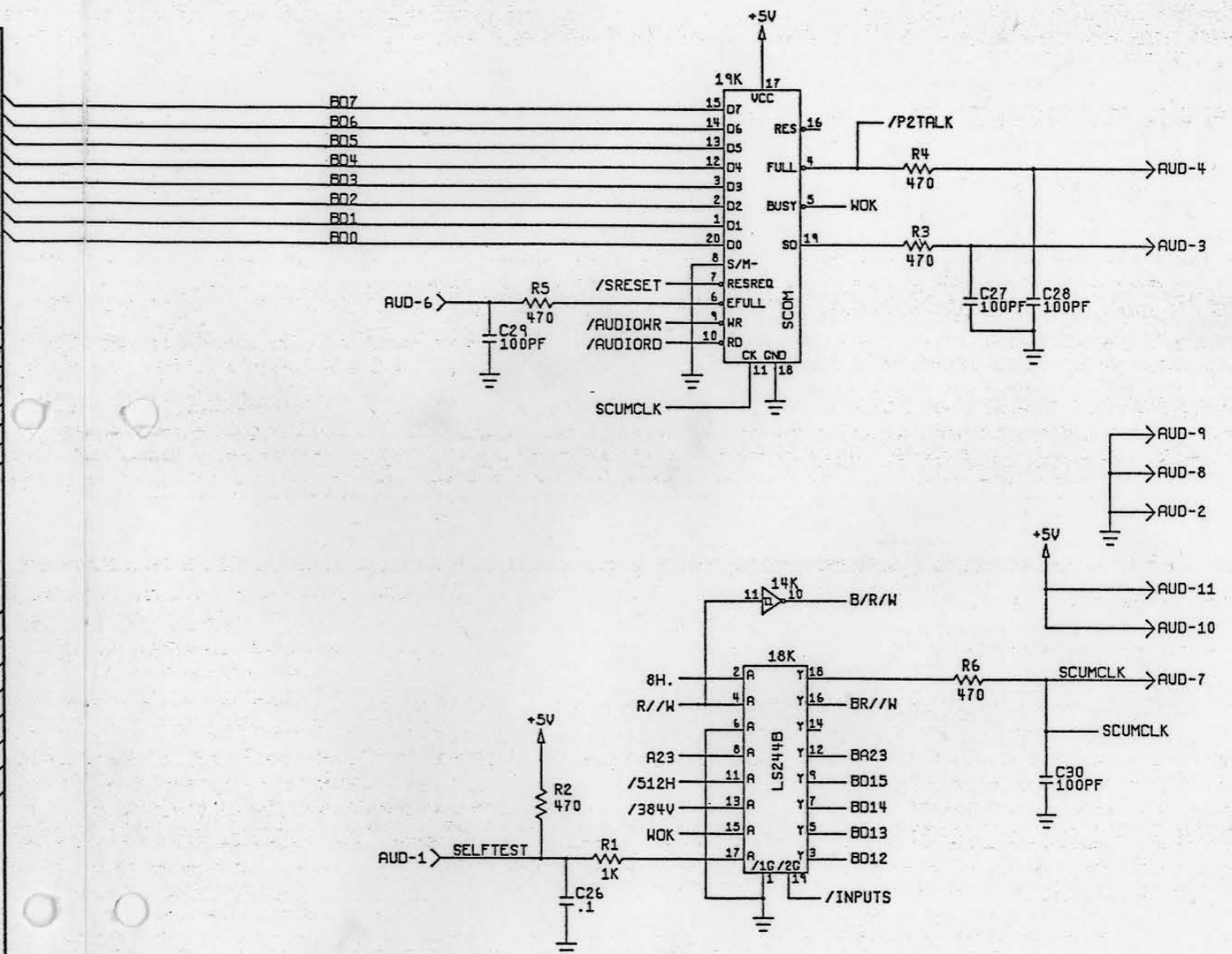
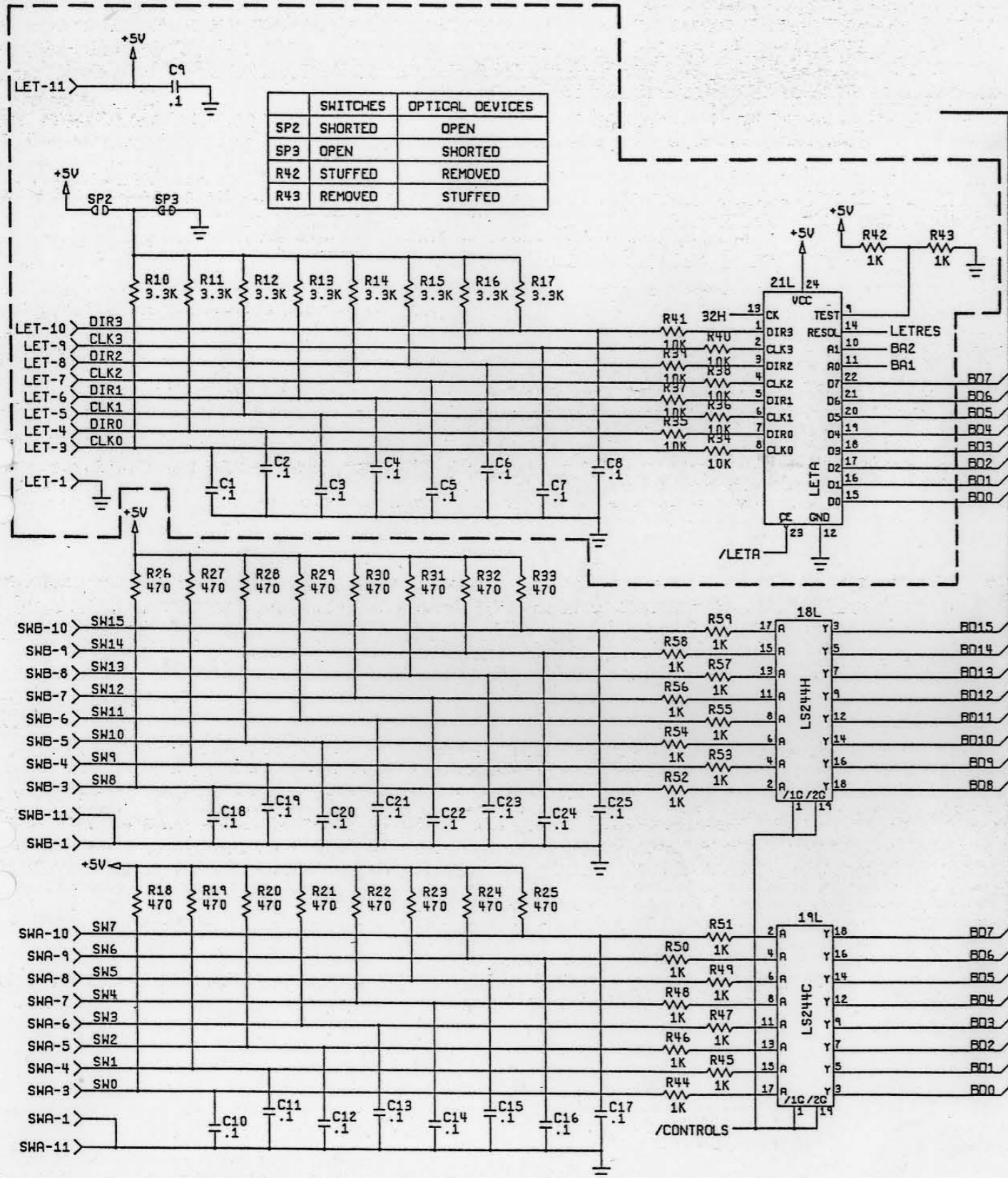

I/O

**NOTICE TO ALL PERSONS RECEIVING THIS DRAWING**  
 CONFIDENTIAL: Reproduction forbidden without the specific written permission of Atari Games Corporation, Milpitas, CA. This drawing is only conditionally issued and neither receipt nor possession thereof confers or transfers any right in, or license to use, the subject matter of the drawing or any design or technical information shown thereon, nor any right to reproduce this drawing, or any part thereof. Except for manufacture by vendors of Atari Games Corporation, and for manufacture under the corporation's written license, no right is granted to reproduce this drawing or the subject matter thereof, unless by written agreement with or written permission from the corporation.

**Toobin™ Game PCB Assembly Schematic Diagram**

© 1988 Atari Games Corporation  
 SP-320 Sheet 4  
 1st printing

044402-xx A

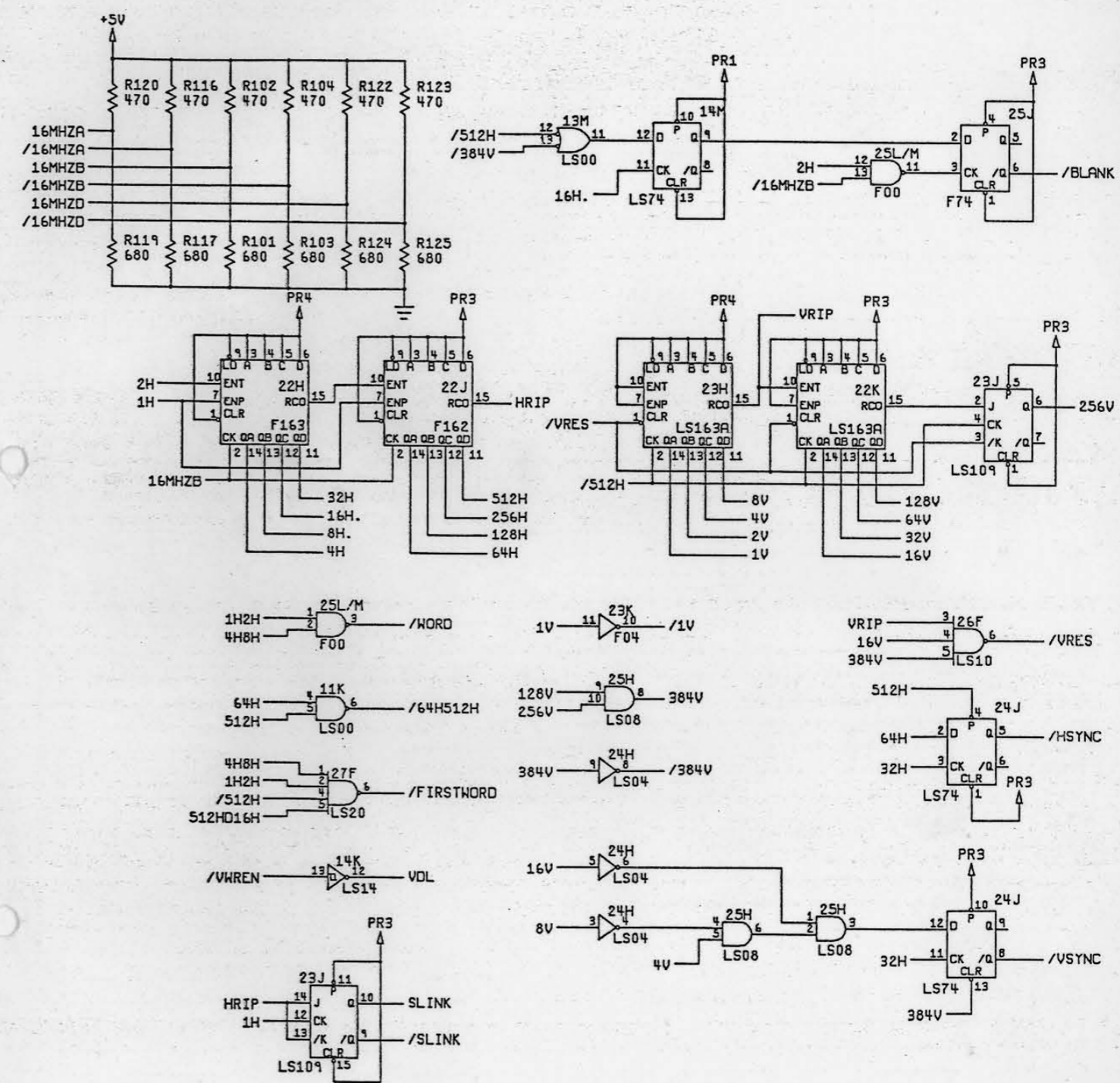
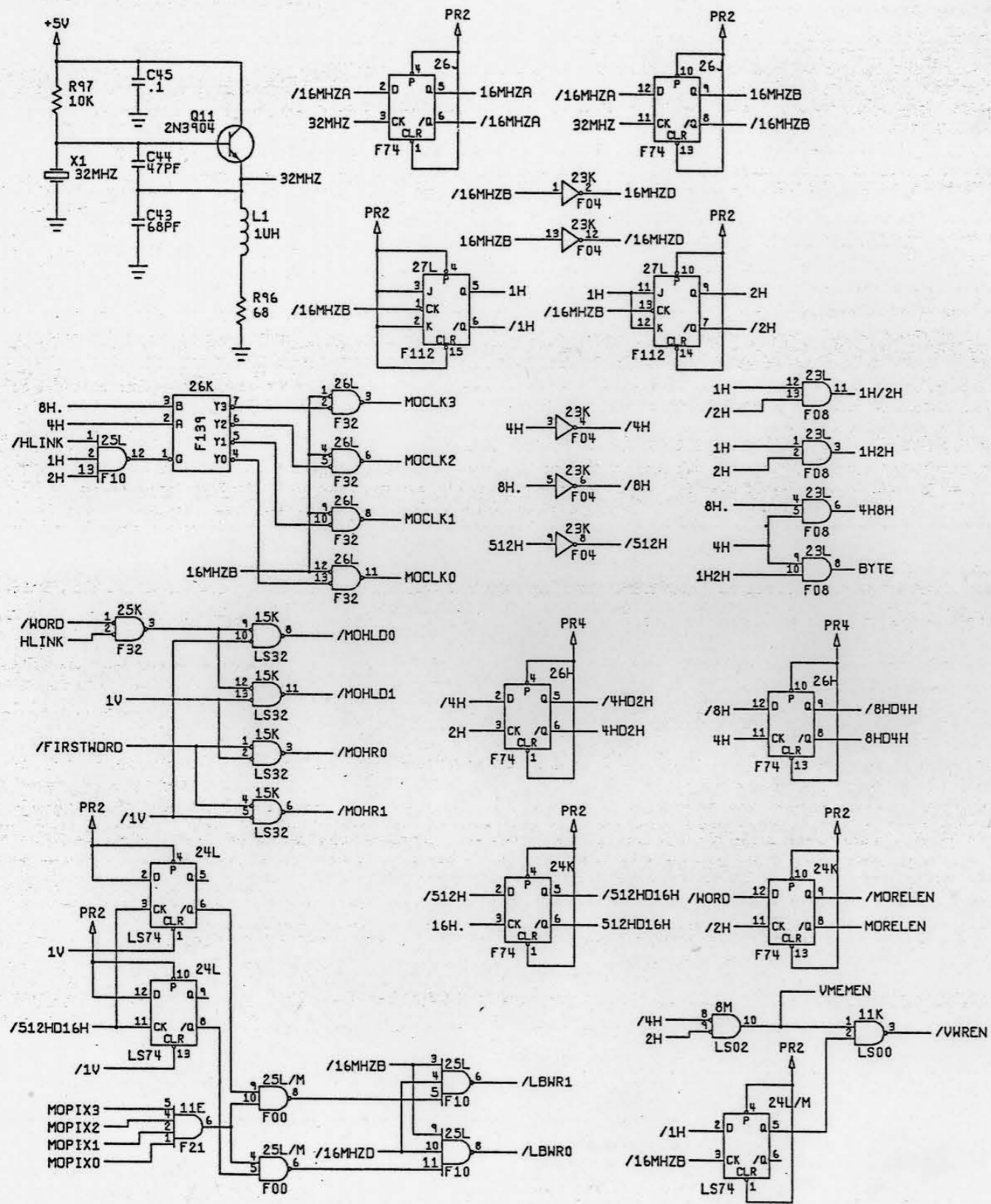

SYNC, TIMING

NOTICE TO ALL PERSONS RECEIVING THIS DRAWING  
 CONFIDENTIAL: Reproduction forbidden without the specific written permission of Atari Games Corporation, Milpitas, CA. This drawing is only conditionally issued and neither receipt nor possession thereof confers or transfers any right in, or license to use, the subject matter of the drawing or any design or technical information shown thereon, nor any right to reproduce this drawing, or any part thereof. Except for manufacture by vendors of Atari Games Corporation, and for manufacture under the corporation's written license, no right is granted to reproduce this drawing or the subject matter thereof, unless by written agreement with or written permission from the corporation.

**Toobin™ Game PCB Assembly Schematic Diagram**

© 1988 Atari Games Corporation  
 SP-320 Sheet 5  
 1st printing  
 044402-xx A



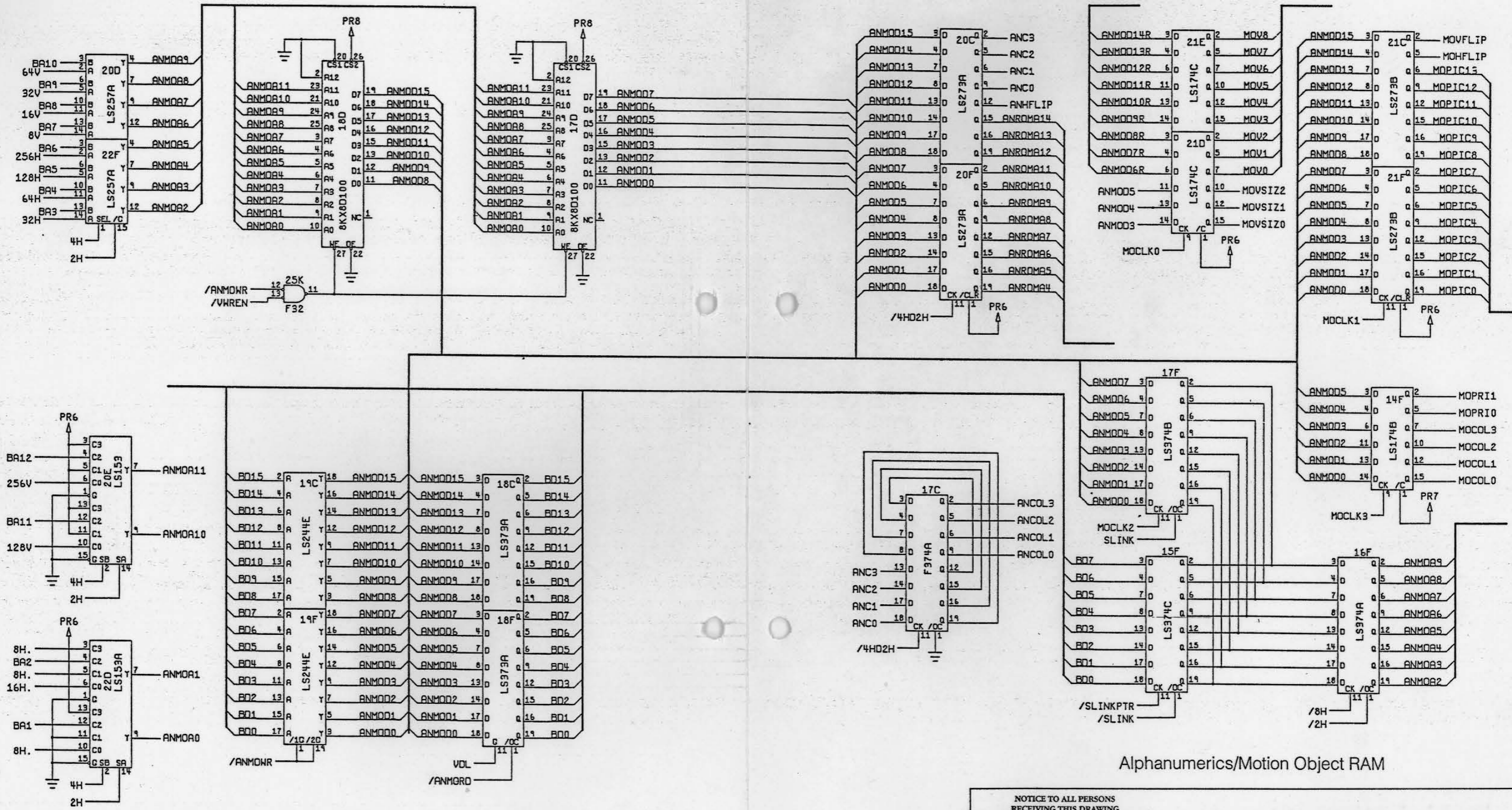

Alphanumeric/Motion Object RAM

**NOTICE TO ALL PERSONS RECEIVING THIS DRAWING**  
 CONFIDENTIAL: Reproduction forbidden without the specific written permission of Atari Games Corporation, Milpitas, CA. This drawing is only conditionally issued and neither receipt nor possession thereof confers or transfers any right in, or license to use, the subject matter of the drawing or any design or technical information shown thereon, nor any right to reproduce this drawing, or any part thereof. Except for manufacture by vendors of Atari Games Corporation, and for manufacture under the corporation's written license, no right is granted to reproduce this drawing or the subject matter thereof, unless by written agreement with or written permission from the corporation.

**Toobin™ Game PCB Assembly Schematic Diagram**

**ATARI**  
GAMES

© 1988 Atari Games Corporation  
SP-320 Sheet 6  
1st printing  
044402-xx A

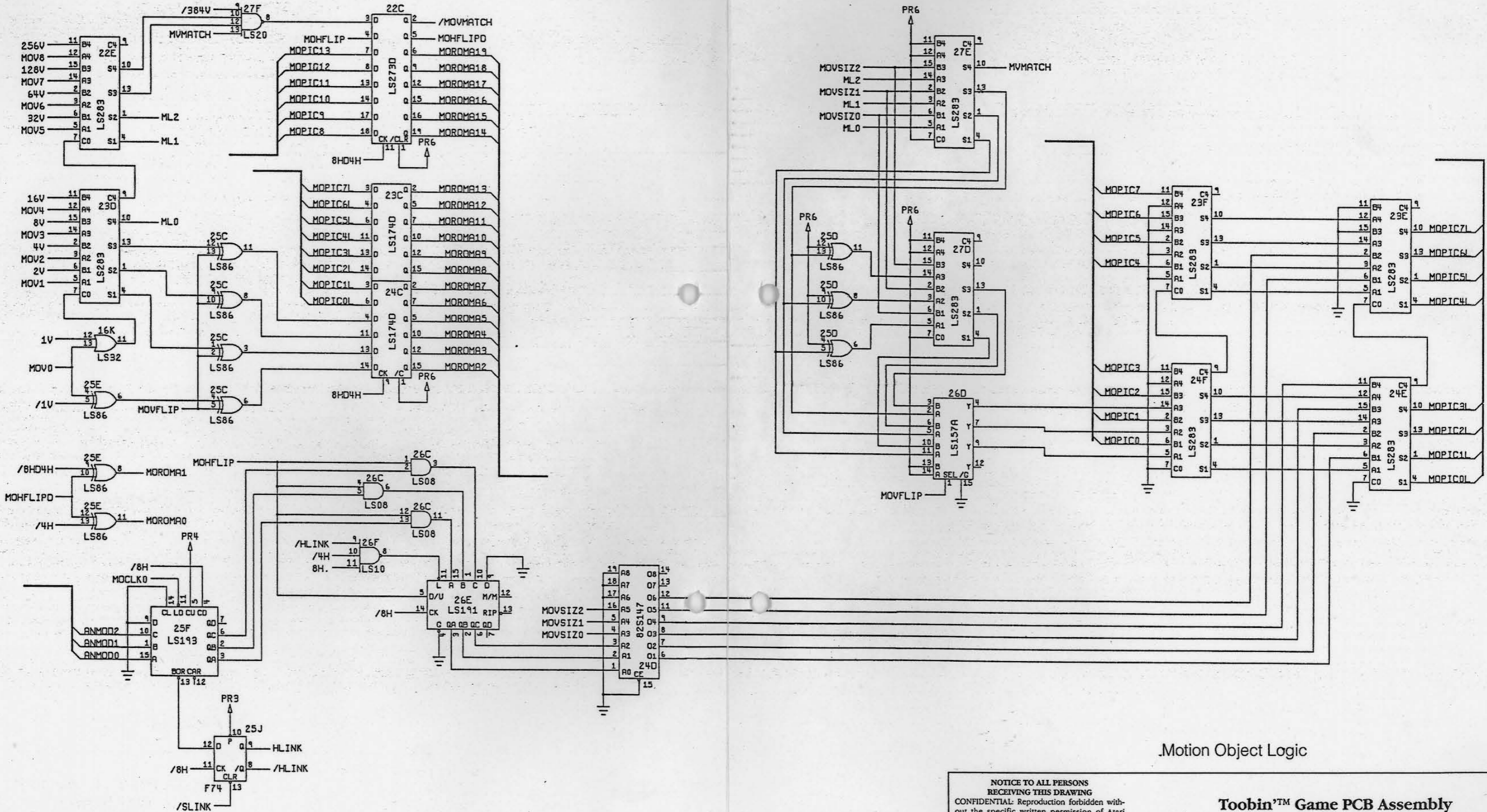

Motion Object Logic

**NOTICE TO ALL PERSONS RECEIVING THIS DRAWING**  
 CONFIDENTIAL: Reproduction forbidden without the specific written permission of Atari Games Corporation, Milpitas, CA. This drawing is only conditionally issued and neither receipt nor possession thereof confers or transfers any right in, or license to use, the subject matter of the drawing or any design or technical information shown thereon, nor any right to reproduce this drawing, or any part thereof. Except for manufacture by vendors of Atari Games Corporation, and for manufacture under the corporation's written license, no right is granted to reproduce this drawing or the subject matter thereof, unless by written agreement with or written permission from the corporation.

**Toobin™ Game PCB Assembly Schematic Diagram**

**ATARI GAMES**

© 1988 Atari Games Corporation

SP-320 Sheet 7  
1st printing

044402-xx A

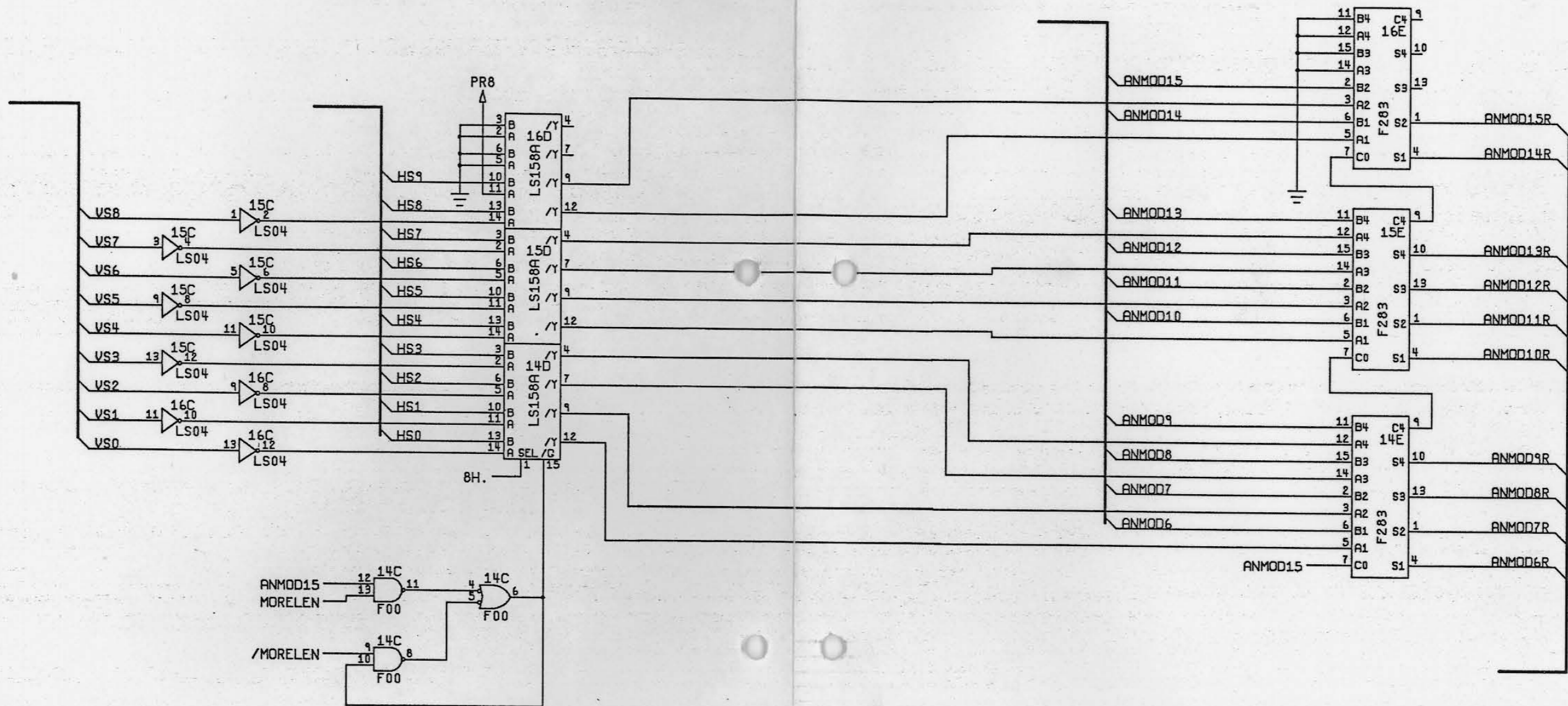

Motion Object Relative/Absolute Position Logic

**NOTICE TO ALL PERSONS RECEIVING THIS DRAWING**  
 CONFIDENTIAL: Reproduction forbidden without the specific written permission of Atari Games Corporation, Milpitas, CA. This drawing is only conditionally issued and neither receipt nor possession thereof confers or transfers any right in, or license to use, the subject matter of the drawing or any design or technical information shown thereon, nor any right to reproduce this drawing, or any part thereof. Except for manufacture by vendors of Atari Games Corporation, and for manufacture under the corporation's written license, no right is granted to reproduce this drawing or the subject matter thereof, unless by written agreement with or written permission from the corporation.

**Toobin™ Game PCB Assembly Schematic Diagram**



© 1988 Atari Games Corporation  
 04402-xx A

SP-320 Sheet 8  
 1st printing

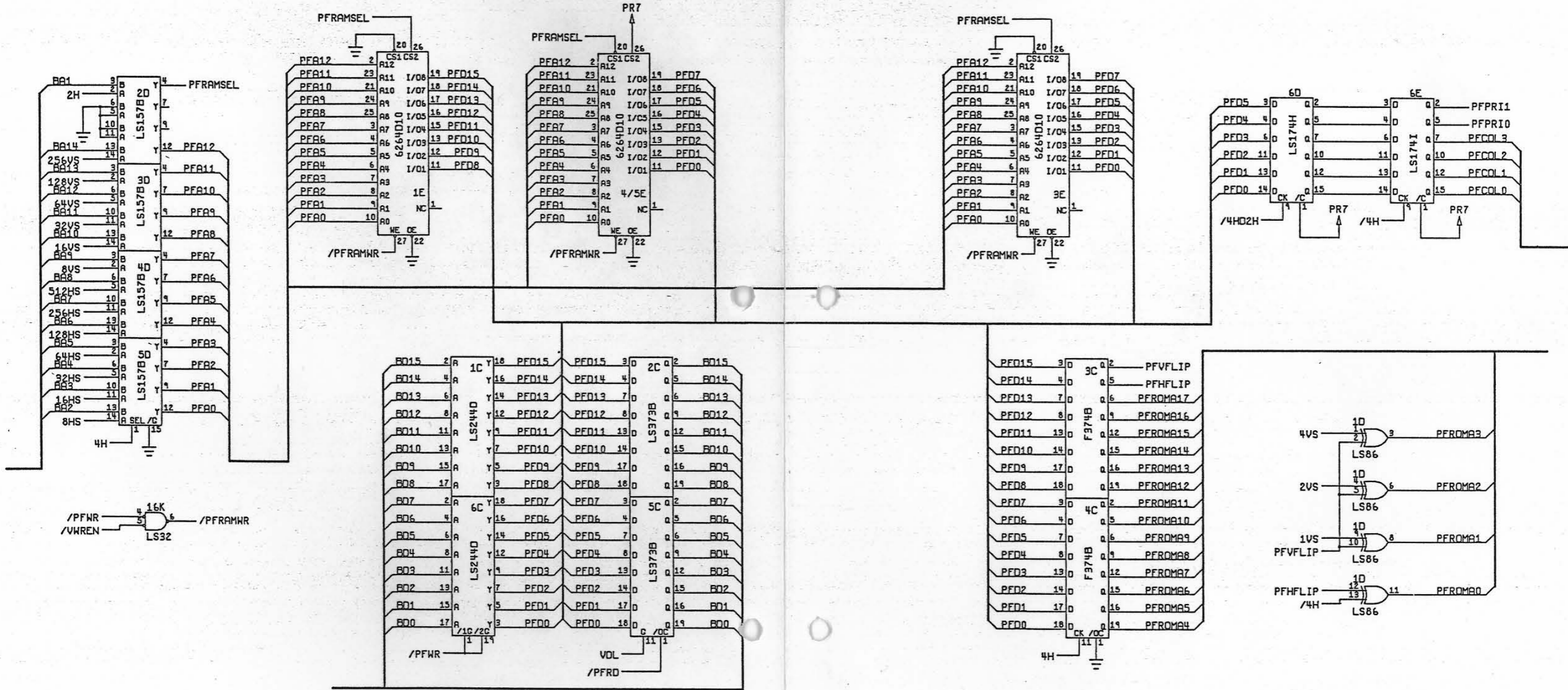

Playfield RAM

**NOTICE TO ALL PERSONS RECEIVING THIS DRAWING**  
 CONFIDENTIAL: Reproduction forbidden without the specific written permission of Atari Games Corporation, Milpitas, CA. This drawing is only conditionally issued and neither receipt nor possession thereof confers or transfers any right in, or license to use, the subject matter of the drawing or any design or technical information shown thereon, nor any right to reproduce this drawing, or any part thereof. Except for manufacture by vendors of Atari Games Corporation, and for manufacture under the corporation's written license, no right is granted to reproduce this drawing or the subject matter thereof, unless by written agreement with or written permission from the corporation.

**Toobin™ Game PCB Assembly Schematic Diagram**

**ATARI GAMES**

© 1988 Atari Games Corporation  
 044402-xx A

SP-320 Sheet 9  
 1st printing

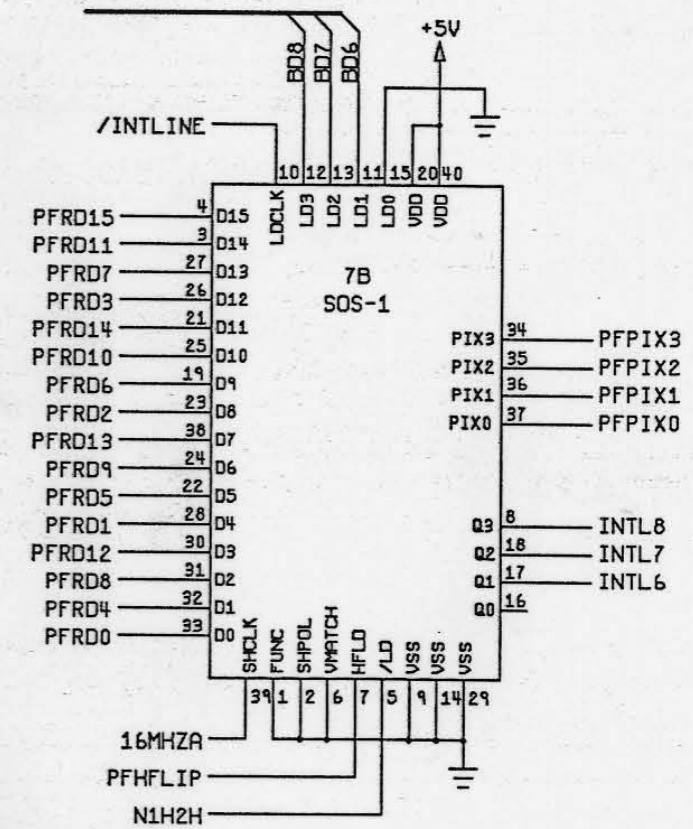
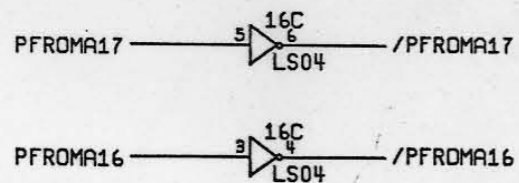
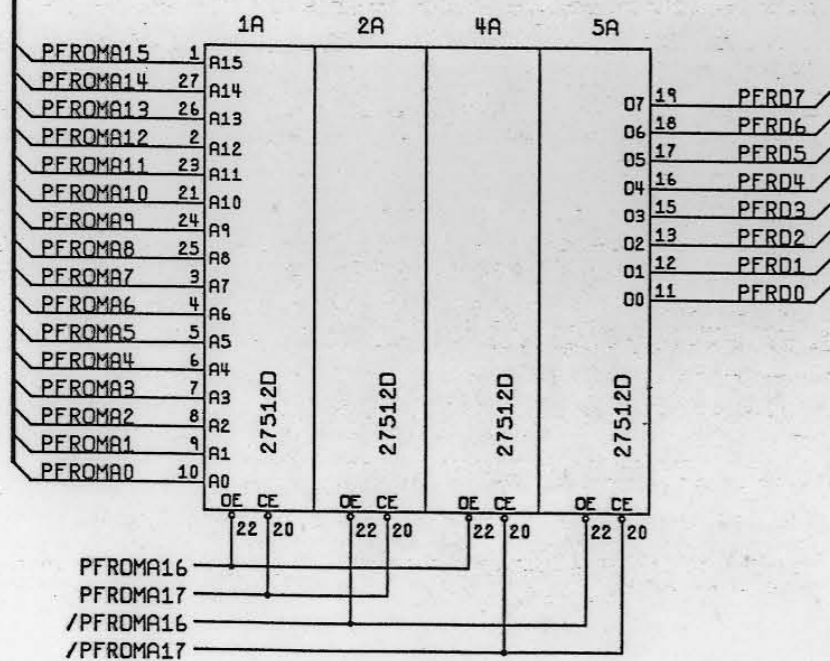
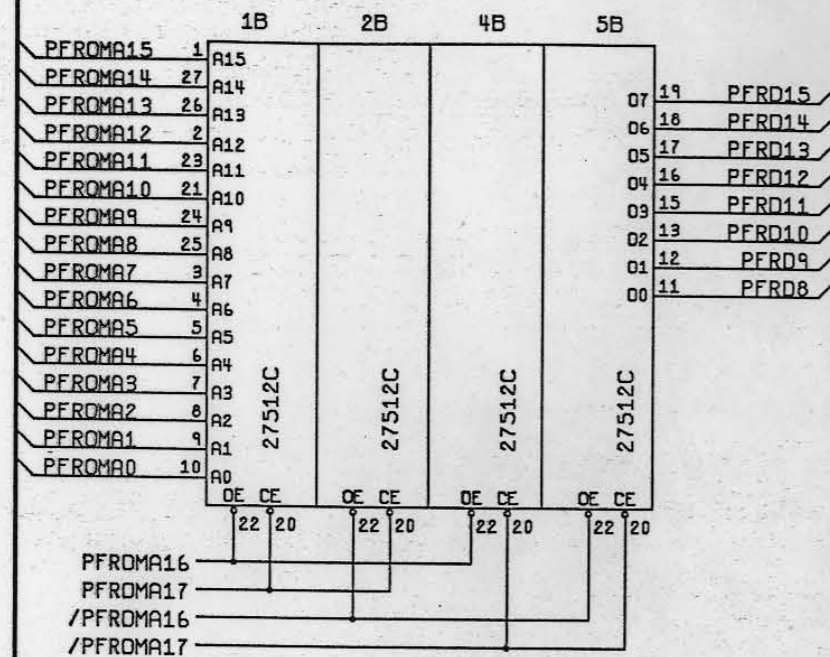

Playfield Graphics ROM, Shifter

**NOTICE TO ALL PERSONS RECEIVING THIS DRAWING**  
 CONFIDENTIAL: Reproduction forbidden without the specific written permission of Atari Games Corporation, Milpitas, CA. This drawing is only conditionally issued and neither receipt nor possession thereof confers or transfers any right in, or license to use, the subject matter of the drawing or any design or technical information shown thereon, nor any right to reproduce this drawing, or any part thereof. Except for manufacture by vendors of Atari Games Corporation, and for manufacture under the corporation's written license, no right is granted to reproduce this drawing or the subject matter thereof, unless by written agreement with or written permission from the corporation.

**Toobin™ Game PCB Assembly Schematic Diagram**

**ATARI GAMES**

© 1988 Atari Games Corporation

SP-320 Sheet 10  
1st printing

044402-xx A

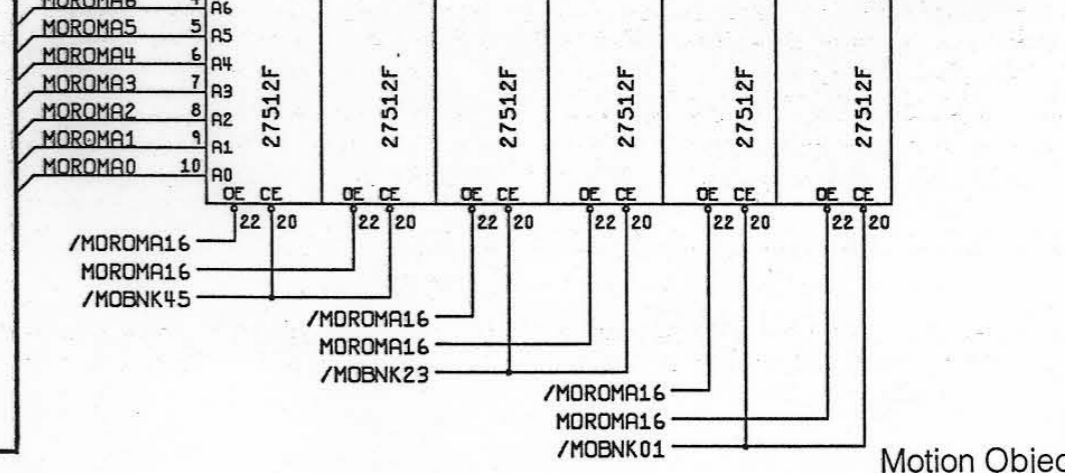
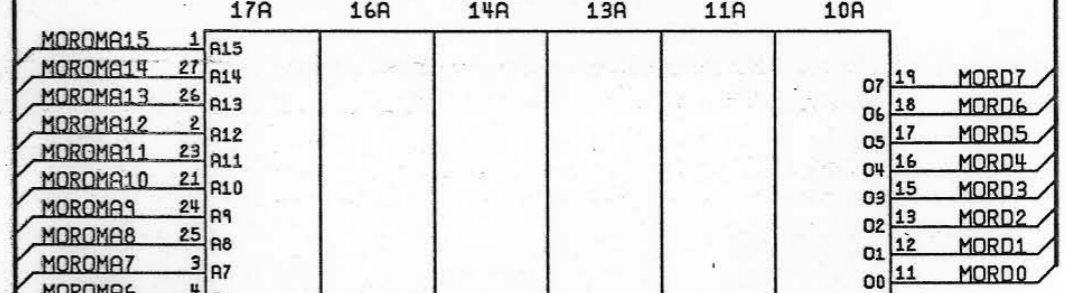
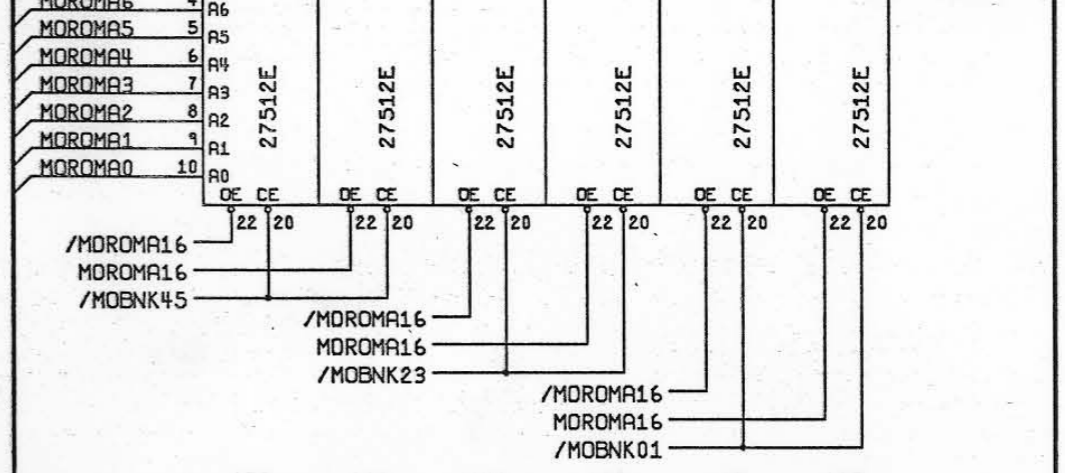
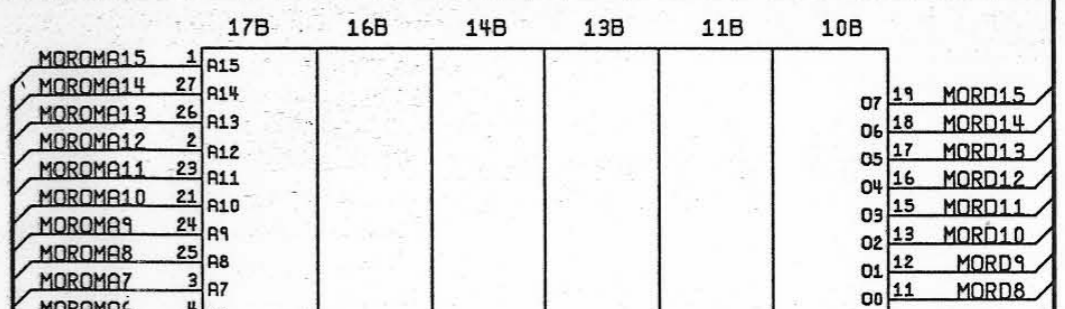
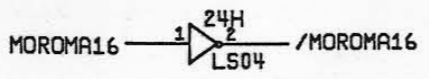
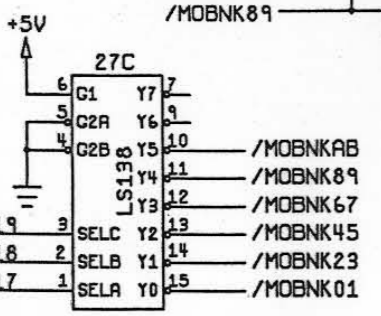
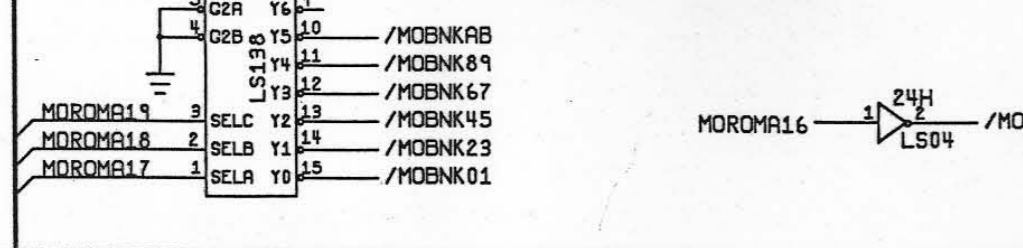
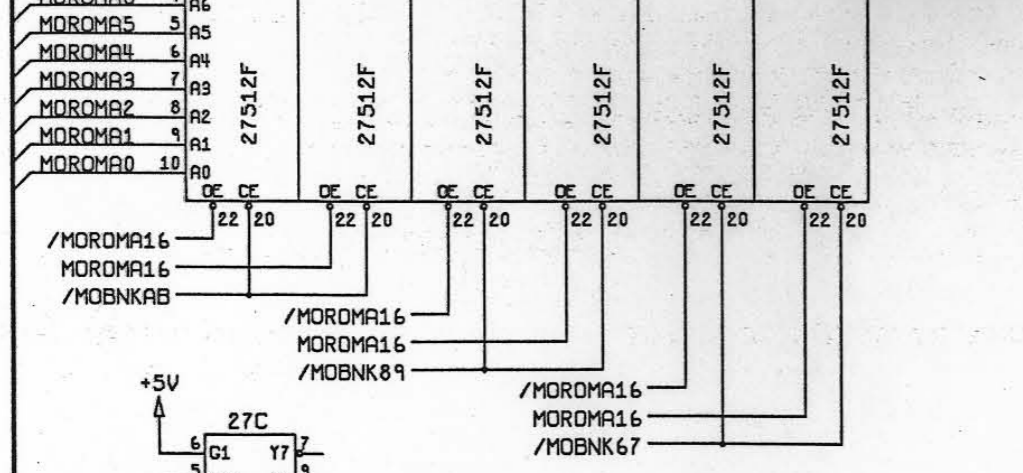
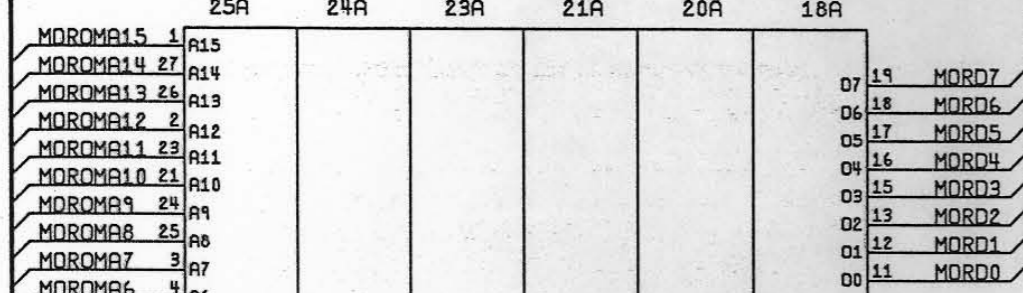
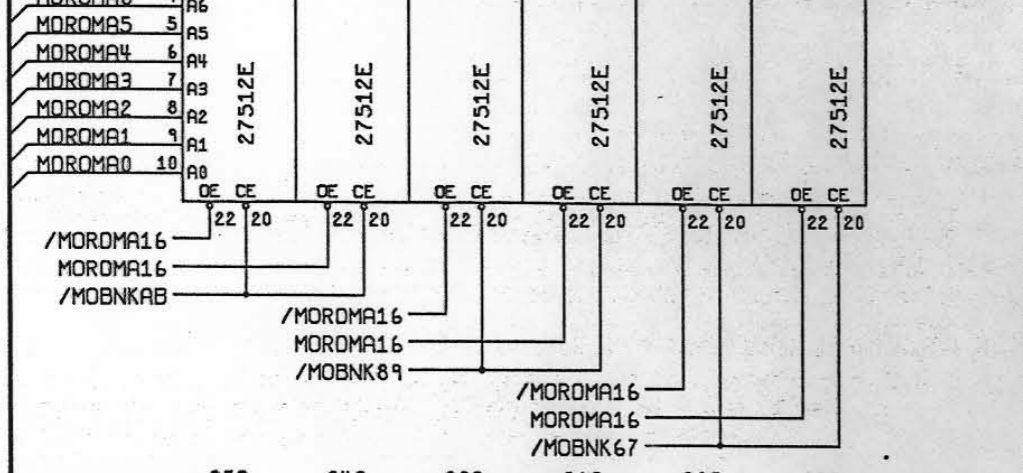
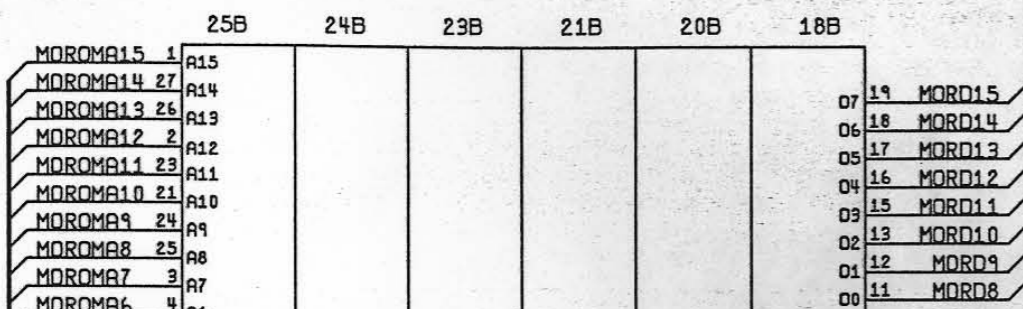

Motion Object Graphics ROM

**NOTICE TO ALL PERSONS RECEIVING THIS DRAWING**  
 CONFIDENTIAL: Reproduction forbidden without the specific written permission of Atari Games Corporation, Milpitas, CA. This drawing is only conditionally issued and neither receipt nor possession thereof confers or transfers any right in, or license to use, the subject matter of the drawing or any design or technical information shown thereon, nor any right to reproduce this drawing, or any part thereof. Except for manufacture by vendors of Atari Games Corporation, and for manufacture under the corporation's written license, no right is granted to reproduce this drawing or the subject matter thereof, unless by written agreement with or written permission from the corporation.

**Toobin™ Game PCB Assembly Schematic Diagram**



© 1988 Atari Games Corporation  
 SP-320 Sheet 11  
 1st printing  
 044402-xx A

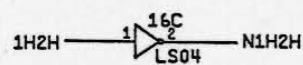
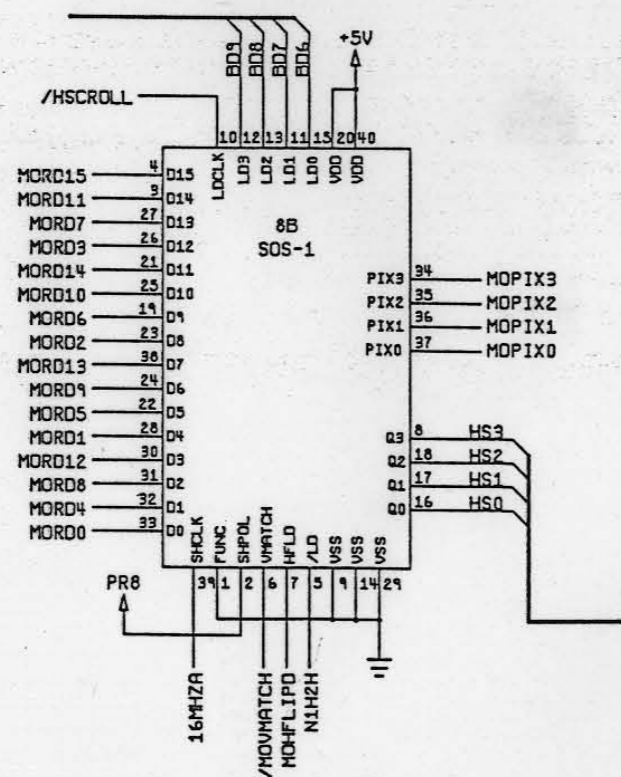
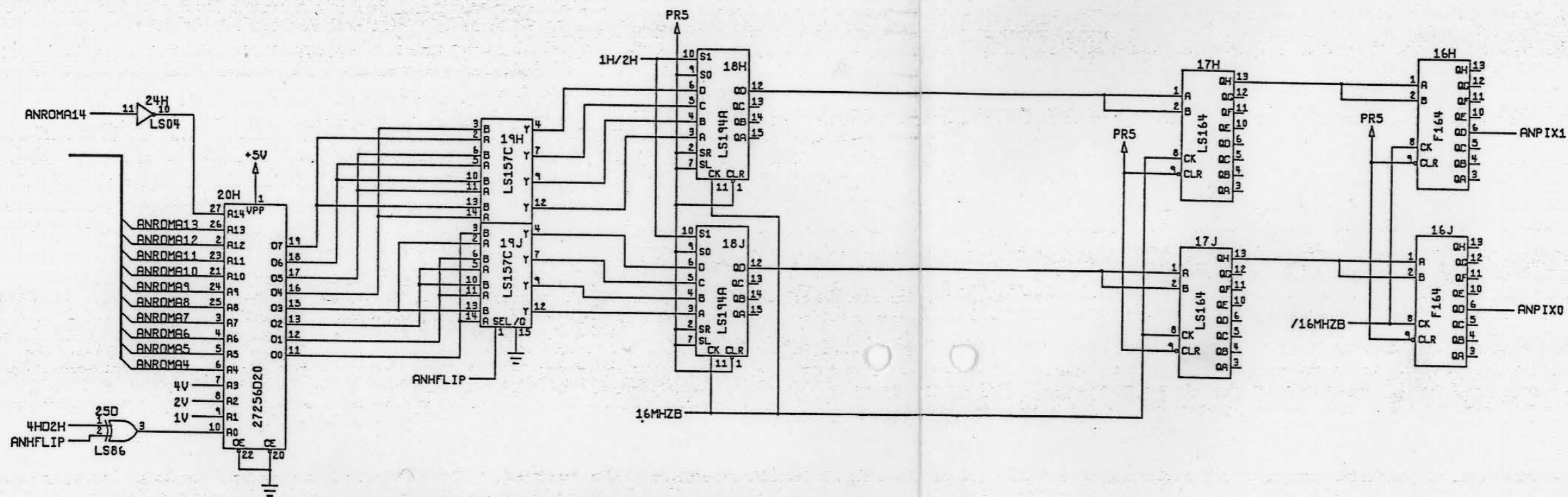

Alphanumeric ROM, Motion Object Shifter

**NOTICE TO ALL PERSONS RECEIVING THIS DRAWING**  
 CONFIDENTIAL: Reproduction forbidden without the specific written permission of Atari Games Corporation, Milpitas, CA. This drawing is only conditionally issued and neither receipt nor possession thereof confers or transfers any right in, or license to use, the subject matter of the drawing or any design or technical information shown thereon, nor any right to reproduce this drawing, or any part thereof. Except for manufacture by vendors of Atari Games Corporation, and for manufacture under the corporation's written license, no right is granted to reproduce this drawing or the subject matter thereof, unless by written agreement with or written permission from the corporation.

**Toobin™ Game PCB Assembly Schematic Diagram**

© 1988 Atari Games Corporation

SP-320 Sheet 12  
1st printing

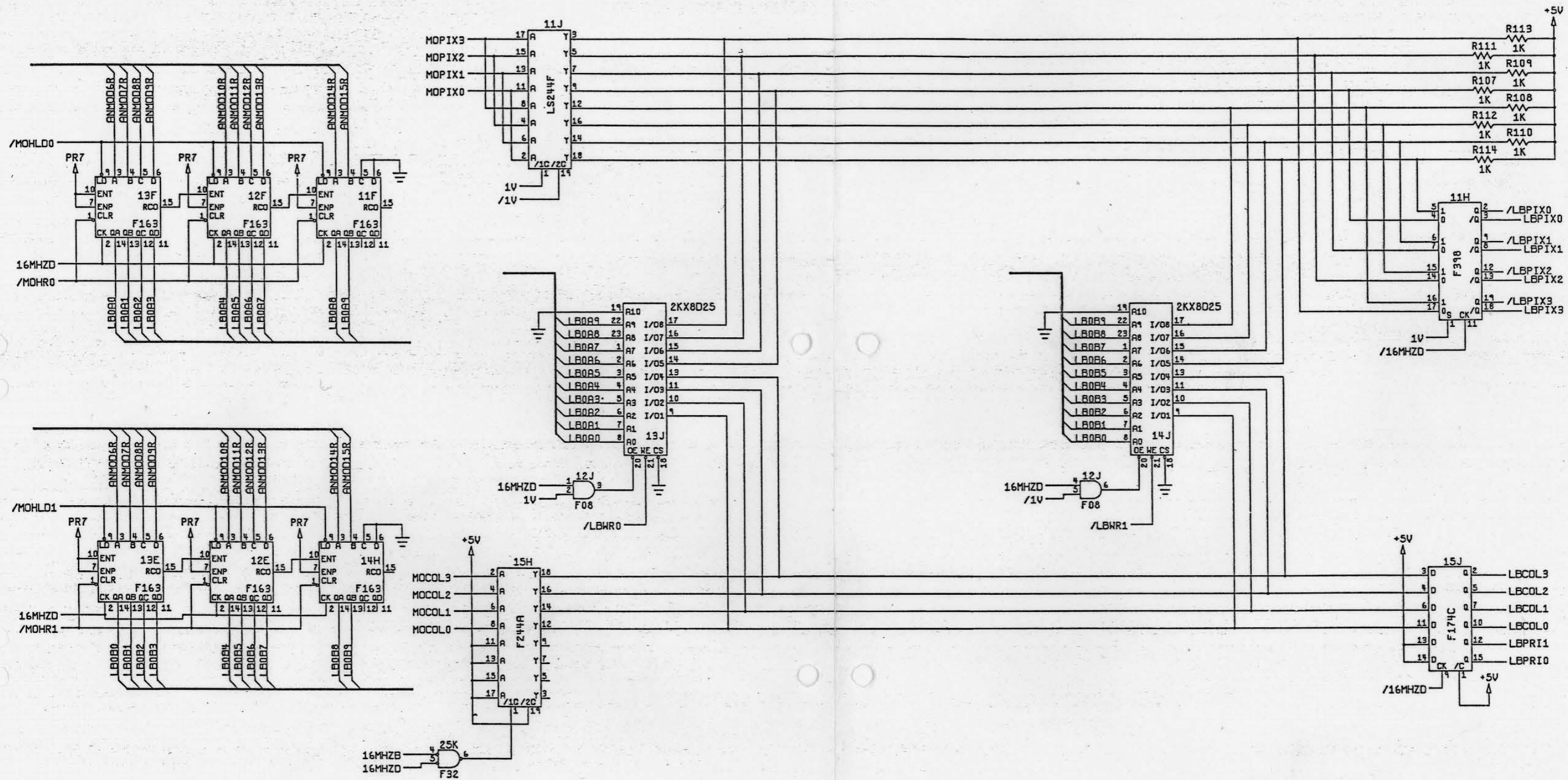

Motion Object Line Buffers

**NOTICE TO ALL PERSONS RECEIVING THIS DRAWING**  
 CONFIDENTIAL: Reproduction forbidden without the specific written permission of Atari Games Corporation, Milpitas, CA. This drawing is only conditionally issued and neither receipt nor possession thereof confers or transfers any right in, or license to use, the subject matter of the drawing or any design or technical information shown thereon, nor any right to reproduce this drawing, or any part thereof. Except for manufacture by vendors of Atari Games Corporation, and for manufacture under the corporation's written license, no right is granted to reproduce this drawing or the subject matter thereof, unless by written agreement with or written permission from the corporation.

**Toobin™ Game PCB Assembly Schematic Diagram**

**ATARI GAMES**

© 1988 Atari Games Corporation  
044402-xx A

SP-320 Sheet 13  
1st printing



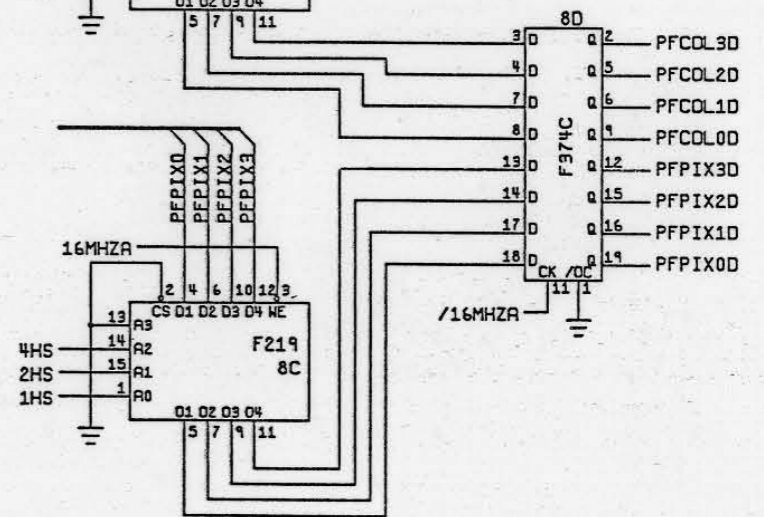
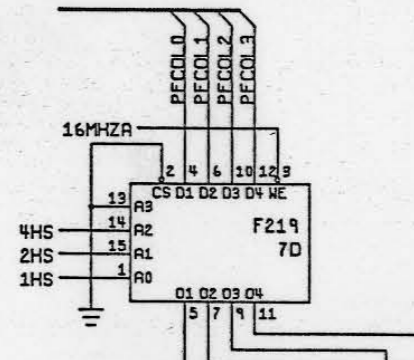
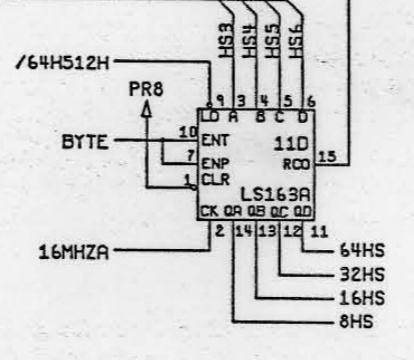
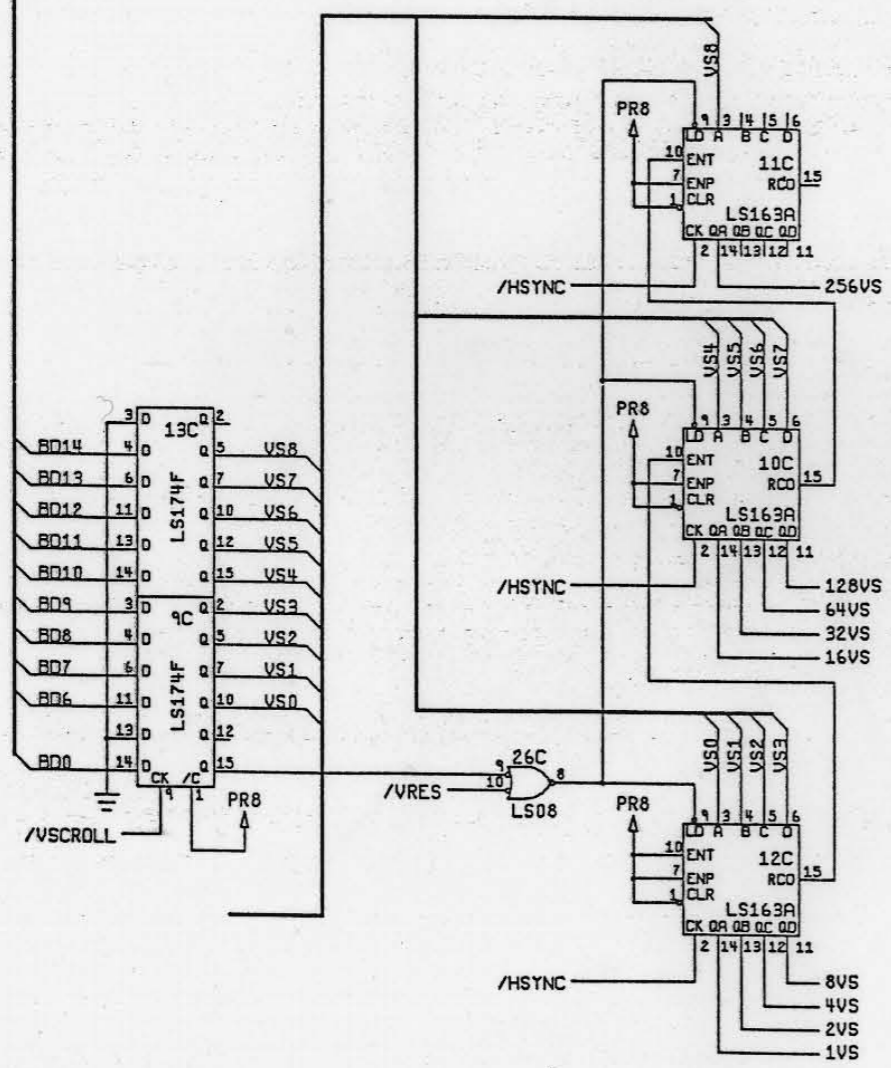
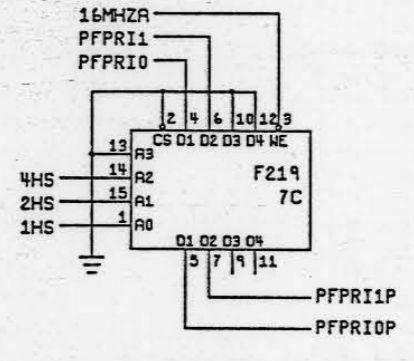
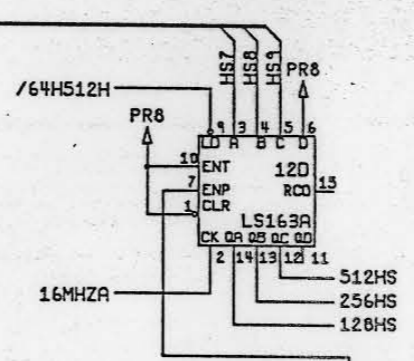
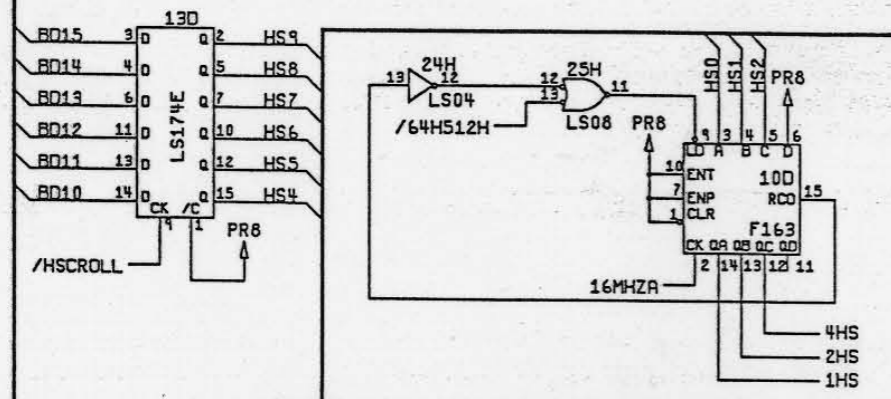

Playfield Scrolling Logic

**NOTICE TO ALL PERSONS RECEIVING THIS DRAWING**  
 CONFIDENTIAL: Reproduction forbidden without the specific written permission of Atari Games Corporation, Milpitas, CA. This drawing is only conditionally issued and neither receipt nor possession thereof confers or transfers any right in, or license to use, the subject matter of the drawing or any design or technical information shown thereon, nor any right to reproduce this drawing, or any part thereof. Except for manufacture by vendors of Atari Games Corporation, and for manufacture under the corporation's written license, no right is granted to reproduce this drawing or the subject matter thereof, unless by written agreement with or written permission from the corporation.

**Toobin™ Game PCB Assembly Schematic Diagram**



© 1988 Atari Games Corporation  
 044402-xx A

SP-320 Sheet 14  
 1st printing

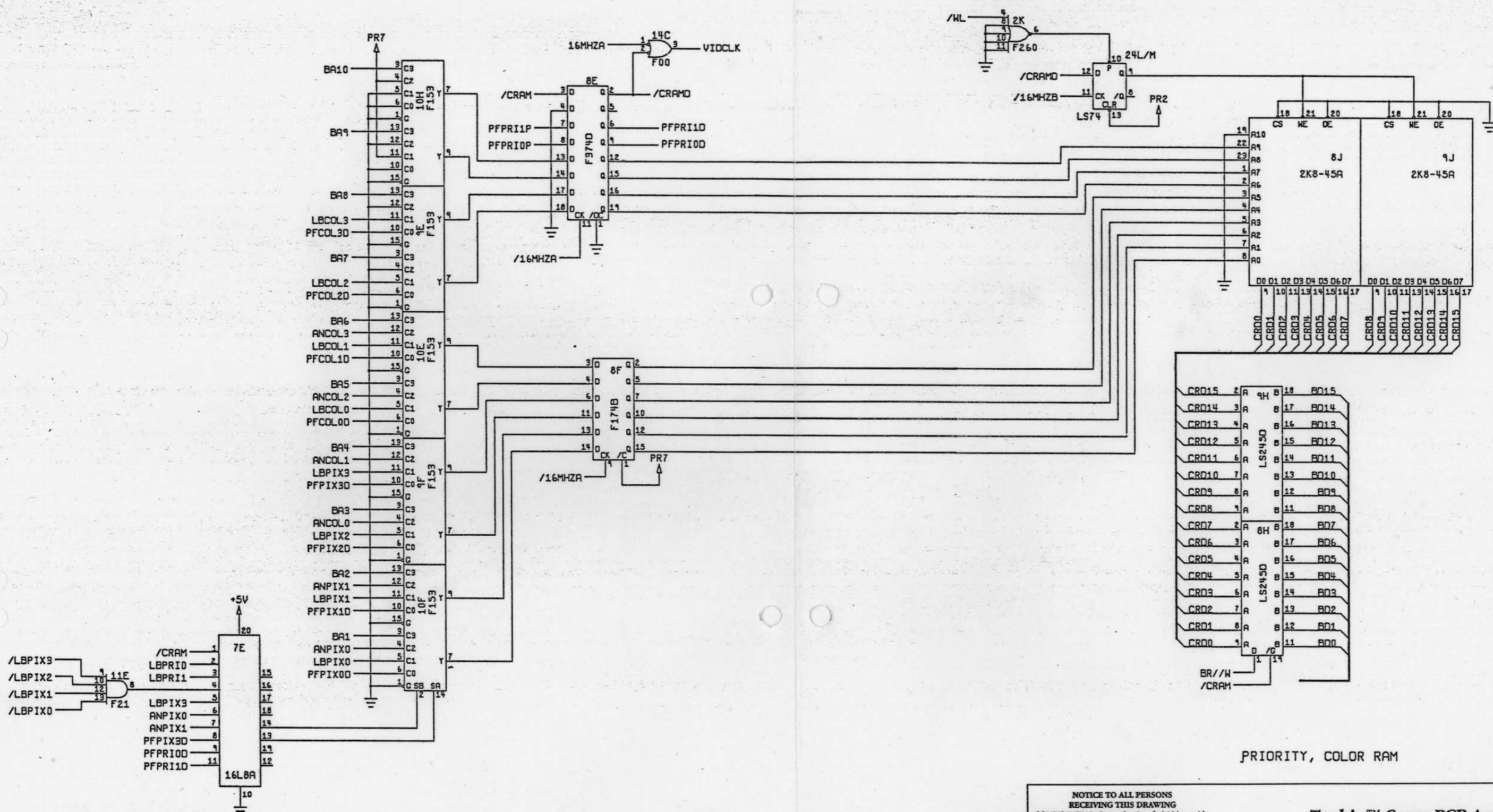

PRIORITY, COLOR RAM

**NOTICE TO ALL PERSONS RECEIVING THIS DRAWING**  
 CONFIDENTIAL: Reproduction forbidden without the specific written permission of Atari Games Corporation, Milpitas, CA. This drawing is only conditionally issued and neither receipt nor possession thereof confers or transfers any right in, or license to use, the subject matter of the drawing or any design or technical information shown thereon, nor any right to reproduce this drawing, or any part thereof. Except for manufacture by vendors of Atari Games Corporation, and for manufacture under the corporation's written license, no right is granted to reproduce this drawing or the subject matter thereof, unless by written agreement with or written permission from the corporation.

**Toobin™ Game PCB Assembly Schematic Diagram**

  
 ATARI GAMES

© 1988 Atari Games Corporation  
 SP-320 Sheet 15  
 1st printing  
 044402-xx A

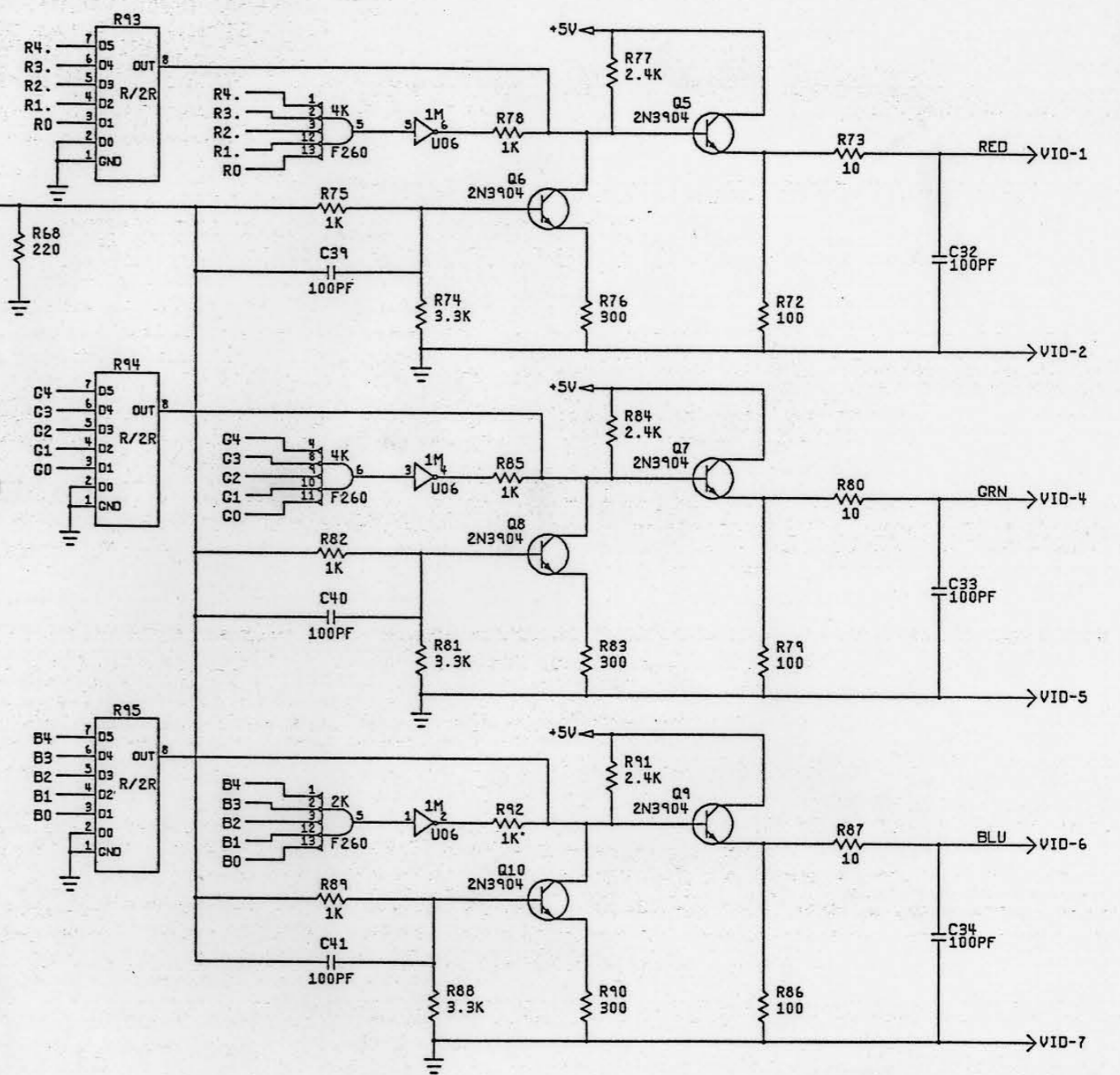
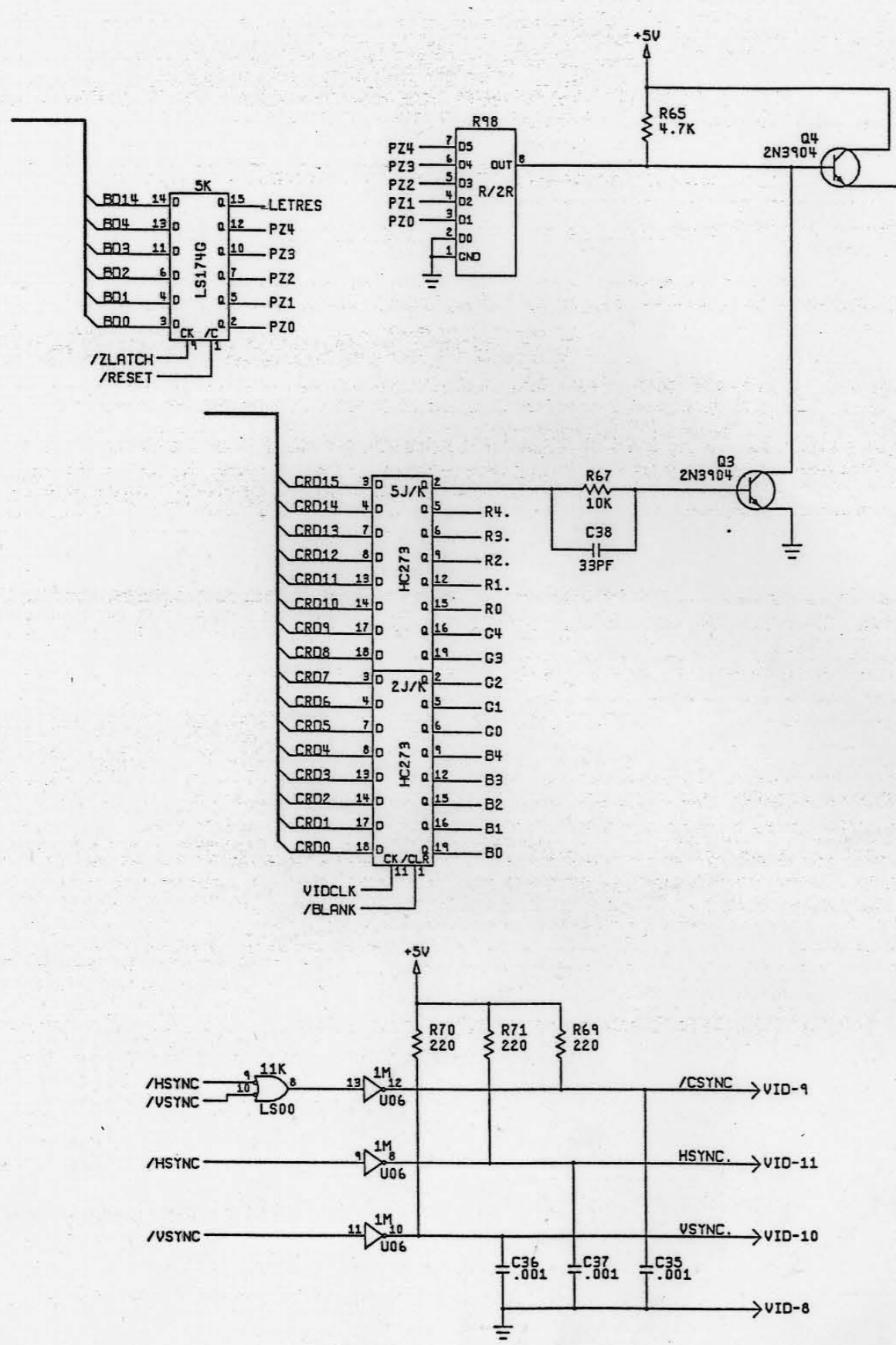

VIDEO DACS

**NOTICE TO ALL PERSONS RECEIVING THIS DRAWING**  
 CONFIDENTIAL: Reproduction forbidden without the specific written permission of Atari Games Corporation, Milpitas, CA. This drawing is only conditionally issued and neither receipt nor possession thereof confers or transfers any right in, or license to use, the subject matter of the drawing or any design or technical information shown thereon, nor any right to reproduce this drawing, or any part thereof. Except for manufacture by vendors of Atari Games Corporation, and for manufacture under the corporation's written license, no right is granted to reproduce this drawing or the subject matter thereof, unless by written agreement with or written permission from the corporation.

**Toobin™ Game PCB Assembly Schematic Diagram**

© 1988 Atari Games Corporation

SP-320 Sheet 16  
 1st printing

# Toobin' Memory Map

HEXADECIMAL	ADDRESS				R/ W	DATA				FUNCTION
	AAAA	AAAA	AAAA	AA		DDDD	DD	DDDD	DDDD	
	2222	1111	1111	11AA		1111	11DD	DDDD	DDDD	
	3210	9876	5432	1098		5432	1098	7654	3210	
000000-07FFFF	0XXX	XAAA	AAAA	AAAA	R	DDDD	DDDD	DDDD	DDDD	512K BYTES PROGRAM ROM
C00000-C07FFC	11XX	XX00	0AAA	AAAA	R/W			DDDD	DDDD	PLAYFIELD PALETTE
C00000-C07FFC	11XX	XX00	0AAA	AAAA	R/W			DDDD		PLAYFIELD PRIORITY
C00000-C07FFE	11XX	XX00	0AAA	AAAA	R/W	D				PLAYFIELD VERTICAL FLIP
C00000-C07FFE	11XX	XX00	0AAA	AAAA	R/W	D				PLAYFIELD HORIZONTAL FLIP
C00000-C07FFE	11XX	XX00	0AAA	AAAA	R/W	DD	DDDD	DDDD	DDDD	PLAYFIELD STAMP CODE
C08000-C09FFE	11XX	XX00	1XXA	AAAA	R/W	DDDD	DDDD	DDDD	DDDD	ALPHANUMERICS/MOTION OBJECT RAM
C08000-C097FE	11XX	XX00	1XXA	AAAA	R/W	DDDD				ALPHANUMERIC PALETTE
C08000-C097FE	11XX	XX00	1XXA	AAAA	R/W		D			ALPHANUMERIC HORIZONTAL FLIP
C08000-C097FE	11XX	XX00	1XXA	AAAA	R/W		DD	DDDD	DDDD	ALPHANUMERIC STAMP CODE
J09800-C09FF8	11XX	XX00	1XX1	1AAA	R/W	D (1 = ABSOLUTE)				M.O. ABSOLUTE/P.F. RELATIVE POSITION
C09800-C09FF8	11XX	XX00	1XX1	1AAA	R/W	DDD	DDDD	DD		M.O. VERTICAL POSITION
C09800-C09FF8	11XX	XX00	1XX1	1AAA	R/W			DD	D	M.O. VERTICAL SIZE
J09800-C09FF8	11XX	XX00	1XX1	1AAA	R/W				DDD	M.O. HORIZONTAL SIZE
J09802-C09FFA	11XX	XX00	1XX1	1AAA	R/W	D				M.O. VERTICAL FLIP
C09802-C09FFA	11XX	XX00	1XX1	1AAA	R/W	D				M.O. HORIZONTAL FLIP
C09802-C09FFA	11XX	XX00	1XX1	1AAA	R/W	D	DDDD	DDDD	DDDD	M.O. BASE STAMP CODE
C09804-C09FFC	11XX	XX00	1XX1	1AAA	R/W	DDDD				M.O. PALETTE
C09804-C09FFC	11XX	XX00	1XX1	1AAA	R/W		DDD	DDDD	D	M.O. LINK POINTER
C09806-C09FFE	11XX	XX00	1XX1	1AAA	R/W	DDDD	DDDD	DD		M.O. HORIZONTAL POSITION
C09806-C09FFE	11XX	XX00	1XX1	1AAA	R/W				DDDD	M.O. PRIORITY
C10000-C101FE	11XX	XX01	0XXX	X00P	R/W	DDDD	DDDD	DDDD	DDDD	PLAYFIELD COLOR RAM (256 WORDS)
C10200-C103FE	11XX	XX01	0XXX	X01P	R/W	DDDD	DDDD	DDDD	DDDD	MOTION OBJECT COLOR RAM (256 WORDS)
C10400-C1047E	11XX	XX01	0XXX	X100	R/W	DDDD	DDDD	DDDD	DDDD	ALPHANUMERICS COLOR RAM (64 WORDS) (P = PALETTE, C = COLOR)
C10000-C107FE	11XX	XX01	0XXX	XAAA	R/W	DDD	DD			COLOR RAM (ALL) - RED
C10000-C107FE	11XX	XX01	0XXX	XAAA	R/W			DD	DDD	COLOR RAM (ALL) - GREEN
C10000-C107FE	11XX	XX01	0XXX	XAAA	R/W				D	COLOR RAM (ALL) - BLUE
C10000-C107FE	11XX	XX01	0XXX	XAAA	R/W	D				COLOR RAM (ALL) - OVERALL INTENSITY DISABLE
FF8300	1XXX	XX1X	1000	0011	W			D	DDDD	OVERALL COLOR INTENSITY
FF8000	1XXX	XX1X	1000	0000	W					WATCHDOG CLEAR
FF8100	1XXX	XX1X	1000	0001	W					COMM. PORT TO SOUND CPU
FF8300	1XXX	XX1X	1000	0011	W			D	DDDD	OVERALL COLOR INTENSITY (D4:D0)
F8340	1XXX	XX1X	1000	0011	W		D	DDDD	DDDD	INTERRUPT SCAN LINE
F83C0	1XXX	XX1X	1000	0011	W					IRQ ACKNOWLEDGE
F8400	1XXX	XX1X	1000	0100	W					SOUND CPU RESET
F8500	1XXX	XX1X	1000	0101	W					EEPROM UNLOCK STROBE
F8600	1XXX	XX1X	1000	0110	W	DDDD	DDDD		DD	HSCROLL
F8700	1XXX	XX1X	1000	0111	W	DDD	DDDD		DD	VSCROLL
F8700	1XXX	XX1X	1000	0111	W				D	RESTART VSCROLL COUNTER (IF 0 DURING HBLANK)
FF8800	1XXX	XX1X	1000	1XXX	R	DDDD	DDDD	DDDD	DDDD	SWITCHES
FF9000	1XXX	XX1X	1001	0XXX	R					INPUTS
FF9000	1XXX	XX1X	1001	0XXX	R	D				HBLANK (0 = TRUE)
FF9000	1XXX	XX1X	1001	0XXX	R	D				VBLANK (0 = TRUE)
FF9000	1XXX	XX1X	1001	0XXX	R	D				SOUND CPU TRANSMIT COMM. LATCH FULL FLAG (0 = FULL)
FF9000	1XXX	XX1X	1001	0XXX	R	D				SELF-TEST SWITCH (0 = ON)
FF9800	1XXX	XX1X	1001	1XXX	R			DDDD	DDDD	COMM. PORT FROM SOUND CPU
FFA000-FFAFFE	1XXX	XX1X	101X	AAAA	R/W			DDDD	DDDD	EEPROM
FFC000-FFFFFE	1XXX	XX1X	11AA	AAAA	R/W	DDDD	DDDD	DDDD	DDDD	8K WORDS RAM (BYTE-ADDRESSABLE)



**NOTICE TO ALL PERSONS RECEIVING THIS DRAWING**  
 CONFIDENTIAL: Reproduction forbidden without the specific written permission of Atari Games Corporation, Milpitas, CA. This drawing is only conditionally issued and neither receipt nor possession thereof confers or transfers any right in, or license to use, the subject matter of the drawing or any design or technical information shown thereon, nor any right to reproduce this drawing, or any part thereof. Except for manufacture by vendors of Atari Games Corporation, and for manufacture under the corporation's written license, no right is granted to reproduce this drawing or the subject matter thereof, unless by written agreement with or written permission from the corporation.

**Toobin™ Memory Map**

**ATARI**  
GAMES

© 1988 Atari Games Corporation  
 SP-320 Sheet 17  
 1st printing  
 044326-xx A

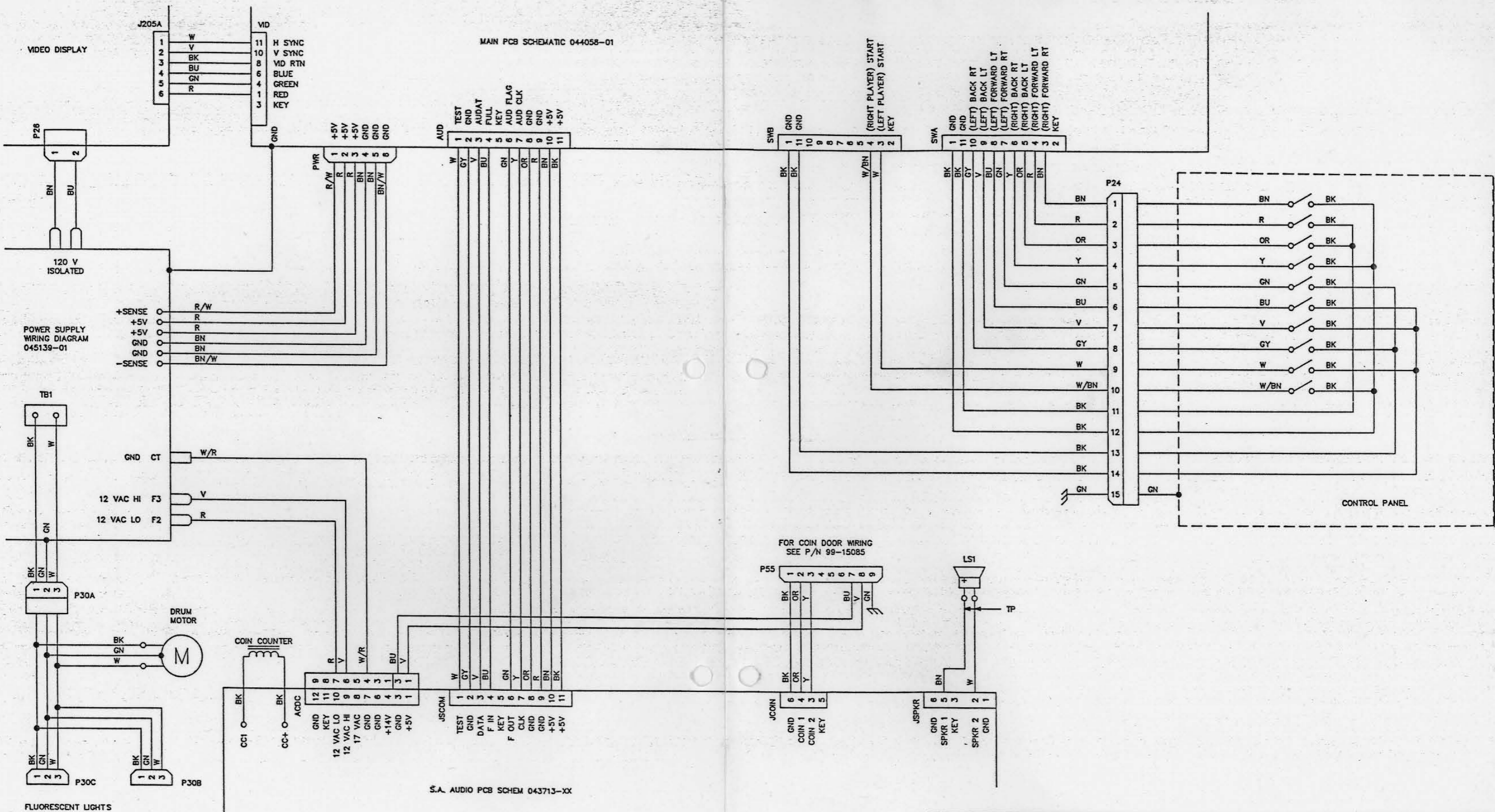

S.A. AUDIO PCB SCHEM 043713-XX

**NOTICE TO ALL PERSONS RECEIVING THIS DRAWING**

CONFIDENTIAL: Reproduction forbidden without the specific written permission of Atari Games Corporation, Milpitas, CA. This drawing is only conditionally issued and neither receipt nor possession thereof confers or transfers any right in, or license to use, the subject matter of the drawing or any design or technical information shown thereon, nor any right to reproduce this drawing, or any part thereof. Except for manufacture by vendors of Atari Games Corporation, and for manufacture under the corporation's written license, no right is granted to reproduce this drawing or the subject matter thereof, unless by written agreement with or written permission from the corporation.

**Toobin™ Main Wiring Diagram**



ATARI GAMES

© 1988 Atari Games Corporation

044326-xx A

SP-320 Sheet 18  
1st printing

ACDC-11 >-- KEY

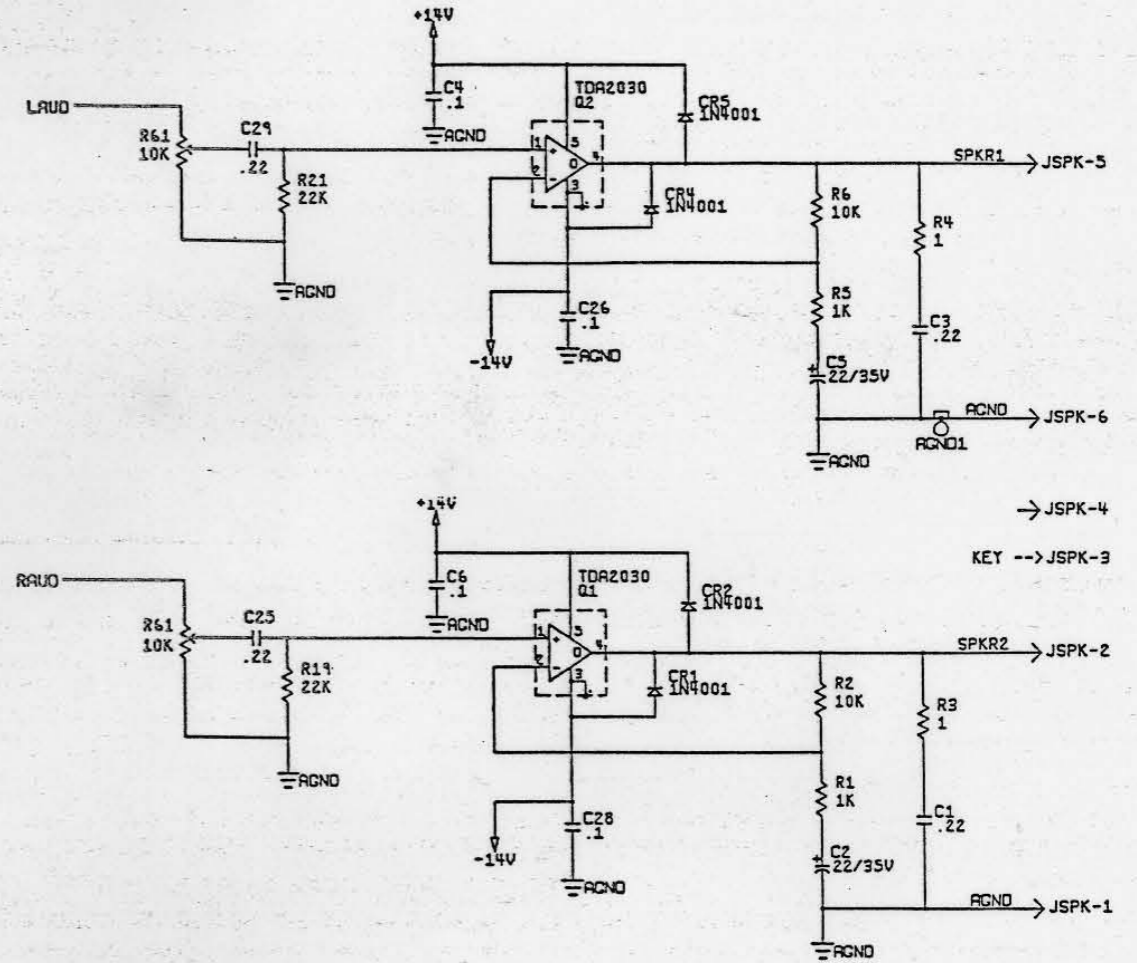
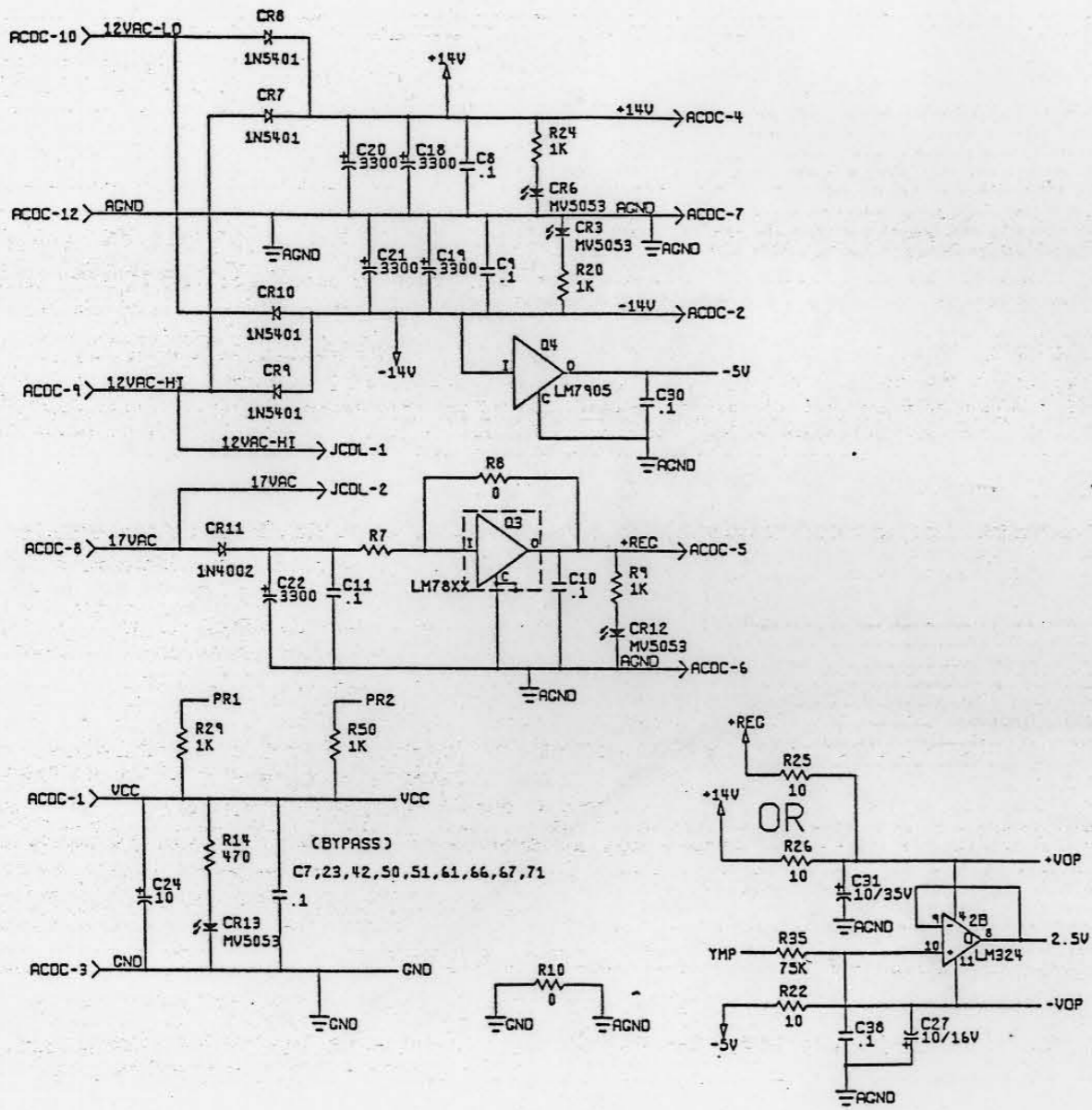

**NOTICE TO ALL PERSONS RECEIVING THIS DRAWING**  
 CONFIDENTIAL: Reproduction forbidden without the specific written permission of Atari Games Corporation, Milpitas, CA. This drawing is only conditionally issued and neither receipt nor possession thereof confers or transfers any right in, or license to use, the subject matter of the drawing or any design or technical information shown thereon, nor any right to reproduce this drawing, or any part thereof. Except for manufacture by vendors of Atari Games Corporation, and for manufacture under the corporation's written license, no right is granted to reproduce this drawing or the subject matter thereof, unless by written agreement with or written permission from the corporation.

**Stand-Alone Audio PCB Assembly Schematic Diagram, Sheet 1**

**ATARI GAMES**

© 1988 Atari Games Corporation  
 043713-xx B

SP-320 Sheet 19  
 1st printing

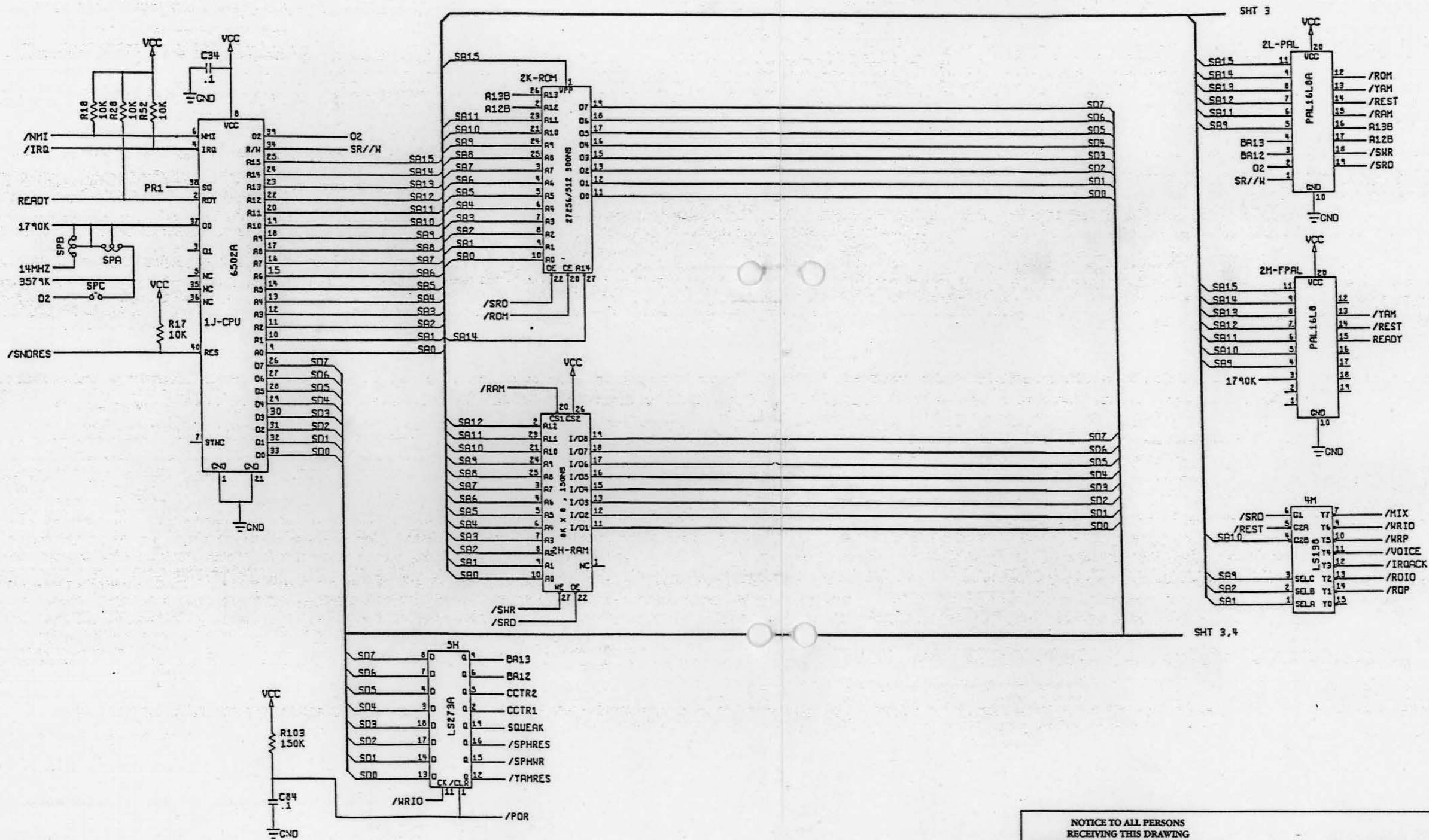

**NOTICE TO ALL PERSONS RECEIVING THIS DRAWING**

CONFIDENTIAL: Reproduction forbidden without the specific written permission of Atari Games Corporation, Milpitas, CA. This drawing is only conditionally issued and neither receipt nor possession thereof confers or transfers any right in, or license to use, the subject matter of the drawing or any design or technical information shown thereon, nor any right to reproduce this drawing, or any part thereof. Except for manufacture by vendors of Atari Games Corporation, and for manufacture under the corporation's written license, no right is granted to reproduce this drawing or the subject matter thereof, unless by written agreement with or written permission from the corporation.



**Stand-Alone Audio PCB Assembly Schematic Diagram, Sheet 2**

© 1988 Atari Games Corporation  
043713-xx B

SP-320 Sheet 20  
1st printing

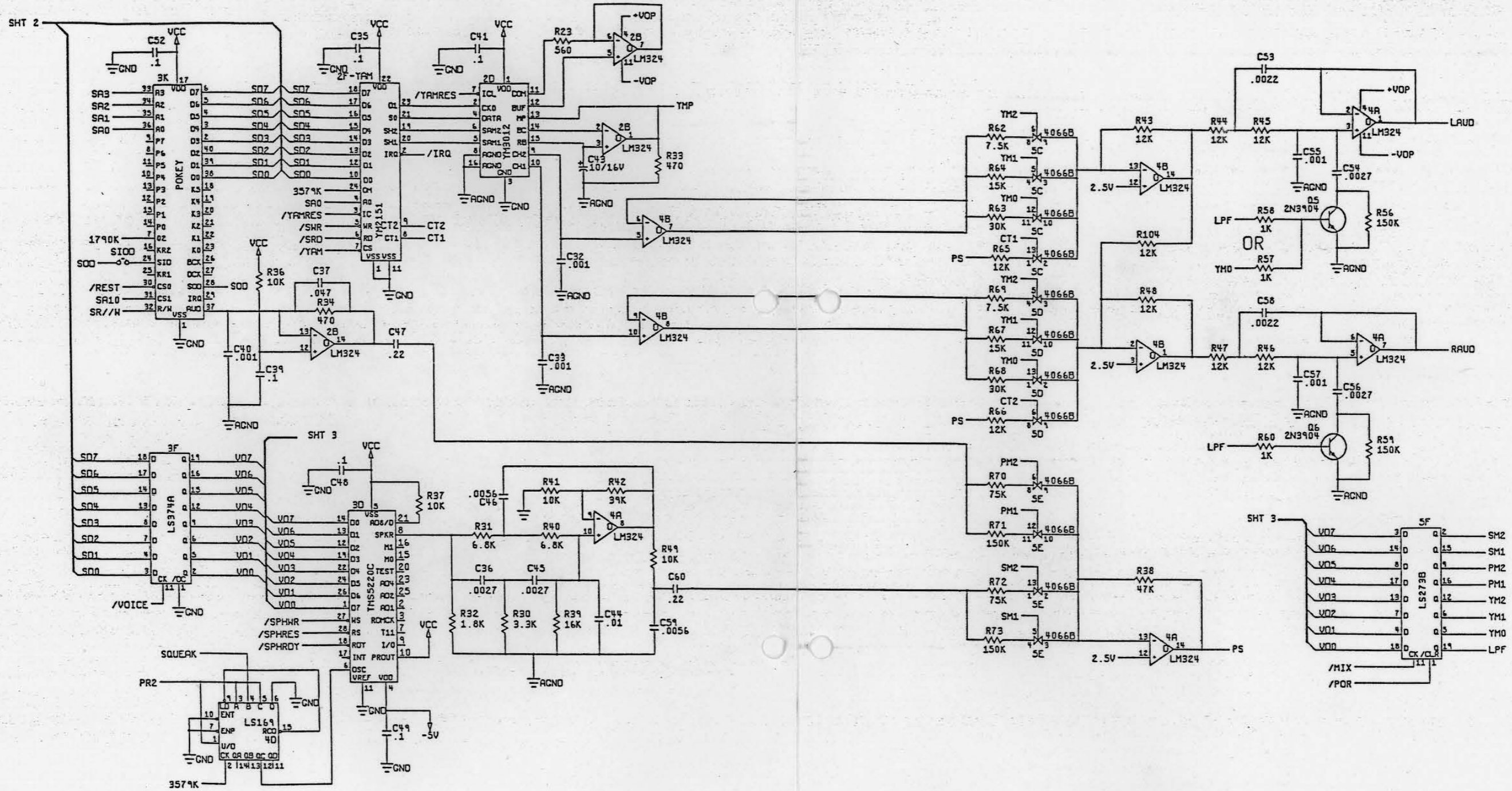

**NOTICE TO ALL PERSONS RECEIVING THIS DRAWING**

CONFIDENTIAL: Reproduction forbidden without the specific written permission of Atari Games Corporation, Milpitas, CA. This drawing is only conditionally issued and neither receipt nor possession thereof confers or transfers any right in, or license to use, the subject matter of the drawing or any design or technical information shown thereon, nor any right to reproduce this drawing, or any part thereof. Except for manufacture by vendors of Atari Games Corporation, and for manufacture under the corporation's written license, no right is granted to reproduce this drawing or the subject matter thereof, unless by written agreement with or written permission from the corporation.

**Stand-Alone Audio PCB Assembly Schematic Diagram, Sheet 3**

**ATARI GAMES**

© 1988 Atari Games Corporation  
043713-xx B

**SP-320 Sheet 21  
1st printing**



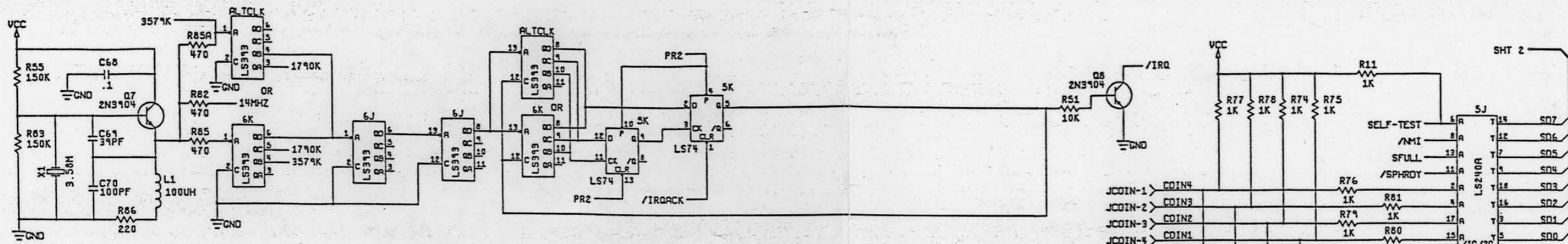

KEY --> JSCOM-5

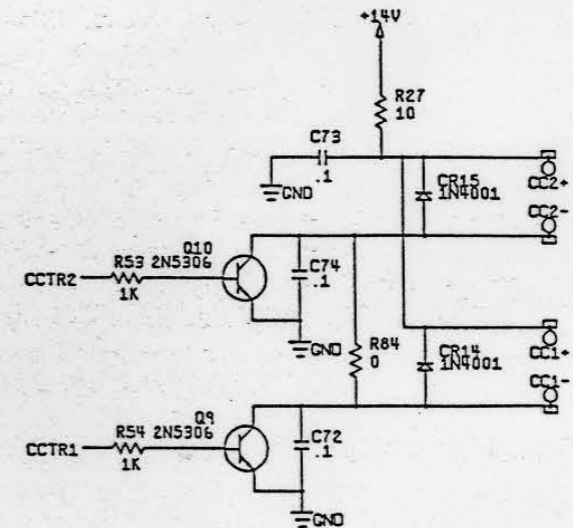
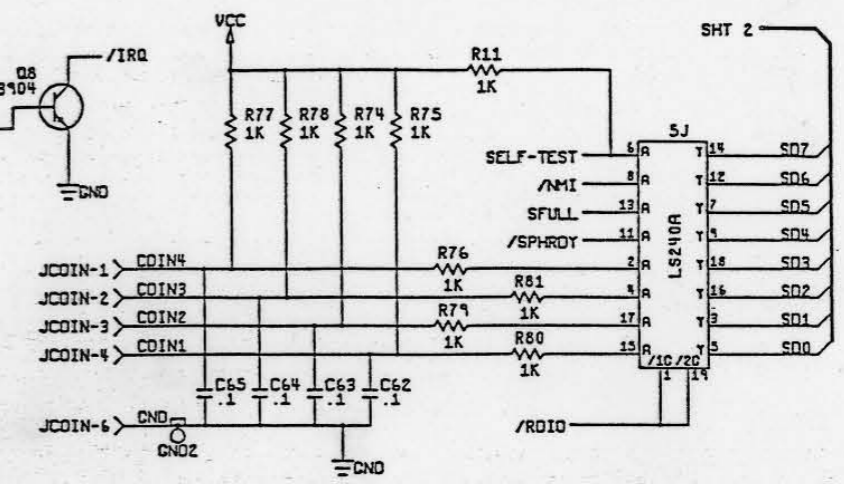
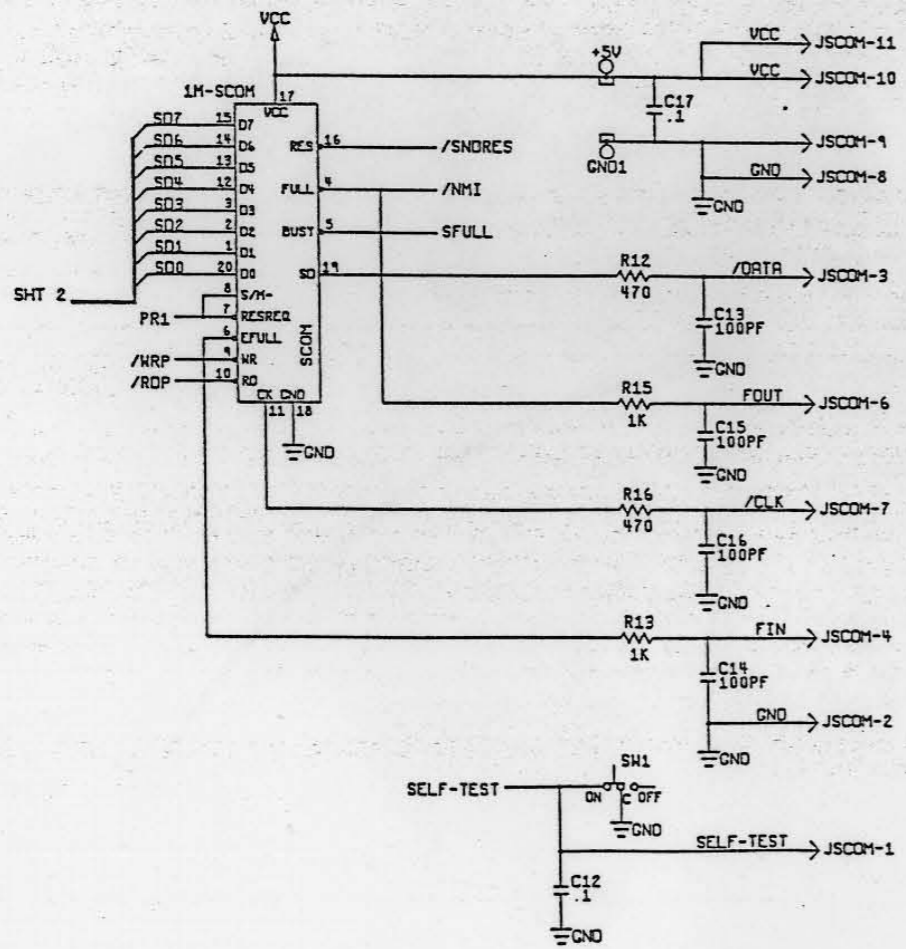

**NOTICE TO ALL PERSONS RECEIVING THIS DRAWING**  
 CONFIDENTIAL: Reproduction forbidden without the specific written permission of Atari Games Corporation, Milpitas, CA. This drawing is only conditionally issued and neither receipt nor possession thereof confers or transfers any right in, or license to use, the subject matter of the drawing or any design or technical information shown thereon, nor any right to reproduce this drawing, or any part thereof. Except for manufacture by vendors of Atari Games Corporation, and for manufacture under the corporation's written license, no right is granted to reproduce this drawing or the subject matter thereof, unless by written agreement with or written permission from the corporation.

**Stand-Alone Audio PCB Assembly Schematic Diagram, Sheet 4**

**ATARI GAMES**

© 1988 Atari Games Corporation  
 SP-320 Sheet 22  
 1st printing  
 043713-xx B

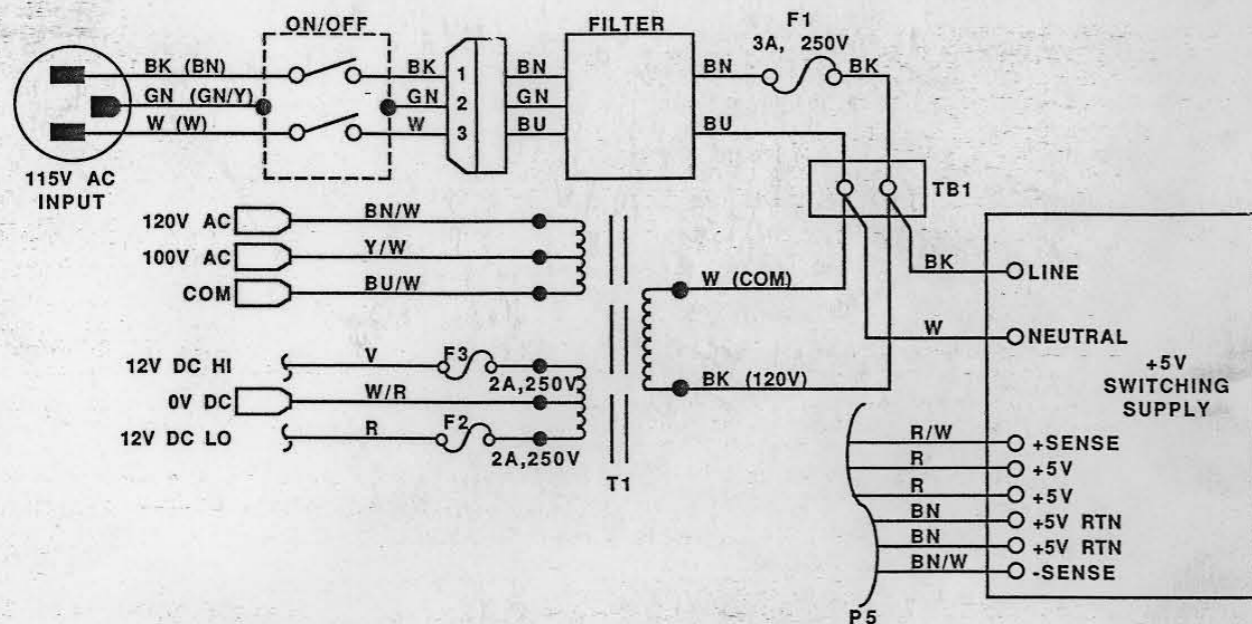

Switching/Linear (SL) Power Supply

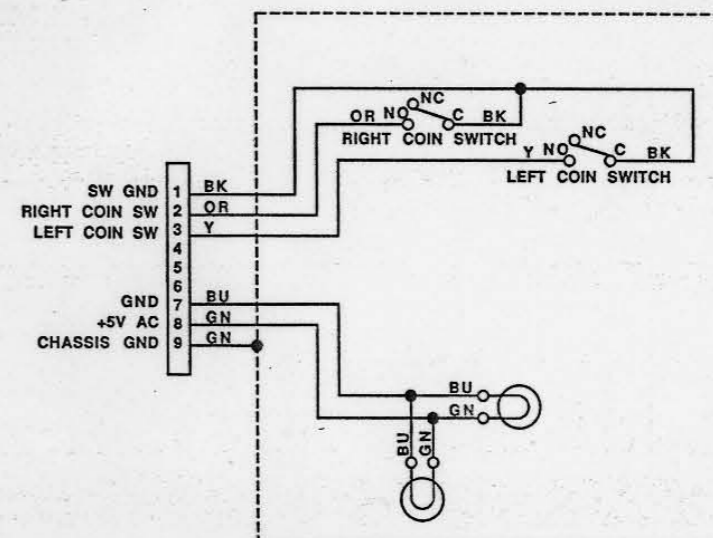

Coin Door Wiring Diagram

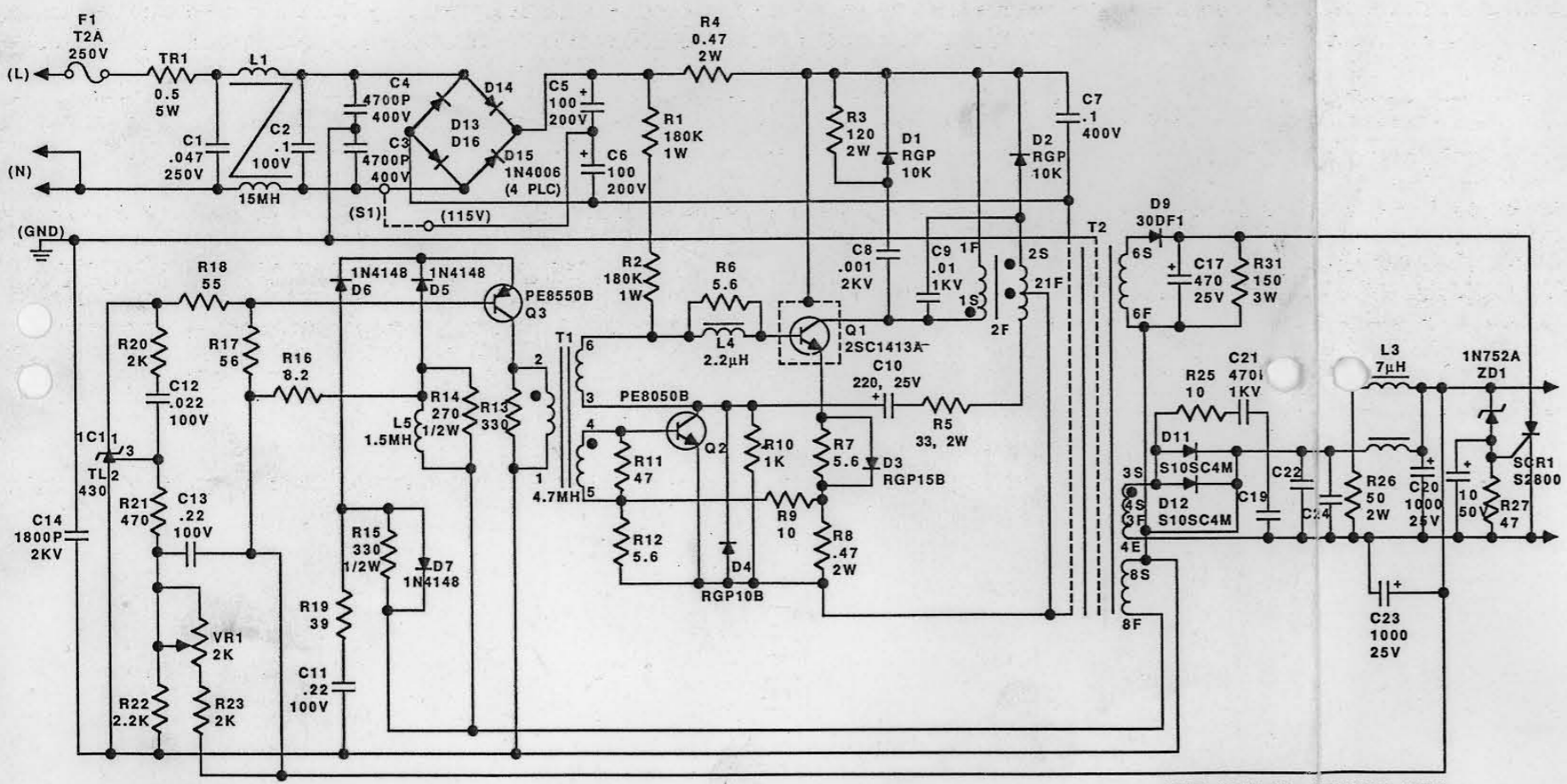

ATARI PART NO: 149003-003 (120V)  
149003-103 (240V)

Hitron 5V 10A Switching Power Supply

**NOTICE TO ALL PERSONS RECEIVING THIS DRAWING**  
 CONFIDENTIAL: Reproduction forbidden without the specific written permission of Atari Games Corporation, Milpitas, CA. This drawing is only conditionally issued and neither receipt nor possession thereof confers or transfers any right in, or license to use, the subject matter of the drawing or any design or technical information shown thereon, nor any right to reproduce this drawing, or any part thereof. Except for manufacture by vendors of Atari Games Corporation, and for manufacture under the corporation's written license, no right is granted to reproduce this drawing or the subject matter thereof, unless by written agreement with or written permission from the corporation.

**Wiring Diagrams for Switching/Linear (SL) Power Supply, Hitron 5V 10A Switching Power Supply, and Coin Door**



© 1988 Atari Games Corporation  
 044871-xx A 149003-003 171027-001

SP-320 Sheet 23  
 1st printing