

CATALOG 2011

DIAMOND PACIFIC
TOOL CORPORATION



THERE'S A GEM-MAKER TO FIT YOUR NEEDS



The Genie Gem-Maker

Known around the world for top performance with its 6" diamond grinding and polishing wheels.



The Pixie Gem-Maker

Its set of 4" diamond wheels makes it the favorite of opal cutters.



BigFoot

Compact, portable, lots of storage with a full set of 2" diamond wheels. Big performance in a little package.

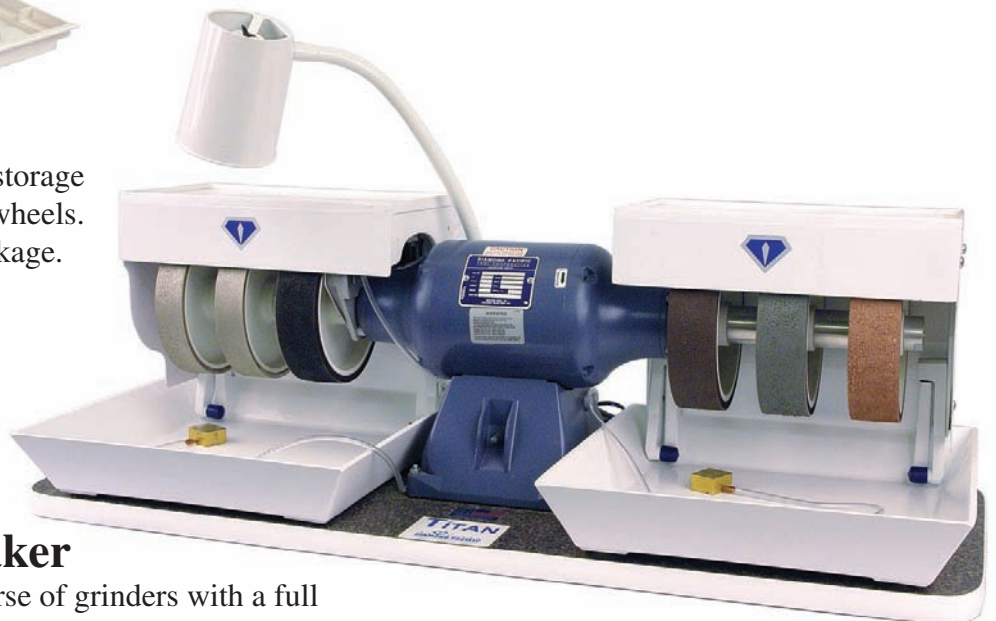

The Titan Gem-Maker

Big, fast, efficient, the workhorse of grinders with a full set of 8" diamond wheels.

Put fun and pride into your lapidary hobby or profession—get the right tools for the job

YOU CAN CUT, shape and polish gemstones with speed and ease if you have the right tool for your particular job. Just as a hammer and saw are the basic tools of a carpenter, so are the grinding/polishing machine and rock saw the basic tools of the lapidary. After those, you can add specialty tools to your heart's content, depending on what you want to do.

Start with the best you can afford, especially with your saw and grinding unit. As any wise buyer knows, price alone is not a guide to a good buy—it's what you get for what you pay.

You get real value for your money when you own one of our Gem-Makers. We've designed them to give you lasting service, unusual convenience, and best of all—top performance to put real pleasure into your lapidary hobby or profession.

OUR GEM-MAKERS ARE TOP PERFORMERS because of our diamond grinding and polishing wheels, the way they are made, and their special grit combination. They work fast and efficiently, giving you a beautiful polish on most stones in a matter of minutes.

PROCEDURE IS SIMPLE. Grind your cabochon to shape on the 80 grit Galaxy metal-bond diamond grinding wheel, then proceed to the 220 grit Galaxy wheel to remove all deep scratches. Coarse sanding is done on the 280 grit Nova resin-bond diamond wheel. Spend enough time on this wheel to completely remove all scratches left by the grinding wheels, then proceed to the three Nova wheels on the right for final sanding and polishing. For those stones needing another step, we include a 14,000 grit Diamond Nova Disc.

OUR NOVA RESIN-BOND diamond sanding and polishing wheels out-perform any other method available.

Novas are permanently charged with diamond embedded in a tough, flexible plastic resin backed by a thick, sponge rubber backing. This soft, flexible construction enables the surface of the Nova to conform to your stone, eliminating flat spots and scratches so difficult to remove with other methods of polishing. Novas are durable and do the job fast and efficiently.

The diamonds in our Galaxy metal-bond diamond grinding wheels are plated on a steel rim with nickel alloy. You'll appreciate their smooth, true-running surface, the fact that they never need dressing, and their fast, cool cutting speed.

ALL SIX WHEELS ARE MOUNTED AT ONCE on the three larger machines so you can proceed from one step to the next during the entire grinding and polishing operation. This is important when you consider time. Even the BigFoot has easy to change wheels.

EQUALLY IMPORTANT TO THE PERFORMANCE OF THE GEM-MAKERS IS THE SPRA-MIST COOLANT SYSTEM. Basically, it's an air pump that operates geysers to supply a fine water spray to the underside of the wheels. This means a trouble-free pump (because it pumps air, not water and can't become clogged) and no special plumbing. Pour a little water in the pan and go to work.

Best of all, you have a grinding and polishing machine so clean you can use it in your kitchen or den without making a lot of mess.

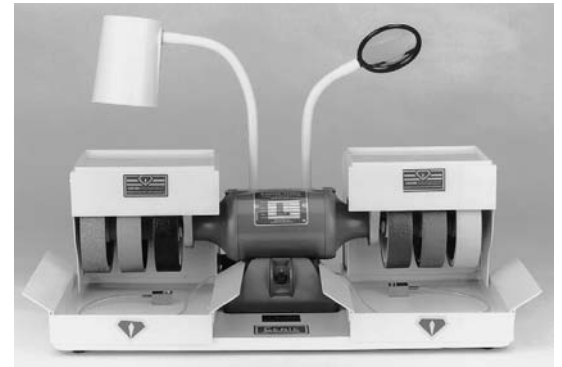

YOU CAN GRIND AND POLISH SMALL FLATS ON ALL FOUR OF THE GEM-MAKERS, eliminating the need for a special flat lap machine for this purpose.

And now you can enjoy the speed and efficiency of polishing flats on our Magnetic Novas. All four machines will accept a steel back-up plate attached to the right hand wheel adaptor. This allows Magnetic Novas to be quickly applied, used, and removed as you proceed through the sanding and polishing sequence.

All four machines accept attachments with a 1/4"-20 thread bolt on the right hand side. You can use "No-Hole" diamond laps, our Nova sanding and polishing discs, canvas and leather pads, and similar attachments.

THE GEM-MAKERS ARE ALL VERSATILE AND EASY TO USE. Three of the machines have trim saw attachments. All can be converted to use buffing wheels for polishing metals. A lamp comes with each machine and magnifiers are available. BigFoot is especially compact with storage for parts and accessories.

OUR MACHINES GIVE YOU VALUE FOR YOUR MONEY.

We start with a motor big enough for the job and the best we can buy, whatever the machine size. Every other part of the unit is the best for its particular function at a cost that allows the machine to be as reasonably priced as we can manage. We use a lot of plastic because it's lightweight and in most cases, even better than metal. We don't skimp anywhere, especially in our wheels.

GENIE—THE “MAGICAL” GEM-MAKER

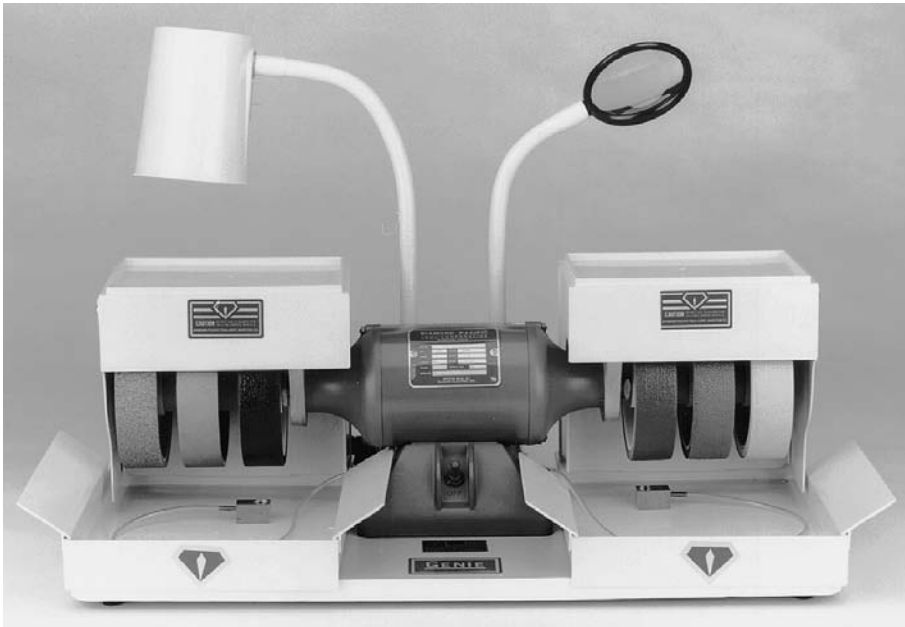

NOTE: Magnifier shown not included. Order from page 20.

GENIE COMES COMPLETE: It's powered by a ¼ HP heavy duty, industrially rated custom Baldor motor. Standard motor is 115 volt/60 HZ. Overseas model uses similar motor in 230 volt/50 HZ. Genie includes two 6" x 1½" Galaxy diamond grinding wheels (80 and 220 grit), four 6" x 1½" Nova sanding and polishing wheels (280, 600, 1200 and 3,000 grits), one 18" lamp, with two mounting buttons (to allow you to move it from left to right or add a second lamp or magnifier—see page 20), Spra-Mist coolant system, cab rest, one 5½" 14,000 grit Diamond Nova Disc, sample bottle Water Aid, four splash guards, and a manual. We also include Safety Goggles WHICH MUST BE WORN WHEN OPERATING THIS MACHINE.

100-GD-100 Genie..... 115 volts, 60Hz motor Shp. Wt. 59 lbs. \$2225.00
100-GD-100X Export Model . 230 volts, 50Hz motor .. Shp. Wt. 59 lbs. \$2325.00



WE NOW INCLUDE A 14,000 NOVA DISC FOR A SUPERB POLISH

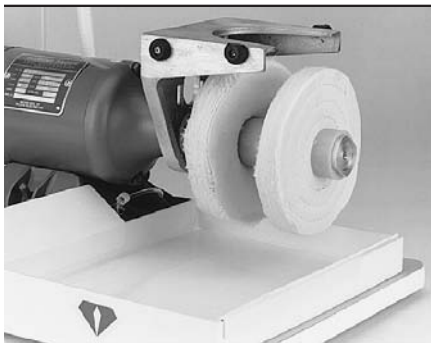

Jeweler's Buff Kit attaches to the right hand side of the Genie. Comes with buffs and rouge for polishing jewelry and other metal parts. See page 19.



Our "Boxer" attachment lets you make perfectly fitted mitered corners for gemstone boxes, or other projects requiring a mitered joint. See page 18.

The Genie is truly a "magic machine."

NOT ONLY DOES IT MAKE SHORT WORK of grinding and polishing gemstones, but with a few accessories added, it becomes a trim saw, jeweler's buffer, flat lap machine, and a way to easily miter perfect corners for gemstone boxes. Put a Genie in your workshop and you'll work wonders!

THE GENIE GIVES TOP PERFORMANCE. First and foremost, the Genie will do your grinding and polishing jobs in the fastest and most efficient manner available. And do it in style. Its unique combination of special diamond wheels all mounted together lets you proceed directly from one step to the next without any delay or a lot of bother. Turn out a 30 x 40 agate cab from preform to finished gem in a matter of minutes.

See page 1 for more information about this Gem-Maker's performance.

GENIE IS VERSATILE. You get more than just a grinding machine. The attachments and accessories described below let you perform a variety of functions. For more information, see the pages listed.

- Trim saw attachment with 8" blade lets you convert your Genie to a trim saw in a matter of minutes. Now you can even take a trim saw along when you travel. Page 3.

- Regular flat laps and discs attach to the left end of the motor shaft, letting you grind and polish flats. See pages 10 & 11.

- Now you can polish flats on the Lapcraft "No Hole" discs. They screw into the right hand wheel adaptor of the Genie, giving you a 6" diameter lap with no bothersome center hole. Listed on page 10.

- Our magnetic Nova Discs make quick work of polishing flats. See page 12 to find out more on the Magnetic Novas. Standard Nova Discs, leather and canvas pads and other accessories with a ¼"-20 thread bolt fit the Genie. See page 13.

TRIM SAW ATTACHMENT FOR THE GENIE

Turn your Genie into a handy 8" trim saw in a matter of minutes. Easy installation—uses no oil.



EASY TO INSTALL AND USE: The Genie trim saw attachment is easy to install; requires no tools. Simply spin off the adaptor with the three Nova wheels on the right hand side of the machine. Place the saw pan under the shaft. Mount the saw blade on the adapter and spin it onto the right hand shaft. Slip the saw table and hood into place, fill the pan with five pints of water, and you are ready to go.

CLEAN TO USE: Since the saw uses water as a coolant, there is no oily mess or dangerous fumes. You can use the trim saw wherever you use your Genie.

SPECIAL FEATURE GIVES A HEAD START ON GRINDING: The unique angle block included with the trim saw allows you to finish-trim the edges of your cabs at a ten degree angle, giving you a headstart towards grinding the bezel of your cab. Saves you time, effort and your grinding wheels as well.

COMES COMPLETE WITH BLADE: Your trim saw comes complete with a sintered continuous thin rim blade, size 8" x .032 x 1" bore. This is a good, all-purpose cutting blade. **It is not recommended that blades that are much thicker or**

thinner than the .032 (rim thickness) blade supplied be used with this attachment. Thicker blades do not cut well with water as a coolant. Thinner blades need a higher RPM to "stiffen" them, and are more hazardous to use.

GENIE VIDEO GUIDE

For new owners of a Genie and old pros as well. This DVD contains a wealth of information about the use and care of the Genie Gem-Maker. Covers such subjects as machine setup, break-in and wheel replacement, pump trouble-shooting, maintenance, and the use of the Genie in the lapidary process. Professionally produced, informative and easy to follow. Contains over 80 minutes of useful technical information.

240-248 Shp Wt. 1 lb. 29.95

TRIM SAW ATTACHMENT: Comes with molded, durable plastic hood and pan, sintered continuous thin rim blade, size 8" x .032 x 1" bore, shaft adapter, angle block, sample bottle of Water Aid, splash guard, and **SAFETY GOGGLES THAT MUST BE WORN WHEN OPERATING THIS TRIM SAW.**

100-TSG-105 Trim Saw	8lbs.....	375.00
100-TSB-106 Blade Only	2lbs.....	73.75
410-WA-108 Water Aid	8 oz.....	3.25
410-WA-116 Water Aid	16 oz.....	5.25

JEWELRY FINDINGS KIT



Here's an assortment of jewelry findings to have handy when you make your first stones. You'll be able to have a finished piece of jewelry to show off your cabochons. Kit contains one belt buckle, two pendants, one bolo set: string, pair of tips, and bolo mounting. *Designs, colors, and sizes vary, but bolo mounting and tips will be the same color—gold or silver.* Mountings are gold or silver colored metal. *No choice in selections, but kit is priced below standard retail prices.*

104-JFK-1 8 oz..... 15.50

TITAN – THE RUGGED, HEAVY DUTY GEM-MAKER

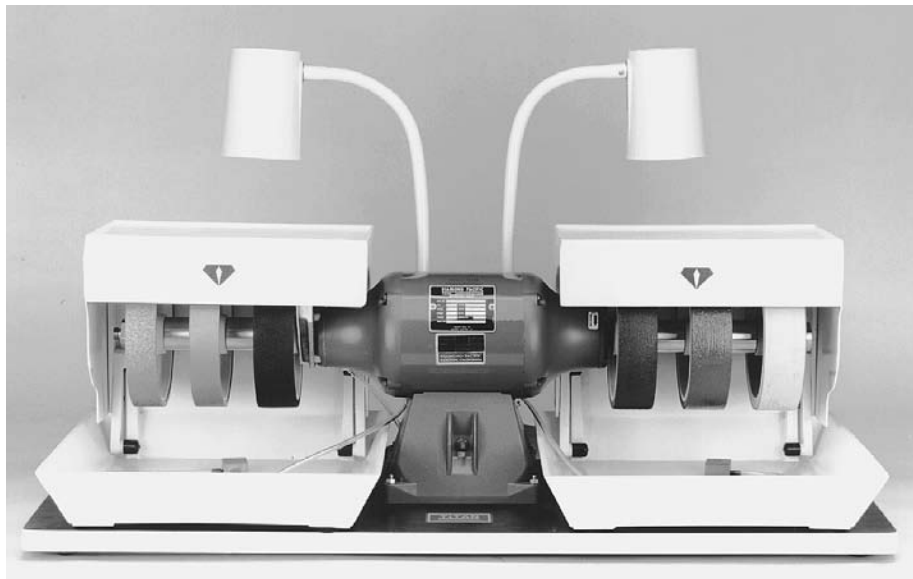

NOTE: Only one lamp included. Order extra lamp from page 20.

THE TITAN COMES COMPLETE. Includes $\frac{3}{4}$ HP, 115/230V industrially rated motor on 16" x 42" Formica baseboard, double pump Spra-Mist coolant system, cast aluminum quick-change hoods and pans, one 80 grit and one 220 grit $7\frac{5}{8}$ " x $1\frac{1}{2}$ " Galaxy metal-bond diamond grinding wheel, four $7\frac{5}{8}$ " x 2" Nova resin-bond diamond sanding and polishing wheels (one each 280, 600, 1200 and 3,000 grit); one 24" flex stem lamp, one $5\frac{1}{2}$ " 14,000 grit Diamond Nova Disc, special disc geyser for laps, cab rest, set of two splash guards, sample bottle Water Aid, and a manual. We also include **SAFETY GOOGLES WHICH MUST BE WORN WHEN OPERATING THIS MACHINE.** Note: Titan comes with two mounting buttons to allow you to move lamp from right to left or add a second lamp or magnifier—see page 20 to order.

100-T-100 Titan..... 115/230V, 60Hz Shp.Wt. 151 lbs. \$3740.00
 100-T-100X Export Model.....230V, 50Hz Shp.Wt. 151 lbs. \$4040.00

Shipped via UPS in 2 cartons. One weighs 94 lbs. and one weighs 57 lbs.



TITAN NOW COMES WITH A 14,000 NOVA DISC TO COMPLETE YOUR ALL DIAMOND POLISHING SEQUENCE.



TITAN IS RUGGED. It features a big $\frac{3}{4}$ HP, 1800 RPM, 115/230V industrially rated motor that is sealed against grit contamination and never needs oiling. (Export motor is 1500 RPM, 230V/50Hz) It has a 1" diameter shaft that is even heavier through the bearings which have a 30 mm bore.

Shown at left is Titan's double pump Spra-Mist system that provides plenty of water to the wheels while you work, keeping your stones cool and the rock dust down. The hoods and pans are rugged, solid cast aluminum, yet are easily removed.

The Titan can take care of your grinding and polishing needs and do it fast and efficiently. It's the choice of dedicated hobbyists and professional cutters.

START WITH IT'S ALL-DIAMOND GRINDING AND POLISHING WHEELS. They are mounted together on the machine, allowing you to proceed from start to finish without wasting time changing wheels. The grit sequence is the best all-around choice for shaping and polishing most stones, and they'll make short work of the task. If you need special grits for your particular job, the wheels are easy to change.

If you need to polish flats, you can attach regular flat laps to the left end using the special lap connector (shown in photo below). On the right hand side use Lapcraft "No Hole" diamond discs, Nova discs, our Magnetic Novas, or similar accessories having a $\frac{1}{4}$ "-20 thread bolt for attachment. A special geyser for use with the flat laps is included with the Titan.

If you need to polish metal, we've made up a Jeweler's Buff Kit for the Titan. See page 19 for more information on the kit.

See page 1 for more information about this Gem-Maker.



PIXIE – THE COMPLETE, PORTABLE GEM-MAKER

Just because the Pixie is compact and lightweight doesn't mean it can't do a great job. It's fast and efficient at polishing stones, and is the Gem-Maker preferred by those working opal.

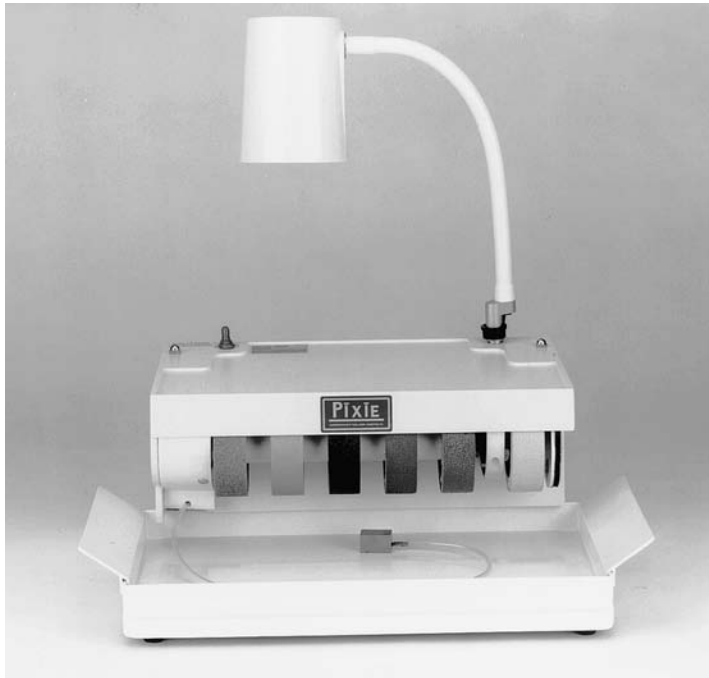

THE PIXIE has the same six-wheel sequence of diamond grinding and polishing wheels as the larger Gem-Makers, and provides you with a fast, efficient way to shape and polish stones. The Pixie is a great favorite of those who specialize in cutting opal.

FOR DOING SMALL FLATS, you can use Lapcraft's 4" "No Hole" diamond discs which fit the right hand side. You can also use 4" Nova discs, 4" canvas or leather pads, or any other attachment with a 1/4"-20 bolt and a diameter of 4" or less. You can turn your Pixie into a buffer for polishing metal with our jeweler's kit. See page 19.

THE PIXIE IS COMPACT, LIGHTWEIGHT. The Pixie features a durable, molded housing of G.E. Noryl® that makes the machine the most lightweight, compact and efficient 4" wheel, grinding and polishing machine available. It weighs less than 30 lbs. including the lamp, and fits on a Formica baseboard that measures only 14 1/2" x 18". It requires no special hook-ups or plumbing, so it can easily be used in your RV or wherever space is limited and a standard 115V outlet is available.

THE PIXIE COMES COMPLETE: Includes one piece housing on a 14 1/2" x 18" Formica baseboard, motor, Spra-Mist coolant system, one 80 grit and one 220 grit 4" x 1 1/4" Galaxy metal-bond diamond grinding wheel, four 4" x 1 1/4" Nova resin-bond diamond sanding and polishing wheels (one each 280, 600, 1200, and 3,000 grit), one 15" flex stem lamp, one 4" 14,000 grit Diamond Nova Disc, handy cab rest, base for geyser, sample bottle of Water Aid, set of two splash guards, and a manual. We also include Safety Goggles WHICH MUST BE WORN WHEN OPERATING THIS MACHINE.

100-P-100 Pixie 115 volt, motor Shp. Wt. 36 lbs. \$1525.00
 100-P-100X Export Model 230 volt, motor Shp. Wt. 36 lbs. \$1635.00



THE PIXIE NOW COMES WITH A 14,000 NOVA DISC.

TRIM SAW ATTACHMENT

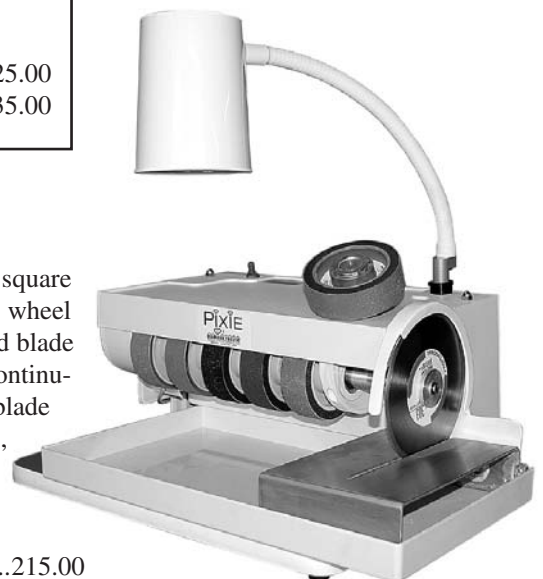

PIXIE TRIM SAW ATTACHMENT

Now you can trim small slabs on your Pixie Gem-Maker. You can cut up to a 5" square slab right in half. Easy to attach the trim saw parts by removing the right hand wheel adaptor, and then attaching the saw blade adaptor with blade. The saw table and blade guard are made of stainless steel for long life. Comes with a 6" x .020 sintered continuous rim blade with 5/8" arbor hole. You can use either a 1/2" or 5/8" arbor hole blade by turning over the blade flange. Comes with saw table, blade guard, 6" blade, adaptor, flanges, and instructions. We also include Safety Goggles WHICH MUST BE WORN WHEN OPERATING THIS MACHINE

100-PTS-105 3 lbs. \$215.00

Big FOOT



Only 12" wide by 11" deep by 6 1/4" high!
Stores even smaller at 12"x 6 1/4" x 6 1/4".

BIGFOOT GEM-MAKER Comes with two 2 3/8"x 1 1/8" Galaxy Wheels (80 and 220 grit), four 2 3/8"x 1 1/8" Nova Wheels (280, 600, 1200 and 3000 grit); two Nova wheel adaptors, one 4" 14,000 grit Diamond Nova Disc, halogen lamp, cab rest, full size Spra-Mist coolant system, and variable speed motor using 115V current.

500-BF-100.....16 lbs..... 1299.00

TRIM SAW ATTACHMENT Comes with 4" x.014 x 5/8" diamond saw blade, blade adaptor and saw table.

500-BFS-105.....2 lbs..... 130.00

NOVA WHEEL ADAPTOR for mounting extra Nova Wheels.

501-ADP-BFR1 lb..... 49.50

NOVA SPACERS Use these spacers when using extra Nova Wheel adaptor. Spacers are 1 1/8" wide with 1" AH.

501-BFSP-1 1/8"6 ozs. 5.75

TRIM SAW ATTACHMENT



It wasn't easy to squeeze most of the capabilities of a Genie into a machine the size of a shoebox, but that's BigFoot!

BigFoot is designed to be more convenient in size and weight with only minor compromises in its capacity to cut stones, and NO COMPROMISE at all in quality.

You can grind and polish calibrated cabochons up to 52 x 38 with ease, as well as larger stones of baroque shapes. You have plenty of room between the wheels for making crosses and hearts.

With the trim saw attachment, BigFoot can trim out your smaller slabs with ease. Takes only a minute to remove the right hand wheel adaptor and spin on the adaptor with the saw blade. And blade, adaptor, and saw table all fit into compartments of BigFoot for convenient storage and transport.

Check out these BigFoot features:

✓ **Uses six 2 3/8" Galaxy and Nova Wheels in our standard sequence. You can grind and polish with ease using these diamond wheels**

✓ **Four wheels are mounted at once for wide (1 1/8") wheel spacing, with the rapid (no tools required) wheel change feature found on the Genie.**

✓ **Uses our standard Spra-Mist coolant system providing plenty of water to the wheels.**

✓ **Special pans for using Nova Discs or Magnetic Novas on right side. 14,000 grit Nova disc now included. Additional grits of Nova discs or Magnetic Novas on page 12-13.**

✓ **Has a variable speed control on a quiet, premium quality motor. You get plenty of power for the job.**

✓ **A halogen lamp is standard equipment, giving you plenty of light right on your work area.**

Shown at left is the trim saw attachment in place. The saw blade is bolted to the wheel adaptor that is then screwed onto the wheel shaft. The saw table fits neatly in the water pan.

NOVA RESIN-BOND DIAMOND SANDING AND POLISHING WHEELS

With Nova Wheels, sanding and polishing stones doesn't have to be a tiresome battle with flat spots and scratches. Nova Wheels get results fast. The diamonds are embedded within a tough, flexible plastic resin and backed by soft, thick rubber. This soft, flexible construction enables the surface of the Nova Wheel to conform to your stones, eliminating flat spots and scratches.

MUST BE USED WITH WATER.

We recommend that Novas be used in sets rather than in combination with other types of sanding and polishing wheels. Our all-purpose sequence is the 280, 600, 1200, and 3,000 grit wheels, followed by the use of a 14,000 Nova disc. This combination will put an excellent polish on most stones. Some hard-to-polish material may require more steps, such as additional grit Nova wheels or discs. You may also use fine diamond compound or other polish such as cerium or tin oxide on a pad to get a higher polish.

Nova Wheels have a 1" arbor hole. To use on other size arbors order bushings listed at right. The two, and four inch diameter wheels take one 1" bushing. The six inch diameter wheels take two 3/4" bushings and the 7 5/8" wheels take two 1" bushings.



BUSHINGS FOR WHEELS

These bushings fit arbor sizes 1", 3/4", 5/8", and 1/2". Come in two widths to fit Nova Wheels and buffing wheels with 1" centers.

TO ORDER FOR NOVA WHEELS: The two and four inch diameter Nova Wheels take one 1" bushing. The six inch diameter Nova Wheels take two 3/4" bushings, and the 7 5/8" Nova Wheels take two 1" bushings.

See page 8 to order bushings for Galaxy Wheels.

101-WB-34 3/4" 2 oz. 2.90
101-WB-44 1" 2 oz. 2.90

NOVA WHEELS MUST BE USED WITH WATER AS A COOLANT.

STANDARD NOVA WHEELS

Grit Size	Wheel Color	2 3/8" x 1 1/8" Wheel		4" x 1 1/4" Wheel		6" x 1 1/2" Wheel		7 5/8" x 2" Wheel	
		Order #	Price	Order #	Price	Order #	Price	Order #	Price
60 COARSE SHAPING	GREEN	100-RW2-70	60.00	100-RW4-70	87.00	100-RW6-70	130.00	100-RW8-70	215.00
140 FINE SHAPING	RUST	100-RW2-15	60.00	100-RW4-15	87.00	100-RW6-15	130.00	100-RW8-15	215.00
280 COARSE SANDING	BLACK	100-RW2-28	60.00	100-RW4-28	87.00	100-RW6-28	130.00	100-RW8-28	215.00
600 FINE SANDING	BROWN	100-RW2-60	60.00	100-RW4-60	87.00	100-RW6-60	130.00	100-RW8-60	215.00
1200 PRE-POLISH	GREY	100-RW2-12	60.00	100-RW4-12	87.00	100-RW6-12	130.00	100-RW8-12	215.00
3000 PRE-POLISH	ROSE	100-RW2-30	60.00	100-RW4-30	87.00	100-RW6-30	130.00	100-RW8-30	215.00
8000 PRE-POLISH	TAN	100-RW2-80	60.00	100-RW4-80	87.00	100-RW6-80	130.00	100-RW8-80	215.00
14000 POLISH	CREAM	100-RW2-14	60.00	100-RW4-14	87.00	100-RW6-14	130.00	100-RW8-14	215.00
50,000 POLISH	LT BLUE	100-RW2-50	60.00	100-RW4-50	87.00	100-RW6-50	130.00	100-RW8-50	215.00
Shp. wt. - 1 item		1 lb.		1 lb.		2 lbs.		2 lbs.	

GALAXY DIAMOND GRINDING WHEELS

Take the “grind” out of grinding stones.

OUR GALAXY DIAMOND GRINDING WHEELS give you the fast, cool cutting efficiency of diamonds, plus a smooth, true-running surface that never needs dressing.

Galaxy Wheels give you lasting service because of their quality construction. The diamonds are held on a heavy steel ring by an extremely hard, nickel alloy plating for durability. The ring is mounted on a tough glass-filled polyester core, making Galaxies a smooth, quiet running wheel.

GALAXY DIAMOND WHEELS are clean to use. Because the wheels themselves don't wear away as silicon carbide wheels do, you don't get all the mess. Galaxy Wheels must be used with water, but you only need a small amount to keep the wheels and stone wet and cool, and to keep down the rock dust.

Galaxy Wheels have 1" arbor holes. To use on other size arbors order bushings listed at right.

Both our standard and carving wheels give you a wide choice of grit and wheel sizes to fit your needs. The diamond shaped, interrupted pattern of the Hex Wheels (one shown above at the right) in 80, 60, and 30 grit sizes makes them the coarsest, fastest grinding wheels available.



BUSHINGS FOR WHEELS

These bushings fit arbor sizes 1", ¾", ⅝", and ½". Come in two widths to fit the various Nova and Galaxy Wheels.

TO ORDER FOR GALAXY WHEELS: The two, four, and six inch Galaxy Wheels take one 1" bushing. The 7⅝" Galaxy Wheels take two ¾" bushings.

See page 7 to order bushings for Nova Wheels.

- 101-WB-34 ¾" 2 oz..... 2.90
- 101-WB-44 1" 2 oz..... 2.90

SAFETY FIRST WEAR YOUR GOGGLES

PRICE LIST FOR STANDARD GALAXY WHEELS

Grit Size	2⅜" x 1⅝"		4" x 1¼"		6" x 1½"		7⅝" x 1½"	
	Order#	Price	Order#	Price	Order#	Price	Order#	Price
Fine 600	100-M2-06F	85.00	100-M4-06F	110.00	100-M6-06F	140.00	100-M8-06F	180.00
Fine 360	100-M2-36	85.00	100-M4-36	110.00	100-M6-36	140.00	100-M8-36	180.00
Fine 220	100-M2-22	85.00	100-M4-22	110.00	100-M6-22	140.00	100-M8-22	180.00
Med Fine 180	100-M2-18	90.00	100-M4-18	120.00	100-M6-18	155.00	100-M8-18	200.00
Med. Fine 120	100-M2-12	95.00	100-M4-12	130.00	100-M6-12	170.00	100-M8-12	220.00
Coarse 100	100-M2-10	100.00	100-M4-10	140.00	100-M6-10	185.00	100-M8-10	240.00
Coarse 80	100-M2-80	105.00	100-M4-80	150.00	100-M6-80	200.00	100-M8-80	260.00
Rough 80 Hex	100-M2-80H	150.00	100-M4-80H	220.00	100-M6-80H	280.00	100-M8-80H	360.00
Rough 60 Hex	100-M2-60H	180.00	100-M4-60H	270.00	100-M6-60H	340.00	100-M8-60H	440.00
Rough 30 Hex	100-M2-30H	240.00	100-M4-30H	350.00	100-M6-30H	450.00	100-M8-30H	580.00
SHIPPING WEIGHTS FOR ALL GALAXY WHEELS								
1 Wheel	1 lb.		2 lbs.		3 lbs.		5 lbs.	

GALAXY WHEELS FOR CARVING



Our Galaxy carving wheels have special shapes and sizes for helping the sculptor grind those difficult grooves and curves in stone.

USE THESE ROUNDED-FACED CARVING WHEELS when doing carving, intarsia, channel work, stained glass and other applications that require curved edges. Use the ¼" and ½" widths for narrow grooves and the 1" wide for larger ones. Four wheel diameters increase your choices.

All Galaxy carving wheels can be used on the Titan. All but the 8" wheels can be used on the Genie. Only the two and four inch wheels can be used on the Pixie. These wheels can also be used on most other grinding machines that have standard arbors.

Galaxy Wheels have 1" arbor holes. To order bushings, see page 8. The four and six inch diameter wheels take one 1" bushing. The two inch wheel takes one ¾" bushing and the 7 5/8" inch wheel takes two ¾" bushings.

ORDERING EXTRA SPACERS FOR MOUNTING CARVERS. You may need to know hub widths to order extra spacers to mount your carvers. Hub width for all 2" dia. carvers is ¾"; for 4" dia. is 1 ¼"; for 6" dia. is 1"; and for 8" dia. is 1 ½".

CONVEX CARVER WHEELS							
Grit Size	Wheel Dia.	¼" Wide Wheel		½" Wide Wheel		1" Wide Wheel	
		Order#	Price	Order#	Price	Order#	Price
600 Grit	2"	100-MC2-46	80.00	100-MC2-26	85.00	N/A	-
	4"	100-MC4-46	105.00	100-MC4-26	110.00	100-MC4-16	120.00
	6"	100-MC6-46	135.00	100-MC6-26	140.00	100-MC6-16	150.00
	8"	100-MC8-46	175.00	100-MC8-26	180.00	100-MC8-16	190.00
360 Grit	2"	100-MC2-43	80.00	100-MC2-23	85.00	N/A	-
	4"	100-MC4-43	105.00	100-MC4-23	110.00	100-MC4-13	120.00
	6"	100-MC6-43	135.00	100-MC6-23	140.00	100-MC6-13	150.00
	8"	100-MC8-43	175.00	100-MC8-23	180.00	100-MC8-13	190.00
220 Grit	2"	100-MC2-42	80.00	100-MC2-22	85.00	N/A	-
	4"	100-MC4-42	105.00	100-MC4-22	110.00	100-MC4-12	120.00
	6"	100-MC6-42	135.00	100-MC6-22	140.00	100-MC6-12	150.00
	8"	100-MC8-42	175.00	100-MC8-22	180.00	100-MC8-12	190.00
100 Grit	2"	100-MC2-41	95.00	100-MC2-21	100.00	N/A	-
	4"	100-MC4-41	135.00	100-MC4-21	140.00	100-MC4-11	150.00
	6"	100-MC6-41	180.00	100-MC6-21	185.00	100-MC6-11	195.00
	8"	100-MC8-41	235.00	100-MC8-21	240.00	100-MC8-11	250.00

 **Caution: Wear Safety Goggles when using any Galaxy Wheel.**



USE EXTRA ADAPTORS FOR MOUNTING CARVING WHEELS

Genie owners can obtain maximum convenience by mounting the special carving wheels on a separate right hand adaptor. This eliminates the need of taking the Nova Wheels off their right hand adaptor and putting on the carving wheels each time. Pixie owners can use an extra right hand adaptor (which holds the far right hand Nova Wheel) for the same purpose. Wheels on the Titan fit directly on the shaft. Call us to determine your particular need.

PRE-CHARGED DIAMOND LAPPING DISCS

STANDARD DIAMOND DISCS “NO HOLE” DIAMOND DISCS

Lapcraft's STANDARD DIAMOND DISCS are designed expressly for the lapidary field and are available in a variety of diameters and mesh sizes. They are made with high quality man-made diamond using single, whole crystals. The diamond is bonded to a solid base that is ground flat and parallel to exacting specifications. Made in USA.

Lapcraft Standard Diamond Discs come with standard 1/2" arbor hole. Special arbor sizes available on request.

Lapcraft's NO HOLE DIAMOND DISCS offer a full face, flat grinding surface without the usual center hole obstruction. Diamond covers the entire work surface. On the back of the disc is a 1/4"-20 machine screw for screwing into the end of any arbor with the same internal thread. Made in USA.

CAUTION: wear Safety Goggles when using these discs.



FOR STANDARD AND “NO HOLE” DISCS

80, 100 EXTRA COARSE: For fast grinding and shaping.

180 COARSE: Fast performing and light cab roughing.

260 MEDIUM: General preforming and opal cab roughing.

360, 600 FINE: Light preforming and cab finish grinding.

1200 EXTRA FINE: General prepolishing finish.

1500, 1800 SUPER FINE: Dead-smooth prepolish.

3000 SUPER FINE: Super smooth prepolish.

8000 ULTRA FINE: For special finishes.

Grit Size	STANDARD DIAMOND DISCS				“NO HOLE” DIAMOND DISCS			
	6"		8"		4"		6"	
	Order #	Price	Order #	Price	Order #	Price	Order #	Price
80	106-6102	155.00	106-6104	225.00	106-4100	95.00	106-4225	155.00
100	106-4019	137.00	106-4028	200.00	106-4101	80.00	106-4226	135.00
180	106-4020	106.00	106-4029	133.00	106-4102	73.00	106-4227	110.00
260	106-4021	97.00	106-4030	115.00	106-4103	62.00	106-4228	100.00
360	106-4022	91.00	106-4031	110.00	106-4104	60.00	106-4229	95.00
600	106-4023	80.00	106-4032	100.00	106-4105	58.00	106-4230	85.00
1200	106-4024	91.00	106-4033	110.00	106-4106	58.00	106-4231	90.00
1500	106-4025	91.00	106-4034	110.00	106-4107	58.00	106-4232	90.00
1800	106-4026	91.00	106-4035	110.00	106-4108	58.00	106-4233	90.00
3000	106-4027	105.00	106-4036	140.00	106-4109	65.00	106-4234	95.00
8000	106-4037	105.00	106-4038	140.00	106-4110	65.00	106-4235	95.00
Ship.Wt. Ea.	1 LB		2 LBS.		1 LB		1 LB	

DIAMOND DURA-DISCS UNCHARGED LAPS

Dura-Discs give you the efficiency of a diamond lap for finishing flat surfaces at an economical price.

Dura-Discs come in a variety of grit sizes, allowing you to process most stones through the coarse and fine sanding processes.

Dura-Discs are precision ground, 1mm thick steel discs heavily plated with diamond for fast cutting and long life. Use them with worn out standard laps as back-plates, or with the Master Lap sold below. Dura-Discs have a 1/2" center hole that allows them to be securely fastened to the back-plate.

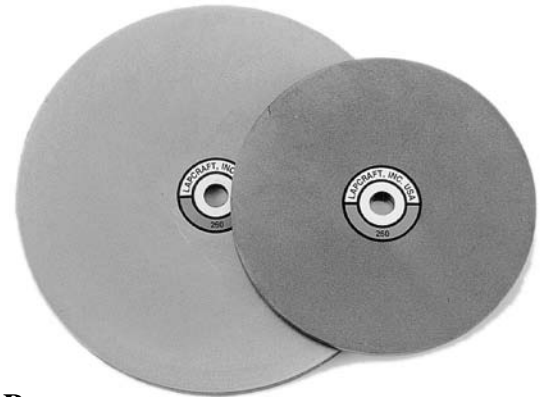

DIAMOND DURA-DISCS				
Grit Size	6"		8"	
	Order #	Price	Order #	Price
60	700-72-06-0060	120.00	700-72-08-0060	168.00
100	700-72-06-0100	88.00	700-72-08-0100	120.00
180	700-72-06-0180	65.00	700-72-08-0180	85.00
260	700-72-06-0260	57.00	700-72-08-0260	80.00
320	700-72-06-0320	49.00	700-72-08-0320	70.00
600	700-72-06-0600	45.00	700-72-08-0600	64.00
1200	700-72-06-1200	42.00	700-72-08-1200	60.00
1500	700-72-06-1500	42.00	700-72-08-1500	60.00
Shp. Wt.	1 lb.		2 lbs.	

MASTER LAP

Use these aluminum laps as backing for a variety of thin laps, including the Dura-Discs. Precision flat, approximately 1/4" thick aluminum. Arbor hole 1/2".

105-4501 6" lap..... 1 lb 35.00
 105-4502 8" lap..... 1 lb 55.00

We offer a variety of laps designed to be charged by the craftsman with his or her personal preference of diamond abrasive or other conventional abrasives. See pages 14-15 for abrasives.

FINALAP

A unique polishing lap that gives a brilliant polish on a variety of stones such as quartz, corundum, beryl, peridot, etc. The FINALAP is designed to be charged with diamond slurry. Has a dense metallized resin surface which resists grooving and gouging. It readily accepts a diamond charge and requires no break-in time.

105-4523 6" lap 1 lb..... 105.00
 105-4524 8" lap 2 lbs..... 125.00

DIAMOND SLURRY

This oil soluble diamond slurry is made especially for use on the FINALAP and other hard laps. It is popular for finishing materials where a highly reflective surface is desired. Has the proper consistency for easy charging of a lap. The 1 Micron size is 14,000 grit and the 1/2 Micron size is 50,000 grit.

106-6058 1 Micron 3 oz..... 5.50
 106-6059 1/2 Micron 3 oz..... 5.50

TIN LAP

Excellent lap for use with cerium oxide or tin oxide as a final polish. Precision surfaced. Comes with 1/2" arbor hole.

105-4505 6" lap 1 lb 96.00
 105-4506 8" lap 2 lbs..... 125.00

COPPER LAP

Can be charged with a variety of abrasives including diamond. Precision surfaced. Standard 1/2" arbor hole.

105-4509 6" lap 1 lb..... 86.00
 105-4510 8" lap 2 lbs..... 115.00

SAFETY FIRST—WEAR YOUR GOGGLES

Wear Safety Goggles when using any of the discs & laps on this and the opposite page.

MAGNETIC NOVA LAPS FOR LAPPING

Our Magnetic Nova Laps give you the fast polishing performance of Novas combined with the convenience of an easy on-off magnetic lap. They attach right onto most flat laps and are easily removed.

Magnetic Nova Laps have a 1/16" thick backing of solid rubber containing magnetized iron particles so the laps will adhere to a cast iron, steel or nickel plated lap. The rubber is coated with a thick layer of our special Nova resin-bond diamond formula for fast action and lasting service. The surface of the Magnetic Nova is made with a grid pattern for better performance.

You can use the Magnetic Novas on your present flat lap set-up in most cases, but they will not work on aluminum or diamond coated discs. If your lap set-up will accommodate an attachment using a 1/4"-20 bolt (such as on the Genie, Titan and Pixie), then you can use one of the special back plates listed below. These steel faced back plates along with the Magnetic Novas will give you a non-interrupted polishing surface for maximum efficiency.

Our recommended general purpose grit sequence for sanding and polishing most flats, is 60, 280, 600 and 1200 grits, followed by our super Premium Cerium Oxide Polish on a felt pad. We also recommend the use of a 60 grit Diamond Plated Disc to precede the 60 grit Magnetic Nova for those slab surfaces with deep saw marks or other features requiring grinding preparation. Other grit sequences can be used with excellent results depending on the materials to be polished.

Shown at right is a Genie with a 6" steel faced back plate attached to the right hand wheel adaptor of the machine. Magnetic Novas (6" size shown lying on machine pan) can be used on the steel-faced back plate, and are easily attached and removed from the plate.



SAFETY
FIRST
WEAR YOUR
GOGGLES



BACK PLATES FOR MAGNETIC LAPS

These back plates offer a full surface area without the usual center hole. They are similar to the "No-Hole" diamond laps with a 1/4"-20 thread bolt for attaching to the BigFoot, Pixie, Genie, Titan or other machines accepting that size bolt accessory.

Face or entire plate made of steel for use with 4", 6" and 8" Magnetic Novas (at left), 8" Magnetic Plated Discs (see page 75). Shown above is the back side of a back plate demonstrating the 1/4"-20 bolt attachment.

MAGNETIC NOVA LAPS			
Grit Size	4" Laps: 26.00 ea.	6" Laps: 52.00 ea.	8" Laps: 84.00 ea
	Order #	Order #	Order #
60	100-RM04-70	100-RM06-70	100-RM08-70
140	100-RM04-15	100-RM06-15	100-RM08-15
280	100-RM04-28	100-RM06-28	100-RM08-28
600	100-RM04-60	100-RM06-60	100-RM08-60
1200	100-RM04-12	100-RM06-12	100-RM08-12
3000	100-RM04-30	100-RM06-30	100-RM08-30
8000	100-RM04-80	100-RM06-80	100-RM08-80
14,000	100-RM04-14	100-RM06-14	100-RM08-14
50,000	100-RM04-50	100-RM06-50	100-RM08-50
Shp. wt.	1 lb.	1 lb.	1 lb.

Order #	Item	Shp. wt.	Price
106-14434	4" Back Plate	1 lb.	50.00
106-14432	6" Back Plate	2 lbs.	60.00
106-14433	8" Back Plate	2 lbs.	70.00

POLISHING PADS

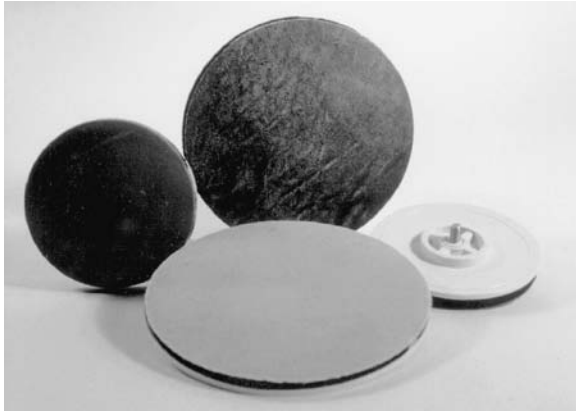

Pads below have a rigid plastic back plate with 1/4"-20 thread bolt that will fit the BigFoot and Pixie (4 inch), Genie and Titan (5 1/2 inch), and other machines designed for such attachments. All pads have a 1/4" thick foam rubber backing so they will conform to the shape of your stone.

Canvas, leather and felt pads may be used with diamond compound, or other polishes (see pages 14-15). Leather pads come either smooth or rough side up. When using diamond compound, use a silicone lubricant, such as our Gem-Lube (see page 16). Shipping Weight: 5 ozs.

Type	4 Inch		5 1/2 Inch	
	Order #	Price	Order #	Price
Canvas, untreated	100-PAD-4CU	8.15	100-PAD-5CU	11.05
Leather, rough	100-PAD-4LR	9.20	100-PAD-5LR	12.10
Leather, smooth	100-PAD-4LS	9.20	100-PAD-5LS	12.10
Felt	100-PAD-4F	9.20	100-PAD-5F	12.10

SAFETY FIRST WEAR YOUR GOGGLES

FELT DISCS

These unbacked discs are 1/8" durable wool felt. Felt discs may be glued to back plates or used in other applications. Polishing compounds will adhere well to the surface of this product.

Diameter	Unbacked		
	Order #	Price	Shp Wt
4"	100-PAD-U-04F	5.00	1 oz.
6"	100-PAD-U-06F	10.00	2 oz.
8"	100-PAD-U-08F	16.50	4 oz.

STANDARD NOVA RESIN-BOND DISCS



Nova Discs are ideal for polishing backs of cabs, nodules, geode faces, and similar flats as well as for sanding and polishing cabs. They have a soft, rubber backing and are slightly convex (domed) so that under pressure of your stone, they provide an even polishing surface in the middle area often missed with other methods. A standard 1/4"-20 thread bolt is molded into their plastic back-up plate to fit our Gem-Makers and most other machines accepting that size bolt. See page 18 to order an adaptor to fit your machine if it is not one of our Gem-Makers.

The 4" Nova Disc is recommended for the BigFoot and Pixie, and the 5 1/2" is used on the Genie and Titan.

Nova Discs must be used with water.

STANDARD NOVA DISCS				
Grit Size	4" Disc		5 1/2" Disc	
	Order#	Price	Order#	Price
280	100-RD4-28	45.00	100-RD5-28	77.50
600	100-RD4-60	45.00	100-RD5-60	77.50
1200	100-RD4-12	45.00	100-RD5-12	77.50
3000	100-RD4-30	45.00	100-RD5-30	77.50
8000	100-RD4-80	45.00	100-RD5-80	77.50
14000	100-RD4-14	45.00	100-RD5-14	77.50
50,000	100-RD4-50	45.00	100-RD5-50	77.50
Shp. wt. - 1 item		1 lb.	1 lb.	

SAFETY GOGGLES

Safety goggles provide limited protection from light to moderate impact hazards such as metal, stone or wood chips, small flying particle and sparks. Have rigid clear faceplate and soft plastic sides for comfort. Can be worn over normal size glasses.

101-GOGGLE..... 6 oz. 3.95

DIAMOND COMPOUND



Our diamond compound is composed of top quality, closely graded diamond particles suspended in a water-based carrier. New smoother formula. Use on pads, discs, or buffs. Color coded for easy identification when using. Packaged in convenient, disposable, plastic syringes. Use with Gem Lube or Microsol lubricant. (see page 16)
Weight: 2 oz per syringe

DIAMOND POLISHING COMPOUND					
Size		2 Gram Syringe		5 Gram Syringe	
Mesh	Micron	Order #	Price	Order #	Price
100,000	0-1/2	340-C100-2	5.00	340-C100-5	10.00
50,000	0-1	340-C500-2	5.00	340-C500-5	10.00
14,000	0-2	340-C140-2	5.00	340-C140-5	10.00
8,000	2-4	340-C800-2	5.00	340-C800-5	10.00
3,000	4-8	340-C300-2	5.00	340-C300-5	10.00
1,200	10-20	340-C120-2	5.00	340-C120-5	10.00
600	20-40	340-C600-2	5.00	340-C600-5	10.00
325	54-80	340-C325-2	5.00	340-C325-5	10.00
260	80-100	340-C260-2	5.00	340-C260-2	10.00

DIAMOND SPRAY

Lapcraft diamond spray comes in a convenient non-aerosol pump spray bottle. The diamond is suspended in a high-tech vehicle packed with 1 full carat of precisely graded diamond powder. This packaging produces the uniformity of particle dispersion needed to make diamond abrasives most effective without a limited shelf life. Shipping weight: 3 oz.



DIAMOND POWDER

This fine quality micron diamond powder has been carefully graded to give you blocky crystals. Use for charging laps, polishing pads—wherever you need a high quality diamond abrasive for polishing stones. Weight, vial: 2 oz

DIAMOND POWDER					
Size		5 Ct Vials		25 Ct vials	
Mesh	Micron	Order #	Price	Order #	Price
100,000	0-1/2	340-P10-05	7.50	340-P10-25	25.00
50,000	0-1	340-P50-05	7.50	340-P50-25	25.00
14,000	0-2	340-P14-05	7.50	340-P14-25	25.00
8,000	2-4	340-P80-05	7.50	340-P80-25	25.00
3,000	4-8	340-P30-05	7.50	340-P30-25	25.00
1,200	10-20	340-P12-05	7.50	340-P12-25	25.00
600	20-40	340-P60-05	7.50	340-P60-25	25.00
325	54-80	340-P32-05	7.50	340-P32-25	25.00
260	80-100	340-P26-05	7.50	340-P26-25	25.00
180	NA	340-P18-05	7.50	340-P18-25	25.00
100	NA	340-P00-05	7.50	340-P00-25	25.00
80	NA	340-P08-05	7.50	340-P08-25	25.00
60	NA	340-P06-05	7.50	340-P06-25	25.00

DIAMOND SPRAY			
Mesh	Micron	Order #	Price
100,000	0-1/2	106-6050	15.00
50,000	0-1	106-6051	15.00
14,000	0-2	106-6052	15.00
8,000	2-4	106-6053	15.00
3,000	4-8	106-6054	15.00
1,200	10-20	106-6056	15.00
600	20-40	106-6057	15.00
325	54-80	106-6049	15.00

POLISHES FOR STONE

The polishing compounds on this page are used on pads (see page 13), flat laps (see Tin Lap page 11), or buffs (see pages 19, 32, 83). To use these polishes, make a slurry by mixing polish with either water, mineral oil (like our Roc-Oil on page 50) or a 50-50 oil and dishwashing detergent mixture.

Cerium Oxide, Aluminum Oxide and Tin Oxide are packaged in durable, reusable plastic containers to prevent damage in transit and provide for easy storage.

TIN OXIDE POLISHING COMPOUND

Puts an excellent polish on almost all gemstones, including the hard-to-polish ones.

402-90-04.....1/4 lb..... Shp wt. 6 oz. 12.00
402-90-01 ...1 lb..... Shp wt. 1 1/4 lbs..... 44.00

CERIUM OXIDE

Cerium oxide is one of the best all-purpose polishes available. Our standard and premium grade cerium oxide will give you an excellent polish when used on pads or for tumbling. For the money, they are a great buy. Our Super grade Cerium Oxide is one of the best polishes we've tested. It gives an excellent polish to almost any stone, especially when used on a felt pad. Packaged in plastic containers.

400-80-01Standard 1 lbShp wt. 1 1/4 lbs..... 7.75
400-80-05Standard 5 lbShp wt. 6 lbs..... 34.90
402-82-01... Premium 1 lbShp wt. 1 1/4 lbs..... 29.70
402-82-05... Premium 5 lbShp wt. 6 lbs..... 131.73
402-83-04.....Super 4 ozShp wt. 8 oz..... 20.96
402-83-01..... Super 1 lbShp wt. 1 1/4 lbs..... 75.00
402-83-05..... Super 5 lbShp wt. 6 lbs..... 338.00

LUSTERITE POLISHING COMPOUND

A hard, finely pulverized pyrochemically produced compound suitable for polishing gems of various hardness. Use as you would cerium or tin oxide. Mixes with water. Packaged in Zip Lock Bag

400-65-01 Lusterite I Shp wt. 1 1/2 lbs. 10.00

DIAMOND "SUPER POLISH"

Super Polish is an extremely concentrated diamond compound, a little bit goes a long way. You can use it on all stones and most metals, especially high karat gold alloys. Very good on Jade or Opal. Can be applied directly to workpiece or to felt, leather, wood, cork, canvas pads, or a brush. No coolant required. Clean up with soap and water. Comes in 3 gram vial or 3 gram stick form. Shp. Wt. each 8 oz.

400-SP-012 VialBlue.....1200 grit 25.00
400-SP-020 VialGreen.....2000 grit 25.00
400-SP-140 Vial Yellow14,000 grit 25.00
400-SPS-012 .. Stick.....Blue.....1200 grit 25.00
400-SPS-020 .. Stick.....Green.....2000 grit 25.00
400-SPS-140 ... Stick..... Yellow14,000 grit 25.00



ALUMINUM OXIDE POLY PRODUCTS

These high grade polishing aluminas have been custom developed for the Lapidary Industry, use as you would cerium or tin oxides.

POLY-AL LS is an AGGRESSIVE powder. At 1.4-1.6 microns, it is an ideal pre-polish.

401-AL-LS-4 4 oz. SizeShip Wt. 8 oz. 4.80
401-AL-LS-1..... 1 lb. SizeShip Wt. 1 1/4 lb..... 13.80
401-AL-LS-5..... 5 lb. SizeShip Wt. 5 1/4 lb..... 59.75

POLY-AL T is a medium fine powder, 0.8 micron particles. Polishes better than Tin Oxide. Particularly good on hard stones. Ideal pre-polish on softer stones, does not undercut. .

401-ALT-4..... 4 oz. SizeShip Wt. 8 oz. 11.50
401-ALT-1..... 1 lb. SizeShip Wt. 1 1/4 lb..... 41.35
401-ALT-5..... 5 lb. SizeShip Wt. 5 1/4 lb.... 190.55

POLY-AL Z most economical of the Poly Products. Particles 0.35 microns. Produces an excellent polish.

401-ALZ-4..... 4 oz. SizeShip Wt. 8 oz. 6.90
401-ALZ-1 1 lb. SizeShip Wt. 1 1/4 lb..... 20.65
401-ALZ-5 5 lb. SizeShip Wt. 5 1/4 lb. 91.85

POLY-AL F the finest of the Poly Products, with particles of only 0.2 microns. This polish will put a superior polish on most any stone that has been properly prepared for polish. Does not break down much during use, so you use less product

401-ALF-4 4 oz. SizeShip Wt. 8 oz. 11.25
401-ALF-1 1 lb. SizeShip Wt. 1 1/4 lb. 40.55
401-ALF-5 5 lb. SizeShip Wt. 5 1/4 lb. 185.95



DOPSTATION™

DOPSTATION™ Features a thermostatically controlled pot for melting waxes used for dopping stones. Features a custom-calibrated ceramic element designed to heat green and black wax fast and then hold it at the proper working temperature. Made of durable plastic, the DopStation™ has a lighted on/off switch, convenient tool storage area, and a flat rim for warming stones prior to dopping.

142-450110115V US plug 1.2 lbs. 32.95
 142-450112230V Euro plug 1.2 lbs. 34.95

ALCOHOL LAMP. For heating wax carvers and spatulas and melting various waxes. Has 3/16" wick and burns denatured alcohol. Faceted body sets at convenient angles for dopping. Wick adjusts with thumb wheel. Replacement wicks come in packages of 2.

150-LMP-422.00... Lamp 9 oz. 6.95
 150-LMP-422.10... Wicks..... 1 oz. 1.35



ALCOHOL LAMP



GEM-LUBE

GEM-LUBE

Use this silicone extender fluid with diamond compound on canvas and leather polishing pads, phenolic laps, etc. Provides a lubricant to the polishing surface to keep your gemstone cool and the rock dust in a fluid form that is easily wiped away. Gem Lube cannot be shipped via air. Use Microsol.

410-LUBE.....2½ oz can 6 ozs. Shp.Wt.8.55
 410-LUBE-C.....Case of 12 7 lbs. Shp.Wt.92.50



MICROSOL

MICROSOL

Silicone based extender fluid. Use about one drop per six drops diamond compound to help spread compound over pad or lap. Makes compound a little more fluid and easy to spread.

106-1112 1 oz vial 2 ozs. Shp.Wt.6.00



WATER AID

WATER AID WETTING AGENT

Water Aid is a concentrated wetting agent. It increases cutting action of sawing, grinding, and sanding/polishing operations using water by eliminating surface tension and preventing hydroplaning. It's biodegradable and normally harmless to skin. Approx. 6 drops per pint is all that's needed.

410-WA-108.....8 oz. bottle 11 oz..... 3.25
 410-WA-116.....16 oz. bottle1½ lbs..... 5.25
 410-WA-110.....1 gal9 lbs..... 27.75



DOP WAX

BLACK DOP WAX. Use with hot dops above. Softens at 170°. Gives excellent adhesion for faceter. Stick 5/8" x 10" ¼ lb. Four sticks per 1 lb pkg.

200-DOP-BL..... 1½lb..... 15.35

GREEN DOP WAX. The standard utility wax for general lapidary work. Provides good adhesion. Use with hot dops above. Softens at 150°. Stick 5/8" x 10" ¼ lb. Four sticks per 1 lb pkg.

200-DOP-GR 1½lb..... 15.10

DIAMOND DOP. High performance tenacious wax used by diamond cutters. Resists flow under pressure. Often holds stones for pre-forming when other waxes fail. Price per stick.

115-32-005..... 2 oz..... 11.00

FACET WAX. Brown wax with high adhesive, high shellac content. Preferred by many facetors. Softens at 145°. Four 3/8" x 4" sticks per pack.

115-32-004..... 12 oz..... 9.00



WOODEN DOP STICKS

WOODEN DOP STICKS. Easy to use, inexpensive. You can dop many stones at one time. Assorted diameters from ¼" to 5/8". About 4" long. Pkg. of ten.

721-70-1001 6 oz. 5.00

TEMPLATES

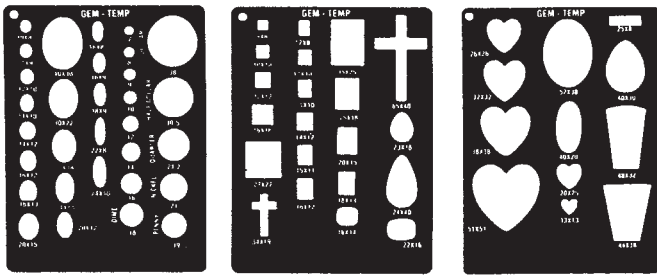

325

326

327

GEM-TEMP TEMPLATES are anodized aluminum, color coded for quick identification. Precision stamped markings are permanent. Precision cut designs stay accurate and resist wear, last for years. Double GEM-TEMP templates enable you to see and scribe both sides of slab while it is held firmly in place.

SINGLE OVALS AND CIRCLES (blue)

130-325 1 oz.7.10

DOUBLE OVALS AND CIRCLES (blue)

130-325D 3 oz.15.75

SINGLE SQUARES AND RECTANGLES (gold)

130-326 1 oz.7.10

DOUBLE SQUARES AND RECTANGLES (gold)

130-326D 3 oz.15.75

SINGLE MISC. SHAPES (red)

130-327 1 oz.7.10

DOUBLE MISC. SHAPES (red)

130-327D 3 oz.15.75

SET OF THREE, one each color, with scribe.

130-GT3 5 oz.20.80

DIVIDER

This good quality 3" divider is used for making circles, measurement transferal and finding centers. Features a quick-adjust setting nut.

150-DIV-300.99 6 oz. 5.60

SCRIBES

SCRIBING PENCILS. The basic tool for making the outline of cabochon shapes on slabs. The pencils, one aluminum and the other brass, come as a set. The scribes are easy to see and will not wash off during sawing or grinding. Sharpen pencils on any grinding wheel.

130-14-115 Set..... 3 oz. 2.20

DIAMOND TIPPED SCRIBE Light weight and slips in your pocket. Scribe plastic, glass, stone and metals.

150-SCB-432 2 oz.10.00

CARBIDE SCRIBE. Our carbide pocket scribe with clip is always where you want it — in your pocket. Hardened carbide tip ensures extended life.

150-SCB-435 2 oz. 6.95



CIRCLE AND OVAL TEMPLATE SET Two piece template set has 36 circles templates from 1mm to 36mm and 27 ovals from 2mm to 50mm. Ideal for metal working and other jewelry making applications..

150-GAU-420set.....3 ozs..... 5.95

GEM-TEMP PLASTIC TEMPLATES are made of heavy duty plastic. Won't corrode or bend out of shape. Precision cut. Set includes 1 of each style, plus scribe.

130-345 1 oz.4.90

130-346 1 oz.4.90

130-347 1 oz.4.90

130-349set of 3..... 3 ozs..... 14.76

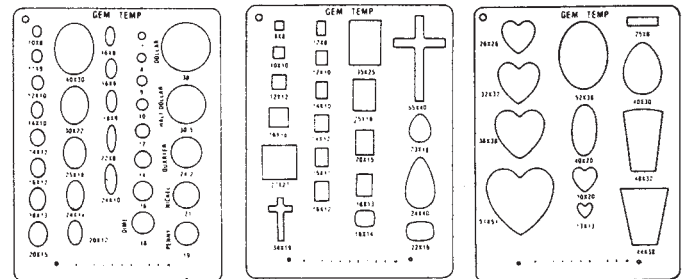

345

346

347



DIVIDER



SCRIBING PENCILS



DIAMOND TIPPED SCRIBE



CARBIDE SCRIBE

THE BOXER

With the Boxer you can easily make gemstone boxes with perfect mitered joints

In the past, if you made a box with the common butt joints, your finished box had four unsightly seams showing where the sides were glued together. With mitered joints, the seams are inconspicuous since they occur precisely at the corners of the box.

The Boxer is used to hold a slab at an angle so that it's ends can be quickly ground to an accurate 45 degree bevel on a diamond lap. Four such slabs will then fit together to make the sides of a box. The sides of the box can be up to 3" deep with no limit on length.

The Boxer can be used with a "No-Hole" lap on the right side of a Genie or a standard lap on the left side. The Pixie will require a 4" "No-Hole" lap. A smaller plastic pan from the super market will have to be substituted for the usual Pixie pan. The Boxer can be adapted to either side of the Titan by clamping a mounting board atop the pans.

The best choices for lap grit size are 80 or 100 grit with 180 grit also being usable. Sanding and polishing can be done on conventional equipment or on our Nova Discs and Magnetic laps.

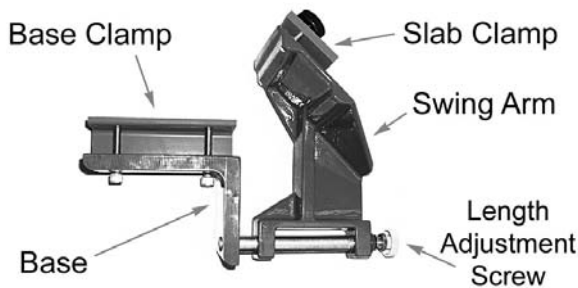

Figure 1

**** IMPORTANT ****

WEAR SAFETY GOGGLES WHEN USING THE BOXER

THE BOXER Made of stainless steel and aluminum	
100-BOXER.....	Shp wt. 5 lbs. 159.00

SHAFT ADAPTORS

SHAFT ADAPTORS FOR GEM-MAKERS

These adaptors fit over the shafts of the Genie, Pixie and BigFoot. Have a 1" OD to fit Galaxy and Nova wheels. Order extra right hand adaptors for specialty wheels for easy change out of wheels while working. Both R/H adaptors have hole for accepting a 1/4"x 20 bolt in pads. The L/H Genie adaptor comes with lap connector nut.

101-ADP-GR	R/H Genie	8 oz.	71.50
101-ADP-GL	L/H Genie	8 oz.	82.50
101-ADP-PR	R/H Pixie	6 oz.	38.50
501-ADP-BFR	R/H BigFoot.....	6 oz.	49.50

SHAFT ADAPTORS FOR ARBORS

These adaptors fit shafts of other machines for using laps, pads with 1/4"x 20 thread bolts. Have plain bore with set screws. The 3/4" size also accepts laps with 1/2" center hole. Arbor sizes listed below.

106-AD-1411	1/2" arbor	6 oz.	9.00
106-AD-1412	3/8" arbor	6 oz.	9.00
106-AD-1413	5/16" arbor	6 oz.	9.00
106-AD-1414	1/4" arbor	6 oz.	9.00
106-AD-1415	5/8" arbor	6 oz.	9.00
106-AD-1416	3/4" arbor	6 oz.	9.00

GENIE WHEEL ADAPTOR KIT



Now you can enjoy the convenience of an extra adaptor for adding wheels to your Genie without having to figure out in advance which spacers you might need. This kit contains the extra Genie right hand adaptor and nut, plus seven extra spacers to accommodate any wheel combination. Contains the following spacers: two 1 3/8" wide, three 3/4" wide, one 5/8" wide, and one 1/4" wide.

101-ADP-GRK	2 lbs.	99.75
-------------------	-------------	-------

JEWELER'S BUFF KITS FOR GEM-MAKERS

You can buff and polish jewelry on your Titan and Pixie as well as on the Genie.

We've put together all the necessary adaptors, spacers, buffs and rouge you need to convert your Gem-Maker to a buffing machine without a lot of expense.

Each kit contains 1 muslin buff, 1 flannel buff, 1 bar of Tripoli, one bar of Red Jeweler's Rouge, and the spacers needed for mounting. The Genie and Pixie kits also contain a right hand adaptor for mounting on a shaft. Wheels are mounted directly onto the Titan shaft. The Genie Kit has 6" buffs, Titan 8" buffs, and the Pixie Kit has 4" buffs.



PIXIE BUFF KIT

Contains: 1- 4" muslin buff, 1- 4" flannel buff, 1 bar of Tripoli, 1 bar red jeweler's rouge, 1 R/H adaptor w/nut, one spacer.

100-JBK-P..... 3 lbs.53.00



GENIE BUFF KIT

Contains: 1- 6" muslin buff, 1- 6" flannel buff, 1 bar of Tripoli, 1 bar red jeweler's rouge, 1 R/H adaptor w/nut, 6 spacers.

100-JBK-G..... 6 lbs. 109.00

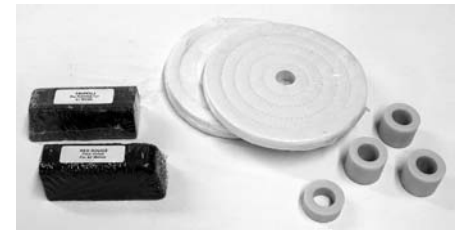

TITAN BUFF KIT

Contains: 1- 8" muslin buff, 1- 8" flannel buff, 1 bar of Tripoli, 1bar red jeweler's rouge, 4 spacers. Buffs and spacers fit directly on Titan shaft.

100-JBK-T 4 lbs. 46.00

ADAPTOR FOR USING TAPERED SPINDLE ON GEM-MAKERS

This adaptor allows you to use a 3/8" R/H tapered spindle for attaching buffs to the right hand of the Genie, Pixie, BigFoot and Titan. You can then use buffs with standard pin hole centers on your Gem-Maker. (See page 83 for buffs.) The adaptor spins into the 1/4-20 adaptor hole on the right hand side of the machine to allow you to attach the spindle. Fits tapered spindle 154-TSR4 shown below.

101-ADP-3/8..... 8 oz. 9.95

TAPERED SPINDLE FOR GEM-MAKERS

Use with adaptor above to attach buffs with standard pin hole centers to your Gem-Maker.

154-TSR4..... Shp. Wt. 6 oz. 10.75

MUSLIN AND FLANNEL BUFFS FOR GEM-MAKERS

Use with polish on stone or metal. Have 1" centers. Use flanges to adapt to 3/4", 5/8" or 1/2" arbor. Order flanges from page 82.

Order #	Fits Machine	Type	Dia.	Stitching	Ply	Shp. Wt.	Price
100-JPK3	Pixie	Muslin	4"	2 Rows	40	2 oz.	4.75
100-JPK4	Pixie	Flannel	4"	2 Rows	30	2 oz.	6.75
100-JPK1	Genie	Muslin	6"	4 Rows	60	5 oz.	10.75
100-JPK2	Genie	Flannel	6"	3 Rows	30	5 oz.	9.45
100-JPK5	Titan	Muslin	8"	4 Rows	55	10 oz.	16.95
100-JPK6	Titan	Flannel	8"	3 Rows	30	10 oz.	12.80

ADAPTOR TAPERED SPINDLE

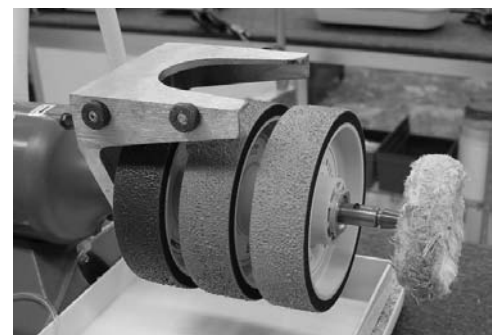
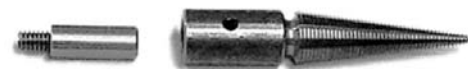

Shown on Genie: adaptor, tapered spindle and buff.

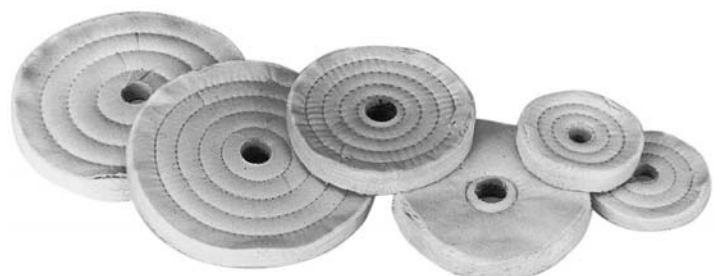

BUFFS FOR GEM-MAKERS

FLEX-STEM LAMPS FOR MACHINES, WORKSHOP, HOME, DISPLAYS

Moffatt Flex-Stem lamps adjust to any position. A quick-coupling base allows the lamp to be removed for storage or attachment to another area. Lamps come in several stem lengths, making them adaptable for use in many places about the shop and home. Flex-stem magnifiers below are interchangeable with lamps on our machines. Mounting base not included. See below to order. All take 100 watt bulb, maximum. Bulb not included. White shades only.

117-0624-T ..24", fits Titan.....	3 lbs.	59.16
117-0618-G ..18", fits Genie	3 lbs.	54.64
117-0615-P ..15", fits Pixie.....	3 lbs.	51.88
117-0636	36", lamp.....	4 lbs. 70.94



FLEX-STEM LAMP



FLEX-STEM MAGNIFIER

FLEX STEM MAGNIFIER

This handy, single lens, two power magnifier can be bent to any position, leaving hands free to examine workpiece. Attach to any flat surface such as workbench, table, or separate base-board. Quick-coupling attachment enables magnifier to be detached from base. See below to order base.

117-MV15 Magnifier, 15" stem	2 lbs.	39.76
117-MV24 Magnifier, 24" stem	2 lbs.	47.74
117-RIM Magnifier Rim	4 oz.	8.75
117-RCS Connector latch	2 oz.	3.95

MOUNTING BASES

Fits flex-stem lamps & magnifiers listed above. Standard base attaches to almost any flat surface that will take screws. Order extra bases for mounting in different locations so lamp can be moved from one area to another.

Standard coupler base - fits all lamps and magnifiers.

117-MS2	3 oz.	5.25
Magnetic base - use on metal surface has 100 Lb. pull on solid steel surfaces.		
117-MB	3 oz.	16.90
C-Clamp base - has 3 3/8" deep throat.		
117-MLCC	1 lb.	26.30

GROUND FAULT CIRCUIT INTERRUPTER

Use with any machine using up to 15 Amps. Portable GFCI plugs into standard 3-prong 115 volt outlet. Use where household outlets have no built-in protection.. Shuts off power to prevent shock.

104-GFCI	Shp. Wt 1 lb.	20.00
----------------	--------------------	-------

MAGNIFIER-SHADE MOUNTED

Fits lamps at left, giving you a handy way to get an illuminated look at what you're doing. (Only fits current toggle switch lamps.) Measures 4" x 2" and attaches to lamp shade. Swivels out of the way. Dust cover included. Black only.



117-DMLM

117-DMLM.....	2X.....	8 oz.	35.00
---------------	---------	------------	-------

CAB REST

Plastic hand rest makes grinding bezels on cabs easy. Lay your cab on the cab rest and grind the bezel to a uniform angle. Comfortable for resting your hands while grinding and polishing stones. Keeps stones from chattering against wheels causing premature wear.



CAB REST

101-CRP for Pixie	6 oz.	23.90
101-CRG for Genie	6 oz.	23.90
101-CRT for Titan	2 lbs.	60.25

GEYSERS FOR GEM-MAKERS

Solid brass geyser sprays water to underside of wheels while Spra-Mist pump is working. (Will not work alone or with other systems.) Use with Base below to provide water to flat laps on Genie, Pixie or BigFoot. Use Disc Geyser, 101-TDG-25, when using flat laps on Titan.

101-GSG-25	Pixie.....	4 oz.	39.75
101-GSG-25	Genie	4 oz.	39.75
101-TSG-25	Titan	8 oz.	48.75
101-TDG-25.....	Disc Geyser	12 oz.	42.95

GEYSER BASE

Plastic base snaps onto bottom of brass geyser to convert it for use with discs. Fits Genie and Pixie geysers.

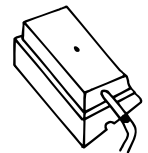

101-BASE	2 oz.	3.75
----------------	------------	------

MAINTENANCE KITS

Kits include pump leathers, vellumoid gasket, tubing for geysers, and pump belts—all that is necessary for each particular pump. Pixie and BigFoot kits have two belts, Genie kit one. For single pump Titans, order kit 101-TMK. For twin pump Titans, order kit 101-TTK which contains two sets pumps leathers, two belts and tubing.

501-BMK BigFoot	6 oz.	42.50
101-PMK for Pixie.....	6 oz.	43.00
101-GMK for Genie.....	6 oz.	36.75
101-TMK for single pump Titan	6 oz.	35.70
101-TTK for twin pump Titan	6 oz.	58.25

SPARE PARTS FOR GEM-MAKERS

When ordering any of the items below, please state catalog number and year and model of your machine, or give a brief description of your machine so that we can send the proper part.

NOTE: There is a \$2.00 service fee for orders under \$20.00

ITEM	PIXIE			GENIE			TITAN		
	Order #	Price	Wt	Order #	Price	Wt	Order #	Price	Wt
Baseboard, Standard	101-PBB-126	37.50	6 lbs.	101-GBB-126	47.20	9 lbs.			
Baseboard Plywood	101-PBB-130	58.50	5lbs.	101-GBB-130	89.50	7 lbs.	101-TBB-126	170.00	17 lbs
Bearings	101-GBE-148	12.75	4 ozs.	101-GBE-148	12.75	4 ozs.	101-TBE-148	27.50	4 ozs.
Belt, plastic pumps	101-PPB-150	17.50	2 ozs.	101-GPB-150	17.50	2 ozs.	101-TPB-193	17.50	2 ozs.
Belt, Titan Metal Pump							101-PPB-150	17.50	2 ozs
Belt, motor	101-PPB-150	17.50	2 ozs.						
Capacitors, motor	101-PCA-65 Before 4/2003	14.20	5 ozs.	101-GCA-65	35.00	5 ozs.	101-TCA-65	35.00	5 ozs.
Hood, RH or LH, state which	101-PHO	240.00	6 lbs.	101-GHO-128	80.00	2 lbs.	101-THO-128	290.00	13 lbs.
Lamp Switch Rotary	117-SKR	15.75	2 ozs.	117-SKR	15.75	2 ozs.	117-SKR	15.75	2 ozs.
Lamp Switch Toggle	117-SKT	7.50	2 ozs.	117-SKT	7.50	2 ozs.	117-SKT	7.50	2 ozs.
Lap Connector w/screw				101-G-LAP	25.00	5 ozs.	101-T-LAP	39.50	4 ozs.
Leathers, pump set	101-GPL-145	5.00	1 oz.	101-GPL-145	5.00	1 oz.	101-TPL-245	10.00	1 oz.
Leathers, Titan Metal Pump							101-TPL-145	7.50	1 oz.
Motor, 115V/60Hz				101-GMO-125	450.00	26 lbs	101-TMO-125	925.00	59 lbs.
Motor, 230V/50Hz				101-GMO-125X	550.00	26 lbs	101-TMO-125X	1,025.00	59 lbs.
Motor, Pixie 115V	101-PMO-125	307.00	6 lbs.						
Motor, Pixie 230V	101-PMO-125X	317.00	6 lbs.						
Pan	101-PPA-130	40.00	2 lbs.	101-GPA-130	35.00	1 lb.	101-TPA-130	280.00	10 lb.
Pump	101-P-PUMP	145.00	1 lb.	101-G-PUMP	145.00	1 lb.	101-T-PUMP-B	345.00	1 lb.
Splash Guards, Set	101-PUO-105	12.00	5 ozs	101-GUO-105	25.00	8 oz	101-TUO-125	15.00	5 oz
Spacers, Wheel Standard	101-PSP-1	4.40	1 oz.	101-GSP- $\frac{3}{4}$	5.50	1 oz.	All Genie Spacers will also fit on the Titan Machine	12.00	5 ozs.
				101-GSP- $1\frac{3}{8}$	5.50	1 oz.			
Spacers, Special Order				101-GSP-1	6.50	1 oz.			
				101-GSP- $\frac{5}{8}$	6.50	1 oz.			
				101-GSP- $\frac{1}{2}$	6.50	1 oz.			
				101-GSP- $\frac{1}{4}$	6.50	1 oz.			
Tubing, geyser, ft.	101-AHS-138	2.75	1 oz.	101-AHS-138	2.75	1 oz.	101-AHT-141	3.75	1 oz.

FOREDOM® HAND POWER TOOLS

RELIABLE – ECONOMICAL – VERSATILE – REVERSIBLE

FOREDOM K2230 JEWELERS KIT

- Features 1/6 HP hang up style motor
- Ball bearing, fan cooled, variable speed
- 66% more power than older CC machine
- 33% more power than old S machines
- Speed up to 18,000 RPM, 39" flex shaft
- Fits most quick disconnect handpieces
- Good for right or left hand users
- Reversible feature helps keep dust away for right hand users
- Alternating motor direction helps extend life of certain abrasives
- Available in 115 volt and 230 volt models. 230 volt is CE approved



Kit 2230

Kit comes with: motor; #30 geared chuck hand piece, 0-5/32 capacity; FCT-1 solid state speed control with wide footprint, plastic housing; chuck key with easy grip handle; flex shaft grease; 60 piece jewelers accessory kit; handy rotating tool holder. **FULL 2 YEAR WARRANTY FROM FOREDOM ELECTRIC**

FOR USE INSIDE THE USA	FOR USE OUTSIDE THE USA
Kit 2230 - 1/6 HP motor, UL and CSA listed	Kit 2230-2CE - 1/6 HP motor, CE approved with Continental European required plug end.
103-K2230 115V 15 lbs.....309.00	103-K2230-2CE230V 18 lbs.....344.00

ROTATING UNIVERSAL BUR HOLDER

This handy, rotating bur holder accommodates all size accessory shanks. Store and organise up to 126 burs and have them all easily accessible. Takes 1/16", 3/32", 1/8" and 1/4" shanks. It measures 7" wide by 4" high, and holds 69-3/32" or 1/8" burs, 12-1/4" burs, and 45-1/16" burs. **BURS SHOWN NOT INCLUDED.**



103-10080 1 lb..... 15.90

EXPANDABLE BUR HOLDER BLOCKS

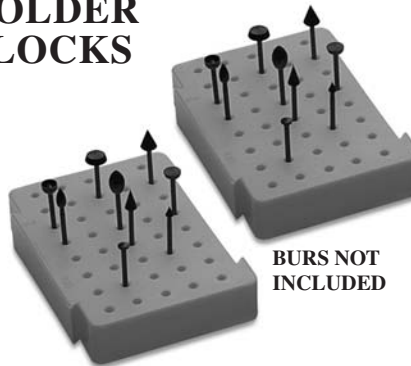

BURS NOT INCLUDED

These simple 40 hole plastic blocks can be attached together to store unlimited numbers of mini brushes, buffs, drills, beading tools, diamond carving points and much more. Each section measures 4 1/4" x 3 1/8" with 3/32" holes. Sold individually.

150-HOL-332.10. 6 oz.2.95

BASE AND YOKE ASSEMBLY



Turn your hang-up style motor into a bench top model with the cast iron base and yoke assembly. It includes all mounting screws. Fits series R, S, and SR motors.

103-UA10451..... 7 lbs. 47.00

FOREDOM® INTERCHANGEABLE HANDPIECES

General purpose handpieces # 30, 44T, 28 and 20 have Foredom's Quick Disconnect feature that makes it fast and easy to interchange handpieces or to attach and remove them. Handpiece # 20 features Foredom's Quick Change Bur Release that allows you to insert and remove burs without the use of a chuck key or pin and wrench. All handpieces have pre-lubricated ball bearings that require no additional lubrication and are suitable for continuous use. **NOTE: Burs shown are not included.**

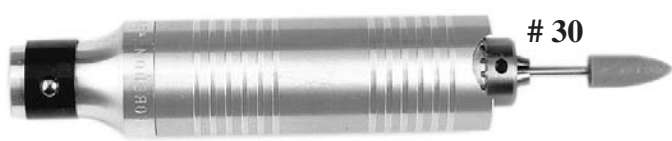

30 Foredom's most popular handpiece features a geared 3-jaw #0 chuck that takes any size shank accessory shank or drill bit up to 3/32" (4mm). Comes with 103-CKH-1 chuck key with molded plastic handle. Various bench top tools are available to work with the versatile # 30, including Foredom's drill press and handpiece holder (page 24). 5 3/16" long, 1" dia, weight, 5.85 oz.
103-HP30Shp Wt 10 oz..... 65.00



44T Collet-type chuck handpiece accommodates accessories with shank sizes up to 1/4" in diameter. Comes with three collets: 3/32" (2.35mm), 1/8"(3.18mm) and 1/4" (6.4mm), and pin and chuck wrench. Other fractional and metric collets are available in Collet Set 440 (page 24). Can also be used in Foredom's handpiece holder and drill presses. (page 24). 5 5/8" long, 1" dia. (center) 3/4"dia, (taper), weight 5.85 oz.
103-HP44Shp wt 9 oz..... 59.00



28 Collet-type chuck handpiece with a slender, comfortable design and tapered grip. Comes with 3/32" (2.35mm) and 1/8"(3.18mm) collets, and pin and chuck wrench. Other fractional and metric collets are available in collet set 600 (page 24). 5 1/4" long, 3/4" dia. (center) 1/2"dia. (taper), weight 3 oz.
103-HP28Shp wt 5 oz..... 59.00



20 Has molded plastic front grip with tapered sides for easy and close handling. Comes with Lever Action for quick and easy insertion and change of accessories. Accommodates 3/32" Shank only. To insert an accessory, rotate lever 90° away from handpiece body, insert accessory, and move lever forward or back 90° into locked position. 5 5/8" long, 1 1/8" dia. (center) 3/8" dia. (front taper), weight 4 oz.
103-HP20Shp wt 5 oz..... 89.00



SPEED CONTROLS FOR 1/6 HP SERIES SR MOTORS



FCT-1

The reliable FCT is Foredom's most popular foot operated speed control. It features solid state circuitry in a heavy duty plastic housing with an extra wide footprint, low profile, and non-skid pads on the bottom for ease of use. It provides smooth control throughout the entire speed range. CSA listed. 7" long, 4 1/2" wide, 2 5/8" high.
103-FCT-1 (115V)Shp Wt 2 lbs.....37.00
103-FCT-2CE (230V)Shp Wt 2 lbs.....73.00



SCT-1

The SCT offers the same electronics and smooth control as the FCT but in a much heavier, cast iron housing. The bottom surface of the SCT is covered with non-skid material. The added weight of the metal housing eliminates any unexpected movement of the control along the floor. CSA listed. 6 3/4" long, 4" wide, 2 5/8" high. Not available for use with SR CE machines.
103-SCT-1 (115V) Shp Wt 6 lbs.65.00

DRILL PRESS STAND

Use your handpiece in this drill press and convert your flexible shaft machine into a drill press for drilling straight, accurate holes in gemstones, metal, wood, plastic and glass. It's a rugged, precision tool made with machined cast iron base, table and housing for stability and accuracy. Sturdy locking nut presets stroke depth from 0 to 1 1/4". Use with #30, 30H, 44, 44T and 44HT handpiece. Handpiece in photo not included.

103-DP-30..... 9 lbs. 169.00

MOTOR HANGERS

Motor hangers suspend hang-up style motors and other power tools above the work bench, allowing ready and convenient access to your work. The MH-5 style shown in photo comes with a BC-1 bench clamp (C clamp) that clamps to any bench up to 2 1/4" thick. The MH-6 style comes with a BC-2 base that screws or bolts to the side or top of bench for permanent mounting.

103-MH-5 3 1/2 lbs. 39.00
 103-MH-6 3 1/2 lbs. 59.00

HANDPIECE HOLDER

Holds handpiece in position for use as a high speed lathe for grinding, carving, etc. while controlling workpiece with both hands. Adjustable height up to 10" above work surface. Rotates 360°. Comes with BC-1 bench clamp. For #30, 30H, 30SJ, 44, 44T & 44HT handpieces.

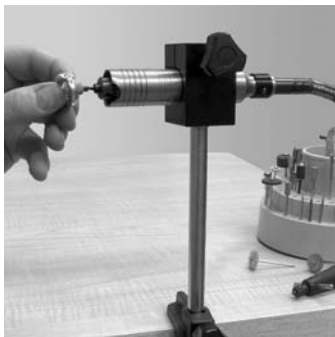

103-HH-30 2 lbs. 41.00

Motor Brushes

Priced per pair. Suitable for 115 & 230V units except where noted.

- 103-132P New pair of brushes for all new 1/4 HP series SR, SRM, and SRB motors..... 8.50
- 103-2019P Pair of motor brushes for 1/4 HP series SR, SRM, SRB, S, SM, and SB motors, H, HM, HB, and series K motors 8.50
- 103-119P Pair of brushes for CC, MM, and DD 115 volt only 8.50
- 103-117P Pair of brushes for CC 230 volt and R, RB, EE, MMG, and GG motors..... 8.50

Replacement Shafts and Sheaths

- 103-93S Inner shaft for series TX, SR, (1/4 and 1/8 HP), I, PG, S, CC, R and K motors 10.00
- 103-77S Standard material outer sheath that comes equipped on all motors except series L, PG, EE, and F 14.00
- 103-77N Neoprene material outer sheath that comes equipped on series L motors and is optional for all other motors except series EE and F.... 15.00

Lubrication supplies

- 103-10005 Foredom Motor and Handpiece Oil in hypodermic dispenser 4.00
- 103-10006 Foredom Flexible Shaft Grease in 1 oz. container..... 3.70

DRILL PRESS STAND



Stroke Length: 1 1/4"
 Throat: 2"
 Post Diameter: 3/4"
 Height: 14 1/4"
 Adjustable Table:
 3 5/16" x 3 5/16"
 Base Plate: 3 3/4" x 3 1/2"

MOTOR HANGER



MAINTENANCE SUPPLIES

Maintenance kits



Maintenance Kits for flex shaft motors contain a shaft, a pair of motor brushes, grease and operating manual. Kits are suitable for 115 and 230 volt motors, except where noted.

- 103-MK-10 New maintenance kit for all new 1/4 HP series SR, SRM, and SRB motors..... 16.80
- 103-MK-8 Maintenance kit for 1/4 HP series SR, SRM, SRB, S, SM, and SB motors..... 17.00
- 103-MK-9 Maintenance kit for 1/10 HP series CC, MM, and DD 115 volt motors only 17.00
- 103-MK-9A Maintenance kit for 230 volt CC motors ... 17.00



#440



#600



103-CKH-1

COLLET SETS FOR HANDPIECES

No. 440 set for handpieces 44 and 44T Seven collets: 1/16", 3/32", 3mm, 1/8", 5/32", 6mm, 1/4".

- 103-440 4 oz. 47.00
- No. 600 set for handpiece 28, 8, 8D, Set of four collets 1/32", 1/16", 3/32" and 1/8"
- 103-600 4 oz. 26.00

CHUCK KEY





Fits handpiece 30, 30H, 30SJ and 25C. Has comfortable plastic handle making accessory change easier, and key more difficult to misplace.

- 103-CKH-1 4 oz. 5.50

NOVA MINIATURE SANDING AND POLISHING POINTS

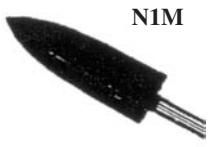
Carvers find these miniature Nova sanding and polishing points answer many of their carving problems. You get the speed and high performance of our Nova resin-bond diamond formulas in shapes and sizes for use on your carvings in

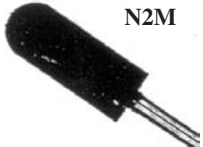
the sanding and polishing processes. Mandrel size is 3/32" which fits most Foredom and Dremel power tools. Illustrations show approximate shape and size. Weight each or set: 2 oz. **Nova points must be used with water.**

										
		Grit Size	Color	Order #	Price	Order #	Price	Order #	Price	Order #
60	GREEN	100-N1M-70	7.50	100-N1L-70	8.00	100-N2M-70	7.50	100-N2L-70	8.00	
140	RUST	100-N1M-15	7.50	100-N1L-15	8.00	100-N2M-15	7.50	100-N2L-15	8.00	
280	BLACK	100-N1M-28	7.50	100-N1L-28	8.00	100-N2M-28	7.50	100-N2L-28	8.00	
600	BROWN	100-N1M-60	7.50	100-N1L-60	8.00	100-N2M-60	7.50	100-N2L-60	8.00	
1200	GREY	100-N1M-12	7.50	100-N1L-12	8.00	100-N2M-12	7.50	100-N2L-12	8.00	
3000	ROSE	100-N1M-30	7.50	100-N1L-30	8.00	100-N2M-30	7.50	100-N2L-30	8.00	
8000	TAN	100-N1M-80	7.50	100-N1L-80	8.00	100-N2M-80	7.50	100-N2L-80	8.00	
14000	CREAM	100-N1M-14	7.50	100-N1L-14	8.00	100-N2M-14	7.50	100-N2L-14	8.00	
50,000	LT BLUE	100-N1M-50	7.50	100-N1L-50	8.00	100-N2M-50	7.50	100-N2L-50	8.00	
Set of four 280, 600, 1200, 3000		100-N1M-S	27.00	100-N1L-S	28.80	100-N2M-S	27.00	100-N2L-S	28.80	

MINI-NOVAS FOR SANDING AND POLISHING

MINI-NOVAS FOR SANDING AND POLISHING THOSE "HARD-TO-GET-AT" PLACES.



Use with power handtools. Flexible, resin-bond diamond sanding and polishing wheels that come in three thicknesses, three diameters, and four grit sizes. The most flexible wheels have diamond on one side of a single layer of canvas. The thickest wheels (about 1/8") are made of two layers of canvas with diamond between them

and on each side. All wheels have a 1/16" arbor hole. Use with mandrels M1 or M6 (see page 32), to mount in your Dremel or Foredom type tool. Mini-Novas should be used with water.

Sets contain one 280, 600, 1200 and 3,000 grit wheels. Wt. 2 oz set.

Wheel Size		Set of four 280, 600, 1200, 3000	
Diameter	No. of Layers	Order #	Price
1/2"	1	100-2Q1-S	4.95
1/2"	2	100-2Q2-S	7.95
1/2"	3	100-2Q3-S	11.90
3/4"	1	100-3Q1-S	9.90
3/4"	2	100-3Q2-S	15.85
3/4"	3	100-3Q3-S	23.75
1"	1	100-4Q1-S	14.85
1"	2	100-4Q2-S	23.75
1"	3	100-4Q3-S	35.65

DIAMOND CARVING POINTS

Now you can have a wide variety of diamond points at a reasonable price. With proper care they will give lasting service. Twenty piece set contains one each of point types shown. Shank size 3/32". Show approx. size. Use with water. Imported.

170-24-08093A 20 piece set 10 oz 9.95

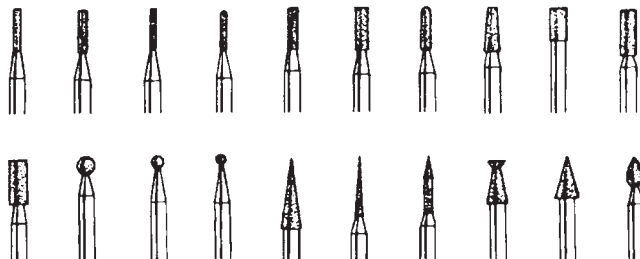

JUMBO HEAD DIAMOND POINT SET

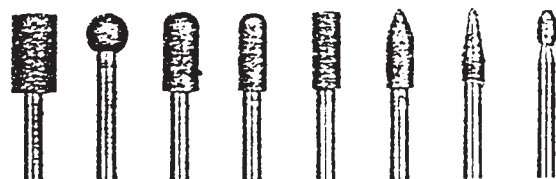

















Use these jumbo sized diamond points on stone, ceramics, carbides & wood. Points shown approximate shape and size. Shank size is 3/32". Set contains one each of the above eight shapes. Use with water. Imported. Standard 150 grit.









170-24-08094 8 piece set 6 oz 12.00









SINTERED DIAMOND CARVING BURS

Sintered carving burs from Inland are professional grade tools. The diamond is all the way through the head, so it will last five to ten times longer than plated diamond tools. All point shapes come in grit sizes: 100, 220, 325 and 600. Shanks are $\frac{3}{32}$ " diameter. Shown approximate shape and size. Suitable for shaping and carving all kinds of minerals. Must be used with water. Shp. Wt. 1 oz. Please specify catalog number.

100 & 220 grit 16.95 325 & 600 grit 17.95								
Order # 100 grit	174-470152	174-470172	174-470232	174-470252	174-470272	174-470332	174-470352	174-470372
Order # 220 grit	174-470154	174-470174	174-470234	174-470254	174-470274	174-470334	174-470354	174-470374
Order # 325 grit	174-470156	174-470176	174-470236	174-470256	174-470276	174-470336	174-470356	174-470376
Order # 600 grit	174-470158	174-470178	174-470238	174-470258	174-470278	174-470338	174-470358	174-470378
Head Size	6mm x 13mm	8mm x 13mm	4mm x 10mm	6mm x 13mm	8mm x 13mm	4mm x 12mm	6mm x 13mm	8mm x 13mm

100 & 220 grit 16.95 325 & 600 grit 17.95								
Order # 100 grit	174-470442	174-470452	174-470632	174-470652	174-470672	174-470732	174-470752	174-470762
Order # 220 grit	174-470444	174-470454	174-470634	174-470654	174-470674	174-470734	174-470754	174-470764
Order # 325 grit	174-470446	174-470456	174-470636	174-470656	174-470676	174-470736	174-470756	174-470766
Order # 600 grit	174-470448	174-470458	174-470638	174-470658	174-470678	174-470738	174-470758	174-470768
Head Size	5mm x 5mm	6mm x 6mm	4mm x 12mm	6mm x 13mm	8mm x 13mm	4mm x 12mm	6mm x 13mm	7mm x 13mm

100 & 220 grit 16.95 325 & 600 grit 17.95								
Order # 100 grit	174-471052	174-471072	174-471092	174-471152	174-471172	174-471192	174-471232	174-471252
Order # 220 grit	174-471054	174-471074	174-471094	174-471154	174-471174	174-471194	174-471234	174-471254
Order # 325 grit	174-471056	174-471076	174-471096	174-471156	174-471176	174-471196	174-471236	174-471256
Order # 600 grit	174-471058	174-471078	174-471098	174-471158	174-471178	174-471198	174-471238	174-471258
Head Size	6mm x 2mm	8mm x 3mm	10mm x 3mm	6mm x 2mm	8mm x 3mm	10mm x 3.5mm	4mm x 11mm	6mm x 13mm

100 & 220 grit 16.95 325 & 600 grit 17.95								
Order # 100 grit	174-471272	174-471342	174-471352	174-471432	174-471452	174-471472	174-471652	174-471662
Order # 220 grit	174-471274	174-471344	174-471354	174-471434	174-471454	174-471474	174-471654	174-471664
Order # 325 grit	174-471276	174-471346	174-471356	174-471436	174-471456	174-471476	174-471656	174-471666
Order # 600 grit	174-471278	174-471348	174-471358	174-471438	174-471458	174-471478	174-471658	174-471668
Head Size	8mm x 13mm	5mm x 13mm	6mm x 13mm	4mm x 12mm	6mm x 13mm	8mm x 13mm	5mm x 12mm	7mm x 13mm

LASCO DIAMOND CARVING BURS

Lasco's diamond tools give you a choice in grit sizes, from 40 grit for roughing out to 600 grit for pre-polish finish. The Lasco-bond process assures a uniform diamond surface that won't peel or pull out. The Lasco tools hold a cutting area without skipping, binding or jumping. You'll enjoy fast, vibration free, self cleaning reduction. Made in USA. Shown approx. size. Ship wt. 2 oz. Order from charts below.



All 1/8" Shanks

CL95 CLR95 B60 B100

Price	\$10.00 ea.	\$10.00 ea.	\$9.00 ea.	\$11.00 ea.
40 Grit	173-CL95-040	173-CLR95-040	173-B60-040	173-B100-040
80 Grit	173-CL95-080	173-CLR95-080	173-B60-080	173-B100-080
150 Grit	173-CL95-150	173-CLR95-150	173-B60-150	173-B100-150
200 Grit	173-CL95-200	173-CLR95-200	173-B60-200	173-B100-200
400 Grit	173-CL95-400	173-CLR95-400	173-B60-400	173-B100-400
600 Grit	173-CL95-600	173-CLR95-600	173-B60-600	173-B100-600

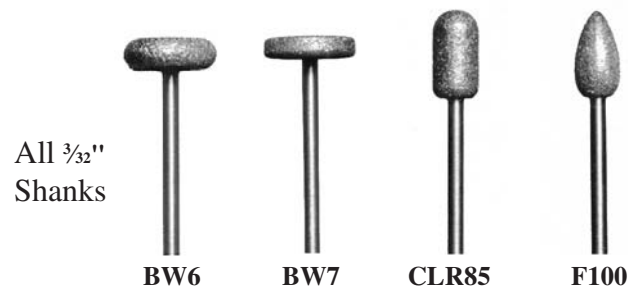

All 3/32" Shanks

BW6 BW7 CLR85 F100

Price	\$10.50 ea.	\$9.50 ea.	\$9.00 ea.	\$10.50 ea.
40 Grit	173-BW6-040	173-BW7-040	173-CLR85-040	173-F100-040
80 Grit	173-BW6-080	173-BW7-080	173-CLR85-080	173-F100-080
200 Grit	173-BW6-200	173-BW7-200	173-CLR85-200	173-F100-200
600 Grit	173-BW6-600	173-BW7-600	173-CLR85-600	173-F100-600

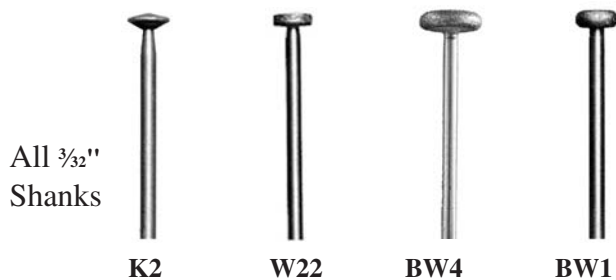

All 3/32" Shanks

K2 W22 BW4 BW1

Price	\$6.95 ea.	\$6.95 ea.	\$7.75 ea.	\$6.95 ea.
80 Grit	173-K2-080	173-W22-080	173-BW4-080	173-BW1-080
200 Grit	173-K2-200	173-W22-200	173-BW4-200	173-BW1-200
600 Grit	173-K2-600	173-W22-600	173-BW4-600	173-BW1-600

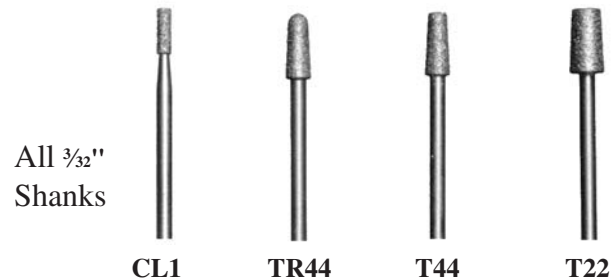

All 3/32" Shanks

CL1 TR44 T44 T22

Price	\$6.95 ea.	\$6.95 ea.	\$6.95 ea.	\$6.95 ea.
80 Grit	173-CL1-080	173-TR44-080	173-T44-080	173-T22-080
200 Grit	173-CL1-200	173-TR44-200	173-T44-200	173-T22-200
600 Grit	173-CL1-600	173-TR44-600	173-T44-600	173-T22-600



All 3/32" Shanks

EL44 CC22 P22 CLR1

Price	\$6.95 ea.	\$6.95 ea.	\$6.95 ea.	\$6.95 ea.
80 Grit	173-EL44-080	173-CC22-080	173-P22-080	173-CLR1-080
200 Grit	173-EL44-200	173-CC22-200	173-P22-200	173-CLR1-200
600 Grit	173-EL44-600	173-CC22-600	173-P22-600	173-CLR1-600

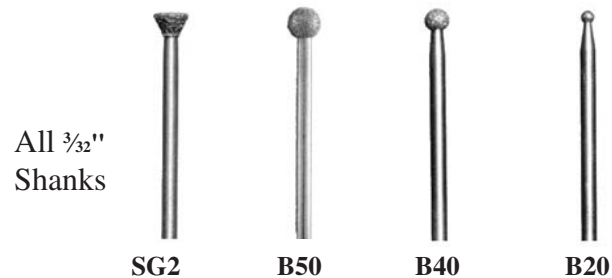

All 3/32" Shanks

SG2 B50 B40 B20

Price	\$6.95 ea.	\$7.75 ea.	\$6.95 ea.	\$6.95 ea.
80 Grit	173-SG2-080	173-B50-080	173-B40-080	173-B20-080
200 Grit	173-SG2-200	173-B50-200	173-B40-200	173-B20-200
600 Grit	173-SG2-600	173-B50-600	173-B40-600	173-B20-600

DIAMOND SPECIALTY TOOLS

These diamond tools from Lasco give carvers large heads for faster reduction. The Lasco-bond process assures a uniform diamond surface that won't peel or pull out. You'll enjoy fast, vibration free, self cleaning reduction. Made in USA. Shank size is 1/8". Shown approximate size. Ship wt. 2 ozs.



DOME WHEEL

Price	\$29.00 each	\$29.00 each
40 Grit	173-DOM-040	173-WHL-040
80 Grit	173-DOM-080	173-WHL-080
150 Grit	173-DOM-150	173-WHL-150
200 Grit	173-DOM-200	173-WHL-200
400 Grit	173-DOM-400	173-WHL-400
600 Grit	173-DOM-600	173-WHL-600



DIAMOND CARVING WHEELS

These mini grinding wheels and discs have diamond nickel plated to the working surfaces of the tool, as shown in the illustrations below. They come in a variety of diameters and thicknesses to help solve your carving problems. All tools are 80 grit. Use with water. Imported.





GRINDING WHEEL







V-SHAPE DISC

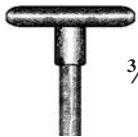

PHENOL POINTS & WHEELS

You can finish extremely hard stone with Phenol Points, especially fire agate free-forms and jade carvings. Tools must be charged with diamond compound. The more the tool is used, the more the diamond becomes embedded in the point. Use any grit combination, but 325, 1200 and 50,000 will do a good job in most cases. Use a separate tool for each grit. Avoid contamination. Use Gem Lube or Microsol (page 16) as lubricant, not water. Tools are most effective using a flex-shaft machine at 500 RPM. Illustrations are approx. size. Shank 1/8" dia, Approx 1 3/8" long. Ship wt. 2 oz. ORDER TOOLS BY NUMBERS SHOWN. Price ea. \$6.50

<p>149-10</p>  <p>5/16"</p>	<p>149-11</p>  <p>5/16"</p>	<p>149-12</p>  <p>1/4"</p>
<p>149-13</p>  <p>3/8"</p>	<p>149-14</p>  <p>1/2"</p>	<p>149-15</p>  <p>3/4"</p>

<p>149-16</p>  <p>3/8"</p>	<p>149-17</p>  <p>1/2"</p>	<p>149-18</p>  <p>3/4"</p>
<p>149-19</p>  <p>3/8"</p>	<p>149-20</p>  <p>1/2"</p>	<p>149-21</p>  <p>3/4"</p>

MINI GRINDING WHEELS				
Order #	Diameter	Thickness	Arbor	Price
170-24-93701	3/4"	1/8"	1/8"	8.00
170-24-93702	3/4"	1/4"	1/8"	8.85

MINI V-SHAPE GRINDING DISC				
Order #	Diameter	Thickness	Arbor	Price
170-24-95710	3/4"	1/8"	1/8"	9.50
170-24-95720	3/4"	1/4"	1/8"	10.50

LAPCRAFT DIAMOND "SLITTER"

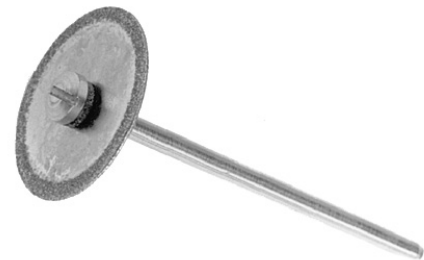

THIN diamond slicing discs that can be mandrel mounted for use with flexible shaft tools. Comes in four different diameters. Use with water. The 1", 3/4" and 5/8" slitters have 1/16" arbor holes. The 2" has 1/8" arbor hole. Made in USA. Wt. 2 ozs. See page 32 for mandrels.

106-12150 ... 5/8"	Requires M01 or M06 mandrel	14.00
106-12155 ... 3/4"	Requires M01 or M06 mandrel	14.25
106-12160 ... 1"	Requires M01 or M06 mandrel	15.00
106-12165 ... 2"	Requires M02 or M14 mandrel	25.00

DIAMOND CORE DRILLS



LAPCRAFT CORE DRILLS are metal-bonded, high strength diamond drills designed for fast cutting and long life. The rigid steel shanks are plated and rust free. Use with water. Made in USA. Ship. Wt. 2 oz. each.

Order #	Outside Drill Dia.	Shank	Price
106-2200	1/8"	3/32"	20.00
106-2201	3 1/2 mm	1/8"	20.00
106-2202	1/4"	5/32"	30.00
106-2203	5/16"	5/32"	31.00
106-2204	3/8"	1/4"	33.00
106-2205A	10 mm	1/4"	35.00
106-2205	7/16"	1/4"	35.00
106-2206	1/2"	1/4"	38.00
106-2207	9/16"	1/4"	40.00
106-2208	5/8"	3/8"	42.00
106-2210	3/4"	3/8"	48.00
106-2212	7/8"	3/8"	55.00
106-2213	1"	3/8"	60.00
106-2214	1 1/16"	3/8"	65.00
106-2220	1 1/4"	3/8"	80.00
106-2240	1 1/2"	3/8"	82.00

CLOCK FACE CORE DRILL packs come three drills per pack in either 3/8" OD, 7/16" or 10mm. Ship. Wt. 3 oz. Use with water.

Order #	Description	Price
106-2205A-3	10 mm 3-pack for Clocks	87.25
106-2204-3	3/8" 3-pack for Clocks	87.25
106-2205-3	7/16" 3-pack for Clocks	87.25

DIAMOND DISC SET



Great for slicing and cutting stone while carving. Six piece set contains five 3/4" discs with diamond plated on both sides and a 1/8" shank mandrel. Diamond is 120 grit. Use with water. Imported. 170-24-50000..... 8 oz..... 16.00

STANDARD DIAMOND DRILLS

MICROMITE DIAMOND DRILLS from Lapcraft are outstanding performers and the choice of professionals. The mandrels are made of durable steel and are plated with rapid cutting man-made diamond. As a result, you get a drill that gives you low cost per hole drilled. Use with water. Speed 5000-20,000 R.P.M. Made in USA. Ship. Wt. 2 oz.

Size MM	Size Inches	Each		Package of 6	
		Order #	Price	Order #	Price
3/4	.030	106-2001	4.00	106-2001-6	22.00
1	.040	106-2002	4.00	106-2002-6	22.00
1 1/4	.050	106-2003	4.00	106-2003-6	22.00
1 1/2	.060	106-2004	4.00	106-2004-6	22.00
1 3/4	.070	106-2005	4.00	106-2005-6	22.00
2	.080	106-2006	4.50	106-2006-6	23.00
2 1/4	.090	106-2007	4.50	106-2007-6	23.00
2 1/2	.100	106-2008	5.00	106-2008-6	24.00
3	.120	106-2009	5.50	106-2009-6	28.00
3 1/2	.140	106-2010	6.00	106-2010-6	30.00
4	.160	106-2011	6.50	106-2011-6	35.00

LAPCRAFT DRILL SETS

MICROMITE ASSORTED DRILL SETS save you money and give you variety as well. Ship. Wt. 3 oz. per set.

Order #	Description	Price
106-2000-3	Three-pak contains one ea: 1mm, 1 1/4 mm, 1 1/2 mm.	12.00
106-2000-6	Six pak contains one ea: 3/4 mm, 1mm, 1 1/4 mm, 1 1/2 mm, 2mm, 2 1/2 mm.	25.00
106-2000-11	Eleven pak contains one ea. of all standard sizes from 3/4 mm to 4mm	50.00



DIAMOND TWIST DRILLS

Use these electroplated, diamond twist drills on stone, ceramics, glass, carbide and other hard non-metallic materials. All drills have 3/32" shanks and are plated with medium-fine diamond grit. Use with all standard hand-pieces. Use water as a lubricant. Imported. Shp. Wt. 2 oz. each. Set 1 lb.

Order #	Size	Price
150-DIB-210.70	1.00 mm	4.80
150-DIB-210.90	1.30 mm	4.80
150-DIB-211.00	1.40 mm	4.80
150-DIB-211.20	1.60 mm	4.80
150-DIB-211.40	1.80 mm	4.80
150-DIB-211.60	2.10 mm	4.80
150-DIB-210.00	SET OF SIX	28.15

METAL AND BRISTLE BRUSHES

Steel, brass and bristle brushes come in three popular shapes. Use metal bristles for a brushed finish on metal. Use steel on white metals and brass on yellow metals. Bristle brushes are used for finishing metal in delicate or pattern areas. Also good for cleaning. Mounted on 3/32" shanks. Come three brushes of one kind per package. Ship Wt. 6 oz. pkg. Maximum Speed Rating: 25,000 RPM.



Material	Wheel		Cup		End	
	Order #	Pkg	Order #	Pkg	Order #	Pkg
Brass	200-BR-102	4.95			200-BR-112	3.75
Steel	200-BR-104	4.95			200-BR-114	3.50
Soft Bristle	200-BR-106	1.60	200-BR-107	3.25	200-BR-116	1.95
Hard Bristle	200-BR-110	1.60	200-BR-111	3.25	200-BR-120	1.95

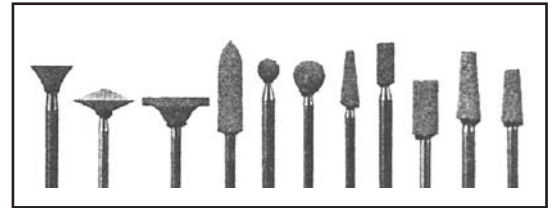

RUBY STONE ABRASIVE POINT SET

Ruby points work best for quick, fine finishing of semi-precious metals, but can also be used for carving stones. Made of aluminum oxide with 3/32" shanks to fit most standard handpieces. This 12-piece assortment comes in a handy, hang-up plastic wallet. Point shapes and sizes approximate those illustrated. Maximum Speed Rating: 35,000 RPM.

152-ABR-616.....SET 8 oz. 16.35

SCOTCH-BRITE RADIAL BRISTLE DISCS FOR METAL FINISHING

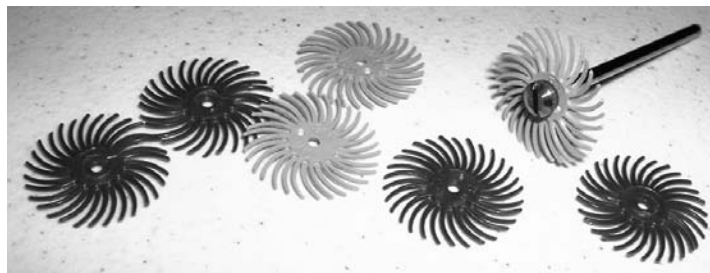

Made in USA
by 3M.



Recommended speed for most applications: 15,000 RPM. More specific speeds are listed in the chart below. DO NOT EXCEED MAXIMUM OPERATING SPEED OF 30,000 RPM. WEAR Safety Goggles WHEN USING THESE DISCS.

Shp. wt. pkg: 2 oz.

RECOMMENDATIONS FOR JEWELRY APPLICATIONS

Heavy Cleaning	36x, 50x	15,000	to	20,000 RPM
Fire-scale removal	50x, 80x	10,000	to	15,000 RPM
Light cleaning	120x, 220x	5,000	to	12,000 RPM
Semi-finishing	400x, Pumice	5,000	to	10,000 RPM
Blending	220x, 400x,	5,000	to	10,000 RPM
Texturing	120x, 220x	5,000	to	15,000 RPM
Pre-Polish	400x, Pumice	10,000	to	15,000 RPM
Polishing	1 micron, 6 micron	15,000	to	20,000 RPM

The Scotch-Brite Radial Bristle Disc has a flexible bristle design that can be used for cleaning, pre-polishing, semi-finishing, blending and texturing. Excellent for gold, silver, copper, pewter and brass applications. Especially good for removing the oxides from jewelry without messy compounds. Great for cleaning hard to reach areas and fine detail.

Easy to Use

- Color coding helps selection of proper abrasive grade.
- Flexible bristles conform to the part and clean without removing detail or forming flat spots. Helps reduce damage and rework.
- Generates little or no dust, and does not generate heat generally associated with wheels or buffs.
- For 3/4" or 1/16" use M01 or M06 mandrels. May mount single or gang up to 6 of a size. The 1" discs use M02 or M35 mandrels. Use single or gang up to 3 discs. Use electric or pneumatic straight shaft grinders. Mandrels listed on page 32.

Order #	Price Pk of 6#	Size Dia.	Grade/ Grit	Color	Order #	Price Pk of 6#	Size Dia.	Grade/ Grit	Color
141-25755	8.25	3/4"	80x	Yellow	141-27614	8.20	1/16"	120x	White
141-25757	8.25	3/4"	220x	Red	141-27615	8.20	1/16"	220x	Red
141-25758	8.25	3/4"	400x	Blue	141-27616	8.20	1/16"	400x	Blue
141-25759	8.25	3/4"	Pumice	Pink	141-27617	8.20	1/16"	Pumice	Pink
141-27610	9.90	1"	36x	Brown	141-27618	8.20	1/16"	1Micron	Lt. Green
141-27611	9.90	1"	50x	Green	141-27619	8.20	1/16"	6Micron	Peach
141-27612	9.90	1"	80x	Yellow	Order mandrels separately - see page 32				
141-27613	9.90	1"	120x	White					

ABRASIVE WHEEL KIT

Save when you buy this 36 piece kit of the most popular rubber bonded Cratex Wheels. Contains 12 of Large Disc (3 ea. of C, M, F & XF) 12 of Knife Edge (3 ea. of C, M, F, & XF) and 12 of Small Bullet (3 ea. of C, M, F & XF). Includes M6 and M25 mandrels with 1/8" shank. Maximum speed 25,000 RPM.
 160-STK-36 1 lb.....29.95



RUBBERIZED ABRASIVE WHEELS

Use these Cratex wheels and points on metal and stone. Especially useful in carving for coarse sanding between diamond burrs and finer sanding. Also great for metal deburring, smoothing, cleaning and polishing. Come in a variety of shapes and sizes to help you work those hard-to-reach surfaces, grooves, holes, etc. Can be used to polish molds, dies, patterns, and light castings, and for cleaning contact points and soldered spots. Contain first quality silicon carbide that has been treated to remove impurities. Graded for proper grit sizes. MAXIMUM SPEED IS 25,000 RPM. Best results are obtained at 30% to 80% maximum speed using light pressure. Come in packages of 3. Shipping Weight 3 oz. per package. See page 32 for mandrels.

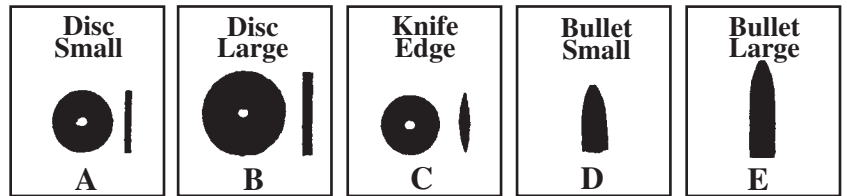

Type Shape	ORDER # BY GRIT SIZE				Pkg. Price	Dimensions			Use Mandrel
	Coarse	Medium	Fine	X Fine		Dia.	Thick-ness	Arbor Hole	
A	160-ST-1504C	160-ST-1504M	160-ST-1504F	160-ST-1504XF	2.00	5/8"	3/32"	1/16"	103-M1
B	160-ST-1506C	160-ST-1506M	160-ST-1506F	160-ST-1506XF	2.55	7/8"	1/8"	1/16"	or
C	160-ST-1500C	160-ST-1500M	160-ST-1500F	160-ST-1500XF	1.85	5/8"	3/32"	1/16"	103-M6
D	160-ST-1552C	160-ST-1552M	160-ST-1552F	160-ST-1552XF	2.55	3/8"	5/8"	1/16"	103-M25
E	160-ST-1553C	160-ST-1553M	160-ST-1553F	160-ST-1553XF	5.00	3/8"	1" long	1/8"	103-M7

CUT-OFF WHEELS						
Type	Order #	Price pkg of 10	Dia.	Thickness	Arbor Hole	Use Mandrel
	160-ST-1310	4.85	7/8"	.030	1/16"	103-M1 3/32"
	160-ST-1315	5.25	1 1/4"	.032	1/16"	or 103-M6 1/8"

CUT-OFF WHEELS

These aluminum oxide (resin bonded) cut-off wheels cut all metals smoothly and rapidly. They are fast, cool, odor-free and long lasting. Come in packs of 10. Weight per pkg: 1 oz.

HEATLESS WHEELS						
Type	Order #	Price pkg of 3	Dia.	Thickness	Arbor Hole	Use Mandrel
	160-ST-1151	1.85	1/2"	1/8"	Pin Hole	103-M1 3/32"
	160-ST-1152	1.85	1/2"	3/16"	Pin Hole	
	160-ST-1161	1.85	3/4"	1/8"	Pin Hole	
	160-ST-1162	1.85	3/4"	3/16"	Pin Hole	
	160-ST-1171	1.85	1"	1/8"	Pin Hole	
	160-ST-1172	1.85	1"	3/16"	Pin Hole	

HEATLESS WHEELS

Heatless wheels are used for the rapid and safe reduction of all types of materials-metals, stone, acrylics and porcelain. They are compounded of hard, sharp, abrasive crystals imbedded in a special binder. This provides for heatless grinding and prevents the grinding surface from clogging allowing for rapid cut. The molded-in bushing maintains proper arbor hole size and reduces wear on mandrels. Come in packages of 3. Wt. per pack: 3 oz.

MINIATURE BUFF WHEELS

MUSLIN BUFFS

SOLID FELT WHEELS

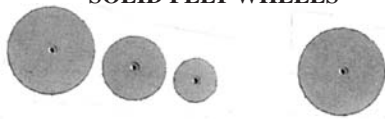

FORMED FELT BOBS

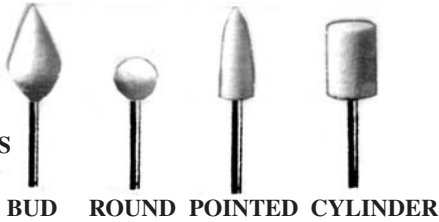

24 PC. ASSORTED FELT BOBS



KNIFE EDGE WHEELS

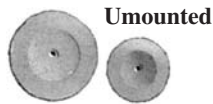

KNIFE EDGE WHEELS For use in crevices and other hard-to-reach places. Unmounted. 3 per package.

Order #	Dia.	Hardness	Use Mandrel	Price/pkg
160-BF-1001	1/2"	H	M01	2.75
160-BF-815	1"	H	M06	4.25

CHAMOIS WHEEL BUFF (Not shown) These fine, soft buffs have a shellac hardened pin hole center. For use with rouge for final coloring of gold. Use 1" with 103-M01 or 103-M06 mandrel. Use 2" buff on tapered spindle.

Order#	Dia.	Stitching	Ply	ShipWt.	Price/Ea
200-CHM-1	1"	1	5	3 oz	4.75
200-CHM-2	2"	3	10	2 oz.	9.25

MINIATURE MANDRELS

Use these miniature mandrels with wheels, points and cones. Made of high quality steel for precision work.

SMALL WHEEL MANDRELS

Mandrels M01 and M06 are for standard wheels. M02 and M35 have reinforced shoulders. M35 comes with extra long screw for mounting thicker wheels or ganging bristle discs or sanding discs.

M14 has enlarged head for support of disc or blade type tools.

POINT AND CONE MANDRELS

Mandrels M07 and M25 are standard mandrels.

Maximum safe speed is 25,000 RPM.



103-M01

103-M02

103-M06

103-M14

103-M35

103-M07

103-M25

MUSLIN BUFFS These miniature buffs are used for final buffing and polishing on soft and precious metals. 160-BF-1030 buffs are chemically treated to hold polishing compound better. Use 103-M01 or 103-M06 mandrel. Package of 3.

Order #	Dia.	Stitching	Ply	Treated	Price/pkg
200-MGTI-OW	1"	2 Rows	16	No	4.50
160-BF-1030	1"	2 Rows	10	Yes	4.25

SOLID FELT WHEELS Good for polishing or lapping metal and stones. Made of highest grade wool felt compressed for uniform texture, hardness and shape. 3 per package except 200-BUF-10 comes in package of 10. Use M01 or M06 mandrel.

Order #	Dia.	Thickness	Hardness	Price/pkg
160-BF-985	1"	1/8"	Hard	.95
160-BF-980	5/8"	1/8"	Hard	.75
160-BF-975	1/2"	1/8"	Hard	.75
200-BUF-10	1"	1/4"	Soft	2.50

FORMED FELT BOBS Made of high quality felt. These formed bobs come in a variety of shapes for difficult polishing jobs. Mounted. Mandrel shank is 3/32". 3 per package.

Order #	Shape	Hardness	Mounted	Price/pkg
160-BF-1070	Bud	H	Yes	5.60
160-BF-1075	Round	H	Yes	5.60
160-BF-1080	Pointed	H	Yes	5.60
160-BF-1090	Cylinder	H	Yes	5.60

24 PIECE ASSORTED FELT BOBS Molded felt bobs in shapes similar to those shown. Shapes come in different sizes, and in medium, hard and rock hard. For use on hard and soft metals and stone. Use with polishing compounds. Mounted on 1/8" shanks.

103-FK3 Shp. Wt 1 lb..... 42.00

MANDRELS Wt. 1 oz. ea.

Order #	Price	Shank Size	Arbor Hole
103-M01	1.10	3/32"	1/16"
103-M02	2.70	3/32"	1/8"
103-M06	1.60	1/8"	1/16"
103-M07	1.60	1/8"	1/8"
103-M14	2.10	1/8"	1/8"
103-M25	1.60	1/8"	1/16"
103-M35	2.10	1/8"	1/8"

Caution: Wear Safety Goggles when using these tools.

GRYPHETTE

Use this handy glass grinder for all your stained glass needs, and apply the same techniques to using stone slabs for creating lampshades, boxes, windows, etc.



This handy glass grinder offers remarkable performance and efficiency at an affordable price that makes it attractive for all your stained glass needs. The Gryphette is handy for wire wrapping too. Use the Grove Grinder Head for a fast easy way to groove around the edges of stone or glass pieces for wrapping your wire.

The Gryphette Grinder features a powerful motor that lets you grind shapes in your material at medium pressure without worry that you will overload the motor, even when using 1" heads.

Working table measures 6-3/4" x 6-3/4". Overall size of grinder is 7-3/4" x 7-3/4" x 6-1/4" high from base to table top. Unit comes with a flexible spray guard that allows large or specially shaped pieces of glass or stone to be ground without removing the guard, it simply bends out of the way.

The Gryphette is made of high impact plastic, and is so simple and well built that Gryphon offers a 5 year limited warranty.

GRYPHETTE GLASS GRINDER comes with 120 grit, 3/4" cylindrical diamond head 115 volt.

725-50 6 lbs Shp Wt \$64.75

DIAMOND GRINDING HEADS



CAUTION:
WEAR Safety Goggles WHEN USING GRINDERS

Gryphon Diamond Products are unsurpassed for grinding and drilling glass, ceramic, marble and granite. These bits are made to be self sharpening to extend wear and improve performance. Heads are guaranteed not to peel. All heads come with hex wrench.

CYLINDRICAL HEADS: The 3/4" and 1" diameters heads come in 4 grits. The Coarse head (C) 60 grit, is used for quick material removal. The Standard or Medium head (M) 120 grit, is best for all around grinding. The Fine (F), 220 grit will smooth the marks left by the coarser grits. Extra Fine (X), 600 grit leaves a smooth final finish.

The smaller 1/8" and 1/4" cylindrical heads or pins, come in Coarse (C) 60 grit, Standard (M) 120 grit and Fine (F) 220 grit. These may be used to drill holes in glass or stone slabs, then used to grind elaborate shapes within the inner surface. Head sits above table

GROOVE GRINDER is great for grooving stone and glass edges to hold wire when doing wire wrapping projects. Comes in Fine (F) 220 grit only.

DIAMOND HEADS					
Dia	Grit	Order #	Dia	Grit	Order #
1/8"	60	726-0125C	1/4"	60	726-0250C
1/8"	120	726-0125M	1/4"	120	726-0250M
1/8"	220	726-0125F	1/4"	220	726-0250F
3/4"	60	726-0750C	1"	60	726-1000C
3/4"	120	726-0750M	1"	120	726-1000M
3/4"	220	726-0750F	1"	220	726-1000F
3/4"	600	726-0750X	1"	600	726-1000X
Groove Grinder			220	726-2000M	
Order Tools by Order Number Shown					
Price ea \$13.95			Ship Wt 8 oz		

THE CARVER'S CHOICE

Now you can carve the fixed-point method, or with a flexible-shaft—either way with the same unit. Plus, you have a unique coolant/shield set-up that protects you from any coolant splash, but with no shields to interfere with a clear line of sight to the work-piece as you carve.

The design of our unique shield and coolant system makes this possible. Your line of sight passes over one adjustable clear plastic shield and under the other, leaving you with an unobstructed view as you work, yet protected from any splash and splatter. You control the coolant flow as well, allowing you to adjust the drip to an efficient minimum.

Not only that, you have plenty of room to maneuver your workpiece around the fixed-point arbor. The chuck accommodates accessory shanks from 0-⁵/₃₂". The motor is 1/2 HP with adjustable speeds from 500-7000 RPM, suitable for most carving needs.

The Carver's Choice easily converts to allow flexible-shaft carving. Just remove the arbor chuck (included with the unit) and attach a flexible-shaft which must have a 5/16" coupling. The Flexade® sold below allows you to use almost any of Foredoms's handpieces (sold on page 23). We do not include a flexible-shaft with the unit.

When you convert to the flexible-shaft method, you can move the Work Station unit out away from the motor, giving you plenty of room for movement of the flexible-shaft. The Work Station is completely self-contained, and can be used elsewhere in your shop.

Work Station comes with handy flex-lamp, and coolant tank with adjustable valve.

The Carver's Choice unit is the suggestion of master carver Dick Friesen, so it works.



THE CARVER'S CHOICE includes 1/2 HP 115 Volt, high torque Foredom bench lathe model BL mounted on a special 11 1/2" x 14" baseboard, 5/16" shaft chuck arbor for fixed point carving, complete Carver's Work Station including lamp. (NOTE: A flexible-shaft attachment is NOT included with this unit.)
 660-CC..... Shp wt 27 lbs..... 444.00

FLEXADE® FLEX-SHAFT

Convert your lathe, drill press or electric drill into a flex-shaft machine. For best performance, motor speed should operate at 3500 RPM or higher, and ONLY in a forward direction. Any Foredom Quick Change handpiece can be attached. The 30" Flexade® comes with motor coupling. For current models of Foredom's M.BL Lathe and other motors with 5/16" diameter shafts.

103-BO-15.....5/16" shaft. Shp wt. 1 lb.....26.00

For older Foredom lathes, and motors with 1/4" motor shafts.
 103-BO-14.....1/4" shaft. Shp wt. 1 lb.....26.00



HANDPIECE AND LATHE SHOWN NOT INCLUDED.

SELECTING SMALL TOOLS FOR CARVING

You will find almost as many methods for carving as you will choice in tools to do the job, from hammer and chisel to create lifesize statues, to a variety of motorized tools and diamond points for intricate carving of agate and similar hard stones. The wide choice in small burrs, buffs and wheels can be particularly confusing to the beginner.

The information below is intended as a beginner's basic guide to the selection and use of small tools for the shaping through polishing process using The Carver's Choice fixed point unit. The tools work as well with our Multiflex Unit, or with any flexible-shaft set-up. Our selection is based on suggestions by a master carver, but is meant to be a beginner's start-up kit. The tools are by no means the only ones you will need or want.

Page numbers listed with the tool descriptions and order numbers below refer to pages in this catalog.

STEP 1. SHAPING YOUR WORKPIECE. The process for carving stone follows the basic steps in finishing gemstones of any kind: the workpiece must be cut or ground to shape, then finished through steps of sanding and polishing. To start, the more matrix you can remove from your stone by trim sawing or rough grinding, the easier time you will have actually carving. Saves your small tools as well.

Diamond burrs are best for shaping your workpiece, and are intended to be used wet. The V-shaped or knife edge burr listed below is used to outline and form the deep valleys. The straight wheel is used to shape the convex areas and the pointed burr is used to form the concave areas. As you will note by looking at the selection of diamond points located on pages 25-29, many more shapes are available.

- Page 27 173-F100-080 Lasco F100 Carving Burr
 Page 28 170-24-93702 Mini Grinding Wheel $\frac{3}{4}$ x $\frac{1}{4}$.
 Page 28 170-24-95720 Mini V-shaped Grinding Disc $\frac{3}{4}$ " x $\frac{1}{4}$ "

STEP 2. THE SANDING PROCESS. In sanding, you are trying to remove all scratches left by the shaping process, and to prepare the surface of the stone for polishing. You will generally spend time going through several sanding steps.

The Cratex wheels listed below are used as coarse sanding wheels and can be used wet (water drip) or dry. If they are used dry, a respirator or face mask should be worn. These wheels wear quickly, so expect to replace them often. On stones of 8 and 9 hardness, the Nova Wheels give better results. They must be used wet. Run the carving arbor at about 6000 RPM (approximately at the 4 o'clock position on the bench lathe dial.)

The Nova Points are used to do fine sanding and prepare the stone for polishing. The sets contain four grit sizes, and must be used wet (water drip). Run between 2000 and 4000 RPM.

- Page 31 160-ST-1506C Cratex Wheel, Large Disc, Coarse, $\frac{7}{8}$ " x $\frac{1}{8}$ "
 Page 31 160-ST-1500C Cratex Wheel, Knife Edge, Coarse, $\frac{5}{8}$ " x $\frac{3}{32}$ "
 Page 25 100-N1M-S Nova Points, Set of 4, Pointed End.
 Page 25 100-N2M-S Nova Points, Set of 4, Round End.
 Page 25 100-4Q1-S Mini Nova Wheel, Set of 4, 1".

STEP 3. FINE SANDING AND POLISHING. Depending on how well the surface of your stone is prepared to this point, you need to proceed with more steps in the polishing process, using Mini-Nova Wheels and/or felt wheels with diamond compound. The Mini Nova's must be used wet. To use the felt wheels, place a small amount of diamond compound on the felt and spread it over the surface. A spray of Gem-Lube or a drop or two of Microsol is then added and spread around the wheel. The carving arbor should be run at about 1500 RPM (approximately the 10 o'clock position on the bench lathe dial). If you are throwing compound, the speed is too high.

When using diamond compound, your workpiece and your hands should be cleaned with soap and water between each step to prevent contamination by the coarser compound grits.

- Page 32 160-BF-985 Hard Felt Wheel 1" x $\frac{1}{8}$ ", Pkg.of 3
 Page 32 160-BF-815 Hard Felt Knife Edge Wheel, 1", Pkg.of 3
 Page 32 103-MO6 Mandrel, $\frac{1}{8}$ " x $\frac{1}{16}$ " (You will need 12).
 Page 14 340-C300-2 Diamond Compound, 3000 grit, 2 grams.
 Page 14 340-C800-2 Diamond Compound, 8000 grit, 2 grams.
 Page 14 340-C500-2 Diamond Compound, 50,000 grit, 2 grams.
 Page 16 410-LUBE Gem Lube Extender

CARVER'S WORK STATION

Stop the splash and mess when you carve with this handy shield developed by master carver, Dick Friesen. The unique arrangement of double, adjustable shields prevents water splashing towards you as you carve, either with a Freedom Flex-shaft unit, or the fixed-shaft Multi-Flex. The Work Station also incorporates a water tank with adjustable valve to control amount of water to your workpiece. A flex-stem lamp easily puts light right to where you work. Made of powder coated metal with clear shields that protect you from splash without obstructing your view as you work.

660-WS Shp. Wt. 8 lbs.198.00

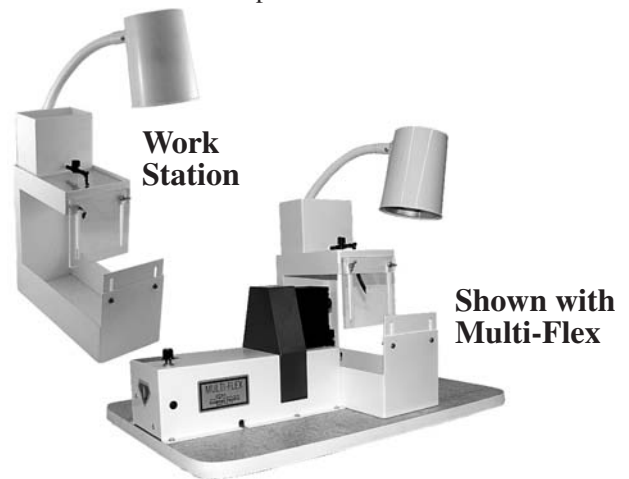

THE MULTI-FLEX SYSTEM

Here's a handy system that lets you start with one machine, and later convert it to another function. You can set up for a capping machine, then add on components for a trim saw, multiple-use carving unit, or a single wheel grinder and flat lap as well.

The heart of the system is the Powerhead (Photo A) It's high torque motor and pulley system provides a variable speed range of 100 to 9000 RPM. You get plenty of power at the turn of a control knob. Comes mounted on 16" x 24" Formica base board. Available in 115V and 230V versions. See page 37.

CABBER SYSTEM (Photo B) Set-up uses 2" wheels. Adaptor (7) mounts 3 wheels at a time. With two adaptors plus a set of 2" Galaxy and Nova Wheels, you have a diamond grinding and polishing unit that's fast and efficient. You will need the Powerhead (1), Hood (6), Pan (4), EZ-Cool recirculating system (2), one or more Adaptors (7), and your choice of 2" wheels. (See pages 7-9.)

TRIM SAW SYSTEM (Photo C) You can trim slabs up to 9" wide or cut fine opal. Uses 4", 5" or 6" blades. The variable speed allows proper blade surface feet per minute. Saw Assembly Kit (5) contains a blade adaptor for 4", 5" and 6" blades with $\frac{5}{8}$ " arbor holes, saw table, and a unique blade guard with direct water feed. You will also need the Pan (4), EZ-Cool recirculating system (2), Powerhead (1), and a blade (See pages 51-53.)

CARVING SYSTEM (Photos D & E) The Multi-Flex system was first designed for carvers, giving them both a fixed point carver that's still preferred by the master carvers in Europe, or a flex-shaft/handpiece system more commonly used here. For the fixed point carver, you need Adaptor (15) and Chuck (14) or Adaptor (13) and Chuck (12). For the flex-shaft setup, you need Adaptor (17) and Flex-Aid (16) plus a handpiece. (See page 23.) For either set-up, you need the Powerhead (1), Pan (4) and a coolant system, either (2) or (3). The Shield (8) will keep the splatter down. Also see Carvers Workstation on page 35.

DISC/WHEEL GRINDER (Photos F & G) Use both flat laps or grinding wheels with the special Hinged-Lid Shield (9). For laps, lid is closed; for wheels, it's open. You can use 4", 5", and 6" discs with $\frac{1}{2}$ " arbor holes, and 4" and 6" wheels. You will need Shield (9), Adaptor (11) for discs and Adaptor (10) for wheels. You also need the Powerhead (1), Pan (4), and either coolant system (2) or (3).

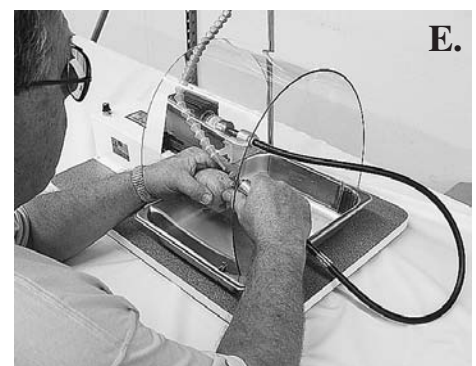
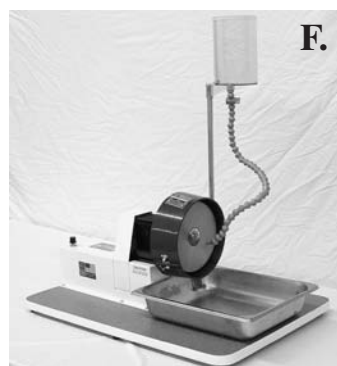
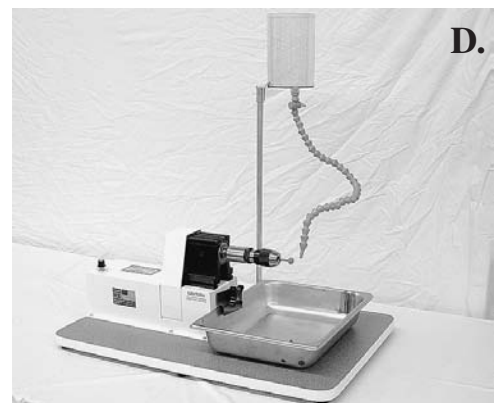

SELECTING YOUR MULTI-FLEX SYSTEM COMPONENTS

Using the Roman Numerals at right, choose the Basic System you need. Refer to the list below and find the Roman numeral you have chosen. Items marked with a ✓ under your Roman Numeral are Basic Requirements. If you have a choice between two items your choices are marked with matching symbols. (☐ ○)

BASIC SYSTEM SET-UPS

- I. Cabber Unit
- II. Saw Unit
- III. Carving Unit, Flexible
- IV. Grinder Unit
- V. Carving Unit, Fixed, Taper Mount
- VI. Carving Unit, Fixed, Thread Mount

	Item	I	II	III	IV	V	VI	Order #	Price	Wt
1	Powerhead with 115V motor, speed control, 16" x 24" base-board, one spanner wrench, Safety Goggles.	✓	✓	✓	✓	✓	✓	660-29-0000	550.00	25lbs.
1x	Powerhead with 230V motor, speed control, 16" x 24" base-board, one spanner wrench, Safety Goggles.	✓	✓	✓	✓	✓	✓	660-29-0000X	650.00	25lbs.
2	EZ-Cool recirculating pump with Locline tubing and valve. Requires pan for water supply. Minimum 1" water depth.	✓	✓	☐	☐	☐	☐	660-70-8000	56.00	2 lbs.
3	Drip tank with valve, Locline tubing. Mounts on powerhead baseboard.			☐	☐	☐	☐	660-70-19002	75.00	1 lb.
4	Pan, stainless steel. Measures 10 ½" x 12 ½". Must be used with cabber hood (6) saw (5) and EZ-Cool (2).	✓	✓	✓	✓	✓	✓	660-29-5021	45.00	2 lbs.
5	Saw Assembly Kit. Contains adaptor for 4", 5", and 6" blades with ⅝" AH, saw table, blade guard with water feed. Must be used with Pan (4) and EZ-Cool recirculating system (2).		✓					660-29-2000	225.00	5 lbs.
6	Hood, metal, for use with 2 inch wheels. 12" W x 8½"H x 3 ½" deep. Comes with metal splash guard, tubing for use with recirculating pumps. Must be used with Pan (4).	✓						660-29-1020	50.00	2 lbs
7	Adaptor, 1" dia., for use with 2" grinding and polishing wheels. 1¼" D x 6¾" L with nut and two ¾" plastic spacers. Holds three 2" wheels. Accepts pads with ¼"-20" bolts for attachments.	✓						660-29-1002	70.00	1 lb..
8	Shield, Polycarbonate. Approx. 8"x 29" long. Slotted to fit in Pan (4). Or use Workstation shown on page 30.			✓		✓	✓	660-29-5070	25.00	1 lb.
9	Shield, cast aluminum. Has hinged lid. Use with 4", 5", and 6" laps or single 4" and 6" wheel set-ups.				✓			660-29-4000	100.00	4 lbs.
10	Adaptor 1" diameter, for attaching 4" or 6" single wheels, expanding drums, buffs. Comes with nut and two 3" flanges. Use with Shield (9).				○			660-29-5040	65.00	2 lbs
11	Adaptor, ½" diameter, for attaching discs with ½" arbor holes. Stainless steel. Use with Shield (9).				○			660-29-5030	35.00	2 lbs.
12	Chuck, keyless drill chuck 0-¼ JT1 for fixed point carving. Use with adaptor (13).					✓		661-29-5065	95.00	1 lb
13	Adaptor, JT1 for use with taper keyless drill chuck (12) for fixed point carving					✓		660-29-5060	40.00	2 lbs
14	Chuck, keyed, ⅜"-24 thread. Use with adaptor (15).						✓	661-29-5055	28.10	1 lb
15	Adaptor 6" long x ⅜"-24 thread, for use with keyed chuck (14) for fixed point carving. Longer length allows more maneuverability, while carving.						✓	660-29-5050	50.00	2 lbs
16	Flex-Aid for ¼" plain shaft. Foredom flexible shaft for use with handpieces for carving, Handpiece not included. (See page 23.) Use with adaptor (17)			✓				103-BO-14	26.00	1 lb
17	Adaptor, ¼" plain, for use with Flex-Aid (16) for handpieces.			✓				660-29-5080	35.00	1 lb
18	Spanner wrench for changing adaptors on Powerhead. Includes pin for use on older Multiflex machines.							690-29-0040	7.75	1 lb
19	Lamp 18" flexible stem. Takes 100 watt bulb (not included). Mounting base not included. See page 10 to select base.							117-0618-G	54.64	3 lbs.
20	Tapered spindle, RH-½" for use with polishing buffs. Must be used with adaptor (21).							154-TSR6	10.75	6 oz
21	Adaptor ½" plain, for attaching RH ½" tapered spindle. (Use with Spindle (20) above.							660-29-3000	35.00	1 lb.

The Gryphon Zephyr Diamond Ring Saw lets you cut in any direction, and operation is very smooth and quiet. It's large work surface is free of obstructions, and the overhead blade support is slender, allowing you to have a very clear view of the material as it is cut. In addition, the Zephyr has a deeper throat and more clearance than other consumer glass saws.

- The saw is designed for quiet operation and for low maintenance. The critical moving parts are shielded to minimize breathing the glass or rock dust that is generated when cutting. The highest quality bearings and wheels are used to extend the life of these critical parts.
- The motor/blade assembly is a separate unit that can be removed from the base and used as a hand-held saw for cutting items that cannot easily be brought to the table. A small water reservoir is built into the blade assembly housing and will hold enough water for a few minutes of hand-held cutting. When the saw is used in the normal configuration (installed in the base), the base will hold enough water for several hours of cutting.
- The Gryphon Zephyr will cut glass, tile, rock and all other similar hard materials. A choice of blades lets you select the one that is best suited to your application. We even offer a Separating Blade that will allow you to make inside cuts without requiring a lead-in slot.

GRYPHON DIAMOND ZEPHYR RING SAW



Above:
Motor/blade assembly combined with tank and large 17.5" X 17.5" table.



Right:
Saw assembly removed from tank for use as a separate saw.

Order #	Description	Shp. Wt	Price
725-60-4000	ZEPHYR DIAMOND RING SAW. comes with 1/3 HP direct drive 115 V motor, Standard 7" diameter diamond ring saw, face shield. Limited 3 year warranty by manufacturer.	19 lbs.	390.00
726-60-4001	Standard 7" Diamond Blade	2 ozs.	59.95
726-60-4002	Separating 7" Diamond Blade	2 ozs.	59.95
726-60-4003	Dichoric Glass Ring Blade, 7", fine grit	2 ozs.	59.95
726-60-4010	Drive Belt, 48" circumference	6 ozs.	29.95
726-60-4011	Purple Idler Wheel, complete	2 ozs.	22.95
726-60-4012	Gold Guide Wheel, complete with bearing and rubber	2 ozs.	24.95
726-60-4013	Rubber Inserts for Gold Drive Wheel, set of 3	2 ozs.	14.95
726-60-4015	Plastic Face Shield, replacement	2 ozs.	10.00
726-60-4016	Work Surface, replacement	1.5 lbs.	40.00

GRYPHON DIAMOND BAND SAW



The simple, rugged construction of the Gryphon Band Saw assures years of service, without expensive and frustrating maintenance. You have a 12" square platform area. The coolant system requires only tap water—add a few drops of our Water Aid (see page 16) to extend blade life. The reservoir measures 10" x 9". Motor is 1/3 HP direct drive at 2850 RPM.

You can make those “impossible” cuts in rock slabs and even fusion glass with this Gryphon C-40 Band Saw. It works like a wood band saw to cut curves and other intricate shapes in stone and glass. Simply guide the workpiece and the saw does the rest. The diamond blade cuts fast and the improved tension adjustment gives you increased control over the cutting process.

- The Gryphon Band Saw uses thin diamond blades which remove less material than wire or ring saw blades, and eliminates “double cutting” on projects such as foiled lampshades. The band saw is also the quietest saw available, and easily cuts the most intricate patterns in glass and stone.
 - Our Lapidary version of the Gryphon C-40 comes with one special Heavy Duty Fuser's Blade. This special heavy duty blade is made with coarse diamonds for cutting dense stone, fused glass and other tough materials.
 - Both the Heavy Duty Fuser's blade and the Standard Black Diamond blade are 37" in circumference and will fit other band saws using this size blade.
 - You can cut material up to 3" thick, but you must cut SLOWLY and CAREFULLY. One inch thick material is the maximum practical thickness.
- FOR EXPORT USE, a transformer is required. Use the one listed in chart below.

Order #	Description	Shp.Wt.	Price
725-70-9800	GRYPHON MODEL C-40 DIAMOND BAND SAW comes with 1/3HP 115V motor, coolant system, one Heavy Duty Fuser's Blade Made in U.S.A. Limited one year warranty by manufacturer.	17 lbs.	375.00
726-70-9801	BLACK DIAMOND BLADE –Twin pack. Two high quality diamond blades. Standard replacement blades. 37" x .020" wide x .020" x .140" deep, Standard diamonds..	1 lb.	106.75
726-70-9807	HEAVY DUTY FUSER BLADE. Coarse grit diamonds make this blade suitable for cutting rock slabs, fused glass, and similiar tough materials. 37" x .020" wide x .020" x .280" deep, Super Power diamonds.	1 lb.	60.25
726-70-9802	BLADE GUIDES. Pack of 4 replacement guides.	8 ozs.	6.85
726-70-9805	MAINTENANCE KIT. Contains upper and lower bands, and replaceable bushing for lower wheel.	8 ozs.	20.50
104-WIZ-8634	TRANSFORMER, For overseas use, converts 230 volt power to 115 volt power.	8 lbs.	80.00

THE WIZARD-4G 6" TRIM SAW



Our Wizard-4G Trim Saw has a new look, improved features and a lower price. Hard to beat that combination. You can't buy a better trim saw anywhere.

- The Wizard-4G makes a full 6" cut—more than some larger saws. Fairly large slabs can be trimmed simply by turning them to cut from opposite directions.
- The Wizard-4G uses water as a coolant and this benefit alone makes the Wizard-4G a pleasure to use. Water is cheap, non-toxic and easy to clean up, unlike every other coolant you can use, especially oils.
- When it comes to cleanup, you can detach the pans from the rest of the saw with the turn of a single thumb screw. Take the pan and the saw table to the sink for cleaning and leave the saw on the work bench. No other saw of any size or description is this easy to clean.
- The Wizard-4G saw housing is stainless steel powder coated for good looks and long life. The saw pan and table are molded from sturdy ABS plastic that's easy to clean and gives years of service.
- The high torque motor has plenty of power for trimming any hardness of rock. Motor has Ground Fault Circuit Interrupter to protect against electrical shock.
- The unique angle block included with the trim saw allows you to finish-trim the edges of your cabs at a ten degree angle, giving you a headstart towards grinding the bezel of your cab.

NOTE: The blade is not included with the saw so that you can choose your own blade. Uses 5/8" or 1/2" arbor hole. To order a blade, see page 52-53 and choose from a number of blade types and thicknesses.

The Wizard-4G measures approximately 12" from front to rear, and 13" from left to right.

WIZARD-4G TRIM SAW

THE WIZARD-4G comes with a sample bottle of Water Aid, angle block and safety goggles.

Shipping Weight 22 lbs.

500-WL-100.....115V Model..... 749.00

500-WL-100X.....230V Model..... 825.00

IMPORTANT SAFETY NOTE

The Wizard-4G is a trim saw and not designed for slabbing rock. Wear Safety Goggles when using saw.

Shown at right is the Wizard-4G with the rip fence attachment and blade, both sold separately. Choose your blade from those on pages 52-53.

RIP FENCE ATTACHMENT: Lets you cut uniform strips. Comes with bracket for attaching to front of saw pan, and adjustable guide bar. Can be used on either side of blade.. Stainless steel, approximately 11" long.

NOTE: The Rip Fence only fits Wizards manufactured after April 2007. Not for older model saws.

500-WL-200.....Shp. Wt. 1 lb. 75.00



MODEL TC-6 6" TRIM SAWS

The MODEL TC-6 trim saw actually accommodates fairly large slabs for trimming on it's 8 1/2" x 9 3/4" flat table. Add the adjustable vise (sold separately), and you have a slab saw for cutting small rocks.

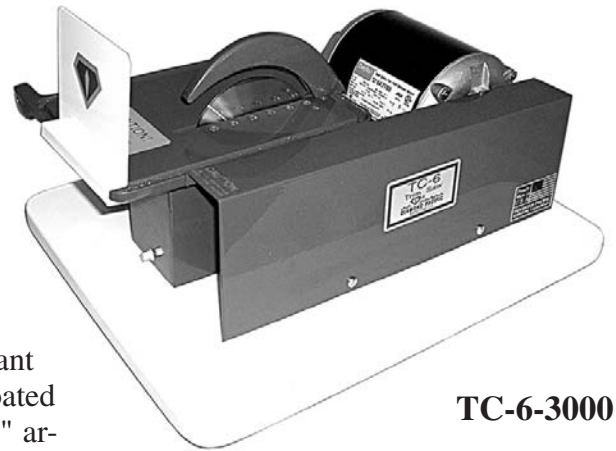

TC-6-3000

The table swings up for easy cleaning and filling of the lubricant tank. The table and tank are cast aluminium with a powder coated finish for easy cleaning and long wear. The stainless steel 5/8" arbor has two sealed bearings and extra neoprene seal on tank side. Laminated baseboard measures 14 1/2" x 18".

This saw must be used with oil as a coolant. It's capacity is approximately two pints. We recommend Roc-Oil, for fast cutting without the usual disadvantages of other cutting oils. See page 50 for lubricants.

Blade shown not included. Order 6" blades with 5/8" arbor from pages 51-53.

MODEL TC-6-1000 BASIC SAW

Includes Tank, Arbor, Table and Blade Guard only

600-06-1000.....Shp. Wt . 9 lbs.....260.00

MODEL TC-6-3000 TRIM SAW

Includes basic saw listed above plus Belt Guard, Splash Guard, Base Board and 1/3 HP motor. (115V/60Hz)

600-06-3000.....Shp. Wt . 32 lbs.....565.00

EXPORT MODEL TC-6-3000X TRIM SAW

Same as above except motor is 220V/50Hz.

600-06-3000X.....Shp. Wt. 32 lbs.....715.00

SLABBING VISE. Converts saw for slabbing. Metal parts with wooden vise jaws. Easy to install and remove.

600-06-5000.....Shp.Wt. 1 lb73.00



TC-6-1000



SPARE PARTS FOR SAWS PAGES 41-44

Item	Order #	Price	Shp. Wt.	Item	Order #	Price	Shp. Wt.
TC-6 Arbor Assy	690-06-2000	140.00	3 lbs.	10TS-B Arbor Assy	690-10-118001	300.00	3 lbs.
TC-6 Arbor Bearing	690-90-1081	12.00	6 oz.	10TS-B Arbor Bearing	690-90-16202	23.25	8 oz.
TC-6 Arbor Seal	690-90-5062	6.00	2 oz.	10TS-B Arbor Seal	690-10-102574	11.50	2 oz.
TC-10 Arbor Assy	690-10-2100	270.00	3 lbs.	10TS-B Arbor Gasket	690-10-100547	3.65	2 oz.
TC-10 Arbor Bearing	690-90-16202	23.25	8 oz.	10TS-B Sump Gasket	690-10-100545	4.95	2 oz.
TC-10 Plastic Hood	690-10-2006	123.00	3 lbs.	TC-14 Arbor Assy	690-14-4100	340.00	6 lbs.
				TC-14 Arbor Bearing	690-90-16204	20.00	4 oz.



MODEL 10TS-B TRIM/SLAB SAW comes with vise, splashguard and $\frac{1}{3}$ HP 115V/60Hz motor.
600-10-1219.....Shp Wt. 68 lbs.....1320.00

EXPORT MODEL 10TS-BX same as above except with 220V 50 Hz motor.
600-10-1219X.....Shp. Wt. 68 lbs.....1495.00

NOTE: This saw does not come with a blade.
To order a 10" blade, see pages 51-53.

See page 41 for spare parts.

MODEL 10TS-B

You'll get years of service from this 10" trim/slab saw.

First, it has all the features needed to make it a versatile trim and slab saw. Easy to use as a trim saw because the vise rotates off to one side to free the table for trimming. With the vise in place, you can slab rocks up to $3\frac{1}{2}$ " in diameter. Table measures 12" W x 17" L. Overall size approx. $29\frac{1}{2}$ " L x 18" W.

Second, it's built solid and rugged with cast aluminum construction with a durable, impact-resistant finish. Arbor shaft is $\frac{5}{8}$ " stainless steel with lubricated, factory sealed ball bearings, and an extra neoprene oil seal on the tank side.

This saw must be used with oil as a coolant. We recommend Roc-Oil, for fast cutting without the usual disadvantages of oil. (See page 50.) Takes approx. $\frac{1}{2}$ gal. coolant

Vise jaws are steel plate with hardwood facings. Designed for a time-tested, economical gravity feed system, the vise has $1\frac{1}{2}$ " lateral movement for cross-feeding and adjustable stop guide for constant thickness cuts.

Tips for slabbing with gravity feed trim/slab saws

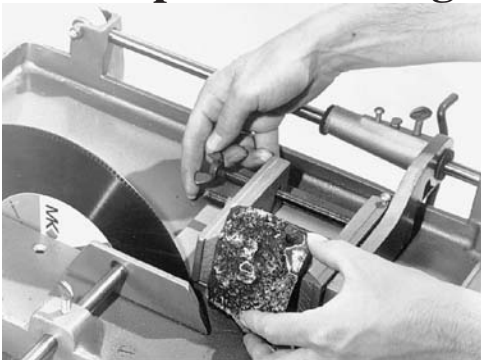

1. Object to be slabbed is clamped in vise. The cut is started by hand pressure.



2. A bucket of sand is attached to the gravity feed cable to maintain an even pressure throughout.

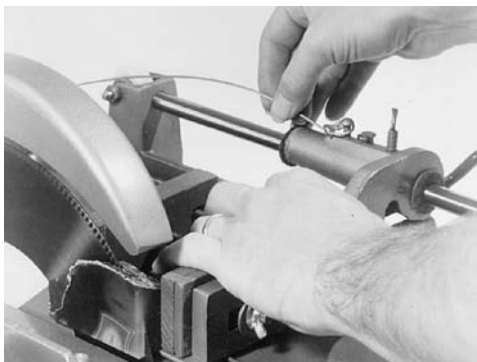

3. Gravity feed and vise are removed. Once this is done, slabs can be held by hand to be trimmed to desired shape.



4. All cuts must be made in a straight line. Be careful not to put side pressure on the blade. Successive straight cuts approximate curved lines that will be finished on a grinding wheel. Make all trim saw cuts outside the template mark.

MODEL TC-10 10" SLAB/TRIM SAW

This 10" saw makes it easy to trim and slab small rocks. A power feed mechanism makes slabbing especially easy.

For slabbing, secure your rock in the vise, push the button, and the power feed goes from there. You can slab rocks up to approximately 3 5/8" x 6" wide by 6" long. The vise glides smoothly and accurately on two stainless steel rails. Vice cross feed is 2". The power feed has an automatic shut-off switch for safety.

Trimming slabs is also easy. The arbor is centered on the table so that you can get a 90° perpendicular cut every time. The stainless steel 5/8" arbor shaft has two sealed ball bearings and extra neoprene seal at the tank for extra long life. The saw table is 13" x 17" with a rim around the edge to contain water and sludge while sawing.

The TC-10 comes with a clear, plastic hood that is easily installed and removed. Splash from the cutting blade is contained within, but you can easily check your progress through the clear hood.

Clean up is easy, too. The table with vise and switches is hinged at one end, and flips up for access to the coolant tank and sludge removal. There is also a drain at one end of the tank.

Tank and table is durable aluminum construction with impact resistant finish for long life. Mounted on a 16" x 24" laminated baseboard.

This saw requires oil as a coolant. Tank capacity is approximately one gallon. We recommend Roc-oil. See page 50.

NOTE: This saw takes a 10" blade with 5/8" arbor hole. To order a blade, see pages 51 to 53.

See page 41 for spare parts or call our Customer Service for more information.

MODEL TC-10 SLAB/TRIM SAW Comes with 1/3 Hp 115V/60Hz motor, power feed, vise, and see-through hood. (Blade not included.)

600-10-2500..... Shp Wt. 66 lbs1615.00

EXPORT MODEL TC-10X
Same as above but with 220V 50 Hz motor.

600-10-2500X..... Shp Wt. 66 lbs1765.00



The Model TC-10 10" saw is attached to a 16" x 24" laminated baseboard. Overall length of the saw is approximately 30" to include motor and power feed controls.



See page 103 for goggles. (Included with all Diamond Pacific trim saws)

MODEL TC-14 SLAB/TRIM SAW

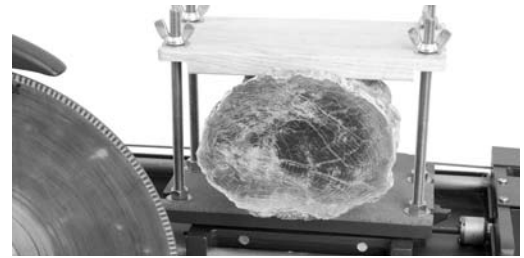
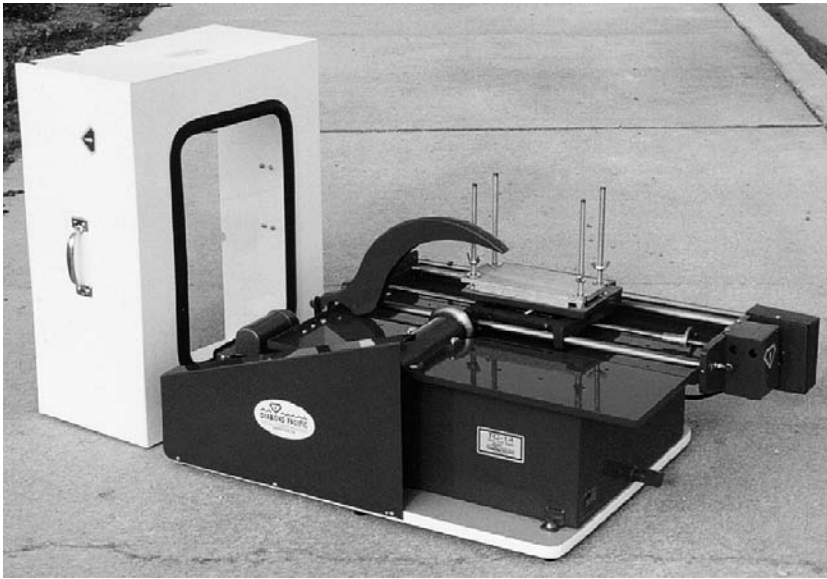

Above: Rock ready for slabbing

Below: Large slice ready to trim

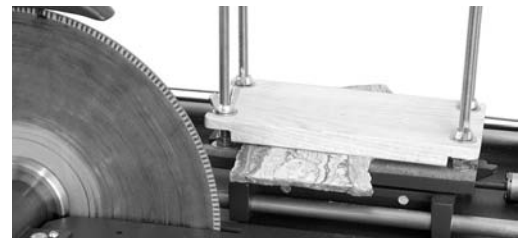

The TC-14 is a convenient size slab/trim saw that will serve the needs of most rockhounds.

The Model TC-14 comes set up to use as a slab saw. The removable table vise easily holds a 5" by 7" rock for slabbing. Larger rocks can be cut depending on their configuration and how they fit into the vise, blade and saw box space.

The vise has over 3" cross feed adjustment, and moves on strong, stainless steel glides. The power feed motor is geared for continuous operation with a slip clutch and safety shut off switch. Once the cut is made, it is easy to pull the vise back to the starting position for the next cut.

The TC-14 is also designed to be used as a trim saw. Large slabs can be held in the vise for trimming off edges or a series of slices. This saw can be converted to a full trim saw by removing the vise system, disconnecting the power feed and leveling the top of the table on one side of the blade (use a piece of board to level) The arbor is mounted on top of the deck so the center of the blade is even with the deck top. This makes 90 degree corner trim cuts easy.

Hood is powder coated steel. Includes acrylic window for viewing

Check these features

- Power feed motor is geared for continuous operation.
- Removable table vise holds a 5" x 7" rock. Will cut a 5 1/4" depth over the vise.
- Saw arbor housing is cast aluminum with 3/4" stainless steel arbor shaft and two sealed ball bearings. Saw table and tank are heavy gauge steel plate. Measures 24"W x 39" L x 21" High.
- Industrial powder coat finish on all appropriate parts.
- Motor available in 1/2 HP 115V/60Hz or 220V/50Hz.

This saw must be used with oil as a coolant. We recommend Roc-Oil, for fast cutting without the usual disadvantages of oil. (See page 50.) Requires approx. 2 1/2 gals. coolant.

NOTE: Blade not included in saw price. Choice of blade depends on your application. See pages 51-53 or call us for more information.

MODEL TC-14 SAW comes complete with base, tank, vise, power feed assembly, 1/2 HP 115V/60Hz motor, guards and hood. (Blade not included.)

600-14-1000..... Shp. Wt. 246 lbs.....2750.00

EXPORT MODEL same as above but with 220V 50Hz motor.

600-14-1000X..... Shp. Wt. 246 lbs.....2880.00

Saw must be crated for shipment.

CRATING FEE for either saw.

600-14C..... Crating fee175.00

SWING ARM SLAB SAWS

In a swing arm type of saw, the blade is mounted on a heavy swinging arm and moves vertically under gravity down through the rock. The rock remains stationary while a cut is being made.

You easily adjust the cutting speed by setting a needle valve that controls the flow of fluid from a hydraulic cylinder that supports the arm.

The arm is raised for the next cut by an electric pump that forces the hydraulic fluid back into the cylinder.

Apart from this smooth, simple feed system that doesn't need the usual sliding (or rolling) carriage, this type of saw has the advantage of using only one-half to two-thirds as much floor space, as they are shorter in the front to rear dimension.

Here are some advantages that you get only in Diamond Pacific's swing arm saws:

- Electric pump to raise the arm rather than a hand pump.
- Single belt drive sealed inside the swing arm,
- Table cross feed uses miter gears so handle can be mounted in front to save your knuckles.
- Table lifts out of saw tank leaving nothing in your way when cleaning the tank.
- Your rock is clamped to a table having a generous amount of travel in both front to rear and left to right directions.
- Adjustable lamp puts light where you need it.
- Saw tank sits on a cabinet type stand that houses the 15 gal. coolant recirculating system. Tank and cabinet are heavy gauge steel plate with a durable powder coat finish. Oil must be used as the coolant. We recommend Roc-Oil—see page 50.

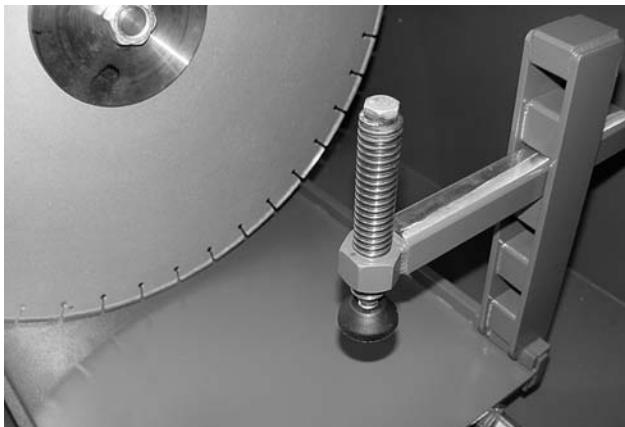
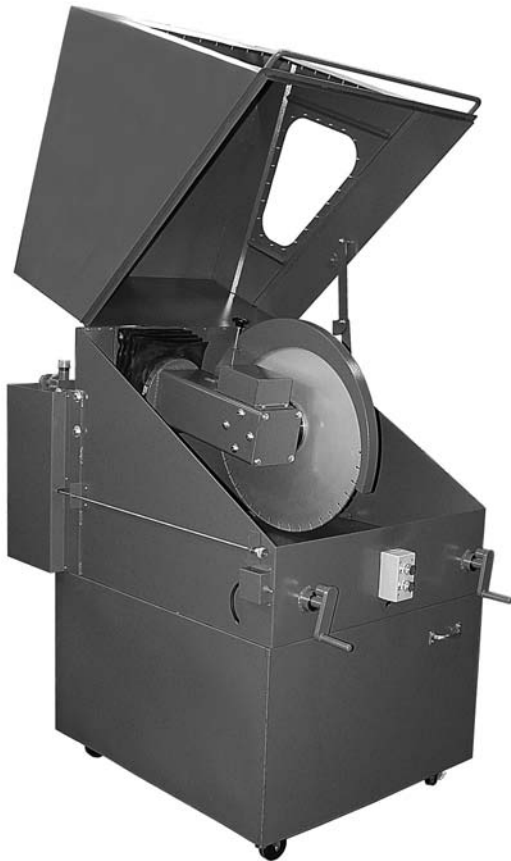

Photo shows *blade, vise and table.

* **Blade Not Included in Saw Price.** Choice of blade depends on your application. Please call for more information.

MODEL SA-18 SWING ARM SLAB SAW

- Overall Size: 38"L x 29" W x 59" H.
 - Table is 12" x 13½" with a crossfeed of approximately 9".
 - Motor: ¾ HP 110V/220V 60 Hz. A 220V 50 Hz is available
 - Shipping Weight: 670 lbs. Must be crated for shipment.
 - SPECIAL ORDER: Allow 6-8 weeks for shipment.
- | | | |
|---------------|------------------|---------|
| 599-18 | 110V 60 Hz..... | 8449.00 |
| 599-18X | 220V 50 Hz..... | 8795.00 |
| 599-18C..... | Crating Fee..... | 375.00 |

MODEL SA-24 SWING ARM SLAB SAW

- Overall Size: 48"L x 38" W x 71" H.
 - Table is 18" x 20" with a crossfeed of approximately 13".
 - Motor: 1 HP 110V/220V 60 Hz. A 220V 50 Hz is available
 - Shipping Weight: 1160 lbs. Must be crated for shipment.
 - SPECIAL ORDER: Allow 6-8 weeks for shipment.
- | | | |
|---------------|------------------|-----------|
| 599-24 | 110V 60 Hz..... | 10,250.00 |
| 599-24X | 220V 50 Hz..... | 10,550.00 |
| 599-24C..... | Crating Fee..... | 425.00 |



The TR Series rock saws (shown above is the TR-24 model) are re-designed and improved saws that we developed from the models we purchased from Contempo Lapidary in 1997. In turn, Contempo had developed their large saws from principles and features used by long time manufacturers such as Highland Park, Beacon Star, Frantom and others. Some of these older saws are still in operation after 30–40 years. We build our modernized saws to the same high standards of long life and performance.

THE MODEL TR SERIES LAPIDARY SLAB SAWS

Built to handle large and heavy pieces of rock, these saws are also widely used in industry for other applications—cutting concrete and asphalt specimens for testing in construction projects, slicing core samples in the oil industry, geological specimens, etc.*

Whatever the job, these rugged slab saws are designed for years of dependable service. Our Powerglide Feed System, coolant recirculating system, hood safety switch, superior materials, etc., give you a large slab saw that is easy to use and built to last.

While the diameter of the saw blades makes a difference in the size of the saw and its components, the features and construction of the TR-18, TR- 24 and TR-36 Slab Saws are much the same.

***NOTE:** The standard TR Series slab saws are designed for lapidary use. For other industrial or commercial uses, modifications must be made to the saws. Please call us with your specifications to receive a quote.

SAW BOX AND HOOD

The tank not only serves to contain the coolant lubricant essential to the cutting process, it also forms the foundation or chassis for the saw mechanisms. In the TR Series, the tank is made of welded steel plate rather than sheet metal. Legs are heavy duty angle iron welded to the tank and braced to support the saw and heavy loads. The saw is solid with almost no vibration. The hood is lighter weight steel for easier lifting, with a clear, plexiglass window for viewing the saw blade in operation. The hood confines the saw while in operation for safety's sake, and also confines the coolant which is thrown in a heavy spray from the rotating blade. The TR-36 has gas springs to help raise and lower the hood. The two smaller saws have locking elbow braces with safety locking pin. Two safety switches on all three saws prevent the motor from running when the hood is up.

MAXIMUM WORKPIECE SIZES

Model	Blade Size	Height	Length
TR-18	18"	6 ¼"	16"
TR- 24	24"	8 ¾"	20"
TR- 36	36"	14"	25"

“V” GUIDE RAIL SYSTEM AND VISE

Since the saws are designed for heavy duty slabbing and quartering of large specimens, the vise and rail system are made to handle the job. V-grooved ball bearing guide rollers glide the vise carriage smoothly on precision ground, steel V-rails attached to heavy steel channels. Exacting tolerances insure matching of hardened bearings, rollers and rails. Alignment of the rails to the blade is within approximately .005 maximum across the full blade diameter.

The vise is readily accessible for loading with wood faced jaws that open extra wide. It's made of cast aluminum for the 18" and 24" saws, and welded steel for the 36" saw. The vise is easily adjustable and will hold the material securely as it passes through the cutting blade.

POWERGLIDE HYDRAULIC FEED SYSTEM

The Powerglide hydraulic feed system is standard on all three saws and is superior to screw feed systems by providing control of cutting speed and length of cut. Your saw blades will cut better and last longer because the hydraulic system feeds the material without slowing down the blade RPM. Another plus is the ability to stop and start the movement of the vise, allowing you to cut a “starting notch” in any surface. This kind of control helps prevent blade damage and “tweaking” of the rock from the vise.

The system consists of a hydraulic pump supplying fluid to a special hydraulic cylinder that in operation, moves the vise carriage with rock through the blade. Speed and pressures are determined by the type of material being cut, and are set by adjusting the easy-to-use regulator, gauge and feed valve.

A safety cut-off device prevents the vise carriage from moving beyond desired length of blade cut.

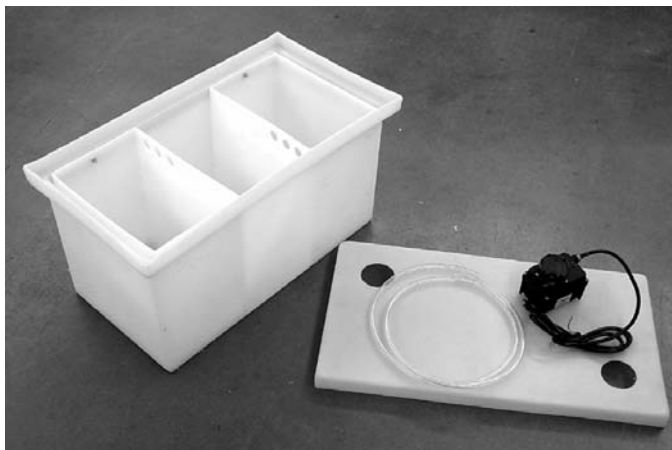

“V” guide rail system is standard on all 18” to 36” saws. Shown is system for TR-24 saw.

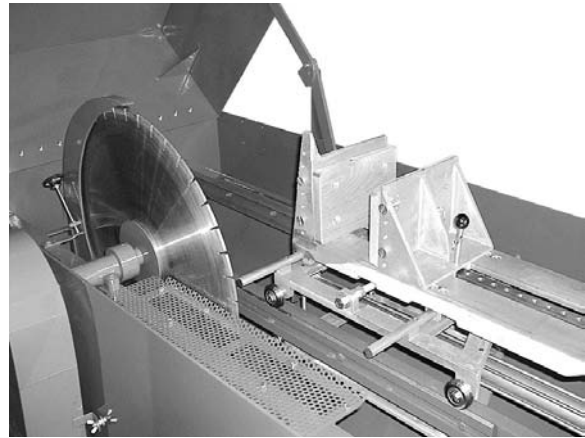

MULTI-STAGE FILTER AND RECIRCULATION SYSTEM FOR SLAB SAWS

We’ve improved and enlarged the coolant recirculating systems for our saws, and have made them available in kits for use on most other large slab saws as well. The system can move large volumes of clean oil over the cutting surface of the saw blade to keep it cool and lubricated. The holding tanks are heavy duty plastic with multiple settling chambers to filter out particles from the coolant. The tank and submersible pump are easily cleaned. See photo below.

Specifications for systems for TR Series saws approximate those given below for separate kits available for other large slab saws.

RECIRCULATING SYSTEMS FOR SLAB SAWS			
The kits contain submersible pump, coolant tank, hose and fittings. Systems will fit most saws and are easily installed using common hand tools.			
Tanks for 14" - 24" saws hold approx. 15 gal. and measure 17"W x 22"L x 12"H. Comes with lid.			
Tanks for 30" - 36" saws hold approx. 30 gal. and measure 18"W x 24"L x 18"H. Comes with lid.			
Kit Size	Order #	Shp. Wt.	Price
For saws 14"-24" pump 1/10 HP 115V 60Hz	600-24-8000	14 lbs.	520.00
For saws 14"-24" pump 1/10 HP 220V 50/60Hz	600-24-8000X	14 lbs.	540.00
For saws 30"-36" pump 1/10 HP 115V 60Hz	600-36-8100	28 lbs.	639.00
For saws 30"-36" pump 1/10 HP 220V 50/60Hz	600-36-8100X	28 lbs.	655.00

MODELS TR-18 AND TR-24 SLAB SAWS

These 18" and 24" saws are the best commercial and industrial models on the market.

The standard TR-18 and TR-24 series slab saws are designed for lapidary use, providing anyone wanting to cut large pieces of rock with a heavy duty, reliable rock saw.

These saws are also ideal for many industrial and commercial needs, such as cutting concrete and asphalt specimens for testing in highway and other construction projects. For those applications, modifications to the saw generally must be made. For anyone with such special requirements, just provide us with your specifications and we will give you a quote on building a saw to fit your particular need.



STANDARD FEATURES FOR BOTH MODELS:

- **Powerglide Hydraulic Feed System** pushes rock to blade for steady cutting. See page 47. Both saws must be used with oil—we recommend Roc-Oil described on page 50.
- **V-Guide Rail System** with heavy cast-aluminum vise features quick release pin and positive screw tightening. (See page 47.)
- **Multi-Stage Filter and Recirculation System.** See page 47 for complete description of this 15 gallon capacity tank system that makes easy work of the process.

- **Arbor Shaft is 1" Diameter** in a one piece, cast aluminum arbor housing with sealed ball bearings.
- **Heavy Duty Tank of 3/16" Steel Plate.** Tank has sloped bottom for proper drainage of coolant. Heavy steel legs on casters allow moving of saw. Leveling screws on each leg. Steel hood has large plexiglass top window for visibility of saw in operation.
- **Safety Features** include full steel belt guard and hood activated cut-off switch.
- **Blade Not Included in Saw Price.** Choice of blade depends on your application. See pages 51-53 or call us for more information.

NOTE: 1 HP saws wired for 115V require a 20 amp circuit and a NEMA 5-20R receptacle.

NOTE: 1½ HP saws wired for 115V require a 30 amp circuit and receptacle, and are special order.

MODEL TR-18 SAW

- Tank Size: 45" L. x 27" W. x 14.75" Deep.
 - Overall size: 50" L x 34" W x 47" Tall.
 - Cross Feed: 6"
 - Vise Opening: 7"
 - Depth of Cut: 6¼" with 5" flange
 - Motor: 1 HP 115V/220V 60 Hz. standard saw wired for 115V 60 Hz.
A 220V 50 Hz is available
 - Shipping Weight: 670 lbs. Must be crated for shipment.
 - SPECIAL ORDER: Allow 4-6 weeks for shipment.
- | | |
|----------------------------------|---------|
| 600-18-8000.....110V 60 Hz..... | 7325.00 |
| 600-18-8000X.....220V 50 Hz..... | 7650.00 |
| 600-18C.....Crating Fee..... | 380.00 |

MODEL TR-24 SAW

- Tank size 61" L x 32" W x 18" Deep.
 - Overall size: 69" L x 37" W x 47" Tall.
 - Cross feed: 8"
 - Vise Opening: 17"
 - Depth of cut: 8¾" with 6" flange.
 - Motor: 1½ HP 110/220V 60 Hz. standard saw wired for 220V 60 Hz.
A 220 V 50 Hz is available.
 - Shipping Weight: 890 lbs. Must be crated for shipment.
 - SPECIAL ORDER: Allow 4-6 weeks for shipment.
- | | |
|----------------------------------|---------|
| 600-24-9000.....220V 60 Hz..... | 9100.00 |
| 600-24-9000X.....220V 50 Hz..... | 9500.00 |
| 600-24C.....Crating Fee..... | 430.00 |

MODEL TR-36 SLAB SAW



This 36" professional slab saw is a giant in size and performance

- For all it's size, the Model TR-36 saw is easy to operate and provides professional cutters of gem material, glass and core samples with reliable performance cut after cut.
- The true workhorse and "secret" of many successful cuts is the Power Glide Hydraulic feed system. (See page 47.) The basic design and simplicity of function insures fast, clean cutting of materials. You are able to set pressure and feed at a constant positive pressure. The Power Glide system for the TR-36 even has a "power return" feature which returns the carriage after a slice has been cut.
- Blade is constantly cooled and cleaned by the recirculating system. (See page 47.) Coolant is directed to both sides of the blade throughout the cutting operation. Recirculation tank holds 30 gallons Oil must be used as a coolant. We recommend Roc-Oil for best performance. See page 50.
- Vise is operated by a 1" Acme thread screw. It has a 23½" opening with 14" depth of cut, 11½" crossfeed for a maximum of 14"H x 23½"D x approx. 30"W rock size. Jaw face is 15" wide. V-Guide rails have 4" U Channel supports. Arbor shaft is 1".
- The tank is made of ¾" steel plate and measures 96" long x 40" wide by 27" deep. The hood has four heavy duty, gas assist springs for lifting. Safety shut off switch stops saw when the hood is raised.
- Comes with 3 HP continuous duty motor. Specify 220V 60 Hz. or 240V 50 Hz. (5 HP and 3-phase motors also available in either frequency. Call for quotation.
- Blade not included in saw price. Choice of blade depends on your application. See pages 51-53 or call us for more information.

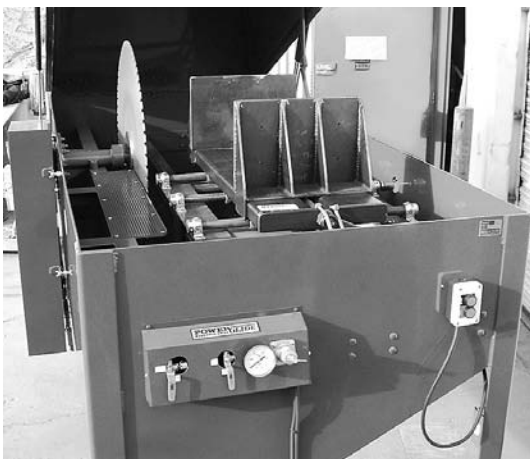

Control panel for Power Glide System is easily accessible.

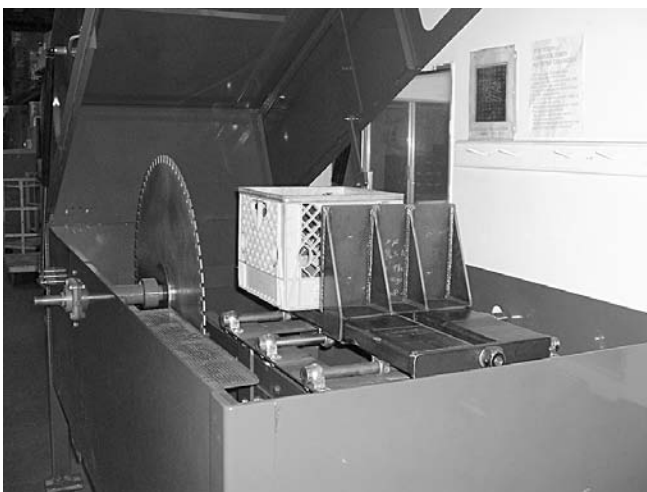

Cuts rocks up to 14" H x 25" D x Approx 35" W.

MODEL TR-36 SAW

The Model TR-36 Saw is SPECIAL ORDER. Allow 6-8 weeks plus delivery time. Saw must be crated. Shipping weight is 2000 pounds. (Crate size: Approx. 6'H x 5'W x 10'L.)

605-36-1000.....	220V 60 Hz	17,000.00
605-36-1000X.....	230V 50 Hz.	17,500.00
605-36C.....	Crating fee	676.00

BLADE COOLANTS

Before buying any saw blade, make certain you know which type of coolant your rock saw requires. All diamond saw blades cut faster in an oil lubricant, but the old standard cutting oils have many undesirable features. Some saw blades and rock saws still must be used with oil, especially the larger blades and saws. Water is now often used as a coolant, but it can rust some blades and rock saws. Using the correct coolant will directly affect blade performance. The following is a general guideline:

- SOFT ROCK: Use water, water soluble oil, or oil.
- MEDIUM HARD ROCK: Use a water soluble oil or oil.
- HARD, DENSE ROCK SUCH AS AGATE: Use an oil coolant only.



ROC-OIL—THE ORIGINAL USER-FRIENDLY, HIGH PERFORMANCE MINERAL OIL SAW COOLANT

Our Roc-Oil is a high quality, food grade mineral oil that out performs other cutting oils and without any of their usual disadvantages. Use it to cut any rock, from soft to hard, and in any saw, large or small. You get top quality performance along with user friendly advantages.

**** IT'S NON TOXIC:** Roc-Oil is rated as a food grade mineral oil so you know it's safe to handle. It doesn't burn your skin, unless you are very sensitive, and has no disagreeable odor.

**** IT' HAS A HIGH FLASH POINT:** Roc-Oil is non-flammable under normal conditions. Its flash point is 309° which is above normal temperatures. It's also above the flash point of similar, lower grade mineral coolants.

Dispose of Roc-Oil following your local requirements for mineral oils.

- 412-RO-1 1 gal. Shp. Wt. 10 lbs. 30.00
- 412-RO-4 4 gal case Shp. Wt. 40 lbs. 115.00

ROCK GRABBER CLAMPS

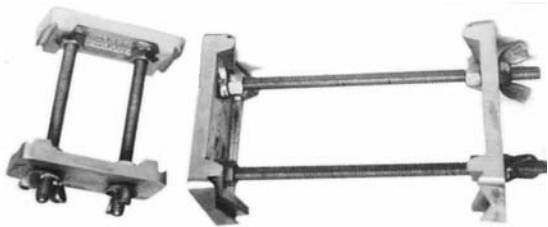

These handy clamps fit easily into most saw vises, making it possible to cut a stone to the last thin slab section. Made of durable cast aluminum. Comes in two sizes: 3" and 5".

- 601-70-1003 3" 1 lb. 22.00
- 601-70-1015 5" 1 lb. 23.75

BLADE DRESSING STICKS

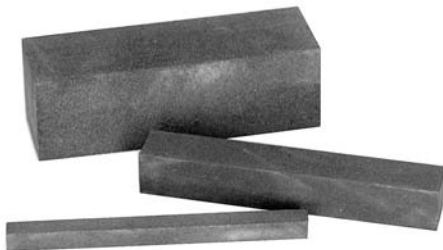

These dressing sticks make it easy to sharpen saw blades to keep them cutting properly. Made of special aluminum oxide and designed for dressing diamond blades. Shp. Wt. : 8 oz.

For Blades:	Stick Size	Order #	Price
4" – 8"	½" x ½" x 6"	109-SS-05	4.60
10" – 14"	1" x 1" x 6"	109-SS-10	10.50
16" +	2" x 2" x 6"	109-SS-20	23.90

“ROC-CUT” WATER SOLUBLE LUBRICANT

Use "Roc-Cut" in your trim saws, cabbers, faceting units, and sanders—whatever uses a splash or recirculating system. It's inexpensive (mix 1 part with 20 parts water for sawing and 1 part with 30 parts water for grinding) and it will prevent rusting as well as give you a great cutting lubricant. Nontoxic, non-allergenic, has no vapors, odor or greasy film. Can be filtered and re-used indefinitely. NOT for slab saws when cutting quartz materials, nor for leaving in tank.

- 711-70-1116. 16 oz..... Shp wt 2 lbs 8.85
- 711-70-1117. 1 gal Shp wt 10 lbs 49.50

WATER AID



Water Aid is a concentrated wetting agent. It increases cutting action of sawing, grinding, and sanding/polishing operations using water by eliminating surface tension and preventing hydroplaning. It's biodegradable and normally harmless to skin. Approx. 6 drops per pint is all that's needed.

- 410-WA-108..... 8 oz. bottle..... 11 oz 3.25
- 410-WA-116..... 16 oz. bottle..... 1½ lbs 5.25
- 410-WA-110..... 1 gal..... 9 lbs 27.75

SELECTING A DIAMOND SAW BLADE

Selecting the best saw blade for your needs requires the consideration of several factors:

1. The type of material to be cut, its value and purpose. The more expensive the material, the thinner the blade you should use to reduce material loss.
2. The capacity of the saw, its condition, blade RPM, and other equipment characteristics. For slabbing, thin blades should only be used on machines that are in good condition and are capable of high RPM's. Thicker blades usually give better service for general slabbing purposes.
3. Production volume to be cut.
4. Operator experience. Generally, thinner blades should only be used by experienced operators as they can be more easily damaged. For school room type conditions, thicker blades will generally last longer.
5. The type of coolant required may vary. Saws with steel parts should be used with oil as a coolant, such as our Roc-Oil, listed on page 50. Steel core blades work best when used with oil. If you use a steel core blade with water or a water based coolant, the blade must not be left immersed in the coolant. Either remove the blade or drain the coolant after each use. Stainless steel saws and blades with a stainless steel core may be used with water or a water based coolant.
6. Type of blade rim. The diamond edge of the segmented and notched rim blades have an interrupted surface which improves cutting ability and coolant flow.

Sintered continuous rim blades mean just that—the edge of the blade has a continuous rim of sintered diamond matrix. Most smaller and thin rimmed blades are either of the sintered continuous or plated rim type.

NOTE: Blades need sharpening as they are worn from use. See page 50 to order blade dressing sticks.

DIAMOND SAW BLADE REPAIRS

Saw blade manufacturers no longer offer the saw blade repair services that they once provided.

We do not repair or offer repair services for diamond blades.

The diamond on Continuous Rim, Notched Rim or Segmented diamond blades cannot be replaced.

TIPS ON THE CARE AND MAINTENANCE OF SAW BLADES

1. For longer life with your saw blade, your saw and equipment must be in proper condition. Whenever you install a new blade, check your arbor shaft for radial and axial play. Try moving the shaft back and forth, and in and out. Any movement indicates the arbor shaft needs adjustment, new bearings, or replacement.

Lapidary blades are manufactured with the arbor hole .005" oversize to provide a snug fit on the shaft. If the shaft is worn, the blade will not spin concentrically with the arbor.

The machine should be located on a level floor or platform so that it will not vibrate during operation. All belts should be properly tensioned.

2. Flanges support the blade over a large surface area and help prevent deflection at the beginning and ending of a cut where there is little or no workpiece support. They must measure at least one quarter of the blade diameter. Make certain the flanges are smooth, flat and parallel, without gouges or burns on the surfaces. Flanges must be recessed about three quarters of their diameter from their center. This provides support to the blade around its outer area while avoiding distortion of its center core.

3. A lapidary diamond saw blade requires a lubricant which also works as a coolant. An ample supply must be directed into the saw cut to lubricate the blade rim and workpiece, and to flush out all debris. A light cutting oil is best, and is required for most slabbing operations. A water soluble oil or plain water can sometimes be used in trimming operations. Rust inhibitors should be used and extra care taken to prevent rusting of the blade and/or saw.

4. With a new blade it is best to make your first cut using a soft, abrasive material. This will assure that the blade is properly broken in by bringing the rim into concentricity with the arbor and will open up the rim, increasing diamond protrusion.

5. Start cuts by feeding in the workpiece when the blade is running at operating speed. Make sure the surface of the workpiece will not cause the blade to deflect at point of contact. If the blade starts cutting to either side of its plane of rotation, you will get a nonparallel cut and even damage to the blade.

When a cut is almost complete, a break will often occur, leaving a jagged spur. This spur can damage the blade. To prevent this, infeed pressure should be reduced or stopped near the end of the cut. Saws with automatic power cut-off, when properly set, will do this for you. With screw feeds, the workpiece and vise can be hand fed.

6. A diamond blade can become dull or glazed along the cutting edge during use, especially when cutting hard or dense material. To sharpen the blade, make a few cuts in a dressing stick, such as those sold on page 50. This will generally abrade away some of the metal bond on the rim exposing more diamond.

GUIDE TO OPERATING SPEEDS FOR BLADES

The chart below shows the recommended operating range for various sizes of blades. Blade speed should be matched to the blade used and the type of material being cut. In general, harder materials and blades with a thicker rim require slower speeds, while softer materials and blades with thin rims require faster speeds.

Blade Diameter (inches)	Revolutions Per Minute	Blade Diameter (inches)	Revolutions Per Minute
4	2400-5700	14	750-1600
5	1900-4500	16	700-1400
6	1600-3800	18	600-1200
7	1400-3200	20	550-1100
8	1200-2800	24	450-950
9	1100-2500	30	350-750
10	950-2200	36	300-700
12	800-1900		

DIA-LASER STAINLESS STEEL BLADES

- **Rust proof stainless steel bodies.**
- **Excellent performance in water only coolant.**
- **Cuts fast and free at standard speeds.**

The DIA-LASER Blades from Lapcraft are ultra-thin, stainless steel blades made to conserve gem materials when cutting precious stones. The cutting teeth are premium multi-pointed diamond crystals chosen for their strength and sharpness. These cutting points are securely metal bonded onto the outer edge of hardened, rust proof, circular stainless steel bodies. The end result—super abrasive circular saw blades that cut with speed and ease through the hardest and toughest materials with minimum effort.

DO NOT DRESS DIA-LASER BLADES.

Order your DIA-LASER stainless steel blade from chart below. Choose correct catalog number for your arbor hole size. For shipping weights, see chart on page 53.

DETERMINING SAW SPEEDS

To make certain your saw runs at the correct RPM's for the diameter of a blade, use the chart below. Chart is based on motors running at 1750 RPM.

Left hand column lists diameter of the motor pulley, while the top column across lists the diameter of the pulley on the equipment. With these two pulley diameters, you can locate the RPM speed of that particular setup. For instance, a motor pulley diameter of 3.0" with an equipment pulley of 2.5" will operate a saw blade at 2100 RPM's. Using the chart Guide to Operating Speeds for Blades, you will find this is a proper speed for blades 5" to 10" in diameter. But if your saw takes either a 4" blade or one with 12" or more in diameter, you will need to change pulleys. If you need assistance with determining proper pulley diameters, please call for technical assistance.

Dia.	Rim Thickness	Order #		Price
		1/2" Arbor	5/8" Arbor	
4"	.010	109-9010	109-9011	25.00
4"	.024	109-9020	109-9021	25.00
5"	.010	109-9030	109-9031	27.00
5"	.024	109-9040	109-9041	27.00
6"	.014	109-9050	109-9051	29.00
6"	.024	109-9060	109-9061	29.00
6"	.045	109-9070	109-9071	32.00
8"	.024	109-9080	109-9081	44.00
8"	.045	109-9090	109-9091	44.00

Motor Pulley Diameter	Table yields arbor shaft rpm (revolutions per minute) for a 1750 rpm motor											
	Equipment Arbor Pulley Diameter											
	1.5	2.0	2.5	3.0	3.5	4.0	4.5	5.0	6.0	7.0	8.0	10.0
1.5	1750	1313	1050	875	750	656	583	525	438	375	328	263
2.0	2333	1750	1400	1167	1000	875	778	700	583	500	438	350
2.5	2917	2188	1750	1458	1250	1094	972	875	729	625	547	438
3.0	3500	2625	2100	1750	1500	1313	1167	1050	875	750	656	525
3.5	4083	3063	2450	2042	1750	1531	1361	1225	1021	875	766	613
4.0	4667	3500	2800	2333	2000	1750	1556	1400	1167	1000	875	700
4.5	5250	3938	3150	2625	2250	1969	1750	1575	1313	1125	984	788
5.0	5833	4375	3500	2917	2500	2188	1944	1750	1458	1250	1094	875
6.0	7000	5250	4200	3500	3000	2625	2333	2100	1750	1500	1313	1050

You can calculate the equipment shaft speed for other motor speeds by multiplying the motor rpm by the motor pulley diameter and then dividing by the equipment pulley diameter.

DIAMOND SAW BLADES

We offer a variety of diamond saw blades for different cutting needs including rock, glass and tile.

BD-301 SUPREME NOTCHED RIM BLADE

The 301 series of blades are manufactured using a high concentration of industrial diamonds on a notched rim. Specially designed to provide superior cutting of hard materials such as agate, petrified wood and jade.

Dia.	Rim Thickness	Arbor Size	Order #	Price
6"	.025	5/8" x 1/2"	300-0602554-81	81.00
8"	.040	5/8" x 1/2"	300-0804054-81	111.00
10"	.040	5/8" x 1/2"	300-1004054-81	134.00
12"	.065	1" x 3/4"	300-1204054-81	210.00
14"	.065	1" x 3/4"	300-1406086-81	312.00
16"	.085	1" x 3/4"	300-1606086-81	402.00
18"	.085	1" x 3/4"	300-1808586-81	478.00
20"	.085	1" x 3/4"	300-2008586-81	525.00

BD-303P PROFESSIONAL TILE & STONE BLADES

Wet cutting diamond blades for lapidary materials such as jasper, agate and geodes. High-grade diamond crystal matrix sintered to high-carbon steel cores. Rim Height 7.5mm.

Dia.	Rim Thickness	Arbor Size	Order #	Price
7"	.067	5/8"	300-0706750-84	75.00
8"	.067	5/8"	300-0806750-84	85.00
9"	.067	5/8"	300-0906750-84	95.00
10"	.067	5/8"	300-1006750-84	115.00
10"	.067	1"	300-1006780-84	115.00
12"	.095	1"	300-1209580-84	145.00
14"	.095	1"	300-1409580-84	168.00

BD-295 CONTINUOUS RIM BLADES FOR CUTTING GLASS

Dia.	Rim Thickness	Arbor Size	Order #	Price
8"	.060	5/8"	300-0806050-85	101.00
10"	.060	5/8"	300-1006050-85	118.00
12"	.080	1"	300-1208080-85	210.50

* SHIPPING NOTE:

All 30" and 36" blades must be crated for shipment. Add \$40.00 crating fee, (Order No 300-36C) to the shipping costs, of your blade.

BD-303 PROFESSIONAL™

The BD-303 Professional series of blades are premium quality with a high diamond concentration. The 4" through 14" blades have a sintered continuous rim for producing smooth cuts. The 16" through 36" diameter blades have a segmented rim. The 303 series blades are ideal for cutting agate, quartz, jasper, jade and rocks of similar hardness. Smaller blades are especially good for cutting valuable materials when waste must be held to a minimum and speed of cut is essential.

Dia.	Rim Thickness	Arbor Size	Order #	Price
4"	.014	1/2"	300-0401440-83	46.00
4"	.014	5/8"	300-0401450-83	46.00
4"	.020	1/2"	300-0402040-83	48.00
4"	.020	5/8"	300-0402050-83	48.00
5"	.020	1/2"	300-0502040-83	50.00
5"	.020	5/8"	300-0502050-83	50.00
6"	.014	1/2"	300-0601440-83	53.00
6"	.014	5/8"	300-0601450-83	53.00
6"	.020	1/2"	300-0602040-83	55.00
6"	.020	5/8"	300-0602050-83	55.00
6"	.032	5/8" x 1/2"	300-0603254-83	58.00
6"	.040	5/8" x 1/2"	300-0604054-83	64.00
7"	.050	5/8" x 1/2"	300-0705054-83	67.00
8"	.025	5/8" x 1/2"	300-0802554-83	69.00
8"	.032	5/8" x 1/2"	300-0803254-83	72.00
8"	.060	5/8" x 1/2"	300-0806054-83	74.00
9"	.060	5/8" x 1/2"	300-0906054-83	75.00
10"	.032	5/8" x 1/2"	300-1003254-83	78.00
10"	.040	5/8" x 1/2"	300-1004054-83	81.00
10"	.050	5/8" x 1/2"	300-1005054-83	106.00
12"	.065	1" x 3/4"	300-1206586-83	195.00
14"	.070	1" x 3/4"	300-1407086-83	219.00

Blades in 16" through 36" diameters listed below are segmented rim blades. Blades 16" and larger may require longer lead times before shipment.

16"	.085	1" x 3/4"	300-1608586-83	294.00
18"	.085	1" x 3/4"	300-1808586-83	356.00
20"	.100	1" x 3/4"	300-2010086-83	459.00
24"	.100	1" x 3/4"	300-2410086-83	777.00
30"*	.125	1"	300-3012580-83	1119.00
36"*	.200	1"	300-3612580-83	1741.00

WEIGHT CHART FOR SAW BLADES

Blade Size	Shipping Weight	Blade Size	Shipping Weight
4-6"	1 pound	18"	8 pounds
8-10"	2 pounds	20"	10 pounds
12"	3 pounds	24"	15 pounds
14"	4 pounds	*30"	40 pounds
16"	6 pounds	*36"	70 pounds

SPARE PARTS FOR SAWS

When ordering any of the items below, please state catalog number and year and model of your machine, or give a brief description of your machine so that we can send the proper part.

SPARE PARTS FOR TR-18, TR-24 and TR-36 SAWS

ITEM	FITS MACHINE	ORDER #	PRICE	WEIGHTS
Arbor Bearing Insert (inner)	TR-18, TR-24	690-90-1160	67.00	8 oz.
Arbor Bearing Flange (outer)	TR-18, TR-24	690-90-4104	70.00	8 oz.
Arbor Bearing Insert (inner)	TR-36	690-90-2220	71.00	8 oz.
Arbor Bearing Flange (outer)	TR-36	690-90-4200	64.00	8 oz.
Coolant Pump, 110 Volt	TR-18, TR-24, TR-36	690-70-7430	150.00	1 lb.
Coolant Pump, 220 Volt	TR-18, TR-24, TR-36	690-70-7430X	157.50	1 lb.
Flange, 5" x 1" (sold individually)	For 18" Saws	690-66-2504	78.00	2 lbs.
Flange, 6" x 1" (sold individually)	For 24" Saws	690-66-2604	94.50	4 lbs.
Flange, 8" x 1" (sold individually)	For 36" Saws	690-36-4006	131.00	6 lbs.
Hydraulic Cylinder	TR-18	690-18-7001	399.00	4 lbs.
Hydraulic Cylinder	TR-24	690-24-7001	468.00	5 lbs.
Hydraulic Cylinder	TR-36	690-36-7001	540.00	7 lbs.
Hydraulic Pressure Regulator	TR-18, TR-24, TR-36	690-24-7102	151.00	1 lb.
Hydraulic Pump	TR-18, TR-24, TR-36	690-24-7201	354.50	1 lb.

SPARE PARTS FOR OLDER HIGHLAND PARK SAWS

We have worm gears and worms for some older Highland Park saws. Most older gears have a part number on them, such as G-1039. Use that number to locate and order a new gear from the chart below. Otherwise, send in the old part so that we can match it with a new gear. If you need both a gear and a worm, make

certain to order the proper corresponding worm for the gear. Since there are many older model saws with different gears and worms, we cannot guarantee a fit in every case, but a new part may be returned if unused and undamaged.

WORM GEARS				MATCHING WORMS			
Order #	Old Part #	Shp. Wt.	Price	Order #	Old Part #	Shp. Wt.	Price
690-49-103010	G-1031	7 oz.	95.00	690-49-102988	HLTH	2 oz.	46.00
690-49-103028	G-1038	7 oz.	110.00	690-49-102996	HLUH	2 oz.	55.00
690-49-103036	G-1039	1 lb.	126.00	690-49-102996	HLUH	2 oz.	55.00
690-49-103051	G-1047	2 lbs.	292.00	690-49-103002	HLVH	4 oz.	61.00
690-49-103052	G-1046	1 lb.	168.00	690-49-103002	HLVH	4 oz.	61.00

SPLIT NUTS (CLUTCH) FOR HIGHLAND PARK SAWS

These split nuts are for older saws manufactured by Highland Park Co. If you are uncertain as to the size you need, give us a call. We cannot guarantee a fit in every case, but a new part may be returned if unused and undamaged.

Highland Park	Split Nut, $\frac{3}{8}$ - 16	690-49-110630	83.00	2 lbs.
Highland Park	Split Nut, $\frac{3}{4}$ - 16	690-49-116533	83.00	2 lbs.
Highland Park	Split Nut, $\frac{1}{2}$ - 20	690-49-110640	83.00	2 lbs.
Highland Park	Split Nut, $\frac{5}{8}$ - 18	690-49-116640	83.00	2 lbs.
Highland Park	Split Nut, Double 1 - 14	690-49-116525	166.00	4 lbs.
Highland Park	Split Nut Spring	690-49-102954	14.25	2 ozs.

Frantom 18"-24" Saws	Split Nut (clutch) $\frac{5}{8}$ - 18	690-92-1700	246.00	3 lbs.
----------------------	---------------------------------------	-------------	--------	--------

TUMBLE POLISHING STONES

The tumbling of stones has been going on in Nature for eons of time, as anyone who has picked up a smooth and rounded stone from a beach can testify. This process in Nature is the same that man uses today to tumble polish gemstones: rubbing one stone against another in an abrasive substance, and generally in water. Man carries the process a step further—uses machines (tumblers) to achieve a high polish on his gemstones.

Tumblers can come in several kinds and dozens of shapes and sizes, as described on the following pages. All use the basic process of grinding, sanding, and polishing stones through movement in a series of abrasives from coarse to fine.

The steps in tumbling vary from the use of an extremely fine polishing material for only a few hours to put a final polish on a valuable gemstone, to the general sequence of coarse grit (60/90) silicon carbide through three, four or more polishing abrasives in subsequently finer grit, to the final polishing step. This can take from a few days to four to six weeks.

Most stones with a hardness of 5 to 7 1/2 on the Moh scale (see page 65) will tumble polish well. Softer and harder stones may still polish, but may require more or special steps and abrasives to achieve a satisfactory polish. Some stones will never polish no matter what you do to them.

Tumble polishing stones is an easy and great way to start kids (and adults) on a lifelong interest in the natural world around them. Finding your own rocks, and turning them into shining marvels of Nature is a rewarding experience.

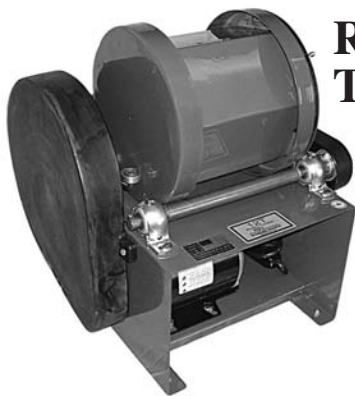

ROTARY TUMBLERS

Shown is the 12T twelve pound Rotary Tumbler. (See page 56.)

Shown is the Mini-Sonic MT-10 Vibratory Tumbler (See page 58.)



VIBRATORY TUMBLERS

TYPES OF TUMBLERS

There are two main types of tumblers—the rotary and the vibratory. The first tumblers were of the rotary type, where a barrel revolves as it rides on two parallel revolving shafts. The vibratory type sits and shakes, causing the load to move within the barrel but without the harsher action of the rotary. Both types require a series of abrasives starting with coarse and working up to a fine polish.

Rotary tumblers are the most familiar type, and range in barrel capacities from around 4 lbs. to commercial sizes that will process hundreds of pounds of material. The smaller units (2–4 lbs. capacity) are popular for youngsters and beginners, but the less expensive kinds have more maintenance problems. A well built rotary tumbler can last for years, however, even decades, if given care.

Rotary (barrel) tumblers are generally easy to load, require a minimum of attention, and produce satisfactory results on most stones and metals. Their main tumbling action abrades away any sharp edges and points, leaving finished stones with rounded surfaces and contours. Rotary tumblers are not suitable for material that is pre-formed and desired to retain its shape.

Rotary tumblers generally take more time to finish a load of stones, from four to six weeks or more, depending on material and abrasives used. They also use more grit per load, but generally need fewer steps in the tumbling process, and less attention the rest of the time.

Vibratory tumblers have either mechanical or electronic drives. Mechanical units use motors for power, while the Mini Sonic tumblers use magnetic energy. They have no moving parts such as shafts, belts or pulleys, and are exceptionally long lived.

The action in vibratory tumblers is more gentle than that found in rotary tumblers. The barrel in a vibratory tumbler remains stationary even as it vibrates, producing a continuous movement of material and grit within the barrel.

Because of their unique, gentle polishing action, vibratory tumblers do not wear away the shapes of stones, so that they retain their original form. Hearts and squares will come out as hearts and squares. This makes vibratory tumblers ideal for polishing preforms, carvings, metal jewelry, castings, etc.

Vibratory tumblers are generally faster in polishing a given load of material than a rotary tumbler, but actual time can vary from one day for a final polish on a preform to several weeks on hard-to-polish stones when starting from scratch.

SEE PAGE 109 FOR BOOKS ON TUMBLING.

HEAVY DUTY COMMERCIAL TUMBLERS



12T

You get the best heavy-duty rotary tumbler on the market with one of these tumblers that are based on the original Highland Park design well known for its efficiency and long life. These rotary tumblers are ideal for tumble finishing large loads of stone and for light deburring, burnishing, peening, cleaning and finishing metal parts. Any material, when properly cushioned, can be tumbled with little fear of chipping or breaking. The barrel for the 65T is one piece, molded polyethelene with a neoprene lid gasket. Other barrels are steel with removable liners. Liner for the 12T is made of heavy rubber for quiet action. The 40T barrel liner is durable, hard polyethelene.

The double pulley drive on the barrel rollers eliminates barrel slippage. Roller shafts are polyurethane covered. Rollers are mounted on heavy duty bronze bearings. Roller bearing barrel guides keep barrels aligned. All units include 1/3 HP motor with three wire cord and switch. Motors are mounted inside the base.

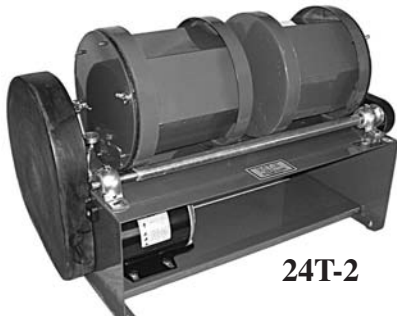

24T-2



40T

IMPORTANT NOTE: The weight of rocks and materials varies, so load capacities listed by weight are approximate and for comparison only. A more accurate capacity of the barrel is given by volume. **Most important, you must load your barrel to about three-quarters full**, regardless of material, and including fillers, abrasives and water. A load that is more or less than three-quarters full **WILL NOT** produce proper tumbling action.



36T-3



65T

Overall Tumbler Dimensions

- 12T: 13" wide x 12" deep x 18" high
- 24T-2: 28" wide x 13" deep x 21½" high
- 36T-3: 34" wide x 13" deep x 21½" high
- 40T: 28" wide x 13" deep x 21½" high
- 65T: 28" wide x 13" deep x 24" high

Model Number	Barrels Included	Load Capacity***		Barrel Dia.	115V 60Hz Models		220V 50Hz Models		Shp. Wt.
		Weight	Volume		Order #	Price	Order #	Price	
12T	1	12 lbs.	5 Qt	9"	610-30-1200	700.00	610-30-1200X	825.00	49 lbs.
24T-2	2	24 lbs.	10 Qt	9"	610-30-2400	865.00	610-30-2400X	990.00	74 lbs.
36T-3	3	36 lbs.	15 Qt	9"	610-30-3600	1000.00	610-30-3600X	1125.00	86 lbs.
40T	1	65 lbs.	4 Gal	12"	610-30-4000	1075.00	610-30-4000X	1200.00	83 lbs.
65T	1	125 lbs.	8.5 Gal	15"	610-30-6500	940.00	610-30-6500X	1065.00	74 lbs.

EXTRA BARREL ASSEMBLIES, LINERS AND GASKETS

Item	Fits Tumbler Model	***Load Capacity Material & Grit	Barrel Dimensions	Order #	Price	Shp. Wt.
Barrel assembly*	12T, 24T, 36T	12 lbs.	9" end dia., 9" length	611-30-1210	145.00	10 lbs.
Liner	For above 12# barrel	12 lbs.	Fits inside 12# Barrel	611-30-1212	55.00	4 lbs.
Lid Gasket	For 12# barrel	-	-	611-30-1219	11.95	1 lb.
Barrel assembly*	40T	65 lbs.	12" end dia., 12" length	611-30-4010	405.50	24 lbs.
Liner	For above 40# barrel	-	Fits inside 40# Barrel	611-30-4012	96.60	6 lbs.
Lid Gasket	For 40# barrel	-	-	611-30-4019	25.00	1 lb.
Barrel with lid**	65T**	125 lbs.	15" end dia., 15" length	611-30-6510	275.00	15 lbs.
Lid Gasket	For 65T barrel	-	-	611-30-6519	34.50	1 lb.

* Includes barrel, liner & lid. ** The 65T Barrel requires no liner. ***Approximate-materials vary.



THE MT-4 MINI-SONIC VIBRATORY TUMBLER

The MT-4 Mini-Sonic Tumbler is the best all-around tumbler on the market when it comes to performance, easy operation, and long-lasting service. You can tumble polish almost any kind of stone, from opal to topaz, delicate carvings and preforms, as well as metal items such as coins, jewelry findings, shell casings, etc.

It's unique tumbling operation is the key to the high performance of the MT-4. The vibratory motion is achieved without any moving parts. It improves the polishing process and uses only a small amount of abrasives compared to ordinary tumblers.

Load capacity is approximately four pounds including stone, fillers and abrasives. You control the rotation and intensity of the tumbler operation with solid state electronic controls.

Hoppers give exceptionally long wear. They are made of cast plastisol. With no motor, belts or pulleys to worry about, you have a tumbler built for years of worry free service.

HOW THE MT-4 WORKS

The MT-4 Mini-Sonic Tumbler operates without shafts, belts, pulleys, eccentric weight or even a motor—no moving parts, so the MT-4 will far outlast other types of tumblers. It operates on a unique principle employing interrupted electrical current that provides vibration as the driving force powering the rotation of the load. Operating frequency is 3600 vibrations per minute on 60Hz models and 3000 vibrations per minute in 50Hz Export models.

Rotation and intensity is adjustable with solid state electronic controls. During rotation, the tumbling load is alternately separated and compacted during each vibratory cycle. This improves the tumbling process and allows fresh abrasive to be drawn in between materials in the tumbler hopper. Only the contents inside the hopper actually rotate while the hopper itself remains practically motionless except for the driving arc of motion.

Only a small amount of abrasives are required in the Mini-Sonic tumbling process compared to ordinary rotary tumblers. As the abrasive begins to pulverize or break down and combines with rock dust and water, a slurry or coating mixture is formed, and it is this coating which should be maintained throughout all the tumbling processes. Too much water or too much abrasives will cause materials to collect in the bottom of the hopper and not rotate properly. It is only necessary to maintain a thin coating of abrasive slurry between the materials in the load to keep the polishing process working properly.

NOTE: when polishing with Vibra-Dry compounds, no water is required, and you will not have the slurry described above.

Model	Voltage	Order #	Price	Shp. Wt.
MT-4	115V	432-004	283.00	11 lbs.
MT-4 *Export	220V	432-004-X	304.00	11 lbs.
MT-4 *Export	240V	432-004-XA	312.00	11 lbs.
Hopper -4 w/ lid	Fits All Models	433-04H	59.00	2 lbs.
Hopper lid	Fits All Hoppers	433-04L	18.50	8 ozs.
Tune up Kit	MT-4	490-402097	49.25	7 ozs.
* Export models come 220 or 240 Volt. Specify voltage or country of ultimate destination when ordering.				

Choose the tumbler that suits your needs: Five MINI-SONIC options to choose from

You control the tumbling action with a Mini-Sonic Tumbler, from the gentle processing of opal to the full power processing of agates, jaspers, topaz, etc. Tumble polish baroques, preforms, beads, sea shells, metals, etc., fast and efficiently and without changing the shapes to any measurable degree. You can even tumble polish carvings without wearing away delicate features.

Both the MT-10 and MT-14 feature dial speed controls for selecting the power required to control tumbling action and speed of rotation.

The Mini-Sonic tumblers are not your ordinary vibratory tumblers—the unique action of the Mini-Sonic tumblers is achieved without shafts, belts, pulleys, eccentric weights or even a motor. Without any moving parts to wear out or a motor to burn up, these tumblers will last longer than other small vibratory type tumblers.

Hoppers are of cast plastisol and the tumbler housing is made of durable ABS plastic. You get quality materials and workmanship in the Mini-Sonic tumbler.

HOW TO ORDER

We offer two tumbler base sizes with a variety of hoppers, as per the options illustrated. First select the base, either the MT-10 or MT-14, that will best suit your needs. Then select the hopper option you prefer, and use the appropriate chart for that option to order from.

You do not necessarily have to limit the number of hoppers you select to the options shown. Having extra hoppers, especially for the polishing stage, is recommended to prevent contamination.

NOTE: Export models come in both 220V and 240V. Please make certain you order the right model for your voltage requirements. Specify voltage or country of ultimate destination.

Choose from two MT-10 options



Option 1
Base with one
MT-10 Hopper



Option 2
Base with two
MT-4 Hoppers

Option 1	Qty to Order	115V Model		220V Model		240V Model		Shp.Wt	
		Order #	Price	Order #	Price	Order #	Price	Ea.	Total
MT-10 Base	1	432-010	380.00	432-010-X	416.00	432-010-XA	424.00	20 lbs.	20 lbs.
Hopper-10	1	433-10H	118.00	433-10H	118.00	433-10H	118.00	5 lbs.	5 lbs.
MT-10 Option 1 Totals			498.00	-	534.00	-	542.00	-	25 lbs.

Option 2	Qty to Order	115V Models		220V Model		240V Model		Shp.Wt	
		Order #	Price	Order #	Price	Order #	Price	Ea.	Total
MT-10 Base	1	432-010	380.00	432-010-X	416.00	432-101-XA	424.00	20 lbs.	20 lbs.
Hopper-4	2	433-04H	118.00*	433-04H	118.00*	433-04H	118.00	2 lbs.	4 lbs.
MT-10 Option 2 Totals			498.00	-	534.00	-	542.00	-	24 lbs.
* Total for two Hopper-4's. Price each 59.00									

Choose from three MT-14 options



Option 1
MT-14 Shown with
One Hopper -14



Option 2
MT-14 Shown with
One Hopper -4, One Hopper -10



Option 3
MT-14 Shown with
Three Hopper -4's

Option 1	Qty to Order	115V Model		220V Model		240V Model		Shp.Wt	
		Order #	Price	Order #	Price	Order #	Price	Ea.	Total
MT-14 Base	1	432-014	422.00	432-014-X	459.00	432-014-XA	467.00	26 lbs.	26 lbs.
Hopper-14	1	433-14H	177.00	433-14H	177.00	433-14H	177.00	6.5 lbs.	6.5 lbs.
MT-14 Option 1 Totals			599.00	-	636.00	-	644.00	-	32.5 lbs.

Option 2	Qty to Order	115V Model		220V Model		240V Model		Shp.Wt	
		Order #	Price	Order #	Price	Order #	Price	Ea.	Total
MT-14 Base	1	432-014	422.00	432-014-X	459.00	432-014-XA	467.00	26 lbs.	26 lbs.
Hopper-4	1	433-04H	59.00	433-04H	59.00	433-04H	59.00	2 lbs.	2 lbs.
Hopper-10	1	433-10H	118.00	433-10H	118.00	433-10H	118.00	5 lbs.	5 lbs.
MT-14 Option 2 Totals			599.00	-	636.00	-	644.00	-	33 lbs.

Option 3	Qty to Order	115V Model		220V Model		240V Model		Shp.Wt	
		Order #	Price	Order #	Price	Order #	Price	Ea.	Total
MT-14 Base	1	432-014	422.00	432-014-X	459.00	432-014-XA	467.00	26 lbs.	26 lbs.
Hopper-4	3	433-04H	177.00*	433-04H	177.00*	433-04H	177.00*	2 lbs.	6 lbs.
MT-14 Option 3 Totals			599.00	-	636.00	-	644.00	-	32 lbs.

* Total for three Hopper-4's. Price each 59.00.

EXTRA HOPPERS WITH LIDS FOR MINI-SONIC TUMBLERS

Hopper Type	Fits Models:	**Load Capacity	Shp.Wt.	Order #	Price
Hopper - 4	All Models	4 lbs. approx.	2 lbs.	433-04H	59.00
Hopper -10	All except MT-4	8 lbs. approx.	5 lbs.	433-10H	118.00
Hopper -14	Fits MT-14 only	12 lbs. approx.	6½ lbs.	433-14H	177.00

** Load capacity for materials and grit is approximate since materials vary.

EXTRA LIDS FOR MINI-SONIC TUMBLERS

Lid Fits	Order #	Price	Shp.Wt.	Lid Fits	Order #	Price	Shp.Wt.
Hopper - 4	433-04L	18.50	8 oz.	Hopper - 14	433-14L	29.00	1 lb.
Hopper -10	433-10L	21.00	1 lb.				

Build your own VIBRA-SONIC tumbler

Select hopper options to suit your own needs

You get to choose the size and number of hoppers for your particular operation with the VSV model series of the Vibra-Sonic tumblers. You can have up to six different loads in various stages of finish going at the same time.

You also get the unique process of the Vibra-Sonic tumblers that produces both a rotary and vibratory tumbling action reducing processing time up to one-tenth that of ordinary tumblers. Only the load rotates at over 2500 vibrations per minute.

Open type hoppers are easy to load and unload, and permit access for inspection during operation. Your materials tumble quietly, quickly and without splash or gas buildup. Even the most delicate of materials can be processed without breakage or loss of detail.

Shown on opposite page are the various combinations for hoppers available for the VSV-12 and VSV-24 machines. The VSV-50 only comes with Hopper-50 which has a 50 lb. load capacity. The capacity of the other combinations varies from 4 lbs. to 28 lbs. Hoppers are individually cast from plastisol for a quiet, long life. Each hopper (except the Hopper-50) is interchangeable with most Mini-Sonic tumblers as well as the VSV models.

There are three adaptors, one for each of the three VSV models. When ordering, make certain the adaptor you select is suitable for the hopper you desire.

Base fits all three VSV models. It is made from solid, cast aluminum with a durable powder coat finish. Motor is 1/3 HP 115V 60 Hz. Export model available in 230V 50 Hz.



UNIVERSAL BASE FOR VIBRA-SONIC VT AND VSV MODELS

Base fits both the Vibra-Sonic VT machines shown on page 62, and the VSV models shown here with their various hopper configurations. VT hoppers are interchangeable without modification; the VSV models do require different adaptors for the different hopper options. Bases are solid cast aluminum with a durable powder coat finish. They have adjustable actions and quiet, sealed bearings. Motor is 1/3 HP 115V, 60Hz. Also available in 230V 50Hz.

HOW TO ORDER

You will first need to choose the VSV model you prefer: VSV-12, VSV-24 or VSV-50. Then you need to choose the proper adaptor for that model, and finally, the quantity and size of the hoppers that will fit the adaptor. The Hopper 50 will only fit on the VSV-50 adaptor. The adaptor for the VSV-12 will hold only a single row of hoppers. In ordering, specify base order number, adaptor order number, and quantity and order number for hoppers you will need to make your machine complete.

PARTS FOR VIBRA-SONIC VSV MODELS

Item	Fits Model:	Order #	Shp. Wt.	Price
Base 115V/60H	All Models	438-BASE	35 lbs.	970.00
Base 230V/50H	All Models	438-BASE-X	35 lbs.	1072.00
Adaptor 12	VSV-12	437-A12	5 lbs.	183.00
Adaptor 24	VSV-24	437-A24	10 lbs.	325.00
Adaptor 50	VSV-50	437-A50	11 lbs.	238.00
Hoppers	See below to order.			

HOPPERS WITH LIDS FOR VSV VIBRA-SONIC TUMBLERS

Hopper Type	Fits Models:	**Load Capacity	Shp.Wt.	Order #	Price
Hopper - 4	All except VSV-50	4 lbs. approx.	2 lbs.	433-04H	59.00
Hopper -10	All except VSV-50	8 lbs. approx.	5 lbs.	433-10H	118.00
Hopper -14	All except VSV-50	12 lbs. approx.	6½ lbs.	433-14H	177.00
Hopper -50	Only fits VSV-50	50 lbs. approx.	12 lbs.	439-50H	238.00
Lid, 50H	Only fits 50H Hopper***	-	2 lbs.	433-50L	48.00

** Load capacity for materials and grit is approximate since materials vary. *** See page 59 for other hopper lids.

Select hopper options to suit your own needs

Base +



Adaptor +



Hoppers =



Tumbler

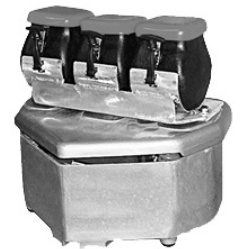

VSV-24



The VSV-24 Model takes the Adaptor-24 on a base.

Hopper options for VSV-24

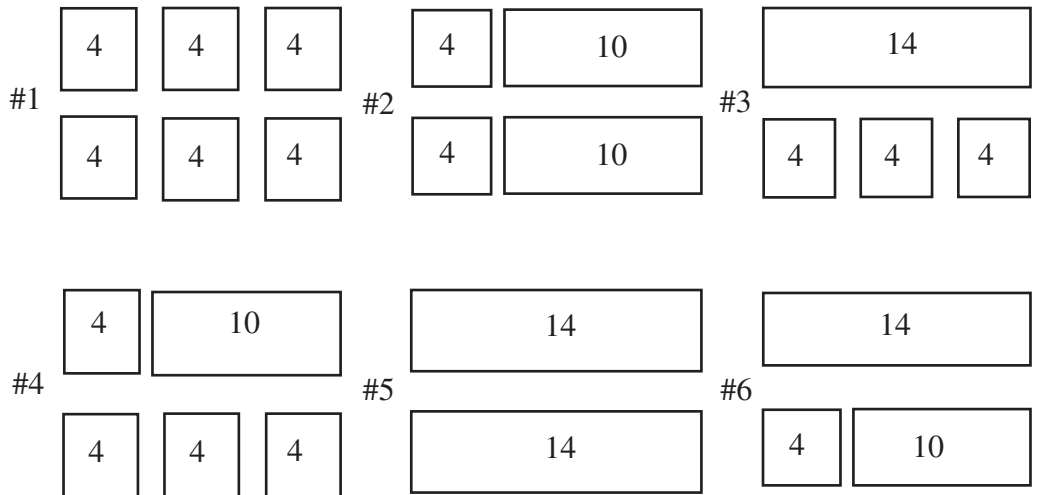

VSV-12

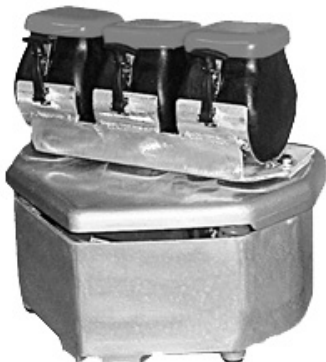

Hopper options for VSV-12

The VSV-12 Model takes the Adaptor-12 on a base.

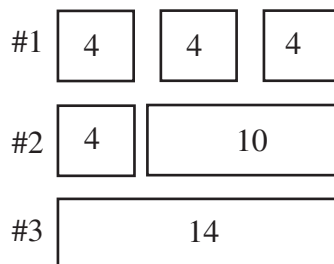

VSV-50

VSV-50 Model

The VSV-50 Model only takes Hopper-50 and Adapter-50 on a base.



See page 60 to order

COMMERCIAL VIBRA-SONIC TUMBLERS

HEAVY-DUTY, LARGE CAPACITY VT MODELS

**VT-12**

Shown with
Two Hoppers VT-12

**VT-14**

Shown with
One Hopper VT-14

**VT-35** Shown with One
Hopper VT-35

**Universal Base for
Vibra-Sonic VT
and VSV Models**

The VT models of the Vibra-Sonic tumblers have been the industry standard for over forty years, and still out-perform and outlast any other type of vibratory tumbler available.

Their unique process for producing both vibratory and rotary tumbling action reduces processing time for loads of both stone and metal. Material can be processed without breakage or loss of detail.

VT hoppers are open for easy access for inspection and loading, and are quickly removable for unloading. Materials tumble quiet, quick and without splash or gas buildup.

The VT-35 hopper has a 35 lb (3.0 gal) capacity. Has a wing-nut lock lid for a liquid tight seal. It's vertical, upright style gives it more aggressive action without the risk of leaking or spilling.

The VT-12 model features two 6 lb hoppers allowing you to perform grinding and polishing operations simultaneously. Removable hoppers are made of cast aluminum, lined with vinyl and are easily interchangeable on all Vibra-Sonic universal base units.

The VT-14 single hopper model is ideal for smaller stones or long pieces. Has a plastisol lined, aluminum lid for a liquid tight seal. Capacity is 14 lbs.

VT HOPPER (VIKING) RE-LINES. VT Hoppers are solid cast aluminum lined with plastisol. Hoppers are re-linable for extended life and use. See page 64 for information on ordering a re-line job.

Base fits both the Vibra-Sonic VT machines and the VSV models shown on page 61 with their various hopper configurations. VT hoppers are interchangeable without modification; the VSV models do require different adaptors for the different hopper options. Bases are solid cast aluminum with a durable powder coat finish. They have adjustable actions and quiet, sealed bearings. Motor is 1/3 HP 115V, 60Hz. Also available in 230V 50Hz. The 115V model has an Appliance Leakage Circuit Interrupter. (ALCI) to protect against electrical shock.

HOW TO ORDER

Select the hoppers that best suit your needs. All three hopper sizes fit the bases. The VT-12 Model takes two of the VT-12 hoppers for better balance of the machine, but just one hopper can be run at a time. To order, state base order number, and quantity and order number of hoppers desired.

PARTS FOR VIBRA-SONIC VT MODELS

Item	Fits Model:	Order #	Shp. Wt.	Price
Base 115V/60Hz	All Models	438-BASE	35 lbs.	970.00
Base 230V/50Hz	All Models	438-BASE-X	35 lbs.	1072.00
Hopper VT-12	VT-12	439-06HC	7 lbs.	238.00
Hopper VT-14	VT-14	439-14HC	16 lbs.	465.00
Hopper VT-35	VT-35	439-35HC	27 lbs.	553.00
Hopper Lid	VT-12	439-06HCL	8 oz.	25.00
Motor, 1/3 HP 50/60 hz	Base	490-860996	20 lbs.	292.75
Bearing, VT	VT Motor	490-865696	10 oz.	74.50
Bearing, old style				
Pillow Block	VT Motor	490-865996	10 oz.	70.35
Drive Belts for VT and VSV models. Set of two.		490-861796-2	8 oz.	19.50

RAYTECH VIBRATORY TUMBLERS



TV-5



TV-10



AV-18



AV-40

Using a vibratory tumbler can save you time and money. Unlike rotary tumbling where just the top, sliding layer of the load is being worked, the entire load in a vibratory tumbler is ground or polished continuously. This makes the finishing time shorter. Vibratory tumbling also has the advantage of retaining the overall shape of pieces better while still removing imperfections such as burs. In gem production, vibratory tumbling is preferred for preforms where shape must be retained.

The TV-5 unit is a favorite of hobbyists. It will process about four pounds of rock. Bowl diameter is 8" with convenient solid lid system. (The TV-5 should not be used for continuous commercial use.)

The TV-10 has a heavy duty drive and suspension combined with a tough, cross linked polyethylene bowl. Bowl has noise dampening cover and drains for liquid. (Cannot be used with steel shot.)

The AV-18 and AV-40 models are built rugged for industrial use. All are designed with heavy duty drive and suspension systems, and equipped with adjustable amplitude. Machine bowls are made of tough polyethylene with a sound dampening lid to reduce noise while in operation. All bowls have a drain for liquids.

All AV style models are SPECIAL ORDER machines. Please allow 2-3 weeks for delivery.

**THE MODELS LISTED ON THIS PAGE ARE FOR STONE FINISHING ONLY,
MAY NOT BE USED FOR BURNISHING.**

Model	Bowl Dia.	**Load capacity Material & Grit	Motor Size	Shp. Wt.	110V 60Hz Models		220V 50Hz Models	
					Order #	Price	Order #	Price
TV-5	8"	5 lbs.	1/57 HP	7 lbs.	113-23-001	106.95	113-24-106	119.95
Bowl TV-5	8"	5 lbs.	-	3 lbs.	113-23-005	24.95	113-23-005	24.95
TV-5 Bowl lid nut/gromet	-	-	-	2 oz.	113-23-004	1.50	113-23-004	1.50
TV-10	10"	10 lbs.	1/25 HP	16 lbs.	113-23-009	269.00	113-24-108	279.00
Bowl TV-10	10"	10 lbs.	-	5 lbs.	113-23-010	93.00	113-23-010	93.00
AV-18	12"	18 lbs.	1/15 HP	21 lbs.	115-23-024*	480.00	115-24-113*	480.00
Bowl AV-18	12"	18 lbs.	-	5 lbs.	115-23-036*	195.00	115-23-036*	195.00
AV-40	17"	35 lbs.	1/3 HP	51 lbs.	115-23-026*	1115.00	115-24-114*	1155.00
Bowl AV-40	17"	35 lbs.	-	16 lbs.	115-23-032*	305.00	115-23-032*	305.00

* Special order, allow 2-3 weeks delivery.

** Approximate-materials vary.

SPARE PARTS FOR TUMBLERS

When ordering any of the items below, please state catalog number and year and model of your machine, or give a brief description of your machine so that we can send the proper part.

NOTE: There is a \$2.00 service fee for orders under \$20.00

FITS MACHINE	ITEM	ORDER #	PRICE	WEIGHTS
Mini-Sonic	Speed Control w/knob	490-401996	31.95	2 oz.
Mini-Sonic	Speed Control w/knob 220V	490-401997	32.80	2 oz.
Mini-Sonic	Compression Spring	490-400196	11.50	1 oz.
Mini-Sonic	Foot Spring	490-401196	8.92	1 oz.
Mini-Sonic	MT Hopper latch	490-405196	13.05	6 oz.
Mini-Sonic	Tune Up Kit for MT-4/KG-1 1 Kit required for MT-4 or KG-1 2 Kits required for MT-10, 3 kits for MT-24	490-402097	49.25	7 oz.
KG-1	2.2 lb. Vinyl Hopper with lid	433-02H	34.15	2 lbs.
KG-1	Lid for 2.2 lb. KG-1 hopper	433-02L	18.50	4 oz.
VR-8/12	Lid	439-06HCL	25.00	8 oz.
VT-Viking	Motor 1/3 HP 50/60 Hz	490-860996	292.75	18 lbs.
VT-Viking	Spring, vinyl coated with cup	490-861696	30.40	5 oz.
VT-Viking	Bearing	490-865696	74.50	11 oz.
VSV-50	Lid, Hopper	433-50L	48.00	2 lbs.
12T	Lid, Barrel	611-30-1218	11.50	1 lb.
12T	Shaft, Long	690-30-104463	6.85	1 lb.
12T	Shaft, Short	690-30-104471	6.35	1 lb.
12T	Shaft Tubing Kit	611-93-001	13.12	5 oz.
24T,40T,65T	Shaft, Short	690-30-104420	11.28	2 lbs.
24T,40T,65T	Shaft, Long	690-30-104430	11.80	2 lbs.
24T, 40T, 65T	Shaft Tubing Kit	611-93-002	24.50	10 oz.
36T	Shaft, Long	690-30-104406	14.60	3 lbs.
36T	Shaft, Short	690-30-104414	14.00	3 lbs.
36T	Shaft Tubing Kit	611-93-003	30.35	1 lb.
65T	Lid, Barrel	611-30-6516	57.90	1 lb.
Rotary	Tumbler Guide, long w/bearing	690-30-102618	20.85	6 oz.
Rotary, All models	Tumbler Shaft Bearing	690-90-2529-1	8.29	8 oz.

VIKING HOPPER RELINES

Viking VT hoppers are solid cast aluminum lined with plastisol. Hoppers are re-lineable for extended usage. To have a hopper relined, send it to us freight pre-paid and allow 45 days for processing your order.	Hopper Model:	Order #	Shp. Wt.	Price
	VT-12 Reline	440-021496	7 lbs.	120.00
	VT-14 Reline	440-021596	16 lbs.	233.00
	VT-35 Reline	440-021696	27 lbs.	297.00
	Lid, VT-14 Reline	440-021796	3 lbs.	34.65
	Lid, VT-35 Reline	440-021896	4 lbs.	34.65

USING TUMBLING ABRASIVES

The main principle in polishing stone is to start with a coarse abrasive for grinding, and work through a series of increasingly finer abrasives to the final polish. The process is basically simple, but there are variations in gemstone properties, types of abrasives, many recommended grit (abrasive) sequences, and results produced by the different types of tumblers. All these variations and choices can be confusing, especially to a beginner, so it should be remembered that tumbling is basically simple, not an "exact science", and can be great fun once the basics are mastered.

The first choice to be made is the type of tumbler to be used, Rotary or Vibratory. A brief description of the two types is given on page 55. Further descriptions can be found on the pages in this catalog listing the tumblers themselves.

Both rotary and vibratory tumblers use the standard silicon carbide grits with water in the mix as well as a filler of some type. However, Vibra-Dry mixes can be used in vibratory tumblers for the polishing steps, and produce higher polishes on almost all stones and metals. (See page 67.) Vibra-Dry mixes do not use water, and can be re-used multiple times.

The beginner should be aware that some stones will not polish in either type of tumbler nor with any grit sequence. In order not to waste your time and money, be selective. See section on "Selecting Stones".

Over the years, individuals have developed procedures and grit sequences that give them good results. As a result, you will find that advice, books and manufacturer's instructions vary in their recommendations. All follow the basic principle of tumbling, but reading "Use 80 grit to start" in one source and "Use 60/90 to start" in another is confusing. Both work, and there is actually little difference between those grit sizes. In fact, most grit sizes that are used actually cover a range in particle size. Finer grits and polishes are more closely graded so that particle size is more uniform and so are the results. Finer grits and polishes are more expensive.

Fillers are recommended for use in both types of tumblers and in each step in almost all grit sequences. Fillers soften the action, fill space between stones, and carry the grit to the stone's surface more efficiently. Fillers generally can be reused if thoroughly cleaned between grit sequences. We recommend the ceramic bits for both stones and metals as they seem to do the best job and will last longer.

ROCK FOR TUMBLING



Package contains assorted gemstone materials of suitable size and hardness for tumbling. Mixed varieties, sorry no choice. Stone size varies, but averages 1" in diameter. Can be broken into smaller pieces if desired. Approximately 2 lbs. per package.

403-TR-10..... Shp. Wt. 2½ lbs..... 12.75

SELECTING STONES

It is important that you select stones that will polish in order to be successful at tumble polishing. The looks of rocks can be deceiving, but in general, those with a hard surface and sometimes shiny look to them, are likely to polish.

Stones with hardness of around 5 to 7½ on the Moh Scale of Hardness are best. This includes the agates and jaspers which are the easiest to polish. Softer and harder stones, and certain stones such as Apache Tears and jade are special challenges, and require special procedures.

MOH SCALE OF HARDNESS

- | | |
|-------------|---------------|
| 1. Talc | 6. Orthoclase |
| 2. Gypsum | 7. Quartz |
| 3. Calcite | 8. Topaz |
| 4. Fluorite | 9. Corundum |
| 5. Apatite | 10. Diamond |

SCRATCH TEST FOR HARDNESS

Use the simple field test below to identify the relative hardness of a stone. Stones in the range of 6.5 to 7.5 will usually polish well.

Fingernails scratch	2 to 2.5
Pennies scratch	3
Knife blades scratch	5.5
Window glass scratches	5.5
Steel files scratch	6.5
Garnet scratches	7 to 7.5
Carborundum scratches	9.5

SILICON CARBIDE ABRASIVES				
GRIT SIZE	ORDER #	NET WT.	SHIP WT.	PRICE
UNGRADED 60/90 COARSE GRIND	400-0090-01	1 lb.	1¼ lbs.	5.40
	400-0090-02	2½ lbs.	3 lbs.	10.10
	400-0090-05	5 lbs.	5½ lbs.	18.90
	400-0090-10	10 lbs.	11½ lbs.	35.05
	400-0090-50	50 lbs.	53 lbs.	134.75
GRADED 220 COARSE GRIND	400-0220-01	1 lb.	1¼ lb.	5.75
	400-0220-02	2½ lbs.	3 lbs.	10.80
	400-0220-05	5 lbs.	5½ lbs.	20.15
	400-0220-10	10 lbs.	11½ lbs.	37.40
	400-0220-50	50 lbs.	53 lbs.	143.75
GRADED 400 FINE GRIND	400-0400-01	1 lb.	1¼ lb.	7.05
	400-0400-02	2 lbs.	3 lbs.	10.60
	400-0400-05	5 lbs.	5½ lbs.	24.70
	400-0400-10	10 lbs.	11½ lbs.	45.85
	400-0400-50	50 lbs.	53 lbs.	176.25
GRADED 600 PRE-POLISH	400-0600-01	1 lb.	1¼ lb.	7.50
	400-0600-02	2 lbs.	3 lbs.	11.25
	400-0600-04	4 lbs.	5 lbs.	21.00
	400-0600-08	8 lbs.	9 lbs.	38.95
	400-0600-40	40 lbs.	43 lbs.	149.80
GRADED 1000 PRE-POLISH	400-1000-01	1 lb.	1¼ lb.	10.05
	400-1000-02	2 lbs.	3 lbs.	15.05
	400-1000-04	4 lbs.	5 lbs.	28.05
	400-1000-08	8 lbs.	9 lbs.	52.10
	400-1000-40	40 lbs.	43 lbs.	200.00

SILICON CARBIDE ABRASIVES



These abrasives have sharp, hard grains for fast cutting. Use in tumblers, flat laps, sphere machines or wherever coarse and fine grinding grits are needed. The grit sequences below are standard, but can be varied depending on material and need. Standard sequence for rotary tumblers is 60/90, 220 and 600 silicon carbide, followed by a polish. For best results, use an aluminum oxide pre-polish 800 grit before the final polish. Use this same silicon carbide sequence including the aluminum oxide pre-polish, in vibratory tumblers. When lapping, add the 400 and 1000 grits to the standard sequence.

NOTE: Silicon carbide abrasives are packaged in sturdy containers for convenient storage and use. Prevents leakage and contamination.

GRIT KITS FOR STONES

Kits are designed primarily for those just learning the fun of tumbling stones. The abrasives included will polish a variety of stones from soft to hard.

The KW-10 kit contains enough abrasives for approximately 8–10 loads for the MT-4 tumbler. You will have less for the Raytech TV-5 and similar

tumblers. The KW-20 kit contains enough abrasives to do about 3–4 loads in tumblers with 8 to 10 pound barrels.

When using larger tumblers, it is more economical to purchase grits in larger quantities, and in the grit sizes to fit your needs.

WET KITS FOR ROTARY OR VIBRATORY TUMBLERS

The KW-10 and KW-20 wet kits can be used in rotary and vibratory tumblers, and use water in each step. Kits contain the following: 60/90, 220 and 600 silicon carbide grits, aluminum-oxide pre-polish, Lusterite polish, ceramic media for filler, measuring cups, instructions.

403-KW-10 Shp.wt. 7 lbs 37.50
 403-KW-20 Shp.wt. 13 lbs 60.00

BEGINNING WET KIT FOR MT-4 MINI-SONIC TUMBLERS

The MT-1 kit is designed for vibratory tumblers such as the MT-4 Mini-Sonic tumbler. The kit contains the following: 60/90, 220 and 600 silicon carbide grits, aluminum-oxide prepolysh, Lusterite polish, and ceramic media for filler. You will have enough grit for several loads.

403-MT-1 Shp.wt. 3 lbs 16.50

VIBRA-DRY+ MIXES

We've added two super-fine mixes of 75,000 and 100,000 grits to our improved line of Vibra-Dry polishes. These two super-fine mixes will give the professional a polish on precious stones and fine jewelry pieces that's been only dreamed of until now. You will enhance both the looks and value of your stones and jewelry. Even our standard Vibra-Dry mixes will produce a brilliant finish seldom achieved by any other method.

Vibra-Dry+ mixes allow you to polish stones and metal pieces without the addition of water, additives, thickeners, or fillers of any kind. Everything you need is in the mix. No more worry about keeping the right amount of liquid or slurry levels, and no mess at the end of each polishing step. Vibra-Dry+ is a dry process, so that your stones, coins or jewelry pieces can be easily removed from the mix, cleaned with only a polishing cloth or rinsed in water. The mix is then ready to process another batch of material. You save time, labor and compound, and achieve a superb polish as well.

There are three main ways to use Vibra-Dry+ to polish stones and metals. For someone, especially a professional jeweler, who wants to put a final, outstanding shine to finished pieces of jewelry, loose faceted stones, pre-formed or poorly finished cabochons, then using the 25,000 and 50,000 Vibra-Dry+ mixes fills the need. This applies to most metal pieces as well, such as finished jewelry, castings, coins, etc. In cases of severe tarnish or fire scale, metal pieces may need to be run through one or more coarser grits of Vibra-Dry+ first.

For those wanting to process valuable or delicate materials such as amber, pearls, opals, etc., most of the finishing process may be done just using a series of Vibra-Dry+ mixes, avoiding the use of most or all silicon carbide steps. It just depends on your material.

Then for those just wanting to tumble polish rough stones such as agate and similar gemstone materials, prepare your stones by processing them through the standard silicon carbide grits: 60/90, 220, and 600 grits, followed by 800 grit aluminum oxide pre-polish. This sequence prepares most stones even for standard final polishes, but a far better shine is achieved by then using the 25,000 or 50,000 Vibra-Dry+ mixes.

NOTE: Vibra-Dry+ mixes are formulated for the pre-polish and final polishing steps in processing stones and metals in vibratory tumblers. They are not recommended for use in rotary or barrel type tumblers.

The Guidelines given here are just that. For most stones from 6 to 8 in hardness, going through the silicon carbide grits will prepare your stones properly. Softer stones are harder to polish, and you might find that using some of the coarser Vibra-Dry+ mixes will help.

GUIDELINE FOR SELECTING GRIT SEQUENCE	
MATERIAL HARDNESS	USE VIBRA-DRY
Soft: 2-4 MOH scale (Amber, coral, pearl, etc.)	600-3000-25,000-50,000
Soft-Medium: 4-5 MOH scale (Apache tears, glass, shell, etc.)	3000-25,000, 50,000
Medium: 5-6 MOH scale (Jade, opal, turquoise, etc.)	3000-14,000-25,000, 50,000
Hard: 7-8 MOH scale (Agates, jasper, topaz, etc.)	14,000, 25,000, 50,000
All stones & metals for super polish	75,000 and 100,000

VIBRA-DRY EXTENDER

This specially formulated extender compound relubricates standard Vibra-Dry abrasives and extends their life so that they can be re-used longer. **NOTE:** Cannot be shipped by air or overseas.

420-100299	4 oz.....	8.75
420-100499	16 oz.....	31.35

VIBRA-DRY PLUS POLISHING COMPOUNDS								
AMOUNT	1 LB.		2 LBS.		5 LBS.		25 LBS.	
GRIT	ORDER #	PRICE	ORDER #	PRICE	ORDER #	PRICE	ORDER #	PRICE
600	421-00600-01	26.00	421-00600-02	46.80	421-00600-05	104.00	421-00600-25	455.00
1700	421-01700-01	26.00	421-01700-02	46.80	421-01700-05	104.00	421-01700-25	455.00
3000	421-03000-01	26.00	421-03000-02	46.80	421-03000-05	104.00	421-03000-25	455.00
8000	421-08000-01	26.00	421-08000-02	46.80	421-08000-05	104.00	421-08000-25	455.00
14,000	421-14000-01	32.00	421-14000-02	57.60	421-14000-05	128.00	421-14000-25	560.00
25,000	421-25000-01	32.00	421-25000-02	57.60	421-25000-05	128.00	421-25000-25	560.00
50,000	421-50000-01	34.00	421-50000-02	61.20	421-50000-05	136.00	421-50000-25	595.00
75,000	421-75000-01	40.00	421-75000-02	72.00	421-75000-05	160.00	421-75000-25	700.00
100,000	421-90000-01	46.00	421-90000-02	82.80	421-90000-05	184.00	421-90000-25	805.00

ALUMINUM OXIDE PRE-POLISH

For use as a pre-polish on soft and difficult to polish stones such as Apache tears and tigereye. Can also be used as a final polish on extremely hard materials (+8 on MOH scale.) Great for slabs. 800 grit. Packaged in plastic containers. Net wt. 1 lb.

GRIT SIZE	ORDER	NET WT.	SHIP WT.	PRICE
800	400-86-01	1 lb.	1¼ lbs.	9.55
	400-86-02	2 lbs.	3 lbs.	14.30
	400-86-05	5 lbs.	5½ lbs.	33.35
	400-86-10	10 lbs.	11½ lbs.	61.95
	400-86-25	25 lbs.	26 lbs.	119.15



ALUMINUM OXIDE POLY PRODUCTS

These high grade polishing aluminas have been custom developed for the Lapidary Industry, use as you would cerium or tin oxides.

POLY-AL LS is an AGRESSIVE powder. At 1.4-1.6 microns, it is an ideal pre-polish.

- 401-AL-LS-4 4 oz. SizeShip Wt. 8 oz.4.80
- 401-AL-LS-1..... 1 lb. SizeShip Wt. 1 ¼ lb..... 13.80
- 401-AL-LS-5..... 5 lb. SizeShip Wt. 5 ¼ lb.....59.75

POLY-AL T is a medium fine powder, 0.8 micron particles. Polishes better than Tin Oxide. Particularly good on hard stones. Ideal pre-polish on softer stones, does not undercut. .

- 401-ALT-4..... 4 oz. SizeShip Wt. 8 oz.11.50
- 401-ALT-1..... 1 lb. SizeShip Wt. 1 ¼ lb..... 41.35
- 401-ALT-5..... 5 lb. SizeShip Wt. 5 ¼ lb.... 190.55

POLY-AL Z most economical of the Poly Products Particles 0.35 microns. Produces an excellent polish.

- 401-ALZ-4..... 4 oz. SizeShip Wt. 8 oz.6.90
- 401-ALZ-1 1 lb. SizeShip Wt. 1 ¼ lb.....20.65
- 401-ALZ-5..... 5 lb. SizeShip Wt. 5 ¼ lb.....91.85

POLY-AL F the finest of the Poly Products, with particles of only 0.2 microns. This polish will put a superior polish on most any stone that has been properly prepared for polish. Does not break down much during use, so you use less product

- 401-ALF-4 4 oz. SizeShip Wt. 8 oz.11.25
- 401-ALF-1 1 lb. SizeShip Wt. 1 ¼ lb. 40.55
- 401-ALF-5 5 lb. SizeShip Wt. 5¼ lb. 185.95

TIN OXIDE POLISHING COMPOUND

Puts an excellent polish on almost all gemstones, including the hard-to-polish ones. Packaged in plastic containers.

- 402-90-04.....¼ lb..... Shp wt. 6 oz.12.00
- 402-90-01 ...1 lb..... Shp wt. 1¼ lbs.....44.00

CERIUM OXIDE

Cerium oxide is one of the best all-purpose polishes available. Our standard and premium grade cerium oxide will give you an excellent polish when used on pads or for tumbling. For the money, they are a great buy. Our Super grade Cerium Oxide is one of the best polishes we've tested. It gives an excellent polish to almost any stone, especially when used on a felt pad. Packaged in plastic containers.

- 400-80-01Standard 1 lbShp wt. 1¼ lbs..... 7.75
- 400-80-05Standard 5 lbShp wt. 6 lbs..... 34.90
- 402-82-01... Premium 1 lbShp wt. 1¼ lbs..... 29.70
- 402-82-05... Premium 5 lbShp wt. 6 lbs..... 131.73
- 402-83-04.....Super 4 ozShp wt. 8 oz..... 20.96
- 402-83-01..... Super 1 lbShp wt. 1¼ lbs..... 70.00
- 402-83-05..... Super 5 lbShp wt. 6 lbs..... 338.00

LUSTERITE POLISHING COMPOUND

A hard, finely pulverized pyrochemically produced compound suitable for polishing gems of various hardness. Use Lusterite I as you would cerium or tin oxide. Use Lusterite II for tumbling. Mixes with water. Zip lock container. Net weight 1 lb. each.

- 400-65-01 Lusterite I Shp wt. 1½ lbs.10.00
- 400-75-01 Lusterite II Shp wt. 1½ lbs.10.00

BURNISHING COMPOUND

Use with steel shot to achieve a bright finish on jewelry metals. Great on both silver and gold. Starting ratio is a heaping tablespoon to a gallon of water. Adjust as necessary. Net Wt. 1 lb.

- 400-BC-20.....Shp. Wt. 1 lb. 4 oz..... 4.95

STAINLESS STEEL SHOT

Use as a burnishing media for metals. Contains a mixture of balls, ball-cones, and angle cut cylinders that are the right shape and size for jewelry work. No pins. Stainless steel shot will not rust. Use with burnishing compound.

- 400-SS-10 ...Net 1 lb..... Shp Wt. 1 lb 4 oz..... 18.00
- 400-SS-20 ...Net 2 lbs. Shp Wt. 3 lbs..... 32.30

FILLERS FOR TUMBLING STONE AND METALS

Fillers are an important addition to the stone/grit mix in almost any tumbling sequence or tumbler. Fillers help distribute the grit to the stone or metal part, and act as a cushion between the parts.

CERAMIC MEDIA

Non-abrasive, angle cut cylinders. Works well as a filler and carrier in tumbler loads of stone. Also used as a burnishing media on jewelry metals. Really speeds the job and helps leave a super finish. Cylinder size approx. 5/32" x 5/16". The one pound size comes in a zip lock bag. The 5, 10, and 50 lb. sizes are packed in reusable plastic containers.

400-CM-01..... Net. Wt. 1 lb..... Shp. Wt. 1 lb. 4 oz. 5.75
 400-CM-05..... Net. Wt. 5 lbs..... Shp. Wt. 5 lb. 4 oz. 25.90
 400-CM-10..... Net. Wt. 10 lbs..... Shp. Wt. 10 lb. 2 oz. 48.90
 400-CM-50..... Net. Wt. 50 lbs..... Shp. Wt. 53 lbs. 230.00

CORN COB FILLER

Ground corn cobs. Makes an excellent filler for polishing stones. Softer than walnut shells. Comes in 1 lb. and 5 lb. bags.

400-CC-1... 1 lb..... Shp. Wt. 1 lb. 4 oz. 4.00
 400-CC-5... 5 lbs. Shp. Wt. 5 lb. 4 oz. 15.00

WALNUT SHELL FILLER - PLAIN

Makes a good filler for tumbling gemstones. Keeps stones from hitting each other during the tumbling process.

400-WS-11 lb Plain Shp. Wt. 1 lb. 4 oz. 3.00
 400-WS-55 lb Plain Shp. Wt. 5 lb. 4 oz. .. 10.00

WALNUT SHELL FILLER WITH POLISH

Ground walnut shells treated with red rouge make an excellent final polish for metals including silver, gold, brass, etc. Keeps items separated and aids in the tumbling process. Packaged in 1 lb. and 5 lb. bags.

400-WSR-1 1 lb with Rouge Shp. Wt. 1 lb. 4 oz.....4.75
 400-WSR-5 5 lb with Rouge Shp. Wt. 5 lb. 4 oz....19.00

POLISHING CLOTHS



DELUXE ROUGE CLOTH

Individually packaged, these cloths are actually a double cloth, one impregnated with rouge, the other without rouge to keep hands clean. Use for final polishing. Size 10" x 10 1/2".

150-POL-169 2 oz. 5.20

BRILLIANT POLISHING CLOTH

This polishing cloth is treated with a specially developed chemical agent which cuts through tarnish better than other cloths. No residue is left behind to dull shine. You get your brass, chrome, copper, silver and gold brilliant without getting any messy rouge on your hands. Size: 12" by 8".

150-POL-705 2 oz. 3.95

DOUBLE BRILLIANT POLISHING CLOTH

This double cloth is chemically treated for a super shine on one side and natural on the other for final polishing. Cleans and polishes all precious metals with little effort for a brilliant and lasting shine. 100% cotton. Size: 7.5" by 12".

150-POL-170 2 oz. 5.15

POLISHING WHEELS

See page 83 for buffing wheels.



POLISHING DISCS

Genuine leather and quality foam rubber discs. Make your own polishing pads or use on regular polishing heads. Rubber is 1/4" thick. Shp. Wt. each, 5 ozs.

Dia.	Leather		Foam Rubber	
	Order #	Price	Order #	Price
6"	101-82-110026	5.50	101-82-106526	3.75
8"	101-82-110028	10.75	101-82-106534	5.25
10"	101-82-110020	16.50	101-82-106542	7.75

LEATHER SQUARE KIT

Use these squares of leather to cover your polishing discs. Leather can be cut to fit. Use piece of strong wire contained in kit to fasten leather to your disc. Charge with any polishing compound. Leather can be used rough or smooth side. Shp. Wt. 12 ozs. each.

703-82-122283 8" sq. fits 6" disc 16.25
 703-82-122291 10" sq. fits 8" disc 19.95
 703-82-122309 12" sq. fits 10" disc 23.95

DOUBLE DECK VIBRATORY LAP

You can be rough grinding and finish polishing at the same time with this 18" double pan set-up. Use the top pan with its special premium grade felt pad for all polishing, and the lower pan for the other stages of grind and pre-polish.

Slabs rotate in a circular orbit so there is little damage to any stone edge. Each pan comes with a heavy duty vinyl tubing around the outer edge to act as a buffer between moving slabs and sides of pan.

The upper pan comes with a premium grade wool felt polishing pad that can be charged with a variety of polishes for the final process on your slabs. Each pad should only be used with one type of polish. If you need to use different polishes, each should have its own polish pad to prevent contamination. The polishing pad is used over a smooth-surfaced aluminium plate.

The lower plate is aluminum finished with special indentations for use with silicon carbide grits for grinding and sanding flat stones. It comes with a heavy duty vinyl bumper ring to serve as a buffer between moving slabs and edge of pan.

Brackets hold the two pans in place, one above the other, and are designed for easy removal of the pans.

Machine is made of non-rusting aluminum castings. Only weighs 50 pounds so it can be moved from place to place but is still heavy enough for stability while in operation.

For use overseas, order the transformer listed below.



DOUBLE DECK LAP MODEL DL-18

The machine comes with frame, motor, two pans, felt polishing pad, set of brackets.



Double Lap shown with top pan removed.

Item	Order #	Shp Wt.	Price
Double Deck Lap	620-42-2000	53 lbs.	1290.00
Smooth Pan	621-42-2003	12 lbs.	260.00
Rough Pan	621-42-2004	12 lbs.	260.00
Polish Pad	621-93-0060	4 oz.	25.95
Bracket (Set of 4)	621-42-2115	2 lbs.	90.10
Rubber Ball	690-42-2005	6 oz.	5.25
Spring	690-42-2007	6 oz.	10.25
Spider	690-42-2002	7 lbs.	131.25
Counterweight	690-42-2009	8 oz.	26.25
115V Motor, Cord, Switch	690-42-5000	8 lbs.	262.50
Transformer	104-WIZ-8634	1 lb.	80.00

GRIT SEQUENCE FOR LAPPING

The choice of abrasive grit sizes for the lapping process follows somewhat that in tumbling or stone polishing procedures. The choice also depends upon the material, and preference of the person doing the work. The following sequence of silicon carbide grits is commonly used, and will generally produce a satisfactory polish on most materials: 60/90, 220, 400, 600, 1000, and then a polish. Generally, the more steps the better the polish. Abrasives sold on pages 66, 68.



“VI-BRO-LAPS” IN TWO SIZES

Both the 20" and 27" Vi-Bro-Lap models give you the satisfaction of achieving flat surfaces on geode halves, agate, petrified wood and other material, yet relieves you of the necessity for constant attention to the lapping process.

The Vi-Bro-Lap can accommodate a number of specimens at the same time. The tempered aluminum lap plate is grooved in a criss-cross pattern. This permits abrasive particles to circulate between the lap plate and the workpiece so that the abrasive itself is continuously being crushed to a smaller size.

When the workpiece surface is ground flat and satin smooth use the felt polishing pad with a fine polishing compound to obtain a fine mirror like finish on your workpiece.

A UNIQUE DOUBLE ACTION WORKS FOR YOU

While the Vi-Bro-Lap plate oscillates, work-piece rotates! This gives faster grinding surface speed; distributes abrasives, assures a flat polished surface, and equalizes wear on lap plate. Allow 3-4 weeks for delivery.

We have most parts for older Vi-Bro-Laps. Call us for information.

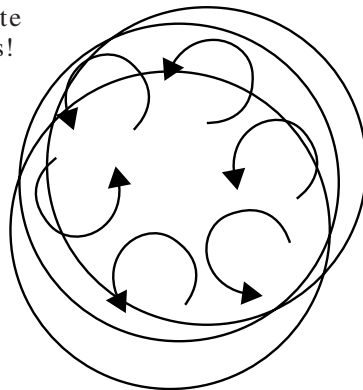

SPECIFICATIONS

- Lap plates are manufactured from heat treated aluminum alloy to produce a tough, wear-resistant surface. Each surface has milled V-grooves in a square grid pattern.
- Suspension is controlled by aircraft strength cable, adjustable for fine leveling to keep workpieces evenly distributed over the lap plate surface.
- 20VL measures 21" W x 21" D x 21" H. 27VL measures 28" W x 28" D x 30" H.
- Frame is welded, fabricated steel for stability.
- Comes with 1/3 HP motor. Felt polishing pad included. Export model, 220 volt/50 HZ available for use outside the USA

Item	20" Model 20VL			27" Model 27VL		
	Order #	Shp Wt.	Price	Order #	Shp Wt.	Price
Model with 1/3 HP 115V 60 Hz motor	620-41-108415	176 lbs.	2010.00	620-41-108423	270 lbs.	2330.00
Export model with 1/3 HP 220V 50 Hz motor	620-41-108415X	176 lbs.	2215.00	620-41-108423X	270 lbs.	2535.00
Crating fee- machine	620-41-C20	-	195.00	620-41-C27	-	225.00
Replacement plate with pad	621-41-118208	28 lbs.	670.00	621-41-118190	84 lbs.	870.00
Crating fee 27VL plate				621-41-118190C	-	65.00
Polish pad, wool felt	621-41-117101	5 oz.	32.00	621-41-117119	6 oz.	59.00
Cable & eye bolt kit	690-41-100438	8 oz.	20.00	690-41-100420	8 oz.	20.00
Rubber foot	690-41-104120	6 oz.	11.50	690-41-104120	6 oz.	11.50
Flange bearing	690-90-4120	2 lbs.	67.00	690-90-4120	2 lbs.	67.00
Pillow block bearing	690-90-5684	2 lbs.	47.00	690-90-5684	2 lbs.	47.00

ROTATING DISC FLAT LAPS

Now you can polish your bookends and large flats on the same machine, using either our Magnetic Novas or the standard process using abrasives on the rotating disc itself.

We've modified our RL Model Rotating Flat Laps to accommodate the speeds and set up necessary for both processes.

For the fastest and most efficient way to polish large flats, we recommend using our Magnetic Nova Laps. You save time in two ways. First, the actual polishing process for each step is reduced by the speed and efficiency of our resin-bond diamond Magnetic Nova Laps. Under normal circumstances, it only takes 15 to

25 minutes for each grit step to polish your large flat. Second, you save a lot of time by not having the usual clean-up job between grit changes. Changing grits with Magnetic Novas simply means removing one flexible lap from the plate and installing the next—taking only a few moments at most. (See photo below.) Since the diamonds in Magnetic Novas are permanently bonded to their working surfaces, there's little chance of contamination.

USING DIAMOND MAGNETIC NOVAS

Our diamond Magnetic Novas are the fastest and most efficient way to polish large slabs on the RL Lap machines.

Our recommended general-purpose grit sequence of Magnetic Novas for RL machines is 60, 280, 600 and 1200 grits, followed by Super Premium Cerium Oxide Polish on a felt pad. We also recommend the use of a 60 grit Plated Diamond Disc to precede the 60 grit Magnetic Nova for those slab surfaces with deep saw marks or other features requiring grinding preparation. Other grit sequences can be used to fit your need

We recommend that Magnetic Novas in diameters 12" and larger be used with 1" arbor holes. The hole prevents the "dead" center of the revolving lap from "grabbing" your workpiece, yet does not prevent you from using the entire surface of the lap.

USING THE STANDARD LAPPING PROCESS

If you need to precision grind and polish a flat surface on stone, glass or optics, use the cast iron lap plate of the RL lap, and a series of silicon carbide or other abrasives. The rotating cast iron plate is built to fulfill the fundamental requirements of precision lapping with maximum stability and wheel balance. Lap plates are machined to exacting tolerances and grooved with concentric V-groove circles for retention of the abrasive. Your surface will be FLAT.

Standard grit sequence for most purposes is 60/90, 220,400, 600, 1000, followed by a polish. We recommend our Super Premium Cerium Oxide sold on page 68.



Magnetic Novas are easy to exchange.

To order Magnetic Novas see page 74.

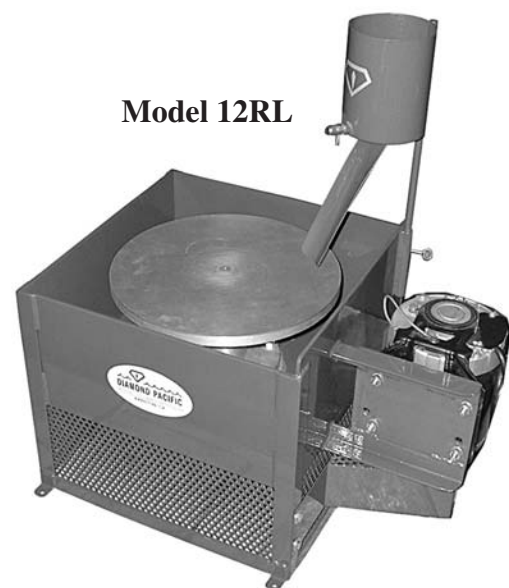

ROTATING DISC FLAT LAPS

Our RL Flat Laps are rugged machines, from cast iron lap plates to metal tanks. They will give years of service.



Model 18RL



Left: Cast iron lap plate

- Motors for both size machines are thermally protected, with manual reset buttons. This prevents any unintentional, unexpected restart of the motor.
- Arbor shafts are 1". Bearings are 1", factory lubricated and sealed to prevent contamination.
- Machine tanks are heavy duty, fabricated steel with powder coating. Safety screen protects the operating mechanisms below the tanks, but still allows some visibility. The 18 RL tank measures 24" x 24" x 7 3/4" deep. Overall height is 34". The 12RL tank measures 15" x 15" x 6 3/4" deep, with and overall height of 13 3/4"
- Drip style water reservoir has an adjustable valve to regulate flow of water or water-abrasive mixtures to the rotating discs. The drip spout is easily moved over the disc surface as needed.
- The cast iron plates are machined to exacting tolerances and grooved with concentric V-groove circles for use and retention of abrasive charges. Magnetic Novas attach easily to the surface of the plates as well.
- Our RL Model Flat laps run at speeds suitable for both the use of abrasive grits on the rotating plates, and for use of Magnetic Novas. Machines with variable speed motors are generally not needed, but are available as a SPECIAL ORDER. Call for technical assistance for your application, and for prices.

Magnetic Plated Diamond Discs and Magnetic Felt Discs listed on page 75

Item	12" Models			Item	18" Models		
	Order #	Shp Wt.	Price		Order #	Shp Wt.	Price
12 RL Lap Machine 1/3 HP 115V-60Hz	620-40-121897	144 lbs.	1725.00	18 RL Lap Machine * 1/2 HP 115V-60Hz	620-40-121889	326 lbs.	2625.00
12 RL Lap Machine 1/3 HP 220V-50Hz For use outside the USA	620-40-121897X	135 lbs.	1960.00	18 RL Lap Machine * 1/2 HP 220V-50Hz For use outside the USA	620-40-121889X	326 lbs.	2870.00
12RL Cast Iron Replacement Plate	621-40-117085	25 lbs.	510.00	18 RL Cast Iron Replacement Plate	621-40-117077	76 lbs.	810.00
12 RL Splash Guards (2)	621-40-118457	2 lbs	57.00	18RL Splash Guards (3)	621-40-118458	3lbs.	99.00
Crating fee RL machine	620-40-C12		109.00	Crating fee 18 RL machine	620-40-C18		213.00
* 18" Laps shipped via truck				Crating fee 18 RLPlate	621-40-117077C		43.00

MAGNETIC NOVA LAPS FOR LAPPING

Our Magnetic Nova Laps give you the fast polishing performance of Novas combined with the convenience of an easy on-off magnetic lap. They attach right onto most flat laps and are easily removed.

Magnetic Nova Laps have a 1/16" thick backing of solid rubber containing magnetized iron particles so the laps will adhere to a cast iron, steel or nickel plated lap. The rubber is coated with a thick layer of our special Nova resin-bond diamond formula for fast action and lasting service. The surface of the Magnetic Nova is made with a grid pattern for better performance.

You can use the Magnetic Novas on your present flat lap set-up in most cases, but they will not work on aluminum or diamond coated discs.

Our recommended general purpose grit sequence for sanding and polishing most flats, especially on our RL lap machines (see pages 72 & 73) is 60, 280, 600 and 1200 grits, followed by our Super Premium Cerium Oxide Polish on a felt pad. We also recommend the use of a 60 grit Diamond Plated Disc to precede the 60 grit Magnetic Nova for those slab surfaces with deep saw marks or other features requiring grinding preparation. Other grit sequences can be used with excellent results depending on the materials to be polished.

We recommend that Magnetic Novas in diameters 12" and larger be used with 1" arbor holes. The hole prevents the "dead" center of the revolving lap from "grabbing" your workpiece, yet does not prevent you from using the entire surface of the lap.

The 24" Magnetic Novas are SPECIAL ORDER.



Shown above is Magnetic Nova being removed from an 18RL lap machine.

HOW TO ORDER ARBOR HOLES

Standard Magnetic Novas do not come with arbor holes unless requested. ALL ARBOR HOLES ARE SPECIAL ORDER, BUT THERE IS NO ADDITIONAL CHARGE FOR THIS SERVICE. Allow 2-3 days extra.

To order an arbor hole in any Magnetic Nova, please specify arbor hole size you require by adding the following Special Order numbers to the standard order number of the Magnetic Nova.

For 1/2" arbor hole, add -4 to the order number.
 For 5/8" arbor hole, add -5 to the order number.
 For 3/4" arbor hole, add -6 to the order number.
 For 1" arbor hole, add -8 to the order number.

Example: 100-RM08-60-5 This signifies an 8" diameter, 60 grit Magnetic Nova with a 5/8" arbor hole.

If you have any questions, please call our Customer Service Representatives.

MAGNETIC NOVA LAPS

Grit Size	8" Laps: 84.00 ea	12" Laps: 165.00 ea	16" Laps: 285.00 ea.	18" Laps: 335.00 ea.	24" Laps: 790.00 ea.
	Order #	Order #	Order #	Order #	Order #
60	100-RM08-70	100-RM12-70	100-RM16-70	100-RM18-70	100-RM24-70
140	100-RM08-15	100-RM12-15	100-RM16-15	100-RM18-15	100-RM24-15
280	100-RM08-28	100-RM12-28	100-RM16-28	100-RM18-28	100-RM24-28
600	100-RM08-60	100-RM12-60	100-RM16-60	100-RM18-60	100-RM24-60
1200	100-RM08-12	100-RM12-12	100-RM16-12	100-RM18-12	100-RM24-12
3000	100-RM08-30	100-RM12-30	100-RM16-30	100-RM18-30	100-RM24-30
8000	100-RM08-80	100-RM12-80	100-RM16-80	100-RM18-80	100-RM24-80
14,000	100-RM08-14	100-RM12-14	100-RM16-14	100-RM18-14	100-RM24-14
50,000	100-RM08-50	100-RM12-50	100-RM16-50	100-RM18-50	100-RM24-50
Shp. wt.	1 lb.	1.5 lb.	2 lbs.	3 lbs.	4 lbs.

MAGNETIC PLATED DIAMOND DISCS

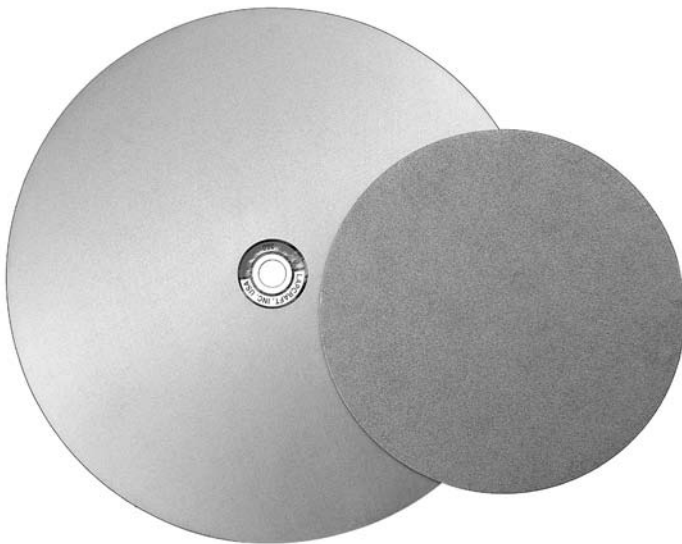

Shown above are the 8" and 12" Magnetic Plated Diamond Discs

Magnetic Plated Diamond Discs have diamond metal-bonded to a magnetic backing which will adhere to a steel back-up plate. Grit sizes range from 60 to 600 for grinding and sanding flats. They are especially efficient at removing saw marks from slabs

The 12" and 18" Plated Discs fit our model 12RL and 18RL rotating lap machines (see page 72 & 73). The 12" Plated Discs have a 5/8" center hole, and the 16" and 18" Plated Discs have a 1" center hole.

The 8" Plated Disc has no center hole for an uninterrupted working surface. It can be used with the 8" steel-faced back plate (see page 12) that fits the right hand side of the Titan.

*THE 16" AND 18" MAGNETIC PLATED DIAMOND DISCS ARE SPECIAL ORDER.



See page 102 for goggles

MAGNETIC PLATED DIAMOND DISCS								
Grit Size	8"		12"		* 16"		* 18"	
	Order #	Price	Order #	Price	Order #	Price	Order #	Price
60	205-08-060	195.00	205-12-060	325.00	205-16-060	775.00	205-18-060	875.00
100	205-08-100	150.00	205-12-100	295.00	205-16-100	650.00	205-18-100	800.00
260	205-08-260	100.00	205-12-260	225.00	205-16-260	525.00	205-18-260	725.00
360	205-08-360	95.00	205-12-360	210.00	205-16-360	495.00	205-18-360	650.00
600	205-08-600	90.00	205-12-600	200.00	205-16-600	475.00	205-18-600	600.00
Shp. Wt	1 Lb.		2 Lbs.		3 Lbs.		3 Lbs.	

SAFETY FIRST WEAR YOUR GOGGLES

FELT DISCS

These discs are 1/8" thick wool felt with high tensile strength and excellent resistance to wear. Discs with magnetic rubber backing can be used on metal back plates and laps. Plain discs can be glued to back plates or used in other applications. Polishing compounds will adhere well to the surface. Weights estimated.

Diameter	Unbacked			Magnetic		
	Order #	Price	Shp Wt	Order #	Price	Shp Wt
8"	100-PAD-U-08F	16.50	4 oz.	100-PAD-M-08F	22.25	8 oz.
12"	100-PAD-U-12F	22.00	6 oz.	100-PAD-M-12F	32.00	1 lb
18"	100-PAD-U-18F	54.95	1 lb.	100-PAD-M-18F	84.95	2 lbs

THE "SCULPTURE" ROCK LATHE

This rock lathe machine lets you preform rounded shapes in stone. You can preform eggs, candlesticks, vases, display bases, handles and spheres up to 8" long and 8" in diameter.

Blade and motor carriage is on a roller crossfeed powered by an independent gear motor and lead screw with a clutch. This complete assembly floats freely up and down on roller bearings as it follows the template of your design. The stone is held in place by the heavy duty tightening rod and is rotated into the blade by another independent gear motor. The complete machine is made from powder coated steel plate and has stainless steel rails and coolant pan.

The blade is cooled by a recirculating pump feeding coolant from the pan through two "Lockline" coolant hoses. These adjustable lines allow you to position the coolant flow where you need it. Flow is controlled by valves.

Our Galaxy Carving Wheels can also be used on the Sculpture so that you can finish grind and sand your workpiece.

Overall size is 33½" x 21". Weight is approx. 75 lbs. Must be crated for shipping. Will ship via UPS/FEDEX. ALLOW 4-6 WEEKS FOR SHIPMENT.

THE SCULPTURE ROCK LATHE INCLUDES:

Frame and carriage assemblies made from steel plate that is powder coated for long life. Has stainless steel carriage rails.

Saw blade is powered by high torque motor. Includes two gearhead motors for driving the Y carriage and turning the rod holding the workpiece.

Coolant system consisting of recirculating pump, stainless steel coolant pan, two adjustable Lockline coolant hoses and two control valves.

Heavy duty 8" x .090 x 5/8" diamond saw blade.

SAFETY GOGGLES WHICH SHOULD BE WORN WHEN USING THIS MACHINE.

Shipping Weight 140 pounds. Must be crated.

640-34-1000 115V Model.....	2995.00
640-34-1000X	..230V Model.....	3095.00
640-34C.....	Crating Fee	195.00
640-925DReplacement Blade 2 lbs. ..	157.00

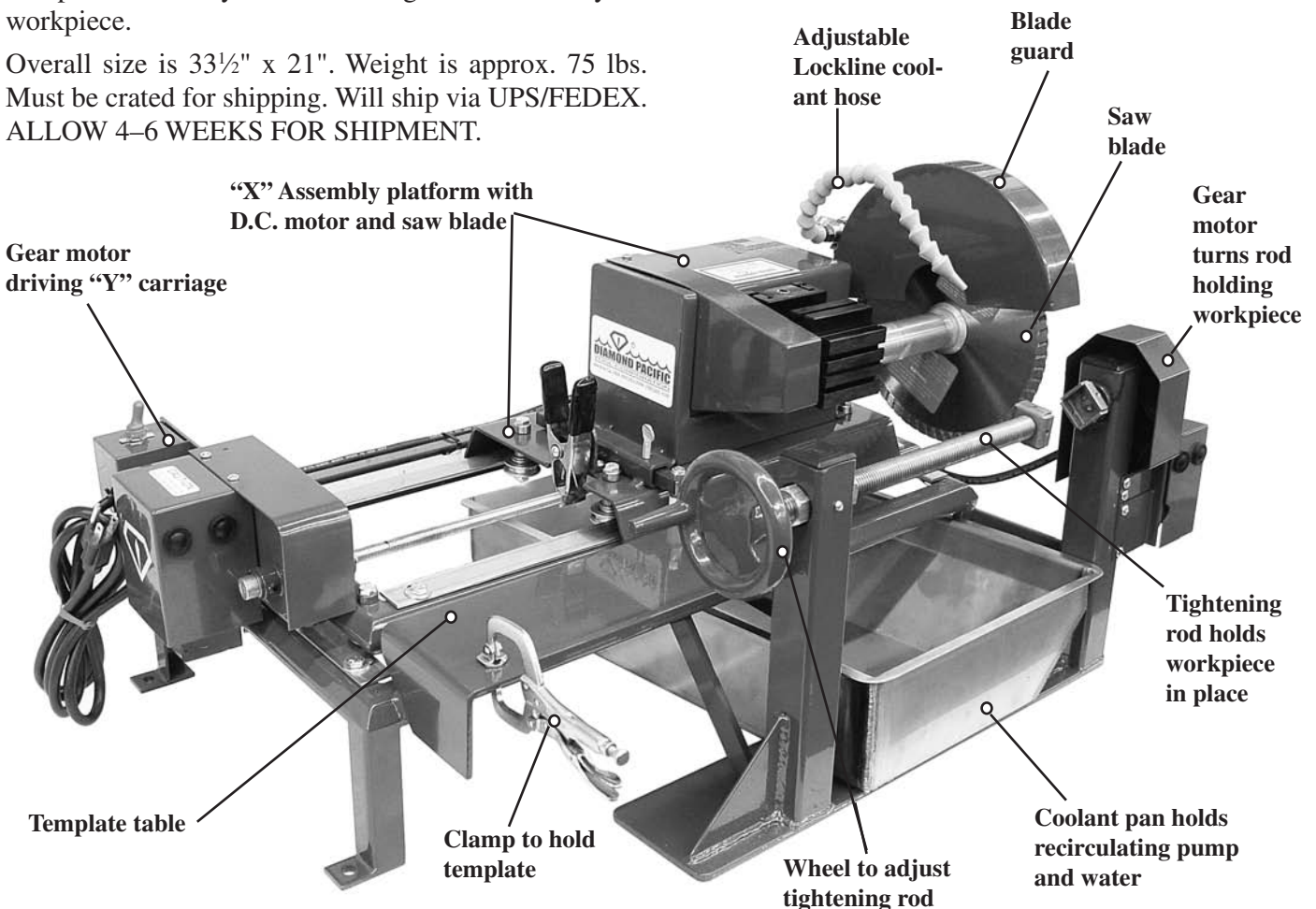

THE "SCULPTURE" ROCK LATHE

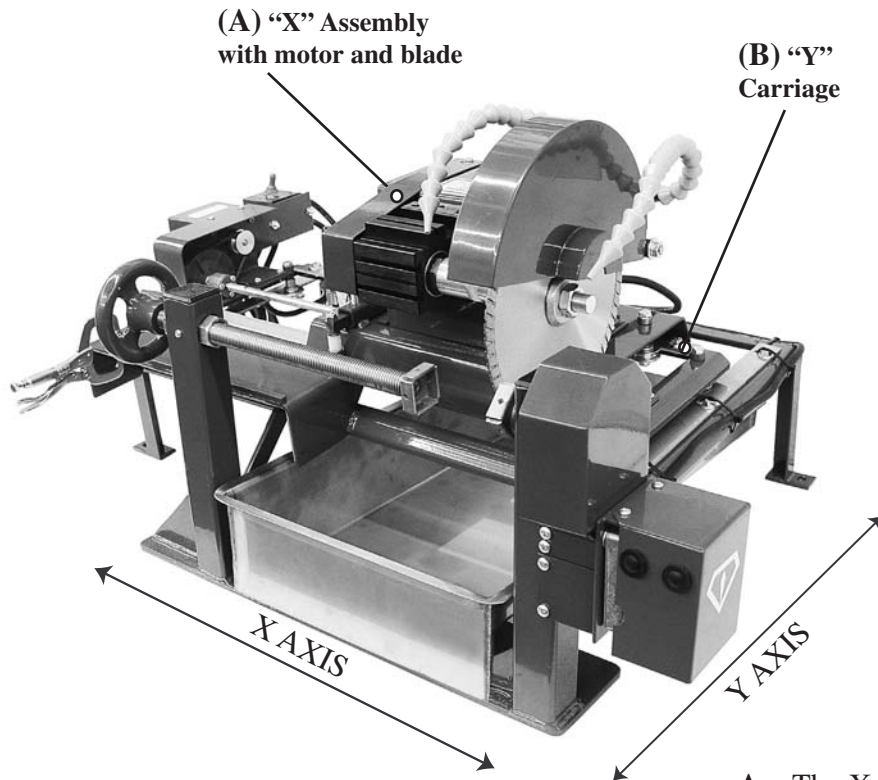

The "Sculpture" is based on the simple XY linear movement principle. The X axis moves across the face of the workpiece (from left to right) and is driven by a power feed screw. The Y axis is then left free to move up and down, guided by the template tracer arm following the shape of the template.

SAFETY
FIRST
WEAR YOUR
GOGGLES

A. The X assembly platform is powered by a gear motor driving a screw feed that moves the platform from left to right, keeping the cutting edge of the blade moving across the length of the workpiece.

B. The Y carriage assembly carries the X platform and moves it up and down, and is guided in its movement by the template tracer arm following the shape of the template.

C. Workpiece is held in place by the tightening rod. The workpiece is rotated in place by a gearhead motor as the blade moves across the workpiece, following the template.

D. Tightening the rod adjusts to fit workpiece between the clamps holding it.

E. Template tracer arm has a special roller bearing that fits the edge of the template which must be at least 1/4" thick. As X platform moves to right, template tracer bearing follows edge of template, guiding Y carriage in moving saw blade to cut desired shape.

F. Template for egg shaped workpiece shown clamped in place on template table. Template represents one-half of desired shape of finished piece.

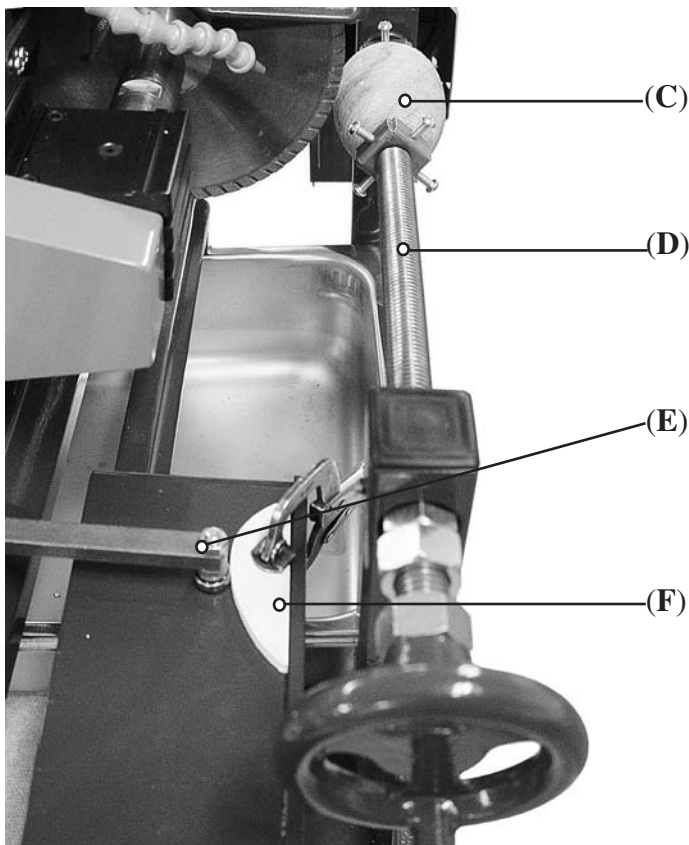

AD-A-UNIT ARBOR SYSTEM

For the shop that needs an extra arbor for those many special jobs, this versatile series can fill the bill

- You can buy the heavy duty 8" Husky Arbor alone as a replacement or addition to your shop, or—
- You can buy the arbor with a heavy duty, powder coated steel hood and pan for use with your own motor for power or—
- You can buy the unit complete with arbor, hood and pan, and ½ HP 115V 60 Hz motor with a baseboard.
- Also available is the complete AD-A-UNIT-MB model with a 220V 50 Hz motor for export.
- A ½ HP variable speed model is available. Call us with your needs.

The complete units are ideal for use in industrial shop set ups and for community center and club workshops. Excellent for multiple stations.

You can mount a wheel or expanding drum on each end of the shaft. Both ends have a ½" step for mounting laps. The right hand will also accept ¼" - 20 screw back discs. You can set up the unit as either a stone or metal finishing unit. Attach our special Galaxy Carving Wheels and you have a machine for carving stone.

You can use expanding drums with belts, a variety of grinding and polishing wheels such as our diamond Galaxy and Nova Wheels, and various buffing wheels.

The 8" arbor is heavy duty, cast aluminum with a split housing so just the removal of four screws allows you to change the belt or remove the shaft for bearing replacement. Arbor shaft is ¾" stainless steel with overall length of 18". Cushion mounted bearings and 3-step pulley.

The hood and pan are powder coated steel. The pan has two pipe threaded drain holes and the hood has an overhead water manifold with two valves for providing coolant (water) to wheels mounted on arbor shaft.

CAUTION: Use Safety Goggles to protect your eyes when using this machine.

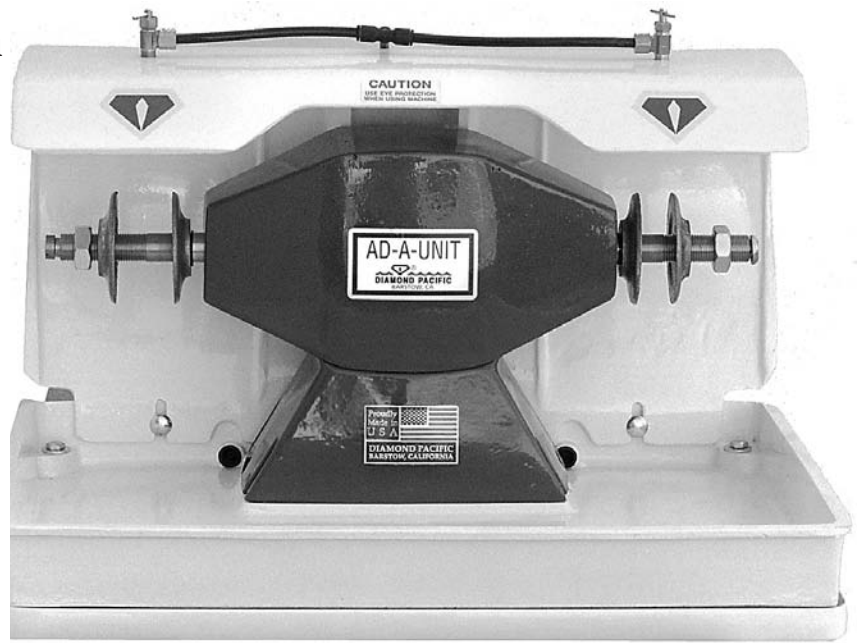

SHOWN ABOVE: Ad-A-Unit with 8" Husky arbor, powder coated steel hood and pan.



AD-A-UNIT-MB: 8" Husky arbor with belt, 3-step pulley, hood, pan, ½ HP 115V motor and laminated baseboard. 20" W x 26"L.

630-28-2200.....Shp Wt. 66 lbs.....970.00

AD-A-UNIT-MB: EXPORT MODEL same as above but with 220V 50 Hz motor.

630-28-2200X.....Shp Wt. 66 lbs.....1125.00

AD-A-UNIT: WITH VARIABLE SPEED CONTROL. ½ HP 115V - Export ½ HP 220V .

630-28-2200V.....Shp Wt. 82 lbs.....2010.00

630-28-2200VX EXPORT ..Shp Wt. 82 lbs ...2115.00

CRATING FEE: Variable speed units only.

630-28C.....120.00

AD-A-UNIT ARBOR SYSTEM

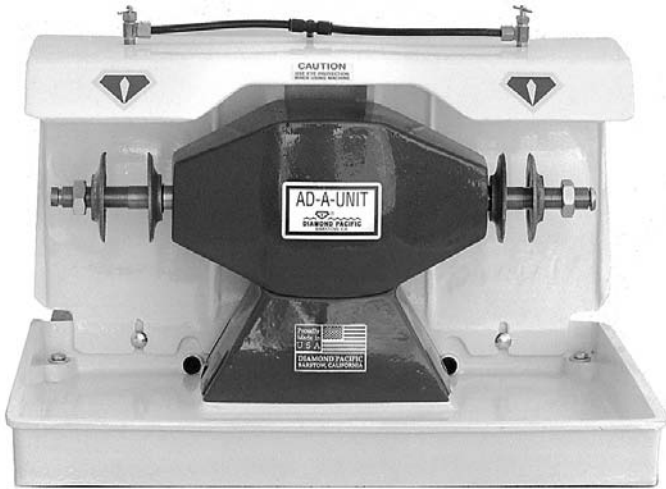

BASIC AD-A-UNIT

AD-A-UNIT: Basic Ad-A-Unit comes with the 8" Husky arbor, belt and three-step pulley. Also includes heavy duty, powder coated steel hood and pan with coolant system consisting of overhead water manifold with two valves for providing the coolant. Fan has two pipe threaded drain holes. Can be used with your own motor and baseboard.

630-28-2000.....Shp. Wt. 47 lbs..... 690.00



HUSKY 8" ARBOR

HUSKY 8" ARBOR: with belt and 3-step pulley. Use with your own motor and coolant system. You can mount a wheel, buff or expanding drum on each end of the shaft. Both ends have a 1/3" step for mounting laps. The right hand shaft will also accept 1/4"-20 screw back discs. See below for various attachments that can be used with any of the models of Ad-A-Units.

630-28-2100.....Shp. Wt. 13 lbs..... 380.00

SAFETY
FIRST
WEAR YOUR
GOGGLES

HOOD with water manifold and two valves
690-28-2002..... Shp.Wt. 12 lbs. 225.00

PAN with two pipe threaded drain holes.
690-28-2001..... Shp. Wt. 19 lbs. 188.00

AD-A-UNIT SHAFT
690-28-2103..... Shp Wt. 3 lbs 145.00

BEARINGS. Need two per arbor.
690-90-16204..... Each..... 4 oz. 20.00

RUBBER BEARING MOUNT
690-90-0002..... Shp Wt. 6 ozs..... 6.80

BELT FOR MB MODEL
690-91-4310..... Each..... 10 oz. 7.75



DRUMS

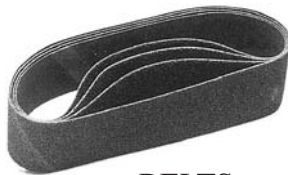

BELTS



WHEELS



BUFFS

These Ad-A-Unit machines are quite versatile. For the wheels, drums, buffs and belts shown, use listings below.

Expanding drums 80
Silicon Carbide Belts 80
Galaxy Grinding Wheels..... 8 - 9
Nova Sanding and Polishing Wheels 7
Polishing Buffs..... 83

SILICON CARBIDE DISCS AND BELTS

High quality silicon carbide discs and belts for sanding and polishing stone or glass. May be used either wet or dry and in both directions. Discs available for 6" or 8" diameter plates. To attach discs use Feathering Disc Adhesive listed on page 81. The 6" and 8" Belts fit the expanding drums below, match diameter and width. Wet Belt sander belts fit any 3" x 4 1/2" machine.

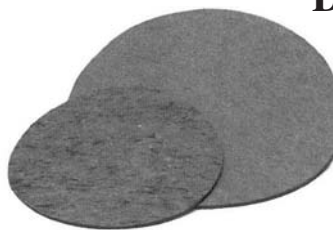

DISCS

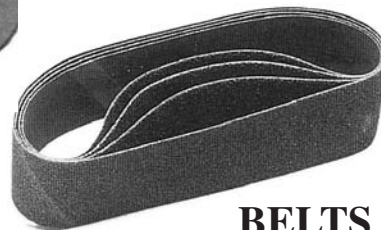

BELTS

Fits	Order number	Description	Mesh	Shp. Wt. Each	Price
6" Discs	702-85-5006-100	DISC, 6"	100 GRIT	6 oz.	1.40
	702-85-5006-220	DISC, 6"	220 GRIT	6 oz.	1.40
	702-85-5006-320	DISC, 6"	320 GRIT	6 oz.	1.40
	702-85-5006-400	DISC, 6"	400 GRIT	6 oz.	1.40
	702-85-5006-600	DISC, 6"	600 GRIT	6 oz.	1.40
8" Discs	702-85-5008-080	DISC, 8"	80 GRIT	6 oz.	2.45
	702-85-5008-100	DISC, 8"	100 GRIT	6 oz.	2.45
	702-85-5008-220	DISC, 8"	220 GRIT	6 oz.	2.45
	702-85-5008-320	DISC, 8"	320 GRIT	6 oz.	2.45
	702-85-5008-400	DISC, 8"	400 GRIT	6 oz.	2.45
	702-85-5008-600	DISC, 8"	600 GRIT	6 oz.	2.45
6" x 2 1/2" Drum	702-85-6625-080	BELT 2 1/2" x 18 15/16"	80 GRIT	6 oz.	2.48
	702-85-6625-100	BELT 2 1/2" x 18 15/16"	100 GRIT	6 oz.	2.44
	702-85-6625-220	BELT 2 1/2" x 18 15/16"	220 GRIT	6 oz.	2.44
	702-85-6625-320	BELT 2 1/2" x 18 15/16"	320 GRIT	6 oz.	2.44
	702-85-6625-400	BELT 2 1/2" x 18 15/16"	400 GRIT	6 oz.	2.44
	702-85-6625-600	BELT 2 1/2" x 18 15/16"	600 GRIT	6 oz.	2.44
8" x 3" Drum	702-85-6830-080	BELT 3" x 25 7/32"	80 GRIT	6 oz.	3.31
	702-85-6830-100	BELT 3" x 25 7/32"	100 GRIT	6 oz.	3.24
	702-85-6830-220	BELT 3" x 25 7/32"	220 GRIT	6 oz.	3.24
	702-85-6830-320	BELT 3" x 25 7/32"	320 GRIT	6 oz.	3.24
	702-85-6830-400	BELT 3" x 25 7/32"	400 GRIT	6 oz.	3.24
	702-85-6830-600	BELT 3" x 25 7/32"	600 GRIT	6 oz.	3.24
Wet Belt Sanders	702-85-6341-080	BELT 3" x 4 1/2"	80 GRIT	6 oz.	5.67
	702-85-6341-100	BELT 3" x 4 1/2"	100 GRIT	6 oz.	5.30
	702-85-6341-120	BELT 3" x 4 1/2"	120 GRIT	6 oz.	5.30
	702-85-6341-220	BELT 3" x 4 1/2"	220 GRIT	6 oz.	5.30
	702-85-6341-320	BELT 3" x 4 1/2"	320 GRIT	6 oz.	5.30
	702-85-6341-400	BELT 3" x 4 1/2"	400 GRIT	6 oz.	5.30
	702-85-6341-600	BELT 3" x 4 1/2"	600 GRIT	6 oz.	5.30

EXPANDING DRUMS



Use these expanding drums with silicon carbide belts for sanding and polishing gemstones. The expansion slots in the rubber rim allow the drum to expand when rotated, thereby locking the belt in place. The rubber drum is soft, resilient and durable. The drum surface flexes to the gemstone's contour to allow for quickly removing scratches even from flat surfaces. Belts may be easily changed by sliding on and off drums when machine is stopped. Come with bushings to fit 1", 3/4", 5/8" and 1/2" arbors. For use with arbors with threaded shafts and retaining nuts.

Order number	Size	Shp. Wt.	Price
710-71-5061	6" DIAMETER X 1 1/2" WIDTH	3 lbs.	61.00
710-71-5062	6" DIAMETER X 2 1/2" WIDTH	3 lbs.	72.00
710-71-5083	8" DIAMETER X 3" WIDTH	5 lbs.	92.00

WARNING:
GLUES CONTAIN TOXIC MATERIALS. READ DIRECTIONS ON LABELS BEFORE USING AND FOLLOW ALL INSTRUCTIONS.

FOR MORE GLUES, SEE PAGE 94.



SUPER SOLVENT For cyanoacrylate glues. Use to clean up excess glue or break an existing bond. Can normally be used on hands, most fabrics and surfaces, but solvent should be tested on a small area first. Should not be used on lacquer, butyrate or nitrate based finishes.

129-US-1 2 oz. 8.95

NEW NCF AEROSOL ACCELERATOR Use with cyanoacrylate glues to speed curing time on difficult-to-bond materials or under adverse conditions. Contains special ingredients which clean bonding surfaces and start curing at even lower temperatures. **CONTAINS NO CHLOROFLUOROCARBONS.**

129-NCF-A 6 oz. 12.95



BOND 527

Crystal clear, strong, durable, quick drying, syrup like viscosity. Craft and total household staple. Bonds ceramic, gemstones, shells, china, glass, metal, tile, leather, wood, most plastics. Tube 2 oz.

153-527-2 3 oz. 6.50



INSTANT CYANOACRYLATE GLUES

Select the cyanoacrylate glue that fits your needs. All are "instant" bonding, dry clear and can be buffed to a high polish, have incredible bonding strength and can be used on almost any type of material. Keep unopened bottles in freezer at 32° or below for extended life. Store used bottles at room temperature.

"SPECIAL" T (Green Label) Sets in 20-50 seconds depending on material. Thicker consistency and greatest gap filling ability.
 129-SPT4 2 oz. 11.50

"SUPER T" (Yellow Label) Sets in 10-25 seconds. Thick like syrup to fill small gaps between parts that don't fit perfectly.
 129-ST1 1/2 oz. 3.95
 129-ST1-C... Case of 12 1 lb. 45.00
 129-ST4 2 oz. 10.50

"HOT STUFF" (Red Label). Normally sets in 3-10 seconds. Thin like water for exact fit or deep penetration.
 129-HS1 1/2 oz. 3.95
 129-HS1-C.. Case of 12 1 lb. 45.00
 129-HS4 2 oz. 10.50

3M FEATHERING DISC ADHESIVES Use to bond sanding and buffing discs to back plates. Bonds instantly but allows discs to be peeled off backing after use. Works on rubber, plastic, metal backup pads. Comes in 5 oz. tube.
 140-08051 Tube 8 oz. 12.55



OPTICON Seals and cements fractures in flat or curved, polished or unpolished stone. Eliminates fracture reflection and structural weakness and in addition accomplishes the filling of pits. Opticon 224 resin is amber clear and when heated to a low viscosity has the property of high penetration of fractures, much like glycerine or oil. 9 oz. Shipped via UPS ground only in USA.
 133-224 1 lb. 22.50

MEASURING CUPS Use these disposable plastic cups for mixing epoxy and resin. Graduated 1 oz. cup makes mixing easy. Translucent, flexible polypropylene. Cups come in packages of 10.
 200-MC-610 10/pk 1 oz.75

SHIPPING NOTICE
 All items on this page can only be shipped via UPS Ground Service within the Continental States. No air or overseas shipments due to Federal regulations. Sorry.

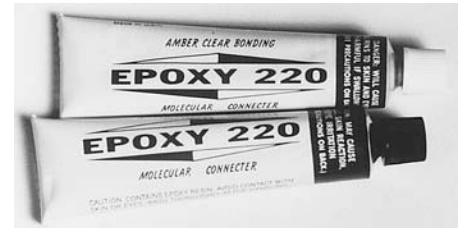

220 EPOXY is a light amber clear adhesive. Ideal for all types of jewelry repair. Bonds stones to metal findings, good for assembling doublets, intarsias and repairing broken stones, china and cloisonne. Cures in 12 hours at room temperature. Super strong bond. Superior for pit filling.

133-220 2 oz. 4.50

330 EPOXY is water clear. Most popular epoxy. Good for same uses as 220 above. Fast setting time, cures in 1 hour at room temperature. Ideal where clarity is important. Especially good when you need an invisible bond on glass, china, ceramics, stone or metals and other nonporous materials.
 133-330 2 oz. 4.50



UV GLUE WITH TIP GLU-112 UV Glue is a Clear crystal adhesive that cures under ultraviolet light or direct sunlight. Tube contains .07 fluid ounces. Special tip for precise application puts glue on uniformly with ease. GLU-113 offers a lighter viscosity than the standard GLU-112 formula. Extra tips available to allow for full use of product, order 150-GLU-114.
 150-GLU-112 2 oz. 8.45
 150-GLU-113 2 oz. 8.65
 150-GLU-114 1 oz. 1.20



WORKING HANDS CREAM—The hand cream that really works. Our own employees use it to effectively relieve dry hands that crack and split. The odorless, concentrated formula stimulates the skin's natural repair process by hydrating skin, adjusting pH balance and retaining moisture. It is chemically different than any other hand care products. Absorbs fast, leaving no mess on your hands. Jar is 3.4 oz.

165-WH34.....Shp wt. 4 oz.6.99

MUSLIN AND FLANNEL BUFFS All six have 1" center holes that can be adapted to 3/4", 5/8" or 1/2" arbors.

Order #	Fits Machine	Type	Dia.	Stitching	Ply	Shp.Wt.	Price
100-JPK3	Pixie	Muslin	4"	2 Rows	40	2 oz.	4.75
100-JPK4	Pixie	Flannel	4"	2 Rows	30	2 oz.	6.75
100-JPK1	Genie	Muslin	6"	3 Rows	60	5 oz.	10.75
100-JPK2	Genie	Flannel	6"	3 Rows	30	5 oz.	9.45
100-JPK5	Titan	Muslin	8"	4 Rows	55	10 oz.	16.95
100-JPK6	Titan	Flannel	8"	3 Rows	30	10 oz.	12.80

ARBOR ADAPTOR FOR BUFF WHEELS

Adaptor has 1/4" shank to fit most electric hand drills. Fits wheels with 1/2" arbor hole. Flanges hold wheels securely. For wheels 4" or more in dia. 200-AA-505 6 oz.5.25



FLANGES FOR WHEEL BUFFS

Use on buffing wheels with 1" bore centers for increased efficiency and safety. Aluminum, sold in pairs. Ship. wt. 3 oz. pr.

Order #	Arbor Size	Price
200-AF-535-1/2	1/2"	1.10
200-AF-535-5/8	5/8"	1.10
200-AF-535-3/4	3/4"	1.10

METAL POLISHES



EURO-SHINE POLISHING CREAM— Specially formulated for cleaning and polishing while leaving a microscopic residue which keeps metals bright and protects from tarnish. Works on gold, silver, copper, brass, chrome, stainless steel and aluminium. Contains no acid and is gentle to the skin. Simply apply with a damp cloth, then wipe off. Tube size 150ml.

150-POL-680Shp wt. 2 oz.9.95

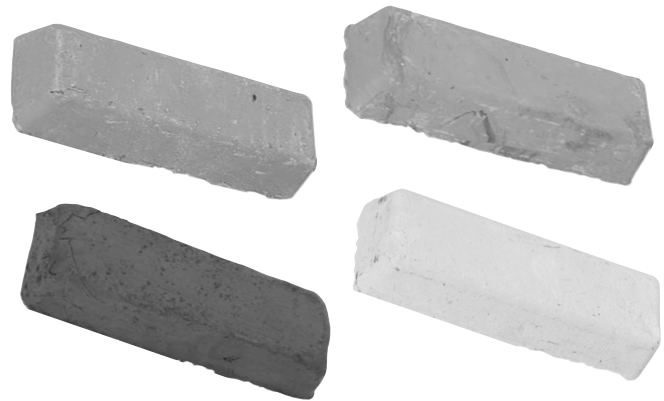

RED ROUGE – The standard compound for a final coloring and a high polish on precious metals such as gold and silver. Not for burnished surfaces. Bar weight 16 ozs.

400-50Shp wt. 1 lb 4 oz..... 7.15

TRIPOLI (Brown) –The most popular general compound for cutting down and buffing base metals. Gives a smooth, satin finish to copper, aluminum, pewter, gold and even hard plastic surfaces. Also ideal for preliminary coloring operations. Bar weight 9 ozs.

400-20Shp wt. 1 lb.3.70

GREEN ROUGE – Produces a super bright finish on most white metals. This rouge has some cutting action and should not be used on plated articles. Works like ZAM on stones. Bar weight 12 ozs.

400-30Shp wt. 1 lb.4.85

WHITE ROUGE – Fast cutting, produces high gloss finish on white metal such as stainless and chrome. Bar weight 12 ozs.

400-40Shp wt. 1 lb.4.00

YELLOW ROUGE – Good all-around, low residue compound for use on gold, chrome, platinum, stainless steel and other hard metals. Bar weight approx 1 lb.

150-POL-625Shp wt. 1 lb.4.20

WHEEL BUFFS

These buffing wheels come in a variety of materials for different applications.

Bufs come with standard pin hole type center to fit tapered spindles. For buf with 1" arbor hole to fit Gem-Makers, see page 19.

1. COARSE MUSLIN - Shellac centers, use with adhesive compounds such as Tripoli for removing scratches.

Order #	Dia.	Stitching	Ply	Shp. Wt.	Price
200-CM4X42	4"	3 Rows	40	2 oz.	3.75
200-CM6X50	6"	4 Rows	50	5 oz.	8.15

2. FINE MUSLIN - Premium White. 80/80. Leather centers, use with any rouge compound for a bright finish.

Order #	Dia.	Stitching	Ply	Shp. Wt.	Price
200-FM4X50	4"	3 Rows	50	2 oz.	4.25
200-FM6X60	6"	4 Rows	60	6 oz.	10.25
200-FM8X50	8"	4 Rows	55	10 oz.	15.95

3. MUSLIN, YELLOW TREATED - Premium 86/80. Chemically treated for use with abrasive compounds for cut down. 4" shellac center. Buff 200-YL6X20 has leather center. Buff 200-YL6X50 has shellac center.

Order #	Dia.	Stitching	Ply	Shp. Wt.	Price
200-YL4X40	4"	3 Rows	40	2 oz.	4.60
200-YL6X20	6"	4 Rows	20	4 oz.	2.50
200-YL6X50	6"	4 Rows	50	6 oz.	8.95

4. CANTON COTTON FLANNEL - Soft 8 oz. flannel with shellac centers, use with rouge for final polish.

Order #	Dia.	Stitching	Ply	Shp. Wt.	Price
200-FL4X30	4"	3 Rows	30	2 oz.	5.75
200-FL6X30	6"	4 Rows	30	5 oz.	8.45
200-FL8X30	8"	4 Rows	30	10 oz.	11.80

5. LOOSE PLY MUSLIN - Premium 80/80. Has no stitching, lead center. Use for final polish with rouge. The 4" buff is made of COARSE muslin, and the 6" buff is FINE muslin.

Order #	Dia.	Stitching	Ply	Shp. Wt.	Price
200-LC4X36 COARSE	4"	None	36	4 oz.	5.60
200-LC6X54 FINE	6"	None	54	8 oz.	10.85

6. RAZOR EDGE - Muslin 86/80, yellow treated, leather center. For use with abrasive or rouge in hard-to reach areas.

Order #	Dia.	Stitching	Ply	Shp. Wt.	Price
200-RE4X12	4"	4 Rows	12	2 oz.	5.00
200-RE6X12	6"	8 Rows	12	3 oz.	5.75



1.



2.



3.



4.



5.



6.



7.

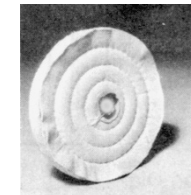

8.

7. SOLID FELT WHEELS

Now in those hard-to-find larger sizes and all three hardnesses. Bufs are made of high grade wool felt compressed for uniform texture and hardness. For polishing and lapping metal and stones. Can be charged with polishing compounds. Wheels are bored to 1", and may be bushed to fit 3/4", 5/8", and 1/2" arbors.

Order #	Size	Hardness	Shp Wt	Price
148-615-H	6 x 1 1/2"	Hard	1 lb.	63.52
148-615-M	6 x 1 1/2"	Medium	1 lb.	54.72
148-615-S	6 x 1 1/2"	Soft	1 lb.	48.86
148-815-H	8 x 1 1/2"	Hard	2 lbs.	112.92
148-815-M	8 x 1 1/2"	Medium	2 lbs.	97.28
148-815-S	8 x 1 1/2"	Soft	2 lbs.	86.86

TAPERED SPINDLES

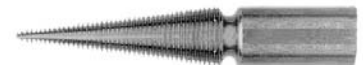

For straight shaft motors. Steel with threads cut deep to provide firm grip on buf s, wheels, etc. Held to shaft by 1 set screw. Length 3" to 4". Choose right or left hand threads. Ship wt 6 ozs.

For Shaft Diameter	L/H		R/H	Price
	Thread	Thread	Thread	
1/4"	154-TSL1	154-TSR2	154-TSR2	10.75
5/16"	154-TSL7	154-TSR8	154-TSR8	10.75
3/8"	154-TSL3	154-TSR4	154-TSR4	10.75
1/2"	154-TSL5	154-TSR6	154-TSR6	10.75
5/8"	154-TSL9	154-TSR10	154-TSR10	10.75



Model DA

OptiLOUPE

optivisor®

The original Binocular Magnifier with optical lenses

Don't settle for plastic lenses when it comes to saving your eyesight and improving your vision for close-up work. OptiVisor's lenses are prismatic, optical glass ground and polished to precise, optical standards. They are bevel edged and mounted in an interchangeable plastic frame, allowing you to have different lens powers for different needs. OptiVisor is still your best buy in a headband magnifier.

Order #	Magnification	Shp. Wt.	Price
116-DA-02	Magnifies 1½ X at 20" focal length	12 oz.	51.95
116-DA-03	Magnifies 1¾ X at 14" focal length	12 oz.	51.95
116-DA-04	Magnifies 2 X at 10" focal length	12 oz.	51.95
116-DA-05	Magnifies 2½ X at 8" focal length	12 oz.	51.95
116-DA-07	Magnifies 2¾ X at 6" focal length	12 oz.	53.75
116-DA-10	Magnifies 3½ X at 4" focal length	13 oz.	53.75
116-DA-LP1	OPTILOUPE Monocular attachable lens. Adds 2½ extra power to your OptiVisor. Attaches to either eyepiece.	2 oz.	11.60
116-DL	Lens Plate Nos. 2, 3, 4 & 5 State number when ordering.	2 oz.	31.55
116-DL-07	Lens Plate No. 7	2 oz.	33.25
116-DL-10	Lens Plate No. 10	2 oz.	33.25
116-DA-00	Headpiece assembly, No lens*	10 oz.	26.75
116-PT3	Leather comfort band	1 oz.	5.85

Optivisor is equipped with these unique features

- **Adjustable Headband** - Conforms to fit all head sizes - fabricated from a special blend of lightweight ABS material - comfortable when worn for long periods of time.
- **It Tilts** - Adjustable pivots allow the visor to be tilted out of the way when not needed and at your fingertips when you need magnification.
- **Genuine Leather Comfort Band** - Padded with orthopedic felt - adds to comfort.
- Made completely in the U.S.A by skilled craftsmen.

OptiVISOR
as seen by
normal vision



1½ X at 20"



1¾ X at 14"



2 X at 10"



2½ X at 8"



2¾ X at 6"



3½ X at 4"



OptiLOUPE Option
Adds 2½ X
to all models
116-DA-LPI

ORDER OPTIVISOR IN ANY OF THESE SIX LENS POWERS

The VisorLIGHT™

Puts light on your viewing area when using your optivisor®

New Visorlight™ attaches to your Optivisor, illuminating the magnified viewing area as you work. Gives you a hand-free light with 6000 candle power Xeonon Laserbeam. Takes two AA batteries for 4 to 5 hours use. Made in U.S.A.

MODEL LT-06 Has 10" cord for mounting on back side of visor (as shown below.)

116-LT-06.....Shp wt. 1 lb.28.20

MODEL LT-42 Has 42" cord and clips to allow battery pack mounting on belt or in pocket.

116-LT-42.....Shp. wt. 1 lb.28.20

REPLACEMENT BULBS for LT-06 and LT-42

116-LT-2204.....Shp. wt. 8 oz.....7.45



• Rotate lens clockwise to turn light on,
Rotate counter clockwise to turn light off

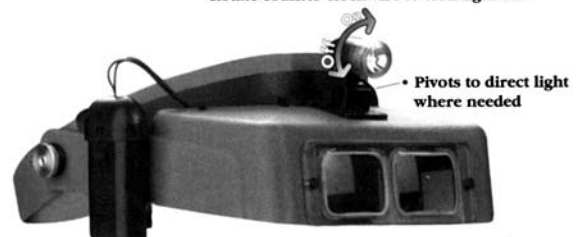

• Pivots to direct light where needed

ULTRA VIOLET LAMPS

Ultraviolet light is commonly used in industrial inspection, medicine, biology, advertising, and mineralogy to identify and display minerals. Some quite drab rocks become glowing beauties under ultraviolet light.

SHORT/ LONG WAVE UV LAMP

This dual bulb lamp can be switched from one wave length to another with a flip of a switch, or used together. Operates on 110 V AC, 9 watts. Shortwave is 254 nm and longwave is 368 nm. Weighs less than 7 lbs, has easy grip handle and ABS plastic housing. Approx. 8" L x 6" W x 3" H.

157-9SL..... 7 lbs. 225.00

UV-LED LONGWAVE FLASH LIGHT

Powerful enough to make longwave reacting gems and minerals fluoresce even in fairly bright light. Has filter to block most visible light. Takes 3 AAA batteries (included). Approx. 3 3/4" long.

157-LED-09 3 ozs. 40.00

“THE TRIPLE” MULTI-WAVE FLUORESCENT LIGHT

This compact, portable ultraviolet lamp emits UV A or UV B or UV C wavelengths. Just change out special insert sheets stored in lamp. Has 4 watt UV C ultraviolet lamp/tube that operates on two AA batteries.

157-3UV 4 ozs. 80.00

HAND LENS

DIAMOND CUT 10X LENS

Diamond Cut is attractive and provides better grip. Triplet. 10X has good depth of field. Comes in either 18mm or the 21.5mm with larger field of view. Black finish. Leather case. (The 747 has larger lens than the 745 shown in photo.)

150-ELP-745..... 18mm 2 oz..... 12.95

150-ELP-747 21.5mm..... 2 oz..... 15.95

TRIplet 10X LENS

Economical yet offers 10X, 18mm triplet lens. Black finish. Comes with leather case.

150-ELP-744 2 oz..... 9.85

LARGE 21.5mm 10X TRIPLET LENS

Case is hexagonal, but head is actually an elegant twelve faceted design. Silver finish. Leather case.

150-ELP-746 2 oz..... 15.65

DIAMOND TRIPLET 10X 20.5mm LENS

Quality three-piece bonded lens is ground for distortion free viewing and extra sharpness. Rubber grip added for comfort and better control. Chrome/Black. Leather case.

152-ELP-759..... 2 oz..... 22.25

HEXAGONAL 15X TRIPLET LENS

A more powerful 15X lens with three-piece, color corrected lens. Has 20.5mm field of view. Chrome/Black. Leather case.

152-ELP-758..... 2 oz..... 19.95



9SL
LAMP



9 LED

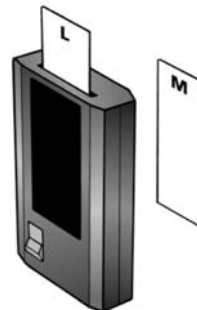

745



744



746



759



758

TWEEZER SET



BEADING TWEEZERS

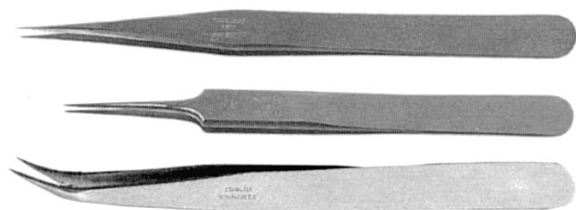

PIN VISES

SINGLE-END SLIDE PIN VISE Pin vise has knurled slide for easy one-hand operation. Capacity of 0 to 0.8mm. Length is 4 1/2".

150-PIN-221 6 oz. 4.65

DOUBLE END PIN VISE A different size steel collet mounted at each end of hollow handle makes this a highly versatile tool. Use to hold drills, taps, reamers, wire, rods, or precision knife blades. Collet capacity: 0 to .10" (0 to 2.5mm). Nickel-plated. Length approx. 4 1/2". May vary slightly from photo.

160-PV-657 6 oz. 4.60

SWIVEL HEAD PIN VISE All metal, hexagonal swivel head pin vise comes with two double end collets for 0 to 3.3mm" capacity. Overall length of pin vise is 3 1/2".

150-PIN-220 10 oz. 4.60



TWEEZERS

ALL PURPOSE TWEEZER SET

Four popular styles cover your basic needs and give years of service. General purpose, medium point is suitable for beading. Curved-point with pin interlock keeps jaws from twisting when doing heavy work. Negative-lock has fine point for delicate jobs. Use the cross-lock with fiber-grip handles for soldering. Lengths vary from 4 1/2" to 6 1/2".

150-TWZ-700Set..... 8 oz.9.95

BEADING TWEEZERS

Designed with needle like points for knotting thread between beads.

Stainless steel, needle like points, Length 5".

150-TWZ-735.1 2 oz.2.25

Stainless steel, length 4 3/4".

150-TWZ-735.5 2 oz.3.00

Bent tip knotting tweezers. Bent tips make it easier to see knotting process. Design may vary from illustration.

153-TW10..... 2 oz.3.95



SINGLE END PIN VISE



DOUBLE END PIN VISE



SWIVEL HEAD PIN VISE

JEWELER'S SHEARS

SUPER SHEARS

These fine German made shears will cut anything from paper to heavy tin. Tempered stainless steel blades with plastic handles for comfort. Come in two lengths.

152-SHR-304 7 1/2" 6 oz. 16.35

152-SHR-305 5 1/2" 6 oz. 14.45

SHEARS

Cut up to 20 gauge sheet stock with these high quality shears. Made of steel with tempered blades. Overall length is seven inches with 1 1/2" blades. Come with straight or curved blades. Made in France.

152-SHR-530Straight..... 6 oz.22.35

152-SHR-531Curved..... 6 oz.25.55



HAMMERS

BRASS MALLET

Nicely balanced, solid brass head will not mar soft or delicate metals. Head 2" long on metal handle.

150-HAM-215..... 4 oz.....6.95



CHASING HAMMER

Use flat head to flatten, shape and form objects in silversmithing, arts and crafts. Also to strike chasing tools. Round end is for forming decorative patterns and designs. Head is 1" diameter.

162-HA-365..... 8 oz.....8.50



BALL PEEN HAMMER

Hardened steel head with hardwood handle. Made especially for the jeweler.

162-HA-350.. 2 oz.shp. wt. 6 oz.....4.70

162-HA-351 .. 4 oz.shp. wt. 8 oz.....5.90



RAWHIDE MALLETS

Made from the finest quality rawhide. Mounted on a smooth hardwood handle. Head is heavily shellacked to prevent marring work. Use for forming or flattening. Head 1 1/4" dia. x approx. 2 1/2" long.

160-MA-171 Shp. wt. 4 oz.....18.00



150-SAW-315

JEWELER'S SAWS

DEEP THROAT SAW FRAME High-quality, well-balanced frame is strongly constructed with hardwood handle. Adjusts to accommodate broken blades. 5" deep throat.

150-SAW-315..... 1 lb.19.35

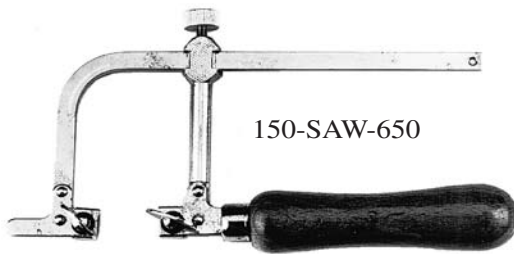

150-SAW-650

DELUXE SAW FRAME WITH TENSION SCREW Ideal for use with diamond wire blades. Holds blades firmly with serrated holders. Tension screw tightens blade to exact tension desired. Frame adjusts to accommodate broken blades. 4" deep. Not shown but similar to SAW-315 above.

150-SAW-334..... 1 lb.20.95

JEWELER'S SAW FRAME This saw frame offers durable construction with a hardwood handle, large thumbscrews and a 3" depth. Frame adjusts to accommodate broken blades.

150-SAW-650..... 1 lb.8.25

JEWELER'S SAW BLADES

These sawblades are premium quality at a reasonable price. Come 12 per package. Blades increase in size from 4/0 to 0 and from 1 to 4. Size #4/0 is smallest blade and #4 is largest. Price is \$2.50 per pack of 12. Shp. wt. 1 oz per pck.

Order No.	Size	Order No.	Size
150-SAW-400.03	4/0	150-SAW-400.07	1
150-SAW-400.04	3/0	150-SAW-400.08	2
150-SAW-400.05	2/0	150-SAW-400.09	3
150-SAW-400.06	0	150-SAW-400.10	4

DIAMOND WIRE SAW BLADES

These diamond wire saw blades cut forms and shapes in any slabbed stone-jade, quartz, agate, glass, etc. Also cut silver and copper. Cut in any direction.



106-31063/4 mm.....	180 grit 2 oz.	18.00
106-31051 mm.....	100 grit 2 oz.	19.00
150-SAW-270.61.5 mm.....	60 grit 2 oz.	8.95
150-SAW-271.01.2 mm.....	100 grit 2 oz.	8.95
150-SAW-271.21.15 mm.....	120 grit 2 oz.	8.95
150-SAW-271.41.1 mm.....	140 grit 2 oz.	8.95

HANDY FOUR PIECE BEAD REAMING SET

This diamond bead reamer set is handy enough to carry in your pocket. Three different diamond plated tools fit into the 4½" long aluminum case/handle. Unscrew cap and select tool type you need and fit into chuck on end of case/handle. Case has clip for attaching to your pocket. Use for reaming out all size beads from seed size to large.

- 150-DIB-275.00.....Four Piece Set..... 4 oz.....14.95
- 150-DIB-275.50.....45° Edging Point..... 1 oz.....1.65
- 150-DIB-275.55.....Large Reamer 1 oz.....2.85
- 150-DIB-275.05.....Small Reamer 1 oz.....1.85



DIAMOND BEAD REAMER SETS

DIAMOND BEAD REAMER SET OF TWO

This bead reamer set is an excellent tool for bead stringers. One diamond tool is long and sharp for reaming bead holes. The other has a 45° point for rounding off the edges of holes so that they do not cut through bead cord. Both tools are mounted in hardwood handles.

- 150-DIB-270.01Set 8 oz.....8.95



REAMERS/BROACHES SET OF SIX

Use for reaming out bead holes and similar jobs with set of six popular sized reamers. Contains No. 45 through 72 (according to English Stubs gauge.) Five sided with regular taper. Made in Germany.

- 152-BRO-174.....8 oz..... 13.95

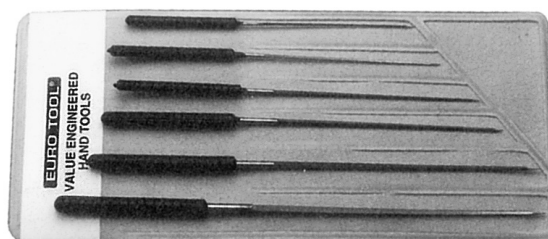

BEADING AWL

Has a comfortable PVC handle. Use it for knotting bead cord, picking and probing knots.

- 150-PIK-400.35 6 oz.....3.45

BEADING AWL

Has sharp, tapered point used to encourage knots into place and for removing misplaced knots. Also use to clean out bead holes. 5" long.

- 153-AWL-1 2 oz.....3.30



KNOT CUTTER

For cutting knots between beads when you prepare to restring. Also handy for cutting tiger tail (jeweler's wire). Approx. 5½" long.

- 153-PL-170 6 oz.....5.95

ALL PURPOSE SCISSOR

Ideal for cutting beading string. Two sharp points and super keen edges make these scissors indispensable for routine as well as specialty applications. Length approx. 3¼".

- 150-SCI-455..... 2 oz.....3.35

THREAD CLIPPER

Sharp, steel blades with pointed ends are ideal for snipping bead thread. Approx. 4" long.

- 153-TC-100..... 6 oz.....2.25



TWIN GRIP

TWIN GRIP with 2X power magnifier. Ball joints permit positioning of clamps and magnifier at any angle. Center bar can be removed and replaced with crosslock tweezers.

164-SP-14 1 lb. 8 oz. 12.50



EXTRA HAND

EXTRA HAND has many uses in jewelry making and other crafts. It keeps your hands free for soldering, gluing, and positioning, while work is held firmly at any angle required. Has a 6 1/2" long, self-locking tweezers mounted in double ball joints connected to a heavy iron base. Base may vary from that shown. Replacement tweezers is nickel plated.

160-HO-475 1 lb. 4 oz. 8.95

160-TW-385 Replacement tweezers 8 oz. 2.75



WIRE PRONG HOLDERS

WIRE PRONG HOLDERS Press top of this unique tool and slim, stainless steel prongs emerge from tip. Release pressure and prongs close around your gemstone, gripping it tightly for inspection or display. Length: 5".

150-HOL-653 3 prong 1 oz. 2.50

150-HOL-654 4 prong 1 oz. 2.50

SET OF 3 PROBES These stainless steel tools have strong yet flexible tips that are very useful for positioning, adjusting and gluing stones or small parts. Overall lengths approximately 5 1/2" - 6".

164-PB4N 3 oz. 8.15

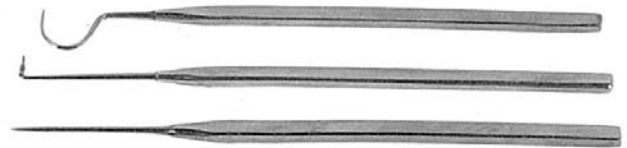

SET OF 3 PROBES

BEZEL ROLLER Polished steel rocker in wooden handle. Rolls and pushes bezel against stone in rings, broaches, pendants, etc. Recommended for larger settings.

160-DI-540 6 oz. 3.90



BEZEL ROLLER

SCRAPER Here is another of those multiple-use tools craftsmen depend on. It is designed for cleaning, smoothing, deburring metals, cleaning surfaces for soldering, removing excess solder, and opening bezels. Has hollow-sided, triangular shape blade with three sharp edges, mounted in hardwood handle.

160-SR-950 2 oz. 5.65



SCRAPER

BURNISHER When smoothing and finishing soft metals or setting edges on knives and scrapers, jewelry hobbyists, model makers, and metal workers reach for these burnishers. Oval-shaped, tool steel, 1 1/2" long blade is set in wood handle.

160-BS-121 Curved 2 oz. 2.95

160-BS-111 Straight 2 oz. 2.95



BURNISHERS

NON-MAR WEDGE CLAMP Holds jewelry, glass, plastics, wire, tiles, metals firmly for painting, polishing, buffing, drilling, filing, gluing, shaping. As wedge is driven in opposite end, leather lined jaws tighten to grip without marring the item. Solid body and wedge made of tough, resilient, mineral-filled nylon.

160-RN-530 6 oz. 6.80

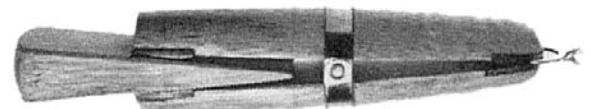

WEDGE CLAMP

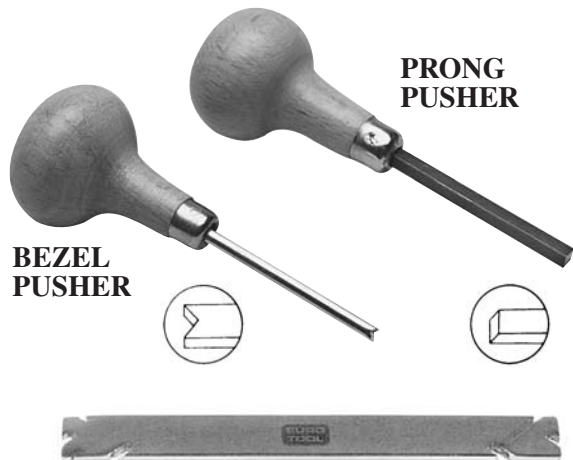

**BEZEL
PUSHER**

**PRONG
PUSHER**

PRONG PUSHER

Polished steel tip set in comfortable wood handle. Use for pushing prongs or crown points around stones.

150-PSH-770.....6 oz.....2.60

BEZEL PUSHER

Has polished groove in tips that wipes and sets bezel against stone. Mounted in wooden handle.

152-DI-535.....6 oz.....3.10

PRONG LIFTER

Special tool in hardened steel. Use for removing stones from claw or prong settings. 7 different sized notches prevent damage either to stones or setting. Total length: 5".

160-DI-555.....2 oz.....6.55

PRONG LIFTER

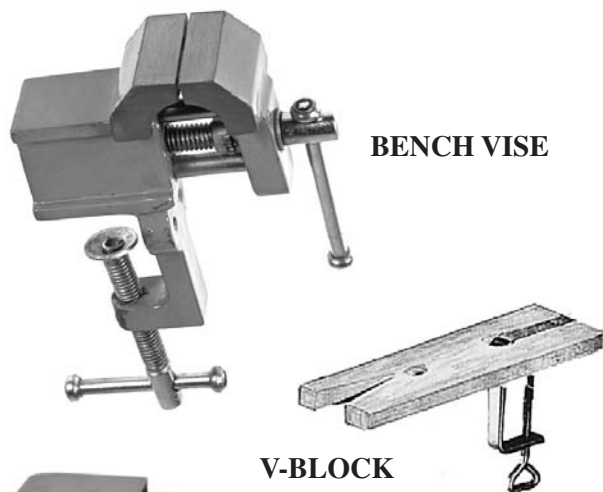

BENCH VISE

V-BLOCK

BENCH VISE

This handy vise can be either clamped or screwed onto the workbench. Has twin guide rods to assure parallel closing and rigidity. Jaws are 1½" wide, and smooth to prevent marring of soft metals.

150-VIS-204 2 lb.....9.95

V-BLOCK AND CLAMP

This handy bench extension gives the extra support and space needed for filing, sawing, and drilling. Especially useful when using jeweler's saw. Block size: 2¼" x 7½". Clamp fits table up to 1¾" thick.

150-BPN-105 1 lb.....7.30

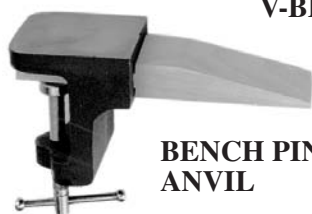

**BENCH PIN
ANVIL**

BENCH PIN-ANVIL COMBINATION

For supporting pieces being flattened, filing and laying out work. Anvil top is smoothly finished. Wood pin measures 4" long by 1¾" wide and is replaceable.

160-AN-118.....3 lbs 8 oz.....13.95

160-BP-170 Pin only4"L x 1¾"W5 oz2.45



**BENCH PIN
WITH HOLDER**

BENCH PIN IN METAL HOLDER

Holder screws onto edge of work bench, extending working space. Thumb screw holds wood bench pin which is included. Pin is 5½"L x 2¼" W.

160-BP-166..... 1 lb. 1 oz.....7.95



BENCH PIN

BENCH PIN

Wooden, fits into metal holder above or slot in workbench as a support for filing, sawing, setting, etc. Pin is 5½"L x 2¼" W.

160-BP-161 8 oz.....3.00

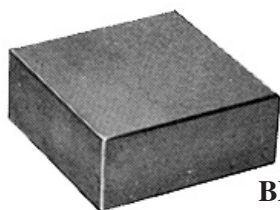

BENCH BLOCK

BENCH BLOCK

Used to support work while flattening or when laying out designs. Case hardened steel milled smooth. Measures 2 ½" x 2 ½" x ¾".

160-AN-1251 lb.....14.45

DIAMOND NEEDLE FILE SET

This TEN piece diamond file set contains just about every shape you need for those small, difficult carving jobs. Shapes shown approximate.



Two layers of diamond plated to steel give long life. Grit size is 220 mesh. Approx. 5" long.

170-24-00010..... Set of 10 4 oz. 22.10



ECONOMY FILE SETS

ECONOMY NEEDLE FILE SETS

An exceptional value for the price. Each set contains files that meet rigid temper requirements with sharp cutting surfaces. Standard shapes in the No. 2 cut. Average length 5½". Imported.

SET OF TWELVE FILES

150-FIL-995..... 12 oz. 12.60

SET OF SIX POPULAR FILES

150-FIL-993..... 8 oz. 6.85

WAX FILE SET

Set provides the six most popular shapes for quick cutting and preforming wax models. Teeth are finer, more per inch than standard files. Points are fine, not blunt. 5½" long.

152-FIL-905.....Set 6 oz. 42.95

WAX FILE SET



BARRETTE

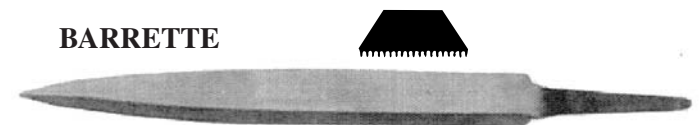

HANDFLAT

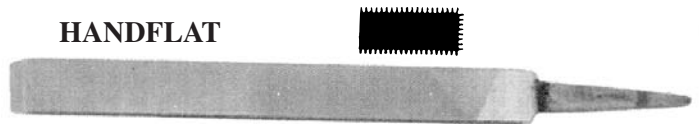

HALF ROUND

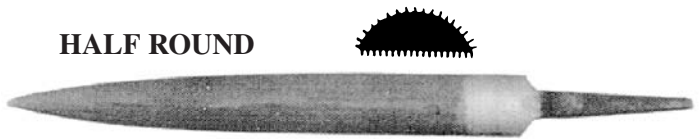

PRECISION SWISS HAND FILES

Made from fine cutting steel, milled to exact shape and size. Files have durability and hardness combined with the right feel. Cut measures 6". Weight 4 ozs.

Order #	Style	Cut	Price
152-FIL-100.2	Barrette	2	17.95
152-FIL-110.2	Hand Flat	2	10.35
152-FIL-120.2	Half Round	2	18.25

HAND FILE HANDLE

Hardwood handle, strong metal collar. Use with 6" hand files above. Twist on.

150-HAN-1756 oz. 2.75

NEEDLE FILE HANDLE

Universal, reuseable, plastic handle. Has non-slip chuck, holds file firmly.

150-HAN-7256 oz. 4.95

FILE CLEANER

Remove all small particles that clog the teeth of your files with this handy file cleaner. Steel wire bristles are set in hardwood handle. Made in USA.

152-FCL-751..... 8 oz. 6.45

HAND FILE HANDLE



NEEDLE FILE HANDLE



FILE CLEANER

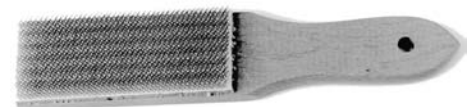

GAUGES

STONE GAUGE Stone diameters are measured with the calibrated gauge holes provided in 1/2mm steps from 2mm to 11mm. Corresponding gauges for mountings are provided on the center wheel. Useful in choosing the right setting bur.

162-GA-172 1 oz.....8.50

STONE AND MOUNTING GAUGE Aluminum gauge

with holes for measuring stones, while the round extensions are used to measure mountings. One side shows mm's and the other the corresponding carat weight.

160-GA-171 2 oz.....5.95

METAL RING SIZE GAUGE

Professional finger ring sizer. Nickel plated, 1/2 round. Easy to read colored numerals. Sizes 1-13 with half sizes according to U.S. standard.

150-GAU-251 3 oz.....13.65

PLASTIC RING GAUGE Graduated in half sizes from 1 to 13. Accurate, durable and inexpensive. On a chain.

150-GAU-255 2 oz.....1.50

PRECISION BRASS GAUGE 80mm sliding gauge includes inch scale in 1/16ths as well. 3" long.

150-GAU-168.80 3 oz.....11.95

PRECISION PLASTIC GAUGE (Similar to brass gauge shown) 75mm sliding gauge includes inch scale in 1/32nds as well. 4 1/2" long. Made in Switzerland.

150-GAU-172 3 oz.....5.20

DIAL CALIPER Easy to read. Quickly and accurately measures inside and outside dimensions of mountings. Measures in millimeters. Maximum is 150 mm with accuracy to 0.1 mm. Has zero adjust dial. Made of high impact, glass-filled nylon. Only 9" long.

150-GAU-184 5 oz.....22.40

STONE GAUGE

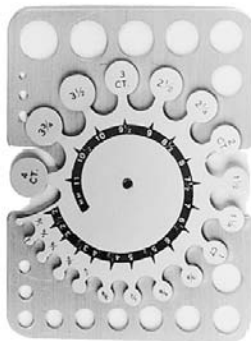

STONE AND MOUNTING GAUGE



METAL RING SIZE GAUGE



PLASTIC RING SIZE GAUGE



BRASS GAUGE



DIAL CALIPER



SOLID STEEL MANDREL



ALUMINUM MANDRELS



PLASTIC MANDREL

RING MANDRELS

Solid steel mandrel. Use for shaping and enlarging rings as well as measuring. Made of hardened and polished tool steel, grooved, graduated in one quarter sizes with long smooth taper to give adequate work space. Handle is knurled for better grip.

154-RG-16 3 lbs. 27.00

Professional ring mandrel made of solid aluminum. Graduated in 1/4 sizes from 0-13. For sizing only.

160-GA-193 2 lbs..... 15.75

Grooved ring mandrel made of solid aluminum. Not shown. Use with faceted stones. Graduated in 1/4 sizes from 0-13. For sizing.

160-GA-192 2 lbs..... 14.95

Plastic ring mandrel. Economical, rigid plastic. Graduated in 1/4 sizes from 1-15. For sizing only. Imported.

160-GA-194 8 oz.....4.95

SOLDER CUTTING PLIER

These solder cutting pliers offer two ways to cut. A EURO TOOL exclusive, it cuts sheet solder in 1/16" (1.60mm) squares or wire solder up to 18 gauge in 1/16" (1.60mm) lengths. Fast and easy, but it does not flip solder pieces and gives you the same amount every time.

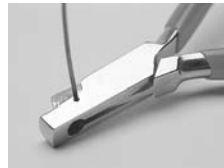

SOLDER CUTTING PLIER

150-PLR-818 6 oz. 16.65

CERAMIC SOLDERING ROD

Keeps rings in position while soldering and prevents collapse or movement. Holds heat longer and more efficiently, and works cleaner than standard carbon rods. Mounted on a pivoting base for easy adjustment and positioning. For rings size 4 and up.

162-HO-625 Base w/rod..... 2 lbs. 26.45

162-HO-626 Ceramic rod only..... 1 lb. 11.40



CERAMIC ROD AND HOLDER

TRIPOD WITH MESH SCREEN

Set tripod with screen over an alcohol lamp or Bunsen burner to heat wax pot or keep it warm. Can also be used so that work can be heated from below while soldering or enameling. Comes with 6" square mesh screen.

162-BT-268 1 lb. 9.65



TRIPOD WITH SCREEN

HEATING SCREEN

Use with tripod (above), or on a block, so that workpiece can be heated from below while soldering or enameling. Measures 6" square.

160-BT-270. 8 oz. 4.00

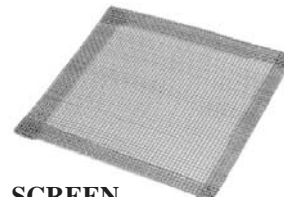

SCREEN

CERAMIC HONEYCOMB SOLDERING BOARD

Popular honeycomb design holds pins to keep work in place while soldering. Made of a non-asbestos ceramic. Board is lightweight and reflects heat. Size is 3 7/8" x 5 5/16"

150-SOL-430 8 oz. 8.50

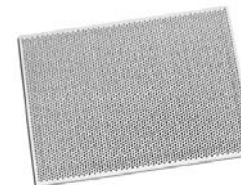

CERAMIC SOLDERING BOARD

COPPER TONGS



COPPER TONGS

Handy for lifting objects from pickling and other acid type solutions. The fishtail type with double points holds more awkward objects securely. Both approx. 8 1/2" long.

150-TWZ-920.01 Fishtail..... 6 ozs. 6.45

150-TWZ-920.02 Curved..... 6 ozs. 6.45

SOLDERING TWEEZERS



SOLDERING TWEEZERS

The polished steel jaws are available either straight or curved. These strong cross-locking tweezers have heat resistant fiber grips and will hold your work securely. Length 6".

150-TWZ-740 Straight 3 oz. 4.45

150-TWZ-741 Bent 3 oz. 4.45

SOLDERING PICK

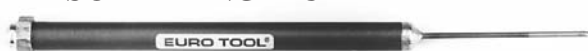

SOLDERING PICK

This deluxe titanium soldering pick is specifically made to lift minute drops of molten solder. Features a number 35 high-tech titanium rod to which solder cannot stick, unlike most soldering picks with steel wire picks. Has a non-conductive, non-roll handle.

150-SPK-930..... 2 oz. 4.55

JEWELRY SHIELD™

This well-known product shields sensitive skin from jewelry irritation. One in four people have an allergy to alloys present in costume and fine jewelry, glasses, watches, even clasps and snaps found on clothing. They suffer itching and skin irritation. Even more people react adversely to metals: their skin turns black, green or suffers from an itchy rash. How does Jewelry Shield work? Brushing transparent Jewelry Shield onto jewelry and metal accessories creates an invisible shield protecting sensitive and allergy-prone skin. Jewelry Shield's specially patented formula lasts much longer than any other product or remedy available. One application lasts three months. Bottle 1/2 oz.

150-JWL-180..... Shp. wt. 1 oz.....5.99



BEAD TIP CEMENT

G-S Hypo Cement is excellent for jewelry making. Comes with precision applicator to allow application of intricate parts. Dries water clear. Ideal for plastics, beads, ceramics, glass and more. Especially great for sealing knots between beads. Will not bond fingers. Sets in 10 minutes. Tube 1/3 oz.

160-CE-411.....Shp. wt. 2 ozs.....6.60



E6000 HEAVY DUTY ADHESIVE

High performance industrial adhesive, ideal for jewelry and beading applications. Works well on wood, metal, concrete, masonry, glass, leather, rubber, vinyl, ceramics and many plastics. Abrasion resistant, waterproof and paintable. Acid Free. 2 oz tube comes with metal tip. (WARNING: May be harmful if used improperly, follow all directions for use.) Ground shipment only.

153-E6002..... Shp. wt. 3 ozs.5.25



BEADSMITH'S BEAD BUDDY

This specially designed bead board has three channels to hold your beads, includes a bracelet channel. Allows you to design multiple strand projects. Surface is flocked to keep beads in place while designing. Snug-fitting snap on lid keeps beads in the channels so your project will not move while transporting when you travel on vacation or to class. Extra compartments for your needles, beads and findings. Board Measures 11.5" x 15.5" x 1".

153-BBDTG..... Shp. wt.12 ozs..9.95



SET OF THREE LARGE BEAD MATS

These bead mats are the solution to having a work surface that keeps your beads from rolling away. The mat's super soft, foam-like material is ideal for working with small beads. Use one on any table or with the bead tray described below. Set of three mats 11" x 14" in assorted colors to contrast with the beads you are using. Perfect for seed beads and delicas.

153-BM3..... Shp. wt. 12 oz.....6.95

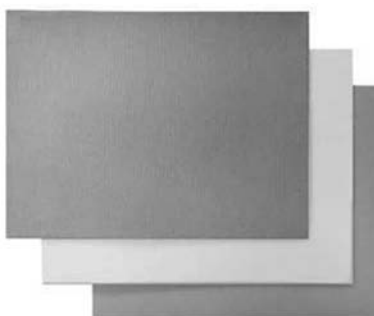

BEAD MAT TRAY

This bead mat tray is designed to be used with the bead mats above, but can be used with other mats or even as a tray to hold loose beads. Tray is light weight, yet durable. Has 1/2" lip to keep your beads from rolling away. Tray is black/grey and measures 11.5" x 14.5".

153-BMT17..... Shp. wt. 1 lb..... 10.95



BEADER'S 8 PIECE MINI-TOOL KIT

This economical set features 3" color-coded mini-pliers plus other handy tools essential to the beader. Compact and portable, your tool set only measures 2.25" x 7" in it's black canvas case, so you can take it with you anywhere. Mini-pliers have polished steel heads, cushion grips handles, spring action, and lapjoint construction. Included in set are:

- * Chain nose plier
- * Round nose plier
- * Flat nose plier
- * Semi-flush side cutter
- * Nylon jaw plier
- * Knotting tweezer
- * Thread cutter
- * Scoop EEZ™ Bead Scoop

153-PLMN08..... Shp wt. 6 oz.15.00



BLACK LEATHERETTE TOOL CASE

Make your own beader's kit or store your pliers and other tools in this handy case. Made of black leatherette, it measures 9" x 6.5" x 1.25". Has zipper and 9 expandable bands to hold your tools secure. You will find this case convenient for storing a variety of tools and supplies.

153-LPOUCH..... Shp wt. 8 oz.7.00



DOT BOX™ STORAGE SYSTEM

The Dot Box is the ultimate small item storage system. Great for beads, findings, finished jewelry, etc. This modular system consists of 6 sizes of hinged inner boxes that fit into an outer case. The boxes allow you to organize your items while the dots keep the boxes in their places.

32 Piece Set contains: 1 outer case, 2 med. long boxes, 8 small boxes, 6 large boxes, 14 med. boxes, 1 large long box.

153-DB4000..... Shp wt. 12 ozs.13.50

53 Piece Set contains: 1 outer. case, 12 small boxes, 22 medium boxes, 6 long med. boxes, 8 large boxes, 3 large long boxes, 1 extra large box.

153-DB4010..... Shp wt. 12 ozs... ..25.00



TRIANGULAR TRAY

Useful 3.75" triangular tray for scooping, counting and putting beads and other small objects into containers. Made of durable white plastic. Sides are slanted for ease of use, nest for storage. Sold in packs of 6.

153-AT6. Shp wt 1 oz.2.60



DIAMOND TWEEZER WITH SHOVEL

This medium tip tweezer has a stone or bead shovel on the end. Measures 7" from tip to shovel end.

164-TW41 Shp wt 1 oz.....3.50



FLEXIBLE POLYSTYRENE DISH

These flexible dishes feature a round footprint for stability. Sides are contoured for easy handling. Flexible for pouring small parts or beads into a container. Smooth surface and rounded corners provide easy removal of powdered products. Also good as mixing trays for epoxy or other small batches. Use as quick freeze trays or heat up to 200° F. Stack for easy storage. 1-5/8" x 5/16" deep. Sold in packs of 10

153-AT8. Shp wt 1 oz.....1.75



CRIMPERS

A. DUAL CRIMPER

The Dual Crimper incorporates two medium crimping cavities to fit crimp tubes and beads of medium size. Each cavity of the Dual Crimper is slightly larger (or smaller) than the other, to give the user the ability to tighten the crimp properly. Works with #1 and #2 Round Crimp Beads or #2 Crimp Tubes, as well as other non-standard crimp bead and tube sizes. The Dual Crimper has soft ergonomic handles that give you a great grip and are more comfortable to use. Approximately 5 inches long.



150-PLR-582..... 6 oz.....16.95.

B. THE MICRO CRIMPER

The Micro Crimper is specially designed for use with smaller size crimp beads and tubes. This crimping tool works well for securing #1 Crimp Tubes and #0 Round Crimp Beads. Use one firm squeeze to crimp with the inner-position grooves, then use the outer position grooves to round off the crimp. The jaw grooves are comparably smaller than other crimpers to make a dependable closure on smaller crimp findings. Approximately 5 inches long.



150-PLR-586..... 6 oz.....13.45.

HOW TO FORM THE PERFECT CRIMP

At the last bead (A), pass the jewelry wire (B) through the crimp bead or tube (C), then through the clasp or jump ring (D), back through the crimp (C), and optionally back through the end bead (A).

Step 1- Secure the crimp in the crimping station (E). Best results are obtained when the two wires are positioned on either side of the center dimple.

Step 2- Final shaping in the rounding station (F) – forming a smooth, rounded crimp.

NOTE: When bead stringing, it is important for the bead crimp to match whatever wire that one is using. The worst case is using too large of crimp with finer wire; then the crimp may not close enough to hold properly. Always test that the crimp is secure on the wire.

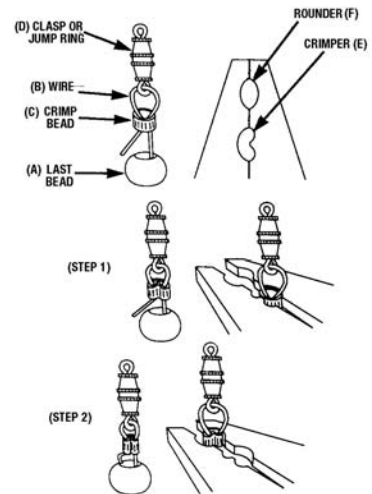

CRIMP BEADS finish off wire connections when beading. Use crimpers shown above. Bead is placed in lower groove of the tool with wires side by side. Make one firm compression. Then put crimp bead into upper position, turn 90° and make another firm compression. This rounds the crimp and creates the perfect crimp connection. Packages contain approx. 1.5 grams of beads. Wt. 1 oz. each pkg.

Order #	Shape	Color	Crimp Size	Wire Size		Price	Recommended Crimping Tool
				inches	mm		
210-JBS-01	Tube	Silver	#1	.010-.013	.25-.33	4.50	Micro Crimper
210-JBS-02	Tube	Gold	#1	.010-.013	.25-.33	4.50	Micro Crimper
210-JBS-03	Tube	Silver	#2	.013-.024	.33-.61	2.50	Dual Crimper
210-JBS-04	Tube	Gold	#2	.013-.024	.33-.61	2.50	Dual Crimper
210-JBS-05	Round	Silver	#2	.024-.026	.60-.66	2.50	Dual Crimper
210-JBS-06	Round	Gold	#2	.024-.026	.60-.66	2.50	Dual Crimper
210-JBS-07	Round	Silver	#1	.010-.021	.25-.53	2.50	Dual Crimper
210-JBS-08	Round	Gold	#1	.010-.021	.25-.53	2.50	Dual Crimper
210-JBS-20	Round	Silver	#0	.010-.013	.25-.33	4.50	Micro Crimper
210-JBS-21	Round	Gold	#0	.010-.013	.25-.33	4.50	Micro Crimper

BASIC PLIERS FOR JEWELRY CRAFTS

The two basic beading pliers are chain nose and round nose. The pliers below are the best quality we could find at a reasonable price. They are approximately 4" to 5" long—the right size to fit in your hand. They feature PVC grips, double leaf springs, box-joint construction with a brush finish for good looks. You get a great value at this price.



 **CHAIN NOSE**

ROUND NOSE



CHAIN NOSE PLIER For closing crimp beads, opening and closing jump rings, holding and forming wires, etc. Has smooth jaws with slightly beveled edges to avoid marring. Nose is tapered to a fine point.

150-PLR-490.00..... 6 oz.....5.95

ROUND NOSE PLIERS Smooth, round, tapered jaws for curving wires such as jump rings, loops, closing bead tips, etc.

150-PLR-490.10..... 6 oz..... 5.95

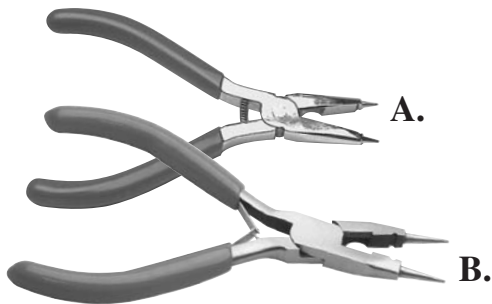

A. BEADER'S DELIGHT PLIERS

This unique plier, developed by EURO TOOL is an essential for bead stringers and wire wrappers because it is a multi-task tool. It offers a round nose for coiling wire, a flat jaw for flattening, straightening or bending at right angles, a groove for closing coils or jump rings and a sidecutter. Made of stainless steel with gentle coil return spring and cushion grip handles for comfort .

150-PLR-577.00..... 8 oz..... 12.95

B. FOUR-IN-ONE BEADER'S DELIGHT

Developed by EURO TOOL, this plier is our Four-in-One "Beader's Delight." A must for wire wrappers too because it offers a finely tapered long nose for coiling, a flat jaw for flattening, straightening or bending, a groove for closing coils and jump rings, plus sidecutter. Great for travel with PVC grips, double-leaf springs.

150-PLR-577.10..... 8oz. 9.95.

MASTER COILER PLIER

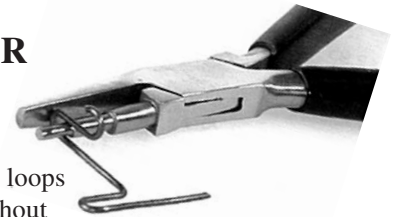

The Master Coiler makes loops and coils consistently without nicking wire. These pliers allow you to hold the wire with the flat jaw while rotating the round jaw to form the perfect loop. Made of polished stainless steel jaws with a standard step-jaw.

152-PLR-747..... 6 oz..... 13.00

NYLON JAW PLIERS FOR WIRE WORKING

The wire workers delight! With these nylon jawed pliers you'll have no more nicks and scratches on your wire to rebuff and refinish. Just place the wire inside the jaws and draw the pliers along the wire several times to straighten. These pliers also harden wire components when squeezed gently between the jaws. Because the jaws are made of nylon, the wire is protected from the damage that can be caused by metal jaws. Pliers are made of polished stainless steel with PVC grips and box-joint construction. Jaws are replaceable. Pliers are approx. 5 3/4" long.

WIRE WORKING NYLON JAW PLIER

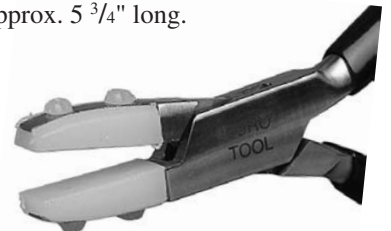

STRAIGHT NOSE PLIERS

150-PLR-830.00Plier.....6 oz..... 22.50

152-PLR-830.05Replacement Jaws.....3 oz. 4.15

THIN STRAIGHT NOSE PLIERS

150-PLR-829.00Pliers6 oz..... 19.95

152-PLR-829.05Replacement jaws3 oz..... 4.15

FLUSH AND SEMI-FLUSH SIDECUTTERS

Here's a reasonably priced flush cutter that offers the perfect answer to craft people who need strength in a precision sidecutter. This cutter, made in Europe, is great for Soft Flex Wire and similar wire for beading, crafts, etc. Available in both ultra-flush and semi-flush with a smooth spring return and ergonomic cushion grip handles. Induction hardened jaws are 61 Rockwell hardness. Length approx. 5".

152-PLR-470.00 Flush.....6 oz..... 25.33

152-PLR-470.10 Semi-Flush6 oz..... 25.87

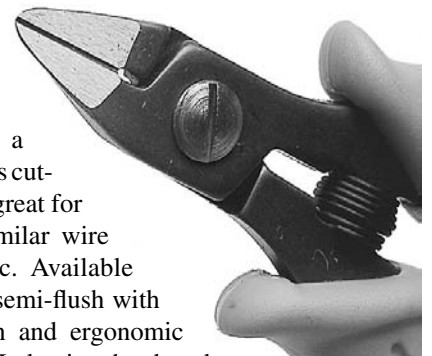

FACTS YOU SHOULD KNOW WHEN CHOOSING PLIERS



CHAIN NOSE PLIERS

Traditional and the most popular pliers. Use to make bends, loops and similar forming operations on wire or sheet metal. In bead stringing, use to lock crimp beads, attach needles to bead cord, etc. Handy for most gripping, pulling, manipulating actions.



FLAT NOSE PLIERS

For gripping and holding flat or square objects securely, and for making angular bends and similar forming operations.



ROUND NOSE PLIERS

For making bends, loops, circles, coils in wire or sheet metal. The tapered, round jaws are smooth and will not scratch or nick soft metals. In bead stringing, use for closing bead tips, curving wire such as jump rings, looping eye pins, etc.

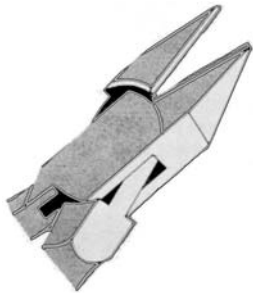

BOX JOINT CONSTRUCTION

Outlasts and outperforms all other types.

- * Retains precise alignment, even under strain and after considerable use.
- * Jaws never develop looseness or wobble, yet open and close smoothly.

SONORA PLIERS

The Sonora line offers a new feel in pliers, with a textured, non-slip grip that will make your work a lot easier. Sonora pliers have box joints and are made of highly polished, stainless steel that will remain rust free. A real value for the money.



CHAIN NOSE

150-PLR-260..... 6 oz..... 11.75



BENT CHAIN NOSE

150-PLR-264..... 6 oz..... 11.75



FLAT NOSE

150-PLR-262..... 6 oz..... 11.75



ROUND NOSE

150-PLR-261..... 6 oz..... 11.75



SIDECUTTER

150-PLR-265..... 6 oz..... 12.55



WIREWRAPPING CUTTERS

SEMI-FLUSH SIDE CUTTERS. Necessary for cutting all types jewelry wire. Features double leaf springs, box joint construction with PVC grips and brush finish. A real value for the money. Approx. 4 1/2" long.

150-PLR-490.15..... 6 oz..... 6.75

SONORA PLIER SET



Save on this set of the four most basic types of pliers from the Sonora line. These pliers are user friendly, with an exclusive textured grip. Grab a Sonora plier and you will experience a touch that makes work easier. These box-jointed, highly polished pliers, are a slender 4 1/2" in length, and made of stainless steel to remain rust-free. Included in the set is a chain nose, flat nose, round nose plier, and a sidecutter, plus a handy pouch to keep the set together.

150-PLR-266..... Shp wt. 1 lb. 45.95

EURO-TOOL® PREMIUM QUALITY PLIERS

These are premium quality German box joint pliers. They are lightweight, suitable for professionals for fine work. Heads are superbly polished highest grade steel. Vinyl coated handles have double leaf springs. Lengths vary.



FLAT NOSE

For gripping flat objects and making right angle bends. Smooth jaws come to fine even taper.

150-PLR-105..... 6 oz..... 20.75



CHAIN NOSE

The most popular style for all purpose bending and holding. Smooth jaws with slightly beveled edges to avoid marking. Nose tapered to a fine point.

150-PLR-100..... 6 oz..... 20.75



ROUND NOSE

Perfectly round and finely tapered to the tips. Used for making loops and round bends. Smooth for delicate wire.

150-PLR-110..... 6 oz..... 20.75

SPECIALTY PLIERS

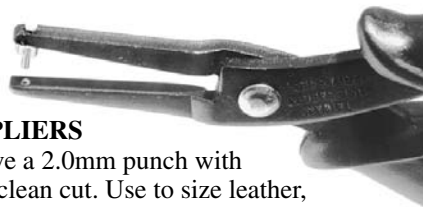

HOLE PUNCHING PLIERS

New, slim line jaws have a 2.0mm punch with precise clearance for a clean cut. Use to size leather, plastic bands, etc. Length is 5 3/4".

150-PLR-138.05..... 6 oz..... 10.95



FLAT NOSE

This extra narrow flat nose plier has jaws only 2.2 mm wide, making it ideal for smaller jobs, especially making 90° angles with wire. Has PVC grips, dual-leaf springs, box joint jaws.

150-PLR-491..... 6 oz..... 7.95

VALUE LINE PLIERS FROM EURO-TOOL®

You get real value for your money with these pliers. They have quality features at a reasonable price. Offer comfort and durability with double-leaf springs, box joint construction, PVC grips and brushed finish.



FLAT NOSE

For gripping and holding flat or square objects securely, and for making angular bends and similar forming operations. Can also be used for some manipulating and pulling. Insides of jaws are smooth.

150-PLR-490.05..... 6 oz..... 5.95



CHAIN NOSE

Use to make bends, loops and similar forming operations with wire or sheet metal, and for gripping, manipulating and pulling. Smooth jaws have slightly beveled edges to avoid marring. Nose tapers to fine point.

150-PLR-490.00..... 6 oz..... 5.95



BENT CHAIN NOSE

Handy for hard to reach places. Has multiple uses for jewelers, crafters, or anyone wanting a handy tool at a handy price.

150-PLR-490.50..... 6 oz..... 6.50



ROUND NOSE

For making bends, loops, circles, coils on wire or sheet metal. Can also be used for some manipulating functions. The tapered circular jaws are smooth so that they will not scratch or nick soft metals.

150-PLR-490.10..... 6 oz..... 5.95

HIGH QUALITY SPECIALTY PLIERS FOR JEWELERS

Pliers on this page, are high quality and are suitable for professionals doing fine work. Lightweight, vinyl coated handles. Polished working surfaces and box joint construction. (except for 152-PLR-469.11).

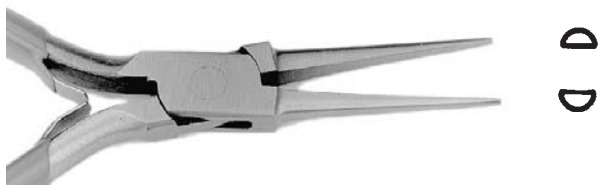

NEEDLE NOSE

This plier has extra-long chain nose jaws for specialty applications such as beading. Double leaf springs, German made.

152-PLR-560..... 6 oz. 23.05



END CUTTER

This semi-flush end-cutter is perfect for cutting close to objects. The jaws are at right angles to the handles. Double leaf springs, German made

150-PLR-120..... 6 oz. 29.60

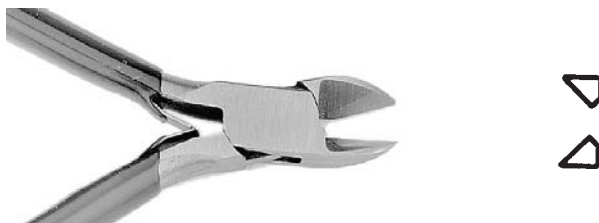

SIDE CUTTER

The most popular cutter. Has a rockwell hardness of 58. Double leaf springs, German made

150-PLR-115..... 6 oz. 26.90



FLUSH CUT WIRE CUTTERS

Shear action means a smooth flush cut on both sides. Gives extended life as 90° cutting edges dull less than conventional cutters. Return springs and ergonomic handles. Made in USA.

152-PLR-469.11..... 6 oz. 19.45



STONE SETTING PLIER

Highly polished stone setting pliers have one smooth jaw, the other notched for bending and tightening prongs. Fine head allows access to tight spots.

152-PLR-700..... 6 oz..... 12.80



LOOPING PLIERS

One jaw is round, the other flat. For looping wire or flat strips of metal. Stainless steel.

152-PLR-735..... 6 oz..... 16.95



BENDING PLIERS

Concave/convex ring bending pliers. Stainless steel.

152-PLR-725..... 6 oz..... 16.95



BENDING PLIERS

For making sharp loops and bends in wire or metal. One jaw is round, the other concave. Designed for jump rings and similar rings. Stainless steel.

152-PLR-745..... 6 oz..... 16.95



BENDING PLIERS

One jaw is flat, the other half-round. For bending and shaping flat metal and wire. Stainless steel.

152-PLR-740..... 6 oz..... 16.95



WESGEM GEM SET PLIERS

This unique tool lets you set and tighten diamonds and other gemstones without fear of breakage. It's fast and easy to use too. Ingenious depth control method eliminates expensive mistakes. Pliers give 10 to 1 power ratio, yet a special control screw stop prevents slipping and breakage. It will tighten almost any type or size of prongs, mountings, findings in seconds. Original Heavy Duty Model 100-NS

- 161-100-NS.....6 oz.....52.00
- “Mini” Model 100. Same features as above, but smaller with long pointed jaws.
- 161-100.....6 oz.....52.00



STONE SETTER KIT FOR WES-GEM PLIERS

Now you can close (or tighten) all prongs at the same time while setting stones in rings, pendants and earrings. Four different setters fit the Wes-Gem Model 100-NS pliers only.

- 161-100-SS8 oz.....40.00



BENT CHAIN NOSE

Box-joint bent chain nose has a multitude of uses in every shop. Great quality at an extremely competitive price. 4 1/2" long.

- 150-PLR-150.....7 oz.....22.80

LOOP-CLOSING PLIERS

Small hollow jaws for holding and closing jump rings, small loops, etc. Made of stainless steel.

- 150-PLR-718.....7 oz.....10.80



SPLIT RING PLIERS

Just put the tooth jaw between the overlapping split ring and squeeze. The split ring pops open, ready for the user to put on chains, etc. Great tool.

- 150-PLR-589.00.....6 oz.....7.95



PRONG-OPENING PLIERS

A revolutionary new idea! A plier for opening prongs which will not fracture stone. You have total control no matter what size prong. Plier puts no pressure on the top of the stone. Top jaw is a claw which grips the prong cleanly and the lower jaw is grooved to hold the prong.

- 150-PLR-132.....7 oz.....27.45



PRONG-CLOSING PLIERS

New bent nose pliers with grooves so that the tip doesn't slip off when closing prongs. Recommended for stonesetters doing small prongs. 4 1/2" long.

- 150-PLR-155.....7 oz.....26.60



RING-HOLDING PLIERS

Hollow jaws hold rings while work is being done, particularly polishing the inside. The pliers are made of stainless steel with box joints and cushioned grips.

- 150-PLR-715.....7 oz.....11.90

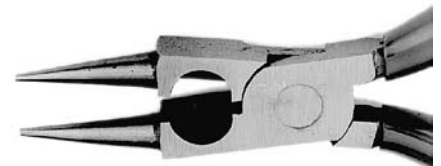

ROSARY PLIERS

Combination round nose/side cutter is especially designed for work on rosaries. Has box joint and is suitable for all assembly operations. Approx. 5" long.

- 150-PLR-572.....7 oz.....9.90

ROCK PICKS

Estwing picks are designed for all sizes. The E3-14P and E3-12BL picks are light enough for kids. The new E6-24PC Estwing's newest Rock Pick combines solid steel construction with the best engineering upgrades including a 50% larger face and the World's Best Shock Reduction Grip permanently molded to the handle. Plus a protective end cap for extra durability.

NOTE: ESTWING TOOLS NOT AVAILABLE FOR SHIPMENT OUTSIDE THE USA AND CANADA.

Estwing

GEOLOGICAL TOOLS

Estwing has been making high quality tools since 1923. You can rely on Estwing rock picks and hammers to be rugged and safe. Estwing Geological Tools are the professional tools chosen by geologists, archeologists and paleontologist worldwide. Made in U.S.A.

CHISELS

These geological chisels are forged in one piece with a new unbreakable polymer cap and an oil resistant cushion grip. It provides 2 1/2 times the striking surface of a standard chisel and reduces shock and sound over 80%. Grip allows comfortable use in both extreme heat and cold weather conditions. Made in USA.



A.

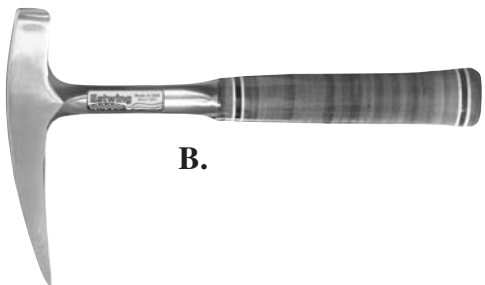

B.



C.

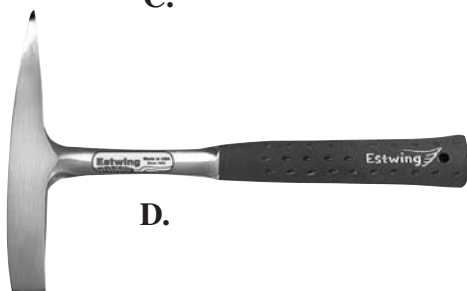

D.



E.

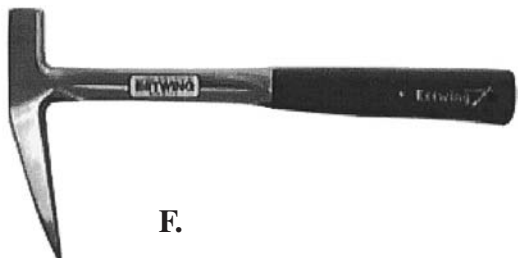

F.



G.

**SAFETY
FIRST**
WEAR YOUR
GOGGLES



H.



K.



I.



J.

GEO-PALEO PICK

THE GEO/PALEO PICK -is an improved version of the former HOE-PICK. The Geo-Paleo Pick has all steel construction. Handle is 25" overall with textured vinyl grip for comfort. Head is 14" from pointed edge to chisel edge. Durable powder coated finish.

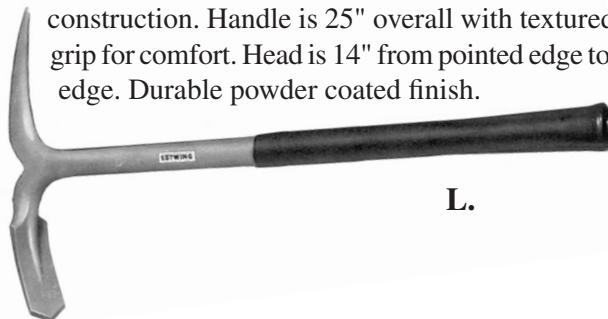

L.

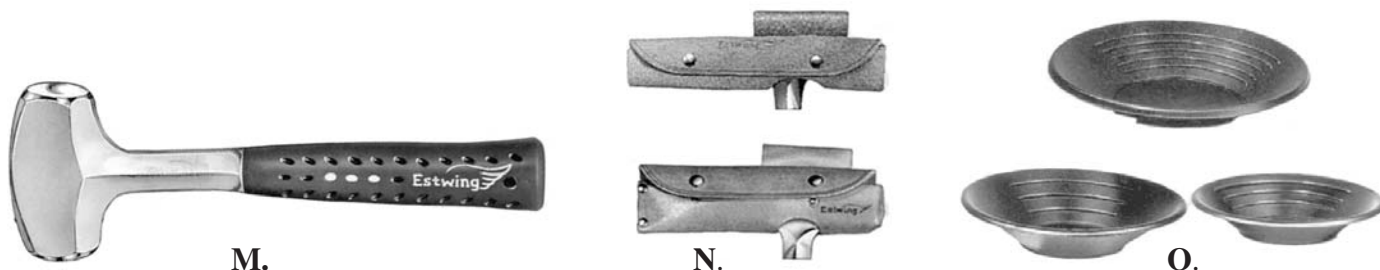

TOOL TYPE	ORDER #	ITEM	WEIGHT	PRICE
A.	110-E3-23LP	ROCK PICK - Pointed tip, full polished, nylon-vinyl grip, 16 $\frac{1}{4}$ " length	22 oz.	45.32
B.	110-E-30	ROCK PICK - Pointed tip, full polished, leather grip	22 oz.	45.72
	110-E3-14P	ROCK PICK - Pointed tip, full polished, nylon-vinyl grip	14 oz..	39.48
	110-E3-22P	ROCK PICK - Pointed tip, full polished, nylon-vinyl grip	22 oz.	40.84
C.	110-E6-24PC	ROCK PICK - Chisel edge. 50% larger face, shock reduction grip and super tough	24 oz.	50.00
D.	110-E3-WC	CHIPPING HAMMER - Full polished, nylon-vinyl grip	20 oz.	33.44
E.	110-E3-12BL	ROCK PICK - Chisel edge, full polished, nylon-vinyl grip	12 oz.	39.08
	110-E3-20BLC	ROCK PICK - Chisel edge. Shock reduction grip and super tough	20 oz.	40.52
	110-E3-24BLC	ROCK PICK - Chisel edge. Shock reduction grip and super tough	24 oz.	42.82
F.	110-E3-13P	ROCK PICK - Lightweight, long pointed tip, full polished nylon-vinyl grip	13 oz.	32.84
G.	110-ERC-12	ROCK CHISEL - For digging out pockets, vinyl cushion grip, $\frac{1}{2}$ "x 12"	8 oz.	21.56
H.	110-ERC-9	ROCK CHISEL - For wedging & prying, vinyl cushion grip, $\frac{5}{8}$ "x 9"	26 oz.	21.38
I.	110-ERC-8	ROCK CHISEL - For splitting, vinyl cushion grip, 1 $\frac{1}{4}$ "x 8"	18 oz.	21.66
J.	110-ERC-7	ROCK CHISEL - For splitting, vinyl cushion grip, 2 $\frac{1}{2}$ "x 7"	24 oz.	21.38
K.	101-GOGGLE	CLEAR SAFETY GOGGLES - Soft vinyl frame (supplier varies)	2 oz.	3.95
L.	110-GP-100	GEO-PALEO PICK - Length 25"	5 lbs.	80.22
M.	110-B3-2LB	CRACK HAMMER - Painted finish, nylon-vinyl grip	2 lbs.	36.26
	110-B3-3LB	CRACK HAMMER - Painted finish, nylon-vinyl grip	3 lbs.	36.26
	110-B3-4LB	CRACK HAMMER - Painted finish, nylon-vinyl grip	4 lbs.	40.88
	110-B3-4LBL	CRACK HAMMER - Painted finish, long handle, nylon-vinyl grip	4 lbs.	42.74
N.	110-3	ROCK PICK BELT SHEATH - For pointed tip picks	3 oz.	7.04
	110-4	ROCK PICK BELT SHEATH - For chisel edge picks	3 oz.	6.62
O.	110-BP-10	BLACK PLASTIC GOLD PAN - Ruffles on one third of inside pan, 10" diameter	5 oz.	4.22
	110-BP-12	BLACK PLASTIC GOLD PAN - Ruffles on one third of inside pan, 12" diameter	6 oz.	5.16
	110-BP-14	BLACK PLASTIC GOLD PAN - Ruffles on one third of inside pan, 14" diameter	9 oz.	7.34
	110-BP-16	BLACK PLASTIC GOLD PAN - Ruffles on one third of inside pan, 16" diameter	16 oz.	8.88

TREASURE SCOOP

The Treasure Scoop is a great tool for rockhounding and beachcombing. Use to scoop up rocks and other treasures without bending over. Lightweight, sturdy, cast aluminium. Comes in two lengths. Makes great walking or balancing stick. Imported.

111-TS-36 ... 36" handle.....shp. wt. 2 lbs. ...40.95
 111-TS-42 ... 42" handle.....shp. wt. 2 lbs. ...46.95



Gem Trails of Nevada

Mitchell. Agate, carnelian, fossils, garnets, geodes, wood and obsidian are just a few of the minerals covered. Lists 75 sites with detailed maps and photos. 224 pages. 240-418 8 oz. 12.95

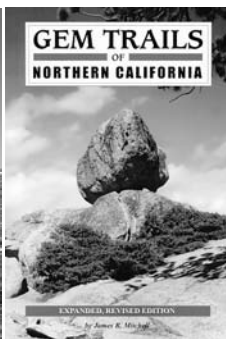
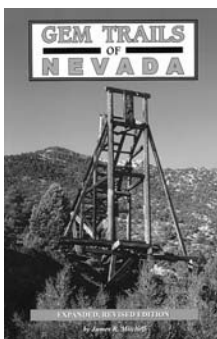

Gem Trails of Northern California

Mitchell. Features sites from the Oregon border south to the Monterey area. Beautiful color photographs showcase the specimens that can be found at the sites described. Detailed text and maps make locating collecting areas easy. 192 pages. 240-441 8 oz. 12.95

Gem Trails of Colorado

Mitchell. New edition. Covers 90 sites for collecting sapphires, topaz, blue barite, and much more. Maps with mileages for every site as well as photos. 224 pages. 240-419 8 oz. 12.95

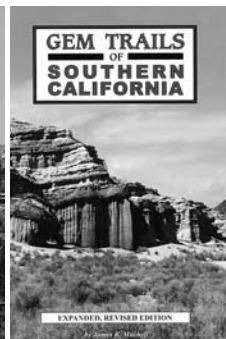
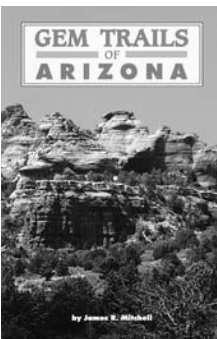

Gem Trails of Southern California

Mitchell. The newest and most definitive guide to 70 of the best collecting sites for gems, minerals and fossils in Southern California from San Luis Obispo to San Diego. Detailed maps, text, and B/W locale photos lead the way and vivid color photos of specimens excite the anticipation of great finds. 70 pages. 240-442 8 oz. 12.95

Gem Trails of Arizona

Mitchell. Over 100 collecting sites and GPS coordinates with clear maps and photographs. Color photos show specimens to be found. Over 272 pages. 240-401 8 oz. 14.95

Gem Trails of Utah

Mitchell. Revised and expanded guide to the many collecting locations in Utah. Detailed descriptions of the fossils and gemstones along with photos and maps fill 168 pages. 240-406A 6 oz. 12.95

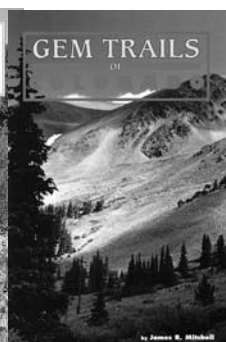

Desert Gem Trails

Strong. The best guide to locations in the Mojave and Colorado Deserts. Over 140 localities mapped out. While some areas are now closed to collecting, it's still the best source for those remaining. Illustrations. Maps. 80 pages. 240-409 6 oz. 5.00

Gem Trails of Oregon

Mitchell. Covers entire state with directions to little known areas as well as popular ones. Over 80 localities described with a special section on beach collecting. Maps and photos throughout. 192 pages. 240-404 6 oz. 14.95

Gem Trails Of Washington

Romaine. Comprehensive collecting guide for the Evergreen State covering all 4 corners. Washington's diverse geology is explored in great detail. Over 75 sites with directions, maps, GPS readings, photos, descriptive text, mineral locator index and glossary. 200 pages. 240-402 8 oz. 14.95

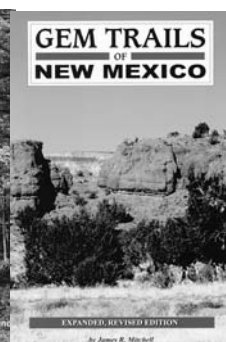
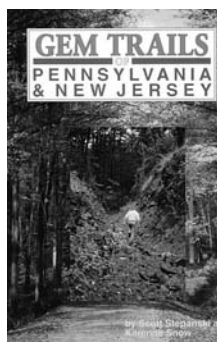

Midwest Gem, Fossil and Mineral Trails Prairie States

Zeitner. Gives descriptions of materials to be found, maps of localities, hints on collecting, with excellent photos throughout. 128 pages. 240-407 6 oz. 10.95

Gem Trails of New Mexico

Mitchell. New Mexico is a rock hound's paradise with gem quality mineral specimens to fossils. Informative text, detailed maps, glossary, mineral index, and a beautiful color insert highlight the variety of minerals found. 240 pages. 240-403 6 oz. 14.95

Gem Trails of Pennsylvania and New Jersey

Stepanski & Snow. Revised edition. Some 47 sites are listed where beautiful mineral specimens and fossils can be found. Authoritative text includes information on equipment, clubs and tourist attractions. B/W photos, detailed maps, and a striking color insert will entice the reader to "hit the trail." 160 pages. 240-446 8 oz. 12.95

Gem Trails of Texas

Cross. Revised and expanded edition of a popular best-selling guide to Texas gem trails. Includes over 50 of the best sites in the state. Written by an experienced rockhound from the state. Includes a new color insert of the best fossils and rocks the state has to offer, detailed maps, numerous B/W photos, glossary, mineral index and clear, exact directions tell what to look for at each site. 160 pgs. 240-405 8 oz. 12.95

Midwest Gem, Fossil and Mineral Trails-Great Lakes States

Zeitner. Maps, photos and detailed firsthand information provides the collector with a guide to the many sites of fossils, garnets, and more in 12 Midwestern states. Revised edition. 128 pages. 240-408 6 oz. 10.95

The GPS Guide to Western Gem Trails

Kelty. The must-have accompaniment to the Gem Trails series and other guidebooks has been revised and expanded. Over 1,300 collecting sites for 12 western states using precise GPS coordinates. Includes maps, location photos and state-by-state overview. 240 pages. 240-487 8 oz. 19.95

Rocks and Minerals of California

Brown, Allan, Stark. Revised edition. Illustrations, color photos, and maps make this a handy reference book. Also provides listing of minerals along with the US topo maps on which they can be found. 200 pages. 240-413 1 lb..... 13.95

Rockhound Guide Series.

Informative guides to collecting sites, featuring maps, detailed directions, advice on field techniques and collecting and preparing specimens. .

- Rockhounding Arizona, Blair. 220 pgs. 242-466 1 lb. 15.95
- Rockhounding California, Butler 190 pgs. 242-443 1 lb. 12.95
- Rockhounding New Mexico, Vaskys & Freed. 260 pgs. 242-491 1 lb. 15.95
- Rockhounding Utah, Kappele, 180 pgs. 242-470 1 lb. 12.95
- Rockhounding Wyoming, Graham, 158 pgs. 242-471 1 lb. 12.95
- Rockhounding Colorado, Kappele. 224 pgs. 242-472 1 lb. 14.95
- Rockhounding Nevada, Kappele, 156 pgs. 242-467 1 lb. 12.95
- Rockhounding Montana, Feldman. 232 pgs. 242-423 1 lb. 14.95

Colorado Rockhounding

Voynick. The "Bible" of Colorado Rockhounds. Covers more than 350 collecting sites, with an overview of the state's geologic origins and mining history. County-by-county guide illustrated with maps and B/W photos. 392 pages. 240-462 1 lb..... 20.00

Arizona Rocks & Minerals: A Field Guide to Arizona

Lynch. This handy durable book features photos that depict the detail needed for identification. Learn about and identify the rocks and minerals you'll find in Arizona. 208 pages. 240-481 1 lb..... 14.95

The Rockhound's Handbook

Mitchell. Updated and Expanded Classic Guide. This handbook goes beyond just listing collecting areas. Provides an excellent resource for learning how rocks are formed, what to look for in the field, preserving and preparing specimens, deciding on the best tools, and more. Illustrated throughout with photos, diagrams, charts, and a new 16 page color insert of over 90 specimens. Softbound. 304 pages. Revised Edition. 240-356 1 lb..... 15.95

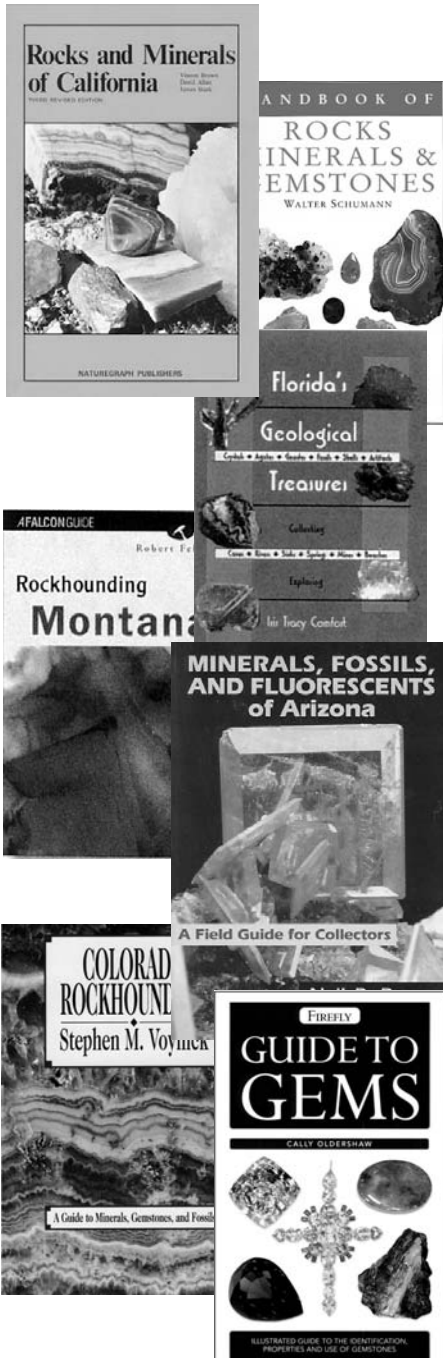

Firefly Guide to Gems

Oldershaw. Richly illustrated guide to the identification and uses of gemstones from around the world. Clear and accessible introductions to the geology, chemistry and properties of gems are included, as well as world maps of gem locations, over 850 photos and more than 50 diagrams and drawings. 224 pages. 240-358 8 oz..... 16.95

An Illustrated Guide to Fossil Collecting

Casanova & Ratkevich. Locations of fossils in the U.S., cataloging, and preserving. 240 pages. 240-447 8 oz..... 9.95

Treasure Hunter's Gem and Mineral Guides

Rygle. Newly revised, these guides give state-by-state details on more than 250 gems and minerals the U.S. has to offer, and affordable "fee-dig" sites where they can be found. Includes maps, illustrations and B/W photos.

- Northwest TH Gem & Mineral Guide (192 pgs) 240-420 8 oz. 14.99
- Northeast TH Gem & Mineral Guide (224 pgs) 240-421 8 oz. 14.99
- Southwest TH Gem & Mineral Guide (224 pgs) 240-424 8 oz. 14.99
- Southeast TH Gem & Mineral Guide (200 pgs) 240-425 8 oz. 14.99

Florida's Geologic Treasures

Comfort. For those seeking natural collectibles in the sunshine state, geologic surprises abound. Minerals and fossils are in abundance. Quarry cuts and off shore coral forests showcase the state's treasures. Explore collecting sites across the state. Includes maps, color photos, and extensive information on clubs, museums. 160 pages. 240-464 1 lb. 11.95

Minerals, Fossils and Fluorescents of Arizona: A Field Guide for Collectors

Bearce. Features 90 collecting sites with photos, topographic maps and GPS coordinates. Covers basic science of minerals, fossils, and fluorescents with geological formations at each site and the proper ties of minerals. 402 pgs. 240-491 1 lb..... 29.00

Field Guide to Geology

Lambert. Excellent basic reference to the ingredients and processes that forged our planet. Diagrams, maps, and photos. 256 pages. 240-341 1 lb..... 16.95

Handbook of Rocks, Minerals & Gemstones

Schumann. This essential guide discusses the science of minerals—origin, properties, structure, and classification. Written for the layman and scientist followed by a description of the properties and characteristics of each rock and mineral. Complete with 600 color photos. 380 pages. 240-359 12 oz..... 22.00

Northwest Gem Fields and Ghost Town Atlas

Johnson. Complete guide to collecting rocks, minerals, bottles and relics from gem fields and ghost towns throughout WA, OR, ID, MT and WY. Detailed maps. 48 pages. 240-437 8 oz..... 5.50

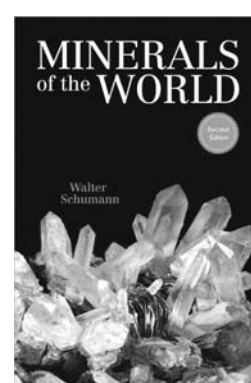
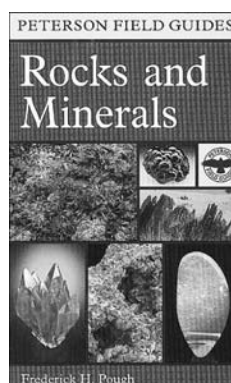
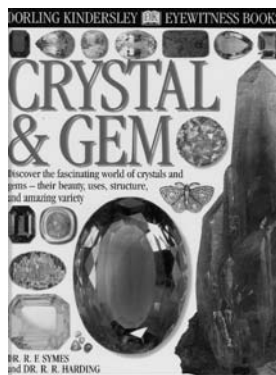

DK Handbook Series (formerly Eyewitness Handbooks)

Designed for beginners and experienced collectors alike, these field guides make identification of individual specimens sure, simple and straightforward. Each entry has a full color illustration as well as color-coded bands that provide at-a-glance facts for quick reference. Easy to use and beautiful to look at, this series is an invaluable resource for every collector. Softcover, 5 3/4" x 8 1/2".

DK Handbook of Gemstones

Pellant. 180 pages.

240-439 1 lb 20.00

DK Handbook of Fossils

Walker & Ward. 320 pages.

240-440 2 lbs 20.00

DK Smithsonian Books

Superb color photographs on every page make this series of books outstanding. Texts are written by experts in a clear, concise style that is suitable for youngsters and adults. Even children who cannot yet read will enjoy the many beautiful photos illustrating the particular subject of the book. These are excellent books, with 8 1/2" x 11" hardbound covers averaging over 72 pages each.

Eyewitness Rocks and Minerals

240-432 1 lb. 4 oz. 16.99

Eyewitness Crystal and Gem

240-433 1 lb. 4 oz. 16.99

Eyewitness Fossil

240-434 1 lb. 4 oz. 15.99

Eyewitness Dinosaur

240-435 1 lb. 4 oz. 16.99

Turquoise Unearthed: An Illustrated Guide

Lowry. The definitive resource for turquoise rockhounds and serious collectors alike. Get the fascinating history of turquoise mining, see beautiful colors and forms that make this gemstone like no other. Lavishly illustrated throughout. 80 pages. 240-346 6 oz. 12.95

Peterson Field Guide To Rocks and Minerals

Pough. Detailed descriptions of 270 minerals: geographic distribution, physical properties, chemical composition, crystalline structure, and more. Simple procedures and tests to ensure accurate identification. Portable format, color photos. 320 pages. 240-485 1 lb. 20.00

Minerals of the World

Schumann. Revised and updated. This photo-filled field guide presents 500 of the most collectable minerals along with the author's unique system for quick identification. Brilliant color photos are color-coded to make this a great reference guide. Hard cover. 232 pgs.

240-309 1 lb. 14.95

Field Geology Illustrated

Maley. This is a fantastic aid in recognizing, interpreting and describing geologic features in the field. Contains 682 B/W photos, and over 300 interpretive sketches. 704 pages.

240-342 1 lb. 35.00

Guide To Rocks & Minerals Of The Northwest

Leaming. Introductory, full-color photo guide that highlights the best and much-prized rocks and minerals of the northwest. 32 pgs.

240-350 6 oz. 5.95

Audubon Field Guide to Fossils: North America

Thompson. Color photos of over 400 fossils. Arrangement by shape and color makes identification quick and easy. 846 pages. 240-303 1 lb. 4 oz. 20.95

Audubon Field Guide To Rocks and Minerals: North American

Chesterman. 794 color plates are cross referenced to detailed descriptions of field patterns and rock locations. Excellent and comprehensive. 850 pages.

240-305 2 lbs. 19.95

Illustrated Guide to Common Rocks and Their Minerals

Brown & Allan. Provides the basic groundwork for understanding and identifying common rocks by addressing the general nature and three main classifications of rocks and the component minerals that make them. 59 pages.

240-483 8 oz. 5.95

Minerals, Identifying, Classifying, Collecting Them

Hochleitner. A deluxe field guide and mini-encyclopedia for amateur geologists, rock collectors, and nature lovers. Identify minerals using 500 full-color photos plus 300 drawings of crystals. The author's color-key identification method, plus the fold-out guide helps for quick identification in the field. Provides information on fundamentals of mineralogy, and much more. Handy 5 1/2" x 8 1/2". 237 pages.

240-308 1 lb. 16.95

Collecting Rocks, Gems and Minerals

Polk. Identification • Values • Lapidary Uses. This book takes you from a casual interest in rocks to becoming a true collector. Makes an excellent field guide. Covers Lapidary and Minerals

242-306 18 oz. 17.99

Gem & Lapidary Materials

Zeitner. A complete handbook of common materials used in the lapidary arts throughout history and up to the present. Lavishly illustrated with full-color photos 350 pgs. 240-484 1 lb. 40.00

A Gem & Jewelry Pocket Guide

Traveler's Guide to Buying Diamonds, Colored Gems, Pearls, gold and Platinum jewelry. Newman. A concise overview of gems, gold, and platinum and what to look for when buying them. Know what the right questions are to ask, how to spot fake and lab-grown gems, jeweler's marketing ploys, and how to avoid hassles with customs. 156 pgs.

240-489 6 oz. 11.95

Simon & Schuster's Guide to Rocks and Minerals

Prinz, Harlow, Peters. Includes over 1000 illustrations, 600 in full color. Contains precise information on appearance, classification and formation on rocks and minerals. 608 pages.
240-300A 1 lb. 19.00

Simon & Schuster's Guide to Gems and Precious Stones

Lyman. Over 450 full-color photos and comprehensive entries on the major gems and precious stones of the world. 384 pgs.
240-301 1 lb. 17.99

Rocks and Minerals: A Field Guide to Identification

Sorrell. This handy reference guide shows everything from common rocks like granite and limestone, to less common crystals and minerals. Entire guide is written in an easy to use format.
Measures 4½" x 7½" with 280 pages.
240-417 14 oz. 14.95

Golden Guides

Handy reference guides to add pleasure and knowledge to your hobby. 4" x 6" size makes them easy to take along on field trips. All have color illustrations. Clear, concise descriptions written by experts. Average 150 pages or more.

- Rocks and Minerals**
240-414 6 oz. 6.95
- Fossils**
240-415 6 oz. 6.95
- Geology**
240-416 6 oz. 6.95

Where To Find Gold in Northern California

Klein. This new and current book reveals the secrets to finding the best gold-bearing areas in northern California with helpful maps, photos and illustrations. Learn about the new tools, methods and equipment from a veteran prospector, miner and treasure hunter. 125 pages.
240-509 1lb. 10.95

You Can Find Gold With a Metal Detector

Garrett & Lagal. Complete information on using detectors to find gold nuggets, veins and ore with illustrated panning instructions. 140 pages.
240-551 1 lb. 9.95

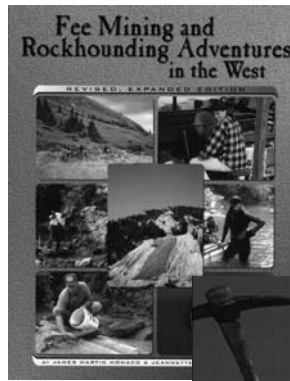

Fee Mining and Rockhounding Adventures in the West

Monaco. Revised edition. Informative guide to over 94 collecting locations. Also includes 150 museums, caves, points of interest and fairs and festivals throughout the western states. Seasons, days and hours of operation are included for each site as well as the address, directions, cost, tools and supplies needed. Organized by state, it is an invaluable guide for the prospector or gem hunter. 240 pages.
240-563 8 oz. 15.95

Fee Mining and Rockhounding Adventures in the East

Monaco. New version for the Eastern states. Contains a guide to the collection locations, points of interest and fairs and festivals in the East.
240-564 8 oz. 15.95

Recreational Gold Prospecting For Fun and Profit

Butler. This informative book is for those who have thought about looking for gold as a hobby. Learn the basic geologic properties of gold and the terrain where it is found: become familiar with the various techniques and equipment used by prospectors; and get tips on how to plan a family gold prospecting adventure. 206 pages.
240-552 1 lb. 12.95

The Essential Guide to Geocaching: Tracking Treasure with Your GPS.

Dryer. This comprehensive guide provides a fun way to learn the fundamentals of the game and its exciting variations, as well as land navigation, outdoor ethics, and safety skills. 148 pages.
240-500 1 lb. 12.95

Gold! Gold!

Petralia. Beginner's handbook. Historic and geographic background. Why gold is where it is and how to recover it. Old and new mining methods. 148 pages.
240-503 8 oz. 12.95

Gold Panning is Easy

Lagal. Presents gold panning methods. Discusses prospecting with the metal and mineral detector as well as traditional gold panning methods. Illustrated. 134 pages.
240-504 8 oz. 9.95

Gold Fever - The Art of Panning and Sluicing.

De Lorenzo. Explains the techniques of panning for gold, how to use a sluice box, where to look for gold, and more. Filled with illustrations and maps. 80 pages.
240-501 6 oz. 6.95

Gold Prospectors' Handbook

Black. Geological background, dynamics of stream flow, how to pan for gold, and what tools to use. Non-technical but advanced book for the prospector. 176 pages.
240-506 1 lb. 10.95

Gold Digger's Atlas

Johnson. This complete book of maps shows where gold has been found in the Western United States. 64 pages.
240-507 8 oz. 7.50

Rocks From Space

Norton. This non-technical introduction to the fascinating meteorites, asteroids, comets, and impact craters is lavishly illustrated and tells the story of cosmic debris—the science, superstition and folklore, and the tales of people who collect them. 467 pages. Second edition.
240-456 2 lbs. 35.00

Where to Find Gold & Gems in Nevada

Klein. Gold-bearing regions and selected gem and rock hound areas organized by county. Maps, photos, directions and interesting historical anecdotes. 110 pages.
240-454 8 oz. 8.95

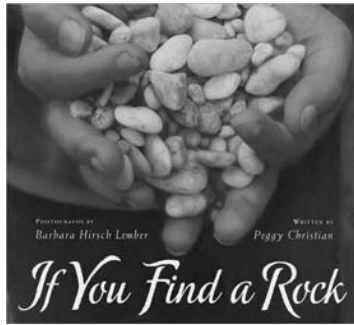

If You Find a Rock

Christian. Children can discover the joy of rock hunting. This beautifully photographed and hand-tinted book celebrates the variety of rocks that can be found, including skipping rocks, chalk rocks and splashing rocks. Ages 6-9 160 pgs.

240-818 1 lb..... 6.99

Let's Go Rock Collecting

Gans. Easy-to-understands text introduces children ages 5 to 9 to rocks, how they are formed, what they are made of, and how they are used. Original color artwork and color photos. 32 pages.

240-854 1 lb..... 5.99

The Magic School Bus: Inside the Earth

Cole. Follow the Magic Bus to a journey inside the earth. Filled with interesting illustrations and dialog on information every kid should know about the Earth's physical make up. 40 pgs.

240-823 8 oz..... 6.99

Discover Nature in the Rocks: Things to Know and Things to Do.

Lawton. Combines dozens of simple, non-intrusive activities with detailed illustrations and information text to provide a friendly introduction to a hands-on study of rocks and the earth. Great for adults & kids. 224 pgs.

240-840 1 lb..... 17.95

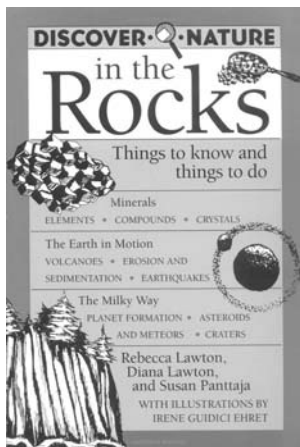

Everybody Needs a Rock

Baylor & Parnall. When children follow this author's highly individualistic rules for finding just the right rock for themselves, they may discover an understanding and interest for rocks as well. Ages 3-7. 31 pgs.

240-802 6 oz..... 7.99

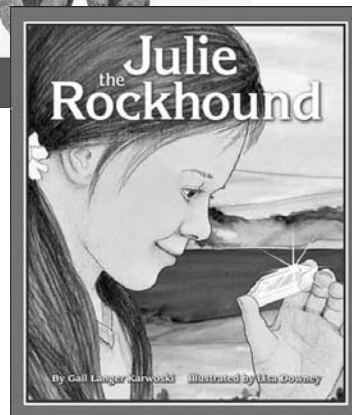
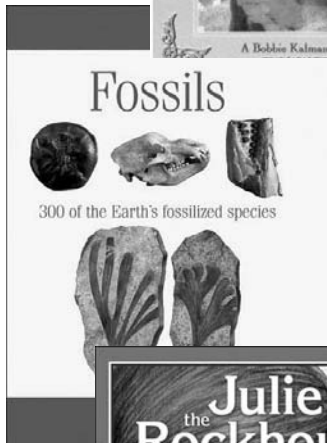
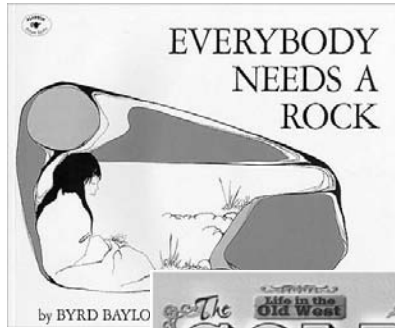

Julie The Rock Hound

Karwoski. The perfect rock book for girls! When a young girl finds a shiny quartz crystal, her dad shows her how to dig for more specimens, and she takes on a new name, Julie the Rockhound. Includes section that describes the different types of rocks and how they are formed. For ages 5-9. 32 pgs

240-820 8 oz..... 8.95

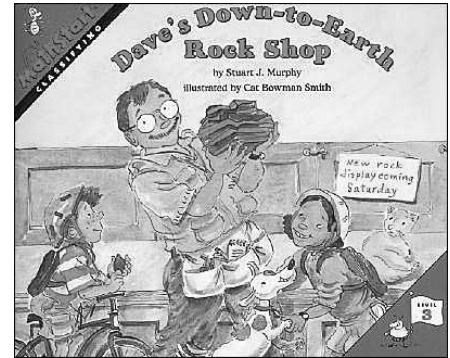

Dave's Down-To-Earth Rock Shop

Murphy. After visiting Dave's Rock Shop, Josh and Amy start collecting rocks, discovering different ways to organize their collections. Children learn to classify rocks by different attributes like color, shape or size. Ages 7 and up. 34 pgs.

240-819 8 oz..... 5.99

Life In The Old West: The Gold Rush

Kalman. Learn about life as a gold miner during the California and Klondike gold rushes. Historic photos and color illustrations show what life was like in the camps, mining techniques and the communities that grew because of the gold rushes. Ages 6-14, 32 pgs.

240-822 1 lb..... 7.95

Fossils: 300 of the Earth's Fossilized Species

Mehling. Includes vertebrates, invertebrates and plants from across the continents. Each fossil has descriptive text, a full color illustration, and information tables with scientific name, order, family, distribution, habitat and geological period. Index makes easy reference. 320 pages.

240-800 1 lb..... 9.95

Wonders of Our World

Morris. This series of books offers young readers 7-14 a lively and visually exciting introduction to the physical world. Each book features full-color photographs and diagrams that illustrate and explain the world around us. 32 pgs.

ROCKS AND MINERALS

240-804 6 oz..... 6.95

EARTHQUAKES

240-849 6 oz..... 6.95

VOLCANOES

240-807 6 oz..... 6.95

Introduction To Lapidary

Kraus. Excellent book for the amateur lapidary and hobbyist. Presents different types of gem cutting and polishing, from tumbled stones, cabochons and bead making to sphere making, carving, and faceting. Describes basic processes and techniques and provides helpful hints. Explains equipment used. Photos on every page, many in full color. 196 pages. Softbound.
240-235 1 lb. 3 oz. 21.95

Cabochon Cutting

Cox. Illustrations, photos, and detailed instructions will tell and show you how to cut a cabochon. Everything to start you on your way to expert cutting.
240-226 6 oz. 6.00

Advanced Cabochon Cutting

Cox. Learn how to master special shaped cabochon cutting, assembled stones, star stones and cat's eyes. Special sections on opal and jade. 64 pages of detailed, illustrated text.
240-227 6 oz. 6.00

How To Use Diamond Abrasives

Riggle. Subjects cover methods of cutting and polishing gemstones with diamond abrasives, from using sawblades on trim and slab saws to diamond grinding wheels and machines. Well illustrated with drawings and photographs.
240-240 6 oz. 5.50

Gem Care

Ward. Contains everything you need to know to properly care for your jewelry and gems from abalone to zoisite. When to use ultrasonic cleaners; which chemicals are safe; how to care for pearls; how to clean precious metals, and much more. Illustrated throughout with the high quality photos that characterize this series. 32 pages.
240-338 8 oz. 12.95

Gemstones of the World

Schumann. With nearly a million copies in print, this revised and expanded edition is the most complete book ever published on the subject. All known gemstone types are discussed, and over 1,500 multi-color photos showcase each gemstone in both its natural state and its polished and cut renditions. A special section on rocks as precious Stones is included as well as new-on-the-market stones, synthetics and imitations. The essential reference for hobbyists, jewelers and rockhounds. 320 pgs.
240-347 1 lb. 24.95



Genie Video Guide For new owners of a Genie and old pros as well. This new DVD contains a wealth of information about the use and care of The Genie Gem-Maker. Covers such subjects as machine setup, break-in and wheel replacement, pump trouble-shooting, maintenance, and use of the Genie in the lapidary process. Professionally produced, informative and easy to follow. Contains over 80 minutes of useful technical information.
240-248 1 lb. 29.95

DVD - Opal Cutting Made Easy Downing. Covers step-by-step instructions for selecting, cutting and polishing opals. About 30 minutes.
240-229 1 lb. 29.99

Fred Ward Book Series

This popular series focuses on individual gems, their color, history and lore. Gives buying tips and sources. All books in the series feature beautiful color photos throughout. 64 pages. Shp. Wt. 1 lb. ea.
240-332 DIAMONDS 19.95
240-333 EMERALDS 19.95
240-334 PEARLS 19.95
240-335 JADE 19.95
240-336 RUBIES & SAPPHIRES .. 19.95
240-344 OPALS 19.95

The Beauty of Banded Agates: An Exploration of Agates from Eight Major World Sites

Carlson. Gorgeously present 12" x 9" photo journal of banded agate sites from around the world, with over 260 museum quality color agate photos. Explore the beautiful features of each specimen as well as the collecting histories for each site; full glossary, references and index. 160 pages.
240-361 1 lb. 38.95

How to Tumble Rocks Into Gems—Secrets of the Pros Revealed

Smith, A guide to tumble-polishing rough rock into finished gemstones. Covers basic types of equipment, selecting materials, fillers, abrasives, etc. along with steps in processing. Covers stone and metal polishing in rotary and vibratory type tumblers. Illustrated with charts in easy-to-follow style. Spiral-bound.
240-236 8 oz. 22.50

How to Tumble Polish Gemstones

Wexler. Step-by-step instructions for turning pebbles and rough stones into sparkling jewels. A guide to the type of tumbling equipment available and how to use it. 32 pages.
240-231 6 oz. 6.50

Gem Tumbling and Baroque Jewelry Making

Victor. Gives detailed information on the various stages of grinding and polishing, how to avoid common mistakes, types of tumblers, and a section on baroque jewelry making. Illustrated. 58 pages.
240-230 6 oz. 6.50

Facet Cutters Handbook

Soukup. Here's what the author says. . . "I took it upon myself to write a book that would help beginners in our club faceting class." This book contains everything one needs to know in order to facet a gemstone expertly. 22 beautiful cuts. 64 pages.
240-200 6 oz. 5.00

Rock Sculpture - The Joy of Stone Carving

Stage. Covers materials suitable for carving; anatomy, proportion, motion in figures; and equipment. Photos. 46 pages
240-233 6 oz. 6.95

Agates: Treasures Of The Earth

Pabian, Jackson, Tandy and Cromartle. The agate is one of the world's most strikingly beautiful semi-precious gems, and collectors worldwide are drawn to the stone's infinite variety of colorations and banding. This identification guide is comprehensive and easy-to-use. It is illustrated throughout with full color photographs and includes a worldwide listing of where agates are found. Hard cover, 192 pages.
240-360 1 lb. 35.00

Beading with Cabochons: Simple Techniques for Beautiful Jewelry

Eakin. The only current comprehensive guide to working with cabochons that covers all the basics, as well as a range of new creative techniques and hot trends. Includes sections on tools and materials, bead selection and fabulous, all color, photos and illustrations. Hard cover. 128 pages.

240-136 12 oz.....24.95

The Jewelry Making Handbook: Simple Techniques and Step-by-Step Projects

McSwiney, Williams & Davies. Produce professional looking jewelry using simple techniques and equipment and learn how to work with a variety of metals, ceramics and plastics. Dozens of projects focus on developing basic jewelry making skills: spiral bound and copiously illustrated with inspiring design ideas. Hard cover. 192 pgs.

240-160 1 lb 14.95

Jewelry Techniques: The Essential Guide to Choosing and Using Materials, Stones and Settings.

Young. Comprehensive guide to exploring All the creative possibilities for Jewelry from metalsmithing to techniques for natural materials such as wood, bone, shell, leather, porcelain and glass, plus mediums like acrylics, resin, rubber, concrete and paper. Step-by-step instructions. Over 400 color photos. Hardcover 256 pgs.

240-165 1 lb. 24.95

How To Repair Jewelry

Phelps. Detailed, step-by-step instructions show the jewelry craftsman how to fix broken chains, replace lost parts, rebuild broken prongs, remove and re-set gemstones, solder without removing gems, size rings and much, much more. Also tells how to remodel old pieces.

240-129 6 oz. 5.00

Jewelry Craft Made Easy

French. For the hobbyist who prefers purchasing already finished gemstones, mountings and findings for assembling beautiful and interesting jewelry.

240-130 6 oz. 5.95

Jewelry Making Techniques Book

Oliver. Guidebook for blending over 50 simple techniques, such as cutting, forming, soldering, casting and stone-setting with more sophisticated methods for creating eye-catching jewelry. Covers weighing, measuring, tools, decoration, assembly, finishings, fittings along with projects that included mixing metals and stones for a variety of jewelry pieces. 128 pgs.

240-123 6 oz. 22.99

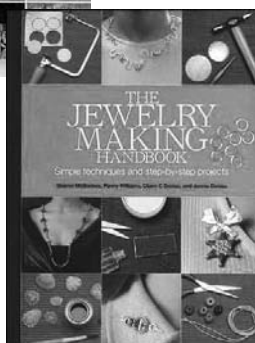
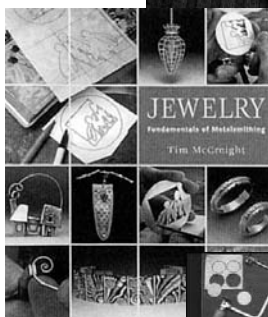
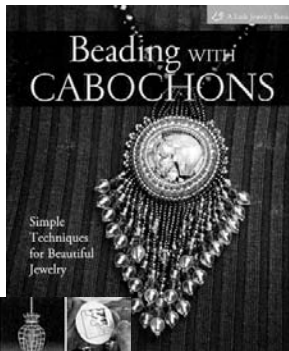

The Art of Gem Cutting

Dake. Teaches how to buy rough stones, cut the gems, choose the right equipment, and how to properly use the equipment. Gets you started on the right path into the hobby of gem cutting.

240-246 6 oz. 6.00

Lost Wax or Investment Castings

Sopcak. A how-to-do manual that shows you how to make the equipment you need and how to use it. Includes chapters on making a vacuum investment mixer, burnout oven, pressure casting machine, wax wire extruder, and more. Explains how to invest wax patterns, make rubber molds and duplicate patterns. Illustrated. 64 pages.

240-101 6 oz.....5.00

Complete Book Of Jewelry Making: A Full-Color Introduction to the Jeweler's Art.

Codina. Learn every aspect of jewelry making in this large source book filled with the essential details on every technique you will need. Includes expert advice from professionals and bonus projects to complete.

240-155 1lb. 19.95

Jeweler's Resource: A Reference of Gems, Metals, Formulas and Terminology for Jewelers

Knuth. A unique and practical tool for the bench jeweler or jewelry student. The most complete counter reference available for the retail jeweler. Easy to follow text and illustrations. Spiral-bound. 112 pages.

240-124 6 oz. 21.95

Making Jewelry With Gemstone Beads

Case. Create beautiful beaded gemstone jewelry from a dazzling range of 32 precious, semi-precious, and ornamental stones. Create eye-catching jewelry from earrings and accessories to necklaces and bracelets. Easy-to-follow techniques with clear artwork and stunning photography ensures flawless results. 128 pages

240-151 12 oz.....19.99

The Complete Metalsmith: An Illustrated Handbook

McCreight. A great workshop manual for the student, teacher or craftsperson. Full of illustrations and descriptions of metal working techniques. Spiral bound. 200 pages.

240-801 10 oz.....15.95

Practical Casting

McCreight. The first six chapters deal with wax investment casting, the method most used in jewelrymaking. Remaining chapters describe alternate casting techniques. Spiral binding. Illustrated. Glossary. 160 pages, 6" x 9".

240-100 9 oz..... 18.95

Indian Jewelry Making

Branson. A beautiful all-color photographic presentation of traditional silversmithing methods. Techniques, tools and designs are clearly shown. Spiral bound for ease in bench work. 120 pages.

240-131 12 oz. 21.95

Jewelry: Fundamentals of Metalsmithing

McCreight. From the author of "The Complete Metalsmith" comes this brilliantly written book examining the basic techniques of this ancient and accessible craft: fabricating, surface treatments, joining, finishing, stone setting, chain making, mechanisms, and casting. Illustrated with photos, drawings, and examples of exceptional contemporary jewelry. Hard cover, 144 pages.

240-204 2 lbs. 29.95

The Encyclopedia Of Jewelry Making Techniques: A Comprehensive Visual Guide to Traditional and Contemporary Techniques.

McCrath. Just a few of the entries covered include acrylics, etching, inlaying, enameling, casting, stamping, blanking, patinating, oxidizing and chain making. Complete with instructions for designing and presenting jewelry concepts as working drawings. Step-by-step color photos make instructions easy to understand. Hardcover, 176 pages.
240-201 1 lb. 27.95

Working With Precious Metal Clay

McCreight. Learn 50 projects that show how to use the material by showing specific applications with 25 techniques. An additional section describes 10 tools that you can make in your own studio. Complete with 300 drawings, directions for making your own tools, and a handy wire binding. A must have book on this new revolutionary material. Hard cover. 128 pgs.
240-139 1 lb. 29.95

Magical Metal Clay Jewelry: Amazingly Simple No-Kiln Techniques for Making Beautiful Jewelry.

Heaser. Clear step-by-step photographs and text to create intricate pieces of pure silver jewelry using metal clay. No need for soldering, sawing, or a kiln for the new low-fire type of metal clay. 128 pages.
240-153 1 lb. 24.99

How to Make Wire Jewelry

Jenkins and Thrasher. Step-by-step instructions and illustrations tell how to make pins, pendants, chains, necklaces, rings, bracelets, earrings, stickpins and novelties.
240-135 6 oz. 6.00

Simple Glass Beading

Wood. Readers will discover the glorious color and vibrancy of glass beads that can be used to create eighteen beautiful projects including purses, boxes, picture frames, cushions and scarves. A wide range of beading techniques is shown and explained to create your project. Hardcover. 112 pages 200 color photos.
240-109 2 lbs. 22.99

Jewelry Making for Beginners

Soukup. Here is an easy-to-learn method for fabricating soldered jewelry pieces. All steps are clearly shown with photos and detailed text. 48 pages.
240-134 6 oz. 5.00

Basic Jewelry Making

Allison. "All the skills and tools you need to get started." Every basic step illustrated in full color and clear close-ups. Covers working with beads, making loops, clamps, etc., and bending gold and silver wire. 9" x 11" spiral bound. 110 pages.
242-102 1.5 lbs. 19.95

Contemporary Wire Wrapped Jewelry

Leonard & Kappel. Unique presentation of the newest designs and techniques in wire wrap. Over a dozen projects are described in detail with numerous photos and illustrations. Spiral bound, lays flat. 8½" x 11". 144 pages.
240-158 2 lbs. 15.95

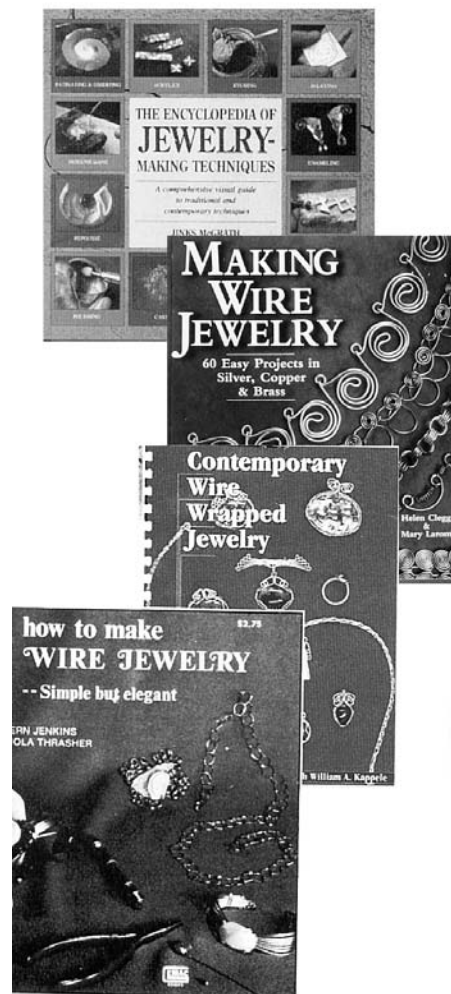

Getting Started With Seed Beads.

Wedekind. First time beaders will learn shopping to storing, and from stringing to sewing a successful beginning project. A good resource of all the basics you will want to know. 128 pages.
240-154 1 lb. 18.95

Designing Jewelry with Glass Beads

Sersich. Learn to incorporate glass beads of all shapes and sizes in twenty colorful projects. Discover the history of glass beads and bead making, complete with photographs of ancient and modern glass beads. Techniques range from wirework and stringing to sewing and knotting, all are fully explained and illustrated. 128 pages
240-156 12 oz. 22.95

Making Silver Chains: Simple Techniques, Beautiful Designs

Waszek. Making your own silver chains is surprisingly easy, and you'll be able to make unique pieces found nowhere else. They're simple to make by hand and you don't need specialized equipment or tools—everything is available at jewelry-supply and hardware stores. 112 pages.
240-122 1 lb. 14.95

Wire Wrapping

Chandler. Learn to create jewelry, no experience needed. Learn the basic and the essential techniques for designing simple projects. Detailed step-by-step photos, hints and tricks, everything you need to make beautiful pendants, bracelets and earrings. 128 pages.
240-152 6 oz. 22.95

Beaded Jewelry With Found Objects

Rodgers. Whether it's something you found in the local hardware store or picked up on your last outdoor adventure, you can convert everyday objects into jewelry pieces. Shows beading techniques, including strap and fringe variations. 225 how-to-illustrations 100 color photos. 128 pages. 8½ x 11.
240-193 1 lb. 19.99

Making Wire jewelry

H. Clegg. Making wire jewelry is easy to learn and fun to do. All it takes is wire, pliers, and a few short hours. Learn how to twist, bend and turn copper, brass or silver into graceful necklaces, earrings, bracelets, and rings with more than 60 projects. With this clearly illustrated "how to" book and some easy to find tools, you can create a wardrobe of fabulous handcrafted metal jewelry. Softcover. 112 pages.
240-202 1 lb. 18.95

All Wired Up: Wire Techniques for the Beadworker and Jewelry Maker

Lareau. Make wire-wrapped cabochons, necklaces, wire hook and eye clasps. Includes step-by-step instructions, detailed line drawings and a color gallery of wirework. 128 pages.
240-144 1 lb. 21.95

Designs for Beaded Jewelry Using Natural Materials

Di Spirito. Learn 48 designs for beaded jewelry using natural materials like coral, wood, and mother of pearl. Designs range from elegant and classic to ethnic and bohemian. 64 pages.
240-1068 ozs. 15.95

Beads: The Art of Stringing

Ragan. Simplified, step-by-step guide with many different knotted designs. 58 pages.
240-1138 ozs. 4.95

The Beader's Bible

Crouchley. One of the largest collections of patterns ever supplied in one book. Contains more than 300 fabulous bead designs with dozens of applications for purses, pendants, chokers, necklaces, bracelets, napkin rings, picture frames and more. Every design is charted in full color using realistic bead graphics plus a photograph to show the finished piece. All essential information provided. Hardbound, spiral. 6¾ x 8". 128 pages, all in color.
240-118 2 lbs. 29.99

Easy Beaded Jewelry

Ray & Wilke. Everyone from the novice beader to the experienced jewelry maker will find plenty to love and learn in this book. Written by experienced jewelry designers who walk you through the basics, then launch into a plethora of designs for you to replicate. Featured are 75 projects along with 250 full color photos and illustrations to provide easy-to-follow instructions. Covers basics, tools, tips, style, color and design options. Softbound, 8½ x 11, 144 pages.
240-119 2 lbs. 21.99

Beginner's Guide to Bead Netting

Rollason. Discover the fun of creating jewelry, and finishing soft furnishings and clothing with bead netting techniques. Perfect for covering large areas quickly, bead netting is adaptable for a variety of projects and media. Learn about the materials used, basic beading and netting techniques, plus how to finish off projects with flair. 8 projects are described with detailed directions and photos, and helpful tips. 96 pages.
240-108 8 ozs. 19.95

Basics of Bead Stringing

Kanan. Gives instructions for the basic steps and techniques for stringing beads. Shows how to repair and restring your old jewelry, and design and string new ones. Illustrations & color photos. 82 pages.
240-141 6 oz. 8.95

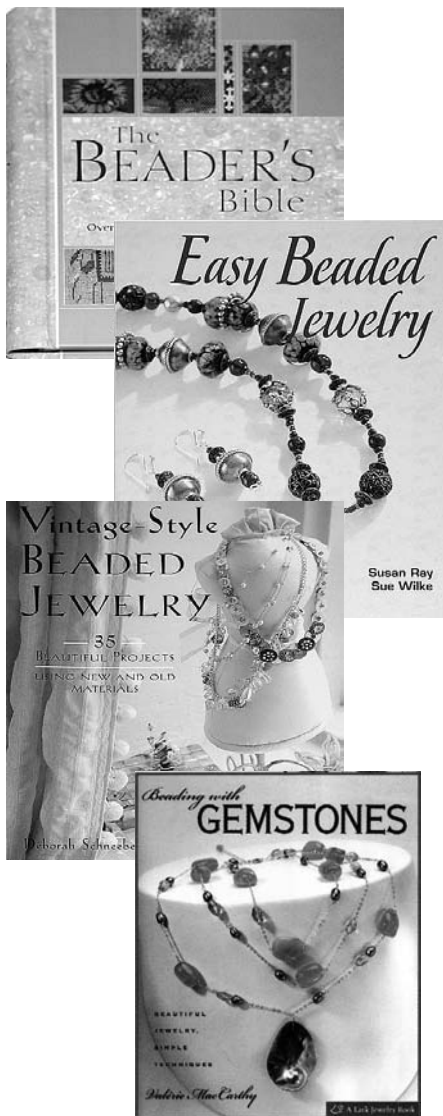

Beading With Gemstones: Beautiful Jewelry, Simple Techniques

MacCarthy. Create contemporary wire and chain jewelry featuring stunning gemstones and beads. From rings and necklaces, to bracelets and earrings. These designs showcase the versatility and beauty of natural gemstones. 126 pages.
240-1458 ozs. 24.95

Vintage-Style Beaded Jewelry

Morrell. The growing revival of interest in vintage style jewelry makes this book a must for those wanting to create their own modern heirlooms, or repair damaged costume jewelry and thrift store treasures. Clear step-by-step projects and the use of simple techniques such as wiring and beading mean that even the beginner can produce stunning results. Shows 35 original projects to make, plus offers ingenious ideas on reusing old junk and thrift store buys. Softbound. 8½ x 11. Color. 128 pages.
240-121 2 lbs. 22.99

The Beaders Companion

Durant. This compact, handy, spiral-bound manual will be the most valuable tool in every bead box. Easy-to-read and filled with definitions and illustrations of techniques, beads and tools. step-by-step instructions on many beading projects. 104 pgs.
240-1178 oz. 19.95

Beautiful Beaded Jewelry: Over 20 Practical and Inspirational Projects

Bourgeois & Garsmeur. Become your own jewelry designer and make gorgeous beaded necklaces, bracelets, and earrings using a range of materials including glass beads, bugle beads sequins, wire, buttons and other readily available items. 64 pages.
240-103 8 oz. 12.99

Pearl and Bead Stringing with Henrietta

Virchick. Create jewelry for a fraction of the cost. Learn to restring your own pearls and beads. Step-by-step instructions, illustrations, color photos. 88 pgs
240-149 1 lb. 9.95

A String & A Prayer: How to Make & Use Prayer Beads

Wiley & Shannon. Learn the use and symbolism of prayer beads for various cultures and religions throughout history, as well as rituals and prayers for their use today. 133 pages.
240-150 1 lb. 14.95

Making Beaded Jewelry

Case. Illustrates the vast choice of beads available, and blends over 80 projects with easy-to-follow instructional techniques and color photos. Whether restringing an old necklace or making something special and new, the information is here, including a glossary of beading terms. 128 pages.
240-104 8 oz. 16.99

Getting Started Stringing Beads

Campbell. A must-have primer for the beginning beader. Learn how to shop for beads and to design your own pieces. Contains over 100 photos and illustrations, plus easy step-by-step instructions. 88 pgs.
240-148 8 oz. 16.95

Bead & Wire Art Jewelry: Techniques & Designs for all Skill Levels

Michler. A great introduction to combining two mediums: bead and wire. Basic wire techniques are covered, along with 50+ easy, intermediate and advanced projects; includes photos, illustrations and instructions for each project. 128 pages.
240-1428 oz. 21.95

A

Abrasives	
Belts	80
Compound	14-15
Points	25-32
Tumbling, lapping.....	65-69
Ad-a-unit system.....	78-79
Adaptors.....	6,18,19,82-83
Adhesives.....	81,94
Alcohol lamp.....	16
Anvil, jeweler's.....	90
Arbor.....	78-79
Awl, beading.....	88

B

Back plates.....	12
Band saw.....	39
Baseboard, Gem-Makers.....	21
Beading tools.....	86,88-89,94-101
Belts	
Abrasive.....	80
Gem-Makers.....	21
Bearings.....	21,41,54,64
Bench tools.....	89-90
Bench pin.....	90
Bezel roller, pusher.....	89-90
BigFoot gem-maker.....	6
Blades, jeweler's saw.....	87
Blades, rock saw.....	51-53
Block, bench.....	90
Block, tool holders.....	22
Block, soldering.....	93
Books.....	104-112
Boxer.....	18
Broaches, reamers.....	88
Brushes, mounted.....	30
Buff kits, Gem-Makers.....	19
Bufs	
Wheel.....	19,82-83
Gem-Makers.....	19
Miniature.....	32
Buffing compound.....	82
Burnisher.....	89
Burnishing compound.....	68
Burs, brushes, bristle discs.....	25-32
Bushing, wheel.....	7-8

C

Cab rest.....	20
Calipers.....	92
Canvas polishing pads.....	13
Capacitors, motor.....	21
Carver's Workstation.....	34-35
Carving tools	
Drills.....	29
Foredom tools.....	22-24

Glass grinder.....	33
Grinding points.....	25-31
Multi-Flex unit.....	36-37
Polishing points.....	25,28,32
Wheels.....	9
Workstation.....	34-35
Cerium oxide.....	15,68
Chisel, rock.....	102-103
Clamps, holders.....	50,89,90
Cloth, polishing.....	69
Coolants, saw.....	50
Compound, polishing.....	14-15,66-69,82
Convex carving wheels.....	9
Copper lap.....	11
Core drills.....	29
Cratex wheels.....	31
Crimps, crimping tools.....	96
Cut-off wheels.....	28-29,31
Cutters.....	86,88,97-98,100

D

Dial caliper.....	92
Diamond	
Carving tools.....	25-29
Carving wheels.....	9
Compounds.....	14-15
Discs, laps.....	10-12,74-75
Drills, points.....	25-29
Files.....	91
Grinding wheels.....	8-9,28
Polishing wheels.....	7,25
Powder.....	14
Scribe.....	17
Slurry.....	11
Spray.....	14
Saw, blades.....	51-53,87
Saw, ring.....	38

Discs

Laps.....	10-12,74-75
Magnetic.....	12,74-75
Nova.....	12-13,74
Silicon carbide discs.....	80
Divider, measurement.....	17
Dopping supplies.....	16
Dressing stick, blade.....	50
Drill press.....	24
Drills, diamond.....	29
Drums, expanding.....	80
Dura Discs.....	11

E

Estwing tools.....	102-103
Extenders, lubricants.....	16,50,67
Expanding drums.....	80

F	
Felt wheels, bobs, discs.....	13,32,83
Files.....	91
Fillers, tumbling.....	69
Flanges, buff.....	82
Flanges, saw.....	54
Flannel buffs.....	19,83
Flexshaft machine.....	22
Flexible shafts.....	34,37
Foredom power tools.....	22-24
G	
Galaxy diamond wheels.....	8-9
Gauges.....	92
Genie Gem-Maker.....	1-3
Accessories.....	3,13,18-20
Maintenance kit, parts.....	20-21
Gem-Lube.....	16
Geyser.....	20
Glass grinders.....	33
Glues, fillers.....	81,94
Goggles, safety.....	103
Gold pans.....	103
Grinders.....	1-6,33-34,36-37,78-79
Grinding wheels	
Galaxy.....	8-9
Miniature.....	27-28
Grit, tumbler.....	65-69
Ground fault circuit interrupter.....	20
Gryphon saws.....	38-39
H	
Hammer	
Jeweler's.....	87
Rock.....	102-103
Hand files.....	91
Heatless wheels.....	31
Holdes, clamps.....	22,24,50,89-90
Hoods, machine.....	21
Husky arbor.....	79
J	
Jeweler's Buff Kits.....	19
Jeweler's rouge.....	82
Jeweler's supplies, tools	
Beading tools.....	86,88-89,94-101
Bench tools.....	89-90
Files.....	91
Findings kit.....	3
Hammers.....	87
Polishing cloths.....	69
Saws.....	87
K	
Knot cutter.....	88
L	
Lamps	
Alcohol.....	16
Machine.....	20
Ultra-violet.....	85
Lap connector.....	21
Laps, discs.....	10-12,74-75
Lapping machines.....	70-73
Lathe, rock.....	76-77
Leathers, pump.....	21
Lens, hand, loupes.....	85
Lubricants.....	16,50
M	
Machine parts.....	21,41,54,64
Magnetic laps & discs.....	12,74-75
Magnifiers.....	20,84-85
Maintenance kits, gem-makers.....	20
Mallets.....	87
Mandrels	
Miniature.....	32
Ring.....	92
Marking tools, templates.....	17
Master lap.....	11
Measuring cups.....	81
Microsol.....	16
Mini-Novas.....	25
Motors, machine.....	21,64
Multi-Flex machine.....	36-37
N	
Needle files.....	91
Nova	
Polishing wheels.....	7
Magnetic Nova Laps.....	12,74
Mini-Novas, carving points.....	25
Disc.....	13
O	
Oil, coolant.....	50
Opticon sealer.....	81
Optivisor.....	84
P	
Pads, polishing.....	13
Parts, machine.....	21,41,54,64
Phenol points.....	28
Pick, rock.....	102-103
Pick, soldering.....	93
Pin-vise.....	86
Pixie Gem-Maker.....	1,5
Maintenance kit, parts.....	20-21
Pliers.....	93,95-101
Polishing	
Arbor 8".....	78-78
Buffs.....	19-83
Cloth.....	69
Compound, grit.....	14-15,65-68
Machine, flats.....	70-73
Pads.....	13

Wheels, points	7,13,25,28,32	Soldering supplies	93
Probe set.....	89	Spacers, wheel.....	6,21
Prong holder.....	89	Spindles, tapered	19,37,83
Prong pusher, lifter.....	90	Splash guards	21
Prospecting tools	102-103	Steel shot.....	68
Pump, machine.....	21	Stone gauge.....	92
Punch, leather.....	99	Swing-Arm saw	45
	R		T
Recirculating systems	47	Tapered spindles.....	19,37,83
Reamers, broaches	88	Templates	17
Ring		Third-hand.....	89
Gauge.....	92	Tin lap	11
Mandrels	92	Tin oxide	15,68
Saw	38	Titan Gem-Maker.....	1,4
Roc Oil.....	50	Maintenance kit, parts.....	21-21
Rock grabber.....	50	Tool holders.....	22,24
Rock, tumbling.....	65	Transformer, International voltage.....	39
Rockhound tools, picks.....	102-103	Trim saws	3-6,40-44
Rotating laps	72-73	Tripoli compound.....	82
Rouge, jeweler's.....	82	Tubing	
	S	Air.....	21
Safety goggles.....	103	Tumbler Shaft	64
Saw blade		Tumblers	55-63
Blades	3,51-53	Tumbler parts	56-64
Blade coolants.....	50	Tumbling grit	66-69
Dressing sticks.....	50	Tweezers.....	86,89,93
Ring blade.....	38	Twin-Grip.....	89
Wire, diamond	87		U
Saws, jeweler's	87	Ultra-violet lamps	85
Saw parts.....	41,54		V
Saws, rock		V-block clamp	90
Band.....	39	Vibra-Dry	67
BigFoot trim saw	6	Vibra-Dry extender	67
Genie trim saw	3	Vibrating lap.....	70-71
Glass, stained.....	38-39	Vice, bench.....	90
Pixie trim saw	5	Vice, pin	86
Recirculating system.....	47	Vice, rock grabber	50
Ring saw	38	Video, Genie	3
Slab	42-49		W
Swing-Arm	45	Water Aid	16,50
Trim	3,5-6,40-44	Wax, dopping	16
Wizard.....	40	Wax file	91
Scissors, shears	86,88	Wedge clamp.....	89
Scraper	89	Workstation, carvers.....	34,35
Scribes.....	17	Wes-Gem pliers.....	101
Sculpture Rock Lathe.....	76-77	Wire cutters	97-98,100
Shield, face.....	35	Wizard trim saw	40
Shipping information	IV-VI		
Silicon carbide			
Belts, discs	80		
Grit.....	66		
Sintered carving tools	26		
Slitter, diamond.....	28-29		
Slurry, diamond.....	11		

ORDER & SHIPPING INFORMATION

Use any one of these easy ways to order:

✓ **By toll free phone**
(USA and CANADA)

1-800-253-2954

International

1-760-255-1030

✓ **By fax**

1-760-255-1077

Fax your order any time of day or night.

✓ **By mail**

Simply fill out our handy order form or your own purchase order and send it to our mailing address below.

OUR BUSINESS HOURS

OFFICE: 8:00 A.M. – 5:00 P.M. Pacific time.
(GMT -8:00) Monday–Friday.

To order, check on a previous order or for other inquiries, please call during the hours above. Office closed Saturday and Sunday.

RETAIL SHOP: 9:00 A.M. – 4:30 P.M. Monday–Friday.
Saturday, 9:00 A.M. – 3:00* P.M.

*We close on holidays, and the Saturday preceding Monday holidays, and sometimes early other days. If you are coming from out of town, please call to make certain we will be open, or to make an appointment.

OUR ADDRESSES

MAILING ADDRESS: For all correspondence, remittances and orders.

2620 W. Main St.
Barstow, CA 92311

SHIPPING AND PLANT LOCATION:

Please send all returns, etc. by UPS to our plant location:

2620 W. Main St.
Barstow, CA 92311

EMAIL: diamondpacific@aol.com

HOW TO ORDER

State catalog number, item description and size when applicable. Also state year (or year purchased) and model type of machine when ordering replacement parts as some parts vary slightly from model to model.

DEALERS

Please write or call for dealer information.

PRICES

All prices subject to change without notice. **Items will be invoiced at current prices.** We reserve the right to correct any errors in this catalog.

MINIMUM ORDER FEE

Orders under \$20.00, including orders for spare parts, will be charged a \$2.00 service fee in addition to shipping and processing fees.

SPECIAL ORDER FEE

For special order items not manufactured by Diamond Pacific there will be a \$10.00 Special Order fee in addition to shipping and processing charges.

PAYMENT

Payment must accompany order. When sending payment with your order please allow enough to cover shipping and processing charges. We do honor Visa, Master Card, Discover Card, and American Express. Send your card number, expiration date, and your signature when ordering by mail if you wish to use a credit card. California residents must add sales tax.

SHIPPING CHARGES

To determine your shipping and processing charges, you will need to find your Zone by consulting the Official Zone Chart on page V. Then use the chart on page VI to find the shipping charge in your zone column for the weight of your order. Use the next full pound for fractions of a pound. Rates on this chart do include insurance coverage up to \$25,000. Shipping charges listed on page VI are subject to change without notice. Large equipment will be shipped via truck freight prepaid and billed to your invoice. For assistance with freight charges on large equipment please call our toll free customer service number, 1-800-253-2954.

USA ORDERS

We generally ship United Parcel Service or Fed Ex Ground Services whenever possible. Include your complete shipping address along with your mailing address and phone number. UPS/FEDEX will not deliver to a post office box.

If you require parcel post, please advise us. Parcel Post or other special services may incur additional charges.

SPECIAL AIR SERVICE*

Please call for quotes if you wish air service. We ship UPS 2nd Day or UPS Next Day service within the USA.

NOTE: We cannot ship adhesives via Air Freight.

ORDER & SHIPPING INFORMATION

CANADIAN ORDERS*

We ship UPS to those Canadian areas having that service, otherwise, orders weighing less than 66 lbs. will be shipped parcel post. Heavier orders will be shipped truck freight. **ORDERS CANNOT BE SHIPPED COD INTO CANADA.**

FOREIGN ORDERS*

We ship parcel post on orders below the weight limits for your country, and air or ocean freight collect on heavier orders. Generally, air freight is the best way. Please include complete shipping instructions. Fed Ex, UPS, or other air services are available to most countries. Brokerage and Customs fees are the responsibility of the Customer. We do not have any information on these charges; they are incurred at your country's Port of Entry.

* Foreign orders must have phone number for freight companies to contact. No orders accepted without phone number.

*** NOTE: We cannot ship adhesive products to Canada or elsewhere outside the USA. Also, we cannot ship these products within the USA via air freight.**

DELIVERY, BACK ORDERS, AND SHORTAGES

Orders for standard catalog items are generally packed within 3-5 business days and shipped by ground carrier. Allow sufficient transit time from our factory to your destination when estimating delivery time.

For large quantities, special order or modified items, please call for prices and delivery time. Orders may be shipped in two or more cartons, and will be marked that way on the carton. If all cartons are not received within 3-4 working days please call customer service. For shortages in complete shipments, contact Customer Service immediately and provide the invoice number as shown on the packing slip.

Be sure to examine the contents and packing material carefully for small items that may have been missed during the unpacking of the parcel.

If an item is not available for shipment within the delivery time, it will be back ordered and shipped as soon as possible by ground carrier. Back ordered items will be indicated on the shipment's packing list.

Our back order policy does not apply to International shipments because of shipping restrictions. These items should be added to your next order.

RETURN OF MERCHANDISE

Any merchandise received that is not satisfactory may be returned to us within ten days of receipt for full refund of **purchase price of item only**, provided merchandise is returned in its ORIGINAL CONDITION and shipping is prepaid. Insure the items for full value as we cannot be responsible for loss or damage in return transit. Any item returned after the 10 days may not be accepted for refund and will be subject to a 20% re-stocking fee.

OFFICIAL ZONE CHART

This chart shows the zone from Barstow, California, for your ZIP Code. To use the chart find your ZIP Code Prefix (the first three numbers of your ZIP Code). Your delivery

ZONE from Barstow is shown to the right of the prefix. To determine the estimated shipping costs use the standard shipping/processing chart on the next page.

ZIP CODE PREFIX	UPS ZONE	ZIP CODE PREFIX	UPS ZONE	ZIP CODE PREFIX	UPS ZONE	ZIP CODE PREFIX	UPS ZONE	ZIP CODE PREFIX	UPS ZONE	ZIP CODE PREFIX	UPS ZONE	ZIP CODE PREFIX	UPS ZONE	ZIP CODE PREFIX	UPS ZONE
004-306	8	399	8	492	8	565	6	636-639	7	700-709	7	797-799	5	865-874	4
307	7	400-402	7	493-495	7	566-567	7	640-649	6	710-711	6	800-812	5	875-877	5
308-324	8	403-418	8	496-497	8	570-576	6	650-652	7	712-716	7	813-815	4	878-879	4
325	7	420-424	7	498-499	7	577	5	653	6	717-719	6	816-832	5	880-885	5
326-349	8	425-426	8	500-503	6	580-588	6	654-655	7	720-725	7	833	4	889-892	3
350-362	7	427	7	504	7	590-591	5	656-676	6	726-738	6	834-838	5	893-898	4
363	8	430-459	8	505	6	592-593	6	677-679	5	739	5	840-847	4	900-935	2
364-367	7	460-469	7	506-507	7	594	5	680-689	6	740-768	6	850-851	3	936-939	3
368	8	470	8	508-516	6	595	6	690	5	769	5	852	4	940-961	4
369-375	7	471-479	7	520-559	7	596-599	5	692	6	770-789	6	853-854	3	970-975	5
376-379	8	480-489	8	560-562	6	600-634	7	691-692	6	790-794	5	855-860	4	976	4
380-397	7	490-491	7	563-564	7	635	6	693	5	795-796	6	863-864	3	977-994	5

Please Note →

DAMAGE IN SHIPMENT

Open your packages upon receipt. **SAVE ALL PACKING AND CARTONS UNTIL YOU ARE CERTAIN MERCHANDISE IS NOT DAMAGED.** Any adjustment for damage to merchandise in shipment must be made to the carrier.

If there is any visible damage at time of delivery, the carrier must make note of this on receipt. In case of concealed damage discovered after unpacking, contact the delivery carrier immediately and request an inspection. **SAVE ALL PACKING AND CARTONS.**

SHIPPING AND PROCESSING CHARGES*

To determine your shipping and processing charges, you will first need to find your Zone by consulting the Official Zone Chart on page V. Then find the shipping charge in your Zone column

for the weight of your order. Use the next full pound rate for fractions of a pound.

* See page V for complete information

We will bill at current shipping charges.

Lbs	Zone 2	Zone 3	Zone 4	Zone 5	Zone 6	Zone 7	Zone 8	Lbs	Zone 2	Zone 3	Zone 4	Zone 5	Zone 6	Zone 7	Zone 8
1	\$9.62	\$9.87	\$10.03	\$10.35	\$10.77	\$10.87	\$10.99	76	\$44.88	\$50.59	\$53.16	\$60.80	\$69.90	\$79.13	\$85.61
2	\$10.08	\$10.54	\$11.20	\$11.39	\$11.98	\$12.17	\$12.53	77	\$46.31	\$51.88	\$54.47	\$62.00	\$71.15	\$80.60	\$86.15
3	\$10.32	\$11.07	\$11.81	\$12.11	\$12.74	\$13.03	\$13.75	78	\$47.67	\$53.12	\$55.64	\$63.13	\$72.40	\$81.99	\$86.70
4	\$10.69	\$11.50	\$12.42	\$12.88	\$13.45	\$13.79	\$14.64	79	\$49.05	\$54.39	\$56.95	\$64.47	\$73.07	\$82.82	\$87.55
5	\$11.13	\$11.75	\$12.96	\$13.40	\$14.02	\$14.45	\$15.42	80	\$50.53	\$55.77	\$58.27	\$65.77	\$74.30	\$83.38	\$88.43
6	\$11.45	\$12.11	\$13.21	\$13.75	\$14.31	\$14.89	\$15.89	81	\$51.55	\$56.73	\$59.53	\$66.73	\$75.33	\$84.54	\$89.11
7	\$11.97	\$12.46	\$13.50	\$14.13	\$14.73	\$15.30	\$16.40	82	\$53.02	\$58.01	\$60.86	\$68.01	\$76.38	\$85.78	\$90.24
8	\$12.43	\$12.87	\$13.90	\$14.45	\$15.22	\$15.94	\$17.31	83	\$54.55	\$59.16	\$62.21	\$69.33	\$77.61	\$87.02	\$91.39
9	\$12.79	\$13.26	\$14.20	\$14.84	\$15.61	\$16.71	\$18.30	84	\$56.08	\$60.48	\$63.49	\$70.64	\$78.84	\$88.20	\$92.55
10	\$13.23	\$13.47	\$14.54	\$15.30	\$16.27	\$17.79	\$19.43	85	\$57.48	\$61.82	\$64.75	\$71.93	\$80.06	\$89.27	\$93.69
11	\$13.72	\$14.06	\$14.89	\$15.69	\$16.88	\$18.88	\$20.63	86	\$58.99	\$63.09	\$66.06	\$73.24	\$81.25	\$90.34	\$94.84
12	\$14.16	\$14.54	\$15.28	\$16.09	\$17.62	\$19.97	\$21.94	87	\$60.47	\$64.45	\$67.50	\$74.52	\$82.36	\$91.40	\$95.96
13	\$14.65	\$15.02	\$15.62	\$16.55	\$18.40	\$21.11	\$23.26	88	\$62.08	\$65.77	\$68.80	\$75.85	\$83.51	\$92.47	\$97.15
14	\$15.03	\$15.52	\$16.02	\$17.00	\$19.37	\$22.19	\$24.58	89	\$63.68	\$67.06	\$70.11	\$77.13	\$84.63	\$93.55	\$98.31
15	\$15.42	\$16.04	\$16.39	\$17.48	\$20.33	\$23.33	\$25.91	90	\$65.24	\$68.21	\$71.20	\$77.95	\$85.45	\$94.22	\$99.39
16	\$15.72	\$16.36	\$16.72	\$17.87	\$21.07	\$24.27	\$27.05	91	\$66.59	\$69.48	\$72.56	\$79.25	\$86.57	\$95.27	\$100.54
17	\$16.05	\$16.94	\$17.30	\$18.62	\$22.18	\$25.53	\$28.48	92	\$68.02	\$70.70	\$73.72	\$80.35	\$87.68	\$96.39	\$101.72
18	\$16.41	\$17.49	\$17.91	\$19.53	\$23.23	\$26.67	\$29.88	93	\$69.43	\$71.96	\$75.09	\$81.48	\$88.64	\$97.33	\$102.83
19	\$16.82	\$18.11	\$18.59	\$20.39	\$24.22	\$27.81	\$31.27	94	\$70.87	\$73.17	\$76.22	\$82.56	\$89.75	\$98.44	\$103.98
20	\$17.27	\$18.75	\$19.28	\$21.30	\$25.27	\$28.98	\$32.69	95	\$72.31	\$74.33	\$77.46	\$83.66	\$90.64	\$99.33	\$105.11
21	\$17.73	\$19.38	\$19.93	\$22.17	\$26.29	\$30.11	\$34.04	96	\$73.74	\$75.51	\$78.76	\$84.76	\$91.62	\$100.24	\$106.22
22	\$18.23	\$20.00	\$20.65	\$23.00	\$27.34	\$31.30	\$35.48	97	\$75.25	\$76.85	\$80.03	\$86.06	\$92.75	\$101.38	\$107.42
23	\$18.73	\$20.64	\$21.34	\$23.84	\$28.36	\$32.44	\$36.89	98	\$76.74	\$78.04	\$81.45	\$87.14	\$93.86	\$102.49	\$108.54
24	\$19.21	\$21.22	\$22.04	\$24.63	\$29.41	\$33.57	\$38.29	99	\$78.26	\$79.24	\$82.89	\$88.26	\$94.98	\$103.60	\$109.73
25	\$19.74	\$21.83	\$22.68	\$25.37	\$30.42	\$34.70	\$39.68	100	\$79.60	\$80.46	\$84.30	\$89.54	\$96.08	\$104.72	\$110.88
26	\$20.31	\$22.41	\$23.39	\$26.22	\$31.53	\$35.84	\$41.09	101	\$80.88	\$81.67	\$85.72	\$90.78	\$97.19	\$105.82	\$112.00
27	\$20.82	\$22.97	\$23.98	\$27.01	\$32.55	\$36.98	\$42.49	102	\$81.72	\$82.82	\$86.71	\$91.91	\$98.21	\$106.85	\$113.11
28	\$21.30	\$23.57	\$24.72	\$27.83	\$33.59	\$38.12	\$43.93	103	\$82.99	\$84.00	\$87.75	\$92.89	\$99.23	\$107.90	\$114.18
29	\$21.82	\$24.09	\$25.44	\$28.57	\$34.57	\$39.16	\$45.26	104	\$84.21	\$85.15	\$88.78	\$93.87	\$100.25	\$108.93	\$115.30
30	\$22.39	\$24.73	\$26.21	\$29.41	\$35.66	\$40.30	\$46.70	105	\$85.48	\$86.35	\$89.79	\$94.87	\$101.25	\$109.98	\$116.36
31	\$22.88	\$25.27	\$26.88	\$30.21	\$36.67	\$41.42	\$48.07	106	\$86.76	\$87.53	\$90.83	\$95.85	\$102.27	\$111.00	\$117.48
32	\$23.23	\$25.86	\$27.60	\$31.06	\$37.70	\$42.57	\$49.49	107	\$87.93	\$88.74	\$91.86	\$96.85	\$103.29	\$112.04	\$118.59
33	\$23.73	\$26.48	\$28.30	\$31.89	\$38.69	\$43.70	\$50.88	108	\$89.09	\$89.91	\$92.87	\$97.83	\$104.30	\$113.06	\$119.67
34	\$24.13	\$27.08	\$28.97	\$32.70	\$39.71	\$44.83	\$52.26	109	\$90.28	\$91.10	\$93.89	\$98.81	\$105.30	\$114.09	\$120.77
35	\$24.62	\$27.73	\$29.67	\$33.52	\$40.73	\$45.96	\$53.62	110	\$91.36	\$92.31	\$94.94	\$99.79	\$106.33	\$115.12	\$121.88
36	\$25.09	\$28.19	\$30.32	\$34.33	\$41.71	\$47.07	\$54.87	111	\$92.32	\$93.29	\$95.96	\$100.75	\$107.31	\$116.12	\$122.93
37	\$25.59	\$28.83	\$30.97	\$35.14	\$42.66	\$48.20	\$55.96	112	\$93.28	\$94.27	\$96.97	\$101.73	\$108.31	\$117.15	\$123.99
38	\$26.02	\$29.32	\$31.64	\$35.94	\$43.59	\$49.31	\$57.02	113	\$94.25	\$95.28	\$98.00	\$102.70	\$109.30	\$118.15	\$125.04
39	\$26.45	\$29.91	\$32.33	\$36.73	\$44.54	\$50.43	\$58.10	114	\$95.20	\$96.27	\$99.00	\$103.67	\$110.30	\$119.14	\$126.10
40	\$26.81	\$30.54	\$33.01	\$37.50	\$45.43	\$51.49	\$59.11	115	\$96.21	\$97.31	\$100.06	\$104.66	\$111.30	\$120.17	\$127.18
41	\$27.26	\$31.06	\$33.65	\$38.28	\$46.32	\$52.55	\$60.13	116	\$97.18	\$98.30	\$101.09	\$105.66	\$112.31	\$121.17	\$128.24
42	\$27.72	\$31.52	\$34.30	\$39.04	\$47.17	\$53.61	\$61.15	117	\$98.12	\$99.29	\$102.09	\$106.60	\$113.27	\$122.17	\$129.31
43	\$28.15	\$32.10	\$34.99	\$39.85	\$48.07	\$54.74	\$62.22	118	\$99.13	\$100.32	\$103.14	\$107.58	\$114.27	\$123.19	\$130.36
44	\$28.54	\$32.63	\$35.56	\$40.63	\$48.91	\$55.83	\$63.26	119	\$100.11	\$101.34	\$104.17	\$108.55	\$115.28	\$124.20	\$131.43
45	\$28.94	\$33.21	\$36.22	\$41.43	\$49.78	\$56.94	\$64.33	120	\$101.64	\$102.36	\$105.24	\$109.56	\$116.29	\$125.21	\$132.54
46	\$29.31	\$33.74	\$36.77	\$42.16	\$50.56	\$58.03	\$65.38	121	\$102.69	\$103.40	\$106.28	\$110.55	\$117.32	\$126.23	\$133.60
47	\$29.69	\$34.16	\$37.36	\$42.92	\$51.29	\$59.12	\$66.43	122	\$103.46	\$104.39	\$107.32	\$111.51	\$118.28	\$127.21	\$134.69
48	\$30.07	\$34.65	\$37.94	\$43.62	\$52.05	\$60.21	\$67.49	123	\$104.48	\$105.42	\$108.39	\$112.50	\$119.31	\$128.23	\$135.77
49	\$30.43	\$35.11	\$38.49	\$44.36	\$52.76	\$61.30	\$68.53	124	\$105.47	\$106.47	\$109.44	\$113.50	\$120.31	\$129.23	\$136.84
50	\$30.79	\$35.55	\$39.03	\$45.00	\$53.45	\$62.39	\$69.57	125	\$106.47	\$107.48	\$110.49	\$114.46	\$121.30	\$130.22	\$137.91
51	\$31.12	\$35.93	\$39.51	\$45.66	\$54.11	\$63.41	\$70.60	126	\$107.49	\$108.52	\$111.55	\$115.47	\$122.32	\$131.24	\$139.03
52	\$31.48	\$36.28	\$39.95	\$46.28	\$54.79	\$64.37	\$71.64	127	\$108.48	\$109.55	\$112.61	\$116.45	\$123.32	\$132.23	\$140.09
53	\$31.81	\$36.69	\$40.35	\$46.88	\$55.43	\$65.16	\$72.66	128	\$109.51	\$110.61	\$113.68	\$117.44	\$124.33	\$133.23	\$141.20
54	\$32.16	\$37.05	\$40.87	\$47.49	\$56.10	\$65.80	\$73.68	129	\$110.51	\$111.64	\$114.74	\$118.44	\$125.33	\$134.23	\$142.27
55	\$32.49	\$37.41	\$41.28	\$48.13	\$56.75	\$66.33	\$74.68	130	\$111.54	\$112.68	\$115.78	\$119.41	\$126.32	\$135.24	\$143.36
56	\$32.81	\$37.77	\$41.74	\$48.78	\$57.39	\$66.87	\$75.69	131	\$112.58	\$113.74	\$116.89	\$120.43	\$127.34	\$136.25	\$144.44
57	\$33.15	\$38.17	\$42.19	\$49.44	\$58.02	\$67.42	\$76.63	132	\$113.58	\$114.78	\$117.95	\$121.40	\$128.35	\$137.24	\$145.51
58	\$33.47	\$38.57	\$42.64	\$49.94	\$58.65	\$67.85	\$77.38	133	\$114.62	\$115.84	\$119.03	\$122.40	\$129.35	\$138.25	\$146.60
59	\$33.77	\$38.95	\$43.10	\$50.40	\$59.17	\$68.28	\$77.97	134	\$115.64	\$116.89	\$120.12	\$123.42	\$130.37	\$139.24	\$147.70
60	\$34.07	\$39.32	\$43.53	\$50.78	\$59.65	\$68.66	\$78.46	135	\$116.67	\$117.97	\$121.20	\$124.44	\$131.42	\$140.29	\$148.78
61	\$34.40	\$39.69	\$43.97	\$51.33	\$60.20	\$69.10	\$78.98	136	\$117.70	\$119.00	\$122.30	\$125.47	\$132.46	\$141.34	\$149.90
62	\$34.64	\$39.99	\$44.34	\$51.74	\$60.63	\$69.52	\$79.47	137	\$118.73	\$120.10	\$123.40	\$126.41	\$133.42	\$142.25	\$150.99
63	\$34.93	\$40.35	\$44.73	\$52.16	\$61.02	\$69.98	\$79.96	138	\$119.79	\$121.23	\$124.56	\$127.58	\$134.60	\$143.43	\$152.10
64	\$35.21	\$40.72	\$45.15	\$52.55	\$61.46	\$70.46	\$80.45	139	\$120.83	\$122.35	\$125.68	\$128.63	\$135.65	\$144.47	\$153.17
65	\$35.50	\$41.14	\$45.64	\$52.92	\$61.99	\$70.88	\$80.97	140	\$121.90	\$123.49	\$126.82	\$129.68	\$136.72	\$145.54	\$154.29
66	\$35.77	\$41.58	\$46.10	\$53.29	\$62.59	\$71.26	\$81.56	141	\$122.94	\$124.58	\$127.98	\$130.72	\$137.78	\$146.58	\$155.40
67	\$36.05	\$41.96	\$46.50	\$53.61	\$63.07	\$71.62	\$81.83	142	\$123.54	\$125.69	\$129.10	\$131.76	\$138.82	\$147.61	\$156.47
68	\$36.31	\$42.33	\$46.89	\$53.92	\$63.41	\$72.02	\$82.06	143	\$124.61	\$126.82	\$130.26	\$132.83	\$139.89	\$148.67	\$157.57
69	\$36.57	\$42.68	\$47.27	\$54.23	\$63.75	\$72.42	\$82.32	144	\$125.66	\$127.94	\$131.41	\$133.87	\$140.96	\$149.72	\$158.66
70	\$36.81	\$43.03	\$47.68	\$54.49	\$63.98	\$72.75	\$82.49	145	\$126.24	\$129.07	\$132.56	\$134.93	\$142.01	\$150.75	\$159.75
71	\$37.71	\$43.87	\$48.09	\$55.10	\$64.56	\$73.09	\$82.89	146	\$127.31	\$130.19	\$133.71	\$135.97	\$143.06	\$151.80	\$160.82
72	\$39.17	\$45.24	\$48.83	\$56.16	\$65.60	\$74.08	\$83.39	147	\$128.36	\$131.34	\$134.89	\$137.04	\$144.15	\$152.85	\$161.96
73	\$40.61	\$46.56	\$49.60	\$57.15	\$66.77	\$75.31	\$83.9								



CUSTOMER ORDER BLANK

PHONE: (800) 253-2954 USA 10/10
 (760) 255-1030 International
 FAX: (760) 255-1077
 2620 W Main St, Barstow, CA 92311

TELEPHONE NUMBER _____

NAME _____ DATE _____

MAILING ADDRESS _____

SHIPPING ADDRESS _____

CITY _____ STATE _____ ZIP _____

QUANTITY	ORDER #	DESCRIPTION OF ITEM	UNIT PRICE	TOTAL	SHIPPING	
					lbs.	oz.

PLEASE INDICATE MANNER OF PAYMENT BELOW
 CHECK VISA MASTER CARD DISCOVER AMEX

CARD # _____

EXPIRATION DATE _____

CARD HOLDER'S SIGNATURE _____

		TOTAL	
		lbs.	oz.
TOTAL FOR GOODS			
ADD \$2.00 FEE ON ORDERS UNDER \$20.00			
CA RESIDENTS ADD 8.25% SALES TAX			
AMOUNT FOR SHIPPING/HANDLING			
TOTAL AMOUNT			
		TOTAL WT. IN POUNDS	

Dear Friends,
 We've taken one of our popular machines and made it even better while trying to lower the cost of its manufacture. That isn't always an easy job, but we think we have succeeded this time. Our new Wizard-4G Trim Saw has most of the features that made it so popular—uses water as a coolant, easy to carry around, large capacity table and high torque motor with plenty of power. What we've changed is some of the components to make it less costly (but just as durable and easy to clean), and eliminated some of the water spray with a modification in design. We still think the Wizard-4G Trim Saw is the best you can buy for its new lower price.

Sincerely,
Bill E. Depue
 Bill E. Depue
 President



For more information on the Wizard, see page 40.

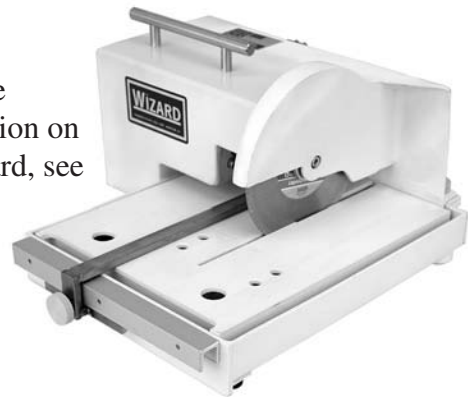

Outside catalog cover photos:	Lara Hartly
Inside catalog cover photos:	Wayne Mallon
Catalog design and production:	Jill Durbin
Computer layout:	Penny Duitsman

We invite you to stop by our plant whenever you are in our area.

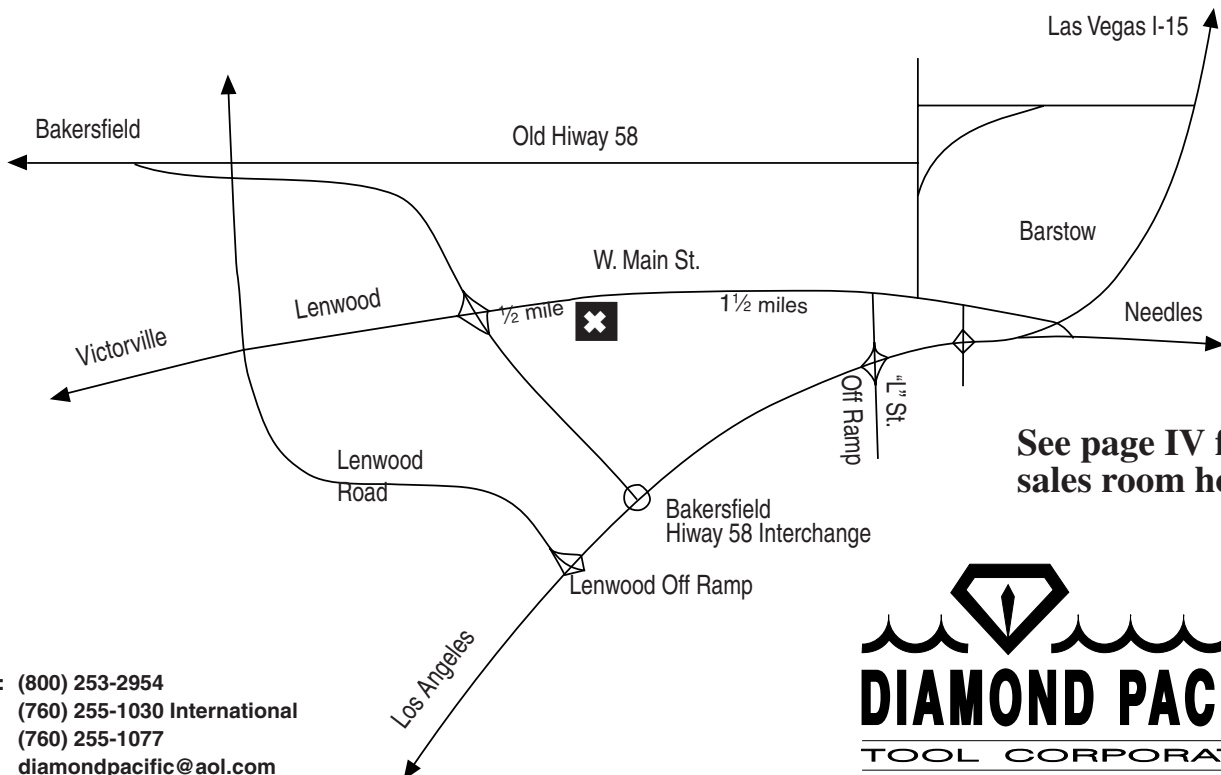

See page IV for sales room hours.

PHONE: (800) 253-2954
 (760) 255-1030 International
 FAX: (760) 255-1077
 EMAIL: diamondpacific@aol.com
 MAIL: 2620 W Main St., Barstow, CA 92311

DIAMOND PACIFIC
 TOOL CORPORATION
 2620 W. Main St., Barstow, CA 92311

TRIM SAW ATTACHMENTS FOR GEM-MAKERS

We've added a trim saw attachment for the Pixie making that Gem-Maker even more handy for it's user. Both the Genie and Big-Foot trim saw attachments have been popular accessories, providing their users with a handy trim saw at an economical price compared to purchasing a separate trim saw.



The Genie 8" Trim Saw Attachment

Shown in the photo above installed on a Genie, this trim saw set-up is easy to install and use. Takes only a few minutes to remove the right hand wheels and attach the trim saw blade, hood and saw table in their place. SEE PAGE 3 FOR MORE INFORMATION AND TO ORDER.

The Pixie 6" Trim Saw Attachment

Turns your Pixie into a handy 6" trim saw. Just spin off the right hand Nova Wheel and its adaptor, and spin on the special saw adaptor with blade, set the stainless steel table in place, and go to work. SEE PAGE 5 FOR MORE INFORMATION AND TO ORDER.

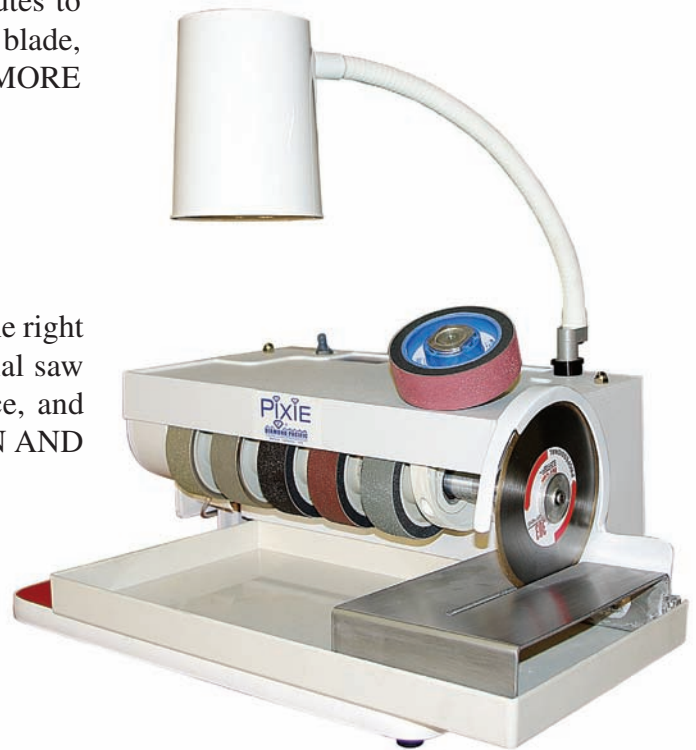

BigFoot 4" Trim Saw Attachment

With the BigFoot 4" trim saw attachment, this little Gem-Maker becomes a big machine in capability and convenience, The trim saw attachment installs easily in the place of the right hand wheels. SEE PAGE 6 FOR MORE INFORMATION AND TO ORDER.

DIAMOND PACIFIC
TOOL CORPORATION
P.O. Box 1180, Barstow, CA 92312
1-800-253-2954

PRESRT STD
US POSTAGE PAID
BARSTOW, CA
PERMIT NO. 170

