

INSTRUCTION MANUAL
MODEL 2001
SWEEP/SIGNAL
GENERATOR

WAVETEK[®] INDIANA INC.

66 N. 1st AVENUE, P.O. BOX 190

BEECH GROVE, INDIANA 46107

317—783-3221

CONTENTS

| | | |
|---|--|------|
| SECTION 1 – GENERAL INFORMATION | | |
| 1.1 | INTRODUCTION | 1-1 |
| 1.2 | SPECIFICATIONS | 1-1 |
| 1.3 | OPTIONS | 1-4 |
| 1.4 | ACCESSORIES | 1-5 |
| SECTION 2 – INSTALLATION | | |
| 2.1 | MECHANICAL INSTALLATION | 2-1 |
| 2.2 | ELECTRICAL INSTALLATION | 2-2 |
| SECTION 3 – OPERATING INSTRUCTIONS | | |
| 3.1 | INTRODUCTION | 3-2 |
| 3.2 | DESCRIPTION OF FRONT PANEL | 3-2 |
| 3.3 | DESCRIPTION OF REAR PANEL | 3-4 |
| 3.4 | TYPICAL OPERATING SET-UP | 3-5 |
| 3.5 | SPECIAL OPERATING NOTES | 3-6 |
| 3.6 | PROGRAMMING | 3-7 |
| SECTION 4 – CIRCUIT DESCRIPTION | | |
| 4.1 | MECHANICAL ARRANGEMENT | 4-3 |
| 4.2 | SIMPLIFIED BLOCK DIAGRAM | 4-3 |
| 4.3 | POWER SUPPLY | 4-4 |
| 4.4 | SWEEP RATE (MODULE M1H) | 4-4 |
| 4.5 | SWEEP DRIVE (MODULE M2H) | 4-6 |
| 4.6 | SWEEP OSCILLATOR, BAND 1 (MODULE M9H) | 4-6 |
| 4.7 | OUTPUT AMPLIFIER, BAND 1 (MODULE M10H) | 4-6 |
| 4.8 | SWEEP OSCILLATOR, BANDS 2 & 3 (MODULE M19H) | 4-7 |
| 4.9 | MARKER ADDER (MODULE M5H) | 4-8 |
| 4.10 | MARKERS (MODULE M6's) | 4-8 |
| SECTION 5 – MAINTENANCE | | |
| 5.1 | INTRODUCTION | 5-1 |
| 5.2 | SERVICE INFORMATION | 5-1 |
| 5.3 | PERFORMANCE CHECKS | 5-3 |
| 5.4 | MECHANICAL ADJUSTMENT OF FREQUENCY INDICATOR TAPES | 5-7 |
| 5.5 | CALIBRATION PROCEDURE | 5-8 |
| 5.6 | TROUBLESHOOTING | 5-12 |
| SECTION 6 – PARTS LISTS | | |
| 6.1 | INTRODUCTION | 6-1 |
| 6.2 | MANUFACTURERS CODE | 6-1 |
| SECTION 7 – SCHEMATICS | | |
| 7.1 | INTRODUCTION | 7-1 |
| 7.2 | SCHEMATIC NOTES | 7-1 |
| 7.3 | ABBREVIATION CODE | 7-2 |
| 7.4 | SCHEMATIC INDEX | 7-2 |

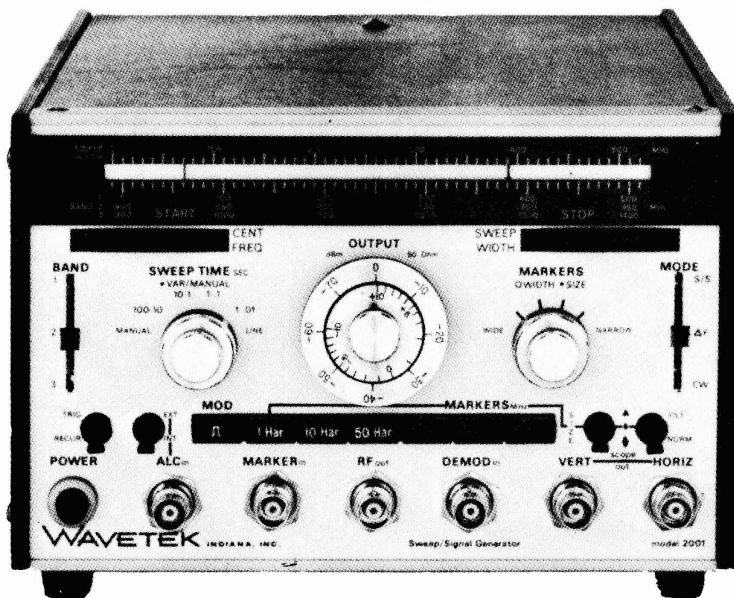

FIGURE i – MODEL 2001 SWEEP/SIGNAL GENERATOR

SCOPE OF THIS MANUAL

This manual provides descriptive material and instructions for the installation, operation, maintenance, and repair of the WAVETEK Model 2001 Sweep/Signal Generator.

SECTION 1

GENERAL INFORMATION

1.1 INTRODUCTION

The compact WAVETEK MODEL 2001 Sweep/Signal Generator offers programming, versatility and an exceptionally wide frequency range (1 to 1400 MHz) in a ruggedized inexpensive instrument. Its unique adaptability promotes sophisticated laboratory applications, as well as automatic production testing.

Each of its three frequency ranges (1-500 MHz, 450-950 MHz, and 900-1400 MHz) may be used in 3 modes of operation; start-stop, Δf or CW. It can be swept from end-to-end, up-or-down, at any rate from 50 sweeps per second to 1 sweep every 100 seconds. Manual, triggered, or recurring sweeps are provided and the sweep frequency, sweep width, and output attenuation all may be controlled by external voltages.

Up to six crystal controlled birdy marker modules (single frequency or harmonic type) may be plugged into the 2001. Each module has its own Front Panel On/Off switch. Front Panel amplitude and width controls enable optimum adjustment of the marker display. In application, the

markers may be tilted 90° for easy viewing when displayed with steep transition signals or rectified for X-Y plotter applications by a Front Panel switch. A 1kHz square wave modulator, providing 100% amplitude modulation of the RF output for low level recovery applications, is available as an optional feature.

Most optional features, as well as the functional circuits for the basic sweep generator, have modular plug-in construction. This allows optional features to be factory installed at the time of purchase, or customer installed at a later date. This concept offers protection against obsolescence since updated and additional features can be simply and economically added as new test procedures dictate.

Maintenance problems can be greatly simplified by stocking several modules instead of hundreds of discrete components. Servicing time of a defective instrument can be cut to a fraction of the time previously required and can be performed by relatively inexperienced technicians. Modules for the 2001 are stocked in Wavetek service centers around the world.

1.2 SPECIFICATIONS

Table 1-1. lists the specifications for MODEL 2001 Sweep/Signal Generator.

**TABLE 1-1.
SPECIFICATIONS**

| <u>RF SPECIFICATIONS</u> | |
|--------------------------|---|
| Frequency Range – | 1 to 1400 MHz in three overlapping bands Band 1 1 to 500 MHz Band 2 450 to 950 MHz Band 3 900 to 1400 MHz |
| Operating Modes – | Start/Stop, Δf , and CW |

TABLE 1-1. Specifications (Con't.)

| | |
|--|--|
| Frequency Dial Calibration — | 10 MHz intervals |
| Accuracy — | Band 1 10 MHz Band 2 2% of selected frequency Band 3 2% of selected frequency |
| Sweep Width — | 200 kHz to 500 MHz-calibrated in 10 MHz intervals |
| Accuracy — | Band 1 ±10 MHz Band 2 ±20 MHz Band 3 ±20 MHz |
| Display Linearity — | 2% |
| Spurious Signals — | Band 1 10 to 500 MHz 26dB below output Band 2 500 to 950 MHz, 26dB below output Band 3 900 to 1400 MHz, 26dB below output |
| Residual FM — | Less than 15kHz |
| Drift — | 100 kHz/5 minutes — 2 MHz/8 hours (after 1/2 hour warm-up at a constant ambient, and allowing a 5 minute stabilizing period after a frequency change) |
| Blanking — | Retrace blanking of the RF output provided for sweep operation. Removed for CW operation. |
| RF Output Amplitude — | Continuously adjustable from +10 to -80 dBm; 70 dB in 10 dB steps, plus a 20 dB vernier, calibrated in 1 dB increments. Step attenuator and vernier attenuator accuracy: ±0.5 dB to 500 MHz ±1 dB to 1000 MHz ±2 dB to 1400 MHz |
| Flatness at +10 dBm — | ±0.5 dB over 1 to 1400 MHz (when read with negative detector) ±0.75 dB over 1 to 1400 MHz (when read with a power meter) |
| Impedance — | 50 ohms |
| REMOTE PROGRAMMING | |
| A Rear Panel REMOTE Jack provides necessary connections for Remote Control of frequency, sweep width and the 0 to 20 dB vernier output control. This jack also provides connections for EXTERNAL amplitude and frequency modulation. | |
| Frequency — | May be remotely programmed within the selected band by a ±16 V signal. (-16 volts corresponds to LOW frequency) |

TABLE 1-1. Specifications (Con't.)

| | |
|------------------------------|---|
| | band end and +16 volts to HIGH frequency band end) Tuning sensitivity: 16 MHz/volt (approx.) |
| Sweep Width – | May be controlled by a remote potentiometer. (Input and output connections provided in Rear Panel REMOTE jack) |
| Vernier 0-20 dB Output – | May be remotely programmed over a 20 dB range with a 0 to -18 volt signal. (-18 volts corresponds to a maximum output) |
| External FM – | Full deviation of ± 250 MHz possible at rates up to 4kHz. With reduced deviation and linearity, modulation rates to 100kHz are possible. Sensitivity: 16 MHz/volt (approx.) |
| External AM – | External AM signals are applied to same connections as for vernier 0-20 dB control. Therefore, vernier range must be restricted so the 0 to -18 volt range is not exceeded or distortion will occur. With average voltage set to mid-range, 100% modulation is possible to 1kHz, 40% modulation possible to a 40kHz rate. |
| <u>SWEEP SPECIFICATIONS</u> | |
| Sweep Modes -- | Repetative sweep Single sweep Externally triggered sweep Manual sweep Line lock sweep |
| Sweep time – | Continuously variable from less than 10 ms to over 100 seconds, in 4-decade steps, plus vernier |
| Horizontal Output – | 16 volts peak-to-peak (symmetrical about ground) |
| <u>EXTERNAL LEVELING</u> | |
| External Monitor (ALC) – | An external negative signal, between 0.2 and 2 volts, may be used to level the RF output |
| <u>MARKER SPECIFICATIONS</u> | |
| Type – | Birdy by-pass markers with provisions for six plug-in marker modules, plus Front Panel external marker input. Markers may be either single frequency or harmonic (comb.) type. (See Options A1 and A2) |
| Accuracy – | 0.005% |

TABLE 1-1. Specifications (Con't.)

| | |
|--|---|
| External Market Input – | Front Panel BNC connector accepts external CW signal for conversion to a Birdy marker. Input level: 100 mV into 50 ohms |
| Marker Width – | Adjustable from (approx.) 15 to 400 kHz in four steps |
| Marker Size | |
| Large – | Adjustable from (approx.) 12 V to 15 mV peak-to-peak |
| Small – | Adjustable from (approx.) 50 mV to 100 uV peak-to-peak |
| Rectified Birdy (for use with X-Y plotters) – | Size varies with detector's impedance. Adjustable from (approx.) 6 V to 1 mV with detector impedance of 1 meg ohm, or from 0.5V to 1 mV with detector impedance of 0 ohms. Rectified birdy is positive polarity |
| Marker Tilt – | Provides horizontal markers have a size equal to approximately 10% of horizontal display. Adjustment of marker size vectority adds the normal vertical marker to the horizontal marker, causing the resulting marker to vary from a horizontal position toward a vertical position. |

POWER REQUIREMENTS

Line Supply 115 or 230 VAC ±10%, 50 to 60 Hz, (approx 20 watts)

MECHANICAL SPECIFICATIONS (See Figure 1-1.)

- A For total length, including knobs, add 11/16 inch
- B For total height, including feet, add 5/8 inch
- C For total width, including screw heads, add 3/16 inch

Weight
 Net – 19 lbs.
 Shipping – 25 lbs.

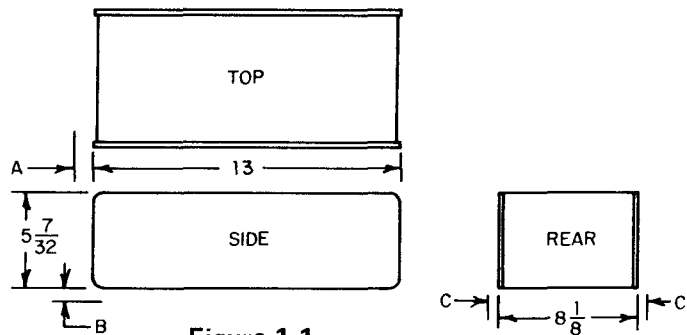

Figure 1-1.

1.3 OPTIONS

- 1.3.1 Marker A-1. Any single frequency between 1 to 1400 MHz.
- 1.3.2 Marker A-2. Harmonic type at 1, 10 or 50 MHz. (Other frequencies available on special order.)
- 1.3.3 Modulator A-4. Provides 100% amplitude modulation at a 1 kHz rate.
- 1.3.4 Perlift A-5. Provides contact closure during sweep time.

1.4 ACCESSORIES

1.4.1 Accessories furnished: Instruction manual and plug to mate with Rear Panel REMOTE jacks.

1.4.2 Accessories Available:

- a. Wide-band RF Detector – Model D-152.
- b. Service Kit – K102. Contains a module extender and extension cables.
- c. Rack Mount Kit – K103. Mounts single instruments in a 5-1/4 inch space. See Figure 2-1.
- d. Rack Mount Kit – K104. Mounts one or two instruments in a 7 inch space. See Figure 2-2.

SECTION 2 INSTALLATION

2.1 MECHANICAL INSTALLATION

2.1.1 Initial Inspection

After unpacking the instrument, visually inspect the external parts for damage to knobs, connectors, surface areas, etc. The shipping container and packing material should be saved in case it is necessary to reship the unit.

2.1.2 Damage Claims

If the instrument is received mechanically damaged in transit, notify the carrier and either the nearest Wavetek area representative or the factory in Indiana. Retain the shipping carton and packing material for the carrier's inspection.

The local representative, or the factory, will immediately arrange for either the replacement or repair of your instrument, without waiting for damage claim settlements.

2.1.3 Rack Mounting

The instrument is 1/2 rack size and two rack mounting kits are available. The K-103 kit provides the necessary hardware to mount the unit to either the right or left of a standard 5 1/4" x 19" opening. The K-104 kit provides

the necessary hardware to rack mount two instruments. These may be two 1000 or 2000 series Wavetek, Indiana Instruments, or two 130 or 140 series Wavetek, San Diego Instruments, or a combination of either. This provides a 7" x 19" package. Facilities are provided for Front Panel mounting of instrument Rear Panel connectors.

2.1.4 K-103, Rack Mounting Kit (Refer to Figure 2-1)

| CONTENTS | | |
|-----------|-------|-----------|
| Item | Qty. | Part No. |
| A (Side) | 1 ea. | B000-608 |
| B (Side) | 1 ea. | C000-691 |
| C (Screw) | 8 ea. | HS101-806 |

Procedure:

Remove the screws from one side panel at a time. Mount item A or B against the side panel of the instrument and secure with screws provided (item C). Repeat operation for other side. NOTE: Items A & B may be interchanged to position the unit to the side of the rack desired.

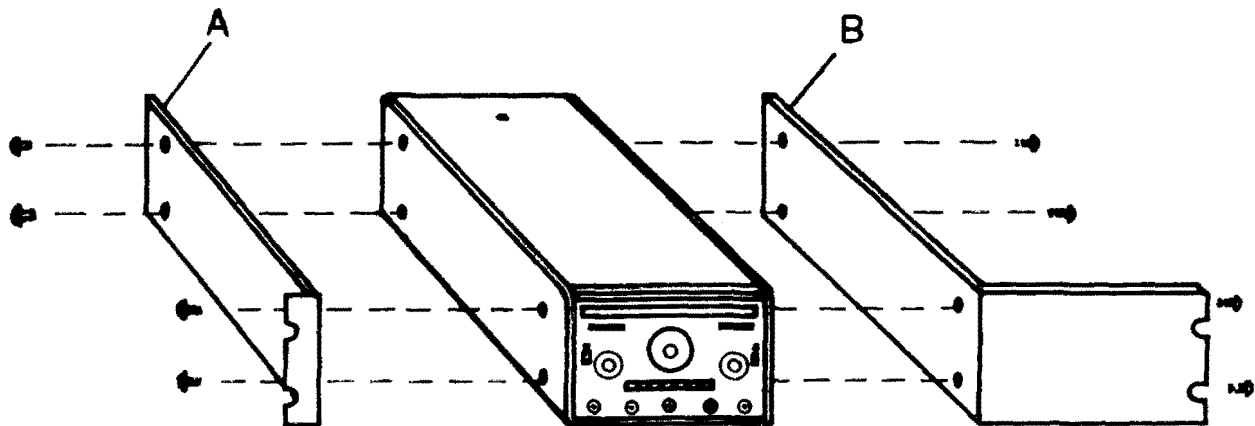

Figure 2-1. K-103 Rack Mounting

2.1.5 K-104 Rack Mounting Kit (Refer to Figure 2-2)

| CONTENTS | | |
|-----------|--------|-----------|
| Item | Qty. | Part No. |
| A (Tray) | 2 ea. | C000-729 |
| B (Side) | 2 ea. | A500-230 |
| C (Screw) | 12 ea. | HS106-905 |

Procedure:

Install both sides (item B) to one tray (item A) using 10-32 x 3/16" screws (item C). Position the instrument on the tray so that the feet extend into the provided holes. Holes are provided for all Wavetek, Indiana 1000 and 2000 series and for most Wavetek, San Diego 130, 140, and 700 series instruments. Other instruments not exceeding 5 1/4" x 8" may also be mounted by drilling additional holes for their feet.

When one or both instruments are properly seated, install the other item "A" and secure with the remaining screws (item C).

NOTE: If the Wavetek instrument has been supplied with a bail, it must be removed before installing in the K-104 rack mounting kit.

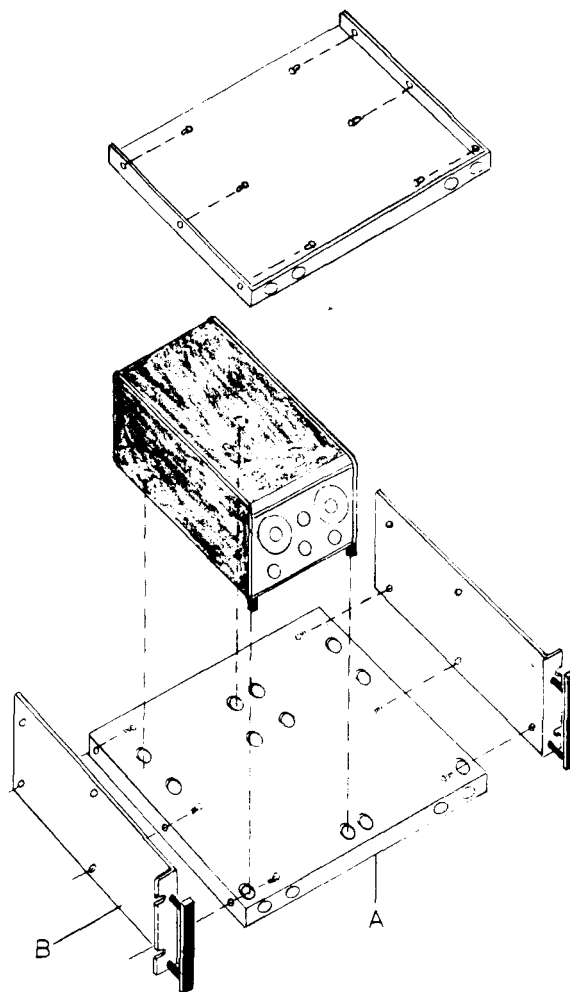

Figure 2-2. K-104 Rack Mounting

2.2 ELECTRICAL INSTALLATION

2.2.1 Primary Power Requirements

These instruments operate from either 115 volt AC or 230 volt AC supply mains as selected by a Slide Switch located on the Rear Panel. Before operating the instrument, check that the fuse mounted in the Rear Panel Fuse Holder corresponds to the correct value for the selected voltage; i.e., 0.5 amp for a 115 volt AC, and 0.25 amp for 230 volt AC.

The power supply has been designed to operate from either 50 or 60 Hz supply mains, however, the line operated sweep rate function must be adjusted to the line frequency.

Instruments are shipped from the factory for operation at 115 volt AC, 60 Hz unless specified for 230 volt AC or 50 Hz operation.

2.2.2 Performance Checks

The electrical performance of this instrument should be verified. Performance checks for incoming inspection are given in Section 5, Maintenance.

Model 2001

SECTION **3** OPERATING INSTRUCTIONS

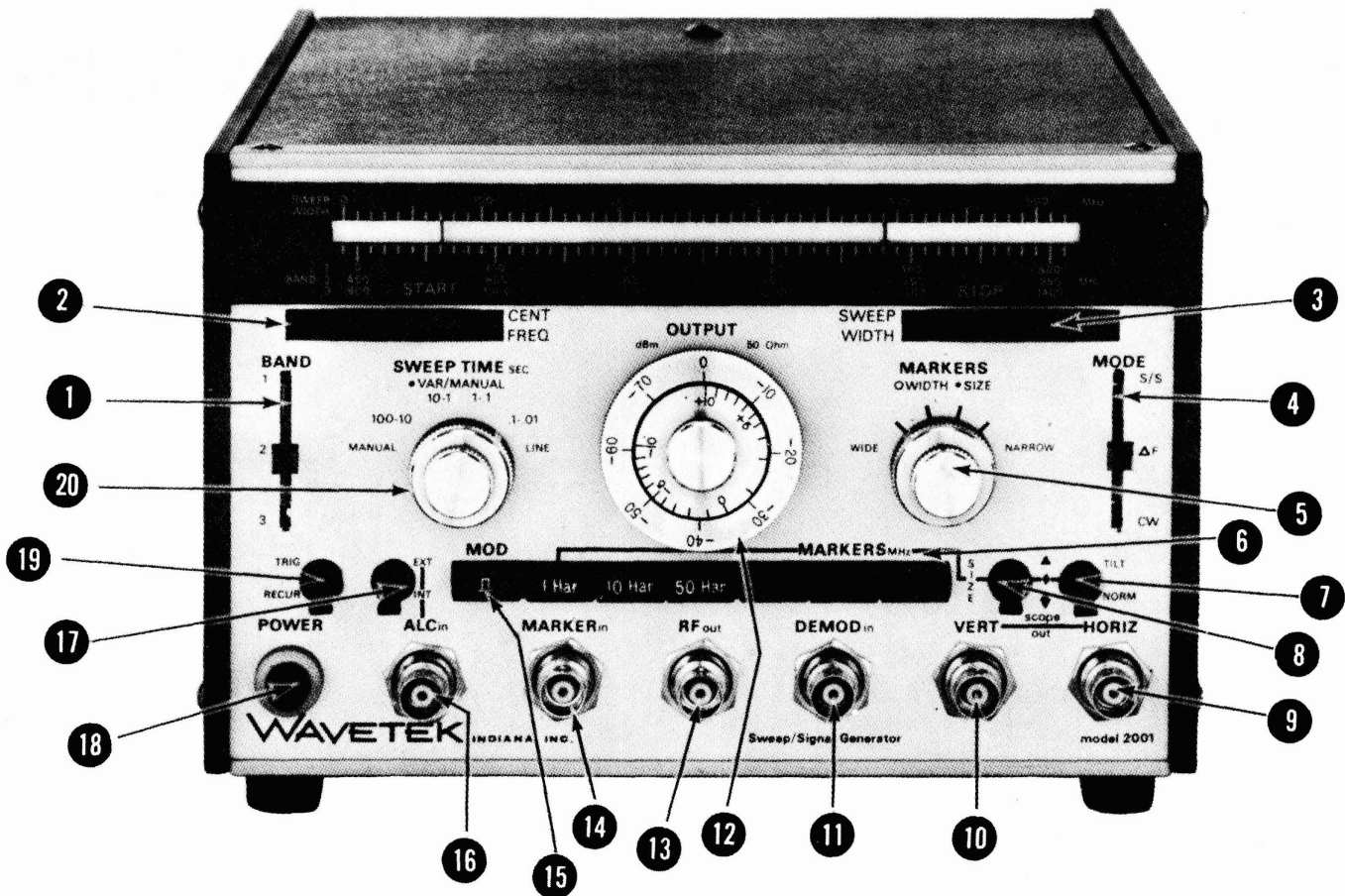

Figure 3-1. Front Panel

3.1 INTRODUCTION

This section provides complete functional control description, operating instructions, and programming instructions for the Model 2001 Sweep/Signal Generator.

In addition, special operating notes cover sweep rate errors, overloading, low level measurements and operation with networks analyzers and X-Y plotters.

3.2 DESCRIPTION OF FRONT PANEL (Refer to Figure 3-1 for control location)

- ① BAND Switch – Selects desired band; 1 to 500 MHz, 450 to 950 MHz or 900 to 1400 MHz.
- ② START/CENT FREQ. – Controls Start Frequency when MODE Switch is set to S/S (Start/Stop) or Center Frequency when MODE Switch is set to Δf and C.W.
- ③ STOP/SWEEP WIDTH – Controls Stop Frequency when MODE Switch is set to S/S (Start/Stop) or controls Sweep Width when MODE Switch is set to Δf .
- ④ MODE Switch – Selects Start/Stop, Δf or continuous wave operation.

- ⑤ MARKERS O WIDTH • SIZE – Dual concentric control; outer knob adjusts marker width from 15 to 400 kHz in four steps; inner knob controls marker size.
- ⑥ MARKERS – Six push button switches control A1 and A2 Marker Options (Marker frequency is engraved on push button).
- ⑦ TILT/NORM Switch – Provides vertical markers in the NORM (down) position. In the TILT (up) position provides horizontal markers having a fixed amplitude of approximately 10% of the horizontal display, when MARKER SIZE is set to minimum.
NOTE: Increasing the marker size will cause the horizontal marker to tilt toward a vertical position. This feature is used to identify frequencies on Steep response skirts.
- ⑧ MARKER SIZE Switch – This three position switch provides; large markers in its Lower position (12 V to 50mV peak-to-peak), small markers in its Center position (50mV to 100uV volts peak-to-peak) and rectified positive markers in its Up position. These rectified markers are for use with X-Y recorders.
- ⑨ SCOPE HORIZ. Out – BNC connector provides a 16 volt peak-to-peak triangle wave, symmetrical about ground, to drive the Horizontal (x) axis of the oscilloscope or other indicating device. (An alternate connection is available at the Rear Panel).
- ⑩ SCOPE VERT. Out – BNC connector provides the combined markers and demodulated RF (when DEMOD in is connected) for connection to the oscilloscope Vertical (y) axis input.
- ⑪ DEMOD in – BNC connector accepts the demodulated, swept, signal from the device under test so RF markers may be added. (The combined signal is available at the SCOPE VERT. OUTPUT connector).
- ⑫ OUTPUT-dBm-50 ohm – Attenuator; Outer knob provides calibrated adjustment of the RF output in 10 dB increments from 0 dBm to -70 dBm; inner knob provides calibrated vernier adjustment of the RF output from +10 dBm to -10 dBm.
- ⑬ RF out – BNC connector provides a connection for RF output signal.
- ⑭ MARKER in – BNC connector accepts an externally generated continuous wave signal to produce a frequency marker on the display.
- ⑮ MOD – Push button switch for A4 option (1 kHz square wave amplitude modulation).
- ⑯ ALC in – BNC connector accepts an automatic leveling control signal from a remote monitor when EXT/INT switch is in the EXT (up) position.
- ⑰ EXT/INT Switch – Closes the internal automatic leveling loop when in INT (down) position.
NOTE: When this switch is in the EXT position, and no external monitor is in use, the RF output is unlevelled and not controlled by the 20 dB vernier attenuator.
- ⑱ POWER – Push button applies A.C. power to the power supply. The light indicates that the instrument is operating.

①9 TRIG/RECUR Switch – Selects recurring sweep of the time selected by SWEEP TIME Control when in RECUR (down) position and with MODE Switch in either S/S or ΔF. When TRIG/RECUR Switch is in the center position, the sweep may be triggered for single sweep operation by momentarily contacting the TRIG (up) position

②0 SWEEP TIME Sec. VAR/MANUAL Control – This is a six position Switch/Control. The outer knob provides selection of MANUAL, LINE or Four Decade Ranges of variable sweep time. The inner knob provides manual frequency sweeping when SWEEP TIME Sec. Switch is set to MANUAL, and variable adjustment of sweep time in each of the four decade ranges. (The sweep may be triggered in the four decade ranges only).

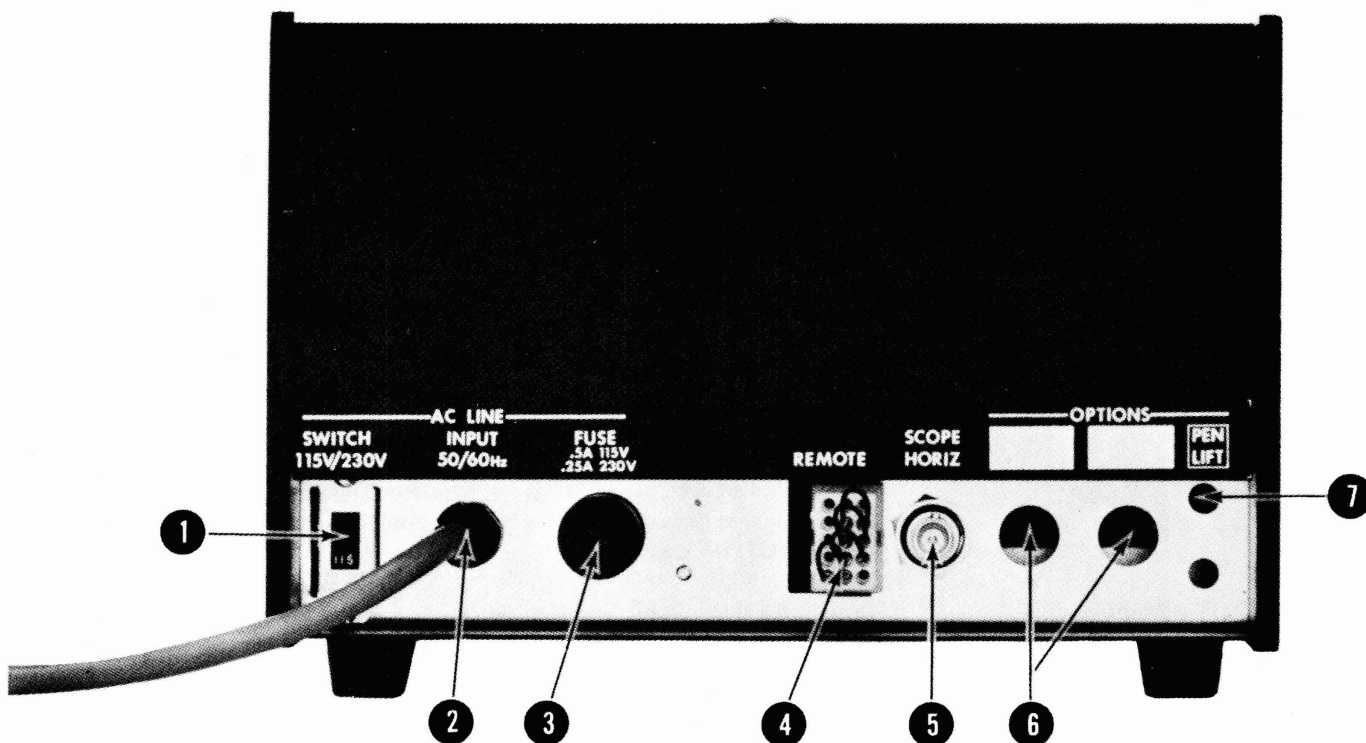

Figure 3-2. Rear Panel

3.3 DESCRIPTION OF REAR PANEL (Refer to Figure 3-2 for location)

- ① SWITCH 115/230V – Selects 115 or 230 V line voltage.
- ② INPUT 50/60Hz – 3 prong AC plug provides connection to AC mains.
- ③ AC LINE FUSE – 0.5A for 115 V AC or 0.25A for 230 V AC.
- ④ REMOTE Jack – Provides connection for programming of frequency, sweep width and RF output level. (See paragraph 3-6 for detailed instructions). This jack is supplied with a mating “jumped plug” which provides Front Panel control.
- ⑤ SCOPE HORIZ. Jack – BNC jack provides connection to (X) axis of oscilloscope or plotter. This connector is in parallel with the SCOPE HORIZ. connector located on the Front Panel.

- ⑥ OPTIONS — Provides mounting holes for BNC connectors used with special modifications or options.
- ⑦ PEN LIFT OPTION (A-5) — When Pen Lift Option is installed, these 2 terminals provide contact closure during sweep "ON" time. This option operates only when the Front Panel SWEEP TIME Selector is set to the 100-10 SEC. position.

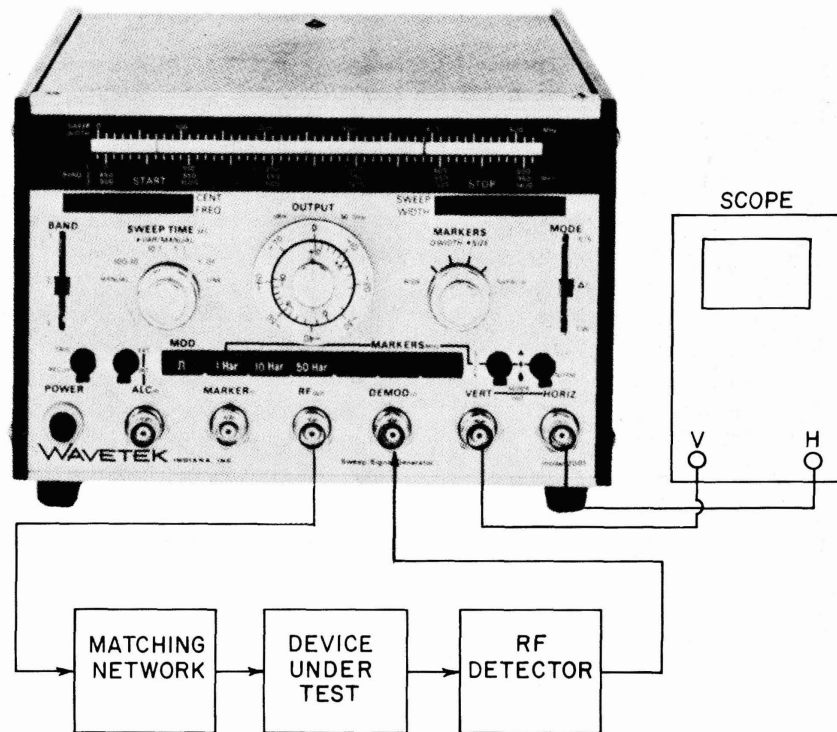

Figure 3-3. Typical Operating Set-up

3.4 TYPICAL OPERATING SET-UP

When initially setting up instrument, first check Rear Panel AC LINE VOLTAGE Selector Switch and Fuse to ensure the instrument is set for operation with the available AC mains.

Make connections between the Model 2001, the device under test, and the oscilloscope as shown in Figure 3-3. Since hum, RF leakage, and spurious signal pick-up must be kept to a minimum, it is essential that good connections and grounds be maintained throughout the entire setup. Use coaxial cables with BNC connectors wherever possible. The RF OUTPUT cable is especially critical. It should

have a characteristic impedance of 50 ohms, and should be kept as short as practical (under 3 feet). If the input impedance of the device under test is not 50-ohms, a matching network, as shown in Figure 3-3, should be used to ensure a constant amplitude input signal to the device under test.

After the RF signal passes through the RF circuit of the device under test it must be demodulated before being connected to the DEMOD IN of the Model 2001. If a demodulator is not a part of the device under test, one must be added externally. (See Figure 3-3). The input impedance of the demodulator must present the proper load to the RF circuit being tested. The Wavetek Model D152 RF Detector is recommended for 50-ohm applications.

Depress the POWER push-button. The light in the switch button should light, indicating an operating condition.

(Note: This instrument does not require a warmup period unless it is to be used at the extreme limits of its specifications.)

After completing the set-up, adjust the Model 2001 controls for the required center frequency, sweep width, output amplitude, and sweep rate. Turn the desired markers on, and adjust their size and width.

3.5 SPECIAL OPERATING NOTES

3.5.1 Errors From Sweep Rate Effects

When sweeping RF circuits having rapid amplitude changes, errors may occur, due mainly to detector delays. Decreasing the detector output time constant will minimize this effect. Figure 3-4 illustrates sweep rate effect.

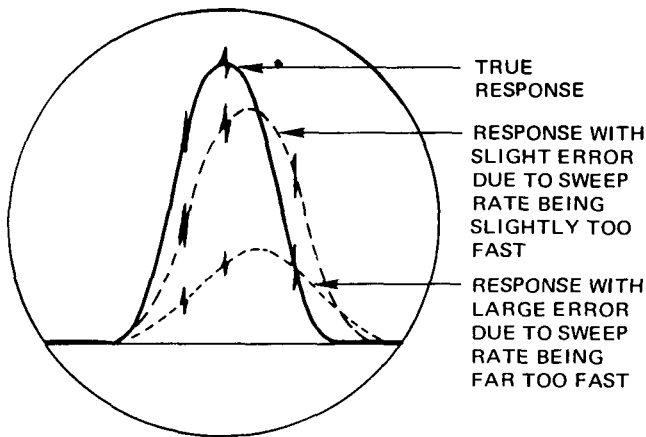

Figure 3-4. Sweep Rate Effects

To check for sweep rate effect, first set the sweep width to its lowest practical amount, then reduce sweep time while closely observing the swept output response. Any change in the response indicates the sweep rate is too fast for a true response. When a further reduction of sweep time does not change the response, a true response has been obtained.

3.5.2 Effects From Overloading

The use of excessive signal from the Model 2001 can overload the receiver circuits. To assure that this condition is not present, and that the response is a true representation of the device under test, turn the OUTPUT dbm controls to minimum output amplitude. Gradually increase

the output amplitude until a response is obtained. Further increase of the output amplitude should not change the configuration of the response envelope except in amplitude. If the response envelope does change, such as flattening at the top, decrease the output just far enough to restore the proper configuration.

3.5.3 Making Measurements At Low Levels

When making measurements at low levels, radiation and ground loops become problems. Using double shielded cables for cables carrying RF signals helps minimize the radiation problem. Ground loops causing hum pick-up can sometimes be eliminated by completing only one ground connection between each instrument. This applies particularly to the scope horizontal input. If the ground connection is made at the vertical input terminal, an additional ground at the horizontal input terminal will often result in hum pick-up.

3.5.4 Operation With Network Analyzers

To operate properly with certain network analyzers several modifications might be required. Some analyzers require the removal of the blanking signal during the sweep return trace. This can be accomplished by disconnecting the single wire connected to pin 10 of the M1H Module. Another modification sometimes required is to provide a horizontal output ramp that varies from zero to some positive voltage instead of the standard -8 to +8 volt ramp. This can be accomplished by connecting a 56 K ohm resistor between pins 2 and 11 of the M1H Module. This connection provides a horizontal output signal from approximately 0 to 11 volts.

3.5.5 Operation With X-Y Plotters

Two features are incorporated into the Model 2001 to facilitate operation with X-Y plotters. First, a marker clamp switch that is a part of the Front Panel SIZE Selector Switch. This marker clamp switch converts the hi-frequency marker signals to a lower frequency which is compatible with the operating speed of the plotter pen.

Second is an optional feature (A5). This feature provides a contact closure during the sweep time to operate the plotter's pen lift. The A5 feature operates only when the sweep time selector switch is set to its slowest position, 10 to 100 sec.

3.5.6 Operation With An External Monitor

Operation with an external monitor can produce a flatter

(less amplitude variation) input signal to the device under test than is obtainable with the internal monitor, since the monitor point is located at the point where greatest flatness is desired, and is not affected by cable VSWR or input impedance of the device under test. Another application is to level at the output point of a wide band power amplifier, in order to increase the output power capability of the sweep generator.

To operate with an external monitor, first set the OUTPUT controls for maximum, +10 dBm. Next, connect the output from the external monitor to the Front Panel BNC jack labeled ALC IN and set the ALC EXT/INT Switch to the EXT position. The signal from the external monitor must be of a negative polarity between 0.2 and 2 volts. If the signal is larger than 2 volts, use a resistive divider to obtain the less than 2 volts signal. While observing the output from the monitor on an oscilloscope, adjust the Vernier OUTPUT Control until the monitor signal becomes leveled. (Refer to Figure 3-5.)

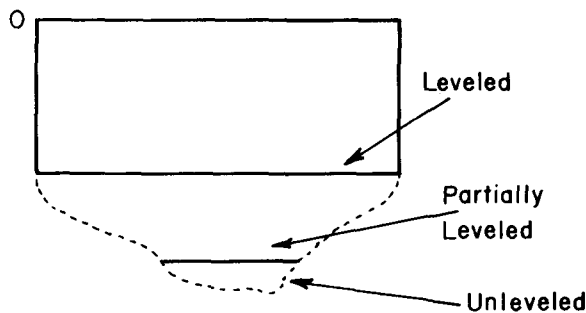
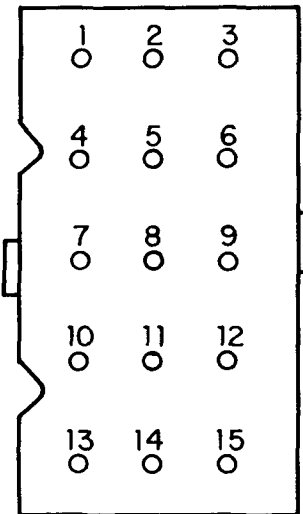

Figure 3-5. External Monitor Output Signal

3.6 PROGRAMMING

Connections for remote operation of OUTPUT AMPLITUDE, FREQUENCY and SWEEP WIDTH plus EXTERNAL AM and FM MODULATION and triggering of the sweep circuit is provided by a Rear Panel REMOTE programming connector. The programming jack and its pin functions are shown below.



Rear Panel Remote Jack J 101

VOLTAGE AND SIGNAL SOURCES

- Pin 1 – Ground
- Pin 2 – +16 volts ↙
- Pin 3 – -16 volts ↘
- Pin 4 – -18 volts ↙
- Pin 10 – Ramp for Driving Sweep Width Control
- Pin 15 – Same as Pin 10 Except Inverted

CONTROL INPUTS

- Pin 6 – Output Level Control (AM Modulation)
- Pin 7 – Sweep Time Trigger Input
- Pin 9 – Frequency Control
- Pin 12 – Sweep Width Control (FM Modulation)

INTERNAL CONTROL

Pins 5, 8 and 11 are used to program internal operation of Output, Frequency and Sweep Width.

UNUSED

Pins 13 and 14 are unused

3.6.1 OUTPUT AMPLITUDE CONTROL
(AM MODULATION)

Normal internal control is provided by a jumper wire connected between pins 5 and 6 of the REMOTE plug as shown below.

To provide external control, remove jumper wire and connect an external OUTPUT Control as shown below. The RF OUTPUT is a linear function of the programming voltage as shown in Figure 3-6.

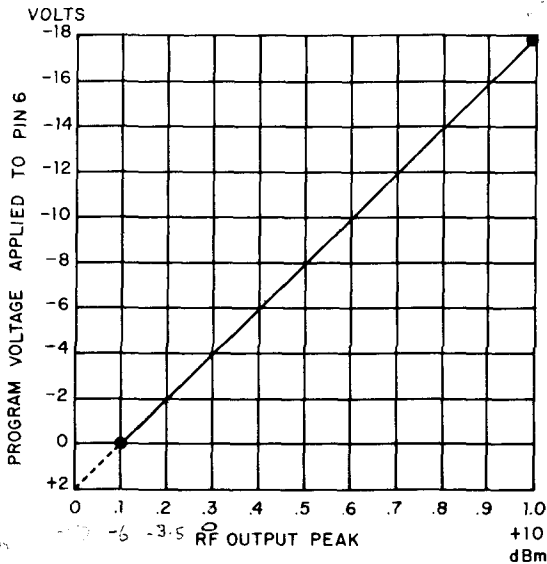
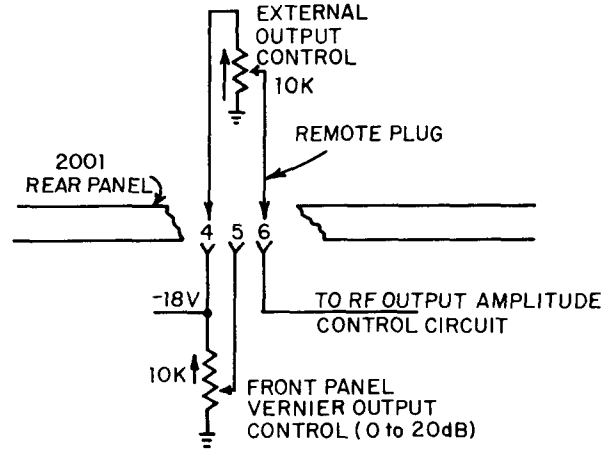
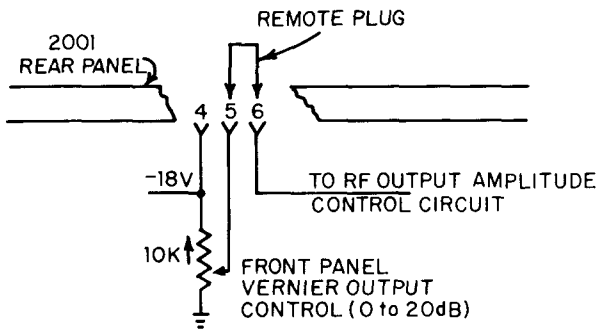
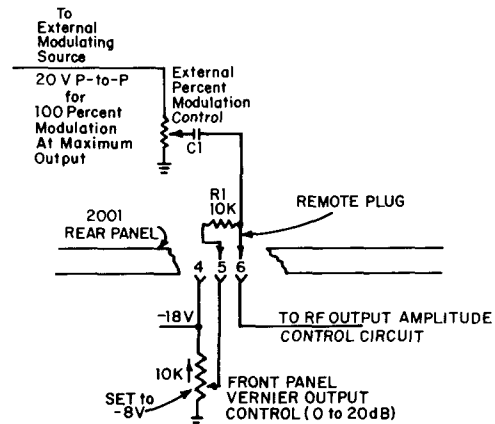

Figure 3-6. Program Voltage/RF Output

To provide AM MODULATION, connect as shown at right. The low frequency modulation will be limited by the reactance of capacitor C1. Lower frequency modulation, down to DC, can be provided with a modulating source having a DC offset. In this case, resistor R1 is omitted. In all cases, the peak modulating voltage plus the DC offset must be within the limits of -18 to +2 volts, as shown in Figure 3-6, or distortion will occur. The modulation frequency limits the maximum useable percentage of modulation as shown in Figure 3-7. This graph was obtained with the DC level set to -8 volts.



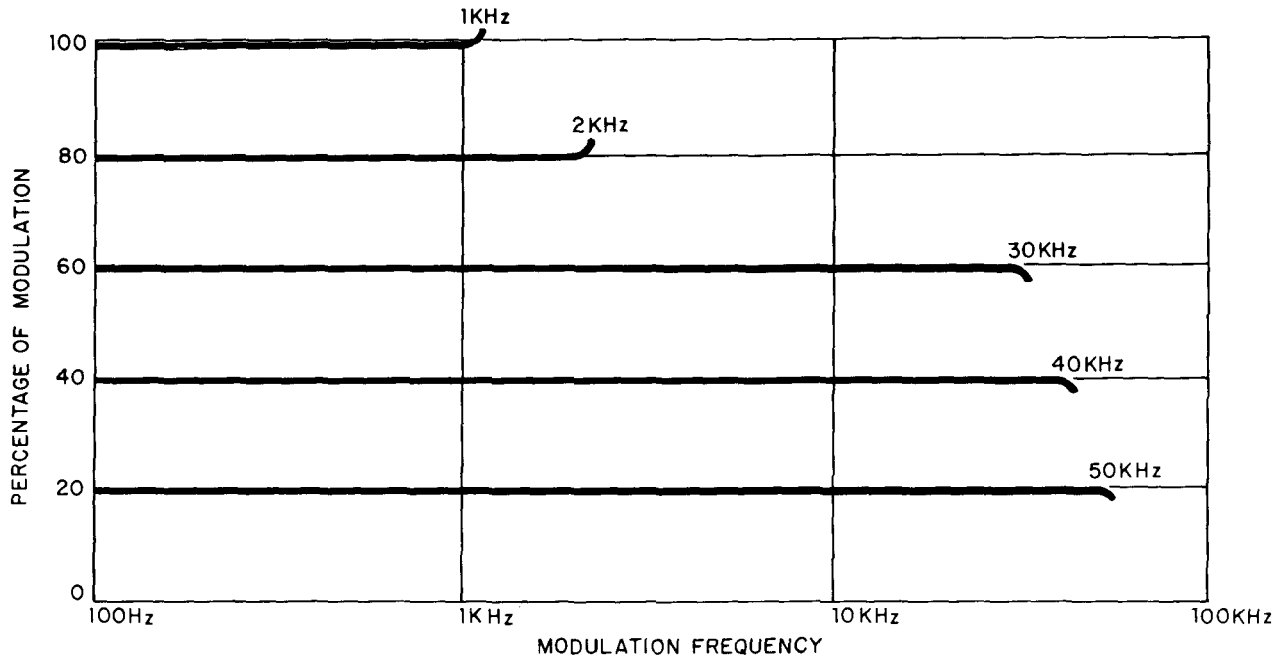
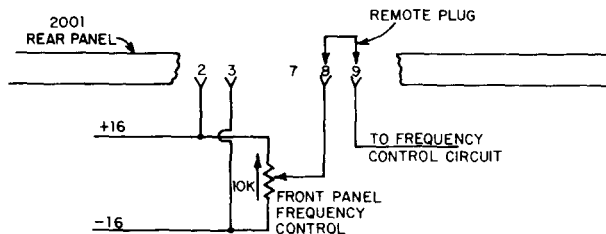

Figure 3-7. Percentage Modulation/Modulating Frequency

3.6.2 FREQUENCY CONTROL

Normal internal control of frequency is provided by a jumper wire connected between pins 9 and 8 of the REMOTE plug as shown below.



To provide external control, remove the jumper and connect pin 9 to an external Frequency control as shown below.

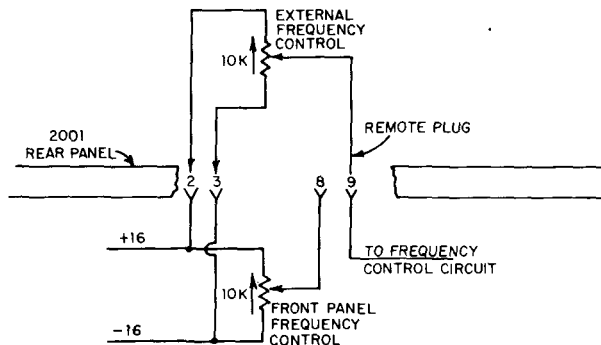

Tuning sensitivity, which is approximately 16 MHz/volt, is shown graphically in Figure 3-8.

3.6.3 SWEEP WIDTH CONTROL (FM Modulation)

Normal internal control of sweep width is provided by a jumper wire between pins 11 and 12 of the REMOTE plug as shown below.

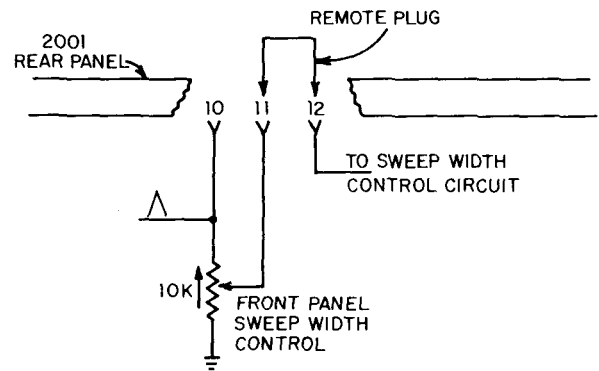

To provide external control, remove the jumper and connect pin 12 to an external Sweep Width control as shown on page 3-10.

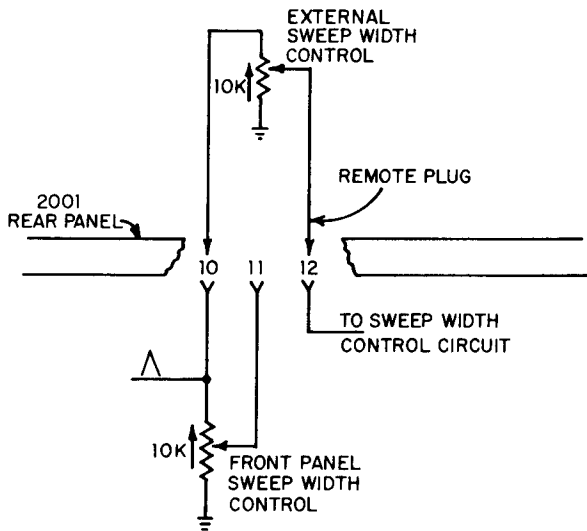

To provide FM modulation, connect as shown at right and set the Front Panel MODE Switch for CW operation.

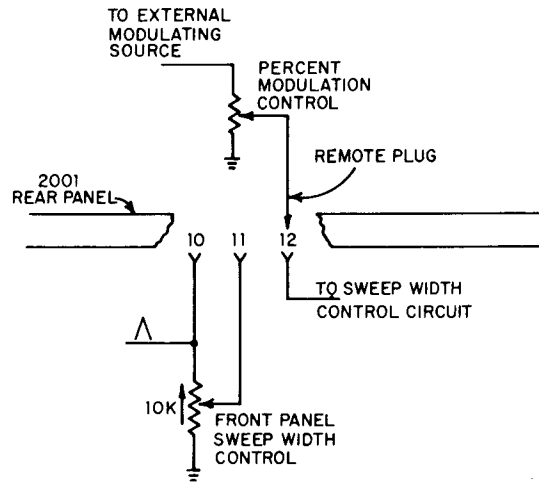

The modulating wave form should have an average potential of zero volts. Frequency sensitivity, which is approximately 16 MHz/volt, is shown graphically in Figure 3-8. The maximum modulating frequency, while still maintaining the 16 MHz/volt relationship, varies from approximately 4 kHz at maximum deviation to 20 kHz for 1 MHz deviation. (See Figure 3-9.) With decreased frequency sensitivity, frequency up to 200 kHz can be used, as shown in the shaded area of Figure 3-9 on page 3-11.

The peak amplitude of the modulating signal plus the DC voltage supplied to the Frequency Control (pin 9 of REMOTE plug) should not exceed + or -16 volts. This amplitude would program the unit to sweep beyond the band limits.

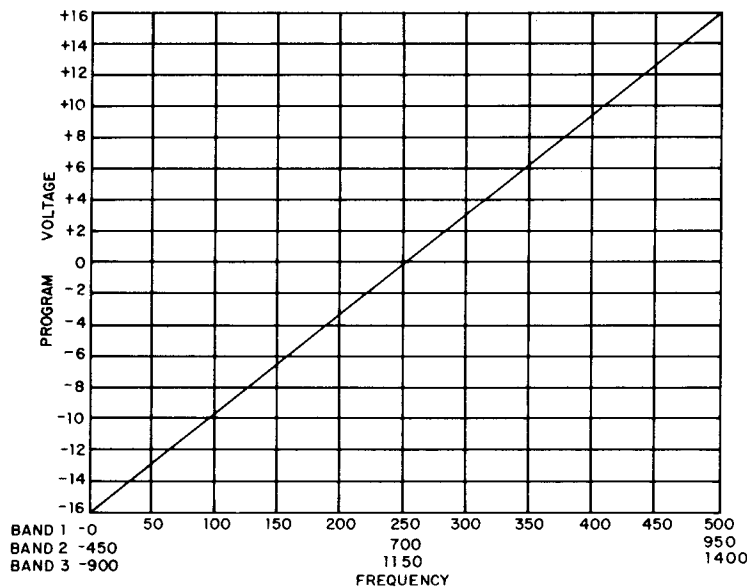

Figure 3-8. Program Voltage (pin 9 or 12)/Frequency

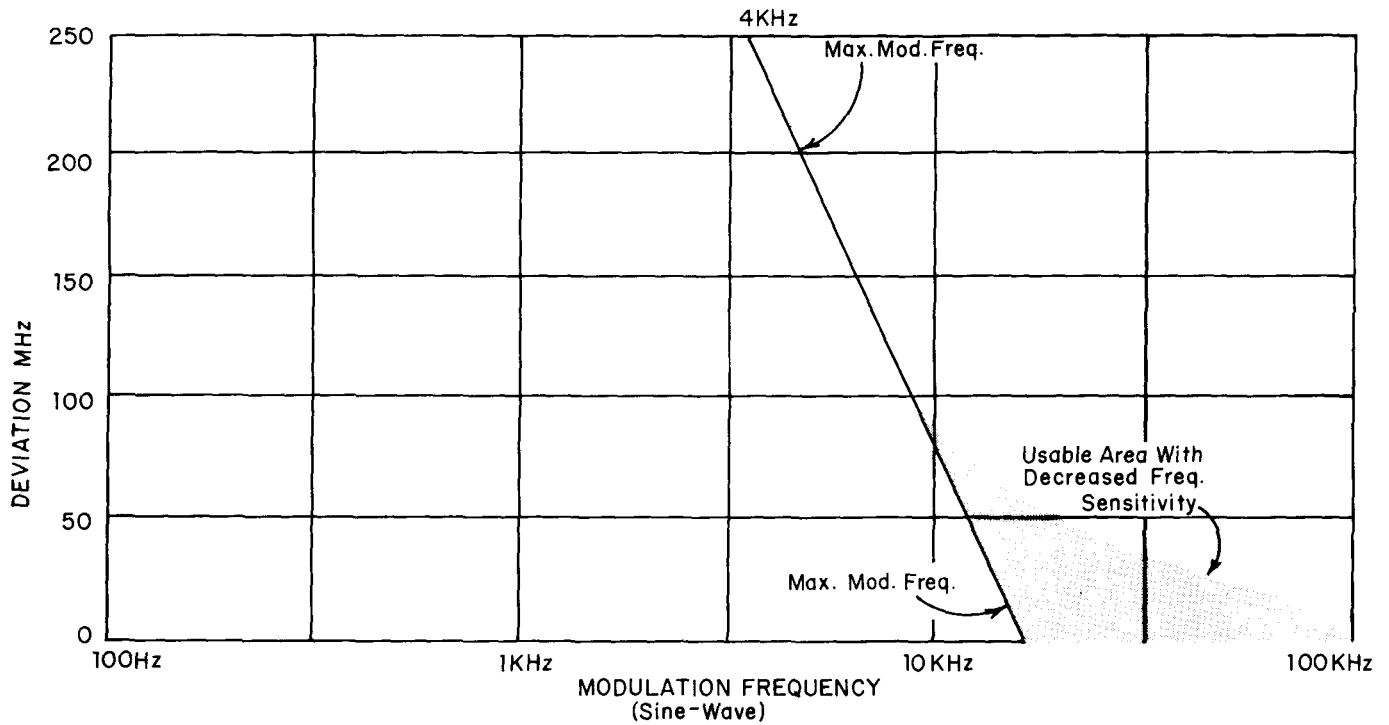

Figure 3-9. FM Modulation Frequency Limits

3.6.4 REMOTE TRIGGERING OF SWEEP TIME CIRCUIT

The Sweep Time Circuit can be remotely triggered by applying a 10 volt positive pulse to pin 7 of the REMOTE plug. For proper operation, the Front Panel SWEEP TIME Selector must be set for one of the four variable sweep

time positions, and the TRIG/RECUR Switch set to the TRIG position. The repetition rate of the external trigger should be slower than the frequency running rate set by the Front Panel SWEEP TIME Selector and VAR/MANUAL Control.

Model 2001

SECTION 4

CIRCUIT DESCRIPTION

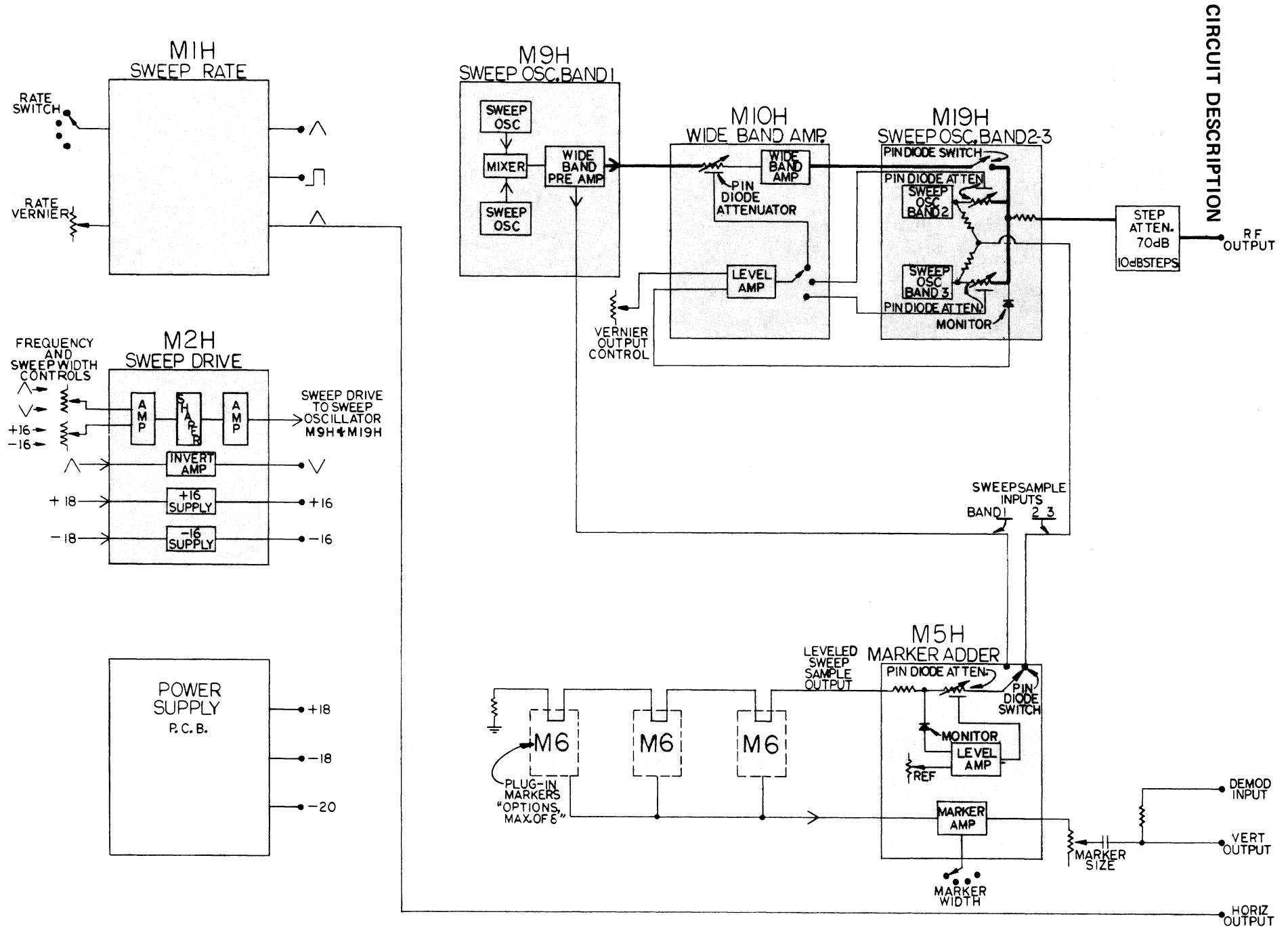

Figure 4-1. Simplified Block Diagram

4.1 MECHANICAL ARRANGEMENT

Before beginning the actual circuit description, it would be well to consider the mechanical arrangement of the instrument. This will enable the following block diagram and circuit description to be associated with its physical position, thereby, providing a better understanding of the overall instrument. The mechanical arrangement can be seen by referring to Figure 5-17 in the Maintenance section. This TOP VIEW shows the Front Panel, plug-in module and the rear chassis Power Supply sections.

4.2 SIMPLIFIED BLOCK DIAGRAM

The block diagram in Figure 4-1 contains both block and module information. The blocks contained within each module are indicated by the **module outline**.

The Power Supply provides three regulated voltage sources of +18, -18, and -20 volts for connections to the plug-in modules.

The M1H module generates the sweep ramp, blanking and scope horizontal voltages.

The M2H module contains four distinct circuits; a -16 volt reference supply, a +16 volt reference supply, an inverted sweep ramp supply, and the sweep drive circuits.

The two reference supplies and the two sweep ramp voltages provide the signals to the Front Panel frequency and sweep width controls. The signal from these controls is then fed to the sweep drive circuit in the M2H module, where they are combined into a single signal, which drives the frequency determined varactor diodes in the sweep oscillator modules. Necessary level shifting, shaping and amplitude control is provided by the sweep drive circuit.

The RF signal for BAND 1 (1 to 500 MHz) is generated in the M9H module where the signal from two sweep oscillators are combined in a diode mixer. The resultant, difference signal, is fed to a 1-500 MHz pre-amplifier and then to the M10H module. This module contains a voltage variable attenuator and the final 1-500 MHz amplifier. The output from this amplifier is then fed to the M19H module where a PIN diode switch completes the circuit to the RF output circuit.

Leveling of the RF output is accomplished by a monitor diode which measures the RF voltage and compares it to a reference voltage supply by the vernier output control. Any

error between the two voltages is amplified in the leveler amplifier located in the M10H module. The error voltage is then connected to the voltage variable attenuator at the input of the final 1 to 500 MHz amplifier. This closed loop system maintains a constant amplitude RF signal at the monitor point, which compensates for amplitude variation in the sweep oscillator, mixer, and amplifier circuit and also creates a zero impedance at the monitor point. In order to create a 50 ohm source impedance, a 50 ohm resistor is connected between the zero impedance point and the RF output system.

The sweep oscillators for bands 2 & 3 are located in the M19H module. The RF output from the oscillators is fed through voltage variable attenuators directly to the RF output circuit without amplification. Leveling for bands 2 & 3 is accomplished in the same manner as for band 1.

The marker circuit is comprised of the marker adder module M5H, and the individual marker generators M6's. In addition to the marker adding function of the M5H module, it also provides for selection and leveling of the sweep sample signal in the same manner as the main RF output signal was leveled. This provides a constant amplitude sweep sample signal to the individual marker modules which is extremely important to obtain a "flat comb" output from the harmonic generating marker modules. It also standardizes the sweep sample amplitude in all 2001 instruments, which insures proper operation of field installed markers.

This constant amplitude sweep sample signal is then fed to the individual M6 marker modules where it is combined in a mixer with a crystal controlled CW signal. The resultant difference signals (birdy markers) are then fed back to the marker adder module where they are combined, amplified, and shaped into a single composite signal. This signal is then fed through the marker size control and to the Front Panel vertical output connector.

The following circuit descriptions are referenced to the schematics appearing in Section 6.

4.3 POWER SUPPLY (PS6)

The PS6 power supply provides three regulated voltages and an optional "pen-lift" circuit.

AC POWER & RECTIFIER CIRCUITS

A dual-primary transformer allows operation at a line voltage of 115 or 230 volts. AC power is supplied through a 4 wire receptacle from the Front Panel ON/OFF switch. The transformer is located away from the sweep drive module to reduce magnetically coupled line ripple. Unregulated plus and minus voltages are supplied by two full wave rectifier circuits and filtered by C1 and C7. A 12 pin plug, mounted to the printed circuit board, provides access to three unregulated voltages as well as the regulated +18, -18, and -20V. This plug also accepts a scope horizontal signal for connection to a Rear Panel connector. The pen-lift switching circuit is also enabled through this plug.

PEN LIFT OPTION

Installation of K50 and Rear Panel jacks provides a contact closure which occurs during the sweep on-time. Q11 is normally conducting from current supplied through pin 9 of the 12 pin plug. When the base drive to Q11 is removed, the relay is energized by the turn-on of Q12. To prevent early failure of the relay contacts, the relay is only energized during slow sweep speeds and in the manual position of the front panel sweep rate selector.

+18 VOLT SERIES REGULATOR

Regulation is provided by IC1 which contains its own internal reference supply. R9 provides an adjustment to +18.00 volts. An external pass transistor, Q2, boosts the current capability, and Q1 improves the current limiting characteristics of IC1 by providing amplification before limiting. The +18 volt supply is protected against reverse voltage by CR7.

-18 VOLT SERIES - SHUNT REGULATOR

The voltage reference for this supply is obtained from the +18 volt supply through R20, and R19 provides the feedback which is applied to IC2 which provides high gain forcing Q5 to maintain a shunt regulated voltage across R13. Q3 and Q4 provide the series pass element and are connected as a compound emitter follower so that the voltage across R13 is not loaded heavily. Short circuit protection of Q5 is provided by CR8. Current limiting is provided by Q5, when Q6 conducts sufficiently to forward bias CR9 and CR10. Reverse voltage protection is provided by CR12.

-20 VOLT SERIES REGULATOR

The reference voltage for the -20V supply is applied to a differential amplifier, Q9 and Q10, which in conjunction with Q8 provides a compound emitter following action similar to the pass element of the -18V supply.

CR 17 provides reverse voltage protection. Current limiting is provided by shutting down of the -18 volt supply by Q7 through CR14 to the base of Q5, reducing the reference voltage to the base of Q9. This action is helped along by the conduction of CR13 if the -20 volt supply drops below -18 volts.

4.4 SWEEP RATE (MODULE M1H)

M1H SWEEP RATE GENERATOR

This module generates a variable rate square and triangular waveform. Front Panel switching provides recurring, triggered, or manual modes. The triangular waveform is a 32 volt peak-to-peak signal with a sweep time variable from 10ms to 100 seconds in four steps. Retrace time is held constant at the fastest sweep time of each range. The triangular waveform is used to provide the sweep drive and the scope horizontal signals.

The square wave output is a -1 to +15 volt signal whose -1 volt level corresponds to the sweep time and whose 15 volt level corresponds to the retrace time. The square wave is used to provide blanking of the RF output during retrace time.

Triangular waveforms are generated in an integrator, Q1, Q2, Q3, and Q4, by applying positive and negative voltage levels to the integrator input. When the integrator positive ramp output exceeds a threshold voltage, a bi-stable hysteresis switch is switched, reversing the polarity of the integrator dc input, causing the triangular waveform to start down toward another threshold. If the module is programmed in a recurring mode, the negative ramp will trip the hysteresis switch producing continuous oscillations. The hysteresis switch output is clipped on the negative polarity and is used for blanking (pin 10).

The symmetrical square wave output from the hysteresis switch (pin 9) is connected, through the Front Panel SWEEP TIME vernier and one of the range determining resistors of the SWEEP TIME selector switch, to the integrator input (pin 7). Since the integrator output voltage change is proportional to the input voltage level, the SWEEP TIME vernier provides a sweep time increase by reducing the hysteresis switch output if the polarity is negative. If the polarity is

positive, full output is retained (a diode opens the vernier ground connection) producing a nearly constant retrace time.

For triggered modes, the negative threshold of the hysteresis switch is shifted out of the way by a diode and resistor connected through Q14 or through S102D, when in "line" position. The integrator will now continue its negative ramp until it is stopped by a clamp circuit turned on by a comparator. The integrator output is now held at this level unless a trigger is applied to the hysteresis switch. A trigger cannot flip the hysteresis switch until this clamp level is reached because the triggers must pass through an amplifier which is gated off until the clamp comparator (Q9) conducts.

Triggers are prevented from reaching the hysteresis switch (pin 6) by a voltage at pin 1, which causes comparator Q8 to open FET switch Q14. The primary function of the voltage at pin 1 is to shift the clamp comparator input out of the way to allow free-running oscillations.

Since the integrator is an inverting amplifier, and both input (pin 7) and output (pin 8) are available, a feedback resistor network allows the SWEEP TIME vernier, R102, to be used as a dc level shifter in the manual mode. A non-inverting amplifier consisting of Q6, Q7 and Q19, with a gain of 2, provide a 32 volt peak-to-peak wave output which is used for sweep drive. This output is divided by R18 and R53 to provide a horizontal drive of about 16 volts peak-to-peak at an impedance of about 23K ohms.

A centering adjustment (R41) provides a dc level adjustment of the integrator and horizontal outputs (pin 8, pin 12, and pin 11) by shifting both positive and negative thresholds of the hysteresis switch. A size adjustment (R45) provides an amplitude adjustment by effectively varying the size of the hysteresis window. Symmetry of trace and retrace time (for equal positive and negative input voltages to the integrator) is established by adjusting the integrator balance control R7. This adjustment also affects the manual mode centering and the sweep period for fully counterclockwise rotation of the SWEEP TIME vernier.

The four sections of the SWEEP TIME selector switch program the M1H module. The functions of each section are listed below:

- Section A Integrator input selector
- Section B Clamp level shift and routing switch disconnect
- Section C Trigger source selector
- Section D Line trigger routing, and hysteresis switch hold.

Circuit operation as modified by the switch positions may be understood by considering the MANUAL, VARIABLE RATE, and LINE positions one at a time.

MANUAL POSITION

Section A. A feedback resistor R113 is connected from output (pin 8) to input (pin 7) of the integrating amplifier, converting it to an inverting dc amplifier. Resistor R114 shifts the amplifier output dc level to -8 volts for zero input voltage to R104. When the SWEEP TIME vernier control R102 is fully clockwise, the negative input voltage to R104 is sufficient to shift the output voltage to +8 volts dc.

Section B. The clamp is disabled in this position by applying +18V to pin 1, causing the hysteresis switch input to be disconnected from any internal source of triggers by opening the routing switch Q14 (since Q8 is turned off). The shift bias is disconnected when Q14 is open.

Section C. The trigger input point pin 4 is grounded.

Section D. The hysteresis switch is held in one state by applying -18 volts to its input through a 33K ohm resistor. This causes the output to be negative (this bistable circuit is a positive feedback amplifier) providing the proper polarity to R102 and preventing blanking of the RF output.

VARIABLE RATE POSITIONS

Section A. Proper integrator input resistors are selected in decade increments in these positions, R105 - R108.

Section B. The clamp is disabled and triggers are held off unless the "pull trigger" switch is opened, removing +18 volts.

Section C. Two trigger sources are connected to pin 4; an external trigger from REMOTE jack J101-7 and triggers from the Front Panel momentary TRIG switch S103.

Section D. No connection is made to pin 6 in any of the four variable rate positions.

LINE POSITION

Section A. The proper value integrating resistor is selected, by-passing the SWEEP TIME vernier, to produce equal sweep and retrace periods.

Section B. Clamping, works in this position independently of the "pull trig" switch.

Section C. The line rate square wave from the power supply is connected to the trigger input.

Section D. Amplified triggers are routed into the hysteresis switch independently of the internal routing transistor, providing additional (redundant) line rate reliability.

4.5 SWEEP DRIVE (MODULE M2H)

The M2H module provides the correct sweep drive voltage required by each oscillator as programmed by the Front Panel Tuning controls, Sweep Width controls, and the Mode switch.

These programs are summed to a standard voltage level and then feed shaping circuits for each band which are enabled by the B-1 and B-2 voltages and by a synthesized B-3 voltage.

The shaping diodes conduct at levels determined by a resistor network driven by a constant current source, Q7. As each diode conducts, an additional current is fed into the summing junction of the output amplifier consisting of Q12, Q13, and Q14.

The output waveform amplitude is controlled by R72, R76, and R80 which are connected by switch transistors Q15, Q16, and Q17 into the feedback path to the summing junction.

This module also provides two regulated voltages for use primarily as programming voltages and an inverting amplifier to furnish an inverted triangle wave for use in the start-stop mode of programming.

4.6 SWEEP OSCILLATOR, BAND 1 (MODULE M9H)

The RF sweep signal for band 1 is developed by the heterodyne method which utilizes two UHF sweep oscillators, a diode mixer, and a wide-band RF amplifier.

Sweep oscillator, Q2, sweeps from approximately 1.4 to 1.65 GHz. The average frequency is adjusted by R2 which controls the average bias on the varactor diodes, CR1, CR2, and CR3. The sweep drive voltage from pin 9 of the module is connected to the opposite side of these diodes causing the frequency to vary above and below this average frequency in a low-to-high frequency direction.

Sweep oscillator, Q5, is similar to the Q2 circuit, however, the varactor diodes have been reversed, and the polarity of the bias voltage supplied by R12, course adjustment, and R13, CENT FINE adjustment, has been changed. These

changes cause the oscillator frequency to vary from a high to low frequency. The approximate output frequency is 1.4 and 1.15 GHz. This out of phase sweep technique has several advantages. First, larger sweep widths are obtainable and second, the nonlinearity (FREQ versus TIME) of one oscillator is cancelled by the nonlinearity of the second oscillator. R9, which is a linearity adjustment, optimizes this cancelling process by controlling the sweep drive ratio between the oscillators.

The two sweep signals are combined in a single balance diode mixer comprised of L4, L5, CR8 and CR9. The resultant, difference frequency, of 0 to 500 MHz, is then amplified in the wide band amplifier consisting of transistor stages Q11, Q12, and Q13.

Transistor stages Q6 and Q7 supply the blanking voltage to the wide band amplifier and causes it to be shut off during the sweep retrace time. The output from the wide band amplifier is connected to J1, which in turn is connected to the output wide band amplifier located in module M10H. A second output is also obtained from this amplifier and is coupled, via R45, to a similar wide band amplifier consisting of transistor stages Q14, Q15, and Q16. The output from this amplifier is connected to J2 which in turn is connected to the marker generating circuits.

Transistors Q8, Q9, and Q10 provide a -15 volt supply to operate the sweep oscillators. This improves stability and provides isolation between the oscillators and the -18 volt supply.

4.7 OUTPUT AMPLIFIER, BAND 1 (MODULE M10H)

The M10H module contains a wide band amplifier, an electronic attenuator, and a leveler amplifier.

WIDE BAND AMPLIFIER

This amplifier provides 2 stages of RF amplification to increase the RF input level present at Q1 by about 40dB.

The frequency response of this amplifier is reduced for frequencies near 0.5 MHz or lower and above 500 MHz.

The input amplifier stage consisting of Q1, Q2, and Q3 is enabled by the B+1 switching voltage, and the output stage, consisting of Q4, Q5, and Q6 by the -20 voltage, when the Front Panel band switch is in the Band 1 position. The -20 voltage also provides current through R30 and the RF out-

put cable to turn on a pin diode, located in the M19H module, which couples the band 1 RF output into the RF output system.

ELECTRONIC ATTENUATOR

Ahead of the first RF amplifier is an electronic attenuator consisting of PIN diodes, CR1, CR2, and CR3 which provides variable RF conductance proportional to the positive current supplied through the switching transistor Q7.

LEVELER OUTPUT (PIN 6)

The leveler amplifier (Q9, Q10, and Q11) provides leveling of the RF output for Bands 1, 2 and 3 by supplying a positive current to the electronic attenuator system for each band as directed by the band switching voltages (B-1, B-2, and B-3) which turn on the correct switching transistor for that band (in the M10H module or the M19H module).

A positively increasing output voltage from the leveler amplifier will increase the RF output level. RF blanking is effected by a positive input voltage (pin 4) to switching transistor Q8 which causes the leveler output (pin 6) to go negative during sweep retrace time shutting off the electronic attenuator.

LEVELER INPUTS (Pin 5 and Pin 7)

A monitor diode, located external to the M10H, provides a negative DC voltage related to the RF output level present in the output system. The output system and monitor diode is located in the M19H module or in an external monitor circuit. This negative voltage is connected to one input of the operational amplifier, consisting of Q9, Q10, and Q11.

Since an increasingly negative voltage at the input will reduce the positive current supplied to each electronic attenuator, the RF output level is held constant, by negative feedback, at a level determined by a reference voltage. This reference voltage varies under control of the LEVEL PROGRAM input voltage at pin 7 of the M10H module. The magnitude of this negative voltage is determined by the MAX pot which sets the maximum RF level when the program voltage is maximum (-18 volts). The MIN pot provides a small negative reference voltage which determines the minimum RF level when the level program voltage at pin 7 is zero.

4.8 SWEEP OSCILLATOR, BANDS 2 & 3 (MODULE M19H)

This module contains two separate sweep oscillators, each with its voltage variable attenuator and the necessary switching circuitry to connect either band 1, band 2, or band 3 to the common monitor and RF output connector.

Band 1 is connected to the RF output circuit by PIN diode CR9. The control current for switching this diode is contained in the M10H module.

Band 2 oscillator, consisting of Q6 and its associated circuitry, is a common base oscillator varactor-tuned by CR2, CR3, CR4 and CR5. Biasing of the varactor diodes is provided by Q1 and Q2. Q3 is a switching transistor which disconnects the bias voltage from the varactors when the unit is operated on band 1 or band 3. The B -voltage for the oscillator is modulated by the blanking signal, from pin 4, in transistor stages Q4 and Q5. This modulation causes the oscillator to be cut off during the sweep retrace period, thereby providing a zero RF output level during the retrace time. The RF signal is coupled from the oscillator, by L9, to a voltage variable attenuator consisting of CR6, CR7 and CR8. This attenuator is part of the closed loop leveling system consisting of the monitor diode CR20, the leveler amplifier, (located in the M10H module) and the voltage variable attenuator. The operation of this circuit maintains a constant amplitude RF signal at the monitor point and also allows adjustment of this signal over a 20dB range. Since the effective impedance at the monitor point is zero ohms, R46 establishes the output impedance at approximately 50 ohms.

Band 3 oscillator is almost identical to band 2. The oscillator tank inductance has been decreased and the oscillator transistor, Q14, is operated at a slightly higher current. The varactor bias is provided by Q9 and Q10 and the B-blanking is provided by Q11 and Q12. Current during the sweep retrace time is not completely removed but is steered by Q13 through CR12. This current will not cause oscillation since L15 has been by-passed. It does, however, provide better frequency stability in the oscillator. The RF signal is coupled from the oscillator, by L20, through the voltage variable attenuator consisting of CR17, CR18 and CR19 and to the RF output.

Q7 and Q8 help provide the proper bias to the shunt diodes in the voltage variable attenuators, in order to maintain a constant load for the oscillator, thus minimizing the frequency pulling effects of the attenuator.

Transistors Q15 and Q16 are switching transistors which connect the output of the leveling amplifier to the voltage variable attenuator associated with the operating band.

4.9 MARKER ADDER (MODULE M5H)

The main function of this module is adding together and amplifying the individual marker signals from the M6 marker modules. It also contains the external marker mixer circuit and the sweep sample selection and leveling circuits.

The desired sweep sample signal (band 1 or band 2 and band 3) is selected by the PIN diode switch CR4 and CR5. The sweep sample signal is then leveled in the same manner as the main RF output signal. The voltage from the monitor, CR7, and the reference voltage from R46 is fed to the leveling amplifier consisting of transistor stages Q12 and Q13. Q11 provides blanking of the leveling amplifier. Any error between the two input signals is amplified and fed to the voltage variable attenuator CR6. The operation of this circuit produces a constant amplitude signal at the monitor point.

The leveled sweep sample signal is connected to the external marker mixer, CR1 and CR2, and to the sweep sample output connector, J4. A 47 ohm resistor, which is connected between J4 and the monitor point, establishes the source impedance at approximately 50 ohm. The signal is then routed to each M6 marker module.

The marker output signals from the individual M6 marker modules are connected to the input pins 1, 2, 3, and 4 of the M5H module. One or two M6 outputs are connected to each input. The signals are then amplified in the input stages (Q2, Q3, Q4, and Q5) and combined in the common collector load. The collector load is an external 10mH choke when the Front Panel MARKER WIDTH Selector is set to "WIDE", or a 3.3k ohm resistor, R21, when the Width Selector is set to "NARROW." The combined marker signals are then amplified in transistor stages Q6, Q7 and Q8. The Front Panel Marker WIDTH Selector also varies the high frequency gain of the amplifier by connecting capacitance across R27, the feedback resistor. The amplified signal is then fed to the complimentary output stage, Q9 and Q10, which is biased so that input signals less than 0.5 volts are not amplified. This eliminates most spurious markers and noise from the output. The output is then connected to the Front Panel MARKER SIZE Control and finally to the Front Panel SCOPE VERT. connector.

4.10 MARKERS (MODULE M6's)

Each marker module contains a crystal oscillator, a tuned or untuned mixer and a marker amplifier. Harmonic generator marker modules also include one or more harmonic generating stages.

Several types of marker modules are required to cover the wide frequency range and to produce both single frequency and harmonic type markers. A single frequency marker generator produces a marker at a single frequency while the harmonic marker generator produces markers at harmonically related frequencies of the crystal oscillator.

The model number for single frequency markers is M6S followed by the marker frequency. The model number for harmonic markers is M6H followed by the harmonic marker frequency.

The Crystal Oscillator operates between the frequencies of 100 kHz and 55 MHz. Several different types of oscillators are required to cover this range of frequencies. The 100 kHz oscillators use a tuned oscillator with the crystal operating at its fundamental frequency in a series resonant mode. The 1 to 17 MHz crystal oscillators are either tuned series resonant mode oscillators or untuned pierce type oscillators. The 17 to 55 MHz oscillators use a tuned Colpits oscillator with the crystal operating at its third overtone frequency in a series resonant mode. The tuning suppresses the crystal fundamental and higher order resonant frequencies. The crystal and marker frequency are the same for frequencies between 100 kHz and 55 MHz. The markers above 55 MHz use harmonic generating techniques.

The output from the crystal oscillator (or harmonic generator) is combined with the sweep sample in the mixer stage. In the case of single frequency markers, the mixer includes a tuned circuit which selects the desired crystal or crystal-harmonic frequency and the sweep sample frequency. In the case of a harmonic marker, the mixer is untuned. The mixer circuit is generally a diode mixer, although transistor mixers are sometimes used. The fundamental and product signals are filtered from the mixer output, leaving the "difference signal" which is applied to the marker amplifier stage.

The marker amplifier is a single stage amplifier having a frequency response of several kHz to approximately 500 kHz. The output of the marker amplifier is connected through the SIZE Control to the output pin of the module.

SECTION 5 MAINTENANCE

5.1 INTRODUCTION

This section provides information for testing, calibrating, and trouble shooting the sweep generator. The performance test is designed for incoming inspection and periodic evaluation. If performance is not to specifications, refer to the calibration and trouble shooting sections.

5.2 SERVICE INFORMATION

5.2.1 DISASSEMBLY INFORMATION

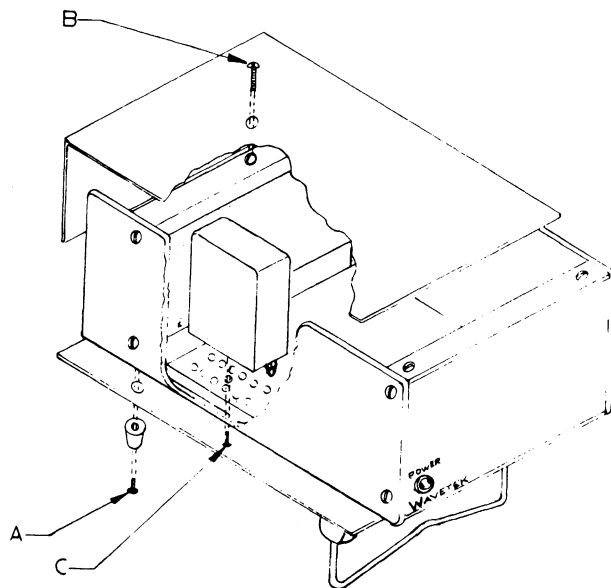

Figure 5-1. Disassembly

REMOVAL OF BOTTOM COVER – Remove the two rear feet (A) and lift cover off with a slight rear movement.

REMOVAL OF TOP COVER – Remove the single screw (B) from the top and lift off cover with a slight rear movement.

REMOVAL OF SIDE PANEL – Either side panel can be removed to provide better access by removing the four screws holding the side panel to the instrument. The Front Panel/Module Section can be removed from the power supply section by removing two screws holding the sections together and by disconnecting the electrical connectors between the two sections. **NOTE:** The separation of the two sections performs no useful purpose during normal

service procedures.

5.2.2 MODULE SERVICING

SERVICE KIT K102 – This service kit contains a module extender and RF extension cables which enables the module to be electrically operated while physically located above the rest of the modules, thereby making all parts easily accessible.

REMOVAL OF MODULE – Modules may be removed by removing any cables attached to the top of the module and removing the hold-down screw (C) from the bottom.

REMOVAL OF MODULE COVER – Remove all nuts and screws from the top of the module and slide the cover off.

REINSTALLING MODULE – Before reinstalling the module, check the module pins for proper alignment, then carefully seat the module pins into the chassis socket and replace the hold-down screw (C) to insure a good ground connection between module and chassis.

MODULE PIN NUMBERING SYSTEM – The module pins are numbered as shown in Figure 5-2. The index studs for the circuit modules are located off center to prevent the module's being plugged in backwards. This off-center stud location also provides a method for locating pin #1.

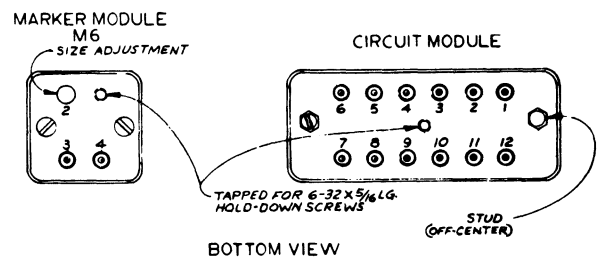

Figure 5-2. Module Pin Numbering System

5.2.3 TRANSISTOR LEAD CONFIGURATION – Transistor lead configurations are shown in Figure 5-3.

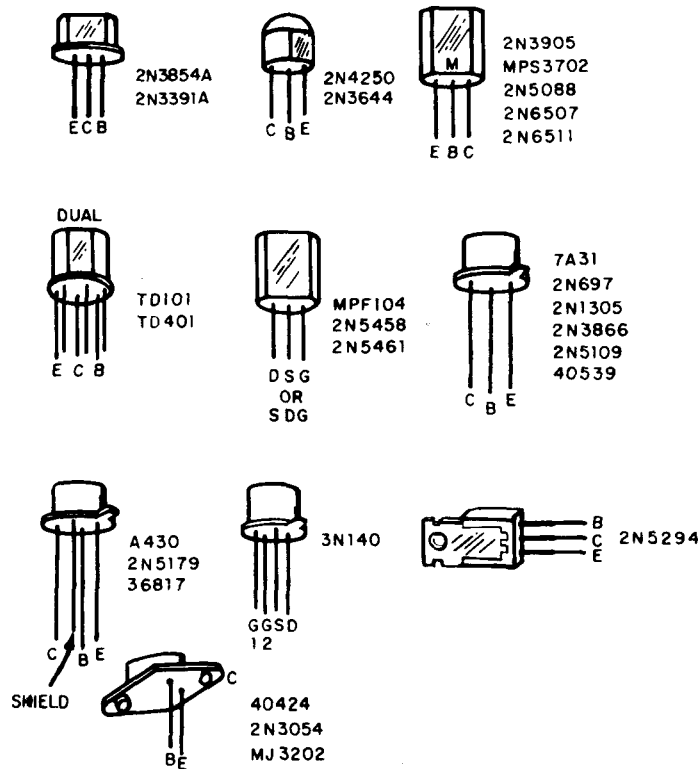

Figure 5-3. Transistor Lead Configuration

5.2.4 RECOMMENDED TEST EQUIPMENT – The following test equipment, recommended for servicing, trouble shooting, and calibrating the Wavetek Model 2001, is shown in Table 5-1.

TABLE 5-1. RECOMMENDED TEST EQUIPMENT

| INSTRUMENT | CRITICAL REQUIREMENT | RECOMMENDED |
|---------------------------|---|----------------------------------|
| Oscilloscope | DC Coupled 1mV/cm sensitivity | HP-130 |
| Digital Voltmeter | 0.1% Accuracy | Weston 1240 |
| Power Meter | Frequency Range 10 to 1500 MHz | HP-437A HP-8485A |
| RF Detector | Frequency Range 1 to 1500 MHz | Wavetek D152 |
| Spectrum Analyzer | Frequency Range 10 MHz to 3 GHz | HP8555A/8552A |
| Precision Attenuator Pads | 10, 20, & 40dB | Weinchel 50-10, 50-20, 50-40 |
| Marker Generators | 1, 10 & 50 MHz Harmonic Markers | Wavetek M6H-1, M6H-10, M6H-50 |
| CW Signal Generator | Adjustable to 925 MHz with 0.1 V output, accuracy ±10 MHz | |

5.3 PERFORMANCE CHECKS

The following procedure is intended to ensure that the instrument meets its published specifications. The checks specified assume that the instrument is equipped with A-2 options at 1 MHz, 10 MHz, and 50 MHz. While it is possible to check the instrument's performance without the use of harmonic markers, by using suitable external CW sources, a complete check by this method is impractical.

5.3.1 PRELIMINARY CHECK

Rotate both START and STOP thumb wheels to their lowest frequency position (turn full left). Both frequency indicators must read 0 MHz, ± 2 MHz, when read on the SWEEP WIDTH frequency scale. (Interpolation on the Sweep Width scale between 0 and 10 MHz is necessary to locate +2 MHz).

Preset controls as follows: BAND to 1, SWEEP TIME to LINE, OUTPUT to +10dBm, MARKER WIDTH to WIDE, MODE to CW, the four paddle switches to their extreme down position, 50 MHz HAR markers to on (in position) and the remaining markers and MOD off. Set the CENT FREQ to 250 MHz (left thumb wheel) and connect the power meter to the RF out connector. (Ensure the power meter is on the +10dBm scale).

Turn AC power on and allow the instrument to stabilize

for 5 minutes. The power meter must read between +9.5 to +10.5dBm. The calibrating procedure calls for +10dBm adjustment at 300 MHz. However, some error must be allowed for changes due to ambient operating temperature and variations between power meters.

5.3.2 FREQUENCY CHECKS

Connect the instrument to the RF detector and scope as shown in typical setup Figure 5-4. Set the SWEEP WIDTH control (right thumb wheel) to 520 MHz and the MODE switch to ΔF . Leave the rest of the controls as previously set in step 5.3.1. Adjust the MARKER SIZE, the scope vertical, and scope horizontal controls to obtain a pattern as shown in Figure 5-5. Use DC coupling on both the vertical and horizontal scope inputs. The output voltage from the detector will be approximately 0.8 volts. A detected output less than 0.7 volts indicates a defective detector or an uncalibrated scope. Each 50 MHz marker must fall within ± 0.2 cm of each CM line on the scope graticule. This is equivalent to a display linearity of 2%. This 2% specification is extremely important since all dial accuracy specifications are directly related to it. Repeat check on BANDS 2 and 3. In order to identify absolute frequencies on bands 2 and 3, an external CW signal can be connected to the EXTERNAL MARKER IN connector to identify one of the 50 MHz harmonic markers. This also verifies the operation of the external marker circuit.

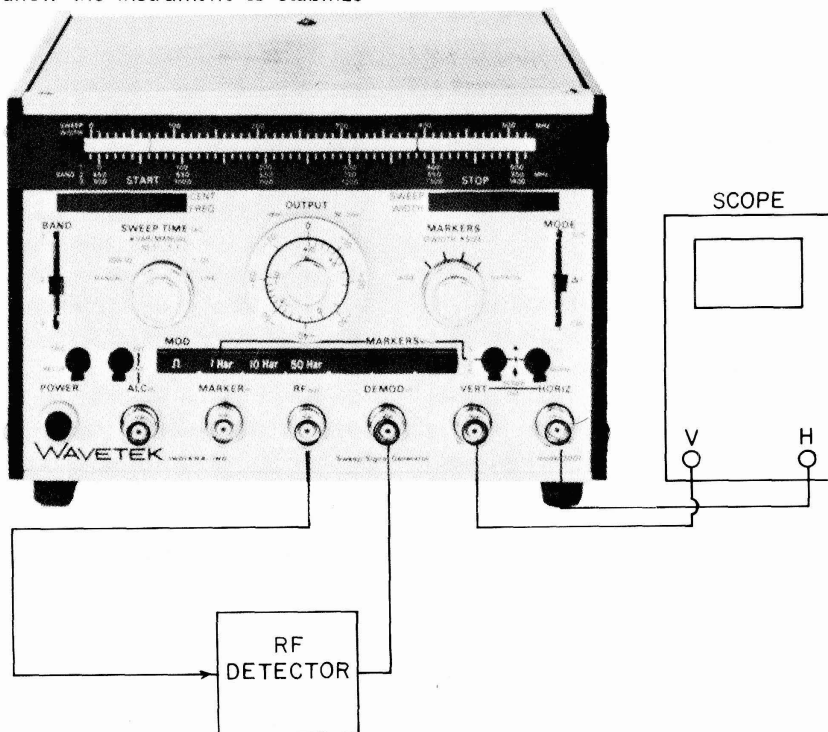

Figure 5-4. Typical Set-Up

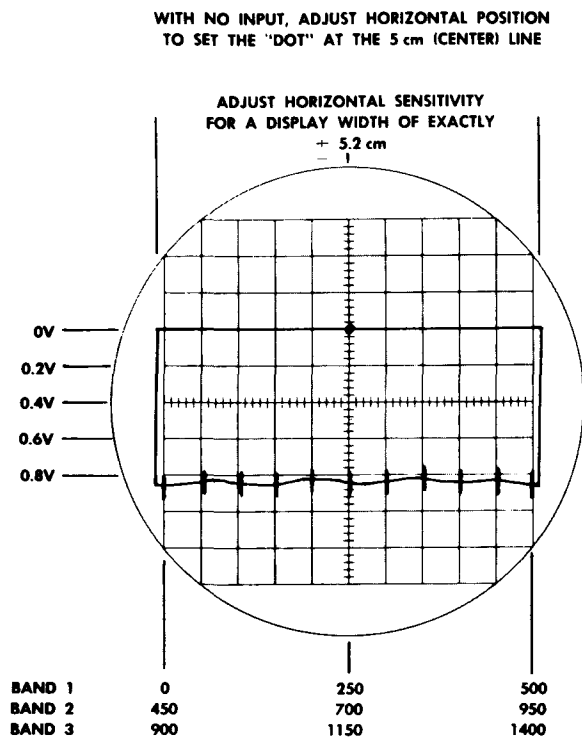

Figure 5-5. RF Detector Display

To check the minimum frequency on band 1, set BAND to 1 and frequency dials (use either S/S or ΔF MODE) to sweep approximately 0 to 10 MHz. Turn on the 10 MHz harmonic marker and locate the first marker on the right of zero lock-in point. Turn on the 1 MHz harmonic marker and count down to 1 MHz. The detected output must be leveled down to the 1 MHz marker at all settings of the OUTPUT vernier.

5.3.3 MINIMUM SWEEP WIDTH CHECK

Set MODE to ΔF and adjust SWEEP WIDTH to exactly 1 MHz (use 1 MHz markers). Adjust the MARKER WIDTH to produce a marker approximately 200 kHz wide. Next, adjust the SWEEP WIDTH to minimum. The 200 kHz wide marker should cover the entire scope display. Repeat the above check for bands 2 and 3, readjusting sweep width and center frequency as required. The minimum sweep width is less than 200 kHz on all bands.

5.3.4 RESIDUAL FM CHECK

Readjust SWEEP WIDTH to produce a calibrated frequency display of exactly 1 MHz full scale. Adjust CENTER FREQUENCY control to center one of the 1 MHz har-

monic markers on the scope display. Residual FM can be read directly on the scope display by noting the amount of jitter of the marker. (A jitter of 0.2cm would be equal to 20 kHz).

Change SWEEP TIME selector from LINE to the 0.1 - 0.01 position and again read the marker jitter. The additional jitter in this position represents the line related residual. Maximum allowable jitter is 15 kHz. Alternate Method to read residual FM is with a spectrum analyzer.

5.3.5 FREQUENCY DRIFT

Return SWEEP TIME selector to LINE and again calibrate the display's sweep width to 1 MHz. Position the marker to the exact center of the oscilloscope display and read frequency drift directly from the scope display by noting the change in the markers position with time. Each centimeter represents 100 kHz. When reading drift over long periods of time, calibrate the display sweep width to 5 MHz, using the 1 MHz harmonic marker. Next turn off the 1 MHz marker and turn on the 50 or 10 MHz harmonic markers. Center a marker on the scope display and read drift as before, except each centimeter now represents 500 kHz.

Maximum allowable drift is 100 kHz per 5 minutes or 2 MHz per 8 hours, after a one hour warm-up at a constant ambient temperature, and allowing a 5 minute stabilizing period after a frequency change.

5.3.6 DIAL ACCURACY CHECK

ΔF MODE: Set MODE to ΔF , BAND to 1, MARKER WIDTH to wide and turn on the 50 MHz harmonic marker. (1 and 10 marker off). Set SWEEP WIDTH to approximately 1 to 2 MHz and adjust CENT FREQ control until the zero frequency lock-in point is exactly center on the scope display. Read the error on the frequency scale. Repeat at each 50 MHz harmonic intervals across the band. The allowable error is ± 10 MHz.

Repeat check on bands 2 and 3. An additional frequency error is produced by the pulling effect of the OUTPUT vernier on bands 2 and 3, therefore, rotate the OUTPUT vernier thru its entire range at each 50 MHz check point. Increasing the SWEEP WIDTH to approximately 5 MHz will simplify reading. The allowable error on band 2 and 3 is 2% of the indicated frequency.

The accuracy of the SWEEP WIDTH scale can be checked with the 50 MHz harmonic marker in a similar manner. Set the actual sweep width to 50, 100, 150, etc., and read the error on the SWEEP WIDTH scale. Accuracy on band 1 is

± 10 MHz, and on band 2 and 3 ± 20 MHz. Again, accuracy on band 2 and 3 is affected by the OUTPUT vernier control.

START/STOP MODE: Return to BAND 1 and set the MODE to S/S (Start/Stop). Set START to -10 MHz and STOP to 510 MHz. A pattern similar to Figure 5-5 should be present on the scope display. Reduce STOP control until the 500 MHz marker just disappears from the right side of its scope display; read error of the STOP frequency indicator (red), repeat at each 50 MHz interval.

Return STOP dial to 510 MHz and adjust START control until the zero lock-in point just disappear from the left side of the scope display; read error of the START frequency indicator (green), repeat at each 50 MHz interval. Allowable error is the same as band 1 in the Δf mode, ± 10 MHz.

Recheck for bands 2 and 3, vary OUTPUT vernier at each 50 MHz check point. Allowable error is 2% of indicated frequency.

5.3.7 CW MODE CHECK

Turn MODE switch to CW. This position removes the return trace blanking and the sweep width drive from the oscillator. The output frequency is controlled by the CENTER FREQ control and the dial accuracy will be the same as previously checked at the Δf mode. The detected pattern on the scope will be a negative voltage equal to that produced in the S/S and Δf mode with the absence of the zero level return trace.

5.3.8 SPURIOUS SIGNAL CHECK

Checking for spurious signal content is not normally required for periodic calibration, only for initial incoming inspection. The only practical way to measure the spurious signal content is with a high quality spectrum analyzer covering the frequency range of 10 MHz to 3 GHz. The spurious check is made in accordance to the instructions furnished with the particular spectrum analyzer.

The main spurious signals on all three bands is the second and third harmonic of the output signal and should be more than 26dB below the main output signal from 10 to 500 MHz on band 1 and 26dB below the output signal from 500 to 1400 MHz on bands 2 and 3. Harmonic content is not specified below 10 MHz on band 1 and an increase of the second harmonic output to approximately 22dB below the output in the 450 to 500 MHz area of band 2 is normal.

In addition to the harmonically related spurious signals, band 1 will have non-harmonic spurious signals due to the

heterodyne method of obtaining the sweep output signal. These spurious signals are typically 40 to 50dB below the output from 10 to 400 MHz and increase to no more than 26dB below the output in the 400 to 500 MHz area.

5.3.9 RF OUTPUT FLATNESS (amplitude variations vs. frequency)

Flatness can be checked with a negative polarity RF detector or a power meter. The power meter method is to be preferred since its own flatness is better than that of most RF detectors. A 0.5dB detector flatness is typical of many detectors over this frequency range. However, the power meter has two limitations not present in the RF detector. First, slow response time and second, not useable below 20 MHz. The first limitation can be overcome by making the flatness measurements in the CW mode, the second by making flatness measurements with a detector in the low frequency area.

To measure flatness, set the MODE switch to CW, OUTPUT control to +10dBm, and connect the power meter to the RF output connector. Tune the entire frequency range from 20 to 1400 MHz and note the frequency where maximum output was obtained. With the OUTPUT VERNIER control set the output at that frequency to exactly +10dBm. Again tune the entire band and note the minimum output reading. A minimum output of 8.5dBm or more is required to meet the flatness specifications of ± 0.75 dB.

5.3.10 RF OUTPUT LEVEL

The MAX RF output level is set to produce exactly +10dBm at 300 MHz. This produces the minimum error over the greatest frequency range and can be checked by using the power meter while operating the instrument in the CW mode.

5.3.11 ATTENUATORS

20dB Vernier: The accuracy of the 20dB vernier can be checked using the power meter while operating the instrument in the CW mode. The vernier dial is calibrated at 300 MHz. Dial accuracy is ± 0.5 dB to 500 MHz, ± 1 dB to 1000 MHz, and ± 2 dB to 1400 MHz. This error is contributed by the vernier and does not include the basic flatness error at +10dBm.

70dB Attenuator: The accuracy of the step attenuator can be measured by using a suitable Attenuation Test Set or by directly substituting precision RF attenuator pads for each 10dB step of the attenuator. The difference between the two outputs represents the attenuator error. An RF

detector can be used to recover the signal at levels down to approximately -40dBm. Below this level an RF amplifier or sensitive receiver (spectrum analyzer) must be used. Allowability error is $\pm 0.5\text{dB}$ to 500 MHz, $\pm 1\text{dB}$ to 1000 MHz, and $\pm 2\text{dB}$ to 1400 MHz. This error is that produced by the step attenuator alone and does not include the basic flatness or the vernier attenuator error.

5.3.12 SWEEP TIME CHECK (Horizontal Output Check)

Connect the horizontal output of the sweep generator to the oscilloscope vertical input. Adjust the oscilloscope controls for an internally generated, automatic, line-triggered sweep of 2ms/cm and a vertical sensitivity of 2V/cm. Adjust the sweep generator SWEEP TIME selector to LINE lock and ensure that the TRIG/RECUR switch is in the RECUR position. Adjust the oscilloscope vertical position, horizontal position, and trigger level to obtain the wave-form shown in Figure 5-6.

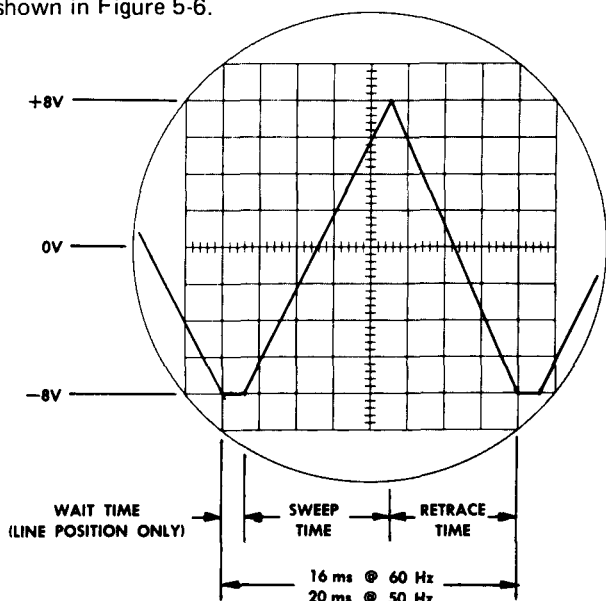

Figure 5-6. Scope Horizontal Output

Adjust the sweep generator SWEEP TIME selector to .1-.01 position. Ensure that the VARIABLE MANUAL control is fully clockwise. The wait time should disappear and the sweep time should be less than 10ms with approximately equal sweep time and retrace time periods. Adjust the oscilloscope time base to 50ms/cm. Adjust the sweep generator VARIABLE/MANUAL control fully counterclockwise. The sweep time should be more than 100ms with approximately a 10:1 ratio between the sweep and retrace time periods.

NOTE: The retrace time period remains constant within any one SWEEP TIME range setting and the VARIABLE/MANUAL control varies the sweep time period. With the

VARIABLE/MANUAL control fully clockwise the sweep and retrace times are both approximately 0.01 seconds. With the control fully counterclockwise the sweep time becomes approximately 0.1 seconds and the retrace time remains 0.01 seconds. On the next lower range (1-.1) the retrace time would remain 0.1 sec and the sweep time would vary from 0.1 to 1 second.

Repeat these checks for the 1-.1, 10-1, and 100-10 sec positions of SWEEP TIME selector switch. Adjust oscilloscope time base as necessary to ensure that the VARIABLE/MANUAL control will adjust the sweep time from faster than the maximum to slower than the minimum specifications for each range.

Adjust the SWEEP TIME selector to MANUAL and adjust the VARIABLE/MANUAL throughout its range. A DC voltage should be present that is variable from -8V, $\pm 5\text{V}$, with the control fully counterclockwise to +8V, $\pm 5\text{V}$, with the control fully clockwise.

Adjust the SWEEP TIME selector to the .1-.01 position and set the TRIG/RECUR switch to TRIG. The sweep should now be disabled. Moving the switch to the upper most position (spring loaded position) and releasing it should produce one complete sweep cycle.

NOTE: The triggered mode of operation is only possible in the variable rate positions and will not operate in the LINE lock position of the SWEEP TIME selector.

5.3.13 MARKER SYSTEM CHECK

Connect the equipment as shown in Figure 5-4. Adjust the sweep generator and oscilloscope controls to obtain the display shown in Figure 5-5. The actual control settings would be the same as in paragraph 5.3.2.

NOTE: The following performance check is for a 50 MHz harmonic marker. Specifications, with the exception of spurious markers, are the same for either single frequency or harmonic type markers and the procedure for verification of performance does not differ.

Single frequency markers should have no spurious markers throughout the swept range. Harmonic type markers may or may not have small spurious markers at one half or one third the specified marker interval.

MARKER SIZE

Observe the markers and ensure they are of equal amplitude throughout the range. Repeat this check for bands 2 and 3.

Set the oscilloscope vertical gain to 2V/cm and adjust the MARKER SIZE control fully clockwise. The markers should be approximately 12V peak-to-peak in amplitude. Set the MARKER SIZE switch to mid-position and adjust the oscilloscope vertical gain to 50mV/cm. The markers should be approximately 50mV peak-to-peak in amplitude. Adjust the MARKERS SIZE control fully counterclockwise and set the oscilloscope vertical gain to 100uV/cm. The markers should be less than 100uV peak-to-peak in amplitude. Set the MARKER SIZE switch to the down position and adjust the oscilloscope vertical gain to 50mV/cm. The markers should be approximately 50mV peak-to-peak in amplitude. Set the MARKER SIZE switch to the up position. Positive rectified markers should be present for use with X-Y recording instruments. The amplitude will be dependent on the output impedance of the RF detector being used. The amplitude should be adjustable from approximately 6V maximum to 1mV minimum with a detector impedance of 1 meg ohm, or from 0.5V to 1mV with a detector impedance of 0 ohms. NOTE: The sweep width must be decreased or the sweep time increased to observe the rectified marker.

MARKER TILT

Set the MARKER SIZE switch to the down position and set the MARKER TILT switch to the up position.

While adjusting the MARKER SIZE control throughout its range, note that the birdy marker is adjustable from a 12V peak-to-peak vertical marker to a horizontal marker approximately equal to 10% of the horizontal deflections (1 cm on a 10cm deflection).

MARKER WIDTH

Return the MARKER TILT switch to the down position. Turn on the 1 MHz markers and adjust the MARKER SIZE control for approximately a 4cm marker. Adjust the CENTER FREQUENCY and SWEEP WIDTH controls to calibrate the oscilloscope for a 1 MHz sweep width.

Adjust the CENTER FREQUENCY to center the birdy zero beat on the oscilloscope center graticule line and note that the marker width is approximately 400 KHz wide (each cm equals 100 kHz). Decrease the MARKER WIDTH switch one position and note that the marker is approximately 200 kHz wide. Decrease the MARKER WIDTH switch one position and note that the marker is approximately 100 kHz wide. Decrease the MARKER WIDTH switch to the most narrow position. The marker is now approximately 10 kHz wide.

MARKER ACCURACY

Marker accuracy may be verified by one of several methods. The first method requires a signal generator and a frequency counter covering the desired marker frequency. First adjust the sweep generator's center frequency to the markers frequency and the sweep width to approximately 2 MHz. Connect the output from the signal generator to the EXTERNAL MARKER IN jack, located on front panel, and carefully adjust the signal generator for a zero beat with the internally generated birdy marker. Next, connect the signal generator's output to the counter and read the signal generator frequency which is now identical to the internal markers frequency. Allowable error is 0.005% of the marker frequency. The second method uses the counter only but requires the removal of the instrument and marker module covers. Probe the marker box with the input lead from the counter until sufficient signal is picked up to provide a counter reading. The highest crystal frequency used is 50 MHz. Markers above this frequency use harmonics of the crystal frequency. Again the allowable error is 0.005% of the crystal frequency.

Test equipment for the marker accuracy check is not listed in the recommended test equipment chart since the requirements vary with the method and the specific markers installed in the unit. Also, the inherent stability of the quartz crystal makes a marker accuracy check unnecessary in all but the most critical applications.

5.3.14 EXTERNAL PROGRAMMING

External programming inputs are not normally checked on incoming inspection unless these special functions are to be used in a particular application. The program input signals, external controls necessary, and input pin connectors are covered in Section 3 under Operating Instructions. If it is necessary to check these functions at incoming inspection, reference can be made to that section of the manual for complete set-up instructions.

5.4 MECHANICAL ADJUSTMENT OF FREQUENCY INDICATOR TAPES

Rotate both START and STOP thumb wheels to their lowest frequency position, turn to left. Both frequency indicators must read 0 MHz \pm 2 MHz when read on the SWEEP WIDTH frequency scale; if not, proceed as follows: With reference to Figure 5-7, disengage IDLER by forcing IDLER SPRING to a disengaged position. While IDLER is disengaged, rotate the TAPE DRIVE until the frequency indicator indicates zero frequency, release the IDLER SPRING and engage the IDLER. If the frequency error is

still more than 2 MHz, loosen the screw holding the TAPE GUIDE and rotate the GUIDE so the TAPE can be disengaged from the sprockets on the TAPE DRIVE. Disengage the TAPE from the TAPE DRIVE sprockets and advance the tape one sprocket in the opposite direction of the frequency error. Engage the TAPE on the sprockets, reposition the TAPE GUIDE and tighten the screw. Again disengage the IDLER and turn the TAPE DRIVE to indicate zero frequency. The Front Panel frequency control thumb wheel must be held against its mechanical stop during the entire adjustment procedure.

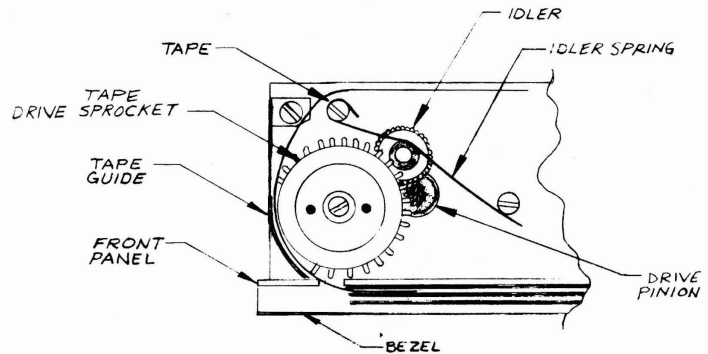

Figure 5-7. Tape Drive

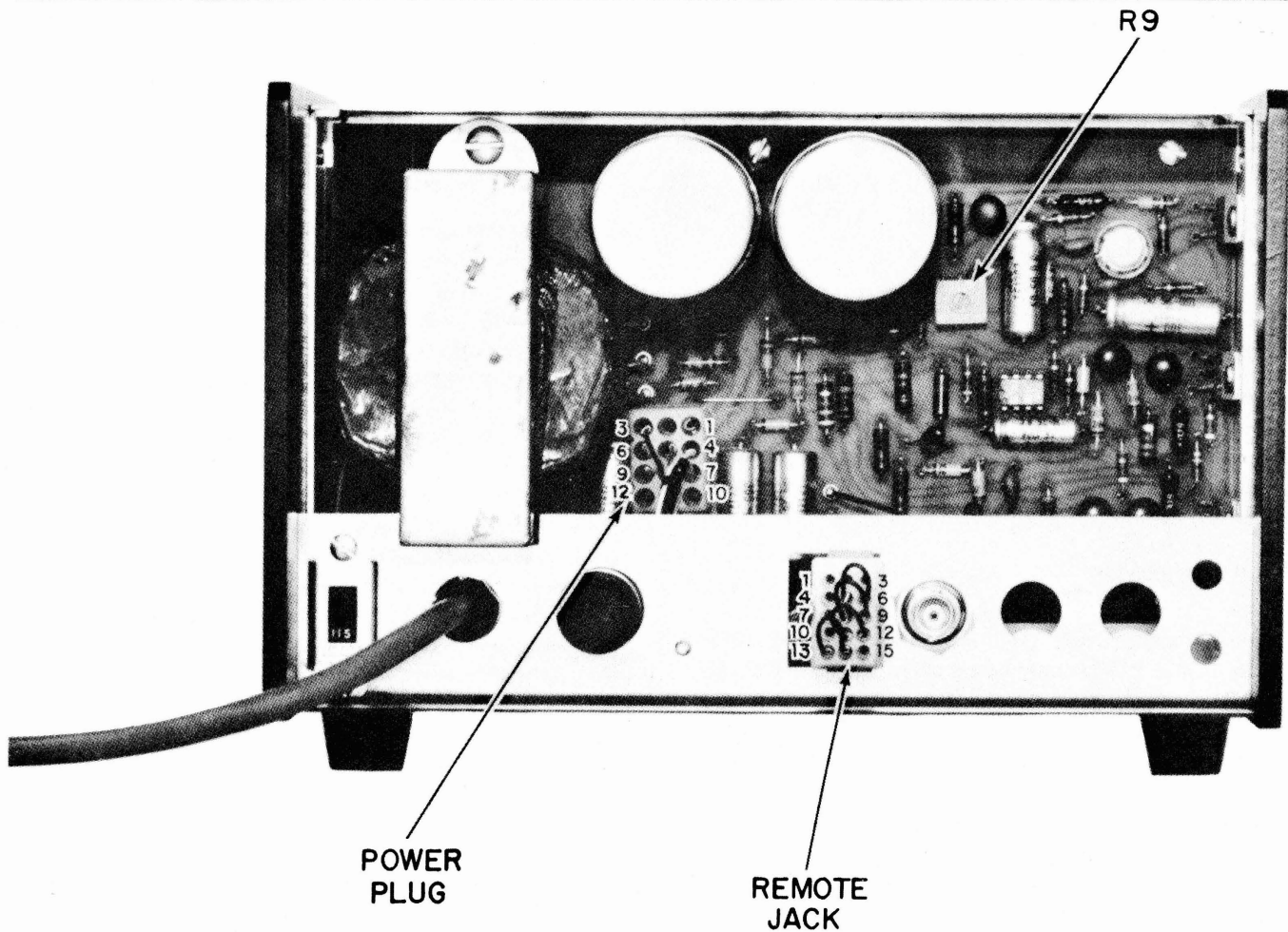

Figure 5-8. Power Supply

5.5 CALIBRATION PROCEDURE

Remove top cover, bottom cover, left side panel and M2H module cover. Allow a 15 minute warm-up period before

calibrating. In general, calibration must be performed in the sequence given. Refer to Figures 5-8, 5-9 and 5-17 for adjustment and test point location.

S/03

✓ 5.5.1 +18 VOLT ADJUSTMENT *18.008*

Connect the digital voltmeter to the +18 volt supply, pin 6 on the power plug and adjust R9 to produce +18V ±10mV. (See Figure 5-8).

✓ 5.5.2 -18 VOLT CHECK *-18.016*

Connect the digital voltmeter to the -18 volt supply, pin 4 on power plug. The reading must be -18 volts ±50mV.

✓ 5.5.3 -20 VOLT CHECK *20.31*

Connect the digital voltmeter to the 20 volt supply, pin 5 on the power plug. The reading must be -20 volts ±0.3V.

✓ 5.5.4 -16 VOLT CHECK *16.005*

CAUTION: The + and -16 volt supplies are not short circuit protected. Connect the digital voltmeter to the -16 volt supply, pin 3 of the remote jack. It must read -16 volts ±0.1 volt. (Record reading).

✓ 5.5.5 +16 VOLT ADJUSTMENT *16.005*

Connect the digital voltmeter to the +16 volt supply, pin 2 of the remote jack, and adjust R95 (see Figure 5-9) to obtain exactly the same voltage, but of opposite polarity, as recorded for the -16 volt supply in paragraph 5.5.4.

5.5.6 SWEEP RATE ADJUSTMENTS – MODULE M1H

See Figure 5-17 for location of M1H module and adjustment. Set Front Panel controls as follows: TRIG/RECUR switch to RECUR, SWEEP TIME switch to .1-.01 sec, and VAR/MANUAL control completely clockwise. Connect the scope vertical input to the output of the rate generator, pin 10 of the REMOTE jack, and adjust the scope vertical and horizontal time base controls to produce a stable pattern similar to Figure 5-10. Adjust M1H CENT control to obtain an output symmetrical about zero volts and the M1H SIZE control to obtain the 32 volt peak-to-peak amplitude. This is a preliminary adjustment, final adjustment will be covered in paragraph 5.5.7. ✓

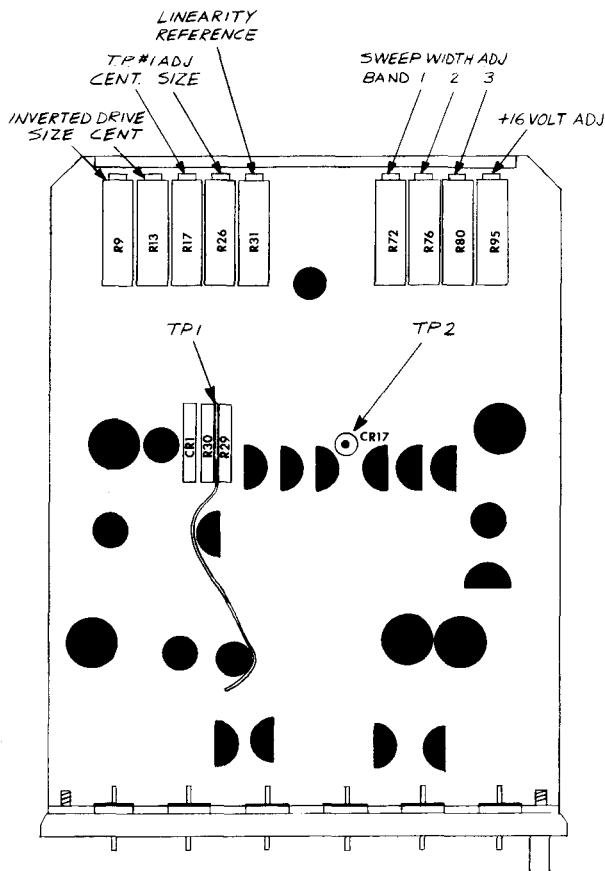

Figure 5-9. M2H Module

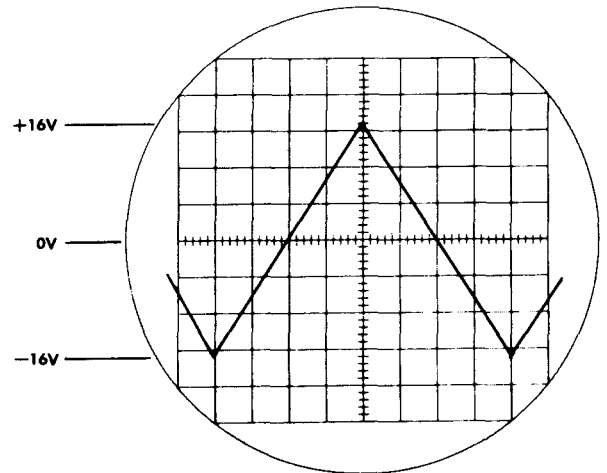

Figure 5-10. Sweep Ramp (M1H Output)

Next set the Front Panel VAR/MANUAL control fully CCW and adjust the M1H INT/BAL to produce a sweep time of 0.12 seconds. See Figure 5-11.

Then set the Front Panel SWEEP TIME to LINE and adjust the M1H CLAMP control to clamp the negative going peak of the M1H output to -16 volts. See Figure 5-12. ✓

Finally adjust the WAIT control mounted on rear of the SWEEP TIME switch assembly, see Figure 5-17, until the wait time as shown in Figure 5-12 is approximately 1 milli-second.

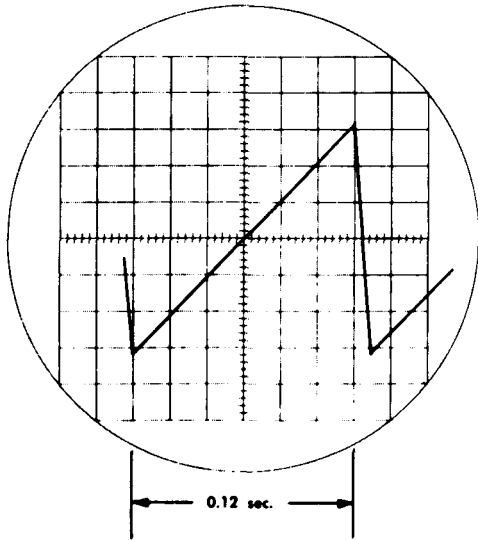

Figure 5-11. M1H Bal Adjustment

The frequency accuracy of the unit is dependent on the +16 volt reference supply, the -16 volt reference supply, the 32 volt peak-to-peak sweep ramp and the inverted 32 volt sweep ramp. These four voltages must be precisely adjusted in relation to each other to maintain dial and display accuracy.

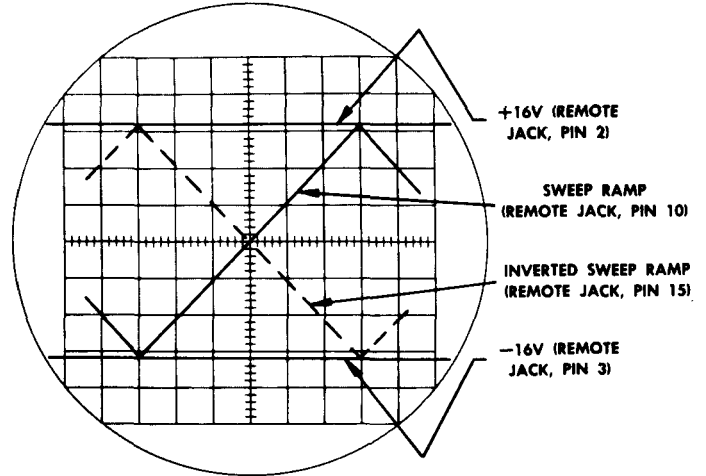

Figure 5-13. Relationship Between Sources

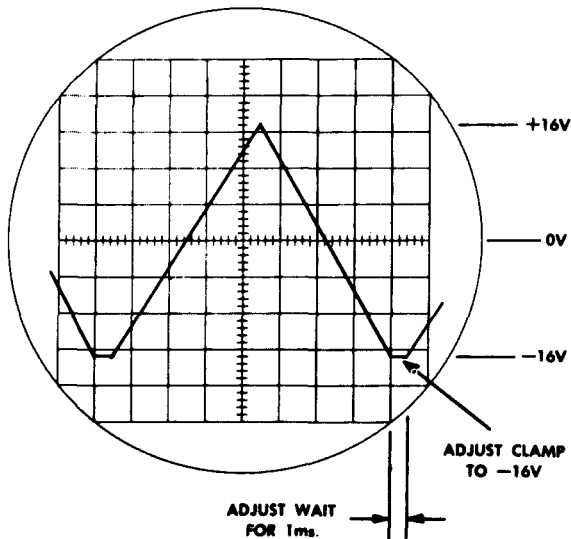

Figure 5-12. Sweep Ramp

5.5.7 RELATIONSHIP BETWEEN +16, -16, SWEEP RAMP and INVERTED SWEEP RAMP

The next step is possibly the most critical to the overall performance of the generator and requires some explanation.

The + and -16 volt references can easily be set up accurately as already described in paragraphs 5.5.4 and 5.5.5. The next problem is to adjust the peak "positive and negative" excursions of the sweep ramp, M1H pin 12, to within 0.1 volt of the +16 volt and -16 volt references.

Since the entire 32 volt change from -16 to +16 volts is equivalent to a frequency change of 520 MHz, the 0.1 volt ramp accuracy would be equivalent to a frequency error, due to the program voltage, of 1.6 MHz, which is allowable.

It can be seen in the initial adjustment of the sweep ramp, made in paragraph 5.5.6, that the required 0.1 volt resolution when viewing the entire 32 volt sweep ramp is not obtainable. Offsetting the scope position control to view only the positive or negative peak is not practical since the M1H CENT and SIZE adjustments vary both the positive and negative peaks. A practical approach is to use a scope probe containing two back-to-back 12 volt zener diodes in a zero suppressing circuit. The schematic of the probe is shown in Figure 5-14.

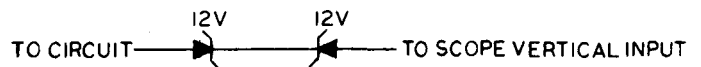

Figure 5-14. Zero Suppressing Probe

Repeat the adjustment procedure outlined in paragraph 5.5.6, with the zero suppressing probe. However, this time set the scope vertical sensitivity to 1 volt/cm. Instead of the waveform shown in Figure 5-10, the waveform shown in Figure 5-15 should be present.

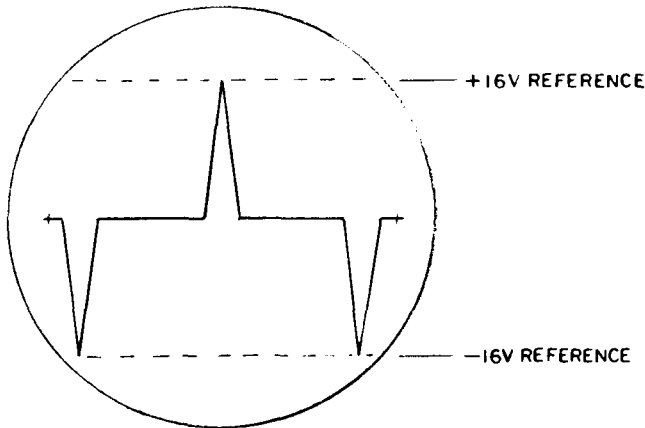

Figure 5-15. Sweep Ramp (Probe)

Calibrate the display by connecting the probe to +16 volts, and then to -16 volts. Mark these points on the scope face or record the exact amplitude of the 16 volt references. Next, connect the probe to the sweep ramp, REMOTE plug pin 10, and adjust the M1H CENT and SIZE controls until the positive and negative peaks agree precisely with the + and -16 volt calibration points. Repeat the calibration to check for scope drift while the adjustments were being made.

Next, adjust the inverted sweep ramp in the same manner

by connecting the probe to REMOTE Plug, pin 15, and adjusting M2H, R9 (SIZE), and M2H, R13 (CENT). See Figure 5-9.

5.5.8 SWEEP DRIVE ADJUSTMENT – MODULE M2H

Connect the scope vertical INPUT (straight connection, do not use the zero suppressing probe) to test point #1 in the M2H module. See Figure 5-9. Set the Front Panel MODE switch to Δf , SWEEP WIDTH control for minimum and the CENTER FREQUENCY control to indicate a dial frequency of 250 MHz on band 1, then adjust M2H, R17 for zero volts at TP1.

Next, adjust the Front Panel SWEEP WIDTH control to MAXIMUM sweep width. Do not move the Front Panel CENT FREQ control. Adjust M2H, R26, for a 28 volt peak-to-peak signal at test point #1.

Without disturbing the Front Panel CENT FREQ or SWEEP WIDTH adjustments return the scope to an X-Y operating mode with the HORIZ OUTPUT of the sweep generator driving the scope X input. Set the SWEEP TIME to .1-.01 sec and adjust the SCOPE display width to 10.4cm (.2cm overlap on each end). See Figure 5-16a.

Connect the scope Y input to M2H test point #2, which is the top side of any of the three diodes adjacent to M2H, Q7. (Linearity correcting resistors may or may not be connected to the diodes depending on the inherent linearity of the sweep oscillator). Adjust M2H, R31, to position the "knee" approximately 2/3cm to the left of the 10cm mark, as shown in Figure 5-16b. The M2H module cover, and the left side panel may now be replaced.

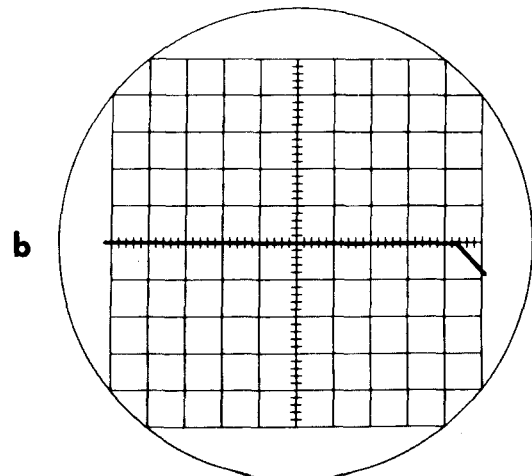
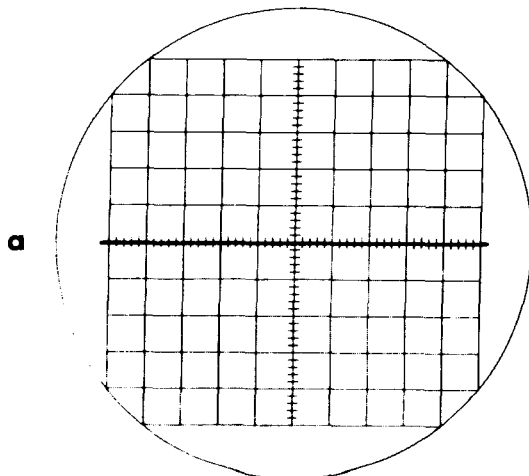

Figure 5-16. M2H Linearity Ref Adj

R15
16, 17

?

✓

✓

✓

✓

✓

✓

✓

✓

✓

✓

✓

✓

✓

✓

✓

✓

MAINTENANCE

5.5.9 LEVEL MIN AND MAX ADJUSTMENT – MODULE M10H

Preset the Front Panel controls as follows:

| | |
|----------------|------------|
| BAND Switch | to 1 |
| MODE Switch | to CW |
| FREQ Control | to 300 MHz |
| OUTPUT Control | to +10dBm |
| ALC Switch | to INT |

✓ Set the power meter to read +10dBm and connect the thermistor mount to the sweep generator's RF output connector. Adjust the M10H LEVEL MAX control to produce a power meter reading of exactly +10dBm. Turn the Front Panel vernier OUTPUT control to -10dBm (completely counterclockwise), change the power meter scale to read -10dBm and adjust the M10H LEVEL MIN control to produce a power meter reading of exactly -10dBm. Some interaction exists between the LEVEL MIN and LEVEL MAX controls so repeat the adjustment until both the +10 and -10dBm readings are obtained.

5.5.10 CENTER FREQUENCY AND SWEEP WIDTH ADJUST – Bands 1, 2 and 3

Connect SWEEP, SCOPE and RF DET as shown in TYPICAL SET-UP, Figure 5-4. Set:

| | |
|--------------------------|--------------------------------------|
| BAND Switch | to 1 |
| MODE Switch | to Δf |
| CENTER FREQUENCY Control | to 250 MHz |
| SWEEP WIDTH Control | to 520 MHz |
| OUTPUT Control | to +10dBm |
| SWEEP TIME Switch | to .1-.01 sec |
| Four Paddle Switches | down |
| 50 har marker Switch | on |
| MARKER WIDTH Switch | to WIDE |
| MARKER SIZE | for a display similar to Figure 5-5. |

The sweep generator should be thoroughly stabilized by operating approximately one hour with all covers in place before the following adjustments are made.

Adjust the scope per Figure 5-5. Adjust the M9H CENT control, band 1, to position the 250 MHz marker at the exact center of the scope display. Adjust the M2H SWEEP WIDTH 1 to position the 0 frequency and 500 MHz markers as shown in Figure 5-5. Compromise between 0 and 500 if necessary.

Set BAND switch to 2, wait 5 minutes, then adjust the M19H CENT, BAND 2, to position the 700 MHz marker to

the exact center of the display. Adjust the M2H SWEEP WIDTH 2, to position the 450 and 950 MHz markers as shown in Figure 5-5. Compromise between 450 and 950 if needed.

Set band switch to 3, wait 5 minutes, then adjust the M19H CENT, BAND 3 to position the 1150 MHz marker to the exact center of the display. Adjust the M2H SWEEP WIDTH, BAND 3, to position the 900 and 1400 MHz markers as shown in Figure 5-5. Compromise between 900 and 1400 if needed.

5.5.11 FINAL ADJUSTMENT OF M1H CLAMP

While operating the sweep generator as set up in paragraph 5.5.10, carefully note the extreme left side of the scope display. The trace should extend 0.2cm beyond the first graticule line, as shown in Figure 5-5.

Switch SWEEP TIME from .1-.01 sec to LINE, and adjust the M1H CLAMP for the identical display width.

5.5.12 SWEEP SAMPLE ADJUSTMENT M5H

Connect the RF detector to the SWEEP SAMPLE OUT Jack of the M5H module, using the adapter cable supplied in the service kit, and adjust the M5H SWEEP SAMPLE ADJ. to produce a detected output of 35 millivolts when the Front Panel BAND switch is set to band 1.

5.5.13 MARKER SIZE ADJUSTMENT

Each marker module has a SIZE adjustment potentiometer which is accessible from the under side of the sweep generator, when the bottom cover is removed. (See Figure 5-2). The control is adjusted until a saturated marker is obtained on the scope display when operating the unit as shown in the typical set-up, Figure 5-4. A saturated marker is obtained when a further increase in the marker modules SIZE adjustment does not increase the marker amplitude on the scope display. Increasing the size adjustment beyond this point will result in spurious markers on the display.

5.6 TROUBLESHOOTING

Trouble shooting is generally a systematic procedure of "divide and conquer." A thorough understanding of the block diagram and circuit description located in Section 4 of this manual will enable the trouble symptom to be associated with a particular module. Once this has been accomplished the module can be replaced or trouble shot with the aid of the module schematic. A problem in a power supply often causes many symptoms pointing to

other areas and should be checked when the symptom does not clearly indicate a specific problem. The +18, -18, and -20V supplies are located on the rear chassis printed circuit board and the +16 and -16 reference voltage supplies are located in the M2H module. Performance of these supplies are indicated in the calibration procedure.

5.6.1 TROUBLE SHOOTING HINTS

The following is a list of several typical symptoms followed by the probable cause or a trouble shooting procedure.

INTERMITTENT OPERATION OF ANY TYPE – Defective module pin sockets or loose RF cables.

NO RF OUTPUT

ALL THREE BANDS – Defective attenuator or RF cables connecting to the input or output of the attenuator.

SINGLE BAND ONLY – Check for the presence of the band switching voltages B-1, B-2, and B-3 at module M9H, M10H, and M19H as shown on the Module Wiring Diagram.

RF OUTPUT NOT FLAT – Most common cause is the external RF detector being defective. Another is the monitor diode located in the M19H module. This is a point contact diode and can be damaged if the RF output is momentarily connected to a B+ voltage. A good monitor diode will produce a negative detected voltage (pin 8 of M19H) approximately twice the amplitude of the external detector. For example, at an RF output of +10dBm an external RF detector will read approximately 0.8V. The internal monitor, pin 8 of M19H, will read approximately -1.6V.

FREQUENCY UNSTABLE (JITTER) – Check all modules for loose hold-down screws, especially module M2H. Check the + and -16V reference supplies. Operating the unit in a strong magnetic field, such as setting on top of or adjacent to another instrument containing a large power transformer, can produce 60Hz HUM modulation.

SWEEP RATE PROBLEM – Probable cause is a defective M1H module or wiring to the Front Panel SWEEP TIME

selector switch. See the calibration procedure for verifying proper operation.

NO RF SWEEP – First check pin 12 of the M1H module for the presence of a 32V ramp. This ramp indicates proper operation of the M1H. Next check for the ramp at the input of the M2H pin 7 (ΔF mode). Finally check the output of the M2H at pin 9. It should be similar to the input except it will be lower in amplitude, approximately 12V peak-to-peak, and will have an average value of 0V when the Front Panel center frequency control is set to mid-band. If the M2H output is correct the trouble would probably be in the M9H or M19H sweep oscillator module.

MARKER PROBLEMS

To isolate the cause of a marker problem when the symptom does not clearly indicate a specific circuit or component, first check the sweep sample output at the M5H Sweep Sample Out connector. It should be a detected signal between 30 to 50 mV. If the proper sweep sample signal is not present it indicates that the trouble is in the sweep oscillator module or connecting sweep sample cables. Next connect the detector in place of the terminating plug P102.

A signal at this point indicates all jumper cables and RF jacks on the M6 modules are intact. Then check for the birdy output at pin 3 of the marker module. A 10 to 15mV peak-to-peak birdy is sufficient to drive the M5H module and indicates the M6 module is operating properly. With the 15mV peak-to-peak birdy present at the input of the M5H, pins 1, 2, 3, or 4, a 32V peak-to-peak signal will be produced at the output pin 7. This indicates proper operation of the M5H. This output signal at pin 7 is controllable in width by the Front Panel MARKER WIDTH control. The signal is now routed through the Front Panel Marker Size control and to the Front Panel SCOPE VERTICAL connector. A 12V peak-to-peak signal is normally at this point when the Front Panel SIZE control is set to maximum. A common marker problem is that caused by one of the interconnecting cables between the M6 modules being loose. This causes a notch in the sweep sample input to the module causing uneven harmonics or weak output.

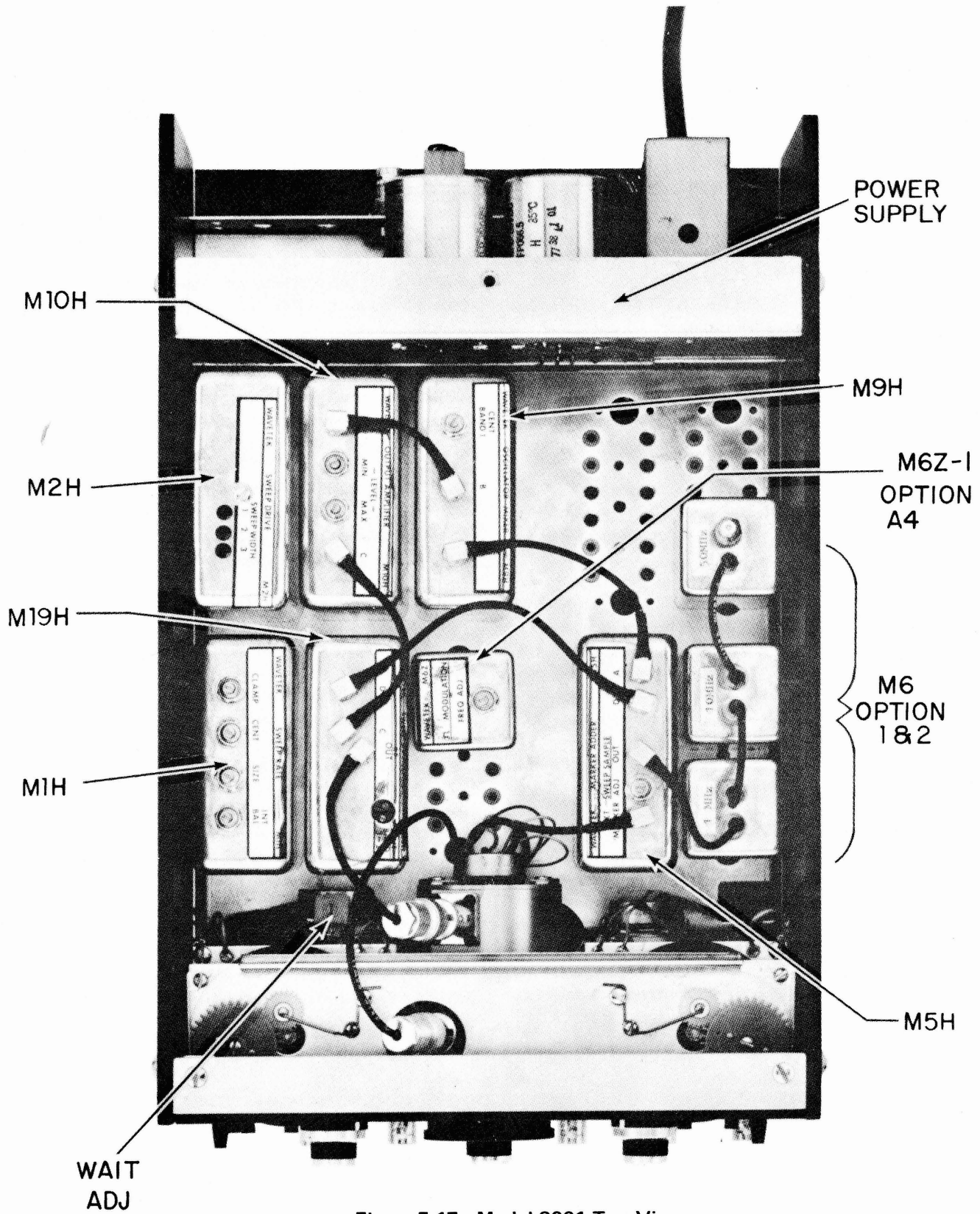

Figure 5-17. Model 2001 Top View

20014

2001

±.33
Air by out
0-63.0
±.9
0

SECTION 6 REPLACEABLE PARTS

6.1 INTRODUCTION

This section contains lists of all replaceable parts for the instrument.

For an assembly containing one or more subassemblies, the assembly list appears first, and is followed by the subassembly list.

The lists appear in the following order.

| <u>PARTS LIST</u> | <u>ASSEMBLY</u> |
|-------------------|--------------------|
| 1010-00-0011 | 2001 |
| 1111-00-0007 | SWEEP - 2001 |
| 1112-00-0008 | SWEEP TIME - 2001 |
| 1112-00-0005 | MKR SHPR/SZ - 2001 |
| 1118-00-0001 | REMOTE PLUG - 2001 |
| 1219-00-0005 | HARNES - 2001 |
| 1115-00-0001 | PS6 |
| 1218-00-0012 | PC - PS6 |
| 1114-00-0002 | M1H |
| 1114-00-0029 | M2H |
| 1114-00-0027 | M5H |
| 1114-00-0003 | M9H |
| 1114-00-0004 | M10H |
| 1114-00-0005 | M19H |
| 1114-00-0050 | M6H-1 |
| 1114-00-0099 | M6H-10 |
| 1114-00-0100 | M6H-100 |
| 1114-00-0045 | M6S-3 |
| 1114-00-0150 | M6Z-1 |

6.2 MANUFACTURERS CODE

The following code is used on the parts lists to identify the manufacturer.

| ABBRV | NAME..... | CITY..... | ST |
|-------|-------------------------------|--------------------|----|
| A-B | ALLEN-BRADLEY | MILWAUKEE | WI |
| A-D | ANALOG DEVICES | CAMBRIDGE | MA |
| A-H | ARROW HART, INC. | KETTERING | OH |
| A-I | ALAN INDUSTRIES | COLUMBUS | IN |
| A-M | AMERICAN MAGNETICS | CARTERVILLE | IL |
| A-P | AMERICAN PLASTICRAFT CO. | CHICAGO | IL |
| ABAC | ABACUS PACKAGING CO. | CHICAGO | IL |
| ACI | ADVANCE COMPONENTS, INC. | CENTERBROOK | CT |
| AER | AVX CERAMICS | MYRTLE BEACH | SC |
| AERTK | AERTECH INDUSTRIES | SUNNYVALE | CA |
| AHAM | AHAM COMPANY | AZUSA | CA |
| AIN | ALPHA INDUSTRIES, INC. | WOBURN | MA |
| ALC | ALCO ELECTRONICS PRODUCTS | NORTH ANDOVER | ME |
| ALLPL | ALL PLASTICS, INC. | INDIANAPOLIS | IN |
| AMP | AMP, INC. | HARRISBURG | PA |
| APL | AMPHENOL CONNECTOR SYSTEMS | BROADVIEW | IL |
| APX | AMPEREX ELECTRONIC CORP. | SLATERSVILLE | RI |
| ARC | ARCO ELECTRIC PRODUCTS | SHELBYVILLE | IN |
| ASC | ASSOCIATED SPRING | BRISTOL | CT |
| ASE | AIRCO SPEER ELECTRONICS | ST. MARYS | PA |
| AT/IN | ATLANTIC INDIA RUBBER COMPANY | CHICAGO | IL |
| ATC | AMERICAN TECHNICAL CERAMICS | HUNTINGTON STATION | NY |
| ATR | ATR COIL CO. | BLOOMINGTON | IN |
| AUGAT | AUGAT, INC. | ATTLEBORO | MA |
| AVT | AVANTEK, INC. | SANTA CLARA | CA |
| AWC | ALPHA WIRE | ELIZABETH | NJ |
| B-T | BEK-TEK, INC. | READING | PA |
| BEK | BECKMAN INSTRUMENTS, INC. | FULLERTON | CA |
| BEL | BELDEN CORP. | GENEVA | IL |
| BER | BERG ELECTRONICS | NEW CUMBERLAND | PA |
| BGH | BEECH GROVE HARDWARE | BEECH GROVE | IN |
| BOU | BOURNS, INC. | RIVERSIDE | CA |
| BREZ | BREEZE CORPORATIONS, INC. | UNION | NJ |
| BUCK | BUCKEYE STAMPING CO. | COLUMBUS | OH |
| BUD | BUD RADIO, INC. | WILLOUGHBY | OH |
| BURND | BURNDY CORP. | NORWALK | CT |
| BUS | BUSSMAN MFG. | ST. LOUIS | MO |
| C-D | CORNELL DUBILIER ELECT. DIV. | NEWARK | NJ |
| C-E | CLINTON ELECTRONICS | ROCKFORD | IL |
| C-H | CUTLER-HAMMER, INC. | MILWAUKEE | WI |
| C-I | COMPONENTS, INC. | BIDDEFORD | ME |
| C-J | TRW/CINCH | ELK GROVE VILLAGE | IL |
| C-K | C & K COMPONENTS, INC. | WATERTOWN | MA |
| C-L | CENTRALAB DIV. | MILWAUKEE | WI |
| C-W | C-W INDUSTRIES | WARMINSTER | PA |
| CAM | CAMBION | CAMBRIDGE | MA |
| CAR | CARLING ELECTRIC, INC. | WEST HARTFORD | CT |
| CDC | COMPONENT DEVELOPMENT CORP. | CARSON | CA |
| CECO | CENTRAL COIL CO. | BRAZIL | IN |
| CGW | CORNING GLASS WORKS | CORNING | NY |
| CHE | CHERRY ELECTRICAL PRODUCTS | WAUKEGAN | IL |
| CIMCO | CIMCO WIRE AND CABLE INC. | ALLENDALE | NJ |
| CKI | CTS KNIGHTS, INC. | SANDWICH | IL |
| CLA | CLAIREX CORP. | MT. VERNON | NY |
| CLAR | CLAROSTAT MFG. CO | DOVER | NH |

| ABBRV | NAME..... | CITY..... | ST |
|-------|--------------------------------|--------------------|----|
| CLFX | COLE-FLEX CORP. | BABYLON | NY |
| CPKG | CREATIVE PACKAGING DIV. | INDIANAPOLIS | IN |
| CTS | CHICAGO TELEPHONE SYSTEMS | CHICAGO | IL |
| CTS-E | CTS OF ELKHART | ELKHART | IN |
| CTSBR | CTS OF BERNE | BERNE | IN |
| CTSBV | CTS OF BROWNSVILLE | BROWNSVILLE | TX |
| DAL | DALE TECHNOLOGY CORP. | HARTSDALE | NY |
| DAV | HARRY DAVIES MOLDING CO. | CHICAGO | IL |
| DEL | DELEVAN DIV. | EAST AURORA | NY |
| DEW | DEWIRE FABRICATING CORP. | LOWELL | MA |
| DIO | DIODES, INC. | CHATSWORTH | CA |
| DRA | DRAKE MANUFACTURING CO. | HARWOOD HEIGHTS | IL |
| E-C | ELECTRONIC CRYSTALS | KANSAS CITY | MO |
| E-M | ELECTRA/MIDLAND CORP. | MINERAL WELLS | TX |
| ELCO | ELCO INDUSTRIES | ROCKFORD | IL |
| ELFX | ELECTRO-FLEX HEAT INC. | BLOOMFIELD | CT |
| EPITK | EPITEK ELECTRONICS | KANATA, ONT., CAN. | ** |
| ETP | ERIE TECHNOLOGICAL PRODUCTS | ERIE | PA |
| EXAR | EXAR INTEGRATED SYSTEMS | SUNNYVALE | CA |
| F-K | FRUST-KING | **** | CT |
| F-S | FEDERAL SCREW | CHICAGO | IL |
| FAN | FANCOURT & CO. | GREENSBORO | NC |
| FCD | FAIRCHILD | MOUNTAIN VIEW | CA |
| FRTE | FAIR RITE PRODUCTS CORP. | WALLKILL | NY |
| FRXC | FERROXCUBE DIVISION | SAUGERTIES | NY |
| G-E | GENERAL ELECTRIC | INDIANAPOLIS | IN |
| G-H | GRAYHILL, INC. | LA GRANGE | IL |
| G-I | GEN'L INSTRUMENT SEMICONDUCTOR | HICKSVILLE | NY |
| GAL | GALILEO ELECTRO-OPTICS | CARMEL | IN |
| GRIES | GRIES REPRODUCER | NEW ROCHELLE | NY |
| GRIP | GRIPMASTER CO. | MARLBORO | NJ |
| GUDL | GUDEBROD BROS. SILK CO. | CHICAGO | IL |
| H-P | HEWLETT-PACKARD | INDIANAPOLIS | IN |
| HEL | HELIPOT | ANAHEIM | CA |
| HEY | HEYMAN MFG. CO. | WAUKESHA | WI |
| HHS | HERMAN H. SMITH, INC. | BROOKLYN | NY |
| HIT | HITACHI AMERICA, LTD. | SAN FRANCISCO | CA |
| HOLUB | HOLUB DISTRIBUTING CO. | NEWPORT | KY |
| HUD | HUDSON TOOL & DIE CO. | NEWARK | NJ |
| HY/PL | HYDRO PLASTICS INC. | GEORGETOWN | KY |
| HYT | HYTRONICS | PINELLAS PARK | FL |
| INT | INTERSIL, INC. | CUPERTINO | CA |
| IRC | INTERNATIONAL RESISTANCE CO. | PHILADELPHIA | PA |
| ITT | INT'L TELEPHONE & TELEGRAPH | W. PALM BEACH | FL |
| JAN | JAN HARDWARE MFG. CO. | LONG ISLAND CITY | NY |
| JEF | JEFFERS | DUBOIS | PA |
| JEFWC | JEFFERSON WIRE AND CABLE | WORCHESTER | MA |
| JEW | JEWELL ELECTRICAL INSTRUMENTS | MANCHESTER | NH |
| JHSN | JOHANSON MANUFACTURING CORP. | BOONTON | NJ |
| JON | E.F. JOHNSON CO. | WASECA | MN |
| K-L | KERRIGAN LEWIS MFG. | CHICAGO | IL |
| K-S | K & S ENGINEERING CO. | CHICAGO | IL |
| KEENE | KEENE CORP. | NEWARK | DE |
| KEM | KEMTRON ELECTRON PRODUCTS | NEWBURYPORT | MA |

| ABBRV | NAME..... | CITY..... | ST |
|-------|------------------------------|-----------------|----|
| KEY | KEYSTONE ELECTRONIC CORP. | NEW YORK | NY |
| KID | KIDCO, INC. | MEDFORD | NJ |
| KIN | KINGS ELECTRONICS | TUCKAHOE | NY |
| KSTR | KESTER SOLDER DIV. | CHICAGO | IL |
| KSW | KSW ELECTRONICS | INDIANAPOLIS | IN |
| LEYSE | LEYSE ALUMINUM CO. | KEWANEE | WI |
| LIT | LITTELFUSE, INC. | DES PLAINES | IL |
| LRC | LRC ELECTRONICS, INC. | HORNELL | NY |
| M-A | MICROWAVE ASSOCIATES | BURLINGTON | MA |
| M-D | MILLER DIAL & NAMEPLATE CO. | EL MONTE | CA |
| M-E | MEPCO ELECTRA, INC. | MORRISTOWN | NJ |
| M-D | ILLUMINATED PRODUCTS INC. | SANTA ANA | CA |
| MAL | MALLORY CONTROLS CO. | FRANKFORT | IN |
| MAND | MANDEX | CHICAGO | IL |
| MDC | MAIDA DEVELOPMENT CO. | HAMPTON | VA |
| MILN | MILLEN MFG. CO. | NEW YORK | NY |
| MMM | 3M COMPANY | ST. PAUL | MN |
| MOL | MULEX PRODUCTS | LISLE | IL |
| MOT | MOTOROLA SEMI. PROD. DIV. | INDIANAPOLIS | IN |
| MSP | MICRO SEMICONDUCTOR CORP. | SANTA ANA | CA |
| MYERS | MYERS SPRING CO. | LOGANSPOUT | IN |
| N-T | NATIONAL TEL-TRONICS | LAREDO | TX |
| NAT | NATIONAL SEMICONDUCTOR CORP. | SANTA CLARA | CA |
| NEC | NIPPON ELECTRIC CO. | TOKYO, JAPAN | ** |
| NEW | NEWARK ELECTRONICS | INDIANAPOLIS | IN |
| NYLO | NYLOMATIC | MORRISVILLE | PA |
| O-G | OPTI-GAGE INC. | DAYTON | OH |
| O-S | OMNI SPECTRA INC. | FARMINGTON | MI |
| OAK | OAK INDUSTRIES INC. | CRYSTAL LAKE | IL |
| OHM | UHMITE MFG. CO. | SKOKIE | IL |
| OMEGA | OMEGA WIRE & CABLE | HARLEYSVILLE | PA |
| OPTRN | OPTRON INC. | CARROLLTON | TX |
| P-B | POTTER AND BRUMFIELD | PRINCETON | IN |
| P-C | POWER COMPONENTS | WOODLAND HILLS | CA |
| P-K | PARKER KALON CORP. | CLIFTON | NJ |
| R-T | PENN TUBE PLASTICS CO. | CLIFTON HEIGHTS | PA |
| PAND | PANDUIT CORP. | TINLEY PARK | IL |
| PARA | PARAMETRIC INDUSTRIES | NORTHFIELD | IL |
| PEC | PACIFIC ELECTRICORD CO. | GARDENA | CA |
| PEC | PACIFIC ELECTRICORD CO. | GARDENA | CA |
| PHC | PHILADELPHIA HANDLE CO. | CAMDEN | NJ |
| PLSSY | PLESSEY ENG. | SCHILLER PARK | IL |
| POM | POMONA ELECTRONICS CO., INC. | POMONA | CA |
| PRMD | PYRAMID INDUSTRIES, INC. | PHOENIX | AZ |
| PRSN | PRECISION TUBE CO., INC | NORTH WALES | PA |
| PTN | PENN TRAN CORP. | BELLEFONT | PA |
| PYRO | PYROFILM CORP. | WHIPPANY | NY |
| PYTT | PYTTRONICS INDUSTRIES, INC. | MONTGOMERYVILLE | PA |
| Q-C | QUALITY COMPONENTS | ST. MARYS | PA |
| RAY | RAYTHEON | INDIANAPOLIS | IN |
| RCA | RCA | CAMDEN | NJ |
| REL | RELIANCE MICA CO. | BROOKLYN | NY |
| RICH | RICHCO PLASTIC CO. | CHICAGO | IL |
| RMC | RADIO MATERIALS CORP. | CHICAGO | IL |
| ROGAN | ROGAN CORP. | NORTHBROOK | IL |

| ABBRV | NAME..... | CITY..... | ST |
|-------|--------------------------------|-------------------|----|
| S-C | SPECIALTY CONNECTOR | INDIANAPOLIS | IN |
| S-G | STANDARD GRIGSBY | AURORA | IL |
| S-I | SWITCHCRAFT, INC. | CHICAGO | IL |
| S-S | SERVICE SUPPLY | INDIANAPOLIS | IN |
| S-T | SARKES TARZIAN | BLOOMINGTON | IN |
| SCBE | SCANBE DIVISION | EL MONTE | CA |
| SCC | STACKPOLE CARBON CO. | ST. MARYS | PA |
| SEAST | SEASTROM MFG. CO. | GLENDALE | CA |
| SEL | SEAELECTRO CORP. | MAMARONECK | NY |
| SEM | SEMTECH | NEWBURY PARK | CA |
| SGM | SIGMA INSTRUMENTS | BRAINTREE | MA |
| SHAM | SHAMROCK PLASTICS & RUBBER CO. | INDIANAPOLIS | IN |
| SIEM | SIEMENS | ISELIN | NJ |
| SIG | SIGNETICS CORPORATION | SUNNYVALE | CA |
| SOUTH | SOUTHCO FASTENERS | LESTER | PA |
| SPE | SPECTROL | DAYTON | OH |
| SPEC | SPECTRUM CONTROL, INC. | FAIRVIEW | PA |
| SPR | SPRAGUE ELECTRIC CO. | INDIANAPOLIS | IN |
| SSS | SOLID STATE SCIENTIFIC | MONTGOMERYVILLE | PA |
| STR | STETTNER TRUSH CO. | CAZENOVIA | NY |
| STSA | STEEL SALES | INDIANAPOLIS | IN |
| SYL | GTE SYLVANIA | WALTHAM | MA |
| SYS | SYSCON INTERNATIONAL, INC. | SOUTH BEND | IN |
| T-I | TEXAS INSTRUMENTS | DALLAS | TX |
| TCPL | TACONIC PLASTIC | PETERSBURG | NY |
| TEK | TEKTRONIX | INDIANAPOLIS | IN |
| TELE | TELETYPE CORP. | ELK GROVE VILLAGE | IL |
| THR | THERMALLOY CO. | DALLAS | TX |
| TIMES | TIMES WIRE AND CABLE | CINCINNAI | OH |
| TIN | TINNERMAN PRODUCTS, INC. | CLEVELAND | OH |
| TKN | TECHNICAL WIRE | CRAWFORD | NJ |
| TLNC | TELONIC ALTAIR | LAGUNA BEACH | CA |
| TORCO | TOR CORP. | VAN NUYS | CA |
| TRU | WALDES TRUARC | LONG ISLAND CITY | NY |
| TRW | TRW CAPACITOR DIV. | OGALLALA | NE |
| U-C | UNIVERSAL COMPONENTS | LOS ANGELES | CA |
| UNIC | UNICORP | ORANGE | NJ |
| UNIT | UNITRODE CORP. | WATERTOWN | MA |
| USECO | USECO DIV. | VAN NUYS | CA |
| VAC | VACTEC INC. | MARYLAND HEIGHTS | MO |
| VAR | VARADYNE CAPACITOR DIV. | SANTA MONICA | CA |
| VARI | VARI-L CO. | DENVER | CO |
| VLIER | VLIER ENGINEERING CORP. | BURBANK | CA |
| VONGT | VONNEGUT HARDWARE | INDIANAPOLIS | IN |
| W-E | WELLS ELECTRONICS | SOUTH BEND | IN |
| W-I | WAVETEK INDIANA, INC. | BEECH GROVE | IN |
| WAG | WAGNER ELECTRIC CORP. | ST. LOUIS | MO |
| WECK | WECKESSER CO., INC. | CHICAGO | IL |
| WKFLD | WAKEFIELD ENGINEERING | WAKEFIELD | MA |
| WSD | WAVETEK | SAN DIEGO | CA |
| WSR | WAVETEK | SANTA ROSA | CA |
| ZEN | ZENITH RADIO CORP. | CHICAGO | IL |
| ZERO | ZERO MANUFACTURING CO. | BURBANK | CA |
| ZPT | ZIPPERTUBING, CO. | LOS ANGELES | CA |

| REFERENCE DESIGNATORS | PART DESCRIPTION | ORIG=MFGR-PART-NO | MFGR | WAVETEK NO. | QTY |
|-----------------------|--------------------------------|-------------------|------|--------------|-----|
| 1 | ATTEN, 5070-01 | 5070-01 | W-I | 1113-30-0024 | 1 |
| 2 | MKR SHPR/SZ ASSY B500-224 | B500-224 | W-I | 1112-00-0005 | 1 |
| 3 | SWEEP TIME SW ASSY B500-225 | B500-225 | W-I | 1112-00-0008 | 1 |
| 4 | REMOTE JUMPER PLUG A500-223 | A500-233 | W-I | 1118-00-0001 | 1 |
| 5 | POWER SUPPLY, PS6 | PS6 | W-I | 1115-00-0001 | 1 |
| 12 | SWP RATE, M1H | M1H | W-I | 1114-00-0002 | 1 |
| 7 | SWP DRIVE, M2H | M2H | W-I | 1114-00-0029 | 1 |
| 10 | MKR ADDER, M5H | M5H | W-I | 1114-00-0027 | 1 |
| 9 | SWP OSC, M9H | M9H | W-I | 1114-00-0003 | 1 |
| 8 | OUTPUT AMP, M10H | M10H | W-I | 1114-00-0004 | 1 |
| 11 | SWP OSC, M19H | M19H | W-I | 1114-00-0005 | 1 |
| A1 | CABLE ASSY, 2-1/4 IN | WX2000-A1 | W-I | 1217-00-0022 | 1 |
| A2 | CABLE ASSY, 3-1/4 IN | WX3001-W7 | W-I | 1217-00-0032 | 1 |
| A3 | CABLE ASSY, 3-1/2 IN | WX2001-A3 | W-I | 1217-80-0008 | 1 |
| A4 | CABLE ASSY, 10-1/2 IN | WX2001-A4 | W-I | 1217-80-0009 | 1 |

| | | | |
|-------------------------------|------------------------|------------------------------|----------|
| WAVETEK PARTS LIST | TITLE SWP GEN, 2001 | ASSEMBLY NO. 1010-00-0011 | REV A |
| | | PAGE: 1 | |

| REFERENCE DESIGNATORS | PART DESCRIPTION | ORIG=MFGR-PART-NO | MFGR | WAVETEK NO. | QTY |
|-----------------------|-----------------------|-------------------|------|--------------|-----|
| A5 | CABLE ASSY, 3-3/4 IN | WX2000-A5 | W-I | 1217-00-0036 | 1 |
| A6 | CABLE ASSY, 5 IN | WX3000-200-W18 | W-I | 1217-00-0050 | 1 |
| A7 | CABLE ASSY, 2-3/4 IN | WX2001-A7 | W-I | 1217-02-0026 | 1 |
| A8 | CABLE ASSY, 8-1/4 IN | WX2001-A8 | W-I | 1217-80-0010 | 1 |
| P102 | SMC TERM, 50 A500-267 | A500-267 | W-I | 1118-00-0007 | 1 |
| 13 | HARNESS ASSY | HY2001 | W-I | 1219-00-0005 | 1 |

| | | | |
|-------------------------------|------------------------|------------------------------|----------|
| WAVETEK PARTS LIST | TITLE SWP GEN, 2001 | ASSEMBLY NO. 1010-00-0011 | REV A |
| | | PAGE: 2 | |

| REFERENCE DESIGNATORS | PART DESCRIPTION | ORIG-MFGR-PART-NO | MFGR | WAVETEK NO. | QTY | |
|-------------------------------|---------------------------------|--------------------------|------|---|-----|----------|
| C105 | CAP,CER,120PF,1KV CD102-112 | 60U121M | MDC | 1510-10-1121 | 1 | |
| C106 | CAP,CER,20PF,1KV CD101-020 | 60C0G200J | MDC | 1510-10-0200 | 1 | |
| C108 | CAP,CER,360PF,1KV CD102-136 | 60U361M | MDC | 1510-10-1361 | 1 | |
| CR102 | DIODE DG100-341 | 1N34A | HIT | 4807-01-0034 | 1 | |
| J103 J105 J106 J107 | CONN,UG911A/U JB109-111 | KC79-146 | KIN | 2110-01-1013 | 4 | |
| L103 L104 | CHOKE, 10.0MH,10% LA005-010 | 08N100K | ASE | 1810-03-0100 | 2 | |
| R101 | RES,C,1/4W,5%,68K RC103-368 | CF1/4-68K | ASE | 4700-15-6802 | 1 | |
| R115 R116 | POT,CONT,10K RV103-310 | 534 | SPE | 4610-20-1103 | 2 | |
| R122 | RES,C,1/4W,5%,47K RC103-347 | CF1/4-47K | ASE | 4700-15-4702 | 1 | |
| R123 | RES,C,1/4W,5%,1M RC103-510 | CF1/4-1M | ASE | 4700-15-1004 | 1 | |
| S101 | SWITCH,PILOT LIGHT SZ000-003 | 616-6-1-A1H | M=0 | 5102-00-0001 | 1 | |
| S103 | SWITCH,TOGGLE ST002-006 | 7107PN-BLK | C-K | 5106-00-0011 | 1 | |
| WAVETEK PARTS LIST | | TITLE SWEEP, A500-222 | | ASSEMBLY NO. 1111-00-0007 PAGE: 1 | | REV G |

| REFERENCE DESIGNATORS | PART DESCRIPTION | ORIG-MFGR-PART-NO | MFGR | WAVETEK NO. | QTY | |
|-------------------------------|-----------------------------------|--------------------------|------|---|-----|----------|
| S106 S110 | SWITCH,TOG,BLK ANOD. ST001-006 | 7101PN | C-K | 5106-00-0009 | 2 | |
| S107 | SWITCH,PB,SZ001-004 | 2KCB070000-3048L | C-L | 5110-00-0006 | 1 | |
| S109 | SWITCH,TOGGLE ST000-006 | 7103PN-BLK | C-K | 5106-00-0004 | 1 | |
| WAVETEK PARTS LIST | | TITLE SWEEP, A500-222 | | ASSEMBLY NO. 1111-00-0007 PAGE: 2 | | REV G |

| REFERENCE DESIGNATORS | PART DESCRIPTION | ORIG-MFGR-PART-NO | MFGR | WAVETEK NO. | QTY |
|-------------------------------|-----------------------------------|---|---|--------------|----------|
| CR101 | DIODE DR000-001 | 1N4004 | P-C | 4806-01-4004 | 1 |
| R103 | RES,C,1/4W,5%,470 RC103=147 | CF1/4=470 | ASE | 4700-15=4700 | 1 |
| R104 R111 | RES,C,1/4W,5%,33K RC103=333 | CF1/4=33K | ASE | 4700-15=3302 | 2 |
| R105 | RES,C,1/4W,5%,47M RC103=647 | CB4765 | A-B | 4700-15=4705 | 1 |
| R106 | RES,C,1/4W,5%,4.7M RC103=547 | CB4755 | A-B | 4700-15=4704 | 1 |
| R107 | RES,C,1/4W,5%,470K RC103=447 | CF1/4=470K | ASE | 4700-15=4703 | 1 |
| R108 | RES,MF,1/8W,1%,47.5K RF213=475 | MF55K=47.5K | ASE | 4701-03=4752 | 1 |
| R109 | POT,50K,RP129-350 | 360S503B | CTS | 4610-00=1503 | 1 |
| R110 R113 | RES,C,1/4W,5%,39K RC103=339 | CF1/4=39K | ASE | 4700-15=3902 | 2 |
| R112 | RES,C,1/4W,5%,47K RC103=347 | CF1/4=47K | ASE | 4700-15=4702 | 1 |
| R114 | RES,C,1/4W,5%,75K RC103=375 | CF1/4=75K | ASE | 4700-15=7502 | 1 |
| S102 | SWITCH ASSY, ROTARY SR000=017 | SR000=017 | w-I | 5104-00=0005 | 1 |
| WAVETEK PARTS LIST | | TITLE SWEEP TIME SW ASSY H500-225 | ASSEMBLY NO. 1112-00=0008 PAGE: 1 | | REV A |

| REFERENCE DESIGNATORS | PART DESCRIPTION | ORIG-MFGR-PART-NO | MFGR | WAVETEK NO. | QTY |
|-------------------------------|----------------------------------|---------------------------------------|---|--------------|-----|
| C101 | CAP,CER,.002MF,1KV CD102=220 | 5GAD20 | SPR | 1510-10=1202 | 1 |
| C102 | CAP,CER,.02UF,50V | TG-S20 | SPR | 1510-10=2203 | 1 |
| C103 | CAP,CER,68PF,1KV CD104=068 | 68U2J680J | MDC | 1510-10=3680 | 1 |
| C104 | CAP,CER,150PF,1KV CD102=115 | 60U151M | MDC | 1510-10=1151 | 1 |
| C107 | CAP,CER,10PF,1KV CD101=010 | 10TCC=010 | SPR | 1510-10=0100 | 1 |
| L101 L102 | CHOKE,10MILH,10% LA004=310 | 15S103K | ASE | 1810-02=1001 | 2 |
| R118 | RES,C,1/4W,5%,2.2K RC103=222 | CF1/4=2.2K | ASE | 4700-15=2201 | 1 |
| R120 | RES,C,1/4W,5%,33K RC103=333 | CF1/4=33K | ASE | 4700-15=3302 | 1 |
| R121 | RES,C,1/4W,5%,2.7K RC103=227 | CF1/4=2.7K | ASE | 4700-15=2701 | 1 |
| S108 | SWITCH ASSY, ROTARY SR000=016 | SR000=016 | w-I | 5104-00=0004 | 1 |
| WAVETEK PARTS LIST | | TITLE MKR SHPR/SZ ASSY H500-224 | ASSEMBLY NO. 1112-00=0005 PAGE: 1 | | REV |

| REFERENCE DESIGNATORS | PART DESCRIPTION | ORIG-MFGR-PART-NO | MFGR | WAVETEK NO. | QTY |
|-------------------------------|----------------------------|---|------|---|-----|
| J101 | PLUG,MC000-017 | 03-06-2151 | MOL | 2113-04-0001 | 1 |
| 2 | TERMINAL,MALE MC000-019 | 1854 | MOL | 2113-05-0002 | 8 |
| WAVETEK PARTS LIST | | TITLE REMOTE JUMPER PLUG A500-223 | | ASSEMBLY NO. 1118-00-0001 PAGE: 1 | |
| | | | | | REV |

| REFERENCE DESIGNATORS | PART DESCRIPTION | ORIG-MFGR-PART-NO | MFGR | WAVETEK NO. | QTY |
|-------------------------------|------------------------------|-----------------------|------|---|-----|
| 1 | PLUG MC000-035 | 03-06-2042 | MOL | 2113-04-0002 | 1 |
| 2 | TERMINAL,MALE MC000-019 | 1854 | MOL | 2113-05-0002 | 4 |
| 3 | RECEPTACLE,MC000-030 | 03-09-1121 | MOL | 2113-08-0001 | 1 |
| 4 | TERM,MALE MC000-033 | 02-09-2143 | MOL | 2113-09-0002 | 1 |
| 5 | TERMINAL,FEMALE MC000-032 | 02-09-1143 | MOL | 2113-09-0001 | 6 |
| 6 | RECEPTACLE,MC000-016 | 03-06-1151 | MOL | 2113-03-0001 | 1 |
| 7 | TERMINAL,FEMALE MC000-018 | 1855 | MOL | 2113-05-0001 | 13 |
| WAVETEK PARTS LIST | | TITLE HARNESS ASSY | | ASSEMBLY NO. 1219-00-0005 PAGE: 1 | |
| | | | | | REV |

| REFERENCE DESIGNATORS | PART DESCRIPTION | ORIG-MFGR-PART-NO | MFGR | WAVETEK NO. | QTY |
|-------------------------------|------------------------------------|----------------------------|------------------------------|--------------|----------|
| F1 | FUSE, S, B, ., .5 AMP MF000-007 | MDL 1/2 | BUS | 2410-05-0004 | 1 |
| J1 | RECEPTACLE MC000-034 | 03-06-1041 | MOL | 2113-03-0002 | 1 |
| J4 | CONN, UG911A/U JB109-111 | KC79-146 | KIN | 2110-01-1013 | 1 |
| P3 | POWER CORD, WL002-088 | 17237SVT | BEL | 6011-80-0001 | 1 |
| Q2 Q3 Q8 | TRANS GA052-940 | 2N5294 | RCA | 4901-05-2940 | 3 |
| S1 | SWITCH, DPDT, LOCKING SS000-003 | 46256LFE | S-I | 5105-00-0003 | 1 |
| T1 | XFMR, PWR, TT000-022 | TT000-022 | W-I | 5610-00-0006 | 1 |
| 13 | TERMINAL, FEMALE MC000-018 | 1855 | MOL | 2113-05-0001 | 3 |
| 17 | TERM, FEMALE MC000-042 | 02-06-1103 | MOL | 2113-05-0004 | 1 |
| 19 | POWER SUPPLY BOARD | PS6 CARD | W-I | 1218-00-0012 | 1 |
| WAVETEK PARTS LIST | | TITLE POWER SUPPLY, PS6 | ASSEMBLY NO. 1115-00-0001 | | REV E |
| | | | PAGE: 1 | | |

| REFERENCE DESIGNATORS | PART DESCRIPTION | ORIG-MFGR-PART-NO | MFGR | WAVETEK NO. | QTY |
|--|--------------------------------------|-----------------------------|------------------------------|--------------|----------|
| C01 C07 | CAP, ELECT, 1250MF, 50V CE114-212 | 1510-20-7122 | MAL | 1510-20-7122 | 2 |
| C02 | CAP, ELECT, 50MF, 50V CE107-050 | TE1307 | SPR | 1510-20-5500 | 1 |
| C03 C06 C10 C11 | CAP, ELECT, 100MF, 25V CE105-110 | TE1211 | SPR | 1510-20-4101 | 4 |
| C04 C12 | CAP, CER, 100PF, 1KV CD102-110 | 60U101M | MDC | 1510-10-1101 | 2 |
| C05 | CAP, CER, .005MF, 1KV CD103-250 | TG-050 | SPR | 1510-10-2502 | 1 |
| C08 | CAP, CER, 120PF, 1KV CD102-112 | 60U121M | MDC | 1510-10-1121 | 1 |
| C09 | CAP, TANT, 10MF, 25V CE120-010 | 162D106X0025DU2 | SPR | 1510-21-7100 | 1 |
| CR01 CR02 CR03 CR04 CR05 CR06 CR07 CR08 CR09 CR10 CR11 CR12 CR13 CR14 CR15 CR16 CR17 | DIODE DR000-001 | 1N4004 | P-C | 4806-01-4004 | 17 |
| IC01 | IC, IC000-001 | LM723CH | NAT | 7000-17-2300 | 1 |
| IC02 | IC, IC000-002 | N5741CV | SIG | 7000-57-4100 | 1 |
| P02 | WAFERCON, MC000-031 | 1840-12-2 | MOL | 2112-09-0001 | 1 |
| WAVETEK PARTS LIST | | TITLE POWER SUPPLY BOARD | ASSEMBLY NO. 1218-00-0012 | | REV F |
| | | | PAGE: 1 | | |

| REFERENCE DESIGNATORS | PART DESCRIPTION | ORIG-MFGR-PART-NO | MFGR | WAVETEK NO. | QTY |
|-------------------------------|-----------------------------------|-----------------------------|------------------------------|--------------|----------|
| Q01 Q04 Q05 Q09 Q10 | TRANS QA036-440 | 2N3644 | FCD | 4901-03-6440 | 5 |
| Q06 Q07 Q11 Q12 | TRANS QA038-541 | 2N3854A | G-E | 4901-03-8541 | 4 |
| R01 | RES,C,1/4W,5%,270 RC103-127 | CF1/4-270 | ASE | 4700-15-2700 | 1 |
| R02 | RES,C,1/4W,5%,1.8K RC103-218 | CF1/4-1.8K | ASE | 4700-15-1801 | 1 |
| R03 R11 R22 | RES,1/2W,1%,5 RD01R-050 | K20-5 | KID | 4701-23-0050 | 3 |
| R04 R14 R21 | RES,MF,1/8W,1%,1K RF212-100 | MF55K-1K | ASE | 4701-03-1001 | 3 |
| R05 | RES,MF,1/8W,1%,12.1K RF213-121 | MF55K-12.1K | ASE | 4701-03-1212 | 1 |
| R06 | RES,C,1/4W,5%,1.5K RC103-215 | CF1/4-1.5K | ASE | 4700-15-1501 | 1 |
| R07 | RES,C,1/4W,5%,220 RC103-122 | CF1/4-220 | ASE | 4700-15-2200 | 1 |
| R08 | RES,C,1/4W,5%,3.9K RC103-239 | CF1/4-3.9K | ASE | 4700-15-3901 | 1 |
| R09 | POT,1K,RP131-210 | 360T102B | CTS | 4610-00-3102 | 1 |
| R10 | RES,C,1/4W,5%,2.7K RC103-227 | CF1/4-2.7K | ASE | 4700-15-2701 | 1 |
| WAVETEK PARTS LIST | | TITLE POWER SUPPLY BOARD | ASSEMBLY NO. 1218-00-0012 | | REV F |
| PAGE: 2 | | | | | |

| REFERENCE DESIGNATORS | PART DESCRIPTION | ORIG-MFGR-PART-NO | MFGR | WAVETEK NO. | QTY |
|-------------------------------|--|-----------------------------|------------------------------|--------------|----------|
| R12 R25 | RES,C,1/4W,5%,470 RC103-147 | CF1/4-470 | ASE | 4700-15-4700 | 2 |
| R13 | RES,C,1/2W,5%,2.7K RC105-227 | CF1/2-2.7K | ASE | 4700-25-2701 | 1 |
| R15 R24 | RES,MF,1/8W,1%,15K RF213-150 | MF55K-15K | ASE | 4701-03-1502 | 2 |
| R16 R17 | RES,C,1/4W,5%,1K RC103-210 | CF1/4-1K | ASE | 4700-15-1001 | 2 |
| R18 | RES,C,1/4W,5%,4.7K RC103-247 | CF1/4-4.7K | ASE | 4700-15-4701 | 1 |
| R19 R20 | RES,SET,2-10K,1/8W QTY:2:4701-03-1002 | RX000-003 | W-I | 4789-00-0004 | 1 |
| R23 R29 | RES,C,1/4W,5%,10K RC103-310 | CF1/4-10K | ASE | 4700-15-1002 | 2 |
| R26 | RES,C,1/2W,5%,2.2K RC105-222 | CF1/2-2.2K | ASE | 4700-25-2201 | 1 |
| R27 | RES,MF,1/8W,1%,825 RF211-825 | MF55K-825 | ASE | 4701-03-8250 | 1 |
| R28 | RES,MF,1/8W,1%,6.81K RF212-681 | MF55K-6.81K | ASE | 4701-03-6811 | 1 |
| R30 | RES,C,1/2W,5%,470 RC105-147 | CF1/2-470 | ASE | 4700-25-4700 | 1 |
| R31 | RES,C,1/2W,5%,220 | CF1/2-220 | ASE | 4700-25-2200 | 1 |
| WAVETEK PARTS LIST | | TITLE POWER SUPPLY BOARD | ASSEMBLY NO. 1218-00-0012 | | REV F |
| PAGE: 3 | | | | | |

| REFERENCE DESIGNATORS | PART DESCRIPTION | ORIG=MFGR-PART-NO | MFGR | WAVETEK NO. | QTY |
|---------------------------|-----------------------------------|-----------------------|---|--------------|----------|
| R17 R30 R31 R48 | RES,C,1/4W,10%,10K RC104-310AB | CB1031 | A=B | 4705-16-1002 | 4 |
| R19 R24 R28 R29 | RES,C,1/4W,5%,100K RC103-410 | CF1/4-100K | ASE | 4700-15-1003 | 4 |
| R21 | RES,C,1/4W,5%,18K RC103-318 | CF1/4-18K | ASE | 4700-15-1802 | 1 |
| R22 | RES,C,1/4W,5%,62K RC103-362 | CF1/4-62K | ASE | 4700-15-6202 | 1 |
| R23 | RES,C,1/4W,5%,560K RC103-456 | CF1/4-560K | ASE | 4700-15-5603 | 1 |
| R25 | RES,C,1/4W,5%,1M RC103-510 | CF1/4-1M | ASE | 4700-15-1004 | 1 |
| R32 | RES,C,1/4W,5%,1K RC103-210 | CF1/4-1K | ASE | 4700-15-1001 | 1 |
| R34 | RES,C,1/4W,10%,10M RC104-610 | CB1061 | A=B | 4700-16-1005 | 1 |
| R35 R43 R52 | RES,C,1/4W,5%,100 RC103-110 | CF1/4-100 | ASE | 4700-15-1000 | 3 |
| R40 R47 | RES,C,1/4W,5%,220K RC103-422 | CF1/4220K | ASE | 4700-15-2203 | 2 |
| R42 R55 | RES,C,1/4W,5%,6,8K RC103-268 | CF1/4-6,8K | ASE | 4700-15-6801 | 2 |
| WAVETEK PARTS LIST | | TITLE SWP RATE,M1H | ASSEMBLY NO. 1114-00-0002 PAGE: 3 | | REV B |

| REFERENCE DESIGNATORS | PART DESCRIPTION | ORIG=MFGR-PART-NO | MFGR | WAVETEK NO. | QTY |
|---------------------------|--------------------------------|-----------------------|---|--------------|----------|
| R44 | RES,C,1/4W,5%,12K RC103-312 | CF1/4-12K | ASE | 4700-15-1202 | 1 |
| R46 | RES,C,1/4W,5%,39K RC103-339 | CF1/4-39K | ASE | 4700-15-3902 | 1 |
| R49 | RES,C,1/4W,5%,470 RC103-147 | CF1/4-470 | ASE | 4700-15-4700 | 1 |
| R50 | RES,C,1/4W,5%,15K RC103-315 | CF1/4-15K | ASE | 4700-15-1502 | 1 |
| R54 R56 | RES,C,1/4W,5%,27K RC103-327 | CF1/4-27K | ASE | 4700-15-2702 | 2 |
| WAVETEK PARTS LIST | | TITLE SWP RATE,M1H | ASSEMBLY NO. 1114-00-0002 PAGE: 4 | | REV B |

| REFERENCE DESIGNATORS | PART DESCRIPTION | ORIG-MFGR-PART-NO | MFGR | WAVETEK NO. | QTY |
|--|---|-----------------------|------------------------------|--------------|----------|
| C01 C07 C08 C09 C12 C14 C15 C16 C17 C20 | CAP,F,T,,6,8PF CF102-R68 | FA5C-6892 | A-B | 1510-30-1689 | 10 |
| C02 C06 C11 | CAP,CER,470PF,1KV CD102-147 | 60U471M | MDC | 1510-10-1471 | 3 |
| C03 | CAP,FILM,,15MF,100V | 60C154K100 | PLSSY | 1510-60-7154 | 1 |
| C04 | CAP,CER,10PF,1KV CD101-010 | 10TCC-Q10 | SPR | 1510-10-0100 | 1 |
| C05 | CAP,CER,,.001MFD,1KV CD102-210 | 5GA010 | SPR | 1510-10-1102 | 1 |
| C10 | CAP,CER,,.02UF,50V | TG-S20 | SPR | 1510-10-2203 | 1 |
| C13 | CAP,CER,120PF,1KV CD102-112 | 60U121M | MDC | 1510-10-1121 | 1 |
| C18 C19 | CAP,F,T,,470PF CF101-147 | FA5C-4712 | A-B | 1510-30-0471 | 2 |
| C21 | CAP,CER,,.01MF,100V CD103-310 | 68U103M | MDC | 1510-10-2103 | 1 |
| CR1 CR2 CR3 CR4 CR5 CR6 CR7 CR8 CR9 | DIODE UR000-001 | 1N4004 | P-C | 4806-01-4004 | 9 |
| Q01 Q02 | TRANS,M/PR,2N5458 QTY:2:4901-05-4580 | QB000-014 | W-I | 4998-00-0002 | 1 |
| Q03 Q04 Q07 Q08 Q09 Q11 Q16 Q17 Q19 | TRANS QB000-009 | MPS3702 | MOT | 4902-03-7020 | 9 |
| WAVETEK PARTS LIST | | TITLE SWP RATE,M1H | ASSEMBLY NO. 1114-00-0002 | | REV B |
| | | | PAGE: 1 | | |

| REFERENCE DESIGNATORS | PART DESCRIPTION | ORIG-MFGR-PART-NO | MFGR | WAVETEK NO. | QTY |
|--------------------------------|----------------------------------|-----------------------|------------------------------|--------------|----------|
| Q05 Q14 | TRANS QA054-580 | 2N5458 | MUT | 4901-05-4580 | 2 |
| Q06 Q15 | TRANS QB000-010 | TD101 | SPR | 4902-00-1010 | 2 |
| Q10 Q12 Q13 Q18 | TRANS QA038-541 | 2N3854A | G-E | 4901-03-8541 | 4 |
| R01 R09 | RES,C,1/4W,5%,220 RC103-122 | CF1/4-220 | ASE | 4700-15-2200 | 2 |
| R02 R03 R05 R11 R14 R37 | RES,C,1/4W,5%,4.7K RC103-247 | CF1/4-4.7K | ASE | 4700-15-4701 | 6 |
| R04 R13 R18 R33 R38 R39 R53 | RES,C,1/4W,5%,47K RC103-347 | CF1/4-47K | ASE | 4700-15-4702 | 7 |
| R06 | RES,C,1/4W,5%,180K RC103-418 | CF1/4-180K | ASE | 4700-15-1803 | 1 |
| R07 R20 R41 R45 | POT,20K,RP129-320 | 360S203B | CTS | 4610-00-1203 | 4 |
| R08 R26 R27 R36 | RES,C,1/4W,5%,22K RC103-322 | CF1/422K | ASE | 4700-15-2202 | 4 |
| R10 | RES,C,1/4W,10%,5.6M RC104-556 | C85651 | A-B | 4700-16-5604 | 1 |
| R12 R57 | RES,C,1/4W,5%,47 RC103-047 | CF1/4-47 | ASE | 4700-15-4709 | 2 |
| R15 | RES,C,1/4W,5%,68K RC103-368 | CF1/4-68K | ASE | 4700-15-6802 | 1 |
| R16 R51 | RES,C,1/4W,5%,10K RC103-310 | CF1/4-10K | ASE | 4700-15-1002 | 2 |
| WAVETEK PARTS LIST | | TITLE SWP RATE,M1H | ASSEMBLY NO. 1114-00-0002 | | REV B |
| | | | PAGE: 2 | | |

| REFERENCE DESIGNATORS | PART DESCRIPTION | ORIG-MFGR-PART-NO | MFGR | WAVETEK NO. | QTY |
|-------------------------------|---------------------------------|------------------------|------------------------------|--------------|----------|
| C01 C04 C05 C06 C07 C14 | CAP,F.T.,6.8PF CF102-R68 | FASC-6892 | A-B | 1510-30-1689 | 6 |
| C02 | CAP,CER,120PF,1KV CD102-112 | 60U121M | MDC | 1510-10-1121 | 1 |
| C03 | CAP,CER,10PF,1KV CD101-010 | 10ICC-Q10 | SPR | 1510-10-0100 | 1 |
| C08 | CAP,CER,15PF,1KV CD101-015 | 10ICC-Q15 | SPR | 1510-10-0150 | 1 |
| C09 | CAP,Q-C,2.4PF,10% CG101-224 | QC-2.4PF | Q-C | 1510-40-0249 | 1 |
| C10 C11 C15 C18 C19 C22 | CAP,F.T.,470PF CF101-147 | FASC-4712 | A-B | 1510-30-0471 | 6 |
| C12 | CAP,CER,25PF,1KV CD101-025 | 60C06250J | MDC | 1510-10-0250 | 1 |
| C13 | CAP,Q-C,10PF,10% CG101-310 | QC-10PF | Q-C | 1510-40-0100 | 1 |
| C16 C20 | CAP,TANT,10MF,25V CE120-010 | 162D106X0025D02 | SPR | 1510-21-7100 | 2 |
| C17 C21 | CAP,CER,470PF,1KV CD102-147 | 60U471M | MDC | 1510-10-1471 | 2 |
| C23 C24 | CAP,CER,.01MF,100V CD103-310 | 68U103M | MDC | 1510-10-2103 | 2 |
| WAVETEK PARTS LIST | | TITLE SWP DRIVE,M2H | ASSEMBLY NO. 1114-00-0029 | | REV H |
| PAGE: 1 | | | | | |

| REFERENCE DESIGNATORS | PART DESCRIPTION | ORIG-MFGR-PART-NO | MFGR | WAVETEK NO. | QTY |
|---|---------------------------------|------------------------|------------------------------|--------------|----------|
| C25 C26 | CAP,Q.C.,3.9PF CG101-239 | QC-3.9PF | Q-C | 1510-40-0399 | 2 |
| C27 C28 | CAP,ELECT,1MF,25V CE120-001 | 162D105X9025HC2 | SPR | 1510-21-7010 | 2 |
| CR01 CR02 CR03 CR04 CR06 CR07 CR09 CR10 CR13 CR14 CR15 CR16 CR17 CR18 CR19 CR20 CR21 CR22 | DIODE DR000-001 | 1N4004 | P-C | 4806-01-4004 | 18 |
| Q01 Q04 Q18 | TRANS DR000-010 | T0101 | SPR | 4902-00-1010 | 3 |
| Q02 Q03 Q05 Q06 Q07 Q19 | TRANS QA042-500 | 2N4250 | FCO | 4901-04-2500 | 6 |
| Q08 | TRANS QA036-440 | 2N3644 | FCO | 4901-03-6440 | 1 |
| Q09 Q10 Q11 Q15 Q16 Q17 | TRANS QA054-610 | 2N5461 | MOT | 4901-05-4610 | 6 |
| Q12 Q21 | TRANS DR000-011 | T0401 | SPR | 4902-00-4010 | 2 |
| Q13 Q14 Q20 Q22 | TRANS QA050-880 | 2N5088 | MOT | 4901-05-0880 | 4 |
| Q23 | TRANS DR000-009 | MPS3702 | MOT | 4902-03-7020 | 1 |
| R01 R29 R54 R55 | RES,C,1/4W,5%,100K RC103-410 | CF1/4-100K | ASE | 4700-15-1003 | 4 |
| R02 R19 R32 R33 R34 R62 R71 R75 R79 | RES,C,1/4W,5%,4.7K RC103-247 | CF1/4-4.7K | ASE | 4700-15-4701 | 9 |
| WAVETEK PARTS LIST | | TITLE SWP DRIVE,M2H | ASSEMBLY NO. 1114-00-0029 | | REV H |
| PAGE: 2 | | | | | |

| REFERENCE DESIGNATORS | PART DESCRIPTION | ORIG-MFGR=PART-NO | MFGR | WAVETEK NO. | QTY |
|--|---|------------------------|------------------------------|--------------|----------|
| R03 R63 | RES,C,1/4W,5%,27K RC103-327 | CF1/4-27K | ASE | 4700-15-2702 | 2 |
| R04 R21 R57 R64 | RES,C,1/4W,5%,47K RC103-347 | CF1/4-47K | ASE | 4700-15-4702 | 4 |
| R06 R08 R23 R25 | RES,C,1/4W,5%,100 RC103-110 | CF1/4-100 | ASE | 4700-15-1000 | 4 |
| R07 R10 R24 R27 R66 | RES,C,1/4W,5%,10K RC103-310 | CF1/4-10K | ASE | 4700-15-1002 | 5 |
| R09 R13 R17 R26 R31 R72 R76 R80 R95 | POT,20K,RP130-520 | 89PR20K | BEK | 4610-00-2203 | 9 |
| R11 | RES,C,1/4W,5%,33K RC103-333 | CF1/4-33K | ASE | 4700-15-3302 | 1 |
| R12 R18 | RES,C,1/4W,5%,470K RC103-447 | CF1/4-470K | ASE | 4700-15-4703 | 2 |
| R14 R15 R16 | RES,SET,3-178K,1/8W QTY:3:4701-03-1783 | RX000-002 | W-I | 4789-00-0001 | 1 |
| R20 R83 R89 | RES,C,1/4W,5%,8.2K RC103-282 | CF1/4-8.2K | ASE | 4700-15-8201 | 3 |
| R28 | RES,C,1/4W,5%,82K RC103-382 | CF1/4-82K | ASE | 4700-15-8202 | 1 |
| R30 R81 R87 | RES,C,1/4W,5%,470 RC103-147 | CF1/4-470 | ASE | 4700-15-4700 | 3 |
| WAVETEK PARTS LIST | | TITLE SWP DRIVE,M2H | ASSEMBLY NO. 1114-00-0029 | | REV H |
| PAGE: 3 | | | | | |

| REFERENCE DESIGNATORS | PART DESCRIPTION | ORIG-MFGR=PART-NO | MFGR | WAVETEK NO. | QTY |
|-------------------------------|--|------------------------|------------------------------|--------------|----------|
| R35 R36 R37 R38 | RES,C,1/4W,5%,2.2K RC103-222 | CF1/4-2.2K | ASE | 4700-15-2201 | 4 |
| R56 | RES,C,1/4W,5%,1M RC103-510 | CF1/4-1M | ASE | 4700-15-1004 | 1 |
| R58 R59 R60 R69 R73 R77 | RES,C,1/4W,5%,10M RC103-610 | CR1065 | A-H | 4700-15-1005 | 6 |
| R61 R67 | RES,C,1/4W,5%,10 RC103-010 | CF1/4-10 | ASE | 4700-15-1009 | 2 |
| R68 | RES,C,1/4W,5%,47 RC103-047 | CF1/4-47 | ASE | 4700-15-4709 | 1 |
| R70 R74 R78 | RES,C,1/4W,5%,18K RC103-318 | CF1/4-18K | ASE | 4700-15-1802 | 3 |
| R82 R88 | RES,C,1/4W,5%,560 RC103-156 | CF1/4-560 | ASE | 4700-15-5600 | 2 |
| R84 R92 | RES,C,1/4W,5%,4.7 RC103-R47 | CF1/4-4.7 | ASE | 4700-15-4708 | 2 |
| R85 R86 | RES,SET,2-10K,1/8W QTY:2:4701-03-1002 | RX000-003 | W-I | 4789-00-0004 | 1 |
| | RES,MF,SET,MAATCHED CONSIST:4799-00-0001 THRU:0002 | RX000-004 | W-I | 4789-00-0003 | 1 |
| R91 | RES,MF,1/8W,1%,19.1K PART OF 4789-00-0003 QTY:1:4701-03-1912 | 4799-00-0001 | W-I | 4799-00-0001 | - |
| WAVETEK PARTS LIST | | TITLE SWP DRIVE,M2H | ASSEMBLY NO. 1114-00-0029 | | REV H |
| PAGE: 4 | | | | | |

| REFERENCE DESIGNATORS | PART DESCRIPTION | ORIG-MFGR-PART-NO | MFGR | WAVETEK NO. | QTY |
|-------------------------------------|--|---|------|--------------|----------|
| R90 | RES, MF, 1/8W, 1%, 21.5K PART OF 4789-00-0005 QTY: 1: 4701-03-2152 | 4799-00-0002 | W-I | 4799-00-0002 | - |
| R93 R94 | RES, C, 1/4W, 5%, 15K RC103-315 | CF1/4-15K | ASE | 4700-15-1502 | 2 |
| R96 | RES, C, 1/4W, 5%, 1.2M RC103-512 | CF1/4-1.2M | ASE | 4700-15-1204 | 1 |
| WAVETEK PARTS LIST | TITLE SWP DRIVE, M2H | ASSEMBLY NO. 1114-00-0029 PAGE: 5 | | | REV H |

| REFERENCE DESIGNATORS | PART DESCRIPTION | ORIG-MFGR-PART-NO | MFGR | WAVETEK NO. | QTY |
|--|-----------------------------------|------------------------|------------------------------|--------------|----------|
| C01 C21 C22 | CAP,FT,500PF,20X250V CF104-150 | 4420-500PF | AER | 1510-30-3501 | 3 |
| C02 | CAP,CER,,025MF,50V CD103-325 | TG-325 | SPR | 1510-10-2253 | 1 |
| C03 C04 C05 C06 C09 C10 C11 C13 C18 | CAP,F.T.,,6,8PF CF102-R68 | FA5C-6892 | A-B | 1510-30-1689 | 9 |
| C07 | CAP,TANT,10MF,25V CE120-010 | 162D106X0025DD2 | SPR | 1510-21-7100 | 1 |
| C08 C14 C15 C19 | CAP,CER,,05MF,100V CD103-350 | TG-350 | SPR | 1510-10-2503 | 4 |
| C12 C24 C26 | CAP,F.T.,,470PF CF101-147 | FA5C-4712 | A-B | 1510-30-0471 | 3 |
| C16 C17 | CAP,ELECT,100MF,25V CE105-110 | TE1211 | SPR | 1510-20-4101 | 2 |
| C20 | CAP,CER,,005MF,1KV CD103-250 | TG-D50 | SPR | 1510-10-2502 | 1 |
| C23 | CAP,CER,470PF,1KV CD102-147 | 60U471M | MDC | 1510-10-1471 | 1 |
| C25 | CAP,CER,120PF,1KV CD102-112 | 60U121M | MDC | 1510-10-1121 | 1 |
| CR02 CR07 | DIODE DG100-821 | 1N82AG | G-I | 4807-01-0082 | 2 |
| CR03 | DIODE DR000-001 | 1N4004 | P-C | 4806-01-4004 | 1 |
| WAVETEK PARTS LIST | | TITLE MKR ADDER,MSH | ASSEMBLY NO. 1114-00-0027 | | REV E |
| | | | PAGE: 1 | | |

| REFERENCE DESIGNATORS | PART DESCRIPTION | ORIG-MFGR-PART-NO | MFGR | WAVETEK NO. | QTY |
|-------------------------------|---------------------------------|------------------------|------------------------------|--------------|----------|
| CR04 CR05 CR06 | DIODE DP000-040 | MA47980 | M-A | 4805-02-0001 | 3 |
| Q01 Q02 Q03 Q04 Q05 | TRANS QA050-880 | 2N5088 | MOT | 4901-05-0880 | 5 |
| Q06 Q12 | TRANS QB000-010 | TD101 | SPR | 4902-00-1010 | 2 |
| Q07 Q08 Q09 Q13 | TRANS QB000-009 | MPS3702 | MOT | 4902-03-7020 | 4 |
| Q10 | TRANS QA038-541 | 2N3854A | G-E | 4901-03-8541 | 1 |
| Q11 | TRANS QA054-580 | 2N5458 | MOT | 4901-05-4580 | 1 |
| R01 R32 R33 R48 | RES,C,1/4W,5%,1K RC103-210 | CF1/4-1K | ASE | 4700-15-1001 | 4 |
| R02 | RES,C,1/4W,5%,180 RC103-118 | CF1/4-180 | ASE | 4700-15-1800 | 1 |
| R03 R35 R36 | RES,C,1/4W,5%,680 RC103-168 | CF1/4-680 | ASE | 4700-15-6800 | 3 |
| R04 R05 | RES,C,1/4W,5%,56 RC103-056 | CF1/4-56 | ASE | 4700-15-5609 | 2 |
| R06 R08 R10 R13 R16 R19 | RES,C,1/4W,5%,22K RC103-322 | CF1/422K | ASE | 4700-15-2202 | 6 |
| R07 R11 R14 R17 R20 | RES,C,1/4W,5%,270 RC103-127 | CF1/4-270 | ASE | 4700-15-2700 | 5 |
| R09 R12 R15 R18 | RES,C,1/4W,5%,5.6K RC103-256 | CF1/4-5.6K | ASE | 4700-15-5601 | 4 |
| WAVETEK PARTS LIST | | TITLE MKR ADDER,MSH | ASSEMBLY NO. 1114-00-0027 | | REV E |
| | | | PAGE: 2 | | |

| REFERENCE DESIGNATORS | PART DESCRIPTION | ORIG-MFGR-PART-NO | MFGR | WAVETEK NO. | QTY |
|--------------------------------|---------------------------------|------------------------|------------------------------|--------------|----------|
| R21 R29 | RES,C,1/4W,5%,3,3K RC103-233 | CF1/4-3,3K | ASE | 4700-15-3301 | 2 |
| R22 R23 R28 R31 R34 R51 R52 | RES,C,1/4W,5%,10K RC103-310 | CF1/4-10K | ASE | 4700-15-1002 | 7 |
| R24 R38 R50 | RES,C,1/4W,5%,4,7K RC103-247 | CF1/4-4,7K | ASE | 4700-15-4701 | 3 |
| R25 R54 R55 R56 | RES,C,1/4W,5%,47K RC103-347 | CF1/4-47K | ASE | 4700-15-4702 | 4 |
| R26 R40 | RES,C,1/4W,5%,2,2K RC103-222 | CF1/4-2,2K | ASE | 4700-15-2201 | 2 |
| R27 | RES,C,1/4W,5%,220K RC103-422 | CF1/4220K | ASE | 4700-15-2203 | 1 |
| R30 | RES,C,1/4W,5%,1,8K RC103-218 | CF1/4-1,8K | ASE | 4700-15-1801 | 1 |
| R37 R39 R49 | RES,C,1/4W,5%,2,7K RC103-227 | CF1/4-2,7K | ASE | 4700-15-2701 | 3 |
| R42 | RES,C,1/2W,5%,47 RC105-047 | EB4705 | A-H | 4705-25-4709 | 1 |
| R43 | RES,C,1/4W,5%,47 RC103-047 | CF1/4-47 | ASE | 4700-15-4709 | 1 |
| R44 | RES,C,1/4W,5%,1M RC103-510 | CF1/4-1M | ASE | 4700-15-1004 | 1 |
| WAVETEK PARTS LIST | | TITLE MKR ADDER,MSH | ASSEMBLY NO. 1114-00-0027 | | REV E |
| | | | PAGE: 3 | | |

| REFERENCE DESIGNATORS | PART DESCRIPTION | ORIG-MFGR-PART-NO | MFGR | WAVETEK NO. | QTY |
|-------------------------------|------------------------------------|------------------------|------------------------------|--------------|----------|
| R45 | RES,C,1/4W,10%,2,2M RC104-522AB | CB2251 | A-H | 4705-16-2204 | 1 |
| R46 | POT,20K RP124-320 | WA2G032S-203MA | A-H | 4610-10-7203 | 1 |
| R47 | RES,C,1/4W,5%,470K RC103-447 | CF1/4-470K | ASE | 4700-15-4703 | 1 |
| R53 | RES,C,1/4W,5%,220 RC103-122 | CF1/4-220 | ASE | 4700-15-2200 | 1 |
| 41 | RES,C,1/4W,5%,100 RC103-110 | CF1/4-100 | ASE | 4700-15-1000 | 1 |
| WAVETEK PARTS LIST | | TITLE MKR ADDER,MSH | ASSEMBLY NO. 1114-00-0027 | | REV E |
| | | | PAGE: 4 | | |

| REFERENCE DESIGNATORS | PART DESCRIPTION | ORIG-MFGR-PART-NO | MFGR | WAVETEK NO. | QTY |
|---|---|-----------------------|------------------------------|--------------|----------|
| C01 C03 C07 C08 C09 C11 C14 C18 C19 C25 C27 | CAP, FT, 500PF, 20X250V CF104-150 | 4420-500PF | AER | 1510-30-3501 | 11 |
| C02 C10 | CAP, CER, 100PF, 1KV CD108-110 | CN1500 | RMC | 1510-10-5101 | 2 |
| C04 C05 C12 | CAP, FT, CER, 100PF, 20X CF104-110 | 4420-100PF | AER | 1510-30-3101 | 3 |
| C06 C13 | CAP, F.T., 6.8PF CF102-R68 | FA5C-6892 | A-B | 1510-30-1689 | 2 |
| C15 C28 C29 C30 | CAP, F.T., 470PF CF101-147 | FA5C-4712 | A-B | 1510-30-0471 | 4 |
| C16 | CAP, CER, 120PF, 1KV CD102-112 | 60U121M | MDC | 1510-10-1121 | 1 |
| C17 C33 C34 | CAP, TANT., 47MF, 50V CE113-447 | 935 | TRW | 1510-21-9470 | 3 |
| C20 | CAP, Q.C., .75PF CG101-175 | QC-.75PF | Q-C | 1510-40-0758 | 1 |
| C21 C24 | CAP, VALUE DETERMINED IN CALIBRATION | CAP, TRIM | W-I | 1519-99-9999 | 2 |
| C22 | CAP, Q-C, 2.4PF, 10X CG101-224 | QC-2.4PF | Q-C | 1510-40-0249 | 1 |
| C23 C26 | CAP, CER., 01MF, 100V CD103-310 | 68U103M | MDC | 1510-10-2103 | 2 |
| WAVETEK PARTS LIST | | TITLE SWP OSC, M9H | ASSEMBLY NO. 1114-00-0003 | | REV I |
| | | | PAGE: 1 | | |

| REFERENCE DESIGNATORS | PART DESCRIPTION | ORIG-MFGR-PART-NO | MFGR | WAVETEK NO. | QTY |
|-------------------------------|--------------------------------------|-----------------------|------------------------------|--------------|----------|
| C31 | CAP, TANT, 10MF, 25V CE120-010 | 162D106X00250D2 | SPR | 1510-21-7100 | 1 |
| C32 | CAP, CER., .05MF, 100V CD103-350 | TG-S50 | SPR | 1510-10-2503 | 1 |
| C35 | CAP, CER., .001MFD, 1KV CD102-210 | SGA010 | SPR | 1510-10-1102 | 1 |
| C36 | CAP, Q.C., 3.9PF CG101-239 | QC-3.9PF | Q-C | 1510-40-0399 | 1 |
| 21 | CAP, M.C., .47PF CG102-147 | MC-.47PF | Q-C | 1510-40-1478 | 1 |
| CR01 CR02 CR03 CR04 CR05 | DIODE DC000-005 | BR141A | IIT | 4889-00-0001 | 5 |
| CR08 CR09 | DIODE DG100-823 | 1N82A | S-T | 4807-03-0002 | 2 |
| J01 J02 | CONN JF000-005 | 37JR116-1 | S-C | 2110-03-0002 | 2 |
| L01 L03 | CHOKE .22MH 10X LA005-R02 | 08NR22K | ASE | 1810-03-0228 | 2 |
| L02 L04 L05 L07 L08 | RF CHOKE | CHOKE | W-I | 1819-99-9999 | 5 |
| L06 | CHOKE, 1MH, 10X LA005-R10 | 08N1R0K | ASE | 1810-03-0010 | 1 |
| L09 L10 | FERRITE CHOKE LA009-004 | T1255-1 | HYT | 1810-05-0001 | 2 |
| WAVETEK PARTS LIST | | TITLE SWP OSC, M9H | ASSEMBLY NO. 1114-00-0003 | | REV I |
| | | | PAGE: 2 | | |

| REFERENCE DESIGNATORS | PART DESCRIPTION | ORIG-MFGR-PART-NO | MFGR | WAVETEK NO. | QTY |
|--------------------------------|---------------------------------|----------------------|------------------------------|--------------|----------|
| 20 | FERR. BEAD,LC000-009 | K5-001-00/38 | FRXC | 1813-00-0007 | 2 |
| Q01 Q04 Q07 Q09 | TRANS QB000-009 | MPS3702 | MOT | 4902-03-7020 | 4 |
| Q02 | TRANS QB000-013 | A430 | APX | 4902-00-4300 | 1 |
| Q03 | TRANS QA050-880 | 2N5088 | MOT | 4901-05-0880 | 1 |
| Q05 Q14 Q16 | TRANS QA051-790 | 2N5179 | RCA | 4901-05-1790 | 3 |
| Q06 Q10 | TRANS QA038-541 | 2N3854A | G-E | 4901-03-8541 | 2 |
| Q08 | TRANS QB000-011 | TD401 | SPR | 4902-00-4010 | 1 |
| Q11 Q12 Q13 Q15 | TRANS QA050-530 | 2N5053 | APX | 4901-05-0530 | 4 |
| Q17 | TRANS QA054-580 | 2N5458 | MOT | 4901-05-4580 | 1 |
| R01 | RES,C,1/4W,5%,22K RC103-322 | CF1/422K | ASE | 4700-15-2202 | 1 |
| R02 R12 | POT,10K,RP129-310 | 360S103B | CTS | 4610-00-1103 | 2 |
| R03 R14 R17 R24 | RES,C,1/4W,5%,10K RC103-310 | CF1/4-10K | ASE | 4700-15-1002 | 4 |
| R04 R19 R39 R40 R47 R48 | RES,C,1/4W,5%,470 RC103-147 | CF1/4-470 | ASE | 4700-15-4700 | 6 |
| R05 R06 R15 R20 R21 R41 R49 | RES,C,1/4W,5%,4.7K RC103-247 | CF1/4-4.7K | ASE | 4700-15-4701 | 7 |
| R07 R22 | RES,C,1/4W,5%,10 RC103-010 | CF1/4-10 | ASE | 4700-15-1009 | 2 |
| WAVETEK PARTS LIST | | TITLE SWP OSC,M9H | ASSEMBLY NO. 1114-00-0003 | | REV 1 |
| | | | PAGE: 3 | | |

| REFERENCE DESIGNATORS | PART DESCRIPTION | ORIG-MFGR-PART-NO | MFGR | WAVETEK NO. | QTY |
|-------------------------------|---------------------------------|----------------------|------------------------------|--------------|----------|
| R08 R29 | RES,C,1/4W,5%,5.6K RC103-256 | CF1/4-5.6K | ASE | 4700-15-5601 | 2 |
| R09 | POT,20K,RP129-320 | 360S203B | CTS | 4610-00-1203 | 1 |
| R11 | RES,C,1/4W,5%,47K RC103-347 | CF1/4-47K | ASE | 4700-15-4702 | 1 |
| R13 | POT,20K RP124-320 | WA2G032S-203MA | A-H | 4610-10-7203 | 1 |
| R16 R30 R33 | RES,C,1/4W,5%,33K RC103-333 | CF1/4-33K | ASE | 4700-15-3302 | 3 |
| R18 | RES,C,1/4W,5%,2.2K RC103-222 | CF1/4-2.2K | ASE | 4700-15-2201 | 1 |
| R25 | RES,C,1/4W,5%,1.5K RC103-215 | CF1/4-1.5K | ASE | 4700-15-1501 | 1 |
| R26 R32 | RES,C,1/4W,5%,27K RC103-327 | CF1/4-27K | ASE | 4700-15-2702 | 2 |
| R28 | RES,C,1/4W,5%,39K RC103-339 | CF1/4-39K | ASE | 4700-15-3902 | 1 |
| R31 | RES,C,1/4W,5%,100K RC103-410 | CF1/4-100K | ASE | 4700-15-1003 | 1 |
| R34 | RES,C,1/4W,5%,12K RC103-312 | CF1/4-12K | ASE | 4700-15-1202 | 1 |
| WAVETEK PARTS LIST | | TITLE SWP OSC,M9H | ASSEMBLY NO. 1114-00-0003 | | REV 1 |
| | | | PAGE: 4 | | |

| REFERENCE DESIGNATORS | PART DESCRIPTION | ORIG-MFGR-PART-NO | MFGR | WAVETEK NO. | QTY |
|-------------------------------|------------------------------------|----------------------|------|------------------------------|-----|
| R36 | RES,C,1/4W,5%,4,7 RC103-R47 | CF1/4-4,7 | ASE | 4700-15-4708 | 1 |
| R37 | RES,C,1/4W,5%,390 RC103-139 | CF1/4-390 | ASE | 4700-15-3900 | 1 |
| R38 R43 R45 R46 R51 | RES,C,1/4W,5%,100 RC103-110 | CF1/4-100 | ASE | 4700-15-1000 | 5 |
| R42 R44 R50 | RES,C,1/4W,5%,47 RC103-047 | CF1/4-47 | ASE | 4700-15-4709 | 3 |
| R52 | RES,C,1/4W,5%,22 RC103-022 | CF1/4-22 | ASE | 4700-15-2209 | 1 |
| R53 | RES,C,1/4W,5%,150 RC103-115 | CF1/4-150 | ASE | 4700-15-1500 | 1 |
| R54 | RES,C,1/4W,10%,10M RC104-610 | CB1061 | A-B | 4700-16-1005 | 1 |
| 18 | RES,C,1/4W,10%,4,7K RC104-247AB | CB4721 | A-B | 4705-16-4701 | 2 |
| 22 | RES,C,1/4W,10%,10K RC104-310AB | CB1031 | A-B | 4705-16-1002 | 3 |
| WAVETEK PARTS LIST | | TITLE SWP OSC,M9H | | ASSEMBLY NO. 1114-00-0003 | |
| | | | | PAGE: 5 | |
| | | | | REV I | |

| REFERENCE DESIGNATORS | PART DESCRIPTION | ORIG-MFGR=PART-NO | MFGR | WAVETEK NO. | QTY |
|-------------------------------|-----------------------------------|--------------------------|------------------------------|--------------|----------|
| C01 C17 C26 C28 C30 | CAP,F,T,,470PF CF101-147 | FA5C-4712 | A-B | 1510-30-0471 | 5 |
| C02 C27 C29 C31 | CAP,CER,,01MF,100V CD103-310 | 68U103M | MDC | 1510-10-2103 | 4 |
| C03 C04 | CAP,FT,500PF,20X250V CF104-150 | 4420-500PF | AER | 1510-30-3501 | 2 |
| C05 | CAP,CER,,025MF,50V CD103-325 | TG-325 | SPR | 1510-10-2253 | 1 |
| C06 C07 C08 C15 | CAP,TANT,,47MF,50V CE113-447 | 935 | TRW | 1510-21-9470 | 4 |
| C09 C13 C14 C23 | CAP,TANT,10MF,25V CE120-010 | 162D106X0025DD2 | SPR | 1510-21-7100 | 4 |
| C10 | CAP,CER,15PF,1KV CD101-015 | 10TCC-Q15 | SPR | 1510-10-0150 | 1 |
| C11 | CAP,CER,4,7PF,1KV CD101-R47 | 10TCC-V47 | SPR | 1510-10-0479 | 1 |
| C12 | CAP,CER,10PF,1KV CD101-010 | 10TCC-Q10 | SPR | 1510-10-0100 | 1 |
| C16 | CAP,FT,CER,100PF,20X CF104-110 | 4420-100PF | AER | 1510-30-3101 | 1 |
| C18 C19 C24 C32 C33 | CAP,F,T,,6,8PF CF102-R68 | FA5C-6892 | A-B | 1510-30-1689 | 5 |
| WAVETEK PARTS LIST | | TITLE OUTPUT AMP,M10H | ASSEMBLY NO. 1114-00-0004 | | REV G |
| | | | PAGE: 1 | | |

| REFERENCE DESIGNATORS | PART DESCRIPTION | ORIG-MFGR=PART-NO | MFGR | WAVETEK NO. | QTY |
|-------------------------------|----------------------------------|--------------------------|------------------------------|--------------|----------|
| C20 | CAP,CER,,001MFD,1KV CD102-210 | 5GAD10 | SPR | 1510-10-1102 | 1 |
| C21 | CAP,CER,360PF,1KV CD102-136 | 60U361M | MDC | 1510-10-1361 | 1 |
| C22 | CAP,CER,,005MF,1KV CD103-250 | TG-050 | SPR | 1510-10-2502 | 1 |
| C25 | CAP,CER,120PF,1KV CD102-112 | 60U121M | MDC | 1510-10-1121 | 1 |
| C34 C35 | CAP,CER,200PF,1KV CD102-120 | 5GA-T20 | SPR | 1510-10-1201 | 2 |
| C36 | CAP,CER,47PF,1KV CD104-047 | 60U2J470J | MDC | 1510-10-3470 | 1 |
| CR01 CR02 CR03 | DIODE DP000-050 | 5082-3080 | H-P | 4805-02-0002 | 3 |
| CR04 CR05 CR06 CR07 | DIODE DC000-008 | 8B205 | APX | 4803-02-0004 | 4 |
| CR08 | DIODE DG000-007 | 5082-2800 | H-P | 4809-02-0001 | 1 |
| CR09 CR10 | DIODE DR000-001 | 1N4004 | P-C | 4806-01-4004 | 2 |
| J01 J02 | CONN JF000-005 | 37JR116-1 | S-C | 2110-03-0002 | 2 |
| L01 L04 L05 L09 L11 | FERRITE CHOKE LA009-010 | T1255-2 | HYT | 1810-05-0002 | 5 |
| L06 L07 L08 L10 | FERRITE CHOKE LA009-004 | T1255-1 | HYT | 1810-05-0001 | 4 |
| WAVETEK PARTS LIST | | TITLE OUTPUT AMP,M10H | ASSEMBLY NO. 1114-00-0004 | | REV G |
| | | | PAGE: 2 | | |

| REFERENCE DESIGNATORS | PART DESCRIPTION | ORIG-MFGR-PART-NO | MFGR | WAVETEK NO. | QTY |
|-------------------------------|-----------------------------------|--------------------------|------|---|----------|
| L12 | CHOKE,10MILH,10X LA004-310 | 15S103K | ASE | 1810-02-1001 | 1 |
| Q01 Q02 | TRANS QA050-530 | 2N5053 | APX | 4901-05-0530 | 2 |
| Q03 Q05 Q06 | TRANS QB000-018 | SD1006 | SSS | 4902-01-0060 | 3 |
| Q04 | TRANS QB000-013 | A430 | APX | 4902-00-4300 | 1 |
| Q07 Q10 Q11 | TRANS QB000-009 | MPS3702 | MOT | 4902-03-7020 | 3 |
| Q08 | TRANS QA054-580 | 2N5458 | MOT | 4901-05-4580 | 1 |
| Q09 | TRANS QB000-010 | TD101 | SPR | 4902-00-1010 | 1 |
| R01 R05 R26 | RES,C,1/4W,5%,47 RC103-047 | CF1/4-47 | ASE | 4700-15-4709 | 3 |
| R02 | RES,C,1/4W,5%,330 RC103-133 | CF1/4-330 | ASE | 4700-15-3300 | 1 |
| R03 R33 R46 | RES,C,1/4W,5%,1K RC103-210 | CF1/4-1K | ASE | 4700-15-1001 | 3 |
| R06 | RES,C,1/4W,5%,150 RC103-115 | CF1/4-150 | ASE | 4700-15-1500 | 1 |
| R07 | RES,C,1/4W,5%,820 RC103-182 | CF1/4-820 | ASE | 4700-15-8200 | 1 |
| R08 R50 | RES,C,1/4W,10%,100 RC104-110AB | CB1001 | A-B | 4705-16-1000 | 2 |
| WAVETEK PARTS LIST | | TITLE OUTPUT AMP,M10H | | ASSEMBLY NO. 1114-00-0004 PAGE: 3 | REV G |

| REFERENCE DESIGNATORS | PART DESCRIPTION | ORIG-MFGR-PART-NO | MFGR | WAVETEK NO. | QTY |
|-------------------------------|--------------------------------------|--------------------------|------|---|----------|
| R09 | RES,C,1/4W,5%,56 RC103-056 | CF1/4-56 | ASE | 4700-15-5609 | 1 |
| R10 | RES,C,1/4W,5%,560 RC103-156 | CF1/4-560 | ASE | 4700-15-5600 | 1 |
| R11 R44 R52 | RES,C,1/4W,5%,220 RC103-122 | CF1/4-220 | ASE | 4700-15-2200 | 3 |
| R12 R21 | RES,C,1/4,5%,27 RC103-027 | CF1/4-27 | ASE | 4700-15-2709 | 2 |
| R13 R30 | RES,C,1/4W,5%,470 RC103-147 | CF1/4-470 | ASE | 4700-15-4700 | 2 |
| R14 R17 R22 R25 | RES,C,1/4W,5%,10 RC103-010 | CF1/4-10 | ASE | 4700-15-1009 | 4 |
| R15 R19 R20 | RES,C,1/4W,5%,82 RC103-082 | CF1/4-82 | ASE | 4700-15-8209 | 3 |
| R16 | RES,C,1/4W,5%,1.5K RC103-215 | CF1/4-1.5K | ASE | 4700-15-1501 | 1 |
| R18 | RES,C,1/4W,5%,22 RC103-022 | CF1/4-22 | ASE | 4700-15-2209 | 1 |
| R23 | RES,C,1/2W,5%,360 W-I/RC105-136AB | EB3615 | A-B | 4705-25-3600 | 1 |
| R24 | RES,C,1W,5%,150 RC107-115 | GB1515 | A-B | 4700-35-1500 | 1 |
| WAVETEK PARTS LIST | | TITLE OUTPUT AMP,M10H | | ASSEMBLY NO. 1114-00-0004 PAGE: 4 | REV G |

| REFERENCE DESIGNATORS | PART DESCRIPTION | ORIG-MFGR-PART-NO | MFGR | WAVETEK NO. | QTY |
|-------------------------------|------------------------------------|--------------------------|------------------------------|--------------|----------|
| R27 R28 R31 | RES,C,1/4W,5%,33K RC103-333 | CF1/4-33K | ASE | 4700-15-3302 | 3 |
| R29 | RES,C,1W,5%,100 RC107-110 | GB1015 | A=B | 4700-35-1000 | 1 |
| R32 | RES,C,1/4W,5%,100K RC103-410 | CF1/4-100K | ASE | 4700-15-1003 | 1 |
| R34 R47 | RES,C,1/4W,5%,10K RC103-310 | CF1/4-10K | ASE | 4700-15-1002 | 2 |
| R35 | RES,C,1/4W,5%,1M RC103-510 | CF1/4-1M | ASE | 4700-15-1004 | 1 |
| R36 | RES,C,1/4W,10%,2.2M RC104-522AB | CB2251 | A=B | 4705-16-2204 | 1 |
| R37 R39 | POT,20K RP124-320 | WA2G032S-203MA | A=B | 4610-10-7203 | 2 |
| R38 | RES,C,1/4W,5%,15K RC103-315 | CF1/4-15K | ASE | 4700-15-1502 | 1 |
| R40 | RES,C,1/4W,5%,470K RC103-447 | CF1/4-470K | ASE | 4700-15-4703 | 1 |
| R41 | RES,C,1/4W,5%,1.2K RC103-212 | CF1/4-1.2K | ASE | 4700-15-1201 | 1 |
| R42 | RES,C,1/4W,5%,680K RC103-468 | CF1/4-680K | ASE | 4700-15-6803 | 1 |
| WAVETEK PARTS LIST | | TITLE OUTPUT AMP,M10H | ASSEMBLY NO. 1114-00-0004 | | REV G |
| | | | PAGE: 5 | | |

| REFERENCE DESIGNATORS | PART DESCRIPTION | ORIG-MFGR-PART-NO | MFGR | WAVETEK NO. | QTY |
|-------------------------------|---------------------------------|--------------------------|------------------------------|--------------|----------|
| R43 | RES,C,1/4W,5%,2.7K RC103-227 | CF1/4-2.7K | ASE | 4700-15-2701 | 1 |
| R45 R51 | RES,C,1/4W,5%,4.7K RC103-247 | CF1/4-4.7K | ASE | 4700-15-4701 | 2 |
| R49 | RES,C,1/4W,5%,47K RC103-347 | CF1/4-47K | ASE | 4700-15-4702 | 1 |
| 20 | RES,C,1/4W,5%,100 RC103-110 | CF1/4-100 | ASE | 4700-15-1000 | 2 |
| WAVETEK PARTS LIST | | TITLE OUTPUT AMP,M10H | ASSEMBLY NO. 1114-00-0004 | | REV G |
| | | | PAGE: 6 | | |

| REFERENCE DESIGNATORS | PART DESCRIPTION | ORIG-MFGR-PART-NO | MFGR | WAVETEK NO. | QTY |
|---|--|-----------------------|------------------------------|--------------|----------|
| C01 C13 C24 C25 C26 | CAP,F,T,,6,8PF CF102-R68 | FASC-6892 | A-B | 1510-30-1689 | 5 |
| C02 C04 C05 C06 C10 C11 C12 C14 C15 C16 C17 C18 C22 C23 C33 | CAP,FT,500PF,20%250V CF104-150 | 4420-500PF | AER | 1510-30-3501 | 14 |
| C03 C08 C09 C19 C20 C21 | CAP,FT,CER,100PF,20% CF104-110 | 4420-100PF | AER | 1510-30-3101 | 6 |
| C07 ML32 | CAP,Q.C.,,75PF CG101-175 | QC-,75PF | Q-C | 1510-40-0758 | 2 |
| C27 C28 C29 C30 C31 | CAP,F.T.,,470PF CF101-147 | FASC-4712 | A-B | 1510-30-0471 | 5 |
| C39 | CAP,VALUE DETERMINED IN CALIBRATION | CAP,TRIM | W-I | 1519-99-9999 | 1 |
| 33 | CAP,Q-C,2,0PF,10% CG101-220 | QC=2,0PF | Q-C | 1510-40-0020 | 1 |
| 34 | CAP,M.C.,,47PF CG102-147 | MC-,47PF | Q-C | 1510-40-1478 | 2 |
| CR01 CR10 CR11 CR21 | DIODE DR000-001 | 1N4004 | P-C | 4806-01-4004 | 4 |
| CR02 CR03 CR04 CR05 CR13 CR14 CR15 CR16 | DIODE DC000-008 | 88205 | APX | 4803-02-0004 | 8 |
| CR20 | DIODE DG100-821 | 1N82AG | G-I | 4807-01-0082 | 1 |
| J01 J02 J03 | CONN JF000-005 | 37JR116-1 | S-C | 2110-03-0002 | 3 |
| WAVETEK PARTS LIST | | TITLE SWP USC,M19H | ASSEMBLY NO. 1114-00-0005 | | REV J |
| | | | PAGE: 1 | | |

| REFERENCE DESIGNATORS | PART DESCRIPTION | ORIG-MFGR-PART-NO | MFGR | WAVETEK NO. | QTY |
|------------------------------------|---|-----------------------|------------------------------|--------------|----------|
| L01 L02 L10 L11 L12 L13 L21 L22 | FERRITE CHOKE LA009-004 | T1255-1 | HYT | 1810-05-0001 | 8 |
| L03 L05 L14 L16 | CHOKE ,22MH 10% LA005-R02 | 08NR22K | ASE | 1810-03-0228 | 4 |
| L24 | FERRITE CHOKE LA009-010 | T1255-2 | HYT | 1810-05-0002 | 1 |
| L25 L26 | FERRITE CHOKE,4 TURN FROM:1813-00-0007 | LA007-004 | W-I | 1210-30-0005 | 2 |
| Q01 Q04 Q07 Q08 Q09 Q11 Q15 Q16 | TRANS QB000-009 | MPS3702 | MOT | 4902-03-7020 | 8 |
| Q02 Q05 Q10 Q12 Q13 | TRANS QA038-541 | 2N3854A | G-E | 4901-03-8541 | 5 |
| Q03 | TRANS QA054-610 | 2N5461 | MOT | 4901-05-4610 | 1 |
| Q06 | TRANS QA051-090 | 2N5109 | SSS | 4901-05-1090 | 1 |
| Q14 | TRANS QB000-015 | 2N5947 | MOT | 4901-05-9470 | 1 |
| R01 R30 | RES,C,1/4W,5%,7.5K RC103-275 | CF1/4-7.5K | ASE | 4700-15-7501 | 2 |
| R02 R07 R31 R39 R40 | RES,C,1/4W,5%,4.7K RC103-247 | CF1/4-4.7K | ASE | 4700-15-4701 | 5 |
| R03 | RES,C,1/4W,10%,10M RC104-610 | CR1061 | A-B | 4700-16-1005 | 1 |
| R04 R22 | RES,VAL DET IN CALIB | RES,TRIM | W-I | 4799-99-9999 | 2 |
| WAVETEK PARTS LIST | | TITLE SWP USC,M19H | ASSEMBLY NO. 1114-00-0005 | | REV J |
| | | | PAGE: 2 | | |

| REFERENCE DESIGNATORS | PART DESCRIPTION | ORIG-MFGR-PART-NO | MFGR | WAVETEK NO. | QTY |
|-------------------------------|---------------------------------|-----------------------|------------------------------|--------------|----------|
| R05 R19 R24 R28 R33 | RES,C,1/4W,5%,22K RC103-322 | CF1/422K | ASE | 4700-15-2202 | 5 |
| R06 R23 R34 | RES,C,1/4W,5%,68K RC103-368 | CF1/4-68K | ASE | 4700-15-6802 | 3 |
| R08 R17 R18 R35 R49 R50 | RES,C,1/4W,5%,100K RC103-410 | CF1/4-100K | ASE | 4700-15-1003 | 6 |
| R09 R10 | RES,C,1/2W,5%,220 RC105-122 | CF1/2-220 | ASE | 4700-25-2200 | 2 |
| R11 | RES,C,1/4W,5%,390 RC103-139 | CF1/4-390 | ASE | 4700-15-3900 | 1 |
| R12 R15 R36 | RES,C,1/4W,5%,2.2K RC103-222 | CF1/4-2.2K | ASE | 4700-15-2201 | 3 |
| R14 R16 | POT,CONT,10K RV102-310 | 3067P-10K | BOU | 4610-20-0103 | 2 |
| R20 | RES,C,1/4W,5%,39K RC103-339 | CF1/4-39K | ASE | 4700-15-3902 | 1 |
| R21 | RES,C,1/4W,5%,91K RC103-391 | CF1/4-91K | ASE | 4700-15-9102 | 1 |
| R25 R29 | RES,C,1/4W,5%,47K RC103-347 | CF1/4-47K | ASE | 4700-15-4702 | 2 |
| R26 R27 | RES,C,1/4W,5%,220K RC103-422 | CF1/4220K | ASE | 4700-15-2203 | 2 |
| WAVETEK PARTS LIST | | TITLE SWP OSC,M19H | ASSEMBLY NO. 1114-00-0005 | | REV J |
| | | | PAGE: 3 | | |

| REFERENCE DESIGNATORS | PART DESCRIPTION | ORIG-MFGR-PART-NO | MFGR | WAVETEK NO. | QTY |
|-------------------------------|------------------------------------|-----------------------|------------------------------|--------------|----------|
| R32 | RES,C,1/4W,5%,6.8K RC103-268 | CF1/4-6.8K | ASE | 4700-15-6801 | 1 |
| R37 | RES,C,1W,5%,160 RC107-116 | GB1615 | A-B | 4700-35-1600 | 1 |
| R38 | RES,C,1/2W,5%,82 RC105-082 | CF1/2-82 | ASE | 4700-25-8209 | 1 |
| R41 | RES,C,1W,10%,470 RC108-147 | GB4711 | A-B | 4700-36-4700 | 1 |
| R42 | RES,C,1/4W,5%,47 RC103-047 | CF1/4-47 | ASE | 4700-15-4709 | 1 |
| R43 | RES,C,1/4W,5%,330 RC103-133 | CF1/4-330 | ASE | 4700-15-3300 | 1 |
| R44 | RES,C,1/4W,5%,1K RC103-210 | CF1/4-1K | ASE | 4700-15-1001 | 1 |
| R45 R48 | RES,C,1/4W,5%,100 RC103-110 | CF1/4-100 | ASE | 4700-15-1000 | 2 |
| R46 | RES,L-A,1/4W,1%,49.9 RF404-990 | SPS-N-347-49.9 | IRC | 4741-49-9007 | 1 |
| R47 | RES,C,1/4W,5%,56 RC103-056 | CF1/4-56 | ASE | 4700-15-5609 | 1 |
| 28 | RES,C,1/4W,10%,4.7K RC104-247AB | CB4721 | A-B | 4705-16-4701 | 8 |
| 30 | RES,C,1/4W,10%,2.2M RC104-522AB | CB2251 | A-B | 4705-16-2204 | 1 |
| WAVETEK PARTS LIST | | TITLE SWP OSC,M19H | ASSEMBLY NO. 1114-00-0005 | | REV J |
| | | | PAGE: 4 | | |

| REFERENCE DESIGNATORS | PART DESCRIPTION | ORIG-MFGR-PART-NO | MFGR | WAVETEK NO. | QTY/PT |
|---------------------------|-----------------------------------|--|---|--------------|----------|
| C01 C07 | CAP,CER,47PF,1KV CD104-047 | 60U2J470J | MDC | 1510-10-3470 | 2 |
| C02 | CAP,CER,330PF,1KV CD104-133 | 10TCU-T33 | SPR | 1510-10-3331 | 1 |
| C03 | CAP,CER,120PF,1KV CD104-112 | 10TCU-T12 | SPR | 1510-10-3121 | 1 |
| C04 | CAP,FT,500PF,20X250V CF104-150 | 4420-500PF | AER | 1510-30-3501 | 1 |
| C05 | CAP,VAR,3.5-13PF250V CV101-013 | 7S-TRIKO-02-3.5-13PF | STR | 1510-70-0130 | 1 |
| C06 | CAP,CER,15PF,1KV CD101-015 | 10TCC-Q15 | SPR | 1510-10-0150 | 1 |
| C08 C09 | CAP,CER,.001MFD,1KV CD102-210 | 5GAD10 | SPR | 1510-10-1102 | 2 |
| C10 | CAP,CER,.01MF,100V CD103-310 | 68U103M | MDC | 1510-10-2103 | 1 |
| C11 | CAP,F.T.,.6.8PF CF102-R68 | FA5C-6892 | A-H | 1510-30-1689 | 1 |
| C12 | CAP,F.T.,.470PF CF101-147 | FA5C-4712 | A-H | 1510-30-0471 | 1 |
| C13 | CAP,TANT,10MF,25V CE120-010 | 162D106X0025DD2 | SPR | 1510-21-7100 | 1 |
| CR1 | DIODE DG100-821 | 1N82AG | G-I | 4807-01-0082 | 1 |
| WAVETEK PARTS LIST | | TITLE 10 MHZ HARMONIC MARKER, M6H-10 | ASSEMBLY NO. 1114-00-0099 PAGE: 1 | | REV C |

| REFERENCE DESIGNATORS | PART DESCRIPTION | ORIG-MFGR-PART-NO | MFGR | WAVETEK NO. | QTY/PT |
|---------------------------|---------------------------------|--|---|--------------|----------|
| J1 J2 | CONN JF000-005 | 37JR116-1 | S-C | 2110-03-0002 | 2 |
| L1 L3 | RF CHOKE | CHOKE | W-I | 1819-99-9999 | 2 |
| L2 | FERRITE CHOKE LA009-010 | T1255-2 | HYT | 1810-05-0002 | 1 |
| L4 | FERRITE CHOKE LA009-004 | T1255-1 | HYT | 1810-05-0001 | 1 |
| Q1 | TRANS QA038-541 | 2N3854A | G-E | 4901-03-8541 | 1 |
| Q2 | TRANS QB000-013 | A430 | APX | 4902-00-4300 | 1 |
| Q3 | TRANS QA054-580 | 2N5458 | MOT | 4901-05-4580 | 1 |
| Q4 | TRANS QA050-880 | 2N5088 | MOT | 4901-05-0880 | 1 |
| R01 | RES,C,1/4W,5%,47K RC103-347 | CF1/4-47K | ASE | 4700-15-4702 | 1 |
| R02 | RES,C,1/4W,5%,56 RC103-056 | CF1/4-56 | ASE | 4700-15-5609 | 1 |
| R03 | RES,C,1/4W,5%,1.5K RC103-215 | CF1/4-1.5K | ASE | 4700-15-1501 | 1 |
| R04 R17 | RES,C,1/4W,5%,100 RC103-110 | CF1/4-100 | ASE | 4700-15-1000 | 2 |
| R05 | RES,C,1/4W,5%,75 RC103-075 | CR1/4-75 | ASE | 4700-15-7509 | 1 |
| R06 | RES,C,1/4W,5%,3.9K RC103-239 | CF1/43.9K | ASE | 4700-15-3901 | 1 |
| WAVETEK PARTS LIST | | TITLE 10 MHZ HARMONIC MARKER, M6H-10 | ASSEMBLY NO. 1114-00-0099 PAGE: 2 | | REV C |

| REFERENCE DESIGNATORS | PART DESCRIPTION | ORIG-MFGR-PART-NO | MFGR | WAVETEK NO. | QTY/PT |
|---------------------------|---------------------------------|--|---|--------------|----------|
| R07 | RES,C,1/4W,5%,470 RC103-147 | CF1/4-470 | ASE | 4700-15-4700 | 1 |
| R08 | RES,C,1/4W,5%,33K RC103-333 | CF1/4-33K | ASE | 4700-15-3302 | 1 |
| R09 | RES,C,1/4W,5%,1M RC103-510 | CF1/4-1M | ASE | 4700-15-1004 | 1 |
| R10 | RES,C,1/4W,5%,1K RC103-210 | CF1/4-1K | ASE | 4700-15-1001 | 1 |
| R11 | RES,C,1/4W,5%,8.2K RC103-282 | CF1/4-8.2K | ASE | 4700-15-8201 | 1 |
| R12 | RES,C,1/4W,5%,15K RC103-315 | CF1/4-15K | ASE | 4700-15-1502 | 1 |
| R13 | RES,C,1/4W,5%,1.5M RC103-515 | CF1/4-1.5M | ASE | 4700-15-1504 | 1 |
| R14 | RES,C,1/4W,5%,10K RC103-310 | CF1/4-10K | ASE | 4700-15-1002 | 1 |
| R15 | POT,20K RP124-320 | WA2G032S-203MA | A-B | 4610-10-7203 | 1 |
| R16 | RES,C,1/4W,5%,100K RC103-410 | CF1/4-100K | ASE | 4700-15-1003 | 1 |
| X1 | CRYSTAL,XX000-321 | X32W-00.00000 | W-I | 2310-00-0321 | 1 |
| WAVETEK PARTS LIST | | TITLE 10 MHZ HARMONIC MARKER, M6H-10 | ASSEMBLY NO. 1114-00-0099 PAGE: 3 | | REV C |

| REFERENCE DESIGNATORS | PART DESCRIPTION | ORIG-MFGR-PART-NO | MFGR | WAVETEK NO. | QTY/PT |
|---------------------------|-----------------------------------|--|---|--------------|----------|
| C01 | CAP,CER,20PF,1KV CD101-020 | 60C0G200J | MDC | 1510-10-0200 | 1 |
| C02 | CAP,CER,120PF,1KV CD104-112 | 10TCU-T12 | SPR | 1510-10-3121 | 1 |
| C03 C07 | CAP,CER,47PF,1KV CD104-047 | 60U2J470J | MDC | 1510-10-3470 | 2 |
| C04 | CAP,FT,500PF,20%250V CF104-150 | 4420-500PF | AER | 1510-30-3501 | 1 |
| C05 | CAP,VAR,3.5-13PF250V CV101-013 | 7S-TRIKO-02-3.5-13PF | STR | 1510-70-0130 | 1 |
| C06 | CAP,CER,15PF,1KV CD101-015 | 10TCC-Q15 | SPR | 1510-10-0150 | 1 |
| C08 C09 | CAP,CER,.001MFD,1KV CD102-210 | 5GAD10 | SPR | 1510-10-1102 | 2 |
| C10 | CAP,CER,.01MF,100V CD103-310 | 68U103M | MDC | 1510-10-2103 | 1 |
| C11 | CAP,F.T.,6.8PF CF102-R68 | FA5C-6892 | A-B | 1510-30-1689 | 1 |
| C12 | CAP,F.T.,470PF CF101-147 | FA5C-4712 | A-B | 1510-30-0471 | 1 |
| C13 | CAP,TANT,10MF,25V CE120-010 | 162D106X0025DD2 | SPR | 1510-21-7100 | 1 |
| CR1 | DIODE DG100-821 | 1N82AG | G-I | 4807-01-0082 | 1 |
| WAVETEK PARTS LIST | | TITLE 50 MHZ HARMONIC MARKER, M6H-50 | ASSEMBLY NO. 1114-00-0100 PAGE: 1 | | REV C |

| REFERENCE DESIGNATORS | PART DESCRIPTION | ORIG-MFGR-PART-NO | MFGR | WAVETEK NO. | QTY/PT |
|-------------------------------|---------------------------------|--|---|--------------|----------|
| J1 J2 | CONN JF000-005 | 37JR116-1 | S-C | 2110-03-0002 | 2 |
| L1 L3 | RF CHOKE | CHOKE | W-I | 1819-99-9999 | 2 |
| L2 | FERRITE CHOKE LA009-010 | T1255-2 | HYT | 1810-05-0002 | 1 |
| L4 | FERRITE CHOKE LA009-004 | T1255-1 | HYT | 1810-05-0001 | 1 |
| R01 | RES,C,1/4W,5%,47K RC103-347 | CF1/4-47K | ASE | 4700-15-4702 | 1 |
| R02 | RES,C,1/4W,5%,56 RC103-056 | CF1/4-56 | ASE | 4700-15-5609 | 1 |
| R03 | RES,C,1/4W,5%,1.5K RC103-215 | CF1/4-1.5K | ASE | 4700-15-1501 | 1 |
| R04 R17 | RES,C,1/4W,5%,100 RC103-110 | CF1/4-100 | ASE | 4700-15-1000 | 2 |
| R05 | RES,C,1/4W,5%,75 RC103-075 | CR1/4-75 | ASE | 4700-15-7509 | 1 |
| R06 | RES,C,1/4W,5%,3.9K RC103-239 | CF1/4-3.9K | ASE | 4700-15-3901 | 1 |
| R07 | RES,C,1/4W,5%,470 RC103-147 | CF1/4-470 | ASE | 4700-15-4700 | 1 |
| R08 | RES,C,1/4W,5%,33K RC103-333 | CF1/4-33K | ASE | 4700-15-3302 | 1 |
| WAVETEK PARTS LIST | | TITLE 50 MHZ HARMONIC MARKER, M6H-50 | ASSEMBLY NO. 1114-00-0100 PAGE: 2 | | REV C |

| REFERENCE DESIGNATORS | PART DESCRIPTION | ORIG-MFGR-PART-NO | MFGR | WAVETEK NO. | QTY/PT |
|-------------------------------|---------------------------------|--|---|--------------|----------|
| R09 | RES,C,1/4W,5%,1M RC103-510 | CF1/4-1M | ASE | 4700-15-1004 | 1 |
| R10 | RES,C,1/4W,5%,1K RC103-210 | CF1/4-1K | ASE | 4700-15-1001 | 1 |
| R11 | RES,C,1/4W,5%,8.2K RC103-282 | CF1/4-8.2K | ASE | 4700-15-8201 | 1 |
| R12 | RES,C,1/4W,5%,15K RC103-315 | CF1/4-15K | ASE | 4700-15-1502 | 1 |
| R13 | RES,C,1/4W,5%,1.5M RC103-515 | CF1/4-1.5M | ASE | 4700-15-1504 | 1 |
| R14 | RES,C,1/4W,5%,10K RC103-310 | CF1/4-10K | ASE | 4700-15-1002 | 1 |
| R15 | POT,20K RP124-320 | WA2G032S-203MA | A-B | 4610-10-7203 | 1 |
| R16 | RES,C,1/4W,5%,100K RC103-410 | CF1/4-100K | ASE | 4700-15-1003 | 1 |
| X1 | CRYSTAL,XX000-331 | X33W-00.00000 | W-I | 2310-00-0331 | 1 |
| WAVETEK PARTS LIST | | TITLE 50 MHZ HARMONIC MARKER, M6H-50 | ASSEMBLY NO. 1114-00-0100 PAGE: 3 | | REV C |

| REFERENCE DESIGNATORS | PART DESCRIPTION | ORIG-MFGR-PART-NO | MFGR | WAVETEK NO. | QTY/PT |
|-------------------------------|--|------------------------------|---|--------------|----------|
| C01 | CAP,CER,47PF,1KV CD104-047 | 60U2J470J | MDC | 1510-10-3470 | 1 |
| C02 | CAP,CER,20PF,1KV CD101-020 | 60C0G200J | MDC | 1510-10-0200 | 1 |
| C03 | CAP,CER,120PF,1KV CD104-112 | 10TCU-T12 | SPR | 1510-10-3121 | 1 |
| C04 C09 | CAP,FT,500PF,20%250V CF104-150 | 4420-500PF | AER | 1510-30-3501 | 2 |
| C05 | CAP,F.T.,470PF CF101-147 | FA5C-4712 | A-B | 1510-30-0471 | 1 |
| C08 | CAP,VALUE DETERMINED IN CALIBRATION | CAP,TRIM | W-I | 1519-99-9999 | 1 |
| C10 | CAP,CER,.01MF,100V CD103-310 | 68U103M | MDC | 1510-10-2103 | 1 |
| C11 | CAP,CER,.05MF,100V CD103-350 | TG-350 | SPR | 1510-10-2503 | 1 |
| C12 | CAP,F.T.,6.8PF CF102-R68 | FA5C-6892 | A-B | 1510-30-1689 | 1 |
| CR1A | DIODE DG000-007 | 5082-2800 | H-P | 4809-02-0001 | 1 |
| CR2 | DIODE DG100-821 | 1N82AG | G-I | 4807-01-0082 | 1 |
| J1 J2 | CONN JF000-005 | 37JR116-1 | S-C | 2110-03-0002 | 2 |
| L2 | CHOKE,2.2MH,10% LA005-R22 | 08N2R2K | ASE | 1810-03-0229 | 1 |
| WAVETEK PARTS LIST | | TITLE SING FREQ MKR M6S-3 | ASSEMBLY NO. 1114-00-0045 PAGE: 1 | | REV A |

| REFERENCE DESIGNATORS | PART DESCRIPTION | ORIG-MFGR-PART-NO | MFGR | WAVETEK NO. | QTY/PT |
|-------------------------------|---------------------------------|------------------------------|---|--------------|----------|
| Q1 Q2 | TRANS QA038-541 | 2N3854A | G-E | 4901-03-8541 | 2 |
| R1 | RES,C,1/4W,5%,47K RC103-347 | CF1/4-47K | ASE | 4700-15-4702 | 1 |
| R2 | RES,C,1/4W,5%,56 RC103-056 | CF1/4-56 | ASE | 4700-15-5609 | 1 |
| R3 R4 | RES,C,1/4W,5%,1.5K RC103-215 | CF1/4-1.5K | ASE | 4700-15-1501 | 2 |
| R5 | RES,C,1/4W,5%,180K RC103-418 | CF1/4-180K | ASE | 4700-15-1803 | 1 |
| R6 | RES,C,1/4W,5%,470K RC103-447 | CF1/4-470K | ASE | 4700-15-4703 | 1 |
| R7 R9 | RES,C,1/4W,5%,10K RC103-310 | CF1/4-10K | ASE | 4700-15-1002 | 2 |
| R8 | POT,20K RP124-520 | WA2G052S-203MA | A-B | 4610-10-7203 | 1 |
| X1 | CRYSTAL,XX000-351 | X35W-00.00000 | W-I | 2310-00-0331 | 1 |
| WAVETEK PARTS LIST | | TITLE SING FREQ MKR M6S-3 | ASSEMBLY NO. 1114-00-0045 PAGE: 2 | | REV A |

| REFERENCE DESIGNATORS | PART DESCRIPTION | ORIG-MFGR-PART-NO | MFGR | WAVETEK NO. | QTY | |
|-------------------------------|---------------------------------------|---|------|---|-----|-----|
| C1 | CAP, FILM, 10KPF, 160V CP105-310 | SXM110 | MAL | 1510-60-5103 | 1 | |
| C2 | CAP, CER, 10PF, 1KV CD101-010 | 101CC-010 | SPR | 1510-10-0100 | 1 | |
| C3 | CAP, CER, F.T. 1000PF CF112-210 | 54-794-010-102P | SPEC | 1510-30-4102 | 1 | |
| C4 | CAP, F.T., 6.8PF CF102-R68 | FA5C-6892 | A-H | 1510-30-1689 | 1 | |
| CR1 CR2 CR3 | DIODE DG109-140 | 1N4148 | FCD | 4807-01-0914 | 3 | |
| IC1 | IC, 8 PIN, IC000-008 | LM301-AN | NAT | 7000-03-0100 | 1 | |
| R1 | POT, 20K RP124-320 | WA26032S-203MA | A-H | 4010-10-7203 | 1 | |
| R2 | RES, C, 1/4W, 5%, 56K RC103-356 | CF1/4-56K | ASE | 4700-15-5602 | 1 | |
| R3 | RES, C, 1/4W, 5%, 150 RC103-115 | CF1/4-150 | ASE | 4700-15-1500 | 1 | |
| R4 | RES, MF, 1/8W, 1%, 47.5K RF213-475 | MF55K-47.5K | ASE | 4701-03-4752 | 1 | |
| R5 | RES, MF, 1/8W, 1%, 48.7K RF213-487 | MF55K-48.7K | ASE | 4701-03-4872 | 1 | |
| R6 | RES, MF, 1/8W, 1%, 46.4K RF213-464 | MF55K-46.4K | ASE | 4701-03-4642 | 1 | |
| WAVETEK PARTS LIST | | TITLE 1 KHZ SQR WAVE MODULATOR, M6Z-1 | | ASSEMBLY NO. 1114-00-0150 PAGE: 1 | | REV |

SECTION 7

SCHEMATICS

7.1 INTRODUCTION

This section contains all schematics for the instrument. A schematic index is given in Section 7.4.

7.2 SCHEMATIC NOTES

The following notes and abbreviations pertain to all schematics. Additional notes pertaining to specific schematics

are included on each schematic if required.

All values are shown in the following units unless otherwise specified.

| Components | Units |
|------------|--------------|
| Resistor | ohms |
| Capacitor | picofarads |
| Inductor | microhenries |



Denotes DC voltage reading in volts unless otherwise specified.

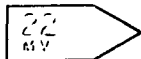

Denotes high impedance crystal detector reading in volts unless otherwise specified.



Denotes 50 ohm crystal detector reading in volts unless otherwise specified.

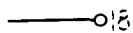

Signal or voltage source.

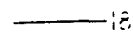

Connects to indicated signal or voltage source.



Arrow indicates clockwise rotation of wiper.



Coaxial jack

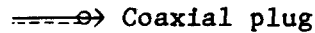

Coaxial plug

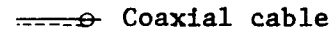

Coaxial cable

* Factory adjusted part.

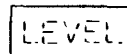

Denotes a front-panel device.

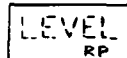

Denotes a rear-panel device.

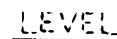

Denotes a PC board adjustment or accessible module adjustment.

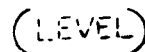

Denotes an internal module adjustment not accessible without removing module cover.

SCHEMATICS

7.3 ABBREVIATION CODE

| | | | | | |
|------|--------------------------|------------|------------------------|----------|------------------|
| A | Assembly | IF | intermediate frequency | Ω | ohm |
| A | ampere | J | jack | OC | opto coupler |
| AC | alternating current | K | relay | P | plug |
| C | capacitor | kHz | kilohertz | pp | peak-to-peak |
| CR | diode | k Ω | kilohm | pF | picofarad |
| CW | continuous wave | kV | kilovolt | Q | transistor |
| cw | clockwise | kW | kilowatt | R | resistor |
| dB | decibel | L | inductor | RF | radio frequency |
| dBm | decibel referred to 1 mW | MHz | megahertz | RMS | root-mean-square |
| dBmV | decibel referred to 1 mV | M Ω | megohm | R.P. | rear panel |
| DC | direct current | μ F | microfarad | S | switch |
| DS | indicating device, lamp | μ A | microampere | T | transformer |
| F | farad | μ H | microhenry | T.P. | test point |
| F.P. | front panel | M | meter | V | volt |
| H | henry | mA | milliampere | VA | voltampere |
| Har | harmonic | mH | millihenry | W | watt |
| Hz | hertz | mV | millivolt | X | crystal |
| IC | integrated circuit | mW | milliwatt | | |

7.4 SCHEMATIC INDEX

The schematics appear in the following order.

| <u>ASSEMBLY</u> | <u>NAME</u> |
|-----------------|----------------------------|
| 2001 | Wiring Diagram |
| PS6 | Power Supply |
| M1H | Sweep Rate |
| M2H | Sweep Drive |
| M5H | Marker Adder |
| M9H | Oscillator - Mixer |
| M10H | Output Amplifier |
| M19H | Sweep Oscillator |
| M6H-1 | Harmonic Marker (1 MHz) |
| M6H-5-50 | Harmonic Marker (5-50 MHz) |
| M6S | Single Freq. Marker |
| M6Z-1 | 1 kHz Modulation |

MODULE WIRING DIAGRAM
2001 HEAD

REV. A

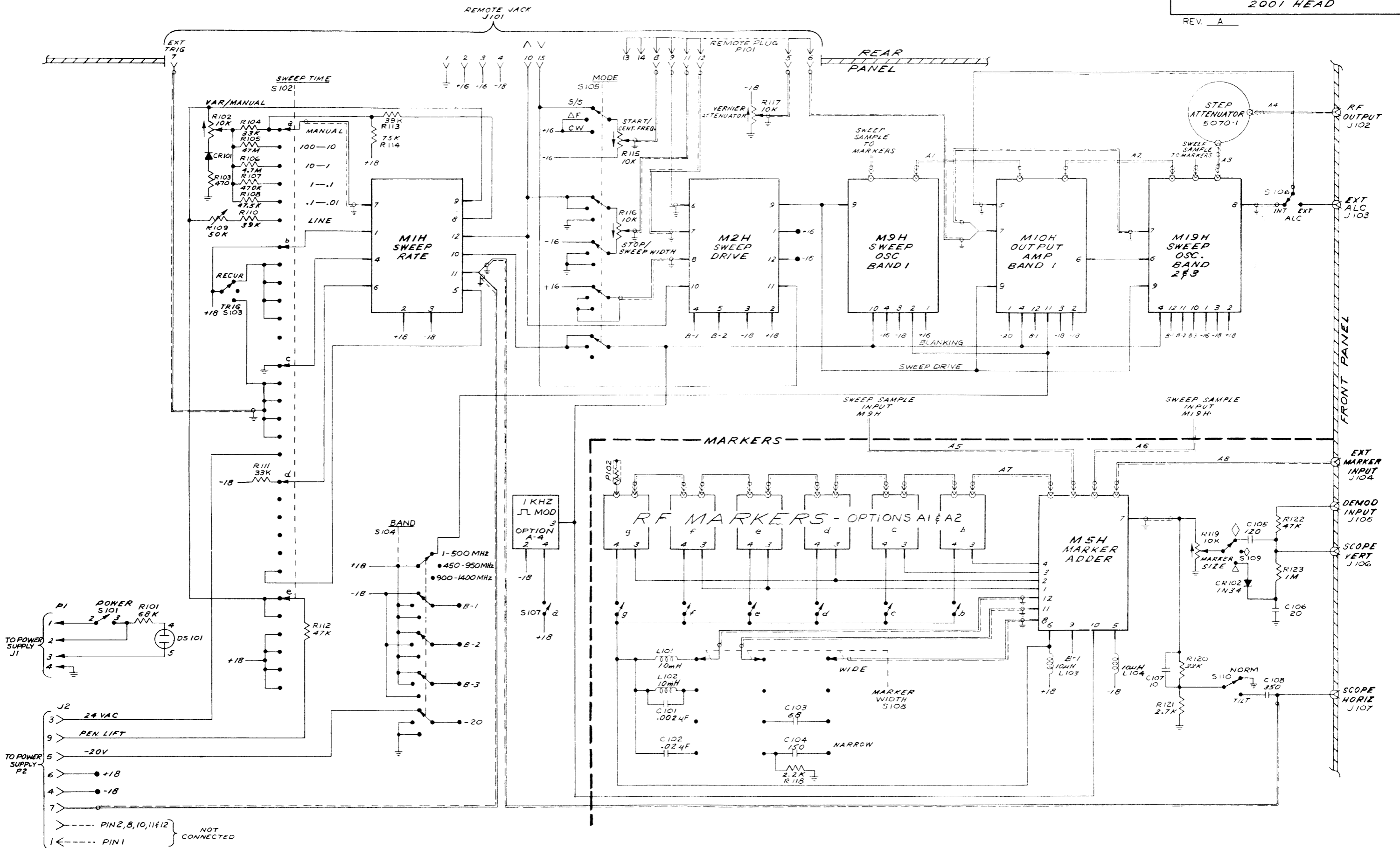

**MODULE WIRING DIAGRAM
2001A HEAD**

REV. _____
TACAN MARKER SYSTEM

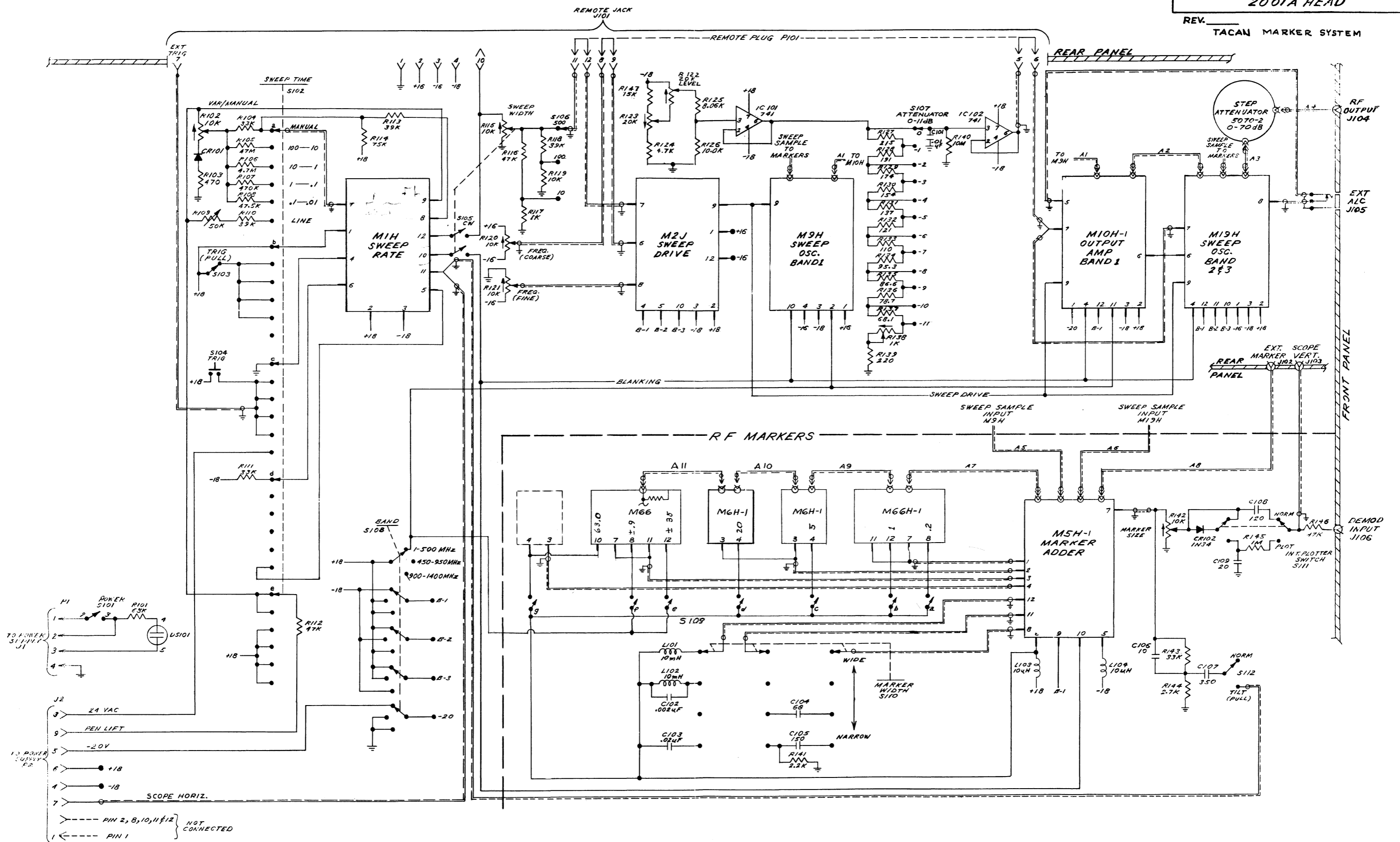

PARTS LIST MODEL 2001A HEAD
with TACAN Markers

MODULE REV A

| REFERENCE SYMBOL | DESCRIPTION | WAVETEK PART NO. | MANUFACTURER | | T Q |
|---|---|------------------|--------------|-------------|--------|
| | | | CODE | NUMBER | |
| <u>STANDARD MODULES</u> | | | | | |
| M1H | Sweep Rate Module | M1H | W-I | M1H | 1 |
| M2J | Sweep Drive Module | M2J | W-I | M2J | 1 |
| M5H-1 | Marker Adder Module (modified) | M5H-1 | W-I | M5H-1 | 1 |
| M10H-1 | Output Amplifier Module, Band 1(modified) | M10H-1 | W-I | M10H-1 | 1 |
| M19H | Oscillator Module, Band 2 & 3 | M19H | W-I | M19H | 1 |
| M66H.2,1 | Harmonic Markers, 200kHz, 1 MHz,(modified) | M66H.2,1-1 | W-I | M66H.2,1-1 | 1 |
| M6H5 | Harmonic Markers, 5 MHz, (modified) | M6H5-1 | W-I | M6H5-1 | 1 |
| M6H20 | Harmonic Markers, 20 MHz (modified) | M6H20-1 | W-I | M6H20-1 | 1 |
| M66 63.0 | Single frequency marker at 63.0 MHz with sidebands at 62.1 MHz and 63.9 MHz and a 62.65 and 63.35 MHz | M66 63.0 | W-I | M66 63.0 | 1 |
| <u>"A"</u> <u>ASSEMBLIES</u> | | | | | |
| 1 | RF Cable, 50 ohm | WX2001A-A1 | W-I | WX2001A-A1 | 1 |
| 2 | RF Cable, 50 ohm | WX2001A-A2 | W-I | WX2001A-A2 | 1 |
| 3 | RF Cable, 50 ohm | WX2001A-A3 | W-I | WX2001A-A3 | 1 |
| 4 | RF Cable, 50 ohm | WX2001A-A4 | W-I | WX2001A-A4 | 1 |
| 5 | RF Cable, 50 ohm | WX2001A-A5 | W-I | WX2001A-A5 | 1 |
| 6 | RF Cable, 50 ohm | WX2001A-A6 | W-I | WX2001A-A6 | 1 |
| 7 | RF Cable, 50 ohm | WX2001A-A7 | W-I | WX2001A-A7 | 1 |
| 8 | RF Cable, 50 ohm | WX2001A-A8 | W-I | WX2001A-A8 | 1 |
| 9 | RF Cable, 50 ohm | WX2001A-A9 | W-I | WX2001A-A9 | 1 |
| 10 | RF Cable, 50 ohm | WX2001A-A10 | W-I | WX2001A-A10 | 1 |
| 11 | RF Cable, 50 ohm | WX2001A-A11 | W-I | WX2001A-A11 | 1 |
| ---- | S102 Assembly with associated parts | B500-225 | W-I | B500-225 | 1 |
| ---- | S107 Assembly with associated parts | B500-232 | W-I | B500-232 | 1 |
| ---- | S108 Assembly with associated parts | B500-224 | W-I | B500-224 | 1 |
| 5070-2 | RF Attenuator | 5070-2 | W-I | 5070-2 | 1 |
| <u>"C"</u> <u>CAPACITORS</u> | | | | | |
| 101 | Ceramic disc, .01uF +20% 100V | CD103-310 | SPR | TG-S10 | 1 |
| 102 | Ceramic disc, .002uF +20% 1kV | CD102-220 | SPR | 5GA-D20 | 1 |
| 103 | Ceramic disc, .02uF +20% 100V | CD103-320 | SPR | TG-S20 | 1 |
| 104 | Ceramic disc, 68pF +5% 1kV | CD104-068 | SPR | 10TCU-Q68 | 1 |
| 105 | Ceramic disc, 150pF +20% 1kV | CD102-115 | SPR | 5GA-T15 | 1 |
| 106 | Ceramic disc, 10pF +5% 1kV | CD101-010 | SPR | 10TCC-Q10 | 1 |
| 107 | Ceramic disc, 350pF +20% 1kV | CD102-135 | SPR | 5GA-T35 | 1 |
| 108 | Ceramic disc, 120pF +20% 1kV | CD102-112 | SPR | 5GA-T12 | 1 |
| 109 | Ceramic disc, 20pF +5% 1kV | CD101-020 | SPR | 10TCC-Q20 | 1 |
| <u>"J"</u> <u>CONNECTORS (JACKS)</u> | | | | | |
| 2 | 12-pin receptacle | MC000-030 | MOL | 1360-R1 | 1 |
| | Contact, female, for above | MC000-032 | MOL | 1433 | 6 |
| | Contact, male, for above | MC000-033 | MOL | 1434 | 1 |
| 101 | 15-pin receptacle | MC000-016 | MOL | 1625-15R | 1 |
| | Contact, female, for above | MC000-018 | MOL | 1855 | 14 |
| 102,103,104 | BNC, Cable | JB000-003 | W-I | JB000-003 | 3 |
| 105 | Phone, receptacle, submin. | MC000-036 | S-I | 142A | 1 |

PARTS LIST

MODULE REV

| REFERENCE SYMBOL | DESCRIPTION | WAVETEK PART NO. | MANUFACTURER | | T Q |
|--|-------------|------------------|--------------|--------|--------|
| | | | CODE | NUMBER | |
| SEE STANDARD 2001A HEAD PARTS LIST FOR SHEET 2 and 3 | | | | | |

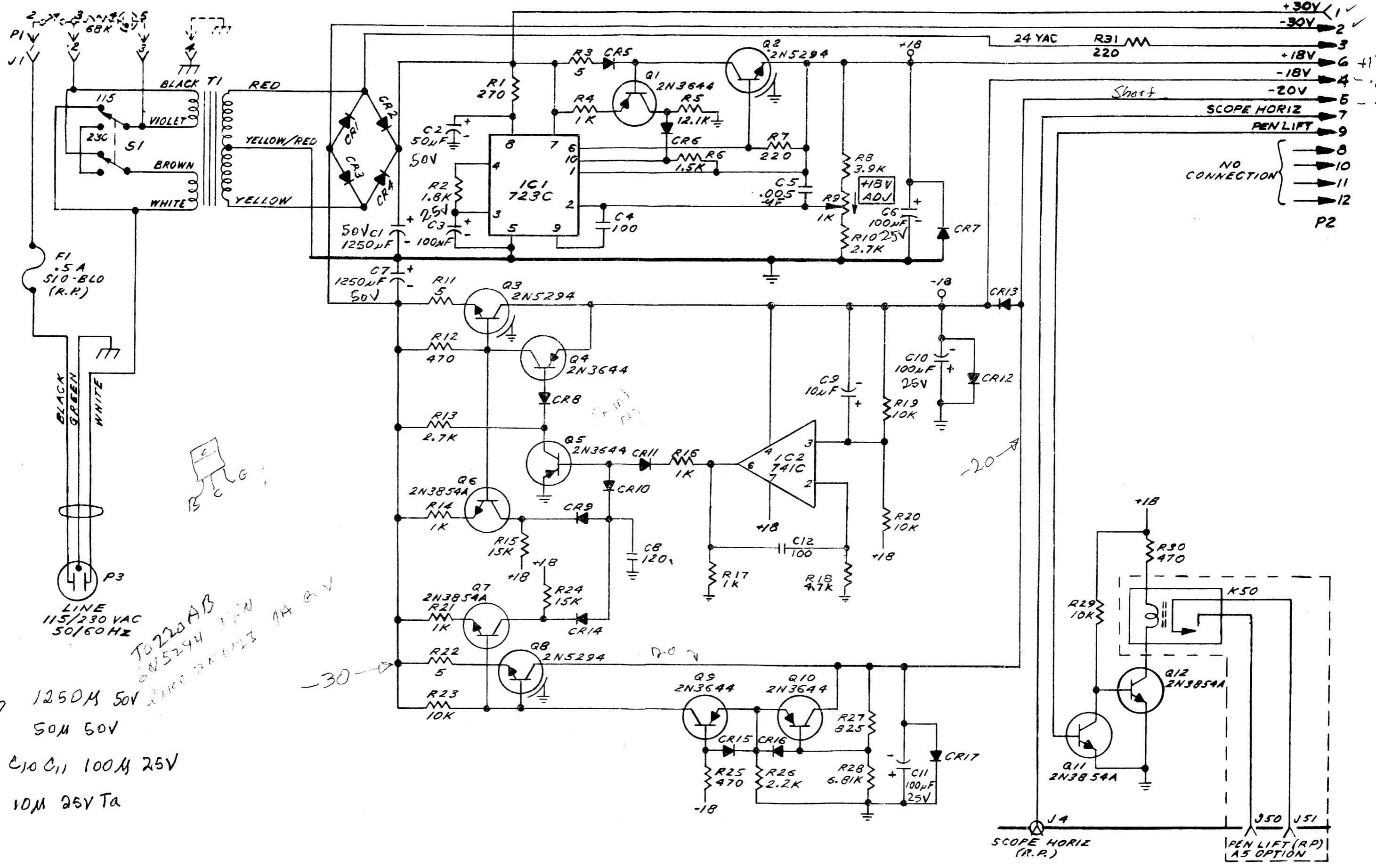

- 1 ✓ +30V
 - 2 ✓ -30V
 - 3 +18V
 - 4 -18V
 - 5 -20V
 - 7 SCOPE HORIZ
 - 9 PEN LIFT
 - 8 NO CONNECTION
 - 10 NO CONNECTION
 - 11 NO CONNECTION
 - 12 NO CONNECTION
- P2

C1, C7 1250M 50V
 C2 50M 50V
 C3, C6, C10, C11 100M 25V
 C9 10M 25V Ta
 T0220AB
 2N5294 12N
 2N3854A 12N

-30V

-20V

J4 SCOPE HORIZ (R.R.)
 J50 J51 PEN LIFT (RP) A5 OPTION

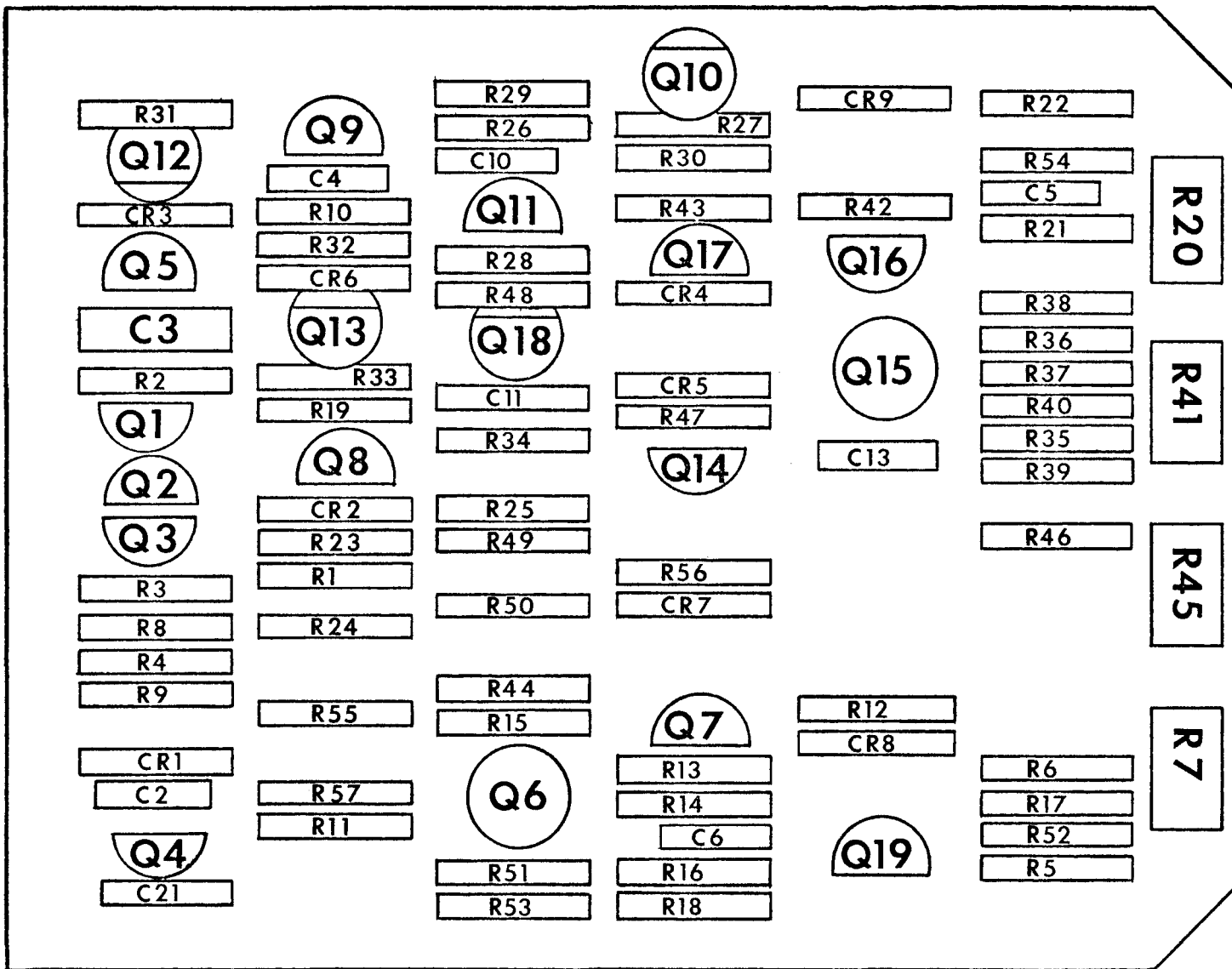

M1H

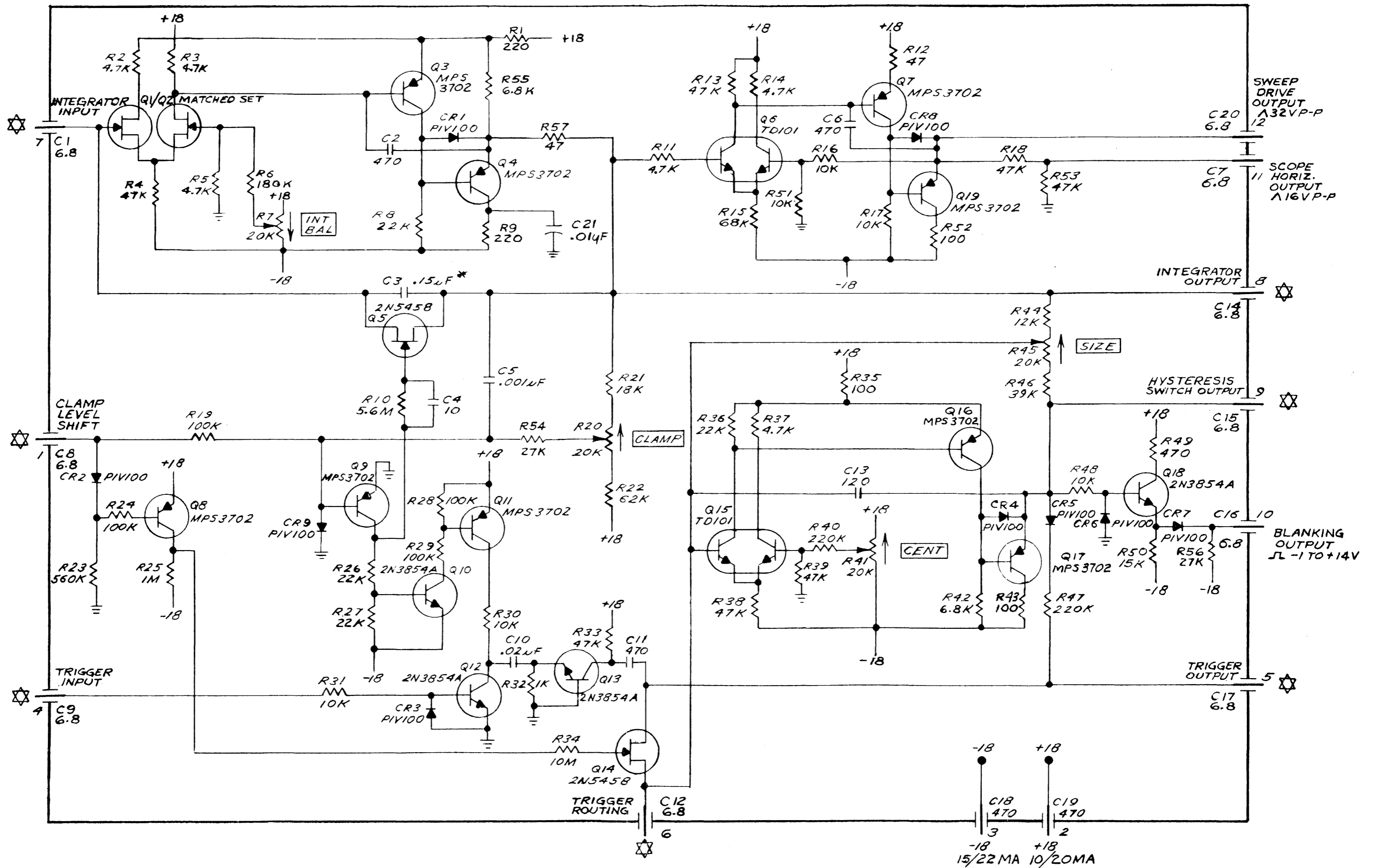

* = CONNECTED TO SWEEP TIME SWITCH

-18 +18
C18 470 C19 470
3 2
15/22 MA 10/20 MA

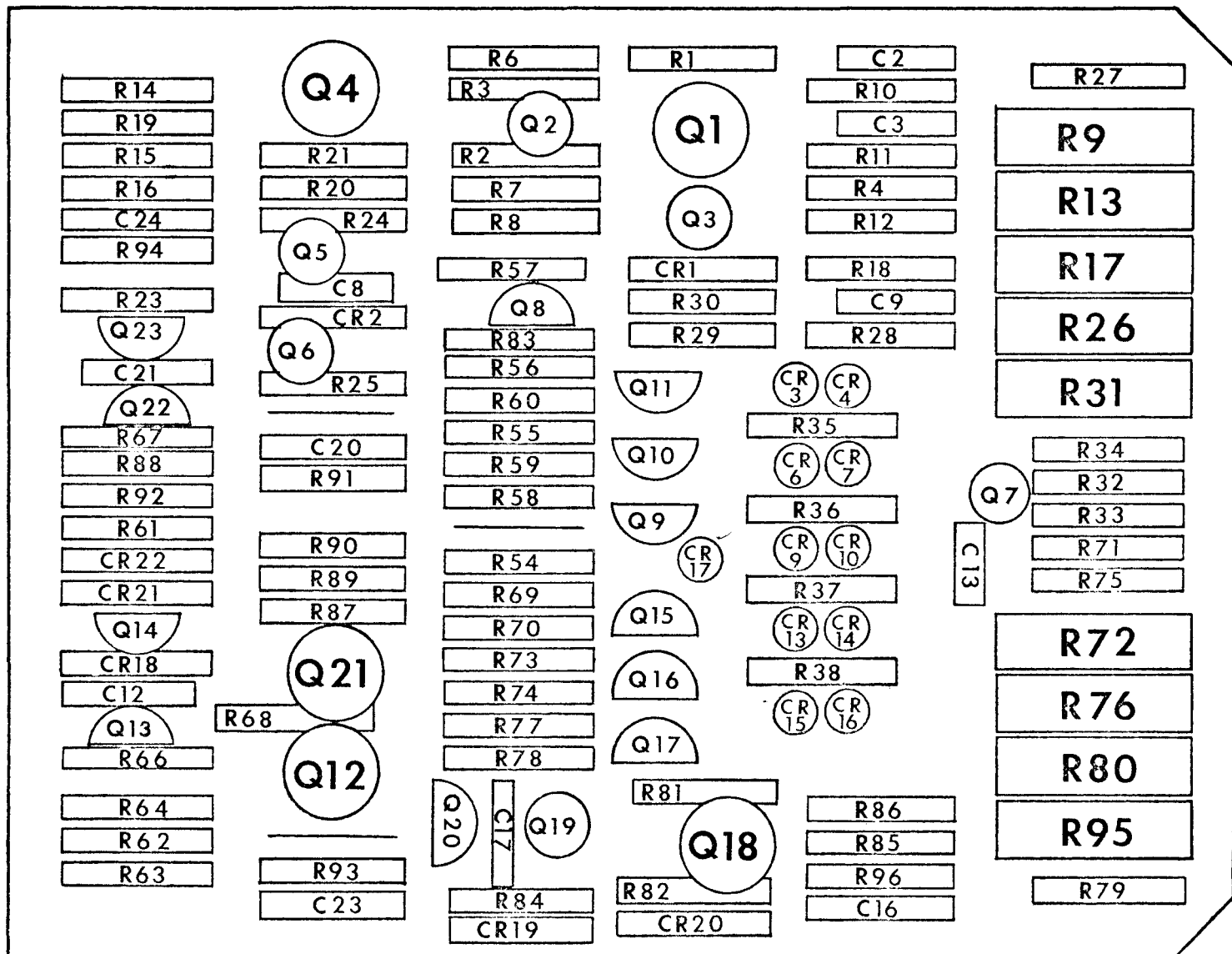

M2H

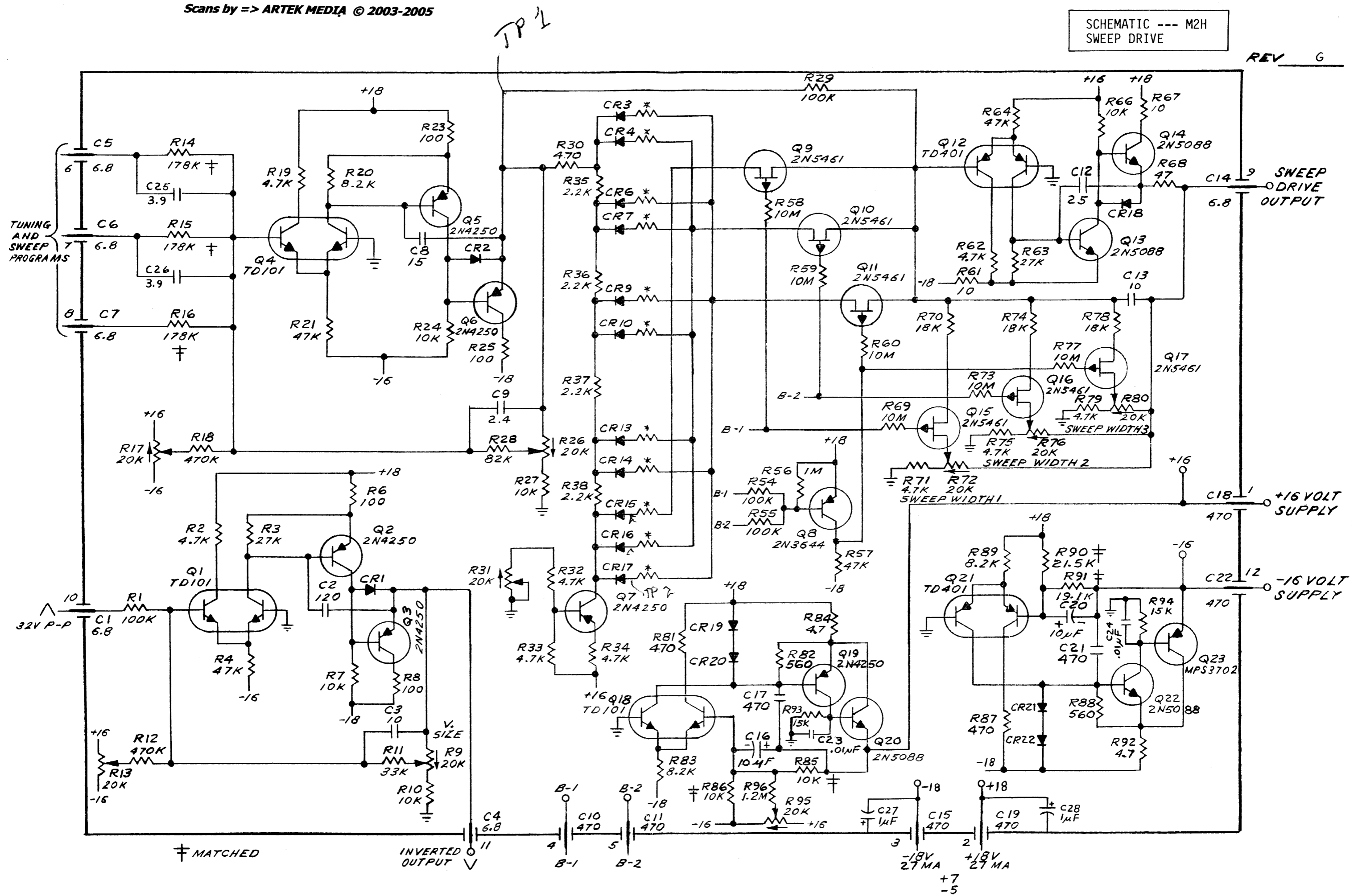

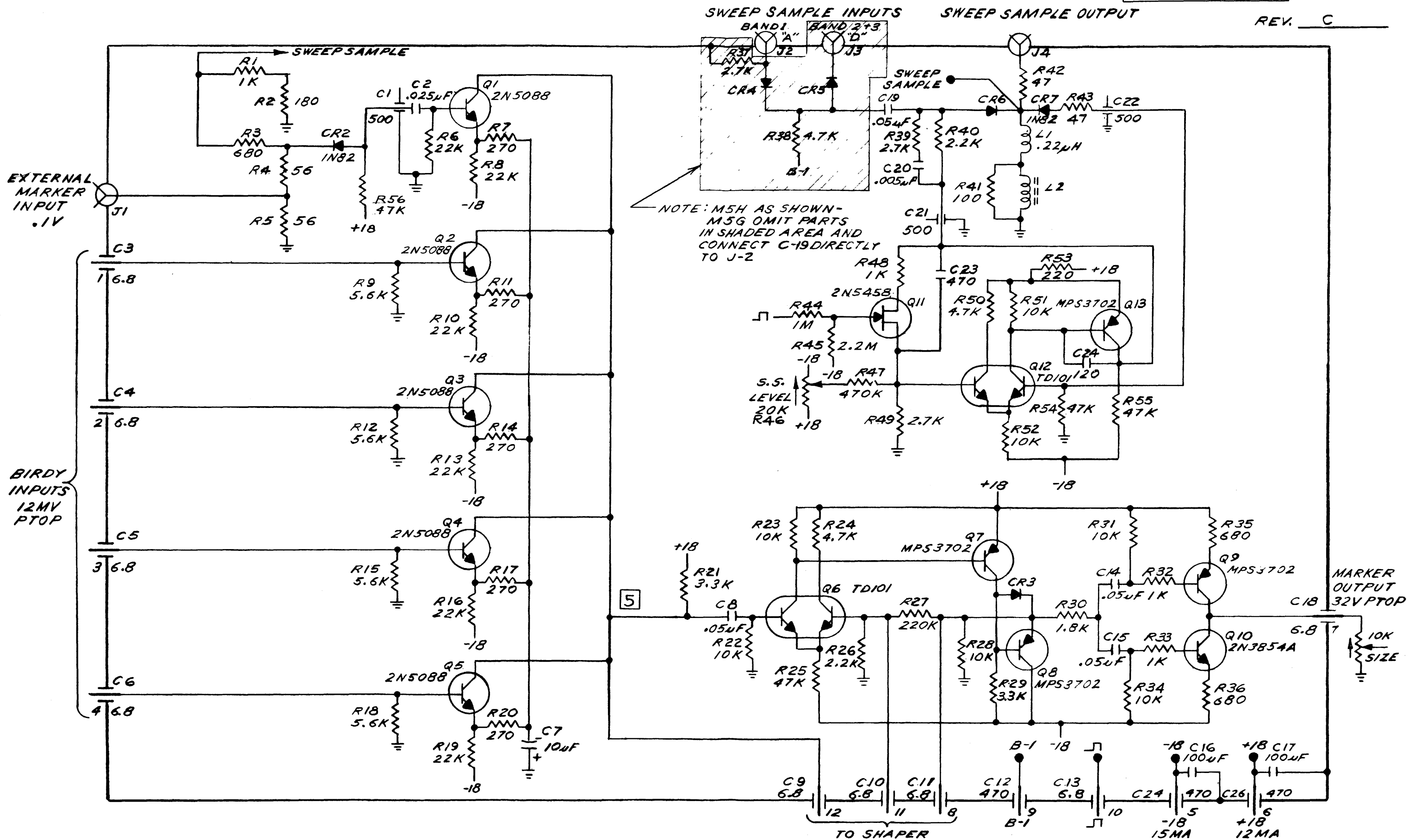

SCHMATIC --- M9H
SWP OSC (BAND 1)

REV I

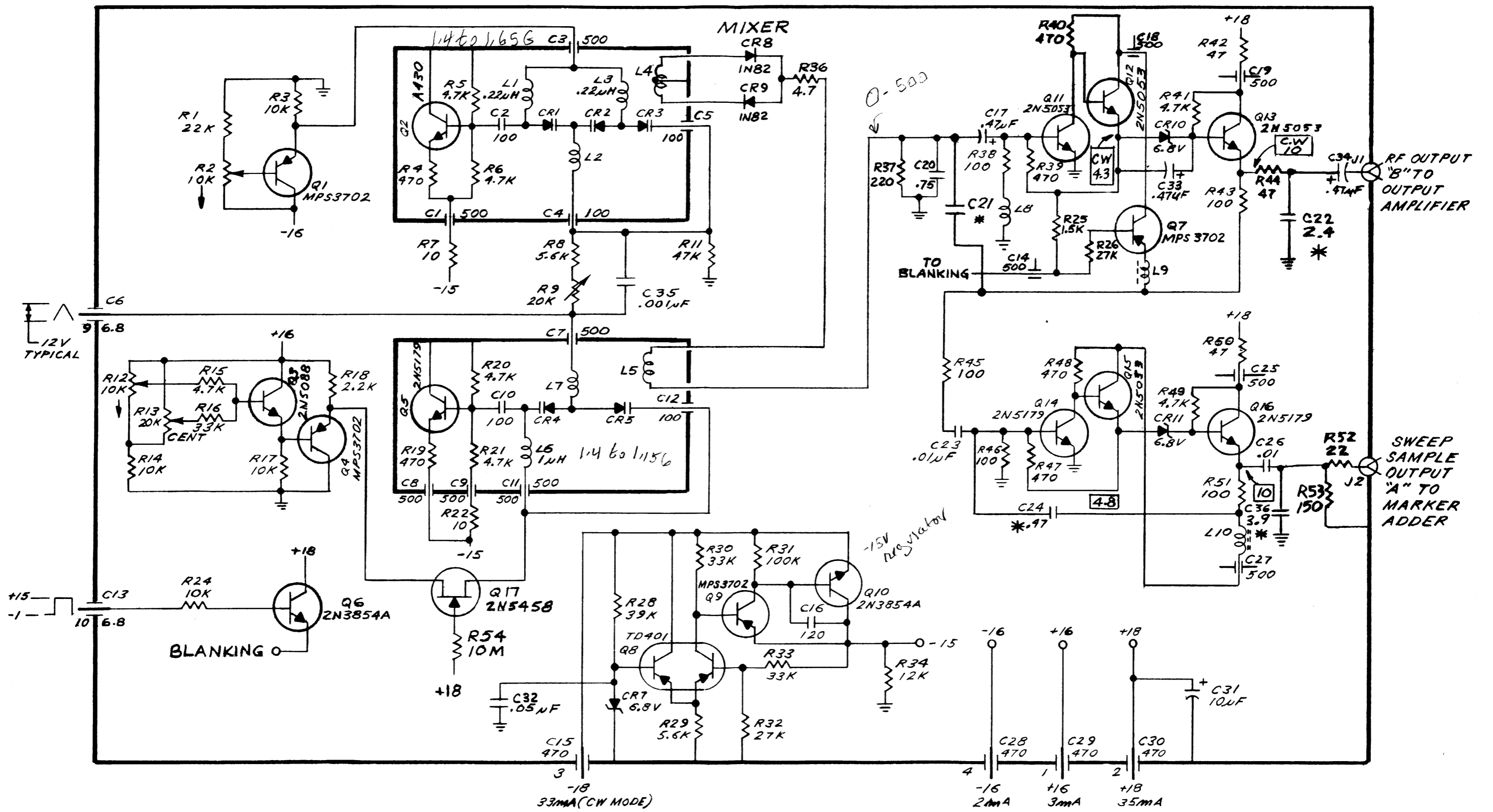

SCHEMATIC --- M10H
OUTPUT AMPLIFIER

REV_F

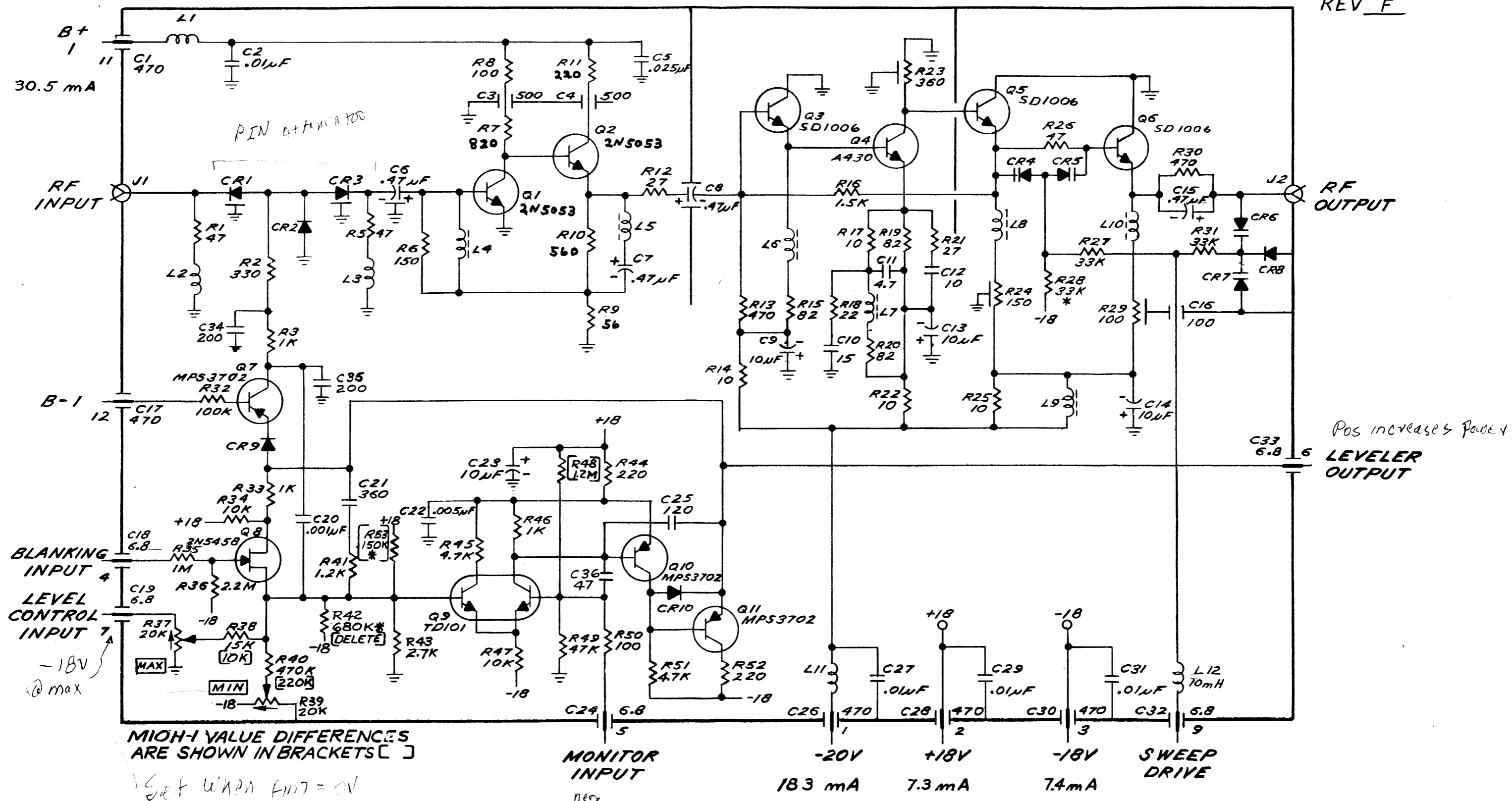

Pos increases Power
LEVELER
OUTPUT

M10H-1 VALUE DIFFERENCES
ARE SHOWN IN BRACKETS []

Set WPA FM7 = 0V

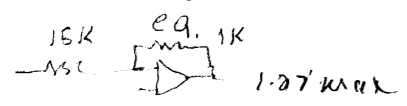

$$18V \times \frac{2.7K}{15 + 2.7K} = 2.7V \text{ max}$$

MONITOR INPUT
neg

-20V 183 mA
+18V 7.3 mA
-18V 7.4 mA
SWEEP DRIVE

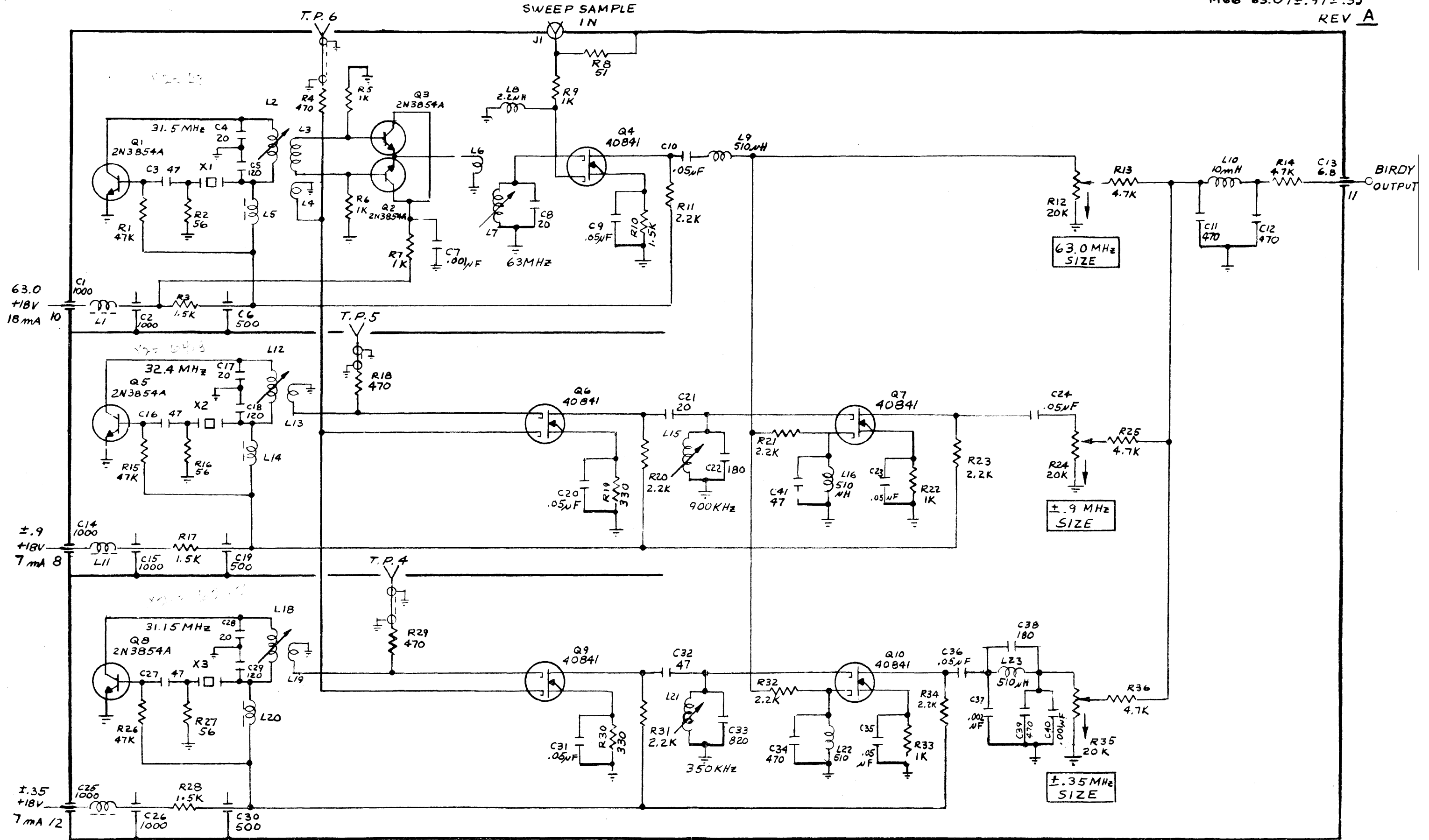

PARTS LIST

MODULE M66
63.0 REV A

| REFERENCE SYMBOL | DESCRIPTION | WAVETEK PART NO. | MANUFACTURER | | T Q |
|----------------------------|----------------------------------|------------------|--------------|-----------|--------|
| | | | CODE | NUMBER | |
| "C" | <u>CAPACITORS</u> | | | | |
| 1,2,14,15 25,26 | Ceramic feedthru 1000pF, 500V | CF112-210 | A-B | FA5C | 6 |
| 3,16,27,32, 41 | Ceramic disc., 47pF +5% 1kV | CD104-047 | SPR | 10TCU-Q47 | 5 |
| 4,8,17,21,28 | Ceramic disc., 20pF +5% 1kV | CD101-020 | SPR | 10TCC-Q20 | 5 |
| 5,18,29 | Ceramic disc., 120pF +5% 1kV | CD104-112 | SPR | 10TCU-T12 | 3 |
| 6,19,30 | Ceramic feedthru 500pF +20% 250V | CF104-150 | AER | EF4 | 3 |
| 7,40 | Ceramic disc., .001uF +20% 1kV | CD102-210 | SPR | 5GA-D10 | 2 |
| 9,10,20,23, 24,31,35,36 | Ceramic disc., .05uF +20% 1kV | CD102-350 | SPR | TG-S50 | 8 |
| 11,12,34,39 | Ceramic disc., 470pF +20% 1kV | CD102-147 | SPR | 5GA-T47 | 4 |
| 13 | Ceramic feedthru 6.8pF +10% 500V | CF102-R68 | A-B | FA5C | 1 |
| 22,38 | Mica, 180pF +5% 500V | CM101-118 | A-E | DM19 181J | 2 |
| 33 | Mica 820pF +5% 500V | CM101-182 | A-E | DM19 821J | 1 |
| 37 | Ceramic disc., .002uF +20% 1kV | CD102-220 | SPR | 5GA-D20 | 1 |
| "J" | <u>CONNECTORS</u> | | | | |
| 1 | Jack, receptacle, 50 ohm | JF000-005 | APL | 27-9 | 1 |
| "X" | <u>CRYSTALS</u> | | | | |
| 1 | 31.5 MHz | Y-8 | W-I | Y-8 | 1 |
| 2 | 32.4 MHz | Y-10 | W-I | Y-10 | 1 |
| 3 | 31.15 MHz | Y-9 | W-I | Y-9 | 1 |
| "L" | <u>INDUCTORS</u> | | | | |
| 1,11,17 | Fixed | LA006-010 | W-I | LA006-010 | 3 |
| 2,12,18 | Variable | Not assign | W-I | ----- | -- |
| 3 | Fixed | Not assign | W-I | ----- | -- |
| 4,13,19 | Fixed | Not assign | W-I | ----- | -- |
| 5,14,20 | Fixed | LA006-004 | W-I | LA006-004 | 3 |
| 6 | Fixed | Not assign | W-I | ----- | -- |
| 7 | Variable | Not assign | W-I | ----- | -- |
| 8 | Fixed 2.2uH | LA001-R22 | JEF | 15 | 1 |
| 9,16,22,23 | Fixed, 510uH | LA002-151 | JEF | 19 | 4 |
| 10 | Fixed, 10mH | LA004-310 | JEF | 15S103K | 1 |
| 15,21 | Variable | Not Assign | W-I | ----- | 2 |
| "R" | <u>RESISTORS</u> | | | | |
| 1,15,26 | Fixed, comp., 47kohm +10% 1/4W | RC104-347 | A-B | CB4731 | 3 |
| 2,16,27 | Fixed, comp., 56 ohm +10% 1/4W | RC104-056 | A-B | CB5601 | 3 |
| 3,17,28,10 | Fixed, comp., 1.5k ohm +10% 1/4W | RC104-215 | A-B | C B1521 | 4 |
| 4,17,29 | Fixed, comp., 470 ohm +10% 1/4W | RC104-147 | A-B | CB4711 | 3 |
| 5,6,7,9,22 23 | Fixed, comp., 1k ohm +10% 1/4W | RC104-210 | A-B | CB1021 | 6 |
| 8 | Fixed, comp., 51 ohm +5% 1/4W | RC103-051 | A-B | CB5103 | 1 |

PARTS LIST

MODULE M66
63.0 REV A

| REFERENCE SYMBOL | DESCRIPTION | WAVETEK PART NO. | MANUFACTURER | | T Q |
|-------------------------|----------------------------------|------------------|--------------|---------|--------|
| | | | CODE | NUMBER | |
| "R" | <u>RESISTORS</u> | | | | |
| 11,20,21,23 31,32,34 | Fixed, comp., 2.2k ohm +10% 1/4W | RC104-222 | A-B | CB2221 | 7 |
| 12,24,35 | Fixed, comp., 20k ohm +10% 1/4W | RP130-320 | BEK | 89PR20K | 3 |
| 13,14,25,36 | Fixed, comp., 4.7k ohm +10% 1/4W | RC104-247 | A-B | CB4721 | 4 |
| 19,30 | Fixed, comp., 330 ohm +10% 1/4W | RC104-133 | A-B | CB3311 | 2 |
| "Q" | <u>TRANSISTORS</u> | | | | |
| 1,2,3,5,8 | NPN, Silicon | QA038-541 | G-E | 2N3854A | 5 |
| 4,6,7,9,10 | N channel IG FET | QB000-020 | RCA | 40841 | 5 |

HARMONIC MARKER SCHEMATIC

INTERVAL: 30MHZ
MODULE M6H 30-1

REV A

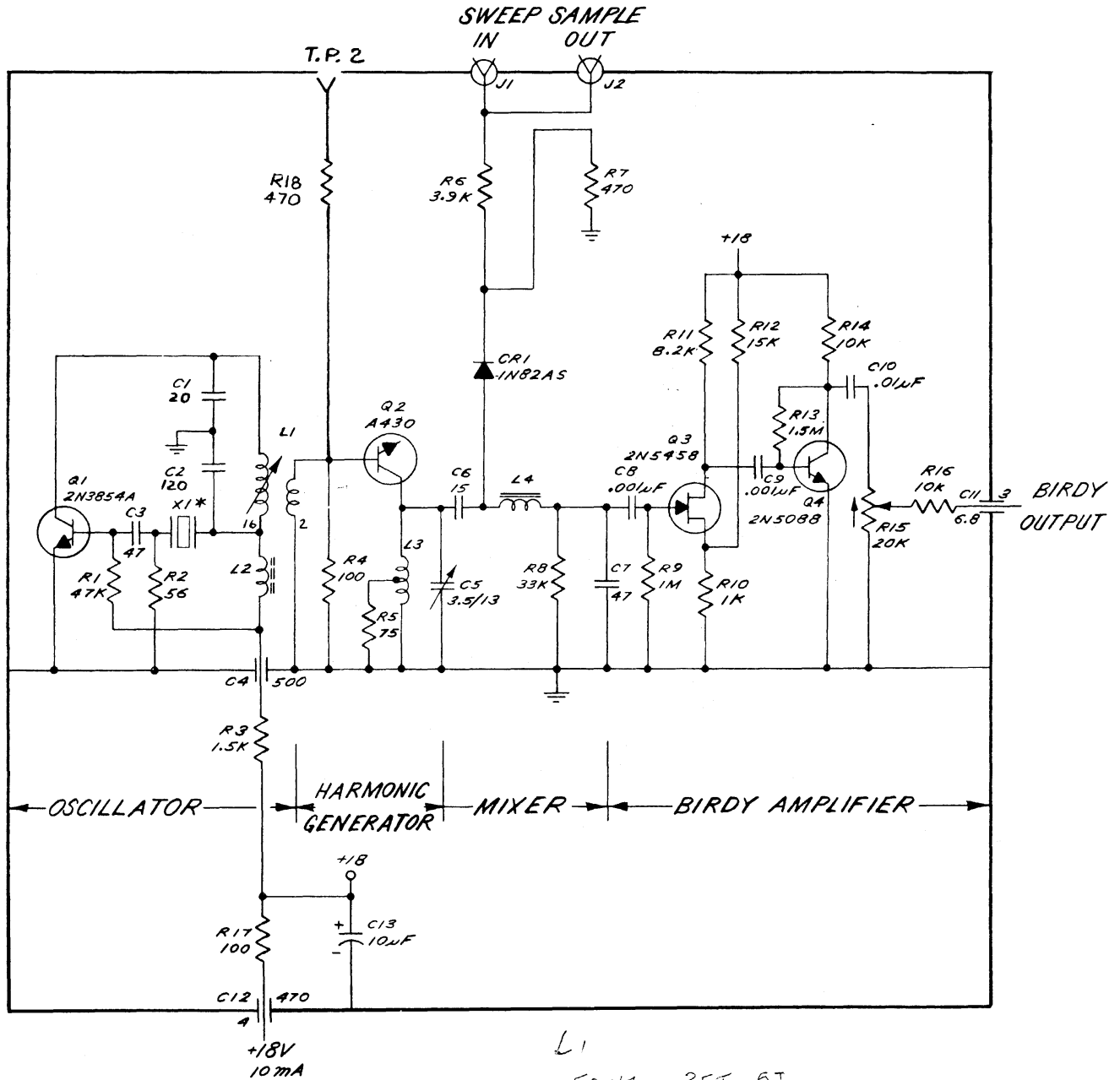

L1
5mH 35T 5T
20 20T 2T
30 16T 2T
50mH 10T 2T
1 16T 2T

PARTS LIST

MODULE M6H 30-1REV A

| REFERENCE SYMBOL | DESCRIPTION | WAVETEK PART NO. | MANUFACTURER | | T Q |
|------------------|---|------------------|--------------|-------------|--------|
| | | | CODE | NUMBER | |
| " C " | <u>CAPACITORS</u> | | | | |
| 1 | Ceramic disc, 20 pF + 5% 1kV | CD101-020 | SPR | 10TCU-Q20 | 1 |
| 2 | Ceramic disc, 120 pF + 5% 1kV | CD104-112 | SPR | 10TCC-T12 | 1 |
| 3,7 | Ceramic disc, 47pF ±5% 1kV | CD104-047 | SPR | 10TCC-Q47 | 2 |
| 4 | Ceramic feedthru, 500pF ±20% 250V | CF104-150 | AER | EF4 | 1 |
| 5 | Variable, ceramic, 3.5/13pF | CV101-013 | STR | 7STRIK 0-02 | 1 |
| 6 | Ceramic disc, 15pF ±5% 1kV | CD101-015 | SPR | 10TCC-Q15 | 1 |
| 8,9 | Ceramic disc, .001uF ±20% 1kV | CD102-210 | SPR | 5GA-D10 | 2 |
| 10 | Ceramic disc, .01uF ±20% 100V | CD103-310 | SPR | TG-S10 | 1 |
| 11 | Ceramic feedthru, 6.8pF ±10% 500V | CF102-R68 | A-B | FA5C | 1 |
| 12 | Ceramic feedthru, 470pF ±20% 500V | CF101-141 | A-B | FA5C | 1 |
| 13 | Electrolytic, 10uF 25V | CE105-010 | SPR | TE1204 | 1 |
| "J " | <u>CONNECTORS</u> | | | | |
| 1,2 | Jack, receptacle, 50ohm submin | JF000-005 | APL | 27-9 | 2 |
| 3 | Pin socket, teflon | MC000-002 | W-I | MC-000-002 | 1 |
| "X " | <u>CRYSTALS</u> | | | | |
| 1 | 30MHz | Y-4 | W-I | Y-4 | 1 |
| "CR " | <u>DIODES</u> | | | | |
| 1 | Silicon, point contact | DG100-821 | SYL | IN82AS | 1 |
| "L " | <u>INDUCTORS</u> | | | | |
| 1 | Coilform LB-003-000 with 16 turns, 2 turns of 32 gage magnet wire | Not Assign. | --- | ----- | --- |
| 2 | Fixed--- | LA006-010 | W-I | LA006-010 | 1 |
| 3 | Formed from 24 ga. buss wire | Not Assign. | --- | ----- | --- |
| 4 | Fixed--- | LA006-004 | W-I | LA006-004 | 1 |
| "R " | <u>RESISTORS</u> | | | | |
| 1 | Fixed, comp., 47kohm ±10% ½W | RC104-347 | A-B | CB4731 | 1 |
| 2 | Fixed, comp., 56ohm ±10% ½W | RC104-056 | A-B | CB5601 | 1 |
| 3 | Fixed, comp., 1.5kohm ±10% ½W | RC104-215 | A-B | CB1521 | 1 |
| 4,17 | Fixed, comp., 100ohm ±10% ½W | RC104-110 | A-B | CB1021 | 2 |
| 5 | Fixed, comp., 75ohm ±5% ½W | RC103-075 | A-B | CB7505 | 1 |
| 6 | Fixed, comp., 3.9kohm ±10% ½W | RC104-239 | A-B | CB3921 | 1 |
| 7,18 | Fixed, comp., 470ohm ±10% ½W | RC104-147 | A-B | CB4711 | 2 |
| 8 | Fixed, comp., 33kohm ±10% ½W | RC104-333 | A-B | CB3331 | 1 |
| 9 | Fixed, comp., 1Mohm ±10% ½W | RC104-510 | A-B | CB1051 | 1 |
| 10 | Fixed, comp., 1kohm ±10% ½W | RC104-210 | A-B | CB1021 | 1 |
| 11 | Fixed, comp., 8.2kohm ±10% ½W | RC104-282 | A-B | CB8221 | 1 |
| 12 | Fixed, comp., 15kohm ±10% ½W | RC104-315 | A-B | CB1531 | 1 |
| 13 | Fixed, comp., 1.5Mohm ±10% ½W | RC104-515 | A-B | CB1551 | 1 |
| 14,16 | Fixed, comp., 10kohm ±10% ½W | RC104-310 | A-B | CB1031 | 2 |
| 15 | Variable, carbon, 20kohm ±20% ½W | RP124-320 | A-B | WA2G032 | 1 |
| "Q " | <u>TRANSISTORS</u> | | | | |
| 1 | NPN, Silicon | QA038-541 | G-E | 2N3854A | 1 |
| 2 | NPN, Silicon | QB000-013 | APX | A430 | 1 |
| 3 | N-channel JFET | QA054-580 | MOT | 2N5458 | 1 |
| 4 | NPN, Silicon | QA050-880 | MOT | 2N5088 | 1 |

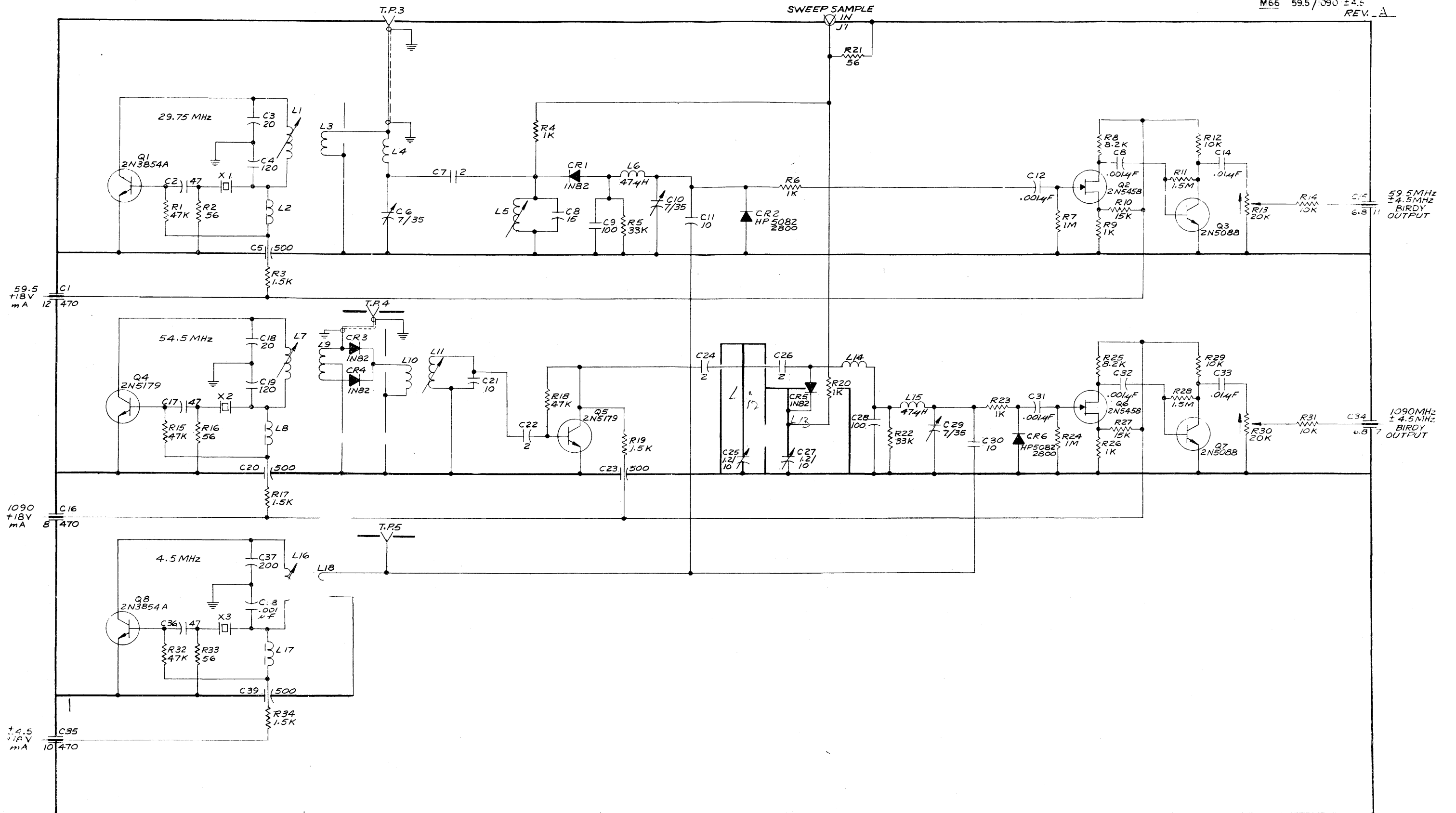

PARTS LIST

MODULE M66 REV A

| REFERENCE SYMBOL | DESCRIPTION | WAVETEK PART NO. | MANUFACTURER | | T Q |
|------------------|-----------------------------------|------------------|--------------|------------|--------|
| | | | CODE | NUMBER | |
| "C " | <u>CAPACITORS</u> | | | | |
| 1,16,35 | Ceramic feedthru, 470pF ±20% 500V | CF-101-147 | A-B | FA5C | 3 |
| 2,17,36 | Ceramic disc, 47pF ±5% 1kV | CD-104-047 | SPR | 10TCU-Q47 | 3 |
| 3,18 | Ceramic disc, 20pF ±5% 1kV | CD-101-020 | SPR | 10TCC-Q20 | 2 |
| 4 | Ceramic disc, 120pF ±5% 1kV | CD-104-112 | SPR | 10TCU-T12 | 1 |
| 5,20,23,39 | Ceramic feedthru, 500pF ±20% 250V | CF-104-150 | AER | EF4 | 4 |
| 6,10,29 | Variable, ceramic, 7/35pF | CV-101-035 | STR | S-TRIKO | 3 |
| 7,22,24,26 | Composition 2pF ±10% 500V | CG-101-220 | Q-C | Q C | 4 |
| 8 | Ceramic disc, 15pF ±5% 1kV | CD-101-015 | SPR | 10TCC-Q15 | 1 |
| 9,19,28 | Ceramic disc, 100pF ±5% 1kV | CD-104-110 | SPR | 10TCU-T10 | 3 |
| 11,21,30 | Ceramic disc, 10pF ±5% 1kV | CD-101-010 | SPR | 10TCC-Q10 | 3 |
| 12,13,31,32 | Ceramic disc, .001uF ±20% 1kV | CD-102-210 | SPR | 5GA-D10 | 4 |
| 14,33 | Ceramic disc, .01uF ±20% 100V | CD-103-310 | SPR | TG-S10 | 2 |
| 15,34 | Ceramic feedthru, 6.8pF ±10% 500V | CF-102-R68 | A-B | FA5C | 2 |
| 25,27 | Variable, ceramic, 1.2/10pF | CV-103-010 | STR | R-TRIKO | 2 |
| 37 | Ceramic disc, 200pF ±5% 1kV | CD-104-120 | SPR | 10TCU-T20 | 1 |
| 38 | Mica, 1000pF ±5% 500V | CM-101-210 | A-E | DM19-102J | 1 |
| "J " | <u>CONNECTORS</u> | | | | |
| 1 | Jack, receptacle, 50 ohm | JF-000-005 | APL | 27-9 | 1 |
| "X " | <u>CRYSTALS</u> | | | | |
| 1 | 29.75 MHz | Y-3 | W-I | Y-3 | 1 |
| 2 | 54.5 MHz | Y-5 | W-I | Y-5 | 1 |
| 3 | 4.5 MHz | Y-2 | W-I | Y-2 | 1 |
| "CR " | <u>DIODES</u> | | | | |
| 1,3,4,5 | Silicon, Point contact | DG-100-821 | SYL | 1N82AS | 4 |
| 2,6 | Silicon, Hot carrier | DG-000-007 | H-P | 5082-2800 | 2 |
| "L " | <u>INDUCTORS</u> | | | | |
| 1 | Variable ---- | Not Assign. | W-I | ----- | -- |
| 2,8,17 | Fixed ---- | LA-006-010 | W-I | LA-006-010 | 3 |
| 3 | Fixed ---- | Not Assign. | W-I | ----- | -- |
| 4 | Fixed ---- | Not Assign. | W-I | ----- | -- |
| 5 | Fixed ---- | Not Assign. | W-I | ----- | -- |
| 6,15 | Fixed, 47uH | LA-001-047 | JEF | 15 | 2 |
| 7 | Variable ---- | Not Assign. | W-I | ----- | -- |
| 9 | Variable ---- | Not Assign. | W-I | ----- | -- |
| 10 | Variable ---- | Not Assign. | W-I | ----- | -- |
| 11 | Variable ---- | Not Assign. | W-I | ----- | -- |
| 12 | Fixed ---- | Not Assign. | W-I | ----- | -- |
| 13 | Fixed ---- | Not Assign. | W-I | ----- | -- |
| 14 | Fixed ---- | LA-006-004 | W-I | LA-006-004 | 1 |
| 16 | Variable ---- | Not Assign. | W-I | ----- | -- |
| 18 | Fixed ---- | Not Assign. | W-I | ----- | -- |

PARTS LIST

MODULE M66 REV A

| REFERENCE SYMBOL | DESCRIPTION | WAVETEK PART NO. | MANUFACTURER | | T Q |
|------------------|-----------------------------------|------------------|--------------|---------|--------|
| | | | CODE | NUMBER | |
| "R " | <u>RESISTORS</u> | | | | |
| 1,15,18,32 | Fixed, comp., 47k ohm ±10% ½W | RC-104-347 | A-B | CB4731 | 4 |
| 2,16,21,33 | Fixed, comp., 56 ohm ±10% ½W | RC-104-056 | A-B | CB5601 | 4 |
| 3,17,19,34 | Fixed, comp., 1.5k ohm ±10% ½W | RC-104-215 | A-B | CB1521 | 4 |
| 4,6,9,20,23,26 | Fixed, comp., 1k ohm ±10% ½W | RC-104-210 | A-B | CB1021 | 6 |
| 5,22 | Fixed, comp., 33k ohm ±10% ½W | RC-104-333 | A-B | CB3331 | 2 |
| 7,24 | Fixed, comp., 1M ohm ±10% ½W | RC-104-510 | A-B | CB1051 | 2 |
| 8,25 | Fixed, comp., 8.2k ohm ±10% ½W | RC-104-282 | A-B | CB8221 | 2 |
| 10,27 | Fixed, comp., 15k ohm ±10% ½W | RC-104-315 | A-B | CB1531 | 2 |
| 11,28 | Fixed, comp., 1.5M ohm ±10% ½W | RC-104-515 | A-B | CB1551 | 2 |
| 12,14,29,31 | Fixed, comp., 10k ohm ±10% ½W | RC-104-310 | A-B | CB1031 | 2 |
| 13,30 | Variable, carbon, 20k ohm ±20% ½W | RC-124-320 | A-B | WA2G032 | 2 |
| "Q " | <u>TRANSISTORS</u> | | | | |
| 1,8 | NPN, Silicon | QA-038-541 | G-E | 2N3854A | 2 |
| 2,6 | N-channel JFET | QA-054-580 | MOT | 2N5458 | 2 |
| 3,7 | NPN, Silicon | QA-050-880 | MOT | 2N5088 | 2 |
| 4,5 | NPN, Silicon | QA-051-790 | RCA | 2N5179 | 2 |

HARMONIC MARKER SCHEMATIC

(OPTION A2) INTERVAL: 5 MHz
MODULE M6H 5-1

REV A

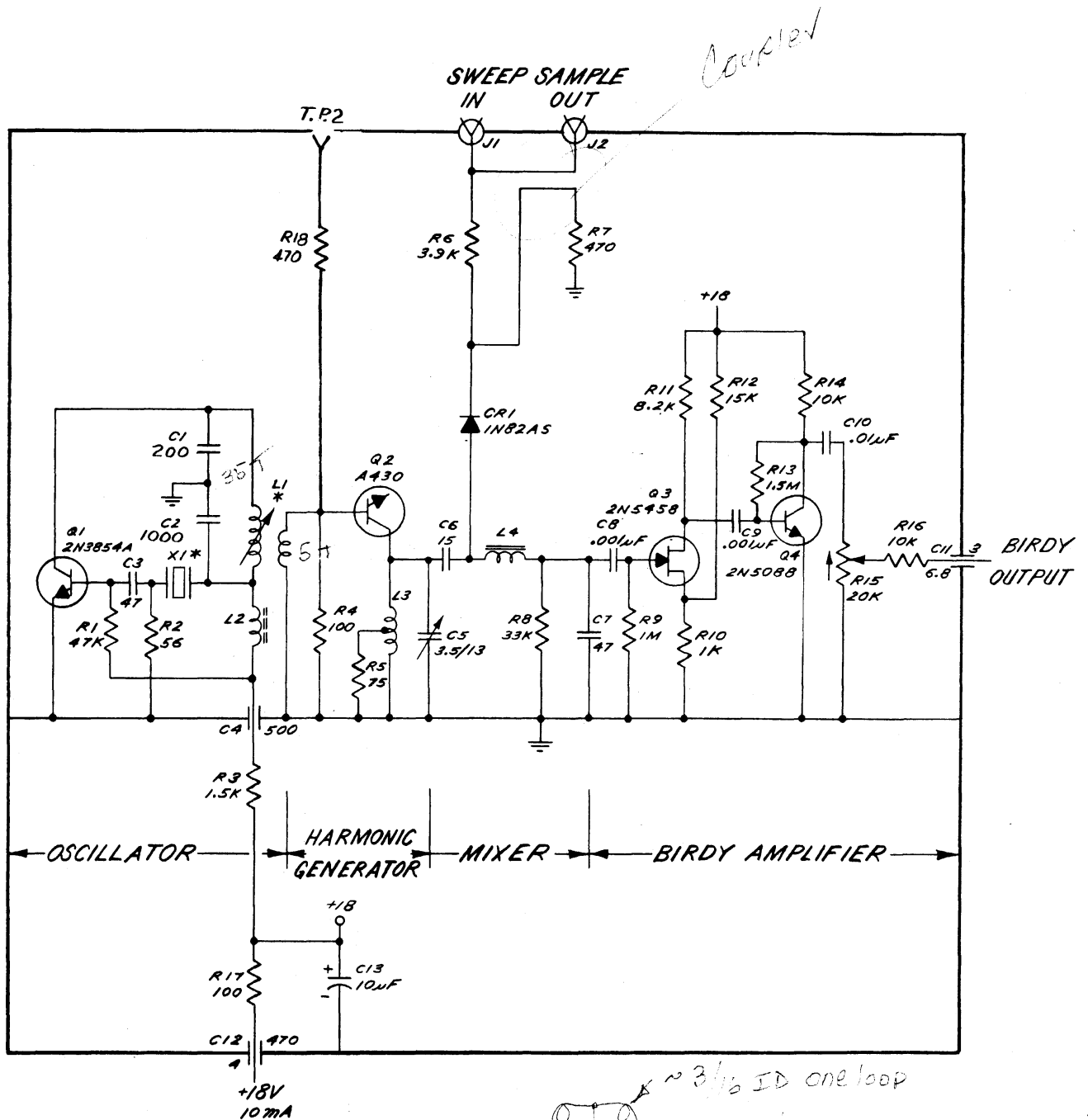

Coupled

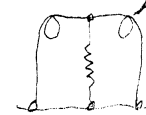
3  $\sim 3/16$ ID one loop
Some cu 20nF
L2 = 9T on ferrite bead
L4 = 5T on ferrite bead

PARTS LIST

MODULE M6H 5-1 REV A

| REFERENCE SYMBOL | DESCRIPTION | WAVETEK PART NO. | MANUFACTURER | | T Q |
|------------------|--|------------------|--------------|------------|--------|
| | | | CODE | NUMBER | |
| " C " | <u>CAPACITORS</u> | | | | |
| 1 | Ceramic disc, pF + 5% 1kV | CD104-120 | SPR | 10TCC-T20 | 1 |
| 2 | Silvered mica, 1000pF + 5% | CM101-210 | A-E | DM-19-102J | 1 |
| 3,7 | Ceramic disc, 47pF ±5% 1kV | CD104-047 | SPR | 10TCC-Q47 | 2 |
| 4 | Ceramic feedthru, 500pF ±20% 250V | CF104-150 | AER | EF4 | 1 |
| 5 | Variable, ceramic, 3.5/13pF | CV101-013 | STR | 7STRIK0-02 | 1 |
| 6 | Ceramic disc, 15pF ±5% 1kV | CD101-015 | SPR | 10TCC-Q15 | 1 |
| 8,9 | Ceramic disc, .001uF ±20% 1kV | CD102-210 | SPR | 5GA-D10 | 2 |
| 10 | Ceramic disc, .01uF ±20% 100V | CD103-310 | SPR | TG-S10 | 1 |
| 11 | Ceramic feedthru, 6.8pF ±10% 500V | CF102-R68 | A-B | FA5C | 1 |
| 12 | Ceramic feedthru, 470pF ±20% 500V | CF101-141 | A-B | FA5C | 1 |
| 13 | Electrolytic, 10uF 25V | CE105-010 | SPR | TE1204 | 1 |
| "J " | <u>CONNECTORS</u> | | | | |
| 1,2 | Jack, receptacle, 50ohm submin | JF000-005 | APL | 27-9 | 2 |
| 3 | Pin socket, teflon | MC000-002 | W-I | MC-000-002 | 1 |
| "X " | <u>CRYSTALS</u> | | | | |
| 1 | 5MHz | Y- 5, 5.0 | W-I | Y-5,5.0 | 1 |
| "CR " | <u>DIODES</u> | | | | |
| 1 | Silicon, point contact | DG100-821 | SYL | IN82AS | 1 |
| "L. " | <u>INDUCTORS</u> | | | | |
| 1 | Coilform LB-003-000 with 35 turns, 5 turns of 32 gage magnet wire. | Not Assign. | --- | ----- | --- |
| 2 | Fixed--- | LA006-010 | W-I | LA006-010 | 1 |
| 3 | Formed from 24 ga. buss wire | Not Assign | --- | ----- | --- |
| 4 | Fixed--- | LA006-004 | W-I | LA006-004 | 1 |
| "R " | <u>RESISTORS</u> | | | | |
| 1 | Fixed, comp., 47kohm ±10% ½W | RC104-347 | A-B | CB4731 | 1 |
| 2 | Fixed, comp., 56ohm ±10% ½W | RC104-056 | A-B | CB5601 | 1 |
| 3 | Fixed, comp., 1.5kohm ±10% ½W | RC104-215 | A-B | CB1521 | 1 |
| 4,17 | Fixed, comp., 100ohm ±10% ½W | RC104-110 | A-B | CB1021 | 2 |
| 5 | Fixed, comp., 75ohm ±5% ½W | RC103-075 | A-B | CB7505 | 1 |
| 6 | Fixed, comp., 3.9kohm ±10% ½W | RC104-239 | A-B | CB3921 | 1 |
| 7,18 | Fixed, comp., 470ohm ±10% ½W | RC104-147 | A-B | CB4711 | 2 |
| 8 | Fixed, comp., 33kohm ±10% ½W | RC104-333 | A-B | CB3331 | 1 |
| 9 | Fixed, comp., 1Mohm ±10% ½W | RC104-510 | A-B | CB1051 | 1 |
| 10 | Fixed, comp., 1kohm ±10% ½W | RC104-210 | A-B | CB1021 | 1 |
| 11 | Fixed, comp., 8.2kohm ±10% ½W | RC104-282 | A-B | CB8221 | 1 |
| 12 | Fixed, comp., 15kohm ±10% ½W | RC104-315 | A-B | CB1531 | 1 |
| 13 | Fixed, comp., 1.5Mohm ±10% ½W | RC104-515 | A-B | CB1551 | 1 |
| 14,16 | Fixed, comp., 10kohm ±10% ½W | RC104-310 | A-B | CB1031 | 2 |
| 15 | Variable, carbon, 20kohm ±20% ½W | RP124-320 | A-B | WA2G032 | 1 |
| "Q " | <u>TRANSISTORS</u> | | | | |
| 1 | NPN, Silicon | QA038-541 | G-E | 2N3854A | 1 |
| 2 | NPN, Silicon | QB000-013 | APX | A430 | 1 |
| 3 | N-channel JFET | QA054-580 | MOT | 2N5458 | 1 |
| 4 | NPN, Silicon | QA050-880 | MOT | 2N5088 | 1 |

HARMONIC MARKER SCHEMATIC

INTERVAL : .2 MHz AND 1 MHz
M66H.2,1-1

REV B

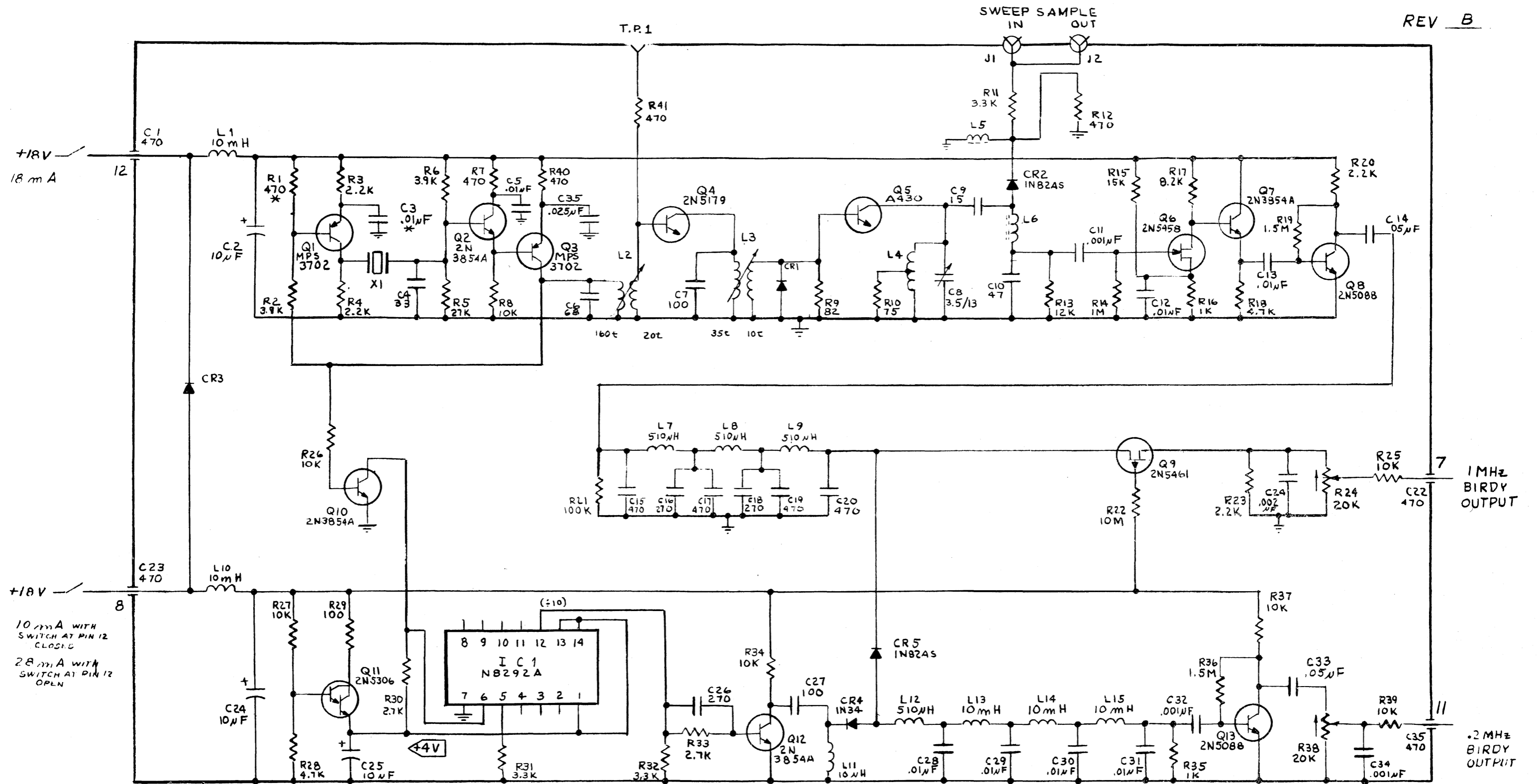

PARTS LIST

MODULE M66H
.2,1-1 REV B

| REFERENCE SYMBOL | DESCRIPTION | WAVETEK PART NO. | MANUFACTURER | | T Q |
|------------------|--|------------------|--------------|-----------|--------|
| | | | CODE | NUMBER | |
| "C" | <u>CAPACITORS</u> | | | | |
| 1,22,23,35 | Ceramic feedthru 470pF ±20% 500V | CF101-147 | A-B | FA5C | 4 |
| 2,24,25 | Electrolytic 10uF 25V | CE105-010 | SPR | TE1204 | 3 |
| 3,5,12,13,28 | Ceramic disc .01uF ±20% 100V | CD103-310 | SPR | TG-S10 | 8 |
| 29,30,31 | | | | | |
| 4 | Ceramic disc 33pF ±5% 1kV | CD104-033 | SPR | 10TCU-Q33 | 1 |
| 6 | Ceramic disc 68pF ±5% 1kV | CD104-068 | SPR | 10TCU-Q68 | 1 |
| 7 | Ceramic disc 100pF ±5% 1kV | CD104-110 | SPR | 10TCU-T10 | 1 |
| 8 | Variable, ceramic 3.5/13 | CV101-013 | STE | S-TRIKO | 1 |
| 9 | Ceramic disc 15pF ±5% 1kV | CD101-015 | SPR | 10TCC-Q15 | 1 |
| 10 | Ceramic disc 47pF ±5% 1kV | CD104-047 | SPR | 10TCU-Q47 | 1 |
| 11,32,34 | Ceramic disc .001uF ±20% 1kV | CD102-210 | SPR | 5GA-D10 | 3 |
| 14,33 | Ceramic disc .05uF ±20% 100V | CD103-350 | SPR | TG-S50 | 2 |
| 15,17,19,20 | Ceramic disc 470pF ±20% 1kV | CD102-147 | SPR | 5GA-T47 | 4 |
| 16,18,26 | Ceramic disc 270pF ±20% 1kV | CD102-127 | SPR | 5GA-T27 | 3 |
| 21 | Ceramic disc .002uF ±20% 1kV | CD102-220 | SPR | 5GA-D20 | 1 |
| 27 | Ceramic disc 100pF ±20% 1kV | CD102-110 | SPR | 5GA-T10 | 1 |
| 35 | Ceramic disc .025uF ±20% 100V | CD103-325 | SPR | TG-S25 | 1 |
| "J" | <u>CONNECTORS</u> | | | | |
| 1,2 | Jack, receptacle, 50 ohm submin | JF000-005 | APL | 27-9 | 2 |
| 3 | Pin socket, teflon | MC000-002 | W-I | MC000002 | 1 |
| "X" | <u>CRYSTALS</u> | | | | |
| 1 | 1 MHz | Y-1 | W-I | Y-1 | 1 |
| "CR" | <u>DIODES</u> | | | | |
| 1 | Silicon, Hot carrier | DG000-007 | H-P | 5082-2800 | 1 |
| 2,5 | Silicon, Point contact | DG100-821 | SYL | 1N82AS | 2 |
| 3 | Silicon, Junction | DR000-001 | ITT | 1N4002 | 1 |
| 4 | Germanium, Point contact | DG100-341 | SYL | 1N34AS | 1 |
| "L" | <u>INDUCTORS</u> | | | | |
| 1,10,13,14 | Fixed, 10mH | LA004-310 | JEF | 15S | 5 |
| 15 | | | | | |
| 2 | Coil form LB002-000 with 160 turns, 20 turns #32 gauge magnet wire | Not assign. | W-I | ----- | - |
| 3 | Coil form LB003-000 with 35 turns, 15 turns #32 gauge magnet wire | Not assign. | W-I | ----- | - |
| 4 | 24 gauge buss wire | Not assign. | W-I | ----- | - |
| 5 | Fixed, --- | LA006-010 | W-I | LA006-010 | 1 |
| 6 | Fixed, --- | LA006-004 | W-I | LA006-004 | 1 |
| 7,8,9,12 | Fixed, 510uH | LA002-151 | JEF | 19 | 4 |
| 11 | Fixed, 10uH | LA001-010 | JEF | 15 | 1 |
| "IC" | <u>INTEGRATED CIRCUITS</u> | | | | |
| 1 | Decade counter | IC000-003 | SIG | N8292A | 1 |
| "R" | <u>RESISTORS</u> | | | | |
| 1,12,7,40,41 | Fixed, comp. 470 ohm ±10% ½W | RC104-147 | A-B | CB4711 | 5 |
| 2,6 | Fixed, comp. 3.9k ohm ±10% ½W | RC104-239 | A-B | CB3921 | 2 |
| 3,4,20,23 | Fixed, comp. 2.2k ohm ±10% ½W | RC104-222 | A-B | CB2221 | 4 |

PARTS LIST

MODULE M66H
.2,1-1 REV B

| REFERENCE SYMBOL | DESCRIPTION | WAVETEK PART NO. | MANUFACTURER | | T Q |
|------------------|----------------------------------|------------------|--------------|---------|--------|
| | | | CODE | NUMBER | |
| "R" | <u>RESISTORS</u> | | | | |
| 5 | Fixed, comp. 27k ohm ±10% ½W | RC104-327 | A-B | CB2731 | 1 |
| 8,25,34,37 | | | | | |
| 39 | Fixed, comp. 10k ohm ±10% ½W | RC104-310 | A-B | CB1031 | 5 |
| 9 | Fixed, comp. 82 ohm ±10% ½W | RC104-082 | A-B | CB8201 | 1 |
| 10 | Fixed, comp. 75 ohm ±5% ½W | RC103-075 | A-B | CB7505 | 1 |
| 11,31,32 | Fixed, comp. 3.3k ohm ±10% ½W | RC104-233 | A-B | CB3321 | 3 |
| 13 | Fixed, comp. 12k ohm ±0% ½W | RC104-312 | A-B | CB1231 | 1 |
| 14 | Fixed, comp. 1M ohm ±10% ½W | RC104-510 | A-B | CB1051 | 1 |
| 15 | Fixed, comp. 15k ohm ±10% ½W | RC104-315 | A-B | CB1531 | 1 |
| 16,35 | Fixed, comp. 1k ohm ±10% ½W | RC104-210 | A-B | CB1021 | 2 |
| 17 | Fixed, comp. 8.2k ohm ±10% ½W | RC104-282 | A-B | CB8221 | 1 |
| 18 | Fixed, comp. 4.7k ohm ±10% ½W | RC104-247 | A-B | CB4721 | 1 |
| 19,36 | Fixed, comp. 1.5M ohm ±10% ½W | RC104-515 | A-B | CB1551 | 2 |
| 21 | Fixed, comp. 100k ohm ±10% ½W | RC104-410 | A-B | CB1041 | 1 |
| 22 | Fixed, comp. 100M ohm ±10% ½W | RC104-710 | A-B | CB1071 | 1 |
| 24,38 | Variable, carbon 20k ohm ±20% ½W | RP124-320 | A-B | WA2G032 | 2 |
| 27 | Fixed, comp. 10k ohm ±5% ½W | RC103-310 | A-B | CB1035 | 1 |
| 28 | Fixed, comp. 4.7k ohm ±5% ½W | RC103-247 | A-B | CB4725 | 1 |
| 29 | Fixed, comp. 100 ohm ±10% ½W | RC104-110 | A-B | CB1011 | 1 |
| 30,33 | Fixed, comp. 2.7k ohm ±10% ½W | RC104-227 | A-B | CB2721 | 2 |
| "Q" | <u>TRANSISTORS</u> | | | | |
| 1,3 | PNP, Silicon | QB000-009 | MOT | MPS3702 | 2 |
| 2,7,10,12 | NPN, Silicon | QA038-541 | G-E | 2N3854A | 4 |
| 4 | NPN, Silicon | QA051-790 | RCA | 2N5179 | 1 |
| 5 | NPN, Silicon | QB000-013 | APX | A430 | 1 |
| 6 | N-channel JFET | QA054-580 | MOT | 2N5458 | 1 |
| 8,13 | NPN, Silicon | QA050-880 | MOT | 2N5088 | 2 |
| 9 | P-channel JFET | QA054-610 | MOT | 2N5461 | 1 |
| 11 | Darlington NPN Silicon | QA053-060 | G-E | 2N5306 | 1 |

SCHEMATIC — M6H-5-50
HARMONIC MARKER (5-50 MHZ)

REV D

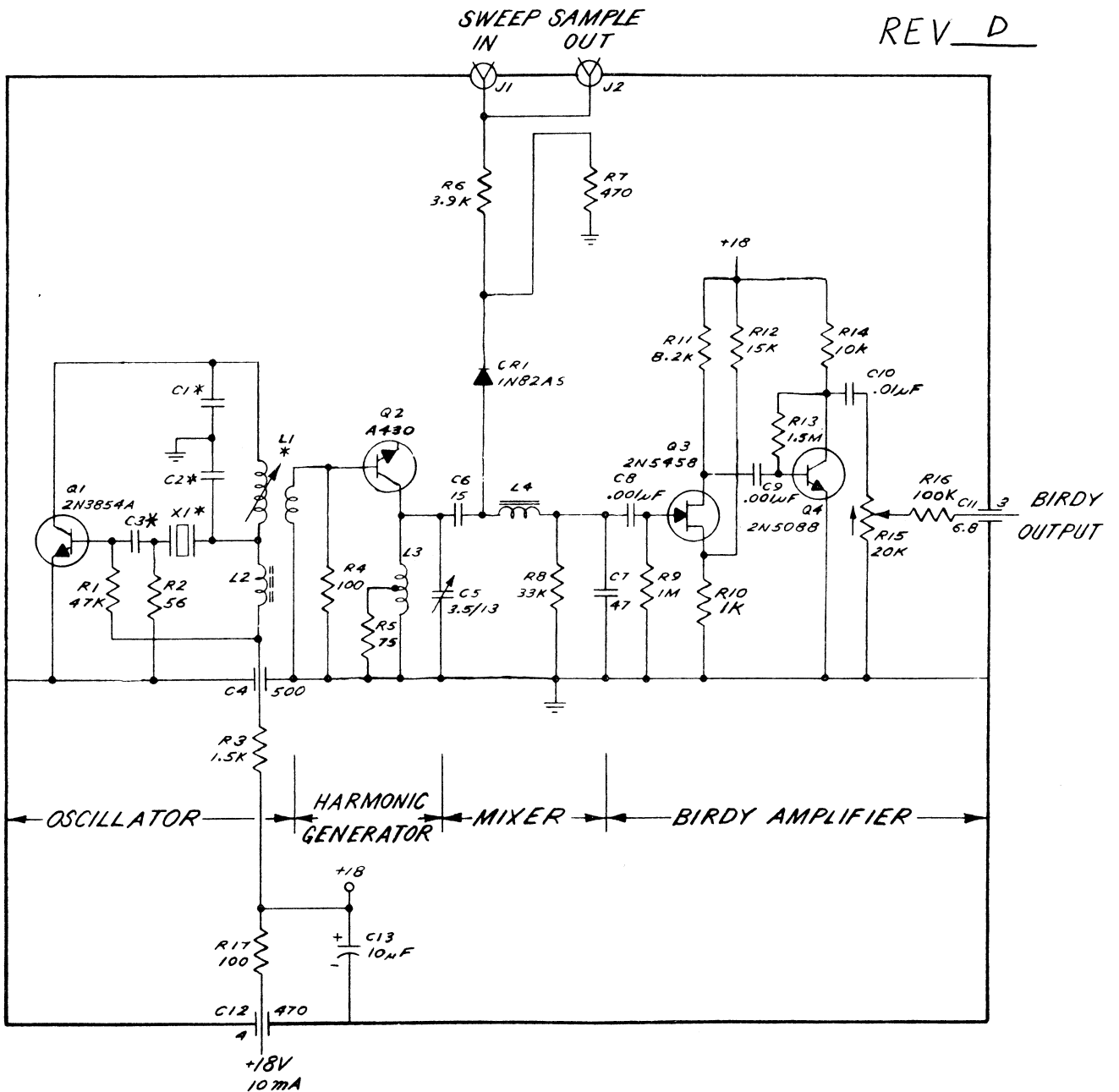

SCHEMATIC — M6S
SINGLE FREQ. MARKER

REV A

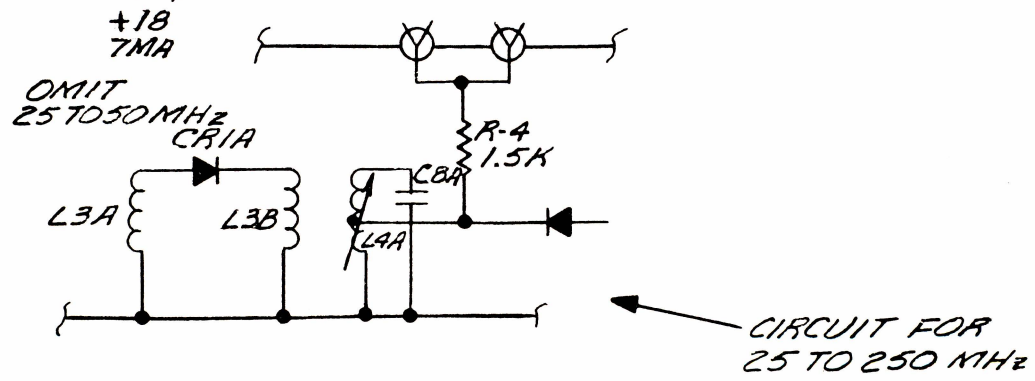
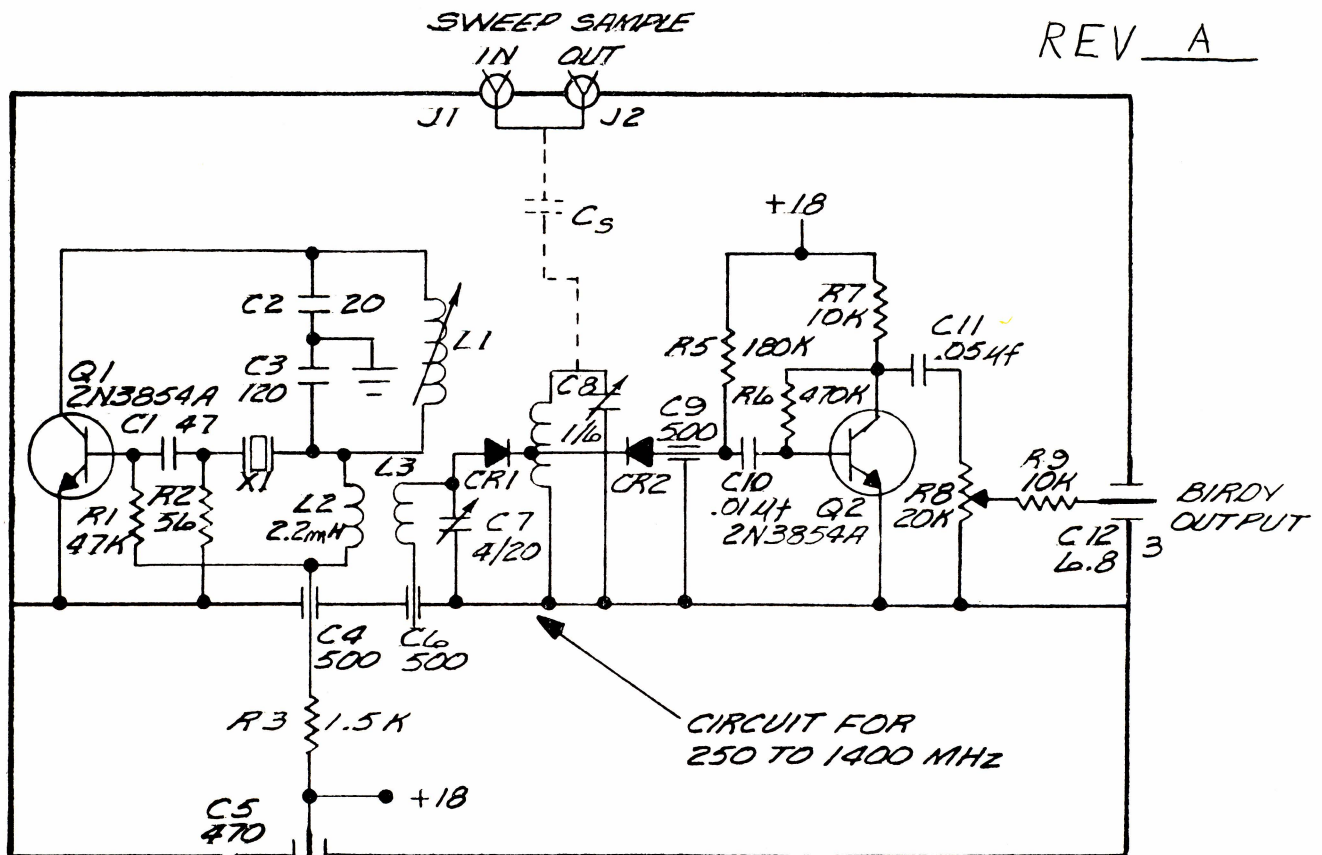

4.11

The preceding paragraph, 4.10, described marker circuits in general. The circuits described below are the specific markers of the model 2001A and 2001B.

4.11.1 M66-59.5/1090/ \pm 4.5 MHz

This module contains two single frequency markers (59.5 MHz and 1090 MHz) and a side band circuit at 4.5 MHz.

The 59.5 MHz marker frequency is obtained from a 29.75 MHz crystal oscillator circuit (Q1). The 2nd harmonic is tuned by L4, C6 and coupled into a tuned mixer circuit consisting of L5, C8 and CR1. Birdies from this mixer are coupled through a low pass filter consisting of L6 and C10. If the side band oscillator is on, 4.5 MHz CW is coupled into the mixer through C11. C10 is tuned to emphasize the 4.5 MHz video, providing side band marker video of about the same amplitude as the 59.5 MHz marker.

Operation of the 1090 MHz marker is the same except for the harmonic generation section. A 54.5 MHz oscillator is doubled by CR3-CR4 and L11-C21 tunes to 109 MHz. Q5 amplifies harmonics of 109 MHz, and 545 MHz is selected by L12-C25. 545 MHz is coupled to the mixer diode CR5 where its 2nd harmonic is emphasized by the sweep sample tuning circuit L13-C27, which is tuned to the desired marker frequency of 1090 MHz. L18 couples 4.5 MHz from Q8 through C30 and C29 to produce the 4.5 MHz side bands.

4.11.2 M66-63/ \pm .9/ \pm .35 MHz

This module contains a single frequency marker 63.0 MHz and two side band circuits \pm .9 and \pm .35 MHz.

The 63.0 MHz marker frequency is obtained from 31.5 MHz crystal oscillator circuit Q1, the output of which is doubled by Q2 and 3, and coupled to the tuned FET mixer circuit consisting of L7, C8 and Q4. Birdies from this mixer are coupled through 63.0 MHz marker size control R12 to the low pass filter C11, 12 and L10 and then to the marker amplifier module.

The 900 kHz (\pm .9 MHz) side band frequency is obtained from a 32.4 MHz crystal oscillator, Q5, the output of which is mixed with the 31.5 MHz signal in the FET mixer, Q6. C21 couples the output to the 900 kHz tuned mixer L15, C27 and Q7 where it is mixed with the 63.0 MHz birdy.

When the 350 kHz (\pm .35 MHz) side band marker is on, the 31.15 MHz oscillator, Q8, output mixed with 31.5 MHz in FET, Q9, produces a 350 kHz difference frequency emphasized by L21, C33 and mixed with the 63.0 MHz birdy marker in Q10. C37, 38, 39 and L23 are a low pass filter which attenuates higher side bands.

4.11.3 M6H-5, 20, 30 MHz

Circuit functions for these markers are labeled on the M6H schematics. A tuned Colpitts oscillator with the crystal operating at its third overtone frequency in a series resonant mode drives a harmonic generator Q2. The CW comb is mixed with sweep sample in CR1 and the resultant birdies are amplified by Q3 and Q4, and coupled through the SIZE control R15 to pin 3 of the module.

4.11.4 M66H-.2/1 MHz

This module contains a 1 MHz harmonic marker and a side band 200 kHz marker generator.

A 1 MHz series crystal oscillator consisting of Q1, Q2 and Q3 drives a harmonic generator, consisting of Q4 and Q5, to produce a CW comb. The comb is mixed with a sweep sample in CR2 to produce birdies, which are then amplified by a video amplifier consisting of Q6, Q7 and Q8. The marker birdies are coupled through Q9 to pin 7 providing the 1 MHz marker output. A low pass filter, comprised of L7, L8, L9 and associated capacitors attenuate the 1 MHz oscillator signal, and any side band video frequencies higher than 500 kHz. This side band video is also used to produce 200 kHz markers by mixing with the CW comb from Q12, in CR4 and CR5, when 200 kHz B+ is applied.

The switch at pin 8 supplies B+ to the 200 kHz marker circuits and if the 1 MHz switch is not on, activates the 1 MHz section through diode CR3, while disabling the 1 MHz birdy output through Q9. The 1 MHz oscillator provides a clock for IC1 connected as a 5:1 frequency divider to produce a 200 kHz CW output. The first and second harmonics are coupled through Q12 into the 200 kHz mixer CR4-CR5. The 200 kHz signal and all video frequencies above 40 kHz are then attenuated by a low pass filter L12-L15. The birdy is then amplified by Q13 and coupled through the SIZE control R38 to pin 11 of the module, providing the 200 kHz marker output.

M6Z-1
1KHZ MODULATOR

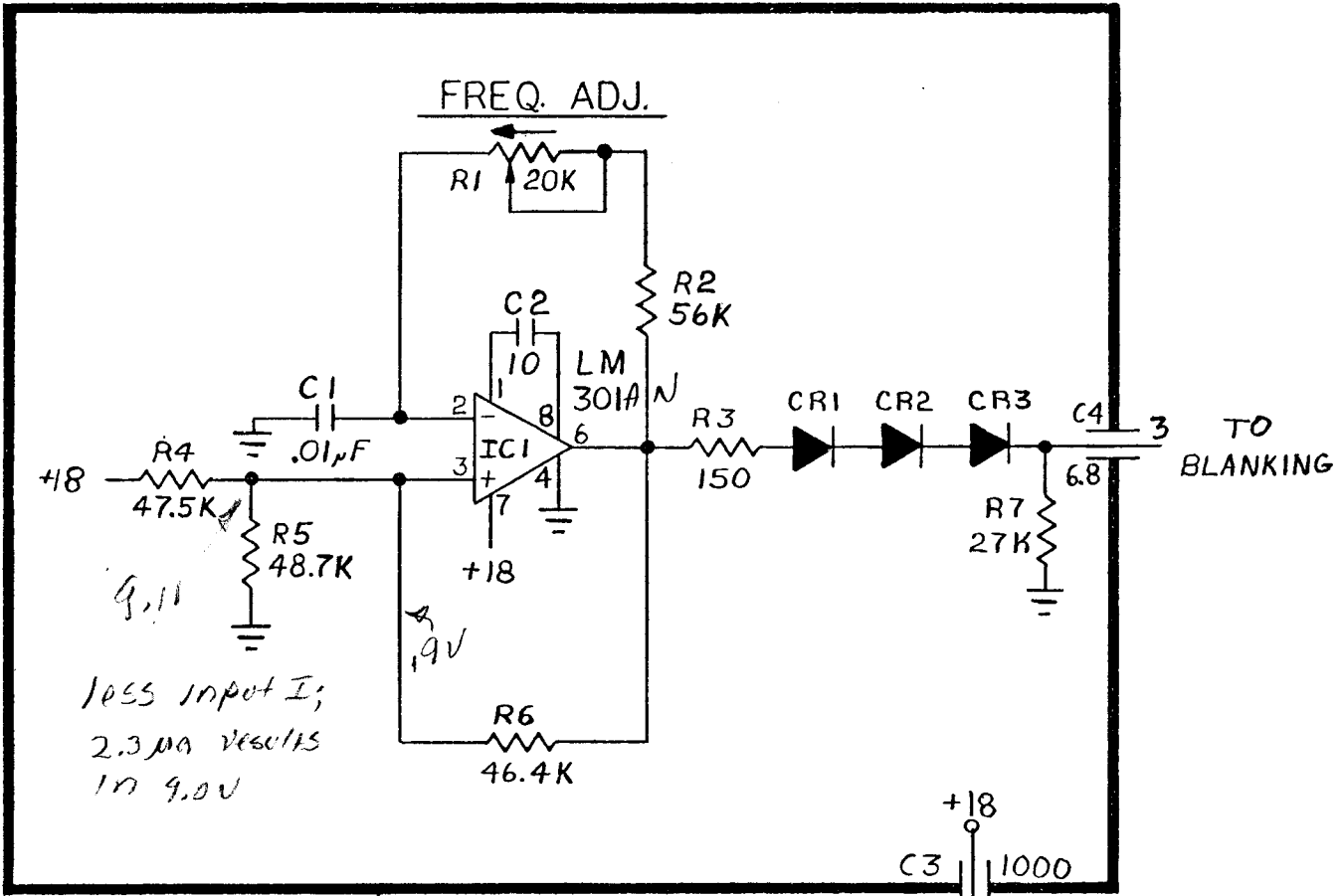

less input I;
2.3mA results
in 9.0V

301AN

+18
C3 | 1000
4
SWITCHED +18

$F = 1/2\pi RC$

$60K; F = 265$