

(12) **United States Patent**
Cheyet et al.

(10) **Patent No.:** **US 10,318,871 B2**
(45) **Date of Patent:** **Jun. 11, 2019**

(54) **METHOD AND APPARATUS FOR BUILDING AN INTELLIGENT AUTOMATED ASSISTANT**

(71) Applicant: **Apple Inc.**, Cupertino, CA (US)
(72) Inventors: **Adam Cheyer**, Oakland, CA (US);
Didier Rene Guzzoni, Cupertino, CA (US)

(73) Assignee: **Apple Inc.**, Cupertino, CA (US)
(*) Notice: Subject to any disclaimer, the term of this patent is extended or adjusted under 35 U.S.C. 154(b) by 0 days.

(21) Appl. No.: **15/299,264**
(22) Filed: **Oct. 20, 2016**

(65) **Prior Publication Data**
US 2017/0039475 A1 Feb. 9, 2017

Related U.S. Application Data
(63) Continuation of application No. 14/141,261, filed on Dec. 26, 2013, now Pat. No. 9,501,741, which is a (Continued)

(51) **Int. Cl.**
G06F 3/00 (2006.01)
G06N 5/02 (2006.01)
(Continued)

(52) **U.S. Cl.**
CPC **G06N 5/022** (2013.01); **G06F 9/54** (2013.01); **G06F 9/542** (2013.01); **G06N 5/02** (2013.01);
(Continued)

(58) **Field of Classification Search**
CPC G06F 9/542
(Continued)

(56) **References Cited**

U.S. PATENT DOCUMENTS

1,559,320 A 10/1925 Hirsh
2,180,522 A 11/1939 Henne
(Continued)

FOREIGN PATENT DOCUMENTS

CA 2694314 A1 8/2010
CA 2792412 A1 7/2011
(Continued)

OTHER PUBLICATIONS

David E. Wilkins, Interactive Execution Monitoring of Agent Teams (Year: 2003).*

(Continued)

Primary Examiner — Lechi Truong
(74) *Attorney, Agent, or Firm* — Dentons US LLP

(57) **ABSTRACT**

A method and apparatus are provided for building an intelligent automated assistant. Embodiments of the present invention rely on the concept of “active ontologies” (e.g., execution environments constructed in an ontology-like manner) to build and run applications for use by intelligent automated assistants. In one specific embodiment, a method for building an automated assistant includes interfacing a service-oriented architecture that includes a plurality of remote services to an active ontology, where the active ontology includes at least one active processing element that models a domain. At least one of the remote services is then registered for use in the domain.

64 Claims, 6 Drawing Sheets

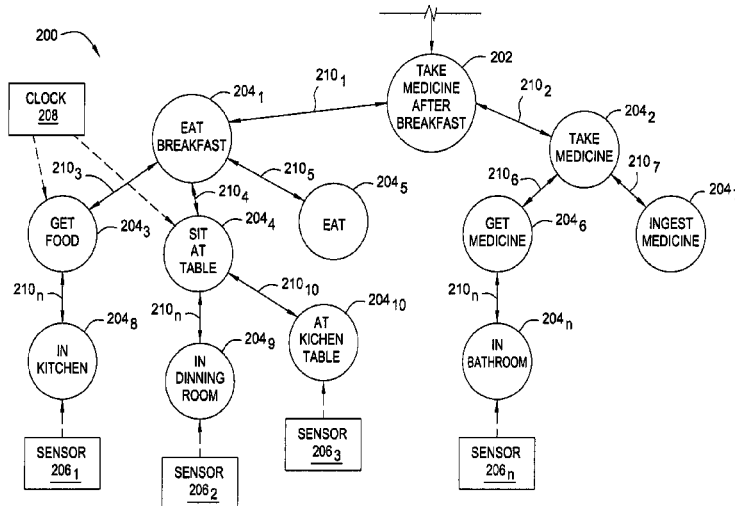

Related U.S. Application Data

- continuation of application No. 11/518,292, filed on Sep. 8, 2006, now Pat. No. 8,677,377.
- (60) Provisional application No. 60/715,324, filed on Sep. 8, 2005.
- (51) **Int. Cl.**
G06F 9/54 (2006.01)
G09B 21/00 (2006.01)
G09B 23/28 (2006.01)
G06N 7/00 (2006.01)
- (52) **U.S. Cl.**
 CPC *G06N 7/005* (2013.01); *G09B 21/00* (2013.01); *G09B 23/28* (2013.01)
- (58) **Field of Classification Search**
 USPC 719/318
 See application file for complete search history.

References Cited

U.S. PATENT DOCUMENTS

2,495,222 A 1/1950 Bierig
 3,704,345 A 11/1972 Coker et al.
 3,710,321 A 1/1973 Rubenstein
 3,787,542 A 1/1974 Gallagher et al.
 3,828,132 A 8/1974 Flanagan et al.
 3,979,557 A 9/1976 Schulman et al.
 4,013,085 A 3/1977 Wright
 4,081,631 A 3/1978 Feder
 4,090,216 A 5/1978 Constable
 4,107,784 A 8/1978 Van Bemmelen
 4,108,211 A 8/1978 Tanaka
 4,159,536 A 6/1979 Kehoe et al.
 4,181,821 A 1/1980 Pirz et al.
 4,204,089 A 5/1980 Key et al.
 4,241,286 A 12/1980 Gordon
 4,253,477 A 3/1981 Eichman
 4,278,838 A 7/1981 Antonov
 4,282,405 A 8/1981 Taguchi
 4,310,721 A 1/1982 Manley et al.
 4,332,464 A 6/1982 Bartulis et al.
 4,348,553 A 9/1982 Baker et al.
 4,384,169 A 5/1983 Mozer et al.
 4,386,345 A 5/1983 Narveson et al.
 4,433,377 A 2/1984 Eustis et al.
 4,451,849 A 5/1984 Fuhrer
 4,485,439 A 11/1984 Rothstein
 4,495,644 A 1/1985 Parks et al.
 4,513,379 A 4/1985 Wilson et al.
 4,513,435 A 4/1985 Sakoe et al.
 4,555,775 A 11/1985 Pike
 4,577,343 A 3/1986 Oura
 4,586,158 A 4/1986 Brandle
 4,587,670 A 5/1986 Levinson et al.
 4,589,022 A 5/1986 Prince et al.
 4,611,346 A 9/1986 Bednar et al.
 4,615,081 A 10/1986 Lindahl
 4,618,984 A 10/1986 Das et al.
 4,642,790 A 2/1987 Minshull et al.
 4,653,021 A 3/1987 Takagi
 4,654,875 A 3/1987 Srihari et al.
 4,655,233 A 4/1987 Laughlin
 4,658,425 A 4/1987 Julstrom
 4,670,848 A 6/1987 Schramm
 4,677,570 A 6/1987 Taki
 4,680,429 A 7/1987 Murdock et al.
 4,680,805 A 7/1987 Scott
 4,686,522 A 8/1987 Hernandez et al.
 4,688,195 A 8/1987 Thompson et al.
 4,692,941 A 9/1987 Jacks et al.
 4,698,625 A 10/1987 McCaskill et al.
 4,709,390 A 11/1987 Atal et al.
 4,713,775 A 12/1987 Scott et al.

4,718,094 A 1/1988 Bahl et al.
 4,724,542 A 2/1988 Williford
 4,726,065 A 2/1988 Froessl
 4,727,354 A 2/1988 Lindsay
 RE32,632 E 3/1988 William
 4,736,296 A 4/1988 Katayama et al.
 4,750,122 A 6/1988 Kaji et al.
 4,754,489 A 6/1988 Bokser
 4,755,811 A 7/1988 Slavin et al.
 4,759,070 A 7/1988 Voroba et al.
 4,776,016 A 10/1988 Hansen
 4,783,804 A 11/1988 Juang et al.
 4,783,807 A 11/1988 Marley
 4,785,413 A 11/1988 Atsumi
 4,790,028 A 12/1988 Ramage
 4,797,930 A 1/1989 Goudie
 4,802,223 A 1/1989 Lin et al.
 4,803,729 A 2/1989 Baker
 4,807,752 A 2/1989 Chodorow
 4,811,243 A 3/1989 Racine
 4,813,074 A 3/1989 Marcus
 4,819,271 A 4/1989 Bahl et al.
 4,827,518 A 5/1989 Feustel et al.
 4,827,520 A 5/1989 Zeinstra
 4,829,576 A 5/1989 Porter
 4,829,583 A 5/1989 Monroe et al.
 4,831,551 A 5/1989 Schalk et al.
 4,833,712 A 5/1989 Bahl et al.
 4,833,718 A 5/1989 Sprague
 4,837,798 A 6/1989 Cohen et al.
 4,837,831 A 6/1989 Gillick et al.
 4,839,853 A 6/1989 Deerwester et al.
 4,852,168 A 7/1989 Sprague
 4,862,504 A 8/1989 Nomura
 4,875,187 A 10/1989 Smith
 4,878,230 A 10/1989 Murakami et al.
 4,887,212 A 12/1989 Zamora et al.
 4,896,359 A 1/1990 Yamamoto et al.
 4,903,305 A 2/1990 Gillick et al.
 4,905,163 A 2/1990 Garber et al.
 4,908,867 A 3/1990 Silverman
 4,914,586 A 4/1990 Swinehart et al.
 4,914,590 A 4/1990 Loatman et al.
 4,914,704 A 4/1990 Cole et al.
 4,918,723 A 4/1990 Iggulden et al.
 4,926,491 A 5/1990 Maeda et al.
 4,928,307 A 5/1990 Lynn
 4,931,783 A 6/1990 Atkinson
 4,935,954 A 6/1990 Thompson et al.
 4,939,639 A 7/1990 Lee et al.
 4,941,488 A 7/1990 Marxer et al.
 4,944,013 A 7/1990 Gouvianakis et al.
 4,945,504 A 7/1990 Nakama et al.
 4,953,106 A 8/1990 Gansner et al.
 4,955,047 A 9/1990 Morganstein et al.
 4,965,763 A 10/1990 Zamora
 4,972,462 A 11/1990 Shibata
 4,974,191 A 11/1990 Amirghodsi et al.
 4,975,975 A 12/1990 Filipiski
 4,977,598 A 12/1990 Doddington et al.
 4,980,916 A 12/1990 Zinser
 4,985,924 A 1/1991 Matsuura
 4,992,972 A 2/1991 Brooks et al.
 4,994,966 A 2/1991 Hutchins
 4,994,983 A 2/1991 Landell et al.
 5,001,774 A 3/1991 Lee
 5,003,577 A 3/1991 Ertz et al.
 5,007,095 A 4/1991 Nara et al.
 5,007,098 A 4/1991 Kumagai
 5,010,574 A 4/1991 Wang
 5,016,002 A 5/1991 Levanto
 5,020,112 A 5/1991 Chou
 5,021,971 A 6/1991 Lindsay
 5,022,081 A 6/1991 Hirose et al.
 5,027,110 A 6/1991 Chang et al.
 5,027,406 A 6/1991 Roberts et al.
 5,027,408 A 6/1991 Kroeker et al.
 5,029,211 A 7/1991 Ozawa
 5,031,217 A 7/1991 Nishimura

(56)

References Cited

U.S. PATENT DOCUMENTS

5,032,989	A	7/1991	Tornetta	5,252,951	A	10/1993	Tannenbaum et al.
5,033,087	A	7/1991	Bahl et al.	5,253,325	A	10/1993	Clark
5,040,218	A	8/1991	Vitale et al.	5,255,386	A	10/1993	Prager
5,046,099	A	9/1991	Nishimura	5,257,387	A	10/1993	Richek et al.
5,047,614	A	9/1991	Bianco	5,260,697	A	11/1993	Barrett et al.
5,047,617	A	9/1991	Shepard et al.	5,266,931	A	11/1993	Tanaka
5,050,215	A	9/1991	Nishimura	5,266,949	A	11/1993	Rossi
5,053,758	A	10/1991	Cornett et al.	5,267,345	A	11/1993	Brown et al.
5,054,084	A	10/1991	Tanaka et al.	5,268,990	A	12/1993	Cohen et al.
5,057,915	A	10/1991	Von Kohorn	5,274,771	A	12/1993	Hamilton et al.
5,062,143	A	10/1991	Schmitt	5,274,818	A	12/1993	Vasilevsky et al.
5,067,158	A	11/1991	Arjmand	5,276,616	A	1/1994	Kuga et al.
5,067,503	A	11/1991	Stile	5,276,794	A	1/1994	Lamb, Jr.
5,072,452	A	12/1991	Brown et al.	5,278,980	A	1/1994	Pedersen et al.
5,075,896	A	12/1991	Wilcox et al.	5,282,265	A	1/1994	Rohra Suda et al.
5,079,723	A	1/1992	Herceg et al.	5,283,818	A	2/1994	Klausner et al.
5,083,119	A	1/1992	Trevett et al.	5,287,448	A	2/1994	Nicol et al.
5,083,268	A	1/1992	Hemphill et al.	5,289,562	A	2/1994	Mizuta et al.
5,086,792	A	2/1992	Chodorow	RE34,562	E	3/1994	Murakami et al.
5,090,012	A	2/1992	Kajiyama et al.	5,291,286	A	3/1994	Murakami et al.
5,091,790	A	2/1992	Silverberg	5,293,254	A	3/1994	Eschbach
5,091,945	A	2/1992	Kleijn	5,293,448	A	3/1994	Honda
5,103,498	A	4/1992	Lanier et al.	5,293,452	A	3/1994	Picone et al.
5,109,509	A	4/1992	Katayama et al.	5,296,642	A	3/1994	Konishi
5,111,423	A	5/1992	Kopec, Jr. et al.	5,297,170	A	3/1994	Eyuboglu et al.
5,119,079	A	6/1992	Hube et al.	5,297,194	A	3/1994	Hunt et al.
5,122,951	A	6/1992	Kamiya	5,299,125	A	3/1994	Baker et al.
5,123,103	A	6/1992	Ohtaki et al.	5,299,284	A	3/1994	Roy
5,125,022	A	6/1992	Hunt et al.	5,301,109	A	4/1994	Landauer et al.
5,125,030	A	6/1992	Nomura et al.	5,303,406	A	4/1994	Hansen et al.
5,127,043	A	6/1992	Hunt et al.	5,305,205	A	4/1994	Weber et al.
5,127,053	A	6/1992	Koch	5,305,421	A	4/1994	Li et al.
5,127,055	A	6/1992	Larkey	5,305,768	A	4/1994	Gross et al.
5,128,672	A	7/1992	Kaehler	5,309,359	A	5/1994	Katz et al.
5,133,011	A	7/1992	McKiel, Jr.	5,315,689	A	5/1994	Kanazawa et al.
5,133,023	A	7/1992	Bokser	5,317,507	A	5/1994	Gallant
5,142,584	A	8/1992	Ozawa	5,317,647	A	5/1994	Pagallo
5,144,875	A	9/1992	Nakada	5,325,297	A	6/1994	Bird et al.
5,148,541	A	9/1992	Lee et al.	5,325,298	A	6/1994	Gallant
5,153,913	A	10/1992	Kandefer et al.	5,325,462	A	6/1994	Farrett
5,157,610	A	10/1992	Asano et al.	5,326,270	A	7/1994	Ostby et al.
5,157,779	A	10/1992	Washburn et al.	5,327,342	A	7/1994	Roy
5,161,102	A	11/1992	Griffin et al.	5,327,498	A	7/1994	Hamon
5,163,809	A	11/1992	Akgun et al.	5,329,608	A	7/1994	Bocchieri et al.
5,164,900	A	11/1992	Bernath	5,333,236	A	7/1994	Bahl et al.
5,164,982	A	11/1992	Davis	5,333,266	A	7/1994	Boaz et al.
5,165,007	A	11/1992	Bahl et al.	5,333,275	A	7/1994	Wheatley et al.
5,167,004	A	11/1992	Netsch et al.	5,335,011	A	8/1994	Addeo et al.
5,175,536	A	12/1992	Aschliman et al.	5,335,276	A	8/1994	Thompson et al.
5,175,803	A	12/1992	Yeh	5,341,293	A	8/1994	Vertelney et al.
5,175,814	A	12/1992	Anick et al.	5,341,466	A	8/1994	Perlin et al.
5,179,627	A	1/1993	Sweet et al.	5,345,536	A	9/1994	Hoshimi et al.
5,179,652	A	1/1993	Rozmanith et al.	5,349,645	A	9/1994	Zhao
5,194,950	A	3/1993	Murakami et al.	5,353,374	A	10/1994	Wilson et al.
5,195,034	A	3/1993	Garneau et al.	5,353,376	A	10/1994	Oh et al.
5,195,167	A	3/1993	Bahl et al.	5,353,377	A	10/1994	Kuroda et al.
5,197,005	A	3/1993	Shwartz et al.	5,353,408	A	10/1994	Kato et al.
5,199,077	A	3/1993	Wilcox et al.	5,353,432	A	10/1994	Richek et al.
5,201,034	A	4/1993	Matsuura et al.	5,357,431	A	10/1994	Nakada et al.
5,202,952	A	4/1993	Gillick et al.	5,367,640	A	11/1994	Hamilton et al.
5,208,862	A	5/1993	Ozawa	5,369,575	A	11/1994	Lamberti et al.
5,210,689	A	5/1993	Baker et al.	5,369,577	A	11/1994	Kadashevich et al.
5,212,638	A	5/1993	Bernath	5,371,853	A	12/1994	Kao et al.
5,212,821	A	5/1993	Gorin et al.	5,371,901	A	12/1994	Reed et al.
5,216,747	A	6/1993	Hardwick et al.	5,373,566	A	12/1994	Murdock
5,218,700	A	6/1993	Beechick	5,377,103	A	12/1994	Lamberti et al.
5,220,629	A	6/1993	Kosaka et al.	5,377,301	A	12/1994	Rosenberg et al.
5,220,639	A	6/1993	Lee	5,377,303	A	12/1994	Firman
5,220,657	A	6/1993	Bly et al.	5,384,671	A	1/1995	Fisher
5,222,146	A	6/1993	Bahl et al.	5,384,892	A	1/1995	Strong
5,230,036	A	7/1993	Akamine et al.	5,384,893	A	1/1995	Hutchins
5,231,670	A	7/1993	Goldhor et al.	5,386,494	A	1/1995	White
5,235,680	A	8/1993	Bijnagte	5,386,556	A	1/1995	Hedin et al.
5,237,502	A	8/1993	White et al.	5,390,236	A	2/1995	Klausner et al.
5,241,619	A	8/1993	Schwartz et al.	5,390,279	A	2/1995	Strong
				5,390,281	A	2/1995	Luciw et al.
				5,392,419	A	2/1995	Walton
				5,396,625	A	3/1995	Parkes
				5,400,434	A	3/1995	Pearson

(56)

References Cited

U.S. PATENT DOCUMENTS

5,404,295	A	4/1995	Katz et al.	5,574,823	A	11/1996	Hassanein et al.
5,406,305	A	4/1995	Shimomura et al.	5,574,824	A	11/1996	Slyh et al.
5,408,060	A	4/1995	Muurinen	5,577,135	A	11/1996	Grajski et al.
5,412,756	A	5/1995	Bauman et al.	5,577,164	A	11/1996	Kaneko et al.
5,412,804	A	5/1995	Krishna	5,577,241	A	11/1996	Spencer
5,412,806	A	5/1995	Du et al.	5,578,808	A	11/1996	Taylor
5,418,951	A	5/1995	Damashek	5,579,037	A	11/1996	Tahara et al.
5,422,656	A	6/1995	Allard et al.	5,579,436	A	11/1996	Chou et al.
5,424,947	A	6/1995	Nagao et al.	5,581,484	A	12/1996	Prince
5,425,108	A	6/1995	Hwang et al.	5,581,652	A	12/1996	Abe et al.
5,428,731	A	6/1995	Powers, III	5,581,655	A	12/1996	Cohen et al.
5,434,777	A	7/1995	Luciw	5,583,993	A	12/1996	Foster et al.
5,440,615	A	8/1995	Caccuro et al.	5,584,024	A	12/1996	Shwartz
5,442,598	A	8/1995	Haikawa et al.	5,586,540	A	12/1996	Marzec et al.
5,442,780	A	8/1995	Takanashi et al.	5,594,641	A	1/1997	Kaplan et al.
5,444,823	A	8/1995	Nguyen	5,596,260	A	1/1997	Moravec et al.
5,449,368	A	9/1995	Kuzmak	5,596,676	A	1/1997	Swaminathan et al.
5,450,523	A	9/1995	Zhao	5,596,994	A	1/1997	Bro
5,455,888	A	10/1995	Lyengar et al.	5,608,624	A	3/1997	Luciw
5,457,768	A	10/1995	Tsuboi et al.	5,608,698	A	3/1997	Yamanoi et al.
5,459,488	A	10/1995	Geiser	5,608,841	A	3/1997	Tsuboka
5,463,696	A	10/1995	Beermink et al.	5,610,812	A	3/1997	Schabes et al.
5,463,725	A	10/1995	Henckel et al.	5,613,036	A	3/1997	Strong
5,465,401	A	11/1995	Thompson	5,613,122	A	3/1997	Burnard et al.
5,469,529	A	11/1995	Bimbot et al.	5,615,378	A	3/1997	Nishino et al.
5,471,611	A	11/1995	McGregor	5,615,384	A	3/1997	Allard et al.
5,473,728	A	12/1995	Luginbuhl et al.	5,616,876	A	4/1997	Gluts
5,475,587	A	12/1995	Anick et al.	5,617,386	A	4/1997	Choi
5,475,796	A	12/1995	Iwata	5,617,507	A	4/1997	Lee et al.
5,477,447	A	12/1995	Luciw et al.	5,617,539	A	4/1997	Ludwig et al.
5,477,448	A	12/1995	Golding et al.	5,619,583	A	4/1997	Page et al.
5,477,451	A	12/1995	Brown et al.	5,619,694	A	4/1997	Shimazu
5,479,488	A	12/1995	Lennig et al.	5,621,859	A	4/1997	Schwartz et al.
5,481,739	A	1/1996	Staats	5,621,903	A	4/1997	Luciw et al.
5,483,261	A	1/1996	Yasutake	5,627,939	A	5/1997	Huang et al.
5,485,372	A	1/1996	Golding et al.	5,634,084	A	5/1997	Malsheen et al.
5,485,543	A	1/1996	Aso	5,636,325	A	6/1997	Farrett
5,488,204	A	1/1996	Mead et al.	5,638,425	A	6/1997	Meador, III et al.
5,488,727	A	1/1996	Agrawal et al.	5,638,489	A	6/1997	Tsuboka
5,490,234	A	2/1996	Narayan	5,638,523	A	6/1997	Mullet et al.
5,491,758	A	2/1996	Bellegarda et al.	5,640,487	A	6/1997	Lau et al.
5,491,772	A	2/1996	Hardwick et al.	5,642,464	A	6/1997	Yue et al.
5,493,677	A	2/1996	Balogh et al.	5,642,466	A	6/1997	Narayan
5,495,604	A	2/1996	Harding et al.	5,642,519	A	6/1997	Martin
5,497,319	A	3/1996	Chong et al.	5,644,656	A	7/1997	Akra et al.
5,500,903	A	3/1996	Gulli	5,644,727	A	7/1997	Atkins
5,500,905	A	3/1996	Martin et al.	5,644,735	A	7/1997	Luciw et al.
5,500,937	A	3/1996	Thompson-Rohrlich	5,649,060	A	7/1997	Ellozy et al.
5,502,774	A	3/1996	Bellegarda et al.	5,652,828	A	7/1997	Silverman
5,502,790	A	3/1996	Yi	5,652,884	A	7/1997	Palevich
5,502,791	A	3/1996	Nishimura et al.	5,652,897	A	7/1997	Linebarger et al.
5,515,475	A	5/1996	Gupta et al.	5,661,787	A	8/1997	Pocock
5,521,816	A	5/1996	Roche et al.	5,664,055	A	9/1997	Kroon
5,524,140	A	6/1996	Klausner et al.	5,664,206	A	9/1997	Murow et al.
5,530,861	A	6/1996	Diamant et al.	5,670,985	A	9/1997	Cappels, Sr. et al.
5,533,182	A	7/1996	Bates et al.	5,675,704	A	10/1997	Juang et al.
5,535,121	A	7/1996	Roche et al.	5,675,819	A	10/1997	Schuetze
5,536,902	A	7/1996	Serra et al.	5,678,039	A	10/1997	Hinks et al.
5,537,317	A	7/1996	Schabes et al.	5,678,053	A	10/1997	Anderson
5,537,618	A	7/1996	Boulton et al.	5,680,617	A	10/1997	Gough G06F 9/4446
5,537,647	A	7/1996	Hermansky et al.	5,682,475	A	10/1997	Johnson et al.
5,543,588	A	8/1996	Bisset et al.	5,682,539	A	10/1997	Conrad et al.
5,543,897	A	8/1996	Altrieth, III	5,684,513	A	11/1997	Decker
5,544,264	A	8/1996	Bellegarda et al.	5,687,077	A	11/1997	Gough, Jr.
5,548,507	A	8/1996	Martino et al.	5,689,287	A	11/1997	Mackinlay et al.
5,555,343	A	9/1996	Luther	5,689,616	A	11/1997	Li
5,555,344	A	9/1996	Zunkler	5,689,618	A	11/1997	Gaspar et al.
5,559,301	A	9/1996	Bryan, Jr. et al.	5,692,205	A	11/1997	Berry et al.
5,559,945	A	9/1996	Beaudet et al.	5,696,962	A	12/1997	Kupiec
5,564,446	A	10/1996	Wiltshire	5,697,793	A	12/1997	Huffman et al.
5,565,888	A	10/1996	Selker	5,699,082	A	12/1997	Marks et al.
5,568,536	A	10/1996	Tiller et al.	5,701,400	A	12/1997	Amado
5,568,540	A	10/1996	Greco et al.	5,706,442	A	1/1998	Anderson et al.
5,570,324	A	10/1996	Geil	5,708,659	A	1/1998	Rostoker et al.
5,572,576	A	11/1996	Klausner et al.	5,708,822	A	1/1998	Wical
				5,710,886	A	1/1998	Christensen et al.
				5,710,922	A	1/1998	Alley et al.
				5,712,949	A	1/1998	Kato et al.
				5,712,957	A	1/1998	Waibel et al.

(56)

References Cited

U.S. PATENT DOCUMENTS

5,715,468	A	2/1998	Budzinski	5,822,743	A	10/1998	Gupta et al.
5,717,877	A	2/1998	Orton et al.	5,825,349	A	10/1998	Meier et al.
5,721,827	A	2/1998	Logan et al.	5,825,352	A	10/1998	Bisset et al.
5,721,949	A	2/1998	Smith et al.	5,825,881	A	10/1998	Colvin, Sr.
5,724,406	A	3/1998	Juster	5,826,261	A	10/1998	Spencer
5,724,985	A	3/1998	Snell et al.	5,828,768	A	10/1998	Eatwell et al.
5,726,672	A	3/1998	Hernandez et al.	5,828,999	A	10/1998	Bellegarda et al.
5,727,950	A	3/1998	Cook et al.	5,832,428	A	11/1998	Chow et al.
5,729,694	A	3/1998	Holzrichter et al.	5,832,433	A	11/1998	Yashchin et al.
5,729,704	A	3/1998	Stone et al.	5,832,435	A	11/1998	Silverman
5,732,216	A	3/1998	Logan et al.	5,833,134	A	11/1998	Ho et al.
5,732,390	A	3/1998	Katayanagi et al.	5,835,077	A	11/1998	Dao et al.
5,732,395	A	3/1998	Silverman	5,835,079	A	11/1998	Shieh
5,734,750	A	3/1998	Arai et al.	5,835,721	A	11/1998	Donahue et al.
5,734,791	A	3/1998	Acero et al.	5,835,732	A	11/1998	Kikinis et al.
5,736,974	A	4/1998	Selker	5,835,893	A	11/1998	Ushioda
5,737,487	A	4/1998	Bellegarda et al.	5,839,106	A	11/1998	Bellegarda
5,737,609	A	4/1998	Reed et al.	5,841,902	A	11/1998	Tu
5,737,734	A	4/1998	Schultz	5,842,165	A	11/1998	Raman et al.
5,739,451	A	4/1998	Winsky et al.	5,845,255	A	12/1998	Mayaud
5,740,143	A	4/1998	Suetomi	5,848,410	A	12/1998	Walls et al.
5,742,705	A	4/1998	Parthasarathy	5,850,480	A	12/1998	Scanlon
5,742,736	A	4/1998	Haddock	5,850,629	A	12/1998	Holm et al.
5,745,116	A	4/1998	Pisutha-Armond	5,852,801	A	12/1998	Hon et al.
5,745,843	A	4/1998	Wetters et al.	5,854,893	A	12/1998	Ludwig et al.
5,745,873	A	4/1998	Braida et al.	5,855,000	A	12/1998	Waibel et al.
5,748,512	A	5/1998	Vargas	5,857,184	A	1/1999	Lynch
5,748,974	A	5/1998	Johnson	5,859,636	A	1/1999	Pandit
5,749,071	A	5/1998	Silverman	5,860,063	A	1/1999	Gorin et al.
5,749,081	A	5/1998	Whiteis	5,860,064	A	1/1999	Henton
5,751,906	A	5/1998	Silverman	5,860,075	A	1/1999	Hashizume et al.
5,757,358	A	5/1998	Osga	5,862,223	A	1/1999	Walker et al.
5,757,979	A	5/1998	Hongo et al.	5,862,233	A	1/1999	Poletti
5,758,024	A	5/1998	Alleva	5,864,806	A	1/1999	Mokbel et al.
5,758,079	A	5/1998	Ludwig et al.	5,864,815	A	1/1999	Rozak et al.
5,758,083	A	5/1998	Singh et al.	5,864,844	A	1/1999	James et al.
5,758,314	A	5/1998	McKenna	5,864,855	A	1/1999	Ruocco et al.
5,758,318	A	5/1998	Kojima et al.	5,864,868	A	1/1999	Contois
5,759,101	A	6/1998	Von Kohorn	5,867,799	A	2/1999	Lang et al.
5,761,640	A	6/1998	Kalyanswamy et al.	5,870,710	A	2/1999	Ozawa et al.
5,761,687	A	6/1998	Hon et al.	5,873,056	A	2/1999	Liddy et al.
5,764,852	A	6/1998	Williams	5,873,064	A	2/1999	De Armas et al.
5,765,131	A	6/1998	Stentiford et al.	5,875,427	A	2/1999	Yamazaki
5,765,168	A	6/1998	Burrows	5,875,429	A	2/1999	Douglas
5,771,276	A	6/1998	Wolf	5,875,437	A	2/1999	Atkins
5,774,834	A	6/1998	Visser	5,875,448	A	2/1999	Boys et al.
5,774,855	A	6/1998	Foti et al.	5,876,396	A	3/1999	Lo et al.
5,774,859	A	6/1998	Houser et al.	5,877,751	A	3/1999	Kanemitsu et al.
5,777,614	A	7/1998	Ando et al.	5,877,757	A	3/1999	Baldwin et al.
5,778,405	A	7/1998	Ogawa	5,878,393	A	3/1999	Hata et al.
5,790,978	A	8/1998	Olive et al.	5,878,394	A	3/1999	Muhling
5,794,050	A	8/1998	Dahlgren et al.	5,878,396	A	3/1999	Henton
5,794,182	A	8/1998	Manduchi et al.	5,880,411	A	3/1999	Gillespie et al.
5,794,189	A	8/1998	Gould	5,880,731	A	3/1999	Liles et al.
5,794,207	A	8/1998	Walker et al.	5,884,039	A	3/1999	Ludwig et al.
5,794,237	A	8/1998	Gore, Jr.	5,884,262	A	3/1999	Wise et al.
5,797,008	A	8/1998	Burrows	5,884,323	A	3/1999	Hawkins et al.
5,799,268	A	8/1998	Boguraev	5,890,117	A	3/1999	Silverman
5,799,269	A	8/1998	Schabes et al.	5,890,122	A	3/1999	Van et al.
5,799,276	A	8/1998	Komissarchik et al.	5,891,180	A	4/1999	Greeninger et al.
5,799,279	A	8/1998	Gould et al.	5,893,126	A	4/1999	Drews et al.
5,801,692	A	9/1998	Muzio et al.	5,893,132	A	4/1999	Huffman et al.
5,802,466	A	9/1998	Gallant et al.	5,895,448	A	4/1999	Vysotsky et al.
5,802,526	A	9/1998	Fawcett et al.	5,895,464	A	4/1999	Bhandari et al.
5,806,021	A	9/1998	Chen et al.	5,895,466	A	4/1999	Goldberg et al.
5,812,697	A	9/1998	Sakai et al.	5,896,321	A	4/1999	Miller et al.
5,812,698	A	9/1998	Platt et al.	5,896,500	A	4/1999	Ludwig et al.
5,815,142	A	9/1998	Allard et al.	5,899,972	A	5/1999	Miyazawa et al.
5,815,225	A	9/1998	Nelson	5,905,498	A	5/1999	Diament et al.
5,818,142	A	10/1998	Edleblute et al.	5,907,597	A	5/1999	Mark
5,818,451	A	10/1998	Bertram et al.	5,909,666	A	6/1999	Gould et al.
5,818,924	A	10/1998	King et al.	5,909,667	A	6/1999	Leontiades et al.
5,822,288	A	10/1998	Shinada	5,912,951	A	6/1999	Checchio et al.
5,822,720	A	10/1998	Bookman et al.	5,912,952	A	6/1999	Brendzel
5,822,730	A	10/1998	Roth et al.	5,913,185	A	6/1999	Martino et al.
				5,913,193	A	6/1999	Huang et al.
				5,915,001	A	6/1999	Uppaluru et al.
				5,915,236	A	6/1999	Gould et al.
				5,915,238	A	6/1999	Tjaden

(56)

References Cited

U.S. PATENT DOCUMENTS

5,915,249	A	6/1999	Spencer	6,005,495	A	12/1999	Connolly et al.
5,917,487	A	6/1999	Ulrich	6,006,274	A	12/1999	Hawkins et al.
5,918,303	A	6/1999	Yamaura et al.	6,009,237	A	12/1999	Hirabayashi et al.
5,920,327	A	7/1999	Seidensticker, Jr.	6,011,585	A	1/2000	Anderson
5,920,836	A	7/1999	Gould et al.	6,014,428	A	1/2000	Wolf
5,920,837	A	7/1999	Gould et al.	6,016,471	A	1/2000	Kuhn et al.
5,923,757	A	7/1999	Hocker et al.	6,017,219	A	1/2000	Adams, Jr. et al.
5,924,068	A	7/1999	Richard et al.	6,018,705	A	1/2000	Gaudet
5,926,769	A	7/1999	Valimaa et al.	6,018,711	A	1/2000	French-St. George et al.
5,926,789	A	7/1999	Barbara et al.	6,020,881	A	2/2000	Naughton et al.
5,930,408	A	7/1999	Seto	6,023,536	A	2/2000	Visser
5,930,751	A	7/1999	Cohrs et al.	6,023,676	A	2/2000	Erell
5,930,754	A	7/1999	Karaali et al.	6,023,684	A	2/2000	Pearson
5,930,769	A	7/1999	Rose	6,024,288	A	2/2000	Gottlich et al.
5,930,783	A	7/1999	Li et al.	6,026,345	A	2/2000	Shah et al.
5,933,477	A	8/1999	Wu	6,026,375	A	2/2000	Hall et al.
5,933,806	A	8/1999	Beyerlein et al.	6,026,388	A	2/2000	Liddy et al.
5,933,822	A	8/1999	Braden-Harder et al.	6,026,393	A	2/2000	Gupta et al.
5,936,926	A	8/1999	Yokouchi et al.	6,029,132	A	2/2000	Kuhn et al.
5,937,163	A	8/1999	Lee et al.	6,029,135	A	2/2000	Krasle
5,940,811	A	8/1999	Norris	6,035,267	A	3/2000	Watanabe et al.
5,940,841	A	8/1999	Schmuck et al.	6,035,303	A	3/2000	Baer et al.
5,941,944	A	8/1999	Messerly	6,035,336	A	3/2000	Lu et al.
5,943,043	A	8/1999	Furuhata et al.	6,038,533	A	3/2000	Buchsbaum et al.
5,943,049	A	8/1999	Matsubara et al.	6,040,824	A	3/2000	Maekawa et al.
5,943,052	A	8/1999	Allen et al.	6,041,023	A	3/2000	Lakhansingh
5,943,429	A	8/1999	Haendel et al.	6,047,255	A	4/2000	Williamson
5,943,443	A	8/1999	Itonori et al.	6,047,300	A	4/2000	Walfish et al.
5,943,670	A	8/1999	Prager	6,052,654	A	4/2000	Gaudet et al.
5,946,647	A	8/1999	Miller et al.	6,052,656	A	4/2000	Suda et al.
5,946,648	A	8/1999	Halstead et al.	6,054,990	A	4/2000	Tran
5,948,040	A	9/1999	DeLorme et al.	6,055,514	A	4/2000	Wren
5,949,961	A	9/1999	Sharman	6,055,531	A	4/2000	Bennett et al.
5,950,123	A	9/1999	Schwelb et al.	6,061,646	A	5/2000	Martino et al.
5,952,992	A	9/1999	Helms	6,064,767	A	5/2000	Muir et al.
5,953,541	A	9/1999	King et al.	6,064,951	A	5/2000	Park et al.
5,956,021	A	9/1999	Kubota et al.	6,064,959	A	5/2000	Young et al.
5,956,699	A	9/1999	Wong et al.	6,064,960	A	5/2000	Bellegarda et al.
5,960,385	A	9/1999	Skiena et al.	6,064,963	A	5/2000	Gainsboro
5,960,394	A	9/1999	Gould et al.	6,067,519	A	5/2000	Lowry
5,960,422	A	9/1999	Prasad	6,069,648	A	5/2000	Suso et al.
5,963,208	A	10/1999	Dolan et al.	6,070,138	A	5/2000	Iwata
5,963,924	A	10/1999	Williams et al.	6,070,139	A	5/2000	Miyazawa et al.
5,963,964	A	10/1999	Nielsen	6,070,140	A	5/2000	Tran
5,966,126	A	10/1999	Szabo	6,070,147	A	5/2000	Harms et al.
5,970,446	A	10/1999	Goldberg et al.	6,073,033	A	6/2000	Campo
5,970,451	A	10/1999	Lewis et al.	6,073,036	A	6/2000	Heikkinen et al.
5,970,460	A	10/1999	Bunce et al.	6,073,091	A	6/2000	Kanevsky et al.
5,970,474	A	10/1999	LeRoy et al.	6,073,097	A	6/2000	Gould et al.
5,973,612	A	10/1999	Deo et al.	6,076,051	A	6/2000	Messerly et al.
5,973,676	A	10/1999	Kawakura	6,076,060	A	6/2000	Lin et al.
5,974,146	A	10/1999	Randle et al.	6,076,088	A	6/2000	Paik et al.
5,977,950	A	11/1999	Rhyne	6,078,885	A	6/2000	Beutnagel
5,982,352	A	11/1999	Pryor	6,078,914	A	6/2000	Redfern
5,982,370	A	11/1999	Kamper	6,081,750	A	6/2000	Hoffberg et al.
5,982,891	A	11/1999	Ginter et al.	6,081,774	A	6/2000	de Hita et al.
5,982,902	A	11/1999	Terano	6,081,780	A	6/2000	Lumelsky
5,983,179	A	11/1999	Gould et al.	6,085,204	A	7/2000	Chijiwa et al.
5,983,184	A	11/1999	Noguchi	6,088,671	A	7/2000	Gould et al.
5,983,216	A	11/1999	Kirsch et al.	6,088,731	A	7/2000	Kiraly et al.
5,987,132	A	11/1999	Rowney	6,092,036	A	7/2000	Hamann et al.
5,987,140	A	11/1999	Rowney et al.	6,092,038	A	7/2000	Kanevsky et al.
5,987,401	A	11/1999	Trudeau	6,092,043	A	7/2000	Squires et al.
5,987,404	A	11/1999	Della Pietra et al.	6,094,649	A	7/2000	Bowen et al.
5,987,440	A	11/1999	O'Neil et al.	6,097,391	A	8/2000	Wilcox
5,990,887	A	11/1999	Redpath et al.	6,101,468	A	8/2000	Gould et al.
5,991,441	A	11/1999	Jourjine	6,101,470	A	8/2000	Eide et al.
5,995,460	A	11/1999	Takagi et al.	6,105,865	A	8/2000	Hardesty
5,995,590	A	11/1999	Brunet et al.	6,108,627	A	8/2000	Sabourin
5,995,918	A	11/1999	Kendall et al.	6,108,640	A	8/2000	Slotznick
5,998,972	A	12/1999	Gong	6,111,562	A	8/2000	Downs et al.
5,999,169	A	12/1999	Lee	6,111,572	A	8/2000	Blair et al.
5,999,895	A	12/1999	Forest	6,115,686	A	9/2000	Chung et al.
5,999,908	A	12/1999	Abelow	6,116,907	A	9/2000	Baker et al.
5,999,927	A	12/1999	Tukey et al.	6,119,101	A	9/2000	Peckover
				6,121,960	A	9/2000	Carroll et al.
				6,122,340	A	9/2000	Darley et al.
				6,122,614	A	9/2000	Kahn et al.
				6,122,616	A	9/2000	Henton

(56)

References Cited

U.S. PATENT DOCUMENTS

6,122,647	A	9/2000	Horowitz et al.	6,260,011	B1	7/2001	Heckerman et al.
6,125,284	A	9/2000	Moore et al.	6,260,013	B1	7/2001	Sejnoha
6,125,346	A	9/2000	Nishimura et al.	6,260,016	B1	7/2001	Holm et al.
6,125,356	A	9/2000	Brockman et al.	6,260,024	B1	7/2001	Shkedy
6,129,582	A	10/2000	Wilhite et al.	6,266,098	B1	7/2001	Cove et al.
6,138,098	A	10/2000	Shieber et al.	6,266,637	B1	7/2001	Donovan et al.
6,138,158	A	10/2000	Boyle et al.	6,268,859	B1	7/2001	Andresen et al.
6,141,642	A	10/2000	Oh	6,269,712	B1	8/2001	Zentmyer
6,141,644	A	10/2000	Kuhn et al.	6,271,835	B1	8/2001	Hoeksma
6,144,377	A	11/2000	Oppermann et al.	6,272,456	B1	8/2001	De Campos
6,144,380	A	11/2000	Shwartz et al.	6,272,464	B1	8/2001	Kiraz et al.
6,144,938	A	11/2000	Surace et al.	6,275,795	B1	8/2001	Tzirikel-Hancock
6,144,939	A	11/2000	Pearson et al.	6,275,824	B1	8/2001	O'Flaherty et al.
6,151,401	A	11/2000	Annaratone	6,278,443	B1	8/2001	Amro et al.
6,154,551	A	11/2000	Frenkel	6,278,970	B1	8/2001	Milner
6,154,720	A	11/2000	Onishi et al.	6,282,507	B1	8/2001	Horiguchi et al.
6,157,935	A	12/2000	Tran et al.	6,282,511	B1	8/2001	Mayer
6,161,084	A	12/2000	Messerly et al.	6,285,785	B1	9/2001	Bellegarda et al.
6,161,087	A	12/2000	Wightman et al.	6,285,786	B1	9/2001	Seni et al.
6,161,944	A	12/2000	Leman	6,289,085	B1	9/2001	Miyashita et al.
6,163,769	A	12/2000	Acero et al.	6,289,124	B1	9/2001	Okamoto
6,163,809	A	12/2000	Buckley	6,289,301	B1	9/2001	Higginbotham et al.
6,167,369	A	12/2000	Schulze	6,289,353	B1	9/2001	Hazlehurst et al.
6,169,538	B1	1/2001	Nowlan et al.	6,292,772	B1	9/2001	Kantrowitz
6,172,948	B1	1/2001	Keller et al.	6,292,778	B1	9/2001	Sukkar
6,173,194	B1	1/2001	Vanttila	6,295,390	B1	9/2001	Kobayashi et al.
6,173,251	B1	1/2001	Ito et al.	6,295,391	B1	9/2001	Rudd et al.
6,173,261	B1	1/2001	Arai et al.	6,295,541	B1	9/2001	Bodnar et al.
6,173,263	B1	1/2001	Conkie	6,297,818	B1	10/2001	Ulrich et al.
6,173,279	B1	1/2001	Levin et al.	6,298,314	B1	10/2001	Blackadar et al.
6,177,905	B1	1/2001	Welch	6,298,321	B1	10/2001	Karlov et al.
6,177,931	B1	1/2001	Alexander et al.	6,300,947	B1	10/2001	Kanevsky
6,179,432	B1	1/2001	Zhang et al.	6,304,844	B1	10/2001	Pan et al.
6,182,028	B1	1/2001	Karaali et al.	6,304,846	B1	10/2001	George et al.
6,182,099	B1	1/2001	Nakasato	6,307,548	B1	10/2001	Flinchem et al.
6,185,533	B1	2/2001	Holm et al.	6,308,149	B1	10/2001	Gaussier et al.
6,188,391	B1	2/2001	Seely et al.	6,310,610	B1	10/2001	Beaton et al.
6,188,967	B1	2/2001	Kurtzberg et al.	6,311,152	B1	10/2001	Bai et al.
6,188,999	B1	2/2001	Moody	6,311,157	B1	10/2001	Strong
6,191,939	B1	2/2001	Burnett	6,311,189	B1	10/2001	deVries et al.
6,192,253	B1	2/2001	Charlier et al.	6,314,397	B1	11/2001	Lewis et al.
6,192,340	B1	2/2001	Abecassis	6,317,237	B1	11/2001	Nakao et al.
6,195,641	B1	2/2001	Loring et al.	6,317,594	B1	11/2001	Gossman et al.
6,199,076	B1	3/2001	Logan et al.	6,317,707	B1	11/2001	Bangalore et al.
6,205,456	B1	3/2001	Nakao	6,317,831	B1	11/2001	King
6,208,044	B1	3/2001	Viswanadham et al.	6,321,092	B1	11/2001	Fitch et al.
6,208,932	B1	3/2001	Ohmura et al.	6,321,179	B1	11/2001	Glance et al.
6,208,956	B1	3/2001	Motoyama	6,323,846	B1	11/2001	Westerman et al.
6,208,964	B1	3/2001	Sabourin	6,324,499	B1	11/2001	Lewis et al.
6,208,967	B1	3/2001	Pauws et al.	6,324,502	B1	11/2001	Handel et al.
6,208,971	B1	3/2001	Bellegarda et al.	6,324,512	B1	11/2001	Junqua et al.
6,212,564	B1	4/2001	Harter et al.	6,324,514	B2	11/2001	Matulich et al.
6,216,102	B1	4/2001	Martino et al.	6,330,538	B1	12/2001	Breen
6,216,131	B1	4/2001	Liu et al.	6,331,867	B1	12/2001	Eberhard et al.
6,217,183	B1	4/2001	Shipman	6,332,175	B1	12/2001	Birrell et al.
6,222,347	B1	4/2001	Gong	6,334,103	B1	12/2001	Surace et al.
6,226,403	B1	5/2001	Parthasarathy	6,335,722	B1	1/2002	Tani et al.
6,226,533	B1	5/2001	Akahane	6,336,365	B1	1/2002	Blackadar et al.
6,226,614	B1	5/2001	Mizuno et al.	6,336,727	B1	1/2002	Kim
6,226,655	B1	5/2001	Borman et al.	6,340,937	B1	1/2002	Stepita-Klauco
6,230,322	B1	5/2001	Saib et al.	6,341,316	B1	1/2002	Kloba et al.
6,232,539	B1	5/2001	Looney et al.	6,343,267	B1	1/2002	Kuhn et al.
6,232,966	B1	5/2001	Kurlander	6,345,240	B1	2/2002	Havens
6,233,545	B1	5/2001	Datig	6,345,250	B1	2/2002	Martin
6,233,547	B1	5/2001	Denber et al.	6,347,296	B1	2/2002	Friedland
6,233,559	B1	5/2001	Balakrishnan	6,351,522	B1	2/2002	Vitikainen
6,233,578	B1	5/2001	Machihara et al.	6,351,762	B1	2/2002	Ludwig et al.
6,237,025	B1	5/2001	Ludwig et al.	6,353,442	B1	3/2002	Masui
6,240,303	B1	5/2001	Katzur	6,353,794	B1	3/2002	Davis et al.
6,243,681	B1	6/2001	Guji et al.	6,356,287	B1	3/2002	Ruberry et al.
6,246,981	B1	6/2001	Papineni et al.	6,356,854	B1	3/2002	Schubert et al.
6,248,946	B1	6/2001	Dwek	6,356,864	B1	3/2002	Foltz et al.
6,249,606	B1	6/2001	Kiraly et al.	6,356,905	B1	3/2002	Gershman et al.
6,259,436	B1	7/2001	Moon et al.	6,357,147	B1	3/2002	Darley et al.
6,259,826	B1	7/2001	Pollard et al.	6,359,572	B1	3/2002	Vale
				6,359,970	B1	3/2002	Burgess
				6,360,227	B1	3/2002	Aggarwal et al.
				6,360,237	B1	3/2002	Schulz et al.
				6,363,347	B1	3/2002	Rozaak

(56)

References Cited

U.S. PATENT DOCUMENTS

6,363,348	B1	3/2002	Besling et al.	6,499,013	B1	12/2002	Weber
6,366,883	B1	4/2002	Campbell et al.	6,499,014	B1	12/2002	Chihara
6,366,884	B1	4/2002	Bellegarda et al.	6,499,016	B1	12/2002	Anderson et al.
6,374,217	B1	4/2002	Bellegarda	6,501,937	B1	12/2002	Ho et al.
6,374,226	B1	4/2002	Hunt et al.	6,502,194	B1	12/2002	Berman et al.
6,377,530	B1	4/2002	Burrows	6,505,158	B1	1/2003	Conkie
6,377,925	B1	4/2002	Greene, Jr. et al.	6,505,175	B1	1/2003	Silverman et al.
6,377,928	B1	4/2002	Saxena et al.	6,505,183	B1	1/2003	Loofbourrow et al.
6,381,593	B1	4/2002	Yano et al.	6,507,829	B1	1/2003	Richards et al.
6,385,586	B1	5/2002	Dietz	6,510,406	B1	1/2003	Marchisio
6,385,662	B1	5/2002	Moon et al.	6,510,412	B1	1/2003	Sasai et al.
6,389,114	B1	5/2002	Dowens et al.	6,510,417	B1	1/2003	Woods et al.
6,397,183	B1	5/2002	Baba et al.	6,513,006	B2	1/2003	Howard et al.
6,397,186	B1	5/2002	Bush et al.	6,513,008	B2	1/2003	Pearson et al.
6,400,806	B1	6/2002	Uppaluru	6,513,063	B1	1/2003	Julia et al.
6,400,996	B1	6/2002	Hoffberg et al.	6,519,565	B1	2/2003	Clements et al.
6,401,065	B1	6/2002	Kanevsky et al.	6,519,566	B1	2/2003	Boyer et al.
6,401,085	B1	6/2002	Gershman et al.	6,523,026	B1	2/2003	Gillis
6,405,169	B1	6/2002	Kondo et al.	6,523,061	B1	2/2003	Halverson et al.
6,405,238	B1	6/2002	Votipka	6,523,172	B1	2/2003	Martinez-Guerra et al.
6,408,272	B1	6/2002	White et al.	6,526,351	B2	2/2003	Whitham
6,411,924	B1	6/2002	De Hita et al.	6,526,382	B1	2/2003	Yuschik
6,411,932	B1	6/2002	Molnar et al.	6,526,395	B1	2/2003	Morris
6,415,250	B1	7/2002	Van Den Akker	6,529,592	B1	3/2003	Khan
6,417,873	B1	7/2002	Fletcher et al.	6,529,608	B2	3/2003	Gersabeck et al.
6,418,431	B1	7/2002	Mahajan et al.	6,532,444	B1	3/2003	Weber
6,421,305	B1	7/2002	Gioscia et al.	6,532,446	B1	3/2003	King
6,421,672	B1	7/2002	McAllister et al.	6,535,610	B1	3/2003	Stewart
6,421,707	B1	7/2002	Miller et al.	6,535,852	B2	3/2003	Eide
6,424,944	B1	7/2002	Hikawa	6,535,983	B1	3/2003	McCormack et al.
6,430,531	B1	8/2002	Polish	6,536,139	B2	3/2003	Darley et al.
6,430,551	B1	8/2002	Thelen et al.	6,538,665	B2	3/2003	Crow et al.
6,434,522	B1	8/2002	Tsuboka	6,542,171	B1	4/2003	Satou et al.
6,434,524	B1	8/2002	Weber	6,542,584	B1	4/2003	Sherwood et al.
6,434,529	B1	8/2002	Walker et al.	6,542,868	B1	4/2003	Badt et al.
6,434,604	B1	8/2002	Harada et al.	6,546,262	B1	4/2003	Freadman
6,437,818	B1	8/2002	Ludwig et al.	6,546,367	B2	4/2003	Otsuka
6,438,523	B1	8/2002	Oberteuffer et al.	6,546,388	B1	4/2003	Edlund et al.
6,442,518	B1	8/2002	Van Thong et al.	6,549,497	B2	4/2003	Miyamoto et al.
6,442,523	B1	8/2002	Siegel	6,553,343	B1	4/2003	Kagoshima et al.
6,446,076	B1	9/2002	Burkey et al.	6,553,344	B2	4/2003	Bellegarda et al.
6,448,485	B1	9/2002	Barile	6,556,971	B1	4/2003	Rigsby et al.
6,448,986	B1	9/2002	Smith	6,556,983	B1	4/2003	Altschuler et al.
6,449,620	B1	9/2002	Draper et al.	6,560,903	B1	5/2003	Darley
6,453,281	B1	9/2002	Walters et al.	6,563,769	B1	5/2003	Van Der Meulen
6,453,292	B2	9/2002	Ramaswamy et al.	6,564,186	B1	5/2003	Kiraly et al.
6,453,312	B1	9/2002	Goiffon et al.	6,567,549	B1	5/2003	Marianetti et al.
6,453,315	B1	9/2002	Weissman et al.	6,570,557	B1	5/2003	Westerman et al.
6,456,616	B1	9/2002	Rantanen	6,570,596	B2	5/2003	Frederiksen
6,456,972	B1	9/2002	Gladstein et al.	6,582,342	B2	6/2003	Kaufman
6,460,015	B1	10/2002	Hetherington et al.	6,583,806	B2	6/2003	Ludwig et al.
6,460,029	B1	10/2002	Fries et al.	6,584,464	B1	6/2003	Warthen
6,462,778	B1	10/2002	Abram et al.	6,587,403	B1	7/2003	Keller et al.
6,463,128	B1	10/2002	Elwin	6,587,404	B1	7/2003	Keller et al.
6,463,413	B1	10/2002	Applebaum et al.	6,590,303	B1	7/2003	Austin et al.
6,466,654	B1	10/2002	Cooper et al.	6,591,379	B1	7/2003	LeVine et al.
6,467,924	B2	10/2002	Shipman	6,594,673	B1	7/2003	Smith et al.
6,469,712	B1	10/2002	Hilpert, Jr. et al.	6,594,688	B2	7/2003	Ludwig et al.
6,469,722	B1	10/2002	Kinoe et al.	6,597,345	B2	7/2003	Hirshberg
6,469,732	B1	10/2002	Chang et al.	6,598,021	B1	7/2003	Shambaugh et al.
6,470,347	B1	10/2002	Gillam	6,598,022	B2	7/2003	Yuschik
6,473,630	B1	10/2002	Baranowski et al.	6,598,039	B1	7/2003	Livovsky
6,473,754	B1	10/2002	Matsubayashi et al.	6,598,054	B2	7/2003	Schuetze et al.
6,477,488	B1	11/2002	Bellegarda	6,601,026	B2	7/2003	Appelt et al.
6,477,494	B2	11/2002	Hyde-Thomson et al.	6,601,234	B1	7/2003	Bowman-Amuah
6,487,533	B2	11/2002	Hyde-Thomson et al.	6,603,837	B1	8/2003	Kesanupalli et al.
6,487,534	B1	11/2002	Thelen et al.	6,604,059	B2	8/2003	Strubbe et al.
6,487,663	B1	11/2002	Jaisimha et al.	6,606,101	B1	8/2003	Malamud et al.
6,489,951	B1	12/2002	Wong et al.	6,606,388	B1	8/2003	Townsend et al.
6,490,547	B1	12/2002	Atkin et al.	6,606,632	B1	8/2003	Saulpaugh et al.
6,490,560	B1	12/2002	Ramaswamy et al.	6,611,789	B1	8/2003	Darley
6,493,006	B1	12/2002	Gourdol et al.	6,615,172	B1	9/2003	Bennett et al.
6,493,428	B1	12/2002	Hillier	6,615,175	B1	9/2003	Gazdzinski
6,493,652	B1	12/2002	Ohlenbusch et al.	6,615,176	B2	9/2003	Lewis et al.
6,493,667	B1	12/2002	De Souza et al.	6,615,220	B1	9/2003	Austin et al.
				6,621,768	B1	9/2003	Keller et al.
				6,621,892	B1	9/2003	Banister et al.
				6,622,121	B1	9/2003	Crepuy et al.
				6,622,136	B2	9/2003	Russell

(56)

References Cited

U.S. PATENT DOCUMENTS

6,623,529	B1	9/2003	Lakritz	6,751,621	B1	6/2004	Calistri-Yeh et al.	
6,625,583	B1	9/2003	Silverman et al.	6,754,504	B1	6/2004	Reed	
6,628,808	B1	9/2003	Bach et al.	6,757,362	B1	6/2004	Cooper et al.	
6,631,186	B1	10/2003	Adams et al.	6,757,365	B1	6/2004	Bogard	
6,631,346	B1	10/2003	Karaorman et al.	6,757,646	B2	6/2004	Marchisio	
6,633,741	B1	10/2003	Posa et al.	6,757,653	B2	6/2004	Buth et al.	
6,633,846	B1	10/2003	Bennett et al.	6,757,718	B1	6/2004	Halverson et al.	
6,633,932	B1	10/2003	Bork et al.	6,760,412	B1 *	7/2004	Loucks	H04M 3/42 379/207.03
6,642,940	B1	11/2003	Dakss et al.	6,760,700	B2	7/2004	Lewis et al.	
6,643,401	B1	11/2003	Kashioka et al.	6,760,754	B1	7/2004	Isaacs et al.	
6,643,824	B1	11/2003	Bates et al.	6,762,741	B2	7/2004	Weindorf	
6,647,260	B2	11/2003	Dusse et al.	6,762,777	B2	7/2004	Carroll	
6,650,735	B2	11/2003	Burton et al.	6,763,089	B2	7/2004	Feigenbaum	
6,651,042	B1	11/2003	Field et al.	6,766,294	B2	7/2004	MacGinite et al.	
6,651,218	B1	11/2003	Adler et al.	6,766,295	B1	7/2004	Murveit et al.	
6,654,740	B2	11/2003	Tokuda et al.	6,766,320	B1	7/2004	Wang et al.	
6,658,389	B1	12/2003	Alpdemir	6,766,324	B2	7/2004	Carlson et al.	
6,658,408	B2	12/2003	Yano et al.	6,768,979	B1	7/2004	Menendez-Pidal et al.	
6,658,577	B2	12/2003	Huppi et al.	6,771,982	B1	8/2004	Toupin	
6,661,438	B1	12/2003	Shiraishi et al.	6,772,123	B2	8/2004	Cooklev et al.	
6,662,023	B1	12/2003	Helle	6,772,195	B1	8/2004	Hatlelid et al.	
6,665,639	B2	12/2003	Mozer et al.	6,772,394	B1	8/2004	Kamada	
6,665,640	B1	12/2003	Bennett et al.	6,775,358	B1	8/2004	Breitenbach et al.	
6,665,641	B1	12/2003	Coorman et al.	6,778,951	B1	8/2004	Contractor	
6,671,672	B1	12/2003	Heck	6,778,952	B2	8/2004	Bellegarda	
6,671,683	B2	12/2003	Kanno	6,778,962	B1	8/2004	Kasai et al.	
6,671,856	B1	12/2003	Gillam	6,778,970	B2	8/2004	Au	
6,675,169	B1	1/2004	Bennett et al.	6,778,979	B2	8/2004	Grefenstette et al.	
6,675,233	B1	1/2004	Du et al.	6,782,510	B1	8/2004	Gross et al.	
6,677,932	B1	1/2004	Westerman	6,784,901	B1	8/2004	Harvey et al.	
6,680,675	B1	1/2004	Suzuki	6,789,094	B2	9/2004	Rudoff et al.	
6,684,187	B1	1/2004	Conkie	6,789,231	B1	9/2004	Reynar et al.	
6,684,376	B1	1/2004	Kerzman et al.	6,790,704	B2	9/2004	Doyle et al.	
6,690,387	B2	2/2004	Zimmerman et al.	6,792,082	B1	9/2004	Levine	
6,690,800	B2	2/2004	Resnick	6,792,083	B2	9/2004	Dams et al.	
6,690,828	B2	2/2004	Meyers	6,792,086	B1	9/2004	Saylor et al.	
6,691,064	B2	2/2004	Vroman	6,792,407	B2	9/2004	Kibre et al.	
6,691,090	B1	2/2004	Laurila et al.	6,794,566	B2	9/2004	Pachet	
6,691,111	B2	2/2004	Lazaridis et al.	6,795,059	B2	9/2004	Endo	
6,691,151	B1	2/2004	Cheyre et al.	6,799,162	B1	9/2004	Goronzy et al.	
6,694,295	B2	2/2004	Lindholm et al.	6,799,226	B1	9/2004	Robbin et al.	
6,694,297	B2	2/2004	Sato	6,801,604	B2	10/2004	Maes et al.	
6,697,780	B1	2/2004	Beutnagel et al.	6,801,964	B1	10/2004	Mahdavi	
6,697,824	B1	2/2004	Bowman-Amuah	6,803,905	B1	10/2004	Capps et al.	
6,701,294	B1	3/2004	Ball et al.	6,804,649	B2	10/2004	Miranda	
6,701,305	B1	3/2004	Holt et al.	6,804,677	B2	10/2004	Shadmon et al.	
6,701,318	B2	3/2004	Fox et al.	6,807,536	B2	10/2004	Achlioptas et al.	
6,704,015	B1	3/2004	Bovarnick et al.	6,807,574	B1	10/2004	Partovi et al.	
6,704,034	B1	3/2004	Rodriguez et al.	6,809,724	B1	10/2004	Shiraishi et al.	
6,704,698	B1	3/2004	Paulsen, Jr. et al.	6,810,379	B1	10/2004	Vermeulen et al.	
6,704,710	B2	3/2004	Strong	6,813,218	B1	11/2004	Antonelli et al.	
6,708,153	B2	3/2004	Brittan et al.	6,813,491	B1	11/2004	McKinney	
6,711,585	B1	3/2004	Copperman et al.	6,813,607	B1	11/2004	Faruquie et al.	
6,714,221	B1	3/2004	Christie et al.	6,816,578	B1	11/2004	Kredo et al.	
6,716,139	B1	4/2004	Hosseinzadeh-Dolkhani et al.	6,820,055	B2	11/2004	Saindon et al.	
6,718,324	B2	4/2004	Edlund et al.	6,829,018	B2	12/2004	Lin et al.	
6,718,331	B2	4/2004	Davis et al.	6,829,603	B1	12/2004	Chai et al.	
6,720,980	B1	4/2004	Lui et al.	6,832,194	B1	12/2004	Mozer et al.	
6,721,728	B2	4/2004	McGreevy	6,832,381	B1	12/2004	Mathur et al.	
6,721,734	B1	4/2004	Subasic et al.	6,836,651	B2	12/2004	Segal et al.	
6,724,370	B2	4/2004	Dutta et al.	6,836,760	B1	12/2004	Bellegarda et al.	
6,725,197	B1	4/2004	Wuppermann et al.	6,839,464	B2	1/2005	Hawkins et al.	
6,728,675	B1	4/2004	Maddalozzo, Jr. et al.	6,839,669	B1	1/2005	Gould et al.	
6,728,681	B2	4/2004	Whitham	6,839,670	B1	1/2005	Stammler et al.	
6,728,729	B1	4/2004	Jawa et al.	6,839,742	B1	1/2005	Dyer et al.	
6,731,312	B2	5/2004	Robbin	6,842,767	B1	1/2005	Partovi et al.	
6,732,142	B1	5/2004	Bates et al.	6,847,966	B1	1/2005	Sommer et al.	
6,735,562	B1	5/2004	Zhang et al.	6,847,979	B2	1/2005	Allemang et al.	
6,735,632	B1	5/2004	Kiraly et al.	6,850,775	B1	2/2005	Berg	
6,738,738	B2	5/2004	Henton	6,850,887	B2	2/2005	Epstein et al.	
6,738,742	B2	5/2004	Badt et al.	6,851,115	B1	2/2005	Cheyre et al.	
6,741,264	B1	5/2004	Lesser	6,856,259	B1	2/2005	Sharp	
6,742,021	B1	5/2004	Halverson et al.	6,857,800	B2	2/2005	Zhang et al.	
6,751,592	B1	6/2004	Shiga	6,859,931	B1	2/2005	Cheyre et al.	
6,751,595	B2	6/2004	Busayapongchai et al.	6,862,568	B2	3/2005	Case	
				6,862,710	B1	3/2005	Marchisio	
				6,862,713	B1	3/2005	Kraft et al.	
				6,865,533	B2	3/2005	Addison et al.	

(56)

References Cited

U.S. PATENT DOCUMENTS

6,868,045	B1	3/2005	Schroder	6,970,915	B1	11/2005	Partovi et al.
6,868,385	B1	3/2005	Gerson	6,970,935	B1	11/2005	Maes
6,870,529	B1	3/2005	Davis	6,976,090	B2	12/2005	Ben-Shaul et al.
6,871,346	B1	3/2005	Kumbalimutt et al.	6,978,127	B1	12/2005	Bulthuis et al.
6,873,953	B1	3/2005	Lennig	6,978,239	B2	12/2005	Chu et al.
6,873,986	B2	3/2005	McConnell et al.	6,980,949	B2	12/2005	Ford
6,876,947	B1	4/2005	Darley et al.	6,980,953	B1	12/2005	Kanevsky et al.
6,877,003	B2	4/2005	Ho et al.	6,980,955	B2	12/2005	Okutani et al.
6,879,957	B1	4/2005	Pechter et al.	6,983,251	B1	1/2006	Umemoto et al.
6,882,335	B2	4/2005	Saarinen	6,985,858	B2	1/2006	Frey et al.
6,882,337	B2	4/2005	Shetter	6,985,865	B1	1/2006	Packingham et al.
6,882,747	B2	4/2005	Thawonmas et al.	6,985,958	B2	1/2006	Zwiegincew et al.
6,882,955	B1	4/2005	Ohlenbusch et al.	6,988,063	B2	1/2006	Tokuda et al.
6,882,971	B2	4/2005	Craner	6,988,071	B1	1/2006	Gazdzinski
6,885,734	B1	4/2005	Eberle et al.	6,990,450	B2	1/2006	Case et al.
6,889,361	B1	5/2005	Bates et al.	6,996,520	B2	2/2006	Levin
6,895,084	B1	5/2005	Saylor et al.	6,996,531	B2	2/2006	Korall et al.
6,895,257	B2	5/2005	Boman et al.	6,996,575	B2	2/2006	Cox et al.
6,895,380	B2	5/2005	Sepe, Jr.	6,999,066	B2	2/2006	Litwiller
6,895,558	B1	5/2005	Loveland	6,999,914	B1	2/2006	Boerner et al.
6,898,550	B1	5/2005	Blackadar et al.	6,999,925	B2	2/2006	Fischer et al.
6,901,364	B2	5/2005	Nguyen et al.	6,999,927	B2	2/2006	Mozer et al.
6,901,399	B1	5/2005	Corston et al.	7,000,189	B2	2/2006	Dutta et al.
6,904,405	B2	6/2005	Suominen	7,002,556	B2	2/2006	Tsukada et al.
6,907,112	B1	6/2005	Guedalia et al.	7,003,099	B1	2/2006	Zhang et al.
6,907,140	B2	6/2005	Matsugu et al.	7,003,463	B1	2/2006	Maes et al.
6,910,004	B2	6/2005	Tarbouriech et al.	7,003,522	B1	2/2006	Reynar et al.
6,910,007	B2	6/2005	Stylianou et al.	7,006,969	B2	2/2006	Atal
6,910,012	B2	6/2005	Hartley et al.	7,006,973	B1	2/2006	Genly et al.
6,910,186	B2	6/2005	Kim	7,007,026	B2	2/2006	Wilkinson et al.
6,911,971	B2	6/2005	Suzuki et al.	7,007,239	B1	2/2006	Hawkins et al.
6,912,407	B1	6/2005	Clarke et al.	7,010,581	B2	3/2006	Brown et al.
6,912,498	B2	6/2005	Stevens et al.	7,013,289	B2	3/2006	Horn et al.
6,912,499	B1	6/2005	Sabourin et al.	7,013,308	B1	3/2006	Tunstall-Pedoe
6,915,138	B2	7/2005	Kraft	7,013,429	B2	3/2006	Fujimoto et al.
6,915,246	B2	7/2005	Gusler et al.	7,015,894	B2	3/2006	Morohoshi
6,915,294	B1	7/2005	Singh et al.	7,020,685	B1	3/2006	Chen et al.
6,917,373	B2	7/2005	Vong et al.	7,024,363	B1	4/2006	Comerford et al.
6,918,677	B2	7/2005	Shipman	7,024,364	B2	4/2006	Guerra et al.
6,924,828	B1	8/2005	Hirsch	7,024,366	B1	4/2006	Deyoe et al.
6,925,438	B2	8/2005	Mohamed et al.	7,024,460	B2	4/2006	Koopmas et al.
6,928,149	B1	8/2005	Panjwani et al.	7,027,568	B1	4/2006	Simpson et al.
6,928,614	B1	8/2005	Everhart	7,027,974	B1	4/2006	Busch et al.
6,931,255	B2	8/2005	Mekuria	7,027,990	B2	4/2006	Sussman
6,931,384	B1	8/2005	Horvitz et al.	7,028,252	B1	4/2006	Baru et al.
6,932,708	B2	8/2005	Yamashita et al.	7,030,861	B1	4/2006	Westerman et al.
6,933,928	B1	8/2005	Lilienthal et al.	7,031,530	B2	4/2006	Driggs et al.
6,934,394	B1	8/2005	Anderson	7,031,909	B2	4/2006	Mao et al.
6,934,684	B2	8/2005	Alpdemir et al.	7,035,794	B2	4/2006	Sirivara
6,934,756	B2	8/2005	Maes	7,035,801	B2	4/2006	Jimenez-Feltstrom
6,934,812	B1	8/2005	Robbin et al.	7,035,807	B1	4/2006	Brittain et al.
6,937,975	B1	8/2005	Elworthy	7,036,128	B1	4/2006	Julia et al.
6,937,986	B2	8/2005	Denenberg et al.	7,036,681	B2	5/2006	Suda et al.
6,944,593	B2	9/2005	Kuzunuki et al.	7,038,659	B2	5/2006	Rajkowski
6,944,846	B2	9/2005	Ryzhov	7,039,588	B2	5/2006	Okutani et al.
6,948,094	B2	9/2005	Schultz et al.	7,043,420	B2	5/2006	Ratnaparkhi
6,950,087	B2	9/2005	Knox et al.	7,043,422	B2	5/2006	Gao et al.
6,950,502	B1	9/2005	Jenkins	7,046,230	B2	5/2006	Zadesky et al.
6,952,799	B2	10/2005	Edwards et al.	7,046,850	B2	5/2006	Braspenning et al.
6,954,755	B2	10/2005	Reisman	7,047,193	B1	5/2006	Bellegarda
6,954,899	B1	10/2005	Anderson	7,050,550	B2	5/2006	Steinbiss et al.
6,956,845	B2	10/2005	Baker et al.	7,050,976	B1	5/2006	Packingham
6,957,076	B2	10/2005	Hunzinger	7,050,977	B1	5/2006	Bennett
6,957,183	B2	10/2005	Malayath et al.	7,051,096	B1	5/2006	Krawiec et al.
6,960,734	B1	11/2005	Park	7,054,419	B2	5/2006	Culliss
6,961,699	B1	11/2005	Kahn et al.	7,054,888	B2	5/2006	LaChapelle et al.
6,961,912	B2	11/2005	Aoki et al.	7,057,607	B2	6/2006	Mayoraz et al.
6,963,759	B1	11/2005	Gerson	7,058,569	B2	6/2006	Cooman et al.
6,963,841	B2	11/2005	Handal et al.	7,058,888	B1	6/2006	Gjerstad et al.
6,964,023	B2	11/2005	Maes et al.	7,058,889	B2	6/2006	Trovato et al.
6,965,376	B2	11/2005	Tani et al.	7,062,223	B2	6/2006	Gerber et al.
6,965,863	B1	11/2005	Zuberec et al.	7,062,225	B2	6/2006	White
6,968,311	B2	11/2005	Knockeart et al.	7,062,428	B2	6/2006	Hogenhout et al.
6,970,820	B2	11/2005	Junqua et al.	7,062,438	B2	6/2006	Kobayashi et al.
6,970,881	B1	11/2005	Mohan et al.	7,065,185	B1	6/2006	Koch
				7,065,485	B1	6/2006	Chong-White et al.
				7,069,213	B2	6/2006	Thompson
				7,069,220	B2	6/2006	Coffinan et al.
				7,069,560	B1	6/2006	Cheyser et al.

(56)

References Cited

U.S. PATENT DOCUMENTS

7,072,686	B1	7/2006	Schrager	7,184,064	B2	2/2007	Zimmerman et al.
7,072,941	B2	7/2006	Griffin et al.	7,185,276	B2	2/2007	Keswa
7,076,527	B2	7/2006	Bellegarda et al.	7,188,085	B2	3/2007	Pelletier
7,079,713	B2	7/2006	Simmons	7,190,351	B1	3/2007	Goren
7,082,322	B2	7/2006	Harano	7,190,794	B2	3/2007	Hinde
7,084,758	B1	8/2006	Cole	7,191,118	B2	3/2007	Bellegarda
7,084,856	B2	8/2006	Huppi	7,191,131	B1	3/2007	Nagao
7,085,716	B1	8/2006	Even et al.	7,193,615	B2	3/2007	Kim et al.
7,085,723	B2	8/2006	Ross et al.	7,194,186	B1	3/2007	Strub et al.
7,085,960	B2	8/2006	Bouat et al.	7,194,413	B2	3/2007	Mahoney et al.
7,088,345	B2	8/2006	Robinson et al.	7,194,471	B1	3/2007	Nagatsuka et al.
7,089,292	B1	8/2006	Roderick et al.	7,194,611	B2	3/2007	Bear et al.
7,092,370	B2	8/2006	Jiang et al.	7,194,699	B2	3/2007	Thomson et al.
7,092,887	B2	8/2006	Mozer et al.	7,197,120	B2	3/2007	Luehrig et al.
7,092,928	B1	8/2006	Elad et al.	7,197,460	B1	3/2007	Gupta et al.
7,092,950	B2	8/2006	Wong et al.	7,200,550	B2	4/2007	Menezes et al.
7,093,693	B1	8/2006	Gazdzinski	7,200,558	B2	4/2007	Kato et al.
7,095,733	B1	8/2006	Yarlagadda et al.	7,200,559	B2	4/2007	Wang
7,096,183	B2	8/2006	Junqua	7,203,297	B2	4/2007	Vitikainen et al.
7,100,117	B1	8/2006	Chwa et al.	7,203,646	B2	4/2007	Bennett
7,103,548	B2	9/2006	Squibbs et al.	7,206,809	B2	4/2007	Ludwig et al.
7,107,204	B1	9/2006	Liu et al.	7,212,827	B1	5/2007	Veschi
7,110,998	B1	9/2006	Bhandari et al.	7,216,008	B2	5/2007	Sakata
7,111,248	B2	9/2006	Mulvey et al.	7,216,066	B2	5/2007	Di et al.
7,111,774	B2	9/2006	Song	7,216,073	B2	5/2007	Lavi et al.
7,113,803	B2	9/2006	Dehlin	7,216,080	B2	5/2007	Tsiao et al.
7,113,943	B2	9/2006	Bradford et al.	7,218,920	B2	5/2007	Hyon
7,115,035	B2	10/2006	Tanaka	7,218,943	B2	5/2007	Klassen et al.
7,117,231	B2	10/2006	Fischer et al.	7,219,063	B2	5/2007	Schalk et al.
7,120,865	B1	10/2006	Horvitz et al.	7,219,123	B1	5/2007	Fiechter et al.
7,123,696	B2	10/2006	Lowe	7,225,125	B2	5/2007	Bennett et al.
7,124,081	B1	10/2006	Bellegarda	7,228,278	B2	6/2007	Nguyen et al.
7,124,082	B2	10/2006	Freedman	7,231,343	B1	6/2007	Treadgold et al.
7,124,164	B1	10/2006	Chemtob	7,231,597	B1	6/2007	Braun et al.
7,127,046	B1	10/2006	Smith et al.	7,233,790	B2	6/2007	Kjellberg et al.
7,127,394	B2	10/2006	Strong et al.	7,233,904	B2	6/2007	Luisi
7,127,396	B2	10/2006	Chu et al.	7,234,026	B2	6/2007	Robbin et al.
7,127,403	B1	10/2006	Saylor et al.	7,236,932	B1	6/2007	Grajski
7,129,932	B1	10/2006	Klarlund et al.	7,240,002	B2	7/2007	Minamino et al.
7,133,900	B1	11/2006	Szeto	7,243,130	B2	7/2007	Horvitz et al.
7,136,710	B1	11/2006	Hoffberg et al.	7,243,305	B2	7/2007	Schabes et al.
7,136,818	B1	11/2006	Cosatto et al.	7,246,118	B2	7/2007	Chastain et al.
7,137,126	B1	11/2006	Coffman et al.	7,246,151	B2	7/2007	Isaacs et al.
7,139,697	B2	11/2006	Häkkinen et al.	7,248,900	B2	7/2007	Deeds et al.
7,139,714	B2	11/2006	Bennett et al.	7,251,313	B1	7/2007	Miller et al.
7,139,722	B2	11/2006	Perrella et al.	7,251,454	B2	7/2007	White
7,143,028	B2	11/2006	Hillis et al.	7,254,773	B2	8/2007	Bates et al.
7,143,038	B2	11/2006	Katae	7,257,537	B2	8/2007	Ross et al.
7,143,040	B2	11/2006	Durston et al.	7,259,752	B1	8/2007	Simmons
7,146,319	B2	12/2006	Hunt	7,260,529	B1	8/2007	Lengen
7,146,437	B2	12/2006	Robbin et al.	7,260,567	B2	8/2007	Parikh et al.
7,149,319	B2	12/2006	Roeck	7,263,373	B2	8/2007	Mattisson
7,149,695	B1	12/2006	Bellegarda	7,266,189	B1	9/2007	Day
7,149,964	B1	12/2006	Cottrille et al.	7,266,495	B1	9/2007	Beaufays et al.
7,152,070	B1	12/2006	Musick et al.	7,266,496	B2	9/2007	Wang et al.
7,152,093	B2	12/2006	Ludwig et al.	7,266,499	B2	9/2007	Surace et al.
7,154,526	B2	12/2006	Foote et al.	7,269,544	B2	9/2007	Simske
7,155,668	B2	12/2006	Holland et al.	7,269,556	B2	9/2007	Kiss et al.
7,158,647	B2	1/2007	Azima et al.	7,272,224	B1	9/2007	Normile et al.
7,159,174	B2	1/2007	Johnson et al.	7,275,063	B2	9/2007	Horn
7,162,412	B2	1/2007	Yamada et al.	7,277,088	B2	10/2007	Robinson et al.
7,162,482	B1	1/2007	Dunning	7,277,854	B2	10/2007	Bennett et al.
7,165,073	B2	1/2007	Vandersluis	7,277,855	B1	10/2007	Acker et al.
7,166,791	B2	1/2007	Robbin et al.	7,280,958	B2	10/2007	Pavlov et al.
7,171,350	B2	1/2007	Lin et al.	7,283,072	B1	10/2007	Plachta et al.
7,171,360	B2	1/2007	Huang et al.	7,289,102	B2	10/2007	Hinckley et al.
7,174,042	B1	2/2007	Simmons et al.	7,290,039	B1	10/2007	Lisitsa et al.
7,174,295	B1	2/2007	Kivimaki	7,292,579	B2	11/2007	Morris
7,174,297	B2	2/2007	Guerra et al.	7,292,979	B2	11/2007	Karas et al.
7,174,298	B2	2/2007	Sharma	7,292,980	B1	11/2007	August et al.
7,177,794	B2	2/2007	Mani et al.	7,296,019	B1	11/2007	Chandrasekar et al.
7,177,798	B2	2/2007	Hsu et al.	7,296,230	B2	11/2007	Fukatsu et al.
7,177,817	B1	2/2007	Khosla et al.	7,299,033	B2	11/2007	Kjellberg et al.
7,181,386	B2	2/2007	Mohri et al.	7,302,392	B1	11/2007	Thenthiruperai et al.
7,181,388	B2	2/2007	Tian	7,302,394	B1	11/2007	Baray et al.
				7,302,686	B2	11/2007	Togawa
				7,308,404	B2	12/2007	Venkataraman et al.
				7,308,408	B1	12/2007	Stifelman et al.
				7,310,329	B2	12/2007	Vieri et al.

(56)

References Cited

U.S. PATENT DOCUMENTS

7,310,600	B1	12/2007	Garner et al.	7,472,061	B1	12/2008	Alewine et al.
7,310,605	B2	12/2007	Janakiraman et al.	7,472,065	B2	12/2008	Aaron et al.
7,313,523	B1	12/2007	Bellegarda et al.	7,475,010	B2	1/2009	Chao
7,315,809	B2	1/2008	Xun	7,475,015	B2	1/2009	Epstein et al.
7,315,818	B2	1/2008	Stevens et al.	7,475,063	B2	1/2009	Datta et al.
7,318,020	B1	1/2008	Kim	7,477,238	B2	1/2009	Fux et al.
7,319,957	B2	1/2008	Robinson et al.	7,477,240	B2	1/2009	Yanagisawa
7,321,783	B2	1/2008	Kim	7,478,037	B2	1/2009	Strong
7,322,023	B2	1/2008	Shulman et al.	7,478,091	B2	1/2009	Mojsilovic et al.
7,324,833	B2	1/2008	White et al.	7,478,129	B1	1/2009	Chemtob
7,324,947	B2	1/2008	Jordan et al.	7,479,948	B2	1/2009	Kim et al.
7,328,155	B2	2/2008	Endo et al.	7,479,949	B2	1/2009	Jobs et al.
7,328,250	B2	2/2008	Wang et al.	7,483,832	B2	1/2009	Tischer
7,345,670	B2	3/2008	Armstrong	7,483,894	B2	1/2009	Cao
7,345,671	B2	3/2008	Robbin et al.	7,487,089	B2	2/2009	Mozer
7,349,953	B2	3/2008	Lisitsa et al.	7,487,093	B2	2/2009	Mutsuno et al.
7,353,139	B1	4/2008	Burrell et al.	7,490,034	B2	2/2009	Finnigan et al.
7,359,493	B1	4/2008	Wang et al.	7,490,039	B1	2/2009	Shaffer et al.
7,359,671	B2	4/2008	Richenstein et al.	7,493,560	B1	2/2009	Kipnes et al.
7,359,851	B2	4/2008	Tong et al.	7,496,498	B2	2/2009	Chu et al.
7,360,158	B1	4/2008	Beeman	7,496,512	B2	2/2009	Zhao et al.
7,362,738	B2	4/2008	Taube et al.	7,499,923	B2	3/2009	Kawatani
7,363,227	B2	4/2008	Mapes-Riordan et al.	7,502,738	B2	3/2009	Kennewick et al.
7,363,586	B1	4/2008	Briggs et al.	7,505,795	B1	3/2009	Lim et al.
7,365,260	B2	4/2008	Kawashima	7,508,324	B2	3/2009	Suraqui
7,366,461	B1	4/2008	Brown	7,508,373	B2	3/2009	Lin et al.
7,373,291	B2	5/2008	Garst	7,516,123	B2	4/2009	Betz et al.
7,373,612	B2	5/2008	Risch et al.	7,519,327	B2	4/2009	White
7,376,556	B2	5/2008	Bennett	7,519,398	B2	4/2009	Hirose
7,376,632	B1	5/2008	Sadek et al.	7,522,927	B2	4/2009	Fitch et al.
7,376,645	B2	5/2008	Bernard	7,523,036	B2	4/2009	Akabane et al.
7,378,963	B1	5/2008	Begault et al.	7,523,108	B2	4/2009	Cao
7,379,874	B2	5/2008	Schmid et al.	7,526,466	B2	4/2009	Au
7,380,203	B2	5/2008	Keely et al.	7,526,738	B2	4/2009	Ording et al.
7,383,170	B2	6/2008	Mills et al.	7,528,713	B2	5/2009	Singh et al.
7,386,438	B1	6/2008	Franz et al.	7,529,671	B2	5/2009	Rockenbeck et al.
7,386,449	B2	6/2008	Sun et al.	7,529,676	B2	5/2009	Koyama
7,386,799	B1	6/2008	Clanton et al.	7,535,997	B1	5/2009	McQuaide, Jr. et al.
7,389,224	B1	6/2008	Elworthy	7,536,029	B2	5/2009	Choi et al.
7,389,225	B1	6/2008	Jensen et al.	7,536,565	B2	5/2009	Girish et al.
7,392,185	B2	6/2008	Bennett	7,538,685	B1	5/2009	Cooper et al.
7,394,947	B2	7/2008	Li et al.	7,539,619	B1	5/2009	Seligman et al.
7,398,209	B2	7/2008	Kennewick et al.	7,539,656	B2	5/2009	Fratkina et al.
7,401,300	B2	7/2008	Nurmi	7,541,940	B2	6/2009	Upton
7,403,938	B2	7/2008	Harrison et al.	7,542,967	B2	6/2009	Hurst-Hiller et al.
7,403,941	B2	7/2008	Bedworth et al.	7,542,971	B2	6/2009	Thione et al.
7,404,143	B2	7/2008	Freelander et al.	7,543,232	B2	6/2009	Easton, Jr. et al.
7,409,337	B1	8/2008	Potter et al.	7,546,382	B2	6/2009	Healey et al.
7,409,347	B1	8/2008	Bellegarda	7,546,529	B2	6/2009	Reynar et al.
7,412,389	B2	8/2008	Yang	7,548,895	B2	6/2009	Pulsipher
7,412,470	B2	8/2008	Masuno et al.	7,552,045	B2	6/2009	Barliga et al.
7,415,100	B2	8/2008	Cooper et al.	7,552,055	B2	6/2009	Lecoecuche
7,415,469	B2	8/2008	Singh et al.	7,555,431	B2	6/2009	Bennett
7,418,389	B2	8/2008	Chu et al.	7,555,496	B1	6/2009	Lantrip et al.
7,418,392	B1	8/2008	Mozer et al.	7,558,381	B1	7/2009	Ali et al.
7,426,467	B2	9/2008	Nashida et al.	7,558,730	B2	7/2009	Davis et al.
7,426,468	B2	9/2008	Coifman et al.	7,559,026	B2	7/2009	Girish et al.
7,427,024	B1	9/2008	Gazdzinski et al.	7,561,069	B2	7/2009	Horstemeyer
7,428,541	B2	9/2008	Houle	7,562,007	B2	7/2009	Hwang
7,433,869	B2	10/2008	Gollapudi	7,562,032	B2	7/2009	Abbosh et al.
7,433,921	B2	10/2008	Ludwig et al.	7,565,104	B1	7/2009	Brown et al.
7,436,947	B2	10/2008	Wadler et al.	7,565,380	B1	7/2009	Venkatachary
7,441,184	B2	10/2008	Frerebeau et al.	7,571,092	B1	8/2009	Nieh
7,443,316	B2	10/2008	Lim	7,571,106	B2	8/2009	Cao et al.
7,444,589	B2	10/2008	Zellner	7,577,522	B2	8/2009	Rosenberg
7,447,360	B2	11/2008	Li et al.	7,580,551	B1	8/2009	Srihari et al.
7,447,624	B2	11/2008	Fuhrmann et al.	7,580,576	B2	8/2009	Wang et al.
7,447,635	B1	11/2008	Konopka et al.	7,580,839	B2	8/2009	Tamura et al.
7,447,637	B1	11/2008	Grant et al.	7,584,093	B2	9/2009	Potter et al.
7,451,081	B1	11/2008	Gajic et al.	7,584,278	B2	9/2009	Rajarajan et al.
7,454,351	B2	11/2008	Jeschke et al.	7,584,429	B2	9/2009	Fabritius
7,460,652	B2	12/2008	Chang	7,593,868	B2	9/2009	Margiloff et al.
7,461,043	B2	12/2008	Hess	7,596,269	B2	9/2009	King et al.
7,467,087	B1	12/2008	Gillick et al.	7,596,499	B2	9/2009	Anguera et al.
7,467,164	B2	12/2008	Marsh	7,596,606	B2	9/2009	Codignotto
				7,596,765	B2	9/2009	Almas
				7,599,918	B2	10/2009	Shen et al.
				7,603,349	B1	10/2009	Kraft et al.
				7,603,381	B2	10/2009	Burke et al.

(56)

References Cited

U.S. PATENT DOCUMENTS

7,606,444	B1	10/2009	Erol et al.	7,716,216	B1	5/2010	Harik et al.
7,609,179	B2	10/2009	Diaz-Gutierrez et al.	7,720,674	B2	5/2010	Kaiser et al.
7,610,258	B2	10/2009	Yuknewicz et al.	7,720,683	B1	5/2010	Vermeulen et al.
7,613,264	B2	11/2009	Wells et al.	7,721,226	B2	5/2010	Barabe et al.
7,614,008	B2	11/2009	Ording	7,721,301	B2	5/2010	Wong et al.
7,617,094	B2	11/2009	Aoki et al.	7,724,242	B2	5/2010	Hillis et al.
7,620,407	B1	11/2009	Donald et al.	7,724,696	B1	5/2010	Parekh
7,620,549	B2	11/2009	Di Cristo et al.	7,725,307	B2	5/2010	Bennett
7,620,894	B1	11/2009	Kahn	7,725,318	B2	5/2010	Gavalda et al.
7,623,119	B2	11/2009	Autio et al.	7,725,320	B2	5/2010	Bennett
7,624,007	B2	11/2009	Bennett	7,725,321	B2	5/2010	Bennett
7,627,481	B1	12/2009	Kuo et al.	7,725,838	B2	5/2010	Williams
7,630,901	B2	12/2009	Omi	7,729,904	B2	6/2010	Bennett
7,633,076	B2	12/2009	Huppi et al.	7,729,916	B2	6/2010	Coffman et al.
7,634,409	B2	12/2009	Kennewick et al.	7,734,461	B2	6/2010	Kwak et al.
7,634,413	B1	12/2009	Kuo et al.	7,735,012	B2	6/2010	Naik
7,634,718	B2	12/2009	Nakajima	7,739,588	B2	6/2010	Reynar et al.
7,634,732	B1	12/2009	Blagsvedt et al.	7,742,953	B2	6/2010	King et al.
7,636,657	B2	12/2009	Ju et al.	7,743,188	B2	6/2010	Haitani et al.
7,640,158	B2	12/2009	Detlef et al.	7,747,616	B2	6/2010	Yamada et al.
7,640,160	B2	12/2009	Di Cristo et al.	7,752,152	B2	7/2010	Paek et al.
7,643,990	B1	1/2010	Bellegarda	7,756,708	B2	7/2010	Cohen et al.
7,647,225	B2	1/2010	Bennett et al.	7,756,868	B2	7/2010	Lee
7,649,454	B2	1/2010	Singh et al.	7,756,871	B2	7/2010	Yacoub et al.
7,649,877	B2	1/2010	Vieri et al.	7,757,173	B2	7/2010	Beaman
7,653,883	B2	1/2010	Hotelling et al.	7,757,182	B2	7/2010	Elliott et al.
7,656,393	B2	2/2010	King et al.	7,761,296	B1	7/2010	Bakis et al.
7,657,424	B2	2/2010	Bennett	7,763,842	B2	7/2010	Hsu et al.
7,657,828	B2	2/2010	Lucas et al.	7,774,204	B2	8/2010	Mozer et al.
7,657,844	B2	2/2010	Gibson et al.	7,774,388	B1	8/2010	Runchey
7,657,849	B2	2/2010	Chaudhri et al.	7,777,717	B2	8/2010	Fux et al.
7,663,607	B2	2/2010	Hotelling et al.	7,778,432	B2	8/2010	Larsen
7,664,558	B2	2/2010	Lindahl et al.	7,778,595	B2	8/2010	White et al.
7,664,638	B2	2/2010	Cooper et al.	7,778,632	B2	8/2010	Kurlander et al.
7,669,134	B1	2/2010	Christie et al.	7,778,830	B2	8/2010	Davis et al.
7,672,841	B2	3/2010	Bennett	7,779,353	B2	8/2010	Grigoriu et al.
7,672,952	B2	3/2010	Isaacson et al.	7,779,356	B2	8/2010	Griesmer
7,673,238	B2	3/2010	Girish et al.	7,779,357	B2	8/2010	Naik
7,673,340	B1	3/2010	Cohen et al.	7,783,283	B2	8/2010	Kuusinen et al.
7,676,026	B1	3/2010	Baxter, Jr.	7,783,486	B2	8/2010	Rosser et al.
7,676,365	B2	3/2010	Hwang et al.	7,788,590	B2	8/2010	Taboada et al.
7,676,463	B2	3/2010	Thompson et al.	7,788,663	B2	8/2010	Illowsky et al.
7,679,534	B2	3/2010	Kay et al.	7,796,980	B1	9/2010	McKinney et al.
7,680,649	B2	3/2010	Park	7,797,265	B2	9/2010	Brinker et al.
7,681,126	B2	3/2010	Roose	7,797,269	B2	9/2010	Rieman et al.
7,683,886	B2	3/2010	Willey	7,797,331	B2	9/2010	Theimer et al.
7,683,893	B2	3/2010	Kim	7,797,629	B2	9/2010	Fux et al.
7,684,985	B2	3/2010	Dominach et al.	7,801,721	B2	9/2010	Rosart et al.
7,684,990	B2	3/2010	Caskey et al.	7,801,728	B2	9/2010	Ben-David et al.
7,684,991	B2	3/2010	Stohr et al.	7,801,729	B2	9/2010	Mozer
7,689,245	B2	3/2010	Cox et al.	7,805,299	B2	9/2010	Coifman
7,689,408	B2	3/2010	Chen et al.	7,809,550	B1	10/2010	Barrows
7,689,409	B2	3/2010	Heinecke	7,809,565	B2	10/2010	Coifman
7,689,421	B2	3/2010	Li et al.	7,809,569	B2	10/2010	Attwater et al.
7,693,715	B2	4/2010	Hwang et al.	7,809,570	B2	10/2010	Kennewick et al.
7,693,717	B2	4/2010	Kahn et al.	7,809,610	B2	10/2010	Cao
7,693,719	B2	4/2010	Chu et al.	7,809,744	B2	10/2010	Nevidomski et al.
7,693,720	B2	4/2010	Kennewick et al.	7,818,165	B2	10/2010	Carlgren et al.
7,698,131	B2	4/2010	Bennett	7,818,176	B2	10/2010	Freeman et al.
7,702,500	B2	4/2010	Blaedow	7,818,215	B2	10/2010	King et al.
7,702,508	B2	4/2010	Bennett	7,818,291	B2	10/2010	Ferguson et al.
7,703,091	B1	4/2010	Martin et al.	7,818,672	B2	10/2010	Mccormack et al.
7,706,510	B2	4/2010	Ng	7,822,608	B2	10/2010	Cross, Jr. et al.
7,707,026	B2	4/2010	Liu	7,823,123	B2	10/2010	Sabbouh
7,707,027	B2	4/2010	Balchandran et al.	7,826,945	B2	11/2010	Zhang et al.
7,707,032	B2	4/2010	Wang et al.	7,827,047	B2	11/2010	Anderson et al.
7,707,221	B1	4/2010	Dunning et al.	7,831,423	B2	11/2010	Schubert
7,707,267	B2	4/2010	Lisitsa et al.	7,831,426	B2	11/2010	Bennett
7,710,262	B2	5/2010	Ruha	7,831,432	B2	11/2010	Bodin et al.
7,711,129	B2	5/2010	Lindahl et al.	7,835,504	B1	11/2010	Donald et al.
7,711,550	B1	5/2010	Feinberg et al.	7,836,437	B2	11/2010	Kacmarcik et al.
7,711,565	B1	5/2010	Gazdzinski	7,840,348	B2	11/2010	Kim et al.
7,711,672	B2	5/2010	Au	7,840,400	B2	11/2010	Lavi et al.
7,712,053	B2	5/2010	Bradford et al.	7,840,447	B2	11/2010	Kleinrock et al.
7,716,056	B2	5/2010	Weng et al.	7,840,581	B2	11/2010	Ross et al.
				7,840,912	B2	11/2010	Elias et al.
				7,844,394	B2	11/2010	Kim
				7,848,924	B2	12/2010	Nurminen et al.
				7,848,926	B2	12/2010	Goto et al.

(56)

References Cited

U.S. PATENT DOCUMENTS

7,853,444	B2	12/2010	Wang et al.	8,005,664	B2	8/2011	Hanumanthappa
7,853,445	B2	12/2010	Bachenko et al.	8,005,679	B2	8/2011	Jordan et al.
7,853,574	B2	12/2010	Kraenzel et al.	8,006,180	B2	8/2011	Tunning et al.
7,853,577	B2	12/2010	Sundaresan et al.	8,014,308	B2	9/2011	Gates et al.
7,853,664	B1	12/2010	Wang et al.	8,015,006	B2	9/2011	Kennewick et al.
7,853,900	B2	12/2010	Nguyen et al.	8,015,011	B2	9/2011	Nagano et al.
7,865,817	B2	1/2011	Ryan et al.	8,015,144	B2	9/2011	Zheng et al.
7,869,999	B2	1/2011	Amato et al.	8,018,431	B1	9/2011	Zehr et al.
7,870,118	B2	1/2011	Jiang et al.	8,019,271	B1	9/2011	Izdepski
7,870,133	B2	1/2011	Krishnamoorthy et al.	8,024,195	B2	9/2011	Mozer et al.
7,873,519	B2	1/2011	Bennett	8,024,415	B2	9/2011	Horvitz et al.
7,873,654	B2	1/2011	Bernard	8,027,836	B2	9/2011	Baker et al.
7,877,705	B2	1/2011	Chambers et al.	8,031,943	B2	10/2011	Chen et al.
7,880,730	B2	2/2011	Robinson et al.	8,032,383	B1	10/2011	Bhardwaj et al.
7,881,283	B2	2/2011	Cormier et al.	8,036,901	B2	10/2011	Mozer
7,881,936	B2	2/2011	Longe et al.	8,037,034	B2	10/2011	Plachta et al.
7,885,390	B2	2/2011	Chaudhuri et al.	8,041,557	B2	10/2011	Liu
7,885,844	B1	2/2011	Cohen et al.	8,041,570	B2	10/2011	Mirkovic et al.
7,886,233	B2	2/2011	Rainisto et al.	8,041,611	B2	10/2011	Kleinrock et al.
7,889,184	B2	2/2011	Blumenberg et al.	8,042,053	B2	10/2011	Darwish et al.
7,889,185	B2	2/2011	Blumenberg et al.	8,046,363	B2	10/2011	Cha et al.
7,890,330	B2	2/2011	Ozkaragoz et al.	8,046,374	B1	10/2011	Bromwich et al.
7,890,652	B2	2/2011	Bull et al.	8,050,500	B1	11/2011	Batty et al.
7,895,531	B2	2/2011	Radtke et al.	8,055,502	B2	11/2011	Clark et al.
7,899,666	B2	3/2011	Varone	8,055,708	B2	11/2011	Chitsaz et al.
7,908,287	B1	3/2011	Katragadda	8,056,070	B2	11/2011	Goller et al.
7,912,289	B2	3/2011	Kansal et al.	8,060,824	B2	11/2011	Brownrigg, Jr. et al.
7,912,699	B1	3/2011	Saraclar et al.	8,064,753	B2	11/2011	Freeman
7,912,702	B2	3/2011	Bennett	8,065,143	B2	11/2011	Yanagihara
7,912,720	B1	3/2011	Hakkani-Tur et al.	8,065,155	B1	11/2011	Gazdzinski
7,912,828	B2	3/2011	Bonnet et al.	8,065,156	B2	11/2011	Gazdzinski
7,913,185	B1	3/2011	Benson et al.	8,068,604	B2	11/2011	Leeds et al.
7,916,979	B2	3/2011	Simmons	8,069,046	B2	11/2011	Kennewick et al.
7,917,367	B2	3/2011	Di Cristo et al.	8,069,422	B2	11/2011	Sheshagiri et al.
7,917,497	B2	3/2011	Harrison et al.	8,073,681	B2	12/2011	Baldwin et al.
7,920,678	B2	4/2011	Cooper et al.	8,073,695	B1	12/2011	Hendricks et al.
7,920,682	B2	4/2011	Byrne et al.	8,077,153	B2	12/2011	Benko et al.
7,920,857	B2	4/2011	Lau et al.	8,078,473	B1	12/2011	Gazdzinski
7,925,525	B2	4/2011	Chin	8,082,153	B2	12/2011	Coffman et al.
7,925,610	B2	4/2011	Elbaz et al.	8,082,498	B2	12/2011	Salamon et al.
7,929,805	B2	4/2011	Wang et al.	8,090,571	B2	1/2012	Elshishiny et al.
7,930,168	B2	4/2011	Weng et al.	8,095,364	B2	1/2012	Longe et al.
7,930,183	B2	4/2011	Odell et al.	8,099,289	B2	1/2012	Mozer et al.
7,930,197	B2	4/2011	Ozzie et al.	8,099,395	B2	1/2012	Pabla et al.
7,936,339	B2	5/2011	Marggraff et al.	8,099,418	B2	1/2012	Inoue et al.
7,936,861	B2	5/2011	Martin et al.	8,103,510	B2	1/2012	Sato
7,941,009	B2	5/2011	Li et al.	8,107,401	B2	1/2012	John et al.
7,945,294	B2	5/2011	Zhang et al.	8,112,275	B2	2/2012	Kennewick et al.
7,945,470	B1	5/2011	Cohen et al.	8,112,280	B2	2/2012	Lu
7,949,529	B2	5/2011	Weider et al.	8,117,037	B2	2/2012	Gazdzinski
7,949,534	B2	5/2011	Davis et al.	8,117,542	B2	2/2012	Radtke et al.
7,953,679	B2	5/2011	Chidlovskii et al.	8,121,413	B2	2/2012	Hwang et al.
7,957,975	B2	6/2011	Burns et al.	8,121,837	B2	2/2012	Agapi et al.
7,958,136	B1	6/2011	Curtis et al.	8,122,094	B1	2/2012	Kotab
7,962,179	B2	6/2011	Huang	8,122,353	B2	2/2012	Bouta
7,974,844	B2	7/2011	Sumita	8,131,557	B2	3/2012	Davis et al.
7,974,972	B2	7/2011	Cao	8,135,115	B1	3/2012	Hogg, Jr. et al.
7,975,216	B2	7/2011	Woolf et al.	8,138,912	B2	3/2012	Singh et al.
7,983,478	B2	7/2011	Liu et al.	8,140,335	B2	3/2012	Kennewick et al.
7,983,915	B2	7/2011	Knight et al.	8,140,567	B2	3/2012	Padovitz et al.
7,983,917	B2	7/2011	Kennewick et al.	8,150,694	B2	4/2012	Kennewick et al.
7,983,919	B2	7/2011	Conkie	8,150,700	B2	4/2012	Shin et al.
7,983,997	B2	7/2011	Allen et al.	8,155,956	B2	4/2012	Cho et al.
7,984,062	B2	7/2011	Dunning et al.	8,156,005	B2	4/2012	Vieri
7,986,431	B2	7/2011	Emori et al.	8,160,883	B2	4/2012	Lecoeuche
7,987,151	B2	7/2011	Schott et al.	8,165,321	B2	4/2012	Paquier et al.
7,987,244	B1	7/2011	Lewis et al.	8,165,886	B1	4/2012	Gagnon et al.
7,991,614	B2	8/2011	Washio et al.	8,166,019	B1	4/2012	Lee et al.
7,992,085	B2	8/2011	Wang-Aryattanwanich et al.	8,166,032	B2	4/2012	Sommer et al.
7,996,228	B2	8/2011	Miller et al.	8,170,790	B2	5/2012	Lee et al.
7,996,589	B2	8/2011	Schultz et al.	8,179,370	B1	5/2012	Yamasani et al.
7,996,769	B2	8/2011	Fux et al.	8,188,856	B2	5/2012	Singh et al.
7,996,792	B2	8/2011	Anzures et al.	8,190,359	B2	5/2012	Bourne
7,999,669	B2	8/2011	Singh et al.	8,195,467	B2	6/2012	Mozer et al.
8,000,453	B2	8/2011	Cooper et al.	8,195,468	B2	6/2012	Kennewick et al.
				8,200,495	B2	6/2012	Braho et al.
				8,201,109	B2	6/2012	Van Os et al.
				8,204,238	B2	6/2012	Mozer
				8,205,788	B1	6/2012	Gazdzinski et al.

(56)

References Cited

U.S. PATENT DOCUMENTS

8,209,183	B1	6/2012	Patel et al.	8,589,911	B1	11/2013	Sharkey et al.
8,219,115	B1	7/2012	Nelissen	8,595,004	B2	11/2013	Koshinaka
8,219,406	B2	7/2012	Yu et al.	8,606,568	B1	12/2013	Tickner et al.
8,219,407	B1	7/2012	Roy et al.	8,620,659	B2	12/2013	Di Cristo et al.
8,219,608	B2	7/2012	alSafadi et al.	8,620,662	B2	12/2013	Bellegarda
8,224,649	B2	7/2012	Chaudhari et al.	8,626,681	B1	1/2014	Jurca et al.
8,228,299	B1	7/2012	Maloney et al.	8,645,137	B2	2/2014	Bellegarda et al.
8,239,207	B2	8/2012	Seligman et al.	8,654,936	B1	2/2014	Tofighbakhsh et al.
8,244,712	B2	8/2012	Serlet et al.	8,655,646	B2	2/2014	Lee et al.
8,255,217	B2	8/2012	Stent et al.	8,655,901	B1	2/2014	Li et al.
8,260,617	B2	9/2012	Dhanakshirur et al.	8,660,843	B2	2/2014	Falcon et al.
8,270,933	B2	9/2012	Riemer et al.	8,660,849	B2	2/2014	Gruber et al.
8,275,621	B2	9/2012	Alewine et al.	8,660,970	B1	2/2014	Fiedorowicz
8,279,171	B2	10/2012	Hirai et al.	8,661,112	B2	2/2014	Creamer et al.
8,285,546	B2	10/2012	Reich	8,661,340	B2	2/2014	Goldsmith et al.
8,285,551	B2	10/2012	Gazdzinski	8,670,979	B2	3/2014	Gruber et al.
8,285,553	B2	10/2012	Gazdzinski	8,675,084	B2	3/2014	Bolton et al.
8,290,777	B1	10/2012	Nguyen et al.	8,676,904	B2	3/2014	Lindahl et al.
8,290,778	B2	10/2012	Gazdzinski	8,677,377	B2	3/2014	Cheyet et al.
8,290,781	B2	10/2012	Gazdzinski	8,681,950	B2	3/2014	Vlack et al.
8,296,124	B1	10/2012	Holsztynska et al.	8,682,667	B2	3/2014	Haughay et al.
8,296,145	B2	10/2012	Clark et al.	8,688,446	B2	4/2014	Yanagihara et al.
8,296,146	B2	10/2012	Gazdzinski	8,688,453	B1	4/2014	Joshi et al.
8,296,153	B2	10/2012	Gazdzinski	8,696,364	B2	4/2014	Cohen
8,296,380	B1	10/2012	Kelly et al.	8,706,472	B2	4/2014	Ramerth et al.
8,296,383	B2	10/2012	Lindahl	8,706,503	B2	4/2014	Cheyet et al.
8,300,801	B2	10/2012	Sweeney et al.	8,713,119	B2	4/2014	Lindahl et al.
8,301,456	B2	10/2012	Gazdzinski	8,713,418	B2	4/2014	King et al.
8,311,834	B1	11/2012	Gazdzinski	8,719,006	B2	5/2014	Bellegarda et al.
8,311,835	B2	11/2012	Lecoeuche	8,719,014	B2	5/2014	Wagner et al.
8,311,838	B2	11/2012	Lindahl et al.	8,731,610	B2	5/2014	Appaji
8,312,017	B2	11/2012	Martin et al.	8,731,912	B1	5/2014	Tickner et al.
8,321,786	B2	11/2012	Lunati et al.	8,731,942	B2	5/2014	Cheyet et al.
8,332,218	B2	12/2012	Cross et al.	8,739,208	B2	5/2014	Rodriguez et al.
8,332,224	B2	12/2012	Di Cristo et al.	8,744,852	B1	6/2014	Seymour et al.
8,332,748	B1	12/2012	Karam	8,760,537	B2	6/2014	Johnson et al.
8,340,975	B1	12/2012	Rosenberger	8,762,145	B2	6/2014	Ouchi et al.
8,345,665	B2	1/2013	Vieri et al.	8,762,156	B2	6/2014	Chen et al.
8,352,183	B2	1/2013	Thota et al.	8,762,469	B2	6/2014	Lindahl et al.
8,352,268	B2	1/2013	Naik et al.	8,768,693	B2	7/2014	Lempel et al.
8,352,272	B2	1/2013	Rogers et al.	8,768,702	B2	7/2014	Boettcher et al.
8,355,919	B2	1/2013	Silverman et al.	8,775,931	B2	7/2014	Fux et al.
8,359,234	B2	1/2013	Vieri	8,781,841	B1	7/2014	Wang
8,370,158	B2	2/2013	Gazdzinski	8,798,995	B1	8/2014	Edara et al.
8,371,503	B2	2/2013	Gazdzinski	8,799,000	B2	8/2014	Guzzoni et al.
8,374,871	B2	2/2013	Ehsani et al.	8,805,690	B1	8/2014	LeBeau et al.
8,375,320	B2	2/2013	Kotler et al.	8,838,457	B2	9/2014	Cerra et al.
8,380,504	B1	2/2013	Peden et al.	8,855,915	B2	10/2014	Furuhata et al.
8,380,507	B2	2/2013	Herman et al.	8,861,925	B1	10/2014	Ohme
8,381,107	B2	2/2013	Rottler et al.	8,868,409	B1	10/2014	Mengibar et al.
8,381,135	B2	2/2013	Hotelling et al.	8,880,405	B2	11/2014	Cerra et al.
8,386,485	B2	2/2013	Kerschberg et al.	8,886,540	B2	11/2014	Cerra et al.
8,386,926	B1	2/2013	Matsuoka	8,886,541	B2	11/2014	Friedlander
8,391,844	B2	3/2013	Lamiroux et al.	8,892,446	B2	11/2014	Cheyet et al.
8,396,714	B2	3/2013	Rogers et al.	8,903,716	B2	12/2014	Chen et al.
8,406,745	B1	3/2013	Upadhyay et al.	8,930,191	B2	1/2015	Gruber et al.
8,423,288	B2	4/2013	Stahl et al.	8,942,986	B2	1/2015	Cheyet et al.
8,428,758	B2	4/2013	Naik et al.	8,943,423	B2	1/2015	Merrill et al.
8,447,612	B2	5/2013	Gazdzinski	8,972,878	B2	3/2015	David et al.
8,452,597	B2	5/2013	Bringert et al.	8,983,383	B1	3/2015	Haskin
8,458,115	B2	6/2013	Cai et al.	8,996,376	B2	3/2015	Fleizach et al.
8,458,278	B2	6/2013	Christie et al.	8,996,381	B2	3/2015	Mozer et al.
8,464,150	B2	6/2013	Davidson et al.	9,009,046	B1	4/2015	Stewart
8,479,122	B2	7/2013	Hotelling et al.	9,063,979	B2	6/2015	Chiu et al.
8,484,027	B1	7/2013	Murphy	9,070,366	B1	6/2015	Mathias et al.
8,489,599	B2	7/2013	Bellotti	9,081,411	B2	7/2015	Kalns et al.
8,498,857	B2	7/2013	Kopparapu et al.	9,081,482	B1	7/2015	Zhai et al.
8,514,197	B2	8/2013	Shahraray et al.	9,098,467	B1	8/2015	Blanksteen et al.
8,515,750	B1	8/2013	Lei et al.	9,117,447	B2	8/2015	Gruber et al.
8,521,513	B2	8/2013	Millett et al.	9,123,338	B1	9/2015	Sanders et al.
8,527,276	B1	9/2013	Senior et al.	9,190,062	B2	11/2015	Haughay
8,560,229	B1	10/2013	Park et al.	9,218,809	B2	12/2015	Bellegarda
8,571,851	B1	10/2013	Tickner et al.	9,223,537	B2	12/2015	Brown et al.
8,583,416	B2	11/2013	Huang et al.	9,255,812	B2	2/2016	Maeoka et al.
8,589,869	B2	11/2013	Wolfgram	9,258,604	B1	2/2016	Bilobrov et al.
				9,292,487	B1	3/2016	Weber
				9,299,344	B2	3/2016	Braho et al.
				9,305,543	B2	4/2016	Fleizach et al.
				9,305,548	B2	4/2016	Kennewick et al.

(56)	References Cited			2002/0069071	A1	6/2002	Knockeart et al.
	U.S. PATENT DOCUMENTS			2002/0069220	A1	6/2002	Tran
	9,311,912	B1	4/2016	2002/0072816	A1	6/2002	Shdema et al.
	9,313,317	B1	4/2016	2002/0072908	A1	6/2002	Case et al.
	9,318,108	B2	4/2016	2002/0072914	A1	6/2002	Alshawi et al.
	9,338,493	B2	5/2016	2002/0072915	A1	6/2002	Bower
	9,349,368	B1	5/2016	2002/0073177	A1	6/2002	Clark et al.
	9,361,084	B1	6/2016	2002/0077082	A1	6/2002	Cruickshank
	9,377,871	B2	6/2016	2002/0077817	A1	6/2002	Atal
	9,423,266	B2	8/2016	2002/0078041	A1	6/2002	Wu
	9,437,186	B1	9/2016	2002/0080163	A1	6/2002	Morey
	9,501,741	B2	11/2016	2002/0083068	A1	6/2002	Quass et al.
	2001/0005859	A1	6/2001	2002/0085037	A1	7/2002	Leavitt et al.
	2001/0020259	A1	9/2001	2002/0086680	A1	7/2002	Hunzinger
	2001/0027394	A1	10/2001	2002/0087306	A1	7/2002	Lee et al.
	2001/0027396	A1	10/2001	2002/0087508	A1	7/2002	Hull et al.
	2001/0029455	A1	10/2001	2002/0087974	A1	7/2002	Sprague et al.
	2001/0030660	A1	10/2001	2002/0091511	A1	7/2002	Hellwig et al.
	2001/0032080	A1	10/2001	2002/0091529	A1	7/2002	Whitham
	2001/0041021	A1	11/2001	2002/0095286	A1	7/2002	Ross et al.
	2001/0042107	A1	11/2001	2002/0095290	A1	7/2002	Kahn et al.
	2001/0044724	A1	11/2001	2002/0099547	A1	7/2002	Chu et al.
	2001/0047264	A1	11/2001	2002/0099552	A1	7/2002	Rubin et al.
	2001/0055963	A1	12/2001	2002/0101447	A1	8/2002	Carro
	2001/0056342	A1	12/2001	2002/0103641	A1	8/2002	Kuo et al.
	2001/0056347	A1	12/2001	2002/0103644	A1	8/2002	Brocious et al.
	2002/0001395	A1	1/2002	2002/0103646	A1	8/2002	Kochanski et al.
	2002/0002039	A1	1/2002	2002/0107684	A1	8/2002	Gao
	2002/0002413	A1	1/2002	2002/0109709	A1	8/2002	Sagar
	2002/0002461	A1	1/2002	2002/0110248	A1	8/2002	Kovales et al.
	2002/0002465	A1	1/2002	2002/0111198	A1	8/2002	Heje et al.
	2002/0004703	A1	1/2002	2002/0111810	A1	8/2002	Khan et al.
	2002/0010581	A1	1/2002	2002/0116082	A1	8/2002	Gudorf
	2002/0010584	A1	1/2002	2002/0116171	A1	8/2002	Russell
	2002/0010589	A1	1/2002	2002/0116185	A1	8/2002	Cooper et al.
	2002/0010726	A1	1/2002	2002/0116189	A1	8/2002	Yeh et al.
	2002/0010798	A1	1/2002	2002/0116420	A1	8/2002	Allam et al.
	2002/0013707	A1	1/2002	2002/0117384	A1	8/2002	Marchant
	2002/0013784	A1	1/2002	2002/0120697	A1	8/2002	Generous et al.
	2002/0013852	A1	1/2002	2002/0120925	A1	8/2002	Logan
	2002/0015024	A1	2/2002	2002/0122053	A1	9/2002	Dutta et al.
	2002/0015064	A1	2/2002	2002/0123891	A1	9/2002	Epstein et al.
	2002/0021278	A1	2/2002	2002/0123894	A1	9/2002	Woodward
	2002/0026315	A1	2/2002	2002/0126097	A1	9/2002	Savolainen
	2002/0026456	A1	2/2002	2002/0128821	A1	9/2002	Ehsani et al.
	2002/0031254	A1	3/2002	2002/0128827	A1	9/2002	Bu et al.
	2002/0031262	A1	3/2002	2002/0128840	A1	9/2002	Hinde et al.
	2002/0032048	A1	3/2002	2002/0129057	A1	9/2002	Spielberg
	2002/0032564	A1	3/2002	2002/0133347	A1	9/2002	Schoneburg et al.
	2002/0032591	A1	3/2002	2002/0133348	A1	9/2002	Pearson et al.
	2002/0032751	A1	3/2002	2002/0135565	A1	9/2002	Gordon et al.
	2002/0035467	A1	3/2002	2002/0135618	A1	9/2002	Maes et al.
	2002/0035469	A1	3/2002	2002/0137505	A1	9/2002	Eiche et al.
	2002/0035474	A1	3/2002	2002/0138254	A1	9/2002	Isaka et al.
	2002/0040297	A1	4/2002	2002/0138265	A1	9/2002	Stevens et al.
	2002/0040359	A1	4/2002	2002/0138270	A1	9/2002	Bellegarda et al.
	2002/0042707	A1	4/2002	2002/0138616	A1	9/2002	Basson et al.
	2002/0045438	A1	4/2002	2002/0140679	A1	10/2002	Wen
	2002/0045961	A1	4/2002	2002/0143533	A1	10/2002	Lucas et al.
	2002/0046025	A1	4/2002	2002/0143542	A1	10/2002	Eide
	2002/0046032	A1	4/2002	2002/0143551	A1	10/2002	Sharma et al.
	2002/0046315	A1	4/2002	2002/0143826	A1	10/2002	Day et al.
	2002/0052730	A1	5/2002	2002/0151297	A1	10/2002	Remboski et al.
	2002/0052740	A1	5/2002	2002/0152045	A1	10/2002	Dowling et al.
	2002/0052746	A1	5/2002	2002/0152255	A1	10/2002	Smith et al.
	2002/0052747	A1	5/2002	2002/0154160	A1	10/2002	Hosokawa
	2002/0052913	A1	5/2002	2002/0156771	A1	10/2002	Frieder et al.
	2002/0054094	A1	5/2002	2002/0161865	A1	10/2002	Nguyen
	2002/0055844	A1	5/2002	2002/0163544	A1	11/2002	Baker et al.
	2002/0055934	A1	5/2002	2002/0164000	A1	11/2002	Cohen et al.
	2002/0057293	A1	5/2002	2002/0165918	A1	11/2002	Bettis
	2002/0059066	A1	5/2002	2002/0166123	A1	11/2002	Schrader et al.
	2002/0059068	A1	5/2002	2002/0167534	A1	11/2002	Burke
	2002/0065659	A1	5/2002	2002/0169592	A1	11/2002	Aityan
	2002/0065797	A1	5/2002	2002/0169605	A1	11/2002	Damiba et al.
	2002/0067308	A1	6/2002	2002/0173273	A1	11/2002	Spurgat et al.
	2002/0069063	A1	6/2002	2002/0173889	A1	11/2002	Odinak et al.
				2002/0173961	A1	11/2002	Guerra
				2002/0173962	A1	11/2002	Tang et al.

(56)

References Cited

U.S. PATENT DOCUMENTS					
2002/0173966	A1	11/2002	Henton		
2002/0177993	A1	11/2002	Veditz et al.		
2002/0178226	A1*	11/2002	Anderson	H04W 4/12	
				709/206	
2002/0184003	A1	12/2002	Hakkinen et al.		
2002/0184015	A1	12/2002	Li et al.		
2002/0184027	A1	12/2002	Brittan et al.		
2002/0184189	A1	12/2002	Hay et al.		
2002/0189426	A1	12/2002	Hirade et al.		
2002/0191029	A1	12/2002	Gillespie et al.		
2002/0193996	A1	12/2002	Squibbs et al.		
2002/0196911	A1	12/2002	Gao et al.		
2002/0198714	A1*	12/2002	Zhou	G10L 15/1822	
				704/252	
2002/0198715	A1	12/2002	Belrose		
2003/0001881	A1	1/2003	Mannheimer et al.		
2003/0002632	A1	1/2003	Bhogal et al.		
2003/0003609	A1	1/2003	Sauer et al.		
2003/0003897	A1	1/2003	Hyon		
2003/0004968	A1	1/2003	Romer et al.		
2003/0009459	A1	1/2003	Chastain et al.		
2003/0013483	A1	1/2003	Ausems et al.		
2003/0016770	A1	1/2003	Trans et al.		
2003/0018475	A1	1/2003	Basu et al.		
2003/0020760	A1	1/2003	Takatsu et al.		
2003/0023420	A1	1/2003	Goodman et al.		
2003/0023426	A1	1/2003	Pun et al.		
2003/0025676	A1	2/2003	Cappendijk		
2003/0026392	A1	2/2003	Brown et al.		
2003/0026402	A1	2/2003	Clapper		
2003/0028380	A1	2/2003	Freeland et al.		
2003/0030645	A1	2/2003	Ribak et al.		
2003/0033148	A1	2/2003	Silverman et al.		
2003/0033152	A1	2/2003	Cameron		
2003/0033153	A1	2/2003	Olson et al.		
2003/0033214	A1	2/2003	Mikkelsen et al.		
2003/0036909	A1	2/2003	Kato		
2003/0037073	A1	2/2003	Tokuda et al.		
2003/0037077	A1	2/2003	Brill et al.		
2003/0037254	A1	2/2003	Fischer et al.		
2003/0038786	A1	2/2003	Nguyen et al.		
2003/0040908	A1	2/2003	Yang et al.		
2003/0046075	A1	3/2003	Stone		
2003/0046401	A1	3/2003	Abbott et al.		
2003/0046434	A1	3/2003	Flanagin et al.		
2003/0048881	A1	3/2003	Trajkovic et al.		
2003/0050781	A1	3/2003	Tamura et al.		
2003/0051136	A1	3/2003	Curtis et al.		
2003/0055537	A1	3/2003	Odinak et al.		
2003/0055623	A1	3/2003	Epstein et al.		
2003/0061317	A1	3/2003	Brown et al.		
2003/0061570	A1	3/2003	Hatori et al.		
2003/0063073	A1	4/2003	Geaghan et al.		
2003/0069893	A1	4/2003	Kanai et al.		
2003/0074195	A1	4/2003	Bartosik et al.		
2003/0074198	A1	4/2003	Sussman		
2003/0074457	A1	4/2003	Kluth		
2003/0076301	A1	4/2003	Tsuk et al.		
2003/0078766	A1	4/2003	Appelt et al.		
2003/0078779	A1	4/2003	Desai et al.		
2003/0078780	A1	4/2003	Kochanski et al.		
2003/0078969	A1	4/2003	Sprague et al.		
2003/0079024	A1	4/2003	Hough et al.		
2003/0079038	A1	4/2003	Robbin et al.		
2003/0080991	A1	5/2003	Crow et al.		
2003/0083113	A1	5/2003	Chua et al.		
2003/0083878	A1	5/2003	Lee et al.		
2003/0083884	A1	5/2003	Odinak et al.		
2003/0084350	A1	5/2003	Eibach et al.		
2003/0085870	A1	5/2003	Hinckley		
2003/0086699	A1	5/2003	Benyamin et al.		
2003/0088414	A1	5/2003	Huang et al.		
2003/0088421	A1	5/2003	Maes et al.		
2003/0090467	A1	5/2003	Hohl et al.		
2003/0090474	A1	5/2003	Schaefer		
2003/0095096	A1	5/2003	Robbin et al.		
2003/0097210	A1	5/2003	Horst et al.		
2003/0097379	A1	5/2003	Ireton		
2003/0097407	A1	5/2003	Litwin et al.		
2003/0097408	A1	5/2003	Kageyama et al.		
2003/0098892	A1	5/2003	Hiipakka		
2003/0099335	A1	5/2003	Tanaka et al.		
2003/0101045	A1	5/2003	Moffatt et al.		
2003/0101054	A1	5/2003	Davis et al.		
2003/0115060	A1	6/2003	Junqua et al.		
2003/0115064	A1	6/2003	Gusler et al.		
2003/0115186	A1	6/2003	Wilkinson et al.		
2003/0115289	A1	6/2003	Chinn et al.		
2003/0115552	A1	6/2003	Jahnke et al.		
2003/0117365	A1	6/2003	Shteyn		
2003/0120494	A1	6/2003	Jost et al.		
2003/0122652	A1	7/2003	Himmelstein et al.		
2003/0122787	A1	7/2003	Zimmerman et al.		
2003/0125927	A1	7/2003	Seme		
2003/0125945	A1	7/2003	Doyle		
2003/0125955	A1	7/2003	Arnold et al.		
2003/0126559	A1	7/2003	Fuhrmann		
2003/0128819	A1	7/2003	Lee et al.		
2003/0130847	A1	7/2003	Case et al.		
2003/0131320	A1	7/2003	Kumhyr et al.		
2003/0133694	A1	7/2003	Yeo		
2003/0134678	A1	7/2003	Tanaka		
2003/0135501	A1	7/2003	Frerebeau et al.		
2003/0135740	A1	7/2003	Talmor et al.		
2003/0140088	A1	7/2003	Robinson et al.		
2003/0144846	A1	7/2003	Denenberg et al.		
2003/0145285	A1	7/2003	Miyahira et al.		
2003/0147512	A1	8/2003	Abhuri		
2003/0149557	A1	8/2003	Cox et al.		
2003/0149567	A1	8/2003	Schmitz et al.		
2003/0149978	A1	8/2003	Plotnick		
2003/0152203	A1	8/2003	Berger et al.		
2003/0152894	A1	8/2003	Townshend		
2003/0154079	A1	8/2003	Ota et al.		
2003/0154081	A1	8/2003	Chu et al.		
2003/0157968	A1	8/2003	Boman et al.		
2003/0158732	A1	8/2003	Pi et al.		
2003/0158735	A1	8/2003	Yamada et al.		
2003/0158737	A1	8/2003	Csicsatka		
2003/0160702	A1	8/2003	Tanaka		
2003/0160830	A1	8/2003	Degross		
2003/0163316	A1	8/2003	Addison et al.		
2003/0164848	A1	9/2003	Dutta et al.		
2003/0167167	A1	9/2003	Gong		
2003/0167318	A1	9/2003	Robbin et al.		
2003/0167335	A1	9/2003	Alexander		
2003/0171928	A1	9/2003	Falcon et al.		
2003/0171936	A1	9/2003	Sall et al.		
2003/0174830	A1	9/2003	Boyer et al.		
2003/0177046	A1	9/2003	Socha-Leialoha et al.		
2003/0179222	A1	9/2003	Noma et al.		
2003/0182115	A1	9/2003	Malayath et al.		
2003/0182131	A1	9/2003	Arnold et al.		
2003/0187655	A1	10/2003	Dunsmuir		
2003/0187659	A1	10/2003	Cho et al.		
2003/0187775	A1	10/2003	Du et al.		
2003/0187844	A1	10/2003	Li et al.		
2003/0187925	A1	10/2003	Inala et al.		
2003/0188005	A1	10/2003	Yoneda et al.		
2003/0188192	A1	10/2003	Tang et al.		
2003/0190074	A1	10/2003	Loudon et al.		
2003/0191625	A1	10/2003	Gorin et al.		
2003/0191645	A1	10/2003	Zhou		
2003/0193481	A1	10/2003	Sokolsky		
2003/0194080	A1	10/2003	Michaelis et al.		
2003/0195741	A1	10/2003	Mani et al.		
2003/0197736	A1	10/2003	Murphy		
2003/0197744	A1	10/2003	Irvine		
2003/0200085	A1	10/2003	Nguyen et al.		
2003/0200452	A1	10/2003	Tagawa et al.		
2003/0200858	A1	10/2003	Xie		
2003/0202697	A1	10/2003	Simard et al.		
2003/0204392	A1	10/2003	Finnigan et al.		
2003/0204492	A1	10/2003	Wolf et al.		

(56)

References Cited

U.S. PATENT DOCUMENTS

2004/0252966	A1	12/2004	Holloway et al.	2005/0119890	A1	6/2005	Hirose
2004/0254791	A1	12/2004	Coifman et al.	2005/0119897	A1	6/2005	Bennett et al.
2004/0254792	A1	12/2004	Busayapongchai et al.	2005/0125216	A1	6/2005	Chitrapura et al.
2004/0257432	A1	12/2004	Girish et al.	2005/0125226	A1	6/2005	Magee
2004/0259536	A1	12/2004	Keskar et al.	2005/0125235	A1	6/2005	Lazay et al.
2004/0260438	A1	12/2004	Chernetsky et al.	2005/0131951	A1	6/2005	Zhang et al.
2004/0260547	A1	12/2004	Cohen et al.	2005/0132301	A1	6/2005	Ikeda
2004/0260718	A1	12/2004	Fedorov et al.	2005/0136949	A1	6/2005	Barnes, Jr.
2004/0261023	A1	12/2004	Bier	2005/0138305	A1	6/2005	Zellner
2004/0262051	A1	12/2004	Carro	2005/0140504	A1	6/2005	Marshall et al.
2004/0263636	A1	12/2004	Cutler et al.	2005/0143972	A1	6/2005	Gopalakrishnan et al.
2004/0267825	A1	12/2004	Novak et al.	2005/0144003	A1	6/2005	Iso-Sipila
2004/0268253	A1	12/2004	Demello et al.	2005/0144070	A1	6/2005	Cheshire
2004/0268262	A1	12/2004	Gupta et al.	2005/0144568	A1	6/2005	Gruen et al.
2005/0002507	A1	1/2005	Timmins et al.	2005/0148356	A1	7/2005	Ferguson et al.
2005/0010409	A1	1/2005	Hull et al.	2005/0149214	A1	7/2005	Yoo et al.
2005/0012723	A1	1/2005	Pallakoff	2005/0149330	A1	7/2005	Katae
2005/0015254	A1	1/2005	Beaman	2005/0149332	A1	7/2005	Kuzunuki et al.
2005/0015751	A1	1/2005	Grassens	2005/0149510	A1	7/2005	Shafir
2005/0015772	A1	1/2005	Saare et al.	2005/0152558	A1	7/2005	Van Tassel
2005/0021330	A1	1/2005	Mano et al.	2005/0152602	A1	7/2005	Chen et al.
2005/0022114	A1	1/2005	Shanahan et al.	2005/0154578	A1	7/2005	Tong et al.
2005/0024341	A1	2/2005	Gillespie et al.	2005/0154580	A1	7/2005	Horowitz et al.
2005/0024345	A1	2/2005	Easty et al.	2005/0154591	A1	7/2005	Lecoeuche
2005/0027385	A1	2/2005	Yueh	2005/0159939	A1	7/2005	Mohler et al.
2005/0030175	A1	2/2005	Wolfe	2005/0159957	A1	7/2005	Roth et al.
2005/0031106	A1	2/2005	Henderson	2005/0162395	A1	7/2005	Unruh
2005/0033582	A1	2/2005	Gadd et al.	2005/0165015	A1	7/2005	Ncube et al.
2005/0033771	A1	2/2005	Schmitter et al.	2005/0165607	A1	7/2005	Di Fabrizio et al.
2005/0034164	A1	2/2005	Sano et al.	2005/0166153	A1	7/2005	Eytchison et al.
2005/0038657	A1	2/2005	Roth et al.	2005/0177445	A1	8/2005	Church
2005/0039141	A1	2/2005	Burke et al.	2005/0181770	A1	8/2005	Helferich
2005/0042591	A1	2/2005	Bloom et al.	2005/0182616	A1	8/2005	Kotipalli
2005/0043946	A1	2/2005	Ueyama et al.	2005/0182627	A1	8/2005	Tanaka et al.
2005/0043949	A1	2/2005	Roth et al.	2005/0182628	A1	8/2005	Choi
2005/0044569	A1	2/2005	Marcus	2005/0182629	A1	8/2005	Corman et al.
2005/0045373	A1	3/2005	Born	2005/0182630	A1	8/2005	Miro et al.
2005/0049862	A1	3/2005	Choi et al.	2005/0182765	A1	8/2005	Liddy
2005/0049870	A1	3/2005	Zhang et al.	2005/0184958	A1	8/2005	Gnanamgari et al.
2005/0049880	A1	3/2005	Roth et al.	2005/0187770	A1	8/2005	Kompe et al.
2005/0055212	A1	3/2005	Nagao	2005/0187773	A1	8/2005	Filoché et al.
2005/0055403	A1	3/2005	Brittan	2005/0190970	A1	9/2005	Griffin
2005/0058438	A1	3/2005	Hayashi	2005/0192801	A1	9/2005	Lewis et al.
2005/0060155	A1	3/2005	Chu et al.	2005/0192807	A1	9/2005	Emam et al.
2005/0071165	A1	3/2005	Hofstader et al.	2005/0192812	A1	9/2005	Buchholz et al.
2005/0071332	A1	3/2005	Ortega et al.	2005/0195077	A1	9/2005	Mcculloch et al.
2005/0071437	A1	3/2005	Bear et al.	2005/0195429	A1	9/2005	Archbold
2005/0074113	A1	4/2005	Mathew et al.	2005/0196733	A1	9/2005	Budra et al.
2005/0075881	A1	4/2005	Rigazio et al.	2005/0201572	A1	9/2005	Lindahl et al.
2005/0080613	A1	4/2005	Colledge et al.	2005/0202854	A1	9/2005	Kortum et al.
2005/0080620	A1	4/2005	Rao et al.	2005/0203738	A1	9/2005	Hwang
2005/0080625	A1	4/2005	Bennett et al.	2005/0203747	A1	9/2005	Lecoeuche
2005/0080632	A1	4/2005	Endo et al.	2005/0203991	A1	9/2005	Kawamura et al.
2005/0080780	A1	4/2005	Colledge et al.	2005/0209848	A1	9/2005	Ishii
2005/0086059	A1	4/2005	Bennett	2005/0210394	A1	9/2005	Crandall et al.
2005/0086255	A1	4/2005	Schran et al.	2005/0216331	A1	9/2005	Ahrens et al.
2005/0086605	A1	4/2005	Ferrer et al.	2005/0222843	A1	10/2005	Kahn et al.
2005/0091118	A1	4/2005	Fano	2005/0222973	A1	10/2005	Kaiser
2005/0094475	A1	5/2005	Naoi	2005/0228665	A1	10/2005	Kobayashi et al.
2005/0099398	A1	5/2005	Garside et al.	2005/0245243	A1	11/2005	Zuniga
2005/0100214	A1	5/2005	Zhang et al.	2005/0246350	A1	11/2005	Canaran
2005/0102144	A1	5/2005	Rapoport	2005/0246365	A1	11/2005	Lowles et al.
2005/0102614	A1	5/2005	Brockett et al.	2005/0246686	A1	11/2005	Seshadri et al.
2005/0102625	A1	5/2005	Lee et al.	2005/0246726	A1	11/2005	Labrou et al.
2005/0105712	A1	5/2005	Williams et al.	2005/0251572	A1	11/2005	McMahan et al.
2005/0108001	A1	5/2005	Aarskog	2005/0254481	A1	11/2005	Vishik et al.
2005/0108017	A1	5/2005	Esser et al.	2005/0261901	A1	11/2005	Davis et al.
2005/0108074	A1	5/2005	Bloechl et al.	2005/0262440	A1	11/2005	Stanciu et al.
2005/0108338	A1	5/2005	Simske et al.	2005/0267738	A1	12/2005	Wilkinson et al.
2005/0108344	A1	5/2005	Tafoya et al.	2005/0267757	A1	12/2005	Iso-Sipila et al.
2005/0108642	A1	5/2005	Sinclair et al.	2005/0268247	A1	12/2005	Baneth
2005/0114124	A1	5/2005	Liu et al.	2005/0271216	A1	12/2005	Lashkari
2005/0114140	A1	5/2005	Brackett et al.	2005/0273332	A1	12/2005	Scott et al.
2005/0114306	A1	5/2005	Shu et al.	2005/0273337	A1	12/2005	Erell et al.
2005/0114791	A1	5/2005	Bollenbacher et al.	2005/0273626	A1	12/2005	Pearson et al.
				2005/0278297	A1	12/2005	Nelson
				2005/0278643	A1	12/2005	Ukai et al.
				2005/0278647	A1	12/2005	Leavitt et al.
				2005/0283363	A1	12/2005	Weng et al.

(56)

References Cited

U.S. PATENT DOCUMENTS

2005/0283364	A1	12/2005	Longe et al.	2006/0106594	A1	5/2006	Brockett et al.
2005/0283726	A1	12/2005	Lunati	2006/0106595	A1	5/2006	Brockett et al.
2005/0283729	A1	12/2005	Morris et al.	2006/0111906	A1	5/2006	Cross et al.
2005/0288934	A1	12/2005	Omi	2006/0111909	A1	5/2006	Maes et al.
2005/0288936	A1	12/2005	Busayapongchai et al.	2006/0116874	A1	6/2006	Samuelsson et al.
2005/0289458	A1	12/2005	Kylmanen	2006/0116877	A1	6/2006	Pickering et al.
2005/0289463	A1	12/2005	Wu et al.	2006/0117002	A1	6/2006	Swen
2006/0001652	A1	1/2006	Chiu et al.	2006/0119582	A1	6/2006	Ng et al.
2006/0004570	A1	1/2006	Ju et al.	2006/0122834	A1	6/2006	Bennett
2006/0004640	A1	1/2006	Swierczek	2006/0122836	A1	6/2006	Cross et al.
2006/0004744	A1	1/2006	Nevidomski et al.	2006/0129379	A1	6/2006	Ramsey et al.
2006/0007174	A1	1/2006	Shen	2006/0129929	A1	6/2006	Weber et al.
2006/0009973	A1	1/2006	Nguyen et al.	2006/0130006	A1	6/2006	Chitale
2006/0013414	A1	1/2006	Shih	2006/0132812	A1	6/2006	Barnes et al.
2006/0013446	A1	1/2006	Stephens	2006/0135214	A1	6/2006	Zhang et al.
2006/0015326	A1	1/2006	Mori et al.	2006/0136213	A1	6/2006	Hirose et al.
2006/0015341	A1	1/2006	Baker	2006/0136280	A1	6/2006	Cho et al.
2006/0015484	A1	1/2006	Weng et al.	2006/0136352	A1	6/2006	Brun et al.
2006/0015819	A1	1/2006	Hawkins et al.	2006/0141990	A1	6/2006	Zak et al.
2006/0018446	A1	1/2006	Schmandt et al.	2006/0142576	A1	6/2006	Meng et al.
2006/0018492	A1	1/2006	Chiu et al.	2006/0142993	A1	6/2006	Menendez-Pidal et al.
2006/0020890	A1	1/2006	Kroll et al.	2006/0143007	A1	6/2006	Koh et al.
2006/0025999	A1	2/2006	Feng et al.	2006/0143559	A1	6/2006	Spielberg et al.
2006/0026233	A1	2/2006	Tenembaum et al.	2006/0143576	A1	6/2006	Gupta et al.
2006/0026521	A1	2/2006	Hotelling et al.	2006/0148520	A1	7/2006	Baker et al.
2006/0026535	A1	2/2006	Hotelling et al.	2006/0149557	A1	7/2006	Kaneko et al.
2006/0026536	A1	2/2006	Hotelling et al.	2006/0149558	A1	7/2006	Kahn et al.
2006/0033724	A1	2/2006	Chaudhri et al.	2006/0150087	A1	7/2006	Cronenberger et al.
2006/0035632	A1	2/2006	Sorvari et al.	2006/0152496	A1	7/2006	Knaven
2006/0036946	A1	2/2006	Radtke et al.	2006/0153040	A1	7/2006	Girish et al.
2006/0041424	A1	2/2006	Todhunter et al.	2006/0156252	A1	7/2006	Sheshagiri et al.
2006/0041431	A1	2/2006	Maes	2006/0156307	A1	7/2006	Kunjithapatham et al.
2006/0041590	A1	2/2006	King et al.	2006/0161870	A1	7/2006	Hotelling et al.
2006/0047632	A1	3/2006	Zhang	2006/0161871	A1	7/2006	Hotelling et al.
2006/0050865	A1	3/2006	Kortum et al.	2006/0161872	A1	7/2006	Rytivaara et al.
2006/0052141	A1	3/2006	Suzuki	2006/0165105	A1	7/2006	Shenfield et al.
2006/0053007	A1	3/2006	Niemisto et al.	2006/0167676	A1	7/2006	Plumb
2006/0053365	A1	3/2006	Hollander et al.	2006/0168150	A1	7/2006	Naik et al.
2006/0053379	A1	3/2006	Henderson et al.	2006/0168507	A1	7/2006	Hansen
2006/0053387	A1	3/2006	Ording	2006/0168539	A1	7/2006	Hawkins et al.
2006/0058999	A1	3/2006	Barker et al.	2006/0172720	A1	8/2006	Islam et al.
2006/0059424	A1	3/2006	Petri et al.	2006/0173683	A1	8/2006	Roth et al.
2006/0059437	A1	3/2006	Conklin	2006/0173684	A1	8/2006	Fischer et al.
2006/0060762	A1	3/2006	Chan et al.	2006/0174207	A1	8/2006	Deshpande
2006/0061488	A1	3/2006	Dunton	2006/0178868	A1	8/2006	Billerey-Mosier
2006/0064693	A1	3/2006	Messer et al.	2006/0181519	A1	8/2006	Vernier et al.
2006/0067535	A1	3/2006	Culbert et al.	2006/0183466	A1	8/2006	Lee et al.
2006/0067536	A1	3/2006	Culbert et al.	2006/0184886	A1	8/2006	Chung et al.
2006/0069567	A1	3/2006	Tischer et al.	2006/0187073	A1	8/2006	Lin et al.
2006/0069664	A1	3/2006	Ling et al.	2006/0190269	A1	8/2006	Tessel et al.
2006/0072248	A1	4/2006	Watanabe et al.	2006/0190436	A1	8/2006	Richardson et al.
2006/0072716	A1	4/2006	Pham	2006/0190577	A1	8/2006	Yamada
2006/0074628	A1	4/2006	Elbaz et al.	2006/0193518	A1	8/2006	Dong
2006/0074651	A1	4/2006	Arun et al.	2006/0194181	A1	8/2006	Rosenberg
2006/0074660	A1	4/2006	Waters et al.	2006/0195206	A1	8/2006	Moon et al.
2006/0074674	A1	4/2006	Zhang et al.	2006/0195323	A1	8/2006	Monne et al.
2006/0074750	A1	4/2006	Clark et al.	2006/0197753	A1	9/2006	Hotelling
2006/0074898	A1	4/2006	Gavalda et al.	2006/0197755	A1	9/2006	Bawany
2006/0075429	A1	4/2006	Istvan et al.	2006/0200253	A1	9/2006	Hoffberg et al.
2006/0077055	A1	4/2006	Basir	2006/0200342	A1	9/2006	Corston-Oliver et al.
2006/0080098	A1	4/2006	Campbell	2006/0200347	A1	9/2006	Kim et al.
2006/0085187	A1	4/2006	Barquilla	2006/0205432	A1	9/2006	Hawkins et al.
2006/0085465	A1	4/2006	Nori et al.	2006/0206313	A1	9/2006	Xu et al.
2006/0085757	A1	4/2006	Andre et al.	2006/0206454	A1	9/2006	Forstall et al.
2006/0093998	A1	5/2006	Vertegaal	2006/0206724	A1	9/2006	Schaufele et al.
2006/0095265	A1	5/2006	Chu et al.	2006/0212415	A1	9/2006	Backer et al.
2006/0095790	A1	5/2006	Nguyen et al.	2006/0217967	A1	9/2006	Goertzen et al.
2006/0095846	A1	5/2006	Nurmi	2006/0218244	A1	9/2006	Rasmussen et al.
2006/0095848	A1	5/2006	Naik	2006/0221738	A1	10/2006	Park et al.
2006/0097991	A1	5/2006	Hotelling et al.	2006/0221788	A1	10/2006	Lindahl et al.
2006/0100848	A1	5/2006	Cozzi et al.	2006/0224570	A1	10/2006	Quiroga et al.
2006/0100849	A1	5/2006	Chan	2006/0229802	A1	10/2006	Vertelney et al.
2006/0101354	A1	5/2006	Hashimoto et al.	2006/0229870	A1	10/2006	Kobal
2006/0103633	A1	5/2006	Gioeli	2006/0229876	A1	10/2006	Aaron et al.
2006/0106592	A1	5/2006	Brockett et al.	2006/0230350	A1	10/2006	Baluja
				2006/0230410	A1	10/2006	Kurganov et al.
				2006/0234680	A1	10/2006	Doulton
				2006/0235550	A1	10/2006	Csicsatka et al.
				2006/0235700	A1	10/2006	Wong et al.

(56)		References Cited					
		U.S. PATENT DOCUMENTS					
2006/0235841	A1	10/2006	Betz et al.	2007/0055514	A1	3/2007	Beattie et al.
2006/0236262	A1	10/2006	Bathiche et al.	2007/0055525	A1	3/2007	Kennewick et al.
2006/0239419	A1	10/2006	Joseph et al.	2007/0055529	A1	3/2007	Kanevsky et al.
2006/0239471	A1	10/2006	Mao et al.	2007/0058832	A1	3/2007	Hug et al.
2006/0240866	A1	10/2006	Eilts et al.	2007/0060107	A1	3/2007	Day
2006/0241948	A1	10/2006	Abrash et al.	2007/0060118	A1	3/2007	Guyette
2006/0242190	A1	10/2006	Wnek	2007/0061487	A1	3/2007	Moore et al.
2006/0246955	A1	11/2006	Nirhamo et al.	2007/0061712	A1	3/2007	Bodin et al.
2006/0247931	A1	11/2006	Caskey et al.	2007/0061754	A1	3/2007	Ardhanari et al.
2006/0252457	A1	11/2006	Schrager	2007/0067173	A1	3/2007	Bellegarda
2006/0253210	A1	11/2006	Rosenberg	2007/0067272	A1	3/2007	Flynt et al.
2006/0253787	A1	11/2006	Fogg	2007/0073540	A1	3/2007	Hirakawa et al.
2006/0256934	A1	11/2006	Mazor	2007/0073541	A1	3/2007	Tian
2006/0258376	A1	11/2006	Ewell et al.	2007/0073745	A1	3/2007	Scott et al.
2006/0262876	A1	11/2006	LaDue	2007/0074131	A1	3/2007	Assadollahi et al.
2006/0265208	A1	11/2006	Assadollahi	2007/0075965	A1	4/2007	Huppi et al.
2006/0265503	A1	11/2006	Jones et al.	2007/0079027	A1	4/2007	Marriott et al.
2006/0265648	A1	11/2006	Rainisto et al.	2007/0080936	A1	4/2007	Tsuk et al.
2006/0271627	A1	11/2006	Szczepanek	2007/0083366	A1	4/2007	Peters
2006/0274051	A1	12/2006	Longe et al.	2007/0083467	A1	4/2007	Lindahl et al.
2006/0274905	A1	12/2006	Lindahl et al.	2007/0083623	A1	4/2007	Nishimura et al.
2006/0277031	A1	12/2006	Ramsey et al.	2007/0088556	A1	4/2007	Andrew
2006/0277058	A1	12/2006	J'maev et al.	2007/0089132	A1	4/2007	Qureshey et al.
2006/0282264	A1	12/2006	Denny et al.	2007/0089135	A1	4/2007	Qureshey et al.
2006/0282415	A1	12/2006	Shibata et al.	2007/0093277	A1	4/2007	Cavacuiti et al.
2006/0282455	A1	12/2006	Lee et al.	2007/0094026	A1	4/2007	Ativanichayaphong et al.
2006/0286527	A1	12/2006	Morel	2007/0098195	A1	5/2007	Holmes
2006/0287864	A1	12/2006	Pusa et al.	2007/0100206	A1	5/2007	Lin et al.
2006/0288024	A1	12/2006	Braica	2007/0100602	A1	5/2007	Kim
2006/0291666	A1	12/2006	Ball et al.	2007/0100619	A1	5/2007	Purho et al.
2006/0293876	A1	12/2006	Kamatani et al.	2007/0100624	A1	5/2007	Weng et al.
2006/0293880	A1	12/2006	Elshishiny et al.	2007/0100635	A1	5/2007	Mahajan et al.
2006/0293886	A1	12/2006	Odell et al.	2007/0100709	A1	5/2007	Lee et al.
2006/0293889	A1	12/2006	Kiss et al.	2007/0100790	A1	5/2007	Cheyser et al.
2007/0003026	A1	1/2007	Hodge et al.	2007/0100814	A1	5/2007	Lee et al.
2007/0004451	A1	1/2007	Anderson	2007/0100883	A1	5/2007	Rose et al.
2007/0005849	A1	1/2007	Oliver	2007/0106491	A1	5/2007	Carter et al.
2007/0006098	A1	1/2007	Krumm et al.	2007/0106497	A1	5/2007	Ramsey et al.
2007/0011154	A1	1/2007	Musgrove et al.	2007/0106512	A1	5/2007	Acerio et al.
2007/0014280	A1	1/2007	Cormier et al.	2007/0106513	A1	5/2007	Boillot et al.
2007/0016563	A1	1/2007	Omoigui	2007/0106657	A1	5/2007	Brzeski et al.
2007/0016865	A1	1/2007	Johnson et al.	2007/0106674	A1	5/2007	Agrawal et al.
2007/0021956	A1	1/2007	Qu et al.	2007/0106685	A1	5/2007	Houh et al.
2007/0022380	A1	1/2007	Swartz et al.	2007/0112562	A1	5/2007	Vainio et al.
2007/0025704	A1	2/2007	Tsukazaki et al.	2007/0116195	A1	5/2007	Thompson et al.
2007/0026852	A1	2/2007	Logan et al.	2007/0118351	A1	5/2007	Sumita
2007/0027732	A1	2/2007	Hudgens	2007/0118377	A1	5/2007	Badino et al.
2007/0028009	A1	2/2007	Robbin et al.	2007/0118378	A1	5/2007	Skuratovsky
2007/0030824	A1	2/2007	Ribaudo et al.	2007/0121846	A1	5/2007	Altberg et al.
2007/0032247	A1	2/2007	Shaffer et al.	2007/0124131	A1	5/2007	Chino et al.
2007/0033003	A1	2/2007	Morris	2007/0124132	A1	5/2007	Takeuchi et al.
2007/0033005	A1	2/2007	Cristo et al.	2007/0124149	A1	5/2007	Shen et al.
2007/0033026	A1	2/2007	Bartosik et al.	2007/0124291	A1	5/2007	Hassan et al.
2007/0033054	A1	2/2007	Snitkovskiy et al.	2007/0124676	A1	5/2007	Amundsen et al.
2007/0036117	A1	2/2007	Taube et al.	2007/0127888	A1	6/2007	Hayashi et al.
2007/0036286	A1	2/2007	Champlin et al.	2007/0128777	A1	6/2007	Yin et al.
2007/0036294	A1	2/2007	Chaudhuri et al.	2007/0129059	A1	6/2007	Nadarajah et al.
2007/0038436	A1	2/2007	Cristoe et al.	2007/0130014	A1	6/2007	Altberg et al.
2007/0038609	A1	2/2007	Wu	2007/0130128	A1	6/2007	Garg et al.
2007/0040813	A1	2/2007	Kushler et al.	2007/0132738	A1	6/2007	Lowles et al.
2007/0041361	A1	2/2007	Iso-Sipila	2007/0133771	A1	6/2007	Stifelman et al.
2007/0042812	A1	2/2007	Basir et al.	2007/0135187	A1	6/2007	Kreiner et al.
2007/0043568	A1	2/2007	Dhanakshirur et al.	2007/0135949	A1	6/2007	Snover et al.
2007/0043687	A1	2/2007	Bodart et al.	2007/0136064	A1	6/2007	Carroll
2007/0043820	A1	2/2007	George et al.	2007/0136778	A1	6/2007	Birger et al.
2007/0044038	A1	2/2007	Horentrup et al.	2007/0143163	A1	6/2007	Weiss et al.
2007/0046641	A1	3/2007	Lim	2007/0149252	A1	6/2007	Jobs et al.
2007/0047719	A1	3/2007	Dhawan et al.	2007/0150403	A1	6/2007	Mock et al.
2007/0050184	A1	3/2007	Drucker et al.	2007/0150444	A1	6/2007	Chesnais et al.
2007/0050191	A1	3/2007	Weider et al.	2007/0150842	A1	6/2007	Chaudhri et al.
2007/0050393	A1	3/2007	Vogel et al.	2007/0152978	A1	7/2007	Kocienda et al.
2007/0050712	A1	3/2007	Hull et al.	2007/0152980	A1	7/2007	Kocienda et al.
2007/0052586	A1	3/2007	Horstemeyer	2007/0155346	A1	7/2007	Mijatovic et al.
2007/0055493	A1	3/2007	Lee	2007/0156410	A1	7/2007	Stohr et al.
2007/0055508	A1	3/2007	Zhao et al.	2007/0156627	A1	7/2007	D'Alicandro
				2007/0157089	A1	7/2007	Van Os et al.
				2007/0157268	A1	7/2007	Girish et al.
				2007/0162274	A1	7/2007	Ruiz et al.
				2007/0162296	A1	7/2007	Altberg et al.

(56)	References Cited						
	U.S. PATENT DOCUMENTS						
2007/0162414	A1	7/2007	Horowitz et al.	2007/0260595	A1	11/2007	Beatty et al.
2007/0165003	A1	7/2007	Fux et al.	2007/0260822	A1	11/2007	Adams
2007/0167136	A1	7/2007	Groth	2007/0261080	A1	11/2007	Saetti
2007/0168922	A1	7/2007	Kaiser et al.	2007/0265831	A1	11/2007	Dinur et al.
2007/0173233	A1	7/2007	Vander Veen et al.	2007/0265850	A1	11/2007	Kennewick et al.
2007/0173267	A1	7/2007	Klassen et al.	2007/0271104	A1	11/2007	McKay
2007/0174057	A1	7/2007	Genly	2007/0271510	A1	11/2007	Grigoriu et al.
2007/0174188	A1	7/2007	Fish	2007/0274468	A1	11/2007	Cai
2007/0174350	A1	7/2007	Pell et al.	2007/0276651	A1	11/2007	Bliss et al.
2007/0174396	A1	7/2007	Kumar et al.	2007/0276714	A1	11/2007	Beringer
2007/0179776	A1	8/2007	Segond et al.	2007/0276810	A1	11/2007	Rosen
2007/0179778	A1	8/2007	Gong et al.	2007/0277088	A1	11/2007	Bodin et al.
2007/0180383	A1	8/2007	Naik	2007/0282595	A1	12/2007	Tunning et al.
2007/0182595	A1	8/2007	Ghasabian	2007/0285958	A1	12/2007	Platchta et al.
2007/0185551	A1	8/2007	Meadows et al.	2007/0286363	A1	12/2007	Burg et al.
2007/0185754	A1	8/2007	Schmidt	2007/0286399	A1	12/2007	Ramamoorthy et al.
2007/0185831	A1	8/2007	Churcher	2007/0288238	A1	12/2007	Hetherington et al.
2007/0185917	A1	8/2007	Prahlad et al.	2007/0288241	A1	12/2007	Cross et al.
2007/0188901	A1	8/2007	Heckerman et al.	2007/0288449	A1	12/2007	Datta et al.
2007/0192026	A1	8/2007	Lee et al.	2007/0291108	A1	12/2007	Huber et al.
2007/0192027	A1	8/2007	Lee et al.	2007/0294077	A1	12/2007	Narayanan et al.
2007/0192105	A1	8/2007	Neeracher et al.	2007/0294083	A1	12/2007	Bellegarda et al.
2007/0192179	A1	8/2007	Van et al.	2007/0294199	A1	12/2007	Nelken et al.
2007/0192293	A1	8/2007	Swen	2007/0294263	A1	12/2007	Punj et al.
2007/0192403	A1	8/2007	Heine et al.	2007/0299664	A1	12/2007	Peters et al.
2007/0192744	A1	8/2007	Reponen	2007/0299831	A1	12/2007	Williams et al.
2007/0198267	A1	8/2007	Jones et al.	2007/0300140	A1	12/2007	Makela et al.
2007/0198269	A1	8/2007	Braho et al.	2008/0001785	A1	1/2008	Elizarov et al.
2007/0198273	A1	8/2007	Hennecke	2008/0010355	A1	1/2008	Vieri et al.
2007/0198566	A1	8/2007	Sustik	2008/0010605	A1	1/2008	Frank et al.
2007/0203955	A1	8/2007	Pomerantz	2008/0012950	A1	1/2008	Lee et al.
2007/0207785	A1	9/2007	Chatterjee et al.	2008/0013751	A1	1/2008	Hiselius
2007/0208555	A1	9/2007	Blass et al.	2008/0015863	A1	1/2008	Agapi et al.
2007/0208569	A1	9/2007	Subramanian et al.	2008/0015864	A1	1/2008	Ross et al.
2007/0208579	A1	9/2007	Peterson	2008/0016575	A1	1/2008	Vincent et al.
2007/0208726	A1	9/2007	Krishnaprasad et al.	2008/0021708	A1	1/2008	Bennett et al.
2007/0211071	A1	9/2007	Slotznick et al.	2008/0021886	A1	1/2008	Wang-Aryattanwanich et al.
2007/0213099	A1	9/2007	Bast	2008/0022208	A1	1/2008	Morse
2007/0213857	A1	9/2007	Bodin et al.	2008/0027726	A1	1/2008	Hansen et al.
2007/0213984	A1	9/2007	Ativanichayaphong et al.	2008/0031475	A1	2/2008	Goldstein
2007/0213986	A1	9/2007	Bodin et al.	2008/0033719	A1	2/2008	Hall et al.
2007/0217693	A1	9/2007	Kretzschmar, Jr.	2008/0034032	A1	2/2008	Healey et al.
2007/0219645	A1	9/2007	Thomas et al.	2008/0034044	A1	2/2008	Bhakta et al.
2007/0219777	A1	9/2007	Chu et al.	2008/0036743	A1	2/2008	Westerman et al.
2007/0219801	A1	9/2007	Sundaram et al.	2008/0040339	A1	2/2008	Zhou et al.
2007/0219803	A1	9/2007	Chiu et al.	2008/0042970	A1	2/2008	Liang et al.
2007/0219983	A1	9/2007	Fish	2008/0043936	A1	2/2008	Liebermann
2007/0225980	A1	9/2007	Sumita	2008/0043943	A1	2/2008	Sipher et al.
2007/0225984	A1	9/2007	Milstein et al.	2008/0046239	A1	2/2008	Boo
2007/0226652	A1	9/2007	Kikuchi et al.	2008/0046250	A1	2/2008	Agapi et al.
2007/0229323	A1	10/2007	Plachta et al.	2008/0046422	A1	2/2008	Lee et al.
2007/0230729	A1	10/2007	Naylor et al.	2008/0046820	A1	2/2008	Lee et al.
2007/0233484	A1	10/2007	Coelho et al.	2008/0046948	A1	2/2008	Verosub
2007/0233487	A1	10/2007	Cohen et al.	2008/0048908	A1	2/2008	Sato
2007/0233490	A1	10/2007	Yao	2008/0052063	A1	2/2008	Bennett et al.
2007/0233497	A1	10/2007	Paek et al.	2008/0052073	A1	2/2008	Goto et al.
2007/0233692	A1	10/2007	Lisa et al.	2008/0052077	A1	2/2008	Bennett et al.
2007/0233725	A1	10/2007	Michmerhuizen et al.	2008/0052080	A1	2/2008	Narayanan et al.
2007/0238488	A1	10/2007	Scott	2008/0052262	A1	2/2008	Kosinov et al.
2007/0238489	A1	10/2007	Scott	2008/0055194	A1	3/2008	Baudino et al.
2007/0238520	A1	10/2007	Kacmarcik	2008/0056459	A1	3/2008	Vallier et al.
2007/0239429	A1	10/2007	Johnson et al.	2008/0056579	A1	3/2008	Guha
2007/0239453	A1	10/2007	Paek et al.	2008/0059190	A1	3/2008	Chu et al.
2007/0240043	A1	10/2007	Fux et al.	2008/0059200	A1	3/2008	Puli
2007/0240044	A1	10/2007	Fux et al.	2008/0059876	A1	3/2008	Hantler et al.
2007/0240045	A1	10/2007	Fux et al.	2008/0062141	A1	3/2008	Chandhri
2007/0241885	A1	10/2007	Clipsham et al.	2008/0065382	A1	3/2008	Gerl et al.
2007/0244702	A1	10/2007	Kahn et al.	2008/0065387	A1	3/2008	Cross et al.
2007/0244976	A1	10/2007	Carroll et al.	2008/0071529	A1	3/2008	Silverman et al.
2007/0247441	A1	10/2007	Kim et al.	2008/0071544	A1	3/2008	Beaufays et al.
2007/0255435	A1	11/2007	Cohen et al.	2008/0075296	A1	3/2008	Lindahl et al.
2007/0255979	A1	11/2007	Deily et al.	2008/0076972	A1	3/2008	Dorogusker et al.
2007/0257890	A1	11/2007	Hotelling et al.	2008/0077310	A1	3/2008	Murlidar et al.
2007/0258642	A1	11/2007	Thota	2008/0077384	A1	3/2008	Agapi et al.
2007/0260460	A1	11/2007	Hyatt	2008/0077386	A1	3/2008	Gao et al.
				2008/0077391	A1	3/2008	Chino et al.
				2008/0077393	A1	3/2008	Gao et al.
				2008/0077406	A1	3/2008	Ganong, III
				2008/0077859	A1	3/2008	Schabes et al.

(56)

References Cited

U.S. PATENT DOCUMENTS

2008/0079566	A1	4/2008	Singh et al.	2008/0163131	A1	7/2008	Hirai et al.
2008/0080411	A1	4/2008	Cole	2008/0165144	A1	7/2008	Forstall et al.
2008/0082332	A1	4/2008	Mallett et al.	2008/0165980	A1	7/2008	Pavlovic et al.
2008/0082338	A1	4/2008	O'Neil et al.	2008/0165994	A1	7/2008	Caren et al.
2008/0082390	A1	4/2008	Hawkins et al.	2008/0167013	A1	7/2008	Novick et al.
2008/0082576	A1	4/2008	Bodin et al.	2008/0167858	A1	7/2008	Christie et al.
2008/0082651	A1	4/2008	Singh et al.	2008/0168052	A1	7/2008	Ott et al.
2008/0084974	A1	4/2008	Dhanakshirur	2008/0168366	A1	7/2008	Kocienda et al.
2008/0091406	A1	4/2008	Baldwin et al.	2008/0183473	A1	7/2008	Nagano et al.
2008/0091426	A1	4/2008	Rempel et al.	2008/0186960	A1	8/2008	Kocheisen et al.
2008/0091443	A1	4/2008	Strope et al.	2008/0189099	A1	8/2008	Friedman et al.
2008/0096531	A1	4/2008	Mcquaide et al.	2008/0189106	A1	8/2008	Low et al.
2008/0096726	A1	4/2008	Riley et al.	2008/0189110	A1	8/2008	Freeman et al.
2008/0097937	A1	4/2008	Hadjarian	2008/0189114	A1	8/2008	Fail et al.
2008/0098302	A1	4/2008	Roose	2008/0189606	A1	8/2008	Rybak
2008/0098480	A1	4/2008	Henry et al.	2008/0195312	A1	8/2008	Aaron et al.
2008/0057922	A1	5/2008	Kokes et al.	2008/0195388	A1	8/2008	Bower et al.
2008/0100579	A1	5/2008	Robinson et al.	2008/0195391	A1	8/2008	Marple et al.
2008/0101584	A1	5/2008	Gray et al.	2008/0195601	A1	8/2008	Ntoulas et al.
2008/0103774	A1	5/2008	White	2008/0195630	A1	8/2008	Exartier et al.
2008/0109222	A1	5/2008	Liu	2008/0195940	A1	8/2008	Gail et al.
2008/0109402	A1	5/2008	Wang et al.	2008/0200142	A1	8/2008	Abdel-Kader et al.
2008/0114480	A1	5/2008	Harb	2008/0201306	A1	8/2008	Cooper et al.
2008/0114598	A1	5/2008	Prieto et al.	2008/0201375	A1	8/2008	Khedouri et al.
2008/0114604	A1	5/2008	Wei et al.	2008/0204379	A1	8/2008	Perez-Noguera
2008/0114841	A1	5/2008	Lambert	2008/0207176	A1	8/2008	Brackbill et al.
2008/0115084	A1	5/2008	Scott et al.	2008/0208585	A1	8/2008	Ativanichayaphong et al.
2008/0118143	A1	5/2008	Gordon et al.	2008/0208587	A1	8/2008	Ben-David et al.
2008/0119953	A1	5/2008	Reed	2008/0208864	A1	8/2008	Cucerzan et al.
2008/0120102	A1	5/2008	Rao	2008/0212796	A1	9/2008	Denda
2008/0120112	A1	5/2008	Jordan et al.	2008/0219641	A1	9/2008	Sandrew et al.
2008/0120196	A1	5/2008	Reed et al.	2008/0221866	A1	9/2008	Katragadda et al.
2008/0120311	A1	5/2008	Reed	2008/0221879	A1	9/2008	Cerra et al.
2008/0120312	A1	5/2008	Reed	2008/0221880	A1	9/2008	Cerra et al.
2008/0120330	A1	5/2008	Reed	2008/0221887	A1	9/2008	Rose et al.
2008/0120342	A1	5/2008	Reed et al.	2008/0221889	A1	9/2008	Cerra et al.
2008/0122796	A1	5/2008	Jobs et al.	2008/0221903	A1	9/2008	Kanevsky et al.
2008/0124695	A1	5/2008	Myers et al.	2008/0222118	A1	9/2008	Scian et al.
2008/0126075	A1	5/2008	Thorn et al.	2008/0226130	A1	9/2008	Kansal et al.
2008/0126077	A1	5/2008	Thorn	2008/0228463	A1	9/2008	Mori et al.
2008/0126091	A1	5/2008	Clark et al.	2008/0228485	A1	9/2008	Owen
2008/0126093	A1	5/2008	Sivadas	2008/0228490	A1	9/2008	Fischer et al.
2008/0126100	A1	5/2008	Grost et al.	2008/0228495	A1	9/2008	Cross et al.
2008/0126491	A1	5/2008	Portele et al.	2008/0228496	A1	9/2008	Yu et al.
2008/0129520	A1	6/2008	Lee	2008/0228928	A1	9/2008	Donelli et al.
2008/0130867	A1	6/2008	Bowen	2008/0229185	A1	9/2008	Lynch
2008/0131006	A1	6/2008	Oliver	2008/0229218	A1	9/2008	Maeng
2008/0132221	A1	6/2008	Willey et al.	2008/0235017	A1	9/2008	Satomura et al.
2008/0133215	A1	6/2008	Sarukkai	2008/0235024	A1	9/2008	Goldberg et al.
2008/0133228	A1	6/2008	Rao	2008/0235027	A1	9/2008	Cross
2008/0133230	A1	6/2008	Herforth et al.	2008/0240569	A1	10/2008	Tonouchi
2008/0133241	A1	6/2008	Baker et al.	2008/0242280	A1	10/2008	Shapiro et al.
2008/0133956	A1	6/2008	Fadell	2008/0242322	A1	10/2008	Scott et al.
2008/0140413	A1	6/2008	Millman et al.	2008/0244390	A1	10/2008	Fux et al.
2008/0140416	A1	6/2008	Shostak	2008/0244446	A1	10/2008	Lefevre et al.
2008/0140652	A1	6/2008	Millman et al.	2008/0247519	A1	10/2008	Abella et al.
2008/0140657	A1	6/2008	Azvine et al.	2008/0247529	A1	10/2008	Barton et al.
2008/0140702	A1	6/2008	Reed et al.	2008/0248797	A1	10/2008	Freeman et al.
2008/0141125	A1	6/2008	Ghassabian et al.	2008/0249770	A1	10/2008	Kim et al.
2008/0141180	A1	6/2008	Reed et al.	2008/0249778	A1	10/2008	Barton et al.
2008/0141182	A1	6/2008	Barsness et al.	2008/0253577	A1	10/2008	Eppolito
2008/0146245	A1	6/2008	Appaji	2008/0254425	A1	10/2008	Cohen et al.
2008/0146290	A1	6/2008	Sreeram et al.	2008/0255837	A1	10/2008	Kahn et al.
2008/0147408	A1	6/2008	Da Palma et al.	2008/0255842	A1	10/2008	Simhi et al.
2008/0147411	A1	6/2008	Dames et al.	2008/0255845	A1	10/2008	Bennett
2008/0147874	A1	6/2008	Yoneda et al.	2008/0256613	A1	10/2008	Grover
2008/0150900	A1	6/2008	Han	2008/0259022	A1	10/2008	Mansfield et al.
2008/0154577	A1	6/2008	Kim et al.	2008/0262828	A1	10/2008	Och et al.
2008/0154600	A1	6/2008	Tian et al.	2008/0262838	A1	10/2008	Nurminen et al.
2008/0154612	A1	6/2008	Evermann et al.	2008/0262846	A1	10/2008	Burns et al.
2008/0154828	A1	6/2008	Antebi et al.	2008/0263139	A1	10/2008	Martin
2008/0157867	A1	7/2008	Krah	2008/0270118	A1	10/2008	Kuo et al.
2008/0161113	A1	7/2008	Hansen et al.	2008/0270138	A1	10/2008	Knight et al.
2008/0162120	A1	7/2008	Mactavish et al.	2008/0270139	A1	10/2008	Shi et al.
2008/0163119	A1	7/2008	Kim et al.	2008/0270140	A1	10/2008	Hertz et al.
				2008/0270151	A1	10/2008	Mahoney et al.
				2008/0277473	A1	11/2008	Kotlarsky et al.
				2008/0281510	A1	11/2008	Shahine
				2008/0288259	A1	11/2008	Chambers et al.

(56)

References Cited

U.S. PATENT DOCUMENTS

2008/0288460	A1	11/2008	Poniatowski et al.	2009/0079622	A1	3/2009	Seshadri et al.
2008/0292112	A1	11/2008	Valenzuela et al.	2009/0083034	A1	3/2009	Hernandez et al.
2008/0294418	A1	11/2008	Cleary et al.	2009/0083035	A1	3/2009	Huang et al.
2008/0294651	A1	11/2008	Masuyama et al.	2009/0083036	A1	3/2009	Zhao et al.
2008/0294981	A1	11/2008	Balzano et al.	2009/0083037	A1	3/2009	Gleason et al.
2008/0298563	A1	12/2008	Rondeau et al.	2009/0083047	A1	3/2009	Lindahl et al.
2008/0298766	A1	12/2008	Wen et al.	2009/0089058	A1	4/2009	Bellegarda
2008/0299523	A1	12/2008	Chai et al.	2009/0092239	A1	4/2009	Macwan et al.
2008/0300871	A1	12/2008	Gilbert	2009/0092260	A1	4/2009	Powers
2008/0300878	A1	12/2008	Bennett	2009/0092261	A1	4/2009	Bard
2008/0303645	A1	12/2008	Seymour et al.	2009/0092262	A1	4/2009	Costa et al.
2008/0306727	A1	12/2008	Thurmair et al.	2009/0094029	A1	4/2009	Koch et al.
2008/0312909	A1	12/2008	Hermansen et al.	2009/0094033	A1	4/2009	Mozer et al.
2008/0312928	A1	12/2008	Goebel et al.	2009/0097634	A1	4/2009	Nambiar et al.
2008/0313335	A1	12/2008	Jung et al.	2009/0097637	A1	4/2009	Boscher et al.
2008/0316183	A1	12/2008	Westerman et al.	2009/0100049	A1	4/2009	Cao
2008/0319738	A1	12/2008	Liu et al.	2009/0100454	A1	4/2009	Weber
2008/0319753	A1	12/2008	Hancock	2009/0104898	A1	4/2009	Harris
2008/0319763	A1	12/2008	Di Fabbri et al.	2009/0106026	A1	4/2009	Ferrieux
2008/0319783	A1	12/2008	Yao et al.	2009/0106376	A1	4/2009	Tom et al.
2009/0003115	A1	1/2009	Lindahl et al.	2009/0106397	A1	4/2009	O'Keefe
2009/0005012	A1	1/2009	Van Heugten	2009/0112572	A1	4/2009	Thorn
2009/0005891	A1	1/2009	Batson et al.	2009/0112576	A1	4/2009	Jackson et al.
2009/0006097	A1	1/2009	Etezadi et al.	2009/0112592	A1	4/2009	Candelore et al.
2009/0006099	A1	1/2009	Sharpe et al.	2009/0112677	A1	4/2009	Rhett
2009/0006100	A1	1/2009	Badger et al.	2009/0112892	A1	4/2009	Cardie et al.
2009/0006343	A1	1/2009	Platt et al.	2009/0119587	A1	5/2009	Allen et al.
2009/0006345	A1	1/2009	Platt et al.	2009/0123021	A1	5/2009	Jung et al.
2009/0006488	A1	1/2009	Lindahl et al.	2009/0123071	A1	5/2009	Iwasaki
2009/0006671	A1	1/2009	Batson et al.	2009/0125477	A1	5/2009	Lu et al.
2009/0007001	A1	1/2009	Morin et al.	2009/0128505	A1	5/2009	Partridge et al.
2009/0011709	A1	1/2009	Akasaka et al.	2009/0132253	A1	5/2009	Bellegarda
2009/0012748	A1	1/2009	Beish et al.	2009/0132255	A1	5/2009	Lu
2009/0012775	A1	1/2009	El Hady et al.	2009/0137286	A1	5/2009	Luke et al.
2009/0018828	A1	1/2009	Nakadai et al.	2009/0138736	A1	5/2009	Chin
2009/0018829	A1	1/2009	Kuperstein	2009/0138828	A1	5/2009	Schultz et al.
2009/0018834	A1	1/2009	Cooper et al.	2009/0144049	A1	6/2009	Haddad et al.
2009/0018835	A1	1/2009	Cooper et al.	2009/0144428	A1	6/2009	Bowater et al.
2009/0018839	A1	1/2009	Cooper et al.	2009/0144609	A1	6/2009	Liang et al.
2009/0018840	A1	1/2009	Lutz et al.	2009/0146848	A1	6/2009	Ghassabian
2009/0022329	A1	1/2009	Mahowald	2009/0150147	A1	6/2009	Jacoby et al.
2009/0024595	A1	1/2009	Chen	2009/0150156	A1	6/2009	Kennewick et al.
2009/0028435	A1	1/2009	Wu et al.	2009/0152349	A1	6/2009	Bonev et al.
2009/0030800	A1	1/2009	Grois	2009/0153288	A1	6/2009	Hope et al.
2009/0030978	A1	1/2009	Johnson et al.	2009/0154669	A1	6/2009	Wood et al.
2009/0043580	A1	2/2009	Mozer et al.	2009/0157382	A1	6/2009	Bar
2009/0043583	A1	2/2009	Agapi et al.	2009/0157384	A1	6/2009	Toutanova et al.
2009/0043763	A1	2/2009	Peng	2009/0157401	A1	6/2009	Bennett
2009/0044094	A1	2/2009	Rapp et al.	2009/0158200	A1	6/2009	Palahnuk et al.
2009/0048821	A1	2/2009	Yam et al.	2009/0158323	A1	6/2009	Bober et al.
2009/0048845	A1	2/2009	Burckart et al.	2009/0158423	A1	6/2009	Orlassino et al.
2009/0049067	A1	2/2009	Murray	2009/0160803	A1	6/2009	Hashimoto
2009/0055168	A1	2/2009	Wu et al.	2009/0164301	A1	6/2009	O'Sullivan et al.
2009/0055175	A1	2/2009	Terrell et al.	2009/0164441	A1	6/2009	Cheyner
2009/0055179	A1	2/2009	Cho et al.	2009/0164655	A1	6/2009	Pettersson et al.
2009/0055186	A1	2/2009	Lance et al.	2009/0164937	A1	6/2009	Alviar et al.
2009/0055381	A1	2/2009	Wu et al.	2009/0167508	A1	7/2009	Fadell et al.
2009/0055648	A1	2/2009	Kim et al.	2009/0167509	A1	7/2009	Fadell et al.
2009/0058823	A1	3/2009	Kocienda	2009/0171578	A1	7/2009	Kim et al.
2009/0058860	A1	3/2009	Fong et al.	2009/0171662	A1	7/2009	Huang et al.
2009/0060351	A1	3/2009	Li et al.	2009/0171664	A1	7/2009	Kennewick et al.
2009/0060472	A1	3/2009	Bull et al.	2009/0172108	A1	7/2009	Singh
2009/0063974	A1	3/2009	Bull et al.	2009/0172542	A1	7/2009	Girish et al.
2009/0064031	A1	3/2009	Bull et al.	2009/0174667	A1	7/2009	Kocienda et al.
2009/0070097	A1	3/2009	Wu et al.	2009/0174677	A1	7/2009	Gehani et al.
2009/0070102	A1	3/2009	Maegawa	2009/0177300	A1	7/2009	Lee
2009/0070109	A1	3/2009	Didcock et al.	2009/0177461	A1	7/2009	Ehsani et al.
2009/0070114	A1	3/2009	Staszak	2009/0177966	A1	7/2009	Chaudhri
2009/0074214	A1	3/2009	Bradford et al.	2009/0182445	A1	7/2009	Girish et al.
2009/0076792	A1	3/2009	Lawson-Tancred	2009/0187402	A1	7/2009	Scholl
2009/0076796	A1	3/2009	Daraselia	2009/0187577	A1	7/2009	Reznik et al.
2009/0076819	A1	3/2009	Wouters et al.	2009/0187950	A1	7/2009	Nicas et al.
2009/0076821	A1	3/2009	Brenner et al.	2009/0191895	A1	7/2009	Singh et al.
2009/0076825	A1	3/2009	Bradford et al.	2009/0192782	A1	7/2009	Drewes
2009/0077165	A1	3/2009	Rhodes et al.	2009/0192787	A1	7/2009	Roon
				2009/0198497	A1	8/2009	Kwon
				2009/0204409	A1	8/2009	Mozer et al.
				2009/0204478	A1	8/2009	Kaib et al.
				2009/0204596	A1	8/2009	Brun et al.

(56)

References Cited

U.S. PATENT DOCUMENTS

2009/0204601	A1	8/2009	Grasset	2009/0307201	A1	12/2009	Dunning et al.
2009/0204620	A1	8/2009	Thione et al.	2009/0307584	A1	12/2009	Davidson et al.
2009/0210230	A1	8/2009	Schwarz et al.	2009/0313014	A1	12/2009	Shin et al.
2009/0210232	A1	8/2009	Sanchez et al.	2009/0313023	A1	12/2009	Jones
2009/0213134	A1	8/2009	Stephanick et al.	2009/0313026	A1	12/2009	Coffman et al.
2009/0215503	A1	8/2009	Zhang et al.	2009/0313544	A1	12/2009	Wood et al.
2009/0216396	A1	8/2009	Yamagata	2009/0313564	A1	12/2009	Rottler et al.
2009/0216540	A1	8/2009	Tessel et al.	2009/0316943	A1	12/2009	Frigola Munoz et al.
2009/0216704	A1	8/2009	Zheng et al.	2009/0318119	A1	12/2009	Basir et al.
2009/0221274	A1	9/2009	Venkatakrisnan et al.	2009/0318198	A1	12/2009	Carroll
2009/0222257	A1	9/2009	Sumita et al.	2009/0319266	A1	12/2009	Brown et al.
2009/0222270	A2	9/2009	Likens et al.	2009/0326923	A1	12/2009	Yan et al.
2009/0222488	A1	9/2009	Boerries et al.	2009/0326936	A1	12/2009	Nagashima
2009/0228126	A1	9/2009	Spielberg et al.	2009/0326938	A1	12/2009	Marila et al.
2009/0228273	A1	9/2009	Wang et al.	2009/0326949	A1	12/2009	Douthitt et al.
2009/0228277	A1	9/2009	Bonforte et al.	2009/0327977	A1	12/2009	Bachfischer et al.
2009/0228281	A1	9/2009	Singleton et al.	2010/0004918	A1	1/2010	Lee et al.
2009/0228439	A1	9/2009	Manolescu et al.	2010/0004931	A1	1/2010	Ma et al.
2009/0228792	A1	9/2009	Van Os et al.	2010/0005081	A1	1/2010	Bennett
2009/0228842	A1	9/2009	Westerman et al.	2010/0010803	A1	1/2010	Ishikawa et al.
2009/0234638	A1	9/2009	Ranjan et al.	2010/0010814	A1	1/2010	Patel
2009/0234655	A1	9/2009	Kwon	2010/0013760	A1	1/2010	Hirai et al.
2009/0235280	A1	9/2009	Tannier et al.	2010/0013796	A1	1/2010	Abileah et al.
2009/0239202	A1	9/2009	Stone	2010/0017212	A1	1/2010	Attwater et al.
2009/0239552	A1	9/2009	Churchill et al.	2010/0017382	A1	1/2010	Katragadda et al.
2009/0240485	A1	9/2009	Dalal et al.	2010/0019834	A1	1/2010	Zerbe et al.
2009/0241054	A1	9/2009	Hendricks	2010/0023318	A1	1/2010	Lemoine
2009/0241760	A1	10/2009	Georges	2010/0023320	A1	1/2010	Di Cristo et al.
2009/0247237	A1	10/2009	Mittleman et al.	2010/0026526	A1	2/2010	Yokota
2009/0248182	A1	10/2009	Logan et al.	2010/0030549	A1	2/2010	Lee et al.
2009/0248395	A1	10/2009	Alewine et al.	2010/0030928	A1	2/2010	Conroy et al.
2009/0248402	A1	10/2009	Ito et al.	2010/0031143	A1	2/2010	Rao et al.
2009/0248420	A1	10/2009	Basir et al.	2010/0036653	A1	2/2010	Kim et al.
2009/0248422	A1	10/2009	Li et al.	2010/0036655	A1	2/2010	Cecil et al.
2009/0249198	A1	10/2009	Davis et al.	2010/0036660	A1	2/2010	Bennett
2009/0249247	A1	10/2009	Tseng et al.	2010/0037183	A1	2/2010	Miyashita et al.
2009/0252350	A1	10/2009	Seguin	2010/0042400	A1	2/2010	Block et al.
2009/0253457	A1	10/2009	Seguin	2010/0042576	A1	2/2010	Roettger et al.
2009/0253463	A1	10/2009	Shin et al.	2010/0046842	A1	2/2010	Conwell et al.
2009/0254339	A1	10/2009	Seguin	2010/0049498	A1	2/2010	Cao et al.
2009/0254345	A1	10/2009	Fleizach et al.	2010/0049514	A1	2/2010	Kennewick et al.
2009/0254819	A1	10/2009	Song et al.	2010/0050064	A1	2/2010	Liu et al.
2009/0254823	A1	10/2009	Barrett	2010/0054512	A1	3/2010	Solum
2009/0259969	A1	10/2009	Pallakoff	2010/0057457	A1	3/2010	Ogata et al.
2009/0265368	A1	10/2009	Crider et al.	2010/0057461	A1	3/2010	Neubacher et al.
2009/0271109	A1	10/2009	Lee et al.	2010/0057643	A1	3/2010	Yang
2009/0271175	A1	10/2009	Bodin et al.	2010/0060646	A1	3/2010	Unsal et al.
2009/0271176	A1	10/2009	Bodin et al.	2010/0063804	A1	3/2010	Sato et al.
2009/0271178	A1	10/2009	Bodin et al.	2010/0063825	A1	3/2010	Williams et al.
2009/0271188	A1	10/2009	Agapi et al.	2010/0063961	A1	3/2010	Guiheneuf et al.
2009/0271189	A1	10/2009	Agapi et al.	2010/0064113	A1	3/2010	Lindahl et al.
2009/0274315	A1	11/2009	Carnes et al.	2010/0064218	A1	3/2010	Bull et al.
2009/0281789	A1	11/2009	Waibel et al.	2010/0064226	A1	3/2010	Stefaniak et al.
2009/0284482	A1	11/2009	Chin	2010/0067723	A1	3/2010	Bergmann et al.
2009/0286514	A1	11/2009	Lichorowic et al.	2010/0067867	A1	3/2010	Lin et al.
2009/0287583	A1	11/2009	Holmes	2010/0070281	A1	3/2010	Conkie et al.
2009/0290718	A1	11/2009	Kahn et al.	2010/0070899	A1	3/2010	Hunt et al.
2009/0292987	A1	11/2009	Sorenson	2010/0071003	A1	3/2010	Bychkov et al.
2009/0296552	A1	12/2009	Hicks et al.	2010/0076760	A1	3/2010	Kraenzel et al.
2009/0298474	A1	12/2009	George	2010/0076993	A1	3/2010	Klawitter et al.
2009/0298529	A1	12/2009	Mahajan	2010/0077350	A1	3/2010	Lim et al.
2009/0299745	A1	12/2009	Kennewick et al.	2010/0079501	A1	4/2010	Ikeda et al.
2009/0299849	A1	12/2009	Cao et al.	2010/0080398	A1	4/2010	Waldmann
2009/0300391	A1	12/2009	Jessup et al.	2010/0080470	A1	4/2010	Deluca et al.
2009/0300488	A1	12/2009	Salamon et al.	2010/0081456	A1	4/2010	Singh et al.
2009/0304198	A1	12/2009	Herre et al.	2010/0081487	A1	4/2010	Chen et al.
2009/0306967	A1	12/2009	Nicolov et al.	2010/0082286	A1	4/2010	Leung
2009/0306969	A1	12/2009	Goud et al.	2010/0082327	A1	4/2010	Rogers et al.
2009/0306979	A1	12/2009	Jaiswal et al.	2010/0082328	A1	4/2010	Rogers et al.
2009/0306980	A1	12/2009	Shin	2010/0082329	A1	4/2010	Silverman et al.
2009/0306981	A1	12/2009	Cromack et al.	2010/0082333	A1	4/2010	Al-Shammari
2009/0306985	A1	12/2009	Roberts et al.	2010/0082346	A1	4/2010	Rogers et al.
2009/0306988	A1	12/2009	Chen et al.	2010/0082347	A1	4/2010	Rogers et al.
2009/0306989	A1	12/2009	Kaji	2010/0082348	A1	4/2010	Silverman et al.
2009/0307162	A1	12/2009	Bui et al.	2010/0082349	A1	4/2010	Bellegarda et al.
				2010/0082970	A1	4/2010	Lindahl et al.
				2010/0086152	A1	4/2010	Rank et al.
				2010/0086153	A1	4/2010	Hagen et al.
				2010/0086156	A1	4/2010	Rank et al.

(56)		References Cited					
		U.S. PATENT DOCUMENTS					
2010/0088020	A1	4/2010	Sano et al.	2010/0250542	A1	9/2010	Fujimaki
2010/0088093	A1	4/2010	Lee et al.	2010/0250599	A1	9/2010	Schmidt et al.
2010/0088100	A1	4/2010	Lindahl	2010/0255858	A1	10/2010	Juhasz
2010/0098231	A1	4/2010	Wohlert et al.	2010/0257160	A1	10/2010	Cao
2010/0100212	A1	4/2010	Lindahl et al.	2010/0257478	A1	10/2010	Longe et al.
2010/0100384	A1	4/2010	Ju et al.	2010/0262599	A1	10/2010	Nitz
2010/0100816	A1	4/2010	Mccloskey et al.	2010/0268539	A1	10/2010	Xu et al.
2010/0103776	A1	4/2010	Chan	2010/0269040	A1	10/2010	Lee
2010/0106486	A1	4/2010	Hua et al.	2010/0274753	A1	10/2010	Liberty et al.
2010/0106498	A1	4/2010	Morrison et al.	2010/0277579	A1	11/2010	Cho et al.
2010/0106500	A1	4/2010	McKee et al.	2010/0278320	A1	11/2010	Arsenault et al.
2010/0106503	A1	4/2010	Farrell et al.	2010/0278453	A1	11/2010	King
2010/0114856	A1	5/2010	Kuboyama	2010/0280983	A1	11/2010	Cho et al.
2010/0121637	A1	5/2010	Roy et al.	2010/0281034	A1	11/2010	Petrou et al.
2010/0125456	A1	5/2010	Weng et al.	2010/0286985	A1	11/2010	Kennewick et al.
2010/0125458	A1	5/2010	Franco et al.	2010/0287514	A1	11/2010	Cragun et al.
2010/0125460	A1	5/2010	Mellott et al.	2010/0293460	A1	11/2010	Budelli
2010/0125811	A1	5/2010	Moore et al.	2010/0295645	A1	11/2010	Falldin et al.
2010/0131269	A1	5/2010	Park et al.	2010/0299133	A1	11/2010	Kopparapu et al.
2010/0131273	A1	5/2010	Aley-Raz et al.	2010/0299138	A1	11/2010	Kim
2010/0131498	A1	5/2010	Linthicum et al.	2010/0299142	A1	11/2010	Freeman et al.
2010/0131899	A1	5/2010	Hubert	2010/0302056	A1	12/2010	Dutton et al.
2010/0138215	A1	6/2010	Williams	2010/0304342	A1	12/2010	Zilber
2010/0138224	A1	6/2010	Bedingfield, Sr.	2010/0304705	A1	12/2010	Hursey et al.
2010/0138416	A1	6/2010	Bellotti	2010/0305807	A1	12/2010	Basir et al.
2010/0138680	A1	6/2010	Brisebois et al.	2010/0305947	A1	12/2010	Schwarz et al.
2010/0138759	A1	6/2010	Roy	2010/0312547	A1	12/2010	Van Os et al.
2010/0142740	A1	6/2010	Roerup	2010/0312566	A1	12/2010	Odinak et al.
2010/0145694	A1	6/2010	Ju et al.	2010/0318576	A1	12/2010	Kim
2010/0145700	A1	6/2010	Kennewick et al.	2010/0322438	A1	12/2010	Siotis
2010/0146442	A1	6/2010	Nagasaka et al.	2010/0324709	A1	12/2010	Starman
2010/0150321	A1	6/2010	Harris et al.	2010/0324895	A1	12/2010	Kurzweil et al.
2010/0153115	A1	6/2010	Klee et al.	2010/0324896	A1	12/2010	Attwater et al.
2010/0153448	A1	6/2010	Harpur et al.	2010/0324905	A1	12/2010	Kurzweil et al.
2010/0161313	A1	6/2010	Karttunen	2010/0325131	A1	12/2010	Dumais et al.
2010/0161554	A1	6/2010	Datuashvili et al.	2010/0325158	A1	12/2010	Oral et al.
2010/0164897	A1	7/2010	Morin et al.	2010/0325573	A1	12/2010	Estrada et al.
2010/0169075	A1	7/2010	Raffa et al.	2010/0325588	A1	12/2010	Reddy et al.
2010/0169097	A1	7/2010	Nachman et al.	2010/0332220	A1	12/2010	Hursey et al.
2010/0169098	A1	7/2010	Patch	2010/0332224	A1	12/2010	Mäkelä et al.
2010/0171713	A1	7/2010	Kwok et al.	2010/0332235	A1	12/2010	David
2010/0174544	A1	7/2010	Heifets	2010/0332236	A1	12/2010	Tan
2010/0175066	A1	7/2010	Paik	2010/0332280	A1	12/2010	Bradley et al.
2010/0179932	A1	7/2010	Yoon et al.	2010/0332348	A1	12/2010	Cao
2010/0179991	A1	7/2010	Lorch et al.	2010/0332428	A1	12/2010	Mchenry et al.
2010/0180218	A1	7/2010	Boston et al.	2010/0332976	A1	12/2010	Fux et al.
2010/0185448	A1	7/2010	Meisel	2010/0333030	A1	12/2010	Johns
2010/0185949	A1	7/2010	Jaeger	2010/0333163	A1	12/2010	Daly
2010/0191520	A1	7/2010	Gruhn et al.	2011/0002487	A1	1/2011	Panther et al.
2010/0197359	A1	8/2010	Harris	2011/0004475	A1	1/2011	Bellegarda
2010/0199180	A1	8/2010	Brichter	2011/0009107	A1	1/2011	Guba et al.
2010/0199215	A1	8/2010	Seymour et al.	2011/0010178	A1	1/2011	Lee et al.
2010/0204986	A1	8/2010	Kennewick et al.	2011/0010644	A1	1/2011	Merrill et al.
2010/0211199	A1	8/2010	Naik et al.	2011/0016150	A1	1/2011	Engstrom et al.
2010/0216509	A1	8/2010	Riemer et al.	2011/0018695	A1	1/2011	Bells et al.
2010/0217604	A1	8/2010	Baldwin et al.	2011/0021213	A1	1/2011	Carr
2010/0222033	A1	9/2010	Scott et al.	2011/0022292	A1	1/2011	Shen et al.
2010/0222098	A1	9/2010	Garg	2011/0022388	A1	1/2011	Wu et al.
2010/0223055	A1	9/2010	Mclean	2011/0022393	A1	1/2011	Waller et al.
2010/0223056	A1	9/2010	Kadiramanathan et al.	2011/0022394	A1	1/2011	Wide et al.
2010/0223131	A1	9/2010	Scott et al.	2011/0022472	A1	1/2011	Zon et al.
2010/0225599	A1	9/2010	Danielsson et al.	2011/0022952	A1	1/2011	Wu et al.
2010/0225809	A1	9/2010	Connors et al.	2011/0029616	A1	2/2011	Wang et al.
2010/0228540	A1	9/2010	Bennett	2011/0030067	A1	2/2011	Wilson
2010/0228549	A1	9/2010	Herman et al.	2011/0033064	A1	2/2011	Johnson et al.
2010/0228691	A1	9/2010	Yang et al.	2011/0035144	A1	2/2011	Okamoto et al.
2010/0229082	A1	9/2010	Karmarkar et al.	2011/0035434	A1	2/2011	Lockwood
2010/0229100	A1	9/2010	Miller et al.	2011/0038489	A1	2/2011	Visser et al.
2010/0231474	A1	9/2010	Yamagajo et al.	2011/0045841	A1	2/2011	Kuhlke et al.
2010/0235167	A1	9/2010	Bourdon	2011/0047072	A1	2/2011	Ciurea
2010/0235341	A1	9/2010	Bennett	2011/0047149	A1	2/2011	Vaananen
2010/0235729	A1	9/2010	Kocienda et al.	2011/0047161	A1	2/2011	Myaeng et al.
2010/0235732	A1	9/2010	Bergman	2011/0050591	A1	3/2011	Kim et al.
2010/0235770	A1	9/2010	Ordning et al.	2011/0050592	A1	3/2011	Kim et al.
2010/0241418	A1	9/2010	Maeda et al.	2011/0054647	A1	3/2011	Chipchase
				2011/0054894	A1	3/2011	Phillips et al.
				2011/0054901	A1	3/2011	Qin et al.
				2011/0055256	A1	3/2011	Phillips et al.
				2011/0060584	A1	3/2011	Ferrucci et al.

(56)

References Cited

U.S. PATENT DOCUMENTS

2011/0060587	A1	3/2011	Phillips et al.	2011/0208511	A1	8/2011	Sikstrom et al.
2011/0060589	A1	3/2011	Weinberg et al.	2011/0208524	A1	8/2011	Haughay
2011/0060807	A1	3/2011	Martin et al.	2011/0209088	A1	8/2011	Hinckley et al.
2011/0064387	A1	3/2011	Mendeloff et al.	2011/0212717	A1	9/2011	Rhoads et al.
2011/0065456	A1	3/2011	Brennan et al.	2011/0218806	A1	9/2011	Alewine et al.
2011/0066366	A1	3/2011	Ellanti et al.	2011/0218855	A1	9/2011	Cao et al.
2011/0066468	A1	3/2011	Huang et al.	2011/0219018	A1	9/2011	Bailey et al.
2011/0066634	A1	3/2011	Phillips et al.	2011/0223893	A1	9/2011	Lau et al.
2011/0072492	A1	3/2011	Mohler et al.	2011/0224972	A1	9/2011	Millett et al.
2011/0076994	A1	3/2011	Kim et al.	2011/0228913	A1	9/2011	Cochinwala et al.
2011/0077943	A1	3/2011	Miki et al.	2011/0231182	A1	9/2011	Weider et al.
2011/0081889	A1	4/2011	Gao et al.	2011/0231184	A1	9/2011	Kerr
2011/0082688	A1	4/2011	Kim et al.	2011/0231188	A1	9/2011	Kennewick et al.
2011/0083079	A1	4/2011	Farrell et al.	2011/0231432	A1	9/2011	Sata et al.
2011/0087491	A1	4/2011	Wittenstein et al.	2011/0231474	A1	9/2011	Locker et al.
2011/0090078	A1	4/2011	Kim et al.	2011/0238407	A1	9/2011	Kent
2011/0093261	A1	4/2011	Angott	2011/0238408	A1	9/2011	Larcheveque et al.
2011/0093265	A1	4/2011	Stent et al.	2011/0238676	A1	9/2011	Liu et al.
2011/0093271	A1	4/2011	Bernard et al.	2011/0239111	A1	9/2011	Grover
2011/0099000	A1	4/2011	Rai et al.	2011/0242007	A1	10/2011	Gray et al.
2011/0103682	A1	5/2011	Chidlovskii et al.	2011/0246471	A1	10/2011	Rakib et al.
2011/0106736	A1	5/2011	Aharonson et al.	2011/0249144	A1	10/2011	Chang
2011/0106892	A1	5/2011	Nelson et al.	2011/0250570	A1	10/2011	Mack et al.
2011/0110502	A1	5/2011	Daye et al.	2011/0258188	A1	10/2011	Abdalmageed et al.
2011/0112827	A1	5/2011	Kennewick et al.	2011/0260861	A1	10/2011	Singh et al.
2011/0112837	A1	5/2011	Kurki-Suonio et al.	2011/0264643	A1	10/2011	Cao
2011/0112921	A1	5/2011	Kennewick et al.	2011/0274303	A1	11/2011	Filson et al.
2011/0116610	A1	5/2011	Shaw et al.	2011/0276598	A1	11/2011	Kozempel
2011/0119049	A1	5/2011	Ylonen	2011/0276944	A1	11/2011	Bergman et al.
2011/0119051	A1	5/2011	Li et al.	2011/0279368	A1	11/2011	Klein et al.
2011/0119715	A1	5/2011	Chang et al.	2011/0282888	A1	11/2011	Koperski et al.
2011/0123004	A1	5/2011	Chang et al.	2011/0282906	A1	11/2011	Wong
2011/0125498	A1	5/2011	Pickering et al.	2011/0288861	A1	11/2011	Kurzweil et al.
2011/0125540	A1	5/2011	Jang et al.	2011/0298585	A1	12/2011	Barry
2011/0130958	A1	6/2011	Stahl et al.	2011/0301943	A1	12/2011	Patch
2011/0131036	A1	6/2011	DiCristo et al.	2011/0302162	A1	12/2011	Xiao et al.
2011/0131038	A1	6/2011	Oyaizu et al.	2011/0306426	A1	12/2011	Novak et al.
2011/0131045	A1	6/2011	Cristo et al.	2011/0307241	A1	12/2011	Waibel et al.
2011/0137636	A1	6/2011	Srihari et al.	2011/0307491	A1	12/2011	Fisk et al.
2011/0141141	A1	6/2011	Kankainen	2011/0307810	A1	12/2011	Hilerio et al.
2011/0143811	A1	6/2011	Rodriguez	2011/0313775	A1	12/2011	Laligand et al.
2011/0144857	A1	6/2011	Wingrove et al.	2011/0314032	A1	12/2011	Bennett et al.
2011/0144901	A1	6/2011	Wang	2011/0314404	A1	12/2011	Kotler et al.
2011/0144973	A1	6/2011	Bocchieri et al.	2011/0320187	A1	12/2011	Motik et al.
2011/0144999	A1	6/2011	Jang et al.	2012/0002820	A1	1/2012	Leichter
2011/0145718	A1	6/2011	Ketola et al.	2012/0005602	A1	1/2012	Anttila et al.
2011/0151830	A1	6/2011	Blanda et al.	2012/0008754	A1	1/2012	Mukherjee et al.
2011/0153209	A1	6/2011	Geelen	2012/0010886	A1	1/2012	Razavilar
2011/0153322	A1	6/2011	Kwak et al.	2012/0011138	A1	1/2012	Dunning et al.
2011/0153324	A1	6/2011	Ballinger et al.	2012/0013609	A1	1/2012	Reponen et al.
2011/0153330	A1	6/2011	Yazdani et al.	2012/0015629	A1	1/2012	Olsen et al.
2011/0153373	A1	6/2011	Dantzig et al.	2012/0016658	A1	1/2012	Wu et al.
2011/0154193	A1	6/2011	Creutz et al.	2012/0016678	A1	1/2012	Gruber et al.
2011/0157029	A1	6/2011	Tseng	2012/0019400	A1	1/2012	Patel et al.
2011/0161072	A1	6/2011	Terao et al.	2012/0020490	A1	1/2012	Leichter
2011/0161076	A1	6/2011	Davis et al.	2012/0022787	A1	1/2012	LeBeau et al.
2011/0161079	A1	6/2011	Gruhn et al.	2012/0022857	A1	1/2012	Baldwin et al.
2011/0161309	A1	6/2011	Lung et al.	2012/0022860	A1	1/2012	Lloyd et al.
2011/0161852	A1	6/2011	Vainio et al.	2012/0022868	A1	1/2012	LeBeau et al.
2011/0166851	A1	7/2011	LeBeau et al.	2012/0022869	A1	1/2012	Lloyd et al.
2011/0167350	A1	7/2011	Hoellwarth	2012/0022870	A1	1/2012	Kristjansson et al.
2011/0175810	A1	7/2011	Markovic et al.	2012/0022872	A1	1/2012	Gruber et al.
2011/0179002	A1	7/2011	Dumitru et al.	2012/0022874	A1	1/2012	Lloyd et al.
2011/0179372	A1	7/2011	Moore et al.	2012/0022876	A1	1/2012	LeBeau et al.
2011/0183650	A1	7/2011	Mckee et al.	2012/0022967	A1	1/2012	Bachman et al.
2011/0184721	A1	7/2011	Subramanian et al.	2012/0023088	A1	1/2012	Cheng et al.
2011/0184730	A1	7/2011	LeBeau et al.	2012/0023095	A1	1/2012	Wadycki et al.
2011/0191271	A1	8/2011	Baker et al.	2012/0023462	A1	1/2012	Rosing et al.
2011/0191344	A1	8/2011	Jin et al.	2012/0029661	A1	2/2012	Jones et al.
2011/0195758	A1	8/2011	Damale et al.	2012/0029910	A1	2/2012	Medlock et al.
2011/0197128	A1	8/2011	Assadollahi et al.	2012/0034904	A1	2/2012	LeBeau et al.
2011/0201385	A1	8/2011	Higginbotham et al.	2012/0035907	A1	2/2012	Lebeau et al.
2011/0201387	A1	8/2011	Paek et al.	2012/0035908	A1	2/2012	Lebeau et al.
2011/0202526	A1	8/2011	Lee et al.	2012/0035924	A1	2/2012	Jitkoff et al.
2011/0205149	A1	8/2011	Tom et al.	2012/0035925	A1	2/2012	Friend et al.
				2012/0035926	A1	2/2012	Ambler
				2012/0035931	A1	2/2012	LeBeau et al.
				2012/0035932	A1	2/2012	Jitkoff et al.
				2012/0036556	A1	2/2012	LeBeau et al.

(56)		References Cited	
U.S. PATENT DOCUMENTS			
2012/0039539	A1	2/2012	Boiman et al.
2012/0041752	A1	2/2012	Wang et al.
2012/0042014	A1	2/2012	Desai et al.
2012/0042343	A1	2/2012	Laligand et al.
2012/0053815	A1	3/2012	Montanari et al.
2012/0053945	A1	3/2012	Gupta et al.
2012/0056815	A1	3/2012	Mehra
2012/0059655	A1	3/2012	Cartales
2012/0066581	A1	3/2012	Spalink
2012/0078624	A1	3/2012	Yook et al.
2012/0078627	A1	3/2012	Wagner
2012/0082317	A1	4/2012	Pance et al.
2012/0083286	A1	4/2012	Kim et al.
2012/0084086	A1	4/2012	Gilbert et al.
2012/0084634	A1	4/2012	Wong et al.
2012/0088219	A1	4/2012	Briscoe et al.
2012/0089331	A1	4/2012	Schmidt et al.
2012/0108221	A1	5/2012	Thomas et al.
2012/0116770	A1	5/2012	Chen et al.
2012/0117499	A1	5/2012	Mori et al.
2012/0124126	A1	5/2012	Alcazar et al.
2012/0128322	A1	5/2012	Shaffer et al.
2012/0136572	A1	5/2012	Norton
2012/0136985	A1	5/2012	Popescu et al.
2012/0137367	A1	5/2012	Dupont et al.
2012/0149394	A1	6/2012	Singh et al.
2012/0150580	A1	6/2012	Norton
2012/0158293	A1	6/2012	Burnham
2012/0158422	A1	6/2012	Burnham et al.
2012/0159380	A1	6/2012	Kocienda et al.
2012/0163710	A1	6/2012	Skaff et al.
2012/0166196	A1	6/2012	Ju et al.
2012/0173464	A1	7/2012	Tur et al.
2012/0174121	A1	7/2012	Treat et al.
2012/0179457	A1	7/2012	Newman et al.
2012/0185237	A1	7/2012	Gajic et al.
2012/0185781	A1	7/2012	Guzman et al.
2012/0191461	A1	7/2012	Lin et al.
2012/0192096	A1	7/2012	Bowman et al.
2012/0197743	A1	8/2012	Grigg et al.
2012/0197995	A1	8/2012	Caruso
2012/0197998	A1	8/2012	Kessel et al.
2012/0201362	A1	8/2012	Crossan et al.
2012/0209853	A1	8/2012	Desai et al.
2012/0209874	A1	8/2012	Wong et al.
2012/0214141	A1	8/2012	Raya et al.
2012/0214517	A1	8/2012	Singh et al.
2012/0215762	A1	8/2012	Hall et al.
2012/0221339	A1	8/2012	Wang et al.
2012/0221552	A1	8/2012	Reponen et al.
2012/0223889	A1	9/2012	Medlock et al.
2012/0223936	A1	9/2012	Aughey et al.
2012/0232885	A1	9/2012	Barbosa et al.
2012/0232886	A1	9/2012	Capuozzo et al.
2012/0232906	A1	9/2012	Lindahl et al.
2012/0239661	A1	9/2012	Giblin
2012/0239761	A1	9/2012	Linner et al.
2012/0242482	A1	9/2012	Elumalai et al.
2012/0245719	A1	9/2012	Story, Jr. et al.
2012/0245941	A1	9/2012	Cheyser
2012/0245944	A1	9/2012	Gruber et al.
2012/0246064	A1	9/2012	Balkow
2012/0250858	A1	10/2012	Iqbal et al.
2012/0252367	A1	10/2012	Gaglio et al.
2012/0252540	A1	10/2012	Kirigaya
2012/0254143	A1	10/2012	Varma et al.
2012/0254152	A1	10/2012	Park et al.
2012/0254290	A1	10/2012	Naaman
2012/0265528	A1	10/2012	Gruber et al.
2012/0265535	A1	10/2012	Bryant-Rich et al.
2012/0271625	A1	10/2012	Bernard
2012/0271634	A1	10/2012	Lenke
2012/0271635	A1	10/2012	Ljolje
2012/0271640	A1	10/2012	Basir
2012/0271676	A1	10/2012	Aravamudan et al.
2012/0275377	A1	11/2012	Lehane et al.
2012/0284027	A1	11/2012	Mallett et al.
2012/0290300	A1	11/2012	Lee et al.
2012/0295708	A1	11/2012	Hernandez-Abrego et al.
2012/0296649	A1	11/2012	Bansal et al.
2012/0296654	A1	11/2012	Hendrickson et al.
2012/0296891	A1	11/2012	Rangan
2012/0297348	A1	11/2012	Santoro
2012/0303369	A1	11/2012	Brush et al.
2012/0303371	A1	11/2012	Labsky et al.
2012/0304124	A1	11/2012	Chen et al.
2012/0309363	A1	12/2012	Gruber et al.
2012/0310642	A1	12/2012	Cao et al.
2012/0310649	A1	12/2012	Cannistraro et al.
2012/0310652	A1	12/2012	O'Sullivan
2012/0311478	A1	12/2012	Van Os et al.
2012/0311583	A1	12/2012	Gruber et al.
2012/0311584	A1	12/2012	Gruber et al.
2012/0311585	A1	12/2012	Gruber et al.
2012/0316878	A1	12/2012	Singleton et al.
2012/0317194	A1	12/2012	Tian
2012/0317498	A1	12/2012	Logan et al.
2012/0321112	A1	12/2012	Schubert et al.
2012/0324391	A1	12/2012	Tocci et al.
2012/0327009	A1	12/2012	Fleizach
2012/0330660	A1	12/2012	Jaiswal
2012/0330661	A1	12/2012	Lindahl
2012/0330990	A1	12/2012	Chen et al.
2013/0005405	A1	1/2013	Prociw
2013/0006633	A1	1/2013	Grokop et al.
2013/0006637	A1	1/2013	Kanevsky et al.
2013/0006638	A1	1/2013	Lindahl
2013/0007648	A1	1/2013	Gamon et al.
2013/0013313	A1	1/2013	Shechtman et al.
2013/0027875	A1	1/2013	Zhu et al.
2013/0030804	A1	1/2013	Zavaliagko et al.
2013/0030815	A1	1/2013	Madhvanath et al.
2013/0035942	A1	2/2013	Kim et al.
2013/0035961	A1	2/2013	Yegnanarayanan
2013/0041647	A1	2/2013	Ramerth et al.
2013/0041654	A1	2/2013	Walker et al.
2013/0041661	A1	2/2013	Lee et al.
2013/0041968	A1	2/2013	Cohen et al.
2013/0054550	A1	2/2013	Bolohan
2013/0054609	A1	2/2013	Rajput et al.
2013/0054613	A1	2/2013	Bishop
2013/0054706	A1	2/2013	Graham et al.
2013/0055099	A1	2/2013	Yao et al.
2013/0055147	A1	2/2013	Vasudev et al.
2013/0066832	A1	3/2013	Sheehan et al.
2013/0067307	A1	3/2013	Tian et al.
2013/0073286	A1	3/2013	Bastea-Forte et al.
2013/0080152	A1	3/2013	Brun et al.
2013/0080162	A1	3/2013	Chang et al.
2013/0080167	A1	3/2013	Mozer
2013/0080177	A1	3/2013	Chen
2013/0085755	A1	4/2013	Bringert et al.
2013/0085761	A1	4/2013	Bringert et al.
2013/0090921	A1	4/2013	Liu et al.
2013/0091090	A1	4/2013	Spivack et al.
2013/0095805	A1	4/2013	Lebeau et al.
2013/0097566	A1	4/2013	Berglund
2013/0103391	A1	4/2013	Millmore et al.
2013/0106742	A1	5/2013	Lee et al.
2013/0110505	A1	5/2013	Gruber et al.
2013/0110515	A1	5/2013	Guzzoni et al.
2013/0110518	A1	5/2013	Gruber et al.
2013/0110519	A1	5/2013	Cheyser et al.
2013/0110520	A1	5/2013	Cheyser et al.
2013/0111330	A1	5/2013	Staikos et al.
2013/0111348	A1	5/2013	Gruber et al.
2013/0111487	A1	5/2013	Cheyser et al.
2013/0115927	A1	5/2013	Gruber et al.
2013/0117022	A1	5/2013	Chen et al.
2013/0124189	A1	5/2013	Baldwin et al.
2013/0132089	A1	5/2013	Fanty et al.
2013/0132871	A1	5/2013	Zeng et al.
2013/0142317	A1	6/2013	Reynolds
2013/0144594	A1	6/2013	Bangalore et al.

(56)		References Cited					
U.S. PATENT DOCUMENTS							
2013/0144616	A1	6/2013	Bangalore et al.	2014/0052791	A1	2/2014	Chakra et al.
2013/0151339	A1	6/2013	Kim et al.	2014/0053082	A1	2/2014	Park et al.
2013/0152092	A1	6/2013	Yadgar et al.	2014/0057610	A1	2/2014	Oliney et al.
2013/0154811	A1	6/2013	Ferren et al.	2014/0059030	A1	2/2014	Hakkani-Tur et al.
2013/0158977	A1	6/2013	Senior	2014/0067371	A1	3/2014	Liensberger
2013/0165232	A1	6/2013	Nelson et al.	2014/0068751	A1	3/2014	Last et al.
2013/0166442	A1	6/2013	Nakajima et al.	2014/0074470	A1	3/2014	Jansche et al.
2013/0170738	A1	7/2013	Capuozzo et al.	2014/0074472	A1	3/2014	Lin et al.
2013/0172022	A1	7/2013	Seymour et al.	2014/0074815	A1	3/2014	Plimton
2013/0176592	A1	7/2013	Sasaki	2014/0078065	A1	3/2014	Akkok et al.
2013/0179440	A1	7/2013	Gordon	2014/0080428	A1	3/2014	Rhoads et al.
2013/0183944	A1	7/2013	Mozer et al.	2014/0081633	A1	3/2014	Badaskar et al.
2013/0185059	A1	7/2013	Riccardi et al.	2014/0082501	A1	3/2014	Bae et al.
2013/0185074	A1	7/2013	Gruber et al.	2014/0086458	A1	3/2014	Rogers et al.
2013/0185081	A1	7/2013	Cheyen et al.	2014/0087711	A1	3/2014	Geyer et al.
2013/0185336	A1	7/2013	Singh et al.	2014/0095171	A1	4/2014	Lynch et al.
2013/0191117	A1	7/2013	Atti et al.	2014/0098247	A1	4/2014	Rao et al.
2013/0197911	A1	8/2013	Wei et al.	2014/0108017	A1	4/2014	Mason et al.
2013/0207898	A1	8/2013	Sullivan et al.	2014/0114554	A1	4/2014	Lagassey
2013/0218553	A1	8/2013	Fujii et al.	2014/0118155	A1	5/2014	Bowers et al.
2013/0218560	A1	8/2013	Hsiao et al.	2014/0122086	A1	5/2014	Kapur et al.
2013/0222249	A1	8/2013	Pasquero et al.	2014/0135036	A1	5/2014	Bonanni et al.
2013/0225128	A1	8/2013	Gomar	2014/0136187	A1	5/2014	Wolverton et al.
2013/0231917	A1	9/2013	Naik	2014/0136195	A1	5/2014	Abdossalami et al.
2013/0235987	A1	9/2013	Arroniz-Escobar et al.	2014/0136212	A1	5/2014	Kwon et al.
2013/0238647	A1	9/2013	Thompson	2014/0136946	A1	5/2014	Matas
2013/0244615	A1	9/2013	Miller et al.	2014/0142923	A1	5/2014	Jones et al.
2013/0246048	A1	9/2013	Nagase et al.	2014/0143550	A1	5/2014	Ganong, III et al.
2013/0253911	A1	9/2013	Petri et al.	2014/0143721	A1	5/2014	Suzuki et al.
2013/0253912	A1	9/2013	Medlock et al.	2014/0146200	A1	5/2014	Scott et al.
2013/0275117	A1	10/2013	Winer	2014/0152577	A1	6/2014	Yuen et al.
2013/0275138	A1	10/2013	Gruber et al.	2014/0155031	A1	6/2014	Lee et al.
2013/0275164	A1	10/2013	Gruber et al.	2014/0157422	A1	6/2014	Livshits et al.
2013/0275875	A1	10/2013	Gruber et al.	2014/0163951	A1	6/2014	Nikoulina et al.
2013/0275899	A1	10/2013	Schubert et al.	2014/0164532	A1	6/2014	Lynch et al.
2013/0283168	A1	10/2013	Brown et al.	2014/0173460	A1	6/2014	Kim
2013/0289991	A1	10/2013	Eshwar et al.	2014/0180689	A1	6/2014	Kim et al.
2013/0289993	A1	10/2013	Rao et al.	2014/0188477	A1	7/2014	Zhang
2013/0289994	A1	10/2013	Newman et al.	2014/0195251	A1	7/2014	Zeinstra et al.
2013/0297319	A1	11/2013	Kim	2014/0195252	A1	7/2014	Gruber et al.
2013/0297348	A1	11/2013	Cardoza et al.	2014/0203939	A1	7/2014	Harrington et al.
2013/0304479	A1	11/2013	Teller et al.	2014/0207582	A1	7/2014	Flinn et al.
2013/0304758	A1	11/2013	Gruber et al.	2014/0214537	A1	7/2014	Yoo et al.
2013/0304815	A1	11/2013	Puente et al.	2014/0218372	A1	8/2014	Missig et al.
2013/0307855	A1	11/2013	Lamb et al.	2014/0222436	A1	8/2014	Binder et al.
2013/0307997	A1	11/2013	O'Keefe et al.	2014/0223377	A1	8/2014	Shaw et al.
2013/0308922	A1	11/2013	Sano et al.	2014/0223481	A1	8/2014	Fundament
2013/0322634	A1	12/2013	Bennett et al.	2014/0232656	A1	8/2014	Pasquero et al.
2013/0325436	A1	12/2013	Wang et al.	2014/0236595	A1	8/2014	Gray
2013/0325443	A1	12/2013	Begeja et al.	2014/0236986	A1	8/2014	Guzman
2013/0325447	A1	12/2013	Levien et al.	2014/0237042	A1	8/2014	Ahmed et al.
2013/0325448	A1	12/2013	Levien et al.	2014/0244257	A1	8/2014	Colibro et al.
2013/0325481	A1	12/2013	Van Os et al.	2014/0244258	A1	8/2014	Song et al.
2013/0325484	A1	12/2013	Chakladar et al.	2014/0244271	A1	8/2014	Lindahl
2013/0325979	A1	12/2013	Mansfield et al.	2014/0247383	A1	9/2014	Dave et al.
2013/0329023	A1	12/2013	Suplee, III et al.	2014/0247926	A1	9/2014	Gainsboro et al.
2013/0332164	A1	12/2013	Nalk	2014/0249817	A1	9/2014	Hart et al.
2013/0332168	A1	12/2013	Kim et al.	2014/0250046	A1	9/2014	Winn et al.
2013/0332400	A1	12/2013	González	2014/0267022	A1	9/2014	Kim
2013/0346068	A1	12/2013	Solem et al.	2014/0267599	A1	9/2014	Drouin et al.
2014/0006012	A1	1/2014	Zhou et al.	2014/0274203	A1	9/2014	Ganong et al.
2014/0006025	A1	1/2014	Krishnan et al.	2014/0274211	A1	9/2014	Sejnoha et al.
2014/0006027	A1	1/2014	Kim et al.	2014/0278349	A1	9/2014	Grieves et al.
2014/0006153	A1	1/2014	Thangam et al.	2014/0278391	A1	9/2014	Braho et al.
2014/0012580	A1	1/2014	Ganong et al.	2014/0278406	A1	9/2014	Tsumura et al.
2014/0019116	A1	1/2014	Lundberg et al.	2014/0278413	A1	9/2014	Pitschel et al.
2014/0019133	A1	1/2014	Bao et al.	2014/0278429	A1	9/2014	Ganong, III
2014/0028735	A1	1/2014	Williams et al.	2014/0278435	A1	9/2014	Ganong et al.
2014/0033071	A1	1/2014	Gruber et al.	2014/0278443	A1	9/2014	Gunn et al.
2014/0039894	A1	2/2014	Shostak	2014/0278513	A1	9/2014	Prakash et al.
2014/0040274	A1	2/2014	Aravamudan et al.	2014/0280138	A1	9/2014	Li et al.
2014/0040748	A1	2/2014	Lemay et al.	2014/0280292	A1	9/2014	Skinder
2014/0040801	A1	2/2014	Patel et al.	2014/0280353	A1	9/2014	Delaney et al.
2014/0040918	A1	2/2014	Li et al.	2014/0281983	A1	9/2014	Xian et al.
2014/0046934	A1	2/2014	Zhou et al.	2014/0282003	A1	9/2014	Gruber et al.
				2014/0282586	A1	9/2014	Shear et al.
				2014/0282743	A1	9/2014	Howard et al.
				2014/0288990	A1	9/2014	Moore et al.
				2014/0297281	A1	10/2014	Togawa et al.

(56)

References Cited

U.S. PATENT DOCUMENTS

2014/0297284	A1	10/2014	Gruber et al.
2014/0304605	A1	10/2014	Ohmura et al.
2014/0316585	A1	10/2014	Boesveld et al.
2014/0317502	A1	10/2014	Brown et al.
2014/0337048	A1	11/2014	Brown et al.
2014/0337266	A1	11/2014	Wolverton et al.
2014/0337751	A1	11/2014	Lim et al.
2014/0337814	A1	11/2014	Kalns et al.
2014/0344627	A1	11/2014	Schaub et al.
2014/0351760	A1	11/2014	Skory et al.
2014/0358519	A1	12/2014	Mirkin et al.
2014/0365209	A1	12/2014	Evermann
2014/0365227	A1	12/2014	Cash et al.
2014/0365880	A1	12/2014	Bellegarda
2014/0365885	A1	12/2014	Carson et al.
2014/0365895	A1	12/2014	Paulson et al.
2015/0003797	A1	1/2015	Schmidt
2015/0006148	A1	1/2015	Goldszmit et al.
2015/0006178	A1	1/2015	Peng et al.
2015/0006199	A1	1/2015	Snider et al.
2015/0012271	A1	1/2015	Peng et al.
2015/0019221	A1	1/2015	Lee et al.
2015/0033219	A1	1/2015	Breiner et al.
2015/0039292	A1	2/2015	Suleman et al.
2015/0039305	A1	2/2015	Huang
2015/0045003	A1	2/2015	Vora et al.
2015/0045068	A1	2/2015	Soffler et al.
2015/0046537	A1	2/2015	Rakib
2015/0050633	A1	2/2015	Christmas et al.
2015/0058013	A1	2/2015	Pakhomov et al.
2015/0065200	A1	3/2015	Namgung et al.
2015/0066506	A1	3/2015	Romano et al.
2015/0066516	A1	3/2015	Nishikawa et al.
2015/0067485	A1	3/2015	Kim et al.
2015/0073804	A1	3/2015	Senior et al.
2015/0074524	A1	3/2015	Nicholson et al.
2015/0088511	A1	3/2015	Bharadwaj et al.
2015/0088523	A1	3/2015	Schuster
2015/0095031	A1	4/2015	Conkie et al.
2015/0100316	A1	4/2015	Williams et al.
2015/0106093	A1	4/2015	Weeks et al.
2015/0113407	A1	4/2015	Hoffert et al.
2015/0120723	A1	4/2015	Deshmukh et al.
2015/0127350	A1	5/2015	Agionmyrgiannakis
2015/0133109	A1	5/2015	Freeman et al.
2015/0135085	A1	5/2015	Shoham et al.
2015/0142420	A1	5/2015	Sarikaya et al.
2015/0142447	A1	5/2015	Kennewick et al.
2015/0148013	A1	5/2015	Baldwin et al.
2015/0149354	A1	5/2015	Mccoy
2015/0149469	A1	5/2015	Xu et al.
2015/0161370	A1	6/2015	North et al.
2015/0170664	A1	6/2015	Doherty et al.
2015/0172463	A1	6/2015	Quast et al.
2015/0178388	A1	6/2015	Winnemoeller et al.
2015/0186012	A1	7/2015	Coleman et al.
2015/0186110	A1	7/2015	Kannan
2015/0186155	A1	7/2015	Brown et al.
2015/0187355	A1	7/2015	Parkinson et al.
2015/0193379	A1	7/2015	Mehta
2015/0193391	A1	7/2015	Khvostichenko et al.
2015/0193392	A1	7/2015	Greenblatt et al.
2015/0194152	A1	7/2015	Katuri et al.
2015/0195379	A1	7/2015	Zhang et al.
2015/0195606	A1	7/2015	McDevitt
2015/0199960	A1	7/2015	Huo et al.
2015/0205858	A1	7/2015	Xie et al.
2015/0227633	A1	8/2015	Shapira
2015/0228281	A1	8/2015	Raniere
2015/0234636	A1	8/2015	Barnes, Jr.
2015/0234800	A1	8/2015	Patrick et al.
2015/0243278	A1	8/2015	Kibre et al.
2015/0245154	A1	8/2015	Dadu et al.
2015/0248651	A1	9/2015	Akutagawa et al.
2015/0255071	A1	9/2015	Chiba
2015/0256873	A1	9/2015	Klein et al.
2015/0261496	A1	9/2015	Faaborg et al.
2015/0278370	A1	10/2015	Stratvert et al.
2015/0279360	A1	10/2015	Mengibar et al.
2015/0287409	A1	10/2015	Jang
2015/0294516	A1	10/2015	Chiang
2015/0309997	A1	10/2015	Lee et al.
2015/0312182	A1	10/2015	Langholz
2015/0324041	A1	11/2015	Varley et al.
2015/0324334	A1	11/2015	Lee et al.
2015/0331711	A1	11/2015	Huang et al.
2015/0339049	A1	11/2015	Kasemset et al.
2015/0339391	A1	11/2015	Kang et al.
2015/0340040	A1	11/2015	Mun et al.
2015/0340042	A1	11/2015	Sejnoha et al.
2015/0347382	A1	12/2015	Dolfing et al.
2015/0347393	A1	12/2015	Futrell et al.
2015/0348547	A1	12/2015	Paulik et al.
2015/0348548	A1	12/2015	Piernot et al.
2015/0348549	A1	12/2015	Giuli et al.
2015/0348551	A1	12/2015	Gruber et al.
2015/0350031	A1	12/2015	Burks et al.
2015/0370531	A1	12/2015	Faaborg
2015/0370780	A1	12/2015	Wang et al.
2016/0027431	A1	1/2016	Kurzweil et al.
2016/0028666	A1	1/2016	Li
2016/0034811	A1	2/2016	Paulik et al.
2016/0042735	A1	2/2016	Vibbert et al.
2016/0042748	A1	2/2016	Jain et al.
2016/0055422	A1	2/2016	Li
2016/0063998	A1	3/2016	Krishnamoorthy et al.
2016/0077794	A1	3/2016	Kim et al.
2016/0080165	A1	3/2016	Ehsani et al.
2016/0086116	A1	3/2016	Rao et al.
2016/0091967	A1	3/2016	Prokofieva et al.
2016/0092447	A1	3/2016	Venkataraman et al.
2016/0093291	A1	3/2016	Kim
2016/0093298	A1	3/2016	Naik et al.
2016/0093304	A1	3/2016	Kim et al.
2016/0094979	A1	3/2016	Naik et al.
2016/0119338	A1	4/2016	Cheyner
2016/0147725	A1	5/2016	Patten et al.
2016/0155442	A1	6/2016	Kannan et al.
2016/0180844	A1	6/2016	Vanblon et al.
2016/0189717	A1	6/2016	Kannan et al.
2016/0212488	A1	7/2016	Os et al.
2016/0225372	A1	8/2016	Cheung et al.
2016/0240187	A1	8/2016	Fleizach et al.
2016/0260436	A1	9/2016	Lemay et al.
2016/0275941	A1	9/2016	Bellegarda et al.
2018/0061400	A1*	3/2018	Carbune G06F 17/30657

FOREIGN PATENT DOCUMENTS

CA	2666438	C	6/2013
CH	681573	A5	4/1993
CN	1263385	A	8/2000
CN	1274440	A	11/2000
CN	1369858	A	9/2002
CN	1378156	A	11/2002
CN	1383109	A	12/2002
CN	1407795	A	4/2003
CN	1125436	C	10/2003
CN	1471098	A	1/2004
CN	1494695	A	5/2004
CN	1535519	A	10/2004
CN	1640191	A	7/2005
CN	1673939	A	9/2005
CN	1864204	A	11/2006
CN	1898721	A	1/2007
CN	2865153	Y	1/2007
CN	1959628	A	5/2007
CN	1975715	A	6/2007
CN	1995917	A	7/2007
CN	101008942	A	8/2007
CN	101162153	A	4/2008
CN	101179754	A	5/2008
CN	101183525	A	5/2008
CN	101188644	A	5/2008

(56) References Cited					
FOREIGN PATENT DOCUMENTS					
CN	101228503 A	7/2008	EP	1047251 A2	10/2000
CN	101233741 A	7/2008	EP	1052566 A1	11/2000
CN	101246020 A	8/2008	EP	1076302 A1	2/2001
CN	101271689 A	9/2008	EP	1091615 A1	4/2001
CN	101297541 A	10/2008	EP	1094406 A2	4/2001
CN	101427244 A	5/2009	EP	1107229 A2	6/2001
CN	101535983 A	9/2009	EP	1229496 A2	8/2002
CN	101632316 A	1/2010	EP	1233600 A2	8/2002
CN	101636736 A	1/2010	EP	1245023 A1	10/2002
CN	101673544 A	3/2010	EP	1246075 A2	10/2002
CN	101847405 A	9/2010	EP	1280326 A1	1/2003
CN	101894547 A	11/2010	EP	1291848 A2	3/2003
CN	101939740 A	1/2011	EP	1311102 A1	5/2003
CN	101951553 A	1/2011	EP	1315084 A1	5/2003
CN	102160043 A	8/2011	EP	1315086 A1	5/2003
CN	102246136 A	11/2011	EP	1345360 A2	9/2003
CN	202035047 U	11/2011	EP	1347361 A1	9/2003
CN	202092650 U	12/2011	EP	1368961 A2	12/2003
CN	103035240 A	4/2013	EP	1379061 A2	1/2004
DE	3837590 A1	5/1990	EP	1432219 A1	6/2004
DE	4126902 A1	2/1992	EP	1435620 A1	7/2004
DE	4334773 A1	4/1994	EP	1480421 A1	11/2004
DE	4445023 A1	6/1996	EP	1517228 A2	3/2005
DE	102004029203 A1	12/2005	EP	1536612 A1	6/2005
DE	19841541 B4	12/2007	EP	1566948 A1	8/2005
DE	102008024258 A1	11/2009	EP	1650938 A1	4/2006
EP	30390 A1	6/1981	EP	1675025 A2	6/2006
EP	57514 A1	8/1982	EP	1693829 A1	8/2006
EP	59880 A2	9/1982	EP	1699042 A1	9/2006
EP	138061 A1	4/1985	EP	1739546 A2	1/2007
EP	140777 A1	5/1985	EP	1181802 B1	2/2007
EP	218859 A2	4/1987	EP	1818786 A1	8/2007
EP	262938 A1	4/1988	EP	1892700 A1	2/2008
EP	138061 B1	6/1988	EP	1912205 A2	4/2008
EP	283995 A2	9/1988	EP	1939860 A1	7/2008
EP	293259 A2	11/1988	EP	651543 B1	9/2008
EP	299572 A2	1/1989	EP	1909263 B1	1/2009
EP	313975 A2	5/1989	EP	1335620 B1	3/2009
EP	314908 A2	5/1989	EP	2069895 A1	6/2009
EP	327408 A2	8/1989	EP	2094032 A1	8/2009
EP	389271 A2	9/1990	EP	2107553 A1	10/2009
EP	411675 A2	2/1991	EP	2109295 A1	10/2009
EP	441089 A2	8/1991	EP	1720375 B1	7/2010
EP	464712 A2	1/1992	EP	2205010 A1	7/2010
EP	476972 A2	3/1992	EP	2309491 A1	4/2011
EP	534410 A2	3/1993	EP	2400373 A1	12/2011
EP	558312 A1	9/1993	EP	2431842 A2	3/2012
EP	559349 A1	9/1993	EP	2551784 A1	1/2013
EP	570660 A1	11/1993	EP	2555536 A1	2/2013
EP	575146 A2	12/1993	EP	2575128 A2	4/2013
EP	578604 A1	1/1994	EP	2733598 A2	5/2014
EP	586996 A2	3/1994	EP	2801890 A1	11/2014
EP	609030 A1	8/1994	EP	2801972 A1	11/2014
EP	651543 A2	5/1995	EP	2938022 A1	10/2015
EP	679005 A1	10/1995	EP	2940556 A1	11/2015
EP	795811 A1	9/1997	FR	2911201 A1	7/2008
EP	476972 B1	5/1998	GB	2293667 A	4/1996
EP	845894 A2	6/1998	GB	2310559 A	8/1997
EP	852052 A1	7/1998	GB	2323694 A	9/1998
EP	863453 A1	9/1998	GB	2342802 A	4/2000
EP	863469 A2	9/1998	GB	2343285 A	5/2000
EP	867860 A2	9/1998	GB	2346500 A	8/2000
EP	869697 A2	10/1998	GB	2352377 A	1/2001
EP	559349 B1	1/1999	GB	2367399 A	4/2002
EP	889626 A1	1/1999	GB	2384399 A	7/2003
EP	917077 A2	5/1999	GB	2402855 A	12/2004
EP	691023 B1	9/1999	GB	2445436 A	7/2008
EP	946032 A2	9/1999	GB	2445667 A	7/2008
EP	981236 A1	2/2000	IT	FI20010199 A1	4/2003
EP	982732 A1	3/2000	JP	55-80084 A	6/1980
EP	984430 A2	3/2000	JP	57-41731 A	3/1982
EP	1001588 A2	5/2000	JP	59-57336 A	4/1984
EP	1014277 A1	6/2000	JP	62-153326 A	7/1987
EP	1028425 A2	8/2000	JP	1-500631 A	3/1989
EP	1028426 A2	8/2000	JP	1-254742 A	10/1989
			JP	2-86397 A	3/1990
			JP	2-153415 A	6/1990
			JP	2-502149 A	7/1990
			JP	3-113578 A	5/1991

(56) References Cited					
FOREIGN PATENT DOCUMENTS					
JP	4-236624 A	8/1992	JP	2002-230021 A	8/2002
JP	5-79951 A	3/1993	JP	2002-524806 A	8/2002
JP	5-165459 A	7/1993	JP	2002-281562 A	9/2002
JP	5-204859 A	8/1993	JP	2002-534716 A	10/2002
JP	5-293126 A	11/1993	JP	2002-342033 A	11/2002
JP	6-19965 A	1/1994	JP	2002-342212 A	11/2002
JP	6-69954 A	3/1994	JP	2002-344880 A	11/2002
JP	6-274586 A	9/1994	JP	2002-542501 A	12/2002
JP	6-332617 A	12/1994	JP	2003-15682 A	1/2003
JP	7-199379 A	8/1995	JP	2003-44091 A	2/2003
JP	7-219961 A	8/1995	JP	2003-84877 A	3/2003
JP	7-320051 A	12/1995	JP	2003-517158 A	5/2003
JP	7-320079 A	12/1995	JP	2003-202897 A	7/2003
JP	8-63330 A	3/1996	JP	2003-233568 A	8/2003
JP	8-185265 A	7/1996	JP	2003-244317 A	8/2003
JP	8-223281 A	8/1996	JP	2003-255991 A	9/2003
JP	8-227341 A	9/1996	JP	2003-527656 A	9/2003
JP	9-18585 A	1/1997	JP	2003-288356 A	10/2003
JP	9-27000 A	1/1997	JP	2003-308079 A	10/2003
JP	9-55792 A	2/1997	JP	2003-533909 A	11/2003
JP	9-62293 A	3/1997	JP	2004-48804 A	2/2004
JP	9-116616 A	5/1997	JP	2004-54080 A	2/2004
JP	9-259063 A	10/1997	JP	2004-56226 A	2/2004
JP	9-265457 A	10/1997	JP	2004-505322 A	2/2004
JP	10-31497 A	2/1998	JP	2004-505525 A	2/2004
JP	10-69578 A	3/1998	JP	2004-86356 A	3/2004
JP	10-78952 A	3/1998	JP	2004-94936 A	3/2004
JP	10-105324 A	4/1998	JP	2004-117905 A	4/2004
JP	10-274997 A	10/1998	JP	2004-152063 A	5/2004
JP	10-312194 A	11/1998	JP	2004-523004 A	7/2004
JP	10-320169 A	12/1998	JP	2004-295837 A	10/2004
JP	11-06743 A	1/1999	JP	2004-310034 A	11/2004
JP	11-45241 A	2/1999	JP	2004-534268 A	11/2004
JP	11-136278 A	5/1999	JP	2004-347786 A	12/2004
JP	11-231886 A	8/1999	JP	2005-55782 A	3/2005
JP	11-265400 A	9/1999	JP	2005-63257 A	3/2005
JP	2000-32140 A	1/2000	JP	2005-70645 A	3/2005
JP	2000-59497 A	2/2000	JP	2005-80094 A	3/2005
JP	2000-90119 A	3/2000	JP	2005-86624 A	3/2005
JP	2000-99225 A	4/2000	JP	2005-506602 A	3/2005
JP	2000-134407 A	5/2000	JP	2005-92441 A	4/2005
JP	2000-163031 A	6/2000	JP	2005-149481 A	6/2005
JP	2000-207167 A	7/2000	JP	2005-181386 A	7/2005
JP	2000-216910 A	8/2000	JP	2005-189454 A	7/2005
JP	2000-224663 A	8/2000	JP	2005-210362 A	8/2005
JP	2000-272349 A	10/2000	JP	2005-221678 A	8/2005
JP	2000-276471 A	10/2000	JP	2005-283843 A	10/2005
JP	2000-331004 A	11/2000	JP	2005-311864 A	11/2005
JP	2000-339137 A	12/2000	JP	2005-332212 A	12/2005
JP	2000-352988 A	12/2000	JP	2006-4274 A	1/2006
JP	2000-352989 A	12/2000	JP	2006-23860 A	1/2006
JP	2001-13978 A	1/2001	JP	2006-30447 A	2/2006
JP	2001-14319 A	1/2001	JP	2006-31092 A	2/2006
JP	2001-22498 A	1/2001	JP	2006-59094 A	3/2006
JP	2001-34289 A	2/2001	JP	2006-80617 A	3/2006
JP	2001-34290 A	2/2001	JP	2006-107438 A	4/2006
JP	2001-56233 A	2/2001	JP	2006-146008 A	6/2006
JP	2001-109493 A	4/2001	JP	2006-146182 A	6/2006
JP	2001-125896 A	5/2001	JP	2006-155368 A	6/2006
JP	2001-148899 A	5/2001	JP	2006-189394 A	7/2006
JP	2001-273283 A	10/2001	JP	2006-195637 A	7/2006
JP	2001-282813 A	10/2001	JP	2006-201870 A	8/2006
JP	2001-296880 A	10/2001	JP	2006-208696 A	8/2006
JP	2002-14954 A	1/2002	JP	2006-244296 A	9/2006
JP	2002-24212 A	1/2002	JP	2006-267328 A	10/2006
JP	2002-30676 A	1/2002	JP	2006-302091 A	11/2006
JP	2002-41276 A	2/2002	JP	2006-526185 A	11/2006
JP	2002-41624 A	2/2002	JP	2007-4633 A	1/2007
JP	2002-82748 A	3/2002	JP	2007-17990 A	1/2007
JP	2002-82893 A	3/2002	JP	2007-500903 A	1/2007
JP	2002-123295 A	4/2002	JP	2007-53796 A	3/2007
JP	2002-132804 A	5/2002	JP	2007-79690 A	3/2007
JP	2002-169588 A	6/2002	JP	2007-171534 A	7/2007
JP	2002-182679 A	6/2002	JP	2007-193794 A	8/2007
JP	2002-182680 A	6/2002	JP	2007-206317 A	8/2007
			JP	2007-264471 A	10/2007
			JP	2007-264792 A	10/2007
			JP	2007-264892 A	10/2007
			JP	2007-299352 A	11/2007

(56) References Cited					
FOREIGN PATENT DOCUMENTS					
JP	2007-325089 A	12/2007	KR	10-2007-0100837 A	10/2007
JP	2008-21002 A	1/2008	KR	10-0776800 B1	11/2007
JP	2008-26381 A	2/2008	KR	10-0801227 B1	2/2008
JP	2008-39928 A	2/2008	KR	10-0810500 B1	3/2008
JP	2008-58813 A	3/2008	KR	10-2008-0033070 A	4/2008
JP	2008-90545 A	4/2008	KR	10-0819928 B1	4/2008
JP	2008-97003 A	4/2008	KR	10-2008-0049647 A	6/2008
JP	2008-134949 A	6/2008	KR	10-2008-0059332 A	6/2008
JP	2008-526101 A	7/2008	KR	10-2008-0109322 A	12/2008
JP	2008-185693 A	8/2008	KR	10-2009-0001716 A	1/2009
JP	2008-198022 A	8/2008	KR	10-2009-0028464 A	3/2009
JP	2008-217468 A	9/2008	KR	10-2009-0030117 A	3/2009
JP	2008-228129 A	9/2008	KR	10-2009-0086805 A	8/2009
JP	2008-233678 A	10/2008	KR	10-0920267 B1	10/2009
JP	2008-236448 A	10/2008	KR	10-2009-0122944 A	12/2009
JP	2008-252161 A	10/2008	KR	10-2009-0127961 A	12/2009
JP	2008-268684 A	11/2008	KR	10-2009-0129192 A	12/2009
JP	2008-271481 A	11/2008	KR	10-2010-0015958 A	2/2010
JP	2008-299221 A	12/2008	KR	10-2010-0048571 A	5/2010
JP	2009-503623 A	1/2009	KR	10-2010-0119519 A	11/2010
JP	2009-36999 A	2/2009	KR	10-2011-0043644 A	4/2011
JP	2009-47920 A	3/2009	KR	10-1032792 B1	5/2011
JP	2009-98490 A	5/2009	KR	10-2011-0068490 A	6/2011
JP	2009-140444 A	6/2009	KR	10-2011-0072847 A	6/2011
JP	2009-186989 A	8/2009	KR	10-2011-0113414 A	10/2011
JP	2009-193448 A	8/2009	KR	10-2011-0115134 A	10/2011
JP	2009-193457 A	8/2009	KR	10-2012-0020164 A	3/2012
JP	2009-193532 A	8/2009	KR	10-2012-0031722 A	4/2012
JP	2009-205367 A	9/2009	KR	10-2012-0120316 A	11/2012
JP	2009-294913 A	12/2009	KR	10-2012-0137435 A	12/2012
JP	2009-294946 A	12/2009	KR	10-2012-0138826 A	12/2012
JP	2010-66519 A	3/2010	KR	10-1193668 B1	12/2012
JP	2010-78979 A	4/2010	NL	1014847 C	10/2001
JP	2010-108378 A	5/2010	RU	2273106 C2	3/2006
JP	2010-518526 A	5/2010	RU	2349970 C2	3/2009
JP	2010-157207 A	7/2010	RU	2353068 C2	4/2009
JP	2010-224236 A	10/2010	RU	2364917 C2	8/2009
JP	4563106 B2	10/2010	TW	468323 B	12/2001
JP	2010-535377 A	11/2010	TW	200601264 A	1/2006
JP	2010-287063 A	12/2010	TW	200638337 A	11/2006
JP	2011-41026 A	2/2011	TW	200643744 A	12/2006
JP	2011-45005 A	3/2011	TW	200801988 A	1/2008
JP	2011-59659 A	3/2011	TW	1301373 B	9/2008
JP	2011-81541 A	4/2011	TW	M348993 U	1/2009
JP	2011-525045 A	9/2011	TW	200943903 A	10/2009
JP	2011-238022 A	11/2011	TW	201018258 A	5/2010
JP	2012-014394 A	1/2012	TW	201027515 A1	7/2010
JP	2012-147063 A	8/2012	TW	201028996 A1	8/2010
JP	2013-511214 A	3/2013	TW	201110108 A1	3/2011
JP	2013-73240 A	4/2013	TW	201227715 A1	7/2012
JP	2013-517566 A	5/2013	TW	201245989 A1	11/2012
JP	2013-134430 A	7/2013	TW	201312548 A1	3/2013
JP	2013-527947 A	7/2013	WO	1989/003139 A1	4/1989
JP	2014-077969 A	5/2014	WO	1993/020640 A1	10/1993
KR	10-1999-0073234 A	10/1999	WO	1994/016434 A1	7/1994
KR	2001-0093654 A	10/2001	WO	1994/029788 A1	12/1994
KR	10-2001-0102132 A	11/2001	WO	1995/002221 A1	1/1995
KR	2002-0013984 A	2/2002	WO	1995/016950 A1	6/1995
KR	2002-0057262 A	7/2002	WO	1995/017746 A1	6/1995
KR	2002-0064149 A	8/2002	WO	1996/003741 A1	2/1996
KR	2002-0069952 A	9/2002	WO	1997/010586 A1	3/1997
KR	2003-0016993 A	3/2003	WO	1997/026612 A1	7/1997
KR	10-2004-0014835 A	2/2004	WO	1997/029614 A1	8/1997
KR	10-2004-0044632 A	5/2004	WO	1997/038488 A1	10/1997
KR	10-2005-0083561 A	8/2005	WO	1997/049044 A1	12/1997
KR	10-2005-0090568 A	9/2005	WO	1998/009270 A1	3/1998
KR	10-2006-0011603 A	2/2006	WO	1998/033111 A1	7/1998
KR	10-2006-0012730 A	2/2006	WO	1998/041956 A1	9/1998
KR	10-2006-0055313 A	5/2006	WO	1999/001834 A1	1/1999
KR	10-2006-0073574 A	6/2006	WO	1999/008238 A1	2/1999
KR	10-2006-0091469 A	8/2006	WO	1999/016181 A1	4/1999
KR	10-2007-0024262 A	3/2007	WO	1999/056227 A1	11/1999
KR	10-2007-0071675 A	7/2007	WO	2000/014727 A1	3/2000
KR	10-2007-0094767 A	9/2007	WO	2000/014728 A1	3/2000
KR	10-0757496 B1	9/2007	WO	2000/019697 A1	4/2000
			WO	2000/022820 A1	4/2000
			WO	2000/029964 A1	5/2000
			WO	2000/030070 A2	5/2000
			WO	2000/038041 A1	6/2000

(56)

References Cited

FOREIGN PATENT DOCUMENTS

WO	2000/041065	A1	7/2000	WO	2008/109835	A2	8/2008
WO	2000/044173	A1	7/2000	WO	2008/120036	A1	10/2008
WO	2000/060435	A2	10/2000	WO	2008/130095	A1	10/2008
WO	2000/060435	A3	10/2000	WO	2008/140236	A1	11/2008
WO	2000/063766	A1	10/2000	WO	2008/142472	A1	11/2008
WO	2000/068936	A1	11/2000	WO	2008/153639	A1	12/2008
WO	2001/006489	A1	1/2001	WO	2009/009240	A2	1/2009
WO	2001/030046	A2	4/2001	WO	2009/016631	A2	2/2009
WO	2001/030047	A2	4/2001	WO	2009/017280	A1	2/2009
WO	2001/033569	A1	5/2001	WO	2009/075912	A1	6/2009
WO	2001/0355391	A1	5/2001	WO	2009/104126	A1	8/2009
WO	2001/044912	A2	6/2001	WO	2009/156438	A1	12/2009
WO	2001/046946	A1	6/2001	WO	2009/156978	A1	12/2009
WO	2001/065413	A1	9/2001	WO	2010/054373	A2	5/2010
WO	2001/067753	A1	9/2001	WO	2010/075623	A1	7/2010
WO	2001/071480	A2	9/2001	WO	2010/141802	A1	12/2010
WO	2002/010900	A2	2/2002	WO	2011/057346	A1	5/2011
WO	2002/025610	A1	3/2002	WO	2011/060106	A1	5/2011
WO	2002/031814	A1	4/2002	WO	2011/088053	A2	7/2011
WO	2002/037469	A2	5/2002	WO	2011/093025	A1	8/2011
WO	2002/049253	A2	6/2002	WO	2011/116309	A1	9/2011
WO	2002/071259	A1	9/2002	WO	2011/133543	A1	10/2011
WO	2002/073603	A1	9/2002	WO	2011/150730	A1	12/2011
WO	2003/003152	A2	1/2003	WO	2011/163350	A1	12/2011
WO	2003/003765	A1	1/2003	WO	2012/129231	A1	9/2012
WO	2003/023786	A2	3/2003	WO	2012/135157	A2	10/2012
WO	2003/036457	A2	5/2003	WO	2012/154317	A1	11/2012
WO	2003/041364	A2	5/2003	WO	2012/155079	A2	11/2012
WO	2003/049494	A1	6/2003	WO	2012/167168	A2	12/2012
WO	2003/056789	A1	7/2003	WO	2013/022135	A1	2/2013
WO	2003/067202	A2	8/2003	WO	2013/048880	A1	4/2013
WO	2003/084196	A1	10/2003	WO	2013/169842	A2	11/2013
WO	2003/094489	A1	11/2003	WO	2013/173511	A2	11/2013
WO	2003/105125	A1	12/2003	WO	2013/184953	A1	12/2013
WO	2003/107179	A1	12/2003	WO	2014/028797	A1	2/2014
WO	2004/008801	A1	1/2004	WO	2014/031505	A1	2/2014
WO	2004/025938	A1	3/2004	WO	2014/066352	A1	5/2014
WO	2004/047415	A1	6/2004	WO	2014/078965	A1	5/2014
WO	2004/055637	A2	7/2004	WO	2014/143959	A2	9/2014
WO	2004/057486	A1	7/2004	WO	2014/144579	A1	9/2014
WO	2004/061850	A1	7/2004	WO	2014/159581	A1	10/2014
WO	2004/072846	A2	8/2004	WO	2014/197336	A1	12/2014
WO	2004/084413	A2	9/2004	WO	2014/204659	A2	12/2014
WO	2005/003920	A2	1/2005	WO	2015/030796	A1	3/2015
WO	2005/008505	A1	1/2005	WO	2015/041892	A1	3/2015
WO	2005/008899	A1	1/2005	WO	2015/084659	A1	6/2015
WO	2005/010725	A2	2/2005	WO	2015/183401	A1	12/2015
WO	2005/027472	A2	3/2005				
WO	2005/027485	A1	3/2005				
WO	2005/031737	A1	4/2005				
WO	2005/034082	A1	4/2005				
WO	2005/034085	A1	4/2005				
WO	2005/041455	A1	5/2005				
WO	2005/059895	A1	6/2005				
WO	2005/064592	A1	7/2005				
WO	2005/069171	A1	7/2005				
WO	2005/101176	A2	10/2005				
WO	2006/020305	A2	2/2006				
WO	2006/037545	A2	4/2006				
WO	2006/054724	A1	5/2006				
WO	2006/056822	A1	6/2006				
WO	2006/078246	A1	7/2006				
WO	2006/084144	A2	8/2006				
WO	2006/101649	A2	9/2006				
WO	2006/129967	A1	12/2006				
WO	2006/133571	A1	12/2006				
WO	2007/002753	A2	1/2007				
WO	2007/036762	A1	4/2007				
WO	2007/080559	A2	7/2007				
WO	2007/083894	A1	7/2007				
WO	2007/125151	A1	11/2007				
WO	2008/030970	A2	3/2008				
WO	2008/071231	A1	6/2008				
WO	2008/085742	A2	7/2008				
WO	2008/098900	A2	8/2008				

OTHER PUBLICATIONS

"Alexa, Turn Up the Heat!", Smartthings Samsung [online], Available online at <https://web.archive.org/web/20160329142041/https://blog.smartthings.com/news/smartthingsupdates/alexa-turn-up-the-heat/>, Mar. 3, 2016, 3 pages.

"SmartThings +Amazon Echo", Smartthings Samsung [online], Available online at <https://web.archive.org/web/20160509231428/https://blog.smartthings.com/featured/alexa-turn-on-my-smartthings/>, Aug. 21, 2015, 3 pages.

2004 Chrysler Pacifica: U-Connect Hands-Free Communication System, The Best and Brightest of 2004, Brief Article, Automotive Industries, Sep. 2003, 1 page.

2007 Lexus GS 450h 4dr Sedan (3.5L 6cyl Gas/Electric Hybrid CVT), available at http://review.cnet.com/4505-10865_16-31833144.html, retrieved on Aug. 3, 2006, 10 pages.

ABCOM PTY. Ltd. "12.1 925 Candela Mobile PC", LCDHardware.com, available at http://www.lcdhardware.com/panel/12_1_panel/default.asp, retrieved on Dec. 19, 2002, 2 pages.

ABF Software, "Lens-Magnifying Glass 1.5", available at <http://download.com/3000-2437-10262078.html?tag=1st-0-1>, retrieved on Feb. 11, 2004, 1 page.

Abut et al., "Low-Rate Speech Encoding Using Vector Quantization and Subband Coding", (Proceedings of the IEEE International Acoustics, Speech and Signal Processing Conference, Apr. 1986), as reprinted in Vector Quantization IEEE Press, 1990, pp. 312-315.

Abut et al., "Vector Quantization of Speech and Speech-Like Waveforms", (IEEE Transactions on Acoustics, Speech, and Signal

(56)

References Cited

OTHER PUBLICATIONS

- Processing, Jun. 1982), as reprinted in *Vector Quantization* (IEEE Press, 1990), 1990, pp. 258-270.
- Adium, "AboutAdium—Adium X—Trac", available at <<http://web.archive.org/web/20070819113247/http://trac.adiumx.com/wiki/AboutAdium>>, retrieved on Nov. 25, 2011, 2 pages.
- adobe.com, "Reading PDF Documents with Adobe Reader 6.0—A Guide for People with Disabilities", Available online at "https://www.adobe.com/enterprise/accessibility/pdfs/acro6_cg_ue.pdf", Jan. 2004, 76 pages.
- Ahlberg et al., "The Alphaslider: A Compact and Rapid Selector", CHI '94 Proceedings of the SIGCHI Conference on Human Factors in Computing Systems, Apr. 1994, pp. 365-371.
- Ahlberg et al., "Visual Information Seeking: Tight Coupling of Dynamic Query Filters with Starfield Displays", Proceedings of the SIGCHI Conference on Human Factors in Computing Systems, Apr. 24-28, 1994, pp. 313-317.
- Ahlstrom et al., "Overcoming Touchscreen User Fatigue by Workplace Design", CHI '92 Posters and Short Talks of the 1992 SIGCHI Conference on Human Factors in Computing Systems, 1992, pp. 101-102.
- Ahmed et al., "Intelligent Natural Language Query Processor", TENCON '89, Fourth IEEE Region 10 International Conference, Nov. 22-24, 1989, pp. 47-49.
- Ahuja et al., "A Comparison of Application Sharing Mechanisms in Real-Time Desktop Conferencing Systems", At&T Bell Laboratories, 1990, pp. 238-248.
- Aikawa et al., "Generation for Multilingual MT", available at <<http://mtarchive.info/MTS-2001-Aikawa.pdf>>, retrieved on Sep. 18, 2001, 6 pages.
- Aikawa, K. "Time-Warping Neural Network for Phoneme Recognition", IEEE International Joint Conference on Neural Networks, vol. 3, Nov. 18-21, 1991, pp. 2122-2127.
- All Music Website, available at <<http://www.allmusic.com/>>, retrieved on Mar. 19, 2007, 2 pages.
- Allen et al., "Automated Natural Spoken Dialog", *Computer*, vol. 35, No. 4, Apr. 2002, pp. 51-56.
- Allewa et al., "Applying SPHINX-II to DARPA Wall Street Journal CSR Task", Proceedings of Speech and Natural Language Workshop, Feb. 1992, pp. 393-398.
- Amano et al., "A User-friendly Multimedia Book Authoring System", The Institute of Electronics, Information and Communication Engineers Technical Report, vol. 103, No. 416, Nov. 2003, pp. 33-40.
- Amano, Junko, "A User-Friendly Authoring System for Digital Talking Books", IEICE Technical Report, The Institute of Electronics, Information and Communication Engineers, vol. 103 No. 418, Nov. 6, 2003, pp. 33-40.
- Amrel Corporation, "Rocky Matrix BackLit Keyboard", available at <http://www.amrel.com/asi_matrixkeyboard.html>, retrieved on Dec. 19, 2002, 1 page.
- Anania, Peter, "Amazon Echo with Home Automation (Smartthings)", Available online at <https://www.youtube.com/watch?v=LMW6aXmsWNE>, Dec. 20, 2015, 1 page.
- ANHUI USTC IFL YTEK Co. Ltd., "Flytek Research Center Information Datasheet", available at <<http://www.ifltek.com/english/Research.htm>>, retrieved on Oct. 15, 2004, 3 pages.
- APLAI, "Android App Review—Speaktoit Assistant", Available at <<https://www.youtube.com/watch?v=myE498nyfGw>>, Mar. 30, 2011, 3 pages.
- Apple Computer, "Knowledge Navigator", published by Apple Computer no later than 2008, as depicted in Exemplary Screenshots from video entitled 'Knowledge Navigator', 2008, 7 pages.
- Apple Computer, Inc., "Apple—iPod—Technical Specifications, iPod 20GB and 60GB Mac + PC", available at <<http://www.apple.com/ipod/color/specs.html>>, 2005, 3 pages.
- Apple Computer, Inc., "Apple Announces iTunes 2", Press Release, Oct. 23, 2001, 2 pages.
- Apple Computer, Inc., "Apple Introduces iTunes—World's Best and Easiest to Use Jukebox Software", Macworld Expo, Jan. 9, 2001, 2 pages.
- Apple Computer, Inc., "Apple's iPod Available in Stores Tomorrow", Press Release, Nov. 9, 2001, 1 page.
- Apple Computer, Inc., "Inside Macintosh", vol. VI, 1985.
- Apple Computer, Inc., "iTunes 2, Playlist Related Help Screens", iTunes v2.0, 2000-2001, 8 pages.
- Apple Computer, Inc., "iTunes 2: Specification Sheet", 2001, 2 pages.
- Apple Computer, Inc., "iTunes, Playlist Related Help Screens", iTunes v1.0, 2000-2001, 8 pages.
- Apple Computer, Inc., "QuickTime Movie Playback Programming Guide", Aug. 11, 2005, pp. 1-58.
- Apple Computer, Inc., "QuickTime Overview", Aug. 11, 2005, pp. 1-34.
- Apple Computer, Inc., "Welcome to Tiger", available at <http://www.maths.dundee.ac.uk/software/Welcome_to_Mac_OS_X_v10.4_Tiger.pdf>, 2005, pp. 1-32.
- Apple, "iPhone User's Guide", Available at <<http://mesnotices.20minutes.fr/manuel-notice-mode-emploi/APPLE/IPHONE%2D%5FE#>>, Retrieved on Aug. 27, 2008, Jun. 2007, 137 pages.
- Apple, "VoiceOver", available at <<http://www.apple.com/accessibility/voiceover/>>, Feb. 2009, 5 pages.
- Applebaum et al., "Enhancing the Discrimination of Speaker Independent Hidden Markov Models with Corrective Training", International Conference on Acoustics, Speech, and Signal Processing, May 23, 1989, pp. 302-305.
- AppleEvent Manager, which is described in the publication *Inside Macintosh* vol. VI, available from Addison-Wesley Publishing Company, 1985.
- Arango et al., "Touring Machine: A Software Platform for Distributed Multimedia Applications", 1992 IFIP International Conference on Upper Layer Protocols, Architectures, and Applications, May 1992, pp. 1-11.
- Arons, Barry M., "The Audio-Graphical Interface to a Personal Integrated Telecommunications System", Thesis Submitted to the Department of Architecture at the Massachusetts Institute of Technology, Jun. 1984, 88 pages.
- Badino et al., "Language Independent Phoneme Mapping for Foreign TTS", 5th ISCA Speech Synthesis Workshop, Pittsburgh, PA, Jun. 14-16, 2004, 2 pages.
- Baechtle et al., "Adjustable Audio Indicator", IBM Technical Disclosure Bulletin, Jul. 1, 1984, 2 pages.
- Baeza-Yates, Ricardo, "Visualization of Large Answers in Text Databases", AVI '96 Proceedings of the Workshop on Advanced Visual Interfaces, 1996, pp. 101-107.
- Bahl et al., "Recognition of a Continuously Read Natural Corpus", IEEE International Conference on Acoustics, Speech, and Signal Processing, vol. 3, Apr. 1978, pp. 422-424.
- Bajarin, Tim, "With Low End Launched, Apple Turns to Portable Future", *PC Week*, vol. 7, Oct. 1990, p. 153(1).
- Barrett et al., "How to Personalize the Web", 1997 In proceedings of the ACM SIGCHI Conference on Human Factors in Computer Systems, Mar. 22-27, 1997, pp. 75-82.
- Barthel, B., "Information Access for Visually Impaired Persons: Do We Still Keep a 'Document' in 'Documentation'?", Professional Communication Conference, Sep. 1995, pp. 62-66.
- Baudel et al., "2 Techniques for Improved HC Interaction: Toolglass & Magic Lenses: The See-Through Interface", Apple Inc., Video Clip, CHI'94 Video Program on a CD, 1994.
- Beck et al., "Integrating Natural Language, Query Processing, and Semantic Data Models", COMCON Spring '90. IEEE Computer Society International Conference, 1990, Feb. 26-Mar. 2, 1990, pp. 538-543.
- Bederson et al., "Pad++: A Zooming Graphical Interface for Exploring Alternate Interface Physics", UIST '94 Proceedings of the 7th Annual ACM symposium on User Interface Software and Technology, Nov. 1994, pp. 17-26.
- Bederson et al., "The Craft of Information Visualization", Elsevier Science, Inc., 2003, 435 pages.

(56)

References Cited

OTHER PUBLICATIONS

- Bellegarda et al., "Tied Mixture Continuous Parameter Modeling for Speech Recognition", *IEEE Transactions on Acoustics, Speech and Signal Processing*, vol. 38, No. 12, Dec. 1990, pp. 2033-2045.
- Bellegarda, Jerome R. "Latent Semantic Mapping", *IEEE Signal Processing Magazine*, vol. 22, No. 5, Sep. 2005, pp. 70-80.
- Benel et al., "Optimal Size and Spacing of Touchscreen Input Areas", *Human-Computer Interaction—INTERACT*, 1987, pp. 581-585.
- Bergmann et al., "An adaptable man-machine interface using connected-word recognition", 2nd European Conference on Speech Communication and Technology (Eurospeech 91), vol. 2, XP002176387, Sep. 24-26, 1991, pp. 467-470.
- Beringer et al., "Operator Behavioral Biases Using High-Resolution Touch Input Devices", *Proceedings of the Human Factors and Ergonomics Society 33rd Annual Meeting*, 1989, 3 pages.
- Beringer, Dennis B., "Target Size, Location, Sampling Point and Instruction Set: More Effects on Touch Panel Operation", *Proceedings of the Human Factors and Ergonomics Society 34th Annual Meeting*, 1990, 5 pages.
- Bernabei et al., "Graphical I/O Devices for Medical Users", 14th Annual International Conference of the IEEE on Engineering in Medicine and Biology Society, vol. 3, 1992, pp. 834-836.
- Bernstein, Macrophone, "Speech Corpus", *IEEE/ICASSP*, Apr. 22, 1994, pp. 1-81 to 1-84.
- Berry et al., "Symantec", New version of MORE.TM, Apr. 10, 1990, 1 page.
- Bertulucci, Jeff, "Google Adds Voice Search to Chrome Browser", *PC World*, Jun. 14, 2011, 5 pages.
- Best Buy, "When it Comes to Selecting a Projection TV, Toshiba Makes Everything Perfectly Clear", *Previews of New Releases*, available at <<http://www.bestbuy.com/HomeAudioVideo/Specials/ToshibaTVFeatures.asp>>, retrieved on Jan. 23, 2003, 5 pages.
- Betts et al., "Goals and Objectives for User Interface Software", *Computer Graphics*, vol. 21, No. 2, Apr. 1987, pp. 73-78.
- Biemann et al., "Disentangling from Babylonian Confusion—Unsupervised Language Identification", *CICLing'05 Proceedings of the 6th international conference on Computational Linguistics and Intelligent Text Processing*, vol. 3406, Feb. 2005, pp. 773-784.
- Biemann, Chris, "Unsupervised Part-of-Speech Tagging Employing Efficient Graph Clustering", *Proceeding COLING ACL '06 Proceedings of the 21st International Conference on computational Linguistics and 44th Annual Meeting of the Association for Computational Linguistics: Student Research Workshop*, 2006, pp. 7-12.
- Bier et al., "Toolglass and Magic Lenses: The See-Through Interface", *Computer Graphics (SIGGRAPH '93 Proceedings)*, vol. 27, 1993, pp. 73-80.
- Birrell, Andrew, "Personal Jukebox (PJB)", available at <<http://birrell.org/andrew/talks/pjb-overview.ppt>>, Oct. 13, 2000, 6 pages.
- Black et al., "Multilingual Text-to-Speech Synthesis", *Acoustics, Speech and Signal Processing (ICASSP'04)*, *Proceedings of the IEEE International Conference*, vol. 3, May 17-21, 2004, pp. 761-764.
- Bleher et al., "A Graphic Interactive Application Monitor", *IBM Systems Journal*, vol. 19, No. 3, Sep. 1980, pp. 382-402.
- BluePhoneElite: About, available at <<http://www.reelintelligence.com/BluePhoneElite>>, retrieved on Sep. 25, 2006, 2 pages.
- BluePhoneElite: Features, available at <<http://www.reelintelligence.com/BluePhoneElite/features.shtml>>, retrieved on Sep. 25, 2006, 2 pages.
- Bluetooth PC Headsets, "'Connecting' Your Bluetooth Headset with Your Computer", *Enjoy Wireless VoIP Conversations*, available at <<http://www.bluetoothpcheadsets.com/connect.htm>>, retrieved on Apr. 29, 2006, 4 pages.
- Bocchieri et al., "Use of Geographical Meta-Data in ASR Language and Acoustic Models", *IEEE International Conference on Acoustics Speech and Signal Processing*, 2010, pp. 5118-5121.
- Bociurkiw, Michael, "Product Guide: Vanessa Matz", available at <http://www.forbes.com/asap/2000/1127/vmartz_print.html>, retrieved on Jan. 23, 2003, 2 pages.
- Borden IV, G.R., "An Aural User Interface for Ubiquitous Computing", *Proceedings of the 6th International Symposium on Wearable Computers*, IEEE, 2002, 2 pages.
- Borenstein, Nathaniel S., "Cooperative Work in the Andrew Message System", *Information Technology Center and Computer Science Department, Carnegie Mellon University*; Thyberg, Chris A. *Academic Computing, Carnegie Mellon University*, 1988, pp. 306-323.
- Boy, Guy A., "Intelligent Assistant Systems", *Harcourt Brace Jovanovic*, 1991, 1 page.
- Boyer et al., "A Fast String Searching Algorithm", *Communications of the ACM*, vol. 20, 1977, pp. 762-772.
- Brain, Marshall, "How MP3 Files Work", available at <<http://www.howstuffworks.com>>, retrieved on Mar. 19, 2007, 4 pages.
- Brown et al., "Browsing Graphs Using a Fisheye View", *Apple Inc., Video Clip, Systems Research Center, CHI '92 Continued Proceedings on a CD*, 1992.
- Brown et al., "Browsing Graphs Using a Fisheye View", *CHI '93 Proceedings of the INTERACT '93 and CHI '93 Conference on Human Factors in Computing Systems*, 1993, p. 516.
- Burger, D., "Improved Access to Computers for the Visually Handicapped: New Prospects and Principles", *IEEE Transactions on Rehabilitation Engineering*, vol. 2, No. 3, Sep. 1994, pp. 111-118.
- Busemann et al., "Natural Language Dialogue Service for Appointment Scheduling Agents", *Technical Report RR-97-02, Deutsches Forschungszentrum für Künstliche Intelligenz GmbH*, 1997, 8 pages.
- Butler, Travis, "Archos Jukebox 6000 Challenges Nomad Jukebox", available at <<http://tidbits.com/article/6521>>, Aug. 13, 2001, 5 pages.
- Butler, Travis, "Portable MP3: The Nomad Jukebox", available at <<http://tidbits.com/article/6261>>, Jan. 8, 2001, 4 pages.
- Buxton et al., "EuroPARC's Integrated Interactive Multimedia Facility (IIIF): Early Experiences", *Proceedings of the IFIP WG 8.4 Conference on Multi-User Interfaces and Applications*, 1990, pp. 11-34.
- Call Centre, "Word Prediction", *The CALL Centre & Scottish Executive Education Dept.*, 1999, pp. 63-73.
- Campbell et al., "An Expandable Error-Protected 4800 BPS CELP Coder (U.S. Federal Standard 4800 BPS Voice Coder)", (*Proceedings of IEEE Int'l Acoustics, Speech, and Signal Processing Conference*, May 1983), as reprinted in *Vector Quantization (IEEE Press, 1990)*, 1990, pp. 328-330.
- Cao et al., "Adapting Ranking SVM to Document Retrieval", *SIGIR '06*, Seattle, WA, Aug. 6-11, 2006, 8 pages.
- Caraballo et al., "Language Identification Based on a Discriminative Text Categorization Technique", *Iberspeech 2012—VII Jornadas En Tecnologia Del Habla and Iii Iberiansl Tech Workshop*, Nov. 21, 2012, pp. 1-10.
- Card et al., "Readings in Information Visualization Using Vision to Think", *Interactive Technologies*, 1999, 712 pages.
- Carpendale et al., "3-Dimensional Pliable Surfaces: For the Effective Presentation of Visual Information", *UIST '95 Proceedings of the 8th Annual ACM Symposium on User Interface and Software Technology*, Nov. 14-17, 1995, pp. 217-226.
- Carpendale et al., "Extending Distortion Viewing from 2D to 3D", *IEEE Computer Graphics and Applications*, Jul./Aug. 1997, pp. 42-51.
- Carpendale et al., "Making Distortions Comprehensible", *IEEE Proceedings of Symposium on Visual Languages*, 1997, 10 pages.
- Casner et al., "N-Way Conferencing with Packet Video", *The Third International Workshop on Packet Video*, Mar. 22-23, 1990, pp. 1-6.
- Castleos, "Whole House Voice Control Demonstration", available online at : https://www.youtube.com/watch?v=9SRCoxrZ_W4, Jun. 2, 2012, 26 pages.
- Chakarova et al., "Digital Still Cameras—Downloading Images to a Computer", *Multimedia Reporting and Convergence*, available at <<http://journalism.berkeley.edu/multimedia/tutorials/stillcams/downloading.html>>, retrieved on May 9, 2005, 2 pages.
- Chamberlain, Kim, "Quick Start Guide Natural Reader", available online at <http://atrc.colostate.edu/files/quickstarts/Natural_Reader_Quick_Start_Guide>, Apr. 2008, 5 pages.

(56)

References Cited

OTHER PUBLICATIONS

- Chang et al., "Discriminative Training of Dynamic Programming based Speech Recognizers", IEEE Transactions on Speech and Audio Processing, vol. 1, No. 2, Apr. 1993, pp. 135-143.
- Chartier, David, "Using Multi-Network Meebo Chat Service on Your iPhone", available at <<http://www.tuaw.com/2007/07/04/using-multi-network-meebo-chat-service-on-your-iphone/>>, Jul. 4, 2007, 5 pages.
- Chelba et al., "Structured Language Modeling for Speech Recognition", Available online at : <http://arxiv.org/pdf/cs/0001023.pdf>, Jan. 25, 2000, 7 pages.
- Chen et al., "An Improved Method for Image Retrieval Using Speech Annotation", The 9th International Conference on Multi-Media Modeling, Jan. 2003, pp. 1-17.
- Cheyser et al., "Demonstration Video of Multimodal Maps Using an Agent Architecture", published by SRI International no later than 1996, as depicted in Exemplary Screenshots from video entitled Demonstration Video of Multimodal Maps Using an Agent Architecture, 1996, 6 pages.
- Cheyser et al., "Demonstration Video of Multimodal Maps Using an Open-Agent Architecture", published by SRI International no later than 1996, as depicted in Exemplary Screenshots from video entitled Demonstration Video of Multimodal Maps Using an Open-Agent Architecture, 6 pages.
- Cheyser, A., "Demonstration Video of Vanguard Mobile Portal", published by SRI International no later than 2004, as depicted in 'Exemplary Screenshots from video entitled Demonstration Video of Vanguard Mobile Portal', 2004, 10 pages.
- Choi et al., "Acoustic and Visual Signal based Context Awareness System for Mobile Application", IEEE Transactions on Consumer Electronics, vol. 57, No. 2, May 2011, pp. 738-746.
- Chomsky et al., "The Sound Pattern of English", New York, Harper and Row, 1968, 242 pages.
- Choullarton et al., "User Responses to Speech Recognition Errors: Consistency of Behaviour Across Domains", Proceedings of the 10th Australian International Conference on Speech Science & Technology, Dec. 8-10, 2004, pp. 457-462.
- Church, Kenneth W., "Phonological Parsing in Speech Recognition", Kluwer Academic Publishers, 1987.
- Cisco Systems, Inc., "Cisco Unity Unified Messaging User Guide", Release 4.0(5), Apr. 14, 2005, 152 pages.
- Cisco Systems, Inc., "Installation Guide for Cisco Unity Unified Messaging with Microsoft Exchange 2003/2000 (With Failover Configured)", Release 4.0(5), Apr. 14, 2005, 152 pages.
- Cisco Systems, Inc., "Operations Manager Tutorial, Cisco's IPC Management Solution", 2006, 256 pages.
- Coleman, David W., "Meridian Mail Voice Mail System Integrates Voice Processing and Personal Computing", Speech Technology, vol. 4, No. 2, Mar./Apr. 1988, pp. 84-87.
- Colt, Sam, "Here's One Way Apple's Smartwatch Could Be Better Than Anything Else", Business Insider, Aug. 21, 2014, pp. 1-4.
- COMPAQ Inspiration Technology, "Personal Jukebox (PJB)—Systems Research Center and PAAD", Oct. 13, 2000, 25 pages.
- COMPAQ, "Personal Jukebox", available at <<http://research.compaq.com/SRC/pjb/>>, 2001, 3 pages.
- Conkie et al., "Preselection of Candidate Units in a Unit Selection-Based Text-to-Speech Synthesis System", ISCA, 2000, 4 pages.
- Conklin, Jeffrey, "A Survey of Hypertext", MCC Software Technology Program, Dec. 1987, 40 pages.
- Copperi et al., "CELP Coding for High Quality Speech at 8 kbits/s", Proceedings of IEEE International Acoustics, Speech and Signal Processing Conference, Apr. 1986, as reprinted in Vector Quantization (IEEE Press), 1990, pp. 324-327.
- Corporate Ladder, BLOC Publishing Corporation, 1991, 1 page.
- Corr, Paul, "Macintosh Utilities for Special Needs Users", available at <<http://homepage.mac.com/corr/macsup/columns/specneeds.html>>, Feb. 1994 (content updated Sep. 19, 1999), 4 pages.
- Creative Technology Ltd., "Creative NOMAD® II: Getting Started—User Guide (On Line Version)", available at <<http://ec1.images-amazon.com/media/i3d/01/A/man-migrate/MANUAL000026434.pdf>>, Apr. 2000, 46 pages.
- Creative Technology Ltd., "Creative NOMAD®: Digital Audio Player: User Guide (On-Line Version)", available at <<http://ec1.images-amazon.com/media/i3d/01/A/man-migrate/MANUAL000010757.pdf>>, Jun. 1999, 40 pages.
- Creative Technology Ltd., "Nomad Jukebox", User Guide, Version 1.0, Aug. 2000, 52 pages.
- Creative, "Creative NOMAD MuVo TX", available at <<http://web.archive.org/web/20041024175952/www.creative.com/products/pfriendly.asp?product=9672>>, retrieved on Jun. 6, 2006, 1 page.
- Creative, "Creative NOMAD MuVo", available at <<http://web.archive.org/web/20041024075901/www.creative.com/products/product.asp?category=213&subcategory=216&product=4983>>, retrieved on Jun. 7, 2006, 1 page.
- Creative, "Digital MP3 Player", available at <<http://web.archive.org/web/20041024074823/www.creative.com/products/product.asp?category=213&subcategory=216&product=4983>>, 2004, 1 page.
- Croft et al., "Task Support in an Office System", Proceedings of the Second ACM-SIGOA Conference on Office Information Systems, 1984, pp. 22-24.
- Crowley et al., "MMConf: An Infrastructure for Building Shared Multimedia Applications", CSCW 90 Proceedings, Oct. 1990, pp. 329-342.
- Cucerzan et al., "Bootstrapping a Multilingual Part-of-Speech Tagger in One Person-Day", In Proceedings of the 6th Conference on Natural Language Learning, vol. 20, 2002, pp. 1-7.
- Cuperman et al., "Vector Predictive Coding of Speech at 16 kbit s/s", (IEEE Transactions on Communications, Jul. 1985), as reprinted in Vector Quantization (IEEE Press, 1990), 1990, pp. 300-311.
- Database WPI Section Ch, Week 8733, Derwent Publications Ltd., London, GB; AN 87-230826 & JP, A, 62 153 326 (SANWA KAKO KK (SANS) SANWA KAKO CO), Jul. 8, 1987, 6 pages.
- Database WPI Section Ch, Week 8947, Derwent Publications Ltd., London, GB; Class A17, AN 89-343299 & JP, A, 1 254 742 (Sekisui Plastics KK), Oct. 11, 1989, 7 pages.
- Davis et al., "Stone Soup Translation", Department of Linguistics, Ohio State University, 2001, 11 pages.
- De Herrera, Chris, "Microsoft ActiveSync 3.1", Version 1.02, available at <<http://www.cewindows.net/wce/activesync3.1.htm>>, Oct. 13, 2000, 8 pages.
- Deedeuvu, "Amazon Echo Alarm Feature", Available online at <https://www.youtube.com/watch?v=fjU8eRkL7c>, Feb. 16, 2015, 1 page.
- Degani et al., "'Soft' Controls for Hard Displays: Still a Challenge", Proceedings of the 36th Annual Meeting of the Human Factors Society, 1992, pp. 52-56.
- Del Strother, Jonathan, "Coverflow", available at <<http://www.steelskies.com/coverflow>>, retrieved on Jun. 15, 2006, 14 pages.
- Diagrammaker, Action Software, 1989.
- Diagram-Master, Ashton-Tate, 1989.
- Diamond Multimedia Systems, Inc., "Rio PMP300: User's Guide", available at <<http://ec1.images-amazon.com/media/i3d/01/A/man-migrate/MANUAL000022854.pdf>>, 1998, 28 pages.
- Dickinson et al., "Palmtips: Tiny Containers for All Your Data", PC Magazine, vol. 9, Mar. 1990, p. 218(3).
- Digital Audio in the New Era, Electronic Design and Application, No. 6, Jun. 30, 2003, 3 pages.
- Digital Equipment Corporation, "OpenVMS RTL DECTalk (DTKS) Manual", May 1993, 56 pages.
- Dittenbach et al., "A Natural Language Query Interface for Tourism Information", In: Information and Communication Technologies in Tourism 2003, XP055114393, Feb. 14, 2003, pp. 152-162.
- Dobrissek et al., "Evolution of the Information-Retrieval System for Blind and Visually-Impaired People", International Journal of Speech Technology, Kluwer Academic Publishers, Bo, vol. 6, No. 3, pp. 301-309.
- Donahue et al., "Whiteboards: A Graphical Database Tool", ACM Transactions on Office Information Systems, vol. 4, No. 1, Jan. 1986, pp. 24-41.

(56)

References Cited

OTHER PUBLICATIONS

- Dourish et al., "Portholes: Supporting Awareness in a Distributed Work Group", CHI 1992, May 1992, pp. 541-547.
- Dragon Naturally Speaking Version 11 Users Guide, Nuance Communications, Inc., Copyright @2002-2010, 132 pages.
- Dual Rate Speech Coder for Multimedia Communications Transmitting at 5.3 and 6.3 kbit/s, International Telecommunication Union Recommendation G.723, 7 pages.
- dyslexic.com, "AlphaSmart 3000 with CoWriter SmartApplet: Don Johnston Special Needs", available at <<http://www.dyslexic.com/procuts.php?catid=2&pid=465&PHPSESSID=2511b800000f7da>>, retrieved on Dec. 6, 2005, 13 pages.
- Eagle et al., "Social Serendipity: Proximity Sensing and Cueing", MIT Media Laboratory Technical Note 580, May 2004, 18 pages.
- Edwards, John R., "Q&A: Integrated Software with Macros and an Intelligent Assistant", Byte Magazine, vol. 11, No. 1, Jan. 1986, pp. 120-122.
- Egido, Carmen, "Video Conferencing as a Technology to Support Group Work: A Review of its Failures", Bell Communications Research, 1988, pp. 13-24.
- Elliot, Chip, "High-Quality Multimedia Conferencing Through a Long-Haul Packet Network", BBN Systems and Technologies, 1993, pp. 91-98.
- Elliott et al., "Annotation Suggestion and Search for Personal Multimedia Objects on the Web", CIVR, Jul. 7-9, 2008, pp. 75-84.
- Elofson et al., "Delegation Technologies: Environmental Scanning with Intelligent Agents", Jour. of Management Info. Systems, Summer 1991, vol. 8, No. 1, 1991, pp. 37-62.
- Eluminox, "Illuminated Keyboard", available at <<http://www.eluminox.com/>>, retrieved on Dec. 19, 2002, 1 page.
- Engst, Adam C., "SoundJam Keeps on Jammin'", available at <<http://db.tidbits.com/getbits.acgi?tbart=05988>>, Jun. 19, 2000, 3 pages.
- Ericsson Inc., "Cellular Phone with Integrated MP3 Player", Research Disclosure Journal No. 41815, Feb. 1999, 2 pages.
- Erol et al., "Multimedia Clip Generation From Documents for Browsing on Mobile Devices", IEEE Transactions on Multimedia, vol. 10, No. 5, Aug. 2008, 13 pages.
- Eslambolchilar et al., "Making Sense of Fisheye Views", Second Dynamics and Interaction Workshop at University of Glasgow, Aug. 2005, 6 pages.
- Eslambolchilar et al., "Multimodal Feedback for Tilt Controlled Speed Dependent Automatic Zooming", UIST'04, Oct. 24-27, 2004, 2 pages.
- European Search Report received for European Patent Application No. 01201774.5, dated Sep. 14, 2001, 3 pages.
- European Search Report received for European Patent Application No. 99107544.1, dated Jul. 8, 1999, 4 pages.
- European Search Report received for European Patent Application No. 99107545.8, dated Jul. 1, 1999, 3 pages.
- Evermann et al., "Posterior Probability Decoding, Confidence Estimation and System Combination", Proceedings Speech Transcription Workshop, 2000, 4 pages.
- Extended European Search Report (includes European Search Report and European Search Opinion) received for European Patent Application No. 06256215.2, dated Feb. 20, 2007, 6 pages.
- Extended European Search Report (includes European Search Report and European Search Opinion) received for European Patent Application No. 12186113.2, dated Apr. 28, 2014, 14 pages.
- Extended European Search Report (includes Partial European Search Report and European Search Opinion) received for European Patent Application No. 13169672.6, dated Aug. 14, 2013, 11 pages.
- Extended European Search Report (includes Partial European Search Report and European Search Opinion) received for European Patent Application No. 15169349.6, dated Jul. 28, 2015, 8 pages.
- Extended European Search Report (includes Partial European Search Report and European Search Opinion) received for European Patent Application No. 15196748.6, dated Apr. 4, 2016.
- Extended European Search Report (includes Partial European Search Report and European Search Opinion) received for European Patent Application No. 16150079.8, dated Feb. 18, 2016, 7 pages.
- Extended European Search Report (includes Supplementary European Search Report and Search Opinion) received for European Patent Application No. 12727027.0, dated Sep. 26, 2014, 7 pages.
- Extended European Search Report (inclusive of the Partial European Search Report and European Search Opinion) received for European Patent Application No. 12729332.2, dated Oct. 31, 2014, 6 pages.
- Extended European Search Report and Search Opinion received for European Patent Application No. 12185276.8, dated Dec. 18, 2012, 4 pages.
- Extended European Search Report received for European Patent Application No. 11159884.3, dated May 20, 2011, 8 pages.
- Extended European Search Report received for European Patent Application No. 12186663.6, dated Jul. 16, 2013, 6 pages.
- Extended European Search Report received for European Patent Application No. 13726938.7, dated Dec. 14, 2015, 8 pages.
- Extended European Search Report received for European Patent Application No. 13770552.1, dated Jan. 7, 2016, 5 pages.
- Extended European Search Report received for European Patent Application No. 14719914.5, dated Oct. 10, 2016, 7 pages.
- Extended European Search Report received for European Patent Application No. 14737370.8, dated May 19, 2016, 12 pages.
- Fanty et al., "A Comparison of DFT, PLP and Cochleagram for Alphabet Recognition", IEEE, Nov. 1991, pp. 326-329.
- Findlater et al., "Beyond QWERTY: Augmenting Touch-Screen Keyboards with Multi-Touch Gestures for Non-Alphanumeric Input", CHI '12, Austin, Texas, USA, May 5-10, 2012, 4 pages.
- Fiscus, J. G., "A Post-Processing System to Yield Reduced Word Error Rates: Recognizer Output Voting Error Reduction (ROVER)", IEEE Proceedings, Automatic Speech Recognition and Understanding, Dec. 14-17, 1997, pp. 347-354.
- Fisher et al., "Virtual Environment Display System", Interactive 3D Graphics, Oct. 23-24, 1986, pp. 77-87.
- Forsdick, Harry, "Explorations into Real-Time Multimedia Conferencing", Proceedings of the Ifip Tc 6 International Symposium on Computer Message Systems, 1986, 331 pages.
- Furnas et al., "Space-Scale Diagrams: Understanding Multiscale Interfaces", CHI '95 Proceedings of the SIGCHI Conference on Human Factors in Computing Systems, 1995, pp. 234-241.
- Furnas, George W., "Effective View Navigation", Proceedings of the ACM SIGCHI Conference on Human Factors in Computing Systems, Mar. 1997, pp. 367-374.
- Furnas, George W., "Generalized Fisheye Views", CHI '86 Proceedings of the SIGCHI Conference on Human Factors in Computing Systems, vol. 17, No. 4, Apr. 1986, pp. 16-23.
- Furnas, George W., "The Fisheye Calendar System", Bellcore Technical Memorandum, Nov. 19, 1991, pp. 1-9.
- Gardner, Jr., P. C., "A System for the Automated Office Environment", IBM Systems Journal, vol. 20, No. 3, 1981, pp. 321-345.
- Garretson, R., "IBM Adds 'Drawing Assistant' Design Tool to Graphic Series", PC Week, vol. 2, No. 32, Aug. 13, 1985, 1 page.
- Gaver et al., "One Is Not Enough: Multiple Views in a Media Space", INTERCHI, Apr. 24-29, 1993, pp. 335-341.
- Gaver et al., "Realizing a Video Environment: EuroPARC's RAVE System", Rank Xerox Cambridge EuroPARC, 1992, pp. 27-35.
- Giachin et al., "Word Juncture Modeling Using Inter-Word Context-Dependent Phone-Like Units", Csel Technical Reports, vol. 20, No. 1, Mar. 1992, pp. 43-47.
- Gillespie, Kelly, "Adventures in Integration", Data Based Advisor, vol. 9, No. 9, Sep. 1991, pp. 90-92.
- Gillespie, Kelly, "Internationalize Your Applications with Unicode", Data Based Advisor, vol. 10, No. 10, Oct. 1992, pp. 136-137.
- Gilloire et al., "Innovative Speech Processing for Mobile Terminals: An Annotated Bibliography", Signal Processing, vol. 80, No. 7, Jul. 2000, pp. 1149-1166.
- Glinert-Stevens, Susan, "Microsoft Publisher: Desktop Wizardry", PC Sources, vol. 3, No. 2, Feb. 1992, 1 page.
- Glossary of Adaptive Technologies: Word Prediction, available at <<http://www.utoronto.ca/atrc/reference/techwordpred.html>>, retrieved on Dec. 6, 2005, 5 pages.

(56)

References Cited

OTHER PUBLICATIONS

- Gmail, "About Group Chat", available at <<http://mail.google.com/support/bin/answer.py?answer=81090>>, Nov. 26, 2007, 2 pages.
- Goldberg, Cheryl, "IBM Drawing Assistant: Graphics for the EGA", PC Magazine, vol. 4, No. 26, Dec. 24, 1985, 1 page.
- Gomez et al., "Mouth Gesture and Voice Command Based Robot Command Interface", IEEE International Conference on Robotics and Automation, May 12-17, 2009, pp. 333-338.
- Gonnet et al., "Handbook of Algorithms and Data Structures: in Pascal and C. (2nd ed.)", Addison-Wesley Longman Publishing Co., 1991, 17 pages.
- Good et al., "Building a User-Derived Interface", Communications of the ACM; (Oct. 1984) vol. 27, No. 10, Oct. 1984, pp. 1032-1043.
- Gray et al., "Rate Distortion Speech Coding with a Minimum Discrimination Information Distortion Measure", (IEEE Transactions on Information Theory, Nov. 1981), as reprinted in Vector Quantization (IEEE Press), 1990, pp. 208-221.
- Greenberg, Saul, "A Fisheye Text Editor for Relaxed-WYSIWIS Groupware", CHI '96 Companion, Vancouver, Canada, Apr. 13-18, 1996, 2 pages.
- Griffin et al., "Signal Estimation From Modified Short-Time Fourier Transform", IEEE Transactions on Acoustics, Speech and Signal Processing, vol. ASSP-32, No. 2, Apr. 1984, pp. 236-243.
- Gruber, Thomas R., et al., U.S. Appl. No. 61/186,414, filed Jun. 12, 2009 titled "System and Method for Semantic Auto-Completion" 13 pages.
- Gruber, Thomas R., et al., U.S. Appl. No. 61/493,201, filed Jun. 3, 2011 titled "Generating and Processing Data Items That Represent Tasks to Perform", 68 pages.
- Gruber, Thomas R., et al., U.S. Appl. No. 61/657,744, filed Jun. 9, 2012 titled "Automatically Adapting User Interfaces for Hands-Free Interaction", 40 pages.
- Gruber, Thomas R., et al., U.S. Appl. No. 07/976,970, filed Nov. 16, 1992 titled "Status Bar for Application Windows".
- Gruhn et al., "A Research Perspective on Computer-Assisted Office Work", IBM Systems Journal, vol. 18, No. 3, 1979, pp. 432-456.
- Guay, Matthew, "Location-Driven Productivity with Task Ave", available at <<http://iphone.appstorm.net/reviews/productivity/location-driven-productivity-with-task-ave/>>, Feb. 19, 2011, 7 pages.
- Guim, Mark, "How to Set a Person-Based Reminder with Cortana", available at <<http://www.wpcentral.com/how-to-person-based-reminder-cortana/>>, Apr. 26, 2014, 15 pages.
- Gurevych et al., "Semantic Coherence Scoring Using an Ontology", North American Chapter of the Association for Computational Linguistics Archive, Proceedings of the 2003 Conference of the North American Chapter of the Association for Computational Linguistics on Human Language Technology, May 27, 2003, 8 pages.
- Haga et al., "A Usability Survey of a Contents-Based Video Retrieval System by Combining Digital Video and an Electronic Bulletin Board", The Internet and Higher Education, vol. 8, No. 3, 2005, pp. 251-262.
- Hain et al., "The Papageno TTS System", Siemens AG, Corporate Technology, Munich, Germany TC-STAR Workshop, 2006, 6 pages.
- Haitsma et al., "A Highly Robust Audio Fingerprinting System", In Proceedings of the International Symposium on Music Information Retrieval (ISMIR), 2002, 9 pages.
- Halbert, D. C., "Programming by Example", Dept. Electrical Engineering and Comp. Sciences, University of California, Berkeley, Nov. 1984, pp. 1-76.
- Hall, William S., "Adapt Your Program for Worldwide Use with Windows.TM. Internationalization Support", Microsoft Systems Journal, vol. 6, No. 6, Nov./Dec. 1991, pp. 29-58.
- Haoui et al., "Embedded Coding of Speech: A Vector Quantization Approach", (Proceedings of the IEEE International Acoustics, Speech and Signal Processing Conference, Mar. 1985), as reprinted in Vector Quantization (IEEE Press, 1990), 1990, pp. 297-299.
- Hartson et al., "Advances in Human-Computer Interaction", Chapters 1, 5, and 6, vol. 3, 1992, 121 pages.
- Hashimoto, Yoshiyuki, "Simple Guide for iPhone Siri, Which Can Be Operated with Your Voice", Shuwa System Co., Ltd., vol. 1, Jul. 5, 2012, pp. 8, 130, 131.
- Headset Button Controller v7.3 APK Full App Download for Android, Blackberry, iPhone, 11 pages.
- Hear voice from Google translate, Available on URL:<https://www.youtube.com/watch?v=18AvMhFqD28>, Jan. 28, 2011, 1 page.
- Heger et al., "KNOWBOT: An Adaptive Data Base Interface", Nuclear Science and Engineering, V. 107, No. 2, Feb. 1991, pp. 142-157.
- Hendrickson, Bruce, "Latent Semantic Analysis and Fiedler Retrieval", Discrete Algorithms and Mathematics Department, Sandia National Labs, Albuquerque, NM, Sep. 21, 2006, 12 pages.
- Hendrix et al., "The Intelligent Assistant: Technical Considerations Involved in Designing Q&A's Natural-Language Interface", Byte Magazine, Issue 14, Dec. 1987, 1 page.
- Henrich et al., "Language Identification for the Automatic Grapheme-To-Phoneme Conversion of Foreign Words in a German Text-To-Speech System", Proceedings of the European Conference on Speech Communication and Technology, vol. 2, Sep. 1989, pp. 220-223.
- Heyer et al., "Exploring Expression Data: Identification and Analysis of Coexpressed Genes", Genome Research, vol. 9, 1999, pp. 1106-1115.
- Hill, R. D., "Some Important Features and Issues in User Interface Management System", Dynamic Graphics Project, University of Toronto, CSRI, vol. 21, No. 2, Apr. 1987, pp. 116-120.
- Hinckley et al., "A Survey of Design Issues in Spatial Input", UIST '94 Proceedings of the 7th Annual ACM Symposium on User Interface Software and Technology, 1994, pp. 213-222.
- Hiroshi, "TeamWork Station: Towards a Seamless Shared Workspace", NTT Human Interface Laboratories, CSCW 90 Proceedings, Oct. 1990, pp. 13-26.
- Holmes, "Speech System and Research", 1955, pp. 129-135, 152-153.
- Hon et al., "Towards Large Vocabulary Mandarin Chinese Speech Recognition", Conference on Acoustics, Speech, and Signal Processing, ICASSP-94, IEEE International, vol. 1, Apr. 1994, pp. 545-548.
- Hopper, Andy, "Pandora—An Experimental System for Multimedia Applications", Olivetti Research Laboratory, Apr. 1990, pp. 19-34.
- Howard, John H., "(Abstract) An Overview of the Andrew File System", Information Technology Center, Carnegie Mellon University; (CMU-ITC-88-062) To Appear in a future issue of the ACM Transactions on Computer Systems, 1988, pp. 1-6.
- Huang et al., "A Novel Approach to Robust Speech Endpoint Detection in Car Environments", Acoustics, Speech, and Signal Processing 2000, ICASSP '00, Proceeding S. 2000 IEEE International Conference on Jun. 5-9, 2000, vol. 3, Jun. 5, 2000, pp. 1751-1754.
- Huang et al., "Real-Time Software-Based Video Coder for Multimedia Communication Systems", Department of Computer Science and Information Engineering, 1993, 10 pages.
- Hukin, R. W., "Testing an Auditory Model by Resynthesis", European Conference on Speech Communication and Technology, Sep. 26-29, 1989, pp. 243-246.
- Hunt, "Unit Selection in a Concatenative Speech Synthesis System Using a Large Speech Database", Copyright 1996 IEEE. "To appear in Proc. ICASSP-96, May 7-10, Atlanta, GA" ATR Interpreting Telecommunications Research Labs, Kyoto Japan, 1996, pp. 373-376.
- iAP Sports Lingo 0x09 Protocol V1.00, May 1, 2006, 17 pages.
- IBM Corporation, "Simon Says Here's How", Users Manual, 1994, 3 pages.
- IBM, "Why Buy: ThinkPad", available at <<http://www.pc.ibm.com/us/thinkpad/easeofuse.html>>, retrieved on Dec. 19, 2002, 2 pages.
- iChat AV, "Video Conferencing for the Rest of Us", Apple—Mac OS X—iChat AV, available at <<http://www.apple.com/macosx/features/ichat/>>, retrieved on Apr. 13, 2006, 3 pages.
- id3.org, "id3v2.4.0-Frames", available at <<http://id3.org/id3v2.4.0-frames?action=print>>, retrieved on Jan. 22, 2015, 41 pages.

(56)

References Cited

OTHER PUBLICATIONS

IEEE 1394 (Redirected from Firewire, Wikipedia, The Free Encyclopedia, available at <<http://www.wikipedia.org/wiki/Firewire>>, retrieved on Jun. 8, 2003, 2 pages.

Jensvoll, Maja Henriette., "The Acquisition of Past Tense in English/Norwegian Bilingual Children Single versus Dual Mechanisms", Proceedings of the 19th Scandinavian Conference of Linguistics, vol. 31, No. 3, 2003, pp. 545-557.

Külekeci et al., "Turkish Word Segmentation Using Morphological Analyzer", 7th European Conference on Speech Communication and Technology, 2nd Interspeech Event, 2001, 4 pages.

Interactive Voice, available at <<http://www.helloivee.com/company/>>, retrieved on Feb. 10, 2014, 2 pages.

Extended European Search Report (includes Supplementary European Search Report and Search Opinion) received for European Patent Application No. 07863218.9, dated Dec. 9, 2010, 7 pages.

International Preliminary Report on Patentability received for PCT Patent Application No. PCT/GB2009/051684, dated Jun. 23, 2011, 10 pages.

International Preliminary Report on Patentability received for PCT Patent Application No. PCT/US1993/012637, dated Apr. 10, 1995, 7 pages.

International Preliminary Report on Patentability received for PCT Patent Application No. PCT/US1993/012666, dated Mar. 1, 1995, 5 pages.

International Preliminary Report on Patentability received for PCT Patent Application No. PCT/US1995/008369, dated Oct. 9, 1996, 4 pages.

International Preliminary Report on Patentability received for PCT Patent Application No. PCT/US2004/002873, dated Feb. 1, 2006, 5 pages.

International Preliminary report on Patentability received for PCT Patent Application No. PCT/US2004/016519, dated Jan. 23, 2006, 12 pages.

International Preliminary Report on Patentability received for PCT Patent Application No. PCT/US2005/030234, dated Mar. 20, 2007, 9 pages.

International Preliminary Report on Patentability received for PCT Patent Application No. PCT/US2008/000042, dated Jul. 7, 2009, 6 pages.

International Preliminary Report on Patentability received for PCT Patent Application No. PCT/US2008/000043, dated Jul. 7, 2009, 8 pages.

International Preliminary Report on Patentability received for PCT Patent Application No. PCT/US2008/000047, dated Jul. 7, 2009, 8 pages.

International Preliminary Report on Patentability received for PCT Patent Application No. PCT/US2009/051954, dated Mar. 24, 2011, 8 pages.

International Preliminary Report on Patentability received for PCT Patent Application No. PCT/US2009/055577, completed on Aug. 6, 2010, 12 pages.

International Preliminary Report on Patentability received for PCT Patent Application No. PCT/US2010/037378, dated Dec. 6, 2011, 9 pages.

International Preliminary Report on Patentability received for PCT Patent Application No. PCT/US2011/020350, dated Jul. 17, 2012, 12 pages.

International Preliminary Report on Patentability received for PCT Patent Application No. PCT/US2011/020825, dated Jan. 13, 2012, 17 pages.

International Preliminary Report on Patentability received for PCT Patent Application No. PCT/US2011/020861, dated Aug. 2, 2012, 11 pages.

International Preliminary Report on Patentability received for PCT Patent Application No. PCT/US2011/037014, dated Dec. 13, 2012, 10 pages.

International Preliminary Report on Patentability received for PCT Patent Application No. PCT/US2012/029810, dated Oct. 3, 2013, 9 pages.

International Preliminary Report on Patentability received for PCT Patent Application No. PCT/US2012/034028, dated Oct. 31, 2013, 7 pages.

International Preliminary Report on Patentability received for PCT Patent Application No. PCT/US2012/040571, dated Dec. 19, 2013, 10 pages.

International Preliminary Report on Patentability received for PCT Patent Application No. PCT/US2012/040801, dated Dec. 19, 2013, 16 pages.

International Preliminary Report on Patentability received for PCT Patent Application No. PCT/US2012/040931, dated Dec. 18, 2014, 9 pages.

International Preliminary Report on Patentability received for PCT Patent Application No. PCT/US2012/043098, dated Jan. 9, 2014, 8 pages.

International Preliminary Report on Patentability received for PCT Patent Application No. PCT/US2012/043100, dated Jan. 9, 2014, 7 pages.

International Preliminary Report on Patentability received for PCT Patent Application No. PCT/US2012/056382, dated Apr. 10, 2014, 9 pages.

International Preliminary Report on Patentability received for PCT Patent Application No. PCT/US2013/028412, dated Sep. 12, 2014, 12 pages.

International Preliminary Report on Patentability received for PCT Patent Application No. PCT/US2013/028920, dated Sep. 18, 2014, 11 pages.

International Preliminary Report on Patentability received for PCT Patent Application No. PCT/US2013/029156, dated Sep. 9, 2014, 7 pages.

International Preliminary Report on Patentability received for PCT Patent Application No. PCT/US2013/041225, dated Nov. 27, 2014, 9 pages.

International Preliminary Report on Patentability received for PCT Patent Application No. PCT/US2013/041233, dated Nov. 18, 2014, 8 pages.

International Preliminary Report on Patentability received for PCT Patent Application No. PCT/US2013/044574, dated Dec. 9, 2014, 8 pages.

International Preliminary Report on Patentability received for PCT Patent Application No. PCT/US2013/044834, dated Dec. 9, 2014, 9 pages.

International Preliminary Report on Patentability received for PCT Patent Application No. PCT/US2013/047659, dated Dec. 31, 2014, 15 pages.

International Preliminary Report on Patentability received for PCT Patent Application No. PCT/US2013/047668, dated Jan. 8, 2015, 13 pages.

International Preliminary Report on Patentability received for PCT Patent Application No. PCT/US2013/052558, dated Feb. 12, 2015, 12 pages.

International Preliminary Report on Patentability received for PCT Patent Application No. PCT/US2013/058916, dated Mar. 19, 2015, 8 pages.

International Preliminary Report on Patentability received for PCT Patent Application No. PCT/US2013/060121, dated Apr. 2, 2015, 6 pages.

International Preliminary Report on Patentability received for PCT Patent Application No. PCT/US2014/015418, dated Aug. 20, 2015, 12 pages.

International Preliminary Report on Patentability received for PCT Patent Application No. PCT/US2014/016988, dated Sep. 3, 2015, 8 pages.

International Preliminary Report on Patentability received for PCT Patent Application No. PCT/US2014/023822, dated Sep. 24, 2015, 12 pages.

International Preliminary Report on Patentability received for PCT Patent Application No. PCT/US2014/023826, dated Sep. 24, 2015, 9 pages.

International Preliminary Report on Patentability received for PCT Patent Application No. PCT/US2014/026871, dated Sep. 24, 2015, 7 pages.

(56)

References Cited

OTHER PUBLICATIONS

International Preliminary Report on Patentability received for PCT Patent Application No. PCT/US2014/026873, dated Sep. 24, 2015, 9 pages.

International Preliminary Report on Patentability received for PCT Patent Application No. PCT/US2014/028785, dated Sep. 24, 2015, 15 pages.

International Preliminary Report on Patentability received for PCT Patent Application No. PCT/US2014/028950, dated Sep. 24, 2015, 8 pages.

International Preliminary Report on Patentability received for PCT Patent Application No. PCT/US2014/029050, dated Sep. 24, 2015, 7 pages.

International Preliminary Report on Patentability received for PCT Patent Application No. PCT/US2014/029562, dated Sep. 24, 2015, 16 pages.

International Preliminary Report on Patentability received for PCT Patent Application No. PCT/US2014/040393, dated Dec. 8, 2015, 15 pages.

International Preliminary Report on Patentability received for PCT Patent Application No. PCT/US2014/040394, dated Dec. 23, 2015, 7 pages.

International Preliminary Report on Patentability received for PCT Patent Application No. PCT/US2014/040397, dated Dec. 17, 2015, 8 pages.

International Preliminary Report on Patentability received for PCT Patent Application No. PCT/US2014/040401, dated Dec. 8, 2015, 6 pages.

International Preliminary Report on Patentability received for PCT Patent Application No. PCT/US2014/040403, dated Dec. 23, 2015, 7 pages.

International Preliminary Report on Patentability received for PCT Patent Application No. PCT/US2014/040961, dated Dec. 17, 2015, 20 pages.

International Preliminary Report on Patentability received for PCT Patent Application No. PCT/US2014/041159, dated Dec. 17, 2015, 8 pages.

International Preliminary Report on Patentability received for PCT Patent Application No. PCT/US2014/041173, dated Dec. 17, 2015, 9 pages.

International Preliminary Report on Patentability received for PCT Patent Application No. PCT/US2014/049568, dated Feb. 18, 2016, 10 pages.

International Search Report & Written Opinion received for PCT Patent Application No. PCT/US2016/021410, dated Jul. 26, 2016, 19 pages.

International Search Report and Written Opinion received for PCT Patent Application No. PCT/US16/23312, dated Jun. 27, 2016, 7 pages.

International Search Report and Written Opinion received for PCT Patent Application No. PCT/US2004/002873, dated Oct. 13, 2005, 7 pages.

International Search Report and Written Opinion received for PCT Patent Application No. PCT/US2004/016519, dated Nov. 3, 2005, 6 pages.

International Search Report and Written Opinion received for PCT Patent Application No. PCT/US2005/030234, dated Mar. 17, 2006, 11 pages.

International Search Report and Written Opinion received for PCT Patent Application No. PCT/US2005/038819, dated Apr. 5, 2006, 12 pages.

International Search Report and Written Opinion received for PCT Patent Application No. PCT/US2006/048669, dated Jul. 2, 2007, 12 pages.

International Search Report and Written Opinion received for PCT Patent Application No. PCT/US2006/048670, dated May 21, 2007, 11 pages.

International Search Report and Written Opinion received for PCT Patent Application No. PCT/US2006/048753, dated Jun. 19, 2007, 15 pages.

International Search Report and Written Opinion received for PCT Patent Application No. PCT/US2007/026243, dated Mar. 31, 2008, 10 pages.

International Search Report and Written Opinion received for PCT Patent Application No. PCT/US2007/088872, dated May 8, 2008, 8 pages.

International Search Report and Written Opinion received for PCT Patent Application No. PCT/US2007/088873, dated May 8, 2008, 7 pages.

International Search Report and Written Opinion received for PCT Patent Application No. PCT/US2008/000032, dated Jun. 12, 2008, 7 pages.

International Search Report and Written Opinion received for PCT Patent Application No. PCT/US2008/000042, dated May 21, 2008, 7 pages.

International Search Report and Written Opinion received for PCT Patent Application No. PCT/US2008/000043, dated Oct. 10, 2008, 12 pages.

International Search Report and Written Opinion received for PCT Patent Application No. PCT/US2008/000045, dated Jun. 12, 2008, 7 pages.

International Search Report and Written Opinion received for PCT Patent Application No. PCT/US2008/000047, dated Sep. 11, 2008, 12 pages.

International Search Report and Written Opinion received for PCT Patent Application No. PCT/US2008/000059, dated Sep. 19, 2008, 18 pages.

International Search Report and Written Opinion received for PCT Patent Application No. PCT/US2008/000061, dated Jul. 1, 2008, 13 pages.

International Search Report and Written Opinion received for PCT Patent Application No. PCT/US2009/051954, dated Oct. 30, 2009, 10 pages.

International Search Report and Written Opinion received for PCT Patent Application No. PCT/US2009/055577, dated Jan. 26, 2010, 9 pages.

International Search Report and Written Opinion received for PCT Patent Application No. PCT/US2011/020350, dated Jun. 30, 2011, 17 pages.

International Search Report and Written Opinion received for PCT Patent Application No. PCT/US2011/020825, dated Mar. 18, 2011, 9 pages.

International Search Report and Written Opinion received for PCT Patent Application No. PCT/US2012/029810, dated Aug. 17, 2012, 11 pages.

International Search Report and Written Opinion received for PCT Patent Application No. PCT/US2012/034028, dated Jun. 11, 2012, 9 pages.

International Search Report and Written Opinion received for PCT Patent Application No. PCT/US2012/040801, dated Oct. 22, 2012, 20 pages.

International Search Report and Written Opinion received for PCT Patent Application No. PCT/US2012/040931, dated Feb. 1, 2013, 4 pages. (International Search Report only).

International Search Report and Written Opinion received for PCT Patent Application No. PCT/US2012/043098, dated Nov. 14, 2012, 9 pages.

International Search Report and Written Opinion received for PCT Patent Application No. PCT/US2012/043100, dated Nov. 15, 2012, 8 pages.

International Search Report and Written Opinion received for PCT Patent Application No. PCT/US2013/028412, dated Sep. 26, 2013, 17 pages.

International Search Report and Written Opinion received for PCT Patent Application No. PCT/US2013/028920, dated Jun. 27, 2013, 14 pages.

International Search Report and Written Opinion received for PCT Patent Application No. PCT/US2013/029156, dated Jul. 15, 2013, 9 pages.

International Search Report and Written Opinion received for PCT Patent Application No. PCT/US2013/040971, dated Nov. 12, 2013, 11 pages.

(56)

References Cited

OTHER PUBLICATIONS

International Search Report and Written Opinion received for PCT Patent Application No. PCT/US2013/041225, dated Aug. 23, 2013, 3 pages. (International Search Report only).

International Search Report and Written Opinion received for PCT Patent Application No. PCT/US2013/044574, dated Sep. 27, 2013, 12 pages.

International Search Report and Written Opinion received for PCT Patent Application No. PCT/US2013/044834, dated Dec. 20, 2013, 13 pages.

International Search Report and Written Opinion received for PCT Patent Application No. PCT/US2013/047659, dated Jul. 7, 2014, 25 pages.

International Search Report and Written Opinion received for PCT Patent Application No. PCT/US2013/047668, dated Feb. 13, 2014, 17 pages.

International Search Report and Written Opinion received for PCT Patent Application No. PCT/US2013/052558, dated Jan. 30, 2014, 15 pages.

International Search Report and Written Opinion received for PCT Patent Application No. PCT/US2013/058916, dated Sep. 8, 2014, 10 pages.

International Search Report and Written Opinion received for PCT Patent Application No. PCT/US2013/060121, dated Dec. 6, 2013, 8 pages.

International Search Report and Written Opinion received for PCT Patent Application No. PCT/US2014/015418, dated Aug. 26, 2014, 17 pages.

International Search Report and Written Opinion received for PCT Patent Application No. PCT/US2014/016988, dated Apr. 29, 2014, 10 pages.

International Search Report and Written Opinion received for PCT Patent Application No. PCT/US2014/023822, dated Sep. 25, 2014, 14 pages.

International Search Report and Written Opinion received for PCT Patent Application No. PCT/US2014/023826, dated Oct. 9, 2014, 13 pages.

International Search Report and Written Opinion received for PCT Patent Application No. PCT/US2014/026871, dated Jul. 23, 2014, 9 pages.

International Search Report and Written Opinion received for PCT Patent Application No. PCT/US2014/026873, dated Jan. 5, 2015, 11 pages.

International Search Report and Written Opinion received for PCT Patent Application No. PCT/US2014/028785, dated Oct. 17, 2014, 23 pages.

International Search Report and Written Opinion received for PCT Patent Application No. PCT/US2014/028950, dated Nov. 25, 2014, 10 pages.

International Search Report and Written Opinion received for PCT Patent Application No. PCT/US2014/029050, dated Jul. 31, 2014, 9 pages.

International Search Report and Written Opinion received for PCT Patent Application No. PCT/US2014/029562, dated Sep. 18, 2014, 21 pages.

International Search Report and Written Opinion received for PCT Patent Application No. PCT/US2014/040393, dated Dec. 8, 2014, 23 pages.

International Search Report and Written Opinion received for PCT Patent Application No. PCT/US2014/040394, dated Aug. 8, 2014, 11 pages.

International Search Report and Written Opinion received for PCT Patent Application No. PCT/US2014/040397, dated Aug. 27, 2014, 12 pages.

International Search Report and Written Opinion received for PCT Patent Application No. PCT/US2014/040401, dated Sep. 4, 2014, 10 pages.

International Search Report and Written Opinion received for PCT Patent Application No. PCT/US2014/040403, dated Sep. 23, 2014, 9 pages.

International Search Report and Written Opinion received for PCT Patent Application No. PCT/US2014/040961, dated Mar. 10, 2015, 5 pages.

International Search Report and Written Opinion received for PCT Patent Application No. PCT/US2014/041159, dated Sep. 26, 2014, 10 pages.

International Search Report and Written Opinion received for PCT Patent Application No. PCT/US2014/041173, dated Sep. 10, 2014, 11 pages.

International Search Report and Written Opinion received for PCT Patent Application No. PCT/US2014/049568, dated Nov. 14, 2014, 12 pages.

International Search Report and Written Opinion received for PCT Patent Application No. PCT/US2014/053951, dated Dec. 8, 2014, 11 pages.

International Search Report and Written Opinion received for PCT Patent Application No. PCT/US2014/053957, dated Feb. 19, 2015, 11 pages.

International Search Report and Written Opinion received for PCT Patent Application No. PCT/US2014/053958, dated Feb. 19, 2015, 10 pages.

International Search Report and Written Opinion received for PCT Patent Application No. PCT/US2015/019320, dated Jul. 2, 2015, 14 pages.

International Search Report and Written Opinion received for PCT Patent Application No. PCT/US2015/019321, dated Jun. 3, 2015, 11 pages.

International Search Report and Written Opinion received for PCT Patent Application No. PCT/US2015/019322, dated Jun. 18, 2015, 16 pages.

International Search Report and Written Opinion received for PCT Patent Application No. PCT/US2015/023089, dated Aug. 20, 2015, 16 pages.

International Search Report and Written Opinion received for PCT Patent Application No. PCT/US2015/023097, dated Jul. 7, 2015, 15 pages.

International Search Report and Written Opinion received for PCT Patent Application No. PCT/US2015/023593, dated Aug. 14, 2015, 16 pages.

International Search Report and Written Opinion received for PCT Patent Application No. PCT/US2015/025188, dated Jun. 23, 2015, 11 pages.

International Search Report and Written Opinion received for PCT Patent Application No. PCT/US2015/029554, dated Jul. 16, 2015, 11 pages.

International Search Report and Written Opinion received for PCT Patent Application No. PCT/US2015/032470, dated Oct. 1, 2015, 13 pages.

International Search Report and Written Opinion received for PCT Patent Application No. PCT/US2015/032724, dated Jul. 27, 2015, 11 pages.

International Search Report and Written Opinion received for PCT Patent Application No. PCT/US2015/033051, dated Aug. 5, 2015, 14 pages.

International Search Report and Written Opinion received for PCT Patent Application No. PCT/US2015/047062, dated Jan. 13, 2016, 25 pages.

International Search Report and Written Opinion received for PCT Patent Application No. PCT/US2015/047064, dated Nov. 13, 2015, 13 pages.

International Search Report and Written Opinion received for PCT Patent Application No. PCT/US2015/047281, dated Dec. 17, 2015, 19 pages.

International Search Report and Written Opinion received for PCT Patent Application No. PCT/US2015/047553, dated Jan. 5, 2016, 10 pages.

International Search Report and Written opinion received for PCT Patent Application No. PCT/US2015/047583, dated Feb. 3, 2016, 11 pages.

International Search Report and Written Opinion received for PCT Patent Application No. PCT/US2015/047584, dated Nov. 9, 2015, 10 pages.

(56)

References Cited

OTHER PUBLICATIONS

International Search Report and Written Opinion received for PCT Patent Application No. PCT/US2015/053365, dated Mar. 10, 2016, 20 pages.

International Search Report and Written Opinion received for PCT Patent Application No. PCT/US2015/053366, dated Apr. 26, 2016, 16 pages.

International Search Report and Written Opinion received for PCT Patent Application No. PCT/US2016/021103, dated Jun. 8, 2016, 15 pages.

International Search Report and Written Opinion received for PCT Patent Application No. PCT/US2016/021104, dated Jun. 8, 2016, 15 pages.

International Search Report and Written opinion received for PCT Patent Application No. PCT/US2016/021409, dated May 26, 2016, 22 pages.

International Search report and Written Opinion received for PCT Patent Application No. PCT/US2016/024666, dated Jun. 10, 2016, 13 pages.

International Search Report and Written Opinion received for PCT Patent Application No. PCT/US2016/025404, dated Jun. 24, 2016, 21 pages.

International Search Report and Written Opinion received for PCT Patent Application No. PCT/US2016/025407, dated Jun. 23, 2016, 18 pages.

International Search Report and Written Opinion received for PCT Patent Application No. PCT/US2016/025408, dated Aug. 11, 2016, 19 pages.

International Search Report and Written Opinion received for PCT Patent Application No. PCT/US2016/031059, dated Aug. 8, 2016, 11 pages.

International Search Report and Written Opinion received for PCT Patent Application No. PCT/US2016/031549, dated Aug. 5, 2016, 35 pages.

International Search Report and Written Opinion received for PCT Patent Application No. PCT/US2016/031550, dated Aug. 4, 2016, 13 pages.

International Search Report and Written Opinion received for PCT Patent Application No. PCT/US2016/035105, dated Aug. 29, 2016, 25 pages.

International Search Report and Written Opinion received for PCT Patent Application No. PCT/US2016/035107, dated Aug. 31, 2016, 26 pages.

International Search Report and Written Opinion received for PCT Patent Application No. PCT/US2016/043005, dated Oct. 7, 2016, 17 pages.

International Search Report and Written Opinion received for PCT Patent Application No. PCT/US2016/047215, dated Oct. 24, 2016, 18 pages.

International Search Report and Written Opinion received for PCT Patent Application No. PCT/US2016/035112, dated Aug. 22, 2016, 21 pages.

International Search Report received for PCT Patent Application No. PCT/GB2009/051684, dated Mar. 12, 2010, 4 pages.

International Search Report received for PCT Patent Application No. PCT/US1993/012666, dated Nov. 9, 1994, 8 pages.

International Search Report received for PCT Patent Application No. PCT/US1994/000687, dated Jun. 3, 1994, 1 page.

International Search Report received for PCT Patent Application No. PCT/US1994/00077, dated May 25, 1994, 2 pages.

International Search Report received for PCT Patent Application No. PCT/US1995/008369, dated Nov. 8, 1995, 6 pages.

International Search Report received for PCT Patent Application No. PCT/US1995/013076, dated Feb. 2, 1996, 1 page.

International Search Report received for PCT Patent Application No. PCT/US1996/01002, dated Oct. 30, 1996, 4 pages.

International Search Report received for PCT Patent Application No. PCT/US2002/024669, dated Nov. 5, 2002, 3 pages.

International Search Report received for PCT Patent Application No. PCT/US2002/024670, dated Sep. 26, 2002, 3 pages.

International Search Report received for PCT Patent Application No. PCT/US2002/033330, dated Feb. 4, 2003, 6 pages.

International Search Report received for PCT Patent Application No. PCT/US2005/046797, dated Nov. 24, 2006, 6 pages.

International Search Report received for PCT Patent Application No. PCT/US2011/037014, dated Oct. 4, 2011, 6 pages.

International Search Report received for PCT Patent Application No. PCT/US2013/041233, dated Nov. 22, 2013, 3 pages.

Invitation to Pay Additional Fees and Partial International Search Report received for PCT Patent Application No. PCT/US2004/016519, dated Aug. 4, 2005, 6 pages.

Invitation to Pay Additional Fees and Partial International Search Report received for PCT Patent Application No. PCT/US2005/046797, dated Jul. 3, 2006, 6 pages.

Invitation to Pay Additional Fees and Partial International Search Report received for PCT Patent Application No. PCT/US2006/048738, dated Jul. 10, 2007, 4 pages.

Invitation to Pay Additional Fees and Partial International Search Report received for PCT Patent Application No. PCT/US2011/020350, dated Apr. 14, 2011, 5 pages.

Invitation to Pay Additional Fees and Partial International Search Report received for PCT Patent Application No. PCT/US2015/023089, dated Jun. 17, 2015, 7 pages.

Invitation to Pay Additional Fees received for PCT Application No. PCT/US2016/021410, dated Apr. 28, 2016, 2 pages.

Invitation to Pay Additional Fees received for PCT Patent Application No. PCT/US2008/000043, dated Jun. 27, 2008, 4 pages.

Invitation to Pay Additional Fees received for PCT Patent Application No. PCT/US2008/000047, dated Jul. 4, 2008, 4 pages.

Invitation to Pay Additional Fees received for PCT Patent Application No. PCT/US2011/037014, dated Aug. 2, 2011, 6 pages.

Invitation to Pay Additional Fees received for PCT Patent Application No. PCT/US2012/040801, dated Aug. 8, 2012, 2 pages.

Invitation to Pay Additional Fees received for PCT Patent Application No. PCT/US2013/047659, dated Feb. 27, 2014, 7 pages.

Invitation to Pay Additional Fees received for PCT Patent Application No. PCT/US2013/052558, dated Nov. 7, 2013, 6 pages.

Invitation to pay additional fees received for PCT Patent Application No. PCT/US2014/029562, dated Jul. 4, 2014, 7 pages.

Invitation to Pay Additional Fees received for PCT Patent Application No. PCT/US2014/040393, dated Sep. 17, 2014, 7 pages.

Invitation to Pay Additional Fees received for PCT Patent Application No. PCT/US2014/040961, dated Jan. 14, 2015, 3 pages.

Invitation to Pay Additional Fees received for PCT Patent Application No. PCT/US2015/047281, dated Oct. 8, 2015, 6 pages.

Invitation to Pay Additional Fees received for PCT Patent Application No. PCT/US2015/053366, dated Feb. 19, 2016, 8 pages.

Invitation to Pay Additional Fees received for PCT Patent Application No. PCT/US2016/025408, dated May 13, 2016, 2 pages.

Invitation to Pay Additional Fees received for PCT Patent Application No. PCT/US2014/028785, dated Jul. 4, 2014, 7 pages.

Invitation to pay additional fees received for the PCT Patent Application No. PCT/US2014/015418, dated May 26, 2014, 5 pages.

iPhone Hacks, "Native iPhone MMS Application Released", available at <<http://www.iphonhacks.com/2007/12/iphone-mms-app.html>>, retrieved on Dec. 25, 2007, 5 pages.

Iphonechat, "iChat for iPhone in JavaScript", available at <<http://www.publicity.com/iPhoneChat/>>, retrieved on Dec. 25, 2007, 2 pages.

Iso-Sipila et al., "Multi-Lingual Speaker-Independent Voice User Interface for Mobile Devices", ICASSP 2006 Proceedings, IEEE International Conference on Acoustics, Speech and Signal Processing May 14, 2006, pp. 1-1081.

Jabra Corporation, "FreeSpeak: BT200 User Manual", 2002, 42 pages.

Jabra, "Bluetooth Headset: User Manual", 2005, 17 pages.

Jabra, "Bluetooth Introduction", 2004, 15 pages.

Jawaid et al., "Machine Translation with Significant Word Reordering and Rich Target-Side Morphology", WDS'11 Proceedings of Contributed Papers, Part I, 2011, pp. 161-166.

(56)

References Cited

OTHER PUBLICATIONS

- Jaybird, "Everything Wrong with AIM: Because We've All Thought About It", available at <<http://www.psychonoble.com/archives/articles/82.html>>, May 24, 2006, 3 pages.
- Jeffay et al., "Kernel Support for Live Digital Audio and Video", In Proc. of the Second Intl. Workshop on Network and Operating System Support for Digital Audio and Video, vol. 614, Nov. 1991, pp. 10-21.
- Jelinek et al., "Interpolated Estimation of Markov Source Parameters from Sparse Data", In Proceedings of the Workshop on Pattern Recognition in Practice May 1980, pp. 381-397.
- Jiang et al., "A Syllable-based Name Transliteration System", Proc. of the 2009 Named Entities Workshop, Aug. 7, 2009, pp. 96-99.
- Johnson, Jeff A., "A Comparison of User Interfaces for Panning on a Touch-Controlled Display", CHI '95 Proceedings, 1995, 8 pages.
- Jouvet et al., "Evaluating Grapheme-to-phoneme Converters in Automatic Speech Recognition Context", IEEE., 2012., pp. 4821-4824.
- Kaappner et al., "Architecture of HeiPhone: A Testbed for Audio/Video Teleconferencing", IBM European Networking Center, 1993.
- Kamba et al., "Using Small Screen Space More Efficiently", CHI '96 Proceedings of the SIGCHI Conference on Human Factors in Computing Systems, Apr. 13-18, 1996, pp. 383-390.
- Kanda et al., "Robust Domain Selection Using Dialogue History in Multi-domain Spoken Dialogue Systems", Journal of Information Processing Society, vol. 48, No. 5, May 15, 2007, pp. 1980-1989. (English Abstract Submitted).
- Kanda et al., "Spoken Language Understanding Using Dialogue Context in Database Search Task", Journal of Information Processing Society of Japan, vol. 47, No. 6, Jun. 15, 2016, pp. 1802-1811. (English Abstract Submitted).
- Kane et al., "Slide Rule: Making Mobile Touch Screens Accessible to Blind People Using Multi-Touch Interaction Techniques", Assets, Oct. 13-15, 2008, pp. 73-80.
- Kang et al., "Quality Improvement of LPC-Processed Noisy Speech by Using Spectral Subtraction", IEEE Transactions on Acoustics, Speech and Signal Processing, vol. 37, No. 6, Jun. 1989, pp. 939-942.
- Katzenmaier et al., "Identifying the Addressee in Human-Human-Robot Interactions based on Head Pose and Speech", Proc. ICMI 04, ACM, 2004, pp. 144-151.
- Kazemzadeh et al., "Acoustic Correlates of User Response to Error in Human-Computer Dialogues", Automatic Speech Recognition and Understanding, 2003, pp. 215-220.
- Kazmucha, Allyson, "How to Send Map Locations Using iMessage", iMore.com, Available at <<http://www.imore.com/how-use-message-share-your-location-your-iphone>>, Aug. 2, 2012, 6 pages.
- Keahey et al., "Non-Linear Image Magnification", Apr. 24, 1996, 11 pages.
- Keahey et al., "Nonlinear Magnification Fields", Proceedings of the 1997 IEEE Symposium on Information Visualization, 1997, 12 pages.
- Keahey et al., "Techniques for Non-Linear Magnification Transformations", IEEE Proceedings of Symposium on Information Visualization, Oct. 1996, pp. 38-45.
- Keahey et al., "Viewing Text With Non-Linear Magnification: An Experimental Study", Department of Computer Science, Indiana University, Apr. 24, 1996, pp. 1-9.
- Kennedy, P. J., "Digital Data Storage Using Video Disc", IBM Technical Disclosure Bulletin, vol. 24, No. 2, Jul. 1981, p. 1171.
- Kerr, "An Incremental String Search in C: This Data Matching Algorithm Narrows the Search Space with each Keystroke", Computer Language, vol. 6, No. 12, Dec. 1989, pp. 35-39.
- Kickstarter, "Ivee Sleek: Wi-Fi Voice-Activated Assistant", available at <<https://www.kickstarter.com/projects/ivee/ivee-sleek-wi-fi-voice-activated-assistant>>, retrieved on Feb. 10, 2014, 13 pages.
- Kikui, Gen-Itiro, "Identifying the Coding System and Language of On-Line Documents on the Internet", International Conference on Computational, Aug. 1996, pp. 652-657.
- Kim, E.A. S., "The Structure and Processing of Fundamental Frequency Contours", University of Cambridge, Doctoral Thesis, Apr. 1987, 378 pages.
- Kirstein et al., "Piloting of Multimedia Integrated Communications for European Researchers", Proc. INET '93, 1993, pp. 1-12.
- Kitaoka et al., "Detection and Recognition of Correction Utterances on Misrecognition of Spoken Dialog System", Systems and Computers in Japan, vol. 36, No. 11 Oct. 2005, pp. 24-33.
- Kjellidahl et al., "Multimedia—Principles, Systems, and Applications", Proceedings of the 1991 Eurographics Workshop on Multimedia Systems, Applications, and Interaction, Apr. 1991.
- Kline et al., "Improving GUI Accessibility for People with Low Vision", CHI '95 Proceedings of the SIGCHI Conference on Human Factors in Computing Systems, May 7-11, 1995, pp. 114-121.
- Kline et al., "UnWindows 1.0: X Windows Tools for Low Vision Users", ACM SIGCAPH Computers and the Physically Handicapped, No. 49, Mar. 1994, pp. 1-5.
- Knight et al., "Heuristic Search", Production Systems, Artificial Intelligence, 2nd ed., McGraw-Hill, Inc., 1983-1991.
- Kohler, Joachim, "Multilingual Phone Models for Vocabulary-Independent Speech Recognition Tasks", Speech Communication, vol. 35, No. 1-2, Aug. 2001, pp. 21-30.
- Kroon et al., "Pitch Predictors with High Temporal Resolution", IEEE, vol. 2, 1990, pp. 661-664.
- Kroon et al., "Quantization Procedures for the Excitation in CELP Coders", (Proceedings of IEEE International Acoustics, Speech, and Signal Processing Conference, Apr. 1987), as reprinted in Vector Quantization (IEEE Press, 1990), 1990, pp. 320-323.
- Kuo et al., "A Radical-Partitioned coded Block Adaptive Neural Network Structure for Large-Volume Chinese Characters Recognition", International Joint Conference on Neural Networks, vol. 3, Jun. 1992, pp. 597-601.
- Kuo et al., "A Radical-Partitioned Neural Network System Using a Modified Sigmoid Function and a Weight-Dotted Radical Selector for Large-Volume Chinese Character Recognition VLSI", IEEE Int. Symp. Circuits and Systems, Jun. 1994, pp. 3862-3865.
- Kurlander et al., "Comic Chat", [Online], 1996 [Retrieved on: Feb. 4, 2013], SIGGRAPH '96 Proceedings of the 23rd annual conference on Computer graphics and interactive techniques, [Retrieved from: <http://delivery.acm.org/10.1145/240000/237260/p225-kurlander.pdf>], 1996, pp. 225-236.
- Ladefoged, Peter, "A Course in Phonetics", New York, Harcourt, Brace, Jovanovich, Second Edition, 1982.
- Laface et al., "A Fast Segmental Viterbi Algorithm for Large Vocabulary Recognition", International Conference on Acoustics, Speech, and Signal Processing, vol. 1, May 1995, pp. 560-563.
- Lafferty et al., "Conditional Random Fields: Probabilistic Models for Segmenting and Labeling Sequence Data", Proceedings of the 18th International Conference on Machine Learning, 2001, 9 pages.
- Lamel et al., "Generation and synthesis of Broadcast Messages", Proceedings of ESCA-NATO Workshop: Applications of Speech Technology, Sep. 1, 1993, 4 pages.
- Lamping et al., "Laying Out and Visualizing Large Trees Using a Hyperbolic Space", Proceedings of the ACM Symposium on User Interface Software and Technology, Nov. 1994, pp. 13-14.
- Lamping et al., "Visualizing Large Trees Using the Hyperbolic Browser", Apple Inc., Video Clip, MIT Media Library, on a CD, 1995.
- Lantz et al., "Towards a Universal Directory Service", Departments of Computer Science and Electrical Engineering, Stanford University, 1985, pp. 250-260.
- Lantz, Keith, "An Experiment in Integrated Multimedia Conferencing", 1986, pp. 267-275.
- Lau et al., "Trigger-Based Language Models: A Maximum Entropy Approach", ICASSP'93 Proceedings of the 1993 IEEE international conference on Acoustics, speech, and signal processing: speech processing—vol. II, 1993, pp. 45-48.
- Lauwers et al., "Collaboration Awareness in Support of Collaboration Transparency: Requirements for the Next Generation of Shared Window Systems", CHI'90 Proceedings, 1990, pp. 303-311.
- Lauwers et al., "Replicated Architectures for Shared Window Systems: A Critique", COCS '90 Proceedings of the ACM SIGOIS and

(56)

References Cited

OTHER PUBLICATIONS

- IEEE CS TC-OA conference on Office information systems, ACM SIGOIS Bulletin, 1990, pp. 249-260.
- Lazzaro, Joseph J., "Adapting Desktop Computers to Meet the Needs of Disabled Workers is Easier Than You Might Think", Computers for the Disabled, BYTE Magazine, Jun. 1993, 4 pages.
- Leahy et al., "Effect of Touch Screen Target Location on User Accuracy", Proceedings of the Human Factors Society 34th Annual Meeting, 1990, 5 pages.
- Lee et al., "A Multi-Touch Three Dimensional Touch-Sensitive Tablet", CHI '85 Proceedings of the SIGCHI Conference on Human Factors in Computing Systems, Apr. 1985, pp. 21-25.
- Lee et al., "On URL Normalization", Proceedings of the International Conference on Computational Science and its Applications, ICCSA 2005, pp. 1076-1085.
- Lee, Kai-Fu, "Automatic Speech Recognition", 1989, 14 pages (Table of Contents).
- Leung et al., "A Review and Taxonomy of Distortion-Oriented Presentation Techniques", ACM Transactions on Computer-Human Interaction (TOCHI), vol. 1, No. 2, Jun. 1994, pp. 126-160.
- Levesque et al., "A Fundamental Tradeoff in Knowledge Representation and Reasoning", Readings in Knowledge Representation, 1985, 30 pages.
- Levinson et al., "Speech synthesis in telecommunications", IEEE Communications Magazine, vol. 31, No. 11, Nov. 1993, pp. 46-53.
- Lewis, "Speech synthesis in a computer aided learning environment", UK IT, Mar. 19-22, 1990, pp. 294-298.
- Lewis, Cameron, "Task Ave for iPhone Review", Mac Life, Available at <http://www.maclife.com/article/reviews/task_ave_iphone_review>, Mar. 3, 2011, 5 pages.
- Lewis, Peter, "Two New Ways to Buy Your Bits", CNN Money, available at <<http://money.cnn.com/2003/12/30/commentary/ontechnology/download/>>., Dec. 31, 2003, 4 pages.
- Li et al., "A Phonotactic Language model for Spoken Language Identification", Proceedings of the 43rd Annual Meeting of the ACL, Jun. 25, 2005, pp. 515-522.
- Lieberman, Henry, "A Multi-Scale, Multi-Layer, Translucent Virtual Space", Proceedings of IEEE Conference on Information Visualization, Aug. 1997, pp. 124-131.
- Lieberman, Henry, "Powers of Ten Thousand: Navigating in Large Information Spaces", Proceedings of the ACM Symposium on User Interface Software and Technology, Nov. 1994, pp. 1-2.
- Lyon, R., "A Computational Model of Binaural Localization and Separation", Proceedings of IEEE International Conference on Acoustics, Speech and Signal Processing, Apr. 1983, pp. 1148-1151.
- Lyons et al., "Augmenting Conversations Using Dual-Purpose Speech", Proceedings of the 17th Annual ACM Symposium on User interface Software and Technology, 2004, 10 pages.
- Lyons, Richard F., "CCD Correlators for Auditory Models", Proceedings of the Twenty-Fifth Asilomar Conference on Signals, Systems and Computers, Nov. 4-6, 1991, pp. 785-789.
- Macchi, Marian, "Issues in Text-to-Speech Synthesis" Proceedings of IEEE International Joint Symposia on Intelligence and Systems, May 21, 1998, pp. 318-325.
- Mackenzie et al., "Alphanumeric Entry on Pen-Based Computers", International Journal of Human-Computer Studies, vol. 41, 1994, pp. 775-792.
- Mackinlay et al., "The Perspective Wall: Detail and Context Smoothly Integrated", ACM, 1991, pp. 173-179.
- Macsimum News, "Apple Files Patent for an Audio Interface for the iPod", available at <http://www.macsimumnews.com/index.php/archive/apple_files_patent_for_an_audio_interface_for_the_ipod>, retrieved on Jul. 13, 2006, 8 pages.
- Mactech, "KeyStrokes 3.5 for Mac OS X Boosts Word Prediction", available at <<http://www.mactech.com/news/?p=1007129>>, retrieved on Jan. 7, 2008, 3 pages.
- Mahedero et al., "Natural Language Processing of Lyrics", In Proceedings of the 13th Annual ACM International Conference on Multimedia, ACM, Nov. 6-11, 2005, 4 pages.
- Mangu et al., "Finding Consensus in Speech Recognition: Word Error Minimization and Other Applications of Confusion Networks", Computer Speech and Language, vol. 14, No. 4, 2000, pp. 291-294.
- Manning et al., "Foundations of Statistical Natural Language Processing", The MIT Press, Cambridge Massachusetts, 1999, pp. 10-11.
- Marcus et al., "Building a Large Annotated Corpus of English: The Penn Treebank", Computational Linguistics, vol. 19, No. 2, 1993, pp. 313-330.
- Markel et al., "Linear Production of Speech", Reviews, 1976, pp. xii, 288.
- Martins et al., "Extracting and Exploring the Geo-Temporal Semantics of Textual Resources", Semantic Computing, IEEE International Conference, 2008, pp. 1-9.
- Masui, Toshiyuki, "POBox: An Efficient Text Input Method for Handheld and Ubiquitous Computers", Proceedings of the 1st International Symposium on Handheld and Ubiquitous Computing, 1999, 12 pages.
- Matsui et al., "Speaker Adaptation of Tied-Mixture-Based Phoneme Models for Text-Prompted Speaker Recognition", 1994 IEEE International Conference on Acoustics, Speech and Signal Processing, Apr. 19-22, 1994, pp. 1-125-1-128.
- Matsuzawa, A., "Low-Voltage and Low-Power Circuit Design for Mixed Analog/Digital Systems in Portable Equipment", IEEE Journal of Solid-State Circuits, vol. 29, No. 4, 1994, pp. 470-480.
- Meet Ivey, Your Wi-Fi Voice Activated Assistant, available at <<http://www.helloivee.com/>>, retrieved on Feb. 10, 2014, 8 pages.
- Mellinger, David K., "Feature-Map Methods for Extracting Sound Frequency Modulation", IEEE Computer Society Press, 1991, pp. 795-799.
- Meng et al., "Generating Phonetic Cognates to Handle Named Entities in English-Chinese Cross-Language Spoken Document Retrieval", Automatic Speech Recognition and Understanding, Dec. 2001, pp. 311-314.
- Menico, Costas, "Faster String Searches", Dr. Dobb's Journal, vol. 14, No. 7, Jul. 1989, pp. 74-77.
- Menta, Richard, "1200 Song MP3 Portable is a Milestone Player", available at <<http://www.mp3newswire.net/stories/personaljuke.html>>, Jan. 11, 2000, 4 pages.
- Merlin et al., "Non Directly Acoustic Process for Costless Speaker Recognition and Indexation", International Workshop on Intelligent Communication Technologies and Applications, Jan. 1, 1999, 5 pages.
- Meyer, Mike, "A Shell for Modern Personal Computers", University of California, Aug. 1987, pp. 13-19.
- Meyrowitz et al., "Bruwin: An Adaptable Design Strategy for Window Manager/Virtual Terminal Systems", Department of Computer Science, Brown University, 1981, pp. 180-189.
- Miastkowski, Stan, "paperWorks Makes Paper Intelligent", Byte Magazine, Jun. 1992.
- Microsoft Corporation, "Microsoft MS-DOS Operating System User's Guide", Microsoft Corporation, 1982, pp. 4-1 to 4-16, 5-1 to 5-19.
- Microsoft Corporation, Microsoft Office Word 2003 (SP2), Microsoft Corporation, SP3 as of 2005, pages MSWord 2003 Figures 1-5, 1983-2003.
- Microsoft Press, "Microsoft Windows User's Guide for the Windows Graphical Environment", version 3.0, 1985-1990, pp. 33-41 & 70-74.
- Microsoft Windows XP, "Magnifier Utility", Oct. 25, 2001, 2 pages.
- Microsoft Word 2000 Microsoft Corporation, pages MSWord Figures 1-5, 1999.
- Microsoft, "Turn on and Use Magnifier", available at <<http://www.microsoft.com/windowsxp/using/accessibility/magnifierturnon.mspx>>, retrieved on Jun. 6, 2009.
- Microsoft/Ford, "Basic Sync Commands", www.SyncMyRide.com, Sep. 14, 2007, 1 page.
- Miller, Chance, "Google Keyboard Updated with New Personalized Suggestions Feature", available at <<http://9to5google.com/2014/03/19/google-keyboard-updated-with-new-personalized-suggestions-feature/>>, Mar. 19, 2014, 4 pages.

(56)

References Cited

OTHER PUBLICATIONS

- Milner, N. P., "A Review of Human Performance and Preferences with Different Input Devices to Computer Systems", Proceedings of the Fourth Conference of the British Computer Society on People and Computers, Sep. 5-9, 1988, pp. 341-352.
- Miniman, Jared, "Applian Software's Replay Radio and Player v1.02", pocketnow.com—Review, available at <<http://www.pocketnow.com/reviews/replay/replay.htm>>, Jul. 31, 2001, 16 pages.
- Moberg et al., "Cross-Lingual Phoneme Mapping for Multilingual Synthesis Systems", Proceedings of the 8th International Conference on Spoken Language Processing, Jeju Island, Korea, Interspeech 2004, Oct. 4-8, 2004, 4 pages.
- Moberg, M., "Contributions to Multilingual Low-Footprint TTS System for Hand-Held Devices", Doctoral Thesis, Tampere University of Technology, Aug. 17, 2007, 82 pages.
- Mobile Speech Solutions, Mobile Accessibility, SVOX AG Product Information Sheet, available at <<http://www.svox.com/site/bra840604/con782768/mob965831936.aSQ?osLang=1>>, Sep. 27, 2012, 1 page.
- Mobile Tech News, "T9 Text Input Software Updated", available at <<http://www.mobiletechnews.com/info/2004/11/23/122155.html>>, Nov. 23, 2004, 4 pages.
- Mok et al., "Media Searching on Mobile Devices", IEEE EIT 2007 Proceedings, 2007, pp. 126-129.
- Morland, D. V., "Human Factors Guidelines for Terminal Interface Design", Communications of the ACM vol. 26, No. 7, Jul. 1983, pp. 484-494.
- Morris et al., "Andrew: A Distributed Personal Computing Environment", Communications of the ACM, (Mar. 1986); vol. 29 No. 3, Mar. 1986, pp. 184-201.
- Morton, Philip, "Checking If an Element Is Hidden", StackOverflow, Available at <<http://stackoverflow.com/questions/178325/checking-if-an-element-is-hidden>>, Oct. 7, 2008, 12 pages.
- Muller et al., "CSCW'92 Demonstrations", 1992, pp. 11-14.
- Musicmatch, "Musicmatch and Xing Technology Introduce Musicmatch Jukebox", Press Releases, available at <<http://www.musicmatch.com/info/company/press/releases/?year=1998&release=2>>, May 18, 1998, 2 pages.
- Muthusamy et al., "Speaker-Independent Vowel Recognition: Spectrograms versus Cochleagrams", IEEE, Apr. 1990, pp. 533-536.
- My Cool Aids, "What's New", available at <<http://www.mycoolaids.com/>>, 2012, 1 page.
- Myers, Brad A., "Shortcutter for Palm", available at <<http://www.cs.cmu.edu/~pebbles/v5/shortcutter/palm/index.html>>, retrieved on Jun. 18, 2014, 10 pages.
- N200 Hands-Free Bluetooth Car Kit, available at <www.wirelessground.com/>, retrieved on Mar. 19, 2007, 3 pages.
- Nadoli et al., "Intelligent Agents in the Simulation of Manufacturing Systems", Proceedings of the SCS Multiconference on AI and Simulation, 1989, 1 page.
- Nakagawa et al., "Unknown Word Guessing and Part-of-Speech Tagging Using Support Vector Machines", Proceedings of the 6th NLPRS, 2001, pp. 325-331.
- Navigli, Roberto, "Word Sense Disambiguation: A Survey", ACM Computing Surveys, vol. 41, No. 2, Feb. 2009, 70 pages.
- NCIP Staff, "Magnification Technology", available at <<http://www2.edc.org/ncip/library/vi/magnifi.htm>>, 1994, 6 pages.
- NCIP, "NCIP Library: Word Prediction Collection", available at <<http://www2.edc.org/ncip/library/wp/toc.htm>>, 1998, 4 pages.
- NCIP, "What is Word Prediction?", available at <http://www2.edc.org/ncip/library/wp/what_is.htm>, 1998, 2 pages.
- NDTV, "Sony SmartWatch 2 Launched in India for Rs. 14,990", available at <<http://gadgets.ndtv.com/others/news/sony-smartwatch-2-launched-in-india-for-rs-14990-420319>>, Sep. 18, 2013, 4 pages.
- Newton, Harry, "Newton's Telecom Dictionary", Mar. 1998, pp. 62, 155, 610-611, 771.
- NG, Simon, "Google's Task List Now Comes to Iphone", SimonBlog, Available at <<http://www.simonblog.com/2009/02/04/googles-task-list-now-comes-to-iphone/>>, Feb. 4, 2009, 33 pages.
- Nguyen et al., "Generic Manager for Spoken Dialogue Systems", In DiaBruck: 7th Workshop on the Semantics and Pragmatics of Dialogue, Proceedings, 2003, 2 pages.
- Nilsson, B. A., "Microsoft Publisher is an Honorable Start for DTP Beginners", Computer Shopper, Feb. 1, 1992, 2 pages.
- Noik, Emanuel G., "Layout-Independent Fisheye Views of Nested Graphs", IEEE Proceedings of Symposium on Visual Languages, 1993, 6 pages.
- Nonhoff-Arps et al., "StraBenmusik: Portable MP3-Spieler mit USB Anschluss", CT Magazin Fuer Computer Technik, Verlag Heinz Heise GMBH, Hannover DE, No. 25, 2000, pp. 166-175.
- Northern Telecom, "Meridian Mail PC User Guide", 1988, 17 Pages.
- Notenboom, Leo A., "Can I Retrieve Old MSN Messenger Conversations?", available at <http://ask-leo.com/can_i_retrieve_old_msn_messenger_conversations.html>, Mar. 11, 2004, 23 pages.
- O'Connor, Rory J., "Apple Banking on Newton's Brain", San Jose Mercury News, Apr. 22, 1991.
- Ohsawa et al., "A computational Model of an Intelligent Agent Who Talks with a Person", Research Reports on Information Sciences, Series C, No. 92, Apr. 1989, pp. 1-18.
- Ohtomo et al., "Two-Stage Recognition Method of Hand-Written Chinese Characters Using an Integrated Neural Network Model", Denshi Jooohoo Tsuushin Gakkai Ronbunshi, D-II, vol. J74, Feb. 1991, pp. 158-165.
- Okazaki et al., "Multi-Fisheye Transformation Method for Large-Scale Network Maps", IEEE Japan, vol. 44, No. 6, 1995, pp. 495-500.
- Omologo et al., "Microphone Array Based Speech Recognition with Different Talker-Array Positions", IEEE International Conference on Acoustics, Speech, and Signal Processing, vol. 1, Apr. 21-24, 1997, pp. 227-230.
- Oregon Scientific, "512MB Waterproof MP3 Player with FM Radio & Built-in Pedometer", available at <<http://www2.oregonscientific.com/shop/product.asp?cid=4&scid=11&pid=581>>, retrieved on Jul. 31, 2006, 2 pages.
- Oregon Scientific, "Waterproof Music Player with FM Radio and Pedometer (MP121)—User Manual", 2005, 24 pages.
- Oxsdaily, "Get a List of Siri Commands Directly from Siri", Available at <<http://osxdaily.com/2013/02/05/list-siri-commands/>>, Feb. 5, 2013, 15 pages.
- Padilla, Alfredo, "Palm Treo 750 Cell Phone Review—Messaging", available at <<http://www.wirelessinfo.com/content/palm-Treo-750-Cell-Phone-Review/Messaging.htm>>, Mar. 17, 2007, 6 pages.
- Palay et al., "The Andrew Toolkit: An Overview", Information Technology Center, Carnegie-Mellon University, 1988, pp. 1-15.
- Palm, Inc., "User Guide: Your Palm® Treo.TM. 755p Smartphone", 2005-2007, 304 pages.
- Pan et al., "Natural Language Aided Visual Query Building for Complex Data Access", In proceeding of: Proceedings of the Twenty-Second Conference on Innovative Applications of Artificial Intelligence, XP055114607, Jul. 11, 2010.
- Panasonic, "Toughbook 28: Powerful, Rugged and Wireless", Panasonic Toughbook Models, available at <http://www.panasonic.com/computer/notebook/html/01a_s8.htm>, retrieved on Dec. 19, 2002, 3 pages.
- Parks et al., "Classification of Whale and Ice Sounds with a cochlear Model", IEEE, Mar. 1992.
- Patent Abstracts of Japan, vol. 014, No. 273 (E-0940) Jun. 13, 1990 (Jun. 13, 1990)-& JP 02 086057 A (Japan Storage Battery Co Ltd), Mar. 27, 1990 (Mar. 27, 1990), 3 pages.
- Pathak et al., "Privacy-preserving Speech Processing: Cryptographic and String-matching Frameworks Show Promise", In: IEEE signal processing magazine, retrieved from <<http://www.merl.com/publications/docs/TR2013-063.pdf>>, Feb. 13, 2013, 16 pages.
- Patterson et al., "Rendezvous: An Architecture for Synchronous Multi-User Applications", CSCW '90 Proceedings, 1990, pp. 317-328.
- Pearl, Amy, "System Support for Integrated Desktop Video Conferencing", Sunmicrosystems Laboratories, Dec. 1992, pp. 1-15.
- Penn et al., "Ale for Speech: A Translation Prototype", Bell Laboratories, 1999, 4 pages.

(56)

References Cited

OTHER PUBLICATIONS

- PhatNoise, Voice Index on Tap, Kenwood Music Keg, available at <<http://www.phatnoise.com/kenwood/kenwoodssamail.html>>, retrieved on Jul. 13, 2006, 1 page.
- Phillipps, Ben, "Touchscreens are Changing the Face of Computers—Today's Users Have Five Types of Touchscreens to Choose from, Each with its Own Unique Characteristics", *Electronic Products*, Nov. 1994, pp. 63-70.
- Phillips, Dick, "The Multi-Media Workstation", SIGGRAPH '89 Panel Proceedings, 1989, pp. 93-109.
- Pickering, J. A., "Touch-Sensitive Screens: The Technologies and Their Application", *International Journal of Man-Machine Studies*, vol. 25, No. 3, Sep. 1986, pp. 249-269.
- Pingali et al., "Audio-Visual Tracking for Natural Interactivity", *ACM Multimedia*, Oct. 1999, pp. 373-382.
- Plaisant et al., "Touchscreen Interfaces for Alphanumeric Data Entry", *Proceedings of the Human Factors and Ergonomics Society 36th Annual Meeting*, 1992, pp. 293-297.
- Plaisant et al., "Touchscreen Toggle Design", CHI'92, May 3-7, 1992, pp. 667-668.
- Poly-Optical Products, Inc., "Poly-Optical Fiber Optic Membrane Switch Backlighting", available at <http://www.poly-optical.com/membrane_switches.html>, retrieved on Dec. 19, 2002, 3 pages.
- Poor, Alfred, "Microsoft Publisher", *PC Magazine*, vol. 10, No. 20, Nov. 26, 1991, 1 page.
- Potter et al., "An Experimental Evaluation of Three Touch Screen Strategies within a Hypertext Database", *International Journal of Human-Computer Interaction*, vol. 1, No. 1, 1989, pp. 41-52.
- Potter et al., "Improving the Accuracy of Touch Screens: An Experimental Evaluation of Three Strategies", CHI '88 ACM, 1988, pp. 27-32.
- Powell, Josh, "Now You See Me . . . Show/Hide Performance", available at <http://www.learningjquery.com/2010/05/now-you-see-me-showhide-performance>, May 4, 2010, 3 pages.
- Public Safety Technologies, "Tracer 2000 Computer", available at <<http://www.pst911.com/tracer.html>>, retrieved on Dec. 19, 2002, 3 pages.
- Quazza et al., "Actor: A Multilingual Unit-Selection Speech Synthesis System", *Proceedings of 4th ISCA Tutorial and Research Workshop on Speech Synthesis*, Jan. 1, 2001, 6 pages.
- Quick Search Algorithm, *Communications of the ACM*, 33(8), 1990, pp. 132-142.
- Rabiner et al., "Digital Processing of Speech Signals", Prentice Hall, 1978, pp. 274-277.
- Rampe et al., "SmartForm Designer and SmartForm Assistant", News release, Claris Corp., Jan. 9, 1989, 1 page.
- Rao et al., "Exploring Large Tables with the Table Lens", Apple Inc., Video Clip, Xerox Corp., on a CD, 1994.
- Rao et al., "Exploring Large Tables with the Table Lens", CHI'95 Mosaic of Creativity, ACM, May 7-11, 1995, pp. 403-404.
- Rao et al., "The Table Lens: Merging Graphical and Symbolic Representations in an Interactive Focus+Context Visualization for Tabular Information", *Proceedings of the ACM SIGCHI Conference on Human Factors in Computing Systems*, Apr. 1994, pp. 1-7.
- Raper, Larry K., "The C-MU PC Server Project", (CMU-ITC-86-051), Dec. 1986, pp. 1-30.
- Ratcliffe et al., "Intelligent Agents Take U.S. Bows", *MacWeek*, vol. 6, No. 9, Mar. 2, 1992, 1 page.
- Reddy, D. R., "Speech Recognition by Machine: A Review", *Proceedings of the IEEE*, Apr. 1976, pp. 501-531.
- Reininger et al., "Speech and Speaker Independent Codebook Design in VQ Coding Schemes", (*Proceedings of the IEEE International Acoustics, Speech and Signal Processing Conference*, Mar. 1985), as reprinted in *Vector Quantization* (IEEE Press, 1990), 1990, pp. 271-273.
- Ren et al., "Efficient Strategies for Selecting Small Targets on Pen-Based Systems: An Evaluation Experiment for Selection Strategies and Strategy Classifications", *Proceedings of the IFIP TC2/TC13 WG2.7/WG13.4 Seventh Working Conference on Engineering for Human-Computer Interaction*, vol. 150, 1998, pp. 19-37.
- Ren et al., "Improving Selection Performance on Pen-Based Systems: A Study of Pen-Based Interaction for Selection Tasks", *ACM Transactions on Computer-Human Interaction*, vol. 7, No. 3, Sep. 2000, pp. 384-416.
- Ren et al., "The Best among Six Strategies for Selecting a Minute Target and the Determination of the Minute Maximum Size of the Targets on a Pen-Based Computer", *Human-Computer Interaction INTERACT*, 1997, pp. 85-92.
- Ricker, Thomas, "Apple Patents Audio User Interface", *Engadget*, available at <<http://www.engadget.com/2006/05/04/apple-patents-audio-user-interface/>>, May 4, 2006, 6 pages.
- Riecken, R. D., "Adaptive Direct Manipulation", *IEEE Xplore*, 1991, pp. 1115-1120.
- Rioport, "Rio 500: Getting Started Guide", available at <<http://ec1.images-amazon.com/media/i3d/01/A/man-migrate/MANUAL000023453.pdf>>, 1999, 2 pages.
- Robbin et al., "MP3 Player and Encoder for Macintosh!", *SoundJam MP Plus*, Version 2.0, 2000, 76 pages.
- Robertson et al., "Information Visualization Using 3D Interactive Animation", *Communications of the ACM*, vol. 36, No. 4, Apr. 1993, pp. 57-71.
- Robertson et al., "The Document Lens", *UIST '93*, Nov. 3-5, 1993, pp. 101-108.
- Roddy et al., "Interface Issues in Text Based Chat Rooms", *SIGCHI Bulletin*, vol. 30, No. 2, Apr. 1998, pp. 119-123.
- Root, Robert, "Design of a Multi-Media Vehicle for Social Browsing", *Bell Communications Research*, 1988, pp. 25-38.
- Rose et al., "Inside Macintosh", vols. I, II, and III, Addison-Wesley Publishing Company, Inc., Jul. 1988, 1284 pages.
- Roseberry, Catherine, "How to Pair a Bluetooth Headset & Cell Phone", available at <http://mobileoffice.about.com/od/usingyourphone/ht/blueheadset_p.htm>, retrieved on Apr. 29, 2006, 2 pages.
- Rosenberg et al., "An Overview of the Andrew Message System", *Information Technology Center Carnegie-Mellon University*, Jul. 1987, pp. 99-108.
- Rosner et al., "In Touch: A Graphical User Interface Development Tool", *IEEE Colloquium on Software Tools for Interface Design*, Nov. 8, 1990, pp. 12/1-12/7.
- Rossfrank, "Konstlose Sprachmitteilungs Festnetz", *XP002234425*, Dec. 10, 2000, pp. 1-4.
- Roucos et al., "A Segment Vocoder at 150 B/S", (*Proceedings of the IEEE International Acoustics, Speech and Signal Processing Conference*, Apr. 1983), as reprinted in *Vector Quantization* (IEEE Press, 1990), 1990, pp. 246-249.
- Roucos et al., "High Quality Time-Scale Modification for Speech", *Proceedings of the 1985 IEEE Conference on Acoustics, Speech and Signal Processing*, 1985, pp. 493-496.
- Routines, "SmartThings Support", Available online at <<https://web.archive.org/web/20151207165701/https://support.smartthings.com/hc/en-us/articles/205380034-Routines>>, 2015, 3 pages.
- Rubine, Dean Harris, "Combining Gestures and Direct Manipulation", CHI '92, May 3-7, 1992, pp. 659-660.
- Rubine, Dean Harris, "The Automatic Recognition of Gestures", CMU-CS-91-202, Thesis Submitted in Partial Fulfillment of the Requirements for the Degree of Doctor of Philosophy in Computer Science at Carnegie Mellon University, Dec. 1991, 285 pages.
- Ruch et al., "Using Lexical Disambiguation and Named-Entity Recognition to Improve Spelling Correction in the Electronic Patient Record", *Artificial Intelligence in Medicine*, Sep. 2003, pp. 169-184.
- Russo et al., "Urgency is a Non-Monotonic Function of Pulse Rate", *Journal of the Acoustical Society of America*, vol. 122, No. 5, 2007, 6 pages.
- Sabin et al., "Product Code Vector Quantizers for Waveform and Voice Coding", (*IEEE Transactions on Acoustics, Speech and Signal Processing*, Jun. 1984), as reprinted in *Vector Quantization* (IEEE Press, 1990), 1990, pp. 274-288.
- Sankar, Ananth, "Bayesian Model Combination (BAYCOM) for Improved Recognition", *IEEE International Conference on Acoustics, Speech, and Signal Processing (ICASSP)*, Mar. 18-23, 2005, pp. 845-848.

(56)

References Cited

OTHER PUBLICATIONS

- Santaholma, Marianne E., "Grammar Sharing Techniques for Rule-based Multilingual NLP Systems", Proceedings of the 16th Nordic Conference of Computational Linguistics, NODALIDA 2007, May 25, 2007, 8 pages.
- Santen, Jan P., "Assignment of Segmental Duration in Text-to-Speech Synthesis", *Computer Speech and Language*, vol. 8, No. 2, Apr. 1994, pp. 95-128.
- Sarawagi, Sunita, "CRF Package Page", available at <<http://crf.sourceforge.net/>>, retrieved on Apr. 6, 2011, 2 pages.
- Sarkar et al., "Graphical Fisheye Views of Graphs", CHI '92 Proceedings of the SIGCHI Conference on Human Factors in Computing Systems, May 3-7, 1992, pp. 83-91.
- Sarkar et al., "Graphical Fisheye Views of Graphs", Systems Research Center, Digital Equipment Corporation., Mar. 17, 1992, 31 pages.
- Sarkar et al., "Graphical Fisheye Views", *Communications of the ACM*, vol. 37, No. 12, Dec. 1994, pp. 73-83.
- Sarkar et al., "Stretching the Rubber Sheet: A Metaphor for Viewing Large Layouts on Small Screens", UIST'93, ACM, Nov. 3-5, 1993, pp. 81-91.
- Sarvas et al., "Metadata Creation System for Mobile Images", Conference Proceedings, The Second International Conference on Mobile Systems, Applications and Services, Jun. 6, 2004, pp. 36-48.
- Sastry, Ravindra W., "A Need for Speed: A New Speedometer for Runners", submitted to the Department of Electrical Engineering and Computer Science at the Massachusetts Institute of Technology, 1999, pp. 1-42.
- Schafer et al., "Digital Representations of Speech Signals", Proceedings of the IEEE, vol. 63, No. 4, Apr. 1975, pp. 662-677.
- Schaffer et al., "Navigating Hierarchically Clustered Networks through Fisheye and Full-Zoom Methods", *ACM Transactions on Computer-Human Interaction*, vol. 3, No. 2, Jun. 1996, pp. 162-188.
- Scheifler, R. W., "The X Window System", MIT Laboratory for Computer Science and Gettys, Jim Digital Equipment Corporation and MIT Project Athena; *ACM Transactions on Graphics*, vol. 5, No. 2, Apr. 1986, pp. 79-109.
- Schluter et al., "Using Phase Spectrum Information for Improved Speech Recognition Performance", IEEE International Conference on Acoustics, Speech, and Signal Processing, 2001, pp. 133-136.
- Schmandt et al., "A Conversational Telephone Messaging System", IEEE Transactions on Consumer Electronics, vol. CE-30, Aug. 1984, pp. xxi-xxiv.
- Schmandt et al., "Phone Slave: A Graphical Telecommunications Interface", Proceedings of the SID, vol. 26, No. 1, 1985, pp. 79-82.
- Schmandt et al., "Phone Slave: A Graphical Telecommunications Interface", Society for Information Display, International Symposium Digest of Technical Papers, Jun. 1984, 4 pages.
- Schmid, H., "Part-of-speech tagging with neural networks", COLING '94 Proceedings of the 15th conference on Computational linguistics—vol. 1, 1994, pp. 172-176.
- Schone et al., "Knowledge-Free Induction of Morphology Using Latent Semantic Analysis", Proceedings of the 2nd Workshop on Learning Language in Logic and the 4th Conference on Computational Natural Language Learning, vol. 7, 2000, pp. 67-72.
- Schooler et al., "A Packet-switched Multimedia Conferencing System", by Eve Schooler, et al; *ACM SIGOIS Bulletin*, vol. I, No. 1, Jan. 1989, pp. 12-22.
- Schooler et al., "An Architecture for Multimedia Connection Management", Proceedings IEEE 4th Comsoc International Workshop on Multimedia Communications, Apr. 1992, pp. 271-274.
- Schooler et al., "Multimedia Conferencing: Has it Come of Age?", Proceedings 24th Hawaii International Conference on System Sciences, vol. 3, Jan. 1991, pp. 707-716.
- Schooler et al., "The Connection Control Protocol: Architecture Overview", USC/Information Sciences Institute, Jan. 28, 1992, pp. 1-6.
- Schooler, Eve M., "Case Study: Multimedia Conference Control in a Packet-Switched Teleconferencing System", *Journal of Internetworking: Research and Experience*, vol. 4, No. 2, Jun. 1993, pp. 99-120.
- Schooler, Eve M., "The Impact of Scaling on a Multimedia Connection Architecture", *Multimedia Systems*, vol. 1, No. 1, 1993, pp. 2-9.
- Schooler, Eve, "A Distributed Architecture for Multimedia Conference Control", ISI Research Report, Nov. 1991, pp. 1-18.
- Schultz, Tanja, "Speaker Characteristics", In: *Speaker Classification I*, retrieved from <<http://ccc.inaoep.mx/~villasen/bib/Speaker%20Characteristics.pdf>>, 2007, pp. 47-74.
- Schütze, H., "Distributional part-of-speech tagging", EACL '95 Proceedings of the seventh conference on European chapter of the Association for Computational Linguistics, 1995, pp. 141-148.
- Schütze, Hinrich, "Part-of-speech induction from scratch", ACL '93 Proceedings of the 31st annual meeting on Association for Computational Linguistics, 1993, pp. 251-258.
- Schwartz et al., "Context-Dependent Modeling for Acoustic-Phonetic Recognition of Continuous Speech", IEEE International Conference on Acoustics, Speech, and Signal Processing, vol. 10, Apr. 1985, pp. 1205-1208.
- Schwartz et al., "Improved Hidden Markov Modeling of Phonemes for Continuous Speech Recognition", IEEE International Conference on Acoustics, Speech, and Signal Processing, vol. 9, 1984, pp. 21-24.
- Schwartz et al., "The N-Best Algorithm: An Efficient and Exact Procedure for Finding the N Most Likely Sentence Hypotheses", IEEE, 1990, pp. 81-84.
- Scott et al., "Designing Touch Screen Numeric Keypads: Effects of Finger Size, Key Size, and Key Spacing", Proceedings of the Human Factors and Ergonomics Society 41st Annual Meeting, Oct. 1997, pp. 360-364.
- Seagrave, Jim, "A Faster Way to Search Text", *EXE*, vol. 5, No. 3, Aug. 1990, pp. 50-52.
- Sears et al., "High Precision Touchscreens: Design Strategies and Comparisons with a Mouse", *International Journal of Man-Machine Studies*, vol. 34, No. 4, Apr. 1991, pp. 593-613.
- Sears et al., "Investigating Touchscreen Typing: The Effect of Keyboard Size on Typing Speed", *Behavior & Information Technology*, vol. 12, No. 1, 1993, pp. 17-22.
- Sears et al., "Touchscreen Keyboards", Apple Inc., Video Clip, Human-Computer Interaction Laboratory, on a CD, Apr. 1991.
- Seide et al., "Improving Speech Understanding by Incorporating Database Constraints and Dialogue History", Proceedings of Fourth International Conference on Philadelphia., 1996, pp. 1017-1020.
- Sen et al., "Indian Accent Text-to-Speech System for Web Browsing", *Sadhana*, vol. 27, No. 1, Feb. 2002, pp. 113-126.
- Sethy et al., "A Syllable Based Approach for Improved Recognition of Spoken Names", ITRW on Pronunciation Modeling and Lexicon Adaptation for Spoken language Technology (PMLA2002), Sep. 14-15, 2002, pp. 30-35.
- Shiraki et al., "LPC Speech Coding Based on Variable-Length Segment Quantization", (IEEE Transactions on Acoustics, Speech and Signal Processing, Sep. 1988), as reprinted in *Vector Quantization* (IEEE Press, 1990), 1990, pp. 250-257.
- Shneiderman, Ben, "Designing the User Interface: Strategies for Effective Human-Computer Interaction", Second Edition, 1992, 599 pages.
- Shneiderman, Ben, "Designing the User Interface: Strategies for Effective Human-Computer Interaction", Third Edition, 1998, 669 pages.
- Shneiderman, Ben, "Direct Manipulation for Comprehensible, Predictable and Controllable User Interfaces", Proceedings of the 2nd International Conference on Intelligent User Interfaces, 1997, pp. 33-39.
- Shneiderman, Ben, "Sparks of Innovation in Human-Computer Interaction", 1993, (Table of Contents, Title Page, Ch. 4, Ch. 6 and List of References).
- Shneiderman, Ben, "The Eyes Have It: A Task by Data Type Taxonomy for Information Visualizations", IEEE Proceedings of Symposium on Visual Languages, 1996, pp. 336-343.
- Shneiderman, Ben, "Touch Screens Now Offer Compelling Uses", IEEE Software, Mar. 1991, pp. 93-94.

(56)

References Cited

OTHER PUBLICATIONS

- Shoham et al., "Efficient Bit and Allocation for an Arbitrary Set of Quantizers", (IEEE Transactions on Acoustics, Speech, and Signal Processing, Sep. 1988) as reprinted in Vector Quantization (IEEE Press, 1990), 1990, pp. 289-296.
- Simkovitz, Daniel, "LP-DOS Magnifies the PC Screen", IEEE, 1992, pp. 203-204.
- Singh et al., "Automatic Generation of Phone Sets and Lexical Transcriptions", Acoustics, Speech and Signal Processing (ICASSP'00), 2000, 1 page.
- Sinitzyn, Alexander, "A Synchronization Framework for Personal Mobile Servers", Proceedings of the Second IEEE Annual Conference on Pervasive Computing and Communications Workshops, Piscataway, 2004, pp. 1, 3 and 5.
- Slaney et al., "On the Importance of Time—A Temporal Representation of Sound", Visual Representation of Speech Signals, 1993, pp. 95-116.
- Smeaton, Alan F., "Natural Language Processing and Information Retrieval", Information Processing and Management, vol. 26, No. 1, 1990, pp. 19-20.
- Smith et al., "Guidelines for Designing User Interface Software", User Lab, Inc., Aug. 1986, pp. 1-384.
- Smith et al., "Relating Distortion to Performance in Distortion Oriented Displays", Proceedings of Sixth Australian Conference on Computer-Human Interaction, Nov. 1996, pp. 6-11.
- Sony Ericsson Corporate, "Sony Ericsson to introduce Auto pairing. TM. to Improve Bluetooth.TM. Connectivity Between Headsets and Phones", Press Release, available at <http://www.sonyericsson.com/spg.jsp?cc=global&lc=en&ver=4001&template=pc3_1_1&z...>, Sep. 28, 2005, 2 pages.
- Soong et al., "A High Quality Subband Speech Coder with Backward Adaptive Predictor and Optimal Time-Frequency Bit Assignment", (Proceedings of the IEEE International Acoustics, Speech, and Signal Processing Conference, Apr. 1986), as reprinted in Vector Quantization (IEEE Press, 1990), 1990, pp. 316-319.
- Speaker Recognition, Wikipedia, The Free Encyclopedia, Nov. 2, 2010, 4 pages.
- Spiller, Karen, "Low-Decibel Earbuds Keep Noise at a Reasonable Level", available at <<http://www.nashuatelegraph.com/apps/pbcs.dll/article?Date=20060813&Cate...>>, Aug. 13, 2006, 3 pages.
- Srihari, R. K., "Use of Multimedia Input in Automated Image Annotation and Content-based Retrieval", Proceedings of SPIE, International Society for Optical Engineering, vol. 2420, Feb. 9, 1995., pp. 249-260.
- Srinivas et al., "Monet: A Multi-Media System for Conferencing and Application Sharing in Distributed Systems", CERC Technical Report Series Research Note, Feb. 1992.
- Stealth Computer Corporation, "Peripherals for Industrial Keyboards & Pointing Devices", available at <http://www.stealthcomputer.com/peripherals_oem.htm>, retrieved on Dec. 19, 2002, 6 pages.
- Steinberg, Gene, "Sonicblue Rio Car (10 GB, Reviewed: 6 GB)", available at <<http://electronics.cnet.com/electronics/0-6342420-1304-4098389.html>>, Dec. 12, 2000, 2 pages.
- Stent et al., "Geo-Centric Language Models for Local Business Voice Search", AT&T Labs—Research, 2009, pp. 389-396.
- Stifleman, L., "Not Just Another Voice Mail System", Proceedings of 1991 Conference, American Voice, Atlanta GA, Sep. 24-26, 1991, pp. 21-26.
- Stone et al., "The Movable Filter as a User Interface Tool", CHI '94 Human Factors in Computing Systems, 1994, pp. 306-312.
- Strom et al., "Intelligent Barge-In in Conversational Systems", MIT laboratory for Computer Science, 2000, 4 pages.
- Stuker et al., "Cross-System Adaptation and Combination for Continuous Speech Recognition: The Influence of Phoneme Set and Acoustic Front-End", Influence of Phoneme Set and Acoustic Front-End, Interspeech, Sep. 17-21, 2006, pp. 521-524.
- Su et al., "A Review of ZoomText Xtra Screen Magnification Program for Windows 95", Journal of Visual Impairment & Blindness, Feb. 1998, pp. 116-119.
- Su, Joseph C., "A Review of Telesensory's Vista PCI Screen Magnification System", Journal of Visual Impairment & Blindness, Oct. 1998, pp. 705, 707-710.
- Sullivan, Danny, "How Google Instant's Autocomplete Suggestions Work", available at <<http://searchengineland.com/how-google-instant-autocomplete-suggestions-work-62592>>, Apr. 6, 2011, 12 pages.
- Summerfield et al., "ASIC Implementation of the Lyon Cochlea Model", Proceedings of the 1992 International Conference on Acoustics, Speech and Signal Processing, IEEE, vol. V, 1992, pp. 673-676.
- Sundaram et al., "Latent Perceptual Mapping with Data-Driven Variable-Length Acoustic Units for Template-Based Speech Recognition", ICASSP 2012, Mar. 2012, pp. 4125-4128.
- T3 Magazine, "Creative MuVo TX 256MB", available at <http://www.t3.co.uk/reviews/entertainment/mp3_player/creative_muvo_tx_256mb>, Aug. 17, 2004, 1 page.
- TAOS, "TAOS, Inc. Announces Industry's First Ambient Light Sensor to Convert Light Intensity to Digital Signals", News Release, available at <http://www.taosinc.com/pressrelease_090902.htm>, Sep. 16, 2002, 3 pages.
- Taylor et al., "Speech Synthesis by Phonological Structure Matching", International Speech Communication Association, vol. 2, Section 3, 1999, 4 pages.
- Tello, Ernest R., "Natural-Language Systems", Mastering AI Tools and Techniques, Howard W. Sams & Company, 1988.
- TG3 Electronics, Inc., "BL82 Series Backlit Keyboards", available at <<http://www.tg3electronics.com/products/backlit/backlit.htm>>, retrieved on Dec. 19, 2002, 2 pages.
- The HP 150, "Hardware: Compact, Powerful, and Innovative", vol. 8, No. 10, Oct. 1983, pp. 36-50.
- Tidwell, Jenifer, "Animated Transition", Designing Interfaces, Patterns for effective Interaction Design, Nov. 2005, First Edition, 4 pages.
- Timothy et al., "Speech-Based Annotation and Retrieval of Digital Photographs", Interspeech. 8th Annual Conference of the International Speech Communication Association, Aug. 27, 2007, pp. 2165-2168.
- Tombros et al., "Users' Perception of Relevance of Spoken Documents", Journal of the American Society for Information Science, New York, Aug. 2000, pp. 929-939.
- Touch, Joseph, "Zoned Analog Personal Teleconferencing", USC / Information Sciences Institute, 1993, pp. 1-19.
- Toutanova et al., "Feature-Rich Part-of-Speech Tagging with a Cyclic Dependency Network", Computer Science Dept., Stanford University, Stanford CA 94305-9040, 2003, 8 pages.
- Trigg et al., "Hypertext Habitats: Experiences of Writers in NoteCards", Hypertext '87 Papers; Intelligent Systems Laboratory, Xerox Palo Alto Research Center, 1987, pp. 89-108.
- Trowbridge, David, "Using Andrew for Development of Educational Applications", Center for Design of Educational Computing, Carnegie-Mellon University (CMU-ITC-85-065), Jun. 2, 1985, pp. 1-6.
- Tsao et al., "Matrix Quantizer Design for LPC Speech Using the Generalized Lloyd Algorithm", (IEEE Transactions on Acoustics, Speech and Signal Processing, Jun. 1985), as reprinted in Vector Quantization (IEEE Press, 1990), 1990, pp. 237-245.
- Turletti, Thierry, "The INRIA Videoconferencing System (IVS)", Oct. 1994, pp. 1-7.
- Uslan et al., "A Review of Henter-Joyce's MAGic for Windows NT", Journal of Visual Impairment and Blindness, Dec. 1999, pp. 666-668.
- Uslan et al., "A Review of Supernova Screen Magnification Program for Windows", Journal of Visual Impairment & Blindness, Feb. 1999, pp. 108-110.
- Uslan et al., "A Review of Two Screen Magnification Programs for Windows 95: Magnum 95 and LP-Windows", Journal of Visual Impairment & Blindness, Sep.-Oct. 1997, pp. 9-13.
- Veiga, Alex, "AT&T Wireless Launching Music Service", available at <http://bizyahoo.com/ap/041005/at_t_mobile_music_5.html?printer=1>, Oct. 5, 2004, 2 pages.
- Viegas et al., "Chat Circles", SIGCHI Conference on Human Factors in Computing Systems, May 15-20, 1999, pp. 9-16.

(56)

References Cited

OTHER PUBLICATIONS

- Viikki et al., "Speaker- and Language-Independent Speech Recognition in Mobile Communication Systems", IEEE, vol. 1, 2001, pp. 5-8.
- Vogel et al., "Shift: A Technique for Operating Pen-Based Interfaces Using Touch", CHI '07 Proceedings, Mobile Interaction Techniques I, Apr. 28-May 3, 2007, pp. 657-666.
- W3C Working Draft, "Speech Synthesis Markup Language Specification for the Speech Interface Framework", available at <<http://www.w3.org/TR/speech-synthesis>>, retrieved on Dec. 14, 2000, 42 pages.
- Wadlow, M. G., "The Role of Human Interface Guidelines in the Design of Multimedia Applications", Carnegie Mellon University (To be Published in Current Psychology: Research and Reviews, Summer 1990 (CMU-ITC-91-101)), 1990, pp. 1-22.
- Waibel, Alex, "Interactive Translation of Conversational Speech", Computer, vol. 29, No. 7, Jul. 1996, pp. 41-48.
- Walker et al., "The LOCUS Distributed Operating System 1", University of California Los Angeles, 1983, pp. 49-70.
- Wang et al., "An Industrial-Strength Audio Search Algorithm", In Proceedings of the International Conference on Music Information Retrieval (ISMIR), 2003, 7 pages.
- Wang et al., "An Initial Study on Large Vocabulary Continuous Mandarin Speech Recognition with Limited Training Data Based on Sub-Syllabic Models", International Computer Symposium, vol. 2, 1994, pp. 1140-1145.
- Wang et al., "Tone Recognition of Continuous Mandarin Speech Based on Hidden Markov Model", International Journal of Pattern Recognition and Artificial Intelligence, vol. 8, 1994, pp. 233-245.
- Ware et al., "The DragMag Image Magnifier Prototype I", Apple Inc., Video Clip, Marlon, on a CD, Applicant is not Certain about the Date for the Video Clip., 1995.
- Ware et al., "The DragMag Image Magnifier", CHI '95 Mosaic of Creativity, May 7-11, 1995, pp. 407-408.
- Watabe et al., "Distributed Multiparty Desktop Conferencing System: Mermaid", CSCW 90 Proceedings, Oct. 1990, pp. 27-38.
- Westerman, Wayne, "Hand Tracking, Finger Identification and Chordic Manipulation on a Multi-Touch Surface", Doctoral Dissertation, 1999, 363 Pages.
- What is Fuzzy Logic?, available at <<http://www.cs.cmu.edu>>, retrieved on Apr. 15, 1993, 5 pages.
- White, George M., "Speech Recognition, Neural Nets, and Brains", Jan. 1992, pp. 1-48.
- Wikipedia, "Acoustic Model", available at <<http://en.wikipedia.org/wiki/AcousticModel>>, retrieved on Sep. 14, 2011, 2 pages.
- Wikipedia, "Language Model", available at <http://en.wikipedia.org/wiki/Language_model>, retrieved on Sep. 14, 2011, 3 pages.
- Wikipedia, "Speech Recognition", available at <http://en.wikipedia.org/wiki/Speech_recognition>, retrieved on Sep. 14, 2011, 10 pages.
- Wilensky et al., "Talking to UNIX in English: An Overview of UC", Communications of the ACM, vol. 27, No. 6, Jun. 1984, pp. 574-593.
- Wilson, Mark, "New iPod Shuffle Moves Buttons to Headphones, Adds Text to Speech", available at <<http://gizmodo.com/5167946/new-ipod-shuffle-moves-buttons-to-headphones-adds-text-to-speech>>, Mar. 11, 2009, 13 pages.
- Windows XP: A Big Surprise!—Experiencing Amazement from Windows XP, New Computer, No. 2, Feb. 28, 2002, 8 pages.
- Wirelessinfo, "SMS/MMS Ease of Use (8.0)", available at <<http://www.wirelessinfo.com/content/palm-Treo-750-Cell-Phone-Review/Messaging.htm>>, Mar. 2007, 3 pages.
- Wong et al., "An 800 Bit/s Vector Quantization LPC Vocoder", (IEEE Transactions on Acoustics, Speech and Signal Processing, Oct. 1982), as reprinted in Vector Quantization (IEEE Press, 1990), 1990, pp. 222-232.
- Wong et al., "Very Low Data Rate Speech Compression with LPC Vector and Matrix Quantization", (Proceedings of the IEEE Int'l Acoustics, Speech and Signal Processing Conference, Apr. 1983), as reprinted in Vector Quantization (IEEE Press, 1990), 1990, pp. 233-236.
- Worldwide Character Encoding, Version 2.0, vols. 1,2 by Unicode, Inc., 12 pages.
- Written Opinion received for PCT Patent Application No. PCT/US2005/046797, dated Nov. 24, 2006, 9 pages.
- Wu et al., "Automatic Generation of Synthesis Units and Prosodic Information for Chinese Concatenative Synthesis", Speech Communication, vol. 35, No. 3-4, Oct. 2001, pp. 219-237.
- Xiang et al., "Correcting Phoneme Recognition Errors in Learning Word Pronunciation through Speech Interaction", Speech Communication, vol. 55, No. 1, Jan. 1, 2013, pp. 190-203.
- Xu et al., "Speech-Based Interactive Games for Language Learning: Reading, Translation, and Question-Answering", Computational Linguistics and Chinese Language Processing, vol. 14, No. 2, Jun. 2009, pp. 133-160.
- Yang et al., "Auditory Representations of Acoustic Signals", IEEE Transactions of Information Theory, vol. 38, No. 2, Mar. 1992, pp. 824-839.
- Yang et al., "Hidden Markov Model for Mandarin Lexical Tone Recognition", IEEE Transactions on Acoustics, Speech and Signal Processing, vol. 36, No. 7, Jul. 1988, pp. 988-992.
- Yarowsky, David, "Homograph Disambiguation in Text-to-Speech Synthesis", Chapter 12, Progress in Speech Synthesis, 1997, pp. 157-172.
- Yiourgalis et al., "Text-to-Speech system for Greek", ICASSP 91, vol. 1, May 14-17, 1991, pp. 525-528.
- Young, S. J., "The HTK Book", Available on <<http://htk.eng.cam.ac.uk>>, 4 pages.
- Youtube, "New bar search for Facebook", Available at "https://www.youtube.com/watch?v=vwgN1WbvCas", 1 page.
- Yunker, John, "Beyond Borders: Web Globalization Strategies", New Riders, Aug. 22, 2002, 11 pages.
- Zainab, "Google Input Tools Shows Onscreen Keyboard in Multiple Languages [Chrome]", available at <<http://www.addictivetips.com/internet-tips/google-input-tools-shows-multiple-language-onscreen-keyboards-chrome/>>, Jan. 3, 2012, 3 pages.
- Zelig, "A Review of the Palm Treo 750v", available at <<http://www.mtekk.com.au/Articles/tabid/54/articleType/ArticleView/articleId/769/A-Review-of-the-Palm-Treo-750v.aspx>>, Feb. 5, 2007, 3 pages.
- Zhang et al., "Research of Text Classification Model Based on Latent Semantic Analysis and Improved HS-SVM", Intelligent Systems and Applications (ISA), 2010 2nd International Workshop, May 22-23, 2010, 5 pages.
- Zhong et al., "JustSpeak: Enabling Universal Voice Control on Android", W4A'14, Proceedings of the 11th Web for All Conference, No. 36, Apr. 7-9, 2014, 8 pages.
- Ziegler, K., "A Distributed Information System Study", IBM Systems Journal, vol. 18, No. 3, 1979, pp. 374-401.
- Zipnick et al., "U.S. Appl. No. 10/859,661, filed Jun. 2, 2004".
- Acero et al., "Environmental Robustness in Automatic Speech Recognition", International Conference on Acoustics, Speech and Signal Processing (ICASSP'90), Apr. 1990, 4 pages.
- Acero et al., "Robust Speech Recognition by Normalization of the Acoustic Space", International Conference on Acoustics, Speech and Signal Processing, 1991, 4 pages.
- Agnas et al., "Spoken Language Translator: First-Year Report", SICS (ISSN 0283-3638), SRI and Telia Research AB, Jan. 1994, 161 pages.
- Ahlbom et al., Modeling Spectral Speech Transitions Using Temporal Decomposition Techniques, IEEE International Conference of Acoustics, Speech and Signal Processing (ICASSP'87), vol. 12, Apr. 1987, 4 pages.
- Aikawa et al., "Speech Recognition Using Time-Warping Neural Networks", Proceedings of the 1991, IEEE Workshop on Neural Networks for Signal Processing, 1991, 10 pages.
- Alfred App, "Alfred", available at <<http://www.alfredapp.com/>>, retrieved on Feb. 8, 2012, 5 pages.
- Allen, J., "Natural Language Understanding", 2nd Edition, The Benjamin/Cummings Publishing Company, Inc., 1995, 671 pages.
- Alshawi et al., "CLARE: A Contextual Reasoning and Co-operative Response Framework for the Core Language Engine", SRI International, Cambridge Computer Science Research Centre, Cambridge, Dec. 1992, 273 pages.

(56)

References Cited

OTHER PUBLICATIONS

- Alshawi et al., "Declarative Derivation of Database Queries from Meaning Representations", Proceedings of the BANKAI Workshop on Intelligent Information Access, Oct. 1991, 12 pages.
- Alshawi et al., "Logical Forms in the Core Language Engine", Proceedings of the 27th Annual Meeting of the Association for Computational Linguistics, 1989, pp. 25-32.
- Alshawi et al., "Overview of the Core Language Engine", Proceedings of Future Generation Computing Systems, Tokyo, Sept. 1988, 13 pages.
- Alshawi, H., "Translation and Monotonic Interpretation/Generation", SRI International, Cambridge Computer Science Research Centre, Cambridge, available at <<http://www.cam.sri.com/tr/crc024/paper.ps.Z1992>>, Jul. 1992, 18 pages.
- Ambite et al., "Design and Implementation of the CALO Query Manager", American Association for Artificial Intelligence, 2006, 8 pages.
- Ambite et al., "Integration of Heterogeneous Knowledge Sources in the CALO Query Manager", The 4th International Conference on Ontologies, Databases and Applications of Semantics (ODBASE), 2005, 18 pages.
- Anastasakos et al., "Duration Modeling in Large Vocabulary Speech Recognition", International Conference on Acoustics, Speech and Signal Processing (ICASSP'95), May 1995, pp. 628-631.
- Anderson et al., "Syntax-Directed Recognition of Hand-Printed Two-Dimensional Mathematics", Proceedings of Symposium on Interactive Systems for Experimental Applied Mathematics: Proceedings of the Association for Computing Machinery Inc. Symposium, 1967, 12 pages.
- Ansari et al., "Pitch Modification of Speech using a Low-Sensitivity Inverse Filter Approach", IEEE Signal Processing Letters, vol. 5, No. 3, Mar. 1998, pp. 60-62.
- Anthony et al., "Supervised Adaption for Signature Verification System", IBM Technical Disclosure, Jun. 1, 1978, 3 pages.
- Appelt et al., "Fastus: A Finite-State Processor for Information Extraction from Real-world Text", Proceedings of IJCAI, 1993, 8 pages.
- Appelt et al., "SRI International Fastus System MUC-6 Test Results and Analysis", SRI International, Menlo Park, California, 1995, 12 pages.
- Appelt et al., "SRI: Description of the JV-FASTUS System used for MUC-5", SRI International, Artificial Intelligence Center, 1993, 19 pages.
- Apple Computer, "Guide Maker User's Guide", Apple Computer, Inc., Apr. 27, 1994, 8 pages.
- Apple Computer, "Introduction to Apple Guide", Apple Computer, Inc., Apr. 28, 1994, 20 pages.
- Archbold et al., "A Team User's Guide", SRI International, Dec. 21, 1981, 70 pages.
- Asanovic et al., "Experimental Determination of Precision Requirements for Back-Propagation Training of Artificial Neural Networks", Proceedings of the 2nd International Conference of Microelectronics for Neural Networks, 1991, www.ICSI.Berkelev.EDU, 1991, 7 pages.
- Atal et al., "Efficient Coding of LPC Parameters by Temporal Decomposition", IEEE International Conference on Acoustics, Speech and Signal Processing (ICASSP'83), Apr. 1983, 4 pages.
- Bahl et al., "A Maximum Likelihood Approach to Continuous Speech Recognition", IEEE Transaction on Pattern Analysis and Machine Intelligence, vol. PAMI-5, No. 2, Mar. 1983, 13 pages.
- Bahl et al., "A Tree-Based Statistical Language Model for Natural Language Speech Recognition", IEEE Transactions on Acoustics, Speech and Signal Processing, vol. 37, No. 7, Jul. 1989, 8 pages.
- Bahl et al., "Acoustic Markov Models Used in the Tangora Speech Recognition System", Proceeding of International Conference on Acoustics, Speech and Signal Processing (ICASSP'88), vol. 1, Apr. 1988, 4 pages.
- Bahl et al., "Large Vocabulary Natural Language Continuous Speech Recognition", Proceedings of 1989 International Conference on Acoustics, Speech and Signal Processing, vol. 1, May 1989, 6 pages.
- Bahl et al., "Multitonic Markov Word Models for Large Vocabulary Continuous Speech Recognition", IEEE Transactions on Speech and Audio Processing, vol. 1, No. 3, Jul. 1993, 11 pages.
- Bahl et al., "Speech Recognition with Continuous-Parameter Hidden Markov Models", Proceeding of International Conference on Acoustics, Speech and Signal Processing (ICASSP'88), vol. 1, Apr. 1988, 8 pages.
- Banbrook, M., "Nonlinear Analysis of Speech from a Synthesis Perspective", A Thesis Submitted for the Degree of Doctor of Philosophy, The University of Edinburgh, Oct. 15, 1996, 35 pages.
- Bear et al., "A System for Labeling Self-Repairs in Speech", SRI International, Feb. 22, 1993, 9 pages.
- Bear et al., "Detection and Correction of Repairs in Human-Computer Dialog", SRI International, May 1992, 11 pages.
- Bear et al., "Integrating Multiple Knowledge Sources for Detection and Correction of Repairs in Human-Computer Dialog", Proceedings of the 30th Annual Meeting on Association for Computational Linguistics (ACL), 1992, 8 pages.
- Bear et al., "Using Information Extraction to Improve Document Retrieval", SRI International, Menlo Park, California, 1998, 11 pages.
- Belaid et al., "A Syntactic Approach for Handwritten Mathematical Formula Recognition", IEEE Transactions on Pattern Analysis and Machine Intelligence, vol. PAMI-6, No. 1, Jan. 1984, 7 pages.
- Bellegarda et al., "A Latent Semantic Analysis Framework for Large-Span Language Modeling", 5th European Conference on Speech, Communication and Technology (EUROSPEECH'97), Sep. 1997, 4 pages.
- Bellegarda et al., "A Multispan Language Modeling Framework for Large Vocabulary Speech Recognition", IEEE Transactions on Speech and Audio Processing, vol. 6, No. 5, Sep. 1998, 12 pages.
- Bellegarda et al., "A Novel Word Clustering Algorithm Based on Latent Semantic Analysis", Proceedings of the IEEE International Conference on Acoustics, Speech and Signal Processing (ICASSP'96), vol. 1, 1996, 4 pages.
- Bellegarda et al., "Experiments Using Data Augmentation for Speaker Adaptation", International Conference on Acoustics, Speech and Signal Processing (ICASSP'95), May 1995, 4 pages.
- Bellegarda et al., "On-Line Handwriting Recognition using Statistical Mixtures", Advances in Handwriting and Drawings: A Multidisciplinary Approach, Euroipa, 6th International IGS Conference on Handwriting and Drawing, Paris, France, Jul. 1993, 11 pages.
- Bellegarda et al., "Performance of the IBM Large Vocabulary Continuous Speech Recognition System on the ARPA Wall Street Journal Task", Signal Processing VII: Theories and Applications, European Association for Signal Processing, 1994, 4 pages.
- Bellegarda et al., "The Metamorphic Algorithm: A Speaker Mapping Approach to Data Augmentation", IEEE Transactions on Speech and Audio Processing, vol. 2, No. 3, Jul. 1994, 8 pages.
- Bellegarda, Jerome R., "Exploiting both Local and Global Constraints for Multi-Span Statistical Language Modeling", Proceeding of the 1998 IEEE International Conference on Acoustics, Speech and Signal Processing (ICASSP'98), vol. 2, May 1998, 5 pages.
- Bellegarda, Jerome R., "Exploiting Latent Semantic Information in Statistical Language Modeling", Proceedings of the IEEE, vol. 88, No. 8, Aug. 2000, 18 pages.
- Bellegarda, Jerome R., "Interaction-Driven Speech Input-A Data-Driven Approach to the Capture of both Local and Global Language Constraints", available at <<http://old.sig.chi.ora/bulletin/1998.2/bellegarda.html>>, 1992, 7 pages.
- Bellegarda, Jerome R., "Large Vocabulary Speech Recognition with Multispan Statistical Language Models", IEEE Transactions on Speech and Audio Processing, vol. 8, No. 1, Jan. 2000, 9 pages.
- Belvin et al., "Development of the HRL Route Navigation Dialogue System", Proceedings of the First International Conference on Human Language Technology Research, Paper, 2001, 5 pages.
- Berry et al., "PIIME: Personalized Assistance for Calendaring", ACM Transactions on Intelligent Systems and Technology, vol. 2, No. 4, Article 40, Jul. 2011, pp. 1-22.

(56)

References Cited

OTHER PUBLICATIONS

- Berry et al., "Task Management under Change and Uncertainty Constraint Solving Experience with the CALO Project", Proceedings of CP'05 Workshop on Constraint Solving under Change, 2005, 5 pages.
- Black et al., "Automatically Clustering Similar Units for Unit Selection in Speech Synthesis", Proceedings of Eurospeech, vol. 2, 1997, 4 pages.
- Blair et al., "An Evaluation of Retrieval Effectiveness for a Full-Text Document-Retrieval System", Communications of the ACM, vol. 28, No. 3, Mar. 1985, 11 pages.
- Bobrow et al., "Knowledge Representation for Syntactic/Semantic Processing", From: AAA-80 Proceedings, Copyright 1980, AAAI, 1980, 8 pages.
- Bouchou et al., "Using Transducers in Natural Language Database Query", Proceedings of 4th International Conference on Applications of Natural Language to Information Systems, Austria, Jun. 1999, 17 pages.
- Bratt et al., "The SRI Telephone-Based ATIS System", Proceedings of ARPA Workshop on Spoken Language Technology, 1995, 3 pages.
- Briner, L. L., "Identifying Keywords in Text Data Processing", In Zekowitz, Marvin V., Ed, Directions and Challenges, 15th Annual Technical Symposium, Gaithersbury, Maryland, Jun. 17, 1976, 7 pages.
- Bulyko et al., "Error-Correction Detection and Response Generation in a Spoken Dialogue System", Speech Communication, vol. 45, 2005, pp. 271-288.
- Bulyko et al., "Joint Prosody Prediction and Unit Selection for Concatenative Speech Synthesis", Electrical Engineering Department, University of Washington, Seattle, 2001, 4 pages.
- Burke et al., "Question Answering from Frequently Asked Question Files", AI Magazine, vol. 18, No. 2, 1997, 10 pages.
- Burns et al., "Development of a Web-Based Intelligent Agent for the Fashion Selection and Purchasing Process via Electronic Commerce", Proceedings of the Americas Conference on Information System (AMCIS), Dec. 31, 1998, 4 pages.
- Bussey, et al., "Service Architecture, Prototype Description and Network Implications of a Personalized Information Grazing Service", INFOCOM'90, Ninth Annual Joint Conference of the IEEE Computer and Communication Societies, Available at <<http://slrohall.com/oublications/>>, Jun. 1990, 8 pages.
- Bussler et al., "Web Service Execution Environment (WSMX)", retrieved from Internet on Sep. 17, 2012, available at <<http://www.w3.org/Submission/WSMX>>, Jun. 3, 2005, 29 pages.
- Butcher, Mike, "EVI Arrives in Town to go Toe-to-Toe with Siri", TechCrunch, Jan. 23, 2012, 2 pages.
- Buzo et al., "Speech Coding Based Upon Vector Quantization", IEEE Transactions on Acoustics, Speech and Signal Processing, vol. Assp-28, No. 5, Oct. 1980, 13 pages.
- Caminero-Gil et al., "Data-Driven Discourse Modeling for Semantic Interpretation", Proceedings of the IEEE International Conference on Acoustics, Speech and Signal Processing, May 1996, 6 pages.
- Car Working Group, "Hands-Free Profile 1.5 HFPP1.5_SPEC", Bluetooth Doc, available at <www.bluetooth.org>, Nov. 25, 2005, 93 pages.
- Carter et al., "The Speech-Language Interface in the Spoken Language Translator", SRI International, Nov. 23, 1994, 9 pages.
- Carter, D., "Lexical Acquisition in the Core Language Engine", Proceedings of the Fourth Conference of the European Chapter of the Association for Computational Linguistics, 1989, 8 pages.
- Cawley, Gavin C. "The Application of Neural Networks to Phonetic Modelling", PhD. Thesis, University of Essex, Mar. 1996, 13 pages.
- Chai et al., "Comparative Evaluation of a Natural Language Dialog Based System and a Menu Driven System for Information Access: A Case Study", Proceedings of the International Conference on Multimedia Information Retrieval (RIAO), Paris, Apr. 2000, 11 pages.
- Chang et al., "A Segment-Based Speech Recognition System for Isolated Mandarin Syllables", Proceedings TEN CON '93, IEEE Region 10 Conference on Computer, Communication, Control and Power Engineering, vol. 3, Oct. 1993, 6 pages.
- Chen, Yi, "Multimedia Siri Finds and Plays Whatever You Ask for", PSFK Report, Feb. 9, 2012, 9 pages.
- Cheyner et al., "Multimodal Maps: An Agent-Based Approach", International Conference on Co-operative Multimodal Communication, 1995, 15 pages.
- Cheyner et al., "Spoken Language and Multimodal Applications for Electronic Realities", Virtual Reality, vol. 3, 1999, pp. 1-15.
- Cheyner et al., "The Open Agent Architecture", Autonomous Agents and Multi-Agent Systems, vol. 4, Mar. 1, 2001, 6 pages.
- Cheyner et al., "The Open Agent Architecture: Building Communities of Distributed Software Agents", Artificial Intelligence Center, SRI International, Power Point Presentation, Available online at <<http://www.ai.sri.com/-oaa/>>, retrieved on Feb. 21, 1998, 25 pages.
- Cheyner, Adam, "A Perspective on AI & Agent Technologies for SCM", VerticalNet Presentation, 2001, 22 pages.
- Cheyner, Adam, "About Adam Cheyner", available at <<http://www.adam.cheyner.com/about.html>>, retrieved on Sep. 17, 2012, 2 pages.
- Codd, E. F., "Databases: Improving Usability and Responsiveness—How About Recently", Copyright 1978, Academic Press, Inc., 1978, 28 pages.
- Cohen et al., "An Open Agent Architecture", available at <<http://citeseerx.ist.psu.edu/viewdoc/summary?doi=10.1.1.30.480>>, 1994, 8 pages.
- Cohen et al., "Voice User Interface Design", Excerpts from Chapter 1 and Chapter 10, 2004, 36 pages.
- Coles et al., "Chemistry Question-Answering", SRI International, Jun. 1969, 15 pages.
- Coles et al., "Techniques for Information Retrieval Using an Inferential Question-Answering System with Natural-Language Input", SRI International, Nov. 1972, 198 Pages.
- Coles et al., "The Application of Theorem Proving to Information Retrieval", SRI International, Jan. 1971, 21 pages.
- Combined Search Report and Examination Report under Sections 17 and 18(3) received for GB Patent Application No. 1009318.5, dated Oct. 8, 2010, 5 pages.
- Combined Search Report and Examination Report under Sections 17 and 18(3) received for GB Patent Application No. 1217449.6, dated Jan. 17, 2013, 6 pages.
- Conklin, Jeff, "Hypertext: An Introduction and Survey", Computer Magazine, Sep. 1987, 25 pages.
- Connolly et al., "Fast Algorithms for Complex Matrix Multiplication Using Surrogates", IEEE Transactions on Acoustics, Speech and Signal Processing, vol. 37, No. 6, Jun. 1989, 13 pages.
- Constantinides et al., "A Schema Based Approach to Dialog Control", Proceedings of the International Conference on Spoken Language Processing, 1998, 4 pages.
- Cox et al., "Speech and Language Processing for Next-Millennium Communications Services", Proceedings of the IEEE, vol. 88, No. 8, Aug. 2000, 24 pages.
- Craig et al., "Deacon: Direct English Access and Control", AFIPS Conference Proceedings, vol. 19, San Francisco, Nov. 1966, 18 pages.
- Cutkosky et al., "PACT: An Experiment in Integrating Concurrent Engineering Systems", Journal & Magazines, Computer, vol. 26, No. 1, Jan. 1993, 14 pages.
- Dar et al., "DTL's DataSpot: Database Exploration Using Plain Language", Proceedings of the 24th VLDB Conference, New York, 1998, 5 pages.
- Davis et al., "A Personal Handheld Multi-Modal Shopping Assistant", International Conference on Networking and Services, IEEE, 2006, 9 pages.
- Decker et al., "Designing Behaviors for Information Agents", The Robotics Institute, Carnegie-Mellon University, Paper, Jul. 1996, 15 pages.
- Decker et al., "Matchmaking and Brokering", The Robotics Institute, Carnegie-Mellon University, Paper, May 1996, 19 pages.
- Deerwester et al., "Indexing by Latent Semantic Analysis", Journal of the American Society for Information Science, vol. 41, No. 6, Sep. 1990, 19 pages.
- Deller, Jr. et al., "Discrete-Time Processing of Speech Signals", Prentice Hall, ISBN: 0-02-328301-7, 1987, 14 pages.

(56)

References Cited

OTHER PUBLICATIONS

- Digital Equipment Corporation, "Open VMS Software Overview", Software Manual, Dec. 1995, 159 pages.
- Domingue et al., "Web Service Modeling Ontology (WSMO)—An Ontology for Semantic Web Services", Position Paper at the W3C Workshop on Frameworks for Semantics in Web Services, Innsbruck, Austria, Jun. 2005, 6 pages.
- Donovan, R. E., "A New Distance Measure for Costing Spectral Discontinuities in Concatenative Speech Synthesizers", available at <<http://citeseerx.ist.osu.edu/viewdoc/summary?doi=1.0.1.1.21.6398>>, 2001, 4 pages.
- Dowding et al., "Gemini: A Natural Language System for Spoken-Language Understanding", Proceedings of the Thirty-First Annual Meeting of the Association for Computational Linguistics, 1993, 8 pages.
- Dowding et al., "Interleaving Syntax and Semantics in an Efficient Bottom-Up Parser", Proceedings of the 32nd Annual Meeting of the Association for Computational Linguistics, 1994, 7 pages.
- Dusan et al., "Multimodal Interaction on PDA's Integrating Speech and Pen Inputs", Eurospeech Geneva, 2003, 4 pages.
- Elio et al., "On Abstract Task Models and Conversation Policies", Proc. Workshop on Specifying and Implementing Conversation Policies, Autonomous Agents'99 Conference, 1999, pp. 1-10.
- Epstein et al., "Natural Language Access to a Melanoma Data Base", SRI International, Sep. 1978, 7 pages.
- Ericsson et al., "Software Illustrating a Unified Approach to Multimodality and Multilinguality in the In-Home Domain", Talk and Look: Tools for Ambient Linguistic Knowledge, Dec. 2006, 127 pages.
- Evi, "Meet Evi: The One Mobile Application that Provides Solutions for your Everyday Problems", Feb. 2012, 3 pages.
- Exhibit 1, "Natural Language Interface Using Constrained Intermediate Dictionary of Results", List of Publications Manually Reviewed for the Search of U.S. Pat. No. 7,177,798, Mar. 22, 2013, 1 page.
- Feigenbaum et al., "Computer-Assisted Semantic Annotation of Scientific Life Works", Oct. 15, 2007, 22 pages.
- Ferguson et al., "TRIPS: An Integrated Intelligent Problem-Solving Assistant", Proceedings of the Fifteenth National Conference on Artificial Intelligence (AAAI-98) and Tenth Conference on Innovative Applications of Artificial Intelligence (IAAI-98), 1998, 7 pages.
- Fikes et al., "A Network-Based Knowledge Representation and its Natural Deduction System", SRI International, Jul. 1977, 43 pages.
- Frisse, M. E., "Searching for Information in a Hypertext Medical Handbook", Communications of the ACM, vol. 31, No. 7, Jul. 1988, 8 pages.
- Gamback et al., "The Swedish Core Language Engine", NOTEX Conference, 1992, 17 pages.
- Gannes, Liz, "Alfred App Gives Personalized Restaurant Recommendations", AllThingsD, July 18, 2011, pp. 1-3.
- Gautier et al., "Generating Explanations of Device Behavior Using Compositional Modeling and Causal Ordering", CiteSeerx, 1993, pp. 89-97.
- Gervasio et al., "Active Preference Learning for Personalized Calendar Scheduling Assistance", CiteSeerx, Proceedings of IUI'05, Jan. 2005, pp. 90-97.
- Glass et al., "Multilingual Language Generation Across Multiple Domains", International Conference on Spoken Language Processing, Japan, Sep. 1994, 5 pages.
- Glass et al., "Multilingual Spoken-Language Understanding in the Mit Voyager System", Available online at <<http://groups.csail.mit.edu/sls/publications/1995/speechcomm95-voyager.pdf>>, Aug. 1995, 29 pages.
- Glass, Alyssa, "Explaining Preference Learning", CiteSeerx, 2006, pp. 1-5.
- Goddeau et al., "A Form-Based Dialogue Manager for Spoken Language Applications", Available online at <<http://phasedance.com/pdf/icslp96.pdf>>, Oct. 1996, 4 pages.
- Goddeau et al., "Galaxy: A Human-Language Interface to On-Line Travel Information", International Conference on Spoken Language Processing, Yokohama, 1994, pp. 707-710.
- Goldberg et al., "Using Collaborative Filtering to Weave an Information Tapestry", Communications of the ACM, vol. 35, No. 12, Dec. 1992, 10 pages.
- Gong et al., "Guidelines for Handheld Mobile Device Interface Design", Proceedings of DSI 2004 Annual Meeting, 2004, pp. 3751-3756.
- Gorin et al., "On Adaptive Acquisition of Language", International Conference on Acoustics, Speech and Signal Processing (ICASSP'90), vol. 1, Apr. 1990, 5 pages.
- Gotoh et al., "Document Space Models Using Latent Semantic Analysis", In Proceedings of Eurospeech, 1997, 4 pages.
- Gray, R. M., "Vector Quantization", IEEE ASSP Magazine, Apr. 1984, 26 pages.
- Green, C., "The Application of Theorem Proving to Question-Answering Systems", SRI Stanford Research Institute, Artificial Intelligence Group, Jun. 1969, 169 pages.
- Gregg et al., "DSS Access on the WWW: An Intelligent Agent Prototype", Proceedings of the Americas Conference on Information Systems, Association for Information Systems, 1998, 3 pages.
- Grishman et al., "Computational Linguistics: An Introduction", Cambridge University Press, 1986, 172 pages.
- Grosz et al., "Dialogic: A Core Natural-Language Processing System", SRI International, Nov. 1982, 17 pages.
- Grosz et al., "Research on Natural-Language Processing at SRI", SRI International, Nov. 1981, 21 pages.
- Grosz et al., "TEAM: An Experiment in the Design of Transportable Natural-Language Interfaces", Artificial Intelligence, vol. 32, 1987, 71 pages.
- Grosz, B., "Team: A Transportable Natural-Language Interface System", Proceedings of the First Conference on Applied Natural Language Processing, 1983, 7 pages.
- Gruber et al., "An Ontology for Engineering Mathematics", Fourth International Conference on Principles of Knowledge Representation and Reasoning, Available online at <<http://www-ksl.stanford.edu/knowledge-sharing/papers/engmath.html>>, 1994, pp. 1-22.
- Gruber et al., "Generative Design Rationale: Beyond the Record and Replay Paradigm", Knowledge Systems Laboratory, Technical Report KSL 92-59, Dec. 1991, Updated Feb. 1993, 24 pages.
- Gruber et al., "Machine-Generated Explanations of Engineering Models: A Compositional Modeling Approach", Proceedings of International Joint Conference on Artificial Intelligence, 1993, 7 pages.
- Gruber et al., "NIKE: A National Infrastructure for Knowledge Exchange", A Whitepaper Advocating and ATP Initiative on Technologies for Lifelong Learning, Oct. 1994, pp. 1-10.
- Gruber et al., "Toward a Knowledge Medium for Collaborative Product Development", Proceedings of the Second International Conference on Artificial Intelligence in Design, Jun. 1992, pp. 1-19.
- Gruber, Thomas R., "A Translation Approach to Portable Ontology Specifications", Knowledge Acquisition, vol. 5, No. 2, Jun. 1993, pp. 199-220.
- Gruber, Thomas R., "Automated Knowledge Acquisition for Strategic Knowledge", Machine Learning, vol. 4, 1989, pp. 293-336.
- Gruber, Thomas R., "Interactive Acquisition of Justifications: Learning "Why" by Being Told "What"", Knowledge Systems Laboratory, Technical Report KSL 91-17, Original Oct. 1990, Revised Feb. 1991, 24 pages.
- Gruber, Thomas R., "Toward Principles for the Design of Ontologies used for Knowledge Sharing", International Journal of Human-Computer Studies, vol. 43, No. 5-6, Nov. 1995, pp. 907-928.
- Gruber, Tom, "(Avoiding) The Travesty of the Commons", Presentation at NPUC, New Paradigms for User Computing, IBM Almaden Research Center, Jul. 24, 2006, 52 pages.
- Gruber, Tom, "2021: Mass Collaboration and the Really New Economy", TNY Futures, vol. 1, No. 6, Available online at <<http://tomgruber.org/writing/tnty2001.htm>>, Aug. 2001, 5 pages.
- Gruber, Tom, "Big Think Small Screen: How Semantic Computing in the Cloud will Revolutionize the Consumer Experience on the Phone", Keynote Presentation at Web 3.0 Conference, Jan. 2010, 41 pages.

(56)

References Cited

OTHER PUBLICATIONS

- Gruber, Tom, "Collaborating Around Shared Content on the WWW, W3C Workshop on WWW and Collaboration", available at <<http://www.w3.org/Collaboration/Workshop/Proceedings/P9.html>>, Sep. 1995, 1 page.
- Gruber, Tom, "Collective Knowledge Systems: Where the Social Web Meets the Semantic Web", *Web Semantics: Science, Services and Agents on the World Wide Web*, 2007, pp. 1-19.
- Gruber, Tom, "Despite Our Best Efforts, Ontologies are not the Problem", *AAAI Spring Symposium*, Available online at <<http://tomgruber.org/writing/aaai-ss08.htm>>, Mar. 2008, pp. 1-40.
- Gruber, Tom, "Enterprise Collaboration Management with Intraspect", *Intraspect Technical White Paper*, Jul. 2001, pp. 1-24.
- Gruber, Tom, "Every Ontology is a Treaty—A Social Agreement Among People with Some Common Motive in Sharing", *Official Quarterly Bulletin of AIS Special Interest Group on Semantic Web and Information Systems*, vol. 1, No. 3, 2004, pp. 1-5.
- Gruber, Tom, "Helping Organizations Collaborate, Communicate, and Learn", *Presentation to NASA Ames Research*, Available online at <<http://tomgruber.org/writing/organizational-intelligence-talk.htm>>, Mar.-Oct. 2003, 30 pages.
- Gruber, Tom, "Intelligence at the Interface: Semantic Technology and the Consumer Internet Experience", *Presentation at Semantic Technologies Conference*, Available online at <<http://tomgruber.org/writing/semtech08.htm>>, May 20, 2008, pp. 1-40.
- Gruber, Tom, "It Is What It Does: The Pragmatics of Ontology for Knowledge Sharing", *Proceedings of the International CIDOC CRM Symposium*, Available online at <<http://tomgruber.org/writing/cidoc-ontology.htm>>, Mar. 26, 2003, 21 pages.
- Gruber, Tom, "Ontologies, Web 2.0 and Beyond", *Ontology Summit*, Available online at <<http://tomgruber.org/writing/ontolog-social-web-keynote.htm>>, Apr. 2007, 17 pages.
- Gruber, Tom, "Ontology of Folksonomy: A Mash-Up of Apples and Oranges", *Int'l Journal on Semantic Web & Information Systems*, vol. 3, No. 2, 2007, 7 pages.
- Gruber, Tom, "Siri, A Virtual Personal Assistant—Bringing Intelligence to the Interface", *Semantic Technologies Conference*, Jun. 16, 2009, 21 pages.
- Gruber, Tom, "TagOntology", *Presentation to Tag Camp*, Oct. 29, 2005, 20 pages.
- Gruber, Tom, "Where the Social Web Meets the Semantic Web", *Presentation at the 5th International Semantic Web Conference*, Nov. 2006, 38 pages.
- Guida et al., "NLI: A Robust Interface for Natural Language Person-Machine Communication", *International Journal of Man-Machine Studies*, vol. 17, 1982, 17 pages.
- Guzzoni et al., "A Unified Platform for Building Intelligent Web Interaction Assistants", *Proceedings of the 2006 IEEE/WIC/ACM International Conference on Web Intelligence and Intelligent Agent Technology*, Computer Society, 2006, 4 pages.
- Guzzoni et al., "Active, A Platform for Building Intelligent Operating Rooms", *Surgetica 2007 Computer-Aided Medical Interventions: Tools and Applications*, 2007, pp. 191-198.
- Guzzoni et al., "Active, A platform for Building Intelligent Software", *Computational Intelligence*, available at <<http://www.informatik.uni-trier.de/~ley/pers/hd/g/Guzzoni:Didier>>, 2006, 5 pages.
- Guzzoni et al., "Active, A Tool for Building Intelligent User Interfaces", *ASC 2007, Palma de Mallorca*, Aug. 2007, 6 pages.
- Guzzoni et al., "Many Robots Make Short Work", *AAAI Robot Contest*, SRI International, 1996, 9 pages.
- Guzzoni et al., "Modeling Human-Agent Interaction with Active Ontologies", *AAAI Spring Symposium, Interaction Challenges for Intelligent Assistants*, Stanford University, Palo Alto, California, 2007, 8 pages.
- Guzzoni, D., "Active: A Unified Platform for Building Intelligent Assistant Applications", Oct. 25, 2007, 262 pages.
- Haas et al., "An Approach to Acquiring and Applying Knowledge", *SRI international*, Nov. 1980, 22 pages.
- Hadidi et al., "Student's Acceptance of Web-Based Course Offerings: An Empirical Assessment", *Proceedings of the Americas Conference on Information Systems(AMCIS)*, 1998, 4 pages.
- Hardwar, Devindra, "Driving App Waze Builds its own Siri for Hands-Free Voice Control", Available online at <<http://venturebeat.com/2012/02/09/driving-app-waze-builds-its-own-siri-for-hands-free-voice-control/>>, retrieved on Feb. 9, 2012, 4 pages.
- Harris, F. J., "On the Use of Windows for Harmonic Analysis with the Discrete Fourier Transform", *In Proceedings of the IEEE*, vol. 66, No. 1, Jan. 1978, 34 pages.
- Hawkins et al., "Hierarchical Temporal Memory: Concepts, Theory and Terminology", *Numenta, Inc.*, Mar. 27, 2007, 20 pages.
- He et al., "Personal Security Agent: KQML-Based PKI", *The Robotics Institute, Carnegie-Mellon University, Paper*, 1997, 14 pages.
- Helm et al., "Building Visual Language Parsers", *Proceedings of CHI'91, Proceedings of the SIGCHI Conference on Human Factors in Computing Systems*, 1991, 8 pages.
- Hendrix et al., "Developing a Natural Language Interface to Complex Data", *ACM Transactions on Database Systems*, vol. 3, No. 2, Jun. 1978, pp. 105-147.
- Hendrix et al., "Transportable Natural-Language Interfaces to Databases", *SRI International, Technical Note 228*, Apr. 30, 1981, 18 pages.
- Hendrix, Gary G., "Human Engineering for Applied Natural Language Processing", *SRI International, Technical Note 139*, Feb. 1977, 27 pages.
- Hendrix, Gary G., "Klaus: A System for Managing Information and Computational Resources", *SRI International, Technical Note 230*, Oct. 1980, 34 pages.
- Hendrix, Gary G., "Lifer: A Natural Language Interface Facility", *SRI Stanford Research Institute, Technical Note 135*, Dec. 1976, 9 pages.
- Hendrix, Gary G., "Natural-Language Interface", *American Journal of Computational Linguistics*, vol. 8, No. 2, Apr.-Jun. 1982, pp. 56-61.
- Hendrix, Gary G., "The Lifer Manual: A Guide to Building Practical Natural Language Interfaces", *SRI International, Technical Note 138*, Feb. 1977, 76 pages.
- Hermansky, H., "Perceptual Linear Predictive (PLP) Analysis of Speech", *Journal of the Acoustical Society of America*, vol. 87, No. 4, Apr. 1990, 15 pages.
- Hermansky, H., "Recognition of Speech in Additive and Convolutional Noise Based on Rasta Spectral Processing", *Proceedings of IEEE International Conference on Acoustics, Speech and Signal Processing (ICASSP'93)*, Apr. 1993, 4 pages.
- Hirschman et al., "Multi-Site Data Collection and Evaluation in Spoken Language Understanding", *Proceedings of the Workshop on Human Language Technology*, 1993, pp. 19-24.
- Hobbs et al., "Fastus: A System for Extracting Information from Natural-Language Text", *SRI International, Technical Note 519*, Nov. 19, 1992, 26 pages.
- Hobbs et al., "Fastus: Extracting Information from Natural-Language Texts", *SRI International*, 1992, pp. 1-22.
- Hobbs, Jerry R., "Sublanguage and Knowledge", *SRI International, Technical Note 329*, Jun. 1984, 30 pages.
- Hodjat et al., "Iterative Statistical Language Model Generation for use with an Agent-Oriented Natural Language Interface", *Proceedings of HCI International*, vol. 4, 2003, pp. 1422-1426.
- Hoehfeld et al., "Learning with Limited Numerical Precision Using the Cascade-Correlation Algorithm", *IEEE Transactions on Neural Networks*, vol. 3, No. 4, Jul. 1992, 18 pages.
- Holmes, J. N., "Speech Synthesis and Recognition-Stochastic Models for Word Recognition", *Published by Chapman & Hall, London*, ISBN 0 412 534304, 1998, 7 pages.
- Hon et al., "CMU Robust Vocabulary-Independent Speech Recognition System", *IEEE International Conference on Acoustics, Speech and Signal Processing (ICASSP-91)*, Apr. 1991, 4 pages.
- Horvitz et al., "Handsfree Decision Support: Toward a Non-invasive Human-Computer Interface", *Proceedings of the Symposium on Computer Applications in Medical Care*, *IEEE Computer Society Press*, 1995, p. 955.

(56)

References Cited

OTHER PUBLICATIONS

- Horvitz et al., "In Pursuit of Effective Handsfree Decision Support: Coupling Bayesian Inference, Speech Understanding, and User Models", 1995, 8 pages.
- Huang et al., "The Sphinx-II Speech Recognition System: An Overview", *Computer, Speech and Language*, vol. 7, No. 2, 1993, 14 pages.
- IBM, "Integrated Audio-Graphics User Interface", IBM Technical Disclosure Bulletin, vol. 33, No. 11, Apr. 1991, 4 pages.
- IBM, "Speech Editor", IBM Technical Disclosure Bulletin, vol. 29, No. 10, Mar. 10, 1987, 3 pages.
- IBM, "Speech Recognition with Hidden Markov Models of Speech Waveforms", IBM Technical Disclosure Bulletin, vol. 34, No. 1, Jun. 1991, 10 pages.
- International Preliminary Report on Patentability received for PCT Patent Application No. PCT/US1994/011011, dated Feb. 28, 1996, 4 pages.
- International Search Report and Written Opinion received for PCT Patent Application No. PCT/US1994/011011, dated Feb. 8, 1995, 3 pages. (International Search Report only).
- International Search Report and Written Opinion received for PCT Patent Application No. PCT/US2010/037378, dated Aug. 25, 2010, 14 pages.
- International Search Report and Written Opinion received for PCT Patent Application No. PCT/US2011/020861, dated Nov. 29, 2011, 12 pages.
- International Search Report and Written Opinion received for PCT Patent Application No. PCT/US2012/040571, dated Nov. 16, 2012, 14 pages.
- International Search Report and Written Opinion received for PCT Patent Application No. PCT/US2012/056382, dated Dec. 20, 2012, 11 pages.
- Intraspect Software, "The Intraspect Knowledge Management Solution: Technical Overview", available at <<http://tomgruber.org/writing/intraspect-whitepaper-1998.pdf>>, 1998, 18 pages.
- Iowegian International, "FIR Filter Properties, DSPGuru, Digital Signal Processing Central", available at <<http://www.dspguru.com/dsp/faq/fir/properties>> retrieved on Jul. 28, 2010, 6 pages.
- Issar et al., "CMU's Robust Spoken Language Understanding System", *Proceedings of Eurospeech*, 1993, 4 pages.
- Issar, Sunil, "Estimation of Language Models for New Spoken Language Applications", *Proceedings of 4th International Conference on Spoken Language Processing*, Oct. 1996, 4 pages.
- Jacobs et al., "Scisor: Extracting Information from On-Line News", *Communications of the ACM*, vol. 33, No. 11, Nov. 1990, 10 pages.
- Janas, Jurgen M., "The Semantics-Based Natural Language Interface to Relational Databases", Chapter 6, *Cooperative Interfaces to Information Systems*, 1986, pp. 143-188.
- Jelinek, F., "Self-Organized Language Modeling for Speech Recognition", *Readings in Speech Recognition*, Edited by Alex Waibel and Kai-Fu Lee, Morgan Kaufmann Publishers, Inc., ISBN: 1-55860-124-4, 1990, 63 pages.
- Jennings et al., "A Personal News Service Based on a User Model Neural Network", *IEICE Transactions on Information and Systems*, vol. E75-D, No. 2, Mar. 1992, 12 pages.
- Ji et al., "A Method for Chinese Syllables Recognition Based upon Sub-syllable Hidden Markov Model", 1994 International Symposium on Speech, Image Processing and Neural Networks, Hong Kong, Apr. 1994, 4 pages.
- Johnson, Julia Ann., "A Data Management Strategy for Transportable Natural Language Interfaces", Doctoral Thesis Submitted to the Department of Computer Science, University of British Columbia, Canada, Jun. 1989, 285 pages.
- Jones, J., "Speech Recognition for Cyclone", Apple Computer, Inc., E.R.S. Revision 2.9, Sep. 10, 1992, 93 pages.
- Julia et al., "<http://www.speech.sri.com/demos/atis.html>", *Proceedings of AAAI, Spring Symposium*, 1997, 5 pages.
- Julia et al., "Un Editeur Interactif De Tableaux Dessines a Main Levee (An Interactive Editor for Hand-Sketched Tables)", *Traitement du Signal*, vol. 12, No. 6, 1995, pp. 619-626.
- Kahn et al., "CoABS Grid Scalability Experiments", *Autonomous Agents and Multi-Agent Systems*, vol. 7, 2003, pp. 171-178.
- Kamel et al., "A Graph Based Knowledge Retrieval System", *IEEE International Conference on Systems, Man and Cybernetics*, 1990, pp. 269-275.
- Karp, P. D., "A Generic Knowledge-Base Access Protocol", Available online at <<http://lecture.cs.buu.ac.th/~f50353/Document/gfp.pdf>>, May 12, 1994, 66 pages.
- Katz et al., "Exploiting Lexical Regularities in Designing Natural Language Systems", *Proceedings of the 12th International Conference on Computational Linguistics*, 1988, pp. 1-22.
- Katz et al., "REXTOR: A System for Generating Relations from Natural Language", *Proceedings of the ACL Workshop on Natural Language Processing and Information Retrieval (NLP&IR)*, Oct. 2000, 11 pages.
- Katz, Boris, "A Three-Step Procedure for Language Generation", *Massachusetts Institute of Technology, A.I. Memo No. 599*, Dec. 1980, pp. 1-40.
- Katz, Boris, "Annotating the World Wide Web Using Natural Language", *Proceedings of the 5th RIAO Conference on Computer Assisted Information Searching on the Internet*, 1997, 7 pages.
- Katz, Boris, "Using English for Indexing and Retrieving", *Proceedings of the 1st RIAO Conference on User-Oriented Content-Based Text and Image Handling*, 1988, pp. 314-332.
- Katz, S. M., "Estimation of Probabilities from Sparse Data for the Language Model Component of a Speech Recognizer", *IEEE Transactions on Acoustics, Speech and Signal Processing*, vol. ASSP-35, No. 3, Mar. 1987, 3 pages.
- Kitano, H., "PhiDM-Dialog, An Experimental Speech-to-Speech Dialog Translation System", *Computer*, vol. 24, No. 6, Jun. 1991, 13 pages.
- Klabbers et al., "Reducing Audible Spectral Discontinuities", *IEEE Transactions on Speech and Audio Processing*, vol. 9, No. 1, Jan. 2001, 13 pages.
- Klatt et al., "Linguistic Uses of Segmental Duration in English: Acoustic and Perpetual Evidence", *Journal of the Acoustical Society of America*, vol. 59, No. 5, May 1976, 16 pages.
- Knownav, "Knowledge Navigator", YouTube Video available at <http://www.youtube.com/watch?v=QRH8eimU_20>, Apr. 29, 2008, 1 page.
- Kominek et al., "Impact of Durational Outlier Removal from Unit Selection Catalogs", 5th ISCA Speech Synthesis Workshop, Jun. 14-16, 2004, 6 pages.
- Konolige, Kurt, "A Framework for a Portable Natural-Language Interface to Large Data Bases", *SRI International, Technical Note* 197, Oct. 12, 1979, 54 pages.
- Kubala et al., "Speaker Adaptation from a Speaker-Independent Training Corpus", *International Conference on Acoustics, Speech and Signal Processing (ICASSP'90)*, Apr. 1990, 4 pages.
- Kubala et al., "The Hub and Spoke Paradigm for CSR Evaluation", *Proceedings of the Spoken Language Technology Workshop*, Mar. 1994, 9 pages.
- Laird et al., "SOAR: An Architecture for General Intelligence", *Artificial Intelligence*, vol. 33, 1987, pp. 1-64.
- Langley et al., "A Design for the ICARUS Architecture", *SIGART Bulletin*, vol. 2, No. 4, 1991, pp. 104-109.
- Larks, "Intelligent Software Agents", available at <<http://www.cs.cmu.edu/~softagents/larks.html>> retrieved on Mar. 15, 2013, 2 pages.
- Lee et al., "A Real-Time Mandarin Dictation Machine for Chinese Language with Unlimited Texts and Very Large Vocabulary", *International Conference on Acoustics, Speech and Signal Processing*, vol. 1, Apr. 1990, 5 pages.
- Lee et al., "Golden Mandarin (II)—An Improved Single-Chip Real-Time Mandarin Dictation Machine for Chinese Language with Very Large Vocabulary", *IEEE International Conference of Acoustics, Speech and Signal Processing*, vol. 2, 1993, 4 pages.
- Lee et al., "Golden Mandarin (II)—An Intelligent Mandarin Dictation Machine for Chinese Character Input with Adaptation/Learning Functions", *International Symposium on Speech, Image Processing and Neural Networks, Hong Kong*, Apr. 1994, 5 pages.

(56)

References Cited

OTHER PUBLICATIONS

- Lee et al., "System Description of Golden Mandarin (I) Voice Input for Unlimited Chinese Characters", International Conference on Computer Processing of Chinese & Oriental Languages, vol. 5, No. 3 & 4, Nov. 1991, 16 pages.
- Lee, K. F., "Large-Vocabulary Speaker-Independent Continuous Speech Recognition: The SPHINX System", Partial Fulfillment of the Requirements for the Degree of Doctor of Philosophy, Computer Science Department, Carnegie Mellon University, Apr. 1988, 195 pages.
- Lemon et al., "Multithreaded Context for Robust Conversational Interfaces: Context-Sensitive Speech Recognition and Interpretation of Corrective Fragments", ACM Transactions on Computer-Human Interaction, vol. 11, No. 3, Sep. 2004, pp. 241-267.
- Leong et al., "CASIS: A Context-Aware Speech Interface System", Proceedings of the 10th International Conference on Intelligent User Interfaces, Jan. 2005, pp. 231-238.
- Lieberman et al., "Out of Context: Computer Systems that Adapt to, and Learn from, Context", IBM Systems Journal, vol. 39, No. 3 & 4, 2000, pp. 617-632.
- Lin et al., "A Distributed Architecture for Cooperative Spoken Dialogue Agents with Coherent Dialogue State and History", Available on line at <<http://citeseerx.ist.psu.edu/viewdoc/summary?doi=10.1.1.42.272>>, 1999, 4 pages.
- Lin et al., "A New Framework for Recognition of Mandarin Syllables with Tones Using Sub-syllabic Unites", IEEE International Conference on Acoustics, Speech and Signal Processing (ICASSP-93), Apr. 1993, 4 pages.
- Linde et al., "An Algorithm for Vector Quantizer Design", IEEE Transactions on Communications, vol. 28, No. 1, Jan. 1980, 12 pages.
- Liu et al., "Efficient Joint Compensation of Speech for the Effects of Additive Noise and Linear Filtering", IEEE International Conference of Acoustics, Speech and Signal Processing, ICASSP-92, Mar. 1992, 4 pages.
- Logan et al., "Mel Frequency Cepstral Co-efficients for Music Modeling", International Symposium on Music Information Retrieval, 2000, 2 pages.
- Lowerre, B. T., "The-Harpy Speech Recognition System", Doctoral Dissertation, Department of Computer Science, Carnegie Mellon University, Apr. 1976, 20 pages.
- Maghbouleh, Arman, "An Empirical Comparison of Automatic Decision Tree and Linear Regression Models for Vowel Durations", Revised Version of a Paper Presented at the Computational Phonology in Speech Technology Workshop, 1996 Annual Meeting of the Association for Computational Linguistics in Santa Cruz, California, 7 pages.
- Markel et al., "Linear Prediction of Speech", Springer-Verlag, Berlin, Heidelberg, New York, 1976, 12 pages.
- Martin et al., "Building and Using Practical Agent Applications", SRI International, PAAM Tutorial, 1998, 78 pages.
- Martin et al., "Building Distributed Software Systems with the Open Agent Architecture", Proceedings of the Third International Conference on the Practical Application of Intelligent Agents and Multi-Agent Technology, Mar. 1998, pp. 355-376.
- Martin et al., "Development Tools for the Open Agent Architecture", Proceedings of the International Conference on the Practical Application of Intelligent Agents and Multi-Agent Technology, Apr. 1996, pp. 1-17.
- Martin et al., "Information Brokering in an Agent Architecture", Proceedings of the Second International Conference on the Practical Application of Intelligent Agents and Multi-Agent Technology, Apr. 1997, pp. 1-20.
- Martin et al., "The Open Agent Architecture: A Framework for Building Distributed Software Systems", Applied Artificial Intelligence: An International Journal, vol. 13, No. 1-2, available at <<http://adam.cheyer.com/papers/oa.pdf>>, retrieved from internet on Jan.-Mar. 1999.
- Martin et al., "Transportability and Generality in a Natural-Language Interface System", Proceedings of the Eighth International Joint Conference on Artificial Intelligence, Technical Note 293, Aug. 1983, 21 pages.
- Matiasek et al., "Tamic-P: A System for NL Access to Social Insurance Database", 4th International Conference on Applications of Natural Language to Information Systems, Jun. 1999, 7 pages.
- McGuire et al., "SHADE: Technology for Knowledge-Based Collaborative Engineering", Journal of Concurrent Engineering Applications and Research (CERA), 1993, 18 pages.
- Mel Scale, Wikipedia the Free Encyclopedia, Last modified on Oct. 13, 2009 and retrieved on Jul. 28, 2010, available at <http://en.wikipedia.org/wiki/Mel_scale>, 2 pages.
- Meng et al., "Wheels: A Conversational System in the Automobile Classified Domain", Proceedings of Fourth International Conference on Spoken Language, ICSLP 96, vol. 1, Oct. 1996, 4 pages.
- Michos et al., "Towards an Adaptive Natural Language Interface to Command Languages", Natural Language Engineering, vol. 2, No. 3, 1996, pp. 191-209.
- Milstead et al., "Metadata: Cataloging by Any Other Name", available at <http://www.iicm.tugraz.at/thesis/cguetl_diss/literatur/Kapitel06/References/Milstead_et_al._1999/metadata.html>, Jan. 1999, 18 pages.
- Milward et al., "D2.2: Dynamic Multimodal Interface Reconfiguration, Talk and Look: Tools for Ambient Linguistic Knowledge", available at <http://www.ihmc.us/users/nblaylock!Pubs/Files/talk_d2.2.pdf>, Aug. 8, 2006, 69 pages.
- Minimum Phase, Wikipedia the free Encyclopedia, Last modified on Jan. 12, 2010 and retrieved on Jul. 28, 2010, available at <http://en.wikipedia.org/wiki/Minimum_phase>, 8 pages.
- Minker et al., "Hidden Understanding Models for Machine Translation", Proceedings of ETRW on Interactive Dialogue in Multimodal Systems, Jun. 1999, pp. 1-4.
- Mitra et al., "A Graph-Oriented Model for Articulation of Ontology Interdependencies", Advances in Database Technology, Lecture Notes in Computer Science, vol. 1777, 2000, pp. 1-15.
- Modi et al., "CMRadat: A Personal Assistant Agent for Calendar Management", AAAI, Intelligent Systems Demonstrations, 2004, pp. 1020-1021.
- Moore et al., "Combining Linguistic and Statistical Knowledge Sources in Natural-Language Processing for ATIS", SRI International, Artificial Intelligence Center, 1995, 4 pages.
- Moore et al., "SRI's Experience with the ATIS Evaluation", Proceedings of the Workshop on Speech and Natural Language, Jun. 1990, pp. 147-148.
- Moore et al., "The Information Warfare Advisor: An Architecture for Interacting with Intelligent Agents Across the Web", Proceedings of Americas Conference on Information Systems (AMCIS), Dec. 31, 1998, pp. 186-188.
- Moore, Robert C., "Handling Complex Queries in a Distributed Data Base", SRI International, Technical Note 170, Oct. 8, 1979, 38 pages.
- Moore, Robert C., "Practical Natural-Language Processing by Computer", SRI International, Technical Note 251, Oct. 1981, 34 pages.
- Moore, Robert C., "The Role of Logic in Knowledge Representation and Commonsense Reasoning", SRI International, Technical Note 264, Jun. 1982, 19 pages.
- Moore, Robert C., "Using Natural-Language Knowledge Sources in Speech Recognition", SRI International, Artificial Intelligence Center, Jan. 1999, pp. 1-24.
- Moran et al., "Intelligent Agent-Based User Interfaces", Proceedings of International Workshop on Human Interface Technology, Oct. 1995, pp. 1-4.
- Moran et al., "Multimodal User Interfaces in the Open Agent Architecture", International Conference on Intelligent User Interfaces (IUI97), 1997, 8 pages.
- Moran, Douglas B., "Quantifier Scoping in the SRI Core Language Engine", Proceedings of the 26th Annual Meeting on Association for Computational Linguistics, 1988, pp. 33-40.
- Morgan, B., "Business Objects (Business Objects for Windows) Business Objects Inc.", DBMS, vol. 5, No. 10, Sep. 1992, 3 pages.

(56)

References Cited

OTHER PUBLICATIONS

- Motro, Amihai, "Flex: A Tolerant and Cooperative User Interface to Databases", IEEE Transactions on Knowledge and Data Engineering, vol. 2, No. 2, Jun. 1990, pp. 231-246.
- Mountford et al., "Talking and Listening to Computers", The Art of Human-Computer Interface Design, Apple Computer, Inc., Addison-Wesley Publishing Company, Inc., 1990, 17 pages.
- Mozer, Michael C., "An Intelligent Environment must be Adaptive", IEEE Intelligent Systems, 1999, pp. 11-13.
- Murty et al., "Combining Evidence from Residual Phase and MFCC Features for Speaker Recognition", IEEE Signal Processing Letters, vol. 13, No. 1, Jan. 2006, 4 pages.
- Murveit et al., "Integrating Natural Language Constraints into HMM-Based Speech Recognition", International Conference on Acoustics, Speech and Signal Processing, Apr. 1990, 5 pages.
- Murveit et al., "Speech Recognition in SRI's Resource Management and ATIS Systems", Proceedings of the Workshop on Speech and Natural Language, 1991, pp. 94-100.
- Nakagawa et al., "Speaker Recognition by Combining MFCC and Phase Information", IEEE International Conference on Acoustics, Speech and Signal Processing (ICASSP), Mar. 2010, 4 pages.
- Naone, Erica, "TR10: Intelligent Software Assistant", Technology Review, Mar.-Apr. 2009, 2 pages.
- Neches et al., "Enabling Technology for Knowledge Sharing", Fall, 1991, pp. 37-56.
- Niesler et al., "A Variable-Length Category-Based N-Gram Language Model", IEEE International Conference on Acoustics, Speech and Signal Processing (ICASSP'96), vol. 1, May 1996, 6 pages.
- Noth et al., "VerbMobil: The Use of Prosody in the Linguistic Components of a Speech Understanding System", IEEE Transactions on Speech and Audio Processing, vol. 8, No. 5, Sep. 2000, pp. 519-532.
- Odubiyi et al., "SAIRE—A Scalable Agent-Based Information Retrieval Engine", Proceedings of the First International Conference on Autonomous Agents, 1997, 12 pages.
- Owei et al., "Natural Language Query Filtration in the Conceptual Query Language", IEEE, 1997, pp. 539-549.
- Pannu et al., "A Learning Personal Agent for Text Filtering and Notification", Proceedings of the International Conference of Knowledge Based Systems, 1996, pp. 1-11.
- Papadimitriou et al., "Latent Semantic Indexing: A Probabilistic Analysis", Available online at <<http://citeseerx.ist.psu.edu/messages/downloadsexceeded.html>>, Nov. 14, 1997, 21 pages.
- Parson, T. W., "Voice and Speech Processing", Pitch and Formant Estimation, McGraw-Hill, Inc., ISBN: 0-07-0485541-0, 1987, 15 pages.
- Parsons, T. W., "Voice and Speech Processing", Linguistics and Technical Fundamentals, Articulatory Phonetics and Phonemics, McGraw-Hill, Inc., ISBN: 0-07-0485541-0, 1987, 5 pages.
- Pereira, Fernando, "Logic for Natural Language Analysis", SRI International, Technical Note 275, Jan. 1983, 194 pages.
- Perrault et al., "Natural-Language Interfaces", SRI International, Technical Note 393, Aug. 22, 1986, 48 pages.
- Phoenix Solutions, Inc., "Declaration of Christopher Schmandt Regarding the MIT Galaxy System", West Interactive Corp., A Delaware Corporation, Document 40, Jul. 2, 2010, 162 pages.
- Picone, J., "Continuous Speech Recognition using Hidden Markov Models", IEEE ASSP Magazine, vol. 7, No. 3, Jul. 1990, 16 pages.
- Pollock, Stephen, "A Rule-Based Message Filtering System", Published in: Journal, ACM Transactions on Information Systems (TOIS), vol. 6, Issue 3, Jul. 1988, pp. 232-254.
- Pulman et al., "Clare: A Combined Language and Reasoning Engine", Proceedings of JFIT Conference, available at <<http://www.cam.sri.com/tr/crc042/paper.ps.Z>>, 1993, 8 pages.
- Rabiner et al., "Fundamental of Speech Recognition", AT&T, Published by Prentice-Hall, Inc., ISBN: 0-13-285826-6, 1993, 17 pages.
- Rabiner et al., "Note on the Properties of a Vector Quantizer for LPC Coefficients", Bell System Technical Journal, vol. 62, No. 8, Oct. 1983, 9 pages.
- Ratcliffe, M., "ClearAccess 2.0 Allows SQL Searches Off-Line (Structured Query Language) (ClearAccess Corp. Preparing New Version of Data-Access Application with Simplified User Interface, New Features) (Product Announcement)", MacWeek, vol. 6, No. 41, Nov. 16, 1992, 2 pages.
- Ravishankar, Mosur K., "Efficient Algorithms for Speech Recognition", Doctoral Thesis Submitted to School of Computer Science, Computer Science Division, Carnegie Mellon University, Pittsburgh, May 15, 1996, 146 pages.
- Rayner et al., "Adapting the Core Language Engine to French and Spanish", Cornell University Library, available at <<http://arxiv.org/abs/cmp-lg/9605015>>, May 10, 1996, 9 pages.
- Rayner et al., "Deriving Database Queries from Logical Forms by Abductive Definition Expansion", Proceedings of the Third Conference on Applied Natural Language Processing, ANLC, 1992, 8 pages.
- Rayner et al., "Spoken Language Translation with Mid-90's Technology: A Case Study", Eurospeech, ISCA, Available online at <<http://citeseerx.ist.psu.edu/viewdoc/summary?doi=10.1.1.54.8608>>, 1993, 4 pages.
- Rayner, M., "Abductive Equivalential Translation and its Application to Natural Language Database Interfacing", Dissertation Paper, SRI International, Sep. 1993, 162 pages.
- Rayner, Manny, "Linguistic Domain Theories: Natural-Language Database Interfacing from First Principles", SRI International, Cambridge, 1993, 11 pages.
- Reddi, "The Parser".
- Remde et al., "SuperBook: An Automatic Tool for Information Exploration-Hypertext?", In Proceedings of Hypertext, 87 Papers, Nov. 1987, 14 pages.
- Reynolds, C. F., "On-Line Reviews: A New Application of the HICOM Conferencing System", IEEE Colloquium on Human Factors in Electronic Mail and Conferencing Systems, Feb. 3, 1989, 4 pages.
- Rice et al., "Monthly Program: Nov. 14, 1995", The San Francisco Bay Area Chapter of ACM SIGCHI, available at <<http://www.baychi.org/calendar/19951114>>, Nov. 14, 1995, 2 pages.
- Rice et al., "Using the Web Instead of a Window System", Proceedings of the SIGCHI Conference on Human Factors in Computing Systems, CHI'96, 1996, pp. 1-14.
- Rigoll, G., "Speaker Adaptation for Large Vocabulary Speech Recognition Systems Using Speaker Markov Models", International Conference on Acoustics, Speech and Signal Processing (ICASSP'89), May 1989, 4 pages.
- Riley, M. D., "Tree-Based Modelling of Segmental Durations", Talking Machines Theories, Models and Designs, Elsevier Science Publishers B.V., North-Holland, ISBN: 08-444-89115.3, 1992, 15 pages.
- Rivlin et al., "Maestro: Conductor of Multimedia Analysis Technologies", SRI International, 1999, 7 pages.
- Rivoira et al., "Syntax and Semantics in a Word-Sequence Recognition System", IEEE International Conference on Acoustics, Speech and Signal Processing (ICASSP'79), Apr. 1979, 5 pages.
- Roddy et al., "Communication and Collaboration in a Landscape of B2B eMarketplaces", VerticalNet Solutions, White Paper, Jun. 15, 2000, 23 pages.
- Rosenfeld, R., "A Maximum Entropy Approach to Adaptive Statistical Language Modelling", Computer Speech and Language, vol. 10, No. 3, Jul. 1996, 25 pages.
- Roszkiewicz, A., "Extending your Apple", Back Talk-Lip Service, A+ Magazine, The Independent Guide for Apple Computing, vol. 2, No. 2, Feb. 1984, 5 pages.
- Rudnicki et al., "Creating Natural Dialogs in the Carnegie Mellon Communicator System", Proceedings of Eurospeech, vol. 4, 1999, pp. 1531-1534.
- Russell et al., "Artificial Intelligence, A Modern Approach", Prentice Hall, Inc., 1995, 121 pages.
- Sacerdoti et al., "A Ladder User's Guide (Revised)", SRI International Artificial Intelligence Center, Mar. 1980, 39 pages.
- Sagalowicz, D., "AD-Ladder User's Guide", SRI International, Sep. 1980, 42 pages.

(56)

References Cited

OTHER PUBLICATIONS

- Sakoe et al., "Dynamic Programming Algorithm Optimization for Spoken Word Recognition", *IEEE Transactions on Acoustics, Speech and Signal Processing*, vol. ASSP-26, No. 1, Feb. 1978, 8 pages.
- Salton et al., "On the Application of Syntactic Methodologies in Automatic Text Analysis", *Information Processing and Management*, vol. 26, No. 1, Great Britain, 1990, 22 pages.
- Sameshima et al., "Authorization with Security Attributes and Privilege Delegation Access control beyond the ACL", *Computer Communications*, vol. 20, 1997, 9 pages.
- San-Segundo et al., "Confidence Measures for Dialogue Management in the CU Communicator System", *Proceedings of Acoustics, Speech and Signal Processing (ICASSP'00)*, Jun. 2000, 4 pages.
- Sato, H., "A Data Model, Knowledge Base and Natural Language Processing for Sharing a Large Statistical Database", *Statistical and Scientific Database Management, Lecture Notes in Computer Science*, vol. 339, 1989, 20 pages.
- Savoy, J., "Searching Information in Hypertext Systems Using Multiple Sources of Evidence", *International Journal of Man-Machine Studies*, vol. 38, No. 6, Jun. 1996, 15 pages.
- Scagliola, C., "Language Models and Search Algorithms for Real-Time Speech Recognition", *International Journal of Man-Machine Studies*, vol. 22, No. 5, 1985, 25 pages.
- Schmandt et al., "Augmenting a Window System with Speech Input", *IEEE Computer Society, Computer*, vol. 23, No. 8, Aug. 1990, 8 pages.
- Schnelle, Dirk, "Context Aware Voice User Interfaces for Workflow Support", *Dissertation paper*, Aug. 27, 2007, 254 pages.
- Schütze, H., "Dimensions of Meaning", *Proceedings of Supercomputing'92 Conference*, Nov. 1992, 10 pages.
- Seneff et al., "A New Restaurant Guide Conversational System: Issues in Rapid Prototyping for Specialized Domains", *Proceedings of Fourth International Conference on Spoken Language*, vol. 2, 1996, 4 pages.
- Sharoff et al., "Register-Domain Separation as a Methodology for Development of Natural Language Interfaces to Databases", *Proceedings of Human-Computer Interaction (INTERACT'99)*, 1999, 7 pages.
- Sheth et al., "Evolving Agents for Personalized Information Filtering", *Proceedings of the Ninth Conference on Artificial Intelligence for Applications*, Mar. 1993, 9 pages.
- Sheth et al., "Relationships at the Heart of Semantic Web: Modeling, Discovering, and Exploiting Complex Semantic Relationships", *Enhancing the Power of the Internet: Studies in Fuzziness and Soft Computing*, Oct. 13, 2002, pp. 1-38.
- Shikano et al., "Speaker Adaptation through Vector Quantization", *IEEE International Conference on Acoustics, Speech and Signal Processing (ICASSP'86)*, vol. 11, Apr. 1986, 4 pages.
- Shimazu et al., "CAPIT: Natural Language Interface Design Tool with Keyword Analyzer and Case-Based Parser", *NEG Research & Development*, vol. 33, No. 4, Oct. 1992, 11 pages.
- Shinkle, L., "Team User's Guide", *SRI International, Artificial Intelligence Center*, Nov. 1984, 78 pages.
- Shklar et al., "InfoHarness: Use of Automatically Generated Metadata for Search and Retrieval of Heterogeneous Information", *Proceedings of CAISE'95, Finland*, 1995, 14 pages.
- Sigurdsson et al., "Mel Frequency Cepstral Co-efficients: An Evaluation of Robustness of MP3 Encoded Music", *Proceedings of the 7th International Conference on Music Information Retrieval*, 2006, 4 pages.
- Silverman et al., "Using a Sigmoid Transformation for Improved Modeling of Phoneme Duration", *Proceedings of the IEEE International Conference on Acoustics, Speech and Signal Processing*, Mar. 1999, 5 pages.
- Simonite, Tom, "One Easy Way to Make Siri Smarter", *Technology Review*, Oct. 18, 2011, 2 pages.
- Singh, N., "Unifying Heterogeneous Information Models", *Communications of the ACM*, 1998, 13 pages.
- SRI International, "The Open Agent Architecture TM 1.0 Distribution", *Open Agent Architecture (OAA)*, 1999, 2 pages.
- SRI, "SRI Speech: Products: Software Development Kits: EduSpeak", available at <http://web.archive.org/web/20090828084033/http://www.speechsri.com/products/eduspeak>html>, retrieved on Jun. 20, 2013, 2 pages.
- Starr et al., "Knowledge-Intensive Query Processing", *Proceedings of the 5th KRDB Workshop*, Seattle, May 31, 1998, 6 pages.
- Stent et al., "The CommandTalk Spoken Dialogue System", *SRI International*, 1999, pp. 183-190.
- Stern et al., "Multiple Approaches to Robust Speech Recognition", *Proceedings of Speech and Natural Language Workshop*, 1992, 6 pages.
- Stickel, Mark E., "A Nonclausal Connection-Graph Resolution Theorem-Proving Program", *Proceedings of AAAI'82*, 1982, 5 pages.
- Sugumaran, V., "A Distributed Intelligent Agent-Based Spatial Decision Support System", *Proceedings of the Americas Conference on Information systems (AMCIS)*, Dec. 31, 1998, 4 pages.
- Sycara et al., "Coordination of Multiple Intelligent Software Agents", *International Journal of Cooperative Information Systems (IJCIS)*, vol. 5, No. 2 & 3, 1996, 31 pages.
- Sycara et al., "Distributed Intelligent Agents", *IEEE Expert*, vol. 11, No. 6, Dec. 1996, 32 pages.
- Sycara et al., "Dynamic Service Matchmaking among Agents in Open Information Environments", *SIGMOD Record*, 1999, 7 pages.
- Sycara et al., "The Retsina MAS Infrastructure", *Autonomous Agents and Multi-Agent Systems*, vol. 7, 2003, 20 pages.
- Tenenbaum et al., "Data Structure Using Pascal", *Prentice-Hall, Inc.*, 1981, 34 pages.
- Textndrive, "Text'nDrive App Demo-Listen and Reply to your Messages by Voice while Driving!", *YouTube Video* available at <http://www.youtube.com/watch?WaGfzoHsAMw>, Apr. 27, 2010, 1 page.
- Tofel, Kevin C., "SpeakToIt: A Personal Assistant for Older iPhones, iPads", *Apple News, Tips and Reviews*, Feb. 9, 2012, 7 pages.
- Top 10 Best Practices for Voice User Interface Design available at <http://www.developer.com/voice/article.php/1567051/Top-10-Best-Practices-for-Voice-User-Interface-Design.htm>, Nov. 1, 2002, 4 pages.
- Tsai et al., "Attributed Grammar—A Tool for Combining Syntactic and Statistical Approaches to Pattern Recognition", *IEEE Transactions on Systems, Man and Cybernetics*, vol. SMC-10, No. 12, Dec. 1980, 13 pages.
- Tucker, Joshua, "Too Lazy to Grab Your TV Remote? Use Siri Instead", *Engadget*, Nov. 30, 2011, 8 pages.
- Tur et al., "The CALO Meeting Assistant System", *IEEE Transactions on Audio, Speech and Language Processing*, vol. 18, No. 6, Aug. 2010, pp. 1601-1611.
- Tur et al., "The CALO Meeting Speech Recognition and Understanding System", *Proc. IEEE Spoken Language Technology Workshop*, 2008, 4 pages.
- Tyson et al., "Domain-Independent Task Specification in the TACITUS Natural Language System", *SRI International, Artificial Intelligence Center*, May 1990, 16 pages.
- Udell, J., "Computer Telephony", *BYTE*, vol. 19, No. 7, Jul. 1994, 9 pages.
- Van Santen, J. P.H., "Contextual Effects on Vowel Duration", *Journal Speech Communication*, vol. 11, No. 6, Dec. 1992, pp. 513-546.
- Vepa et al., "New Objective Distance Measures for Spectral Discontinuities in Concatenative Speech Synthesis", *Proceedings of the IEEE 2002 Workshop on Speech Synthesis*, 2002, 4 pages.
- Vershelde, Jan, "MATLAB Lecture 8. Special Matrices in MATLAB", *UIC, Dept. of Math, Stat. & CS, MCS 320, Introduction to Symbolic Computation*, 2007, 4 pages.
- Vingron, Martin, "Near-Optimal Sequence Alignment", *Current Opinion in Structural Biology*, vol. 6, No. 3, 1996, pp. 346-352.
- Vlingo Incar, "Distacted Driving Solution with Vlingo InCar", *YouTube Video*, Available online at <http://www.youtube.com/watch?v=Vqs8XEXgz4>, Oct. 2010, 2 pages.
- Vlingo, "Vlingo Launches Voice Enablement Application on Apple App Store", *Press Release*, Dec. 3, 2008, 2 pages.

(56)

References Cited

OTHER PUBLICATIONS

- Voiceassist, "Send Text, Listen to and Send E-Mail by Voice", YouTube Video, Available online at <<http://www.youtube.com/watch?v=0tEU61nHHA4>>, Jul. 30, 2009, 1 page.
- Voiceonthego, "Voice on the Go (BlackBerry)", YouTube Video, available online at <<http://www.youtube.com/watch?v=pJqpWgQS98w>>, Jul. 27, 2009, 1 page.
- Wahlster et al., "Smartkom: Multimodal Communication with a Life-Like Character", Eurospeech-Scandinavia, 7th European Conference on Speech Communication and Technology, 2001, 5 pages.
- Waldinger et al., "Deductive Question Answering from Multiple Resources", New Directions in Question Answering, Published by AAAI, Menlo Park, 2003, 22 pages.
- Walker et al., "Natural Language Access to Medical Text", SRI International, Artificial Intelligence Center, Mar. 1981, 23 pages.
- Waltz, D., "An English Language Question Answering System for a Large Relational Database", ACM, vol. 21, No. 7, 1978, 14 pages.
- Ward et al., "A Class Based Language Model for Speech Recognition", IEEE, 1996, 3 pages.
- Ward et al., "Recent Improvements in the CMU Spoken Language Understanding System", ARPA Human Language Technology Workshop, 1994, 4 pages.
- Ward, Wayne, "The CMU Air Travel Information Service: Understanding Spontaneous Speech", Proceedings of the Workshop on Speech and Natural Language, HLT '90, 1990, pp. 127-129.
- Warren et al., "An Efficient Easily Adaptable System for Interpreting Natural Language Queries", American Journal of Computational Linguistics, vol. 8, No. 3-4, 1982, 11 pages.
- Weizenbaum, J., "ELIZA—A Computer Program for the Study of Natural Language Communication Between Man and Machine", Communications of the ACM, vol. 9, No. 1, Jan. 1966, 10 pages.
- Werner et al., "Prosodic Aspects of Speech, Universite de Lausanne", Fundamentals of Speech Synthesis and Speech Recognition: Basic Concepts, State of the Art and Future Challenges, 1994, 18 pages.
- Winiwarter et al., "Adaptive Natural Language Interfaces to FAQ Knowledge Bases", Proceedings of 4th International Conference on Applications of Natural Language to Information Systems, Austria, Jun. 1999, 22 pages.
- Wolff, M., "Post Structuralism and the ARTFUL Database: Some Theoretical Considerations", Information Technology and Libraries, vol. 13, No. 1, Mar. 1994, 10 pages.
- Wu et al., "KDA: A Knowledge-Based Database Assistant", Proceeding of the Fifth International Conference on Engineering (IEEE Cat.No. 89CH2695-5), 1989, 8 pages.
- Wu, M., "Digital Speech Processing and Coding", Multimedia Signal Processing, Lecture-2 Course Presentation, University of Maryland, College Park, 2003, 8 pages.
- Wu, M., "Speech Recognition, Synthesis, and H.C.I.", Multimedia Signal Processing, Lecture-3 Course Presentation, University of Maryland, College Park, 2003, 11 pages.
- Wyle, M. F., "A Wide Area Network Information Filter", Proceedings of First International Conference on Artificial Intelligence on Wall Street, Oct. 1991, 6 pages.
- Yang et al., "Smart Sight: A Tourist Assistant System", Proceedings of Third International Symposium on Wearable Computers, 1999, 6 pages.
- Yankelovich et al., "Intermedia: The Concept and the Construction of a Seamless Information Environment", Computer Magazine, IEEE, Jan. 1988, 16 pages.
- Yoon et al., "Letter-to-Sound Rules for Korean", Department of Linguistics, The Ohio State University, 2002, 4 pages.
- Zeng et al., "Cooperative Intelligent Software Agents", The Robotics Institute, Carnegie-Mellon University, Mar. 1995, 13 pages.
- Zhao et al., "Intelligent Agents for Flexible Workflow Systems", Proceedings of the Americas Conference on Information Systems (AMCIS), Oct. 1998, 4 pages.
- Zhao, Y., "An Acoustic-Phonetic-Based Speaker Adaptation Technique for Improving Speaker-Independent Continuous Speech Recognition", IEEE Transactions on Speech and Audio Processing, vol. 2, No. 3, Jul. 1994, pp. 380-394.
- Zovato et al., "Towards Emotional Speech Synthesis: A Rule based Approach", Proceedings of 5th ISCA Speech Synthesis Workshop-Pittsburgh, 2004, pp. 219-220.
- Zue et al., "From Interface to Content: Translingual Access and Delivery of On-Line Information", Eurospeech, 1997, 4 pages.
- Zue et al., "Jupiter: A Telephone-Based Conversational Interface for Weather Information", IEEE Transactions on Speech and Audio Processing, Jan. 2000, 13 pages.
- Zue et al., "Pegasus: A Spoken Dialogue Interface for On-Line Air Travel Planning", Speech Communication, vol. 15, 1994, 10 pages.
- Zue et al., "The Voyager Speech Understanding System: Preliminary Development and Evaluation", Proceedings of IEEE, International Conference on Acoustics, Speech and Signal Processing, 1990, 4 pages.
- Zue, Victor W., "Toward Systems that Understand Spoken Language", ARPA Strategic Computing Institute, Feb. 1994, 9 pages.
- Zue, Victor, "Conversational Interfaces: Advances and Challenges", Spoken Language System Group, Sep. 1997, 10 pages.

* cited by examiner

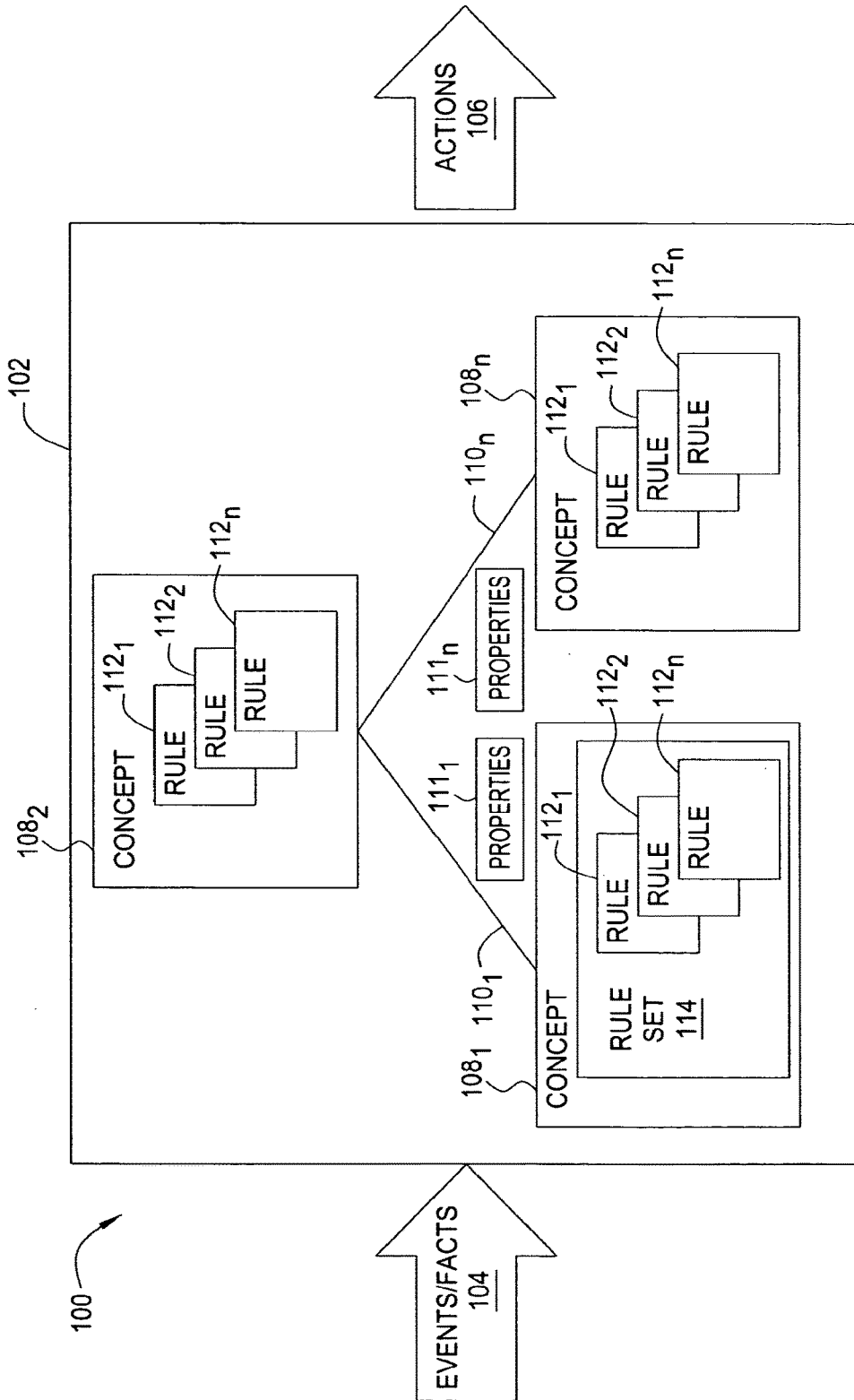

FIG. 1

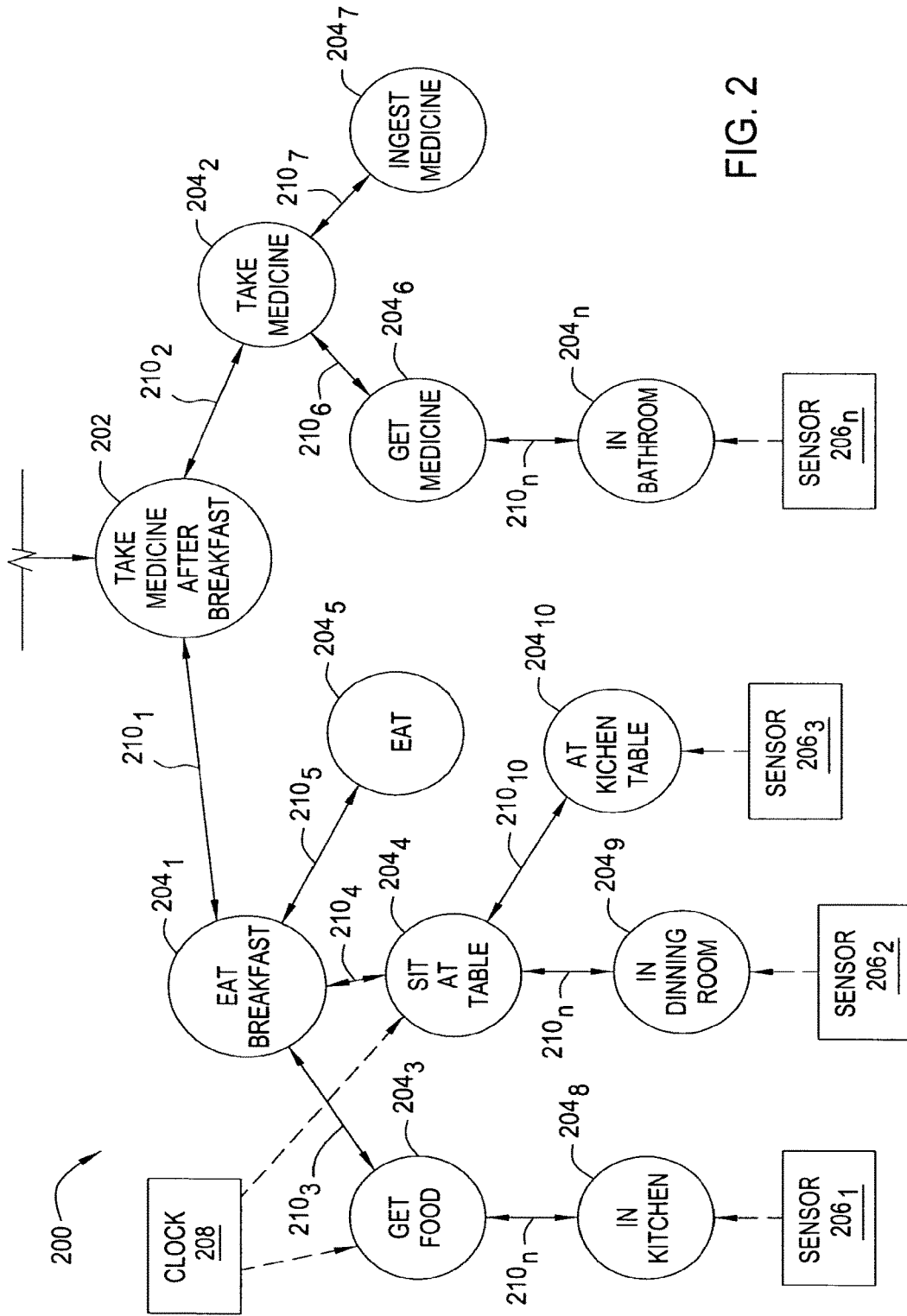

FIG. 2

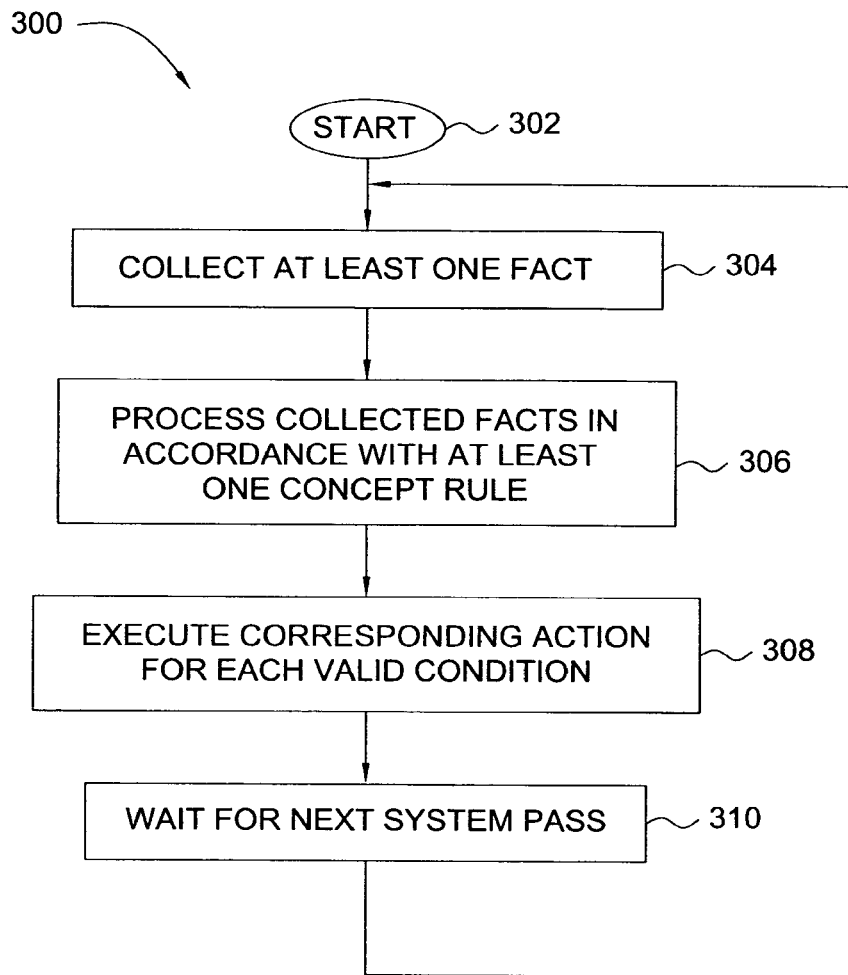
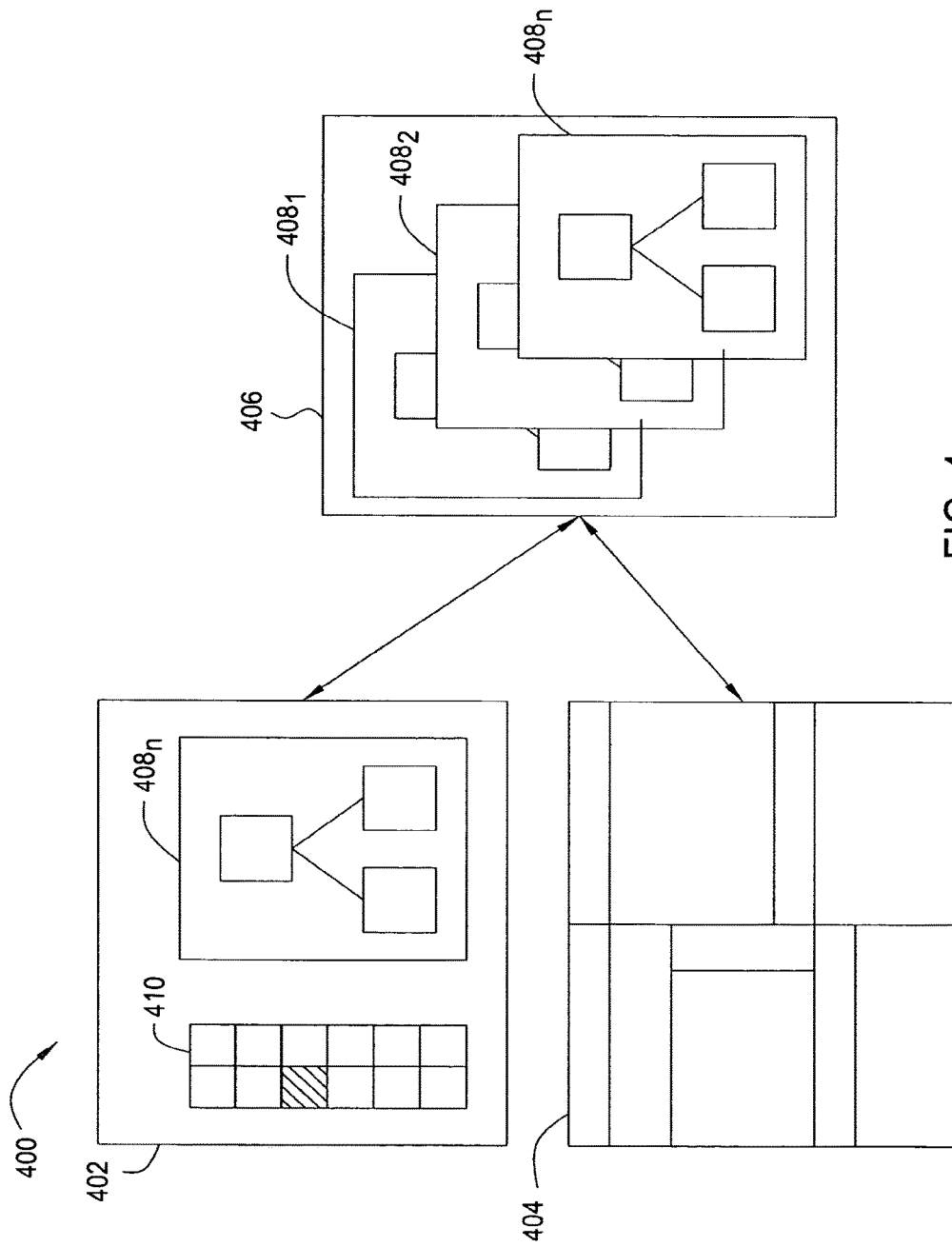

FIG. 3



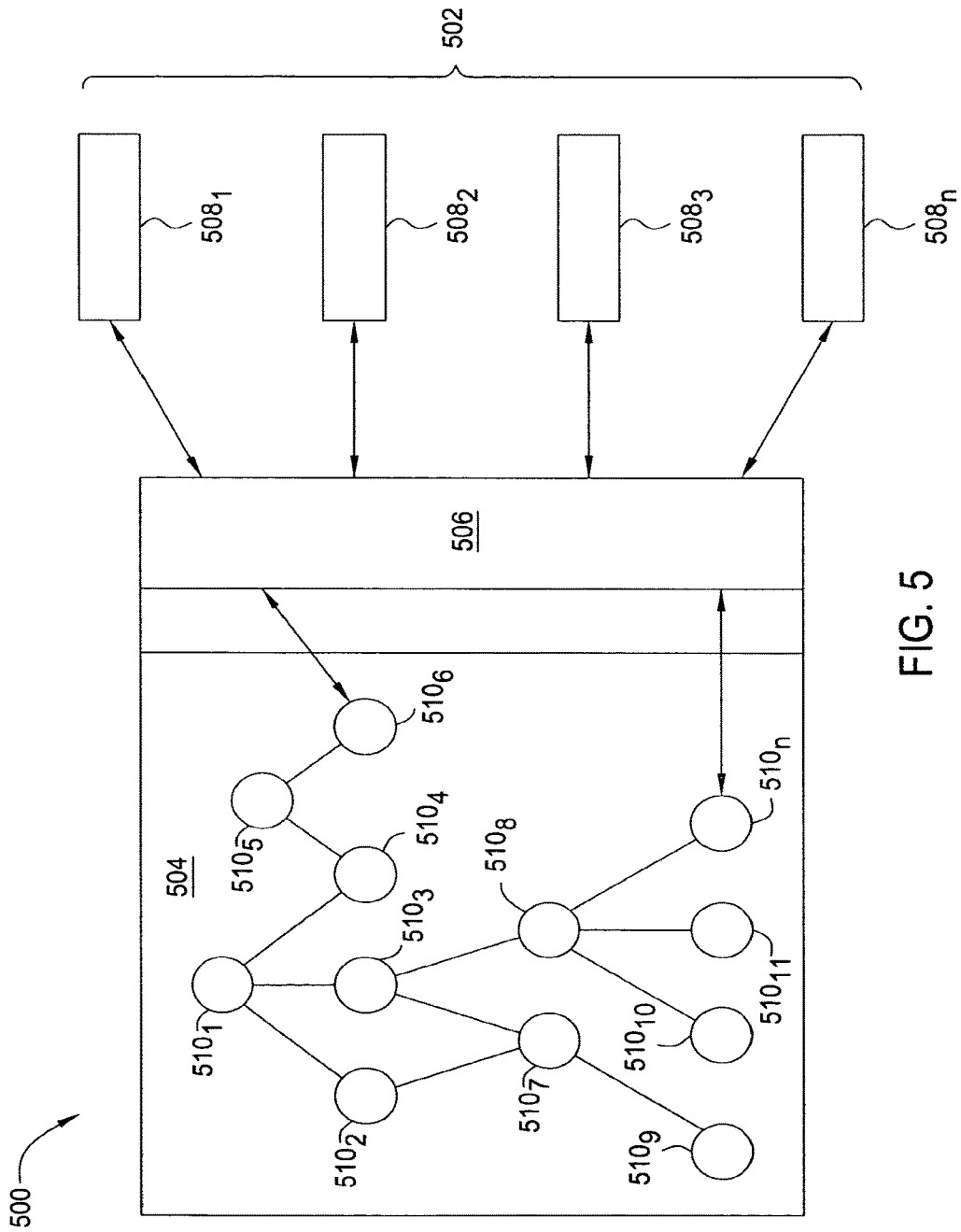

FIG. 5

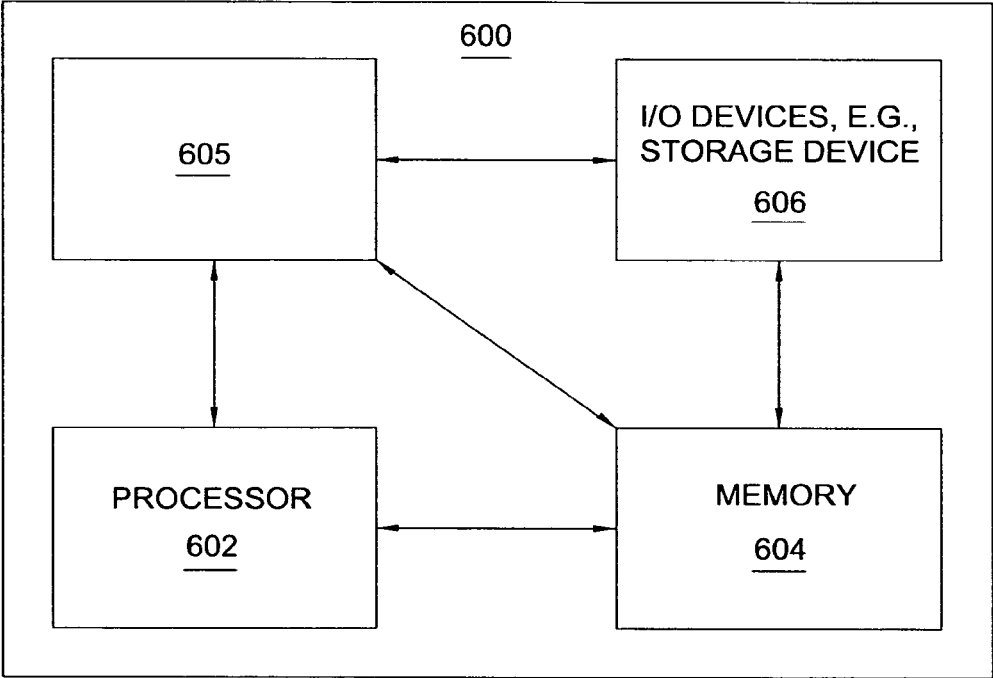

FIG. 6

METHOD AND APPARATUS FOR BUILDING AN INTELLIGENT AUTOMATED ASSISTANT

CROSS REFERENCE TO RELATED APPLICATIONS

This application is a continuation of U.S. application Ser. No. 14/141,261, filed Dec. 26, 2013, entitled "METHOD AND APPARATUS FOR BUILDING AN INTELLIGENT AUTOMATED ASSISTANT," which is a continuation of U.S. application Ser. No. 11/518,292, filed Sep. 8, 2006, entitled "METHOD AND APPARATUS FOR BUILDING AN INTELLIGENT AUTOMATED ASSISTANT," (now U.S. Pat. No. 8,677,377, issued on Mar. 18, 2014), which claims the benefit of U.S. Provisional Patent Application Ser. No. 60/715,324, filed Sep. 8, 2005, entitled "METHOD AND APPARATUS FOR BUILDING AN INTELLIGENT AUTOMATED ASSISTANT." All above applications which are herein incorporated by reference in their entirety for all purposes.

FIELD OF THE INVENTION

The invention relates generally to intelligent systems and relates more specifically to tools for building classes of applications for intelligent automated assistants.

BACKGROUND OF THE DISCLOSURE

Intelligent systems, such as intelligent automated assistants, that are capable of interacting with humans (e.g., by observing user behavior, communicating with users, understanding observed situations, anticipating what a user may need and acting to produce useful behavior) are valuable in a variety of situations. For example, such systems may assist individuals who are impaired in some way (e.g., visually, auditorially, physically, cognitively, etc.), including elderly people (who may be stricken by one or more ailments), surgeons (whose eyes, hands and brains are constantly busy/when performing operations) and business executives (who may have numerous tasks to accomplish), among others.

To accomplish all of these objectives, intelligent automated assistants integrate a variety of capabilities provided by different software components (e.g., for supporting natural language recognition, multimodal input, managing distributed services, etc.). Development of a system incorporating these different software components typically requires knowledge of numerous different programming languages and artificial intelligence-based methods. Thus, the development of an intelligent automated assistant is a complex task that typically requires contribution from a plurality of highly skilled individuals each having expertise in different aspects of programming; it is nearly impossible for a lone software developer to build an intelligent automated assistant due to the breadth and variety of expertise that is required to build the system. The typical development process for building intelligent automated assistants is therefore relatively inefficient in terms of time, cost and manpower.

Thus, there is a need in the art for a method and apparatus for building an intelligent automated assistant.

SUMMARY OF THE INVENTION

A method and apparatus are provided for building an intelligent automated assistant. Embodiments of the present

invention rely on the concept of "active ontologies" (e.g., execution environments constructed in an ontology-like manner) to build and run applications for use by intelligent automated assistants. In one specific embodiment, a method for building an automated assistant includes interfacing a service-oriented architecture that includes a plurality of remote services to an active ontology, where the active ontology includes at least one active processing element that models a domain. At least one of the remote services is then registered for use in the domain.

BRIEF DESCRIPTION OF THE DRAWINGS

FIG. 1 is a schematic diagram illustrating one embodiment of an active ontology execution environment according to the present invention;

FIG. 2 is a schematic diagram illustrating one embodiment of an exemplary active ontology that is configured as an autominder for reminding a user to take medicine after meals (e.g., configured for activity and/or time recognition);

FIG. 3 is a flow diagram illustrating one embodiment of a method for processing facts in accordance with an active ontology (e.g., configured in a manner similar to the active ontology of FIG. 1) according to the present invention;

FIG. 4 is a schematic diagram illustrating one embodiment of an open standard-based system for developing and managing an intelligent system using active ontologies;

FIG. 5 is a schematic diagram illustrating one embodiment of a framework for dynamically registering and coordinating distributed services using active ontologies; and

FIG. 6 is a high level block diagram of the present intelligent system building method that is implemented using a general purpose computing device.

DETAILED DESCRIPTION

In one embodiment, the present invention is a method and apparatus for building an intelligent automated assistant. Embodiments of the present invention rely on a developer-friendly unified framework, referred to as an "active ontology", which integrates multiple system-building capabilities in a single tool. An "ontology", generally, is a passive data structure that represents domain knowledge, where distinct classes, attributes and relations among classes are defined. A separate engine may operate or reason on this data structure to produce certain results. Within the context of the present invention, an "active ontology" may be thought of as an execution environment in which distinct processing elements are arranged in an ontology-like manner (e.g., having distinct attributes and relations with other processing elements). These processing elements carry out at least some of the typical tasks of an intelligent automated assistant. Although described within the context of an intelligent automated assistant, it will be understood that the concepts of the present invention may be implemented in accordance with any application that involves interaction with software.

FIG. 1 is a schematic diagram illustrating one embodiment of an active ontology execution environment **100** according to the present invention. The execution environment comprises an active ontology **102** that is adapted to receive one or more input facts or events **104** and process these inputs **104** to produce useful actions **106**. In one embodiment, the active ontology **102** is tailored to a specific context. For example, the active ontology **102** may be adapted to remind a user to take medication after meals, where at least some of the input facts **104** relate to events collected from the user's surrounding environment (e.g.,

“the user is in the kitchen”, “the user is eating”, “the time is 8:00 AM”, etc.) and at least one of the actions **106** is produced in response to these facts (e.g., prompting the user to take the medication at the appropriate time).

To this end, the active ontology **102** comprises at least one active processing element or concept **108₁-108_n**, (hereinafter collectively referred to as “concepts **108**”). The concepts **108** may be thought of as the basic building block of the active ontology **102**; concepts **108** both represent a sub-part of the execution environment **100** and perform computations or actions (e.g., natural language understanding, task execution, etc.) related to the sub-part. Concepts **108** are adapted to match to specific types of facts in order to perform these actions, and may be specifically configured to manage temporal constraints, service brokering strategies, fusion strategies, or other tasks.

In one embodiment, the concepts **108** are prioritized such that the input facts **104** are processed against the concepts **108** starting with a highest-ranked concept **108** and proceeding in descending order to a lowest-ranked concept **108**. In one embodiment, at least two of the concepts **108** are communicatively coupled by a channel **110₁-110_n**, (hereinafter collectively referred to as “channels **110**”) that allows the concepts **108** to communicate and to share information. For example, concepts **108** may share all or part of their respective computation results with other concepts **108** over these channels **110**. In this case, information propagated using the channels **110** may be weighted or associated with a probability such that joining concepts **108** may use these weights or probabilities when determining how further results derived from incoming information should be propagated.

In one embodiment, channels **110** possess properties **111₁-111_n**, (hereinafter referred to as “properties **111**”) that configure the relationship expressed between connected concepts. For example, a property “Mandatory” associated with a channel that connects a first concept and a second concept may express that the first concept cannot be valid if the second concept is not satisfied. Thus, for instance, if the first concept represents “MovieListing”, and the second concept represents “GeographicalArea”, the “Mandatory” property expresses that a user cannot request a MovieListing (e.g., “Find action movies starring actor X”) without also supplying a geographical location (“e.g., near San Francisco”).

Each concept **108** comprises a template including at least one rule **112₁-112_n**, (hereinafter collectively referred to as “rules **112**”) or rule set **114** (comprising multiple rules **112**). Each rule **112** comprises a condition and an associated action. If an input fact matches a rule’s condition, the associated action is triggered. In one embodiment, conditions may be evaluated as Java Script Boolean expressions (e.g., comprising slots), while associated actions are executed as Java Script programs. In further embodiment, rules **112** are prioritized within each concept **108** so that the rules are processed in an order of descending priority. Prioritization of rules allows for applications including activity recognition and action validation to share a common ontology structure. For example, a decision tree may be traversed in one direction for action execution, and then traversed in the opposite direction for action validation.

Among other advantages, active ontologies such as those described above can enable a simplified, efficient development scheme for intelligent automated assistants. Such a framework can be implemented to tie together multiple different programming applications, including applications capable of processing multimodal input, generating adapt-

able presentations, producing natural language dialogues, performing reactive planning, performing activity recognition and/or scheduling, and brokering, registering and coordinating distributed services, in a unified, visual framework. Thus, a single software developer may quickly and easily build an intelligent automated assistant using such a unified, developer-friendly development scheme.

As described in further detail with respect to FIG. 3, an active ontology such as the active ontology **102** may be built to process facts in order to achieve any one of a number of goals, including activity recognition (e.g., natural language processing, human activity, recognition, etc.), reactive activity execution (e.g., pseudo-reactive planning, rule-based planning, etc.) and management of temporal constraints (e.g., for activity execution times), among others. A plurality of individual active ontologies may be built to execute a plurality of different goals, and these individual active ontologies may be integrated into a single processing unit such as an intelligent automated assistant. As described further below, these active ontologies may be managed in a manner that is significantly simpler than the traditional development process for intelligent automated assistants.

FIG. 2 is a schematic diagram illustrating one embodiment of an exemplary active ontology **200** that is configured as an assistant for reminding a user to take medicine after meals (e.g., configured for activity and/or time recognition). As illustrated, the active ontology **200** comprises at least one target task **202** (e.g., “take medicine after breakfast”) and a plurality of concepts **204₁-204_n**, (hereinafter collectively referred to as “concepts **204**”) representing potential user actions related to the target task **202** and to the modeled domain in which these actions are likely to occur (e.g., the user’s home). The concepts **204** are communicatively coupled to other concepts **204** via a plurality of channels **210₁-210_n**, (hereinafter collectively referred to as “channels **210**”).

The active ontology **200** is also in communication with a plurality of sensors **206₁-206_n**, (hereinafter collectively referred to as “sensors **206**”) that are distributed throughout the modeled domain and are adapted to convey observed facts relating to the user’s behavior (e.g., “the user is in the kitchen”; “the user is in the dining room”; “the user is in the bathroom”; etc.) to the higher-level concepts **204** for appropriate processing. Concepts **204** also communicate processing results (or at least partial processing results) to other concepts for further processing (e.g., if concept **204₈** verifies that the user is in the kitchen, concept **204₈** may convey this information to concept **204₃**, which is configured to determine whether the user is getting food). In addition, a clock **208** may also be in communication with the concepts **204** to enable the management of temporal constraints (e.g., the user is expected to sit at the table for approximately twenty-five minutes while eating breakfast; the user should take his/her medicine approximately thirty minutes after finishing breakfast; etc.).

Thus, if the target task **202** is not observed as being executed (e.g., the active ontology **200** does not determine that the user has taken the medicine after a meal or within a predefined period of time after finishing a meal), one or more of the processing elements (concepts **204**) may generate a reminder to prompt the user to perform the target task **202**. Although the active ontology **200** illustrated in FIG. 2 is configured to manage activity and time recognition tasks, those skilled in the art will appreciate that similarly constructed active ontologies may be built for natural language recognition, task automation and other useful tasks. In

general, the same structure or rule or set of rules can be used both to observe and understand the surrounding world and to act on such observations.

FIG. 3 is a flow diagram illustrating one embodiment of a method 300 for processing facts in accordance with an active ontology (e.g., configured in a manner similar to the active ontology 102 of FIG. 1) according to the present invention. The method 300 may be executed at, for example, an intelligent automated assistant that interacts with a user in accordance with an active ontology.

The method 300 is initialized at step 302 and proceeds to step 304, where the method 300 collects at least one fact from the operating environment. In one embodiment, facts may be received via sensors (e.g., cameras, motion sensors, environmental and/or physical monitoring devices, etc.) distributed through the operating environment or from other multimodal user interfaces (e.g., a natural language interface, a graphical user interface, etc.). In one embodiment, collected facts are “tagged” upon receipt to identify an associated context and evaluation pass of the method 300.

In step 306, the method 300 processes the collected facts in accordance with at least one concept rule to identify valid conditions. In one embodiment, only facts that are associated (or “tagged”) with the current execution pass are processed in step 306. In one embodiment, concepts are processed in accordance with a predefined order of priority, and rules for each concept are likewise processed in accordance with a predefined order of priority. Thus, step 306 begins by processing relevant facts against the highest priority rule of the highest priority concept, and then processes the facts against the second-highest priority rule of the highest priority concept, and so on until all rules of the highest priority concept have been processed. Step 306 then moves on to the next-highest priority concept and proceeds in a likewise manner.

In one embodiment, processing of facts in accordance with step 306 also includes the sharing of information among concepts (e.g., via channels as described above). The processing priority order described above ensures that higher priority concepts are evaluated first while lower priority concepts are still executable within a common execution pass of the method 300.

In step 308, the method 300 executes the corresponding action for each valid condition that is identified in accordance with 306. The method 300 then proceeds to step 310 and waits for the next execution pass. In one embodiment, the execution passes of the method 300 are predefined such that the method 300 automatically executes at a given pace (e.g., once every x seconds). At the next execution pass, the method 300 returns to step 304 and proceeds as described above to evaluate a new set of facts.

FIG. 4 is a schematic diagram illustrating one embodiment of an open standard-based system 400 for developing and managing an intelligent system using active ontologies. In one embodiment, the system 400 includes an editor 402, a console 404 and a server 406. In one embodiment, the editor 402 and the console 404 communicate with the server 506 using SOAP-based communications.

The server 406 is adapted to store a plurality of individual active ontologies 408₁-408_n (hereinafter collectively referred to as “active ontologies 408”) and to run selected (deployed) active ontologies 408 in an application domain. In one embodiment, the server 406 also stores observed facts for processing in accordance with an active ontology such as one of the stored or deployed active ontologies 408. Specifically, these facts may be used to stimulate currently

deployed active ontologies 408. In one embodiment, the server 406 is a stand-alone application (e.g., a Java stand-alone application).

The editor 402 is interfaced to the server 406 and is adapted to retrieve active ontologies 408 from the server 406 for editing. Specifically, the editor 402 is adapted to edit the concepts and/or rules embodied in the active ontologies 408 and to deploy or remove active ontologies 408 from use. To this end, the editor 402 comprises a plurality of editing tools 410, for example embodied in a graphical user interface such as a task bar. In further embodiments, the editor 402 is also adapted to receive feedback directly from deployed active ontologies 408. In one embodiment, the editor 402 is a stand-alone application (e.g., a Java (Swing) stand-alone application).

The console 404 is also interfaced to the server 406 and is adapted to graphically model the application domain as an active ontology (e.g., by enabling the dragging and dropping and linking of objects and tasks) and to construct user queries (e.g., service requests) to be posed to the server 406, for example using a graphical user interface. Active ontologies constructed using the console 404 are stored at the server 406. The console 404 is further adapted to receive and display query results (e.g., specific stored active ontologies 408) sent by the server 406. In further embodiments, the console 404 is also adapted to stimulate deployed active ontologies 408 by sending new observed facts to the server 406. In one embodiment, the console 404 is a stand-alone application (e.g., a Java (Swing) stand-alone application).

FIG. 5 is a schematic diagram illustrating one embodiment of a framework 500 for dynamically registering and coordinating distributed services using active ontologies. Specifically, the framework 500 uses active ontologies to register remote services 508₁-508_n (e.g., information services such as those for hotels, movies, etc., hereinafter collectively referred to as “services 508”) from a service-oriented architecture 502 (e.g., Web Services). These services 508 may then be implemented by an intelligent automated assistant, “on the fly”, to accomplish one or more tasks. Service-oriented architectures such as Web Services allow the standardized integration of web-based applications using the extensible markup language (XML), simple object access protocol (SOAP), web service definition language (WSDL) and universal description, discovery and integration (UDDI) open standards over an Internet Protocol (IP) backbone.

Thus, the framework 500 includes at least one active ontology 504 interfaced to a service-oriented architecture 502 via a service broker 506. As described above, the active ontology 504 graphically models a relevant domain (e.g., the objects in the relevant environment and the associated tasks to be accomplished) using a plurality of concepts or active processing elements 510₁-510_n (used, for example, for service registration, language recognition, activity and/or time recognition, task automation, etc.) that communicate through message passing.

The service broker 506 is adapted to communicate asynchronously with the remote service-oriented architecture 502 and with the active processing elements 510 to select specific services 508 (e.g., based on meta-data about the services 508, including, for example, the service’s call patterns or quality across various dimensions such as time, cost and completeness), to delegate tasks, queries and updates, and to monitor requests for services.

A service 508 registers with the active ontology 504 by specifying the active processing elements 510 that the

service **508** can or cannot accept. Thus, the active ontology **504** is used to filter service requests to the appropriate services **508**.

The framework **500** enables the rapid development of a system having capabilities similar to an open agent architecture framework (e.g., the framework **500** can dynamically, broker, register and coordinate distributed services to resolve user queries and perform requested tasks). Moreover, the framework **500** enables better follow-ups and dialogues with users, flexible definition of timing constraints and task execution and recognition, and can adapt a user interface to the level of a specific user.

FIG. **6** is a high level block diagram of the present intelligent system building method that is implemented using a general purpose computing device **600**. In one embodiment, a general purpose computing device **600** comprises a processor **602**, a memory **604**, an intelligent system building module **605** and various input/output (I/O) devices **606** such as a display, a keyboard, a mouse, a modem, and the like. In one embodiment, at least one I/O device is a storage device (e.g., a disk drive, an optical disk drive, a floppy disk drive). It should be understood that the intelligent system building module **605** can be implemented as a physical device or subsystem that is coupled to a processor through a communication channel.

Alternatively, the intelligent system building module **605** can be represented by one or more software applications (or even a combination of software and hardware, e.g., using Application Specific Integrated Circuits (ASIC)), where the software is loaded from a storage medium (e.g., **110** devices **606**) and operated by the processor **602** in the memory **604** of the general purpose computing device **600**. Thus, in one embodiment, the intelligent system building module **605** for building intelligent systems described herein with reference to the preceding Figures can be stored on a computer readable medium or carrier (e.g., RAM, magnetic or optical drive or diskette, and the like).

Thus, the present invention represents a significant advancement in the field of intelligent systems. The methods and apparatuses of the present invention enable intelligent systems, such as intelligent automated assistants, to be quickly and efficiently developed an “average” programmer (e.g., programmers who are not extensively versed in all necessary fields of technology). Capabilities including natural language interpretation and dialog, multimodal input, adaptable presentation (output), reactive planning, activity recognition/scheduling and coordination of distributed services, among others, can be integrated using a single, visual, unified framework. The manner in which software is built can thus be greatly simplified for many industries, including those which develop or rely on intelligent systems.

While foregoing is directed to the preferred embodiment of the present invention, other and further embodiments of the invention may be devised without departing from the basic scope thereof, and the scope thereof is determined by the claims that follow.

What is claimed is:

1. An electronic device, comprising:
one or more processors;
memory; and

one or more programs, wherein the one or more programs are stored in the memory and configured to be executed by the one or more processors, the one or more programs including instructions for:

receiving, at a processor, at least one request for services, the request for services being in natural language form;

determining, at the processor, one or more active processing elements of an active ontology that are associated with the request for services, each active processing element associated with the request for services with a probability greater than zero; and
prioritizing, by the processor, the one or more active processing elements associated with the active ontology;

wherein:

the active ontology is configured to perform natural language processing on user input, the natural language processing performed in response to the request for services, and

the active ontology comprises a plurality of active processing elements adapted to match specific types of facts.

2. The electronic device of claim **1**, further comprising:
determining the one or more active processing elements using facts relating to events collected from a user's environment.

3. The electronic device of claim **1**, wherein each of the one or more active processing elements specifies one or more request for services that the one or more active processing elements can accept.

4. The electronic device of claim **1**, further comprising:
filtering the one or more active processing elements by the associated probability.

5. The electronic device of claim **1**, further comprising:
selecting an active processing element.

6. The electronic device of claim **5**, further comprising:
selecting the active processing element with a highest associated probability.

7. The electronic device of claim **6**, further comprising:
performing the request for services in accordance with the selected active processing element.

8. The electronic device of claim **7**, wherein the active ontology models a domain, and wherein each active processing element of the active processing elements represents at least one of: an object in the domain and an associated task to be accomplished.

9. The electronic device of claim **7**, wherein at least two of the active processing elements communicate information via a channel.

10. The electronic device of claim **9**, wherein the information communicated via the channel comprises processing results generated by at least one of the at least two of the active processing elements.

11. The electronic device of claim **10**, further comprising:
determining the probability associated with the information communicated via the channel;

determining, based on the probability associated with the information, the propagation of additional processing results generated by one or more of the at least two of the plurality of active processing elements.

12. The electronic device of claim **9**, wherein the channel is associated with one or more properties.

13. The electronic device of claim **12**, further comprising configuring a relationship between at least two active processing elements based on the one or more properties, wherein the at least two active processing elements are communicatively coupled.

14. The electronic device of claim **1**, wherein at least one of the active processing elements comprises at least one rule.

15. The electronic device of claim **14**, wherein the at least one rule comprises a condition and an associated action, wherein the associated action is executed upon matching of the condition to at least one of the input facts.

16. The electronic device of claim 14, wherein the at least one rule comprises a plurality of prioritized rules.

17. The electronic device of claim 1, wherein the active ontology is further configured to perform at least one of: activity recognition; activity execution; and management of temporal constraints associated with activity execution.

18. The electronic device of claim 1, further comprising interfacing the active ontology to a service-oriented architecture via a service broker.

19. The electronic device of claim 18, wherein the service broker is configured to perform at least one of:

- selecting at least one service,
- delegating at least one task,
- issuing at least one query,
- providing at least one update, and
- monitoring service requests.

20. The electronic device of claim 1, wherein each of the services is invoked to accomplish one or more tasks.

21. The electronic device of claim 1, wherein at least one of the active processing elements is configured to send at least one fact to at least one other active processing element.

22. The electronic device of claim 1, wherein at least one of the active processing elements is configured to receive at least one fact from at least one other active processing element.

23. The electronic device of claim 1, wherein the active ontology communicates with one or more sensors adapted to convey facts associated with a user's behavior to at least one of the active processing elements.

24. A or building an automated assistant, the method comprising:

- receiving, at a processor, at least one request for services, the request for services being in natural language form;
- determining, at the processor, one or more active processing elements of an active ontology that are associated with the request for services; each active processing element associated with the request for services with a probability greater than zero; and
- prioritizing, by the processor, the one or more active processing elements associated with the active ontology;

wherein:

- the active ontology is configured to perform natural language processing on user input, the natural language processing performed in response to the request for services, and
- the active ontology comprises a plurality of active processing elements adapted to match specific types of facts.

25. The method of claim 24, further comprising: determining the one or more active processing elements using facts relating to events collected from a user's environment.

26. The method of claim 24, wherein each of the one or more active processing elements specifies one or more request for services that the one or more active processing elements can accept.

27. The method of claim 24, further comprising: filtering the one or more active processing elements by the associated probability.

28. The method of claim 24, further comprising: selecting the active processing element with a highest associated probability; and performing the request for services in accordance with the selected active processing element.

29. The method of claim 24, wherein the active ontology models a domain, and wherein each active processing element of the active processing elements represents at least one of: an object in the domain and an associated task to be accomplished.

30. The method of claim 24, wherein at least two of the active processing elements communicate information via a channel.

31. The method of claim 30, wherein the information communicated via the channel comprises processing results generated by at least one of the at least two of the active processing elements.

32. The method of claim 31, further comprising:

- determining the probability associated with the information communicated via the channel;
- determining, based on the probability associated with the information, the propagation of additional processing results generated by one or more of the at least two of the plurality of active processing elements.

33. The method of claim 30, wherein the channel is associated with one or more properties.

34. The method of claim 33, further comprising, configuring a relationship between at least two active processing elements based on the one or more properties, wherein the at least two active processing elements are communicatively coupled.

35. The method of claim 24, wherein at least one of the active processing elements comprises at least one rule.

36. The method of claim 35, wherein the at least one rule comprises a condition and an associated action, wherein the associated action is executed upon matching of the condition to at least one of the input facts.

37. The method of claim 35, wherein the at least one rule comprises a plurality of prioritized rules.

38. The method of claim 24, wherein the active ontology is further configured to perform at least one of:

- activity recognition;
- activity execution; and
- management of temporal constraints associated with activity execution.

39. The method of claim 24, further comprising, interfacing the active ontology to a service-oriented architecture via a service broker.

40. The method of claim 39, wherein the service broker is configured to perform at least one of:

- selecting at least one service,
- delegating at least one task,
- issuing at least one query,
- providing at least one update, and
- monitoring service requests.

41. The method of claim 24, wherein at least one of the active processing elements is configured to send at least one fact to at least one other active processing element.

42. The method of claim 24, wherein at least one of the active processing elements is configured to receive at least one fact from at least one other active processing element.

43. The method of claim 24, wherein the active ontology communicates with one or more sensors adapted to convey facts associated with a user's behavior to at least one of the active processing elements.

44. A non-transitory computer readable storage medium storing one or more programs, the one or more programs comprising instructions, which when executed by an electronic device, cause the device to:

- receive, at a processor, at least one request for services, the request for services being in natural language form;

11

determine, at the processor, one or more active processing elements of an active ontology that are associated with the request for services; each active processing element associated with the request for services with a probability greater than zero; and

prioritize, by the processor, the one or more active processing elements associated with the active ontology; wherein:

the active ontology is configured to perform natural language processing on user input, the natural language processing performed in response to the request for services, and

the active ontology comprises a plurality of active processing elements adapted to match specific types of facts.

45. The electronic device of claim 1 further comprising: determining the request for services from a natural language input.

46. The computer readable storage medium of claim 44, further comprising:

determining the one or more active processing elements using facts relating to events collected from a user's environment.

47. The computer readable storage medium of claim 44, wherein each of the one or more active processing elements specifies one or more request for services that the one or more active processing elements can accept.

48. The computer readable storage medium of claim 44, further comprising:

filtering the one or more active processing elements by the associated probability.

49. The computer readable storage medium of claim 44, further comprising:

selecting the active processing element with a highest associated probability; and

performing the request for services in accordance with the selected active processing element.

50. The computer readable storage medium of claim 44, wherein the active ontology models a domain, and wherein each active processing element of the active processing elements represents at least one of: an object in the domain and an associated task to be accomplished.

51. The computer readable storage medium of claim 44, wherein at least two of the active processing elements communicate information via a channel.

52. The computer readable storage medium of claim 51, wherein the information communicated via the channel comprises processing results generated by at least one of the at least two of the active processing elements.

53. The computer readable storage medium of claim 52, further comprising:

determining the probability associated with the information communicated via the channel;

12

determining, based on the probability associated with the information, the propagation of additional processing results generated by one or more of the at least two of the plurality of active processing elements.

54. The computer readable storage medium of claim 51, wherein the channel is associated with one or more properties.

55. The computer readable storage medium of claim 54, further comprising, configuring a relationship between at least two active processing elements based on the one or more properties, wherein the at least two active processing elements are communicatively coupled.

56. The computer readable storage medium of claim 44, wherein at least one of the active processing elements comprises at least one rule.

57. The computer readable storage medium of claim 56, wherein the at least one rule comprises a condition and an associated action, wherein the associated action is executed upon matching of the condition to at least one of the input facts.

58. The computer readable storage medium of claim 56, wherein the at least one rule comprises a plurality of prioritized rules.

59. The computer readable storage medium of claim 44, wherein the active ontology is further configured to perform at least one of:

activity recognition;
activity execution; and
management of temporal constraints associated with activity execution.

60. The computer readable storage medium of claim 44, further comprising, interfacing the active ontology to a service-oriented architecture via a service broker.

61. The computer readable storage medium of claim 60, wherein the service broker is configured to perform at least one of:

selecting at least one service,
delegating at least one task,
issuing at least one query,
providing at least one update, and
monitoring service requests.

62. The computer readable storage medium of claim 44, wherein at least one of the active processing elements is configured to send at least one fact to at least one other active processing element.

63. The computer readable storage medium of claim 44, wherein at least one of the active processing elements is configured to receive at least one fact from at least one other active processing element.

64. The computer readable storage medium of claim 44, wherein the active ontology communicates with one or more sensors adapted to convey facts associated with a user's behavior to at least one of the active processing elements.

* * * * *

UNITED STATES PATENT AND TRADEMARK OFFICE
CERTIFICATE OF CORRECTION

PATENT NO. : 10,318,871 B2
APPLICATION NO. : 15/299264
DATED : June 11, 2019
INVENTOR(S) : Adam Cheyer et al.

Page 1 of 1

It is certified that error appears in the above-identified patent and that said Letters Patent is hereby corrected as shown below:

In the Claims

In Claim 8, at Column 8, Line 36, delete “claim 7,” and insert -- claim 1, --, therefor.

In Claim 9, at Column 8, Line 41, delete “claim 7,” and insert -- claim 1, --, therefor.

In Claim 24, at Column 9, Line 32, delete “A or building” and insert -- A method for building --, therefor.

In Claim 24, at Column 9, Line 38, delete “services;” and insert -- services, --, therefor.

In Claim 44, at Column 11, Line 3, delete “services;” and insert -- services, --, therefor.

Signed and Sealed this
Sixth Day of August, 2019



Andrei Iancu
Director of the United States Patent and Trademark Office