

# wireless world

JULY 1978 40p

Australia \$A1.25  
Canada \$1.75  
Denmark Kr. 11.00  
Germany Dm. 3.50  
Greece Dr. 47.00  
Holland Dfl. 4.50  
Italy L. 1100  
New Zealand \$NZ1.50  
Norway Kr. 11.00 incl. moms  
Singapore M. \$3.25  
Spain Ptas. 80.00  
U.S.A. \$1.65



**Phase-change metal  
detector**

**Paperless revolution**



# A Synthesized Signal Generator from **mi**

## £8,000? £6,000? £4,000? under £2,000?

Somehow some of our customers have been persuaded that our prices are as big as we are. Sometimes the biggest brains are the most cost-conscious brains. For example, our illustration shows a synthesized signal generator which costs £1,900\*: the new 520MHz TF2015/1 Signal Generator with its associated Synchronizer. With this combination, synthesizer operation is obtainable without any degradation of generator signal purity, performance and versatility.

Leakage specification is lower than any other available VHF/UHF source and output accuracy at low levels beats all others in the price range.

Building on the enviable reputation of the TF2015 for performance, reliability and value, we have now introduced two new a.m./f.m. versions: the TF2015/1 for narrow band mobile radio testing and TF2015/2 for telemetry and other wideband applications. The U.K. price for TF2015/2 with Synchronizer is £2,150\*. All have a frequency coverage of 10 to 520MHz with calibrated a.m. and f.m.

Tuning in 100Hz steps whilst under locked conditions provides a valuable facility for bandwidth measurements and channel stepping. Digital setting of frequency with direct readout means no waiting for counter gate times when you want high resolution, and no r.f. leakage from display holes.

\*Special U.K. price

### One in four

Only one in four of our customers tells us he needs the stability of a synthesizer. So the other three can save almost half the cost of the synthesizer combination by buying the analogue part alone. So, whether you require a synthesizer or a signal generator you can now obtain quality at ordinary prices.

Optional accessories include Pulse Modulator TF2169, i.f. probes for 'squell killing', multiple calibration plates for units of output level, matching pads, attenuators, reverse power protection and carrying case.

Write or 'phone for full details:

# **mi** MARCONI INSTRUMENTS

Marconi Instruments Limited · Longacres · St. Albans · Hertfordshire · England AL4 0JN · Tel: (0727) 59292 · Telex: 23350

Marconi Electronics Inc · 100 Stonehurst Court · Northvale · New Jersey 07647 USA · Tel: (201) 767-7250 · Twx: 710-991-9752

Marconi Instruments · 32 avenue des Ecoles · 91600 Savigny-Sur-Orge · France · Tél: 996.03.86 · Télex: 600541.F

Marconi Messtechnik GmbH · 8000 München 21 Jörgstrasse 74 · West Germany · Tel: (089) 58 20 41 · Telex: 5 212642

A GEC-Marconi Electronics Company

[www.americanradiohistory.com](http://www.americanradiohistory.com)

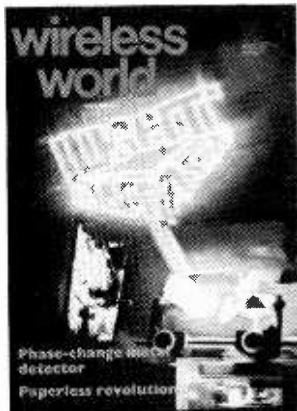

Front cover shows words traced by a deflected laser beam (photographed by Paul Brierley at the Royal Academy). Details inside.

IN OUR NEXT ISSUE

**The alternator in road vehicles.** Theory behind the change from the dynamo and a practical regulator circuit using the ignition light.

**Versatile waveform generator.** Varying the ramps and plateaus of a trapezoidal waveform gives useful signals in the range 0.005Hz to 20kHz.

**Measuring electrical noise in audio engineering.** Explaining the large discrepancies in measured s/n ratios when different standards are followed.

Current issue price 40p, back issue (if available) 50p. at Retail and Trade Counter, Paris Garden, London SE1. Available on microfilm please contact editor.

By post, current issue 55p, back issues (if available) 50p, order and payments to Room 11, Dorset House, London SE1 9LU.

**Editorial & Advertising offices:** Dorset House, Stamford Street, London SE1 9LU.

**Telephones:** Editorial 01-261 8620. Advertising 01-261 8339.

**Telegrams / Telex:** Wiworld Bispres 25137 BISPRS G. Cables: Ethaworld, London SE1.

**Subscription rates:** 1 year: £7.00 UK and \$23.40 overseas (\$24 USA and Canada).

**Student rate:** 1 year, £3.50 UK and £4.50 overseas (\$11.70 USA and Canada).

**Distribution:** 40 Bowling Green Lane, London EC1R 0NE. Telephone 01-837 3636.

**Subscriptions:** Oakfield House, Perrymount Road, Haywards, Heath, Sussex, RH16 3DH. Telephone 0444 59188. Please notify a change of address.

**USA mailing agents:** Expeditors of the Printed Word Ltd, 527 Madison Avenue, Suite 1217, New York, NY 10022. 2nd-class postage paid at New York.

IPC Business Press Ltd, 1978  
ISSN 0043 6062

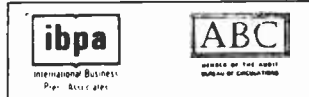

# wireless world

ELECTRONICS/TELEVISION/RADIO/AUDIO

JULY 1978 vol 84 No 1511

37 In the beginning was the word

38 The paperless revolution  
by A. E. Cawkell

43 Discriminative metal detector  
by R. C. V. Macario

47 News of the month  
Home Office's WARC summary European satellite in orbit  
How accurate are audio reviews?

51 Colour receiver design  
by Erik Albert Jensen

55 Valves versus transistors  
by James Moir

59 Letters to the editor  
Microwave hybrid i.cs Audio equipment reviews  
Open letter to Finniston

63 Logic design — 14  
by B. Holdsworth and D. Zissos

66 Time coded transmission

68 The Telemobiloscope  
by V. J. Phillips

73 Circuit Ideas  
High quality stereo decoder Sound-to-light unit  
Low voltage d.c. to d.c. converter

76 Audio power amplifier design — 4  
by P. J. Baxandall

83 Current dumping — does it really work? — 2  
by J. Vanderkooy and S. P. Lipshitz

86 World of amateur radio

87 New products

90 Sidebands  
by Mixer



**The world over-  
You get the  
best service  
from Haltron**

For high quality electronic valves, semiconductors and integrated circuits – and the speediest service – specify Haltron. It's the first choice of Governments and many other users throughout the world. Haltron product quality and reliability are clearly confirmed. The product range is very, very wide. And Haltron export expertise will surely meet your requirements. Wherever you are, get the best service. From Haltron.



Hall Electric Limited,  
Electron House,  
Cray Avenue, St. Mary Cray,  
Orpington, Kent BR5 3QJ.  
Telephone: Orpington 27099  
Telex: 896141

Ww-045 FOR FURTHER DETAILS

# LOW COST TESTERS



## LEVELL

### PORTABLE INSTRUMENTS

#### INSULATION TESTER

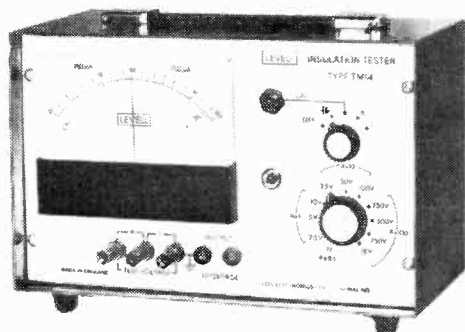

A logarithmic scale covering 6 decades is used to display either insulation resistance or leakage current at a fixed stabilised test voltage. The current available is limited to a maximum value of 3mA for safety and capacitors are automatically discharged when the instrument is switched off or to the CAL condition. The instrument operates from a 9V internal battery.

##### RESISTANCE RANGES

10M  $\Omega$  to 10T  $\Omega$  ( $10^{13}$   $\Omega$ ) at 250V, 500V, 750V and 1kV.

1M  $\Omega$  to 1T  $\Omega$  at 25V, 50V and 100V.

100k  $\Omega$  to 100G  $\Omega$  at 2.5V, 5V and 10V.

10k  $\Omega$  to 10G  $\Omega$  at 1V.

Accuracy  $\pm 15\% + 800 \Omega$  on 6 decade logarithmic scale.

Accuracy of test voltages  $\pm 3\% \pm 50\text{mV}$  at scale centre.

Fall of test voltages  $< 2\%$  at 10 $\mu\text{A}$  and  $< 20\%$  at 100 $\mu\text{A}$ .

Short circuit current between 500 $\mu\text{A}$  and 3mA.

##### CURRENT RANGE

100pA to 100 $\mu\text{A}$  on 6 decade logarithmic scale.

Accuracy of current measurement  $\pm 15\%$  of indicated value.

Input voltage drop is approximately 20mV at 100pA, 200mV at 100nA and 400mV at 100 $\mu\text{A}$ .

Maximum safe continuous overload is 50mA.

##### MEASUREMENT TIME

$< 3\text{s}$  for resistance on all ranges relative to CAL position.

$< 10\text{s}$  for resistance of 10G  $\Omega$  across 1 $\mu\text{F}$  on 50V to 500V.

Discharge time to 1% is 0.1s per  $\mu\text{F}$  on CAL position.

##### RECORDER OUTPUT

1V per decade  $\pm 2\%$  with zero output at scale centre.

Maximum output  $\pm 3\text{V}$ . Output resistance 1k  $\Omega$ .

type  
TM14

## £120

#### TRANSISTOR TESTER

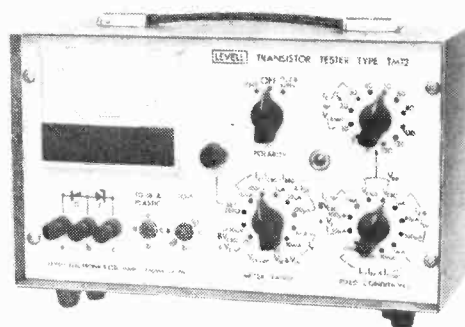

Tests bipolar transistors, diodes and zener diodes. Measures leakage down to 0.5 nA at 2V to 150V. Current gains are checked from 1 $\mu\text{A}$  to 100mA. Breakdown voltages up to 100V are measured at 10 $\mu\text{A}$ , 100 $\mu\text{A}$  and 1mA. Collector to emitter saturation voltage is measured at 1mA, 10mA, 30mA and 100mA for  $I_C/I_B$  ratios of 10, 20, 30. The instrument is powered by a 9V battery.

##### TRANSISTOR RANGES (PNP OR NPN)

$I_{CBO}$  &  $I_{EBO}$ : 10nA, 100nA, 1 $\mu\text{A}$ , 10 $\mu\text{A}$  and 100 $\mu\text{A}$  f.s.d. acc.  $\pm 2\%$  f.s.d.  $\pm 1\%$  at voltages of 2V, 5V, 10V, 20V, 30V, 40V, 50V, 60V, 80V, 100V, 120V, and 150V acc.  $\pm 3\% \pm 100\text{mV}$  up to 10 $\mu\text{A}$  with fall at 100 $\mu\text{A}$   $< 5\% + 250\text{mV}$ .

$BV_{CBO}$ : 10V or 100V f.s.d. acc.  $\pm 2\%$  f.s.d.  $\pm 1\%$  at currents of 10 $\mu\text{A}$ , 100 $\mu\text{A}$  and 1mA  $\pm 20\%$ .

$I_B$ : 10nA, 100nA, 1 $\mu\text{A}$ ... 10mA f.s.d. acc.  $\pm 2\%$  f.s.d.  $\pm 1\%$  at fixed  $I_E$  of 1 $\mu\text{A}$ , 10 $\mu\text{A}$ , 100 $\mu\text{A}$ , 1mA, 10mA, 30mA, and 100mA acc.  $\pm 1\%$ .

$h_{FE}$ : 3 inverse scales of 2000 to 100, 400 to 30 and 100 to 10 convert  $I_B$  into  $h_{FE}$  readings.

$V_{BE}$ : 1V f.s.d. acc.  $\pm 20\text{mV}$  measured at conditions on  $h_{FE}$  test.

$V_{CE(sat)}$ : 1V f.s.d. acc.  $\pm 20\text{mV}$  at collector currents of 1mA, 10mA, 30mA and 100mA with  $I_C/I_B$  selected at 10, 20 or 30 acc.  $\pm 20\%$ .

##### DIODE & ZENER DIODE RANGES

$I_{DR}$ : As  $I_{EBO}$  transistor ranges.

$V_Z$ : Breakdown ranges as  $BV_{CBO}$  for transistors.

$V_{DF}$ : 1V f.s.d. acc.  $\pm 20\text{mV}$  at  $I_{DF}$  of 1 $\mu\text{A}$ , 10 $\mu\text{A}$ , 100 $\mu\text{A}$ , 1mA, 10mA, 30mA and 100mA.

type  
TM12

## £110

### LEVELL ELECTRONICS LTD.

Moxon Street, High Barnet, Herts. EN5 5SD  
Tel: 01-449 5028/440 8686

Prices are ex-works with batteries. Carriage and Packing extra. VAT extra in U.K. Optional extras are leather cases and mains power units. Send for data covering our range of portable instruments.

# Five Great Kits from DORAM

Kit  
£79.95 + VAT  
Ready Built  
£99.95 + VAT

## DISTORTION METER

Range 20Hz to 40KHz.  
T.H.D. down to 0.003%.



Kit  
£69.95 + VAT  
Ready Built  
£89.95 + VAT

## AUDIO MILLIVOLTMETER

Measurement from 15Hz to 100KHz  $\pm 1/2$  db. Input impedance 1M $\Omega$  with 600 $\Omega$  load.

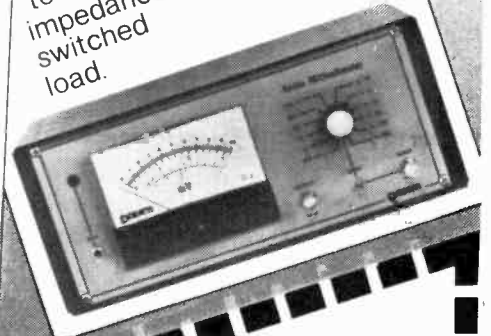

## FUNCTION GENERATOR

Sine, triangle and square waves from 0.1Hz to 100KHz  
Adjustable sweep (10:1) and burst facilities.

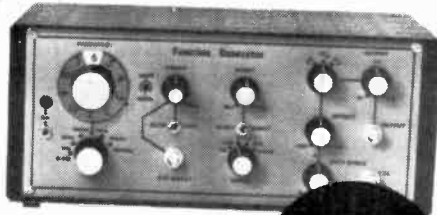

Kit  
£59.95 + VAT  
Ready Built  
£79.95 + VAT

Kit  
£79.95 + VAT  
Ready Built  
£99.95 + VAT

Please send me the following, I enclose cheque/PO made payable to Doram Electronics value £.....

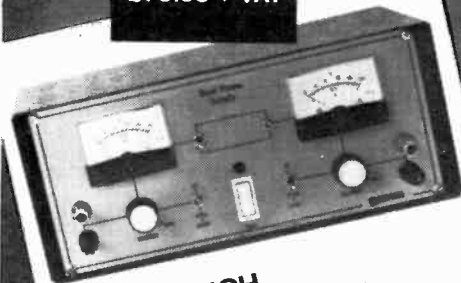

## DUAL BENCH POWER SUPPLY

Dual independent 3-20v dc.  
Current limits are switched at 100mA and 1A.

## LOW DISTORTION OSCILLATOR

Extremely low distortion (0.005% @ 1KHz). Range 10Hz to 100KHz in 4 decades.



Kit  
£79.95 + VAT  
Ready Built  
£99.95 + VAT

<b>Order Code</b>	<b>Distortion Meter</b>	
60-612-1	Kit	£79.95 + VAT
74-720-0	Ready Built	£99.95 + VAT
<b>Order Code</b>	<b>Function Generator</b>	
60-638-9	Kit	£79.95 + VAT
74-740-6	Ready Built	£99.95 + VAT
<b>Order Code</b>	<b>Audio Millivoltmeter</b>	
60-614-5	Kit	£69.95 + VAT
74-730-3	Ready Built	£89.95 + VAT
<b>Order Code</b>	<b>Dual Bench Power Supply</b>	
60-631-0	Kit	£59.95 + VAT
74-750-9	Ready Built	£79.95 + VAT
<b>Order Code</b>	<b>Low Distortion Oscillator</b>	
60-610-7	Kit	£79.95 + VAT
74-710-7	Ready Built	£99.95 + VAT

Name .....  
Address .....

**DORAM** Dept W. W.  
PO Box TR8, Wellington Road Industrial Estate, Wellington Bridge, Leeds LS12 2UF.

It's a mobile radio world

# Talk this way about the future-today



Pocketfone 5002  
**The New Universal Communicator**  
 A go anywhere rugged portable two way radio. Body worn, hand held or vehicle plug in.



The Pye Pocketfone P5002 is a go-anywhere, rugged, portable, hand held or vehicle plug in, two-way radio. Used in many applications, it is simply put, the best of its kind. Used in optimum mode.



Mascot 1000  
**The World's leading radio control system**

gives you all the options

A time-division multiplex electronic exchange, specifically designed for radio control. A fraction the size of conventional equipments, yet allows from 1 to 99 operators access up to 99 channels. The M1000 system incorporates C-MOS integrated circuit logic switching with dual in-line control gates allowing access to all positions.

M206 VHF FM Mobile

**The multi option, international high spec mobile**  
 Exceeding today's world wide specifications. Precision built to cope with spectrum congestions of tomorrow.

The Pye M206 is a ruggedised VHF FM mobile designed to present world markets with new standards of performance. Easy to install, easy to maintain and compatible with today's and tomorrow's selective call and data systems. Single and twin head options for duplex and simplex working. The M206 provides supreme flexibility for international communications needs.



Now you're talking

Use this coupon. We'll send you the complete run down  
**To: Pye Telecommunications Ltd.,**  
 St. Andrews Road, Cambridge CB4 1DW England  
 Please post full technical information on  
 P5000  Mascot 1000  M206 Mobile   
 (Tick as appropriate)

Name \_\_\_\_\_ Position \_\_\_\_\_

Company \_\_\_\_\_

Address \_\_\_\_\_

Postal Code \_\_\_\_\_ Telephone \_\_\_\_\_

46/WW/7

WW-020 FOR FURTHER DETAILS

# F.M. TUNERS, MODULES & UNITS by *Icon Design*

**T3** Six touch tuned pre-set stations plus manual tune, with digital frequency readout, combined with 1.8 micro-volt sensitivity and anti-birdy stereo make this one of the finest tuners available. Intelligent tuning indicator, a.f.c. and interstation mute included for easy operation by all the family. Two tone gold and brown front panel with teak veneer cabinet will blend with any surroundings. **£149.00**



**M1** This module is the heart of the above tuner, giving a mono output with a.f.c., mute, and tuning indicator functions. Drift free tuning by 10 turn pot over the range 88 to 108 MHz. This module will not let you hear out-of-tune stations, and the fine tuning lamp is extinguished unless a station is received. The ideal basis for any High quality F.M. system. **£29.95**



**M2** The ideal choice for adding stereo to the M1 module or any suitable mono receiver, this module has anti-birdy filters and pilot tone output filters, together with a phase-locked decoder for stable performance. **£8.36**



**M4** An integrated circuit regulator supplies all the power for the M1, M2 and M5, in addition to being short circuit proof and having automatic thermal shut-down, and ensuring hum free reception. **£6.93**

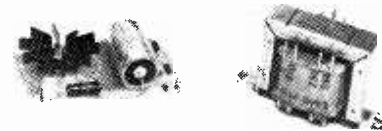

**M5** The M5(mk2) touch module adds 6 touch selected pre-set stations to the manual tuning already provided by the M1 module. Illuminated buttons indicate the channel selected, while remote control using a single contact push button steps the channels in an endless loop, including the manual control channel. Auto power-up channel selection may be set to any of the seven available channels. Remote inhibit and a lamp test facility are provided. **£17.54**



**M6** Using the optimum selection of discrete, E.C.L., T.T.L. and C-MOS technologies, this module will add the luxury of digital readout to the M1 module above, or any other LP1186 based receiver. The small (95 x 103mm) board contains all the logic, displays, and regulated power supply. Range is 60 to 99.9MHz, resolution 0.1KHz, and stability better than 40 p.p.m. per deg. C. It comes complete with mains transformer, polarised filter, and list of station frequencies. **£44.40**

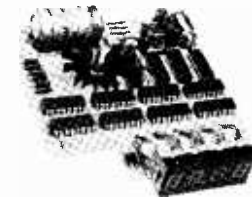

★★ PLUS TWO NEW ONES ★★

**M7** This new module is a 4 way touch select switch having illuminated touch buttons, and C-MOS logic level outputs. Features pre-set power-up selection, and remote step facility. Multiple units may be cascaded to give 8, 12 or more channels of switching, and two modules may be paralleled to give full remote control from two or more locations. The outputs may be used to control logic etc., or to drive the new M8 channel selector opposite. **£6.95**

**M8** Controlled from single pole switches, or the M7 module, this unit will switch 4 mono or two stereo audio channels. Two M8 modules will therefore switch 4 stereo signals driven by one M7 touch switch, or other combinations may be controlled by multiple touch switches, providing a flexible system of audio selection and control. The ideal module for pre-amplifier source selection, avoiding long signal wires to and from control panels, and their associated hum and cross-talk problems. **£4.95**

## ORDERING INFORMATION

Small orders <£5.00 plus 50p handling charge.

U.K. Orders post free, plus 12.5% V A T.

Overseas, send for Pro-forma invoice first, or send £3.00 air mail for small items.

SEND FOR ILLUSTRATED DATA PACK  
(Reply coupons please overseas)  
ACCESS MASTERCHARGE BARCLAYCARD VISA  
CREDIT CARDS TAKEN  
(Just quote number when ordering)

## KITS AND COMPONENTS

SL301	£1.67	BC184	£0.15	Cermet pre-sets	£1.20
SL3046	£0.94	BC214	£0.15	Transformers: 120/240v	
TBA750	£1.71	1N4001	£0.06	6VA 4.5v	£2.33
SL1310	£2.15	1N4148	£0.04	6VA 20v	£2.33
TBA625C	£1.65	P.C.B. M1	£2.64	Kit K14 (M1)	£27.95
UA78M20	£1.65	P.C.B. M2	£1.65	K57 (M2)	£6.84
UA78M05	£1.65	P.C.B. M3	£1.65	K112 (T3)	£137.80
SFJ10-7MA	£1.71	P.C.B. M4	£1.65	Descriptive booklet	50p
LP1186	£8.53	Coil ass.	£0.55	Overseas	£1.50
2N3904	£0.20	10t 50K pot	£3.89		

**TO ICON DESIGN** 33 Restrop View  
Purton, Wilts., SN5 9DG

Please supply data on (Circle as required)

M1 M2 M4 M5 Mk 2 M6 M7 M8 ALL

Address label . . . . . Block letters

.....  
.....  
.....



# MAPLIN

everything for the modern D.I.Y. electronics enthusiast and more.



### 100W RMS STEREO DISCO

A genuine 100W RMS per channel (both channels driven) stereo disco with auto fade on microphone, VU meters, full monitoring and cueing facilities and a very high quality light show. Complete construction booklet MES41 price 25p. Cabinet comes complete with lid and carrying handles.



### 10 CHANNEL STEREO GRAPHIC EQUALISER

A new design with no difficult coils to wind, but a specification that puts it in the top-flight hi-fi class. All this for around £70 including fully punched and printed metalwork and woodwork. Send for our component schedule now. Full construction details price 25p. (All prices include V.A.T. and p & p.)



### 'PE' STRING ENSEMBLE

Unbeatable prices and finest quality components only when you buy from Maplin. All parts available to build this fascinating project. Component schedule available shortly (s.a.e. appreciated). Demonstration model in our shop soon. Phone now and compare our prices.



### VERY LOW-DISTORTION AUDIO OSCILLATOR

The very low distortion sine wave (<math>< 0.01\%</math>) output is suitable for testing very high quality hi-fi audio equipment. Also includes square wave output. Range 20Hz to 26kHz. Output 0V to 1V in three continuously variable steps. Total cost around £21. Full construction details in our catalogue. Send the coupon below, now! (all prices include V.A.T. and p & p.)



### TOUCH-SENSITIVE PIANO

The revolutionary new IC AY-1-1320 first seen on 'Tomorrow's World' is now available. Complete kit of IC's to build a 60-note piano (18 x IC's) order as HQ53H price £36.86. Preliminary circuit details in our October newsletter. Complete design, pcb's attractive veneered wooden cabinet available soon! It's the most realistic-sounding electronic piano we've ever heard and includes simulated 'damping, loud and soft pedals. Full details in our newsletters. (All prices include V.A.T. and p & p.)

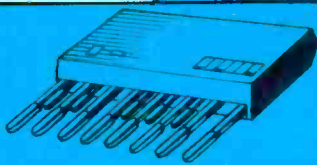

### PEDAL UNIT

A completely self-contained pedal unit. 13-note, 2-Octave range. 4 organ stops. It can be added to any organ. A really unusual extra is the bass guitar stop which uses four envelope shapers to give a real bass guitar sound. A must for the solo guitarist. Full construction details in our catalogue—post the coupon below, now!

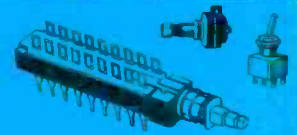

### SWITCHES

We stock a wide range of switches including a really low-priced high quality interlocking push-button switch system which is extremely versatile. We've got toggle switches, slide switches, push switches, rotary switches—there are dozens to choose from, but it's only a tiny part of our fantastic range.

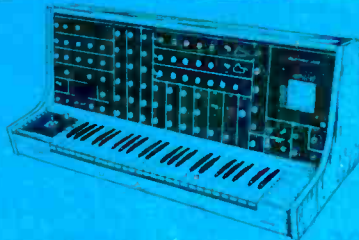

### SYNTHESISER

The International 4600 Synthesiser. A very comprehensive unit. Over 400 sold. We stock all the parts costing less than £500 including fully punched and printed metalwork and a smart teak cabinet. Far less than half what you'd pay for a ready-made synthesiser of equal quality. Specification on request. Full construction details in our construction book £1.50. (All prices include V.A.T. and p & p.)

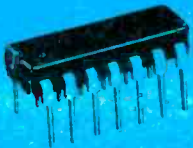

### INTEGRATED CIRCUITS

Over 35 pages in our catalogue devoted to hundreds of useful IC's. All with data pin connections and many with applications circuits and projects to build. Post the coupon now!



Our bi-monthly newsletter keeps you up to date with latest guaranteed prices - our latest special offers - details of new projects and new lines. Send 30p for the next six issues (5p discount voucher with each copy)



### POST THIS COUPON NOW FOR YOUR COPY OF OUR CATALOGUE PRICE 60p

Please rush me a copy of your 216 page catalogue I enclose 60p, but understand that if I am not completely satisfied I may return the catalogue to you within 14 days and have my 60p refunded immediately.

NAME \_\_\_\_\_

ADDRESS \_\_\_\_\_

(WW7)

**IT'S A FANTASTIC BESTSELLER!**  
216 big (11" x 8") pages! Over a thousand illustrations! Over 30 pages of complete projects to build! Thousands and thousands of useful components described and illustrated! No wonder it's a bestseller!

**DON'T MISS OUT! SEND 60p NOW!**

**MAPLIN ELECTRONIC SUPPLIES**

P.O. BOX 3 RAYLEIGH ESSEX SS6 8LR

Telephone: Southend (0702) 715155

Shop: 284, London Road, Westcliff-on-Sea, Essex

(Closed on Monday) Telephone Southend (0702) 715157

WW-013  
FOR FURTHER DETAILS



## If you want an advantage in connectors specify Ferranti.

Ferranti circuit board edge connectors win on service. They're designed for a far higher number of insertions than you're likely to make. They need to be, so that you can rely on them throughout their working life.

You'll like our other design features too. Low force spring contacts. Gold flash or full gold plating on the contacts as you wish. Terminals for wire wrapping or soldering. Many options: pitches of .100" (2.54 mm)—modular connector, .150" (3.81 mm), .156" (3.96 mm) and .200" (5.08 mm).

Contact: Connector Sales, Ferranti Limited,  
Professional Components Department, Dunsinane Avenue,  
Dundee DD2 3PN, Scotland. Telephone: 0382 89321 Telex: 76166  
Distributors: Giltech Components Ltd., 22 Portman Road,  
Battle Farm Industrial Estate, Reading, Berks. RG3 1ES.  
Telephone: 0734 582131

**FERRANTI**  
Connector Capability

WW — 104 FOR FURTHER DETAILS

DS/T 324 

# Fairchild's new data subscription service brings you four pillars of wisdom.

Because, when you subscribe, Fairchild will send you four data books during 1978.

Plus four copies of their applications oriented journal 'Semiconductor Progress.'

Moreover, by subscribing, you'll be a V.I.P. engineer which we'll augment by also sending you our price list, our shortform catalogue, and anything else that appears relevant. Before others get them!

Not ordinary data books.

But volumes which have been created from scratch as the result of a major

commitment by Fairchild to give engineers just what they need: high quality, accurate, information.

Our first book contains 408 pages on Low Power Schottky TTL.

Our second, 343 pages on Optoelectronics.

Next, a fat tome specialising in ECL. And the year's service concluding with 517 pages of CMOS.

For all the details, just use our enquiry number.

You'll discover it's a very wise move.

## FAIRCHILD

Camera & Instrument (UK) Ltd.,  
230 High St., Potters Bar,  
Herts EN6 5BU, England.  
Telephone: (0707) 51111.  
Telex: 262835.

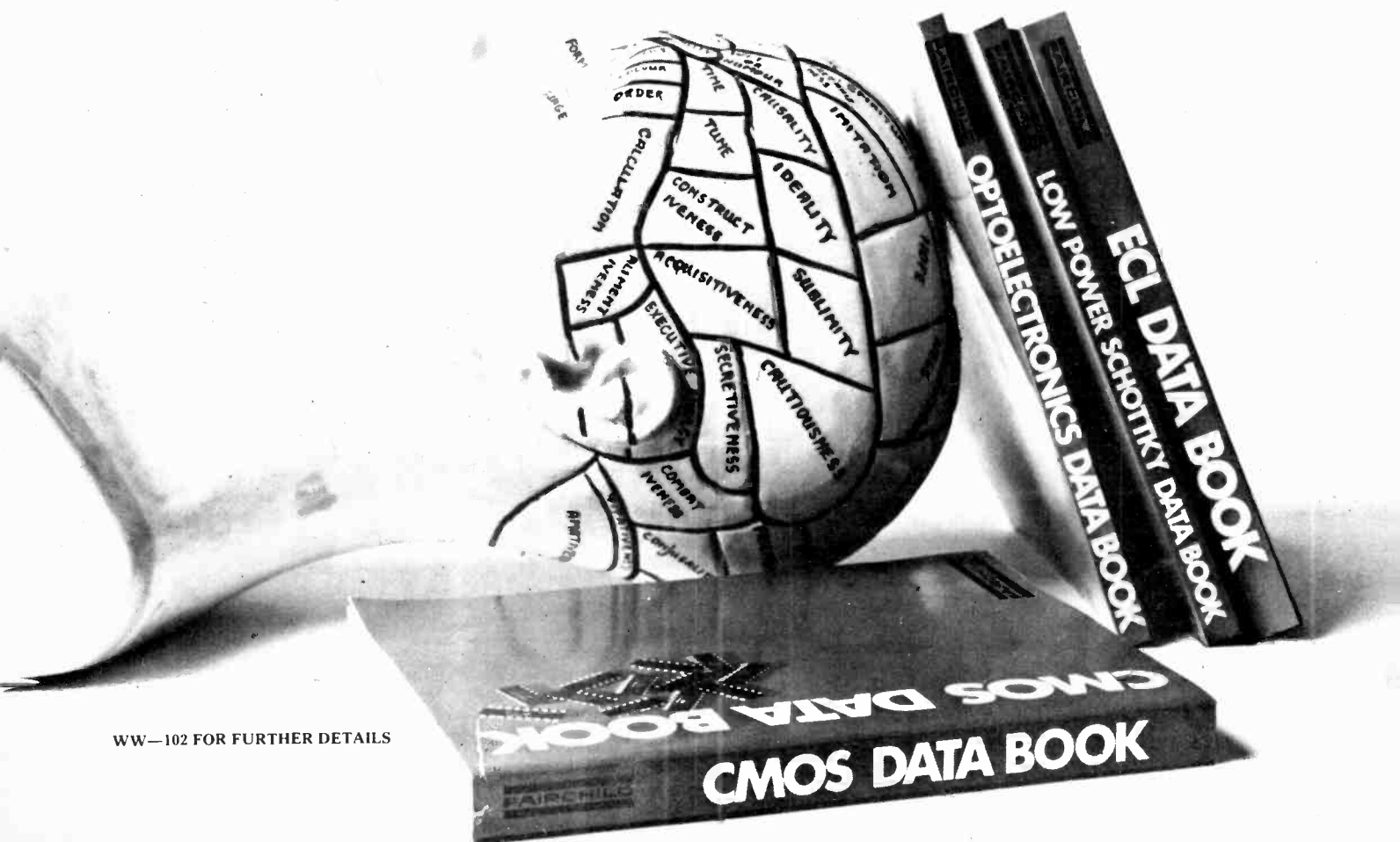

**OLSON**

**MINICASES**

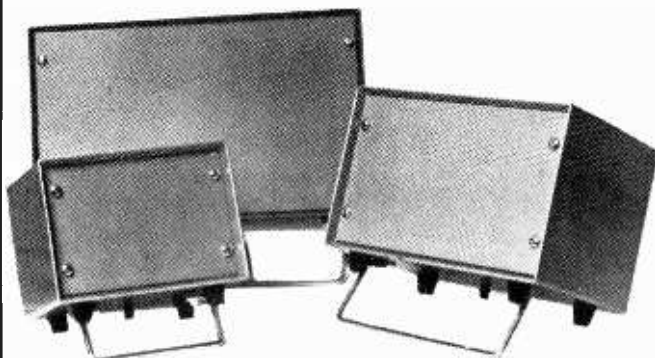

Type	Overall Dimension			Case	Case	Chrome
	Width	Height	Depth	no vents	with vents	leg
21	6½"	4½"	4½"	—	5.35	1.10
22	8½"	5½"	5½"	—	5.90	1.10
23	10½"	6½"	6½"	—	7.00	1.20
24	12½"	7½"	7½"	—	7.65	1.20
25A	6½"	4½"	4½"	5.10	5.70	1.20
25B	6½"	4½"	6¼"	5.45	6.05	1.20
26A	8¾"	5¾"	6¼"	7.15	7.75	1.20
26B	8¾"	5¾"	8¼"	7.50	8.10	1.20
27A	12¼"	7½"	5½"	7.85	8.55	1.20
27B	12¼"	7½"	8"	8.50	9.20	1.20
28A	14"	10½"	6½"	9.25	9.95	—
28B	14"	10½"	8½"	10.10	10.80	—
29A	10"	4"	6"	6.50	7.10	1.20
29B	10"	4"	8"	6.85	7.45	1.20
30A	12"	5"	6"	7.10	7.80	1.20
30B	12"	5"	8"	7.40	8.10	1.20
31A	14"	6"	6"	7.70	8.40	1.20
31B	14"	6"	8"	8.10	8.80	1.20
61	15½"	7½"	9½"	—	11.75	—
62	17½"	8½"	9½"	—	13.60	—
63	16½"	9½"	9½"	—	13.60	—
64	15½"	7½"	12½"	—	13.60	—
65	17½"	8½"	12½"	—	15.50	—
66	16½"	9½"	12½"	—	15.50	—

Postage & VAT extra

**C.R.T. TESTER/REACTIVATOR**

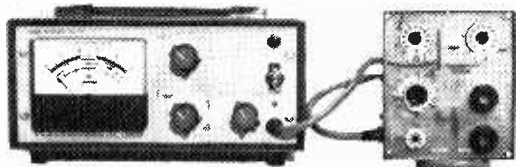

Suitable for Monochrome or Colour. Tests, emission and inter electrode leakage. A three step reactivation facility to boost worn tubes.

**£66** + V.A.T.

**INSTANT TRUNKING SYSTEM!**



Ready to use Price **£21.50** + P. & P. & V.A.T.  
Internal wiring suitable for 30 amp

**PORTABLE POWER DISTRIBUTION FOR INSTANT MAINS!**

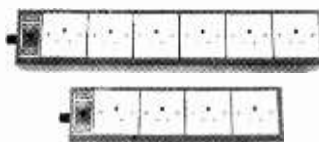

COMPLETE WITH 6FT. CABLE AND 13 AMP FUSED PLUG

- 4 sockets 13A ..... **£11.00**
- 6 sockets 13A ..... **£13.00**
- 4 sockets 13A switched ..... **£12.50**
- 6 sockets 13A switched ..... **£14.00**

ALL DISTRIBUTION PANELS ARE FITTED WITH MK SOCKETS & PLUG  
Send for details of complete range + postage 85p each + 8% V A T  
**OLSON ELECTRONICS LTD., FACTORY NO. 8, 5-7 LONG ST., LONDON E2 8JH**  
TEL: 01-739 2343

WW-054 FOR FURTHER DETAILS

**seen from the professional angle**



**the 201 is something quite personal...**

The M 201 Hypercardioid moving coil microphone is designed for recording or broadcasting. The M 201 offers excellent separation characteristics in extreme accoustical conditions.

**Specifications:**

Frequency Response: 40-18000 Hz.  
Output Level at 1 kHz: 0,14 mV/μ bar  
± -56 dbm (0 dbm ± 1 mW/10 dynes/cm<sup>2</sup>). EIA Sensitivity Rating: -149 dbm. Hum Pickup Level: 5 μ V/5 μ Tesla (50 Hz). Polar Pattern: Hypercardioid. Output Impedance: 200 Ω. Load Impedance: > 1000 Ω. Connections: M 201 N (C) = Cannon XLR-3-50 T or Switchcraft: 2+3 = 200 Ω, 1 = ground. M 201 N = 3-pin DIN plug T 3262: 1+3 = 200 Ω, 2 = ground. M 201 N (6) = 6 pin Tuchel.  
Dimensions: length 6", shaft Ø 0,95".  
Weight: 8,60 oz.



**BEYER DYNAMIC (GB) LIMITED**

1 Clair Road, Haywards Heath, Sussex.  
Tel: Haywards Heath 51003

WW-058 FOR FURTHER DETAILS

# Mainline

a tremendous range from Mainline, a division of one of the largest industrial electronic component distribution groups in the business.

The enormous resources, buying power and organisation guarantees fast reliable service and top quality components at the right price.

- Diodes
- Transistors
- Integrated circuits
- Resistors
- Capacitors
- Switches
- Relays
- Diecast Boxes
- Potentiometers

Fill in coupon below for the Mainline Components Catalogue.

Learn all about **MICROPROCESSORS** with the MOTOROLA Microprocessor Evaluation Design Kit M6800.

featuring:-

- 24 Key Keyboard
- 7 Segment Display
- Cassette Interface
- EROM Expandable
- RAM Expandable
- Wire Wrap Capability
- Parallel and Serial Interface Capability
- Single 5 Volt Supply Required
- Layout on Boards
- Documentation

Please send for detailed descriptive leaflet & prices.

## Mainline

380 Bath Road, Slough, Berks.  
Tel: 06286 (Burnham) 63616

Manufacturers and trade enquiries invited for larger quantities.

## Motorola Semiconductors.

We are pleased to announce that in conjunction with our parent company we can offer the complete range of Motorola semiconductors including zener diodes, diodes, transistors, SCR's, Triacs, digital and linear integrated circuits etc. As the available range is far too large to be listed please ask for your specific requirements.

The following are the more popular types of 2N TRANSISTORS by well known manufacturers such as Motorola, SGS, RCA, Fairchild. They are brand new and should not be confused with surplus offers often being advertised! Also we stock, or can obtain, other 2N transistor types not listed below. So please write and let us know what you are looking for.  
Please add 8% VAT to your 2N transistor orders, plus 25p per order for postage and packing.

Type	price	Type	price
2N697	£0.36	2N3442	£1.63
2N706	0.37	2N3766	0.86
2N706A	0.24	2N3866	1.05
2N708	0.30	2N4033	0.60
2N718	0.41	2N4123	1.94
2N914	0.32	2N4125	0.20
2N916	0.96	2N4400	0.15
2N918	0.38	2N4401	0.18
2N929	0.24	2N4402	0.21
2N930	0.24	2N4403	0.23
2N930A	0.25	2N4441	1.06
2N1132	0.85	2N4442	1.30
2N1613	1.27	2N4443	1.43
2N1711	0.32	2N4444	1.88
2N1890	0.77	2N4870	0.78
2N1893	0.30	2N4871	0.74
2N2102	0.93	2N4918	0.67
2N2218	0.29	2N4919	0.70
2N2218A	0.32	2N4920	0.74
2N2219	0.30	2N4921	0.63
2N2219A	0.31	2N4922	0.67
2N2221	0.23	2N4923	0.70
2N2221A	0.26	2N5060	0.42
2N2222	0.18	2N5061	0.43
2N2222A	0.21	2N5062	0.49
2N2369	0.21	2N5063	0.52
2N2369A	0.23	2N5064	0.55
2N2646	0.56	2N5088	0.21
2N2904	0.30	2N5108	4.03
2N2904A	0.31	2N5190	0.69
2N2905	0.38	2N5191	0.74
2N2905A	0.32	2N5192	0.80
2N2906	0.23	2N5193	0.75
2N2906A	0.23	2N5194	0.80
2N2907	0.23	2N5195	0.85
2N2907A	0.23	2N5400	0.27
2N3053	0.35	2N5401	0.28
2N3054A	0.84	2N5415	0.81
2N3055	0.89	2N5416	1.11
2N3055H	1.08	2N6027	0.62
2N3439	1.09	2N6028	0.79
2N3440	0.83		

Special quotations for quantities of 25 or more of one type.

## Mainline

TO: MAINLINE, 380 BATH ROAD, SLOUGH, BERKS.

Tel: 06286 (Burnham) 63616

Please send me your latest FREE catalogue

I enclose cheque/P.O. £ \_\_\_\_\_

Please send me the following devices

\_\_\_\_\_  
\_\_\_\_\_  
\_\_\_\_\_

Name \_\_\_\_\_  
Address \_\_\_\_\_  
Tel. \_\_\_\_\_

WW 7 / 78

WW-063 FOR FURTHER DETAILS



**BFD-1**  
£522.00 ASS.  
**BFD-2**  
£785.00 ASS.  
**BFD-3**  
£1045.00 ASS.



**SOROC IQ.120**  
£699.00  
ASS.



**SWTPC 6800**  
LEVEL 2  
£300.00  
KIT

**GROW YOUR SYSTEMS  
FROM**

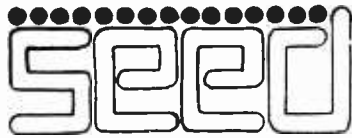

**CI.30/60**  
KIT £18.95  
ASS. £25.00

**16K RAM** £350  
ASS.  
**8k RAM**  
£141.75  
KIT



**FULL SUPPORTING  
SOFTWARE**  
**SUPER BASIC** £48.00  
**COMPILER** £185.00  
**EDITER/ASS.** £36.00  
ETC.



**MSI 6800**  
£375.00 KIT  
£565.00 ASS.



**FD-8W** £935.00  
**FD-8DW**  
£1640.00

*Sole U.K. Distributor for M.S.I. and S.S.B.*

**STRUMECH ENGINEERING LTD.**

Portland House, Coppice Side  
Brownhills, Walsall, Staffs.  
Phone: BRO 4321

**NEW!**

# Test Equipment

Here's a brand new multimeter from Eagle: 100,000 opv, 3-colour scale anti-parallax mirror, taut band movement, electronic protection, reversible polarity, 15 amps AC range. Complete with real leather carrying case, shoulder strap and probes.

**And all that for a retail list price of under £47.00!**

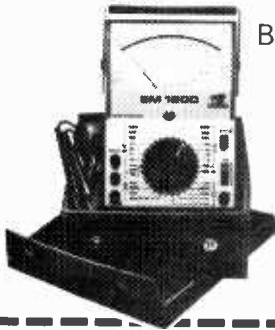

But that's not all - we've got a range of other meters to cover every possible need of the electrical or electronic engineer from about £6.50 upwards. Send the coupon now for the complete catalogue.

Please send me your catalogue with full details of all your test equipment.

Name \_\_\_\_\_  
Address \_\_\_\_\_



Eagle International, Precision Centre, Heather Park Drive, Wembley HA0 1SU Middlesex Tel: (01)-902 8832

# Eagle

W.W.

WW-037 FOR FURTHER DETAILS

Cambridge Learning Enterprises

**SUMMER OFFER until 1st. August 1978**

Just send this token with your order for a 10% discount

which entitles you to books at the following prices

Digital Computer Logic & Electronics £4.95

Design of Digital Systems £8.10

Combined set £11.70

Algorithm Writer's Guide £3.06

# Join the Digital Revolution

**Understand the latest developments in calculators, computers, watches, telephones, television, automotive instrumentation . . .**

Each of the 6 volumes of this self-instruction course measures 11¼" x 8¼" and contains 60 pages packed with information, diagrams and questions designed to lead you step-by-step through number systems and Boolean algebra, to memories, counters and simple arithmetic circuits, and on to a complete understanding of the design and operation of calculators and computers.

Design of Digital Systems

**£8**

plus £1 packing and surface post anywhere in the world. Overseas customers should send a bank draft in sterling drawn on a London bank. Payment by credit cards accepted.



Also available - a more elementary course assuming no prior knowledge except simple arithmetic.  
Digital Computer Logic and Electronics

In 4 volumes

**£4.60**

plus 90p P.&P.

1. Basic Computer Logic
2. Logical Circuit Elements
3. Designing Circuits to Carry Out Logical Functions.
4. Flipflops and Registers

Offer Order both courses for the bargain price £12 plus £1 P&P. A saving of £1.50.

**Designer  
Manager  
Enthusiast  
Scientist  
Engineer  
Student**

These courses were written so that you could teach yourself the theory and application of digital logic. Learning by self instruction has the advantages of being quicker and more thorough than classroom learning. You work at your own speed and must respond by answering questions on each new piece of information before proceeding to the next.

**FLOW CHARTS & ALGORITHMS - The Algorithm Writer's Guide** - Construction, content, form, use, layout of algorithms and flow charts. Vital for computing, training, wall charts, etc. **£2.95**

Size A5, 130 pages. plus 45p P.&P.

**Guarantee** - If you are not entirely satisfied your money will be refunded.

CAMBRIDGE LEARNING ENTERPRISES, Unit 3 Freepost, RIVERMILL LODGE, ST. IVES, HUNTINGDON, CAMBS. PE17 4BR, ENGLAND. TELEPHONE ST. IVES (0480) 67446. PROPRIETORS DRAYRIDGE LTD. REG. OFFICE RIVERMILL LODGE, ST. IVES. Giro Ac No 278 9815 REGD. IN ENGLAND NO. 1328762

Cambridge Learning Enterprises, Unit 3 Freepost Rivermill Lodge, St. Ives, Huntingdon, Cambs. PE17 4BR, England

Please send me the following books

- sets Digital Computer Logic & Electronics @ £5.50 p&p included
- sets Design of Digital Systems @ £9.00 p&p included
- Combined sets @ £13.00 p&p included
- The Algorithm Writer's Guide @ £3.40 p&p included

Name \_\_\_\_\_  
Address \_\_\_\_\_

I enclose a cheque / PO payable to Cambridge Learning Enterprises for £  
Please charge my \*Access / Barclaycard / Visa / Eurocard / Mastercard  
Interbank account number

Signature \_\_\_\_\_ delete as appropriate  
Telephone orders from credit holders accepted on 0480-67446 (AnsaFone)  
Overseas customers should send a bank draft in sterling drawn on a London Bank

WW7

# A. D. BAYLISS & SON LTD.

## Behind this name there's a lot of real POWER!

### Illustrated right is a TITAN DRILL

Mounted in a multi-purpose stand This drill is a powerful tool running on 12v DC at approx 9000 rpm with a torque of 350 gm cm Chuck capacity 3.00 m/m  
The multi-purpose stand is robustly constructed of steel and aluminium The base and bracket are finished in hammer blue  
Also available for use in the stand is the RELIANT DRILL which is a smaller version of the Titan Approx speed 9000 rpm 12v DC torque 35 gm cm Capacity 2.4 m/m

#### TITAN DRILL & STAND

**£21.45**

+ 8% VAT = £23.17 + £1 P&P

TITAN DRILL ONLY

**£9.79** + 8% VAT = £10.57 + 35p P&P

#### RELIANT DRILL & STAND

**£18.44**

+ 8% VAT = £19.92 + £1 P&P

RELIANT DRILL ONLY

**£6.34** + 8% VAT = £6.85 + 35p P&P

#### TITAN MINI DRILL KIT

**£16.25**

Drill Plus 20 Tools

+ 8% VAT = £17.55 + 50p P&P

#### RELIANT MINI DRILL KIT

**£13.20**

Drill Plus 20 Tools

+ 8% VAT = £14.26 + 50p P&P

#### TRANSFORMER UNIT

**£9.40**

+ 8% VAT = £10.15 + 75p P&P

These are examples of the extensive range of power tools designed to meet the needs of development engineers laboratory workers, model makers and others requiring small precision production aids

To back up the power tools, Expo offer a comprehensive selection of Drills Grinding Points and other tools

SEND STAMP for full details to main distributors

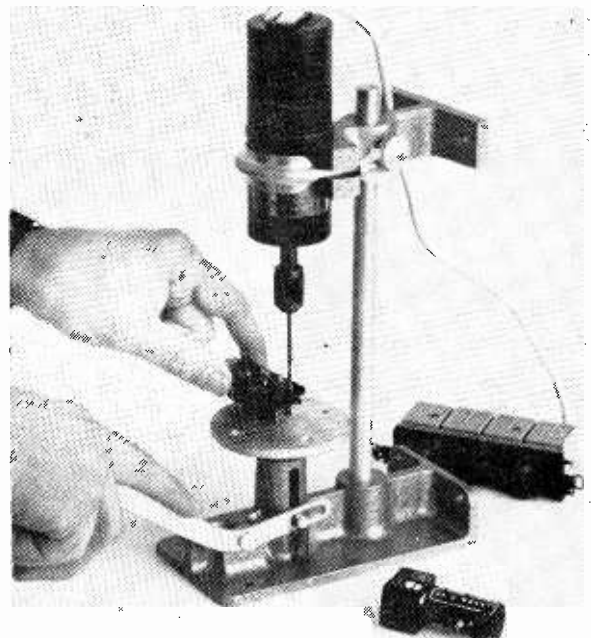

**A. D. BAYLISS & SON LTD.,** Pfera Works, Redmarley, Glos. GL19 3JU

Stockists Richards Electric, Gloucester; Hoopers of Ledbury; Hobbs of Ledbury; D&D Models, Hereford; Bertella, Gloucester; J. Power Services & Co. Ltd., Worcester

WW-046 FOR FURTHER DETAILS

After the introduction of the CQ 110 E and CQ 301, NEC have completed their CQ-Line with the CQ 201 Digital VFO, the SP 110 Speaker and the M110 SSB Microphone. The NEC CQ-Line represents highest technical standard, with regard to design, quality, reliability and price which is available to the modern radio communicator today.

**NEC CQ 110 E,** 300 watts Digital transceiver Modes: FSK/USB/LSB/CW/AM, 100-240V AC/13.5DC handmike, Control speaker, VOX Sidetone, 3 Xtal filters, Blower, RCA 7360 RX Mixer, 22 fix-channels, 60 Page Manual, 160-10 meter, 11 Ranges of 500 Khz.

**NEC CQ 301** 2-3 KW SSB/AM Linear Amplifier 160-10 meter, 2 EIMAC 3-500Z. Handbook, 100-240 V AC, High Speed Blower, incorp. Power Supply.

**NEC CQ 201** Digital Additional VFO for Split-Frequency Operation, containing 3 VFO systems, usable as frequency counter, 100-240 V AC/13.5VDC, Handbook.

**NEC SP 110** Communication Speaker with Electronical Digital Clock, timer, etc. handbook 100-240 VAC.

**NEC M 110** SSB Communications Microphone. designed for CQ - Line.

Colour of CQ line brown military sand-touch.

- ★ Dealer inquiries welcome
- ★ ASK ABOUT OUR UP TO 120 DAYS FINANCING FACILITIES
- ★ ASK FOR OUR COLOUR CATALOGUE against payment of SFR 16 — or any other equivalent currency.
- ★ Shipments to EVERYWHERE



Sole distributor in Europe:

**CEC** Corp., Via Valdani 1 — CH 6830 CHIASSO—SWITZERLAND  
Phone: (091) 44 26 51. Telex: 79959 CH

WW-031 FOR FURTHER DETAILS



# Crellon: No.1 for RCA Solid State and Industrial Tubes.

When you're the No. 1 distributor for RCA you've got to be good—big on stocks, big on service, big on technical know-how. And when you're handling Industrial Tubes as well as solid state devices you really need to be on your toes. The range is tremendous—everything from CMOS to Vidicons, linear IC's to Lasers, Power transistors to LED's, Op Amps to Image Intensifiers, Microprocessors to Photomultipliers.

Crellon are at the top because they put it all together under one roof. With some essential help from very knowledgeable in-house engineers and highly qualified sales engineers. Plus a large computer to keep control of the stock and deliveries—and provide you with fast information whenever you need it.

Call Crellon when you need RCA Solid State or Industrial Tubes—you'll find it pays to go to the top.

Crellon Electronics Ltd., 380 Bath Road, Slough, Berks. Tel: Burnham (06286) 4435.

Please send me data on RCA: Linear devices CMOS  
Microprocessors and memories Industrial Tubes Power transistors.

Name \_\_\_\_\_

Company \_\_\_\_\_

Address \_\_\_\_\_

WW 7 / 78

Tel: \_\_\_\_\_

WW — 111 FOR FURTHER DETAILS



## New from AMCRON

### Real Time Analyser RTA2

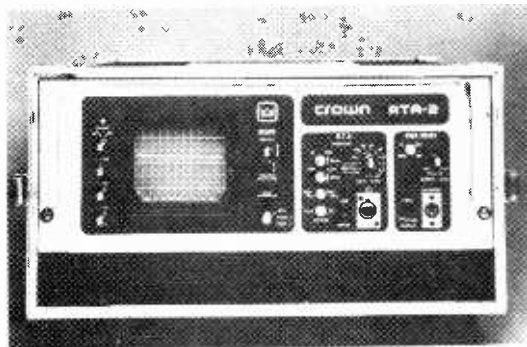

The Amcron RTA2 Real Time Analyser is designed as much for use as a production tool as it is for on-site audio analysis of theatres, and recording studios. A flight case is available.

- ★ 5" CRT Display
- ★ Internal Pink Noise Source
- ★ 1/3 or 1 octave Display
- ★ Frequency range 20 - 20kHz
- ★ Outputs for X-Y Recorders
- ★ Compatible with any microphone
- ★ Price £1,960 ex. VAT

### POWER AMPLIFIER D75

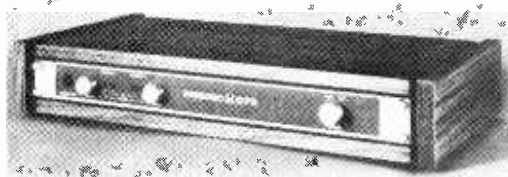

The AMCRON D75 power amplifier replaces the previous model D60. Employing completely new type circuitry it offers also many new features but without any increase in the price.

- ★ New Amcron IOC comparator.
- ★ Balanced XLR input connectors.
- ★ Signal Presence indicators.
- ★ Separate Signal/chassis earth.
- ★ 45 watts into 8 ohms per channel.
- ★ Price £230 ex. VAT.

### Other AMCRON products include:

DC300A amplifier 500 watts/chan. ....	£550
D150A amplifier 200 watts/chan. ....	£350
VFX2A Electronic Variable Filter .....	£270
EQ2 Equaliser .....	£599
IC150A Pre-amplifier .....	£260
IMA Intermodulation Distortion Analyser unit .....	£610

**MACINNES LABORATORIES LTD.**  
 Carlton Park Industrial Estate  
 Saxmundham, Suffolk, IP17 2NL  
 Tel. Saxmundham (0728) 2262/2615

WW-022 FOR FURTHER DETAILS

## METER PROBLEMS?

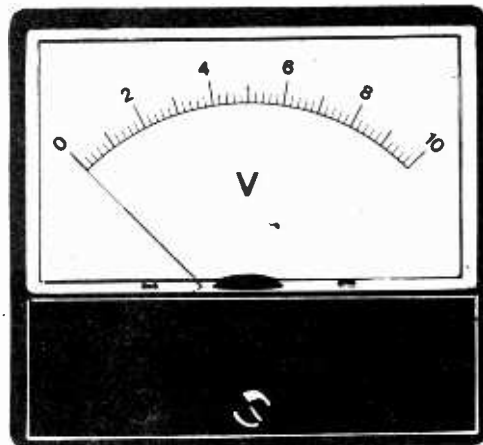

137 Standard Ranges in a variety of sizes and stylings available for 10-14 days delivery. Other Ranges and special scales can be made to order.

Full Information from:

**HARRIS ELECTRONICS (London)**

138 GRAYS INN ROAD, W.C.1 Phone: 01/837/7937

WW-040 FOR FURTHER DETAILS

## VIDEO or AUDIO BULK ERASURE



**LR71**  
 MAX REEL SIZE 11 1/2"  
 VIDEO AND AUDIO

**LR70**  
 MAX REEL SIZE 8 1/2"  
 AUDIO ONLY

LR70/71 bulk tape erasers are simple to operate and will erase cassettes, cartridges and reels of tape up to a maximum reel size of 11 1/2" and tape width of 1", quickly and efficiently.

LR70/71 bulk erasers are currently used in Broadcast Companies, Recording Studios, Government Departments, Educational Establishments and the Computer Industry.

Quality equipment moderately priced



**LEEVERS-RICH EQUIPMENT LIMITED**

319 Trinity Road, Wandsworth  
 London SW18 1YQ

01 874-9054 Telex 923455

WW-019 FOR FURTHER DETAILS

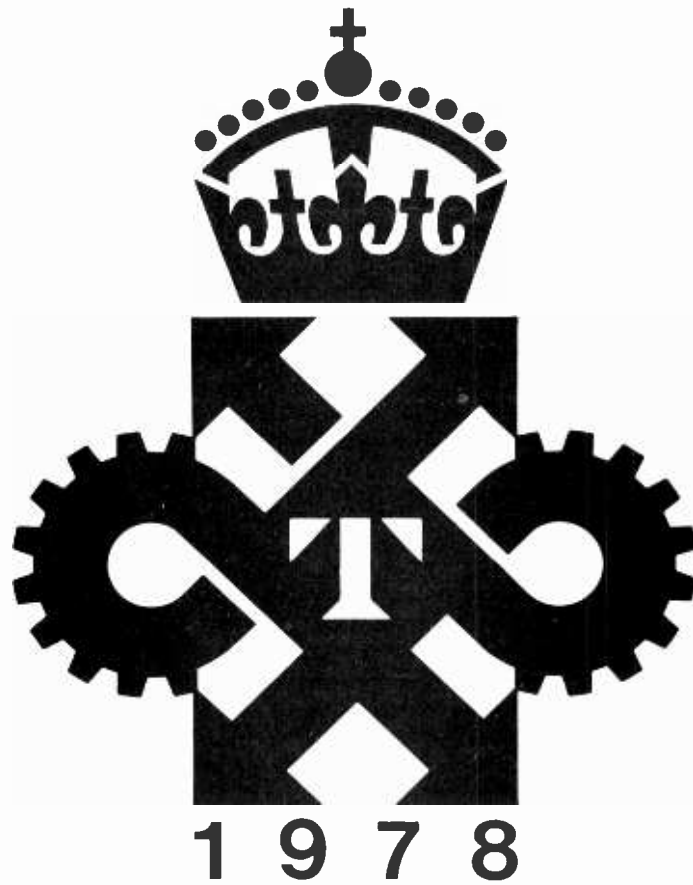

# The Queen's Award for Technological Achievement

Quad has been granted the Queen's Award for Technological Achievement 1978, the first audio manufacturer ever to have been so honoured.

The Award is given for outstanding achievement in the design of a new product incorporating technological development which confers market leadership. We are unreservedly proud of this recognition for the Quad 405 - current dumping amplifier

The sonic accuracy of the 405 demonstrably

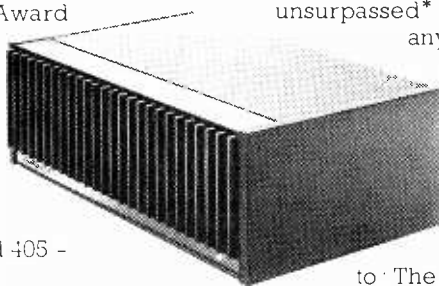

unsurpassed\* by any amplifier at any price made anywhere in the world - has led to its

becoming a market leader in most of the sixty countries in which Quad products are sold.

Isn't it nice to know that Britain can still be one or two steps ahead of the rest?

For further details on the full range of QUAD products write

to: The Acoustical Manufacturing Co. Ltd., Huntingdon, Cambs. PE18 7DB. Telephone (0480) 52561

## QUAD

for the closest approach to the original sound

QUAD is a registered trade mark

\* At any power not exceeding its full rating.

WW-080 FOR FURTHER DETAILS

# Instant LCR Answers.



The B424 is an easy-to-operate component meter, providing accurate measurements over an extremely wide range for under £600.

For every type of component: capacitor, resistor or inductor, the liquid crystal display shows the value in full. The decimal point is shown in position and the numerical readout is followed directly by the appropriate symbol for each range. No multiplying or scaling factors are ever needed, eliminating a prime source of operator error.

The meter automatically selects the test signal level and frequency, so that the operator doesn't have to calculate and reset for each type of measurement. The range finder will indicate on the display when a higher

or lower range could give a more precise readout.

In addition to the basic meter, a component jig, the CA4, is now available for rapid connection of components with axial, radial or pre-formed leads. The CA4 has built-in limits circuits for an automatic indication of 'Low', 'Pass' or 'High' as each component is connected. Setting of the limits takes only a few seconds, no external equipment or standards being necessary.

These features, combined with the 0.25% accuracy over the wide measurement range, make the equipment equally valuable in Goods Inwards sections or design laboratories.

For more details fill in the coupon or contact your nearest distributor:

## ...with the right contacts



## B424/CA4 New Simplicity in LCR Measurements

Tekelec-Airtronic, Cite des Bruyeres,  
Rue Carle-Vernet, 92310 Sevres,  
Paris, France, Tel: 027 75 35.  
Keithley Instruments GmbH, Heiglhofstrasse 5,  
8000 Munchen 70, West Germany.  
Tel: (089) 7144065.  
G & P Electronics AG, Bernerstrasse-Nord 182,  
Ch-8064 Zurich, Switzerland. Tel: (01) 643231.  
C N Rood BV, PO Box 42,  
11-13 Cort van der Lindenstraat,  
Rijswijk ZH 2109, Holland. Tel: (70) 99 63 60.  
Unitronics SA, Torre de Madrid, Princesa 1,  
Piso 12 Oficina 9, Madrid 8, Spain, Tel: 242 5204  
Scandia Metric AB, Fack 171 19, Solna 1,  
Banhavsvagen 20, Sweden, Tel: (08) 820 410.

Please send me details of the Wayne Kerr B424/CA4

Name \_\_\_\_\_

Company \_\_\_\_\_

Address \_\_\_\_\_

Tel: \_\_\_\_\_



**Wayne Kerr**

Wilmot Breeden Electronics Limited  
442 Bath Road, Slough, Berkshire SL1 6BB  
England

ww/7/78

WW - 079 FOR FURTHER DETAILS

# SME SERIES III

*The best pick-up arm in the world*

*is one of the 1978 Design Awards given by the British Design Council*

**Design Council  
Award 1978**

*The Series I precision pick-up arm was similarly honoured 1962*

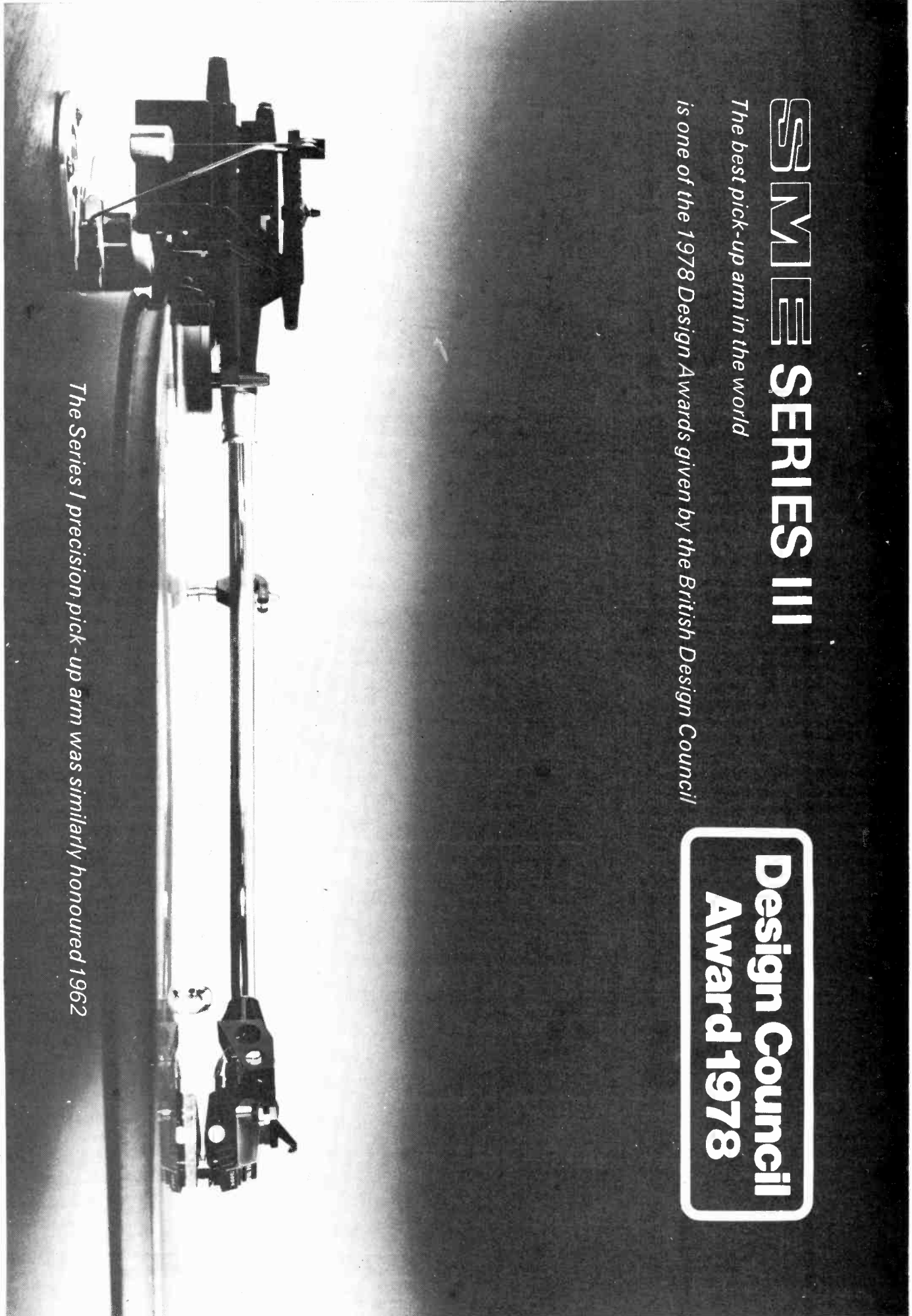

Write to Dept 0648A · SME Limited · Steyning · Sussex · BN4 3GY

WW — 008 FOR FURTHER DETAILS





## In future, recording the present will be a thing of the past.

What's past is past. And said to be best forgotten.

But it's fundamental to the very existence of communications recording to be able to replay a selected portion of tape to find out what was said by who, to whom... and when. And 'when' can be vital.

Equally vital, particularly in emergencies when every second counts, is the ability to obtain such replay access rapidly, precisely, automatically. With absolute certainty — and without time-consuming multiple knob-twiddling aided by guesswork.

Racal-Thermionic has recognized this need and produced TIMESEARCH — designed specifically for its ICR range of multi-channel communications recorders — and providing just these facilities.

TIMESEARCH can generate a coded time reference signal of crystal accuracy and index it onto the tape. It can read and display that signal. It can search a tape at high speed for a pre-selected time signal and automatically initiate replay at that time.

In communications recording, the future becomes the present; the present becomes the past. And when you need to recall the past with precision, you need TIMESEARCH.



*And for providing precise time signals every 10 seconds for recording onto magnetic tape: the International Timing Unit.*

**Racal-Thermionic** the recording people

Racal-Thermionic Limited, Hardley Industrial Estate, Hythe, Southampton, SO4 6ZH, England Telephone 0703 843265 Telex 47600

WW-009 FOR FURTHER DETAILS

[www.americanradiohistory.com](http://www.americanradiohistory.com)

**RACAL**

# Give your project layers of ceramic reliability!

## with MULTILAYER CERAMICS from ITT

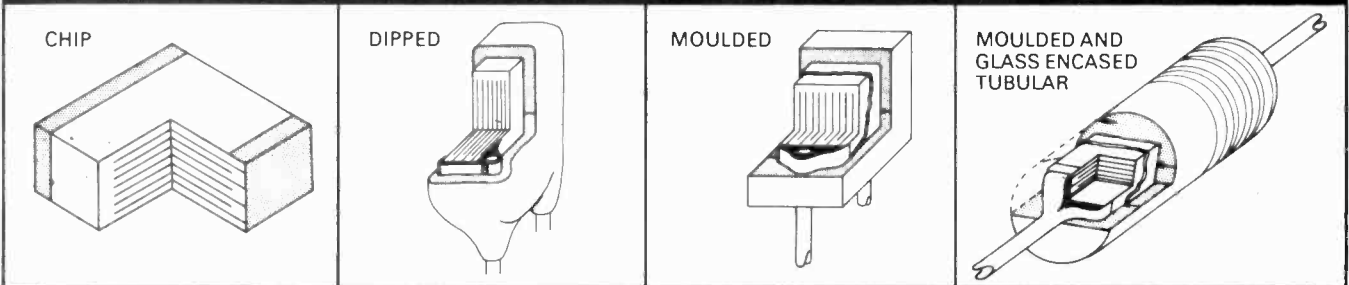

**\*Reliability to meet BS9075**

Multilayer ceramic capacitors are available from ITT in four basic styles — chips for thick film IC applications or direct bonding to p.c.b.s; radial and axial lead moulded units and glass encased axial components for superior environmental performance, and radial lead dip-coated for general applications.

There's a choice of three dielectrics: COG, X7R, and Z5U. And three voltage ratings: 50, 100 and 200 volts.

\*BS9075 Approvals: F005, F022, F041, F042, No 23, No 24 and No 25.

For a copy of the latest multilayer catalogue, contact:

**ITT Components Group Europe**

MULTILAYER CERAMICS DIVISION,  
South Denes, Great Yarmouth,  
Norfolk NR30 3PX.

Tel: 0493 56122. Telex: 97421.

**UK DISTRIBUTORS:**

ITT Electronic Services: 0279 26777

Intel Electronics Ltd: 0462 812 505

Compstock: 0268 27722.

Bosledge: 061-834 7339



WW—023 FOR FURTHER DETAILS

# Autocrat

*The absolute leader in its class*

Farnell offer the only  
**DIGITAL MULTIMETER**  
with all these features

- ★ AUTORANGING (with hold) ★ AUTOPOLARITY
- ★ AUTOZERO ★ SIX RESISTANCE RANGES
- ★ LARGE DISPLAYS ★ A.C. & D.C. VOLTS & CURRENTS
- ★ TEMPERATURE MEASUREMENT

DM 131  
(mains powered)

**£159**

DM 131/B  
(mains battery)

**£195**



Details from: Farnell Instruments Limited - Wetherby - W. Yorks LS22 4DH  
Telephone: 0937-63541 or 01-864 7433

WW—093 FOR FURTHER DETAILS

# FYLDE

## TRANSDUCER and RECORDER AMPLIFIERS and SYSTEMS

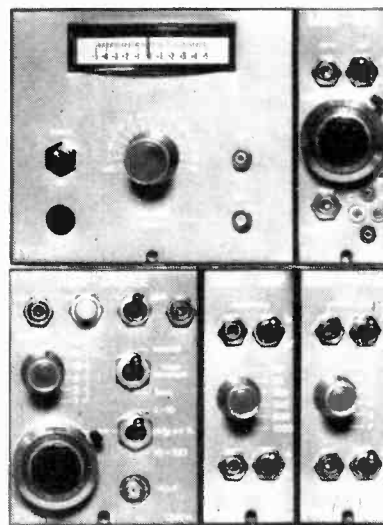

reliable high performance & practical controls. individually powered modules—mains or dc option single cases and up to 17 modules in standard 19" crates small size—low weight—realistic prices.

# FYLDE

**Fylde Electronic Laboratories Limited.**

49/51 Fylde Road Preston

PR1 2XQ

Telephone 0772 57560

WW—049 FOR FURTHER DETAILS



# BIMCONSOLES BIMBOXES BIMBOARDS BIMDRILLS BIMDICATORS

## MINI DESK BIMCONSOLES

Moulded in Orange, Blue, Black or Grey ABS and incorporating guides on all sides for holding 1.5mm thick pcb's. 1mm Grey Aluminium panel sits recessed into front of console and held by screws running into integral brass bushes. Stand-off bosses in base for supporting small sub-assemblies etc. 4 self adhesive rubber feet also included.

BIM1005 (161x96x58mm) £2.12\*  
BIM1006 (215x130x75mm) £2.94\*



## LOW PROFILE BIMCONSOLES

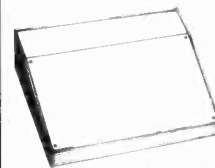

1mm Grey Aluminium panel sits recessed into front of console base, which is moulded in Orange, Blue, Black or Grey ABS and sits on 4 self adhesive rubber feet. Incorporating guides for holding 1.5mm thick pcb, the base also has stand-off bosses for supporting small sub-assemblies etc. and ventilation slots. Front panel is held by 4 screws which run into integral brass bushes.

BIM6005 (143x105x55.5 [31.5] mm) £2.32\*  
BIM6006 (143x170x55.5 [31.5] mm) £3.08\*  
BIM6007 (214x170x82 [31.5] mm) £4.12\*

## ABS & DIECAST BIMBOXES

5 sizes, in either ABS or Diecast Aluminium ABS moulded in Orange, Blue, Grey or Black Diecast Aluminium available in Grey Hammertone or Natural

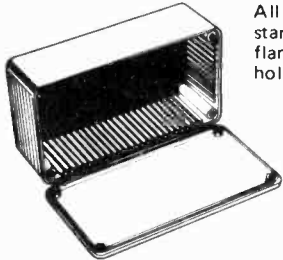

All boxes incorporate guides on all sides for holding 1.5mm thick pcb's and stand-off bosses in base for supporting small sub-assemblies etc. Close fitting flanged lids held by screws running into integral brass bushes (ABS) or tapped holes (Diecast).

	ABS	Diecast	Hammertone	Natural
(100x50x25mm)	BIM2002/12 £0.95*	BIM5002/12 £1.20*		£0.97*
(112x62x31mm)	BIM2003/13 £1.05*	BIM5003/13 £1.50*		£1.20*
(120x65x40mm)	BIM2004/14 £1.15*	BIM5004/14 £1.86*		£1.49*
(150x80x50mm)	BIM2005/15 £1.30*	BIM5005/15 £2.38*		£1.91*
(190x110x60mm)	BIM2006/16 £2.04*	BIM5006/16 £3.41*		£2.85*

Also available in Grey Polystyrene (112x61x31mm) with no slots and self tapping screws BIM2007/17 £0.88\*

## ALL METAL BIMCONSOLES

All aluminium, 2 piece desk consoles with either 15° or 30° sloping fronts, sit on 4 self-adhesive non slip rubber feet. Ventilation slots in base and rear panels permit efficient cooling.

Colour Code	Top Panel	Base	15° Sloping Panel	
A	Off White	Blue	BIM7151 (102x140x51 [28] mm)	£ 9.43*
B	Sand	Green	BIM7152 (165x140x51 [28] mm)	£10.43*
C	Satin Black	Gold	BIM7153 (165x216x51 [28] mm)	£11.42*
			BIM7154 (165x211x76 [33] mm)	£12.39*
			BIM7155 (254x211x76 [33] mm)	£13.66*
			BIM7156 (254x287x76 [33] mm)	£14.65*
			BIM7157 (356x211x76 [33] mm)	£15.80*
			BIM7158 (356x287x76 [33] mm)	£16.78*

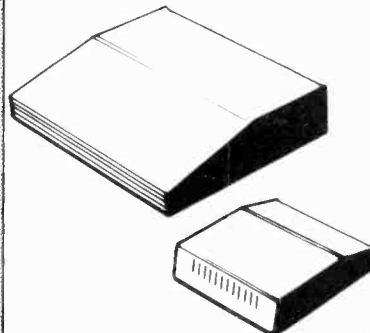

30° Sloping Panel	
BIM7301 (102x140x76 [28] mm)	£ 9.43*
BIM7302 (165x140x76 [28] mm)	£10.43*
BIM7303 (165x183x102 [28] mm)	£11.42*
BIM7304 (254x140x76 [28] mm)	£12.39*
BIM7305 (254x183x102 [28] mm)	£13.66*
BIM7306 (254x259x102 [28] mm)	£14.65*
BIM7307 (356x183x102 [28] mm)	£15.80*
BIM7308 (356x259x102 [28] mm)	£16.78*

## MULTI-PURPOSE BIMBOXES

Moulded in Orange, Blue, Black or Grey ABS with 1mm thick Grey aluminium recessed front cover which is retained by 4 screws running into integral brass bushes. 1.5mm pcb guides are incorporated on all sides and as with all ABS boxes they are 85°C rated. 4 self adhesive rubber feet also included.

BIM 4003 (85x56x28.5mm) £1.24\*  
BIM 4004 (111x71x41.5mm) £1.56\*  
BIM 4005 (161x96x52.5mm) £2.08\*

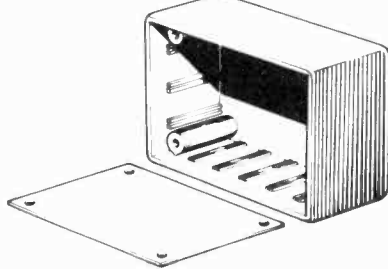

## DIL COMPATIBLE BIMBOARDS

Bimboards accept all sizes of DIL packages as well as resistors, diodes, capacitors and LED's etc. They have integral Bus Strips running up each side for carrying Vcc and ground as well as Component Support Brackets for holding lamps, fuses and switches etc. Available as either single or multiple units, the latter mounted on 1.5mm thick, matt black aluminium back plates which stand on non slip rubber feet and have 4 screw terminals for incoming power.

Bimboard 1 contains 500 individual sockets whereas the multiple units containing 2, 3 or 4 Bimboards incorporate 1,100, 1,650 or 2,200 individual sockets, all arranged on a 2.5mm (0.1") matrix.

Bimboard 1 £ 9.72\* Bimboard 2 £22.68\*  
Bimboard 3 £32.40\* Bimboard 4 £42.12\*

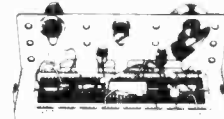

## BIMDICATORS

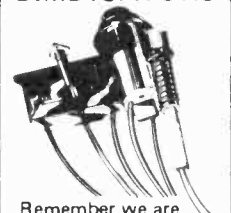

Remember we are also one of Europe's largest manufacturers of Filament, Neon and LED indicators. Send for our BIMDIATOR DATA

## MAINS BIMDRILL

Operates directly from 220-240Vac and supplied with 2 metres long cable fitted with 2 pin DIN plug. Will drill brass, steel and aluminium as well as pcb's etc. Has integral biased-off switch and accepts tools with 1,2 and 3.2mm dia shanks £9.72\*

Accessory Kit including 1mm, 2mm, .125" twist drills, 5 burrs and 2.4mm collet £2.20\*

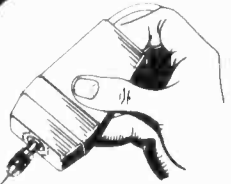

## 12 VOLT BIMDRILLS

2 small but powerful 12V dc drills, easily held in hand or used with lathe/stand adaptor. Both drills have integral on/off switches and 1 metre long cable.

Mini Bimdrill with 2 collets up to 2.4mm capacity £7.56\*

Major Bimdrill with 3 collets up to 3mm capacity £12.96\*

Mains to 12 Volts adaptor, lathe, stand and accessory kits also available, details on request.



# BOSS

## INDUSTRIAL MOULDINGS LIMITED

2 Herne Hill Road, London SE24 0AU

Telephone: 01-737 2383

Telex: 919693 Answer Back 'LITZEN G'

Cables & Telegrams: 'LITZEN LONDON SE24'

\*All quoted prices are 1 off and include Postage, Packing and VAT. Terms are strictly cash with order unless you have authorised BOSS account. For individual data sheets on all BOSS products send stamped, self addressed envelope

The new, comprehensive JVC 3/4" video cassette range

# See-and believe

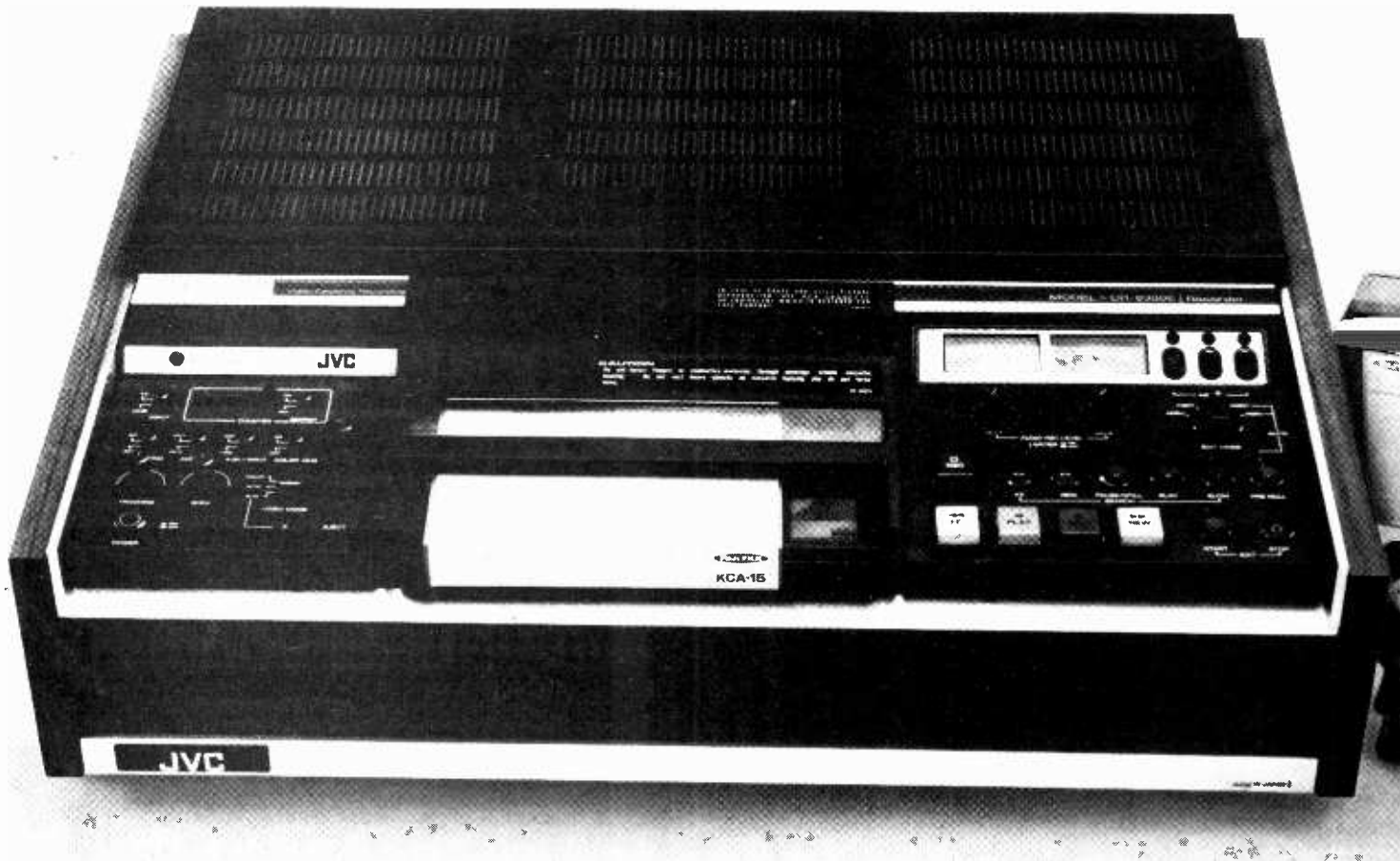

**A pioneering electronics organisation with 51 years' experience of high-technology engineering, JVC has been developing and introducing new and better video products for 21 years.**

**Now, for the first time in Britain, you can choose from a new and comprehensive range of JVC 3/4" U-format colour-plus-monochrome video cassette units, up to 38% smaller than directly competitive equipment.**

**From the compact portable CR-4400E for location work to the versatile CR-8300E for production studios, these easy-to-use models meet every video cassette recorder demand. They give you exactly the same top-quality recording and playback throughout the range. Price differences simply reflect the number of facilities available, not the performance.**

**The range.** For those needing NTSC as well as PAL playback (perhaps for shipboard entertainment), JVC has the new CR-5060ED.

If you're looking for stop-action playback and PAL record/playback facilities, the new CR-6060E with its specially engineered still-frame system is the one for you. (Optional remote control available.)

PAL recording, plus PAL and NTSC playback, come together in the new CR-6060ED. Again, with optional remote control.

Full electronic editing facilities are built into the superb new CR-8300E, a PAL record/playback unit. For even more flexible editing, add the JVC RM83 editing suite.

Where you must have portable video equipment, able to record cassettes that can also be replayed by a mains cassette unit without an adaptor, it's got to be the new assembly-edit CR-4400E. This comes complete with built-in video/RF replay facilities. And, of course, there's a colour camera to match.

Use the inquiry service to get the literature from Bell & Howell and the name and address of an audio-visual centre where you can test for yourself the versatility of these new JVC units. Admire the outstanding picture quality each provides. Seeing is believing. You'll believe, as we do, that JVC U-format equipment is the best in the world.

WW-075 FOR FURTHER DETAILS

# SINTROM MICROSHOP



? Has your chosen Microprocessor system ?  
and Supplier these Unique features

- \* Motorola 6800 by Southwest Technical
- \* Plug in expansion for memory and I/O
- \* Proven software: Assemblers, editors, floppy disc operating system and BASIC from 4K to 4 user.
- \* Kansas City cassette tape and Shugart minifloppy fully supported
- \* New, system oriented, documentation
- \* Walk-in hobbyshop with experienced staff
- \* Demonstrations always available
- \* Hands-on selection of software
- \* Manuals, Magazines and Data to browse or buy
- \* Ten years experience in minicomputers, disks, cartridge tapes and VDUs



		KIT £	BUILT £
MP-68	M6800 by Southwest Technical With 4K RAM, Mikbug ROM and TTY/RS232 input output interface	275	353
CT-64	VDU controller with keyboard, serial ASCII	260	345
CT-VM	Video monitor for use with CT 64, 12 volt operation		140
CT-606	Kansas City cassette interface for use with CT-64 Instals inside		50
AC-30	Freestanding dual Kansas-City cassette interface	60	100
MF-68	Twin Shugart minifloppy, controller, interface card, and Disc Operating System with Disc 8K BASIC		
PR-40	40 Column alphanumeric printer 75 lines per minute	800	860
MP-4	4K memory board	200	250
MP-8	8K memory board	80	107
MP-S	Serial ACIA board	200	240
MP-L	Dual 8 bit parallel interface board	30	37
MF-D10	Pack of ten Diskettes	30	37
SWTBUG	Improved ROM Operating System, Mikbug compatible	26 50	16 00

Software on paper tape or Kansas-City cassette £10 25 per application  
Professional Commercial packages to special quotation  
All units include full documentation  
All units include full documentation, power supply and case where required and interface directly to MP-68 system  
All prices exclude VAT (8%) and carriage

Write now for Free Catalogue and lists

Microcomputer Hobby Shop  
14 Arkwright Road  
Reading Berks  
RG2 0LS

Monday to Saturday

Tel 0734 84322  
Telex 847395

WW-027 FOR FURTHER DETAILS

## Fuji Beridox tape

To get the optimum results from any U-format equipment use Fuji Beridox tape. Provably superior to conventional CrO<sub>2</sub> tape, it's now available from every Bell & Howell dealer.



Beridox 3/4" (19mm) video cassettes

- KCA- 10** (10 min. playing time)
- KCA- 15** (15 min. playing time)
- KCA- 20** (20 min. playing time)
- KCA- 30** (30 min. playing time)
- KCA- 50** (50 min. playing time)
- KCA- 60** (60 min. playing time)

1/2", 1" and 2" video tape also available.

Bell & Howell A-V Ltd.  
Alperton House,  
Bridgewater Road,  
Wembley, Middlesex, HA0 1EG.



# Thick Film resistor networks by ITT -of course

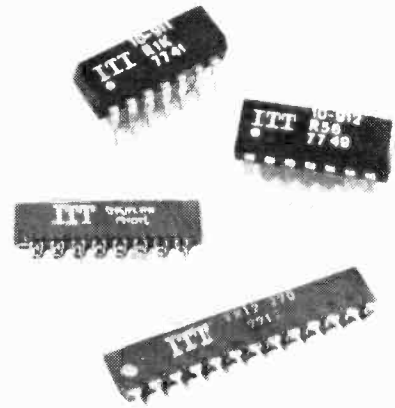

A wide range of low-cost Single-in-line and Dual-in-line resistor networks in standard circuit configurations are available from ITT on short delivery. Each resistor network is backed by many years' experience of thick film technology, and made to exacting specifications. Typical applications include pull-up resistors and line termination for TTL, ECL and CMOS logic.

S.I.L. units are ruggedly constructed in two basic package heights (8.55mm and 5mm) with 3 to 20 leads, giving designers the maximum flexibility to cater for various power-dissipation and board-density demands.

D.I.L. resistor networks from ITT are available in 14-pin and 16-pin transfer moulded packages.

In both styles resistor values are available up to  $10M\Omega$  with standard tolerances as close as 1%.

Custom designed networks are also available, offering a cost effective solution to many board-space problems. For more information on standard or non-standard ITT resistor networks, contact:

## ITT Components Group Europe

RESISTOR DIVISION,

South Denes, Great Yarmouth, Norfolk NR30 3PX  
Tel: 0493 56122. Telex: 97421.

Components **ITT**

WW-024 FOR FURTHER DETAILS

## ELECTRONIC INDUSTRIAL THERMOMETER

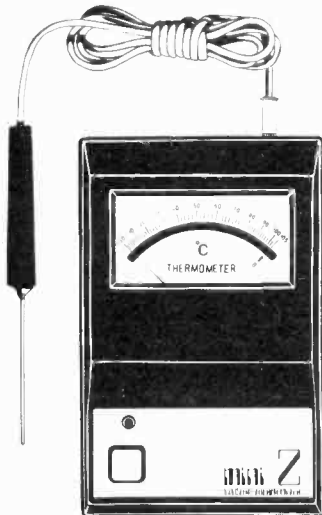

### THE MODERN WAY TO MEASURE TEMPERATURE

A Thermometer designed to operate as an Electronic Test Meter. Will measure temperature of Air, Metals, Liquids, Machinery, etc., etc. Just plug-in the Probe, and read the temperature on the large open scale meter. Supplied with carrying case, Probe and internal 1½ volt standard size battery.

Model "Mini-Z 1" measures from  $-40^{\circ}\text{C}$  to  $+70^{\circ}\text{C}$ . Price £30.00

Model "Mini-Z 2" measures from  $-5^{\circ}\text{C}$  to  $+105^{\circ}\text{C}$ . Price £30.00

Model "Mini-Z Hi" measures from  $+100^{\circ}\text{C}$  to  $500^{\circ}\text{C}$ . Price £33.00  
(VAT 8% EXTRA)

Write for further details to

**HARRIS ELECTRONICS (LONDON)**  
138 GRAY'S INN ROAD, LONDON, WC1X 8AX  
(Phone 01-837 7937)

WW-035 FOR FURTHER DETAILS

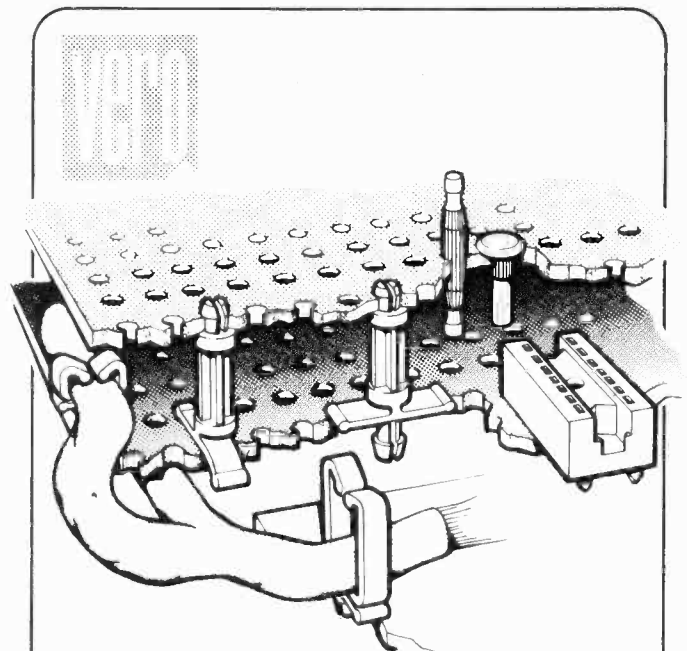

Our new 1978 catalogue lists circuit board accessories for all your projects — DIP sockets, pins, standoffs, cable clips, hand tools. And we've got circuit boards, module systems, cases and boxes — everything you need to give your equipment the quality you demand. Send 25p to cover post and packing, and the catalogue's yours.

**VERO ELECTRONICS LTD. RETAIL DEPT.**  
Industrial Estate, Chandlers Ford, Hants. SO5 3ZR  
Telephone Chandlers Ford (04215) 2956

WW-007 FOR FURTHER DETAILS

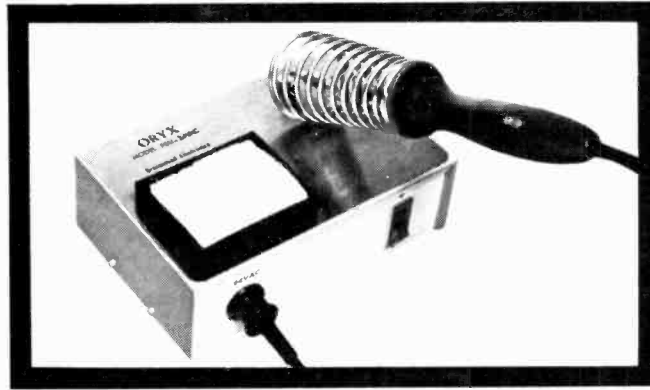

# Introducing the ORYX PSU 24

a new compact self-contained 24 volt power supply unit for ORYX temperature controlled soldering irons.

Styled in tough plastic, the ORYX PSU 24 is a smart new supply unit that is self-contained and small enough for the smallest of benches. Designed to meet BSS 3456 the ORYX has all the features you need - and more: - ON/OFF illuminated rocker switch; 3 pin non-reversible socket supplying 24 volts; a BSS 3535 transformer; an outside primary fuse; 1.5 metre white cable to BSS 6500 and fuse protection for transformer secondary wiring.

*A unique feature is the facility to modify a 3 wire power system to a 2 wire fully isolated unit and vice versa.*

## A new product from Greenwood Electronics

For full technical data write for information to Greenwood Electronics, Portman Road, Reading, RG3 1NE Telephone: Reading (0734) 595844 Telex: 848659

WW — 012 FOR FURTHER DETAILS

# FAST RESPONSE STRIP CHART RECORDERS

Made in USSR

## Series H3020

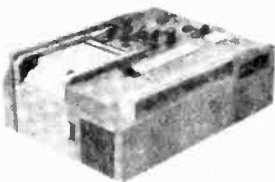

Basic error 2.5%  
Sensitivity 8mA F.S.D.  
Response 0.2 sec.  
Width of each channel  
Single and three-pen  
recorders: 80mm  
Five-pen recorders: 50mm

Chart speeds, selected by push buttons: 0.1-0.2-0.5-1.0-2.5-5.0-12.5-25 mm/sec.  
Chart drive 200-250V 50Hz  
Recording: Syphon pen directly attached to moving coil frames.  
Curvilinear co-ordinates  
Equipment: Marker pen, timer pen, paper footage indicator, 10 rolls of paper, connectors, etc.

- H3020-1 (Single pen):** 285mm wide x 384mm deep x 165mm high **PRICE £108.00**
- H3020-3 (Three pen):** 475mm wide x 384mm deep x 165mm high **PRICE £160.00**
- H3020-5 (Five pen):** 475mm wide x 384mm deep x 185mm high **PRICE £295.00**

## Series H327

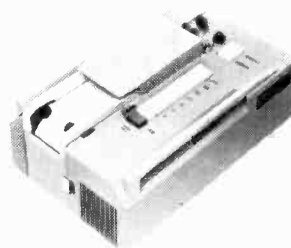

Polarized moving iron movements with syphon pens directly attached. Built-in solid state amplifier (one per channel) provides 8 calibrated sensitivity steps. Two marker pens are provided.  
Basic error 4%. Frequency response from DC to 100Hz 2dB

Sensitivity 0.02 - 0.05 - 0.1 - 0.2 - 0.5 - 1 - 2 - 5 volts/cm  
Width of each recording channel: 40mm  
Chart drive 220-250V 50Hz  
Chart speeds 1-2-5-10-50-125-250mm/sec.

- Type H3271-1. Single pen:** Dimensions: 259 x 384 x 165mm  
Weight 15 kilos **PRICE £265.00**
- Type H327-3. Three pen:** Dimensions: 335 x 384 x 165mm  
Weight 20 kilos **PRICE £520.00**
- Type H327-5. Five pen:** Dimensions: 425 x 385 x 165mm.  
Weight 25 kilos **PRICE £770.00**

Note: Prices are exclusive of VAT

Available for immediate delivery

# Z & I AERO SERVICES LTD.

44A WESTBOURNE GROVE, LONDON W2 5SF

Tel. 01-727 5641

Telex: 261306

WW—065 FOR FURTHER DETAILS

# WHY SETTLE FOR LESS— THAN A 6800 SYSTEM

## MEMORY—

All static memory with selected 2102 IC's allows processor to run at its maximum speed at all times. No refresh system is needed and no time is lost in memory refresh cycles. Each board holds 4,096 words of this proven reliable and trouble free memory. Cost—only £80.00 for each full 4K memory.

## INTERFACE—

Serial control interface connects to any RS-232, or 20 Ma. TTY control terminal. Connectors provided for expansion of up to eight interfaces. Unique programmable interface circuits allow you to match the interface to almost any possible combination of polarity and control signal arrangements. Baud rate selection can be made on each individual interface. All this at a sensible cost of only £30.00 for either serial, or parallel type

## PROCESSOR—

"Motorola" M6800 processor with Mikbug® ROM operating system. Automatic reset and loading, plus full compatability with Motorola evaluation set software. Crystal controlled oscillator provides the clock signal for the processor and is divided down by the MC14411 to provide the various Baud rate outputs for the interface circuits. Full buffering on all data and address busses insures "glitch" free operation with full expansion of memory and interfaces.

## POWER SUPPLY—

Heavy duty 10.0 Amp power supply capable of powering a fully expanded system of memory and interface boards. Note 25 Amp rectifier bridge and 91,000 mfd computer grade filter capacitor.

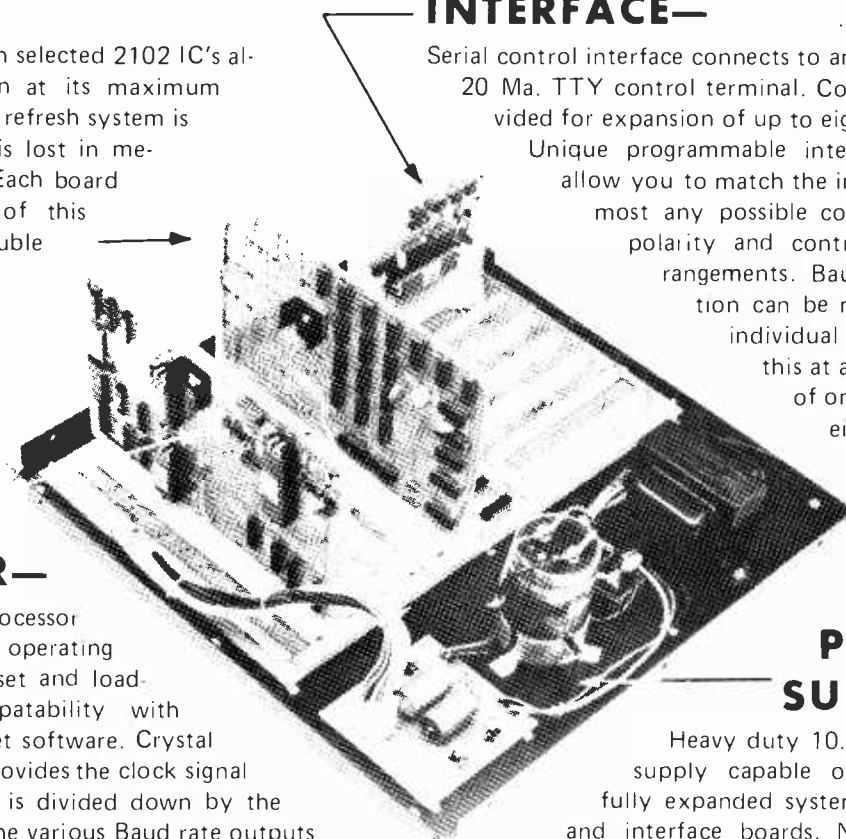

## DOCUMENTATION—

Probably the most extensive and complete set of data available for any microprocessor system is supplied with our 6800 computer. This includes the Motorola programming manual, our own very complete assembly instructions, plus a notebook full of information that we have compiled on the system hardware and programming. This includes diagnostic programs, sample programs and even a Tic Tac Toe listing.

Mikbug® is a registered trademark of Motorola Inc.

**SWTP 6800**  
Computer System

with serial interface and 4,096 words of memory. . . . . **£275.00**  
(Kit form only)

**PRICE EFFECTIVE 1st OCTOBER, 1977**



Prices quoted do not include VAT

Please send me details of your full range of computer equipment and software.

Name .....

Address .....

.....

**Southwest Technical Products Co.**  
**Unit 12, Tresham Rd.,**  
**Orton Southgate, Peterborough**

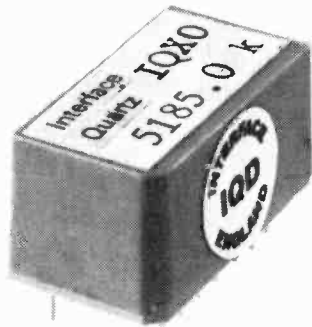

# 10X0

MINIATURE  
QUARTZ  
CRYSTAL  
OSCILLATORS

## INTERFACE QUARTZ DEVICES LTD.

World-wide exporters of crystals & filters  
Manufacturers of DIP crystal oscillators  
from 240Hz to 20MHz

sole agents for

- FILTRONETICS** LC & crystal filters from 10Hz to 100MHz
- STATEK** Ultra miniature low frequency crystals
- ELECTRO DYNAMICS** High volume timing crystals

29 Market Street, Crewkerne, Somerset England TA18 7JU  
Telephone (0460) 74433 Telex 46283 inface g

WW-048 FOR FURTHER DETAILS

# New from GREENWOOD

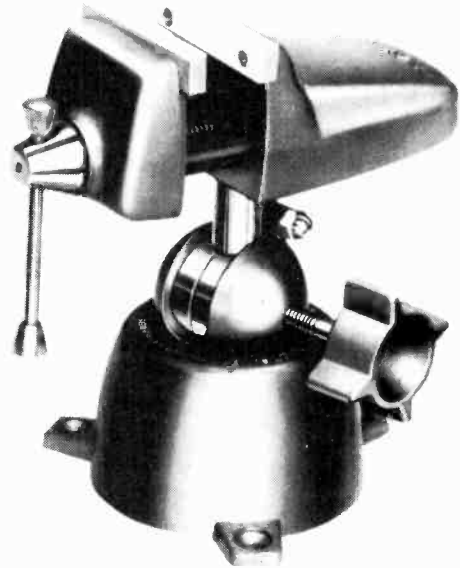

## PANAVISE®

a precision vice  
that rotates a full  
360 degrees - tilts  
180 degrees from  
vertical to horizontal,  
and offers a choice  
of 3 bases, 3 heads,  
a bench clamp and  
a PCB holder.

We think it's like no other vice you've ever used. Its head rotates a full 360 degrees - and tilts 180 degrees from vertical to horizontal.

One conventional knob locks work in any desired position, firmly yet gently. You can choose a standard, low profile or vacuum base - a standard, low profile or wide opening head - a bench clamp mounting base - a printed circuit board holder and of course replacement jaws and pads if ever you need them.

Panavise is more than just a vice - it's a system.

## Greenwood Electronics

Greenwood Electronics Portman Road, Reading, RG1 1NE  
Telephone 0734 595511 Telex 53561

Obtainable also from our distributors:

**Electroplan Ltd**  
P.O. Box 19, Orchard Road,  
Royston, Herts SG8 5HH.

**Toorange Ltd**  
Upton Road, Reading RG3 4JA.

**West Hyde Developments Ltd**  
Unit 9, Park Street Industrial Estate,  
Aylesbury, Bucks HP20 1ET.

**Special Products Distributors Ltd**  
81, Piccadilly, London, W1.

WW - 103 FOR FURTHER DETAILS

## TWO NEW SUPERMODULES: 170W INTO 4 OR 8 OHMS

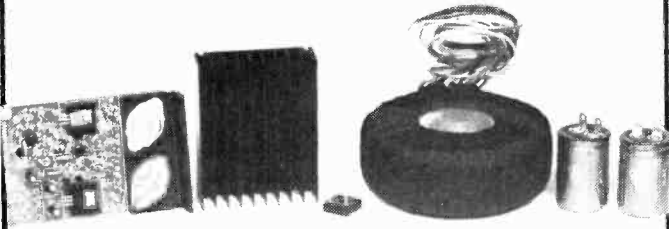

By popular demand we have designed higher powered versions of our well known modules. The CE 1704 which gives 170W into 4 ohms and the CE 1708 which gives 170W into 8 ohms are physically similar to the original types and have the same combination of compatible performance features which makes CRIMSON amplification audibly superior to the competition and the only choice if you have an ear for music. We have also produced suitable power supplies which again use our superb TOROIDAL TRANSFORMERS only 50mm high, with a 120-240 primary and single bolt fixing. Write of phone for more information and biased opinions.

### POWER AMPLIFIER MODULES

	Home	Europe
CE 608 60W/8 ohms 35-0-35V	£16.30	£16.80
CE 1004 100W/4 ohms 35-0-35V	£19.22	£19.30
CE 1008 100W/8 ohms 45-0-45V	£23.22	£23.00
CE 1704 170W/4 ohms 45-0-45V	£28.12	£28.46
CE 1708 170W/8 ohms 60-0-60V	£31.90	£31.04

### TOROIDAL POWER SUPPLIES

	Home	Europe
CPS 1 for 2xCE 1004	£14.47	£18.40
CPS 2 for 2xCE 1004 or 2x4xCE 608	£16.82	£20.57
CPS 3 for 2xCE 1008 or 1xCE 1704	£17.66	£21.35
CPS 4 for 1xCE 1008	£15.31	£19.18
CPS 5 for 1 x CE 1708	£22.68	£26.50
CPS 6 for 2 x CE 1704 or 2 x CE 1708	£23.98	£27.70

### HEATSINKS

	Home	Europe
Light Duty 50mm 2°C/W	£0.90	£1.30
Medium Power 100mm 1.4°C/W	£1.60	£2.40
Discs/Group 150mm 1.1°C/W	£2.30	£3.65

### THERMAL CUT-OUTS

	Home	Europe
Recommended for improved reliability		
70°C for use with free air heat sink	£1.60	£1.90
40°C for use with fan cooled heat sink	£1.60	£1.90

T.H.D.	Typically 01% any power 1kHz 8 ohms
T.I.D.	Insignificant
Slew rate limit	25V/μs
S.N ratio	110dB
Freq. response	10Hz-35kHz 3dB
Stability	Uncritical
Protection	Drives any load safely
Sensitivity	775mV (250mV or 100mV on request)
Size	120 x 80 x 25mm

## CRIMSON ELEKTRIK

Please note our new address and telephone number:  
Stamford House, 1A Stamford Street,  
Leicester LE1 6NL. Telephone: (0533) 537722

Home prices include V.A.T. & postage. C.O.D. 90p extra. £100 limit. Export no problem. European prices include carriage, insurance and handling, payment in Sterling by bank draft, P.O., International Giro or Money Order. Outside Europe, please write for specific quote by return. Send SAE or two International Reply Coupons for full literature. Favourable trade quantity price list on request. High quality Pre-amp circuit 20p.

WW-032 FOR FURTHER DETAILS

# WILMSLOW AUDIO

The firm for Speakers

## HI-FI DRIVE UNITS



Audax HD12.9 D25	£7.50
Audax HD13 D34H	£12.50
Audax HD20 B25H4	£14.65
Audax HD20B25J4	£10.95
Audax HD11 P25EBC	£6.95
Baker Superb	£22.50
Castle 8RS/DD	£11.95
Chartwell CEA205 8 bass. matched pairs only	£59.90
Coles 4001	£6.25
Coles 3000	£6.25
Celestion HF1300 II	£8.25
Celestion HF2000	£9.75
Dalesford D20/105 4	£10.95
Dalesford D30/110 5	£10.95
Dalesford D50/153 6 1/2	£11.95
Dalesford D50/200 8	£11.95
Dalesford D70/250 10	£24.95
Dalesford D100/310 12	£34.95
Decca London	£37.25
Decca CO/1000/8	£7.95
Decca DK30	£24.50
E.M.I. type 350 4 ohm	£9.25
E.M.I. 14A/770 14 x 9	£12.50
E.M.I. 8 x 5 d/c 10 watt	£3.95
Isophon KK10/8	£8.25
Isophon KK8/8	£7.50
Jordan Watts Module	£17.95
Jordan 50mm Unit	£22.50
Jordan CB Crossover	£22.50
KEF T27	£8.50
KEF T15	£10.75
KEF B110	£10.95
KEF B200	£11.95
KEF B139	£24.95
KEF DN13	£4.95
KEF DN12	£7.25
Lowther PM6	£43.75
Lowther PM6 MK1	£45.90
Lowther PM7	£78.95
Peerless DT10HFC	£9.50
Peerless K010DT	£8.25
Peerless K040MRF	£10.50
Radford BD25 II	£26.95
Radford MD9	£14.50
Radford MD6	£17.95
Radford FN8/FN831	£19.95
Richard Allan CG8T	£8.95
Richard Allan CG12T Super	£19.95
Richard Allan HP8B	£13.50
Richard Allan LP8B	£9.25
Richard Allan HP12B	£21.50
Richard Allan DT20	£6.75
Richard Allan DT30	£6.95
Shackman Electrostatic C/W polar network & X/O pair	£99.95
Tannoy HPD 295A	£91.50
Tannoy HPD 315A	£102.95
Tannoy HPD 385A	£119.95

## PA GROUP & DISCO UNITS



Baker Group 25	£13.00
Baker Group 35	£14.50
Baker Group 50/12	£21.00
Baker Group 50/15	£25.75
Celestion G12M	£12.95
Celestion G12H	£16.95
Celestion G18C	£41.95
Celestion G12/75 (alum. dome)	£22.50
Celestion G12/75 (d/cone)	£24.50
Celestion G12M/50 (cambric edge)	£16.95
Celestion G15/100 (alum dome)	£32.50
Celestion MH1000	£13.50
Celestion Powercell 12/100	£45.95
Celestion Powercell 15/100	£48.95
Celestion Powercell 15/125	£51.95
Fane Pop 40	£10.95
Fane Pop 50H	£12.50
Fane Pop 75	£16.95
Fane Pop 65	£19.95
Fane Pop 80	£21.95
Fane Pop 100	£35.95
Fane J44 horn	£6.50
Fane J104 horn	£13.75
Fane J73 horn	£9.75
Fane Guitar 80L	£19.75
Fane Guitar 80B	£19.95
Fane Disco 80	£21.50
Fane PA80	£19.50
Fane Bass 85	£29.95
Fane Crescendo 12A	£42.95
Fane Crescendo 12B	£44.95
Fane Crescendo 15/100	£54.95
Fane Crescendo 15/125	£64.95
Fane Crescendo 18	£75.95
Fane 920 II Horn	£45.95
Fane HPX1/HPX2	£2.50
Fane PH50	£6.50
Goodmans 8PA	£3.95
Goodmans 10P	£6.95
Goodmans 12P	£16.95
Goodmans 12PD	£19.95
Goodmans 12PG	£19.50
Goodmans 18P	£39.95
Goodmans 50HX	£18.95
McKenzie Forte 12	£22.95
Motorola Piezo Horn	£8.50
Richard Allan HD8T	£12.95
Richard Allan HD10T	£13.25
Richard Allan HD12T	£18.75
Richard Allan HD15T	£29.95
Richard Allan HD15T	£30.50

## WILMSLOW AUDIO

KITS FOR MAGAZINE DESIGNS etc.



Kits include drive units, crossovers, BAF/Long fibre wool, etc. for pair of speakers.

Carriage £3 50	
Practical Hifi & Audio PRO9-TL (Rogers)	£118.00
Felt panels for PRO9-TL	£5.50 + £1.50 p&p
Hifi Answers Monitor (Rogers)	£129.00
Hifi News State of the Art (Atkinson)	£161.00
Hifi News No Compromise (Frisby)	£126.00
Popular Hifi Mini Monitor (Colloms)	£63.00
Popular Hifi Round Sound (Stephens) including complete cabinet kit	£65.00
Practical Hifi & Audio Monitor (Giles)	£119.00
Practical Hifi & Audio Triangle (Giles)	£76.00
Practical Hifi & Audio BSC3 (Rogers)	£60.00
Hifi News Tabor (Jones)	£57.75
Hifi News Tabor (with H4 bass units)	£65.00
Wireless World Bookshelf (Wilkinson)	£56.50
Wireless World T.L./KEF (Bailey)	£112.00
Wireless World T.L./Radford (Bailey)	£154.00

SMART BADGES FREE WITH ALL ABOVE KITS (TO GIVE THAT PROFESSIONAL TOUCH TO DIY SPEAKERS!)

Send 3 x 7p stamps for reprints/ construction details of any of above designs.

### CARRIAGE & INSURANCE

Tweeters/Crossovers	40p each
Speakers up to 10"	75p each
Speakers 12"	£1.25 each
Speakers 15"	£2.00 each
Speakers 18"	£2.95 each
Speaker Kits	£2.50 pair
Mag. design kits	£3.50 pair

## SPEAKER KITS

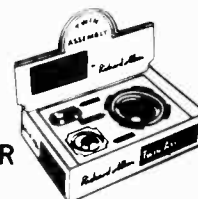

Prices per pair. Carriage £2 50.

Dalesford System 1	£52.90
Dalesford System 2	£55.75
Dalesford System 3	£101.75
Dalesford System 4	£108.00
Dalesford System 5	£139.00
Dalesford System 6	£93.00
Eagle SK210	£13.90
Eagle SK215	£23.50
Eagle SK320	£33.50
Eagle SK325	£59.00
Eagle SK355	£79.90
Goodmans DIN20	£31.50
Goodmans Mezzo Twinkit	£51.95
Lowther PM6 Kit	£91.75
Lowther PM6 MK1 Kit	£96.50
Peerless 1060	£66.95
Peerless 1070	£115.00
Peerless 1120	£129.50
Peerless 2050	£45.95
Peerless 2060	£60.95
Radford Studio 90	£154.00
Radford Monitor 270	£208.00
Radford Studio 270	£275.00
Radford Studio 360	£390.00
Richard Allan Twin	£29.90
Richard Allan Triple 8	£45.50
Richard Allan Triple 12	£55.90
Richard Allan Super Triple	£65.90
Richard Allan RA8	£42.75
Richard Allan RA82	£67.75
Richard Allan RA82L	£73.50
Seas Mini	£17.90
Seas 203	£35.50
Seas 302	£43.90
Seas 303	£73.90
Seas 503	£111.90

Wharfedale Denton 2XP	£26.95
Wharfedale Linton 3XP	£41.95
Wharfedale Glendale 3XP	£56.95

Everything in stock for the speaker constructor! BAF, long fibre wool, foam, crossovers, felt panels, components, etc. Large selection of grille fabrics. (Send 15p in stamps for fabric samples) (Prices correct at 12/4/78)

**SWIFT**  
OF WILMSLOW  
The firm for Hi-Fi  
5 Swan Street,  
Wilmslow, Cheshire.

Send 15p stamp for free 38 page catalogue 'Choosing a Speaker'

Telephone: Speakers, Mail Order and Export:  
Wilmslow 29599 Hi-Fi: Wilmslow 26213

Lightning service on telephoned credit card orders!

**WILMSLOW**  
**AUDIO**  
The firm for Speakers

Swan Works, Bank Square,  
Wilmslow, Cheshire.



# You always perform better with the right equipment

With Neal Ferrograph you get the right equipment for the job, and the best in its class. A good formula for success, of which you can be assured every time you choose from the fully - integrated range of specialist recording and ancillary equipment in the NEAL FERROGRAPH range.



### The NEAL 302.

Incorporating a 3-motor mechanism, controlled by a full solid state logic system actuated by ultra light touch buttons, this is the machine used by top recording studios and broadcasting stations, for quality cassette copies and for in - cassette duplication masters.

### Studio 8

A professional studio tape recorder logic controlled for superb tape handling characteristics, offering a choice of stereo, twin track and full or half track mono heads, PPM or VU meters, IEC (CCIR) or NAB equalisation, console or transportable models.



### The Ferrograph Logic 7.

A transportable tape recorder of unrivalled facilities, taking all spool sizes up to 27 cm, and providing three speeds, plus positive action push buttons in association with logic circuits ... for fast, safe tape handling under all conditions.



### The RTS 2.

Combines in one easy to use compact instrument the measurement of gain, noise, frequency response, input sensitivity, output power, distortion and the parameters relating to recording equipment, such as wow and flutter, crosstalk, drift and erasure. Its range of application can be extended even further by the addition of the Auxiliary Test Unit **ATU 1**.

**NEAL FERROGRAPH**  
TOTAL TAPE TECHNOLOGY

SIMONSIDE WORKS · SOUTH SHIELDS · TYNE & WEAR NE34 9NX Telephone SOUTH SHIELDS (0632) 566321 Telex 537227

WW-016 FOR FURTHER DETAILS

# *middle east* **ELECTRONICS**

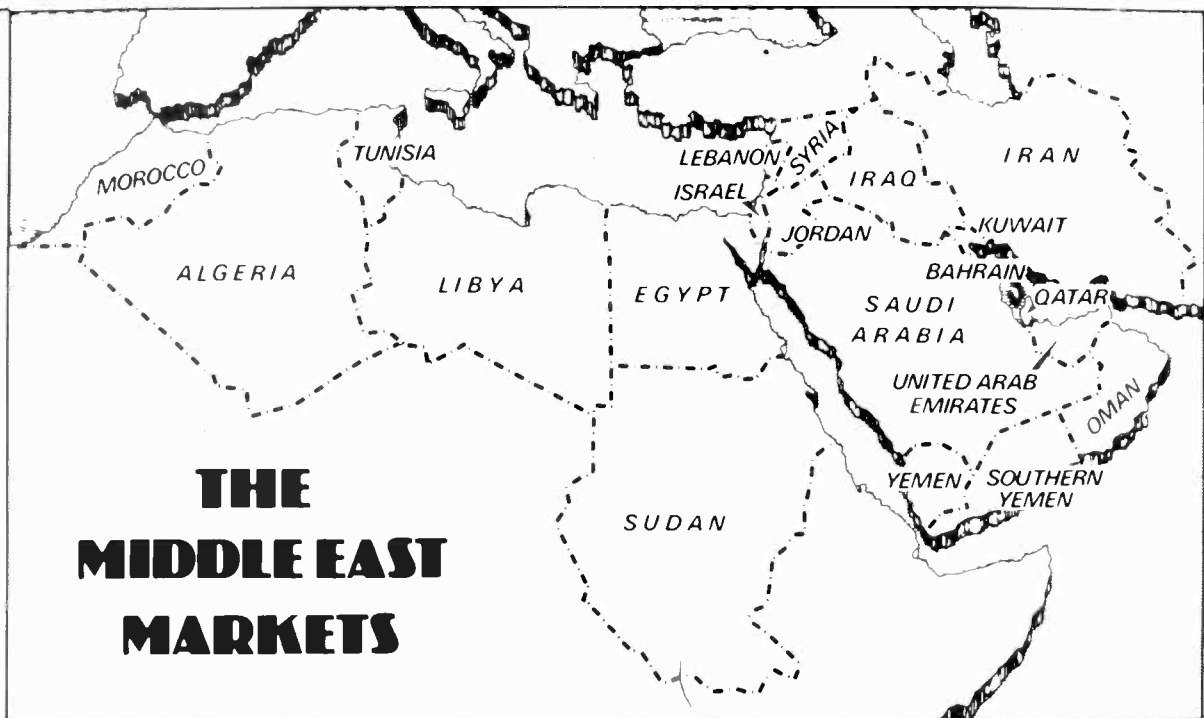

**YOUR SALES LINK WITH A MULTI BILLION DOLLAR MARKET,  
IN THE MIDDLE EAST AND NORTH AFRICA, FOR ELECTRONICS  
EQUIPMENT AND SERVICES**

## ***MIDDLE EAST ELECTRONICS***

The first issue, October 1977, produced an average of 50 enquiries for each advertiser.

All future issues will receive the same response based on figures to date.

Can you afford to miss the next issue?

### ***CONTACT:***

**BRIAN MOLONEY, *Advertisement Manager***  
DORSET HOUSE • STAMFORD STREET • LONDON SE1 9LU • ENGLAND  
or Telex BUSINESS PRES 25137 LDN. Tel: 01-261 8638



**AUDIO MEASURING INSTRUMENTS**

**NEW ITEMS**

**DMS4 Distortion Measuring Set. Precision**

**DMS5 Distortion Measuring Set. General Purpose.**

The DMS4 is a precision instrument intended for laboratory use capable of measuring total harmonic distortion to better than 5 parts per million (0.0005%).

The DMS5 is intended for general purpose use in the studio, test department, or factory and can measure to 0.001% T.H.D.

Both instruments cover the frequency range 10Hz-100kHz and are semi-automatic nulling.

The instruments will operate from any signal source. Nulling to zero is automatic after the DMS has been tuned to the test frequency. The instrument will thus continually read distortion whilst adjustments are made to equipment under test providing the test frequency is not changed.

**EXISTING ITEMS**

**LDO3 Low Distortion Oscillator**

A continuously variable frequency laboratory oscillator with a range 10Hz to 100kHz having virtually zero distortion over the audio frequency band with a fast settling time.

**LDO3B Low Distortion Oscillator, balanced output**

As LDO3 but additionally fitted with output amplifier and screened transformer providing a 600 ohm floating balanced output and 150 ohms unbalanced.

Unbalance —80dB 1kHz —60dB 10kHz.

**ANM1 Audio Noisemeter, Average sensing.**

**ANM2 Audio Noisemeter, True r.m.s. reading.**

**ANM3 Audio Noisemeter, Quasipeak / True r.m.s. reading.**

The noisemeters have 16 measurement ranges from 10µV f.s.d. to 300V f.s.d. and incorporate a 5" mirror scale of excellent linearity calibrated in Volts and dBv or dBm. The instruments are in accordance with DIN 45 405 and include the following recommended weighting characteristics.

WIDE BAND (flat response voltmeter)

DIN AUDIO BAND

IEC/DIN 'CURVE A'

CCIR

**RADFORD LABORATORY INSTRUMENTS LTD.**

4 High Street, Nailsea, Bristol BS19 1BW

Tel: Nailsea 6637

U.S.A.: Patrick McVeigh. Tel: 201-746-5461



**STEREO DYNAMIC RANGE CONTROLLER  
CP-DR1**

The CP-DR1 has two main applications. It may be used to compensate for any compression or peak limiting which may have been applied to radio broadcasts or commercial gramophone recordings and thus restore lost realism. It may also be used to make "noise free" tape recordings, as an additional 30-40 db of dynamic range can be encoded and recorded on to most cassette recorders and then decoded and recovered on replay. The unit may also be used as a compressor for listening in high noise environments (the motor car or workshop?) and for the preparation of "constant volume" background music.

CP-DR1 — £41.40 incl. (U.K.). £43.40 incl. (Export).

Also available: Pre-Amplifiers, Power Amplifiers, Filters, Peak Programme Monitors, Active Crossovers, Stereo Function Modules, Power Supplies, plus all pots, switches, etc

**MAGNUM AUDIO Ltd.**

DEPT. W7, 13 HAZELBURY CRESCENT

LUTON, BEDS. LU1 1DF

TELEPHONE: 0582 28887

SEND LARGE S.A.E. FOR DETAILS

WW-100 FOR FURTHER DETAILS

**KONTAKT 60**

**EUROPE'S LEADING CONTACT CLEANING SPRAY**

Kontakt products 60-61 and WL provide an unsurpassed cleaning capability for contacts and switchgear

**KONTAKT 60**

Safely dissolves oxides and sulphides and disposes of resinated contact greases and dirt, but does not attack plastics or any standard production materials

Is silicone free.

Contains a light lubricant to avoid possible corrosion of contact paths — and obviates further oxydisation and "creep" currents.

**Quality Industrial Sprays from Kontakt Chemie**

K70 Protective Plastic Spray K72 Insulating Spray K75 Cold Spray

K80 Siliconised Polish K90 Video Spray K100 Antistatic Spray

K101 Dehydrating Spray and Pos. 20 POSITIVE PHOTO RESIST VARNISH.

Distributed by

**SPECIAL PRODUCTS DISTRIBUTORS LTD.**

81 Piccadilly, London W1V 0HL

Tel 01-629 9556

Cables, Speciprod, London W1

Descriptive leaflets of the above products are freely available on request.

WW-076 FOR FURTHER DETAILS

**HARMSWORTH**

**070-681 2601**

**POWER DIODES & THYRISTORS  
RECTIFIER STACK ASSEMBLIES  
SEMICONDUCTOR FUSES**



Westcode Semiconductors



International Rectifier



**BBC British Brown Boveri BBC**

**GEC Fusegear GEC**

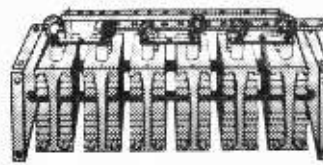
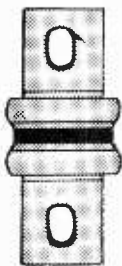

Express delivery by our own transport or Securicor

**HARMSWORTH, TOWNLEY & CO. LIMITED**

HAREHILL TODMORDEN LANCS OL145JY

PHONE: TODMORDEN 2601 & 5246

TELEX: 635091 Attn. HARMSWORTH

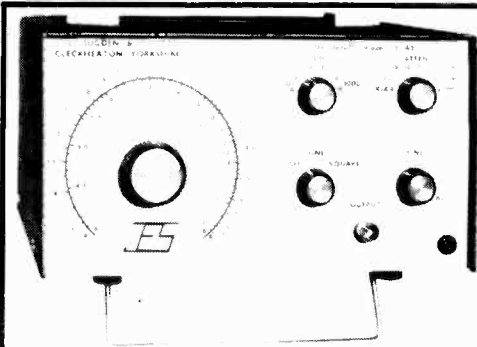

**Si451 Millivoltmeter**

- ★ 20 ranges also with variable control permitting easy reading of relative frequency response

£60.00

also available

**JES AUDIO INSTRUMENTATION**

**Illustrated the Si453 Audio Oscillator**

**SPECIAL FEATURES:**

- ★ very low distortion content—less than 0.03%
- ★ an output conforming to RIAA recording characteristic
- ★ battery operation for no ripple or hum loop
- ★ square wave output of fast rise time

£60.00

**Si452 Distortion Measuring Unit**

- ★ low cost distortion measurement down to 0.01% with comprehensive facilities including L.F. cut switch, etc.

£48.00

ALL PRICES PLUS VAT

J. E. SUGDEN & CO. LTD., CARR STREET, CLECKHEATON, W. YORKS. BD19 5LA.

Tel. 0274-872501

WW — 085 FOR FURTHER DETAILS



**Wonderboard**  
patents pending

solderless circuit cards

'one for each circuit'

capacity 12 IC (DIL-14)

£2.50

(plus 30p VAT & P.P.)

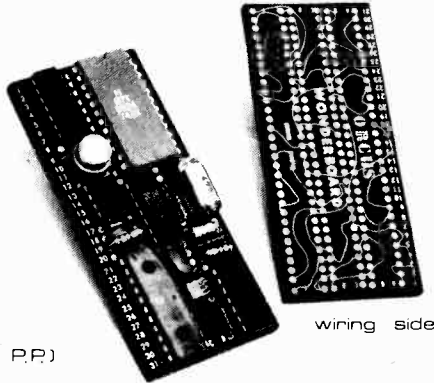

wiring side

component side

**Special Introductory Offer**  
Limited in Time

WONDERBOARD solderless circuit boards use ORCUS intl. conductive elastomer multicontacts. Each contact will hold one component lead and up to six interconnection wires. The components are plugged into one side of the board, the wires into the other. Make prototypes of single, double sided, plated hole and multilayer PC boards. WONDERBOARDS are the most rapid, compact, and economical method available for prototype circuitry. They can be used directly in finished equipment. They are reusable and allow construction of the most complex circuits. Small boards can be joined together to form larger size boards. Distributor inquiries invited. Send cheque or Postal Order to:



conductive elastomer contact

**CHARCROFT ELECTRONICS LTD.**

CHARCROFT HOUSE,  
STURMER, HAVERHILL,  
SUFFOLK CB9 7XR

WW — 078 FOR FURTHER DETAILS



625 line UHF/VHF

**PAL COLOUR BAR GENERATOR**  
(CM 6052/CB)

for on-the-spot diagnosis of TV receiver faults

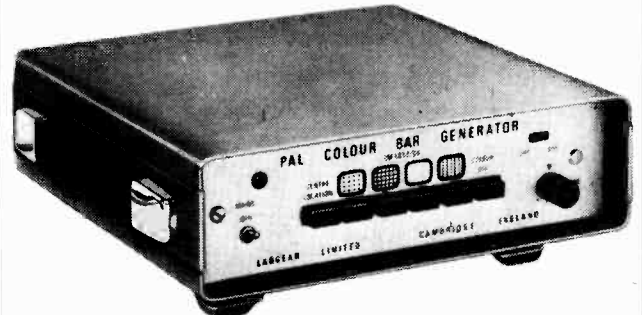

Red Raster · Centre Dot · Centre Cross · Dots.  
Crosshatch · Grey Scale · Colour Bar · Blank Raster

Instant push-button selection of screen test patterns greatly simplifies setting up and allows rapid diagnosis and correction of picture faults either in the viewer's home or at base workshop.

**Labgear**

Labgear Limited Abbey Walk  
Cambridge CB1 2RQ England  
Telephone: 0223 66521 (7 lines) Telex: 81105 LAB  
Telegrams: Labgear, Cambridge

WW — 018 FOR FURTHER DETAILS

**we wondered why....**

The B.B.C., British Rail, B.A.C., Decca Acoustics, Institute of Sound and Vibration Research, I.C.L., Post Office Telecommunications, Philips Research, U.K. Atomic Energy Authority, and many Universities were among our customers.

Maybe they liked the competitive prices of our modules, or the fact that all modules have a frequency response from 20Hz to 22kHz, 0.2dB, a slewing rate of 8 volts per microsecond, input sensitivity of 0dB/0.775V, a damping factor greater than 400 to 1kHz and a total harmonic distortion less than 0.05% at 1kHz.

Or could it be that they went for the reliability and the comprehensive protection circuitry. Then there's the full 2 year guarantee which accompanies our range of modules.

OR PERHAPS..... THEY JUST LIKED THE SOUND OF US!

J.P.S. ASSOCIATES  
(ASTONKILN LTD.)  
BELMONT HOUSE  
STEELE ROAD  
PARK ROYAL  
LONDON NW10 7AR  
Tel: 01-961 1274 5



**DENMARK**

LE RADIO  
Bakkegaardvej 36  
3300 Frederiksberg  
Denmark  
Tel: 033 12 07 39  
Mr. Ole Juul-Møller

**BELGIUM**

IATA  
Kerstlaan 18  
Wigmal 3020  
Belgium  
Tel: 0161 44 33 77  
Mr. Leo Maes

**ENGLAND Midlands**

CROXFORD CUSTOM EQUIP  
64 London Road  
Leicester  
Tel: 0533 538465  
Mr. Phil Croxford

**ENGLAND West**

SEVERNSIDE AUDIO & LTD  
28 The Promenade  
Gouletter Road  
Bristol BS2 8JZ  
Tel: 0272 81816  
Mr. Peter Hannay

**ENGLAND South**

HEW AUDIO VISUAL  
126 Charing Cross Road  
London W.C.2  
Tel: 01-816 2372  
Mr. John Cowan

**SCOTLAND**

ATMOSPHERE LTD & SOUND  
53 Newbig Street  
Aberdeen  
Scotland  
Tel: 0224 572906  
Mr. Keith Main

J.P.S. 60 60 Watt  
J.P.S. 100 100 Watt  
J.P.S. 150 150 Watt

Power supplies available to suit all modules. Send for further information on our range of pre-amplifier modules. J.P.S. products are now stocked at the distributors shown below. Further information on all products available direct from J.P.S. Associates or via reader reply service.

All modules are made in the United Kingdom.

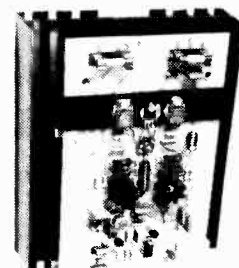

WW — 083 FOR FURTHER DETAILS

the indispensable  
**BIRO43**

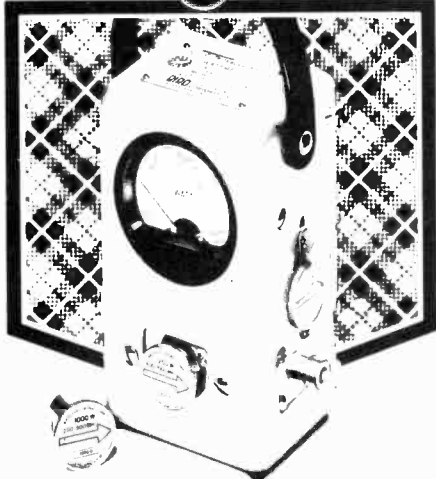

**THRULINE WATTMETER**

0.45-2300 MHz / 0.1-10,000 watts

The Standard of the Industry  
What more need we say...

Exclusive UK representative

**aspen electronics limited**

2 KILDARE CLOSE, EASTCOTE, MIDDX. HA4 9UW  
TELEPHONE: 01-868 1188 — TELEX 8812727  
WW-052 FOR FURTHER DETAILS

**STEREO  
FUNCTION  
MODULE  
CP-FG1**

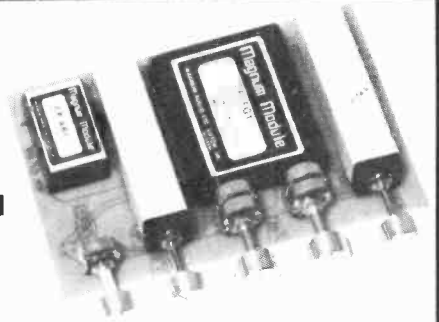

For comprehensive hi and lo filtering and control of stereo separation (image width) mount a **CP-FG1**, 2 switches and 3 pots on a Magnum **CP-MPC2** Interconnection Board. This fully encapsulated function module incorporates some unique features. Two stereo filters ("rumble" and "hiss") are provided, each with its own slope control and choice of three cut-off frequencies. Stereo separation control allows variation of the apparent image width to suit listening conditions — if you can't place your speaker where it really ought to be, let the **CP-FG1** do it for you! All modules are, of course, available separately — Magnum boards aren't essential but coupled with their specially designed P.C. mounting pots and switches, they are an easy way to build the system of your choice.

**CP-FG1 — £13.22 incl. (U.K.). £15.22 incl. (Export).**

**Also available:** Pre-Amplifiers, Filters, Power Amplifiers, Peak Programme Monitors, Compressor/Expander, Active Crossovers, Power Supplies, plus all pots, switches, etc.

**MAGNUM AUDIO Ltd.**

DEPT. W7, 13 HAZELBURY CRESCENT  
LUTON, BEDS. LU1 1DF  
TELEPHONE: 0582 28887  
SEND LARGE S.A.E. FOR DETAILS

WW-101 FOR FURTHER DETAILS

Contractors to H.M. Govt. P.O.

**REPAIRS**  
OF ELECTRICAL MEASURING INSTRUMENTS  
**7-14 DAYS SERVICE**

◀ MODEL 8 MK.V



**STOCKISTS**  
ALSO SUPPLIERS OF GEC  
RISSO AND OTHER  
MULTI-RANGE TEST SETS

WE SPECIALISE IN ASSEMBLIES, AND IN THE  
REPAIR, CALIBRATION AND CONVERSION  
OF ALL TYPES OF INSTRUMENTS, INDUSTRIAL  
AND PRECISION GRADE

**LEDON INSTRUMENTS LTD.**

GLADSTONE WORKS, GLADSTONE RD,  
FOLKESTONE, KENT.  
TEL: (STD) 0303 57555

WW-072 FOR FURTHER DETAILS

**Accept  
Reject  
Hi, Lo Pass  
Oscillate**

**Q 0.5 to over 300  
90 dB notch  
12 dB per octave  
0.5 percent THD**

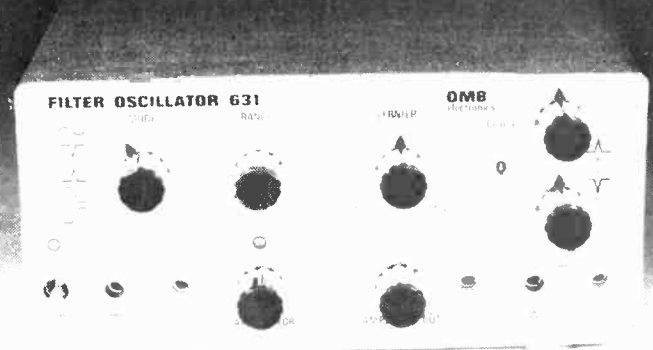

**FILTER OSCILLATOR 631 £108**  
+ £2.50 P&P WW 114  
**631 LF £113 + VAT WW 115**

631-0 1Hz to 100 KHz 631 LF-0.01Hz to 10 KHz

Other products include —	
745 Counter Timer	£94 WW 094
746 Autoranging Frequency Meter	£68 WW 095
615 Off-Air Standard	£85 WW 096
643 Function Generator	£98 WW 097
643A Function Generator	£85 WW 098
35 Series DPMs from	£26 WW 099

Delivery is normally ex-stock — telephone for confirmation  
Prices correct at time of going to press — subject to change without notice

**OMB**electronics, Riverside, Eynsford, Kent. Tel 0322 863567

**Stay ahead-follow this sign**

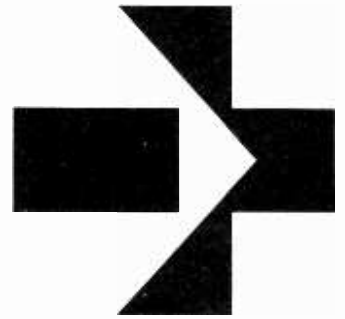

# GOULD ADVANCE INSTRUMENTS HAVE A WORLDWIDE REPUTATION. BUT THEY NEED NOT COST YOU THE EARTH.

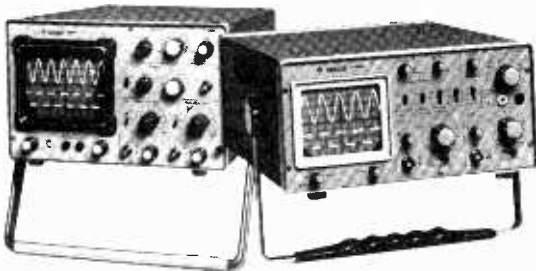

## OS245A AND OS250B OSCILLOSCOPES

Two dual trace oscilloscopes, with sensitivity of 5mV/div., and 2mV/cm respectively. The OS250B offers variable trigger level with or without bright line. The OS245A has a bandwidth of 10MHz, the OS250B offers 15MHz. Fully portable, these are the ideal instruments for servicing, educational and general purpose applications.

## ALPHA III DIGITAL MULTIMETER

A tough, attractive, 3½ digit multimeter with 25 ranges and a basic accuracy of  $\pm 0.2\%$ . A bright red LED display gives a clear reading even in high ambient light conditions, and yet power consumption is low enough for extensive field applications.

A purpose built CMOS chip incorporates all analogue and digital circuitry, giving a low component count and increased reliability.



## TC 320 TIMER COUNTER

This new, tough, 5-digit unit has an operating frequency of 35MHz. Plated through hole PCB construction keeps the component count down, for exceptional reliability. Frequency measurements up to at least 35MHz can be easily read from the clear 7-segment display. The TC320 offers outstanding performance – including "disciplined" triggering – at a remarkably modest price.

## BETA DIGITAL MULTIMETER

A general-purpose multimeter, offering 29 ranges, including temperature (optional), and a basic accuracy figure of  $\pm 0.2\%$ . A clear, 3½ digit Liquid Crystal Display, 0.5" high, gives a high-contrast read-out. Fully portable, with a minimum of 300 hours' battery life, the Beta has already established a reputation for accuracy and reliability.

For details of any of these instruments and the Gould Advance 2 year guarantee, write or phone today.  
**Gould Instruments Division,**  
Roebuck Road, Hainault, Essex IG6 3UE.  
Telephone: 01-500 1000 Telex: 263785.



 **GOULD**

WW-025 FOR FURTHER DETAILS

# wireless world

## In the beginning was the word

**Editor:**  
TOM IVALL, M.I.E.R.E.

**Deputy Editor:**  
PHILIP DARRINGTON  
Phone 01-261 8435

**Technical Editor:**  
GEOFFREY SHORTER, B.Sc.  
Phone 01-261 8443

**Projects Editor:**  
MIKE SAGIN  
Phone: 01-261 8429

**Communications Editor:**  
RAY ASHMORE, B.Sc., G8KYY  
Phone 01-261 8043

**News Editor:**  
JOHN DWYER  
Phone 01-261 8620

**Drawing Office Manager:**  
ROGER GOODMAN

**Production:**  
D. R. BRAY

**Advertisement Controller:**  
G. BENTON ROWELL

**Advertisement Manager:**  
BOB NIBBS  
Phone 01-261 8622

DAVID KITCHENER  
Phone 01-261 8037

**Classified Manager:**  
BRIAN DURRANT  
Phone 01-261 8508 or 01-261 8423

BARRY LEARY (*Classified Advertisements*)  
Phone 01-261 8508

JOHN GIBBON (*Make-up and copy*)  
Phone 01-261 8353

**Publishing Director:**  
GORDON HENDERSON

THE IDEA that information can be treated as a commodity and measured and processed in various ways quite regardless of any meaning it might have has long been accepted by electronics and communications engineers. Now these same engineers are introducing the electronic embodiments of this idea to the wider world of industry and industrialized society, where it is being received with some bewilderment and dismay. In this issue A. E. Cawkell surveys the technology of electronic information systems and what is influencing their application to the world. Their purpose, of course, is to increase the effectiveness of communication and control. They work through machines and people and combinations of these. The trouble is that while the operation of the hardware and software is totally determined the human beings involved are unpredictable and may well produce reactions which the system designers had not bargained for.

The replacement of marks on paper by electrical states is not to be dismissed as a mere technicality. It is a metamorphosis which profoundly affects the positions and relationships of all the people caught up in it. First, electronics is so fast that the information in process cannot be grasped or seen like documents in transit. Secondly, the information is inscrutable: it is held in coded form in stores and can only be translated by permission with special equipment at certain times. Thirdly, the information is inaccessible: it is transmitted and processed within a fixed network which excludes human intervention. Fourthly, the operation of this network demands that the information shall be fed in and taken out in a form prescribed and directed by the system. People must adapt themselves to the environment of such systems and learn

their language — to understand, for example, that a word (so far from St John's gospel) is a mere string of digits, an address a movable slot.

We do not yet understand the detailed consequences of these changes, but the overall effect is quite clear: an increase in the separation of industrial man from his own products and from those who co-operate with him in making them. In mass-production the shop-floor worker is already alienated. Now not only he, but also accountants, salespeople and all those service workers who are already accustomed to the idea of symbols standing for real objects and services, will be isolated from even the representations of reality. The National Computing Centre, in a recent case study, noted: "In the case of foremen and supervisors, for example, there was evidence that the introduction of a computer-based system can change roles in ways that may induce covertly hostile attitudes towards both the system and the management of the enterprise". A further result will be an increase in moral distancing — from remote consequences of one's acts.

Electronic information systems seem necessary for fast and accurate control of the complicated and interdependent processes of modern civilization. But as a result the new systems will become instruments of unprecedented power over individuals in the hands of industrialists, professional specialists and administrators. This could worsen the division in society between the well-educated managerial class, which understands and controls the systems, and the rest. We might even see a new instance of the Marxist principle that when new production technology comes into conflict with the existing social relations of production the conditions are set for social change.

# The paperless revolution

## Forces controlling the introduction of electronic information systems

by A. E. Cawkell, Institute for Scientific Information

The rate at which electronic information systems will take over from paper depends on various technological and social factors. This article looks first at developments in the technology and the rapid fall in the price of devices; also at input and output methods and the control, cost and future of communication channels. European and American politics are contrasted and the conditions for innovation described. Electronic information systems are expected to develop more quickly in non-domestic areas where the incentives and economics are more favourable. Social forces, such as unemployment, disruption of social activity, and fears about intrusion, secrecy, the control of information sources and "the machines taking over," (discussed next month) will slow down the introduction of the technology. Engineers should make it their business to understand the issues and publicise the accumulating evidence about trends in this revolution.

---

*"The difference between Orwell's 1984 and a hypothetical participatory democracy lies in the question of who controls the sending and receiving of information."*

---

E. B. PARKER

---

THE DRAWING on this page represents an information console as it may exist in any home, or with slight modifications, in any office or work-place in the year 2000. This all-purpose communication/information facility is based, in nearly every detail, on currently feasible technology. Many human activities involve information processing, and nearly all of them could be performed without leaving the console.

*The "consumersole", an information console that could be in use in the home or at work by the end of the century.*

This report is a review of the forces which will control the rate of widespread introduction of such a facility. Of course, all the systems shown in the drawing will not come into existence suddenly. Various devices and alternative channels will be introduced, improved, varied in price, etc. in an evolutionary way, not necessarily in the home first; the several channels shown may be eventually unified into, say, an all-satellite system — but these are details in the sweep of events. Factors controlling these events will be the technology and the vested interests tending to force a sometimes premature introduction of new devices. They will have to do with market forces which will encourage new developments; availability of communication channels and the politics of their control and pricing; resistance to change by those people likely to be displaced and organizations with an interest in preserving the status quo; and resistance by

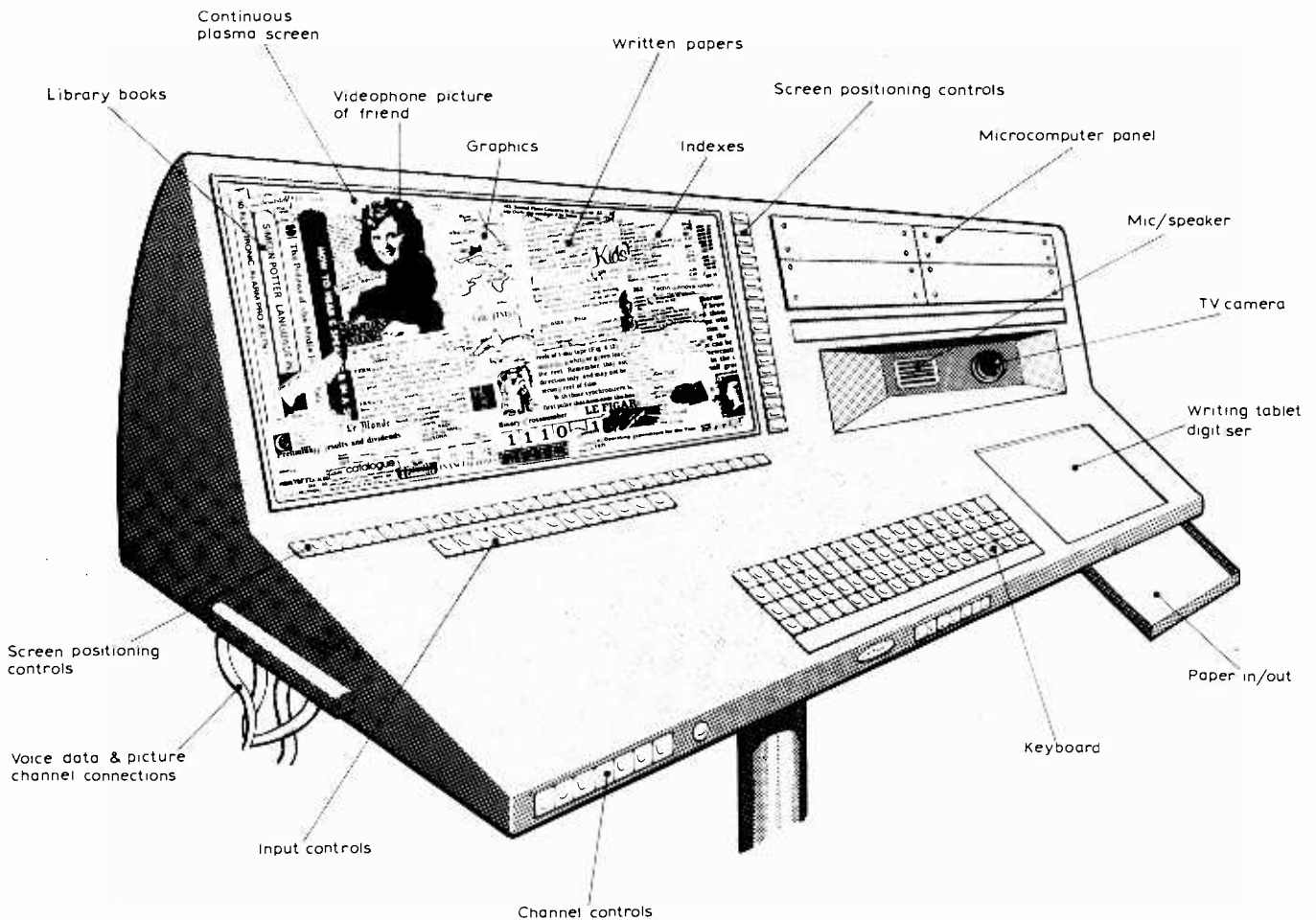



an informed public and later by a better informed general public who will find it difficult to distinguish between beneficial and harmful changes. This resistance will be concentrated against developments which provoke profound social changes or those considered to be intrusive or of a "big brother" nature. Economic forces will be very important and the gap between information-rich and information-deprived people will probably widen. For instance it seems unlikely that the 30 million people in Cairo and Teheran will benefit much; neither city has a telephone directory; hotels in Athens are used by Cairo businessmen who fly there to place international calls<sup>1</sup>.

### New device technology

The basis for much of the new technology is the development of semiconductor chips and large scale integrated (l.s.i.) circuits. An assembly of these devices can enable extremely complex data processing and control functions to be reliably carried out at high speed while occupying a very small space and consuming little power. Basic material research and production know-how owe much to military and space exploration requirements.

Microprocessors are already being introduced into cars experimentally and will soon be used as a matter of course in domestic appliances. Do-it-yourself computer kits are available for a few hundred dollars and software — always the main problem — is catching up with new languages like Micro-Cobol.

Projections based on what has already happened in this field and in developments in storage devices can be made with some confidence. The first four- and eight-bit word microprocessors — the 4004 and 8008 — were introduced in 1972 by Intel; 16-bit microprocessors are now available. Developments in m.o.s. semiconductor devices and p-m.o.s./n-m.o.s. combinations known as c.m.o.s. (complementary metal oxide silicon) now seem to be of importance. Since 1960 minimum integrated circuit dimensions have halved every five years to about  $4\mu\text{m}$  with correspondingly reduced capacitances and time-delays because of shorter circuit paths and interconnections; optical limits are being approached. At this rate, internal delays of 1 nanosecond and complexity increases of 2,000 times would be achieved in 15 years. The cost of including redundancy for greater reliability will drop; error correction for an 8-bit word requires 4 bits, but for a 64-bit word only 7 bits are needed. Arrays of 250,000 gates at 0.04cent per gate are foreseeable<sup>2</sup> (see Fig. 1 for a graphic representation).

The rate of development and cost reduction of storage has also been very rapid. In five years' time 250 Kbyte chips costing \$100 may be available<sup>3</sup>, but this forecast may be already out of date

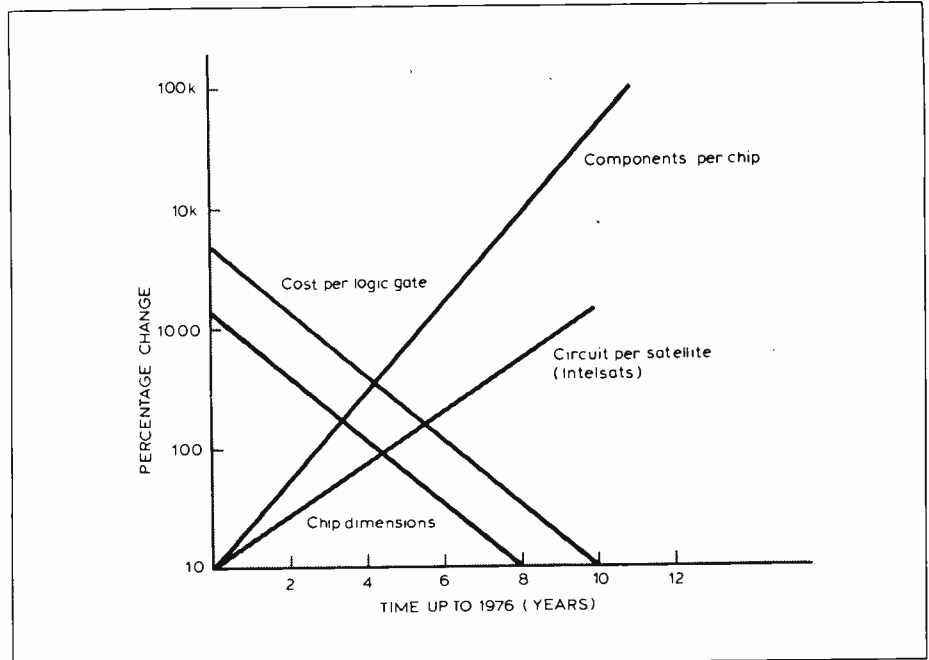

Fig. 1. Rates of change in integrated circuit and other technology up to the year 1976.

since 16K r.a.m. chips at \$25 have just been announced.

Work is in progress on a whole range of new storage technologies including charge-coupled devices (c.c.d.), magnetic bubbles, electron-beam accessed semiconductor memories, and optical memories<sup>4</sup>. Magnetic bubble memories first became available commercially in 1977 as a 92,000 bit storage chip; the 1978 quantity price is expected to be \$75; these devices look like a powerful competitor for microcomputer storage, versus, say, the floppy disc, since they are more reliable and the cost per bit is about 0.08cent compared with about 0.3cent (1977) for the floppy<sup>5</sup>.

Complete instruments embodying holographic storage have been described; one such has been designed for textual information storage and retrieval using film for holographically stored text with associated graphics stored on microfiche frames<sup>6</sup>. In another a terminal is available commercially, capable of retrieving information stored on a  $4\text{in} \times 6\text{in}$  film strip<sup>7</sup>. The film carries 200Mbit in the form of holograms. The information is read out by a laser which projects the image onto a photo-detector array from which an electrical output is available to drive, say, a c.r.t. display.

The rate of progress is so fast that keeping up with current work and deciding which of the new companies will endure is extremely difficult, even although a number of new specialised journals have been introduced covering the various fields. Sufficient has been said in this rather brief review to convey the flavour of the technology.

### Information input

The transfer of most non-verbal information starts with writing or typing;

since many people cannot type, some ingenious ideas have been tried out to enhance the writing process. In one, digital codes are generated by writing with a magnetic stylus on a tablet within which a fine wire matrix is embedded<sup>8</sup>. Co-ordinates of induced e.m.fs formed by character patterns are read out. The wire pattern is arranged so that Gray not binary code is generated; for example, 11 not 1024 terminating connections are needed for a resolution of 1 in 1024, and since a 1-position error differs by only 1 bit from the desired position the effect of errors in the writing process is quite small. This idea illustrates one of many methods all having the same purpose — the second stage of the information transfer process — that is, the conversion of information from the human-generated form into a form suitable for machine processing or transmission. The commonest method of doing this is probably the direct generation of digital codes by keying as with Telex, Teletype machines, computer terminals etc; the codes are then stored on disc, tape, or other media by direct connection between keyboard and storage device, or by transmission and storage remotely on similar devices.

Since the paperless revolution is at an early stage, a huge fund of already keyed or typeset information exists as print on paper. Optical character recognition (o.c.r.) machines, usually requiring preferred fonts to make the machine's pattern recognition task easier, have been developed for converting print to digital codes. Advances in pattern recognition, typified in the Kurzweil reading machine<sup>9</sup>, enable almost any printed text to be recognised. In this machine, scanning is carried out by a 500-element c.c.d. device, with a 2ms sampling period; a "split analysis" module isolates character entities, and a character is then recognised and transformed into the appropriate digital code by a "minimal in-

variable property extraction" process, followed by a "disambiguator" module which makes a final decision; the phonemes formed by character sequences are determined by rule look-up associates with an exception dictionary; a syntax analyser adds prosody across sentences so that the emitted sounds will not emerge as a monotone; finally, control signals actuate a set of electronic synthesisers which generate speech sounds. The machine was developed to enable blind people to read a variety of printed material, and acceptable speech is generated.

This brief description of the Kurzweil machine has necessarily overlapped into another area of this subject — information output. However, this particular technology — speech communication with machines, in which intensive research has been carried out — certainly merits inclusion in this section.

It is important to distinguish between word recognition and speech-machine communication. Machine recognition of speech uttered by any person may or may not be achieved early in the next century; nevertheless there has already been some substantial progress. Speaker verification systems have been developed, to operate over the dial telephone system, which are capable of an identification accuracy of 91% on a set of 100 persons with several thousand impostors (Bell Telephone). Of more interest here is the state of the art of speech-machine communication. One current system uses adaptive differential pulse code modulation (a.d.p.c.m.) for carrying out a machine-prompted standardised-phrase dialogue — for instance in a flight booking system<sup>10</sup>. In the design of such a system decisions must be made about the size of the stored vocabulary which the machine will be required to recognise and the analysing resources which are needed to extract sufficient information from the speech to enable it to be correctly matched against the stored vocabulary. In the flight booking system a 24k bit/s rate is generated from the incoming speech, compared with a rate of about 60kbit/s normally used for good quality p.c.m. speech transmission. This is achieved by generating, say, 3 bits per quantized speech sample, with a sampling frequency of 8kHz. With a.d.p.c.m. the quantizer step size is continuously adjusted to follow changing speech characteristics. The codes generated are then matched against the stored vocabulary. In the flight booking system, the machine utters questions like "where would you like to fly to?" and recognises replies like "Washington" from a trained speaker. It will recognise dates, times, destinations, classes, number of seats required etc. Research continues into more sophisticated systems in which a detailed computer analysis of the characteristics of the actual speech is made — a requirement for

comprehensive speech recognition<sup>11, 12</sup>. Quite recently a speech-recognising microcomputer, selling for \$249, has been offered in the USA by Speechlab<sup>13</sup>. It stores 64 different words, each word being stored as 64 bytes, and embodies the software for speech analysis and matching. 95% recognition accuracy is claimed after machine "training" by a particular speaker.

### Information output

Again it is only possible to highlight here some current developments in order to show that most of the technology is available or being developed for the "information console" shown earlier.

There are two ways of composing textual information displays, although the distinction between them is blurred. A display can be built up character by character, or by words, sentences, etc, which are individually called up from computer store, processed, ordered, and displayed in some desired way. Alternatively the smallest available element can be a complete page — as in the viewdata system — although of course pages are received as a character by character bit-stream in this case; a microfiche image is another example based on a page-at-a time display.

The conception of an all-purpose information machine was put forward by Vannevar Bush in an often quoted 1945 article<sup>14</sup>. This machine — the "Memex" — would embody various input facilities, a large store, associative indexing of the stored information, and a comprehensive display system. Bush was of course well aware of cathode ray tube displays which received an enormous development effort during the war. Twenty-five years later he reviewed the situation and concluded "... a long time from now, I fear, will come the personal machine"<sup>15</sup>. Insofar as displays are concerned, Bush's remarks still hold good.

Although c.r.t. terminals have received enormous development and the electronics can be contained on a microprocessor chip<sup>16</sup> today's c.r.t.s are not greatly different, at least in their capacity for displaying textual information. A good terminal — say a Tektronix 4006-1 — can display about 2600 characters at a time, assuming that the user knows what he wants. In reality, information requirements for forming successive sets of mental images often cannot be precisely specified in advance. A convenient arrangement is a very large display of ordered information, in anticipation of the general need, from which a specific selection can be made by using the extremely rapid scanning and information-processing power of the eye-brain. A set of pre-selected papers on a desk can present at least a quarter of a million characters; adjust the papers and a new set of a quarter of a million characters is presented. Two volumes of an index, opened to display four pages of 6 point

characters — admittedly rather small — can alone present 180,000 characters at one time.

The contrast between the c.r.t. and the print-on-paper "windows" presenting 2600 characters and 100 times that number respectively, is very marked. What is needed is a window of the size represented by the papers, served by the full power of an on-line information retrieval system in which all the information likely to be needed is stored. High speed computer selection then replaces the laborious business of assembling the right collection of papers for each requirement. In a practical arrangement a screen would be required for the display of whole pages, notes, illustration, ordered lists etc. — at least 50,000 characters at a time — which could be called up from store, scanned, noted in a voice-controlled computer, re-arranged, etc. As with papers and indexes on a desk, the power of the eye-brain may then freely be utilised to scan and absorb what is required from a mass of material.

The screen would need to be at least 4ft × 2ft with light-pen or touch control of discrete areas enabling information in various formats to be displayed, repositioned, expanded, contracted etc. This screen size would accommodate about 150 rows of 12-point characters; since about 12 lines or dots are needed to resolve a character satisfactorily, and allowing for space between rows, this screen would require at least 2400 × 5000 dots for matrix addressing. Facilities of this kind have been suggested in at least two cases, one using a conventional c.r.t.<sup>17</sup> and the other a so-called plasma display 8.5in square<sup>18</sup>. However, the "window" size in both cases is quite inadequate for the purpose and the requirements made above do not seem to have been recognised.

New display technology under development includes piezo-electric ceramic storage, magnetic particle, banks of l.e.ds or l.c.ds, electrophoretic and electroluminescent displays. Of the so-called "plasma" displays, a promising development is a 3ft square bank of neon-filled capillary tubes controlled by an electrode matrix. Resolution is at present 33 lines/inch<sup>19</sup>. The driving electronics is manageable, and a light-pen controlled cursor for area manipulations is described. A device of this kind coupled to a microprocessor controlled trackball/cursor facility<sup>20</sup>, might, one day, be available at the right price for the "consumersole."

Small window displays are adequate for the more limited requirements of reading page-by-page sequences, look-ups in specific lists, display of information in response to specific questions demanding relatively short answers, and so on. Such displays could form a part of a larger panel, perhaps being projected onto it. Currently available displays are usually based on the cathode ray tube or on enlarged projec-

tions of a film image. Microfilm and microfiche (multi-image film cards) and associated equipment are of particular interest. Their advantage lies in cheap storage of an enormous quantity of information in a very small space; one application has been for archival storage, as in libraries. However, microforms of this type have never taken off, primarily because of user resistance to inconvenient microform reading equipment of poor quality. The low priced reader which can successfully compete with the convenience, portability, clarity, and resolution of print on paper is as yet unavailable<sup>21</sup>. A reader like the new book-size Izon machine, which incorporates 500 micro-lenses and a fibreoptics lighting system from a 12-volt lamp may be the answer<sup>22</sup>.

A more recent development is the production of microform from machine-readable information (computer output microfilm — c.o.m.), as opposed to the photo-reduction of print on paper, and the introduction of computer controlled equipment for mechanically retrieving and projecting one frame out of tens of thousands carried on film strip or fiche cards. In the Marconi automated microfiche terminal<sup>23</sup> one hundred and twenty fiche cards, each containing 3500 size A4 page images are carried in a magazine — a total of 420,000 pages; magazines can be quickly changed. An indexing and fiche-selection programme is held in a minicomputer connected to the terminal and controlled by the terminal user with a keyboard. A desired fiche is selected and projected onto the terminal's screen in a few seconds after typing the appropriate indexing terms. A typical Marconi system consists of a number of terminals with locally updated fiche, each connected by telephone line to a common time-shared minicomputer which performs the selection operation for all terminals.

Stabletron<sup>24</sup>, on the other hand, offers a system in which there is one central fiche-selecting machine with a time-shared mini beside it. Terminals, connected by lines to the central facility, consist of keyboard and a c.r.t. screen with local page storage. A user's commands are received by the machine and the desired image is despatched down the line, where it is stored locally and viewed at leisure on the terminal. Since the central facility embodies a queuing buffer and in any case takes only about 1.8 seconds to select a fiche and transmit its image, and most users spend most of the time reading or thinking, response time is normally quite adequate. An advantage of this system is that only one central up-date is needed, and since the system is television based, urgent up-dating may be achieved by overlaying part or all of a given fiche image with keyed characters inserted at the central facility. The disadvantage is that, unlike the

Marconi, the terminal to central facility connection has to be a wideband channel, or a narrow-band channel with slow scan equipment at either end. Stabletron use a 15MHz 875-line system for transmission of small typeface. The facilities for quickly changing part of the fiche provided by Stabletron is reminiscent of another new development, computer input microfilm (c.i.m.) which enables film or fiche to be quickly changed. All material is stored in machine readable form and can be selectively viewed and modified from a c.r.t. terminal. New material is re-photographed and added to the file<sup>25</sup>.

Turning from non-verbal to verbal machine-man communication, one sophisticated way of doing this was discussed earlier in connection with the Kurzweil machine. In general, the problem consists of applying digitally coded representations of speech to a speech synthesiser. For example in the commercially available Votrax multilingual synthesiser<sup>26</sup> one of 122 phonemes at one of 8 pitches and one of 4 durations is selected by a 12-bit command word. When fed with appropriate driving information — for example ASCII code at a rate as low as 300 bit/s — usable audio output is generated. The driving code is pulled from some external storage media, such as disc, by appropriate computer software. Less sophisticated microprocessor speech synthesisers for home computers requiring an appropriate microprocessor c.p.u. and storage<sup>13</sup>, are already available in the U.S. for \$400.

### Communication channels—the politics

For communication at a distance, human-generated information is changed into a form suitable for transmission through a communication channel operating within the frequency bands shown on the spectrum in Fig. 2. To avoid chaos, national and international control has been organised for orderly usage of the available communication channels within the frequency bands which it is physically

possible to use. More information demands more channels and technological developments have provided them — for example by satellite communication at e.h.f. — but there is a limit. Once it becomes feasible to use a channel the question arises, by whom should it be controlled and used? Because transmission of information is of such vital importance the politics of communication channel control is equally vital. I am referring here to the higher-order politics — for example governmental versus private control — rather than to the politics of channel allocation for broadcasting, radio communication, etc. which is agreed internationally through the International Telecommunication Union (ITU).

Telecommunications history started with telephone systems, organised in most countries as public services with the object of providing a universal service at minimum cost; heavy R & D costs and investment are involved in the setting up of plant with a working life of decades. Telephone organisations are usually large bureaucratic monopolies which change slowly. As radio communication developed, channel allocation in the electromagnetic spectrum was reasonably well managed, but conflict soon arose about public and private control of communications generally, including telephone voice and data transmission, radio and television broadcasting, cable television, computer communications and satellite networks. Ownership and government control is arranged on the basis of mutually exclusive applications, whereas in reality there are now no sharp divisions — for example computer data communications may be established along analogue telephone lines where ownership and tariffs are geared to universal voice communication requirements.

In this situation the contrast in the styles of change as between USA and Europe is very marked. The "... freedom of speech or of the press" referred to in the First Amendment in the US Constitution extends to broadcasting, cable etc. (Winters v. New York 1948, when it was held that one person's entertainment is another's doctrine). Furthermore, although the early activities of the Federal Communications Commission in broadcasting appeared

Fig. 2. Spectrum of sound, ultrasound and electromagnetic waves, showing where various information transmission systems fit in.

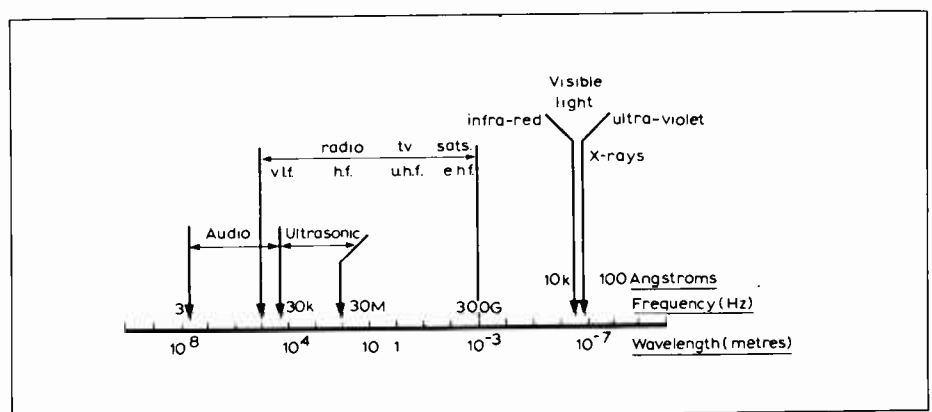

to be restrictive, its regulations were later considered to support the First Amendment by ensuring the expression of diverse views (e.g. NBC v. US, 1943). Freedom of choice issues do not arise in the same way in cable television (c.a.t.v.) — there is no shortage of channel space as in broadcasting — and the FCC's attempts to regulate c.a.t.v. have run into considerable criticism<sup>27</sup>. It has been suggested that c.a.t.v. is being strangled by regulations, and that the treatment of it should be similar to that of the press, which is free of restraint<sup>28</sup>. These issues are discussed openly in the US; frequent suits brought under the anti-trust laws, with lengthy discussion, confirm this generally open style (for example MCI's suit against AT&T, 1974).

Of particular interest here are the events following the 1934 Communications Act, passed in order to establish an integrated universal telephone network provided by controlled monopolies. As new devices became available for connection to the network, the public became frustrated by monopolistic inertia, which, in this respect, was broken in 1968. In that year an anti-trust suit was brought against AT&T, the largest US telephone company (it includes Bell R & D and Western Electric manufacturing associates). The FCC established a precedent for the connection of competitive devices to the telephone system by allowing connection of Carterphone equipment via acoustic or inductive coupling. In 1975 the principle was extended when the FCC ruled against preferential tariffs offered by the telephone companies when their own equipment was used<sup>29</sup>.

Meanwhile communication technology was developing in the area of microwave and satellite communication, packet-switched networks etc., accompanied by the formation of new innovative companies. In 1968 MCI applied to the FCC to operate a microwave link using local telephone lines for distribution; the FCC agreed (with support in a later legal appeal "the Specialised Common Carrier" decision 1971), on the grounds that the public interest would best be served by communication innovations. In consequence of this a number of "Value Added Network Services" (VANS) now operate in the United States (or, to use the current jargon, Resale and Sharing Carriers). The FCC took the same viewpoint in 1972 with its "open skies" satellite communications policies. A rash of appeals followed and in 1976 (Docket 20097) the FCC produced rules which are an attempt to encourage innovative services. They do not permit the degree of "cream-skimming" which would affect the revenue of the telephone companies to the extent of endangering universal service.

During 1976/77 discussions started about reforming the 1934 Act; proposals are (at the time of writing) before Con-

gress committees. Major issues include the effect of competitive equipment and private line services on the national telephone network, and whether groups, such as large businesses, are likely to benefit at the expense of low-income users<sup>30</sup>. These issues, particularly the last, are of course as relevant in Europe as in the US. While the US system of discussion before regulatory commissions, followed by appeals, court rulings etc, is laborious, costly, and time consuming, it seems to me that the outcome will be a relatively free flow of information. It should also be remembered that the flow of information generally is subject to the beneficial effect of the Freedom of Information Act.

I am unable to report comparable progress in Europe, or in the UK in particular. Here the climate is symbolised by the suffocating effect of the Official Secrets Act, passed on the nod after a half-hour debate in 1911 during a spy scare<sup>31</sup>. (In the US the 1973 Federal Advisory Committee Act requires that some 2,000 committees should meet in public.)

In the UK communications are provided by the Post Office (PO), a Corporation whose Board is accountable to the Secretary of State for Industry, a member of the government. The Secretary present the PO's annual report before parliament; although he has the right to issue directives he seldom does. "Without the stimulus of regular public hearings there is relatively little public debate, consequently the community of informed commentators who can act as advisers or write about policy is relatively small"<sup>32</sup>. The main discussion forum is, therefore, parliament, the supreme institution, whose supremacy is an expression of custom and is nowhere defined. This is certainly not the place to discuss the unwritten British constitution, but it is the place to discuss briefly the prospects for the free flow of information through electrical channels vis-a-vis the PO.

Post Office activities were reviewed in the "Carter Report" presented to the Secretary of State in 1975; separate corporations for postal and telecommunications services were recommended. In 1977 a government committee made proposals (the "Bullock Report") about Trade Union representation on boards, and proposals about the constitution of the PO's board have been made; in consequence the Carter proposals have been shelved. Attempts to extend the very limited liability of the Post Office have also failed.

(To be continued)

## References

1. Guzzardi, W. I. The great world telephone war. *Fortune*, 96(2), 142-154, 1977.
2. Noyce, R. N. Large scale integration; what is yet to come? *Science*, 195(4283), 1102-1106, 1977.

3. Hodges, D. A. Review and projection of semiconductor components for digital storage. *PIEEE*, 63(8), 1136-1147, 1975.
4. Rajchman, J. A. New memory technologies. *Science*, 195(4283), 1223-1227, 1977.
5. Juliussen, J. E., Lee, D. M. & Cox, G. M. Bubbles appearing first as microprocessor mass storage. *Electronics*, 50(16), 81-86, 1977.
6. Anon. Holography microfiche retriever. *Laser & Electro-optik*, number 2, 14-15, 1976.
7. See 'Holofile' brochure from Holofile Industries Ltd. 10850 Wiltshire Boulevard, Los Angeles, U.S.A.
8. Gordon, J. A. Digital X-y position indicator using Walsh functions. *Electron Letts*, 11(1), 5-6, 1975.
9. Kurzweil, R. The Kurzweil reading machine — a technical overview. Paper presented at "Science Technology and Handicapped" symposium, 1976, AAAS Annual Meeting, Washington D.C.
10. Flanagan, J. L. Computers that talk and listen; man-machine communication by voice. *PIEEE*, 64(4), 405-415, 1976.
11. Underwood, M. J. Machines that understand speech. *Radio & Electronic Eng.* 47(819), 368-376, 1977.
12. Reddy, D. R. Speech recognition by machine — a review. *PIEEE*, 64(4), 501-531, 1976.
13. Wiener, H. For hobbyists — computers that talk and listen. *Computer Weekly*, page 16, Oct. 13, 1977.
14. Bush, V. As we may think. *Atlantic Monthly*, 176, 101, 1945.
15. Bush, V. Memex revisited. In "Science is not enough." (Apollo Editions, New York, 1969).
16. Miller, M. S. Design a low-cost c.r.t. terminal around a single chip microprocessor. *Electronic Design News*, 22(9), 88-94, 1977.
17. Kay, A. C. Microelectronics and the personal computer. *Scientific American*, 237(3), 231-244, 1977.
18. Anon. "The GCC-1 graphic communication console." 1977 report from Science Applications Inc., Arlington, Va., U.S.A.
19. Jurgen, R. K. Competing display technologies struggle for superiority. *IEEE Spectrum*, 11(10), 90-95, 1974.
20. Strom, R. A. High-speed low cost selection circuitry for large-area plasma displays. *Proc. SID*, 18(1), 94-99, 1977.
21. Adams, J., & Wallis, R. New concepts in display technology. *Computer*, 10(8), 61-69, 1977.
22. Spauling, C. M. The fifty dollar reading machine. *Library J.* 10(18), 2133-2138, 1976.
23. Wallace, W. L. Developing a book size reader system. *J. Micrographics*, 10(4), 161-165, 1977.
24. Duerden, F. Automated microfiche terminal. *GE J. Sci. & Tech.* 43(2), 51-60, 1976.
25. See brochure "The Stabletron integrated display system" from Stabletron Ltd., Fareham, Hants., England.
26. Griffith, A. K. From Gutenberg to Grafix 1 — new directions in OCR. *J. Micrographics*, 9(2), 81-89, 1975.
27. See brochure "The Votrax ML-I multi-lingual voice system" from Dicoll Electronics, Basingstoke, Hants., England.
28. Kenney, B. L. The future of cable communications in libraries. *J. Library Aut.*, 9(4), 299-317, 1976.
29. Anon. Cable television and content regulations; FCC, the first amendment, and electronic newspaper. *New York Univ Law Rev*, 51, 133-147, 1976.
30. For a review of events see Wiley, R. E. The U.S. communications consumer and the monopoly supply. *Telecomms. Policy*, 1(2), 99-111, 1977.
31. Johnson, L. L. A review of the FCC and AT&T position. *Telecomms. Policy*, 1(2), 119-124, 1977.
32. Cawkell, A. E. Information and privacy. *Financial Times*, October 20, 1977.
33. Pye, R. The British Post Office — an extensive monopoly. *Telecomms. Policy*, 1(4), 356-359, 1977.

## Information systems conference

The sociological and psychological effects of computer based information systems will be the subject of a conference with mainly European and American contributors, "Computer Impact 78", to be held in Copenhagen, October 25-27. Details are available from: Spadille Congress Service, Sommervej 3, DK-3100 Hornbaek, Denmark.

# Discriminative metal detector

A sensitive instrument which can differentiate between ferrous and non-ferrous metals by measuring a phase change

by R. C. V. Macario, B.Sc., Ph.D., M.I.E.E., University College of Swansea

This metal detector combines high sensitivity with the ability to differentiate between ferrous and non-ferrous metals. Unlike conventional detectors, a visual display by l.e.d.s is used for producing a sense of phase change. Headphones can also be used to give a Geiger counter type of audio indication. The complete unit will operate for over eight hours from a small battery.

THE ARTICLE by D.E.O'N. Waddington in *Wireless World* April 1977 was interesting because it outlined the rules by which metal detection may be legally carried out, and also showed how the sensitivity of a search coil alters with size. The sensitivity was discussed in terms of change in resonant frequency from a nominal value, which was shown to be a few hertz for a small object.

However, it is well-known that a change in frequency between one oscillator such as that connected to the search coil  $f_S$ , and another similar reference oscillator  $f_R$ , can be measured by observing the relative phase shift between the two oscillator signals<sup>1</sup>. For example, if the frequency difference between  $f_S$  and  $f_R$  is  $\Delta f$ , then the phase shift, which will be observed between the two oscillators after a time  $\Delta T$ , is given by  $\Delta\phi = 360 \cdot \Delta T \cdot \Delta f$  . . . . . (1)  
Therefore if  $\Delta f = f_S - f_R = 1\text{Hz}$ , a phase shift of  $360^\circ$  will take one second. This effect is illustrated in Fig. 1 where  $f_S$  changes at time  $T_0$  to a frequency slightly greater than  $f_R$ . After a time  $\Delta T$  there is a considerable phase shift  $\Delta\phi$  between the two signals. Clearly, if the phase differences can be observed, then very small differences of frequency can be detected and a very sensitive frequency difference detector can be built.

An interesting feature of this system is that the sign of  $\Delta\phi$  is equal to the sign of the increasing or decreasing frequency. A metal detector based on the phase measuring principle will therefore have the ability to indicate whether a hidden object within the vicinity of the search coil is intensifying the magnetic field, ferro-magnetic, or diluting the magnetic field, dia-magnetic. In theory, differentiation between, for example, buried iron or brass objects can be indicated. Because

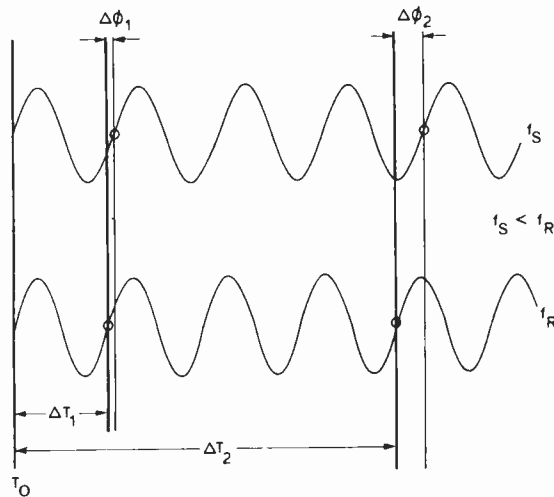

Fig. 1. Oscillator waveforms showing phase difference changing with time.

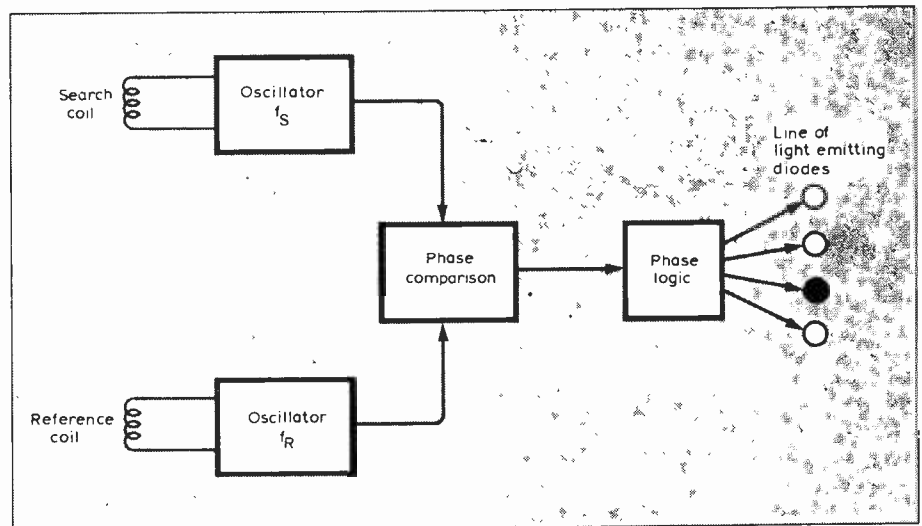

Fig. 2. Basic detector arrangement.

the dia-magnetic effects are usually small, search coil self-capacitance and sample eddy-currents can mask the self-inductive effects. Nevertheless, the potential to differentiate exists and some investigators may find a study of alternative search coils worthwhile.

In the author's prototype system as shown in Fig. 2, the search coil phase is compared with a similar-reference oscillator. The phase dif-

ference is displayed by a line of l.e.ds arranged to indicate in which quadrant the phase difference exists, see Fig. 3. As the phase changes a different l.e.d. is turned on. The rate of change is dictated by equation (1). For a frequency difference of 1Hz the illuminated l.e.d. will move along the row in one second, sweeping from left to right for a ferro-magnetic object, and from right to left for a diamagnetic object. As the search

coil moves closer to the object the speed of sweep increases until all of the i.e.d.s appear to be on.

**Circuit design**

Because the circuit uses c.m.o.s. i.c.s throughout, the current consumption of around 5mA is almost entirely used by the i.e.d. which is on. The oscillator design shown in Fig. 4 is very suitable for this application because it is clearly defined by a coil inductance and an associated tuning capacitor, therefore  $f_S$ , or  $f_R = 1/2\pi\sqrt{LC}$ . The output is also conveniently squared-up to the c.m.o.s. logic level.

The unit uses the search coil and frequency of 120kHz proposed by Waddington in *Wireless World* April 1977. The coil consists of 45 turns of 26 s.w.g. wire wound around a circle of 6½in diameter. A circular wooden former is used to support the coil and the complete assembly is covered with tape, aluminium foil, tape, expanded polystyrene and a final layer of tape. The foil is connected to the screen together with one end of the coil. Other coils and allowable frequencies, however, are just as suitable. The reference oscillator needs a frequency of four times  $f_S$ , i.e. 480kHz. This is also very convenient because a simple i.f. coil can be used.

The circuitry for determining the phase difference between  $f_R$  and  $f_S$  uses two D type flip-flops as shown in Fig. 5. If  $f_S$  is applied to the two clock inputs, and the phase quadrant inputs of  $f_R$  are fed to the two D inputs, the input is only transferred to the output on a positive clock which produces the truth table below.

Phase quadrant	0-90°	90°-180°	180°-270°	270°-0
$f_R:f_S$				
$Q_1$	1	1	0	0
$\overline{Q}_1$	0	0	1	1
$Q_2$	1	0	0	1
$\overline{Q}_2$	0	1	1	0

The four outputs are then NANDed so that only one gate goes positive in each quadrant. The i.e.d.s are arranged so that as the phase difference moves through the truth table, one device switches on after the other. To obtain the phase quadrature  $f_R$  signals, the well-known divide-by-four circuit shown in Fig. 6 is used. Another dual D-type flip-flop device is used to produce the outputs  $f_R/4$  and  $f_R/4 + 90^\circ$  which is why  $f_R$  runs at  $4f_S$ .

The complete metal detector circuit is shown in Fig. 7. Five i.c.s and four i.e.d. driver transistors perform all of the circuit operations. The signals are all square waves except at the oscillator coils where the frequencies  $f_S$  and  $4f_R$  should be observed. The reference oscillator frequency can be tuned with a

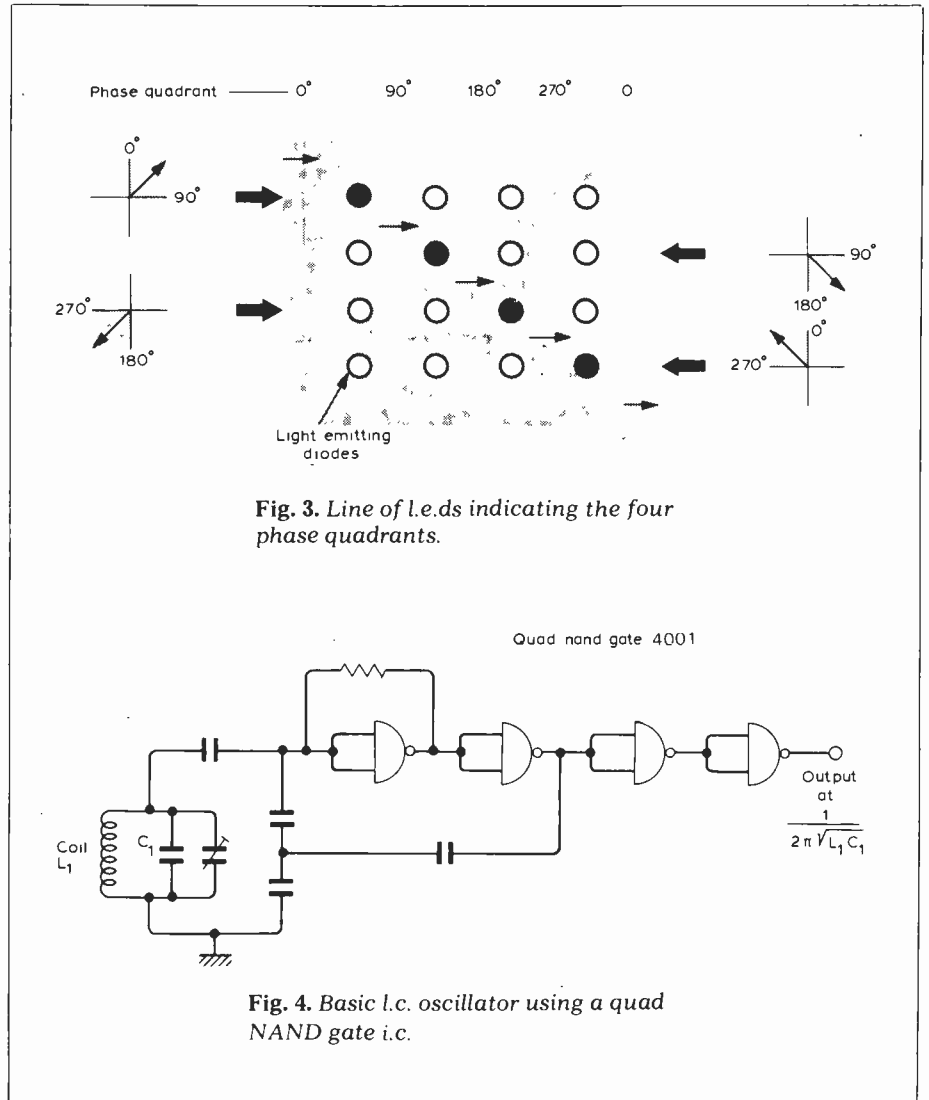
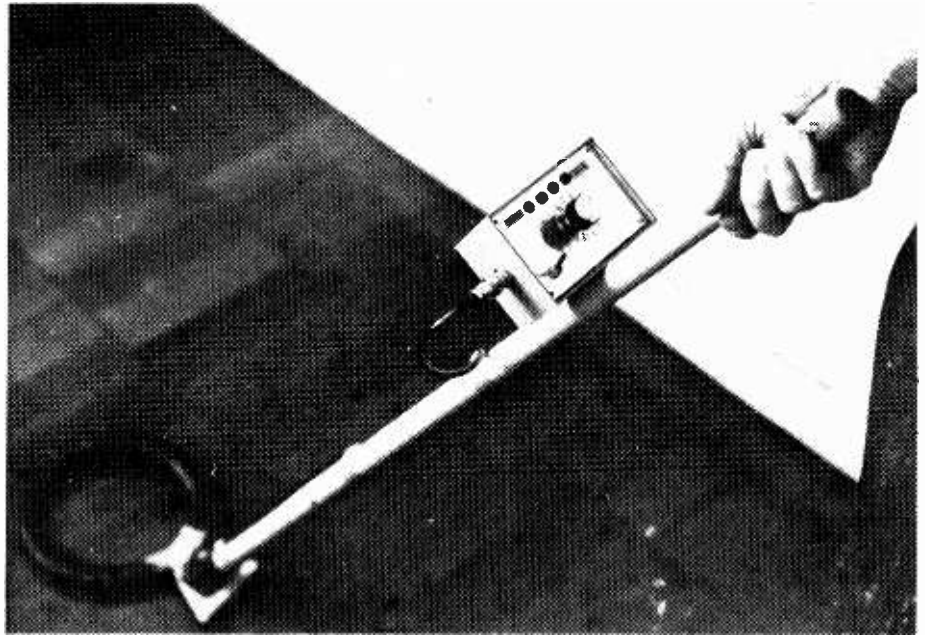

**Fig. 3.** Line of i.e.d.s indicating the four phase quadrants.

**Fig. 4.** Basic i.c. oscillator using a quad NAND gate i.c.

ferrite slug in the i.f. transformer coil  $L_2$ . The search coil is tuned by  $C_1$  with the trimming capacitor in the mid position. When correctly tuned only one i.e.d. should be on which gives a stationary display except for the occasional hop. Adjusting  $C_{14}$ , or detecting an object, causes the light to run along the display

in one direction or the other.

A suggested layout for the circuit is shown in Fig. 8. This printed circuit fits into an RS plastic box type 509-642 which measures 4½ × 2¾ × 2in together with all of the controls. The unit operates from a 9V PP3 battery which can be the rechargeable type. The

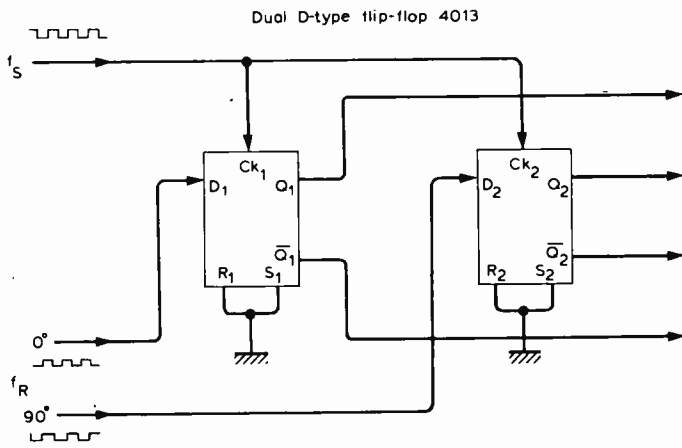

Fig. 5. Phase quadrant comparison circuit

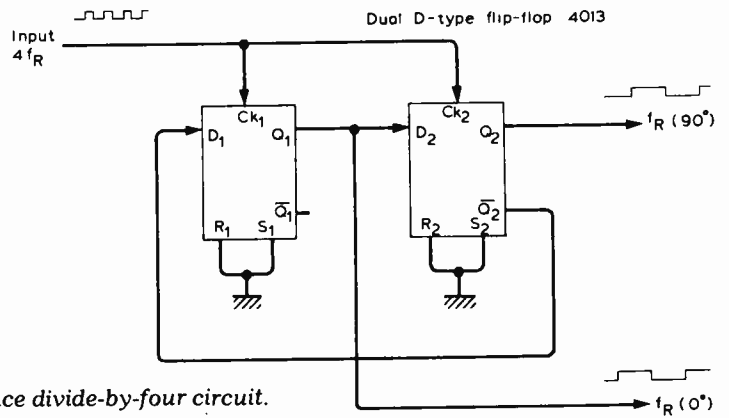

Fig. 6. Reference divide-by-four circuit.

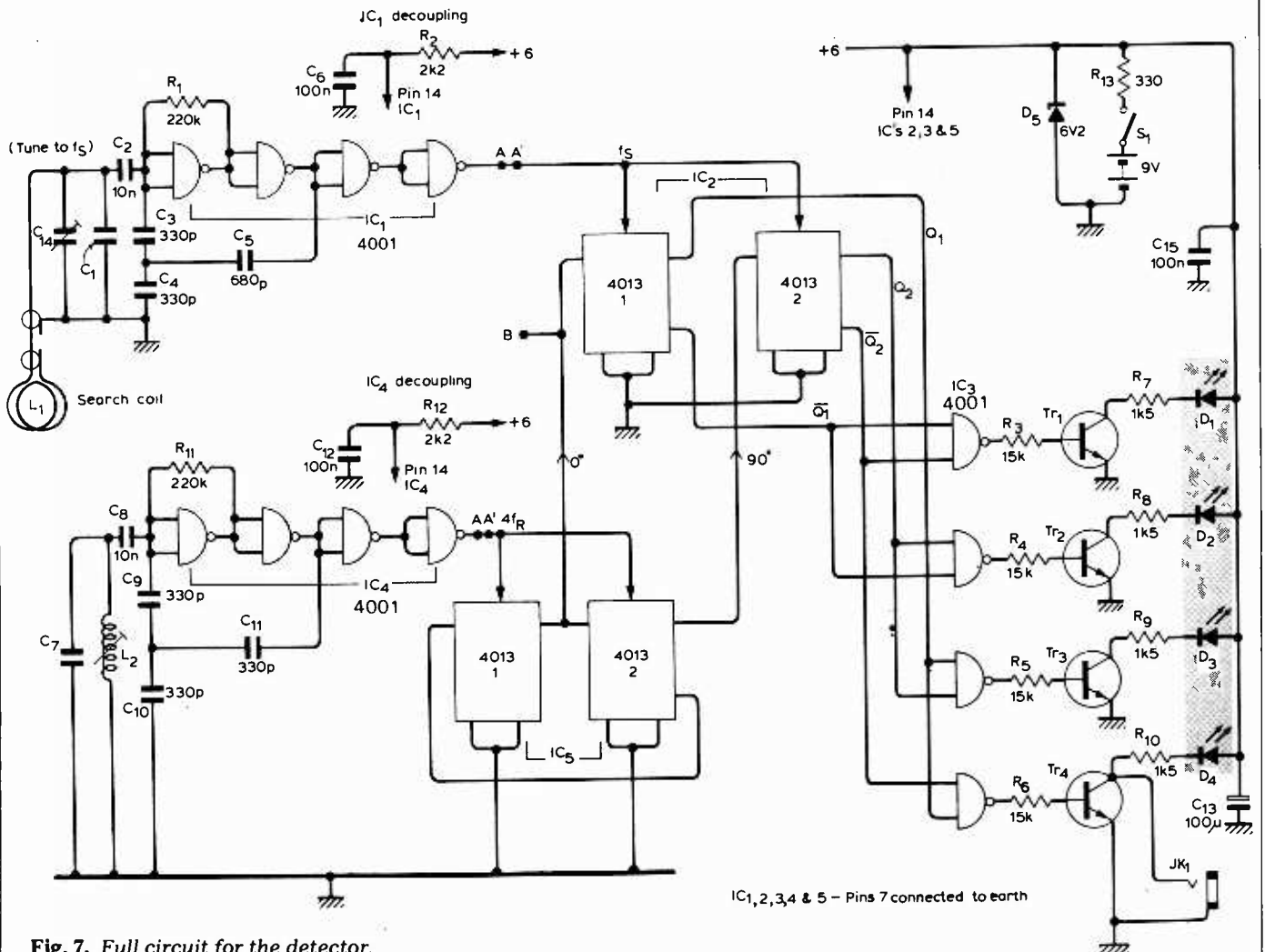
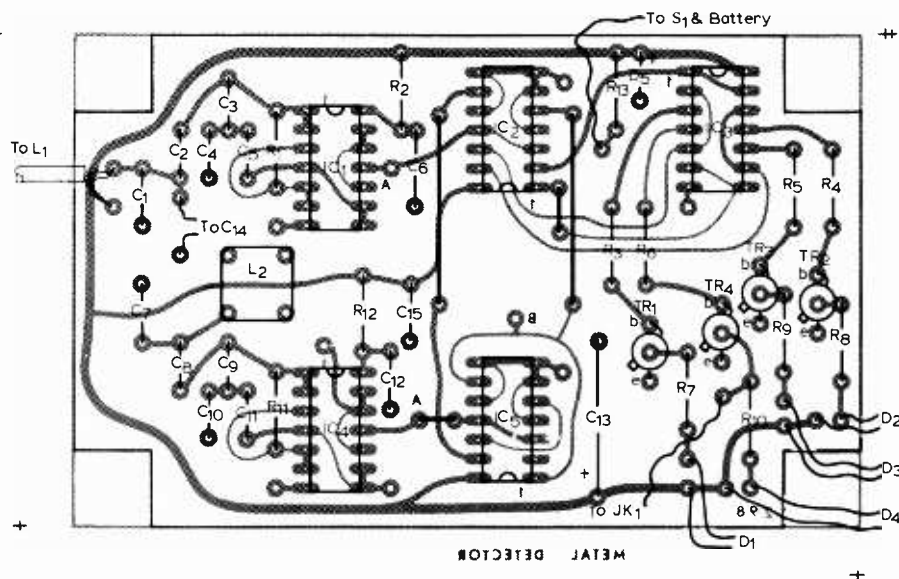
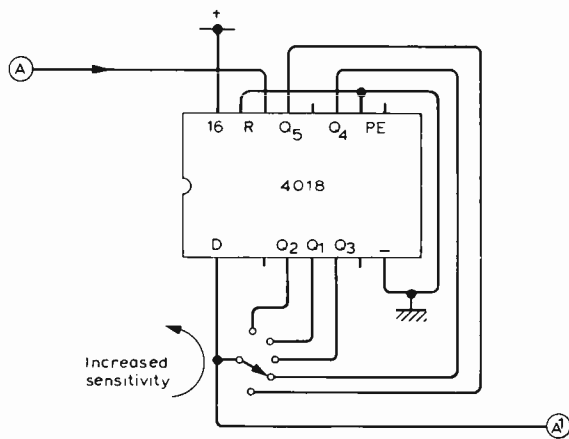

Fig. 7. Full circuit for the detector.

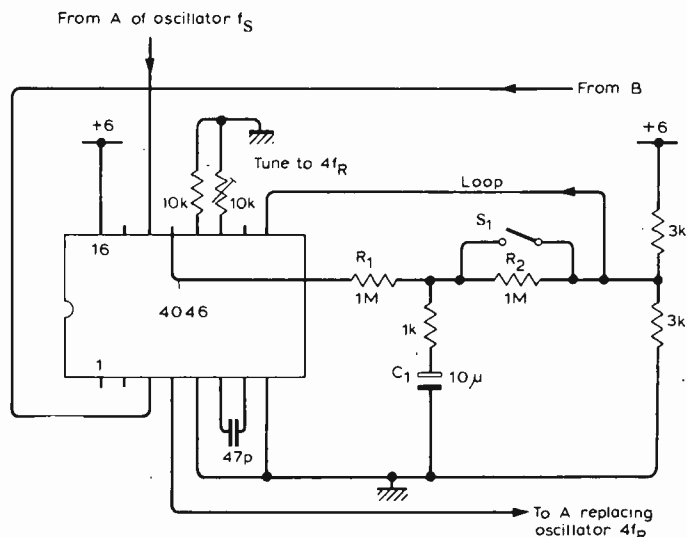

**Fig. 8. Printed circuit board layout and component overlay.** A double sided board is used with the top copper layer forming a ground plane. All component leads connected to single pads are soldered to the top of the board. All other component connections are made on the underside of the board. The ground plane should be cleared with a small drill where necessary. Some additional pads have been provided on the layout to assist with the modification shown in Fig. 10.

**Printed circuit board**  
A double sided glass fibre p.c.b. for the metal detector will be available for £3.50 inclusive from M. R. Sagin at 23 Keyes Road, London, N.W.2.



**Fig. 9. Divide-by-N circuit for variable sensitivity.**



**Fig. 10. Voltage controlled oscillator**  
This circuit replaces the  $f_R$  oscillator. The switch is a tune / operate control. When closed,  $C_{14}$  is adjusted for frequency balance, and when open the detector operates with a slow p.l.l. action. If the 4046 is mounted on the pcb in place of IC<sub>4</sub>, the copper tracks should be cut where necessary.

supply is regulated at 6V to reduce the tendency for  $f_R$  and  $f_S$  to lock.

**Further considerations**

The unit described is very sensitive to changing conditions around the search coil, and some form of sensitivity control is worth considering. The sensitivity is proportional to the frequency  $f_S$ , so a less sensitive version can be made by reducing the frequency of  $f_S$  and  $4f_R$ . One possibility is to reduce  $4f_R$  to 120kHz and  $f_S$  to 30kHz, both of which are legal frequencies. A better method, however, is to divide  $f_S$  and  $f_R$  before comparison as shown in Fig. 9. Two identical divide-by-N circuits can be inserted between points A and A' of Fig. 7. With the switch connections shown, five sensitivity ranges can be selected from 1/2 to one-tenth of the full value.

Another characteristic which determines the sensitivity is temperature variation. Because the reference oscillator has to remain constant in

frequency to within 1Hz, a frequency control is provided to compensate for small drifts. Although the problem is eased because both oscillators tend to drift in the same way, an interesting solution is to phase lock the two oscillators together. Fig. 10 shows a modification which can be made to the circuit shown in Fig. 7. A c.m.o.s. voltage controlled oscillator and phase detection device is used in place of the  $f_R$  oscillator. The v.c.o. section of the 4046 operates at  $4f_R$ , and the phase detection section compares  $f_S$  with the divide-by-four output of  $f_R$  to provide a control signal for the v.c.o. With this system the metal detector will always settle down and turn on the 0°-phase i.e.d. Moving the search coil past a buried metal object will cause the frequency  $f_S$  to change, but because  $f_R$  will then try and follow, a maximum indication may occur beyond the object. The choice of time constant can therefore depend on how fast the search coil is moved and is best determined by

experimentation.

Because this metal detector has a visual display, headphones are not required. If the user prefers an audio indication and does not mind the loss of "directional" information for the type of magnetic material, a headphone can be connected across one of the i.e.ds which produces clicks rather like a Geiger counter.

**Reference**

1. Hewlett-Packard Application Note No. 52, 'Frequency and Time Standards,' 1962.



# NEWS OF THE MONTH

## UK proposals to WARC to be published — when final

THE HOME OFFICE has published a summary of its preparations for the World Administrative Radio Conference in Geneva next year. The 22 page booklet\* is critical of the quality of the submissions received as a result of the Home Secretary's invitation to submit comments. "Many were concerned principally with or included matters of domestic frequency management which, upon examination, were found to have no implications for the WARC. Inevitably most contributions were concerned with particular sectional interests, and few made any attempt to identify or balance competing demands on the frequency spectrum. There was also a concentration on the table of allocations to the virtual exclusion of those technical, operational and administrative factors which, together with the table, will constitute the work of the WARC 1979." Nevertheless, the process of public consultation "has proved valuable". "It has made the Government more aware of the strength of interest in particular issues. It has provided an external source of ideas and proposals relevant to the WARC, all of which have been carefully considered before decisions were reached. Thus it has ensured that the work done has at least covered the right ground."

The statement notes that "some" of the 91 contributions, resulting from 104 specific invitations to submit comments, "evidenced much thought and hard work". It gives a broad outline of some of the proposals the Home Office has been able to accept or felt compelled to reject in its preliminary discussions with other PTTs before the WARC meets, as follows:

### 0 to 150 kHz

No major changes, but "several redundant radionavigation provisions" should be eliminated where they share with fixed and maritime services. To offset this, a broad band should be set aside for exclusively world wide radionavigation. Radio location and radionavigation will not be merged.

### 150 to 1605 kHz

The increasing interference with aeronautical beacons, which share frequencies with broadcasting from 255-285 kHz, has become "unacceptable in view of the safety of life service provided by the beacons". The Home Office's proposal is a classic illustration of the conflict between sound economics and common sense: the broadcasters should be allowed to drive out the aeronavigational beacons, which should be reallocated to space now used by the unoffending mobile maritime service. The latter should meet its requirements "by improved channel arrangements"(?) and a narrower distress and calling band. In addition, the broadcasters should get extra frequencies for their road traffic information service; the BBC had asked for 10kHz below the present medium wave radio band and it looks like they've got it.

### 1605-4000 kHz

In partial compensation for the above, the mobile maritime service, one of the most poorly regarded and administered in the spectrum, should have several exclusive allocations in this section. There should also be several exclusive narrow sub-bands for position-fixing systems. The requirements of the amateurs, who had asked for some of their shared frequencies in this band to be made exclusive, and the industrial, scientific and medical interests, who particularly wanted an exclusive allocation around 3.4 MHz, could not be met in full. Some amateur bands may be allocated, exclusively, and "the possibility of meeting the ISM requirement, but with a more restrictive tolerance than that requested, is being considered."

### 4-30 MHz

This section is one of the most congested, and may prove the one where the developing countries prove to have most determination to improve their allocations. Although the West may be able to accommodate the increasing requirements of h.f. broadcasting (now largely achieved by out-of-band assignments), h.f. maritime mobile, amateurs

and ISM by replacing its fixed services by satellite services above 1 GHz, the developing countries are still heavily reliant on h.f. fixed services. The Home Office will propose enough increases in broadcasting allocations to eliminate out-of-band assignments and provide some extra "for growth", and increases in the maritime mobile allocations by widening the existing provisions at 4, 6, 8, 12, 16 and 22MHz and making new allotments at 18 and 25 MHz. They have allowed for the narrow radio astronomy assignments and part of the amateur radio allocations, but all these proposals depend on the attitude of the developing countries.

### 30-108 MHz

The Home Office accepts that the growth of the land mobile service is such that an additional 70-90MHz will be needed to accommodate the expected growth beyond 1985; the spectrum currently available to land mobile radio will be enough, say the Home Office, to meet its needs until then. The document summarises all the conflicting arguments over the reallocation of Bands I

*Continued on page 67*

## C.b communications likened to robbery, plunder and rape

AT THE end of April the House of Lords staged one of the longest debates yet on citizens' band — three columns in Hansard.

The noble Lords amply justified their reputation for maintaining a high level of debate, raising such matters as the inefficient use of radio frequencies, the vulnerability of communications in isolated areas, civil defence, and the freedom to communicate. Lord Wells-Pestell, for the Government, stonewalled all of them.

In reply to Lord Torpichen, Lord Wells-Pestell said that there were no plans to introduce c.b. in this country and it was a national matter unsuited to discussion by the WARC. Lord Tanlaw retorted that the answer was "depressing". Citizens' band frequencies that could be made available were "lying unused already in this country." C.b. could make a great contribution to civil defence in times of national emergency.

"My understanding is," replied the minister, "that there are not bands which are available. Some of the bands that the noble Lords may think available are used, I am informed, for important and essential Government purposes". He then recounted his horror at the possible misuses of c.b.: traffic was once held up on an American motorway, he said. This was because "somebody using a citizens' band radio gave an instruction that it was dangerous to go

along there." He did not say whether the instruction was justified.

Against Lord Wells-Pestell's dedication to the unimpeded flow of motor traffic Lord Tanlaw offered the news that 500 lives had been saved in the great blizzard through c.b. according to Ohio's chief of police.

Lord Harmar-Nicholls asked whether the Government frequencies were reserved unused or were being used. "Are they used for rehearsals or for practice in case an emergency arises, or are they just being left and not being used at all?" "I would not say," said Lord W-P, "they are used for 24 hours a day, but they are in fairly continuous use."

Lord Torpichen complained that in the recent snow farmers were reduced to making signs in the snow to attract helicopters, and the Earl of Cromartie jumped up to support him, to cries of "Order."

The Government replied: "I think we have seriously to consider the enormous disadvantages of having a vast army of people who can communicate with each other very easily . . ." Viscount St Davids asked, "Is the noble Lord aware that there is a point of liberty in this and that there ought to be freedom to communicate?"

"I do not think," said Lord W-P, "that society takes very kindly to people who feel that they have liberty to rob, plunder, rape and do all kinds of things."

# First European communications satellite in orbit

THE REPLACEMENT for the Orbital Test Satellite (OTS) destroyed on September 13 last was launched at 22.59 GMT on May 11. It went into synchronous orbit on May 13 at 12.12 GMT before being manoeuvred to its position 35,900 km above Gabon (10°E) on May 24.

The launch had originally been planned for April 27 but was delayed because of technical problems with the Japanese communications satellite due to precede it and because of faulty cable connectors. The launcher was then re-examined because of a lightning strike. On May 3 the following day's launch was postponed because of "anomalies registered in the electrical ground support equipment at the launch site." Two days later it was again delayed for three more days because "part of the required redundancy in the launcher's first stage engine control circuitry was not working." A further delay resulted from a fault in the second stage inertial measuring unit.

OTS2 is Europe's first communications satellite. It is the forerunner of the European communications satellite (ECS) which will carry some European telephone, telex and tv traffic after the first ECS is launched at the end of 1981. The capacity of ECS will begin at 5,000 telephone circuits and rise to 20,000 in 1990. The four ECS satellites will be launched on Europe's own Ariane launcher rather than the presently troublesome McDonnell Douglas Thor-Delta rockets.

The payload of OTS2 developed by AEG-Telefunken and Selenia represents about a third of that of ECS. When OTS becomes fully operational in September it will have a capacity of one or two television channels and 2,000 to 5,000 telephone circuits, equivalent to about 6,000 telephone circuits in all. OTS2 operates at 11 to 14 GHz, among the first communications satellites to do so,

because the normal 4 to 6 GHz satellite links would, in a regional service, be affected by radio interference. Although it is a regional satellite its coverage area includes Western Europe, the Middle East, North Africa, the Azores, Canary Isles, Madeira and Iceland.

The aims of OTS2 are: to demonstrate the performance and reliability in orbit of all the equipment on board; to carry out experiments on the transmission of radio waves through the atmosphere, frequency re-use and so on; and to provide adequate capacity for European traffic before the ECS programme is under way.

There will be two kinds of experiments: those requiring large earth stations with 15-19m aerials; and those with smaller, cheaper terminals. Four large stations at Fucino (near Rome), Bercenay-en-Othe (France), Goonhilly, and Usingen (near Frankfurt), will have special OTS2 aerials.

## New frequency synthesiser techniques

PYE TELECOMMUNICATIONS appear to have moved closer to producing an easily-programmable single-channel frequency synthesiser. Delegates to a two-day symposium at Pye's new telecommunications headquarters at Cambridge in April were shown a demonstration of equipment which could be programmed to the assigned frequency in seconds using a device similar to a pocket calculator. Such synthesisers are about to be introduced into Pye products, but details of the technique are not yet available.

The growth in the development and use of frequency synthesisers — devices which are able to manufacture several frequencies by the mathematical manipulation of a reference frequency — is largely attributable to the growth in the citizens' band market. In the US a c.b. set needs to operate on any of 23, now 40, channels with a fair degree of accuracy. As the number of citizens' band sets in use increases the provision of a separate quartz crystal for generating each channel frequency in each set becomes impossible, and the frequencies are provided by the addition and subtraction of frequencies provided by a smaller number of crystals.

The techniques used have been well-suited to c.b. since the specification is not hard to meet and the frequency, 27 MHz, low. The synthesisers are not expensive to produce since the market is large enough to enable manufacturers to take advantage of l.s.i. In military applications, where the same techniques can be used in specialised equipment, cost is not an object since the customer is the tax-payer. The two-way private mobile radio market, however, is too small to benefit from l.s.i., each set is a special case, and the frequencies used make the need for better specifications imperative, with a consequent increase in cost. At the seminar Pye's Hugh Hamilton used the example of two components with the same frequency stability, one operating at v.h.f. and the other at u.h.f. If the frequency stability is  $\pm 0.001\%$  then, when operating at 80MHz, this will represent a deviation of  $\pm 800\text{Hz}$ , well within the limits of a 12.5kHz channel. At 480MHz, however, which is a frequency around half way to the limit of the range covered by two-way mobile radio, the deviation would be  $\pm 4.8\text{kHz}$ , which would be unacceptable in the same channel width.

Another 300 smaller terminals will be used by telecommunications authorities, universities and about 50 European institutes with aerials between 3 and 14m.

OTS2 will carry out propagation experiments at 11 and 14 GHz and other experiments concerned with new applications for communications satellites in Europe, including data transmission between small terminals, semidirect broadcasting of television programmes, and facsimile transmission of document and newspaper pages. The responsibility for carrying out the experiments will belong jointly to the European space agency and an organisation set up by the European conference of postal and telecommunications organisations (CEPT) called Interim Eutelsat.

The first OTS (see WW News November 1977 p.53) exploded 55s after takeoff. The cause was traced to a burn-through in one of the strap-on solid propellant Castor IV motors at the bottom of the first stage. The motor has since been modified by thickening of insulation. OTS2 was originally the back-up satellite for OTS1. □

The greater accuracy needed for two-way mobile radio therefore drives up both costs and power consumption. Crystals have to be aged before use in the device and either operated in an oven when working, or temperature-compensated in a specially designed oscillator.

"By using mixing principles, harmonics, and division, and some ingenious mathematics, it is possible to use one reference frequency crystal to obtain all of the channels required. However, when another part of the spectrum coverage or channel spacing is needed an alternative process of mixing, harmonics and division may be identified, and these changes usually preclude a repeat of the original circuit or construction. Thus each design becomes an individual development. In the two-way radio application the number of variants would be excessive with this design approach." Few applications would provide a big enough market to justify the use of l.s.i.

As outlined in a paper presented at Communications '78, held in Birmingham, Philips Research Laboratories have been exploring synthesiser design using digital instead of the usual mixing and division techniques. Hamilton announced that they had now arrived at an i.c. design which used a programmable read-only memory and which would be suited to a wide range of applications. Unique requirements could be met merely by altering the p.r.o.m. programme.

The new single-loop design allows division ratios as high as  $10^7$  or  $10^8$ , instead of the present upper limit of  $10^3$  or  $10^4$ . It "permits a low close-in sideband noise level to be achieved. It is this close-in sideband noise which normally limits the overall performance of a conventional frequency synthesiser to a restricted division ratio." The design also provides higher loop-cutoff frequency, faster lock time and greatly reduced microphony, according to Hamilton's paper. Hamilton was invited to the USA to lecture on the technique.

Pye are hoping that future techniques will allow the use of plug-in p.r.o.ms so that the same equipment can be used in different applications. There is, however, the risk that the Home Office would not type approve such equipment unless the p.r.o.m. were inaccessible mechanically and electrically.



Mr George Banner (left), area manager of the Post Office's earth stations, and Neil White, who will carry out the test transmissions with OTS2, in front of the newly-completed 19m aerial dish at Goonhilly. The aerial and equipment is made by Marconi Communications Systems with the support of the Department of Industry.

# How accurate are audio reviews?

A RECENT issue of *Private Eye* carried a story alleging that *Hi Fi News* had "hurriedly concocted" a new review of the Bowers and Wilkins DM7 speaker when B & W threatened to withdraw advertising. As usual, *Private Eye* got it wrong. Minor adjustments were made to the April *Hi Fi News* review, as a result of a rather naive decision to send an advance copy to B & W's advertising agency, but these changes did little more than tone down what remained quite a critical report. A one-page advertisement for B & W did appear in the same issue, though for the DM5, not the DM7. The *Gramophone's* February issue, however, carried a highly favourable review of the same speakers by John Gilbert.

At least they are said to be the same speakers, but subscribers to both *Gramophone* and *Hi Fi News* may have been puzzled by certain differences between the two reports.

The *Gramophone* notes a "considerable" improvement in stereo imagery". Trevor Attewell of *HFN*, however, noted that, although the DM7 produced excellent images with simple sources, a full orchestra "gave more diffuse images, with a tendency for the size of individual instruments to be enlarged, especially in the bass."

The *Gramophone* said that "Speech, and particularly male speech, has a naturalness sadly lacking in many loudspeakers and one could easily be deceived into believing that one is hearing a live conversation." *Hi Fi News*: "Some speaking voices were virtually indistinguishable from the electrostatic version, while others acquire a hollowness, with more sibilance and bass loss. The effect was greater with 'fruitier' voices...."

John Gilbert noted "seating positions are not so critical as with some other speakers," while Attewell thought, "the DM7 is more particular about correct positioning than many speakers".

There were, of course, substantial points of agreement between the two reviews. Nevertheless, even the published frequency response curves seemed to disagree. The *HFN* curves appeared to show a steep roll-off in the bass, while the *Gramophone* curves, though different from the curves published in B & W's specification, showed greater similarity to the B & W curves than those published by *HFN*.

We wondered whether the circumstances under which the measurements were made might help to explain the subjective points of disagreement. *Hi Fi News* told us that their frequency response curve and all the other measurements had been made by Trevor Attewell either at his home or at James Moir & Associates. The *HFN* curves had been measured in open air. Attewell added that, although he did consultancy work, all of it was concerned with pure electronics, none of it in the hi fi industry. He had not seen Gilbert's review until after he had written his own, and then only briefly.

The *Gramophone* review says, "An unusual opportunity enabled me to measure the performance of the DM7 speakers in the largest anechoic chamber in the UK." This is a reference to the chamber owned by the Department of the Environment's Building Research Establishment at Garston, near Watford. The hire rates are £75 a day plus

VAT, and hirers have to provide their own measuring equipment. B & W are frequent users of Garston, and the DM7 specification notes that that is where all their measurements were taken.

John Gilbert told *Wireless World* that the "unusual opportunity" referred to was a reference to the fact that the *Gramophone* usually used the anechoic chamber at the North London Polytechnic, a facility no longer available to them.

The discrepancies might have arisen, he said, because the performance of a speaker depended so much on the room in which it was being assessed. He added that B & W had not seen the review before it was published.

But he told *Wireless World* that, on the occasion on which the measurements for the *Gramophone* review were made, the Garston chamber was hired for him by B & W, that measuring equipment was transported from B & K Laboratories to the chamber by B & W, and the B & W staff were there when the measurements were taken.

He said he had never been a consultant for B & W, but agreed that he had, on behalf of B & W, invited audio journalists to B & W functions by telephone. They had asked him

to compile a list of people to invite, he said, because he knew a lot of people in the industry. He had phoned the journalists "at my own expense". It was not until April, some three months after the appearance of the *Gramophone* review, that John Gilbert became press officer for the Federation of British Audio, a trade group of 65 hi fi and audio manufacturers, among them B & W.

Before we went to press John Bowers of B & W told us that he did not see any difference between measurements taken during a session which had been booked by B & W and those John Gilbert could have taken on his own. The measurements had been taken, he said, by a B & W lab assistant under Mr Gilbert's direction. The equipment used had not been hired, he told us, it was standard B & K equipment owned by B & W and taken to Garston for the measurements.

- We feel that John Gilbert's review in the *Gramophone* should have stated the circumstances under which the measurements were taken, as he readily did to us on the telephone. This would have made his position as an independent reviewer abundantly clear.

- Hi-fi reviewers came in for more criticism at a recent product launch. Leak and Wharfedale manager Roger Fearn told journalists at a press conference to mark the launch of a

*continued on page 58*

## PIONEERS

THE NAME of Professor Dr H. C. Manfred von Ardenne has been respected in electronic engineering circles for many years. His early work on cathode-ray tubes and television in the 1930s is well-known. Since 1959 he has been engaged in research into medical electronics and it was in this connexion that he was recently in London and paid a visit to the *Wireless World* offices. We had an interesting talk, during the course of which he mentioned that he had helped considerably in the development of British radar, since Sir Robert Watson-Watt had used several hundred of his cathode-ray tubes immediately before the war. Indeed, Watson-Watt was given to describing the c.r.t. as an Ardenne tube. Professor von Ardenne also told us that he had a magnetron-powered p.p.i. radar, very like H<sub>2</sub>S, working before the war and had proposed production of the equipment to Reichsmarshal Goering. He was told, fortunately for us, that it was unnecessary to produce

such devices, since the war would be quite short and would be won by the Germans without fancy bombing aids of that kind.

The work on which Professor von Ardenne is now engaged is of a much less bellicose nature and is directed towards the eradication of cancer. He was in London to read a paper to an audience of radiologists, describing his work in stopping the flow of blood through a cancer by selectively irradiating it with high-powered (8kW) 28MHz radiation and associated chemical treatment. Tests on animals have been successful and we will doubtless hear more about the technique.

He left us a photograph which shows himself and another famous television worker, Dr V. K. Zworykin, also equally well known for his medical researches. The picture was taken in 1972 at the International Congress of Medical Engineering, which was founded by Dr Zworykin.



Professor Dr H. C. Manfred von Ardenne (right) and Dr V. K. Zworykin.

## BBC's digital plans

THE BBC have begun test transmissions of digitally encoded audio signals from Pontop Pyke, near Newcastle. The experiments are being conducted on 47 MHz in Band I using a four phase differential phase-shift-keying (p.s.k.) system to send the digital signals at a bit rate of 704 kbit/s. The BBC proposed the use of such a system in its evidence to the Annan Committee (WW News, August 1976 p.36). They suggested then a four phase p.s.k. system modulating the carrier and channels of 250 or 500 kHz width. Four phase p.s.k. does not require a high field strength to give good national coverage.

In general, the BBC will be keen to demonstrate the effectiveness of the system in order to keep its grip on Band I, currently used for 405-line television transmissions. It is not known how many 405 line sets are in use, and the BBC's lease on Band I is likely to be under increasing pressure after 1982 in the present climate of lobbying for changes in spectrum allocations.

The Annan Committee's report suggested that Bands I and III should be used for a fifth colour channel "but some frequencies in Band I might well be available for services other than broadcasting."

The BBC and IBA carried out joint tests on V.H.F. teletext transmissions in Bavaria, Germany, in April 1975. The tests were held in co-operation with the Institut für Rundfunktechnik (IRT). The broadcasters are also considering the transmission of teletext pages on channels totally reserved for teletext.

The BBC's digital broadcasting experiments are an indication of their reluctance to attempt to re-engineer Band I, which suffers from sporadic E interference, for television. The plan is that all four radio channels could be multiplexed all over the country on the same signal. The idea's main drawback is that everyone would have to buy totally new types of receiver.

The ability to send digitally-encoded sound signals is a spin-off from the work on teletext. No transmitter can send out square wave pulses, but engineers have learned a great deal from teletext about the shaping of broadcast pulses and the avoidance of inter-symbol interference, wherein the pulses merge into one another.

In the present experiments the BBC are using the same coding and demodulating equipment as that used by BBC outside broadcasts in December 1977 to send live stereo concerts from Cardiff and Lancaster over a microwave link to Post Office circuits to London. As well as objective measurements, the BBC say they are carrying out subjective tests on the quality of the transmissions of two audio signals.

They describe the experiments as the initial phase of an investigation into the reception of digital signals under various listening conditions, such as with a whip aerial in a car, a fixed dipole at home or a ferrite rod inside the receiver, which could provide an efficient aerial for v.h.f. portables. "It is hoped," said a BBC statement, "to answer questions on how effective digital transmissions might be when used for a very high grade sound programme service, or for a reliable alternative to the present medium-wave service which has a rather variable night time range caused by overcrowding of the band. Indeed, several signals or types of signal, including new data services, could be made up into a common package using the time-division multiplexing

facility afforded by digital operation." Digital signals could also be used for low-capacity links distributing stereo programmes to v.h.f. transmitters in remote areas.

● The BBC decided on standards for digital links some months ago, but their announcement drew a rapid counterblast from the IBA.

The BBC settled on a modified near-instantaneous companding and multiplexing (n.i.c.a.m.) method for sound transmission along the 2048 kbit/s links the Post Office is to introduce from this year. A statement was issued at the end of October last year.

The full n.i.c.a.m. system (WW June 1975, p.248) was first used for a live transmission from the Edinburgh Festival in 1976. It can transmit up to six sound channels along the 2048 kbit/s link but the Corporation were looking for a way to take advantage of the opportunity to use fewer channels and allow the Post Office to send telephone calls down the link at the same time. Sound signals rarely need to be transmitted six at a time, and the broadcaster can send his signals in any convenient multiple of 64 kbit/s provided the 128 kbit/s the Post Office needs for framing and signalling the telephone calls in the other channels are left alone. This meant the BBC had to find a way of transmitting the data at a little less than  $n$  times the 64kbit/s bit rate.

Engineers therefore carried out subjective tests to decide which of the many digital sound coding systems now proposed will give adequate sound quality and fit conveniently into a whole number of 64 kbit/s telephone channels. Among the systems tested were n.i.c.a.m., a French variant of n.i.c.a.m., an Italian system based on the 'A-law' characteristic used for telephony, and two more variants on n.i.c.a.m. "specially devised with partial access in mind." The statement said the 13 bit linear p.c.m. system now used for radio distribution was also included as a basis for comparison. The best system in their view was one of the modified n.i.c.a.m. systems, which the BBC will now use on all appropriate distribution networks. With a sampling frequency of 32kHz the signal required 320kbit/s with 3kbit/s for scaling the rest of the information, additional bits for framing, signalling, justification and error correction. The total bit rate is 384kbit/s, corresponding to six telephone channels.

The BBC added cryptically that the new system had other applications than sending signals down the 2048kbit/s links, "and in some of these applications the error rate could be high," hence the need for comprehensive error checking.

The IBA's statement, issued a week later, said their view was that "it is still too early to state categorically that any particular system has emerged as optimum or that systems can be interfaced simply, since some degradation of performance quality occurs in practice when this is done." The subject had been discussed by the appropriate working party of the European Broadcasting Union, which reduced the choice of two systems: the French near-instantaneous companding technique, and an Italian one based on the "A-law". The EBU had referred the matter to the CCIR, which was studying the systems with the aim of achieving an international standard. "It is preferable to continue to seek, and endeavour to expedite, international agreement for a system that will be suitable for both international and national

distribution links." No decision appears to have been made yet by the CCIR.

The BBC seem to be taking the view that the choice can be made before the European Broadcasting Union has agreed on an international standard, and that if the choice the EBU makes is different from that already made by the BBC then the two systems can easily be matched up. The IBA's view is that the choice should be made on the basis of an agreed standard, with all countries using the same system nationally and across national boundaries. Any attempt to match dissimilar systems will, in their view, cause a deterioration in quality which will outweigh any individual advantages the BBC or anyone else may attribute to a system chosen by one country alone. The IBA believe the BBC has made the decision hastily; since the European discussions are now drawing to a close. It is noteworthy that the IBA came out with their strongly-worded statement even though their need for international or even national high quality sound distribution links is a great deal less than that of the BBC.

One point that does spring to mind, however, is that not much of our programming originates from overseas anyway. The initial ambitious prospectus for Eurovision has deteriorated to a confinement to football matches, "It's a Knockout" and, worst of all, the Eurovision Song Contest. The most desirable international linking system might well be an open circuit, at that rate.

## "Longest optical fibre link"

THE ALBERTA Government, Canada, is to install "the longest, highest capacity optical fibre communications link proposed to date." Laser light will carry telephone signals along a 32-mile bundle of fibres between Calgary and Cheadle in the south-west of the province. Work will begin on the \$6.6 million contract this year, for completion in the autumn of 1979. The system, to be built by the Harris Corporation, will transmit 274 million bits/over six optical fibre pairs encased in a sheath half an inch in diameter. It will be able to handle 20,160 phone calls at once, and could also transmit tv or computer data.

Harris claim several advantages for optical fibres over copper conductors, among them large capacity, immunity to interference, possibly lower cost, and resistance to moisture and temperature changes. They expect the glass fibre cable to last 20 to 30 years, instead of the normal five to seven years.

A similar view on fibre-optics was offered at a recent symposium in Amsterdam organised by Arthur D. Little and attended by 150 telecommunications executives from Europe, the US, the Middle East and Asia. Cambridge Consultants managing director Richard Cutting presented the view that "long before the year 2000 practical cables will be readily and cheaply available with attenuations better than the best copper cables available in 1978.

"Apart from reducing the dependence on copper for cable links, the very high bandwidth capability of a fibre-optic link will bring a considerable reduction in cable dimensions and hence ease the problem of distributing urban cabling in underground ducts." □

# Colour receiver design

## Remote control and designing for reliability and stability

by Erik Albert Jensen, Bang and Olufsen, Struer, Denmark

During development of a new range of colour receivers, one of the major aims has been to keep power consumption as low as possible. Low power consumption means low dissipation inside the set, giving low working temperatures and leading to a marked improvement in reliability.

Television receivers using ultrasonic signals for remote control have often been plagued with problems of random switching, alteration of volume or picture adjustments. This happens because ultrasonic frequencies can be generated in the room by many sources, for example a bunch of keys and other transient sounds. The solution has been to lengthen reaction times, and to use very high working levels from the remote unit, with relatively insensitive receivers. A patented, automatic cut-off control circuit ensures that colour reproduction does not deteriorate with gradual changes in the cut-off points of the picture tube.

ONE OF THE PROBLEMS with the reproduction of colour on the traditional colour receiver is that the three-gun picture tube is extremely sensitive to drift in the cut-off points. Incorrect balance of the cut-off points results in a constant back-ground shade of some colour, most easily recognised on a

black and white picture, but also affecting colour pictures.

The cut-off point of the electron guns occurs when the electrode voltages result in an electron beam which is so weak that the corresponding tint on the screen just becomes undetectable. For the correct reproduction of colour it is important to adjust the cut-off points of all three guns to occur at the same point. The cut-off points are set by adjusting one of the electrode voltages, normally the acceleration voltage of  $g_2$ .

Experience shows that the cut-off point drifts in normal use. The cause is not only ageing of the components in the receiver but, most importantly, ageing of the picture tube itself. Any error in the cut-off point can be corrected by a service engineer.

### Automatic cut-off control

In order to eliminate the visual effects due to drift, Bang and Olufsen introduced automatic cut-off control in the Beovision 4000 receiver in 1973. This generation of receivers had RGB control-grid drive, so that the three

cathodes were free to be coupled individually to the separate automatic cut-off control circuits.

In the new Beovision 4402 generation, automatic cut-off control is integrated in a RGB video amplifier for cathode drive. Thus, the receiver has conventional video drive, measuring the cut-off point of the electron gun and adjusting the direct bias voltage to the correct cut-off point on one electrode only, the cathode. This is less expensive, more elegant and more efficient than the system used earlier.

**Video amplifier.** A simplified diagram of the principal elements of the video amplifier is shown in Fig. 1.  $Tr_8$  and  $Tr_1$  are fed with R-Y and Y signals respectively, from low-impedance sources. The signals are added across  $R_{81}$ , so that the video content of the output of  $Tr_1$  is the required R signal.

During the field fly-back period, the low end of  $C_{48}$  is fixed at 24V, while the high end is charged to the output voltage of the video amplifier via  $R_{86}$ , with a time constant appreciably lower than the fly back time. The output voltage of the video amplifier is partly set by the actual bias from  $C_{47}$ , but also by a reference level, coupled to give field blanking of the Y channel. The voltage across  $C_{48}$  at the end of the blanking period is therefore

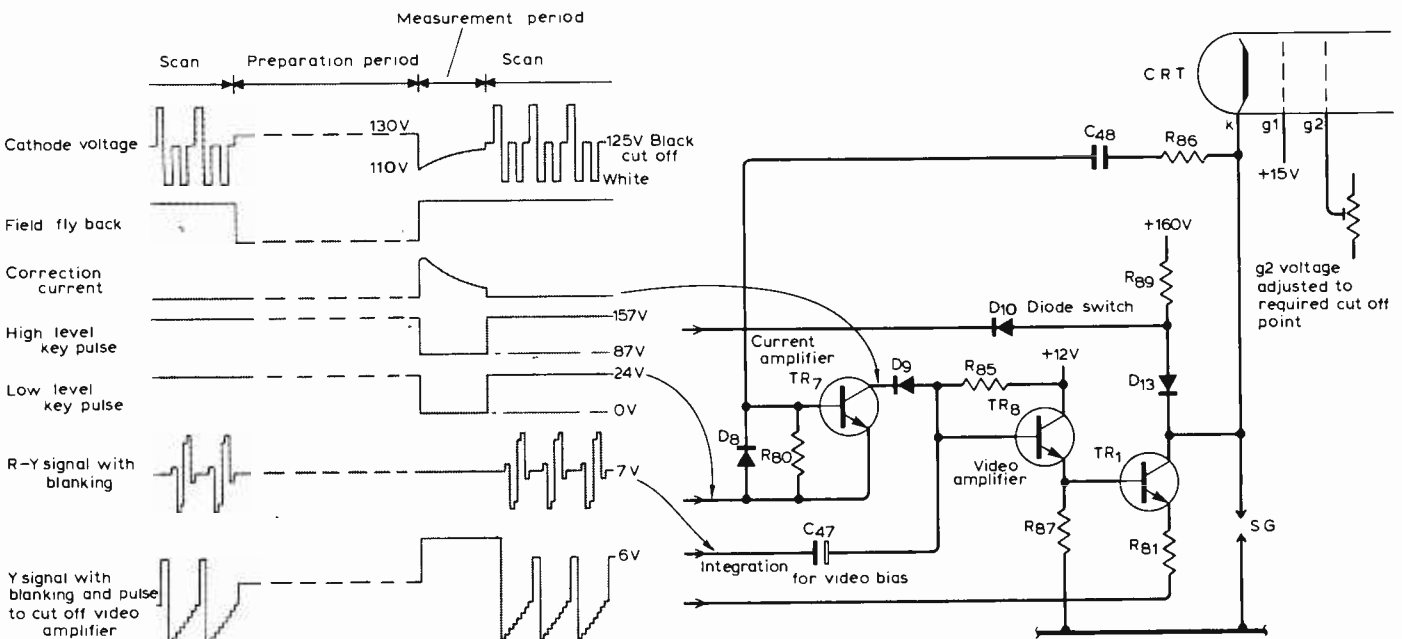

Fig. 1. Automatic cut-off control of the red gun, with waveforms.

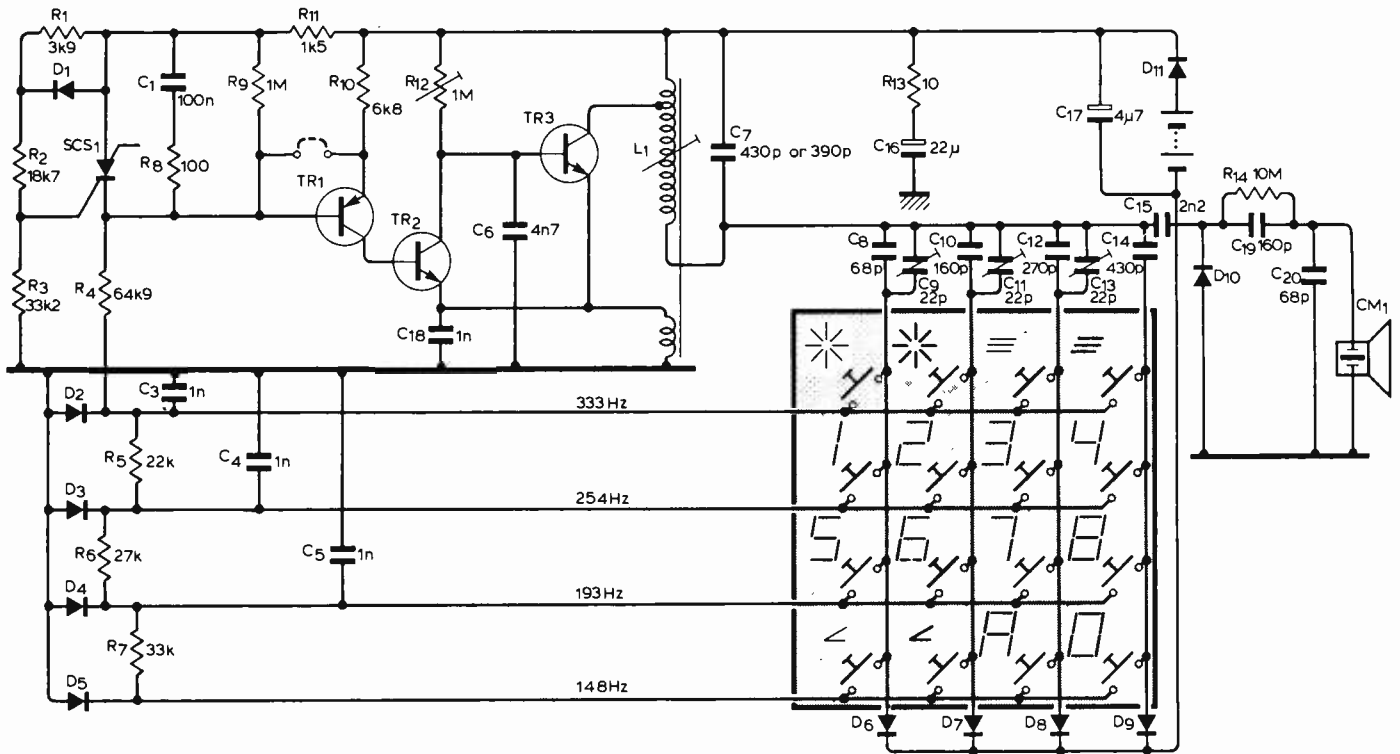
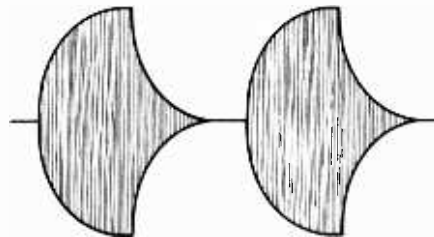

Fig. 2. Circuit diagram of the ultrasonic remote-control transmitter.

Fig. 3. Ultrasonic signal modulated by the tone oscillator.



resistors between the case and emitter of the current amplifier  $Tr_7$ . Thus, the three cut-off points may be adjusted to the best possible colour reproduction, and the automatic cut-off control will maintain correct colour rendering.

The automatic cut-off circuit is able to compensate for errors of the order of 15V on the cathode ( $\pm 50V$  on grid 2), without visible effects on the picture.

### Remote control

The remote control system works on the same basic principle as most similar systems in use today, the working medium being ultrasound. At this point, however, the similarity ends. In the traditional system, commands are transmitted as discrete frequencies adjacent to each other. Such systems are extremely sensitive to noise which has components in the frequency range used. Sensitivity to noise can be reduced by introducing a delay on the receiving end of the ultrasonic signal, and by making the receiving system of low sensitivity, with a corresponding

representative of the bias voltage of the video amplifier, approximately 130V, and is for all practical purposes independent of the video content of the signal.

The circuit is now prepared to measure the conditions of the red electron gun in the region of the cut-off point. The picture tube is blanked during field fly back, the three  $g_2$  voltages being adjusted to give a cathode voltage of approximately 125V at cut-off, giving a margin of 5V for field blanking. The measurement period lasts 0.2 ms, and occurs immediately after field fly back. Coupling to the video amplifier is replaced and the measuring amplifier  $Tr_7$  is activated so that any cathode current is led to  $Tr_7$ , and amplified. The amplified measuring current is bled from  $C_{47}$ , to correct the d.c. working point of the video amplifiers.

Current in  $R_{88}$  is bled via  $D_{10}$  to the generator for the 70V key pulse, while a positive pulse in the Y channel cuts off  $Tr_1$ , to deactivate the video amplifier. The key pulse of 24V, via  $Tr_7$ ,  $C_{48}$  and  $R_{86}$ , pulls the cathode voltage on the picture tube in a negative direction, during the transition from blanking to measurement period. This introduces a beam current in the picture tube, which is led from the cathode, via  $R_{86}$  and  $C_{48}$ , to the base of  $Tr_7$ . Since the measurement period occurs immediately after the field fly-back period, where the electron beam is deflected to strike the picture tube above the picture area, measurement has no visible effect.

With the automatic cut-off control in balance the measurement currents of the three electron guns are around 8 $\mu$ A, in a practical case. These currents can be adjusted by means of

increase in the transmitted signal (up to 110dB s.p.l.). Another method is to use some form of code in the transmitted signal, but both methods introduce longer reaction time in operation, and the delay increases with the amount of security against random operation required.

In 1974, Bang and Olufsen introduced the two-tone matrix modulation system, which has extremely low sensitivity to random noise, with a reaction time to an instruction from the remote control of less than 50 ms.

**Transmitter.** Fig. 2 shows the circuit diagram for the remote control unit. The 16 orders that be given are arranged in a matrix of four ultrasonic frequencies and four modulation frequencies. A single switch activates both oscillators, current from the battery being led through diodes  $D_2$  to  $D_5$  and  $D_6$  to  $D_9$  to select particular frequencies. The i.f. oscillator generates a sawtooth wave built up around the silicon controlled switch SCS<sub>1</sub>, its frequency determined by  $C_1$  and resistors  $R_4$  to  $R_7$ . Oscillator frequency for the circuit shown is for all practical purposes independent of battery voltage.

The ultrasonic oscillator directly feeds the transmitter transducer and its frequency is determined by  $L_1C_7$  and capacitors  $C_8$  to  $C_{14}$  in conjunction with  $Tr_3$ . The ultrasonic oscillator is blocked by the modulation oscillator for half the time period by transistors  $Tr_1$  and  $Tr_2$ . Thus the i.f. signal is modulated on the h.f. signal, and the resultant transmitted signal is shown in Fig. 3. Most of the power in the remote control unit is used while the ultrasonic signal is being generated, so keeping the ultrasonic transmission

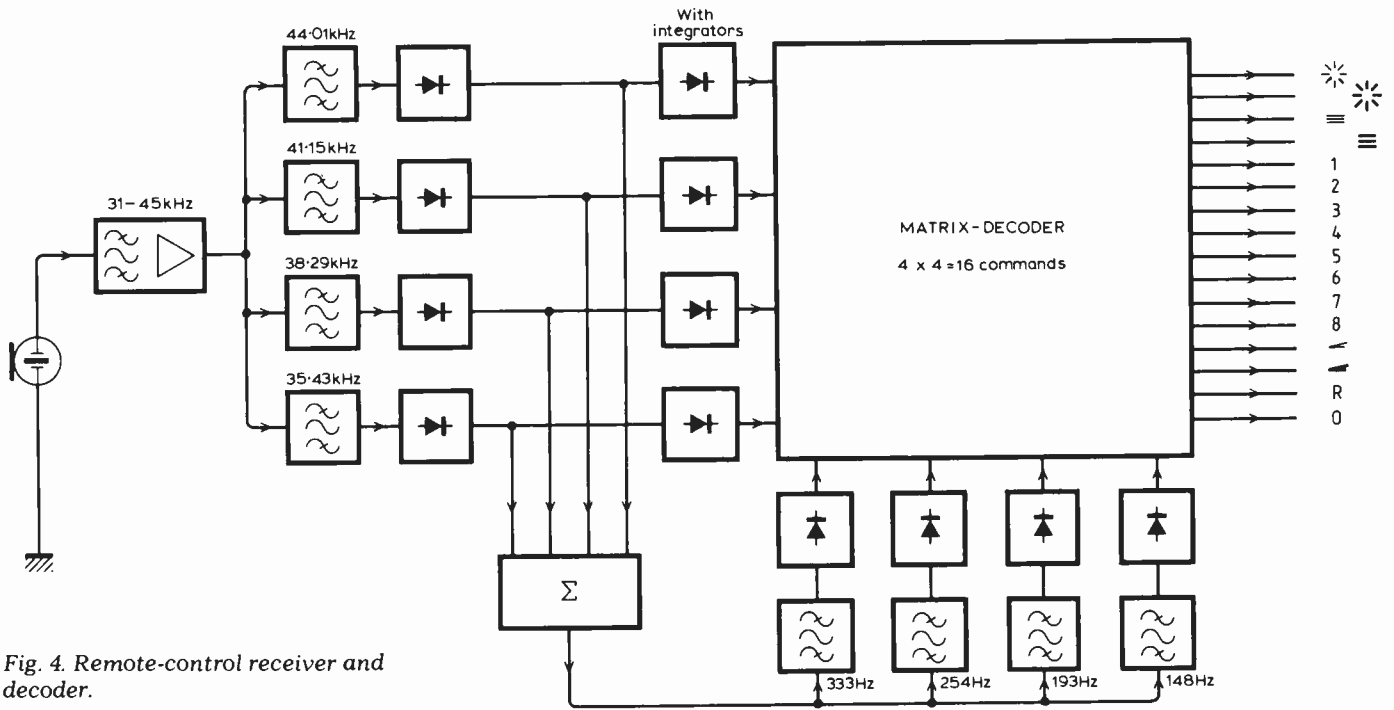

Fig. 4. Remote-control receiver and decoder.

time to less than half the total results in comparatively low current consumption from the built-in dry batteries (about 5mA).

**Receiver.** The two tone matrix system allows the transmission of 16 different commands arranged in a 4x4 matrix of l.f. and h.f. signals. Fig. 4 shows a block diagram of the circuit of the signal receiver. After necessary amplification, the modulated ultrasonic signal is decoded in two stages. After the stage consisting of filters and detectors for the four high and the four low frequencies, the commands are represented by l.f. and h.f. signals in the 4x4 matrix. In the stage consisting of 16 AND gates built around diodes and resistors, the 4x4 matrix is decoded to one of the 16 possible commands. The bandwidths of the filters are sufficiently narrow for frequencies half-way between those specified to be rejected by the decoder. Frequencies used for other products in the range are chosen so that no combination of tones can be mistaken as a positive command for a television receiver, or vice versa. Thus, a colour receiver and remotely-controlled audio equipment can be used in the same room with no danger of false operation of either.

**Reliability**

In recent years, reliability and long-term stability of colour television components have improved to an extent where the need for regular service adjustments has been considerably reduced. This trend is particularly welcome at a time of rising service costs. The inclusion of the automatic cut-off control is a further step in the same direction.

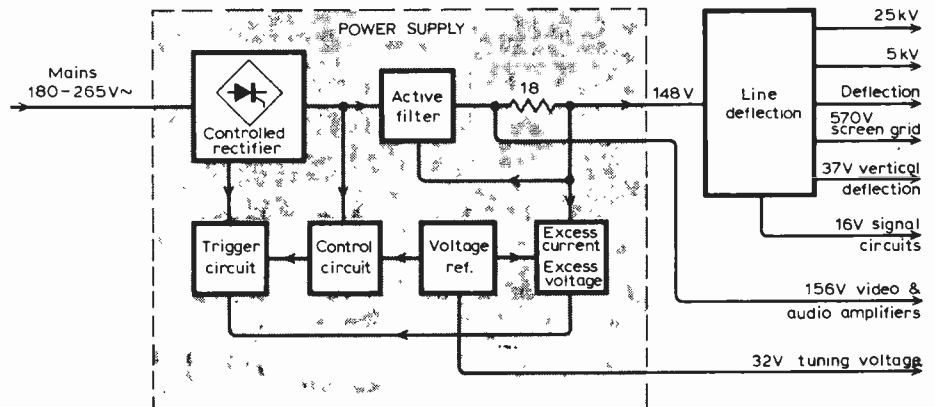

Fig. 5. Power supply block diagram.

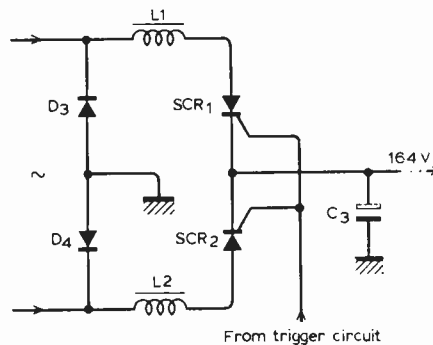

Fig. 6. Controlled rectifier.

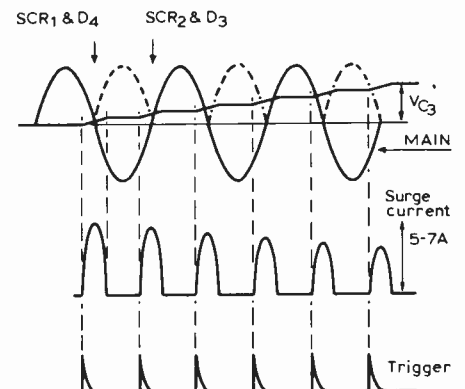

Fig. 7. Principle of surge-current limiting.

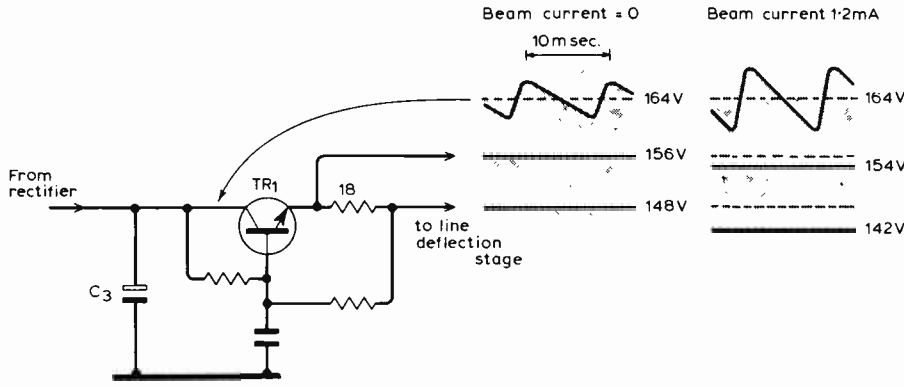

Fig. 8. Active filter.

As the need for adjustments is reduced, it becomes more and more attractive to reduce the risks of a fault occurring in the receiver. One of the factors which has a major influence on reliability is the ambient temperature inside the set. Amongst other reasons, lower temperatures lead to less ageing of components, adding to their life expectancy.

One of the most obvious ways to lower the working temperature is to reduce waste heat generated, due to power losses within the set, resulting in a reduction in the total power consumption of the set. In general, it would be true to say that the lower the power consumption of a receiver, the lower will be the internal working temperature. The largest power saving is in the power supply, which must be explained in some detail.

The power supply is of the s.c.r. type, which delivers stabilized voltage to the line-deflection and high-voltage generators of 148V at zero beam current and 141V at 1.2mA. The voltage drop is intentional, to compensate for variations in picture size with beam current, which cannot be removed cheaply by other means. The stabilized voltages, and therefore picture size, are constant for mains voltage between 180 and 265V. Fig. 5 shows a block diagram of the power supply. The line deflection block is included to show the connexions to the high-voltage supply, and voltage sources of the vertical deflection and signal circuits.

There are two details in the function of the controlled rectifier which help to reduce power consumption. Full-wave rectification gives a lower ripple voltage across  $C_3$ , for the same capacitance. With only half the ripple voltage to cope with, power loss in smoothing is reduced. A surge resistor will normally be necessary to limit charging current through the semiconductors to  $C_3$ , when the receiver is switched on. By using choke  $L_1$  in Fig. 6, and the controlled rectifier to limit surge current, 8-10W continuous power loss in the surge resistor is saved. The surge current is limited to 5-7A, by triggering  $SCR_1$  and  $SCR_2$  late in the sine wave of the mains voltage, as seen in Fig. 7.

Stabilization is designed to maintain voltage across  $C_3$  constant. The active filter used, besides reducing ripple voltage on  $C_3$  from 5-8 Vpp to less than 0.1V, also serves to ensure the dependence on the beam current of the supply voltage to the line deflection circuits. The principle diagram for the active filter is shown in Fig. 8. The voltage drop across  $Tr_1$  is determined by the voltage drop across  $R_{18}$  and the voltage divider to the base of  $Tr_1$ . The voltage drop across  $R_{18}$  is directly proportional to the line deflection current requirement, which in turn is determined by beam-current requirements. The two cases, with zero beam current or 1.2mA, also show that the voltage drop across  $Tr_1$  is not larger than that needed for smoothing, and protection against saturation, giving the minimum load on  $Tr_1$ . □

### Viewdata journal

A quarterly journal for people interested in the rapidly developing use of the television screen as a comprehensive information service, especially the viewdata technique, is to be launched later this year by our publishers, IPC Electrical Electronic Press. To be called *Viewdata and TV User*, it will have in the first issue feature articles by experts explaining what Prestel (the Post Office's viewdata system) can do for domestic, business and professional users. It will explain how viewdata works and how the layman can use the system to the best advantage. The first issue will also describe teletext, showing how this service differs from viewdata, and will contain the first of a series on other tv screened information services. Video games and home video "film" making will be covered in later issues.

Each issue will contain an updated official Post Office Prestel (viewdata) directory for users of the service. All users will receive the magazine, which will also be available to other people for a subscription of £2, including postage, or 40p per copy.

## Mobile radio users' conference

A co-ordinated effort to assert the needs of mobile radio users and impress them on the Government, the equipment makers and the public will be made at a conference "The Freedom of the Air" to be held at Bristol University on 18-19 July. It will be the first ever conference of the Mobile Radio Users' Association and is sponsored by *Wireless World* and *Electronics Weekly*. Sessions will cover present-day mobile radio usage, requirements of specific groups, administration of mobile radio and future developments. Speakers will include Frank Lawson (Post Office head of marketing), Hugh Taylor (Home Office head of licensing), Walter Stevenson (Motorola), Graham West (Pye Telecommunications), Norman Cohen (London Transport) and Malcolm Sinclair (Sinclair Communications).

The number of delegates is limited to 120, so it is advisable to apply early. An inclusive charge of £24 per head covers conference papers, accommodation in single rooms and all meals. Write to: MRUA Conference Secretary, c/o Greater Manchester T.E., 2 Devonshire Street North, Manchester, M12 6JS.

## Stereo power and phase meter — corrections

Regrettably, several errors occurred during preparation of this article. The circuit diagram in Fig. 5 on page 65 of the May issue should show the zero-crossing detector as in the accompanying diagram. In Fig. 6 both

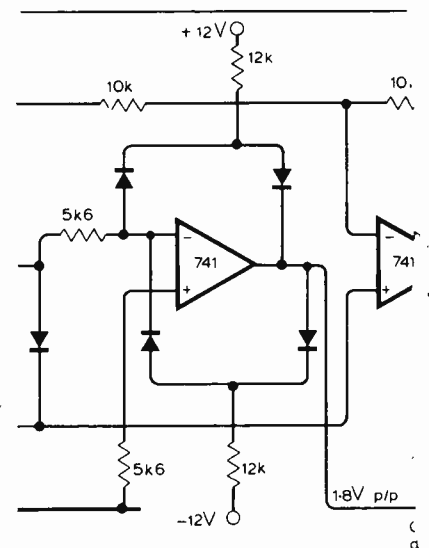

electrolytic capacitors across the meter should have their connexions taken to earth and in Fig. 7 the feed to the 5V regulator should come directly from the rectifier output.

Apologies for the errors to readers and to Mr Hodgson.



# Valves versus transistors

The results of a comparison among three different amplifiers

by James Moir, F.I.E.E. James Moir and Associates

What follows is the result of a series of listening tests commissioned by the Acoustical Manufacturing Company ("Quad"). The intention of the tests was to investigate claims that valve amplifiers sound better than transistor amplifiers.

IN recent years a cult has arisen in which the members worship valve amplifiers, claiming that amplifiers employing transistors are incapable of achieving the same high standard of sound quality that is obtainable from amplifiers using valves. The reasons for the claimed superiority of valved designs are never set out in detail, nor is there any attempt to prove the claims, but instead they appear to be based on the bottomless argument that *absolute* contradiction of their claims is not possible, so by a process of accelerated inference a remote possibility becomes converted to an absolute certainty. It is to be expected that a valve amplifier costing, say £1000, will have a better performance than a transistorised model costing £100, but it appears to the writer that the claims go beyond this and that it is being suggested that all present designs of transistorised amplifiers include some ingredient 'X' that, being beyond any possible measurement, automatically ensures that it is impossible to duplicate the performance of a valve amplifier with any unit employing transistors.

The discussion that follows describes one attempt at the professional level to discover whether there is in fact any basic difference in the performance of a group of valve and transistor amplifiers, all of them recognised as being at the top of their class at the time they were in production. Ingredient 'X' being, by definition, impossible to measure, any attempt at assessing the performance of the amplifiers by objective techniques would have been unconvincing and was therefore discarded, leaving listening tests as the only alternative likely to be acceptable to members of the cult. However it was decided that if listening tests did reveal any significant difference in the sound quality, then the subjective judgement would be followed by a determined attempt to segregate the cause of the observed quality differences by objective means. Listening test techniques that are completely free from any criticism are not

easy to arrange. There is a IEC Publication No. 543 covering the ground in a rather vague manner and a more recent IEC document 29B/WG5 providing a more detailed discussion of the subject. This is more specific in its suggestions and will presumably appear as a British Standard in due course. Where this document was applicable to the tests described, it was followed as far as possible.

In designing a listening test it appears reasonable to try to ensure that all the other elements in the reproducing system are at least an order better in performance than the element being submitted to a subjective judgement, although this is manifestly difficult to ensure when the components being judged are amplifiers of the highest class. If it is assumed that the non-linear distortions are at least a rough guide to the sound quality that can be obtained, then it is impossible to ensure that the recordings and loudspeakers that must be employed in any subjective assessment have a performance that is at all comparable to that of the best current amplifiers. Broadly speaking the situation is as follows.

There are power amplifiers on the market having distortions that are at least 90dB below their rated power output. The best current loudspeaker designs have distortions around 40dB down, professional tape recordings are perhaps 30 to 40 dB down, while the best current disc recordings have distortions that are no better than 25 dB below maximum output. Amplifiers have the additional advantage of having a large amount of headroom allowing the amplifier to be worked well below its overload point without compromising the system signal-to-noise ratio. In consequence the working distortions are much lower than are indicated by a quotation of the distortion content at full power output.

It is not the purpose of the present contribution to discuss all the distortions that exist in a reproducer system, but, assessed on the basis of the amplitude dependent components, it is reasonable to suggest that the best amplifiers have distortion products that are at least 40 to 50 dB lower than in the other elements in a hi-fi sound system. Thus it is a major weakness of a subjective assessment that the programme material and the equipment that must

be used for the evaluation has a performance that is far far worse than the amplifiers being evaluated.

The amplifiers employed for the listening tests were all the products of one manufacturer, Acoustical Manufacturing Co. Ltd, (Quad in other words), who commissioned the tests. It seems likely in any case that most people would agree that their amplifiers have been in the top class for very many years, right back to the time when valved types were the only models available. In addition, using the products of one manufacturer seems essential if comparison with other manufacturers' products and design skills is to be avoided. Quad II amplifiers were the valve model used and the performance was compared with that of the type 303, their first transistor design, and with their model 405, the present current dumping transistor design.

Choosing the programme material for a listening comparison is a very difficult problem when the products being judged are 'state-of-the-art' amplifiers. About forty programme samples on 15 i.p.s. tape were available from four of the best-known studios in the country, with some additional material from several other sources. All were original recordings or first generation copies of original recordings made on machines of the highest professional standard. These samples had been provided as the best examples of current recording practice in the particular studio, but these samples were further distilled by careful listening comparisons until we were left with four selections that were considered to be outstanding in respect of frequency response, low distortion and acoustic clarity. The examples of programme finally used consisted of a concert orchestra, a light orchestral section, a group of male singers and finally a 'pop' group, all thought to be broadly representative of the type of music played at home by the average enthusiast.

The tapes were replayed on a Studer A80 recorder, the signal output being applied directly to the three amplifiers through resistive potentiometers to achieve the same output voltage from each of the power amplifiers. Pre-amplifiers were not necessary and were not used. A double-beam 'scope was installed to monitor the output signal from the amplifier to ensure that over-

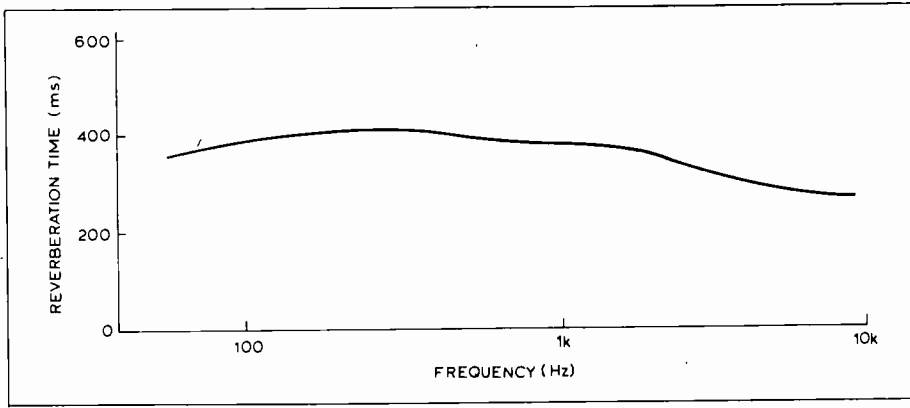

**Fig. 1. Listening room reverberation time response.**

loading did not appear even on instantaneous peaks of very short duration.

Yamaha Type NS 1000 loudspeakers were employed, the choice being that of one of the cult members as a condition of his participation in the tests.

The cult members that were invited to take part in the tests accepted but subsequently withdrew from the listening group, but by that time considerable effort had been devoted to determining the effect of the speaker impedance on the frequency response of each of the amplifiers and by then there was inadequate time available to investigate the performance of any substitute speaker system.

The output from the amplifiers being compared was switched to the loudspeakers by relays with gold-plated contacts to avoid any suggestion that contact-resistance or rectifying-action at the contacts was in any way responsible for the findings. These relays were operated through a switching system that allowed a randomised selection of any pair of amplifiers to be connected to the loudspeakers. At the same time the switching system operated a series of lamps that indicated the number of the particular test to the listening panel. Separate A and B lamps were employed to indicate which of the two amplifiers being compared was connected to the loudspeaker, although the panel had no means of knowing the types of amplifier in use in any particular comparison; all the technical equipment was operated in an adjacent room. In a large number of the comparisons the same amplifier was used in both the

'A' and 'B' positions.

The listening panel were all well known and experienced listeners. They were seated in two rows at a distance of approximately 4.0 metres from the two loudspeakers, but they were free to interchange seating positions as often as they wished. The test was conducted in a typically-furnished lounge having the measured reverberation time/frequency relation shown in Fig. 1 and an ambient noise level around 22dBA in the absence of the panel, rising to 28 dBA at the quietest moments when the panel in a form suitable for statistical training run before judging commenced, the loudness level was adjusted to that thought reasonable by the panel, the level being continuously monitored by the double-beam crt across the speaker line to ensure that this level was maintained through the series of tests.

It is probably impossible to assemble a reproducing system that is absolutely beyond all criticism but the system used had a 'state-of-the-art' performance that was far beyond the facilities of any ordinary enthusiast.

Each item in the musical programme was presented to the panel as two 30s repeats, separated by an interval of one or two seconds during which the amplifiers were switched. This was followed by an interval of about 15-20s before the second piece of music was presented in the same general format.

Obtaining the opinion of a listening

panel in a form suitable for statistical analysis requires some careful consideration, for it is not as simple as might appear at first thought. When three identical amplifiers are compared, then if a sufficiently large number of opinions are taken, each amplifier will get one-third of the votes in much the same way as an unbiased penny will come up heads on 50% of the throws, but only if there are a large number of attempts. Thus a large number of independent quality judgements are required if the result is to be even moderately conclusive. If a small number of judgements are made, any one of the three amplifiers is likely to find favour by sheer chance, in much the same way as the neutral penny tossed three times will confirm that it is weight-biased because heads will come up twice as often as tails.

To judge the amplifier performance, each of the four pieces of music was played twenty-four times to a panel of six judges, their opinion on the performance of each pair of amplifiers being given after hearing each of the four pieces on music on each of two amplifiers. After each of the four pieces of music, the panel members were asked to record their opinion on that particular pair if amplifiers in the form:—

1. I prefer A.
2. I prefer B.
3. I have no preference.

If a preference was expressed the panel members were asked to indicate their reasons for that preference. It was thought just possible that an expressed preference might be connected in some way with the particular seating position, so each panel member was also asked to mark his position on a small seating plan on the score sheet.

To avoid listening fatigue there were gaps in the comparison process after twelve judgements had been made, with longer gaps after twenty-four judgements. Lunch was taken in the interval between the first and second groups of twelve judgements, a whole day being devoted to the comparisons. Every possible effort was made to ensure that the test conditions were as free from criticism as could be achieved, but it would be too optimistic to believe that the arrangements were beyond all criticism.

**Table 1.**

**PAIRED COMPARISON TEST RESULTS**

Comparison	Quad II/405			Quad II/303			Quad 303/405			Same Amplifier	
	Prefer II	Prefer 405	No. Pref.	Prefer II	Prefer 303	No. Pref.	Prefer 303	Prefer 405	No. Pref.	Preference	No Preference
Listener a	5	4	15	7	6	11	5	6	13	11	13
Listener b	2	2	20	1	3	20	4	3	17	3	21
Listener c	3	6	15	5	3	16	4	1	19	7	17
Listener d	4	9	11	2	4	18	7	4	13	8	16
Listener e	2	3	19	2	2	20	3	1	20	3	21
Listener f	8	7	9	8	10	6	7	4	13	14	10
Group results	24	31	89	25	28	91	30	19	95	46	98

When statistically analysed using the 50% Probability Test none of these results indicates either on a group basis, or an individual basis, that there are any audible differences among the performance of the three amplifier.

A summary of the listening panel's scoring is given in Table 1. Each panel member had 24 opinions to record on each paired comparison and the Table indicates his views.

The data collected is sufficient to allow two of the many standard statistical tests to be applied to determine how far the result obtained is likely to be due to sheer chance (luck) rather than to any real difference in the performance of the three amplifiers. There are several statistical tests that can be used for this purpose, but two that appeared particularly applicable have been applied. The 50% probability test applied to a paired comparison of samples thought to be identical reveals how far the consensus opinion is due to sheer chance and how far it is due to a real difference between the amplifier being compared.

As a second test of the validity of the listening panel's opinion the Chi-square test was applied to their scoring. Both tests confirm that the residual preferences expressed by the panel were no more than would be achieved by sheer chance (guesswork is the crude term). The analysis is not reproduced in detail but one simple and easy-to-understand result is worth quoting.

There were a large number of 'no preference' votes, sufficient to allow them to be separated into a 'no preference' group when a single amplifier was used in both the A and B positions and a second group of 'no preference' votes when two different amplifiers were being compared. The percentage of 'no preference' votes when one amplifier was being compared with itself was 68%, while the number of 'no preference' votes when two different amplifiers were being compared was 64%. The panel judgements amplifiers indicated that they did not prefer any one amplifier to either of the other types and that there are no consistent audible differences between any of the amplifiers being compared.

It is worth commenting that during a trial run some days before the test described, a different expert panel and different programme material were used, but the result did not differ in any significant respect from those obtained in the 'official' test. There was no indication of a consistent preference for any one type of amplifier either by any individual member of the panel, or by the panel as a group, or by the combined result of two separate group tests.

The test was primarily aimed at discovering whether there were any real differences in the sound quality that could be achieved from valve and transistor amplifiers, but there were other incidental differences between the designs that reflect the developments in technology that have taken place since the appearance of the valve design around 1960. The valve design necessarily employed an iron-cored output transformer, whereas the 303 includes a series capacitor of 2000 $\mu$ F, while the 405

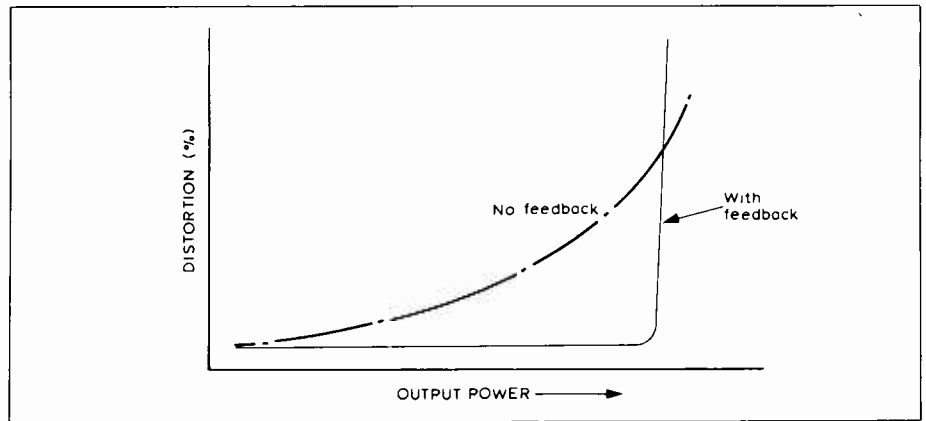

Fig. 2. Output power against percentage distortion characteristics for amplifiers with and without feedback.

amplifier has the loudspeaker directly-coupled to the output transistor. Separate power supplies are used in the Quad II but a common power supply is used for both channels in the 303. Protection circuits of different designs are used in both the 303 and 405. The 405 includes a circuit that provides a sharp cut-off below a frequency of 20Hz whereas the Quad II falls away more slowly below 20Hz.

The comparison also includes amplifier designs completed before t.i.d. (transient intermodulation distortion) became a misunderstood explanation for every subjectively-assessed difference in amplifier performance. All of these differences have at some time been claimed to be responsible for large difference in sound quality, but it will be appreciated that the comparison tests quoted show that in the hands of a skilled designer none of these factors appears to be of real importance.

It seems reasonable to conclude that if a dozen expert listeners working for a day with the best available equipment and the best obtainable programme material cannot find any significant difference between the amplifier types, then it is highly unlikely that such differences as are inherent in designs that span more than twenty years will be of any significance to any user.

Finally it is worth considering how far the findings are reasonable from an engineering point of view. Insofar as the understood distortions in any of the three amplifiers are far lower than in any part of the record-replay system, the findings are logical and are what might be expected. The residual amplifier distortions are likely to have been masked by the much greater distortions in the recording/replay elements, even though these were representative of the best current professional practice.

The absence of preference for any one type of amplifier is exactly what an engineer might expect, so it is reasonable to ask why other published listening tests and reviews appear to show differences so large that one expert was able to speak of the type 405

amplifier as producing '100 watts of squawking sound'. This aspect is worthy of some comment.

It has been stressed that the amplifiers were all operated within their power ratings and this may be one possible key to the difference between findings of this listening panel and of others that have been published. An amplifier which employs a relatively small amount of feedback overloads in an entirely different way to an amplifier having a large amount of negative feedback, a result indicated by Fig. 2. Negative feedback can reduce amplifier distortions by a large factor, but only below the point at which the distortion without feedback is less than a few per cent. Above this power the overall distortion is greatly increased by the application of negative feedback.

In consequence an amplifier design employing a small amount of feedback will approach its rated distortion limit rather slowly, the overall distortion increasing gradually as the input signal is increased. In contrast an amplifier employing a large amount of feedback will exhibit much lower amounts of distortion at output powers below the rated value, but the distortion will increase very rapidly above this 'overload' value.

The difference is well illustrated by the distortion/power output curves of Fig. 2. In practice it is almost impossible to specify with any real accuracy the distortion content of an amplifier employing large amounts of negative feedback at output power levels near, or above, the overload point. Beyond this point the distortion increases so rapidly that small changes ( $\pm 1\%$  etc.) in mains supply voltage or signal input voltage may increase or decrease the measured distortion by four or five times without there being any significant increase in the power output.

Above its overload point, every amplifier type exhibits its own particular overload characteristics depending on the cause of the distortion. Slew-rate limiting, transient intermodulation distortion, dynamic intermodulation distortions, amplitude compression, mains frequency modulation and the well-understood distortions due to curvature in the overall transfer characteristics will all introduce their own

characteristic acoustic effects.

However it is unreasonable to operate any amplifier above its claimed power output. If the amplifier has to be overloaded to achieve an adequately loud signal then a more efficient loudspeaker or a more powerful amplifier should be substituted.

Differences in the acoustic performance of an amplifier can also be induced by applying test signals that are outside the designed frequency band of the amplifier. In a misguided attempt to assess the transient performance of an amplifier short square wave dc pulses or short pulses of sinusoidal tone are often applied to an amplifier, but it is easy to show that such short pulses contain components up to a frequency in the region of 80 to 100kHz. For example a pulse 10 $\mu$ s long will have a first zero in its amplitude response at 100kHz and the amplitude of components at 80kHz will be only a few dB lower than the maximum. In most amplifiers this is well outside the designed frequency range and overloading is easily produced by signals that would be far from overloading the amplifier if they were of the same amplitude but inside the designed frequency pass band.

Finally some comment about the pitfalls that are possible when connecting up the components in any hi-fi system. Fig. 3 shows the same units having their earthing connections set out in different ways that are superficially identical. Yet in practice there may be large differences in the performance of the system in respect of sound quality depending on just where the earthing wire is connected to the circuit earth bus or the chassis. An assembly in which two or more amplifiers are connected to the same earthing system and the same loudspeaker will almost certainly not achieve their catalogue performance unless some considerable expertise is employed in assembling and testing the completed system.

The writer took no part in reaching the judgements discussed, but it is his firm personal opinion that no 'X' ingredient, nor any 'black magic' is necessary to explain the results. As Mr. Peter Walker has commented, "If an engineer finds that a couple of measurements appear to contradict Ohm's Law he does not immediately rush into print with his findings, he looks again at the measuring technique employed."

This comment should be taken to heart by all those reviewers who are so eager to print comment that flatly contradicts all reason. They might, with advantage, look at the experience of a Canadian journal.<sup>1</sup> Their reviewing panel listened to half a dozen amplifiers, all in the top class and found large differences in sound quality. Doubting the findings, they set out to investigate the reasons for this. After having eliminated all the little problems that they were able to unearth, a repeat of the listening test revealed that all the quality differences had vanished. It is a

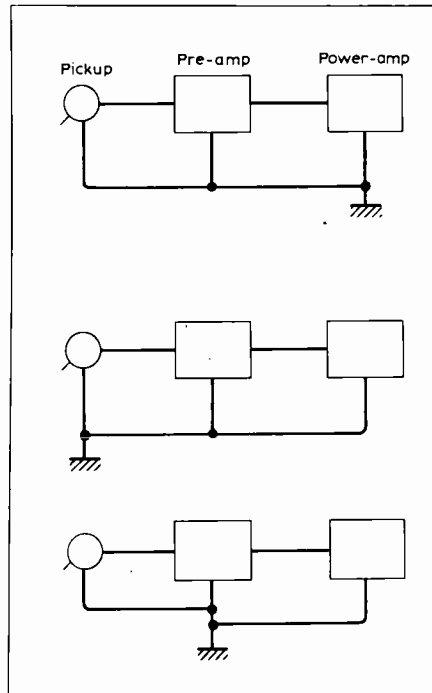

Fig. 3. Nominally-equivalent earthing arrangements.

mundane explanation perhaps, and one that is without journalistic appeal, but then the truth is often less sensational than pseudo-science or witchcraft.

#### Reference and further reading

1. Six Amplifiers, How Did They Compare? Ian G. Masters, *Audio Scene*, May 1977.
2. Audible Amplifier Distortion is not a Mystery, P. Baxandall, *Wireless World*, Nov. 1977.
3. Rational Amplifier Testing, P. Walker, *Hi-Fi News*, July 1977.
4. Can You Hear Any Difference? Adrian Hope, *Hi-Fi News*, June 1978.

## How accurate are audio reviews? *From p. 67*

new range of Wharfedale speakers that British hi fi customers had bought more of their XP speakers than any other brand in the past ten years, in spite of no press coverage or adverse reviews. The four large comparative reviews of bookshelf speakers that had appeared in the previous four months had grouped up to 16 loudspeakers, not one of them a Wharfedale, yet 20% of readers, he asserted, would be buying a Wharfedale product. At least five competitors had appeared in three out of four reviews.

"When the Wharfedale Denton or Linton products have been reviewed there has been virtually no consideration of the price the consumer will pay. A recent letter in the hi fi magazine had a customer asking advice on the purchase of a pair of Dentons, to which the magazine said there were a lot better products on the market and proceeded to list some which would cost the consumer between 30% and 100% more than the Denton, hardly fair advice."

"We have survived this approach for some years, but we are naturally concerned about the eventual impact of what we consider to be slightly unfair journalism. Particularly with the increasing competition from Japanese loudspeakers, who have the weight of advertising expenditure to overcome any type of press coverage."

Reviewers should take price into account, he said. Later he told *Wireless World* that he also questioned the usual method of reviewing, by comparing the tested equipment with a reference monitor. "It's a bit like comparing a Cortina to a Jensen: you are always going to find areas of performance that are not quite up to the standard of the Jensen, whereas a Cortina would normally be measured against standards expected of that category of car." □

## Electronics well-represented in Queen's awards

THE FOLLOWING firms are among those listed in the latest Queen's awards to industry: Brookdeal Electronics, for technical achievement in signal recovery; General Instrument Microelectronics, for exports; International Aeradio, for exports; Marconi Avionics, for exports; Racal Dana, for technological achievement in programmable synthesised signal generators.

Three audio companies were represented. Electrosonic won an export award for audio visual and lighting equipment. The Acoustical Manufacturing Company won a technology award for their Quad current dumping amplifier, and Bowers & Wilkins won an award for exporting almost 90% of production. □

## Disaster avoided

Over 300 mobile radio users attended Pye's two-day symposium, (see other news items, this issue) including some from the Ministry of Defence, the Home Office, police forces, area health authorities, fire brigades and water authorities. The symposium was a triumph over adversity. Pye employees at first said they would picket the week's events as a protest against their £1 million cost. No sooner had they been persuaded not to do so than the giant marquees in which the symposium was to be held, set up on fields next to the Cam river, were flooded by three feet of water, this only days before the opening. The same employees won the eternal gratitude of Pye executives by working day and night to clean up the mess. They did, so effectively that delegates had to be shown photos of the inundated marquees to believe what had happened.

## MICROWAVE HYBRID INTEGRATED CIRCUITS

I write regarding the very interesting article by Drs Davies and Newton, "Microwave hybrid integrated circuit technology" in the February issue. Review articles with this kind of flavour seem an ideal choice for this journal with its wide professional readership.

It is especially important, I feel, that the mainly "non microwave" engineers who read Davies's and Newton's article do not in fact get "the wrong end of the stick" on anything – if this can possibly be avoided. To this end I should like to offer the following comments on certain aspects of the article.

1. In the article summary, m.i.c. have been made at frequencies well above 40 GHz.<sup>1,2</sup>
2. Gunn diodes are still very useful (and conveniently) made in waveguide – and a smaller waveguide (than standard) is used so that the higher-Q and higher stability can be achieved by operating near cut off. Also impedance "matching" is hardly a problem since the device only has to be correctly located with respect to a short-circuit.
3. Dispersion in microstrip is very significant at frequencies even well below 12GHz – sometimes down to 3 or 4GHz.<sup>3</sup> The paper referred to here quotes very reliable formulas for alumina as well as sapphire.
4. In the table, the dielectric constant of "alumina" can vary greatly over the approximate range:  $8.5 \leq \epsilon_r \leq 10.2$ . A value of 9.6 is typical of thick-film substrates (not often used at microwave frequencies). 10.1 is often the case for thin-film substrates.<sup>3</sup> The permittivities of sapphire are 9.4 and 11.6<sup>4</sup>, and not the values given.
5. Sapphire is not employed because of its high dielectric constant (only marginally greater than alumina). It is used because of its surface finish, repeatability and transparency etc.<sup>5</sup>
6. It is difficult to see how coupling the X-band oscillator to a (relatively low-Q) microstrip resonator provides "... the necessary temperature stability." Perhaps the authors can enlighten me on that point.

Notwithstanding these comments, the article is certainly wide-ranging and informative. I am especially interested in the "low-cost" parametric amplifier of Fig. 8, and would be grateful if the authors could supply any further information on this item.

T. C. Edwards  
La Trobe University  
Bundoora  
Victoria  
Australia

### References

1. Schneider, M.V., Bernard Glance and Bodtmann, W.F. "Microwave and millimetre wave hybrid integrated circuits for radio systems." *Bell System Technical Journal*, July-August 1969, pp. 1703-1726.
2. Oxley, T.H. "Microwave integrated circuit techniques." *GEC Journal of Science and Technology*, vol. 43, No. 1, 1976, pp. 21-31.
3. Edwards, T.C. and Owens, R.P. "2-18GHz dispersion measurements on 10-100Ω microstrip lines on sapphire." *IEEE Trans MTT-24*, No. 8, Aug 1976, pp. 505-513.
4. Owens, R. P., Aitken, J.E. and Edwards, T.C. "Quasistatic characteristics of microstrip in an anisotropic sapphire substrate." *IEEE Trans. MTT-24*, No. 8, Aug 1976, pp. 499-505.
5. Ladbroke, P.H. "Some effects of field perturbation upon cavity-resonance and dispersion measurements on MIC dielectrics." *IEEE Trans. MTT-25*, No. 11, Nov 1977, pp. 892-893.



### The authors reply:

With reference to the items in our article discussed by Mr Edwards we would like to make the following comments.

1. Microwave integrated circuits have been made at frequencies well above 40GHz (90GHz in reference 2 of Mr Edwards' letter) but the losses due to radiation from discontinuities (especially from connectors) and surface waves make open microstrip unattractive for use at frequencies much above Q-band. At these frequencies alternative circuit structures such as coplanar waveguide, trapped inverted microstrip (TIM), suspended microstrip etc, which do not radiate as much energy offer improved unloaded Q-factors.
2. We agree that waveguides are still widely used in constructing, for example, Gunn oscillators. Furthermore, the solid-state devices can be conveniently resonated by an appropriately positioned short-circuit and the correct resistive termination can be provided by adjustment of the output circuit. See for example the Q-band Gunn oscillator used as the pump for the X-band paramp. Even so our point in the article was to emphasise the integration capabilities of microstrip circuits which applies throughout the microwave spectrum.

With regard to the matching problem, we believe it is much easier to match semiconductor devices (Gunn diode, mixer diode, induct, trapatt etc.) to a given circuit load impedance if the stray series inductance and shunt capacitance associated with the encapsulation are removed. Then any series and parallel resonance effects (to which the usual encapsulations are prone in C and X band) are eliminated. The spurious resonant frequency of the stray reactances surrounding an unencapsulated diode occur well above 12GHz.

3. There is no doubt that dispersion effects occur at lower microwave frequencies but note that in the design of many circuits below 4GHz, e.g. trapatt oscillators, dispersion effects are often negligible.
4. Our experience in the design of narrow band thin film directional filters is that a value of  $\epsilon_r = 9.6$  for M.R.C. Superstrate gives excellent agreement between predicted and experimental results. A value of 10.1 would certainly be noticed in our designs. (It is probable that Mr Edwards is referring to Allsimag 800 for which the permittivity is 10.1). The values of  $\epsilon_r$  for sapphire which we quote are not too different from Mr Edwards's values. A 1% difference is not going to introduce a significant design error in, say, a bandpass coupled line filter compared to the tolerance involved in the technological process for making the circuit.
5. We agree with this comment.

6. It was not within the scope of the article to discuss the details of the stability of the microstrip Gunn oscillator. However a detailed account is given in reference 6 of our article. Basically, the Gunn oscillator is locked to a capacitively coupled microstrip line to give a basic temperature stability of 1 MHz/°C. With a thermistor compensation technique this value was reduced to 0.3 MHz/°C over the temperature range -10° to +50° which was sufficient for the application.

We thank Mr Edwards for his interesting comments.

R. Davies and B. H. Newton

## NEGATIVE FEEDBACK AND HARMONICS

I read the article "Distortion in low-noise amplifiers" by Eric F. Taylor in the August and September 1977 issues with great interest. I would like to correct one error which perpetuates a common misconception. I quote from the August article: "... the effect of negative feedback has been to reduce the coefficients of the terms of the power series representing the non-linearity by a factor  $(1 + A\beta)$  compared with the open-loop configuration." It is not even approximately true that all harmonics are reduced by the same factor; the proof given is incorrect.

In Appendix I of the August article, the non-linear gain,  $A$ , of an amplifier without feedback is expanded in a power series

$$A = A_0 + A'v + A''v^2/2 + \dots$$

where  $v$  is the input voltage in appropriate units,  $A_0$  is the gain for an infinitesimal signal, and  $A'$ ,  $A''$ , ... are the successive derivatives  $dA/dv$ ,  $d^2A/dv^2$ , etc. Following the article, we obtain the 2nd order term for an amplifier with feedback:

$$A_f'' = A''/(1 + A\beta)^2 - 2(A')^2/(1 + A\beta)^3$$

In the original article it is stated that the second term on the right-hand side can be neglected, and this statement is implicitly generalized for higher order terms. The gain is reduced by a factor  $(1 + A\beta)$ , so that the (erroneous) conclusion is that all distortion components are reduced relative to the fundamental by a factor  $(1 + A\beta)$  when feedback is applied.

We shall assume  $A\beta \gg 1$ , which simplifies the algebra; the gist of the argument is valid for any  $A\beta$ . The ratio of the neglected term to the retained term is, with the above approximation,

$$-2(A')^2/AA''$$

We ask the vital question: is  $(A')^2$  really very much smaller than  $AA''$ , justifying the approximation? The answer is no; I will give some heuristic arguments here, and will deal rigorously with the common-emitter amplifier in an Appendix.

Let us consider an amplifier with constant transconductance,  $g_m$ , and variable load,  $R$ . The gain will be  $A = g_m R$ , which can be expanded in a power series as before. If we now increase  $R$  without changing the input voltage, we expect the relative distortion to remain constant (if it increases, the argument is reinforced; only a decrease in distortion can invalidate this discussion). In other words we expect the absolute distortion components (voltages, not ratios) to increase by at least the same factor as the gain; in mathematical terms, we expect the derivatives to be approximately proportional to

$A_0$ . This argument shows that a more appropriate power series is

$$A = A_0(1 + pv + qv^2 + \dots),$$

where  $p = A'/A_0$ ,  $q = A''/2A_0$ , etc. The new coefficients are now a true measure of linearity, being independent of the gain. The 2nd harmonic distortion is essentially given by  $p$ , the 3rd by  $q$ , etc. The ratio discussed above is equal to  $-p^2/q$ , which is clearly only negligible if the square of the 2nd harmonic component (relative to the fundamental) is much less than the 3rd harmonic. This is normally not so, and the term neglected by the author of the article is not small, invalidating the proof. We conclude that negative feedback does not normally reduce all harmonics by a factor  $(1 + A\beta)$ . I state without proof (exercise for the reader!) that higher harmonics may be (and in general will be) reduced by a smaller factor. I conjecture that under certain circumstances some harmonics could conceivably be enhanced relative to the fundamental – unpleasant high harmonics, of course (Murphy's law).

Roughly speaking, the effect of feedback is to convert a given distortion component into a  $(1 + A\beta)$  times smaller component of the same order, plus terms of higher order. The higher order terms will add (algebraically) with the higher order components already present. It is not difficult, although tedious, to calculate the effect of feedback on a given transfer function. The results are thought-provoking. An interesting hypothetical example was given by M. G. Scroggie in his "Essays in Electronics" (out of print, but not out of date); the effect of 40dB of negative feedback was to convert 20% of pure second harmonic distortion into a set of distortion components giving a higher weighted total harmonic distortion. The application of feedback to a non-linear amplifier can be compared with hammering out dents from a metal sheet: a large, smooth dent tends to become a mountain range of nasty small dents.

I will not delve deeply here into the audible aspect of distortion, but will simply point out that feedback reduces the magnitude but increases the order of distortion, and should not be used blindly.

M. G. Salem  
London NW1

## Appendix

Consider a common-emitter amplifier with no resistance in the base-emitter circuit. The

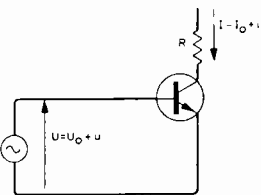

instantaneous collector current,  $I$ , is given approximately by

$$I = I_s e^U$$

where  $I_s$  is a constant, and  $U = qV/kT$ , with  $V$  = base-emitter voltage,  $q$  = electron charge,  $k$  = Boltzmann's constant,  $T$  = absolute temperature. We have  $q/kT = 40$  at room temperature. Normally both  $I$  and  $U$  have a steady component ( $I_0$ ,  $U_0$ ) and a time-varying (signal) component ( $i$ ,  $u$ ). In terms of these components

$$I = I_0 + i = I_s e^{U_0 + u} = I_0 e^{u/U_0}$$

and thus

$$i/I_0 = e^u - 1 = u + \frac{1}{2}u^2 + \frac{1}{6}u^3 + \dots$$

The gain is:

$$A = A_0(1 + \frac{1}{2}u + \frac{1}{6}u^2 + \dots),$$

$$\text{where } A_0 = I_0 R q / kT \approx 40 I_0 R.$$

We have for small  $u$ :  $A' = A_0/2$ ,  $A'' = A_0/3$ , etc. The ratio  $-2(A')^2/AA''$  is thus  $-3/2$ ; the neglected term is actually larger in magnitude than the retained term. In this particular instance the neglected term decreases the magnitude of the distortion; this is fortuitous, and higher harmonics are, in general, enhanced in magnitude by the term neglected in the August article. We have  $A'' = A_0/3$ ,  $A''_f$  (uncorrected) =  $1/(3\beta A_0)$ ,  $A_f$  (corrected) =  $-1/(6\beta^2 A_0)$ .

## PICKUP-ARM DESIGN

Mr Randhawa, in his first article on this subject in your March issue, comments "One of the first problems faced by pickup arm designers was tracking error . . . . ."

It will continue to be a problem while ever designers try to make a curved line fit a straight one.

I see no reason why the cutting head *must* follow a straight line. Why cannot it be fixed on the end of a radius arm? The cutting head would then follow a curve, and without any difficulties or abstruse calculations the pickup head would follow exactly the same curve.

There is probably a best compromise for the length of the radius and the amount of overhang beyond the centre of the disc; there might even be an actual indisputable best. In any case it could be standardised, and no more trouble.

F. Holloway  
Rayleigh  
Essex

*Editor's note:* We understand from recording engineers that what Mr Holloway suggests is in fact possible but difficult to achieve. There is perhaps an argument here for concentrating difficulty and cost of mechanical design once and for all in the recording equipment rather than allowing it to be distributed forevermore as a permanent problem in the manufacture of reproducing equipment.

## AUDIO EQUIPMENT REVIEWS

Paul Messenger (Letters, June) said that *Hi Fi Choice* "should try to provide comprehensive and comparable data on a significant proportion of the available products in whatever category . . . to enable the reader to make his own choice according to his particular need." A modest enough claim one might think, but in the newly published *Loudspeakers* we read (p.10) "What we're saying is this; we can point you towards the best hi-fi system in the world. The best turntable, the best amplifier, the best cartridge, the best tape deck, the best loudspeakers." Since Mr Messenger has actually invited discussion of *Loudspeakers* by readers of *Wireless World* perhaps the following observations will be of interest.

The strength of the publication seems to lie in the technical introduction (p.31-38) and in some, if not much, of the conclusion (p.169-173). Insights are to be found, and pertinent comments are made about 'characteristic

forward response' in particular, and about coloration. Having admitted this it must then be said that "the most comprehensive guide to buying loudspeakers ever published" is very weak.

There are three principal areas of weakness that invalidate the entire report. First, procedures for test are not properly correlated; second, the marking procedure in listener-panel evaluation cannot provide satisfactory sample material for the statistical procedures employed; and, thirdly, there are serious inconsistencies in the presentation of the evaluations.

No integrated response measurements are given for the 'sound window' – the virtual listening rectangle prescribed by the included angles 20° vertical and 60° horizontal for each speaker. Instead the traditional on-axis sine-wave drive response curves at 1 and 2 metres are quoted in all cases. Unexplained anomalies between subjective comment and frequency response measurements abound – p.57, 75, 81, 85.

We are told that the reference for evaluation is "provided by the mean standards of the group as a whole" (p.169). This apparent tautology simply means that the average is a statistic not a loudspeaker, and we are brought to the heart of the problem. The testing was done in an average-size listening room that happened to agree in essential characteristics with the IEC recommended test room. Live versus recorded tests were made using voice and instruments. This is notoriously difficult (as Colloms himself admits) but quite misleading as a general comparative test procedure simply because amplitude mis-matching between live sound and the recordings inevitably occurs. A difference of only a fraction of a decibel will affect assessment of fidelity. Also the human voice changes subtly but significantly from day to day and recording should be updated accordingly.

Anyway the results were analysed to achieve an average. The listening panel of six – "a mixture of trained and untrained ears" (p.19) – "was asked to give a numerical mark to each loudspeaker, an evaluation of its general impact, and errors or attributes of frequency balance . . . marks were used to denote judgements like clarity, accuracy, too much or too little treble, too much or too little mid-range . . . to identify (again with numerical marks) the coloration they could hear". (p.20). An attempt was made at standardisation on colorations as bumps or resonances in certain frequency bands. Each classification – 'tube', 'chesty', 'cup-like', 'sharp', 'fizzy' etc – is given a numerical mark. Then, we are assured, "it is possible to run a statistical analysis of what the panel hears and thinks of what it has heard". p.20.

A strange contrast appears throughout the book between the results obtained on the live versus recorded test and the stereo sessions where high quality recordings were replayed (p.46, 50, 53 etc). No explanation is offered.

The absence of pulse tests is quite unfor-giveable when so much attention now is being paid to phase accuracy and time domain behaviour by loudspeaker designers and manufacturers. It is partly explained by a disregard of phase phenomena in favour of a new slim-speaker theory of stereo accuracy (p.171) which seems to emerge from the statistics. However, the book is also luminous with revelations on such things as plastic cone drive units with some degree of "quack" on the upper mid voice band (p.74).

The third criticism mentioned was that of

inconsistencies in the presentation of evaluations. Loudspeakers that previously had been favourably reviewed by Martin Colloms were very positively presented again (p.50, 58, 60, 94), the identity of such speakers emerging noticeably better than others that appear as shadowy and intangible as the statistics quoted to delineate them. Each report had a comment from Tony Faulkner which is a little less statistical than the main panel result since it is a solo performance. At times he contradicts the panel (p.77, 85, 95, 133). Also, in the summary a recommended speaker is said to have "fine distortion and stereo imaging" (p.175) whereas TF comments "I scored this speaker above average in all respects except stereo image, which I found slightly overwide and out of focus" (p.150). Similar inconsistencies abound with respect to wording (and apparent censoriousness) on matters of sensitivity, low frequency performance, and value for money.

It is my belief that loudspeaker evaluation cannot be done to any worthwhile purpose in a piecemeal, dissecting and comparative manner. Loudspeakers will always have individual character in so far as they are mass market contenders, and the 'average' speaker that emerges from the text of *Loudspeakers* is a pure fiction. I certainly hope that the lessons will be learnt.

John Greenbank

Tangent Acoustics Ltd  
Bar Hill  
Cambridge

---

## DEFENDING THE NRDC

There is no need for me to respond to Mr Catt's biased complaint of his treatment by NRDC published in your May issue (letters), since that organisation could undoubtedly present their view of his case with greater commercial and financial sobriety of expression than Mr Catt displays. When Mr Catt attempts, however, by tortuous illogicality and irrelevancy to involve me with your readers in his personal affairs and through this channel denigrate in advance the report of the Government Committee which I am privileged to chair, he cannot be allowed the luxury of public expression of his spite without reply.

Strangely, Mr Catt was one of the first of the many to write to me on 21 December last just after formation of the Committee asking to be allowed to give evidence. For somebody who lacks confidence in the activities of the Committee this would seem rather an odd action.

Although it is no part of the purpose of my Committee to comment on NRDC, Mr Catt may care to have my personal views. I believe that the concept of NRDC is essentially sound and that the help they provide in developing and exploiting inventions from all sources can play an increasingly important role in advancing innovation in this country's industries and services. During the period 1963-73 when I served on the Board of the Corporation, we had our share of both successes and failures. Not all inventors were always right, but not all were always wronged and I suspect that this pattern will continue. If NRDC's track record can be improved I am sure that nobody would be happier than the present Board of NRDC. Where they have made mistakes of judge-

ment, I am equally certain they would in so far as they can be recognised wish to correct them; whilst Mr Catt clearly believes that in his own case this has not happened perhaps NRDC would not, even with hindsight, have acted differently.

Finally, I find Mr Catt lacks a sense of proportion as well as abusing the English language. If Mr Catt believes that the NRDC with its limited investment over the past 28 years is "doing more damage to the economy than shop stewards in the car or shipbuilding industries," he will believe anything, and to consider NRDC as "cancer" which is a destructive growth, can hardly be supported on the past record of NRDC.

Monty Finniston

Committee of Inquiry into the Engineering Profession  
London SW1

---

## OPEN LETTER TO FINNISTON

My son completed grammar school with ten 'O' levels and three 'A' levels, the latter in physics and mathematics with A, B, A grades. Last year he left university with B.Sc (Hons) to his credit. Fifteen to twenty years ago he would have proceeded to a science or engineering based profession. In fact, he has taken articles with an international firm of accountants and is working for chartered accountant, not chartered engineer, status.

It is relevant, to the current Inquiry into the Engineering Profession, to ask why not engineering? No doubt the vicissitudes of my own career have been observed. I have discussed the matter with my son and his contemporaries and there can be no doubt that the lack of a coherent, and recognised, career structure within the profession coupled with the transparent career assurances of the engineering employer is responsible for this lack of interest. Too, the run-down of job prospects with the advent of integrated circuits (WW April 1978 — "Mixer") has been observed. Also, the first job of one of his friends, an electronics graduate, with one of our large companies was a hack job of ONC technician level, and responsible to an unqualified time server having no conception of graduate aspirations. This graduate is now in technical marketing. Heigh ho!

For myself, at the age of fifty-one, I feel like Kipling's time expired soldier. "Me! Wot 'as" made major contributions to the radar industry of this country. "Me! Wot 'as" contributed to the technical press and to institution affairs. "Me! Wot 'as..." but the list is so long.

The fact is that the undoubted shrinking of the electronics industry (an unfashionable statement) coupled with social and pay policies acts to discount experience. Young graduates are recruited as short term industrial fodder, bright eyed and bushy tailed with digital technology, having little knowledge of fundamentals, least of all radio techniques, no knowledge of the impedance of a copper conductor or of circuit transit time. As a pointer, Honeywell have recently dropped their high speed CML based computer for lack of ability to cope with the problems of high speed transmission, a lack of fundamental electromagnetic theory (*Computing*, March 16, 1978).

Our industry, sadly, is managed by narrow and small-minded people, themselves work-

ing in slots and unwilling to depart from a rigid job specification, unable to appreciate that an experienced engineer has a breadth of knowledge transcending the limits of a job label. One of our companies has, as a senior general manager, a legal type whose problem solving approach is to decide on the answer and then to gather data in justification. Another has a recruiting policy that requires a recruit, irrespective of experience, to start at the bottom of the salary grade. Only in-house experience is recognised.

To the young electronics engineer I would say be wary, do not succumb to the Myth of Management, broaden your knowledge and seek excellence within a marketable speciality, do not communicate your special knowledge, for the game is personal survival and knowledge is power. This is at variance with normal engineering instinct, certainly with mine, but is offered seriously in the current climate. And do not forget that you will be fifty, one day.

Chartered Engineer A.M.B.I.M.  
(name and address supplied)

---

## HI-FI IMPORTS

Earlier this year a great deal of publicity was given both in your magazine (January 1978 issue) and in the national press to the campaign by Mr Jack Akerman, managing director of the Philips subsidiary Mullard, to keep any further development by Japanese manufacturers out of the UK. The forecast of the ensuing unemployment among British manufacturers, should Hitachi commence operations, was sufficient for the government to send them on their way. Since this action numerous British workers have found themselves out of work from the closure of tv production plants without, it seems, any help from the Japanese.

Now the Philips group and its sister organization, Pye Ltd, have launched two new ranges of hi-fi equipment, into what is already a market overloaded with similar products. One might expect that the manufacturer of these products would provide much needed employment for the workers of the UK, or perhaps on the Continent. No such luck. They are assembled in the Philips plant — in Japan! I leave you to draw your own conclusions.

Michael Hutchinson  
Kings Lynn  
Norfolk

---

## REACTANCE

The drinking driver is such a serious cause of death and suffering on our roads that it is not a source of surprise that electronic cobblers sometimes leave their lasts and want to join in the discussions [*Sidebands*, April 1978 issue — Ed.].

Reaction time, allied with accuracy, has been a subject studied many times over and can be very useful in certain experiments, but it is only a very small part of the overall problem. Many experimenters have demonstrated what we would all expect to happen. Typically, a group of sober mature people are tested with a skill resembling driving a motor vehicle and then the group are given increasing quantities of alcohol. Not sur-

prisingly, as the group gets drunker their performance gets worse.

Because the extraordinarily diverse collection of human attributes such as social consciousness and intelligence which tend to make a driver safe on the roads far outweigh reaction time, one tends to relegate the latter to a small part in laboratory experiments.

When a person is arrested, the police and the police surgeon have to concern themselves with a number of possible circumstances. Of course the "drunk-in-charge" driver and "breathalyser" driver are common enough with no complications, but some of the complicating factors are: driving under the influence of drugs, the presence of concomitant illness and injury or the presence of a disability or mental illness.

Let me quote the kind of case which illustrates. A young man is arrested for driving with high blood alcohol concentration and the circumstances leading up to his arrest are as follows. It is alleged that the driver has taken and driven away a motor vehicle without the owner's consent and has had an accident with the vehicle. He has, so the police say, hit a pedestrian on a pedestrian crossing, the pedestrian having suffered serious injuries. The driver, in swerving the car after the accident, has run into a lamp-post and, because he was not wearing a seat belt, has a severe nose bleed, many small scratches and a bump on his head. The police surgeon discovers during his comprehensive medical examination that the subject is a sufferer from epilepsy and should not hold a driving licence.

What possible valid results could come of attempting to test such a subject for reaction time? Multiple factors could have degraded his mind when considering the results of such a test: alcohol; drugs properly prescribed; drugs improperly taken; head injury; emotional factors because of the circumstances leading up to his arrest.

If every case was straightforward and uncomplicated life would be so much easier for the courts, the police and the police surgeon, but these cases are full of pitfalls.

David V. Foster, G3KQR  
(Police Surgeon and Deputy Coroner)  
Tolworth  
Surrey

## DIRECT PERCEPTION OF RADIO WAVES

I would like to comment on the subject of direct perception of radio waves (Letters, December, February, March and May).

There has been well documented research into this and related phenomena. In his book "Electromagnetic fields and life" A. S. Presman of Moscow University\* describes how A. Frey investigated sound sensations due to radio waves. Briefly, pulse-modulated r.f. will produce, in people exposed to it, buzzing or whistling noises. The sounds are similar to that of noise with the same envelope as the pulses, with all frequencies below 5kHz cut off. It is suggested that this "radiosound" effect, as it is called, is perceived in the auditory nerves, and in the auditory zone of the cerebral cortex.

The field of biological effects of r.f. seems a relatively unresearched one when compared to other fields, yet appears to have enormous

possibilities. The same book describes many experiments that have been undertaken, mainly in the USSR, with applications that range from increasing crop yields (simultaneously retarding weed growth) to bionics, medicine, behavioural control of animals and fish and possibly even telepathy.

As much of the described research seems to use pulsed r.f. for its effects, I wonder if the "Kiev buzzsaw" transmissions that regularly blot out much of the short-wave spectrum are in fact not just a form of radar, as is generally accepted, but something more sinister.

P. J. Quinn  
Romford  
Essex

\* Translated by F. L. Sinclair. English language edition by Plenum Press, New York and London, 1970m.

## RECORDINGS OF WIRELESS TRANSMISSIONS

With reference to Mr E. S. Walker's letter in the April issue, I have an Edison "Voice-writer" Dictaphone which records and plays back from discs similar to those of Mr Walker's. The discs are 7.05in diameter, the central hole is 1.5in diameter, and the thickness 1/64 inch. The groove modulation is transverse, not vertical.

I believe my machine is circa 1950.  
J. C. W. Waghorn  
Crawley  
West Sussex

## INTEGRATED CIRCUIT OF THE 1920s

I was most interested in the letter by Mr T. R. Thompson in the November 1977 issue.

The accompanying photograph is of a complete radio using the 3NF valve. It is not, however, in an operational condition due to the glass pip having been broken (for which any information on how to evacuate and reseal the valve would be appreciated). The supply wires have the appropriate values on them, and it would be interesting to have the radio operating once again.

The history is not known, but similar early wireless equipment, such as crystal detectors, iron filing coherers and other early valves, such as Marconi's W.T. Co. Ltd 2VPF, Ediswan 68530X, were used in experiments



around the 1900s by the Midland Railway Company.

My thanks to British Rail for allowing me to publish this information.

N. Gresty  
Chief Signal and Telecommunications  
Engineer's Laboratory  
British Railways  
Crewe

T. R. Thompson asks for information on the Loewe valve (November Letters). In the early 1930s, I used to make specialised radio items particularly for commercial broadcasting stations. One item was a condenser microphone, a cheap version for hams, and a fully adjustable one for the stations. Because of its very low output, the microphones were supplied with the Loewe tube which could be wired up as a three-stage RC amplifier. Many years later, Radio 2UE retired the microphone and the station's chief engineer and founder, Mr Murray Stevenson, returned it to me as a memento. However, the tube was missing.

P. Levenspiel, VK2TX  
Wyong, N.S.W.  
Australia

## MICROCOMPUTER SIMPLIFICATION

The growing popularity of microprocessors for use in microcomputer systems is very evident from the articles and advertisements in your magazine. When using these computers the most frequently employed high level language is BASIC, though ALGOL60, FORTRAN and COBOL compilers are rapidly becoming available. The majority of the computers sold include some form of ASCII keyboard with possibly a separate numeric keypad as well. In using any high level language the most commonly used groups of characters are those making up the languages' commands, such as LET, GOTO, OR and the mathematical operators \*, + / - and =. It would make sense if these groups of letters could be available at the touch of a key. Thus instead of keying in several letters (or a single letter holding the shift key down) one deft action would input the required string of letters. This would save time and reduce errors. If the letter codes were stored in a r.o.m. then, on changing to another language, a new r.o.m. could simply be substituted for the old one.

Having spent many hours typing in commands at a v.d.u. keyboard, I feel a time saving innovation like this would be very welcome.

M. J. Shepherd  
Wadham College  
Oxford

## CAMPBELL SWINTON

We are endeavouring to gather together material for a biography of the Scottish electrical engineer and broadcasting pioneer A. A. Campbell Swinton (1863-1930) and would be grateful for any information to which your readers might have access.

Ian Mowatt and George Cooper, Department of Humanities, Glasgow College of Technology, Cowcaddens Road, Glasgow G4 0BA.



# Logic design — 14

## Action / status interfaces

by B. Holdsworth\* and D. Zissos† \*Chelsea College, University of London

†Dept of Computing Science, University of Calgary, Canada

The two-wire interface is explained from first principles and clear cut step-by-step methods for the design and implementation of interfaces for action-status equipment are described. For the sake of clarity simple equipment such as paper tape readers, tape punches and printers are used to demonstrate the design steps. It must, however, be stressed that the design steps apply to all types of digital equipment irrespective of their complexity.

THE DESIGN PHILOSOPHY adopted is one that allows the inexperienced user to produce sound and reliable interfaces simply, while at the same time providing the specialist with tools to improve his technique in dealing with more sophisticated assemblies.

### Conventional interfaces

A block diagram of a conventional interface between two devices is shown in Fig. 1. The function of the interface logic is to co-ordinate the activities of the two devices by monitoring their status signals k, m, x and z and generating in the correct sequence the appropriate command signals l, n, w and y.

Any devices, unless they are identical, require a dissimilar set of command signals and a different interface logic configuration will be needed for each data channel, a fact which has contributed greatly to the complexity of interfaces. This has resulted in a great deal of the design effort in recent years being directed towards the development of standard interfaces. A number of such interfaces have been produced, notably the CAMAC interface and more recently the Hewlett-Packard Interface Bus. Several other universal interface schemes are currently under consideration by standards-making organisations<sup>1</sup>. However, for relatively small dedicated systems the above solutions appear to be unnecessarily complex, particularly when compared with the two-wire interface discussed next.

### Two-wire interface

The two-wire interface was developed by Zissos, Duncan and Collins<sup>2,3</sup> and is an alternative approach to the problem. It is based on the fact that interface logic is not required between

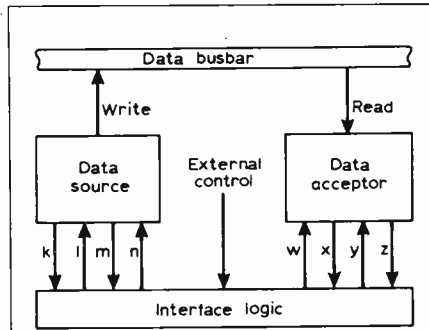

Fig. 1. Conventional interface.

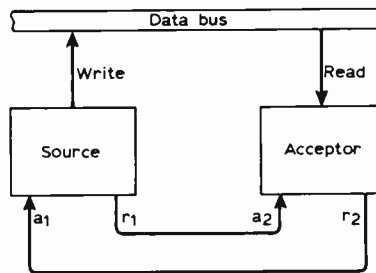

Fig. 2. Two-wire interface.

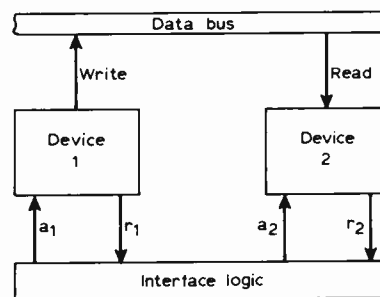

Fig. 3. Interface logic.

two devices that are triggered into action, as shown in Fig. 2. That a pair of action/status devices do not require synchronising logic can be shown by considering the step-by-step design of the logic block shown in Fig. 3, which is used to interface devices 1 and 2. Each device has two terminals, a status terminal r and an action terminal a. On the leading edge of a pulse 'a' the device is triggered into action. While the device is busy, r=0, and when it has fully responded (i.e. it becomes ready), r changes to 1. Activation of the device is not possible when r=0. The interface will be designed to ensure that only one of the two devices is activated at any time. This mode of operation, commonly referred to as the *handshake system*, avoids the need for timing signals.

A suitable state diagram for the interface and the corresponding time diagrams are shown in Figs. 4(a) and 4(b), where  $t_1$  and  $t_2$  are the response times of devices 1 and 2. External control signals have been omitted for the sake of clarity, but will be introduced later.

The step-by-step operation of the system may be described as follows. Assume that device 1 is active ( $r_1=0$ ) and device 2 is dormant or free ( $r_2=1$ ). This corresponds to state  $S_1$  in Fig. 4(a). When device 1 has fully responded, its status signal  $r_1$  changes to 1, thus initiating the  $S_1-S_0$  transition. On assuming state  $S_0$ , action signal  $a_2$  changes from 0 to 1, thus activating device 2, whereupon  $r_2$  changes to 0, causing the circuit to move to state  $S_2$ . The change of the action signal  $a_1$  from 1 in state  $S_0$  to 0 in state  $S_2$  has no effect

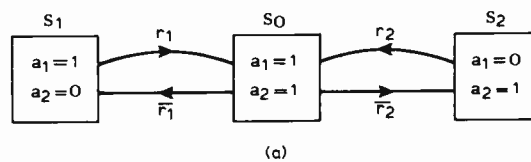
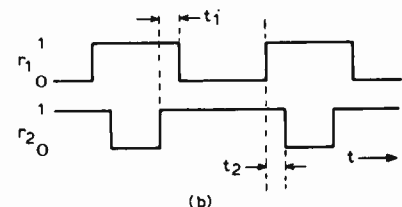

Fig. 4. State diagram (a) and timing diagram (b) for interface.



on device 1, since the devices are triggered on the leading edge of the action pulses, that is, by a 0 to 1 transition. When device 2 has completed its response, status signal  $r_2$  changes to 1, moving the circuit from its current state  $S_2$  to state  $S_0$ . On assuming  $S_0$  the second time, device 1 is triggered into action, causing the circuit to move to state  $S_1$ . As with signal  $a_1$ , the change in signal  $a_2$  from 1 to 0 does not affect device 2. When device 1 has fully responded,  $r_1$  changes to 1 resulting in the  $S_1-S_0$  transition and the cycle repeats itself.

Translating the state diagram into the state table shown in Fig. 5(a) and applying Caldwell's merging rules described earlier in this series<sup>4</sup>, it can be seen that its three rows can be merged into the single row shown in Fig. 5(b).

By direct reference to the reduced state table,

$$a_1 = r_1 r_2 + r_1 \bar{r}_2 + (r_1 r_2) = r_2$$

$$a_2 = r_1 r_2 + r_1 \bar{r}_2 + (r_1 r_2) = r_1$$

Note that  $r_1 r_2 = 0$  because the two devices are never active together. Since optional product  $r_1 r_2$  has not been used in deriving the final expression of  $a_1$  and  $a_2$ ,  $a_1 = a_2 = 0$  in the first square of the reduced table.

The implementation of the above logic equations, shown in Fig. 2, proves that synchronizing logic is not needed for data transfers between a pair of action/status devices.

Clearly all interfaces must be provided with turn-on arrangements for starting the transfer of data between the two devices, and also turn-off arrangements for terminating the transfer of data. These two modes will be designated as 'go' and 'no-go' and they are indicated by  $G = 1$ ,  $G = 0$  respectively, where  $G$  will be referred to as the go/no-go signal.

In order that information is not lost, it is necessary that data transfer which started with a read operation ends with a write operation and vice-versa. If it is decided that the data transfers will always start with a read operation and end with a write operation, the corresponding interface equations are:

$$a_1 = r_2$$

$$\text{and } a_2 = Gr_1$$

Their implementation is shown in Fig. 6(a). Data transfers are started by setting the go/no-go flip-flop and are terminated by resetting it. One method of implementing this is to apply two successive pulses on the clock terminal of a T flip-flop as shown in Fig. 6(b). If the designer wishes to reverse the read/write cycle, then the above equations are rewritten:

$$a_1 = Gr_2$$

$$a_2 = r_1$$

**Front-end logic**

Most devices in practice require a sequence of command signals to operate them and do not therefore

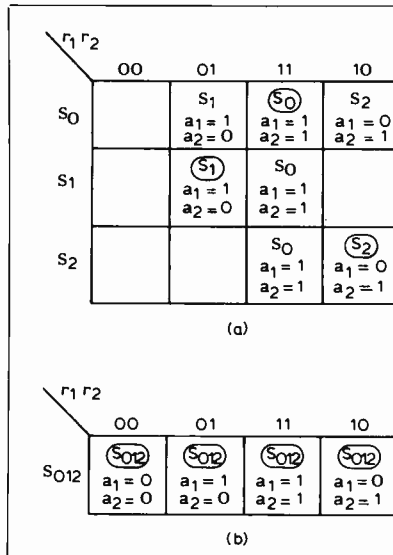

Fig. 5. State table for interface (a) and reduced table (b).

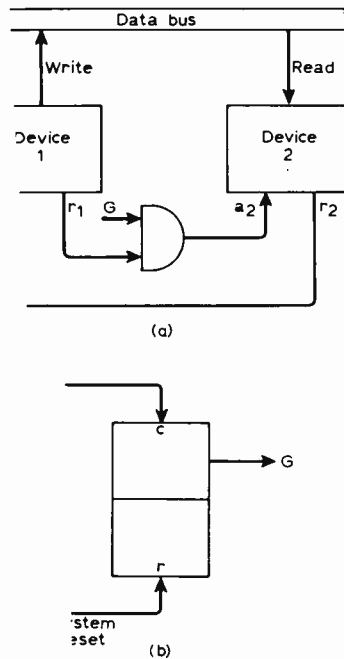

Fig. 6. Two-wire interface (a) and go/no-go generator (b).

immediately fit the action/status model. Such devices can be readily modified and turned into action/status devices by the inclusion of some simple circuitry called the front-end logic. This is basically a sequential circuit that generates, on the receipt of a single action pulse, the correct sequence of command signals required to operate the device, as shown schematically in Fig. 7. In addition, the front-end logic generates the status signal  $r$ . The design of the front-end logic in this diagram follows the established procedures which have been described in previous articles in this series.

The main difficulty likely to be experienced in designing the front-end logic for a device lies in the interpretation of command and status signals. Such an exercise, however, provides the

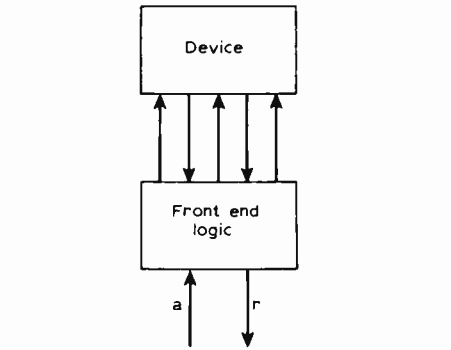

Fig. 7. Arrangement of front-end logic.

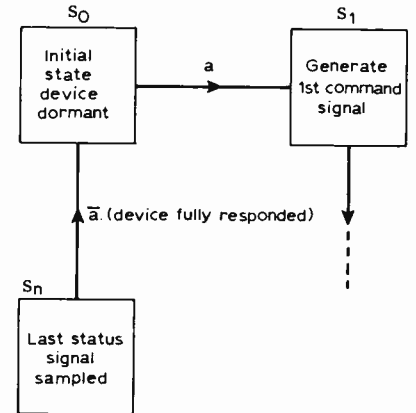

Fig. 8. General state diagram of front-end logic of action/status device.

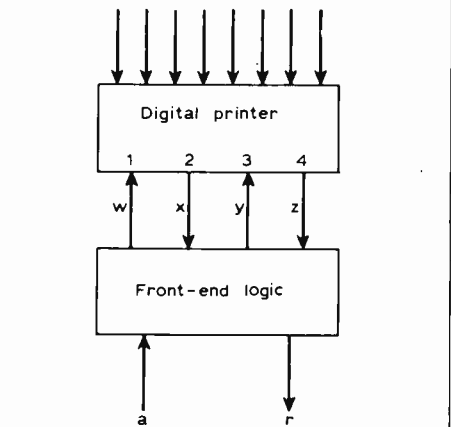

Fig. 9. Block diagram of digital printer.

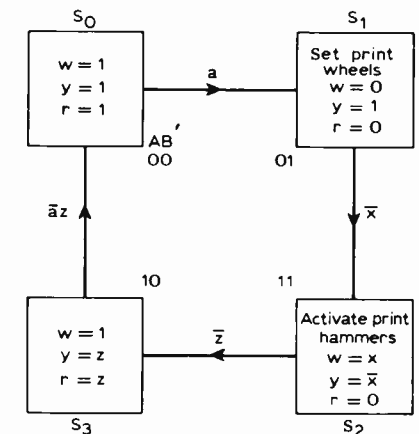
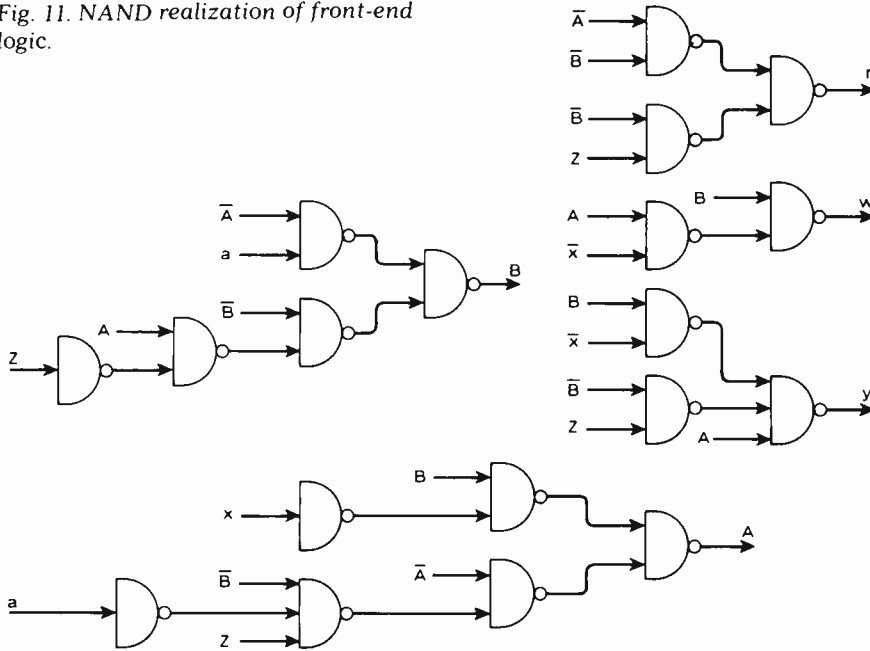

Fig. 10. Internal state diagram for front-end logic of Fig. 9.

Fig. 11. NAND realization of front-end logic.



logic designer with a clear understanding of the operational features and idiosyncracies of the devices to be used.

In order that the input drive requirements of all devices equipped with front-end logic are identical, the action pulse is not used as an input signal to the device, but it is used simply to initiate a transition from  $S_0$ , its initial state, to its next state  $S_1$ , shown in the state diagram of Fig. 8. In state  $S_1$  the first command signal is generated and the corresponding status signals are monitored. When the device has fully responded to the first command signal, the next command signal in the sequence is generated and the process is continued until the device has fully responded to the complete sequence of command signals.

State  $S_0$  is re-entered with signal  $\bar{a}$ . This ensures that the front-end logic responds to the leading edge of the action pulse and allows the device to free-run, by connecting its ready or status signal to its action terminal.

The design of a particular front-end logic will now be demonstrated by means of an example.

**Example.** Design the front-end logic of the digital printer, shown in Fig. 9, whose terminal characteristics are listed below.

Terminal 1: A ground on this terminal ( $w = 0$ ) positions the print wheels according to the input data.

Terminal 2: While the print wheels are being positioned the status signal  $x$  on this terminal is at 0 and changes to 1 when the wheels are correctly positioned.

Terminal 3: Grounding ( $y = 0$ ) terminal 3 causes the print hammers to strike and the paper to advance to its next line position.

Terminal 4: While the print hammers are being activated and the paper is advancing  $z = 0$ , otherwise  $z = 1$ .

In this example  $a, x$  and  $z$  are input signals and  $w, y$  and  $r$  are outputs. A

suitable state diagram for the required front-end logic of the printer is shown in Fig. 10.

In  $S_0$ ,  $x$  and  $z$  are monitored by the front-end logic. If they are both 1 the printer is ready and the status signal  $r = 1$ . When the action signal  $a$  changes from 0 to 1 the circuit makes a transition from  $S_0$  to  $S_1$  and on entering that state the status signal  $r$  is turned off. In state  $S_1$ ,  $w = 0$ , and this is a command signal telling the print wheels to move. As soon as they do so, the status signal on  $x$  becomes 0 and a transition is made from  $S_1$  to  $S_2$ . The wheels carry on moving until the specified position has been reached when  $x$  goes to 1 and  $y = x = 0$ . This is the condition for activating the print hammers and advancing the paper to its next position, and results in the status signal  $z$  becoming 0, thus initiating the transition from  $S_2$  to  $S_3$ . The circuit remains in this state until printing has been completed, the paper has advanced, and the action signal  $a$  has returned to zero, when it returns to the initial state  $S_0$ .

- From the state diagram
- Turn-on set of  $A = B\bar{x}$
- Turn-on set of  $B = \bar{A}a$
- Turn-off set of  $A = \bar{B}\bar{a}z$
- Turn-off set of  $B = A\bar{z}$

$$A = B\bar{x} + A(B + a + \bar{z})$$

$$B = \bar{A}a + B(\bar{A} + z)$$

$$w = S_0 + S_2x + S_3 = \bar{B} + A\bar{x}$$

$$y = S_0 + S_1 + S_3z + S_2x =$$

$$\bar{A}\bar{B} + \bar{A}B + A\bar{B}z + AB\bar{x}$$

$$r = S_0 + S_3z = \bar{A}\bar{B} + A\bar{B}z = \bar{A}\bar{B} + \bar{B}z$$

The NAND circuit implementation of the front-end logic is shown in Fig. 11.

**References**

1. "Universal Process Interfaces," R. Merritt, *Instrumentation Technology*, August 1976.
2. "Logic Free Data Channels," D. Zissos, F. G. Duncan and T. J. Collins, *Electronics Letters*, Vol. 10, No. 17, August 1974.
3. "Logic Free Data Channels," T. J. Collins, M.Sc. Thesis, University of Calgary, 1974.
4. Logic design-3. B. Holdsworth and D. Zissos, *Wireless World*, March 1977.

To be continued

# Laser projection

This month's front cover shows the words "light fantastic" written by an argon-ion laser beam. A scanning technique has been developed from the simple mirror deflection systems used to produce geometric patterns and symbols in laser light shows. Although the principle is quite simple - X and Y galvanometer movements with mirrors to deflect a light beam rather like the XY plates of an oscilloscope - there are some difficult problems associated with the fast scanning that is necessary for long or complex motifs.

At present the frequency limit of a galvanometer movement loaded with a small mirror is around 20kHz. In a practical system this value falls to around 8kHz because a more rugged mirror has to be used to cope with the heat generated by a large 20 to 30W continuous wave laser. Another difficulty with laser scanning is the continuous beam, which can be considered as a pen that cannot leave the paper. For alphanumeric, the characters can be joined together with a line like long-hand writing. For other symbols where this is not desirable, the beam can be speeded up to make the line faint.

Because of the enormous costs of high powered lasers and the ancillary equipment, very few people are developing this technology. John Woolf, an entrepreneur already well known for his activities with "The Who" rock group and, more recently, Holoco, a company dedicated to research and development in holography, has pioneered laser projection in the UK. A new company called Laser Command has been formed to offer a laser projection service such as an advertising scheme planned for Piccadilly Circus in London. For this venue an argon and a krypton laser will project their beams 120 metres onto a 27 x 8 metre screen.

Due to the complexity of the galvanometer drive electronics, a computer based system has been developed to control the laser programme. This package, designed by Integrex Ltd., uses a Z80 microprocessor and a floppy disc store which loads data into a large r.a.m. The XY information is turned into galvanometer drive voltages by d-to-a converters, while other instructions such as enlarge, turn, change motif, also stored on the disc, are used to control the programme.

After the Piccadilly installation has been completed, John Woolf has plans to light up several other sites in the UK and Europe.

If this venture is a success and the initial investment of around £400,000 is recouped, future developments may include the projection of holograms, and animated pictures using laser beams. The possibilities are almost limitless when the financial budgets of advertising agencies are considered together with the amount of street advertising space currently in use.

# Time coded transmission

## Details of the additional slow code

SINCE publication of the time code clock design, August, September, October 1976 and June, July 1977, a "slow code" has been added to the 60kHz transmission from MSF Rugby. Fig. 1 shows the original fast code which takes 330ms from the minute marker. The new code starts at second number 17 and extends to second 59. A logic 0 is denoted by the carrier break of 100ms, and a logic 1 is denoted by a carrier break of 200ms. Parity bits and a BST bit are denoted by carrier breaks of 100ms but displaced by 200ms from the start of the seconds interval as shown in Fig. 2. A minute identifier sequence of 01111110 is

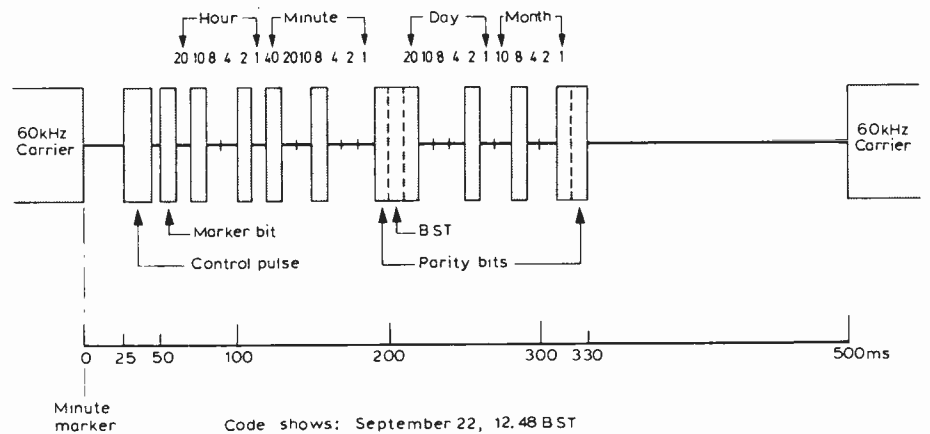

Fig 1

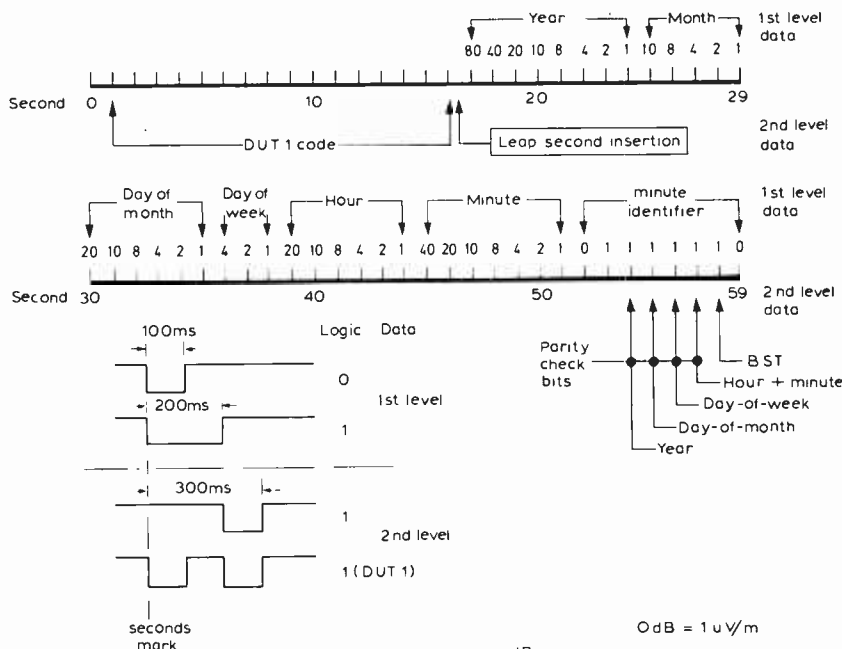

Fig 2

always transmitted from second 52 to 59 which enables a positive identification of the minute to be made. The transmitted data is based on the civil time scale currently in use where BST = UTC + 1 hour. As can be seen from the diagram, year, month, day-of-month, day-of-week (Sunday is 0), hour and minute are transmitted and this information corresponds to the next minute marker.

The graph in Fig. 3 shows an estimated field strength trace from Rugby. The power supplied to the antenna is about 120kW but due to losses in the system the e.r.p. is approximately 50kW. Although the useful range is around 1000m, reports of signal reception have come from as far as Newfoundland.

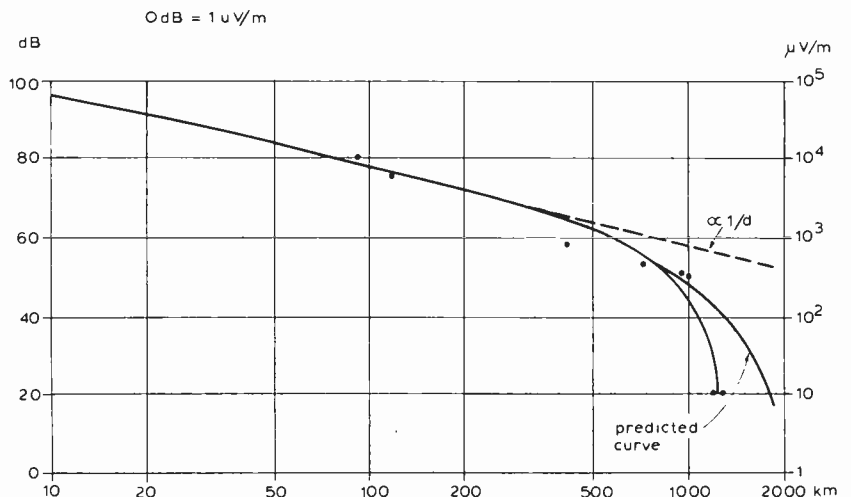

Fig 3

continued from page 47

and III, but is able to reach no conclusions: "At this stage it is too early to say what the future of Bands I and III will be since a decision on the United Kingdom position has still to be taken. However, whatever position the United Kingdom adopts it has to be recognised that many European countries may want to retain broadcasting in these bands and that the international consensus of views at the 1979 WARC will determine the outcome . . . If the v.h.f. television bands were to be given up in the United Kingdom, the availability of the bands for our mobile services would be severely restricted if the broadcasting services of neighbouring countries did not also surrender the bands." There is likely to be pressure to increase the broadcasting Band II up to 104MHz, but not up to 108MHz.

#### 108-470MHz

No action. "Criticisms have been made that there is wasteful use of the band 108-136MHz occupied by the aeronautical services, and of the band 225-400MHz which is reserved mainly for defence purposes. These criticisms do not appear well-founded." Aeronautical channels were already being reduced to 25kHz and could not be reduced further. "Regarding the defence band, a thorough examination is being made but with the continued national importance of the requirement, together with the inter-relationship with European countries, there would appear to be little prospect of satisfying any of the land mobile requirements identified [above] at this part of the spectrum."

#### 470-960MHz

No change. Any proposals would be concerned with the long term, in frequencies above 854MHz.

#### 960-2700MHz

The amateurs should be allowed extra space for their amateur satellite sub-band, and keep their existing allocations. Maritime mobile satellite and radionavigation satellite allocations ought to be increased but "overwhelming pressure from other services" prevents an increase for aeronautical mobile satellite services. Frequencies for the development of coded response secondary maritime radar should be found slightly lower in the spectrum. Tropospheric scatter systems should be kept clear of satellite broadcasting frequencies, but the 1.9-2.3GHz band should cater for foreseen tropo requirements to the end of the century. Few changes will be required for electronic newsgathering links.

The paper notes that no contributions were received on space research in this part of the spectrum. Provision would be made for this, as well as for "passive space research and earth exploration satellites in radio astronomy bands, taking advantage of their sharing compatibility, and to increase and strengthen the radio astronomy provisions". It also says "considerable attention is being given" to satellites beaming solar power to earth by microwave.

#### 2700-10500MHz

Two sub-bands at 4 and 6GHz for fixed satellite feeder links to maritime mobile satellites, and an amateur satellite allocation, but within the existing amateur band at 10GHz. Amateurs may lose some frequencies in this section. The Home Office seeks to limit deep space research in this section to allow

"other research activities nearer the earth" which are not specified. In general, there is no proposal to increase the allocation for radar, or give ISM any extra frequencies.

#### 10.5-15.4GHz

Fixed satellite allocations should be increased, particularly for Intelsat. 1GHz in each direction of transmission should be available within the section. Broadcasting satellite feeder links are being considered near 11GHz. Other changes include allocations for passive earth exploration satellites and space research services in radio astronomy bands.

#### 15.4-38GHz

Improved allocations for the fixed satellite services to provide feeder links for broadcast satellites, and extra intersatellite allocations to meet growing Intelsat requirements. Passive space research and earth exploration satellite allocations will be provided in some radio astronomy bands. The replanning of the band for likely future developments should take account of the need for transportable television links and outside broadcasts.

#### 38-275GHz

Intersatellite services should share with such terrestrial applications as intra-urban links. High atmospheric attenuation should allow for considerable frequency re-use. Allocations include fixed and mobile satellite services, one band for the broadcasting satellite service, terrestrial communications, and amateur and amateur satellite services. Allocations are proposed up to 135GHz, but above that there would be quiet bands, and there would be no allocations above 275GHz.

The Home Office paper says that the geographical dimension of the table, wherein the world is split into three regions, and its frequency dimension is a construction which "has stood the test of time and should continue". As we noted in April (p.51) the developing countries are likely to attack this assumption.

The introduction to the paper seems keen to defuse any controversy over the proposals for land mobile radio. It says that operational provisions for the various mobile radio services will be revised by further conferences to be held late in 1981 or early 1982. The frequency table does not distinguish among various classes of radio user, such as civil or military, or among the different elements within the same service, such as between controlling equipment in base stations and that in the mobiles, or between paging and message handling. The task of selecting and assigning such classes and uses belongs to each national administration. In a footnote, the paper says, "A number of the contributors who commented on the land mobile service made detailed technical comments concerning recommended channel spacing, methods of working, etc. These matters are for national consideration after the conference."

It is a matter of great rejoicing that the Home Office have published anything at all. While they are to be congratulated there are still some reasons for concern. The first, simple point is that we are no nearer learning what the Home Office has in mind for the UK. That, at least, should be public knowledge with or without WARC 1979. The second point is that the sources of information remain almost entirely anonymous. It seems quite unsatisfactory to accept the views of those who are not prepared to say who they are or why they express those views.

Worse, though, is the Home Office's eagerness to be on the winning side. We do not expect our representatives to put forward proposals that have no hope of success, but neither do we elect Home Office ministers to act as honest brokers at international meetings. That is the job of the Foreign and Commonwealth Office. The Home Office should be pressing as hard as it can for proposals on which the British people have previously agreed. Instead the document constantly refers to gaining the support of other countries, particularly those in Europe, for the Home Office's proposals before the WARC has even met. It is after this consultation process that the Home Office intends to publish its submission, passing it off as that of the United Kingdom.

The most glaring example of this absurdity is the absence of any proposal at all for the re-engineering of Bands I and III. In this case the Home Office is unwilling to follow the logical course and insist that those bands be cleared for more efficient use, preferring instead to wait and see what the Europeans decide. We can be absolutely certain that those countries will not choose the same approach; if they did no decision would be reached at all.

Yet the Home Office's apparent concern for European unity collapses when the small ISM interests ask for an extra provision at 433MHz to bring them into line with some European countries; their case, say the HO with peerless pomposity, "has not so far been sufficiently substantiated". Inside Waterloo Bridge House, it would seem, the only sound to be heard is the faint rustle of ties being straightened for the 1980 New Year Honours ceremony at Buckingham Palace.

\* *Preparation for the World Administrative Radio Conference 1979, published by the Home Office Radio Regulatory Department. The publication is the result of a decision by the Home Secretary, announced in the Commons on May 10.*

#### News in brief

The technical sessions at the seventh **International Broadcasting Convention** at Wembley from September 25 to 28 will cover the following topics: microprocessors and minicomputers in broadcasting; point to point transmission; video signal origination and processing; transmitters and transposers; video and audio recording and storage; transmitting antennae; satellites in broadcasting; teletext broadcasting systems; stereo and quadraphonic sound systems; teletext sub-titling systems; new broadcasting systems; future possibilities in radio receiver design. All papers will be available to delegates on registration.

**Breadboard '78**, an exhibition of "kits and bits for the home electronics enthusiast", will be held at Seymour Hall, London W1 from November 21-25. Two thirds of the available space had been sold by the beginning of May. **Ritro Electronics** and Surrey Electromaterials are holding two seminars on anti-static materials, at Maidenhead on July 3 and Bristol on July 5. Details from Ritro at Maidenhead. **The IEE** have published papers from conferences on maritime aeronautical satellite communication and navigation, and communications equipment and systems. conference publications 160 and 162 respectively.

# The Telemobiloscope

An Edwardian radar

by V. J. Phillips Ph.D., B.Sc(Eng)

University College, Swansea

If one were to ask the proverbial man-in-the-street when radar was invented, and by whom, he would probably reply that it came into being sometime around the date of the second world war, and was the work of Watson-Watt and his colleagues. In the sense of producing a reliable operational device this answer would indeed be correct, but the average person is usually most surprised to learn that the first working demonstration of radar seems to have been given in 1904 by one Christian Hülsmeyer of Düsseldorf. His device was not known by that name of course but was called the Telemobiloscope. This article outlines the invention and relates it to other early devices.

MANY of the text-books on radar refer to the fact that Heinrich Hertz had demonstrated during the course of his classic experiments (1886-8) that metallic objects reflect radio waves. Some mention that related techniques were being used during the 1920s to measure the height of the ionosphere by reflection of radio waves, either by phase-shift measurements on the received signal or by pulse techniques. Naturally these experiments had nothing to do

with navigation or the avoidance of collisions at sea.

The chance observation in 1922 of Taylor and Young, who noticed that the movement of ships on the Potomac river caused phase-shifts in radio signals received nearby, usually gets a mention, as do the words of Marconi who, during the course of a lecture to the Institute of Radio Engineers, in New York in June 1922 said:

"It seems to me that it should be possible to design apparatus by means of which a ship could radiate or project a divergent beam of rays in any desired direction which rays, if coming across a metallic object such as another steamer or ship would be reflected back to a receiver screened from the local transmitter on the sending ship and thereby reveal the presence of the other ship in fog or thick weather. One further advantage of such an arrangement would be that it would be able to give warning of the presence and bearing of ships even should these ships be unprovided with any kind of radio."

Fig. 1. Hülsmeyer's first patent. Parts identified by letters are described in the text.

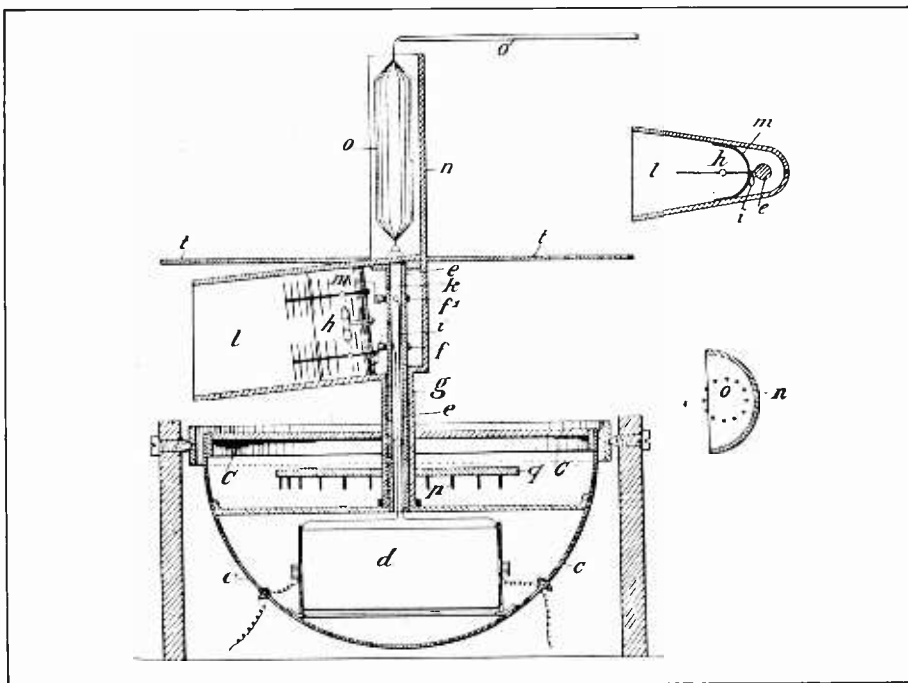

The general impression usually given is that the germ of the idea appeared in the 1920s but that nothing much was done about it until the following decade. Very few books mention the earlier work of Hülsmeyer\*.

The matter was brought to my notice by a short note in the *Electrical Magazine* of 1904<sup>1</sup> which is a report of

"apparatus brought out by Mr Hülsmeyer of Düsseldorf and demonstrated to the North German Lloyd. The new invention is based on the principles of wireless telegraphy and is intended for viewing ships and metallic objects at sea. In wireless telegraphy the transmitter and receiver are used separately on different ships, but are both on the same ship with the telemobiloscope. The electric waves, not being able to reach directly the receiver, must be reflected by metallic objects on the sea (that is ships) so as to arrive at the receiver on a broken path. The advantage afforded by this invention is mainly that ships fitted with the transmitter and receiver will be able to view any other ship devoid of these apparatus. It will even be possible to inform the captain on the bridge in the case of distances ranging from 3 to 5 km of the position of an approaching ship to enable him, when luminous and fog signals fail, to alter his vessel on the right course so as to avoid accidents in time. Experiments made so far on small instruments designed for shorter distances have given every satisfaction."

Hülsmeyer was granted British Patent No. 13,170 on his apparatus in 1904, and in the same year he was granted a further patent, No. 25,608, embodying certain improvements on the original device. The drawing of his first patent is reproduced here in Fig. 1. An induction coil *d* contained in the hemispherical bowl *C* generates a high voltage which is fed up inside the hollow shaft *e* to two slip rings *f* and *f'*. Two brushes *k* and *i* bearing upon these rings convey the voltage to a Hertzian spark transmitter. This appears to be of the type which is often known as a Righi spark gap, consisting of four balls, the inner two being enclosed in oil which has the effect of quenching the spark after a short time. Two rods, with

\* The Encyclopaedia Britannica and the book "Radar System Engineering" by L. N. Ridenour (McGraw Hill 1947) are two exceptions.

cross-pieces, are fixed to the outer balls. The capacitor formed by the gap and rods is charged by the coil and when the voltage is sufficiently large a spark occurs which effectively causes it to be discharged through the inductance associated with the rods. The result is a damped oscillatory flow of charge, the associated electric and magnetic fields causing the emission of a pulse of r.f. By means of a reflector *m* and a shaped tube or funnel *l* these radiations are emitted in one direction only. The reflector and funnel are also shown in plan view in the small drawing at the top of Fig. 1. In the words of one of Hülsmeyer's patents it forms

"a projector which throws the electric waves in the form of a cylindrical bundle."

The funnel *l* is mounted on the outer tube *g* which enables it to be turned to point in any desired direction. Above this spark transmitter, and screened from it by the metal plate *t*, is the receiving aerial *o*. A semi-circular screen *n* rotates with the transmitting funnel so that the aerial is affected only by signals arriving from the appropriate direction. It also screens it from unwanted interfering signals from other directions.

The whole arrangement is mounted in gimbals to combat the motion of the ship. The receiving aerial is connected by wire *o'* to a coherer-type receiver. For those readers who may not be familiar with the coherer it is illustrated in Fig. 2. It was found in many different forms but essentially it consisted of a mass of metal filings lying between two metal plugs, the whole being contained in a glass tube. Normally the mass of filings exhibits a very high electrical

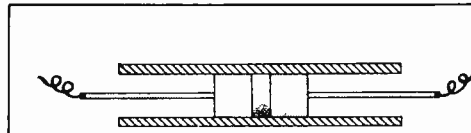
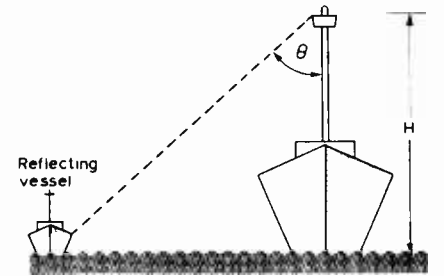

Fig. 2. Basis of the coherer, which was used as a detector in the radar.

Fig. 3. Trigonometrical principle of estimating the distance of a reflecting vessel. *H* is the height of the radar aerial.



resistance but when a voltage such as that induced in the aerial is applied across the plugs the resistance drops very markedly. This change in resistance can be sensed by connecting a battery, in series with a galvanometer or telephone receiver, across the device. The coherer remains in this low-resistance condition until it is mechanically disturbed and so it was customary to provide an automatic tapper to shake it back to the high resistance condition and prepare it for the reception of another pulse of voltage from the aerial.

It was suggested in Hülsmeyer's specification that in operation the whole apparatus would be rotated slowly in a stepwise manner by a clock-work or electric motor acting on cog-wheel *q*. When a signal was received

this gave an indication of the direction of the reflecting vessel. As a further convenience it was suggested that the officer who would be sitting in his cabin listening to the signals might be provided with a remote indication of the direction in which the transmitter was pointing at any time.

The apparatus described so far is only able to indicate the direction from which the signal is coming. In his second patent Hülsmeyer suggested making use of the fact that if the height *H* of the aerial is known together with the vertical angle  $\theta$  (see Fig. 3) from which the reflections are arriving, then it is a matter of simple trigonometry to determine the distance of the reflecting vessel. Two devices are described in this patent, the first (shown in Fig. 4) being a simple modification of the previous apparatus. A horizontal rod *Q* is mounted on the screening plate *t*. A weight *G* can be moved along this rod, causing the whole transmitter to tilt in the gimbals. The transmission can then be beamed at any vertical angle  $\theta$  and, if desired, the rod can be calibrated directly in terms of distance. It is not really clear from the patent whether the receiving aerial is also on tilt, or whether it is mounted separately. The weight is moved until the received signal is greatest and then the distance may be read off the rod directly.

Fig. 4. Hülsmeyer's first modification; to allow the transmission to be beamed at any vertical angle.

The second modification is rather more complicated, and is shown in Fig. 5. Two lenses, *R* and *S*, are mounted in the transmitter tube. (There is nothing in the patent on how these lenses are constructed or on what material they are made of.) The tops of the lenses are connected to the threaded pieces *U* and *V* which project through a slot and engage with the threaded rod *V*. The bottoms of the lenses are connected by the bar *X*. Rod *Z* sliding in guide *Y* is connected to the centre of *X*. As the screw thread turns the lenses will be tilted but will still remain parallel to each other. The radiations, it is stated, will then be emitted at a vertical angle which may be varied. When the lenses are not required they may be parked in the position shown in dotted lines, presumably by pushing in the rod *Z*.

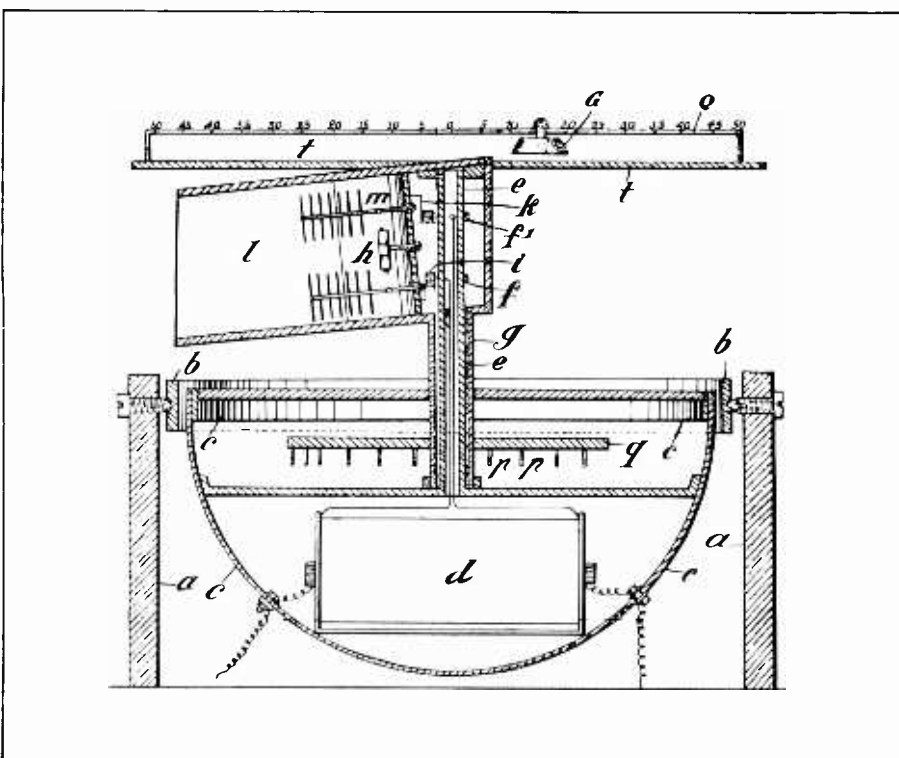

The limitations imposed upon this invention by the technology of the day are very apparent here. Quite apart from the vagueness about the construction and action of the lenses in Fig. 5, how was one to determine the vertical angle of the maximum signal? The coherer was really only capable of giving a simple yes/no indication. Under carefully controlled laboratory conditions it was sometimes possible to obtain a quantitative measure of the strength of the signal from the resistance in the cohered state, but such an indication was far too unreliable to be of any use operationally in an environment such as that aboard ship. Many writers on the subject of coherers, the present author included<sup>2</sup>, testify to the extreme sensitivity of the device to the slightest mechanical vibration. Some workers with them<sup>3</sup> were reduced to making their measurements at dead of night to avoid disturbance from people walking about the building. What hope was there aboard ship with the engines thumping away and the whole vessel bouncing up and down on the waves?

Again, how was one to ensure that the height  $H$  in Fig. 3 remained constant, since the ship would be moving vertically up and down on the swell in addition to the other motions which the gimbals attempted to counteract. Perhaps one ought not to be too pessimistic here when one remembers that in a thick fog the sea is often calm.

Anyhow, whether from indifference on the part of the maritime community or simply from the limitations of the technology, the idea never caught on and, if you will pardon the phrase in the circumstances, seemed simply to sink from sight. Let us acknowledge, however, that if the report in *The Electrical Magazine* is to be believed the device seems to have worked to some extent. It must, therefore, be counted as the first attempt to use the phenomenon of reflection in a practical way for purposes of navigation. One is tempted to say that it must also be considered as the first *pulsed* radar since the emission was in the form of short damped pulses of r.f. Perhaps this is overstating the case, though, as no attempt was made to time the arrival of reflections as in the subsequent development of radar proper. I wonder whether it is just possible that, seventy-odd years later, there might be someone who has some first-hand knowledge of these trials or might perhaps remember a colleague reminiscing about them?

As a footnote to this story it is perhaps of interest to mention that a patent was granted to John Logie Baird (none other) in 1928<sup>4</sup> for a method of "seeing in darkness by utilising radiation outside the visible spectrum". His proposal is illustrated in Fig. 6. Object 6 is "illuminated" by radiation from the spark transmitter 2. The scene is then viewed by one of his normal television scanning discs 8, a radio aerial 10 being substituted for the photo-cell used when

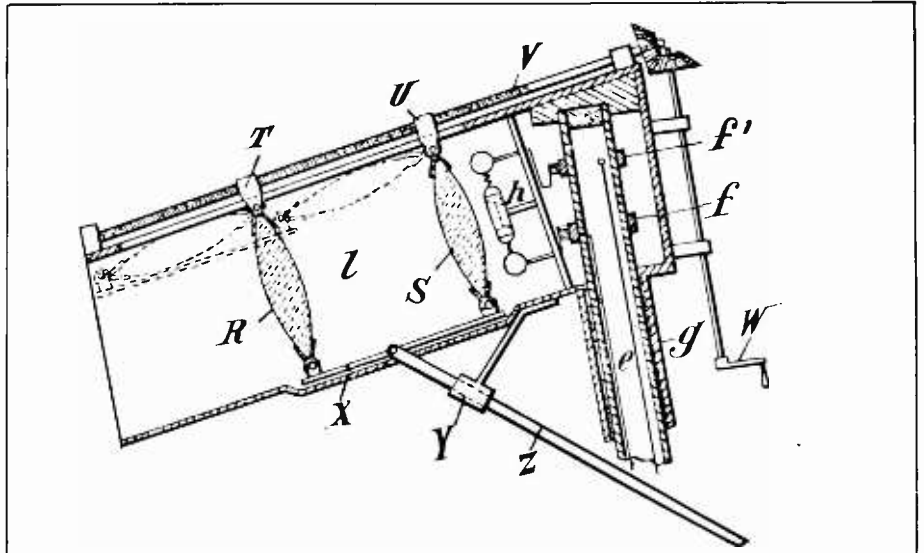

Fig. 5. Second modification, for tilting lenses to vary the vertical angle of the transmission.

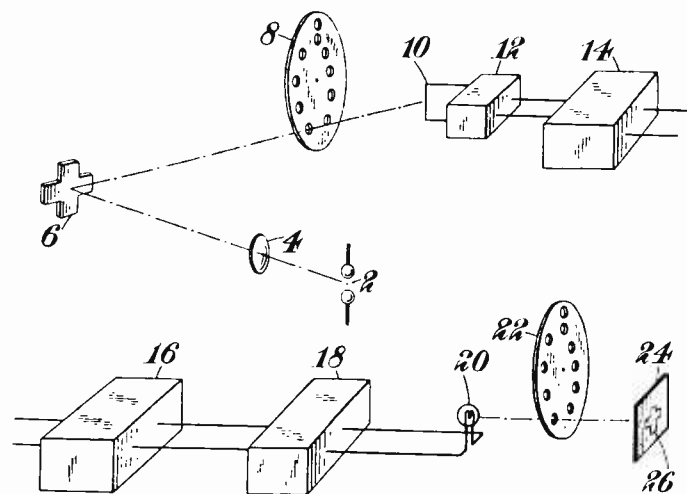

Fig. 6. Baird's patented proposal for "seeing in darkness."

illumination was by visible light. A detector 12 is followed by various amplifiers which vary the brightness of lamp 20. The disc 22 then reconstructs the image as in his television receiver.

Two further points are of interest here. The first is that Baird was also granted an almost identical patent<sup>5</sup> which proposed using infra-red radiation for illuminating the object. The second point is that the transmitter shown is a simple Hertzian spark gap, although by that time generators of continuous r.f. were readily available. It is difficult to see how a simple spark transmitter which essentially produced pulses of r.f. would be compatible with a continuously rotating scanning device.

In view of all the controversy which has recently surrounded the work of Baird one is very reluctant to stick one's neck out too far, but let me just say that I know of no practical demonstration of this apparatus having been given, and from the details in the patent I would be most surprised if it ever worked. □

### Acknowledgement

The patent drawings are reproduced by permission of the Controller of Her Majesty's Stationery Office.

### References

1. "The Telemobiloscope", *The Electrical Magazine* (London) vol.2, 1904, p.388.
2. Phillips, V. J., "Some filings-coherer experiments," I.E.E. Weekend meeting on the History of Electrical Engineering, Manchester, July 1975.
3. Taylor, A. H., "The coherer - a review," *Physical Review* (New York) vol.16 No. 4, April 1903, p.199.
4. British Patent No. 292,185.
5. British Patent No. 288,882.



# MK14-the only low-cost keyboard-addressable microcomputer!

## The new Science of Cambridge MK14 Microcomputer kit

The MK14 National Semiconductor Scamp based Microcomputer Kit gives you the power and performance of a professional keyboard-addressable unit - for less than half the normal price. It has a specification that makes it perfect for the engineer who needs to keep up to date with digital systems, or for use in school science departments. It's ideal for hobbyists and amateur electronics enthusiasts, too.

But the MK14 isn't just a training aid. It's been designed for practical performance, so you can use it as a working component of, even the heart of, larger electronic systems and equipment.

### MK14 Specification

- ★ Hexadecimal keyboard
- ★ 8-digit, 7-segment LED display
- ★ 512 x 8 Prom, containing monitor program and interface instructions
- ★ 256 bytes of RAM
- ★ 4MHz crystal
- ★ 5V stabiliser
- ★ Single 6V power supply
- ★ Space available for extra 256 byte RAM and 16 port I/O
- ★ Edge connector access to all data lines and I/O ports

### Free Manual

Every MK14 Microcomputer kit includes a free Training Manual. It contains



operational instructions and examples for training applications, and numerous programs including math routines (square root, etc) digital alarm clock, single-step, music box, mastermind and moon landing games, self-replication, general purpose sequencing, etc.

### Designed for fast, easy assembly

Each 31-piece kit includes everything you need to make a full-scale working microprocessor, from 14 chips, a 4-part keyboard, display interface components, to PCB, switch and fixings. Further software packages, including serial interface to TTY, and cassette, are available, and are regularly supplemented.

The MK14 can be assembled by anyone with a fine-tip soldering iron and a few hours' spare time, using the illustrated step-by-step instructions provided.

### Tomorrow's technology - today!

*"It is not unreasonable to assume that within the next five years... there will be hardly any companies engaged in electronics that are not using micro-processors in one area or another."*

Phil Pittman, Wireless World, Nov. 1977.

The low-cost computing power of the microprocessor is already being used to replace other forms of digital, analogue, electro-mechanical, even purely mechanical forms of control systems.

The Science of Cambridge MK14 Standard Microcomputer Kit allows you to learn more about this exciting and rapidly advancing area of technology. It allows you to use your own microcomputer in practical applications of your own design. And it allows you to do it at a fraction of the price you'd have to pay elsewhere.

Getting your MK14 Kit is easy. Just fill in the coupon below, and post it to us today, with a cheque or PO made payable to Science of Cambridge. And, of course, it comes to you with a comprehensive guarantee. If for any reason, you're not completely satisfied with your MK14, return it to us within 14 days for a full cash refund.

Science of Cambridge Ltd,  
6 Kings Parade,  
Cambridge,  
Cambs., CB2 1SN.  
Telephone: Cambridge (0223) 311488



To: Science of Cambridge Ltd,  
6 Kings Parade, Cambridge,  
Cambs., CB2 1SN.

Please send me an MK14 Standard  
Microcomputer Kit. I enclose cheque/  
Money order/PO for £43.55 (£39.95  
+ 8% VAT and 40p p&p).

Name \_\_\_\_\_

Address (please print) \_\_\_\_\_

\_\_\_\_\_  
\_\_\_\_\_  
\_\_\_\_\_ WW / 7

Allow 21 days for delivery.

# Science of Cambridge

WW-010 FOR FURTHER DETAILS

# The Logic Probes

When you see what these new CSC logic probes can do, in such a small size, and at such small prices, there's only one word for it:—

## Amazing!

**LP-1** Unit Price £31.00 • Post & Package £1.50 • VAT £2.60 • **Total £35.10.**

Clip the leads to the power supply of the circuit under test, touch the probe tip to any pin, pad or component and you're in business. The 'HIGH' and 'LOW' LEDs show logic states 1 or 0; if neither come on you've got open circuit, tri-state, signal out of tolerance (or no power!).

The 'PULSE' LED flashes once for any pulse 50nsec or longer, and flashes regularly at 3Hz for high frequency trains. Then, while 'PULSE' is flashing, 'HIGH' will come on alone to show duty-cycles over 85%. 'LOW' alone to show less than 15%, and with both on together duty-cycles can be estimated between 15% and 85% by relative brightness.

In the MEMORY mode, the leading edge (positive- or negative-going) of any pulse will latch a flip-flop on and keep the PULSE LED lit as long as power is applied to the probe. You can catch events that are hard to see even with a high quality scope!

LP-1 is switch-selectable for DTL/TTL and HTL/CMOS circuits.

**LP-2** Unit Price £18.00 • Post & Package £1.25 • VAT £1.54 • **Total £20.79.**

Economy version of LP-1, with the same HTL/CMOS and DTL/TTL capability. 'HIGH' or 'LOW' LEDs function as in LP-1, 'PULSE' catches pulses as short as 300nsec and shows pulse trains as 10Hz blink. When pulsing, 'HIGH' comes on to show duty-cycles above 70%. 'LOW' shows below 30%, both on together show between 30% and 70%. 300,000 Ohm input impedance protects your circuit under test, and the low price brings the advantages of our quick, easy LOGIC PROBE technique to anyone interested in logic circuitry.

**LP-3** Unit Price £49.00 • Post & Package £1.50 • VAT £4.04 • **Total £54.54.**

Super-high speed version, captures pulses as short as 10nsec, and monitors pulse trains as rapid as 50MHz. That's better performance than many oscilloscopes! And no bulky instruments, no set-up time. At frequencies up to 1.5MHz you can estimate duty-cycles by the High/Low relative intensity, as with LP-1. DTL/TTL and HTL/CMOS are switch-selectable, of course, plus 'MEM' memory mode to latch on to any pulse, pulse train or passing transient. LP-3 is the ideal trouble-shooter for your fastest logic circuits, and like all CSC probes is well-designed, handy and easy to use, robust, reliable and individually tested before it leaves the factory.

**And the new pulser DP-1** Unit Price £51.00 • Post & Package £1.50 • VAT £4.20 • **Total £56.70.**

The Digital Pulser, another new idea from CSC. The DP-1 registers the polarity of any pin, pad or component and then, when you touch the 'PULSE' button, delivers a single no-bounce pulse to swing the logic state the other way. Or if you hold the button down for more than a second, the DP-1 shoots out pulse after pulse at 100Hz. The single LED blinks for each single pulse, or glows during a pulse train. If your circuit is a very fast one, you can open the clock line and take it through its function step by step, at single pulse rate or at 100 per second. Clever! And a very reasonable price.

**How to order.** Telephone 01-890 0782 and give us your Access, Barclaycard or American Express number, and your order will be in the post that night. Or, write your order, enclosing cheque or postal order, or stating credit card number and expiry date. (Don't post the card!). Alternatively, ask for our latest catalogue, showing all CSC products for the engineer and the home hobbyist.

(Prices are for UK only. For Europe add 10%, outside Europe add 12 1/2% to total prices.)

Specification	LP-1	LP-2	LP-3	DP-1
Input Impedance	100,000Ω	300,000Ω	500,000Ω	Output Tri State
Minimum Detectable Pulse	50ns	300ns	10ns	Autopolarity Pulse Sensing
Max. Input Signal (Freq.)	10MHz	1.5MHz	50MHz	Sink and Source 100ma
Pulse Detector (LED)	High Speed Train or Single Event	High Speed Train or Single Event	High Speed Train or Single Event	Pulse Train: 100pps
Pulse Memory	Pulse or Level Transition Detected and Stored	None	Pulse or Level Transition Detected and Stored	LED indicator flashes in Single Pulse. Stays lit on Pulse Train

CONTINENTAL SPECIALTIES CORPORATION (UK) LTD  
SPUR ROAD, NORTH FELTHAM TRADING ESTATE, FELTHAM  
MIDDLESEX TW1 40TJW  
TELEPHONE 01-890 0782-TELEX 881 3669 CSC LTD

CONTINENTAL SPECIALTIES CORPORATION



WW — 021 FOR FURTHER DETAILS

REGISTERED IN LONDON 1303780 VAT No. 224 8074 71  
DEALER ENQUIRIES WELCOME

TRADE MARK APPLIED FOR © CSC (UK) LTD 1977

# CIRCUIT IDEAS

## High quality stereo decoder

THE HA 1196 is a relatively unknown stereo decoder IC which can offer a performance beyond the capabilities of the transmitted signal.

In this application a 60kHz low-pass filter is formed around a coil/capacitor pi-network so that virtually no phase error is created. The filter characteristic may be trimmed for optimum performance with the core of the coil.

The input to the "birdy" filter, whose characteristic is shown in the graph, is driven directly from a CA3089E type of output. Input level to the HA1196 is set with the 25kΩ preset to about 200mV which is optimum for an average devia-

tion level of 40kHz. A stereo/mono switch on the chip at pin 12 is designed to operate from the muting output of a CA3089E/HA1137W. When the device is fully unmuted with a carrier present, the muting output goes low, and thus switches the HA1196 to stereo automatically.

For alignment, insert a known stereo transmission, set the input level to 200mV, and adjust the v.c.o. potentiometer until the l.e.d. lights. The stereo separation control, which in fact compensates for phase errors introduced by i.f.s, should initially be set at maximum, and slowly reduced until

optimum separation is achieved. In the absence of a stereo generator, Radio 3 provides suitable test tones after the evening broadcasts.

The de-emphasis shown is for 50μs. For 75μs, capacitor Cd should be 1500pF. The best method of adjusting the low-pass filter is to tune for best separation or best stereo channel balance while listening to a test tone. A correctly adjusted decoder offers a separation approaching 60dB, a t.h.d. figure of 0.15% at 10kHz, and a signal-to-noise ratio of 80dB.

W. S. Poel,  
Ambit International,  
Brentwood, Essex.

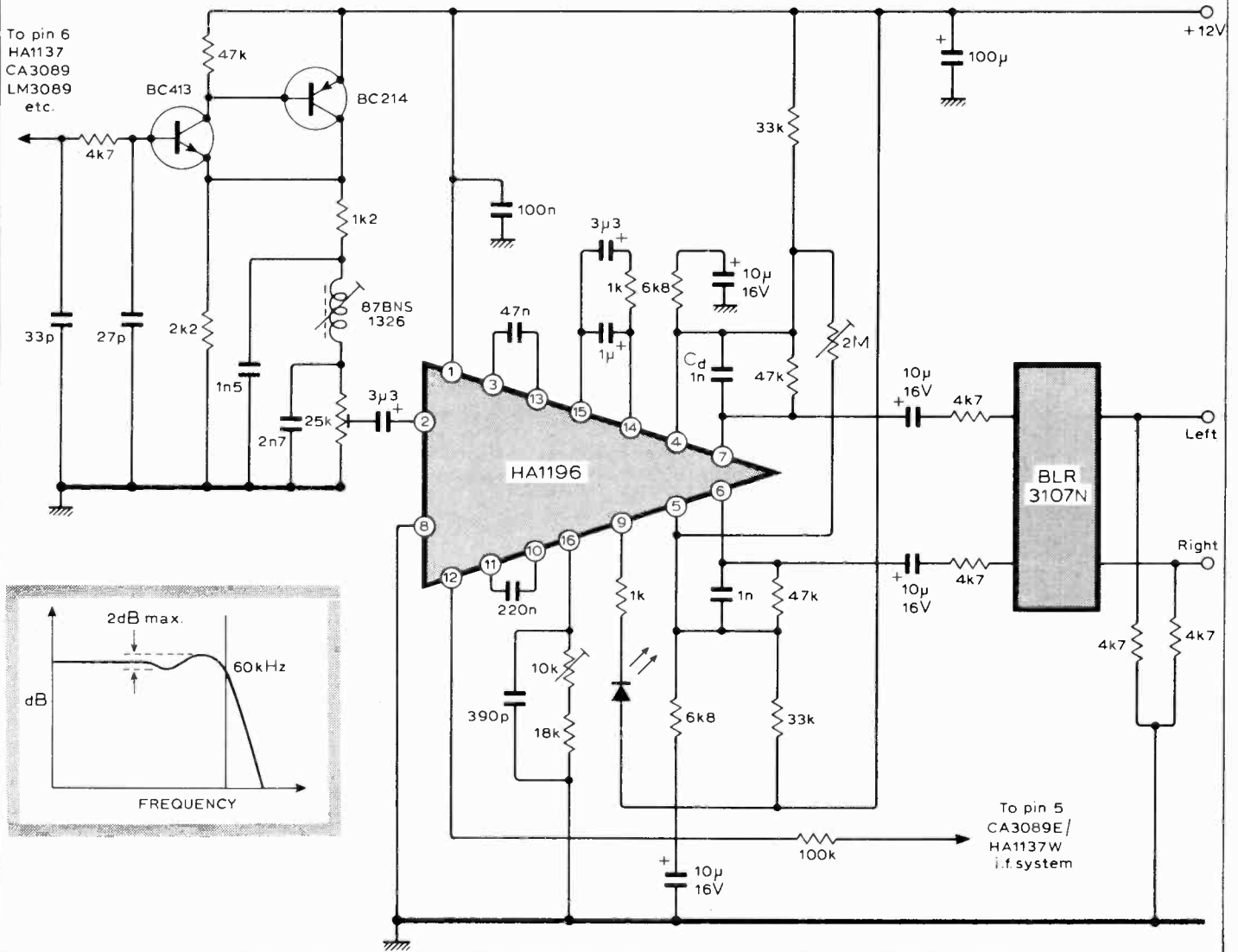

## Audio compressor

GAIN of the single stage virtual earth amplifier IC<sub>1</sub> is determined by the drain-source resistance of the f.e.t. Resistors R<sub>1</sub>, R<sub>2</sub> and R<sub>3</sub> linearise the f.e.t.s V-I characteristic. A control voltage is derived from the output signal by using a precision rectifier and peak detector. Attack and decay times are adjustable by resistors R<sub>4</sub> and R<sub>5</sub>, and with the values shown give time constants of 1 and 517ms respectively.

The two way switch allows the compressor to act as a conventional amplifier by applying a fixed control voltage which may be varied with a potentiometer for a gain control.

In the compress mode, a 29dB change in the input signal level produces a 9dB change in the output.

L. Mayes,  
Ipswich,  
Suffolk.

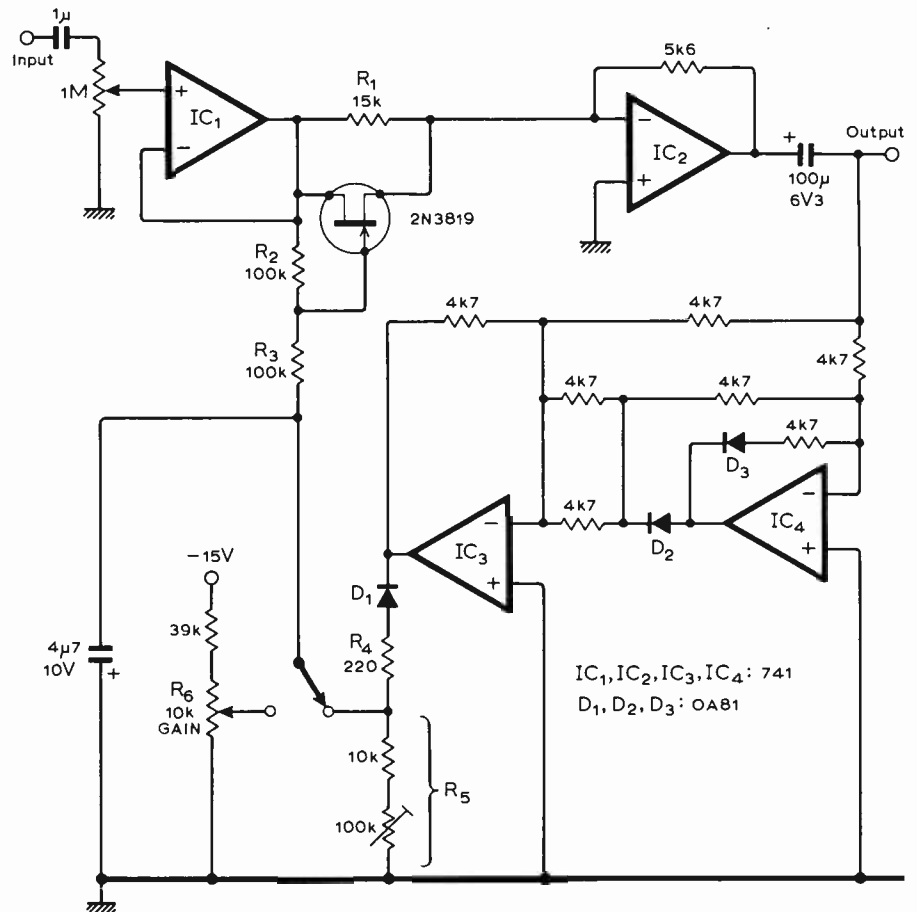

## Low voltage d.c.-to-d.c. converter

A CONVERTER operating from 2 or 3V is not easily made efficient because the voltage drop across the switching device in the on state can be a large fraction of the supply voltage. With a bipolar transistor as the switching device,  $V_{CEsat}$  can be made tolerable by providing a large base current, but this normally leads to extra loss in the base drive circuit. It is possible, however, to place the load in series with the transistor base-emitter junction so that the load acts as a high current base drive circuit and the transistor acts as a rectifier for load current. Both functions are performed without any extra power dissipation. The circuit shows this principle applied to an otherwise conventional self-oscillating converter, with the saving of two diodes. The usual separate base driver winding on the transformer is eliminated, which leaves space for thicker primary and secondary windings. Also, the base current is large and varies with loading. These two factors provide good regulation and high efficiency over a wide range of load currents.

An added advantage of this circuit is that the oscillation ceases if the load is open circuit, which reduces battery

drain to a few microamps. The converter can therefore be controlled by a switch in series with the output. The prototype circuit, supplied from 2 nickel-cadmium cells, delivered 1A at 6V with an efficiency of 75 to 80%. The oscillation frequency was about 10kHz.

It is possible to modify the circuit by changing the transformer windings. If an audible whistle is undesirable, the frequency can be increased by reducing the number of primary turns. This will, however, reduce efficiency because commutation will take a larger fraction

of the time, and the peak  $I_c$  will be higher. The output voltage can be raised by increasing the number of secondary turns. Above about 10V, diodes must be used to protect the base-emitter junctions against reverse breakdown.

A wide range of transistors can be used but they should be selected for low  $V_{CEsat}$  at the design current, and the  $BV_{EBO}$  must be adequate for the design output voltage.

F. Ainscow,  
Winchester,  
Hants.

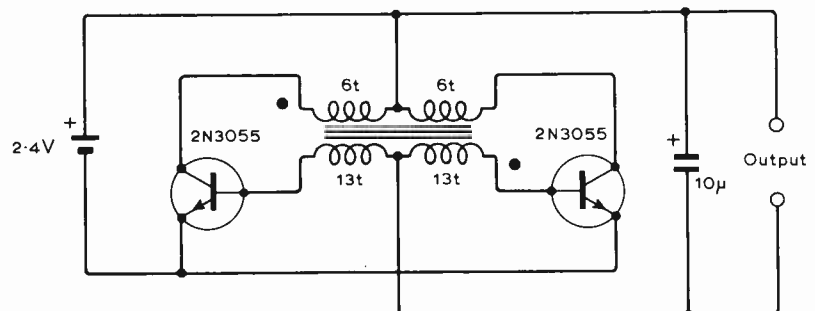

Transformer core: FX2239

# Sound-to-light unit

THIS circuit uses zero-voltage switching to achieve interference-free proportional control of a lamp intensity from a sound source. Both inputs to the AND gate IC<sub>15</sub> must be high for the triac to turn on. One of these inputs comes from the zero-crossing detector IC<sub>1</sub>, Tr<sub>1</sub> and IC<sub>2</sub> which produces a 100Hz series of positive-going pulses. Transistor Tr<sub>1</sub> and the 7413 invert the waveform twice to make it t.t.l. compatible. The other input to the AND gate comes from the filter/rectifier/comparator circuit. The negative-going output of IC<sub>13</sub> provides a signal for the non-inverting input of the comparator IC<sub>14</sub>.

The inverting input of IC<sub>14</sub> is fed from a d-to-a converter IC<sub>4</sub>, which produces a stepped ramp waveform from the outputs of the counter.

is used so that it counts to five before internally resetting. Therefore, the lamp has five possible brightness levels.

Op-amps IC<sub>5</sub> and IC<sub>6</sub> detect when the audio input falls below about 10mV. When this happens IC<sub>7</sub>, IC<sub>8</sub> and IC<sub>9</sub> are released from their reset state and the two 4-bit counters start to count the 100Hz waveform. They are again reset when the audio input next passes the 10mV level. If the input remains below this level for more than 2s, output C of IC<sub>9</sub> is set, Tr<sub>3</sub> is saturated and the triac is turned on until the audio signal exceeds 10mV again. Therefore, the lamp will automatically turn on after the music has stopped. The resistor values listed below are for filters in a three channel system, but more channels can be used if required. The audio input at point I

should preferably have a peak value of around 6 to 10V.

All i.c.s are 741s or equivalent except where stated otherwise. All diodes are 1N4148 types except for D<sub>1</sub> which must be a higher current type. Capacitors C<sub>1</sub> and C<sub>2</sub> are electrolytic types and all others are 100nF polyester. The transistors can be any general purpose n-p-n or p-n-p devices as necessary.

- |                                   |      |        |        |
|-----------------------------------|------|--------|--------|
|                                   | bass | middle | treble |
| R <sub>21</sub> , R <sub>22</sub> | 12k  | 3k3    | 820    |
| R <sub>25</sub> , R <sub>26</sub> | 56k  | 12k    | 3k3    |
| R <sub>27</sub>                   | 1M   | 220k   | 56k    |
- Andrew R. Ward,  
Bath, Somerset.

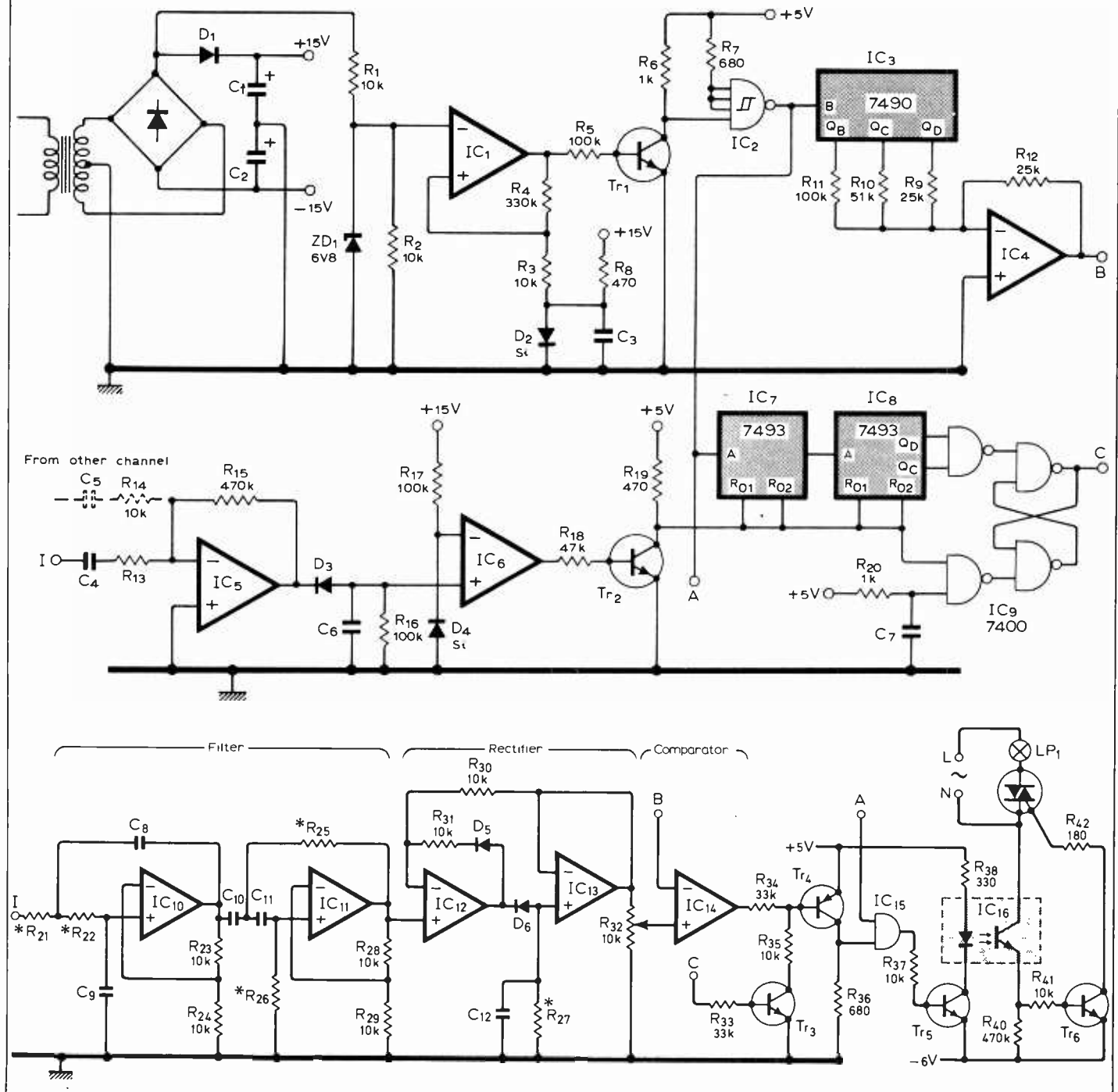

# Audio power amplifier design — 4

## More on feedback stability

by Peter J. Baxandall, B.Sc.(Eng), F.I.E.E., F.I.E.R.E.

The May article ended by discussing Bode's ideal loop-gain attenuation characteristic, which maintains full loop gain up to a certain frequency and then attenuates the gain as rapidly as possible consistently with not exceeding an excess phase shift of  $150^\circ$ . This ideal characteristic cannot normally be realized in practice, and the present article deals with some more realistic techniques.

THE 33dB/decade (10dB/octave) attenuation rate of Bode's ideal characteristic, which must be produced by minimum-phase-shift networks, is assumed to continue to indefinitely high frequencies. In practical multistage amplifiers this cannot be achieved, for the attenuation rate at very high frequencies is determined by unavoidable shunt capacitances and by transistor characteristics. Thus in the absence of circuit elements added for controlling the loop-gain attenuation, it will typically be as shown by curve 1 in Fig. 1. With suitable elements added within the forward path of the amplifier circuit, a close approximation to the Bode Ideal characteristic may be obtained up to a certain high frequency, but above this frequency, as shown by the full-line curve 2, the response inevitably follows curve 1. However, provided the 33dB/decade slope is continued for a sufficient number of dB, marked  $x$ , below unit loop gain, the resultant phase margin will not be very significantly reduced below  $30^\circ$ . Bode showed that in these practical circumstances, the desired  $30^\circ$  margin can be retained, together with the advantage of starting the loop-gain attenuation at a somewhat higher frequency, by adopting the characteristic shown in curve 3. The flat portion between P and Q delays the onset of further phase lag until the loop gain is well below unity. This and related topics are discussed in much greater detail in Bode's book<sup>1</sup>. It should be noted that the definitions of phase and gain margins used by Bode are different from those illustrated in Fig. 7 of my May 1978 article. Bode takes the phase margin as applying at a loop gain which is below unity by the quoted gain-margin figure, usually 9dB. The definition I have given is also in wide-

spread use<sup>2,3,4</sup> and seems more convenient for practical purposes.

It is very rare in the practical design of feedback amplifiers, either for audio or for other purposes, for any great effort to be made to follow accurately the Bode or other similar precepts for achieving full feedback up to the maximum possible frequency. Designs of this type tend to be complex and expensive, containing LCR networks to give the rapid drop in loop gain below the point A in Fig. 1, and the flat between points P and Q, together with staggered transitional-lag networks to give a close approximation to the 33dB/decade slope. Such designs have sometimes been used in critical Post Office repeater amplifier circuits.

The simplest stabilization technique is always to put in one dominant lag to attenuate the loop gain at 20dB/decade (6dB/octave), starting from a corner

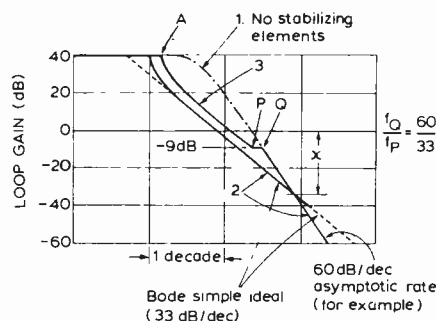

**Fig. 1.** Bode simple and modified loop-gain-attenuation characteristics. See text.

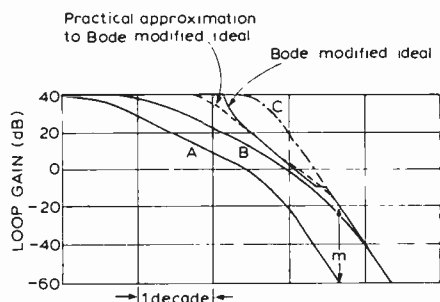

**Fig. 2.** Dominant lag loop-gain-attenuation characteristics compared with Bode modified ideal. See text.

frequency which is sufficiently low to ensure that the loop gain is reduced to unity before the other lags inevitably present at high frequencies have produced too much further phase lag. In a multistage amplifier, the dominant lag is most straightforwardly introduced simply by putting a sufficiently large capacitor across the first stage collector load. This will produce a loop gain characteristic such as that represented by curve A in Fig. 2. The technique is in all respects sub-optimum, and it is important to note that the curve remains below curve C, obtained without any stabilizing elements, even at very high frequencies. This is the inevitable result of using any type of shunt stabilizing network, in the forward path of the amplifier, whose impedance becomes that of a capacitor at very high frequencies. The ultimate high-frequency asymptote position is lowered by  $m$  decibels, as shown in Fig. 2, where:

$$m = 20 \log \frac{\text{total shunt capacitance}}{\text{original shunt capacitance}}$$

The introduction of any network which acts as a three-terminal potential-divider at very high frequencies will have a similar effect.

Clearly, if we wish to attenuate the loop gain in a simple 20dB/decade manner, starting at the highest possible frequency, a characteristic such as that represented by curve B in Fig. 2 must be aimed at. The simplest way to achieve this is to put a series combination of  $C$  and  $R$  across the first stage collector load. The transitional lag introduced by these elements is arranged to "flatten out" in the frequency region where the other lags come in, thus maintaining a fairly uniform rate of loop gain attenuation.

So far a single overall feedback loop has been assumed, with stabilization by means of added passive loop-gain-attenuating circuits within the forward path of the amplifier. Most modern amplifiers, however, incorporate local feedback loops as well as the main overall loop. Nyquist's criterion, in the simple form already given, is applicable to such multiple-loop amplifiers only if the circuit remains stable when the overall feedback loop is broken. How-

ever, it is possible, for example, to make amplifiers in which internal positive feedback is employed to enhance the gain of part of the forward path, and such amplifiers may be unstable when the overall feedback loop is broken. An extension of Nyquist's criterion to cover such cases is described in Bode's book<sup>1</sup>, but in many years of circuit design work involving diverse applications of feedback, I have never had to make use of this more elaborate criterion. This is because:

- (a) Nearly all practical multiple-loop feedback systems employ only quite tame and stable local feedback loops.
- (b) Even if the amplifier is unstable with the overall loop broken at the  $\beta$ -network, it is sometimes possible to break the loop at a different place, within the amplifier's forward path, leaving a stable system.

Thus, in all normal circumstances, one merely uses the closed-loop response of each internal local-feedback "sub-amplifier" as an element contributing to the total forward-path response of the complete amplifier,

arranging matters so that the ordinary Nyquist stability criterion is satisfied for the overall loop.

The advantages of using local feedback, rather than purely passive networks, to tailor the internal responses of a feed-back amplifier, are often very great. One reason is that the local feedback, if applied in enlightened ways, can be exploited, like overall feedback, to reduce non-linearity distortion. Another reason is that local feedback provides a means for modifying the input and output impedances of individual stages so that they may be connected together with little interaction<sup>5,6</sup>. These matters will be considered in greater detail in later articles.

**Stabilizing elements in the feedback arm**

It has been implied so far that  $\beta$  is frequency-independent and that all modification of the loop-gain-attenuation characteristic to secure good stability is done in the forward path of the amplifier. There are usually advantages, however, in including one or more stabilizing elements in the feedback arm, but just what constitutes an optimum design depends upon many

factors, and particularly upon the application for which the amplifier is being designed.

In feedback amplifiers for some non-audio purposes, the aim is to achieve the widest possible bandwidth of flat response, and in such cases the  $\beta$ -arm must have a flat response up to about the unity-loop-gain frequency. Even then it is often advantageous to add a capacitor of quite small value across the feedback resistor as shown in Fig. 3(a), sufficient to cause a little phase advance around the unity-loop-gain frequency and a reduction in the rate of attenuation of loop gain at frequencies above this. This will improve the phase margin and give a better-damped step response.

In an audio amplifier, on the other hand, if other conditions permit, there is no reason why  $C$  in Fig.3(a) should not be made much larger, giving a substantial reduction in the bandwidth of the amplifier above audio frequencies. The use of a more complex double-phase-advance network as show in Fig. 3(b) is also a possibility. In general, if the very lowest distortion up to the highest possible frequency is the requirement, the forward gain should be attenuated as little as possible and the required gradualness of loop-gain attenuation achieved as far as can be managed by arranging for the value of  $\beta$  to increase with rising frequency. Such designs are liable to have a very high frequency of unity loop gain, however, and it is necessary to take particular care over layout and the effects of tolerances in transistor parameters.

A feature of audio amplifiers stabilized on the Fig. 3(a) basis, with a substantial value of  $C$ , is that the step response becomes quite rounded. If, at the same time, the stability margins are rather small, the total step response is liable to be of the type shown in Fig. 4.

Very often the rapidly-increasing rate of attenuation of the forward gain at very high frequencies, with an accompanying large phase lag, prevents the possibility of carrying the technique of stabilization by manipulating the  $\beta$ -network very far, but from a distortion point of view it has everything in its favour.

**Circles of constant gain rise**

The gain of a feedback amplifier is:

$$\frac{V_{out}}{V_{in}} = \frac{A}{1-A\beta}$$

which may be written as:

$$\frac{V_{out}}{V_{in}} = (1/\beta) \times \frac{A\beta}{1-A\beta} \dots (1)$$

Consider now the part of a Nyquist diagram shown in Fig. 5. It is clear that for points on the Nyquist curve in the region of the point (1, 0), the  $A\beta$  phasor  $\hat{O}P$  becomes much longer than the

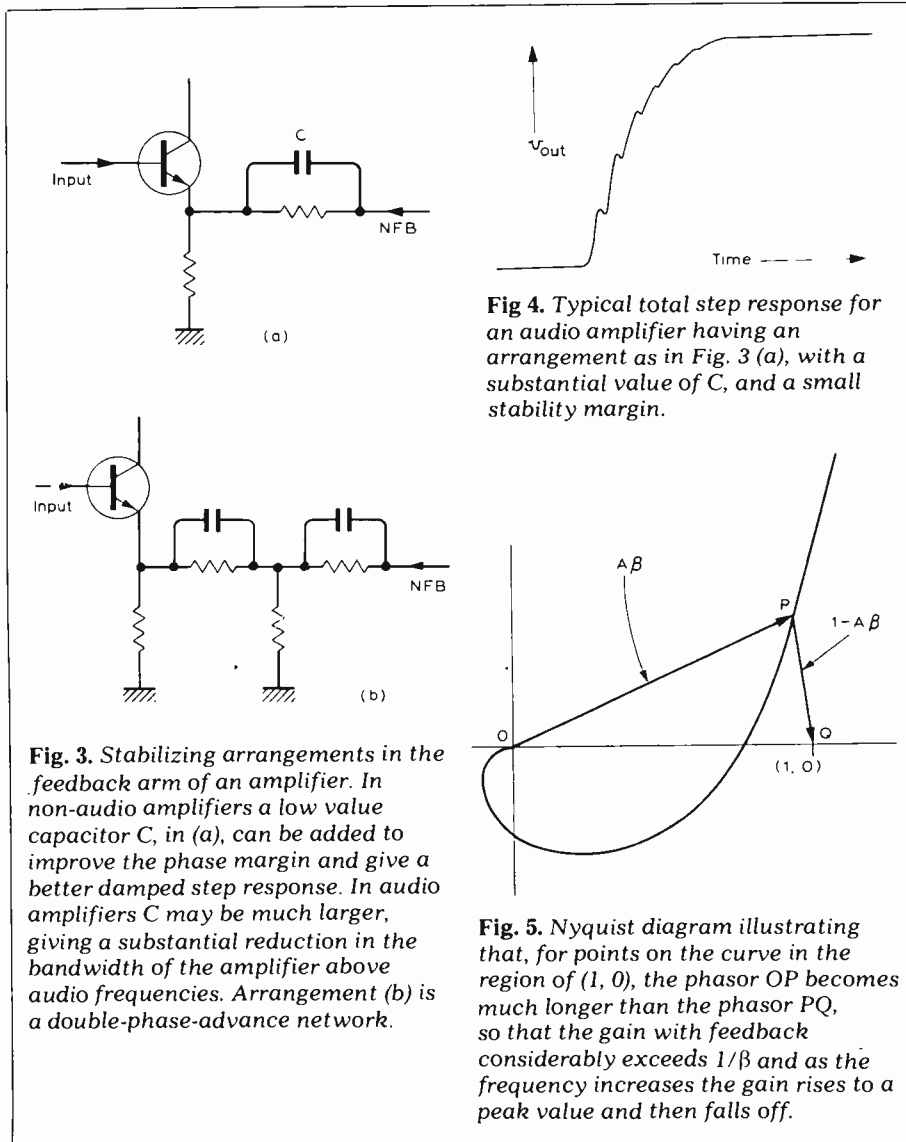

**Fig. 4.** Typical total step response for an audio amplifier having an arrangement as in Fig. 3 (a), with a substantial value of  $C$ , and a small stability margin.

**Fig. 3.** Stabilizing arrangements in the feedback arm of an amplifier. In non-audio amplifiers a low value capacitor  $C$ , in (a), can be added to improve the phase margin and give a better damped step response. In audio amplifiers  $C$  may be much larger, giving a substantial reduction in the bandwidth of the amplifier above audio frequencies. Arrangement (b) is a double-phase-advance network.

**Fig. 5.** Nyquist diagram illustrating that, for points on the curve in the region of (1, 0), the phasor  $OP$  becomes much longer than the phasor  $PQ$ , so that the gain with feedback considerably exceeds  $1/\beta$  and as the frequency increases the gain rises to a peak value and then falls off.

$(1-\beta)$  phasor PQ, so that, from (1), the gain with feedback then considerably exceeds  $1/\beta$ . Thus as the frequency increases and the point P moves down from the top of the Nyquist curve, the gain rises to a peak value and then falls off.

One may draw a set of curves on such a Nyquist diagram, each curve being for a constant ratio of OP to PQ. The simplest of these is a straight line through the point  $(\frac{1}{2}, 0)$ , and if P lies anywhere on this line,  $OP = PQ$  and the gain with feedback is then exactly  $1/\beta$ .

Consider now the curve for  $OP = 2PQ$ , i.e. a 6dB gain rise above  $1/\beta$ . To determine this curve is a typical school geometry problem—"what is the locus of a point P such that  $OP = 2PQ$  everywhere on the curve?". The locus turns out to be a circle, centre  $(\frac{4}{3}, 0)$  and radius  $\frac{2}{3}$ . For other ratios of OP to PQ, the loci are all circles of various radii and centre positions, as shown in Fig. 6. Note that the radial scale in this diagram is a linear one, not a decibel scale as sometimes used. This is quite satisfactory since only a small part of the complete Nyquist diagram has to be drawn.

Given the loop gain and phase information for an amplifier, the relevant part of its Nyquist diagram may be quickly sketched in on Fig. 6, and the magnitude of the high-frequency peak thereby deduced. For the Nyquist diagram shown in broken line as an example, the closed-loop response will be +3dB with respect to  $1/\beta$  at  $f_1$ , will reach a maximum of +9dB at  $f_2$ , and will be -6dB at  $f_3$ , etc. If the  $\beta$ -network does not have a flat response at these frequencies, due allowance must be made for this in deducing the overall closed-loop response, since the diagram only gives response variations with respect to  $1/\beta$ .

Mere inspection of the Fig. 6 circles gives one a pretty shrewd idea of the sort of phase margins to aim at for various types of amplifier application, bearing in mind that the step response is in practice fairly closely related to the degree of high-frequency response peaking — see Fig. 2 of the May 1978 article.

**Maximum phase shift for transitional-lag circuit**

In controlling the rate of attenuation of loop gain in feedback amplifiers, frequent use is made of transitional-lag circuits having one or other of the configurations shown in Fig. 7. The circuits are, of course, equivalent, since the combination of  $R_1$  and  $I_{in}$  in Fig. 7(a) may be replaced by a voltage source  $I_{in}R_1$  acting in series with  $R_1$ . The circuits give no phase lag at zero or infinite frequencies, but contribute a phase lag which reaches a maximum value at the geometric mean of the two corner frequencies given in the table on page 44 of the March 1978 issue. The larger the ratio of  $R_1$  to  $R_2$  the larger is

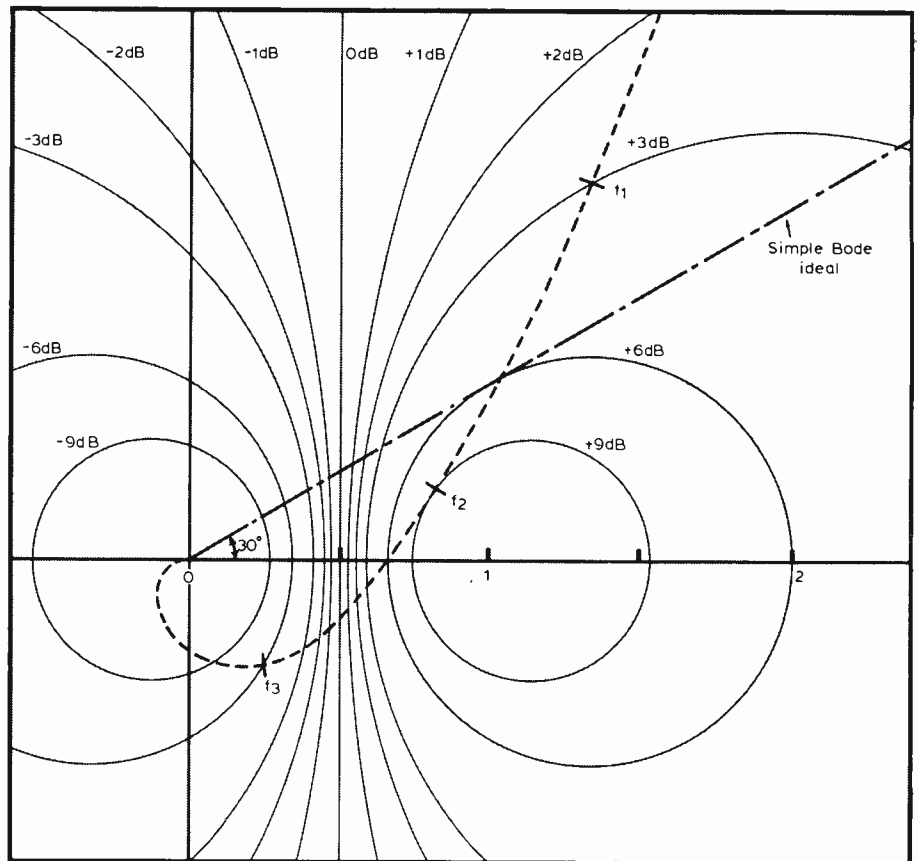

**Fig. 6.** Nyquist diagram with circles of constant gain change with respect to  $1/\beta$ .

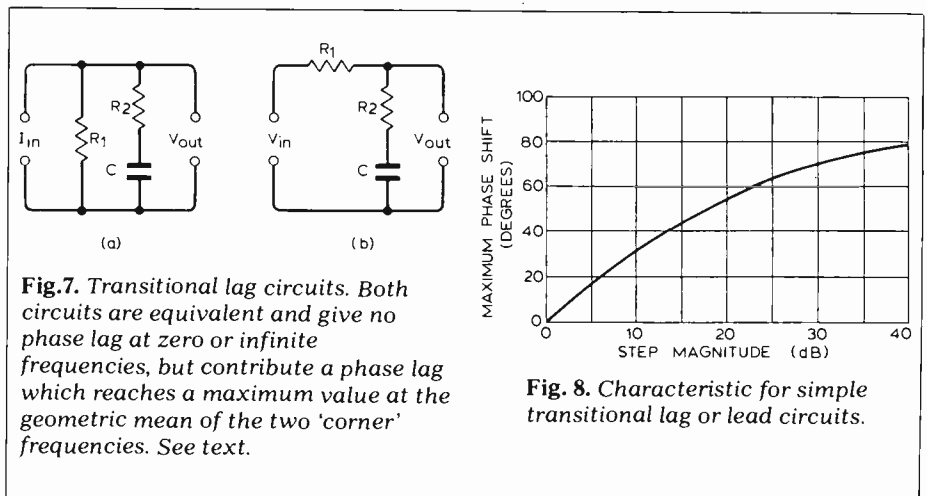

**Fig. 7.** Transitional lag circuits. Both circuits are equivalent and give no phase lag at zero or infinite frequencies, but contribute a phase lag which reaches a maximum value at the geometric mean of the two 'corner' frequencies. See text.

**Fig. 8.** Characteristic for simple transitional lag or lead circuits.

the step in attenuation between very low and very high frequencies and the more nearly does the maximum phase lag approach  $90^\circ$ . Fig. 8 gives the relationship between the step magnitude in decibels and the maximum phase shift, and has been found useful for some design purposes. The graph may also be applied to the corresponding phase-lead networks sometimes used in the low-frequency stabilization of a.c.-coupled amplifiers.

**Amplifier with only two lags**

A particularly simple case is that of an amplifier having only two significant lags, of time-constants  $T_1$  and  $T_2$ , in the forward path, and a frequency-

independent  $\beta$ -network. If the low-frequency loop gain is large, then, to avoid a large high-frequency peak in the closed-loop response,  $T_1$  and  $T_2$  must be made very unequal, so that most of the loop-gain attenuation is done by the larger time constant without too much additional phase lag from the smaller one. A set of universal curves for this situation, calculated many years ago and recently rechecked, is given in Fig. 9. Knowing the low-frequency loop gain, the required ratio of time constants to give a specified magnitude of high-frequency peak in the response may be immediately obtained. As with Fig. 8, this data may also be applied to the corresponding low-frequency problem in an amplifier having two a.c.-



coupling time constants in the forward path.

**Addition of small time constants**

In many practical cases where a feedback amplifier is stabilized by the dominant lag technique, there will be one large lag plus several significant smaller lags. These smaller lags can often be satisfactorily considered as approximately equivalent to one lag of time constant equal to the sum of the individual small time constants. Some calculations relating to this are presented in graphical form in Fig. 10. It will be seen that provided the total lag introduced by the small time constants does not exceed about 40°, there is no great error in the calculated phase angle if they are taken as equivalent to a single lag of time constant equal to their sum. This procedure is very satisfactory for amplifiers having large phase margins such as 50°, and is a useful guide to approximate values, as a basis for experimentation, even when smaller phase margins are used. In this way the information of Fig. 9 may be used to some extent even when there are actually more than two time constants.

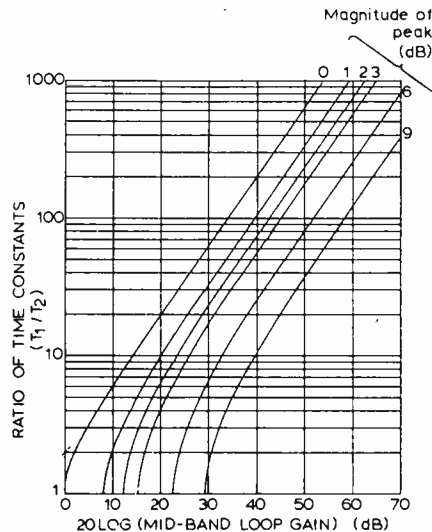

**Fig.9.** Curves relating to amplifier with only two lags, or leads, in forward path, and a frequency-independent  $\beta$ -network.

**References**

1. Bode, H. W., Network Analysis and Feedback Amplifier Design (van Nostrand, 1945). (See section 18.5, p.464, re the "Bode flat" in

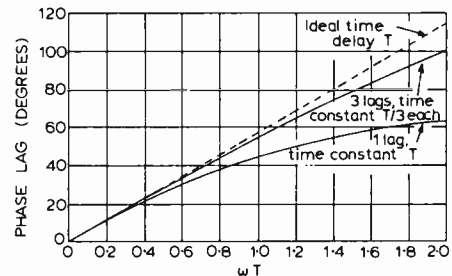

**Fig. 10.** Phase lag characteristics.

loop-gain attenuation characteristic. See section 8.8, p.157, re stability criterion for multiple-loop case.)

2. Hakim, S. S., Feedback Circuit Analysis. (Iliffe, 1966).  
 3. West, J. C., Textbook of Servomechanisms. (E.U.P., 1953).  
 4. Ghauri, M. S., Electronic Circuits. (van Nostrand Reinhold, 1971).  
 5. Cherry, E. M., An Engineering Approach to the Design of Transistor Feedback Amplifiers, *J. Brit. I.R.E.* Vol. 25, No. 2, Feb. 1963.  
 6. Cherry, E. M. and Hooper, D. E., The Design of Wide-band Transistor Feedback Amplifiers, *Proc. I.E.E.* Vol. 110, No. 2, pp.375-389, Feb. 1963. (Note, the material in refs. 5 and 6 is also covered in the book by Cherry & Hooper previously referenced.)

**WHOSE LASER?**

FROM THE USA comes news of the grant to Gordon Gould of a patent on laser technology and an impressive climb in share price of Refac Technology Corporation, the company with which Gould is associated. The climb in share prices was hardly surprising, bearing in mind the claim bandied around, namely that the new Gould patent on lasers could cover more than half of all the lasers now being used and manufactured in the United States and abroad. If this were true Refac and Gould would without doubt be in a highly enviable and lucrative position. A cold and closer look at the overall situation however, suggests that the recent grant to Gould of USA patent 4,053,845 may be more valuable as p.r. than as a legal weapon.

Although Einstein is credited with the idea behind the laser and Theodore Maiman of Hughes made the first to actually work, it was Arthur Schawlow and Charles Townes of Bell Labs, New York who first proposed the technology for a workable laser. They also patented their proposals; USA patent 2,929,922 was applied for in July 1958 and granted in March 1960. The patent described itself as relating to masers, and listed a large number of metal vapours (including sodium, potassium and rubidium) as suitable for "optical pumping" to generate a beam of coherent monochromatic light, itself amplified by further pumping in a generally similar second device. The inventors instanced infra-red, visible and ultra-violet wave lengths and claimed the broad concept of modulating the generated beam while amplifying it, for the purposes of communication. The pumping chambers have reflective ends and transparent sides, Schawlow and Townes drawing the analogy between optical pumping and microwave cavity amplification. This patent has now expired (having run its natural legal life) and what it described and claimed is now in the

public domain. What then was left for Refac and Gould to claim as novel over Schawlow and Townes? Not very much, it would seem from a comparative reading of the various documents. Schawlow and Townes variously claimed a maser generator, an amplifier, a modulated amplifier and a communications system incorporating a generator, modulated amplifier and remote detector. All the Gould claims relate to a light amplifier *per se*. Moreover, the US Patent Office was quite clearly not anxious to allow even these limited claims over prior documents such as the Schawlow patent. The Gould patent was finally granted in October 1977 but dates back to an application made in April 1959! Gould was therefore negotiating with the US Patent Office for *eighteen* years before his patent application was allowed.

An indication of how drastically the original 1959 Gould application was limited to satisfy the US Patent Office examination can be had from a comparison with the series of seven very lengthy British patents which in 1964 were granted in the UK (to TRG Inc. with Gould as inventor) and relying on the same April 1959 priority. British patents 953721-953727 inclusive together contain nineteen different system drawings whereas the US case contains only seven. Moreover the string of British applications variously claimed monopoly on a maser, an apparatus for intensifying light, a heat generating apparatus and an apparatus for illuminating a reflecting body by stimulated emission light and producing an electrical signal in response. A light communication system capable of carrying over a hundred tv channels each of 6MHz bandwidth is also described.

The string of British patents have now all expired, mainly through "natural causes". The relatively rapid acceptance of the British patents, compared with the eighteen-year battle for the US counterpart, is not in itself

significant. British patent office examination has (at least until now) been generally less stringent than that encountered in the USA. It is however, significant – or at least interesting – that the Official Register of the British Patent Office shows no record of any infringement action on any one of the seven patents during their lifetime and no licence granted to any rival laser manufacturer or supplier. This poses an obvious question. If the single relatively limited US Gould patent is as important as Refac and the US Stock Exchange appear to believe, how is it that no licences were granted and no court actions brought on any of the seven, and more far-reaching, British equivalents during their legal working life? **Adrian Hope** □

**Users must press for more p.m.r. spectrum**

"THE TIME might now be approaching when we can no longer economically satisfy the mobile radio users' needs by further channel splitting or fairly simple technical innovation," according to Joe Whelan of Pye Telecommunications' Mobile Radio Management Group. Speaking on WARC 1979 at the Pye seminar he said the use of mobile radio had grown by 10½% a year for 20 years, but the spectrum allocation had not grown with it. However, manufacturers had been able to get round this by design improvements enabling users to operate in less spectrum and users had been willing to replace their equipment at "rather frequent intervals". Those days, said Whelan, may be over.

"These services need more space and, hopefully, someone at WARC will stand up

*continued on page 85*

# Case for cellular mobile radio "not yet proved"

THE BEST USE of private mobile radio could be achieved by narrower channel-widths, not digital techniques, according to a paper presented at the Pye symposium.

Rodney Gibson and Rick Mitchell of Philips Research Laboratories said that the spread spectrum technique, where several users operate simultaneously in the same frequency range, each signal being identified by a coded digital carrier rather than by time or frequency division, would be "a disaster" with the wide signal ranges found in normal mobile radio use. "The problem with this technique is that the signals cannot be perfectly separated unless the carrier codes are all synchronised to much greater accuracy than is possible in mobile radio. Without this synchronisation each transmission produces noise-like interference on all the others and, even with careful control of relative signal levels, unsynchronised spread spectrum systems provide very inefficient use of the spectrum." The technique would provide fewer available channels than with current frequency multiplex techniques.

Their assessment of various techniques was based on the assumption that a signal should take up the smallest range of frequencies over the smallest geographical area for the smallest length of time if the spectrum were to be properly used. They concluded that narrower channels would make the best use of the spectrum. "The result showed that either a.m. or f.m. could

probably be developed to give adequate performance at 6.25kHz channel spacing . . . S.s.b. is feasible for v.h.f. working at 5kHz channel spacing and the performance will at least equal that of current 12.5kHz equipment."

On digital techniques the authors noted that for adequate speech quality the digital encoders currently available needed a bit rate of 10-16 kbits/s, requiring channel spacings of about 25kHz. Digital speech at these bit rates should only be used where its other advantage, that of privacy, outweighs the extra use of the spectrum. Nevertheless, speech encoding could become an attractive use of the spectrum if adequate quality could be provided at 2400 bits/s, using 5kHz channeling.

"It is sometimes claimed that broad channels of 25kHz or even 50kHz can be just as spectrally efficient as narrow ones because the strong capture effect of wide deviation f.m. allows better rejection of co-channel interference and therefore more efficient re-use. However, the gain in re-use often cannot be realised . . . because multipath fading severely reduces the capture effect, the local terrain often dictates coverage areas, and the demand for radio channels is usually concentrated in big cities and a high proportion of permissible re-use areas fall in regions of low population." There was little sense, the authors said, in reducing the number of channels in central London to

make channels available in East Anglia. "By contrast two frequency simplex working is a technique in which the apparent reduction in bandwidth efficiency really does pay off in increased use of simultaneous transmissions within the same coverage area." The frequency separation between receivers and transmitters allowed so much extra freedom in frequency allocation that it more than offset the apparent waste of using two frequencies for the same channel.

The cellular schemes that had been proposed against the day when every car would have a radiotelephone had not yet proved their case for such an ordered network, "still less is it proved for the more relaxed conditions of ordinary mobile operations.

In the cellular system (see WW June '77, p.40) an area is divided into small hexagonal cells, each served by three low power transmitters on the boundary of each cell. Mobiles transmit only with their own cell's base station, and land-lines carry the signal from one cell to another to give coverage over a wide area. "The mobiles all have diversity reception to minimise the effects of multipath propagation and the use of three transmitters per cell helps to even out the signal received in different parts of the cell." The capacity of the system can be increased by making the cells smaller, though this would increase the number of base stations needed. Cellular systems would probably work well only in flat terrain, where vehicles were equally-spaced throughout the cellular array. There would be additional problems caused by the progression of mobiles from one cell to another. The authors say that p.m.r. uses spectrum most efficiently where there are narrow channels, where low transmitter power and directional aeriels are used, where channel sharing is adopted, and where there is an incentive to keep transmissions short. In the latter case, routine messages could be transmitted by data saying, for example, "I have a job for you", leaving speech channels better used. □

## Will the dish antenna replace the chimney pot?

HOMES of the future should have satellite aeriels built into them, according to Dr. G. J. Phillips of the BBC Research Department, who hoped that the result would be more attractive than chimney pots had been on houses in the past. He was speaking about antenna requirements for satellite television broadcasting at a joint meeting of the British Aerial Standards Council (BASC — See "Inferior tv antennas dominate the market") and the Radio Industries Club (RIC) in May.

Although the UK still has the fourth television channel to develop before turning to satellite broadcasting, Germany and the Scandinavian countries foresee themselves finding applications within the next decade.

A plan for the use of the 11.7 to 12.5GHz band for satellite broadcasting was drawn up by the Geneva Broadcasting Satellite Conference in 1977 and, with only a few exceptions, each country in Europe and Africa was assigned five wide-band channels suitable for the present 625-line television standard, but using f.m. for transmission. The plan provides for sufficient transmitter power to allow individual home reception with a microwave receiving dish no more than 80 or 90cm in diameter. This antenna would not have to be mounted high above the ground provided there was a line-of-sight view to the satellite at an elevation angle of 25 degrees—the UK satellite position being 31° West.

An antenna of this kind, of course, must be rigidly mounted to maintain a pointing

accuracy of the order of half a degree and, as stated by the Vice Chairman of BASC, Mr A. N. V. Pedersen, "rigging will be an exact science requiring advanced training." The significance of this is that rigging standards must change dramatically when satellites begin transmission in the '80s or '90s because, according to Mr Pedersen\*, "rigging standards are abysmally low (in the UK) compared with West Germany."

In addition, because of an attenuation problem with feeders, the antenna must incorporate a frequency changer so that signals in the down lead are about 1000MHz. To remove one of the variables in mounting and aligning the antenna, circular polarization can be used but this must have good rejection of signals of the opposite circular polarization.

Yet another problem will be that of interference due to harmonics radiating from microwave ovens — the science of which has been given the name "radio gastronomy". To reduce this interference the antenna will also require a good sidelobe performance.

Both the BBC and the IBA are studying this type of broadcasting system and tests are being carried out with the European Space Agency's communication satellite, OTS-2, which was launched on May 11 and was placed into geostationary orbit on May 24. □

\*Mr Pedersen is also Chairman of the Radio Industries Club, marketing director for Antiference Ltd. and a director of Antenna Specialists (UK) Ltd.

## Tory government would break up Post Office monopoly

ONE OF the earliest pieces of legislation sought by an incoming Conservative government would be to release the supply of telecommunications equipment from the Post Office monopoly. Private enterprise would be allowed to supply equipment to link the home, the office and the factory with the telecommunications network, according to Sir Keith Joseph in an interview with *Computer Weekly*. Sir Keith, who is head of the Conservative Party Centre for Policy Studies, said that although there would be some other legislation that would take priority, and although the Conservatives would aim to legislate rather less than recent governments, action to free as much of the whole spectrum of Post Office activity as possible from monopolistic control would be one of a new Conservative administration's first acts.

The Party was still discussing whether this should also apply to the postal service, which is likely to develop into electronic mail, where letters are sent by display or printing terminals attached to the telecommunications network.

He said that although he was no enthusiast of the Government's committees and sector working parties within the National Economic Development Office, they should not be "lightly abolished." □

# Radio and Television Servicing 1977-1978

Editor R. N. Wainwright, T.Eng. (CEI) F.S.E.R.T.

## Circuit Analysis of Colour Television Designs

Reference Charts for Pye, Ekco, Ferranti, Invicta, Dynatron Models and I.T.T. Ltd.  
Adjustment Procedures  
Unusual Fault Symptoms  
Receiver Alignment

This latest volume in the *Radio and Television Servicing* series reflects the servicing data produced during the year prior to publication or relating to domestic entertainment equipment currently available.

The information contained within this volume continues to provide a valuable tool to both amateur and professional service department alike in ensuring a high and safe standard of repair and maintenance.

An essential reference book for all service engineers.

**£10.50**

**Special Price** for six volume set £45.00.  
*Consisting of vols. 72|73, 73|74, 74|75, 75|76, 76|77, 77|78*

From booksellers or, in case of difficulty, please use the form below:

To: The Sales Manager, Macdonald and Jane's Publishers, 8 Shepherdess Walk, London N.1.

From: Name.....

Address.....

Please send me.....copy(ies) of *Radio and Television Servicing 1977-78 Models*.

I enclose cheque/PO made out to Macdonald and Jane's for.....

GIRO A/C NO 205/4221 Macdonald and Jane's.

**Macdonald and Jane's**

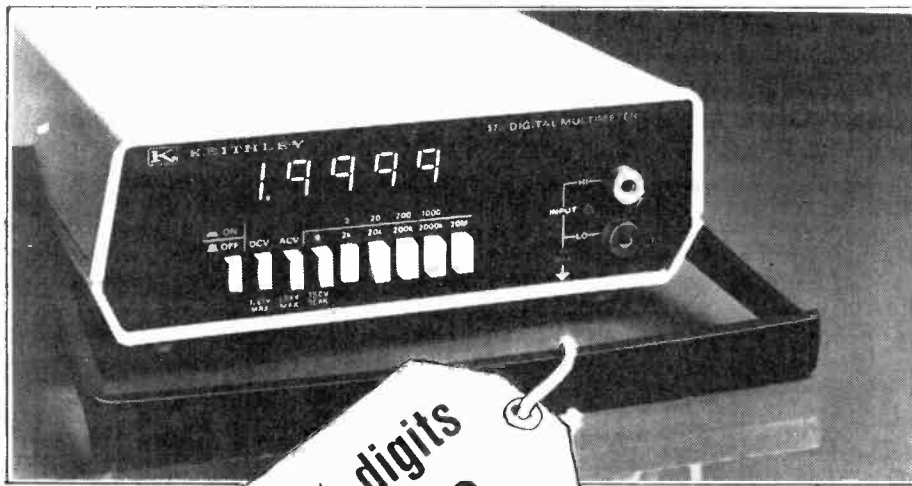

Model 178

## Now . . . the next generation of bench DMMs!

Two New Keithley Models offer uncompromising performance and outstanding value!

- Accuracy 3½'s can't match: 0.4% + 1 digit on dc volts and ohms
- Large, bright, 20,000-count LED display that's quick and easy to read.
- Convenient bench size that won't get "lost" yet doesn't crowd.
- Exceptional reliability

Model 178 offers functions and ranges for most measurement needs 100 $\mu$ V to 1200V dc, 100 $\mu$ V to 1000V ac, 0.1 $\Omega$  to 20M $\Omega$ .

Model 179 is a full-function, multi-feature model offering the same advantages as the 178. Plus

**TRMS AC**, 10 $\mu$ V Sensitivity; Hi and Lo Ohms; AC and DC Current Yet it's still half the price you'd expect. Only £199.

Both models feature designed-in reliability. Rugged circuits use a minimum of parts — high quality, off-the-shelf parts — carefully assembled and tested by Keithley. Outstanding overload protection and rugged mechanical design keep both units going even after severe abuse. One-year accuracy specifications minimise recalibration costs. A battery option, user installable, gets you off "line" for critical measurements or for field use.

**For complete specifications on the 178 and 179, call Keithley Instruments, 1 Boulton Road, Reading. Phone 0734 861287**

# KEITHLEY

The measurement engineers.

WW—056 FOR FURTHER DETAILS

## 'Wenden' range modular amplifiers

A range of communications amplifiers having power ratings from 15 to 200 watts, plug-in input facilities ensure individual requirements can be provided.

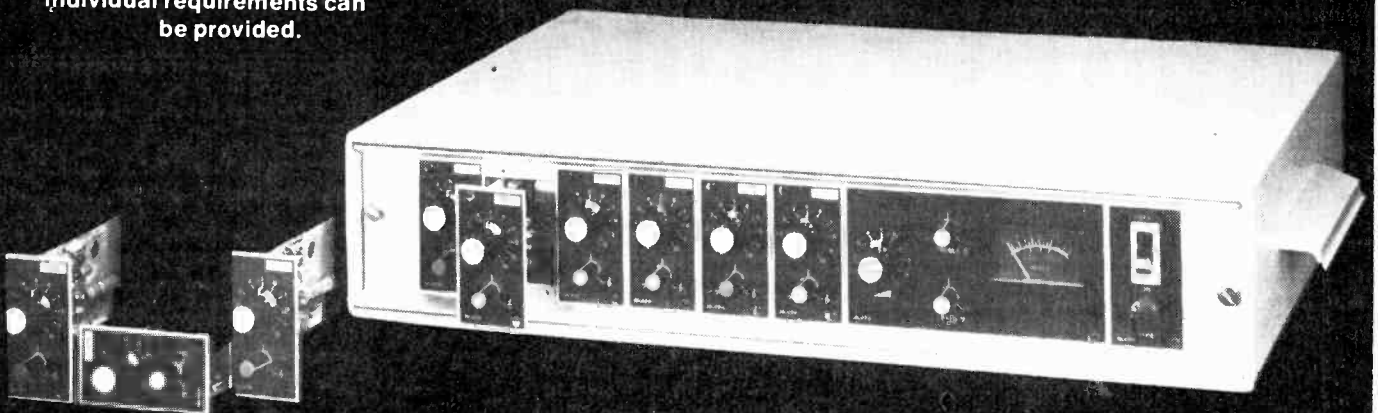

Manufacturers of  
sound systems  
and electronics

Station Road, Wenden  
Saffron Walden  
Essex CB11 4LG  
Saffron Walden  
(0799) 40888

# audix

# Current dumping — does it really work?

## 2—Measurements

by J. Vanderkooy and S. P. Lipshitz University of Waterloo, Ontario

This article (part 1 appeared in the June issue) shows theoretically that the current dumping principle is quite sound. Whether it should be called feedforward error correction in the feedback loop is perhaps still open to debate. In several respects the distortion reduction appears due to a passive bridge balance. Dumper beta variation results in distortion, fortunately very low, which cannot be balanced out in present circuits, and readers are challenged to produce a circuit which nulls out such current distortion as well.

Measurements show that the amplifier performs very well, and analyses of the distortion oscillograms and wave analyser measurements show that, qualitatively, much of this data can be understood. We both heartily agree that the current dumping principle as embodied in the Quad 405 amplifier has significantly advanced the state of the art in class B power amplifier design.

IN ATTEMPTING TO MAKE distortion measurements on a Quad 405 amplifier (SN1861), we found no oscillator with sufficiently low distortion was available to us. After a number of modifications, we employed a Heathkit IG-18 whose distortion finally measured out at  $<0.002\%$  at audio frequencies around 1kHz. We found that the Hewlett-Packard 302 wave analyzer, when fed a full scale signal, produced internal distortions or intermodulation with internal noise such that distortion components lower than 0.005% were difficult to measure. Accordingly, we employed a switchable passive twin-tee notch filter to remove the fundamental to the wave analyzer in all our measurements.

Correction factors for the twin-tee filter were applied to the measured harmonics to give total harmonic distortion, which excludes the wide-band amplifier noise. While making measurements we found it very interesting to observe with an oscilloscope the twin-tee filter output, having the fundamental largely removed. The noise of the Quad 405 is considerably higher than that of the Quad 303 power amplifier, probably because of the integrated operational amplifier used in the 405. This noise interfered with the oscilloscope display and in several instances we found it

useful to place a capacitor across  $C_6$  of the amplifier circuit.

The most important point we wished to check was the operation of the distortion nulling bridge. We did this firstly by observing the distortion signal with the amplifier as supplied, and also with  $Z_4$  (the  $3\mu\text{H}$  inductor  $L_2$ ) shorted. This is easy to do and not very upsetting to the amplifier's stability. Fig. 4 shows a photograph of the

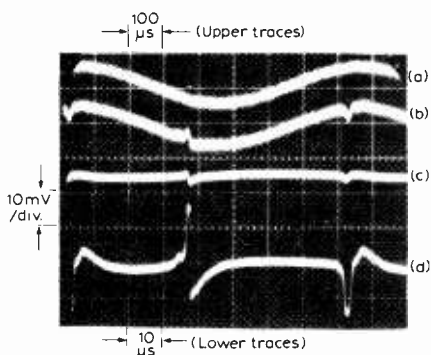

Fig. 4. Oscilloscope illustrating residual distortion voltage at output of twin-tee filter at 1.32kHz (top two traces) and 13.2kHz (bottom two). In each case the lower trace shows the effect of shorting the inductor  $Z_4$ . (Output 1V r.m.s. into  $10\Omega$ .)

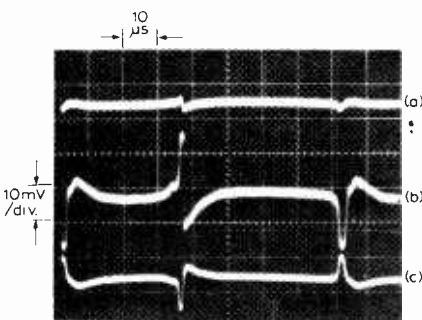

Fig. 5. Oscilloscope illustrating the effect of unbalancing the bridge in both directions. Upper trace is with amplifier as supplied; middle trace with bridge unbalanced in one direction ( $Z_4$  shorted), and lower trace with bridge unbalanced in opposite direction ( $Z_1$  shunted). All at 13.2kHz, 1V r.m.s. output across  $10\Omega$ .

distortion output after the twin-tee for four cases. Starting from the top, (a) is the resultant at 1.32kHz for 1Vrms output into a 10-ohm load, amplifier as supplied; (b) is the same with  $Z_4$  shorted; (c) the same as (a) but with signal frequency of 13.2kHz; and (d) the same as (c) but with  $Z_4$  shorted. Notice that the twin-tee allows some fundamental residue to remain in (a) and (b). The traces clearly show the beneficial effect of the bridge element  $Z_4$ , especially at high frequencies, as one might expect. They also clearly answer Mr Bennett's objections (ref. 2, part 1): vastly larger amounts of negative feedback would be required to achieve as low a distortion as can be achieved by inserting  $Z_4$  and balancing the bridge.

The fact that the amplitude of the notch distortion in Fig. 4 increases visibly with frequency and consists in large measure of sharp spikes, suggests very strongly that this remaining distortion is due to residual bridge unbalance. This is as predicted by our analysis, and is further reinforced by Fig. 6 (see later). The spikes are roughly constant for output levels from 1.5 to 10Vrms; to understand this feature even qualitatively requires a more complete treatment of crossover distortion than we can give here.

It is worth remarking that for outputs less than about 200mVrms the notches disappear completely, as the dumpers remain off and the amplifier operates in pure class A. Hence at very low power, crossover distortion is totally absent. As the output signal amplitude is increased beyond about 10Vrms (at 13.2kHz), the peak-to-peak notch amplitude rises, until at 25Vrms output it has risen by a factor of four from 5 to 20mV pk-pk. This strongly suggests that this effect is due to  $\beta$  variation in the dumpers, as our theory predicts that this contribution should rise in amplitude with output level. We have not, however, been able to correctly predict the magnitude of this effect from our equations. It may well be that the slow dumper transistors have a region near crossover where  $\beta \approx 0$  or  $\beta < 0$  after a quick turnoff.

Finally, each spike in trace (d) in Fig. 4 is in fact composed of two spikes of vastly different amplitudes. It would appear that the smaller spike is caused by the switching of the upper (single)

dumper, while the larger spike is contributed by the lower dumper pair (with its higher speed).

Fig. 5 shows that the amplifier as supplied has a bridge roughly in balance. All traces are at 13.2kHz with 1Vrms out across 10 ohms; horizontal scale 10μs/division, vertical scale 10mV/division; twin-tee in circuit. The upper trace shows the amplifier as supplied. The middle trace shows the effect of shorting Z<sub>4</sub>, the inductor L<sub>2</sub>. This unbalances the bridge in one direction. The lower trace is produced by restoring Z<sub>4</sub> and resistively shunting Z<sub>1</sub> (the 500Ω resistor) to unbalance the bridge in the opposite direction. Comparing traces, the bridge as supplied is reasonably well balanced, perhaps within 10%, which is to be expected with four 5% components.

The remaining glitches in the distortion waveform suggest that the bridge is not perfectly balanced, or that some other distortion mechanism such as dumper β variation may be occurring. Fig. 6 shows the results of several attempts to achieve better bridge balance. The signal frequency is 13.2kHz, horizontal scale 10μs/division, vertical scale 5mV/division. The upper trace shows the twin-tee output for the amplifier as supplied. The middle trace shows the best balance that can be achieved by shunting Z<sub>1</sub> (the 500Ω resistor) with a resistance which for our amplifier was about 5kΩ. The lower trace is the result when Z<sub>1</sub> is shunted by two resistors in series, with their junction going via a 100μH inductor to ground.

This was an attempt to balance the bridge, taking into account the effect of C<sub>9</sub>(330pF), R<sub>19</sub>(3.3kΩ) and the collector capacitance of Tr<sub>3</sub>. Although one may think that such effects should be negligible because Tr<sub>3</sub> has a β of say 100, any collector current due to capacitance goes through an active base and is

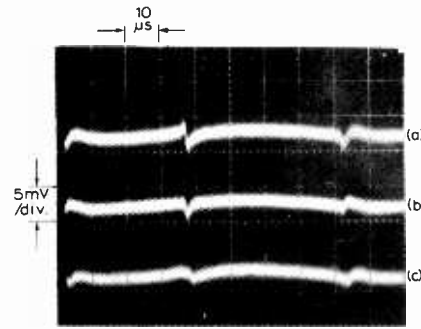

Fig. 6. Oscillogram illustrating attempts at achieving perfect bridge balance. Upper trace is twin-tee output of amplifier as supplied, middle trace shows best balance achieved by resistively shunting Z<sub>1</sub>, and lower trace is best balance with complex shunt. All at 13Hz, 1V r.m.s. across 10Ω.

multiplied by β. (A recent Quad 405 circuit shows C<sub>9</sub> and C<sub>11</sub> replaced by a single capacitor, a configuration we have not analysed). The slightly better appearance of the lower trace indicates some success on our part, but the problem is complex and subtle. There may also be an effect due to the separation of Z<sub>1</sub> and Z<sub>2</sub>, these being fed back to opposite ends of Tr<sub>2</sub>, the input transistor. The distortion signals fed back through Z<sub>1</sub> and Z<sub>2</sub> will not be quite right, due to the different impedances at opposite ends of Tr<sub>2</sub>. We believe that this effect can be seen in Figs 4 and 5 with Z<sub>4</sub> shorted. The large spikes are followed by an exponentially decreasing waveform with a time constant of about 5μs. If one estimates the impedance at the collector of Tr<sub>2</sub> (the input transistor, triple input, and the current source Tr<sub>1</sub>) at about 50kΩ, the 120pF capacitor (Z<sub>1</sub>) gives a time constant with this impedance of 6μs. No other time constant seems near to this value, indicating that

an effective bridge unbalance may have resulted from the separation of Z<sub>1</sub> and Z<sub>2</sub>. The only other possible cause could be a slow dumper turnoff.

Several other features tend to influence the bridge and the dumper β variation. Although C<sub>10</sub> bootstraps R<sub>30</sub>(560 Ω), this resistor now forms a shunt across the dumper stage from bases to emitters. This will influence the effective β for the dumpers in the crossover region (there will be a small current region for which β < 0, using a d.c. analysis). As the dumpers are slow, an a.c. analysis is almost impossible, and they may well be the cause of much of the residual distortion. Because of the bootstrap capacitor C<sub>10</sub>, R<sub>31</sub> (also 560 Ω) now forms a load to an a.c. ground (the negative rail), which tends to unbalance the bridge. Our calculations show that this has an almost negligible effect at audio frequencies, because the relevant ratio turns out to be the conductance of R<sub>31</sub> relative to that of Z<sub>4</sub>. (The presence of the loading effect of R<sub>31</sub> slightly changes the bridge balance condition B = 0 by, in effect, modifying β very slightly. The possibility of achieving a balance is not affected.)

Another source of distortion in the Quad 405 amplifier is the non-linearity in the modulation of β of Tr<sub>2</sub> (the input transistor following the operational amplifier) due to collector voltage variations. This transistor has a collector-to-emitter voltage which is modulated by 180/680ths of the output voltage, due to the feedback resistors. Suppose that the non-linearity of the collector current with voltage variation is 1% of the quiescent current of about 6mA. Using a simple diode model for Tr<sub>2</sub> we can easily show that such non-linearity of β with voltage results in a distortion of around 0.001% at full output level. Such distortion is mainly second harmonic and will become negligible at low power levels.

Harmonic distortion measurements with Quad 405 bridge balanced as accurately as possible

Fundamental		n <sup>th</sup> order harmonic distortion (%)																
		2	3	4	5	6	7	8	9	10	11	12	13	14	15	16	17	t.h.d. (%)
1.32 kHz	signal generator	.0011	.0004	N	N	N	N	N	N	N	.0001	N	N	N	N	N	N	.0012
	Quad 405. 1V <sub>rms</sub> . best resistive balance	.0051	.0072	.0058	N	.0042	N	.0024	.002	N	.0021	N	N	N	N	N	N	.012
	Quad 405. 1V <sub>rms</sub> . Z <sub>4</sub> shorted	.017	.016	.022	.0049	.021	.005	.016	.012	.0089	.014	.0021	.013	.0031	.01	.0062	.0072	.051
	Quad 405. 10V <sub>rms</sub> . best resistive balance	.004	.0005	.0007	.0007	.0004	.0005	N	.0004	N	.0003	N	.0003	N	N	N	N	.0042
	Quad 405. 10V <sub>rms</sub> . Z <sub>4</sub> shorted	.0046	.0014	.001	.0023	.0009	.0023	.0009	.0022	.0009	.0021	.0011	.002	.0011	.002	.0011	.002	.0079
	signal generator	.0081	.0004	N														.0081
13.2 kHz	Quad 405. 1V <sub>rms</sub> . best resistive balance	.012	.0063	.0039														.014
	Quad 405. 1V <sub>rms</sub> . Z <sub>4</sub> shorted	.14	.14	.18														.27
	Quad 405. 10V <sub>rms</sub> . best resistive balance	.011	.0034	.0023														.012
	Quad 405. 10V <sub>rms</sub> . Z <sub>4</sub> shorted	.017	.027	.0015														.032

N denotes signal below noise: wave analyzer bandwidth 2Hz

To gain some insight into the magnitude of the remaining distortion components in the Quad 405, it may be instructive to quote some figures. The table gives harmonic distortion measurements (of harmonics up to 50kHz) made as outlined earlier, with the Quad 405 bridge resistively balanced as accurately as possible, as in Fig. 6, trace (b).

Clearly, the low-order harmonics expected, the measured residuals are of a very low amplitude indeed, and are frequently barely above the residual noise. Particularly impressive is the absence of measurable high-order harmonics, even at low powers. The enormously beneficial effect of  $Z_4$ , already evident from the oscillograms, is again emphasized by these numbers. Much of the residual second and third harmonic distortion may be due to the class A stage, as this stage sets a limit on the ultimate performance of the whole amplifier. The contribution due to the input operational amplifier (which is outside the overall a.c. feedback loop) should also not be ignored.

About part 1\*. In connection with our reference to Peter Baxandall's letter, page 38, Mr Baxandall has recently justified his approach quite clearly to us. We hope he will expand his elegant argument in his own series of articles. The second term in the last equation of the middle column on page 39 should have a minus sign between  $v_1$  and  $e_r$  word relaxed should have been used at the foot of column two, page 38, instead of "related."

\*Script originally received October 1976.

#### Additional reading

Quadi-complimentary, *Elekto* 8, December 1975, pp. 1220-2.

Quadi-complimentary complemented. *Elekto* 21, January 1977, pp. 1-39.

Letters to the editor, *Wireless World* vol. 82, November 1976, pp. 52/3.

Letters to the editor, *Wireless World* vol. 83, April 1977, p. 76.

Letters to the editor, *Wireless World* vol. 83, June 1977, p. 49. □

Having a keen interest in electronics and audio, **John Vanderkooy** has contributed a number of articles in these fields. He is an assistant professor in the Department of Physics at the University of Waterloo, having previously spent two years on post-doctoral research at the University of Cambridge. John graduated from McMaster University, Hamilton, Ontario with a B.Eng. degree in engineering physics in 1963 and a Ph.D. in physics four years later.

With a long interest in audio and electronics, **Stanley Lipshitz** has recently begun investigating some of the mathematical problems associated therewith. He's an assistant professor in the Department of Applied Mathematics at the University of Waterloo. Before that he obtained his first degree in mathematics, applied mathematics and physics from the University of Natal, Durban, in 1964, an M.Sc. degree in applied mathematics from the University of South Africa, Pretoria, and the Ph.D. degree in mathematics from the University of the Witwatersrand, Johannesburg in 1970.

continued from page 79

and say so." It was essential that the conference recognise the true value of mobile radio to the world community. A study of the spectrum would show that, despite the now massive use of mobile radio, "a surprisingly small amount of frequency space is allocated for the use of a very significant list of users." Many public and private undertakings all over the world would suffer considerable inconvenience, reduction in efficiency and increased costs if they were to lose their radios, yet all of them are to some extent at risk during the WARC.

- Successful competitors might take their allocations.
- Equipment might cost more because of changing technology.
- Spectrum might be leased, perhaps to the highest bidder.
- Restriction on non-priority users might reduce freedom to use or expand existing allocations.

Pressure will come from the developing countries which might cause disharmony at the conference, and from well-entrenched user groups. "It can be anticipated that all countries will give first priority to defence needs, and will also consider broadcasting and telecommunications to be essential services. One can perhaps be forgiven for feeling that not all defence services are defensive, and that not all broadcasting is essential but, whilst many would agree, such sentiments are unlikely to be allowed to affect the outcome."

"Additional radio spectrum for mobile radio use can be made available only by other users conceding some of the space at present occupied or reserved by them. Is it not time for the needs of defence or broadcasting users to be more thoroughly scrutinised and should they not be made to respond in the same manner as mobile radio to pressures for better utilisation of bandwidth simply through the discipline of restricted allocation?" □

## Inferior television antennas dominate the market

WILL THE poor quality antennas, which make up about half of the UK television antenna market, be adequate for teletext, the fourth tv channel and data communications, which are on the way?

That was one of the questions being asked at a meeting of the British Aerial Standards Council (BASC) and the Radio Industries Club (RIC). Chairman of BASC, and Managing Director of Wolsey Electronics, Mr A. C. F. Leadbitter, said that even now there are many antennas in the television broadcasting field that do not function adequately.

"These antennas could be just a collection of rods with little or no attention being paid to dimensions or optimisation for the required frequency bands," he said.

In his view, these low-grade products were the result of smaller manufacturers, with little or no expertise, producing antennas which, although competitively-priced, do no justice to either the quality of the transmissions or the receivers installed.

Of the other 50% of the present UK market, 25% are set tops and only 25% are good quality antennas or fringe types. Clearly, consumers should be more aware than they are about technical standards when selecting their receiving antennas. One suggestion by Mr Leadbitter was that, with the mass market being dominated by rental organisations, the antenna installation is often contracted-out to the cheapest installer, who in turn is forced to use the cheapest materials.

It is thought that there is no guarantee that the low-grade antennas will have sufficient bandwidths for the fourth channel and may give mediocre performance.

In the field of digital communications and

teletext the situation is expected to be much worse, with close-space reflections seriously affecting the received information. In surveys carried out by the IBA, some existing domestic installations, in three areas of the UK, were compared against a reference — a vehicle equipped with a standard, domestic ten-element u.h.f. antenna mounted at 10m with a 15m length of standard domestic feeder. The results of the surveys showed that the standard ten-element test antenna often shows a significant improvement over the average domestic installation.

On the subject of satellite transmissions, which will require a high standard of technical know-how, BASC feel that it may not be within the capabilities of many of the smaller manufacturers.

BASC was reformed in 1973 by the leading UK antenna manufacturers to try to improve the technical standards of domestic receiving antennas. In an attempt to promote the highest possible level of both mechanical and electrical excellence in their antennas, these manufacturers, through the technical committee of BASC, have prepared a technical standard for the design and manufacture of receiving antennas. This standard, which was first published in 1975, is currently being introduced into the BSI and IEC regulations.

Any manufacturer wishing to obtain full membership of BASC must themselves maintain a high technical standard because they must demonstrate that their electrical and mechanical design, test and quality control capabilities meet the minimum standards laid down by BASC. In addition, they must possess the appropriate equipment and facilities and employ suitably-qualified engineers. At present BASC has only five full members. □

## "Revolutionise" amateur radio?

The amateur satellite organization, Amsat (Amsat Phase III, PO Box 27, Washington DC, 20044, USA), in appealing for funds to help further their interesting and laudable Phase III project to put an amateur satellite into geostationary orbit may unwittingly raise a few hackles in the process. For they have as their tag line the phrase "help to revolutionize amateur radio communications". Few amateurs will quarrel with the concept of providing a new band comparable to 14MHz "a resource usable by hundreds of stations at a time". But what is questionable is whether the hobby will in the long term benefit from reliable, 24-hour, consistent dx operation. When it becomes as straightforward to talk to the West Coast of America as telephoning across town, will the hobby suddenly lose its appeal? This is perhaps what is at the root of the long-lasting pro- and anti-repeater controversy that has already done so much harm to the hobby.

Then again, I recently received a letter from someone who has held an amateur licence for more than four decades, as well as spending a lifetime in professional radio communications. He questions the current interest in amateur h.f. radio teleprinting and even more the now-permitted high-speed data transmissions at 600 and 1200 bauds, or above, on v.h.f. He asks where amateurs will get all the traffic that needs shifting in such a hurry or the paper to print it all out on. Who, he asks, will take the trouble to receive and digest great spurts of data?

"I just cannot think what the appeal of r.t.t.y. is to amateurs when those of us who used it for real traffic knew from the beginning what a poor system of synchronism 'stop/start' is when applied to ionospheric-reflected signals" he adds provocatively.

Clearly one can see the attractions of communicating by speech or c.w. at speeds well suited to an individual operator, or even occasionally sending images by s.s.t.v. or facsimile. But the idea of spending hours preparing to send a two-minute burst of data or linking up two home computers seems a curious way of improving the hobby. Though I suspect that to say so is to invite the label reactionary!

### Czech summer of 1968

Traditionally, amateur radio steers well clear of international politics but just occasionally, willy-nilly, the lines get crossed. There was for instance the Hungarian business of 1956 when several Hungarian amateur stations could be heard desperately trying to get messages through to broadcasting stations in West Germany. But the most unusual — and to all who listened one of the most moving — episodes occurred



ten years ago during the later stages of that Czech summer which culminated in the military intervention of Russia. Yet little has ever appeared in print of what took place.

For several days during August 1968 a number of apparently "official" Czech mobile stations using callsigns such as OK5CSSR and OK9CSSR operated on the amateur bands sending out streams of highly political messages in support of Dubcek and a "democratic socialist republic" and containing such phrases as "go home Russian army" and "we want no Soviet politics and pressure in our lives". The messages were often dramatic and moving in their appeals for moral support. Using the QRR (Amateur SOS) procedure one of the last messages heard on 14MHz was "Please moral help for us in your countries. Now I am moving to 3.5MHz for our democratic service. 73 to all good hams of the world. The situation here very bad."

Soon afterwards the CSSR stations went off the air. Whether, as appeared to be the case, the activity had been officially planned, co-ordinated and encouraged, or whether it was simply some Czech amateurs who took matters into their own hands has never been revealed. One day the full story of those CSSR "amateurs" may perhaps become known.

### A new "Guide"

Like many other would-be amateurs, the very first publication I ever read devoted entirely to amateur radio was a pre-war edition of "A Guide to Amateur Radio" published by the RSGB. Over 20 years later, in 1958, I took over responsibility for the contents at a time when there were still less than 10,000 amateurs in the UK and little activity other than on c.w. and a.m. (A3). Just how much the hobby has changed since then has been very evident during the preparation of the latest (17th) edition and in fact the entire publication has had to be re-set and expanded. The changes have not been technical only; it has been necessary to take into account the new syllabus and style of the Radio

Amateur's Examination to be introduced in May 1979. The 120-page limp cover edition is available from RSGB, 35 Doughty Street, London WC1 (£1.71 including post and packing) For those with very long memories, the concept of a low-cost guide to the hobby originated with a publication called "What is amateur radio?" as early as 1932, and several of the amateurs mentioned in that original publication are still active.

### Here and there

Television dx enthusiasts have long discovered that favourable tropospheric paths exist quite often between the UK and Spain, but it was only in September 1977 that the first 432MHz contact was made (G3AUS and EA1AM). More recently, during March 1978, GJ8ORH and GJ8KMU both in Jersey were included among several UK amateurs to work Spanish stations on 144MHz and 432MHz.

Several papers and demonstrations are being given by radio amateurs at the three-day IERE conference on radio receivers and associated systems at Southampton University, July 11-14.

According to CQ-TV, A. H. Turner, one of several amateur tv stations active in the Luton/Dunstable area, has made colour transmissions and is also active on the 23cm band. Most activity in the UK is on the 70cm band and a weekly "activity period" for amateur tv stations in the North London, Watford, Cambridgeshire, Northamptonshire and Buckinghamshire area has been proposed (contact John Wood, G3YQC, 54 Elkington Road, Yelvertoft, Northampton, telephone 0788-823250).

A 144MHz transequatorial mode contact has been made over a distance of 5972km between ZE2JV in Rhodesia and 5B4WR in Cyprus.

### In brief

British nationals holding an amateur licence issued by any administration with which the UK has a reciprocal licensing agreement can now obtain a UK licence without taking the UK examinations . . . The conditions governing the use of crystal control by British maritime mobile stations have been relaxed . . . ITU callsign prefixes now include J4A to J4Z for Greece and J5A to J5Z for Republic of Guinea-Bissau

. . . The Home Office is now prepared to issue GB8 "special event" permits for operation on bands open to Class B operators . . . The French REF balloon-borne v.h.f. activities have been resumed again this summer . . . The 21st Jamboree-on-the-Air, the amateur radio event organised by the Scouts, is to be held on October 21-22 . . . The special expedition to Clipperton Islands made 29,069 contacts, an average of 187 per hour.

PAT HAWKER, G3VA



# NEW PRODUCTS

## Oscilloscope camera

The Shackman 7000 oscilloscope camera is claimed to be half the price of comparable existing equipment and is available with a choice of mounting systems. This camera has been introduced as an up-dated replacement to the CR-9, which was manufactured by Shackman Instruments Ltd for Polaroid in the late '60s. Its lens has been improved (now f3.5 instead of f5.6) and it has eight shutter speeds starting at 1s. According to the makers, the 7000 weighs less than 24 ounces and produces  $83 \times 108$ mm prints, with virtually no picture distortion, in just 30s. The camera needs no focussing and the exposures can be controlled to take account of the brightness of the display and the type of phosphor used. The lens has a 70mm focal length and includes aperture control down to f32. Speeds on the self-cocking shutter may be adjusted down to 1/125th second and a 'B' control, for time exposures, and an 'X' contact, for event triggering, are included. The shutter is activated by cable release. The camera takes quick-loading, Polaroid, black-and-white 8-exposure film packs of the type 107C 3000ASA or, where extra prints are required, the type 665 75ASA pos./neg. A range of ten hoods are available and the camera can be fitted to any one of over 60 adaptors, enabling it to be used with over 27 different makes of oscilloscope. Price is from £130 to £160. Shackman Instruments Ltd, Mineral Lane, Chesham, Bucks HP5 1NU.

WW 301

## Radio code clock

The Radiocode clock, which automatically receives a 60kHz transmission from Rugby MSF and decodes all of the time and date information, is claimed to provide the most authoritative portable and self-contained time source available. A liquid crystal display shows either hours, minutes and seconds or day, month and year. Because the unit has a crystal backup, the clock will continue to operate even if the transmission stops during a maintenance period. The instrument can also be supplied with an alarm/timer module which en-

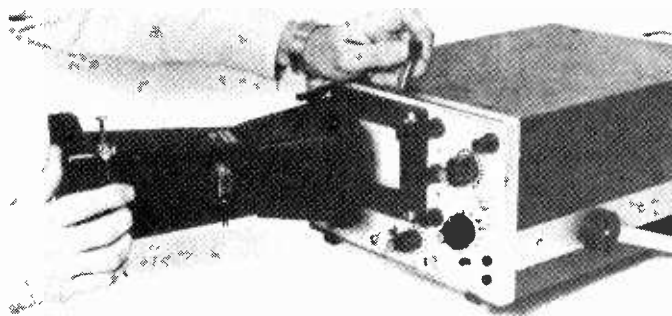

WW 301

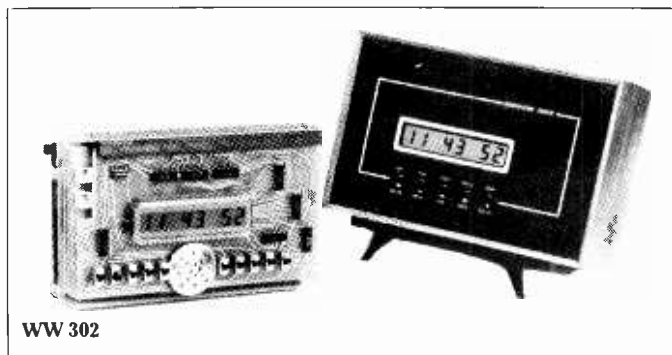

WW 302

ables the clock to control other equipment at certain times for precise periods. No initial or subsequent adjustments are required because the clock sets itself and accounts for leap seconds, leap years, and BST. Internal standard batteries allow a year's continuous use even with a built-in sounder operating. The estimated range is around 1000 miles, and the receiver delay, after compensation, is quoted as 5ms. For use on the Continent, the clock has an add-on-hour facility. Alternatively, a modified version can be supplied which receives a similar signal from the DCF 77 transmitter at Mainflingen, West Germany. This allows the clock to be used in eastern Europe where the MSF transmission may be weak. Various optional outputs are also available, enabling the clock to be used with a complementary record/replay unit. This interface allows the "time" to be recorded on one track of a conventional tape machine. On replay the recorded time is displayed by the clock. If very low frequency signals or d.c. levels are to be recorded on the other tracks of

the tape recorder, an additional f.m. interface unit can be supplied. For applications which require an accuracy of around  $1\mu\text{s}$ , details of an NPL system using a Radiocode clock and television sync pulses can be supplied. Prices for standard clocks range from £275 to £365. Circuit Services, 6 Elmbridge Drive, Ruislip, Middlesex HA4 7XB.

WW 302

## Seven-segment display

A seven-segment l.e.d. display, introduced by Highland Electronics Ltd, has a rectangular presentation measuring  $24 \times 18$ mm and mounts in a 16mm diameter round hole. The 31D, as



WW 303

it is called, includes a memory and a decimal point and operates from a 5V d.c. source. It accepts a b.c.d. negative input and displays 16 characters: figures 0 to 9 and letters A to F. Highland Electronics Limited, Highland House, 8 Old Steine, Brighton, East Sussex BN1 1EJ.

WW 303

## Microwave isolators

A range of X-band microwave isolators, in waveguide 16 (WR90, R100), has been designed and manufactured by Nore Microwave Ltd. Characteristics include bandwidths up to 500MHz, an operating temperature range of  $-40$  to  $+85^\circ\text{C}$  and isolation, at the centre frequency, in excess of 40dB. A typical 100MHz-bandwidth unit has a v.s.w.r. of 1.15:1, an insertion loss of 0.4dB and a power handling capability of 10W. Since they weigh only 50g, and are packed into only one half-inch of wavelength, they are particularly suited to severe military and airborne environment conditions. Nore Microwave Limited, 36 Towerfield Road, Shoeburyness, Southend-on-Sea, Essex SS3 9QT.

WW 304

## Serial data analyser

The model 1640A analyser is claimed by its makers, Hewlett-Packard, to make the troubleshooting of data communication networks easy. A keyboard enables a range of functions to be selected to alleviate the need for programming by the user. When used passively, the analyser can be connected to an RS232C (V24) interface and monitor to record both transmit and receive data. When used actively, it can simulate a computer, modem or terminal and can interact with the network to which it is connected. In its 'copy' mode of operation, instead of having to enter complex format sequences via the keyboard, the analyser can simply monitor the format changes between the c.p.u. and the terminal, and then automatically transfer either the receive or transmit data into the analyser's transmit message buffer. The data can then be edited prior

to transmission by the analyser. This feature reduces the need for the user to be intimately familiar with the network format and practically eliminates the possibility of human error during message composition. Hewlett-Packard Limited, King Street Lane, Winnersh, Wokingham, Berkshire RG11 5AR.  
**WW 305**

**WW 305**

### Driver-amplifier i.c.

The ICL8063 is a driver-amplifier which will interface low level signals from operational amplifiers directly with power transistors. It is capable of providing up to 100mA of drive current in this mode. A useful feature of the device is that it has built-in regulators which may be used to provide supply rails for other devices in the system. The ICL8063 is fully short-circuit protected. Intersil Incorporated, 8 Tessa Road, Reading, Berkshire RG1 8NS.  
**WW 306**

### Low-cost function generator

The FG601, from Feedback Instruments Limited, is an all-purpose function generator which is claimed to provide users with facilities normally only found on much more expensive instruments. It produces sine, square and triangular waveforms, as well as t.t.l. pulses, at frequencies between 0.001Hz and 1MHz, in nine overlapping ranges. The output level is variable up to 20V pk-to-pk, while switched attenuators are provided for control of low level signals. A direct voltage offset of up to  $\pm 10V$  may be superimposed on the output and an oscillator control voltage input is provided for sweeping of up to two decades of frequency. Price is about £250. Electroplan Limited, P.O. Box 19, Orchard Road, Royston, Herts SG8 5HH.  
**WW 307**

### Attenuation meter for optical fibres

The Fibre-Link 3140 has been designed to measure the attenuation in optical fibre links using the insertion loss method. Its built-in light source is a visible

red l.e.d., with Fibre-Link 3100 computing hardware, but alternative external sources may be powered from the controlled and metered "external emitter power supply" terminals. In addition, accessories for alternative couplings can be supplied to meet customers' special requirements. The instrument, which is suitable for loss measurements in fibres, couplings and assemblies under both laboratory and production conditions, operates from either 120V or 240V and incorporates a stabilized power supply. Price is £392 ex UK works. Lee Green Precision Industries Limited, Grotes Place, Blackheath, London SE3 0RA.  
**WW 308**

### Multi-crystal r.f. sources

The ML12000 series of very-low-noise, r.f. signal sources can now be supplied to give up to ten switch-selectable, fixed output frequencies — contained within a 2% bandwidth — over the total range of 1 to 11GHz. Each unit comprises a low-noise, crystal-controlled oscillator and amplifier, driving a high efficiency varactor-type frequency multiplier to achieve the specified output frequency. Standard models include

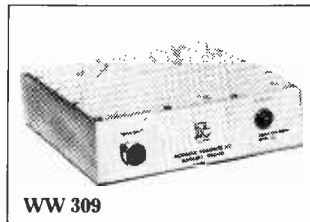
**WW 309**

the ML12024, delivering 80mW at up to ten frequencies in a 2% band between 1.7 and 3.2GHz; the ML12025 with an output of 1W at three frequencies, between 2.4 and 2.6GHz; the ML12055 and 12491 with 10mW outputs and ten frequencies between 5.1 and 5.7GHz, and 9.4 and 10.3GHz respectively; and the ML12100, which can deliver 100mW at three frequencies between 9.4 and 10.3GHz. All of the units have a frequency stability of better than 50 p.p.m. from  $-20^{\circ}$  to  $+50^{\circ}C$  and are designed for coaxial operation, via a 3mm SMA connector, with an integral isolator allowing operation with load v.s.w.r.s up to 3:1. Microwave Associates Limited, Dunstable, Bedfordshire LU5 4SX.  
**WW 309**

### Microprocessor system for v.d.us

Scrumpi 3 is a small business computer system for o.e.m. applications and d.i.y. en-

thusiasts. It is based on a S6/MP11 n.m.o.s. microprocessor and has video and u.h.f. outputs for  $32 \times 8$  character v.d.us. It also has a 20-key keyboard allowing 64 ASCII-code inputs, a 1K p.r.o.m. plus a 1K socket, a 128-byte r.a.m. plus a 1K socket and u.a.r.t. and teleprinter interfaces. Optional extras include a minicassette transport and interface and a 50mm v.d.u. monitor. Bywood Electronics, 68 Ebbens Road, Hemel Hempstead, Herts.  
**WW 310**

### Lead forming machine

The model WLF-300, from Eraser International Ltd, is designed to straighten the leads of d.i.l. components for 0.3in lead spacing. By straightening the leads of a component in this way, the component is more easily inserted

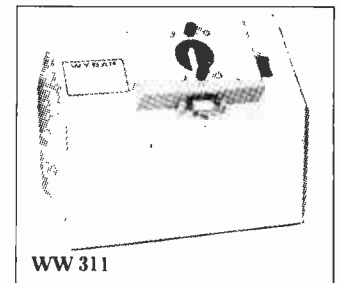
**WW 311**

into a p.c.b., and damage to plated-through holes or the leads themselves is eliminated. The forming machine, which is electrically-operated, is fully automatic and is adjustable for components with different body thicknesses. Setting-up time is minimal and production rates are in excess of 40,000 pieces per hour. The WLF-300 weighs 20lb and measures 11x12x10in. Eraser International Limited, 2/3 Hampton Court Parade, East Molesey, Surrey KT8 9HB.  
**WW 311**

### Radio pager with visual backup

A digital radio-paging receiver, from Multitone Electric Co. Ltd, provides a visual display as well as eight tone call-codes. The f.m. receiver, known as the RB151, has call memory and silent-alert facilities, an out-of-range warning facility and the ability to receive group alert calls. Up to four pagers may be called every second, enabling the requirements of large and busy systems to be met. In one mode, the visual facility is a single-digit number, from one to eight, on a large l.e.d. display. This number is associated with its own tone signal. In a second mode, the display can show any number up to 9999 as a sequence of single digits which can be used, for

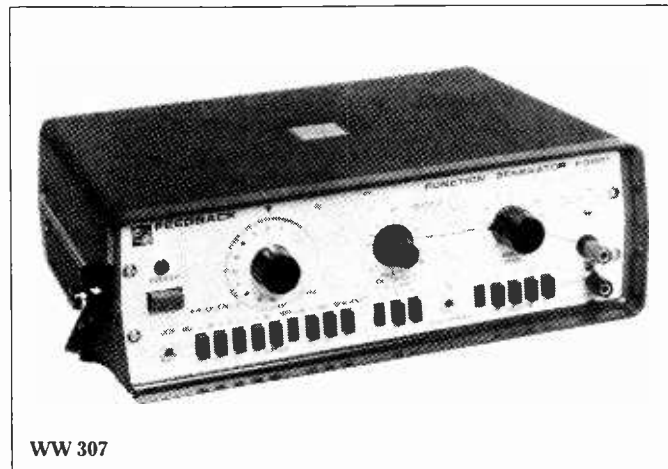
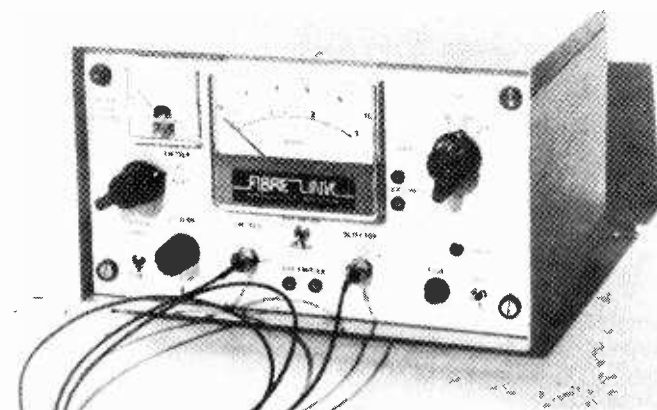
**WW 307****WW 308**

example, to inform the called person of a telephone number, or the degree of urgency of a call. According to Multitone, the RB151 receiver can be used to convey more information than any other pager on the market and the programming and re-programming of the receiver — to meet almost any requirement — can be done speedily by unskilled personnel. All of these facilities are made possible by the use of c.m.o.s. and bi-polar custom-designed integrated circuits. Multitone Electric Company Limited, 6-28 Underwood Street, London N1 7JT.

WW 312

**P.c.b. mains transformers**

A range of p.c.b.-mounting mains transformers, claimed to offer cost savings to bulk buyers, includes open and encapsulated-construction models, of both the power and isolation type. The power ratings are in the range 1 to 125VA, with a large number of the models at the smaller end of the range being quoted as short-circuit proof. The transformers, which are made by Eichhoff-Werke, all comply with VDE and DIN specifications and can therefore be used in double-insulated electrical equipment. Typical specifications for the smaller versions could be: 240V primary, 2.4 to 24V secondary for about 1.5VA power, and measuring 25.5 x 27 x 32mm (h x w x l). For bulk orders, special designs with dual secondary outputs and short-circuit-proof operation can usually be supplied. Prices for the smaller versions start at £1.20. Selig Electromagnetics Limited, 2 Powis Gardens, London NW11 8HY.

WW 313

**X-Y recorder**

An X-Y recorder, introduced by B & K Laboratories Ltd, is designated as the Type 2308 and is claimed to have a slewing speed of 1000mm/s. It is designed for fast, accurate recording of linear d.c. characteristics and it can handle rapidly changing voltages without difficulty, it is claimed. Despite the fast slewing speed, overshoot is less than 1% and the error is only 0.2%. The recorder provides 15 calibrated sensitivity ranges from 0.02 to 1000mV/mm and nine calibrated sweep rates from 0.2 to 100mm/s. Paper sizes up to A4 can be accommodated on the 2308 and the writing area is 185 x 270mm. The recorder which has an input impedance of 1MΩ, has floating and grounded input modes with high common-mode rejection and reversible

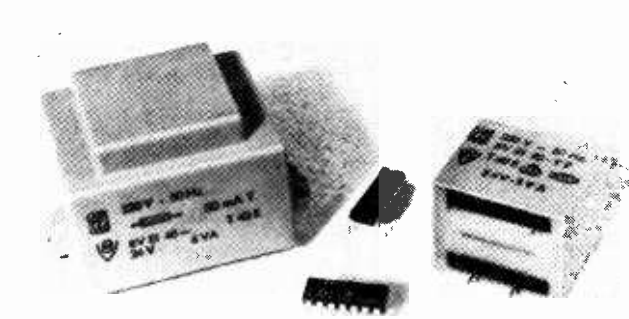

WW 313

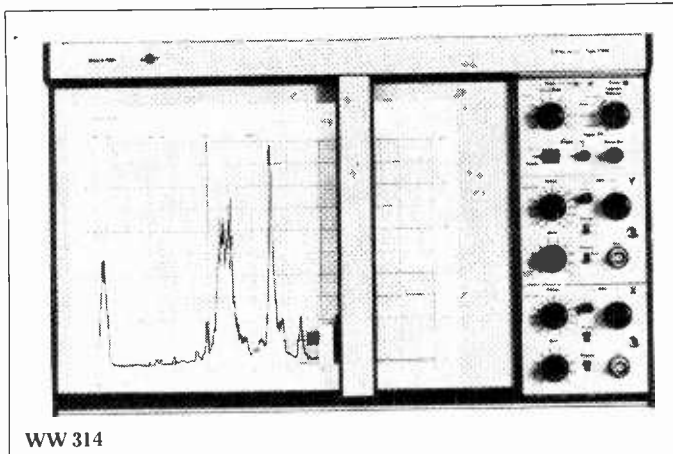

WW 314

polarity. B & K Laboratories Limited, Cross Lances Road, Hounslow, TW3 2AF.

WW 314

**U.h.f. amplifier**

A u.h.f. amplifier, designated the CM7043, has been designed specifically for serving a second tv receiver in instances where



WW 315

only a single outlet or aerial is available. The CM7043, which has a bandwidth from 470 to 860MHz, requires a 220/240V alternating supply and has a maximum output of 16mV (24dBmV). Other specifications include a typical gain of 4dB — to each outlet — and a noise figure of 6dB. Labgear Limited, Abbey Walk, Cambridge CB1 2RQ.

WW 315

**Light-emitting diodes**

Two red l.e.d.s, types MIL30 and MIL50, have typical minimum light intensities of 0.5mcd at 20mA and are available in a choice of sizes, lens effects and mounting configurations. The diodes are gallium-arsenide-phosphide types in plastic encapsulations and the choice of lens effects includes diffused, clear, transparent and diffused/clear types. Type MIL30 is a 3mm l.e.d. and type MIL50 is a 5mm l.e.d. Both diodes are available with plastic adaptor clips for panel mounting, and are suitable for p.c.b. mounting with wire-wrap leads. Specifications include maximum forward currents of 70mA, maximum reverse voltages of 5V, a spectral half-bandwidth of 40nm, and a peak wavelength of 660nm at 20mA. Micro Electronics Limited, York House, Empire Way, Wembley, Middlesex.

WW 316

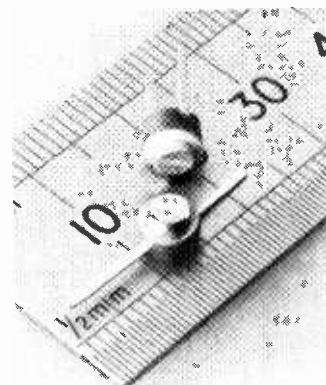

WW 317

**Trimmer capacitor**

New developments in ceramic technology have enabled the CD5 series of 5mm miniature ceramic-disc trimmers, from Oxley Developments Company Ltd, to be extended to include a high capacitance value of up to 40pF. This trimmer, type CD5/40, has a minimum capacitance of 4pF and is particularly suitable for crystal pulling in quartz-controlled circuits. The CD5 series is BS9000-approved in the capacitance range 0.9–2.0pF to 3.5–25pF. Other recent developments in the CD5 series have been the introduction of horizontal- and back-adjustment configurations. The CD5/40 has a Q value at 1MHz of greater than 200 and a self-resonant frequency of greater than 750MHz. Oxley Developments Company Limited, Ulverston, Cumbria LA12 9QG.

WW 317

**Audio frequency test set**

On show for the first time in the UK at the Communications '78 exhibition was a test set for measuring transmission levels, frequencies, noise and weighted noise of audio frequency channels and systems. The test set, designated the TTI 1120, has a built-in microprocessor and memory which, in addition to controlling measurements and transmit functions, automati-



WW 318

cally test all major instrument components. This diagnostic routine takes only 12s and the results are shown in word form on an alphanumeric display. A low-distortion precision oscillator acts as the signal source, and this may either be tuned in the bands 50Hz to 4kHz and 1kHz to 20kHz or used in a fixed push-button mode at predetermined frequencies. Level is auto-ranging from -50 to +10.5dBm, noise readings are from -90 to +10dBm, and the frequency range is 50Hz to 20kHz. The Model TTI 1120 is a battery-powered set weighing only 14lb, but a second set, the model TTI 1122, is also available for mains operation. Both sets are manufactured to CCITT specifications and are available from Wandel & Goltermann (UK) Limited, 40-48 High Street, Acton, London W.3.

WW 318

## If it's Radio 3, this must be Thursday

They tell me you can now buy a tuner which you can programme to switch to any station at any time on any day for a week or more ahead. Well, I can't tell you how happy I am to know that. You realize what it means, of course? No? It means that Friday evenings will be properly occupied from now on.

Can't you just see it? You arrive home after the legendary hard day at the office, and after you've kissed the wife, kicked the cat and got Coronation Street safely out of the way, you settle down with *Radio Times* and calculator for an enjoyable evening's programming. I dare say the choices may sometimes be a little on the agonizing side — in our ménage the decisions are fairly clearly defined between pop and music, although one can imagine this not always being so. But having made the decisions and commanded the wireless to do the right thing at the right time, that's it. No more worries until next Friday.

Mind you, you've got to stick to it. None of these spur-of-the-moment idiocies like wanting to listen to the Archers instead of that fascinating talk on Radio Three entitled "The private life of the dung-beetle." One will have to be very firm with people wanting to go off to bed early or expressing a desire for an hour's quiet read. All back-sliders of that kind are asking for the ultimate penalty — a ten-minute closed-loop sound recording of a Kenny Everett commercial.

## Smoothese

All those who are accustomed to hearing and speaking Double Dutch might as well switch off for a couple of minutes, because I'm about to go on again about plain English. My intention is to initiate an on-going elucidation situation, but I doubt very much that I shall do any such thing.

Actually, I was just reflecting that not only is ordinary English maltreated in the most cavalier way to make new, technological words, but these new words themselves are often used in a way that wasn't originally intended. Look at 'software,' for example, Years ago, we used the word 'hardware' in a jocular sense, meaning the equipment itself rather than its circuit diagram. It has always been the fashion to use homely words in our industry — perhaps to show that we are so familiar with the subject that we needn't use the technical description. Then, along came computers and 'software' was used not to mean a circuit diagram, but all the paper associated with the use of a computer. It is now the respectable antonym for a word that was originally used in a slang way. There's another one — "state-of-the-art." No self-respecting PR or marketing man can afford to



ignore a buzz-word like that. I remember it being used by our chief engineer back in the '50s, when he would stalk into the lab. and say "Right, what's the state of the art this morning, then?" Presumably, he really meant to ask how the work was going and why were we just sitting there? How it became an adjective, complete with hyphens, I just don't know.

Marketing in its broader sense, meaning sales, market research, press and public relations and the rest, has done its share of debasing the language (*the language?* I wonder if they do it in French and German, as well?) and every time I read one of the publications concerned more with commerce than technique I come across another word I don't understand. Some time ago I kept seeing references to turkey contracts, or I thought I did, but now I know that I was misreading the word 'turnkey.' Well, at least I don't have to wonder why people are spending millions on turkeys any more, but I'm a bit at sea again, because the Concise Oxford says a turnkey is a person in charge of prison keys. I reckon a turnkey contract is one where the vendor has been nicked for laying about him with bribes and finishes up in Brixton.

I was going on to have a go at 'interface' and a passing crack at "hopefully" and "orientated," but I've said enough. It's an on-going deterioration situation, but I've run out of software, so a termination condition is mandatory.

## Panic button

Six months of my life. Gone, just like that, in vain expectation. I began to listen to the latest form of mass sado-masochism, the 'phone-in radio programme, last year and ever since I've been waiting with breath well bated for the first naughty word to come resounding through the ether.

Each time the presenter has put down a caller or has cut him off short in the customary loutish way, I've been expecting a faint, pathetic cry of "Oh, knickers", or perhaps something a little more trenchant, to disturb the ordered calm of the studio. I've offered the odd

exhortation myself, but it's not the same as hearing it broadcast. I remember my brother-in-law, who operates microphones and things on a film unit, telling me that when they approach a 'man-in-the-street' for his opinion on Mrs Thatcher and ask him if he has a comment, they sometimes get the reply "Yes, I have. — off!" Now, that would be really something. I wouldn't mind paying the licence fee at all, for that.

But it seems that I am the last person in the country to realize that the phone-in presenters have a delay unit with a 'delete expletive' button, so that they can bowdlerize the conversation and, of course, my brother-in-law's tape never sees the light of day at all. I think it's disgraceful, personally — a shameful curtailment of the public's right to be as offensive to the presenter as he is to them. But I don't care — I've stopped listening, now.

## No, really?

I heard an interview on the radio the other morning, in the course of which a delightful nun was asked how her order conducted its financial affairs. She thought about it for a bit and said "We don't worry much about money — it doesn't pay." The quote of the week, and it set me off trying to remember quotes from people I have known in the electronics industry. Like the member of the guided weapons trials team at Hatfield who, when their round had missed the target, said "Well, they're expensive, you know — we can't have them colliding with every bit of tin up there."

Or the chap who wanted to show me just how one of our colleagues had collected an 800V shock. "The twid leaned on it like this" he said; whereupon he screamed and went out like a light. Then there was the American reporter who complained, about 60 years ago, that he couldn't get Guglielmo Marconi to give him an interview. "Mr Marconi is a very uncommunicative man," he said, in what must be the canard of the century.

I well remember reading a description of an f.m. carrier deviation monitor in which the writer claimed "The inherent a.m. noise is better than —80dB; and, in fact, with the instrument switched off it is unmeasurable." It is unfair to take remarks like that out of context because, believe it or not, it did make sense when read with the full description, but it stuck in my memory and I couldn't resist it.

## Relative

*There was a young spaceman called Farr  
who went there and back to a starr  
and when he came down  
just outside Kentish Town  
an elderly gent called him "Parr!"*

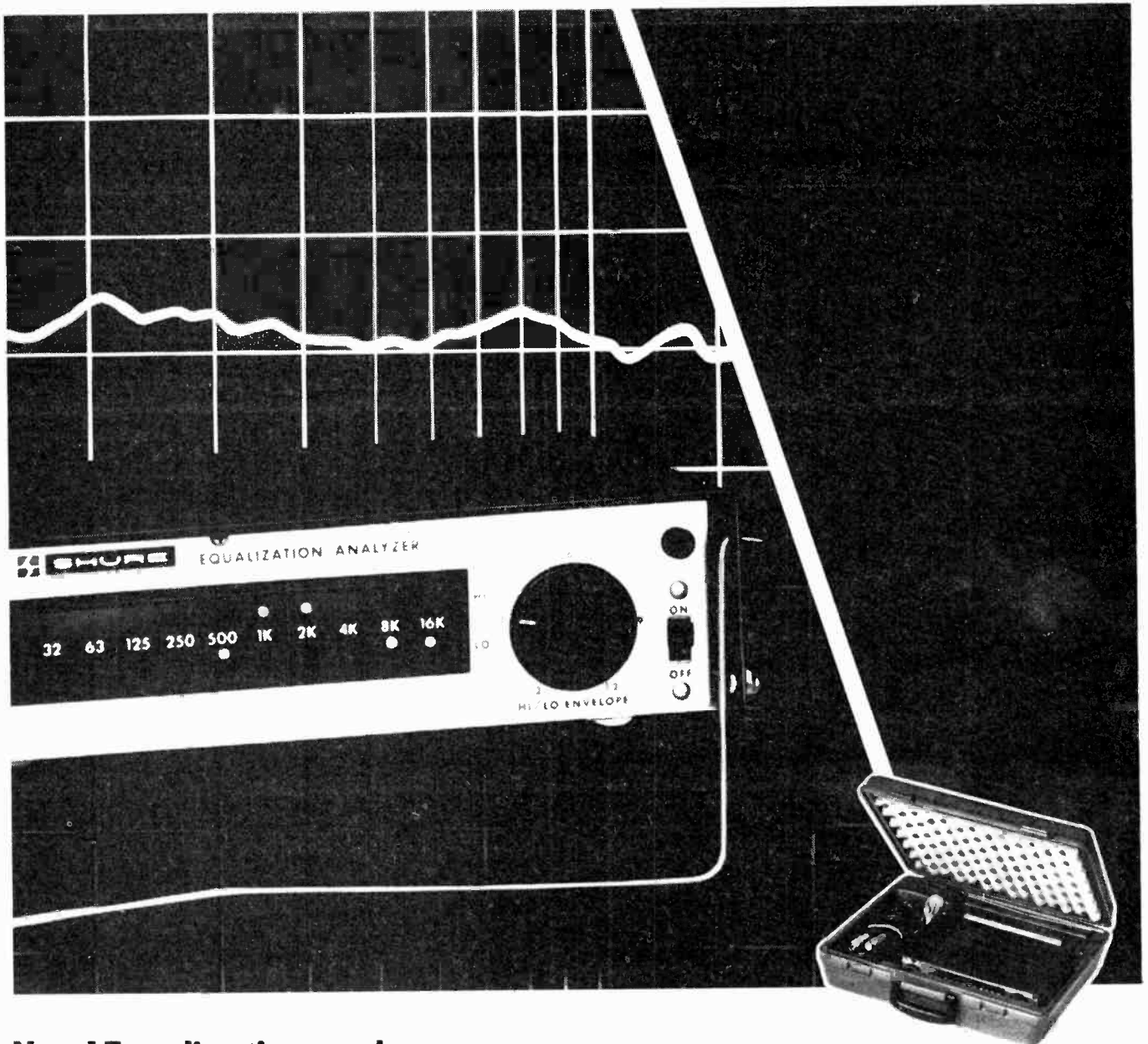

**New! Equalization analyzer...**

## Balance a system...Balance a budget.

Quick and accurate adjustment of sound system frequency response is finally within the reach of most budgets. The Shure M615AS Equalization Analyzer System is a revolutionary breakthrough that lets you "see" room response trouble spots in sound reinforcement and hi-fi systems—without bulky equipment, and at a fraction of the cost of conventional analyzers.

The portable, 11-pound system (which includes the analyzer, special microphone, accessories, and carrying case) puts an equal-energy-per-octave "pink noise" test signal

into your sound system. You place the microphone in the listening area and simply adjust the filters of an octave equalizer (such as the Shure SR107 or M610) until the M615 display indicates that each of 10 octaves are properly balanced. You can achieve accuracy within  $\pm 1$  dB, without having to "play it by ear."

Send for complete descriptive brochure.

Shure Electronics Limited  
Eccleston Road  
Maidstone ME15 6AU  
Telephone: Maidstone (0622) 59881

### TECHNICORNER

The M615 Analyzer's display contains 20 LEDs that indicate frequency response level in each of 10 octave bands from 32 Hz to 16,000 Hz.

A rotary hi/lo envelope control adjusts the HI LED threshold relative to the LO LED threshold. At minimum setting, the resulting frequency response is correct within  $\pm 1$  dB. Includes input and microphone preamplifier overload LEDs. A front panel switch selects either flat or "house curve" equalization.

The ES615 Omnidirectional Analyzer Microphone (also available separately) is designed specifically for equalization analyzer systems.



WW-041 FOR FURTHER DETAILS



# FULL ASCII KEYBOARD

**LOW COST!**  
Model 756  
Full ASCII  
Keyboard

- \* Intended for professional micro-processor applications.
- \* This one Keyboard will meet most present and future requirements.
- \* Full 128-character ASCII 8-bit code
- \* Tri-mode MOS encoding.
- \* Applications notes for auto repeat, numeric pad, serial output.
- \* Upper and lower case characters generated by keyboard with latching shift-lock.
- \* Selectable polarity.
- \* Size 305 X 140 X 32mm (12 1/4 X 5 1/2 X 1 1/4 in)
- \* MOS/DTL/TTL compatible outputs.
- \* New guaranteed OEM grade components.
- \* Needs +5 and -12V supply

- \* Board has space for small low-cost DC/DC converter so that entire unit operates off single 5 V rail.

- \* User selection of positive or negative logic data and strobe output.
- \* Alpha lock.
- \* Extra loose keys available.
- \* Supplied complete with gold-plated PCB connector and full technical data.
- \* Rugged mil. spec. G-10 PCB with plated through holes.
- \* 2-key roll-over
- \* DC level and pulse strobe signal for easy interface to any 8-bit input port microprocessor system, video display or terminal board. Strobe pulse width 1 ms.

PRICED LOWER THAN  
SURPLUS KEYBOARDS

Please write for full technical details and price, and for names and addresses of our UK and European stockists.

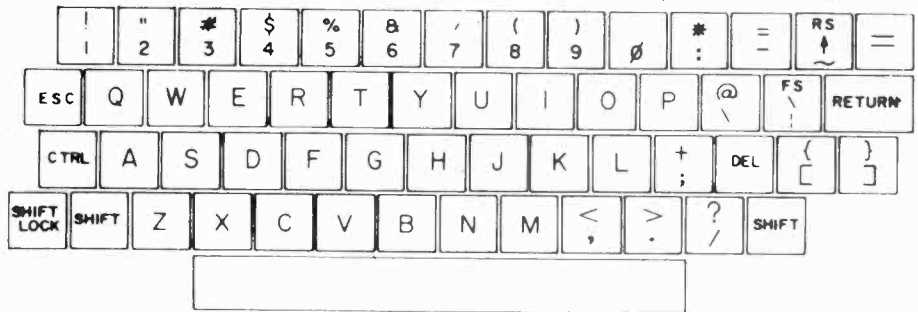

## Carter Associates

P.O. Box 11262  
VLAEBERG  
South Africa  
postal code 8018

WW-033 FOR FURTHER DETAILS

## TEST YOUR SKILL

by saving it for the **really** difficult problems!  
**NEW DATEST 2** makes **finding** a fault the **easy** bit.

It locates faulty transistors, FETs, SCRs, & Triacs while still in-circuit and is hardly ever beaten even by 20 ohm shunt resistors.

Unique test probes, fully automatic operation, and low cost save temper, time and money.

**ENGINEERING TALENT IS EXPENSIVE**  
— LET **DATEST 2** HELP IT TO GO FURTHER

**DATONG ELECTRONICS LIMITED**  
Spence Mills, Mill Lane, Bramley, Leeds LS13 3HE  
Telephone: Pudsey (0532) 552461



**ONLY £39.50**  
+ VAT (8%)  
WITH PROBES

WW-107 FOR FURTHER DETAILS

## Audio Connectors

Broadcast pattern jackfields, jackcords, plugs and jacks.

Quick disconnect microphone connectors. Amphenol (Tuchel) miniature connectors with coupling nut.

Hirschmann Banana plugs and test probes, XLR compatible in-line attenuators and reversers.

Low cost slider faders by Ruf.

**Future Film Developments Ltd.**  
36-38 Lexington Street  
London W1R 3HR  
01-437 1892/3



WW-038 FOR FURTHER DETAILS

**NEW**  
for  
**electronic**  
**design**  
**engineers!**

### FIX-PRINT JIG for printed circuits

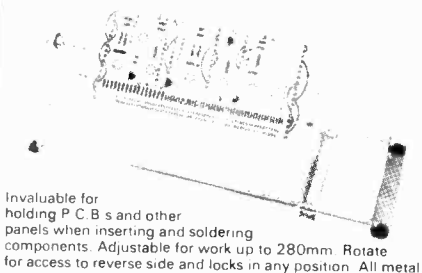

Invaluable for holding P.C.B.s and other panels when inserting and soldering components. Adjustable for work up to 280mm. Rotate for access to reverse side and locks in any position. All metal.

Write of phone for full details. Price **£10** inc. VAT P&P £1

### S2 Drill Stand

Robust, all metal with ample throat dimensions. Adjustable height cantilever with lever actuated feed. Spring return. Will accept both drills.

**£18.50.**  
inc VAT  
P&P 106p

**P2 Mk. 2 Drill**  
**£18** inc. VAT  
P&P 86p

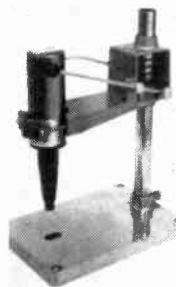

### S1 Drill Stand

Constructed to take the popular P1 drill and ensure a high degree of accuracy in all types of electrical precision work.

**£5.13**  
inc VAT P&P 38p

**P1 Drill £9.67**  
inc. VAT P&P 38p

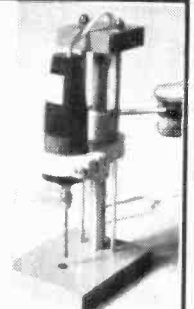

**HAVE YOU TRIED SPADE DRILLS** for printed circuit boards and other soft materials? No clogging — cooler — cleaner holes — there's a range of sizes, 0.1 to 2.5mm

**PRECISION PETITE LTD** 119a HIGH STREET TEDDINGTON MIDDLESEX TW11 8HG  
TEL: 01-977 0878 Sole UK Distributors

WW-011 FOR FURTHER DETAILS

# TRUE PROFESSIONALS

Including: EMI, Decca (UK), BBC, Pink Floyd, Hawker Sidley, Metropolitan Police, The Who, Queen, Thames TV, ITN, Capital Radio, Decca (France), Ministry of Defence, Birds Eye, Rolls Royce, Crown Agents, Madame Tussaud's, Island Music, Chappells, Dick James Music, Neve, Alice, Israel Defence Ministry, Yes Music, University of Bucharest, Pye TVT, Avon Health Authority, Government of Seychelles, Philippines Radio, London Broadcasting, Rolling Stones, Thin Lizzie, British Railways, Natural History Museum, Virgin Records, Kirilo Savic Institute of Belgrade, all British Universities, London Weekend TV, BOC, Wings, IBM, every Local Radio Station, Post Office Research, Rank Organisation, and many others.

## ACKNOWLEDGE

That ITA has more to offer:

- **Location.** In Central London - easy parking.
- **Delivery.** Large stockholding covering 500 versions for immediate delivery.
- **Servicing** By ITA factory trained staff. Quickest turnaround time. Machines supplied or rebuilt for special requirements.
- **Pricing.** Check our prices - you will find them lowest ALWAYS.

## ITA'S ADVANTAGES



### REVOX

A wide range of two channel recorders from this famous manufacturer, with tape speeds from 15/16 ips to 30 ips. Options include variable speed and sel-sync. Models include A77, B77 and 3.77 with 3 speeds and editing (designed and modified by ITA specifically for professional applications).



### TEAC

Recorders for logging and studio use - tape speeds from 1 1/2 to 15 ips. 2, 4 or 8 channel. A range of mixers is also available.



### ITAM

4 and 8 channel recorders for studio use. Any tape speed from 1 1/2 ips for logging and data recording.

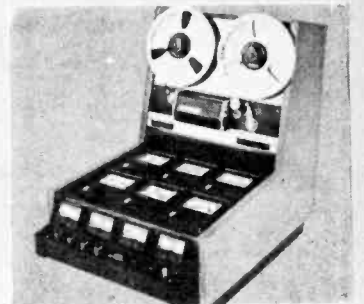

### OTARI

Duplicating equipment for high speed cassette copying, including the DP4050 model - the world's finest in-cassette copier, with 6 slave units.

1-7 Harewood Avenue, Marylebone Road, London NW1. Tel: 01-724 2497.  
Telex: 21879.

WW - 110 FOR FURTHER DETAILS  
[www.americanradiohistory.com](http://www.americanradiohistory.com)

# ITA



THE NEWBEAR COMPUTING STORE



PETITEVID VDU KIT £85

- \* 110 to 1200 band V24
\* 64ch x 16 line, scrolling
\* All on 8 x 4 pcb
Needs TV set, UHF modulator and ASCII keyboard

BOOKS

- p&p 50p unless otherwise stated
Computer designs. 77-68 a 6800 Microcomputer £7.50
Spare diagram set for 77-68 £1.50
WB-1 a TTL Microcomputer £6.50
Spare diagram set for WB-1 £1.00
Zilog, Z-80 Technical Manual £4.00
Z 80 PIO Technical Manual £2.50
Motorola. Understanding Microprocessors (30p p&p) £2.75
M6800 Microprocessor Programming Manual £4.50
M6800 Microprocessor Applications Manual (£1 p&p) £9.50
M.O.S. Technology. KM1 User Manual £5.00
6500 Programming Manual £5.00
6500 Hardware Manual £5.00
Adam Osbourne. Introduction to Microcomputers
Vol 0 Beginners Book £5.95
Vol 1 Basic Concepts £5.95
Vol 2 Some Real Products (£1 p&p) £11.95
8080 Programming for Logic Design £5.95
6800 Programming for Logic Design £5.95
Some Common Basic Programs £9.95
Payroll with Cost Accounting in Basic £9.95
Sybex. Microprocessors Rodney Zaks £8.00
Microprocessor Interfacing Techniques C207 £8.00
Some Common Basic Programs P-10 £7.95
Scelbi. 8080 Software Gourmet Guide Cookbook £7.95
6800 Software Gourmet Guide Cookbook £7.95
The Scelbi Byte Primer (£1 p&p) £9.95
What to Do After your Kit Return £7.00
(PCC First book of Computer Games)
PCC Reference on Home Computers £4.95
Instant Basic £4.95
Your Home Computer £4.95
My Computer Likes Me £1.65
Games with a Pocket calculator £1.75
Games Tricks & Puzzles for a hand calculator £2.45
Best of Creative Computing Vol 1 £6.95
Best of Creative Computing Vol 2 £6.95
Hobby Computers are here £3.99
Our range of books is constantly expanding Please write for latest list plus full range of 6800 and Z 80 software

Hardware Components Section

MEMORIES

Table with columns for item number, price, and description of memory modules.

MOTOROLA MICROCOMPUTING ICs

Table listing Motorola microcomputing ICs like MC6800P, MC6820P, etc.

ZILOG MICROPROCESSORS

Table listing Zilog microprocessors like Z-80 CPU, Z-80 PIO, etc.

MICROPROCESSORS

Table listing microprocessors like SC/MP Mk II, 6502, 6502, etc.

INTERFACING ICs

Table listing interfacing ICs like SFF96364, MC1488P, etc.

CONNECTORS & SOCKETS

Table listing connector and socket types like Subminiature D Type, 9 way plug, etc.

BEAR BAGS (Kits)

Table listing Bear Bags kits like 1 177 68 components and edge connectors, etc.

LOW POWER SCHOTTKY TTL PRICE LIST

Table listing Schottky TTL components like 74LS00, 74LS01, etc.

PRINTED CIRCUIT BOARDS

Table listing PCB components like CPU, 4K RAM, Soft Monitor, etc.

Goods are normally shipped within 24 hours. subject to availability Barclaycard & Access V.A.T at 8% for Hardware Components 30p postage and packing unless otherwise stated.

TIME PEACE £9.45\*



Not a spelling mistake, but another descriptive term for the National MA1012 complete clock & display module

Featuring sleep and snooze timers, 24 hour alarm format, fast and slow setting, alarm output switch. Display area 76 x 20 mm. Total size 3 1/2 x 8 x 2 cm.

REFERENCE SERIES TUNER MODULES

Table listing tuner modules like EF5803, Ref. FMIF, Ref. MPX with their specifications and prices.

Table listing other ranges of FM and AM tuner modules available.

COILS FOR LW, MW, SW 1,2, and 3 now listed in catalogue 30 & 33p ea TOKO 10k series coils now for 1.5 to 30MHz...

Low cost meters: Internally illuminated edgewise meters 200uA, and back lit flat face meters 200uA, A wide choice of scales - or material to DIY.

Equipment boxes: These must be the best value in ABS (black) equipment boxes with close fitting (flanged) lids. 8x6x4 (cms) 54p ea\*, 10x7.5x4 (cms) 66p ea\*, and 12x10x4.5 (cms) 76p ea\*.

DETECKNOWLEDGEY: theory and practise of metal locator principles including BFO IB, phase angle, pulse induction. A unique reference for users and constructors. £1.00

Our usual unique range of coils, filters etc for radio: from TOKO; 350.000 in stock. The best in linear ICs for RF, HA1137:£2.20; HA1196:£4.20; HA1197:£1.40, plus all common radio and multiplex devices, audio ICs (TBA810AS £1.09), MOSFETs, a unique line in varicap diodes for AM tuning

Postage 25p per order, VAT 12.5% except where otherwise indicated (\*8%). Send to 2 Gresham Road, Brentwood, Essex. tel (0277) 216029. Only 200m from station!



Lion House BUDGET HI-FI DEPARTMENT advertisement featuring a MATSI TFS60 system with a £100 off offer. Includes images of the tuner/amp, speakers, and turntable.





The Only Firm for Quality Audio Kits

# HART ELECTRONICS

Are proud to offer the only DESIGNER APPROVED kit for the

## J. L. Linsley-Hood High Quality Cassette Recorder

Now offered with Super Quality Sendust Alloy Head at no extra cost, and incorporating noise reduction modifications given in the postscript article.

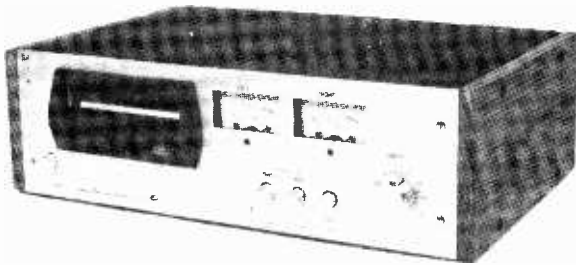

As these circuits are capable of such an excellent performance we feel that it is not sensible to sacrifice this potential by designing a kit down to a price. We have therefore spent a little more on professional hardware allowing us to design a very advanced modular system. This enables a more satisfactory electrical layout to be achieved, particularly around the very critical input areas of the replay preamps. These are totally stable with this layout and require no extra stabilising components. Many other advantages also come from this system which has separate record and replay amps for each channel plugging in to a master board with gold-plated sockets. The most obvious is the reduction of crosstalk and interaction which could cause trouble on a single plane board with our modular system the layout is compact but there is no component crowding. Testing is very easy with separate identical modules and building with the aid of our component-by-component instructions is childishly simple but the finished result is a unit designed not to normal domestic standards but to the best professional practice.

All printed circuits are of glassfibre material, fully drilled with a tinned finish for easy and reliable soldering. Component locations are printed on the reverse side of the board and are arranged so that all identification numbers are still visible after assembly.

71x Complete set of parts for Master Board includes bias oscillator relay controls, etc £9 83 + £1 23 VAT

72x Parts for Motor Speed and Solenoid Control for Lenco CRV deck. This is the proper board layout as given in the articles £3 52 + 44p VAT

73x Complete set of parts for stereo Replay Amps and VU Meter drive £8 12 + £1 02 VAT

74x Complete set for stereo Record Amps £6 74 + 84p VAT

75x Complete set of parts for Stabilised Power Supply to circuit given in Article. This uses a special low hum field transformer with better characteristics than the commonly used toroid £8 79 + £1 10 VAT

700M2 Individual High Quality VU Meters with excellent ballistics £8 48 + £1 06 VAT Per Pair

700C/2 High Quality Custom built steel Case Complete with Brushed aluminium front plate, mains switch, record microswitch, turned record level knob, plastic cabinet feet, all bolts, nuts and mounting hardware. All necessary holes are punched and all surfaces are electroplated. Complete step-by-step assembly instructions are included. The cover is finished in an attractive black crackle surface. £16 50 + £2 06 VAT

### LENCO CRV CASSETTE MECHANISM — Now fitted with Super Quality Sendust Alloy Head.

High Quality robust cassette transport for Linsley-Hood recorder. Features fast forward fast rewind record, pause and full auto stop and cassette ejection facilities. Fitted with Record / play and erase heads and supplied complete with Data and extra cassette ejection spring for above horizontal use. Price £21 60 + £2 70 VAT

Total cost of all parts £83 58  
Special offer for Complete Kits £81 50 + £10 19 VAT

Complete with data and set up notes to achieve best results with the Super Head. Optional extra solid teak end cheeks, £3 pair + 38p VAT

Reprint of 3 Linsley-Hood Cassette Recorder articles. 45p post and VAT free

### OTHER CASSETTE SPECIALITIES

LENCO MECHANISMS For industrial or domestic use. We have in stock SPFF, FFR and CRV with DC and AC motors. Mini T8500 502, 504 and Mini TB 'U' for endless loop cassettes. Send for details. Super Quality Sendust Alloy R/P Stereo Head for replacement use. £6.50 + 81p VAT

Set of components and data for optimising L-H Cassette circuits for use with this head 50p + 6p VAT  
Standard Quality Stereo R/P Head, £4 50 + 56p VAT  
Economy Cassette Stereo R/P Head, £2 80 + 35p VAT  
4-track Cassette R/P Head £7 40 + 93p VAT

TEST CASSETTE to enable the user without instruments to easily set up the Head Azimuth, tape speed and VU level. £1 50 inc VAT

Blank Cassettes, reliable mechanics and Super Ferric Low Noise tape. C90, 80p inc VAT C10 35p inc VAT

### MILITARY VEHICLE NAVIGATION EQUIPMENT

**INVERTORS SOLID STATE** for use on 24v DC, provides stab sine wave o/p of 26v 3 phase 400c/s max total load 120 watts with short circuit protection, fitted in heavy finned die cast case size 12 x 6 1/2 x 5 1/2", 1/P 7.4 amps for 100 watts o/p connections via two AN type plugs, supplied tested. Price £43.20.

**NAVIGATIONAL COMPUTER**, Accepts mechanical o/p from vehicle via multi ratio gearbox 9 to 11.1 in 40 steps, also contains two Autosyn Tx units 26v 400c/s, Servo Motor & transis amplifier Mech Ball resolver with elec shaft coders, precision gears, etc. in case size 8 x 5 x 8". Price £16.20.

**INDICATOR UNIT** display unit shows heading, eastings and northings, contains 26v 400c/s Autosyn Rx unit, two 4 digit veeeder counters with shaft digitizers and reset these are driven by two precision 27v DC motors in case size 8 x 4 x 6". Price £10.80.

**INDICATOR** remote heading indicator with 26v 400c/s Autosyn Rx scale 0 to 64 mils x 100, 3 1/4" dia. Price £3.50.

The above items were made in Canada and contain components of American make or style, all units in good condition.

**GENERATOR UNIT**, Hand or foot operated portable unit provides nom o/p of 110v AC 40 watts with o/p voltage indicator, comes with various accessories (table and tree clamps), breaks down into 6 major components, supplied in fitted transit container along with carrying haversacks, new unused made for M.O.D. Price £32.40.

**SIGNAL GENERATOR**, Portable VHF, UHF spot freq generator crystal controlled (crystal fitted in oven) provides o/ps at 105, 125, 150, 230, 300 and 390Mc/s CW or Int IKc Mod, intended for checking operation of VHF/UHF DF equip. Operates from internal 6v lead acid battery with int battery charger 115v 60c/s, supplied with two batteries mounting tripod and copy of handbook, new American equipment. Price £65.

**CLOSED CIRCUIT T.V. EQUIPMENT** limited number of Marconi Industrial TV systems valve type complete except for camera lens, consists of Camera, Camera C.U. Monitor 14" and camera cable, serviceable condition, with circs, for callers only. Price £108.

**SPECIAL PURPOSE EQUIP.** AN/TMQ-14 Infra Red Cloud base measuring equipment and AN/TPQ-11 Radar Cloud height measuring equipment, Q Band, GPA-70 Video Map unit, enquire.

Above prices include carriage and VAT goods ex-equipment unless stated new. SAE for list or enquiry. Shop open Tuesday to Saturday.

### A. H. SUPPLIES

122 Handsworth Road, SHEFFIELD S9 4AE  
Phone 444278 (0742)

WW—088 FOR FURTHER DETAILS

## REGULATED POWER SUPPLIES



### Protection:

All models internal foldback, overload, thermal and short circuit protected Fully fused.

**2-YEAR GUARANTEE**

Type AD12 - AD24 (Illustrated)

### TYPES AVAILABLE

MODEL NO.	AD12	AD24	AD2412	ADV030
<b>OUTPUT CURRENT</b>	8 amp	8 amp	16 amp	5 amp
<b>NOMINAL OUTPUT VOLTS</b>	12	24	12	0 to 30 Fully variable and metered
<b>INPUT VOLTS</b>	115-230-250 50 cycles a/c	115-230-250 50 cycles a/c	24 DC	115-230-250 50 cycles a/c
<b>TOLERATED MAINS VARIATION</b>	15%	15%		15%

### PRICES

1 off — AD 12-AD24 £52 50  
1 off — AD 2412 £48.00  
1 off — ADV030 £102 00  
All subject to VAT @ 8%

## SOUTHERN ELECTRONICS

6 WESTCLIFF ARCADE, RAMSGATE, KENT  
TEL. THANET (0843) 57888

WW — 118 FOR FURTHER DETAILS

## Penylan Mill, Oswestry, Salop

Personal callers are always welcome  
but please note we are closed all day Saturday

# THE EXPANDABLE GENERAL-PURPOSE MICROCOMPUTER

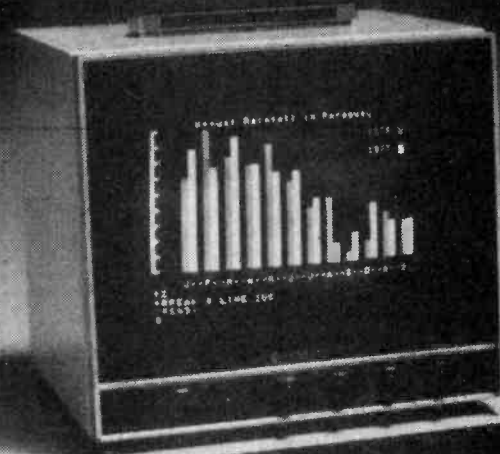

## RESEARCH MACHINES 380Z

### COMPUTER SYSTEMS

A professional microcomputer system with excellent support for scientific and educational users.

380Z systems come complete with:

- Z80A Processor
- RAM Memory
- 3K ROM Operating System
- VDU Interface
- Cassette Interface
- Parallel Input/Output
- Keyboard
- Room for Expansion
- Documentation

Only an inexpensive cassette recorder and a television are needed to make the system fully operational. No teletype or VDU terminal are required.

The standard 380Z system is expandable to include:

- Additional Memory
- Printers
- Serial Interfaces
- Parallel Interface with Real Time Clock
- Floppy Disc Systems
- Analogue Interface

The RESEARCH MACHINES 380Z is a professional general-purpose microcomputer. It has found broad application in Scientific Research and Education with a large number of systems in use in the field. The system is supported by an excellent range of software including Text Editor, Basics and Assemblers.

**RESEARCH MACHINES 380Z System**  
with 16K Bytes of RAM

**£965.00**

**RESEARCH MACHINES 380Z System**  
with 32K Bytes of RAM

**£1158.00**

RESEARCH MACHINES Computer Systems are distributed through SINTEL, P.O. Box 75, 209 Cowley Road, Oxford. Telephone: OXFORD (0865) 49791. Please contact SINTEL for the 380Z Information Leaflet. Prices do not include VAT @ 8% or Carriage.

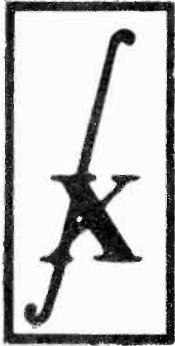

# NEW PRODUCTS!

## NRDC-AMBISONIC UHJ



### SURROUND SOUND DECODER

The **first ever** kit specially produced by Integrex for this British NRDC backed surround sound system which is the result of 7 years' research by the Ambisonic team. W.W. July, Aug., '77.

The unit is designed to decode not only UHJ but virtually all other 'quadrophonic' systems (Not CD4), including the new BBC HJ 10 input selections

The decoder is linear throughout and does not rely on listener fatiguing logic enhancement techniques. Both 2 or 3 input signals and 4 or 6 output signals are provided in this most versatile unit. Complete with mains power supply, wooden cabinet, panel, knobs, etc.

Complete kit, including licence fee **£45.00 + VAT**  
or ready built and tested **£61.50 + VAT**

## INTRUDER 1 RADAR ALARM



**With Home Office Type approval**

As in "Wireless World", designed by Mike Hosking, 240V ac mains operated and disguised as a hardbacked book. Detection range up to 30 feet.

Complete exclusive designer approved kit **£46.00 + VAT**  
or ready built and tested, **£54.00 + VAT**

## Wireless World Dolby<sup>TM</sup> noise reducer

Trademark of Dolby Laboratories Inc.

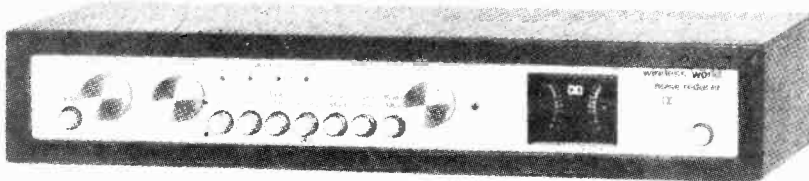

Featuring:

- switching for both encoding (low-level h.f. compression) and decoding
- a switchable f.m. stereo multiplex and bias filter
- provision for decoding Dolby f.m. radio transmissions (as in USA).
- no equipment needed for alignment.
- suitability for both open-reel and cassette tape machines
- check tape switch for encoded monitoring in three-head machines.

### Typical performance

Noise reduction better than 9dB weighted  
Clipping level 16.5dB above Dolby level (measured at 1% third harmonic content)

Harmonic distortion 0.1% at Dolby level typically 0.05% over most of band, rising to a maximum of 0.12%

Signal-to-noise ratio: 75dB (20Hz to 20kHz, signal at Dolby level) at Monitor output

Dynamic Range >90db

30mV sensitivity

Complete Kit **PRICE: £39.90 + VAT**

Also available ready built and tested

**Price £54.00 + VAT**

Calibration tapes are available for open-reel use and for cassette (specify which) **Price £2.20 + VAT**

Single channel plug-in Dolby<sup>TM</sup> PROCESSOR BOARDS (92 x 87mm) with gold plated contacts are available with all components **Price £8.20 + VAT**

Single channel board with selected fet **Price £2.50 + VAT**

Gold Plated edge connector **Price £1.50 + VAT**

Selected FETs **60p** each + VAT, **100p** + VAT for two, **£1.90** + VAT for four

Please add VAT @ 12½% unless marked thus\*, when 8% applies (or current rates)

We guarantee full after-sales technical and servicing facilities on all our kits, have you checked that these services are available from other suppliers?

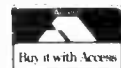

Please send SAE for complete lists and specifications

**Portwood Industrial Estate, Church Gresley,  
Burton-on-Trent, Staffs DE11 9PT  
Burton-on-Trent (0283) 215432 Telex 377106**

# INTEGREX LTD.

# INTEGREX

## S-2020TA STEREO TUNER / AMPLIFIER KIT

**SOLID MAHOGANY CABINET**

*A high-quality push-button FM Varicap Stereo Tuner combined with a 24W r.m.s. per channel Stereo Amplifier.*

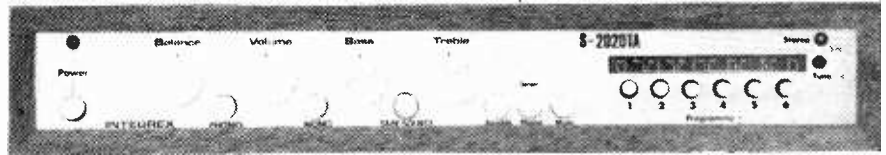

**Brief Spec.** Amplifier Low field Toroidal transformer, Mag. input, Tape In/Out facility (for noise reduction unit, etc.), THD less than 0.1% at 20W into 8 ohms. Power on/off FET transient protection. All sockets, fuses, etc., are PC mounted for ease of assembly. Tuner section uses 3302 FET module requiring no RF alignment, ceramic IF, INTERSTATION MUTE, and phase-locked IC stereo decoder. LED tuning and stereo indicators. Tuning range 88—104MHz. 30dB mono S/N @ 1.2 $\mu$ V. THD 0.3%. Pre-decoder 'birdy' filter.

**PRICE: £58.95 + VAT**

## NELSON-JONES STEREO FM TUNER KIT

*A very high performance tuner with dual gate MOSFET RF and Mixer front end, triple gang varicap tuning, and dual ceramic filter/dual IC IF amp.*

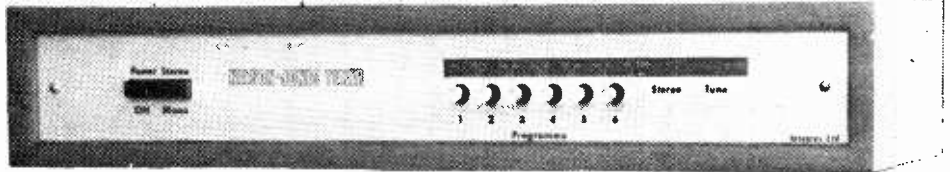

**Brief Spec.** Tuning range 88—104MHz. 20dB mono quieting @ 0.75 $\mu$ V. Image rejection — 70dB. IF rejection — 85dB. THD typically 0.4%.

IC stabilized PSU and LED tuning indicators. Push-button tuning and AFC unit. Choice of either mono or stereo with a choice of stereo decoders.

*Compare this spec. with tuners costing twice the price.*

**Mono £32.40 + VAT**

**With ICPL Decoder £36.67 + VAT**

**With Portus-Haywood Decoder**

**£39.20 + VAT**

## STEREO MODULE TUNER KIT

*A low-cost Stereo Tuner based on the 3302 FET RF module requiring no alignment. The IF comprises a ceramic filter and high-performance IC Variable INTERSTATION MUTE. PLL stereo decoder IC. Pre-decoder 'birdy' filter Push-button tuning*

**PRICE: Stereo £31.95 + VAT**



Sens. 30dB S/N mono @ 1.2 $\mu$ V

THD typically 0.3%

Tuning range 88—104MHz

LED sig. strength and stereo indicator

## S-2020A AMPLIFIER KIT

*Developed in our laboratories from the highly successful "TEXAN" design. PC mounting potentiometers, switches, sockets and fuses are used for ease of assembly and to minimize wiring*

*Power 'on/off' FET transient protection.*

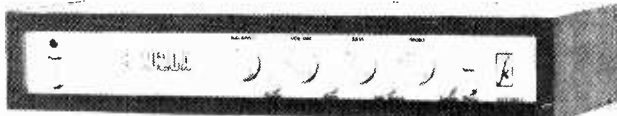

**Typ Spec.** 24+24W r.m.s. into 8-ohm load at less than 0.1% THD. Mag. PU input S/N 60dB. Radio input S/N 72dB. Headphone output. Tape In/Out facility (for noise reduction unit, etc.). Toroidal mains transformer.

**PRICE: £33.95 + VAT**

**ALL THE ABOVE KITS ARE SUPPLIED COMPLETE WITH ALL METALWORK, SOCKETS, FUSES, NUTS AND BOLTS, KNOBS, FRONT PANELS, SOLID MAHOGANY CABINETS AND COMPREHENSIVE INSTRUCTIONS**

<b>BASIC NELSON-JONES TUNER KIT</b>	<b>£14.28 + VAT</b>	<b>PHASE-LOCKED IC DECODER KIT</b>	<b>£4.47 + VAT</b>
<b>BASIC MODULE TUNER KIT (stereo)</b>	<b>£16.75 + VAT</b>	<b>PUSH-BUTTON UNIT</b>	<b>£5.00 + VAT</b>
<b>PORTUS-HAYWOOD PHASE-LOCKED STEREO DECODER KIT</b>			<b>£8.00 + VAT</b>

BRAND NEW COMPONENTS

Table listing various electronic components including Linear Circuits, TTL, Transistors, Carbon Film Resistors, Potentiometers, Preset Potentiometers, Ceramic Capacitors, Polyester Capacitors, Diodes, Electrolytic Capacitors, Axial leads, Tantalum Bead Capacitors, Regulators, Optoelectronics, and DIL Sockets. Each entry includes part numbers, quantities, and prices.

C. N. STEVENSON (W1) 236 High Street, Bromley, Kent BR1 1PQ

MARCONI TEST EQUIPMENT

- MARCONI TF1064B/5 VHF Signal Generator
TF455E Wave analyser. New £135
TF1101 RC oscillators £65
TF1099 20MHz sweep generators
TF1041B & C. VT Voltmeters
TF1102 Amplitude modulator. 500MHz
TF1020A Power meter. 100W 250MHz. £85
TF1152A/1 Power meter. 25W 500MHz. £75
TF890A/1 RF test set. £425
TF801B/3S Signal generator £175
TF1417 200MHz counter (imperfect)
TF1400 Pulse generator
TF675F Pulse generator
TF1370 Wide-range RC oscillator £125
TF2904 Colour gain delay test set
TF1058 UHF / SHF signal generator
TF 995A/4 AM / FM signal generator
TF1066 AM / FM signal generator

ZENITH 8 AMP VARIACS £28 50 (carr. 150p)
ADVANCE CONSTANT VOLTAGE TRANSFORMERS
Input 190-260V AC. Output constant
220 Volts 250W £25 (£2 carriage)

POLARAD TYPE TSA. SPECTRUM ANALYSER. C/w type STU/2M plug-in unit covering from 950 to 4500 MHz.

EVER-READY NICKEL CADMIUM BATTERIES
Size 'F' 6 A.H. 1.24 Volts £2.75 (post 25p)

POWER SUPPLIES
ADVANCE PM51 0-30V @ 5 Amps £36
ADVANCE PMA20 0-7V @ 20 Amps £39
Both brand new, boxed, with book
APT 10459 / 11. 10-15V @ 7.5A £25
APT 10459 / 13. 24V (var) 5A £25
(All items + £1 carr.)

BECKMAN TESTS COUNTER DIALS
Miniature type (22mm diam.) Counting up to 15 turn Helipot. Brand new with mounting instructions Only £2.50 each
Wandel & Gottman Equipment
Level Meter 0.2-1600KHz
Level Oscillator 0.2-1600KHz
Level Transmitter 3-1350 KHz
Carrier Frequency Level Meter

P. F. RALFE ELECTRONICS

10 CHAPEL STREET, LONDON, NW1 TEL: 01-723 8753

- TEST EQUIPMENT
LEADER TV FM Sweep and marker generator
ADVANCE HR100 X-Y Recorder. £105.00
HEWLETT-PACKARD 302A Wave-Analyser
RACAL type 801R. 100mHz digital frequency meter
TEXSCAN X-Y oscilloscope. 9-inch CRT.
TELETYPE ASR33 now in stock.
SOLARTRON 1420.2 digital voltmeter. 6 ranges to 1kV
AIRMEC 254 High-power oscillator / amplifier
BOONTON 80 Signal generator. 2.400MHz £105
BOONTON 230A RF Power Amplifier £325
BPL Capacitance decade (5) CD133 100pf-1uF £45
GERTSCH Frequency meter and deviation meter 20-1000MHz £250
HEWLETT PACKARD 693D sweep oscillator £350
DERRITRON Digital Wheatstone Bridge £110
MUIRHEAD K-134-A Battery op. wave analyser
PYE EHT scalamp voltmeter 0-40kV £125

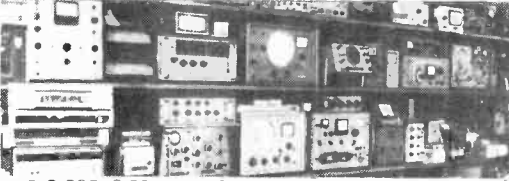

- RADIO CORPS PB1 pulse & bar generator £45
SIEMENS Level oscillator 12-160KHz
SCHOMANDL type FD1 frequency meter £125
Bruel & Kjoer type 3301 Automatic Frequency Response Recorder 200Hz-20KHz
MUIRHEAD-PAMETRAMA D489EM Wave Analyser
TEKTRONIX 555 scope with plug-ins types CA (2 off) 21 and 22
TEKTRONIX 545 main frames £210 Choice of p'ug-in units extra
TEKTRONIX 585A oscilloscope with 82 P I DC-80MHz
TEKTRONIX type 180A Time-mark generator £110
TELEQUIPMENT D53 Oscilloscope
TEKTRONIX 556 50MHz Oscilloscope
NOTICE. All the pre-owned equipment shown has been carefully tested in our workshop and reconditioned where necessary. It is sold in first-class operational condition and most items carry our three months guarantee. Calibration and certificates can be arranged at cost. Overseas enquiries welcome. Prices quoted are subject to an additional 8% VAT

ROHDE & SCHWARZ EQUIPMENT

- HUZ Field Strength Meter 47-225MHz
AMF TV Demodulator 55-90MHz
Selective UHF v/meter. bands 4&5 USVF
Selectomat. RF Voltmeter. USVV. BN 15221. £450
Standard attenuator 0-100db 0-300 mHz DPR
UHF Sig gen type SDR 0.3-1 GHz. £750
UHF Signal generator type SCH. £175
UHF Test receiver type USVD £325
POLYSKOP SWOB I

PYE-LING VIBRATORS
3 ohm coil. Overall dimensions 9 x 6 1/2 x 6 1/2 cms. Each £5.25 (25p P&P)

TEXTRONIX TYPE 561A OSCILLOSCOPES
Supplied in first-class condition complete with types 3A1 and 3B3 plug-in units. DC-10MHz double-beam 10mV/div. Calibrated sweep delay and single-shot. Time-base 0.5us/div £350.00

'CENTAUR' INSTRUMENT COOLING FANS
Made by Rotron Holland. These are very high quality, quiet running fans, specially designed for the cooling of all types of electronic equipment. Measures 4.5x4.5x1.5. 115V AC. 11 Watts. The list price of these is over £10 each. We have a quantity available brand new for only £4.50 each

500V TRANSISTORISED INSULATION TESTER
Lightweight, small size (13x7x4cms) Reads insulation from 0.2-100MΩ at 500V pressure. Runs from standard 9V PP3. Brand new £16.50

TELEVISION MONITORS
Phillips studio quality precision colour monitors and Pye monochrome 405 / 525 / 625 lines
PACE ELECTRONICS VARI PLOTTER
Type 1100E £175

MUIRHEAD DECADE OSCILLATORS type 890A.
1Hz-110kHz in four decade ranges. Scope monitored output for high accuracy of frequency. Excellent generator.

# LANGREX SUPPLIES LTD

## Climax House, Fallsbrook Rd., Streatham, London SW16 6ED

### RST Tel: 01-677 2424 Telex: 946708

### RST

#### SEMICONDUCTORS

AA119 0.20	AS215 1.25	BC177 0.19	BD136 0.36*	BF338 0.50*	GJ3M 1.75	OAZ207 1.65	OC205 1.75	ZTX504 1.50	.2N1671 1.50	2N3773 2.65
AA330 0.13	AS116 1.25	BC178 0.18	BD137 0.37*	BF337 0.50*	GM0378A 0.50	OC216 1.25	OC206 1.75	ZTX531 0.20*	.2N1893 0.33	2N3819 0.36*
AA332 0.15	AS220 1.75	BC182 0.11*	BD138 0.40*	BF338 0.55*	KS100A 0.40*	OC220 2.00	OC207 1.25	ZTX550 0.16*	.2N2147 1.60	2N3820 0.46*
AAZ13 0.25	AS221 1.50	BC183 0.11*	BD139 0.43*	BF521 2.27	MJE340 0.58*	OC222 2.50	OC208 1.25	IN914 0.07	.2N2148 1.65	2N3823 0.50*
AAZ15 0.31	AU113 1.70*	BC184 0.12*	BD140 0.47*	BF528 1.38	NJE370 0.65	OC223 2.75	ORP12 0.83	IN916 0.07	.2N2218 1.60	2N3866 1.00
AAZ17 0.25	AY110 1.70*	BC212 0.14*	BD181 1.38	BF528 1.38	MJE 520 0.65	OC224 3.50	R2008B 2.25*	IN4001 0.06	.2N2219 0.42	2N3904 0.21*
AC107 0.75	BA145 0.15*	BC213 0.14*	BD182 1.48	BF529 0.25*	MJE 520 0.65	OC225 0.90	R2009 2.25*	IN4002 0.07	.2N2220 0.35	2N3905 0.22*
AC125 0.30	BA154 0.10*	BC214 0.17*	BD217 1.00	BFW10 0.90	MJE 2955 1.25	OC228 2.00	R2010B 2.25*	IN4003 0.08	.2N2221 0.22	2N3906 0.20*
AC126 0.25	BA156 0.12	BC237 0.17*	BD238 0.85	BFW11 0.90	MJE 3055 0.75	OC229 2.00	IC44 2.35	IN4004 0.09	.2N2222 0.25	2N4058 0.22*
AC127 0.25	BA155 0.13	IC238 0.12*	BDX32 2.25	BFX85 0.41	MJE 102 0.30*	OC235 1.50	IC226D 1.30	IN4005 0.13	.2N2223 2.75	2N4059 0.15*
AC128 0.25	BA156 0.11	IC301 0.45	BDY20 1.42	BFX90 0.35	MJE 103 0.30*	OC236 1.50	IC235 1.50	IN4007 0.15	.2N2268 0.17	2N4060 0.20*
AC141 0.20	BA213 0.07	IC303 0.60*	BDY60 0.75	BFX98 0.28	MJE 105 0.30*	OC241 0.50	IC240 0.60	IN4009 0.15	.2N2484 0.21	2N4061 0.17*
AC141K 0.35	BA214 0.07	IC303 0.60*	BF115 0.39	BFY51 0.26	MJE 105 0.30*	OC242 0.50	IC242 0.50	IN4010 0.15	.2N2646 0.50	2N4124 0.17*
AC142 0.20	BA216 0.07	IC308 0.18*	BF152 0.25	BFY52 0.26	MPSA06 0.25*	OC243 1.50	IC243 1.50	IN4011 0.15	.2N2904 0.35	2N4126 0.17*
AC142K 0.30	BC107 0.12	IC322 0.22*	BF154 0.25	BFY64 0.30	MPSU10 0.32*	OC245 0.50	IC245 0.50	IN4015 0.13	.2N2905 0.35	2N4286 0.25*
AC176 0.25	BC108 0.12	IC328 0.18*	BF159 0.35	BFY64 0.30	MPSU10 0.32*	OC245 0.50	IC245 0.50	IN4015 0.13	.2N2905 0.35	2N4286 0.25*
AC187 0.25	BC109 0.12	IC337 0.18*	BF160 0.30	BSX19 0.34	MPSA 06 0.25*	OC247 0.45	IC247 0.45	IN4015 0.13	.2N2905 0.35	2N4286 0.25*
AC188 0.25	BC113 0.15*	IC337 0.18*	BF169 0.30	BSX20 0.34	MPSA 06 0.25*	OC247 0.45	IC247 0.45	IN4015 0.13	.2N2905 0.35	2N4286 0.25*
AC188 0.25	BC113 0.15*	IC337 0.18*	BF169 0.30	BSX20 0.34	MPSA 06 0.25*	OC247 0.45	IC247 0.45	IN4015 0.13	.2N2905 0.35	2N4286 0.25*
AC188 0.25	BC113 0.15*	IC337 0.18*	BF169 0.30	BSX20 0.34	MPSA 06 0.25*	OC247 0.45	IC247 0.45	IN4015 0.13	.2N2905 0.35	2N4286 0.25*

#### VALVES

E92CC 4.98	EF55 2.55*	GU50 12.15	PC887 0.85*	QV08 100 89.30	UF41 1.00*	V341 1.00*	6B76 1.78*	12AU6 0.50*	4212E 118.95
E92CC 4.98	EF55 2.55*	GU50 12.15	PC887 0.85*	QV08 100 89.30	UF41 1.00*	V341 1.00*	6B76 1.78*	12AU6 0.50*	4212E 118.95
E92CC 4.98	EF55 2.55*	GU50 12.15	PC887 0.85*	QV08 100 89.30	UF41 1.00*	V341 1.00*	6B76 1.78*	12AU6 0.50*	4212E 118.95
E92CC 4.98	EF55 2.55*	GU50 12.15	PC887 0.85*	QV08 100 89.30	UF41 1.00*	V341 1.00*	6B76 1.78*	12AU6 0.50*	4212E 118.95
E92CC 4.98	EF55 2.55*	GU50 12.15	PC887 0.85*	QV08 100 89.30	UF41 1.00*	V341 1.00*	6B76 1.78*	12AU6 0.50*	4212E 118.95

#### BASES

B7G unskirted 0.15	2AP1 8.50	4EP1 25.00	VCR138 10.00	7400 0.20	7422 0.25	7453 0.20	7493 0.70	74125 0.80	74159 2.50	74198 2.25
B7A unskirted 0.30	2AP1 8.50	4EP1 25.00	VCR138A 12.50	7401 0.20	7423 0.35	7454 0.20	7494 0.80	74126 0.80	74170 2.60	74199 2.25
B7B unskirted 0.30	2AP1 8.50	4EP1 25.00	VCR138A 12.50	7402 0.20	7424 0.35	7455 0.20	7495 0.80	74127 0.80	74171 1.75	74200 2.30
B7C unskirted 0.30	2AP1 8.50	4EP1 25.00	VCR138A 12.50	7403 0.20	7425 0.35	7456 0.20	7496 0.80	74128 0.80	74172 5.00	74201 2.30
B7D unskirted 0.30	2AP1 8.50	4EP1 25.00	VCR138A 12.50	7404 0.20	7426 0.35	7457 0.20	7497 0.80	74129 0.80	74173 1.75	74202 2.30

#### INTEGRATED CIRCUITS

7492 0.60	74125 0.80	74159 2.50	74198 2.25
7493 0.70	74126 0.80	74170 2.60	74199 2.25
7494 0.80	74127 0.80	74171 1.75	74200 2.30
7495 0.80	74128 0.80	74172 5.00	74201 2.30
7496 0.80	74129 0.80	74173 1.75	74202 2.30

Terms of business: CWO. Postage and packing valves and semiconductors 25p per order. CRTs 75p. Items marked \* add 12 1/2 % VAT. Others 8%. P & P at 8%.

1 Indicates cheap quality version or surplus, but also available by leading UK and USA manufacturers. Price ruling at time of despatch.

Account facilities available to approved companies with minimum order £10. Carriage and packing £1 on credit orders.

Over 10,000 types of valves, tubes and semiconductors in stock. Quotations for any types not listed. S.A.E.

Telephone 01-677 2424 /  
Telex 946708  
E & O.E.







ASCENSION ISLAND YUGOSLAVIA UNITED STATES OF AMERICA JORDAN GREECE INDIA GUYANA PORTUGAL FALKLAND ISLANDS UNITED ARAB EMIRATES JAMAICA HOLLAND KENYA

IRENE GRENADA SAUDI ARABIA NEW ZEALAND NORWAY SINGAPORE ICELAND SWEDEN MALAYA INDONESIA BRAZIL SWITZERLAND ZAMBIA GIBRALTAR CHILE SPAIN

# AUDIO KITS OF DISTINCTION FROM **POWERTRAN**

## **NEW!** TRANSCENDENT 2000

### SINGLE BOARD SYNTHESIZER

*As featured in Electronics Today International (July, August 1978)*

Live performance synthesizer designed by consultant Tim Orr (formerly synthesizer designer for EMS Ltd) and featured as a constructional article in Electronics Today International. The TRANSCENDENT 2000 is a 3 octave instrument transposable 2 octaves up or down with portamento pitch bending, a VCO with shape modulation, a versatile VCF with both low and high pass outputs and a separate dynamic sweep control, a noise generator and an ADSR envelope shaper. There is also a slow oscillator and a new pitch detector amongst its many features.

Kit includes fully finished metalwork, solid teak cabinet and really is complete — right down to the last nut and bolt! Virtually everything is on one circuit board and construction is so simple it can be built easily in a few evenings by almost anyone capable of neat soldering! When finished you will possess a synthesizer comparable in performance and quality with ready built units selling for between £500 and £700!

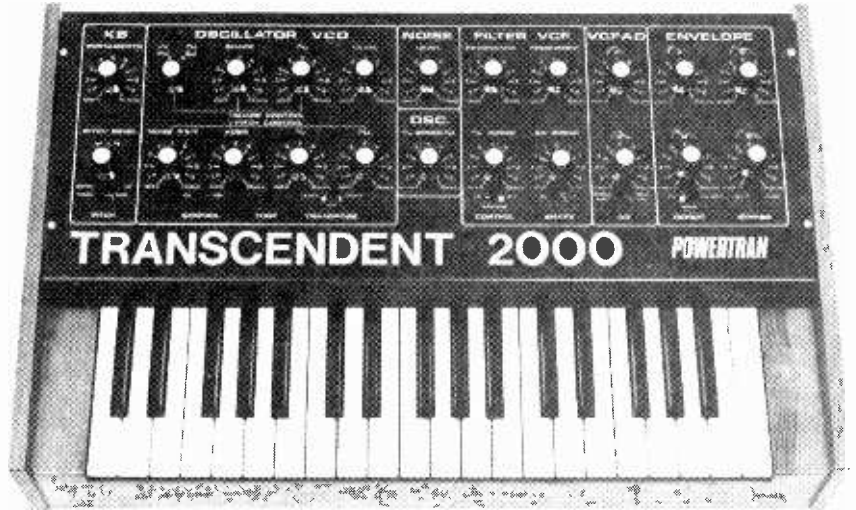

**INTRODUCTORY OFFER**  
**£172!**  
until July 30th 1978

# INTERNATIONAL POWERSLAVE 200 + 200 watt AMPLIFIER

*As featured in Electronics Today International*

**400W rms continuous — 800W peak!**  
**0.03% THD at FULL power!**  
**PLUS all the following features too!**

- \* Each channel totally independent with its own stabilised power supply driven by custom designed TOROIDAL transformers!
- \* Inherent reliability — monster heat sinks for cool running at the hottest venues — electronic open and short circuit protection!
- \* Ultra low feedback (an incredible low 14dB overall!) super high slewing rate (20V/μs), 200W rms continuous to 4 ohm from EACH channel, input sensitivity 0.775V (0dB)
- \* Professional quality components, sturdy 19" rack mounting chassis complete with sleeve and feet for free standing work too
- \* Easy to build — plenty of working space with ready access to all components, minimal wiring extensive instruction suitable for both experienced constructors and newcomers to electronics
- \* Value for money — quality and performance comparable with ready-built amplifiers costing over £600!

Pack	Price
1. Fibre glass printed circuit board for power amp	£4.20
2. Set of capacitors, metal oxide resistors, thermistor, cornel pre-sets for power amp	£6.40
3. Set of semiconductors for power and with mounting hardware, cooling tabs	£27.60
4. Pair of monster black drilled heat sinks, transistor mounting bracket	£6.90
5. Toroidal transformer, Primary 0-117V-234V, Secondaries 42-0-42V, 0-15V, 0-15V, Electrostatic screen	£19.20
6. Set of all parts for stabilized power supply including fibre glass printed circuit board, mounting bracket, semiconductors, resistors, capacitors, etc	£20.50
7A. Set of all parts for buffer/overdrive unit including fibre glass printed circuit board, semiconductors, resistors, capacitors, controls — required for PSI 4001 only	£3.80
7B. Set of parts for peak power meter including professional quality meter, fibre glass printed circuit board, components, controls — required for PSI 4002 only	£11.50
8. Set of all miscellaneous parts including sockets, illum. mains switches, fuse holders, fuses, cut-outs, cable, etc	£12.10
9. Cabinet, including chassis, anodised silver on black panels, fixing parts, etc. Please state whether Slave or Studio model required	£27.50
10. Handbook £0.50 or free on request when ordering any of above packs.	
2 each of packs 1-7 (A or B), 1 each 8, 9 and 10 are required for complete 200 + 200W professional amplifier.	
Total cost of individually purchased packs	PS1 4001 £216.80 PS1 4002 £232.20

### PSI 4001 SLAVE MODEL



### PSI 4002 STUDIO MODEL



**SPECIAL PRICES FOR COMPLETE KITS!**  
PS1 4001—£205.00  
PS1 4002—£220.00

### DE LUXE EASY TO BUILD LINSLEY-HOOD 75W AMPLIFIER

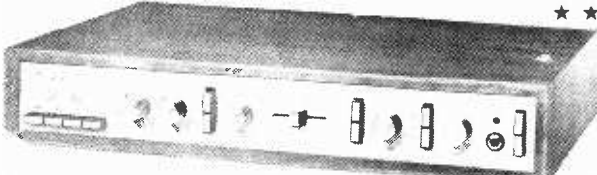

AVAILABLE AS SEPARATE PACKS  
PRICES IN OUR FREE CATALOGUE

**SPECIAL PRICE FOR COMPLETE KIT £99.30**

The standard model of our kit for Mr. Linsley Hood's 75 watt design has for a long time offered exceptional performance at a very modest cost with high quality high power ready built units of comparable quality generally being over three times the price.

Features of the amplifier include very low distortion (less than 0.01%), 75W rms per channel power output, rumble filter, variable slope scratch filter, variable transition frequency tone controls, tape monitoring facilities and individually adjustable inputs. This model is based on 5 circuit boards which, not having the controls mounted on them can, if desired, be effectively used separately in high performance audio systems not based on our metalwork.

Our new De Luxe model uses 14 boards which interconnect with gold plated contacts and are designed to have the potentiometers and switches mounted upon them. This system almost eliminates internal wiring, making installation after their assembly delightfully straightforward and as each board can be easily removed in seconds from the chassis, checking and maintenance is so simple that even newcomers to electronics will be able to cope competently with this kit. Additional features of our new model are inclusion of the latest circuit improvements, generously sized heat sinks for heavy duty use, even in tropical climates, and metal oxide resistors throughout for long term stability and reliability.

### STANDARD LINSLEY-HOOD 75W AMPLIFIER

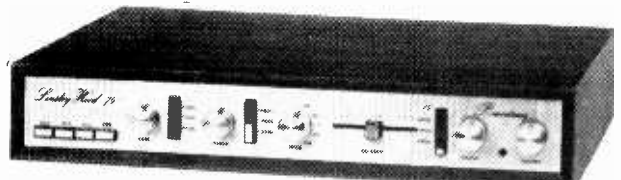

**SPECIAL PRICE FOR COMPLETE KIT £79.80**

Pack	Price
1. Fibreglass printed circuit board for power amp	£1.15
2. Set of resistors, capacitors, pre-sets for power amp	£2.50
3. Set of semiconductors for power amp	£6.50
4. Pair of 2 drilled, finned heat sinks	£1.10
5. Fibreglass printed circuit board for pre-amp	£1.90
6. Set of low noise resistors, capacitors, pre-sets for pre-amp	£4.10
7. Set of low noise, high gain semiconductors for pre-amp	£2.40
8. Set of potentiometers (including mains switch)	£3.50
9. Set of 4 push-button switches, rotary mode switch	£5.40
10. Toroidal transformer complete with magnetic screen/ housing primary, 0-117-234 V; secondaries: 33-0-33 V, 25-0-25 V	£12.95

Pack	Price
11. Fibreglass printed-circuit board for power supply	£0.85
12. Set of resistors, capacitors, secondary fuses, semiconductors for power supply	£5.40
13. Set of miscellaneous parts including DIN skts., mains input skt., fuse holder, interconnecting cable, control knobs	£6.20
14. Set of metalwork parts including silk screen printed fascia panel and all brackets, fixing parts, etc.	£8.20
15. Handbook	£0.30
16. High Quality Teak Veneer cabinet 18.3" x 12.7" x 3.1"	£10.70
2 each of packs 1-7, 1 each of packs 8-16 inclusive are required for complete stereo amplifier. Total cost of individually purchased packs	£92.80

**PACK PRICES FOR STANDARD KIT**

OMAN MUSCAT DENMARK FRANCE GAMBIA AUSTRALIA HONG KONG NAURU GERMANY TUNISIA LUXEMBOURG FINLAND SOUTH AFRICA CZECHOSLOVAKIA

NEW GUINEA ISRAEL GUERNSEY CYPRUS BELGIUM UGANDA BRUNEI TRINIDAD SOUTH WEST AFRICA ITALY JAWA SIERRA LEONE WINDWARD ISLANDS CANADA MALTA

Designed in response to demand for a tuner to complement the world-wide acclaimed Linsley-Hood 75W Amplifier, this kit provides the perfect match. The Wireless World (Skingley and Thompson) published original circuit has been developed further for inclusion into this outstanding slimline unit and features a pre-aligned front end module excellent a m rejection and temperature compensated varicap tuning, which may be controlled either continuously or by push-button pre-selection. Frequencies are indicated by a frequency meter and sliding LED indicators, attached to each channel selector pre-set. The PLL stereo decoder incorporates active filters for "birdy" suppression and power is supplied via a toroidal transformer and integrated regulator. For long term stability metal oxide resistors are used throughout.

AVAILABLE AS SEPARATE PACKS — PRICES IN OUR FREE CATALOGUE

**LINSLEY-HOOD CASSETTE DECK**

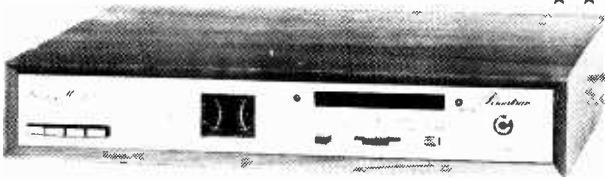

**SPECIAL PRICE FOR COMPLETE KIT £79.60**

Published in Wireless World (May, June, August 1976) by Mr. Linsley-Hood this design, although straightforward and relatively low cost nevertheless provides a very high standard of performance. To permit circuit optimization separate record and replay amplifiers are used, the latter using a discrete component front-end designed such that the noise level is below that of the tape background. Pushbutton switches are used to provide a choice of equalization time constants, a choice of bias levels and also an option of using an additional pre-amplifier for microphone use. The mechanism used is the Goldring-Lenco CRV, a unit distinguished in its robustness and ease of operation. Speed control and automatic cassette ejection are both implemented by electronic circuitry. This unit which is powered by a toroidal transformer and uses metal oxide resistors throughout offers an excellent match for the Wireless World Tuner and the Linsley-Hood 75 Watt Amplifier. Circuit changes as published in February, 1978, follow-up article are included in the kit AT NO EXTRA COST! A higher performance head (Matsushita WY 436 AZ head as recommended in the follow-up article) is offered as an optional extra but this will be automatically supplied FREE OF CHARGE with all orders for complete kits!

**T20 + 20 AND T30 + 30 20W, 30W AMPLIFIERS**

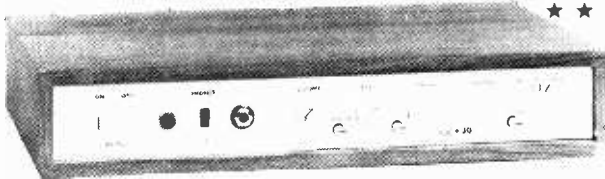

**WWII TUNER**

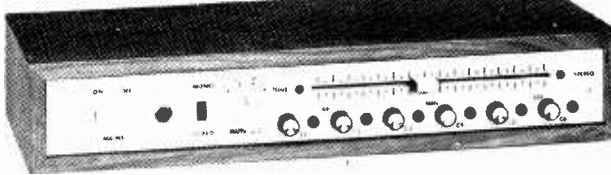

**SPECIAL PRICE FOR COMPLETE KIT £47.70**

AVAILABLE AS SEPARATE PACKS — PRICES IN OUR FREE CATALOGUE

Following the success of our **Wireless World FM Tuner Kit** this cost reduced model was designed to complement the **T20 + 20** and **T30 + 30** amplifiers and the cabinet size front panel format and electrical characteristics make this tuner compatible with either

**Wireless World Designs:** Full kits are not available for the projects below but PCBs and component sets are stocked. Further details of these and other packs are in our Free Catalogue

<b>30W Bailey Amplifier</b>		<b>Regulated Power Supply for Bailey Amplifier</b>	
BAIL Pk 1 F Glass PCB	£1.00	60VS Pk 1 F Glass PCB	£0.85
BAIL Pk 2 Resistors Capacitors	£2.35	60VS Pk 2 Resistors Capacitors	£2.20
BAIL Pk 3 Semiconductors	£4.70	60VS Pk 3 Semiconductors	£3.10
		60VS Pk 6A Toroidal transformer	£8.80

<b>Bailey Burrows Stereo Pre-Amp.</b>		<b>Stuart Tape Recorder</b>	
BBPA Pk 1 F Glass PCB (stereo)	£2.80	TRRC Pk 1 Replay Amp F G PCB (stereo)	£1.30
BBPA Pk 2 Resistors capacitors (stereo)	£6.70	TRRC Pk 1 Record Amp F G PCB (stereo)	£1.70
BBPA Pk 3R Rotary potentiometers (stereo)	£2.85	TRUS Pk 1 Bias Erase F G PCB (stereo)	£1.20
BBPA Pk 4R Rotary switches (stereo)	£3.60		

<b>Linsley-Hood Low Distortion Oscillator.</b>		<b>E. F. Taylor Pre-Amplifier</b>	
LDO Pk 1 Fibreglass PCB	£1.65	EFTP Pk 1 Fibreglass PCB (stereo)	£1.45
LDO Pk 2 M O Resistors capacitors	£2.60	EFTP Pk 2 M O Res caps (stereo)	£3.20
LDO Pk 3 Semiconductors	£3.90	EFTP Pk 3 Semiconductors (stereo)	£4.20

**EXPORT A SPECIALITY!**

Our Export Department can readily despatch orders of any size to any country in the world. Some of the countries to which we sent kits last year are shown in this advertisement. To assist in estimating postal costs our catalogue gives the weights of all packs and kits. This will be sent free on request by airmail, together with our Export Postal Guide which gives current postage prices. There is no minimum order charge. Prices same as for U K customers but no Value Added Tax charged. Postage charged at actual cost plus 50p documentation and handling. Please send payment with order by Bank Draft, Postal Order, International Money Order or cheque drawn on an account in the U K. Alternatively for orders over £500 we will accept Irrevocable Letter of Credit payable at sight in London.

**Value Added Tax not included in prices UK Carriage FREE**

**SERVING FACILITIES:** Available for all \*\* complete kits  
**PRICE STABILITY:** Order with confidence! Irrespective of any price changes we will honour all prices in this advertisement until August 31st, 1978, if this month's advertisement is mentioned with your order. Errors and VAT rate changes excluded.  
**U.K. ORDERS:** Subject to 12½% surcharge for VAT (i.e. add ½ to the price). No charge is made for carriage or current rate if charged.  
**SECURICOR DELIVERY:** For this optional service (U K mainland only) add £2.50 (VAT inclusive) per kit.  
**SALES COUNTER:** If you prefer to collect your kit from the factory, call at Sales Counter (at rear of factory) Open 9 a.m. - 4.30 p.m. Monday - Thursday.

**WIRELESS WORLD FM TUNER**

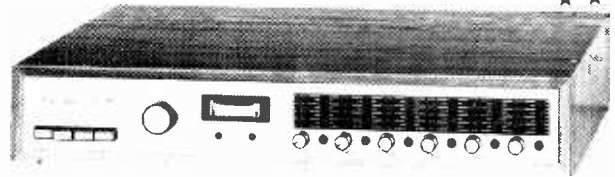

**SPECIAL PRICE FOR COMPLETE KIT £70.20**

<b>Pack 1.</b> Stereo PCB (accommodates 2 rep. amps, 2 meter amps, bias/erase osc. relay) . . . . .	<b>Price</b> £3.35	<b>Pack 10.</b> Set of capacitors, rectifiers, I.C. voltage regulator P.C.B. for power supply (Powertran design) £2.80	<b>Price</b>
<b>2.</b> Stereo set of capacitors, M.O. resistors, potentiometers for above . . . . .	£7.95	<b>11.</b> Set of miscellaneous parts, including sockets, fuse holder, fuses, interconnecting wire, etc. . . . .	£3.40
<b>3.</b> Stereo set of semiconductors for above . . . . .	£8.50	<b>12.</b> Set of metalwork including silk screened fascia panel, internal screen, fixing parts, etc. . . . .	£7.10
<b>4.</b> Miniature relay with socket . . . . .	£2.90	<b>13.</b> Construction notes . . . . .	£0.25
<b>5.</b> PCB, all components for solenoid, speed control circuits . . . . .	£3.80	<b>14.</b> High Quality Teak Veneer cabinet 18.3" x 12.7" x 3.1" . . . . .	£10.70
<b>6.</b> Goldring-Lenco mechanism as specified . . . . .	£18.50		
<b>7.</b> Function switch, knobs . . . . .	£1.90		
<b>8.</b> Dual VU meter with illuminating lamp . . . . .	£6.95		
<b>9.</b> Toroidal transformer with E.S. screen prim 0-117V, 234V, Sec. 15V . . . . .	£4.90		

One each of packs 1-14 inclusive are required for complete stereo cassette deck. Total cost of individually purchased packs . . . . . £83.00

Matsushita WY 436 AZ head (optional extra) . . . . . £4.50 (free with complete kit)

Designed by Texas engineers and described in Practical Wireless, the Texan was an immediate success. Now developed further in our laboratories to include a Toroidal transformer and additional improvements, the Slimline T20 + 20 delivers 20W rms per channel of true Hi-Fi at exceptionally low cost. The easy to build design is based on a single Fr. Glass PCB and features all the normal facilities found on quality amplifiers including design and rumble filters, adaptable input selector and headphones socket. In a follow up article in Practical Wireless further modifications were suggested and these have been incorporated into the T30 + 30. These include RF interference filters and a tape monitor facility. Power output of this model is 30W rms per channel.

**SPECIAL PRICES FOR COMPLETE KITS**

**T20+20 KIT PRICE £33.10**

**T30+30 KIT PRICE £38.40**

AVAILABLE AS SEPARATE PACKS — PRICES IN OUR FREE CATALOGUE

**POWERTRAN SFMT TUNER**

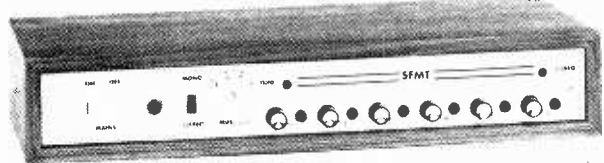

**PRICE FOR COMPLETE KIT £35.90**

AVAILABLE AS COMPLETE KIT ONLY

This is a simple, low cost design which can be constructed easily without special alignment equipment but which still gives a first-class output suitable for feeding any of our very popular amplifiers or any other high quality audio equipment. A phase-locked-loop is used for stereo decoding and controls include switchable afc, switchable muting and push-button channel selection (adjustable by controls on the front panel). This unit matches well with the **T20 + 20** and **T30 + 30** amplifiers.

**NEW!** Improved stereo decoder (as described in April 1978 W W) F Glass PCB M O Res Caps Cermet pre-sets, IC IC socket. **£6.30**

**SQ QUADRAPHONIC DECODERS**

These state-of-the-art circuits described by CBS are offered as kits of superior quality with (low-tolerance capacitors, metal oxide resistors and Fibreglass PCBs designed for edge connector insertion. Further information on these kits is given in our FREE CATALOGUE

M1 Basic matrix decoder	£5.90
L1 Full logic decoder	£17.20
L2A Full logic decoder with variable blend	£22.80
L3A As L2A but with high performance discrete component front end (tor with carbon film resistors)	£30.10
SQM1.30 Decoder complete with 30W rear channel amplifiers. Complete kit matches T30 + 30 amplifier.	£25.90
	£40.75

**QUALITY:** All components are brand new first grade full specification guaranteed devices. All resistors (except where stated as metal oxide) are low noise carbon film types. All printed circuit boards are fibreglass drilled roller tinned and supplied with circuit diagrams and construction layouts.

**FOR FURTHER INFORMATION PLEASE WRITE OR TELEPHONE FOR OUR FREE CATALOGUE**

DEPT. WW7

**POWERTRAN ELECTRONICS**  
 PORTWAY INDUSTRIAL ESTATE ANDOVER  
 ANDOVER HANTS SP10 3NN (0264) 64455

# West Hyde have more than 600 different instrument cases in stock + accessories

**WH BRIGHTCASE**



Adds sophistication to any equipment  
In anodised aluminium with top and bottom panels grained black P.V.C.

	L	B	H	
BC2 121	4.37	2.68	1.01	23.01
BC2 222	2.19	2.68	0.89	16.53
BC3 121	4.37	2.68	1.13	25.24
BC3 222	2.19	2.68	1.13	18.61

**WH PRINCESS**



Moulded in two parts in ABS; in four sizes

- The largest for keyboards displays etc.
- Prestige display of data inputs, large calculators
- Still ample room for keyboard and visual display or meters
- Elegant hand held keyboards take a forecourt

Colour: black case base and either a black or tan top.

PR1	£16.50	PR2	£12.90
PR3	£7.00	PR4	£3.90

**WH MOD-2**



A very popular case of universal use  
Modular design. Stores flat. Chassis fixes between front and back panels of PVC/aluminium. Covers of PVC/steel. Cheap enough for production, ideal for development work.

MD2 A	9.05	MD2 I	14.51	MD2 Q	12.98
MD2 B	9.70	MD2 J	13.82	MD2 R	15.25
MD2 C	11.34	MD2 K	16.17	MD2 S	13.28
MD2 D	9.72	MD2 L	20.00	MD2 T	15.27
MD2 E	10.90	MD2 M	10.67	MD2 U	17.92
MD2 F	12.80	MD2 N	11.48	MD2 V	16.77
MD2 G	10.76	MD2 O	13.53	MD2 W	19.64
MD2 H	12.36	MD2 P	11.36	MD2 X	24.10

**WH FRONT FURNITURE**

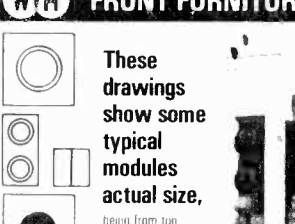

These drawings show some typical modules actual size,  
being from top downwards, light emitting diode, test jack, dual test jack, fuse holder, wirewound potentiometer, slide switches, toggle switch and step switch

Send for catalogue

This is logical miniaturisation.

It all fits together on a 0.1" module, look at the front panel work this saves.

Already used as standard by leading continental manufacturers like AEG and Siemens. FF front panel furniture parallels behind panel advances. Each unit on a 10.16 mm module fitting into a slot as a standard panel in any combination, means swift exact work. All module pins are on a 2.5 mm grid and each part locates to its neighbour. This is an important advance in front panel assembly.

**WH CONTIL-ELF**

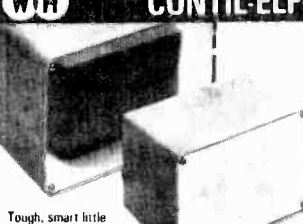

Tough, smart little cases that add very little to the cost of the job  
Design moulded in grey glass polyester with protection aluminium front panel in four sizes with front and aluminium chassis included. The cases and chassis taper 10 mm from front to back.

	L	B	H	
Elf Long	153	101	101	3.52
Elf Giant	228	76	101	3.96
Elf Jumbo	203	127	138	4.95
Elf	273	130	134	5.94

**WH MOD 4**



A quick assembly case in eight parts  
A mass produced economy case in intensely shiny black or royal blue leather textured PVC steel with bright white steel panel. Eight pieces inc. aluminium chassis assembled with only eight screws.

	L	B	H	
401	178	152	6	4.84
402	178	152	114	5.12
403	178	152	152	5.39
404	278	152	76	5.72
405	278	152	114	6.11
406	278	152	152	6.55
413	165	152	157	5.45
416	305	152	157	6.88

Send for catalogue  
Prices are correct at time of going to press. Prices are one off inc P&P, but not VAT. Discounts for quantities.  
Note new address

# West Hyde have the greatest range of instrument cases

**WH CONTIL**



West Hyde's best selling case, strong, rigid and smart

	L	B	H	
CON 250	178	127	127	8.68
CON 325	278	127	127	10.30
CON 367	304	152	127	10.30
CON 177	108	128	128	11.86
CON 163	108	105	128	16.36
CON 191	108	54	128	22.53
CON 181D	168	81	128	28.36

**WH SWIFT**



Swiftcase wins industrial design award at Hannover

A case for good looks, strength and efficiency. Particularly suitable for applications needing power dissipation.

	L	B	H	
SWF 212	432	268	88	18.70
SWF 222	219	268	88	14.49
SWF 312	432	268	133	22.26
SWF 322	219	268	133	17.74

**WH CONTIL WOODEND**



Leather textured PVC steel body with polished teak ends.

Two wooden ends and two tie bolts, result in a simple, light, inexpensive case. A toroidal transformer of 130W is available to fit. Ideal for Hi-Fi applications and domestic and office equipment.

	L	B	H	
WEC 801	202	240	80	12.80
WEC 802	417	240	80	14.97
WEC 803	550	240	80	16.29

**WH CONTIL-DIN**

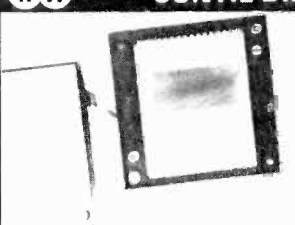

The ready-made DIN case you have been waiting for

Heavy aluminium extrusions lock rigidly together providing, heat dissipation, screening and strength, with provision for 16 P.C. boards and quick component mounting.

To order: See catalogue

DIN 111	6.01	DIN 115	7.10	DIN 114	10.07
DIN 211	6.25	DIN 112	8.19	DIN 115	11.01
DIN 215	6.57	DIN 114	9.01		

**WH ENCASE**

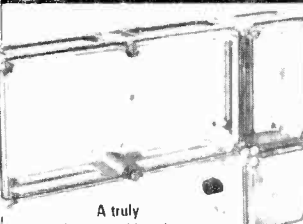

A truly environmental housing

Encase solves your aluminium and die-cast problems and benefits of the Temco case, a rugged process industries. The polycarbonate is virtually unbreakable. Covers clean PC. Case glass filled PC. Gaskets screws and gland plates (things available)

	L	B	H	
EN A	190	180	130	8.87
EN B	300	180	130	11.56
EN D	400	180	130	15.40
EN D	400	240	130	16.03
EN L	400	300	130	20.51
EN L	400	360	130	28.51
EN A	200	240	130	39.29

**WH SAMOS**

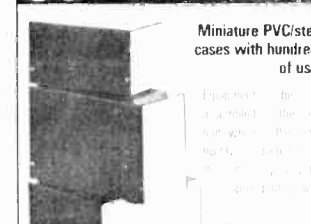

Miniature PVC/steel cases with hundreds of uses

Equipment for a compact, the SAMOS that gives the same rugged performance as the larger cases.

	L	B	H	
SM 100	1.36	SM 100	1.36	2.24
SM 100	1.56	SM 100	1.56	2.63
SM 100	1.74	SM 100	1.74	2.32
SM 100	1.96	SM 100	1.96	

**WH MINOS**

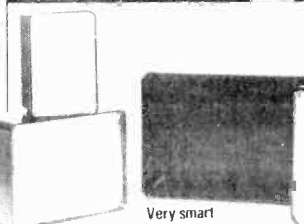

Very smart miniatures moulded in gloss black or white ABS with high impact strength

Front panels in aluminium, white PVC/steel or moulded. Guides for P.C.Bs, dividers or screens, also internal pillars for 'P' clips Recess on the back for decals etc.

	L	B	H	
MIN 100	50	50	50	73
MIN 100	50	50	50	85
MIN 100	50	50	50	94
MIN 100	50	50	50	177

**WH MOD-3**

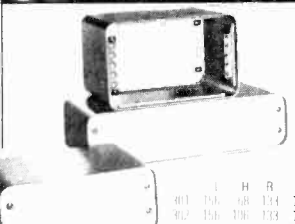

Attractive gloss blue PVC/Steel cases of wrap round construction. Removable front and back panels give full access. Grey PVC/steel panels accept Letraset. Supplied with W.H. self adhesive feet. Black cases also available, slight extra cost.

	L	B	H	
301	108	108	133	7.39
304	156	145	133	8.59
301	217	145	133	7.85
305	217	145	133	9.19
306	217	145	133	10.99

NOTE NEW ADDRESS All West Hyde cases are available with substantial discounts for quantities. Most cases have discounts at 5, 10 and 25 off with discounts up to 25% at 100 off. Prices include P & P and are less 10% if collected on first two price breaks on cases only. Send for catalogue. Prices correct at press date.  
WEST HYDE DEVELOPMENTS LIMITED, Unit 9, Park Street Industrial Estate, AYLESBURY, BUCKS. HP20 1ET. Phone: Aylesbury (0296) 20341. Telex: 83570

WW-082 FOR FURTHER DETAILS

# L.P. ENTERPRISES

Room W7  
313 Kingston Road, Ilford  
Essex, IG1 1PJ England  
01-553 1001

From the representatives in Europe . . . for America's leading Micro-computer magazines and books, for the hobbyist, educationist and professional alike, we bring you a little light browsing!  
Reading maketh a full man . . . Francis Bacon (1561-1626)

Tick or indicate quantity ordered.	
From Adam Osborne Associates	
<b>INTRODUCTION TO MICROCOMPUTERS</b>	
Volume 0: The Beginners Book	£5.95
Volume 1: Basic Concepts	£5.95
Volume 2: Some Real Products (Revised Late 1977)	£11.95
6800 Programming for Logic Design	£5.95
8080 Programming for Logic Design	£5.95
Z80 Programming for Logic Design (Available May 78 approx.)	£5.95
8080A/8085 Assembly Language Programming	£6.95
6800 Assembler Language Programming	£6.95
Some Common BASIC Programs	£5.95
<b>BUSINESS PROGRAMS IN BASIC</b>	
Payroll with Costing Accounting	£9.95
Accounts Payable & Account Receivable (Available from Midsummer 78)	£9.95
General Ledger (Available from late summer 1978)	£9.95
From Scelbi Computer Consulting Inc.	
6800 Software Gourmet Guide & Cookbook	£7.95
8080 Software Gourmet Guide & Cookbook	£7.95
8080 Programmers Pocket Guide	£2.25
8080 Hex Code Card	£2.25
8080 Octal Code Card	£2.25
8080 Guide and One 8080 Code Card	£4.20
8080 Guide and Both Code Cards	£6.00
SCELBAL High Level Language for '8008/8080' Systems	£39.25
SCELBAL String Handling Supplement	£8.00
SCELBAL Extended Maths Supplement	£4.00
Understanding Microcomputers & Small Computer Systems	£7.95
SCELBAL 'BYTE' Primer	£9.95
8080 Standard Assembler (In Book Format)	£15.95
8080 Standard Editor (In Book Format)	£9.95
From Peoples Computer Company	
Reference Books of Personal & Home Computing	£4.95
What to Do After You Hit Return	£7.00
Dr. Dobbs Journal Volume 1	£10.00
From Kilobaud/73 Magazine Inc.	
Hobby Computers Are Here	£3.95
New Hobby Computers	£3.95
From Dymax Inc.	
Instant BASIC by Jerald R. Brown	£4.95
Your Home Computer by James White	£4.95
My Computer Like Me . . . When I Speak BASIC by Bob Albrecht	£1.65
Games with a Pocket Calculator by Thiagarajan & Stilovitch	£1.75
Games, Tricks and Puzzles for a Hand Calculator by W. Judd	£2.49
From BYTE Publications Inc.	
Paperbytes:	
Tiny Assembler for 6800 Systems	£5.75
Bar Code Loader for 6800, Z80 & 6502 Micros	£1.75
Best of BYTE Volume 1	£8.95

Tick here or indicate quantity ordered		Price UK	Price Overseas if Different
From Creative Computing Press			
Best of Creative Computing Volume 1		£6.95	
Best of Creative Computing Volume 2		£6.95	
101 BASIC Games (Revised & Reprinted Feb. 78)		£5.50	
The Colossal Computer Cartoon Book		£3.95	
Computer-Rage (A new Board Game)		£6.95	
Artist and Computer		£3.95	
From Everyone Else			
Magazine Storage Boxes (holds 12 minimum)		£1.75	
Sybox: Microprocessors from Chips to Systems by R. Zacs		£7.95	
Sybox: Microprocessors Interfacing Techniques by R. Zacs		£7.95	
Dilithium: Home Computers Volume 1: Hardware		£6.50	
Dilithium: Home Computers Volume 2: Software		£5.95	
Getting involved with your Own Computer		£4.75	
TV Typewriter Cookbook by Don Lancaster		£7.50	
TTL Cookbook		£7.50	
CMOS Cookbook		£7.95	
IC Timer Cookbook		£7.50	
IC OP-AMP Cookbook		£9.50	
RTL Cookbook		£4.25	
Computer Programs that work (In BASIC)		£2.55	
From Basic Software Library			
(from Scientific Research Instruments)			
Vol 1: Business and Personal Booking Programs		£17.50	
Vol 2: Maths and Engineering Programs		£17.50	
Vol 3: Advanced Business Programs		£26.95	
Vol 4: General Purpose Programs		£7.95	
Vol 5: Experimenters Programs (General Purpose)		£7.95	
Vol 6: General Ledger Program		£32.50	
Vol 7: Professional Programs		£26.95	
<b>Magazines: Back Issues</b>			
Personal Computing		£1.75	
Interface Age		£2.25	
Dr. Dobbs Journal		£1.75	
Computer Music Journal		£2.20	
Peoples Computers		£1.75	
'BYTE		£2.25	
Creative Computing		£1.75	
Calculators & Computers		£1.75	
ROM		£1.75	
Kilobaud		£2.25	
73		£2.25	
<b>MAGAZINES: Subscriptions</b>			
Personal Computing (Twelve Issues Yearly)		£16.00	£17.00
Interface Age (Twelve Issues Yearly)		£20.00	£20.50
Dr. Dobbs Journal (Ten Issues Yearly)		£13.00	£13.50
Computer Music Journal (Four Issues Yearly)		£8.50	£9.00
Peoples Computers / Six Issues Yearly)		£8.00	£8.50
Kilobaud (Twelve Issues Yearly)		£20.00	£21.00
'BYTE (Twelve Issues Yearly) via USA		£15.00	
'BYTE (Twelve Issues Yearly) via U.K.			
Creative Computing (Six Issues Yearly)		£8.50	£9.00
Calculators & Computers (Seven Issues Yearly)		£10.00	£10.50
73 (Twelve Issues Yearly)		£20.00	£21.00

WW2

**HOW TO ORDER**

Please note our prices include postage and packing but not insurance if wanted add 12p for every £10 of Books ordered. Make cheques, PO's etc payable to

**L.P. Enterprises**  
CREDIT CARDS accepted  
BARCLAYCARD VISA ACCESS  
DINERS CLUB AMERICAN EXPRESS

Phone 01-553 1001 for Credit Card orders (24-hour service)

Send to address above for the attn. of David, Room W6  
Indicate Payment Method:

**All Orders must be Prepaid**  
Total Enclosed £.....

..... My cheque, P.O., I.M.O. is enclosed in Sterling on U.K. Bank

..... Charge to Barclaycard Visa/Diners, American Express/Access

Credit Card No ..... Expiry date .....

Name .....

Address .....

..... POSTCODE .....

Signature .....

All publications are published in U.S.A. and shipped air-freight by L.P. Enterprises. In unusual cases, processing may exceed 30 days  
'BYTE' subscriptions are processed in USA and are air-freighted & posted from Amsterdam and will take 3 months to start.

**TRADE ENQUIRIES WELCOME**

Due to fluctuations of the dollar prices are subject to change. Please mention Wireless World when ordering.



# 15 — 240 Watts!

## HY5 Preamplifier

The HY5 is a mono hybrid amplifier ideally suited for all applications. All common input functions (mag Cartridge, tuner etc.) are catered for internally, the desired function is achieved either by a multi-way switch or direct connection to the appropriate pins. The internal volume and tone circuits merely require connecting to external potentiometers (not included). The HY5 is compatible with all I.L.P. power amplifiers and power supplies. To ease construction and mounting a P.C. connector is supplied with each pre-amplifier.

**FEATURES:** Complete pre-amplifier in single pack — Multi-function equalization — Low noise — Low distortion — High overload — two simply combined for stereo

**APPLICATIONS:** Hi-Fi — Mixers — Disco — Guitar and Organ — Public address

**SPECIFICATIONS:**

**INPUTS:** Magnetic Pick-up 3mV Ceramic Pick-up 30mV Tuner 100mV: Microphone 10mV Auxiliary 3-100mV, input impedance 47k $\Omega$  at 1kHz

**OUTPUTS:** Tape 100mV Main output 500mV R.M.S

**ACTIVE TONE CONTROLS:** Treble = 12dB at 10kHz Bass = + at 100Hz

**DISTORTION:** 0.1% at 1kHz Signal/Noise Ratio 68dB

**OVERLOAD:** 38dB on Magnetic Pick-up **SUPPLY VOLTAGE:**  $\pm$  16.50V

**Price £5.22 + 65p VAT P&P free**

HY5 mounting board B1 48p + 6p VAT P&P free

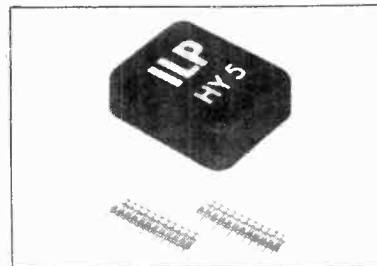

## HY30 15 Watts into 8 $\Omega$

The HY30 is an exciting New kit from I.L.P. it features a virtually indestructible I.C. with short circuit and thermal protection. The kit consists of I.C., heatsink, P.C. board, 4 resistors, 6 capacitors, mounting kit together with easy to follow construction and operating instructions. This amplifier is ideally suited to the beginner in audio who wishes to use the most up-to-date technology available.

**FEATURES:** Complete kit — Low Distortion — Short, Open and Thermal Protection — Easy to Build

**APPLICATIONS:** Updating audio equipment — Guitar practice amplifier — Test amplifier — Audio oscillator

**SPECIFICATIONS:**

**OUTPUT POWER:** 15W R.M.S. into 8 $\Omega$  **DISTORTION:** 0.1% at 15W

**INPUT SENSITIVITY:** 500mV **FREQUENCY RESPONSE:** 10Hz-16kHz — 3dB

**SUPPLY VOLTAGE:**  $\pm$  18V

**Price £5.22 + 65p VAT P&P free.**

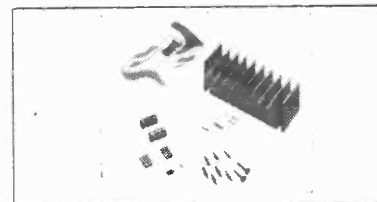

## HY50 25 Watts into 8 $\Omega$

The HY50 leads I.L.P.'s total integration approach to power amplifier design. The amplifier features an integral heatsink together with the simplicity of no external components. During the past three years the amplifier has been refined to the extent that it must be one of the most reliable and robust High Fidelity modules in the World.

**FEATURES:** Low Distortion — Integral Heatsink — Only five connections — 7 Amp output transistors — No external components

**APPLICATIONS:** Medium Power Hi-Fi systems — Low power disco — Guitar amplifier

**SPECIFICATIONS:** **INPUT SENSITIVITY:** 500mV

**OUTPUT POWER:** 25W RMS in 8 $\Omega$  **LOAD IMPEDANCE:** 4-16 $\Omega$  **DISTORTION:** 0.04% at 25W at 1kHz

**SIGNAL/NOISE RATIO:** 75dB **FREQUENCY RESPONSE:** 10Hz-45kHz — 3dB

**SUPPLY VOLTAGE:**  $\pm$  25V **SIZE:** 105 50 25mm

**Price £6.82 + 85p VAT P&P free**



## HY120 60 Watts into 8 $\Omega$

The HY120 is the baby of I.L.P.'s new high power range, designed to meet the most exacting requirements including load line and thermal protection, this amplifier sets a new standard in modular design.

**FEATURES:** Very low distortion — Integral Heatsink — Load line protection — Thermal protection — Five connections — No external components

**APPLICATIONS:** Hi-Fi — High quality disco — Public address — Monitor amplifier — Guitar and organ

**SPECIFICATIONS:**

**INPUT SENSITIVITY:** 500mV

**OUTPUT POWER:** 60W RMS into 8 $\Omega$  **LOAD IMPEDANCE:** 4-16 $\Omega$  **DISTORTION:** 0.04% at 60W at 1kHz

**SIGNAL/NOISE RATIO:** 90dB **FREQUENCY RESPONSE:** 10Hz-45kHz — 3dB **SUPPLY VOLTAGE:**  $\pm$  35V

**Size:** 114 x 50 x 85mm

**Price £15.84 + £1.27 VAT P&P free.**

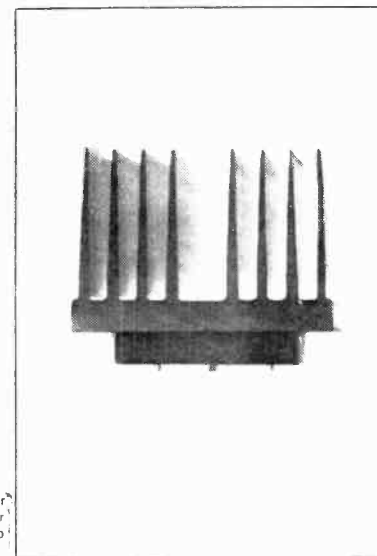

## HY200 120 Watts into 8 $\Omega$

The HY200, now improved to give an output of 120 Watts, has been designed to stand the most rugged conditions, such as disco or group while still retaining true Hi-Fi performance.

**FEATURES:** Thermal shutdown — Very low distortion — Load line protection — Integral Heatsink — No external components

**APPLICATIONS:** Hi-Fi — Disco — Monitor — Power Slave — Industrial — Public address

**SPECIFICATIONS:**

**INPUT SENSITIVITY:** 500mV

**OUTPUT POWER:** 120W RMS into 8 $\Omega$  **LOAD IMPEDANCE:** 4-16 $\Omega$  **DISTORTION:** 0.05% at 100W at 1kHz

**SIGNAL/NOISE RATIO:** 96dB **FREQUENCY RESPONSE:** 10Hz-45kHz — 3dB **SUPPLY VOLTAGE:**  $\pm$  45V

**SIZE:** 114 x 100 x 85mm

**Price £23.32 + £1.87 VAT P&P free.**

## HY400 240 Watts into 4 $\Omega$

The HY400 is I.L.P.'s "Big Daddy" of the range producing 240W into 4 $\Omega$ ! It has been designed for high power disco or public address applications. If the amplifier is to be used at continuous high power levels, a cooling fan is recommended. The amplifier includes all the qualities of the rest of the family to lead the market as a true high power hi-fidelity power module.

**FEATURES:** Thermal shutdown — Very low distortion — Load line protection — No external components

**APPLICATIONS:** Public address — Disco — Power slave — Industrial

**SPECIFICATIONS:**

**OUTPUT POWER:** 240W RMS into 4 $\Omega$  **LOAD IMPEDANCE:** 4-16 $\Omega$  **DISTORTION:** 0.1% at 240W at 1kHz

**SIGNAL/NOISE RATIO:** 94dB **FREQUENCY RESPONSE:** 10Hz-45kHz — 3dB **SUPPLY VOLTAGE:**  $\pm$  45V

**INPUT SENSITIVITY:** 500mV **SIZE:** 114 x 100 x 85mm

**Price £32.17 + £2.57 VAT P&P free.**

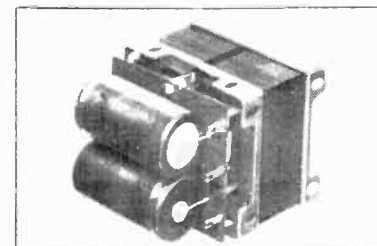

### POWER SUPPLIES

PSU36 suitable for two HY30 s **£5.22** plus 65p VAT P. P. free  
 PSU50 suitable for two HY50 s **£6.82** plus 85p VAT P. P. free  
 PSU 70 suitable for 2 HY 120 s **£13.75** plus £1.10 VAT P. P. free  
 PSU90 suitable for one HY200 **£12.65** plus £1.01 VAT P. P. free  
 PSU180 suitable for two HY2000 s or one HY400 **£23.10** plus £1.85 VAT P. P. free  
 48p plus 6p VAT

TWO YEARS' GUARANTEE ON ALL OF OUR PRODUCTS

I.L.P. Electronics Ltd  
 Crossland House  
 Nackington, Canterbury  
 Kent CT4 7AD  
 Tel (0227) 63218

Please Supply \_\_\_\_\_  
 Total Purchase Price \_\_\_\_\_  
 I Enclose Cheque  Postal Orders  Money Order   
 Please debit my Access account  Barclaycard account   
 Account number \_\_\_\_\_  
 Name & Address \_\_\_\_\_  
 Signature \_\_\_\_\_

WW—060 FOR FURTHER DETAILS





### T.T.L. 74 I.C.s By TEXAS, NATIONAL, I.T.T., FAIRCHILD ETC.

7400 14p	7426 25p	7473 30p	74121 30p	74151 65p	74179 140p
7401 14p	7427 25p	7474 30p	74122 40p	74153 65p	74180 100p
7402 14p	7428 40p	7475 30p	74123 60p	74154 120p	74181 200p
7403 14p	7430 15p	7476 40p	74125 50p	74155 70p	74182 75p
7404 14p	7432 25p	7477 15p	74126 50p	74156 70p	74184 150p
7405 14p	7437 25p	7485 100p	74130 130p	74157 70p	74185 150p
7406 40p	7438 25p	7486 30p	74132 65p	74160 90p	74188 350p
7407 40p	7440 15p	7489 250p	74133 65p	74161 90p	74189 350p
7408 20p	7441 65p	7490 35p	74135 100p	74162 90p	74190 140p
7409 20p	7442 65p	7491 75p	74136 80p	74163 90p	74191 140p
7410 15p	7445 80p	7492 45p	74137 100p	74164 125p	74192 120p
7400 20p	7446 80p	7493 40p	74138 125p	74165 125p	74193 120p
7412 20p	7447 75p	7495 60p	74139 100p	74166 125p	74194 100p
7413 30p	7448 70p	7496 70p	74141 60p	74167 325p	74195 100p
7414 60p	7450 15p	74100 95p	74142 270p	74170 200p	74196 100p
7416 30p	7451 15p	74104 90p	74143 270p	74173 150p	74197 100p
7417 30p	7453 15p	74105 40p	74144 270p	74174 100p	74198 185p
7420 15p	7454 15p	74107 30p	74145 75p	74175 75p	74199 185p
7422 20p	7460 15p	74109 50p	74147 230p	74176 100p	
7423 25p	7470 30p	74118 90p	74148 150p	74177 100p	
7425 25p	7472 25p	74120 90p	74150 120p	74178 140p	

C.MOS	4030 55p
4000 14p	4032 95p
4001 14p	4033 120p
4002 14p	4047 100p
4006 90p	4048 55p
4007 16p	4049 40p
4009 55p	4040 40p
4011 14p	4054 120p
4012 14p	4055 140p
4013 50p	4056 135p
4015 90p	4060 120p
4016 40p	4062 55p
4017 90p	4069 20p
4018 90p	4071 16p
4020 100p	4072 16p
4022 90p	4081 16p
4023 16p	4082 16p
4024 65p	4083 120p
4025 16p	4510 150p
4026 150p	4511 150p
4027 50p	4516 110p
4028 90p	4518 130p
4029 110p	4528 100p

IN4148 BY I.T.T./TEXAS 100 for £1.50. FULLSPEC
UNENCODED HEXADECIMAL 19 KEY- BOARD O 9 A B C D E F 2 OPTIO- NAL KEYS SHIFT KEY £12.50
555 Timer 10 for £2.50.
741 Op amp 10 for £2.00.
RCA SCR TO 3 case 100V 12 5A £2.50.
MURATA ULTRASONIC TRANSDUCERS MA40WR/S £2.50 each, £4.00 pair
210AN-2L 1024 x 1 BIT 250 NANO SEC STATIC RAM £2.60. 47 £8.40. 8/£16.00.
2102AN-4L 1024 x 1 BIT 450 NANO SEC STATIC RAM £2.60. 4/ £6.00. 8/£11.60.

2112-4 256 x 4 BIT 450 NANO SEC. STATIC RAM £2.95 each 4/ £11.60. 8/£22.80.
2513 CHARACTER GENERATOR UPEER CASE £7.00.
2513 CHARACTER GENERATOR LOWER CASE £7.00.
MM5204AQ PROM 4096 BIT READ ONLY MEMORY £8.00.
8212 B BIT IN/OUT PORT £3.00.
BB31 TRI-STATE QUAD LINE DRIVER £2.00.
BB33 TRI-STATE TRANSCIEVER (TRUE) £2.00.
BB35 TRI-STATE TRANSCIEVER (INVER- TING) £2.00.
AY5-1013 UAR/T £6.00 LM309K/LM340K VOLT- AGE REGULATOR £1.00 each.

63 KEY KEYBOARD UNEN-  
CODED SUITABLE FOR  
M.P.U. PROJECTS, ETC.  
£30.00.

### T. POWELL (ALL PRICES INCLUSIVE OF POSTAGE AND VAT)

306 ST. PAUL'S ROAD  
HIGHBURY CORNER, LONDON N.1

Telephone: 01-226 1489

Barclay / Access Credit Cards accepted

## RECHARGEABLE BATTERIES

'AA' pcell (HP7) £1.32, Sub 'C' £1.64 'C' (HP11) £2.43. 'D' (HP2) £3.56. PP3 £4.98. Matching chargers £6.98 each, except PP3 charger £5.82. Charging holders for 2, 3, 4, 5 or 6 pcells 50p. 'C' and 'D' size holders, 4 cell only 80p. Prices include VAT. Add 10% post-package and insurance orders under £20 (5% over £20).

SAE for full details plus 75p for 'Nickel Cadmium Power' booklet. Mail orders to

**SANDWELL PLANT LTD.**  
Dept. W/W, 201 Monmouth Drive, Sutton Coldfield  
West Midlands. Tel. 021-354 9764  
Callers to: TLC, 32 Craven Street, Charing Cross, London, WC2

WW-015 FOR FURTHER DETAILS

## TV TUBE REBUILDING

Faircrest Engineering Ltd., manufacture a comprehensive range of equipment for processing all types of picture tubes, colour and mono. Standard or custom built units for established or new businesses. We export world-wide and have an excellent spares service backed by a strong technical team.

Full training courses are individually tailored to customers' requirements.

For full details of our service contact Rodger J. Sandiford

### FAIRCREST ENGINEERING LTD.

Willis Road, Croydon  
CRO2XX. Tel. 01-689 8741

WW-053 FOR FULL DETAILS

# click

**Light on the scene.**  
Local lighting just where you want it with Click's elegant, adjustable Spotlight or snake-arm Reading Lamp.

**Tidy wires.**  
With Click you can hide all your leads and wires inside the uprights, with a neat, snap-in cover strip.

**Keeping it steady.**  
With shelves fixed firmly to the wall, you eliminate floor vibration problems.

**Finding a level.**  
Click brackets are infinitely adjustable for height so you can always get your shelves level.

## Shelving for hi-fi. We've solved the problems.

**FREE** Post this ad. with your name and address for a 10-page leaflet to **Click Shelving Ltd.**  
Lowmoor Rd, Kirkby in Ashfield, Notts, NG17 7LH

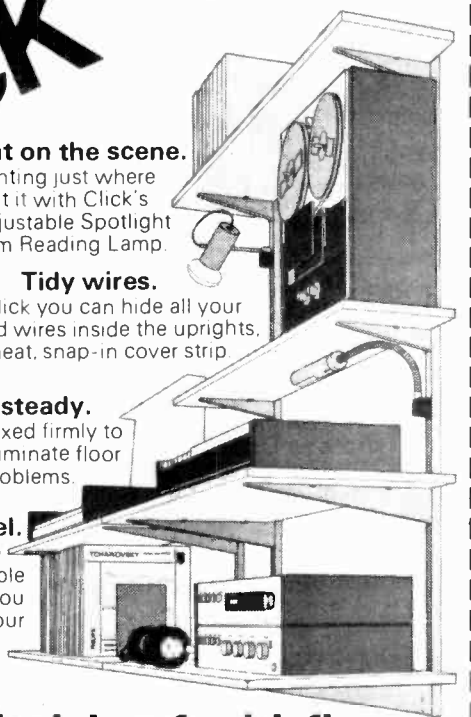

## FANTASTIC GOLDRING SAVINGS

### GOLDRING G103 Belt Drive Turntable

Famous name turntable slashed to near half price. Complete with plinth, cover and leads. Accepts any standard cartridge (not included). FULL 12 MONTH GUARANTEE

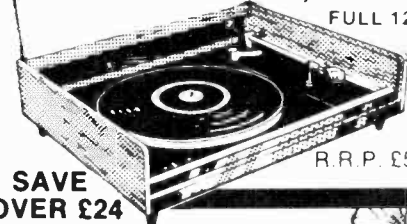

**OUR PRICE**  
**£26.95**  
R.R.P. £54 (- p/p & Ins £2.50)

**SAVE OVER £24**

### Build your own GOLDRING CK2 Belt Drive Turntable

Beautifully engineered unit from the famous Goldring company, comes complete with instructions and all necessary parts. Ready to incorporate into your design plinth and cover. The pleasure of assembling your own deck. (Plinth, cover and cartridge not included). Usually sold for £54.95 with plinth and cover.



**ONLY**  
**£16.95**  
(+ p.p & Ins. £1.75)

**ALL PRICES INC. VAT**  
Call in or send cheque, P.O., M.O., Access, Barclaycard, Diners Club or American Express Number.

## Sonic Sound Audio

248/250 TOTTENHAM COURT ROAD, LONDON W1. TEL: 01-637 1908

WW-028 FOR FURTHER DETAILS

# STOP HUNTING



**4S·6**  
 6MHz Bandwidth.  
 10mV/cm Sensitivity.  
 1µS/cm-100mS/cm  
 Timebase (16 Calibrated Ranges)

**4S·6LS**  
 (£145) Designed for  
 LOW SPEED  
 Measurements.  
 10µS/cm-1sec/cm  
 Timebase.

**SCOPEX® 4S6** keeps running  
 SINGLE BEAM OSCILLOSCOPE

**£125**  
UK EX VAT

Scopex Instruments Ltd. Pixmore Industrial Estate, Pixmore Avenue,  
 Letchworth, Hertfordshire. SG6 1JJ. Letchworth 72771 (STD 046 26)

® Regd Trade Mark

WW - 087 FOR FURTHER DETAILS

# TEN GOOD REASONS FOR BUYING THE NEW FLUKE 8020A DMM.

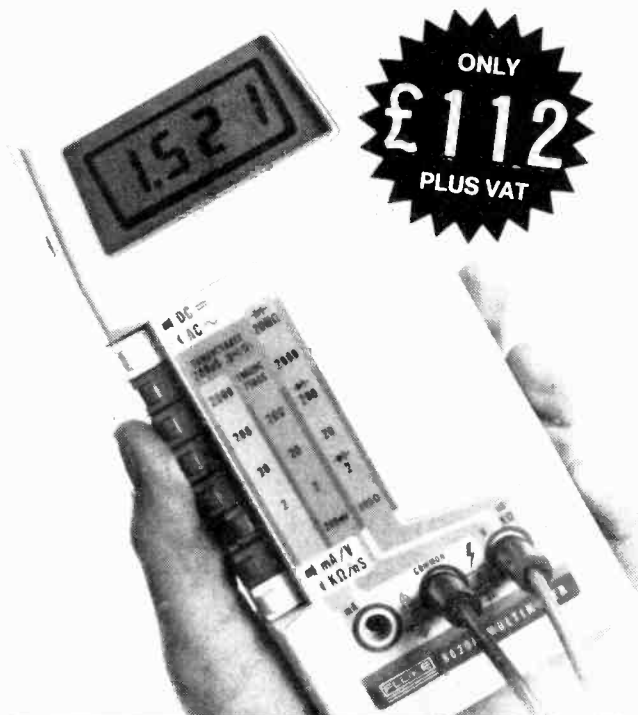

ONLY  
**£112**  
 PLUS VAT

1. 26 ranges of AC/DC volts and amps, ohms and conductance.
2. 0.25% vdc accuracy over 10°C range for 1 year.
3. 'High power' ohms for diode testing.
4. 'Low power' ohms for in-circuit resistance measurement.
5. Conductance ranges allow leakage measurement to 10,000 MΩ.
6. 9v battery gives typically 200 hrs. life.
7. Protected to 250v dc or rms on any range, any function.
8. Protects to 6kv for 10µs on any range, any function.
9. 2 year warranty on parts and labour.
10. Large liquid crystal display.

**Harlow(0279)29522**

**ITT instrument services**

Edinburgh Way, Harlow, Essex. CM20 2DF. Telex: 81525

**The only way to buy.**

WW-061 FOR FURTHER DETAILS

**EASY BUILD SPEAKER DIY KITS**  
Specially designed by RT-VC for cost-conscious hi-fi enthusiasts, these kits incorporate two teak-simulate enclosures, two EMI 13" x 8" (approx.) woofers, two tweeters and a pair of matching crossovers. Supplied complete with an easy-to-follow circuit diagram, and crossover components. Input 15 watts rms, 30 watts peak, each unit. Cabinet size 20" x 11" x 9 3/4" (approx.).

**£2800**  
STEREO PAIR + p & p £5.50  
\*SPEAKERS AVAILABLE WITHOUT CABINETS.

It's the units which we supply with the enclosures illustrated Size 13" x 8" (approx.) woofer (EMI), £1700 per tweeter, and matching crossover components. stereo pair Power handling 15 watts rms, 30 watts peak. + p & p £3.40

**COMPACT FOR TOP VALUE** These infinite baffle enclosures come to you ready mired and professionally finished. Each cabinet measures approx. per stereo pair 12" x 9" x 5" deep, and is in wood simulate. £850 Complete with two 8" (approx.) speakers for maximum power handling of 7 watts. + p & p £2.20

**SPEAKERS** Two models - Duo IIb, teak veneer, 12 watts rms, 24 watts peak. 18 3/4" x 13 3/4" x 7 3/4" (approx.). Duo III, 20 watts rms, 40 watts peak. 27" x 13" x 11 1/2" appx Duo IIb £17 PER PAIR Duo III £52 PER PAIR p & p £6.50 p & p £7.50

**DECCA 20 WATTS STEREO SPEAKER** stereo pair This matching loudspeaker system is hand made, kit comprises of two 8" diameter approx. base drive unit, with heavy die cast chassis laminated cones with rolled P.V.C. surrounds, two 3 1/2" diameter approx. domed tweeters complete with crossover networks. £4.00 p & p £20.00

**PORTABLE DISCO CONSOLE** Here's the big-value portable disco console from RT-VC! It features a pair of BSR MP 60 type auto-return, single play professional series record decks Plus all the controls and features you need to give fabulous disco performances. Simply connects into your existing slave or external amplifier. p & p £6.50 £64.00

**Tourist IV CAR RADIO KIT** For the experienced constructor only Output 4 watts into 4 ohms. Complete with speaker, baffle and fixing strip, for the experienced constructor only. The Tourist IV has five push buttons, four medium band and one for long wave band. The tuning scale is illuminated and attractive small aluminium control knobs for manual tuning and volume control. 12 volts pos or neg (altered internally). Size approx. 7" x 2" .4" £12.50

**A MOTOR TOP 10 ACCESSORY WINNER** p & p £1.50  
**FREE TO PERSONAL SHOPPERS BUYING CAR RADIO KIT** worth £3.00  
**ELECTROMATE** Rear window heater, modern line element

**PERSONAL SHOPPERS**

**UNIK** electronic digital alarm clock mains operated, large bright LED display tilted display for easy viewing, silent operation. Alarm and 9 minute repeater, PM and secs display size 105mm x 115mm x 50mm approx. £7.95

**16016 VOLT MAINS TRANSFORMER**, 2 1/2 amp. £2.50

**BSR** Record auto deck on plinth with stereo cartridge ready wired £11.95

**LED 5** function men's digital watch stainless steel finish £5.95

**LCD 5** function men's digital watch stainless steel finish £8.95

**LCD 8** function CHRONOGRAPH men's digital watch stainless steel finish £13.95

**STEREO CASSETTE** record/replay fully built P.C. board. Used, without guarantee. (Ex Equipment) £1.95

**AM. FM. TUNER** P.C.B. with Mullard L.P. 1186, 1185, 1181 modules £9.50

**100K** Multiturn Varicap tuning pots, 6 for £1.00

**MUSIC CENTRE CABINET** with hinged smoke acrylic top, finished in natural teak veneers, size 30 1/2" x 14 1/2" x 7 1/4" approx. £5.95

**MULLARD** Built power supply £1.50

**DECCA** DC1000 Stereo Cassette P.C.B. complete with switch oscillator coils and tape-heads £2.95

**FERGUSON**, 3-speed, 7" HIFI tape transport mechanism, complete with top covers. £15.95

**125 Watt Power Amp Module** £13.95

**Mains power supply parts** £3.50

# Mullard

## AUDIO MODULES IN BARGAIN PACKS

### CURRENT CATALOGUE

**PRICE & AT OVER 25 PER PACK**

**SEE OUR PRICES**

- PACK 1**, 2 x LP1173 10w. RMS output power audio amp modules, + 1 LP1182/2 Stereo pre amp for ceramic and auxiliary input. OUR PRICE £4.95 p+p £1.00
- PACK 2**, 2 x LP1173 10w. RMS output power audio amp modules + 1 LP1184/2 Stereo pre amp for magnetic, ceramic and auxiliary inputs. OUR PRICE £7.45 p+p £1.00
- PACK 3**, 1 x LP1179/2 FM Tuning head with AM gang, 1 x LP1165/1 AM/FM IF module, 2 x LP1173/10w. RMS output power audio amp modules + 1 LP1182/2 Stereo pre amp for ceramic and auxiliary input. OUR PRICE £9.95 p+p £1.00

**ACCESSORIES**  
Suitable power supply parts including mains transformer, rectifier, smoothing and output capacitors. £1.00 p+p £1.95

Recommended set of rotary stereo controls comprising BASS, TREBLE, VOLUME and BALANCE. p+p 50p 95p

**TRADE ENQUIRIES INVITED**

**20 x 20 WATT STEREO AMPLIFIER** £29.00  
Superb Viscount IV unit in teak finished cabinet. Silver fascia with aluminium rotary controls and p & p pushbuttons, red mains indicator and stereo jack £2.50 socket. Function switch for mic, magnetic and crystal pick-ups, tape, tuner, and auxiliary Rear panel features two mains outlets, DIN speaker and input sockets, plus fuse. 20 + 20 watts rms, 40 + 40 watts peak.

**30 x 30 WATT AMPLIFIER KIT**  
For the experienced constructor complete in every detail. Similar facilities as Viscount IV amplifier. 60 + 60 peak £29.00 p & p £2.50

**AVAILABLE NOW** built and fully tested with output £39.00 p & p £2.50  
30 + 30 watts rms, 60 + 60 peak.

**SPECIAL OFFER**  
**PACKAGE PRICE WITH 30 x 30 KIT Mk. II** version, operates into 4 to 15 OHMS speakers. Designed by R & TVC for the experienced constructor. Complete in every detail. facilities as Viscount IV amplifier 60 + 60 peak. Supplied with 2 Goodmans Compact 12" bass woofer with cropped 14,000 Gauss Magnel, 30 watt rms, handling +3 1/4" approx. tweeters and crossovers. £49.00 p & p £4.00

**ADD-ON STEREO CASSETTE TAPE DECK KIT**  
Designed for the experienced D.I.Y. man. This kit comprises of a tape transport mechanism, ready built and tested record/replay electronics with twin V.U. meters and level control for mating with mechanism. Specifications: Sensitivity - Mic. 0.85 mV u 20K OHMS; Din. 40mV u 400K OHMS; Output - 300mV RMS per channel u 1KHz from 2K OHMS source. Cross Talk - -30db; Tape Counter - 3 Digit; Resetttable; Frequency Response - 40Hz - 8KHz ± 6db; Deck Motor - 9 Volt DC with electronic speed regulations; Key Functions - Record, Rewind, Fast Forward, Play, Stop & Eject. p & p £2.50 £19.95  
Opt. Extras: Mains Trans. to suit £2.50 p.p. £1.

**RTVC**  
323 EDGWARE ROAD, LONDON W2  
21a HIGH STREET, ACTON, W3 6NG  
ALL PRICES INCLUDE VAT AT 12 1/2%  
All items subject to availability  
Price correct at 23.5.78 and subject to change without notice

Send stamped addressed envelope for further details  
Order by giving credit card number ONLY

**50 WATT MONO DISCO AMP** £29.95  
P&P £2.50  
Size approx. 13 1/4" x 5 1/4" x 6 1/4"  
50 watts rms, 100 watts peak output. Big features include two disc inputs, both for ceramic cartridges, tape input and microphone input. Level mixing controls fitted with integral push-pull switches. Independent bass and treble controls and master volume.  
**SPECIAL OFFER**, The above 50 watt amp plus 4 Goodmans Type 8P, 8" speakers. Package price £45.00 + £4.00 P&P.

**70 & 100 WATT MONO DISCO AMP**  
Size approx. 14" x 4" x 10 1/2"  
Brushed aluminium fascia and rotary controls.  
Five vertical slide controls - master volume, tape level, mic level, deck level. PLUS INTER-DECK FADER for perfect graduated change from record deck No. 1 to No. 2, or vice versa. Pre-fade level control. 70 watt £57 (PFL) lets YOU hear next disc before fading p & p £4.00  
100 watt £65  
Output 100 watts RMS 200 watts peak.

**CHASSIS RECORD PLAYER DECKS**  
Record changer with cue, stereo ceramic cartridge. P&P £2.00

**GARRARD DECK GC10A** £7.95  
BSR MP60 TYPE Single play record player less cartridge. p & p £2.55  
Cartridges to suit above  
Acos, magnetic stereo £4.95  
Ceramic stereo £1.95  
BSR automatic record player deck cueing device and stereo ceramic head, p & p £2.55 £9.95

BSR MP 60 type, complete with magnetic cartridge, £29  
diamond stylus, and de luxe plinth and cover. p & p £4.50  
Home 8 Track cartridge player. This unit will match with the Viscount IV 9" x 8" x 3 3/4". p & p £2.50 £16.50

**EASY TO BUILD RECORD PLAYER KIT**  
for the D-I-Y man who requires a stereo unit at a budget price, comprising ready assembled stereo amp, module, Garrard auto / manual deck with cueing device, pre-cut and finished cabinet work Output 4 watts per channel, phones socket and record/replay socket, including 2 SPHERICAL HIFI speakers. £19.95 p & p £4.05





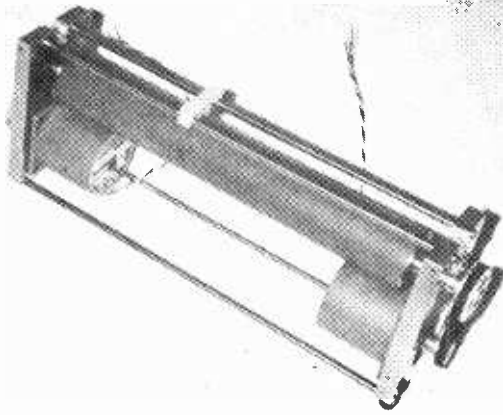

### BARREL TYPE X-Y PLOTTER ASSEMBLY

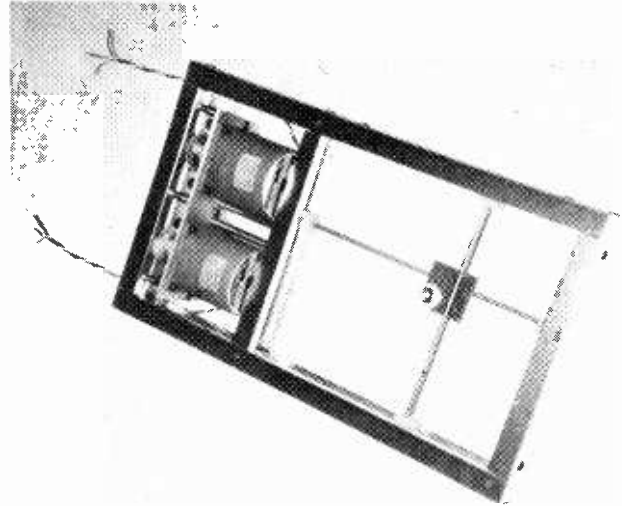

### X-Y PLOTTER ASSEMBLY

Two Sizes 6 x 4 1/2  
and 12 x 9

## THE NEWBEAR COMPUTING STORE

### SYSTEMS

#### S-100 bus.

Cromenco Z-2 Kit (C.P.U & Card Frame Z-80 Based) **£395.00**  
Bytesaver programming board kit (2708) **£95.00**  
TU-ART Interface kit **£130.00**  
16K Byte Dynabite RAM card (fully tested) **£415.00**  
North Star Mini Floppy Kit **£490.00**

#### S-50 bus.

MSI 6800 Microcomputer Kit **£375.00**

### SMOKESIGNAL BROADCASTING

Floppy discs.  
Fully built and tested.  
Single drive **£522.00**  
Double drive **£785.00**  
Treble drive **£1045.00**  
Newbury Laboratory V.D.U.s from **£520.00**

8% VAT on ALL items  
**For demonstrations:**  
**Southern England: Phone 0635-46898, or call at:**  
**Newbear Computing Store, 7 Bone Lane, Newbury Berkshire**  
**Northern England: Phone 061-491 2290, or call at:**  
**Newbear Computing Store, 2 Gately Road Cheshire SK8 1PY**  
**N.C.S. is a division of Newbury Laboratories Ltd.**

FOR RESEARCH MACHINES 380Z COMPUTER SYSTEMS PLEASE SEND FOR INFORMATION AND PRICES

# S I N T E L

CD4015	0.83	CD4032	0.89	CD4049	0.50	CD4072	0.20	CD4099	1.85
CD4016	0.48	CD4033	1.25	CD4050	0.43	CD4073	0.20	CD4502	0.81
CD4017	0.79	CD4034	1.71	CD4051	0.82	CD4075	0.20	CD4510	1.01
CD4018	0.83	CD4035	1.06	CD4052	0.82	CD4076	1.17	CD4511	1.25
CD4019	0.50	CD4036	2.86	CD4053	0.82	CD4077	0.39	CD4514	2.47
CD4000	0.15	CD4020	1.11	CD4037	0.85	CD4054	1.04	CD4078	0.20
CD4001	0.17	CD4021	0.90	CD4038	0.96	CD4055	1.18	CD4081	0.20
CD4002	0.17	CD4022	0.82	CD4039	2.78	CD4056	1.18	CD4082	0.20
CD4006	1.04	CD4023	0.18	CD4040	0.97	CD4059	4.29	CD4085	0.64
CD4007	0.18	CD4024	0.70	CD4041	0.75	CD4060	1.00	CD4086	0.64
CD4008	0.87	CD4025	0.20	CD4042	0.69	CD4063	0.98	CD4089	1.39
CD4009	0.50	CD4026	1.55	CD4043	0.88	CD4066	0.55	CD4093	0.80
CD4010	0.50	CD4027	0.44	CD4044	0.84	CD4067	3.35	CD4094	1.69
CD4011	0.18	CD4028	0.77	CD4045	1.26	CD4068	0.20	CD4095	0.94
CD4012	0.20	CD4029	1.03	CD4046	1.20	CD4069	0.20	CD4096	0.94
CD4013	0.43	CD4030	0.50	CD4047	0.89	CD4070	0.48	CD4097	3.35
CD4014	0.83	CD4031	2.00	CD4048	0.50	CD4071	0.20	CD4098	0.98

### CMOS

Mainly RCA

### COMPONENTS

SOLDERCON	CLOCK CHIPS	DISPLAYS	CRYSTALS	MEMORIES/μ Ups	MEK68002
PINS	AY1202	3.10 TYPE FM500 C C	1.30 32 768 KHz	2.95	190.00
100	0.50 AY1224	3.45 TYPE TTL 321 C A	1.30	MC6800	13.80
1000	4.00 MK50253	5.40 5101	4.90	MC6820	15.94
3000	10.50			780-CPU	18.80
				780-CPU	22.40
				780-CTC	10.15
				780-PD	10.15

Free data is available on some of these items **SEND FOR FREE CATALOGUE**

### DATA BOOKS

Intel Memory Dis qn Handbook	£5 20
Intel 8080 Microcomputer System User's Manual	£5 25
Intel 8085 Microcomputer System User's Manual	£5 15
Motrola Book et From the Computer Mic processor	£1 80
Motrola CMOS Databook Vol 5 Series B	£3 50
Motrola M6800 Microprocessor Applications Manual	£12 95
Motrola M6800 Programming Manual	£5 35
National S. MP Interf User's Manual	£0 75
National S. MP Technical Description	£1 80
National Semiconductor TTL Databook	£2 10
RCA CMOS and Linear C Databook	£5 45
Texas Instruments Pin Configuration Guide, A very useful set of glass cards showing pin configurations of 7400 ICs plus many other TI Memories Op Amps	£2 95
Z80 Assembly Language Programming Manual	£7 50
Z80 CPU Technical Manual	£5 60
Z80 CTC Programm Manual	£0 80
Z80 P10 Technical Manual	£3 30
<b>THE BEST OF BYTE Vol. 1</b> A selection of best articles from the first twelve issues of BYTE magazine	£11 95

**FAST SERVICE:** We guarantee that Telephone Orders for goods in stock, received by 4.15 p.m. (Mon-Fri) will be dispatched on the same day by 1st Class Post (some heavy items by parcel post) and our stocking is good. Private customers should telephone and pay by giving their Access or Barclaycard number with a minimum order value of £5. Official orders no minimum. Official orders, Companies, Govt., Nats., Inds., and Univs

**ORDERS:** (A) BY POST (B) BY TELEPHONE (C) BY FAX (D) BY COURIER (E) BY AIR MAIL (F) BY AIR MAIL (G) BY AIR MAIL (H) BY AIR MAIL (I) BY AIR MAIL (J) BY AIR MAIL (K) BY AIR MAIL (L) BY AIR MAIL (M) BY AIR MAIL (N) BY AIR MAIL (O) BY AIR MAIL (P) BY AIR MAIL (Q) BY AIR MAIL (R) BY AIR MAIL (S) BY AIR MAIL (T) BY AIR MAIL (U) BY AIR MAIL (V) BY AIR MAIL (W) BY AIR MAIL (X) BY AIR MAIL (Y) BY AIR MAIL (Z) BY AIR MAIL

**SEND YOUR ORDER TO**

**SINTEL**  
PO BOX 75C OXFORD  
Tel: 0865 49791

**SINTEL**

# NOW — AN X-Y PLOTTER ASSEMBLY THAT EVERYBODY CAN AFFORD

Due to a large purchase we have an assembly consisting of frame with X & Y assemblies (no pen — but provision provided), pulleys and cords; and **YES** two high quality stepping motors, these alone are worth the asking price for the entire assembly. Two basic sizes are available, with various stepping motor options. All motors 200 steps per rev, 20oz. inch torque

120V Stepping Motor  
750.0-1000 ohm will step at 50V  
Bed Size 6 x 4 1/2" £26.50 ea  
Bed Size 12 x 9 £39.50 ea

120V Stepping Motor  
1000.0-1000 ohm.  
These can be changed with care to 12 or 24V. Data supplied  
Bed Size 6 x 4 1/2" £33.50 ea. Bed Size 12 x 9 £46.50 ea  
**P & P ALL OPTIONS £2 each**

These are supplied for 12-24V operation, but will effectively step at reduced torque down to 5V  
Bed Size 6 x 4 1/2" £51 ea. Bed Size 12 x 9 £64 ea

### STEPPING MOTORS ONLY

Stepping Motor.  
1000.0-1000 ohm  
Can be changed with care to 12/24/48V. Data Supplied  
£8 each. P & P £1  
Supplied for 12/24V operation.  
£13 each. P & P £1  
**Just think about the uses!**

## BARREL TYPE X-Y PLOTTER ASSEMBLY

For HIGHER ACCURACY AND GREATER FLEXIBILITY

Accepts paper up to 11in width. Can also be used as Pen Recorder, or with suitable Print Head as basis of Printer etc.  
Fitted with Two Superior Electric Stepping Motors for 120V operation. Other Voltage Options available. Provision for pen.  
**FRICITION FEED @ £78 each**      **SPROCKET FEED @ £94 each**  
P & P £3.25 both models

## ★ TRANSISTORS/DIODES/ RECTIFIERS, ETC. ★

Guaranteed all full spec devices. Manufacturers' Markings.  
At 5p each.  
BC147, 2N3707, BC172B, BC251B, BC348B, BC171A/B, BC413, D10, BC182, BAX13, 1N937, BA102BE, BZX83, TIS61, 2N5040.  
At 10p each.  
BFX85, 1N4733A, SN7451N: BYX10-1.5 KV 0.36A, BYZ10 15p ea TIP30 — 20p ea TIP34A — 50p ea BD538 — 40p ea Heavy Duty Bridge Rectifier — 20p ea CA3123E — £1 ea. BDY55 — £1 ea 2N3055 — 40p ea TIP31B 12p ea TBA560C0 £2 ea 1N4436T—T03 Flat mount 10A200piv £1ea 2N5879 with 2N5881 Motorola 150W Comp. pair £2 pr BD535, BD538 Comp. pair — 75p pr  
Linear Amp 709 — 25p ea  
High Speed Voltage Comparator 710 — 15p ea  
P & P Extra on all items  
**FINNED HEAT SINK** — single T03 — size 4 3/4in x 3in x 1 1/4in 50p ea P & P 75p  
Texas Bridge Rectifier 5S805-50V 5A 60p ea P & P 20p

## DON'T MISS THE TELEFUNKEN D14-131 REPLACEMENT TUBES FOR SOLARTRON (SCHLUMBERGER) CD1740 COSSOR CDU 150 — S.E. LABS SM112 and the GEC/MOV 1474 TUBE

These tubes were fitted in one of the above oscilloscopes, but were removed on the authority of the British Ministry because they were not of British manufacture. They are warranted by us as being of as new condition.

PRICE £55 EA. P & P £2.75

## ALSO BRAND NEW TUBES FOR THE FOLLOWING OSCILLOSCOPES: TELEQUIPMENT

S52 at £10 ea D53A at £20 ea  
D51 at £15 ea D52 at £15 ea  
S42 at £10 ea S31 at £10 ea

BRADLEY 200 at £85 ea  
ADVANCE OS 3000 at £85 ea  
**P & P all types £2.75 ea**

## AND MULLARD & BRIMAR OSCILLOSCOPE TUBES BRAND NEW—BOXED—ALL RECTANGULAR

D13-46GM P7 £35 ea GEC type 1496B £75 ea  
D13-51GH Green £65 ea Carriage all types £2.75  
D10-210GH/32 £40 ea

**TELEPHONES.** Post Office style 746 Black or two-tone £6.50 ea. Modern style 706 Black or two-tone grey £4.50 ea. P & P £1 each. Old black style £1.50 each. P & P £1.  
**HANDSETS** only 706 style £1.75 each. Older style £1. P & P 75p.  
**TELEPHONE EXCHANGES.** Eg 15-way automatic exchange only from £95.

**EX-DYNAMCO Oscilloscopes INVERTORS**  
30V Input 6KV Output. Size 2" x 4 1/2" x 1 1/2". Complete with circuit £10 ea P & P £1

**EX-MINISTRY OSCILLOSCOPE CT436**  
Double Beam DC-6 HMZ £1.20

**MARCONI TF801D/8/S SIGNAL GENERATOR**  
Very good condition £385 each

**MARCONI R.F. POWER METER**  
Type TF 1152A/1 (CT419)  
2 ranges 10 watts fsd and 25 watts fsd. 50 ohms  
£65 each

**HIGH NOISE IMMUNITY LOGIC**  
Dual in Line 16 pin ceramic packages  
(Texas series 15300) 12V Power rail. Normal polarity.  
Type 326 dual 2 input dual 3 input NAND Gate.  
Type 332 dual 2 input and with 4 invertors.  
Type 370 Quad Flip Flop.  
Mixed package — our selection. All Brand New.  
**10 for 50p. P & P 25p.**

**DON'T FORGET YOUR MANUALS S.A.E. WITH REQUIREMENTS**

**POWERFUL MINIATURE GERMAN 12V REVERSIBLE MOTOR.** No load current 70MA, excessive load 400MA. Size 1 1/2 x 1 3/16" dia. Shaft 5/16 x approx 1/16" dia. 50p each. P & P 40p

## NOW — INCREASED AREA GIVEN TO PICK-A-PACK AT 50p per lb.

Larger volume of new components you can't afford to miss

### TEKTRONIX OSCILLOSCOPES

541A with G Plug-in £160. 545 with CA Plug-in £200. 547 Main Frame 581A Main Frame 585 with B2 Plug-in £425. 661 with 4S1 £350.

Stocks of better oscilloscopes always changing. Enquiries please. Plug-in units not sold separately

R & S Audio Freq. Spectrograph BN48301 £650.  
MARCONI Sweeper TF1099 £45 each  
H.P. Oscilloscope type 185B £100 each

**TEKTRONIX OSCILLOSCOPE** type 502 High gain Limited bandwidth £185 each  
**R & S POWER METER** BNRD-BN 2412/50 £50.  
**R & S POWER SIGNAL GENERATOR** BN41001 100KHZ to 30MHZ £275.

**R & S SWEEP GENERATOR** BN4242 50KHZ-12MHZ £145.  
**R & S Z-g DIAGRAPH** 300-2400MHZ BW3512. Good condition £60 ea  
**R & S ENOGRAPH G** Type BN18531 £120.

**H.P. TRANSMISSION GENERATOR** 3701A with 3702A Demodulator Display and 3703A Group Delay Detector £500.  
**H.P. TRANSFER OSCILLATOR** 540B £30 ea  
**H.P. AC/OHMS CONVERTOR** 2410B £80.  
**H.P. DIGITAL COMPARTOR** £80

**VARIOUS PLUG-INS** for Telonic Sweeper SM2000. From £50 each  
**TELEONIC SWEEPER SD3M.** 425 930 MHZ £120 ea  
**ALFRED OSCILLOSCOPE.** Model 8000 with SWEEP NETWORK ANALYSER Model 7051 with info £240 ea

**KNOTT WOBBULATOR SYSTEM** type WMB2B BN851 with WMC BN852 and WMA BN850 0-50MHZ £700.  
**MARCONI TF868 UNIVERSAL BRIDGE** £70 ea  
**AIRMEC SIGNAL GENERATOR** type 204 1-320 MHZ £250.

**R & S POLYSCOPE** SW0B1 at the low price of £375 each. Some POLYSCOPE SW0B11 at £550 each.

**MARCONI SIGNAL GENERATORS.** Freq. range 10-470MHZ Type TF801B/3/S £160 each.  
**POLARAD RECEIVER** Model FIM-B2. Complete 1-10GHZ £325.

**RHODE & SCHWARZ** Turntable Indicating Amplifier UBM £75.  
**FM / AM SIGNAL GENERATOR** type AN/USM 16. 10 to 420MHZ. Limited quantity £195 each

**TRIPODS P & T HEAD £22.50 each**

**BRUEL & KJOER** Automatic Vibration Exciter type 1016 Sine Wave sweep from 5HZ to 10KHZ £75 each.  
**GENERAL RADIO PULSE SWEEP GEN.** Type 1391B £90.  
**GENERAL RADIO.** Osc. Unit 1209B. 250-920Megs £50

**MARCONI VALVE VOLTMETER TF428B £12.50 each**

**MARCONI RF POWER METER.** TF1020A/1 75 ohm £65.  
**JERROLD SWEEP GENERATOR 900A £165.**

### WANDEL & GOLTHERMANN and SIEMANS EQUIPMENT

**LEVEL OSCILLATOR** 3W51B: SWEEP UNIT WZ-1  
**LEVEL OSCILLATOR** 3D935: RECEIVER LDE-1  
**SWEEP OSCILLATOR** 3W938b1a: TRANSMITTER LDS-1  
**LEVEL TRACER (Display)** 3D346b1a  
**CARRIER FREQUENCY LEVEL METER** TFM.76  
**LEVEL TRANSMITTER** TFP5.75 CRT Indicator with Plug-ins SG-1  
**SWEEP CONVERTER** WU-1  
Other units available. Average price £120 per unit. Reduction for quantity

## A LARGE QUANTITY OF MISCELLANEOUS TEST GEAR— CHASSIS UNITS, ETC., ON VIEW AT LOW COST

Minimum Mail Order £2. Excess postage refunded. Unless stated — please add £3.25 carriage to all units.  
**VALUE ADDED TAX** not included in prices — Goods marked with \* 1 1/2 % VAT, otherwise 8 %.  
Official Orders Welcomed. Gov./Educational Dept., Authorities, etc., otherwise Cash with Order.  
Open 9 a.m. to 5.30 p.m., Mon. to Sat.



7/9 ARTHUR ROAD, READING, BERKS. (near Tech. College, King's Road). Tel: Reading 582605





# Electronic Brokers Ltd

## The Test Equipment People

Calibrated & Guaranteed 12 Months

### GOULD ADVANCE

**Double Pulse Generator PG.56.** Pulse Amplitude 0.1V-10V Sq. wave 0-10V. Rise Time 10nsec (typically) £100.00

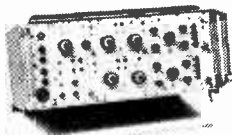

**Pulse Generator PG59 (Type CT600).** Produces a pulse controllable in frequency, width, amplitude, delay and rise and fall times. Also produces prepulse and gate outputs. Repetition frequency 1Hz to 10MHz. Pulse width 25nsec to 1sec. Rise and fall times 12nsec to 1 sec. Delay 25usec to 1sec. Trigger; Internal, external and single shot £595.00

**LR100X-Y Plotter.** Specification, Main frame, Frequency response 1Hz. Plug-in amplifiers, LR120 general purpose amplifier, LR121 time base. Full specification on request £235.00

**R.F. Signal Generator B487.** 30kHz-30MHz O/p. 1µV to 100mV. Output z -75Ω Int. Mod. 400Hz 0-80%. Provision for Ext. Mod Audio o/p 0-10V at 400Hz into 600Ω £165.00

**AF Signal Generator H1E.** Specification, Frequency range, 15Hz-50kHz. AF Output; Sine Wave 200µV. to 20V r.m.s. ±2 dB. Square Wave 1.4mV to 14V peak to peak approximately £80.00

**Signal Generator J3.** Frequency range 10Hz to 100kHz Sine & Square output Metered o/p £150.00

**Signal Generator J4.** Frequency range 10Hz to 100kHz. Sine and square o/p £140.00

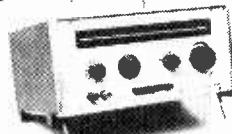

**Wide range oscillator SG 67A.** Frequency range 1Hz to 1MHz. Sine and square wave £95.00

**Low Distortion Oscillator SG 68A.** 1.5Hz-150kHz Output waveforms Low distortion - <0.01% (40Hz-20kHz) Low distortion - <0.05% (20kHz-150kHz) Square wave. Typically 6000 impedance. Max. output 4V (r.m.s.). Battery operated £175.00

**True R.M.S. Voltmeter DRM6.** 100mV-1kV (6 ranges) 100% over-range. C.M.R. 90dB (DC-50Hz) £395.00

**Frequency Counter TC16.** 5Hz-80MHz. 5 digit display. 1MHz crystal. Frequency and count functions £110.00

**Timer Counter TC17A.** 6 digit DC-80MHz Gate times 10µs to 10s in decade steps. Sensitivity 25mV (r.m.s.) sine wave. Overload protected £215.00

**Timer Counter TC18.** Specification, Frequency Measurement, Input 1 10Hz to 100MHz. Input 2 10MHz-512MHz. Both inputs direct counting Sensitivity 35mV r.m.s. to 40MHz. 50mV r.m.s. at 100MHz Input 2 sensitivity 35mV r.m.s. 40MHz to 400MHz. 50mV r.m.s. to 512MHz Display 6 digit dot matrix L.E.D. £245.00

**Timer Counter TC22.** Measures Frequency DC-100MHz 6 digit, time, period, period average, count, totalise, pulse width, ratio £275.00

**Digital Multimeter DMM3.** 3½ digit Maximum reading 1999 25 ranges of measurement. AC and DC volts AC and DC current. Resistance Dual Polarity Remote hold £115.00

**STRIP CHART RECORDER OMNISCRIBE A.5000 Series.** One & Two Pen. "As New Condition" Full specification on request

A.5110-1	£200.00
A.5112-2	£225.00
A.5123-1	£300.00
A.5120-5	£300.00
A.5132-4	£320.00
A.5221-4	£400.00
A.5212-4	£380.00
A.5230-4	£450.00
A.5222-2	£410.00

**Off Air Frequency Standard OFS-1** £120.00

**VHF Square Wave Generator SG21.** 10kHz-100MHz £60.00

**A.F. Signal Generator J2E.** 15Hz-50kHz o/p (600Ω) 0.1mV-1W £120.00

**A.C. Millivoltmeter VM77C.** 0.001V-300V f.s.d. (12 ranges) 15Hz-4.5MHz £55.00

**Timer Counter TC14.** 9 digit. Display storage. DC-250MHz. Time gate selectable 0.1µs-100s. Multiple period average 10-10°. Sensitivity 10mV, 100mV, 500mV. Overload protected £400.00

**Timer Counter TC15.** 9 digit with storage and plug-in capability. DC-250MHz. Spec similar to TC14 £500.00

**Plug In Unit TC15 P1.** 1MHz-500MHz. 10mV-1V. Full 500MHz display with 1Hz resolution in only 2 secs £150.00

**Portable Oscilloscope OS245A.** Dual trace. DC-10MHz 5mV/div 4" rectangular CRT BRAND NEW £232.00

**Dual Trace Portable Oscilloscope Type OS 3000.** DC-40 MHz 5mV-20V, DIV Delayed Sweep £495.00

### TEKTRONIX

**Bench Oscilloscope Type 531A** c/w dual trace vertical plug-in unit CA. DC-13.5MHz Sensitivity 50mV-20V/Div Time base ranges 100ns to 5S/Div Timebase modes, A, X5 Internal voltage calibrator 0.2mV-100V 1kHz square wave £290.00

**Bench Oscilloscope Type 647A** c/w dual trace vertical plug in unit 10A2A & delayed time base plug in unit 11B2A. DC-100MHz Sensitivity 10mV-20V/Div. Time base ranges 100ns-5S/Div on A & B. Time base modes A only, Intensified, delayed sweep. X10 Internal voltage calibrator 0.2mV-100V. 1kHz square wave £1200.00

**Bench Oscilloscope Type 585A** c/w dual trace vertical plug in unit Type B2 DC-80MHz Sensitivity 10mV-50V/Div Time base ranges A 50ns-2s/Div, 2 2µs-1s/Div Time base modes A, B, intensified, delayed. X5 Internal voltage calibrator 0.2mV-100V. 1kHz square wave £775.00

**Bench Oscilloscope Type 547** c/w dual trace vertical plug in unit 1A1. DC-50MHz Sensitivity 5mV-20V/Div Time base ranges 100ns-5S/Div A and B Time base modes A, B, intensified, delayed sweep, alternate sweep, X 2.5-10 Internal voltage calibrator 0.2mV-100V 1kHz square wave £775.00

**Bench Oscilloscope Type 546,** c/w dual trace vertical plug in unit 1A1 As 547, but without alternate sweep £740.00

**Bench Oscilloscope 545B** c/w dual trace vertical plug in unit CA DC-24MHz, sensitivity 50mV to 20V/Div Time base ranges A 100ns - 5S/Div B2 µs/1s/Div Time base modes A, B, intensified delayed sweep, X5 Internal voltage calibrator 0.2mV-100V 1kHz square waves £555.00

**Bench Oscilloscope Type 543B** c/w dual trace vertical plug in unit CA As 545B & CA, without B time base. With X2-X100 Horizontal gain £450.00

**Time Marker Generator 184.** 16 marker intervals, 5 sine wave frequencies 500MHz sine wave output Crystal controlled oscillator 10MHz ± 0.001% £275.00

**2101 5ns Pulse Generator with Delay.** 2 5Hz-25MHz repetition rate. Variable baseline offset 5ns risetime and fall time Paired, undelayed, delayed and output latched on modes External gate input Simultaneous positive and negative going pulses 10volts into 50Ω £575.00

**2901 Time Mark Generator.** 16 marker intervals, 4 sine wave frequencies 500MHz sine wave output Crystal controlled oscillator. 8 trigger pulse intervals £450.00

**TV Waveform Monitor 525** £165.00

**Plug In Unit Power Supply 132** £120.00

**Spectrum Analyser Plug In 3L10** (for 560. and 564 series scopes). 1-36MHz £415.00

**4-Trace Plug In Unit "M"** (for use with 530, 540 & 580 series) £250.00

**Differential Plug In Unit "W"** £325.00

**Oscilloscope Camera Unit C12** £190.00

**Digital Readout Oscilloscope 567.** Price of plug-ins available Mainframe price £510.00



**Constant Amplitude Signal Generator 191.** 350kHz-100MHz Sine wave 5mV-5 5V constant amplitude 50kHz Amplitude reference £350.00

**Colour TV Vector Scope Type 526** £425.00

**Colour TV Waveform Monitor Type 529** £350.00

### E.N.I.

**RF Power Amplifier Type 500L.** 2-500 MHz 27dB gain. O/P 300mW Superb condition £315.00

### COSSOR

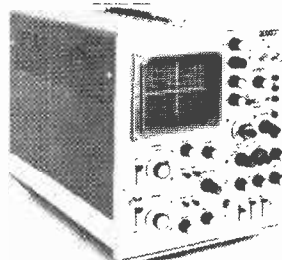

**Dual Trace Scope 4000.** 50MHz 7nsec Rise Time 5mV cm sensitivity Calibrated sweep delay Gated trigger X-Y display B x 10cm display Unused £495.00

### TELEQUIPMENT

**Portable Oscilloscope D75.** DC-50MHz at 5mV/Div Dual Trace Delay Mixed Sweep £575.00

**Dual Trace Modulator Oscilloscope D83/V4/S2A.** DC 50 MHz 5m V-20V DIV Delayed Sweep Excellent condition £610.00

A copy of our trading conditions is available on request

## ELECTRONIC BROKERS LIMITED

49-53 Pancras Road, London NW1 2QB

Tel. 01-837 7781. Telex: 298694

Hours of Business: 9 a.m.-5 p.m.  
Mon.-Fri.: closed lunch 1-2 p.m.

Carriage and Packing charge extra on all items unless otherwise stated.

WW-112 FOR FURTHER DETAILS

ADD 8%  
VAT  
TO ALL  
PRICES

**Calibrated & Guaranteed 12 Months**

# Electronic

## The Test Equipment People

### ROHDE & SCHWARZ

**Stereocoder Type MSC. BN4192/2.** Superb condition £1,200.00  
**Stereocoder MSDC. BN4193.** Superb condition £850.00  
**Z-g Diagraph ZDU** £860.00  
**Selective Level Voltmeter . USWV.** 30-400 MHz 10µV-3V £800.00  
**U.H.F. Millivoltmeter. URV.** 1 KHz-1.6 GHz £235.00

### HEWLETT PACKARD

**True R.M.S. Voltmeter 3400A.** 1mV-300V. (12 ranges) dB range -72 to +52 dBm. Frequency range 10Hz to 10MHz £415.00  
**D.C. D.V.M. 3430A.** 3 digit 5 ranges 100mV-100V Input Resistance 10MΩ. Overload protected £145.00  
**Digital Multimeter 34702A.** C/w 34740 display 4½ digit. 4 ranges of A.C. & D.C. & 6 ranges of ohms. A C = 45Hz-100kHz £350.00

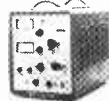

**U.H.F. Signal Generator 612A.** 450-1200MHz in 1 band Output Voltage 0 µV to 0.5V. Output impedance 50Ω A.M. 0-90% Ext. A.M. Facility Pulse mod. facility Various modern versions from £900.00-£1250.00

**Frequency Doubler 10515A** £75.00  
**A.M. Signal Generator 606A.** 50kHz-65MHz £550.00  
**Bench Oscilloscope 175A.** C/w Plug Ins 1754A & 1781B. 4 trace 40MHz bandwidth Sweep Delay £550.00  
**Programmable Step Attenuator 355E.** DC-1000MHz 0-12 dB in 1dB steps. Unused £60.00  
**Distortion Analyser 332A.** 5Hz-600kHz Distortion levels 0.1%-100% are measured full scale in 7 ranges A.M. Detector operating from 550kHz-65MHz £495.00  
**DC Standard/Differential Voltmeter 740B.** Designed for calibrating digital voltmeters differential voltmeters, potentiometers, voltage dividers and for general standards lab application. 6 digit resolution with discrete steps of 1 p.p.m. of full scale Full specification on request £1,850.00  
**A.C. Voltmeter 400F.** 100V to 300V 1 s (14 ranges) Freq. range 20Hz-4MHz £195.00  
**Microwave Power Meter 430C.** C/w Thermistor mount 477B 10MHz-10GHz Full scale ranges 0.1, 0.3, 1, 3 & 10mW  
**Portable Oscilloscope 1700B.** DC-35MHz 10mV/div sensitivity. Dual Channel Solid State £575.00

**A.C. Voltmeter 400EL.** 1 mV-300V 12 Ranges 10Hz-10MHz. BRAND NEW £325.00

**S.H.F. Signal Generator 628A.** 15-21GHz 50Ω £495.00

**5½ Digit DMM Type 3490A.** DC-AC Volts Resistance Auto Ranging, excellent condition £725.00

**AM-FM Signal Generator Type 8654A.** 10-512 MHz 0.3 µV-V into 50 ohm £850.00

**AC-DC Differential Voltmeter/DC Standard Type 741B** £1,095.00  
**SHF Signal Generator Type 628A.** 15-21 GHz £495.00

### FLUKE

**Multifunction Counter 1900A-01.** Same spec as 1900A but with battery pack £215.00

**Multifunction Counter 1900A-02.** Same spec as 1900A but with BCD o/p £230.00

**Frequency Synthesiser 6011A.** Performs function of an oscillator, counter and level meter 10Hz-11MHz. Output 0.4mV-5V r.m.s. 7 digit LED display. Accuracy ± 3

parts in 10" for one year. Freq. storage. Full spec. on request £2650.00

**Frequency Synthesiser 6160A/DX.** 4MHz-30MHz in 1Hz steps. Output 1V into 50Ω. Full spec. on request UNUSED, BARGAIN PRICE £675.00

**Industrial Counter Totaliser 1941A.** 5Hz-40MHz 40mV sensitivity R P M measurement £150.00

**VHF, UHF Telecomms. Frequency Counter 1980A.** C/w Battery Pack. 5Hz-515MHz. 6 digit LED Display. 50mV sensitivity over whole range £400.00

### MULTIFUNCTION 6 DIGIT AUTORANGING COUNTER 1900A

Modes  
 Frequency, period, totalize  
 Frequency range 5Hz-80MHz. In put sensitivity 25mV  
 BRAND NEW  
 £175.00



### GENERAL RADIO

**Frequency Meter & Discriminator 1142A.** Frequency Range 3Hz to 1.5MHz Accuracy ±0.2% Can be used with a recorder to produce records of frequency change and drift £235.00

**Standard Frequency Multipliers. Type 1112 series.** Providing microwave range standard freqs. Output 20mW. Output impedance 50Ω. Low noise and excellent phase stability  
 Type 1112A £520.00  
 Type 1112B £495.00

**Electronic Voltmeter 1806A.** AC+DC voltage. 9 resistance ranges. ±2% accuracy Wide frequency range — up to 1500MHz £175.00

**Adjustable Attenuator 874 GAL.** 100MHz to 4GHz 120 dB range 50Ω Impedance BRAND NEW £150.00

### METRONIX (POLAND)

**Function Generator G432.** 1Hz-1.1MHz. Sine, Square & Triangle. BRAND NEW Full specification on request £60.00

### RADIOMETER

**Stereo Signal Generator SMG1C.** Solid state, pushbutton operation. Full specification on request £350.00

### AVO

**Multimeter model 7** £40.00  
 Leads, prods & croc clips for models 7, 8 & 9 £4.50 set

### PHILIPS

**Universal Counter Type PM 6615.** 10Hz-1GHz 10mV rms. as new condition £795.00

**Frequency Counter Type PM 6645B.** 30Hz-512MHz 5mV rms. as new condition £710.00

**Dual Trace Portable Oscilloscope Type PM 3276.** DC-15MHz. 2mV-10V/DIV TV Triggering as new condition £415.00

**Dual Trace Portable Oscilloscope Type PM 3260.** DC 120MHz 5mV-2V/DIV Delayed Sweep as new condition £1,385.00

**Dual Trace Portable Oscilloscope Type PM 3260E.** As PM 3260 but no horizontal mag and prob. power as new condition £1,300.00

**Dual Trace Portable Oscilloscope Type PM 3240.** DC-50 MHz 5mV-10V/DIV. Delayed Sweep. as new condition £950.00  
**Universal RCL Bridge Type PM 6302** £390.00

**Single Channel Chart Recorder Type PM 8110.** 10mV-10V FSD. as new condition £300.00

**3½ Digit DMM Type PM 2513A.** AC-DC Volts and Current Resistance. as new condition £90.00

**4½ Digit DVM Type PM 2443.** 10µV-1000V DC only High accuracy. Auto Ranging. As new condition £430.00

**4 Digit DMM Type PM 2424.** AC-DV Volts and Current Resistance As new condition £300.00

**Function Generator Type PM 5167.** 0.0001Hz-10MHz. Various o/p waveforms 40V PK-PK into 50 ohm As new condition £875.00

**Low Distortion LF Oscillator Type PM 5107.** 0.02% As new condition £210.00

**100MHz Single output Pulse Generator PM5775.** Specification on request £800.00

**100MHz Double Output Pulse Generator PM5776.** Specification on request £900.00

**50MHz Pulse Generator PM5712**  
 £495.00



Specification on request.

**50MHz Pulse Generator PM5715.** Specification on request £600.00  
**Low Frequency Generator PM5105.** 10Hz-100kHz sine & Square wave £156.00

**Sine & Square Wave Oscillator PM5125.** 10Hz-1MHz £145.00  
**U.H.F. TV Generator PM5525A.** 470-850MHz. Can be modulated with black & white as well as colour TV £95.00

### RACAL

**Universal Counter Timer 9838.** Frequency, single and multiple period, time interval. Freq range 10Hz-100MHz £285.00

**H.F. Communications Receiver RA117E.** 1-30MHz Full specification on request £350.00

**Modulation Meter 210A.** 2.5-300MHz. A.M. range 0-100%. F.M. range 0 to ±100kHz £245.00-£285.00

**A.M./F.M. Modulation Meter 409.** Freq. 3-1500MHz A.M. 0-100% F.M. 0-600kHz £345.00

### T.E.S. (Milan)

**L.F. Signal Generator G1165B.** Solid State. 10Hz-100kHz 1mV-10V 600Ω impedance Square Wave facility £195.00

**Wow & Flutter Meter WF971.** DIN & CCIR 1/µ signal 20mV-20V. Flutter ±0.1% ±0.3% ±1% 1/µ impedance 10KΩ £210.00

**A.F. Power Meter MU964.** 1mW-10W (4 ranges) 20Hz-50kHz Load input resistance 40 values £175.00  
 All ex-demonstrators as new condition

### DUMONT

**Portable Scope 1100P.** DC-100MHz at 5mV/cm Dual Trace 5ns/cm Sweep rate. Delayed time base Full 8 x 10cm display. Calibrated X-Y to 5MHz £825.00

### MARCONI INSTRUMENTS

**F.M./A.M. Signal Generator TF995B/2.** Frequency Range 20kHz to 220MHz in five bands Output 0.1µV-200mv. Output

A copy of our trading conditions is available upon request

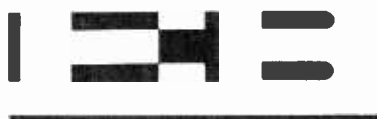

49-53 Pancras Road  
 London NW1 2QB  
 Tel: 01-837 7781. Telex: 298694

ADD 8% VAT  
 TO ALL PRICES

WW-112 FOR FURTHER DETAILS

# Brokers Ltd



49-53 Pancras Road, London NW12QB  
Tel: 01-837 7781

Calibrated & Guaranteed 12 Months

Impedance 75Ω. Modulation (F.M.). Normal deviation continuously variable in two ranges ±25kHz and ±75kHz on all bands. Greater deviation is available on most bands. Modulating Frequency Internal FM. 1kHz. External FM 50Hz to 15kHz Modulation (A.M.) Internal AM 1kHz. 0-50%. External AM 50Hz to 10kHz. 0-50% **£675.00**

**U.H.F. Signal Generator TF1060.** Frequency range 450-1250MHz (1 band). Output 0.15μV to 445mV. Output Impedance 50Ω. Int. sine A.M. 1kHz. Ext. pulse mod. **£400.00**

**A.M. Signal Generator TF144H & H/S.** Frequency range 10kHz to 72MHz in twelve overlapping bands. Output Attenuator 2μV to 2V. Output Impedance 50Ω. Modulation Internal AM 400Hz & 1kHz to 0 to 80%. External AM 20Hz to 20kHz. 0 to 80% **£275.00-£400.00**

**A.M. Signal Generator TF144H/4.** A later version of TF144H with similar spec. **£375.00-£600.00**

**A.M. Signal Generator TF144H/4S.** Electrical specification, as TF144H/4 **£375.00-£700.00**

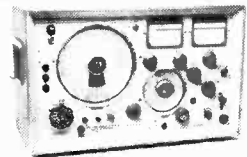

**A.M. Signal Generator TF801D/1.** Frequency Range 10MHz to 470MHz in five bands. Output Attenuator 0.1μV to 1V. Output Impedance 50Ω (Type N connector). Modulation Internal AM 1kHz. 0 to 90%. External AM 30Hz to 20kHz. 0 to 90% **£400.00-£750.00**

**Carrier Deviation Meter TF791D.** Carrier Freq. range 4 to 1024MHz. Deviation range up to ±125kHz. Modulating Frequency range: Up to 35kHz. Late models **£295.00**

**20MHz Sweep Generator TF1099.** Video sweep output. Lower limit 100kHz fixed. Upper limit continuously variable up to 20MHz. 0.3 to 3V p-p. Z=75Ω. Input & Output detector probes. Markers at 1MHz intervals **£295.00**

**A.M. Signal Generator TF801D/8S.** Same spec. as TF801D/1S + freq. counter o/p facility **£695.00**

**F.M./A.M. Signal Generator TF995A/2M.** 1.5 to 220MHz. 2μV to 200mV. int. & Ext. A.M. Int. F.M. at 1kHz deviation 0.75kHz **£375.00-£475.00**

**Sensitive Valve Voltmeter TF2600.** 12 ranges 1mV-300V I.s.d. 1% accuracy up to 500kHz. Usable up to 10MHz **£175.00**

**R.F. Electronic Voltmeter TF2604.** 7 ranges 300mV-300V I.s.d. from 20Hz-1500MHz. 8 ranges 300mV-1kV DC. 7 ranges. Resistance 500Ω to 500MΩ **£225.00**

**U.H.F. Signal Generator TF1060/3A.** Frequency range 500 to 1200MHz. Remainder of spec. on TF1060 **£575.00**

**R-C Oscillator TF1101.** Frequency Range 20Hz to 200kHz in four bands. Output Attenuator 1mV to 20V. Maximum Output 20V across external 600Ω load. Output impedance 600Ω **£120.00**

**Phase A.M. Signal Generator TF2003.** 0.4-12MHz **£150.00**



**Two-Tone Signal Source TF2005R.** Frequency Range 20Hz-20kHz in six bands

Carriage and packing charge extra on all items unless otherwise stated

Hours of business: 9a.m.-5p.m. Mon.-Fri. Closed lunch 1-2p.m.

(each oscillation can be adjusted and used independently). Harmonic Distortion. Less than 0.05% between 63Hz and 6kHz when using unbalanced output. Intermodulation Below 80 dB with respect to the wanted signal. Amplitude Reference Level Up to +10dBm from each oscillator. Output Attenuator 111dB in 0.1dB steps **£415.00**

**Blanking and Sync Mixer TF2908.** For 405, 525 and 625 line television systems. Reshapes and mixes blanking and sync pulse waveform with video test waveform **£90.00**

**L.F. Extension Unit TM6448.** For use with Spectrum Analyser OA 1094A series. 100Hz to 3MHz **£200.00**

**Wide Range R.C. Oscillator TF1370A.** 10Hz to 10MHz sine wave. 10Hz to 100kHz square wave. Output up to 31.6V **£275.00**

**DC Multiplier TM5033A.** HV probe up to 30kV. Impedance 3000MΩ for use with TF1041 series or TF2604 **£25.00**

**5 watt Dummy Load TM5582** for use with TF2604 **£25.00**

**A.F. Oscillator TF2100.** 20kc/s to 20Kc/s. Extremely low distortion. Output Impedance 600Ω unbalanced **£150.00**

**M.F. Oscillator TF2101.** 30c/s to 550kc/s. Stable frequency. Low distortion. Output Impedance 600Ω unbalanced **£115.00**

**F.M./A.M. Modulation meter TF2300S.** Incorporating Oscillator TM8045/1. 3.5 to 1000MHz. Full specification on request **£825.00**



**M.F. Transmission Measuring Set TF2333.** Frequency range 30Hz to 550kHz. The TF2333 is a transmission measuring set of the conventional type that normally forms part of the essential test gear for audio and baseband equipment of multi-channel telecommunication systems. Signal Source, oscillator-frequency range 30Hz to 550kHz in five ranges. Attenuator. Range 70dB in 10dB and 1dB steps **£600.00**

**F.M. Signal Generator TF1066B/6.** 10-470MHz. R.F. output 0.2μV-200mV e.i.f. Output Impedance 50Ω. Modulation Internal AM 1kHz & 5kHz 0.40% External AM 30Hz to 15kHz 0.40% Internal FM 1kHz & 5kHz deviation 0 to 100kHz or up to 400kHz according to carrier freq. range. External FM 30Hz to 100kHz deviation same as int. Crystal Calibrator facility **£685.00**

**Variable Attenuator TF338C.** 0-105dB Freqs. up to 100kHz. 600Ω impedance **£90.00**

**M.F. Attenuator TF2162.** DC-1MHz. 0-111dB in steps of 0.1dB **£120.00**

**Portable Scope TF2203.** Single beam DC-15MHz. Rise time 23 nanosecs. 50mV/cm. Z modulation available. X5 expansion **£150.00**

**10-Watt A.F. Power Meter TF893A.** Frequency range 20Hz to 35kHz. Five power ranges. 1mW to 10W full scale. Impedance 25Ω to 20KΩ in 48 steps. Balanced or unbalanced inputs. Direct calibration in watts and dBm **£165.00**

**100-Watt R.F. Power Meter TF1020A Series.** Frequency range D.C. to 250 MHz. Two power ranges 50 and 100W full scale. Output Impedance 75Ω **£105.00**

**In Situ Universal Bridge TF2701.** Measures capacitance, capacitance with R in parallel Resistance & Inductance. Int. source 80Hz & 1kHz **£395.00**

**R.F. Power Meter TF1020A/4M1.** 75 ohms. 1-50 watts & 2-100 watts. DC-250MHz **£120.00**

**R.F. Power Meter TF1020A/5M1.** 50 ohms. 1-50 watts. 2-100 watts. DC-250MHz **£135.00**

**Output Test Set TF1065A.** AF Power 10uW to 3W (5 ranges) Freq. Range 250Hz-10KHz. RF Power 1-25W. FM & AM measurements. DC current & voltage measurements. Full spec on request **£225.00**

**Noise Generator TF1106.** 1-200MHz. 71 ohm impedance **£150.00**

**FM Signal Generator Type TF 2006.** 10-220 MHz. FM up to 200 KHz deviation. 0.2μV-200 MV into 50 ohm **£950.00**

**In Situ Universal Bridge Type TF 2701.** **£395.00**

## DYNAMCO

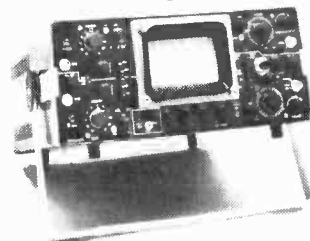

**Portable Solid State Scope 7500.** DC-40MHz. 10mV/div. sensitivity ×10 gain extends sensitivity to 1mV/div. (3Hz-5MHz). Mixed & calibrated sweep delay. Dual trace. AC & DC coupled Z mod. BRAND NEW **£495.00**

**Dual Trace Portable Oscilloscope Type D7210.** DC-15MHz. 10mV-5V/DIV. Delayed Sweep. Immaculate **£350.00**

**Dual Trace Portable Oscilloscope Type D7200.** Same as D7210 but with smaller CRT and no delay **£315.00**

## COHU

**Precision DC Voltage Standard 304.** 0-1 kV in 3 decades. 0-50mA at any voltage setting. Accuracy 10V range 0.003% +10uV. 100V range 0.003% +20uV. 1kV range 0.003% +40uV **£450.00**

## WAYNE KERR

**Universal Bridge B221A = CT530.** 10S/948-8768. 0.1% accuracy. Measures R + ve or -ve G + ve or -ve C (x1) L (1592Hz). Source frequency (1592Hz) (int). 50Hz-20Hz (Ext). Mains operated. Weight 11 kg **£275.00**

**Low Impedance Adaptor Q221A.** For use with B221A permitting impedance measurements of <10Ω to be made **£75.00**

**Component Bridge B521 (Ministry Type CT375).** A general purpose component bridge for measuring L C & R & combinations of R & Reactance. It can be used to measure components in situ. Capacitance 1pF to 5F. Resistance 1 milliohm to 100Mohm. Inductance 1uH to 500kH **£115.00**

This is only a selection of the equipment we have available. If your requirement is not listed please give us a call.

A copy of our trading conditions is available upon request

Please note: All instruments offered are secondhand and tested and guaranteed 12 months unless otherwise stated

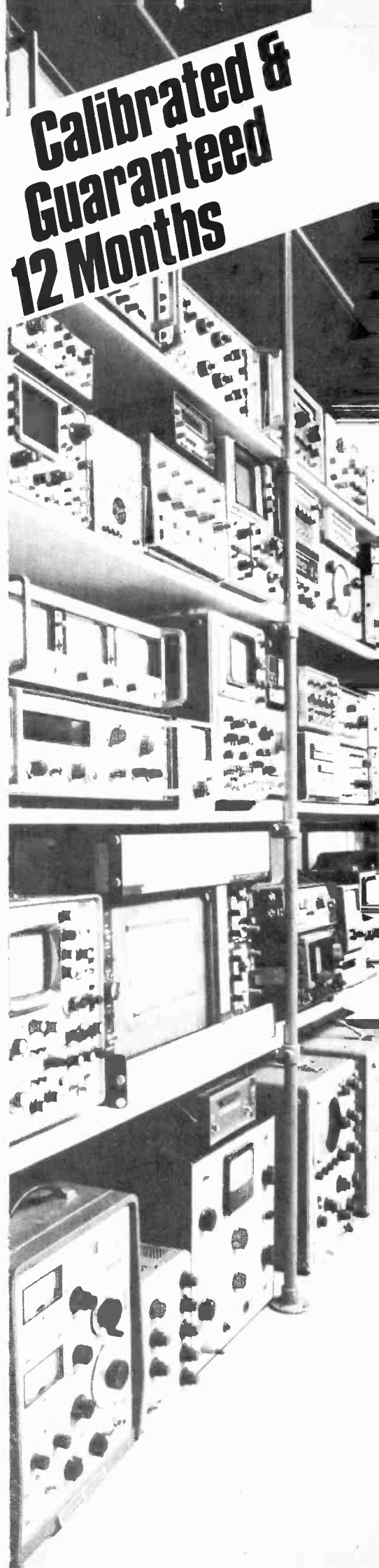



# Electronic Brokers The Computer People

## STOP PRESS

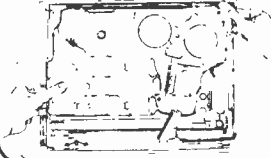

Special purchase of MITE 123P Alphanumeric printer mechanisms solenoid-operated page printer using standard reversible typewriter ribbon. Prints standard 64 — ASCII character set on 8½" paper (80 characters per line, 6 lines to the inch). Maximum speed 11 cps. Power requirements 115VDC. Compact, lightweight unit 12" x 9" x 2¾", 9¾lbs. Supplied complete with full technical manual. **BRAND NEW SURPLUS. Only £75.00 + £3.50 P. & P. + 8% VAT.** (Mail order total £84.78).

## SCOOP! MASSIVE BULK PURCHASE BRINGS YOU HAZELTINE VDU's AT LOWEST EVER PRICES

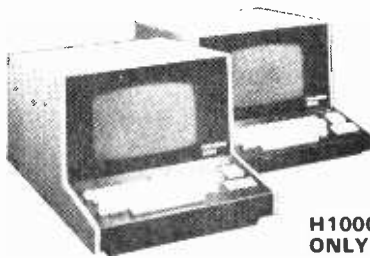

**H1200 ONLY £425**

**H1000 ONLY £350**

### HAZELTINE H1000 and H1200 SPECIFICATION

SCREEN SIZE — 12 diagonal.

**SCREEN CAPACITY** —  
**H1000** — 960 characters 80 per line x 12 lines.  
**H1200** — 1920 characters 80 per line x 24 lines.  
**CHARACTER GENERATION** — 5 x 7 dot matrix 625 line raster  
**CHARACTER SET** — 64 ASCII alphanumeric and symbols  
**CHARACTER SIZE** —  
**H1000**—1/8 inch (32cm) nominal height. 3/32 inch (.24cm) nominal width  
**H1200** — 1/10 inch (.25cm) nominal height 3/32 inch (.24cm) nominal width.  
**CURSOR** —  
**H1000** underline. **H1200** reverse image block.  
**TUBE PHOSPHOR** — P4 (white on black)  
**REFRESH RATE** — 50 fields per second.  
**KEYBOARDS** — TTY format attached  
**INDICATORS** — Power On. Parity Error Dataset ready.  
**PARITY** — Parity error indicated by Parity light and question mark (?) displayed in character position  
**TRANSMISSION** — Asynchronous Switch-selectable for any two standard rates up to 9600 baud  
**OPERATING MODES** — Full/half Duplex  
**MEMORY** — High speed MOS refresh  
**STANDARD INTERFACE** — CCITT V-24. (EIA RS-232 B/C), 202C Optional

### HAZELTINE H2000 SPECIFICATION

**SCREEN SIZE** — 12 diagonal. 1998 characters; 74 per line x 27 lines.  
**CHARACTER GENERATION** — 5 x 7 dot matrix 625 line raster.  
**CHARACTER SET** — 64 alphanumeric and symbols. 32 ASCII control codes.  
**KEYBOARD** — Detachable, solid state, teletypewriter design 10-key numeric cluster plus editing and cursor control keys.  
**TRANSMISSION** — Asynchronous Switch-selectable for combinations of 5 standard rates. 75 to 9600 baud.  
**OPERATING MODES** — Switch-selectable, full duplex, half duplex or batch (buffered)  
**MEMORY TYPE** — 2048 x 8 RAM  
**EDITING FEATURES** — Full Cursor controls plus Insert / Delete Character, Insert / Delete Line, Clear Screen, Clear Foreground Data Only, Tab  
**STANDARD INTERFACE** — CCITT V-24 (EIA RS-232 B/C) or 202C Compatible  
**REMOTE COMMANDS** — Insert / Delete Line, Clear Screen, Clear Foreground Data Only, Home Cursor, Address Cursor, Set Background Intensity, Set Foreground Intensity, Carriage Return, Backspace, Ring Bell, Transmit, Print.



**H2000 FROM £495**

**AUXILIARY OUTPUT** — Standard printer interfaces, standard cassette interface, remote monitor interface  
**TUBE PHOSPHOR** — P39 (green on black).

## Mini-Computer Exchange

**SPECIALISTS IN DIGITAL EQUIPMENT, PROCESSORS PERIPHERALS, FEATURES ETC.**

**DEC PDP11-04 BD PROCESSOR**  
 8K MOS MEMORY  
 DLIIWA INTERFACE  
 5¼ CHASSIS  
 BRAND NEW CONDITION — **£2,500**

**DEC ADD-ON CORE**  
 Dramatic savings on further bulk purchase of new DEC Core MFII-UP 16K Parity Core complete with backplane — NOW ONLY £1 500  
 MMII-UP 16K Expander Core (prerequisite MFII-UP). NOW ONLY £1 250

**DEC RK05 DISKS**  
 RKIID /RK05 Disk Drive and Control from **£4,950**.  
 RK05-J Slave disk drive from **£2,500**.  
 RK05-F Dual Density Drive from **£2,850**.

**DEC PDP8E & PDP8M Series** — NEW LOW PRICES 4K Processors with TTY Interface from **£1,500** (Add on core available)

Large stocks of other DEC equipment — CPUs, Core, Modules, etc. Let us know your requirements.

## Printers and Terminals

**SUPER SAVINGS ON SPECIAL PURCHASE OF PORTABLE TEXAS SILENT 700 TERMINALS. Our special price £695**

Model 725 KSR. ASCII Keyboard. Silent high speed operation up to 300 baud 5 x 7 dot matrix electronic printhead. Full or half duplex operation. Built in acoustic coupler. Mounted in integral carrying case. Gross weight 35lbs. Dimensions 21½" x 19" x 6½"

### LARGE STOCKS OF ASR33 AND KSR33 TELETYPE TERMINALS

- ★ ASCII Keyboard
- ★ Hard-copy unit (friction or sprocket paperfeed)
- ★ Paper Tape punch and reader (ASR33 only)
- ★ Line Unit (20mA/6V/80V)

Overhauled in our own workshops to the highest standards and sold with 90-day warranty.

Prices from **£425** (KSR) and **£650** (ASR). **SPECIAL OFFER** — Standard ASR 33 Teletypes with custom built acoustic (Sound-reducing) cover **£675.00**.

### SAVE OVER 2/3 of list price on these superb TEKTRONIX 611 STORAGE DISPLAYS

Flicker-free bistable storage of combined alphanumeric and graphic information from digital computers and other data transmission systems 11" Storage CRT Vertical sensitivity 1V/16.2CM (sq format) or 1V/21CM (rect. format) within 2% FSD Maximum input voltage ±50V DC and peak AC Settling time 3.5 microsec./CM + 5 microsec. Stored resolution 4000 clearly legible characters .90 x 70mil matrix) viewing time 15 minutes or less. Recommended for specified resolution  
**OUR PRICE ONLY £950, WITH FULL THREE-MONTH WARRANTY.**

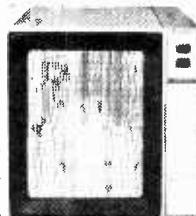

## Keyboards

### NEW ASCII KEYBOARD MODEL KB756



### NOW IN STOCK — BRAND NEW 56-STATION ASCII KEYBOARDS

Full 128 character set with ROM encoder (upper and lower case + control shift). Fully TTL — compatible — power requirements + 5v-12v. Supplied with full technical data, code chart, pin connections, circuit diagram and applications notes.

### FANTASTIC VALUE AT £60.00

+ £1.50 p.&p. + 8% VAT (mail order total £66.42)  
 Also available — a range of spares and accessories for the KB756 — edge connector, mounting frame, plastic or steel enclosure, spare ROMs. Send for data sheet/price list.

*All items quoted are refurbished second-user equipment unless otherwise stated.*

## ELECTRONIC BROKERS LIMITED (COMPUTER DIVISION)

49-53 Pancras Road, London NW1 2QB. Tel. 01-837 7781. Telex: 298694

A copy of our trading conditions can be supplied on request

Hours of business:  
 9 a.m.-5 p.m. Mon.-Fri. Closed lunch 1-2 p.m.

ADD 8% VAT  
 TO ALL PRICES

Carriage & Packing charge extra  
 on all items unless otherwise stated



# ANNOUNCING THE **MICROS**

JOIN THE MICRO REVOLUTION



£399 for a Z80 based microcomputer, built and tested

Designed for educational establishments, personal computing and small business users

- \* Includes 1K monitor Eprom, 47 key solid state keyboard, video, TV, cassette and teletypewriter interfaces, serial i/o, 2 parallel i/o ports, 2K bytes RAM, power supplies and instrument housing.
- \* Connect to domestic TV or video monitor to complete the system
- \* 48 x 16 character video matrix
- \* 47 key contactless ASC11 keyboard
- \* Hard copy on teletypewriter
- \* 2 TTL compatible parallel i/o ports
- \* RS232 serial i/o port

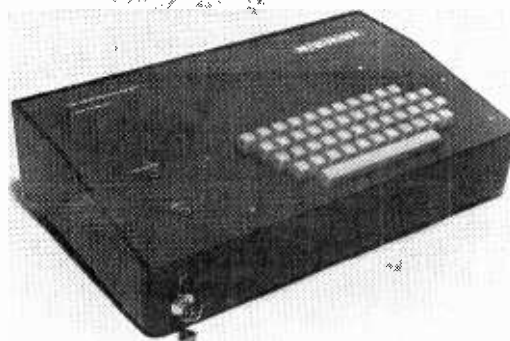

- \* Load and dump programmes on unmodified cassette recorder
- \* Up to 16K byte mixed RAM and Eprom in table top housing
- \* Expandable up to 64K bytes
- \* Security locked power switch
- \* British designed and built
- \* Available in kit form for £360
- \* Credit terms available

**THE MICRONICS COMPANY**

1, STATION ROAD TWICKENHAM MIDDLESEX

**PART OF THE MICRO REVOLUTION**

Prices exclusive of VAT and carriage

WW-105 FOR FURTHER DETAILS

## TV MONITOR KITS

### VISIONKITS

**gives you professional TV equipment in kit form for all data display and picture applications, providing far superior results to converted TV receivers.**



Top quality monitors exactly as produced by one of today's leading manufacturers. All parts plus comprehensive assembly instructions supplied, along with full application notes. 9" or 12" tube plus chassis kits are available with a separate printed circuit module kit to fit either size of tube.

**SPECIFICATION:**

Video — Composite 1V ± 6dB. Input impedance 10K ohms  
 Power — +12 volts stabilised Current 1 amp  
 System — 625 lines 50 fields and 525 lines 60 fields  
 Video response to 10MHz  
 Operating temperature — 0—50° C

**PRICE LIST:** (Including VAT and inland postage and packing)

9" tube and chassis kit	£45.00
12" tube and chassis kit	£45.00
P.C. module kit	£55.00
Ready-built 9" monitor	£150.00
Ready-built 12" monitor	£150.00
Mains power supply for 12" monitor (built)	£40.00

Please allow 21 days for delivery  
 Send s.a.e. for copy of application notes only  
 Mail order only

### VISIONKITS

9 Claymill Road, Leicester LE4 7JJ

WW-073 FOR FURTHER DETAILS

# a fully built & tested microcomputer system ONLY £159 + VAT

## KIM-1 CARD

- \* COMPLETE WITH KEYBOARD & DISPLAY
- \* AUDIO CASSETTE INTERFACE FOR PROGRAM STORAGE
- \* TELETYPE INTERFACE
- \* PROGRAM DEVELOPMENT SOFTWARE
- \* R6500 PROGRAMMING MANUAL
- \* R6500 HARDWARE MANUAL

## IDEAL FOR THE HOME USER, STUDENT AND ENGINEERS

Fully built & tested, with keyboard & display for editing, de-bugging and running programs. Complete with 1K bytes of RAM and 2K bytes of ROM—resident monitor and executive software controlling operation & de-bug modes. Interface circuitry for program storage on a cheap audio cassette and teletype connection, with baud-rate determined automatically.

An additional 15 unused I/O lines for use as inputs or outputs and 8 bit programmable Interval Timer. De-bug facilities to 'single-step' the program and trace the actions of the registers. 16-bit address bus, data and control buses brought to an edge connector for extending the system to 65K memory locations. Comes complete with full Rockwell R6500 programming and user manuals for only £159 + VAT. Available Ex-Stock.

## Pelco (Electronics) Ltd

Enterprise House,  
 83-85 Western Road, Hove, Sussex BN3 1JB  
 Telephone: Brighton (0273) 722155

Buy it with your Access or Barclaycard



WW-074 FOR FURTHER DETAILS

# NEW

## from Eddystone

**UHF receiver Model 1990S**  
 This high-grade, professional UHF receiver is designed for use by –  
 Government Departments at home and overseas  
 Educational Establishments  
 Research Laboratories  
 Television Authorities  
 Satellite Ground Stations

- 470MHz – 1000MHz**
- AM: FM: PULSE
  - Modular construction
  - Wide/narrow IF filter
  - Tune frequency setting to 1 kHz
  - Panoramic display unit available

Please ask for illustrated brochure



### Eddystone Radio Limited

Member of Marconi Communication Systems Limited

Alvechurch Road, Birmingham B31 3PP, England  
 Telephone: 021-475 2231 Telex: 337081  
 A GEC-Marconi Electronics Company.

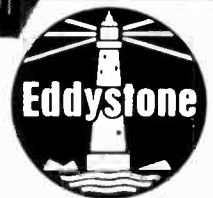

WW – 109 FOR FURTHER DETAILS

## Xcelite

- 99PS-40BP Ballpoint Allen Hex Type Screwdriver set, 9 blades, Extension Handle and Case** £15.10
- XL75 Offset Ratchet Screwdriver Set, 19-piece Midget Reversible** £5.66

Prices include postage / packing

**D.P. SUPPLIES**  
 P.O. BOX 56, READING RG3 6TF

WW – 081 FOR FURTHER DETAILS

## FOTOLAK

**POSITIVE LIGHT SENSITIVE AEROSOL LACQUER**

Enables YOU to produce perfect printed circuits in minutes!  
 Method: Spray cleaned board with lacquer. When dry, place positive master of required circuit on now sensitized surface. Expose to daylight, develop and etch. Any number of exact copies can of course be made from one master. Widely used in industry for prototype work.

FOTOLAK	£1.50	Pre-coated 1/16 Fibre-glass board
Developer	30p	204mm x 114mm
Ferric Chloride	40p	204mm x 228mm

Plain Copper-clad Fibre-glass.	Single-sided	Double-sided
Approx. 3.18mm thick sq. ft.	£1.25	£1.50
Approx. 2.00mm thick sq. ft.	£2.00	£2.25
Approx. 1.00mm thick sq. ft.	£1.50	£1.75

Single sided Copper-clad Paxolin. 10 sheets 245mm x 150mm £2.50  
 Clear Acrylic Sheet for making master. 260mm x 260mm 10p

Postage and packing 60p per order. VAT 8% on total.  
**G. F. MILWARD ELECTRONIC COMPONENTS LIMITED.**  
 369 Alum Rock Road, Birmingham B8 3DR. Telephone: 021-327 2339

### REDUCED PRICES . . . ONLY LIMITED STOCKS AVAILABLE

TRANSISTORS		
Device	10	100
*BC 107	.89	7.80
*BC 118	1.12	10.00
*BC 132	.95	8.00
*BC 147	.85	7.00
*BC 149	.85	7.00
*BC 204B	.85	7.00
BC 348	1.00	8.50
BC 351	1.00	8.00
BD 131	3.30	29.00
BD 695A	5.50	42.00
BD 696A	5.50	42.00
BF 185	2.40	20.00
BF 324	3.30	29.00
BT 106	10.00	72.00
*BU 205	18.50	130.00
*BU 208	17.50	139.00
*ME 1075	5.75	4.80
*TIP 29	3.40	29.00
*XK 1152	.68	3.90
*ZTX 212B	1.05	8.50
ZTK 302	1.00	8.00
ZTX 502	1.10	9.00
ZTX 510	1.10	9.00
*2N 2647	8.50	—
*2N 3703	.85	6.50
*2N 3705	.85	6.50

DIODES		
Device	100	1000
AA119	4.50	30.00
BA 154	6.50	4.00
BY 127	8.50	70.00
1s 44	4.00	25.00
1s 940	3.00	15.00
1s 941	3.50	16.00

DIGITAL I.C.'s TEXAS		
Device	10	100
74L00	2.40	18.00
74L04	2.70	21.00
74L73	4.90	38.00
74L74	4.30	35.00
74L91	14.50	105.00

SURPLUS COMPONENTS			
Transistors	Capacitors		
BC351	MoT	0 01 / 25	Disc
7 000		5000	
2N 3703	TI	0 01 / 30	Disc
11 000		5000	
Diodes		0 1 / 600	Axial
1S 940		2000	
1S 941	FI	6 8 / 6	Tant
120 000		20 000	
		Union Carbide	

CAPACITORS		
Device	10	100
*0.01 / 25	Disc	.65 4.50
*0.01 / 30	Disc	.70 4.50
*0.1 / 200		344 .90 7.00
*0.1 / 600	Axial	.50 3.50
*0.68 / 100	Axial	.90 7.00
*2.2 / 100		344 .90 7.00
*6.8 / 6	Tant	1.40 9.00
*25 / 25	Axial	.50 4.00
*100 / 250	Axial	3.50 28.00
*680 / 25	Axial	2.90 23.00

W/W RESISTORS		
Device	10	100
CR6 2.5W	0.2 to 2K2 Ohms	4.000
CR15 5W	0.47 to 10L Ohms	3.500
CR12 10W	3.3 to 2K2 Ohms	2.000
CR17 15W	1 to 22K Ohms	3.000

ALL ITEMS ARE NEW AND SURPLUS TO REQUIREMENTS. WE INVITE OFFERS FOR THE WHOLE OR PART OF ANY ITEMS LISTED ABOVE IN WCVTING OR BY TELEPHONE

RAM		
Device	10	100
2102-2N	16.00	—

WIREWOUND RESISTORS		
Device	10	100
2.5W Axial		
0.2 To 2K2 Ohms	.90	6.50
5W Radial		
0.47 To 10K Ohms	.80	6.00
10W Axial		
3.3 To 2K2 Ohms	.80	5.50
15W Radial		
1 To 22K Ohms	.85	6.00

MERCURY RELAY BY C.P. CLARE		
Device	1	10
HGRM 55211-T00	3.50	29.00
24v 1c/o		

LINEAR I.C.'s		
Device	10	100
741 8P DIL	1.90	17.00
NE 555	2.50	23.00
M252 B1 AA	50.00	—

Minimum order £5 00. P. & P. 25p.  
 VAT please add 8% except those marked \* which are 12.5%.  
 Export, Wholesale and Manufacturers enquiries welcome  
 K & A Distributors. 52 Barkby Road, Syston, Leicester LE7 8AF.  
 Tel. 0533 609391





# SPECIAL LOW PRICE ARRANGEMENTS FOR VISITING OVERSEAS TRADE FAIRS



IPC Electrical-Electronic Press Ltd., the world's largest publishers of computer, electrical and electronic journals, have made special arrangements for readers wishing to visit important overseas trade fairs. The cost, in most cases, is little more than the normal air fare but includes - travel by scheduled airline from Heathrow and Manchester \* first-class hotel accommodation \* arrival and departure transfers \* admission to the trade fair \* services of an experienced tour manager. The current programme comprises the following tours.

.....

To obtain a brochure and booking form, tick the box against the tours in which you are interested, complete the coupon and post to the exclusively appointed travel agent, Commercial Trade Travel Ltd., Carlisle House, 8 Southampton Row, London WC1. Telephone 01-405-8666 or 01-405-5469.

<input type="checkbox"/> Sicob	<input type="checkbox"/> Paris	September 20-22, 1978
<input type="checkbox"/> Electric Vehicle Expo	<input type="checkbox"/> Philadelphia	October 3-5, 1978
<input type="checkbox"/> Nuclex	<input type="checkbox"/> Basel	October 3-7, 1978
<input type="checkbox"/> Electronica	<input type="checkbox"/> Munich	November 9-15, 1978

Please send details of the tours indicated above.

NAME..... COMPANY.....

ADDRESS..... Telephone.....

.....

# Appointments

Advertisements accepted up to 12 noon Monday, July 3, for the August issue, subject to space being available.

**DISPLAYED APPOINTMENTS VACANT:** £7.50 per single col. centimetre (min. 3cm).  
**LINE advertisements (run on):** £1.10 per line, minimum three lines.

**BOX NUMBERS:** 50p extra. (Replies should be addressed to the Box Number in the advertisement, c/o Wireless World, Dorset House, Stamford Street, London SE1 9LU.)  
**PHONE: Barry Leary on 01-261 8508**

*Classified Advertisement Rates are currently zero rated for the purpose of V.A.T.*

## No more long goodbyes

### Radio Officers

With the Post Office Maritime Service, you can do the job you're trained for, and still work close to home!

Several coast stations need qualified Radio Officers to carry out a wide variety of duties ranging from Morse and teleprinter operating to traffic circulation and radio telephone operating. It's a secure job that pays well, and if you're ambitious, the prospects of promotion to senior management are excellent.

You must have a United Kingdom Maritime Radio Communication Operator's General Certificate or First Class Certificate of proficiency in Radio-telegraphy or an equivalent certificate issued

by a Commonwealth Administration or the Irish Republic. And, ideally, you should have some sea-going experience.

Salary starts at 25 or over around £4093 and rises after three years to about £5093. (Starting salary for those between 19-24 varies between £3222-£3732). Overtime is additional, and there is a good pension scheme, sick-pay benefits and at least 4 weeks' holiday a year.

For further information, please telephone Andree Trionfi on Freefone 2281 or write to her at the following address:

ETE Maritime Radio Services Division (WW/B/7),  
ETE 17.1.1.2, Room 643, Union House,  
St. Martins-le-Grand, London EC1A 1AR.

Post Office Telecommunications

(7141)



**OXLEY** 

## ELECTRONIC ENGINEERS

(male / female)

We are long-established Electronic Consultants and Component Manufacturers with a modern factory located in open countryside in the southern part of the Lake District.

We are seeking Electronic Engineers for interesting work in a wide range of subjects including

VHF / UHF and microwave passive components  
Test and control instrumentation  
Digital circuit design

Qualifications to degree or equivalent level preferable, although a practical aptitude is more important than qualifications.

If you are looking for a challenging career and have experience in any of the above fields, or having a good background knowledge, and are keen to learn, please send for application form to

**Director and Personnel Officer**  
**OXLEY DEVELOPMENTS COMPANY LIMITED**  
Priory Park, Ulverston, Cumbria, LA12 9QG

8227

## ENGINEER

VISION CONTROL

Yorkshire Television have a vacancy for a Vision Control Engineer. Duties include line-up, operation and maintenance of colour television cameras, vision mixers and associated systems. Experience in an engineering capacity in professional broadcasting, in a relevant area is desirable.

Salary in accordance with ACTT rates with additional benefits.

Applications in writing to.

**Personnel Dept.**  
**YORKSHIRE TELEVISION LTD.**  
The Television Centre  
Leeds, LS3 1JS

(8312)

## Service and Test Engineers

As aircraft and electronics equipments become more sophisticated and our servicing programme expands, the need for experienced Service and Test Engineers increases.

At Stanmore, we are involved in the provision of spares and the repair, maintenance and overhaul of a variety of British and American airborne electronic equipment.

We need Engineers who can successfully maintain the high standards and efficiency required both in the aircraft and the workshop.

It's skilled work, calling for sound practical experience of radio and electronics theory, ranging from audio to microwave and including the use of advanced test equipment for fault diagnosis. Training in this field will be given to suitable, less experienced engineers.

The Company offers excellent salaries and benefits together with first-class working conditions in well-equipped workshops. This Unit is conveniently situated in pleasant surroundings within easy reach of the A1 and M1.

# MARCONI AVIONICS

A GEC-Marconi Electronics Company

If the job sounds interesting and you'd like to put us to the test, write with details of experience to: Mrs. E. Wagg, Marconi Avionics Ltd., 22-26 Dalston Gardens, Stanmore, Middlesex HA7 1BZ. Tel: 01-204 3322

## Test Gear

The following vacancies have occurred at the Springfield Road Works of EMI Electronics Ltd., a medium sized, self contained unit concerned mainly with large quantity production of precision electro-mechanical devices

### Laboratory Technician

To assist Engineers with testing and development of electronic circuits and test equipment and to produce breadboards and prototype test equipment. Qualification C & G or O.N.C. (Electronics) and/or relevant experience in electronic prototype work

### Test Gear Maintenance Engineer

With sound experience of radio and TV servicing and some further knowledge of maintenance of electronic instrumentation. Qualification of C & G R & TV servicing or equivalent is desirable

For further details contact Miss Pedley, Personnel Officer, EMI Ltd, Springfield Road Works, Hayes, Middlesex. Tel. 01-573 2701



## EMI Limited

The international music, electronics and leisure Group.

(4308)

### UNIVERSITY OF LIVERPOOL Institute of Child Health Alder Hey Children's Hospital TECHNICIAN

To assist with research. Work includes assistance with design and development of medical electronic instruments and operation of the Institute's digital computer. Applicants must possess ONC or equivalent as a minimum qualification and be experienced in fault diagnosis and use of digital and analogue integrated circuits.

Knowledge of programming an advantage. Salary within range up to £3,720 per annum, according to qualifications and experience. Post tenable to September, 1979, in the first instance.

Application forms may be obtained from the Registrar, The University, P.O. Box 147, Liverpool L69 3BX. Quote ref. RV/794/WW.

(8268)

### BAYERO UNIVERSITY - NIGERIA Applications are invited for the post of CHIEF ENGINEER

in the DEPARTMENT OF MASS COMMUNICATION. Candidates for the post should be corporate members of a relevant professional institution, with a degree in engineering or an equivalent qualification in television, plus 8-10 years' experience of broadcast television, including substantial colour experience. Experience of digital television equipment would also be an advantage. The appointee will be responsible for the technical facilities to be provided in the Department of Mass Communications. He/she will be required to supervise the installation of the equipment for the complex and to arrange the training of junior staff in the maintenance of the facility. He/she will also be required to make a contribution to the teaching work of the department in the fields of television operations, lighting and sound. Salary N8,868-N9,828 p.a. (£ sterling = N1.18). 25% of salary contract addition (partly taxable) is also payable. Family passages: various allowances: superannuation or gratuity: biennial overseas leave. Detailed applications (2 copies), including curriculum vitae and naming three referees to be sent airmail marked "Application for Senior Post", to Registrar, Bayero University, PMB 3011, Kano, Nigeria, as soon as possible. Applicants resident in UK should send one copy to Mrs. K. Macrowan, Inter-University Council, 90/91 Tottenham Court Road, London W1P 0DT. Further details may be obtained from either address.

(8222)

### ST. BARTHOLOMEW'S HOSPITAL London EC1A 7BE DEPARTMENT OF MEDICAL ELECTRONICS

Applications are invited for the post of  
Medical Electronics Technician  
Grade III  
(Salary £3787 to £4708 with review pending)

to service radio-telephone equipment in use by District Medical and Ancillary staff. The equipment includes both VHF and UHF base stations, controllers, mobiles and pagers. The successful applicant will be responsible to the Head of the Communications Engineering Section and be required to construct and maintain special purpose data links between patient and computer areas which requires a wide knowledge of digital and analog techniques in addition to R.F. experience. A current driving licence is also necessary.

For application form and job description please ring 01-600 9000 Ext 3186 or write to the Personnel Department at the above address quoting ref. PTB/158

(8269)

# Discuss your career with the decision-makers not the go-betweens



Go to some agencies and you may have 2 or 3 interviews before you even get to meet an employer ... let alone one who's actually interested in meeting you.

This won't happen at Lansdowne - in fact, it can't.

As soon as we receive the coupon below, we'll send you a confidential application form - treat it as an interview ... simply fill in relevant details about your work, ambitions and the companies you don't want to join. We'll take it from there.

We'll match this information to the needs of our clients - over 3000 influential companies who actively look for key personnel. Every time the two match up, you'll be shortlisted for an important job ... one that may never have been advertised. Then our client will contact you direct.

There's absolutely no risk, no cost, no obligation and very little chance of being sent on a wild goose chase.

**Lansdowne Appointments Register, Design House, The Mall, London W5 5LS. Tel: 01-579 2282 (24 hour answering service).**

Our clients are keen to meet men and women aged 20 to 40 years, with potential earnings of between **£4000 and £7000 p.a.**

Name .....

Address .....

WW 21/6

Lansdowne Appointments Register, Design House, The Mall, London W5 5LS. Tel: 01-579 2282 (24 hour answering service).

(8257)

**Lansdowne**

For those too busy doing a good job to find a better one.

## Road Transport Industry Training Board TV Studio Engineer

The Road Transport Industry Training Board has in operation at its Wembley Headquarters a 3-camera broadcast-quality colour television studio with full telecine and video recording facilities, which includes RCA TR50-2, also 1" Helical Scan systems. We now wish to appoint an experienced studio engineer to join a small team working on the production of training and educational television programmes. Applicants, aged not less than 24 years, should have a good working knowledge of the above equipment.

An attractive starting salary will be offered dependent on qualifications and experience; other benefits include four weeks' holiday, contributory pension and life assurance scheme.

Please send relevant personal history stating how the above requirements are met, quoting reference ZH.563, to Personnel Department, Road Transport Industry Training Board, Capitol House, Empire Way, Wembley, Middlesex HA9 0NG.

(8221)

## WE'VE TRIED SEX

facetiousness, flamboyant statements, and downright vulgarity to attract attention to our company's advertisements.

### WHAT HAS IT BROUGHT US??

- The nickname "Charlie's Angels"
  - Considerably more applicants and vacancies than before.
  - Unsolicited praise from the Sunday Times, Sunday Telegraph, Observer and Titbits for our seductive prose and eye-catching panache.
  - Charlie's Angels don't play, they mean business. Try us.
- Like those illustrious ladies, we don't reveal all (our vacancies) - just sufficient to whet the appetite.

#### 1. PROJECT DESIGN ENGINEER

RF equipment particularly frequency synthesisers and spectrum analysers. To £7,000.

South Coast.

#### 2. COMPUTER ENGINEERS

Vacancies throughout UK for field service, permanent site, systems test or technical support. Salaries vary enormously, but up to £11,000 for IBM 360/370 experience.

#### 3. SYSTEMS APPLICATIONS ENGINEERS

Modems and multiplexers for dynamic group marketing US projects. To £6,500.

Middlesex.

#### 4. DESIGN DEVELOPMENT ENGINEERS

For advanced projects group working on application of advanced technology to the widest range of communications imaginable. DC-Blue Light. To £7,000.

Berkshire.

Always in demand  
**TEST ENGINEERS, COMMISSIONING ENGINEERS, TRIALS ENGINEERS, TECHNICIANS.**

Also:  
**NEW GRADUATES, COLLEGE LEAVERS and H.M. FORCES PERSONNEL.**

For further details of qualifications and experience required, salary levels and precise geographical locations, telephone 01-581 0286, or write to

(8173)

**Charles Airey Associates**

RECRUITMENT CONSULTANTS TO THE INDUSTRY, 155 Knightsbridge, LONDON SW1. Tel: 01-581 0286

# ELECTRONICS TECHNICIANS

## When you see a good job advertised what do you look for next?

Obviously, before you contemplate a change of job and possibly area you must weigh-up your present job prospects, pay and surroundings and measure them against those that have attracted you.

Really that's all we want you to do NOW—we are confident that the combination of Marconi Instruments and its locations in St. Albans and Luton will persuade you to give very serious consideration to the appointments we have vacant.



### Job Satisfaction

If you would like working for a successful Company you'll like us—66% of our products ranging from microwave test equipment to automated test systems are exported. Unlike any other in the business we achieved the 'double' in 1977 with the Queen's Award for

both Exports and Technological Achievement—just two reasons why our people have every reason to be proud of their Company and its expertise.

### Housing

The Hertfordshire/Bedfordshire area is probably one of the most picturesque of the counties surrounding London and contains some very reasonably priced housing both of the modern and rural varieties. The average family house is priced in the region of £16,000 to £22,000.



### Schooling

The family man will be particularly impressed with the local schools both Junior and Senior—modern, spacious buildings are the order of the day and individual successes are very encouraging.

### Sports and Social Activities

For the energetic our own sports and social club is very active, particularly with the recent addition of a squash court. Golf courses, cricket and football clubs abound and for the less energetic many social activities are available.



### Local Amenities

If you still have time on your hands you will enjoy a visit to the theatre in either St. Albans, Luton or Watford. The local Rep. is very well supported.

All in all we can offer you a really worthwhile job, attractive pay, relocation and equally important, excellent local surroundings. Why not ring John Prodger, Personnel Officer, he lives locally and can give you first hand information about the jobs and surrounding districts.

**MARCONI INSTRUMENTS LIMITED**  
Longacres, Hatfield Road, St. Albans, Herts.  
Tel: St. Albans 59292 or after 6pm and weekends  
St. Albans 30602



A GEC MARCONI ELECTRONICS COMPANY

8254

# RADIO TECHNICIANS

Government Communications Headquarters has vacancies for Radio Technicians. Applicants should be 19 or over.

**STANDARDS** required call for a sound knowledge of the principles of electricity and radio, together with appropriate experience of using and maintaining radio and electronic test gear.

**DUTIES** cover highly skilled telecommunications/electronic work, including the construction, installation, maintenance and testing of radio and radar telecommunications equipment and advanced computer and analytic machinery.

**QUALIFICATIONS:** Candidates must hold either the City and Guilds Telecommunications Part 1 (Intermediate) Certificate or equivalent HM Forces qualification.

**SALARY** (inc. supps.) from £2,673 at 19 to £3,379 at 25 (highest pay on entry) rising to £3,883 with opportunity for advancement to higher grades up to £4,297 with a few posts carrying still higher salaries.

Opportunities for service overseas.

Further particulars and application forms available from:



## GCHQ

Recruitment Officer (Ref. WW/7)  
GCHQ, Oakley  
Priors Road, Cheltenham, GL52 5AJ  
Cheltenham (0242) 21491 ext 2270

(8035)

## HEALTH EDUCATION DEPARTMENT

# Production Assistant/ Technician

£3,405-£4,353 p.a. incl. supplements (increase pending)

required in a small developing C.C.T.V. Studio. The successful applicant, who should be a well-qualified technician with several years' experience, will be trained to professional standards in the lighting and production of C.C.T.V. programmes.

As a member of the Health Education Department the applicant should have a pioneering spirit and will be required

- to assist producer in video and audio recordings and editing.
- to train and supervise technical staff.
- to maintain and repair colour and black and white educational television equipment throughout the Area.
- to build and develop ancillary equipment.

Job description and application forms are available from

**Area Personnel Department**  
Northamptonshire Area Health Authority  
Beaumont Villa  
Cliftonville  
Northampton  
Telephone Northampton 21155, Ext. 331

Closing date for applications July 21, 1978.

(8309)

# NORTHAMPTONSHIRE

AREA HEALTH AUTHORITY

# Engineering Training Lecturers

**in a high-  
technology  
industry**

**North  
Hertfordshire**

**£4000 - £6000**

ICL operates at the forefront of computer technology, and in 1977 increased turnover by 45% to nearly £420m.

Our Customer Engineering Division alone employs over 4000 people spread throughout the U.K. The Division's Training function is seeking additional lecturing staff to meet increasing demands. Accordingly we are planning to make increased use of Multi-Media methods to ensure cost effective training in our dispersed staff deployment situation.

The people we need must:

- be capable of running formal training courses on complex equipment to high professional standards
- be able to adapt to new training methods and techniques
- be prepared to run training courses anywhere in the U.K. or Overseas
- have high written and verbal communications skills.

You will have a degree or HNC preferably in a scientific or technical subject and several years' experience in a technical industrial environment. Experience in lecturing in a high technology industry will be an advantage, but is not essential.

However, due to the technical nature of the task and the professional standards required, comprehensive training will be given. This will include technical lecturing techniques and Multi-Media methods. These appointments will be based at our Training Centre in Letchworth and assistance with removal expenses will be given where appropriate.

For further details and/or an application form call David Reeves on 01-788 7272 Ext. 4150 or write to him at ICL, 85/91 Upper Richmond Road, Putney, London SW15 2TE, quoting reference WW1830.

## International Computers

think computers - think ICL



(8240)

## APPLICATIONS ENGINEER

**ELECTRONICS**

**£6K + BONUS**

BURR-BROWN ARE OFFERING a rare opportunity for an ambitious enthusiastic young Engineer to accelerate career and earnings

We urgently need someone to solve applications problems for a variety of Analogue Instrumentation and Data Conversion products. Responsibilities include technical support for the U.K. and Scandinavia, and liaison with the U.S. parent Co.

Candidates should have HNC (Electronics) or equivalent, and plenty of practical analogue experience

The Rewards    Excellent salary and growth potential  
                          Annual bonus  
                          Contributory Pension Scheme  
                          Occasional overseas travel  
                          Interesting, technical work  
                          Relocation expenses  
                          (A Company car may be offered in the future).

If you think you can meet this engineering challenge, call Roger Isaacson at



**BURR-BROWN  
INTERNATIONAL LTD.  
WATFORD (0923) 33837**

(8261)

## FIELD SERVICE ENGINEERS

**(SCHOOLS ELECTRONIC EQUIPMENT)**

**£3584 - £3962**

**Ewell/Pirbright**

For the Media Resources Centre. To carry out on-site service to schools A/V equipment, i.e. TV/VCR installations, language laboratories — fault-finding and repairing equipment — and some repair work in workshop base.

The department is responsible for the repair of all A/V items in schools, i.e. projectors, record players, radio, tape recorders, TV/Video, etc., and practical experience in some aspects is essential. City and Guilds or ONC in radio/TV/electronic service work desirable.

Casual car user allowance payable for use of own vehicle

Application form from Media Resources Centre, Glyn House, Church Street, Ewell. Tel. 01-393 0208.

(8256)



**SURREY  
COUNTY COUNCIL**

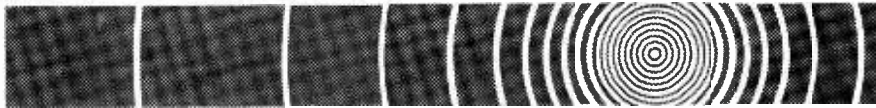

## Graduate Electrical/ Electronic Engineers —

### Research and Development in Telecommunications

The Directorate of Telecommunications, London, is responsible for the extensive and sophisticated facilities used by the police, fire, prison and associated services. The role of the Research and Development Section is to ensure that maximum benefit is derived from the use of modern techniques.

The training and experience given to Graduate Engineers covers the training requirements of the IEE — ranging from the initial interpretation of a non-technical statement of requirement through to the management of design, development and contract — and is carefully planned by a senior engineer.

You must have (or obtain in 1978) a good honours degree in electronics or electrical engineering or an allied subject.

Your starting salary will be at least £4150. Completion of training (usually one or two years) leads to a salary rising to £6200. Further promotion prospects to £11000 and above. Non-contributory pension scheme.

For further details and an application form (to be returned by 20 July, 1978) write to Civil Service Commission, Alencon Link, Basingstoke, Hants RG21 1JB, or telephone Basingstoke (0256) 68551 (answering service operates outside office hours). Please quote reference T/9848/1.

### HOME OFFICE



## Electronic Test Engineers

We manufacture and market professional audio noise reduction equipment which is widely used by major recording companies, recording studios and broadcasting authorities throughout the world and have enjoyed successful growth since incorporation in 1968.

The success of such films as "Star Wars" and "Close Encounters of the Third Kind" has led to an increased demand for our cinema equipment and a need for experienced test engineers.

If you have practical knowledge and experience of electronic testing, think you can test, calibrate and trouble-shoot our sophisticated equipment, enjoy the challenge of quality and delivery pressures and want to hear about the excellent pay and conditions, telephone Tony Hill, 01-720 1111.



Dolby Laboratories Inc.  
346 Clapham Road  
London SW9 9AP  
Telephone 01-720 1111

(8255)

### APPOINTMENTS IN ELECTRONICS

Take your pick of the permanent posts in:

- MISSILES — MEDICAL
- COMPUTERS — COMMS
- MICROWAVE — MARINE
- HARDWARE — SOFTWARE

For expert advice and immediate action on career improvement, phone, or write to, Mike Gernat BSC

**Technomark**  
*Engineering and Technical Recruitment*

11 Westbourne Grove  
London W2. 01-229 9239.

7098

### We pay top salaries for the right engineers Starting at £4000 p.a. for Bench Engineers Increasing appreciably for Field Service Engineers

London's largest independent radio-telephone company is expanding fast! We have built a reputation for reliable efficient service. If you have the capability we need you urgently.

Knowledge or experience of mobile V.H.F. equipment is what we're looking for. Call Mike Rawlings or Bill Clarke on 01-328 5344 Now! (7994)

London  
**Communications**

(Equipment) Ltd  
40 Boundary Road London NW8 01 328 5344

### AMBITIONS IN COMPUTING?

Use your experience to improve your life style

- DESIGN — TEST
- SERVICE — SUPPORT
- SALES — SOFTWARE

For expert confidential advice contact GEOFF ALDRIDGE

01-229 9239

**Technomark**  
*Engineering and Technical Recruitment*

11 Westbourne Grove  
London, W2

Royal Holloway College  
University of London  
Egham Hill, Egham, Surrey

### GRADE 4 ELECTRONICS TECHNICIAN

Required to work on the construction and maintenance of electronic equipment in the Physics Department. Salary on the scale £3349-£3931, plus £275 London Weighting. 4 weeks' holiday a year plus bank holidays and discretionary days. Please apply to the Personnel Officer (WW) giving details of age, qualifications, experience, and the names and addresses of 2 referees. (8223)

#### SERVICE ENGINEER

Service Engineer with preferably 2 years' audio and hi-fi servicing experience required to repair high quality audio products. As a broad range of products are covered, versatility in all technically related matters is required.

The successful applicant will have a thorough knowledge of electronics with direct application to hi-fi equipment.

Written applications only to **Tom Barclay**  
**MARANTZ AUDIO UK LIMITED**  
Debmarc House, 203 London Road  
Staines, Middlesex (8229)

#### 194 RADIO FORTH

Invites applications for the important position of

#### MAINTENANCE ENGINEER

Applicants must have a thorough working knowledge of Broadcast Audio Systems together with some experience of Telecommunications. Salary will be commensurate with age and experience. For an application form write to **The Chief Engineer, Radio Forth, P.O. Box 194, Edinburgh.** (8238)

#### ELECTRONICS TECHNICIAN

required for production testing and repair of a wide range of Digital and Audio circuit boards. Also alignment of high quality film recording equipment.

GEG Tech plus one year's experience; or several years relevant experience required.  
**Ring — Nigel Gardiner at PAG Films, Raynes Park, SW20. 01-542 1171.**



# Development Engineers

(Hampshire)

Our Engineering Headquarters at Crawley Court was built just over five years ago on a 32 acre site in a pleasant woodland setting.

We offer first class facilities in our laboratories for engineers who are employed on stimulating new projects relating to development in broadcasting technology.

Current major projects include:

- Digital Video Tape Recording \***
- Application of microprocessors to network measurement and control \***
- Adaptive Aerials \* Data Broadcasting**
- Digital Audio \* Surround Sound \***
- Digital Video Transmission**

If you are a graduate, male or female, with development experience we should like to hear from you. Equally, if you have a good honours degree, but have little or no experience, we should be interested in considering you for an appointment, initially at a lower level.

Providing you have the right level of qualifications and experience, you could start on a salary range which goes up to £5314 per annum (inclusive of pay supplements) our Phase 3 settlement is pending. Generous re-location expenses are paid, where appropriate and subsidised transport is available from local centres.

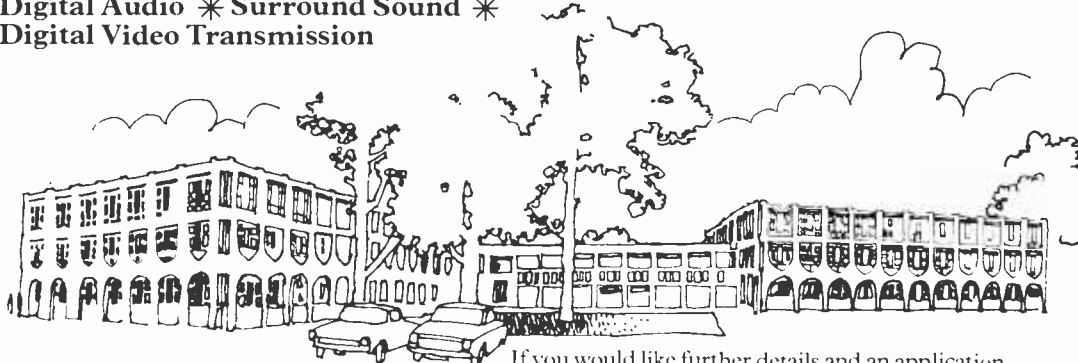

**INDEPENDENT BROADCASTING AUTHORITY**

If you would like further details and an application form, please write or telephone, quoting reference DT/ED to: Glynis Powell, Personnel Officer, Independent Broadcasting Authority, Crawley Court, Winchester, Hampshire, SO21 2QA. Telephone: Winchester 822270.

**SOUND DEVELOPMENTS PROJECTS DEPARTMENT** requires an **ASSISTANT ENGINEER** to help design and construct (with suitable training), professional equipment for its broadcast and sound recording studios (shortly to be updated to 24 track). Preference will be given to keen motivated applicants, 18-23 years old, with some successful constructional experience, who do not quake at the prospect of hard but rewarding work. We offer good friendly working conditions and excellent promotion prospects. Salary negotiable. Write with relevant details to Robert Haggas at Sound Developments Ltd., Spencer Court, 7 Chalcot Rd., London N W 1 8L7. (8285)

## DESIGN ENGINEER

Design Engineer with DIGITAL and ANALOGUE experience especially in the field of MICROPROCESSORS required by leading manufacturer.

Applicants should have a good working knowledge of Audio and Radio in order to be able to apply the most up-to-date techniques to these fields. Salary c£6000 per annum plus large Company Benefits. London area.

**APPLY TO BOX NO. WW8239** (8239)

**CA CAPITAL APPOINTMENTS LTD.**

**FREE JOBS LIST** for **FIELD SERVICE ENGINEERS** **BASIC SALARIES TO £5,000 + CAR** (7707)

**30 Windmill Street, London, W1**  
**01-637 5551**

## TELEVISION ENGINEER

A vacancy occurs with an old establishment Retailer.

The Post requires someone with a wide range of experience in Television and Audio equipment, a clean driving licence is essential. Large flat available for suitable applicant.

**HYDES OF CHERTSEY LTD.**  
**56/60 Guildford Street, Chertsey**  
**Telephone: Chertsey 63243** (8225)

**UNIVERSITY OF KENT AT CANTERBURY**

### PHYSICS LABORATORY—ELECTRONICS TECHNICIAN

A Grade 3 Technician is required for the Electronics section of the Physics Laboratory. Applicants should have an O.N.C. or equivalent qualification and 3-5 years' appropriate experience. Salary scale £2688-£3060 p.a. Application forms and particulars may be obtained from the Assistant Registrar, Faculty of Natural Sciences, Chemical Laboratory, The University, Canterbury, Kent. Closing date 30th June, 1978. Please quote ref T78/6 (8231)

*Engineers*

- DESIGN / DEV
- TEST
- FIELD SERVICE

High Salaries - Most Areas  
Phone 01 - 731 4353

*Apex* Personnel

### MANAGEMENT OPPORTUNITY FOR A.V. TECHNICIAN . . .

Our expansion programme means we're looking for additional staff including **A SENIOR AUDIO-VISUAL TECHNICIAN** with management potential and real ability. This is a genuine opportunity for rapid, excellent career progress with a well-established company working for blue-chip clients. Good basic salary, commission, bonuses, car and BUPA cover.

**Detailed CV please to Alan Lovejoy, Communications Centre Group 39 Long Acre, London, W.C.2** (8248)

## ELECTRONICS ENGINEERS

Are you technically ambitious? Are you looking for a challenging job? If you are then opportunities exist at Rank Research Laboratories, a Company within the Rank Organisation.

We are looking for engineers, male or female, who are keen to tackle interesting work in the following fields — automatic production aids, automatic test equipment, specialised machining processes and controls, new electronic device applications and thermal imaging systems for industrial, military and medical applications.

If this is the type of work that excites you and are seeking to broaden your knowledge, then you could be the person we are looking for.

Ideally you will possess a degree, HND or HNC in Electronic Engineering and have two to three years practical experience in electronic circuit design. Your salary will be competitive and negotiable, supplemented by the excellent Rank Organisation benefits package.

If interested, please drop a line to the Director of Rank Research Laboratories for an application form at: PO Box 33, Phoenix Works, Great West Road, Brentford, Middlesex TW8 9AG.

### RANK FILM LABORATORIES

(8307)

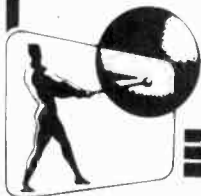

**CAMBRIDGESHIRE COUNTY COUNCIL**  
**HUNTINGDON TECHNICAL COLLEGE**  
 California Road, Huntingdon, Cambs.  
 Telephone Huntingdon 52346/7

**DEPARTMENT OF ENGINEERING AND CONSTRUCTION**

### FULL-TIME LECTURER GRADE I

required for 1st September, 1978, to teach ELECTRICAL/ELECTRONICS Principles, Practice plus Associated Studies to TEC National Level.

Salary Burnham F.E. Report, 1978, £3192 to £5334 by 14 increments, commencing salary dependent upon experience and qualifications.

Application forms and further information obtainable from the Principal at the College. (829B)

**PRESTON POLYTECHNIC**  
**SUBJECT AREA OF ELECTRICAL AND ELECTRONIC ENGINEERING**

Applications are invited for the post of

### SENIOR LABORATORY/WORKSHOP TECHNICIAN

(Research) with experience in Electronics to assist Academic Staff and Research students engaged in research.

Salary Grade T3/4 £2922-£3702 plus salary supplements up to a maximum of £520.

36¼-hour, 5-day week. Post superannuable.

Application forms and further details from Deputy Chief Administrative Officer (Staffing), Preston Polytechnic, Corporation Street, Preston.

Closing date 31st July, 1978. (8306)

## Telecine Operator

A major advertising agency requires a Rank Cintel MKIII telecine operator with first line maintenance ability.

The operation is mainly concerned with transfer of commercials to non-broadcast V.T. systems.

Salary is open to negotiation and will depend upon experience.

Please write giving details of experience and salary required to Bill King, Ogilvy, Benson & Mather Ltd., Brettenham House, Lancaster Place, London WC2E 7EZ.

(8274)

## ADVANCED TECHNOLOGY

Against a background of long-term government contracts we are expanding our teams working on advanced underwater projects and currently have the following posts available.

**Electronics Design Engineers**  
**Electronics Technicians**

For the senior posts, applicants should be qualified to degree or HNC standard; experience in working with aerodynamicists or hydrodynamicists would be an advantage. For the technicians vacancy, applicants should have practical experience and preferably ONC or equivalent qualifications.

The company is situated on the Avon/Somerset border, a few minutes drive from Junction 21 of M5. Working conditions are excellent and salaries are negotiable. Please contact Ron Moir, quoting reference EA and the position in which you are interested.



**BRISTOL AEROJET LTD.,**  
**BANWELL,**  
**WESTON-SUPER-MARE,**  
**AVON**

(8288)

### LUXMAN DISTRIBUTORS

Require an additional

## HI-FI ENGINEER

Must be experienced and capable of servicing high quality equipment. Good prospects.

Apply: **Sales Manager,**  
**HOWLAND-WEST LTD.**  
**3/5 Eden Grove**  
**London N7 8EQ**  
**Tel: 01-609 0293**

(8277)

## RADIO ENGINEER HAITI

Required to work as technical adviser to the Haitian Radio School team working on a new adult literacy scheme. Responsibility for the maintenance and repair of the Radio station equipment and the training of Haitian counterparts.

A British Volunteer Programme Post. language training provided.

For further information write with details of curriculum vitae to CIR Overseas Volunteers, 1 Cambridge Terrace, London NW1 4JL.

(8282)

**CAPITAL APPTS.**

**FREE LISTS**  
 101 Design/Development and Test Jobs  
 Permanent and Contract  
**To £6,000**  
 7708

29 Windmill St. London, W.1.  
**637 5551 day, 636 9659 eve.**

**V.H.F. SERVICE TECHNICIAN** required by London Car Telephones to work on base station and mobile radio equipment. Very well equipped busy workshop in Croydon, but also field service engineers required in the home counties. Ample opportunities for unlimited overtime. Experienced persons only. Salary and bonuses commensurate with ability. Contact J. S. CLARK, 01-680 1010. (7987)

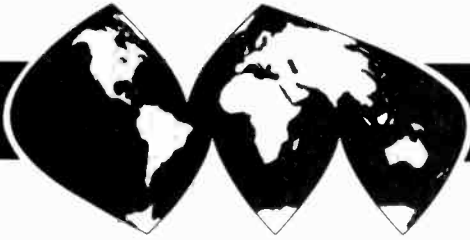

## Communicate with Racal

### Chief of Sales-U.K. Systems Engineers

**Windsor**

**RACAL**

The Racal Electronics Group have an outstanding growth record based upon sound management and a controlled development programme.

Racal (Slough) Limited located at Windsor is an expanding member of the Group and is engaged in the design and manufacture of sophisticated communications equipment.

The Marketing Department are seeking to appoint:

#### Chief of Sales—U.K. (MALE/FEMALE)

We offer a very challenging opportunity with excellent career prospects.

Reporting directly to the Marketing Director, responsibilities will include maintaining existing areas of business, seeking and negotiating new contracts and active liaison with U.K. customers such as M.O.D., Post Office and Government establishments.

Applicants preferably to have had at least five years sales/marketing experience and to have worked in the radio communications field. Ex-service personnel without marketing experience will be seriously considered.

#### Systems Engineers (MALE/FEMALE)

Reporting to the Chief Engineer (Systems), duties will include the detailed planning and engineering of radio communication systems to customer requirements, and the provision of assistance to Marketing personnel to promote the Company's products.

Applicants should preferably be educated to degree level or equivalent and possess experience of systems work.

Located in the pleasant Berkshire town of Windsor, we offer attractive conditions, benefits, and salaries. Assistance with relocation expenses is available in appropriate cases.

If you are interested in either of the above posts please write giving details of age, experience and present salary to:

Personnel Officer, Racal (Slough) Limited, Duke Street, Windsor, BERKS.

8279

## Hide and seek is something we take very seriously

Especially when the object to be found is a crashed aircraft or a survivor at sea, or a nuclear submarine hiding on the sea bed. These are just some of the activities we're engaged on at UEL Electronic Communications Limited.

A member of the international Dowty Group, we are one of the leading companies in Europe in the development and manufacture of sonar and communications systems. Products include homing and rescue beacons, sonobuoys for anti-submarine and seismic exploration, airborne emergency radios, and communications control systems and intercom installations for civil and military aircraft.

Our latest project is in the area of VHF radio where we are providing British Rail with a communication system between signal boxes and trains.

We are now looking for experienced men and women to work on a variety of interesting projects:

#### Senior Development Technicians

We require men or women to join project teams working on the design and development of analogue systems and circuits for prototype equipment. Will be responsible for building, testing and evaluating experimental equipment and for assisting with the development of analogue circuitry.

Applicants, aged between 25 and 45, should hold City & Guilds Electronics, Radio & TV, or Telecommunications Certificates up to Part 1 or Intermediate level and have at least 5 years' development experience, preferably involving government contracts.

#### Electrical Development Engineers

We are looking for men or women to join a small team of Engineers and Technicians working on the design of analogue systems and circuits. Visits to trials may be necessary and opportunities might arise for visits to clients and suppliers.

Applicants should be qualified to HND or preferably degree level with several years design experience.

We are offering attractive salaries, negotiable according to qualifications and experience, plus a wide range of attractive large company benefits. There are good promotion prospects and generous relocation package is available where necessary covering all legal and estate agency fees, Building Society survey fees, viewing expenses, and a disturbance allowance.

For further information and an application form phone or write to: Mr Gavin Rendall, Personnel Manager, Ultra Electronic Communications Limited, 419 Bridport Road, Greenford, Middlesex.

UB6 8AU. Tel: 01-578 0081.

**UEL**

Electronic Communications Limited

(8293)

## It takes a lot of MICROPROCESSORS to control city traffic from Bristol to Bangkok

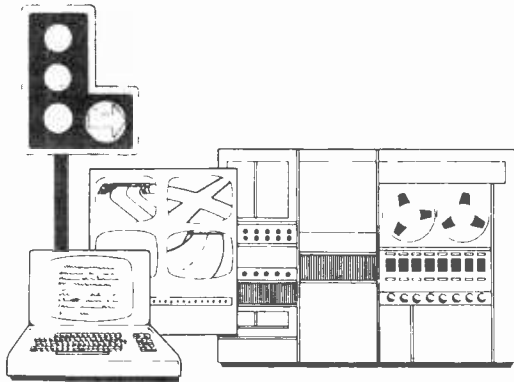

**WE SUPPLY...**  
 Micro computer systems for:  
**TRAFFIC CONTROL**  
**POLICE VEHICLE LOCATION**  
**CREDIT CARD FUEL DISPENSING**  
**RAILWAY TICKET ISSUE**

**WE PAY...**  
 Very competitive and attractive salaries for all positions, excellent fringe benefits and assistance with relocation costs where appropriate.

**WE WANT...**  
**ASSISTANT CHIEF ENGINEER**  
 to head-up design groups responsible for products. At least 10 years experience is required.  
**PRINCIPAL ENGINEERS**  
 to take responsibility for the design and introduction of new products using micro-processor techniques.  
**SENIOR ENGINEERS**  
 to be responsible for the electronic design of new products using micro-processors.  
**SENIOR SALES ENGINEER**  
 to develop the market for our electronic money-card fuel dispensing system in the UK and overseas.  
**HEAD OF TECHNICAL SERVICES**  
 to be responsible for providing technical support service to a large number of UK Depots.

**WE CAN PROVIDE**  
 real job involvement in a dynamic and progressive company with opportunities for overseas travel.

For a full list of equipment please complete the coupon and phone or fax. Applications from overseas

Mrs E. Manson  
 C/O ELLIOTT TRAFFIC AUTOMATION LIMITED  
 Elm Way, Borehamwood, Herts, UK, Pk42 8RF Str. 3342

Ref ETA 14

FREE POST - postage to your nearest C/O ELLIOTT TRAFFIC AUTOMATION LTD. FREE POST - BOREHAMWOOD, HERTS. WD6 1BR

Please state position applied for

Drive experience over

4 years	6 years	8 years	longer
---------	---------	---------	--------

My present salary is in the range

£4000-£4500	£4500-£5000	£5000-£5500	higher
-------------	-------------	-------------	--------

Please tick the boxes

Name \_\_\_\_\_

Address \_\_\_\_\_

Daytime phone No. \_\_\_\_\_

Evening phone No. \_\_\_\_\_

Ref (8303)

# INSTALLATION TECHNICIANS

Vacancies exist for Installation Technicians who have experience of the manufacture, commissioning or operation and maintenance of electronic equipment and who are qualified to ONC or equivalent standard in electrical engineering.

The work includes supervision of craftsmen, liaison with contractors and other specialists at site and assisting professional engineers in the scheduling, assembly, installation, testing and commissioning of broadcasting installations.

The successful candidates, male or female, will be based in the London area but must be prepared to work anywhere in Great Britain for periods which do not normally exceed 4 weeks at a time.

Salary, depending on experience and qualifications, will initially be in the range of £3535 to £3835 rising by annual increments of £150/165 to a maximum of £4800 per annum. Additional allowances are paid for on-site working.

4 weeks and 2 days annual leave.

Requests for application forms to **Engineering Recruitment Officer, BBC, Broadcasting House, London W1A 1AA**, quoting reference 78.E.2138/WW. Please enclose an addressed envelope with your application; no stamp is required. Closing date for completed application forms is 14 days after publication.

8276

## TELEVISION OR RADIO ENGINEER

Capable of servicing a wide range of coin-operated equipment including pintables and the latest video games. This vacancy would suit an applicant with previous experience in the radio or television industry. Salary will be commensurate with the successful applicants' qualifications, but will be in the region of £3000-£4000 per annum, plus bonus payments.

Please contact **Mr. B. Meaden at 6 Ponsford Road, Minehead, Somerset. Tel: Minehead (0643) 4186.**

8273

## WESTWARD TELEVISION have a vacancy for an **ELECTRONICS MAINTENANCE ENGINEER**

to work on studio broadcast equipment including cameras and video and audio equipment. Shift working may be involved. Salary £5,000 plus. Excellent conditions of service and relocation assistance may be available. Written applications, giving full details, should be forwarded to the **Personnel Manager, Westward TV, Derry's Cross, Plymouth, PL1 2SP.**

8272

Northern Regional Health Authority  
Regional Medical Physics Dept.  
Newcastle General Hospital  
Newcastle Upon Tyne NE4 6BE  
The following vacancy exists

## Technician (Electronics)

Grade III (2 posts)

The work, which is varied and interesting, includes the design, development and maintenance of medical electronics equipment and ranges from small portable instruments to large fixed installations. Candidates should have reached a high standard of expertise in electronics construction with experience in digital and analogue circuitry.

The successful applicant will have served a recognised course of training followed by a minimum of three years relevant experience, which may be outside the Health Service.

A HNC in electronics, electrical engineering or applied physics or equivalent is required. Salary £3,744 p.a. rising to £4,788. These posts may be offered at a lower grade if no suitable Grade III applications are received.

Applications should be received within 14 days of the appearance of this advertisement.

Application forms and job description may be obtained from the Regional Personnel Officer, Northern Regional Health Authority, Benfield Road, Walker Gate, Newcastle Upon Tyne NE6 4BY (8304)

UNIVERSITY OF CAPE TOWN

## MARINE ELECTRONICS TECHNICAL OFFICER

An electronics Technical Officer is required to assume duty as soon as possible in the Marine Geoscience Group of the Department of Geology. Duties will include the maintenance and development of marine geophysical equipment both in the laboratory and at sea. Some experience in this field would be a recommendation. The successful applicant will spend several 2-3 week cruises per year aboard the University's research vessel "Thomas B. Davie".

The salary will be on the scale R4 020 x 180 - 5 100 x 240 - 5 580 // x 240 - 6 300 // x 360 - 6 660 per annum plus a pensionable allowance of 15.5% of salary (i.e. maximum monthly salary of R641). In addition, the University offers a housing subsidy, plus medical and pension schemes.

Further details may be obtained from the Professor of Marine Geoscience, Department of Geology, University of Cape Town, Rondebosch, 7700 South Africa.

Applications giving names of two referees must reach the Registrar, University of Cape Town, Private Bag 18, Rondebosch 7700, by 30th June, 1978.

The University's policy is not to discriminate in the appointment of staff or the selection of students on the grounds of sex, race, religion or colour. Further information on the implementation of this policy is set out in a memorandum which is obtainable from the Registrar. (8178)

# BBC

## TECHNICAL OPERATIONS TRAINING

### Staff required at the ENGINEERING TRAINING DEPARTMENT, EVESHAM, WORCESTER.

**Duties** Contributing towards the operational training of Technical Staff in Television and/or Radio Broadcasting. This includes instructing Technical Operators who are responsible for sound coverage, audio mixing, camera work and lighting in Television Studios and Outside Broadcasts. In Radio, Technical Operators operate the Radio Network Continuity Suites and carry out duties in connection with programme routing and switching.

**Qualifications** Recent experience in some aspect of Technical Operations or Engineering in the Broadcast or Closed Circuit field. A good technical knowledge of audio or video equipment. A willingness and ability to undertake internal training if necessary to obtain a qualification equivalent to City & Guilds Full Technological Certificate in Telecommunications.

**Reward** A base in the Worcestershire countryside. Working in well equipped Radio and Colour Television Studios. Excellent welfare and Club facilities. A starting salary in the range £4600 to £5475 depending upon experience and qualifications, rising to £6150.

**Further Details** If you would like to hear more and receive an application form please send a stamped addressed envelope of at least 9" x 4" to **Head of Technical Operations Training Section, Engineering Training Department, Wood Norton, Evesham WR11 4TF**, quoting reference number 78.E.2177/WW. Closing date for return of application forms 14 days after publication.

8220

# Skilled in Electronics? You could become a Systems Engineer

- Are you at least 20 years of age?
- Have you 2 years' practical electronics experience plus any one of the following?
  - City & Guild's full electronic certificate
  - HNC in electronics
  - A completed electronics apprenticeship
  - An H.M. Forces electronics training
- Will you accept the challenge of maintenance and diagnosis on ICL's complex computer systems?

**YES?** Then we are interested in training you to join our skilled teams of Systems Engineers in maintaining our customers' computers. After a thorough initial training you will be based in one of our many Regions throughout the UK. Within 18 months you should be a fully trained Systems Engineer with a career rich in opportunity ahead of you. You will have the satisfaction of using all your technical expertise, tact and personality as a representative of ICL.

If you are interested in one of these jobs, with excellent salaries and conditions even during training, then return the coupon or

phone David Reeves on 01-788 7272 ext 4150 for an application form.

TO: David Reeves, CED Recruitment, ICL, 85/91 Upper Richmond Road, London SW15 2TE.

**I would like to find out more about being a Systems Engineer.**

Name \_\_\_\_\_

Address \_\_\_\_\_

\_\_\_\_\_

8275

## International Computers

think computers - think ICL



Ref: VAV1860

## SITUATIONS VACANT

# Radio Officers—

## Leaving the Service soon?

If your trade involves radio operating, and you are no more than 35 years of age, you qualify to be considered for a Radio Officer post with the Composite Signals Organisation.

A number of vacancies will be available in 1979 for suitably qualified candidates to be appointed as Trainee Radio Officers. Candidates must have had at least 2 years' radio operating experience or hold a PMG or MPT certificate.

On successful completion of 35 weeks' specialist training, appointees move to the Radio Officer Grade. Salaries under review — details will be available upon application.

Closing date for applications August 31, 1978.

**The Recruitment Officer (Ref. ROWW/7)**  
**Government Communications Headquarters**  
**Priors Road**  
**Oakley, Cheltenham**  
**Glos, GL52 5AJ**

Telephone: Cheltenham 21491, Ext. 2269

## GCHQ

Recruitment Officer,  
 GCHQ, Oakley,  
 Priors Road, Cheltenham, GL52 5AJ.  
 Cheltenham (0242) 21491 Ext 2270



## Southern Television Limited have a vacancy for an ENGINEER at their DOVER STUDIO.

Duties will include the operation and maintenance of television broadcast equipment (VTR, Telecine, Cameras, etc.)

Salary, dependent upon experience, will be within the range of £2998 to £4357 per annum, plus £312 Stage 1 supplement, plus Stage 2 supplement.

Applications should be made in writing to  
**The Personnel Administrator, Southern Television Ltd.**  
**Northam, Southampton SO9 4YQ**

**ELECTRONICS TECHNICIAN** for educational services unit. Candidate should have interest in television as a teaching and research tool, sound background in electronics with ability to communicate with patience, students and staff at all levels. Major part of the post involves maintenance of small studio in Dept of Psychiatry and replay of video recordings. Salary scale £3,186 to £3,720 p.a. Reference 496/C/135. Application forms from Assistant Secretary Personnel Office, University of Birmingham, P.O. Box 363, Birmingham B15 2TT. (8305)

## ARTICLES FOR SALE

### TRANSFORMER PROBLEMS?

1VA-1KVA Prototypes in 7-10 days Phone Vince Sellar on 06076-66716.

**TRENT TRANSFORMERS LTD**  
 Chapel Street  
 Long Eaton, Nottm.

7909

## ARTICLES FOR SALE

**FMAM.** A high performance tunable receiving stereo FM. Medium wave and Long wave. 1.5 microvolt sensitivity typical FM. Switched AFC. Board is supplied complete and tested for £19.50.  
**M-13** A sophisticated varicapped tunable 1 microvolt sensitivity typical FM. Switched mute and AFC. Double tuned IF for low capture ratio and minimum distortion. AM employs the HA197 IC, the last word in selectivity and sensitivity for Medium and Long Wave reception. Board includes full switching and regulated power supply. Supplied complete and tested for £29.50.

**POWPAK.** Stereopower amplifier on 1 PCB 20 watts RMS per channel. 1% RMS distortion at full output. 5A stereo amplifier, complete with bass, treble, volume and balance controls, includes a power supply. Amplifier is capable of 20 watts RMS per channel (two channels are active). Bazardall type power supply includes 20 volt regulated output. Board as it stands can be driven by a linear direct. Supplied complete and tested for £18.50.

**SPEAKERS.** 8 ohm 25 watt RMS two way speakers cabineted. £35.00 pair. All prices include VAT. Postage and Packing. Cheques or postal orders please.

**SILTER, HARLYN DRURY LANE**  
**RIDGEWELL, ESSEX**  
 Allow 14 days delivery

### MSF 60KHz

TIME RECEIVER gives you SECONDS, MINUTES and output for MONTH, DATE and YEAR internal ferrite rod agc 9V or external 12V operation All parts printed circuit case battery postage etc instructions, money back assurance, send £13 70 NOW

**CAMBRIDGE KITS, 45(WG)**  
 Old School Lane  
 Milton, Cambridge

(8299)

## ARTICLES FOR SALE

### SOWTER TRANSFORMERS

WITH 37 YEARS' EXPERIENCE we have the expertise to design and manufacture ANY TYPE OF AUDIO TRANSFORMER AT THE RIGHT PRICE

Whilst we specialise in every kind of transformer for audio control decks and mixers, demands are increasing for **LOUDSPEAKER TRANSFORMERS** and **100 VOLT LINE AUDIO OUTPUT TRANSFORMERS** for most kind of amplifier from 30 watts to 500 watts output. We have standard designs for AMCRON and BOSE amplifiers and can also supply **Multi-output transformers for COLUMN LOUDSPEAKERS** in a wide variety of powers. A recent tendency is the demand for **OUTPUT TRANSFORMERS FOR ULTRA LINEAR VALVE AMPLIFIERS** using KT88 and KT66 BEAM TETRODES and for these we have standard designs with exceptional performance. Many of our output transformers for loudspeakers have been installed in Theatres, Television Studios, Lecture and Concert Halls, Churches and Outdoor Arenas whilst others are in constant use for high quality portable Public Address Systems. We will supply single transformers, or any quantity, with short delivery times and, without obligation on your part, will quote price and exact dispatch on receipt of your requirements.

**KINDLY NOTE OUR NEW ADDRESS AND TELEPHONE NUMBER: E. A. SOWTER LTD., Transformer manufacturers and designers, P.O. BOX No. 36, IPSWICH IP1 2EL, ENGLAND. Tel: Ipswich (0473) 52794-219390.**

(8289)

### THE FABULOUS D2 MICROPROCESSOR EVALUATION KIT FROM MOTOROLA

Featuring 24 key keyboard Seven segment display Cassette interface Rom & Ram Expandable Interface Capability Full Documentation 5 Volt power supply required One year's FREE membership of The Amateur Computer Club with every purchase £176 + £1 50 P&P + 8% VAT

### ENAMELLED COPPER WIRE

SWG	1 lb	8 oz	4 oz	2 oz
14-19	2 60	1 40	66	55
20-29	2 80	1 60	85	65
30-34	3 00	1 70	95	70
35-40	3 35	1 90	1 10	79
40-43	4 50	2 50	1 90	1 25
44-46	5 00	3 00	2 10	1 65
47	8 00	5 00	3 00	1 76
48	15 00	9 00	6 00	3 30

Tinned Copper, Even Gauges 14-30 £3 per lb Multicore 60/40 Solder 18SWG £3 24 per lb Prices include P&P and VAT SAE brings list of copper and resistance Wires

**THE SCIENTIFIC WIRE COMPANY**  
 PO Box 30 London E.4 (7771)

**TV TUBE** rebuilding. For all supplies, equipment plant and training. — Western-Whybrow Engineering, Praa Sands Cross, Penzance (073 676) 2265. (8048)

**VHF MONITOR RECEIVERS**, air, marine or business bands (low, mid, high or AM or FM). All crystal controlled high performance models. Send 15p P.O., not stamps, Radio Communications Ltd, St Sampsons, Guernsey, Channel Isles.

**LAB CLEARANCE:** Signal Generators; Bridges; Waveform, transistor analysers; calibrators; standards; millivoltmeters; dynamometers; KW meters; oscilloscopes; recorders; Thermal, sweep, low distortion true RMS, audio FR, deviation. Tel. 040-376236. (8250)

**LINSLEY-HOOD** 75 watt power amp modules from £12.50, built and tested. Linsley-Hood 75 watt amplifiers constructed and repaired. Large range of spares in stock. SAE for lists. I. G. Bowman (Dept WW), 59 Fowey Avenue, Torquay, S. Devon. (8246)

**WAYNE KERR** Universal Bridge B224 L.C.R. Excellent condition. Little used. £500 o.n.o. (0527) 23914, Harris. (8244)

**ELECTRONIC KITS** — SAE for new catalogue, and clearance list of obsolete kits. AMTRON, 7 Hughenden Road, Hastings, Sx. (8226)

**TRANSFORMERS**, British made. Twin primaries 115/230V Twin isolated secondaries 0-4.5-0-4.5, 0-6-0-6, 0-9-0-9, 0-15-0-15. All 6VA. Great value £2.05 inc VAT & P & P. Other values available. Try us for all your components. T.D. Components, Staincliffe Hills, Dewsbury, W. Yorks. (8233)

**REWINDING TRANSFORMERS**, a new manual covering 1VA to 5KVA single phase, from Magnum Power Tools, Brinksway, Trading Estate, Stockport, Cheshire, SK3 0BZ. £4.30 post paid by return. (8230)

## AN INTRODUCTION TO MICROCOMPUTERS

### VOL 0 — BEGINNERS BOOK

Price: £5.30

written for the complete beginner explains what a computer system consists of — its component parts and what they can do for you.

### VOL 1 — BASIC CONCEPTS

Price £5.30

takes you by the hand from elementary logic and simple binary arithmetic, every aspect of microcomputers is covered.

### VOL II — SOME REAL PRODUCTS

Price: £10.80

covers real microcomputers in considerable detail. Every major microcomputer 4 bit, 8 bit or 16 bit is described. More than 20 microcomputers in all.

### 8080 PROGRAMMING

Price: £5.30

for logic design.

### SOME COMMON BASIC PROGRAMS

Price: £6.30

describes 76 short programs.

### 6800 PROGRAMMING

Price: £5.30

for logic design.

★ ALL PRICES INCLUDE POSTAGE ★

**THE MODERN BOOK CO.**  
 SPECIALISTS IN SCIENTIFIC & TECHNICAL BOOKS  
 19-21 PRAED STREET  
 LONDON W2 1NP

Phone 723 4185

Closed Sat 1 p.m.

44:

### ENAMELLED COPPER WIRE

SWG	1 lb reel	1/2 lb reel
10 to 19	£2.95	£1.60
20 to 29	£3.15	£1.80
30 to 34	£3.45	£1.90
35 to 40	£3.65	£2.10

All the above prices are inclusive of postage and packing in UK

### COPPER SUPPLIES

102 Parrwood Road, Withington,  
 Manchester 20  
 Telephone 061 445 8753

100

**LARGE QUANTITY** of "Wireless World" and "Radio Communication". Most mint. S.a.e. please. Stacey Three Westpark, South Molton, Devon. (8245)

**60KHz MSF Rugby Receiver**, BCD TIME OF DAY OUTPUT. High performance, phase locked loop receiver, 5V operation with 1 second LED indication. Kit complete with tuned ferrite rod aerial £14.08 (including postage and VAT). Assembled circuit and cased-up version also available. Send for details, Toolux, Sherborne (4359), Dorset. (8252)



**ARTICLES FOR SALE**

## SPECIAL OFFER

Limited number of 1mA Panel Meters, face dimensions 43 x 43 cm. Hurry while stocks last!

**£4.30** each including VAT postage & packing.

Generous discounts for quantity. Send PO, Cheque or Barclaycard/ Access No. to **Protimeter Ltd., Meter House, Marlow, Bucks, SL71LX Tel: (06284) 72722.** (8247)



## 9" MONITOR & POWER SUPPLY

Monitor all inputs TTL 20 compatible wide band width MHz mixed or separate HMV sink 625 line 50Hz for 525 line 60Hz power supply + 11 volts at 1.2 amps (monitor supply) plus 12 at 4 amps-5V at .4 amps minus 12V at 30 MA + 5V at 4 amps Easily modified to give - 5V at 30MA + 5V at 4 amps £195.00 including VAT.

**VIDE TERMINALS**  
197 HORNBEAMS  
HARLOW, ESSEX  
TEL: HARLOW 30132

(8301)

**SEEN MY CAT?** 5000 odds and ends. Mechanical. Electrical. Cat free. Whiston Dept. WW, New Mills, Stockport. (7983)

**ADAPTOR AERIAL TO TRANSMITTER** ZA56234 MWB/XB/940 highwattage, first class engineering, wide communications frequency range, f45. CT423 Calorimeter power meter for radar frequencies, ex W.D. 10AF/6625-99-943-9347, £50. Scam Clark 40ft pneumatic mast, superb quality in unopened original pack, £300. 10 way 300 volt max. cable 7/010 max temp. 80°C. All prices plus carriage and V.A.T. will negotiate for quantity. Many wholesale and retail bargains for callers. Surplus purchased — established over 20 years. G. W. M. Radio Ltd., 40/42 Portland Road, Worthing, Sussex. Tel. 34897.

**C8305 STANDARD** 1 watt 5 channel VHF Marine hand portable, fitted with 6 and 16 other channels to order complete with leather carry case and carry strap, full range of accessories available, £145 plus 12½% VAT. (Send large SAE for leaflet) to: **LEE ELECTRONICS LTD.**, 400 Edgware Road, London W2. Telephone 01-723 5521. Telex 298765. (8280)

**OLIVETTI TELETYPE MODEL TE 300.** Offers. — Tel: 021-454 1392 evenings 021-783 3500. (8251)

**RACAL** universal counter/timers manual, little used, £110. plus P&P Edith (Kent) 30556. (8302)

**RACAL 9905** counter/timer 200 MHz £260; advance 054000 digital storage scope (mint). Offers c £1,380; new 10 MHz cathode oven oscillator(s) £33. Phone Edenbridge (Kent) 863600. (8300)

**VOLTAGE PROBLEMS?** Advance CVT 6KVA 230 volts, sensible offers invited. Sunbury 87959. (8290)

**LOGIC PROBE**, suitable CMOS/TTL supply 5-17v from board under test detects both states and pulses down to 50ns. Only £10. C. Marshall, 22 Oakfield Road, Croydon, Surrey. (8277)

**THE CATCH-A-PULSE** Logic Probes are small, highly sophisticated, shirt-pocket portable, multi-family (RTL, DTL, TTL, MOS, CMOS, Microprocessors), digital test instruments designed to analyze and troubleshoot static and dynamic conditions of logic circuitry. They also eliminate the need for carrying complicated and heavy test equipment.

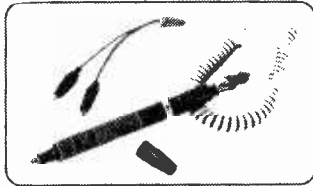

**AVR ELECTRONICS SERVICES**  
2 Wharf Street, Shipley, W. Yorks. BD17 7DW. (8279)

## MAGNETIC MICROPHONE/SPEAKERS

Ex Government surplus stocks of 4T inserts. Ideal for all sound speaking and listening applications. Very rugged DS rec ohms Size 1½" dia. ½" deep. 50p ea. 5 for £2.35. 10 for £4.50 incl P.P.

**C.W.O. B.B. SUPPLIES**  
DEPT. WW 125  
HIGH STREET, DEAL, KENT

(8206)

**EQUIPMENT WANTED**

## BROADFIELDS AND MAYCO DISPOSALS

21 Lodge Lane, N. Finchley  
London, N12 8JG  
Telephone:  
01-445 2713

01-445 0749 01-958 7624

MAY WE ASSIST YOU TO DISPOSE OF YOUR SURPLUS AND REDUNDANT STOCKS.

We will call anywhere in the British Isles, and pay **SPOT CASH** for Electronic Components and Equipment.

## A.R. Sinclair

Electronic Stockholders  
Stevenage 812193

We purchase all types of Mechanical and Electronic Equipment and Surplus stocks.

(8189)

**ARTICLES WANTED**

**WANTED**, storage 'scope, DM64 or similar. Mr Rimell, Spalding Grammar School, Spalding, Lincs. (0775) 67181. (8263)

**H.P. SPECTRUM ANALYSER**, 8551B or later. Any condition. Wayne Kerr LCR Bridge, TEK 547, any condition. Branson, 111 Park Road, Peterborough. 67604 W/E. (8311)

**STORAGE SPACE** is expensive, why store redundant and obsolete equipment? For fast and efficient clearance of all test gear, power supplies, P.C. boards, components, etc., regardless of condition or qualities. Call 01-771 9413. (8209)

**TURN YOUR SUPPLUS** Capacitors, transistors, etc., into cash. Contact **COLES-HARDING & Co.**, 103 South Brink, Wisbech, Cambs. 0945-4188. Immediate settlement. We also welcome the opportunity to quote for complete factory clearance. (7439)

**COURSES**

# Make your hobby more Constructive and Profitable!

## Now what — 'A' levels, OND, C&G of London Institute . . . ?

Are you thinking about a career in Electronics? If you have Maths, Physics and English Language 'O' levels then why not consider our Technical Engineer Certificate Course. This two-year **full-time** course gives you a qualification recognised by industry — the Full Technological Certificate — and also provides an entrance qualification for a degree course. Specialisations include Computer Engineering (including Microprocessors), Sound Studio Engineering and Radar and Microwaves.

**Write to the Secretary, Department of Electronic and Communications Engineering, Polytechnic of North London, Holloway Road, London N7 8DB, for details.**

The Polytechnic of North London

(8224)

**ARTICLES WANTED**

★ **MINICOMPUTERS**  
★ **PERIPHERALS**  
★ **INSTRUMENTATION**

For fastest, best **CASH** offer, phone

**COMPUTER APPRECIATION**  
Godstone (088 384) 3221

7677.

**WE PURCHASE ALL FORMS OF ELECTRONIC EQUIPMENT AND COMPONENTS, ETC.**

SPOT CASH

**CHILTMead LTD.**  
7, 9, 11 Arthur Road  
Reading, Berks.  
Tel. (0734) 582 605

**MINICOMPUTERS PERIPHERALS INSTRUMENTATION**

For fastest, better **CASH** offer  
Phone

**CHILTMead LTD.**  
Reading (0734) 586419

**ELECTRONIC SCRAP.** Components, etc., Receivers, Transmitters Test Equipment wanted. Ferrographs from £15 in stock. Contact M & B Radio, 88 Bishopgate Street, Leeds 1, Tel. Leeds 35649. (8011)

## WANTED IN LARGE QUANTITIES

Electronic components resistors capacitors, potentiometers, chassis loudspeakers, semi-conductors, diodes, TV tubes, especially colours, etc., etc., etc. First or second grades. Finished or incomplete products, record players, amplifiers, radios, tuners, tape recorders, enclosures, etc etc etc

We will buy complete factories and pay cash

TEL. 01-491 4636  
**E.C.E. AVON HOUSE**  
360/366 OXFORD STREET  
LONDON, W.4 (7950)

**WANTED**, all types of GEC mobile radio telephone equipment, top prices paid. Telephone Milford Haven (06462) 5534 evenings. (8234)

**B.D. ELECTRONICS** offer prompt settlement for surplus electronic components, t.v./audio spares are of particular interest. Contact Miss Hughes, 9 Westhawe, Bretton, Peterborough. Tel 265219. (7632)

**WE PURCHASE, FOR CASH** the following: R. F. Power Transistors, Varactor Diodes, and all special components normally used in VHF/UHF Transmitting equipment. **MODGLAR ELECTRONICS**, 95 High Street, Selsey Sussex. PO20-0QL. Tel. Selsey 2916. (7696)

**WANTED**, all types of communications receivers and test equipment. Details to R. T. & I. Electronics Ltd., Ashville Old Hall, Ashville Rd., London, E.11. Ley 4986. (163)



## SERVICES

### W.K.F. ELECTRONICS

(R.P.C.B.S. Ltd.)

THE CIRCUIT BOARD SPECIALISTS — UNIVERSAL SUPPLIERS

**Contractors for:** P.C.B. Production, Contract Drilling, Electroplating, Laminate Cutting  
**Services for:** Master Artwork Preparation, Process Photography, Circuit Diagrams, Layouts & Legends  
**Consultants for:** Instrument Engineering, Automatic Control & Applications

**Do-It-Yourself Won't Do:** Today's assemblies demand close tolerances  
**Goodbye to the Long Wait:** 3 to 7 Day Prototype P.C.B. Production Service  
**Quotations:** By Return Guaranteed Quality on every process  
**Short or Long Term Production** now acceptable from 1 to 10,000 units.

**We Universally Distribute:** Laminate, Carbide Drill Bits & Routers, Process Chemicals (any), Pre-sensitised Laminate, Drilling Machines (Manual, Multi-spindle N.C./C.N.C. Control), Graphic Art Draughting materials & aids

**We Manufacture to Specification:** Quality Circuit Boards (Single or Double Sided with any finish). Due to expansion we now have space available for prototype or long term production

**For Quotations:** Submit Copy Masters Roughs, Circuit or Sample units for costing  
 To:

W.K.F. ELECTRONICS  
 FLEET HOUSE, WELBECK STREET  
 WHITWELL, WORKSOP, NOTTS  
 TEL. WORKSOP (0909) 720895  
 TELEX: 547818  
 Telephone Quotations: Ask for pricing

### NOTICE TO OTHER MANUFACTURERS

IS YOUR DRILLING / ROUTING DEPARTMENT A BOTTLENECK?  
 IF SO TRY OUR SERVICE FOR DRILLING AND ROUTING

THE RATES ARE VERY REASONABLE AND THE FAST SERVICE WILL ENSURE THAT YOUR CUSTOMERS' DELIVERIES ARE MET

### VIDEO EQUIPMENT

May we assist in your purchase or disposal? We specialise in the sale and purchase of all Video equipment both new and secondhand. We maintain a register in order to quickly and efficiently cross reference both disposal and wants

\* Ring Derek Pattinson now and discuss your requirements

#### Crofton Electronics Ltd.

35 Grosvenor Road,  
 Twickenham, Middlesex  
 Tel. 01-891 1923 (8211)

### RADIO OPERATED REMOTE CONTROL SYSTEMS

(Home Office approval)

Range up to 50 mtrs

We welcome inquiries for your particular application.

**R.D. ELECTRONICS**  
 112 High Street, Barry  
 South Glamorgan CF6 8DT  
 Tel: Barry 739653 (82811)

**PRECISION SHEET METAL** work, chassis, panels, etc., steel, stainless or aluminium, long/short runs, good deliveries. EES Ltd., Clifford Rd Monks Road, Exeter 56280 36489 (8060)

**CIRCUIT DESIGN** and prototype construction. Instrumentation, test rigs, production run designs to your requirements. Professional audio, analogue, digital, SC/MP microprocessor circuits our specialties. **HAMILL ELECTRONICS LTD.**, Box BCM-2090, London WC1V 6XX. Tel.: 01-542 9203. (7984)

**CIRCUIT DESIGN**, development and prototype construction. Analogue/digital. Offers for existing instrumentation designs. List available. Also PCB assembly and wiring to sample. Box No. WW 8235. (8235)

**SIGNAL** Generators, Oscilloscopes, Output Meters, Wave Voltmeters, Frequency Meters, Multi-range Meter, etc., in stock. R. T. & I. Electronics Ltd, Ashville Old Hall, Ashville Rd., London, E.11. Ley 4986. (64)

## CAPACITY AVAILABLE

### Specialised PCB Service

Layouts - Photography - Drilling  
 Roller Tinning - Gold Plating  
 Legend Printing - Profiling  
 Special quick prototype service

**Crofton Electronics Limited**  
 35 Grosvenor Road, Twickenham  
 Middlesex - Tel. 01-891 1923

8210

### ELECTRONIC ASSEMBLY AND WIRING CAPACITY AVAILABLE

M.O.D. approved

**J.N. Electronic Supplies**  
 Osiers Road, London, SW18  
 Tel. 01-874 6162 (7417)

**AIRTRONICS LTD.** for coil winding Large or small production runs. Bobbin - Layer - Wave - Bifilar - Miniature Toroidals, Airtronics Limited, Gardner Industrial Estate, Kent House Lane, Beckenham, Kent BR3 1UG. Tel. 01-659 1147. (7158)

**BATCH** Production Wiring and Assembly to sample or drawings. McDeane Electricals, 19B Station Parade, Ealing Common, London, W.5. Tel: 01-992 8976. (7531)

**SMALL BATCH PRODUCTIONS** wiring assembly to sample or drawings. Specialist in printed circuits assembly. Rock Electronics, 42 Bishopsfield, Harlow, Essex. 0279 33018. (7674)

**PRINTED CIRCUITS.** Ultra fast turnaround. Very competitive prices paper or glass. Punched or drilled. Single or double sided. Also prototypes, artwork, photography. Kibmore Circuits Ltd., 120 Garlands Road, Redhill, Surrey RH1 6NZ. Phone Redhill 68850. (7283)

**PRINTED CIRCUITS.** Screen printed boards from your artwork. Small batches or Prototypes. Also complete Artwork Service. Winston Promotions, 9 Hatton Place, London EC1N 8RU. 01-405 0960. (8040)

### I.M.S. SYSTEMS

Due to expansion of our manufacturing facilities we are able to undertake assembly and testing of circuit boards or complete units in addition to contract development

We can produce, test and calibrate to a high standard digital analogue and RF equipment in batches of 10s to thousands

Telephone to arrange for one of our engineers to call and discuss your requirements, or send full details for a prompt quotation

**TEL: 01-253 4562**

or reply to Box No. WW 8237 (8237)

**A COMPLETE** and efficient PCB Service from layout through to assembly. Incorporating quality reliability and price. No order too large or too small. Also mechanical detailing is undertaken. For details and free estimates please contact: J. S. Roberts on 01-553 2577 H.R.C. Artwork Design, 45 High Street, Maldon, Essex. (7731)

**PRINTED CIRCUIT ASSEMBLY.** Assembly services to customer specification. Also, design, layout and wiring service available. A. E. Electronics, 4-6 Sandy Lane, Stockton Heath, Warrington WA4 2AY. Tel. 0925-68339. (7912)

**PRINTED CIRCUITS BOARDS.** Quick deliveries, competitive prices. Quotations on request, roller tinning, drilling, etc. Speciality small batches. Larger quantities available. Jamison Automatic Ltd., 1-5 Westgate, Bridlington, North Humberside. For the attention of J. Harrison (0262) 74738 or 77877. (8114)

**PCB ARTWORK DESIGN SERVICE** with component notation masters and assembly drawings. PADS Electrical Ltd, 01-850 6516, 45 Southwood Road, New Eltham SE9. (7905)

**YOUNG, EXPANDING** electronics company invites orders for electronic design/assembly and transformer production. SEI Electronics, 109 Southbridge Road, Croydon. Tel. 01-688 0385. Telex 21879 for SEIGB. (8262)

## RECEIVERS AND AMPLIFIERS —

**HRO** Rx5s, etc. AR88, CR100, BRT400 G209, S640, etc., etc. in stock. R. T. & I. Electronics, Ltd, Ashville Old Hall, Ashville Rd., London, E11. Ley 4986. (65)

**SIGNAL** Generators, Oscilloscopes, Output Meters, Wave Voltmeters, Frequency Meters, Multi-range Meter, etc., in stock. R. T. & I. Electronics Ltd, Ashville Old Hall, Ashville Rd., London, E.11. Ley 4986. (64)

# CLASSIFIED ADVERTISEMENTS

## Use this Form for your Sales and Wants

To "Wireless World" Classified Advertisement Dept., Dorset House, Stamford Street, London, SE1 9LU

PLEASE INSERT THE ADVERTISEMENT INDICATED ON FORM BELOW

- Rate £1.10 PER LINE. Average six words per line. Minimum THREE lines.
- Name and address to be included in charge if used in advertisement.
- Box No. Allow two words plus 50p.
- Cheques, etc., payable to "Wireless World" and crossed "& Co"

NAME.....

ADDRESS .....

REMITTANCE VALUE..... ENCLOSED

PLEASE WRITE IN BLOCK LETTERS. CLASSIFICATION..... NUMBER OF INSERTIONS.....

# I.C.E. MULTIMETERS

## TWICE the information in HALF the size

The I.C.E. range of multimeters provides an unrivalled combination of maximum performance within minimum dimensions, at a truly low cost. Plus, a complete range of add-on accessories for more ranges, more functions.

All I.C.E. multimeters are supplied complete with unbreakable plastic carrying case, test leads, etc., and a 50-plus page, fully detailed and illustrated Operating and Maintenance Manual.

Now available from selected stockists. Write of phone for list, or for details of direct mail-order service

### Supertester 680R (illustrated)

20k $\Omega$ /V,  $\pm$ 1% fsd on d.c.  
4k $\Omega$ /V,  $\pm$ 2% fsd on a.c.  
80 Ranges — 10 Functions  
140 x 105 x 55mm

**£32.00 + VAT**  
(For Mail Order add 80p P&P)

### Supertester 680G

20k $\Omega$ /V,  $\pm$ 2% fsd on d.c.  
4k $\Omega$ /V,  $\pm$ 2% fsd on a.c.  
48 Ranges — 10 Functions  
109 x 113 x 37mm

**£24.50 + VAT**  
(For Mail Order add 80p P&P)

### Microtest 80

20k $\Omega$ /V,  $\pm$ 2% fsd on d.c.  
4k $\Omega$ /V,  $\pm$ 2% fsd on a.c.  
40 Ranges — 8 Functions  
\*Complete with case — only 93 x 95 x 23mm

**£16.60 + VAT**  
(For Mail Order add 80p P&P)

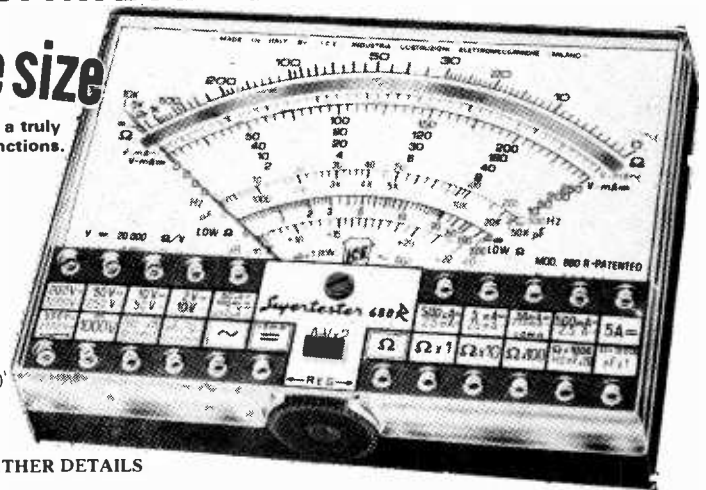

Electronic Brokers Ltd.  
49-53 Pancras Road, London NW1 2QB  
Tel. 01-837 7781

WW — 091 FOR FURTHER DETAILS

## INDEX TO ADVERTISERS

Appointments Vacant Advertisements appear on pages 129 - 143

	PAGE		PAGE		PAGE
Acoustical Mfg. Co.	17	Hall Electronics Ltd.	2	Patrick, J. B.	114
AEL Crystals Ltd.	20	Harmsworth Townley & Co. Ltd.	33	Pelco	125
A. H. Supplies	96	Harris Electronics (London) Ltd.	16, 26	Physical & Elec. Labs. Ltd.	95
Ambit International	94	Hart Electronics	96	Powertran Electronics	104, 105
Aspen-Electronics Ltd.	35	Icon Designs	6	Precision Petite Ltd.	92
Astra-Pak	110	ILP Electronics Ltd.	109	Pye Telecommunications Ltd.	5
Audix Ltd.	82	Industrial Tape Applications	93	Pye Unicam Ltd.	Cover iii
Barrie Electronics Ltd.	103	Integrex Ltd.	98, 99	Quality Electronics	110
Bayliss, A. D. & Sons Ltd.	14	Interface Quartz Devices Ltd.	29	Racal Thermionic	21
Bell & Howell	24, 25	ITT Components (Multilayer)	22	Radford Audio Ltd.	33
Bentley Acoustic Corp. Ltd.	114	ITT Components (Resistors)	26	Radio Components Specialists	102
Beyer Dynamics (GB) Ltd.	10	ITT Instrument Services	112	Radio Shack Ltd.	103
BIB Hi-Fi Accessories (Multicore Solders Ltd.)	Cover iv	JPS Associates	34	Ralfe P. Electronics	100
Bi-Pak Semiconductors Ltd.	127	K. & A. Distributors	126	R.C.S. Electronics	20
Boss Industrial Mouldings Ltd.	23	Keithley Instruments Ltd.	82	R.S.T. Valves Ltd.	101
Bull, J.	115	Labgear Ltd.	34	RTVC	113
Cambridge Learning	13	Langrex Supplies Ltd.	101	Sandwell Plant Ltd.	111
Carter Associates	92	Ledon Instruments Ltd.	35	Samsons (Electronics)	110
Catronics	103	Leeds University	114	Science of Cambridge	71
CEC Corporation	14	Leavers-Rich Equipment Ltd.	16	Scopex Instruments Ltd.	112
Charcoft Electronics	34	Levell Electronics Ltd.	3	Service Trading Co.	124
Chiltmead Ltd.	116, 117	Lion House	94	Servo & Elec. Sales Ltd.	110
Chromasonic Electronics	20	L.P. Enterprises	107	Shure Electronics Ltd.	91
Colomor (Electronics) Ltd.	108	McKnight Crystals	141	Sintel	97, 116
Commercial Trade Travel	128	MacDonald & Janes	81	Sintrom Electronics Ltd.	25
C. N. Stevenson	100	MacInnes Laboratories Ltd.	16	SME Ltd.	19
Continental Specialities Corp.	72	Magnum Audio Ltd.	33, 35	Sonic Hi-Fi Discount	118
Crellon (RCA)	15	Main Line (Crellon)	11	Sonic Sound Audio	111
Crimson Elektrik	29	Maplin Electronic Supplies	7	Southern Electronics	96
Datong Electronics Ltd.	92	Marconi Instruments Ltd	Cover ii	Southwest Technical Prods. Ltd.	28
Doram Electronics	4	Marshall, A. (London) Ltd.	108	Sower, E. A.	140
D. P. Supplies	126	Martin Associates	118	Special Products Ltd.	33
Eagle International	13	Micronics	125	Strumech Engineering Ltd.	12
Eddystone Radio Ltd.	126	Middle East Electronics	32	Sugden, J. E. & Co. Ltd.	34
E.L. Instruments	95	Milward, G. F.	126	Surrey Electronics Ltd.	122
Electronic Brokers Ltd.	119, 120, 121, 144	Modern Books, The	140	Swanley Electronics Ltd.	110
Electronic Brokers Ltd. (Second User Computer)	123	Neal Ferrograph	31	Technomatic Ltd.	122
Farnell Instruments Ltd.	Readers Card, 22	Newbear, The Computer Store	94, 116	T. Powell	111
Faircrest Eng. Ltd.	111	Nexus/Click	111	Television	118
Fairchild Semiconductor Ltd.	9	Olson Electronics Ltd.	10	Trampus Electronics	122
Ferranti Dundee	8	OMB Electronics	35	Vero Electronics Ltd.	26
Future Film Developments	92	Overseas Advertisement Agents:		Vision Kits	125
Fylde Electronic Labs. Ltd.	22	Hungary: Mrs. Edit Bajusz, Hungexpo Advertising Agency, Budapest XIV, Varosliget Telephone: 225 008 — Telex: Budapest 22-4525. INTFOIRE.		West Hyde Developments Ltd.	106
Gould Advance	36	Italy: Sig. C. Epis, Etas-Kompass, S.p.a. — Servizio Estero, Via Mantegna 6, 20154 Milan. Telephone: 347051 — Telex: 37342 Kompass.		Wilmot Breeden Electronics Ltd.	18
Greenway Elec. Ltd.	95	Japan: Mr. Inatsuki, Trade Media — IBPA (Japan), B.212, Azabu Heights, 1-5-10 Roppongi, Minato-ku, Tokyo 106. Telephone: (03) 585-0581.		Wilmslow Audio	30
Greenwood Electronics	27, 29	United States of America: Ray Barnes, IPC Business Press, 205 East 42nd Street, New York, NY 10017 — Telephone: (212) 689 5961 — Telex 421710. Mr. Jack Farley Jnr., The Farley Co. Suite 1584, 35 East Wacker Drive, Chicago, Illinois 60601 — Telephone: (312) 6 3074. Mr. Richard Sands, Scott, Marshall, Sands & Latta Inc., 5th Floor, 85 Post Street, San Francisco, California 94104 — Telephone: (415) 421 7950 — Telephone Dascotcco, San Francisco. Mr. William Marshall, Scott, Marshall, Sands & Latta Inc., 1830 West Eighth Street, Los Angeles, California 90057 — Telephone: (213) 382 6346 — Telegrams Dascotcco, Los Angeles.		Z. & I. Aero Services Ltd.	20, 27, 95

Mr Jack Mentel, The Farley Co., Suite 650, Ranna Building, Cleveland, Ohio 4415 — Telephone: (216) 621 1919  
Mr Ray Rickles, Ray Rickles & Co., P.O. Box 2008, Miami Beach, Florida 33140 — Telephone: (305) 532 7301  
Mr Jim Parks, Ray Rickles & Co., 3116 Maple Drive N.E., Atlanta, Georgia 30305 Telephone: (404) 237 7432  
Mike Loughlin, IPC Business Press, 15055 Memorial, Ste 119, Houston, Texas 77079 — Telephone: (713) 783 8673

Canada: Mr. Colin H. MacCulloch, International Advertising Consultants Ltd., 915 Carlton Tower, 2 Carlton Street, Toronto 2 — Telephone: (416) 364 2269

\*Also subscription agents.

# The Ultimate Multi-mate

## What other DMM offers all this for £127?

It's easy to see why Philips new PM 2517 digital multimeter is called The Ultimate Multi-mate. No other DMM comes anywhere near its

combination of laboratory performance and handy form - for such a handy price. Take a look at some of the features it packs in.

**Full 4-digit display** giving higher resolution than 3½ digits for 80% of measurements. Parameter readout, too.

**Small and sturdy construction** makes this DMM ideal for bench or field work.

**Choice of LED or LCD display** - choose the one that suits you, the price is the same. Mains unit supplied free with LED version.

**Ergonomic design** allows it to work in any position without fuss or fumble.

**Autorangeing** with manual override. Average auto response time less than two seconds.

**True RMS** rather than "average" detection. The Ultimate Multi-mate measures non-sinewave AC signals more accurately.

**High accuracy** - necessary to make full use of those four digits. An impressive 0.2% of reading  $\pm 0.05\%$  of scale on d.c. volts.

**Current to 10A** via a separate input is standard, not optional, on the PM 2517.

**Overload protection** that is so comprehensive you have to try very hard to do any damage, even with mains and TV booster voltages.

**Low-cost temperature option** makes possible measurement from  $-60$  to  $+200^{\circ}\text{C}$ .

**Data hold option** means that in tricky situations you can "freeze" measurements for increased operator safety and convenience.

**Built to international standards** - you name them and the PM 2517 meets them. But what else would you expect from an international company like Philips?



**The no-compromise 4-digit instrument**

The Ultimate Multi-mate is available from Wessex Electronics Ltd., 114 - 116 North Street, Downend, Bristol BS16 5SE. Tel: (0272) 571404; Rank Radio International, Watton Road, Ware, Herts. (Tel: Ware 3966); and Philips

Service Centres (phone 01-686-0505 for the address of your nearest branch).

It can also be purchased from the U.K. marketing organisation -



**Pye Unicam Ltd**

Philips Electronic Instruments Dept  
York Street, Cambridge, England CB1 2PX  
Tel. Cambridge (0223) 58866 Telex: 817331



**Test & Measuring Instruments**

# PHILIPS



# gets it together...

**Toolbox Reels**  
Three solders that cover all your electrical applications.  
40/60 Tin/Lead 16SWG size 3 £2.16 each  
60/40 Tin/Lead 22SWG size 10 £2.38 each  
Savbit Alloy 18SWG size 12 £2.29 each

**Handy Dispensers**  
Size 19A All electrical work 63p  
Size PC115 For small components 69p  
Size SV130 Use with copper bits and wires £1.08p  
Size AR140 Metal repairs 86p  
Size AL150 Aluminium 76p  
Size SS160 Stainless Steel £1.08p

**Savbit Dispenser**  
Contains Ersin Multicore Savbit solder which increases life of copper bits by 10 times.  
**Size 5 58p**

**Solder Cream**  
For jointing most metals. Easy to use and ideal where solder wire cannot penetrate.  
Size BCR 10 For electrical use. £1.08  
Size BCA 14 For metal joints. £1.08  
Size BCA 16 Tin/Silver (lead free) £1.38

**Economy Pack**  
This convenient dispenser contains enough general purpose solder for about 200 average joints. Suitable for all electrical work.  
**Size 6 37p**

# ... Bib keeps it playing

**Cassette Editing & Splicing Kit**  
Make editing simple with Bib splicer, tape cutters, tape piercer, splicing tape and tape winder/remover. Patent Pending Splicer.  
British Pat. No. 1258280 (Method of Splicing)  
**Ref 98 £2.48**

**Universal Tape Head Maintenance Kit**  
Includes everything necessary for cleaning heads, capstan and pinchwheel on all types of recorders.  
**Ref 99 £2.48**

**Bib Groov-Stat Static Reducer**  
Neutralises in seconds the static charge that attracts harmful dust to record surfaces. Safe and simple to use.  
**Ref 100A £5.98**

**1/4" Tape Care Kit**  
Combined editing/splicing/cleaning kit with splicer, tape cutters, marker, cleaning fluid.  
**Ref 111 £3.49**

**Bib Groov-Kleen**  
Supplied with two bases to suit all modern single play decks, the Bib Groov-Kleen cleans records while they play.  
**Ref 2000S/P £3.48** Reg Des No. 967842

Send S.A.E. for free copy of colour catalogue detailing complete range.  
**Bib Hi-Fi Accessories Limited,**  
Kelsey House, Wood Lane End,  
Hemel Hempstead, Herts., HP2 4RQ.

All prices shown are recommended retail, inc VAT