

JUNE, 1927

25 CENTS

RADIO

(REG. U. S. PATENT OFF.)

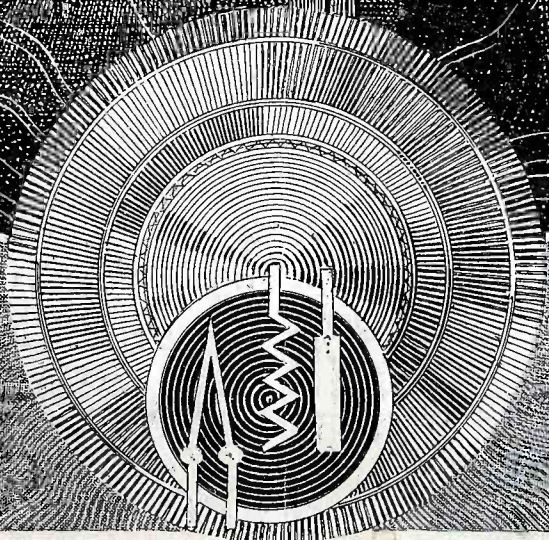

Cunningham

RADIO TUBES

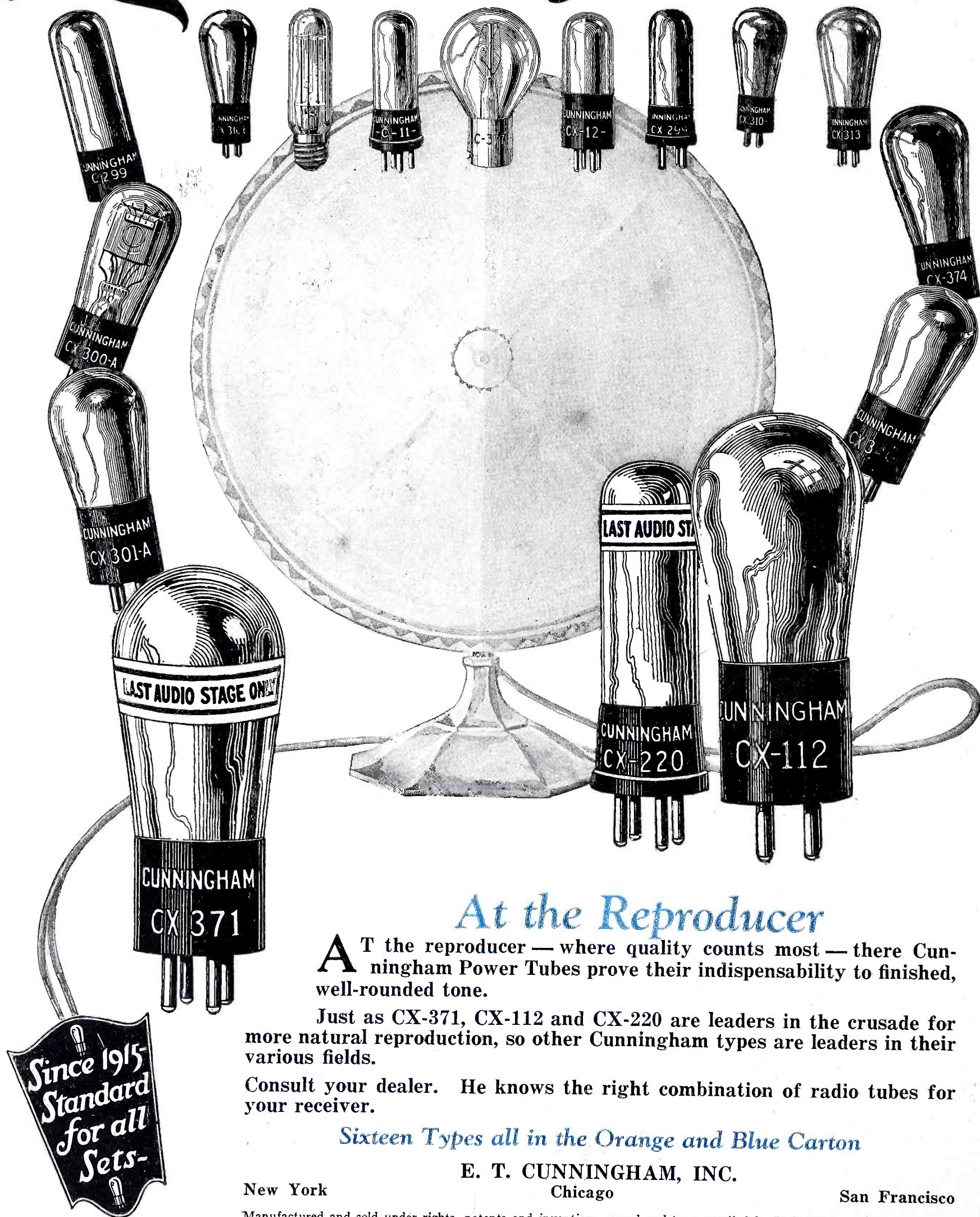

At the Reproducer

AT the reproducer — where quality counts most — there Cunningham Power Tubes prove their indispensability to finished, well-rounded tone.

Just as CX-371, CX-112 and CX-220 are leaders in the crusade for more natural reproduction, so other Cunningham types are leaders in their various fields.

Consult your dealer. He knows the right combination of radio tubes for your receiver.

Sixteen Types all in the Orange and Blue Carton

E. T. CUNNINGHAM, INC.

New York

Chicago

San Francisco

Manufactured and sold under rights, patents and inventions owned and/or controlled by Radio Corporation of America.

Since 1915
Standard
for all
Sets-



Tower

A^{and}B POWER UNITS

EVERYONE realizes that ultimately the radio set will be operated directly from the house current — just as the Washing Machine, Toaster or Vacuum Cleaner.

Almost every radio manufacturer has been experimenting with Power Units. But it remained for TOWER definitely to establish a new standard in electric light socket operation — at lowest prices consistent with maximum quality.

Coming, in next month's issue, full particulars regarding TOWER Power Units.

TOWER MFG. CORP. Boston, Mass.

RADIO

With Which Is Incorporated "Radio Journal"

Established 1917

Published Monthly by the Pacific Radio Publishing Co.

ARTHUR H. HALLORAN,
Editor

GERALD M. BEST,
Technical Editor

H. W. DICKOW,
Business Manager

A. I. RIVETT,
Draughtsman

Branch Offices:

New York City, 20 East 42nd St.
Chicago, 307 N. Michigan Ave.
Boston, 86 St. Botolph St.
Kansas City, Mo., Davies & Dil-
lon, 707 Land Bank Bldg.

Rates:

Issued Monthly, 25c a copy.
Subscription price, \$2.50 per year
in the U. S., \$3.00 per year else-
where.

Correct Addresses:

Instructions for change of address
should be sent to the publisher
two weeks before the date they
are to go into effect. Each old
and new addresses must always
be given.

Advertising:

Advertising Forms Close on the
First of the Month Preceding
Date of Issue.

Member Radio Magazine Publishers' Association
Entered as second-class matter at Post Office at San Francisco, Calif.
Copyright 1927 by the Pacific Radio Publishing Co.

Address all communications to

Pacific Radio Publishing Company

Pacific Building, San Francisco, California

VOLUME IX

JUNE, 1927

NUMBER 6

Forecast of Contributions for July Issue

Of all places that will interest a radio enthusiast this June, none has more attractions than Chicago. Here, during the convention of the Radio Manufacturers Association, are to be exhibited the new things in radio which will be put on sale next Fall. Here will be radio as the user will know it next year.

But this is a trade show, not a consumer exhibition. Admission is granted only to the trade. Contrary to the usual radio show, the public is not invited. The purpose is to acquaint the seller of radios with all that is new in the art. He can compare and decide upon the lines which in his judgment will have the greatest appeal to the buying public.

Yet the public is also intensely interested. Sensing this interest the editors of RADIO are devoting the July issue to illustrated descriptions of all the new ideas brought out at the R. M. A. show. Thus by pictures and text the user will be informed concerning those things which many jobbers and dealers are traveling thousands of miles to see.

Efforts to secure this information have been under way for months. Every large manufacturer has promised to give full details regarding his new products. Our representatives will be on the ground to report new and unanticipated developments. The first complete record of all that is shown and all that transpires will be published within a few days after the show closes.

The July issue is a forecast of 1928 radio. It pictures and describes in advance what will be seen at the radio shows next Fall. It will be the largest single issue of this magazine which has yet been published. It will interest not only the consumer but also such of the trade as is unable to get to Chicago in person.

More worth-while changes in radio design are in store this season than ever before. Although they involve no radical circuit innovations, they represent refinements which give greater efficiency and convenience in operating, greater selectivity, and better tone quality. Nor is beauty in design overlooked.

The constructional details and operating functions of all these new devices are to be revealed and interpreted in the first annual "Premier Display of Next Season's Models" which is the motif of July RADIO. This gives the user all that he looks for in a trade magazine, together with an analysis and explanation that the trade papers take for granted.

CONTENTS

	PAGE
RADIOTORIAL COMMENT	7
DIRECTION FINDERS FOR MAIL PLANES	8
By D. R. Lane	
PROGRESS IN TELEVISION	10
By Arthur Hobart	
A NEW "ABC" SOCKET POWER	11
By G. M. Best	
MULTI-VALVE SYSTEMS	13
By Manfred von Ardenne	
WHY THE GRID LEAK?	14
By J. B. Dow	
EXPERIMENTAL SHOP METHODS	15
By Samuel G. McMeen	
TIME CONVERSION CHART	16
By Arthur Hobart	
DX LOVE	17
By Armstrong Perry	
THE PORTABLE CONDENSER MICROPHONE	18
By Alexander L. Sherwood	
A RADIO IN THE PHONOGRAPH CABINET	19
By I. M. Ingerson	
WHAT IS THE RANGE OF A BROADCAST STATION?	21
By C. W. Morris	
LETTERS FROM LARRY	22
By Jack Bront	
A LABORATORY TRANSMITTER FOR SHORT WAVES	23
By Everett W. Thatcher	
HANDY HINTS	24
By C. F. Felstead	
A. C. MEASUREMENTS WITH A WATTMETER	25
By Harry R. Lubcke	
RADIO STANDARDS	26
QUERIES AND REPLIES	29
THE COMMERCIAL BRASS-POUNDER	31
WITH THE AMATEUR OPERATORS	34
CALLS HEARD	35
TEMPORARY BROADCAST WAVELENGTH ALLOCATIONS	53
FROM THE RADIO MANUFACTURERS	57

Gerald M. Best Raytheon A-B-C- Socket Power Electric Receiver

Built exclusively with

RAYTHEON MANUFACTURING COMPANY
MAKERS OF RELIABLE RECTIFIERS
KENDALL SQUARE BUILDING
CAMBRIDGE, MASS.

March 31, 1927

Aerovox Wireless Corporation
70 Washington Street
Brooklyn, New York

Attention of Mr. S. I. Cole

Gentlemen:

From time to time our laboratory has made careful and constructive tests on the condensers manufactured by your company for use with our type "B" rectifier in B-Power Supply Units, for use with the "BH" rectifier in B-Power Supply Units and in "A-B-C" Units using both the "BH" and "BA" 350 milliamper rectifier.

The performance of these condensers has been entirely satisfactory when used in these circuits and the actual measured capacitance has not varied from the rated value more than three percent.

The non-inductive type of construction used in your condensers is highly recommended for these circuits as our tests show filter circuits using this non-inductive type of capacitance to have greater efficiency for a given number of microfarads used.

Manufacturers of high quality B-Power Units have realized that an adequate safety factor in condenser construction is essential for continuous satisfactory service and your efforts to develop a high quality condenser will undoubtedly react to the mutual benefit of those now interested in the socket power field.

From the results of our tests we are glad to recommend your condensers to manufacturers interested in the development of quality B-Power Units.

Sincerely yours,

RAYTHEON MANUFACTURING COMPANY

By

D. E. Replogle

D. E. Replogle
Sales Engineer

DER:AV

CABLE ADDRESS, RAYTHMANCO

AEROVOX

"Built Better"

Filter Condensers

One Filter Block	C-4-8-8-1-1-1	
Type Number	400 VDC	200 VDC
ABC 421	Working Voltage	Working Voltage
Price	\$26.00	

One Buffer Condenser	.1-C-.1
Type Number 646	600 VDC
(Connected in series)	Working Voltage
Price	\$2.00

If your dealer has not yet stocked these, we will send them to you upon receipt of money order accompanied by your dealer's name.

AEROVOX

70 Washington Street • Brooklyn, N. Y.

Now You can Build have Always

IT IS ONLY three or four short years ago that the mere fact that one could hear a squeaky voice or a few notes of tin-panny music from "out of the air" was so marvelous that thousands rushed to buy the radio receivers of that day.

But those days are gone forever. Our radio is no longer just a magic plaything. Whether we buy our set, or prefer the fascinating pastime of building our own, we now demand that the radio receiver of today be a satisfactory means of entertainment.

This change in public viewpoint and other changing conditions, like the multiplication of broadcasting stations and the greatly increased power of many of them, have brought forth new problems to be solved and set up a new standard of requirements for the modern radio receiver.

First, the quality of reproduction must be unblemished. The tonal quality must be true and harmonious with all overtones and harmonics present—an actual re-creation of the selection broadcast.

Second, it must possess the quality of selectivity in a satisfying degree, especially when operated close to a powerful broadcasting station. Nothing is more distressing when listening to a distant program you want to hear than to

have a local station always breaking thru in the background.

Third, the receiver must be capable of producing the maximum volume desired without the slightest trace of distortion. This volume must be smoothly adjustable down to the faintest whisper, to suit the operator's mood or the occasion.

Fourth, while most people are satisfied at first to listen to the programs of nearby stations, it is seldom long before the average user is dissatisfied with a receiver on which he is limited to local programs. Therefore our ideal receiver must have distance-getting ability.

Fifth, a high degree of amplification must be obtained on all wavelengths, and not at only the lower wavelengths, as with so many of the ordinary variety of receivers.

Sixth, the ease of tuning should be in accord with the idea that any member of the family, from the six year old to the grandfather, should be able to tune in most stations without the slightest semblance of trouble.

Seventh, the circuit must be of such design that there will be no manifestation of what is commonly known as oscillations: unearthly squealing and howling noises that so often upset the peace of a neighborhood.

That's the kind of a radio receiver you and I have always wanted!

Now it doesn't take much heavy thinking to come to the conclusion that such a set would be the product of:

- (a) a powerful, selective and distortionless radio frequency amplifier,
- (b) a distortionless audio amplifier,
- (c) efficient tubes, proper plate voltages, and a good loud speaker.

Wonderful steps have been made this last year in audio amplification. The new audio transformers now available, the much improved design of resistance and impedance coupled amplifiers, or the remarkable double impedance Truphonic, together with the new amplifier tubes that have been developed solve one part of our problem in designing the radio receiver we have always wanted. Loud speakers, while still far from perfect, have been improved to a remarkable degree. Good B eliminators are now available to give us proper and constant plate voltages.

There remains but the problem of a powerful, selective and distortionless radio frequency amplifier.



Tell them that you saw it in RADIO

the Radio You Wanted

AND NOW I come to the point I have been leading up to. Recent laboratory developments make it possible to have just such a radio frequency amplifier, and better still you can easily install it in place of the less efficient one now in your present set.

Unfortunately, I haven't the space here to tell you the story of the development of the Quadraformer system of tuned radio frequency amplification. Invented nearly five years ago, it has been the subject of ceaseless laboratory experimentation.

Two models of Quadraformer radio frequency transformers have been made available to the radio fan in the last two years and remarkable results in comparison with other coils were obtained by their use.

Now we introduce to you the perfected *shielded* Quadraformers in the form of an Essential Kit which contains all the parts necessary to install the Quadraformer system in any existing tuned radio frequency type of receiver that uses 17 or 21 plate tuning condensers; or with the Essential Kit and a few other standard parts you can build the QUADRAFORMER VI, an unusually efficient six tube, two-dial receiver designed by Edward A. Schlueter and fully described in our Instruction Book.

GEARHART-SCHLUETER RADIO CORP'N
1719-21 VAN NESS AVENUE, FRESNO, CALIFORNIA

NO MATTER whether you want to improve a set you now have or build a new one—to describe what the Quadraformers will do for you would only seem like the greatest exaggeration to you—until you have heard it play.

So we'll let *facts* talk — not type. Any one can *claim* things, but facts can't be duplicated overnight by any little fakir.

Order a Quadraformer Essential Kit on the special *on approval* coupon in the corner. And if you're not MORE than pleased with the results you get, you get your money back. That's fair, isn't it?

Order From Your Dealer or Direct FROM US

Quadraformer parts are carried in stock by reliable dealers in most cities. If your dealer happens to be out of stock you may order direct from us by using the coupon to the right. Send no money. Just pay the postman the price of the parts plus a few cents postage.

Inside Facts on the New Quadraformer Coils

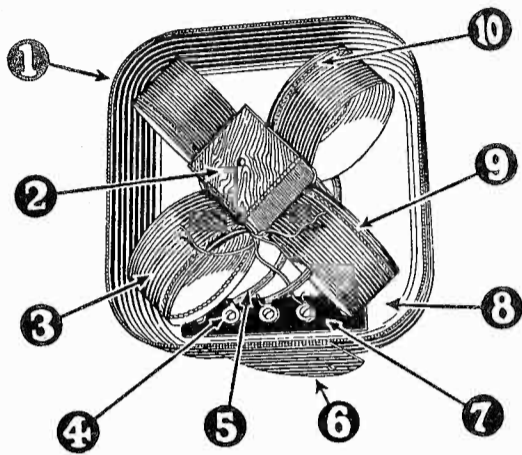

1. A scientifically designed shield against impact reception and electrostatic coupling. Heavy drawn copper, handsomely finished in natural copper lacquer, trimmed in gold.
2. The Quadraformer coil sections are self-supporting, being mounted on a single central insulating block. This gives the lowest possible dielectric losses and the least insulating material in the field. It is the elimination of just such losses in the new *Quadraformer* coils that keep the high frequency resistance at a minimum, securing increased selectivity, volume and natural tone quality.
3. This shows one of the four windings making up the complete secondary. Special triple insulated heavy copper (No. 28) magnet wire is now used in both primaries and secondaries. The extra heavy insulation separates the turns more than is usual and reduces the inter-turn capacity greatly. The resulting complete transformer has the highest inductance combined with the lowest distributed capacity of any closed magnetic field coil.
4. All connections between the windings and the terminal binding posts are first securely fastened mechanically and then firmly soldered, using rosin flux, for permanency.
5. All primary leads, which carry the B battery voltage, are protected by genuine Italian flame-proof varnished insulating—the highest grade "spaghetti" that can be bought.
6. The mounting bracket is of sturdy construction and holds the completed transformer firmly in place on baseboard or sub-panel.
7. The binding post terminal strips are genuine Celoron.
8. An accurate laboratory determined air-space separates the Quadraformer windings at all points from the shield. All interstage Transformers are accurately matched on a master oscillator and packed in matched pairs for most efficient operation with dual condensers.
9. The primaries are now wound with the same heavy wire used in the secondaries. The primary windings will stand a load of 3 amperes without heating, and are *positively guaranteed not to burn out*.
10. A heavy insulating string separates each primary winding from its associated secondary winding, eliminating the bad effects (broad tuning, for one) of the capacity coupling between primary and secondary present in most transformers. It is also a further guaranty against burn-outs.

GEARHART-SCHLUETER RADIO CORP'N
1719-21 Van Ness Ave., Fresno, California.

Please send me the new Quadraformer Essential Kit, containing the three shielded Quadraformers; the Selectivity Control; the Amplitrol; and complete Instruction Book, for which I will deposit with the postman \$17.50, plus postage, upon delivery. It is understood that if I am not MORE than pleased with this purchase that I have the privilege of returning this kit in salable condition within 30 days and you will refund my money.

NAME

ADDRESS.....

CITY STATE.....

(Send cash with order and we will ship prepaid)

Tell them that you saw it in RADIO



New!

*You don't have to be
water boy to this
battery charger*

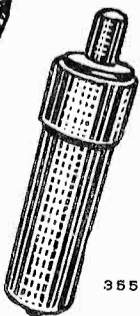
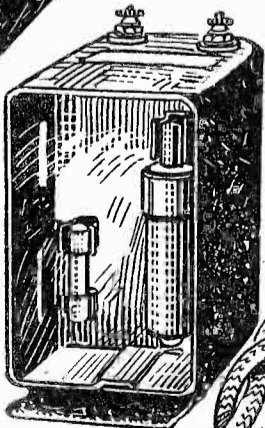
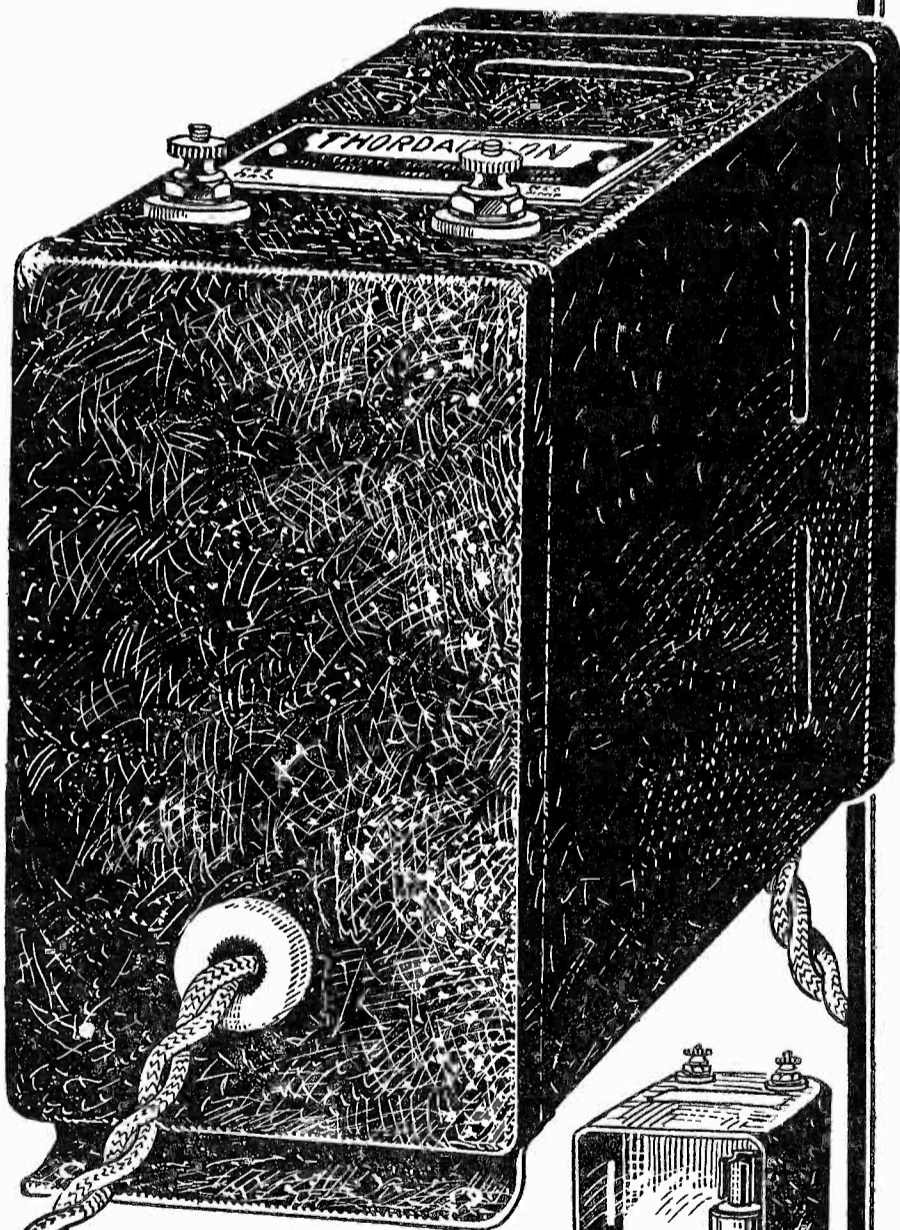

The Thordarson Battery Charger R-175 employs the Raytheon Rectifying Cartridge guaranteed as above.

3555

THORDARSON BATTERY CHARGER R-175

Radically new,—sound in principle,—proven in performance.

The Thordarson Battery Charger makes its bow as a welcome relief to the army of butlers to thirsty battery chargers.

Dry—As dry as they make 'em. In fact the rectifying element is contained in a moisture proof cartridge.

Silent—No vibrating parts. Current is rectified through a patented electro-chemical process.

Safe—There is no hazard to rugs or woodwork for there is no acid to spill. The tubes of the set are safe even if turned on when charger is in operation.

Compact—Fits into battery compartment easily. Only 2¾" wide, 5¾" long and 4¾" high, overall.

Efficient—This charger is always ready for service. No overhauling required. Rectifying element can be replaced in thirty seconds.

Guaranteed—The rectifying unit is guaranteed for 1,000 hours full load operation, or approximately one year's normal service. The Transformer will last indefinitely.

Charging Rate 2 amperes

*For Sale at Good Dealers Everywhere
or direct from factory*

Price Complete \$12.50

THORDARSON ELECTRIC MANUFACTURING CO.
Transformer Specialists Since 1895
WORLD'S OLDEST AND LARGEST EXCLUSIVE TRANSFORMER MAKERS
Thuron and Kingsbury Streets — Chicago, Ill. U.S.A.

RADIO

WITH WHICH IS INCORPORATED "RADIO JOURNAL"

VOLUME IX

JUNE, 1927

No. 6

Radiatorial Comment

The informed observer of some of the methods used in merchandising radio devices cannot but conclude that misrepresentation is being used in selling some of them. Usually this misrepresentation is by veiled inference, which creates undue expectation of performance, rather than by direct false statement. Although careful analysis may fail to reveal any single untruth, yet the un-informed person is led to expect results of which the device is incapable.

The Evils of Misrepresentation

Such a criticism is a severe indictment of an industry that allows this evil to continue. It calls for either a rebuttal or a house-cleaning. Otherwise the entire industry will lose the confidence of the public because a few have betrayed their trust. The legitimate manufacturer, jobber or dealer, who may be guiltless of this practice, suffers from the actions of those who do not strictly abide by the truth. That this criticism is not unfounded may be indicated by the citation of a few cases.

The most frequent trick in this game of fooling the public is the sale of obsolete apparatus without a qualifying statement as to its limitations. A department store recently advertised a well-known radio receiver at fifty per cent off its list price. This set was made two years ago. It was not selective enough to separate local stations. It would not tune below 250 meters. Hundreds of these sets were returned by dissatisfied users. Yet the store continued to advertise and sell them without warning as to their deficiencies.

Another favorite catch-penny employed by the unscrupulous is the trick aerial or ground. While it must be conceded that the inventor or maker may have been as ignorant of the principles which govern radio reception as were the purchasers of this equipment, this does not absolve him from blame after he has been shown that his claims are false. Nor does the law regard ignorance as innocence.

Trick Aerials And Grounds

We have yet to be shown that any patent receiving aerial is more efficient than a single length of stranded wire properly installed. The Signal Corps and the amateurs have found that the same is true as regards transmitting aerials, especially for short wavelengths.

Much the same comment applies to various freak grounds that have been proposed as substitutes for a counterpoise or a soldered water-pipe ground. One of these devices has been found to be but slightly better than no ground whatsoever. The effectiveness of a ground is largely dependent upon its area of exposure to the soil and also upon the dampness of the earth. A ground having small exposure to dry earth cannot give signals as loud as one having large exposure to damp earth.

The favorite bait for the unwary dollar is the static eliminator. Although warnings as to the uselessness of these devices, unless some such elaborate scheme as used by McCaa, have repeatedly been published, a new claimant for the honor of accomplishing the impossible pops up every summer. It usually takes the form of a high resistance ground which certainly does reduce static, but only in the ratio that it also diminishes the strength of desired signals.

Recently much publicity has been given to various so-called *A* battery eliminators in which a storage battery masquerades as an electrolytic condenser.

Masked Batteries

Often this battery is inferior to that which it is supposed to replace. While the advertisements may not directly state that the eliminator does not contain a battery, the wording is skillfully intended to inculcate this idea. Many a user cannot believe that he has been fooled until the outfit, when not connected to the electric supply mains, is caused to light his tube filaments. This case is especially unfair to the manufacturer who, at great expense, has devised a real *A* battery eliminator whose price is necessarily higher than that of a pseudo eliminator. It also discriminates against the socket power devices wherein the presence of a battery is frankly stated.

Many devices herein mentioned will give satisfactory service. But our point is that they are not good enough to justify the exaggerated claims and extravagant prices at which they are sold. The error lies not in the device but in the claims which are made for it.

Just what steps can be taken to correct these various evils is difficult to determine. Some of the most flagrant abuses have been investigated and put out of business by the Better Business Bureaus as a part of their campaign for truth in advertising. But often they have not had sufficient grounds upon which to base prosecution for half-truths.

Possible Remedies

Perhaps the best means for putting a stop to these nefarious methods would be the establishment of vigilance committees by the radio trade associations. They could make impartial investigations and issue reports thereof for publication in the newspapers and magazines, most of whom would refuse the advertising of devices thus discredited. For any single publication to undertake this task would introduce the possibility of prejudice or of a poor sample which might unfairly discredit a meritorious device. The investigating agency must enjoy the confidence of both the seller and the buyer, a confidence based upon implicit faith in the truth of its findings. Until this is done any new announcement is likely to be under suspicion until time tells its tale.

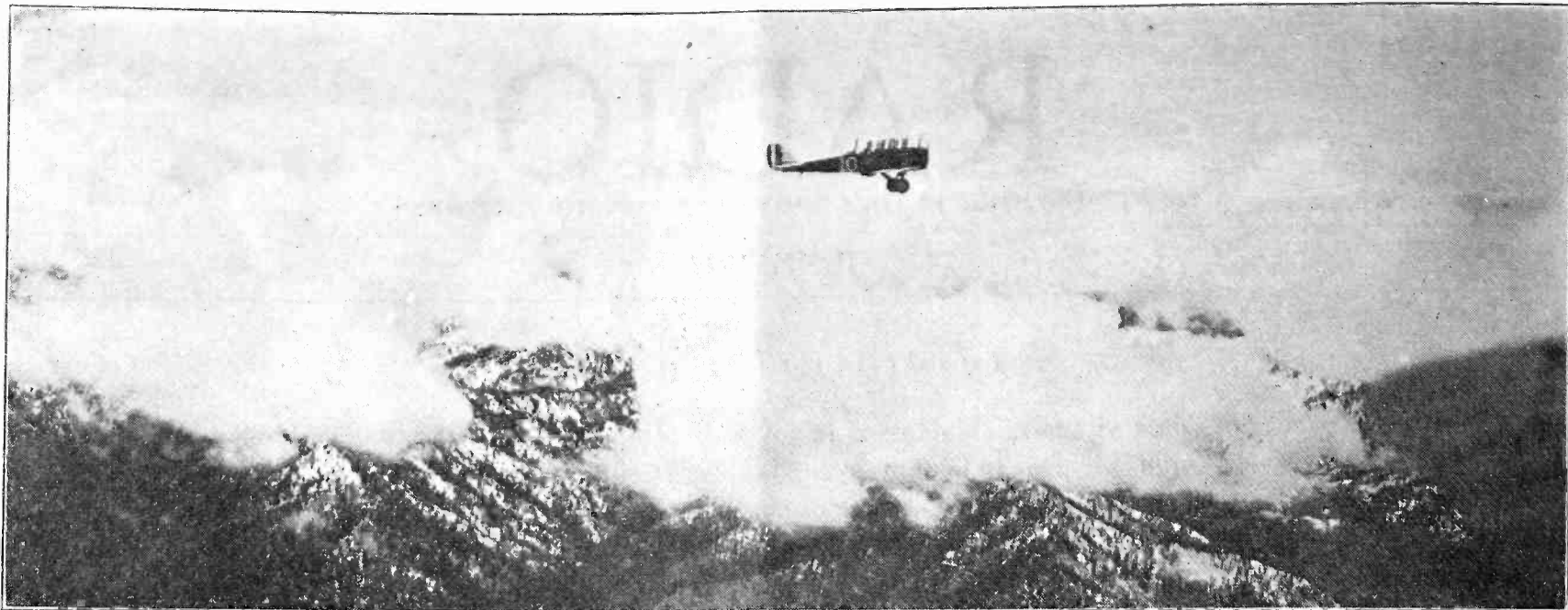

Plane in Clouds Above Mt. Shasta

—Official Photograph U. S. Army Air Corps

Direction Finders For Mail Planes

Radio Provides Another Factor of Safety in Flying

By D. R. Lane

THE big plane hummed along through the upper reaches of the night. The pilot, mentally reviewing the pleasures of the evening before, operated the controls mechanically, not noticing that the wind was carrying the ship slightly off her course. Presently the little green light on his instrument board began to flicker.

With a start, he came back from his reverie, pressed a trifle on a rudder pedal, glanced around him at the cloud crests. Far below was a solid layer of cloud. Fifty miles away Shasta reared a snowy peak, glistening faintly in the starlight. To right and left, ahead and behind, were rolling masses of thin cloud, nebulous, ghostly. When he looked at the instrument board again the green light had winked out and the white one next to it was glowing steadily.

"Back on the course," he thought. "I couldn't fly in this weather without that gadget."

The plane raced on, its big radial engine roaring and the collector ring glowing red from the heat of the exhaust gases pouring out through it. The pilot pulled off his gloves and rubbed his hands together.

"Nice cold night," he thought. "By jacks, the blankets will feel good when I roll in."

The white light began winking at him, a regular series of dots and dashes which he recognized as his own call letters. "I I," he tapped on a key beside his throttle.

Then, in long and short flashes of light, the white globe spelled out a message. "Don't land Medford," he read. "Field fogbound go on Portland if possible stop Better gas up at Yreka."

"A dog's life," groaned the aviator, rapping out an answering signal. "A dog's life," he repeated, as the lights of a little town glowed through a rift in the clouds below. "No sleep for me tonight

but, hell, what's a pilot for? Anyway, I'll get extra mileage. And I'd rather know now that Medford's all tied up with fog than wait till I get there to find it out."

This little drama has not yet been enacted. But next winter, when the fog shuts down on the west coast air mail lanes, it will be produced a dozen times or more. The reason is that there have been no radio direction finders for the mail planes, anywhere in the west. The result was that whenever a heavy fog came up, a pilot had to take chances in landing blindly on whatever field was nearest, if his gasoline was near exhaustion, or perhaps greater chances in driving on to his regular destination.

Fog is the worst enemy of the flier. Lights will not pierce it, no signal can be heard above the roar of the motor, only radio can penetrate it. Fog is responsible for more delays to the air mails than all other causes combined. Without a direction finder and an adequate system of radio beacons it is sheer foolhardiness to attempt to fly through it.



Ground Operator at Medford, Oregon.

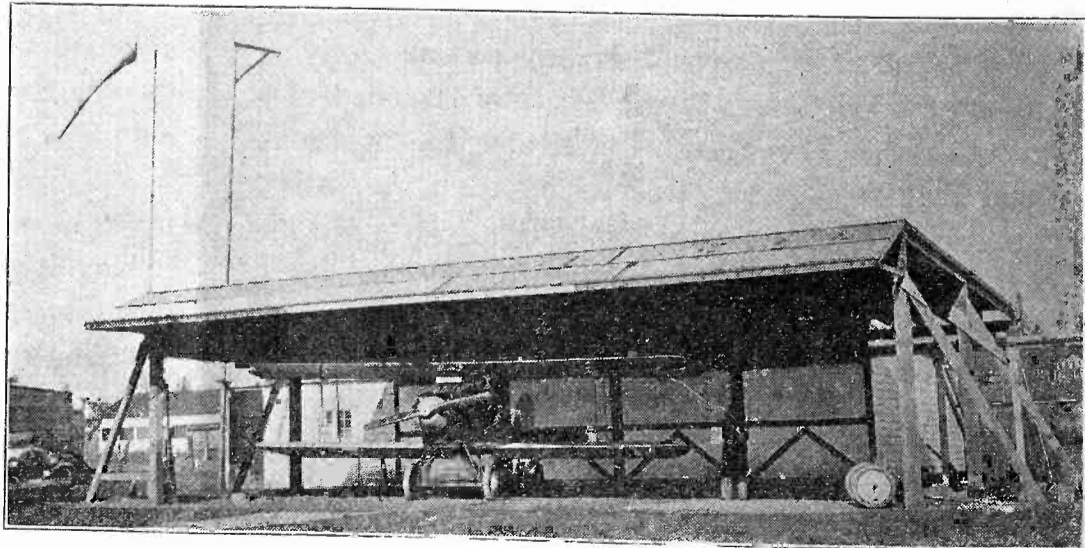

Typical Pacific Air Transport Hangar.

RADIO FOR JUNE, 1927

To combat this and offset the costly loss of time to the air mails, the Pacific Air Transport is now arranging to equip all its planes with radio direction finders and to re-arrange its entire chain of short wave stations, maintained for dispatching planes, so that each will function as a radio beacon. The work is expected to be completed within 60 days from the time this is published. Already much of the material has been purchased and complete plans for the job have been worked out by R. D. Lemert, the line's radio engineer.

The system is virtually that worked out by the Bureau of Standards. It employs three loops, mounted at slight angles to each other on the fuselage of the plane. These loops are tuned to wavelengths about 50 meters apart. The central one is mounted parallel to the axis of the plane, so that when the ship is flying directly toward the beacon it will be in position to receive signals. The signals, sent out in an uninterrupted series, keep a white light glowing on the airplane's instrument board.

The other loops are so mounted that when the plane gets off its course to the right, one of them comes into receiving position on a second waveband and lights a red globe; when the plane is off course to the left the third loop comes into action and lights a green globe. The white light constitutes a visual receiver and messages intended for the pilot are flickered off in dots and dashes on it much as, under other conditions, they would be transformed into sound in a pair of receivers.

For sending, Lemert has arranged a twenty-pound set using the plane's loop antenna. It will have a radius of about 300 miles.

The Western Air Express, the other western line which makes use of short wave radio sets for dispatching its planes, is experimenting with a radio communication set for use in the air. The installation of such a device will be the next improvement made in its facilities, according to Major C. C. Mosely, vice-president and general superintendent of the line. Mosely believes



Plane Passing Mt. Hood

—Official Photograph U. S. Army Air Corps

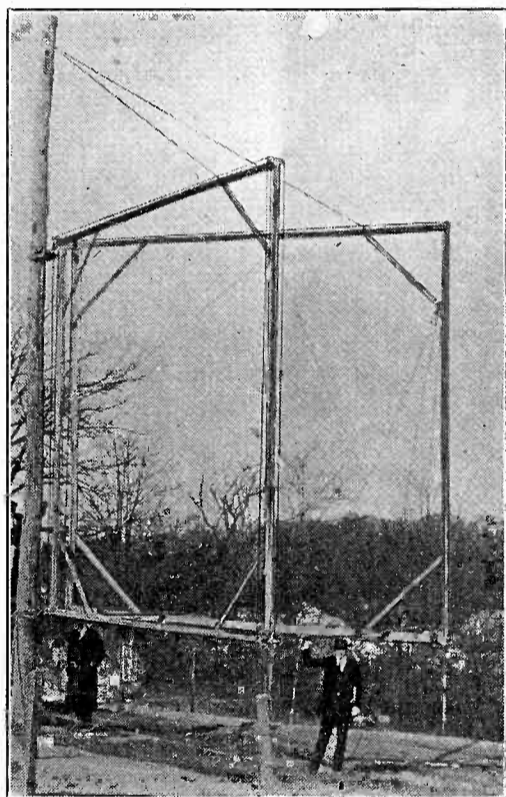

Experimental Type of Equi-Signal Double Coil Aerial

that any set used in a plane should have a working radius of 400 miles and holds that none yet developed in this country has that capacity, combined with sufficiently low weight. The Western Air Express' chain of stations runs north-east from its field at Montebello, in Los Angeles, through Las Vegas and to Salt Lake City. The three installations are identical. They are 500 watt stations, using two 250 watt tubes in parallel. The circuit employed is of the Hartley self-rectification type and the tubes themselves are an importation from Germany.

The stations are operated on the natural period of the antenna, requiring very careful tuning. The wavelengths employed are 48 meters in daylight hours and 70 to 75 meters at night.

Inductive coupling is employed. On the 48 meter wavelength about 1½ amperes are radiated; on the longer wavelength about 3½. With these radiations the tubes run quite cool. A time-lag relay, operating in the filament circuit, is employed. Actually, two relays are used, one in the key circuit operating a second in the center of the tap circuit.

The antenna is a single piece, 45 ft. long, strung vertically. The counterpoise is 80 ft. long and is tapped in the middle. For reception, a second aerial and counterpoise are used, enabling the operators to get a break-in effect. The receiving aerial is 75 ft. long, all in one piece. The counterpoise is 80 ft. long and is tied to a ground before it leads into the set. This tends to collect the power noises incident to the location and also some static and puts these dis-

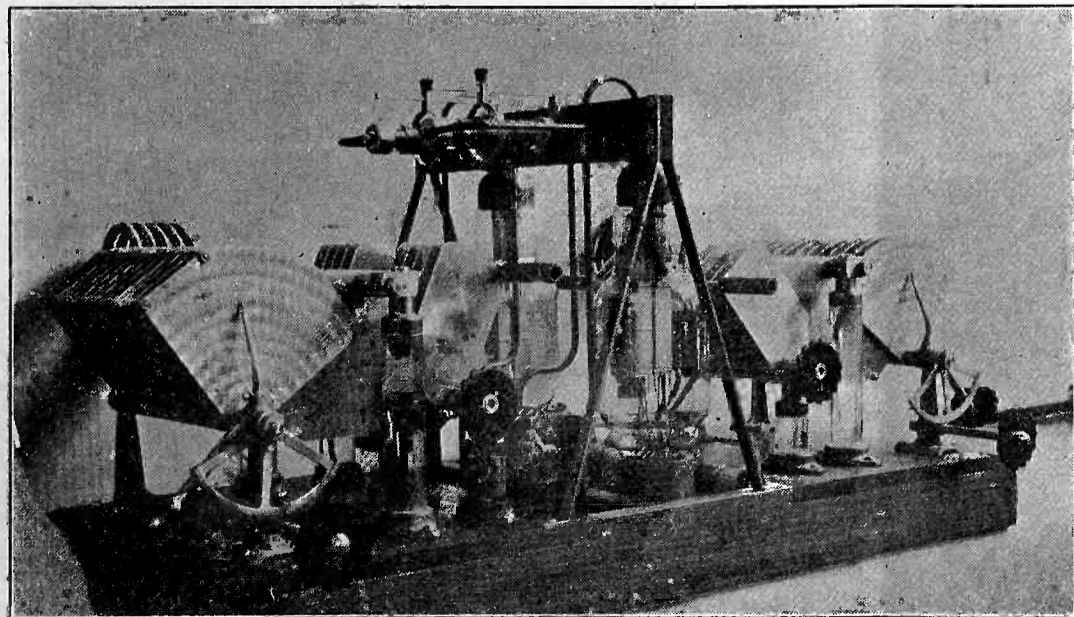

Short Wave Transmitter at Beacon Station.

(Continued on page 40)

Progress in Television

A Brief Review of Recent Developments and Future Probabilities

By Arthur Hobart

TELEVISION has been humanity's dream since man first realized that interesting events were happening beyond the limits of his normal sight. Many a fairy tale was built around this theme. And now science is gradually making it a reality.

First came the telescope to enlarge the visible and reveal the otherwise invisible in space. Then came photography to give permanent record that could be subsequently viewed at a distance. Next the telephone wires were used to transmit photographs and thereafter the radio was employed for the same purpose. And now both are being used to gain instantaneous view of motion in distant places.

The results are still too crude and the apparatus too cumbersome to constitute more than a laboratory experiment. But the same was true of wireless telegraphy in the '90's. Five years ago the prophecy was made in these columns that radio movies would be in practical use within ten years. Half that time has elapsed and a moving picture of Herbert Hoover at Washington is seen by W. S. Gifford at New York while the two are talking by either wire or radio telephony.

This semi-public demonstration is a milestone in the

progress of this new art. It comes after years of patient experiments by engineers of the American Tel. & Tel. Co. Many other individuals, notably Korn in Germany, Belin in France, Baker and Baird in England, and Jenkins, Ranger, and others in America, are striving toward the same objective.

In most of their work they employ the common method of converting variations in light to variations in electrical current. The latter modulate a carrier wave which is received, amplified, demodulated, and the electrical variations converted back to light variations. The means whereby these several processes are accomplished vary with each inventor. However, the trend seems to be toward the general adoption of the

photoelectric cell, which is an integral part of the Bell apparatus.

The Bell system of still picture transmission by wire and the Ranger system by radio are in regular commercial use. The Baker system is being tried out by a broadcast station in Vienna, where three pictures are broadcast each night.

Undoubtedly some enterprising broadcaster will soon do likewise in America. Simple receiving equipment has been devised to give permanent record of the transmission. So that any possibility of waning interest in the reception of radio voice and music will be counteracted by renewed interest in receiving pictures. When the radio amateur starts to play with this toy the art will leap forward with a new impetus.

The Radio Commission will undoubtedly allocate special channels for picture transmission and within five years radio pictures, whether moving or still, will be as common as was radio music five years ago. Much work has yet to be done before these visions become practical. New principles must be developed to speed up the process and new equipment perfected to apply these principles. Thus will an age-long dream soon come true.

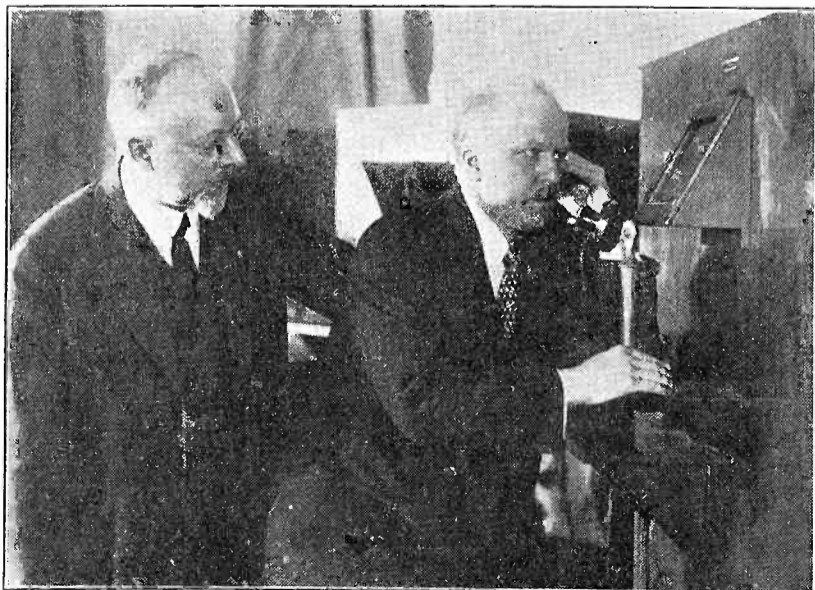
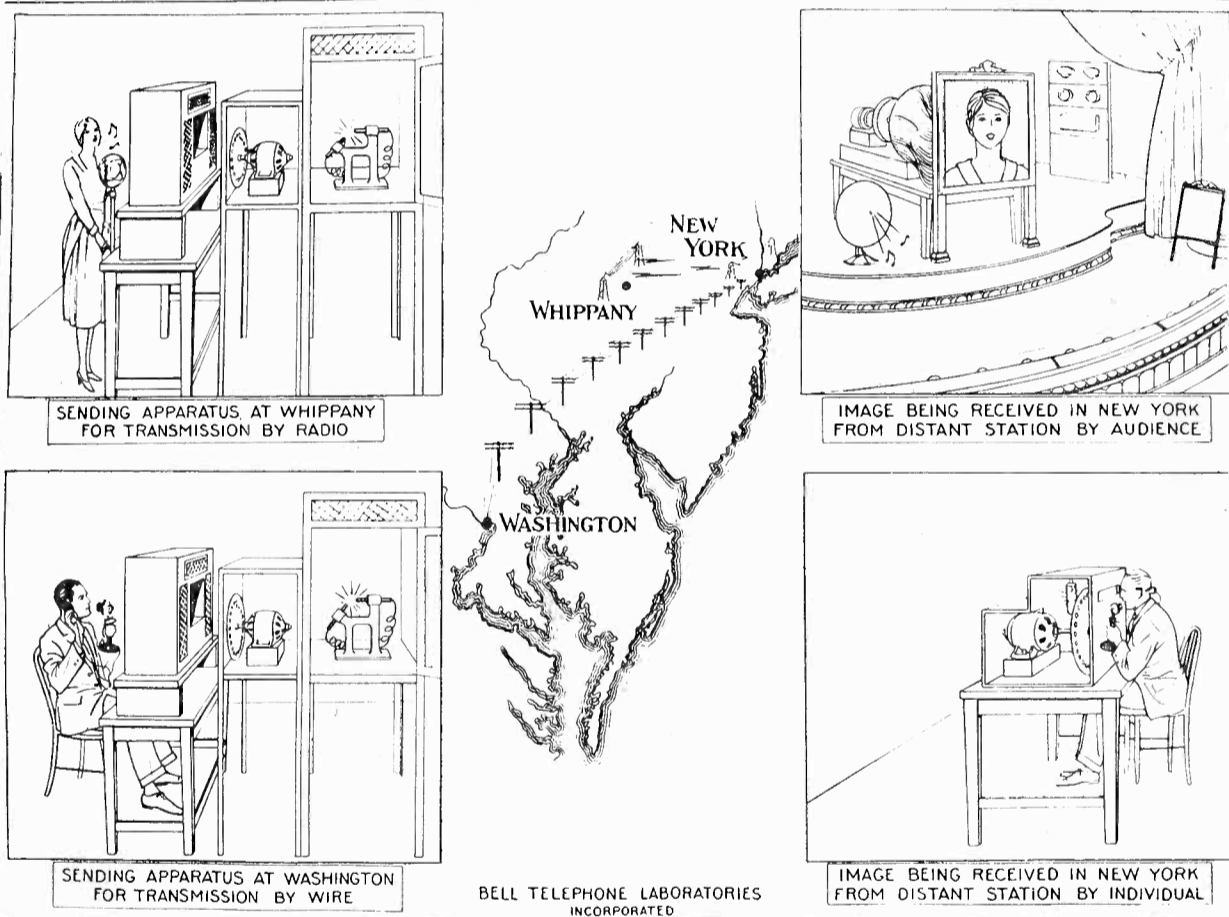

President Gifford Simultaneously Seeing and Hearing Hoover.
—International Newsreel Photo

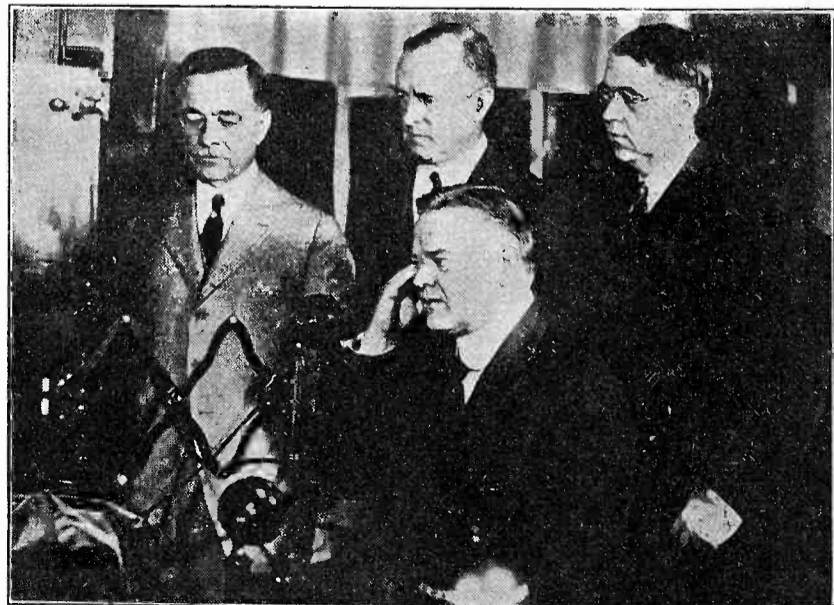

Secretary Hoover Being "Tele-Photographed" As He Telephones.
—International Newsreel Photo

A New "ABC" Socket Power

For Rectifying Alternating Current as The Filament, Plate and Grid Supply to Series-Connected 5-Volt Tubes

By G. M. Best

THE first constructional data on a complete A, B and C battery eliminator for use with standard types of broadcast receivers appeared in the December, 1925 issue of RADIO. Since that time rapid progress has been made in the design of suitable rectifier and filter circuits, as well as the apparatus with which to build the eliminator.

The original arrangement comprised a two element, filament type rectifier supplying 80 milliamperes at about 150 volts, which limited its use to tubes of the 60 milliampere type, such as the CX-299, except the power tube, whose filament was lighted from alternating current through a step-down transformer. For new receiving sets this arrangement was very satisfactory, since apparatus especially designed for the '99 tubes could be installed. But where the set was already designed for the 6 volt tubes operated in parallel, the '99 tubes would not function as well as was desirable, usually due to the greater number of turns they require for radio frequency transformer primary windings.

Several A eliminators capable of supplying 250 milliamperes at a maximum of 110 volts have been developed, using the Tungar battery charger bulb. But due to its inherent characteristics, voltages in excess of 110 could not be applied to the filament and plate. Consequently these devices were limited to the supply of A power to ¼ ampere tubes wired in series, and to B voltages not exceeding 90 volts.

However, a new gaseous rectifier known as the Raytheon Type BA has been perfected, and is now available for general use. This tube is similar in construction and characteristic operation to the familiar Raytheon 85 milliampere tube now used extensively in B eliminators, and in ABC eliminators where '99 tubes are used, except that it has larger elements and a greatly increased power output. With 320 volts applied to each of the two rectifier anodes, a maximum direct current output of 350 milliamperes at approximately 300 volts can be obtained. This gives sufficient

current and voltage for any radio set having ¼ ampere tubes wired in series. The drop or loss in the tube itself does not exceed 45 volts when the current drain from the rectifier is from 250 to 350 milliamperes, so that allowing for a 90 volt drop in the filter choke coils, due to their internal resistance, a total voltage of at least 200 is available for B supply.

To better understand the theory and operation of the new tube, a schematic diagram of a complete rectifier-filter circuit is shown in Fig. 1. The 110 volt supply is stepped up through a suitable transformer, so that the center-tapped secondary gives a voltage of at least 320, with 350 milliampere drain. The resistance in the primary winding is to prevent flashing the tube by temporary line surges when the current is first turned on, and will be explained in the data on the power transformer.

henry chokes wound with wire of much larger size than is used for B eliminator service. Under average conditions, about 220 volts at 300 milliamperes will be delivered at the output of the filter. The curve shown in Fig. 4 gives the effective

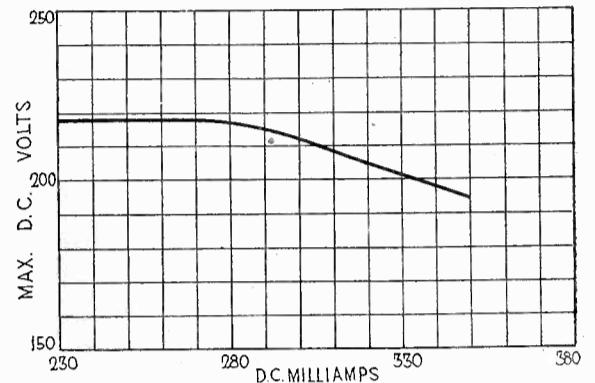
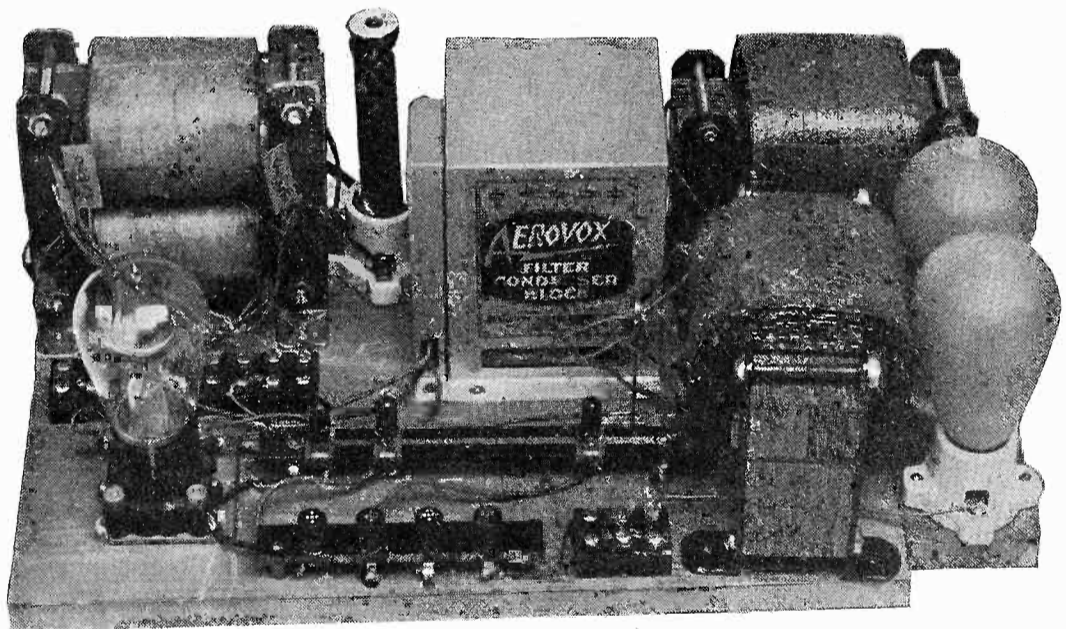

Fig. 4. Regulation Curve of Raytheon Type BA Tube.

voltage at various current drains. The receiving set used with the eliminator must have its filaments wired in series.



Experimental Model of ABC Eliminator Using the New Rectifier Tube.

The rectifier tube is connected to the transformer secondary windings in the same manner as for the other types of Raytheon tubes, with .1 mfd. buffer condensers across each secondary section to absorb any stray r.f. currents present in the rectifier tube or transformer. The output of the tube is passed through a filter system consisting of a bank of condensers totalling 16 mfd. and two 10

For a six tube tuned r.f. set such as is shown in schematic form in Fig. 5, where there are five A tubes and one type 112 power tube, the five A tubes in series will require 25 volts at 250 milliamperes, since each tube takes 5 volts, 250 milliamperes. As the voltage output of the filter system is roughly 200 volts, the remaining 175 volts must be absorbed by a resistance, which is shown in Fig. 1 as a 500 ohm resistance connected between the positive terminal of the filter, and the plus A binding post. Added to the 500 ohms in the positive A lead is the 150 ohm resistance of the C biasing rheostat, placed in series with the negative of the filter output, so that a total of 650 ohms can be used, in series with the A tube

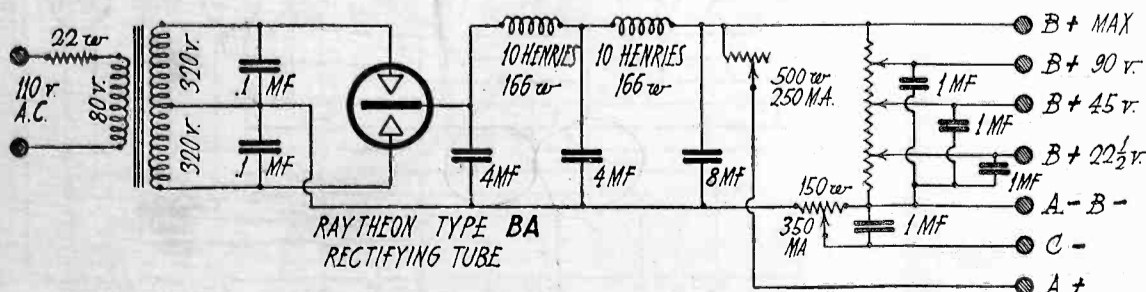

Fig. 1. Wiring Diagram of ABC Eliminator for .25 Ampere Tubes.

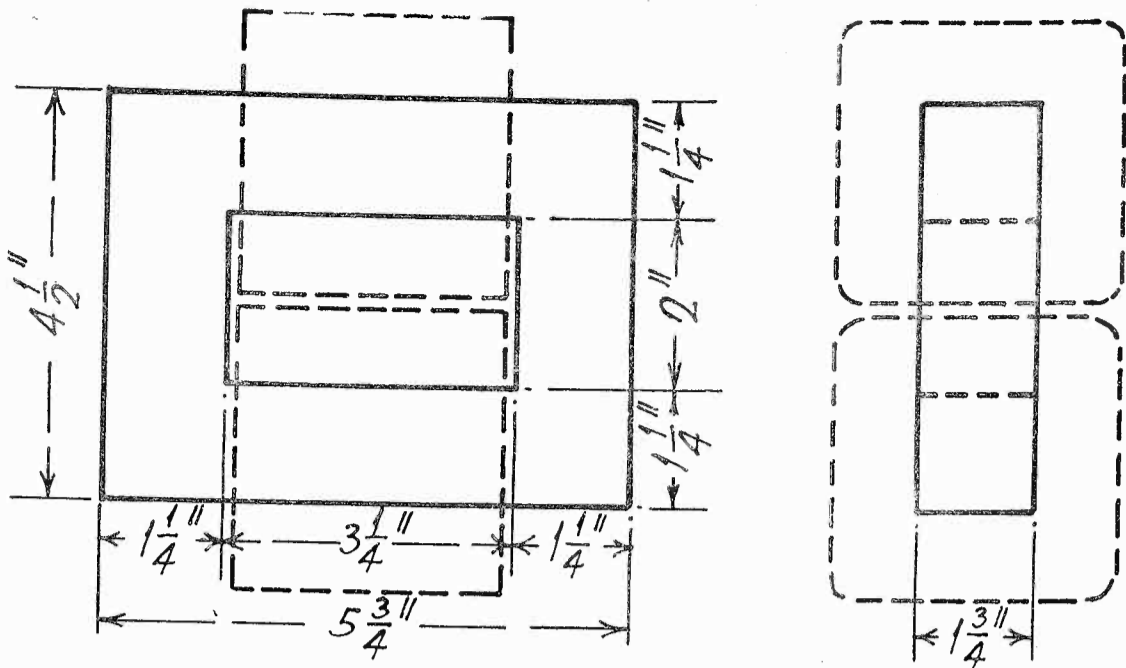

Fig. 2. Dimensions of Power Transformer Core.

filaments, to limit the current to 250 milliamperes.

The *C* biasing resistance is to provide *C* voltage for the power tube, which is not a part of the series filament arrangement, but has its filament operated from a 5 volt secondary added to the power transformer supplying the rectifier tube. The *A* current, in passing through the 150 ohm resistance, causes a drop in voltage, which can be used as *C* voltage by connecting the grid return of the power tube to the negative side of the resistance. For the various *B* voltages, a 7500 ohm wire wound resistance unit is connected between the positive and negative terminals of the filter. By setting the three sliders with which this resistance unit is provided, at various positions, any *B* voltage up to the maximum voltage of the filter output can be had for the plates of the tubes. By-pass condensers are connected between each slider and the negative end of the circuit, to by-pass r.f. or audio frequencies around the resistances. When the *B* voltage taps are disconnected, the 7500 ohm resistance will draw a steady current of 25 milliamperes from the filter circuit. But as soon as the sliders are connected, the plate circuits of the tubes in the receiver will split the current flow into several paths, and very little current will be carried by the resistance wire itself.

To test the new tube, and learn more of its characteristics, and to check and verify its rated life of 1000 hours continuous service, the experimental outfit shown in the picture was assembled so that the tube could be put through a long test under actual load conditions. Within a few weeks, factory made transformers and chokes for use with the new tube, will be on the market but for those who want to build their own coils, data for building a suitable power transformer, and two 10 henry chokes is here-with given.

The construction of the power transformer core is shown in Fig. 2, it being assumed that silicon steel laminations of

customary 28 gauge will be used. On account of the extremely high current capacity of the tube, it is necessary to include some regulating means in the transformer circuit to limit the surge of current when the transformer is first connected to the line. This may be ac-

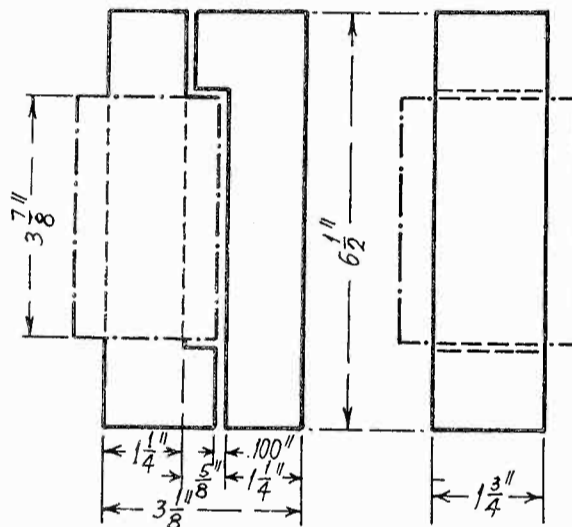

Fig. 3. Assembly Details of Choke Coil Core.

complished either by placing a 15 or 20 ohm resistance in series with the transformer primary, thus limiting the value of the starting surge current, or by designing the transformer with a high leakage reactance so that the secondary voltage will be changed from 320 volts at 350 milliamperes load, to below 150 volts if the load is temporarily increased to 1 1/2 amperes, as would be caused by a sudden surge. For the home made transformer, the resistance method, while less economical of power, is the

safest to use, and the transformer has been developed on this basis.

Assuming a resistance of 22 ohms in the primary, and a current of about 1 1/2 amperes, approximately 30 volts will be lost by drop in the resistance, so that the transformer must be designed for an 80 volt primary, instead of 110. Using the core dimensions given in Fig. 2, the transformer coils are wound in two identical sections, one section being mounted on each leg of the core. In each section, the primary winding is wound first, over a layer of empire cloth, and consists of 113 turns of No. 16 d.c.c. wire. After a layer of empire cloth is wound over the primary, the high voltage section is added, and consists of 932 turns of No. 25 d.c.c. wire. Over this secondary, with suitable insulating cloth in between, is wound the filament lighting secondary for the receiving set power tube, with 8 turns of No. 22 d.c.c. wire. The total number of turns in both legs of the transformer coils will be twice that of each section.

The coils are assembled on the core so that the beginnings of the two windings are tied together, which places the two primary coils in series, and the same for the secondaries. In the case of the secondaries, where both high and low voltage windings must be center tapped, the junction of the two secondary coils is used as the mid-tap, thus assuring an accurate electrical mid-point. The assembled transformer should be securely clamped at each end, insulating the clamps from the core with fiber or heavy cardboard strips. Do not connect the transformer directly across the 110 volt power circuit without the series resistance and tube load, or the transformer will quickly become hot.

The choke coils are identical in construction, each coil consisting of 6000 turns of No. 26 enameled copper wire, wound on a core whose dimensions are given in Fig. 3. An air gap of .100 in. is placed on each side of the core, at opposite ends, as shown, to prevent saturation of the core, and consequent lowering of the inductance. The d.c. resistance of each choke will be about 166 ohms, so that with 275 milliamperes flowing through the windings, each coil will produce a voltage drop somewhere

(Continued on page 40)

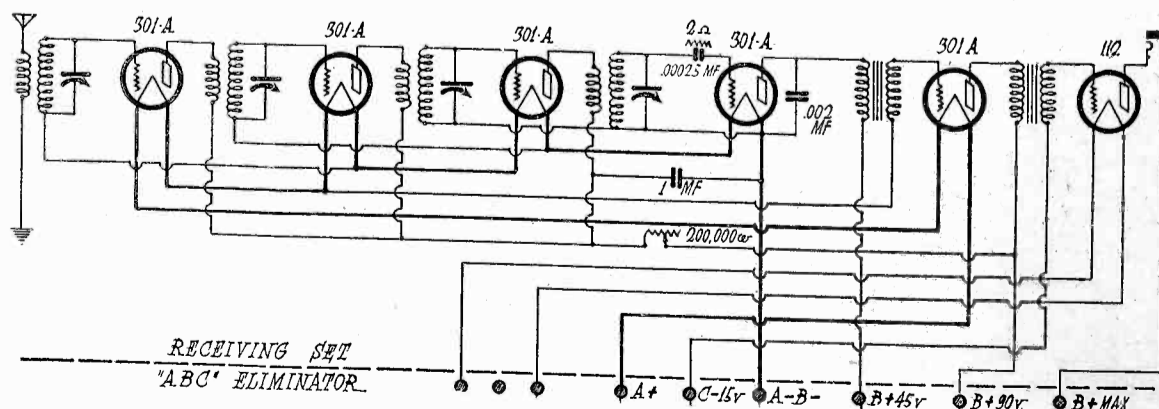

Fig. 5. Typical Series Filament Connection of Six Tube Set.

Multi-Valve Systems

Performance of a Vacuum Tube Having Two or More Sets of Elements So That It Replaces Several Amplifier Tubes

By *Manfred von Ardenne*

ALL the tube elements necessary for a two-stage radio amplifier, or three-stage audio amplifier have been enclosed in a single tube not much larger than that ordinarily used in radio receivers. Such tubes have been developed by Dr. S. Lowe and the writer at Berlin where exceedingly satisfactory results have been secured.

The original reason for doing this was to utilize ultra-short connections to reduce the stray capacities inherent in connecting several tubes. Not only has this been practically secured, but the cost of such a single tube is also less than that of the three which it replaces.

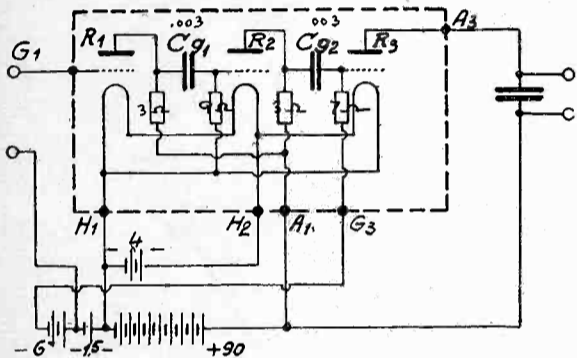

Fig. 1. Circuit Used with Low Frequency Triplex Valve

Fig. 1 is the theoretical circuit diagram of a single triplex valve used as a three-stage audio amplifier. The first two stages have an amplification factor of 33 when working into a plate resistance of about 3 megohms. The low filament emission required with these high plate-circuit resistances is of greatest advantage with regard to the long life of the filament. This fact naturally is of

primary importance with multi-valve systems. It is of interest to note that, should such a valve become damaged in any way, the repair is little more difficult than with ordinary valves.

The interior of a low-frequency triplex system is shown in Fig. 2. The

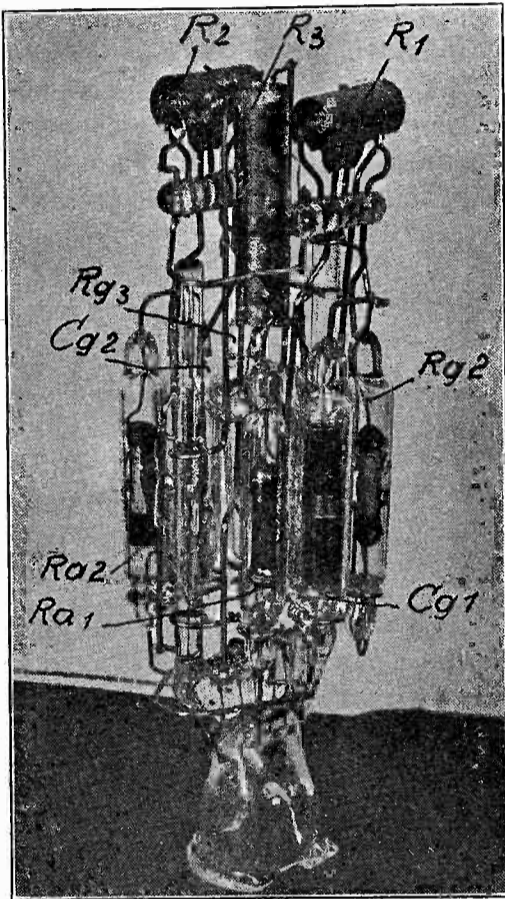

Fig. 2. Internal Construction of Triplex Valve

different components are marked by letters corresponding to those in Fig. 1.

To facilitate satisfactory evacuation, the coupling condensers and resistances

are enclosed in small glass tubes. Notwithstanding the minute distances between the separate stages and the large overall voltage amplification of about 1000 (actual), low-frequency self-oscillation has been completely repressed, although this problem at first seemed insurmountable.

The actual amplification of such a triplex valve at different audio-frequen-

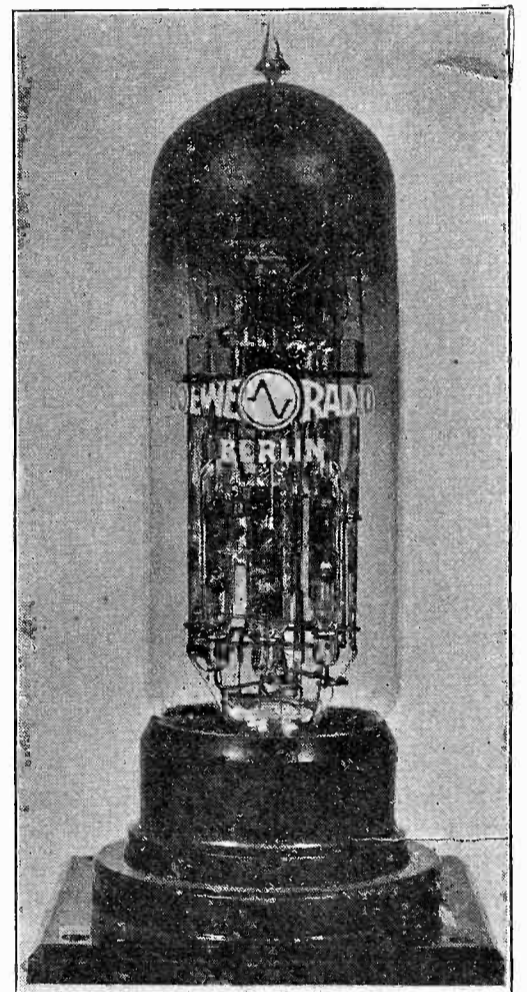

Fig. 4. Triplex Valve Mounted in Socket

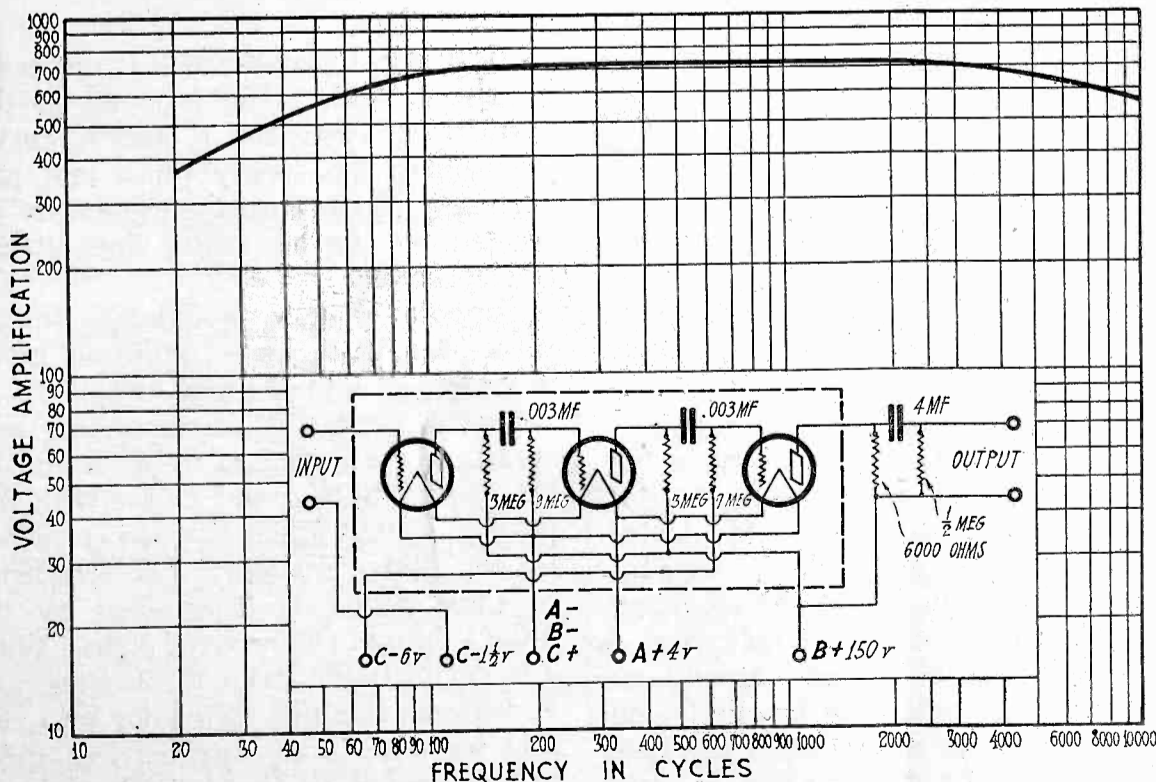

Fig. 3. Voltage Amplification Obtained with Triplex Valve.

cies is shown by the measured curve given in Fig. 3. As will readily be seen, the distortion due to inconstancy of amplification across the range of audible frequencies is remarkably small in comparison to other amplifying arrangements. Normal plate potentials are quite sufficient for satisfactory operation, since both the two high-impedance valves and the power-valve in the last stage are dimensioned for plate-potentials of about 90-100 volts. Should a larger output wattage be required to fill a large room with a minimum of distortion, it is advisable to use plate voltage up to about 150 volts, together with correspondingly higher grid-bias potentials.

The filaments of the valves are dimensioned for voltages between 3.5 and 4.5 volts. The low-frequency triplex valve, as shown in Fig. 4, requires a

Why the Grid Leak?

By J. B. Dow

filament current of 0.3 amp. As is the case with all such resistance coupled amplifiers, a very useful receiver for the more powerful stations is obtained if a tuned circuit consisting of a coil of suitable inductance with a variable condenser in parallel is connected across grid and filament of the first valve and loosely coupled with the aerial. Rectification takes place in the first valve as plate rectification, mainly due to the influence of the stray capacities parallel to the first plate resistance. Apart from this simple arrangement, numerous other circuits exist, where multi-valve systems are used to great advantage either by themselves or in conjunction with ordinary single valves.

The high-frequency duplex-valve appears in Fig. 5. This tube contains two

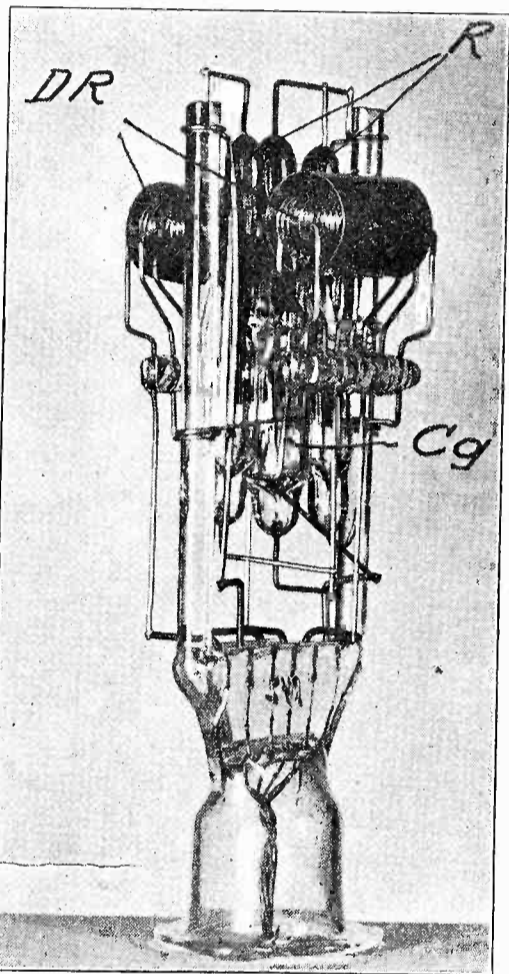

Fig. 5. Interior of High Frequency Valve

special four-electrode-valves, constructed and dimensioned in accordance with research work carried out by the writer, together with the necessary coupling condenser and resistance. This duplex-valve allows very efficient aperiodic high-frequency amplification to be obtained on all wavelengths down to about 200 meters. Its filament consumption amounts to 0.17 amp. at 4 volts. The high-frequency-valve may, for example, be connected to the input

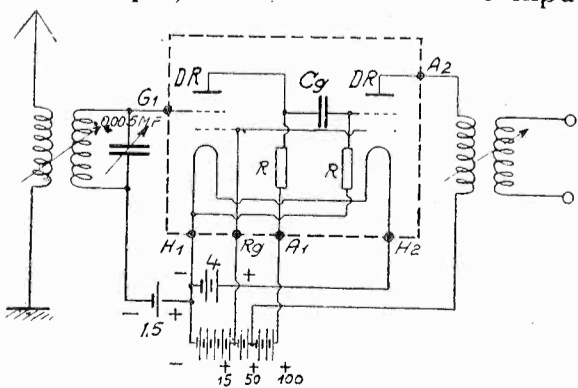

Fig. 6. Circuit of High Frequency Valve

PROBABLY no other single piece of radio apparatus in a receiver is so little understood as the grid leak. Why is it used? How much resistance should it have? What is the purpose of the grid condenser and what limits its size? These are questions whose answers should be generally known.

A detector tube can be made more sensitive by the use of a grid leak and condenser, than without. That is the reason for using such a combination. The complete treatment of detection is too involved to fit into a descriptive article of this kind. For this reason, the process of detection will be explained in a manner which is not entirely rigid but sufficiently accurate for present purposes.

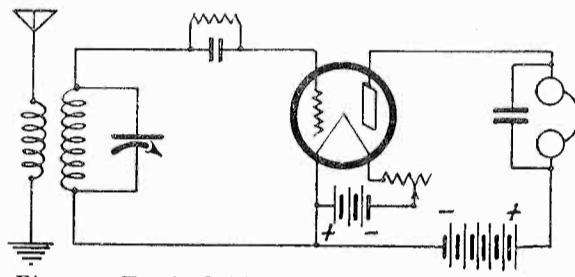

Fig. 1. Typical Non-Regenerative Detector Circuit

Fig. 1 shows a typical non-regenerative detector circuit. This is made non-regenerative for simplicity only. Fig. 2 shows two curves plotted from data taken in the circuit illustrated with the curves. The plate voltage was maintained constant at the normal value and the grid voltage was varied throughout the range of positive and negative values indicated, by altering the C battery

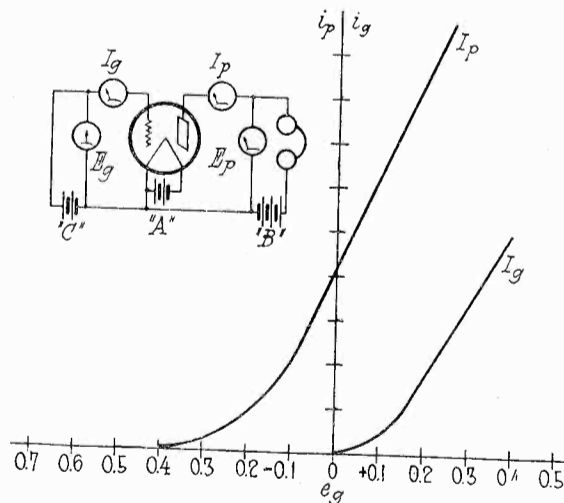

Fig. 2. Variation of Plate and Grid Current with Change in Grid Voltage

circuit of any receiver as shown in Fig. 6. In practice the effect thus obtained is a great improvement, and the receiver becomes much more sensitive without distortion, while the slight additional tuning control complication is scarcely noticeable. Good results are obtained even under less favorable conditions, with arrangements embodying a high-frequency duplex-valve in series with a low frequency triplex-valve.

voltage. Plate and grid current readings of meters I_p and I_g were plotted on the vertical scale against corresponding grid voltage readings of meter E_g , which were plotted on the horizontal scale. The grid current readings were exaggerated in order to move the grid current curve well above the E_g scale. Fig. 3 is a repetition of Fig. 2 with certain added matter.

Suppose now that the grid of Fig. 1 is polarized at 0.1 volt positive by connecting the grid return to the positive end of the filament. (If it were not for the $R I_g$ drop in the grid leak, the grid would be about 2.5 volts positive in the case of a UV-201A tube as a result of such a connection.) This steady polarizing voltage is shown in Fig. 3 by the

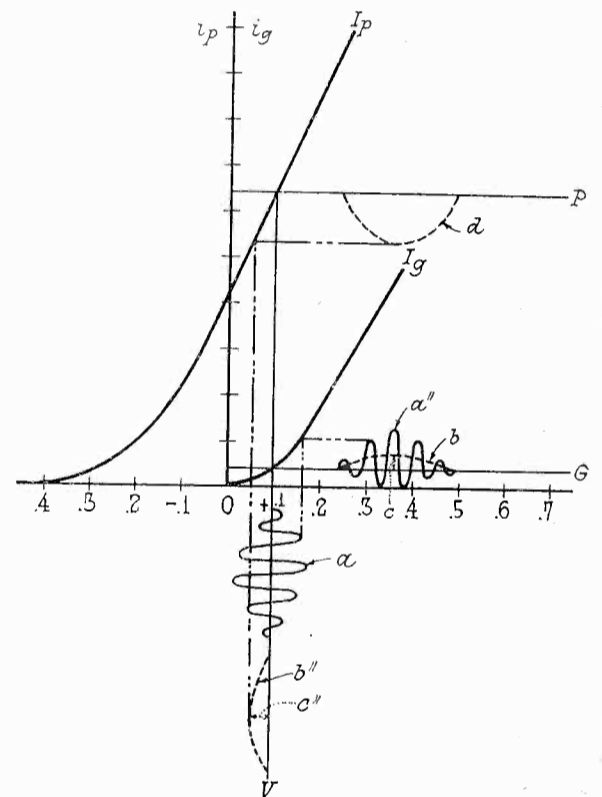

Fig. 3. Effect of Modulated Wave on Grid and Plate Current

vertical line through the 0.1 volt point on the e_g scale. The junction of this vertical line with the I_p and I_g curves determines the steady plate and grid currents. These steady currents are indicated by the horizontal lines P and G respectively.

Suppose that a modulated voltage wave-train, such as is indicated by a , is impressed into the grid circuit by an incoming signal. A corresponding grid current wave indicated by a'' would be produced. Both a and a'' are high frequency waves which are freely passed by the grid condenser. The frequency of these waves is determined by the wave length of the received signal. Wave a is symmetrical about the vertical axis V , whereas the high frequency grid current wave a'' is not symmetrical about axis G owing to the fact that the I_g

(Continued on page 49)

Experimental Shop Methods

Miscellaneous Small Equipment

By Samuel G. McMeen

AS helical springs are in frequent demand during laboratory construction jobs, it is well to have a simple little tool for winding them. That shown in Fig. 1 is well adapted to

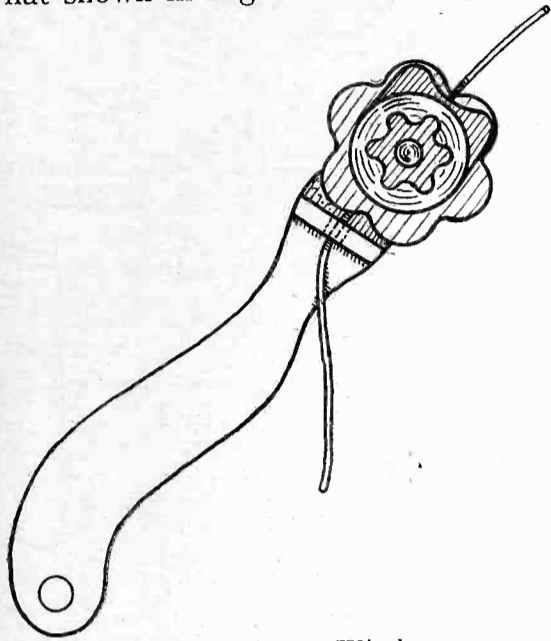

Fig. 1. Spring Winder

this work. As indicated in the drawing, one end of the wire, whether spring-brass or spring-steel, is passed through the hole and stem and is engaged in the end of the lathe chuck which holds a rod of the diameter desired for the spring. The lathe is turned backward by the belt and meanwhile the spring-winder is held against the rod until a spring of the desired length is wound. This tool will wind an open or expansion spring in one position and a closed or compression spring in the other.

An admirable tool for grinding concave surfaces on wood is shown in Fig.

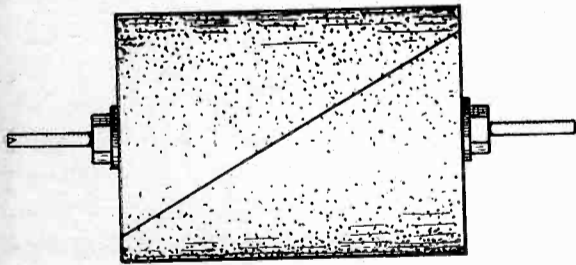

Fig. 2. Grinder for Concave Surfaces

2. This is simply a wooden cylinder on which is glued a strip of garnet paper. The ends of the garnet paper are cut at an angle, so that they will join correctly, and attached by means of liquid glue, useless for many purposes but satisfactory for this. It is remarkable how well the garnet paper so applied will cut wood, or even metal in a pinch. If much metal cutting has to be done, it is well to have a special cylinder covered with carborundum cloth.

For sanding flats on wood, a good tool is the sanding machine shown in Fig. 3.

This is a table across the top of which runs an endless belt of garnet cloth. The garnet belt runs over two pulleys, somewhat wider than the belt. A good di-

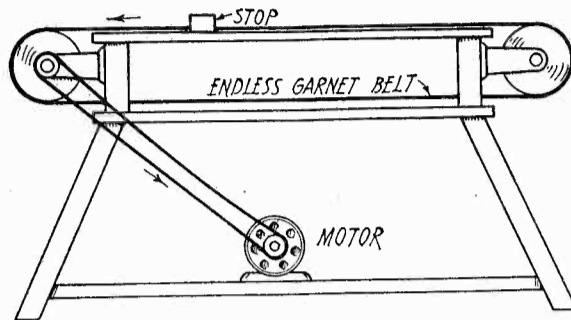

Fig. 3. Sanding Machine

mension for the belt is 6 in. wide by 12 ft. long, which, when the belt is spliced, gives a clear distance of about 5 ft. between 6 in. pulleys. A stop is placed across the belt near one end of the table, straddling the belt, against which the work may be rested as it sands. The machine is more formidable in description than in fact. It has no drawbacks in construction, being very simple to make, and only one drawback in use, which is its tendency to make considerable dust.

A fourth abrasive tool is that for forming small cylinders, in the nature of dowels. Dowels can be bought in the market for small sums, being usually made of birch, and are excellent material. Often, however, they do not come the exact size needed, so that a ready means of reducing diameter is useful. Then, too, cylinders of other materials are often needed, and for these purposes of making square strips into round ones the "book" shown in Fig. 4 is a good

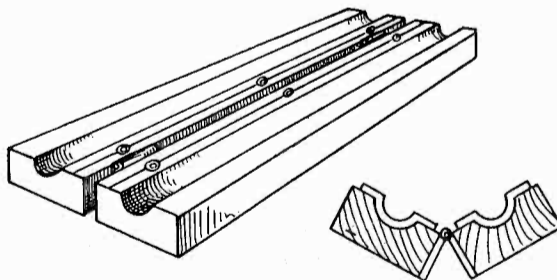

Fig. 4. Cylinder-Forming "Book"

device. It consists of two strips of wood hinged together, in each of which strips has first been formed a semi-cylindrical groove, of say, 1/2 in. diameter. Over this groove, and pressed into it as will be described, is a sheet of garnet paper. The pressing into the groove is done by clamping the book in a vise while a rod of iron is laid along the groove between the garnet paper linings. The garnet paper is attached to each strip of wood by means of screws and washers, at the edge nearest the hinges. No other at-

tachment is necessary. The paper lies like a flap across the wood strip.

To make a dowel—a wood cylinder, of any length up to say 1 1/2 times the length of the tool, the wood is first sawed on the circular-saw table into a prism of, for example, 3/8 in. by 3/8 in. by the desired length. It is then laid in a groove in a wooden strip, this groove being V-shaped, with its sides at 90 degrees with each other. With a jack plane, the four corners are taken off. It becomes an octagon in section. It is now caught in the chuck of the lathe and spun rapidly, say at 2500 a minute. The "book" is now closed gently around it, hinge side up, and a little—but only a little—pressure applied. The stick at once becomes round, and by continued and slightly increasing pressure is reduced to the desired size. If the caution is noted as to the application of only gentle pressure at first, the rod of wood will come out of the book entirely straight and will remain so throughout its life, which is in itself a great triumph in woodworking.

Occasionally, in the multitudinous practices of the small shop, there arises the problem of placing ferrules on the ends of small wooden rods such as have just been mentioned. If only a few such have to be set, the end of the rod can be filed to the required shoulder. But such a method is unworkmanlike, and is also less accurate than often the needs demand. In such a case the tool shown in

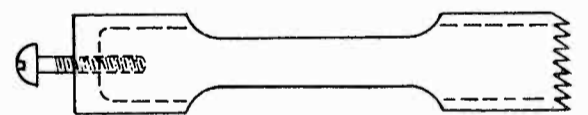
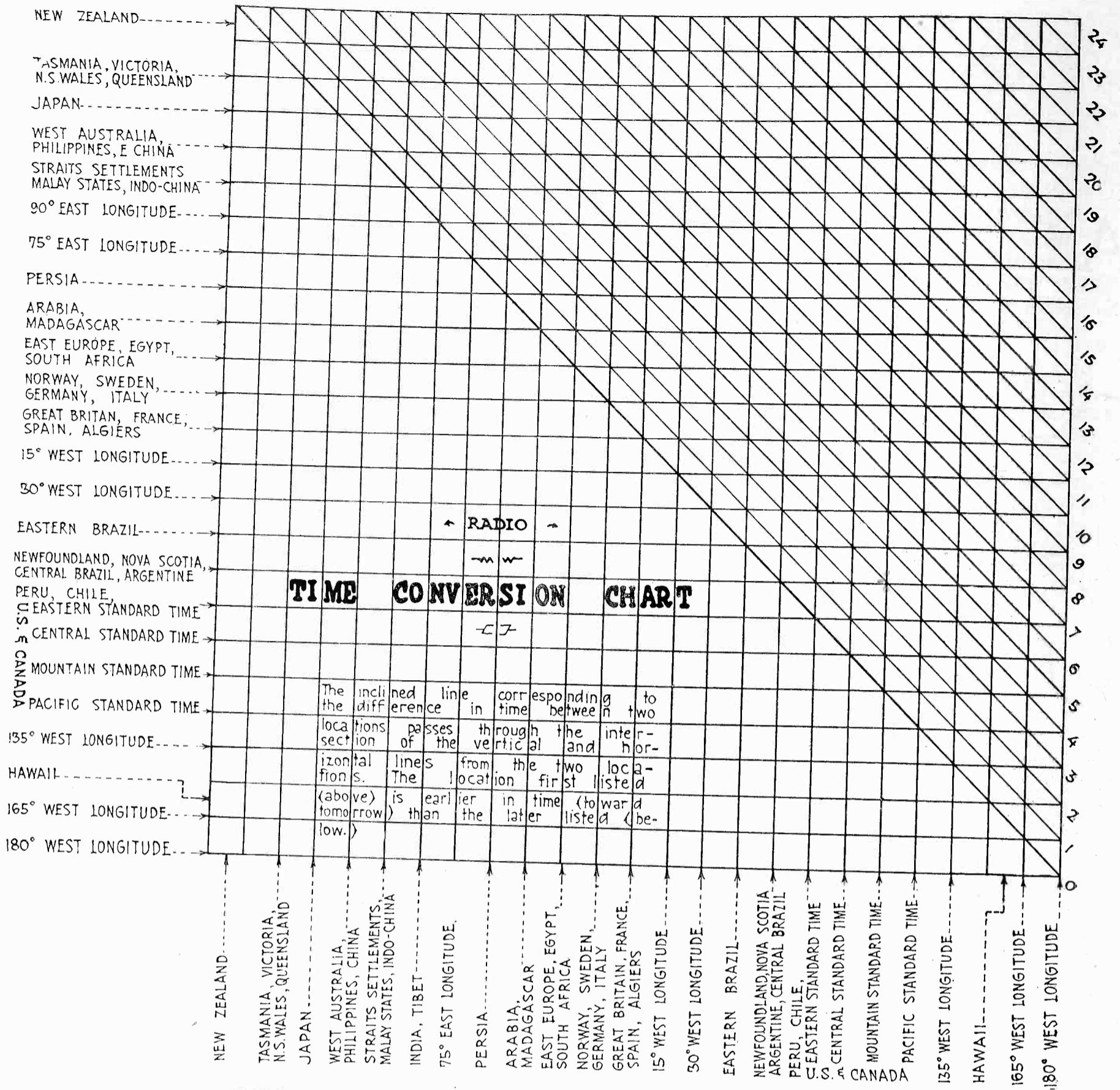

Fig. 5. End-Mill for Shoulders

Fig. 5 is the most useful. It is merely a hollow mill, made in a few minutes from a bit of Stub's drill rod. The rod is first drilled almost through at the size desired in the finished work, then drilled for a screw at the other end—this screw serving as an adjustable stop—then teeth are cut in the end and the sides relieved as shown in the drawing. The tool is now hardened and tempered. The object of relieving the sides is to avoid heating the work when the milling is done on the harder woods. If the tool be left solid the surface of the hardwoods will be charred. Of such minutia is the code of laboratory practice composed.

The aspiring craftsman will not long be content without accurate means of weighing and measuring solids and

(Continued on page 50)



Time Conversion Chart

By Arthur Hobart

THE confusion sometimes experienced in converting the time as observed at one place on the globe into the time then existing at some other place can easily be obviated by using the accompanying chart. It is based upon the fact that there is a difference of one hour in time for each 15 degrees of longitude, or 24 hours for 360 degrees, the circumference of the earth. Any place east of a given location is earlier in time, nearer to tomorrow. Any place west is later in time than at the given location, towards yesterday. For each 15 degrees that a place is east of another, its time is one hour earlier. For each 15 degrees that it is west, its time is one hour later.

It will be noticed that the chart consists of a series of horizontal, vertical and inclined lines, each of the inclined lines passing through an intersection of a horizontal and vertical line. The horizontal lines are drawn to correspond to 15 degree separations from 180 degrees east longitude to zero longitude (Greenwich) to 180 degrees west longitude. The principal countries or sections of a country through which the several 15 degree lines pass are designated at the left of the chart. The vertical are laid out in the same way, the corresponding countries appearing along the bottom of the chart. There are 24 horizontal lines, corresponding to the 24 hours of the day, their lower right terminals be-

ing marked to indicate time difference in hours.

The difference in time between any two places is found by identifying the inclined line which passes through the intersection of the horizontal and vertical lines corresponding to these two places. If a country is listed above another, the first is earlier in time.

Thus the vertical line corresponding to *U. S. Pacific Time* intersects the horizontal line corresponding to *Queensland* on the 18 hour inclined line. As *Queensland* is listed above *Pacific*, it is 18 hours earlier in time, or *Pacific* is 18 hours later than *Queensland* time. So that when it is 11 p. m. today in Se-

(Continued on page 49)

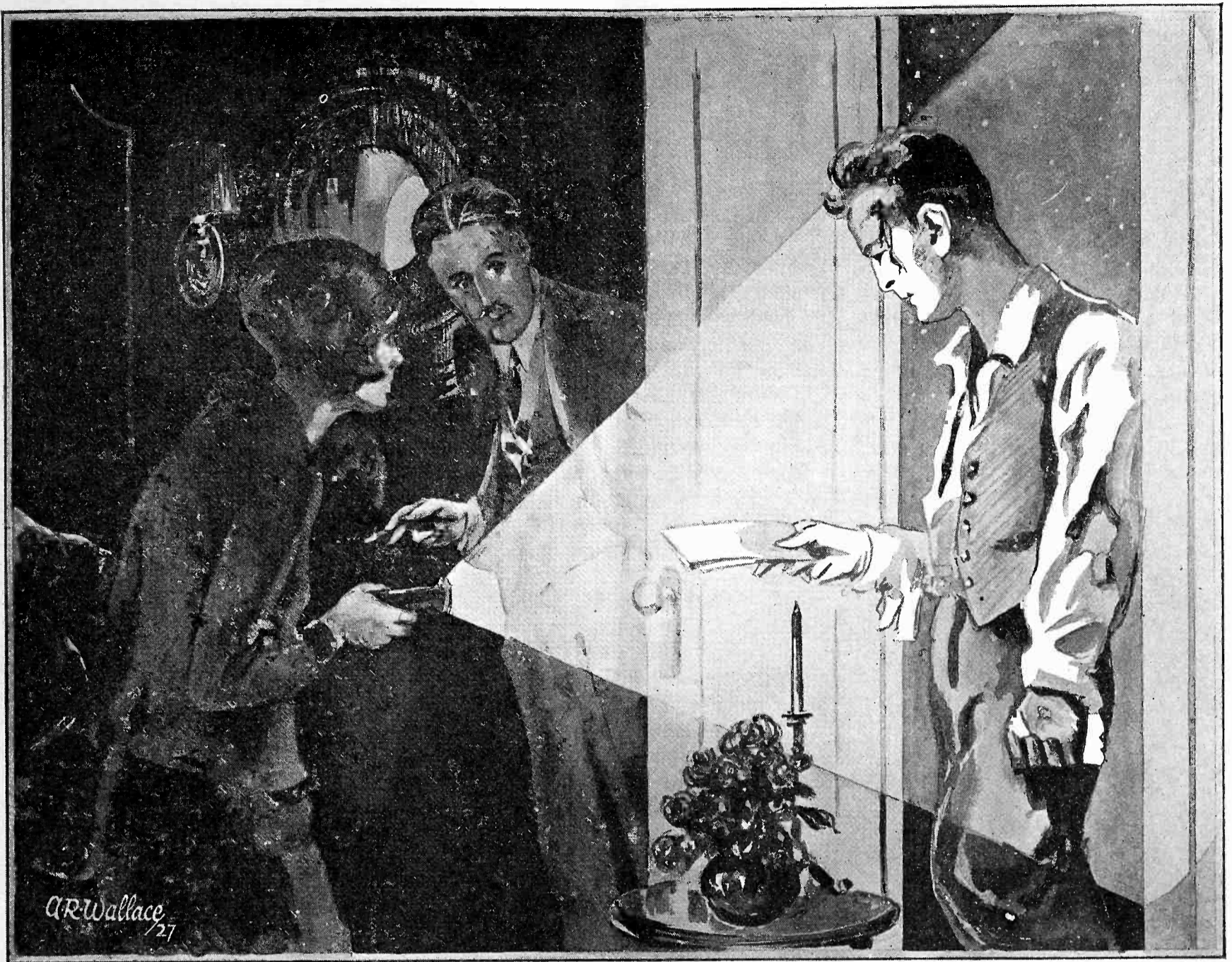

"I have a radio message requesting me to find you and get you out of here."

DX Love

By Armstrong Perry

ANNE WARNER was the kind of girl who looks you in the eye and if you don't get what she means it is your fault. She had good looks to spare. She pulled her college team out of a hole in the last crucial contest of her senior year by winning three firsts and a few odd points. She starred in the dramatic club, played the piano at sorority dances and classical concerts with equal artistry, and turned down flask toters with courteous finality. From every angle of vision Anne was a girl to be sought after. Her father was wealthy and she had a fortune in her own right, so the number of seekers was even larger than it would have been if it were only Anne who was to be won.

Among them were two who had been her playmates from childhood. One of them was Roland Downs, who took himself and the world with the utmost seriousness. He was tall, well proportioned and good looking enough, with brown eyes, and hair that usually was mussed

by his restless fingers. The other was Harry Hunter, short, blonde, curly and gay. He was master of small talk and could adapt himself instantly to a conference with the college dean about grades at the end of a semester, or to a petting party.

When Anne announced that she was about to start on a trip around the world with her father, Roland hastened to seek an interview. He wanted to express his entire approval of her course. Travel, he believed was a necessary part of a liberal education. On the other hand, he wanted to let her know how very lonely he would be while she was gone. With the optimism of youth, he liked to feel that his opinions and the state of his feelings might make a difference, that at least she would like to know. But it so happened that, with shopping trips to the city and the busy whirl of preparation at home, she gave him no opportunity to say what he wished to say, to her alone, although he was among the guests at her farewell party.

He was waiting for her on the deck of the *President* when she embarked, having secured a visitors' pass from the office of the steamship company. He felt rather proud of himself for being there, especially since Harry was absent. He sent orchids to her stateroom, so that she would find them after he was gone. They had cost him some perilous climbs over slippery roofs to erect aials for broadcast listeners, for all of Roland's money had to be earned.

She was able to give him but a fleeting moment in the midst of her family and friends. She put out her hand. His face flushed as he took it, unable to conceal the intensity of his emotions. It responded to his pressure in a way that melted him like steel in an electric furnace and put into him the backbone and fight that the same steel has after it comes through the tempering process. It was not a promisory squeeze, nor one to arouse any false hopes. It seemed to assure him that she considered him a

(Continued on page 44)

The Portable Condenser Microphone

By Alexander L. Sherwood

THE Westinghouse broadcasting stations are achieving the quality of voice and music reproduction in their programs picked up by telephone from outside points, through the development of a portable, shock-proof condenser microphone. After more than three years in the experimental stage, the peculiarities of this microphone were surmounted by engineers at KDKA, Pittsburgh and is now standard pick-up equipment at WBZ-WBZA, Springfield and Boston; KYW, Chicago, and KFKX, Hastings, Neb.

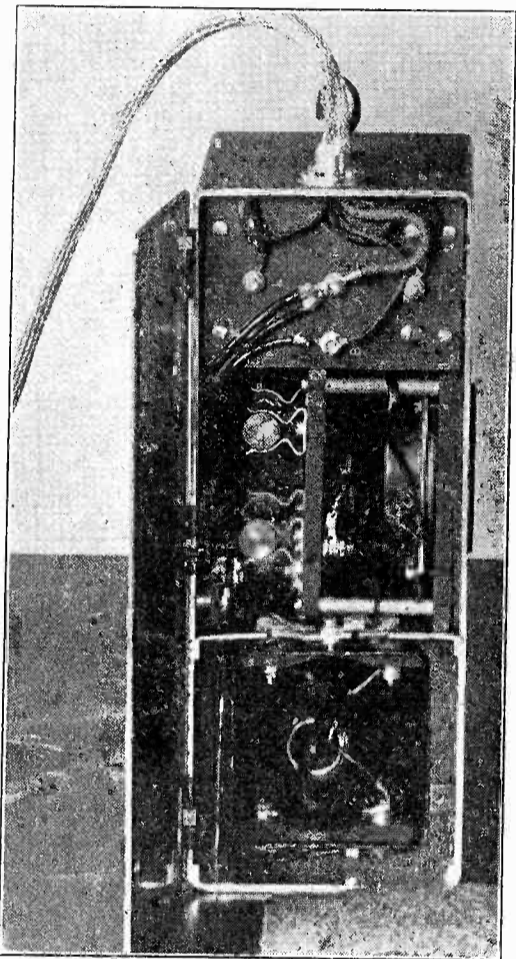

Rear View of Condenser Microphone

The engineering features which contributed most to its development were (1) placing a stage of amplification in the carrying case; (2) extreme shielding of lead wires; (3) vacuum tube of high-amplification characteristic, completely shielded from sound vibration; (4) elimination of tube sockets and questionable contacts; (5) return circuit made practically impervious to outside electrical disturbances.

Even with amplifiers close at hand in the studio, it was a difficult problem to use condenser microphones. Despite its superiority for high-quality reproduction, only a few studios are thus equipped today. Very small electromotive forces are set up; its adjustments are extremely delicate; but the hissing noises produced by carbon-grain microphones are absent in the condenser mike.

When properly adjusted, it produces no noise of its own.

At first it could not be placed more than 15 ft. from the amplifier. Away from the studio, a line amplifier is used to feed the signals into the telephone line; and it was seldom possible to have the mike within the require 15-ft. limit.

Practically all the handicap of the short connecting cable was eliminated by incorporating a stage of audio-frequency amplification in the carrying case. With its improvements, it can now be placed 1,000 ft. from the line amplifier without impairing the quality of the signals or introducing foreign disturbances. At athletic fields and in concert and theaters, it is frequently necessary to place the mike several hundred feet from the line amplifier. With the portable Condenser Mike, KDKA and sister stations are meeting all kinds of unusual pickup conditions, and are presenting programs equally as fine as those from the permanent studios.

The principle of the condenser microphone has been known for several years. It consists essentially of an air condenser, one of whose plates is a steel plug. The other plate is a diaphragm of duralumin—the alloy used in dirigible frames—no thicker than tissue paper (about 0.0018 inch). The diaphragm is stretched nearly to the elastic limit in order to raise the frequency of resonance above the range of audibility, or to 8000 cycles per second or higher. The plug and diaphragm are separated about 0.0015 inch, forming a condenser with air serving as the dielectric.

An electric charge of 200 volts is maintained on the condenser by means of a battery. As the diaphragm vibrates from the impact of sound waves, it varies the electrical capacity of the condenser; this, in turn, changes the voltage applied to the grid of the amplifying tube.

The complete apparatus is enclosed in an aluminum case about 4 x 10 in. The microphone is suspended in the center section, shielded by steel partitions. The amplifying tube is in the bottom, surrounded by a thick layer of felt, and cradled in such a way that shock can not reach it. In the top section is the transformer which steps up the current of the tube output. The heavy current, coupled with shielding of metal-covered connecting cable, renders the return circuit practically insensible to induced currents. The metal-covered cable contains battery leads as well as wires from microphone to line amplifier and telephone.

Until this instrument was perfected KDKA used a pick-up truck, with broadcasting station mounted on an automobile. Using short-wave the pick-up from the football field or music hall was broadcast to KDKA, where it was re-broadcast on the regular 309-metre set. The use of the portable transmitter, however, was discontinued when the mike was brought to its present stage.

Automatic measurement of the thickness of paper and of sheet rubber is industrially accomplished by the change produced in the capacity of a condenser, between whose plates the sheet is passed. The condenser is connected to a tuned radio circuit whose resonance meter is adjusted to zero position when the sheet is of the desired thickness. Any small change in thickness changes the capacity of the condenser and consequently the meter reading.

Rubber patching material, with the cold cement, helps to patch a cracked rubber cell jar of a storage battery, to hold coil windings in place, or as an adhesive of high insulating value.



Condenser Microphone with Line Amplifier

RADIO FOR JUNE, 1927

A Radio in The Phonograph Cabinet

By I. M. Ingerson

AN exceedingly satisfactory solution to the problem of utilizing a phonograph cabinet for housing a radio receiving set is here illustrated and described. Directions are given for putting a good four-tube set within a drawer whose inside dimensions are 17 by 13x2 $\frac{3}{8}$ in.

This is the drawer of a standard Victrola console. A "stop" is put on the bottom to prevent its being opened more than just enough to expose the tuning dials which are mounted horizontally on a recessed panel in the front. When a station is tuned in the drawer is pushed back into place so as to be out of the way. Besides this "disappearing" feature, the horizontal placement of the dials furnishes a comfortable hand-rest while tuning. The batteries are placed in the compartment beneath.

The "L C Circuit" as first published by G. M. Best in October 1925 RADIO is used. With a parallel-series arrangement of the filaments of four 3-volt tubes the current drain is 0.185 amperes. This gives satisfactory operation of a cone speaker with a fine quality of output obtained by using good a. f. transformers, power tube, high capacity cabled battery leads and positive grid bias of the detector tube. If the antenna is less than 75 ft. long the set tunes sharply without the aid of a wave trap. Oscillations are easily balanced out.

The panel is 3/16 in. bakelite stock, 7 in. wide and 13 in. long, recessed in the drawer so that the top surface of the panel is 1 in. below the top edge of the drawer. This allows 1/16 in. clearance over the top of the dials. Kurz-Kasch "Aristocrat" dials seem to be the flattest of the vernier type. The panel controls consist of two tuning dials, an oscillation control in the left front corner, a volume control in the right front

corner, and the main power switch in the center front. A hooded panel light mounted on a vertical bakelite strip along the back edge of the panel illuminates the dials and acts as a pilot light.

Beneath the panel in the remaining 1 $\frac{3}{4}$ in., the two Pacent straight line frequency .00035 mfd. variable tuning condensers are mounted. Their shafts are short enough to be applicable here. These condensers are placed 4 in. center to center. It was necessary to cut out the bottom of the drawer in order to allow a full swing of the condenser rotor. The radius of the ends of this cut-out is 3 in. It is recommended that the stators be located relatively as shown in the picture so as to prevent interference of the plates.

The oscillation control is a .00005 mfd. midget variable condenser. The volume control should be a 0 to 200000 ohm variable resistance. ("Centra-lab" or "Clar-o-stat.")

The space limitations required a re-design of the radio frequency transformers. With the aid of a logarithmic

nomographic chart it was found that the antenna coupler coil, in order to be not longer than 2 $\frac{1}{4}$ in., must be made on a 3 $\frac{1}{2}$ in. diameter bakelite tube wound with 49 turns for the secondary and 11 turns for the primary, totalling 60 turns of No. 22 D.C.C. wire.

In the same manner it was found that the intertube radio frequency trans-

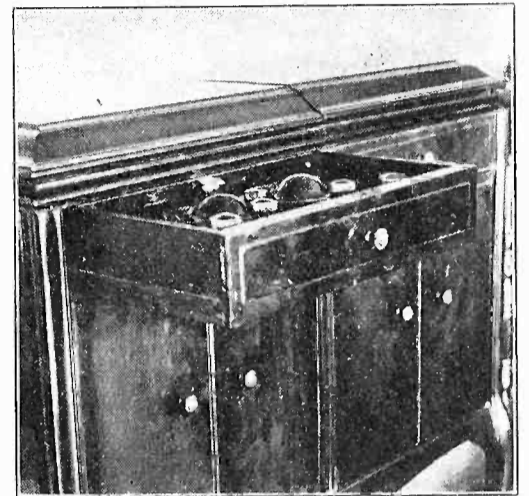

Radio Set in Console Drawer

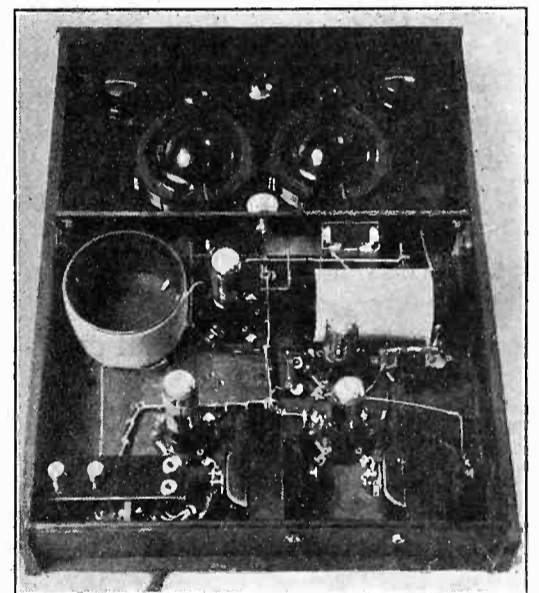

Rear View of Set

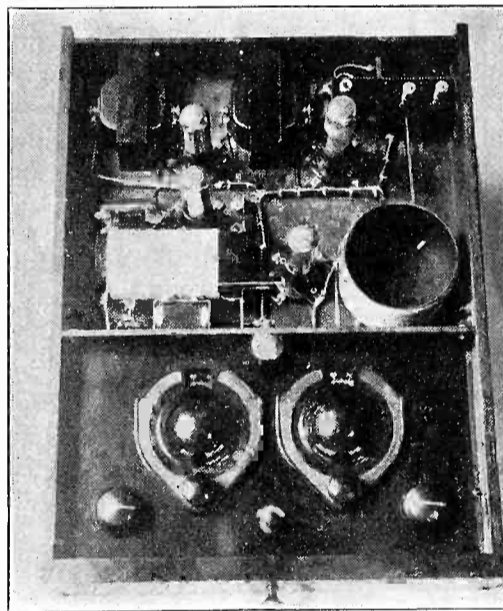

Front View of Set

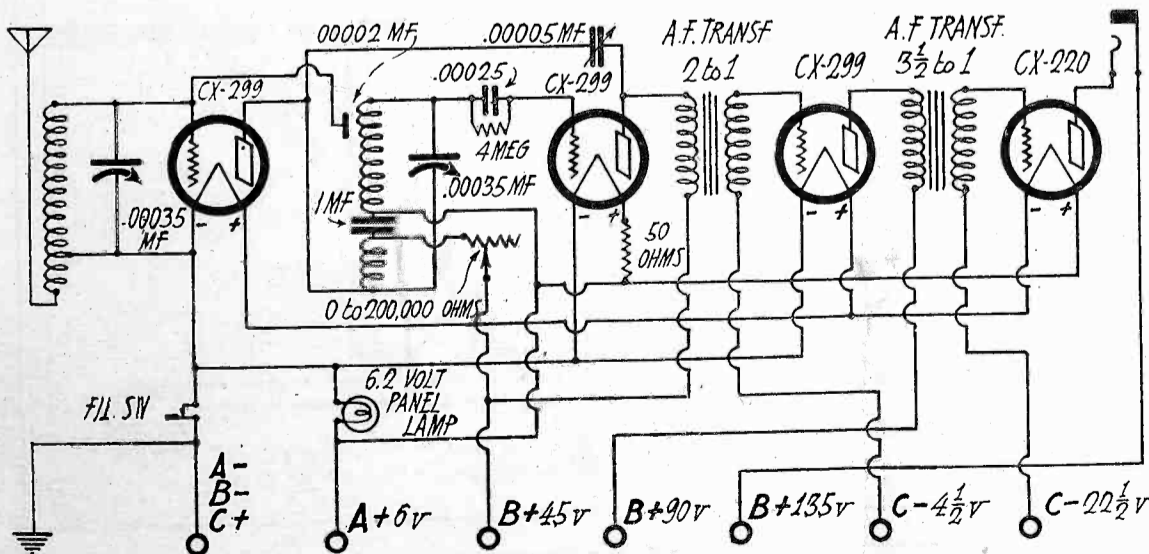

Circuit Diagram for Set.

former must be made on a 2 in. diameter bakelite tube 4 $\frac{1}{2}$ in. long, wound with a total of 101 turns of No. 22 D.C.C. wire, of which the secondary is 67 turns and the primary 34 turns. Coils of different diameters were used so as to avoid the placement of other metallic parts directly in the spray of magnetic flux from these coils.

The filaments of the radio frequency tube and of the first audio frequency tube are operated in parallel with their negative leads direct from the A battery and their positive leads joined to the negative filament post of the second audio frequency power tube. The positive power tube filament lead returns directly to the A battery with no intervening rheostat in the circuit. Each '99 tube has an internal voltage drop of 3 volts, and is in series with the type '20

power tube having the same drop. Current is supplied by a standard 6-volt

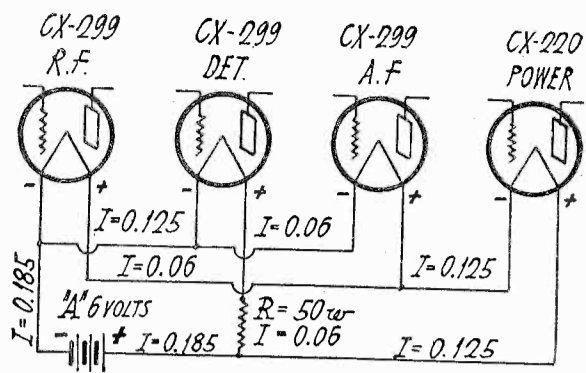

Parallel Series Filament Circuit

storage A battery of small capacity. A 50 ohm fixed resistance is in series with the detector tube filament so that a 6-volt A supply will furnish only a 3-volt drop through the tube.

An added feature to the original circuit is the volume control, which is a variable 0 to 200000 ohm resistance placed in series with the B battery plate lead to the radio frequency transformer. This method of control gives a control without the "flating" effect of some other schemes.

The neutralizing condenser is made from a brass "slug," the size of a nickel, soldered to a brass screw mounted on a small piece of bakelite. (Just in case no one knows what a "slug" is, let it be told that these were used in pre-Volstead days when it was five cents a glass.) The hole through the bakelite mounting is drilled slightly smaller than the outside diameter of the screw. The screw is then gradually worked through the hole to cut its own threads in the bakelite, thus making a rigid support. A brass nut screwed lightly against the bakelite acts both as a lock nut and as a

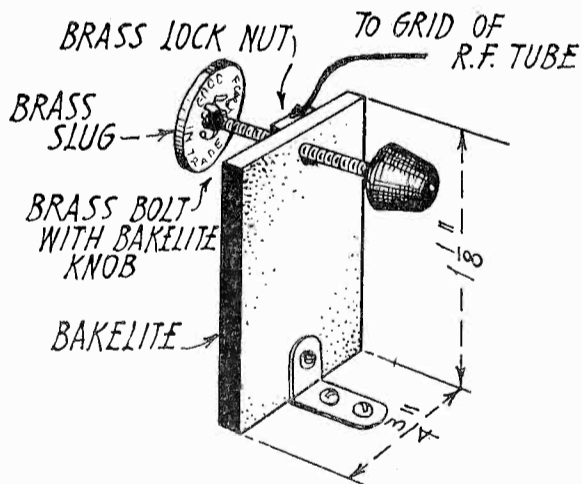

.00002 Mfd. Neutralizer

contact brush. The lead wire from the grid of the radio frequency tube is soldered to this nut.

It has been found that if this neutralizing condenser is placed near the filament end of the secondary of the intertube radio frequency transformer, a very close capacity setting is necessary and the action is critical, while if it is set near the grid end, the limits of satisfactory neutralization are broad and little difficulty will be experienced in adjusting for proper operation. Attention

is directed to the description of the "L-C Circuit" in October 1925 RADIO for method of neutralization. Numerous other articles have appeared in RADIO giving various satisfactory methods to accomplish this end.

A 3 volt positive grid bias is obtained for the detector tube by connecting the grid-return from that tube to the A battery side of the 50 ohm fixed resistance. When a type '99 tube is used for a detector tube the grid leak should be considerably higher than the standard 2 meg ohm leak used on the type '01A tubes. Values from 4 meg ohms to 8 meg ohms may be used; in this case a 4 meg ohm leak was used.

All leads connected to the grounded side of the set, directly or indirectly, are cabled. All others must not be cabled. The latter include the antenna lead, all grid leads between transformer secondary and grid of tube, all plate leads between plate of tube and transformer primary (excepting last audio

stage), and all leads connected between the grid and plate leads of the radio frequency and detector tubes, such as neutralizing, tuning, and feed-back condenser leads.

The good effects of cable leads are many-fold. One of the most important is the by-pass condenser effect between leads that makes the set operate with a uniform efficiency while either B or C batteries drop in voltage and increase in internal resistance. Thus good quality is practically assured even though the volume may become very weak.

An inexpensive cable connection block was used in this set as is illustrated in Fig. 7. The skinned ends of the cable wires are placed in the flat loop, which is then pinched tight upon the cable wire before it is soldered. A seven strand cable is necessary for this set. The connections between the negative B battery and the negative A and the positive

(Continued on page 52)

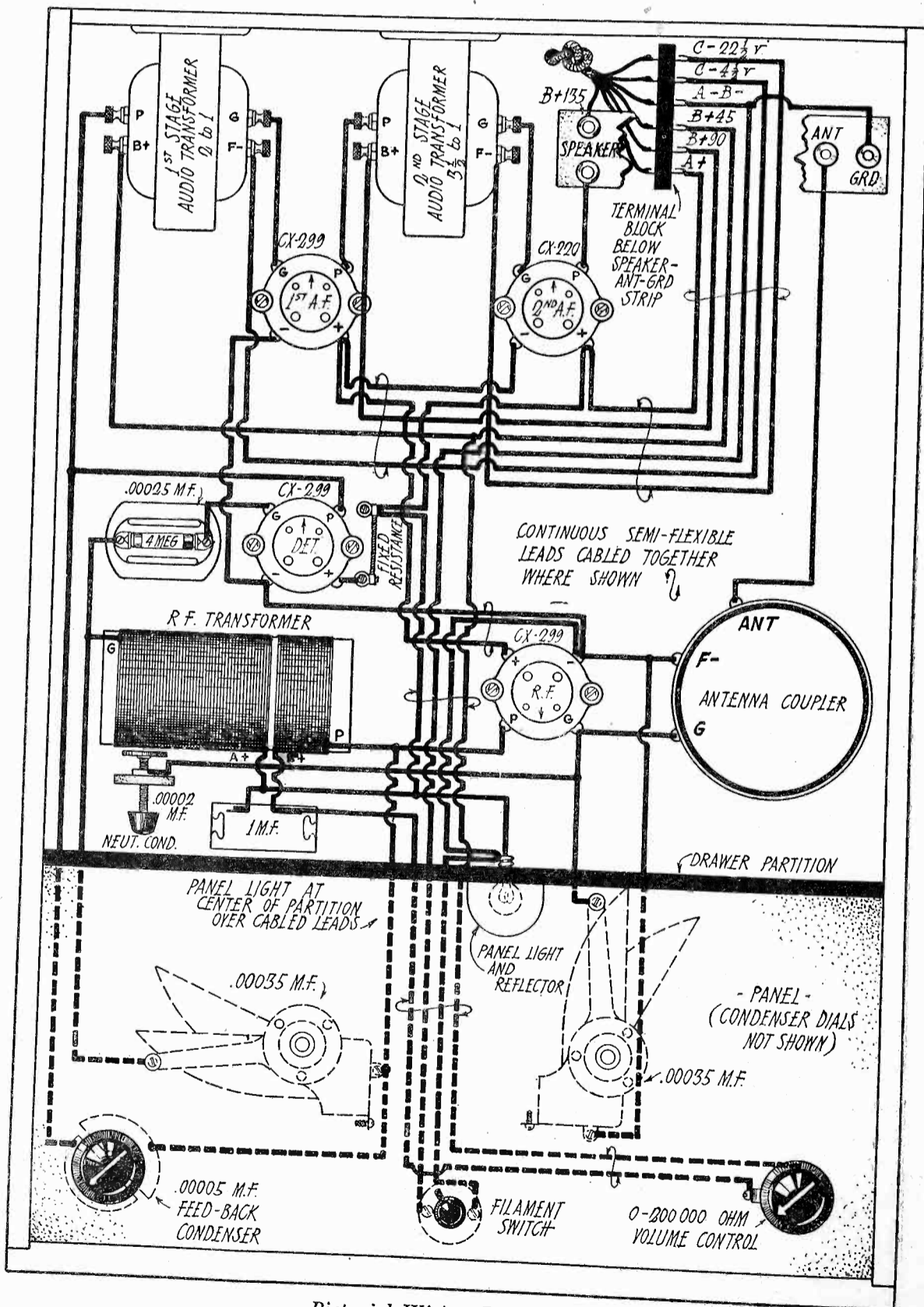

Pictorial Wiring Diagram.

What Is a Broadcast Station's Range

A Summary and Simple Interpretation of Recent Experiments on Absorption of Radiant Energy

By C. W. Morris

THE question as to why a broadcast station may be received with greater strength at one location than at another less distant point is being investigated by the Radio Division of the Department of Commerce. Surveys have been made of the strength of signals in the vicinity of several Eastern stations. The general conclusions from these tests substantiate the theory that signal weakness is generally due to absorption of radiation by intervening

objects. This absorption, where noted in the vicinity of large cities, has invariably been traced to groups of steel office or apartment buildings, which absorb part of the energy transmitted from the stations, and cast "radio shadows" which reduce the field intensity throughout the area covered by the shadow.

These surveys were made by means of the department's radio test car, which is equipped for measuring the field strength of radiation at various frequen-

cies. These measurements were in terms of "microvolts per meter." A microvolt is one-millionth of a volt. The meter refers to the exposed length of wire in the receiving loop. Thus with a loop antenna having 100 feet of wire (33 meters), a reading of 100 microvolts, as measured across the two terminals of the loop, would be equivalent to 3 microvolts per meter.

The results of a great number of tests were plotted on a map of the district so that points of equal intensity could be connected with curves. The ideal map would show a series of concentric circles with the broadcast station as the center, and gradually diminishing strength on the circles more distant therefrom. The actual maps show wide deviations from this ideal because the absorbed energy is conducted to ground and the radiation thus lost.

As steel buildings are the greatest offenders in this respect, one obvious remedy is to remove the station from a congested city center into the open country far from steel structures. Thereby the station secures greater efficiency of transmission and the residents in the surrounding territory get better service. Recent tests conducted by the Bell Telephone Laboratories with a portable radio transmitter showed that for the metropolitan area of New York City, the best position for a transmitter, in order to adequately cover this area with signals of great field strength, was in the open country of New Jersey, due west from the Island of Manhattan, and at a considerable distance from congested building areas. Where the transmitter was located in the heart of New York City, the effective area covered by the same transmitter was greatly reduced by the large groups of steel buildings, which cast shadows in five different directions, making it difficult for listeners at points even at close as 25 miles to obtain satisfactory reception at certain times of the day or night.

If the station cannot be moved, another remedy is to change the station's wavelength to one that differs from the absorbing steel structure's natural period of oscillation. This is not always possible in the present day condition of many stations on the air, but where this has been done, it has increased the effective area of the station, particularly when most of the absorption was by the steel building upon which the transmitter was located.

(Continued on page 62)

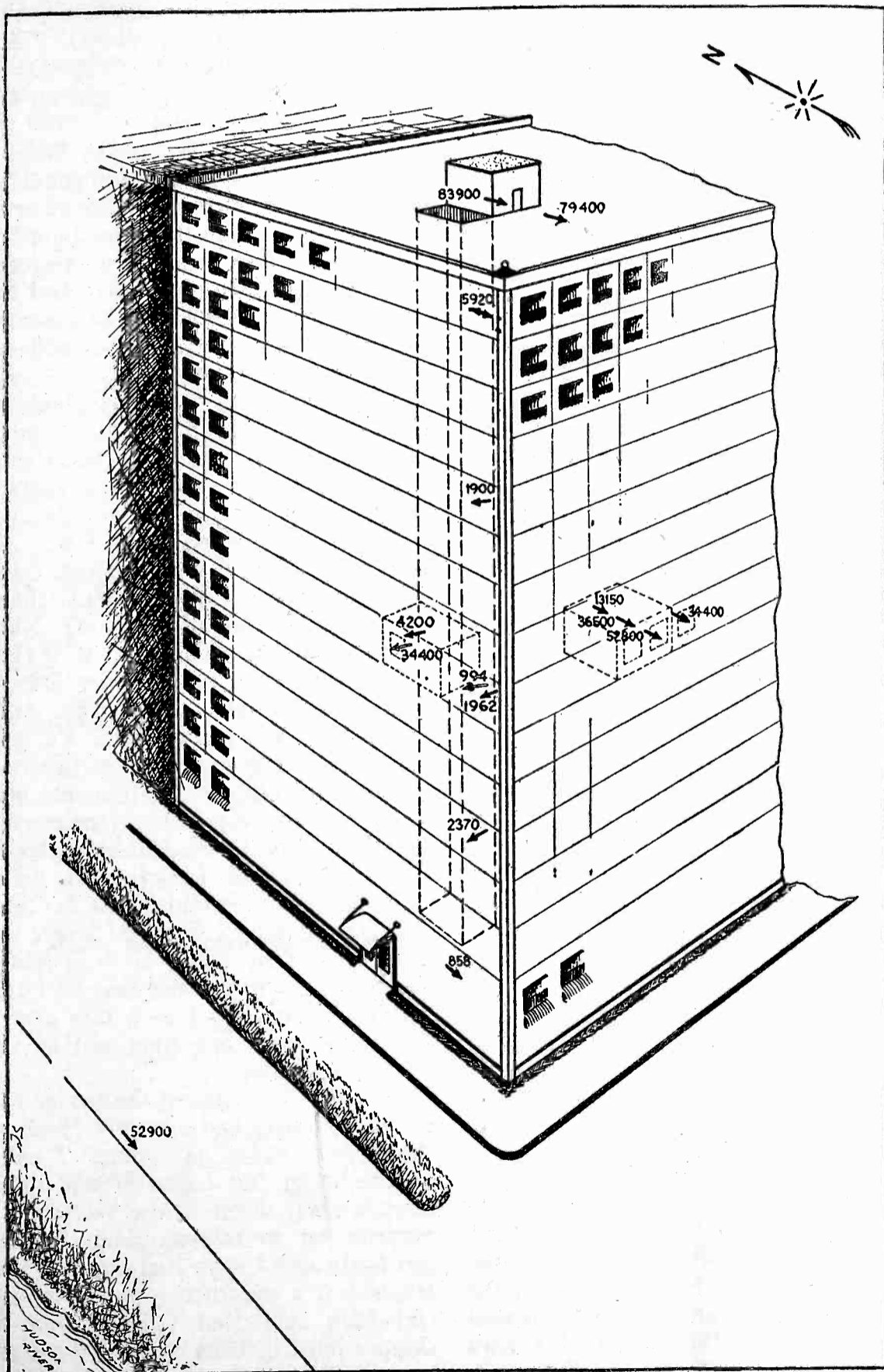

Fig. 1. Effect of Steel Building in Shielding Radio Reception.

"Letters From Larry"

By Jack Bront

Nr. 29, Ck \$4.32, Radio, SS Lake Discomfort, 7.65 P. M., Date
George Hassenpeffer, 218 River Street, Hoboken.

Dear Gimmick (stop) Well OM I was just headed into port this morning when I got your DH from the Beach (stop) We tried out the new radio compass OM and its KO (stop) That wise third engineer was up to the shack and he says says he how do you find the directions with that thing (stop) Well I says the directions comes with the set (stop)

Well OM the third operator stutters so bad we cant let him stand a watch (stop) We just get him to send V when we test the set (stop) We would like to have him take a stammering course but there dont seem to be any institoots which cure the malady among brass-beaters (stop) Honk suggests that we use him for driving an oscillator (stop) I expect we would have to send him to the Bureau of Standards for calibration OM (stop)

Say OM last night my third point in the triangle thats the stewardess friend from B deck come up and wanted to hear a radio concert (stop) Well I told her there was something very appropriate (stop) A lecture on sponges (stop) She didn't get the drift though and said it was sure swell (stop) I told her she was a swell jane too (stop) Shes always sponging on the boy friends (stop)

Gosh it was foggy this morning (stop) So foggy I missed my breakfast (stop) You see OM I left my store teeth in the radio room and in the mist Honk thought they was the ash tray (stop)

Well OM Mr. Gillis was down from the office and he says why aint the radio shack floor painted (stop) I says well Mr Gillis we painted it this morning but theres been so many down here from the office to see if it was painted that its all wore off (stop) He gets hostile OM and says Tut Tut young man (stop) I says I aint seen him lately (stop) Tut took a oil tanker over to Egypt the last time the radio operators got a raise (stop) Mr Gillis then says after I see the manager youll get whats coming to you real fierce like (stop) Well I says I hope so (stop) About sx 160 per month if you can manage it (stop)

Well OM I made a crystal set for Blonde Preferred (stop) She sat up all night listening to the ships dynamo (stop) I asked her did she hear anything (stop) She says no but youre going to hear something yourself right away (stop) Shes a swell stewardess but she dont savvy technical things like I do (stop)

Say OM I seen Gurk Wilson hes on a Light House Tender (stop) He says them light house tender jobs is pretty tough (stop)

We had a lot of trouble this trip tuning in on KDKA (stop) We got the barn dance program KO but the navy station came in on the third harmonica fierce (stop)

Well OM I told the third that the steward was kicking about the wear and tear on the bed clothes (stop) Third says I dont sleep much more than anyone else (stop) I got to have my rest he says (stop) Yes Honk says you rest so much that the rest of us dont get no rest (stop) Aw go sit on the key he says and resumes prone practice (stop)

Say Cronk Kitrick over at the station on the point collected by capricornus (stop) In other words that crimp he obtained a lien on my nanny (stop) In bad QRM he shot me a "love and kisses" at about 45 per minute (stop) Wheres the fire I says (stop) Look out he says or it will be up at the office when you turn in your abstracts (stop)

Well OM they may put us on the run over to France (stop) We got enough CW on board to work the Frogs clear across the big frog pond (stop) But say OM if you used a frog I mean a regular frog to drive an oscillator wouldnt it give a swell ACW note (stop) There would be quite a kick in the frog set OM (stop) And lots of skip distance like the army calls it OM (stop)

Say OM us three ops including Honk and me and the third entertained the customers in the dining saloon last nite (stop) We sang in unison with the radio (stop) We call it the triode trio (stop) The customers called us different names OM (stop) After the concert Blonde Preferred come down from the boat deck and she says was some body hurt (stop) No I says why (stop) Well she says there was a crowd around the door of the dining saloon and she heard someone in agony OM (stop) Women sure likes to hurt your feelings (stop)

But they aint so bad after all OM (stop) Well C U next trip OM (stop)
(sig) Larry

Nr. 43, Check \$2.89 Radio, SS Lake Discomfort, 9:98 Pm, Date.
George Hassenpeffer, 218 River Street, Hoboken

Dear Old Horse (stop) Well OM Mr Carter come aboard up north in the passengers (stop) He worked with the Joly-Arco outfit and the Kontinental Syndicate arcs OM (stop) He says where is the longest distance ship work

being done (stop) Well Mr. Carter I says if you approach the lee side of any static room in the city youll hear them working 8900 miles on one ampere any day in the week OM (stop) What is the static room he says (stop) Well Mr Carter I says the static room is where the banded operators gather to regale the events of their frivolous lives at sea (stop) And I says the scouts for publishing houses lurk in the offing (stop) Well says Mr Carter why the lurking in the er offing (stop) Well they pick up pointers on current fiction I says OM (stop)

A dear old lady with a ear trumpet looked into the radio room while we was testing the new amplifier which squawked like a angora (stop) I mean a angora cat OM (stop) Well OM she says Young man You get right up from setting on that cat (stop)

I wrote a long article on losses in dielectrics and sent it to the publishers in Frisco (stop) It was a good article because they said in the letter I got back that "due to lack of space we regret we are unable to use it" (stop) And they said they sent it back OM because they are feeding the goat on mush and milk now any how (stop)

Well Old Horse yesterday Honk was charging the Edisons all day and he come in and he says Jack theres something the matter with them batteries and he says the specific gravity wont come up atall (stop) Well I says this is a matter of great gravity Honk (stop) You say them Edisons wont change their gravity atall (stop) Not a single gravity he says (stop) Well Honk I says Im going to run over and see Tom about it right away (stop) And I says maybe somebody on board is using one of them anti-gravity gags (stop)

The third got a letter from the office which said quote you are transferred to the West World vice Clink Adams incumbent unquote (stop) Poor fellow said the third I wonder was he taken sick at sea (stop) Say you Honk says incumbent dont mean he was sick it means well its incumbent that all (stop) The third says yes I seen him over at Constable Hook one time and he sure limped bad (stop)

Well OM we repaired the bridge telephone yesterday and somehow Honk got the circuits mixed up (stop) I called up the bridge but I got through to the electric shop down below (stop) Red Stevens got to talking about his new girl again and I says Red you and your troubles is a nuisance (stop) Sos your Old Man says Red (stop) Well the skipper must of been connected too and he says Who said that (stop) I guess
(Continued on page 63)

A Laboratory Transmitter For Short Waves

By Everett W. Thatcher

THIS transmitter should appeal not only to traffic operators anxious to maintain their stations at top-notch efficiency but also to experimenters handling an occasional message. It is simple to construct and operate and is quickly adjustable to any one of the three short-wave bands in general use.

Fig. 1 shows the arrangement of the instruments upon the base, and Fig. 2 a rear view of the transmitter. This type of mounting has the advantage of accessibility to all the parts, facilitating changes when they are desired. The absence of cabinet and panels (with the exception of the abbreviated condenser supports) removes that much dielectric from the field, with its attendant loss.

No meters are included in the transmitter unit. This is of value in a laboratory where meters are sometimes wanted for other work. They are mounted on small individual panels and placed beside the baseboard in convenient position. Binding posts are provided for the filament voltmeter, the antenna current meter, and the milliammeter in the plate circuit. They may then be removed at will without interrupting the operation of the transmitter.

The arrangement shown makes possible the use of any standard circuit. Of those tried at the writer's station, the Meissner circuit (Fig. 3) was eminently successful. The fourth coil is not shown in the pictures, as it was suspended from a horizontal bar 2 ft. above the transmitter. Coupling was varied by slipping the support along the bar to any desired position.

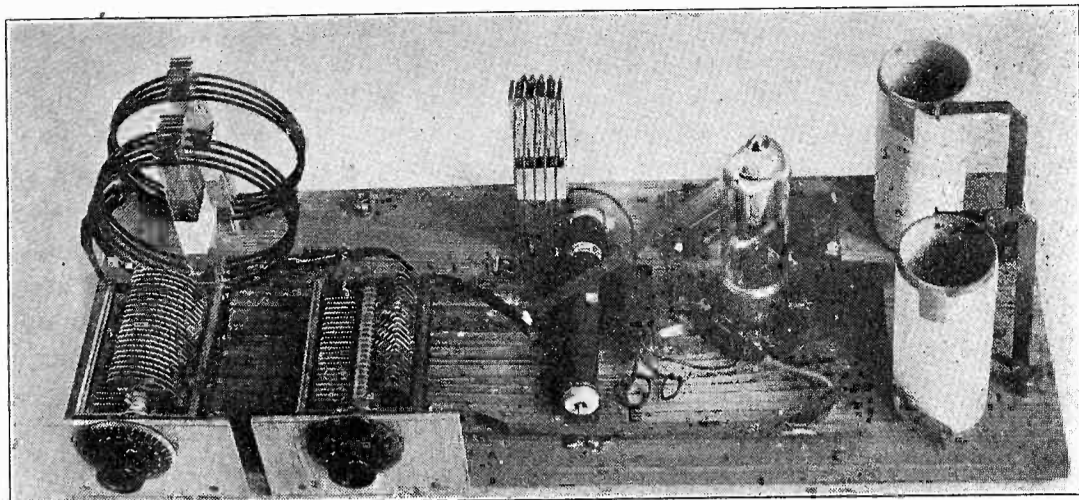

Fig. 1. Arrangement of Instruments on Base.

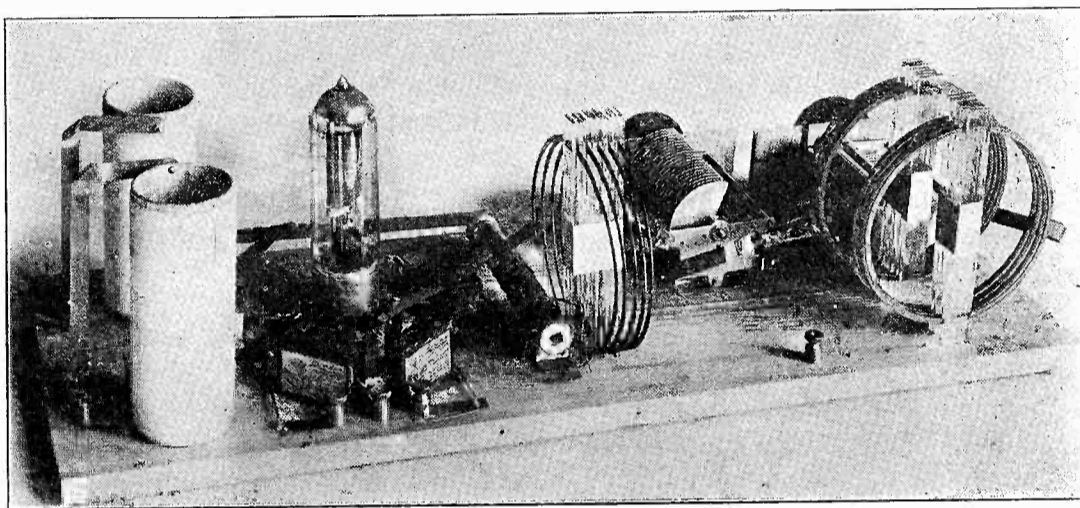

Fig. 2. Rear View of Transmitter.

The construction of the inductances is of special interest. A number of strips of glass (secured from ex-photograph plates), $\frac{3}{4}$ in. wide and 7 in. long were placed between the turns of an edgewise wound copper strip of 6 in. diameter. The separators were then bound tightly at the center, forming a rigid unit. The

spacing between turns can be changed by varying the number of strips.

The right hand half of the baseboard is given over to the oscillating circuit, for which a symmetrical arrangement was worked out so as to cut the leads to a minimum. This is shown schematically in Fig. 4. Surrounding the tube

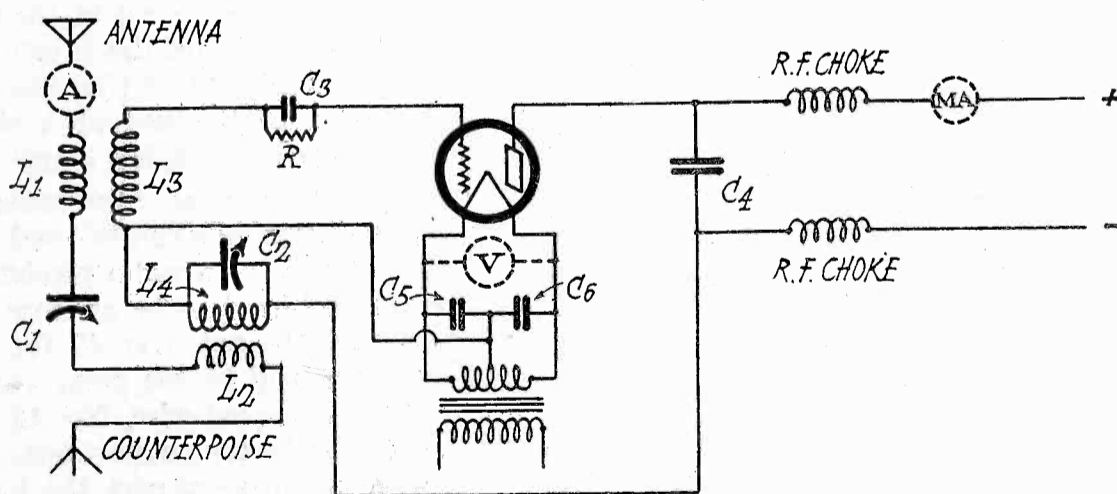

Fig. 3. Meissner Circuit As Used by Author.

- L_1 Antenna coil.
- L_2 Counterpoise coil.
- C_p Counterpoise.
- L_3 Grid coil.
- L_4 Plate coil.
- C_1 Antenna series Cond. .0004 mf.
- C_2 Secondary tuning Cond. .0004.

- C_3 Grid Condenser .0003 - .0005 mf.
- C_4 Plate By-pass Cond. .002.
- $C_5 - C_6$ Fil. By-pass .002.
- R.F.C. Radio freq. chokes.
- R Grid leak 5000 ohms.
- A Ammeter (0 - 3).
- V A. C. Voltmeter (0 - 15).
- MA D. C. Milliammeter (0 - 200).

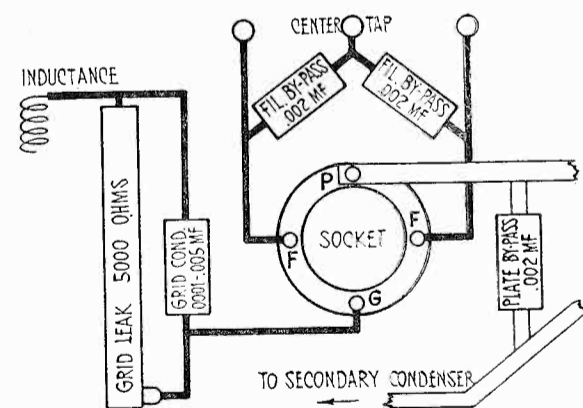

Fig. 4. Oscillating Circuit

socket can be seen four small fixed condensers. One of these (.002 mfd.) forms a by-pass for the radio frequency currents across the high voltage input. The next two serve the same purpose in relation to the filament circuit. The fourth, which has three available capacities, .0003, .0004, and .0005 mfd., is the grid condenser, and is connected, in parallel with a 5000 ohm resistance, to the grid inductance. The copper strip

Handy Hints

By C. F. Felstead

that is sold for ribbon antennas provides at once an inexpensive low resistance and convenient connector. Two choke coils of 200 turns each, No. 26 D.C.C. wire, serve to keep the radio frequency from backing up into the power supply circuit.

Due partly to the location of the antenna, a large system involving harmonic transmission seemed advisable. It also proved to be an efficient radiator, and convenient in shifting from one wave to another. The natural period of the system corresponded to a wavelength of 120 meters. For 80 meter work, the series condenser was adjusted until the fundamental was brought down to the working wave. The 40 meter band was reached by "shorting" the series condenser, and then tuning the oscillator to resonance with the third harmonic of the antenna. Similarly operation of 20 meters could be carried on, either by tuning the antenna circuit to 100 or to 60 meters, and working on the fifth or third harmonic.

Experience has indicated that operation of an antenna on odd multiples of its fundamental frequency is more advantageous than the use of even multiples. Thus the third, fifth and seventh harmonic seem, in general, to give better results than the second, fourth, sixth, etc.

This may be understood from Fig. 5. *A* shows the voltage-current distribution in an antenna (ungrounded oscillator) oscillating at its fundamental or first harmonic. *B* gives the distribution for half-wave, second harmonic transmission, and *C* that for the third harmonic.

It will be seen that at the center of the system, which usually falls somewhere near the inductance, the even multiples present a voltage maximum and current node, while the odd multiples present a voltage minimum and corresponding current maximum. The high potential in the proximity of the set in the case of the second, or other even harmonics, will tend to produce a leakage of the radio frequency currents at points where the conductors come in

contact with supports. We are led to the conclusion that the voltage node which occurs as a consequence of odd harmonic excitation is highly desirable to reduce losses to a minimum.

The final test is in the "workability" of the transmitter in actual operation. The writer's experience here has left nothing to be desired. Some idea of the results that can be obtained may be had from the fact that over 75 per cent of the total calls from the station were answered, and resulted in communication. The range is limited only by the size of the globe, consistent work having been carried on with antipodal stations, sometimes under the most unfavorable conditions.

Any receiving set can be re-built into a low-loss set by rewinding the coils with heavy, insulated wire, ranging in size from No. 14 to 20, and using low-loss tuning condensers. As little support as possible should be used to hold the windings, and that should be of the best, preferably Pyrex or glass. The windings should be at least three inches away from all the other parts of the set, including the panel, to keep the resistance of the coils low. Under no circumstances should more than a slight bit of shellac or other coil "dope" be used on the windings; or the improved results obtained by the use of the heavy wire will be lost.

The filament of a UX-201A or CX-301A tube can be run directly off the 110-volt line without the necessity of a filament transformer if a 25-watt, 110-volt electric light is connected in series with it. The drop across the light is just 105 volts, leaving five volts at $\frac{1}{4}$ ampere for the filament. If a 25-watt light is not available, a 50-watt and a 60-watt light can be connected in series in its stead. It does not matter whether direct or alternating current is used. This stunt will save the amateur the expense of a filament transformer for his small transmitter. If he be ingenious, he will use the 105-volt drop across the lamp for the plate voltage for the tube.

AN ordinary *C* battery can be used in place of the *A* battery in a portable set having '99 type tubes. The battery will not last very long when used in this way; but the saving in space and weight more than compensates for the increased upkeep.

It is not good practice to shield radio-frequency amplifiers by placing them in individual metal boxes unless more than two stages are employed. In fact, it is really not advisable to shield a one-stage or two-stage RF amplifier in this manner. With three stages of amplification, the shielding is usually necessary to prevent coupling between the stages, which causes oscillation and interferes with the operation of the receiver.

People often wonder how the abbreviation *DX* for "long distance" was derived. It is a commercial radio abbreviation that was originated more than twenty years ago. *D* is the first letter of *distance*; and *X* represent the letters that are left off. *WX* for "weather" and *PX* for "press" (the wireless newspaper of the sea) are contractions that were similarly derived.

A sun bath occasionally is as good for a receiving set as it is for a person. The set should be taken out into the open, and the inside exposed to hot sunlight for several hours. This will dry out the insulation on the wire in the coils, and any other parts that have a tendency to absorb moisture. All the dust and dirt can be cleaned out of the set at the same time. The dust should be removed from between the plates of the variable condensers particularly. This can be done easily with a pipe cleaner. A handy brush to clean away the dust in the set can be made by breaking the brush off of a worn-out circular typewriter eraser, and fastening it to the end of a thin piece of wood about six inches long.

In case of an emergency, the storage battery in an automobile can be used on the filament circuit of a radio receiving set. The automobile must be as close as possible to the set—not over 20 ft., or the voltage drop will be too great—and heavy leads of insulated wire, No. 12 or larger, used to make the connections. It is not necessary to disconnect the battery from the auto ignition system, as the rubber tires insulate it from the ground.

Bed springs, or the frame of a metal bed, can be used as a substitute aerial when traveling. It will work quite well for reception from local broadcasting stations. A ground to a steam radiator, water pipe, or gas pipe will have to be used. This stunt is almost as old as radio itself.

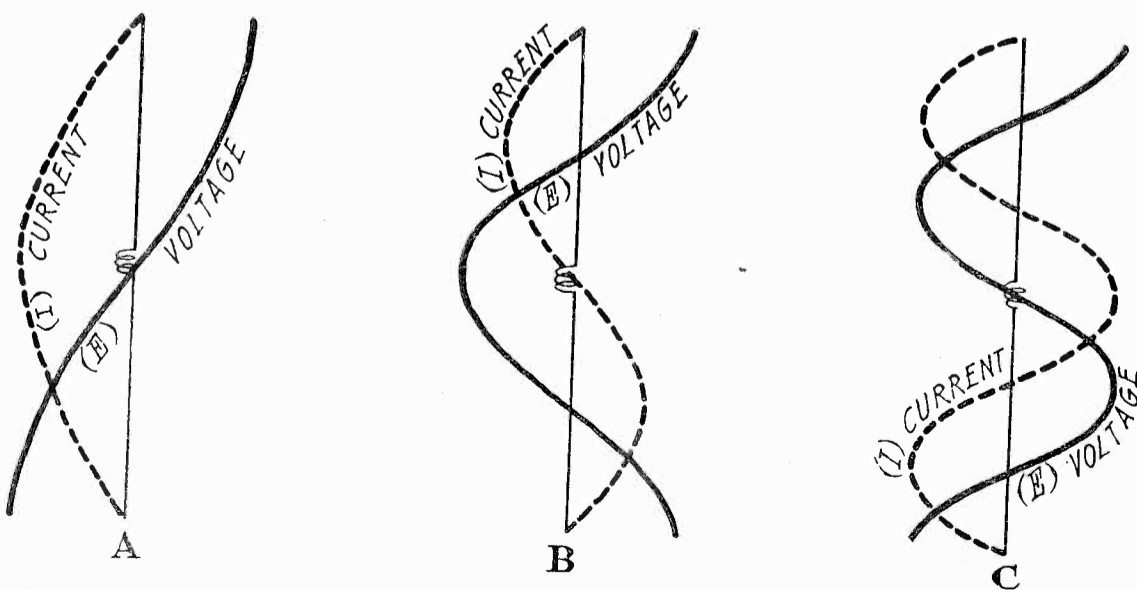

Fig. 5. Voltage Current Distribution in Antenna at Various Harmonics.

A. C. Measurements With a Wattmeter

By Harry R. Lubcke

As mentioned in the writer's article "How to Make a Single-Phase Wattmeter" in February 1927 RADIO it is possible to determine practically all alternating current circuit constants by the use of a wattmeter, voltmeter and ammeter. It is the purpose of this paper to tell how to do this. For 110 volt 60 cycle circuit, a voltmeter of 0-150v. range and an ammeter of approximately 0-3 amp. range will be required. The moderately priced small sized meter will be satisfactory.

Power factor is easily determined by taking simultaneous readings of wattmeter, voltmeter, and ammeter, connected as shown in Fig. 1. The apparatus

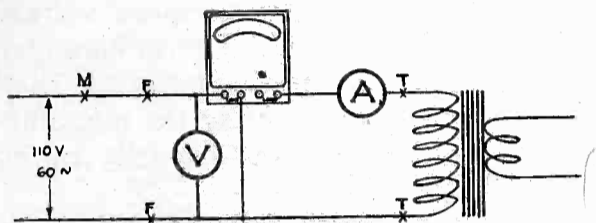

Fig. 1. Connections for Measurement of Power Factor.

under test is connected at T-T, and to illustrate the calculation to follow, is shown as a transformer primary. The power factor, designated by $\cos \phi$, is equal to the wattmeter reading W divided by the product of the ammeter reading I and the voltmeter reading E : $\cos \phi = W/EI$(1)

A good explanation of the meaning of power factor appeared on page 30, March 1926 RADIO by A. Hobart, to which the reader is referred. For this discussion it will be considered as the cosine of the phase angle ($\cos \phi$) between the current and the voltage. The current will be lagging behind the voltage because of the inductance of the transformer, in this case.

The impedance of the circuit, or what might be called the alternating current resistance Z , is secured by dividing the voltage E by the current I .

$$Z = E/I \quad (2)$$

In circuits the impedance consists of resistance and reactance. The resistance is the same as found in d. c. circuits, while the reactance is an added resistance effect caused by the presence of inductance or capacity. When caused by inductance, as in the case of the transformer being considered, it is called the inductive reactance, designated by X .

$X = 2\pi fL$ (3) when f = frequency = 60 for all ordinary power supplies: L = inductance of circuit, measured in henries; $\pi = 3.1416$. X is also equal to the impedance Z multiplied by the sine of the phase angle, ϕ .

$$X = Z \sin \phi \quad (4)$$

Since we know Z and $\cos \phi$ we can find X . Simply look up, in a table of natural trigonometric functions, the sine that corresponds to $\cos \phi$.

Since X is now known and $2\pi f$ is also a known constant we can solve for L , the inductance of the circuit, from eqt. (3). It equals the reactance X divided by $2\pi f$.

$$L = X/2\pi f \quad (5)$$

The apparent resistance of the circuit R' is equal to the wattmeter reading divided by the current squared.

$$R' = W/I^2 \quad (6)$$

We can also determine the loss in the circuit due to eddy-current or hysteresis losses in the iron. This quantity, which we shall designate by S , equals the wattmeter reading W minus the product of the current squared and the d. c. or actual copper resistance R .

$$S = W - I^2 R \quad (7)$$

With the apparatus generally available R can best be determined by connecting a storage battery shunted with a low range d. c. voltmeter at F-F in Fig. 1, the a. c. source being disconnected. From Ohm's Law, R equals the d. c. voltmeter reading divided by the ammeter reading (assuming the a. c. ammeter reads correct on d. c.). $R = E_d/I_d$ --- (8).

Assume that the characteristics of the primary of a step-up transformer, such as might be used for transmitter plate supply, are to be determined. When the line voltage is 110v. the following readings are obtained.

$$W = 25 \text{ watts} \quad E = 110 \text{ volts} \\ I = 1.2 \text{ amps.}$$

Power Factor, (1), $\cos \phi = W/EI = 25/110 \times 1.2 = 0.1893$.

Impedance, (2), $Z = E/I = 110/1.2 = 91.7$ ohms.

Reactance, (4), 0.1893 is cos. of $79^\circ 05'$ whose sine is 0.9819.

$$X = Z \sin \phi = 91.7 \times 0.9819 = 90.$$

Inductance, (5), $L = X/2\pi f = 90/2 \times 3.1416 \times 60 = 0.239$ henries.

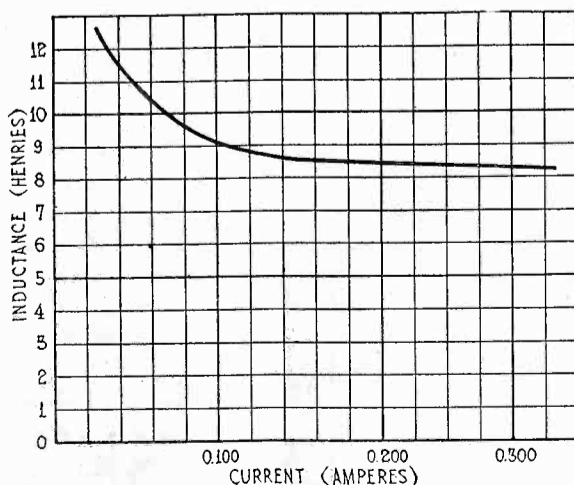

Fig. 2. Variation of Inductance With Current.

Apparent Resistance, (6), $R' = W/I^2 = 25/(1.2)^2 = 17.36$ ohms.

True Resistance, (8), $R = E_d/I_d = 6/0.5 = 12$ ohms.

Core Loss, (7), $S = W - I^2 R = 25 - (1.2)^2 \times 12 = 7.7$ watts.

In the same manner the inductance can be calculated for different voltages and currents as determined by a rheostat at M in Fig. 1 while current is drawn from the secondary of the transformer. Practically all the values will be changed with a change in any of the conditions of the circuit. It is often desirable, therefore, to plot a graph of the values of some of the more important characteristics, showing their variation with some circuit condition. Fig. 2 shows the variation of inductance of a Dongan radio B Choke with the current flowing through it. This is useful in showing the inductance corresponding to any given current.

The range of a direct-current ammeter, such as used in receiving sets, can be increased by connecting a proper shunt across its terminals. The right size for the shunt can be determined very easily. The ammeter is connected in series with a load that draws enough current to give nearly a full scale reading on the ammeter. If the ammeter has a range of zero to five amperes, a load that draws just four amperes should be used. A piece of wire is then connected across the terminals of the ammeter; and its length varied until the ammeter reads just half what it did before—two amperes in this case. The size of the wire may have to be changed to get this reading, though the wire used must be large enough to carry one-half the load. When this shunt is used, the ammeter will give a full scale deflection when connected in series with a ten-ampere load. A heavier shunt wire could be used, one that would cut the original four-ampere reading down to one ampere; and then the meter would give a full scale deflection on twenty amperes. New scales can be made for the meter to be used with these shunts; or the old scale can have the new readings marked on it. A number of shunts of different sizes can be made; and thus one ammeter can be given a very wide range.

It is advisable to paint an aerial pole with one or more coats of heavy lead paint before it is erected. White paint will make the pole show up best. The paint not only protects the pole, but also greatly improves its appearance.

Radio Standards

A Summary of Important Standards Adopted and Practices Recommended By National Electrical Manufacturers Association

THE Nema Handbook of Radio Standards, while intended primarily for the guidance of manufacturers and therefore largely concerned with dimensions, contains many items of interest to the user of radio equipment. Among these are the radio symbols presented herewith. These are not rules but merely represent the customs adopted by the association members. These start with the fundamental unit symbols for inductance, capacity and resistance and continue with various combinations that make up the composite symbols.

The standard of size for antenna wire is No. 14 bare or enamelled hard drawn copper or its equivalent. The lead-in is No. 14 weather-proof wire, solid or stranded. The flat type of insulated flexible lead-in conductor has not yet been approved by the National Board of Fire Underwriters, although this approval is possible at some future date.

It is recommended that the printed instructions furnished with all radio and audio transformers specify the use of pure resin flux only, in soldering connections to the transformer terminals.

In the standard markings of radio and audio transformer terminals, *G* denotes to grid circuit of vacuum tube, *F* denotes to filament circuit of vacuum tube,

P denotes to plate circuit of vacuum tube, *+B* denotes to positive (+) terminal of B battery, *PRI* denotes winding between terminals *P* and *+B*, *SEC* denotes winding between terminals *G* and *F*.

The term "amplification per stage" is defined as the product of the amplification factor of the tube used and the ratio of voltage output to voltage input of the interstage coupling, whether resistance, impedance or transformer. This ratio is measured at audio frequencies by means of a tube voltmeter in accordance with methods described in the handbook.

The impedance of standard radio head sets shall come within the limits of 9,000 ohms minimum and 25,000 ohms maximum, when measured with an alternating current of 800 cycles per second.

The terminals of each telephone ear piece of a standard radio head set shall be marked with a plus sign (+) to denote the terminal to which the "positive" connection shall be made and with a minus sign (-) to denote the terminal to which the "negative" connection shall be made.

It shall be standard to rate filament heating storage *A* batteries in ampere-hours based upon a continuous discharge at the 100-hour rate, at 80 deg. F. cell







temperature, to a cut-off voltage of 1.75 volts per cell. The ampere discharge rate, for testing purposes, shall be determined by dividing the manufacturer's ampere-hours capacity rating of the battery by 100.



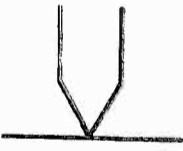

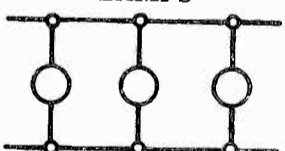
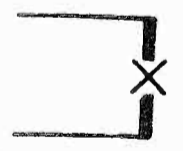

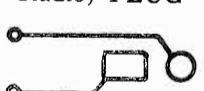
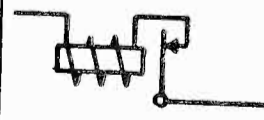

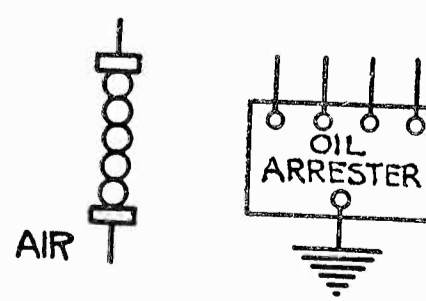
A battery which fails to deliver its rated capacity on the third repeated cycle of charge and discharge, under the conditions specified, shall be considered to be improperly rated.

It shall be standard to rate plate current storage *B* batteries in milliampere hours, based upon a continuous discharge at the 200-hour rate, at 80 deg. F. cell temperature, to a cut-off voltage of 1.75 volts per cell. The milliampere discharge rate, for testing purposes, shall be determined by dividing the manufacturer's milliampere-hour capacity rating of the battery by 200.

A battery which fails to deliver its rated capacity on the third repeated cycle of charge and discharge, under the conditions specified shall be considered to be improperly rated.

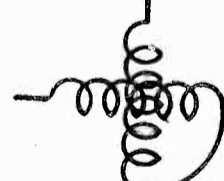
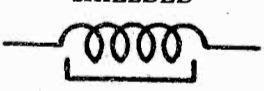
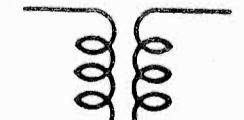
For the purpose of this standard any radio installation in which the energy for the filament, or plate circuits, or both, is supplied from storage batteries, shall be considered as consisting of three essential components, namely, the re-

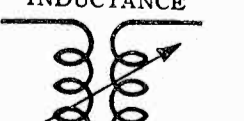
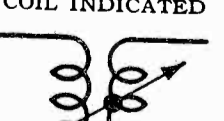
MISCELLANEOUS SYMBOLS		
THERMO-ELEMENT 	ELECTRIC BELL 	INCANDESCENT LAMPS 
ARC 	PIEZO-ELECTRIC CRYSTAL 	TELEPHONE (or Radio) PLUG 
BUZZER 	JACK 	AMMETER SHUNT 
LIGHTNING ARRESTER 		

INDUCTANCE	CAPACITANCE	RESISTANCE
		
INDUCTANCE SYMBOLS		
INDUCTOR OR INDUCTANCE FIXED AIR CORE 	INDUCTOR OR INDUCTANCE VARIABLE AIR CORE Continuously variable by "variometer" principle 	INDUCTOR SHIELDED 
INDUCTOR, MUTUAL FIXED MUTUAL INDUCTANCE 	INDUCTOR OR INDUCTANCE VARIABLE AIR CORE Continuously variable 	INDUCTOR OR INDUCTANCE VARIABLE. AIR CORE Adjustable by taps or steps 
INDUCTOR, MUTUAL, VARIABLE VARIABLE MUTUAL INDUCTANCE 	INDUCTOR, MUTUAL VARIABLE MUTUAL INDUCTANCE MOVING COIL INDICATED 	INDUCTOR OR INDUCTANCE IRON CORE Commonly called a "choke coil." (Note: The representation for iron core is the same for all inductance symbols, i. e., for fixed or adjustable inductance.) 

CAPACITANCE SYMBOLS		
CAPACITOR OR CAPACITANCE FIXED 	CAPACITOR OR CAPACITANCE VARIABLE, MOVING PLATE INDICATED 	CAPACITOR OR CAPACITANCE SHIELDED
CAPACITOR OR CAPACITANCE VARIABLE 		
RESISTANCE SYMBOLS		
RESISTOR OR RESISTANCE FIXED 	RESISTOR OR RESISTANCE ADJUSTABLE BY TAPS OR STEPS 	RESISTOR OR RESISTANCE CONTINUOUSLY VARIABLE
AERIAL AND GROUND SYMBOLS		
AERIAL OR ANTENNA 	COUNTERPOISE 	GROUND
COIL ANTENNA 		

SYMBOLS PECULIAR TO RADIO USAGE		
CRYSTAL DETECTOR 	ELECTRON TUBE THREE ELEMENT (TRIODE) 	SPARK GAP QUENCHED
ELECTROLYTIC RECTIFIER 	ELECTRON TUBE TWO ELEMENT (DIODE) 	ELECTROLYTIC DETECTOR
ANODE CATHODE		
SPARK GAP ROTARY, NON-SYNCHRONOUS 	SPARK GAP PLAIN, OPEN TYPE 	SPARK GAP ROTARY, SYNCHRONOUS
HEADPHONE, SPEAKER AND MICROPHONE SYMBOLS		
HEADPHONES HIGH RESISTANCE SUCH AS USED IN RADIO 	LOUD SPEAKER 	TELEPHONE RECEIVER SINGLE, LOW RESISTANCE UNIT
	MICROPHONE 	

WIRING SYMBOLS		
WIRES ELECTRICALLY CONNECTED 	WIRES NOT ELECTRICALLY CONNECTED CROSS OVER 	
MEASURING INSTRUMENT SYMBOLS		
AMMETER 	GALVANOMETER 	FREQUENCY METER
VOLTMETER 	WATTMETER 	WAVE METER
SYMBOLS FOR SWITCHES, FUSES, ETC.		
SELECTOR OR TAP SWITCH 	REVERSING SWITCH 	KNIFE SWITCH SINGLE POLE, DOUBLE THROW

KNIFE SWITCH SINGLE POLE, SINGLE THROW 	CIRCUIT BREAKER
KNIFE SWITCH DOUBLE POLE, SINGLE THROW 	MAGNETIC SWITCH
KNIFE SWITCH DOUBLE POLE, DOUBLE THROW 	FUSE
KNIFE SWITCH THREE POLE, SINGLE THROW 	TRANSMITTING KEY
	MAGNETIC TRANSFER SWITCH
	BATTERIES
TRANSFORMER SYMBOLS	
KNIFE SWITCH THREE POLE, DOUBLE THROW 	AUDIO OR POWER TRANSFORMER

ceiver, the storage battery, or batteries, and the charging means.

It shall be standard for any manufacturer who supplies any two, or all three, of these components to include in the assembly a fuse, or fuses, as required by Article 37 of the National Electric Code.

It shall be standard for manufacturers of radio receivers and charging devices, sold as separate units, for assembly into a complete equipment by the customer, to include in the accompanying instruction card or book, a statement to the effect that the complete installation, if it include storage *A* or *B* batteries, or both, must also include fuses.

Vacuum Tube Definitions

A vacuum tube is defined as a device consisting of a number of electrodes contained within an enclosure evacuated to a low pressure. This term is also commonly used less broadly in referring to the type of vacuum tube having grid, plate and filament (triode).

A diode is a type of vacuum tube containing two electrodes which passes current wholly or predominantly in one direction. A vacuum tube having a single cathode and two anodes which operate alternately may properly be called a double diode.

A triode is a type of vacuum tube containing an anode, a cathode and a third electrode, in which the current flowing between the anode and the cathode is controlled by the relative potential of the third or control electrode.

The cathode is the electrode to which the current flows through the vacuum space. The cathode is usually the source of the electron emission which constitutes this current. The filament is the cathode in the common type of vacuum tube (triode). The filament voltage is the voltage between the terminals of the filament. Filament current is the current supplied to the filament to heat it.

The control electrode is that whose relative potential controls the current flowing between the anode and the cathode. Grid is the common name for the control electrode in a vacuum tube. The grid potential is the electric potential of the grid relative to the cathode. The grid current is the conduction current passing from the grid through the vacuum space. Reversed grid current is the conduction current passing to the grid through the vacuum space.

Grid conductance is the quotient of the change in grid current divided by the change in grid potential producing it, under the condition of constant plate potential. The grid characteristic curve is the curve plotted between grid potential as abscissa and grid current as ordinate.

The grid detection coefficient is the quotient of the change in the direct grid current produced in a vacuum tube with

no external grid or plate resistance, due to an impressed alternating grid voltage, divided by the square of the r.m.s. alternating voltage.

A grid condenser is a condenser connected in series in the grid or control circuit of a vacuum tube. A grid leak is a resistor, usually of very high resistance, used in association with a condenser and connected directly or indirectly between the cathode and the grid of a vacuum tube.

The anode is the electrode from which the current flows through the vacuum space. The plate is the common name for the anode in a vacuum tube. Plate potential is the electric potential of the plate relative to the cathode. Plate current is the conduction current passing from the plate through the vacuum space.

Amplification factor is a measure of the effectiveness of the grid potential relative to that of the plate potential in affecting the plate current; it is the quotient of the change in plate potential divided by the negative change in grid potential, under the condition that the plate current remains unchanged.

Mutual conductance is the quotient of the change in plate current divided by the change in grid potential producing it, under the condition of constant plate potential. The unit ordinarily used is the micromho.

Plate conductance is the quotient of the change in plate current divided by the change in plate potential producing it, under the condition of constant grid potential.

Plate resistance is the reciprocal of the plate conductance.

The plate characteristic curve is the curve plotted between plate potential as abscissa and plate current as ordinate.

A plate choke coil is a coil of relatively high inductance inserted in the anode supply circuit of a vacuum tube amplifier, modulator, or oscillator to maintain substantially constant current in this circuit throughout a cycle of the amplified or generated current.

Filament capacity is the sum of the direct capacities between the filament and all other conductors of a vacuum tube. Grid capacity is the sum of the direct capacities between the grid and all other conductors of a vacuum tube. Plate capacity is the sum of the direct capacities between the plate and all other conductors of a vacuum tube.

Direct capacity between two conductors is the quotient of the charge produced on one conductor by the voltage between it and the other conductor divided by this voltage, all other conductors in the neighborhood being at the potential of the first conductor.

Grid-plate capacity is the direct capacity between the grid and the plate.

Grid-filament capacity is the direct capacity between the grid and the filament.

Plate-filament capacity is the direct capacity between the plate and filament. All capacities are ordinarily understood to be taken with the vacuum tube in its completed form but not in its socket or other holder.

The internal output impedance (of any electrical device having output terminals) is the quotient of the alternating voltage impressed on the output terminals divided by the alternating current thereby produced at these terminals, in the absence of impressed alternating voltages at other points. This is sometimes called simply "output impedance," but the prefix "internal" is preferred in order more surely to distinguish it from the impedance of the external output circuit. Internal output admittance is the reciprocal of internal output impedance.

The input impedance (of any electrical device) is the quotient of the alternating voltage impressed on the input terminals of the device divided by the alternating current thereby produced at these terminals, in the absence of impressed alternating voltages at other points. Input admittance is the reciprocal of input impedance.

The mutual detection coefficient (of a vacuum tube) is the quotient of the change in the direct plate current produced in a triode with no external grid or plate resistance, due to an impressed alternating grid voltage, divided by the square of r. m. s. alternating voltage.

Mutual characteristic curve (grid-plate characteristic curve), is the curve plotted between the grid voltage as abscissa and the plate current as ordinate.

Electron emission is the phenomenon of the liberation of electrons from the surface of a body into the surrounding space, usually under the influence of heat, ultra-violet rays, x-rays, impact excitation, or chemical disintegration. The value of the current carried by electrons emitted from a cathode under the influence of a voltage such as will draw away all the electrons emitted.

The emission characteristic curve is the curve fitted between a factor controlling electron emission, (such as the temperature, voltage or current of the cathode or filament) as abscissa and the emission current from the cathode or filament as ordinate.

Glazed porcelain, glass, and Pyrex are the three best kinds of insulators to use for receiving aerials. If a porcelain insulator is not glazed, it is considerably inferior to the other two kinds of insulators, because it will absorb moisture. Pyrex is the best because moisture does not adhere to it.



QUERIES and REPLIES



Questions of general interest are published in this department. Questions should be brief, typewritten, or in ink, written on one side of the paper, and should state whether the answer is to be published or personally acknowledged. Where personal answer is desired, a fee of 25c per question, including diagrams, should be sent. If questions require special work, or diagrams, particularly those of factory-built receivers, an extra charge will be made, and correspondents will be notified of the amount of this charge before answer is made.

What is the law governing the number of turns, size of wire and closeness of coupling of the grid and plate coils of an oscillator in a superheterodyne? What relation is there between sharpness of tuning of the oscillator dial and the intermediate amplifier? —E. G. S., Denver, Colo.

The sharpness of tuning on the oscillator dial is practically all controlled by the intermediate amplifier. If your oscillator settings are broad, it is not due to any inherent broadness of the oscillator itself, but to the selectivity of the intermediate amplifier. If your intermediate transformers have a very flat amplification characteristic, and your filter circuit is broad, then your oscillator settings will likewise be broad, and the set will not be selective. If your intermediate transformers have a fairly definite peak at a certain frequency, and the filter is well designed and has a sharp maximum at the same frequency as the intermediates, then your oscillator dial settings will probably be very sharp.

The design of the oscillator was fully covered by an article by G. M. Best in September, 1926, RADIO. The usual oscillator circuit consists of a grid coil tuned with a variable condenser, the number of turns in the grid coil being designed to work over the broadcast band with the particular type of condenser to be used. The plate coil is not tuned, and has sufficient inductance so that the tube will oscillate at all frequencies within the broadcast range.

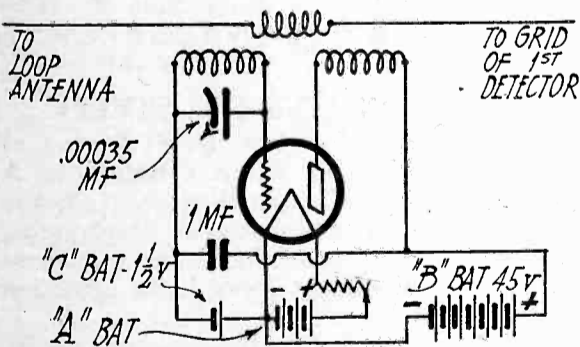

Fig. 1. Superheterodyne Oscillator Circuit.

Such a coil is shown in Fig. 1, with 90 turns of No. 24 enameled wire on a 2 in. tube, for use with a .00035 mfd. variable condenser, and 45 turns of No. 30 silk-covered wire wound jumble fashion at the filament end of the grid coil, for the plate inductance. The rotor of the condenser should be connected to the filament end, and the stator to the grid. The grid coupling coil is wound on a 1 in. tube, placed inside the oscillator, and consists of 25 turns of No. 30 silk-covered wire.

Please publish a circuit diagram of the Diamond of the Air receiver, using two stages of transformer coupled audio. —H. G., Str. Willamette.

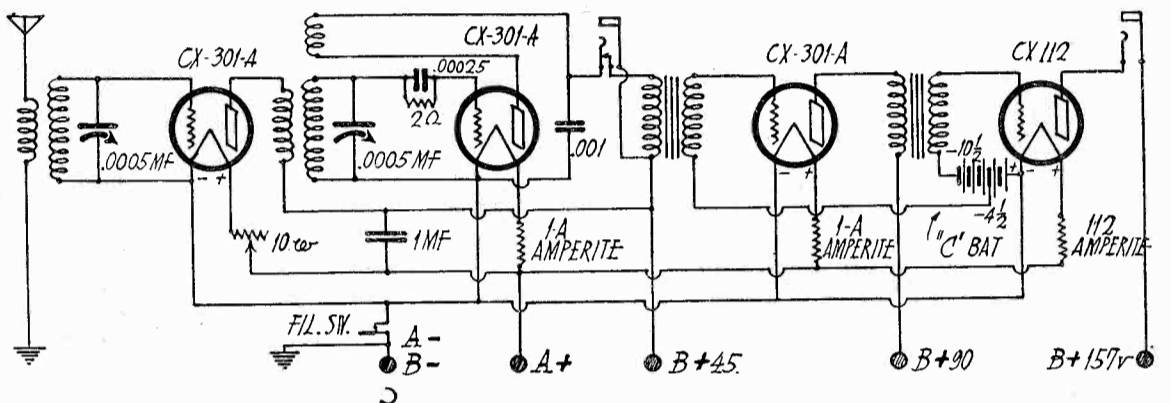

Fig. 2. Diamond of the Air Receiver, Using Transformer Coupled Audio.

The circuit is shown in Fig. 2. For further details about the operation of the receiver, see the December, 1926, issue of RADIO.

In the Western Electric 25-B amplifier, what is the purpose of the 50,000 ohm resistance in series with the "C" bias lead to the amplifier tube? What are the differences in characteristics of Western Electric types 205-B, 205-D and VT-2 tubes? Using one of these amplifiers as a power unit, what sort of an amplifier should precede it, for use with a Bosch phonograph unit? I do not wish to connect the unit to my receiving set, but as it requires a two stage amplifier, I want a separate stage to go with the 25-B.—R. R. W., Philadelphia, Pa.

The 50,000 ohm resistance is for the purpose of reducing any a.c. noise which might be present in the "C" biasing resistor, and also to protect the input transformer secondary from short circuits.

The Western Electric tubes you mention are all the same, insofar as their intended purpose is concerned, but are classified as follows: The 205-B has an oxide coated filament which requires 1.35 amperes at slightly over 6 volts. It normally uses 350 volts plate, and 25 to 30 volts negative grid. As an oscillator, it is rated at 5 watts output, and as an amplifier, its output will probably be about 1 watt. During the Great War, the tube was made for the Army under the code VT-2, and for the Navy as the CW-931. Both tubes were identical with the 205-B, except the code number. About two years ago, however, the Western Electric Company developed an improved filament of nickel alloy, and the five-watt tube was supplied with this filament, so that the code was changed to 205-D. The plate and grid voltages for the 205-D are the same as for the older models, but

the filament current is 1.6 amperes at 4.4 volts.

A stage of amplification using a type 99 tube is shown in Fig. 3. It consists

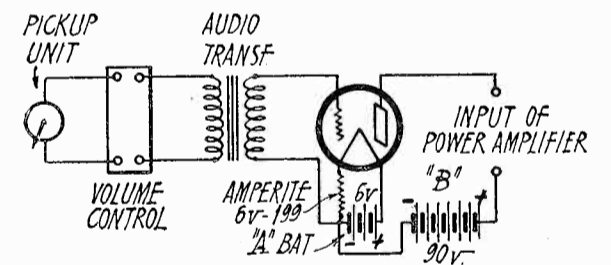

Fig. 3. Amplifier for Phonograph Pick-up Unit.

Have a Fada neutrodyne kit assembled in a five tube receiver, and have trouble from oscillation on certain dial settings. Is there a better method of neutralizing which can be used in this receiver?—J. F. B., Oakland, California.

For the particular kit you have, a small variable condenser of 5 mmf. maximum capacity, connected between the tap on the secondary of each r.f. transformer and the grid of the preceding tube is the most satisfactory.

Can a regenerative receiver be used as a transmitter? How far will it reach? Is there a method by which a broadcast receiver may be made short wave without using more tubes?—H. E. S., Wendell, Idaho.

A regenerative receiver, when the detector tube is oscillating, will radiate into the antenna. The distance over which the radiated signals could be heard would depend upon the plate voltage of the detector, the wavelength on which it was oscillating, the type of an-

tenna system and its adjustment, as well as many other variable factors. Probably 25 miles at night on the short waves, although phenomenal results have been had with a type 99 tube with 90 volts plate, on 40 meters. A good short wave converter which will not require additional tubes to convert your set into a short wave outfit was described by Perry Graffam in May, 1927, RADIO.

Built a bulb charger according to data published in September, 1926, RADIO, but the transformer primary heats up. How can I connect the bulb to the transformer so as to charge a 6 volt storage battery?—A. P., Mountain View, Calif.

The diagram in Fig. 1, page 35, of September, 1926, RADIO, which you have, is the only good way of connecting the tungar bulb to the transformer. If the transformer heats too much, the core is probably of poor grade, and there is insufficient magnetic flux for the number of turns in the primary and secondary. A good grade of 28 gauge silicon steel should be used, where obtainable.

In building a two dial, five tube neutrodyne, would a tandem condenser be as good as two condensers connected by means of a link motion, as was done in the 1927 Best Superheterodyne?—J. F. B., Dayton, Ohio.

Most tandem condensers have the same construction of each condenser unit, as would be had with individual condensers, so that no objection to the use of the tandem condenser would be had. For standard neutrodyne coils such as are generally sold in kit form, .00025 mfd. variable condensers should be used.

Please furnish a circuit diagram for the Madison Moore superheterodyne, using 99 tubes with series filament connection, so that I may use the set in

G. M. Best in the same issue, calling for .00035 mfd. condensers. With the Silver Marshall coils, which condenser is correct? What intermediate frequency should I use with the 215-A tubes? Would an output transformer in the audio circuit be advisable? Could I use the same panel and apparatus layout for the series filament circuit, as was specified for the 1927 Best superheterodyne?—H. O. W., San Francisco, Calif.

The Silver Marshall coils were designed to be used with their .00035 mfd. rated capacity variable condenser. When Remler condensers are to be used, it is advisable to use the .0005 mfd. rated capacity, in order to be sure of tuning to 550 meters maximum, as it was found that with the .00035 mfd. rated capacity in the Remler condenser, the maximum tuning range was 525 meters. No difficulty with tuning to the lower wavelengths using the Remler condenser will be experienced, due to the low minimum capacity of the condenser.

Any intermediate frequency transformer designed for use with type 99 tubes will be suitable for the 215-A tubes, as their grid-filament capacity is approximately the same, with the 215-A perhaps slightly lower. If a type 171 power tube, or other tube having a plate current in excess of 15 milliamperes is used, it is advisable to use an output transformer. With the type 112 tube, the transformer is not necessary.

What is the best procedure for balancing a set of three Hammarlund Midline condensers which are connected in line on the same shaft, and installed in an Infradyne receiver?—H. R., Cambridge Springs, Pa.

These condensers are so constructed that the rotor group can be slipped on the main control shaft by loosening the set screws located on the rotor frame.

I have trouble in tuning my five tube receiver, and suspect that the apparent broadness of tuning is due to my extra long antenna, which is 130 feet. What should I have in the way of an antenna for my particular receiver?—J. M. L., Holcomb, Wash.

Your antenna is undoubtedly too long for your set. Either reduce its length to 60 feet, or place a series condenser in the antenna circuit, between the antenna and the antenna binding post on the set. A good method of determining the proper series condenser to use is to install a variable mica condenser having a range of from .0001 to .0005 mfd. and try different settings of the condenser until the best selectivity is obtained.

I am very much interested in the article on the electric phonograph which appeared in February RADIO, and note that no needle scratch filter was employed, as is customary in the Victor Electrola. Could you give me data on how to make a filter for use with my Hanscom pickup unit?—C. B. D., Cincinnati, O.

A needle scratch filter can easily be constructed by connecting a 250 millihenry inductance in series with a .006 fixed mica condenser, and shunting the combination across the output of the pickup unit. The inductance may be made by winding 2500 turns of No. 30 enameled or cotton covered wire on a spool which has a slot 1¼ in. wide and a hub 1 in. thick. It is important that the filter has a frequency cutoff above 5000 cycles, or the quality of the output from the phonograph amplifier will be seriously impaired. If the tone sounds muffled, the filter has too low a cutoff, and turns should be removed from the inductance until the filter has no apparent effect in the circuit except to reduce the needle scratch noise.

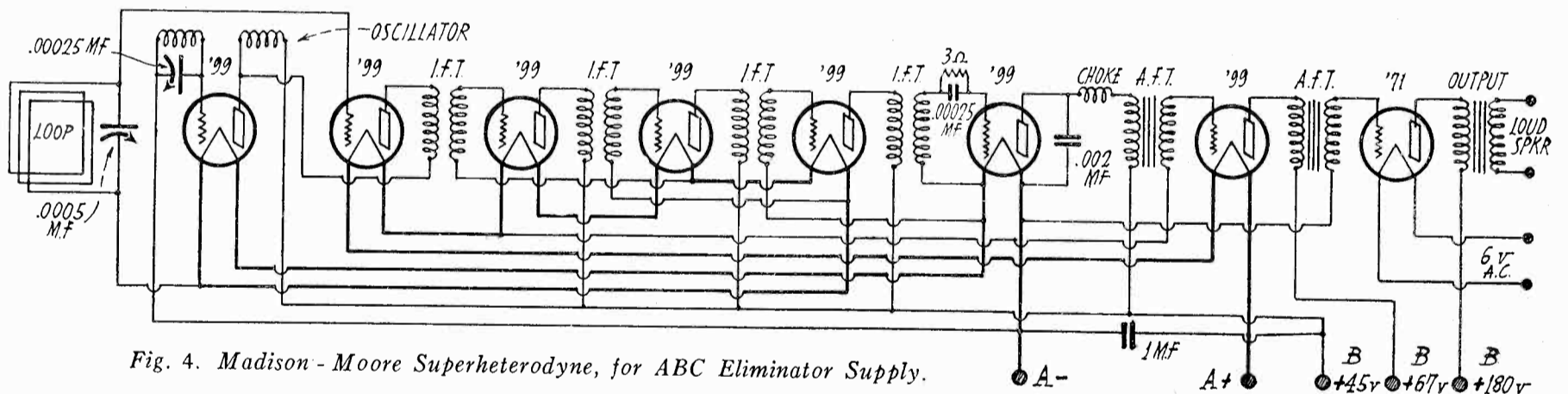

Fig. 4. Madison-Moore Superheterodyne, for ABC Eliminator Supply.

connection with an "ABC" eliminator.—R. D. H., Columbus, Ind.

The circuit you describe is shown in Fig. 4. The Madison Moore transformers are designed to work with type A tubes, and the use of type 99s may disturb the peak frequency of the intermediate transformers. In order to obtain the proper volume control, it will be necessary to shunt the primary of the second intermediate transformer with a 50,000 ohm variable resistance. The connections to the power supply are those required for use with the "ABC" eliminators described by G. M. Best in August and December, 1926, issues of RADIO.

Notice in the Queries and Replies of February RADIO, a circuit for a 9 tube superheterodyne using 215-A. Northern Electric tubes and calling for .0005 mfd. condensers, whereas a similar circuit using 99 tubes appears in an article by

Connect the Infradyne temporarily as a five tube set, and adjust the condenser group to bring in a station at about the midpoint on the dial. Loosen the set screws on the front condenser and with the fingers move the rotor group back and forth slightly to see if there is a marked change in volume. Reset the screws and do the same in turn to the other condensers. If one condenser shows a setting in advance of those of the other condensers, a trimmer of sufficient capacity to bring the capacity of the low section up to that of the others should be used. If the reverse is true, trimmers should be installed across the two sections having the lower capacity, and should be adjusted until all three tuned circuits are in resonance at different settings of the tuning dial. It is a good idea to install trimmers under any circumstances, as they facilitate lining up the set.

PUBLICATIONS RECEIVED

Scientific Paper No. 544, U. S. Bureau of Standards, "Effect of Eddy Currents in A Core Consisting of Circular Wires," by Chester Snow. This is a mathematical development of an equation in integral calculus to express the variation of current losses in an induction coil.

"Standards Yearbook, 1927," compiled by Bureau of Standards, Publication No. 77, sold by Superintendent of Documents, Washington, D. C., price \$1.00.

This 400 page book gives a complete survey of the present status of standardization in all branches of American scientific, governmental, and industrial activity. It also summarizes foreign results. It is consequently invaluable as a handy reference preliminary to a detailed study of any one subject. Included within its contents is a definition of various electrical standards of measurement and a description of the instruments used to attain them. Recent studies in fading of radio signals and measurements of field intensity are summarized.

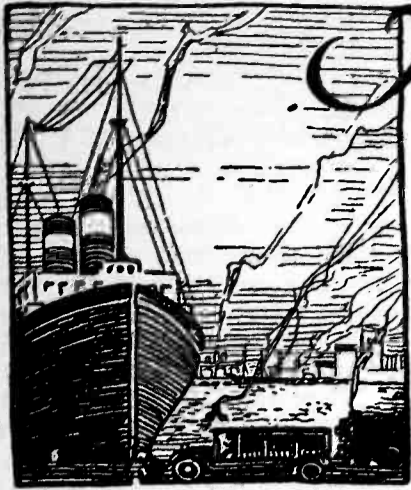

R. O. KOCH, *Great Lakes Correspondent*

The COMMERCIAL BRASSPOUNDER

A Department for the Operator at Sea and Ashore



Edited by P. S. LUCAS



C. WILLIAM RADOS, *Boston Correspondent*

TAKE YOUR CHOICE

As this is being written we are just beginning to realize that Spring is upon us and good old Summertime approacheth. That is, *where* this is being written; featuring the Northern Hemisphere. Balmy breezes predominate—and so does static.

Will you sign on for the usual Pacific Coast summertime sport—a trip to the Alaska salmon canneries? Where the sun shines of a morning and an hour later it rains? Where the mosquitos are wafted down the rivers in dead of night, and gorge themselves until the wind takes them back again?

"In the wintertime we know it isn't warm, In summer mosquitos do swarm. Churches are few, cusswords not new, But if you don't like our style just mush on."

Thus sings the "winterman" after pay-day, when his heart, or should we say stomach, is tuned to singing.

Or will you regret the passing of winter up here and choose a run into the Southern Hemisphere in search of rougher seas and more boisterous winds? Or try the coast for awhile, where you may set foot on shore now and then and join in the merrymaking of the vacationists?

Whatever it be, the man who goes to sea cannot complain of a "humdrum" existence. Perhaps he will never know how free he is until he drops his book and settles down to a "shoreside" job. But, of course, freedom of choice isn't everything.

ETHEREAL SARCASM

By GEORGE IMLACH

Say OM, don't U ever get tired?
No.
Then U ought to!!

What abt trying the other foot!

It wudnt hurt U to listen before puting ur foot on the key!

If U are using ur foot wud U mind taking off ur sock!

Say, don't sit on the key pse!!

Passenger—Good morning Sparks, any press today?

Operator—Yea.

Passenger—And how's the president this morning?

Operator—Fine, how's yourself?

About a month ago I happened to be in a gang of commercial ops when the conversation turned to Ku Kluxers. Not wishing to display my ignorance I inquired in a round about way just what was referred to by that expression. It turned out to be the ships of the Southern Pacific Company—KKH, KKT, KKK, KKY, etc.

W M W, Manitowoc, Wisconsin

By C. O. SLYFIELD, *Radio Supervisor*
Ann Arbor R. R. Co.

One of the first of the old time ether-busters to be installed on the Great Lakes by the United Wireless Telegraph Company, was at Manitowoc, Wisconsin, known in those days of American Morse as "MW," but now bearing the more dignified monicker, "WMW."

All of the tall buildings in Manitowoc were looked over carefully, and finally it was decided that the Rahr brewery was about as tall as any, and quite a suitable place for a radio station. So they built a nice little shack up on the roof of the seventh story, and started carting the most modern radio apparatus in the country into it. A new steel tower 125 ft. high was erected, but came down in a heap a few years ago in the teeth of a mighty gale. At the present time, one 50 ft. and one 20 ft. tower on the tops of elevator shafts, support the 280 ft. two-wire aerial. A good ground connection is secured by a brazed connection to the steel framework of the building.

The *modern* apparatus consisted of one of the old familiar 2 k.w. coffin—Leyden jar—straight gap composite transmitters with conductive coupling. Inductive coupling replaced the conductive in a few years, and in 1915 a non-synchronous rotary spark gap was added. With these two improvements, the transmitter remained practically unchanged in the eleven years which followed.

WMW, like all other stations, passed through the various stages of receiver design, having types D, E, 107 and 107A in the order named. The Navy took over control of the station in 1917 and brought with them, an SE-1420. When the Navy relinquished control in 1921, they lifted this receiver, and left in its place, a CN-113. This was remodeled and used with good success, but was finally replaced by a modern composite receiver of good design and efficiency, and employing three stages of a.f. amplification.

With the old spark set, the call "WMW" had become a very familiar one to every operator on the Great Lakes, and ship and coastal stations on the Atlantic and Gulf were often worked. KSE reported hearing the old spark in the early morning hours too.

In September, 1921, the Navy Department wished to dispose of the station, and the Ann Arbor and Pere Marquette Railroad Companies purchased it jointly for the handling of their railroad business to and from that port. Shortly after the purchase of WMW, it was decided that the wave of 450 meters should no longer be used for point-to-point work, so a wave of 1666 meters was assigned. This wave is still used with good efficiency for limited public service.

Keeping pace with the rapid progress in radio, the old spark transmitter, whose note had become familiar to every Great Lakes operator, was silenced, and in its place is a neat RCA type ET-3634 master oscillator, power amplifier, CW-ICW transmitter of the

latest design. The new transmitter employs one UV-211 as a master oscillator, and four UV-211's as power amplifiers. The Leach break-in relay is standard equipment with this transmitter, and is a great help in speeding up traffic handling. 715 and 875 meters are used for PG service, and 1666 meters for point-to-point traffic.

The transmitter sets at right angles to the desk, and on the operators' left, so that all wave shifting can be accomplished with the left hand, leaving the right free for manipulation of the key and receiver. With this arrangement, all meters, switches and so forth, are plainly visible to the operator. Since this transmitter has been in service, WMW has been heard all along the Atlantic and Gulf coasts, and as far south as the Canal Zone.

WMW is one of the busiest stations on the Great Lakes, averaging between 35,000 and 40,000 words per month the year 'round. The greater portion is railroad business. WMW is an alert station and collects considerable traffic from ships which are not able to raise stations on the Lakes which are open primarily for the purpose of handling PG traffic. Manitowoc is, of course, a very busy port.

For several years after the war, WMW was just a station. There was nothing at all out of the ordinary about it, until one day about three years ago, "Bob" Koch, "MP" as he is known to most of us, took charge of the station, and it is under his guiding hand that WMW has prospered and built up a reputation which few stations enjoy. WMW is always on the job, and the occasion is very rare when a ship or coastal station finds it necessary to give WMW more than one short call to get a speedy and prompt reply. Bob has been very ably assisted in his efforts to put WMW on the map and give it the prestige which it now enjoys, by two excellent operators, Carl Sturdy "CL," and Walter Biesemeyer "BZ". WMW has continuous service with the word *continuous* used in its true sense. With these three operators at WMW, it is never necessary to QRS, the only thing they require is that you send continental code, and when Bob is on the job, you can even use Morse if you like. Hi.

After Bob had been West and seen some of the nice salmon (they may have been canned), he decided that he would like to get a ticket of that particular hue, so he packed his bag, came over to WFK, spent two months brushing up on Morse while holding down a trick there, went down to Detroit and brought home the bacon in the form of Commercial Extra First Class license number 108.

Neither MP, CL nor BZ use tobacco in any form! This is one of the reasons that the station is always immaculate. On one corner of the operating table is a copy of the International List and supplements, U. S. call book and bulletins, a Western Union tariff book, a standard dictionary, a Telephone directory and the latest radio books and periodicals. Do you wonder that operators call it "The station that's different?"

Letters to the Editor

Sir: Many thanks for your splendid Brass-pounders section, it's worth many times the cost of your magazine, particularly the lists of skeds.

I have a couple of little wrinkles to suggest which you may use as you see fit.

The first, No. 1, is an idea for using a single pole double throw switch, in connection with a Leach break-in key, as a protection against lightning.

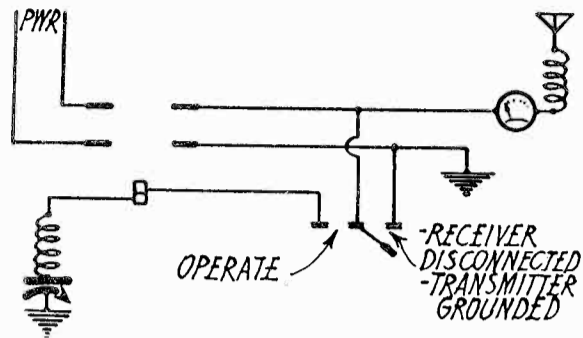

Fig. 1. S. P.-D. T. Switch for Break-in.

I saw the need of something of the sort after a recent experience.

I had stepped up-town for an hour or so to do some shopping and while there, be-thought me that the apparatus was not grounded and masses of heavy QRN accumulating in the offing.

I rapidly hied me back to the ship, arriving there about twenty minutes before the storm, finding a merry ticking across the primary condenser of the receiver.

Attempting to adjust Mr. Leach's justly celebrated relay so that the open circuit contacts closed, thereby grounding through the transmitter, and to slack off on the back-stop contacts, I picked up a static charge that had accumulated which jarred my shoelaces open.

The job was finished by poking the knurled knobs with a wooden handled screwdriver, without a great deal of good being done to the relay during the process.

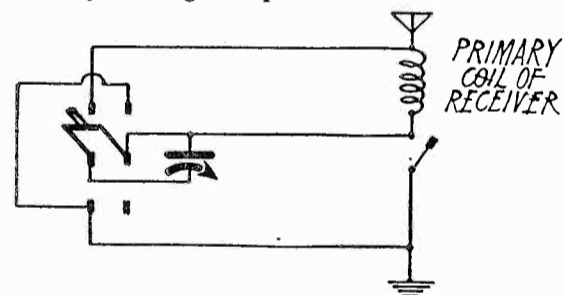

Fig. 2. Series-Parallel Switch.

The second, No. 2, is simple enough. I saw the need of just such a compact series-parallel switch while constructing a three honeycomb coil affair, and after using up enough paper to paper a six-room house in experimental diagrams, finally hit upon this. Don't know how many use just this, but have found plenty of ops. who were skeptical at first, then glad to copy this DPDT switch for series-parallel. Of course there are other uses for this beside that in a receiver primary, but that's what I'm showing.

More watts to your splendid magazine, particularly the CB section. 73.

CHARLES A. LUCK.

Philadelphia, Pa.

Sir: We have been reading your magazine here at "Woe" for some time now, and I intended dropping you a line before this, needless to tell you that we think RADIO is one of the finest radio magazines on the market, that's understood. Now as to a little information about "Woe." We are located at Palm Beach, Florida, the station is about the center of a 930 foot fishing pier, two steel masts 500 feet high with a 4-wire aerial, Pyrex insulators throughout.

Our transmitters consist of a 2 k.w. Marconi P8 spark, our wave is 650 on calling

and working with vessels on spark. We have a 5 k.w. I.W.T. arc CW, working and calling wave 2275. We can QSY to 1850, 2100 and 2800 CW upon request, but generally do all work on 2275 meters. We radiate 18 amperes on 4 KW, which power we generally use, and have been reported as QSA in the River Thames off London by the "KDKK." Also have worked ships near Honolulu, and numerous ships off Frisco, tested with "KFS" few mornings ago and was reported there as "QSA." Our CW schedule is listening for CW ships on 2100 meters the first 15 minutes of every hour, the full 24 hours, if traffic calls for it we stay on CW 2275 until everything is cleared, our daylight range appears to be 1500 miles. The staff here is only three operators, Mr. Stanley Ferson is manager and in full charge, has had a number of years' experience in both CW and spark work, then there is Mr. Bookwalter and myself. We have an 8 hour watch apiece, and all try to give the boys on the ships the best of service at all times. We are willing to fight Old Man Static here as long as they are to get their traffic, and the boys running over this way know what static is during the summer months.

We would appreciate it if the boys on the Frisco to the Orient run would drop us a line some time and let us know how they get "Woe" and the strength of our signals. Since they all work on 2400 meters on the West Coast we cannot raise them, as they evidently do not tune down to 2275, but we listen different schedules on 2400 as well when we can. Have heard several "President" ships here "QRK" working "KFS," and believe no doubt we could work them direct from here. Hope some of the boys see this and will drop us a line sometime.

We have one of the most ideal locations of any coast commercial radio station that I know of, with a little sea here some nights and the old pier shaking you almost think you are back on the old "wagon" again.

If there is any other information we can give you here do not fail to drop us a line and we will see what we can do. The station is owned by the "Palm Beach Radio Co., Palm Beach, Fla.," Coast tax 10 cents per word; landline charge the same as from Miami, Florida. Give us a call some time, boys, whenever you can.

DAVID L. CAWMAN, *Opn.*,
Palm Beach Radio Co.

P. O. Box 2176, Palm Beach, Fla.

Sir:

Lars Christensen, lately of LHD, *SS Regulus*, got off at KEK to look over some homestead lands. He is running true to form as all good operators go back to the farm to look at the pigs and sigh with content. T. A. Toppi, ex-KFEW and KDJT, takes his place on LHD, a South America line boat.

Say fellows, why lose a lot of sleep waiting for press to come on after midnight, when there is plenty of it going over the air early, —that is on the Pacific Coast. I copy these two stations and go to sleep, when I used to just begin.

WNU, New Orleans, on 3331 meters at 8:45 p.m., P.S.T., is a very QSA station up and down the coast. I have copied him very QSA on detector at KPE and expect to hold him all the way to South America.

2UO, New York City, on 40 meters at 10 p.m., P.S.T., is another very QSA station on the Pacific Coast. I also expect to hold him. He sends to QST and sends items of the morning New York Times. So fellows, a short wave receiver added to your own ship equipment is a very handy thing. Get one.

The Pacific Coast press stations have been quoted before in this section, but all the press a fellow wants can be had from the two above, hours before the Pacific stations send. Here is a summary of Pacific Coast press stations that send to QST.

KPH, San Francisco, at 12:10 a.m., P.S.T., with valve ICW.

VAE, Estevan, B. C., at 1:00 a.m., P.S.T., with valve.

NPL, San Diego, at 2:00 a.m., P.S.T., with arc.

For the fellows with the Alaska fishing fleet, the three later stations are sure to be received very QSA, if the mob of spark stations aren't operating up there in the vicinity. For the former two, I don't know how they will come in, but if it was anything like it was last year at Nushagak on WNU's QRH, I would say a fellow couldn't with the racket at that time. 2UO may be all right if there are no close spark stations operating then. NPM paid press though not to QST would be a good station to get in line with for that part of the world, in Alaska, with its signal strength.

Keep this section rolling fellows. It is up to us.
LHD.

NEW ZEALAND STATIONS

By WM. A. BRENNIMAN

A weather forecast is broadcast at 10:10 P. M. excepting Saturday and Sunday from VLA, Wanui, Kaitia, near Auckland, on 600 meters. This is 2:40 A. M. P.S.T. Five minutes following weather, a free press dispatch is broadcast on 2000 meters daily excepting Sunday. The press consists of local New Zealand news. VLA is mainly occupied in a commercial service with Radio-Apia, but ship stations are worked if station VLD (Auckland Radio) is unable to do so.

The radio beacon on Cape Maria Van Diemen transmits on 1000 meters during foggy weather only. Signals are letter "J" for two minutes, followed by a three minute interval. Call signal VLU.

A dead screened area is found between East Cape, and Cape Palliser on the East Coast of the North Island of New Zealand. Ships should call either Auckland (VLD) or Wellington (VLW) if unable to raise their nearest station, which may be Auckland or may be Wellington. A similar area is on the West Coast of the South Island between Farewell Spit and Greymouth. Wellington is the nearest coast station. If unable to raise call VLD.

Ships north of East Cape should clear their business with VLA. Stations south of East Cape and north of Banks Peninsula should clear with VLW. South of Banks Peninsula should clear through VLB.

Station tax of New Zealand stations is 63 centimes, 6 pence, or 13 cents. No landline charges. Credit to New Zealand Government.

Stations VLD, VLW use valve transmitters. These stations are supplied with the 9 A. M. and 4 P. M. weather reports received from important points on the coast. Masters of vessels may, by means of a paid message addressed to one of the above mentioned stations, obtain information as to the weather conditions at any of the places mentioned in the report. The charge for a message (including reply from the coast station) is 2/- for twenty words and 1d for each additional word.

Time signals are transmitted by station VLY (this is station VLW but uses different call letters during official transmission) at 3:00 P. M. P.S.T. (23.00 GMT) daily except Saturday and Sunday and at 1 A. M., P.S.T. (09.00 GMT) on Tuesdays and Fridays.

An excellent weather forecast in the Oceania district is transmitted by the Apia wireless station VMG, on 2000 meters spark at 08.30 and 23.30 GMT. Two weather summaries a day during the months November to April, inclusive. For the months May to October only the 08.30 GMT summary is broadcast. These weather reports are in plain language from Papeete, Society Islands, Avarua Island; Vila, New Herbrides, Rarotonga, Apia, Samoa; Vavau and Nukualofa, Tonga; Suva, Fiji and

(Continued on page 52)

EXPOSURE NUMBER 4

(Most of you on the East Coast, or who have been sailing on the East Coast, have probably had the pleasure of meeting George W. Nicholls at one time or another. Although no longer actually pounding brass, his heart is still with the fellow who does. And his experiences and reminiscences are certainly interesting in comparison with modern radio. But read them yourselves.)

GEORGE W. NICHOLLS

By C. WILLIAM RADOS

George W. Nicholls, known to the boys as "Nick," is one of New England's pioneer operators. Born in Providence, Rhode Island, in 1891, he evidently grew up between then and 1909, for the latter part of 1909 saw him pounding brass on a small passenger vessel running out of Boston to Canadian ports. From then on until 1913 he worked as a "wireless operator" with the United Wireless straight gaps, broad waves, and electrolytic detectors.

In thinking over the old days, Mr. Nicholls mentioned the great contrast between the radio apparatus and methods of his day and the present equipment and customs. Then, some sixteen years ago, only a very few passenger vessels were equipped with radio. For the most part the installations on American ships consisted of 1 k.w. transformers feeding directly into a straight gap. The antenna circuit consisted of a loop antenna, anchor gap, and single circuit inductance connection. When the anchor gap sparked greatest, the set was evidently working at its maximum output. No meters were used but their lack was more than made up by the impressive sparks and terrific noises emitted when the set was using all the power it could. It was a favorite thing in those days, Mr. Nicholls tells us, for the radio men on passenger vessels to attract business by starting transmitting with the gaps as noisy as possible. Soon a group of curious passengers would form about the door enviously watching the young son of Marconi. To make it all the more impressive, fans would be whirring, the motor generator humming, lights glowing, and tremendous sparks crashing. Then the operator would suddenly stop telegraphing and reach around to the controls. Around the room he would move, turning switches, rheostats, pulleys, and levers. As long as his audience's interest held he would act for them. At the critical moment he would produce a scrap of paper with some news (two days old) which he said he had just received. Of course no one knew that by working the ship's transmitter he would not receive press, but many messages were bought and the operator could look forward to another night of trying to send them to land.

Before the advent of the tube detector and the crystal, electrolytic detectors were found fairly reliable. They were, however, subject to burning out when the transmitter was used. When this occurred, the operator removed the metallic point which dipped into the acid, and by application of sandstone prepared a new point. One of the first ships Mr. Nicholls had was one which the former operator had left, disgusted with the non-operative receiver. When G. W. Nicholls went aboard he repaired the detector and remained on the job. Nicholls repaired in five minutes what the other man had been attempting to discover for several days!

Why do commercial radio men sniff disdainfully when broadcast listeners become enthused over 1000 mile reception with six tube sets? Back in the "old days" when every ship used an individual wavelength and judgment was the sole law, many were the records piled up. Manhattan Beach at New York, was "DF." Every once in a while, this station would work some ship 1000 to 1500 miles distant. After such an occurrence a little meet-

ing in Maloney's brass rail parlor would occur, accompanied by many glasses of good beer and pretzels. Them wuz the happy daze.

At sea the marine operators would bend over the crystal, electrolytic, and magnetic detectors to listen to ships hundreds of miles away. Then they would attempt to get into communication with one another and many times succeeded.

All Atlantic City, New Jersey, is known for now is WPG and the beauty contests. But some sixteen years ago, when "Nick" would finally raise "AX," after long calling, it was considered that the 5 k.w. United Wireless straight gap transmitter at AX was about the last word in radio communication. This transmitter wore out gap after gap. Finally, a non-synchronous rotary gap was put in and with improved results. One night, when coasting off New Jersey, Nicholls was out on deck looking towards Atlantic City, some few miles away. Off a little to one side of the city lights could be seen the intermittent flash of a rotary gap. As it was a quiet night, and the gap was almost out on the beach, its



GEO. W. NICHOLLS

tremendous snap could be heard several miles. Operators of rival concerns claimed that AX could be seen farther than it could be heard!

When Operator Nicholls was given a message to transmit it was not as easy to communicate with shore as it is now. Now the operators of one concern are supposed to handle traffic only with stations of the company. But in those early days the operator's judgment plus the distance his set might be heard were the sole factors which determined where a message might be sent.

While Operator Nicholls was on the *S. S. Governor Cobb* in 1911, the Wellmann Zeppelin made the first attempt to fly across the Atlantic Ocean. Among the few men who comprised her crew was Jack Irwin the radio operator. George W. was listening with his electrolytic receiver one night when he heard the faint Wellmann spark sending CQD CQD! Carefully tuning, he heard of the disaster which had befallen the airship. The Wellmann ship was about three hundred miles out, but several other ships had also picked up the faint message for help. As the Royal Mail Steamer *Trent* was the nearest, she was delegated to pick up the survivors.

But while George Nicholls grew up with commercial radio, he received a thorough foundation in the other branches of electrical communication. Before he went to sea, he worked from 1905 to 1909 in the General Electric Company learning the principles of electricity. Then again, in the winter of 1911-12, it evidently was too cold and stormy at sea so Nick went down to Florida. But in-

stead of starting an orange plantation or a land boom he stuck to communication and worked for the railroad being built across the Florida Keys down to the island of Key West. All along that low lying coast of Florida are hundreds of small, flat islands. Florida itself is raised but little from the seas which surround it on all sides. So when it was decided to construct the railroad, these keys were utilized. Steel bridges were erected, caissons driven, and little by little the railroad went ahead from island to island. George Nicholls was in the very forefront of all this activity as he sent and received the various orders, messages of description, reports from field parties, and orders for men and money. Finally the first steam train rolled onto the island of Key West. It was a great occasion and duly fitted with a hearty celebration for many of the inhabitants had never seen a steam train before! But Operator Nicholls had seen enough of railroading. Back to the sea he went until he thought of trying land radio. During 1913 and 1914 he operated at the Boston station of the Marconi Company; old WBF. Here he applied himself and remained in the service when the Radio Corporation of America was formed to take over the Marconi Company.

During the war he was an ensign in the U. S. Navy. The war over, "Nick" engaged actively in the private communication business again. Being in charge of all the RCA marine operators of New England he has come in contact with about every operator licensed in the first district. All the boys agree that he is fair, considerate, and popular.

But while George W. Nicholls is now District Manager for New England, and no longer actively engaged in pounding brass, he keeps a commercial tuner at home and occasionally listens to the trawlers, colliers, tugs, and tankers with their tube transmitters and superhets!

BLIND CALLING

By LESLIE M. HART, *M/S Standard Service*

The "double stand by" waves are causing much confusion which might be avoided if a more efficient system of calling were used. Ships are normally required to standby on 600 meters. But because the coast stations call on waves around 700 meters, ships expecting traffic or waiting their turn to send traffic in, listen on 700 meters most of the time. This causes "blind" calling as the ship may not be listening on the wave used by the calling station.

The 700 wave for calling is due to a ruling made when all the coast stations used the "mile-wide" sparks, and when the majority of B.C.L. tuners were broad. But now that tube transmitters are replacing the sparks, would it not be a good plan to restore the 600 meter standby point?

Under the present plan of calling on 600 and working on 706 all calling is not on 600. In fact, coast stations call more on 700 than on 600. If coast stations all called on 600 it would make the 700 channel much clearer for traffic handling. Another point: a ship calling a coast station at present knows that in all probability he will be answered on 706 meters and sets his tuner accordingly. He starts calling on 600, resulting in QRM to ships within his range on that wave, while he may not know they are working.

Walnut cabinets can be finished by sanding the surface and rubbing it with a rag dipped in ordinary linseed oil. After the oil dries, the surplus can be wiped off, and the wood polished with a soft cloth. The linseed oil brings out the natural grain in the wood and gives it a dark, rich gloss that is very pleasing and will last for years.

With the Amateur Operators

THE UX-852 75-WATT SHORT-WAVE AMATEUR TRANSMITTING TUBE

Of particular interest to radio amateurs is the new UX-852 75-watt shortwave transmitting tube. This tube has been designed especially for extremely short-wave work, particularly in connection with amateur short-wave power amplification and transmission. It is conservatively rated, free from excessive strains, readily wired, relatively cool in operation, and capable of oscillating at frequencies even below one meter.

The UX-852 is of the round bulb design, with three arms or extensions of the glass envelope. The largest or filament arm of the tube is provided with a standard UX base, suitable for use in either the push type or the Navy type socket. The socket must be mounted so that the filament of the tube will be in a vertical position. Contrariwise, the horizontal grid and plate arms are not based. Instead, two heavy stranded leads, arranged in parallel, are brought from each stem for connection with grid and plate, respectively. The double grid and double plate leads serve greatly to increase the current-carrying capacity at exceptionally high frequencies, and both leads for each element should be employed at all times so as to carry safely the large circulating currents which flow at very high frequencies.

Due to the fact that filament, grid and plate leads are brought out of the tube through individual and widely separated seals arranged about the main spherical portion of the glass bulb, the glass is subjected to minimum strain, while leakage and internal breakdown are reduced to negligible proportions as compared with tubes in which all leads are closely grouped, particularly when using a base for all connections. Furthermore, the general design of this new tube permits of supporting the internal electrode elements without the use of internal insulation or "spacers," which accounts for the exceptionally low inter-electrode capacitance and therefore the very high frequencies at which the tube will oscillate.

The internal construction of the UX-852 is as simple as it is ingenious. A cylindrical plate or anode, having six radial fins, is supported in place by two stiff wires passing through a press in the sides of the bulb. Flexible wires welded on these supports act as the plate lead. A cylindrical grid, composed of a spiral of wire, is placed inside the plate and is concentric with it. The grid is supported in the same manner as the plate. The filament consists of a double spiral of thoriated tungsten wire supported at its midpoint and ends by stiff wires embedded in the filament lead seal and press.

This simple construction, with inter-electrode capacitance reduced to a minimum, permits of operating the UX-852 at wavelengths below 100 meters. The tube provides excel-

lent results on the popular 80, 40 and 20 meter channels, and it has been successfully operated on wavelengths below 5 meters and even down to 77 centimeters (0.77 meters), or a frequency of 390,000 kilocycles, which is by no means the limit for the amateur who desires to explore the lowest wavelengths of short-wave radio.

The wiring of the ultra-short-wave transmitter is materially simplified when employing the UX-852, since with the grid and plate leads coming out of the bulb at different points, all connections do not have to be concentrated at the base and the wiring can be made proportionately shorter and with wider spacing. The base, while of the UX type with four contact prongs, makes use of only two for the filament connections. Mounted upright in the usual UX push type or Navy type socket, the tube has ample air circulation and operates much cooler than the 50-watt UX-203-A and other tubes. The ample cooling capacity is due in large part to the large area of the glass envelope.

The UX-852 is capable of handling high plate voltages without danger of internal breakdown. In this connection it is pertinent to call attention to the fact that the 203-A Radiotron is often abused and seriously misused by radio amateurs who subject it to an excessive plate voltage at high frequencies, resulting in internal breakdown. The tube is generally blamed for such failure, whereas the fault lies with the operator. Even when unbased, as is often the practice, the 203-A tube is rapidly impaired in efficiency if abused in this manner, and its life is greatly shortened. The new UX-852, on the other hand, is especially intended for high-frequency operation, and will handle plate voltages of 2,000 normally, and even up to 3,000 with proper precautions, without internal breakdown.

Alternating current should be used to operate the filament when possible. A center tap on the secondary of the filament transformer should be used for the grid and plate circuit returns. Rheostat control should be provided on the power supply side of the transformer. When it is necessary to use direct current to light the filament, the plate and grid return leads should be connected together and to the positive lead. Filament voltmeter leads should always be connected as closely as possible to the socket terminals.

The characteristics of the UX-852 Radiotron are as follows:

Filament Voltage	10
Filament Current	3.25 amp.
Filament Power	32.5 watts
Filament type	Thoriated Tungsten
Plate Voltage	2,000—3,000
Plate Current (oscillating).....	.075 amp.
Input Power	150 watts
Maximum Safe Power Dissipation	100 watts
Amplification Constant	16
Nominal Output	75 watts

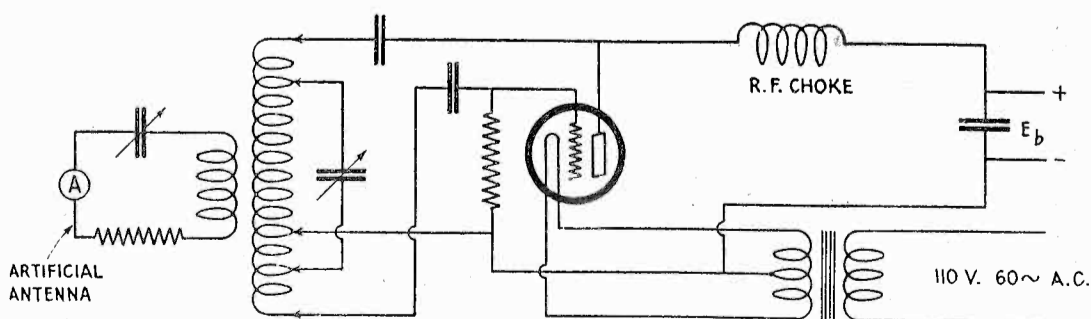

Fig. 1. Circuit Diagram of 80-Meter Transmitter.

Plate Impedance ($e_g=0$).....8000 ohms
The accompanying diagrams indicate the circuits employed in the RCA Laboratory tests. Referring to Fig. 1, which indicates the general arrangement for the 80-meter transmission, the constants are as follows: Oscillating circuit inductance, 10 turns of edge-wise wound copper strip, $\frac{3}{8}$ in. wide and space $\frac{1}{2}$ in. on an 8-in. form. The tuning

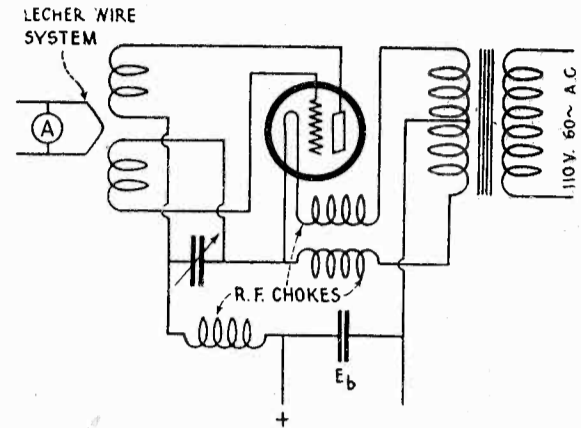

Fig. 2. 5-15 Meter Transmitter.

condenser is a 250 micro-microfarad maximum capacitance. The plate stopping condenser is a 2000 micro-microfarads. The grid condenser is the same. The grid leak is 20,000 ohms. The radio-frequency choke comprises 200 turns of No. 30 D. C. C. wire on a 1-in. form. The lighting transformer is 110-10 volts, with mid tap. For a dummy antenna, use has been made of an inductance similar to an oscillating circuit inductance, with taps, a tuning condenser of 250 micro-microfarads maximum capacitance, and a resistance of 15 to 30 ohms total.

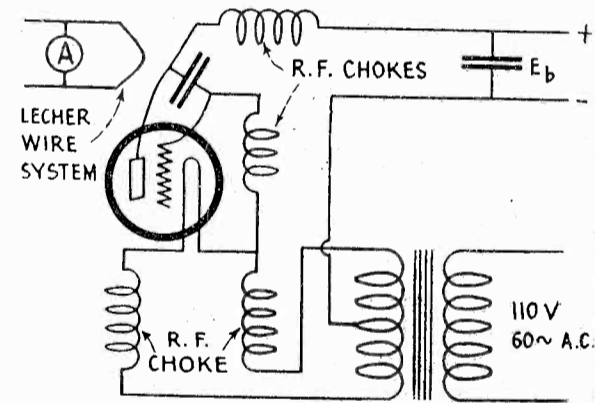

Fig. 3. Less Than 5 Meters.

In the 5-15 meter tests, represented by Fig. 2, the oscillating circuit inductances comprised each 2 turns 3 inches in diameter. The tuning condenser is of 250 micro-microfarads maximum. The radio frequency chokes for filament leads comprise 10 turns on $1\frac{1}{2}$ -in. form. For plate leads, they are 100 turns on a 1-in. form.

In the tests below 5 meters, the inductance is comprised of the plate and grid leads. The plate stopping condenser is of 2000 micro-microfarads capacitance. The radio-frequency chokes comprise 10 turns on a 1-in. form.

The apparatus used in these tests does not represent the best for this particular work, but was chosen because of its availability. Probably much better operational characteristics would obtain if specially selected apparatus were used.

One of these new tubes has been in use for some time at an amateur station on Long Island on all the amateur wavelength bands. Particularly good results have been obtained on 19 meters, two-way communication having

been established during the daylight hours with English stations and also with Western Canadian stations and with amateur stations in the far corners of the United States. In all cases the signals of the UX-852 were reported as of good quality and as being steady.

RADIO STATION NS-1FMH

Many U. S. and Canadian amateurs who have heard ns-1FMH of San Salvador will be interested in the appearance of the station as shown in the accompanying picture. J. Fred Mejia, the operator, played an active part in the International Relay Tests under the auspices of the I. A. R. U. and is always willing to handle traffic for American hams. His working hours are 8 to 11 p. m., P. S. T.

He uses a 50 watt transmitter, Hartley circuit, with 1200 volts rectified a.c., "S" tube, on the plate. He works on 42.6 meters, using a single wire for antenna and counterpoise. His address is 14a Avenida Norte, No. 21, San Salvador, Salvador, Central America.

NEWS OF THE AMATEUR OPERATORS

7JL, portable call at 7ACN, James L. Young, 303 13th Ave. So., Nampa, Idaho. All cards appreciated. Always QSR here. Slip me your traffic. Tnx.

7HK, Nampa High School Radio Club, Nampa High School, Nampa, Idaho. Always glad to QSR, chew the rag, or what have you? All reports appreciated.

INEXPENSIVE METERS

By GEO. B. HART, 8DK.

Substitutes for several of the expensive meters necessary for checking a transmitter's operation can be improvised from a 98 cent 0-50 volt d.c. B battery voltmeter. Thus one of these cheap meters can be re-calibrated against some friend's a.c. filament voltmeter by placing the two meters in parallel and noting the position of the cheap meter's pointer for each change in voltage. At the 7.5 volts a.c. calibration mark a red line so that you can tell at a glance whether you are forcing your tubes.

Similarly one of these battery voltmeters can be re-calibrated as a 0-250 millimeter by placing it in series with a good milliammeter and noting the pointer position for each change in current. Likewise one may be used as a 0-500 volt d.c. voltmeter by placing it in series with a 0-400 ohm variable resistance. It is calibrated by putting it in parallel with an accurate voltmeter and varying the resistance until every 10 points on the battery meter is equal to 100 volts.

The Short Wave Club of Pasadena (Calif.) is a recently formed association of persons interested in transmission and reception below 200 meters. F. R. Abbott is president; Ted Swift, 2510 Mar Vista, Altadena, Calif., is secretary. The first function of the technical committee, of which K. V. Dilts is chairman, is to co-operate with BCL's in minimizing interference from amateur transmitters. The Club conducts a code class, transmitting nightly between 8 and 8:30 on 80 meters.

CALLS HEARD



By 8CFL, Charles Justice, 433 S. 17th St., Columbus, Ohio.

(40 meters)
 oa-2tm, oa-2sh, oa-2rx oa-5wh, sb-1aa, sb-1an, sb-1aw, sb-1bi, sb-1ia, sb-1ib, sb-1id, sb-2ab, sb-2ad, sb-1ao, sb-2af, sb-2ag, sb-2aj, sb-2ao, sb-5ab, sb-5ad, sb-6qb, sb-5pc, sb-9qa, sc-2ah, sc-2ar, sc-2ld, sc-2as, sc-3ij, se-1fg, sh-bzl, su-1cd, su-1br, su-zak, sa-afi, sa-cb8, sa-ee2, oz-1ao, oz-1ax, oz-2ac, oz-2ae, oz-2xa, oz-3ak, oz-3am, oz-3ar, oz-4ac, oz, 4am, oz-4av, oh-6axw, oh-6dea, oh-6buc, oh-fxl, eb-4ww, ef-8ix, ef-8gi, ef-8jf, ef-8qrt, ef-8kf, ef-8jn, ef-8yor, ef-8fj, ef-8tis, eg-2kf, eg-2nm, eg-2dn, eg-5dh, eg-6yd, ei-1co, ep-1ae, fb-1ya, fo-a3b, fo-ayo, na-wwdo, nc-lax, nc-lei, nc-lad, nc-1am, nc-led, nc-lar, nc-4bt, nc-4fc, nc-4dw, nc-4gt, nc-4ck, nc-5ef, nc-5ct, nc-5gf, nd-hik, nj-2ac, nj-2pz, nm-1aa, nm-1af, nm-1g, nm-1j, nm-1k, nm-1n, nm-jh, nm-5b, nm-5c, nm-9a, nm-cyy, nm-xc5i, nm-xda, nn-m3y, np-4ja, np-4je, np-4kt, np-4sa, np-4ur, np-2mk, np-8kp, nr-cto, ns-fmh, ny-rxy, nz-99x, nz-nba, kjoe, octn, wyf sgl, hjg, lpl, ab, aa7, wvx, nem, perr, pell, agc, decz, nixb, nidk, f8z, x-lw, kgbb, wnp, voq, nitc, niss, nisq, nerkl, fw, glq.

(20 meters)—1-abz, 1-adm, 1-aqt, 1-byv, 1-cfo, 1-sw, 1-zz, 4-fa, 4qb, 5bd, 5-ajs, 5-rz, 6-fr, 6-ckk, 7-pu, 7-ek, 8-aly, 9-acf, 9-cjt, 9-dcm, 9-dfr, 9-cwn, 9-cvn, 9-brh, 9kv, 9-dpb, nc-lap, nc-lar, nc-1co, nc-1dx, nc-4dw, nc-4fv, np-4sa, sc-3ag, su-1cd, su-2ak, eg-2nh.

WL QSL all crds es WL QSL all reports on MI sigs.—1-cx-310 on 20, 40, 80 meters. 73.

By G2BZC, 38 Purley Ave., London, N.W. 2, England.

1avl, 1akm, 1ajf, 1bdw, 1cnz, 1do, 1lj, 1lx, 1in, 1se, 1zs, 2agt, 2avg, 2ayj, 2baa, 2bc, 2et, 2la, 2gk, 2qu, 2uk, 3auv, 3cc, 3ee, 3gi, 3py, 3qf, 3xk, 4ov, 4si, 4uq, 4vs, 5eh, 8bqi, 8cdv, 8ks, 8ve, 9adg, 9adk, 9axh, 9axz, 9dod, 9sj, silca, sb2ae, sb2ae, sb2ax, nc2fo, nc3wab, oz2bx, sabg9, oplau, foa6n, nj2pz, tfhv, kdtf. WI reply at once to all crds recd.

By R. W. Minton, 62 Barton St., Woolston, Ch. Cch., New Zealand.

1aap, 1aga, 1aqi, 1aza, 1bes, 1bhs, 1bhw, 1bnt, 1bsd, 1ccz, 1cd, 1fl, 1ca, 1ic, 1ig, 1jv, 1ka, 1kk, 1py, 1qc, 1vc, 1xv, 1yb, 2aan, 2ahj, 2aml, 2apd, 2bc, 2bl, 2hr, 2kx, 2nz, 2lo, 2xaf, 2xg, 3agg, 3bhv, 3bms, 3ekl, 3gp, 3ld, 3qw, 3tc, 3wf, 4aae, 4fl, 4ft, 4he, 4lm, 4pk, 4qb, 4rm, 4tz, 5ai, 5aid, 5aio, 5ajz, 5ajr, 5ala, 5ao, 5aq, 5aqe, 5taf, 5auz, 5ev, 5hz, 5kc, 5oa, 5qj, 5ql, 5rg, 5tt, 5zai, 6abg, 6acz, 6adk, 6adt, 6ain, 6aiv, 6alg, 6alr, 6alz, 6am, 6aoy, 6aps, 6auk, 6avb, 6bbv, 6bd, 6bdi, 6bhv, 6bjf, 6bjl, 6bjp, 6bjv, 6bmo, 6bpm, 6btm, 6bvb, 6bve, 6bvw, 6bxc, 6bxd, 6bxi, 6bya, 6bzd, 6bzf, 6bzm, 6bzn, 6cbj, 6cdw, 6chy, 6cii, 6cng, 6cnn, 6cpf, 6cqw, 6csl, 6csx, 6ctx, 6cua, 6cub, 6cxf, 6cyd, 6czx, 6czz, 6deq, 6ddo, 6dp, 6er, 6ew, 6fg, 6fp, 6hm, 6hu, 6jn, 6kb, 6ku, 6np, 6nx, 6or, 6pv, 6rf, 6rn, 6vr, 6ta, 6zat, 6zbi, 7alk, 7dd, 7ek, 7hc, 7kr, 7ll, 7mp, 7ou, 7rl, 7tm, 7tx, 7wu, 8aj, 8ajn, 8aly, 8asb, 8aul, 8avs, 8axs, 8axz, 8baj, 8bas, 8bbe, 8bbk, 8bj, 8bm, 8bps, 8bth, 8buy, 8ccm, 8ccq, 8cav, 8cwt, 8cvs, 8cyi, 8cqu, 8ded, 8dfo, 8dke, 8drq, 8eb, 9acl, 9aek, 9aem, 9alh, 9aoj, 9ara, 9arn, 9atq, 9ayk, 9ays, 9axb, 9be, 9beq, 9bht, 9bjz, 9bke, 9bpb, 9bqo, 9bwb, 9bwn, 9bwo, 9ccs, 9ccs, 9cet, 9cks, 9clr, 9cpm, 9etg, 9cv, 9cvn, 9cwn, 9cww, 9cwz, 9cxc, 9deg, 9dla, 9dkc, 9dol, 9dqr, 9dqu, 9dr, 9dsr, 9dtm, 9duc, 9dvg, 9dwg, 9dww, 9dwp, 9efk, 9ehn, 9ekf, 9ekn, 9eli, 9ell, 9emd, 9km, 9lc, 9ln, 9mn, 9mo, 9nk, 9nr, 9pt, 9sj, 9sv, 9uu, 9xi, 9za, 9zk.—eb.rs, ed7bx, ef8ay, ef8cp, ef8ct, ef8fz, ef8fj, ef8gaz, ef8gdb, ef8gm, ef8jf, ef8kz, ef8max, ef8qrt, ef8sst, ef8trv, ef8udi, ef8yor, eg2lz, eg2sz, eg2xy, eg5dh, eg5nj, eg5yx, eg6yv, eilau, eilco, eilcr, eiler, eilgw, eilma, eilmt, ek4yae, em5mvj, fm8st, ac8em, ajlka, aj3aa, ajhbb, ajjps, nclar, nc3wab, nc5ef, nj2pz, nmlj, nmln, nm5b, nm5g, nm9a, nflax, saee2, saga2, sahd4, sahd5, sb1ac, sb1aj, sb1bi, sb1ib, sb2ab, sc2as, sc2bl, sc2ld, sp5oa, sulbu, su2ak, su2bc, oh9dl, oh6acg, oh6aff, oh6axw, oh6bc, oh6adh, oh6bdl, oh6buc, oh6ch, oh6cxy, oh6def, oh6deu, oh6oa, oh6xk, acd, agb, aqe, bam, ds, fu9, new, ohk, ocv, pcmm, perr, pke, rxy, spw, voc, wik, wvx.

By 9DDE, 3034 Leland Avenue, Chicago, Ill.

40 meter band: eg5hw, foa4z, xnudcz, nq8np, nc3xi, nc3fu, nc5au, nc5ya, ca2tm, oa2yi, oa2ij, oa3ef, oa4cz, oa4bq, oa5bg, oa5hg, oa7rs, oa7cw, oa7dx, oz2ak, oz3ar, oz4aa, oz4am, sc2ah, aqe, ardi, pj, amae, npu, pl, giky.

20 meter band: nu6ahp, nu6bjl, nu6cer, nu6ciw, nu6dag, nu6rw, nj2pz, nclam, nc2fo, nc2al, nc4dw, sb1ad, hik, perr, fw, nitc.

(Continued on page 38)

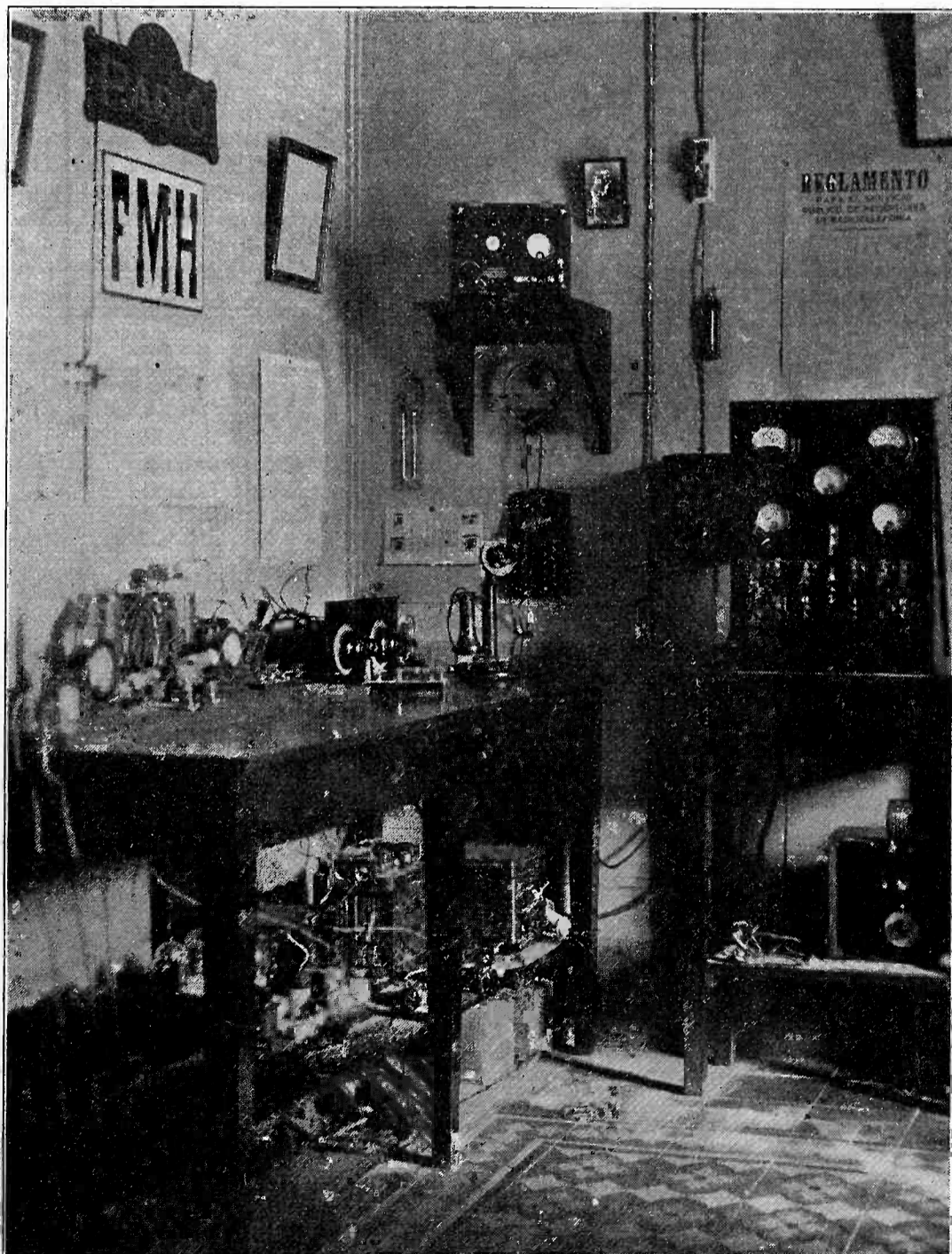

Radio Station NS-1FMH

NEW RADIO CATALOGS

High Resistance Voltmeters for B Battery Eliminators are the subject of an interesting leaflet from the Westinghouse Electric & Mfg. Company.

BOOK REVIEWS

"Nema Handbook of Radio Standards," published by National Electrical Manufacturers Association, 420 Lexington Ave., New York City; price \$1.00.

This 48-page pamphlet specifies the various radio standards recommended by the association which sponsors it. As regards radio parts and sets these are principally specifications as to mechanical dimensions, markings and insulation requirements. For dry cells and storage batteries specifications are given for discharge rates, capacity ratings and terminal conditions under standard tests. Vacuum tube nomenclature is identical with that of the I. R. E. report; dimensions of the standard base and the average characteristics of WX-12, UX199, and UX201A tubes are given. An appendix contains the standard symbols used in wiring diagrams and the proposed standards of the Underwriters' Laboratories for socket power devices.



Never Before At This Sacrifice Price

HIGH VOLTAGE

RCA KENOTRON RECTIFYING TUBES RCA
MODEL U. V. 217

A. C. Plate Voltage 1500 volts. Filament Voltage 10 volts.

Used with U. P. 1016 Power Transformer or similar Transformer.

These GENUINE R.C.A. U. V. 217 Tubes are very efficient Rectifiers and they will pass plenty of current and voltage for 50 watters and H. Tubes and also can be used for 250 watters.

EVERY TUBE IS BRAND NEW AND PACKED IN ORIGINAL CARTON

List Price \$26.50 ea.

EXTRA SPECIAL \$12.50 EA.

AMERICAN SALES COMPANY

21 WARREN STREET

NEW YORK CITY

Portable Short Wave Transmitter



Complete with all accessories including one power supply

\$90.00

We are glad to quote prices on complete amateur and commercial installations

Crystal Control a Specialty

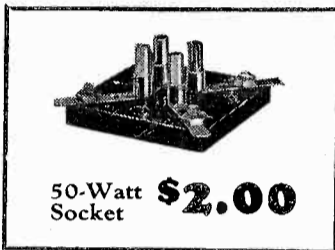

50-Watt Socket **\$2.00**

Wavemeter 10 to 110 Meters **\$17 Complete**

TRANSMITTING EQUIPMENT LABORATORIES

3982 Woodlawn Avenue

Los Angeles, Calif.

USE "RADIO's" NEW LABORATORY SERVICE

Write today for rate schedule for matching and testing your radio parts. We are equipped to give you prompt service.

"RADIO"—Pacific Building, San Francisco, Cal.

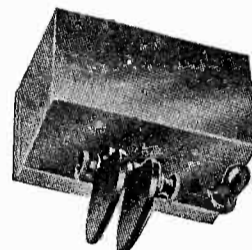

\$12.50 DIRECT TO YOU

Semi-automatic transmitter; platinum points, adjustable speed, nickel plated case with lock and key. Order today. K. N. FORD, 1411 1/2 Alta Vista Blvd., Los Angeles, Calif.

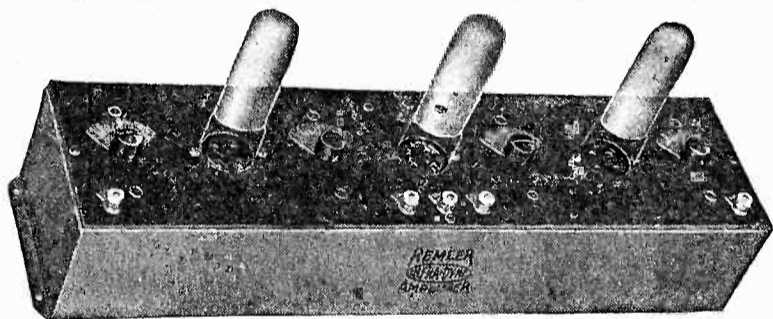

Bakelite Panel Copper Case

A precision instrument in every sense of the word

Remler **INFRA-DYNE** Amplifier

Designed and built to meet the exacting demands of the Infradyne Circuit. Also easily adapted to tuned radio frequency and neutradyne circuits.

Price **\$27.50**

REMLER

Division of

GRAY AND DANIELSON MANUFACTURING COMPANY

260 First St., San Francisco

160 N. LaSalle St., Chicago

THIS EASY WAY TO LEARN THE CODE CUTS LEARNING TIME IN HALF

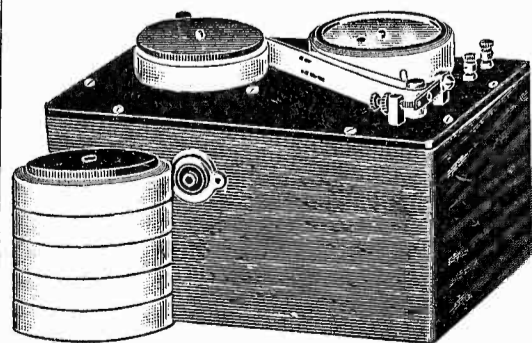

The famous **TELEPLEX** for self-instruction at home

Sends Morse or Continental The quickest, easiest and most economical way of learning Morse or Continental. Replacing all other means. Improves operating ability to a remarkable degree. Faithfully reproduces actual sending of EXPERT operators. The only instrument that sends MORSE and Continental in the exact form used in everyday work. Equivalent to experience. Sends FIVE TIMES as many words with one roll of tape as any other instrument, and SIX ROLLS are furnished. Dustproof cabinet. With or without key and sounder, or buzzer. Complete graduated course in Morse or Continental with each instrument. Send TODAY for descriptive literature, Circular "R."

76 Cortlandt St. TELEPLEX COMPANY New York City

"JACOBS' ANTENNA SPREADER" Made in both 5 in. and 7 in. diameters Pat. Sept. 8, 1925; Sept. 7, 1926

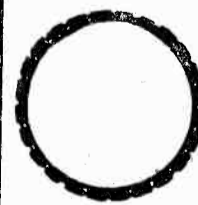

Made of metal for erecting either 4, 6 or 8 wire Cage Antenna Systems. J. C. Saltzgeber, 3JJ writes: "I am using the Spreaders in a 6 wire Antenna and Counterpoise System and achieve very fine results from a phone transmitter on 176 meters. Besides being very efficient, it makes a very fine appearance." Price \$6 per dozen; \$3.25 for a half dozen. Circular upon request.

Charles F. Jacobs, [2EM] 279 Park Place, Brooklyn, N. Y.

10c Radio Log Books Handy—Convenient "RADIO," San Francisco

The publishers
of "RADIO"

Announce

—the premier showing of new radio models in the next issue of RADIO—the July number, out on June 25th, a few days after the Radio Manufacturers' Association Show closes in Chicago. This PREMIER NUMBER will bring to you the very latest of radio's new developments for the 1927-1928 season. It will be the first consumer magazine to feature a complete "Style Number." New sets, parts, kits and accessories will be illustrated in what promises to be the largest issue in our history. This information will be rushed to us from Chicago on June 15th. Ten days later the PREMIER NUMBER will be on the street; 100,000 copies will be printed; 30,000 copies are reserved for the

radio trade. Any dealer, jobber, distributor or manufacturer who writes us for a copy of this special number will be supplied with same—free of charge—if this request is made on the company's letterhead. Individuals can send 25 cents now to insure prompt delivery of copy. Use the coupon below—attach 25 cents to it and mail now. The demand for copies of this special number will be greater than the supply. Dealers, particularly, should not fail to write for their free copy. The PREMIER NUMBER of RADIO will be the 1927 fall season reference guide of the industry. Advertising copy for this feature issue can be accepted as late as June 10th.

Don't Miss It—

*Mail Coupon
NOW—*

Order for Individual Copy

"RADIO"
Pacific Building,
San Francisco, Calif.

Here is 25 cents in stamps or coin for which you will mail me a copy of the PREMIER NUMBER of "RADIO." It is understood that this copy is to be mailed no later than June 23rd.

Name.....

Address.....

City and State.....

Dealer's Order Coupon

Paste This Coupon On Your Business Letterhead

"RADIO"
Pacific Building,
San Francisco, Calif.

We are radio dealers, as shown by our letterhead, —and we request that you send us a free copy of your PREMIER NUMBER of "RADIO" on June 23rd. It is understood that this places us under no obligations.

Name.....

Address.....

City and State.....

Tell them that you saw it in RADIO

CALLS HEARD

(Continued from page 35)

By 6DIC, A. G. Gerfen, 231 So. Bunker Hill, Los Angeles, Calif. (40 Meter)

ladh, lamq, lar, lawc, laqm, laqr, lbd, lbeg, lbhs, lbkq, lbqq, lcdp, lchr, lga, lgui, lhr, lgu, lhr, lhb, lrd, 2agp, 2am, 2amq, 2ao, 2au, 2bb, 2bg, 2crb, 2cur, 2lde, 2le, 2mq, 2my, 2or, 2se, 2sq, 2uf, 2uo, 3abq, 3afw, 3ag, 3ais, 3blf, 3bm, scl, 3ep, 3kw, 3nje, 3pk, 3ue, 3ql, 3zo, 4aa, 4ck, 4dt, 4fr, 4ga, 4ilk, 4iz, 4jj, 4gp, 4tai, 4pf, 4qb, 4si, 5aas, 5ad, 5ain, 5ais, 5aka, 5akx, 5aps, 5ape, 5arb, 5apq, 5aaq, 5ajs, 5aky, 5auz, 5aqe, 5ba, 5bcy, 5bf, 5ew, 5ck, 5cm, 5de, 5eb, 5fk, 5gm, 5go, 5h, 5hg, 5in, 5jk, 5kn, 5lf, 5ls, 5lx, 5mb, 5on, 5ql, 5rq, 5uk, 5us, 5zav, 5abb, 7adf, 7ak, 7am, 7aw, 7aws, 8adm, 7bad, 7dg, 7dk, 7dx, 7fm, 7im, 7it, 7jf, 7jm, 7js, 7hb, 7kr, 7lz, 7ll, 7mp, 7nw, 7nc, 7oo, 7oz, 7kw, 7pp, 7ry, 7sf, 7sek, 7tm, 7tk, 7yc, 7wc, 7wu, 7zn, 8acv, 8adg, 8akk, 8aip, 8aly, 8atv, 8baj, 8bfq, 8bja, 8bho, 2bp, 8cbr, 8ccm, 8ci, 8chac, 8cjb, 7co, 8csa, 8csm, 8csu, 8csr, 8dde, 8ded, 8dcm, 8don, 8dl, 8drl, 8drq, 8dzd, 8fp, 8gm, 8gz, 8jj, 8jk, 8sh, 8xe, 9aao, 9afb, 9afl, 9aau, 9ahg, 9al, 9alk, 9anj, 9ang, 9asd, 9ajd, 9aln, 9auv, 9awa, 9awb, 9arn, 9axb, 9axz, 9ayq, 9ban, 9beg, 9beq, 9bec, 9bcw, 9bff, 9bvk, 9bht, 9bil, 9bjk, 9blu, 9bnd, 9bpm, 9bqo, 9bvp, 9bwi, 9bwo, 9bwj, 9bwn, 9caj, 9cbr, 9ccs, 9cdf, 9che, 9chn, 9ckf, 9ch, 9cmq, 9cn, 9cnd, 9cp, 9cv, 9cwa, 9cwn, 9cwz, 9dac, 9dax, 9dec, 9dfr, 9dej, 9dha, 9dix, 9dkq, 9dla, 9dmy, 9dol, 9dpt, 9dr, 9drw, 9dra, 9dto, 9dul, 9duo, 9dwd, 9dwz, 9dyo, 9dzl, 9dzn, 9ef, 9ebj, 9eer, 9eji, 9ehq, 9ehn, 9ekn, 9eky, 9elb, 9ell, 9ez, 9fu, 9gh, 9h, 9iw, 9j, 9kg, 9km, 9kn, 9kr, 9ld, 9ek, 9nv, 9oa, 9ps, 9ph, 9sk, 9sb, 9sd, 9sv, 9un, 9ub, 9uu, 9wb, 9xi, 9y, 9zk, sa-db2, sa-hd4, sa-fc6, ef-8qr, ed-7fv, nj-2pz, su--am, su-1cg, su-1hr, oh-bacw, oh-6axw, oh-6buc, oh-6def, oh-6bhc, oh-6ch, oh-6clj, oh-6xk, oz-1fs, oz-1fq, oz-2aj, oz-3bx, oz-4az, sc-2as, sc-2bl, sc12ld, sc-3ag, sc-3bl, oa-1lj, oa-1ts, oa-2bc, oa-2bq, oa-2ak, oa-2ay, oa-2ch, oa-2dy, oa-2mh, oa-ob, oa-2rb, oa-2rt, oa-2ss, oa-2rx, oa-2sh, oa-2yi, oa-2yb, oa-3jk, oa-3wm, oa-2yj, oa-4ak, oa-4nw, oa-5bg, oa-5dx, oa-5hg, oa-5kn, oa-5lx, oa-5fi, oa-7dx, op-1pd, nc-3aj, nc-4bb, nc-4dq, nc-5gf, nc-4fz, nc-3fc, nm-5h, na-7pq, de-voc, de-ved, de-bbr. Stations wkd under 6abc pse QSL. All crds answered.

By A. H. McCallum, 1507 14th Street, San Pedro, California

lags, lfn, los, 2agn, 2awr, eaxe, 2ava, 2cvs, 2jg, 3bel, 3er, 4ed, 5aio, 5aur, 5avb, 5iu, 5ls, 5uk, 7ace, 7ako, 7cg, 7jc, 7no, 7ou, 7op, 7ox, 7ur, 7rj, 7zn, 8bps, 8cjo, 8bno, 8dhu, 9awr, 9ahj, 9ahq, 9beq, 9bht, 9bhx, 9bqo, 9cmq, 9eev, 9eez, 9emb, 9ddw, 9dez, 9fu, 9gj, 9sk, 9xe, nc3cs, nc4at, nc5dl, nc5fl, na7kk, nm7cy, oh6axw, oa2mh, oa2xi, oa4an, oa5ja, oa6bw, oa7hl, ozife, oz4an, oz4arm, sc2bl.

By nu-9CN, 4183 Barry Ave., Chicago, Illinois

Australia—2ay, 2sh, 2bv, 2rc, 2rt, 2sa, 2ms, 2ss, 2xi, 2rx, 2yi, 2no, 2mh, 3bq, 3bc, 3al, 3ef, 3fk, 3xo, 3wn, 3yx, 3dc, 3bl, 3en, 3ls, 3kb, 3dj, 3es, 3sr, 3hl, 3lg, 3am, 4cb, 4rb, 4lb, 4an, 4go, 4cg, 5wh, 5ma, 5bg, 5hg, 5bw, 5dx, 5rm, 7cw, 7cs, 7ks, 7hl. New Zealand—Aac, 2ae, 2qa, 2xa, 3ai, 3ar, 3ij, 4aa, 4ac, 4ak, 4ar. South America—1aa, 1ad, 1af, 1aj, 1ak, 1an, 1ao, 1aw, 1aq, 1ay, 1bc, 1ib, 2af, 2ab, 2ad, 2as, 2ig, 5aa, 6qa, (Brazil). South Africa—1sr, a3b, a3m, a4x, a4z, a5o. Uruguay—1br, 1bu, 1fb, 2ak. Canada—4ac, 4al, 4aq, 4dw, 4fo, 5bn, 5ef, 5dx, 5hp, 5hi, 5se, 8aza. Mexico—1n, 1j, 9a. France—octn, 8kf, 8qrt, 8jj, 8yor, 8max, 8st, 8ix, 8sm. Hawaiian Islands—6ddl, 6buc, 6bg. South America (Chile)—2is, 2ij, 2ar. Cuba—8kp. Portugal—1ae, 3fz. England—2zz, 2z. Jamaica—8pz. Suomi (Finland)—2co. Lesser Antilles—2t. Venezuela—1tm. Spain—6aer. Miscellaneous—vgjl, wwdo, kel, bbt, trcl, sih, kdgl, dio, sm-ip, nau, pz-2as, j7ef, r-cb8, xzl, xg, npo, nba, nitc, nezb, hik, x-paw.

By 6ALV, Alameda, Cal.

Europe—ES-2co, EK-4dba, EF-8ct. America—NJ-2pz, NR-cto, NM—1j, 1k, 9a. South America—SA-hd4, hb5, hml, fc6, z4a, SC-2ab, 2as, 2ld, 2bl, 8ag, SO-1a, SU-1cd, SD-6aa. Australia—2rx, 2no, 3hr, 3al, 3es, 3xo, (3am), 5lf, 7dx. New Zealand—1ax, 2ae, 3ac, 3ai, 4ap. Philippine Islands—1bd, 1as, 1dl, 2nd, (3ac), xc3. China—1rcc, (8em), (8xx), 8fLo. Japan—1sk. Africa—fn-ac, fo-a3b, ot-(bam). Miscellaneous—novq, pkl, wwdo, wvx, A-bia, fr3, du4, pjc. Xmitter on 4lm. 150 Watts input. QRK?

By G-2ACI, 27 Hurst Grove, Bedford, England

NU: 1nms, 1dm, 1or, 1we, 1apv, 1axa, 1cmx, 1cmf, 1dke, 1ctp, 1lc, laga, lyc, lasa, 1amd, 1zs, 1aay, 1ag, 1akz, 1bhm, 1aof, 1ora, 1cjc, 1ad, 1axa, 1gr, 1lo, 1asr, 1cpb, 1rd, 1dx, 1bqp, 1mv, 1sw, 1bke, 2uf, 2cft, 2co, 2bq, 3cjd, 2bad, 2ber, 2ha, 2ga, 2apv, 2beo, 2lm, 2cvj, 2tp, 2apd, 2crb, 2czz, 2me, 2xs, 2bm, 2bkr, 2al, 2md, 2wc, 2ag, 2kx, 2fj, 2dh, 2aby, 2amj, 2nm, 2xt, 2uk, 2ace, 2cuz, 2gq, 2alw, 2tp, 3py, 3jw, 3qw, 3ahp, 3lw, 3ay, 3any, 3tr, 3qw, 3pf, 3ni, 4lz, 4ap, 4lo, 5ac, 5ab, 6gt, 8ez, 8br, 8azs, 8kp, 8it, 8amt, 8brd, 8amu, 8ahc, 8am, 9bqe, 9by, 9bz. Salvador: 1gw. Brazil: 1bd, 1ad, 1ao, 1ar, 1aw, 1ai, 1aa, 1al, 2aq, 2ag, 2af, snii. Who wants a Crd? I always QSL.

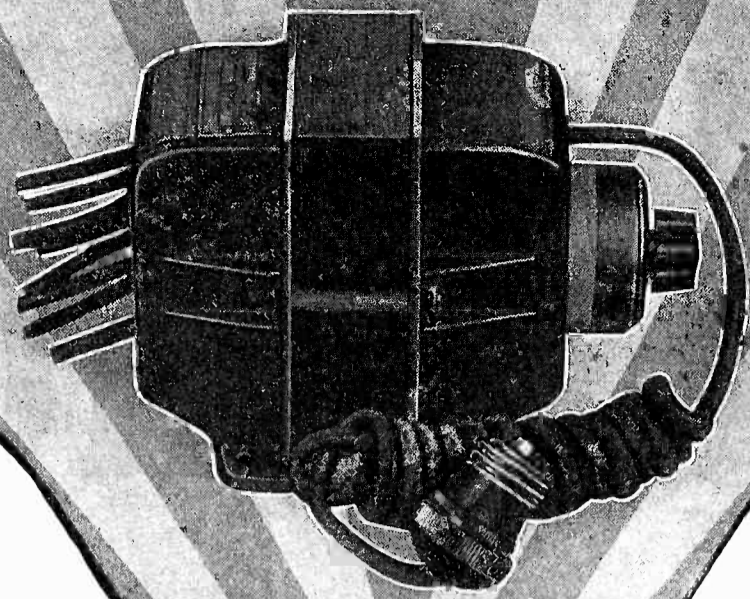

AmerTran Power Transformer Type PF52



AmerTran De Luxe Audio Transformer

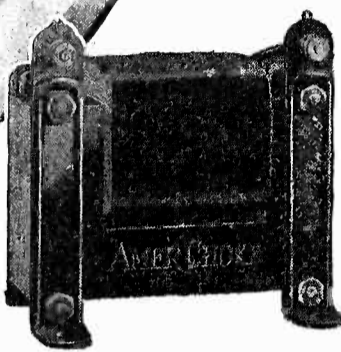

AmerChoke Type 854

BETTER RADIO NEEDS THESE QUALITY AMERTRAN UNITS

You wouldn't consider a cheaply built engine in a \$3,000 car— Then why spend money for a good loudspeaker and good tubes for use in the new set you are building and put into it poorly designed, inefficient audio transformers?

AmerTran DeLuxe transformers are so perfected that they cause tubes to amplify with all their natural fullness. Lesser transformers cannot equal the AmerTran DeLuxe for dependable volume and tone quality. Properly installed, they result in uniform reception over the entire useful audible range.

There is no question about the AmerTran DeLuxe. Time and again it has proved to the satisfaction of engineers and laboratory workers that it is the truly outstanding audio transformer. Finest results with modern speakers and tubes are easily obtainable, and comparison will convince you that the AmerTran DeLuxe sets an entirely new standard of audio amplification.

BATTERY ELIMINATION

The AmerTran Power Transformer Type PF52, AmerChokes Type 854, and the AmerTran Resistor Type 400 are recommended for the construction of a highly efficient high voltage plate supply. Through slight changes in your set, you may replace all batteries with an unexcelled source of reliable power. Write for information on building this apparatus—also free booklet "Improving the Audio Amplifier."

THE AMERICAN TRANSFORMER COMPANY

178 EMMET STREET

NEWARK, N. J.

"Transformer Builders for over 26 Years"

Pacific Coast Office

Rialto Building

San Francisco

Snap a switch

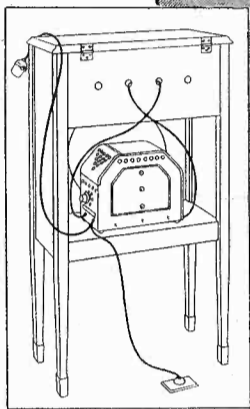
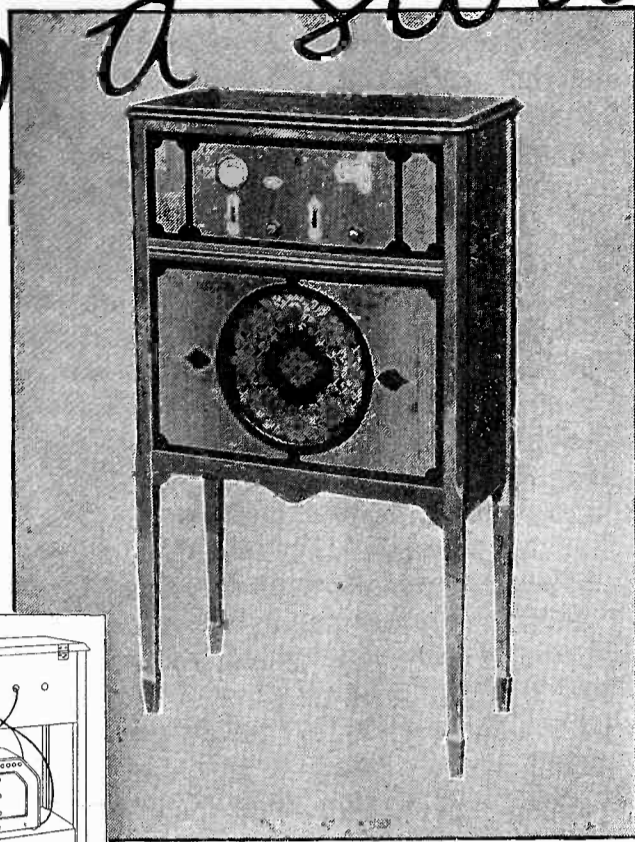

The 6 tube Console pictured above stands 40 inches high—contains skillfully engineered shielded circuit—single drum dial control. Musicone built in. Price, without tubes and power unit, \$95.00.

- No more batteries.
- No battery charger to watch.
- No batteries to water.
- No failure of the power plant just as you sit down to a fine program.
- No upsetting the house to have the radio serviced.
- No apologies to make to callers that the batteries have just run down.
- No batteries to recharge.
- No batteries to renew.

A, B and C Power from the light socket for the latest model Crosley AC Radios

This power unit weighs 13 lbs., stands 9 inches high and is 4 inches wide and requires no more attention than a vacuum cleaner or an electric iron. It transforms mechanically ordinary 110 volt 60 cycle house current into smooth quiet radio energy. **No interfering hum!**
PRICE \$50.00

Crosley radios especially designed to use this battery eliminator are the 6 tube AC-7, a neat table model of the famous Crosley single drum control receiver selling at \$70, and the 6 tube console model AC-7-C pictured above at \$95.

Prices slightly higher west of the Rocky Mountains

Crosley Musicones \$9.75 and \$14.75

Write Dept. 19 for Descriptive Literature.

THE CROSLEY RADIO CORPORATION
Powel Crosley, Jr. Cincinnati, Ohio.

Crosley sets are licensed under Armstrong U. S. Patent No. 1,113,149 or under patent applications of Radio Frequency Laboratories, Inc., and other patents issued and pending.

TO SET

CROSLEY
BETTER ... COSTS LESS
RADIO

Tell them that you saw it in RADIO

Build Yourself a
Genuine
Balsa
Wood
Loud Speaker

(Patented)

KITS
of genuine
LATTA
Balsa Wood

direct from distributor
with complete instructions
for assembly

- 20 inch size for sets using 90 volts of "B" Battery \$6.50
30 inch size for 90 volts or more; recommended for tone quality.... \$10.00
40 inch size for sets using 112 or 171 power tubes..... \$13.50
Special AMBROID Cement, per can 75c

Prices f. o. b. New York City
Beware of cheaper imitations

Send Express or P. O. Money Order, Bank Draft or Certified check; none shipped C.O.D.

PENN RADIO SALES CO.
104 Fifth Ave. Suite 2301 New York City

Make Your Own
Three-Foot Cone Speaker
in Less Than an Hour

WORLD'S FINEST LOUD SPEAKER
~ GENUINE ~
"ENSCO" 3" CONE KIT

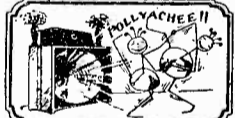
ONLY \$10
Can be Assembled
in Less Than an
- HOUR -

The Original Three-Foot
Cone Speaker
- KIT -
ONLY \$10

NO DISTORTION THE SOLUTION OF THE LOUD-SPEAKER PROBLEM
The Choice of Leading Engineers
PERFECT FIDELITY

Complete parts furnished in kit form. We guarantee this speaker the equal of any manufactured cone speaker at any price.

With this **THREE FOOT CONE SPEAKER** you hear all the tones. It brings out the true depth and beauty of orchestral and instrumental music. Can be operated softly for Living Room Music or full volume for dancing, and without trace of distortion.

Kit includes famous "ENSCO" cone unit, the only direct-drive, distortionless unit for large cones; Alhambra Fonotex for big cone, with brass apex, two Sepia Prints showing cabinet or simple stand construction. All necessary instructions.

Buy this wonderful speaker under our absolute guarantee. Your money back if you are not convinced that it is the finest reproducing medium obtainable at any price. It works on any Set, with ordinary Tubes or with Power Output.

Engineers' Service Company
25 Church St. (Desk Y)
New York City

Send No Money!

Write your name plainly, as indicated below, then mail and complete kit will be forwarded to you. Just pay postman \$10.00 upon delivery.

Engineers' Service Company
25 Church St. (Desk Y)
New York City

DIRECTION FINDERS

(Continued from page 9)

turbances directly into the ground, thus improving reception.

The receiver employs three tubes, one as a detector and the other two to effect two stages of audio amplification. Interchangeable coils are used and all tuning is done on one dial, though a second is used to control oscillation. A Utah Bell speaker is used for standing by. George Morris, in charge of the set at Los Angeles, is enthusiastic regarding the performance of the chain and Mosely declared it had been highly satisfactory. He said it had saved his company many thousands of dollars in telephone and telegraph tolls, beside giving much greater ease and flexibility in the dispatching of the airplanes.

The schedules begin at 7 a. m. and thereafter are arranged according to the position of the planes along the line. When the weather is bad the schedules are as close as 15 minutes to each other. They continue until the last plane is in. This usually is around 5 p. m.

The Pacific Air Transport operates stations at Vancouver, Washington; Medford, San Francisco, Fresno and Los Angeles and one is being set up at Bakersfield. The Medford and San Francisco stations are 500 watt affairs; the others are 250 watts. However, at no station is the full capacity used. The wavelength throughout is 46 meters. The large stations have tuned plate tuned grid circuits using 60 cycle current for the plate supply. They radiate about 6 amperes.

In the Los Angeles and Fresno stations and the projected Bakersfield station kenetron rectification without a filter is used for plate supply. Lemert declared that it had been found reliable service could be maintained under this system with as little as 50 watts. Fifteen volts are used on the plates of the kenetrons and about three amperes is put on the antenna.

In Medford, Vancouver and San Francisco, self-rectification is employed. The difference in type was the result of a desire to ascertain the most efficient plan. Standardization will be effected later, the sets being much the same in all stations except that in the smaller ones lower powered tubes are employed.

Lemert said the kenetron scheme had enabled the line to cut the power used at Los Angeles from 250 to 50 watts and still maintain good service to Vancouver, an airline distance of 1070 miles, with two mountain ranges intervening. The Vancouver station, with self-rectification circuit, gave equally efficient service, he said, but required 100 watts. The antenna and receiving systems are the same in all stations. Capacity feedback with detector and two stages of audio frequency amplification is employed.

The operating hours north of San Francisco are from 8 a. m. to 6 p. m., with schedules arranged as the position of the planes dictates. The southern stations operate until the last ship has left. This permits Los Angeles to close at midnight but San Francisco is practically a 24-hour station.

The average traffic handled is 4000 words per station daily. The Western Air Express stations were built by the Airways Radio Service company and cost approximately \$1,000 each. The Pacific Air Transport stations were built by Lemert and cost slightly less than \$3,000 in all.

NEW "ABC" SOCKET POWER

(Continued from page 12)

between 40 and 50 volts. This represents a power dissipation of about 15 watts, and the chokes will become quite warm when operated for some time, but they should not become so hot that they cannot be touched with the hand.

In the experimental layout, the chokes were placed at right angles with each other, and in a permanent set-up, it would be an excellent idea to place a steel or iron shield between them to prevent excessive interaction. If the filter condenser block is mounted between the transformer and the nearest choke, it will be a fairly effective shield, particularly when the separation is considerable. In the factory built jobs which will soon be ready, the transformers and chokes will be installed in metal cans, thus insuring isolation of magnetic fields.

The filter condensers should be of a type capable of withstanding 300 volts continuous d.c. load, and the .1 mfd. buffer condensers will require a 350 volt a.c. rating. The by-pass condensers may be of the 200 volt d.c. maximum type, including the one across the C biasing resistor.

LIST OF PARTS

- 1 Power transformer, 90 volt primary, 320-320-5 volt secondaries. See text.
- 2 10 henry filter chokes—see text.
- 1 Aerovox filter condenser block, 4-4-8 mfd.
- 4 Aerovox by-pass condensers, 1 mfd.
- 2 Aerovox .1 mfd. by-pass condensers.
- 1 Carter Voltage Control unit—7500 ohms.
- 1 Ward-Leonard Type EB-22 — 22 ohm resistance.
- 3 Porcelain lamp sockets for resistances and lamps.
- 1 General Radio vacuum tube socket—UX base.
- 2 40 watt Mazda lamps—see text.
- 1 Baseboard 12x16x½ in.
- Miscellaneous binding posts, etc.

One very important point which anyone who builds this type of eliminator should be warned about is that the device should be thoroughly protected against fire by the proper fusing of the input leads. The normal power consumption of the outfit is 1½ amperes at 110 volts, or roughly 150 watts. The smallest size plug fuse readily obtainable in electrical shops is 3 amperes, so that a fuse block for two 3-ampere screw type fuses should be connected ahead of the primary winding and the

(Continued on page 42)

SM

The Penalty of Leadership

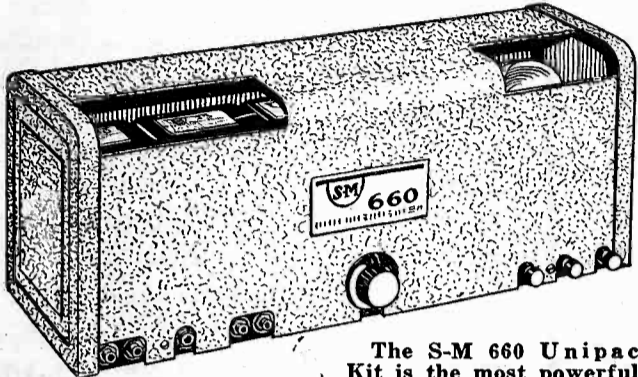

The S-M 660 Unipac Kit is the most powerful receiving amplifier available, combined with a self-contained A, B and C power supply. Using two 171 tubes, the undistorted power output of the new push-pull power amplifier stage is greater than that of a 210 tube with 400 volts while with a pair of 112 tubes it is practically equal to a 210 power pack. The Unipac furnishes practically constant B voltage for receiver operation—10 milliamperes at 45 volts and up to 45 milliamperes at 90 volts—ample for the largest sets. Used with any standard receiver, the Unipac will provide a stage of power amplification of surprisingly perfect quality, thus serving to modernize last year's set, and will eliminate B batteries as well. It operates from any 60 cycle, 105 to 120 volt home light socket.

The 660 kit contains all parts for assembling the push-pull power amplifier, ABC power, and receiver B supply, with steel cabinet and chassis. Price \$62.00.

Type 660-B, a slightly lower powered unit, superior to any standard 171 power pack, contains a regular one stage power amplifier of 220 and 221 transformers for a 171 tube, and is priced at \$57.00.

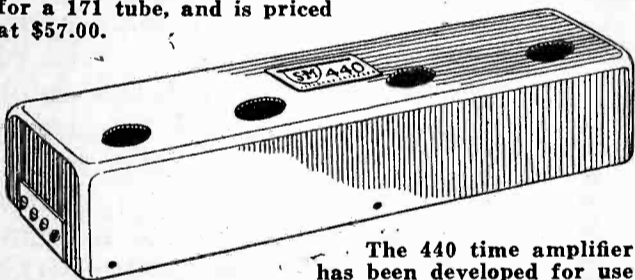

The 440 time amplifier has been developed for use by jewelers and advanced experimenters in receiving standard time signals transmitted daily by the Naval Observatory Station at Arlington, Va. (NAA).

Consisting of a three stage tuned R. F. amplifier and detector, it requires only batteries, phones, antenna and ground leads, and four 201-A tubes to be put in operation. The unit has been pre-tuned at the factory to Arlington's exact wavelength, thus eliminating all operating adjustments and rendering the amplifier capable of receiving but a single wavelength. Price \$35.00.

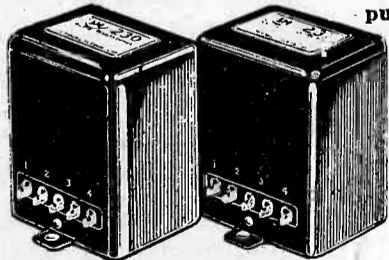

S-M 230 and 231 push-pull audio transformers are the latest development in high quality audio amplifying equipment. They account for the remarkable quality of the 660 Unipac, and for its tremendous undistorted power output.

Type 230 input transformer characteristics are similar to those of the famous 220 transformer, except that it is provided with two 3:1 secondaries, thus allowing its use as a 6:1 audio transformer if desired.

Type 231 has an extra primary, otherwise is similar to the 221 output transformer, and is designed to boost low note reproduction. It may also be used with 112 and 210 tubes to obtain maximum undistorted power output.

230 and 231 transformers, in a push-pull circuit with two 171 tubes will provide greater undistorted power than a 210 tube, but may be used with 201-A, 112, 171 or 210 tubes. Price, each \$10.00.

Leadership in any line of endeavor, though once gained, cannot be retained without effort. The penalty of leadership lies in the fact that greater effort and accomplishment is actually necessary to retain it than is frequently exerted to gain it!

Leadership in the field of radio parts manufacturing and engineering has been gained by Silver-Marshall, Incorporated, only through the sheer excellence of S-M products and engineering. In the past season, S-M audio transformers set standards for size and excellence that are—a year later—just beginning to be copied. S-M transformers introduced the 5,000 cycle cut-off in audio amplification, a revolutionary development, but to be found adopted by the most progressive manufacturers this season! And so with S-M output transformers—they are the only types actually boosting low note reproduction, helping loud speakers toward perfect performance. Again, S-M leads, and this season other manufacturers will follow with improvements that S-M introduced a year ago.

Behind every S-M transformer that has ever been sold was a money-back guarantee that it would give better reproduction than the buyer had ever heard. Yet the factory returns were less than one in every four thousand—a record of 3,999 satisfied users out of every four thousand!

The S-M Shielded Six receiver kit set a standard in home built receivers that has not been approached, and in 1927 it will continue as the finest receiver kit money can buy.

S-M plug-in coils are everywhere, for every use. Their reputation has gone beyond America, and in England they have served as the design basis for nearly every popular English coil!

The S-M Reservoir B power supply was the first unit to offer the advantages of ballast tube voltage regulation—the first and only power supply ever to be sold with a guarantee against “motor-boating” and all other eliminator troubles. And not a single return to date.

It is achievements such as these—the will to give the best and the ability to do it—that have earned for S-M absolute leadership in the radio parts field in less than three years.

Mindful of the penalty of leadership, S-M offers four new items—the most powerful power pack ever developed for home use, push-pull transformers as far ahead of those of three years ago as 220's are of other types, and a jewelers' time receiver representing the finest of engineering in long wave amplifiers.

S-M has faith in these products, knowing that they are RIGHT, and backs them with a satisfaction or money-back guarantee.

SILVER-MARSHALL, Inc.

852 West Jackson Blvd.

Chicago, U. S. A.



Listed— by Underwriters

The Jewell Lightning Arrester is a product which because of its high quality of workmanship enjoys Underwriters Laboratories Listing. Every Jewell Lightning Arrester must pass underwriters tests before it is packed for sale.

Because of the careful test supervision the Jewell arrester is the best protection for the radio set that can be obtained and it is suitable for either indoor or outdoor installation.

Write for descriptive circular No. 1019

Jewell Electrical Instrument Co.
1650 Walnut Street

Chicago

"27 Years Making Good Instruments"

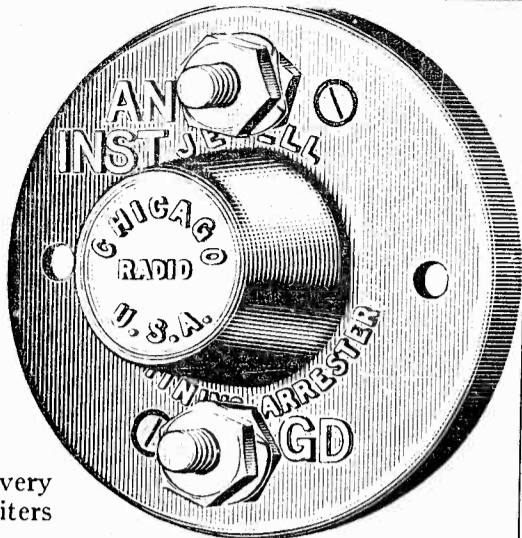

Jewell Lightning Arrester

An accurately calibrated air gap enclosed in a glazed brown porcelain case and sealed to exclude moisture constitutes the main parts of the Jewell Lightning Arrester.



NEW ABC SOCKET POWER

(Continued from page 40)

22-ohm resistance. The 10-ampere size fuse will not do, as the 22-ohm resistance, even with the transformer primary entirely shorted out, will permit only 5½ amperes of current to pass.

The danger from fire would come from short circuits in the receiving set *B* voltage lead, which would in turn short out sections of the 7500 ohm *B* supply resistance, thereby causing an excess of current to flow through the remaining sections of the resistance wire, and heating the wire red hot. Such shorts can be caused by defective tubes, or short circuited bypass condensers, and with the proper primary fuses, a heavy overload will cause them to blow before any damage is done.

At the time this article is written, wire wound rheostats of 150 and 500 ohms were not ready for distribution, and a bank of mazda lamps was used. Two 40 watt lamps in series will make a 600 ohm resistance with a current carrying capacity of 350 milliamperes, as each lamp has 300 ohms resistance, and normally consumes .36 ampere at 110 volts. If the current is in excess of 250 milliamperes, when the circuit of Fig. 5 is set up, additional lamps can be added in series until the current is reduced to the right value. A 60 watt lamp has a resistance of 200 ohms, and a 100 watt lamp a little over 100 ohms. Lamps of 10 or 25 watt capacity should not be used, since they are not designed to carry current up to 250 milliamperes. For the *C* biasing resistance, where a type 112 tube with 180 volts plate is used, two 100 watt lamps in parallel will be about right. While they take up more room than the other lamps, they are not expensive, and are really a very satisfactory vacuum type resistance.

In the July issue of RADIO, directions for building a similar *ABC* eliminator using factory built parts will be given, together with directions for wiring, testing and operating a receiver having its filaments wired in series, for use with the eliminator.

A radio repair man's tool kit should include side-cutting pliers, or "diagonals," heavy combination pliers, smaller round-nose pliers, pocket knife, large and small screw drivers, small file, electric soldering iron, soldering flux, and solder. These are about all the tools needed for general repair work; and they would constitute a good kit for the set builder. If panels are to be drilled, it will be necessary to add a center punch, small hammer, dividers, ruler and square, saw, hand drill, countersink, and a number of drills to the kit. A set of taps and dies are also very useful. A brace, several bits, and a large hammer must be added to the first kit if aerials are to be erected.

AERIAL WIRE

ENAMELED
TINNED COPPER
BARE COPPER
SOLID
STRANDED
BRAIDED

COILS

MAGNET WINDINGS
FOR LOUD SPEAKERS
TRANSFORMER AND
CHOKE WINDINGS
FOR BATTERY
CHARGERS
AND ELIMINATORS
COILS FOR AUDIO
TRANSFORMERS

MAGNET WIRE

ENAMELED
COTTON COVERED
SILK COVERED
SINGLE OR DOUBLE
WHITE OR COLORED



Dudlo Manufacturing Corporation

FORT WAYNE, IND.

A. S. LINDSTROM CO.—Western Representative

274 Brannan Street
San Francisco

324 N. San Pedro Street
Los Angeles

95 Connecticut Street
Seattle

146½ N. 10th Street
Portland

221 South West Temple
Salt Lake City

10 High Grade **TOOLS** \$200 Postpaid

The Radio Tool Set contains circle cutter, scriber, drills, taps, reamer, countersink and instructions.

Wingra Tool Co., Dept. B, Box 626, Madison, Wis.

You Can't Go Wrong

If you get it from

"RADIO" Laboratory

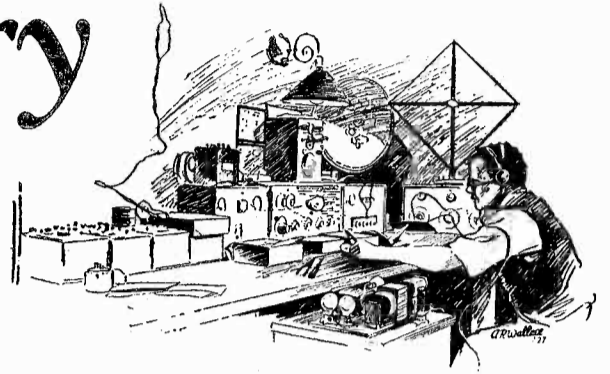

A superior service—the personal attention of Best and McGown—the assurance of success and protection against defects ◆

HERE—in the laboratory of "RADIO"—we solve the intricate problems of our readers. We take the grief out of radio. We make it easy for you to build or rebuild your apparatus. Any standard make or radio apparatus can be purchased from our laboratory at the regular list price. Complete kits—or small individual parts can be furnished you without delay. Before the apparatus leaves the laboratory it is given a thorough test by Gerald M. Best, our Technical Editor and D. B. McGown, formerly with the Radio Service, U. S. Department of Commerce. We match intermediate frequency transformers—tubes, condensers of all kinds—transformers, coils and miscellaneous electrical devices. We make no charge for the matching, testing

and inspection of radio parts when these parts are purchased from our laboratory. A very modest charge is made for apparatus sent us for test. Our clientele now extends to the far corners of the country. Of particular interest to us is the number of matched tubes purchased through the laboratory. It is a known fact that tubes have various characteristics. Some are good detectors—others are good oscillators, radio frequency or audio frequency amplifiers and by properly selecting and testing these tubes you are assured of better results from your receiver. We make no charge for "picking" tubes for various parts of your circuit. The retail price of the tube covers everything. We "chase bugs" in multi-tube receivers. Dozens of complete sets are received regularly for overhauling.

Now is the time to put your receiver in condition for the fall season. Let us help you make the necessary improvements. Our advice is cheerfully given on any circuit. Send your set to us by express if you want to have it completely checked and balanced. Complete kits can also be supplied. All parts for the Infradyne—\$118.00. Loftin White — \$85.10. Browning-Drake, Hammarlund Hi-Q, Karas, Pacent and other kits at standard prices. New Balsa Wood Loud Speaker Kits — \$10.00 for largest size. Let us know your wants and prices will be quoted. When shipping apparatus to the laboratory be sure to securely pack it in wooden boxes to prevent damage. You can order your supplies from us by wire — if you are in a hurry. C. O. D. orders accepted if half cash accompanies order.

~ Write for Rate Schedule ~

CALIBRATION LABORATORY

Pacific Radio Publishing Co., 435 Pacific Building, San Francisco, Calif.

Tell them that you saw it in RADIO

Penn Cone Speaker UNIT

Endorsed by Builders and
Leading Radio Authorities

Enjoy the speaker you build instead
of regret that you built it.



Use a genuine PENN
Cone Speaker Unit
endorsed by such out-
standing authorities as
Cockaday of *Popular
Radio*, Hurd of *Chris-
tian Science Monitor*,
Casey of *Chicago
Daily News*, Kenneth
Harkness and many
others.

Adjustable to Output of Set

Every set has a different output. The
PENN C. S. Unit is adjustable to
output of set with which it is used.
Operates at maximum efficiency of
set. Has full 16 oz. seasoned horse-
shoe magnet, unalloyed to prevent rust
and preserve magnetism; shortest,
stoutest drive rod of any unit; straight-line drive.
Reproduces perfectly all frequencies at all voltages
—90, 135, 180 to 450 volts. Price, unit only, \$9.50.
Complete parts for 3 ft. DOUBLE round Con-
centric Cone Speaker, \$14.15 including gen. PENN
C. S. Unit, 2 shts. FONOTEX, pr. PENN Back
Rings, set PENN Unit Mountings; can Special
AMBROID Cement.

What Builders Say

That unit sure is a wonder—G. Haywood. Am a
lucky owner of one of your loud speakers—W. K.
Taylor. Sure is fine—R. Hanson. Is a wonderful
speaker; heard instruments in a band selection I
had never heard over radio—Leslie Roberts. Have
never heard a speaker so wonderful—Karl Tuarski.
Finest speaker I ever owned or heard—W. A. Rapley.
All and more than you say it is—E. E. Adcock.
Ask Your Dealer

Insist on a genuine PENN Cone Speaker Unit. If
he hasn't it and will not get it for you, order
direct from any of the firms below.

Herbert H. Horn Co. Offenbach Electric Co.
1629 S. Hill Street 1452 Market Street
Los Angeles, Cal. San Francisco, Cal.

PENN RADIO SALES CO.

104 Fifth Ave. Suite 2000 New York City

Exclusive National Selling Agents for
G. R. Penn Manufacturing Co.

SPECIAL AMBROID

CEMENT FOR CONE SPEAKERS

Specified for Balsa Wood and other
types of Cone Speakers..... **75¢**
At dealers or direct from us for 5 oz. can

PENN RADIO SALES Co., Exclusive National Sales Agents
104 Fifth Ave. Suite 2000 New York City

Licensed by
Rider Radio
Corporation
Pats. Pend.
Pat'd 5-2-'16
Pat'd 7-27-'26

Distance
Without
Howls!

Phasatrols

YOU can get distance with-
out oscillation squeals
with this true balancing
device for radio frequency
amplifiers. Price \$2.75 at your
dealers.

["QUALITY PARTS FOR
QUALITY RECEPTION"]

Write for FREE Hook-up Circular.
175 Varick St. Dept. 32 New York

ELECTRAD

D. X. LOVE

(Continued from page 17)

nice boy and had faith to believe that he would develop into a good man. That was all, but it gave him something to strive for that was worth all he had to put into the battle.

Roland mumbled his good-byes and escaped from the crowd. It would be fifteen minutes before the black-faced steward would sing out: "All ashore that's goin'!" so he naturally wandered up to the radio cabin. A new operator was receiving instructions from the chief. His natty uniform and cap concealed for a moment the fact that his face and figure were familiar. He glanced up, discovered Roland, thrust out his hand and smiled triumphantly.

"Good-bye, old man! So good of you to come to see me off! Hope to see you when we get back from the trip."

Roland tried hard to conceal his surprise and a good deal besides. Harry, an indifferent radio amateur, had turned pro. Harry, who knew perhaps one-tenth as much radio as his rival, had secured a commercial license and a job that would make him the shipmate of the object of their affections for four months, under conditions that regularly produce more engagements per unit of population than any other combination of circumstances known to statistical science.

THAT night Roland sat in his den with his head on his hands. He could think only of the *President*, plowing the Atlantic on the first leg of her long voyage. He tuned her in and listened to the messages that the passengers were sending to folks back home. There were a lot of them.

He sat and listened until the dog watch. This, of course, was wished onto the new operator with a junior to break him in. Roland heard Harry take the key. Anybody who had ever heard Harry would remember his fist. Among all the ham fists in the world his was undoubtedly the worst. The man at WNY, the coastal station, showed his feelings after the manner of operators. Cuss words and superfluous signals are prohibited by international convention, but an old operator can express a good deal in dots and dashes that does not appear in the literal translation of the "Q signals." Roland hoped that it was not lost on Harry, but knowing him to be as erratic on the receiving end as he was at the transmitter, he feared that it was.

Suddenly a certain individuality of expression in the wording of a message made him conscious that it was from Anne. The addressee, whose name he had just heard, he had already forgotten. With instinctive delicacy he took off the phones. Strangers' messages to strangers made no difference, but eaves-

dropping on the one whom he loved, even under conditions that made him entirely safe from discovery, was unthinkable. It was maddening to realize that any message that he might send to Anne, or that she might send to him, would pass through his rival's hands. If he were not on watch when the correspondence was handled, he would find it on the hook when he went on duty again. Roland sat staring bitterly at nothing while the great liner put knots between her churning propellers and the young man whose hopes she was reducing to a slender thread that might snap at any moment.

THE Solent was alive with craft of all sorts when the *President* slowed down and nosed her way up the channel between the mainland of England and the Isle of Wight toward Southampton. Hardly was she out of the chop of the channel when a slim, speedy motor launch came alongside.

An Englishman in immaculate yachting clothes saluted the steamer's captain on the bridge high above him while a sailor tossed a weighted note aboard. A steward carried the note to the captain, who read it and nodded assent to the man on the launch. A rope ladder was lowered on the port side forward and a younger Englishman, also faultlessly arrayed, swung up it as lightly as a cat. He handed a steward a half crown and was conducted to the promenade deck, where Anne was leaning on the rail feasting her eyes on her first prospect of Merrie England.

"I beg your pardon, Miss Warner—I have a message for you, if you don't mind. It came by amateur wireless."

Instantly Anne was tense with eagerness. "It couldn't be from America, could it?"

"Right-o! You hit it the first try! Woman's intuition, and all that sort of thing. Maybe now you can tell me who it is from?" The English youth was as charmingly at ease as he was well bred. She liked him.

"No—o," she replied, "Who is it?"

"Fact is, I don't know myself. You know we amateurs know each other by our call letters. He signs u2AF. For the past week we have been in communication rather regularly. He said he hesitated to send you messages through the regular channels because the ship's operators might jolly well garble them, don't you know?"

Anne presented him to her father. He too liked the young Britisher. They talked of the South Downs, the regatta about to start at Henley, the cathedrals, the Lake Region, and of London. The talk ended by all three swinging down the rope ladder while the passengers murmured their admiration of Anne's agility. The motor launch increased her speed as soon as they were aboard and left the ship in her wake. Harry Hunter came out of the radio cabin and looked

Tell them that you saw it in RADIO

after her. Like all operators he was expecting shore leave while the ship was in port, and he seemed to have plans that were entirely upset by the sight of Anne waving back to him from the launch.

"Well I'll . . . !" he exclaimed.

THE tour of England finished at Croyden, where Anne and her father left the Rolls-Royce that had carried them smoothly over hundreds of miles of perfect highways and hopped off for Paris in a Handley-Page airplane with twenty other passengers. In less than three hours they crossed the Channel, viewed the battle-scarred villages and fields of northern France, and spiraled gently to earth at Le Bourget, the flying field outside of Paris.

An excited Frenchman crashed the gate, or got through on a pass, and hopped about in an effort to locate someone whom he seemed to expect would alight from the roomy cabin.

"Ah—it must be—it *est* Mademoiselle Varner?" he inquired.

Anne replied in Parisian French, and after that she could have put a leash on him and led him.

"Je suis le president de la Societe Radio Telegraphique," he explained. "Un Americain m'a envoye cette message . . ."

It was the English experience repeated, except for the change of scene and the effervescent French temperament. Mr. Warner tested the would-be host and found him unimpeachably a gentleman. He had a motor car whose performance explained the necessity for the isles of safety at the crossings in the streets of Paris. After visiting Versailles, Fontainebleau and a score of points of interest, he drove them south to Gibraltar, where they were to re-embark on the *President*.

As he was taking his leave, Anne asked him for the name of the sender of the radio message. She had reread it many times. It was long, and contained intimate little bits about folks at home. She suspected, of course, that it was from Roland, but there was nothing in it to identify it positively.

The Frenchman shrugged his shoulders. "*U2AF—je ne sais pas de plus.*"

THE blue Mediterranean, under a subtropical moon, is more than most women can stand. It made Anne lonely and pensive. Home seemed very far away, and her surroundings at the moment were a fairyland through whose mysteries one needed to roam hand in hand with someone who understood.

Harry found her by the rail on the boat deck, away from the huddle in the promenade and the salons. She knew all about him and liked him just the same. He stood close—pressed closer. Their hands touched. His insisted and

Two Radio Magazines

for a few cents more than the price of one

Co-operation among two radio publishers has made possible a substantial reduction in the subscription price of "CITIZENS RADIO CALL BOOK," published four times a year, and "RADIO," published monthly. You can save \$2.00 on a one-year subscription by subscribing to both of these magazines at one time. The full price for a one-year subscription to both magazines is now \$3.00. The regular subscription price for both is \$4.50. If you buy copies of both these magazines from a news dealer you pay \$5.00 per year. You can save \$2.00 by subscribing now. This special summer subscription offer will be withdrawn shortly. You profit by subscribing now. A subscription also insures you against missing a single issue of both these well known magazines.

"CITIZENS RADIO CALL BOOK" is published four times a year and brings to you a complete radio encyclopedia of constructional data, circuits, and all of the broadcast station schedules, wavelengths, photos of artists and much data of great value to every radio enthusiast. "RADIO" gives you the practical side of radio—the ABC of radio's XYZ. This is a fine combination of magazines. Better send the coupon today. Attach \$3.00 in currency, check or money order to the coupon and mail now—before you turn this page.

YOU SAVE \$2.00 by subscribing now

Remember—it will cost you \$5.00 to buy these magazines from a news dealer over a 12 months' period. Get in on this money-saver before the offer is withdrawn. It's worth your while.

-----COUPON-----

"RADIO"
Pacific Building,
San Francisco, Calif.

Here is \$3.00 for which you will enter my subscription for a full year to both "RADIO" and the "CITIZENS RADIO CALL BOOK."

Name.....

Address.....

City and State.....

Tell them that you saw it in RADIO.

SM

Do You Hear 'em?



When you listen to your set do you really *hear* the sibilant "SSS" and "th" sounds, or does your imagination have to supply them? Do you actually

feel the low notes of the cello or is your imagination again supplying the notes your set loses?

Simply because S-M audio and output transformers installed in any set eliminate the necessity for "imagining" good reproduction—because they actually give it—you'll find them in almost all of the better circuits.

That's why Sargent and Rayment specified them for the Infradyne—because they knew of no better guarantee of perfect tone quality.

You can have it too—just get a pair of 220 audios and a 221 output transformer from your dealer on a satisfaction or money-back guarantee and prove it.

S-M 220 audio and 221 output transformers are \$8.00 and \$7.50 each, respectively.

652 Reservoir B

The S-M 652 B supply kit is the guaranteed answer to your B eliminator or B battery troubles. It won't run down, its output voltages are constant to a few per cent, and it won't "motor-boat" or "putt."

Its power output is sufficient for the largest set-up to 45 milliamperes at 90 volts, 10 milliamperes at 45 volts and plenty of current for a 171 power tube on the 180 volt tap. And, all adjustments are automatic!

You can put it together in a few hours on the living room table, hook it to your set and enjoy reception with B troubles at an end, for the 652 is a veritable reservoir of ample, constant, reserve power.

All parts ready to assemble, less CX-313 and CX-374 tubes; price \$34.50.

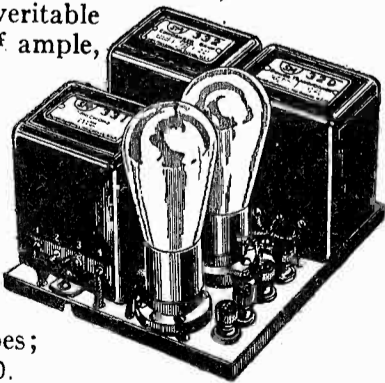

SILVER-MARSHALL, Inc.

852 West Jackson Blvd.
Chicago, U. S. A.

hers yielded. The moonbeams glimmered across the waves as the ship rolled gently on the heaving bosom of the sapphire sea. His lips were at her ear.

"Anne—I love you!"

She drew back a little. Their eyes met. He took her other hand. There was an answering pressure.

She turned her face upward toward the stars. She saw the lighted doorway of the radio cabin, high on the bridge deck. A serious young man sat at the apparatus, keying, listening, copying with a typewriter the messages that whispered in his ear phones.

"Do you ever tune in for Roland?" she asked.

"No—amateurs are not permitted to communicate with ships, nor ships with amateurs, except in cases of emergency," he answered.

"Will you show me the apparatus, and explain it to me?" She drew him toward the lighted doorway.

At Naples a dark-eyed Italian delivered a message from u2AF, and took Anne and her father in his Isotta to Rome and Venice. From Piraeus a Greek engineer, who brought another message from the same American station, drove them to Athens, marvelling the while at the way in which American youth was annihilating space with its home-made radio sets. A railroad telegrapher on the Joppa to Jerusalem road told them how he had taken up radio and how, during the past two weeks, he had heard his call letters night after night until he found that he was actually being called by an unknown American who eventually, and without receiving the QSL that he was unable to send in response, even through relays, made him understand what was wanted. The ether message requested that any amateur in the Holy Land who heard it should extend all possible courtesies to an American girl named Anne Warner who would arrive on *U. S. S. President*.

At Cairo, and again far up the Nile, English officials delivered messages and found pleasure in the acquaintance to which they led. In the harbor of Calcutta, India, the ship was boarded by the supervisor of a tea plantation, far inland, who spread before Anne and her father an amazing sheaf of traffic that he had received from the American, who relayed it through the Scotchman's old home town radio club in Aberdeen. He showed them the jungle and gave them their first tiger shooting.

Harry continued to press his attentions. Sometimes success seemed almost within his grasp. Anne tired quickly of the social activities on board. After the first few dances they bored her. She preferred the upper decks and, if she had any companionship, she wanted that of her old friend. But Harry could not

induce her to answer the question that involuntarily came to his lips at every opportunity. Without rebuffing him she managed to slip out of each situation so deftly that it seemed perfectly natural to turn to some other subject.

MR. WARNER had his heart set on ascending the gorges of the Yangtse-Kiang River, in China. The four hundred miles of swirling, seething waters which he had seen in the motion pictures shown by a lecturer back home fascinated him. Anne was equally interested.

He was warned that China was in the throes of civil war, that the journey even under the best conditions was dangerous. In spite of all, he and Anne made their way to the city where the river steamers start their battles with the rushing currents that sweep them back almost as fast as their powerful engines and propellers can drive them ahead.

There was no radio message for them at Shanghai. They expected none at Hankow, in the interior. It seemed impossible that there could be any. As they stood on the deck of the river boat waiting for the lines to be cast off, an olive skinned Chinaman in military uniform seemed to be watching them, but he made no effort to come nearer. They did not like his face.

A week between the towering cliffs that shut in the tossing rapids seemed to separate them from America by ages. Junks and sampans were ascending the river also, much more slowly. They were drawn by teams of twenty to fifty coolies, laboring along paths cut in the rock, so narrow that they seemed to give scarcely a toehold. Often, the weight of the boat they were towing seemed about to drag them off to certain death, then the lash of a brutal, screaming driver would cut their naked backs and, with bleeding toes and fingers dug into every fissure in the rocky trail, they would lie flat, hold and strain until the deadly current relaxed an instant and the boat gained a foot or two.

It was a relief to reach the cliffs of the western gateway of the gorges at last, but the relief was short. While approaching the first landing, the boat was greeted by a rain of shells and machine gun bullets that cut down crew and passengers indiscriminately.

The boat moved out of range. Anne bandaged a scratch on her father's arm where a swift messenger of death had missed an artery by a scant inch. "Well, we've seen it, anyhow!" he smiled, grimly.

"And we will see America again, as soon as ever we can get there!" declared Anne. If it had been lighter in the cabin, her father might have detected a pallor under the tan that the sun and wind had spread upon her fair skin.

Tell them that you saw it in RADIO

The boat anchored at dusk. It was unsafe to navigate the channel in the dark. All lights were extinguished, or completely shielded so as not to make a target for a gunner on the shore. No one had much appetite for dinner in the darkened saloon, and after the meal was over Anne and her father sat in the pitchy blackness of their stateroom. Now and then a report was heard, or the drumming of a machine gun. Sometimes bullets spatted against the side of the boat.

"I wonder if there is any way to reach Harry—he might radio for help," she said.

Like an answer to her wish, there came a rap on the door. Cautiously, Mr. Warner opened it.

"I have a radio message—" came a whisper.

"But there is no radio equipment on this boat," Mr. Warner replied sharply.

"No, sir, but let me explain," said the man.

Anne shaded a pocket flashlight and faintly illumined the face on the other side of the crack in the door. It was an English face, though muddy water mixed with blood was dripping from dishevelled hair and giving it a fearsome appearance.

"Let him in, father," she said.

"I must be quick," the stranger said. "I have a radio message requesting me to find you and get you out of here if possible. The country is entirely topsyturvy—anything may happen at any moment. I have a small boat and can get you down to the mouth of the gorges by daylight. There we may catch one of the junks and get through. It's risky, but anything is safer than staying here. The gunboats are fully occupied farther up. I am at your service."

They snatched up what things they could carry, crept through the black corridor, out on deck, and lowered themselves into the waiting boat. Immediately it floated away from the steamer and drifted down the current. At daybreak a junk captain took them aboard, after a period of bargaining with the Englishman. Once between the stern walls of the gorge she and they were at the mercy of the river. A greasy, yellow helmsman with the imperturbable face of a fatalist guided the craft, while sailors, or whatever the poor wretches might be called who had pulled the boat up stream, fended her off when she headed for the rocks. At night she was steered into an eddy where an anchor would hold her until daylight. With the first streak of dawn she was racing madly downward again, with maddened, deadly water underneath, vertical walls of granite hemming her in on either side, and not a ray of hope except from the far distant heavens overhead.

THE Warners were sitting hand in hand before the open fire in their great living room. Harry Hunter, brilliant in his radio operators' uniform with its bright buttons and lightning flashes, stood not far from Anne. Roland, standing near Mr. Warner, seemed ill at ease. He remained where the light would not fall upon him with too much intensity.

"Tell me something about this amateur radio, boys," said Mr. Warner. "It is the most mysterious thing I ever encountered. Everywhere we landed we were met by someone or other who claimed to have received a message from some amateur radio station in America. They were all most interesting fellows, well educated and evidently well to do. The Italian had a ducal crest on his car. Whoever this American radio man was, he must have been well connected. None of them could tell us his name. They knew him by some outlandish combination of letters and figures."

No one replied, and Mr. Warner went on: "Of course I know that the commercial radio services are well developed—we use them constantly in our business—and of course the fact that the wireless on our steamship could reach the interior of China, where there was an occasional British station, could be understood. By the way, no record of the message that saved our lives could be found on the *President*. The chief operator told us that you, Harry, must have sent it and failed to record it. When you failed to appear in time for the sailing of the ship we felt sure that you had followed up the message by trying to reach us in person. We were greatly relieved when the chief operator learned that you had shipped on another steamer and were quite safe."

"You certainly saved our lives that time," said Anne. "In the excitement of running the rapids in that terrible little Chinese junk I never thought to ask the nice, battered up Englishman for details, but we knew it must be you—no one else who could have reached us by radio knew where we were."

"I was doing my best," Harry replied. "It was impossible to raise anyone on the ship's wavelengths, so I went ashore. I tried to find an amateur station. I knew that somewhere up there in the interior there must be some ham—you find them everywhere. God, those Chinamen! How they sent me through those rotten, stinking streets. When I found they were stringing me I got mad. Then I found one who seemed to know English and who seemed to understand what I wanted, and he sent me miles inland. It took days, and I missed the ship. I can't account for the radio message, unless someone heard the story I told a thousand times to as many stolid, imbecile Chinks, and passed it along to an amateur."

Tell them that you saw it in RADIO

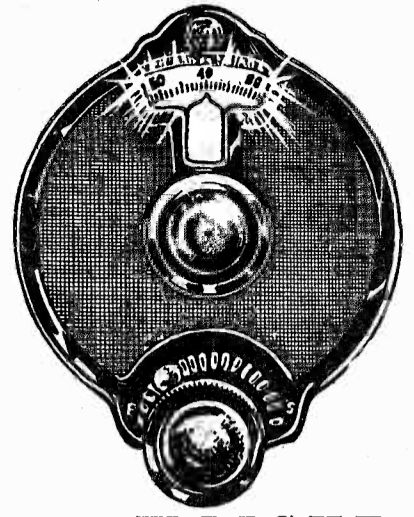

NEW LIGHT

on Fine Tuning

The Illuminated Dial
NATIONAL VELVET - VERNIER
Type C

More widely used in carefully engineered sets than ever before. Its brilliant, indirectly-lighted scale, lasting beauty, variable-ratio of 6-1 to 20-1, and ease of attachment are responsible for its deserved popularity SPECIFIED in INFRADYNE and SC-II.

Send for Bulletin 116-P-6

NATIONAL COMPANY INC.
W. A. Ready, Pres. Cambridge, Mass.

NATIONAL

RADIO PRODUCTS

Style Number

The first showing of
next season's radio
models in next issue.

"RADIO" For July

Raytheon
LONG LIFE RECTIFYING TUBE

TOBE CONDENSERS
and
VERITAS RESISTORS

Stand up on their Jobs
Tobe Deutschmann Co.
Cambridge, Mass.

HOYT

B ELIMINATOR VOLTMETER

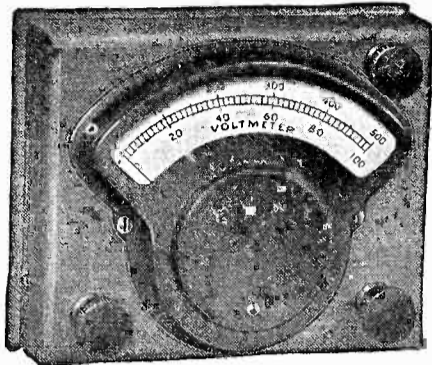

A new sensitive voltmeter, for regular dealers' service work as well as for laboratory and precision measurements. Resistance 1,000 ohms per volt. Provided with two scales — 0-100 volts and 0-500 volts, covering the entire range of ordinary B-Eliminator and Power-Amplifier work.

Prices, HOYT Standard B-Eliminator Voltmeter, 0-100 and 0-500 volts, \$28.00.

Supplied on special order with additional scale, either: 0-10 volts or 0-100 ma. at \$32.50.

Send for Price List P-6

BURTON-ROGERS COMPANY

Sales Dept. for HOYT Electrical Instrument Works

Boston

Massachusetts

There was a moment of puzzled suspense, then Anne asked a question, eagerly:

"American amateur calls all begin with figures that stand for the different districts, don't they?"

"Yes," Harry answered.

"And district 2 is around here, in the vicinity of New York, isn't it?"

"Yes."

"Well then, how can I find out who u2AF is?"

"It's in the call book — that's the directory of amateur stations. Let's see, u2AF? Why that's your call, Roland."

Anne and her father turned to Roland with one accord.

"So you are the mysterious American!" exclaimed Mr. Warner.

"I just knew it must be!" declared Anne.

Roland crimsoned, stammered, and hesitated. "It really was very simple, sir," he said at last, addressing the father. "We amateurs have an international union. We all help each other out by handling messages or any way we can."

"And from your little radio room in an attic you reached England, France, Italy, Greece, Syria, Egypt, India—and China?"

"It was all very easy, sir, except China. China was a little difficult, because of the upset conditions there, but of course a ham gets to know a lot of brother hams if he works long enough, and they all help each other. A lot of them get into the armies of different countries, or get sent around on different jobs. China was the hardest, but I relayed through Los Angeles, Hawaii and the Philippines and we got closer and closer. Then the news came that there was fighting up beyond the gorges of the Yangtse and I knew you might be there and I told the gang. A Chinaman saw you go aboard the river steamer at Hankow and he passed the word along to the Britisher up the river. The Englishman knew me because we used to work each other when he was in London, before he was sent to China. He got a QSL back to me over the same route and I was awfully glad to know that you had someone to help you when you were up against it."

"What a marvel of organization! What an asset in international relations! What a weapon for peace! What a —."

Roland was not following Mr. Warner, whose enthusiasm for amateur radio opened a number of interesting possibilities. He was looking, spellbound, into the eyes of Anne. They were glowing with a magnetic intensity such as he had never experienced before and flashing a message that a girl like her could send but once in a lifetime and to only one man on earth.

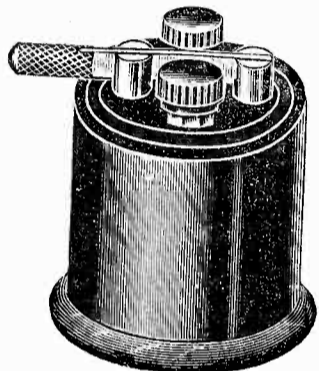

Eliminate Interference!

THE NEW KLOSNER STATION-SEPARATOR

Positively overcomes crowding and "cross talk" between stations, especially on lower wave lengths. No skill necessary to attach or operate it with your set.

JUST CONNECT IN SERIES BETWEEN YOUR
AERIAL AND SET.

Unconditionally Guaranteed

\$1.00 Ask Your Dealer \$1.00
or send direct

KLOSNER RADIO CORPORATION
1022 EAST 178 STREET NEW YORK

THE New Klosner Station Separator is unconditionally guaranteed to work to your satisfaction.

Your Neighbor Probably Owns a "Majestic-B" Ask Him Why Majestic "B" Current Supply

is the best B-Unit regardless of price—it will improve your radio reception.

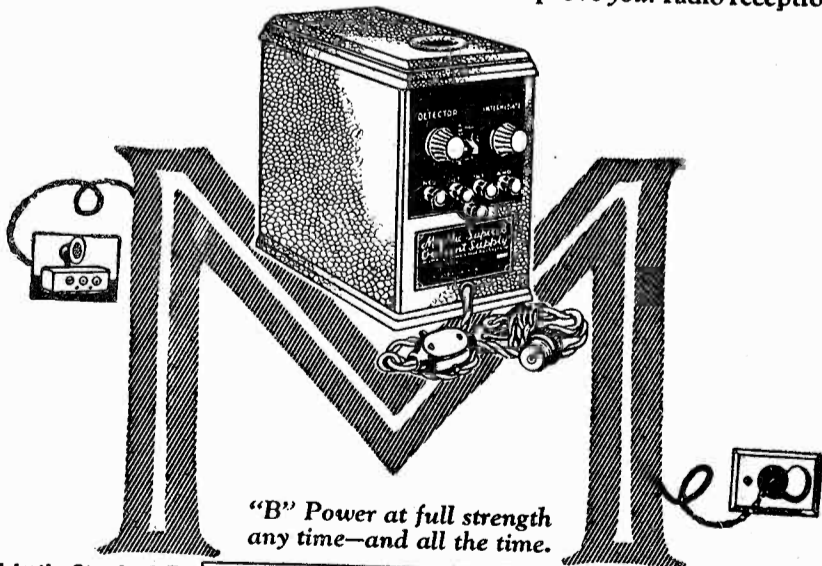

"B" Power at full strength
any time—and all the time.

Majestic Standard-B
Capacity, nine 201-A tubes
or equivalent. 45 milliamperes
at 135 volts.

\$26.50

West of Rocky Mts. \$29
Raytheon Tube \$4.50
extra

MAJESTIC SUPER-B
Capacity 1 to 12 tubes, including the use of
power tubes. 45 mls. at 150 volts.

AS ILLUSTRATED

West of Rocky Mts. \$31.50
Raytheon Tube \$4.50 extra

\$29.00

Majestic Master-B

Positive control of all output
voltage taps. For sets having
high current draw or heavy
biasing batteries. 60 mls at
150 volts.

\$31.50

West of Rocky Mts. \$34.00
Raytheon Tube \$4.50 extra

GRIGSBY · GRUNOW · HINDS · CO., 4580 Armitage Ave., Chicago, Ill.
W. J. Seroy, Pacific Coast Sales Mgr., 122 Broadway, Oakland, Calif.

WHY THE GRID LEAK

(Continued from page 14)

curve is bent in the region of the selected polarizing voltage. The method of projecting a to obtain a'' is indicated for one point.

Due to the fact that a'' is not symmetrical about axis G there is an average increase in the grid current throughout the time consumed by the wave-train. The magnitude of this increase is indicated by dotted curve b , the shape of which depends upon the modulation of the carrier wave at the transmitting station. The pulse of current b flows through the grid leak and causes a maximum audio frequency change in grid potential equal to the product of the ordinate c in amperes by the resistance of the grid leak in ohms. The maximum change in grid potential is indicated by c'' .

Dotted curve b'' shows the audio frequency change in grid potential resulting throughout curve b . In order that the pulse of grid current represented by b will pass through the leak where it will produce a maximum grid voltage variation, the grid condenser is made sufficiently small so as not to by-pass it there. The audio frequency variation in grid potential b'' causes the audio frequency variation in plate current represented by dotted curve d and this pulse of plate current operates the receiver diaphragm.

Amplitude c'' is determined in a rather complicated way by the square of the impressed radio frequency voltage on the grid, by the grid leak resistance, by the input resistance of the tube, and by other factors. Owing to the fact that the square of the impressed grid voltage enters, detection is inefficient for weak signals. This is one of the important reasons for using radio frequency amplification. For weak signals, it helps to make the grid leak resistance larger than that commonly employed for strong signals and resistances of 5 to 10 megohms are often used for this purpose.

Like all other resistances, grid leaks are power loss devices. An audio frequency choke coil might more efficiently be used in place of the resistance leak and doubtless one having the desired characteristics will be developed for this purpose.

Summarizing, it may be said that the grid condenser serves only as a radio frequency by-pass for waves a and a'' .

As such it should pass these waves with a minimum of voltage drop due to its reactance. But this condenser should not be large enough to pass the audio pulse b , since it is desired that b go through the leak. These facts limit the minimum as well as the maximum capacity that can be used.

As a general rule for wave lengths below 600 meters, good results are had if the capacity is so selected that its reactance at the carrier frequency is 600 ohms. Such a rule requires a capacity of 260 micro-microfarads for a 300 meter carrier wave and one of 43 micro-microfarads for a 50 meter carrier. For best results the grid leak should be as large as it is possible to use without causing distortion. For very weak signals, this requires the use of a 5 to 10 megohm leak whereas if the signal strength is good, a 2 megohm leak is best.

TIME CONVERSION CHART

(Continued from page 16)

attle, San Francisco or Los Angeles, it is 5 p. m. tomorrow in Queensland. Or when it is 5 p. m. today in Queensland, it is 11 p. m. yesterday in Seattle.

Likewise the vertical line from *U. S. and Canadian Atlantic* time passes through the horizontal line from *Great Britain* on the 5 hour inclined time, showing that London is 5 hours ahead of New York in time. The intersections can be easily located by means of a square card whose edges pass along the lines designating the two locations. If a vertical line from one location does not intersect a horizontal line from another on that half of the chart containing the inclined lines, merely reverse the horizontal and vertical lines. Thus as the vertical line from *Victoria* does not meet the horizontal line from *South Africa* within the inclined line area, follow the horizontal line from *Victoria* till it crosses the vertical line from *South Africa* on the 8 hour inclined line, indicating that *Victoria* is 8 hours earlier in time than *South Africa*.

It will be noted that for New Zealand, the $\frac{1}{2}$ hour plus time is shown.

The real "secret" of making a one-tube receiving set "reach out" is to make it so efficient that there is practically no loss in the set. Radio sets were in existence for many years before it occurred to some bright individual that "low-loss" parts were the solution to the problem of making a super-efficient single-tube set. That was several years ago; but the rule still holds good. If a low-loss, three-circuit tuner (untuned primary, secondary, and tickler) and low-loss variable condensers are used, and the wiring done carefully, the resistance of the tuning circuit will be very slight, which will result in much louder signals and a set that is positively amazing in its sharpness of tuning.

LOG BOOKS — 10c.
ONLY A FEW LEFT
"Radio" San Francisco

Tell them that you saw it in RADIO

LYNCH METALLIZED

WARRANTED FIXED RESISTORS

HEAVY-DUTY TYPE

The new Lynch wire-wound heavy duty resistors for eliminator and power work are now ready. These units are ideal for use in Raytheon and all other power circuits.

EQUALIZORS

For perfect filament control use the Lynch Equalizers. There is a type for every type of tube and for any combination of tubes. A Lynch Equalizer will take the place of your filament rheostats. Complete, with mounting, \$1.00.

Lynch Suppressors and Low-loss mountings mean better radio.

At All Good Dealers

ARTHUR H. LYNCH, INC.,  Gen. Motors Bldg. B'way & 58th St. New York, N. Y.

"B" BATTERY ELIMINATOR

Only \$4.75

MONEY-BACK GUARANTEE
No more worry with "B" Batteries! Hook up a Perfect "B" Battery Eliminator and forget battery troubles forever. This wonderful new invention means better reception, sharper tuning. Gives you more real pleasure from your set. **Completely Equipped—No "Extras" to Buy**
Operates perfectly on direct or alternating current, giving up to 90 volts current, and using the full wave of the power supply. Simple directions enclosed—anyone can plug it in to any kind of set up to six tubes. Constant voltage gives set more power. Costs no more than set of good "B" Batteries.
SEND YOUR ORDER NOW
Don't blame your set because run down "B" Batteries won't let it work right. Order your Eliminator NOW. Write name and address on a piece of paper, pin a dollar bill to it, and mail it TODAY. Pay post-man balance (\$3.75 plus a few cents postage) when he delivers your Eliminator. Use it ten days. If not more than satisfied, return it and get your money back.
PERFECT ELIMINATOR CO.
14 National Theatre Bldg., Cincinnati, Ohio

Make Any Good Receiver

CECO BETTER
TUBES
C. E. Mfg. Co., Inc.
Providence, R. I.



KARAS EQUAMATIC MANUAL

Price 10c.
Build the Karas Equamatic 5-Tube Radio Sensation—the most selective receiver ever designed. Mail 10c today for 16-page Manual of wiring diagrams and complete instructions for building this remarkable receiver. Address:

KARAS ELECTRIC COMPANY
1049 Association Building Chicago, Ill.

HEAR the wonderful New Acme Speaker at your dealer's

ACME
for amplification



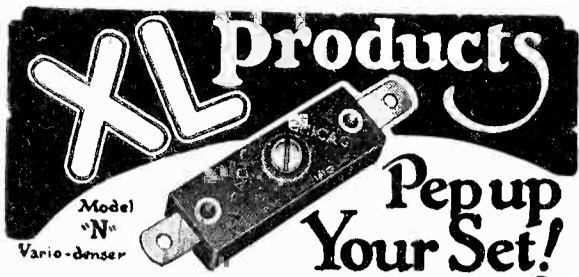

VARIO DENSER

Tune quickly—adjust accurately—eliminate distracting noises—get correct tube oscillation—with X-L VARIO DENISERS in your circuit. Designers of all latest and best circuits specify and endorse them.

MODEL "N"—Slight turn obtains correct tube oscillation on all tuned radio frequency circuits. Neutrodyne, Roberts two tube, Brown-ing - Drake, McMurdo Silver's Knockout, etc. Capacity range 1.8 to 20 micro-microfarads.

Price \$1.00

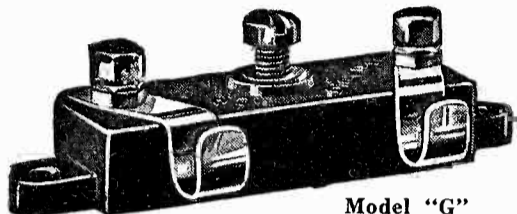

Model "G"

MODEL "G"—With grid clips obtains the proper grid capacity on Cockaday circuits, filter and intermediate frequency tuning in heterodyne and positive grid bias in all sets.

Capacity range:

Model G-1 .00002 to .0001 M. F. D.

Model G-5 .0001 to .0005 M. F. D.

Model G-10 .0003 to .001 M. F. D.

Price \$1.50

X-L PUSH POST—Push it down with your thumb, insert wire, remove pressure and wire is firmly held. Vibrations will not loosen. Releases instantly.

Price 15c

X-L PUSH POST PANEL—Permanently marked in white on black insulating panel. In box including soldering lugs, raising bushings and screws for mounting, etc.

Price \$1.50



X-L Push Post

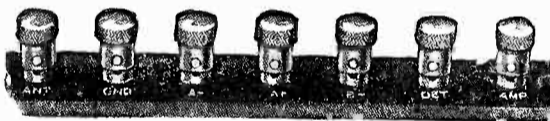

X-L Push Post Panel

Build the new LOFTIN-WHITE constant coupled radio frequency circuit. FREE wiring diagrams showing use of this and other popular circuits sent on request.

XL Radio Laboratories

2428 Lincoln Ave.

Chicago, Ill.

SOUND EXPERT ADVICE

On Radio and Scientific Patents
Specializing in Radio Patents and
Trade Marks and Investigations
Relating Thereto

John Flam, Patent Attorney

821 Merchants National Bank Building
Los Angeles California

BALSA WOOD KITS

40-Inch Size.....\$10.00

Small Size..... 5.00

Laboratory of "RADIO"
435 Pacific Bldg. San Francisco

Ideal for the new HI-MU tubes

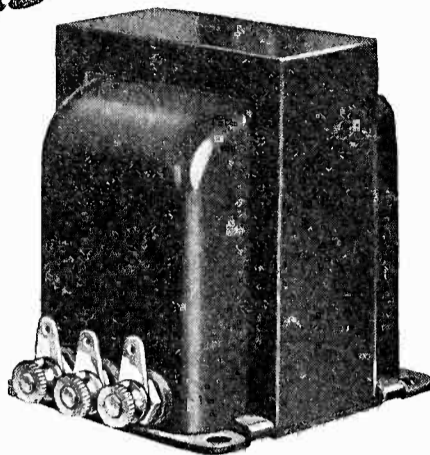

THORDARSON Autoformer

Trade-Mark Registered

All Frequency Amplifier

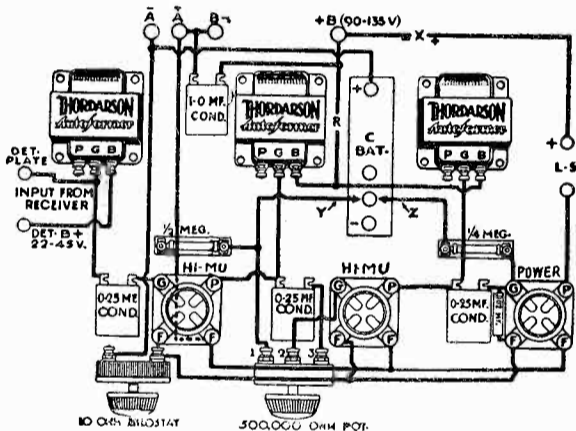

The Thordarson Autoformer used as a straight impedance makes an ideal coupling medium for the new Hi Mu tubes UX-240 and CX-340.

The excellent tonal reproduction of the Autoformer combined with the high amplification of the Hi Mu tubes plus a power tube on the output will transform your receiver into a real musical instrument.

The Autoformer is available at all good dealers at a price of \$5.00.

Mail this coupon today for more detailed information.

Thordarson Electric Mfg. Co.,
500 W. Huron Street,
Chicago

Gentlemen:

Please send me more detailed information on the use of the Autoformer with Hi Mu tubes.

Name.....

Address.....

3553-C

SHOP METHODS

(Continued from page 15)

liquids. For the liquids his needs will in the main be met by a minim (drop) graduate, and one each of 2, 4, and 16 ounces.

A satisfactory scale is one with two removable pans and a sliding bob balancing from 1 to 50 grains as well as having weights to be placed in one of the pans. As sold by dealers in photographic supplies, the weights are on the avoirdupois system with 7000 grains to the pound or 437½ grains to the ounce. The Troy and druggists' pound is 5760 grains and the ounce 480 grains. The grain is the same in each case. The metric system of weights and measures is better in every respect.

Shop practice is increased in convenience, comfort and accuracy by the use of simple and compound microscopes. The former need is well met by a jeweler's eye glass fitted with helical spring instead of a hard rubber cup. The spring can be held by the muscles surrounding the eye or its free end can be hooked over the lens of a pair of eye glasses. For the most accurate work use a compound microscope. The lenses should be kept clean with soft linen. The objective should never be allowed to touch the object under examination.

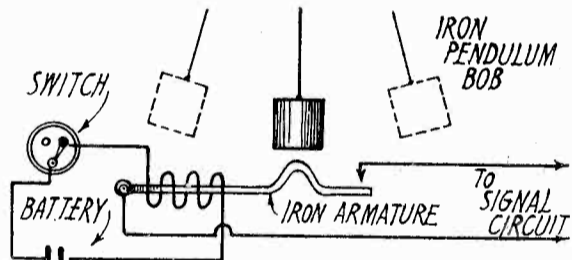

Fig. 6. Signaling Pendulum

A signaling pendulum is useful in measuring small intervals of time. In that shown in Fig. 6 an iron or steel bob is suspended by a fine wire so that the pendulum as it swings, just clears the armature of a suspended electromagnet. The magnetized armature rises as the bob passes, and thus completes the signal circuit to a single-stroke bell. A 39 in. pendulum swings approximately once a second and can be adjusted to desired accuracy by lengthening or shortening the suspending wire.

BEST'S SHIELDED

SUPER BLUE PRINTS \$1.00

"Radio"

San Francisco

Valley "B" Power Unit

Manufactured by
VALLEY ELECTRIC CO.
ST. LOUIS, MO.

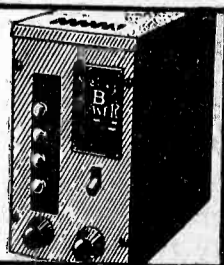

Tell them that you saw it in RADIO

1930 RADIO

*for the
MAN
who looks
and thinks
AHEAD*

Ready Now

Sargent's New Infradyne Manual

Today the Infradyne commands national recognition. The best that radio had to offer in 1922, seems feeble enough now. In the same way many of today's sets will prove a disappointment in 1930. But the Infradyne idea will grow — because it is different. It is the 1930 receiver. An Infradyne owner in Alaska hears South Africa, Japan and Australia. A Pennsylvania owner picks up KFI in Los Angeles the first night his Infradyne goes in operation. But most of all—selectivity—extreme selectivity—put the Infradyne where it is today. E. M. Sargent, L. C. Rayment and the publishers of "RADIO" have constantly watched the progress of this unusual circuit. Every time a new "wrinkle" was discovered it was given wide publicity among all Infradyne owners. During the last few months the circuit has been developed to a stage of satisfaction not thought possible a year ago. To pass

the latest information along to everybody a new Infradyne Manual was published. It is just being released as this issue of "RADIO" goes to press. In the new Manual the inventors of the Infradyne show you how to wire and assemble the improved de-luxe model. How to test each individual piece of apparatus. How to trace circuits and how to inspect the parts. It is one of the finest reference books on radio yet published and it contains so much important data on testing circuits that any radio fan can hardly afford to be without a copy—whether you are an Infradyne enthusiast—or not.

This latest Infradyne Manual will be sent to you postpaid upon receipt of a quarter in coin. Stamps also accepted. Your money refunded without question if you don't think it's worth four times the price.

**Send 25c and the
Coupon now for
the new Infradyne
Manual.**

Dealers and jobbers are invited to write for trade information.

The Publishers of "RADIO"
433 Pacific Building,
San Francisco, Calif.

Here is my order for a copy of the new Infradyne Manual. Also 25 cents to cover cost of same.

Name.....

Address.....

City and State.....

**Best by YOUR test—
a confident challenge!**

*For All
Power Work*



12 Watts
These units do not deteriorate or change in resistance value

**EL MENCO
HY-WATT**
TRADE MARK
**HEAVY DUTY
RESISTORS**

For best results with Raytheon and other power circuits you must have permanently accurate resistors capable of carrying heavy loads without change or deterioration. "HY-WATT" Heavy Duty Resistors dissipate up to 12 watts.

100—500—1000—2000—5000 ohms \$1.25
10,000—25,000—50,000 ohms \$1.50
100,000 ohms \$2.00

Write for full details and literature on El Menco Gridleaks and Resistors

Electro-Motive Engineering Corp.
127 West 17th St. New York, N. Y.



SETS REBUILT REWIRED

*Reasonable Prices.
Write for Estimate.*

We carry a stock of the latest KITS—

Hammarlund
Bremer-Tully
Quadrphase
Infradyne

**WESTERN ELECTRIC
LOUD SPEAKERS**

N. E. BORCH & CO.
426 Pacific Bldg.,
San Francisco - - - Calif.

RADIO IN PHONOGRAPH CABINET

(Continued from page 20)

C are made at the batteries instead of in the set. The negative A lead is grounded. The main filament switch is in the negative A lead.

The pilot light is a 6.2 volt miniature lamp connected across the A battery on the controlled side of the filament switch. The socket for the pilot light is in reality a "reducer" from "candelabra" size to "miniature" size and excellently adapted to such a purpose. The hole in the vertical bakelite strip is reamed to such a size that the socket will screw (wedge) in tightly. The hood over the bulb is made by pinning a piece of thin pure tin or copper to a partial cup which is fastened to the bulb by a spring wire U-clip over the brass base of the bulb.

The set is wired with insulated stranded wire for all the "low" leads, and with No. 14 nickel-plate copper bus wire for all "high" leads. The reason for the two kinds of wire is obvious.

All the "high" leads are made as short as possible but the first consideration is location regardless of length.

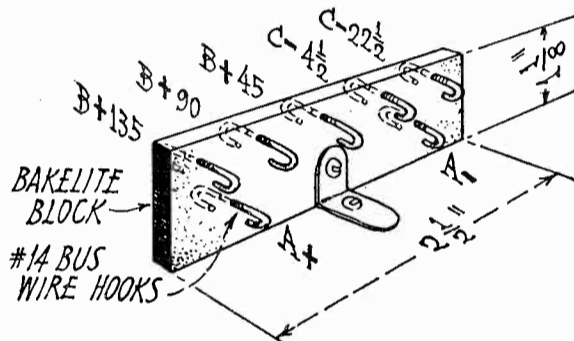

Cable Connection Block

LIST OF PARTS

- 1— $\frac{1}{8}$ " Panel Bakelite 7"x13".
- 1— $\frac{1}{8}$ " Bakelite strip 1"x13".
- 2—"Pacnet" .00035 MFD condensers (variable).
- 2—Kurz-Kasch "Aristocrat" Vernier Dials.
- 1—"General Radio" midget .00005 MFD condenser (variable).
- 1—Claro-stat.
- 1—"Carter Imp" filament switch.
- 1—Bakelite tube $2\frac{1}{4}$ " long and $3\frac{1}{2}$ " diameter.
- 1—Bakelite tube $4\frac{1}{2}$ " long and 2" diameter.
- 4—"Klosner" UX bases.
- 1—"Sangamo" .00025 grid condenser with leak mounting.
- 1—4 megohm "Lynch" grid leak.
- 1—1 MFD "Tobe" condenser (fixed).
- 1—50 ohm "Yaxley" resistance unit.
- 1—"Dongan" Type H 2 to 1 Audio Transformer.
- 1—"Dongan" Type H $3\frac{1}{2}$ to 1 Audio Transformer.
- 2—Screw binding posts.
- 3—Phone tip jacks (Carter).
- 1—Bakelite strip $1\frac{1}{2}$ "x5" for input and output terminals.
- 1—Bakelite strip $1\frac{1}{2}$ "x3" for cable connection block.
- 1—"Reducer"—Candelabra size to Miniature size.
- 1—6.2 volt tungsten flashlight bulb.
- 1—Package of "Flexibus" wire.
- 6—Ft. of nickel plated No. 14 copper bus wire.
- 3—Type '99 tubes (Cunningham).
- 1—Type '20 tube (Cunningham).
- 4—Ft. Belden 7 strand cable.
- 7—Spring battery clips.
- 3—45 volt dry "B" batteries (Eveready).
- 1— $22\frac{1}{2}$ volt dry "C" batteries (Eveready).
- 1—6 volt storage battery (Philco).
- 1—"Magnavox" phonograph unit.

These "high" leads can not be placed too close to other wires or apparatus.

All grid leads should be kept away from other parts of the set. To this end the grid of the antenna coupler transformer has been placed at the top of the coil, and the grid end of the inter-tube radio frequency transformer has been placed at the end opposite the radio frequency tube which is located between the two transformers as shown.

No output transformer or filter is necessary as most of the cone speakers are designed to carry the output of even larger power tubes than the type '20. The plate-current of this tube will not injure the better types of horn speakers.

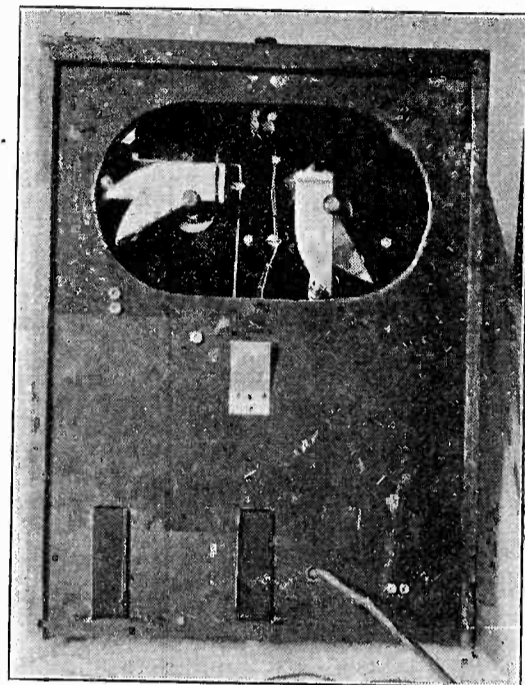

Bottom Cut-Out Holes

The speaker unit may be installed in the console cabinet in either of two ways. Either a phonograph attachment may be placed on the tone-arm of the phonograph in place of the needle diaphragm, or a small cone-speaker unit may be mounted directly in the phonograph sound bell in back of the front louvres.

In case room is not available under the console lid to permit the tubes to be placed upright, they may be placed in a horizontal position by mounting the tube sockets either on brackets or on the sides of the drawer.

This set costs about \$30 for the parts and \$80 completely equipped. It is the third complete set that the writer has made, using the "L-C Circuit." Each one has been exceptionally satisfactory and the selectivity and sensitivity obtained are far better than the average.

NEW ZEALAND STATIONS

(Continued from page 32)

Norfolk Island. These reports are in each case repeated by Suva, Fiji on 600 meters.

Station VMG, 2000 meters, spark can be heard a few nights out of San Francisco and nearly to the southern extremity of New Zealand. All operators should copy his report when in South Sea waters.

Tell them that you saw it in RADIO

TEMPORARY WAVELENGTH ALLOCATIONS
LIST OF TEMPORARY ALLOCATIONS TO "K" BROADCAST STATIONS
 (Corrected to May 1, 1927)

Call Letters	LOCATION AND OWNER	Power Watts	Frequency Keys	Wave Length Meters
KDKA	Westinghouse E. & M. Co., East Pittsburgh, Pa.	50,000	970	309.1
KDLR	The Radio-Electric Co., Devils Lake, N. D.	15	1300	230.6
KDYL	Intermountain Broadcasting Corporation Ezra Thompson Bldg., Main Street, Salt Lake City, Utah.	100	1220	245.8
KELW	Earl L. White 3702 Magnolia Avenue, Burbank, Calif.	250	560	535.4
KEX	Western Broadcasting Co. 201 Terminal Sales Bldg., Morrison Street, Portland, Oregon.	5000	1240	241.8
KFAB	Nebraska Buick Auto Company 13th and Q Streets, Lincoln, Nebraska.	2000	880	340.7
KFAF	San Jose, Calif.	50	1380	217.8
KFAU	Independent School District of Boise City 311 North Tenth Street, Boise, Idaho.	4000	1070	280.2
KFBB	F. A. Buttrey Company 3rd Avenue and 2nd Street, Havre, Montana.	50	1090	275.1
KFBC	Union League Radio Station (Dr. W. K. Azbill and Dr. Arthur W. Yale) 207 Electric Bldg., San Diego, Calif.	100	1080	277.6
KFBK	Kimball-Upson Co. 80 South Stone Avenue, Sacramento, Calif.	100	560	535.4
KFBL	Leese Bros. 2814 Rucker Avenue, Everett, Washington.	100	1340	223.7
KFBS	Trinidad High School High School Building, Trinidad, Colo.	15	1260	238
KFBU	Bishop N. S. Thomas Thorburg and Third Streets, Laramie, Wyo.	1000	800	374.8
KFCB	Nielsen Radio Supply Co. 311 North Central Avenue, Phoenix, Arizona.	125	1260	238
KFCR	Santa Barbara Broadcasting Co. 1200 Anacapa Street, Santa Barbara, California.	100	720	416.4
KFDM	Magnolia Petroleum Co. Beaumont, Texas.	500	950	315.6
KFDX	First Baptist Church 527 Travis Street, Shreveport, La.	500	1270	236.1
KFDY	South Dakota State College Station A, Brookings, South Dakota.	500	1000	299.8
KFDZ	Harry O. Iverson 2510 Thomas Avenue, South, Minneapolis, Minn.	10	1300	230.6
KFEC	Meier and Frank Co. 5th, 6th, Morrison and Alder Streets, Portland, Oregon.	50	1190	252
KFEL	Eugene P. O'Fallon, Inc. 233 East Colfax Street, Denver, Colo.	1000	1180	254.1
KFEQ	Scroggin & Co., Bank, Oak, Nebr.	1500	1120	267.7
KFEY	Union High School 521 Main Street, Kellogg, Idaho.	10	1290	232.4
KFGL	N. L. Cotter 219 West Main Street, Trinidad, Colo.			
KFGQ	Boone Biblical College 924 West Second Street, Boone, Iowa	10	1000	299.8
KFH	Hotel Lassen, Wichita, Kansas.	500	1120	267.7
KFHA	Western State College of Colorado, Gunnison, Colo.	50	1190	252
KFHL	Penn College, Oskaloosa, Okla.	10	1250	239.9
KFI	Earle C. Anthony, Inc. 1000 South Hope Street, Los Angeles, Calif.	5000	640	468.5
KFIF	Benson Polytechnic School East 12th and Hoyt Streets, Portland, Oregon.	100	1210	247.8
KFIO	North Central High School Howard and Nora Streets, Spokane, Wash.	100	1100	272.6
KFIQ	I. M. Miller, M. D. 332 Miller Building, Yakima, Washington.	100	1170	256.8
KFIZ	Fond du Lac Commonwealth 18 West First Street, Fond du Lac, Wisc.	100	1100	272.6
KFJB	Marshall Electric Co. 1603 West Main Street, Marshalltown, Iowa.	15	1210	247.8
KFJF	National Radio Mfg. Co. Oklahoma City, Okla.	1000	1150	260.7
KFJI	E. E. Marsh 551 Commercial Street, Astoria, Oregon.	15	1220	245.8
KFJM	University of North Dakota Grand Forks, N. D.	100	1080	277.6
KFJR	Ashley C. Dixon & Son 1350 East 36th Street, Portland, Oregon.	100	1140	263.0
KFJY	C. S. Tunwall 1004 Central Avenue, Ft. Dodge, Iowa.	100	1220	245.8
KFJZ	Mr. E. V. Branch 3219 Avenue "L," Ft. Worth, Texas.	50	1180	254.1
KFKA	Colorado State Teachers College 1800 Tenth Avenue, Greeley, Colorado.	100	1100	272.6
KFKB	John R. Brinkley, M. D. Corner 5th and Berry Streets, Milford, Kansas	3500	1370	218.8
KFKU	University of Kansas Lawrence, Kas.	500	1090	275.1
KFKX	Westinghouse Electric & Mfg. Co. Hastings, Nebr.	20,000	1040	288.3
KFKZ	Northeast Missouri State Teachers College 800 South Mulanix Street, Kirksville, Mo.	15	1330	225.4
KFLR	The University of New Mexico Albuquerque, New Mexico.	100	1180	254.1
KFLU	San Benito Radio Club San Benito, Texas.	15	1270	236.1
KFLV	The Swedish Evangelical Mission Church of Rockford 1503 Fourth Avenue, Rockford, Ill.	100	1310	228.9
KFLX	George Roy Clough, 3327 Avenue "P," Galveston, Texas	250	1250	234.9
KFMR	Morningside College Morningside Avenue, Sioux City, Iowa.	100	1150	260.7
KFMX	Carleton College College Campus, Northfield, Minnesota.	500	890	336.9
KFNF	Henry Field Seed Co. 407 Sycamore Street, Shenandoah, Iowa	1000	650	461.8
KFOA	Rhodes Department Store, 1231 Second Avenue, Seattle, Washington.	1000	660	454.8
KFON	Nichols and Warinner, Inc. 210-212 Jergins Trust Bldg., Long Beach, Calif.	500	1290	232.4
KFOR	The Lincoln Hatchery, Lincoln, Nebr.	100	1330	225.4
KFOX	Board of Education 33rd Street at Cuming Street, Omaha, Nebraska	100	1210	247.8
KFOY	Mr. Maurice Gordon Goldberg 711 Dayton Avenue, St. Paul, Minnesota	250	1190	252.0
KFPL	C. C. Baxter 1105 Grafton Street, Dublin, Texas.	15	1190	252
KFPM	The New Furniture Company Greenville, Texas.	15	1270	236.1
KFPW	Rev. Lennie W. Stewart, 120 West Main Street, Cartersville, Mo.	50	1160	258.5
KFPY	Symons Investment Co. Spokane, Washington.	250	1100	272.6
KFQA	The Principia 5539 Page Boulevard, St. Louis, Mo.	100	1150	260.7
KFQB	Lone Star Broadcast Co., Inc. Basement, Westbrook Hotel, Fort Worth, Texas.	1000	590	508.2

(Continued on next page)

Aero Coils

Recommended Again

for use in the

SHORT WAVE CONVERTER

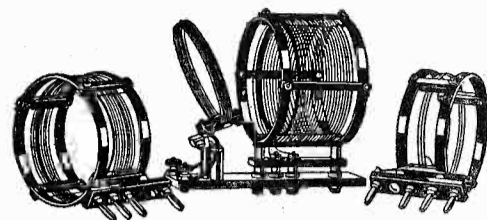

Low Wave Tuner Kit Price \$12.50

In his article printed in "RADIO" for May, Mr. Perry Graffam describes the construction of an unusually efficient short wave converter. Of course he specifies AERO Low Wave Tuner Kit as the inductances to use in this converter. This kit is completely interchangeable and has a gapless range of 15 to 130 meters. Kit includes 3 coils and base mounting. Range can be reduced to 13 meters by use of AERO Coil INT. 0 (Price \$4.00) or increased to cover broadcast band by use of AERO Coil INT. 4 (Price \$4.00) and INT. 5, described below.

Aero Interchangeable Coil No. 5

Normal range 235 to 550 meters. Range can be increased to 725 meters by use of .0001 Sangamo fixed condenser across rotor and stator of .00014 variable condenser. This gives coverage of Airplane to Airplane, Land to Airplane, and Ship to Shore (Great Lakes and Atlantic and Pacific Oceans) bands. Price of INT. 5, \$4.00.

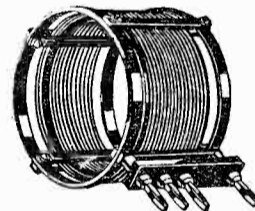

You can get these AERO coils from your nearest dealer. If he should be out of stock, order direct from the factory.

AERO PRODUCTS, Inc.

Dept. 103, 1772 Wilson Avenue, Chicago, Ill.

Pacific Coast Representative
HENDER - SELTZER CO.
Los Angeles and San Francisco

NEXT MONTH

The largest issue in our history. "RADIO" for July will be our "New Models Number." Be sure to get a copy. A subscription protects you. Send \$1.00 for the next 6 issues.

"RADIO"—San Francisco

TEMPORARY WAVELENGTH ALLOCATIONS

Letters Call	LOCATION AND OWNER	Watts Power	Keys Frequency	Meters Wave Length
KFQU	W. E. Riker, Holy City, Alma P. O., Calif.	100	1300	230.6
KFQW	Mr. Carl F. Knierin, KFQW, Incorporated 315 Seneca Street, Seattle, Washington.	100	1390	215.7
KFRC	Don Lee, Incorporated, 1000 Van Ness Avenue, San Francisco, Calif.	50	750	399.8
KFRU	Stephens College Broadway, Columbia, Mo.	500	600	499.7
KFSD	Airfan Radio Corporation 326 Broadway, San Diego, California.	1000	1220	245.8
KFSG	Echo Park Evangelistic Association 1100 Glendale Boulevard, Los Angeles, Calif.	500	1090	275.1
KFUL	Thomas Goggan Bros. 2126 Market Street, Galveston, Texas.	750	1160	258.5
KFUM	W. D. Corley 114 West Del Norte Street, Colorado Springs, Colorado.	100	1250	239.9
KFUO	Concordia Theological Seminary 3558 South Jefferson Avenue, St. Louis, Mo.	500	550	545.1
KFUP	Fitzsimmons General Hospital and Educational and Recreational Department, U. S. A. Colfax and Peoria Streets, Denver, Colorado.	100	1280	234.2
KFUR	Peery Building Co., 420 Twenty-fifth Street, Ogden, Utah.	50	1340	223.7
KFUS	Dr. L. L. Sherman 1444 Havenscourt Boulevard, Oakland, Calif.	50	1170	256.3
KFUT	University of Utah East Second, South, Salt Lake City, Utah.	50	1140	263.0
KFVD	Venice, Calif.	250	1460	205.4
KFVE	Greater St. Louis Broadcasting Corporation (The Benson Radio Corporation) 4965 Lindell Boulevard, St. Louis, Mo.	1000	1250	239.9
KFVG	First Methodist Episcopal Church 204 South Penn Avenue, Independence, Kansas	50	1270	236.1
KFVI	Headquarters Troop, 56th Cavalry Brigade 1817 Main Street, Houston, Texas.	50	1250	239.9
KFVR	The Olinger Broadcasting Corporation 1429 Champa Street, Denver, Colorado.	250	1230	243.8
KFVS	Hirsch Battery & Radio Co. 312 South Frederick Street, Cape Girardeau, Mo.	50	1340	223.7
KFWB	Warner Bros. Broadcasting Corporation 5842 Sunset Boulevard, Los Angeles, Calif.	750	1190	252
KFWC	Lawrence E. Wall California Hotel, 5th and E Streets, San Bernardino, Calif.	200	1080	277.6
KFWF	St. Louis Truth Center, Inc. 4030 Lindell Boulevard, St. Louis, Mo.	250	1400	214.2
KFWH	F. Wellington Morse 525 2nd Street, Eureka, Calif.	100	1130	254.1
KFWI	Radio Entertainments, Inc. 1400 Van Ness Avenue, San Francisco, Calif.	500	1200	249.9
KFWM	Oakland Educational Society 1520 Eighth Avenue, Oakland, Calif.	1000 daytime 500 evenings	1400	214.2
KFWO	Major Lawrence Mott—Signal Corps—ORC-USA Avalon, Catalina Island, California.	250	1420	211.1
KFWV	K. F. W. V. Broadcast Studios, Inc. 385 58th Street, Portland, Oregon.	50	1410	212.6
KFXD	Bertram O. Heller and Alexander Hurst 414 West 8th Street, Los Angeles, Calif.	500	1350	222.1
KFXF	Pikes Peak Broadcasting Co., Inc. 209 Sixteenth Street, Denver, Colo.	500	710	422.3
KFXH	W. S. Bledsoe 115 South El Paso Street, El Paso, Texas.	100	1240	241.8
KFXJ	Mr. R. G. Howell 2938 Benton Street, Edgewater, Colorado	15	1390	215.7
KFYF	Carl's Radio Den (Newcomb Radio Co., Inc.) 207 Fifth Street, Oxnard, California.	25	1400	214.2
KFYR	Hoskins-Meyers 200 Fourth Street, Bismarck, N. D.	250	1210	247.8
KGA	Northwest Radio Service Co. 614 Terminal Sales Building, Seattle, Wash.	5000	880	340.7
KGAR	Citizen Publishing Co., 607 K Street Sacramento, Calif.	100	560	535.4
KGBS	Arthur C. Daily, Seattle, Washington	100	1320	227.1
KGBU	Alaska Radio and Service Co., Upland Way, Ketchikan, Alaska.	500	1310	228.9
KGBX	Foster-Hall Tire Co. 1221 Frederick Avenue, St. Joseph, Mo.	100	860	348.6
KGBY	Thelen & Taddiken Shelby, Nebr.	100	1480	202.6
KGBZ	Dr. George R. Miller 715-717 Grant Avenue, York, Nebraska	100	900	333.1
KGCA	Mr. Charles W. Grenley 201-203 Water Street, Decorah, Iowa.	10	1070	280.2
KGCB	Wallace Radio Inst., Oklahoma City, Okla.	125	940	319.0
KGCG	Moore Motor Company Newark, Arkansas.	100	1280	234.2
KGCH	S. A. Lutgen, M. D. 918 Main Street, Wayne, Nebraska.	250	1240	241.8

(Continued on page 56)

STATEMENT OF OWNERSHIP, MANAGEMENT, CIRCULATION, ETC., REQUIRED BY THE ACT OF CONGRESS OF AUGUST 24, 1912.

"RADIO," published monthly at San Francisco, Calif., for April 1st, 1927.

State of California, County of San Francisco, ss.

Before me, a Notary Public in and for the State and county aforesaid, personally appeared H. W. Dickow, who, having been duly sworn according to law, deposes and says that he is the Business Manager of "RADIO," and that the following is, to the best of his knowledge and belief, a true statement of the ownership, management, etc., of the aforesaid publication for the date shown in the above caption, required by the Act of August 24, 1912, embodied in section 443, Postal Laws and Regulations, printed on the reverse of this form, to-wit:

1. That the names and addresses of the publisher, editor, managing editor, and business managers are:

Publisher, Pacific Radio Publishing Co., Pacific Bldg., San Francisco; Editor, Arthur H. Halloran, Berkeley, Calif.; Managing Editor, None; Business Manager, H. W. Dickow, Pacific Bldg., San Francisco.

2. That the owner is:

Pacific Radio Publishing Co., Pacific Bldg., San Francisco; Arthur H. Halloran, Berkeley, Calif.; H. W. Dickow, Pacific Bldg., San Francisco; H. L. Halloran, Berkeley, Calif.

3. That the known bondholders, mortgagees, and other security holders owning or holding 1 per cent or more of total amount of bonds, mortgages, or other securities are: None.

4. That the two paragraphs next above, giving the names of the owners, stockholders, and security holders, if any, contain not only the list of stockholders and security holders as they appear upon the books of the company but also, in cases where the stockholder or security holder appears upon the books of the company as trustee or in any other fiduciary relation, the name of the person or corporation for whom such trustee is acting, is given; also that the said two paragraphs contain statements embracing affiant's full knowledge and belief as to the circumstances and conditions under which stockholders and security holders who do not appear upon the books of the company as trustees, hold stock and securities in a capacity other than that of a bona fide owner and this affiant has no reason to believe that any other person, association, or corporation has any interest direct or indirect in the said stock, bonds, or other securities than as so stated by him.

H. W. DICKOW,
Business Manager.

Sworn to and subscribed before me this 23rd day of March, 1927.

(SEAL) JOHN L. MURPHY,

Notary Public in and for the City and County of San Francisco, State of California. My commission expires May 20, 1929.

FREE

A 110-Volt Standard BRACH Electric Soldering Iron

Subscribe to "RADIO" for 1 year (\$2.50) and get the Iron free of cost

Every radio set builder needs a good electric soldering iron. Every good set builder needs "RADIO" regularly. Why not get both for the price of one? The publishers of "RADIO" will send you—free of cost—the new L. S. Brach 110 volt electric soldering iron with your subscription to "RADIO" for one year. The total cost of the magazine and iron is only \$2.50—exactly what the magazine would cost if you bought ten copies from a news-dealer.

These Brach electric soldering irons are made especially for radio work. They have remov-

able and renewable heavy pointed copper tips and are just the right size for the radio constructor. The irons are guaranteed to be perfect in every respect. They are new, standard factory products and we will gladly refund your money in full if you are not convinced that this is the best radio value for the month. Use the coupon. Pin a check or money order to it and mail today. Prompt delivery assured. The Brach electric soldering iron goes to you by parcel post. We even pay the forwarding charges.

SUBSCRIPTION COUPON

"RADIO"
Pacific Bldg., San Francisco, Cal.
Here is \$2.50. Send me "RADIO" for one full year and the Brach Electric Soldering Iron.

Name.....

Address.....

City and State.....

Tell them that you saw it in RADIO

Amazing Value!

Tested
and
Approved
By
Foremost
Engineers

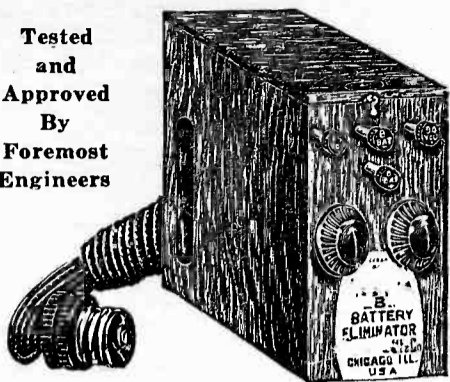

EDDYSON "B"
Battery Eliminator

\$9.95 Complete

Nothing Else To Buy.

Money Back Guarantee.

NO HUM
ACID OR TUBES.

Better Reception and More Volume.

La Salle Merchandising Co.

309 S. LaSalle St., Dept. 53
CHICAGO, ILL.

Radio Declares War on "B" Batteries

A sudden revolt from set owners. A fight against the costly upkeep of "B" batteries! Startling tests revealed that the average life of "B" batteries is only a few months. Think of it. Not alone money wasted, but the grief that goes with it.

This amazing "B" Eliminator now used by thousands of set owners on every make of radio sets has revolutionized the "B" battery problem. Just plug it in light socket and turn on your set. Will operate from 1 to 15 tubes A.C. or D.C. current. 4 taps 10 to 135 volts. 45 mills. at 100 volts.

LASALLE MERCHANDISING CO.
309 S. LaSalle Street
Chicago, Ill.

This coupon and money order for \$9.95 or C.O.D. will bring you an Eddyson "B" Eliminator.

Name.....
Street.....
Town.....State.....

BRACH Storm King LIGHTNING ARRESTER



Over 2,000,000 Radios
are Now Protected
by Brach Arresters

Price
Only **\$1**

Like all Brach Arresters
the Storm King is backed
by our

**\$100 INSURANCE
GUARANTY**

Electrify your Radio
with the Wonderful

BRACH

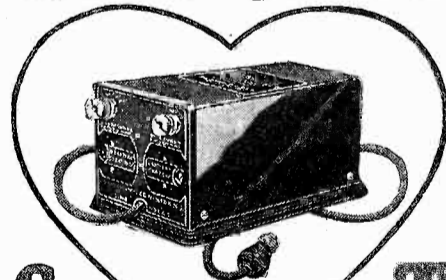

CONTROL IT
THE HEART OF THE POWER PLANT

Over 75,000
used within
First Four Months

L.S. BRACH MFG. CO.



NEWARK, N. J. TORONTO, CAN.

DIRECT FROM FACTORY TO YOU

Western "B" Power Unit

Ample power for
171 tube.

Two voltage
controls.

No hum.

No distortion.

Full wave recti-
fication.

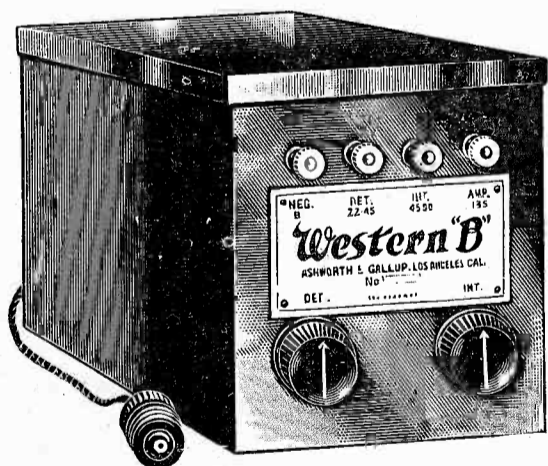

180
VOLTS

\$18.50

Why be troubled with batteries when you can now buy a guaranteed Western "B" Power Unit for less than half the price of others.

The Western "B" Power Unit is a quality product throughout, made of the finest materials, absolutely guaranteed to give complete satisfaction or money refunded.

OPERATES ANY SET FROM THE LIGHT SOCKET.
LIKE HAVING NEW BATTERIES EVERY NIGHT.

Mail the Coupon Today

Shipped same day order received.

Endorsed by the Calibration Laboratory
of RADIO Magazine for use with
sets from one to ten tubes.

ASHWORTH & GALLOP,
5845 S. Broadway, Los Angeles.

Gentlemen:—Please send me at once one
Western "B" Power Unit. If after seven
days' trial it is not satisfactory, I will re-
turn it and you will refund my money.

Payment Enclosed, \$18.50.
 Send C. O. D.

Name.....
Address.....
City.....State.....

Tell them that you saw it in RADIO

SANGAMO

MICA CONDENSERS

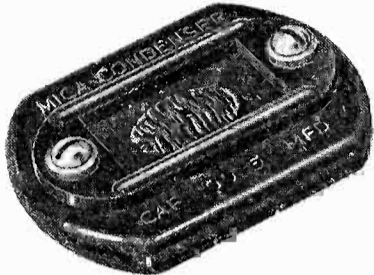

CAPACITIES and PRICES

0.00004	0.001	} 50c.
0.00005	0.0012	
0.00006	0.0015	
0.00007	0.00175	
0.00008	0.002	
0.0001	0.0025	} 60c.
0.00012	0.003	
0.00015	0.0035	
0.000175	0.004	
0.0002	0.005	
0.00025	0.006	70c.
0.0003	0.007	85c.
0.00035	0.0075	90c.
0.0004	0.008	95c.
0.0005	0.01	\$1.00
0.0006	0.012	1.15
0.0007	0.015	1.20
0.0008		1.25

With Resistor clips, 10c extra



We Recommend Parvult Wound Condensers

SANGAMO ELECTRIC COMPANY

SPRINGFIELD, ILLINOIS

Wonderful Bargain

at \$2.90



Piedmont

Dimensions

- 7" x 18" x 10" Deep
- 7" x 21" x 10" Deep
- 7" x 24" x 10" Deep
- 7" x 26" x 10" Deep

Your Choice at \$2.90 Ea.

f.o.b. Hickory

Cash with Order.

No C. O. D.'s

At this special price.

12 hour service
factory to you.

Southern Toy Co. Inc.
Manufacturers Hickory N.C.

TEMPORARY WAVELENGTH ALLOCATIONS

(Continued from page 54)

Call Letters	LOCATION AND OWNER	Power Watts	Frequency Keys	Wave Length Meters
KGCI	Liberto Radio Sales 409 South Flores Street, Wasmer & Taft, Seattle, Wash.	15	1250	239.9
KGCL	San Antonio, Texas.	50	1260	238.0
KGCN	Concordia Broadcasting Co. 1117 Hill Street, Concordia, Kansas.	50	1430	209.7
KGCR	Cutler's Radio Broadcasting Service, Inc. 415 Main Street, Brookings, S. D.	15	1190	252
KGCU	Mandan Radio Association 105 Third Avenue, Northwest, Mandan, N. D.	100	1050	285.5
KGDX	First State Bank of Vida Vida, Montana.	10	1250	239.9
KGDA	Home Auto Company (J. R. Nelson) 307 Third Street, Dell Rapids, S. D.	15	1180	254.1
KGDE	Jaren Drug Co. Main Street, Barrett, Minn.	50	1290	232.4
KGDJ	Mr. R. R. Rathert 316 Fifth Avenue, West, Cresco, Iowa	10	1480	202.6
KGDM	Victor G. Koping and E. F. Peffer 42 South California Street, Stockton, Calif.	10	1880	217.3
KGDP	Pueblo Council, Boy Scouts of America Room 4, Court House Building, Pueblo, Colorado.	10	1150	260.7
KGDR	Joe B. McShane 206 Laurel Heights Place (Rear) San Antonio, Texas.	15	1250	239.9
KGDW	Mr. Frank J. Rist Plainview Hog and Seed Farm, Humboldt, Nebraska.	100	1240	241.8
KGDY	J. Albert Loesch Oldham, South Dakota	15	1430	209.7
KGEF	Los Angeles, Calif.	500	570	526
KGEH	Eugene Broadcast Station 9th Street, between Oak and Pearl, Eugene, Oregon.	50	1270	236.1
KGEK	Beehler Electrical Equipment Co. 109 West Second Avenue, Yuma, Colorado	10	1190	252.0
KGEN	E. R. Irey and F. M. Bowles 679 Main Street, El Centro, Calif.	15	1080	277.6
KGEO	Hotel Yancey 2nd Street, at Locust, Grand Island, Nebr.	100	1110	270.1
KGEQ	Fred W. Herrmann, 920 Fifth Avenue, North, Minneapolis, Minnesota.	50	900	331.1
KGER	C. Merwin Dobyms 435 Pine Avenue, Long Beach, Calif.	100	920	325.9
KGES	Central Broadcast Co. 1516 23rd Street, Central City, Nebraska.	10	1460	205.4
KGEU	L. W. Clement Lotewana Lodge, Lower Lake, California.	50	1350	222.1
KGEW	City of Fort Morgan City Hall, Fort Morgan, Colo.	10	1170	256.3
KGEY	J. W. Dietz 1917 East 28th Avenue, Denver, Colorado.	15	1470	204
KGEZ	Flathead Broadcasting Association Elks' Temple, Main Street, Kalispell, Montana.	100	850	352.7
KGFB	Mr. Albert C. Dunkel 205 College Street, Iowa City, Iowa.	10	1340	223.7
KGFF	Earl E. Hampshire Alva, Oklahoma.	25	1460	205.4
KGFG	The Full Gospel Church East 9th and Phillips Streets, Oklahoma City, Okla.	50	780	384.4
KGFG	Oklahoma City, Okla.	50	780	384.4
KGFH	Frederick Robinson La Crescenta, California.	100	1370	218.8
KGFI	Mr. M. L. Eaves P. O. Box 496, Fort Stockton, Texas.	15	1360	220.4
KGFJ	Ben S. McGlashan 2333 21st Street, Los Angeles, Calif.	100	1390	215.7
KGFJ	Los Angeles, Calif.	100	1390	215.7
KGFK	Kittson County Enterprise Second Street, Hallock, Minn. Trinidad, Colo	50	1340	223.7
KGFL	George W. Johnson 336 Plumas Street, Yuba City, Calif.	50	1350	222.1
KGFM	Henry Haralson and Carl Thingstad Aneta, N. D.	15	670	447.5
KGFN	Mitchell Broadcast Co. 113 West 4th Avenue, Mitchell, S. D.	15	1350	222.1
KGFP	Mitchell, S. D.	10	1140	268
KGO	General Electric Co. 5555 East Fourteenth Street, Oakland, Calif.	12,500	830	361.2
KGRS	Gish Radio Service (E. B. Gish) 108 East 8th Street, Amarillo, Texas.	150	1280	234.2
KGTT	Glad Tidings Temple and Bible Institute 1441 Ellis Street, San Francisco, California	50	1450	206.8
KGW	Oregonian Publishing Co. 135 Sixth Street, Portland, Oregon.	1000	610	491.5
KGY	St. Martins College Lacey, Washington.	50	1080	277.6
KHJ	The Times Mirror Co. 100 North Broadway, Los Angeles, Calif.	500	740	405.2
KHQ	Louis Wasmer, Inc. Davenport Hotel, Spokane, Wash.	1000	760	394.5
KICK	Atlantic Automobile Co. 3 Popular Street, Anita, Iowa.	100	1100	272.6
KJBS	Julius Brunton & Sons Co. 1380 Bush Street, San Francisco, California.	5	1360	220.4
KJR	Northwest Radio Service Co. Seattle, Wash.	5000	780	384.4
KKP	City of Seattle, Harbor Department Pier One, Ft. Yeslor Way, Seattle, Washington.	50	1150	260.7
KLDS	Reorganized Church of Jesus Christ of Latter Day Saints, Independence, Mo.	1000	680	440.9
KLIT	Lewis Irvine Thompson, 475 21st Street, Portland, Oregon.	10	860	349.0
KLS	Warner Bros. 2201 Telegraph Avenue, Oakland, Calif.	250	1200	249.9
KLX	Tribune Publishing Co. Oakland, California.	500	590	508.2
KLZ	The Reynolds Radio Co., Inc. 1534 Glenarm Street, Denver, Colorado.	500	780	384.4
KMA	May Seed & Nursery Company Shenandoah, Iowa.	500	650	461.3
KMBU	Paul J. Miller 1133 Creedmoor Street, Pittsburg, Pa.	50	740	405.2
KMED	W. J. Virgin, Sparta Bldg., Main and Riverside Streets, Medford, Oregon.	50	1200	249.9
KMIC	James R. Fouch 219 North Market Street, Inglewood, Calif.	250	1150	260.7
KMJ	The Fresno Bee Fresno, Calif.	50	1280	234.2
KMMJ	The M. M. Johnson Company, Clay Center, Nebr.	1000	1310	228.9
KMO	K M O, Inc. 950 11th and Broadway, Tacoma, Washington.	500	1200	249.9
KMOX	"The Voice of St. Louis, Inc." St. Louis, Mo.	5000	1070	280.2

(Continued on page 58)

Tell them that you saw it in RADIO

FROM THE RADIO MANUFACTURERS

The Teleplex is a machine for either learning or increasing speed in code work. The code is heard from a buzzer whose signals are varied by a perforated

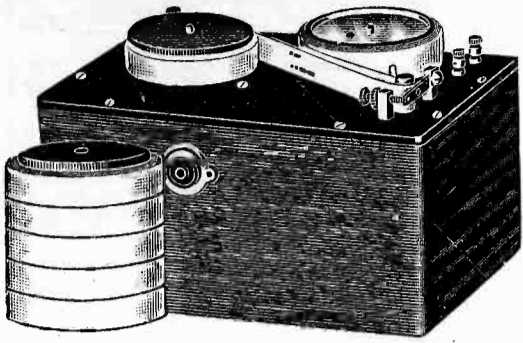

tape roll, six of which are furnished with each machine. More than one hundred rolls are available on various commercial subjects.

The Weston Model 519 radio set tester is a sensitive milliammeter (0-20 m.a.) with non-inductive high resistance multipliers for voltage measurements 0-8, 0-80 and 0-200 volts. As the voltage ranges have a resistance of 1000 ohms per volt, a current of 1 milliampere gives full scale deflection. It is conveniently ar-



anged in a carrying case and is equipped with adapters and cables so that it may be used for testing voltages at both the battery terminals and tube sockets. All tests are made while using the regular batteries or eliminator used in the set, with no change in connections, so that no auxiliary batteries are required.

The Dayfan Quietus is a device intended to eliminate interference to radio reception by small motors used on house-

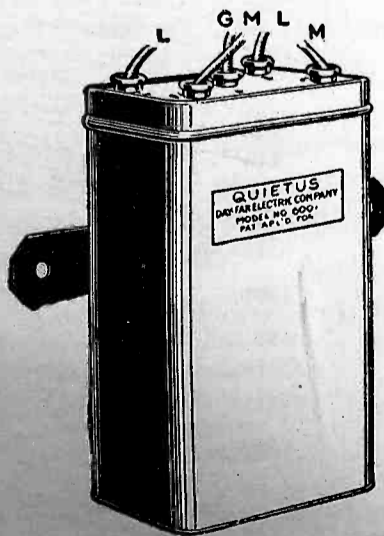

hold devices. Two of its terminals are connected to the supply line, two to the motor and one to ground.

HERE IT IS!

Marvelous Townsend
"B" ELIMINATOR
(Complete)

only
495
\$100 down
Balance COD

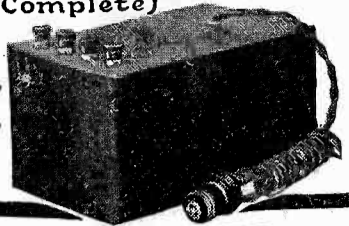

Direct From Factory
at Lowest Price on Record

Great news! For half the price of a set of "B" batteries you can now enjoy greatly improved reception and be done with unreliable "B" batteries. We make the Townsend "B" Eliminator complete in our own factory. That's the reason we can give you at such a remarkably low price a high quality instrument backed by a real guarantee. Users report splendid results. A fine "B" Eliminator at the lowest price on record. Our 10 days Free Trial proves it.

MONEY BACK if Not Amazed and Delighted
You alone are the judge. We could not afford to make this guarantee if we were not sure of the Townsend "B" Eliminator's splendid performance. Delivers up to 100 volts on any set on direct or alternating current—any cycle. Gives full wave rectification. Full tone, clarity and volume.

Rush Order Today Simply put your name and address on a piece of paper, pin a \$1 bill to it and get it into the mail at once. Your "B" Eliminator will be sent you promptly. Deposit only \$3.95, plus postage, with the postman. Try out for ten days—then if not thrilled by improvement in operation, return Eliminator to us and purchase price will be refunded in full. You don't need to put up with battery nuisance another day when it is possible to own a "B" Eliminator at this startlingly low price. Send for it today.

Townsend Laboratories, 713 Townsend St., Dept 18 Chicago, Ill.

10 Days FREE TRIAL
You are the Judge!

Tubes Matched for Ten Cents Each

Send us your vacuum tubes. Let us select the best detector, oscillator, r.f. or audio amplifier and see how much better your set will work. Price only ten cents per tube. Each tube will be plainly marked. We also sell selected tubes at regular retail prices.

Laboratory of "Radio," 435 Pacific Bldg., San Francisco



Specified in these
and other
Circuits

Madison-Moore
Browning-Drake
Hammarlund-
Roberts
Infradyne
Kenneth Hark-
ness KH 27
Victoreen
General Radio 400
All American
R.F. Set
Loftin White
S. C. 2
Cockaday LC 27

Radio Has Learned To Rely Upon EBY BINDING POSTS

—because they have proven to be the one sure, safe and fool-proof way of insuring a positive contact.

That's why eight out of ten radio manufacturers and the majority of the great circuit designers use and specify EBY exclusively.

Your dealer has all of the different markings. Insist on and get genuine EBY binding Posts—15c each.

THE H. H. EBY MFG. CO., Inc.

4710 STENTON AVE.,



PHILA., PA.

EBY

BINDING POSTS

SEND FOR THIS RATE SCHEDULE

THE LABORATORY OF "RADIO" HAS A COMPLETE RATE SCHEDULE
READY FOR YOU. A COPY SENT FREE ON REQUEST.

"RADIO"—Pacific Building

San Francisco

INDISPENSIBLE

for 100%
Tube Efficiency

Only Amperite supplies automatically the self-adjusting filament current your tubes require. Eliminates hand rheostats. Simplifies wiring. Insist on Amperite. Accept nothing else. Price \$1.10 complete. Sold everywhere. Write for Free Hook-Ups and construction data to Dept. R-6

RADIALL COMPANY
50 Franklin Street
New York City

AMPERITE

REG. U.S. PAT. OFF.

The "SELF-ADJUSTING" Rheostat

POSITIVE ELIMINATION OF INTERFERENCE

"WEB" WAVE TRAP

PRICE

\$200

Positively eliminates interference. Increases Distance. Increases Volume. Increases Selectivity. Reduces Static. Works on all sets, including loop sets. Tested and Approved by radio experts. ON SALE AT YOUR DEALERS, or will be sent upon receipt of check, money order or cash by the manufacturer, under money back guarantee.

Manufactured by
WALTER E. BATHGATE CO., Inc.
65 West Broadway, N. Y.

**FIRST SHOWING
OF NEXT SEASON'S
RADIO MODELS
In "RADIO" Next Month
DON'T MISS IT!**

"ENSCO" 3 Ft. Cone
Assemble it in less than an hour — Use
\$10. The "ENSCO" Kit \$10.
Send for Free Booklet
ENGINEERS SERVICE COMPANY
25 Church Street — or — 911 Steger Bldg.
New York Chicago



HOTEL GIBSON

Royal hospitality in the
Queen City

Delightful Comforts

luxuriously provided at prices
considered reasonable
in much lesser hotels

1000 ROOMS

Two large ball rooms seat
2,500 guests

Florentine Dining Room
America's most beautiful
Restaurant

**Largest Hotel in
CINCINNATI**

Popular priced Coffee Shop
serves same carefully selected
and prepared foods as the
main dining room



RALPH HITZ, Manager

TEMPORARY WAVELENGTH ALLOCATIONS

Call Letters	LOCATION AND OWNER	Power Watts	Frequency Keys	Wave Length Meters
KMTR	Los Angeles, Calif.	500	790	379.5
KNRC	Clarence B. Juneau Municipal Auditorium Santa Monica, Calif.	500	1260	238
KNX	Los Angeles Express Publishing Co. 236 South Hill Street, Los Angeles, California.	500	890	336.9
KOA	General Electric Company 1370 Krameria Street, Denver, Colo.	12,500	930	322.4
KOAC	Oregon State Agricultural College Corvallis, Ore.	500	1070	280.2
KOB	New Mexico College of Agriculture and Mechanic Arts State College, New Mexico.	1500	860	348.6
KOCH	Central Radio School (Central High School) Omaha, Nebr.	500	1160	258.5
KOCW	Oklahoma College for Women 1800 South 18th Street, Chickasha, Okla.	500	1110	270.1
KOIL	Mona Motor Oil Co. 1124 South 6th Street, Council Bluffs, Iowa.	5000	980	303.9
KOIN	KOIN, Inc. 5th and Main Streets, Portland, Oregon.	1000	940	319
KOLO	Gerald K. Hunter, 988 Main Street, Durango, Colo.	5	850	352.7
KOMO	Fisher's Blend Station, Inc., Harbor Island, Seattle, Washington.	1000	980	303.9
KOWW	Frank A. Moore, President, Frank A. Moore, Inc. 711 Baker Bldg., Walla Walla, Wash.	500	1160	258.5
KPJM	Frank Wilburn Box 730, Prescott, Arizona.	15	1400	214.2
KPNP	Central Radio Co. 213 Chestnut Street, Muscatine, Iowa.	100	1380	217.3
KPO	Hale Bros. and The Chronicle, 5th and Market Streets, San Francisco, Calif.	1000	700	428.3
KPPC	Pasadena Presbyterian Church Colorado and Madison Streets, Pasadena, Calif.	50	1310	228.9
KPPR	Los Angeles, Calif.	500	1300	230.6
KPRC	Houston Printing Co. Polk and Dowling Streets, Houston, Texas.	500	1010	296.9
KQV	Doubleday-Hill Electric Co. 719 Liberty Avenue, Pittsburg, Pa.	500	850	352.7
KQW	San Jose, Calif.	500	1120	267.7
KRAC	Gaddo Radio Club, State Fair Grounds Shreveport, Louisiana.	50	1360	220.4
KRE	Berkeley, Calif.	50	1170	256.3
KRLD	KRLD, Inc. (Formerly Dallas Radio Laboratories) Akard and Commerce Streets, Dallas, Texas.	500	890	336.9
KRLO	Freeman Long & A. B. Scott 218 North Larchmont Boulevard, Los Angeles, Calif.	250	680	440.9
KROX	N. D. Brown and W. J. Casamalia 4728 Bennett Street, Seattle, Wash.	100	1130	265.3
KRSC	Radio Sales Corporation 1202 Fifth Avenue, Seattle, Washington.	100	600	499.7
KSAC	Kansas State Agricultural College Manhattan, Kansas.	500	880	340.7
KSBA	W. G. Patterson 406 Market Street, Shreveport, Louisiana.	1000	1150	260.7
KSCJ	Perkins Bros. Co. (Sioux City Journal) 5th and Douglas Streets, Sioux City, Iowa.	500	1150	260.7
KSD	The Pulitzer Publishing Co. St. Louis, Mo.	500	550	545.1
KSEI	KSEI Broadcasting Association 141 South 6th Avenue, Pocatello, Ida.	500	1150	260.7
KSL	Radio Service Corporation of Utah South Temple Street, Salt Lake City, Utah.	1000	1000	299.8
KSMR	Santa Maria Valley Railroad Co. Santa Maria, California.	100	1060	282.8
KSO	Berry Seed Co. Logan Street, Clarinda, Iowa.	500	740	405.2
KSOO	Sioux Falls Broadcast Association Sioux Falls, S. D.	250	1370	218.8
KTAB	The Associated Broadcasters 1410 Tenth Avenue, Oakland, California.	1000	990	302.8
KTAP	Robert B. Bridge 2412 Main Avenue, San Antonio, Texas.	10	1140	263
KTBI	Bible Institute of Los Angeles, Inc. 536 South Hope Street, Los Angeles, California.	750	1020	293.9
KTBR	M. E. Brown 393 1/2 Yamhill Street, Portland, Oregon.	50	1140	263
KTCL	American Radio Telephone Co. 1520 Westlake Avenue, Seattle, Wash.	1000	1050	285.5
KTHS	Arlington Hotel Co. Hot Springs, Ark.	500	800	374.8
KTNT	Norman Baker, "KTNT" 2nd and Lombard Streets, Muscatine, Iowa.	1100	900	333.1
KTSA	San Antonio, Texas.	2000	1140	263
KTUE	Uhalt Electric 614 Fannin Street, Houston, Texas.	5	1140	263.0
KTW	First Presbyterian Church 7th Avenue and Spring Street, Seattle, Wash.	1000	660	454.3
KUOA	University of Arkansas Fayetteville, Ark.	500	1000	299.8
KUOM	The State University of Montana Missoula, Montana.	500	800	374.8
KUSD	University of South Dakota University Campus, Science Hall, Vermillion, S. D.	250	1080	277.6
KUT	University of Texas University Campus, Austin, Texas.	500	1100	272.6
KVI	Puget Sound Radio Broadcasting Co. 20 Tacoma Avenue, Tacoma, Wash.	15	870	344.6
KVOO	Southwestern Sales Corporation Roland Hotel Bldg., West 6th Street, Bristow, Okla.	1000	800	374.8
KVOS	L. Kessler 1208 10th Avenue, W., Seattle, Washington	500	900	333.1
KWBS	Schaeffer Radio Co. 226 East 41st Street, Portland, Oregon.	15	1490	201.2
KWCR	H. F. Paar, 1444 2nd Avenue, East, Cedar Rapids, Iowa.	500	1360	220.4
KWG	Portable Wireless Telephone Co. 902 Commercial & Savings Bank Bldg., Stockton, Calif.	50	1210	247.8
KWKC	Wilson Duncan Broadcasting Co. 3912 Main Street, Kansas City, Mo.	100	1270	236.1
KWKH	W. K. Henderson, Fannin and Spring Streets, Shreveport, La.	1000	900	333.1
KWLC	Luther College, 600 Hill Street, Decorah, Iowa	50	700	428.3

(Continued on page 60)

YAXLEY

APPROVED RADIO PRODUCTS

Radio Convenience Outlets

No longer need radio reception be confined to one room—nor need battery wires be a tangled, unsightly mass strewn about the set. With the neat and efficient Yaxley Radio Convenience Outlets you can enjoy your favorite programs in any room in the house. Your batteries can be placed in the basement, closet or any out-of-the-way place and wires brought to set from Convenience Outlet with cable and plug that keep wires together in an attractive way. Plug cannot be inserted incorrectly. Yaxley Radio Convenience Outlets are easily installed in any standard switch box.

- No. 135—For Loud Speaker.....\$1.00
- No. 137—For Battery Connections 2.50
- No. 136—For Aerial and Ground 1.00

At your dealer's. If he cannot supply you, send his name with your order to

Direct Representatives:
HENGER-SELTZER CO.
 1111 Wall Street
 Los Angeles
 877 Brannan Street
 San Francisco
DON H. BURCHAM
 1553 E. Everett St.
 Portland
YAXLEY MFG. CO.
 Dept. A
 9 So. Clinton St.
 Chicago

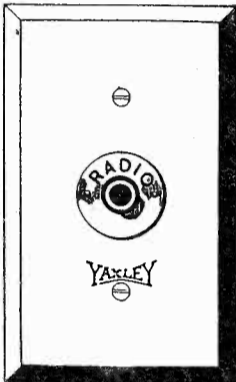

Out Goes Your A & B Batteries in comes the "VERNON"

the latest in Batteryless Radio

(This New Wonderful receiver operates from 110 A. C. Current. (This is the current used in over 95% of American Homes.)

Uses No A or B Batteries and works direct from your house Lighting Circuit... Ready to install in your own...

Radio or Phonograph Cabinet



This Complete Electric Radio occupies very little space. Anyone can install it. You don't even have to know anything about a Radio.

Direct from Factory to You...

\$32.50

PANEL 7 x 14 Inches

COMPLETE including TUBES!

Today's Greatest Value!

(All you need is your own Cabinet and Loud Speaker)

This modern Radio is more efficient than many radios that sell for many times its price. The "VERNON" comes to you completely built—panel and sub-panel—wired by experts and every set is thoroughly tested before leaving the factory. Together with this Radio comes the "VERNON" Filter System which replaces both A and B Batteries.

The "Vernon" is the most economical radio that has yet been built

This Receiving Set uses less than one half as much electricity as is used by one ordinary house lamp.

The "VERNON" Batteryless Radio has a circuit different from any other make. It uses only three tubes, and its tone, selectivity and volume surprises everyone. This Radio uses a Tube Detector (No Crystals)

MAIL \$5.00, BALANCE C. O. D. Charges collect. Shipping weight 20 lbs.

Address your order to the VERNON RADIO COMPANY, 724 West Vernon Avenue, Los Angeles, California
 All orders are sent out within less than 24 hours from the time they are received.

QUALITY **DONGAN** PRODUCTS

YOUR SOURCE OF SUPPLY

Manufacturers find the newest approved features—in Audio transformers, B Power and Power Amplifier transformers and chokes—designed by Dongan, builders of radio parts, exclusively.

This is the season to secure the maximum service from our engineering staff.

Complete information on Power Units for the new 350-400 MA Tubes. Several types, mounted or unmounted.

Dongan Electric Manufacturing Company
 2981-3001 Franklin St. Detroit

TRANSFORMERS of MERIT for FIFTEEN YEARS

The Alamac Hotel

Broadway and Seventy-First Street
 New York City

The perfect selection when visiting the Metropolis.

600 Rooms each with bath, shower and Servidor.

Not too large, not too small—a hostelry that offers personal service and courtesy.

Renowned CONGO ROOM & Aerial Balcony
 Coolest Place in Town!

Because of location it is an ideal summer hotel.
 Many garages nearby—plenty of parking space.

TARIFF MODERATE

Lutz Management

WIRE AT OUR EXPENSE FOR RESERVATIONS!

TEMPORARY WAVELENGTH ALLOCATIONS
(Continued from page 58)

Call Letters	LOCATION AND OWNER	Power Watts	Frequency Keys	Wave Length Meters
KWSC	State College of Washington Pullman, Washington.	500	860	348.6
KWTC	Dr. John Wesley Hancock 1101 North Ross Street, Santa Ana, California.	5	1140	263
KWUC	Western Union College 10th Street, LeMars, Iowa	1500	1190	252.0
KWWG	Chamber of Commerce (for City of Brownsville, owner) Corner 11th and Levee Streets, Brownsville, Texas	500	1080	277.6
KYA	Pacific Broadcasting Corp., San Francisco, Calif.	500	1040	288.3
KXL	KXL Broadcasters 17 Iversdale Street, Portland, Oregon.	50	770	389.4
KYW	Westinghouse Electric & Mfg. Co. Radio Broadcasting Station KYW, 508 Michigan Avenue, Chicago, Ill.	5000	560	535.4
KZM	Preston D. Allen Hotel Oakland, 13th and Harrison Streets, Oakland, California.	100	1250	239.9

**INFRADYNE
KITS @ PARTS**
\$118.00 for the complete set of Parts as specified by Sargent
N.E. BORCH & CO.
426 Pacific Bldg, San Francisco

FROST-RADIO

PARTS ARE BEST FOR YOUR



Ask Your Dealer for these Parts
When You Build Your Infradyne

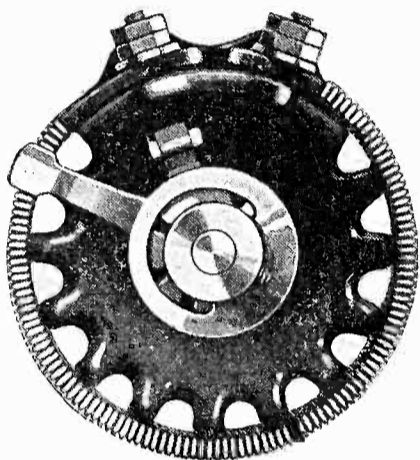

FROST-RADIO

You will obtain best results with your Infradyne if you use the **FROST-RADIO** parts specified by Sargent. These parts are standard in scores of high grade receivers such as the Infradyne.

Your dealer has them; see him today.

FROST-RADIO Parts You Will Need

- 1 No. 660 Base Mounting Rheostat.....\$.75
- 7 No. 530 Bakelite Sockets, each..... .40
- 1 No. 730 30 ohm Metal Frame Rheostat..... .50
- or, if preferred,
- 1 No. 830 30 ohm Bakelite Rheostat..... .75
- 1 No. 710 10 ohm Metal Frame Rheostat..... .50
- or, if preferred,
- 1 No. 810 10 ohm Bakelite Rheostat..... .75
- 1 No. 882 200,000 ohm Variable High Resistance..... 1.25
- 1 No. 886 50,000 ohm Variable High Resistance..... 1.25
- 1 No. 608 Push-Pull Switch..... .30
- 1 No. 954 Gem-Jac..... .45
- or, if preferred,
- 1 No. 234 Pan-Tab Jack..... .75
- 1 No. 953 Gem-Jac..... .40
- or, if preferred,
- 1 No. 233 Pan-Tab Jack..... .65

HERBERT H. FROST, Inc.

160 North La Salle Street

New York

CHICAGO

Los Angeles

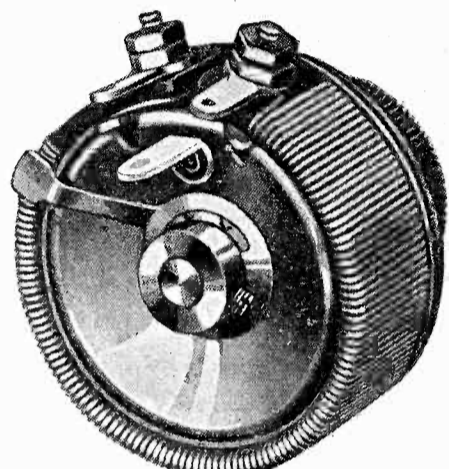

FROST-RADIO

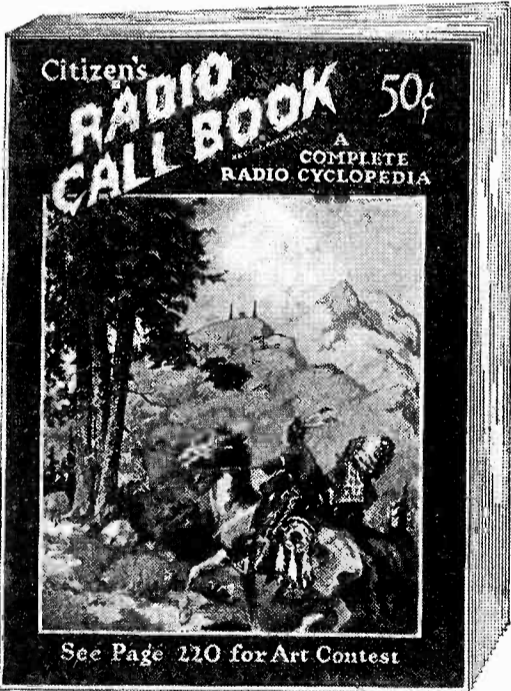

RADIO'S GREATEST PUBLICATION

The March issue of the **CITIZENS RADIO CALL BOOK** is just off the press.

This issue contains a wealth of live radio information, including a complete and up-to-date list of all broadcasting stations in the world, showing schedules, wavelengths, etc.; a wonderful picture section of 150 radio celebrities, a new department known as Ampere Andy's Assistors, giving the latest shop hints, showing illustrations how to maintain and repair your receiver.

SEVENTEEN FEATURE ARTICLES

The following receivers are featured in this issue: The Camfield Super-Selective Nine, the Lodge "N" Receiver, the "Phasatrol Five" Receiver, the Citizens "Super" Eight, an Impedance Coupled Super-Heterodyne, a Self-Modulated Oscillator, the Victoreen Universal Super-Heterodyne Receiver, a Shielded Localized Control Receiver, the Melo-Heald Super-Heterodyne Receiver. Further Notes on the Completely Shielded Six Tube Neutralized Receiver, the World's Record "Super" Nine, a Compact "B" Supply with Voltage Regulator Tube, a 30 K. C. Super-Heterodyne Receiver, the Improved Browning-Drake Receiver, a 100 K. C. Super Using Air Core Transformers, a Complete Plug-in Power

Amplifier, and the Improved Nine-in-Line "Super." Also a wonderful circuit section with descriptions and reviews of the season's most popular circuits.

The **CITIZENS RADIO CALL BOOK** is published four times yearly, January 1st, March 1st, September 1st, and November 1st. You may now subscribe by using the coupon below for one, two or three years and save money. By subscribing you will receive each issue by mail promptly upon date of issue.

Fill in the coupon at the bottom of this ad and mail at once.

TEAR OFF HERE

CITIZENS RADIO SERVICE BUREAU, Inc. Publishers **B** Date.....192.....
508 So. Dearborn St., Chicago, Ill., U. S. A.

Please enter my subscription for the **CITIZENS RADIO CALL BOOK** for [] one year, \$1.75; [] two years, \$3.25; [] three years, \$4.50. Enclosed please find.....in payment for same, mailed postpaid four times yearly, January, March, September and November. Canada and Foreign \$2.00 yearly.

Name..... Address.....
State.....

WEATHER — TIME — PRESS IN THE FAR EAST

By WM. A. BRENNAN

The following tables of Time and Weather reports for Japan, China and the Far East will prove quite invaluable to the operator who is not acquainted with the various stations and their schedules.

Pacific Standard Time	Station	Wave System	Remarks
8:00 to 8:15 AM	VPS	600 spk	Weather
10:30 AM	NPM	5552 cw	Weather
11:55 to Noon	NPG	3600 cw	Time
2:30 PM	NPM	5552 cw	Weather
3:55 to 4:00 PM	NPM	12490 cw	Time
4:10 PM	JFRA	4000 cw	Weather
4:27 to 4:30 PM	XRT	1000 spk	Time
4:30 PM	JFRA	600 icw	Weather
4:30 PM	JTJ	2650 cw	Weather
4:30 PM	JTJ	600 icw	Weather
4:57 PM to 5:00 PM	PKX	8800 cw	Time
5:55 PM to 6:00 PM	BXY	2000 icw	Time
5:59 PM to 6:04 PM	JJC	7700 cw	Time
6:54 PM to 7:10 PM	FFZ	750 spk	Weather and Time
Noon 135 Meridian East.			
7:30 PM	NPM	5552 cw	Weather
8:00 PM	VPS	600 spk	Weather
9:00 PM	VPS	2800 cw	Weather
10:00 PM	JFRA	4000 cw	Weather
10:00 PM	KZRC	600 icw	Weather
10:00 PM to 10:30 PM	VPS	600 spk	Weather
10:10 PM	JFRA	600 icw	Weather
10:30 PM	JTJ	2650 cw	Weather
10:30 PM	JTJ	600 icw	Weather
Midnight to 12:10 AM	VPS	600 spk	Weather
12:54 to 6:05 AM	FFZ	750 spk	Time and Weather
1:57 to 2:10 AM	RCV	1500 spk	Time and Weather
2:00 to 2:10 AM	VPS	600 spk	Weather
3:10 AM	JFRA	4000 icw	Weather
3:20 to 3:30 AM	VPS	600 spk	Weather
3:30 AM	JFRA	600 icw	Weather
3:59 to 4:04 AM	JJC	7700 cw	Time
4:00 AM	VPS	600 spk	Weather
4:30 AM	JFK	600 icw	Weather
4:30 AM	JTJ	2650 cw	Weather
4:30 AM	JTJ	600 icw	Weather
4:55 to 5:00 AM	BXY	2000 icw	Time
5:00 AM	VPS	2850 cw	Weather
6:00 to 6:05 AM	FFZ	750 spk	Weather
6:00 AM	VPS	600 spk	Weather
6:30 to 6:35 AM	FFZ	750 spk	Weather

The weather bulletins as sent out by Japanese stations in their meteorological code is as follows:

1. Actual meteorological condition of the various districts (Code).

2. Storm Warnings—Plain English.

Both are broadcast from JFRA every day including Sundays on a wavelength of 600 meters icw in Plain English Only, and 4000 cw in code and Plain English at 9:10 AM; 3:00 and 8:10 PM local time 135 E. Meridian or 4:10 PM; 10 PM and 3:10 AM Pacific Coast Time.

Information code consists of five letters in one group and twenty groups or less sent out.

X XX X X

1 2 3 4

1. Name of districts, Table One.

2. Baro. See Japanese meteorological code Table One, Barometric pressure or Year Book of Wireless Tel. & Tel. of 1925 which contains schedules.

3. Force of the wind and state of the weather, see same.

4. Direction of the wind. Table Two.

TABLE ONE

A—Ishigakijima	V—Hamamatsu	O—Moppo
B—Naha	H—Fura	S—Genzan
C—Nase	J—Chichijima	P—Yuki
D—Miyazaki	Z—Nemuro	Q—Dairen
W—Kagoshima	K—Minatsuki	R—Choshun
I—Murotozaki	L—Ishinomaki	T—Shanghai
F—Tomie	M—Hakodate	U—Taihoku
G—Sakai	N—Shana	X—Shirotsu

TABLE TWO

T—SSW	Z—NNW	E—E
U—SW	C—Calm	F—ESE
V—WSW	N—N	G—SE
W—W	O—NNE	H—SSE
X—WNW	P—NE	S—S
Y—NW	Q—ENE	

EXAMPLE

AQDGZ, BOMIZ, CLENN, WQVGP, IRWIE, FREGN, VSXLE, HTPKZ, JSJAG, GSOLO, KTGBP, LUNKX, MUWAQ, NUZAX, OSFBN, SSZAE, PTNHT, QSTFH, RQPGU, TSEAP.

TRANSLATION

Name of Districts	Baro	Weather	Force	Direction
Ishigakijima	754.6	Cloudy	4-5	NNW
Naha	750.4	Cloudy	8-9	NNW
Nase	744.4	Rain	8-9	N
Kagoshima	756.4	Cloudy	4-5	NE
Murotozaki	759.1	Cloudy	8-9	East
etc., etc.				

It might be of interest to know that there is a new station controlled by the Yokohama Harbor Office, call JFSA; also one at Kobe call JANB. Their service is information regarding entering port, Quarantine, Berth No., etc. Only.

Weather reports are sent out by station XPI (Pratas Shoal) in plain English and by the New International Codes at 03.00 PM and 08.00 PM 135 E. Meridian Time or 10 PM and 3 AM Pacific Coast Time on a wavelength of 600 meters spark and 1450 cw.

For those sea-going operators who have become proficient in Continental to such an extent that they are now studying Jap code and language I will advise that excellent practice can be obtained by listening in to JAA on 14,500 meters cw as follows:

5:00 to 5:20 PM Japanese and English press.
7:00 to 7:30 PM Japanese press.
8:00 to 8:30 PM Japanese press.
1:00 to 1:30 AM English press.

JJC also sends press on 6500 meters cw in Japanese at 9 to 9:30 PM and again at 4 to 4:40 AM on 7700 meters cw.

The English part is not very comprehensive but often gives items that cannot be copied from GBR, POZ or elsewhere.

Box Shields of "ALCOA ALUMINUM"

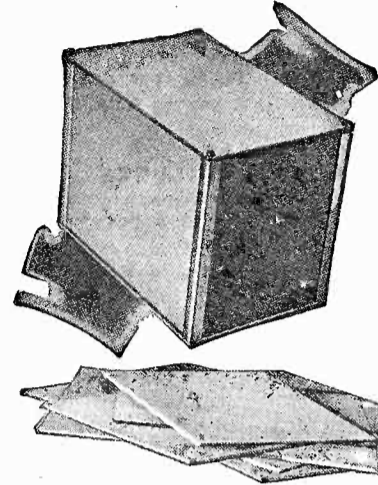

"Alcoa Aluminum" Box Shields

Consist of:
Top, Bottom, Sides
4 Extruded
Corner Posts
8 Aluminum Screws

MEETING the highest radio standards—shipped to you in the most convenient knocked-down form for easy assembly. These Box Shields are made of heavy aluminum (.080"—No. 12 B. & S.) and are supplied 5"x9"x6", which will cover most requirements. If the size does not meet your exact needs, change it—aluminum is easy to work.

Manufacturers can obtain these shields made to their exact specifications or they can secure the necessary corner-post moulding and sheet to manufacture under their own supervision.

Those who use Aluminum have ample proof of its advantages. Insist on "Alcoa Aluminum," ask your dealer or write us.

"ALCOA ALUMINUM"

is furnished to manufacturers in the following forms:

- Sheet: for shields, chassis, variable condensers, cabinets.
- Panels finished in walnut and mahogany.
- Die and Sand Castings.
- Screw Machine Products.
- Foil for fixed condensers.
- High Purity Rods for rectifiers.
- Stamping, rod, wire, rivets.

ALUMINUM IN EVERY COMMERCIAL FORM

ALUMINUM COMPANY of AMERICA
2323 Oliver Building Pittsburgh, Pa.



Tell them that you saw it in RADIO

**Lowest
Wholesale/
Prices!**

**ULTIMAX KITS
NOW READY FOR DELIVERY**

Madison Multi-Chokes, Cockaday LC-27, R. B. Lab., Hammarlund-Roberts, Alden Tru-phonic, Amer-Tran Power Packs, LR-4, In-fradyne, Benjamin Controlladyne Kits in stock.

**JOBBER-DEALERS
PROFESSIONAL SET BUILDERS**
Before buying, get our quotations on our Guaranteed Kits. 3-Hour Shipping Service.

1927 BUYING GUIDE
A few copies left for Dealers and Profes-sional Set Builders. Send for yours today. It's free! Address Dept. R.

We are the exclusive direct representatives of the Committee of 21 Manufacturers.

Allen-Rogers
Incorporated
"Kit Headquarters"
118 East 28th St., New York NY

**Intermediate Transformers
MATCHED**

Let Gerald Best and D. B. McGown match and "peak" the intermediate transformers for your super. Proper fixed condensers will be attached. This entire service for \$2.50.

Laboratory of "RADIO," San Francisco

**Valley
Chargers**

Manufactured by
VALLEY ELECTRIC CO.,
ST. LOUIS, MO.

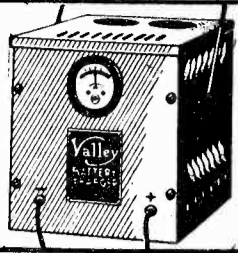

BRASS POUNDERS

Do you know that THE LIGHTNING JERKER is a live wire monthly published exclusively for YOU? Edited by commercial ops and owned and controlled by NO interests with an "axe to grind" it gives you the straight on things you want to know about your game. Sample copy on request. THE LIGHTNING JERKER, P. O. Box 2123 Seattle, Wash.

COILS MATCHED

Radio frequency coils accurately matched for In-fradynes and other sets. What a difference this makes. Only 35 cents per coil. Send them to Labora-tory of "RADIO," Pacific Bldg., San Francisco. We also are in a position to pur-chase these coils for you.

NOW OUT!

NEW INFRADYNE MANUAL, 25 CTS.
"RADIO," San Francisco

RANGE OF BROADCAST STATION

(Continued from page 21)

For example, the first Bell telephone station was located on the roof of the 24 Walker Street building in New York City. Using a wavelength of 400 meters, the radiation from the station was quite low and ineffective. By plotting a curve of the radiation of power at various wavelengths through the broadcast band, it was found that 400 meters was the poorest wave that could possibly be used with that particular installation. When the wave was later changed to 492 meters, the field strength at certain distant points was found to be about five times greater.

In defining what constitutes good re-ception, the Radio Division establishes 10,000 microvolts per meter as sufficient to override the noises ordinarily encoun-tered in the making and breaking of electrical circuits in the home. Lower values give less satisfactory reception and greater values are likely to cause interference with other stations, due to the spreading of energy over too broad a band of frequencies on the average radio receiver. With a good superheterodyne 3 microvolts per meter are faintly aud-ible. At least 100 microvolts per meter must be had to give clearly audible re-ception on head phones, and 1000 mi-crovolts per meter is necessary for fair loud-speaker reception.

A 1-kilowatt transmitter whose en-ergy is not absorbed has a field of about 10,000 microvolts per meter nine miles away. Steel buildings or electrical net-works reduce this to less than four miles in several cases. The Radio Division suggests that a broadcast station be rated on the basis of its radiation in microvolts per meter rather than in watts input into the antenna. The in-tensity of the electric field from a broad-cast station is approximately propor-tional to the square root of the power used, according to tests made by the Bureau of Standards, and hence the area reached with signals of a given intensity is approximately proportional to the power. By adopting a standard of field strength in accordance with the above rule, the radio public could soon master the technicalities of the new term, and thereby obtain a better idea of the prob-ability of hearing any particular station.

All the tests regarding field strength from given stations were made either in the open country, or in the center of city streets, at ground level. To deter-mine the effect of placing the receiving set, where it is of the loop antenna type, inside a large steel building tests made by the Bell Telephone Laboratories were recently described in the Bell Sys-tem Technical Journal. It was found that not only was the strength of re-ceived signals greatly reduced by the shielding effect of the steel frame of the building, but the noise level was raised

LET US BRING YOUR



UP-TO-DATE!

WE specialize on the DeLuxe Model of the Sargent-Rayment Infradyne. This receiver is acknowledged to be the outstanding set of the 1927 season. Our own experience with the set convinces us that it is destined to lead the radio field for many years to come. In our test laboratory we have received two Japanese Stations—JOAK and JOBK; 2BL in Sydney, Australia, as well as PWX, CZE, WBZ, WEAN, WNYC, WRNY, WGY and WJZ. Selectivity is razor-edged.

We guarantee to rebuild or service any Infradyne and make it the equal of our laboratory model. We have installed special laboratory test instruments to do this. Charges are reason-able. Send in your set and when you get it back all parts will be matched. It will be tested on DISTANCE and DIALS LOGGED for direct reading in wavelength.

[NOTE] When shipping the set, remove it from the cabinet and put in heavy carton or wooden box. If shipped in a box, screw the baseboard to the inside of the box. Ship by prepaid express.

**INFRADYNE
KITS**

Containing only specified parts, each part laboratory-tested and matched to the oth-ers. Full instructions accompany each Kit. SARGENT-RAYMENT KIT, Complete

\$118.00

INFRADYNE BLUE PRINTS—\$1.00 per set, postpaid

RADIO SERVICE COMPANY

357 TWELFTH STREET, OAKLAND, CALIFORNIA

considerably by interference from electrical power apparatus in the building, including elevators and other motorized equipment.

The results of observations inside a large steel building are shown in Fig. 1, the groups of figures representing the field strength of one particular station, in microvolts per meter. It can be seen that where the field strength was 52,900 in the street, and 83,900 on the roof where the shielding effect was not apparent, the strength was reduced to the astonishingly low value of 858 microvolts per meter inside the building on the first floor. This explains why owners of loop sets often have such poor reception in certain parts of a steel building, and notice a remarkable improve by moving the set to some other part of the same structure. It was found that for outside rooms, the field strength near the window was about eight times that further in the room, thus making it advisable for the set owner to place his set as near the window as possible.

From these tests it is obvious that an outdoor antenna would be preferable to a loop, for satisfactory reception of distance stations. To protect an outdoor antenna from local interference in the building, it was recommended that the antenna lead be shielded while passing near other electrical circuits.

Another absorption phenomena on which much has been written is fading. The results of fading tests conducted by the Bureau of Standards indicates that it is due to variable absorption in the upper atmosphere.

If a receiving set suddenly goes "dead," the first things to do are to check the *A*, *B* and *C* batteries and tubes. The batteries can be tested with a voltmeter, and ammeter or hydro-meter; and the tubes with a regular tube tester. If no tube tester is available, the clerk at the nearest radio store will be glad to test them. This service is usually free. Then, if the tubes and batteries are all right, the aerial and ground should be examined; and the loud speaker should be tested by connecting it across a 45-volt *B* battery for a second. If there is a loud click, the speaker is OK. If everything else proves to be all right, the trouble will probably be found to be in a burned-out transformer. The windings of the transformers can be tested by connecting a 4½-volt or 6-volt battery, a filament voltmeter, and one of the transformer windings (either primary or secondary) in series. If the winding is not burned out, the voltmeter will show a reading of one or two volts. If a high-reading voltmeter is used for this test, a *B* battery should be substituted for the 6-volt battery. Should the winding be burned out, it will be necessary to replace the transformer. A burned-out transformer is the most common cause of a set going dead suddenly.

LETTERS FROM LARRY

(Continued from page 22)

it was Will Rogers captain I says (stop) Grxzclpkv he says (stop) Yes sir I says right away (stop)

Say OM Honk put new fuses in the DC line yesterday (stop) Now Honk has a new idea in fuses I guess (stop) He connects them across the line (stop) After he burnt out fourteen and then got twelve more up town to burn out I says Honk I know that Xmas is coming and that since theres no snow we usually celebrate with fireworks (stop) But I says dont do it in working hours (stop) Well he says Im doing the best I can (stop) Yes I says that just the trouble (stop) Now I says just try sort of careless like and put them fuses in series with the line (stop) Sometimes they work that way Honk (stop) Well Honk says your startling information takes my breath away (stop) Yes I says that the insidious thing about it Honk (stop)

Well OM they brought down new *B* batteries this trip and I asked the boy was they charged (stop) No he says the boss told me to get the money or bring them back (stop) He says hes been beat too often (stop) My boy I says never be a radio operator and I says I can tell you from experience dating from when Guglielmo and I ran around together as kids (stop) That was in 1812 more than ninety years ago (stop) Gee he says I betcha you know the code all right (stop) Well pretty good I says but sometimes I get mixed up a little bit (stop) Ho I got a radio he says and he says there seems to be unique situations encountered in the computation of skip distances and atrociously distorted interpretations of the manifestations differentiating polarization from anti-polarization (stop) You go right home and wash your mouth out with soap I says (stop) Well OM I went up town to get some more smelling salts (stop)

Say OM I see the new general call for Navy vessels is NOB (stop) I guess they named it after these navy receivers (stop) Theres so many knobs on this set that I havent been able to get around to all of them this trip yet (stop) I guess if we work three watches steady we can cover all by the first of the year (stop)

Well OM Blonde Preferred just came up and says aint you going ashore like you said (stop) I want to see the Radio Sheik at the Crescent she says (stop) Kind lady I says observe at your side the very original himself not a moving picture (stop) Aw gwan she says (stop) So we both gwant (stop) Well more next trip OM (stop)

(sig) Larry

Tell them that you saw it in RADIO

RADIO ADS

ø ø ø

A Classified Advertising Section Read by Better Buyers.

ø ø ø

The rate per word is eight cents net. Remittance must accompany all advertisements. Include name and address when counting words.

ø ø ø

Ads for the July Issue Must Reach Us by June Fifth

QUARTZ CRYSTALS: Limited number of quartz crystals available; guaranteed to oscillate. Suitable for frequency standards, or for the control of transmitters. Frequency calibration furnished with each crystal. Price \$10 each, holders included. D. B. McGOWN, 435 Pacific Bldg., San Francisco

SET BUILDERS—We furnish jobs for you. (No fee) Competent men needed today in every community to build LC-27, Hammarlund-Roberts, Ultradyne, Loftin-White and Browning-Drake sets. Big money for you if you can qualify. Register NOW, giving particulars, experience, references. Allen-Rogers, Inc., 118 E. 28th, New York City.

FOR SALE—Specially Built Italian Style Walnut finish Infradyne Cabinet—panel size 8x30. Cost plenty. Sell for \$18.00. A snap. Square Deal Radio, 2139 Roscoe St., Chicago, Ill.

"BEST CRYSTAL ON EARTH"—Postpaid. fifty cents each. Fully Guaranteed. Harry Grant, Jr., 904 Oak Grove Ave., Burlingame, Calif. Average \$11.00 daily. No bunk. No selling. Send 6c. R. Harris, Grimes, California.

FREE—Selective Crystal Set Hook Up. Send two cent postage stamp with request. California Radio Minerals Co., 904 Oak Grove Ave., Burlingame, Calif.

BAKELITE PANELS, Tubes and Rods. Engraving and Drilling. W. A. Vetter, 24 12th St., San Francisco, Calif. (6T)

FOR SALE—Western Electric 7-A Amplifier. three 216-A tubes, 518-W Speaker, \$50.00. Filament transformer for amplifier, \$10.00. F. J. Scherer, Burbank, California.

RADIO SCHOOL—Extension course in practical radio offered for the radio repair man and the enthusiast. McKay Instrument Co., 424r Morgan Building, Portland, Oregon.

GET the 1927. Third Edition Revised of "Radio Theory and Operating" by Mary Texanna Loomis, member Institute of Radio Engineers. President and lecturer on Radio, Loomis Radio College of Washington, D. C. This is a thorough text and reference book of 886 pages, 700 illustrations and bound in flexible, red Kraft leather, lettered in gold. Used by practically all the radio schools in U. S. and Canada in addition to many Universities, Technical Colleges and High Schools. The standard reference book of the Department of Commerce, Radio Supervisors, and used by U. S. Naval Training Schools and Coast Guard Academy. The only radio book that is right down to date; contains much valuable matter never before published; it covers the field more thoroughly than any six radio books on the market. Price \$3.50, postage paid to any place in U. S. and Foreign countries. Get it of your book dealer. If he does not handle, send check or money order to Loomis Publishing Company, Dept. X, 405 9th St., Washington, D. C.

CASH IN on your Artistic Ability. Your home, your office, your spare time, your gold mine. Not a correspondence course. Sample and particulars 10c. Stayco, 1017 Mulberry, Springfield, Ohio.

FOR SALE—Two Pyrex lead-in bowls equipped with machined bronze collars, Corona shields and rods, studs and brass locking nuts. Suitable for high power broadcasting station or amateur transmitter where extremely high finished insulating equipment for lead-in is needed. Cost new \$30.00. Never used. First offer of \$12.50 takes them both. G. M. Best, 1460 Grand Ave., Piedmont, Calif.

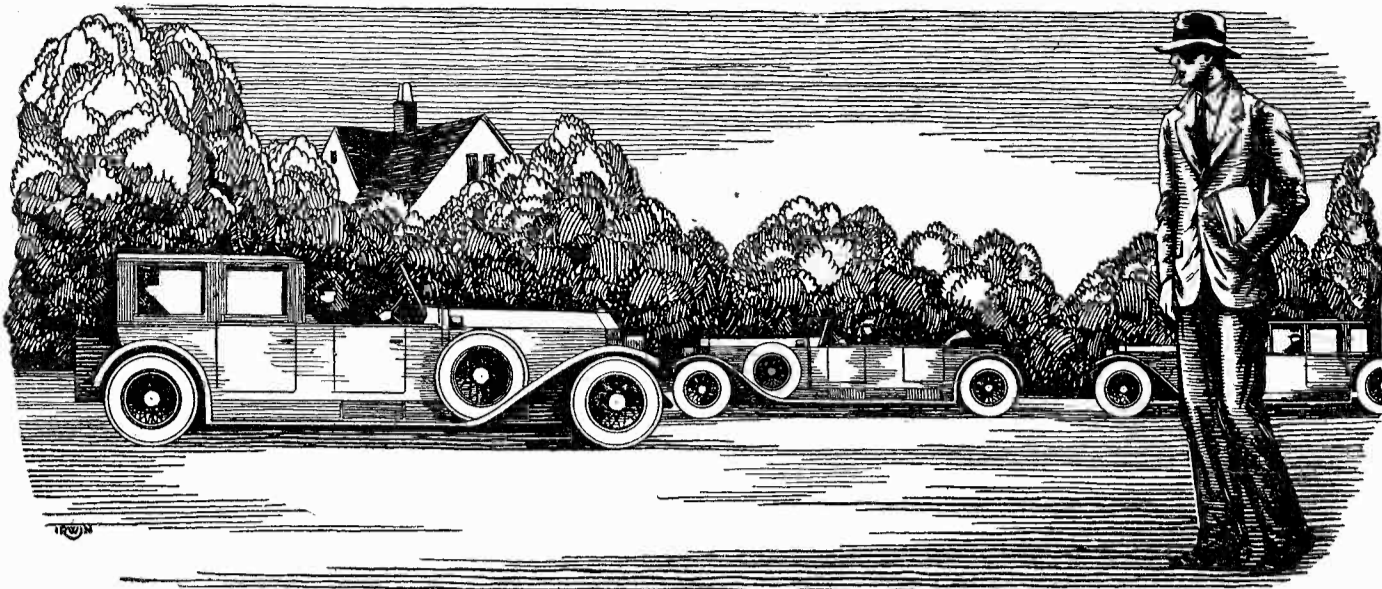

Many times in the old days, while I trudged home after work to save car-fare, I used to gaze enviously at the shining cars gliding by me, the prosperous men and women within. Little did I think that *INSIDE OF A YEAR*, I, too, should have my own car, a decent bank account, the good things of life that make it worth living.

I Thought Success Was For Others

*Believe It Or Not, Just Twelve Months Ago
I Was Next Thing To "Down-and-Out"*

TODAY I'm sole owner of the fastest-growing Radio store in town. And I'm on good terms with my banker, too—not like the old days only a year ago, when often I didn't have one dollar to knock against another in my pocket. My wife and I live in the snuggest little home you ever saw, right in one of the best neighborhoods. And to think that a year ago I used to dodge the landlady when she came to collect the rent for the little bedroom I called "home"!

It seems like a dream now, as I look back over the past twelve short months, and think how discouraged I was then, at the "end of a blind alley." I thought I never had had a good chance in my life, and I thought I never would have one. But it was waking up that I needed, and here's the story of how I got it.

I WAS a clerk, working at the usual miserable salary such jobs pay. Somehow I'd never found any way to get into a line where I could make good money.

Other fellows seemed to find opportunities. But—much as I wanted the good things that go with success and a decent income—all the really well-paid vacancies I ever heard of seemed to be out of my line, to call for some kind of knowledge I didn't have.

And I wanted to get married. A fine situation, wasn't it? Mary would have agreed to try it—but it wouldn't have been fair to her.

Mary had told me, "You can't get ahead where you are. Why don't you get into another line of work, somewhere that you can advance?"

"That's fine, Mary," I replied, "but *what* line? I've always got my eyes open for a better job, but I never seem to hear of a really good job that I can handle." Mary didn't seem to be satisfied with the answer but I didn't know what else to tell her.

It was on the way home that night that I stopped off in the neighborhood drug store, where I overheard a scrap of conversation about myself—a few burning words that were the cause of the turning point in my life!

With a hot flush of shame I turned and left the store, and walked rapidly home. So that was what my neighbors—the people who knew me best—really thought of me!

"Bargain counter sheik—look how that suit fits," one fellow had said in a low voice. "Bet

he hasn't got a dollar in those pockets." "Oh, it's just 'Useless' Anderson," said another. "He's got a wish-bone where his back-bone ought to be."

As I thought over the words in deep humiliation, a sudden thought made me catch my breath. Why had Mary been so dissatisfied with my answer that "I hadn't had a chance"? *Did Mary secretly think that too?* And after all, wasn't it *true* that I had a "wish-bone" where my back-bone ought to be? Was that why I never had a "chance" to get ahead? It was true, only too true—and it had taken this cruel blow to my self-esteem to make me see it.

With a new determination I thumbed the pages of a magazine on the table, searching for an advertisement that I'd seen many times but passed up without thinking, an advertisement telling of big opportunities for trained men to succeed in the great new Radio field. With the advertisement was a coupon offering a big free book full of information. I sent the coupon in, and in a few days received a handsome 64-page book, printed in two colors, telling all about the opportunities in the radio field and how a man can prepare quickly and easily at home to take advantage of these opportunities. I read the book carefully, and when I finished it I made my decision.

WHAT'S happened in the twelve months since that day, as I've already told you, seems almost like a dream to me now. For ten of those twelve months, *I've had a Radio business of my own!* At first, of course, I started it as a little proposition on the side, under the guidance of the National Radio Institute, the outfit that gave me my Radio training. It wasn't long before I was getting so much to do in the Radio line that I quit my measly little clerical job, and devoted my full time to my Radio business.

Since that time I've gone right on up, always under the watchful guidance of my friends at the National Radio Institute. They would have given me just as much help, too, if I had wanted to follow some other line of Radio besides building my own retail business—such as broadcasting, manufacturing, experimenting, sea operating, or any one of the score of lines they prepare you for. And to think that until that day I sent for their eye-opening book, I'd been wailing "I never had a chance!"

NOW I'm making real money. I drive a good-looking car of my own. Mary and I don't own the house in full yet, but I've made a substantial down payment, and I'm not straining myself any to meet the installments.

Here's a real tip. You may not be as bad-off as I was. But, think it over—are you satisfied? Are you making enough money, at work that you like? Would you sign a contract to stay where you are now for the next ten years, making the same money? If not, you'd better be *doing* something about it instead of drifting.

This new Radio game is a live-wire field of golden rewards. The work, in any of the 20 different lines of Radio, is fascinating, absorbing, well-paid. The National Radio Institute—oldest and largest Radio home-study school in the world—will train you inexpensively in your own home to know Radio from A to Z and to increase your earnings in the Radio field.

Take another tip—No matter what your plans are, no matter how much or how little you know about Radio—clip the coupon below and look their free book over. It is filled with interesting facts, figures, and photos, and the information it will give you is worth a few minutes of anybody's time. You will place yourself under no obligation—the book is free, and is gladly sent to anyone who wants to know about Radio. Just address J. E. Smith, President, National Radio Institute, Dept. FB-5, Washington, D. C.

**J. E. Smith, President,
National Radio Institute,
Dept. FB-5, Washington, D. C.**

Dear Mr. Smith:

Please send me your 64-page free book, printed in two colors, giving all information about the opportunities in Radio and how I can learn quickly and easily at home to take advantage of them. I understand this request places me under no obligation, and that no salesmen will call on me.

Name.....

Address.....

Town..... State.....

Tell them that you saw it in RADIO

Radio Reception

*depends primarily upon two things—
an efficient circuit and use of GOOD PARTS*

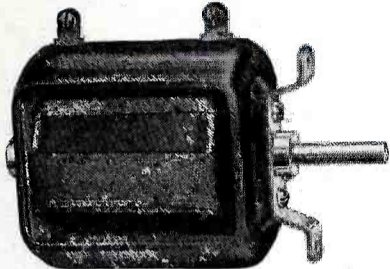

Type 269
Variometer
Price \$5.00

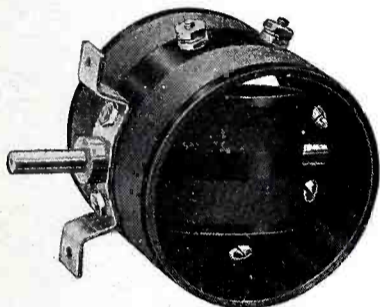

Type 268
Vario Coupler
Price \$2.75



Type 285
Audio Transformer
Price \$6.00

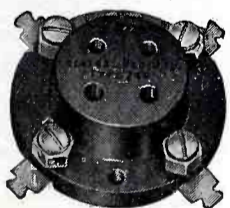

Type 349
UX-Tube Socket
Price 50c.

Always remember this fact in set-building—and remember that General Radio parts have long been recognized by radio editors, test laboratories, and experimenters as the universal standards of radio.

They have a laboratory background of over a decade.

The same outstanding craftsmanship and materials are embodied in General Radio parts for use in broadcast receivers as in General Radio apparatus used as precision standards in the leading radio and electrical laboratories of the world.

Whenever you find a popular circuit, you will invariably find General Radio parts—they are adapted to use in practically all of the better circuits.

Write for Catalog 926-R

GENERAL RADIO COMPANY
Cambridge, Mass.

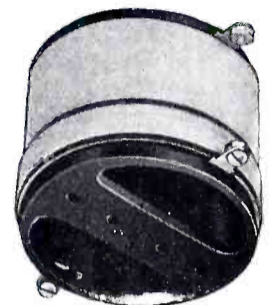

Type 277-D
Coupling Coil
Price \$1.50

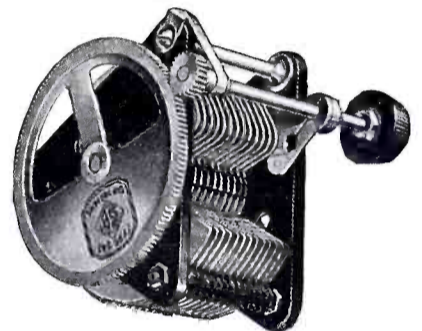

Type 247-H
Variable Condenser
Price \$5.00

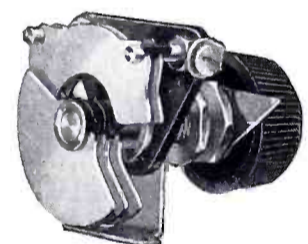

Type 368
Micro-Condenser
Price \$1.50



Type 410
Rheostat
Price \$1.25

GENERAL RADIO

PARTS and ACCESSORIES

The General Radio Company has endeavored to make it possible for the experimenter to obtain its products with minimum of effort. A careful selection of distributors and dealers has been made. They are best suited to serve you. If, however, you are unable to obtain our products in your particular locality, they will be delivered to you, postpaid, direct from the factory upon receipt of list price.

The Official BROWNING-DRAKE Kit Set

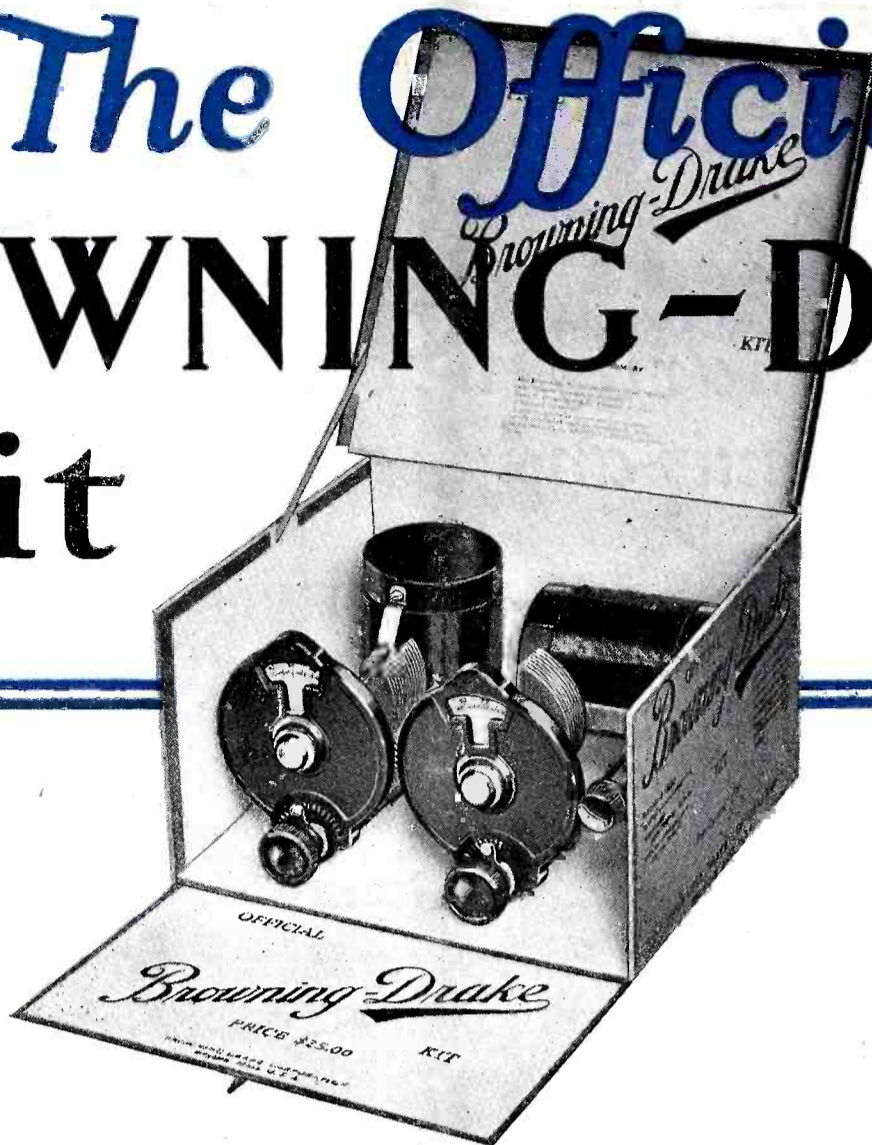

THE life of the average radio design offered to the home builder has been a few months. Rarely has a design endured over a year without undergoing radical changes. Browning - Drake's popularity has increased with every passing year, ever since its presentation in the summer of 1924. Three years have elapsed, yet no radical changes or improvements in the Browning - Drake design have been necessary to maintain its popularity.

This April, a standard design known as the Official Browning-Drake Kit Set, incorporating refinements to take care of present broadcasting conditions and make the set adaptable to power units and "B" eliminators, was presented to the radio public. This Official Kit Set is now standard on the market.

To obtain the rare Browning - Drake performance, be sure you get the Official Browning-Drake Kit, Foundation Unit, Neutralizer and Resistance Cartridge, products of the Browning-Drake Corporation, together with the approved parts of associate manufacturers, which are handled by reputable radio dealers. Get your parts TODAY and build the Official Browning-Drake Kit Set.

DEALERS: There should be at least one distributor in your territory handling complete receivers, as well as all the parts for the Official Kit Assembly. We will be glad to forward the name of our nearest jobber.

BROWNING-DRAKE CORPORATION
BRIGHTON :: MASS.

BROWNING-DRAKE RADIO

H. L. KRIEDT CO., SAN FRANCISCO, CALIF.