

JANUARY, 1924

25 CENTS

# RADIO

(Reg. U. S. Pat. Off.)



Armstrong Perry ❁ M. B. Sleeper ❁ Paul Oard ❁ D. B. McGown  
Don Lippincott ❁ K. H. Stark ❁ Earl Ennis ❁ Florian J. Fox



**CUNNINGHAM  
RADIO TUBES**

C-301A—5 Volts 1-4  
Ampere filament... \$6.50

C-200—3 Volts .06 amp.  
Dry Battery Det. &  
Amp. .... \$6.50

C-300—5 Volts Gas Con-  
tent Detector ... \$5.00

C-11—1.1 Volts .25 amp.  
Dry Battery Det. and  
Amp. Special Base \$6.50

C-12—Similar to C-11  
with standard base  
..... \$6.50

**PATENT  
NOTICE**

Cunningham tubes are  
covered by patents dated  
11-7-05, 1-15-07, 2-18-  
08, and others issued and  
pending. Licensed for  
amateur, experimental  
and entertainment use in  
radio communication.  
Any other use will be an  
infringement.

Type C-301A gives greater Power Amplifica-  
tion with only  $\frac{1}{4}$  Amp. Filament Current.

*Cunningham*

## RADIO TUBES

*For Every Make of Receiving Set*

**T**HROUGHOUT the entire country today  
Cunningham Radio Tubes are recognized  
as the ideal tube for use in all makes of Radio  
Receiving Sets.

The famous Cunningham C-301A Amplifier  
shown above is a high vacuum tube designed  
for use as an amplifier and detector containing  
a new Tungsten Filament, the characteristics  
of which are long life, low power consumption,  
low operating temperature and greater power  
amplification than any previous amplifier tube.  
This tube has a standard four prong base, and  
the glass bulb has the same dimensions as

C-300 and C-301. The filament current is only  
one-fourth of the filament current of the pre-  
vious type of Amplifier tube and it is, there-  
fore, possible to use four of these tubes in a set  
without exhausting the storage battery any  
faster than when using only one of the previous  
types of tubes.

The care and operation of each model of Re-  
ceiving Tube is fully explained in our new 40  
page "Radio Tube Data Book."  
Copies may be obtained by send-  
ing ten cents in stamps to our  
San Francisco office.

*A. J. Cunningham Inc.*



Home Office:  
182 Second Street  
San Francisco

154 West Lake Street  
Chicago

30 Church Street  
New York



# RADIO

Established 1917 as Pacific Radio News

Volume VI

for January, 1924

Number 1

## CONTENTS for JANUARY, 1924

Front Cover: The New Year Assumes New Pleasures.  
*Drawn by W. H. ANDREWS from idea of R. F. BROWNE*

Radiatorial Comment ..... 9

Radio Reception in the Grand Canyon, *By G. M. BUTLER*..... 10

Observations of Radio in Europe, *By ARMSTRONG PERRY*..... 11

How to Cut Out Local Broadcasters, *By DR. WILLIAM M. COLLINS*.. 13

Building Inverse Duplex Sets, *By M. B. SLEEPER*..... 15

New Instruments Make Code Learning Easy, *By B. F. STARES*..... 17

A Radio Circuit Testing Board, *By PAUL OARD*..... 18

Neutrodyne Circuit Radio Receivers,..... 19  
*By KIMBALL HOUGHTON STARK*

The "Q-Drawler", *By EARL ENNIS*..... 21

Practical Filter Design, *By DON LIPPINCOTT*..... 23

Panel Layout and Drilling, *By D. B. MCGOWN*..... 25

Comments on Audio-Frequency Transformers..... 26  
*By ORRIN E. DUNLAP, JR.*

Radio Condensers, *By L. H. LAMONTAGNE*..... 27

Construction of a High Voltage Transformer, *By FLORIAN J. FOX*... 29

A Break-In System, *By A. E. BANKS*..... 31

The Use of Taps, Drills and Machine Screws in Assembling Radio Apparatus, *By H. A. HIGHSTONE*..... 32

Static: Radio's Greatest Problem, *By JEROME SNYDER*..... 33

Queries and Replies, *By GERALD M. BEST*..... 35

News of the Radio Amateurs..... 38

Letters To The Editor..... 40

Hints on Radio, *By D. B. MCGOWN*..... 41

New Apparatus and Supplies from Radio Manufacturers..... 42

RADIO is Published Monthly by the Pacific Radio Publishing Co., Inc., Pacific Building, San Francisco, Calif.

ARTHUR H. HALLORAN	Editor
LAWRENCE MOTT	Associate Editor
GERALD M. BEST	Technical Adviser
H. W. DICKOW	Advertising Manager

Branch Offices: 17 West 42nd St., New York City; Telephone Longacre 8248; 157 E. Ontario St., Chicago; 761 Spitzer Bldg., Toledo, Ohio; 52 Irving Street, Boston, Telephone Copley 5107-R; 1102 Republic Bldg., Kansas City, Mo.; Suite 511, 456 So. Spring St., Los Angeles, Cal., Telephone 12050; 2218 Third W., Seattle, Wash., Telephone Elliot 1903.

European Representatives: Compagnie Universelle De Representation wt de Commerce. Rue des Fortifications, 69, Anvers, Belgium.

Advertising Forms Close on the First of the Month Preceding Date of Issue.

Issued Monthly, 25c a copy. Subscription price \$2.50 per year in the U. S., \$3.00 per year elsewhere. Instructions for change of address should be sent to the publisher two weeks before the date they are to go into effect. Both old and new addresses must always be given.

Entered as second-class matter at the Post Office at San Francisco, Calif., under the Act of March 3, 1879.

Copyright 1924, by the Pacific Radio Publishing Co., Inc.

### Forecast of Contributions for February Issue

Brooke Sawyer, in the course of a narrative of the British advance expedition to prepare for a world-circling airplane trip, gives the details of the four-electrode tube receiver used on the *Frontiersman*.

E. W. Kersten gives the details for the construction of a push-pull radio frequency amplifier in an article entitled "One Pushee, One Pullee, She Workee Like Hellee."

Chas. F. Filstead has devised an adjustable fixed condenser whose construction he describes for the benefit of those who wish to duplicate his success. The constructor will also be helped by Elgin B. Whigam's account of an efficient coil winder.

Jack Ward, 6CKC, tells how he has modified the Reinartz receiver so as to require but three controls.

Samuel G. McMeen describes a remarkable receiving set employing one stage r. f., crystal detector and one stage a.f. amplification.

Florian J. Fox continues his series on the C. W. transmitter with an article on the functions and construction of a filter.

E. H. Swanson has an interesting suggestion for equipping a radio set with window-dials.

"Clearing The Trans-Atlantic Shipping Lanes by Radio" is the subject of an interesting story by S. R. Winters. It carries with it some unusual pictures.

Chas. Bruere, Jr., has a long article on the construction of an efficient low wave regenerative tuner. Detailed directions are given for winding a variometer, variocoupler and grid coupler as well as for making the panel.

Paul Oard comes to the defense of the honeycomb coil in a well-written article showing its superiority for several purposes. He also gives some excellent radio construction pointers that are different from the usual.

"The Jinx of the Bobolink" is another Samuel Jones yarn from Volney G. Mathison. This gives a glimpse of life aboard a modern freighter while handling rather a serious mystery humorously.

In "Some Principles of Amplifier Tube Operation" Maurice Buchbinder explains the subject in terms that are unusually clear.

The vexing subject of interference is treated by two authors from different points of view. Jesse Marsten explains the action of side-bands in causing interference between broadcasting stations and Dr. A. E. Banks takes up all causes of interference and their elimination.

Form 1204

CLASS OF SERVICE	SYMBOL
Telegram	
Day Letter	Blue
Night Message	NIN
Night Letter	N L



# WESTERN UNION TELEGRAM

NEWCOMB CARLTON, PRESIDENT      GEORGE W. E. ATKINS, FIRST VICE-PRESIDENT

CLASS OF SERVICE	SYMBOL
Telegram	
Day Letter	Blue
Night Message	NIN
Night Letter	N L

If none of these three symbols appears after the check (number of words) this is a telegram. Otherwise its character is indicated by the symbol appearing after the check.

---

RECEIVED AT<sup>21</sup>NORTH WASHINGTON ST.  
JAMAICA, N. Y.  
IN CBU 50 NL

AVALON CALIF OCT 25-26 1923

DOUGLAS RIGNEY

A. H. GREBE & CO VANWYCK BLVD RICHMONDHILL L.I. NY

COPIED MACMILLIAN SHIP TWO HOURS LAST NIGHT ON THIRTEEN TOOK  
MANY MESSAGES AND PRESS REPORTS THEY ARE ELEVEN DEGREES FROM  
POLE ALL WELL HEAVY SNOW TEMPERATURE BELOW ZERO SAW SUN  
FOR LAST TIME YESTERDAY EASILY WORK HIM ON YOUR SPLENDID  
RECEIVER AM FIRST AMERICAN PACIFIC COAST STATION TO HEAR HIM

MAJOR LAWRENCE MOTT

81GA



*"The coming of a friend from a far-off land—is this not true joy?" —Confucius.*

*Talking with a friend in a far-off land is also true delight when one uses a Grebe "13."*

*Doctor Wu*



## Copying the "Bowdoin" with the Grebe "13"

Major Lawrence Mott, 6XAD—6ZW, Avalon, Cal., needs no introduction to the amateur fraternity.

We congratulate Major Mott upon his success in copying the "Bowdoin" for two hours. That his should be the first U. S. Pacific Coast Station to hear the MacMillan ship for so long a period is fitting testimony of the Major's ability as an operator and of the excellence of his equipment.

We are pleased to learn that the Grebe "13" was the Receiver used by Major Mott.

Write us.

**A. H. GREBE & CO., Inc.**  
79 Van Wyck Blvd., Richmond Hill, N. Y.  
Western Branch: 451 East 3rd Street, Los Angeles, Cal.



Licensed under Armstrong  
U. S. Pat. No. 1,113,149

Tell them that you saw it in RADIO

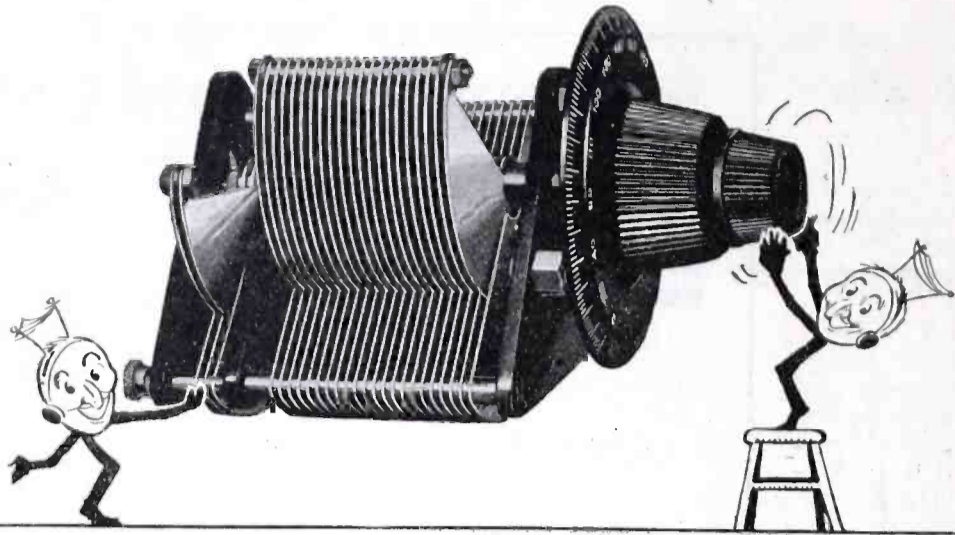

## "Some Condenser" says the "Radio Bug"

Makes your receiving set respond to every broadcasting station operating. The size of the Kellogg Condenser and dial gives easy, accurate tuning. The vernier makes unusually sharp tuning a simple matter.

The end plates are of the best radio insulation in use today—Bakelite. The Kellogg accurately built dial is also of Bakelite, which retains its handsome appearance indefinitely. Its heavy reinforced construction and beauty of design add to the appearance of any set.

The rotor plates are properly spaced and bolted together, making it impossible for them to make contact with the stator plates.

Large bearing surfaces assure smooth, even rotation of the rotor plates and reduce wear to a minimum.

The high class workmanship, with the fine materials used in Kellogg Variable Condensers place them in a class by themselves.

The relations of the capacities is such that as great a flexibility as desired in any set may be maintained by the use of the various models.

The resistance to alternating currents at the average wave length is low thus assuring full use of all current intercepted by the antenna.

The Kellogg variable condenser is a precision instrument built in size, proportion and ratio for use as a decimeter or wave meter, as well as for control of capacity in the radio broadcasting and receiving sets. This makes it of far greater value to the amateur as well as the laboratory expert.

*Kellogg Variable Condensers are made in the following styles:*

Code No.	Zero Cap.	Max. Cap.	Ratio	Price
601-11 plate Vernier	.000120	.000262	2.1:1	
with vernier All Plates	.000120	.000600	5 :1	\$6.75
602-11 plate	.000045	.000396	2.8:1	4.50
603-23 plate Vernier	.000071	.000210	3 :1	
with vernier All Plates	.000071	.000990	14 :1	7.75
604-23 plate	.000071	.000885	12.6:1	5.50
605-43 plate Vernier	.000102	.000250	2.4:1	
with vernier All Plates	.000102	.001800	17.6:1	8.75
606-43 plate	.000082	.001690	20.7:1	6.50



Have your dealer furnish you with Kellogg radio equipment and know you have the best.

*All Kellogg Radio Parts are manufactured and guaranteed by*

**Kellogg Switchboard & Supply Company**  
CHICAGO, ILLINOIS

COLUMBUS, OHIO KANSAS CITY, MO. SAN FRANCISCO, CAL. PORTLAND, ORE.

*Kellogg Apparatus exclusively is used in building the Symphony Receiver*

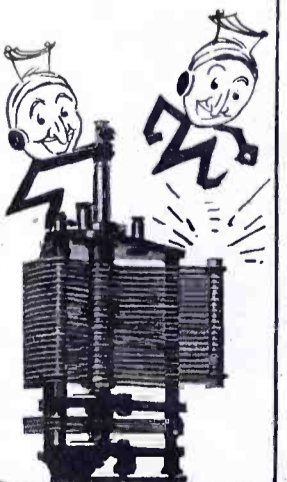
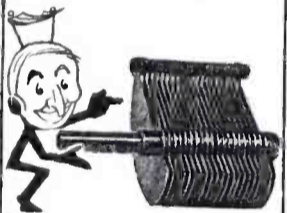
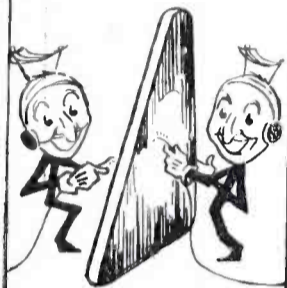

Tell them that you saw it in RADIO

*In an easy chair  
at home MAGNAVOX  
gives you the melody  
of concert and opera*

---

**MAGNAVOX**  
*Radio  
Reproducers and Amplifiers*

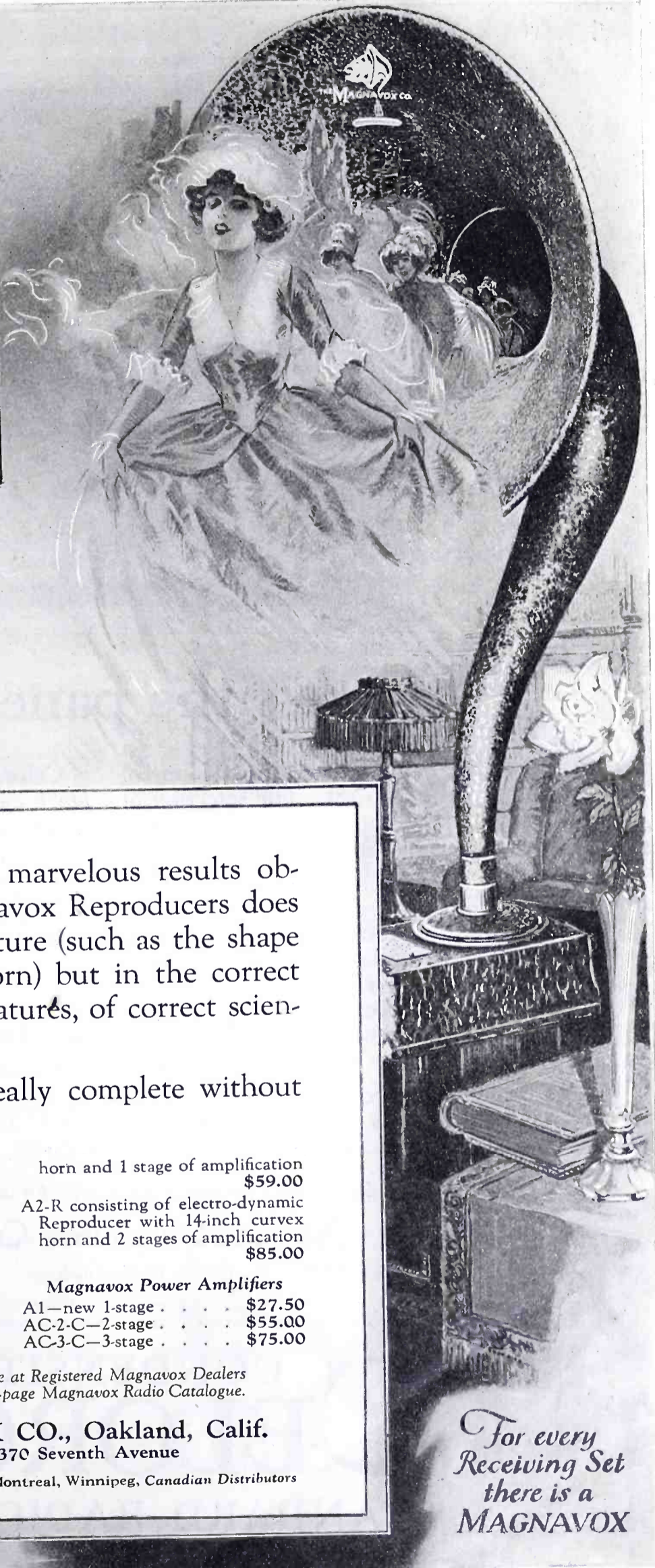

THE secret of the marvelous results obtained with Magnavox Reproducers does not lie in any one feature (such as the shape or material of the horn) but in the correct working out, in all features, of correct scientific principles.

No receiving set is really complete without Magnavox.

**Magnavox Reproducers**

- R2 with 18-inch curvex horn \$60.00
- R3 with 14-inch curvex horn \$35.00
- M1 with 14-inch curvex horn.  
Requires no battery for the field. \$35.00

- horn and 1 stage of amplification \$59.00
- A2-R consisting of electro-dynamic Reproducer with 14-inch curvex horn and 2 stages of amplification \$85.00

**Magnavox Combination Sets**

- A1-R consisting of electro-dynamic Reproducer with 14-inch curvex

**Magnavox Power Amplifiers**

- A1—new 1-stage . . . . \$27.50
- AC-2-C—2-stage . . . . \$55.00
- AC-3-C—3-stage . . . . \$75.00

Magnavox Products are for sale at Registered Magnavox Dealers everywhere. Write for new 32-page Magnavox Radio Catalogue.

**THE MAGNAVOX CO., Oakland, Calif.**  
New York Office: 370 Seventh Avenue

Perkins Electric Limited, Toronto, Montreal, Winnipeg, Canadian Distributors

1R

*For every  
Receiving Set  
there is a  
MAGNAVOX*

Tell them that you saw it in RADIO



## “Here’s the panel I want”

THE panel is the “front door” of your radio set. The selection of the panel is an important step. You want a good-looking panel. And you want a panel that has high dielectric strength.

Your Celoron panel comes wrapped in a dust-proof glassine envelope. Dust and grit cannot scratch it. Human hands cannot leave greasy fingerprints on it.

Because of its high dielectric strength, Celoron, a bakelite product, is approved by the U. S. Navy and the U. S. Signal Corps.

Celoron radio panels are finished in *black, oak and mahogany*. They come ready to use in these standard sizes:

1—6 x 7 x $\frac{1}{8}$	5—7 x 18 x $\frac{3}{16}$
2—7 x 9 x $\frac{1}{8}$	6—7 x 21 x $\frac{3}{16}$
3—7 x 12 x $\frac{1}{8}$	7—7 x 24 x $\frac{3}{16}$
4—7 x 14 x $\frac{3}{16}$	8—12 x 18 x $\frac{3}{16}$
	9—7 x 26 x $\frac{3}{16}$

Other sizes are cut to order from sheet Celoron. *Ask your dealer.*

An interesting booklet for the radio set builder is “*Getting the Right Hook-Up.*” This booklet is sent *free* upon request.

*To radio dealers: Send for special dealer price list showing standard assortments*

### Diamond State Fibre Company

BRIDGEPORT (Near Philadelphia) PENNSYLVANIA

Offices in Principal Cities

In Canada: Diamond State Fibre Company of Canada, Limited, 245 Carlaw Ave., Toronto

# CONDENSITE CELORON STANDARD RADIO PANEL

Tell them that you saw it in RADIO



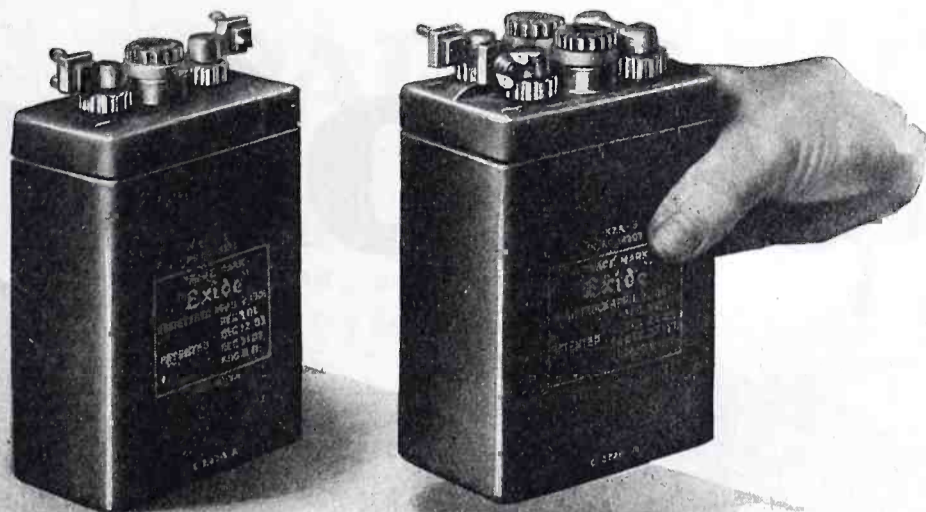

## What you have been waiting for

**H**ERE are two rugged little storage batteries designed particularly for low-voltage tubes.

Although they weigh only 5 and 6 pounds, they are of true Exide quality. Highly efficient and with ample power for long-distance receiving, these batteries will give you a type of service that you would find it hard to duplicate.

These sturdy little batteries are neat and compact. They were specially designed for WD-11 and UV-199 vacuum tubes, but can be used with any low-voltage tube. The two-volt Exide A Battery consists of a single cell. It will heat the filament of a WD-11 or other quarter-ampere tube for approximately 96 hours. The four-volt A battery, having two cells, will light the filament of a UV-199 tube for 200 hours.

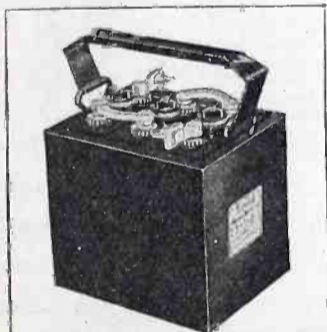

**For six-volt tubes**  
Like all Exide Storage Batteries, the Exide A Battery for six-volt tubes is dependable and long-lasting. It is made in four sizes, of 25, 50, 100, and 150 ampere hour capacities.

### *Service you will appreciate*

Exide Radio Batteries are carefully constructed on sound engineering principles. They give the kind of service every radio fan would like to get from his storage battery.

As you know, any variation of current in the plate circuit produces weird sounds in your phones.

With an Exide B Battery hooked up to your set, static is the only undesirable sound you will have to contend with. The Exide B Battery supplies steady, noiseless current. It permits the

niceties of adjustment that make radio receiving an unalloyed pleasure.

The Exide A Battery for six-volt tubes has extra-heavy plates, assuring constant potential and uniform current over a long period of discharge. Like all Exide Batteries, it embodies the finest materials available.

### *In marine and commercial wireless*

On sea and on land the Exide plays an important role in the industrial life of the nation. In marine wireless, Exide Batteries provide an indispensable store of emergency current. A majority of all government and commercial wireless plants are equipped with Exides.

Exide Radio Batteries are sold by radio dealers and Exide Service Stations everywhere. Ask your dealer for booklets describing in detail the complete line of Exide Radio Batteries. Or write direct to us.

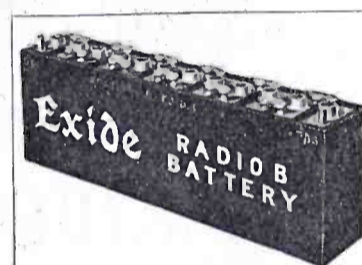

**Exide B Batteries**  
give noiseless, full-powered service over a long period of discharge. Designed throughout to prevent electrical leakage. Capacity, 3 ampere hours.

# Exide

## RADIO BATTERIES

THE ELECTRIC STORAGE BATTERY COMPANY, PHILADELPHIA

*Oldest and largest manufacturers in the world of storage batteries for every purpose*

Service Stations Everywhere

Branches in Seventeen Cities

Tell them that you saw it in RADIO

# Radiotron

REG. U. S. PAT. OFF.

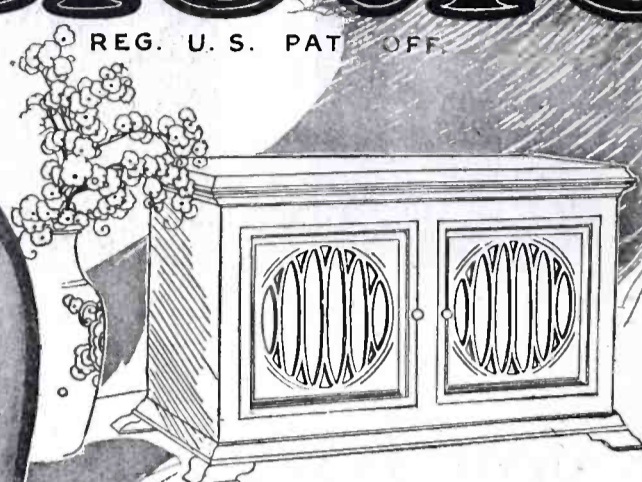

Radiola IV

In high quality receiving sets, the vacuum tubes — the heart of their fine performance — bear the name Radiotron and the RCA mark. Be sure to look for this identification when you replace your tubes.



This symbol of quality is your protection



Radiola Grand

- Radiotron WD-11
- Radiotron WD-12
- Radiotron UV-199
- Radiotron UV-200
- Radiotron UV-201-A

Send for the free booklet that describes all Radiotrons and Radiolas.

Radio Corporation of America

Sales Offices:

233 Broadway, New York 10 So. La Salle St., Chicago, Ill. 433 California St., San Francisco, Cal.

RADIO CORPORATION OF AMERICA  
Dept. 51 (Address office nearest you.)  
Please send me your free Radio Booklet.

Name \_\_\_\_\_

Street Address \_\_\_\_\_

City \_\_\_\_\_ R.F.D. \_\_\_\_\_

State \_\_\_\_\_

# Radiola

REG. U. S. PAT. OFF.

Tell them that you saw it in RADIO

January  
1924

# RADIO

Established 1917

Trademark Registered U. S. Patent Office

Volume 6  
No. 1

## Radiotorial Comment

**W**ITH this issue, RADIO celebrates its seventh birthday. The first number was published in January, 1917, as *Pacific Radio News*. It has been published continuously since then, except during the war period, when the staff was in the service and a governmental ban was placed on all amateur radio activities. But just as radio itself is fettered by no barriers of locality so likewise it seemed wise in November, 1921, to eliminate the limitation of *Pacific* in the name of the magazine and it was changed to RADIO. This change was coincident with a broadening of editorial policy to give a world-wide service.

Since then the magazine has grown as popular interest in radio has increased, until now the magazine has "grown up." Although far from feeling a self-satisfied sufficiency, RADIO can walk alone, like the cat in one of Kipling's most fascinating yet whimsical stories.

A magazine, unlike a child, can serve others from the hour of its birth. And so for seven years the mission of this magazine has been service to the reader, an effort to anticipate the reader's needs. This work has been done quietly and conservatively, without "sounding brass or tinkling cymbals," notwithstanding the fact that every mail brings its letters of appreciation and praise. None of these are being published because they would crowd out material that we believe is of greater interest to the reader. Yet we are deeply appreciative of them because they indicate what the readers prefer, and we take this opportunity to thank the writers.

RADIO has great things in store for its readers during 1924. Many of the best informed radio men in the country will be regular contributors. While practical articles will continue to predominate, an effort will be made to present simplified explanations of radio theory so that every reader may fully understand the "why" of all the equipment he uses. Its constant aim will be to help you, the reader.

And so may we be permitted to wish you a Happy Radio New Year, and, also, ourselves many more birthdays.

**I**T was a disappointment to all interested in the betterment of radio to note that President Coolidge's message to Congress did not urge the necessity for new legislation to replace the obsolete radio regulations of 1912. An angle of lag is to be expected in the phase relations between the progress of any art and the law under which it is regulated, but when the law lags twelve years behind the advancement of an art that is going ahead as fast as radio, chaos results.

Great hopes were held that the much-needed relief would be afforded by the White-Kellogg bill. But when this bill failed to pass the last Congress these hopes were dashed to the ground. The problems to which its remedial action was to be applied have become even more serious during the past

year with the tremendous increase in the popularity of radio in spite of the fact that the revised rulings of the Department of Commerce have given some relief.

To bring this matter emphatically to the attention of the present Congress becomes the duty and responsibility of each person interested in radio. If you are a member of a radio club have your club adopt a set of resolutions such as those adopted by the San Diego Radio Club and printed elsewhere in these columns. If you are not a club member you can write to your congressman as an individual and urge upon him your interest in seeing proper legislation.

A substitute for the White-Kellogg bill will undoubtedly be introduced in this session. But in view of the political complexion of the body there is danger that it will fail to pass unless great pressure is brought to bear. It is up to the radio public to apply this pressure.

**T**HE administration and control of all branches of radio communication, except certain governmental departments, is vested in the Bureau of Navigation of the Department of Commerce. The actual work is done by the supervisors and inspectors in nine radio districts throughout the country. The number of these men has not been increased in anything like the increase in radio communication and consequently they are unable to exercise the watchfulness necessary to minimize interference. There are not enough radio police to keep the traffic moving smoothly.

Even if the Bureau were authorized to employ an adequate force of inspectors, the conditions of the service are not sufficient to attract the high type of men necessary for this duty. Men possessing the requisite qualifications are in demand for private service and it is little more than a sense of loyalty that prevents those now in the public service from leaving it.

This situation has been intensified by the recent action of the Personnel Reclassification Board at Washington in rating radio supervisors and inspectors as "sub-professional." When it is realized that these men are called upon to inspect and approve the work of radio and electrical engineers who are rightly graded as "professional" it is manifest that they must have professional qualifications of the highest degree if the radio service is to be maintained at the desired high standard.

The personnel of radio inspection should not be allowed to deteriorate. Prospective applicants for employment in this service should be encouraged. This can be accomplished only if the positions carry with them the standing and remuneration commensurate with the professional grade. Consequently a resolution embodying these facts and addressed to the Personnel Reclassification Board and to the Secretary of Commerce is very much in order.

# Radio Reception in the Grand Canyon

By G. M. Butler

*How radio kept the Grand Canyon exploring party in touch with world affairs is almost on a par with the service of radio in keeping in touch with the MacMillan expedition to the Arctic. While experiments on transmission from these depths would have been even more interesting, the fact that reception is practical is noteworthy.*

CALIFORNIA broadcasting stations were of considerable assistance in making the recent Grand Canyon expedition of the United States Geological Survey a success, for, in spite of adverse prophecies, some of them widely circulated in print, that a radio set could receive nothing in the depths of the canyon, broadcasting was heard from Los Angeles, San Francisco, Phoenix, Ariz., Salt Lake City, and on one occasion from Colorado Springs.

Here was an expedition made up solely for surveying the wild reaches of the Colorado, often tossed about like egg shells in the roughest waters of that mighty chasm—sometimes facing death when thrown out of their boats by the seething rapids or forced to flee to the highlands when the river suddenly rose 21 feet overnight and at other times groping about in the canyon a mile below the rim where the sun's rays did not penetrate until noon—and yet, in spite of it all, the current events of the world were within their grasp through the invisible radio waves.

The party left Lees Ferry on August 1 and camped that night at the head of Badget Creek rapids, 7½ miles below. Here the radio set was put into use for the first time and, although the canyon at this point is narrow and nearly a



Marble Canyon

thousand feet deep, KHJ at Los Angeles was heard plainly.

The next day the party reached Soap Creek rapids—11 miles below Lees Ferry, and here they learned of the death of President Harding, three-quarters of an hour after it occurred—

perhaps sooner than most of the people of the United States—because station KHJ at Los Angeles had broadcasted the message. Before the expedition started, arrangements had been made with KHJ and KZN (The Desert News, Salt Lake City, Utah) for broadcasting half an hour's program each day for the benefit of the explorers.

Ten days later found the party at Nankoweap Creek, and you may be sure they were glad to find there a small stream of clear water suitable for drinking and bathing—a decided relief from the ever-muddy Colorado. That night the campers at the mouth of Kwagunt Creek, 3000 feet below the rim of the canyon, heard and enjoyed the items of the daily news, baseball scores, as well as the musical program from KHJ.

It is not at all surprising that an accident should occur to the radio outfit because of the rough treatment given it while in transit in shooting the numerous rapids of the river, and for a number of days the receiving set was out of commission. On the evening of September 8, at the mouth of Tapeats Creek, it was once more in commission and KHJ came in clear, although the campers were nearly a mile below the canyon's rim. That night they heard that a seri-

*Continued on page 76*

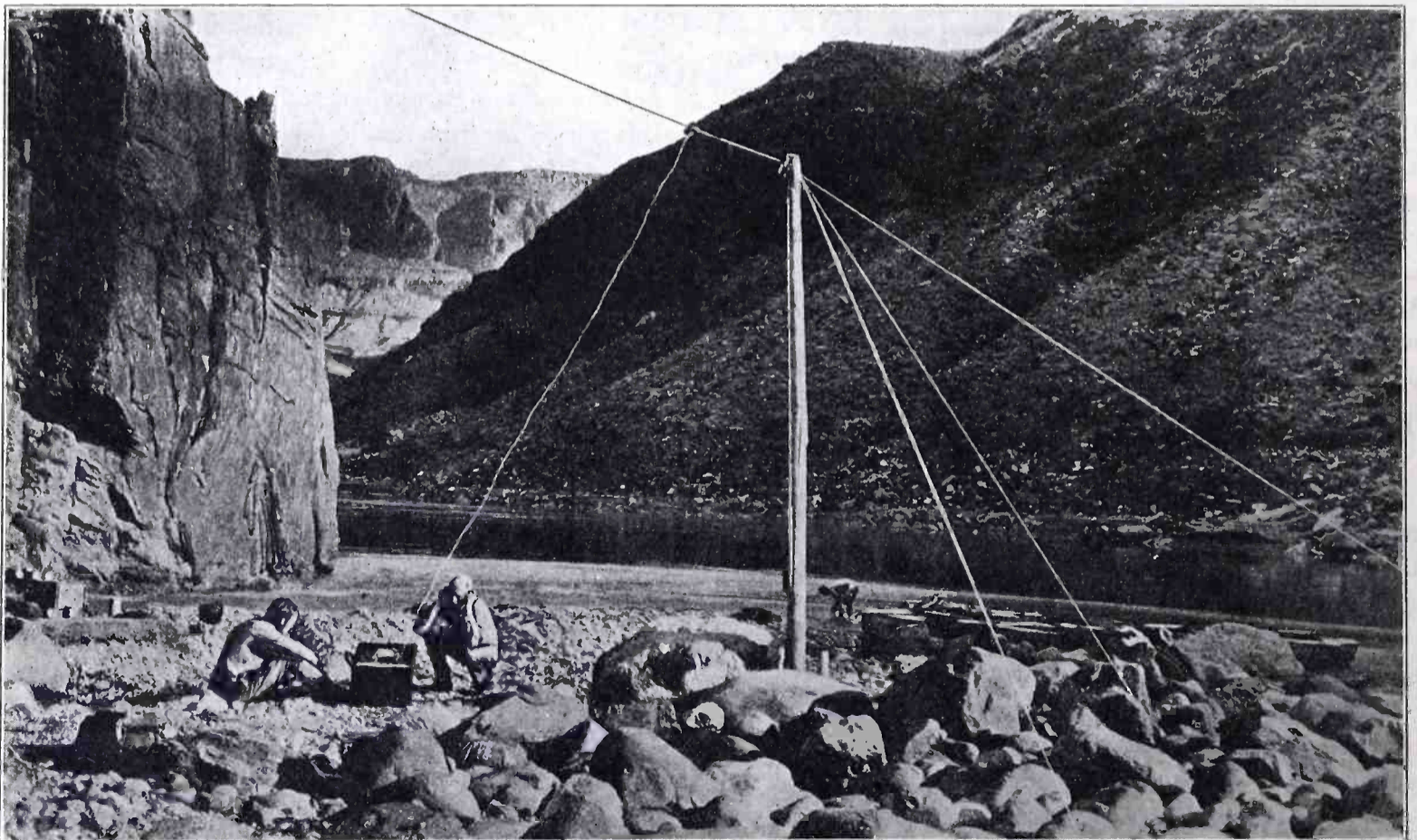

Radio Reception in the Depths of the Grand Canyon

# Observations of Radio in Europe

By Armstrong Perry

*'Tis always interesting to learn of what other countries are doing with radio. This comprehensive article not only gives this information but also other valuable facts about conditions overseas.*

NO one can visit Europe with his eyes open and escape the fact that radio apparatus is being sold there in large quantities and that the quantities may increase very rapidly and to enormous figures. The first thing that impresses the radio fiend bound for Europe is the sinful waste of a large opportunity by the companies that operate supposedly first-class steamships. Many improvements relating to safety have appeared since the days when a very comfortable stateroom could be had at \$42.00 per berth, but there is little more radio service for the passenger since the cost of a ticket has increased to a minimum of \$135.00. An officer will tell you on inquiry that the ship now keeps in touch with both sides of the Atlantic all the way across, but the "press" they give to passengers is little if any more ample than I used to set up in the print shop of the old *Ivernia* fifteen years ago. After copying press night after night for the past several years it peevs me to pay sixpence for eight pages of "boiler plate" and ads. with less press than I can pick up from NAA in thirty minutes. There is no adequate reason why any Atlantic steamship company should not give its passengers the full service from Italy, France, England, Germany and the United States.

If the steamship companies are too indifferent to provide the service, then the operators ought to have gumption enough to suggest it and put it across. They could make money with it, for themselves, the company, or both, make a name for their ships, and save themselves from having so much spare time to kick about the way wages are being cut to nothing. Most of the passengers have nothing to do but eat, sleep and buy

copies of ship's newspapers. They buy half a dozen editions a day of the papers ashore and would do as well at sea, especially if they received racing results, baseball scores, stock market reports and other things that help them to spend still more money.

And then there are the amusement broadcasts. Here and there a ship on which somebody is awake besides the quartermaster at the wheel may have a short wave receiver for the entertainment of the passengers, but they are almost as scarce as sea serpents. If there is any place where the romance of radio is stronger than elsewhere, it is on ship-board. It is not strong enough to induce many passengers to send radio greetings a hundred miles to shore for 21 cents a word, when they can wait till they land three thousand miles away and send the message all the way back for ten cents a word, but they would be willing to contribute two bits or more for the privilege of enjoying their accustomed radio concerts and bragging afterwards to their home folks about it. The British Marconi Company, at its last ordinary general meeting, was told by its managing director that the matter of broadcasting on board ship, and radio telephony between ships and shore, was having the close attention of the various governments concerned, its associated companies and itself. As the company paid 12½% in dividends this year, it would appear to be in a position to extend its service.

In Paris, where it is said good Americans go when they die, and where some other kinds are seen that should have waited until then, radio is going strong. There are many shop windows full of apparatus and everybody seems to know

about the radio concerts. A favorite type of receiver that is shown has a coil aerial rigidly mounted on top of the cabinet. There are radio publications on the news stands.

BETWEEN Dover and London I saw more aerials than I have ever seen in America within an equal distance. England has, as British experts told me, tried to avoid the errors made in America in developing broadcasting and has fallen into others. One incident that occurred while I was in London illustrates the present situation. A man got a receiver on credit. It did not bear the stamp of the British Broadcasting Company and therefore could not be used legally, for this company, assisted by the post office department, has set up a monopoly on radio entertainment so that the listeners-in can be compelled to pay for it. The purchaser, wishing to comply with the law, applied for an experimental license, the only kind available. On application he was required to state the purpose for which he wished to use the apparatus. He replied, quite truthfully, that he purchased it to entertain his wife. The authorities did not consider this a scientific purpose and he agreed with them. He sought to return the apparatus instead of paying for it and the dealer sued him. The fight was still on when I left.

I learned that a considerable propor-



Shooting One of the Many Rapids in the Canyon



Aerial at Diamond Creek, 3000 Ft. Below the Rim

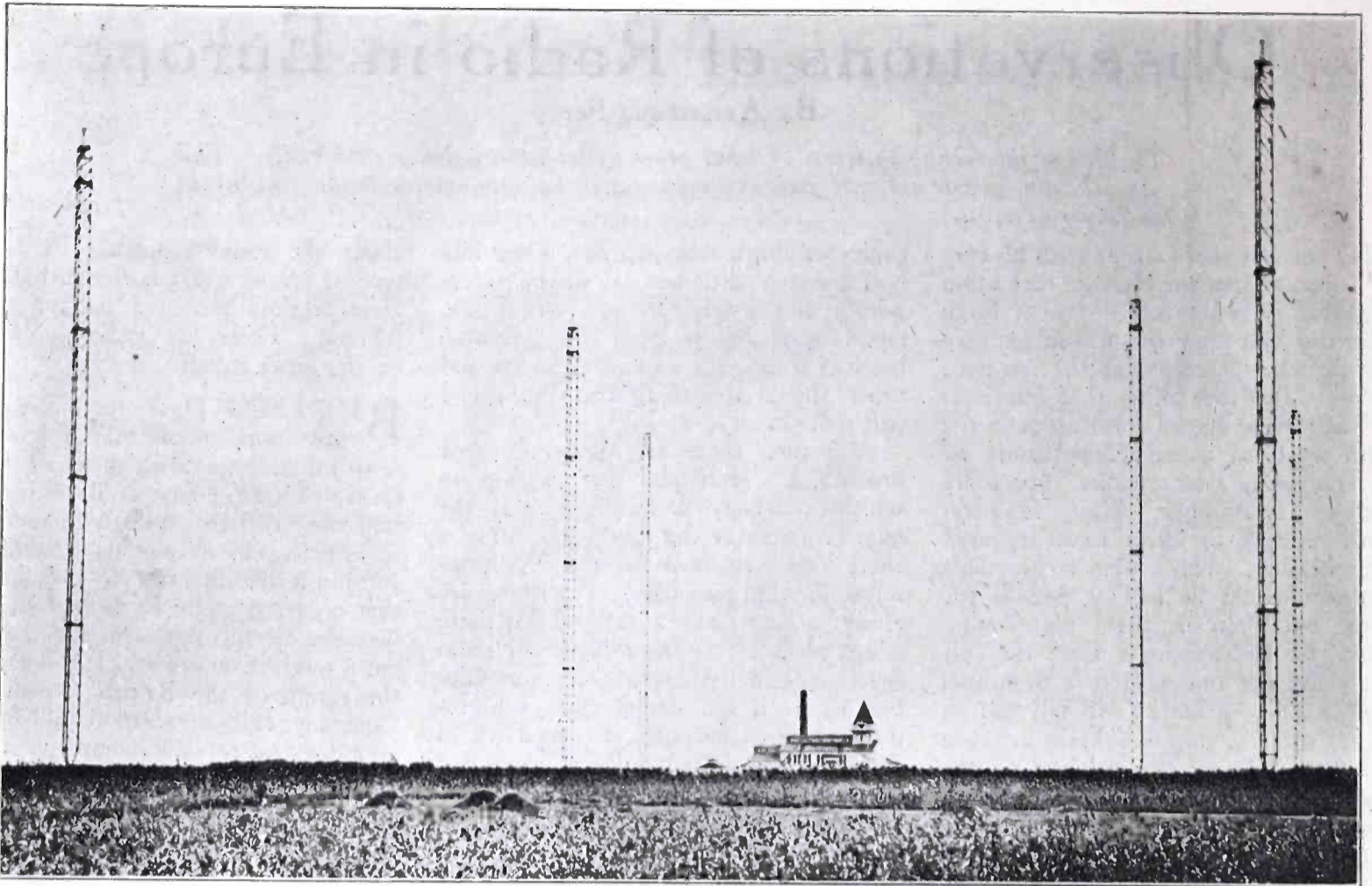

*Mitsui & Company's Station XYZ-SKY at Pekin, China, equipped with six towers and a 400-kw. Alexanderson alternator driven by a steam turbine.*

tion of the listeners-in were ignoring the Broadcasting Company's regulations and the license requirements, making their own sets or buying what they wanted, and listening-in when and as they pleased, the same as we do. The monopoly gives them the advantage of being able to get one concert at a time, while we are lucky if we can cut down the number heard simultaneously to three or four. With only half a dozen broadcasting stations working in the British Isles, they are beginning to worry about interference. Instead of increasing the number of programs by having a separate one for each station established, the B.B.C. will have stations that pick up the London broadcasts and relay them on a different wavelength, provided experiments now being made at Sheffield are successful.

Holland is full of radio, and is near enough to England and France to hear them with tube sets, or valve sets as they call them in Europe. Switzerland listens-in on Eiffel Tower and other foreign stations, but may have one of her own soon. Belgium has progressed so far as to have a wide-awake radio magazine, published in Brussels. Strange to say, there was no radio apparatus to be found at the International Exhibition of Mechanical and Electrical Industries in Ghent in June except a few electron tubes.

**B**UT it is in Central Europe that a virgin opportunity is waiting to be grabbed by some radio sheik. Many of the folks in Austria are still so near

broke as a result of the war that they are not in the market for anything that costs much money. The traveler sees few of the citizens on the railroads unless he travels third-class. They carry their earthly possessions in rucksacks on their backs, which is a much more sensible custom than toting heavy weights in the hands, but always reminds Americans of peddlers. The rucksack usually contains a hunk of black bread and a morsel of cheese or sausage, for that saves restaurant and dining car charges. Nevertheless there are many well-to-do Austrians and all classes are interested in radio. The installation of a local broadcasting station in any city would immediately create a demand for receivers. Since a well-educated person speaking several languages can be employed to do office work for 1,500,000 crowns a month, about \$22.50 in American money; a good apartment rented for seventy-five cents a month; and tuition secured for six months at the leading technical school for \$2.00, the radio receiver will have to be offered at a reasonable price, but the Austrian loves music so much that he would save on anything else in order to buy anything that would bring him concerts in his home. They would have to be good concerts, for Austria knows music.

Several of the intellectuals in Vienna told me that the Marconi Company had bought the government station at Laarburg, near that city, and would start a program of broadcasting. I asked a Marconi man at the London head-

quarters how the rumor started and he said it must have been started by someone who thought he had something to gain by starting such a rumor. The company had bought the station, he said, but it was understood to be in poor condition and furthermore the present laws of the country prevented the use of radio for popular broadcasting. What might develop in the future he was not in a position to say. I discovered that there had been some broadcasting by amateurs and some listening-in, but, being illegal, it has been kept under cover. At a time when a little American money will buy so much more over there, and when the feeling toward America is so very cordial, it seems probable that someone could influence the government to permit broadcasting. During the general unrest it would be well to give the masses something interesting to think about besides the next war. Or, if another war continues to be considered as necessary, the government no doubt would see the opportunity of sandwiching propaganda between Strauss waltzes in the radio program.

**O**VER the eastern frontier in the Czechoslovakian Republic interest in radio is developing also. In spite of the fact that this new country is composed of races that hate each other most cordially, the nation as a whole is one of the most promising in that part of the world. It has had the courage to stabilize its currency in spite of the disadvantages involved in competing with

*Continued on page 78*

# How to Cut Out Local Broadcasters

By Dr. William M. Collins

*This discussion of wave traps is written by a broadcast listener for the benefit of the B.C.L. It presents the details of a loose-coupled trap that is truly effective in cutting out a nearby powerful station so as to receive distant stations.*

THIS article is for those who live under the sunshine of a large broadcasting station. Those who live a dozen miles or so away can laugh at our troubles. My 200-ft. aerial is two miles from one of the best broadcasting stations in the world, KPO (Hale Bros., Inc., S. F.), so when our friends call we usually have some perfect music to enjoy without interruption from code and static. However, on other occasions I am reminded of a picture in the office of Mr. Oliver Morosco showing a level, fertile plain with a fence in the

in series from the aerial to the antenna post on the set when it is called a series trap (see Fig. 1), or a parallel trap when connected to antenna and ground posts on set (Fig. 2).

However, let us try the old series trap and see what happens, because if we understand how this works we will be in a position to correct its faults. First, we will close switch 1 (Fig. 1), which shorts the trap out of active circuit, and tune KPO on the set. Then open the switch, thus causing the incoming waves to pass through our trap. Now, by

quency choke coil which offers a high resistance or impedance to the wavelengths to which it is tuned, and not much resistance to others 40 meters or so away. Furthermore, it is a practical choke only for C. W. The great objection is that it tunes so broad that in choking out KPO at 423 meters it also chokes out KHJ at 395, but not KFI which is farther away in wavelength.

There are several ways of sharpening the tuning or choking effect. One is by lessening the resistance in the circuit, and another by loose coupling. Either system accomplishes the result and enables me to tune out, or literally choke out, KPO on only two degrees on a condenser and let KHJ through in full volume for a loud speaker. Kansas City at 411 meters, only 12 meters away, comes through with no interference from KPO. On last Hallow'een we heard the entire program of WTAM (Willard Storage Battery, Cleveland, O.) on the loud speaker, operating on 390 meters from 7 to 9:57 P.M. while KHJ was  $\frac{1}{2}$  degree above on the secondary condenser and no sound from "Uncle John" or KPO even during the intermissions. Using a 200-ft. aerial and standard 3-circuit receiver with 2-step audio, the music sounded better three rooms away because the doors acted as sound filters and drained off much of the static. Personally, for all stations beyond 1000 miles, I prefer only the detector and head phones as the code and static is amplified seemingly on the loud speaker out of proportion to the signal, excepting on unusually good nights.

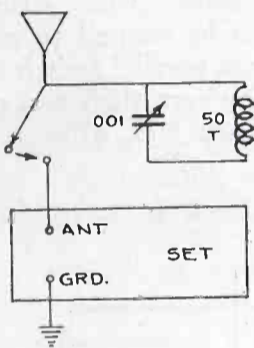

Fig. 1. Series Trap

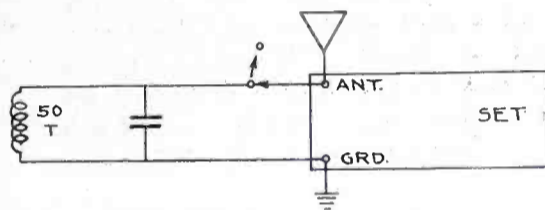

Fig. 2. Parallel Trap

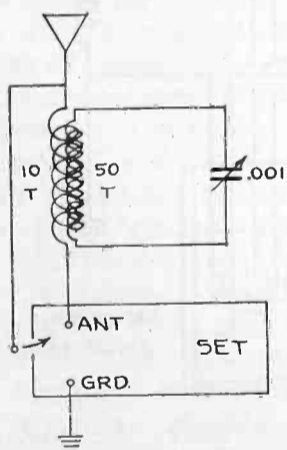

Fig. 3. Series Loose-Coupled Trap

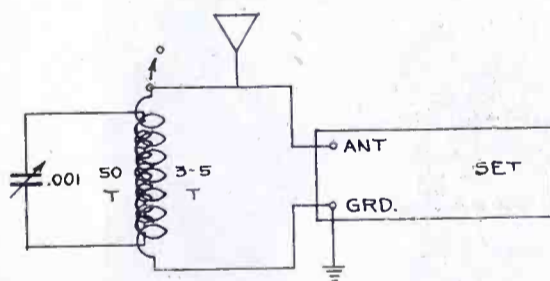

Fig. 4. Parallel Loose-Coupled Trap

middle and two donkeys—one on each side of the fence—each donkey with his head strained through the barbed wires and laboriously reaching for grass on the other side, neither satisfied with what he could reach.

The principal objective is to cut out KPO—423 meters—and bring in KHJ—395M—from a distance of about 350 miles, using an ordinary single circuit or 3-circuit receiver. By using a shorter aerial (say 50 ft.) and zero beat, reception was possible, but the quality of speech and music was poor and soft.

Old style wave traps are not efficient to work at such a short distance, although at six miles or more they work quite well. By "old style trap" I mean: say a 50-turn coil, honeycomb or otherwise, shunted by a .001 variable condenser and the whole thing connected

varying the condenser, we notice it has no effect on Hale's music except for 5 or 10 degrees on each side of one setting, at about 50 degrees, where KPO becomes quite soft. If now we leave condenser there and tune our set to 360-meter stations or to KFI, 469 meters, we find that they come in a little softer than if KPO was off the air, but there is no sound of KPO.

But KHJ, 395 meters, is made so faint that we cannot hear it, even though KPO is fainter. So we have not gained here. Also spark code and static are not eliminated. If now we tune in KUO on 360 meters and lower the condenser to about 25 we find he softens very much as well. Amateur C. W. softens with a 35-turn coil and low setting of condenser. Comparing results we find we have a variable radio-fre-

Fig. 3 shows the hook-up used. The same 50-turn honeycomb and condenser as before, but loosely coupled, hence sharply tuned, by means of 10 turns of No. 22 double cotton-covered copper wire wound tightly around the coil and connected to the aerial at one end and antenna post on set at other end, with a switch to short it out when not in use.

With one of these we tuned out KPO five blocks (2000 ft.) away, using 150-ft. aerial, and brought in KHJ on a loud speaker with a 3-circuit receiver with no interference, while at the same time KPO was tuned in on a loud speaker on another set connected to the same aerial.

The closer the coupling the broader it tunes and also the more it softens KPO. Here as usual we have to compromise. If you live within a few blocks of KPO you will have to use more turns in your antenna circuit to get closer

coupling to effectively soften KPO. At the same time the trap will tune broader and consequently somewhat soften KHJ. On the other hand, if you are six miles away from KPO a looser coupling such as 3 or 5 turns will suffice to blanket KPO and have almost no blanketing effect on KHJ.

Therefore, a more efficient trap would be one with 40 turns of 22 DCC wire on a 3-in. cardboard tube with a .001 variable condenser across it and 8 turns of No. 18 bell wire wound over it with taps at open circuit 3, 5, and 8 turns and short circuit. Such a trap was described in QST (June 1923) and is on the market as the General Radio wavemeter and filter. It is calibrated in wavelengths so you set it like a safe combination for whatever station you may wish. This is the best all-around trap I have used.

When I first used this filter with a single-circuit receiver all I could hear was a terrible a.c. hum. This was due to inductive reaction between trap and receiver. By turning the trap coil at right angles to the coils in receiver or by shielding the trap, or by placing a flat piece of sheet copper between set and trap everything worked finely.

With the different wavelengths, aeri-als and sets, the trap works better with antenna condenser of the set in series in some cases and in parallel in others.

It seems in radio that you can only clear one trouble at a time. I found that, while the series trap enabled me to get all stations below 423 M. without interference, it does not cut out KPO entirely when listening to KFI above him at 469 M. However, by connecting the trap in parallel, as in Fig. 4, it is possible to cut out KPO again, but the tuning is harder, more critical, and requires a slight retuning of the receiver. This connection also lessens static, arc light noises, and spark code to some extent. To get maximum effect with parallel trap the receiver primary should be in series.

In this instance if we use only 3 to 5 turns of wire we are shorting our antenna to ground outside the set for all wavelengths excepting that to which the trap is tuned—say to KFI, 469 meters, in which case the impedance forces that wavelength through the set. The tuning of the trap here is very sharp because of the loose coupling, preferably only 3 turns, and KFI tunes in and out on  $\frac{1}{2}$  degree. PWX (Havana) tunes out on a few degrees of a vernier.

If you use the old style trap in parallel without loose coupling, or even with as much as eight turns of coupling, the tuning becomes broad, and the short to ground has enough resistance so that it is not of much use as a short for spark code, static, etc.

This trap is not so effective in radio-frequency or reflex sets, because, al-

though the trap will keep KPO out of the aerial circuit, the sets are so sensitive that they pick him up on the coils, etc., with aerial entirely disconnected.

In some instances three of these traps at a time are a help. At 4:30 P.M., when KPO, KLX and KWG are on, I set one series trap on 423 meters, another on 360 meters, and bring in on a loud speaker KWG in Stockton nominally on the same wavelength as KLX, but actually a few meters below him, with no sound from either interfering station. Then, if amateur spark coils near me are bad, I put in a parallel trap with three turns of coupling and short most of the racket to ground, retaining KWG by tuning trap to 355 meters, which chokes him out of the short to ground and forces him, in reduced strength, through the receiver circuit to ground.

### SUCCESSFUL MAIL PLANE RADIO TESTS

Postoffice Department tests of radio telephone transmitting and receiving sets on a mail airplane have been successful at Omaha, Nebraska, where Pilot Jack Knight used a makeshift set while flying from Omaha to North Platte. Official tests are also being car-



Jack Knight, American Air Mail Ace, Talking with Joe Mullen, Government Radio Expert. Wide World Photo.

ried on at Schenectady, N. Y., with equipment built by the General Electric Company.

Knight's broadcasts were made from an average height of 2000 ft. and were heard 245 miles on November 22.

The General Electric equipment consists of a transmitter using five 50-watt XL filament tubes similar to the UV 203-A and a super-heterodyne receiver using seven UV199 tubes. The plates of the transmitting tubes are supplied

with 1000 volts from a 700-watt dynamotor operated by a 12-volt storage battery which is continuously charged from a generator driven by the plane motor. The receiving set has but two controls. The antenna is a 200-ft. trailing wire mounted on a reel in the cockpit and the counterpoise is the plane body and equipment.

The transmitting equipment has a normal range of 100 miles and normal output of 100 watts. During the Schenectady tests 175 miles have already been covered.

### A COMPACT SERIES PARALLEL SWITCH By E. H. PRICE

A customer walked into my store in Vallejo, Calif., one night and told me his troubles. He had built a honeycomb set and made no provisions for changing the primary condenser from series to parallel and when he wanted to put in the customary series parallel switch there was no room. However, there was room for a standard jack and, after a few

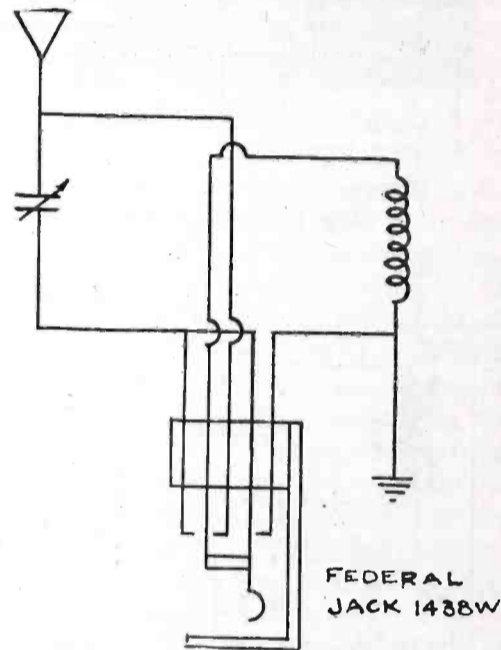

moments of brain work, the hook-up shown herewith was used. The means of changing from one circuit to the other may be made either by the end of an old plug with the composition top of a binding post put on the panel end or by means of an eccentric cam such as used in the Carter switch. In the former method pushing the plug in and pulling it out changes the circuit.

When using a larger sized drill as a reamer, always grind the cutting edge away at right angles to the flutes, instead of the usual sharp edge. This prevents the drill from tearing things, although it will cut slower.

The voltage of an Edison battery on LOAD is the only good means of indicating the state of charge. This should not be allowed to drop below 0.9 volts on normal operation, although the battery may be entirely discharged without damage.



# Building Inverse Duplex Sets

By M. B. Sleeper

*This, the second in a series of three articles on the Grimes circuit, gives the basic circuit for loop reception and various modifications for an outdoor aerial and for a crystal detector. The next and concluding installment will give additional data on construction and trouble hunting.*

TO the radio experimenter the Grimes inverse duplex circuit—it would be more correct to say “system”—appeals particularly because it is not merely a special way to hook-up a receiving set but a basic circuit from which an endless variety of types can be worked out.

To illustrate this point, a Grimes set can be built with transformer coupling, non-oscillating tuned transformer coupling, or a combination of both. It can be operated on a loop antenna, short antenna and ground, or long antenna and ground. A crystal detector or an audion detector can be used. Straight audio-frequency amplification can be added. And so it goes—all kinds of different sets for as many different purposes. Consequently, instructions will not be given in detail for particular types of set, but rather details of various designs which can be adapted to the individual tastes in mechanical design of the constructor.

In Fig. 1 you will see the basic circuit from which special types can be worked out. It is the exact circuit of the Sleeper Monotrol. Since all the constants and terminal markings are given, very little explanation is required. All the fixed condensers are Dubilier Micadons. Paper condensers are not practical because their capacities are not accurate, nor will they stand the voltages applied to them. A Malone-Lemmon condenser of 0.001 mfd. is used to tune the loop. The filaments are controlled by 1-amp. Ermcostats, a continually variable type of rheostat. Although 90 volts are indicated for the amplifier, 135 give better results for loud speaker reception. This is a simple and practical

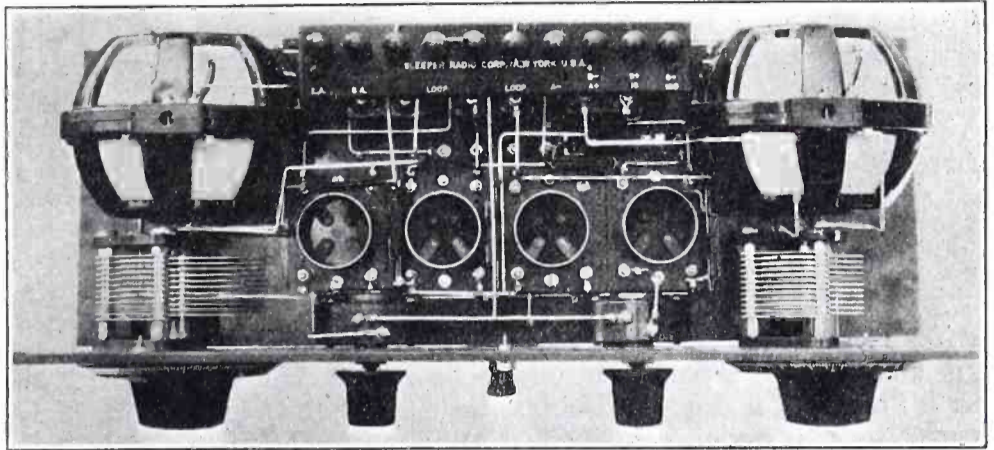

Completed Inverse Duplex Set

type of Grimes circuit which can be depended upon to work well without experimenting.

For home-made sets it is not necessary to use a loop if an antenna can be erected. In fact, there is an advantage in using an antenna in that it can be depended upon to bring in long distance in practically any location. The simplest way to adapt the Grimes circuit to use with an antenna and ground is to substitute the secondary of a fixed coupler for the loop, and connect the antenna and ground to the primary winding. Then you will have to take off five or six taps from the secondary

coil for the volume control switch. The capacity of the tuning condenser must be reduced to 0.00025 mfd.

If the antenna is of a single wire 100-ft. or more in length, connections should be made as just described. Fig. 2 shows the method and also the wiring for a short antenna, or one erected in-doors. In the latter case, the antenna runs to the grid of the secondary coil, with a micadon of 0.00025 mfd. in series, while the ground goes to the primary coil, as before.

Particularly for portable use, a two-tube amplifier set with a crystal detector makes a splendid outfit. A circuit for

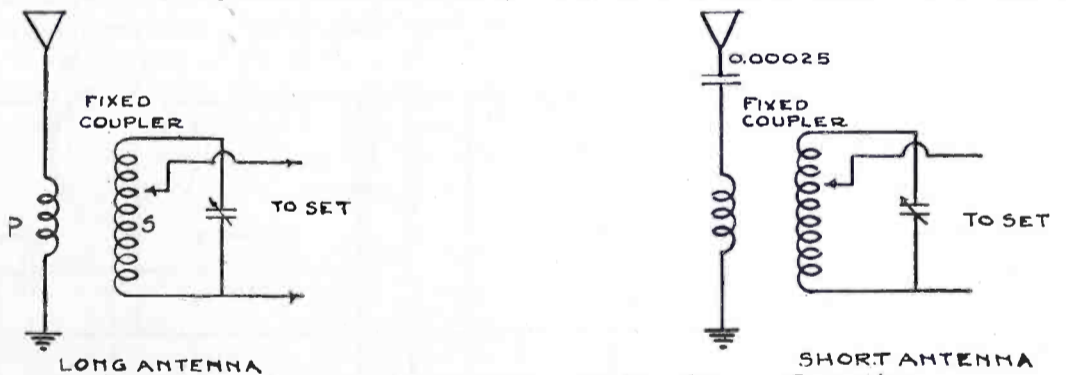

Fig. 2. Modification for Long and Short Antenna Connection

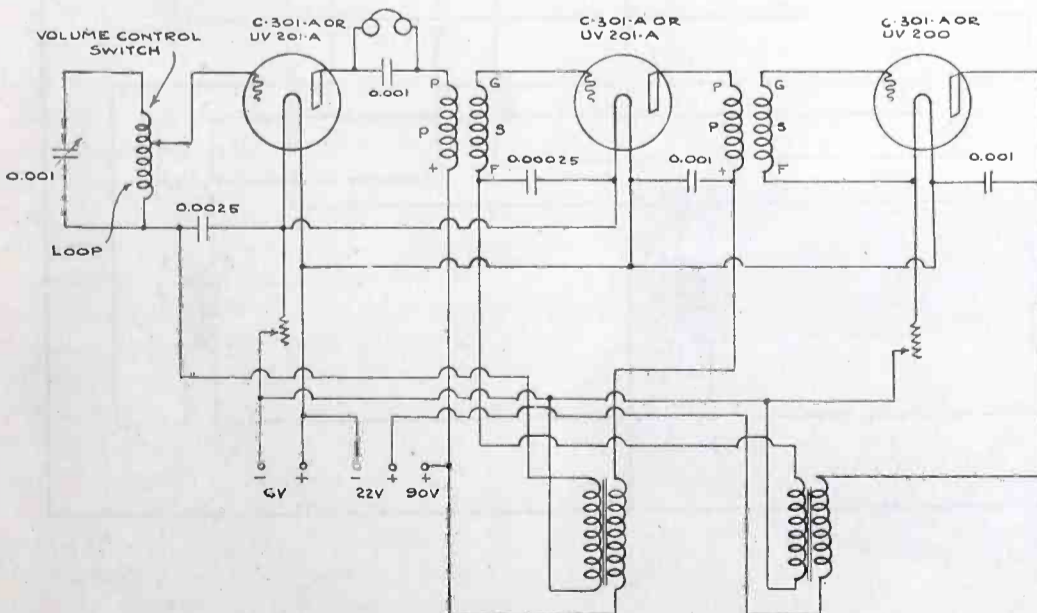

Fig. 1. Grimes Inverse Duplex Basic Circuit for Loop Aerial

such an outfit is given in Fig. 3. This can be used with a loop instead of the fixed coupler, though it is generally advisable to use the antenna and ground. For portable work, the antenna may be an insulated wire thrown into a tree, or the chassis of a motor car. A wire fence is also a good antenna. The best ground available should be used, either a metal plate dropped in a brook or lake, or connection can be made to several 5-in. spikes driven into the roots of trees.

With the new semi-adjustable or fixed crystal detectors, there is no real drawback to the use of a crystal in place of an audion detector.

Splendid results can be obtained with this type of set. The volume is increased sufficiently for loud speaker re-

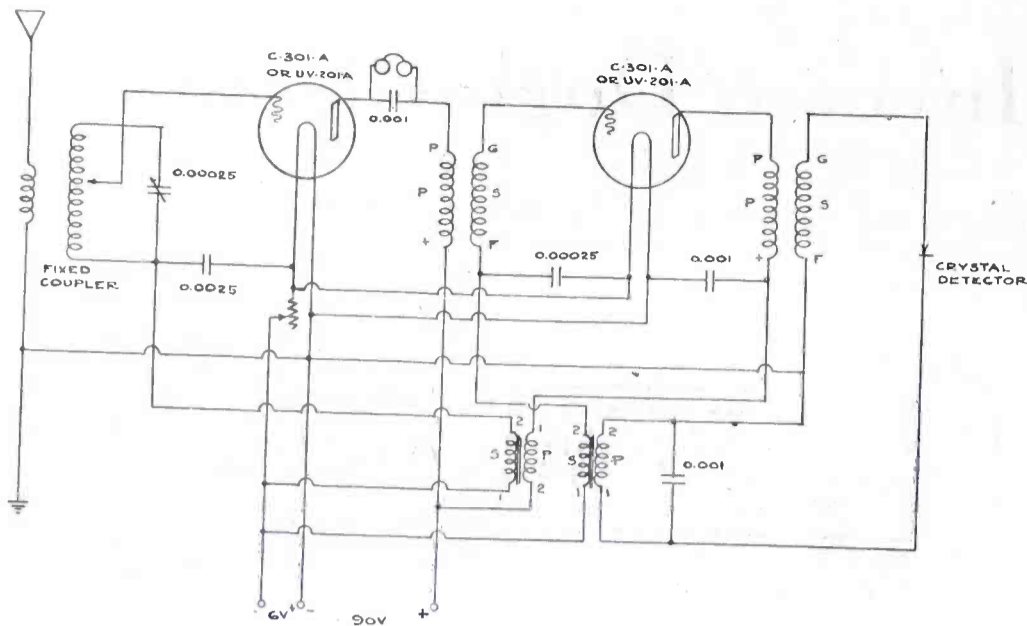

Fig. 3. Hook-up for Crystal Detector

ception if a single audio-frequency amplifier is added. An arrangement of that sort is illustrated in Fig. 4. Using C299's or UV199's, a wonderful little set can be made up, for they allow the use of the new Eveready type 771 batteries of 4½ volts for filament lighting. One of these batteries is needed for each tube. They can be put in parallel, though it is better to connect them separately to each tube. One rheostat of 60 ohms can handle all three tubes.

Radio experimenters frequently ask about using more than three tubes for Inverse Duplex sets. For example, some builders want to have two steps of Inverse Duplex using two radio and two audio-frequency transformers with one step audio amplifier added. This can be done, but until full information is

available it is not recommended to those who are not willing to spend a certain amount of time in the elimination of squealing. That is the only objection to the addition of a fourth tube for straight audio-frequency amplification. In the ordinary type of circuit the fourth tube introduces considerable howling and makes the detector rheostat adjustment extremely critical. Mr. Grimes has spent a great deal of time in developing the 4-tube set and has succeeded in building such an outfit with the tendency to howl entirely eliminated, but data on that receiver cannot be made public yet.

The same thing may be said of a set to use three steps of Inverse Duplex giving three radio and three audio steps of amplification. It can be done, but it is not recommended. However, a set has been built which involves no un-

usual problems using one step of plain radio-frequency amplification followed by two steps of Inverse Duplex. This is of material assistance in increasing the receiving range. When that is done practically as good results are obtained as when an audion detector is employed. However, it is generally better to use the audion because so many people object to adjusting a crystal detector.

An excellent set can be made up using a fixed coupler as a tuned radio-frequency amplifying transformer followed by two steps of Inverse Duplex. That makes a four-tube outfit if an audion detector is employed.

**CAUSE OF FADING**

The general result of tests conducted by the U. S. Bureau of Standards, in cooperation with the American Radio Relay League, substantiates the theory that the causes of fading are intimately associated with the conditions at the Heaviside surface, which is a conducting surface some sixty miles above the earth. Daytime transmission is largely carried on by means of waves moving along the ground, while night transmission, especially for great distances and short waves, is by means of waves transmitted along the Heaviside surface. Waves at night are thus free from the absorption encountered in the daytime, but are subject to great variations caused by irregularities of the ionized air at or near the Heaviside surface. These variations probably account for fading. The results of these tests are embodied in Scientific Paper No. 476 of the Bureau of Standards.

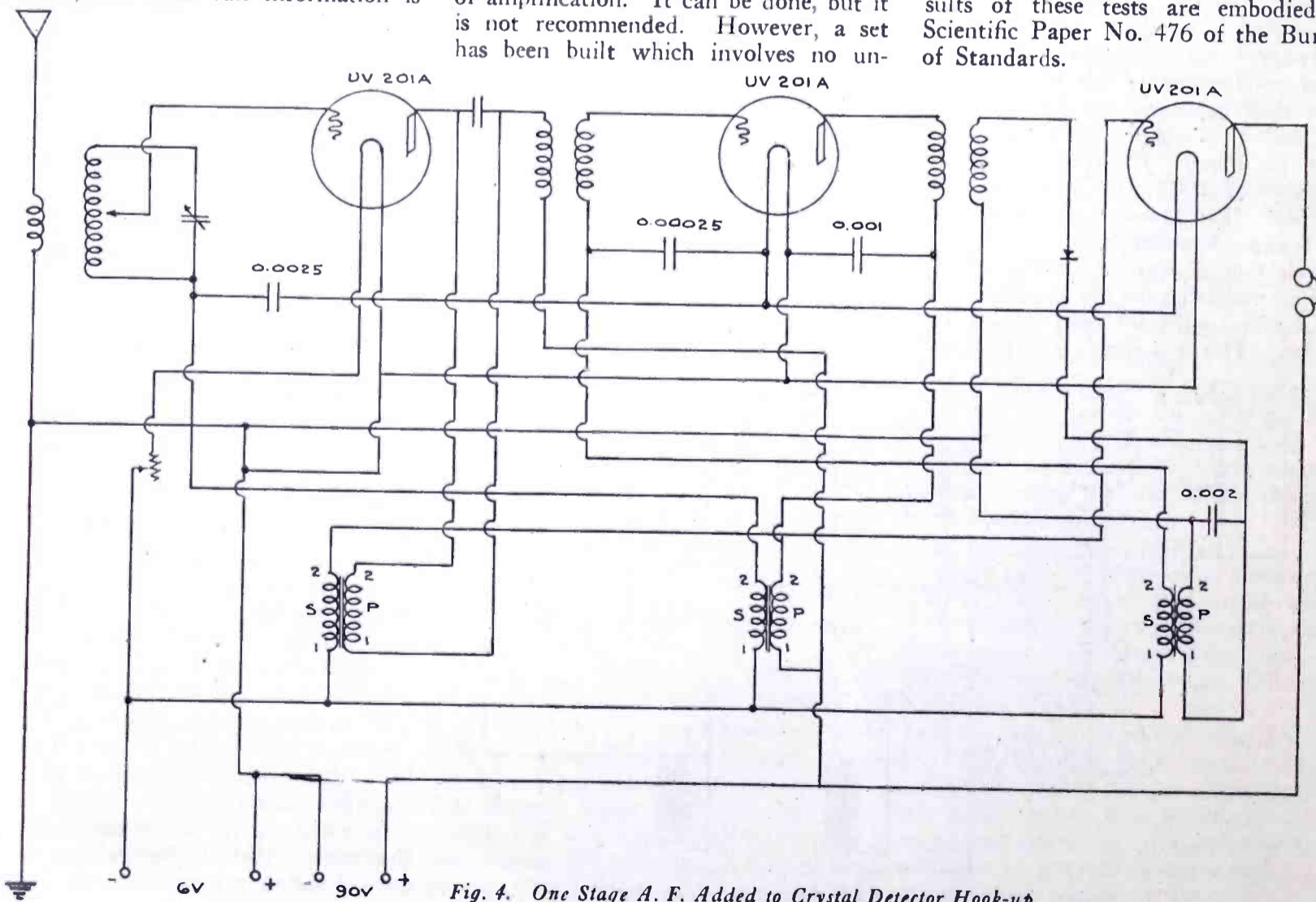

Fig. 4. One Stage A. F. Added to Crystal Detector Hook-up

# New Instruments Make Code Learning Easy

By B. F. Stares

*This is a clever short-cut on the road to learning speed in code reception. The home-made instruments take the place of rather expensive mechanical transmitters.*

TO memorize the characters of the telegraphic code is one thing; to fix them so firmly in mind that each letter is instantly recognized when converted into code characters is still another matter. "I must learn the code," we often hear ambitious radio fans say, as though the mere memorizing of the various dot-and-dash combinations were going to permit them to decipher copy at thirty words a minute. Learning the code is a matter of hours; learning to use it with any respectable speed is usually a matter of weeks.

The writer devised the instrument described in this article with the object of obviating the necessity of two persons learning the code together, which, of course, usually facilitates matters. However, with this instrument this procedure is not necessary, for the whole process is reduced to an automatic basis. A person learning the code has at his command all of the devices necessary to gain perfect control of the Morse or Continental characters within a reasonably short time, providing he is not one of the type who wants to swallow a pill and wake up in the morning to find himself a seasoned operator.

The first instrument described will be the automatic sender itself, and the parts of this contraption are so simple and common that they are bound to be found about the average home. The most essential part of the transmitter is the works of an old alarm clock. The

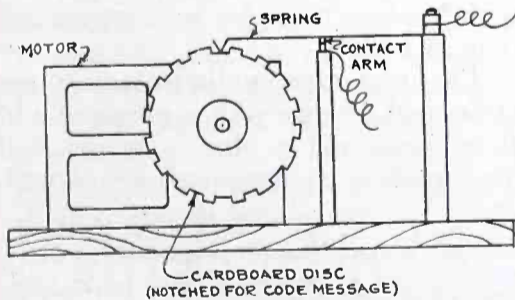

Fig. 1. Automatic Code Transmitter

alarm clock is mounted on a base which is provided with a flexible contact arm made of a thin phosphor-bronze strip with the end bent into a V-shape as depicted in the sketch. This bent end rests lightly upon the edge of a prepared cardboard disc and the latter is attached to the driving shaft of the clock motor in such a way that it may be removed with little or no trouble. It will be noticed that it is sandwiched in between two large metal washers so that it will run true without wobbling.

The disc is made by cutting out little notches in the edge to correspond with the characters of the code. Several should be made and different messages put on each. The indentations need not

be over 1/16th of an inch deep. It will be found that an old safety razor blade will permit the builder to cut these notches with little or no trouble.

The matter of producing a suitable hum that will in some way match the high-frequency buzzes sent out by modern radio transmitters will now be considered. The reader is probably familiar with the trick of putting a telephone receiver to the transmitter. It is known that this creates a disturbance in the telephone line which demonstrates its presence with a shrill buzz not unlike that which used to be characteristic of the quench-gap radio stations. It is possible to duplicate this trick and to use it in making a code transmitter, which gives a note most pleasant to listen to. In Fig. 2 the diagram of this simple

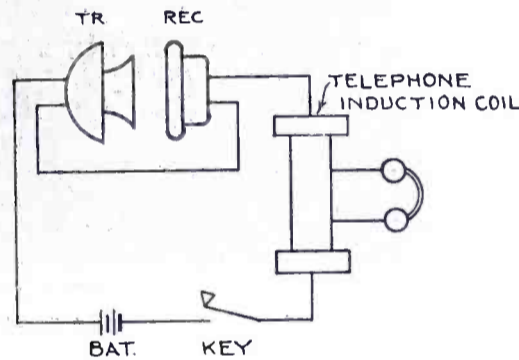

Fig. 2. High Frequency Buzzer

little apparatus will be seen. This particular high-frequency buzzer, if we may call it such, is admirably suited to the requirements of a home telegraph transmitter of the automatic type. It produces a pleasant sound because of whose high-frequency, clear-cut sharp characters are formed.

There is still another method of producing suitable high-frequency currents if the material required for the aforementioned is not readily available. Here a small dry battery motor is used as the basis of a miniature high-frequency alternator. First a gear wheel with forty or fifty teeth is mounted on the shaft of the motor. It is well to anneal the wheel in a gas flame. Directly under the gear

wheel, which forms the rotor of the alternator, are placed two electromagnets. These may be taken from an electric bell and rewound with No. 28 single cotton-covered wire. We will notice from the diagram in Fig. 3 that

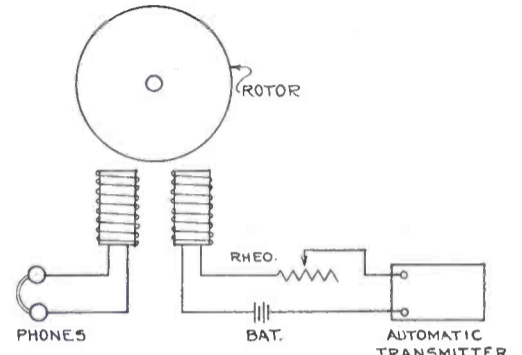
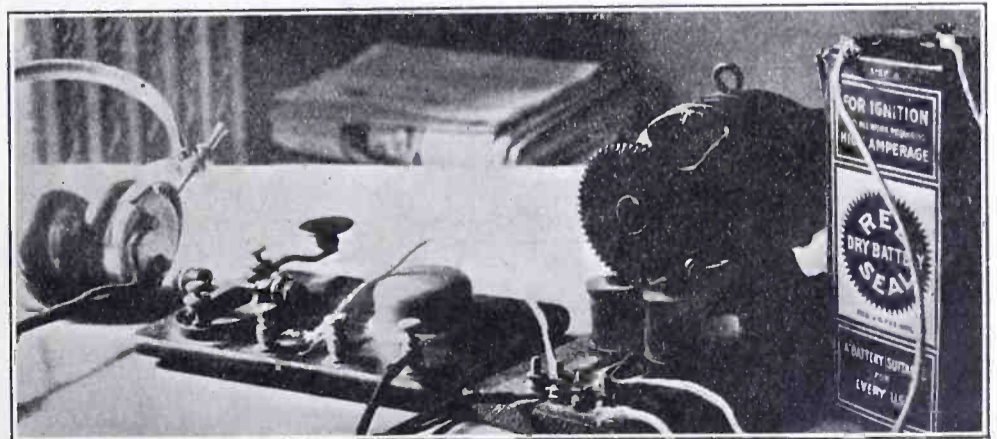

Fig. 3. Apparatus for Producing High Frequency Current

these magnets are used in two independent circuits. One is connected directly to a dry cell and when current passes through it a magnetic field is set up which is cut by the rotor when it is moved by the motor. This action causes an alternating current to be generated in the other coil, for each tooth in the gear acts as a magnetic pole and the frequency of the current produced in the second coil will depend upon the number of teeth in the wheel and the speed of the motor. A small rheostat should be placed in series with the battery and the motor and this will give perfect control over the frequency of the tone. The apparatus is used with the motor connected in series with the first magnet as illustrated in Fig. 3. Of course, it is understood that the motor must be revolving while the apparatus is in use. Interruptions in this circuit will be heard in the second circuit, since there will be no current flowing in this circuit unless there is a current flowing in the first one. If heavier magnets are used for this alternator, together with a larger gear wheel, sufficient current will be generated to permit a large number of persons or an entire radio club to practice the code.



Assembly without Automatic Transmitter

# A Radio Circuit Testing Board

By Paul Oard

*The advice of an experienced experimenter is here placed at the disposal of those who wish to more intelligently try out new circuits. From the suggestions given, any amateur can duplicate the construction and derive much help from its use.*

**S**YSTEM is desirable in the pursuit of any form of knowledge, particularly if the knowledge sought is of a nature that requires careful attention to detail. With the multiplicity of radio circuits that are being brought to the attention of the experimenter, the need of system in testing such circuits becomes paramount. The frequent duplication of circuits through a rearrangement of the diagrams is a common occurrence which the experimenter can avoid to a great extent if he systematizes his testing.

The attainment of system is, however, a rather difficult matter for the average radio enthusiast. In the testing out of a circuit diagram with unsatisfactory results, probably much of the blame may rest upon the experimenter, rather than upon the circuit, because of the lack of system. It is neither practical nor desirable in testing out a new circuit that the apparatus necessary for its operation be mounted permanently in a finished instrument.

One of the first steps toward systematization is a portable instrument board to which is attached the apparatus most likely to be needed. Furthermore, the apparatus should be grouped in such units as to do away with as much unnecessary making of connections as possible, but with such units interchangeable to a wide variety of purposes. In the testing out of the more elaborate circuits, it is not entirely practical that all of the apparatus that will be necessary be grouped upon one board; rather, the common units that are necessary should be so arranged, with special equipment kept separately, but so that it may be used in connection with the main testing board.

The board shown herewith is made up of the following units: One 2-stage audio-frequency amplifier and detector complete, one 3-gang socket assembly, one separate rheostat, one potentiometer, two variable condensers, one honeycomb coil mounting, two variometers, one variocoupler.

Fixed condensers, grid leaks, radio-frequency transformers and extra audio-frequency transformers for certain forms of reflex circuits are not mounted, but

a convenient method of taking care of regulation circuit experiments. It may likewise be utilized for certain super-regenerative circuit arrangements. Binding posts are provided for all terminals of the mounting.

The variometer and variocoupler arrangement allows of a multiplicity of uses. The three units may be used interchangeably in single, two and three-circuit tests, and in tuning units in reflex and radio-frequency circuits. One

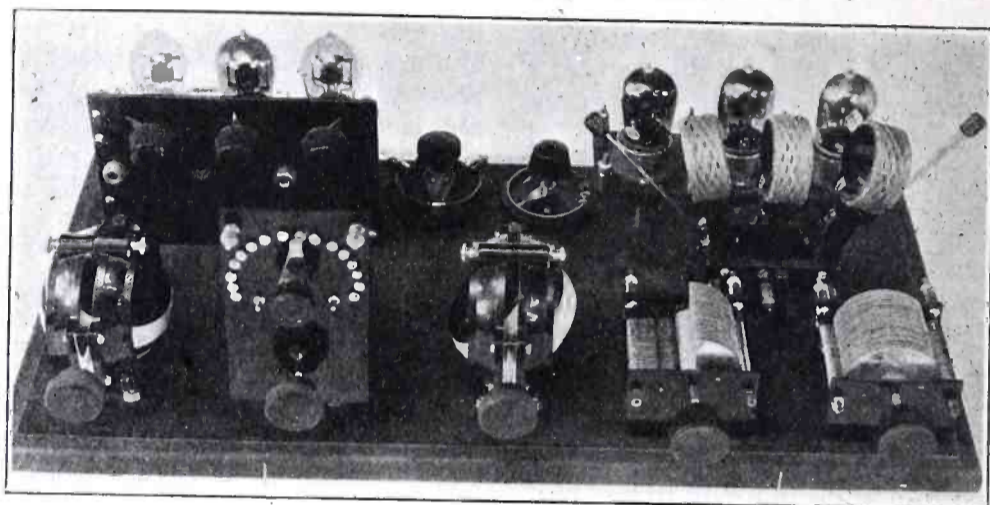

Paul Oard's Testing Board

are left independent of the board so that they may be placed as desired.

The three-gang socket is connected in series as regards the filament terminals, controlled by a single rheostat, while binding posts are brought out for all plate and grid terminals in this unit. Such an arrangement permits different types of radio-frequency transformers to be connected at will. This unit also may be used in testing single-tube circuits.

The honeycomb coil mounting allows

may readily satisfy himself as to whether a two-variometer-one variocoupler regenerative arrangement is more suitable for short wave reception than the honeycomb coil circuit, or vice versa.

The variable condensers are provided with binding posts for separate connections at will.

The two-stage audio-frequency amplifier and detector unit is provided with three jacks and a plug. Its use with loud speaking equipment allows of ready

Continued on page 68

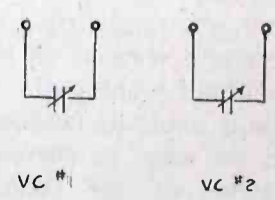
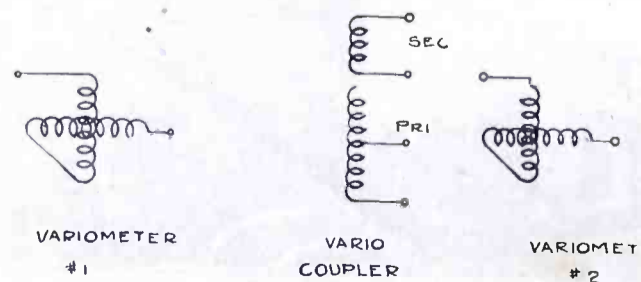
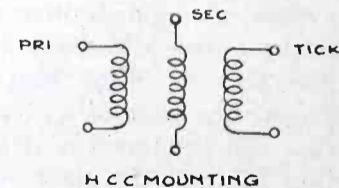
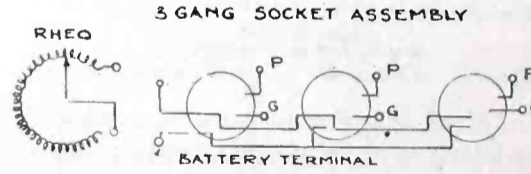
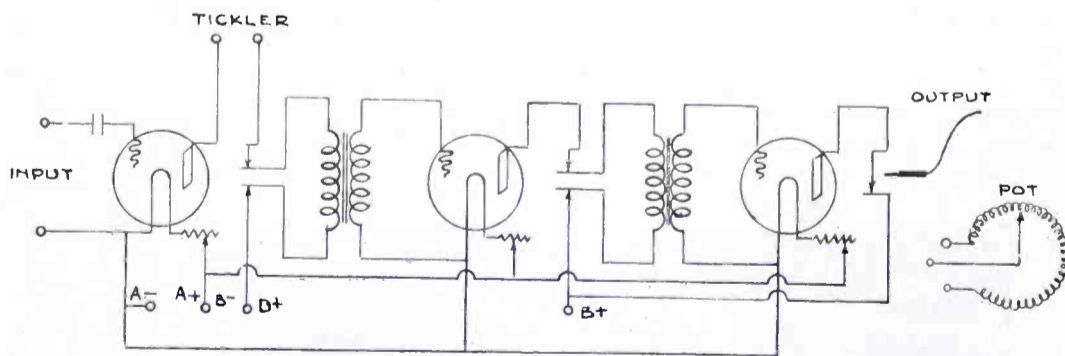

Layout for Circuit Testing Board

# Neutrodyne Circuit Radio Receivers

By Kimball Houton Stark, Chief Engineer, F. A. D. Andrea, Inc.

*In this article, the first of a complete series on the Neutrodyne circuit and its possibilities, the fundamental theory is given in detail. By understanding the principle of tuned radio-frequency amplification with neutralization of capacity coupling, the experimenter can appreciate the difficulties that Professor Hazeltine overcame when in 1918 he devised his now famous Neutrodyne circuit.*

IN 1918, Professor Louis A. Hazeltine was in the employ of the United States Government as consulting radio engineer at the Washington Navy Yard, where he had charge of the development work on radio receiving equipment for the navy. One of the problems was the design of an efficient radio receiver to cover a wavelength range of from approximately 250 to 7500 meters. Obviously, with thousands and thousands of radio stations in operation on the battle fronts and on the high seas, the problem of preventing interference was of enormous consequence. In working with the proposed design for the SE-1420 receiver, as it was called, it was found that at times short wave signals interfered with the operation of the receiver when listening-in on the longer wavelengths and vice-versa. In studying this matter Professor Hazeltine found that such interference was in many cases caused by the capacity coupling existing between various portions of the receiver circuit. The more obvious steps of arranging the circuits so that electrostatically-exposed parts and wires were at or near ground potentials and of enclosing the primary and secondary apparatus in separate metal compartments were quickly taken.

The primary tuning coil and the secondary coupling coil had to be electrostatically exposed to one another in order to obtain the necessary magnetic coupling between the primary and secondary circuits. Overcoming this problem in the design of the SE-1420 receiver gave birth in the mind of Professor Hazeltine to the idea of neutralizing the capacity coupling between portions of radio receiver and amplifier circuits.

In general, Professor Hazeltine has taken advantage of the principle that electrostatic or capacity coupling between two circuits behaves like electromagnetic coupling, in that it may be reversed in sense and in particular may be reduced to zero. Such a condition is accomplished by balancing the capacity of one portion of the circuit against another portion, it being necessary to reverse the phase of a voltage, this involving the use of an electro-magnetic transformer in addition to the capacities.

Fig. 1 illustrates a fundamental circuit arrangement showing capacity coupling and methods of neutralizing. *A* and *B* are circuits coupled through the direct connection at the bottom and

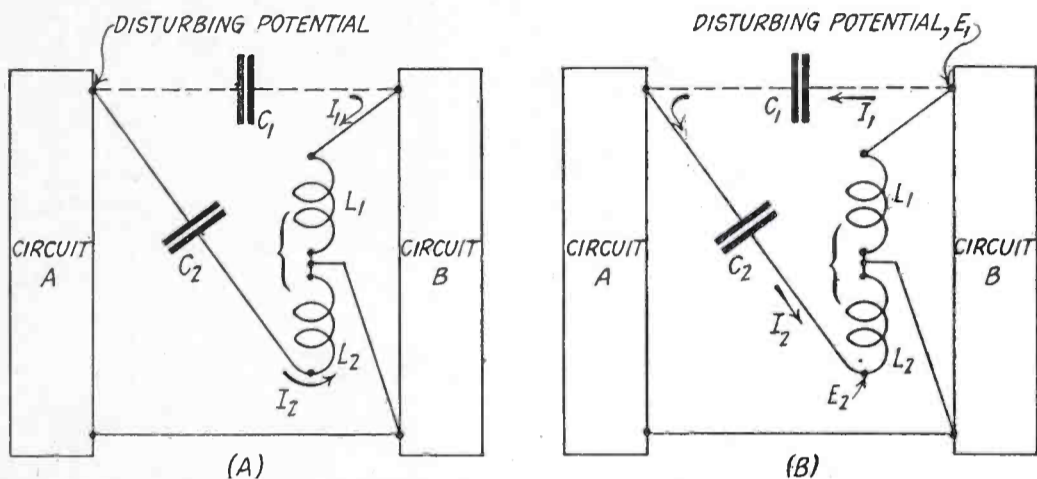

Fig. 1. Fundamental Circuit Arrangements Showing Principle of Capacity Coupling Neutralization

through the coupling capacity  $C_1$ . If circuit *A* has a source of alternating current, the alternating potential of its upper terminal (marked "disturbing potential"—Fig. 1a) would send a current through the coupling capacity  $C_1$  to circuit *B*, which current flowing through the impedance of circuit *B* would set up a voltage between its terminals. Thus in the absence of capacity neutralization energy would be transferred from circuit *A* to circuit *B*.

To overcome this transfer of energy from one circuit to another two closely coupled inductance coils  $L_1$  and  $L_2$  and a neutralizing capacity  $C_2$  are arranged as shown in Fig. 1. The inductance  $L_1$  is connected between one terminal of  $C_1$  and the common connection, and  $L_2$  is connected in series with  $C_2$  between the other terminal of  $C_1$  and the common connection. The terminals of  $L_1$  and  $L_2$ , which are connected together, are of unlike polarity.

Now if the neutralizing circuit  $L_1 L_2 C_2$  be so adjusted that the current  $I_2$  through  $L_2$  magnetically balances the current  $I_1$  through  $L_1$ , no voltage will exist across either of these coils or across the terminals of circuit *B* which is in parallel with the inductance  $L_1$ . The condition of magnetic balance is

$$N_1 I_1 = N_2 I_2 \text{ ampere turns} \quad (1)$$

where the  $N$ s are the respective number of turns of wire on the inductance coils and the  $I$ s the current flowing through the coils. Obviously, if no voltage exists across circuit *B* no current will flow through it and all of the current through the coupling capacity  $C_1$  will be the current  $I_1$  of coil  $L_1$ . The current through  $C_2$  is likewise the current  $I_2$  through coil  $L_2$ . Since under this condition of neutralization no volt-

age exists across the inductances, the two condensers (the neutralizing condenser  $C_2$  and the coupling condenser  $C_1$ ) have equal voltages and their currents are therefore in the ratio of their capacities.

$$\frac{I_2 C_2}{I_1 C_1} = 1 \quad (2)$$

combining these relations,

$$\frac{N_1 C_2}{N_2 C_1} = 1 \quad (3)$$

which is therefore the condition for the neutralization of the capacity coupling between the circuits.

The general reciprocal relation of electrically coupled circuits proves that if a source of energy in circuit *A* does not affect circuit *B* (as described above) then a source of energy in circuit *B* will not affect circuit *A*. However, it seems worth while to examine the details in this instance as illustrated in Fig. 1b. The "disturbing potential" at the upper terminal of circuit *B* will send a current  $I_1$  through  $C_1$ . If adjustments are so made that the current  $I_2$  through  $C_2$  is equal to the current  $I_1$ , then no current flows into circuit *A* and no voltage is set up in circuit *A*. Since the current through a capacity is proportional to the capacity and to the voltage, we then have

$$C_1 E_1 = C_2 E_2 \quad (4)$$

where  $E_1$  and  $E_2$  are the voltages across  $C_1$  and  $C_2$  respectively. There being no voltage across circuit *A*, the junction of the inductances  $L_1$  and  $L_2$  is at the same potential as the junction of the capacities  $C_1$  and  $C_2$ ; so  $E_1$  and  $E_2$  are also the voltages of inductances  $L_1$  and  $L_2$  and

these voltages are proportional to the respective numbers of turns:

$$\frac{E_1}{E_2} = \frac{N_1}{N_2} \quad (5)$$

Hence, combining equations, we must have

$$\frac{N_1}{N_2} = \frac{C_2}{C_1} \quad (6)$$

as before in equation (3).

If the capacity  $C_2$  is smaller than given by equation (3) the capacity  $C_1$  will be under-neutralized, and the circuits will be so coupled in the same sense as if there were no capacity neutralization. If the capacity  $C_2$  is larger than given by equation (3), the capacity  $C_1$  will be over-neutralized, and the circuits will be coupled in the opposite sense, by which is meant that the phases of all currents and voltages produced in one circuit by a source in energy in the other circuits will be opposite to what they would have been without capacity neutralization. The adjustment of  $C_2$  is

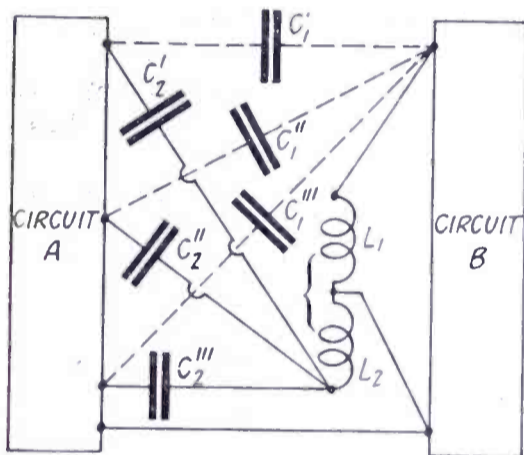

Fig. 2. Coupling of Circuits by an Infinite Number of Capacities

thus analogous to the adjustment of magnetic coupling by the rotation of a coil through the position of zero mutual inductance.

It sometimes happens that two circuits will be coupled by a number of capacities extending from a single point of one circuit to various points of the other as indicated by  $C_1'$ ,  $C_1''$ , and  $C_1'''$ , in

Fig. 2. In this case a single transformer  $L_1, L_2$  is all that is necessary, but each coupling capacity must be separately balanced by a neutralizing capacity, as  $C_2', C_2'', C_2'''$ . The relations for a

ceiver; and thus the idea of employing the currents in the coils to more effectively eliminate capacity coupling, led to the general methods described in the above paragraphs.

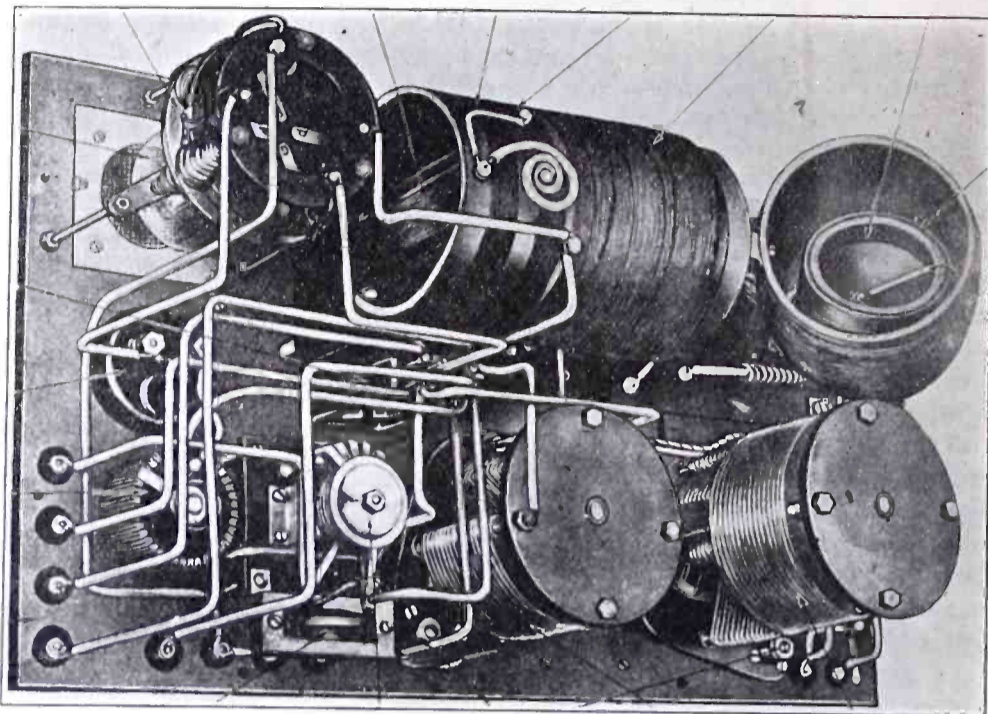

Fig. 4. Interior View of Navy SE-1420 Receiver. Note the antenna Coil, Coupling Coil, and Coupling Coil Shield at the Right End.

capacity balance under these conditions are, as previously,

$$\frac{N_1}{N_2} = \frac{C_2' C_2'' C_2'''}{C_1' C_1'' C_1'''} \quad (7)$$

In studying the problem of eliminating the capacity coupling existing in the circuits of the SE-1420 navy receiver, Professor Hazeltine, while at the Washington navy yard, devised a general theory of capacity neutralization.

The conditions to be overcome in this receiver have been mentioned earlier in the article and Professor Hazeltine's first thought was to eliminate the residual circuit capacity coupling by wrapping a grounded wire around the coupling coil of the receiver. In considering the most practical way of arranging such a wire screening device, he realized that it would carry a current due to its exposure to the primary coil of the re-

Fig. 3 shows the exterior view of the Navy SE-1420 receiver and Fig. 4 illustrates the interior of this same radio receiver. The various parts of the instrument are indicated in Fig. 4 and particular note should be taken of the position and arrangement of the coupling coil and the coupling coil shield as developed by Hazeltine, this being the first practical application of the Neutrodyne principle.

Fig. 5 shows in diagrammatical detail the system employed for neutralizing the coupling capacity in this receiver. The large or outside coil shown at the right

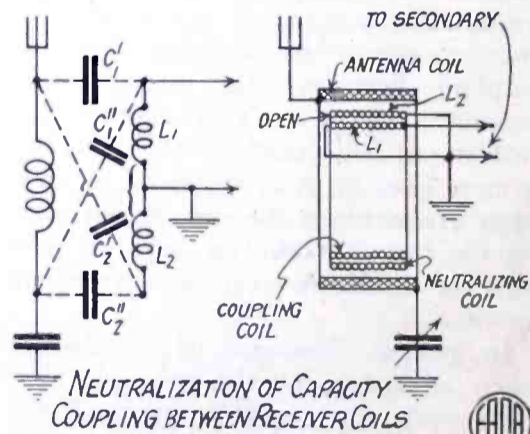

Fig. 5. Neutralization of Capacity Coupling Between Receiver Coils

is the primary or antenna tuning coil;  $L_1$  is the coupling coil in series with the secondary inductance and  $L_2$ , the inductance wound outside of  $L_1$ , is the neutralizing coil. The inherent capacity from the high potential end of the coupling coil  $L_1$  to the various parts of the primary or antenna tuning coil are shown at the left of Fig. 5 by coupling capacities  $C_1'$  and  $C_2'$ , etc. The various capacities between the inductances have

Continued on page 74

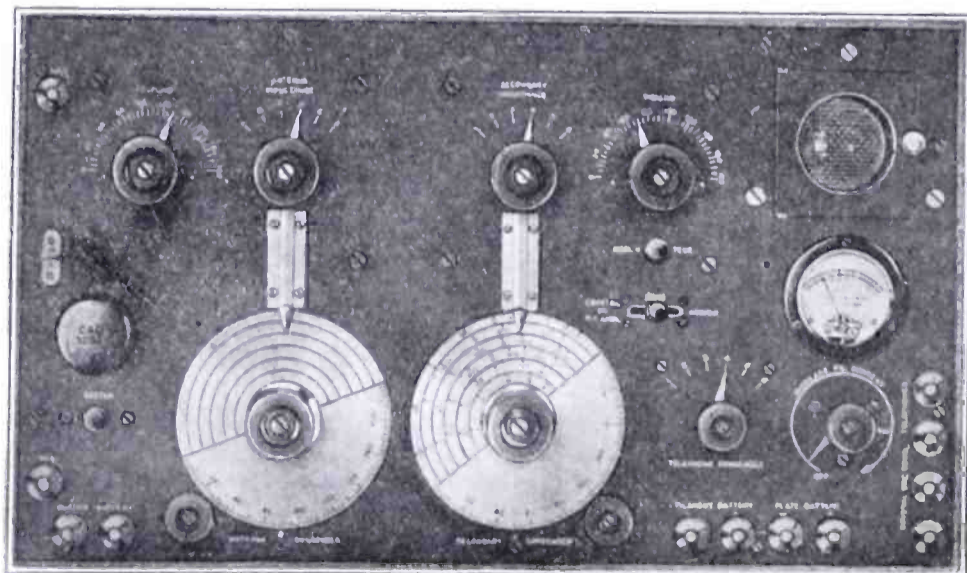

Fig. 3. Front View of Navy SE-1420 Receiver



"Cassidy—the cop—off duty"

## The "Q-Drawer"

By Earle Ennis

*This is a clever detective story featuring radio and the geometrical axiom that a straight line is the shortest distance between two points, the two points being the crime and the criminal.*

FOR an ordinary policeman, Cassidy had picked up a lot of valuable information. He had started young in life as a special agent for a big railroad—the C. M. and St. J.—a confidential man in confidential service. In this job he picked up a knowledge of human nature and a smattering of telegraphy. Not such a smattering, either, for that matter. In the Higby Smelter robbery, for instance, it will be recalled that it was Cassidy, tapping a "pony" wire with his understanding of Morse, that led a posse to a mountain shack and landed an entire gang in jail.

When Cassidy changed over to the city department, he broadened his knowledge of human nature and added a few other accomplishments. For one thing, he learned to pick a gun-man on sight, to spot a two-timer by his shuffle, to side-step a bullet through a door panel when tackling a barricaded "weazle," and where a hop-head usually carries his "snow" cargo. Also he learned to disbelieve a police court "mouthpiece," to know the sound of a blown "can," and where to find any section of his penal code. And when young Cassidy Jr., yclept "Mike," went in for radio, Cassidy plunged with him.

"'Tis only a small difference bechune some of the letters I know and them I don't," said Cassidy, comfortably. "So for the likes of a couple of smart men like us, I'm thinkin' we can master the trick of it."

They did. In a year, the Cassidys, father and son, were neck and neck, in the give and take of the buzzer talk.

"Do ye moind the lad takin' it as fast as I can shoot it to him, now," Cassidy would say pridefully over the back fence to a neighbor. "But for that matter, I'm no slouch misself." And he wasn't.

ALL of which brings the story to a November evening at the Cassidy home, with Mrs. Cassidy bustling around her kitchen, busy with clattering pans and kettles, Mike battling with a stub pencil and the intricacies of fractions as outlined by the seventh grade, and Cassidy in his sock feet, "sitting in" on the baseball and other entertainment of the air on the Cassidy receiving equipment—value, approximately, nine dollars.

It was not much of a set—that Cassidy outfit. Its base was a cigar box. But it owned to a lamp and batteries, and each Cassidy had a pair of head-

phones. Over the table was a map stuck full of pins, and in the drawer was a log of places heard. During the long nights—these two, father and son—intrigued by the mystey of distant whispirings, in the staccato lilt of the code, spent many pleasant and satisfying hours twirling the one knob the set possessed, and quarreling over letters.

Only once did Mrs. Cassidy, knitting under the lamp and in a gossipy mood, make protest at the comradeship of these two in an expressed wish that "a body could have a word with the family now and then." To which Cassidy made terse and epigrammatic reply:

"Would ye rather the young lad was in a pool room now, mother?" he asked, "than sittin' here enjoyin' hisself?"

To which Mrs. Cassidy, being a true diplomat of the old sod, made reply:

"I was thinkin' maybe ye could let me lissen the now, Dennis."

The next night Cassidy bought another pair of receivers and Mrs. Cassidy joined the circle and wept over many an Irish tune that trickled in from another state.

So then—it being November 3rd—we find Cassidy, feet on table, nickel cigar going nicely, phones, knob, cushion,

elbows and disposition, all comfortably adjusted, listening to the start of the night's radio traffic down the air-lanes—ship calling to ship, or to shore station—chattering away with affairs as myriad as the lives of men.

Now—get these two pictures!

Cassidy—the cop—off-duty, comfortable in his "sittin'" room, with a tiny wire among his chimney pots, linked to the wizardry of a box and a lamp by a scant six feet of cord, and—

James V. Corot—international crook, confidence man, and thief of a dozen aliases—one thousand miles away, aboard the *S. S. Tuscania*—sprawled in his berth watching with idle eyes the thin line of smoke that trailed upward from his cigarette.

"A good night for distance!" muttered Cassidy, who had never heard of Corot.

"A cinch bet," murmured Corot, who had never heard of Cassidy.

WITH the stage practically set, we will now concern ourselves with "The Countess"—at that particular moment in the dining room of the *S. S. Tuscania*, with the superlative glitter of life and light around her like a social halo, exchanging table amenities with young Harrington Forbes, polo player, dilettante, globe-trotter, wealthy in six figures, and matrimonially desirable. Oh yes, quite.

Elsie Jannison was not, as a matter of fact, a countess. Such ancestral estates as she possessed were at the moment, in her brass-bound steamer trunk. But she was known by that title from the Riviera to Piccadilly, despite her lack of demesne, and no one ever questioned her rights in the matter. But to those in the "know" she was one of the greatest "pick-ups" in the jewel smuggling traffic.

The acquaintance of "The Countess" and young Harrington Forbes had developed by the merest chance. That is what young Forbes thought. How did he know that a confidential agent in London had wired Elsie that Forbes was enroute to New York with the finest collection of unset diamonds known to the trade to be matched with a seventh stone at an American lapidary's? Elsie caught the Liverpool express by a narrow margin—but she made it.

Forbes visited at the Cheltenham-Haskows for two days before his departure. By the merest chance—a chance that cost her five pounds sterling to accomplish, her motor broke down at that point. There was telephoning to be done—such things. Young Forbes gallantly threw himself into the breach, and was most delighted to learn that the charming lady, in distress, was booked like himself on the *Tuscania* . . . They would meet later? To be sure. Just like that!

THUS—at the moment when Cassidy settled down for a quiet evening, and Corot lay chuckling at some inner thought of his own, the Countess was engaged in accomplishing the thing for which she had discreetly angled for a number of hours,—a sight of the famous Forbes diamonds.

"I suppose it is foolish to carry them around this way," said young Forbes, as he took a chamois bag from an inside pocket. "I shall put them back in the ship's safe as soon as you have looked at them. But I really couldn't resist the sight of your face when . . ."

He broke off to unfasten the thong that held the bag. Tilting it up, he poured a cool three-quarters of a million in glittering crystal baubles upon the white cloth of the dining table, where they sparkled under the overhead lights like bits of star-dust.

"Oh—how . . . magnificent!"

The excited scream of delight attracted the attention of others in the dining room and instantly the table was ringed with an excited, thrilled group of passengers, to whom young Forbes and his diamonds were already known through the newspapers.

"How unutterably magnificent!" exclaimed the Countess.

They were—stupidly, fatuously so, as they sparkled with myriad colors—spread in irregular pattern under the lights—six superb stones of different sizes.

"They were intended for a necklace," young Forbes explained. "That's why I am taking them across. The seventh stone is to be the pendant, and is, I understand, finer than any of these. It will make rather a neat little collection."

He spoke with a certain degree of pride. A London banker at his elbow chuckled.

"Neat—my word! A king's ransom rolls on the cloth and the man calls it neat! Handsome—I think. Eh what?"

A general laugh went up;

"They are beautiful—dangerously beautiful," said the Countess, shuddering becomingly. "I would be frightened to death to—to even have them near me!"

Forbes laughed and, rolling the stones together, rewrapped them in their tissue paper covers and dropped them back into the bag.

"I am not only not superstitious about them, but I would be willing to let you wear them . . . if they were set!" he challenged.

The Countess blushed—it had taken her many a weary day to determine the exact shade of a blush for distraught registration—and flashed him a confused look. The others were drifting away, talking about the stones.

"I . . . let us go on deck . . ." said the Countess, her eyes refusing to meet those of young Forbes.

He laughed—rather nervously—and fell in with the suggestion.

"Yes—do. The moon is wonderful..."

Carelessly he dropped the chamois bag into his pocket. He would have the steward place it back in the safe later in the evening . . .

Young Forbes followed the Countess on deck, to find her staring out at the rippling moonlight on the water. As he came up beside her, he touched her on the arm.

"Wonderful night!" he said.

The Countess started violently and gave a sharp cry.

"How you startled me!"

A handkerchief which she held in her fingers fluttered away over the rail. Young Forbes clutched at it, leaning far out . . . Then he whirled with a quick apology.

"I thought you heard me behind you," he explained.

The Countess was laughing, now.

"I was moon-dreaming," she said. "It is nothing, I assure you. I am just a bit distraught . . . a woman's nerves, I guess."

Forbes waved a hand toward the white bit of linen that still gleamed far behind in the moonlight.

"Shall I dive for it?" he asked, laughing.

The Countess tapped him playfully on the arm.

"Hardly," she replied. "Shall we walk?"

Nothing to it all, of course. Persiflage, fluff, shipboard drivel, social badinage—anything to fill in the hours, from a flirtation to a scandal. Forgotten when the boat docks, but played like a card game—while it lasts. Only that—

James V. Corot happened to be standing a bit farther along the deck when the incident occurred. The darkness masked Corot's smile. The churn of the screws muffled his softly-spoken "good work", though to what he referred was not apparent. He glanced casually at a fast-disappearing bit of white—a lady's handkerchief—hummed softly to himself, and turned into his own cabin. There, one standing behind him, would have seen him penning a radiogram to an address ashore.

The message read:

"Arrive Thursday. All well. Regards.—Jim."

The night operator chuckled as he took the message and flipped out a call to a station ashore, which was to take all the *Tuscania's* business. Pretty work! And right under the nose of Scotland Yard, and the ship's officers, too. Neat, eh? Oh, well—it proved that using the old bean was the only system—that and carefully laid plans.

CASSIDY, the cop, sitting in his kitchen, his feet on the table and half asleep from the drone of the cease-

Continued on page 56



# Practical Filter Design

## Part II

By Don Lippincott

Careful study of this article and its predecessor on theory should enable the reader not only to construct the especial filter described but also to design and build filters for other purposes. The author has succeeded in explaining the subject in simple terms.

**A**BSTRACT electrical theory means little to most of us. The ordinary mind does not think of reactances and impedances in terms of x's and z's but as coils and condensers. Therefore, a filter design, not in numerics only, but as a physical structure, seems to be indicated as the proper conclusion for my previous paper on "Electric Current Filters" in December RADIO.

The problem, then, shall be to design a filter to supply plate current for two 5-watt UV202 or C302 tubes, from a rectified 60-cycle a.c. supply.

The filter will consist of two sections. (See Fig. 1.) Section I is the familiar

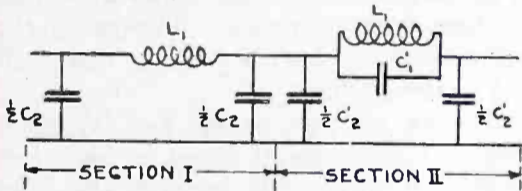

Fig. 1. General Design of Plate Current Filter

low-pass filter of the  $\pi$  type, giving a reasonable degree of attenuation at the lower frequencies, the filtering becoming better as the frequency increases. This section alone might prove satisfactory for sharpening the tuning for telegraph use, but for phone work would let through sufficient of the 120-cycle fundamental frequency to give a very unpleasant hum.

Section II is designed to eliminate this. It, too, is a low pass,  $\pi$  type, but it reaches its maximum attenuation at 120 cycles. Above this point the attenuation falls again to a moderate value, to rise more gradually toward infinity as the frequency becomes infinitely great.

As in any design problem, we have several types of elements entering. Certain of these are fixed for us by the conditions of the problem. Certain others we choose arbitrarily, or modify for convenience of construction or to utilize available materials. Still others are resultants of the values chosen in the first two classes.

In our case, the fixed factors are the impedance into which our filter is to work and the frequency of the supply, which determines the point where we need maximum attenuation.

The first of these factors—the impedance—is determined by the tube characteristics. It is *not*, however, the "output impedance" of the tube, which is an a.c. quantity. The function of the filter is to deliver direct current, hence

the impedance in question is a pure resistance, determined by Ohm's law:

$$R = E_p / I_p \quad (1)$$

Manufacturers' specifications give the normal plate voltage as  $350 = E_p$ , and the plate current as  $.045 = I_p$ . As there are two tubes to be supplied,  $I_p$  must be doubled. Therefore, substituting  $350 \div .045 \times 2 = 3890$  ohms, or accurately enough for our purposes, and easier to handle,  $R = 4000$  ohms.

Our exact cut-off point is not important, but we choose, arbitrarily, 40 cycles as being likely to lead to satisfactory attenuations at 120 cycles and above.

The conditions for cut-off are

$$Z_1 = -4Z_2 \quad (2)$$

From this is derived another equation of condition, more convenient for our use. Cut-off occurs when

$$Z_1 = 2R \text{ (numerically)} \quad (3)$$

As  $Z_1 = 2\pi L_1 f$ , at  $f = f_0 = 40$ , our cut-off frequency  $2\pi L_1 \times 40 = 8000$ ,  $L_1 = 31.8$  henrys.

This brings us to our next equation for filters of this type:

$$R = \sqrt{\frac{L_1}{C_2}} \quad (4)$$

Substituting:

$$4000 = \sqrt{\frac{31.8}{C_2}}$$

$$C_2 = \frac{31.8}{16,000,000} \text{ farads}$$

$$= 1.99 \text{ m.f.}$$

One buys condensers in 1 m.f. units. The cut-off point was chosen arbitrarily anyway, so we call  $C_2 = 2$ , which makes  $L_1$  (by equation 4) = 32 henrys, and gives cut-off at 39.8 cycles—a change of no moment whatsoever, even 5 or 10 cycles here being unimportant.

Section I is now completely specified—a 32-henry inductance coil in series with the line, and a 1 m.f. condenser ( $\frac{1}{2} C_2$ ) connected across the line at each end of the coil.

The design of Section II is derived from Section I with the aid of two coefficients. The first:

$$m = \sqrt{1 - \left(\frac{f_0}{f_\infty}\right)^2} \quad (5)$$

The second:

$$c = \frac{1 - m^2}{4m} \quad (6)$$

$f_\infty$ , the frequency of infinite attenuation, is 120 cycles.  $f_0$  is the cut-off point, 39.8 cycles, (40 is close enough). Therefore:

$$m = \sqrt{1 - \left(\frac{40}{120}\right)^2} = \sqrt{\frac{8}{9}} = .944$$

$$\text{and } C = \frac{1 - \frac{8}{9}}{3.775} = .0294$$

These coefficients are applied as follows:

$$L_1' = mL_1 \quad C_1' = cC_2 \quad C_2' = mC_2$$

or

$$L_1' = .944 \times 32 = 30.2 \text{ henrys.}$$

$$C_1' = .294 \times 2 = .588 \text{ m.f.}$$

$$C_2' = .944 \times 2 = 1.888 \text{ m.f.}$$

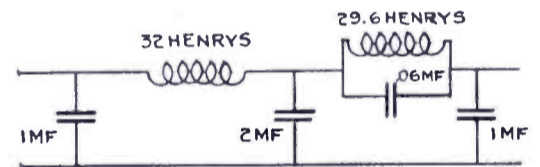

Fig. 2. Specific Design and Constants

Again we have capacities not readily available commercially, and again we solve the problem by taking the nearest commercial sizes. For  $C_2' = 1.888$  we take  $C_2' = 2$ , and in place of  $C_1' = .0588$  we adopt the value  $C_1' = .06$ .

In adopting the latter approximation there are further changes to be made. Cut-off points we may juggle more or less at will, but the value of maximum attenuation is fixed at 120 cycles.  $L_1'$  and  $C_1'$  together form a parallel circuit resonant to a frequency of 120 cycles. If we increase  $C_1'$  from .0588 m.f. to .06 m.f., we must decrease  $L_1'$  in the same ratio, in order to keep the product  $L_1' C_1'$ , and hence the resonant frequency, a constant. We have then:

$$L_1' = 30.2 \times \frac{.0588}{.0600} = 29.6 \text{ henrys.}$$

The only result of these changes is to shift slightly the cut-off again, this time to 39 cycles.

Fig. 2 shows the hook-up of the resulting two section filter.

In building the filter the condensers used will be those manufactured by any one of several telephone manufacturing companies. The shunt condensers have to withstand the full line potential constantly, and those chosen should have been tested to a voltage at least  $1\frac{1}{2}$  times as great. The series condenser, owing to its position in the filter system, has to withstand no such voltage, and

any telephone condenser of the proper capacity will serve admirably.

The inductance coils used have cores of the closed magnetic circuit type, but provided with an air gap. If a complete closed circuit were used, a great deal less material would be necessary to give the required values of inductance when measured on pure a.c. The direct current which constantly traverses the coils, however, would bring the core to magnetic saturation and the actual inductance would not only be smaller than computed (which we might allow for), but would also change greatly in value throughout the a.c. cycle, which would defeat the purpose of the filter completely. By adjusting the length of the air gap, the value of the inductance may be changed. Therefore we will make

On this basis then

$$L \times 10^9 = \frac{2.54 N^2 A}{7} \quad (7)$$

where  $A$  = the cross sectional area of the core in square inches,  $7$  = the length of the air gap in inches,  $N$  = the number of turns, and  $L$  = the inductance in henrys.

The air gap must be long enough to constitute the major part of the reluctance of the magnetic circuit to make the effect of "accidental" gaps—where the core plates are lapped—negligible. It must be short enough to keep the ampere turns required to magnetize it within reasonable limits. .1 inch is a reasonable value, and we will assume 1 square inch as the cross section of the core.

winding being kept as level as possible, but without any attempt being made to wind it exactly in layers—about 80% as many turns will occupy the same space. On this basis 8950 turns will take about 1.85 square inches of winding space, and we will interpret this as meaning a coil 2 inches long, with a winding depth of 15/16 inch.

Wind this coil on a core 1 1/2 inches square, solder flexible leads to the ends of the winding, remove from the form and tape. A coating of shellac is advisable.

Cut the plates as shown in the drawings. Silicon steel transformer sheets are best, of course, but soft black stove-pipe iron, gage 26 to 30, will serve perfectly. The tinsmith will sell you the latter and cut it for you into the bargain.

Lay up the core inside of the coil as shown, lapping joints at corners  $A$ ,  $B$  and  $C$ . The clamps are made of strips of hardwood 1/2 in. x 1 in. x 6 in., with 1/4-in. bolts, 2 3/4 in. long at the corners. The free end of the core at  $D$  must also be kept from vibrating. Wrapping the whole leg tight with friction tape will take care of that.

In the air gap, at  $G$ , put layers of felt to a thickness of about 1/4 in. when loose. A turnbuckle between the bolts at corners  $C$  and  $D$  serves to adjust the gap by compressing this felt.

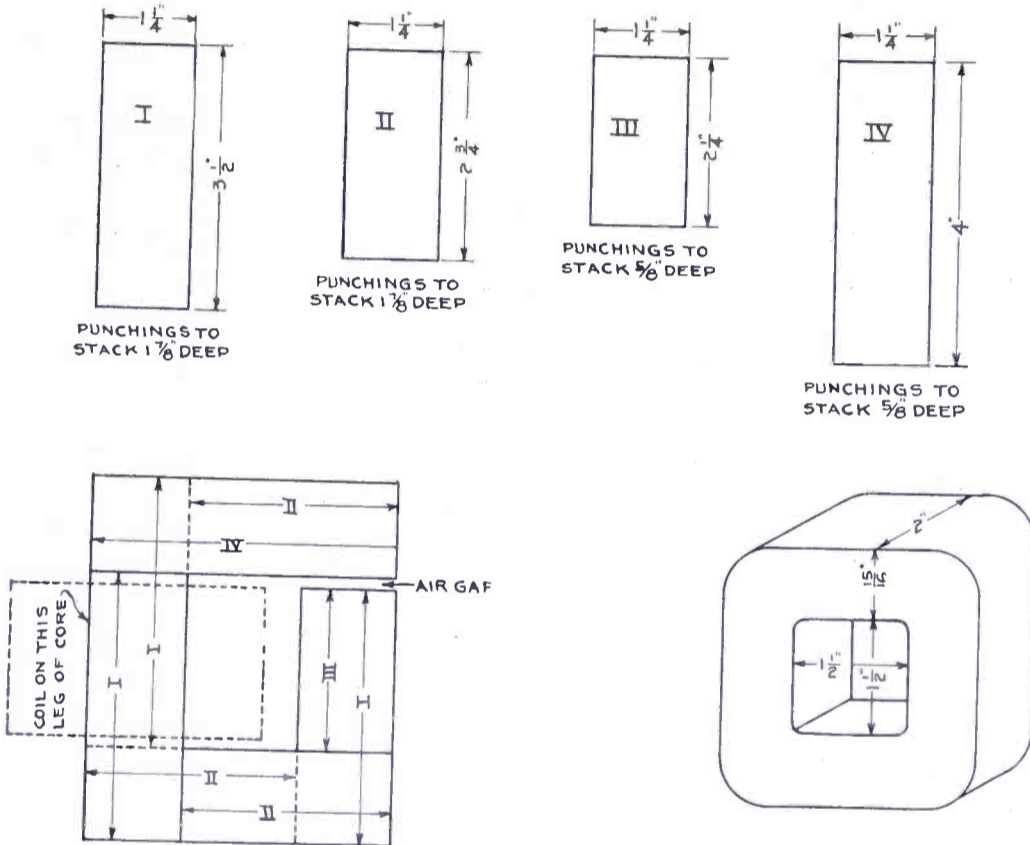

Fig. 3

the reactors used in the two sections identical and adjust for the exact value later.

The current in the coils is .09 amp. 800 circular mils is a conservative value to use in determining the size of wire to use. This gives 73 circular mils, and therefore 31 wire, with a cross section of 79 circular mils, is chosen.

The method of design is selected on account of its simplicity and ease of application. It is based on several assumptions, none of which are true, but which are sufficiently accurate for our purposes. These are, that all the flux threads all the turns of the coil, that the effective area of the air gap is equal to the cross sectional area of the iron core, and that no magnetomotive force is required to magnetize the iron, the entire amount being expended on the gap. The error involved in the last two approximations is in opposite directions, and they serve practically to neutralize each other.

We can now substitute in equation 7.

$$32 \times 10^9 = \frac{2.54 N^2}{.1}$$

Solving,  $N = 8950$  turns.

Wire tables show that with No. 31 single cotton-covered magnet wire, solid layer winding, 6000 turns will occupy 1 square inch of winding space. With "random winding,"—that is, with the wire wound into a form or bobbin, the

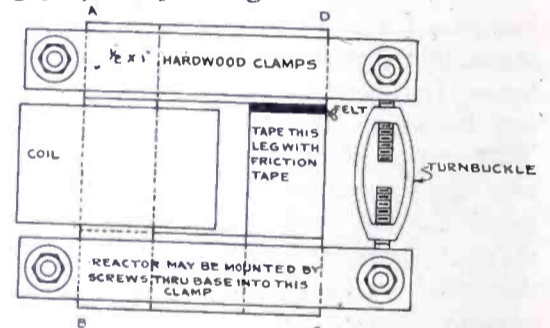

Fig. 4

The reactor for Section I of the filter will give best results with the air gap nearly closed—the turnbuckle drawn up as tight as possible.

Section II must be tuned. This may be done directly if proper precautions are taken, but a better way is to listen in on a receiving set while using Section II alone as plate supply filter in the transmitter. Adjust the turnbuckle until the characteristic hum (the so-called "60-cycle hum") is a minimum. Then connect Section I, and the results should be practically perfect filtering.



# Panel Layout and Drilling

By D. B. McGown

*This installment in the author's series on Home Radio Shop Practice is concerned with the details of laying out and drilling panels. Directions are given for mounting rheostats, meters and condensers and for working bakelite.*

THE laying out of a panel and its preparation for drilling is one of the most exacting tasks in home radio construction. It is especially difficult for the average amateur to properly place parts with offset holes, even when templates are provided by the manufacturer.

As an example, consider the methods of mounting a simple rheostat with  $\frac{1}{4}$ -in. shaft and two screws for panel support. The simplest method for mounting a single rheostat is to drill a  $\frac{1}{4}$ -in. hole at the point in the panel where the rheostat center is to be and then screw it fast to the panel by means of a  $\frac{1}{4}$ -in. machine screw which temporarily replaces the rheostat shaft. Then drill the two smaller holes of the same size as the fastening screws, and fasten the rheostat tightly in place with these screws after replacing the shaft.

If several such rheostats are to be mounted make a metal template fitted with a  $\frac{1}{4}$ -in. pin to fit the shaft hole and drilled with two smaller holes to match those containing the supporting screws.

An even better way is to use a center square as shown in Fig. 1. This is a

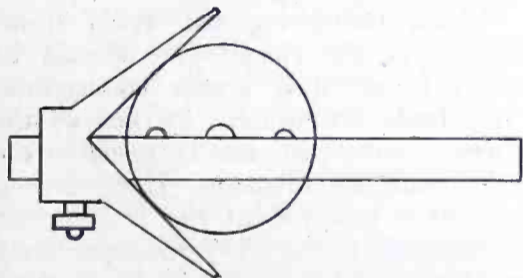

Fig. 1. Center Square Used for Rheostat Layout

steel scale with a sliding head cut at a right angle. The scale passes through the center of any circular object, when held as shown, so that a light line may be ruled with a steel scriber. The distances between holes are measured with a pair of dividers, and laid off on the panel for any number of rheostats. Then center-punch the holes and drill them, without bothering with a template. A center-square is also useful in laying off an object whose holes are off center. Front mounting meters are usually of this kind. Slide the center square around until it is equidistant from the two projecting terminal screws, which are represented by *A* and *B* in Fig. 2. A pair of small inside calipers should be used to lay off the distances so it is exactly even, the first position of the calipers being shown at *C*, and the second at *D*. These two distances being equal, a scribe line is drawn along the upper edge of the steel

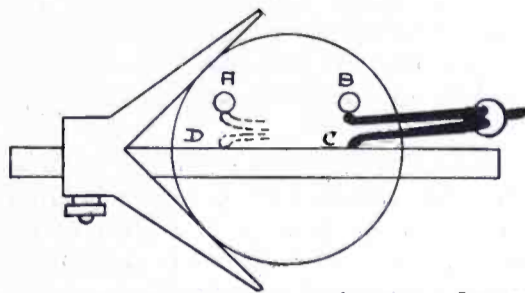

Fig. 2. Center Square Used for Meter Layout

scale, which is the center line of the meter, with reference to the terminals. The square being removed, we have a line across the meters, as shown in Fig. 3; this line is then bisected, by setting the dividers at each end, and swinging on a radius greater than half the distance across the meter, and erecting a perpendicular, which gives us two center lines, from which we work. Take a pair of calipers, which are illustrated in Fig. 3, and take the distance *FG*, as

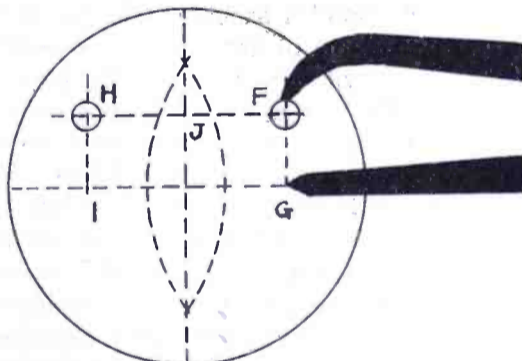

Fig. 3. Method for Determining Meter Layout

shown. This will be the exact distance from the center line of the meter to the center of the terminal hole one-half the diameter of the terminal stud, this latter distance to be taken off the distance *FG*, when it is laid out on the panel, which will give the exact distance of the center of the terminals from the center line of the meter. This process is repeated at points *HI*, and laid off on the panel. The same process is then repeated between the points *FJ* and *HI*, and these distances laid off. The intersection of the two lines, *FG*, and *HF* at *F* is the point to mark and drill for one stud, and the point of intersection of *HI* and *HF* will be the point for the other terminal. In like manner, it is possible to lay off many other irregular objects. It is much harder to lay off an irregular object such as a "square-law" condenser, where the centers of the holes are not true to any circular function. But a little patience and thought will enable the exact size to be laid off.

Another simple method is to wet the screw-ends with paint or shellac and

press them onto a piece of cardboard (or the panel if desired). The exact template of the object to be drilled will be left, and the holes may then be center-punched and drilled.

THE materials on the market under various names such as "Bakelite," "Condensite," "Formica," etc., are of the same general consistency, being made up of a paper or other base, saturated with bakelite and pressed into working shape. Bakelite is formed when carbo-lic acid and formaldehyde are permitted to react upon each other so as to form a brown jelly which can be vulcanized and formed into the shape desired. This amber jelly can be dyed any shade. If soft, porous paper is allowed to absorb this jelly, the resulting mass may be vulcanized by heating under hydraulic pressure, and the sheet bakelite of commerce will thus be formed. The thickness of the bakelite sheet will depend on the amount of paper used and the pressure applied.

Bakelite tubing is made up of similarly prepared paper tubing. Bakelite rod is either made similarly or by sawing sheet bakelite into square strips, which are turned into round rods. Such rods are almost impossible to turn in a lathe, as they have a bad cross-grain and cannot be knurled, or finished, like the moulded rod can.

Moulded bakelite, such as knobs, receiver caps, switch and jack parts, etc., is the raw bakelite sufficiently hardened to take on a powdery form. This bakelite powder is placed in moulding dies, and then, under pressure and heat, the moulded part is made. Such parts are of fair mechanical strength, but are quite brittle, and do not compare with the sheet bakelite for durability.

Bakelite may be punched, drilled, sawed, turned, and milled in the same machines that are used for metal. It is considerably softer than most metals, and naturally has a great deal more grain, which must be taken into account when working it; indeed, when working the edge of a piece of bakelite it will be found to possess almost as much grain as many hardwoods, and for this reason edgewise tapping or drilling should be done very carefully.

Bakelite drilling should be carried on at a moderate speed, using carbon steel twist drills, and the feed should be rather slow. Hand-feed is the best and the drill should never be crowded. Rather let it bite into the bakelite and

*Continued on page 70*

# Comments on Audio Frequency Transformers

By Orrin E. Dunlap, Jr.

*These comments, being based on experience, may be used as a guide in the choice of the general type of transformer to meet given needs. They are accompanied by a two-stage a. f. circuit with honeycomb coils.*

THE most serious criticism of most amplifying transformers is their inability to accurately reproduce notes below middle C of the piano. This fault decreases the accurate reproduction of the bass saxophone, violoncello, bass baritone, bass of organs and pianos, trombone and drums. Tinny music is not always caused by the loud speaker. It is traceable in many cases to a poorly designed amplifying transformer.

It is a puzzle to many radio followers whether to employ a high ratio transformer on the first stage and a low ratio transformer on the second stage or low ratio transformers on both stages. Some manufacturers recommend a high ratio transformer on the first stage and a low ratio transformer on the second step. They feel that the voltage on the first stage is low enough to warrant the use of a high ratio transformer without distortion. A high ratio transformer such as 9 or 10 to 1 is not recommended for the second stage because it would so greatly intensify the voltage that distortion would result.

There is another group which advocates the use of low ratio audio transformers on all stages of the audio amplifier unit. They claim that if distortion results from the use of a high ratio transformer on the first stage the distortion as well as the signal will be amplified by the second amplifier. The high ratio transformers may give superior amplification between certain frequencies, but, for best results on all frequencies, the low ratio transformers should be used on both stages.

When it is said that an amplifying transformer has a ratio of 5 to 1, the meaning is that the voltage of the secondary is five times as great as that applied to the primary. This step-up voltage increases the variations in the grid voltage. The grid voltage must not be increased too much because after a certain voltage is applied to the grid the tube reaches a saturation point. If a high ratio transformer is employed which increases the grid voltage past the saturation point the music or voice will be distorted.

The majority of audio-frequency amplifying transformers on the market today operate efficiently on one particular frequency but do not do justice to other frequencies. A musical instrument produces many different sound frequencies, that is, the sound varies from low vibrations to high pitched tones. Therefore, if an amplifying transformer is particularly adapted to intensify the electrical current representing a particular fre-

quency and is opposed to other frequencies, the music will be distorted. This misrepresentation makes little difference in the case of jazz because a certain amount of distortion adds to the syncopated effect.

Few transformers are made with an effective amplification greater than four, that is, if the voltage is applied to one side of the primary of the transformer it will be increased in strength four times after passing through the secondary. Most transformers rated with amplification factors of seven or eight are capable of such amplification only at a particular frequency. Few transformers, even of the same manufacturer, prove capable of equal performance under tests.

More than two stages of audio-amplification are not practical because circuit noises and battery disturbances are also amplified, making it unpleasant to listen to the music.

An audio-frequency amplifier does not increase the range of the receiving set. If no signal is audible in the phones without the use of the audio-frequency amplifier it will not be audible even if two amplifier tubes are employed. If signals are faint, yet strong enough to actuate the detector, they can be amplified by audio-frequency amplification. If one tube is capable of intensifying a signal twenty times, two tubes theoretically would be capable of amplifying four hundred times and three tubes eight hundred times.

The average radio enthusiast little realizes the elaborate workmanship which enters into the standard audio-frequency amplifying transformer. One transformer on the market has 3,800 turns of No. 40 enamel wire for the primary winding. No. 40 wire is about the diameter of a hair. The secondary winding consists of 13,300 turns of No. 40 enamel wire and is separated from the primary by three thicknesses of

.005-inch moleskin paper. The primary and secondary leads are sixteen strands of No. 38 bare copper wire stranded together and covered with a wrapping of green silk. The coil is impregnated under a vacuum process in a compound of beeswax and resin and then covered with a black cloth.

A transformer which will reproduce frequencies ranging from 100 to 4000 cycles with little distortion is ideal for audio-frequency amplification. However, it is difficult to obtain such a device, although a few transformers on the market will operate well on frequencies ranging from 300 to 4000 cycles. If a loud speaker is used it is well to have the transformers favor the higher frequencies. Transformers having a ratio ranging from 5 to  $3\frac{1}{2}$  to 1 have proven successful for general use.

The type of tube has considerable to do with the success of the amplifying transformer. If the tube has a high plate resistance it will have a tendency to distort at the higher and lower frequencies. If an audio-amplifying transformer is designed to operate with a particular tube and it is used with another type of tube the results will not be satisfactory.

When connecting the audio transformer in the circuit care should be taken to establish proper connections. The leads are usually marked so the correct connections can be made to the grid, plate and filament. If the wrong secondary terminal of the transformer is connected to the grid howling is likely to occur. All wire should be as short as possible, especially those leading from the grids and plates. By connecting the cores of audio transformers to the ground binding post on the set howls are minimized. A .001 mfd. fixed condenser should be used across the primary of the first amplifying transformer to aid regeneration and help to eliminate howls.

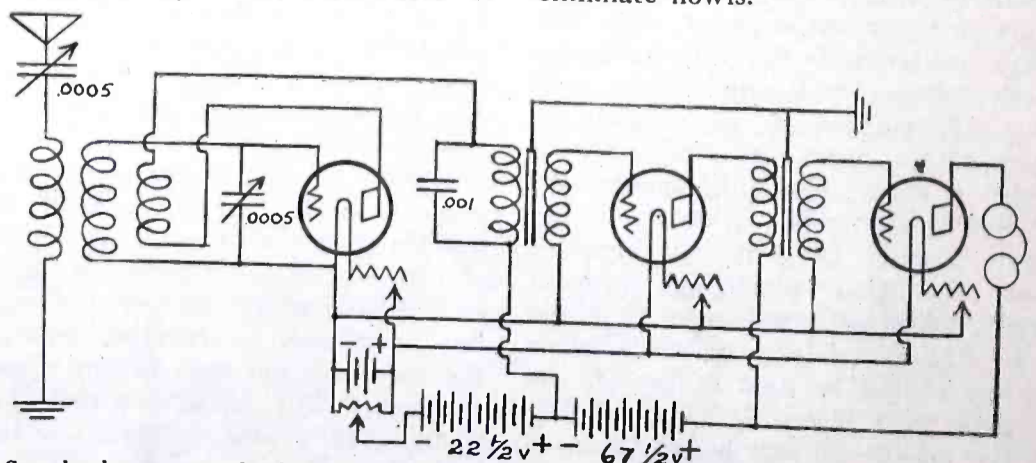

*Standard vacuum tube detector and two-stage audio-frequency amplifier circuit using honeycomb coils No. 75 for primary, No. 50 for secondary and No. 35 for tickler; potentiometer across "A" battery 400 ohms; audio-amplifying transformers 5 to 1 ratio.*

# Radio Condensers

By L. H. La Montagne

*After pointing out the factors which should govern the choice of a condenser, the author presents simple formulas and tables for calculating the capacity of condensers connected in series and in parallel. He concludes with instructions for measuring capacity.*

**A** CONDENSER, as used in radio, may be considered as two or more plates, separated by an insulating medium termed the dielectric. Since its electrostatic capacity is the most important and desired property, care is taken to exclude leakage, resistance losses and inductance. In radio work, since the frequencies are high, the dielectric is practically limited to air, glass, or mica, which will show the lowest losses. Of these three, air will show the least, and is generally used where the voltage is low. For direct current work, as in filters, etc., the losses are small as compared to high-frequency work, and paper, oiled silk, etc., may be used, if the material is of such thickness as to stand the applied voltage.

For receiving condensers, the dielectric should be air or mica—preferably air, unless the condensers are fixed. For transmitting, mica is generally used and of sufficient thickness to stand the voltage. Glass has been used for spark work, but on C. W. mica is used because of the lower voltages employed. The thickness of the dielectric should be such that arcing or breaking down of the material is prevented. The plates should be of a good conducting material such as copper, brass or aluminum. Tinfoil may be used, but its resistance is somewhat higher, though for most uses this is no disadvantage. The leads should be of copper firmly fixed to the plates. On variable condensers the leads from the rotary plates should preferably be of flexible copper, though if a good type of scraping contact is used a low resistance contact will be made.

Probably the most important part is the insulating material used to support the plates, and insulate them from each other. This material should be as perfect as possible, have a small change in size with temperature, and very little change with age. The plates, especially in a variable condenser, should be located so that no great dielectric field is

set up in them. The ends should be of such a size and shape as to have a minimum leakage. Most condensers that have a small insulating bushing set in a metal collar will show large losses, and so will ones with fibre ends.

Bakelite will show large dielectric losses, but it is a better insulator, and has more mechanical strength than most other substances, so it is usually used. Porcelain and hard rubber have lower losses. In the Bureau of Standards standard condensers, quartz is used for insulating the plates, but this method is out of the question for ordinary work.

The condenser as a whole should be rigid so that there is little danger of the plates rubbing, as sometimes happens in variable condensers. For fixed condensers, the terminals need to be rigid to prevent breaking the connections to the plates. The plates in rotary variable condensers should be heavy enough to prevent bending if accidentally hit. The spacing should be sufficient so that the plates do not have too great a tendency to rub. On the other hand the spacing should not be too great so as to decrease the capacity too much. The rotary plates should be fastened to the shaft so that there is no danger of their loosening. The use of stops is not advisable, as they tend to loosen the rotary plates or the dial. The back connection should exert a slight pressure on the shaft to hold it in any position, and to make a good firm connection if a flexible lead is not used. Most condensers are weak at this point and using them for a while will cause dirt to accumulate, which makes a high resistance connection.

**T**HE capacity of a rotary condenser as used in receiving sets is

$$C = 0.1390 \frac{K(N-1)(r_1^2 - r_2^2)}{t}$$

where  $C$  is the capacity in microfarads.  $K$  is the dielectric constant,  $N$  is the number of plates,  $t$  is the thickness of the

dielectric in cm.,  $r_1$  is the outer radius of variable plates, and  $r_2$  inner radius of plates. By inner radius is meant the part of the fixed plate that is cut out to allow the rotary plates to fit into them. The formula gives the maximum capacity possible.

If several condensers are connected in parallel, the resultant capacity is

$$C = C' \div C'' \div C''' \dots \text{etc.}$$

$C'$ ,  $C''$  being the capacity of each individual condenser. If the condensers are in series, we have

$$1/C = 1/C' + 1/C'' + 1/C''' \text{ etc.}$$

It will be seen that the resultant capacity is always less than the smallest unit. Table 1 gives the resultant capacities when two condensers are connected in series. If more than two condensers are connected in parallel the method of procedure is as follows:

Suppose  $C'$  is .0004 mfd.  $C''$  is .0006 mfd. and  $C'''$  is .0002. Taking first  $C'$  and  $C''$  together, we find that their resultant series capacity will be .00024 mfd. Using this value of .00024 with  $C_3$  we find that the capacity of the three condensers in series would be .00011 mfd. more or less.

Condensers are usually connected in series to lessen the applied voltage to each unit, but in direct current work, such as filters, each unit should be able to stand the full potential, as the breaking down of the insulation in one to a slight extent will throw the full voltage on the remaining ones.

**T**HE usual method of measuring the capacity of an unknown condenser is to compare it with one which has been previously calibrated. In order to obtain any degree of accuracy, introducing the two condensers separately into the circuit must be arranged so as not to change leads, etc. The condensers should be shielded and the shields attached to ground, but for ordinary work

TABLE 1. RESULTANT CAPACITIES WITH TWO CONDENSERS IN SERIES  
Capacity of  $C'$  in Mfd.

	.0001	.0002	.0003	.0004	.0005	.0006	.0007	.0008	.0009	.001
.0001	.00005	.00006	.00007	.00008	.00008	.00009	.00009	.00009	.0009	.0009
.0002	.00006	.00010	.00012	.00013	.00014	.00015	.00015	.00016	.00016	.00017
.0003	.00008	.00012	.00015	.00017	.00019	.00020	.00021	.00022	.00023	.00023
.0004	.00008	.00013	.00017	.00020	.00022	.00024	.00025	.00026	.00027	.00028
.0005	.000083	.00014	.00019	.00022	.00025	.00027	.00029	.00030	.00032	.00033
.0006	.000086	.00015	.00020	.00024	.00027	.00030	.00032	.00033	.00035	.00036
.0007	.000088	.00015	.00021	.00025	.00029	.00032	.00035	.00037	.00039	.00041
.0008	.000089	.00016	.00022	.00026	.00031	.00034	.00037	.00040	.00042	.00044
.0009	.00009	.00016	.00023	.00027	.00032	.00036	.00039	.00042	.00045	.00047
.0010	.000091	.00017	.00023	.00028	.00033	.00038	.00041	.00044	.00047	.00050
.0011	.000092	.00017	.00024	.00029	.00034	.00039	.00043	.00046	.00049	.00053
.0012	.000096	.00017	.00024	.00030	.00036	.00040	.00044	.00048	.00051	.00055
.0013	.000093	.00017	.00024	.00031	.00036	.00041	.00045	.00050	.00053	.00057
.0014	.000093	.00018	.00025	.00031	.00037	.00042	.00046	.00051	.00055	.00058
.0015	.000094	.00018	.00025	.00032	.00038	.00043	.00047	.00052	.00057	.00060
.0017	.000094	.00018	.00026	.00032	.00039	.00044	.00049	.00054	.00059	.00063
.0020	.000095	.00018	.00026	.00033	.00040	.00046	.00052	.00057	.00062	.00066

this need not be done as long as the condensers are in the open and not near other objects.

If the unknown condenser is fixed, we need only substitute it in the circuit as shown in Fig. 1, and obtain the wave-

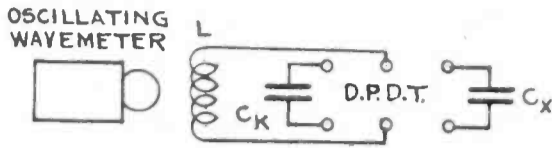

Fig. 1. Circuit for Measuring Condenser Capacity

length. Then throwing the switch to the calibrated one, which may be fixed or variable, we have

$$\lambda_x = 59.6 \sqrt{L C_x} \quad \lambda_k = 59.6 \sqrt{L C_k}$$

$$\text{or } \lambda_x / \lambda_k = C_x / C_k$$

where  $\lambda_x$  = wavelength with unknown,  $\lambda_k$  = wavelength with known,  $L$  = fixed inductance,  $C_x$  = unknown capacity and  $C_k$  = known capacity.

If our known capacity is variable, it would only have been necessary to determine the wavelength with the unknown, and then substitute the known condenser and vary its capacity until the same wavelength is found. Then  $C_x = C_k$ .

The above method is used in nearly all cases except for very high or low capacities.

If the unknown capacity was small, then the circuit would be as in Fig. 2.

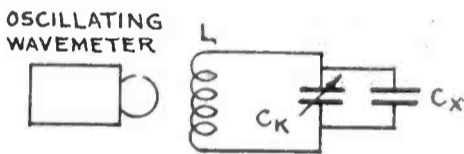

Fig. 2. Measurement of Small Capacities

The unknown capacity would be computed as before, or if  $C_k$  was variable, we would first set it at some capacity  $C_x$  and determine the wavelength,  $\lambda_x$ . Then connecting in  $C_x$ , we would decrease  $C_k$  until we obtained the same wavelength as before. Then

$$C_x = C_k = C'_k$$

$C'_k$  being the last condenser setting obtained on the calibrated one.

The limit to which the measurement may be carried depends upon how close we can tune the two circuits. For these measurements,  $C_k$  should be a variable not over .0002 mfd. in capacity. The circuits should be coupled as loosely as possible in order to still further sharpen the tuning.

For very large capacities, the circuit is shown in Fig. 3. The large condenser is set at a low reading and the capacity is determined as in the first instance. Then the two condensers are connected in series, and the large unknown is set at the previously determined point, and the smaller known condenser at its maximum reading. Then, keeping the wavelength constant, the smaller known con-

denser is lowered while the unknown is increased, keeping the wavelength constant, with each increase in the larger

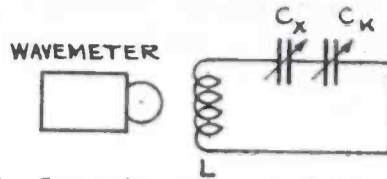

Fig. 3. Comparison of Large Variable with Small Standard Condenser

one. The capacity is determined as in the case with small capacities. When the capacity of the small standard may no longer be reduced, the larger condenser is again set at its last determined point, the standard is set at its maximum, the new wavelength determined, and the same procedure is again gone through.

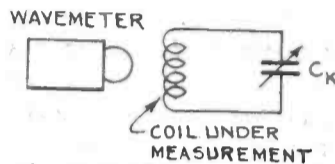

Fig. 4. Circuit for Measuring Coil Capacity

The capacity of a coil may be determined as follows: Fig. 4 shows the connections. The wavelength is determined for various values of  $C_k$  and then plotted as the wavelength squared against the values of  $C_k$ , thus giving a straight line, Fig. 5. If this straight line

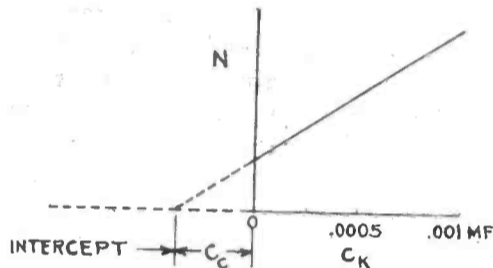

Fig. 5. Graphic Determination of Coil Capacity

is extended until the line intercepts the  $C_k$  line (in other words wavelength is zero), the intercept will give  $C_c$ , the capacity of the coil.

If the above measurements are carried out with a vacuum tube oscillator very accurate results will be obtained, if care is taken to prevent stray capacity to nearby objects.

### CRYSTAL-TUBE COMBINATION FOR EMERGENCIES

By HARRY A. NICKERSON

There comes a time in every experimenter's life when, due either to accident to the tube or neglect in keeping the batteries in condition, his tube set is temporarily out of commission. It is in an emergency of this kind that the crystal detector will demonstrate its worth, and in many cases win a permanent berth with your valued tube equipment.

To guard against such an emergency as this it is advisable to have a crystal detector handy, but better still is a combination crystal and tube set especially

built for the occasion. To make a combination receiver of this type requires but a few simple changes in your present set as shown in the diagram of Fig. 1, and as explained in detail here:

Carry a wire from the tube socket plate terminal (or from nearest point on wire connecting the plate coil to plate terminal of the tube) to one side of a crystal detector stand (as shown at A). This stand should be mounted outside on the panel of the set near the plus B binding post. The stand should also be mounted where it will be accessible in order to adjust the catwhisker on a sensitive spot of the crystal.

When it is desired to use the crystal detector, turn off the filament current of the tube at the rheostat, disconnect the B battery entirely from the set and run a "jumper" or wire from the plus B battery external binding post on the set to the terminal side of the crystal detector stand marked B.

The set is now ready for use as a crystal set. Tuning of the antenna circuit is accomplished in the same manner as when using the tube, but the secondary circuit is left untuned, variation of the rotor serving to control the coupling between circuits.

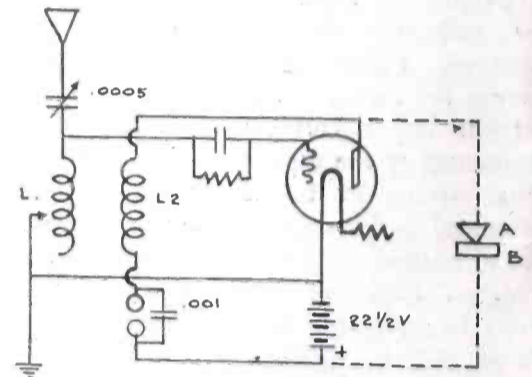

Crystal Tube Combination.

Note that when using the crystal detector its output goes to the same binding posts or jacks as used for the output of the tube. This makes possible the addition of audio amplification to the crystal or tube from the same output terminals of the set. If a two-stage audio amplifier be added to the crystal the volume from local stations should be sufficient to operate a loud speaker and the quality of the reproduction will be better than with a tube detector. Another advantage is less static and, of course, no battery expense for the crystal.

To change over to the tube set simply remove the jumper connecting the plus B binding post of set and the detector stand, connect the B battery to its usual binding posts, light the filament and the set becomes the same old "single-circuit" again.

Don't slam the spark-coil ham—he doesn't know any better: grab him, and steer him right; he is the future radio engineer of tomorrow, and deserves help, not hindrance.

# Construction of a High Voltage Transformer

By Florian J. Fox

*This is the third article in the series on the construction of a C. W. transmitter. It will be completed by a discussion on filters in February RADIO.*

## Transformer Construction

We shall now describe the construction of a suitable high voltage transformer. This transformer contains a filament-heating secondary and double high voltage windings tapped for 350, 450 and 600 volts.

There are several ways of obtaining core iron. The most obvious is to use the core of an old spark transformer, or any other transformer of suitable size. If a spark transformer is to be rebuilt, save the primary winding, as it can be used. To find out how many turns the primary contains, simply wind a few turns of wire around the core, apply 110 volts to the primary, and measure the voltage induced in this test winding. Knowing the number of turns wound on, and the voltage induced in them, we obtain the primary turns (approximately) by the simple ratio:

$$\frac{E_{\text{sec}}}{T_{\text{sec}}} = \frac{E_{\text{pri}}}{T_{\text{pri}}}$$

Say that 20 turns were wound on and 5 volts were measured.

$$\frac{5}{20} = \frac{110}{\times} \quad \times = \text{turns pri} = 440$$

This information will be required when the secondaries are designed.

Sometimes electricians have old transformers from which core iron can be obtained. Core iron can always be bought—cut to size—from electrical supply houses.

The writer once tried to make a core by cutting up stove pipe iron. At the expense of considerable physical effort, the core was finally completed, but it proved to be poor and inefficient, and was later discarded.

Sufficient laminations should be procured to make a core whose cross sectional area will be about two square inches. To make a square core of approximately this cross section the laminations should be about 1.4 in. wide and stacked up to about the same height. These dimensions do not have to be adhered to strictly.

When an old spark transformer is used, only the leg containing the secondary need be removed. In any case, remember how the core was originally put together and assemble it again in the same way.

If U or L type of laminations are used, alternate them in such a way that each layer of laminations covers the joint of the preceding layer. The coils are placed on a bench the proper distance apart and the laminations are then slipped into place.

If strip laminations are used, build up two legs by piling them up so that each lamination is shifted alternately to one side and to the other by a distance equal to the width of a lamination. See Fig. 5. Stack up the right number, then clamp both ends and tape the portion between the clamps.

The windings can later be slipped over these legs. The laminations of the side legs can then be slipped in one by one. These will also be staggered in a similar way. The diagram Fig. 5 will probably make this point a little clearer. The core window should be about 4 in. x 5 in. In the construction of the coils we must first find out how many turns are required for the primary winding. The number of turns will fix the point on the magnetization curve at which the iron is worked. Too many turns cause a waste of copper, too few overheat the core.

A formula is made use of.

$$E = \sqrt{2} \pi f n A B 10^{-8}$$

$E$ —induced voltage.  
= impressed voltage.  
= 110 in most cases.

or solving for  $n$

$$n = \frac{E 10^8}{4.44 f A B}$$

$f$ —frequency—usually 60.

$A$ —cross section of core in square in.

$B$ —flux density at which iron is to be worked. Let  $B=60,000$  lines per square inch.

Example—using typical data:

$$n = \frac{110 \times 100,000,000}{4.44 \times 60 \times 2 \times 60,000}$$

$n=344$  or roughly 350 turns.

In case the builder has a core of a different cross sectional area, simply substitute this value for the 2 in the denominator, and solve. To make this a little easier we can write the expression

$$n = \frac{K}{A} = \frac{688}{A}$$

$n$ —No. of turns.

$A$ —area of core; cross section; square inches.

This assumes that 110 volts are used at 60 cycles. In case a different voltage or frequency is used it will be necessary to use the original formula.

Remember that the larger the cross section of the core, the fewer will be the turns required on the primary. Since the ratio will be about 6 to 1, this means a much greater saving in secondary turns also. We can save a great deal of copper at the expense of a little iron. This cannot be carried too far, for increasing the core size will also increase the length per turn. Cores of cross sectional areas between 2 and 3 square inches work out very well.

The primary then, let us say, should have 350 turns (core 2 sq. in.). Use No. 18 D.C.C. wire.

A wooden winding form should be made. This consists of a tapered wooden block. The cross section should be similar to that of the core; namely, square if the core is square. The dimensions of the smallest end should be somewhat larger than the corresponding dimensions of the core. The dimensions of the larger end should be about  $\frac{1}{4}$  in. larger than the dimensions of the smaller end. The block is to be as long as the desired length of the coil. In our case this was 4 in. Two end pieces are made for this form. The piece that goes on the larger end of the block can be permanently fastened to it. The other end-piece should be attached with screws so as to be readily removable. A  $\frac{3}{8}$ -in. hole is drilled through the center of this form. To one end-piece affix some sort of a crank. A large brad will serve. Clamp a piece of  $\frac{1}{4}$ -in. rod in a vise and use this for an axle. Before winding, it is well to lay a piece of wire lengthwise along the core block on each of two opposite sides. Next wind on a layer of insulating paper (of 4-in. width), then wind on the wire. Guide the wire

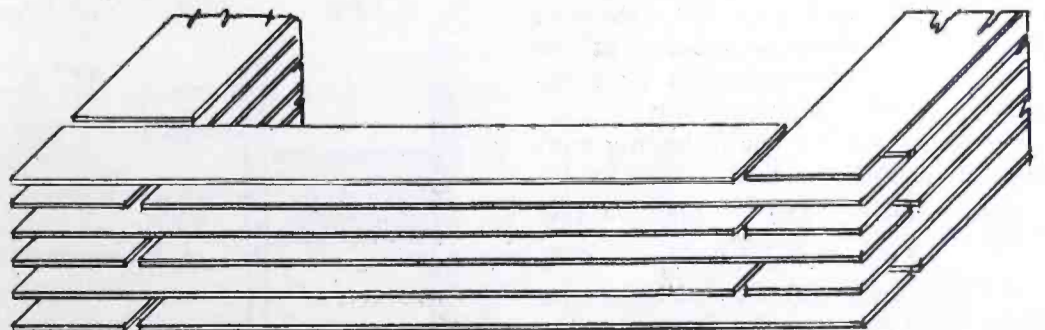
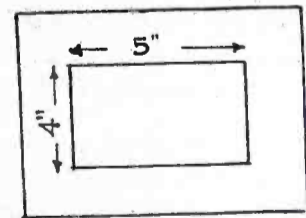

Fig. 5. Method of Stacking Laminations

with the hand. Count the turns accurately. The writer never attempts smooth layer winding. It takes too long and is hardly worth the trouble.

When the coil is finished, wind on a few more layers of insulating material and wind over this primary coil, the filament-heating secondary. To allow for voltage drop, this coil is designed to deliver 110 volts at no load. Using the

$$\text{ratio } \frac{10}{X} = \frac{110}{350} \text{ we have } X = 32 \text{ turns.}$$

Use No. 12 D.C.C. wire. Take a tap at the 16th turn and finish.

The ends of the wires that were laid along the core are now tied together. These will serve to hold the coil together when it is removed. Take off the end-piece, tap the core, and the coil will slip off without trouble.

Now tape the coil longitudinally; that is, pass the tape in through the core hole and out around the outside. To do this the tape will have to be cut into 4-ft. lengths. This produces a neat, business-like, rugged product. Some pictures are shown which can be profitably studied.

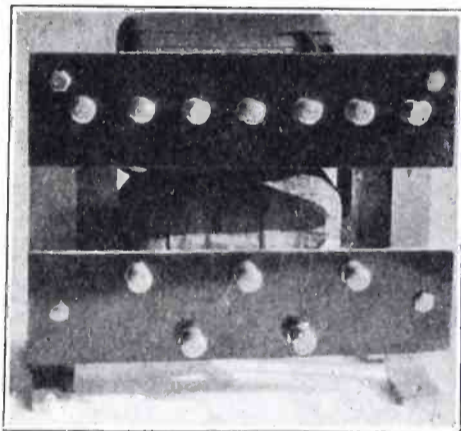
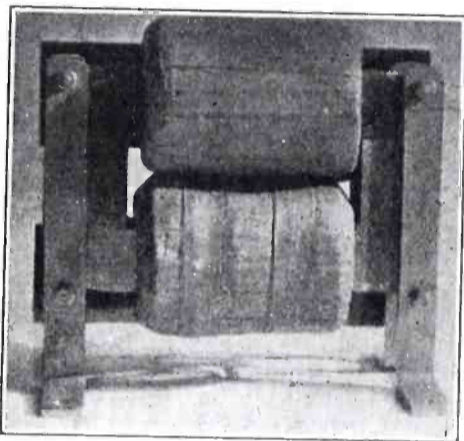

Assembled Transformer

The purpose of the center tap on the filament winding is to furnish the neutral of the filament voltage. The inductance and other leads are connected to this rather than to one leg of the filament. This eliminates to a great extent the so-called filament hum.

The secondary has the following voltages: 350, 450, and 600. This corresponds to  $\frac{350}{X_1} = \frac{450}{X_2} = \frac{600}{X_3} = \frac{110}{350}$   
 $x_1=1112 \quad x_2=1430 \quad x_3=1910$  turns.

The 1112 may be called 1120 for simplicity.

Because we are going to obtain full wave rectification, the secondary will have two similar halves. See Fig. 6.

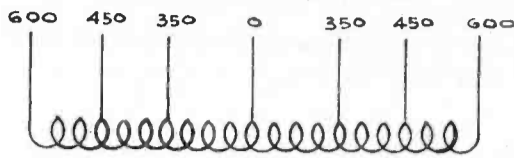

Fig. 6. Secondary Winding

The secondary winding is made in the same manner as was the primary coil. The same form is used. Wind with No. 28 D.C.C. wire. D.C.C. enameled wire is even better. This heavy insulation permits random winding.

In order to insure the voltages coming in the right order, wind as follows:

- 1st tap or lead . . . beginning of coil
- 2nd lead . . . . . at 480 turns
- 3rd lead . . . . . at 790 turns
- 4th lead . . . . . at 1910 turns

This last is the neutral wire, or center of the secondary. For convenience we can call this zero and begin counting again for the rest of the secondary.

- 5th lead . . . at 1120 turns beyond 4
- 6th lead . . . at 1430 turns beyond 4
- 7th lead . . . at 1910 turns beyond 4 or—end of coil.

Some means of marking these leads as the winding progresses should be devised. Cardboard labels or ink marks on the leads will serve. Care in this respect will save confusion later. Care should also be exercised in counting the turns. It is surprisingly easy to forget how many hundred turns have been wound. A difference of a hundred turns will cause a sufficient unbalance in

voltage to produce an objectionable hum or ripple in the C. W. This point is very important.

A great deal could be said about the mounting of the transformer. One or two suggestions will be offered and the rest left to the ingenuity of the reader.

The writer generally mounts his transformers by means of heavy brass strip stock. The strips are cut, screw holes drilled, and then bent to shape. The laminations are clamped between these supports by means of bolts. Binding post panels, as shown in the pictures, not only add to the convenience, but also add greatly to the appearance.

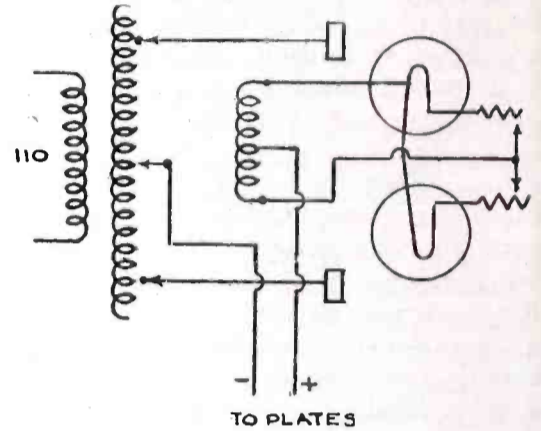

Fig. 8. Method of Using Kenetron Rectifiers with Transformer

A word of caution: In mounting be very careful that no complete metallic path is made around the core, similar to a turn of wire on the coils. Such a condition would be the same as a short-circuited turn of low resistance. Chances are that if the house fuses held out long enough, the transformer primary would burn out.

When changing the plate voltage, always have the same voltage on each side of the neutral.

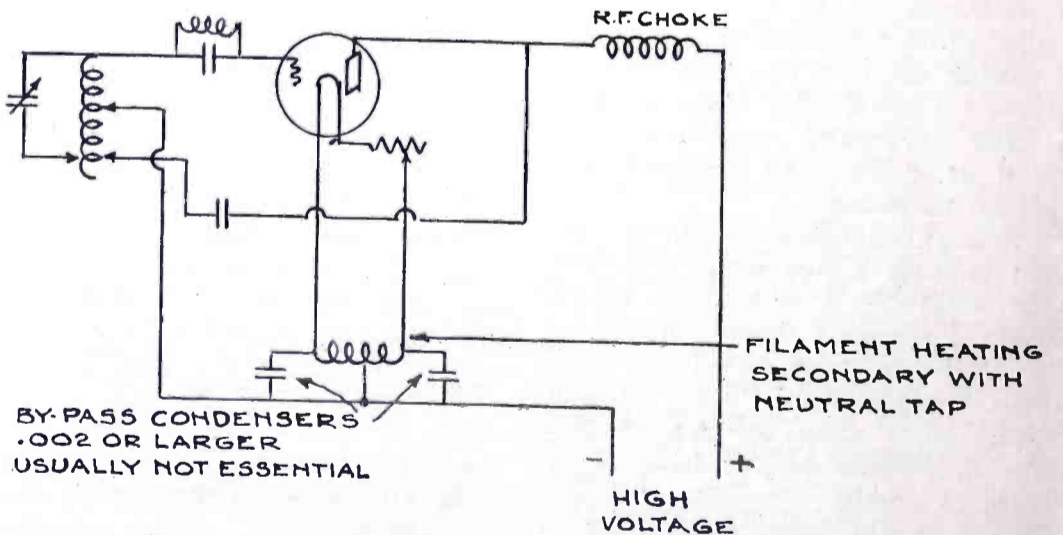

Fig. 7. Method of Using Neutral Lead of Filament Heating Secondary

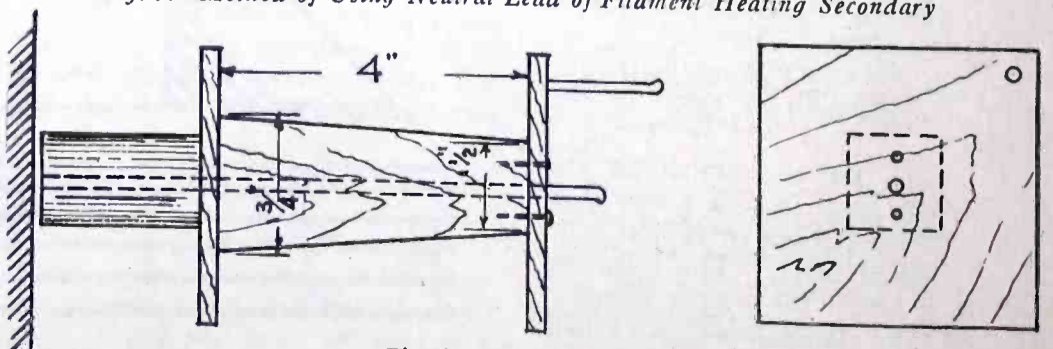

Fig. 9. Winding Form



# A Break-In System

By A. E. Banks

IN the good old spark days, now gone beyond recall, one of the chief delights of the air was the use of a competent "break in." To listen to two good operators handle traffic in the "wee sm' hours," employing such a device, was the essence of niftiness. No long calls, and "Pse repeat, start—stop....." When a word was "gummed up" in local or other QRM, the receiving station simply stepped on the key a moment and the transmitter immediately stopped, and, with practically no loss of time, continued when again transmitting at the point where the interruption came. It was in pure unadulterated "Hamming," however, that the "break in" came into greatest prominence. With two "hum-dingers" at the keys of the respective stations, nothing so simulated phone conversations as the use of this system. Interruptions in the middle of a sentence and interjections by one or the other in no way broke up the sense or continuity of correspondence. In other words, a "break in" was the real dope.

The antenna is connected to the moving member, the central tongue, and the transmitter and receiver to the respective contacts. The spring holds the tongue in contact when the key current is off. This contact is the one for connection to the receiver. The antenna current from the transmitter will always find things ready, providing proper adjust-

is a non-oscillatory circuit and perhaps lead to disaster.

If a separate receiving antenna is used, of course we have a "break in." Also, as some of us have discovered, we have a robber of antenna "jazz" at times, and again Mr. BCL occasionally finds a nice young harmonic. Of course all these things can be obviated and there

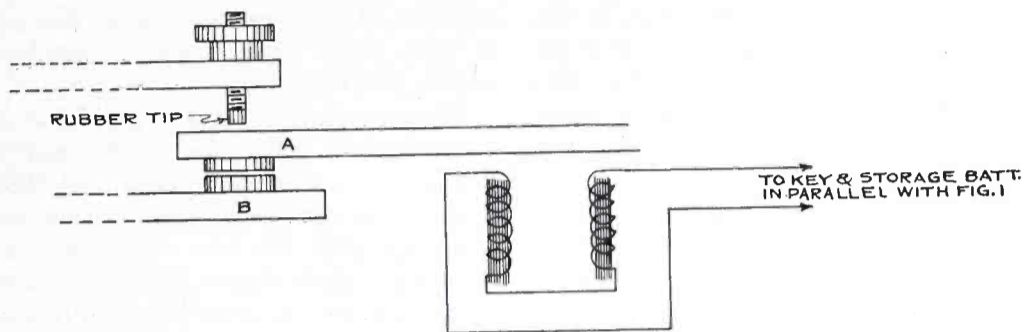

Fig. 2. Power Control by Sounder, A and B Connections for Replacing Old Key

ments are made initially. As to permanence of adjustment, one such installation was made for a "Y L Opr" about eighteen months ago and nothing has been changed since. Response to the key is as good as ever, and operating with the set so arranged is a pleasure.

It will be noted from the diagram that a Western Union sounder is used to break the transmitter potential. This sounder takes the place of the key in the conventional C. W. set. These separate units are better, permitting the antenna break to be as free as possible from all capacity effects, and doing away with all unnecessary wiring where it is least desirable, viz.: in proximity to the antenna current of a transmitter.

Nearly all old stations will have a sounder lying around. Fortunately the old-time "dime contacts" are unnecessary considering the amount of current the C. W. input represents. Probably the "relay" will have to be obtained.

is no argument against a separate receiving wire. In this case the use of the sounder instead of the key brings only six volts to the operating table and in those sets where the key has been placed in the plate lead direct, this is decidedly nice.

In conclusion, may it not be suggested that more of us interest ourselves in the installation of "break ins?" If our ideals include long distance with minimum input, clean signals, and high grade operating, then such a device should be welcome. The diagram shows only those essentials necessary for an advanced amateur. Those noting absence of essential wires, etc., to make a circuit, and not understanding the HOW, should inquire of the nearest old-time Ham, who will set things right.

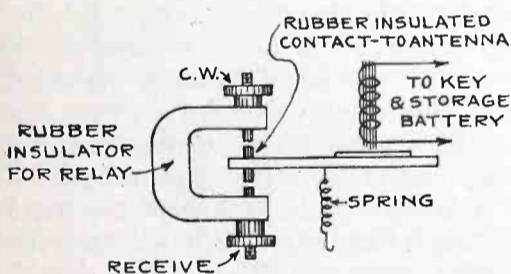

Fig. 1. New Insulated Jaw for Relay

With the advent of C. W., "break ins" seem to have gone by the board, yet there is no real reason for this. The same celerity of operating pertains as in the case of spark, providing that installations are made with a view to efficiency. In these days of etherial congestion and limited time on the air for amateur traffic, it seems that an effort to popularize the "break in" should be worth while. The system about to be described, while not the only method by any means, has been in use at three local stations for over two years, all using C. W. There may be better methods, but this is offered as one which is practical, inexpensive, and more or less fool-proof. Also with this system the transmitter may be operated by distant control, and only the six-volt potential brought to the operating table if desired.

In the first place, whatever device is employed to break the antenna from send to receive, it must be practically an anti-capacity affair, or there is danger of embarrassment from a non-oscillating set by leakage to ground. The commercial telegraph relay was selected for the breaking unit, appropriate contacts being substituted for the original equipment.

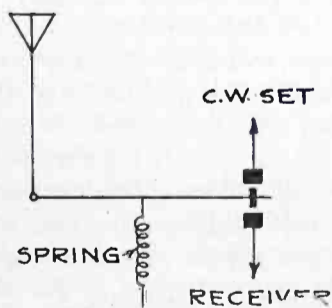
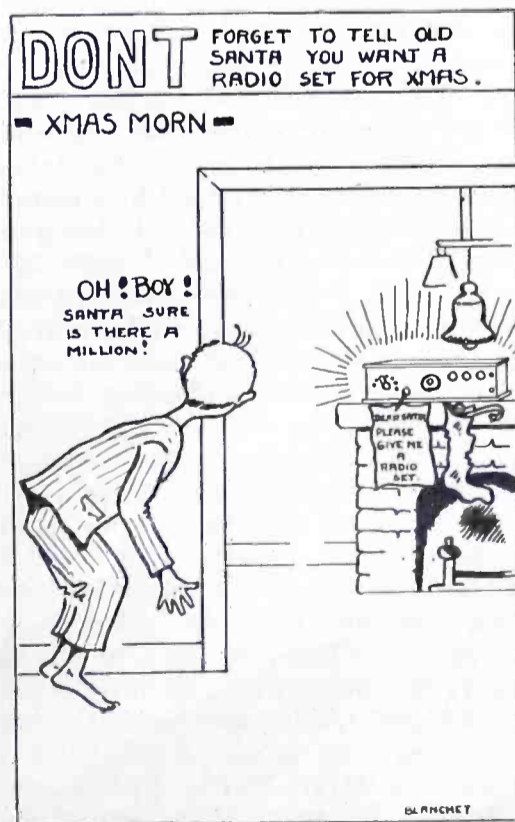

Fig. 3. Antenna Connection to Tongue of Relay

In making the final adjustment, the writer has made it a habit to arrange the relay and sounder contacts so that, with the transmitting key depressed, the relay will close a fraction of a second before the sounder makes contact to operate the high potential. This might not be necessary advice, yet if the reverse were to occur it would obviously produce



# The Use of Taps, Drills and Machine Screws in Assembling Radio Apparatus

By H. A. Highstone

A knowledge of machine screw sizes and the proper use of taps and drills in connection with them is necessary in the assembly of radio receiving apparatus if any kind of mechanical accuracy and neatness is desired. But, sad to relate, there are a considerable number of "hams" and, more especially, broadcast listeners, who do not understand the proper use of them. Apparatus built by the "cut and try" method is seldom satisfactory; oversize drill holes and a lack of mechanical strength combining to make an instrument of poor quality. Even in the assembling of a receiving set from standard parts, the use of taps and the proper drills will result in a surprising increase in mechanical accuracy, simplicity and neatness of appearance. I say simplicity because, with the use of taps, a great deal of unnecessary bolting and soldering can be eliminated.

**MACHINE SCREWS.**—The small threaded bolts used in the construction and assembly of receiving apparatus are known as machine screws. Each screw is designated by two numbers separated by a dash, for instance: 8-32. The first number refers to the diameter, the second, to the number of threads to the inch, thus by 8-32 is meant a machine screw of size 8, having 32 threads to the inch. The scale of number designating the diameter is not the same as the B&S Gauge used for copper wire, although of the same character. Machine screws increase in diameter with an increase in number. There are three sizes of these screws which are used for practically all work in receiving apparatus, namely: 6-32, 8-32 and 10-32. 6-32 is the size of the shank on 90% of the switch points on the market, 8-32 is the size used on nearly all binding posts. 10-32 is used in a few cases for very large binding posts, and some large composition knobs have a 10-32 thread in the bushing. 2-56 and 3-48 being of small diameter (.09 and .1 inch, approximately are sometimes used in miniature receiving sets, while 4-36 is the size of the binding posts on some telephone receivers. However, these last three are uncommon. The brass hexagonal, or "hex" nut, as it is commonly abbreviated, is used without exception in the construction of radio apparatus.

Machine screws are made in both brass and iron, the latter being much the cheaper. Brass, needless to say, is always the most desirable in radio work.

**DRILLS.**—The numbered drills are the proper ones to use in radio work, as they are designed to be used in conjunction with the machine screw and machine screw tap. The numbers run

from 1 to 80, the diameter of the drill decreasing with an increase in number. No. 1 has a diameter of .2280 inch and No. 80 .0135. Needless to say, the entire set is not necessary, four of them, Nos. 10, 19, 28 and 35 being capable of covering every need which may arise in the construction of the ordinary receiving set. Excepting, of course, the usual 3/16-in. and 1/4-in. drills for condenser shafts and the like.

The numbered drills are divided into two classes: clearance drills and tap drills. There is no mechanical difference involved; the names indicate only the class of work the drills are to be used for. A clearance drill is one which will cut a hole of sufficient size to allow a given machine screw to pass through it with a snug fit. For instance, a 10-32 screw will fit closely in a hole made by a No. 10 drill, likewise a No. 19 drill hole will hold an 8-32 screw tightly, while No. 28 is the proper clearance drill for a 6-32 screw.

**TAPS.**—A tap is a steel instrument somewhat resembling a machine screw in appearance, and is used for threading the interior of a drill hole. These are designated in the same manner as are machine screws: a 6-32 screw will fit in a hole properly threaded by a 6-32 tap.

A hole is first cut through the material to be threaded by the *tap drill* for the desired screw, after which the tap is run through it in the same manner as inserting a screw into a nut. For instance, if a 6-32 thread is desired through a hole in a panel, a No. 35 drill hole is first made through it, this drill being the tap drill for a 6-32 thread, after which the tap is run through. If an 8-32 thread is wanted, No. 28 is the correct tap drill, and No. 19 the tap drill for 10-32.

Anyone who does any amount of constructional work will find that the money expended for a tap holder and a 6-32 and 8-32 tap is well invested. Clearing jammed or solder-filled threads on the nut of a binding post is one invaluable use of these tools. Another use to which they are well adapted is the threading of holes in a panel wherein switch points are to be placed, doing away with the necessity of using nuts to secure them in place. Anyone who has ever constructed his own receiving set will recognize the advantage thus gained. The uses of taps in the construction of individual instruments are too many and varied to be gone over here. "Once tried, always used" sums the matter up.

While plug taps may be used with the above mentioned tap drills, the writer prefers taper taps, especially in

threading panels. Plug taps or bottoming taps are necessary where the hole to be threaded does not extend completely through the material. Taps are made of very hard steel, which is brittle; therefore a tap should never be forced too hard, no matter what the material. In any case, pause occasionally while running a thread to make a half turn backward. This makes for a better job and lessens the danger of breakage.

**DIES.**—While dies are not often necessary in assembling or constructing a radio set, they are often useful for clearing jammed or solder-filled threads on machine screws or shafts. The die is simply a round piece of steel with a hole in the center so constructed as to cut a thread on a smooth round piece of material of the proper diameter. They are also designated in the same manner as machine screws, 6-32, 8-32, etc. The ten-cent stores carry a line of taps and dies and holders for them, selling at fifteen cents each. These tools, while naturally not of a very high quality, are capable of threading brass, bakelite, formica, etc. It is recommended that these be purchased from a hardware store, however, as they are more accurate and have a longer life, although dies of good quality are rather high priced.

A half-inch drill often comes in handy for countersinking a drill hole for flat-headed screws. While it cannot be used in ordinary hand drill, a handle may be fitted upon the shank and the countersinking done by hand. A very neat job can be done in this manner.

A very necessary tool which a great many beginners fail to make use of is the center punch, something which is an absolute necessity where accurate location of drill holes is desired. This is nothing more than a piece of steel, pointed at one end, with which a small depression is made where the exact center of the drill hole is to be located. In this small hole the point of the drill is started, with the result that the hole is exactly where it was intended to be, not an eighth or a sixteenth of an inch to one side. Failure to observe this trivial step is a fruitful cause of tight condenser shafts and misaligned groups of switch points.

Tools for holding taps and dies come in different styles. The best tap holder for radio construction work is of a "T" shape, consisting of a small chuck somewhat resembling that upon a hand drill, with a small steel rod running through the end serving as a handle. The die holder is an iron rod of about 3/8-in. diameter, enlarged in the middle, with a hole to take the die. A set screw is provided to grip it firmly in place.

# Static: Radio's Greatest Problem

By Jerome Snyder

*After outlining the nature of atmospheric disturbances to radio communication, the author tells of some of the practical methods of alleviating, though not yet of eliminating, the trouble. Some of these may form the basis for practical application by the reader.*

THE tremendous obstacle to reliable radio communication offered by static has been recognized from the early beginnings of the art. Every radio engineer and scientist of note has made some effort to solve this problem. While long distances may be bridged by relatively small amounts of power, as may be witnessed by amateur trans-Atlantic transmission and reception, yet this cannot be accomplished consistently every day and night in the year on account of static, and every-day consistent transmission is essential to a good communication system. In order to overcome the effects of static and secure a favorable signal-to-static ratio it is necessary to increase the power at the transmitter to enormous magnitudes, 200 to 500 kw. The cost of such installations and power as compared to a few kw. is the price that must be paid for the existence of static. Of course very powerful amplifiers could be used at the receiving end to amplify the weak signals from a low power station. But the unfortunate part of such a system is that static is equally amplified, with the result that nothing is gained. The only way the ill effects of static may be overcome is to use brute force and ride over it with a power greater than its own, which means powerful transmitters. In order that maximum use may be made of the power of the transmitter it must be radiated most efficiently. This means high towers and large antenna structures, which make up the major cost of the transmitter. Thus it is at once seen that if static could be eliminated the tremendous cost of building and maintaining transoceanic transmitters would be reduced to small sums. The weak signals of the low power transmitters could be sufficiently amplified at the receiving end. Cost of messages would be reduced considerably, fairly constant communication would be maintained and the cables would meet an active and aggressive competition.

This problem is the bugbear of radio. More money has been spent in the search for the solution than on any other problem in radio. The man who solves it will go down in radio history as the saviour of radio. Many solutions have been offered in the course of time and it is of great interest to go over these solutions to see what progress has been made toward the solution of the problem, and to see in what direction modern research is leading.

Before touching the advanced solu-

tions it is important to understand just what static is, how it is produced and the explanations advanced by leading scientists as to its origin. It is an atmospheric disturbance which must be electrical in its nature, since it produces on a radio receiver the same general effect as an electromagnetic wave, namely it gives rise to electrical oscillations in the receiving system, which oscillations are converted into sound. But the sounds produced are of such erratic and irregular nature that they interfere with the reception of signals. These atmospheric disturbances are due to electrical discharges in the atmosphere, as, for example, between clouds. In order that electrical discharges should be possible there must be a source of electricity in the atmosphere, and according to one of the most prominent theories this source is the sun. It is now well known that hot bodies give off electrons, the vacuum tube filament being an excellent illustration of this fact. The sun, therefore, emits enormous numbers of electrons, since its temperature is so great. Due to the loss of these electrons, the sun must be at a great positive potential. The great positive potential of the sun and the emitted electrons constitute the source of atmospheric electricity which results in static.

There are two types of static which give most of the trouble. These are called "clicks" and "grinders" and are expressive of the nature of the disturbance. Clicks are widely separated disturbances which are of sufficiently strong intensity to interfere with reception. The grinders consist of all sorts of continuous noises of a grinding and grating nature which cause most of the trouble. The difficulty of weeding out static will be apparent from an elementary consideration of what happens in the antenna circuit.

When an atmospheric discharge takes place, as for example between two clouds, it acts as an electrical impulse on the antenna and sets the antenna oscillating at its own natural frequency, and these vibrations are transmitted and rectified in the receiver and give the bothersome noises known as static. But this is also what happens when a signal wave strikes the antenna, the antenna, being tuned to the signal wave, vibrates at its natural period and gives a signal. Thus it is seen that the behaviour of static with respect to an antenna is identical to the behaviour of a signal wave with respect to an antenna. This

is the reason it is so difficult to separate static from the incoming signal. If an attempt is made to amplify the signal so that it will be more intense than static we run into the difficulty of having to amplify the static in the same proportion and therefore gaining nothing. If on the other hand an attempt is made to weaken the intensity of static we run into the other difficulty of weakening the incoming signals in the same proportion and hence again gaining nothing, both these difficulties arising because signals and static affect an antenna in the same way. It is for this reason that many of the panaceas for static elimination have failed. For, when they have either weakened or eliminated static they have likewise weakened and eliminated the signals. This statement applies to most of the earlier methods, such as loose-coupled receivers, Marconi's balanced detector, and audio-frequency compensation. Let us now see what have been the progressive steps which have led us to our present position in which static seems to be attacked by methods which show promise of its demise.

Other methods have had the effect not so much of eliminating static, as of increasing the signals, so that the ratio of signal to static increased, thus making reception possible through static. Of these, one of the most practicable is the method of heterodyne reception. Most methods of detection take place on the square law basis, that is, their response is proportional to the square of the applied signal voltage. But these detectors are not very sensitive to weak signals, and as a result the ratio of static to signal is large and the signal is generally lost in the static. The heterodyne method, on the other hand, is not a square law detecting method, but its response is proportional to the first power of the incoming signal. But, due to the effect of the local heterodyne oscillator, it is extremely sensitive to weak incoming signals, as a result of which it gives a very powerful response to weak signals, while its response to strong static is equal or less than that of the square law detector. As a result the ratio of signal to static is considerably greater, and reception is possible. Here the ill effects of static are overcome, not by elimination, but by increasing the advantageous effects of the signal itself. The manner in which this is done is more evident from a consideration of the response curves of both types of detectors, as in Fig. 1. Curve A shows how a square law detector,

such as a straight vacuum tube with grid condenser and leak, or a crystal, responds to signals of different intensities. Curve *B* shows how the heterodyne detector responds. *Oa* represents the value of a weak incoming signal. The square law detector gives a response equal to *ab*, while for the same signal excitation the heterodyne detector gives the response *ac*, several times louder. On the other hand we have a large static impulse exciting these detectors, the intensity of the static excitation being represented by *Od*. The response of the square law detector is given by *de*, while that of the heterodyne detector is given by *df*, which is not much greater than that of the square law detector. It is at once evident that the ratio of signal to static in the case of the heterodyne detector is much greater than in the other case. This means has therefore been valuable in reducing the harmful effects of static, though it has not eliminated static.

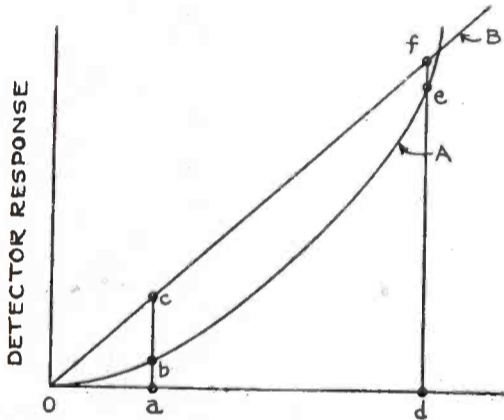

Fig. 1. Detector Response Curves

Another reason why this method has proved so beneficial in counteracting static is that by properly adjusting the heterodyne note the operator can more easily read through the static. He can arrange to receive a musical 500-cycle note, or 1000 or 2000-cycle note, or whatever note will give best results, by the simple expedient of varying the beat frequency. This method of reception is one of the best yet available.

Some of the most promising methods are those involving the use of an aerial differing from the usual vertical antenna, which receive equally well in all directions. Thus, although it may be receiving signals from a transmitter due north, it may at the same time be receiving static from all directions. Obviously such a system gives a poor signal-to-static ratio. The step was therefore taken to reverse the process by receiving static from but one direction, and at the same time to receive the signal best in the desired direction. As a result of eliminating all the other static except that coming from the signalling direction the signal-to-static ratio was increased many times. This is accomplished by the use of different types of antenna. The very first of these was the Marconi horizontal antenna, which was found to have marked directional characteristics, it received better in the direction along its

length than along any other direction. Thus signals from the direction in which it pointed were received more efficiently, and at the same time static from other directions, though not eliminated, was reduced, thus giving a very favorable ratio.

Another form of antenna which was very effective along the same lines is the loop aerial. The loop aerial has very marked directional characteristics, as shown in Fig. 2. It will therefore

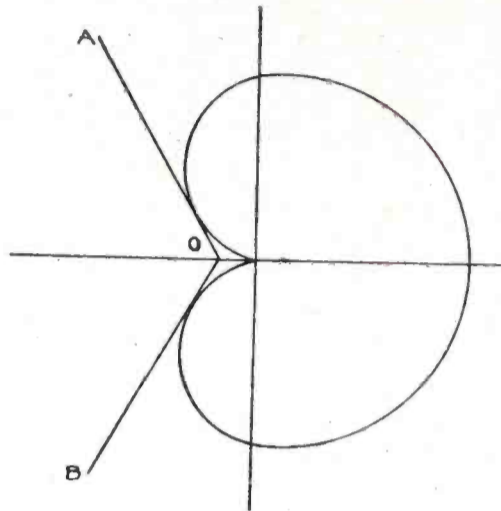

Fig. 2. Directional Characteristics of Single Loop

eliminate signals coming from directions in the angle *AOB*. Thus, by using a loop, static from these directions is likewise eliminated. Pickard has found that the use of a number of these loops gives still greater improvement in directional reception, thereby still further improving the signal-to-static ratio. The loop aerial has the added advantage that it is possible to orient the loop very easily to pick out the station it is desired to hear. For its dimensions are relatively small, and it is mounted so that it can easily be rotated by a handle. It is for this reason that it is so largely used as a direction finder and radio compass.

Most of the important work, until recently, on the elimination of static was done with the loop and low horizontal antennas. Fairly good results were obtained by the various investigators, but not good enough. The next step was the utilization of a number of these means together. Work was done with a number of loops working in conjunction, and also with loops and open wire antennas working in conjunction. The net result of such methods is to increase still more the directional properties of the system, thereby eliminating to a greater extent static from other directions, and thus increasing the signal-to-static ratio. This is shown graphically in Fig. 3, which was originally given by Pickard. The dotted curve shows the directional properties of a single-loop antenna. The dash-and-dot curve shows the directional properties of two loop collectors working in conjunction, which is seen to be better than the single loop. The full line curve shows that for three-loop aerials, which is seen to be

the most directive. By such arrangements whatever static does come in is confined to a small angle.

One of the most prominent systems of static reduction based on the working of a number of wave collectors together is that due to Weagant. He based his investigations on the theory that static originated from some point overhead. On this basis he devised an ingenious system for eliminating its effect. Since static came from above, it would strike two loops at the same distance, no matter how far apart they were separated. Also since these loops were impulsed simultaneously by the static excitation the static voltages set up in these loops would be exactly equal. Thus by combining these two voltages in a differentially-wound transformer so that their voltages opposed these two static voltages could be made to neutralize each other. On the other hand signal waves are known to be propagated

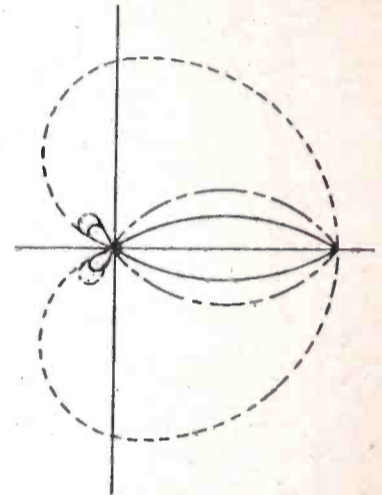

Fig. 3. Directional Characteristics of One, Two and Three Loops

horizontally, hence one loop would be impulsed by the signal sooner than the other. These voltages would therefore be different and out of phase, but, since they were likewise sent through the differential transformer, they would not neutralize each other, since they were out of phase and were unequal. They would, however, add up and give a resultant signal. Thus it is possible to obtain a signal voltage, while eliminating the effect of static. Although the theory of vertical propagation of static has not been definitely proved, yet it is possible to obtain the effect here described. However, the arrangement of apparatus required for such a system is extremely complex and sensitive, and it is often difficult to obtain the necessary balance and adjustment of apparatus to effectively balance out static.

One of the most recent methods advanced is the use of the so-called Rice-Beverage wave antenna. This is a modification of the Marconi horizontal antenna. It is a single wire, or sometimes two wires, whose length is of the order of the wave length to be received. This antenna has the receiver at one end, but the other end is closed by a "surge re-

Continued on page 86

# QUERIES & REPLIES

## ON C.W. PRACTICE

BY  
**Gerald M. Best**  
TECHNICAL ADVISOR

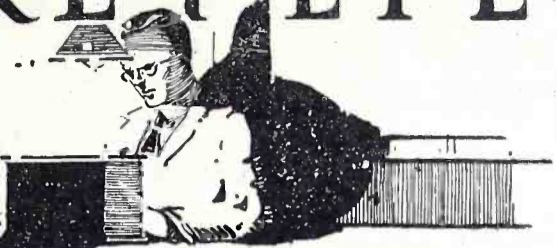

Questions submitted for answer in this department should be typewritten or in ink, written on one side of the paper. All answers of general interest will be published. Readers are invited to use this service without charge, except that 25c per question should be forwarded when personal answer by mail is wanted.

Kindly advise connection of three modulator tubes of 5 watts each, to a 50-watt transmitter. Also connection of filament as to positive and negative and primary and secondary of microphone transformer. — W. E. T., Huntington, W. Va.

It would not be practicable to use 5-watt tubes to modulate the output of a 50-watt tube, in the Heising circuit, as the modulator

rheostat, fixed condensers and power transformer. Give me the amount of wire required for a 200-watt transformer on a 2½ by 2½ silicon steel core, with a secondary voltage of 1200, tapped at 300, 600 and 900 volts. The filament voltage desired is 12, and tapped in the center. What is the natural wavelength of a 6-wire fan, 45 ft. high and 50 ft. long, lead-in 12 ft. long, ground lead 5 ft. long and

proximately 2 lbs. of wire. The filament secondary consists of 9¼ turns of No. 12 D. C. C. wire, with a tap at the 4.6 turn, and should not require more than ¼ lb. of wire. The natural wavelength of your antenna system, with counterpoise, is approximately 150 meters.

Please publish a good circuit for a variocoupler, variable condensers and a peanut tube.—E. S. V., Naples, N. Y.

Several good circuits have been published in recent issues of RADIO. Read the article by C. S. Mundt in December RADIO, entitled "Again that one-tube Receiver."

In regard to article on the DX-Bringer-In in May RADIO, why do I have to reverse the connection on the primary coil in the opposite manner to that shown in the circuit diagram, to make the set work? Why will the set not work without howling on stations under 400 meters? Is an .002 M. F. condenser across the phones too large? Am bothered with body capacity, and do not get the volume I can get with my three-

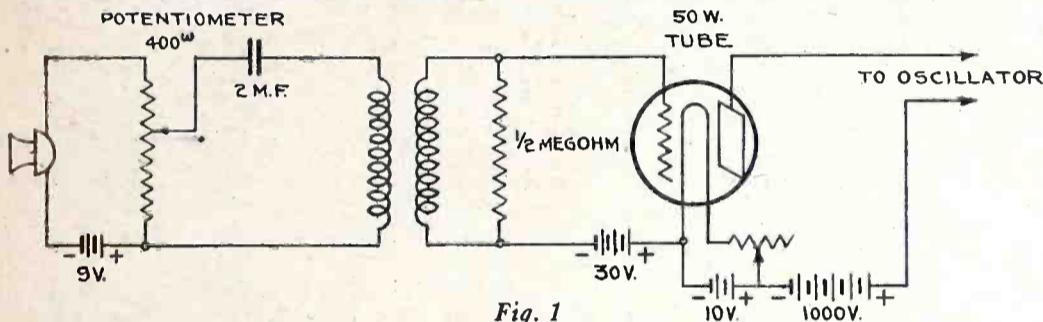

Fig. 1

and oscillator tubes should have like characteristics and power. The only method you could use would be a master oscillator-power amplifier type, which involves considerable apparatus over and above what the Heising circuit requires. A means of connecting the modulation transformer to the modulator tube is shown in Fig. 1.

Please correct and publish the circuit diagram enclosed, for a transmitter using one 5-watt tube, with Ford spark coil for plate supply. Kindly explain the action of this set.—H. A. M., Hingham, Mass.

The diagram is shown in Fig. 2. High voltage from the spark coil is supplied to the plate of the 5-watt tube, which is connected through a suitable oscillatory circuit to an antenna-ground system. The tube oscillates only when the voltage supplied by the spark coil is positive, and rejects the negative half

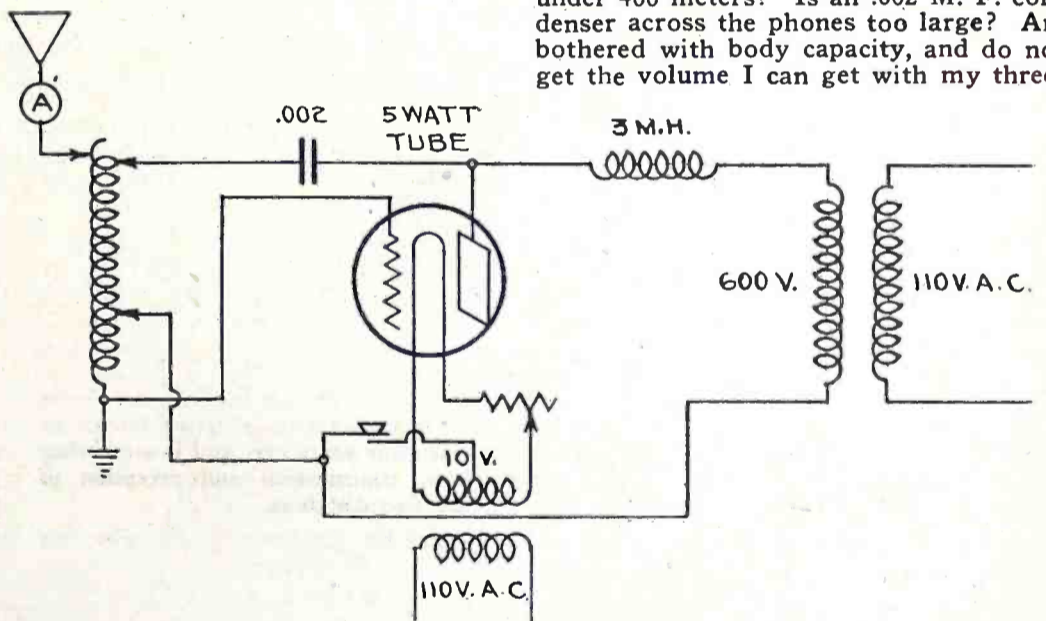

Fig. 2

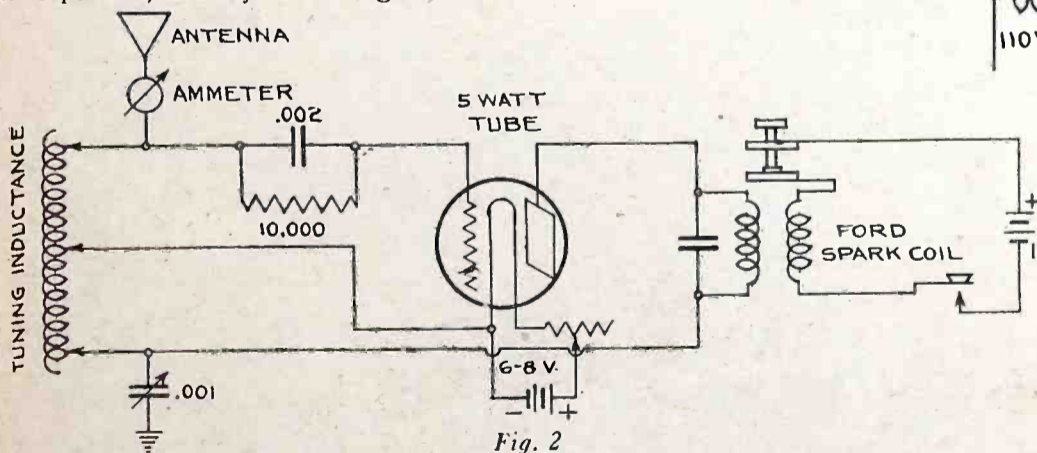

Fig. 3

of each wave, the radiated high-frequency wave thus being intermittent, depending upon the frequency to which the primary vibrator is adjusted. Due to the presence of harmonics in the output of the coil, the voltage supply is irregular, and the decrement of the set will not be sharp.

Please publish the improved Hartley circuit for a 5-watt transmitter, using the following apparatus: Inductance, key, 5-watt tube, voltmeter, ammeter, socket,

a counterpoise of four wires 55 ft. long and 8 ft. above the ground?—R. B. L., Palo Alto, Calif.

The circuit you request is shown in Fig. 3. For the primary of the transformer, you will require 85 turns of No. 18 D. C. C. wire, which should not amount to more than ½ lb. The secondary should consist of 924 turns of No. 28 D. C. C. wire, with taps at the 230th, 460th and 690th turns for 300, 600 and 900 volts respectively. This will require ap-

coil honeycomb outfit.—J. A. S., Plaza, N. Dak.

It should not make any difference in the operation of the circuit, whichever way the coil is connected. It may be that you had a high resistance joint when you first connected up the coil, as is often the case with soldered joints. You are probably working your variometer at too high values of inductance for the shorter waves. The trouble would be difficult to locate from your description. A condenser of .002 M. F. will work O.K. A shield made of sheet tin or copper placed on the back of the panel, and connected to ground should eliminate body capacity. The shield should be at least 30 gauge, and should not touch any of the apparatus.

Please publish a diagram that shows how to wind coils like those in the Kennedy Universal receiver.—J. W. C., Jr., Memphis, Tenn.

On page 31 of December RADIO you will find a complete story by D. B. McGown on how to wind bank-wound coils.

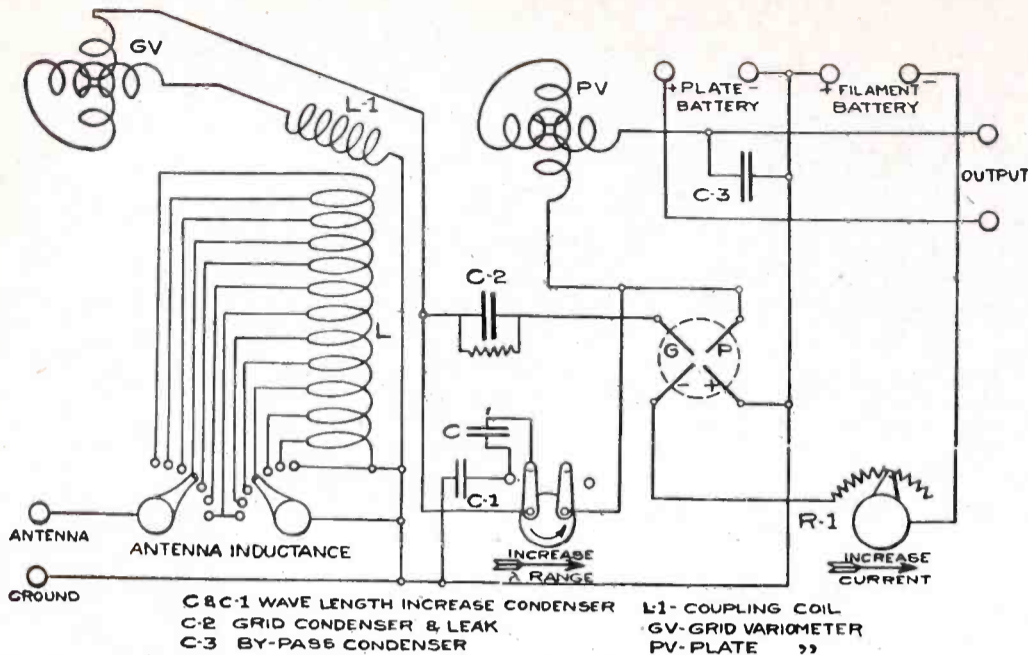

Fig. 4

Please publish the circuit of the Grebe CR-8 receiver.—W. B., Bakersfield, Calif. The circuit is shown in Fig. 4.

Please publish a circuit for a variocoupler, two variometers, rheostat and detector tube. Is a Welsh Peanut tube good for distance in this circuit?—I. L., Los Angeles, Calif.

The circuit shown in Fig. 4 contains the apparatus you mention. There is no reason why you should not receive over a considerable distance with a Welsh Peanut tube, if properly operated.

In an article by 6ZJ in July RADIO, reference is made to a coupling coil for inductively connecting the grid circuit to the plate variometer, the statement being made that the windings should be in opposite directions. Mr. McCartney in the same issue gave a circuit similar to this stating that the coupling coils were wound in the same direction. Which is correct?—R. J., New York City.

Inductances which are to be used in a regenerative circuit should be wound in the same direction, so as to be series aiding. Otherwise they will oppose each other, and the tube will neither oscillate nor regenerate.

I have an R. C. Westinghouse Receiver which is not selective enough. How can I make this receiver selective?—T. J. P. S., Maywood, Calif.

Single-circuit receivers in congested city districts are not selective enough. The Westinghouse Company has suggested the placing of an additional tuning unit alongside the regular tuner, thus providing a primary and a secondary circuit. A wave trap consisting of a 75-turn honeycomb coil shunted with a .0005 M. F. condenser would probably assist in eliminating some of the 600-meter spark interference you are having. The trap should be placed in series with the antenna lead, and adjusted until the interfering spark is tuned out. You will of course have to readjust your receiver each time you change the wave trap.

Kindly publish a diagram giving specifications of instruments similar to the types which are employed on board ships for receiving long distance code. Are honeycomb coils preferable for this? Can a change over switch be put in so as to make it suitable for receiving short wave broadcasting stations?—J. C. H., Cleveland, Ohio.

With the exception of some of the newer vessels, the receivers furnished most ships are hardly the kind you would wish to build, being usually of the crystal detector type, without amplifiers. The wavelength I presume you wish to receive is 600 meters, and

a very good set may be made from three honeycomb coils and two air condensers, such as is shown in Fig. 1, page 35, of October RADIO. All that would be necessary for receiving shorter wavelengths would be a set of smaller coils.

Please publish a diagram of the Armstrong 3-circuit tuner. Could I use a Ford spark coil to transmit up to 1000 feet? If so, will you please publish a circuit, without tube.—H. F. L., Worcester, Mass.

Figs. 4 and 5 both are examples of the Armstrong circuit. You could use a Ford spark coil for transmitting short distances, provided that you have a transmitting license, but I must decline to publish circuits of spark transmitters, as they are entirely obsolete, and are the cause of so much interference that the fewer of them there are the better off the radio industry will be.

Please publish the Grebe single-circuit regenerative receiver. What does DX stand for?—M. H. A., Schenectady, N. Y.

Although this circuit has been published several times in the past, it is being reprinted herewith in Fig. 5 for the benefit of new readers. It is the circuit used in the Grebe CR-5 set. DX is an abbreviation coined by the amateur some years ago, and is used when referring to transmission and reception of radio over long distances.

Kindly advise the correct size wire for connecting a storage battery to a receiving set at a distance of 30 ft.—J. R. H., San Jose, Calif.

The size wire depends upon the current drain. If you are using 3 or 4 C-301-A tubes, which consume .25 amperes at 6 volts,

then the maximum drain is 1 ampere, and 60 ft. of No. 14 wire would give you practically 6 volts at the set. If tubes drawing 1 ampere each are to be used, then No. 12 wire should be used, if you wish to have any kind of regulation at the set. For C-299 tubes, where the current consumption is .06 amperes per tube, No. 18 or No. 20 wire will be ample to take care of several tubes.

I would like to know how long an aerial is needed for a Crosley Model X set. The height above ground will be 20 ft.—C. M., Los Gatos, Calif.

The antenna should be at least 100 ft. long, and higher if possible, although you should be able to receive over a considerable distance even at 20 ft. in height.

### RESOLUTIONS ADOPTED BY SAN DIEGO RADIO CLUB

WHEREAS, at the present time radio communication is subject to serious interference of a preventable nature, and

WHEREAS, it is imperative that the full privileges of radio communication be accorded all parties equally, and

WHEREAS, the Department of Commerce is unable under the existing law of 1912 to so administer and control radio communication as to eliminate certain types of interference,

THEREFORE, Be It Resolved by San Diego Radio Club of the City of San Diego, County of San Diego, State of California, that it is the sense of this Club that immediate action should be taken by the House and Senate to the end that adequate legislation be enacted to supersede the law of 1912. Be it

FURTHERMORE, Resolved that our White-Kellogg Bill as introduced in the 67th Congress is the most suitable form in which legislation could be written. Be it

FURTHERMORE, Resolved that our Representatives and Senators be urged to give this matter their immediate attention and that a copy of this resolution be forwarded to said Representatives and Senators, to the Secretary of Commerce, the Supervisors of Radio for the various United States Districts, Executive Headquarters of American Radio Relay League, the Signal Officer U. S. Army, the Chief of the Bureau of Radio Communication of U. S. Navy and the Press.

Adopted at a regular meeting of the San Diego Radio Club held November 9th, 1923.

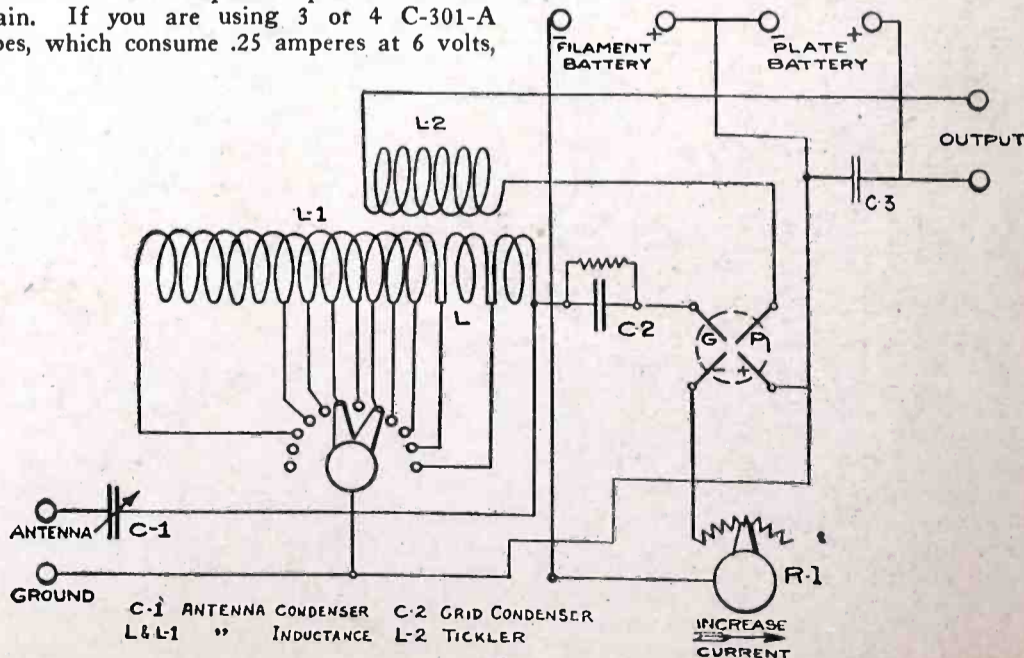

Fig. 5

# NEW BROADCAST STATIONS

## NEW MEXICO STATE COLLEGE GIVEN RADIO PLANT

Through the efforts of Dean Goddard, the New Mexico College of Agriculture and Mechanic Arts is the recipient of a new radio station. The donors have requested that their names be withheld. This gift will include the equipment for constructing a 100-watt vacuum tube transmitter and the building to house it. The station will be utilized for experimental purposes and amateur relay work under the government license of 5XD. It will be separate and distinct from the present radio house and its equipment, which will then be used solely for broadcasting service under its present call letters of KOB.

Plans for the new radio house call for a frame building 15x24 ft. with concrete floor. An operating room will occupy the east end of the building, while a club room for the College Radio Club will be at the west end. The center will contain a work shop and closets for the storage of miscellaneous equipment and batteries.

It is planned to support the new T cage type aerial from two 60-ft. A-frame towers, spaced 125 ft. apart. A counterpoise system of twenty wires is planned. These wires will radiate from the roof of the building in all directions to steel post supports at their outer ends.

The transmitter planned is of the reversed-feed-back type, using two 50-watt tubes for oscillators. The plate current will be supplied by a kenotron rectifier and filter system. The materials for this have already been purchased, and the set will be constructed by members of the Radio Club from designs by Dean Goddard.

KOB is equipped with two combination telephone-telegraph transmitters, one of 500 watts output and the other of 50 watts. Both these transmitters are of the vacuum tube type, and either may be connected instantly to the 140-ft. fan aerial over the Engineering building. Two other telegraph transmitters of the spark type are also available, and are at present being utilized for experimental purposes. One of these is a 1000-watt set of the synchronous gap type, while the other is a standard Navy 500-watt quenched gap

transmitter, complete with motor-generator power supply. The station is equipped with several receivers, including a Westinghouse type RC, a Grebe type CR 8, a three-circuit regenerative honeycomb coil universal wavelength set with detector and two-stage amplifier, a Reinartz tuner and detector, and a two-circuit honeycomb coil set with six-tube detector-amplifier. The latter set is very selective and sensitive, being adapted to all wavelengths, and having three stages of radio-frequency amplification, a detector and two stages of audio-frequency amplification. A Western Electric loud speaker, with push-and-pull power amplifier, and a large-sized Magnavox loud talker are included in the equipment. A Kolster decimeter, such as is used by the Radio Inspection Service of the Department of Commerce for standardization work, has recently been added.

The motor-generators for supplying the high-voltage direct current for the telephone transmitters are located in a special generator room, and remotely controlled from the operator's desk in the radio house. There is a 500-watt, 1000-volt set for the small transmitter, and a 2000-watt, 2000-volt set for the large transmitter. There is also a 250-watt, 1000-volt set in reserve to be used in case of trouble with the regular machines, and for experimental purposes.

The college is also provided with two complete portable stations licensed under the call letters of 5FY and 5FZ. These stations have five-watt combination telephone-telegraph transmitters and single-circuit regenerative receivers with detectors and two-stage audio-frequency amplifiers. They are used for experimental work and for communication with the College station from points in the field. At the recent convention of the New Mexico Boys' and Girls' Club members, held at State College, a mesa picnic was enlivened with a radio concert received by one of these stations. The football game in El Paso of the Aggies and the El Paso High School was broadcasted, and the coming game with the Texas School of Mines will be broadcasted from one of these stations erected on the side lines. They have, since the war, served as the communication link between the annual College R.O.T.C. unit camp in the

Organ Mountains and the college. Two years ago at the time of the Hatch flood one of these stations was rushed to the scene of the disaster, and supplied a quick means of communication with the lower valley towns, from which assistance and supplies were sent.

The work of the present station at the college has gained for it a national reputation in this branch of engineering. A number of students are now attending this institution because of the exceptional facilities offered along these lines. With the widespread of interest in and use of radio as a means of communication, it is anticipated that industry will require a large number of electrical engineers especially trained in this branch.

## RADIO STATION CYR

Radio Station CYR, which was installed two months ago at Mazatlan, Mexico, for Rossetter & Company, has been heard by many Pacific Coast listeners. It has been reported from Denver, Colorado, and also from Willows, Calif., on a loop.

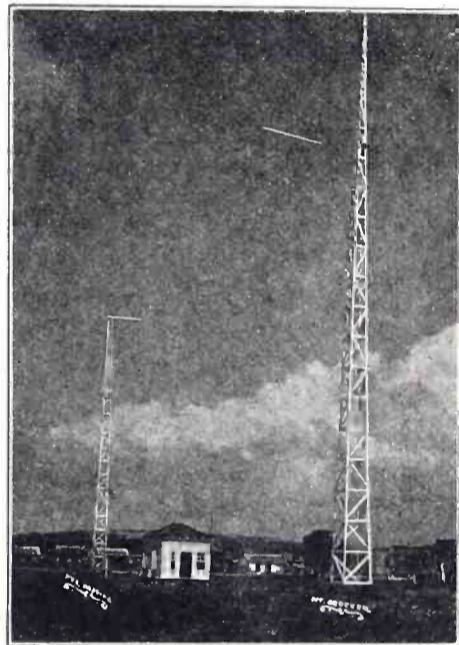

CYR, Showing One of the Two Towers

The equipment includes the 50-watt transmitter formerly in operation at KDN, the Fairmount Hotel, San Francisco, together with a 50-watt power amplifier. The station was installed and the towers erected by C. Thompson, 6UQ, who will also put up a more powerful station for Rossetter & Company at Mexico City.

Broadcasting is conducted between 8 and 9 p.m. on a wavelength of about 423 meters.

## NEW SIGNAL CORPS STATIONS

The Army signal corps is installing at Fort Douglas, near Salt Lake City, Utah, the largest radio telegraph station of the Army. It will have but one tube, the new 10 kilowatt radiotron developed by the General Electric Company, which is building the equipment. Another similar station is being erected at Leavenworth, Kans., but this station will operate with two tubes and will have a telephone circuit as well as the radio telegraph. The radio circuit between these two stations, the Arlington, Va., station and a land line from Leavenworth to San Francisco, will span the United States. Each of the two interior stations will be equipped with two steel 300-ft. towers. It is the plan of the Army radio service not to use coastal stations, that part of the work being handled by the Naval Communication Service, and the Army does not desire to interfere with ship-to-shore communication.

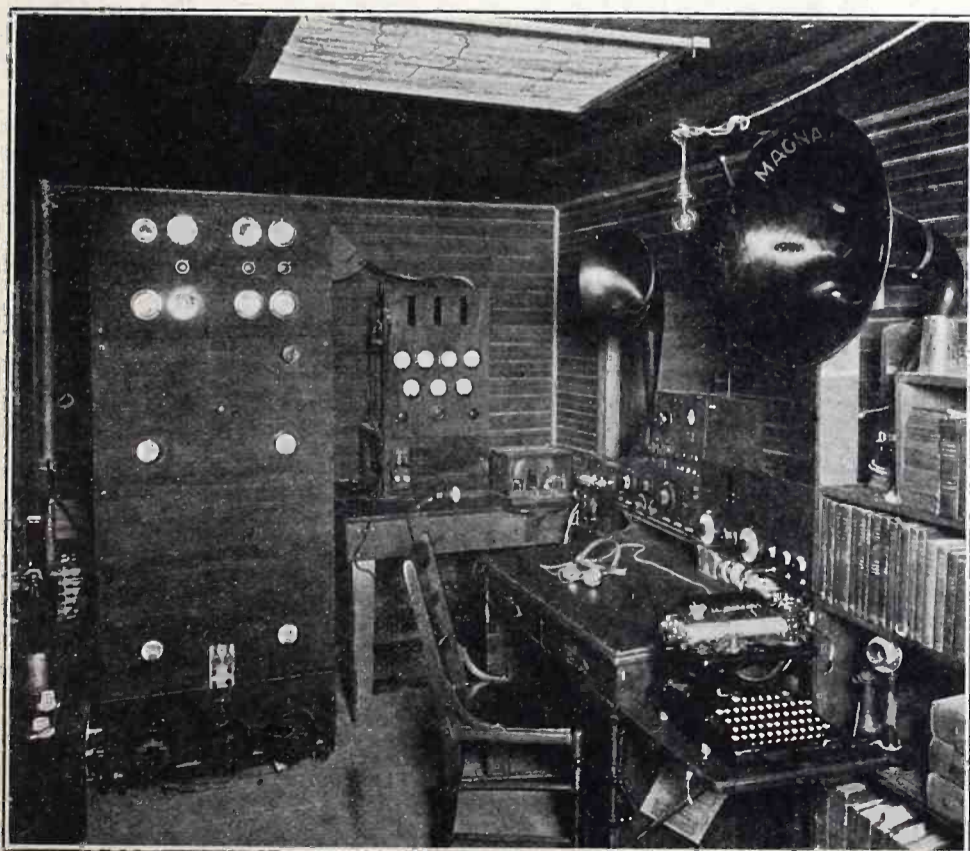

Radio Station KOB





# WITH THE AMATEUR OPERATORS

## RADIO STATION 9MC

9MC was built and is owned by A. H. Cain at Roodhouse, Ill., and is located in a specially built radio shack 14x18 out in an open field where there is nothing to consider except building an efficient set. The ground is 12 3/4-in. pipes driven 5 ft. in the ground and also an underground counterpoise of 60 No. 14 copper wires in the form of a large oval 160 ft. wide by 230 ft. long filled with wires radiating from the center 6 degrees apart, over 7000 ft. of wire 6 in. under the ground.



Radio Station 9MC

The station is equipped with two C.W. transmitters employing the Hartley circuit, a 500-watt radiating 4.5 amp. with 2000 volts on the plate and a 100-watt radiating 2.3 amps. with 1000 volts. Plate voltage is supplied from three motor-generators, two 500 volts and one 1500 volts.

The aerial is a 5-wire, flat top T, 80 ft. high and 65 ft. top, with 74 ft. lead-in and ground.

9MC has been reported from every state in the union and has worked every state but three, has been heard in England, New Zealand, Mexico, Cuba, Porto Rico, North Pole, and all over the Atlantic and Pacific and Gulf.

The operators are A. H. Cain and W. W. Fraley. The call 9DNW is used by junior operators. 9MC is an official A.R.R.L. broadcast station and also A.R.R.L. district superintendent of District No. 3 of Illinois. A recent list of calls heard and worked is published elsewhere in this issue.

## STATION 2WA AND 2XAT

Station 2WA and 2XAT, owned and operated by D. J. Pieri at 154 East 175th, New York City, has been doing some fine D.X. work, including the handling of many messages from 6XAD. On November 6th he was in communication with 6XAD for over an hour and a half.

The antenna consists of two 30-ft. sticks on top of an apartment house supporting a 4-wire inverted L aerial of No. 12 enameled wire. The counterpoise is a four-wire fan running from the radio room window to a rear court enclosed by buildings, it not being possible to place it directly under the antenna.

The transmitter uses three 50-watt tubes with a plate voltage of 1500 at 300 milliamperes, this being supplied from kenotron-rectified and filtered 110 volt a.c. The keying is done in the grid, the circuit being a Colpitts. The receiver was designed and built by Mr. Pieri, detector and one-step being sufficient to hear 6XAD.

## NEWS OF THE AMATEUR OPERATORS

6AFX, R. J. Mortimer, has moved from 32 Walnut Ave., Los Gatos, Calif., to 334 45th St., Oakland, Calif., and will soon be on the air with 10 watts C.W.

The new QRA of 6AFO is 271 21st Ave., San Francisco, Calif.

6AUB has moved from 3369 28th St. to 4095 Ohio St., San Diego, Calif.

6BVG, J. F. Wainwright, of Los Angeles, has established a direct relay route with 9ZT.

N. E. Brown has been engaged to give a series of lectures on the construction and operation of efficient radio equipment before the Southern California Radio Association at Los Angeles.

6LG, M. E. McCreery, has been selected by the Southern California Radio Association as assistant division manager for the southern section of the A.R.R.L. Pacific Division.

6JD expects to establish inter-communication with Australia before the winter is over.

6KA is back on the air with a 250-watt bottle.

6EA and 6EB have a new station under construction at Los Angeles.

Walter Hemrich, 7SC-7ZT, P. O. Box 511, Aberdeen, Wash., worked WNP on Nov. 15. He is now installing a 1 kw. tube set.

Call letters 5ANC have been issued to W. Easley, 223 So. 3rd St., Enid, Okla. Call letters 5JE have been issued to J. B. Reeves,

2002 E. Pine St., Enid, Okla. Both on 5 watts. Pse. qsl if heard.

Call 9BBZ has been reassigned to Everett H. Marshall, Hayward, Wis., who will answer all cards.

6BJS has been reassigned to Bruce Lawrence, 535 Tennyson Ave., Palo Alto, Calif. Please note QRA. and QSL, my 10-watt C. W. and phone set. All cards answered promptly.

## A NEW DISTANCE-AND-SPEED RECORD BY 1HX-6XAD-WNP

A complete message was transmitted from 1HX, Boyd Phelps, at Hartford, Conn., via 6XAD, Lawrence Mott, Avalon, Calif., to WNP, Donald Mix, radio operator with the MacMillan expedition, Etah, Greenland, with reply by the same relay, in five minutes, eight seconds, between 2:00 and 3:00 A.M. on November 27th, P.S.T. The transmitted message was "To WNP de 1HX via 6XAD, cool and wet tonight, how with you? sig. Phelps." The reply was "To Beep, ten below and starlight here. sig. Donald Mix."

This hangs up a new record in amateur transmission—9000 miles in 308 seconds, surpassing the previous Hartford-Honolulu test record in both distance and time. The time, which was officially kept at Hartford, was taken from the instant that Phelps touched the key to call Mott until the answer was received at Hartford.

This record came as a climax to a long series of messages between 1HX, 6XAD and WNP. During November Major Mott handled many messages to and from WNP, as has been reported in the daily press. An attempt to transmit a Thanksgiving message to WNP on the morning of November 29th did not succeed, as no one was able to hear WNP. The same message was also transmitted over a seven-station relay to Can. 9BP, especially arranged by the American Radio Relay League, without reply from WNP.

Major Mott reports the following lists of stations that he has worked or that have heard him. These DX reports cover the period from October 30 to November 26.

### Stations Worked.

1cmp-1hx (Hartford, Conn.), 1er, 2agb, 2adm, 2wa (N. Y. City—many times), 3ckd, 3bhm, 3bwt, 3te (Baltimore, Md.), 4ku, 5je, 7zu, 7zf, 7jf, 7gq, 7fl, 7afn, 7wm, 7sf, 8se, 8ab, 8cwu, 8aig, 8afn, 8ago, 8zy, 8bke, 8xe

Continued on page 89

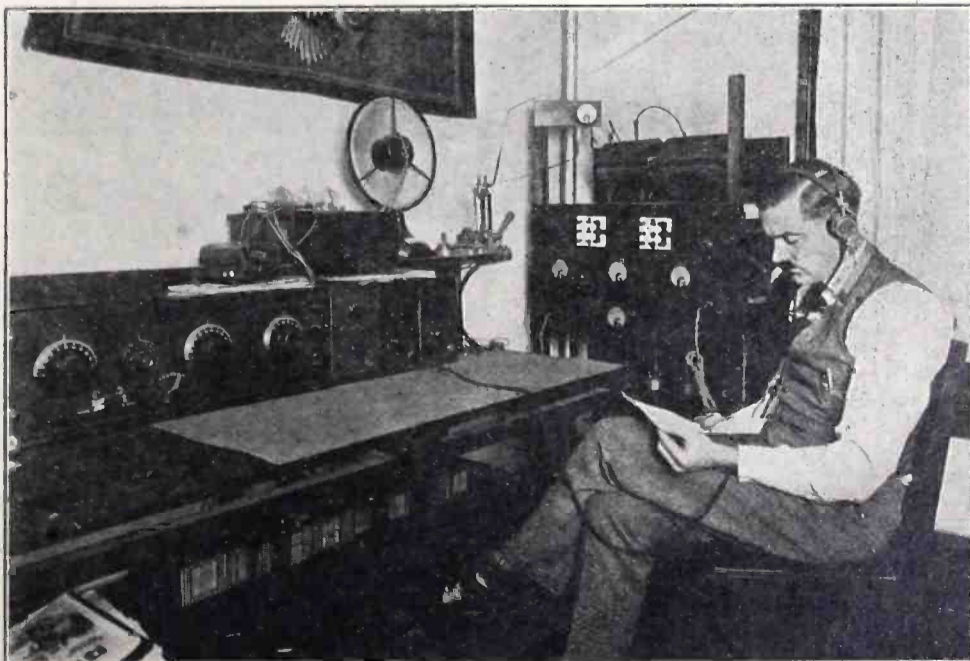

Radio Station 2WA and 2XAT

# LETTERS TO THE EDITOR

## Loud Speaker Construction

Sir: With reference to the article on Loud Speaker Construction by Stewart Hendricks in November RADIO, the constructor will get better results by using a piece of bakelite or other insulating material instead of using a copper strip in the movable coil. The copper short-circuits the coil and cuts down the efficiency.

Oakland, Calif.

HARRY MORSE.

## Be Careful With Chemical Rectifiers

Sir: While my chemical rectifier was in operation the other day I pulled out the aluminum rod to examine it and, in replacing it, a spark was caused when the rod came in contact with the electrolyte. This spark ignited the gases in the jar and caused a violent explosion which completely wrecked the rectifier.

Tacoma, Wash.

J. R. CHRYST.

## Rectifier

Sir: Having been a subscriber to your magazine for over two years, and reading many valuable articles, I have decided that it was my duty to contribute any good wrinkle that I could discover. Enclosed you will find a drawing of a rectifier for both A and B batteries.

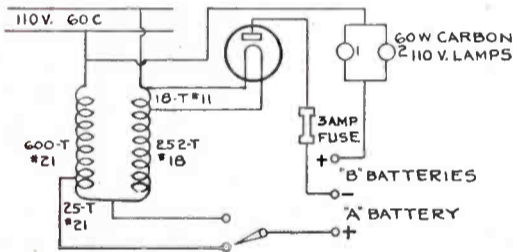

The laminations are made of transformer iron, pieces 1 in. x 4 1/16 in. and 1 3/16 in. x 2 1/4 in. enough of each to make two 1-in. stacks, as the core is 1 in. square. The winding consists of 600 turns and tap, and then 25 turns of No. 21 on the one leg. The other leg has 252 turns of No. 18, and 18 turns of No. 12 for the filament section on the other leg.

The tap that connects the two coils together will charge the A battery at about 2 1/2 amperes, while the tap at the 25 turns of the 21 wire will charge about 3 amperes. A 3-ampere fuse is placed in the negative side and will protect both A and B circuits when charging.

The B battery charger has a tap off the line side opposite to the filament-heating winding. The lamps in the circuit reduce the amperage, as it is not wise to charge the B battery with high amperage. One lamp will give about 1/4 amp., while two in parallel will give 1/2 amp. charge. I have not tried to charge both at once, as I have to buy all my lamps and the rectifier bulb costs \$4.00 and I'm not taking any chances, although I think it will work all right.

2409 Fifth Ave.  
McKeesport, Penna.

Sincerely yours,  
EMIL KLOB.

## A Converted Crystal Set

Sir: I have experimented with several kinds of single tube sets, but have never found one that works as well as my converted Signal Corps crystal set. Some people say I am crazy when I show them the hook-up, but I have brought in WDAF, Kansas City; WHAS, Louisville; WGI, Medford Hillside; and WDAJ, College Park, Ga., regularly; besides working a loud speaker on one tube (WD-11) with this hook-up. Of course the stations I use the loud speaker on

are local ones, WRC and WCAP. I have a good deal of trouble with body capacity, but sometimes this can be overcome by cutting out the secondary condenser or the grid leak. (I find that a 1/2 meg. works best on local stations.) I am not bothered much with static at any time, though, and I think I would rather have body capacity than static.

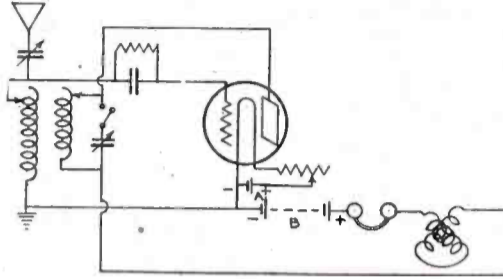

As I said before, the set is composed almost entirely of an Army crystal set, and the tube and variometer are the only additions. The variometer is an Atwater-Kent.

To anyone with a Signal Corps (or Army) crystal set or the parts equivalent to one, I am sure this will prove an interesting experiment.

Yours truly,  
1622 Allison St. N. W.,  
Washington, D. C. FRANKLIN W. CLARKE.

## Radio: The Farmer's Ruination

Sir: There is a lot printed in magazines about the value of radio to the farmer. May I write a word from the farmer's standpoint. I am a small farmer. I have ten acres set out in prunes, twelve acres in grapes, and fifteen acres in almonds. For twenty years I have been working to bring the place to a point where it would pay. And then—I bought a radio set. It has changed my whole life.

At the present time I am \$450 in debt. There are three mortgages on my house and one on my barn. The last one was for a loud speaker. The crop reports come in fine, but I am so busy tuning out interference on my radio set I have no time to cultivate a crop.

My tube bill is \$60 a month and my battery cost is \$75 a year. My children used to study hard in the evenings and stood high at school. Now they are so busy with crystal sets they never look at a book. Even the school teacher has taken up radio. Just today my boy came home with an A plus in grid leaks.

The Farm Bureau used to lecture on scale, and plant lice. This week's lecture was on regenerative sets. Despite eight pairs of receivers, I never get a chance to listen over my set until everybody else goes to bed.

The help refuses to get up at 5 a.m., because they sit up too late trying to tune in Kansas City. My wife forgot to put up the year's jam and preserve supply because of KPO's programs. In October the frost killed my prunes because I was tuning for Chicago and forgot to start my smudges. Even the cows will not give down milk any more without radio music. Last year I bought mittens, socks, a bicycle and some skates for Christmas presents. This year I have got to spend \$300 for two radio frequency outfits, or the family will not speak to me.

No one knows what radio has done for the farmer. As the situation stands now, I may have to sell the farm and move into town to get nearer to the broadcasting stations, to get away from my neighbor's one-tube set, three miles down the state highway.

In conclusion, I wish to say that radio is a great boon for the manufacturer, and its effect on the farmer cannot be measured by

either the Department of Agriculture or the State Insane Asylum.

Hoping this may be of value to some other farmer, who is a reader of your columns, I remain,

Yours truly,  
Yolo, Yolo Co., Calif. JAMES K. HASKINS.  
P.S.—I forgot to mention that in June I cut down two acres of eight-year-old prunes to make way for a counterpoise ground so I could hear the "Hoot Owls" in Portland.

## Transformer Ratings

Sir: I read the article on Distortionless Amplifiers by D. B. McGown in November RADIO with a great deal of interest, as I am interested in that particular branch of radio. I do not, however, altogether agree with Mr. McGown that the so-called "ratio" rating of transformers be dropped.

I think I am safe in saying that not fifty per cent of the people buying a transformer know what the impedance should be, or what impedance really is. The salesman's statement that "the primary has so many thousand ohms at so many cycles" means nothing to the average prospective buyer.

In general, he knows that a high ratio transformer may be used on the first stage and lower ratio on following stages.

His question is: "Will this transformer work in my set?"

In line with all other radio goods, transformers are sold under a binding guarantee that protects the buyer from a transformer that has only 10 or 12 turns to a winding.

It would seem just as logical for a phonograph salesman to deliver a lecture on the size, length, number of turns, torque developed, and other details of the driving spring of one of their models, when all the customer wants is to know, "Will it work?"

I agree that a certain amount of technical specifications are necessary, but it should be so that the layman can understand it.

One thing more. A good many companies are advertising their goods with the caption "Free demonstration," and when the goods arrive they are C.O.D. and usually more than one has to pay at the local dealer. I think this is misleading. How about it?  
Indian Creek, Pa. PHILIP N. EMIGH.

## When Will It Cease?

Sir: The science of radio communication, and art of its application, have made rapid strides. Time was when the term "interference" was connected with spark only. The law of 1912 saw fit to designate certain methods of eliminating interference. A decrement of two-tenths was once standard. Today decrement has little value as a measurement. Spark has become obsolete—archaic.

Ever to the forefront of progress, constantly eager for the annihilation of "more miles with less watts," amateurs practically without exception have abandoned the spark as inadequate, nuisance-producing, inefficient and in every way unsatisfactory. It remained for the amateurs to develop the broadcast movement, and later for the broadcast station to prove the practicability of constant public service utilizing continuous wave energy, in order to seal forever the doom of the spark. Class B broadcast stations with five hundred watts are today giving continuous adequate public service over a range not to be attempted by spark installations with ten times that power.

The "powers that be" have taken certain steps to protect the thousands of "listeners-in" who nightly depend upon the broadcast for education and entertainment. No longer can the broadcast listener be ignored either

from a technical standpoint or his political strength. Today the broadcast listeners can poll a vote which would swing any issue which seemed desirable to them. Does it not seem strange that, despite the "writing on the wall," any section of the public service should be dilatory in instituting such changes as might be necessary to protect the rights and privileges of the several millions devoted to the art of radio? Yet, sad to state, such is the case.

The Navy maintains radio stations at many points on the sea coast, notably NPL at San Diego, California. The use of spark and arc at this station antedates the development of the broadcast. Many and bitter have been the complaints as to the interference by both arc and spark due to inefficient installation, careless or negligent maintenance and poor operating. The arc is notoriously rich in harmonics, "mush" to a greater or lesser degree has been the source of innumerable complaints for several years past. While partial remedies have been sporadically applied there has not been a *resident* radio engineer constantly on duty to eliminate causes of interference, which would not be tolerated in any commercial plant on the globe. While the law requires changes of power adequate to maintain communication with the least possible input for a given transmission, none of the NPL apparatus has been observed changing power at any time. It is a scream to observe a five-kilowatt spark set in use on full power for the purpose of communicating with a ship lying alongside the operator, practically—the distance measurable in feet not miles—yet such tactics have been logged repeatedly. Blinkers could be used, buzzers, a five-watt telephone transmitter or, better still, a land line could be thrown aboard the ship lying in the harbor and the ether left for more useful purposes. Only last night at 8:15 P.M. or thereabouts NPL called NPG eight times within a period of fifteen minutes on spark! How does this happen? Do the rules and regulations applying to ethereal communication not apply to the public service as well as the commercial branches of communication and the amateur? What is pernicious interference anyway? How lovely it is to listen to a spark QST from NPL at 9:00 P.M. right in the middle of a lecture on astronomy or an organ recital. Why could not the QST be postponed until 11:00 P.M. or given earlier? Surely someone is asleep at the switch! Let us look into this.

It is a curious fact that Naval radio communication stations are frequently officered by those whose only training in the science of radio seems to have been the signing on the dotted line for property and personnel. The experts who visit NPL in times of mechanical or electrical grief seldom wear the uniform — never have authority. "Theirs but to do or die, theirs not to reason why." Were the radio communication officers of the Navy radio-experts in all cases—with sufficient authority to abate electrical deficiencies, and co-ordinate official communication so as to cause minimum interference, this protest would have no function.

Patience, it is true, is a virtue. When three long years pass, however, and a public nuisance continues to flourish despite all reasonable efforts, patience gets rather frazzled. Surely it is time for something radical to be done.

San Diego Radio Club, representing the seven thousand owners and operators of receiving stations in the County of San Diego, has at last boiled over and is insistent on immediate relief from pernicious and altogether avoidable disturbance nightly, due to the tender ministrations of the operators on duty at NPL. Realizing that it is useless to appeal to the enlisted operator, almost as useless to the Chief Petty officer nominally in charge of operations, and that all efforts through local commissioned officers in charge

of radio matters for the Navy have evidently drawn a blank, the Club framed, adopted and will follow up to the last ditch a resolution which demands the attention of Washington in no uncertain terms. The resolution, it is hoped by San Diego residents, will affect not only NPL but all other Naval radio stations.

Destructive criticism is one of the most pernicious things imaginable. Constructive criticism on the other hand promises something in the future. Nothing that has been said should be construed as having a personal tinge. The present situation on the air in territory contiguous to NPL is simply abominable. The United States Navy contains the finest brains on the continent and when this talent is really applied to the problem on hand with the honest intent of "doing unto others as they would be done by" the outcome will be most refreshing. Ordinarily, even in peace times, the United States Navy desires popularity. One of the worst advertisements it can have it is now flaunting in the ears of the listening public. Let us hope that now, *immediately* — not tomorrow, not next week—WE SHALL HAVE ACTION and that no more complaints nor criticisms need be offered in the future along these lines.

In conclusion it must be remembered that whatever can be done in civilian life can be done by the Navy. DR. A. E. BANKS, San Diego, Calif. 6XN, 6ZB.

### Converting the B.C.L.

Sir: I would like to call your attention, as well as all transmitting amateurs, to the importance of converting the B.C.L.s into the amateur's ranks. I know many B.C.L.s are getting tired of listening to canned music and such and would like to learn the code if there were any way possible. The amateur who is pounding out C.Q. by the yard when he has nothing else to transmit is not getting anywhere. The amateur should try to devote a few hours a week to the transmitting of code for the beginner. Is that asking too much for such a good cause? There is more sport in receiving code than anything else. The phone fiend would soon be tuning into code transmission, and calling you up on his new C. W. transmitter!

Here is another thing. The amateur signs off some old fancy way, not caring whether he will be readable at some D.X. hound's stations. There are a lot of new amateurs just breaking into the game that are not speed artists yet. So here is a little experiment. Make it a rule for a week or two to sign off your call at a slow rate of speed, and I can bet a five-watt bottle that your mail will be cluttered with more "I heard you" cards than you ever got before. We would like to hear from others as to what they think of it. How about it, O.M.? Oak Park, Wash. STANLEY WHITEKUS.

### THE "CQ" PEST

By 6XAD-6ZW

*Of all the wearying things o' earth—  
Of all despoilers of one's mirth—  
He who 'rouses one's ire with zest—  
Is that tiresome chap—the "CQ" Pest!*

*With never a "sign" and never a pause—  
The key clutched fiercely in his claws—  
He hammers away through the hours o'  
dark*

*With any old thing from a buzzer to spark!*

*"CQ-CQ-CQ"—with never a little "de"—  
"CQ-CQ-CQ"—over the lands and the sea!  
"CQ-CQ-CQ"—with unflagging vigor and  
zest!*

*Oh Lord above!—Do save us . . . . .  
From the nerve-racking "CQ" . . PEST!*

Catalog No. 10 from National Chelsea Radio Corporation shows three types of Chelsea regenerative receivers and a complete line of radio parts.

### HINTS ON RADIO

By D. B. McGOWN

Don't forget that telephone receivers are gradually weakened if they are jarred, due to the fact that jarring weakens the permanent magnets.

If you build a transformer from data that is reliable, and it heats up, or draws too much on no load, check up first on your core material; soft iron, commonly called stove-pipe iron, must be worked at much lower flux density than silicon steel.

When using power transformers (so-called "pole transformers") for vacuum tube plate supply be careful not to get mixed up in the high potential side, as this might be fatal, as such transformers will deliver power from their secondary, which is about the same as getting across a pole-line of the same potential.

Don't try to operate vacuum tubes as amplifiers on potentials over 100 volts without proper grid bias batteries. Great distortion and probably burned out inter-tube transformers will result if you do.

Always connect fuses in your transmitting tube filament circuits; if anything happens it is cheaper to blow a fuse than a tube.

One of the weakest links in the amateur transmitting set is usually the lead-in insulator. Be sure you have this point well insulated.

Don't think that if you use twice as many tubes you should get twice the number of amperes in your antenna ammeter; remember that the power output varies as the SQUARE of the antenna current.

To get the average range of a radio set, take the distance the owner claims, extract the cube root, and divide your answer by the fifth root of unity.

Don't cuss the nearby broadcaster for your inability to tune him out, and get "distance"—remember that he may be distance to some other fellow, and that a "trap" in the antenna may cut him out for you entirely, when off his wave.

Why not use a simple switch to change from the detector to the second stage of your amplifier? You will then do away with the fuss of plugs and jacks.

Don't think that with umpty-umph tubes on a super-punkodyne circuit that you are doing wonders to get some broadcasting station 2000 miles away; in the olden days such distances, and greater, were common with spark transmitters and crystal receivers, without any fancy fuss.

Possibly some of the static does come from Mexico, as the report was some time ago, but noisy filament and plate batteries probably are where at least 61.21 per cent of it originates.

If two get together and learn the code, they will do it about five times as fast as one alone.

# FROM THE RADIO MANUFACTURERS

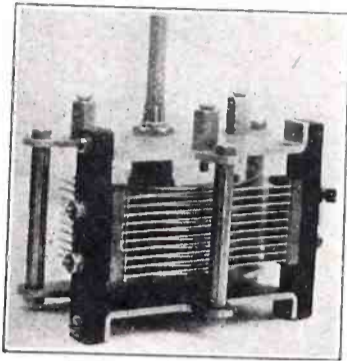
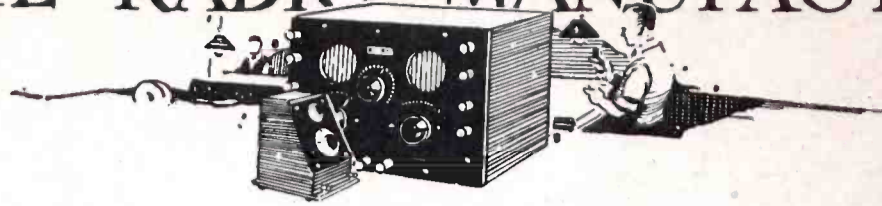

The new Type "B" Cardwell condenser has the same general design as the older Type "A" but has several special features. These include drill holes for mounting special coils as in the Cockaday or Hazeltine circuit, special spring contacts, white-nickel end plates and ball bearings. The new type is being made in 11, 17, 21 and 41-plate sizes.



The distinguishing feature of Samson transformers is the use of a helical winding to reduce to a minimum distributed capacity, resistance and current leakage, resulting in clear reception without howling. An amplification of 37 times is secured from a Samson HW-A1 transformer used with a 201-A tube with 80 volts on the plate.



The new Valley ABC battery charger may be used to charge all types of low voltage storage batteries. It has taps for 1, 2, 3, 4, 6, 12 and 24 volts and thus is adaptable to rectify alternating current for both A and B batteries. The charger has a bakelite panel and parts to harmonize with a radio receiving set.

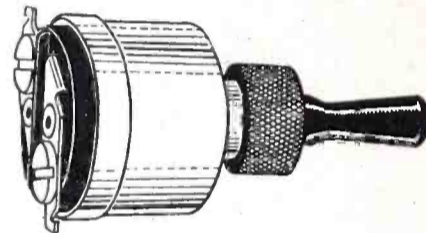

The new Bradley switch is a compact, completely enclosed, single-pole switch for opening battery circuits. It is mounted by drilling a hole in the radio panel and securing the switch by means of a knurled nut. It is operated by pulling or pushing the switch button. The switch is nickel-plated and the button is polished black.

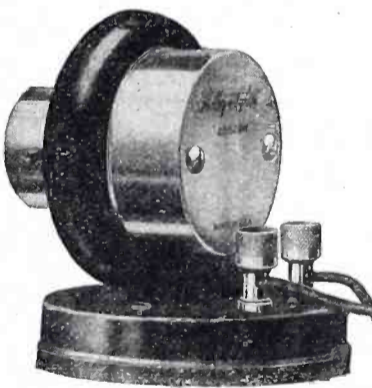

The Holtzer-Cabot loud speaker attachment for phonographs is intended to be fastened to the tone arm instead of the usual reproducer. The device consists of a Holtzer-Cabot telephone receiver and "audio filter" which eliminates practically all side noise. It is claimed to bring in the low notes with volume and trueness and the high notes with clearness and mellowness. It may be easily attached or detached without tools.



The Eisemann resistance adapter has been developed to utilize UV199 or C299 tubes in a receiving set equipped with standard base sockets and low resistance rheostats. It not only adapts the small tube to the standard socket but also inserts an 18-ohm resistance in the circuit. It is designed to have low distributed capacity and minimum leakage. The projecting knurled edge simplifies insertion and removal.

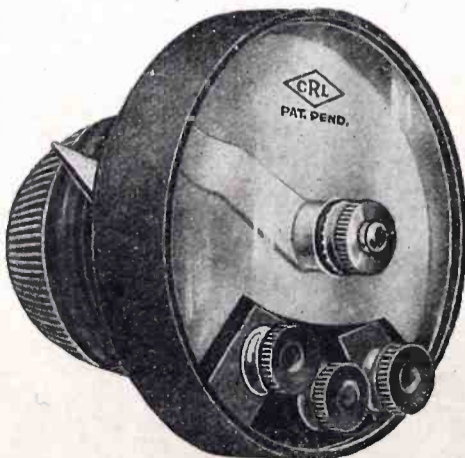

A new potentiometer from the Central Radio Laboratories employs a graphite resistance element which is non-inductive, free from "skin effect" and choke coil action, and offers the same resistance to radio-frequency as to direct current; made with a resistance of 400 ohms for adjustment of plate potential and grid bias or of 2000 ohms for special applications.

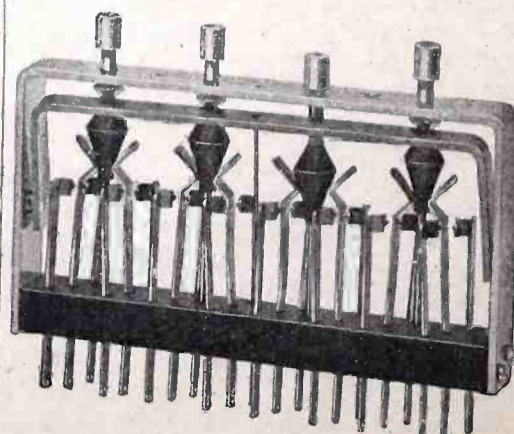

The Se-Ar-De automatic selector switch is intended to eliminate two jacks, thus allowing the phones or loudspeaker to be shifted from the detector to the first or second step without the necessity of removing them from the binding post or single jack to which they are connected. For full filament control this switch shifts both the A and B battery by simply pushing the respective buttons.

# The filament kontrol of infinite adjustment FIL-KO-STAT

## Everywhere

In current Radio literature, the FIL-KO-STAT is being praised by foremost authorities as the supreme achievement in vacuum tube filament control.

Kenneth Harkness in his recent volume, "Radio Frequency Amplification," says the FIL-KO-STAT is indispensable. W. J. Merrit Garvey's "Experimenters' Pocket Reference" tells why he prefers FIL-KO-STAT to all other filament controls and R. P. Clarkson Radio Data Sheet Expert, in his card on Filament Control, states that only FIL-KO-STAT gives ideal results.

All these endorsements are the result of laboratory tests and actual use of the FIL-KO-STAT. Put one in your set to-day and you will be of the same opinion.

## FIL-KO-STAT

- Provides scientifically correct filament control
- Assures longer tube life
- Is not a carbon powder rheostat
- Has no discs to break
- Has no wires
- No puzzling adjustments
- Ideal "off" position for all tubes adjusted at the laboratory
- Full resistance 30 ohms

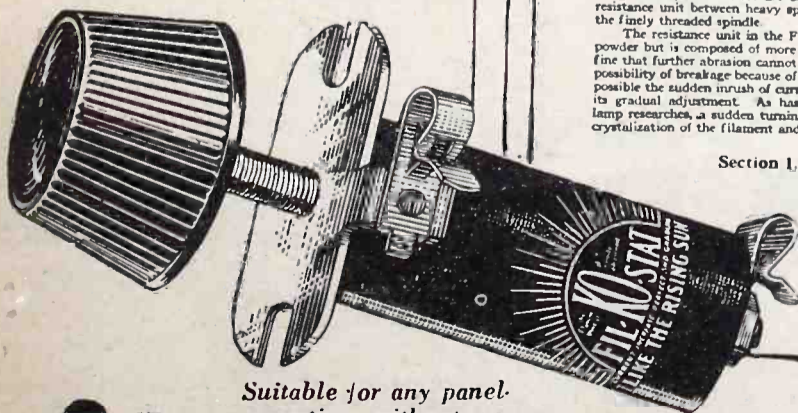

Suitable for any panel-mounting without re-drilling. Equipped with Fahnestock clips. Heavy nickel plated drilled and tapped mountings for rigidly setting up FIL-KO-STAT on table or board—15 cents.

**\$2** AT DEALERS EVERYWHERE  
In Canada 2.75

### RADIO FREQUENCY AMPLIFICATION

THEORY AND PRACTICE

KENNETH HARKNESS



PAGE 119

"Fil-KO-Stats \*\* provide fine regulation essential if maximum efficiency is to be obtained \*\* particularly useful tuning in weak stations. Fil-KO-Stat gives such fine control of filament temperature that it has become \*\*\* almost indispensable\*\*."

### RADIO CONSTRUCTORS AND EXPERIMENTERS POCKET REFERENCE

By W. J. MERRIT GARVEY

Including Special Treatise on Vacuum Tubes and Filament Control

Price 15 Cents

PAGE 9

"\*\*\*found Fil-KO-Stat\*\* enabled operator to make micrometer adjustments \*\*allowing infinitesimal current changes\*\*eliminating\*\*noises."

"\*\*\*\*but only the Fil-KO-Stat construction appears to give the ideal results\*\*microphonic noises are eliminated\*\* makes possible sudden inrush of current and then its gradual adjustment."

### SUN-GLOBE RADIO DATA SHEETS

Copyrighted by R. P. Clarkson.

#### FILAMENT CONTROL

Card No. 2

The previous card has indicated the necessity for delicate filament control for sharp tuning. It is essential that the tube used for the detector should operate at the exact required filament potential, that the grid potential should be correct, and that the proper plate potential should be furnished for the desired intensity of signal. Both grid and plate potential, which are usually fixed unless a potentiometer is used, are correct only for some best filament potential. Filament adjustment is, therefore, fundamental.

The wire type of rheostat is limited in resistance, and only roughly adjustable. Its construction makes it very difficult to provide good contact at all times. Both of these faults affect filament control. The heating of the filament depends upon the current which in turn depends upon the impressed voltage. The actual heat given off—the temperature of the filament—determines the electron flow. It is, however, a function of the square of the current multiplied by the resistance (I<sup>2</sup>R). Any filament adjustment must therefore be very fine for its effect is multiplied immensely in electron emission. Any varying contact between parts immediately more than offsets direct adjustment.

Various types of compression resistances have been devised such as carbon discs pressed together, a disc and a ball of carbon susceptible to varying pressure, and various forms of pressure devices using powdered carbon. All of these are temporarily good except for microphonic noises, but inevitably soon wear either by abrasion of the plates or their breaking or the packing of the powdered carbon. The proper solution of the problem is undoubtedly the compression type but only the Filkostat construction appears to give the ideal results. In this design microphonic noises are eliminated by cushioning the resilient resistance unit between heavy spring members which are operated by the finely threaded spindle.

The resistance unit in the Filkostat type of control is not carbon powder but is composed of more than 4-5 metal granules powdered so fine that further abrasion cannot take place in operation. There is no possibility of breakage because of the use of metal and it further makes possible the sudden inrush of current to light up the filament and then its gradual adjustment. As has been determined from incandescent lamp researches, a sudden turning on and off of the current prevents crystallization of the filament and gives it a longer life.

Section 1, Card 1.0986

MADE AND GUARANTEED BY



## RADIO STORES CORPORATION

Sole International Distributors

218-222 West 34th Street, New York

Dept. R-124

Chicago

Minneapolis

Kansas City

Los Angeles

Tell them that you saw it in RADIO

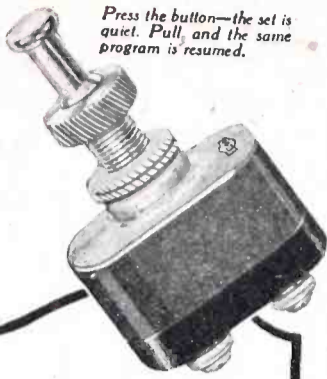

Press the button—the set is quiet. Pull, and the same program is resumed.



## Can You Interrupt Reception Without Losing the Station Received?

*This Little Switch Can Be Installed in a Few Minutes to Give Hours of Increased Pleasure*

With the C-H Radio Switch on your panel in the "A" battery circuit, just a touch of the nicked button and the set is quiet—pull it out and the same program is resumed. It is not necessary to turn back the rheostats and disturb the tuning of the set. You have instant, positive control with a real switch mechanism designed by the C-H Engineers to break up to 3 amperes at 110 volts, yet so precise that no microphonic noises are introduced, even when used in the most delicate circuits.

The cost of this little convenient necessity is only 60c, and it can be mounted on any panel in a few minutes to protect tubes and batteries worth many dollars. It is installed by drilling only a single  $\frac{1}{16}$ " hole, and can be used for the control of practically any radio circuits.

The bright orange and blue boxes with the C-H trademark designate the genuine. Dealers everywhere are featuring them. If yours has not yet been stocked, send 60c plus 10c for packing and mailing, and you will be supplied direct very promptly.

**THE CUTLER-HAMMER MFG. CO.**

Member Radio Section, Associated Manufacturers of Electrical Supplies  
MILWAUKEE · WISCONSIN



Disconnecting a battery lead is one way of shutting off a radio set, but many tubes and batteries have been ruined by pulling it back on the wrong post. A C-H Radio Switch costs 60c—if you save only a few dry cells it quickly earns the cost.

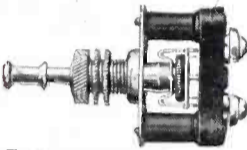

The C-H Engineers designed this radio switch mechanism so that the contact member floats, independent of the button. Touching it, or jarring the table does not cause noise in the phones.



The large capacity and easy mounting make it ideal for any use in radio.



# RADIO SWITCH

## CALLS HEARD

Continued from page 38

By 9BJI, Denver, Colo.

C. W.—1ajt, 1ap, 1boq, 1emp, 1rv, 1yb, 2agb, 2cfd, 2cla, 2cox, (2cxl), 2el, 2rb, 2wa, 2xat, 2za, 3bdo, 3bmt, 3bqv, 3gk, 3rf, 3su, 3tb, 3tj, 3vh, 3we, 3yw, 4cw, 4eb, 4gx, 4jh, (4ku), 4qf, 5abh, 5abz, 5acf, 5adb, 5adi, 5aee, 5afq, 5ahj, 5air, 5aiu, 5ajb, 5ajt, 5akf, 5aki, (5akn), 5ama, 5amb, 5amc, 5amb, 5amp, 5ana, 5az, 5bm, 5br, 5bw, 5bx, 5ce, 5dr, 5ds, 5dw, 5ek, 5fc, 5ft, 5fx, 5fv, 5ga, 5gj, 5gm, 5gn, 5gw, (5if), (5in), 5jc, 5jh, 5jj, 5kc, 5kn, 5lj, (5lr), 5ma, 5mo, 5nn, 5nw, 5ov, 5pf, 5ph, 5pv, 5ql, 5qq, 5qy, 5sd, 5sg, 5sr, 5uk, 5up, 5wa, 5wi, 5xb, 5yg, 5za, 5yk, (5zav), 5zb, (5zgc), 5zk, (5zm), 5zv, 6abx, (6acg), 6adt, 6agk, (6ajh), (6alv), (6ams), 6anb, (6aol), (6aoq), 6aou, 6aos, 6arb, 6atc, (6auy), 6avr, (6avv), (6awt), 6bah, 6bel, 6bfb, 6bfy, 6bic, (6bih), 6bjc, (6bjy), 6blw, 6bmt, (6bnf), 6bny, 6bon, 6boo, 6bou, (6bpf), 6bpz, (6bqc), (6bqe), 6brf, 6bso, (6buo), 6bur, 6bvg, (6bwe), (6bwp), 6cbi, 6cbu, 6cbw, 6cc, 6cga, 6cgv, 6chv, 6cib, 6cid, 6ekp, (6cmr), 6cnn, (6cod), 6dd, 6ej, 6en, 6eo, (6fh), (6fy), 6iq, 6pe, 6pl, 6rm, 6ts, 6uw, 6vf, 6xh, (6zah), 6zar, 6xad, 6zb, 6zi, 6zo, (6zz), 7abb, 7agv, (7bb), 7bj, 7cx, 7em, (7hw), (7io), 7ks, 7ln, 7ly, 7om, 7pj, 7sf, (7sy), (7wm), 7ws, 7ya, (7yl), 7zd, 7zi, 7zk, (7zt), 7zu, 7zx, 8aa, 8adg, 8adk, 8ai, 8aih, 8agp, 8aje, 8ajn, 8amm, 8ams, 8apn, 8apy, 8ard, 8avd, 8avs, 8azh, 8bah, 8bch, (8bcp), 8bou, 8bda, 8bf, 8bfv, 8bnh, 8bod, 8bwz, 8bxh, 8bym, 8bez, 8cgj, (8cjd), 8clc, 8clk, 8cod, 8cqx, 8crw, 8erm, 8cwr, 8daw, (8dgc), 8dez, 8eo, 8er, 8fu, 8gt, (8gz), 8ij, 8ki, 8lb, 8pd, 8pl, 8ri, 8tt, 8ty, 8wx, 8xe, 8ye, 8yn, 8yv, 8zae, 8zc, 8zx, 8zz, (9ahh), (9avn), (9avv), (9awv), (9bez), (9bmu), (9brk), (9bxt), (9bzi), (9ccz), (9ccs), (9cle), (9cwc), (9nr), (9wv), (9ze), (9zm), (9zv), (9zz), (9aa), (9ab), (9ac), (9ad), (9ae), (9af), (9ag), (9ah), (9ai), (9aj), (9ak), (9al), (9am), (9an), (9ao), (9ap), (9aq), (9ar), (9as), (9at), (9au), (9av), (9aw), (9ax), (9ay), (9az), (9ba), (9bb), (9bc), (9bd), (9be), (9bf), (9bg), (9bh), (9bi), (9bj), (9bk), (9bl), (9bm), (9bn), (9bo), (9bp), (9bq), (9br), (9bs), (9bt), (9bu), (9bv), (9bw), (9bx), (9by), (9bz), (9ca), (9cb), (9cc), (9cd), (9ce), (9cf), (9cg), (9ch), (9ci), (9cj), (9ck), (9cl), (9cm), (9cn), (9co), (9cp), (9cq), (9cr), (9cs), (9ct), (9cu), (9cv), (9cw), (9cx), (9cy), (9cz), (9da), (9db), (9dc), (9dd), (9de), (9df), (9dg), (9dh), (9di), (9dj), (9dk), (9dl), (9dm), (9dn), (9do), (9dp), (9dq), (9dr), (9ds), (9dt), (9du), (9dv), (9dw), (9dx), (9dy), (9dz), (9ea), (9eb), (9ec), (9ed), (9ee), (9ef), (9eg), (9eh), (9ei), (9ej), (9ek), (9el), (9em), (9en), (9eo), (9ep), (9eq), (9er), (9es), (9et), (9eu), (9ev), (9ew), (9ex), (9ey), (9ez), (9fa), (9fb), (9fc), (9fd), (9fe), (9ff), (9fg), (9fh), (9fi), (9fj), (9fk), (9fl), (9fm), (9fn), (9fo), (9fp), (9fq), (9fr), (9fs), (9ft), (9fu), (9fv), (9fw), (9fx), (9fy), (9fz), (9ga), (9gb), (9gc), (9gd), (9ge), (9gf), (9gg), (9gh), (9gi), (9gj), (9gk), (9gl), (9gm), (9gn), (9go), (9gp), (9gq), (9gr), (9gs), (9gt), (9gu), (9gv), (9gw), (9gx), (9gy), (9gz), (9ha), (9hb), (9hc), (9hd), (9he), (9hf), (9hg), (9hh), (9hi), (9hj), (9hk), (9hl), (9hm), (9hn), (9ho), (9hp), (9hq), (9hr), (9hs), (9ht), (9hu), (9hv), (9hw), (9hx), (9hy), (9hz), (9ia), (9ib), (9ic), (9id), (9ie), (9if), (9ig), (9ih), (9ii), (9ij), (9ik), (9il), (9im), (9in), (9io), (9ip), (9iq), (9ir), (9is), (9it), (9iu), (9iv), (9iw), (9ix), (9iy), (9iz), (9ja), (9jb), (9jc), (9jd), (9je), (9jf), (9jg), (9jh), (9ji), (9jj), (9jk), (9jl), (9jm), (9jn), (9jo), (9jp), (9jq), (9jr), (9js), (9jt), (9ju), (9jv), (9jw), (9jx), (9jy), (9jz), (9ka), (9kb), (9kc), (9kd), (9ke), (9kf), (9kg), (9kh), (9ki), (9kj), (9kl), (9km), (9kn), (9ko), (9kp), (9kq), (9kr), (9ks), (9kt), (9ku), (9kv), (9kw), (9kx), (9ky), (9kz), (9la), (9lb), (9lc), (9ld), (9le), (9lf), (9lg), (9lh), (9li), (9lj), (9lk), (9ll), (9lm), (9ln), (9lo), (9lp), (9lq), (9lr), (9ls), (9lt), (9lu), (9lv), (9lw), (9lx), (9ly), (9lz), (9ma), (9mb), (9mc), (9md), (9me), (9mf), (9mg), (9mh), (9mi), (9mj), (9mk), (9ml), (9mn), (9mo), (9mp), (9mq), (9mr), (9ms), (9mt), (9mu), (9mv), (9mw), (9mx), (9my), (9mz), (9na), (9nb), (9nc), (9nd), (9ne), (9nf), (9ng), (9nh), (9ni), (9nj), (9nk), (9nl), (9nm), (9no), (9np), (9nq), (9nr), (9ns), (9nt), (9nu), (9nv), (9nw), (9nx), (9ny), (9nz), (9oa), (9ob), (9oc), (9od), (9oe), (9of), (9og), (9oh), (9oi), (9oj), (9ok), (9ol), (9om), (9on), (9oo), (9op), (9oq), (9or), (9os), (9ot), (9ou), (9ov), (9ow), (9ox), (9oy), (9oz), (9pa), (9pb), (9pc), (9pd), (9pe), (9pf), (9pg), (9ph), (9pi), (9pj), (9pk), (9pl), (9pm), (9pn), (9po), (9pp), (9pq), (9pr), (9ps), (9pt), (9pu), (9pv), (9pw), (9px), (9py), (9pz), (9qa), (9qb), (9qc), (9qd), (9qe), (9qf), (9qg), (9qh), (9qi), (9qj), (9qk), (9ql), (9qm), (9qn), (9qo), (9qp), (9qq), (9qr), (9qs), (9qt), (9qu), (9qv), (9qw), (9qx), (9qy), (9qz), (9ra), (9rb), (9rc), (9rd), (9re), (9rf), (9rg), (9rh), (9ri), (9rj), (9rk), (9rl), (9rm), (9rn), (9ro), (9rp), (9rq), (9rr), (9rs), (9rt), (9ru), (9rv), (9rw), (9rx), (9ry), (9rz), (9sa), (9sb), (9sc), (9sd), (9se), (9sf), (9sg), (9sh), (9si), (9sj), (9sk), (9sl), (9sm), (9sn), (9so), (9sp), (9sq), (9sr), (9ss), (9st), (9su), (9sv), (9sw), (9sx), (9sy), (9sz), (9ta), (9tb), (9tc), (9td), (9te), (9tf), (9tg), (9th), (9ti), (9tj), (9tk), (9tl), (9tm), (9tn), (9to), (9tp), (9tq), (9tr), (9ts), (9tt), (9tu), (9tv), (9tw), (9tx), (9ty), (9tz), (9ua), (9ub), (9uc), (9ud), (9ue), (9uf), (9ug), (9uh), (9ui), (9uj), (9uk), (9ul), (9um), (9un), (9uo), (9up), (9uq), (9ur), (9us), (9ut), (9uu), (9uv), (9uw), (9ux), (9uy), (9uz), (9va), (9vb), (9vc), (9vd), (9ve), (9vf), (9vg), (9vh), (9vi), (9vj), (9vk), (9vl), (9vm), (9vn), (9vo), (9vp), (9vq), (9vr), (9vs), (9vt), (9vu), (9vv), (9vw), (9vx), (9vy), (9vz), (9wa), (9wb), (9wc), (9wd), (9we), (9wf), (9wg), (9wh), (9wi), (9wj), (9wk), (9wl), (9wm), (9wn), (9wo), (9wp), (9wq), (9wr), (9ws), (9wt), (9wu), (9wv), (9ww), (9wx), (9wy), (9wz), (9xa), (9xb), (9xc), (9xd), (9xe), (9xf), (9xg), (9xh), (9xi), (9xj), (9xk), (9xl), (9xm), (9xn), (9xo), (9xp), (9xq), (9xr), (9xs), (9xt), (9xu), (9xv), (9xw), (9xx), (9xy), (9xz), (9ya), (9yb), (9yc), (9yd), (9ye), (9yf), (9yg), (9yh), (9yi), (9yj), (9yk), (9yl), (9ym), (9yn), (9yo), (9yp), (9yq), (9yr), (9ys), (9yt), (9yu), (9yv), (9yw), (9yx), (9yz), (9za), (9zb), (9zc), (9zd), (9ze), (9zf), (9zg), (9zh), (9zi), (9zj), (9zk), (9zl), (9zm), (9zn), (9zo), (9zp), (9zq), (9zr), (9zs), (9zt), (9zu), (9zv), (9zw), (9zx), (9zy), (9zz).

By 6ADT, Orange, R. R. 3, Calif.

1bj, 3aoo, 4db, 4ft, 5aci, 5adt, 5ahd, 5anr, 5arg, 5asr, 5av, 5db, 5ht, 5la, 5lg, 5xz, 5zv, 5zav, 6abs, 6acn, 7aci, 7afk, 7agd, 7ags, 7aj, 7akk, 7avg, 7as, 7az, 7bjk, 7cs, 7io, 7ks, 7lr, 7pg, 7qd, 7qj, 7qt, 7sy, 7un, 7um, 7uu, 7ve, 7ya, 7zi, 7zu, 7zy, 7zd, 7ad, 8amf, 8bok, 8cax, 8cve, 8lw, 8zi, 9aau, 9adt, 9ady, 9aem, 9apf, 9avf, 9awb, 9awe, 9bak, 9bdx, 9bge, 9bik, 9bis, 9bjd, 9bjk, 9ll, 9hoe, 9bze, 9ccv, 9cjj, 9cvi, 9cvc, 9cwc, 9czg, 9di, 9dus, 9eea, 9fo, 9me, 9tt, 9zv.

By 6CLV, 155 Marston Ave., San Francisco

1asi, 4ku, 5aby, 5adb, 5akf, 5ama, 5ah, 5cm, 5et, 5lr, 5za, 5zav, 6add, 6adt, 6alo, 6ani, 6bih, 6pkx (vy qsa), 6blb, 6bpj, 6bge, 6brf, 6bsf, 6bts, 6bua, 6bur, 6bn, 6pe, 6dgc, 6cmr, other sixes too numerous to mention, 7aea, 7abb, 7acx, 7agi, 7agv, 7akk, 7ak, 7bo, 7by, 7de, 7dt, 7lr, 7ly, 7ms, 7pi, 7qd, 7qj, 7qu, 7qy, 7rp, 7rw, 7ry, 7sf, 7sy, 7ve, 7vn, 7ws, 7zt, 7zu, 7zi, 8gd, 8gz, 8wa, 8ced, 8cjd, 9aaw, 9aim, 9amb, 9apf, 9bgi, 9bjk, 9bzi, 9cfj, 9cjj, 9cvi, 9cvc, 9dfh, 9dgy, 9di, 9eea, 9eky, 9lz, 9vm, 9yy, 9zt. Anyone hearing my 5 wats pse qsl crd. Any of the above may hvé crd by request.

By 9BIK, Ames, Iowa

1aig, (1ajx), 1ali, 1ap, 1awn, 1bdi, 1bhk, 1bkq, 1br, 1bd, 1emp, 1erw, 1yb, 2aiv, 2ana, 2arf, 2ba, 2be, 2bhq, 2bse, 2ced, 2ccx, 2cei, 2cr, 2ctd, 2cqi, 2cgo, 2cva, 2cxl, 2kf, 2rm, 2wa, 2wb, 2bwj, 2bya, 3atb, 3ava, 3avv, 3bgt, 3ble, 3blp, 3bof, 3bqp, (3bt), 3buv, (3bvn), 3bwa, (3cbl), 3cs, 3hs, 3iw, 3jj, 3mo, 3qs, (3su), 3tj, 3tr, 3vo, 3xa, 3yp, 3ze, 3zo, 4bk, 4cs, 4dd, 4dt, 4eb, 4fy, 4jk, 4ka, 4kc, 4kf, 4ku, (4mb), 4me, 4mu, 4ou, 4om, 4qf, 4rs, 6ahz, 6ajh, (6anb), 6ani, 6asx, (6ate), 6avr, 6avv, 6awt, 6bbe, 6bbv, 6beo, 6blu, 6bhv, 6bic, 6bkb, 6bnf, 6bon, 6bqe, 6brf, 6cbi, 6cbu, 6cfz, 6cgv, 6ckp, 6cej, 6cmu, 6dbc, (6dd), 6fh, 6fy, 6hp, 6ii, 6ka, 6od, 6pb, 6pe, (6pl), 6vf, 6xj, 6zae, 6zo, 7aci, 7age, (7dc), 7lh, 7uu, (7zo), 7zu, Can. 4ca. Qra Box J, Station A, Ames, Ia. Qrk?

By 9DKY, Mason City, Ia.

1af, (1er), 1gv, 1il, 1kc, 1mc, 1sn, 1yb, 1acu, 1ajp, (1ape), 1ajx, 1alz, 1arf, 1arp, 1ary, 1asi, 1awz, 1bbu, 1bcg, 1bdi, 1bes, 1bkq, (1boq), (1bv), 1bwj, 1ckp, (1cmp), (1cpn), (1crw), 1cti, 1cvs, 2by, 2dx, 2el, 2fp, 2gk, 2gr, (2rm), 2rs, (2wr), 2afp, (2agb), 2ana, 2bck, 2bml, 2bmr, (2bqb), 2bqh, 2brb, (2bse), 2bsk, (2bte), 2ccx, (2cfb), 2cka, 2cnk, 2coh, (2cua), 2cuo, 2cxl, 3mo, 3om, 3ph, 3su, (3te), (3uu), (3vo), 3zs, 3abw, 3acq, 3alw, 3ava, (3bbv), 3bkl, (3bji), 3bnu, 3buv, 3bvl, (3cbl), (3ccu), 4db, 4dn, 4eb, 4eq, 4ft, 4gl, 4gx, 4jk, 4kc, 4ku, 4ly, 4mb, 4my, (4on), 6bm, 6cu, 6en, (6et), 6fh, 6hp, 6ih, 6km, 6mh, 6pl, 6ti, 6ts, 6ua, 6vf, 6zr, 6zz, 6aak, 6agj, 6ajf, 6ajh, 6alv, (6anb), 6ani, (6aos), (6arb), 6asx, 6auw, 6auy, 6avv, (6awt), 6bbe, 6bel, 6bic, 6bih, 6bjc, 6bkd, 6bqe, 6bqc, 6bql, 6brf, 6bsg, 6buo, 6bvs, 6bwp, 6cbu, 6cbx, 6cer, 6cdq, 6ceu, 6efi, 6efu, 6cfz, 6cgv, 6chl, 6ckp, 6ckr, 6cmu, 6cmr, 6cnn, 6zaf, 6zah, 6zar, 7ak, 7bb, 7fl, 7hg, 7lu, 7lw, 7sf, 7wm, 7ag, 7zf, 7zu, (7oh).

Continued on page 46

\$10



"THE BABY GRAND" 24 inches high

Loud Speaker without horn only \$6.00

## The Greatest Loud Speaker Value in the History of Radio

### SPECIFICATIONS

The reproducing element is the result of extensive experimenting and research. It has a super-sensitive electromagnetic element, actuating a large bachelite impregnated diaphragm. The unit has a micrometer adjustment which permits its tuning to give maximum output with any receiving set. The volume of the speaker can also be adjusted from a low whisper to a mighty volume. Horn is of non-metallic fibre composition, giving pure undistorted reproduction of exceptional volume and clarity. Particularly sensitive for long distance receiving.

ONLY \$10.00

## RADIO SPEAKER CO.

659 Hobbie St.  
289 Second St.

Chicago, Ill  
San Francisco, Cal.

A complete loud speaker with horn, unit, base, and cord for only \$10.00

The Biggest Contribution to Radio

FREE TRIAL We will ship this loud speaker C.O.D. on 10 day trial

Money positively refunded if you are not satisfied

Tell them that you saw it in RADIO

A NEW ERA IN RADIO



**The Golden Rule Tube**

The discovery of the principle upon which the Sodion Tube was developed marks a new and better Era in Radio.

The tube itself is different from any you have ever known.

Different in principle, different in operation and different in results.

As its name implies, it makes such effective

use of the peculiar properties of the sodium ion that there is no need of regeneration to build up the strength of your reception.

The fact that it does not oscillate not only eliminates all semblance of whistles and howls in your own reception, but makes it impossible for you to interfere

with the reception of others.

It is the practical application of the Golden Rule to Radio.

Crystal tone reception.

Unusually sensitive to weak signals.

Stable and uniform in operation.

Runs for hours without adjustment.

Operates on dry cells or storage battery.

*Bulletin A-100 upon request*



**CONNECTICUT** TELEPHONE & ELECTRIC  
MERIDEN Radio Division



**COMPANY**  
CONNECTICUT

# Charge Your Radio or Auto Battery Overnight for a nickel

Why be bothered with the inconvenience and expense of taking your storage battery to a service station every time it requires recharging? The

**GOLD SEAL**  
**HOMCHARGER**  
*The World's Most Popular Battery Charger*

charges any AUTO, RADIO or "B" storage battery in the quickest, simplest and most efficient manner possible. Connects to any lamp socket—operates silently—requires no watching. Fully automatic in operation—absolutely safe.

Beautifully finished in mahogany and gold. No danger from shock or fire—approved by Underwriters. UNQUALIFIEDLY GUARANTEED. Over 125,000 already in use.

Six-ampere size for all Radio, Auto and "B" storage batteries. Complete with ammeter—no extras to buy—\$18.50 (\$25.00 in Canada).

**FREE.** Ask your Dealer or write direct for free copy of Ho.ncharger List of Broadcasting Stations, and Gold Seal Bulletin.

*Insist*  
on the **GOLD SEAL**

which appears on Nameplate and Package. No other charger is just as good!

**The Automatic Electrical Devices Co.**  
117 W. Third St., Cincinnati, Ohio, U. S. A.  
*Largest Manufacturers Vibrating Rectifiers in the World.*



Western Distributor: **BERTRAM SMITH**  
516 San Fernando Bldg., Los Angeles, Calif.  
Shipments to all points west of Rockies from Los Angeles stock.

## CALLS HEARD

Continued from page 44

By Geo. R. Johnson, Milton, Oregon

1bvw, 1fs, 1xm, 2am, 2bqc, 2bzb, 3aao, 3bof, 3bvn-1cw, 3ts, 4eb, 4eq, 4ft, 4gu, 4mb, 5aby, 5adb, 5afq, 5ahh, 5ajj, 5aiv, 5aji, 5akn, 5bp, 5dw, 5ek, 5gi, 5gn, 5ht, 5if, 5in, 5ko, 5lg, 5lr, 5xv, 5zb, 5zg, 5zav, 6afq, 6ajd, 6avj-fone, 6awt, 6bsg-1cw, 6bqc, 6bua, 6bve, 6bvz, 6bwe, 6cbw, 6cfz, 6cnh, 6cnz, 6czw, numerous 7's, 8acn, 8afi, 8ajh, 8bda, 8brm, 8clk, 8cnw, 8cse, 8dge, 8dkm, 8ab, 8kg, 8vy, 8xe, 8zz, 9aem, 9ahz, 9aim, 9ajv, 9apf, 9aay, 9ayl, 9bab, 9bal, 9bez, 9bfe, 9bji, 9bri, 9bsh, 9bsp, 9bzi, 9caa, 9ces, 9ccz, 9ccv, 9ceh, 9clq, 9ctk, 9evc, 9dch, 9ddy, 9dgi, 9dkb, 9dky, 9dmj, 9dxy, 9eea, 9efq, 9mf, 9nr, 9nu, 9uh, 9zg, 9zy.

Can.: 3oh, 3xn, 4cl, 5cn, 5ct.

By 6KJ, J. E. Penrose, Grass Valley, Calif.

1aw, 1ana, 1acu, 2acd, 2rb, 3bva, 4ku, 5kc, 5ux, 6aos, 6as, 6awt, 6aut, 6adn, 6alv, 6bel, 6bm, 6bfy, 6cl, 6cae, 6col, 6cp, 6cj, 6cgw, 6cey, (6dc) qra, 6fh, 6gr, 6gf, 6ib, 6id, 6iy, 6vx, 6zk, 7age, 7ny, 7lu, 7vn, 7zu, 7qj, 7uh, 7ks, 7oy, 7me, 8gz, 9aau, 9bzi, 9dli, 9ans, 9bel, 9ig, 9ayl, 9eky, 9awm, 9bny.

Can.: 4cl, 5cn, 9bp. Hawaiian: 6ecu. Mexican: jh.

By H. L. Smith, 711 D Street, Oxnard, Calif.

Cw.: 5ga, 5nn, 5ui(?) 5zh, 6adt, 6aou, 6ask, 6auu, 6bnf, 6ii, 6ban, 6ce, 6fh, 6fy, 6pe, 7agv, 7em, 7io, 7ks, 7ln, 7lw, 7pj, 7so, 7ve, 7wm, 7ya, 7yl, 7zu, 9bez, 9bji, 9cay, 9cay. WI be on the air in two months with 5-watts.

By 6ALV, Alameda, Calif.

1ii, 1er, 2blu, 2cqz, 3auv, (4eb), (4ku), 4my, 5bf, (5dw), 5gj, (5ht), (5lr), 5nn, 5nn, 5pb, 5qw, 5sk, 5tj, (5uo), 5vv, 5adb, 5atu, 5amh, 5zav, 6ceu, 7mn, 8fu, (8gz), 8jj, 8nb, 8tt, 8ago, 8apt, 8atp, 8bda, (8bfh), 8bwk, 8bwz, 8cqx, 8yv, 8yn, 9bg, 9cr, (9cp), 9mc, 9rc, (9vm), 9aim, 9aog, 9apf, (9aem), 9bak, 9bav, 9bgk, 9bh, 9bmx, 9bq, (9bji), 9ayp, (9caa), (9cev), (9de), (9ceh), (9cfk), 9chd, 9cjk, 9epi, (9ctr), 9evc, 9daw, (9dhg), (9djb), (9dkb), (9dsw), 9dxn, 9dxy, 9eea, (9ekf), (9eky), 9yaj.

Can.: 4cl, (5cn), (5go), 9bp, 9bx.

By 9CTR, St. Louis, Mo.

(1adn), 1af, 1afa, 1afp, 1aln, 1alz, 1asi, 1aww, 1bdi, 1bge, 1bhk, (1bom), 1boq, 1bwj, 1cab, (1cmp), 1cnd, (1cpn), (1evs), 1er, 1fb, 1gv, (1hx), 1ii, 1mo, 1mc, 1my, 1ow, 1rr, 6acm, 6acg, 6afq, 6aix, (6alv), 6ams, 6arb, 6asx, 6auy, (6awt), 6bbw, 6bcl, 6bic, 6bih, 6bja, 6bjc, 6bjq, 6bm, 6bpz, 6bql, 6bsn, 6bua, 6buo, 6bve, 6bvg, 6cbi, 6cek, 6cfz, 6cgd, (6cgw), (6chl), 6ckr, 6ckp, 6cmr, 6et, 6hp, 6ii, 6ka, 6pe, 6pl, 6yc, 6zah, (6zar), (7abb), 7bj, 7hg, 7hw, 7it, 7iw, 7ln, 7ob, 7oh, 7qj, 7wm, (7zd), 7zf, 7zl, 7zu.

Can.: (2cg), 5go, 5cn.

By 7AIY, Frank A. Mueller, Jr., New Ora: 514 2nd St. N., Wenatchee, Wash.

Cw: 1usi, 1bbo, 1ccz, 2aff, 2bjg, 2ccd, 2cxl, 2by, 2gk, 3atz, 4bc, (4eb), 4el, 4ku, 4nq, 4os, 5abz, 5ago, (5aiu), 5amh, 5bm, 5pb, 5ek, 5fa, 5gj, 5hh, 5ht, 5hz, 5lv, 5ph, 5px, 5uk, 5vv, 5xv, 5za, 5zav, 6aak, 6aur, 6aat and icw, 6abx, 6acm, 6adh, 6adm, 6afp, 6afq, 6afy, 6aga, 6agb, 6age, 6ahw, 6ahz, 6alv, 6alx, 6amg, 6amh, 6ams, 6anb, 6ani, 6any, 6aob, 6aoh, 6aol, 6aoo, 6aos, 6aou, 6arb, 6atc, 6aty, 6atz, 6aup, 6auy, 6avi, 6avv, 6aws, 6awt, 6awz, 6baa, 6bab, 6baf, 6bbc, 6bbh, 6bbw, 6bcl, 6bes, 6bds, 6bdy, 6bcj, 6beh, 6beq, 6bez, 6bfb, 6bic, 6bih, 6biq, 6bjc, 6bkk, 6bdx, 6blb, 6blg, 6blm, (6bly), 6bmd, 6bmy, 6bmz, 6boi, 6bon, 6bou, 6bpz, 6bqe, 6bql, (6brf), 6bsg, 6bsj, 6bsv, 6bts, 6bua, 6buf, 6buh, 6buo, 6bur, 6buu, 6buy, 6buz, 6bve, 6bvg, 6bvs, 6bwp, 6cax, (6cbb), 6cbl, 6cbr, 6cbw, 6ccu, 6ccy, 6cdg, 6cej, 6ceu, 6cfm, 6dfz, 6cgd, 6cgg, 6cgl, 6cgl, 6cgw, 6chl, 6chu, 6chv, 6chz, 6cid, 6cix, 6ciz, 6ckh, 6ckp, 6cll, (6cmi fone), 6cmr, 6cmu, 6cng, 6cni, 6cnl, 6cod, 6cuz, (6cyr), 6xbj, 6zam, (6zar), 6bq, 6bm, 6cc, 6cu, 6dd, 6eb, 6ec, 6en, 6et, 6ff, 6fh, 6fl, 6fy, 6gx, 6hp, (6ii), 6jh, 6jm, 6jq, 6js, 6kj, 6km, 6mg, 6mh, 6nx, 6oh, 6ok, 6pl, 6rm, 6su, 6ts, 6uf, 6uh, 6xh, 6zh, 6zi, 6zo, 7it, 8abx, 8amm, 8apt, 8aqo, 8asv, 8avn, 8awp icw, 8bda, 8bdw, 8bfh, 8bfq, 8bfs, 8bym, 8dhq, 8ced, 8erc, 8ab, 8bf, 8dw, 8fr, 8gd, 8hn, 8ij, 8pl, 8tt, 8wx, 8xe, 8zz, 9aaw icw, 9aay, 9aen, 9aic, 9aim, 9ajf, 9amb, 9amu, 9any, 9aog, 9aom, 9aou, 9apf, 9aps, 9aua, 9aus, 9avn, 9bav, 9bed, 9bfe, 9bh, 9bjk, 9bkc, 9bqj, 9bqk, 9bqq, 9bqy, 9bmm, 9bmo, 9bri, 9bsz, 9bun, 9bvn, 9bzi, 9caa, 9caj, 9cbj, 9cev, 9ccz, 9cfi, 9cfk, 9cfy, 9clq, 9cme, 9cns, 9csy, 9ctr, 9cvc, 9cvh, 9cvs, 9czg, 9czw, 9daw, 9dch, 9dge, 9dgi, 9dgw, 9dha, 9djm, 9dkb, 9dkq, 9dky, 9dlm, 9dqm, 9dqu, 9dug, 9dys, 9dxn, 9ebt, 9eea, 9ekf, 9eky, 9emf, 9yaj, 9am, 9bg, 9bw, 9ck, 9dr, 9eh, 9gd, 9hk, 9jk, 9lz, 9na, 9pm, 9rc, 9uh, 9vm, 9yy, 9zg, 9zn, 9zt, 9zy.

Can.: 2ab, 3dti, 3ge, 3ni, 3zl, 4cw, 4hf, 4cl, 4dq, (5ah), (5ct), (5go), 9bp.

Spark: 6akt, 6ge, (6qk). WNP—500 cycle icw. Will qsl upon request.

Continued on page 48

## We Repair RADIO TUBES

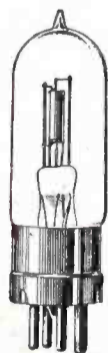

WD-11	.....	\$3.50	UV-199	.....	\$3.50
WD-12	.....	3.50	C-299	.....	3.50
UV-200	.....	2.75	UV-201A	.....	3.50
UV-201	.....	3.00	C-301A	.....	3.50
C-300	.....	2.75	UV-202	.....	4.00
C-301	.....	3.00	C-302	.....	4.00
DV-6	.....	3.00	DV-6A	.....	3.50

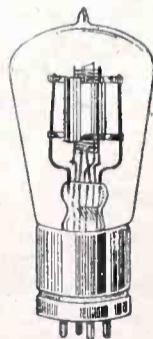

Dealer's and Agent's Special Discount

Mail orders solicited and promptly attended to

## H. & H. RADIO CO.

P. O. Box 22-M Clinton Hill Sta. Newark, N. J.

Tell them that you saw it in RADIO



# Establishing a New Horizon for Radio



## The New MU-RAD RECEIVER MA-15

**T**HE HORIZON of the radio art extended and broadened by this new perfection of radio reception—the more versatile, more simply operated receiver, *Mu-Rad MA-15*. Many important refinements—plug-in type radio frequency transformers, so that the MA-15 can be accommodated to any future changes of wave lengths or tubes, volt-meter for instantaneous

readings of “A” or “B” batteries, new type vernier dials, operated by cams to eliminate back-lash, no other aerial than a 2-foot loop needed, and a wave length switch for bringing in short wave stations. Solid mahogany cabinet, with an engraved Formica panel. The MA-15 anticipates every possible use and requirement. *Guaranteed range, 1,000 miles using 2-foot loop.*

### Another New MU-RAD Receiver MA-17

Three stages of radio and two of audio frequency amplification and detector. *One* tuning dial and two selecting dials, each independent of the other. Plug-in type r. f. transformers to care for changes of tube type or wave lengths. Panel-mounted volt-meter for quick reading of A and B batteries. Solid mahogany, Adam Brown hand-rubbed finish cabinet with loop fitted into top and compartment in base for B batteries. Guaranteed for 1,000 miles reception using only a 2-foot loop.

WRITE FOR BOOKLET AND THE NAME OF THE NEAREST DEALER

**MU-RAD LABORATORIES, INC.**

806 FIFTH AVE. ASBURY PARK, NEW JERSEY

Tell them that you saw it in RADIO



# The Music of the Immortals in Your Own Home

People sometimes sit hours in hot, stuffy opera houses to hear our famous opera singers. Yet the immortal notes of those same stars are broadcasted from radio stations and are listened to by thousands in the comfort and seclusion of their own homes.

Perhaps you would rather follow an athletic contest play by play, or listen to a speech by some famous man. Or perhaps the market, crop and weather reports would prove more interesting to you.

## PARAGON RADIO PRODUCTS

With the new PARAGON Three-Circuit Receiver Type RB-2 you can pick out the program you wish to hear and hear it clearly from beginning to end. For the greatest enjoyment of radio, for complete satisfaction, you should listen in with a Paragon set.

In appearance it is an addition to any home. All cabinet work is of mahogany with a brown mahogany finish. All metal parts showing, inside as well as outside of the cabinet, are nickel plated. 98% of the wiring is invisible. The whole outfit is compact, neat, solidly built, and finely finished. It is the ideal Radio receiver and the ideal holiday gift.

### Illustrated Bulletins on Paragon Radio Products Are Yours for the Asking.

DEALERS: We believe in the proper distribution of Paragon Radio Products. Our exclusive Distributors are particularly interested in territorially protected dealers, who will concentrate, solicit and serve the consumer in the sale of Paragon Radio Receivers. If interested, write us for details.

ADAMS-MORGAN COMPANY  
2 Alvin Avenue, Upper Montclair, N. J.

Pacific Coast Sales Representative:  
Paul Sutcliffe, Room 400, San Fernando Bldg., Los Angeles, Cal.



Illustration shows the new Paragon R-B-2 Regenerative Receiver with two-stage tone amplifier Price \$135.00

(Licensed under Armstrong Patent No. 1,113,149)

### CALLS HEARD

Continued from page 46

At 8ADA

5ac, 5bm, 5bp, 5dw, 5fa, 5fc, 5fx, 5ga, 5ge, 5gi, 5gp, 5je, 5jf, 5kc, 5kg, 5lr, 5mn, 5nj, 5pb, (5qi), (5qq), (5re), (5uc), (5up), (5uk), (5abt), 5acr, 5ado, 5adb, 5ads, (5ahj), 5air, (5aiu), 5ajp, 5akn, 5amb, 5amf(icw), 5ana, 5za, (5zav), 5zm, 5zx, 6bm, 6km, 6lk, 6pl, 6tj, 6tv, 6vm, 6acm, 6adt, 6alv, 6arb, 6asx, 6aty, 6auy, 6avv, 6bbe, 6bbq, 6bbr, (6bcl), 6bgy, 6bhg, 6bis, 6bmd, 6brf(icw), 6bvg, 6cbi, 6cbu, 6cbw, 6cdg, 6cfz, 6cgd, 6cgw, 6chl, 6cka, (6cui), 6ra?, 6zah, 6awt, 7ca, 7hg, 7ks, 7oh, 7po, 7sh, 7wp, 7abb, 7akz, 7zu, (9amb), (9aog), (9apf), 9ack, 9avs, 9avu, 9bji, 9bjk, 9caa, (9ccz), 9cfy, 9evc, 9dff, (9yu).

Can.: 1ar, 2am, 2bn, 4cl, 4cn, 4dy, 5cn, 5go.  
Fones: 5amf, 9bil, (9aic), 9dkt, 9hk.  
Dalite: (1rv), (1bwj), (4ku), (6bcl), (9yu).  
Mex.: jk?  
wnp

By H. T. Mapes, BDO "BX" Guanajuato, Gto., Mexico

2xn, 4by, 4ft, 4ku, 4mb, 4xj, 5akw, (5ama), 5ado, 5ahd, 5aew, 5akn, 5akj, (5acr), 5aiu, (5adi), 5amb, 5amj, (5adb), 5aib, 5adh, 5afh, 5ahh, 5ana, 5af, 5aky, 5alh, 5aic, 5aij, 5amp, 5bm, 5be, (5bx), 5cv, 5dr, 5dw, 5en, 5ek, (5ft), (5fa), 5fc, 5fx, 5gw, 5ga, 5gn, 5gi, 5gf, 5gm, (5hz), (5ht), (5in), 5if, 5jf, 5je, 5ji, 5jc, 5je, (5kg), (5ke), 5kf, 5lj, (5lr), 5ll, 5lp, 5lc, 5mt, 5meg, 5mn, 5nr, 5ng, 5nh, 5pk, 5nj, (6nk), 5nz, 5nn, (5ov), (5pb), (5ph), 5qi, 5ql, 5qy, 5qq, 5sd, 5tj, 5uo, 5vv, 5vy, 5vf, (5xaj), (5xv), 5xab, (5yg), (5yk), 5yk Spk, 5zh, 5zg, 5zax, 5zak, (5za), 5zav, 5zx, 5amw, 6alk, 6and, 6awt, 5asx, 6arb, 6agk, 6avv, 6aak, 6acg, 6asx, 6avr, 6ao, 6aup, 6ava, 6auy, 6alv, 6bbe, 6bic, 6bih, 6bur, 6brf, 6bwz, 6ban, 6bqc, 6bts, 6blg, 6bwp, 6cgw, 6cgd, 6cfi, 6cbi, 6chl, 6cfz, 6cic, 6cmr, 6ckp, 6ckr, 6cmu, 6cmi, 6cga, 6fh, 6ff, 6km, 6mh, 6mg, 6ts, 6vf, 6zh, 6zi, 6zz, 6zah, 7abb, 7zu, 8awp, 8ame, 8asv, 8bda, 8ef, 8kh, 8vk, 8xe, 8yv, 9avz, 9apf, 9aau, 9aim, 9aps, 9avn, 9atn, 9apf, 9auy, 9amb, 9aon, 9bx, 9bzi, 9bed, 9bbw, 9bez, 9bxq, 9ccz, 9ccv, 9czw, 9ca, 9cns, 9dxy, 9eky, 9cfy, 9ox, 9xaq, 9yaj, 9yy, 9zt, 9zv. Would appreciate reports on how you are getting Mex-bx.

By 6AMS, 72 Henry St., San Francisco Calif.

4eb, 5be, 5ga, 5ht, 5ig, 5tj, 5acq, 5ajb, 5aky, 5yav, (Can5cn), 6fy, 6ka, 6pl, 6mh, 6aoi, 6bbx, (6bgd), 6bih, (6biq), 6bqe, (6brf), 6bsn, 6bxq, 6cbd, 6ebi, 6cbu, (6cbw), 6ceu, (6cim), (6cju), 6cok, (6ckh), (6cms qra?), (7bj), (7ei), 7ev, 7fl, (7gq), 7hq, 7hw, 7hi, (7hj), 7mg, 7qw, 7rf, (7to), (7ws), 7zi, 7aba, 7aci, 7afe, 7afo, 7age, 7akt, 8hv, 8zz, 8gj, 9ei, 9me, 9uc, 9zt, 9bx, 9aav, 9aau, 9aic, 9aim, 9amb, 9apt, 9ast, 9aul, 9auw, 9ban, 9bch, (9bji), 9bjk, 9bmu, 9bvf, 9bxq, 9caa, 9ccv, 9dfh, 9dfs, 9dhp, 9dkb, 9ekf, 9eky. Anyone hearing my cw or fone please qsl qrk?

By 9BIS

1er, 1xp, (1aww), 1afc, 1ajx, 1ayi, 1yb, 1caz, 1cmp, (1bbo), 2agb, 2cxl, 2bse, 2, 3bv, 3aic, 3ber, 3bml, 3adj, (3bei), 4db, 4ai, 4wl, 4ay, 6bgy, 6bvc, 6pl, 6bhu, 6bqe, 6alv, 6cgw, 6bcs, 6aoc, 6km, 6cbu, 6bcl, 6cid, 6bua, 6tv, 6ec, 6nx, 6cbi, 6bih, 6avv, 6bpm, 7hg, 7ve.  
Can.: (2ic), (3ada), (3tb), (3de), 3xi, 3oh, 3bq, (4dq), (4hh).

By 5KC, Vincent Rosso, Plaquemine, La.

Can.: (3co), 3jl, (3jt), 3qt, 3ss, 3sx, 3tb.  
Daylite: (3uj), 3ws, 3xn, 3zn, 3zt.  
Mex.: (bx).

U. S.: 1fb, 2fp, 2pf, (2wa), 2bqd, (2bue), 2ccx, 2zs, 3bbv, (3bdo), 3brm, 3ebm, 4hz, (4me), 4qf, 5 too numerous, 6cf, 6ka, 6pl, 6vd, 6vf, 6alv, 6avv, 6awt, 6bbe, 6bic, 6bih, 6blk, 6bpe, 6bpz, 6bqc, 6brf, 6but, 6bvf, 6bwp, 6cah, 6caj, 6cbi, 6cdc, 6cdg, 6cgw, 7agv, 7bcf, 7yl, 7zu. 8, 9 too numerous.

By 8DKI, Nick Geracimos, Warren, Pa.

4ay, 4cs, 4db, 4fy, 4gf, 4gw, 4hs, 4kc, 4on, 5abt, 5abh, 5acb, (5agj), 5aic, (5aiu), 5akn, 5amp, 5ajp, 5bp, 5bw, 5ek, 5fx, 5gj, 5gl, 5gm, 5in, (5kc), 5kw, 5kr, 5lr, 5up, (5wo), 5wx, 5zav, 6ajh, 6alv, 6awt, 6avv, 6ckp, 6cnc, 6cgw, 6fy, 6za, 6xad, 6zar, 7ah, 7ih, 7ks, 7nm, 9aau, 9aav, 9ahr, 9ami, 9aou, 9apf, 9auf, 9axd, 9ayi, 9ayp, 9bed, 9bhi, (9bhn), 9bpy, 9bji, (9bqy), 9bta, 9bun, 9cfk, 9chf, 9cki, (9clx), (9ceb), (9dis), 9djk, 9dlm, 9dxu, 9eak, 9ebt, 9elc, 9ecv, 9ehi, (9eky).

At 6FY, Modesto, Calif.

Wnp, 2bqu 3byn, 4ku, 4jv, 4za, 5lg, 5lr, 5mo, 5sk, 5mn, 5nn, 5agj, 5ahd, 5aku, 5amu, (5za), 5zav, (6ceu), (6rm), (7aci), (7ab), 8gz, 8hu, 8jj, 8kg, 8vf, (8bda), 8bux, 8cod, 8ahu, 8xc, 8zc, 8zx, 8zz, 9aau, 9aim, (9aki), (9akc), 9amb, 9apl, (9apf), 9awm, 9bik, 9bjk, 9bun, 9bvd, (9bxa), 9bzi, 9caa, 9ccy, 9cde, 9ceh, 9cns, 9esy, 9dfh, 9dkb, 9dte, 9eea, 9eky, 9yy, 9zt.  
Can.: 3bp, (4cl), (5ah), (5cn). 20 watts hr.  
Would appreciate a report on my sigs.

Continued on page 50

Tell them that you saw it in RADIO





# Save $\frac{1}{3}$ on Guaranteed Radio Equipment

**Write us a post card**  
Address Dept. 39-R

and we will send you free this 52 page catalogue of radio sets and parts. It also contains explanation of radio terms, map and list of broadcasting stations and much radio information, including an explanation of successful hook-ups and circuits.

You will be amazed at the low prices Ward's quote. A complete tube set having a range of 500 miles and more, including tube, head set, batteries, and antenna equipment, as low as \$23.50.

This catalogue contains everything for the expert and amateur. Complete sets and every improved part for building sets, all the most up-to-date devices—at the lowest possible prices.

### Headquarters for Radio

Montgomery Ward & Co. is headquarters for Radio, selling everything direct by mail without the usual "Radio-profits." Why pay higher prices? Ward quality is the best and the prices will often save you one-third. Everything sold under our Fifty Year Old Guarantee—Your Money Back if You Are Not Satisfied. Write today for your copy of this complete 52-page Radio Book.

**Write to our house nearest you. Address Dept. 39-R**

Chicago	Kansas City	St. Paul	Portland, Ore.
	Ft. Worth	Oakland, Cal.	

**This Radio Catalogue FREE**

Established 1872

# Montgomery Ward & Co.

The Oldest Mail Order House is Today the Most Progressive

Tell them that you saw it in RADIO

**Dubilier  
Duratran  
Price \$5.00**



## Why he couldn't hear XZBQ

**H**IS set had a radio-frequency transformer with an amplification factor that was good only for the 360-400 meter stations. That was why XZBQ and other 500 and 550 meter stations were almost inaudible.

This very difficulty the Duratran, the new Dubilier radio-frequency transformer, overcomes. It has an amplification factor of over 20 for the entire wave-length band of 225 to 550 meters and amplifies well on an even wider band.

**Dubilier Condenser & Radio Corp.**  
48-50 West Fourth Street, New York

# DUBILIER DEVICES

Address Dept. 11 for free booklet, which simply and accurately describes radio-frequency amplification, with valuable hook-ups.



**NEW BLACK GUN METAL  
FINISH, NICKEL TRIM**

**\$3.50** List

Regular Repeater Quality

Radio experts are enthusiastic boosters for this remarkable instrument.  
**DEALERS**—Write today for discounts and descriptive folder.

**MOSS-SCHURY MFG. CO., Inc.**

Manufacturers of precision electrical devices. Radio division 2011-2015 Franklin St., Detroit U. S. A.

## CALLS HEARD

Continued from page 48

By 7BY, R. E. Priebe, Bellingham, Wash.

5akf, 5bm, 5er, 5ga, 5gm, 5kg, 5za, 6acm, 6afq, 6ahc, 6amg, 6anb, 6oad, 6aos, 6aou, 6aqq, 6asx, 6aup, 6auy, 6aws, 6awt, 6bab, 6baa, 6bbc, 6bfl, 6bic, 6bif, 6bih, 6bkg, 6blb, (6blm), 6bql, 6bua, 6buo, 6buz, 6bvs, 6bza, 6cax, 6cbw, 6cdg, 6cet, 6ceu, 6cfl, 6cfs, 6ogd, 6ogl, 6chl, 6cid, 6ckf, 6ckh, 6ckp, 6cmi, 6cmt, (6et), 6lu, 6mh, 6tu, 6vf, 6wt, 6xh, 6zar, 7's too num., 8bu, 8bch, 8ced, 8cgl, 8fu, 8uu, 9aau, 9aon, 9ape, 9bg, 9bak, 9bav, 9bik, 9bji, 9bjk, 9bly, 8bzi, 9okm, 9cly, 9cnf, 9coa, 9co, 9cmk, 9dgi, 9dxy, 9eau, 9ebt, 9eev, 9egu, 9eky, 9pw, 9rc, 9yy, 9zt, 9zy. Would appreciate a card from those hearing the cw signals of 7by.

At 5ADB, 2117 Grant Ave., El Paso, Tex.

All C. W.: 1alz, 1bes, 1bkq, 1bwj, 1cab, 1cmp, 1er, 1kw (?), 1mo, 1ow, 1yb, 2acy, 2awf, 2bjr, 2by, 2cua, 2cxl, 2wr, 2xap, 3bfv, 3bnu, 3buc, 3bvn, 3cel, 3chg, 3jj, 3mc, 3ov, 3qv, 3vw, 3xt, 3zt, 4ag, 4do, 4ft, 4jv, 4kc, 4ku, 4lj, 4mb, 4na, 5aby, 4acf, 5acu, 5adh, 5ae, 5aao, 5aer, 5aee, 5agj, 5ahd (fone), 5aht, 5aj, (5aiu), (5ajb), (5akn), 5ama, 5amb, 5amw, (5anc), 5be, 5bm, 5bw, 5bx, 5ce, (5dw), (5fa), (5ga), (5gi), (5gj), 5gm, 5gn, 5ho, 5hy, 5hz, 5if, (5in), (5jc), 5ji, 5kc, (5kg), 5kn, 5lr, (5mn), 5nk, 5nn, (5ov), 5oz, 5pb, (5ph), 5ra, (5ui), 5uo, 5up, 5va, (5vf), 5vv, 5vy, 5xad, (5xv), 5yg, (5za), (5zav), 5zg, (5zh), 5zm, 6aak, 6aao, 6afg, 6afq, (6ahc), 6aiu, (6ajd), 6aja, (6ao), (6aoi), 6aor, 6arb, 6asj (6auy), 6avr, (6avv), 6bfb, (6bic), (6bjq), (6bkx), (6bqe), (6bqk), 6brk, 6brf, 6brs, (6bts), (6buo), (6cbi), 6cfz, (6cgg), (6cgv), (6chl), 6chv, (6bvs), 6cmq, 6cmu, 6ff, (6hv), 6ii, 6jd, 6ka, 6km, (6mg), (6pl), (6ts), 6yc, (6zz), 7abb, 7abg, 7go, 7hw, 7ks, 7lo, 7ny, 7qj, 7ws, 7ya, 7zd, 7zo, 7zu, 8agn, 8ame, 8apn, 8apy, 8asv, 8bch, 8bda, 8bf, 8bfh, 8bjv, 8bxs, 8bzc, 8bsy, 8cdk, 8cgl, 8cl, 8cmu, 8cmv, 8csj, 8cvg, 8cwh, 8fu, 8gz, 8jj, 8kg, 8kh, 8pd, 8vy, 8vq, 8xe, 8yu (?), 8zc, 8zz, 9aau, 9aci, 9aeb, 9aed, 9auw, (9aim), 9axx, (9avn), 9awg, 9aml, 9ajv, 9awv, (9apf), 9aic, 9ape, 9ayp, 9ayl, 9aua, (9aus), 9an, 9agl, (9bjk), (9bed), 9bhx, (9bez), 9bvw, 9blg, 9buj, 9bsp, 8bhh, 9bdu, 9bav, 9bqj, 9bvn, 9bra, 9bfp, (9bz), (9bkk), (9bik), 9bab, 9caj, 9cte, (9cvc), 9cms, 9cnw, 9cfy, 9ccz, 9cjj, 9czl, 9ceb, 9cog, 9cxf, 9cf, 9cvs, 9ctr, 9cao, 9cee, (9czg), 9che, (9cfj), 9dmj, 9djq, 9dfh, 9dlm, 9dxn, 9dxy, (9dch), 9duu, 9des, 9dky, (9dkb), (9dfh), 9eea, 9ekf, (9eky), (9ehn), 9ew, (9ebt), 9er, 9fe, 9fg, 9gd, 9hn, 9ig, 9ih, (9mc), 9nr (fone), 9ox, 9pw, 9rc, (9uh), 9vi, 9vm, 9yaj, 9yu, 9yy, 9zv, (9zg).

Can.: 3ni, 3qs, 8rp, 4cn, 5cn, 5go.

Mex.: (bx).

Cards on above signals sent on request. Will appreciate qsls on our sigs.

By Glenn E. West, 7ZU, Polytechnic, Montana

Sept. 20-30: 5qq, 6hp, 6cbu, 9amu, 9apf, (9ccz), 9bzi, (9cns), 9dch, 6bih, 6chl. October: 1bwj, 2xap, (4ku), 5gj, 5zav, 5ci, (5ia), (5ja), 5if, 5akn, 5an, 5ajv, 5qq, 5lr, 5hw, 5ek, 5er, 5ga, 5akf, 5zm, 5agv, 5ql, 5ht, 6bih, 6cmr, 6zar, 6ckp, 6cgv, 6kjb, 6ckp, 6cvb, 6cgo, 6cnh, 6aos, 6pi, 6cgg, 6cai, 6cej, 6ban, 6zir, 6bts, 6avy, 6bcs, 6agk, 6car, 6avv, (6bvg), (6chl), 6kz, (6xad), 6cqw, (6brf), (6bvo), (6cbi), 6cbw, 6pl, 6ck, 6aob, 6acg, 6bqi, 6ckp, (6anb), 6bnv, (6fh), 6fi, 6awt, 6sp, 6chv, 6jw, 6cil, 6ajh, 6aoi, 6avv, 6bcl, 6arb, 6bwe, 7igf, 7zo, 7ag, 7sw, 7ca, 7zf, 7gv, 7ln, 7hw, 7by, 7to, 7bj, 7zz, 7wx, 7kr, 7vv, 7aw, 7lr, 7sc, 7abb, 7agv, 8xe, 8bbi, (8er), 8ex, 8apn, 8bes, (8pd), 8asy, 8mt, 8ard, 8bnh, (8bfh), 9cbj, 9dch, (9vm), (9yaj), 9dkb, 9che, 9aim, 9bhx, 9bri, 9bez, 9ckp, 9dzy, 9dkb, 9ayy, 9hc, 9aen, 9dah, 9jp, (9czw), (9zg), 9eak, 9aia, 9dsw, (9aog), 9aqb, 9cje, 9doz, 9cci (fone), 9cmk, 9bzi, 9bji, (9ebt), 9acx, 9bjk, 9aov, 9edb, 9clj, (9czw), 9cet, 9bg, 9bof, 9bmv, 9bgy, 9awv, 9cfc, (9dxv), 9aom, 9cnb, 9bkk, 9dkb, 9aav, 9cmk, 9eea, 9avv, 9bqj, 9ebt, 9eky, 9bof, 9ehj.

Can.: 3cl, 3ni, 4cl, 4dy, 4hh, 4cn, 5go, 9bx.

Nov. 1-19: (1yb), 1rfb, 1bom, 1dh, 1ccd, 1bsk, 2ck, 2afd, 2cfb, 3bcm, 4kv, 4eb, 4cl, 4dy, 5za, 5aq, 5ajv, 5qr, 5jn, (5ok), 5ahd, 5ajj, (tdn), (5ql), (5eb), (5gj), 5go, 5gn, 5lr, 5hq, 5qq, 5app, 5in, 5cn, 5zav, (5ahr), 5aki, 5kc, (5kax), 5zaq, (6avv), (6xad), 6bes, 6ckh, 6cmr, 6lv, (6kw), 6xl, 6cek, 6bmy, 6ajh, (6bvw), (6awt), 6arb, 6blm, (6bql), 6aix, 6bcq, 6cix, 6clr, 6bnt, 7ea, 7go, 7ks, 7abb, 7oh, 7em, 7yl, 7ih, 7hg, 7ln, 7zd, 7ly, 7so, 8ih, 8cnl, 8ov, (8abm), 8bda, 8bal, 8dat, 8adg, 8bp, 8atn, 8bnh, 8aim, 8bf, 8dcq, 8cww, 8ame, 8ju, 8jj, 8em, 9amb, 9dww, 9ccs, 9gt, 9bnk, 9dyy, 9df, 9bji, 9xi, 9dfh, 9eea, 9zt, 9vm, 9byc, 9apf, 9qi, 9dxw, 9bke, 9aom, 9vk, (9blg), 9dkk, 9boj, 9bez, 9dew, 9cv, 9cvi, (9bvn), 9ebt, 9dky, 9bal, 9cki, (9bez), 9dgo, 9bcg, 9ebt, 9eet, 9clh, 9avv, 9bkl, 9czy, 9bzi, 9cnb, (9aic), 9xi, 9ddy, 9yy, 9dte, 9bji, 9bsz, 9xi, 9kke, 9bof, 9zt, 9dxy, 9zy, 9bri, (9ccs), 9amb.

Can.: 3ir, 4er, 4ag, 4en, 4ca, 4fn, 5hk, 5hb, 5go, 5gg, Bowdoin, WNP.

Continued on page 52

Tell them that you saw it in RADIO



## “IF WE DON’T GET ’EM ON THE LOUD SPEAKER WE DON’T COUNT ’EM”

The FADA “One-Sixty” Neutrodyne receiver will consistently bring in stations one thousand to fifteen hundred miles distant on the loud speaker, and with pleasing purity and clarity of tone. The following is characteristic of what is repeatedly being done from New York City. Radio reception conditions on the Pacific coast being much better than in the East, even better results can be obtained.

Call Letters	City and State	Dial 1	Dial 2	Dial 3
WDAP	Chicago, Ill.	17	30	31
WJAX	Cleveland, Ohio	26	38	38
PWX	Havana, Cuba	28	42	41
WLAG	Minneapolis, Minn.	30	40	41
WHAS	Louisville, Ky.	31	40	41
WSB	Atlanta, Ga.	38	49	48
WJAZ	Chicago, Ill.	38	54	54
WOS	Jefferson City, Mo.	40	51	50
WCAP	Washington, D. C.	41	54	58
WBAP	Ft. Worth, Texas	51	61	60
WOC	Davenport, Iowa	56	67	66
WFAA	Dallas, Tex.	64	75	76
WOAW	Omaha, Neb.	65	77	77
KSD	St. Louis, Mo.	70	85	84

*Pacific Coast Representatives—Globe Commercial Company, 709 Mission Street, San Francisco, Calif.*

**F. A. D. ANDREA, INC.—1581-F JEROME AVE.—NEW YORK CITY**

# *The* **FADA "ONE SIXTY"** ~ WITH THE NEUTRODYNE CIRCUIT ~

Tell them that you saw it in RADIO

# From New York to Honolulu With Erla Synchronizing Transformers

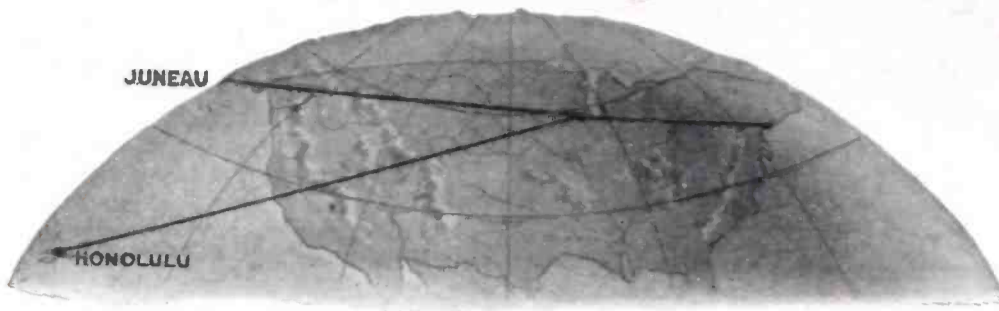

Unequaled range and power, over a waveband of 200 to 700 meters, is assured by Erla synchronizing reflex transformers. List, \$5 each



Unduplicated amplification without distortion enables Erla audio transformers to improve any receiving unit. Ratios: 3½ and 6 to 1. \$5



Solve crystal troubles by installing an Erla fixed crystal rectifier. Once installed, no attention is required. Jolt and jar proof. List price, \$1

Dealers and Jobbers: Erla scientific advancement is reflected in sensationally increasing Erla sales and correspondingly enlarged jobber-dealer profit. Write for our liberal discounts.

## "All U.S. Stations on Loud Speaker, Using Only Three Tubes"

Typical of the thousands who have discarded complicated multi-stage receiving units in favor of simple, efficient Erla reflex design, is the experience of J. G. Hamock, 1917 So. Western Avenue, Chicago, who writes:

"During my first week with your three-tube hook-up, tuning through high power Chicago stations, I got Jefferson City, Dallas, Memphis, Atlanta, Omaha, Kansas City, St. Louis, New York, Springfield, Pittsburgh, Harrisburg, Louisville, Cincinnati, Fort Worth and Tampa.

"The Sunday following I added Fresno, Denver, Astoria, Ore., Los Angeles; Honolulu, Hawaii Naval Maneuvers; and Juneau, Alaska, the Alaska Electric Light and Power Company.

"The United States Stations all were clear on the loud speaker. Also I re-tuned every station by checking them with my twelve-year old son, who would get them on the re-tune, whereupon I would, when required, sharpen the re-tune myself."

Such power, selectivity and ease of control, with three tubes, are attainable only through Erla reflex design, incorporating Erla synchronizing radio and audio frequency transformers.

Guaranteeing the perfect synchronization of received and reflexed currents having the same phase characteristics, Erla transformers enable vacuum tubes to do triple duty, as simultaneous amplifiers of received radio frequency, reflexed radio frequency and reflexed audio frequency currents. For complete details, ask your dealer for Erla Bulletin No. 14, giving Erla one, two and three-tube reflex hookups. Or write direct, giving your dealer's name.

**Electrical Research Laboratories**  
Dept. H 2515 Michigan Avenue, Chicago

# ERLA

## CALLS HEARD

Continued from page 50

By 6CLZ, 2131 Grant St., Berkeley, Calif.

C. W.: 1aw, 5agj, 5ahd, 5aij, 5akf, 5aku, 5ama, 5au, 5be, 5dw, 5ek, 5lr, 5nn, 5ok, 5qq, 5sk, 5uo, 5za, 5zm, 5zav, 6acg, 6adb, 6aig, 6ahw, 6aja, 6alu, 6aol, 6aqw, 6asa, 6asr, 6avr, 6bah, 6bbh, 6bbq, 6bbw, 6bes, 6bdw, 6beg, 6bel, 6beo, 6bfb, 6bge, 6bh, 6bic, 6bjc, 6bju, 6bjw, 6bkx, 6blk, 6blw, 6bmd, 6bqe, 6bqr, 6bqs, 6bra, 6brf, 6brk, 6bsf, 6bta, 6buo, 6bvq, 6caa, 6ebb, 6ebi, 6ebr, 6ebu, 6eck, 6ecu, 6efi, 6efa, 6efy, 6efz, 6egd, 6egg, 6egw, 6ehj, 6ehu, 6ehv, 6ehz, 6ejb, 6emr, 6emt, 6emu, 6eng, 6enl, 6daa, 6eb, 6ek, 6ff, 6fp, 6iq, 6js, 6pe, 6pi, 6pl, 6rm, 6tq, 6yc, 7aa, 7abb, 7aby, 7acg, 7aci, 7acs, 7adg, 7adq, 7adr, 7ada, 7adt, 7aea, 7ael, 7ain, 7age, 7agr, 7agv, 7aif, 7aiy, 7ajv, 7akv, 7ald, 7ame, 7bj, 7by, 7dc, 7eo, 7fl, 7gl, 7go, 7gq, 7hg, 7io, 7it, 7jd, 7js, 7kr, 7ks, 7ln, 7lw, 7ly, 7no, 7nt, 7ob, 7oh, 7om, 7ot, 7pf, 7pj, 7pk, 7qc, 7qj, 7qu, 7rd, 7sh, 7so, 7sy, 7to, 7tt, 7ve, 7vn, 7we, 7wm, 7yl, 7zd, 7ze, 7zi, 7zu, 7zx, 8aa, 8ab, 8acn, 8afc, 8aih, 8aim, 8ame, 8apy, 8bda, 8bmg, 8brm, 8dat, 8dhq, 8er, 8fu, 8gz, 8qn, 8tv, 8wx, 8xan, 8xe, 8zy, 8zz, 9aa, 9aec, 9aim, 9ami, 9an, 9aon, 9aou, 9aps, 9auw, 9avn, 9avs, 9avz, 9ayh, 9bak, 9bdu, 9bed, 9bhd, 9bik, 9bji, 9bjk, 9bly, 9bqq, 9bri, 9buj, 9bun, 9bzi, 9caa, 9cev, 9cfi, 9cjc, 9cjj, 9clq, 9cly, 9cns, 9ete, 9cul, 9cyw, 9daw, 9dfh, 9dky, 9dpx, 9ei, 9eky, 9lz, 9ma, 9mc, 9qr, 9ss, 9uh, 9vm, 9zt.

Can. C. W.: 3bp, 3ni, 4cl, 4cw, 4dy, 5cn, 5ct, 5eb, 4go.  
I. C. W.: 7sc (Daylite).  
Daylite C. W.: 5za, 6ahw, 6bah, 6bhc, 6brf, 6bur, 6ebu, 6efz, 6egd, 6egw, 6ehv, 7ael, 7akh, 7ha, 7hg, 7ks, 7ln, 7to, 7zu, 9zt.

At 8NQ-8XBE (Ex-8BUM), 113 W. Raynor Ave., Syracuse, N. Y.

All C. W.—(5abt), 5ads, 5afs, 5agj, 5ago, 5aiu, 5akn, 5ama, 5amb, 5amh, 5amk, 5amf (fone), (5bm), 5dw, 5ek, 5er, 5fx, 5ga, 5gj, 5gm, 5gn, 5hl, 5ht, 5hz, 5if, 5je, 5kg, 5lr, 5lu, 5me, 5ml, 5mn, (5mo), 5nn, 5ov, 5pf, 5qg, 5ud, 5uo, 5up, (5xaj), 5za, 5zav, 5zb, 5zg, 5zm, 5zu, 6ame, 6acv, 6agj, 6alk, 6arb, 6asx, 6avv, 6awt, 6bmd, 6cbi, 6cfx, 6ckp, 6cmr, 6gc, 6ka, 6lx, 6mg, 6pl, 6xad, 6xl, 6zar, 6zh, 6zw, 7abb, 7du, 7hg, 7ks, 7lu, 7tk, 7ws, 7ya, 7yl, 7zo, 7zu, 7zz, 9amb, 9bji, 9dxy, 9yu, other too numerous.

Can.: 4by, 4cn, 5cn.  
Wl qsl all cards on above. Pse qsl if hr my 50-watter.

By 5AIA, Lake Charles, La.

C. W.—1ajx, 1asd, 1bqd, 1bwj, 1dd, 1fd, 1fi, 2agb, 2ago, 2cei, 2exl, 2el, 2ts, 3abw, 3ahp, 3atb, 3auw, 3bg, 3bmn, 3cdn, 3cfv, 3co, 3hd, 3ph, 3zo, 4ay, 4bk, 4by, 4cl, 4eb, 4er, 4et, 4fa, 4ft, 4gw, 4hr, 4lz, 4jh, 4my, 4ob, 4qf, 4qw, 4za, 6ams, 6asx, 6awt, 6bcl, 6bic, 6bjj, 6bsn, 6cbi, 6ebu, 6eqw (qra?), 6cwo, 6pl, 6zah, 6zh, 6zq, 7iw, 7zd, 8aa, 8aen, 8ago, 8agp, 8ahq, 8aih, 8ajh, 8amd, 8amf, 8apt, 8apy, 8atp, 8atz, 8bdm, 8bdu, 8bf, 8bnn, 8bpu, 8brm, 8bsy, 8byi, 8bze, 8caz, 8cc, 8cdz, 8ced, 8ceo, 8ogj, 8clc, 8cqh, 8cqx, 8crw, 8ese, 8evg, 8cwk, 8cwl, 8cwu, 8dac, 8daw, 8dza, 8gz, 8hn, 8ig, 8jv, 8kg, 8pd, 8px, 8qn, 8uk, 8vx, 8xe, 8zo, 8zz, 9aci, 9aeb, 9afw, 9ic, 9ajv, 9apf, 9auw, 9awf, 9awv, 9az, 9bav, 9bds, 9bed, 9bji, 9bjk, 9bkh, 9bkm, 9blg, 9bqq, 9bzi, 9cnd, 9cde, 9cdo, 9cea, 9che, 9cjc, 9kp, 9col, 9ctr, 9cye, 9dcr, 9dfh, 9dia, 9dkx, 9dlg, 9dnd, 9dpc, 9dwa, 9dwd, 9dxn, 9dxy, 9dzj, 9ebq, 9ef, 9eht, 9ehv, 9eif, 9ekf, 9eky, 9es, 9fg, 9iw, 9lh, 9lt, 9ox, 9pb, 9pw, 9px, 9ta, 9zv.  
Spk.—8 bda, 9aqe, 9lf.  
Fone—5gm, 5ma, 9ame.

Can.—3ni, 3tb, 4cl, 5go. Particulars on any of above sent on request. Rpts fm any distance on my 5-watt spk tube I. O. W. wl be greatly appreciated. All crds qsl'd. Tnx om.

By 4AG, Ralph Slade, 15 Harbour Tce., Dunedin, New Zealand, May 20-Oct. 28

4my, 4ku, 5cn, 5akn, 6bjq, 6cbi, 6cgw, 6ka, 6bbc, 6emu, 6bru, 6bvo, 6ckp, 6bvs, 6bsg, 6pl, 6buo, 6evd, 9ciw, 9bze, 9mc, 9bzi, 9avn, 9bz, 9vm, 9cns, 9zt.

By "BX", H. T. Mapes, Guanajuato, Gto., Mexico

1yb, 1hx, 2rk, 2by, 2gk, 3tb, 4ft, 4ku, 5ama, (5arc), 5ahd, (5amw), 5amu, 5aiu, 5akn, 5ali, 5adv, (5adb), 5ajj, 5amj, 5aij, 5akf, 5ado, 5ahr, 5abh, (5be), 5bx, 5dw, 5ek, 5fc, 5fa, (5ft), (5fx), 5gn, 5gf, (5gj), (5ht), (5hz), 5hl, 5if, 5in, (5jc), 5je, 5kg, 5kn, 5lr, 5lg, 5mz, (5mm), 5nr, 5nn, 5nk, (5ov), 5ok, 5of, 5ph, 5pb, (5qy), 5qf, 5qw, 5qi, 5rr, 5sd, 5sk, 5tj, (5tg), 5ur, 5uk, (5uo), 5vf, 5vy, 5wg, 5xa, 5xab, (5yk) spk, (5yg), 5yw, 5zav, 5zb, (5zg), 5zax, (5za), (5adi), 6ak, 6awt, 6aol, 6afq, 6ahc, 6avv, 6ajd, 6bic, 6bjq, 6bdr, 6bbc, (6bra), 6cgw, 6chl, 6cdg, 6cfz, 6cu, 6chu, 6ec, 6fp, 6lu, 6zh, (7ln), 7qc, 7qj, 7zu, 8dat, 8zz, 8zy, 9ami, 9avn, 9apf, 9aim, 9aps, 9aec, 9bkk, 9caa, 9cv, 9cfy, 9ccz, 9dfh, 9dsw, 9dzy, 9djb, 9dwb, (9efc), 9mc, 9dqu, 9zt.

Mex.: ax, ex, 1b. Wud appreciate reports on how u r getting Mex-BX.

Continued on page 54

# RADIO INSTITUTE OF AMERICA

## TRAINING IN ALL COMMERCIAL BRANCHES OF RADIO

If you cannot attend the Radio Institute of America in person the same instruction can come to you through our recently inaugurated "HOME STUDY COURSE"—Investigate.

Detailed information free on request.

Conducted by

## THE RADIO CORPORATION OF AMERICA

331 Call Bldg.  
98 Worth St.

Phone Douglas 3030  
Phone Franklin 1144

San Francisco, Calif.  
New York City

Tell them that you saw it in RADIO



# AMPLION

The World's Standard Loud Speaker

## A Few Practical Points About Amplion Supremacy

The Amplion requires no power amplifier—no battery. You simply attach it to regular head phone connections.

The diaphragm is made of a special alloy, found to have no equal after years of experiment with all other materials.

The electro-acoustical device is insulated entirely from the horn to eliminate distortion, ring or resonance.

Its Non-vibrating wood horn surpasses all other materials for true tone and clearness.

An Adjustable feature makes the Amplion sound true with any make of receiving set, and ensures faithful reproduction.

The Amplion mechanism is not new—it has not been hurriedly devised to meet the radio boom. Rather, it is a development, for radio purposes, of a loud speaking device used for years by leading Navies of the world.

The Amplion is manufactured by the oldest manufacturer of loud speakers in the world.

The Mahogany horn—the enameled sound conduit—the highly polished nickeled base—the reproducing mechanism—all are of the highest quality.

Ask your dealer for a demonstration.

Patentees: ALFRED GRAHAM & CO.

### SIGNAL ELECTRIC MFG. COMPANY

Sole United States Distributors

Menominee, Michigan

BURND EPT OF CANADA, LTD.— Canadian Distributors — 172 King St. W., Toronto



Amplion Deagon AR-19  
\$40.00



Phonograph Unit AR-35  
\$24.00

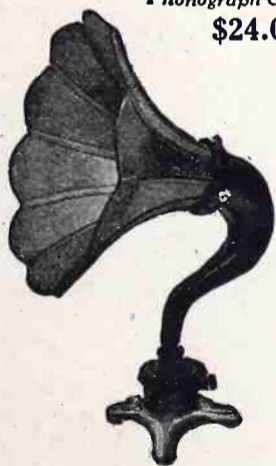

Amplion Beauty AR-15  
\$46.00



Amplion Junior DeLuxe AR-45  
\$26.00

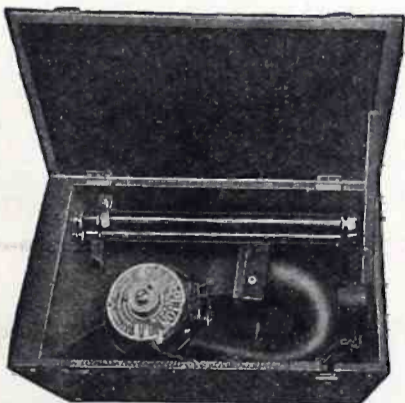

Amplion Portable AR-61  
\$50.00



Amplion Junior AR-39  
\$18.00

The Supremacy of The Amplion is The Supremacy of Actual Performance

Tell them that you saw it in RADIO

# Impartial Experts Testify!

For a long time set builders have wanted some definite, authoritative guide to condenser quality. Complying with this demand, HEATH RADIANT CONDENSERS were submitted to two of the greatest radio testing laboratories. Below are salient phases from their reports. Copies of the complete reports free to anyone interested.

## Electrical Testing Laboratories of New York Say—

"... the equivalent series resistance of each of the condensers is very small. That is, it is so small that it may be considered as negligible."

## Radio News Laboratories Says—

"... considered one of the best condensers we have tested. A dielectric loss resistance of 46 ohms at 1000 cycles ..."

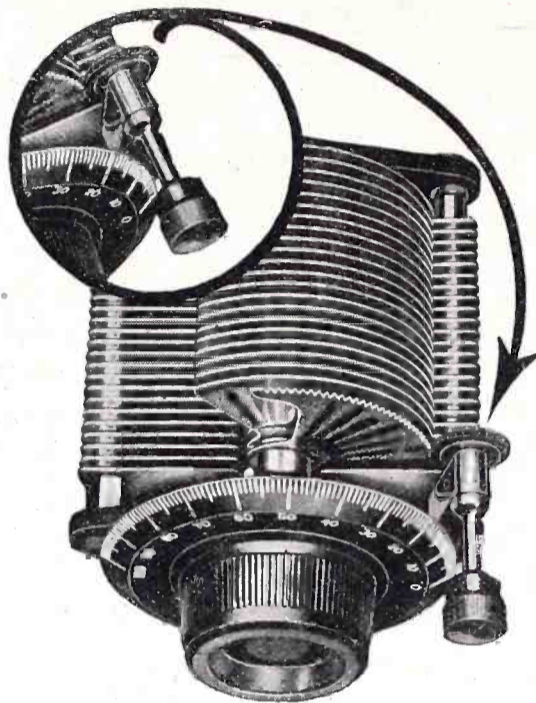

# Heath Radiant Condensers

**Permanently Flat Plates**

Precise, when you examine it at the store and, still more important, p-r-e-c-i-s-e always, for years—the most durable, continuously efficient part of your set. Warping plates made impossible by the Heath process of stamping and hardening which makes each one permanently FLAT.

**Micrometer-Adjusting Geared Vernier**

Reducing gear, engaging with teeth cut into the outer rim of the vernier plate, affords infinitely delicate adjustment. An added feature of satisfaction that makes it well worth your while insisting upon Heath Radiant Condensers.

Write for Booklet

List Prices—Vernier Type (with 2 7/8" dial and knob)  
13 Plate \$5.00; 25 Plate \$5.50; 45 Plate \$6.50

**HEATH RADIO & ELEC. MFG. CO.**  
208 First Street Newark, N. J.

## CALLS HEARD

Continued from page 52  
By 9BCJ, Prescott, Ariz.

Nov. 18, Daylite C. W.: 2by, 2cqi, 5uw, 5qq, 5afq, 5amu, 5zh, 6bbh, 6cch, 6cia, 6cjk, 7qt, 9ss, 9aim, 9avs, 9ayl, 9ayp, 9bri, 9chj, 9clq, 9eky, Night C. W.: 1fd, 2cqi, 3atb, 4mh, 5cv, 5fj, 5gw, 5hq, 5kg, 5uw, 5adh, 5aiu, 6hc, 6li, 6wt, 6ahu, 6ani, 6bbg, 6bcs, 6bpf, 6bqe, 6bwp, 6cbb, 6cdg, 6chc, 6cia, 6enh, 6zau, 7pi, 7qt, 7tt, 7zx, 7aci, 8dx, 8gz, 8bep, 9eq, 9gw, 9le, 9ti, 9zt, 9aal, 9afm, 9agr, 9aim, 9amu, 9avs, 9ayp, 9bdr, 9bge, 9ebb, 9cfy, 9dbr, 9dzh, 9dlm, 9dph, 9efu, Spark: 6gt, 9bof (daylite).  
I. C. W.: 5za.

Nov. 19, Daylite, C. W.: 1aqi, 2by, 3chg, 5as, 5bx, 5ez, 5lw, 5td, 5uo, 5yg, 5aat, 5ahc, 5aij, 5ams, 5amu, 5xac, 6afq, 6alk, 6bih, 6bjj, 6bui, 6cgd, 6cgl, 6cng, 6cnl, 8ij, 8jj, 8uf, 8afn, 8aih, 8bgo, 8bvt, 8ctp, 8cz, 9jf, 9mc, 9ql, 9qw, 9au, 9alz, 9alk, 9avn, 9bde, 9bdh, 9bge, 9bgl, 9bgw, 9bhi, 9bit, 9bnh, 9bsh, 9bzb, 9bzs, 9ccj, 9ccz, 9cdj, 9ceh, 9ekw, 9ejc, 9eln, 9clq, 9coj, 9dfw, 9dhp, 9dqu, 9dtt, 9dwn, 9ehj, 9edm, 9elw.

Can.: 3oh. Spark: 5gf, 6aud, 9bof. I. C. W.: 9brx.

By 6CID, Richard E. Smith, P. O. Box 33, Merced, Calif.

3adi, 3bua, 6aao, 6aci, 6acr, 6ahu, 6ak, 6aai, 6aqq, 6bbh, 6bba, 6bbw, 6bcj, 6bca, 6bch, 6bhd, 6bic, 6bix, 6bjq, 6bkl, 6blm, 6blw, 6bna, 6bmi, 6bmd, 6bnx, 6bun, 6bos, 6bdz, 6boa, 6bqr, 6brf, 6bsa, 6buo, 6ega, 6cgw, 6chu, 6cnk, 6dd, 6mh, 6nb, 6pl, 6zz, 7al, 7ca, 7cd, 7gi, 7gy, 7io, 7ks, 7ln, 7nc, 7ne(sp), 7ot, 7qe, 7oq, 7ze, 7zt.

Can.: 4io. Continued on page 90

## How?

can you expect good reception, no matter how expensive your set, if you haven't the right plug! Sounds strange—still the plug is the last link to perfect reception.

### The ORIGINAL

COMSCO  COMSCO

### AUTOMATIC BULLDOG GRIP PLUG

Licensed under Pat. Pnd. Serial No. D3010—No. 578540

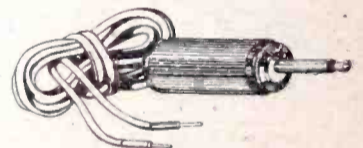

Saves you from short circuits and battery kicks. No more burned out phones or ruined transformers. No more broken finger nails.

### Simple to operate

**INSERT**  
By a single touch and the connecting tip of your phone cords accomplish automatically the most perfect electrical contact

**RELEASE**  
By pressing the small knob and the tip will slide out easily without pulling the electrical contacts

For one pair phones, \$1.00  
For two pair phones, \$1.50

For sale at your dealer. Otherwise send purchase price to us and you will be supplied.

**GENERAL INSTRUMENT CORP.**  
123 Liberty Street  
NEW YORK CITY

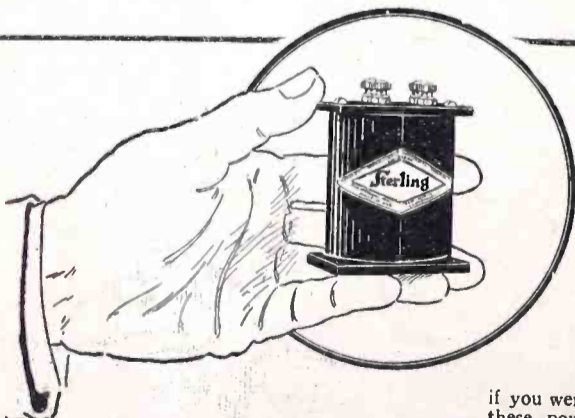

## Sterling

AUDIO & RADIO  
AMPLIFYING TRANSFORMERS

Give You More Volume  
With Less Distortion

When you want to extend the range of your radio messages and make every sound wave as clear as if you were in the same room as the broadcaster, try putting these powerful little Sterling Transformers in your circuit. The Audio type gives louder signal amplification, best tone qualities and uniform results. List Price \$4.00  
The Radio types are made in several ranges from 200 to 600 meters. List Price \$4.00

**THE STERLING MANUFACTURING CO.**  
2859 Prospect Ave. Cleveland, O.

**DEUTSCH & COMPANY**  
555 Turk St., San Francisco, Calif.  
Factory Representatives

Tell them that you saw it in RADIO



Member  
Radio Section



Manufacturers  
of Electrical  
Supplies

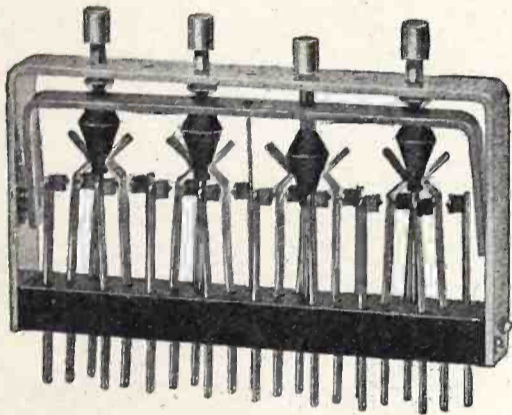

Cat. No. 110 Automatic Selector Switch, \$6.50. This switch controls both phones "A" and "B" batteries, phones or loud speaker changed from Det. to 1 or 2 step by simply pushing respective button, Sterling Silver Contacts.

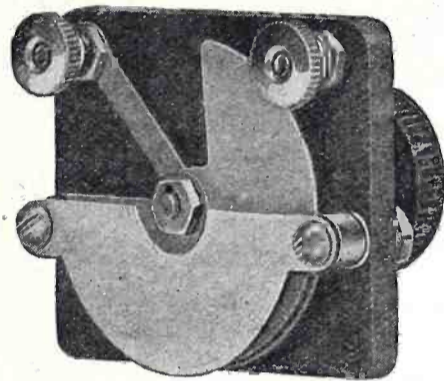

Cat. No. 246 Vernier Cond. (.00001 Cap.), \$1.15. Should be used in connection with regular condenser to obtain fine variation in capacity. Efficiency is much higher than when a regular vernier condenser.

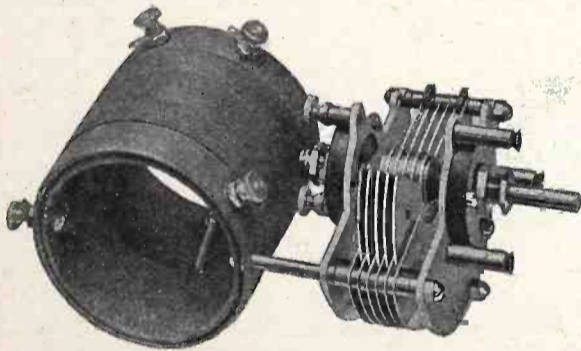

Cat. No. 123 Air Core R.F. Unit, \$6.75.

Furnished with or without Primary winding, primary turns 6 second 61, can be tapped if desired. Ideal for any type of tuned R.F.

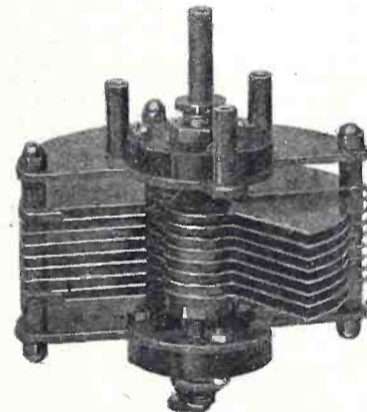

- Cat. No. 200 3-plate (.00005).....\$3.25
- Cat. No. 184 9-plate (.000175)..... 3.75
- Cat. No. 111 11-plate (.00025)..... 4.00
- Cat. No. 185 17-plate (.00035)..... 4.25
- Cat. No. 190 23-plate (.0005)..... 4.50
- Cat. No. 186 35-plate (.001)..... 5.00

**R. MITCHELL CO. :** 255 Atlantic Avenue  
Boston, Massachusetts

For 47 years Manufacturers of Scientific and other equipment  
Look for trade mark on every piece

Jobbers and Dealers write for discounts

Cable Address—Searde-Boston

PACIFIC COAST OFFICE  
EXPORT OFFICE

709 Mission St.,  
44 Whitehall St.,

San Francisco, Cal.  
New York, N. Y.

Tell them that you saw it in RADIO

**THE "Q-DRAWLER"**

*Continued from page 22*

less code,—what has he to do with it all? Listen!

When the night operator of the *Tuscania* flashed a call for the shore station, he signed off with the designation of the *S. S. Tuscania*, the combina-

tion of call letters under which the boat was listed to the radio world—"WWFF".

There might have been ten thousand persons who heard that four-letter sign—"WWFF" from a thousand miles out to sea this night—ten thousand on whose ears the letters drummed, failed to register and were forgotten. But to at least two persons they meant something.

To the shore station operator, rushed with a night's business, the call "WWFF" meant that the *S. S. Tuscania* had a message for him—one more to be added to a long total before midnight saw his relief. To Cassidy, sucking the dead stub of a saliva-soaked cigar, it meant something entirely different.

Half asleep though he was, Cassidy awoke suddenly as the mystic call of the *Tuscania* reached him—"WWFF".

His eyes opened. His cigar dropped to the floor unheeded. His feet came off the table with a bang. The next instant he had jumped to his feet, his face a mirror of astonishment.

"It is . . . by golly . . . it aint . . . it can't be! By jing! It is! . . ." There was sheer wonder in his voice.

He struck the table with his fist, causing Mrs. Cassidy—herself dozing beside the fire—to hurl a lapful of sewing to the floor with an involuntary motion.

"What is it dad?" asked young Mike, looking up from a quarter section of two-thirds of a dozen which he was trying to add with one eye shut.

"It's the Q-Drawler!" exclaimed Cassidy excitedly. It's him and no other. Holy mackerel! And him dead these ten years. Would ye believe it now?"

He clutched the phones to his head and began to dance around.

Off somewhere in the Atlantic Operator Jesse McDorn fingered an expert key and chanted the call of the shore station which did not hurry with its answer.

"WWFF-WWFF!" he signed.

As Cassidy listened, the shore station came through with a "GA", and the boat dropped into the message.

"Arrive Thursday. All well. Regards—Jim", it said.

Cassidy listened, his hand held up for silence in the room, while Mrs. Cassidy rocked speculatively and wondered did old age affect the mind, or was it corned beef that made a man act so.

After a bit, when boat and station had cleared each other, Cassidy took the phones from his head and sat down—his mouth open. Mrs. Cassidy sniffed audibly.

"Would ye mind tellin' me what it is all about?" she asked with a certain sarcasm.

And Cassidy, being twenty years married, did!

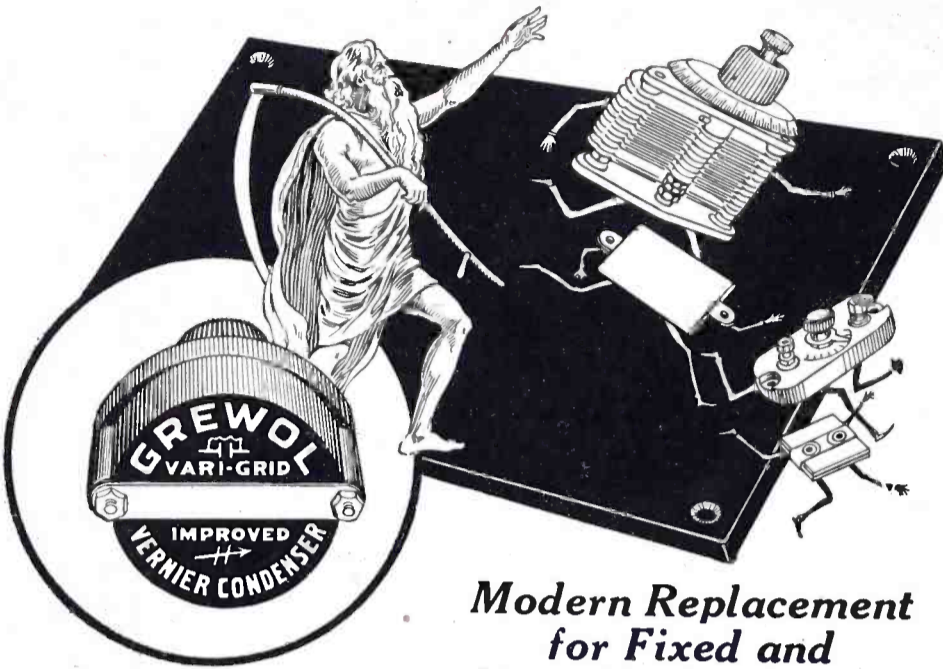

**Modern Replacement  
for Fixed and  
Variable Condensers**

**The GREWOL Vari-Grid**

Used as an 11 or 23 Plate Vernier Condenser as well as a variable grid control.

The capacity of the grid of your tube must be varied to secure maximum efficiency, distance, clearness and sharp tuning. This is the purpose of the Grewol vari-grid.

Equipped with grid leak, removable when Vari-Grid is used as vernier condenser in other circuits than the grid. Costs less! One hole to drill 1 3/4" in diameter, an efficient quality instrument. Write for descriptive booklet.

**\$2.25**

**GREWOL Fixed Detector**

Positive, sensitive adjustment ALWAYS, instead of continual guessing and adjusting. Therefore preferred for all reflex and other super-sensitive circuits. Glass-enclosed, solid mounting (vibration-proof). Adds to the appearance of your set, imitated but never equaled. Others cost more, but none give better satisfaction—\$2.00. Each detector equipped with Special Reflex Crystal, guaranteed not to burn out.

**Price  
\$2**

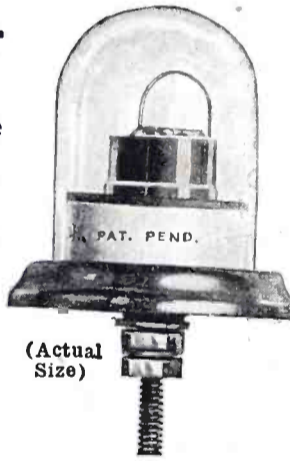

(Actual Size)

Write for New Reflex Hookup Free  
Both of these GREWOL Products at Your Dealer's or  
Direct Upon Receipt of Price

*Jobbers and Dealers write for proposition!*

**RANDEL WIRELESS CO.**

2 Central Avenue

Newark, N. J.

**TUBES---REPAIRED**

We repair vacuum tubes and guarantee them to work like new. Money refunded if not satisfied.

WD11-WD12	\$3.50	UV200-C300	\$2.75
201A-301A	3.50	UV201-C301	3.25
DeForest & AP'S	3.50	UV199	3.50

No other tubes than above accepted

**THE ONLY LABORATORY IN THE WEST**  
Broken Glass Shells replaced—No extra charge

**AL. D. BERGEZ CO.**

Dealers Write for Special Proposition

172 FIFTH STREET

SAN FRANCISCO, California

Tell them that you saw it in RADIO

WHEN Cassidy pounded a key for the C. M. & St. P., it was in the days when a special agent was a general utility man. One day he was heaving bums out of a box car. The next he was riding herd on a hold-up man with a sheriff's posse. Between times he read up on rate regulations, or guarded the third vice-president on a tour of inspection.

Trailing the phantom traces of a gang of car thieves, Cassidy had uncovered the alliance of a division operator—one Hangtown Haley. He worked the night trick at "NO" station—a central point of major importance. In league with the gang, he kept them posted on car movements and their loot ran into the thousands.

Cassidy tapped a wire, and with his heels up in a hotel room, listened through the long nights to their private code until headquarters had enough of it to work out a translation. Hangtown Haley had a way of his own on the wire—a queer, dragging stroke of certain dash letters. It was the drag—the drawl of his sending—that identified him. More especially it was the queer lag of his "qs" that named him at headquarters—the "Q-Drawler".

Came a night, when, with the case complete, a sheriff and a squad of rail police closed in on four towns. Eight of the gang were netted in the catch. Hangtown, known to be dangerous, gun-fought his way through a cordon that surrounded his boarding house. Two days later, he crossed with a sheriff's posse and was shot to death, or at least this had been the history of the matter, turned in to Cassidy.

And yet—

It was Hangtown's stroke on the key that had set Cassidy by the ears this night—the "Q-Drawler's" touch—the fingers of a dead man, dragging, drawling the Continental code of the radio in the inimitable lag of Haley's old-time swing.

There was one difference. The "Q" in Morse is "F" in Continental. Cassidy knew this, and his fingers sought a call book swung from a string on the end of the table.

He turned to "WWFF". It was the *Tuscania*, pride of the Red Belt line, somewhere out on the Atlantic—perhaps headed for home. Perhaps, the other way. Was it possible that Hangtown, by some miracle, had popped up again, after all these years?

Cassidy was thorough. Besides he had a telephone. Ten minutes later, he had learned from the Red Belt that the *Tuscania* was due on Tuesday, and that her three operators were named Madison, McDorn and Lumley respectively. No Q-Drawler there. A coincidence then? Cassidy did not think so.

Police experience had taught Cassidy one thing, viz., that when only the im-

# The Second Annual Radio and Electrical Exposition



Under the Auspices of the  
**AMERICAN RADIO EXPOSITION CO.,**  
of NEW YORK

Feb. 5th to 10th, Inc., 1924

*In the main Ballrooms of the*

## BILTMORE HOTEL

LOS ANGELES, CALIF.

*Endorsed and Approved by Radio Division,  
Music Trades Association, Los Angeles  
Chamber of Commerce*



FOR FURTHER PARTICULARS WRITE  
OR WIRE TO:—

J. C. JOHNSON, Gen. Mgr.  
Room 707, Bank of Italy Bldg., 7th and Olive Sts.

LOS ANGELES

PHONE 631-88



## THE DOUBLE KNOB SEXTON CONDENSER

Most compact vernier condenser built.  
Furnished with 3 inch black bakelite dial.  
Separate button for vernier control.  
Ball thrust bearing insures perfect action.

**Balanced Models contain Half  
Capacity Switch**

*For name of Distributor write our Western Representa-  
tive, F. L. Tomlinson, P. O. Box No. 2308, San Francisco, or*

**THE HARTFORD INSTRUMENT CO., Inc.**

308 Pearl Street

Hartford, Conn.

23 SD

Tell them that you saw it in RADIO

# New York Coil Company's

## Radio Products

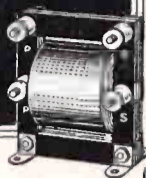
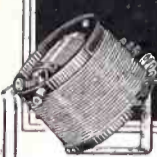

Are leaders everywhere in quality, ease of installing and utmost efficiency

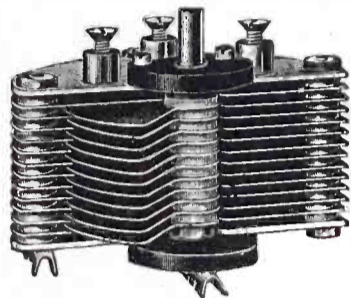

11 Plate... \$1.50  
23 Plate... 2.00  
43 Plate... 3.00  
3 Plate... 1.25

Genuine Bakelite Insulation—a quality product.

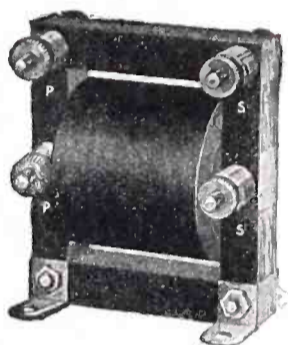

Amplifying distortionless Transformers, correct for any tubes.  
Price \$4.00

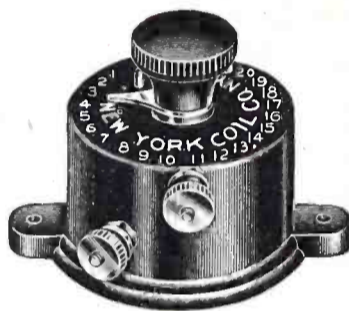

The New York Variable Grid Leak Easily tops the field in precision, permanency, and efficiency. PRICE \$1.50



Mica Fixed Condensers Of tested and permanent capacity, ranging from .0001 to .006, 35c to 75c, of superior quality.

.00025 with Leak Mounting, 45c

Our Variometers and Couplers are large, full size instruments—correct for complete broadcast range. Mica Fixed Condensers—all capacities.

### New York Coil Company

338 Pearl Street

Pacific Coast—MARSHANK SALES CO., 1240 S. Main St., Los Angeles, Calif.

New York City, N. Y.

### BROADCAST PROGRAM

A weekly magazine devoted to Western Broadcasting.

5c per copy.  
26 issues for \$1.00.

### BROADCAST PROGRAM

433 Pacific Bldg.  
San Francisco, Cal.

## RADIO

### BIG MONEY IN A BIG FIELD

Be a RADIO EXPERT. Make big money. Win success in this new uncrowded field. Trained men needed. Learn quickly, at home in spare time, to construct, install, operate, repair, maintain and sell radio equipment.

**RADIO EXPERTS EARN \$3,000 TO \$10,000 a Year!**

Short course, low cost, easy terms, money back guarantee.

**FREE** Wonderful tube receiving set of latest design. Range of over 1000 miles. Write today for "RADIO FACTS."

A. S. Mobaupl, Radio Eng. American Radio Association  
4513 Ravenswood Ave., Dept. 812, Chicago



possible seems reasonable, then it is probably probable, no matter how improbable it seems. An aphorism, perhaps, but good police practice. Wherefore, while Cassidy argued to himself that it couldn't be the Q-Drawler, something deep inside told him that it might be, and that was enough for Cassidy.

Cassidy went to bed and slept on it. That is, one-half of his brain slept. The other half kept mulling it over. He woke to find that he had another mystery on his hands which piqued his police instinct. As the matter stood, it didn't matter a tinker's dam whether the Q-Drawler was alive or not. Only, Cassidy had to know. He had a point and he had the urge to draw a straight line. The problem to locate the other point.

It came quicker than he anticipated—the following morning. Going downtown on the car, a small item in the morning paper caught his attention:

"The police were asked to meet the liner *Tuscania* when it docks Tuesday, in a radio dispatch received last night from Captain Hanson, who said that a jewel robbery had been committed aboard. No details were given. Detectives will board the vessel at quarantine."

"Ah-ha!" said Cassidy. He had located the second point. Now for the line, which was the shortest distance between the two of 'em!

CASSIDY did a little investigating of his own, during the next few days. For one thing, he looked up the address to which the message signed "Jim" had gone ashore. It led him to a dark stairway, up a narrow flight of stairs, to a dingy back room.

The place was south of the old "deadline" across which known crooks dare not set foot. Cassidy was somewhat out of his element there, but he knew the types and he gathered his information cautiously, and in fragments. What he gathered told him a great deal.

The "J. J. McGuire," to which the message had been addressed was "Spike" McShane, ex-prize fighter, and now a hanger-on at Lannigan's place—the rendezvous for the underworld gang. "Spike" was well known to Cassidy and the central office. He was understood to be a "smear" or runner for Abe Lotz, a notorious fence, or receiver of stolen property.

"Spike's" job was to keep track of burglars, second-story workers and others and, when they made a kill, steer them into Abe Lotz's hands. He received a commission from Lotz—a reasonably safe way of living in the underworld where one is never sure, at any time, when one may be "turned up" or peached on by a pal.

When Cassidy learned that the message had gone to "Spike" McShane, he

Continued on page 60

Tell them that you saw it in RADIO

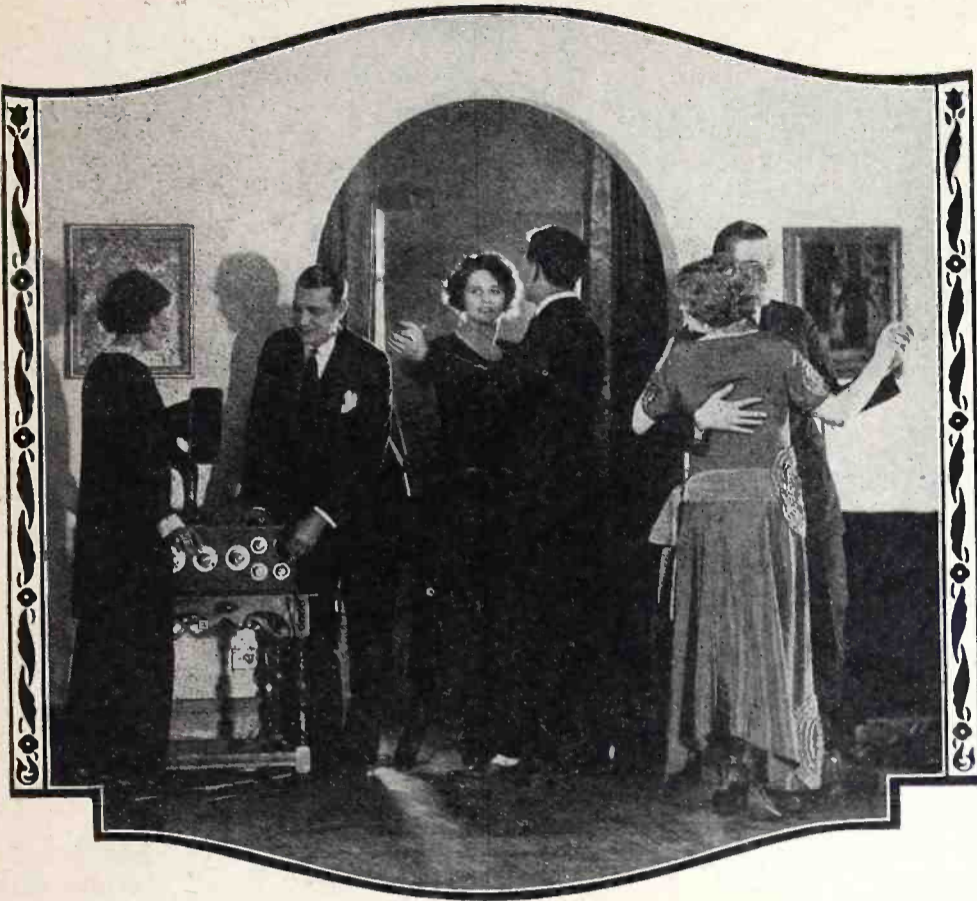

Today's Cinderella needs no fairy god-mother! She calls up Prince Charming and together they waltz at her Radio Dance, while out of the air, over her C&W Receiver, come the rhythmic swing of Schubert melodies, Strauss waltzes, fascinating modern two-steps as played by the nation's best orchestras.

# Get the *Best* Program with a C&W Receiver—

Tested with other broadcast receivers---on the same antenna---listening to the same stations, Model 11B, the Cutting & Washington Receiver illustrated above, proved to give greater volume from the desired station, with less interference from all other stations.

Highly selective, a 3-tube, double circuit regenerative receiver, with remarkably long range and clear reception. Uses dry cell A battery; 3UV 199 tubes; special sharp tuning C & W Circuit shock absorbing tube mounts, automatic rheostat switch, shielded panel. Leader of the C&W Line, the set that will get your station if the station is to be had.

Price complete, ready to operate - - - - - \$160.00

**CUTTING & WASHINGTON RADIO CORPORATION, Minneapolis, Minn.**

*Pacific Coast Distributors:*

Western Radio, Inc., Los Angeles  
 Alexander & Lavanson, San Francisco  
 E. W. Murray Lighting Co., Spokane  
 Pacific Coast Representative—J. I. Hermans, 585 Mission St., San Francisco

**ASK YOUR DEALER TO DEMONSTRATE**

# Cutting and Washington

*Standard of Excellence in Radio Since 1914*

Tell them that you saw it in RADIO

Continued from page 58

pulled his nose and walked out of the district thoughtfully.

Anything that "Spike" mixed in was crooked—somewhere. And "Spike" had received a message from "Jim" announcing his arrival on the *Tuscania* on Tuesday. And the message had been sent by the "Q-Drawer".

"There's a bunch of 'em workin' the boat," said Cassidy, drawing his straight line with canny precision. "I'll bet they're in on the jewel robbery, whatever it was."

With which deduction, not based particularly upon acumen, but good police work nevertheless, he went to headquarters.

Cassidy stood well at headquarters, as might be suspected. He was closeted with the "chief" of his bureau. Several things developed from that circumstance.

For one thing, Cassidy was detailed to be with the squad that boarded the *Tuscania* in quarantine. For another, "Cupid" Kurtz, a slender, girlish-appearing detective who could, on occasion, masquerade as a woman, was detailed to the task of keeping a close watch on "Spike" McShane and his movements. Another was a wire which Cassidy sent to his old chief on the C. M. & St. P., asking for the exact status of the case against the "Q-Drawer".

This done, Cassidy returned to routine and waited for Tuesday.

"I may be wrong," he said to himself, "but by golly, I'll bet the old lady's pianny I ain't!"

Tuesday, with the *Tuscania* gliding gracefully into port, a flock of mosquito tugs clustering around and the police boat in the offing.

Four Central office men, including Cassidy, went aboard, to be met by Captain Hanson and his first officer—an Englishman named Grimes.

In the captain's quarters, they heard for the first time the details of the theft of the famous Forbes diamonds.

"As near as we can determine, Forbes showed them to only a small group at his own table. Most of these persons he vouches for personally."

Detective Sergeant Moran, a veteran on the waterfront, cut in quickly.

"That's of no value," he said. "Thieves that work liners aren't wearing overalls, you know."

The captain nodded.

"Very true," he said. "I tried to suggest that to young Forbes, but he wouldn't listen. Said his friends were above reproach."

"New type then," remarked Sergeant Moran sarcastically. "Forbes must be a fool."

"No doubt of that," said Captain Hanson. "Else he'd never been carrying around stones like that uninsured."

Continued on page 62

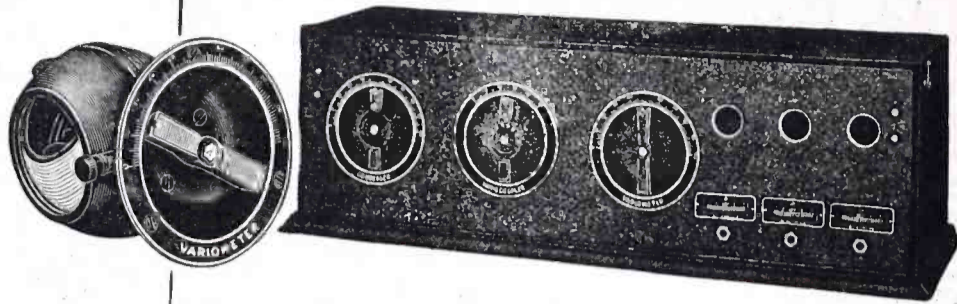

## Build your own Radio Set

—and save half the labor customarily involved.

The panels are completely drilled, and the parts are simply fastened with screws and nuts.

Any circuit desired may be employed. We have eight different types of panels.

The crystal black panel finish, together with the concave dials, lend a pleasing effect—the absence of knobs giving a clean, flush appearance.

You can build, or buy, a cabinet to suit your individual taste.

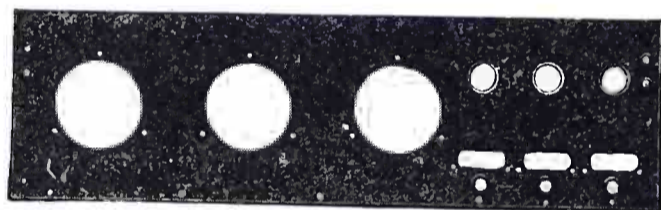
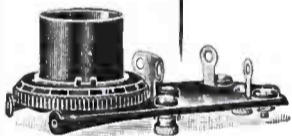
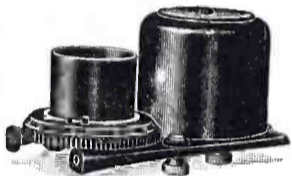
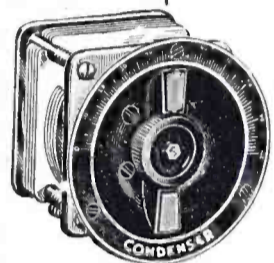
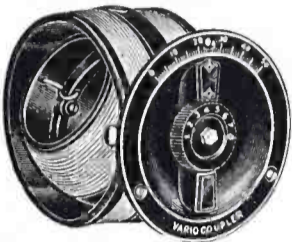

Illustrated catalog upon request



EISEMANN MAGNETO CORPORATION

William N. Shaw, President

48-33rd STREET, BROOKLYN, N. Y.

## GERMAN HEADPHONES

### 6000 OHMS

Special Introductory Offer **\$8.50** Per Pair

(Regular Price \$14.50)

WITH HEADBAND AND CORD

Made by Neufeldt & Kuhnke, Kiel, Germany

## C. H. RUBY

535 MARKET ST.,  
SAN FRANCISCO, CAL.

**THE IDEAL HEADSET FOR DX RECEPTION!**  
Guaranteed to be superior to any Phone on the market or your money refunded without question.

Tell them that you saw it in **RADIO**

"THE AIR IS FULL OF THINGS YOU SHOULDN'T MISS"

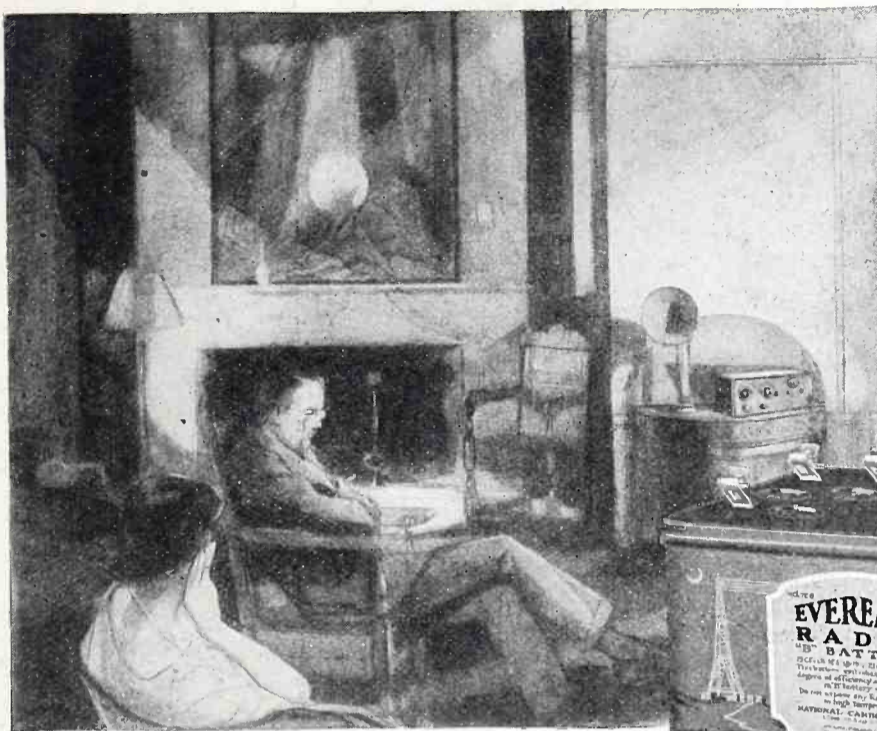

Radio has moved from the laboratory and amateur's work-table out into the refined surroundings of the family living room. In keeping with this new companionship we offer this reliable, long-lived Eveready "B" Battery, in an attractive, new metal case, worthy to stand beside the rich cabinets of fine radio sets.

Eveready "B", 22½ volts, No. 766 with Six Fahnestock Spring Clip Connectors.



## When Radio called, Eveready was ready

TWENTY-ONE years ago, when wireless telegraphy had its first birthday, National Carbon Company's dry cell batteries were nine years old. Even then its batteries were world famous as convenient, economical and efficient sources of electric energy.

With the introduction of broadcasting, radio leaped into universal service. Radio engineers used Eveready Batteries as their standard in designing tubes and receiving sets. Eveready engineers, backed by the most complete research and testing laboratories known to the industry, worked with

them to discover how the known dry cell could be improved for radio work.

The fruit of these efforts is the Eveready family of radio batteries, conspicuous for vitality and endurance—the right battery by test and proof for every radio use.

To be certain of battery satisfaction, insist on Eveready Radio Batteries—they last longer. All reliable radio dealers sell them.

Informative and money-saving booklets on Radio Batteries sent free on request.

NATIONAL CARBON COMPANY, INC., New York, N. Y.

### Headquarters for Radio Battery Information

If you have any battery problem, write to RADIO DIVISION, NATIONAL CARBON COMPANY, INC.  
210-212 Orton Street, Long Island City, N. Y.

Eveready 6-volt Storage Battery

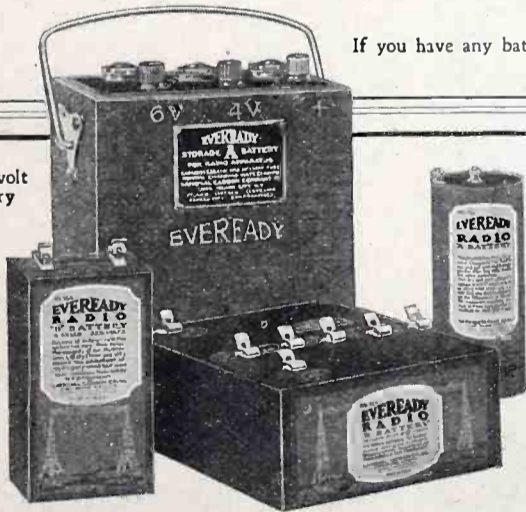

Eveready Radio "A" Dry Cell  
Specially manufactured for use with low amperage tubes

No. 764 The Space Saver Vertical 22½-volt "B" Battery

No. 767 "B" Battery, 45 volts Variable taps Fahnestock Clips

Eveready Three or "C" Battery Clarifies tone and increases "B" Battery life

# EVEREADY Radio Batteries

— they last longer

Tell them that you saw it in RADIO

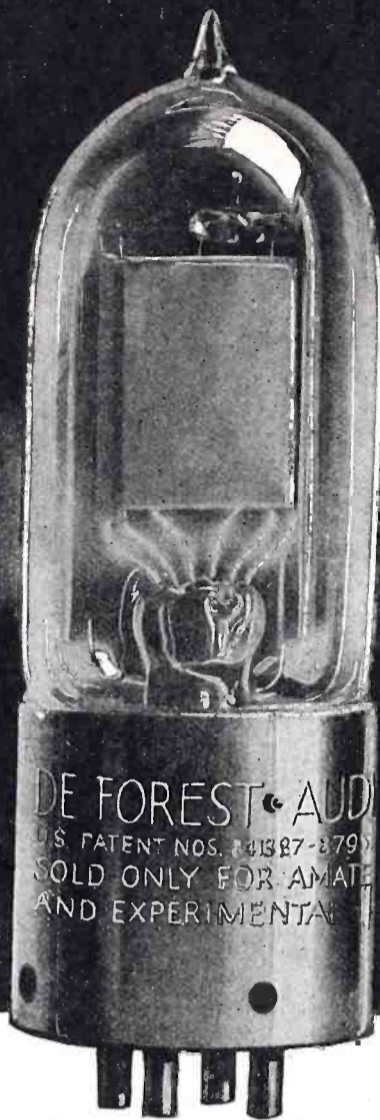

The De Forest Audion is commended on Jack Binns' Radio Page of the New York Tribune as "an excellent tube around which to build a set." Such expert endorsement and the satisfaction of thousands of users of De Forest Audions is what you naturally expect from this product. Remember that De Forest invented the three-electrode vacuum tube which makes all present-day radio possible.

DE FOREST RADIO TEL. & TEL. CO.  
Dept. R. 5 Jersey City, N. J.

Use  
**De Forest**  
**Audions**

Tell them that you saw it in RADIO

*Continued from page 60*

The point is, what are we going to do about it?"

Moran's answer was to the point.

"Bring Forbes and his friends here!" he ordered.

The captain nodded to his first officer and the latter left the cabin.

It was fifteen minutes before they were all assembled—half a dozen men and women with whom young Forbes had interchanged amenities during the trip. They entered the captain's cabin in varying moods according to their style. One or two were openly resentful. Captain Hanson handled them suavely.

"These gentlemen," he began without preface, "are from the Central office of the police department. They were summoned at my request to investigate the theft of Mr. Forbes' diamonds. I trust you will give them all the information in your power, as we hope to catch the thief before any of the passengers are released from quarantine."

The air in the cabin grew tense. There was a mutter here and there, but no one dared object.

"You believe the thief is still aboard, Captain?" asked young Forbes, whose haggard face showed that he had begun to feel the strain of the situation.

"Undoubtedly," replied the vessel's commander. "We have seen to it that no one could leave."

The examination was short and to the point. Forbes was requested to tell the manner of his loss. He had little to offer.

"I had shown them in the cabin," he said. "Later I went on deck with— with the stones still in the leather case in my pocket. I walked about for a time, and when I summoned the steward with the intention of returning the stones to his safe—to my astonishment discovered that the case was missing. I haven't the slightest idea where it went."

"At whose request did you display the stones in the cabin?" asked Sergeant Moran, studying the young man intently.

Young Forbes hesitated.

"Why—someone—I don't recall who?"

"Are you sure?" Moran's tone was suspicious. Forbes flushed.

"Quite," he said shortly. "It was a casual request."

"Did you walk with anyone on deck?"

"Why—yes."

"Who was it?"

Again Forbes hesitated, unwilling to breathe suspicions on an innocent person—especially one with midnight eyes, and the elusive charm of a wood sprite.

"Some one who is above suspicion in this matter," he replied steadily.

*Continued on page 64*



# A FREE GIFT FOR YOU!

*A wonderful device that eliminates those bothersome hums and noises from any type of radio receiving set*

Gone forever is that terrible hum from power & telephone lines and other induction noises so common to the listener.

**T**HE NEW GENIE INDUCTION FILTER was designed by Don Lippincott, Radio Engineer. It is manufactured by the Aerovox Corporation of San Francisco, and carries the guarantee of entire satisfaction. We offer only standard, high-grade merchandise for premium use, and we will positively refund your money if this offer does not "fill the bill."

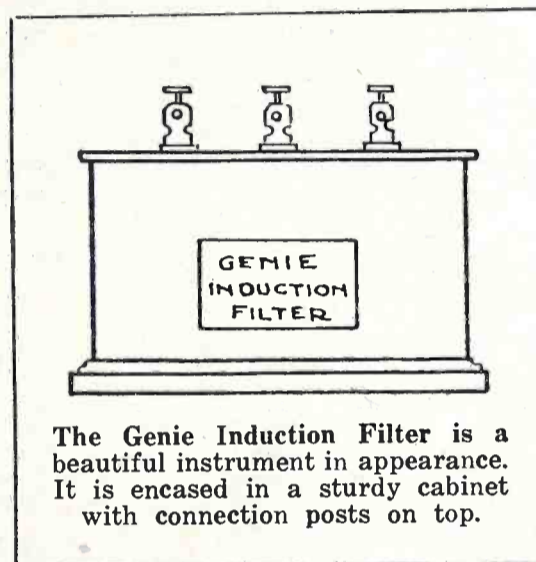

The Genie Induction Filter is a beautiful instrument in appearance. It is encased in a sturdy cabinet with connection posts on top.

**WE DO NOT OFFER THEM for SALE. THEY ARE GIVEN FREE!**

# FREE—

This diagram shows the utter simplicity for connecting this Filter to your set. You simply run two wires to your apparatus and the Filter is ready for use. There is no danger of any kind from high voltages, etc. Nothing to get out of order.

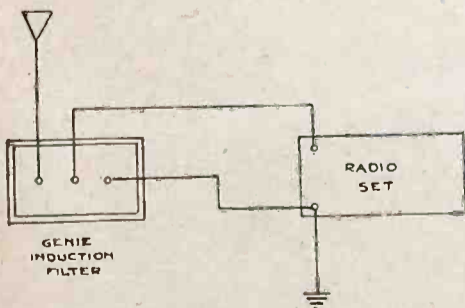

One of these GENIE INDUCTION FILTERS will be sent to you absolutely free of charge if you subscribe to "RADIO" for only one year (\$2.50). Only 5000 of these instruments will be given free. Better get your order in the mail right now, because there will be a heavy demand for this filter. If you are already a subscriber you can extend your subscription for one year and get one of these instruments. But **GET ONE** by all means. Order now. Don't wait until tomorrow. This offer good only for 60 days.

"RADIO", Pacific Building, San Francisco, Cal.  
 Herewith is \$2.50 and 36 cents for mailing charges for which you will at once send me the GENIE INDUCTION FILTER and "RADIO" for one full year.

Name .....

Address .....

City and State .....

Tell them that you saw it in RADIO

Continued from page 62

Moran grunted.

"That is for me to determine, Mr. Forbes," he said sharply. "Who was it?"  
 "I decline to answer that question!"  
 Forbes' reply was equally firm.

Moran shrugged. There was a slight movement in the little group and Elsie Jannison—"The Countess"—thrust her way forward.

"If you are protecting me, Mr. Forbes," she said graciously, "please do not do so." She turned to the detective sergeant. "Mr. Forbes was with me on deck," she said quickly. "His reticence was probably due to the fact that he did not want to subject me to suspicion. But I would rather be perfectly frank about the matter, because there is nothing to hide. We walked on deck for perhaps half an hour before Mr. Forbes left to go to his own stateroom."

Moran bowed. Whatever his quick opinion of "The Countess" he masked it behind an immobile countenance.

"Did you talk to anyone, during that walk—outside of yourselves?"

The Countess pursed her forehead in thought.

"No—o, I think not."

Moran studied her for a moment.

"It was at your request that Mr. Forbes displayed the diamonds, was it not?" he asked.

A slow tint of crimson stole into the girl's face. She raised her head defiantly.

"Yes," she said, even as young Forbes held out a restraining hand.

Moran bowed.

"You are sure you did not drop the packet from your pocket during that walk?" he asked abruptly, turning to Forbes.

"I might!" Forbes jumped at the "out" quickly. "I very possibly might, but I did not notice it at the time."

Moran nodded thoughtfully. His questions of the others were more or less perfunctory—at attitude which he explained to Captain Hanson later.

"When the thing boils down," he said, "we don't actually know that Forbes was robbed. Forbes certifies the girl—and there you are!"

But Cassidy was not satisfied. The chief had said that Cassidy was to have his own way, and he took it.

"Have you a passenger aboard whose first name is Jim—James?" he said.

The first officer secured the passenger list and traced down the entries. There were three—James Trent, James Rutherford, and James V. Corot. Cassidy considered.

"Could I speak with the radio operator that signs his messages 'JM'?" he asked.

"Certainly," said Captain Hanson.

He picked up his telephone and issued an order. A moment later the door swung open and a ship's operator—Jimmy McDorn—stood in the entrance.

# Clear as a Silver Bell

## O-T SILVERTONE TUBES

(Registered)

In your radio set assure—

sharp, clear, mellow tones—  
 music with its delightful and thrilling modulations—  
 speeches without distortion, audible down to a whisper—  
 and all the other joys of Radio at their best

### Three Models

O. T. 1A—2 to 4 volts,  
 Battery Draw .15 amps. Price, \$6.00

O. T. 9—2 to 4 volts,  
 Battery Draw .06 amps. Price, \$6.50

O. T. Power Tube—5 volts,  
 Battery Draw .25 to .35 amps. Price, \$7.50

At your dealer or direct by mail.  
 Write for complete literature.

Manufactured by DeForest Tel. & Tel. Co.

Exclusively for the

O. & T. Electric Corporation

1819 Broadway, New York  
 High class representatives wanted.



The O-T is the only genuine Silver-tone Tube.  
 Fully guaranteed.  
 Beware of imitations.

# THE TRINITY LOUD SPEAKERS

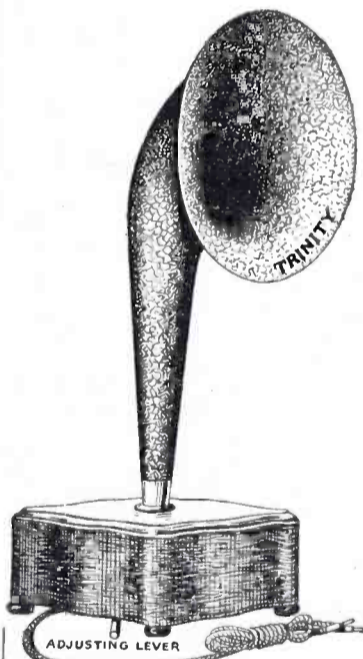

TYPE "C 2"  
 21" Fiber Horn \$30

a horn. It is a sturdy loud speaking element always. Send for literature.

TRINITY RADIO CORPORATION

446 TREMONT ST., BOSTON, MASS.

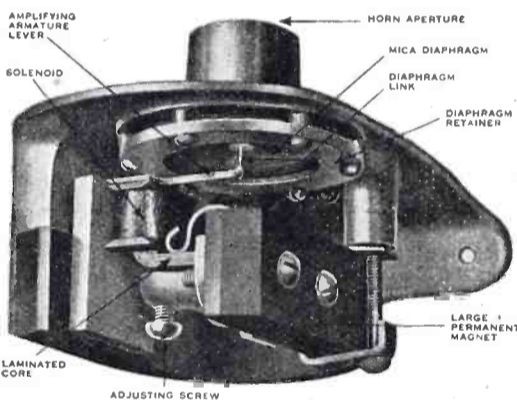

### Interior Construction of all Trinity Speakers

An ear phone is an ear phone no matter how fancy the horn that covers it may be, and, due to the delicate construction of an ear phone, it is utterly incapable of giving true tone reproduction, especially when relatively large currents are passed thru its coils, such as the output of a two-stage or power amplifier.

The Trinity Loud Speaker element embodies the well-proven principles of the phonograph reproducer with the soundest principles of electromagnetic design best adapted for loud speaker operation. It is not an ear phone when placed on a head band and a loud speaker when covered with

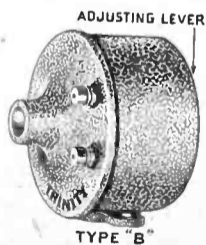

Phonograph \$12.50 Unit

## Ask your dealer for a Montrose Vernier Condenser

The condenser with genuine bakelite end pieces.  
 Has positive contact between the vernier plate and main shaft.  
 Will get the results where others fail.  
 Guaranteed to Give Entire Satisfaction

MONTROSE MFG. CO.

1200 Bedford Ave., Brooklyn, N. Y.

## Let Radio Experts Buy For You

Why hunt from store to store? Save time, trouble and money—a group of Radio Experts in New York will act as your personal representative, buy for you any standard make of radio equipment you want, from the smallest part to a complete set, either assembled or unassembled, and deliver it to you prepaid. Satisfaction guaranteed. Advice on all radio problems—free to our clients. Write for plan.

PERSONAL SERVICE PURCHASING BUREAU  
 505 Fifth Ave., Desk 14, New York

Tell them that you saw it in RADIO

"Come in," said the Captain. Cassidy crossed the cabin until he came face to face with the newcomer. Without any explanation of his presence, he asked a question.

"Do you know a man named Trent?" he asked.

McDorn's face mirrored surprise.

"Trent? No sir."

"Rutherford?"

"No sir."

"James Corot?"

Something flickered in the operator's eyes and he hesitated.

"I . . . seems I have, sir," he replied. I believe he's a passenger."

"You sent a message for him to J. J. McGuire last Friday," announced Cassidy.

There was no doubt of it—this shot had gone home. The operator whitened.

"I don't recall. I send quite a few during a trip, sir."

"Could I have the log?" asked Cassidy turning to the Captain.

The latter, his eyes studying the operator intently, nodded and the first officer left the cabin, to return presently with the operator's log and a stack of filed messages.

Cassidy took the book and the file and ran a spatulate finger through them until he came to what he sought. He held it out.

"This was the message," he said.

The operator stared at it with glassy eyes, his face the color of chalk.

"I remember that message—yes sir," he mumbled.

"Corot sent it, didn't he?" asked Cassidy.

"I—I don't recall."

For a moment Cassidy studied him in the silent room. The central office men were standing motionless—silent spectators of a drama familiar to them as one species of the third degree.

"Hangtown Haley—come clean!" Cassidy's voice cut like a whiplash. "Come clean lad—It's Cassidy talking . . .!"

The operator staggered back and clutched at the door behind him. Moran, unnoticed by the others, slipped behind the rest, until he stood close to the operator.

"Cassidy . . . of the C. M. & St. Pa . . .?"

"The same—old 'Sorrel' Cassidy. It's no use bluffin' lad. You know that."

There was sympathy in Cassidy's voice—sympathy and understanding. The operator slowly slipped down into a chair, his knees refusing to hold him longer.

"Cassidy—" he muttered, "after all these years . . ."

"Aye," said his questioner. "Everybody thought you was dead . . . but Cassidy. I did misself, do y'moind, until I heard your fist on the air. Says I—'tis

the Q-Drawler hisself and none other—me sittin' at home, tryin' to enjoy a radio concert. I wires the company for in-

formation and I learns they still want ye back there, lad . . . Look out!"

He broke off sharply, as Hangtown

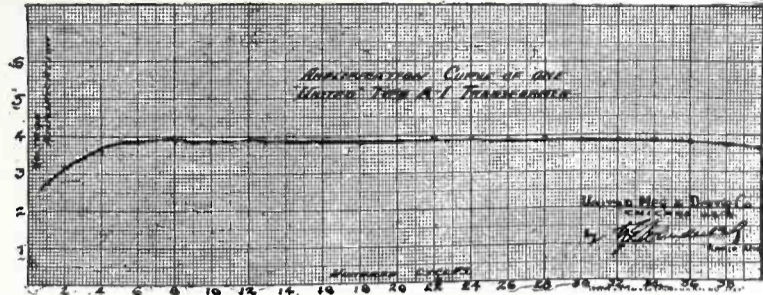

## Let Us Once and for All Times Settle This Question of Audio Amplification

Transformers, in order to give perfect audio amplification must have a characteristic curve as near to a straight line as possible.

*United Audio Transformers have just such a curve as can be seen from the above chart.*

A perfect audio transformer necessitates the best of core and winding design and construction.

*In the United the best of core iron is used, a proper air gap is another reason for their perfect performance, and the winding construction and impedance further combine to make it the absolute best.*

The winding ratio and shielding present other items necessary to a perfect transformer.

*The Good United Transformers have solved both questions in an admirable manner.*

Last, but really first, a perfect audio transformer must give perfect practical results.

*Recently, United Audio transformers came out FIRST in tests conducted by the University of California—conclusive proof that United is supreme.*

Ask your dealers to show you these transformers, and other United efficient Radio parts. Variable Condenser, plain and Vernier, Audio and Radio Frequency Transformers, Radio Frequency Amplifier Units.

### United Mfg. & Distributing Co.,

9705 Cottage Grove Avenue

CHICAGO

New York Office, 50 Church Street, New York, N. Y.

San Francisco Office, 709 Mission St., San Francisco, Cal.

# UNITED TRANSFORMERS



Type A-1 Ratio 5 to 1

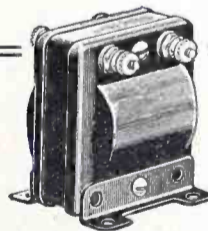

Type A-2 Ratio 3.5 to 1

#### FOR IMMEDIATE DELIVERY

- No. 228 Tuska Superdyne Receiver \$125.00
- No. 225 Tuska 3-Tube Receiver . . . 75.00
- No. 224 Tuska Single-Tube Rec. . . 35.00
- Bristol Audiophone Jr. L'd Sp'k. 22.50
- Bristol Audiophone Sr. L'd Sp'k. 32.50
- Bristol Sing.-Stage Power Ampl. 25.00
- Klosner 30-ohm Rheo't with knob .90

(new style) Klosner 30-ohm Rheo't with dial 1.25

Dealers write for literature and Discounts. Amateurs send 10c for complete catalog and price sheet.

#### Empire Radio Corporation

271 West 125th St., New York City



WILL SAVE YOU TIME, LABOR AND MONEY

Ask your dealer for HORTON'S. Imitations will not operate. List Price \$2.00

Attractive Discounts to Dealers and Jobbers Salesmen and Distributors Wanted

Write for FREE Literature

HORTON-SNYDER MFG. CO. 333-5 Washington St., Brooklyn, N. Y.

Tell them that you saw it in RADIO

# DX--10-POINT

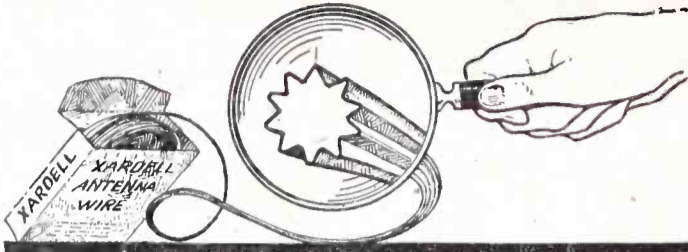

## ANTENNA WIRE

**\$2.00**

PER  
HUNDRED  
FEET  
DEPT.-P-

Designed for long distance reception and is different and better than the usual make-shifts, being hard drawn from the finest copper, having a corrugated surface with ten collecting points on the circumference. This gives a greater collective surface to the high-frequency radio currents. The result is extremely sensitiveness and increase in range and clearness of any set from the simplest Crystal to the finest multiple tube receiver.

Use this antenna wire and enjoy the full possibilities of your set.

Sold in coils 100 feet, 200 feet and 500 feet. Order direct or from your nearest dealer.

**XARDELL CORP. UTICA, N.Y.**

# WALNART TWIN

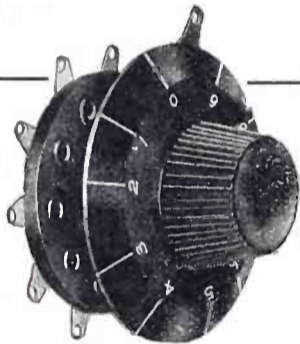

Variable  
Grid Resistance  
\$1.00

Inductance Switch  
\$1.25

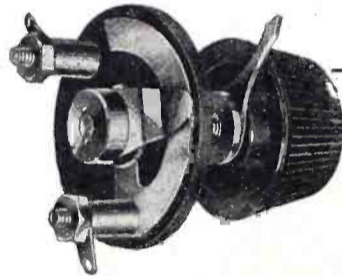

To get distance you must have positive contacts. The average arrangement of switch points is not satisfactory. Walnart inductance switch gives positive contacts, insuring better reception.

Different tubes require different grid resistance—Walnart Variable grid resistance vary-

ing from minimum to maximum of six Megohms clears up signals and adds to the efficiency of the set.

The instruments are made of highest quality material; base is genuine condensite Celoron made under Bakelite patents.

**WALNART ELECTRIC MFG. CO.**

Dept. 204, 1249 W. Van Buren Street  
CHICAGO

## MARLE Transformers

Audio and Radio  
Frequency. Give  
best results.

Superior Quality  
Reasonably  
Priced

Insist on them.

Sold by the best Dealers

Manufactured by

**MARLE ENGINEERING CO.**  
ORANGE, N. J.

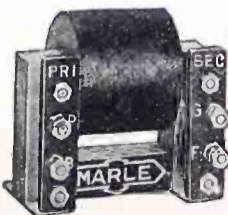

Type A4  
Ratio 3 1/4 to 1  
Price \$3.75

## READABLE HOOK-UP PRINTS

"Proven by Test to Be the Best"

1. Hazeltine Neutrodyne with two steps of R. F. amplification.
2. Cockaday Four Circuit tuner showing how to add 1 or 2 stages of A. F. amplification. Great selectivity.
3. Armstrong Super Heterodyne using only 7 dry battery tubes. Has but 2 controls. A Rolls Royce set.
4. Improved Ultra Reinartz with 2 stages of A. F. amplification. The best Reinartz.
5. Grimes Inverse Monotrol Duplex with 3 tubes, reflexed inversely on 2. The best Reflex.

Each blue print is informative, naming manufactured parts to buy, giving exact assembly directions, and telling how to wind special coils where fan likes to make everything possible. Price, 50 cents each or all five for \$1.75. Send money orders only to:

**HOME WORKSHOP CO.,**  
P. O. Box 1062A, Chicago, Ill.

Haley, with a sudden quick glance around the room, whirled in his chair, and jumped for the door, one hand jerking at his hip pocket.

The warning cry was unneeded. Moran, anticipating just such a move, swung with a leather-covered instrument—a short, quick blow. And Hangtown, an automatic half out of his pocket, crumpled at their feet unconscious.

"Well—that's one of 'em, anyhow," chuckled Moran, as he snapped the handcuffs into place.

Cassidy sighed.

"Yeah—there's two others aboard, and one ashore," said Cassidy.

Captain Hanson, for whom events were moving too swiftly, asked the question:

"Who?" he said.

"Corot and that dame—The Countess. The other, is J. J. McGuire—the gent to whom this message was sent, known b' the police byes as Spike McShane."

"Well," said Moran, "let's grab 'em!"

Cassidy shook his head.

"We'll grab Corot after he gets ashore," he said. "We'll let the fancy lady go. She'll connect with McShane and then we've got something on him."

"But the stolen diamonds?" interposed the captain.

Cassidy considered.

"Which of the three of 'em—Corot, the lady or Hangtown Haley could get ashore without annybody askin' 'em any questions?" he asked.

"The operator," said Captain Hanson.

"The operator is it," said Cassidy. "I'll bet the old lady's pianny he's got them stones cached in his bunk, the now."

And he had. Six of the finest stones in the world—neatly tucked beneath his pillow—the safest spot in the world, taking all things into consideration.

With the boat out of quarantine, two hours later, the police program went like a greased schedule.

Corot, arrested on the dock, protested and was taken protesting to the identification bureau, where a complete set of prints from Scotland Yard established his identity as "Slippery" Smith, an international smuggler.

The Countess checked in at a leading hotel, rang for a maid and gave herself over to being beautiful. Several hours later, when she felt official vigilance had relaxed, she telephoned to a certain number that she carried in her head.

As a result of that message "Spike" McShane, closely followed by his police shadow, met the Countess in a tea-room off a side street close to the downtown district, where one could hold tete-a-tetes without general observation. The Countess also brought a shadow—a Central office man, loitering discreetly in the background. Even as she and

Tell them that you saw it in RADIO

McShane shook hands, the two shadows closed in and interrupted the greetings.

It was all outlined to young Forbes the next morning at police headquarters—just how the Countess, under Corot's direction, had "worked" him for a sight of the stones. The episode of the dropped handkerchief figured prominently.

"That's when she took them from you," said the detective chief. "It's an old trick. You lean over the rail . . . she empties your pockets. Then she drops the stones, Corot picks them up, files a message in code to McShane ashore which informs him the robbery has been successful, and slips the operator the stones. The op goes ashore with the loot—walks right off the boat unsuspected and later the gang get together, arrange a sale, and split profits."

"By jove—it's damnably clever," said young Forbes. "You know—I feel like I ought to have a keeper of some sort. Letting myself in for such a mess."

"You've got Cassidy to thank for your diamonds," said the chief significantly. "If he hadn't recognized the sending of a 'dead man' we wouldn't have had a clue to it. It's lucky for you Cassidy was a radio fan!"

Young Forbes shook Cassidy by the hand gratefully.

"It's lucky for him, too," he said cryptically; a remark which left Cassidy considerably mystified.

The explanation came Saturday night. Cassidy, in his sock feet, answered the front door himself.

An expressman staggered in with a man's-sized box, containing the best radio set that a wealthy man's bank account could buy in America. Attached was a card:

"To my friend Mr. Cassidy with the compliments of a damned fool," it read.

And Cassidy, who was plain cop, and used to drawing straight lines between points, did another little piece of detective work.

"By golly, I believe it's a present for Policeman Cassidy," he said. "And be the color of the string, I'm thinkin' it's from that young Mr. Forbes."

Which ends the true and correct story of the "Q-Drawler" and Policeman Cassidy, right where it began—in Mr. Cassidy's front parlor.

By the auld lady's pianny—it does!

Do you know that your distances as computed on a flat map in an atlas are probably badly off? That is, unless you allow for the curvature of the earth, which cannot be done easily on flat maps. As the shortest distance from one point to another on the earth's surface is along a "great circle" apparent directions are often different from the true ones. Get a globe, and try it.

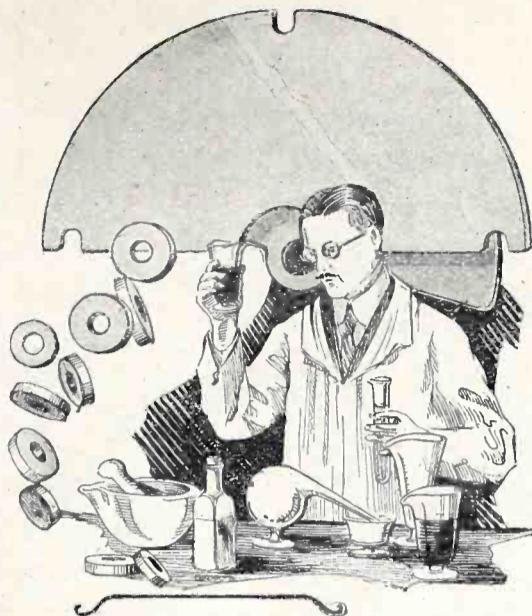

## U. S. TOOL CONDENSERS

*Plates Protected Against Oxidization*

YOU can't SEE the difference between ordinary plates and the plates and spacers in U. S. Tool Condensers, but eventually ordinary plates and spacers oxidize, setting up a high resistance. Our chemists fought this deterioration of the plates with a counter-chemical treatment. Loss of efficiency prevented by Laminated Condensite-Celoron end plates. Reasons for the persistent efficiency of *U. S. Tool Condensers*. Unconditionally guaranteed. Write for booklet.

U. S. TOOL *Newark, N. J.*  
COMPANY INC. 114 *Mechanic St.*

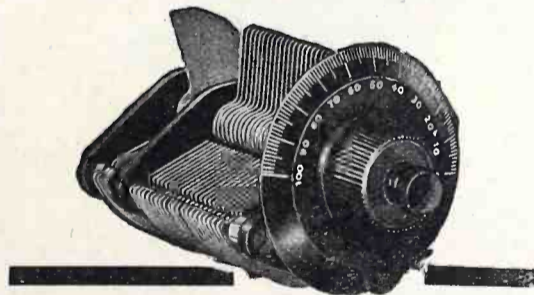

## RADIO

SEND FOR OUR COMPLETE  
MONEY SAVING CATALOG  
**TIMES SQ. AUTO SUPPLY CO., INC.**  
MAIL ORDER DEPARTMENT  
1743 BROADWAY at 56th STREET  
NEW YORK, N. Y.

"Hear it by Radio"  
*Denver's Largest Exclusive Radio Wholesalers*  
**PARAGON DISTRIBUTORS**  
THE ROCKY MOUNTAIN RADIO CORPORATION  
1512-1516 Broadway Denver, Colorado

Tell them that you saw it in RADIO

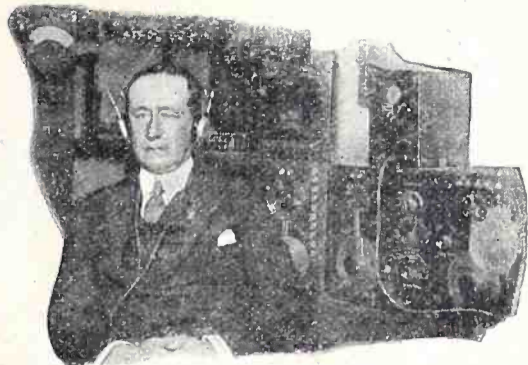

Guglielmo Marconi, as he appears today. Signor Marconi is Honorary Chairman of the Radio Institute of America

## Train for the big Jobs in Radio

There are big radio jobs waiting. Over 6,000 operators have already graduated from the Radio Institute of America. But the radio industry is just in its infancy. There are more demands for operators than there are trained men to meet the demand.

Conducted by the Radio Corporation of America, the Radio Institute offers the soundest instruction and the most logical means of employment after graduation. Write for information concerning our classes.

### Home Study Courses

Conducted from New York City. Full instruction for those who cannot attend the San Francisco resident school.

- A. *Complete Home Study Course.* From beginnings of magnetism through code and commercial practice. Prepares you for U. S. operator's license.
- B. *Advanced Home Study Course.* For the advanced radio student and experienced amateur. Specializes in C. W., I. C. W., telephone and radio measurements.

Send the coupon for full information

**Radio Institute of America**  
(formerly Marconi Institute)  
Established 1909

Western District Resident School  
New Call Bldg., New Montgomey St.  
San Francisco, Cal.

**HOME STUDY DIVISION**  
322 Broadway, New York City

Indicate by a cross X the course you are interested in:

Radio Institute of America,  
322 Broadway, New York  
Please send me full information about  
radio opportunities today, and your  
COMPLETE RADIO COURSE   
ADVANCED RADIO COURSE   
Name.....  
Address.....

# The Supreme Insulation

# RADION Panels

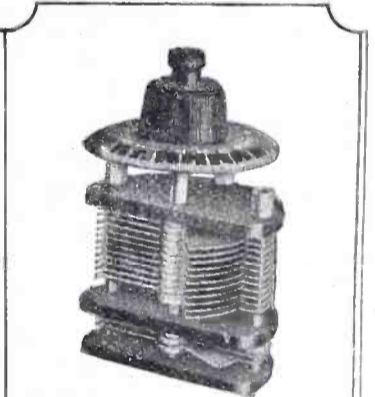
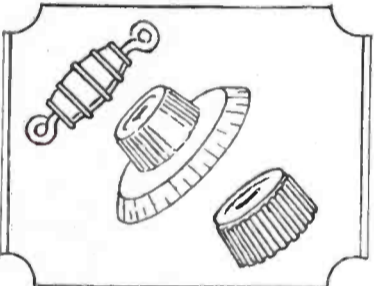

These leading manufacturers of CONDENSERS adopted RADION ENDS—

Amsco Products, Inc.  
Commercial Screw Machine Prod. Co.  
Elgin Tool Works, Inc.  
Freed Eiseman Radio Corp.

General Radio Co.  
Heath Radio & Electric Mfg. Co.

Jewett Mfg. Corp.  
S. S. Novelty Co.  
Pacent Electric Co.

Superior Instrument Co.  
Thompson Levering Co.  
because Radion is the Best Possible insulation against current losses in high frequency reception.



are easiest to drill, saw, or engrave with simple tools at home

18 Stock Sizes Radion Panels

Black and Mahogany

6 x 7	6 x 10½	6 x 14
6 x 21	7 x 9	7 x 10
7 x 12	7 x 14	7 x 18
7 x 21	7 x 24	7 x 48
9 x 14	10 x 12	12 x 14
12 x 21	14 x 18	20 x 24

AMERICAN HARD RUBBER COMPANY, 11 Mercer St., N. Y.

Tell them that you saw it in RADIO

## TESTING BOARD

Continued from page 18

comparison of various circuits in volume output.

It might not seem that such an arrangement is suitable for portable experimental work, but it adapts itself to such requirements nicely. Particularly in camping out, when one oftentimes has plenty of leisure time on his hands, such an arrangement helps while away the hours.

Since the construction of this board, the writer has oftentimes loaned it to experimenters floundering with some particular circuit, and its value has been shown in a number of instances. For the inexperienced, the arrangement is valuable in its saving of good tubes, that otherwise might be lost through carelessness in arrangement of new circuits.

The construction of such a board is limited to some extent by the amount of apparatus on hand. The best way is to lay out a board of suitable size, and, as material is accumulated, to place it as one progresses.

The biggest help in operation is a large number of flexible leads to be used as connectors. Black or brown lampcord is suitable. A quantity of this should be cut up in lengths suitable for varying purposes, and the terminals should be so fixed as to allow of ready connection of binding posts. To this end, the writer makes use of a little device that may be purchased at automobile accessory houses, and possibly in radio supply stores as well. This device crimps a hollow brass rivet around the wire and forms an ideal connecting means. A less expensive but satisfactory way is to skin back the lampcord a short ways, loop the stranded wire, and then cover the loop with solder. The binding posts on the board units should be of the type in which the head may be removed readily. For work of this nature, they are more satisfactory than the type intended to accommodate a pin terminal.

## RUSONITE

CRYSTAL RECTIFIER

(Patent Pending)

THE PERFECT SYNTHETIC CRYSTAL DETECTOR

SENSITIVE OVER ENTIRE SURFACE

No hunting for "Spots." Loud and Clear. Endorsed by Thousands of Satisfied Users.

Sensitiveness Guaranteed	Price Mounted	50c
--------------------------	---------------	-----

14 K. Gold Supersensitive RUSONITE CATWHISKER, Price Permanent. Will not Oxidize.	25c
---	-----

RUSONITE REFLEX CRYSTAL Manufactured Expressly for Reflex Circuits. Will Stand Up Under Heavy Plate Voltage	Price Mounted	\$1.00
---	---------------	--------

Order from your dealer or direct from  
RUSONITE PRODUCTS CORP.  
15 Park Row. New York, N. Y.

An Absolute Guarantee  
with every instrument  
made them famous!

**SHAMROCK**  
(FOR SELECTIVE TUNING)

180°

**Vario-Coupler**

List price,  
**\$3<sup>50</sup>**  
each

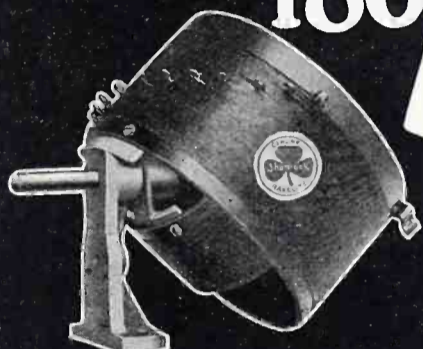

DOUBLE  
DUTY  
PIG-TAIL  
**Variometer**



**SHAMROCK MFG. CO.**  
314 W. Market St. ~ Newark N. J.

# F - R - E - E

Here are a few diagrams showing how to use this Transformer.

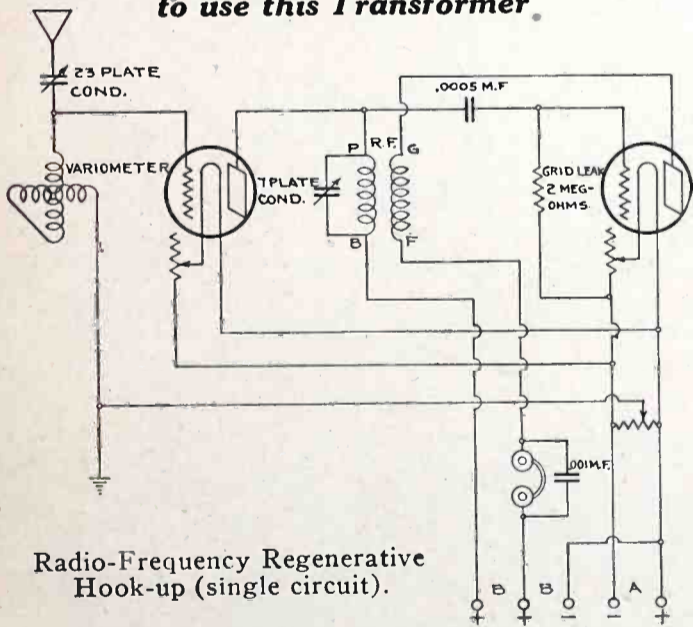

Radio-Frequency Regenerative Hook-up (single circuit).

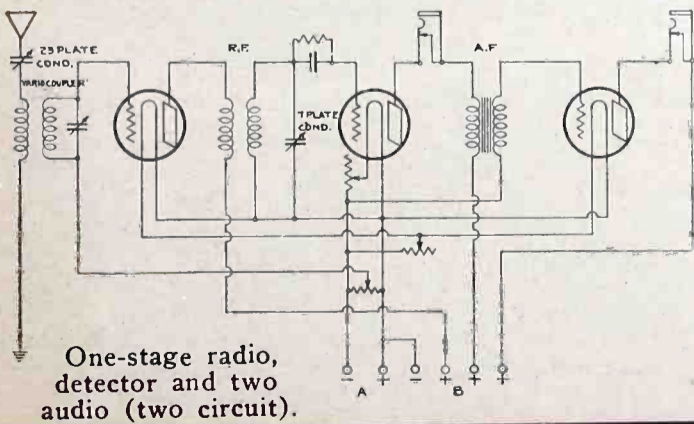

One-stage radio, detector and two audio (two circuit).

Send us only \$2.50 and a few cents for mailing charges and you will receive "RADIO" for one full year and one of these MARATHON RADIO-FREQUENCY TRANSFORMERS. There are positively no other payments. You get this dandy instrument absolutely free with only one subscription to "RADIO." Increase your range with this new transformer. It is a guaranteed instrument and will deliver the goods or your money back. **THIS GREAT OFFER EXPIRES IN 60 DAYS.**



ILLUSTRATION SHOWS EXACT SIZE OF THIS TRANSFORMER

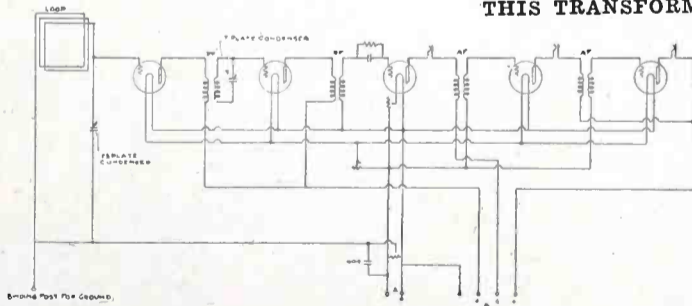

Two radio, detector and two audio with loop.

**ACT NOW!**

Subscribe Today

Your Money  
Refunded If Not  
Satisfied

RADIO—Pacific Bldg., San Francisco, Calif.  
Herewith is \$2.50 and 36 cents for mailing charges. Send me at once one MARATHON TRANSFORMER AND SEND ME "RADIO" for one full year. I understand this offer carries your full guarantee in every respect.

Name .....

Address .....

Tell them that you saw it in RADIO

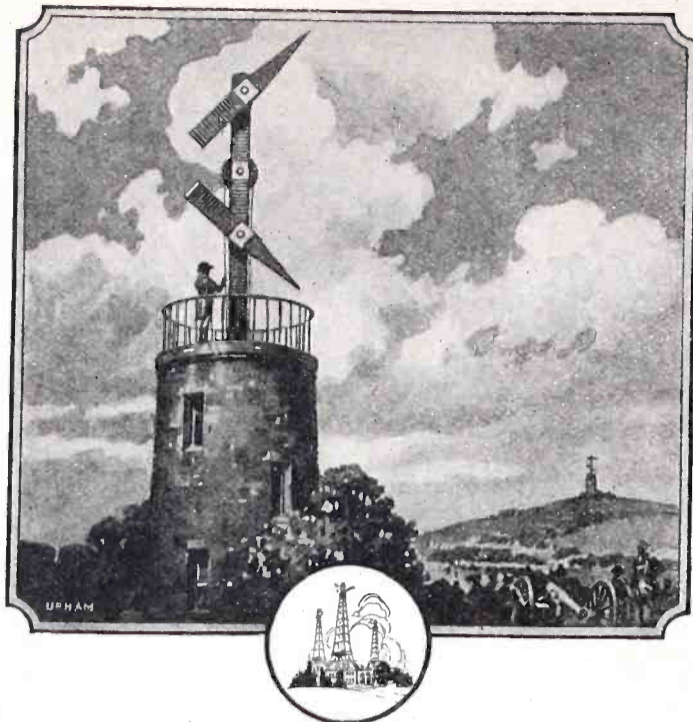

## IN NAPOLEON'S DAY

**I**N the early part of the nineteenth century the semaphore was the quickest means of transmitting information. Great battles often hinged on the information received or sent by this method.

Today, due to sensitive instruments and electricity, messages are conveyed over vast distances with the speed of light.

Your radio set receives the faint electric waves sent through space and builds them up into relatively strong currents, but it is your head phones that transform this current into the music or spoken words that you hear.

Your set can be no better than your head phones and, as the enjoyment of broadcasting depends upon the quality of sound, you cannot be satisfied with inferior phones.

Holtzer-Cabot Phones are the perfected results of over twenty-five years specialization in sensitive electrical instruments. With Holtzer-Cabot Head Sets you may be sure that you are getting all the enjoyment that your radio set can give.

Holtzer-Cabot Loud Speaker,	\$25.00
Holtzer-Cabot Phonograph Attachment	10.00
No. 2 Universal Head Phones,	9.50
No. 4 National Head Phones,	6.00

Write for booklets "What you should know about Radio Reception" and "A better Loud Speaker."

THE HOLTZER-CABOT ELECTRIC CO.

125 Amory Street, Boston, Mass.  
6161-65 South State Street, Chicago, Ill.  
Department C

*Holtzer-Cabot*  
BUSINESS ESTABLISHED 1875

HEAD-SETS

## PANEL LAYOUT

Continued from page 25

cut just as much as it can get away with comfortably, without binding or heating too much. When drilling thick bakelite it is essential that the drill frequently be *backed out* of the hole to permit it to clear itself. No lubricant should be used when drilling bakelite. The drill must be very sharp. If the drills have been used for some time, even if they have been kept sharp on their cutting edge, they should be ground off for a distance about equal to their diameter. The bakelite wears the drill flutes rapidly, and before long the drill is down to the size of the backed-off portion of the drill, which will then bind and burn. Great care is necessary when the drill comes through the panel; if too much pressure has been used, the drill will break through rather than cut through, and a jagged hole will be left. When the drill starts to cut through, practically all pressure should be taken off, and the drill eased through slowly.

It will be found that the cutting edge of the drills will be rapidly dulled, and frequent grindings are necessary. It is quite a trick to grind a modern twist drill so that it will cut evenly on both lips. Probably the best way to learn to sharpen drills is to take new drills that have become dulled, but which have not lost the general shape of their points, and grind the new edge to correspond with the angle of the old. This takes some time to learn, especially if the drill is rather small, but will well repay the user if the time is taken at first. The face of the emery wheel should be used, generally, although some find the side to be easier. Sharpening twist drills is a procedure that can only be learned through experience; it cannot be described.

High speed drilling apparatus is ideal for drilling bakelite. In such a case the drill will turn over about 5000 rpm with No. 28 or 30 drills, and the drill can be used almost like a punch. The drill turns over so fast that it goes through the bakelite almost instantly, and makes a much cleaner and more accurate job than when carbon steel drills are used. This requires a special drill-press, however, as the ordinary type would burn out in almost no time.

In turning bakelite in the lathe it will be found that a moderate speed is needed; this speed should be considerably slower than brass speed, but should not be as slow as the speed used to cut steel or cast iron. A moderately light cut should be taken; a heavy cut will cause the bakelite to "ride the tool." If the tool starts to dig into the soft bakelite, it will cut so fast that it may ruin the work before the lathe can be stopped. The quality of steel used to cut bakelite is not very important, but it should be

Continued on page 75

### CARTER

#### Inductance Switch

Positive contact. 1-15 Indicator on dial. Adjustable stop pin. Pigtail connection eliminates friction contact. Solder terminal and contact one piece. Only one hole to drill in panel. Can be used as a "B" Battery tap switch.

Ask your dealer. Illustrated catalog on request.

Coast Distributors:

Alt. Pac. Sales Co., San Francisco



1-15 Points  
\$2.00

**Carter Radio Co.**  
201 S. STATE STREET  
CHICAGO



**WOC**  
**TRESCO**

Licensed under Armstrong U. S. Patent  
No. 1,113,149.

A Long Distance 1,000-mile, 600-meter Range Regenerative Tuner for \$12.00. Add Parcel Post on 6 lbs. New Circuit, Startling Results. Cheaper than Crystal Set. Uses any Aerial. Amplifiers to match set for your loud speakers. Circulars free. Full instructions.

TRESCO  
DAVENPORT, IOWA

Tell them that you saw it in RADIO



# The COURT JESTER of TODAY

"No wit to flatter left of all his store,  
No fool to laugh at, which he valued more."  
—Pope

SINCE the earliest days, laughter and gaiety have been the most sought after things in life. In ancient times stately rulers unbent, courtly knights forgot seriousness; beautiful ladies became more alluring as the clever quips and merry pranks of the court jester brought a sparkle to their eyes and drove dull care away. But they were limited to the clownish antics and slap stick comedy of the jester.

Moderns have unlimited sources of amusement. Every broadcasting station has its Jester; its humorous stories; amusing songs and clever comedies. Each night the air is filled with merriment.

With a Crosley Model X-J radio receiver, amusement may be brought clearly and distinctly to your fireside. Sitting comfortably in an easy chair you forget dull care. The magic wand of the radio sends worry scurrying.

The very moderate prices of all Crosley instruments bring radio within the reach of all.

No matter which Crosley Model you may select you can be assured of the maximum results at the lowest cost.

Let a Crosley Radio Receiver bring fun, laughter and good humor into your home.

**CROSLEY**  
Better - Cost Less  
Radio Products

See the Crosley Line at Good Dealers Everywhere

Write for Free Catalog. This fully describes the Crosley line of Radio receivers which range in price from the Model VI, a 2 tube set at \$30, to the graceful Consolette Model X-L at \$140. It also shows the complete line of Crosley parts.

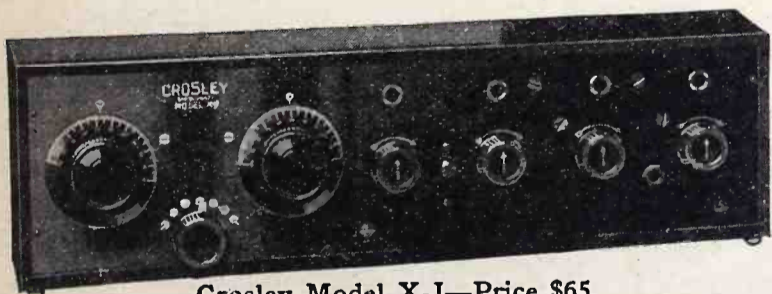

Crosley Model X-J—Price \$65

For tuning out local interference and bringing in distant stations this receiver is unexcelled. It is a 4 tube set combining one stage of tuned radio frequency amplification, detector and two stages of audio frequency amplification.

**For bringing in distant stations no set can excel it.**

Cost of necessary accessories \$40.00 and up.

**CROSLEY MANUFACTURING COMPANY**  
Powel Crosley Jr., President

119 Alfred Street

Cincinnati, Ohio

Tell them that you saw it in RADIO



**CROSLEY** \$  
*Model X-J* **65**

The Broadcasting Station WLW is maintained by the CROSLEY MANUFACTURING COMPANY

**MAIL THIS COUPON TODAY**

Crosley Manufacturing Co.,  
119 Alfred St., Cincinnati, O.

Gentlemen: Please mail me free of charge your complete catalog of Crosley instruments and parts together with booklet entitled "The Simplicity of Radio."

Name .....

Address .....



# ACE RADIO SETS

MEAN  
CLEAR RECEPTION  
AND  
REAL SATISFACTION

The  
ACE TYPE V  
\$20.00

Licensed under Arm-  
strong U. S. Patent  
No. 1,113,149

**T**HE very first evening you enjoy the Ace Type V Armstrong Regenerative Radio Receiver you'll wonder how you ever did without it.

Its low cost is not indicative of its efficient service because it performs equally as well as any one tube at any price.

Under ordinary conditions you can pick up stations from coast to coast, one after the other, with this long-range regenerative receiver. A loud speaker can be operated in connection with the Ace Type V by simply adding an Ace Type 2-B, a new two-step Audio-Frequency Amplifier, which sells for \$20.00. This makes it possible to hear a concert all over the house.

This set is so low in cost that everyone can now afford to enjoy radio. Don't be without radio entertainment any longer—listen to the world's best talent—both instrumental and vocal.

Prices do not include tubes or batteries.

*If your dealer cannot supply you,  
order direct, mentioning his name*

## THE PRECISION EQUIPMENT CO.

Powel Crosley, Jr., Pres.

119 Vandalia Ave.

Cincinnati, Ohio

Tell them that you saw it in RADIO

### The Ace Type 3B

This set is equal to a combination of the Ace Type V and the Ace two-stage amplifier. Manufactured under Armstrong U. S. Patent No. 1,113,149. A filament switch eliminates necessity of turning out rheostats when set is not in use. You may turn off the set by throwing switch and come back later without retuning. Has telephone jack in between first and second stage. Crosley multistats. Universal filament control rheostats for all makes of tubes. Price \$50.00.

**F**OR those who are discriminating and demand the finest in both appearance and quality the Ace Type 3C Consolette has no equal. It is a new addition to the Ace Family. Has beautiful solid mahogany, wax-finished cabinet. Set consists of a regenerative tuner, detector and two stages of amplification, with built-in loud speaker. The tuning circuit is licensed under the Armstrong U. S. Patent No. 1,113,149 and due to the particular method of winding Crosley coils it is exceptionally selective. Has sufficient room inside Cabinet for dry batteries making a complete self-contained long range receiving outfit. Phone jack for tuning with head phones; Crosley multistat, filament switch, Crosley moulded condenser; beautifully engraved Formica panel. Uses all kinds of tubes. A wonderful set at a remarkable price, \$125.00—without tubes or batteries.

*Ask your dealer to show you this unusual set*

**THE PRECISION EQUIPMENT CO.**

Powel Crosley, Jr., Pres.

119 Vandalia Ave.

Cincinnati, Ohio

The  
**ACE TYPE 3C  
CONSOLETTTE**

**\$125.00**

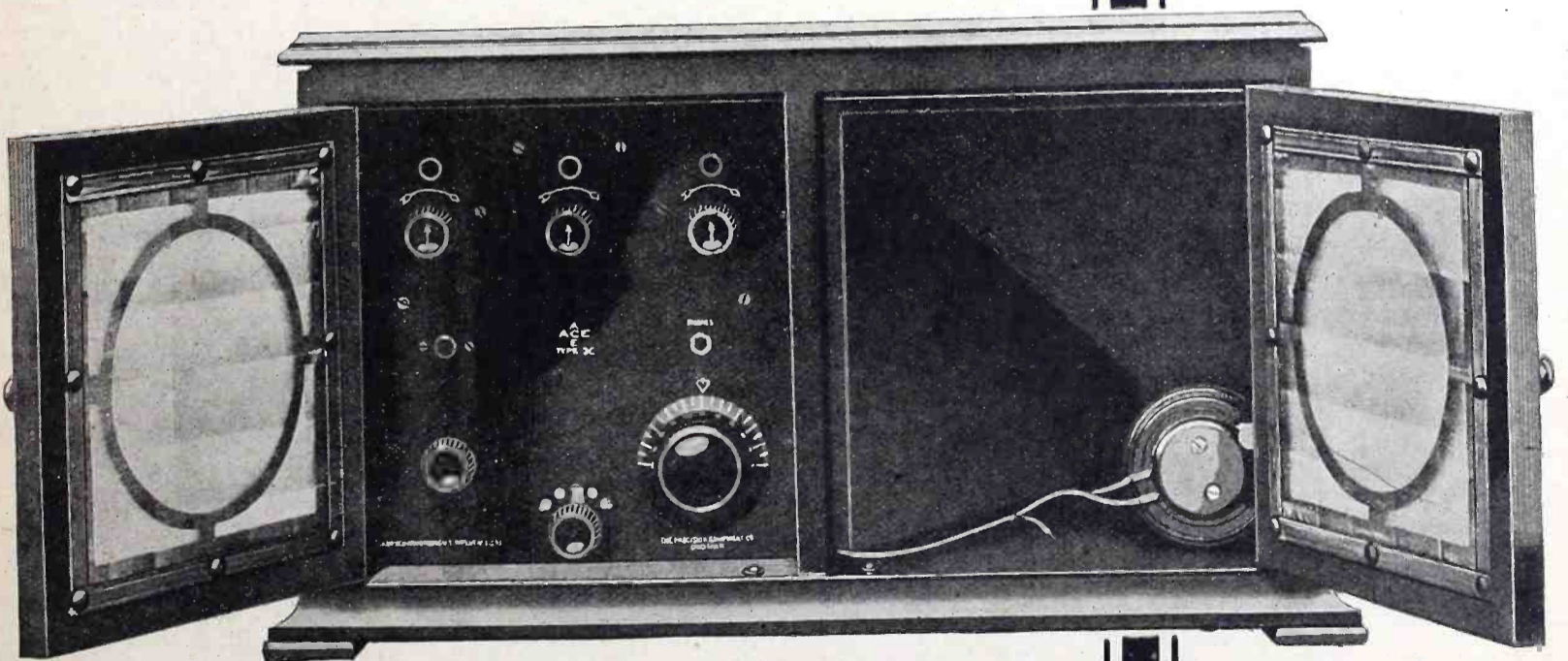

Tell them that you saw it in RADIO

**NEUTRODYNE CIRCUIT**

*Continued from page 20*

a constant ratio because the inductances  $L_1$  and  $L_2$  have practically the same elec-

trostatic exposure to the primary coil of the receiver. Because of this fact it becomes only necessary to give the inductance  $L_2$  a proper number of turns rela-

tive to the inductance  $L_1$  in order to satisfy the conditions as expressed in equation (7).

Since the inductance  $L_2$  is outside of the coupling inductance  $L_1$ , it also has a direct screening action, making  $C_1'$ ,  $C_1''$ , smaller than they would otherwise be and smaller than  $C_2'$  and  $C_2''$ . Hence the inductance  $L_2$  requires fewer turns of wire inductance than  $L_1$ . In experimenting with the proper number of turns  $N_2$  was determined by putting the inductances at right angles (so as to eliminate the magnetic coupling of the coils) and adjusting the number of turns  $N_2$  until no signal was transmitted because of the capacity coupling.

The mathematics resorted to in explaining the fundamental relations in circuits necessary to achieve capacity neutralization have been kept as simple as possible. Readers are asked to carefully study these simple equations and the circuit drawings, because, by an understanding of this first article of the series, the more detailed arrangements to be studied in the coming issues will be easy to comprehend.

In the second article, the application of the Neutrodyne principle to vacuum tube circuits will be studied, the question of the elimination of electro-magnetic coupling and basic radio-frequency transformer design being treated in detail.

# Teleradio

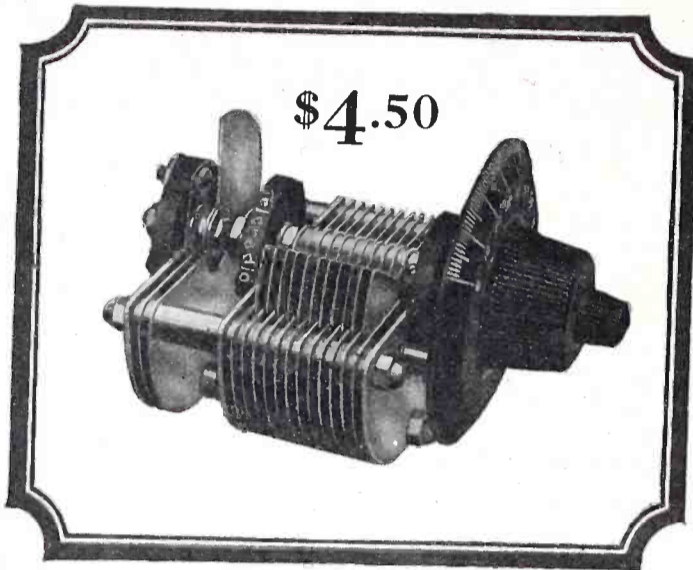

## Continuous Satisfaction



### SUPER-SENSITIVE FILAMENT RHEOSTAT

Is reversible and can be mounted on either panel or base. Double brass bearing on spindle insures smooth action and prevents looseness. Contact arm is phosphor bronze. Will carry  $1\frac{1}{2}$  amperes without heating.

Price (6 or 30 ohm) .....\$1

The expectations of the radio enthusiast who is endeavoring to get sharp tuning in his set, are fulfilled by the continuous satisfaction of the Teleradio Vernier Condenser. His joy in finding accuracy and dependability in this instrument reflects the efforts of the manufacturer to fully please the owners of Teleradio products.

With extra heavy polished hard aluminum plates that will not warp, a special locking feature preventing short circuiting of vernier and providing permanent and perfect contact, an accurate and constant capacity, and with rigid construction throughout, there is positive assurance of continuous satisfaction from this precision instrument. Guaranteed electrically and mechanically.

**Teleradio Engineering Corp.**  
484-488 Broome St., New York City

VERNIER CONDENSERS, 23 plate \$4.50, 43 plate \$5.50. VARIABLE CONDENSERS, 3 plate \$2.00, 11 plate \$2.50, 23 plate \$3.00, 43 plate \$5.50. HEAD PHONES 2000 ohm \$5.50, 2200 ohm \$6.00, 3000 ohm \$7.00. LIGHTNING ARRESTER \$1.00.

## T E L E R A D I O P R O D U C T S



### Pat. Pend. PREMIER Audio-Frequency Transformer

HERE you have it—the smallest Audio-Frequency Transformer ever made, and yet the most efficient for volume and tone quality. Think of it! This "Little Wonder" (about the size of an English walnut) gives you maximum reproduction volume with minimum distortion. The secret is in its patented construction. It is 100% shielded against foreign noises. Mounts anywhere—saves space in assembly. Constructed of highest quality material. Made in tube socket types also. We guarantee it unconditionally. Try them in your next "hook-up." You'll be agreeably surprised and pleased.

Write now for Bulletin No. 93

#### RATIOS

1 to 3, 1 to 4, 1 to 5 ..... \$3.50  
1 to 10 ..... 4.50

**Premier Electric Company**  
3813 Ravenswood Ave. CHICAGO

Ask for and insist on Premier at Your Dealers

**WEIGHS ONLY 8 OZ.**

**The Scientific**

A 200,000.00 COMPANY stands squarely back of the guarantee on every Scientific headset

**SEND NO MONEY!**

20,000 TURNS EQUIVALENT TO 3,000 OHMS

**2.95**

Order TODAY by Postcard and Pay Postman on arrival

THE PHONE IT TOOK A SOLID YEAR TO DESIGN

**POST-PAID**

**LOUD SPEAKER UNIT '195**

**We Guarantee** The Scientific Headset to be the greatest value on the market. Try it for five days. If not satisfactory send it back and your money will be refunded immediately. Circular on request. Dealers wanted.

**THE SCIENTIFIC ELECTRIC WORKS**  
98 Brookline Ave. Dept. E BOSTON, MASS.

**The Radio Dealer YEAR BOOK**

1923-1924

—now out—

Complete classified Manufacturers' Lists. An encyclopedia of Radio Jobbers. A directory of Radio Trade Marks.

Complete in one volume. One Dollar per copy.

Issued by the publishers of The Radio Dealer, the Radio Trade's Monthly, and the Radio Dealer WEEKLY, for Manufacturers.

**THE RADIO DEALER CO.**  
1133 Broadway, New York City.  
512 Pacific Bldg. Western Office San Francisco, Calif.

Tell them that you saw it in RADIO

**PANEL LAYOUT**

*Continued from page 70*

as hard as possible, as the tool-point pressure is rather low and no great strength is needed. The so-called "glass-hard" carbon steel may be used with success. This steel will usually last about as long as any other, although high-speed steel will last a little better, and has, of course, the advantage of being able to stand overheating to any temperature without danger. In any case, it will be found that as much time is spent in tool-sharpening as in cutting. When the tool starts to cut slowly, to heat, and to leave a sort of polished surface, it will be necessary to stop and either resharpen or renew the tool, as this is a sure sign the edge is gone.

In sawing bakelite, it is necessary to use a metal-cutting saw, and then only indifferent results are obtained. In hand sawing an ordinary hacksaw with soft-backed blades with fine teeth should be used, as coarse teeth will tear the bakelite and damage the surface. Never use a wood-cutting saw for bakelite; it will speedily be ruined. In power sawing, a metal circular saw is usually used. Saws for bakelite should turn at a moderate speed, and should have little or no set. In fact, a thin milling cutter, with the teeth backed off, so as to get a good heavy strong cutting edge, usually will serve best. The ordinary thin circular saws, such as are used for brass, copper and soft metal cutting will not last if used for bakelite. The bakelite should be fed slowly to the saw, or milling cutter. Do not attempt to crowd the saw, as it will be burned.

One of the hardest jobs that come up in bakelite working is to make holes of greater or less size for flush-mounting meters. A hole could be drilled in thin bakelite and then a wood-worker's jig-saw used to cut the holes, but these are rather irregular and jagged. A device known as a "fly-cutter" is used to perform such operations, and is illustrated in Fig. 4. A steel form is turned out,

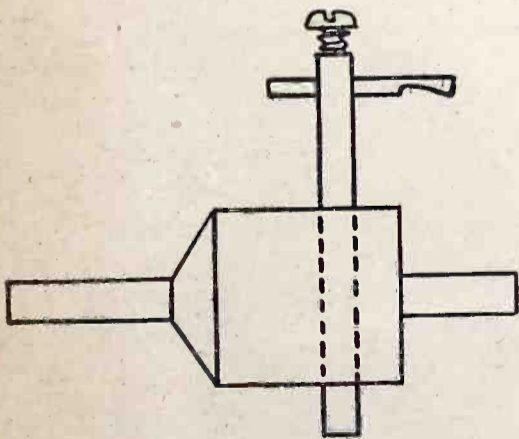
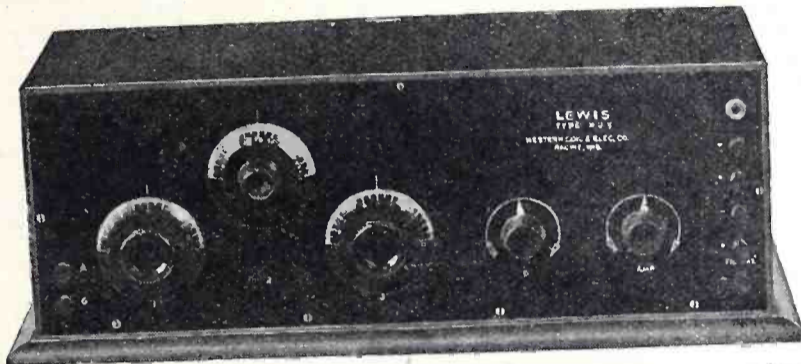

Fig. 4. Fly-Cutter

with one end of such size that it fits the lathe chuck, whilst the other fits in a hole already drilled in the exact center of the large hole that is so wanted.

This hole should just fit the extended spindle of the fly-cutter, and should go through, and fit into a hole drilled for the purpose in the drill-press table. This steadies the tool on the bottom, whilst the chuck holds it securely at the top. A steel cutter is fastened to a projecting arm, as shown, and the whole apparatus revolves, when the power is applied to the chuck, and the required hole cut out. It is best to start the hole from one side, and then turn the panel over, and finish it from the other side, as this prevents any ripping or tearing of the surface when the tool breaks through. A set-screw is provided (although not shown

in the figure), which allows the arm to be set firmly in any position. This arm may be of round section, in which case the set-screw will have to keep it from turning, as well as from slipping from position, but it is much better, if possible, to have a square hole broached through the spindle, and a square arm used. The cutter can be either of round or square section, also, but square is to be preferred for similar reasons. The tool used in this fly-cutter will meet with the same service as a lathe tool, and should receive the same treatment, as far as sharpening it, cutting, etc., is concerned.



**A Special Low Wave Set for Transmitting Amateurs**

Does your receiving set respond readily to short wave signals? The WC-5-SW set shown above was designed by short wave specialists to help you. It picks up signals on wave lengths from 90 to 380 meters sharp and clear. In many tests. The WC-5-SW has proven itself to be the most practical receiving set for low wave specialists.

**WC-5-SW**

**Built Especially for Transmitting Amateurs**

The WC-5-SW is a 4-tube set. One stage of tuned Radio-Frequency amplification is employed ahead of the detector to make it super-sensitive. Two stages of audio-frequency are used to bring up the signal strength. Uses any type of tubes. Gives perfect control of audibility. Detector rectifies only. Uses antenna compensating condenser. Only two control adjustments. Pure negative biasing on all tubes, thus marked saving on "B" Battery current. Tuned Radio-Frequency sharpest known and most selective principle ever adopted. Plate potential non-critical. Mono-block tube socket. No grid plate leads on audio amplifiers. Audio amplification absolutely necessary when using low efficiency receiving antenna, i.e., underground or indoor. Mahogany cabinet, piano rub finish. Rabbited-in panel. Split lid cover. The Price is \$85.00.

*Write for complete description and illustrated folder on this practical set for low wave specialists. All transmitting amateurs will be interested in this literature.*

**OTT RADIO, Inc.**

226 Main Street

La Crosse, Wis.

Tell them that you saw it in RADIO

# Burgess "A" Battery Introduces a New Silent Partner

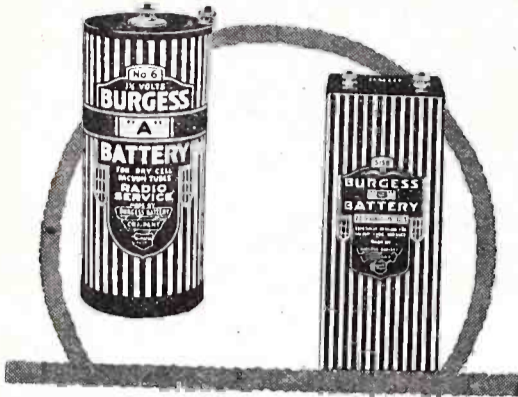

Notice that—

He's exactly my size—same height—same width—same weight. We look like twins. (He's good looking, too.) Look us over.

Burgess is a big family. I have a lot of brothers. Perhaps the most famous of them is BIG BROTHER "B." He had the field to himself until Burgess introduced Vertical "B."

Now comes my new partner. He is VERTICAL "B" JUNIOR. He has the same 22½ volts of pep as the rest of the Burgess "B" family. He is quiet—never talks to himself and he never lays down on the job.

Burgess calls us "Work-mates." He ought to know. We are silent partners in your radio entertainment.

Your radio set is no better than your batteries. Without them would be like having a marriage license and no bride. One is no good without the other.

Try it tonight. I'll heat your tube filament while my twin partner takes care of the plate circuit.

A Laboratory Product

# BURGESS BATTERIES

"ASK ANY RADIO ENGINEER"

## BURGESS BATTERY COMPANY

ENGINEERS - DRY BATTERIES - MANUFACTURERS  
FLASHLIGHT - RADIO - IGNITION - TELEPHONE  
GENERAL SALES OFFICE: HARRIS TRUST BLDG., CHICAGO  
LABORATORIES AND WORKS: MADISON, WISCONSIN

BRANCHES

NEW YORK BOSTON KANSAS CITY MINNEAPOLIS  
WASHINGTON PITTSBURGH ST. LOUIS NEW ORLEANS

IN CANADA

PLANTS: NIAGARA FALLS AND WINNIPEG  
BRANCHES: TORONTO MONTREAL ST. JOHN

Regardless of what  
you now have

# THE SONOCHORDE

Is the Radio Loud Speaker  
you will eventually buy

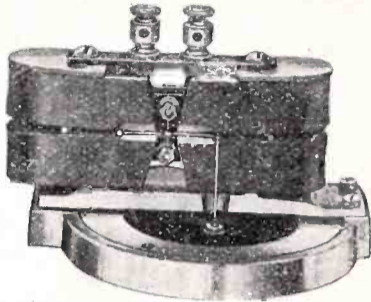

### Scientifically Developed Sound Producing Mechanism

The 17 features listed below permanently establish this Speaker as the standard of comparison.

- Balanced magnets.
- Balanced magnetic field of forces.
- Continuous attractive and repulsive field.
- Each impulse is result of attraction and repulsion.
- Multiple magnets.
- Multiple, independent, magnets.
- Multiple, permanent, magnets.
- Magnetic force lifts 8 pounds.
- Angular spacing of magnets.
- Minimum air-gap.
- Ratio of vibration arc to air-gap is 12 to 1.
- Parallel vibration of armature.
- Eight points of flux concentration.
- Sixteen paths of magnetic flux.
- More armature surface exposed to flux.
- Natural period of vibration of diaphragm destroyed.
- Non-resonant, non-vibrating, non-sound absorbing horn.



Type B  
Height 16  
in. \$27.50

Type C  
Mahogany  
or Walnut  
Cabinet  
\$50.00

Type D—Height 20 in.  
\$35.00

Manufactured by the  
**BOUDETTE MANUFACTURING CO.**  
Revere, Mass.

We invite correspondence with parties  
qualified to handle distribution of our products.

## RADIO IN EUROPE

Continued from page 12

countries having cheaper and more fluctuating money. It looks busy and prosperous. While the Germans complain bitterly against the practices of the Czechs, who have had the base ingratitude to imitate more or less closely in their dealings with the German minority the things the Germans did to them when the Kaiser ruled; and while the Slovaks have gained no love for the Czechs as a result of being included in the same republic, everybody works as hard as he grumbles and that means prosperity in the long run.

The broadcasting station at Prague is heard by the few who have receivers, but there is room for enormous development. President Masaryk is a broad-minded statesman of the finest type, thoroughly familiar with American ways through long residence in our country. He knows the value of radio. Intellectuals such as Professor Karl Absolon, the world's champion cave explorer, who mapped the elusive Punkvy near Blansko and discovered over a hundred still larger underground rivers in the Balkans, are awake to radio and ready to boost. At Brno, ancient capital of Moravia, there is an Anglo-American Club that furnishes guides, information and assistance to American visitors and correspondents. In the same city the government maintains a foreign office, in charge of Ingenieur Joseph Theimer, for the spread of information and the rendering of service to all visitors who may need it. Ingenieur Theimer is a chemist and, while not a radio man, might easily be developed into an enthusiast for the ethereal sport. He can push a passport visé through a consulate in fifteen minutes, and anyone who can do that can do anything.

ANYONE who is not primarily interested in getting dollars, and can look at radio from the standpoint of service to humanity, will be able to see in the European situation an incomparable opportunity. In fact, there is a world opportunity, as I was convinced after talking with delegates at the World Conference of Y. M. C. A. Workers among boys, where all the continents and fifty-three countries were represented. Europe is, literally, shot to pieces. It looks better than it did just after the armistice, but there are so many undernourished folks, sick folks, folks who will never have a decent chance of life, that only an optimist can get much cheer from present evidences of improvement. Furthermore, Europe is getting ready for another war as rapidly as her wounds and her feebleness will permit. England does not want it, France does not want it, Germany does not want it, Austria does not want it—

Continued on page 80

# AMPERITE

AUTOMATIC FILAMENT CURRENT ADJUSTER  
FOR EVERY STANDARD TUBE  
ELIMINATES RHEOSTATS

FROM YOUR DEALER OR  
RADIALL COMPANY  
654 GRAND AVE., NEW HAVEN, CONN. \$1.10 WITH MOUNTING

EXPELS ALL TUBE TROUBLES

# RATHBUN

SINGLE-HOLE MOUNTING  
SUPERIOR CONDENSERS

Die-cast. Light, compact, highly efficient. Proven by 2 years' service. Plain and vernier combination types. Dealers, Jobbers, write!

Rathbun Mfg. Co.  
Jamestown, N. Y.

# RADIO HORN

Made of 4-ply black cardboard, knocked down, ready to glue together. 50c, prepaid.

50c

FOX MFG. COMPANY, DEPT. B  
247 So. Broadway, Los Angeles Cal.

Tell them that you saw it in RADIO

•• FOUR WAY CO. ••  
Springfield, Mass.

**New model!**

**"4-WAY"  
Switch Plug**



**\$1.50**  
at  
your  
dealer's

SWITCH ON  
LOUD SPEAKER  
OR HEAD  
PHONES BY  
TURNING DIAL  
WITHOUT RE-  
MOVING PLUG  
FROM JACK.  
TWO HEAD SETS  
MAY BE USED IF  
PREFERRED OR  
BOTH LOUD SPEAKER  
AND HEAD SET AT  
THE SAME TIME.

**The new 1-9-2-4  
model "4-WAY"  
SWITCH PLUG**

embodies many improve-  
ments, making the manip-  
ulation much easier. The  
improved Spring Locking  
Terminal Connections are  
far superior to binding  
screws. They form per-  
manent electrical contacts  
which never work loose, as  
binding posts are apt to do.

**The new  
SINGLE  
Radio Plug**

Positively the  
finest yet  
produced

—employing our  
positive spring ter-  
minal connections  
that have proved so  
successful in our  
FOUR-WAY PLUG  
—never works loose.



**50c.**

See these beautiful new plugs  
AT YOUR DEALER'S

**Four Way Co.**  
Myrick Bldg., Springfield, Mass.

**It's the contact  
that counts**

Weak reception due to inferior contacts is banished when Na-ald sockets are placed in a set. Na-ald contacts exert a strong, wiping pressure on tube prongs over a broad surface, regardless of frequent removal of bulbs or variation in the length of prongs.

You can count on Na-ald Sockets under all conditions. They are moulded of genuine Bakelite, with uniform cross-section and cure. These features prevent plate to grid losses and insure full efficiency from tubes.

Insist on Na-ald Sockets, and put an end to weak reception. All good dealers carry them.

**Na-ald Inside Facts, No. 499.**

Making a socket for U. V. 199 and C 299 tubes would seem comparatively simple. When we came to design the No. 499 socket, we did not find the task so easy. Compactness and neatness were requisites; and to be true to Na-ald standards this socket required a dependable contact. Owing to the shortness of the tube prongs, the dual-wipe contact of our De Luxe socket was impossible. In the No. 499 we avoided capacity effect and secured positive contact over the full surface of the end of the tube prongs. This again justified the phrase "It's the contact that counts."

In constructing this socket we have provided a real resilient base that actually absorbs all vibration. The socket floats in air, and all rubber with its corroding effect is kept away from the contact clips and screws. Again this forethought in design adds efficiency in service.

Send for "Why a Bakelite Socket" for further facts.

**Alden Manufacturing Company**

Largest makers of radio sockets and dials  
in the world

Dept. H 52 Willow Street  
SPRINGFIELD, MASS.  
Cable Address, Aldenco



NA-ALD W. D. 11  
No. 411, Price 75c



No. 3023-4, 2-Inch Dial  
Price 35c, 3 for \$1.00



No. 3783-4  
1/2-in. Insert 1/4-in. Insert  
3 3/4-in. Dial Price 75c  
3-in. Dials, 35c, 3 for \$1.00



NA-ALD Special Socket  
No. 499  
Price 50c for U.V. 199 tubes



Small Space Socket, No. 401  
35c, 3 for \$1.00



De Luxe No. 400. Price 75c



Adapter No. 429 for U. V.  
199 Tubes. Price 75c

**An Easy Way  
to tune out Interference**

The FERBEND "Wave Trap"  
Makes Every Night Silent Night

Get the station you want quickly. Listen in on the distant stations without annoying squawk-k-k-s or irritating whistles. Listen like this St. Louis user: "Heard Havana clearly with three St. Louis stations broadcasting. My receiver works like a new set. The 'Ferbend' is certainly a wonder."

**YOU Can Obtain These Remarkable Results**

You can obtain results as satisfactory as this St. Louis user. If you don't, it doesn't cost you a penny, for the "Wave Trap" is sold with a positive guarantee that it will tune out your powerful local stations. Don't wait. Order now at our risk.

SEND NO MONEY. You need not send a penny. Pay Postman \$6.00 (plus postage). If you prefer, send \$6.00 with order and Wave Trap is mailed postpaid. Money-back guarantee either way. You see, you take no risk, so order TODAY.

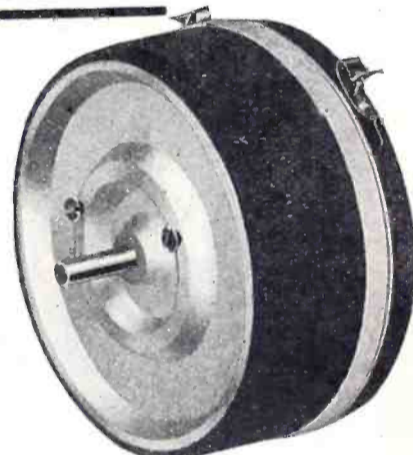
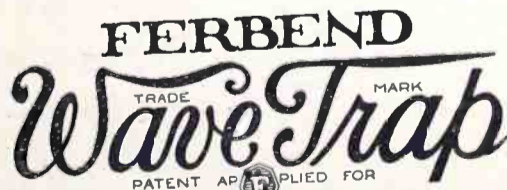

Ferbend Wave Trap ready for mounting, \$6.00.

Wave Trap mounted on formica panel in mahogany finished cabinet 6x5x6 at \$8.50 complete. Circular on request.

FERBEND ELECTRIC Co., 17 E. S. Water St., Chicago.

Send me a Ferbend Wave Trap. I will pay Postman \$6.00, plus postage. I understand you guarantee Wave Trap to tune out our local stations or refund money.

Name .....  
Address .....

—Only a few left  
\$1.00 per copy  
"RADIO"  
Pacific Bldg.,  
San Francisco

**C. W. MANUAL**

Tell them that you saw it in RADIO

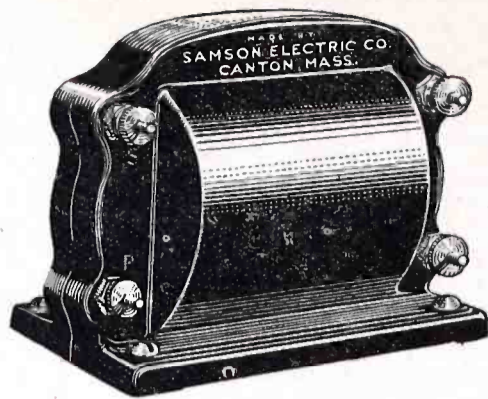

## Tests Prove It Best!

Below we print extracts from reports of tests made by experts under the most exacting conditions. These tests establish the indisputable superiority of the SAMSON HW-A1 Audio Frequency Transformer and place it first in efficiency from every desirable angle.

**Results: Less Distributed Capacity; 40% More Amplification; No Distortion**

### Samson HW-A1 AUDIO FREQUENCY Transformer

EXPERTS marveled when they tested the SAMSON HW-A1 Audio Frequency Transformer. Never had they used an audio frequency transformer which gave them such remarkable results! One stage of amplification with a SAMSON proved far more satisfactory, in most cases, than two stages of some and better than three stages of other transformers. No howling.

You need the results which a SAMSON gets you. Insist on a SAMSON from your supply dealer; if he hasn't it we'll ship one, prepaid, on receipt of \$7.00. Ratio 6 to 1.

#### Helical Winding Does It

Here is the secret of SAMSON'S success. Note that the wire is laid in layers without paper insulation. This reduces distributed capacity to an absolute minimum, increases amplification, eliminates distortion. Helical Winding is exclusive with the SAMSON.



Made by

**SAMSON ELECTRIC COMPANY**

Factory: Canton, Mass.

Sales Offices: Boston, New York, Philadelphia, Pittsburgh, Chicago, Cleveland, Detroit, Indianapolis, St. Louis, Atlanta, Minneapolis, San Francisco, Los Angeles, Seattle, Portland, Montreal and Toronto.

1

"Amplification is very well maintained toward the lower end of the frequency band, in this particular improving on the performance of any other audio transformer. . . . Was agreeably surprised to find a transformer which would give such a characteristic and yet give the comparatively high amplification shown by the SAMSON."

(Name on request)

2

"Are pleased to inform you that a certificate of merit will be issued shortly. . . . As far as distortion is concerned, this instrument is much better than the average."

(Name on request)

3

"Our technical adviser states that the SAMSON HW-A1 Audio Frequency Transformer stood the highest test of any transformer ever tested in his laboratory."

(Name on request)

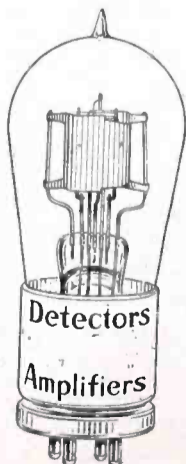

#### GUARANTEED TUBE REPAIRS

W.D.11	\$3.50
W.D.12	3.50
U.V.200	2.75
U.V.201	3.00
C.300	2.75
C.301	3.00
U.V.201A	3.50
C.301A	3.50
D.V.6A	3.50

All tubes positively guaranteed to be satisfactory.

Special discounts to dealers.

Tubes returned P.P., O.O.D.

**HARVARD RADIO LABORATORIES**  
200-204 Old Colony Ave.  
So. Boston, Mass.

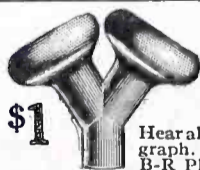

#### Loud Speaker \$1

**\$1** **Radio Adapter**  
Hear all broadcasting through phonograph. Make your own horn. Attach B-R Phonadapter to YOUR phonograph. All can hear. Entire family, neighbors, guests can hear operas, lectures, latest news, with this adapter. Stretches over receiver of any standard type head-set and attaches to tone-arm of ANY phonograph. Made of soft, pure gum rubber. Quickly attached and removed. Thousands in use. Will not amplify or distort. For single receiver **.50**  
For pair of receivers (more than twice the volume) **\$1**

Go to your dealer. If he cannot supply you send money order, check or currency at our risk. Prompt delivery—postpaid. Also send us name of favorite radio dealer.

**The Beckley Ralston Company**  
1815 So. Michigan Ave., Chicago, Ill.

Continued from page 78

nobody wants it; but the German-speaking peoples say they are too numerous and too strong to submit to the domination of France on the one hand and the Czechs on the other. The Austrians point to the fact that all they have left as a nation is a manufacturing center cut off from raw materials and food for workers. Ask an Austrian business man if American money is helping in the reconstruction and he asks you what is the use of cutting off a man's hands and legs and then giving him money to get onto his feet. So artificial are the boundaries created by the Versailles treaty that it is reported that a man who grew strawberries in his garden and carried them into his kitchen was arrested for taking them across the frontier without paying duty!

The only thing that prevents the next war from starting right now is that these under dogs have to wait for new teeth and claws to grow. In the meantime, friction increases and neutral travelers are annoyed. The French stopped a German train four times for an hour each time within twenty-five miles of Cologne for purposes known only to themselves. An English officer held up a train from Cologne to Brussels two hours in the middle of the night while women stood in crowded corridors, just because he objected to having the Belgian customs officials enter his private car, which their orders compelled them to do. These seem like petty assertions of authority that serve no useful purpose and irritate the whole world, and especially the efficient, chafing Germans, against nations whose main principles may be correct but who are sometimes unfortunate in their selection of representatives.

The Germans acknowledge that they have made some mistakes during the past few years. They are not insensible to the fact that but for those mistakes they might have won the war. They are confident that with another fair chance they would win. And, while others bungle the railroads and mess up things in general and get on the nerves of visitors to occupied territory, the German works hard, shows results, entertains his late American enemies and wins their admiration in spite of any suspicion they may have that it is all done for effect.

So far as the adults are concerned, the race hatreds will continue and bear the usual bitter fruit. But that World Conference on work with boys revealed the astonishing fact that boys seem to be immune to it. If given a chance, they mingle amicably under the auspices of leaders who are interested in overcoming hatred instead of teaching it. In the Czechoslovakian Republic an organization segregated national groups with-

Continued on page 82

Tell them that you saw it in RADIO



## The H. K. Switch

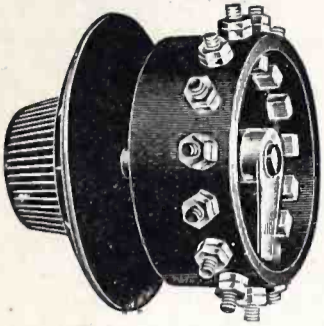

Pat. Pending

The H. K. Multipoint Switch does away with the difficulty of drilling holes in a panel for switch points, only takes a few minutes to mount. Assures good contact. Is neat in appearance. Contacts are arranged so wires can be attached with ease. 2½ in. Dial, calibrated to show contact in use.

**PRICE COMPLETE WITH DIAL \$2**

*Awarded Certificate of Merit 38 by Radio News Laboratories.*

Do not receive postage stamps. Be sure to send enough Extra money to cover postage.

Special prices to Dealers and Jobbers.

**KNOOP & PENCE CO.**  
PEOTONE, ILL.

## RADIO VETERANS DEMAND

**\$7.65**  
"Professional"



The finest instrument of its kind that money and science can produce. Moulded Bakelite cases and ear caps; single bar Tungsten steel magnets; light weight; exceptional tone and volume. A \$12.00 quality for \$7.65.

**\$10.00**  
**Acousticola**  
Phonograph Attachment

**TRIMM**  
Head Sets

Positively the only head sets on the market sold with a lifetime guarantee that covers every detail of materials and workmanship excepting only cords and shells which cannot be guaranteed against breakage if dropped. Absolutely no charge AT ANY TIME for repairs, replacements or for re-magnetizing.

The head sets to buy; the head sets to sell.

**SEE! HEAR!**  
**These Trimm**  
**Loud Talkers**

**\$22.50**  
**Composition Horn**  
**Acousticola**

"Dependable" **\$5.00**

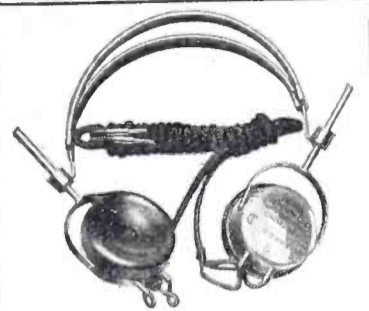

Standard bi-polar construction. Aluminum case. Splendid finish; beautiful appearance. Wonderful volume and clarity of tone. Compare the Trimm "DEPENDABLE" with any \$6.50 to \$8.00 head set on the market. Money back if not satisfied with any TRIMM product.

**\$35.00**  
**Acousticola Grand**  
with Cast Aluminum Horn

All fitted with Special TRIMM jumbo size loud Talker Unit. Write for folder. Or order samples with privilege of return after 5 days' examination and test.

**TRIMM RADIO MFG. CO., Dept. 58.**

**24-30 S. Clinton St., Chicago, Ill.**

## RHAMSTINE\*

Presents the New Victophone  
--for all Phonographs and Loud-Speaking Horns



**\$7.50 Postpaid**  
Complete with Cord

Relentless research in the field of loud-speaker units has resulted in Rhamstine\* achieving the ultimate in tone and volume. The New Victophone will exceed your expectations; you will appreciate its superiority upon comparison with other loud-speakers. Every part of this new Phonograph unit was designed and built to excel in efficiency and in beauty all other makes. It can be furnished to fit all phonographs—the Standard Type fits the Victrola, Columbia, Jewett or Sonora. Specify make of phonograph when ordering. List Price, Standard Type, \$7.50.

Order the New Victophone and test it before buying any other loud-speaker.

Manufactured by

**J. THOS. RHAMSTINE\***

500 E. Woodbridge, Detroit, Michigan  
\*Maker of Radio and Electrical Products

## RADIO WALL MAP 10c

Up to date, just off the press. Shows call letters, location, wave length, and kilocycles of all radio broadcasting stations also American Relay divisions and radio districts. Complete with scale for measuring distances. Size 28 x 34 inches printed in three colors. Postpaid for a dime.

**OZARKA, INC.**

862 Washington Blvd., Chicago

## Introducing the "SR 25"

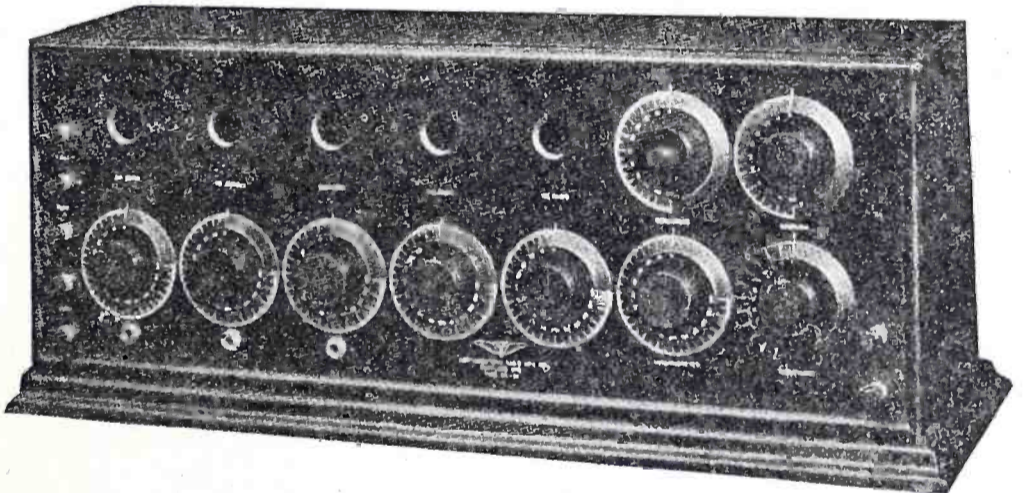

WE INVITE YOUR ENQUIRIES

**Hallock and Watson Radio Service**

192 Park Street

"KGG"

Portland, Ore.

## "B" BATTERIES

AN

**EVEREADY**

PRODUCT

43V. Batteries, tapped..... \$5.00  
22½V. Batteries, Navy Type..... 3.00  
22½V. Batteries, Commercial Type... 2.00

Latter two types especially adapted to Cunningham and Radiotron Tubes.  
Postage Prepaid Anywhere in U. S.

**ETS-HOKIN & GALVIN**  
Wireless Engineers

10 Mission Street

San Francisco

## "EURACO PRODUCTS"

(Guaranteed)

Compact — Interchangeable — Accurate  
Most Efficient



Price 60 cents per Unit  
Mfgs. of

**MICA CONDENSERS, GRID LEAKS, MOUNTINGS**

Interesting Proposition for Dealers

**European Radio Company**

1342 East 22nd Street

Brooklyn, N. Y.

Tell them that you saw it in RADIO

## A Pleasant Surprise Awaits the User of the A C H Sharp Tuner Dials

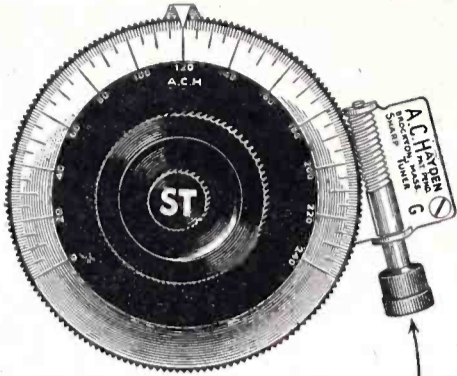

Rough tuning or 1,000th of an inch in either direction.

Can be installed and will improve any receiving set, making difficult tuning easy.

Why the A.C.H. is different

- 3 in. DIAL → A.C.H. → 156-T0-1
- 4 in. DIAL → A.C.H. → 215-T0-1

Price 3-inch size .....\$2.50  
 Price 4-inch size .....\$5.00  
 Regular fitting 5/16 shaft 1/4 and 3/16.....5c each extra

### Money Back Guarantee

The principle of the A C H Sharp Tuner has only been embodied on very expensive instruments where the most delicate adjustment is necessary, and then as a permanent part.

### Extra Advantage of the A C H

1. Can be attached or removed from any instrument.
2. Rough tuning same as any dial.
3. Movement so fine that the eye cannot detect but the ear can.
4. Automatically locks instrument so no jar can disturb it.
5. Dial grounded reducing the body capacity to a minimum.
6. Special dial 2 graduations where ordinarily one.

Mail Orders Sent Prepaid in U.S.A.

**A. C. HAYDEN RADIO & RESEARCH CO.**

Brockton, Mass., U. S. A.

Sold by Radio, Ltd., Montreal, Can.

Continued from page 80

in its membership to prevent trouble and then found that the boys of different nationalities got together in spite of the system and had a good time. The system, needless to say, was immediately scrapped so that nature could take its course.

In India, after an uprising and massacre, boys from the contending groups were gathered into one camp but in separate units. It rained, and the group that was getting the worst of it, owing to leaky tents and poor equipment, suddenly received donations of carpets, rubber mats and other materials for shedding water, from boys who, if they had followed the precedents of their elders, would more likely have pulled the tents down over their heads. Little Japs from Tokyo, though as hungry as any other boys in their first week of camp, unanimously voted to go without a meal a day in order to send a contribution of food to chaps of the same age in a central European country against which Japan had joined her forces in the world war. At the conference it was a hard matter to distinguish a delegate from a country of the Allies from one representing central Europe, or either one from the delegate of a neutral country. Their contact with the spirit of youth had seemingly broken down even the prejudices acquired by adults.

Now, it is obvious that it is only necessary to give this feeling of the boys a chance to spread throughout the world in order to solve the hardest problems created by distrust, suspicion and enmity. It is equally obvious that the way to spread that feeling is to provide unlimited communication. The American Radio Relay League, by shooting its messages across the Atlantic, has stimulated the organization of a similar league in Great Britain, already well under way. It is hardly to be supposed that British amateurs are going to spend all their time signalling to Americans and to each other when there are a dozen other countries right at their doors that can be reached as soon as government restrictions are removed and radio stations installed. The spirit of youth permeates the whole radio world. The radio bug bites a man and he begins to do exactly as he did when he was a kid, sitting up till all hours of the night, spending his money recklessly for anything that will make his hobby go faster or kick harder; overriding anything and everything that stands in his way. This particular type of activity, the exchange of individual messages, will interest the technical type of boy and man and establish unofficial international relationships of a helpful sort.

The quicker, more effective method of helpfully interesting the masses of one country in those of another is, of

Continued on page 84

## The New



## Vernier Variable Condenser

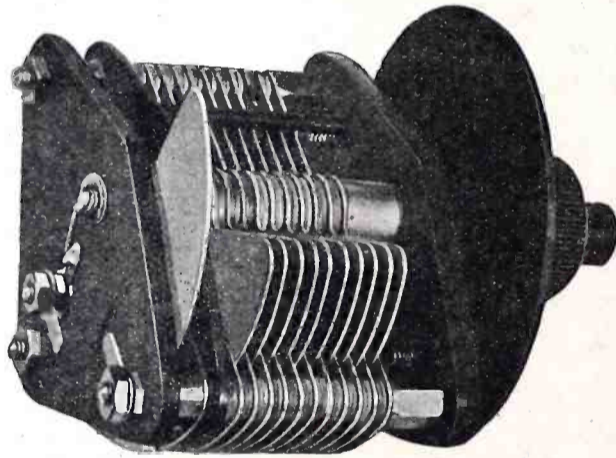

A Vernier Variable condenser with positive contact between vernier and rotor plates. Here is a condenser which ends your troubles. The closest tuning can be obtained with the Vernier the entire range being 2-1/100 of the larger dial. The contact be-

tween the Vernier and rotor plates is a special bushing insuring positive contact at all times. Vernier adjustments, close tuning, never before obtained can now be yours. Distant stations elusive and hard to get can be brought in clear and strong.

Ask your dealer to show you the New Signal Vernier Variable Condenser. Catalog on request.

**SIGNAL Electric**  
Mfg. Co.

Factory and General Offices  
1913 Broadway,  
Menominee, Michigan

Boston, Chicago, Cleveland, Minneapolis, Montreal, New York, Pittsburgh, St. Louis, San Francisco, Toronto, Philadelphia, Los Angeles.

You'll find our local address in your Telephone Directory

Tell them that you saw it in RADIO



**HEAR  
HERE**

100%  
with the  
**PREMIER**

**"Microstat"**

Trade Mark

**Super Vernier  
RHEOSTAT**

**\$3.00**

AND WORTH IT

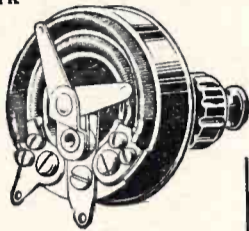

THERE is no substitute for the Premier "Microstat"—no other instrument that gives such perfect control of the current delivered to the filament of radio tubes. New principle—two windings in parallel—one 6 ohm—other 40 ohm. Absolutely noiseless—infinite control—handles any tube. Cap. 3 Amp. Bakelite moulded—silver etched dial. Do not install a Rheostat until you know all about the "Microstat." Our bulletin No. 93 explains it in detail. Send for it. It's FREE.

**Premier Electric Company**  
3813 Ravenswood Ave. CHICAGO

Ask Your Dealer For  
"MICROSTAT"



**The Improved  
MIRACO** Gets 'Em From Coast  
to Coast

Clearly and distinctly, too! For our users tell us that Cincinnati hears Frisco, Denver hears Schenectady, New York hears Havana; Scores of long distance records were made on these instruments last year, so with the many new refinements incorporated the result obtained now will be far better than ever.

HIGHEST QUALITY AT LOWEST PRICE

This has always been the MIRACO key-note and the thousands of sets now in use are a fitting tribute to MIRACO'S excellent performance. Many new improvements, such as new sockets resting on shock absorbing pads—a refinement found only in the most expensive sets—rheostats with multiple resistance windings, making it possible to use either dry cell or storage battery tubes, and a new aluminum shield that prevents annoying body capacity effects, are embodied.

Cabinet is of solid mahogany—workmanship the finest—operation extremely simple yet always dependable.  
2 tube outfit shown above..... \$29.50  
4 tube outfit shown below..... \$54.50

Write for our new bulletin today  
DEALERS—JOBBER: Write for our proposition quickly.  
AGENTS: There's still some territory open—write or wire.



**THE MIDWEST RADIO CO.**  
814 Main Street—Cincinnati, Ohio

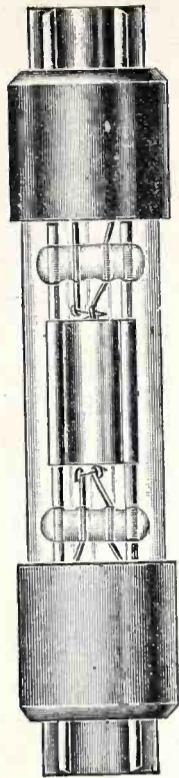

**The Tube's the Thing!**

GET RADIO RECEPTION WITHOUT NOISE

**MYERS RADIO VACUUM TUBES**  
GUARANTEE PERFECT CLARITY

Hear without noise or tube hiss with Myers Tubes. They give much greater amplification, are perfect Detectors and Oscillators. They add 50% to the efficiency of your set because they reduce interference.

**TWO TYPES:** Myers Dry Battery Tube 2½ Volts—¼ Ampere Myers Universal operates on either 3 Dry Cells or storage batteries. \$5.00 each. Ready for mounting. No sockets or extra equipment needed.

See that you get the New Improved Myers Tubes. You will know them by the Silver Coating. Others are not guaranteed.

At Your Dealer, otherwise send purchase price and you will be supplied Postpaid.

Sole Manufacturers:

**F. B. Myers Co. Ltd.**  
*Radio Vacuum Tubes*

240 Craig St., West Montreal, Canada

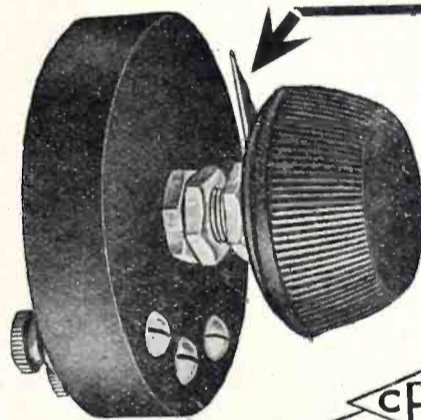

Note—Single hole mounting feature.

**QUIET—EASILY ADJUSTED for  
MAXIMUM SIGNAL STRENGTH**

Mr. G. D. M. Jones of the Western Radio Company installed a C R L (400 ohm) Non-Inductive Potentiometer on his radio set and wrote us this unsolicited letter:

"With my old potentiometer I was unable to operate below 300 meters on the same loop which I used to get the 500-meter stations because in operating on the shorter wave lengths, the set would oscillate because of the inductance of the wire potentiometer.

"With the C R L there is no noise and no difficulty when adjusted for maximum signal strength, and last night I brought in a station operating on 234 meters which was absolutely impossible before. I am able to tune in KDKA without interference from either of two local stations, WOQ (500 watts) and WHB (750 watts). There is no question about the C R L Non-Inductive Potentiometer being the best on the market."

**WHY**

The movable shoe on a C R L makes contact with an impregnated resistance strip through a circular disc, not by actual contact. No inductance—no choking of high frequency currents—no wires or other parts to loosen. All parts are enclosed.

You'll get the most out of your set with a C R L Potentiometer—why work at a disadvantage?

If your dealer cannot supply you promptly we will mail one direct.  
No. 110 (400 ohm).....\$1.75  
No. 111 (2000 ohm).....\$2.00

Descriptive pamphlet sent on request.

Gentlemen:  
I would like to know more about the C R L Non-Inductive Potentiometer, C R L Grid Leak, and your offer to Radio Dealers.

Name.....

Address.....

City & State.....

**CENTRAL RADIO LABORATORIES**  
309 16th Street Milwaukee, Wisconsin

**SIMPLIFIED REINARTZ**

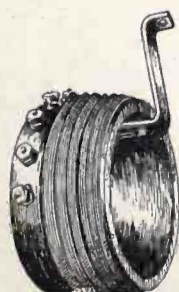

Improved circuit using pile-banked inductance eliminates four controls. No switches, taps or soldering. EASIEST and CHEAPEST to build. Greater distance and volume by eliminating switch tap losses. Pile-banked windings give extra sharp tuning and low distributed capacity. One control tunes 200 to 600 meters. Complete instructions, hook-up, panel layout, etc., 25c; stamps accepted. TYPE "R" INDUCTANCE, Vesco Banked, with all circuit instructions, \$2.50 postpaid.

**VESCO RADIO SHOP**

Box R-117

OAKLAND, CALIF.

Tell them that you saw it in RADIO

*Continued from page 82*

# Q All You Want to Know about RADIO

Here is a Radio information mine. It can't grow old nor out-of-date. It grows with new Radio discoveries. It is in loose leaf form and every purchaser is a registered owner. Every month, by mail, you get in printed, finely illustrated, punched pages every new fact concerning Radio without extra charge. You buy the book ONCE.

## LEFAX Perpetual Radio Handbook

was written by Dr. J. H. Dellinger and L. E. Whittemore, Chiefs of the Radio Laboratory, U. S. Bureau of Standards, Washington, D. C. You simply insert the pages instantly and easily in the handy pocket size, flexibly bound Lefax Handbook.

It is finely, accurately illustrated. It has linen index tabs. It is clearly, cleanly printed. It gives a full list of broadcasting stations with full information about them—and new ones as they are established. Lefax is a reference and instruction book that takes all the mystery out of Radio.

Ordinary Radio guides become obsolete rapidly. Radio is developing every day. Only Lefax develops with it. The best way to keep up is to own Lefax and get the added facts every month by mail. See it, examine it, buy it from your Radio supply house, your stationer or bookseller.

## Lefax, Incorporated Publishers

9th St. above Walnut, Philadelphia.

course, broadcasting. If a man of one country can get hold of an efficient receiver, he will listen-in on the programs of another country and no one can stop him unless his apparatus is taken away from him. If as much energy and money as had been wasted in our own country by folks who want to hear stations only because they are a long way off should ever be used in Europe by folks who really want to understand what neighboring countries are doing, mutual understanding will come quickly.

Is it too much to hope that American radio will interest itself in furthering popular international communication even before it can see how it is going to sew up the business and get its profits? The numerous examples of heavy contributors to world-wide philanthropy dispel any doubt that radio could be promoted for welfare purposes. Missionaries have often preceded merchants into new fields.

World-wide broadcasting is possible through the use of such means as the pallophotophone and transmitting stations of ordinary power. There is no insurmountable obstacle to prevent the voice of America from being heard in China or the voice of Australia in America. The delegate from Iceland knew about radio and was looking forward with high hopes to the time when it could be used to instruct and entertain the boys on his frigid island. South America, South Africa, Hawaii, and many widely separated regions reported radio beginnings or at least radio hopes. The conference exhibit contained photographs of boys building and operating radio apparatus in the most widely separated places. A philanthropist with the necessary means, utilizing the genius of radio men, and working through world-wide organizations such as the Y. M. C. A. and the Boy Scout Movement, could accomplish astonishing results even within a year. Within a generation he could evangelize the world or accomplish any other purpose that depends upon a universal form of communication, adaptable to all conditions, and having a romantic appeal in itself. The radio man or organization that could visualize the opportunity could find and interest the man, and the result might surpass in its magnitude and significance even the achievements of Julius Caesar, Martin Luther, Napoleon and Henry Ford.

## Loud Tone Crystals at Half the Regular Price

# 20c

BUY DIRECT FROM THE MANUFACTURER AND SAVE THE MIDDLE-MAN'S PROFIT

# Save 50%

These great crystals sell for 40 cents each but we save you half by purchasing from manufacturer. Every crystal is guaranteed. If it is not better than any crystal you ever used, your money refunded without question.

C. E. Madsen, 1938 Cabrillo St., San Francisco, Cal.

Tell them that you saw it in RADIO

# Is the C. I. C. Loud Speaker "Different"?

*Yes*, if pipe organ metal for the horn, a mica diaphragm, and years of knowledge of acoustics and telephone engineering can make it so. The only way to prove it to yourself, however, is to "Listen to the Difference" and see how the C. I. C. Loud Speaker excels others on the market at twice the price. Your dealer will be glad to give you a demonstration. Send for leaflet "Loud Speaker Facts."

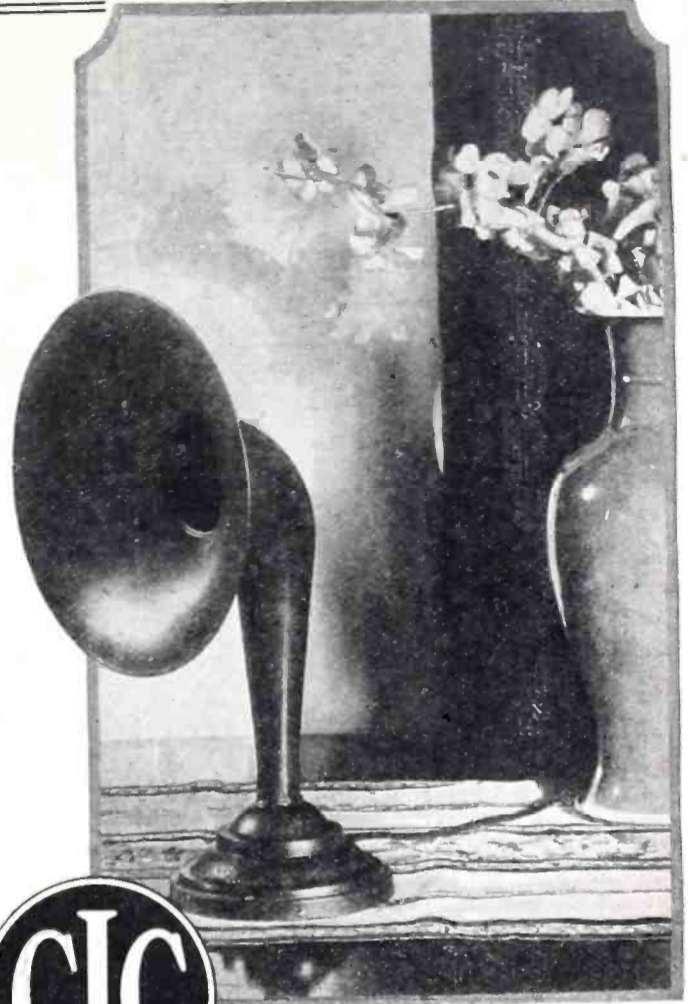

**Connecticut Instrument Co.**  
Stamford, Connecticut

**REPRESENTATIVES**

**Globe Commercial Co.**  
San Francisco, Los Angeles &  
Salt Lake City

**L. D. Read**  
919 Lake View Boulevard  
Seattle



**\$14.50 LOUD SPEAKER**

## No delays in our Mail Order Department We Ship Within 4 Hours

*The following stock of brand New and Latest equipment is offered for XMAS*

- FADA Neutrodyne ..... **\$120.00**
- FADA Neutrodyne Parts ..... **\$25.00**
- FADA Neutrodyne Books ..... **50¢**

**MAGNAVOX EQUIPMENT**

- M1 (gold or black finish) ..... **\$35.00**
- R3 (black finish) ..... **\$35.00**
- 1, 2 and 3-Stage Amplifiers.

**GREBE SETS**

- CR9 ..... **\$130.00** | CR8 ..... **\$80.00**
- CR12 ..... **\$175.00** | CR13 ..... **\$95.00**

**DUTHO "B" BATTERIES**

- 25 volt, **\$5.00** 50 volt, **\$9.00** 100 volt, **\$17.00**
- New Nov. Edition Citizens Radio Call Book ..... **50¢**

**BURGESS BATTERIES**

- 45 volt No. 2306 ..... **\$5.50**
- 22½ volt No. 4156 ..... **\$1.75**
- 22½ Small (Tapped), No. 5155 ..... **\$2.75**
- 22½ Large (Tapped), No. 2156 ..... **\$3.00**

**NEW TYPE HOMECHARGERS**  
Just Out ..... **\$18.50**

- TUNGAR Rectifiers—**
- 2 Amp. .... **\$18.50**
  - 5 Amp. .... **\$28.00**

- "BUG" Keys ..... **\$17.50**
- ESCO 500-volt Generator ..... **\$70.00**
- 1000 volt ..... **\$135.00**

**THREE STORES**

# WARNER BROS.

**THREE STORES**

**350 Market Street**

**San Francisco**

**428 Market Street**

**Oakland—Twenty-second and Telegraph Avenue**

Tell them that you saw it in RADIO

# TINY-TURN

## A New and Superior Vernier Control

TINY TURN makes possible an exactness in tuning never before attained. It has a 30 to 1 gear ratio instead of only 4 or 5 to 1 as in the ordinary vernier. No lost motion! The vernier turns in the same direction as dial. It can be instantly disengaged, leaving dial free. **INSTALLED ON ANY SET IN 3 MINUTES.** Handsome nickel and black finish. Packed in individual containers. We furnish counter display demonstrating boards.

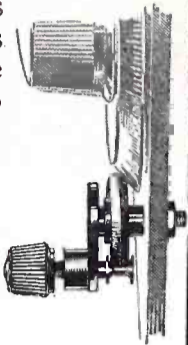

*Pats. Pend.*  
Side View showing friction drive against dial.

Price 75c.

# DUO-SPIRAL

## The Leading Loop Aerial

With New Dial and Handle

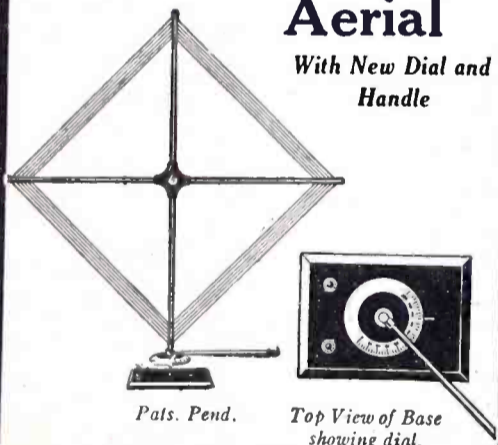

*Pats. Pend.*

Top View of Base showing dial.

The DUO-SPIRAL Loop spans the continent on a loud speaker with many types of radio-frequency sets. Careful tests by leading manufacturers and radio engineers have proved its superiority. Used exclusively by the largest manufacturers of radio frequency sets. It is trim and neat in appearance and handsomely finished. It rotates freely on its base. Adjustment is made easy by handsome dial and a long handle which eliminates all body capacity effects. The green double silk covered wire is kept always taut by hidden springs. The DUO-SPIRAL loop completely replaces roof antenna and ground and practically eliminates static.

24-inch size \$8.50 12-inch size \$7.50  
(These prices include new dial and handle)

The above products (folders on request) are sold through dealers and jobbers. If your dealer cannot supply you, write us direct.

## RADIO UNITS INC

Suite 504 Webster Bldg., Chicago, Illinois

## STATIC

*Continued from page 34*

sistance," which is a resistance depending upon the characteristics of the antenna, i.e., upon its inductance, capacity and resistance per unit length. This type of antenna has been found to be the most directional obtained thus far, and hence is most effective in weeding out static from most directions. But since it still receives static from some directions it has not solved the problem of the elimination of static, though it has considerably improved the signal-to-static ratio obtainable.

It is thus seen that static yet remains

the greatest obstacle to greater expansion of radio communication, although, as this article shows, great advances have been made toward its effectual reduction. It is evident from the foregoing account of the development of static eliminators that the tendency has been toward directional reception and the elimination of static by exclusion rather than actual elimination. However, great work yet remains to be done in this field and the engineer who finally solves this problem and eliminates static will go down in history as one of the greatest benefactors of the world, as well as of the radio art.

# THE UNIVERNIER

## The Scientifically Correct Vernier Control

Micrometrical control of the whole variable condenser, the variometer, the tickler coil, etc., is the only logical and the most efficient vernier.

The entire range of your set is, therefore, under continuous vernier control, permitting reception of all signals, most of which ordinarily are passed by when intermittent or no vernier control is used.

Applied to Neutroformers of Neutrodyne sets, 100% more stations will be received with infinitely less trouble than ever before.

As easy to apply as an ordinary knob, and without altering the set.

Approved with enthusiasm by leading radio authorities and many thousands of users.

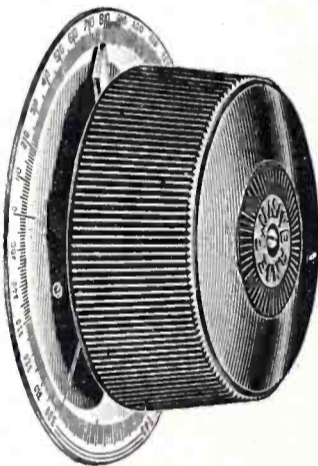

Ratio 12 to 1—Direct or 1 to 1 control at will.

No. 251 for 1/4-inch shafts.

No. 188 for 3/16-inch shafts.

Dial 3 1/4 inches in diameter.

The Univernier and finely graduated silver plated dial—\$1.25.  
At your dealer's or post paid upon receipt of the above amount.

*Jobbers and Dealers Write for Discounts.*

**Walbert Manufacturing Company**  
927 Wrightwood Ave. Chicago, Ill.

Tell them that you saw it in RADIO

# The Essence of Simplicity

K & C New "Series Automatic" Phone Plug is Winner

Costs No More Than Any Standard Plug

*But*

It enables you to add any number of headsets in the circuit instantaneously.

No multi-jacks or terminal blocks to fuss with. Just "Plug plugs" into each other.

Moulded bakelite.

K & C "Series Automatic" Plug ..... \$1.25 each

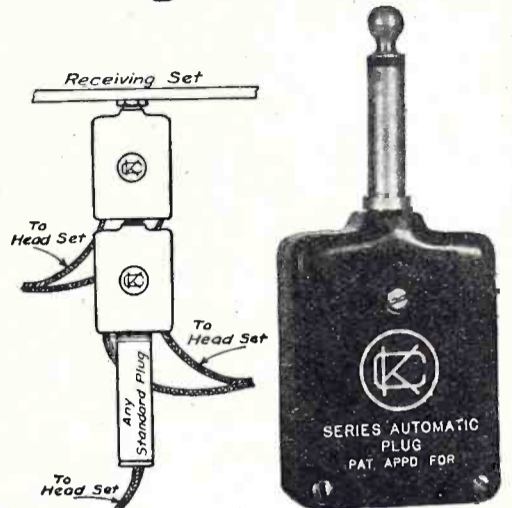

## Kilbourne & Clark Mfg. Co.

Head Office & Works, Seattle

BRANCH OFFICES

Portland, 305 Larrabee St. Phone East 6156.  
 San Francisco, 591 Mission St. Phone Sutter 40.  
 Los Angeles, 1103 W. 10th St. Phone 581-002.  
 New York City, 80 Washington St.

A HIGH-GRADE COMPLETE LINE OF RADIO PARTS FOR EXCLUSIVE USERS

For 10 years we have built radio apparatus for ships, shore stations, U. S. Navy, amateur and experimental use.

*"Plug in a Plug"*

Can be used with any other standard plug

SAVES YOUR TIME

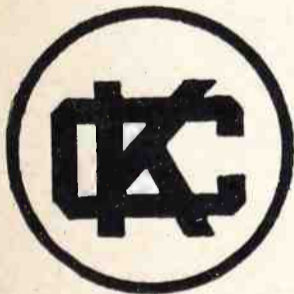

K C Your Guarantee

## FROST-RADIO

*Ask Your Neighbor*

Aluminum Shell **FROST-FONES**



FOR those who wish the economies made possible by the aluminum shell type of head-fone construction we offer a superior head-set with the added attraction of a low price both on 2000 ohm and 3000 ohm sizes.

Made with drawn aluminum shells, highly polished, composition caps, special head band and all of the sterling qualities which have made **FROST-FONES** famous among hundreds of thousands of discriminating users. Extremely sensitive.

**FROST-FONES** also made in genuine Maroon Bakelite and in Composition Shell and Cap Types.

**HERBERT H. FROST, Inc.**

154 WEST LAKE STREET, CHICAGO, ILLINOIS.  
 550 Gates Bldg., Kansas City, Mo.  
 30 Church St., New York

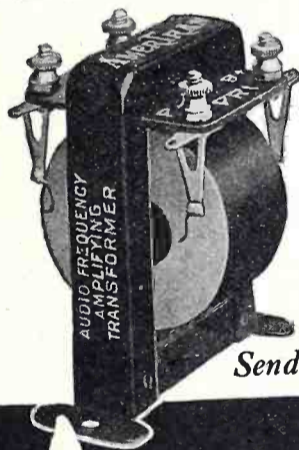

STANDARD OF EXCELLENCE for audio amplification

—With all tubes—  
 —In all stages—

Send for Circular 1005



Improve your set with an AmerTran

ITS flat-top, distortionless amplification curve assures a pure tone rendering of the full musical scale. It amplifies in one stage from 30 to 40 times in the flat part of the curve, depending on the tube constant—the amplification is approximately 5 times the tube constant.

In one type only. Turn ratio 5:1. Price \$7. Ask your Electrical Dealer; or, sent carriage charges collect.

**AMERICAN TRANSFORMER COMPANY**  
 Designers and builders of radio transformers for over 22 years

174 Emmet St., Newark, N. J. Cal. Office. Rialto Bldg. San Francisco



Tell them that you saw it in RADIO

## extreme selectivity—

A single tuning adjustment—assuring the greatest degree of program selectivity—enabling one to tune in desired stations and enjoy their broadcasting without the slightest sign of interference by other stations, is one of the features of



## Melco-Supreme

The Tuned Radio Frequency Amplifying Receiver that also

PRICE ONLY **\$140**

Complete knock-down parts for Melco-Supreme including drilled engraved Bakelite panel and solid mahogany cabinet  
PRICE \$90

1. Operates with merely a 10 FT. WIRE—not even a ground necessary.
2. Offers exceptional CLARITY without the slightest loss of tone quality.
3. Affords real LONG DISTANCE by covering all Broadcasting ranges from 180 to 610 meters.

We also manufacture a complete line of standard parts under the Amsco Brand. Write for our complete descriptive literature

## AMSCO PRODUCTS, Inc.

Broome and Lafayette Streets Dept. R New York City

Dr. Wm.D. Reynolds,  
Denver, Colo.

Hyattville, Wyo.  
May 30. 23.

Dear Dr:

As to results obtained with the little Electric Specialty Dynamotor, I am pleased to say I have been getting wonderful results with it, but instead of running off 6 volt battery, have been using an 8 Volt, which gives me a high voltage of 600 volts and, what everybody says, a Beautiful Tone, every card I get mentions that a fine note I have; I have talked Fone (using loop modulation) with 5SK at Fort Worth Texas, after daylight in the morning, Falconi at 5ZA Roswell New Mex. says my fone so QSA he can hear it 10 feet from Fones, and work him with CW way after sun rise, which is going some; I work most all the Boys in Denver and they're all crazy about my tone. I am more than pleased with the Dynamotor, and any time I can be of service to you regarding its action just let me know.

Yours truly,

*L. G. Vandlyke*

TRADE "ESCO" MARK

*Quality always Supreme*

ELECTRIC SPECIALTY COMPANY  
STAMFORD, CONN., U. S. A.

## A Resolution for the New Year

"Resolved—that I will not miss a single issue of 'RADIO' during 1924."

Make good your resolution by subscribing NOW!

Tell them that you saw it in RADIO

# \$3 75

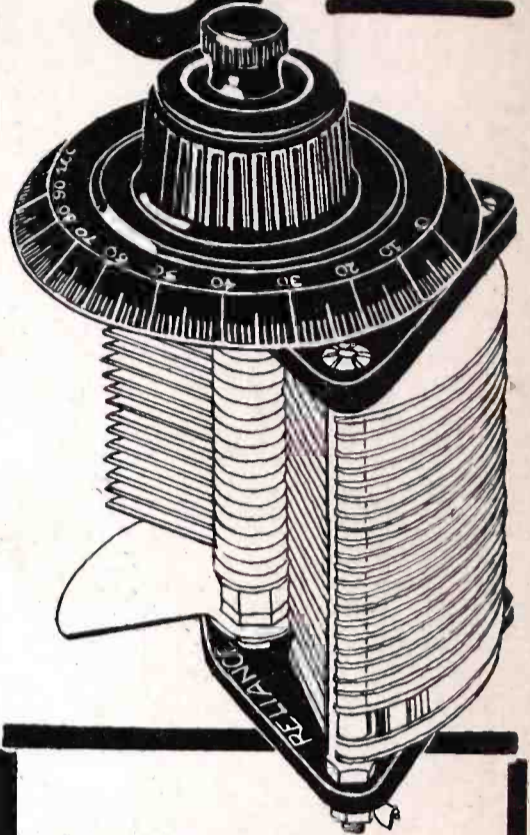

## Reliance

### 23 Plate Bakelite Vernier Condenser

The RELIANCE 23 plate Bakelite Vernier Condenser is made and guaranteed by us to be mechanically and scientifically correct in every detail concerning construction and capacity.

The 23 plate RELIANCE comes complete with dial and knob—price \$3.75 F. O. B. Chicago. The 11 plate vernier is \$3.50 and the 43 plate \$4.00. Our products are sold exclusively thru jobbers and retailers but if your dealer can not supply you, write us direct.

We manufacture 20 other types of Vernier Condensers. For FREE on request. Manufactured and Guaranteed by

RELIANCE  
Die & Stamping Co.  
505 N. La Salle St., Chicago, Ill.



**NEW RECORD**

*Continued from page 39*

(often), 8blh, 8bxt, 8dqh, 8cgj, 8nb, 8afd, 8bdv, 8byn, 8apv, 8avd, 8tr, 8bcp, 8adg, 8czz, 8aqo, 8cei (often), 8caz, 8se, 8ctz, 8cqj, 8gz, 8alt, 8apv, 8cwu, 8zc, 8ab, 8bxx, 8bcp, 8dhq, 8bxt, 8dgo, 9ox, 9cyf, 9cgu, 9czw, 9ccs, 9cns, 9awm, 9aic, 9aps, 9cp, 9rc, 9ac, 9bly, 9elv, 9doe, 9mc, 9dyy, 9ccm, 9djb, 9bly.

**Stations Reporting 6XAD-6ZW**

1ccr, 1aoe, 1ajx, 1adn, 1rv, 1bqd, 1bt, 1bsp, 1mo, 1bni, 1ii, 1ka, 1sn, A. Zavorella, W. Hartford, Ct., 1afa, 1ali, 1rv, 1cdo, 1bvb, 2bt, 2bqc, 2bww, 2cdm, 2adh, B. C. Lord, Mahwah, N. J., 2bqb, 2kf, 2aah, 2ciz, 2brb,

2cee, 2cqj, 2cwk, 2cxv, 2cxd, 2bxw, 2bbn, 2cei, 2adu, 2cla, 2cmk, 2ctf, 2cla, 2cuv, 3bfe, J. Lacey, Washington Grove, Md., 3bsb, 3bgg, Holland Bros., Crisfield, Md., 3bji, 3bdo, 3bpm, 3aic, Master Sergeant Silvermaster, Camp Meade, Md., 4eb, 4io, 4qf, 5na, 4kj, E. J. Bourgeois, Baton Rouge, La., 5mb, 5kr, 5amh, 8boa, C. W. Boltz, Buffalo, N. Y., 8amr, 8alm, 8bvd, 8abx, 8sz, 8nq, 8yae, 8aoi, 8djd, C. Vogt, Cinn., O., 8bke, 8wy, 8bhe, 8ced, 8hj, 8bvj, 8aun, 8dpg, 8wz, 8dfv, 8bnh, H. Brown, Connellsville, Pa., 8xh, 8nq, 8cux, 8px, 8cwr, 8cnl, 8bjn, 8eb, 8amr, 8ddq, 8deg, E. Poyser, Canton, O., O. Hagen, Stoughton, Wis., 8dcw, 8qn, 9dc, 9bpy, 9cah, 9cvs, 9bij,

9bhk, 9yb, 9hk, 9efc, 9aqq, 9ckt, 9bsh, 9zt, 9vc, 9ctc, 9bat, 9dzs, 9aro, 9ceq, 9cfd, 9boo, 9cpo.

**Canadian List.**

*Worked:* 2bn (Montreal), 3si (Toronto), 4cn (Winnipeg), 5hg (Vancouver).

*Reporting 6XAD-6ZW:* 2cg (Montreal), 3bm, 3mv, 3gg (in Timiskaming wilderness), 3jt, 3adu, 3du, 3jl, 3si, 3ws, 3abg, 4fc.

*Notably:* 1bq (Halifax, Nova Scotia) and 9ak (Prince Edward Island, N. Atlantic Ocean).

**Australia and New Zealand.**

*Reported by:* L. S. Spackman, 1ac; G. H. Robins, Auckland, N. Z.; Charles Maclurcan, Sydney, Australia. The above gentlemen copied complete messages that I was transmitting to East-Coast (U.S.) stations. I was also reported by Major Prescott, Signal Corps, Panama, and from Bagnio, Philippine Islands.

My report on work with WNP needs be but brief: He is consistently QSA at my station, and from the first time that I actually exchanged signals with him—on November 17th, at 1:50 A.M. (Pacific Standard time)—I have worked him effectively nearly every night.

One word about the fine reception of Mr. J. D. Brewer, at Ada, Ohio. In a report to me he correctly states work that I was doing with WNP, and also quotes WNP correctly!

Using a Grebe—CR-6—the following BC stations have been distinctly heard, the majority of them sufficiently QSA to put on the WE-loud-speaker: kdka, kdpm, kdyl, kdys, kfec, kfgj, kgb, kgn, kgu, kgw, klx, kmo, kpo, kuo, kzn, kyw, waaf, waak, wmap, wbay, wbu, wby, wbz, wcae, wca, wcx, wdae, wdaf, wdam, wdap, wdar, weaf, wean, wfaa, wfat, wgaz, wgi, wgr, wgy, whas, whn, wip, wjan, wjaz, wjy, wnat, wmaq, wco, wor, wqan, wqao, wsb, wsl, wsy, wwj.



**Bristol One Stage Power Amplifier**

**No C Battery Required**

A unit that can be used as a third stage without howling. The usual objections against a third stage of audio-frequency amplification are entirely eliminated by the use of the new Patented circuit.

The Bristol One Stage Power Amplifier does not require separate "A" or "B" battery. It uses common tubes such as U.V. 201A, 216A and U.T.2.

A remarkable achievement—a third stage audio that works RIGHT—install one today and give that distant station a chance to come in like the locals.

Ask your dealer or send for bulletin 3011-W.

Give your loud speaker a treat.

**THE BRISTOL COMPANY**

Waterbury, Conn.

BRANCH OFFICES:

Boston New York Pittsburg Philadelphia Detroit Chicago St. Louis San Francisco

**New "Regal" Products This Season—Ask Your Dealer Why They Are Better**

New "Regal" Double Arm Inductance Switch with Hard Rubber Knob and Dial No. 162



A 15 point Inductance Switch complete in one unit. No more messy soldering—no more drilling of holes with chipped panels—no more switch points to assemble. Mounted on panel with one bushing. Ask for the genuine "REGAL." Complete with Knob and Dial \$1.50

New "Regal" Vernier Rheostat No. 120

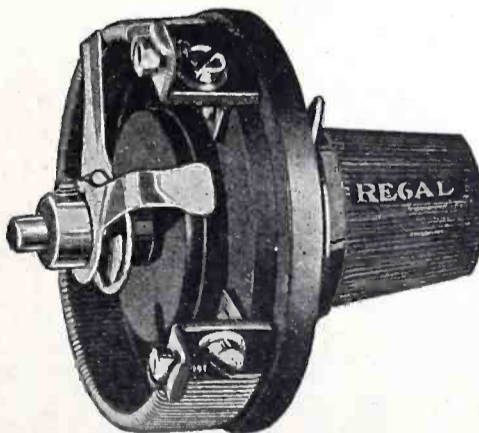

A Vernier Rheostat the trade has been waiting for. Smooth filament current control, enabling finest adjustment.

A superior Regal Product for exacting radio fans.  
6 Ohms ..... \$1.25  
30 Ohms ..... 1.25

If Your Dealer Does Not Carry Regal Products We Will Ship Direct. Send Us Your Dealer's Name and Ask For Our Catalog No. 22 Showing Our Complete Line of 30 Regal Items.  
**THE AMERICAN SPECIALTY COMPANY, Bridgeport, Conn.**

**Burns Loud Speaker for Phonograph or Horn**

Excellent volume, pleasing tone. Used with any set having amplification.



The Burns Speaker Unit is adaptable to phonograph or loud speaker horn. No battery required. Convenient adjuster for regulating tone.

Speaker Unit only ..... \$10.00  
Complete with horn ..... 20.00

**HEAD SETS**

These several styles of Head Sets have been designed to meet requirements of different types of receiving sets.



Victor ..... \$5.00  
Keystone ..... 5.00  
Swedish-American ..... 6.00  
Army & Navy 2500 ohm ..... 8.00  
Army & Navy 3200 ohm ..... 10.00

Dealers' inquiries solicited

**American Electric**  
COMPANY  
Chicago, U. S. A.

Tell them that you saw it in RADIO

**CALLS HEARD**

*Continued from page 54*

**By 6AAN, Calwa, Calif.**

6bih, 7it, 6bba, 6gt, 6bur, 7ag, 7st, 6awy, 6cdg, 6cmz, 6bcs, 6bua, 6aug, 6cnl, 6bcj, 7to, 6cgw, 7qt, 6cmd, 6bp, 6cw, 6blo, 6aat, 6ot, 6bw, 6aol, 6cmi, 6pl, 6aar, 6bbm, 6bio, 6bic, 6brf, 6oh, 7bz, 9ach, 9cw, 9tv, 6bsm, 5rm, 5an, 6ahu, 6buy, 6aw, 6cih, 6buh, 6blg, 6cgd, 9dww, 6adr, 6avj, 6bfg, 6bjc, 6bqr, 6bsg, 6ada, 6aal, 6acv, 6bqa, 6bmg, 6bbw, 6lx, 7ob, 7sz, 6awx, 6vd, 9yk, 6bom, 6fp, 5la, 6agk, 9bjk, 7ot, 6ckr, 7sy, 6mh, 6ege, 6cia, 6cfz, 6caw, 6bjj, 6bpw, 6dt, 6ceb.

**By Radio 3BVA, 40 S. Beaver, St., York, Pa.**

C. W.: (4bx), (4bw), 4eb, (4mi), 4qf, 4za, 5bw, 5ek, 5fu, 5fv, 5hl, 5in, 5kc, 5kg, (5lr), 5mi, 5ov, 5qf, 5ua, 5uk, 5up, 5uy, 5xv, 5za, 5aat, 5abt, 5abh, 5adi, 5aij, 5aja, 5akn, 5alj, 5amh, (5xac), (5zas), (5zav), 5zax, 6cgw, 6xad, 6zah, 6zr, 6zw, 7zu, 9id, 9ig, 9ih, (9ox), 9ss, 9wu, 9zt, 9aaw, 9aec, 9aek, 9aic, 9ajv, (9aps),

9apf, 9aou, 9aqk, 9awv, (9azj), (9aus), (9ayh), 9bak, (9bez), (9bff), 9bdl, 9bfi, 9bge, 9bhd, 9bly, 9bna, 9bqj, 9brx, 9btt, 9bvn, (9bwa), 9bzt, (9bzi), 9ceck, 9cgy, 9cml, (9cnb), 9cte, 9cyt, (9day), 9ddu, 9dct, 9dcw, 9dfh, 9dis, 9djb, 9dki, 9dlf, 9dlg, 9dpx, 9dtt, 9dxy, 9dwn, 9eak, 9edm, 9eky, (9elv).

Can. C. W.: 1ar, 2ic, (3hq), 3oh, (3ni), 4cn, 4dy, 4er(?), 5cn, (9bx).

**By 8CTQ, Walter C. Olson, 103 Sturgis St., Jamestown, N. Y.**

C. W. (all 1,000 miles or over): 5abc, 5ac, 5acs, 5adh, 5ahd, 5aiu, 5aje, 5akn, 5ama, 5amh, 5anv, qra? 5be, 5dw, 5gg, 5ga, 5gi, 5gj, 5ht, 5je, 5jn, 5kc, 5kg, 5lr, 5mn, 5nj, 5nn, 5op, 5ov, 5qi, 5qq, 5qy, 5uk, 5up, 5za, 5zav, 6alk, 6alv, 6anb, 6bbu, 6bel, 6bic, 6bih, 6bm, 6bbw, 6bpz, 6bqc, 6bql, 6brf, 6bua(?), 6buo, 6bve, 6bvs, 6bwe, 6bwp, 6ebd, 6ebu, 6cc, 6cfi, 6cgd, 6ego, 6cgw, 6chl, 6du, 6en, 6et, 6fh, 6fy, 6ii, 6iq, 6nx, 6pl, 6vf, 6zah, 6zh, 6zar, 6zz, 7am(?), 7be(?), 7agr, 7ih, 7sf, 7du, 7wm, 7zd, 7zl, 7zu, 9amb, 9apf, 9auw, 9bjs, 9caa, 9cfy, 9evc, 9dyl.

**By HJ, J. J. Young, 717 W. Gray St., Elmira, N. Y.**

(1bvb), 4qf, 5zav, 5kc, 5za, 6pl, 6asx, 6zz, 6cgw, 6bih, 6avv, 6ak, 6cbu, 6cc, 6lv, 6bes, 6bua, 6bbu, 6chu, 7abb, 7ks, 7ky, 7zd, 7ads, 9amb, 9dll, 9caa, 9bjk, 9css, 9bxm, 9bji, 9dte, 9apf.

Can.: 4ay.

**By 6ZAT-6UW, L. Farwell, Los Gatos, Calif.**

1er, 1mo, 1yb, 1bkq, 2bnu, 2cxl, 3ko, 3zs, 3aao, 4gx, 4ku, 4za, 5kc, 5oo, 5tj, 5vv, 5acf, 5acc, 5zav, 8ab, 8er, 8fu, 8gz, 8ig, 8sz, 8uf, 8vn, 8vt, 8xe, 8zz, 8acn, 8afd, 8aft, 8aih, 8ajh, 8aqm, 8awp, 8axz, 8bbi, 8bcu, 8bda, 8bfm, 8bjv, 8bob, 8bzc, 8ced, 8cjo, 8crw, 8cwk, 8dat, 8dgo, 8div, 8djp, 9eq, 9es, 9kp, 9mc, 9pw, 9adn, 9aom, 9ahz, 9aog, 9aow, 9api, 9aps, 9ase, 9avn, 9avs, 9bhz, 8bjk, 8blv, 8bz, 9ccv, 9cgu, 9ckp, 9ckw, 9ctg?, 9czw, 9dor, 9dct, 9dgi, 9dpx, 9dqu, 9dsm, 9dsr, 9dtm, 9dxn, 9eeg, 9efg, 9eky, 9elv.

Can.: 3ba, 3co, 3ie, 3ni, 3tb, 4cw, 4cn. Drop me a line if you want a crd om.

**Why do you do it?**



**Is your battery always fully charged and fit?**

Is it always toned up for best results, whenever friends happen in—throughout every concert?

Keep it at full strength and prolong its life—the simple, easy, inexpensive Tungar way.

Tungar—the go-between from house-lighting circuit to storage battery—attaches wherever there is a lamp or convenience outlet.

You don't have to move the battery. Just connect Tungar, and leave it—any time, day or night.

Tungar is *certain, clean, quiet*. No moving parts to get out of order or make noise.

Good for the auto battery too—the same Tungar.

See one at any good electrical store, or write for literature. Address Section Rd5.

*Tungar Battery Charger. Operates on Alternating Current.*  
2 Ampere Outfits—\$18.00  
5 Ampere Outfits—\$28.00  
(Prices east of the Rockies)

Special attachment for charging 12 or 24 cell "B" Storage Battery—\$3.00—fits either size Tungar.



*Charge 'em at Home, with*

**Tungar**

**BATTERY CHARGER**

Rd1

A GENERAL ELECTRIC PRODUCT

**"START THE NEW YEAR RIGHT"**



**Get a Pair of T-B-H Phones for That New Radio Set and Listen to the Difference.**

"T-B-H JUNIOR"  
16,000 Turns (2000 ohms)  
"T-B-H 6-A"  
20,500 Turns (3200 ohms)

T-B-H Phones are the best. They will not rattle or distort even on two stages of amplification. They are ornamental in design and are durably constructed with aluminum cases.

If your dealer does not carry them, order direct from us. Send no money, just pay the Postman when he delivers them.

**WE PAY THE POSTAGE**

*Dealers and Jobbers write for Discounts*

**The T-B-H Corporation**  
Dansville, N. Y., U. S. A.

**DISTRIBUTORS:**  
Donaldson Radio Company  
Kansas City, Mo.  
Overseas Trading Company  
Chicago, Ill.  
Marie A. Alvarez  
Havana, Cuba  
V. B. & A. C. Johns  
Auckland, New Zealand

"The Kilogram" is an interesting monthly publication from the Kilbourne & Clark Mfg. Co. of Seattle, Wash. In it may be found recent broadcasting news, the Seattle broadcast schedule, new circuits, and many practical hints on radio.

Catalog No. 15 from The H. H. Eby Manufacturing Co. of Philadelphia, Pa., is a beautifully-printed 20-page brochure devoted entirely to the subject of binding posts and insulated knobs.

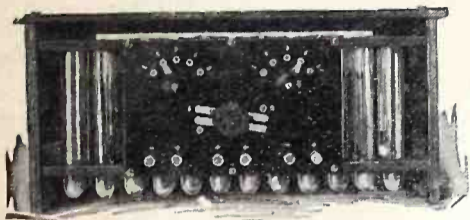

100 Volt Panel Type

**"The most popular in this vicinity"**

"We wish to commend your storage 'B' battery," says the Southern Radio Sales Co., Newport News, Va. Such endorsements come to us unsolicited. KIC-O Batteries always make good. Alkaline type, won't sulphate or buckle. Life unlimited. Not harmed by short-circuiting, overcharging, idleness. Panel switches give single cell variations. Recharge from any 110-volt A. C. line with small home rectifier. Charge lasts 3 to 6 months in detector plate circuit.

**GUARANTEE**

Your money back on any KIC-O Battery if not satisfied within 30 days.

Write for full information on "A" and "B" Batteries.

Unmounted Rectifier \$1.00  
Mounted Rectifier \$2.50

Cells	Volts	Price, Plain	With Panels
16	22	\$ 5.50	.....
24	32	7.25	\$11.75
36	48	9.50	14.00
50	68	12.50	17.00
78	100	17.50	22.50
108	145	23.50	28.50

**KIMLEY ELECTRIC COMPANY, Inc.**  
2661 MAIN STREET BUFFALO, N. Y.

**KIC-O** Storage "B" Batteries  
--long service, low cost

*The New Freshman*  
**CAPACITY FINDER**

permits you to actually measure the condenser values necessary in your hook-up.



**31**  
capacities  
for the  
price of  
**5**

**FIND OUT**

just what value of a condenser will give your hook-up the best results in the grid circuit, across the phones, in the antenna circuit, across transformers, battery circuits, etc.

31 different capacities in steps of .00005 up to .0015 possible with this combination.

**Price \$2.25**

including the 5 special Freshman Condensers

At your dealer; otherwise send purchase price and you will be supplied postpaid. Ask your dealer or write direct for complete instructions free.

**Chas. Freshman Co. Inc.**  
*Radio Condenser Products*  
186 SEVENTH AVE., NEW YORK

# BAKELITE

REG. U.S. PAT. OFF.

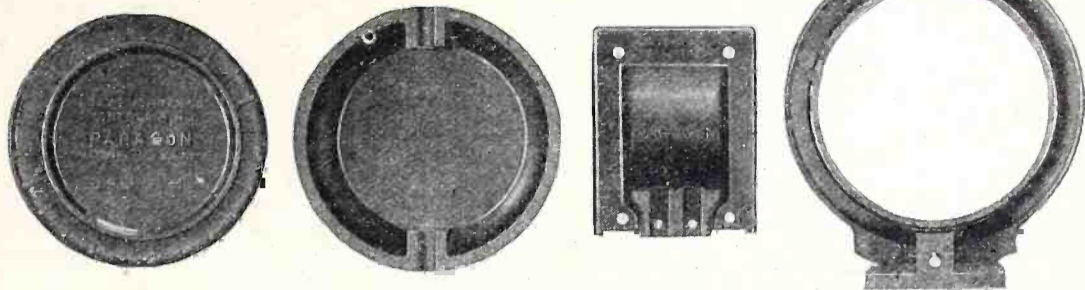

## Paragon and Bakelite

The pleasure and satisfaction that the Paragon Receiver brings to the family circle is appreciably increased through the use of Bakelite.

Bakelite possesses a combination of properties not found in other materials, which makes it peculiarly suitable for this service. Its excellent electric properties provide complete insulation that remains unimpaired under all atmospheric conditions.

Because of its high temperature resistance and non-absorbent properties, Bakelite performs equally well in all climates.

Its great mechanical strength, permanent beauty of finish and color enhances the value of any Radio Equipment in which it is used.

The Adams-Morgan Company chose Bakelite because of these desirable qualities and, for the same reason, leading Radio Manufacturers have adopted Bakelite as standard insulation for the manufacturers of parts and complete units.

Send us your name and address and we will mail you a copy of our Radio Booklet S.

**BAKELITE CORPORATION**

247 Park Avenue, New York, N. Y.  
Chicago Office: 636 West 22nd St.

**BAKELITE**  
Condensite  
*REDMANOL*

are the registered Trade Marks for the Phenol Resin Products manufactured under patents owned by

**BAKELITE CORPORATION**

3275-B



THE MATERIAL OF A THOUSAND USES

## 2000 OHM PHONES FREE

Subscribe to "RADIO" for only 2 years (\$5.00) and we will send you a pair of aluminum case, double 2000 ohm phones free. Fully guaranteed or money back!

"RADIO"—Pacific Bldg.—San Francisco, Cal.

Tell them that you saw it in RADIO

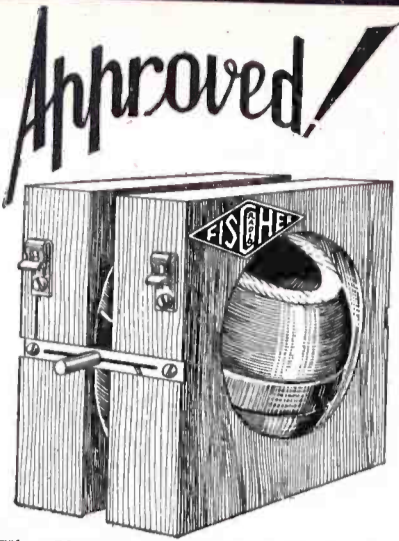

**The Champ—VARIOMETER No. 53**  
**Approved as a Record Breaker**  
*Approved*—because it makes 600 Meters.  
*Approved*—because perfectly constructed.  
*Approved*—because it has a genuine mahogany stator and a kiln dried rotor.  
*Approved*—because of Fahnestock spring clip connections and non-conductive adhesive.  
*Approved*—because—you'll know why when you

**GET ONE FOR \$3.50**  
**20 Diagrams FREE with Each**  
 For sale at your dealer's—otherwise send the \$3.50 directly to the manufacturer and you will be supplied postpaid.

**G. H. FISCHER & CO.**  
 123 Liberty St. New York City

**NEW RADIO CATALOGS**  
 An unusually complete catalog of radio apparatus produced by America's leading manufacturers has just been issued by Pettingell-Andrews Co. of Boston, Mass. An idea of its comprehensiveness may be gained from the fact that nearly 200 items are listed in the index, ranging from simple parts to elaborate sets. This volume contains 100 pages, 8½x11, including 15 pages of general information for the amateur.  
 An attractive catalog from the Magnavox Company illustrates and describes the principles, the construction and the application of various types of Magnavox reproducers and amplifiers. Diagrams of connections to various kinds of radio sets are shown, together

with considerable information of general interest.  
 Eisemann Radio Products are attractively portrayed in a new catalog from the Eisemann Magneto Corporation. These include head-phones, variometers, variocouplers, variable condensers, a.f. transformers, detector and amplifier units and various styles of metal panels.  
 "Start Right" is the title of an attractive booklet describing and illustrating Radio Current Control Apparatus, manufactured by the Cutler Hammer Mfg. Co. of Milwaukee. This covers rheostats, potentiometers, grid leak, resistance units, one-hole battery switch, battery charging rheostats, radio soldering irons, etc.

## The Fastest Selling Transformers

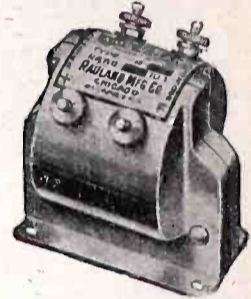

All the "old-timers" must be telling their friends to buy "All-Americans". Always the biggest sellers, "All-Americans" are simply sweeping the boards in popularity this year. If your dealer is supplied, buy without delay.  
**Special Offer!** All-American diagram and circular describing Power Amplification; also Book of Hook-ups containing 22 tested circuits. Send 4c in stamps.

All-American Audio Frequency Transformers—ratios: 3:1, 5:1, 10:1.

**RAULAND MFG. CO., 200 N. Jefferson St., CHICAGO**  
*Pioneers in the Industry*



# ALL-AMERICAN

## AMPLIFYING TRANSFORMERS

*Largest Selling Transformers in the World*

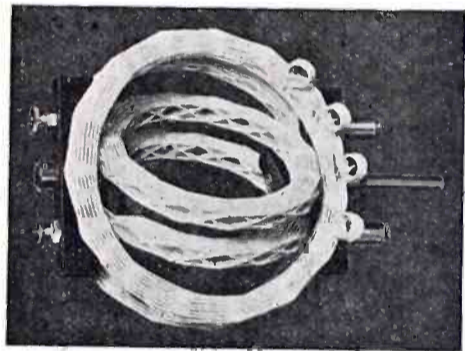

### Diamond Weave Variocoupler an R-M-C Product

Seven-eighths of windings are in mid-air, thus reducing dielectric losses to a minimum.  
 Diamond Weave construction reduces distributed capacity to a minimum.  
 The R. M. C. Variocoupler has a wave range of 150 to 600 meters. The Variometer is the same size and general construction as the variocoupler, and has a variance in inductance of 300 meters.  
 Outside diameter of primary windings is 4½"; of secondary, 3¼"; extreme length 5¼".  
 These R. M. C. products will greatly improve any circuit where a variometer or variocoupler can be used.

Variocoupler	\$4.50
Variometer	\$4.50

Write for catalog of other diamond weave coils, and Radio Frequency Transformer

**THE RADIO MANUFACTURING COMPANY**  
 of Springfield, Massachusetts  
 Dept. D 97 Dwight Street



### The Saturn

## "Above the Ordinary" Radio Products

Automatic Plug

Phone cords connected, disconnected in a moment. Pulling on cords automatically tightens grip, lever instantly releases. No taking apart or soldering.

List Price **\$1**

**Perfect Jack**  
 Easy soldering crowfoot, off-set terminals with solder flux compound, nickel-plated rounded corner brass brackets, spring German silver blades and sterling silver contact points.

List Prices	
No. 1 Single Circuit, Open	50c
No. 2 " " closed	55c
No. 3 Double " "	70c
No. 4 Single Filament control	75c
No. 5 Double " "	80c

Write for Folder  
**The SATURN Mfg. & Sales Co.**  
 48 Beekman St.  
 New York, N. Y.



### HUNT'S UNIVERSAL HAIR-LINE RADIO TUNING DEVICE

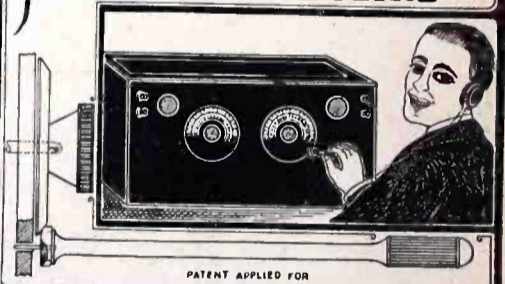

### One Vernier for all Dials

Overcomes Body Capacity.

Gives micrometric adjustment outside the field of inductivity. Tested and approved by amateurs and experts. Enables you to tune distant stations easier and more clearly. Simple as A B C. Installed from outside, no dismantling of your set necessary. Audibility made more natural or less distorted by the fine adjustments obtained. One Hunt's Device handles all dials on set or several sets. Costs only one dollar on guarantee of money refunded if not satisfied. Ask your dealer or order direct from Hunt Co., 484 Shrine Bldg., Memphis, Tenn.

## WD11 and WD12 REPAIRED

ALSO OTHER TYPES OF TUBES for \$3.00

and guarantee them to work like new. We prepay parcel post back to you.

### QUICK SERVICE

**THOMAS BROWN CO.**  
 515 ORANGE ST. NEWARK, N. J.

Tell them that you saw it in RADIO

# MICHIGAN MIDGET

Detector \$27

Amplifier \$30

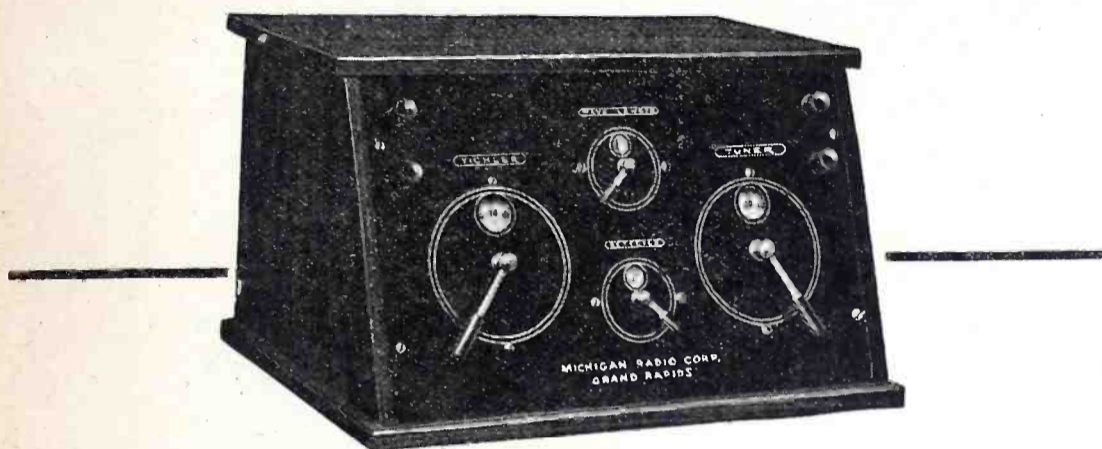

## The Sensation of Radio

No matter what you pay, you can't get a receiving set that will give you any better results than the Michigan "Midget."

*Distance*, it has received in Grand Rapids, stations from coast to coast.

*Selectivity*, the smallest turn of the dial throws out or brings in stations.

*Clearness*, the clearness of the reception will surprise and please you.

*The cost*, you could not build a set, buying the parts yourself, at anything like the price at which the Midget is sold.

Made in these styles:

M 10 Midget Detector . . . . \$27.00

M 11 Midget Amplifier . . . . 30.00

M 12 Midget Detector and Amplifier in one case . . 57.00

Ask your dealer to demonstrate this wonder to you.

*Write us for illustrated folder*

## MICHIGAN RADIO CORPORATION

GRAND RAPIDS, MICHIGAN

# GAROD-RAF

A better NEUTRODYNE with the 5 Points of Superiority.  
The NEW MODELS are now out.

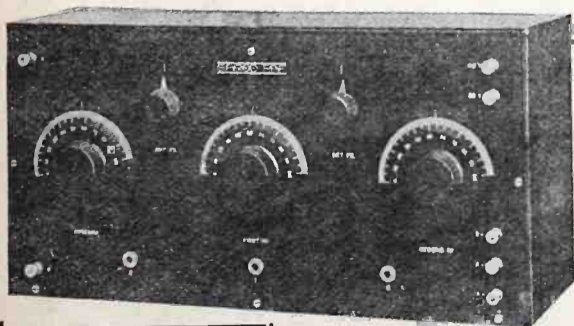

**JOBBER  
PLEASE WRITE  
FOR TERRITORY**

*Until the present time our supply has been far below the great demand. We can now make shipments of this—the greatest of all Neutrodyne.*

Factory Representative:—

**E. A. CORWIN**

333-11th St., San Diego, Cal.

# The Radio Sensation of the Coast

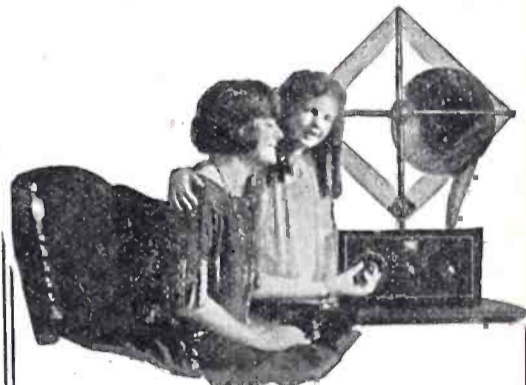

## SLEEPER MONOTROL

Wherever you go you find the Sleeper Monotrol making nightly records that no other radio receiving set approaches.

In Texas, owners boast of hearing New York whenever they wish. In the lonely mountains of North Carolina you will find the Sleeper Monotrol in two hundred homes, while in Los Angeles it has been the radio sensation of the year.

If you have heard the Sleeper three-tube set at any friend's house you will understand why it has become the most popular receiver on the Western Coast. But you have yet a surprise in—

### The New Sleeper FOUR TUBE Monotrol

You have supposed that no set could be more perfect than the 3-tube Sleeper model, but this new four-tube gives you even greater volume, pick-up and punch.

With no outdoor aerial or ground connection it seems impossible that any set could bring in so many stations with so little tuning and such exceptional loudness and clarity. Truly there is no set like it. You can prove this without question if you will have your dealer send one home and try it out yourself tonight.

## Sleeper Radio Corporation

88 E. Park Place, New York, N. Y.

**WEST COAST REPRESENTATIVES**

A. S. Lindstrom,  
111 New Montgomery St.,  
San Francisco, Cal.

H. A. Killam, Electric Sales Corp.,  
312 McKay Bldg., 1144 Maple Ave.,  
Portland, Ore. Los Angeles, Cal.

George H. Maire,  
95 Connecticut St.,  
Seattle, Wash.

Alexander & Lavenson Elect. Supply Co.  
926 Howard St., San Francisco  
San Francisco Jobbers

Tell them that you saw it in RADIO

# ★ ★ RADIO ADS ★ ★

**A CLASSIFIED ADVERTISING SECTION READ BY BETTER BUYERS**

The rate per word is five cents, net. Remittance must accompany all advertisements. Include name and address when counting words.  
**ADS FOR THE FEBRUARY ISSUE MUST REACH US BY JANUARY FIRST**

**C. W. and RADIO PHONISTS**—Our new converters will satisfy your need for a more efficient and durable direct current plate supply. No armatures to burn out. Output from seven hundred to two thousand volts at .4 amperes. Synchronous Motors, Transformers and other parts sold separate. Write immediately. Kimley Equipment Mfg. Co., 290 Winslow Ave., Buffalo, N. Y. (tc)

**ARC & SPARK SYSTEMS**  
 Send for Descriptive Circular QRD.  
 Interesting and Instructive. (tc)  
 Pacific Radio School 433 Call Bldg., San Francisco

**BRANCH MANAGERS WANTED AT ONCE.**  
 WOULD YOU LIKE TO TAKE THE MANAGERS CHAIR AND DIRECT SALESMEN IN YOUR TERRITORY, EACH ONE OF THEM BRINGING YOU A GOOD PROFIT?  
 OUR NEW BUSINESS METHOD IS SO PROFITABLE THAT TERRITORY IS BEING ASSIGNED RAPIDLY. WE ARE GETTING SALESMEN ALL OVER THE COUNTRY AND MUST HAVE YOUNG MEN TO MANAGE THEM.  
 QUALIFICATIONS NECESSARY:  
 WE PREFER YOUNG MEN;  
 MUST HAVE HAD SOME EXPERIENCE ASSEMBLING RADIO SETS, OR HAVE YOUNG MAN AS ASSOCIATE WHO HAS HAD SUCH EXPERIENCE;  
 MUST BE ABLE TO GIVE REFERENCE.  
 IF YOU THINK YOU MIGHT WANT THIS PLACE DON'T WAIT, WRITE AT ONCE, SOME ONE ELSE MAY BEAT YOU TO IT.  
**NATIONAL RADIO SERVICE CO.,**  
 858 PACIFIC BLDG., SAN FRANCISCO, CAL.

**RADIO WORLD, THE GREAT NATIONAL WEEKLY**—published every seven days with all the latest news, developments and pictures of the radio field. 15c a copy. \$6.00 a year (52 numbers), \$3.00 six months, \$1.50 three months. Special to radio readers. Send \$1.00 and we will send you the next eight issues of RADIO WORLD. Pub. Office, 1493 Broadway, New York. (tc)

**WE CAN USE MORE SALESMEN.**  
 OUR NEW BUSINESS METHOD IS HELPING NEW RADIO SALESMEN TO MAKE QUICK SALES AND BIG PROFITS. WE FURNISH LIVE LEADS AND ASSIST YOU IN CLOSING SALES. EASY TERMS, LONG TIME TO PAY IS MAKING SALES EVERYWHERE. IF NO MANAGER APPOINTED IN YOUR TERRITORY, SEE OUR "MANAGER ADV." ABOVE.  
**NATIONAL RADIO SERVICE CO.,**  
 858 PACIFIC BLDG., SAN FRANCISCO, CAL.

Vacuum Tube Hospital  
 We repair and guarantee them.  
 Agents, Dealers, and Customers Wanted.  
 George H. Porell Co., Inc.  
 West Somerville, Mass. (tc)

**RADIO MECHANIC WANTED.**  
**NATIONAL RADIO SERVICE ASSOCIATION** WANTS RADIO MECHANIC IN EVERY TOWN TO ASSEMBLE A NEW SUPER-RADIO FREQUENCY RECEIVER AND TO GIVE SERVICE ON OTHER KINDS OF SETS. WELL ADVERTISED REGULAR INFORMATION FROM THE ENGINEERING DEPARTMENT IS VERY VALUABLE, BEST OF CHANCES TO GROW UP WITH THE RADIO INDUSTRY. BIG PERCENTAGE PROFIT.  
**NATIONAL RADIO SERVICE CO.,**  
 858 PACIFIC BLDG., SAN FRANCISCO, CAL.

**C. W. AND RADIOPHONISTS.** One hundred Ohio and Wagner 110v., sixty cycle A. C. synchronous motors built in 1/4 H. P. frames with 1/2" shafts are yours for \$18.00 each F. O. B. Buffalo, N. Y. Original selling price \$28.50. We also have the parts to attach to these motors to make synchronous rectifiers which will handle 2000 volts. **KIMLEY ELECTRIC CO., Inc.,** 2665 Main St., Buffalo, N. Y.

A good pair of phones free. The new Navy Type \$8.00 Atlas adjustable diaphragm headsets will besent free of charge to anybody sending us five subscriptions to "RADIO" for one year each. Send \$12.50 to cover full payment and the phones are yours. "RADIO," San Francisco.

**RADIO GENERATORS**—500 Volt 100 Watt \$28.50 each. Battery Charger \$12.50—High Speed Motors. Motor-Generator Sets, all sizes. **MOTOR SPECIALTIES Co.,** Crafton, Penna. (tc)

**FOR SALE**—1000 V. 250 Esco Motor Generator, practically new—\$100.00; regular price \$154.00. Western Elec. Power Amplifier, complete, practically new, \$100.00; regular price \$161.00. Magnetic Modulator 3 1/2 Amps. \$5.00. Magnavox Transmitter \$8.00; regular price \$25.00. C. W. Inductance \$4.00. Two 5-watt tubes, new, \$5.00 each. **C. BROWN,** Redding, Calif.

**FOR SALE.**—Large stock of Radio Apparatus. Write immediately for reduced price list. **Carlton Tennant,** Box 565, Fort Dodge, Iowa.

**MUST SELL** my two-step radio-frequency detector and two-step audio-frequency receiver, complete. Tubes include three Signal Corps VT-11's and two C-301A's. Storage batteries with tube rectifier. **Joe Cappa,** Sunnyvale, Cal.

**VACUUM TUBES REPAIRED AND GUARANTEED**

WD-11-12 .....	\$3.50
U.V.201-A .....	3.50
U.V.199 .....	3.50
U.V.200-201 .....	2.75

**ARLINGTON RESEARCH LABORATORY**  
 27 Warren St., New York City  
 Tubes returned Parcel Post C.O.D.

2 Kilowatt transformers and reactances, 220 to 12,000 volts, 500 cycles, absolutely new, \$60.00 per set. **R. A. Ghigliotti,** 5503 Telegraph Ave., Oakland, Cal.

**FOR SALE.**—1 National Monodyne Tube Set. Brand new, \$6.50. **Maurice Bergerson,** Hartford, Wash.

**SMALL FUSE WIRE** Protects tubes, generators, etc. Sizes 1/8 ampere up. Five feet assorted, 50c. Specify load. **9CZP,** Junction City, Kansas. (tc)

**TUBE SPECIAL—GUARANTEED**

1 1/2 Volt Tubes .....

With regular base—like W.D.12 .....

\$4.25

**ARLINGTON RESEARCH LABORATORY**  
 27 Warren St., New York City

**COPPER BRAID**—best conductor known for high frequencies. Twenty-five sizes. No. 9 for CW inductances, 50 feet \$4. **9CZP,** Junction City, Kansas. (tc)

Westinghouse Aeriola Junior crystal set—\$15. Panel-mounted crystal set in cabinet—\$10. **G. Nogues,** Mayfield, Calif.

**MAKE BIG MONEY OUT OF RADIO**

Thousands of People want to buy a good Radio instrument. They have read that vast improvements have been made and they are ready to buy now if you show them the best.

It is one thing to make a good radio instrument for your own amusement, but why not cash in now on your experience? Let us send you full particulars of the Ozarka Plan which shows you how to

**"MAKE \$120 WEEKLY"**

selling long-distance Radio sets. The season is on right now. Let us tell you how to combine the clear signal of the crystal detector with the distance of the vacuum tube. Write today and don't fail to give the name of your county.

**OZARKA INCORPORATED**  
 814 Washington Blvd., Chicago

**MAGNAVOX R3 or M1.** Latest nationally advertised reproducers. List \$35. Introductory \$25. The factory sealed carton is your guarantee. **Radio Central,** Dept. P, Abilene, Kansas.

**BIG BARGAIN:** U.V.199, U.V.201A, W.D.11, W.D.12—\$5.65; Loud Speaker with Baldwin Unit—\$11.00; Freshman Variable Grid Leak with Condenser—80c; \$10.00 Phones bought at auction—\$4.00; Rheostats up to 40 ohms—50c. Everything postpaid. Anything in Radio line cheap. **Walter Wickstrom,** 2224 Melrose Street, Chicago, Illinois.

**RCA UL-1008 OSCILLATION TRANSFORMERS** at \$9.90 PREPAID. (See page 8, November RADIO.) **I SELL ALL RADIO CORPORATION OF AMERICA PRODUCTS** at 10% DISCOUNT, and SHIP SAME PREPAID. **EDWARD GIESEKE,** Radio 9EBH, 312 So. LIBERTY ST., ELGIN, ILLINOIS.

Lightning strange battery compound. Charges discharged batteries instantly. Eliminates old method entirely. Gallon free to agents. **Lightning Co.,** St. Paul, Minn.

**Grebe Dials,** 4-in. tapered grip, \$1.50; **Nathaniel Baldwin (C)** \$10.00, Singles \$5.00; **DeForest Vernier Condensers .0015** \$12.00—.001 \$11.00; **UV199, WD11, WD12, UV201A,** \$5.95—**King Amplitone Horns** \$6.00; **Pathe Molded Variometer or Variocoupler** \$3.75; **Erla Reflex Transformers** \$4.50, **Samson Transformers** \$6.50; **Pathe Dials,** Almost duplicate of Grebe, 4-in. \$1.25, 3-in. \$1.00, **Rheostat Dial 90c;** **Thordarson Transformers** 3-1 \$3.50, 6-1 \$4.15, **Federal 65** \$6.75; **Acme Radio or Audio** \$4.25; **Murdock Phones** 2000 \$3.75; 3000 \$4.25; **All-Wave Couplers** \$6.50, **Push-Pull Transformers** \$12.50 Set; **Fada Triple Sockets** \$2.75, **Brandes Superiors** \$5.25. Everything Postpaid. Write for prices on anything in the radio line. Dealers, get our discount sheet.

**Hendrick Radio Equipment,**  
 85 West 181st Street, New York City

**RADIO CORPORATION, ACME, THORDARSON TRANSFORMERS, JEWELL METERS, POWER TUBES, FILTER CONDENSERS and CHOKES, and EVERYTHING FOR THAT CW SET. ALSO FULL LINE RECEIVING EQUIPMENT, 10% DISCOUNT ON ALL STANDARD MAKES OF APPARATUS. EDWARD GIESEKE,** Radio 9EBH, 312 So. Liberty St., ELGIN, ILL.

Circumstances force me to sell my Radio Equipment, which consists as follows:

1 pair Baldwin C Phones .....	\$ 8.00
1 Two-plate Vernier Condenser .....	1.00
3 All American R.F. Transformers, each .....	1.75
1 Honeycomb 300-turn coil .....	1.00
1 Honeycomb 35-turn coil .....	.50
1 Honeycomb 1250-turn coil .....	1.50
1 Honeycomb 1500-turn coil .....	1.50
1 Remler Moulded Variometer .....	4.00
3 Two-Stage Filament control Jacks, ea. ....	.65
1 R.C. Vocarola Phonograph Attachment .....	8.00
10 Micadons .00025, each .....	.20
1 Truetone Horn with Baldwin C. Unit .....	6.50
1 Regenerative Set complete with dry cell tube and all batteries in cabinet .....	45.00
1 2-stage R.F. detector and 2 stages A.F. complete in walnut cabinet with 5 tubes 12x20 panel .....	110.00
1 3-stage R.F. detector and 2-stage A.F. completely shielded cabinet with 6 tubes, size of panel 12x24 .....	135.00

Everything Standard Material only, in guaranteed New Condition, shipped postage prepaid on receipt of Money Order and the guarantee of money refunded if not satisfactory.

**H. C. PETZWAL**

1111 1/2 19th Street Sacramento, Calif.  
**Spiderweb Inductance Coil for Reinartz.** 22 taps. Green wire. No shellac. Covers 700 meters. Marvelous selectivity. Unequaled for D.X. 95c postpaid with hookup. Satisfaction guaranteed. **Greenweb,** 3157 Broadway, New York City.

**SALESMAN, REPRESENTATIVES, OUT OF TOWN TO SELL RADIO PARTS FOR MANUFACTURER. TILLMAN PRODUCTS,** 473 HUDSON AVE., BROOKLYN, N. Y.

THEY PAY!

These little ads are big producers.

USE THEM FOR RESULTS!

Tell them that you saw it in RADIO

# Coto

"Built First to Last"

## The Real Enjoyment of Radio Belongs to those who Build

You just double the fascination of radio, planning, assembling and wiring your own set. Also you double the satisfaction of bringing in D. X. stations as far and often further than your neighbor with his ready-made set.

You will find it easy to get splendid results with Coto Radio Apparatus. Your dealer will gladly help and advise you at the start.

**Demand Coto! Get Coto!**  
**A Marvel of Manufacturing**  
**Efficiency and Economy**

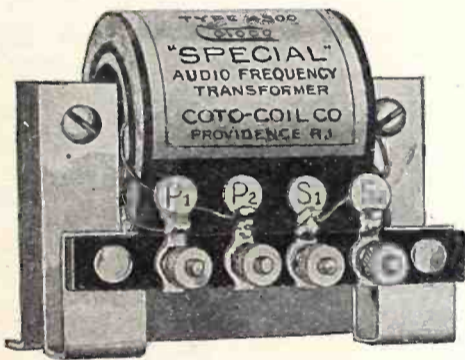

Manufactured in such volume and by such improved methods that we are able to offer a really superior Audio Frequency Transformer at a surprisingly low price. Turn ratio is 3 to 1. Ample volume and tone to satisfy the most exacting.

**\$2.50**

**Jobbers are Ordering in 1,000 Lots**

The Coto line is stocked by Jobbers in all parts of the country. Insist on Coto. If jobber or dealer fails you, write us, enclosing his name.

**Coto-Coil Co.** 87 Willard Ave., Providence, R. I.

**Pacific Coast Branch:**  
 329 Union League Bldg., Los Angeles, Cal.

**Northwestern Branch:**  
 Geo. F. Darling, 705 Plymouth Bldg., Minneapolis, Minn.

**Southeastern Branch:**  
 C. P. Atkinson, Atlanta Trust Co. Bldg., Atlanta, Ga.

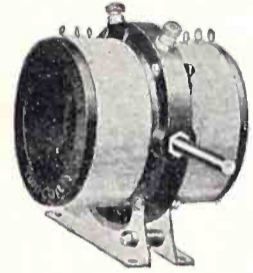

**Coto Compact Moulded Variocoupler**

A companion piece of the Variometer. Size only 3 1/4 x 3 x 3 3/4. Range 200 to 600 meters. Panel or base mounting. Sells on sight. Type 9000. \$5.50.

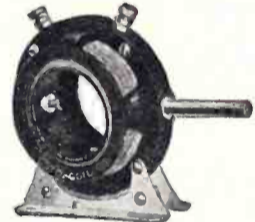

**Coto Compact Moulded Variometer**

Size is only 3 1/4 x 1 3/4 x 3 3/4 inches. Range 200 to 600 meters. Stator is honeycomb wound. Pigtail connections to rotor. Panel or base mounting. In highly polished brown bakelite. Type 8000. \$5.00.



**Coto Compact Air Condenser with Vernier**

Only 2 7/8 inches square. Rotor plates soldered to shaft. Stator plates soldered at three points. .0005 Mfd. \$5.00. .001 Mfd. \$6.00.

**JOBBERS!  
 DEALERS!**

Beyond question it is true that your business success in radio will be measured by the quality of radio apparatus you sell and the service you render to the real radio enthusiasts who are building their own sets.

These are the customers who count. Serve them expertly. Sell them Coto Reliability.



**The Original Honeycomb Wound Inductances**

Popular low-priced favorites of the amateur and experimenter. Allow easy variation of set to receive any desired wave length. Quality maintained second to none. Sold mounted or unmounted.



**Coto Tapped Radio Frequency Transformer**

Efficiently covers the whole broadcasting range, because it is **tapped**. Just turn the switch. Type 5000. \$7.50.



**The Coto grip Vacuum Tube Socket**

Has unique double positive grip of tube terminal posts. Best hard rubber insulation. Rugged and efficient. Type 7000. 85c.

Tell them that you saw it in RADIO

# Radio Broadcast Contest reveals Bradleystat supremacy for Long Distance Reception



RADIO Broadcast recently conducted a prize contest, open to all radio enthusiasts, for the purpose of interesting amateurs in long-distance reception. Ninety contestants were entered, and the names of all, including prize winners, were published in several issues of Radio Broadcast, after the contest closed.

*How the remarkable Bradleystat records were discovered!*

AFTER the names were published, a letter was written by the Allen-Bradley Co. to each contestant to ascertain what filament rheostat was used in each radio set. Seventy-two reports were received, and after they were tabulated, the most amazing discoveries were made about Bradleystat performance and Bradleystat popularity.

*The Bradleystat captured first place in all leading events!*

The superiority of the Bradleystat was proved, conclusively, by these facts:

1. The First Prize Winner used the Bradleystat in his set.
2. The greatest mileage record of 305,420 miles, total, was made by a Bradleystat user.
3. The Bradleystat was the most popular rheostat in the entire contest.
4. More Bradleystats were used than the next four types of rheostats, combined, see diagram.
5. No carbon or metallic powder rheostat was reported in competition with the Bradleystat in this record-breaking contest.

*Your radio set needs a Bradleystat. Try one tonight!*



**\$1.85**

IN CANADA  
**\$2.50**

PARCEL POST  
10¢ EXTRA

## Bradleystat Leads by Big Margin



### Analysis of Returns

Each line represents a different type of rheostat used in the contest. The numbers indicate how many of each were used. Note the overwhelming popularity of the Bradleystat, first on the list.

**Allen-Bradley Co.**  
Electric Controlling Apparatus

288 Greenfield Avenue

MILWAUKEE, Wisconsin

THE ALLEN-BRADLEY CO. HAS BUILT GRAPHITE DISC RHEOSTATS FOR OVER 20 YEARS

Tell them that you saw it in RADIO



# REMLER

## VARIOMETER

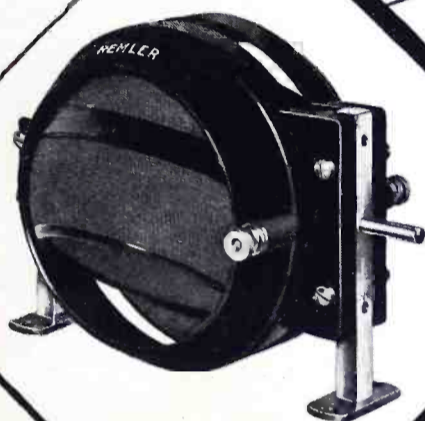

Acknowledged  
Everywhere

AS THE MOST EFFICIENT RADIO ITEM ON THE MARKET

INTERNAL PIGTAIL CONNECTIONS  
—WAVE LENGTH RANGE 180 - 570  
METERS POSITIVELY GUARANTEED

TYPE  
500

WITH  
CLOSED  
ROTOR

\$7.50

FROM the enthusiastic reports constantly received from all points of the country, this new type Remler Variometer has proved a winner in appearance and performance from the day it was placed on the market.

The perfect contact and quiet operation obtained by reason of the pigtail connection between stator and rotor is a big feature in itself, but the low minimum and high maximum wave length—the greatest ever obtained in a Variometer is a Remler accomplishment.

The wave length variation is exactly proportional to the reading of the dial scale. It will cover the entire range of amateur and broadcast wave lengths when used with any vario-coupler. When used with a *Remler vario-coupler* the wave length is guaranteed to be from 180 to at least 570 meters.

All metal parts are buffed and nicked; green silk wire is used on both stator and rotor. The general appearance and quality of the bakelite molding is the best ever built into a radio item.

If your dealer cannot supply you, send the attached coupon direct to us with certified check or postal money order. Write for complete descriptive circular.

Remler Radio Mfg. Co.,  
182 Second St.,  
San Francisco, Calif.

Gentlemen:

As my dealer is unable to supply me with your new Remler Variometer I wish to place my order direct with you and am enclosing certified check or money order for \$7.50.

It is understood that if after a 10 day free trial I find that this Variometer does not conform to your statements, my money will be refunded upon return of the instrument to you in the condition it was received.

Name.....

Address.....

## Remler Radio Mfg. Co.

Home Office

154 West Lake Street  
Chicago

182 Second Street  
San Francisco

30 Church Street  
New York City

# Your Radio-Knowledge Worth Big Money

**M**ANY Radio enthusiasts are so absorbed in the fascinating fun of Radio that they do not realize the big opportunities awaiting them in the commercial field. Thousands of men operating amateur stations have never considered that they can earn amazingly big salaries doing the same easy, interesting work.

Don't waste your knowledge of Radio! Don't use it only as a fad or a hobby. Radio is more than that. It is a gigantic, six-billion-dollar industry—and growing bigger every day! Hundreds of commercial stations are in operation today; thousands more are being erected. Nearly every vessel on the seas is a floating radio station. Hundreds of manufacturers, thousands of stores, millions of people are interested in this great, new, marvelous industry!

## Trained Men Needed Now

Do you realize what this worldwide expansion means to you? Many land radio interests employ a force of a thousand or more Radio men. Every vessel needs from one to three operators. Schools, stores, factories, newspapers and cities need operators, demonstrators, salesmen, instructors, technicians, designers, inventors, engineers. Everywhere you turn you see the tremendous demand for more trained certified Radio-tricians.

Here is your greatest opportunity for fortune and success. Take advantage of it. Radio needs YOU NOW! Get into this fascinating profession. The field is uncrowded. Jobs are literally going begging for competent trained men. The pay is big, and the work fascinatingly easy.

## "Cash In" On Your Knowledge

Don't be a stay-behind. Don't let the other fellow beat you to the wonderful positions now waiting for you in Radio. Make Radio a profession—not a plaything.

Don't let your Radio-knowledge go to waste. "Cash in" on it—Big!

Thousands of men with no knowledge or experience now, are preparing for wonderful careers in this great profession. Will you allow these beginners to get ahead of you? Will you let them get all the big jobs while you sit idly by? Will you always be satisfied with being just an extra-good amateur when it is so easy to earn big money as a professional Radio-trician?

## "Radio Headquarters" Will Help You

The knowledge you have now of Radio operation and maintenance makes it easy for you to train yourself and obtain a wonderful position. You can work up to positions paying as high as \$10,000 a year. If you are attracted by the adventure and excitement of travel, Radio offers you a glorious opportunity to see the four corners of the earth, with all expenses paid and a fine salary besides, or you can stay at home and take one of the fine positions all around you.

Use your present Radio experience to help you achieve a wonderful success in this great field. America's "Radio Headquarters," the National Radio Institute, has devised an amazing new plan that will complete your Radio education in spare time at home, and enable you to qualify for a Government Commercial operator's license so you can take your place in the Radio profession in the shortest possible time.

One of the features of this remarkable course which is approved by the Government, is that you are furnished free with four wonderful instruments for practical work at home. Among them is the wonderful Natrometer which quickly helps you acquire expert speed and accuracy in sending and receiving code.

In addition to this splendid, simplified short-cut course and the four patented instruments, nationally known Radio experts are your instructors. They correct your papers, give you the advice you seek, help you in every way with their wide experience to become a successful Certified Radio-trician.

## Get This New, Free Book

The National Radio Institute is ready to give you the same practical help that has put hundreds of its graduates on the highway of Radio success. Read the letters in the panel from just a few of our 8,000 students and graduates. You have the basic knowledge now. Just a part of your spare-time spent in learning the professional side of Radio, will qualify you for your career in this field of unparalleled opportunities.

Radio is paying enormous earnings to men all over the country today—it is making hundreds of men wealthy. Find out at once about your opportunity in Radio. Send for the interesting big Book which tells all about the future waiting for you in this great field, and gives complete details of the plant by which the National Radio Institute prepares you quickly in your spare time to become an expert Radio-trician and helps you through its Free Employment Service to a good Radio position. Mail the coupon, or write a letter NOW!

**NATIONAL RADIO  
INSTITUTE,**

Radio Headquarters  
Dept. 10AA

Washington,  
D. C.

**NATIONAL  
RADIO INSTITUTE,**

Radio Headquarters  
Dept. 10AA

Washington, D. C.

Please send me your free book "Your Opportunity in Radio," and how you will quickly train me in my spare time at home to become a certified Radio-trician. Also, tell me how your free employment service will help me to a position and particulars of your special short-time offer.

Name..... Age.....

Address.....

City..... State.....

